

POPULAR MECHANICS

MAGAZINE

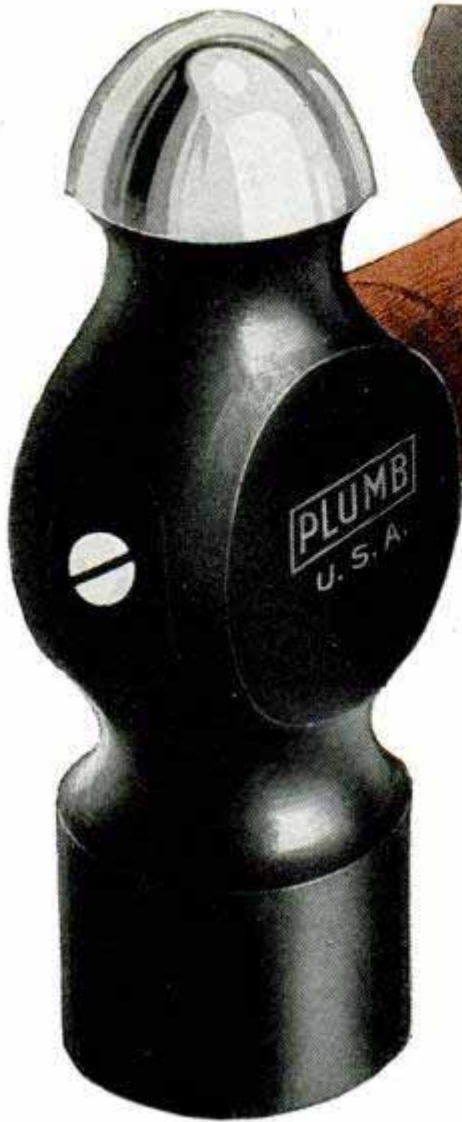
WRITTEN SO YOU CAN UNDERSTAND IT

REGD. TRADE MARK GREAT BRITAIN No. 410426

REG. U.S. PAT. OFF.



SEE PAGE 282



*“One tool
that must be right
is my **Ball Pein
Hammer**”*

— says this garage man

“Power! Accuracy! Balance! I need those qualities in a ball pein hammer as much as I need strength in my right arm,” says Edwin Bennett, Proprietor, Bennett’s Garage, Avalon, N. J.

“Tearing down a transmission . . . driving off frozen parts when taking a job down . . . tapping a center punch . . . riveting . . . on these jobs accuracy counts. A false blow can do plenty of damage.

“Or removing a balky tire . . . straightening a kink in a rim . . . you want power there. Solid blows, with plenty of force.

“Plumb must have studied what garage

men need before designing the Plumb Ball Pein Hammer.”

An expert’s tool! The head is mounted off-center to put more weight behind your blows. Oblong eye takes a sturdy, full-size handle. Cone-shaped pein spreads rivets instead of mashing them.

And the patent screw wedge tightens the handle (when it finally loosens) just by a turn of the screw.

Own a Plumb Ball Pein for your workbench or car. Price—HF 375, 1½ lbs., only \$1.30—and it lasts a lifetime. (Prices slightly higher in Far West and Canada.)



**More Than
Two Million Blows!**

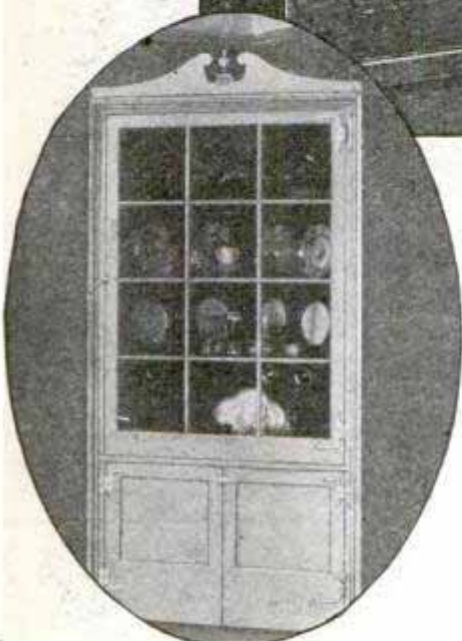
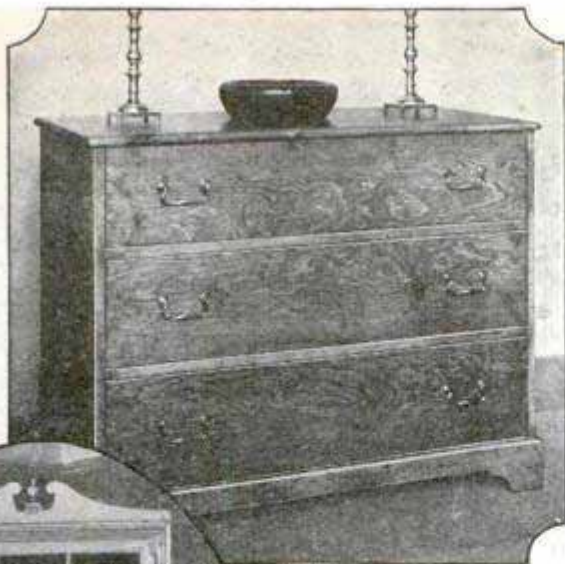
Straightening bayonets during the war, this veteran is estimated to have struck 2,400,000 blows. The pressure of the mechanic’s hand wore grooves in the hard hickory handle, yet the face did not “mushroom” or chip. It is still good for years of service.



FAYETTE R. PLUMB, Inc., Phila., U. S. A.
Send me free booklet “How to Keep Tool Handles Tight.”

Name.....

Address.....



(Above) Cape Cod Chest of Drawers
See LePage's Book, page 3
(Left) Plymouth Built-in China Closet
See LePage's Book, page 6
(Right) Old Salem Ship's Cupboard
See LePage's Book, page 5

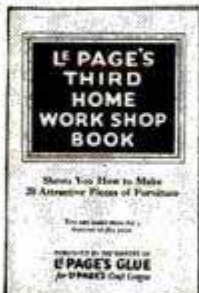
Famous Colonial Furniture You Can Make Yourself

LEPAGE'S New Book Shows How To Reproduce These Beautiful Pieces at a Fraction of Store Prices

12 NEW Job Plans, Too!

There is, of course, a limit to what we can give in LePage's New Third Home Work Shop Book for only a dime. But we realize many men want additional projects. Hence our 12 new Job Plans. These also were made by Mr. Klenke. They are projects that require more elaborate presentations than we can give in our book. Each Job Plan presents one project on a single large sheet of paper. Each is well worth its price, one dime. Look over these projects and order those you want by number (see coupon), enclosing 10 cents for each.

- 16 Sheraton Writing Desk
- 17 Sheraton Desk Chair
- 18 Colonial Hanging Book Shelves
- 19 Smoking and Reading Cabinet
- 20 Colonial Mirror
- 21 Tea Wagon
- 22 Telephone Cabinet
- 23 Stool for Telephone Cabinet
- 24 Manual Training Work Bench
- 25 Home Worker's Tool Cabinet
- 26 Spanish Galleon
- 27 Vanity Table



LePage's latest book, "The Third Home Work Shop Book," contains complete directions for making 20 attractive pieces of household furniture, 5 of which are reproductions of famous old Colonial pieces, including the 3 shown above and in addition, an Alexandria Nest of Tables and a Lady Washington Sewing Cabinet.

This versatile book also gives you for the first time, directions for making 5 pieces of modernistic furniture, so popular today. These include Set-back Book Shelves, Modernistic Desk, Modernistic Table, Modernistic Folding Screen and a Modernistic Fire Screen.

Expert Instruction

Any man handy with tools can make any or all of these 20 pieces of furniture, for a fraction of their retail price, which a careful check in shops showed would be about \$1000 for the 20.

You have expert instruction to guide you. The designs, dimension drawings, photographs, step-by-step directions

and the actual furniture itself were made by William W. Klenke, Instructor in Woodworking, Central Commercial and Manual Training High School, Newark, New Jersey. His experience as an expert gives assurance that each project and the directions for making it are thoroughly practical.

The other popular 10 pieces which this LePage's Book shows you how to make, are: Chess and Checkers Table, Smoking Table, Caned Side Chair, China or Book Cabinet, Book Trough and Magazine Stand, Magazine Carrier, Vanity Case, Book Stand, Fernery Stand and Folding Sewing Screen. Where else could you get complete directions for making all these for only 10 cents?

Send 10 cents for this NEW LePage's Home Work Shop Book

Simply use the coupon below, sending it to us with 10 cents in coin or stamps, and we will at once send you a copy of this latest LePage's Book, postage paid.

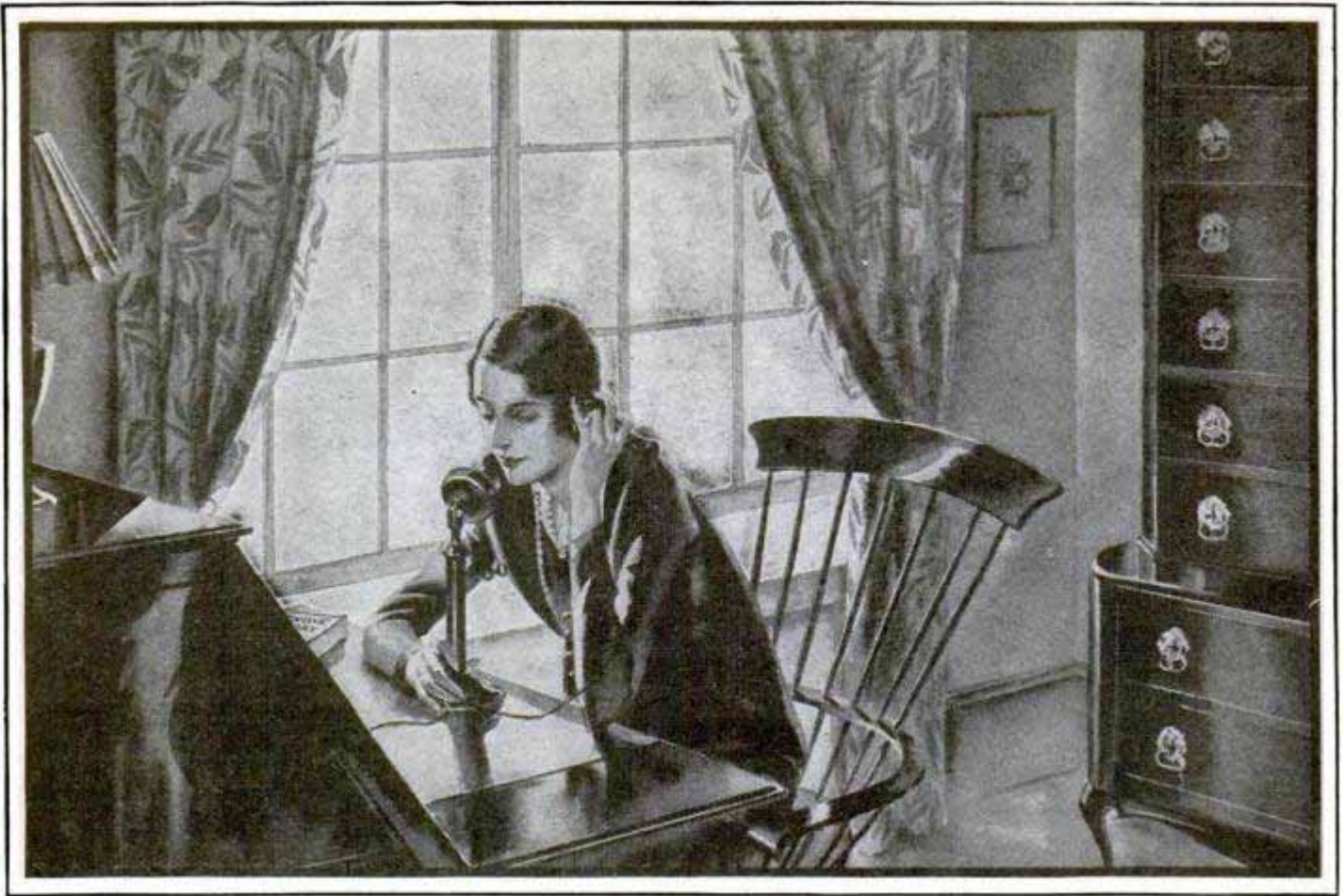
MAIL THIS COUPON

LEPAGE'S CRAFT LEAGUE
619 Essex Ave., Gloucester, Mass.
Gentlemen: Enclosed please find 10 cents (coin or stamps) in payment for LePage's New Third Home Work Shop Book. Please send a copy of this book to:

Name.....
Street.....
City..... State.....

Please also send the following Job Plans..... (Indicate by number those you want. See column at left), for each of which I enclose an additional 10 cents.

**LEPAGE'S
GLUE**
HANDIEST TOOL IN YOUR WORK SHOP



There is no standing still . . .

*An Advertisement of the
American Telephone and Telegraph Company*

DURING the past two years 6000 switchboards have been reconstructed in the larger cities served by the Bell System to enable the operators to give a more direct and faster service.

Previously in towns where there were more than one central office, your operator would hold you on the line while she got the operator at the other central office on an auxiliary pair of wires. Now she connects directly with the other central office and repeats the number you want to the other operator. You hear her do this so that you can correct her if there is any mistake.



This little change cost millions of dollars. Likewise, it saves millions of minutes a day for the public and it has cut down the number of errors by a third.

It is one of the many improvements in methods and appliances which are constantly being introduced to give direct, high-speed telephone service.

There is no standing still in the Bell System. Better and better telephone service at the lowest cost is the goal. Present improvements constantly going into effect are but the foundation for the greater service of the future.

"THE TELEPHONE BOOKS ARE THE DIRECTORY OF THE NATION"

Popular Mechanics Magazine

200 E. Ontario Street, Chicago, U. S. A.

H. H. WINDSOR, Founder

H. H. WINDSOR, Jr., Editor and Publisher

London: Hachette & Cie.,
16-17 King William Street, Charing Cross, W. C. 2

Paris: Hachette & Cie.,
111 Rue Reaumur

Melbourne: Gordon & Gotch
509-513 Little Collins St.

ISSUED MONTHLY

SUBSCRIPTION:

SINGLE COPY, 25 CENTS

In United States and its possessions, also Canada, Cuba, and Mexico, per year, postpaid - \$2.50

To all other countries in the Postal Union 3.00

All subscriptions are discontinued at expiration. Please examine the date printed on your wrapper.

Entered as Second Class Matter Sept. 15, 1903, at the Post Office at Chicago, Illinois, under Act of March 3rd, 1879.

Entered as Second Class Matter at the Post Office Department, Canada.

Published monthly by POPULAR MECHANICS CO.

Copyright, 1929, by Popular Mechanics Co.

Copyright in Australia. Copyright in France

Vol. 51

Contents for February, 1929

No. 2

Special Features

<i>Wireless Light</i> Flying Blind!	194
Two Hours behind the Market!	200
Extra Special Hazardous	211
Do Some Foods Poison You?	227
New Homes from Old	234
What You Should Know about the Weather	242
Exploring the Earth under the Sea	251
Steel Rails to the Midnight Sun	258
The Art of Noise Making	270
How Do They Get That Weight?	274

Acoustics—photographing sound helps improve build-ings	254
Advertising—radio signboard that talks	269
Agricultural Implements—sheep-foot tamper rollers press soil firmly	210
Agriculture	
fruit-jar seed-corn tester	240
lava flow forms rich soil for growing grapes	226
Air Mail—plane picks up mail on fly	288
Airplanes	
cowling for motor increases speed	250
lighted, as bird lure	295
rack for washing planes	257
see safer landings with new altimeter	248
twin-motored seaplane has high speed	281
Animals	
produce moss to decorate hats	267
strange faces to be found only in deep seas	297
Automobiles—Accessories	
chair and baby crib in one	206
chemical cooler for	224
clamps hold luggage on car	268
force ventilator for, is draftless	225
lever that blows horn fits on steering wheel	254
rumble seat top with side curtains	193
steam-heat system for	273
trunk on running board saves extra luggage	223
wiper heats auto windshield	226
Automobiles—Driving—light for hand signal	231
Automobiles—Engines—two-speed, has valve control	205
Automobiles—Repairing	
dashboard holder for tools	281
jack for spring repairs	230
spark plug contact makes changes easy	233
Automobiles—Tires	
changed in seconds with new tool	199
combined hammer and wrench simplifies changing	208
Automobilists—guide map tells weather to aid	193
Aviation	
horn helps guide airships through fogs	240
tuning fork to guide planes in fog	226

Balloon	
observation, easily turned into dirigible	225
pole aids jumper in taking off	249
Bank—deposit money from autos in chute outside	232
Bicycle—radio set built on	241
Books	
at three cents each	257
wax coat on bindings prolongs life	288
Boots and Shoes—wheel that welds, speeds production	199
Bottle—drifts many miles on ocean currents	267
Bridges	
built in sections of precast concrete	268
magnet test on wire reveals defects	283
Building Construction—add new beauty to burned earth of ancients	232
Building Materials—soundproof room devised with new materials	223
Chimes—electric, rung thrice a second	295
China—ideas from, aid Western world	256
Circus—latest stunts thought up by clowns	285
Clothing—aluminum suits to resist tearing	209
Coal—food and fuel from	225
Concrete	
waves in pavements removed with cutter	266
waving flag of, is war memorial	209
Crime—bullet-proof vest has gun, fired in raising hands	226
Cutting Machine—portable, makes many designs	289
Diamonds	
find in Indiana traced to Canada	230
guard mystery mine to prevent smuggling	272
Electric Appliances—neon signal saves current on	241
Envelope Sealer—hand, has no wicks or sprays	240
Equestrian—reflector on saddle stirrup guards night riders	252
Excavation—watcher on hunt for relics	210
Fire—oil-well, put out with snuffer	198
Fish and Fishing	
deep-sea water imported for aquarium	209
grow larger under lights in hatchery pools	250
natural lighting aids sardine fishers	269
Fruit—dump-bottom bucket saves pickers' time	253

[Continued on Page 4]

Walking—why we walk in circles	224
Wall Paper—machine for papering walls	278
Windows—sliding sash swings in to aid cleaning	288
Winds—pressures exerted by	199

AMATEUR MECHANICS

Aquarium—suggestions for your aquarium	320
Automobiles	
advertising feature on closed	315
shade roller holds auto-seat cover	333
thawing out frozen radiators	324
Ballroom—the magic	323
Bottle—simple cap remover	313
Boxes—Ballotini inlays for	311
Brushes, Paint—and how to use them	322
Camera—phonograph crank for winding spring of movie	332
Carbon—simple device for scraping from exhaust pipes	333
Closets—wallboard used for making	331
Curtain—improvised stretcher	330
Door—fool-proof lock	334
Door, Basement—arrangement for opening	320
Fuse Box—that throws switch automatically	321
Guns—small corks used for cleaning rifle barrel	325
Handsaws—gauge for side-dressing	332
Inner Tube—what to do when, gets porous	314
Ladder—making the, longer	321
Lamp—improvised guard for	314
Logs—rolling heavy, single-handed	331
Motor—spark plugs often cause of missing	330
Pan—false bottom in, prevents burning biscuits	315
Photography—short-stopping photographic prints	314
Plane Guide—detachable aids in squaring work	325
Rats—keeping brooder house free from	329
Roof—screen keeps gravel out of gutters	333
Ship Model—the "Flying Cloud" contest	326
Siding—bar for removing	314
Snowshoes—make your own	316
Spark Plug—snap terminals for	332
Spray—repairing bath	330
Stairways—to prevent accidents on cellar	315
Stove—toasting on coal	320
Swing—truck casing makes novel	315
Table—storing asbestos mats	329
Tractor—power plant from old wheel	329
Wheels—boxed wagon, for mud roads	322
Workbench—simple vise for	334

SHOP NOTES

Automobiles—Repairing—circuit breaker for testing wiring	346
Brick—curing efflorescence on	338
Building Construction	
helpful hints for builders	349
saving time in	342
Carbon—adjustable scraper	339
Circle—centerless marker	348
Clamps, Machine—swivel ends improve	339
Cleaning—lard removes tar spots	343
Concrete—form for making hotbed frame	343
Counterweight—catch for the	347
Drilling—holes of varying depths	342
Floor Wiper—handy for janitors	338
Furniture—holding tacks in webbing	339
Grinding—two kinks	341
Hand Truck—attachment for the	350
Ice Box—space for milk bottle in	341
Irrigation—auto valves in standpipes	342
Joints—wood, for the amateur	345
Machines	
grouting small	339
screw, clip for catching work	348
Manure—hauling in winter	340
Oil Cups—safety covers	347
Pipe—lifting with wrench	341
Poultry—house made of straw	341
Protractor—improvised is made from two scales	338
Saws and Sawing—dadoing on small power	335
Shears—power, made in small shop	350
Spring, Bendix—preventing kink in	338
Spring, Coil—adjustable holder for compressing	247
Tool Box—improvement on the	340
Transformer—clamping laminations	346
Trucks—getting out of mud holes	343
Tweezer—cardboard, for holding balls	337
Workshop—vacuum cleaner useful in the	343

Fuel—mix coal dust and cement for	268
Gasoline—neutralized, stops danger of deadly fume	266
Guns—Range—fires steel balls in target practice	273
Helium—leaks through glass, test shows	198
Homes—average one-family house costs five thousand	233
Hotels—wonders of modern, shown at exposition	273
Household Devices	286
House Plan	351
House Wrecking—war tanks wreck old prison	199
Ice—cubes formed in tray of special metal	233
Ice Cream—Eskimo, is made from oil of fish	281
Incense Burner—electrical, eliminates matches	248
Knife—razor blades serve as	295
Lantern—electric flasher replaces signal	224
Mail—air, delivered on fly into net	207
Manhole—ventilating with pipe and blower	283
Motor Bus—combined with trailer has great speed	206
Motorcycle—run by rockets planned for high speed	266
Moving Pictures	
cabinet for home motion-picture projector	241
revolving merry-go-round films card game	231
Museum—keep specimens by freezing for Russian	253
Musical Instruments—banjo and ukulele in one	223
Noise—the art of making	270
Orchard—sheep dip keeps deer away from	296
Package Tyer—uses bands cut from inner tubes	267
Photography—split-second shotgun photos show firing results	256
Piano—tiny, with few octaves	296
Pictures—pole for hanging	250
Popcorn—paper cones for, keep fingers clean	199
Printing—lightweight plate substitute for metal	257
Psychology—machine helps choose career	208
Pump—of few parts invented by invalid	224
Radio—a handy resistance clip	310
Radio—Aerials—switch for short and long antenna	304
Radio—A—supply from farm plant	309
Radio—Batteries—charging wet B	304
Radio—Broadcasting—improved "police" watch radio stations	249
Radio—Eliminator	
automatic A-power unit	310
automatic switch from Ford cut-out	309
Radio—Hints and kinks for fans	306
Radio—Loud Speaker	
a simplified dynamic	304
a handy hookup	309
Radio—new things seen along radio row	298
Radio—Receiver	
new Hammarlund-Roberts a.c.	300
television, run by fan motor	305
Radio—Repairing—a sensitive circuit tester	310
Radio—Transformer—rebuilding burned-out	308
Railroads	
jolt recorder for, aids smoother riding	250
steel-container freight car	296
train on one-man railroad run by auto engine	210
Rails—flexible work-rail track simplifies curves	283
Range, Gas—glass-door cabinet for, stops smoke and odors	254
Riveter—for motor cars	224
Roads—pipe track for auto trucks aids construction work	253
Safes—small, carried in auto	267
Safety Devices and Measures—push button traffic sign aids pedestrians	272
Sand Painting—Indian, shows dance of four seasons	284
Scraper—has hooked blade for better results	224
Seats—hard, inflated pad for	289
Seeds—machine counts small	248
Sewer—city's aerial line substitute for tunnel	284
Shaving Accessories—brush with tube of cream for handle	249
Ships and Shipping	
radio "echoes" locate position at night	296
sailing ship is picture queen	209
Soldering—dry gas torch needs no generator	289
Stoves, Oil—wick cleaner for	294
Submarines	
better light for to reduce accidents	208
rescue, has an underwater exit	282
Sugar—from cornstalks seen as future food	284
Table—rubber top protects	269
Tools—vertical milling head fits all types of machines	233
Tractor—armed with cutter helps reclaim desert	295
Traffic—plan underground auto park to relieve Paris	279
Trees—how heat affects	278
Tricks—easy escape	290
Typewriter—tool roughens roll to prevent slip	269

Hand Photography 254 Sand Photography 254

near Signs 241

Milling Head Vertical 233

Measurement Suburbane

PAINTERS-DECORATORS ARTISTS-SIGN MAKERS

Here's Help for You

We publish books that help men do better work and make more money. EACH BOOK IS AN ENTIRE COURSE OF INSTRUCTION IN ONE VOLUME. They will raise your pay. Written in plain language, and with many illustrations.

STUDY THE LIST:

The Lacquer System of Sign Painting.....	\$3.00
How to Draw Funny Pictures.....	3.00
Layouts for Advertising.....	3.00
Practical Estimating for Painters and Decorators.....	2.00
Furniture, Furniture Finishing, Decoration and Patching.....	5.00
Studio Handbook—Letter and Design.....	3.00
Interior Wall Decoration.....	4.00
Mixing of Colors and Paints.....	2.00
Wood Finishing, Plain and Decorative.....	2.00
House Painting Methods.....	2.00
The Art of Sign Painting.....	4.00
Scene Painting and Bulletin Art.....	4.00
"A Show at" Sho' Cards.....	4.00
Art of Show Card Writing.....	4.00
Strong's Book of Designs.....	4.00
New Stencils and Their Use.....	1.25
Automobile Painting.....	1.50
Modern Painter's Cyclopedia.....	2.00
Estimates, Costs and Profits.....	1.50
New Hardwood Finishing.....	1.50
The Signist's Modern Book of Alphabets.....	1.50
The Amateur Artist.....	1.50
The Ross Crane Book of Home Furnishing and Decoration.....	3.00
Owens' Paint Guide.....	1.00
Chalk Talk and Crayon Presentation.....	1.25
Graining and Marbling.....	.75

200 MORE PRACTICAL HOME STUDY BOOKS

each a complete treatise of its subject, covering Radio, Electricity, Carpentry and Building, Steam Engineering and 20 other Trades. All fully described in our big FREE CATALOG. You will find some that fit your work. Send the coupon now.

Make Up Your Order from
this page and mail direct to us. We will send the books postpaid. Satisfaction guaranteed.

FREDERICK J. DRAKE & CO., Publishers
Room 508—179 No. Michigan Blvd.
CHICAGO, U. S. A.
Drake Books Are For Sale at All Book Stores

(COUPON)

Frederick J. Drake & Co.,
Room 508-179 No. Michigan Blvd.,
Chicago, U. S. A.

() I enclose \$..... Please send me the books marked.

() Please send large FREE CATALOG.

Name.....

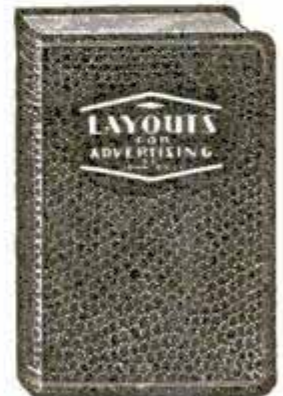
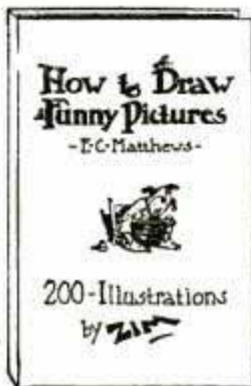
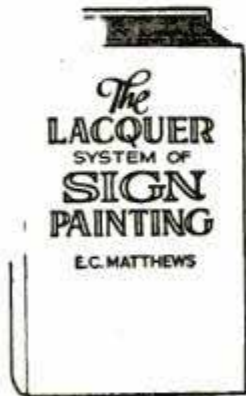
This One

Address.....

City.....



KU2L-B32-HLS2



1929 1930 1931 1932 1933 1934 1935 1936 1937 1938



Will You Be Clerk or Manager Ten Years from Now?

SURELY, this could never happen to *me*," you say—"that I should be sitting at the same desk—be doing the same work, *for ten straight years!*"

But wait a minute—

Exactly the same thing is happening to thousands upon thousands of men thruout the country. It has probably happened to men right in the company you now are working for. *And—unless you deliberately fit yourself for a better job—there is a very good chance that it will happen to you!*

Unthinkable? That's what R. M. Whitney, of Rochester, N. Y., said to himself. Yet lack of training kept him slaving away at low wages for more than twenty years . . .

Trebled His Salary in Three Years

—For more than twenty years, till finally, at the age of 47, and still receiving only thirty dollars a week, R. M. Whitney resolved to be a bookkeeper no longer. He enrolled with LaSalle for training in Higher Accountancy, and completed the course. Almost immediately came the offer of a bigger job.

Less than three years later, the Davenport Machine Tool Company—the very company he had worked for as a clerk—invited him to come back. He returned as Auditor, at a salary-increase of better than 300 per cent.

Today, he is Treasurer of this great company; and in a letter to LaSalle, after commenting on the opportunities LaSalle affords to men in their forties or early fifties, he adds, "And for the young man, who is just getting a foothold in the business world, LaSalle Extension University training is the most profitable investment he could make."

Says Good-bye to Clerkship— Now Heads Successful Firm

We have told you about a man who *waited*—at a cost to himself of probably not less than \$100,000. Now consider the experience of a younger man—G. Roy Eshelman, of Decatur, Illinois—

Eshelman was occupying a subordinate position in the purchasing department of a manufacturing concern—salary \$16 a week. Visualizing the opportunities for skilled accountants, he enrolled with LaSalle for training in Higher Accountancy.

"Thru this training," writes Mr. Eshelman, "I became interested in the Auditing Department and often remained after working hours watching the Auditor at his work. Observing my interest, he soon placed me in his department at a 50% increase in pay, and as I progressed with my LaSalle work, I was shortly rewarded with an additional 40% increase.

"My studies rapidly equipped me to strike out for myself, and at present I have an extensive practice as a Public Accountant, employing four accountants. It is sufficient to say that my present income is *many, many times greater than when I enrolled.*"

Send For These Two Books and Start Toward Real Success

Need you hear more before you investigate the opportunities in Accountancy? Shall we tell you about Pentland—or Gray—or McDuffie—all of them commanding incomes better than \$10,000 a year *and all of them still in their thirties?*

Or will you face the problem of your future NOW—and send to LaSalle and get further facts and particulars?

Without cost or obligation, the coupon will bring you two books—one a 64-page book entitled, "Accountancy, the Profession that Pays;" the other, "Ten Years' Promotion in One."

How about those next ten years—will you wait, or will you START TODAY to realize the opportunities that lie ahead of you thru sound and practical home-study business training?

Measure your grit and ambition by what you do with this coupon—NOW.

— — — Find Yourself Through LaSalle — — —

LaSalle Extension University

The World's Largest Business Training Institution

Dept. 264-HR

Chicago

Opportunities in Accountancy—Check below and we will send you copy of "Accountancy, the Profession that Pays," also copy of "Ten Years' Promotion in One," all without obligation

Higher Accountancy:

Leading to position as Auditor, Comptroller, Certified Public Accountant, Cost Accountant, etc.
Other LaSalle Opportunities: If more interested in one of the other fields of business indicated below, check here:

- Business Management
- Modern Salesmanship
- Traffic Management
- Railway Station Management
- Law: Degree of LL.B.
- Commercial Law
- Industrial Management
- Business Correspondence
- Credit and Collection Correspondence

- Banking and Finance
- Modern Foremanship
- Personnel Management
- Expert Bookkeeping
- C. P. A. Coaching
- Business English
- Commercial Spanish
- Effective Speaking
- Telegraphy
- Stenotypy—Stenography



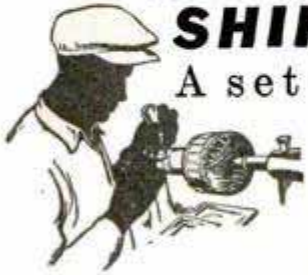
Name

Present Position

Address

ELECTRICITY

Complete Study Course and Pocket Library \$10



SHIPPED FREE

A set of **HAWKINS GUIDES** is a true friend to the electrical worker. It tells you how to do any job the right way—without guessing or taking chances.

Hawkins Guides put all the facts about modern electrical engineering at your finger tips. Therefore your chances for advancement in the electrical field are unlimited.

HAWKINS GUIDES DOUBLE YOUR VALUE



Electricity is king! It is the ruling force of today—transportation, communication, light, heat, power—indeed every modern activity is dependent on electricity. Industry is crying for electrical men that know their jobs!

Hawkins Guides teach you all you need to know about electricity in easy, step-by-step lessons. Daily spare time reading of the Guides will greatly increase your value to yourself and your employer in a few weeks. Hundreds of our friends have written us and told us this!

READERS OF HAWKINS GUIDES KNOW HOW



"You can't stump him on an electrical job." "He certainly knows his business." "Certainly have to hand it to him for knowing how." —These are the things employers say about our friends who are readers of **Hawkins Guides**. No matter what question or problem comes up the Ready Reference Index enables you to give an expert answer at once.

HAWKINS STARTS YOU WHERE OTHERS LEFT OFF

Why should you work at low wages when easy reading of **HAWKINS GUIDES** will give you the money-making knowledge of the expert? Easy daily reading of the Guides will teach you in a few months what it has taken the expert a lifetime to learn!

With **HAWKINS GUIDES** in hand you have a running start to success in the electrical field. You will actually begin where others left off!

NOW!

This coupon is your golden opportunity. Tear it out—send it now!



FOR EXAMINATION!

REAL ELECTRICAL EDUCATORS

"Hawkins Guides at \$10 is the best investment I have ever made. Am able to take up almost any electrical job and have never gone to an electrical school."—B. Roessler, Oenaville, Texas.

AS EASY AS A. B. C.

"Everything in Hawkins Guides is very plain and anybody can read and understand them as easy as A. B. C."—J. Knight, Tobyhanna, Pa.

OTHER ENTHUSIASTIC READERS SAY

"Worth ten times their price." "Helped me to two raises in four months." "Better than a school of instruction." "Studied them when I was laid up and got further ahead than if I had been on the job."

Hawkins Guides Explain These Points So You Can Easily Understand:—

Magnetism—Induction—Experiments—Dynamos—Electric Machinery—Motors—Armatures—Armature Windings—Installing of Dynamos—Electrical Instrument Testing—Practical Management of Dynamos and Motors—Distribution Systems—Wiring—Wiring Diagrams—Sign Flashers—Storage Batteries—Principles of Alternating Currents and Alternators—Alternating Current Motors—Transformers—Converters—Rectifiers—Alternating Current Systems—Circuit Breakers—Measuring Instruments—Switch Boards—Wiring—Power Stations—Installing—Telephone—Telegraph—Wireless—Bells—Lighting—Railways. Also many Modern Practical Applications of Electricity and Ready Reference Index.

Hawkins Guides—10 POCKET SIZE NUMBERS

Each number easy to carry around and read in spare time. Big type and clear diagrams. Easy to study and learn. Durable, flexible binding—gold edges. 3,500 pages—4,700 illustrations. Shipped free for examination. Pay only \$1 a month if satisfied. Price of set, complete, \$10.



EXAMINE GUIDES FREE!

Let the Guides themselves demonstrate their practical value to you—as a study course, reference work and complete electrical library. You are the judge. Simply send this coupon. No obligation unless you are entirely satisfied. Tear out on dotted line—fill in—mail it NOW!

\$1 PER MO.

FREE EXAMINATION COUPON

Theo. Audel & Co., 65 W. 23rd St., New York City

Please send me (postpaid) for my approval **Hawkins Electrical Guides**, 10 numbers (price \$1 each). If satisfactory I will mail you \$1 in 7 days and further mail \$1 monthly until purchase price of \$10 is paid.

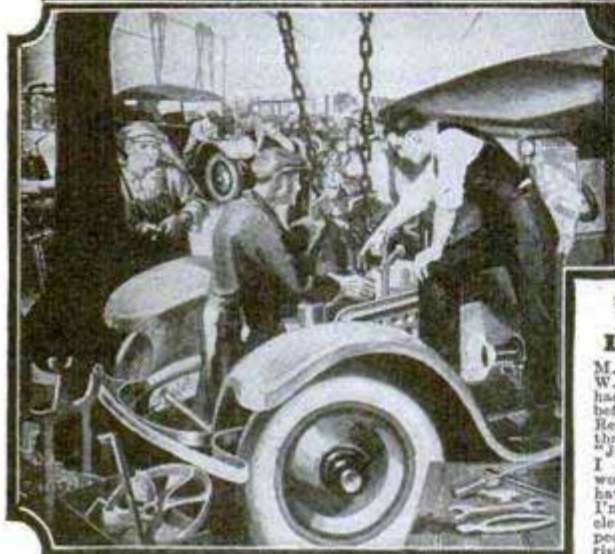
Name

Address

Occupation

Employed by

Learn AUTOS



up to **EARN \$5000** A YEAR

Start to Make Money Quick Like Morrision

M. J. Morrision, Parkersburg, W. Va. (photo at right), never had a day's experience on cars before starting my training. Read what he says when less than half-way through his "JOB-WAY" course. "What I have already learned is worth over \$500 to me. I have gone into business and I'm making over \$50 a week clear, with wonderful prospects." And what Mr. Morrision and hundreds of others have done I will help you to do!



M. J. MORRISON, Parkersburg, W. Va.

Clip this Coupon Now-for my Big **FREE AUTO BOOK**

3 repair & testing OUTFITS INCLUDED

AVIATION Training FREE of extra cost

Coupon brings full details of complete Aviation Training. I am offering FREE of extra charge. Send it now.

The World's biggest, most fascinating business needs you!

You needn't slave away at small wages another minute—mail coupon and I'll tell you how I train you at home in your spare time for positions paying up to \$150 a week. Unlimited opportunities for trained Electrical and Mechanical Auto Experts. Let me show you how my "JOB-WAY" training has prepared hundreds of men just like yourself for a quick, brilliant success in the Auto business.

Earn Up to \$150 a Week!

Don't sell your time for low pay! You don't need to when you have my "JOB-WAY" training. As Directing Engineer of this Institution I know what training you need to succeed, AND I GIVE YOU THAT TRAINING right in your own home. MASTER every branch of Auto, Truck and Tractor work. I train you with JOBS—not books. I bring the original "JOB-WAY" training TO YOUR HOME!

Read My Agreement!

Ten agreements in my big free Auto Book. No. 1 is "I will refund every cent of your money if after receiving my training you are not absolutely satisfied." This and nine other wonderful agreements make my "JOB-WAY" course the training for you! Be sure to get my book and read all ten agreements.

Experience, Education Not Needed!

I don't care how little schooling you have, I will train you to become an Auto Mechanic or refund your money! Boys and men of all ages have become Garage owners and managers, Superintendents, Foremen, Auto Experts, BIG PAY executives, after completing Cooke "JOB-WAY" training. I prove to you that I will prepare you to take advantage of the many wonderful opportunities of the great auto business!

Get My Big Book Quick!

I will send it to you without one penny of cost. Read all the facts, find out about the demand for trained Auto Experts. Let me tell you how easily and quickly you, too, may become an Auto Expert. Splendid offer right now to ambitious men. Coupon brings complete information. Mail it today!

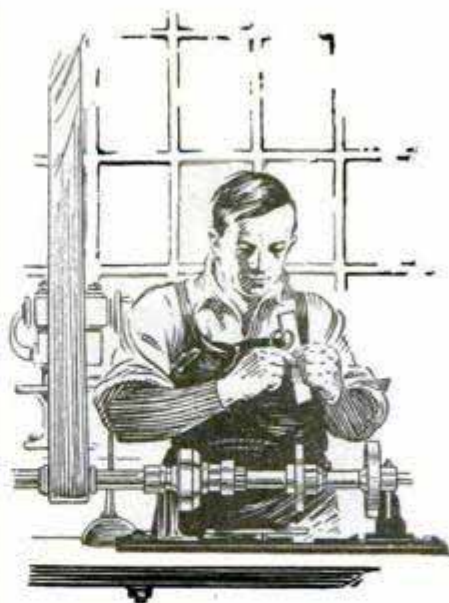
Address Me Personally **B. W. COOKE** DIRECTING ENGINEER
CHICAGO MOTOR TRAINING CORPORATION
 1916 Sunnyside Ave., Dept. 1162 CHICAGO, ILL.

MAIL THIS COUPON NOW!

Free Auto Book

B. W. COOKE, Directing Engineer, Chicago Motor Training Corp., Dept. 1162, 1916 Sunnyside Avenue, Chicago. Send me FREE your Big Auto Book "Auto Facts" and proof that you will train me in spare time at home. Also reserve Complete Aviation Course and 3 Testing and Repair Outfits without obligating me.

Name.....
 Address.....
 City..... State.....
 Age..... Occupation.....



J. G. Vincent was once a toolmaker!

Today he is Vice-president in charge of Engineering of the Packard Motor Car Co., and one of the big figures in the automobile field

TWENTY-SEVEN years ago, J. G. Vincent, the farmer boy of Little Rock, Arkansas, was working as a toolmaker.

He loved to tinker about and he had a natural aptitude for the work of the machine shop. But he knew that wasn't enough. Fortunately he realized in time that he needed specialized training in order to make the most of his natural ability. So he enrolled for a course in Mechanical Engineering with the International Correspondence Schools.

Such a combination could not fail. In 1902 Mr. Vincent was made head of the toolmaking department of the Universal Adding Machine Co. In 1903 he was engaged by the Burroughs Adding Machine Co., first as tool designer and then as Superintendent of Inventions. In 1910 the Hudson Motor Car Co. engaged him as Chief

Engineer. Today J. G. Vincent is Vice-president in charge of Engineering of the Packard Motor Car Co.

Jesse G. Vincent is only one of many prominent men in the automobile field who got their early training through spare-time study with the International Correspondence Schools.

Walter P. Chrysler, Chairman of the Board of the Chrysler Corporations, also studied with the I. C. S. So did J. R. Hall, Vice-president and Factory Manager of the Chandler Motor Car Co., and Hiram Walker, the Chief Engineer.

E. V. ("Eddie") Rickenbacker, America's flying ace, now Sales Manager of La Salle Division of General Motors, and Max H. Thoms, Supervisor of Inspection of the Marmon Motor Car Co., are other prominent men who studied with the International Correspondence Schools.

If the I. C. S. can help these men to succeed, it can help you. If it can help other men to win advancement and more money, it can help you too. At least find out how.

MAIL THE COUPON FOR FREE BOOKLET

INTERNATIONAL CORRESPONDENCE SCHOOLS, Box 5592-F, Scranton, Penna.

"The Universal University"

Without cost or obligation, please send me a copy of your booklet, "Who Wins and Why," and full particulars about the subject before which I have marked X in the list below:

BUSINESS TRAINING COURSES

- Business Management
- Industrial Management
- Personnel Management
- Traffic Management
- Cost Accounting

- Accounting and C. P. A. Coaching
- Bookkeeping
- Secretarial Work
- Spanish French

- Salesmanship
- Advertising
- Business Correspondence
- Show Card and Sign Lettering
- Stenography and Typing

- Civil Service English
- Railway Mail Clerk
- Common School Subjects
- High School Subjects
- Illustrating Cartooning

TECHNICAL AND INDUSTRIAL COURSES

- Electrical Engineering
- Electric Lighting
- Mechanical Engineer
- Mechanical Draftsman
- Machine Shop Practice
- Railroad Positions

- Gas Engine Operating
- Civil Engineer
- Surveying and Mapping
- Mining
- Steam Engineering
- Architect

- Architects' Blueprints
- Contractor and Builder
- Architectural Draftsman
- Concrete Builder
- Structural Engineer
- Plumbing and Heating

- Chemistry Pharmacy
- Automobile Work
- Airplane Engines
- Agriculture Navigation
- Mathematics
- Radio

Name..... Occupation.....

Street Address..... City..... State.....

Persons residing in Canada should send this coupon to the International Correspondence Schools Canadian, Limited, Montreal, Canada



Step Into Aviation

*Adventure...
Thrills...
Big Money!*

The Game for Daring Young Men

GET away from the dull, prosaic grid of humdrum work—the narrow restrictions of petty, uninteresting jobs! Break into one of the most fascinating, most thrilling occupations since time began—Aviation—the virile, exciting, romantic game for men of sporting blood!

Many of the big men of the coming generation will be men with the foresight to get into Aviation now—while opportunities abound. They can see that the Golden Age of Aviation has just begun—that the future is almost too stupendous to be imagined.

What other occupation offers you more amazing opportunities? Thrills such as you never had before—the praise and plaudits of the multitude—and a chance to get in on the ground floor where rewards may be unlimited.

Aviation is growing so swiftly that one can hardly keep track of all the astonishing new developments. The skies are dotted with daring young men—from every country come stories of new feats—new victories—new heroes! Everything is set for one of the greatest booms in history. Big fortunes came out of the automobile industry and out of motion pictures. Big fortunes will also come out of Aviation! The development of Aviation as an industry is bringing with it a call for trained men. Those who qualify quickly should find themselves on the road to undreamed of money—success—popularity—and prominence!

Easy to Get Into Aviation by This Home Study Method

Get into this thrilling business at once while the field is new and uncrowded. Now—by a unique new plan—you can quickly secure the preliminary training necessary to get a start in the Aviation Industry, either flying or ground work, at home during your spare time. Experts will teach you the secrets—give you the inside facts

that are essential to your success. And, the study of Aviation by our method is almost as fascinating as the actual work itself. Every lesson is chock-full of interest—and so absorbing that you actually forget you are studying. But best of all are the ultimate rewards you are fitting yourself to gain!

Send for FREE Book

Send the coupon for our new free booklet—*Opportunities in the Airplane Industry*. It is vitally interesting, reads like a romance and tells you things about this astonishing profession you probably never even dreamed of. You owe it to yourself at least to read it. We offer you a free copy now, no obligation. Mail the coupon for yours, today.

PICK YOUR JOB!

Flying
Airplane Instructor
Airplane Engineer
Airplane Repairman
Airplane Assembler
Airplane Mechanician
Airplane Inspector
Airplane Builder
Airplane Salesman
Exhibition Manager
Airplane Contractor
Airplane Motor Expert
Airplane Designer



American School of Aviation

Dept. 1352
3601 Michigan Ave.
CHICAGO, ILLINOIS

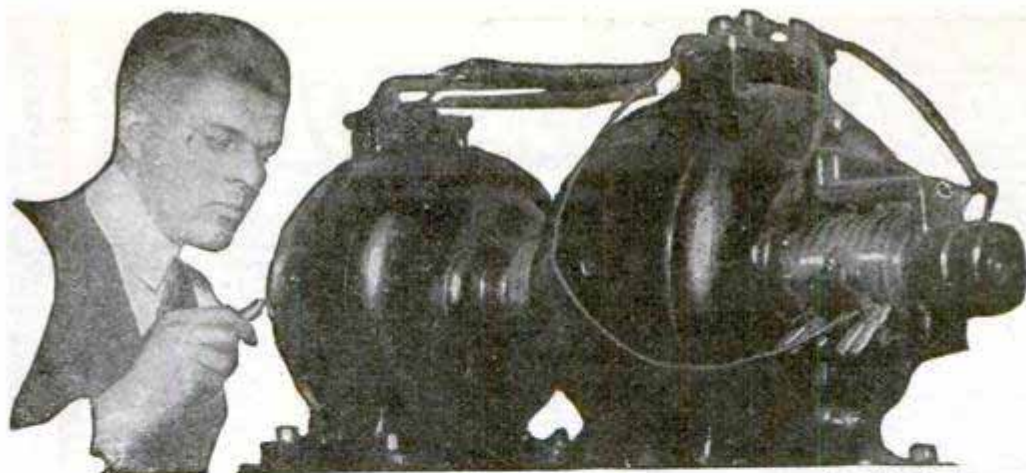
American School of Aviation,
Dept. 1352, 3601 Michigan Ave.
Chicago, Ill.

Without obligation, please send me your FREE book *Opportunities in the Airplane Industry*. Also information about your Home Study Course in Practical Aviation.

Name.....Age.....

Address.....

City.....State.....



Amazingly Easy Way to get into ELECTRICITY

Don't spend your life waiting for \$5 raises in a dull, hopeless job. Now . . . and forever . . . say good-bye to 25 and 35 dollars a week. Let me teach you how to prepare for positions that lead to \$50, \$60 and on up to \$200 a week in Electricity — Not by correspondence, but by an amazing way that teaches you Electricity in 90 days! Getting into electricity is far easier than you imagine!

Learn Without Books in 90 DAYS

Lack of experience—age, or advanced education bars no one. I don't care if you don't know an armature from an airbrake—I don't expect you to! It makes no difference! Don't let lack of money stop you. Most of the men at Coyne have no more money than you have. That's why I have worked out my astonishing offers.

Earn While Learning

If you need part-time work to help pay your living expenses I'll help you get it. Then, in 12 brief weeks, in the great roaring shops of Coyne, I train you as you never dreamed you could be trained . . . on one of the greatest outlays of electrical apparatus ever assembled . . . real dynamos, engines, power plants, autos, switchboards, transmitting stations . . . everything from doorbells to farm power and lighting . . . full-sized . . . in full operation every day!

NO BOOKS No Classes

No dull books, no baffling charts, no classes, you get individual training . . . all real actual work . . . building real batteries . . . winding real armatures, operating real motors, dynamos and generators, wiring houses, etc.,



Prepare for Jobs Like These

Here are a few of hundreds of positions open to Coyne-trained men. Our free employment bureau gives you lifetime employment service.

- Armature Expert . . . \$100 a Week
- Substation Operator . . . \$65 a Week
- Auto Electrician . . . \$110 a Week
- Inventor . . . Unlimited
- Maintenance Engineer . . . \$150 a wk.
- Service Station Owner . . . \$200 a wk.
- Radio Expert . . . \$100 a Week
- Aviation Electricity, \$76 a wk. up

etc. That's a glimpse of how we help to make you a master electrician, and fit you to hold big jobs after graduation.

Jobs, Pay, Future

Our employment department gives you lifetime service. Two weeks after graduation Clyde F. Hart got a position as electrician with the Great Western Railroad at over \$100 a week. That's not unusual. We can point to many Coyne men making up to \$600 a month. \$60 a week is only the beginning of your opportunity.

AVIATION ELECTRICITY

I am including my new Aviation Electrical Course to all who enroll now.



Students wiring and checking ignitor on one of the late type Radial Aircraft Engines in our aviation department

Get the Facts

Coyne is your one great chance to get into electricity. Every obstacle is removed. This school is 30 years old—Coyne training is tested—proven beyond all doubt—endorsed by many large electrical concerns. You can find out everything absolutely free. Simply mail the coupon and let me send you the big, free Coyne book of 150 photographs . . . facts . . . jobs . . . salaries . . . opportunities. Tells you how many earn expenses while training and how we assist our graduates in the field. This does not obligate you. So act at once. Just mail coupon.

Get this FREE Book



H. C. LEWIS, Pres.
COYNE ELECTRICAL SCHOOL, Dept. 29-72
 500 S. Paulina Street, Chicago, Illinois

Dear Mr. Lewis:
 Without obligation send me your big free catalog and all details of Free Employment Service, Aviation Electricity, Radio and Automotive Courses without extra cost, and how I can "earn while learning." I understand I will not be bothered by any salesman.

Name

Address

City State

COYNE ELECTRICAL SCHOOL
 H. C. LEWIS, Pres., Dept. 29-72
 500 S. PAULINA ST. Founded 1899 CHICAGO, ILL.

You can make the BIG Money



in Auto Painting

Average \$75 a Week for Yourself!

Are you satisfied with your present work and income? If you are beginning to see how utterly impossible it is to get along in this tough old world without training—then I have the best proposition you have ever heard of. I'll take you just as you are and in a short while I'll have you ready to manage and own one of my chain of auto-paint shops. Auto painting is the best end of the great auto industry. Short hours—easy work—big pay.



G. King Franklin
Superintendent

We Furnish All Equipment

While you are preparing for this big chance as owner and manager of a paint shop in your locality—I am going to furnish you with every bit of equipment you will need to learn—13 BIG OUTFITS FREE of extra cost. And every outfit complete so you get the actual practice in every operation. This is not just theory—no long, tiresome book reading—every move you make is interesting and practical.

Own Your Own Business

Don't worry about money—I'll furnish that. What I want is men who will learn to manage and operate a shop in their town according to my system. I'll have your name on a growing, profitable auto paint shop in no time if you mean business.

Here's 3 Free Lessons! in Auto Painting



Just to prove that this isn't too good to be true—I want to send you absolutely FREE of charge or obligation, 3 free lessons in auto painting. I want you to see how easy my new system is—I want you to know how interesting it is. I want you to realize that anyone with the knowledge to read or write ordinary English can master this training quickly and easily.

LEARN AT HOME!

You don't have to give up any of the things you are doing at present. Keep your job. Have your fun. All I want is a few minutes a day of your time—no more. I find I can get better results training a man in his own home—where there is nothing to divide his attention.

I haven't the space here to tell you all about this wonderful opportunity, but I do say that if you are a normal red-blooded fellow with ambition and desires for the better things in life here is the biggest and best chance you've ever had to make your dreams come true.

Just mail the coupon—filled in with name and address—and I'll send you a big book outlining this proposition fully and 3 Lessons All FREE. Be fair to yourself and get complete details. Come on—do it NOW.

G. King Franklin, Supt.

AMERICAN AUTO PAINTING SCHOOL
Dept. 2301, 425 S. Ashland Ave., Chicago

GET THE PROOF

G. King Franklin, Supt.
American Auto Painting School
Dept. 2301, 425 S. Ashland Ave., Chicago

Send sample shop-tickets free and information on how I may learn auto painting and Duco at home in spare time, also details about your chain shop Plan.

Name.....

Street No.....

City..... State.....

FREE

We have placed machinists, carpenters, masons, plumbers, railroad men, office clerks, farmers and even laborers in fine Drafting Jobs under this plan. Mail coupon for details of our remarkable offer.



Men Who Work With Their Hands Make the Best DRAFTSMEN



and We'll Back Them With This Contract of a DRAFTING JOB and RAISE!



"Only one other man and I, of six taking California State Board examination for Architect passed. Then I realized the thorough and practical training given by American School. In 18 months I have gone from tracer to Chief Draftsman, in charge of all architectural and engineering work in one of the oldest offices here." R. L. WARREN, Los Angeles, Calif.

We are looking for more ambitious young fellows with factory, building-trade or any other kind of mechanical experience to prepare for and help place in well-paid Drafting positions. Such men, we find, are unusually successful as Draftsmen, because they know how things are done, and that's a priceless asset to the man who makes the blueprint plans. For there's a great deal more to Drafting than "mechanical drawing" and reading blueprints. The real jobs, those paying \$50 to \$100 a week, give you a chance to cash in on your entire past mechanical experience. Get in touch with me and I'll tell you how.

DRAFTING Is Logically YOUR NEXT MOVE!

Of course you realize the biggest handicap to mechanical work is that you're limited in earning capacity to the output of your two hands, as long as you live. Even the skilled mechanic earning \$50 to \$60 a week has reached his limit. He can never earn more and when he gets old he will earn less. So I don't blame any man for wanting to get away from his futureless outlook. For wanting to get into something where he can use his head as well as his hands—where he will be paid for what he knows, instead of only for what he does. . . . You know enough about blueprints to understand that PLANS govern every move in factory and construction job. The Draftsman who makes them is several jumps ahead of the workman who follows them. And so I want you to know that DRAFTING is a logical, natural PROMOTION from mechanical and building work—better-paid, more interesting—just the kind of work you'd enjoy doing.

Get My NO-RISK Plan

The way to a fine Drafting job for you—is easier than you think. It takes no "artistic talent" or advanced education. Thousands of men no smarter than you, with no more education or ability have learned it quickly and you can, too. With the co-operation of some of the biggest employers and engineers in the U. S. we have worked out a plan to prepare you for Drafting work in your spare time at home—to actually help place you in a fine position and to raise your pay. Backed by the guarantee shown above to refund the small cost, if we fail. Mail the coupon and I'll be glad to tell you all about this life-time chance to get into Drafting.

The American School

Dept. D-274, Drexel Ave. and 58th St., Chicago, Ill.



3 Drafting Lessons Actually FREE

To Show You How Interesting
and Simple Drafting Is . . .

I wish I had the room here to tell you all about DRAFTING—how it has become the most important branch of every kind of manufacturing and construction work—how fascinating the work is—what a fine bunch of fellows Draftsmen are, the big salaries paid—how while Drafting is white-collar office work, it is closely hooked-up with big projects and big men. All that takes a 36-page book to tell and I'll be glad to send it to you free, and in addition I want to send you the first three lessons of our home-training so you can see how you'll like the work and how simple it is to learn. Coupon brings everything—mail it right away.

O. C. Miller (Signature), Director Extension Work.

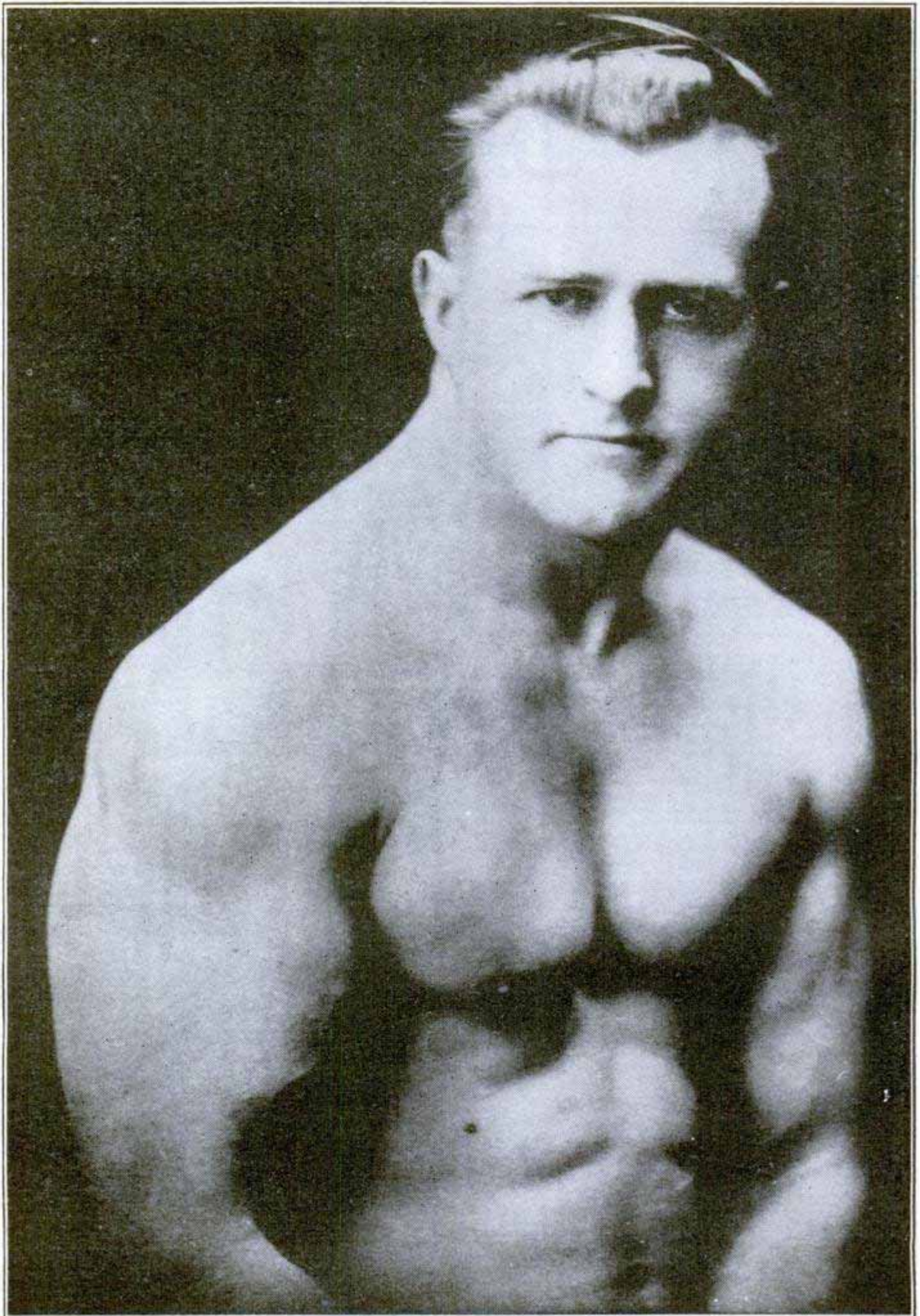
American School, Dept. D-274,
Drexel Ave. & 58th St., Chicago, Ill.

Please send free and without the slightest obligation 3 Drafting lessons, 36-page book about the opportunities in Drafting and your Guarantee to help me to a Drafting Job and a Raise.

Name
St. No.
City State
Age Occupation



"When I started American School training in the Spring of 1915 I was working 14 hours a night, seven nights a week for \$1.83 a night. That Fall I got a job in the Engineering Dept. of a large firm near here. Today I work 5 1/2 days a week and my salary is larger than I ever dreamed of when I began that course in Mechanical Drafting." B. H. SEAVERN, South Bend, Ind.



EARLE LIEDERMAN, *The Muscle Builder*

Author of "Science of Wrestling," "Muscle Building," "Secrets of Strength," "Here's Health," "Endurance," etc.

DOES SHE LOVE YOU ENOUGH ?

Give a Thought to Your Physical Self

If your wife or sweetheart acts cool and dissatisfied with you, give a thought to your physical self. A woman looks at more than a man's face. She's thinking of his ability to protect her; provide for her; of her pride in his appearance in a bathing suit, on the athletic field, on the dance floor.

When you hear a woman exclaim, "Oh, what a handsome man!" she's not looking at his face alone. She's sized him up from top to toe. Those broad shoulders, that graceful athletic stride, the well-shaped neck and head, those strong muscular arms and legs. They thrill any woman. Every wife and every sweetheart wants her man to be like that. Are you?

Well, you can be!

I Build Strong, Handsome, Healthy Bodies

People call me the Muscle-BUILDER. I make men's bodies strong and healthy. My list of over 100,000 wonderful successes includes doctors and lawyers, bookkeepers and clerks, grandfathers and grandsons, fat men and skinny men, weaklings and nervous wrecks. By a method of scientific body-building I go all over your body, strengthening your internal organs, broadening your shoulders, cutting off fat, and generally turning you inside out until you're a healthy, handsome fighting he-man any woman will be proud of.

In just 30 days I add one whole inch of live, flexible steely muscle to each of your arms and two full inches of rippling, muscular strength across your chest. Your legs will become straight and strong, your head snap back erect, and little lumps of red-blooded muscle will begin to stand out on your broadening shoulders. What a hit you are going to make with that girl of yours. How proud and happy she will be.

90 Days and You Have One

But I'm not through with you yet. I don't make men by halves. Give me just 60 days more and then look yourself over. Now you sure are somebody! The pathway to happiness and success is easy.

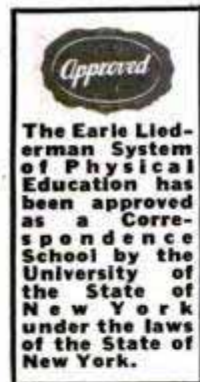
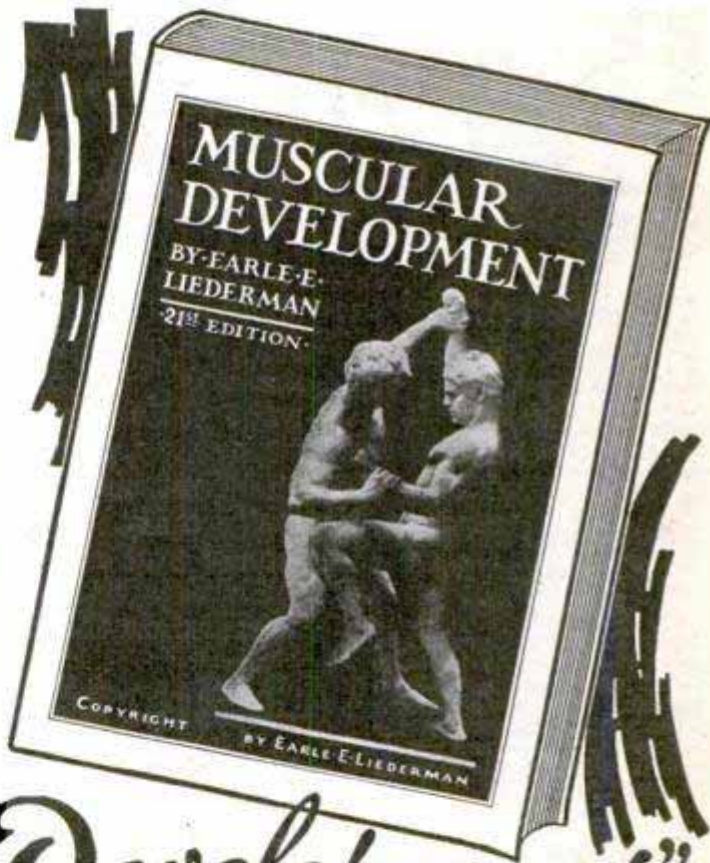
People will ask to meet you. Successful business men will realize that here is another man to accept as one of their own group. Your boss will treat you with a new respect, and that girl of yours will have that look of love and affection in her eyes that in itself will more than repay you.

I Do More Than Promise: I guarantee it

With a body like that the thrill of living is as great as the thrill you get when you fall in love. It's wonderful! Just check off on your fingers what such a body gives you—pep, vitality, health, strength, love, affection—everything a man desires.

What a picture you'll be in a bathing suit. What a sight in a gymnasium. You'll be a magnet for all women's eyes. That healthy, aggressive, erect stride of the man who knows what he wants and is going to get it, just commands attention.

Well, that's the story in a nutshell. If you're man enough to work a little for the sake of your strength, success and happiness, just sit right down and mail me this coupon. It won't cost you a penny, and you can see for yourself why thousands of men have so much faith in Earle Liederman, the Muscle-BUILDER.



Send for His New
64 Page Book

"Muscular Development"

IT'S FREE

What do you think of that? I don't ask one cent. And it's the peppiest piece of reading you ever laid your eyes on. I swear you'll never blink an eyelash till you've turned the last cover. And there's 48 full-page photos of myself and some of my prize-winning pupils. This is the finest art gallery of strong men ever assembled. And every last one of them is shouting my praises. Look them over. If you don't get a kick out of this book, you had better roll over—you're dead. Come on, then. Take out the old pen or pencil and sign your name and address to the coupon. If you haven't a stamp, a postal will do. But snap into it. Do it now. Tomorrow you may forget. Remember, it's something for nothing and no strings attached, no obligation. GRAB IT!

EARLE LIEDERMAN

Dept. 2002, 305 Broadway, New York City

EARLE LIEDERMAN

Dept. 2002, 305 Broadway, New York City

Dear Sir: Please send me, absolutely FREE and without any obligation on my part whatever, a copy of your latest book, "Muscular Development."

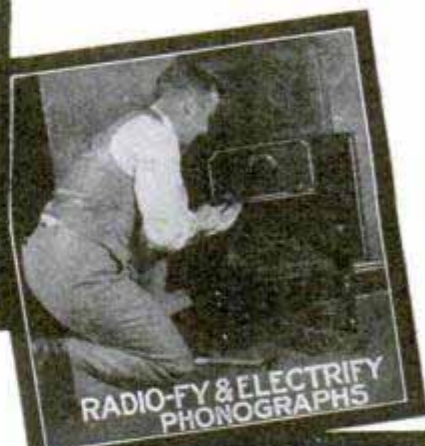
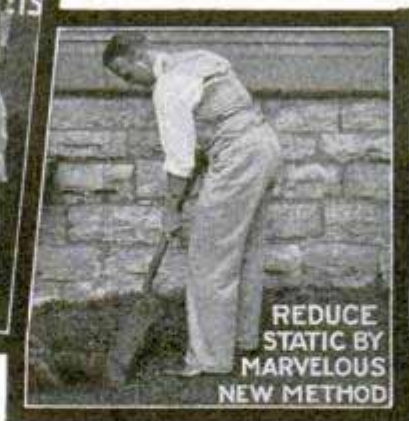
Name.....Age.....

Street.....

City.....State.....

(Please write or print plainly)

Send Coupon Below for
FREE
Radio Idea Book



5 Easy Ways to Make \$3⁰⁰ an hour in Your Spare Time in **RADIO**

Earned \$500 Spare Time

Frank J. Deutsch, Penn.: "I have made over \$500 out of Radio in my spare time. Yours is a great plan for ambitious men."

Becomes Radio Engineer in One Year

Claude DeGrave, Canada: "I knew nothing about Radio when I joined the Association a year ago. I am now a member of the engineering staff of the DeForest Company and my income is 225% greater than at the time I joined."

Doubles Income in 6 Months

W. E. Thon, Chicago: "You have an excellent plan. Six months after I enrolled I secured the managership of large Radio store and doubled my income."

EACH of these Association-developed plans a big money-maker. Set owners everywhere want their sets modernized, freed from static, made to operate electrically, transformed into single dial controls. Learn to render these services and you can easily make \$3.00 an hour spare time, to say nothing of the money you can make installing, servicing, repairing, building radio sets and selling supplies. Our members cleaning up! You can do the same.

Join the Radio Association

A membership in the Association will give you the training you need to render these services,—that will enable you to earn \$25 to \$75 a week spare time—train you to install, repair, build all kinds of sets—start you in business without capital—prepare you for the \$3,000 to \$10,000 big-pay radio positions—help you secure a better position at bigger pay for you—give you the privilege of buying supplies at wholesale. A membership need not cost you a cent.

Act NOW—IF YOU WISH NO-COST MEMBERSHIP PLAN

To limited number, we will give Special Memberships that may not—need not—cost you a cent. To secure one, write today. With the details we will send you copy of our Radio Idea Book that will open your eyes. Mail the coupon now.

RADIO ASSOCIATION OF AMERICA

Dept. P. M.-2 4511 Ravenswood Ave. Chicago, Ill.

RADIO ASSOCIATION OF AMERICA,
Dept. P. M.-2, 4511 Ravenswood Ave., Chicago.

Gentlemen: Please send me by return mail full details of your Special Membership Plan and a copy of your Radio Idea Book.

Name.....

Address.....

City.....State.....

ROUTINE**LONG HOURS****LOW PAY****NO FUTURE**

Human cogs in a great machine. No chance to meet people, travel, or have interesting experiences. A long, slow, tiresome road that leads nowhere.



The Time Clock—a badge of hawk-like supervision and The Rut. A constant reminder that one is "just another name on the pay-roll."

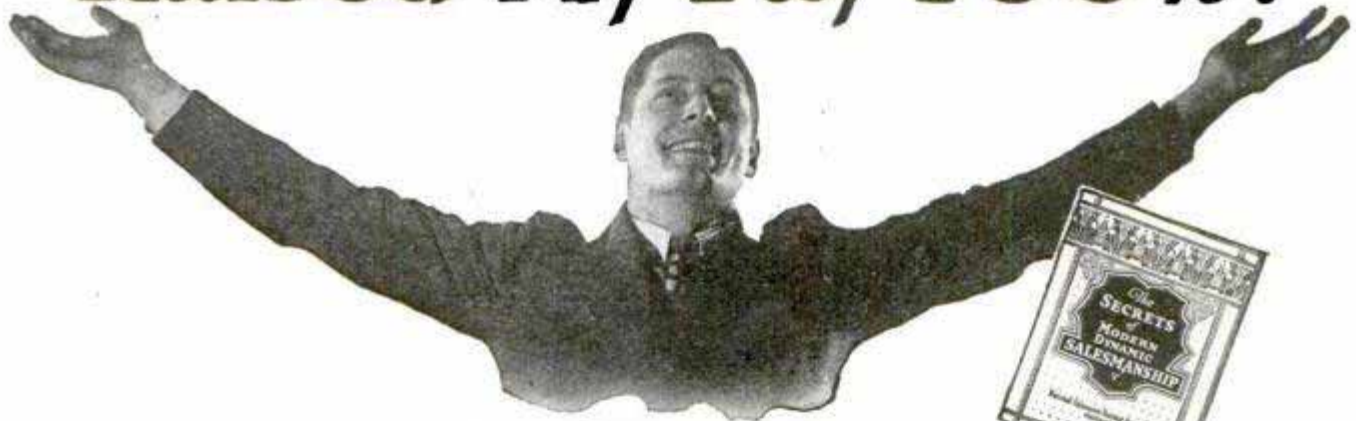


Always worrying over money. Always skimping and economizing—going without the comforts and luxuries that every man DESERVES for his family and himself.



Always wondering what would happen in case of a "lay-off" or loss of job. No chance to express ideas and ability—no chance to get ahead. COULD there be a way out?

I Said "Good-bye" to It All After Reading This Amazing Book— Raised My Pay 700%!



Where Shall We Send Your Copy—

WHEN a man who has been struggling along at a low-pay job suddenly steps out and commences to earn real money—\$5000, \$7500, or \$10,000 a year—he usually gives his friends quite a shock. It's hard for them to believe he is the same man they used to know . . . but such things happen much more frequently than most people realize. Not only one, but HUNDREDS have altered the whole course of their lives after reading the amazing book illustrated at the right.

True, it is only a book—just seven ounces of paper and printer's ink—but it contains the most vivid and inspiring message that any ambitious man can read! It reveals facts and secrets that will open almost any man's eyes to things he has never even dreamed of!

Remarkable Salary Increases

For example, R. B. Hansen of Akron, Ohio, is just one case. Not long ago he was a foreman in the rubber-curing room of a big factory at a salary of \$160 a month. One day this remarkable volume, "Secrets of Modern, Dynamic Salesmanship," fell into his hands. And from that day on, Mr. Hansen clearly saw the way to say "good-bye" forever to low pay, long hours, and tiresome routine! Today he has reaped the rewards that this little volume placed within his reach. His salary runs well into the 5-figure class—actually exceeding \$10,000 a year!

Another man, Wm. Shore of Neenach, California, was a cowboy when he sent for "Secrets of Modern, Dynamic Salesmanship." Now he is a star salesman making as high as \$525 in a single week. O. D. Oliver of Norman, Oklahoma, read it and jumped from \$200 a month to over \$10,000 a year! C. V. Champion of Danville, Illinois, raised his salary to over \$10,000 a year and became President of his company in the bargain!

Your Income Multiplied Or You Pay Nothing

N.S.T.A. is now offering, to every man who wants to increase his income, an amazing Double Money-Back Bond that assures you a definite stipulated addition to your income, within three months after your training is completed—or the course costs you nothing. This daring offer is possible only because of the success of thousands of members. Remember, if you are really ambitious to increase your earnings, this opportunity is offered you by a million dollar institution, the oldest and largest of its kind in the world. Send coupon immediately for full details.

A Few Weeks—Then Bigger Pay

There was nothing "different" about any of these men when they started. None of them had any special advantages—although all of them realized that SALESMANSHIP offers bigger rewards than any other profession under the sun. But, like many other men, they subscribed to the foolish belief that successful salesmen are born with some sort of "magic gift." "Secrets of Modern, Dynamic Salesmanship" showed them that nothing could be farther away from the truth! Salesmanship is just like any other profession. It has certain fundamental rules and laws—laws that you can master as easily as you learned the alphabet.

City and traveling sales positions are open in every line all over the country. For years, thousands of leading firms have called on the N. S. T. A. to supply them with sales-

Free?

men. Employment service is free to both employers and members, and thousands have secured positions this way.

FREE TO EVERY MAN

See for yourself WHY "Secrets of Modern, Dynamic Salesmanship" has been the deciding factor in the careers of so many men who are now making \$10,000 a year. Learn for yourself the REAL TRUTH about the art of selling! You do not risk one penny or incur the slightest obligation. And since it may mean the turning point of your whole career, it certainly is worth your time to fill out and clip the blank below. Send it now!

NATIONAL SALESMEN'S TRAINING ASSOCIATION

Dept. 101-B
N. S. T. A. Bldg. Chicago, Ill.

NATIONAL SALESMEN'S TRAINING ASSN.,
Dept. 101-B, N. S. T. A. Bldg., Chicago, Ill.

Without cost or obligation, send me your free book "Secrets of Modern, Dynamic Salesmanship." Also include a free copy of the new N.S.T.A. money-back bond that assures me a definite addition to my income within three months after completing training—or a complete refund of tuition fee.

Name.....
Address.....
City..... State.....
Age..... Occupation.....

How Fred Fisher made \$30 a week Extra in Spare Time with the TENOR BANJO

Found Course Easy Right from Start; Now Enjoys More Friends, More Parties

"Had no idea it was so easy, until I received my first two Lessons. Ever since then, things have gone right along easily. Nobody could go wrong with your clear, sure method. I now have more friends, and never miss any house parties. Recently I have been earning thirty dollars a week, in my spare time, playing in a cafe. There is always a job for a Tenor Banjoist."—Fred Fisher, 123 Ridge St., Steelton, Pa.



YOU Can Learn Quick Right at Home to Make Big Spare-Time Money

Why "wish" for plenty of friends, fun and ready cash when you can have them—**QUICK!** Our tested, easy system—"The Play-Way"—in 1 to 3 months at home will teach you how to make \$5 to \$15 an evening for spare-time playing; \$65 to \$100 a week or even more playing in orchestras, etc. Be popular, be invited everywhere; have the money you want. Don't let lack of cash keep the good times and good things of life away from you any longer! Learn quick and earn quick! Find out now about the Tenor Banjo Play-Way to Popularity and Big Pay.

C. E. Samwell
20 Devonshire Ave., Brantford, Ont., (shown above) writes: "Was only quarter way through Course when playing in one of the best orchestras here. Have found Tenor Banjo a real easy, sure way to Big Money. My playing now paying for fine \$650 Banjo. Owe success to you."

FREE BOOK tells how

This inspiring book—that has shown countless others the short-cut to **SUCCESS**—is yours **FREE** immediately upon receipt of the coupon below. No obligation—we'll rush it to you gladly. It will show you how to get the friends you want, the popularity you deserve and the money you need—**quick!** Get all the facts about this fascinating method. The same amazing course that taught Fisher, Samwell and thousands of other prosperous Tenor Banjoists can teach you, too. No extras to buy. We teach everything; furnish everything you need. Clip the coupon, fill it in and mail at once.

Big Tenor Banjo Records and Outfit FREE When You Enroll

with First Lesson

The same day we receive your enrollment for this tested, time-saving Course, you are shipped a handsome, full-tone, professional size Tenor Banjo worth \$29—lessons and Complete Outfit—and correct, fool-proof Demonstration Phonograph Records of every selection in the Course!



Mail Coupon Now

A. F. Bloch, President,
New York Academy of Music,
Studio 1029,
100 Fifth Ave., New York City.
Dear Mr. Bloch: Please rush me your **FREE** Book telling how I too can make a **Quick Success** and **Big Money** with the Tenor Banjo.

Name.....
Address.....

Learn to Write

I Teach by Mail

I CAN make a good penman of you at your home during spare time, no matter where you live or how poorly you now write. My simplified system has shown thousands of others the way to good penmanship during the past twenty years — it can and will do the same for **YOU!**

Beautifully Illustrated Book "How to Become a Good Penman" FREE!

It contains general information, with testimonials and beautiful specimens of penmanship showing what others have accomplished by the Tambllyn System. (Your name elegantly written on a card if you enclose stamp for postage.) **WRITE TODAY.** Address

F. W. TAMBLYN

418 Ridge Bldg., Kansas City, Mo., U. S. A.



THESE BOOKS MAKE PROMOTION SURE!

HERE in seven handsome volumes is a complete education in power plant practice. Under the editorship of Terrell Croft, a staff of engineering specialists have put into the books everything the power plant man needs to know in order to get to the top.

Power Plant Practice 7 Volumes—2795 Pages 3706 Illustrations

With the aid of this library hundreds of ambitious men have stepped into bigger jobs. You have the same opportunity. With a little spare-time reading you can have the identical knowledge possessed by the highest paid engineers.

With these books to guide you, you can fit yourself for the big-pay jobs in the power plant field.

The library covers the entire field—boilers—valve setting—engine operation—turbines—injectors—foundations—electrical machinery—combustion—refrigeration—fuels—governors—boiler stresses—fire tubes—feed water treatment—selection of boilers and engines—pumps and pump governors—steam traps—condensers—pipings, etc.

Every page is packed with the kind of information that the power plant man needs in his daily work.

If you want to get ahead in your work—if you want to pass an examination for an engineer's license—if you want the big pay that comes with increased knowledge—get these books.

Free Trial—No Money Down—7c a Day!

FREE EXAMINATION COUPON

McGraw-Hill Book Co., Inc.
370 Seventh Ave., New York

Ship to me, charges prepaid, the seven volumes of the **POWER PLANT LIBRARY**. If satisfactory, I will send \$1.50 in ten days and \$2.00 a month until the special price of \$17.50 has been paid. If not wanted I will return.

Name.....
Home Address.....
City and State.....
Occupation or Position.....
Firm or Employer.....



I'll Give You Magnetic Power in 24 Hours—Or No Cost!

I'll give you the magnetic power to attract people to you *instantly*, wherever you go—

I'll give you the magnetic power to be popular anywhere, in any society—

I'll give you the magnetic power to influence the minds of men and women, to make them do what you want them to—

I'll give you the magnetic power to become a dynamic, forceful, fascinating personality—

I'll give you the magnetic power to dominate situations—

I'll give you the magnetic power to win quick and conspicuous success in your business or profession—

And I'll give you the secret of these magnetic powers in just twenty-four hours—or I don't want a cent of your money.

That's my unconditional guarantee! I don't care how colorless your personality is—how lacking you are in the qualities of leadership—how timid and self-conscious you may be. Unless my secrets of instantaneous personal magnetism give you new magnetic powers within twenty-four hours—you don't pay a cent!

Results are Instantaneous

I'll show you how to sway the minds of others—how to always appear at your best—how to dominate all situations through the sheer force of your personality.

You can't expect life to bring you success when your entire attitude invites failure! You can't expect to rise to glorious heights of achievement when you are shackled by fear and worry and self-consciousness!

The moment you read my secrets of personal magnetism you can apply them. Instantly the fetters that have held you down are struck off. You are FREE. You will laugh at obstacles that once seemed insurmountable—you will toss aside timidity and awkwardness—you will feel your powers doubled, trebled!

My methods of personal magnetism should enable you to achieve your fondest ambitions. They will give you individuality, show you how to acquire a vibrant, charming voice, a fascinating manner. With the power of personal magnetism at your command, you will be enabled to go through life supremely happy—reaping the glowing rewards which a magnetic personality—and only a magnetic personality—can give you.

Personal magnetism is not limited to a fortunate few—it is Nature's gift to every man and woman! You need only release the full sweep of your magnetic potentialities to become the dynamic, forceful, fascinating person you were intended to be.

The Facts are Free

My secrets of personal magnetism have been put into a beautiful extra large size volume under the title of "Instantaneous Personal Magnetism."

The scope of "Instantaneous Personal Magnetism" is as broad as life itself. "Fires of Magnetism," "Sex Influences," "The Magnetic Voice," "Physical Magnetism,"

"The Magnetic Eye," "Oriental Secrets," "Rapid Magnetic Advancement," "The Magnetic Mind" and "Magnetic Healing," are only a few of the subjects covered in this amazing book. A magnificent book—entirely different from anything of the kind ever published—that tells you just how to cultivate the magnetic influence of your nature.

Originally published to sell for \$5—this remarkable volume, bound in handsome dark burgundy with the title gold embossed, is being offered at the special price of only \$3. Send no money with the coupon—pay no C. O. D. You get the book first.

Remember, if this book does not do all I claim for it—simply return it within 5 days, and it costs you nothing! Otherwise keep it as your own and remit only \$3 in full payment.

You are the sole judge. You do not pay unless you are absolutely delighted. And then only \$3. You simply can't delay! Clip and mail the coupon NOW. Ralston University Press, Dept. 13-B, Meriden, Conn.

Ralston University Press,
Dept. 13-B, Meriden, Conn.

All right—I'll be the judge. You may send me the volume "Instantaneous Personal Magnetism" for 5 days' FREE EXAMINATION in my home. Within the 5 days I will either remit the special low price of only \$3, or return the book without cost or obligation.

Name.....

Address.....

City.....State.....

Special cash price \$2.00 if payment accompanies coupon. This saves heavy book-keeping and clerical expense. Money refunded if dissatisfied and book is returned within five days.

Earn \$75 to \$100 a Week as AUTO MECHANIC—

Learn Easily in 8 Weeks on Real Machinery—

**No Dry Books
No Lectures**

Eight short weeks of pleasant, fascinating, practical auto work in my big shops—and then a real job paying \$75.00 to \$100.00 a week! You can step right out of low pay, long hours, and no future into the job of a high-salaried auto mechanic. Everywhere jobs are waiting for men trained as I train them. Change the whole course of your life in 8 weeks!

Not a Correspondence Course

Money Back Guarantee

If, after completing my training, you are not satisfied, if you are not qualified to accept a big-pay job, your tuition will be refunded.

Come to my shops. I will make you a mechanic able to handle the hardest auto jobs quickly and easily. I'll teach you to know autos inside out. You don't need education. You don't need previous experience. All you need is ambition. You learn by doing—by working on actual cars with real tools. This is not a correspondence course.



"I'll Pay Your
R. R. Fare"



Earn
While
You
Learn
"I help
you find
spare
time
work."
J. F. B.

OHIO STATE AUTO SCHOOLS,
1815 E. 24th St., Dept. G-11, Cleveland, O.
or 654 E. McMillan St., Dept. G-11,
Cincinnati, Ohio

Please send me FREE BOOK on Auto Mechanics, and details
of special railroad fare and tuition offer.

Name.....

Address.....

City..... State.....

Short Cut to Big Pay

Learn how easy it is to get a steady, big-pay job in the great auto field. Learn what other fellows like you have done with OHIO STATE Auto Training.

**Mail Coupon for Book
to School Nearest Your Home**

OHIO STATE AUTO SCHOOLS

1815 E. 24th St. or 654 E. McMillan St.
Cleveland, O. or Cincinnati, O.

Learn Advertising at HOME

Send your name and address for free booklet giving interesting information and vital facts about Advertising. Find out how we prepare you at home, in your spare time, for the opportunities open in this fascinating business. Practical work. No text books. Old established school. Successful graduates everywhere. Just the plan you have always wanted. Write today. No obligation.

PAGE-DAVIS SCHOOL OF ADVERTISING
Dept. 1352 3601 Michigan Ave. Chicago, U. S. A.

MUSIC LESSONS IN YOUR HOME



You can read Music like this quickly

Write today for our FREE booklet. It tells how to learn to play Piano, Organ, Violin, Mandolin, Guitar, Banjo, etc. Beginners or advanced players. Your only expense about 3c per day for music and postage used. American School of Music, 51 Manhattan Bldg., Chicago.

LEARN CARTOONING

AT HOME DURING SPARE TIME

with the course that has trained HUNDREDS of beginners successfully. The Landon Picture Chart Method of teaching ORIGINAL drawing by mail makes cartooning easy to learn. This school is a Member of The National Home Study Council. Write today for sample picture chart to TEST YOUR ABILITY and examples of the work of successful students now earning from \$50 to \$200 and more per week. Enclose 6c in stamps and STATE YOUR AGE.

THE LANDON SCHOOL, 2838 National Bldg., Cleveland, Ohio



PATENTS

Booklet Free Highest References
Promptness Assured Best Results

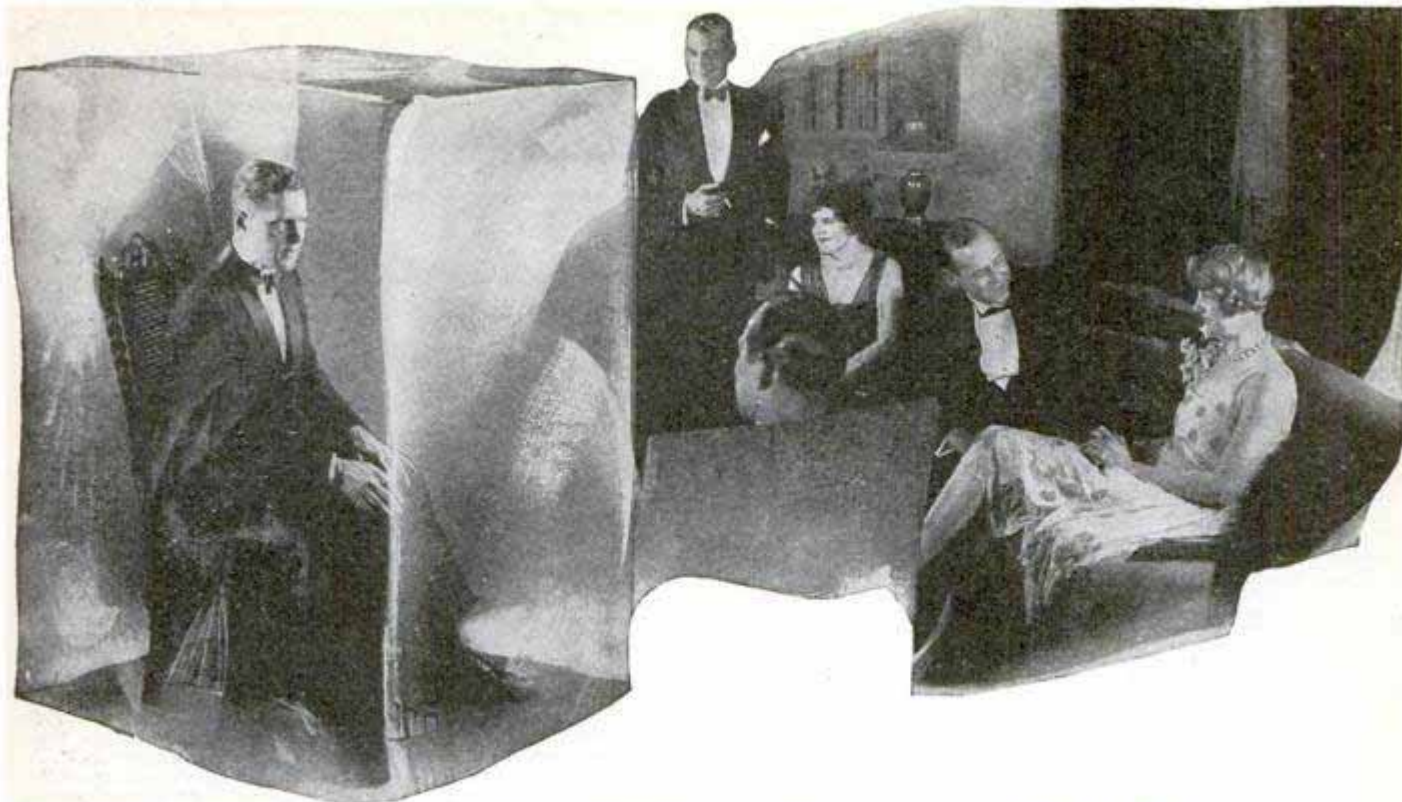
Send drawing or model for preliminary
examination of Patent Office records.

ALL BUSINESS GIVEN PROMPT AND PROPER ATTENTION

Listed Patent Lawyer in the latest editions of the Rand-McNally Directory of Bankers and Bonded Attorneys, published by Rand-McNally & Co., Chicago, Ill.; The Baggott & Ryall Directory of Guaranteed Attorneys, published by the Ryall Legal Directory Company, New York City; Flugel's List, published by the Legal Directory Publishing Co. of St. Louis, Mo.; the American Lawyers Annual, published in Cleveland, Ohio; Eyre's Law List, Bush Terminal Building, New York City.

WATSON E. COLEMAN,
REGISTERED PATENT LAWYER

Victor Building, 724 Ninth Street, N. W.
WASHINGTON, D. C.



I Turned To Ice When I Tried To Talk

-But Now I Can Sway An Audience of Thousands!

I HAD always been painfully bashful. When trying to carry on even the most commonplace conversation my voice would sound unnatural and my hands and knees would tremble. Often I would listen to an argument among a group and become so keenly interested that I would want to voice my own opinion—yet timidity would keep me silent. I never had the courage to stand up for what I knew to be my rights—I was always afraid of "what people would say," of ridicule. Since my childhood I had had a secret desire to appear in public—to be active in politics—but my shyness was so great that I turned to ice when I tried to talk—in even the smallest gathering!

My inability to talk was also affecting my business success. I dreaded going in and asking for a raise—I was afraid of any situation that meant using my voice—having to express myself. I didn't know how to present the ideas which I was sure the firm could use. I was just a plodder—a truck horse, capable of doing a lot of heavy work but of no use where brilliant performance was required. Often I would see men who were not half so thorough nor so hard working as I, promoted to positions where they made a brilliant showing—not through hard work, but through their ability to talk cleverly and convincingly—to give the appearance of being efficient and skillful.

What 20 Minutes a Day Will Show You

- How to talk before your club or lodge
- How to propose and respond to toasts
- How to address board meetings
- How to tell entertaining stories
- How to make a political speech
- How to make after-dinner speeches
- How to converse interestingly
- How to write letters
- How to sell more goods
- How to train your memory
- How to enlarge your vocabulary
- How to develop self-confidence
- How to acquire a winning personality
- How to strengthen your will-power and ambition
- How to become a clear, accurate thinker
- How to develop your power of concentration
- How to become master of any situation

In Twenty Minutes a Day

And then suddenly I discovered a new easy method which made me a forceful speaker almost overnight. I learned how to dominate one man or an audience of thousands—how to say just the right words at the right time, how to win and hold the attention of those around me, how to express my thoughts simply and clearly, yet in a pleasing, interesting and amusing way. In just a few months I was able to make campaign speeches for a

local candidate—I who a short time before had turned to ice when I tried to carry on an ordinary conversation!

Soon I had won salary increases, promotion, popularity, power. Today I always have a ready flow of speech at my command. I am able to rise to any occasion, to meet any emergency with just the right words, to approach all types of people with ease and fearlessness. And I accomplished all this by developing the natural power of speech possessed by everyone, but cultivated by so few—by simply spending 20 minutes a day in my own home on this most fascinating subject.

Send for This Amazing Book

This new method of training is fully described in a very interesting and informative booklet which is now being sent to everyone mailing the coupon below. This book is called *How To Work Wonders With Words*. In it you are shown how to conquer stage fright, self-consciousness, timidity, bashfulness and fear—those things that keep you silent while men of lesser ability get what they want by the sheer power of convincing speech. Not only men who have made millions, but thousands have sent for this book—and are unending in their praise of it. You are told how to bring out and develop your priceless "hidden knack"—the natural gift within you—which will win for you advancement in position and salary, popularity, social standing, power and real success. You can obtain your copy absolutely free by sending the coupon.

Now Sent
FREE



**NORTH AMERICAN
INSTITUTE**

3601 Michigan Ave. Dept. 1352
Chicago, Illinois

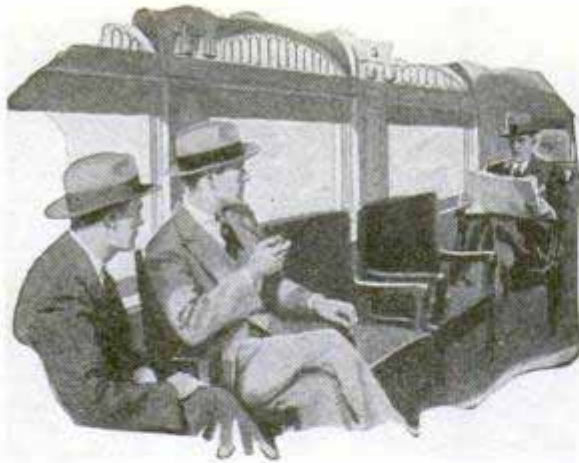
North American Institute,
3601 Michigan Ave., Dept. 1352,
Chicago, Illinois.

Please send me FREE and without obligation my copy of your inspiring booklet, *How To Work Wonders With Words*, and full information regarding your Course in Effective Speaking.

Name.....

Address.....

City..... State.....



“What’s Andy Blair Doing Now?”

Bill—“Haven’t you heard? He’s the new sales-manager for Hess & Schoble and they say his salary is \$7500 a year.”

Tom—“He certainly has come up fast. He wasn’t getting over \$50 a week the last time I saw him. How’d he do it?”

Bill—“Took up a course with the I. C. S. and studied at night. That’s why the old crowd hasn’t seen so much of him in the last few years. I wish I’d had the sense to do it too. I’d be making more money right now if I had.”

Why don’t you study and get ready for promotion too? We’ll be glad to help you if you will only make the start. And the way to do that is easy.

Choose the work you like best in the coupon below; then mark and mail it to the International Correspondence Schools today. This doesn’t obligate you in the least, but it will bring you information that will help to start you on a successful career. This is your opportunity. Don’t let it slip by.

Mail the Coupon for Free Booklet

INTERNATIONAL CORRESPONDENCE SCHOOLS

“The Universal University”

Box 5596-F, Scranton, Penna.

Without cost or obligation, please send me a copy of your booklet, “Who Wins and Why,” and full particulars about the subject before which I have marked X in the list below:

BUSINESS TRAINING COURSES

- | | |
|--|---|
| <input type="checkbox"/> Business Management | <input type="checkbox"/> Salesmanship |
| <input type="checkbox"/> Industrial Management | <input type="checkbox"/> Advertising |
| <input type="checkbox"/> Personnel Management | <input type="checkbox"/> Business Correspondence |
| <input type="checkbox"/> Traffic Management | <input type="checkbox"/> Show Card and Sign Lettering |
| <input type="checkbox"/> Accounting and C. P. A. Coaching | <input type="checkbox"/> Stenography and Typing |
| <input type="checkbox"/> Cost Accounting | <input type="checkbox"/> English <input type="checkbox"/> Civil Service |
| <input type="checkbox"/> Bookkeeping | <input type="checkbox"/> Railway Mail Clerk |
| <input type="checkbox"/> Secretarial Work | <input type="checkbox"/> Common School Subjects |
| <input type="checkbox"/> Spanish <input type="checkbox"/> French | <input type="checkbox"/> High School Subjects |
| | <input type="checkbox"/> Illustrating <input type="checkbox"/> Cartooning |

TECHNICAL AND INDUSTRIAL COURSES

- | | |
|---|--|
| <input type="checkbox"/> Electrical Engineering | <input type="checkbox"/> Architect |
| <input type="checkbox"/> Electric Lighting | <input type="checkbox"/> Architects’ Blueprints |
| <input type="checkbox"/> Mechanical Engineer | <input type="checkbox"/> Contractor and Builder |
| <input type="checkbox"/> Mechanical Draftsman | <input type="checkbox"/> Architectural Draftsman |
| <input type="checkbox"/> Machine Shop Practice | <input type="checkbox"/> Concrete Builder |
| <input type="checkbox"/> Railroad Positions | <input type="checkbox"/> Structural Engineer |
| <input type="checkbox"/> Gas Engine Operating | <input type="checkbox"/> Chemistry <input type="checkbox"/> Pharmacy |
| <input type="checkbox"/> Civil Engineer <input type="checkbox"/> Mining | <input type="checkbox"/> Automobile Work |
| <input type="checkbox"/> Surveying and Mapping | <input type="checkbox"/> Airplane Engines |
| <input type="checkbox"/> Plumbing and Heating | <input type="checkbox"/> Agriculture <input type="checkbox"/> Navigation |
| <input type="checkbox"/> Steam Engineering | <input type="checkbox"/> Mathematics <input type="checkbox"/> Radio |

Name.....

Street Address.....

City..... State.....

Occupation.....
Persons residing in Canada should send this coupon to the International Correspondence School, Canadian, Limited, Montreal, Canada

Make Yourself a Popular Favorite with the TENOR BANJO

Easy to Play—Learn at Home in Spare Time

\$18 TENOR BANJO GIVEN with case When You Enroll



Play for Fun or Money

Don’t be a wallflower. Entertain your friends. Be popular. Play at dances, parties, etc. Form an orchestra. Earn extra money. Our 52-lesson course will soon make you a real Tenor-Banjo player. Everything explained clearly.

Our Simple Method Makes It Easy

Even if you don’t know the first thing about music, even if you can’t read a single note, you are sure to learn by our simple, easy method of teaching. In 20 minutes you play a complete piece! You study in spare time—your lessons always before you. 51,000 successful students.

Pay as You Play

We make it easy for you to obtain the many advantages of this Conservatory. Our course is low in cost—only a few cents a day. No class to wait for. Start any time with a small first payment—then pay while learning.

Write for Special Offer

Sweet toned professional style TENOR BANJO, in genuine Seal Grain Fabrikoid Case, valued at \$18 to \$20 given when you enroll. Write for full information and special offer. A postal will do. ACT! **FIRST HAWAIIAN CONSERVATORY OF MUSIC, Inc.** 9th Floor, Woolworth Building, Dept. 22 New York, N. Y. Approved as a Correspondence School Under the Laws of the State of New York—Member National Home Study Council

BE AN ARTIST

WE CAN TEACH YOU DRAWING in your own home during your spare time. Twenty-five years of successful teaching proves our ability. Artists receive large salaries.

Write Today for Art Year Book

SCHOOL OF APPLIED ART
ROOM NO. 2 BATTLE CREEK MICH.



Learn Watchwork, Jewelrywork and Engraving

A fine trade commanding a good salary, and your services always in demand. Address **Horological**, Dept. P, Bradley Institute, PEORIA, ILLINOIS, for our latest catalog.

“AERONAUTICAL Executive Training in Addition to the Finest Flying Course in the Country.”

Write for Free Catalog

MARSHALL FLYING SCHOOL, Marshall, Missouri

IF YOU STAMMER

Write for my free book “Millard’s Advanced Natural Corrective Course” and a free copy of my speech magazine. 10,000 cases successfully treated. Est. 24 years. Largest school for stammerers in world. **Millard Inst. of Normal Speech, 2317 Millard Bldg., Milwaukee, Wis.**

GOV'T. POSITIONS \$35 TO \$75 WEEKLY

- | | | |
|--------------|---|--|
| WOMEN | <input type="checkbox"/> Ry. Mail Clerk | <input type="checkbox"/> Steno-Typist |
| | <input type="checkbox"/> Prohibition Inv. | <input type="checkbox"/> Immigrant Inspector |
| | <input type="checkbox"/> R. F. D. Carrier | <input type="checkbox"/> Seamstress |
| | <input type="checkbox"/> Special Agent (investigator) | <input type="checkbox"/> Auditor |
| | <input type="checkbox"/> City Mail Carrier | <input type="checkbox"/> Steno-Secretary |
| | <input type="checkbox"/> Meat Inspector | <input type="checkbox"/> U. S. Border Patrol |
| | <input type="checkbox"/> P. O. Clerk | <input type="checkbox"/> Chauffeur-Carrier |
| | <input type="checkbox"/> File Clerk | <input type="checkbox"/> Watchman |
| | <input type="checkbox"/> General Clerk | <input type="checkbox"/> Skilled Laborer |
| | <input type="checkbox"/> Matron | <input type="checkbox"/> Postmaster |
| | <input type="checkbox"/> Typist | |

AGE 18 to 55

OZMENT INSTRUCTION BUREAU, 111 Arcade Bldg., St. Louis, Mo. Send me FREE particulars How To Qualify for positions marked “X”. Salaries, locations, opportunities, etc. **ALL SENT FREE.**

NAME.....

ADDRESS.....

POCKET EDUCATORS

For all BUILDERS AND MECHANICS



Read Audels Pocket Educators for advancement and profit in your work. Every mechanic in the building trades should have this inside trade information at his fingers' ends. Learn the scope and possibilities of your profession. Any job can be done better if you are well informed. To earn more, learn more.



AUDELS CARPENTERS AND BUILDERS GUIDES—4 VOLS. \$6

Inside Information for Carpenters, Builders, Joiners, Building Mechanics—all Woodworkers. **1600 pages; 3700 diagrams; flexible; pocket size.** Short-cut instructions, new methods, ideas, solutions, plans, systems—money saving suggestions. An easy progressive course for the apprentice. A practical daily helper and Quick Reference for the master worker. A Helping Hand to Easier and Better Work and Better Pay. To get this aid for yourself, simply fill in and mail the FREE COUPON below.

INSIDE TRADE INFORMATION ON:

How to use steel square; How to file and set saws; How to build furniture; How to use mitre box; How to use chalk line; How to use rules; How to make joints; Carpenters' arithmetic; Mensuration problems; Estimating strength of timbers; How to set girders and sills; How to frame houses and roofs; How to estimate costs; How to build houses, barns, garages, bungalows, etc.; How to read and draw plans; Drawing up specifications; How to excavate; How to use settings 12, 13 and 17 on the steel square; How to build hoists and scaffolds—skylights; How to build stairs; How to put on interior trim; How to hang doors; How to lay floors; How to paint.

"Audels Guides worth four times their price—handy too as I carry them in pocket for reference." **W. J. Eates, Knoxville, Pa.**



AUDELS PLUMBERS AND STEAMFITTERS GUIDES—4 VOLS. \$6

A new set—just out! A practical, illustrated, Reference Library and Study-Course for Master Plumbers, Journeymen and Apprentice Steamfitters, Gas Fitters and Helpers, Sheet Metal Workers, Draughtsmen, Master Builders, Engineers and all Building Trade Students. **1670 pages; 3642 diagrams; flexible; pocket size.** Guides explain all the principles, advances and short cuts of the Plumbing and Heating trade. Contains instructions on how to figure and estimate jobs. Use FREE COUPON below to examine, without obligation, this valuable work.

INSIDE TRADE INFORMATION ON:

Soldering, tinning, joint wiping, bending, beating. Pipe—iron—steel, threading. Mathematics, tables, physics. Materials—iron, steel, copper, brass, lead, tin, antimony. Sheet metal—galvanized—plate. Sanitation, syphonage, tanks. Drainage, sewage, purification. Fixtures—bath—kitchen. Pipe fittings, soil pipe, tools. Laying out work. Roughing. Screwed fittings, flanges, joints. Pipe bending, examples. Elbows. Heating, ventilation, refrigeration. Water supply, mains, wells, tanks. Gas-fittings. Underwriters. Sheet metal work, problems, methods, brazing, heating, lead burning. Welding; various welds, methods. Blacksmithing; forges, tools.

"Audels Guides are practical, easy to understand, reliable. Cover the field in plain language." **W. F. Arminger, Annapolis, Md.**



AUDELS MASONS AND BUILDERS GUIDES—4 VOLS. \$6

A new, complete, illustrated trade reference library, for Bricklayers, Cement Workers, Plasterers, Tile Setters and Stone Masons, including a practical outline of Steel Construction. **1100 pages; 2067 diagrams; flexible; pocket size.** A practical Trade Assistant explaining modern methods of masonry construction. Easy to understand and apply. A reliable and authentic reference work and study-course for Master Journeyman and Young Mechanic. Use FREE COUPON below and find out for yourself, without obligation, whether this set will benefit you.

INSIDE TRADE INFORMATION ON:

Bricklaying, tools, materials; Brick designs, patterns, bonds; Setting frames and foundations; Mortars, scaffolds, estimating; Mortars and mortar mixing; Tile setting, mosaic, hollow tile; Straight edge test, troweling; How to figure brick work; Safe loads, piers, chimneys; Boiler settings, anchors, fire stops; Labor tables; Concrete, forms; How to figure concrete work; Stucco—on old and new buildings; Plastering—wood lath—metal; Plasterers agreement; Plastering on various surfaces; Stonemasonry; Cutting, finishing, estimating stone; Derricks, rigging; Steel construction; Fire proof; How to read blue prints.

"Audels Masons Guides are the best books on the subject. Have laid brick 12 years and am able to judge." **H. A. Sonnett, Corliss, Pa.**

PRACTICAL ELECTRICITY — 1 VOL. \$4

Audels Handy Book of Practical Electricity is a simplified Ready Reference and Study Course in one pocket size, leather bound volume—for Engineers, Professional Electricians and Students. **1040 pages; 2600 diagrams; flexible red leather bound.** A reliable authority and handy helper for every electrical worker. Contains important and valuable wiring diagrams, calculations, machine sketches, helps on maintenance and repair. Use this FREE COUPON today and find out, without obligation, how this handy book will help you in your daily work.



INSIDE TRADE INFORMATION ON:

Electro-Therapeutics, X-Rays, Shocks, Welding, Brazing, Radio Hook-ups, Motion Pictures, Telephone, Telegraph, Cranes, Bells, Elevators, Pumps, Tools, Ship Drive, Railways, Vehicles, Automobile Electric Systems, Ignition, Generation, Lighting, Plant Management, Power Plans, Armature Winding, Repairing, A. C. Motors and Apparatus, D. C. Motors and Apparatus, Alternator Construction, Dynamos, Wiring Diagrams, Sign Flashers, Cable Splicing, Power Wiring, Outside Wiring, Switches, Lighting, Rectifiers, Converters, Transformers, Fuses, Circuit Breakers, Rheostats, Electro Plating, Electrolysis, Storage Batteries, Magnetism, Electrical Energy, Conductors, Insulators, Static, Dynamic, Radio Electricity, Applications, Ready Reference and Index Covering the entire field of Modern Electricity.

Learn More and You Will Earn More!

Know your job and you'll never be without one. The skilled man is always in demand. Knowledge is power. Learn your trade thoroughly by easy reading. This coupon is your opportunity for advancement and better pay. You risk nothing in sending for Audels Guides for free examination. Send it NOW!

FREE EXAMINATION COUPON

THEO. AUDEL & CO.,
65 W. 23 ST., NEW YORK CITY

Please mail me for free examination the books marked (x) below. If I find them satisfactory, I agree to mail \$1 in 7 days, on each set ordered, and to further mail \$1 monthly on each set until I have paid the purchase price.

4 CARPENTERS GUIDES \$6 4 PLUMBERS GUIDES \$6

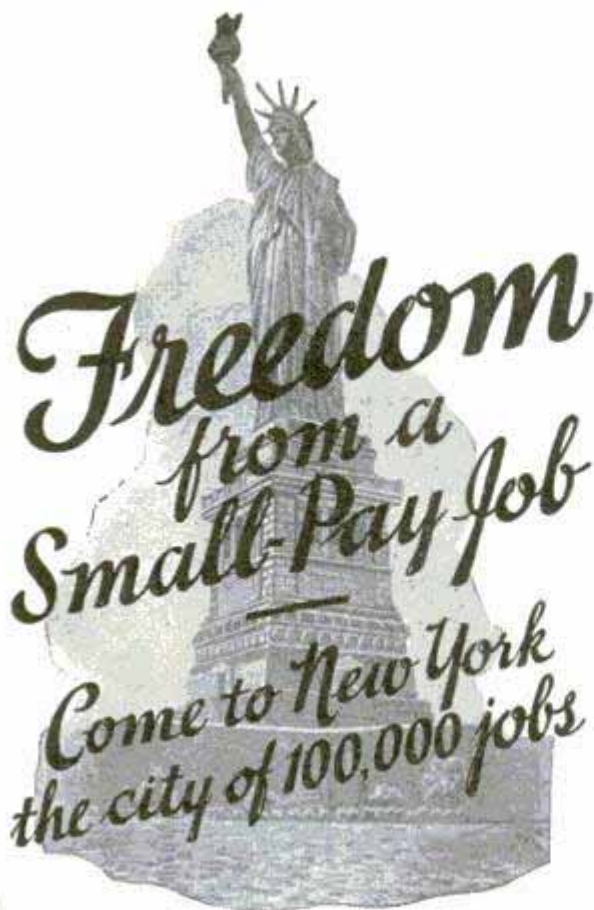
4 MASONS GUIDES \$6 1 ELECTRICIANS HANDY BOOK \$4

NAME

ADDRESS

OCCUPATION

EMPLOYED BY.....



ANY MAN who can read and write and use a pair of pliers can become an electrical expert and free himself forever from the long hours and drudgery of a small pay job.

And you can learn the **BIG PAY** profession of electricity right in New York City—the heart of the electrical world—the city of 100,000 jobs. At the same time you are learning the **BIG PAY** profession you can be enjoying the sights and wonders of New York, the modern Bagdad.

Be An Electrical Expert

Graduates of the **NEW YORK ELECTRICAL SCHOOL** are in demand by all the big electrical companies. Or, if you prefer the independence of a business of your own, there are thousands of opportunities for efficient, dependable men to become electrical contractors. When you are your own boss the money you can make is limited only by your own energy and ability.

Personal Instruction

The **NEW YORK ELECTRICAL SCHOOL** is not a correspondence school. You learn by doing—by personal instruction on full size standard electrical equipment under the personal supervision of trained instructors.

At N. Y. E. S. you train your hands and mind at the same time. You learn the theories of electricity—and then you are shown how to put the theories into actual practice by solving the problems with your own hands.

The man who has learned electricity by actually doing electrical work under intelligent personal instructors can go to any part of the world and be sure of a good living. There are N. Y. E. S. graduates in all the countries of the world.

Write today for the 48-page booklet giving full information about the N. Y. E. S. Course and showing pictures of the equipment available for your personal use in our two seven-story buildings. Mail coupon now! The New York Electrical School, 44 W. 17th Street, New York.

The New York Electrical School,
44 W. 17th Street, New York.

Please send me FREE your 48-page booklet. It is understood that this request puts me under no obligation.

Name.....

Address.....

Books on 65 Practical Subjects

Popular Mechanics Press specializes in supplying the outstanding best book on any subject. Clip the books you want, and mail with coupon.

AIRCRAFT Modern (Just Out).....\$5.00	HAND FORGING Hand Forging and Wrought Iron Ornamental Work.....\$2.00
AIRCRAFT ENGINES Dyke's New Instructor (Just Out).....\$5.00	HOME REPAIRS Practical Book of Home Repairs.....\$2.50
ARCHITECT Design and Lettering.....\$2.00	INTERIOR DECORATOR Interior Wall Decoration.....\$4.00
ARTIFICIAL FLOWERS How to Make for All Purposes.....\$2.50	INVENTOR Inventions and Patents \$2.50
AUTOMOBILE Modern Gasoline Automobile.....\$5.00	JOINT WIPING and Lead Work.....\$1.00
AVIATION Popular Guide.....\$2.00	LANDSCAPE GARDENING Practical.....\$2.50
BOAT BUILDING and Outdoor Sports.....\$2.00	LATHE WORK and Drilling and Thread Cutting.....\$1.00
BOOKKEEPER Bookkeepers' Handbook.....\$1.00	LEATHER WORKER Leather Work.....\$1.50
BOYS' BOOKS The Boy Mechanic (4 vols.).....\$7.00	LETTER WRITING Effective.....\$3.00
BRICKLAYER Plain and Fancy Brickwork.....\$1.50	LIFE WORK Choosing.....\$2.50
BUILDER'S BLUEPRINTS How to Read.....\$2.00	LOOM FIXER Practical Loom Fixing.....\$1.50
CABINET MAKER Furniture Making.....\$3.50	MACHINIST 419 Machinists Kinks.....\$1.50
CALCULATOR Ropp's Calculator.....\$1.00	MAGIC 200 Tricks You Can Do.....\$1.00
CARBURETORS Everything About All Makes.....\$2.00	MAIL-ORDER AND DIRECT-MAIL Selling.....\$5.00
CARPENTER 366 Carpentry Kinks.....\$1.50	MATHEMATICS Mathematics for the Practical Man.....\$1.50
CARTOONING How to Draw Cartoons.....\$3.00	MECHANICAL DRAFTSMAN Practical Course in Mechanical Drawing.....\$1.00
CIVIL SERVICE Course in Civil Service.....\$1.50	MODEL AIRPLANES Building and Flying.....\$2.50
CONCRETE 173 Ways of Using and Home Mechanics.....\$1.00	MOVIE MAKING For Amateurs.....\$3.00
COOKING Settlement Cook Book.....\$2.50	OUTDOOR OPPORTUNITIES Fur Farming.....\$2.00
DIESEL ENGINES Diesel Engines, Marine, Locomotive, Stationary.....\$5.00	PAINTING House Painting Methods.....\$2.00
DOG FANCIER Dog Encyclopedia.....\$2.00	PLASTERING and Stucco Work.....\$1.25
DRAWING Freehand and Perspective.....\$1.50	PLUMBING Repair Your Own.....\$1.50
ELECTRICIAN 214 Electrical Kinks.....\$1.50	RADIO Trouble Shooting.....\$3.00
ELECTROPLATER Electroplating.....\$1.00	REAL ESTATE Making Money In.....\$5.00
ENGINEER Bailey's Handbook for Stationary, Marine, Diesel.....\$2.00	SHIP MODELS Ship Model Making.....\$2.50
ENGLISH Self-Improvement in English.....\$2.50	SHOP NOTES Set of 16 vols.....\$5.00
ENTERTAINMENTS Producing Amateur Entertainments.....\$2.00	SHOW CARDS 1000 Practical Layouts.....\$5.00
ETIQUETTE Book of Etiquette (2 vols.).....\$2.00	TAXIDERMIST Methods in Taxidermy.....\$3.50
FARMERS' HANDBOOK and Handbook for Farmers' Wives.....\$1.00	TELESCOPE Amateur Telescope Making.....\$3.00
FORD (New) Treated in Dyke's Auto Encyclopedia.....\$6.00	TELEVISION Practical.....\$3.75
FORMULAS 10,000 Formulas.....\$4.00	TOY MAKER Toy Manufacture.....\$1.50
FURNITURE MAKING Built-In Style.....\$2.50	WELDER Welding Encyclopedia.....\$5.00
GARAGE Management and Control.....\$3.00	WIRING House Wiring.....\$2.50
	WOOD FINISHING Plain and Decorative.....\$2.00

Books sent C. O. D. anywhere in U. S.

Just clip the ones you want, write your name and address below, and mail with coupon. It is your order blank. When postman hands you books, pay him the price and the postal charges. If outside the U. S. remit when ordering and include 10 cents per book extra for postage. We have many other books on these and 2,000 other subjects. Catalog free.

Name.....

City..... State.....

Address.....

Mail to Popular Mechanics Press,
Room P2—200 East Ontario St., Chicago, Ill.

5 Dancing Lessons FREE

*—if you can do
this step*

NO matter how poorly you dance now—even if you've never been on a dance floor in your life—if you can do the simple step pictured at the right, I'll give you five of my famous dancing lessons *absolutely free*.

Think what that means! My new method of teaching dancing is so simple and easy to understand that *you can master any of the latest steps in one evening*—without music, partner, or teacher!

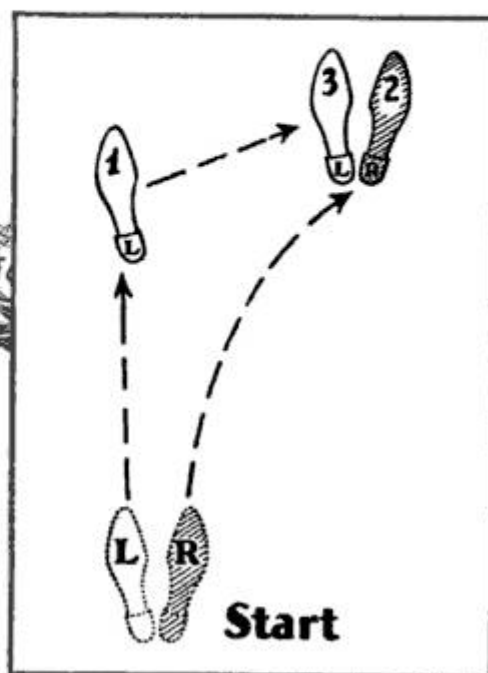
For I have discovered that all modern dancing is based upon *five fundamental movements*. The step pictured here is one of these basic movements. *The other four are just as simple*. Once you have mastered these key steps you can learn to do *any* dance—no matter how complicated it may appear—in almost no time.

There's no excuse now for playing wallflower—no excuse now for passing up good times because you can't dance! As soon as you receive the lessons you can learn the fundamental steps—in just a few hours. Then the very next time dancing starts you can surprise your friends by stepping right on the floor with the best dancers in your set—and with as much ease and assurance as if you had been dancing for years!

How to Be Popular

You'll never regret being an accomplished dancer! Think what it means to be popular, sought after, sure of a good time wherever you go!

And dancing is great fun—wonderful exercise. It takes your mind off your worries and cares. Keeps you happy and healthy—always on your toes and full of pep. Develops poise and self-confidence—enables you to make friends easily—and often opens the door to important business and social contacts.



And it's so easy now to be a *good* dancer, able to do all the newest, smartest steps.

My new method makes learning to dance just as simple as taking one step after another. Nothing is omitted—nothing taken for granted. You start right at the beginning, and go through the entire field of social dancing. You learn to master every step from the simple waltz to the newest, smartest dances and all their variations.

Five Lessons FREE

I have already taught over 400,000 men and women how to dance at home without music, partner, or teacher. And I'm so sure that you, too, can become a good dancer and get your full share of fun and popularity through my amazingly easy method that I'm willing to send you five lessons from my remarkable course, **without charge**.

Simply send the coupon, with 10c, to cover cost of printing and mailing, and these valuable lessons will be forwarded at once. Also a free copy of my new booklet, "The Short Cut to Popularity." Don't wait—you owe it to yourself to clip and mail the coupon NOW. ARTHUR MURRAY, Studio 878, 7 East 43rd St., New York City.

ARTHUR MURRAY,
Studio 878, 7 East 43d Street, New York City

To prove that I can learn to dance at home you may send the FIVE FREE LESSONS. I enclose 10c (stamps or coin) to pay for postage, printing, etc. You are to include free "The Short Cut to Popularity."

Name.....
Address.....
City..... State.....

Quickly Learn to Play Hawaiian Guitar

Play Like This Native

Bring the romantic, enchanting, entrancing and melodious strains of the great instrument of the Hawaiian Islands into your soul. Become popular and successful. This **short cut method** of home instruction enables you to quickly master Hawaiian Guitar so you will **play as well as Native Hawaiians.**

Our staff of Hawaiian instructors have perfected a method of teaching, so **simple**, that without musical knowledge, you quickly learn to play real music from notes. **Simple as learning your A B C's** and it will not be long before you will play latest Broadway hits.

Only four simple motions to learn.

You will then play any music, whether it be popular, dance or classical. Almost from first lesson, you play love songs like Aloha Oe.

To help you get started, we furnish without extra charge when you enroll as a student, a beautiful, full tone, genuine \$18.00 Hawaiian Guitar. Only 1,000 free instruments given away; if you want to get in on this offer, write for particulars at once—you must **act quickly.**



New Invention— Kno-All-Chart QUICKLY TEACHES YOU HOW TO PLAY

The newest invention of our Hawaiian instructor, which is exclusively used by us and which we call the "Kno - All - Chart."

quickly teaches you how to play and read notes. So simple is this device that anyone can understand it and begin to **play immediately.**

Picture Method Easy

We do not depend upon our printed instructions alone for your success as a student, but we also supply you with many pictures of our professors' playing. This enables you to imitate the pictures. **Isn't this easy?**

Phonograph Records Given

As an additional guide, we also furnish you with **phonograph records** of our Hawaiian instructor's own playing of the piece you are learning. This practically brings our professors from our studio to your own home and enables you to listen to their playing just as if they were actually in front of you.

Genuine \$18.00 Hawaiian Guitar Given

Enroll as a student, and secure a beautiful full tone, genuine \$18.00 Hawaiian Guitar.

We also furnish every bit of equipment so it is never necessary for you to spend an extra penny. When you graduate, you get a **beautifully engraved diploma** and after graduation, we also give you **six months' free service and consultation.** Send for free particulars now.

GIVEN \$18 Hawaiian Guitar when you enroll!

JAZZ
Your Way to Popularity and Success

No forming class to wait for. Start at once and join band wagon of success and popularity. Do it through Hawaiian Guitar.

Send for free First Lesson and Book. So positive are we you will become one of our students, that if you write at once we will send you **free** our first lesson which will enable you to see just what you can expect when you enroll. You will also receive our **big book** of full particulars. Write for your copy and **free lesson** today.

Write at **Hawaiian Studio No. 52029** of New York Academy of Music, 100 Fifth Ave., New York, N. Y.

HAWAIIAN STUDIO No. 52029 of New York Academy of Music, 100 Fifth Avenue, New York, N. Y.

Please rush your book, "How to Learn Hawaiian Guitar," and my first free lesson. Also reserve a Hawaiian Guitar for me without extra charge. This obligates me in no way whatever.

Name.....
Address.....
City.....State.....

THE CHICAGO DAILY NEWS School and College Bureau

Offers You Its Specialized Services in Choosing a School

Last year the School and College Bureau of The Chicago Daily News saved many busy parents and questioning boys and girls both time and worry by sending them prompt, reliable information about just the kind of school they wanted—personal requirements as to location and tuition charges being considered in each individual case.

Again this year many young people will be perplexed by the problem of finding the right school. Why not let us help you?

The Chicago Daily News maintains this service absolutely free of charge to you. No need to hurriedly select a school on mere hearsay when expert advice can be obtained by telephoning Dearborn 1111, writing or calling for a personal interview at

THE CHICAGO DAILY NEWS
School and College Bureau
Dept. K, 15 N. Wells St., Chicago, Illinois

Gain VIGOROUS MANHOOD with this Pocket Gymnasium only \$1.98



Get this marvelous new patented apparatus that you can easily carry in your pocket, and use in your spare time wherever you go. Specially designed so that every part of your body is strengthened by its use. Truly a complete pocket gymnasium.

Better Than the Ordinary Cable Exerciser

Because it is more elastic, lasts longer, and can be used in many more exercises. **Complete Free Course of Instructions** Sent with each pocket gymnasium. Special instructions for developing the important parts of your body, like wrists, chest, waist, etc. Charts clearly show method of using. Excellent for banishing constipation, stimulating the spinal cord, and cleansing the internal organs.

SEND NO MONEY. . . . Merely fill in, clip and mail the coupon, then pay postman \$1.98, plus a few cents postage, on delivery. Return in five days if not satisfied.

GIBRALTAR EXERCISER COMPANY, Dept. G-4002, 225 West 34th St., New York City.

Gentlemen: Please send me your Complete Pocket Gymnasium with Course, for which I agree to pay postman \$1.98, plus postage, when delivered.

Name.....
Address.....
City.....State.....



FREE BLUE PRINTS

AND FREE BOOK "HOW TO READ BLUE PRINTS"
SHOW YOU THE WAY TO

9 BIG PAY JOBS

- | | |
|---|--|
| 1 Building Superintendent — \$5,000 to \$12,000 | 6 Building Estimator — \$6,000 to \$10,000 |
| 2 Building Inspector—\$4,800 to \$8,000 | 7 Real Estate Expert—\$5,500 to \$12,000 |
| 3 Appraiser — \$6,000 to \$10,000 | 8 Construction Foreman—\$4,500 to \$8,500 |
| 4 Material Buyer—\$5,000 to \$7,500 | 9 CONTRACTOR AND BUILDER IN A BUSINESS OF YOUR OWN—\$5,000 to \$12,000 |
| 5 Material Salesman—\$5,000 to \$12,000 | |

FIND OUT HOW
Easy it is to Make
\$4,500 to \$12,000 a Year

Learn to read Blue Prints this amazing new way! Get into the world's richest industry—Building! See how quickly and easily you can train to make \$4,500 to \$12,000 a year! My FREE Book "How to Read Blue Prints" discloses all the so-called "mysteries" of Blue Print Reading—also gives some startling facts about the nine best jobs in America. Don't send one penny—just mail the coupon!

NO longer need you spend years trying to pick up the "mysteries" of Blue Print Plan Reading. For now a quick, sure practical method has been perfected that has made thousands of men Blue Print Experts in a surprisingly short time.

This is no ordinary "school course." It is practical from start to finish. It is based on many sets of real Blue Prints—plans that would cost thousands of dollars if purchased from architects. Twenty famous experts in all lines of construction work talk over these Blue Prints with you in plain simple language. Show you every detail. Explain every short cut. Tell you the "secrets" of quick, accurate estimating. Explain Superintending. Give you for the first time many inside facts and money-making methods used by the "Giants" of the Building Industry.

This is the kind of training that quickly puts men into \$4,500 to \$12,000 a year jobs—or into profitable contracting businesses of their own. Yet now you get it right at home in only 2 or 3 months. It requires no extensive education. If you can read and understand what is written here you can easily master it.

See what this training has done for others: Bartholomew, Calif., became a contractor at an in-

crease of over 300% his first year; Blair, Okla., stepped up to Superintendent at 100% increase; Diekerson, R. I., increased his salary 700% in 12 months; Marchand, La., says: "My income has increased 200% and I now have more contracting work than I can do."

Over seven billion dollars will be spent this year in new construction! No wonder then, such tremendous opportunities are open to you when you have this "head-work" training in Blue Prints. If you want more money—real big money! Then choose a "Blue Print" job in Building. Clerk or Salesman, Carpenter or Bricklayer, here is the one field where there are unlimited opportunities for advancement.

So accept my FREE gift of a complete set of real working Blue Prints, and my fascinating Book "How to Read Blue Prints" that tells all the interesting and instructive facts about Blue Print Plans. Don't send one penny—pay no C. O. D.—it's all FREE. Just fill out and mail the coupon today—NOW!

TWO BOOKS also FREE



IF YOU LIVE NEARBY

Visit our big day or evening school attended by over 1000 Builders. You can get the same training at home by mail—same plans, lessons and instructors. Your spare time is enough.

Chicago Technical School for Builders—Dept. B-142, Chicago Tech. Building, 118 East 26th Street, Chicago, Ill.

Please send me your free book, "How To Read Blue Prints," and complete set of real Blue Prints. I understand these are mine to keep without obligation. It is also understood that no salesman will call on me.

Name.....
Address.....
City.....State.....
Age.....Occupation.....

Chicago Technical School for BUILDERS

Dept. B-142, 118 East 26th St., Chicago, Ill.





Here's FUN and SPENDING MONEY

How'd you like to have a pocketful of spending money all the time—\$5 or \$10 or even \$15 every week—all your own—and a lot of real fun at the same time! It would be great, wouldn't it? Well, you can have it! Hundreds of boys still in school are getting it! And they're no different from you except that they are "Cooke" Trained—they know how to do little electrical jobs in their spare time, after school hours, for which they get real money. I showed them how. And I'll show you, too, just as easily!

I Will Train You at Home

With my easily learned, fascinating Electrical Course, I'll train you at home like I've trained hundreds of other boys who are now successful men with jobs paying \$60 to \$100 a week! It's all done after school hours, without interfering with your school work or with your regular job if you're working. And it's more like play than study. But it's practical. It's sound. It's up-to-the-minute. It fits you thoroughly to land a Big-Pay job when school days are over. And it pays for itself as you learn and gives you plenty spending money besides, through the spare-time work I tell you how to get, how to do and what to charge for.

Tools—Apparatus and Radio Course—Given Without Extra Charge

You'll need tools to do Electrical work with, so I give them to you—six big outfits of instruments and apparatus, and a real electric motor—a dandy layout that you can do any kind of spare-time work with—and it's all yours for "keeps." And not only that, but I also give you a brand new Course in Radio! All without extra cost!

Makes \$200 a Month

"Dear Mr. Cooke: When I began with you I was a sophomore in High School. Was making \$40 a month as grocery clerk. Now I am a \$200 a month electrician. Not so bad for a 17 year old boy, eh?"
Oliver P. Cooper
1131 Middle St.
Ashland, Pa.

Mail Coupon Now!

You want lots of spending money! You want a Big-Pay job when you're through school! Sure, you do! Then don't wait a minute—don't hesitate a second—set right this instant to get into this Big-Pay field where you can make \$2 or \$3 or more spare-time money every day while learning. Mail coupon at once and I'll send you my big 72-page book and a sample lesson: too—All FREE. See for yourself how easy it is. Fill in and mail coupon this minute!

6 BIG WORKING OUTFITS—NO EXTRA CHARGE

FOR YOUR FUTURE



INVESTIGATE THIS VOCATIONAL TRADE OPEN TO ALL WHETHER 18 OR 50

The opportunity of a lifetime to become financially independent. Earn up to \$5,000 a year. Great demand and always will be because it is a human necessity. Easily learned in three to six months by actual practice with the regular tools of the trade. No previous training required. Business of your own if desired. Oldest establishment in this field is now ready to train an additional number of men for this work. Remarkably low cost—starting fees as low as \$15. R. R. Fare to nearest school included. Earn while you learn if necessary—regular arrangement for part time positions. Investigate this opportunity. The facts are convincing. Write today for Bulletin No. 2 which gives complete information.

BODEE INSTITUTE

New York 1755 Broadway Philadelphia 1305 North Broad Street Brooklyn 85 Court Street

PREPARE FOR AN ART CAREER

—thru the only art school operated as a department of a large art organization, who have actually produced over a quarter million drawings for leading advertisers. Where else can you get so wide an experience? Home study instruction. Write for illustrated book telling of our successful students.

MEYER BOTH COMPANY
Michigan Ave. at 20th St. Dept. 16, Chicago, Ill.

Learn to Mount Birds



Learn at home by mail, to mount birds, animals, game heads; tax furs, make rugs and robes. Complete lessons. Easily and quickly learned by men, boys and women.

FREE Write today for Free Taxidermy Book. Tells all about it. Every Sportsman, Hunter, Trapper and Nature lover should know this wonderful fascinating art. Save your trophies. Big profits. Success guaranteed. Our school is 20 years old—75,000 graduates. Investigate today. Write for Free Book.

Northwestern School of Taxidermy 3372 Elwood Bldg., Omaha, Neb.

"STAMMERING

Its Cause and Cure"

You can be quickly cured if you stammer. Send 10 cents coin, or stamps, for 288 page cloth bound book on Stammering and Stuttering. It tells how I cured myself after Stammering and Stuttering for 20 years. **BENJAMIN N. BOGUE**
1114 Bogue Building, 1147 N. Ill. St. Indianapolis



12 FEMALE WHY NOT spend Spring, Summer and Fall gathering butterflies, insects? I buy hundreds of kinds for collections. Some worth \$1 to \$7 each. Simple outdoor work with my instructions, pictures, price-list. Send 10 cents (not stamps) for my illustrated Prospectus before sending butterflies.
MR. SINCLAIR, DEALER IN INSECTS.
Dept. 6, Box 1424. San Diego, Calif.

Be a Doctor of Surgical CHIROPODY

Dignified professional field. Call for doctors everywhere. Make \$5000 to \$15,000 a year. Course only 2 years at best known College of Chiroprody in America equips you for practice, 15th year. You are ready to enter with 4 years high school or equivalent. Largest foot clinic in world—large faculty physicians, surgeons, chiroprodists—study in Chicago—you can earn while you learn. Write for catalog. No obligation. Dept. 1111.



ILLINOIS COLLEGE OF CHIROPODY
1327 North Clark Street Chicago

Use this FREE BOOK COUPON

L. L. COOKE, Chief Instruction Engineer.
L. L. COOKE School of Electricity,
Dept. O12, 2150 Lawrence Ave., Chicago, Ill.
Send me your big Electrical Book, Sample Lesson and particulars about your Electrical Course and extra Radio Course. This does not obligate me in any way.

Name.....

Address.....

(This Coupon only for boys 15 years old or more)



~but when I started to play the laugh was on them!

"WELL, folks, I guess we'll have to lock up the piano and make faces at ourselves."

Helen Parker's party was starting out more like a funeral than a good time.

"Isn't Betty Knowles coming?" an anxious voice sang out.

"Unfortunately Betty is quite ill tonight and Chet Nichols is late as usual," replied Helen gloomily.

"I know some brand new card tricks," volunteered Harry Walsh.

"Great!" said Helen. "I'll go and find some cards."

While she was gone I quietly stepped up to the piano bench, sat down, and started to fumble with the pedals underneath. Someone spotted me. Then the wisecracks began.

They Poke Fun at Me

"Ha! Ha! Ted thinks that's a player-piano," chuckled one of the boys.

"This is going to be a real musical comedy," added one of the fair sex.

I was glad I gave them that impression. So I kept fiddling around the pedals—making believe that I was hunting for the foot pumps.

"Come over to my house some night," said Harry, "I've got an electric player and you can play it to your heart's content. And I just bought a couple of new rolls. One is a medley of Victor Herbert's compositions—the other . . ."

Before he had a chance to finish I swung into the strains of the sentimental "Gypsy Love Song." The joking suddenly ceased. It was evident that I had taken them by surprise. What a treat it was to have people listening to me perform. I continued with "Kiss Me Again" and other popular selections of Victor Herbert. Soon I had the crowd singing and dancing, and finally they started to bombard me with questions . . . "How? . . . When? . . . Where? . . . did you ever learn to play?" came from all sides.

I Taught Myself

Naturally, they didn't believe me when I told them I had learned to play at home and without a teacher. But I laughed myself when I first read about the U. S. School of Music and their unique method for learning music.

"Weren't you taking a big risk, Ted?" asked Helen.

"None at all," I replied. "For the very first thing I did was to send for a free Demonstration Lesson. When it came

and I saw how easy it was to learn without a teacher I sent for the complete Course. What pleased me so was the fact that I was playing simple tunes by note from the very start. For I found it easy as ABC to follow the clear print and picture instructions that came with each lesson. Now I play several classics by note and most all of the popular music. Believe me there's a real thrill in being able to play a musical instrument."

* * * * *

This story is typical. The amazing success of the men, women and children

who take the U. S. School of Music course is largely due to a newly perfected method that makes reading and playing music—*actually simple!*

Even if you don't know one note from another now, you can easily grasp each clear, inspiring lesson of this surprising course. You can't go wrong. First you are *taught* how a thing is done, then a picture *shows* you how, then you do it yourself and *hear* it.

Free Book and Demonstration Lesson

Our wonderful illustrated Free book and our Free demonstration lesson explain all about this remarkable method. They prove just how anyone can learn to play his favorite instrument by *note*, in almost no time and for just a fraction of what old slow methods cost.

Forget the old-fashioned idea that "talent" means everything. Read the list of instruments to the left, decide which you want to play, and the U. S. School of Music will do the rest. *At the average cost of only a few pennies a day!* Act NOW. Clip and mail this coupon today, and the fascinating free book and Free Demonstration Lesson will be sent to you at once. No obligation. Instruments supplied when needed, cash or credit. U. S. School of Music, 72 Brunswick Bldg., New York City.

U. S. SCHOOL OF MUSIC,
72 Brunswick Bldg., New York City.

Please send me your free book "Music Lessons in Your Own Home" with introduction by Dr. Frank Crane, Free Demonstration Lesson and particulars of your easy payment plan. I am interested in the following course:

.....

Have you above instrument?.....

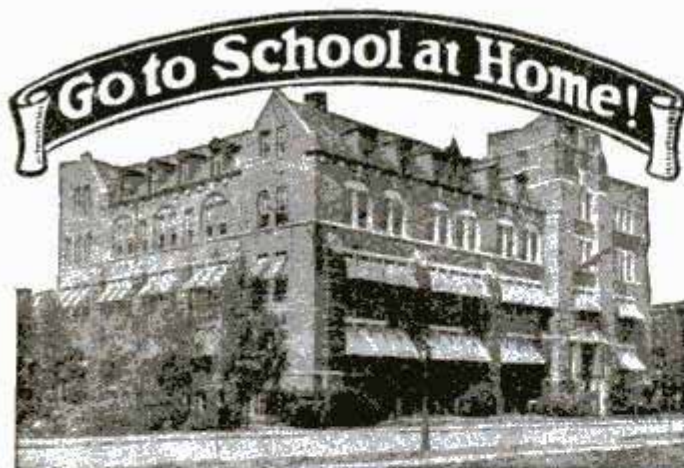
Name.....
(Please Write Plainly)

Address.....

City..... State.....

Pick Your Instrument

- | | |
|-------------------------------------|-----------|
| Piano | Violin |
| Organ | Clarinet |
| Ukulele | Flute |
| Cornet | Saxophone |
| Trombone | Harp |
| Piccolo | Mandolin |
| Guitar | Cello |
| Hawaiian Steel Guitar | |
| Sight Singing | |
| Piano Accordion | |
| Voice and Speech Culture | |
| Drums and Traps | |
| Automatic Finger Control | |
| Banjo (Plectrum, 5-String or Tenor) | |



High School Course in Two Years!

You Want to Earn Big Money!

And you will not be satisfied unless you earn steady promotion. But are you prepared for the job ahead of you? Do you measure up to the standard that insures success? For a more responsible position a fairly good education is necessary. To write a sensible business letter, to prepare estimates, to figure cost and to compute interest, you must have a certain amount of preparation. All this you must be able to do before you will earn promotion. Many business houses hire no men whose general knowledge is not equal to a high school course. Why? Because big business refuses to burden itself with men who are barred from promotion by the lack of elementary education.

Can You Qualify for a Better Position

We have a plan whereby you can. We can give you a complete but simplified high school course in two years, giving you all the essentials that form the foundation of practical business. It will prepare you to hold your own where competition is keen and exacting. Do not doubt your ability, but make up your mind to it and you will soon have the requirements that will bring you success and big money. **YOU CAN DO IT.**

Let us show you how to get on the road to success. It will not cost you a single working hour. Write today. It costs you nothing but a stamp.

American School

Dept. H-274 Drexel Ave. and 58th St., Chicago

American School

Dept. H-274 Drexel Ave. and 58th St., Chicago

Send me full information on the subject checked and how you will help me win success.

- | | |
|-----------------------------|---------------------------|
|Architect |Business Law |
|Building Contractor |Lawyer |
|Automobile Engineer |Machine Shop Practice |
|Automobile Repairman |Mechanical Engineer |
|Civil Engineer |Shop Superintendent |
|Structural Engineer |Employment Manager |
|Business Manager |Steam Engineer |
|Cert. Public Accountant |Foremanship |
|Accountant and Auditor |Sanitary Engineer |
|Bookkeeper |Surveyor (& Mapping) |
|Draftsman and Designer |Telephone Engineer |
|Electrical Engineer |Telegraph Engineer |
|Electric Light & Power |High School Graduate |
|General Education |Wireless Radio |
|Vocational Guidance |Undecided |

Name.....

Address

LEARN TO FLY~



WHERE LINDBERGH LEARNED!

GET the same complete, thorough, foundational training that Lindbergh received. Get it now—under greatly improved facilities—at the Lincoln Airplane School. Much better than when Lindbergh learned here. Get the best training now available. Here competent, experienced instructors teach you practical Flying and Ground Work. You go right up into the sky in our famous Lincoln Page Government Licensed Planes—with transport pilots. Learn on actual planes and motors supplied by the Lincoln Aircraft Factory. Write for full information today!

LINCOLN AIRPLANE SCHOOL
201 Aircraft Bldg., LINCOLN, NEBR.

Electrical Engineering

Course for men of ambition and limited time. Over 5000 men trained. Condensed course in Theoretical and Practical Electrical Engineering including the closely related subjects of Mathematics and Mechanical Drawing.

Students construct motors, install wiring, test electrical machinery. Course designed to be completed in one college year. Prepare for your profession in the most interesting city in the world. Est. 1893. Catalog on request.



Bliss Electrical School

132 Takoma Ave., Washington, D. C.

Don't Envy The Plumber—BE ONE!

\$11.00-\$16.00 PER DAY and work EVERY day, is the Plumber's wage.

LEARN IN 8 TO 12 WEEKS without previous experience.

If you are making less than \$61.00 a week you owe it to yourself to investigate. Get FREE catalog that tells in pictures and words how we teach this trade. Special rates now.

UNIVERSAL PLUMBING SCHOOL, 2030 Troost Avenue, KANSAS CITY, MO.

Learn to **PAINT SIGNS and SHOW CARDS**

We quickly teach you by mail, or at school, in spare time. Enormous demand. Big future. Interesting work. Oldest, foremost school.

EARN \$50 TO \$200 WEEKLY

John Vassos, N. Y., gets \$26 for single show card. Crawford, B. C., says: "Earned \$200 while taking course." Send today for free information samples and guarantee.

DETROIT SCHOOL OF LETTERING
154 Stimson Ave. Est. 1899 Detroit, Mich.



Book on Law Free



Write today for this new book. It tells you how a law training will shorten your road to success. It also carries a vital and inspiring message to every ambitious man! Find out about the opportunities that await the law trained man. Find out how you can learn law right in your own home. No obligations. Book is absolutely free. Write Today while low tuition fee is in force.

American Correspondence School of Law
3601 Michigan Avenue Dept. 1352 Chicago, Illinois

LEARN WATCHMAKING

and become independent. We help you secure a position. Easy to learn. Send for FREE CATALOG.

ST. LOUIS WATCHMAKING SCHOOL, Dept. 5, ST. LOUIS, MO.

HOT PIANO



Ultra-modern Piano
Jazz taught by mail. Note or ear. Easy rapid lessons for adult beginners. Also Self-instruction system for advanced pianists. Learn 358 Bass Styles, 976 Jazz Breaks, hundreds of Trick Endings, Hot Rhythms, Sock, Stomp and Dirt Effects; Symphonic and Wicked Harmony in latest Radio and Record Style. Write for Free Booklet.

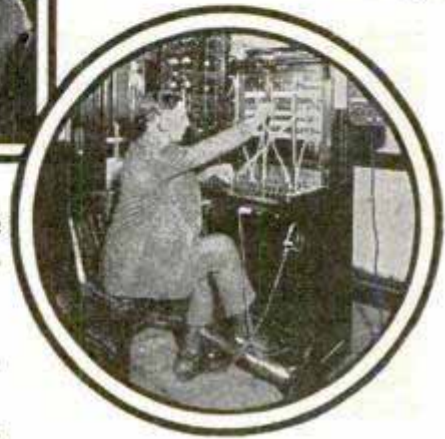
WATERMAN PIANO SCHOOL, 1826 W. Adams St., Los Angeles, Calif.

Pick the RADIO JOB you want and fill it 9 in only months!



Radio Operator
\$90 to \$200 per month
with all expenses paid

Broadcast Operator
\$1,800 to \$4,800 a year



By means of this "Big-League" home-training sponsored by Radio Corporation of America, General Electric and Westinghouse

WHY struggle along on less than \$45 a week? Why wait years for success that can be yours in only 9 months?

As a result of a marvelous new kind of home-study training in Radio, hundreds of men are today leading straight for financial independence! Radio pays from \$2,000 to \$25,000 a year. The work is thrilling... the hours are short. Vacations with pay... opportunities for seeing the world... adventure galore!

Prepare at Home with this Big Laboratory Outfit

Get the "How" as well as the "Why" of Radio—with this expert training! Only an hour or so a day—in spare time—is all you need! As part of your course, you receive absolutely free of extra charge—a magnificent outlay of apparatus. With this outfit you learn to



Limited space permits of only small picture of the great outlay of apparatus given with the course.



build fine sets and solve the problems that bring big pay.

Training sponsored by
RCA... General Electric...
Westinghouse

Our graduates are in big demand everywhere. They enjoy greater success because they're posted right up-to-the-minute in everything in Radio. Radio's progress each year is measured by the accomplishment of the great engineers at work in the research laboratories of RCA, General Electric and Westinghouse. These three Radio organizations set the standards for the industry, and stand back of every lesson in the course.

Money Back if Not Satisfied

The lessons prepare you for success in all phases of Radio—manufacturing, servicing, selling, ship and shore broadcasting, Television, Photoradiograms and Radio equipment. A signed agreement backed by RCA assures you of complete satisfaction upon completion of the training—or your money will be promptly refunded.

Read this Thrilling Free Book

It gives you the real "dope" about Radio

and describes in detail the famous training that has enabled us to place thousands of our students in fine positions, usually from 3 to 10 days after graduation. It may mean the turning point in your life. It tells in 50 fascinating pages and photos all about Radio's brilliant opportunities for adventure and success. Mail the coupon now—the book is absolutely free!

Radio Institute of America
Dept. PM-2, 326 Broadway, New York

Send for FREE BOOK about Radio



Radio Institute of America
Dept. PM-2, 326 Broadway, New York

Gentlemen: Please send me your big FREE 50-page book which tells about the brilliant opportunities in Radio and about your famous laboratory-method of guaranteed radio instruction at home.

Name.....
Address.....

DRAFTING



Learn at Home

DRAFTING is one of the best professions a young man can choose because it pays good salaries and it is the stepping stone to even better positions. Many leading architects, mechanical engineers and electrical engineers got their start at the drafting board.

There is no easier way to learn Drafting than through the home-study courses of the International Correspondence Schools. The practical value of these courses is shown by the success of I. C. S. students and also by the fact that employers are constantly writing us for trained men. We receive more calls for I. C. S. draftsmen than for graduates of any other course.

F. E. King was "a poorly paid clerk" when he enrolled for the I. C. S. Drafting Course. By study, industry, and perseverance he became Chief Draftsman of the U. S. Steel Furniture Company, of Syracuse. He is now earning more in a day than he used to earn in a week.

A. J. Hutchins became Chief Draftsman for the American Strawboard Company and increased his salary 300 per cent—also as a result of I. C. S. Training.

There is no doubt that Drafting offers a real opportunity to ambitious men and it will pay you to investigate it. Just mark and mail the coupon and we'll gladly send you a booklet telling all about the I. C. S. courses in Drafting or other subject in which you are interested.

INTERNATIONAL CORRESPONDENCE SCHOOLS
Box 5597-F, Scranton, Penna.

Without cost or obligation on my part, please send me one of your booklets and tell me how I can qualify for the position or is the subject before which I have marked an X:

- | | |
|---|--|
| <input type="checkbox"/> Mechanical Drawing | <input type="checkbox"/> Sheet Metal Worker's Course |
| <input type="checkbox"/> Draftsman's Course | <input type="checkbox"/> Sheet Metal Pattern Drafting |
| <input type="checkbox"/> Boilermaker's Course | <input type="checkbox"/> Boilermaker's Laying Out |
| <input type="checkbox"/> Structural Drafting | <input type="checkbox"/> Ship Drafting |
| <input type="checkbox"/> Architectural Drawing | <input type="checkbox"/> Illustrating and Designing |
| <input type="checkbox"/> Mechanical Engineer | <input type="checkbox"/> Machinist |
| <input type="checkbox"/> Electrical Engineer | <input type="checkbox"/> Toolmaker |
| <input type="checkbox"/> Civil Engineer | <input type="checkbox"/> Iron and Steel Worker |
| <input type="checkbox"/> Steam Engineer | <input type="checkbox"/> Patternmaker |
| <input type="checkbox"/> Structural Engineer | <input type="checkbox"/> Foundryman |
| <input type="checkbox"/> Architectural Engineer | <input type="checkbox"/> Automobile Mechanic |
| <input type="checkbox"/> Surveyor | <input type="checkbox"/> Architect's Blueprint Reading |
| <input type="checkbox"/> Concrete Builder | <input type="checkbox"/> Electrician |
| <input type="checkbox"/> Contractor and Builder | <input type="checkbox"/> Apprentice Trades |
| <input type="checkbox"/> Business Management | <input type="checkbox"/> Salesmanship |
| <input type="checkbox"/> Traffic Management | <input type="checkbox"/> Advertising |
| <input type="checkbox"/> Bookkeeping | <input type="checkbox"/> Business English |
| <input type="checkbox"/> Secretarial Work | <input type="checkbox"/> Civil Service |
| <input type="checkbox"/> Spanish and French | <input type="checkbox"/> Common School Subjects |
| <input type="checkbox"/> Mathematics | <input type="checkbox"/> High School Subjects |

Name.....

Address.....

Increase Your Earning Power

Apply time and labor-saving kinks to your work. Your efficiency will soon be recognized and you will be in line for advancement.

If you do machine shop work of any kind, sheet-metal work, painting, carpentry, auto repairing, farming, concrete work, plumbing, electrical work, welding, building, glass work, general repairing, tool-making, poultry raising, masonry or home repair work, get this

LIBRARY OF 6000 TIME AND LABOR SAVING IDEAS FOR SHOPMEN AND HANDYMEN

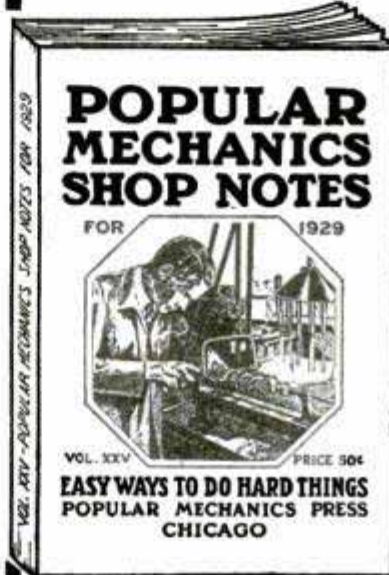
JUST PUBLISHED

SHOP NOTES for 1929

347 Articles
400 Illustrations

PRICE
50 CENTS

See list of partial contents below



Including the new 1929 issue illustrated above, there are now 16 volumes in the Shop Notes Library of 6,000 easily understood short cuts to every-day jobs. Here are just a few of the subjects taken from the 347 articles in the latest issue.

- | | | |
|-------------------------|---------------------------|---------------------------|
| Aluminum Meeding | Drilling Kinks | Plant |
| Artistic Doorplates | Dumb Waiter | Practical Mimeograph |
| Artistic Plaques | Electric Crucible | Resamer Holder |
| Attractive Lampshades | Furniture Designing | Removing Roller Bearings |
| Bird Bath in Concrete | Handy Workshop | Renewing Old Pumps |
| Blowtorch Making | Homemade Jack | Repairing Gaskets |
| Brass Pipe Handling | Homemade Silo | Repairing Laundry Tubs |
| Build Your Own Garage | Insulating Hot Water Tank | Rush or Fibre Seats |
| Burning Coke | Lathe Kinks | Safe Folding Ladder |
| Burning Out Carbon | Long Narrow Photographs | Six-Inch Bench Shaper |
| Camera Exposure Meter | Machine for Making Rope | Softening Leather Belting |
| Candlestick Making | Paint Removing | Tables in Art Moderne |
| Chute for Parcels | Piston Ring Compressor | Tin Can Mechanics |
| Colonial Spinning Wheel | Pneumatic Soldering | Tractor for Light Work |
| Crane for Small Garage | | |
| Double Vise Press | | |
| Draft Regulator | | |

Each volume contains approximately 500 articles and 400 illustrations and has 224 Pages. At the regular price of 50 cents per single volume this library costs \$8.00, but for a limited period we will supply the 16 vols. when ordered at one time at the special reduced price of only \$5.00.

SPECIAL OFFER COUPON

POPULAR MECHANICS PRESS,
200 E. Ontario St., Room P2, Chicago, Ill.

Send me, as per your special offer the following books. I will pay for books C. O. D. when they arrive. My money will be refunded if I am not satisfied. (Check what you want.)

- 1929 Shop Notes and Lathe or Drilling and Thread Cutting Handbooks, 98c.
 Complete Shop Notes Library (16 vols.) \$5.00.

Name.....

Street and No.....

City..... State.....

At Last! Real College Instruction in Drafting At One-Third the Cost!

Right at Home!

Unquestionably, hundreds of the readers of this magazine have waited and hoped to run across just such a message as this. For an old-established and recognized engineering school now makes an important announcement about Drafting. At last, you can get real college training right at home, inexpensively, in this big-pay profession. The trial lesson and other material offered below bear convincing proof and may now be obtained without cost simply by mailing the coupon.

LOOK here, men. It is true that this message is addressed to men who would like to have the very highest type of college training in drafting. But let's understand one another right at the start. Just because some of the most successful business and professional men in America are Chicago Tech graduates is no sign that anybody is going to try to get "high-brow." And because students come to Chicago from all over the world—often spending many hundreds of dollars—doesn't mean that you have to pay a lot of money for this practical, simplified, easily mastered training. Far from it! For now as part of the Chicago Tech new plan you may obtain complete home training in Drafting at a mere fraction of the usual cost of a college course.

Experience Is the Best Teacher

Nearly everyone has heard of Chicago Technical College. Over 1,000 men each year attend this well-known school. Here they quickly learn engineering and architecture, including Drafting. Not out of dry, hard-to-master text books. Not by a lot of tedious "study." But by the wonderful "practice" system developed by Chicago Tech. By this method everything is far easier to learn because it is more interesting. In fact man after man will tell you that learning any subject the Chicago Tech way is more like playing a fascinating new game than anything else. It is almost as different from the drudgery that you will find in ordinary "schooling" as night is from day. And now this easily mastered, pay-raising training is yours quickly, right at home, in spare time, at nominal cost.

Earn \$50 to \$100 a Week

This is the type of training that really leads to the big-pay positions in Drafting, where many earn from \$5,000 to \$7,500 a year and up. The largest employers of skilled draftsmen recognize the value of College-Training-in-Drafting, and con-



stantly apply to Chicago Tech for Draftsmen. Hundreds of Chicago Tech graduates who are now in top-notch positions of authority or in business for themselves do the same. The Chicago Tech employment department makes no charge either to student or employer if you accept one of these jobs. The entire success of this College-Training-in-Drafting has been proved so thoroughly that the "at-home" training is covered by a binding money-back agreement. With the Chicago Tech course you are supplied a full set of high-grade drawing instruments in pocket case. A special drawing table for home use. And a valuable drawing outfit. These are the same as used in the College. You get them without any extra cost whatever.

Learn the Facts—Now!

Where else on earth can you get real college training in Drafting like this? Yet now it is offered to you as part of the new Chicago Tech Home-Study plan on amazingly liberal terms. So if you want to learn Drafting the successful, approved and easy way—get the Free Trial Lesson and other valuable information. Simply mail the coupon without obligation.

**Get Free
Proof**



CHICAGO TECHNICAL COLLEGE

Dept. B-202, Home Study Division,
Chicago Tech. Building, 118 E. 26th St., Chicago, Ill.
"College-Training-At-Home"

COLLEGE-TRAINING-AT-HOME COUPON
Chicago Technical College, Dept. B-202, Home Study
Division
118 E. 26th Street, Chicago, Ill.

Please send me the facts about your new system that enables men to master professional Drafting at home just as you teach it at the college in Chicago. Include your FREE TRIAL LESSON. This does not obligate me in any way.

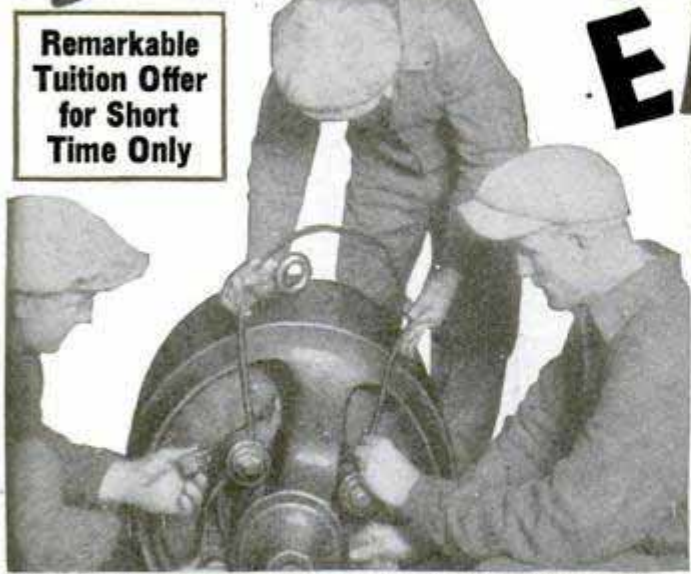
Name.....

Address.....

Town.....State.....

() Check here only in case you prefer coming to Chicago to take our short course in Drafting at Chicago Tech.

90 Days the PRACTICAL WAY...then an ELECTRICAL JOB at Big Pay



Remarkable Tuition Offer for Short Time Only

FREE RADIO COURSE INCLUDED

Also FREE AUTOMOTIVE ELECTRICAL COURSE

\$40 to \$200 a Week
MAIL COUPON TO-DAY FREE BOOK
 for Big, Illustrated, 64-PAGE

Not a Correspondence Course — No Books — No Lessons

J. H. McSweeney, Pres.,
 McSweeney Electrical Schools,
 Dept. 51-X, Cleveland, O.
 Dear Mac: Without obligation, send me a copy of your big book on ELECTRICITY; also details of Special FREE Radio and Automotive Electrical Course.
 Name.....
 Address.....
 Town..... State.....

McSWEENEY ELECTRICAL SCHOOLS
 DEPT. 51-X, CLEVELAND, OHIO



1000

HOTEL POSITIONS OPEN!

Proof

Hotels, restaurants, clubs, apartments, hospitals, institutions, schools and colleges everywhere need trained men. Over 70,000 positions paying \$2,500 to \$10,000 a year open annually in hotels of the United States. Nearly one and three quarter billions of dollars worth of NEW HOTELS, CLUBS and INSTITUTIONS being built this year will need over 200,000 trained men and women. Hotels start you at salaries up to \$3,500 a year, with living usually included.

Our files are crammed with letters like these, which prove that the hotel industry is the field of big opportunity today.
Elwood V. Matlack, Jr.—Akron, Ohio. "Less than two years ago, I was an elevator boy. Sept. 18th I was made Manager of a 200-room hotel. I gladly give you most of the credit for my success."
Henry Simon—Morgantown, W. Va. "I have made a connection with a country club as manager. The salary is excellent."
Ernest Crowder—Indianapolis, Ind. "The Lewis Schools are entirely responsible for my appointment as Assistant Mgr."

BE A HOTEL MANAGER
 Hotels, clubs, apartments everywhere are calling for managers, etc. Splendid salaries, fine living, luxurious surroundings for you!

Previous Experience Unnecessary

You can have one of these fascinating, big-pay positions. Through our Simplified Study Plan we give you the valuable knowledge that it has taken successful hotel men years to obtain. Age is no obstacle — young and old alike have equal chance for success. A common school education is all you need.

We Put Our Students in Touch With Positions

We train you and put you in touch with big opportunities. All of your training under the personal supervision of Clifford Lewis, Managing Consultant for over 300 hotels throughout the United States. Our students employed by leading hotels everywhere. Send today for Free Book, "Your Big Opportunity," showing how we can train you for one of these splendid positions, and explaining our Money-Back Agreement.

EARN \$2,500 TO \$10,000 A YEAR

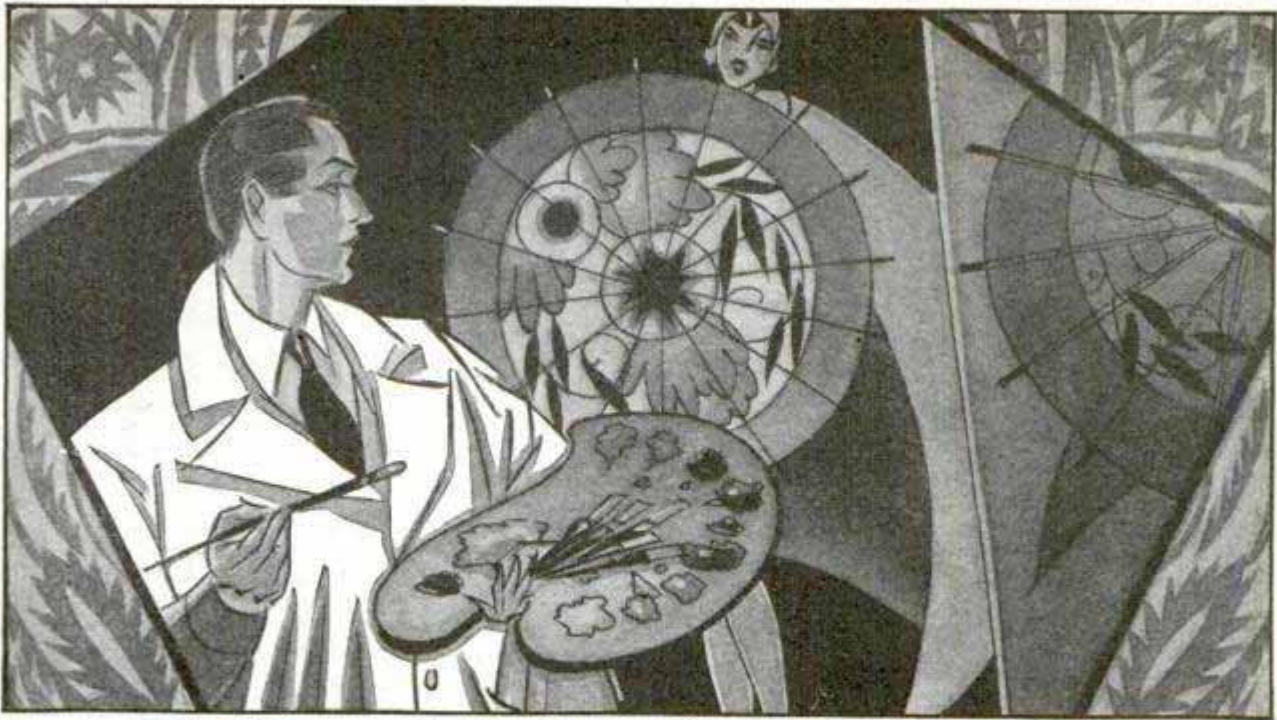


LEWIS HOTEL TRAINING SCHOOLS

Room BH-301 Washington, D. C.
 Clifford Lewis, President
 Charter Member National Home Study Council

Lewis Hotel Training Schools, Room BH-301, Washington, D. C.
 Send me the Free Book, "Your Big Opportunity," without obligation.
 Name.....
 Address.....
 City..... State.....

OPPORTUNITY COUPON



BE AN ARTIST

Earn a Big Name and a Fat Income

WHAT would you give to be this artist—earning a big income—enjoying studio life? He has learned the secret of forming simple lines into finished illustrations.

It was only a short time ago that this young artist filled out a coupon like the one below and mailed it to the Federal School of Illustrating. Now he is not only trained in modern art on which magazines are spending millions every year, but he has also had thorough instruction in all branches of illustration. Careful training by Federal Instructors has taught him to turn simple lines into dollars.

More than fifty famous artists—making big incomes themselves—have contributed to the Federal Course. Clare Briggs, Neysa McMein, Sid Smith, Fontaine Fox, Charles Livingston Bull, Norman Rockwell and many others teach you their “tricks of the trade” about illustrating, cartooning, lettering, poster designing, window card illustrating, etc.

Why drudge at routine work? Opportunities for artists have never been better. Drawing is easy to learn the Federal Home Study way. Earn while you learn, if you wish. Many students find a market for their work after a comparatively short time of study.

Test Your Drawing Talent

If you like to draw, train your talent. Open the way to success and a fine income. Write your name, age and address on the coupon and get our Free Book, “A Road to Bigger Things,” illustrated below. With it, you will receive our Free Vocational Art Test to find out your ability. Hundreds of successful artists got their start by sending for these. This is your opportunity—grasp it. **MAIL THE COUPON NOW.**



FEDERAL SCHOOL of ILLUSTRATING

2139 Federal Schools Bldg.
Minneapolis, Minnesota

COUPON

FEDERAL
SCHOOL of
ILLUSTRATING
2139 Federal Schools Bldg.
Minneapolis, Minn.

Please send me free book “A ROAD TO BIGGER THINGS” and Standard Art Test.

Name _____

Age _____ Occupation _____

Address _____

There's Quicker, Bigger MONEY for YOU in POULTRY RAISING!



Wherever You Live—
Whatever You Do Now—
\$1000 to \$5000 a Year
Can Be Yours!



Spare Time or Full Time YOU Can Cash-In BIG

Instead of knocking at your door, Opportunity is waiting for you in your back yard! Hundreds, thousands of my students have turned to Poultry Raising for PART TIME EXTRA MONEY or FULL TIME BIG PAY. Many start off in just a small way—with a back-yard or vacant-lot flock. Only a few hens—but my profit-producing methods make them pay. Whether you live in a city, town or on the farm—and no matter what kind of work you're doing now—I will show you how to start and how to keep going successfully. **Mighty successfully!** The Poultry Market is growing by leaps and bounds. Eggs and poultry meat are commanding real prices, high prices—prices that mean a handsome margin of profit on every egg or bird you can produce. There's not a doubt or question about it—**YOU CAN CASH-IN BIG.** Why wait—why lose? I'll PROVE that I can put YOU among the big money makers—**QUICK.**

My Proved Methods Assure Success Right from START

All the "mystery," all the "secrets," all the guesswork are taken out of Poultry Raising by my sure, tested, proved successful methods. I will teach them all to you. Nothing left out, nothing for you to have to figure yourself. I make it easy for you, it's fascinating, beautiful, pleasant, profitable. You'll be your own boss—I'll show you how to make \$1.00 to \$3.00 for every hour of your spare time. What's more, I'll show you the way to a salary of \$5,000 a year AND UP! Start as small as you want; my methods will get the maximum profits out of your flock and make it grow automatically, into a sure source of steady, big income for YOU.

FREE BOOK Shows Way to BIG PROFITS

My big new FREE book, "How to Raise Poultry for Profit," will amaze you! It brings evidence a-plenty—absolute proof—of what I have done for thousands of others. My forty years experience as Commercial Poultryman and former Senior Poultryman in the U. S. Dept. of Agriculture is yours for real Success and Independence. The Poultry Business needs you—and you need the profits that the poultry business brings. You need my book. Get mine for **QUICKER, BIGGER MONEY.** Do it this minute—don't delay a day. Get this coupon into the very next mail!

YOU Can Do What They Have Done

"Your Course on Poultry Raising is the most practical and complete in the country. You have opened up a pleasant and profitable way for me to gain an independent living."—S. Anderson, Harrington, R. I.
"I have a back-yard flock that has improved fully 100% since I have been following your methods. I am of the opinion that a poultryman cannot be successful without taking your Course."—David Tognelli, Chicago, Ill.



48 Pages
of Money-
making FACTS

Get this FREE Book NOW!

Harry M. Lamon, Pres.,
NATIONAL POULTRY INSTITUTE
Dept. 411-F, Washington, D. C.

Dear Mr. Lamon: Send me your FREE Book, "How to Raise Poultry for Profit." I want to know more about MY opportunity to make \$1,000 to \$5,000 a year, spare time or full time.

Name.....
Address.....
City..... State.....

Be Your Own MUSIC Teacher



Learn at Home

by wonderful new method that teaches in half usual time. Simple as A. B. C.—a child can master it. Your lessons consist of real selections instead of tiresome exercises. When you finish one of these delightfully easy lessons you've added a new "piece" to your list. You read real notes, too—no "numbers" or trick music. Method is so thorough that many of our half million students are band and orchestra LEADERS.

Automatic Finger Control

Our own invention—limbers, trains and guides your fingers so that they fall into proper place almost automatically.

Pick Your Course

- Piano
- Organ
- Violin
- Drums & Traps
- Mandolin
- Clarinet
- Flute
- Saxophone
- 'Cello
- Voice and Speech Culture
- Automatic Finger Control
- Piano Accordion
- Banjo (Plectrum, 5-String or Tenor)

Free Book and Demonstration Lesson

You may quickly become a fine player or singer through the U. S. School home study method. Write now, however, before free books and Free Demonstration Lessons are gone. Mention your favorite instrument or whether you prefer vocal music. Please write your name and address plainly. Instruments supplied when needed, cash or credit. Address:

U. S. SCHOOL OF MUSIC
72-A Brunswick Bldg. NEW YORK CITY



A powerful electric motor equipped with driving pulley, and two-blade fan, mounted on polished wooden base, binding posts, control switch. Runs mechanical toys beautifully from battery. A little gem, you may have it free.

With The Open Road for Boys Magazine

50 pages a month crammed with thrilling fiction and action stories, written for real live, red-blooded boys. It is the hit of the year. Regular subscription price \$1 a year. We will send you 12 issues—a year's subscription—and this great electric motor all for \$1. Order now. Just drop a dollar bill to us, we pay shipping charges.

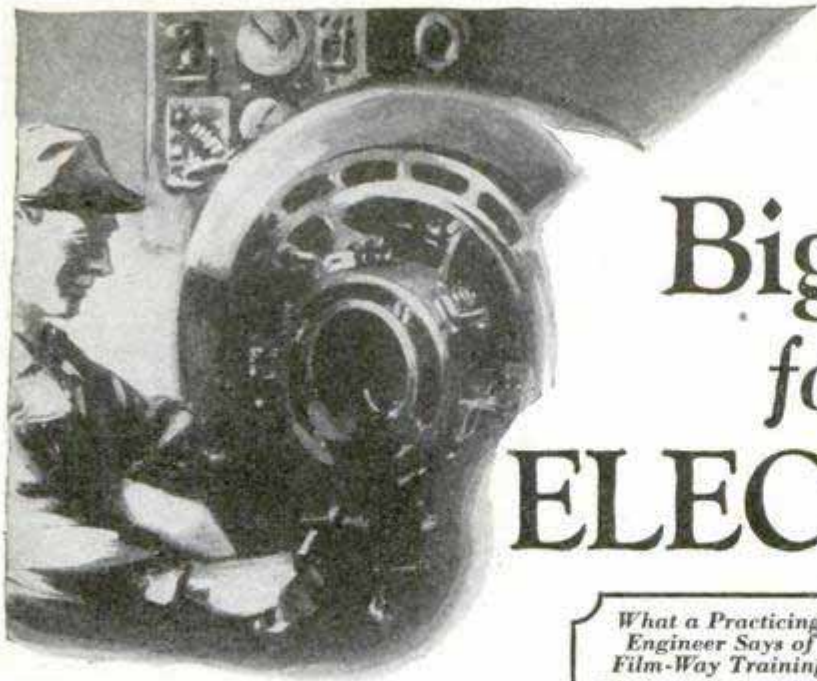
A Whole Year of Breathless Reading



Both for
\$1

OPEN ROAD FOR BOYS
MAGAZINE, Dept. 705 (Feb.)
130 Newbury St., Boston, Mass.
Friends: Here's my \$1. Rush me the electric motor and put me down for one year for the OPEN ROAD FOR BOYS MAGAZINE.

Name.....
Street.....
Town or City.....
State.....



Bigger Pay for You in ELECTRICITY

We Help You Get the Job and More Money

Our employment service starts working for you the moment you enroll for Film-Way Training. Employers want Film-Way trained men and we keep our students in touch with these opportunities, placing them in big pay jobs as rapidly as they are prepared. Opportunities are open in radio, aviation and automotive electricity, sub-station operation, wiring, contracting, etc.

This part of our service to every student costs you nothing extra. Remember, you must be satisfied with Film-Way Training and service or it costs you nothing.

Thousands of Feet of Film Sent to You; No Extra Cost



Actual motion picture films show you the inside of great power plants, broadcasting stations. They show you close-ups of men doing electrical work and of various types of electrical machinery in operation. Animated diagrams, too, make the facts about Electricity simple as A B C.

This DeVry \$75 Projector GIVEN

To show these movies in your own home you are given a \$75 DeVry standard model school projector. So simple to operate anyone can use it without previous experience. Operates from light socket or with farm lighting equipment, or automobile battery. Think of it, everything for these movies furnished to every student at *no extra cost*. It's all a part of our course and service and *you can get this nowhere else*. And you own a projector you can use in showing all kinds of movies at home!

What a Practicing Engineer Says of Film-Way Training

Charles E. Fitz, M.E., E.E., formerly associated with Steinmetz in the General Electric Laboratories, says: "I am amazed at how clearly and simply you explain the facts about electricity. The points are so much easier to grasp than by usual methods of instruction that the student must make quicker, surer progress."

THIS giant industry is constantly calling for more trained men to fill jobs that pay \$70 to \$200 and more weekly. You can fit yourself for a big pay job in Electricity in a new and amazingly easy way. At home, in your spare time, *with real moving pictures to guide you*, you learn how to do electrical work, and you are soon ready to enter big pay ranks.

This Entirely New Way is Easier, Quicker, Surer

Film-Way Training is endorsed by experts both in teaching and in practical electricity, as the *easiest and quickest way to master this subject*. Think of it, real moving pictures of all kinds of electrical machinery in operation, shown right in your own home! *Moving diagrams explain how electricity acts and how to control it.*

You Need Not Pay a Cent

We pledge to give you the training and employment service necessary to get you a better job and more money, or you need not pay a cent. We make this pledge in writing to every student on enrollment. So you take no chance, you cannot lose!

Fascinating as Seeing a Show

No wading through a lot of dry text book matter. The facts about electricity and electrical work are here made as live and fascinating as any picture show you ever saw.

FREE SEND NOW
for this Book
"The Film Way to Bigger Pay"

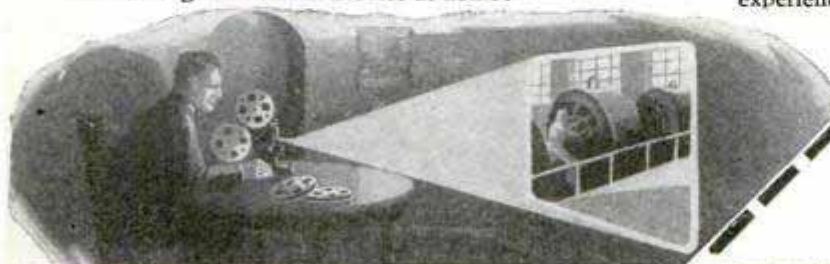
Our big free book explains and pictures how we use movies to train you. Send for it today. Representatives with school experience wanted.

**THE NATIONAL SCHOOL of
VISUAL EDUCATION**
"The Film Way to Bigger Pay"

537 S. Dearborn Street, Chicago, U.S.A. Dept. 2H

Send your book "THE FILM WAY TO BIGGER PAY" with full facts about this new, easier way to master electricity.

Name.....
St. or R.F.D.....
City.....
State.....
Age.....



TAKE THE FILM WAY TO Bigger Pay

We Will Train You in a Few Months



Day and Night Schools in Chicago, Detroit, Cleveland, Boston, Phila.

**No Books—
No Classes—
Wonderful Future in this Uncrowded Field**

Experts Earn Up To

\$125 A WEEK

as MECHANICAL DENTISTS

We teach you to make rubber plates, crowns, bridge work, metal base dentures, etc., for dentists. After graduating you are ready for a job or can open your own laboratory. We assist you.



Big Demand for Men!

Mechanical Dentistry is the laboratory bench work which the dentist turns over to the laboratory worker. Master this profession and help meet the demand of 64,000 dentists for laboratory work. Every city and every town where dentists are located offers work to the mechanical dentist. We train you in a few months in day or night school for this uncrowded field—no classes—no books—no mechanical experience necessary.

Work Your Way Thru School

We will help you find a job to meet your expenses while taking our training. And we will help you find satisfactory living quarters when you arrive.

Schools located in Chicago, Detroit, Cleveland, Boston, Philadelphia. Day and night schools.

INTERESTING FREE BOOK

Our illustrated free book on Mechanical Dentistry will acquaint you with some surprisingly interesting facts. It tells about the thriving profession of Mechanical Dentistry—the way to swift and certain success. And it tells about the progress of many of our graduates—men who have succeeded beyond their expectations, also full details of our liberal offers. Mail the coupon and find out more about this fascinating opportunity.

**McCarrie School of Mechanical Dentistry
1338 S. Michigan Ave., Dept. 198, Chicago, Ill.**

**McCARRIE SCHOOL OF MECHANICAL DENTISTRY
1338 S. Michigan Ave., Dept. 198, Chicago.**

Without cost or obligation, send me your illustrated book on Mechanical Dentistry, and complete information as to my opportunities in dental laboratory work.

Name.....

Address.....

\$2500 DRAWING COURSE for \$298



Haven't you often wished that you could draw cartoons, illustrate some idea, sketch some pretty face, etc.? You can do all of these things. One of America's most famous Cartoonists and Illustrators has developed a great, simple system for success in all branches of Commercial Art. This system has revolutionized the entire theory of drawing. It means that drawing can be as easy for you as writing—much simpler than learning shorthand, bookkeeping or typewriting. We are now placing this original system for learning Drawing, Art and Cartooning, consisting of 34 lessons with over 500 illustrations, within reach of every one. If you will devote a few hours each week to the Course WE ABSOLUTELY GUARANTEE that you will learn to draw and draw well before you have half finished the Course. If we fail to make this claim good, we will refund every cent paid us. By eliminating a large office force for answering correspondence, expensive catalogs, etc., we are enabled to make a price of \$2.98, the cheapest price ever known for a high-grade, home study course. Many have sent us letters similar to that of Rob't P. Davis of Detroit, who wrote: "I can't see how you ask so little. It is more than I expected." Learn to draw. It is a big asset, no matter what field you are in.

Send No Money

Just order the course and \$2.98 on arrival pay postman plus a few cents postage, payment in full for the entire Course and Drawing Outfit. If not entirely satisfied, return within five days and we will Refund Money. Address:

If you order the course at once, we will include a drawing outfit, consisting of artist's pencils, pens, paper, erasers, thumb tacks, etc., enabling you to go to work without any additional cost.

LEDERER SCHOOL of DRAWING, Dept. 462-S, Chattanooga, Tenn.
Orders from outside the U. S. A. are payable \$3.28 cash with order.

DEVELOP POWER

AT HOME

to initiate, persevere, achieve; carry on through life your education; earn credit toward a Bachelor degree, by using the 450 courses

**The University of Chicago
Gives by Correspondence**

Inquire, or check the advertisement to show desire and mail to 327 Ellis Hall, University of Chicago, Chicago, Illinois.

LEARN WATCH REPAIRING



You can learn by our modern and original system of instruction every part of the **Watch Repairing Trade** at home as good or better than at a shop. You can earn money while learning and secure a well paying position or start in business after completing our course of instruction. Good watch repairers are always in demand and earn from \$50 to \$75 per week. For particulars apply to the **Wisconsin School of Watch Repairing**
166 Mason St., MILWAUKEE, WIS.

STOP HUNTING JOBS

GET ONE YOU LIKE. Men-women, 18-55, earn \$95 to \$300 a Month in Post Office, Railway Mail and other branches of U. S. Government. Get Big List and requirements FREE. Write, Ozment Institute, 111-B. St. Louis, Mo., IMMEDIATELY.



LUCKY POCKET PIECE, triple horse shoe puzzle, always keep one with you—10c, 4 sets 25c pp., with secret solution. Western Puzzle Works, St. Paul, Minn.



Anyone CAN LEARN

No talent or experience necessary. Fascinating work. Pays Big Money. Complete instruction book tells about Alphabets, Colors, How to Write Signs, Show Cards, Window Board and Wall Signs. Ready made letters, Gilding, Tricks of the Trade, also gives 100 Alphabets and Designs. Book bound in flexible imt. leather-gold edges, and four ball bearing Show Card Pens. Sent postpaid \$3.00. (C.O.D.) 10c ex. Ogilvie Pub. Co., 57 Rose St., Dept. 20, N.Y. City



**EARN MONEY IMMEDIATELY—
WE FURNISH EQUIPMENT TO START !!**

"AVIATION GUIDE" Given Free!

For a limited time only we will give Major PAGE'S sensational "best seller" among aviation books—absolutely free with our Auto Encyclopedia.

Thousands of men have each paid \$2.00 in cold cash for this great flying hand-book, but you can have one WITHOUT COST if you act promptly. Mail coupon, send no money.



AUTO

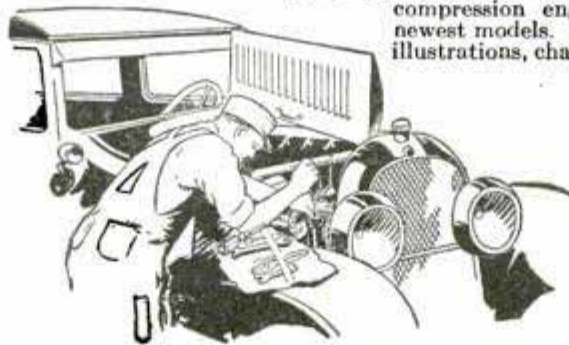
5 AUTO BOOKS SENT FREE!



AVIATION for BEGINNERS!

256 pages, 140 illustrations, 600 questions and answers on aviation. Everything about ships and flying explained in simple language, pictures and diagrams. All aeronautical terms explained. Airplanes and airships, balloons and dirigibles. Elementary aerodynamics, how an airplane flies, airplane parts and functions, fuelage forms, landing gear, wing design and construction, power requirements, airplane engines, propellers, equilibrium and control, etc., written in lesson form. Prepares for positions in ground-work, paves the way for flying. The most instructive and interesting book on aviation on the market.

Mail the coupon and we will send you a set of these remarkable auto books, just off the press. Whether you are mechanic or helper, expert or student, owner or driver—if you're interested in autos by all means take advantage of this opportunity to see and USE the latest and most complete reference work on autos ever published. Built by eighteen of America's greatest Automotive Engineers. So simple, so clear, so fully illustrated with pictures, charts, diagrams and blue prints that even men with little schooling can understand every fact. Yet in daily use by thousands of engineers, service-station superintendents and shop foremen as the most dependable reference encyclopedia available. The new edition includes straight eights, four-wheel brakes of all types, high compression engines and other features of the newest models. 5 volumes, 2400 pages, over 2000 illustrations, charts, diagrams and blue-prints.



Can You FIX IT?

Can you take the "play" out of differentials? Can you kill the SHIMMY in steering? Can you reset TIMING? Can you put your finger on ENGINE TROUBLE instantly without guessing or tinkering? Can you pull the STARTER off and fix it? Can you adjust and repair transmissions, rear-axes, engines and electrical systems? Can you make emergency repairs on the road or are you helpless when some little thing goes wrong? Is your hand always in your pocket, paying, paying, paying?

These Books Tell HOW!



The ten-billion-dollar a year auto industry offers rich prizes to men with gumption enough to really learn all branches of Automotive mechanics. A better job—bigger pay—the chance to go into business for yourself and get a share of the huge profits, are waiting for any man who even half tries to improve his ability to deliver service. And here's the quickest, easiest, cheapest way—no studying, no memorizing, no "lessons" or examinations. At a small fraction of the cost of a trade-course. **Just LOOK UP the facts you seek!** You'll find the answer to any auto problem literally at your finger tips in the remarkable **JIFFY INDEX**, now a feature of this encyclopedia. Mail coupon quick, and get "AVIATION GUIDE," free with these books.

DON'T SEND A PENNY!

American Technical Society,
Dept. A-219,
Drexel Ave. and 58th St.,
Chicago, Ill.

AVIATION BOOK FREE

I would like to see the new 5-volume edition of your AUTO BOOKS, but without obligating me to buy them. I will pay the few cents delivery charges only and if I choose to, I will return them express collect. If after 15 days' use I prefer to keep them, I will send you \$2 and pay the balance at the rate of only \$3 a month, until \$24.80 is paid. Please include a year's consulting membership free, and send "AVIATION GUIDE" without cost after I notify you I will keep the books.

Name.....

Address.....

Employer's Name.....

Employer's Address.....



American Technical Society
Dept. A-219, Drexel Ave. & 58th St.,
Chicago, Illinois

You can play the HAWAIIAN GUITAR just like the Hawaiians!

Play all the latest hits just as the Hawaiians do. Be the most popular member of your set, a happy crowd always around you, everybody enjoying and admiring your playing. Get in on all the good times. Entertain your friends—or play professionally. We will help you.



Native Hawaiian expert directs you

You get expert instruction, directed by a world-famous player and teacher, Prof. Walter Kolomo-ku. He quickly reveals to you the secrets of this fascinating instrument.

Complete Conservatory Course

You get 52 complete printed lessons. Nothing is omitted. Pictures explain every move. And no matter how

little you know about music when you begin, no matter if you have never touched a musical instrument, you can positively learn to play by our plain, easy picture method. You are sure to learn! What we can do for others we can do for you. \$1,000 successful students. This record assures your success.

Learn at home in spare time

Study in spare time—in absolute privacy—when you like—as long as you like. Even if you don't know one note from another, our method is so simple you begin a piece your first lesson. In half an hour you can play it!

Only 4 motions to learn

Then you can play any music—popular songs, classical, old-time melodies, native Hawaiian airs—or real jazz—separately or with accompaniment. You'll never be lonesome after you learn to play on this beautiful Hawaiian Guitar.

GIVEN when you enroll—
\$18 to \$20

Hawaiian Guitar

With Genuine Seal Grain Fabrikoid Cover and Complete Playing Outfit

Reliable retailers ask \$18 to \$20 for a similar instrument and outfit without the fine Fabrikoid Case, which alone is valued at \$3.50. Yet you receive this sweet-toned splendidly built Hawaiian Guitar, case and entire playing outfit, including picks, steel playing bar, tuning pipe, etc., without one penny of expense, as soon as you enroll.

Pay as you play

We make it easy for you. Start any time with a small first payment—then pay while learning. It comes to only a few cents per lesson. And bear in mind: Your only investment is the cost of the course—we furnish everything else.

No waiting—begin now

No waiting for a class to form—begin at once. The sooner you do, the sooner you will realize your ambition to become a real Hawaiian Guitarist. ACT!

OTHER COURSES] Tenor Banjo, Violin, Tiple, Tenor Guitar, Ukulele, Banjo Ukulele—well-known instructors.

FIRST HAWAIIAN CONSERVATORY OF MUSIC, Inc.

9th Floor Woolworth Bldg. Dept. 648 New York, N. Y. Approved as a Correspondence School Under the Laws of the State of New York.

Member of National Home Study Council.



Send This Coupon for Liberal Offer!

FIRST HAWAIIAN CONSERVATORY OF MUSIC, Inc.
9th Fl., Woolworth Bldg., Dept. 648, New York, N. Y.

Please send full information about your 52-lesson Hawaiian Guitar Course. I am not obligated to enroll unless I want to.

Name _____

Address _____

City _____

State _____

Poor English!

How much is it costing you in wasted opportunity?

Every day your associates are judging you—by what you say and how you say it! Hazy ideas, ill-chosen words, halting sentences, crude, slovenly speech—these mark a man as loose in thinking. Thoughts clear-cut, words that give true shape and color, sentences aflame with power and originality—these are the things that proclaim ability, that win for their users swift advancement. Stop apologizing for poor English—it's inexcusable! In the quiet of your home—with LaSalle's help—you can learn to speak and write with real distinction, learn to make the words you utter and the letters you compose stamp you as educated, cultured, a power to reckon with in the business world. Complete details in an attractive 32-page book, "Effective Business English," sent you free upon request. Ask for it TODAY.

LaSalle Extension University, Dept. 264-BE Chicago

Learn Photography at HOME

Make money taking pictures. Prepare quickly during spare time. Also earn while you learn. No experience necessary. New easy method. Nothing like it. Send at once for free book, OPPORTUNITIES IN MODERN PHOTOGRAPHY and full particulars.

AMERICAN SCHOOL OF PHOTOGRAPHY
Dept. 1352 3601 Michigan Ave. Chicago, U. S. A.

Pathfinder

TRIAL
EVERY WEEK 13 WEEKS
\$1 A YEAR 15 CENTS



Your neighbors know the Pathfinder and you will like it—the every week news digest from the Nation's Center. Bright, interesting, dependable, different—nothing else like it. Washington gossip, politics, science, travel, fun, lots of pictures, instruction, entertainment. Trial 13 weeks—13 big issues—only 15c or \$1 for full year—52 issues. Send now. Address Pathfinder, Dept. 25, Washington, D. C.

LAW Free Book

Write today for FREE 64-page book, "THE LAW-TRAINED MAN", which shows how to learn law in spare time through the Blackstone home-study course prepared by 80 prominent legal authorities, including law school deans, and U. S. Supreme Court justices. Combination text and case method of instruction used. All material necessary furnished with the course, including elaborate 25-volume law library, delivered immediately upon enrollment. Many successful attorneys among our graduates. LL. B. degree conferred. Moderate tuition, low monthly terms. Money-Back Agreement.

Write for free book today.

BLACKSTONE INSTITUTE, 307 N. Michigan Ave. Dept. 52 Chicago



Want a Gov't Job?

\$1700 to \$2300 a Year

MAIL CARRIERS—POSTAL CLERKS

Men 18 up

Steady Work Paid Vacation

Write immediately for FREE list of positions and full particulars telling how to get a position.

FRANKLIN INSTITUTE
Dept. M312 Rochester, N. Y.

Learn Watchwork, Jewelrywork and Engraving

A fine trade commanding a good salary, and your services always in demand. Address Horological, Dept. P, Bradley Institute, PEORIA, ILLINOIS, for our latest catalog.

LEARN ELECTRICAL TRADES

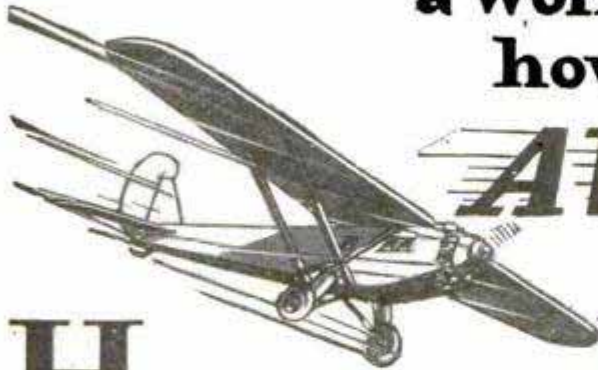
Practical Training on Massive Lay-Out of Expensive Electrical Equipment. Armature Winding, House Wiring, Electric Welding, Electric Refrigeration, Power Plants, Switchboards, Transformers, Motors, Generators, Radio Batteries. Automobile Course included without extra cost. Write Today for Free Catalog.

COLEMAN ELECTRICAL SCHOOL, 1628 Main St., Kansas City, Missouri

In this FREE BOOK

a World-Famous Flier shows
how YOU can get into

AVIATION



HERE is the book that tells you straight from the shoulder what Aviation offers YOU. You've been wondering how to break into the field—wanting all the facts, all the information. Here it is! A story more exciting, more thrilling, more inspiring than fiction—yet a man-to-man message of FACTS from cover to cover. Walter Hinton—hero of history-making flights—gives you the brass tacks of Aviation Today. He shows you exactly *where* your opportunities lie—exactly *what* to do to make the most of them—exactly *how* to fit yourself for them. Here is a book for men with too much backbone to stay chained to a small-pay job—too much adventure in their blood for a humdrum grind—too much good sound business sense in their heads to let this opportunity of a lifetime outgrow them!

The Richest, Fastest Growing Industry the World Has Ever Known

You haven't heard anything about this being a "bad year" for Aviation! Men like Ford, DuPont—millionaires—are investing fortunes in the field. Cities everywhere are building more airports; 24 hour shifts are racing construction on new plane and equipment plants. Air lines, air service of every kind is doubling and redoubling itself almost while you watch! There's no doubt about there being BIG PAY plus a real future for YOU in Aviation. Your one sure move is to get the right training—QUICK!

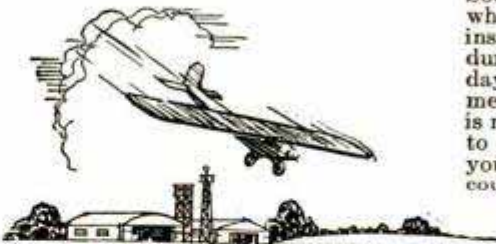
You Must Be 16 or Over

To take an active part in Aviation you must be at least 16 years of age. If you are under 16, please do not ask for Lieut. Hinton's Book because it will not interest you.

Aviation Is Ready, Hinton Is Ready—Now It's Up to YOU

Right at home in spare-time Hinton will teach you all the essential facts about plane construction, rigging, repairs, motors, instruments, theory of flight, navigation, commercial Aviation. Whether you plan to fly, or to cash-in on one of the

more than forty Big-Pay ground jobs, you must have this ground-work to land the job you want at the pay you expect. Learn just where you stand and what first steps to take. This Free Book tells how. Clip the coupon and send it TODAY. Hinton will rush your book by return mail.



40

Jobs on the Ground
for Each One in
the Air

Fliers are in demand—certainly! But for every man in the air, trained men are needed in over 40 highly-paid jobs on the ground. Hinton's training gives you your ground-work to earn real money as one of these:

Engineers, Designers and Draughtsmen, Pilots, Engine and Plane Mechanics, Riggers, Electricians, Welders, Instrument Makers, Wood and Metal Workers, Plane and Motor Inspectors, Airport Operators, Radio Experts, Assemblymen, Aerial Surveyors and Photographers, Aerial Transport Managers, Salesmen.

Walter Hinton

Trail-blazer, pioneer, explorer, author, instructor, AVIATOR. The first man to pilot a plane across the Atlantic—the famous NC-4—and first to fly from North to South America. The man who was a crack flying instructor for the Navy during the War; who today is training farsighted men for Aviation. Hinton is ready to back YOU up to the limit. His Book is yours FREE for the coupon below.

Rush Back to Washington!

Walter Hinton, Pres.,
Aviation Institute of U. S. A.,
1115 Conn. Ave., Washington, D. C.

1-P

Dear Lieut. Hinton: Send me your FREE Book telling how I can train under you right at home for Aviation.

Name.....

Street..... Age.....
(must be over 16)

City..... State.....

Aviation Institute of U. S. A.

Walter Hinton, President

1115 Connecticut Ave., Washington, D. C.





The Boss Was Afraid to Make Me Foreman

"HE SAID he had always liked me and he thought I could handle men, but he was afraid to make me Foreman until he was sure I knew more about the work.

"Tell you what I'll do," he said. "You take up a course with the I. C. S.—let me see that you really want to prepare yourself for advancement—and I'll promise to keep you in mind the next time there's a good job open."

"That sounded like a good proposition, so I began studying with the International Correspondence Schools. It changed my whole life.

"In three months the Boss called me in and said he was ready to make me Foreman. Just fourteen months after that he went before the Board of Directors to urge my appointment as Superintendent because he said I knew more about the business than anybody else in the plant.

"I'm making five times as much as I did before the Boss woke me up and literally forced me to take up an I. C. S. course and prepare to earn more money."

Isn't that good advice for you too?

Why don't you take up a home-study course with the International Correspondence Schools and get ready for a real job at a salary that will enable you to give your wife and children the comforts you would like them to have?

Right at home, in the odds and ends of spare time that now go to waste, you can prepare for the position you want in the work you like best. At least find out how.

Mail the Coupon for Free Booklet

INTERNATIONAL CORRESPONDENCE SCHOOLS

"The Universal University"

Box 5594-F, Scranton, Penna.

Without cost or obligation, please send me a copy of your booklet, "Who Wins and Why," and full particulars about the subject before which I have marked X in the list below:

BUSINESS TRAINING COURSES

- | | |
|--|---|
| <input type="checkbox"/> Business Management | <input type="checkbox"/> Salesmanship |
| <input type="checkbox"/> Industrial Management | <input type="checkbox"/> Advertising |
| <input type="checkbox"/> Personnel Management | <input type="checkbox"/> Business Correspondence |
| <input type="checkbox"/> Traffic Management | <input type="checkbox"/> Show Card and Sign Lettering |
| <input type="checkbox"/> Accounting and C. P. A. Coaching | <input type="checkbox"/> Stenography and Typing |
| <input type="checkbox"/> Cost Accounting | <input type="checkbox"/> English <input type="checkbox"/> Civil Service |
| <input type="checkbox"/> Bookkeeping | <input type="checkbox"/> Railway Mail Clerk |
| <input type="checkbox"/> Secretarial Work | <input type="checkbox"/> Common School Subjects |
| <input type="checkbox"/> Spanish <input type="checkbox"/> French | <input type="checkbox"/> High School Subjects |
| | <input type="checkbox"/> Illustrating <input type="checkbox"/> Cartooning |

TECHNICAL AND INDUSTRIAL COURSES

- | | |
|---|--|
| <input type="checkbox"/> Electrical Engineering | <input type="checkbox"/> Architect |
| <input type="checkbox"/> Electric Lighting | <input type="checkbox"/> Architects' Blueprints |
| <input type="checkbox"/> Mechanical Engineer | <input type="checkbox"/> Contractor and Builder |
| <input type="checkbox"/> Mechanical Draftsman | <input type="checkbox"/> Architectural Draftsman |
| <input type="checkbox"/> Machine Shop Practice | <input type="checkbox"/> Concrete Builder |
| <input type="checkbox"/> Railroad Positions | <input type="checkbox"/> Structural Engineer |
| <input type="checkbox"/> Gas Engine Operating | <input type="checkbox"/> Chemistry <input type="checkbox"/> Pharmacy |
| <input type="checkbox"/> Civil Engineer <input type="checkbox"/> Mining | <input type="checkbox"/> Automobile Work |
| <input type="checkbox"/> Surveying and Mapping | <input type="checkbox"/> Airplane Engines |
| <input type="checkbox"/> Plumbing and Heating | <input type="checkbox"/> Agriculture <input type="checkbox"/> Navigation |
| <input type="checkbox"/> Steam Engineering | <input type="checkbox"/> Mathematics <input type="checkbox"/> Radio |

Name.....

Street Address.....

City..... State.....

Occupation.....

Persons residing in Canada should send this coupon to the International Correspondence School, Canadian, Limited, Montreal, Canada

ELECTRICITY

Graduates in Constant Demand at Big Salaries

Intensive, practical training. **Low Tuition Rates.** Diploma in 1 year. Engineering degree in 2 years. Also special 12 weeks' courses. No time wasted. Expert instructors. Personal attention. Extensive modern equipment. Free employment service for graduates. Part-time work secured during training. 27th year. **Write Today for Free Illustrated Catalog.**
FINLAY ENGINEERING COLLEGE, 1001-B Indiana Ave., Kansas City, Mo.

Learn to **PAINT SIGNS and SHOW CARDS**

We quickly teach you by mail, or at school, in spare time. Big demand, big future. Interesting work. Oldest, foremost school. **EARN \$50 TO \$200 WEEKLY**

Otto Wiegand, Md., home-study graduate, made \$12,000 from his business in one year; John Vasson, N. Y., gets \$25 for a show card. Crawford, H. C., writes: "Earned \$290 while taking course." Write for complete information.

DETROIT SCHOOL OF LETTERING
150 Stimson Ave. Est. 1899 DETROIT, MICH.

LEARN WATCHMAKING AND ENGRAVING

BY OUR PROFIT-SHARING PLAN OUR GRADUATES SUCCEED

One of our Iowa students started in a very small way—now doing over \$30,000 a year. Another in Wisconsin, over \$10,000 the first year. Day or night classes. Call or write for FREE BOOK.

Chicago School of Watchmaking, Dept. 4901, 549 W. Randolph St., CHICAGO

STAMMERING

easily, permanently corrected. Win happiness and success. Ask for full information and special phonograph record. Send dime for postage

12972 Woodward Ave., LEWIS INSTITUTE, Detroit

ALWAYS Ask For DENISON'S—53 Years of Hits

Comedy-Dramas, Farces, Musical Comedies, Revues, Musical Readings, Comedy Songs, Blackface Skits, Make-up Goods.

PLAYS Vaudeville Acts, Monologs, Dialogs, Entertainments, Chalk Talk Books, Minstrels, Catalog FREE.

T. S. DENISON & CO., 623 S. Wabash, Dept. 9, CHICAGO



Wonderful, new device, guides your hand; correct your writing in few days. Big improvement in three hours. No failures. **Complete outline FREE.** Perfect Penmanship Inst., D-34, St. Louis, Mo.

This is the GUITAR

you hear on the radio and records.

The Gibson Mastertone Guitar, with its rich tone of such depth beauty and carrying power, embodies finest materials and most expert craftsmanship; acclaimed as *world's finest guitar*. Easy playing qualities make it easy to learn.



Send coupon NOW for FREE BOOK and details of Easy Payment plan. Mention which interests you: Guitar, Banjo; Mandolin; Ukulele.

Gibson

GIBSON, Inc. 203 Parsons St. Kalamazoo, Mich. Gentlemen: Send Free Book and details of payment plan on

[Instrument]

Name.....

St. or R.F.D.....

City..... State.....



I Can Help You

If Your Aim is a University Course—Barbering Will Help You to It. Saturday Work Alone Will Make Your Living While Learning. Short Course—

Easy to Learn—Quick to Earn

YOU may never want to go beyond this Splendid Paying Work—probably will not when you know its possibilities, but if—

AVIATION
IS YOUR HEIGHT
ELECTRICITY
YOUR SPARK
LAW
YOUR PLEA

MEDICINE
YOUR DOSE
ART
YOUR EYE
MUSIC
YOUR CHORD

BARBERING WILL HELP YOU TO IT

Barbering Has Other Appeals

You Can Be Your Own Boss—Travel and See the World—South in Winter—North in Summer.

Moler Made Barbers

Have Exceptional Opportunities on De Luxe Trains—on Ocean Steamships—in Hospitals—in Universities, Office Buildings, etc.

Moler Shop Owners—the Big Majority—Employ Moler Graduates

Send Coupon Today for Booklet B

MOLER SYSTEM OF COLLEGES

As a Moler Barber

You Are Standardized by the Educational Council of the Master Barbers of America and Employed in Organized Shops Everywhere. You Are Placed in Your Own Community, If Desired, Through Our Publicity Contest, the Most Original Plan of Placing Graduates Ever Thought of.

**You Are One of
60,000 Successes**

*What's
Your
Aim
?*



THE STANDARDIZED BRANCHES

- | | | |
|------------------|-----------------|--------------------|
| New York, N. Y. | Cleveland, Ohio | New Orleans, La. |
| Chicago, Ill. | Detroit, Mich. | Atlanta, Ga. |
| St. Louis, Mo. | Denver, Colo. | Memphis, Tenn. |
| Kansas City, Mo. | Omaha, Nebr. | Dallas, Tex. |
| Cincinnati, Ohio | Milwaukee, Wis. | Minneapolis, Minn. |

MOLER SYSTEM OF COLLEGES

Address Nearest Branch
(Street Address NOT Needed)

Please send me without obligation on my part your Booklet B.

Name

Address

City State

Caruso's



A post-mortem of Caruso's throat showed a superb development of his *Hyo-Glossus* muscle—the basic reason for his tremendous vocal power.

Strengthen your *Hyo-Glossus*

-and YOUR Voice will be Powerful, Rich, Compelling

YOU have a *Hyo-Glossus* muscle in your throat. But you never use it because the nerve center in the brain controlling this muscle is dormant.

The great secret of isolating this great vocal muscle was discovered by Eugene Feuchtinger, A.M., famous European musician-scientist, who has now made his simple scientific method of voice development available to everyone. It is ideally adapted to correspondence instruction. The exercises are silent. You can practice them in the privacy of your own home. The results are sure.

100% Improvement Guaranteed

The Perfect Voice Institute guarantees that Physical Voice Culture will improve your Voice 100%. You are to be your own judge—take this training—if your voice is not improved 100% in your own opinion, your entire tuition will be refunded.

Inspiring Book FREE Send the coupon below and we'll send you FREE this valuable work, "Physical Voice Culture." You assume no obligation. It may be the first step in your career. Do not delay.

Perfect Voice Institute

1922 Sunnyside Ave., Studio 13-52 Chicago

Perfect Voice Institute 1922 Sunnyside Ave. Chicago
Studio 13-52

Please send me a copy of your new book, "Physical Voice Culture," FREE. I understand that it is mine to keep and there is no obligation on my part. I am interested in

Singing Speaking Stammering Weak Voice

Name.....

Address.....

Age.....

GIVEN TO YOU

A Brand New High Grade Fine Tone
VIOLIN, TENOR BANJO, HAWAIIAN GUITAR, BANJO, CORNET, UKULELE, BANJO UKULELE, GUITAR OR MANDOLIN

We will give you without extra charge when you enroll, any instrument you select and teach you to play it by our NEW copyrighted easy to learn home-study course. Over 500,000 men, women, boys and girls have learned to play by our simplified method. Cost is only a few cents a day for lessons. No other charge. You pay while you learn. Instrument and first lessons sent on FREE trial. Write today. **CHICAGO CORRESPONDENCE SCHOOL OF MUSIC, INC.** 1632 No. Halsted St., Dept. 752 Chicago, Ill.

"BECOME A LIGHTNING TRICK CARTOONIST"
Send \$1.00 for Laugh Producing Program of 23 Trick Drawings with Instructions. Catalog of Chalk Talk Supplies Free. **BALDA ART SERVICE, Dept. 1, Oshkosh, Wis.**

ILLINOIS COLLEGE of PHOTOGRAPHY

Prepares you in from 6 to 8 months to earn \$200 to \$500 a month as a photographer or photo-engraver. Thorough practical training. Expenses low. Constant demand for our graduates. 35th year. Enroll immediately. Free catalog. **Box 429, Effingham, Illinois.**

6 FT. LONG GIVEN Here's the great navy model Airship. Large 6-foot air bag with inflators, parachute with automatic release and complete instructions for flying. Will fly for miles at height of 1000 feet. Great chance to study aerial navigation. Send name and we'll send 6 of our new art pictures to dispose of on special 25c offer. Send the \$1.50 you collect and as a reward for this service we will send this wonderful Airship with full instructions free. **C. M. THOMAS, 337 W. Madison St. 2-K-91, CHICAGO**

NERVES?

Are You Always Excited? Fatigued? Worried? Gloomy? Pessimistic? Constipation, indigestion, cold sweats, dizzy spells and bashfulness are caused by **NERVE EXHAUSTION**. Drugs, tonics and medicines cannot help you, sick nerves! Learn how to regain Vigor, Calmness and Self Confidence. Send 25c for this amazing book. **RICHARD BLACKSTONE, N-472 FLATIRON BUILDING, NEW YORK**

Panama Canal Clerk	Internal Revenue Position	Railway Postal Clerk	Motor Rural Carrier
--------------------	---------------------------	----------------------	---------------------

Check Here The Government Job YOU Want

Which of these four fine jobs do you want? I will help you get it! Good pay, travel if you want it, steady interesting work, and no worry about strikes and hard times! I have helped thousands to get well-paid Government positions. I can help you, too. I know just how to train you so that **YOU SURELY QUALIFY**. Do you want one of these four jobs—or would you rather be a Carrier, Custom House Clerk, Postmaster? Many others are open. The pay runs from \$1900 to \$3300 a year!

My FREE Book Tells How To Get It

Gives complete details of all Civil Service positions and how my 8 years as Civil Service Secretary, Examiner help you get the job you pick. Send for this book now. It costs you nothing and may get you "set for life." Mail the coupon TODAY. **ARTHUR R. PATTERSON, Civil Service Expert Patterson School, 82 Wisner Building, Rochester, New York.**

Patterson School, 82 Wisner Building, Rochester, N. Y. Send me your big FREE BOOK telling how I can secure a position with the U. S. Government paying from \$1900 to \$3300 a year to start, with excellent chances for advancement. This doesn't cost me a penny.

Name.....
Address.....
City..... State.....



If You Pledge Yourself To Secrecy I'll Teach You



Dr. Harlan Tarbell
Master of Magic
who has mystified
magicians as well as lay-
men with his
marvelous tricks.

Secrets of Magic! At Home—By Mail

Baffling secrets of the world's greatest magicians—mysteries never before divulged—supernatural effects of the Orient—massive stage illusions—the most priceless, most treasured Secrets of the Magic Profession now—for the first time—disclosed to YOU in the great Tar-

bell Course in Magic. Learn to perform like a real magician in a short time—in your spare time—at home. Be the life of every party—the center of every crowd, wherever you go. Business and Social Success are YOURS when you know Magic. And it's EASY with the Tarbell System!

Earn \$250 to \$1000 a Month!

There is a tremendous demand for Magic Entertainment. Clubs, churches, schools, conventions, theaters are on the lookout for Magicians—pay \$25 to \$100 for perhaps half an hour's program. Keep your job. Make EXTRA MONEY on the side. Salesmen—business men—professional men—all can use Magic to gain popularity and profits. Easy for YOU to make \$250 to \$1000 a month!

Astonish Your Friends Study the first lesson and your friends will be amazed at your wonderful Magical powers. You will have that Magnetic power that gives you instant popularity in any crowd. Everyone will marvel at your apparently supernatural, psychic power. YOU possess this talent now! Surprisingly easy to bring it out. Send the coupon below now—find out how easily you can do it.

Send for FREE Literature

Write! Mail coupon now for big free Magic circular telling all about the great Tarbell Course in Magic. Find out how you can learn to be a real magician—easily and quickly!—at home!—by mail! Learn what I have done for others—people just like yourself. Get our Prices and Easy Payment Plan. Mail coupon NOW!

Tarbell System, Inc., Studio 13-52
1926 Sunnyside Avenue, Chicago, Ill.

Tarbell System, Inc., Studio 13-52
1926 Sunnyside Avenue, Chicago, Illinois

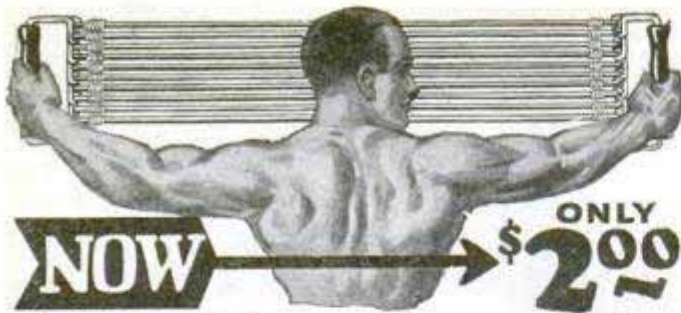
Please send me your big FREE illustrated and colored booklet giving full information on the Tarbell System of Magic. No obligation on my part whatever.

Name

Address

Age

City and State



NOW **Giant Chest Expander**

and

Progressive Exerciser

Be a muscular marvel. Have the muscles of a superman. Become strong for your health's sake or to astound your friends with extraordinary feats which only men of giant strength can do. In a few short weeks you will easily do stunts which now seem difficult—then real

Send No Money
Use This
Money
Saving
Coupon

muscles and strength will be yours—and yours to keep. If you want exercise to just keep in good shape you can reduce the strength of the Progressive Exerciser by eliminating as many cables as you wish. If you want great resistance so as to build up big solid muscles then use the full strength.

How the Giant Chest Expander and Progressive Exerciser is Made

The Giant Chest Expander and Progressive Exerciser is made with new live, springy rubber so as to give it long wearing and great resisting qualities. Do not pay more for an exerciser that has forty or less rubber strands to each cable. Get the best and most durable. The Giant Progressive Exerciser has 50 strands of the finest rubber procurable to each cable.

Free Instructions

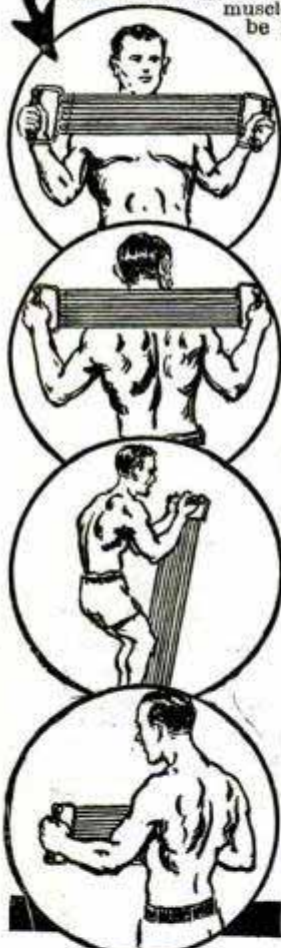
We do not think it enough to send you an exerciser worth double what we ask, so for a limited time, we will also include instructions absolutely free. These instructions are interesting and simple to follow—they show you the short cut to health and strength. Order today before this wonderful offer is withdrawn.

Your Guarantee

The Giant Chest Expander is sold with a guarantee that you will say it is the finest you ever saw or your money back.

5 Cables or double 10 Cables
for strength for
\$2 The double strength exerciser has resistance of over 200 lbs. **\$4**

How to Order—Send No Money
Sign your name and address to coupon below and get your Giant Exerciser at the present low introductory price by return mail. The price is made low because we want everyone to enjoy muscles and strength at the lowest possible cost. Don't pay more—order from us—get the most for your money. Use coupon now.



PROGRESSIVE EXERCISER CO.,
4032 Langdon Bldg.,
Broadway and Duane Street, New York

Please send Your 10 cable Progressive,
 Your 5 cable Exerciser.

Check the Exerciser you want, and it will be sent you by return mail. Pay postman introductory price, plus few cents postage on arrival. It is understood that if you are not entirely satisfied with your exerciser you may return it within 5 days and get your money back.

Name.....
Street.....
City..... State.....

If you live outside the United States, send cash with order.

I POSITIVELY GUARANTEE that you can produce wonderful, sweet music in three days and quickly play popular and classical selections.



Complete Outfit
Sent on
Trial

PLAY A SAW

No notes to read. No dreary practice. Just three short, simple lessons revealing every secret of my 12 years' success as a professional saw musician. Amaze your friends with this sensation of radio, vaudeville, orchestra and lodge entertainment. Send 10c for phonograph record of two beautiful Musical Saw solos which also entitles you to complete information about my special introductory offer of Saw, Bow, Hammer, and Resin, FREE with Course of Instruction.

MUSSEHL & WESTPHAL
113 So. 3rd St. Fort Atkinson, Wis.

MEN TO LEARN
MOTION PICTURE PROJECTION
A BIG-MONEY PROFESSION—\$2,000 TO \$4,000
We Assist Students to Earn While Learning
MOVIE OPERATORS SCHOOL
61 Sproat Street Detroit, Michigan

MAKE MONEY AT HOME!
Painting photos and miniatures. No talent required. Fascinating work. **Make \$35-\$100 a week.** Earn while learning. We teach you at home. Professional artist's outfit, employment service, given. Write for FREE book TODAY.
NATIONAL ART SCHOOL, Dept. 24-2, 1008 N. Dearborn, Chicago.

TELEGRAPHY
(Morse and Wireless) and **RAILWAY ACCOUNTING**, taught thoroughly. Big salaries; great opportunities. Oldest, largest school. Endorsed by Telegraph, Railway, Radio, and Government officials. Expenses low—opportunities to earn large portion. Catalog free. **DODGE INSTITUTE, Jones St., Valparaiso, Ind.**

DRAFTING
BOOKS SENT FREE!

For Beginners
Written so you can understand every word, by 18 famous Engineers and Architects. Deluxe, flexible binding. 1750 pages, 1050 blue prints, charts and diagrams. Prepares you for a good Drafting job in mechanical or architectural lines. Sent for 15 days' free use, if you mail coupon immediately.

Only fifteen minutes a day with these WONDER BOOKS will prepare you for a good Drafting job in less than a year! Mechanical and Architectural Drafting from simple straight lines to important, complex plans, a step at a time! Built especially for beginners, for men with only grammar schooling. Drafting room practice plus engineering made easy and clear!

Big Field—Big Demand—Big Pay!

Competent Draftsmen are urgently needed right now in all building and manufacturing lines at \$50 to \$100 a week. That's just the beginning—for draftsmen have the best chances for advancement! Pleasant, fascinating work, easy to learn and do. Learn quick with these books—send coupon for a set FREE, and see for yourself!

A year's Consulting Membership in the American Technical Society now given free to all readers of this famous Cyclopaedia of Drafting. Many say that's worth more than cost of books.

American Technical Society
Dept. D-219, 58th & Drexel Ave., Chicago

Modern American Homes FREE!

American Technical Society
Dept. D-219, 58th & Drexel Ave., Chicago

Send for 15 days' free use 4-volume set of **DRAFTING**. In return for mailing this coupon promptly send absolutely FREE "Modern American Homes," 112 plates, exteriors, interiors and plans. I will pay the few cents delivery charges. If I wish I may return books in 15 days and owe you nothing. But if I prefer to keep them I will send \$1.80 after 15 days, then \$2.00 a month until \$14.80 (special reduced price) is paid.

Name.....
Address.....
Employed by.....
Address.....



I GUARANTEE NEW HAIR in These Three Places—

OR DON'T PAY ME A CENT!

ARE you sincerely anxious to be done with dandruff, itchy scalp, falling hair and baldness? Do you *really* want to grow new hair?

Perhaps you've *already* tried hard to overcome these afflictions. Perhaps you've put faith in barbershop "tips," and used all kinds of salves, massages, tonics, all with the same results . . . lots of trouble and expense but no relief!

Now, consider what *I* offer you. I GUARANTEE to grow new hair on your head—on the top, front or temples—IN 30 DAYS . . . or not one red penny of cost to you.

Isn't that a different story from those you've heard before? I don't say, "try my wonderful remedy—it grows hair!" I say, and I put it in *writing*, "I GUARANTEE to grow hair . . . or no cost!"

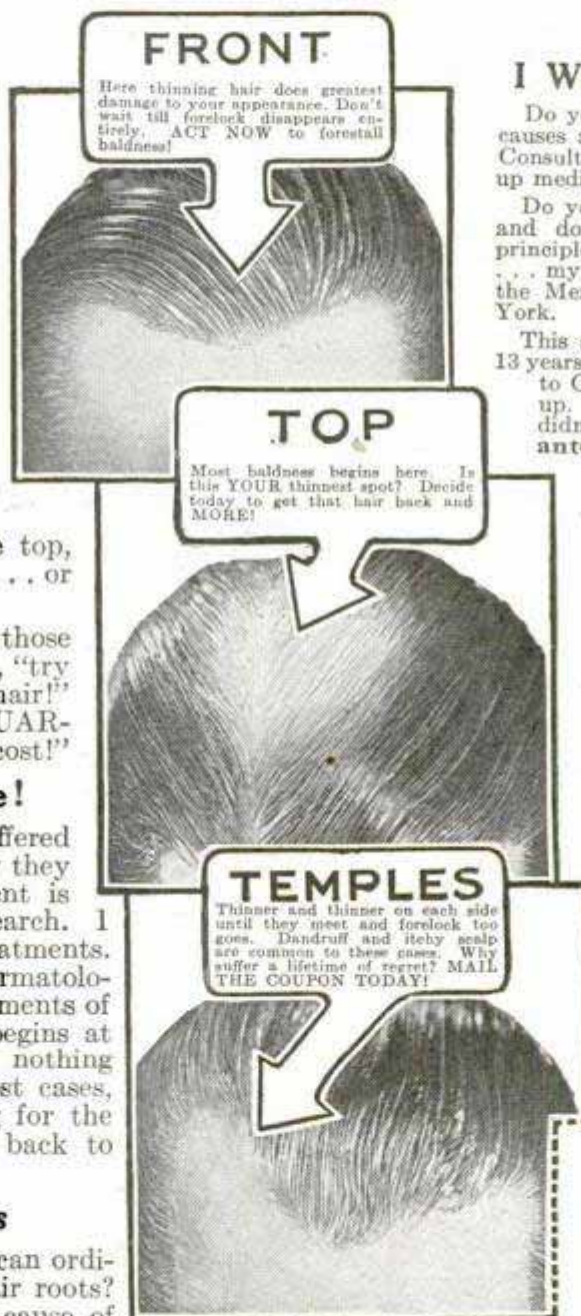
My Method is Unique!

Thousands who formerly suffered from scalp troubles bless the day they heard of me. For my treatment is based on science, on years of research. I *studied scalps*, not how to sell treatments. And I found, as did leading dermatologists, that ordinary surface treatments of the scalp are futile. Baldness begins at the **ROOTS**. If roots are dead, nothing can grow new hair. But in most cases, roots are only *sleeping*, waiting for the right treatment to bring them back to healthy, normal life.

I Reach the Roots

Now, I leave it to you. How can ordinary treatments penetrate to hair roots? How can they remove the *real* cause of baldness?

My treatment goes *below* the scalp, right down to the hair roots, awakening them to new action. And with just the mere investment of a few minutes a day thousands get these results from my treatment . . . or they never pay a cent!



I Welcome Investigation

Do you want absolute proof of the true causes and proper treatment of baldness? Consult your family physician. Or look up medical reference books.

Do you want positive proof that I can and do apply these accepted scientific principles? I offer you the best proof of all . . . my personal guarantee, backed up by the Merke Institute, Fifth Avenue, New York.

This scalp research bureau, established 13 years, is known to thousands from Coast to Coast. It has a reputation to keep up. It wouldn't dare to back me if I didn't tell the truth. So when I guarantee to grow hair or not a penny of cost, you're absolutely sure of a square deal.

Why Suffer Years of Regret?

Take a look in the mirror at those thin spots on your head! Think how you'll look when **all** your hair is gone. Consider how much prestige and attractiveness you'll lose. Then decide to act at once. Right now, mail the coupon below for the **FREE** booklet giving my complete story. In it you'll find, not mere theories, but scientific **FACTS**, and the details of my "hair grown or no pay" offer. My treatment can be used in any home where there is electricity. Send the coupon **NOW!** And by return mail the booklet is yours without the slightest obligation. Allied Merke Institutes, Inc., Dept. 162, 512 Fifth Avenue, New York City.

MAIL IT TODAY!

Allied Merke Institutes, Inc.,
Dept. 162, 512 Fifth Ave.,
New York City

Please send me—without cost or obligation—in plain wrapper, copy of your book, "The New Way to Grow Hair," describing the Merke System.

Name

Address

City State

(My age is.....)

DANGER: One, two, three—**BALD!** And, perhaps total baldness, say leading dermatologists, if you neglect any one of the three places shown above. Thousands fail to heed the warnings. But there is hope, no matter how thin the hair. Read my message. Study my guarantee. Then **ACT!**



"We can't get married until—"

"WE CAN'T get married until I earn more money." Thousands of young men are saying that today. Thousands of girls are giving that as the reason the marriage date is being put off and off. Sometimes it gets a little embarrassing, too, to have to keep on giving that excuse. *For no girl likes to admit that the man she is going to marry is a failure!*

It takes money to support a home these days. And you're right in waiting. But don't wait too long. The years of youth are precious years. They will never return.

Thousands of men have happy prosperous homes because they had the foresight to prepare themselves for advancement through the home-study courses of the International Correspondence Schools. Hundreds of them report salary increases of \$10, \$15 and \$25 a week. Many are earning \$75, \$100 and \$150 a week. Some have doubled and even tripled their salaries. Some are earning \$10,000 and \$15,000 a year. Others have become owners of businesses of their own.

If the I. C. S. can help other men to raise their salaries, it can help you. At least find out how. It won't obligate you to ask for our Free Booklets, but that one little simple act may change your entire life. Do it now. Do it for HER!

Mail the Coupon for Free Booklet

INTERNATIONAL CORRESPONDENCE SCHOOLS

"The Universal University"

Box 5595-F, Scranton, Penna.

Without cost or obligation, please send me a copy of your booklet, "Who Wins and Why," and full particulars about the course before which I have marked X in the list below:

BUSINESS TRAINING COURSES

- | | |
|--|---|
| <input type="checkbox"/> Business Management | <input type="checkbox"/> Business Correspondence |
| <input type="checkbox"/> Industrial Management | <input type="checkbox"/> Show Card and Sign Lettering |
| <input type="checkbox"/> Personnel Management | <input type="checkbox"/> Stenography and Typing |
| <input type="checkbox"/> Traffic Management | <input type="checkbox"/> English |
| <input type="checkbox"/> Accounting and C. P. A. Coaching | <input type="checkbox"/> Civil Service |
| <input type="checkbox"/> Cost Accounting | <input type="checkbox"/> Railway Mail Clerk |
| <input type="checkbox"/> Bookkeeping | <input type="checkbox"/> Mail Carrier |
| <input type="checkbox"/> Secretarial Work | <input type="checkbox"/> Common School Subjects |
| <input type="checkbox"/> Spanish <input type="checkbox"/> French | <input type="checkbox"/> High School Subjects |
| <input type="checkbox"/> Salesmanship | <input type="checkbox"/> Cartooning |
| <input type="checkbox"/> Advertising | <input type="checkbox"/> Illustrating |
| | <input type="checkbox"/> Lumber Dealer |

TECHNICAL AND INDUSTRIAL COURSES

- | | |
|--|---|
| <input type="checkbox"/> Architect | <input type="checkbox"/> Automobile Work |
| <input type="checkbox"/> Architectural Draftsman | <input type="checkbox"/> Airplane Engines |
| <input type="checkbox"/> Building Foreman | <input type="checkbox"/> Plumber and Steam Fitter |
| <input type="checkbox"/> Concrete Builder | <input type="checkbox"/> Plumbing Inspector |
| <input type="checkbox"/> Contractor and Builder | <input type="checkbox"/> Foreman Plumber |
| <input type="checkbox"/> Structural Draftsman | <input type="checkbox"/> Heating and Ventilation |
| <input type="checkbox"/> Structural Engineer | <input type="checkbox"/> Sheet-Metal Worker |
| <input type="checkbox"/> Electrical Engineer | <input type="checkbox"/> Steam Engineer |
| <input type="checkbox"/> Electrical Contractor | <input type="checkbox"/> Marine Engineer |
| <input type="checkbox"/> Electric Wiring | <input type="checkbox"/> Refrigeration Engineer |
| <input type="checkbox"/> Electric Lighting | <input type="checkbox"/> R. B. Positions |
| <input type="checkbox"/> Electric Car Running | <input type="checkbox"/> Highway Engineer |
| <input type="checkbox"/> Telegraph Engineer | <input type="checkbox"/> Chemistry |
| <input type="checkbox"/> Telephone Work | <input type="checkbox"/> Pharmacy |
| <input type="checkbox"/> Mechanical Engineer | <input type="checkbox"/> Mining Engineer |
| <input type="checkbox"/> Mechanical Draftsman | <input type="checkbox"/> Navigation <input type="checkbox"/> Assayer |
| <input type="checkbox"/> Machine Shop Practice | <input type="checkbox"/> Iron and Steel Worker |
| <input type="checkbox"/> Toolmaker | <input type="checkbox"/> Textile Overseer or Supt. |
| <input type="checkbox"/> Patternmaker | <input type="checkbox"/> Cotton Manufacturing |
| <input type="checkbox"/> Civil Engineer | <input type="checkbox"/> Woolen Manufacturing |
| <input type="checkbox"/> Surveying and Mapping | <input type="checkbox"/> Agriculture <input type="checkbox"/> Fruit Growing |
| <input type="checkbox"/> Bridge Engineer | <input type="checkbox"/> Poultry Farming |
| <input type="checkbox"/> Gas Engine Operating | <input type="checkbox"/> Mathematics <input type="checkbox"/> Radio |

Name.....

Address.....

City..... State.....

If you reside in Canada, send this coupon to the International Correspondence Schools Canadian, Limited, Montreal, Canada

LAW THIS BOOK FREE!

Study at Home

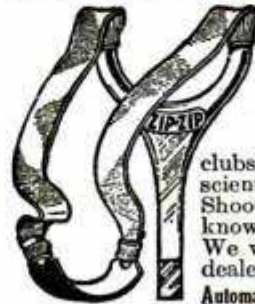
Become a lawyer.

Legally trained men win high positions and big success in business and public life. Greater opportunities now than ever before.

Earn \$5,000 to \$10,000 Annually!

We guide you step by step. Degree of LL.B. LaSalle law graduates practicing in every state. We furnish all text material, including 14-volume Law Library. Low cost. Easy terms. Valuable, interesting 96-page book free. Send for it NOW.

LaSalle Extension University, Dept. 264-L Chicago



ZIP-ZIP SHOOTER

BOYS; join a Zip-Zip Shooter's club, everywhere boys are forming these clubs, fine sport using this shooter which is scientifically and practically made. Zip-Zip Shooter is the best buy we know of for 35c or 3 for \$1. We will ship to you if your dealer can't supply you.

Automatic Rubber Co., Columbia, S. C.



BASHFUL?

"Shame on you!" Are you nervous, embarrassed in company of the other sex? Stop being shy of strangers. Conquer the terrible fear of your superiors. Be cheerful and confident of your future! Your faults easily overcome so you can enjoy life to the fullest. Send 25c for this amazing book. RICHARD BLACKSTONE, BB-472, FLATIRON BLDG., NEW YORK

BIG Demand for Skilled Mechanics!

The entire country is calling for skilled mechanics! Good pay—steady work—good opportunities for advancement! Master this fascinating trade with the aid of the

AMERICAN MACHINISTS LIBRARY

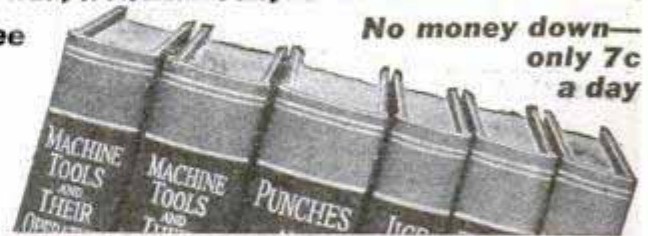
6 volumes—2,000 pages—2,500 illustrations

(A combined home-study course and reference library)

This library of machine shop practice was written for practical men. It gives you the best methods for every kind of machine shop work. It explains machine tools and their operation, tool work, gears and grinding, jigs and fixtures, automatic screw machines, their tools, punches, dies, etc. Plainly written—completely illustrated—the best kind of help to the machine-shop man who wants to advance himself.

Free TRIAL

No money down—only 7c a day



FREE EXAMINATION COUPON

McGraw-Hill Book Co., Inc., 370 Seventh Ave., New York

Send me for 10 days' free examination the AMERICAN MACHINISTS LIBRARY. If satisfactory, I will send \$1.50 in 10 days and \$2 monthly until the special price of \$17.50 is paid. If not wanted, I will return the books at your expense.

Signed.....

Address.....

City and State.....

Position.....

Employer..... P. M. 2-29

Learn AVIATION at GREER COLLEGE

Come into Aviation

Man's Dream Is Answered—Aviation Is Here

Transport Flyers will train you

Chief Pilot Meyer, operator of Meyer Air Transport, supervises all Flying instruction. He has for 14 years been an Instructor, Transport and Photographic Flyer, and has never had an accident to Student or Passenger.

Capt. Bryan superintends ground training

Captain Bryan—with years of Army

and Civilian Aviation Experience—supervises all ground schooling. He has been in Aviation and actual Flying for over twelve years.

Earn Big Money in a 4 Hour Day

What are a Flyer's hours? **Four Hours**—not work—but fun—nevertheless those are usually the hours for him.

And the pay! Many make \$300 on a single Sunday. My Free Book gives astonishing details. Send for it now!

Adventure—Prestige—Thrills—BIG PAY—Easy, Fascinating work that IS Aviation.

I'll pay your fare to Chicago

Come to Chicago. I'll pay your fare when you enroll. Here is the **real** hub of the Aviation Industry. The World's finest and biggest Airport is here. Get my Free Book — tells all remarkable facts.

LEARN DAYS OR EVES A Job while Learning

You can attend the Great Shops of Greer College and learn Aviation either days or evens. We even help get you a job so you earn as you learn—in short—what does this wonderful training cost? Nothing!



Erwin Greer



HOW!

I offer you a \$100 a week opportunity, perhaps more. But you must prepare. \$100 a week jobs mean nothing unless you can hold those jobs—so Prepare. I make it easy—26 years doing it—proves it, so when those jobs arrive—be ready—I'll help you get them—but be able to hold them.

TODAY

Tomorrow is just a day—but think—is it to be a day **wasted** or a day **rushing** to success? Think of it. Tomorrow, may be just the second day to your real triumph—but tomorrow can't possibly come before today. I ask you to do nothing but find out for yourself. My Book is Free. Look at it at least, it costs you nothing and it **will** help you if you enroll or don't.

Sincerely, **ERWIN GREER, Pres.**

GREER COLLEGE

**Dept. 201
2024 So. Wabash Ave.
CHICAGO**



ERWIN GREER, President

**Dept. 201
2024 So. Wabash Avenue,
Chicago, Illinois**

Send Free Book and details of Special offer, without obligation to me.

Name.....
Address.....

Your Mistakes in English STAND OUT!

YOU can not hide your mistakes in English—they stand out sharply, giving others an unfortunate impression of you. You may not make such glaring errors as "He don't," "You was," "I ain't." But perhaps you may make other mistakes which offend the ears of cultured people, and cause them to judge you unfairly.

"Can't hardly"
"He don't"
"You was"
"I ain't"



No one will correct *your* mistakes in English. People are too polite. They fear you will feel insulted, and unconsciously you keep on making the same mistakes. And, though you may think your English is good, it may be dotted with errors which *others* notice, and which destroy many of your opportunities for advancement.

What Can You Do?

For many years Sherwin Cody studied the problem of creating *the habit* of using good English. After countless experiments, he finally invented a simple method by which you can acquire a better command of the English language in only 15 minutes a day.

Under old methods rules are memorized, but correct habits are not formed. Soon the rules themselves are forgotten. The new Sherwin Cody method provides, on the contrary, *for the formation of correct habits* by constantly calling attention only to the *mistakes you make*—and then showing you the right way, so that correct English soon becomes "second nature." Already over 50,000 people have used this method with the most marked results.

FREE Book on English

A new book explaining Mr. Cody's invention is ready. If you are ever embarrassed by mistakes in grammar, spelling, punctuation, pronunciation, or if your vocabulary is limited, this new free book, "How to Speak and Write Masterly English," will prove a revelation to you. Send the coupon or a letter or postal card for it now. SHERWIN CODY SCHOOL OF ENGLISH, 52 Searle Building, Rochester, N. Y.

SHERWIN CODY SCHOOL OF ENGLISH
52 Searle Building, Rochester, N. Y.

Please send me your free book, "How to Speak and Write Masterly English."

Name.....

Address.....



DRAW CARTOONS

TURN YOUR TALENT INTO MONEY

Cartoonists earn from \$50 to \$250 per week—some even more. Remarkable *Circle System of Drawing* teaches you in half the usual time. Students from all parts of the world are enrolling for this exceptional instruction. *Personal criticism* service and up-to-the-minute instruction make it easy for National students to attain success. Send for interesting **BOOKLET** and **SAMPLE LESSON PLATE** explaining full details of the Course and what National students are accomplishing. No salesman will call.

The National School of Cartooning
623 Penton Bldg., Cleveland, Ohio

BE A MAGICIAN!

I WILL TEACH YOU, FREE!



Be popular in any crowd. Give exhibitions at clubs, parties and lodges. I can teach you hundreds of entertaining tricks in just a few hours so you can delight your friends and be invited everywhere.

12 MAGIC TRICKS SENT FREE

To prove how quickly you can learn, I will send you 12 amazing magic tricks and teach you how to do them—**ABSOLUTELY FREE.** Send only 25c to cover postage, packing, etc. Write today to
A. P. FELSMAN, Dept. 45, 154 No. Clark St., Chicago, Ill.

Learn Watchwork, Jewelrywork and Engraving

A fine trade commanding a good salary, and your services always in demand. Address **Horological, Dept. P, Bradley Institute, PEORIA, ILLINOIS,** for our latest catalog.

BE AN OIL EXPERT!

Trained men needed! Geologists, Drillers, Refiners (Chemists and Still Men), Oil Salesmen, earn 2 to 10 times more than in other fields. Write today! **FREE Booklet!** Petroleum Engineering University, Dept. 222, Fort Wayne, Ind.

BE A RAILWAY TRAFFIC INSPECTOR

A Quick Way to a Permanent, Big Pay Job

Would you like to earn \$250 per month salary in Railway Traffic Inspection? Many of our graduates do—and many of them have been promoted to salaries of \$5000 to \$10,000 a year. It only takes a few weeks of our spare time home study training and you'll be qualified to step into a position paying at least \$120 per month to start.

—and after completion of your training, we'll assist you to a position at a definite salary or refund every penny of your tuition.

Traffic Inspection is healthy, outdoor work with regular hours. You'll be practically your own boss, see new faces and places each minute, deal only with high officials. Promotions to \$150, \$175, \$200 and up per month come rapidly.

Send for Free Booklet

For 10 years we have trained and placed men in this interesting profession. Read what they say about it in our free booklet, which also shows why we are able to assist you to a position after graduation, or refund your tuition. Send coupon for free booklet.

MAIL THIS COUPON TO-DAY

STANDARD BUSINESS TRAINING INST.,
Div. -2, Buffalo, N. Y.
Please send me your free booklet "A Profession of Protection."

Name.....

Address.....



Be a Jazz Drummer!

easy, extra, money

Learn at home!

Ludwig TRADE MARK Trap Drum Outfit!
10 Days free trial at home!

Cultivate Your Rhythmic Instinct!

**"Peacock" Kelly
The Idol of Thousands**

How would you like to trade places with Jack "Peacock" Kelly, shown above? "Peacock" Kelly is one of the world's highest paid drummers, his salary being \$10,000.00 a year for playing an average of two shows a day, plus extra hours in cabarets, private dances, etc., etc. He learned on a Ludwig Trap Drum outfit and has used Ludwig equipment ever since. Peacock Kelly admits that he wasn't born with any unusual ability. He just developed his natural sense of rhythm until he is now one of the world's best trap drummers.

If you envy him, remember that mere wishing won't get you there! Sending in the coupon is the first necessary step! The rest, because of the simple free instruction Book, is easy. Read "Peacock's" letter below.

Play in 10 Minutes

Popularity! Easy Extra Money! Fascinating Fun! Life! New Friends! Adventure! Opportunities! These are just a few of the things the idolized dance, theatre, or stage orchestra Trap Drummer enjoys today. All this and more can be yours for the asking. Trap drumming is easy—natural. It is simply the carrying out of natural rhythmic instincts which everyone has. With every Ludwig trap drum outfit, we furnish an instruction book—free. So simple and understandable that within very little time you will be jazzing away on your traps like the best of them. Mr. Wm. F. Ludwig, the president of this company, is one of the world's foremost drummers, and has built up, over a period of 22 years, the world's largest trap drum plant. We are offering you any Ludwig trap drum outfit you select for a 10-day free trial—a small down payment and the balance in easy monthly installments. Why not cultivate your rhythmic instinct and play away many happy hours to bigger and better things?

FREE Instruction Books

We will furnish you a free Beginner's instruction book for "jazz" drumming. It makes everything clear, plain, and easily understandable. It was written by one of the world's greatest drummers.

Also, we will send you three times a year, the Ludwig Drummer, full of "tips," photos, orchestras, illustrations, and the latest trap drum effects. This service is absolutely free.

Small Down Payment Puts a Ludwig Outfit Into Your Hands

We want to make it as easy as possible for you to own and play a Ludwig Trap Drum outfit. All you have to do is to send in a small down payment with your order as evidence of good faith, and we will ship the outfit you select at once. Set it up, play it, use it as if it were your own, for 10 days. With one of our free instruction books in front of you, you will be jazzing away in merry style after a few minutes of practice. If you like it (and we are sure you will) keep it and send us the balance in small monthly payments.

A Trap Drum Outfit to Fit Your Purse—and Your Ability

From the very smallest Trap Drum outfit for beginners, to the marvelous gold outfits used by all the best professional drummers in the world, you will find the same high standard of workmanship. No matter what outfit you select, it is built to fit your need—your talent—your purse. Our free illustrated catalog describes them all.

Why Not You?

"The wonderful Ludwig Trap Drum outfit I use helps me to put my work across. I have used Ludwig outfits for the past 12 years. Several times I have heard people say, 'Look at those beautiful drums.' I am not kidding myself when I say that the class and quality of my Ludwig drum outfit have done much to get me into the big money!"

—Jack Kelly, Now playing with Mark Fisher's Stage Orchestra, Chicago.

Don't Delay—Write Today For Full Information!

Don't waste time! Don't delay if you want to make easy, extra money, if you want to make new friends, if you want to be the life of any party, if you want to take up Trap Drumming as sheer fascinating fun, if you want to develop your natural sense of rhythm send in the coupon. We will forward to you our big illustrated catalog which tells you all about

the Ludwig Trap Drum Outfits. Now—while you are thinking of it, sign the coupon and send today. Wm. F. Ludwig, the president of this company has a personal regard and interest in every drum and trap that leaves the factory. He is never satisfied unless you are. When you buy a Ludwig trap drum outfit you are buying the product of a master drummer, coupled with the finest engineering talent, giving you the last word in practical drum instruments for amateur or professional alike.

LUDWIG & LUDWIG

1611 N. Lincoln Street Dept. 8-2 Chicago, Ill.
The World's Largest Makers of Professional Drum Outfits and Traps
—Established 1907—

Send Coupon Now!

LUDWIG & LUDWIG, DEPT. 8-2, 1611 N. Lincoln St., Chicago, Ill.
Gentlemen:

Without obligation, please send me one of your Big Illustrated Catalogs showing Ludwig Trap Drum Outfits, along with details about your 10-day Free Trial Offer, Free Instruction Book, Drummer's Magazine, and Easy Payment Plan.

Name.....
Address.....
City.....State.....



He Kept the Job He Liked

—and increased his salary 73%

W. A. Day, of Woonsocket, R. I., wanted more money. But he liked his job—didn't want to change—made up his mind to get more money *right where he was.*

That meant that he must make himself worth more money to his employer—and that, in turn, meant *training.*

His first step was to enroll with LaSalle for home-study training in Higher Accountancy. Four months later he enrolled also for training in Modern Business Correspondence. Two years later he had completed both courses, had enlisted the aid of LaSalle in preparing for C. P. A. examinations, and was pursuing a LaSalle elective in Construction Company Accounting. More recently he enrolled for LaSalle training in Business Management.

"I entered upon the study of these courses," writes Mr. Day, "with the sole idea of increasing my business knowledge for the benefit of my own particular firm and with the desire to lay a foundation for the future. In this I am sure that I have succeeded. In actual results I have received a salary increase of exactly 73.3% since the date of my first enrollment, but I consider this equal to 100% in the average case, for I have earned this increase without changing my position."

Send for Salary-Doubling Plan

Are you in earnest when you say that you want to get ahead?

Then send today for full particulars of the LaSalle Salary-Doubling Plan. The coupon brings it to you *free*, together with a 64-page book setting forth the opportunities in the business field in which you most prefer to win success. *This book shows you how you can quickly turn those opportunities to your advantage.*

"Tomorrow" means "next week"—"next month"—never! Clip and mail the coupon NOW!

— — — Find Yourself Thru LaSalle! — — —

LA SALLE EXTENSION UNIVERSITY

The World's Largest Business Training Institution
Dept. 264-R Chicago

I should be glad to learn about your salary-doubling plan as applied to my advancement in the business field checked below. Send also copy of "Ten Years' Promotion in One," all without obligation.

- Business Management
- Higher Accountancy
- Modern Salesmanship
- Traffic Management
- Railway Station Management
- Law—Degree of LL.B.
- Commercial Law
- Industrial Management
- Modern Foremanship and Production Methods
- Personnel and Employment Management

- Banking and Finance
- Modern Business Correspondence and Practice
- Expert Bookkeeping
- C. P. A. Coaching
- Business English
- Commercial Spanish
- Effective Speaking

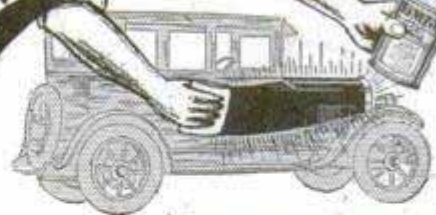


Name.....

Present Position.....

Address.....

30 MINUTES AND IRE NIUZITT
Makes Old Cars Look Like New!



The Greatest Automotive

Discovery of Scientists in Recent Years

You just flow ReNUZit onto any automobile with a piece of cheesecloth, and instantly the ORIGINAL color and lustre of that car is like new again! NOT A POLISH, CLEANER, WAX, OR PAINT. No tiresome rubbing or polishing; harmless, lasting, sure. GUARANTEED NOT TO TURN WHITE.

AGENTS' NEW PLAN

Make \$50.00 a Day

Millions are waiting to buy ReNUZit. That is why ReNUZit Agents all over the country can make almost unbelievable profits. And our PROPOSITION is so GOOD that you should have no trouble making \$50.00 a day and up.

Test ReNUZit FREE!

You have the privilege of trying ReNUZit yourself right now without risk. Prove to yourself what miracles it accomplishes. Write TODAY for full details and Free Test Offer.

The ReNUZit System

154 E. Erie St.,

Dept. 805-B.R.

Chicago, Ill.

Be a
Civil
Engineer!

Learn
at
Home!



Cyclopedia of Civil Engineering

9 great volumes.
4000 pages.
3000 illustrations.
New edition just off the press, by twelve of America's greatest engineers. Includes: Surveying, bridges, railroads, steel structures, municipal engineering, water supply, road building, etc.

Earn
\$5000
a Year—and Up!

"CIVIL ENGINEERING"—in plain English written so you can understand it, even if you have only a limited education. Prepares you for a well-paid railroad structural or public works position. Covers every branch of Civil Engineering practice. At once a reading course for the ambitious student and an authoritative reference work for the experienced engineer. Borrow a set—free! Look over the test questions which help you master each subject quickly. Mail the coupon without obligation today!

American Technical Society
Dept. C-219 Chicago

Loaned Free!

To prove you can learn Civil Engineering at home in your spare time. And because no description here could do it justice, to let you see for yourself the scope and simplicity, the authority and quality of this great home reading course. Cost and terms are within your reach. Send no money—just mail the coupon.

American Technical Society,
Dept. C-219, Chicago

I want to BORROW the CIVIL ENGINEERING Cyclopedia for 15 days FREE. I will gladly pay the few cents express, but I am to pay nothing for the loan of the 9 big volumes if I return them within 15 days. If I wish to keep them I will send you \$2 after the 15 days, then \$3 a month until special advertising price, \$34.80, is paid.

Name.....

Address.....

(Attach letter stating age, occupation, employer's and references' names and addresses.)

Here's REAL Money

The World's Most Interesting Industry

\$50 to \$250
a Week

Positions Open
or Start Your
Own Business



Motion Picture, Portraiture, Advertising and News Photography ALL PAY BIG

YOU are needed NOW! Find out about YOUR big opportunity in one of the most fascinating and best paying businesses on earth! Send for the handsome FREE BOOK that tells how you can make \$20 to \$40 a week in your SPARE TIME—how you can earn up to \$250 a week as Cameraman in one of the great Motion Picture Studios—how you can earn \$4,000 to \$10,000 a year in Advertising, Commercial or Portrait Photography—how you can start your own business with little or no capital. There are all kinds of opportunities and they all pay REAL MONEY. Photography is one of the fastest growing industries today—trained men and women are urgently needed everywhere.

Learn at Home or in Our Studios

No experience needed. New method quickly prepares you for the job you want. Personal instruction by famous experts. Learn at home on correspondence plan or come to our great New York studios. Free Employment Service helps you get the job you want.

CAMERA GIVEN

Your choice of professional Motion Picture or View Camera given free with home-training plan. Actual practice in taking artistic, up-to-date pictures that command highest prices. Earn while learning.

Send for Illustrated Book and Job Chart FREE

Get the facts about this wonderful profession and what it offers YOU. No cost, no obligation. Handsome illustrated Book and Job Chart sent free on request. Pick the job you want—we'll show you how to get it. Mail coupon or write—TODAY.

New York Institute of Photography 10 West 33rd St., Dept. 49, New York, N. Y.

Motion Picture Projection Pays \$50 to \$125 a Week for 6 Hours Work a Day!

Want to be a Movie Operator? Trained men are needed by theatres, movie houses and wherever motion pictures are shown. The hours are short, the work easy and pleasant, and the salaries BIG. Motion Picture Operating and Projection is one of the best-paying vocations in the world!

Now You Can Become a Movie Operator in Spare Time at Home

For the first time, it is now possible to become a Movie Operator at home. New method created by world-famous authority on Projection quickly makes you a trained operator. Practical, intensive training in spare time. The greatest opportunity ever offered to qualify for a high-salaried position in this fascinating field.

PROJECTOR GIVEN

Gain actual experience at home with the brand new Projector we give you absolutely free of extra charge. Operates on professional principles and gives you practical training in projecting motion pictures on the screen. Make money with a home movie show or projecting for churches, clubs, schools, etc.

Mail Coupon or Write

Get the facts about Motion Picture Operating and Projection—the big-paying positions—our practical home-study method and Free Projector Offer. Mail coupon or write.

New York Inst. of Photography
Dept. 49
10 West 33rd Street
New York, N. Y.

Clip This Coupon

Gentlemen: Please send me FREE your big illustrated Book and Job Chart explaining big-money opportunities for me in Professional and Motion Picture Photography and Motion Picture Projection. I am particularly interested in:

- General Photography
- Motion Picture Photography
- Motion Picture Operating and Projection

Name

Address

City State

PICK YOUR JOB
Camera-man-
Portrait
Photographer-
Advertising
Photographer-
News
Photographer-
Commercial
Finisher-
Retoucher-
Motion
Picture
Operator

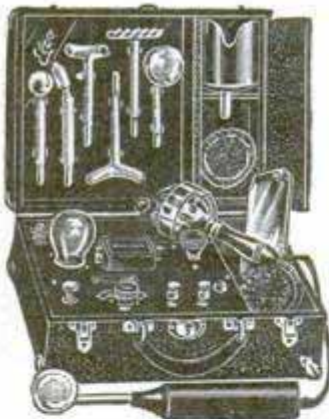


**Stop
That
Pain!**

**With Violet Ray Vibration
Ozone Medical Electricity**

*The Four Greatest Curative Powers
Generated by This*

Great New Invention!



Elco Health Generators at last are ready for you! If you want more health—greater power to enjoy the pleasures and delights about you, or if more beauty is your desire—write! Ask for the book on these inventions which has just been prepared. It will be sent to you without cost. It tells you how Elco Health Generators aid you in leaving the lethargy and hopelessness of bad health and weakness behind forever. Re-vitalize yourself. Bring back energy. Be wholly alive. Write today!

Here's What Elco Users Say—

"Wouldn't take \$1000 for my Elco."
"Has done me more good in 2 weeks than doctors did in three."



years." "Cured my Rheumatism." "My Eczema gone." "Cured my stomach trouble." "Cured my weakness." "Now I sleep soundly all night." "Thanks to Elco my strength and vigor are back." "No more pain." "Colds never bother me now." "Chronic Constipation banished."
These great new inventions generate Violet Ray, Vibration, Electricity and Ozone—combined or separate. They operate on the electric light in your home or on their own motive power at less than 50 cents per year. Elco Health Generators are positively the only instruments which can give you in one outfit Electricity, Violet Ray—Vibration and Ozone—the four greatest curative agents. Send the coupon below. Get the Free Book NOW!

Free Trial

**MAIL COUPON
for FREE BOOK**

Do not put this paper down without sending the coupon. Don't go on as you are with pains and with almost no life and energy. You owe it to yourself to be a better man or woman. You were put here to enjoy life—not just to drag through it. So do not rest another day until you have put your name on the coupon here. That will bring the whole story of these great new inventions. Do it today—now.

**Health
Power
Beauty**

Lindstrom & Company
2322 Indiana Ave. Dept. 13-52 Chicago
Please send me your free book, "Health—Power—Beauty" and full information of your 10-day Free Trial Offer.

Name.....
Address.....



**Get the
"RIGHT STEER"
on AVIATION!**

How can you earn your way while learning to fly? What must you do to get a pilot's license? . . . An aviation mechanic's license? How can you tell the difference between a reliable aviation school and a "fly-by-night" school?

ISN'T it worth one dollar to get the right answers to these questions? —and to any other questions about aviation, any time within a year? Isn't it worth a dollar to get the "right steer" now — the friendly, sincere advice of "men who know" — advice that may save you untold "grief" later on, perhaps hundreds or thousands of dollars? Isn't that worth a dollar to you? If so — send a \$1 bill to address shown below. You will receive by return mail, the answers to all the questions in this advertisement as well as Government bronzed wings (official emblem of the A. S. L.), and membership card entitling you to free advisory service and unlimited aviation information for one year. Write now to Aviation Service League, Dept. A, Plankinton Bldg., Milwaukee, Wis.

Join the
A.S.L.
today!



Wear this
official
emblem

AVIATION SERVICE LEAGUE

MINSTRELS Musical Comedies and Revues. Unique Minstrel First - Parts for complete show with special songs, opening choruses, etc. Full line of plays, stage songs, crossfire, monologues, afterpieces, vaudeville acts and make-up. CATALOGUE FREE.

T.S.DENISON & CO., 623 So. Wabash, Dept. 19, Chicago



**Commercial Cartooning
NEW INSTRUCTION**

Owing to the increased demand by business firms for cartoons for advertising, sales promotion letters, house-organs, bulletins, etc., we have added new special instruction in commercial cartooning to Cartoonist W. L. Evans' regular course.

If you like to draw send 6c in stamps for portfolio of cartoons and full information. You can earn while you learn.

THE W. L. EVANS SCHOOL OF CARTOONING
521 Leader Bldg. Cleveland, Ohio

Learn WHEEL AND AXLE ALIGNMENT

Tremendous money-making possibilities. New Home Study Course teaches all causes of hard steering, tire scuffing and shimmy, and how to correct them. Everything you need to know to become an expert. Alignment specialists in demand everywhere. Write for information and sample pages of the course—no obligation.

BEAR SCHOOL Dept. A-301 Rock Island, Ill.

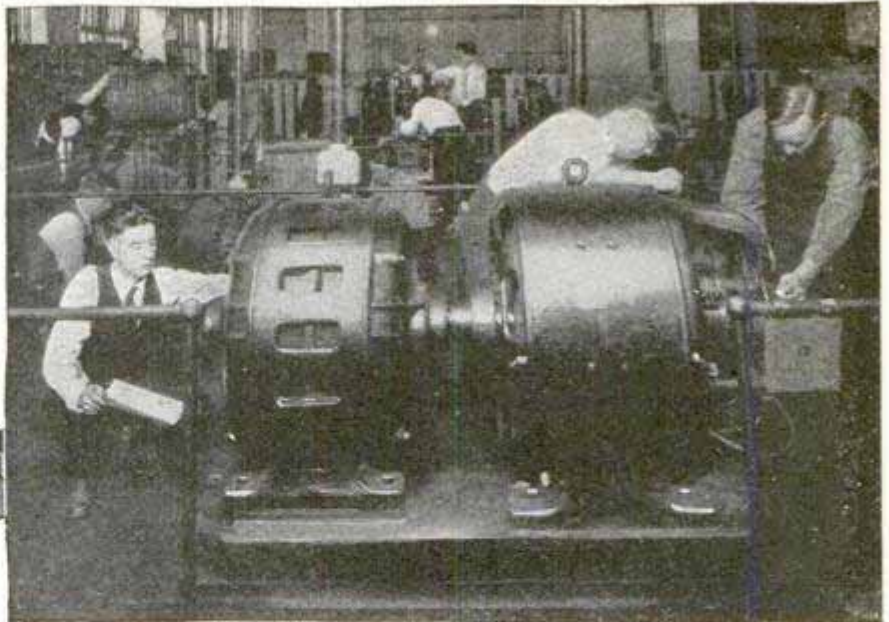
10c NEW SCIENTIFIC WONDER



3 for 25c X-RAY CURIO
SILVER ONLY
BOYS You apparently see thru Clothes, Wood, Stone, any object. See Bones in Flesh. **FREE—PKG. RADIO BIG FUN**
PICTURE FILMS. Takes pictures without camera. "You'll like 'em." 1 pkg. with each 25c order.
MARVEL MFG. CO. Dept. 31 NEW HAVEN, CONN.



"The Old Way"



A Small View of one Department at Coyne

ELECTRICITY Becomes Amazingly Easy When Taught Without Books In 90 Days

WHY work at dull, uninteresting jobs that will never pay you more than \$35, \$40 or perhaps \$50 a week? Make up your mind **now** to learn electricity! Train in 12 easy weeks to hold down the kind of a job that pays \$50 and up to \$200 a week, and which creates a constant demand for your services nearly any place in the world!

Not Books—No Classes

Electricity, as taught in the Great Shops of Coyne, is surprisingly easy to grasp. That's because we don't train you by books. You learn by doing actual, **practical** work on big, electrical machinery—finest outlay in the country. You learn by **doing**—and you learn from the ground up.

Not a Correspondence School

Experts work right along with you every step of the way. You get personal attention—it's not a bit like trying to figure out a lot of correspondence school pamphlets and diagrams all by yourself. The *Coyne Way* gives you real, **sound** knowledge that fits you to do **practical** electrical work in all its branches.

COYNE ELECTRICAL SCHOOL

H. C. Lewis, Pres.

500 S. Paulina St., Chicago, Ill.

Department 29-72C

No Experience or Advanced Education Needed

You don't need one day's previous electrical experience or any advanced education to master electricity the Coyne way. Some of our most successful graduates never went farther than the 8th grade.

Earn While You Learn

By our special arrangement, our employment department will help you locate part-time work, if you want to earn while you learn. And after graduation we give you the benefit of our **FREE EMPLOYMENT** Service for life. Every week we help secure positions for Coyne men.

Get FREE Book

Write today for my big book on electricity with over 150 photographs. Learn what great opportunity Coyne Training opens up for you. Also get full details of my Big-3 Special offer. No obligation. Mail the coupon now.

Included If You Act Now

1 **R. R. Fare** will be refunded upon enrollment from any point in the U. S. to Chicago.

2 **Radio** course given absolutely without any extra charge. Covers new developments in this fascinating field.

3 **Auto** course, covering truck and tractor electricity. Especially valuable if you ever want to start electrical business of your own. See coupon!

FREE BOOK Coupon

H. C. Lewis, Pres.
Coyne Electrical School, Dept. 29-72C
500 S. Paulina St., Chicago, Illinois

Please send me your free catalog on electricity and details of your 3 special offers. No obligation on my part.

Name

Address

City State



\$2⁰⁰ DOWN
BALANCE EASY TERMS

HERE'S your chance to own that genuine Model T Corona you've wanted—on the easiest terms ever offered—at **ONE-THIRD OFF** regular price! Complete in every detail; back spacer, etc., **NEW MACHINE GUARANTEE**. Recognized the world over as the finest, strongest, sturdiest,

portable built. Only a limited number of these splendid machines available. To get one, you must act now!

Yours for 10 Days FREE—Send No Money

Experience the joy this personal writing portable typewriter can give you! Use it 10 days free! See how easy it is to run and the splendidly typed letters it turns out. Ideal for the office desk, home, traveling. Small, compact, light, convenient. Don't send out letters, reports, bills in poor handwriting when you can have this Corona at such a low price or on such easy terms.

Carrying Case Included—If You Act Now

Leatheroid carrying case, oiler, instructions free on this offer. Send no money—just the coupon. Without delay or red tape we will send you the Corona. Try it 10 days. If you decide to keep it, send us only \$2—then \$3 a month until our special price of \$39.90 is paid (cash price \$36.40). Now is the time to buy. This offer may never be repeated. Mail coupon now.

Money Saved By Using This Coupon

Smith Typewriter Sales Corp.
 (Corona Division)
 469 E. Ohio St., Chicago, Dept. 32

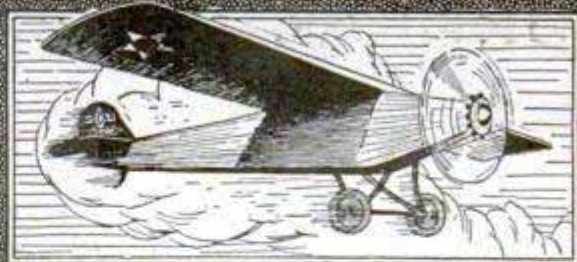
Ship me the Corona, F. O. B. Chicago. On arrival I'll deposit \$2 with express agent. If I keep machine, I'll send you \$3 a month until the \$37.90 balance of \$39.90 price is paid; the title to remain with you until then. I am to have 10 days to try the typewriter. If I decide not to keep it, I will repack and return to express agent, who will return my \$2. You are to give your standard guarantee

Name

Address

Employed by

The MOCAR



Model Airplanes That FLY BOYS Here is the Greatest Value You've Ever Seen—A Genuine Aluminum Model Airplane That Really Flies at a Small Price.

The "Mocar" monoplane—Set No. 1—is a copy of Lindbergh's famous Spirit of St. Louis. Wing spread 18 inches, fuselage 12 inches, powerful motor, special propeller, rubber tired disc wheels. Weight complete only about 2 1/2 oz. This is a practical, simple, real model plane that gives you a whole lot of fun at a very moderate cost. The all metal construction makes a sturdy plane that will stand a lot of abuse. The outfit is mounted on cardboard with all parts plainly marked and full instruction for assembly. Pliers only tool necessary. Construction set No. 1. Complete with rivets, bolts, wheels, wing and fuselage covering material, only \$1.50 postpaid (3 for \$4.00). Model L made up ready to fly \$2.25 (3 for \$6.00) postpaid.

Great fun, learn how to make and fly airplane Order now—or see your dealer

THE MOUNT CARMEL MFG. CO.
 Dept. M NEW HAVEN, CONN.



Break Into AVIATION

BRILLIANT futures and big pay jobs await trained Airplane Mechanics. Men are wanted daily at every airport and factory. Our recognized Extension Course in Practical Aviation—prepared and directed by airplane manufacturer—trains you quickly for this thrilling, profitable career.

LEARN RIGHT AT HOME

Don't close your eyes to this amazing opportunity. Tear out the coupon—sign and mail it at once for our FREE Book which tells all about the opportunities in aviation, describing our practical Diploma Course of simple lessons, free employment service and easy payment plan.



NOW SENT FREE

Use Coupon to Receive Book Without Cost

"NATIONAL AERO SCHOOL"

Dept. 229 YOUNGSTOWN, OHIO

Send me your FREE Book entitled "The Lure of the Air," and full particulars concerning your Extension Course and easy payment plan.

Name Age

Address

City State

Read what BIG money these fellows have made in the RADIO BUSINESS

\$375 One Month Spare Time



"Recently I made \$375 in one month in my spare time installing, servicing, selling Radio sets. And, not so long ago, I earned enough in one week to pay for my course."
EARLE CUMMINGS,
 18 Webster St., Haverhill, Mass.

\$1597 in Five Months



"The N. R. I. is the best Radio school in the U. S. A. I have made \$1597 in five months. I shall always tell my friends that I owe my success to you."
HENRY J. NICKS, Jr.,
 302 Safford Ave.,
 Tarpon Springs, Fla.

\$1164 Spare Time Profits



"Look at what I have made since I enrolled, \$1,164—money I would not have had otherwise. I am certainly glad I took up Radio with N. R. I. I am more than satisfied."
HENRY R. HEIKKINEN,
 123 W. Erie St., Chicago, Ill.

Over \$1000 in Four Months



"My opinion of the N. R. I. course is that it is the best to be had at any price. When I enrolled I didn't know a condenser from a transformer, but from December to April I made well over \$1000 and I only worked in the mornings."
AL. JOHNSON,
 1109 Shelby St., Sandusky, Ohio.

I will show you too how to start a spare time or full time Radio Business of Your Own without capital



J.E. SMITH Pres.

Radio's amazing growth is making many big jobs. The world wide use of receiving sets and the lack of trained men to sell, install and service them has opened many splendid chances for spare time and full time businesses.

Ever so often a new business is started in this country. We have seen how the growth of the automobile industry, electricity and others made men rich. Now Radio is doing the same thing. Its growth has already made many men rich and will make more wealthy in the future. Surely you are not going to pass up this wonderful chance for success.

More Trained Radio Men Needed

A famous Radio expert says there are four good jobs for every man trained to hold them. Radio has grown so fast that it simply has not got the number of trained men it needs. Every year there are hundreds of fine jobs among its many branches such as broadcasting stations, Radio factories, jobbers, dealers, on board ship, commercial land stations, and many others. Many of the six to ten million receiving sets now in use are only 25% to 40% efficient. This has made your big chance for a spare time or full time business of your own selling, installing, repairing sets.

So Many Opportunities You Can Make Extra Money While Learning

Many of our students make \$10, \$20, \$30 a week extra while learning. I'll show you the plans and ideas that have proved successful for them—show you how to begin making extra money shortly after you enroll. G. W. Page, 1807-21st Ave., S., Nashville, Tenn., made \$935 in his spare time while taking my course.

I Give You Practical Radio Experience With My Course

My course is not just theory. My method gives you practical Radio experience—you learn the "how" and "why" of practically every type of Radio set made. This gives you confidence to tackle any Radio problems and shows up in your pay envelope too.

You can build 100 circuits with the Six Big Outfits of Radio parts I give you. The pictures here show only three of them. My book explains my method of giving practical training at home. Get your copy!

I Will Train You At Home In Your Spare Time

I bring my training to you. Hold your job. Give me only part of your spare time. You don't have to be a college or high school graduate. Many of my graduates now making big money in Radio didn't even finish the grades. Boys 14, 15 years old and men up to 60 have finished my course successfully.

You Must Be Satisfied

I will give you a written agreement the day you enroll to refund your money if you are not satisfied with the lessons and instruction service when you complete the course. You are the only judge. The resources of the N. R. I. Pioneer and Largest Home-Study Radio school in the world stand back of this agreement.

Get My Book

Find out what Radio offers you. My 64-page book, "Rich Rewards in Radio" points out the money making opportunities the growth of Radio has made for you. Clip the coupon. Send it to me. You won't be obligated in the least.

Address

**J. E. Smith, Pres.
 Dept. 9NP**

**National Radio Institute
 Washington, D. C.**

This Book points out what Radio offers you Get a copy!

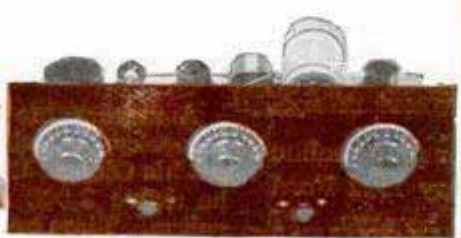
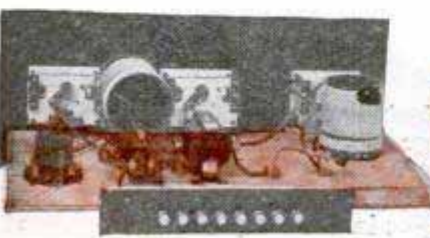
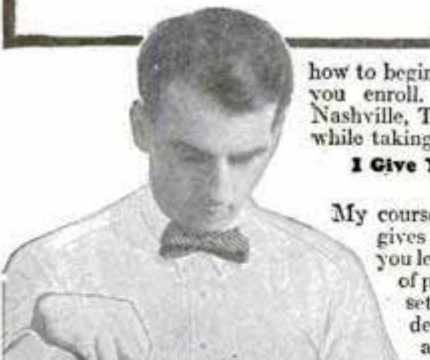


This coupon is good for a FREE copy of my Valuable Book. Mail it NOW!

J. E. Smith, President, Dept. 9NP, National Radio Institute, Washington, D. C.

Dear Mr. Smith: Send me your book. I want to know more about the opportunities in Radio and your practical method of teaching at home in spare time. This request does not obligate me to enroll and I understand no agent will call on me.

Name..... Age.....
 Address.....
 City..... State.....



Who Else Wants

CHEVROLET
40.8 Miles Per Gallon

BUICK
36 Miles on a Gallon

FORD
40 Miles on a Gallon

OLDSMOBILE
1300 MILES OF FREE GASOLINE

SAVED \$340
In Gasoline

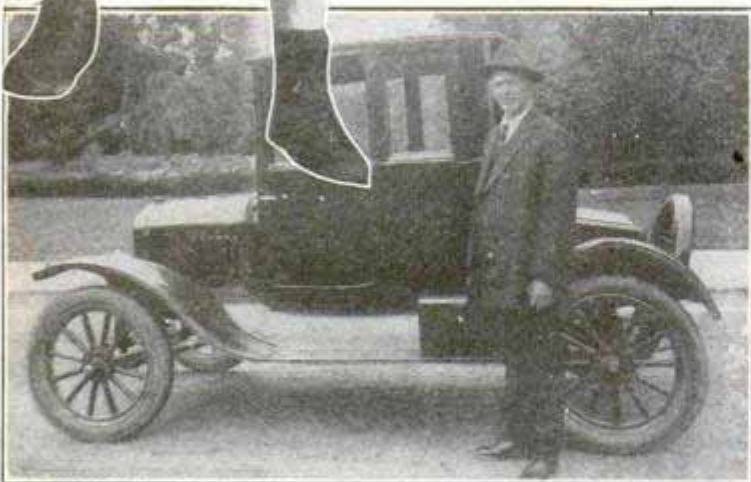
CHRYSLER
38 Miles Per Gallon

Reduces Carbon
Without Touching
the Engine

Battling Nelson, the Durable Dane

Bat made 40 miles on a gallon with a roadster and 33 1/2 miles a gallon with a touring car.

Bat writes: "Most of the public know me well enough to know that I never bunked them in my life. And when I say your vaporizer is all you say it is, I mean it."



H. H. Cummings has saved 1,905 gallons of gasoline on 50,000 miles. "I have used one on my 1922 Ford which I have driven over 50,000 miles," he says. "I am getting 30 miles a gallon."



Drives 1300 Miles Without Buying Gasoline!

A remarkable test was recently made on the Stransky Vaporizer by J. R. Wood of St. Louis. On his Oldsmobile, after installing the Stransky, he drove 3,000 miles and averaged 30 miles a gallon. Thus he got in effect 1,300 miles of free gasoline.

to Save Gasoline?

A South Dakota man has discovered an amazing gas-saving invention now installed on over three million cars of every make. Already over ten thousand car owners say it increases gas mileage . . . and saves an astonishing amount of money in gasoline and repair expense. There is a model for every car, truck, tractor or gasoline engine. Anybody can install it in a few minutes.

This invention is based on newly-discovered facts about potential gasoline power . . . startling facts, that few car owners know about. For example, it is now found that the average man wastes at least 20% to 30% of his gasoline through improper combustion. And many more interesting discoveries, too detailed to mention here.

Read on the left what other car owners say about it. Then accept the inventor's special introductory offer. He will send you samples to test without obligation to buy. If you find it doesn't do for you what it has done for other car owners, he will pay a cash forfeit for the few minutes you've spent in testing it.

**MEN
EARN
\$100 IN A
DAY**

Big money selling Stransky Vaporizers. Full or spare time. Write for samples.

Don't send a penny now. Simply send your name in coupon below and get full description of this queer little device that is saving money for other car owners. No obligation, of course. But if you really want to cut down the high cost of running your car, this is your opportunity. Tear out the coupon below and mail it to J. A. Stransky Mfg. Co., B-10 Stransky Block, Pukwana, S. Dak.

FORD

J. H. Alruth—35,000 miles at 28 to 30 miles a gallon.

BUICK

G. M. Rathburn—Saved \$40 on 287 mile trip.

MARMON

B. Holmes, garage owner, raised speed from 72 to 84 miles per hour.

CHEVROLET

M. E. Miller—Now gets 40.8 miles per gallon.

NASH

H. T. McCallon—Saved \$11.00 on one trip from Los Angeles to San Francisco.

PIERCE-ARROW

J. Berger—Greatly increased gas mileage. Has never scraped carbon.

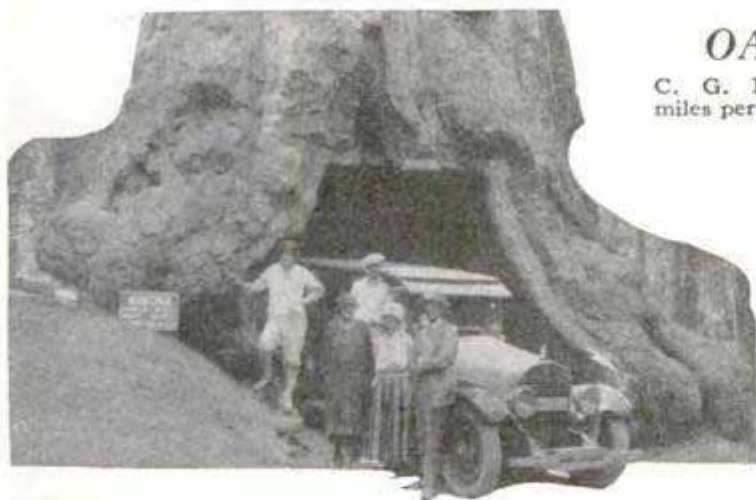
OAKLAND

C. G. Betts—Getting 30 miles per gallon of gas.



Virgil Barnes

N. Y. Giant Pitcher—Installed vaporizer in New York on Chrysler. Drove 2,000 miles home. Averaged about 38 miles per gallon of gas.



Touring in California

Above is a scene taken 'neath one of California's giant redwoods. This group has been touring in a Lincoln sedan. The owner writes: "Your vaporizer has added 8 miles to my former gasoline mileage."

SAVES GAS or No Cost!

J. A. Stransky Mfg. Co.,
B-10 Stransky Block, Pukwana, S. Dak.

Yes, send me full description of this new way to save gasoline. This request does not obligate me in any way.

My name is.....

Street.....

City.....State.....

() Check here if you want agents' proposition.



Learn Piano JAZZ Quickly by Ear

Beginners and advanced students learn quickly at home—in spare time. Wonderful Niagara Method clearly shows you how. Complete course 20 lessons. 10 years successful teaching.

By R. C. JAMES

How I used to wish that I could sit down at the piano and pour out the golden syncopation of American melody, like the jazz piano players I had heard. How I used to wish that I could be the popular one in every crowd. But I could not play a note.

Niagara Method Showed Me The Way

Then somewhere—just as you are reading this—I read of the Niagara Method which makes piano playing wonderfully simple. I sent for Director Wright's book "The Niagara Secret." I read the book, and I knew it was right.

I followed Director Wright's principles, and in no time I had caught on to his ideas.

So Simple—So Easy—So Delightful

And the best part of it all is that there is nothing hard about the Niagara Method. In a short time, by following Director Wright's principles and by devoting a part of my spare time to the practical application of his course, I soon learned to play.

No tiresome scales—no arpeggios to learn—no weary hours of practice—no do-re-mi—no meaningless exercises. If you know the Niagara Method, you can sit down and reel off any popular song which the high-priced orchestra leaders play in cabarets, clubs, hotels, dance halls, or theaters.

Clip Coupon Now—Play In Few Months

If you have never played a note, or if you do play—no matter how well—you too may become a master of jazz and melody by learning the simple, wonderful Niagara Method.

FREE BOOK

Don't wait another day. Send the coupon now for the "Niagara Secret." This book is yours absolutely FREE. If 10c (coin or stamps) is enclosed you also receive wonderful booklet "How to Entertain at Piano"



Ronald G. Wright, Director
Niagara School of Music
314 Cleveland Ave., Niagara Falls, N.Y.

CLIP THIS COUPON NOW!

NIAGARA SCHOOL OF MUSIC, 314 Cleveland Avenue
Niagara Falls, N. Y.

Without obligation mail me your book "The Niagara Secret." I enclose 10c for book "How to Entertain at Piano"

Name _____
Street _____
City _____ State _____

FREE BOOK TIME STUDY

Tells how to become a Time Study Engineer. Learn at home in spare time. Special low rates, easy terms. Free employment service. Guarantee of satisfaction or money back. Write for free catalog NOW! A postal will do.
Michael's School, Inc., Dept. 21, Dayton, Ohio



Recharge Your Dry "B" Batteries

With Amazing New Invention



Recharges RUN-DOWN OR WEAK "B" Batteries (dry) overnight. Makes them last three times as long. Uses less current than 25-watt lamp. For DC or AC any cycle. Don't throw away your "B" batteries—invest \$1.00 in this guaranteed charger, renew their life and save money. No extras to buy.

No Harmful Acids—No Tubes to Burn Out

Only
\$1.00
Complete

Send \$1.00 currency, stamps, check or money order, plus 10c to cover mailing cost. Charger will be sent postpaid. If not satisfied, return within 5 days and your money will be refunded.

Order today—NOW! You can't lose—we guarantee you satisfaction or money back.

ROLL-O RADIO COMPANY

Dept. K-23, 3rd and Sycamore Sts., Cincinnati, Ohio



Here's a New
Big Pay
Opportunity
for You



AIRPLANE ELECTRICITY

Get into this great new field. Aviation Electricity offers a wonderful future to the wide-awake fellows who get in on the ground floor. This branch of aviation is calling for experts at salaries of \$75 and up a week.

Experts in Aviation Electricity must be thoroughly trained in electricity and then that knowledge must be applied to aviation. Here at Coyne you are trained on actual electrical machinery then on airplane engines, both whirlwind and "V" type models as well as all parts of the airplane and engines that are electrical.

My big FREE book will tell you the whole story.

SEND NOW FOR BIG FREE BOOK

COYNE ELECTRICAL SCHOOL
Not a Correspondence School Est. 1899

H. C. LEWIS, President 500 S. Paulina St. Dept. 29-72B

H. C. LEWIS, Pres., COYNE ELECTRICAL SCHOOL, Dept. 29-72B
500 South Paulina Street, Chicago, Illinois

Please send me Illustrated FREE Book on Electricity and Coyne. No obligation. Also details on free employment service, Radio, automotive and Airplane electrical courses that are included.

Name.....
Address.....
City..... State.....

The U.S. Government Job is a Good Job,

**\$1260 to \$3400
A YEAR**

STEADY WORK

**MEN—WOMEN
18 to 55**

**VACATION WITH
FULL PAY**

Is Your Job Steady?

Compare these conditions with your present condition. DO YOU GET \$1,900 EVERY YEAR? HAVE YOU ANY ASSURANCE THAT A FEW YEARS FROM NOW YOU WILL GET \$2,300 to \$2,700 A YEAR?

Work for "Uncle Sam"

These positions are not hard to get. Country residents and city residents stand equal chance. Experience is usually unnecessary, and political influence is not permitted. Let us show you how.

Get Free List of Positions

Fill out the following coupon. Tear it off and mail it today—now, at once. DO IT NOW—This investment of two cents for a postage stamp may result in you getting a Government Job.



PICK YOUR JOB

(Not connected with U. S. Government)

FRANKLIN INSTITUTE, Dept. M-173, Rochester, N. Y.

Rush to me, free of charge (1) a full description of the position checked below; (2) Free Copy of 32-page book, "How to Get a U. S. Government Job"; (3) A list of the U. S. Government Jobs now obtainable; (4) Tell me how to get the position I have checked.

- | | | |
|--------------------------|--------------------------------------|-----------------|
| <input type="checkbox"/> | Railway Postal Clerk | (\$1900-\$2700) |
| <input type="checkbox"/> | Postoffice Clerk | (\$1700-\$2300) |
| <input type="checkbox"/> | City Mail Carrier | (\$1700-\$2100) |
| <input type="checkbox"/> | Rural Mail Carrier | (\$2100-\$3300) |
| <input type="checkbox"/> | General Clerk | (\$1260-\$2100) |
| <input type="checkbox"/> | Prohibition Agent-Investigator | (\$2300-\$3400) |



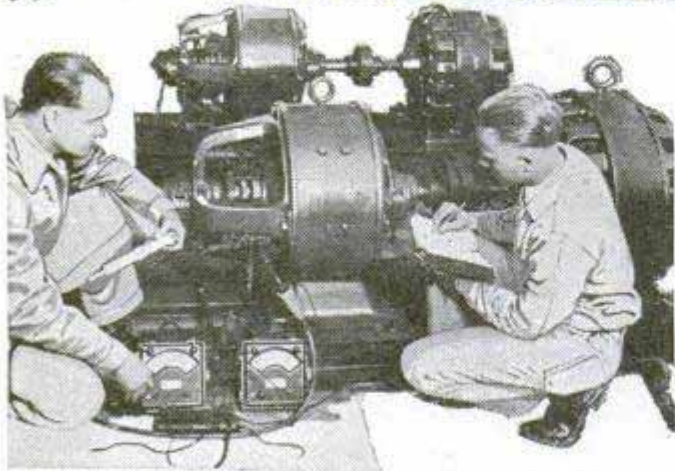
Name.....

Address.....

Use This Coupon Before You Mislays It.



Learn Electricity IN LOS ANGELES



FREE Employment Service!

Plenty of Good Electrical Jobs Open Now

There are more calls for "National-Trained-Electrical-Men" than we can supply. Jobs are open now paying \$50 to \$200 a week—but you must first get the right training. Get it at National—a world-famous institution with a quarter century record of success in training big pay men. Learn in Los Angeles. The center of Electrical activity. Special tuition rates now. Earn Room and Board while learning.

All These Advantages:

1. Unlimited Training Until Competent.
2. Free Employment and Welfare Service.
3. Million Dollar Training Shops.
4. Personal, Individual Training Guaranteed.
5. You actually perform work that employers pay big money for.

6. Official Diploma and certified record of work performed.

FREE

New Illustrated Catalog.

Read how National insures your success. Send for this free Electrical catalog—illustrated by actual photos of students training under instructors on a half million dollars' worth of new electrical equipment. Mail coupon now. Book will be sent FREE—Postpaid.



**Electricity—
YOUR
Opportunity!**

This Big, Free Book Shows You How to Quickly Make BIG PAY



National Electrical School

Dept. 527, 4006 Figueroa St., Los Angeles, California.

Send me your big free illustrated catalog of Electrical Opportunities showing how I can learn quickly and get a Big-Pay Electrical Job.

Name.....
Address.....
Age..... City..... State.....

PAIN and DISEASE

Quickly Conquered by

VIOLET RAY



Let us tell you how thousands of men and women suffering from rheumatism, neuritis, paralysis, nervousness, skin diseases, headaches, constipation, sprains, prostate trouble, goitre and many other ailments, even hay fever and asthma, have found quick relief—new health and vitality with this marvelous, scientific invention. Pains vanish almost instantly.

Violetta

Ten Days FREE Trial

For Health—Beauty—Vigor

Endorsed and used by hospitals, sanitariums and physicians. Every home can now have one. Saves hours, days, months of suffering. No medicine. Painless, pleasant treatment. Only the violet ray can penetrate to every nerve affected. Simple, safe, painless—anyone can use VIOLETTA. Why suffer pain and poor health when you can try VIOLETTA 10 days FREE.

This Book FREE

Tells all about violet rays—how this marvelous discovery by Nikola Tesla, the electrical wizard, now brings this mysterious curative power to all. Contains many astounding testimonials from our thousands of satisfied users. Send for the facts and our liberal trial offer today. Mail the coupon now.



VI-REX CO., Dept. 231
2304 Warren Avenue, Chicago

VI-REX CO., 2304 Warren Ave., Dept. 231 Chicago

Please send me your free book on Violet Rays and details of your 10 days' free trial offer.

Name.....
Address.....
City..... State.....
Ailment.....

FREE

My
Pay-
Raising
Plan

**"My Pay-
Raising Plan"**
It Shows You How I
Prepare You At Home
For—

*I send you these
Genuine high quality,
Imported Drawing Instru-
ments, 14 Other Tools and a
Drafting Table—All included
in my Home Training Course.*

*My
Pay-Raising
Plan*
Engineer Dobe

EMPLOYMENT

In These and Other Great Industries

Automobile — Electricity — Mo-
tor Bus — Aviation — Building
Construction.

There are jobs for Draftsmen in all of
these industries and in hundreds of
others.

Aviation is expanding to enormous
proportions.

Electricity is getting bigger every day.
Motor Bus building is becoming a lead-
ing world industry.

Building of stores, homes, factories and
office buildings is going on all the time.
No structure can be erected without
plans drawn by a draftsman. No mach-

ery can be built without plans drawn
by a draftsman.

I train you at home, in Drafting. Keep
the job you have now while learning.

Earn As You Learn

I tell you how to start earning extra
money a few weeks after beginning
my training.

I will train you in drafting right where
you are in your spare time. I have
trained men who are making \$3,500.00
to \$9,000.00 a year. Get started now to-
ward a better position, paying a good,
straight salary, the year around. Com-
fortable surroundings. Inside work.

Employment Service

After training you I help you to get a
job without charging you a cent for
this service. Employers of Draftsmen
come to me for men. Employers know
they are not taking chances on men
trained by me.

No Experience Necessary

You do not need to be a college man
nor high school graduate to learn by
this method. No previous experience
necessary. I make a positive money
back guarantee with you before I be-
gin to train you.

If you are now earning less than

\$70⁰⁰ a WEEK

**Write For My FREE Pay-
Raising Plan TODAY**



"I'll train you at home"
—Engineer Dobe

Mail this coupon at once. Get "My Pay-Raising
Plan". It certainly points the way to success. You
owe it to yourself to send for this book. Find out
how I help you find big opportunities in practically
all big industries. The book will come to you post
paid and FREE. Mail the coupon for it today.

ENGINEER DOBE

1951 Lawrence Av., Div.13-52 Chicago

ENGINEER DOBE, Div. 13-52
1951 Lawrence Ave., Chicago

Send me Free of all cost, "My Pay-Raising Plan". Also plan to
earn money while learning to be a draftsman and proof of big
money paying positions in great industries.

Name.....Age.....

Address.....

Post Office.....State.....

Get a Job Like These!



\$20 a Day for Schreck

"Use my name as a reference and depend on me as a booster. The biggest thing I ever did was answer your advertisement. I am averaging better than \$500 a month from my own business now. I used to make \$18 a week."

A. Schreck,
Phoenix, Arizona.



Makes \$700 in 24 Days in Radio

"Thanks to your interesting Course I made over \$700 in 24 days in Radio. Of course, this is a little above the average but I run from \$10 to \$40 clear profit every day, so you can see what your training has done for me."

Fred G. McNabb,
843 Spring St., Atlanta, Ga.

\$3500 a Year for Beckett

"When I began with you I was just a common laborer, going from one job to another, working for anything I could get, and that wasn't much. Now my salary is \$3,500 a year and the Company furnishes me with an automobile."

C. O. BECKETT
108 Maple Heights,
New Lexington, Ohio



\$70 to \$80 a Week for Jacquot

"Now I am specializing in Auto Electricity and battery work and make from \$70 to \$80 a week and I am just getting started. I don't believe there is another school in the world like yours. Your lessons are a real joy to study."

Robert Jacquot,
2005 W. Colorado Ave.
Colorado Springs, Col.



Learn to **EARN \$3000 to \$5000 a Year**

ELECTRICITY
~The Big Pay Field~
NEEDS YOU NOW



I Will Train You at Home - Spare time Only Needed

Send Coupon Now

It's your own fault if you don't earn more. Send the coupon and I'll *prove* it to you. Blame yourself if you stick to your small pay job when I have made it so easy for you to learn to earn \$3,000 to \$5,000 a year in Electricity. One billion dollars a year is being spent in electrical work. *Electrical Experts* are badly needed. Just send the coupon. Thousands of men are needed—trained as I train them. They can practically name their own salaries. Everything is ready but the men. Will you answer the call of this big-pay field? Get ready now for the big job I will help you get. The biggest money of your life is waiting for you. Send the coupon.

6 Outfits—Tools and Apparatus Included—No Extra Charge

In addition to giving my students employment service and consultation service, I give them also 6 complete working outfits without extra charge. These include tools, measuring instruments, material and a real electrical motor—among the finest outfits ever put together. You do practical work right from the start. After the first few lessons it enables you to make extra money every week doing odd electrical jobs in your spare time. Some students make as high as \$25 to \$35 a week in spare-time work while learning.

L. L. Cooke, Chief Engineer

L. L. COOKE

SCHOOL OF ELECTRICITY

2150 Lawrence Ave., Dept. 12, Chicago

You Can Do It Too!

Let me show you that I can train you just like I trained the four men whose pictures you see here. Just like I have trained thousands of other men—ordinary every-day sort of fellows—lifting them up from starvation wages and starting them on the road to jobs that pay \$60.00 to \$100.00 a week. With my easily learned, spare-time course, I can fit you for one of the biggest jobs in electricity. Send the coupon and I'll tell you how.

Quick and Easy to Learn

Don't have any doubt about your being able to do what these other men have done. McNabb and Schreck and these other fellows didn't have a thing on you when they started. You can easily duplicate their success. Age, lack of experience or limited education do not bar you. Start just as you are and I will guarantee to train you at home with a **signed money back agreement**. If you are not 100 per cent satisfied with my course it won't cost you a cent. Mail coupon to me today.

Sample Lessons and Book FREE

The coupon at the right will bring you free sample lessons and my big Electrical Book. The real dope about your opportunities in electricity—positive proof that you, too, can learn to earn \$3,000 to \$5,000 a year. Send it now. Send it while the desire for a better job and more money is upon you.

MAIL COUPON NOW

L. L. COOKE,

Chief Engineer

Dept. 12

2150 Lawrence Ave., Chicago

Without obligating me in any way send me your Free Book and particulars of your Electrical Outfit Offers, Employment Service and proof that you can fit me for a big-pay electrical job.

Name.....

Address.....

Occupation.....

*The Cooke Trained Man is—
The Big Pay Man—Always*

Classified Advertisements

WORLD'S BEST WANT AD MEDIUM

Advertisements in this section, 30 cents per word, each insertion, minimum 10 words, payable in advance.
To be inserted under proper classification in March issue, copy should be in our office January 18th

ADVERTISING AGENCIES

MAIL Order advertisers. Tell us your troubles. Our copy department can help you. Sixty page Advertiser's Rate Book mailed free. Frank W. Lenhoff Advertising Agency, 66 East Lake St., Chicago.

ADVERTISE in 24 Big Sunday Newspapers, 24 words \$15.00. Excellent for securing agents, salesmen and business opportunities. Catalog listing 1,000 leading dailies, weeklies, mail order magazines. Everything. Free. Wade Advertising, Baltimore Bldg., Chicago.

BEFORE Advertising get our catalog. No charge. 25 years in business. The largest classified agency in the world. Ankrum Advertising Agency, 100 No. LaSalle St., Chicago, Ill.

GET into advertising. Learn quickly at home. Experience unnecessary. New easy plan. No text books used. Practical work. Old established school. Send name and address for interesting free booklet. Page-Davis School of Advertising, Dept. 3431, 3601 Michigan, Chicago.

FREE—New 1929 Advertisers Rate Guide, 44 pages. Includes everything. Lowest rates. E. H. Brown Advertising Agency, 140 S. Dearborn, Chicago.

ADVERTISE 50 Magazines 5c word; \$4.00 inch. 5,000 country weeklies 1c line. per paper; lists free. Evans King Co., 672P, Wilmington, Del.

TIME Counts in applying for patents. See pages 154 and 155. Clarence A. O'Brien, Registered Patent Attorney, Washington, D. C.

INCH Display 50 Monthlies Thrice \$8.00. Meyer Agency, 4112M Hartford, St. Louis, Mo.

FOR ADVERTISERS

ADVERTISE 20 Words 100 weeklies, 50 monthlies \$5.00. Lists free. Allen, 234, Bound Brook, New Jersey.

GREATEST Money opportunity in twenty-five years. Read our Salesmen Wanted ad. T. D. Shea Company, 7042 East Seven Mile Road, Detroit, Mich.

ADVERTISE 300 Country newspapers, 28 words, \$10. Business getter. Lists free. Keator, Hartford Bldg., Chicago.

ADVERTISER'S Manual, 1929 edition. Postpaid 25c. Owl, Times Bldg., New York.

40 WORDS Insert 50 magazines \$2.00. Empire Agency, Shawano, Wis.

SALES PROMOTION

\$70 TO \$50,000 Daily Sales Developed during 28 years for clients by our direct mail plans, copy, campaigns. One product, 1923, an idea; this year \$100,000 orders booked. Fifty year old concern desired 50 national representatives in 1925; we produced 40 in three months. 700 dealers in 10 months at \$3 each, for another. Ten years Sales Promotion Manager Larkin Co. Submit sales problems for free diagnosis. James C. Johnson, 118A Woodbridge Ave., Buffalo.

DON'T Experiment! Dollar-doubling letters, circulars, literature, campaigns. Long, successful experience. Moderate charges. Finkel-Advertising, 131-P, Glenwood, Jersey City, N. J.

LETTER SPECIALISTS

SIX Proven collection letters \$1.00 (no checks). C. A. Beeman, 173 Washington St., Newark, N. J.

SALES (creating letters written). G. Anderson, P. O. Box 1244, Phoenix, Ariz.

AUTOMOBILES

TIME Counts in applying for patents. See pages 154 and 155. Clarence A. O'Brien, Registered Patent Attorney, Washington, D. C.

AUTOMOBILE SUPPLIES

ACME Radiator cleaner for your auto cooling system. Stops overheating, adds power, prevents rust and scale. Generous size can enough for six months sent for one dollar postpaid. Acme Water Treatment Company, 1226 E. 37th St., Los Angeles, Calif.

AUTO Parts new and used. Lowest prices. Bankrupt supplies, motors, wheels, radiators, transmissions, generators, gears, carburetors, touring tops complete \$15. Brake lining 50% off. Brightman, 2065 Main St., Hartford, Conn.

RADIATORS At wholesale prices. All standard makes. Satisfaction guaranteed. Send for prices, stating make and model. Independent Radiator Co., 1119 S. Wabash Ave., Chicago.

42 MILES On 1 gallon. Wonderful moisture gas saver. All autos. 1 free. Critchlow, N3-805, Wheaton, Ill.

AUTOMOBILE SERVICE EQUIPMENT

SAVE Money—Garage equipment reconditioned and guaranteed like new. Unusual bargains in test stands, car washers, battery chargers, air compressors, etc. Shipped on trial, easy terms. What do you need to complete your equipment? E. C. Galbreath, Box M-295, Troy, Ohio.

SAVE More than half—new garage shop equipment and tools at less than one-half factory cost—all kinds—fully guaranteed. Write for prices on what you need. Box 201-A, % Popular Mechanics, 200 E. Ontario St., Chicago.

SLIGHTLY Used battery chargers—Service station sizes—for sale cheap. Factory guaranteed. 10 and 15 battery capacities. \$23.50 and up. Investigate. Adams-Barr, Columbus, Ohio.

USED Constant potential outfit—120 ampere fully equipped. Guaranteed like new, overhauled and repainted. A wonderful bargain. Will ship on trial and allow plenty of time. E. M. Connor, Box M-296, Troy, Ohio.

MECHANICS: Set eight semi-spiral expansion reamers \$11.95. Catalog. W. Barnitz, 203 Briggs, Harrisburg, Penna.

RUBBER Top dressing made from old inner tubes, makes old tops new. Send \$1.00 for formula and instructions. Glover Rubber Co., Rome, Ga.

BARGAINS in repossessed battery chargers, rectifiers of all kinds and a few constant potential 8-hour chargers, several of them practically new. Lowest prices, terms if wanted. 30 days' trial. Write today to I. C. Helmick, Box M-294, Troy, Ohio.

YOU Are wanted to resilver mirrors at home. Immense profits plating autoparts, tableware, etc. Write for information. Sprinkle, Plater, 77, Marion, Ind.

FOR FORD OWNERS

AURORA Underslung parts and 3.1 racing gears, speedster bodies, headlights, hi compression head. See Sport Factories ad, page 152.

42 MILES On 1 gallon. Wonderful moisture gas saver. All autos. 1 free. Critchlow, N2-805, Wheaton, Ill.

MOTORCYCLES, BICYCLES AND SUPPLIES

MOTORCYCLES Cheaper than bicycles, \$25 to \$50. Easy terms. Tires \$2.50; Frames \$3; Forks \$3; Tanks \$5; Wheels \$4; Chains \$2; Saddles \$5; Handle Bars \$5; Engines \$15; Motorcycle Tires \$2.50; Truck Tires \$7; Airplane Engines \$15; Bicycle Tires \$1.25; Side cars \$25. Send 50c for catalog. Price Cutter Deninger, Rochester, N. Y.

BARGAINS in used motorcycle parts for all makes. No Catalogs. J. B. Dahl, 3661 Archer Ave., Chicago, Ill.

SLASHING Price Reduction! Fine Harley-Davidson motorcycle bargains. New, used and rebuilt motorcycles, \$50.00 and up. Send for our new free bargain bulletin just off the press. Knuth's Harley-Davidson Agency, 2525 Fond du Lac Ave., Milwaukee, Wis. Exclusive Harley-Davidson Distributors.

USED Motorcycles, all makes, lowest prices; price list free; used parts half price and less. Rochester Harley Davidson Corp., 129 West Main St., Rochester, N. Y.

AVIATION

NEW Book "Making Good in Aviation" tells you how to fit yourself for marvelous opportunities open to flyers and mechanics. Contains stirring of Col. Lindbergh as our chief air mail pilot and instructor. Rise of "Bud" Gurney from barnstormer to chief pilot. Published by well known Robertson School of Aviation, 10 years old, hundreds of graduates, no accidents. Army school system of flying taught by active air mail pilots. Government licensed and inspected training ships. No bond, no breakage charges. 700-acre field. "Ryan" and "Robin" factories on site. Send 25c for book, "Making Good in Aviation." Robertson Flying Services, Inc., Division Universal Airlines System, Dept. 0-2, Lambert-St. Louis Airport, Anglum, St. Louis Co., Mo.

NEW Burd piston rings for OX-5, 10c each. Brand new Hispano Stromberg carburetors, complete, \$55.00; new type extra strength ribbed wrist pins for OX-5, \$1.00; OXX-6, \$1.00. Hispano, \$1.00; new Berling OX-5 magnetos, \$60.00. Gasoline level gauges, \$2.50, any depth. Dixie converted booster magnetos, \$7.50. Air Transport Equipment, Inc., Carlisle Place, N. Y.

HEATH Propellers represent the most efficient form of aerial drive for airplane, sleds, boats. Each propeller individually designed to meet the particular conditions required as figured by America's oldest aeronautical engineers. Send 4c for propeller catalog. Heath Airplane Company, Chicago, Ill.

HOME Study aviation course by pioneer school at new low price. Covers motors, meteorology, nomenclature, aviation, design, flying and 100 other fascinating subjects. Endorsed by experts. Diploma given. Free employment service. Complete details sent free. National Aviation Training, Dept. 113, 1031 So. Broadway, Los Angeles, Calif.

AVIATORS Gaberdine helmets. Flannel lined \$1.00. Aviation Service, Chatsworth, Ga.

BUILD A whizbang monoplane and fly with Ford motor. Blue prints \$5. Plane, motor and propeller circulars 10c. Storms Aviation Co., Spartanburg, S. C.

TIME Counts in applying for patents. See pages 154 and 155. Clarence A. O'Brien, Registered Patent Attorney, Washington, D. C.

BLUEPRINTS. For light two place cabin monoplane. Easy to build. Plans \$5.00. Circular 10 cents. Roland Aircraft Company, 921 Baltimore, Kansas City, Mo.

COMPLETE Parts for sport monoplane, \$150.00. John Kamm, 45 Mt. Vernon St., C-4kosh, Wis.

MODEL Airplanes, supplies. Send stamp for price list. Junkers "Bremen" blueprint 25c. Hawthorne Model Aero Co., Hawthorne, N. J.

JUST Out—Booklet and blueprints on construction of sportplane. Contains also flight instruction, motors to use, etc. All for one dollar. Russell Aero Co., Stadium Place, Ft. Wayne, Ind.

MODEL Airplane supply. August Schaefer, 45 North Ave., New Rochelle, N. Y. Send 5 cents for catalog.

BARGAINS in model airplanes and supplies: Catalog 5c. Marx Aircraft, 668 East 8th South, Salt Lake, Utah.

AUTO Owner tire agent wanted each locality to use free demonstrating tires and take orders for new heavy duty Mellinger tires, guaranteed 15 months against all road trouble. Shipped on free trial. Get your own tires and earn \$300 monthly—no capital or experience needed. Write Mellinger Tire Co., Dept. 282, Kansas City, Mo., Warren, Ohio, Oakland, Calif.

BIG Money and Fast Sales. Every owner buys Gold Initials for his auto. You charge \$1.50; make \$1.35. Ten orders a day easy. Write for particulars and free samples. American Monogram Co., Dept. 40, East Orange, N. J.

DON'T Sell for others. Employ agents yourself. Make your own products. Toilet articles, household specialties, etc. 500% profit. Valuable booklet free. National Scientific Laboratories, 1984W Broad, Richmond, Va.

AGENTS: \$10 day and earn new Ford auto. Sell groceries. Over 400 items used daily every home. Steady all year job. Your own groceries about half. Send for samples. Harley Company, Dept. B-2015, Dayton, Ohio.

HIGH-GRADE SALESMEN WANTED

A GOOD Side line—We sell pass books, check covers, coin bags, etc., mainly to banks. They are centrally located and do business quickly. Little time is lost. Our samples are light, compact, easily carried. Sales run into money, items repeat well, commission is liberal, and all paid immediately. We also have a splendid line of printing and advertising novelties for merchants. Our quality is good, the styles interesting. Line is big enough to devote your whole time if you wish. We are manufacturers, own our building, been in business fifteen years, make ten thousand sales a year, ship to every state. You could work wherever you happen to be. Correspondence invited. Continental Bank Supply Co., Mexico, Mo.

AMAZING New advertising free distribution plan makes you \$75.00 to \$150.00 weekly. Powerful, different, year-around proposition. When you can give \$1.00 sanitary dental cabinet, 50c tooth brush free with every 50c toothpaste sale, is it any wonder Sheppardson, Blackburn, Winters and hundreds of others are making larger, steadier incomes than ever before? This large and influential toothpaste manufacturer needs a few more dependable men and women at once. Our territories are always closed quickly, so you must hurry. First come—served best. T. D. Shea Company, 7042 East Seven Mile Road, Detroit, Mich.

AN Unusual opportunity! Internationally known and advertised line of colors that have sold on their own merits for more than twenty-five years is now offered to an exceptional salesman who visits confectioners, artists' materials dealers, photo supply houses or similar lines. Commission basis that will show wonderful returns. Lines carried, territory covered and other particulars in first letter. Information confidential. Japanese Water Color Co., Peerless Bldg., Rochester, N. Y.

CAN You appoint agents? More men wanted at once to travel and appoint agents to sell large line soaps, toilet preparations, food flavors, etc., direct to the home. Good territories now open in various states. Real proposition for the right men. If you mean business and are strictly reliable give us complete details about yourself in first letter and particulars will be sent at once. The Davis Brothers Co., Dept. 210, Greenfield, Ind.

\$40.00 SUITS For \$23.50! Union made to special order, of finest quality virgin wool. You don't have to know anything about selling clothing. We guarantee your success if you are honest and willing to work. Write at once. Madison Brothers, 133 South Peoria, Dept. 624, Chicago.

THIRTY Large split pants pattern samples; silk labels. Strong commercial traveler's case. 18 to 20c ounce wools. No second choices. No substitutions. Tailored from individual patterns. Commissions \$8.25 to \$18.00! Strictly high class line. Experienced tailoring salesmen apply in own handwriting. References required. Hansen & Clavier, Inc., Great Falls, Mont.

A PAYING position open to representative of character. Take orders shoes-hosiery direct to wearer. Good income. Permanent. Write now for free book "Getting Ahead." Tanners Shoe Mfg. Co., 2001 C St., Boston, Mass.

BUSINESS Stationery—Largest line; highest quality; quickest delivery; biggest commissions; liberal bonuses. Free copyrighted cuts every business. Experience unnecessary; instructions and outfit free. David Lionel Press, Dept. 14, 406 S. Sangamon, Chicago.

COVERALL Salesmen—Make \$20 daily selling new \$3.50 improved coveralls, also service coats with customer's name embroidered on back. Unusual construction. Commission 75c! Wonderful advertising value. Lowest priced; highest commission. Free outfit. Am. B. Co., S-329 W. Monroe, Chicago.

AMAZING New automotive invention. \$75-\$125 weekly. Oilpistol—pocket size. Fast seller. Garages, oil stations, car owners, are prospects. Oilpistol Corp., 4554 Broadway, Dept. 2-D, Chicago.

SALESMAN. Business getter. Clean cut. Establish with large industries. Product that has stood the test. Highly endorsed. Non-seasonable. 40% commission. Advance on sales. Exclusive territory. Give qualifications and reference. Mfrs., 10703 Quebec Ave., Cleveland.

OUR Salesmen earn \$250.00 to \$350.00 monthly, selling our staple merchandise. Big repeat business. Permanent position. We need sales managers. Write Don Juan Products Co., 225, Robson-Prichard, Huntington, W. Va.

\$10-\$20 DAILY Selling printed stationery and new advertising specialties, blotters and envelopes. Good sideline. Liberal commission. Free sample outfit. Embograp, 4558-62 Elston, Chicago.

WONDERFUL Invention. Seals fifty envelopes minute. Sells on sight at \$3.50. Attractive proposition. Square deal. Bank references. Kendall Sealer Co., 08 East Jaffrey, N. H.

EVERY Home a prospect. Make big money. Take orders tree, shrubbery. Experience unnecessary. No dull season. Commissions paid weekly. We deliver, collect. Write Perry Nurseries, Dept. R-2, Rochester, N. Y.

\$18 TO \$25 Daily; biggest selling line of 2-piece suits, \$9.95 and \$12.50; 3-piece wool suit, \$17.95 (regular \$28.00 value). All-wool overcoats, \$18.50. Splendid raincoats, slickers and boys' suits. Biggest commission. Free outfits. "Jim" Foster, Inc., Dept. 22, 2250 S. Spaulding Ave., Chicago, Ill.

PUNCHBOARD Salesmen. \$200 weekly. Liberal plan assures sales. Latest assortments. Nothing to carry. Full commissions on repeats. M&L Sales Co., 301 W. Adams, Chicago.

NEW Invention—Sells every business and professional man; used by Bell Telephone Co., Armour & Co., etc.; costs \$2.50; retails \$7.50. Walker made \$165 first day. Write Adjustment Service, Dept. PM, Mobile, Ala.

SELL Union label printing—Brand new proposition. Copyright cuts and elaborate outfit free. 40% commissions advanced. Beats all competition. Meyerson, G1132 So. Racine, Chicago.

NEWEST, Finest and most complete line of novelties and pencils for 1929. State experience. Advertising Novelties Company, Newton, Iowa.

SALESMEN—Calling on stationery, department, drug, novelty trade. New "Twin Pencil," popularly priced. Sells immediately and repeats. Liberal commission. References. Multipoint, Corona, N. Y.

SALESMEN Calling on auto and accessory dealers—to sell two live sideline items, exclusive territory. Dept. H. P. O. Box 316, Toledo, Ohio.

SALESMEN! Sell Bostonian shirts. We will start you in a money-making business of your own without a penny of capital. No experience necessary. Wonderful complete selling outfit free with everything you need to start collecting your profits at once. Write today, sure! Bostonian Mfg. Co., 106 Bickford St., Mass. Est. 1863.

WORLD'S Finest union printing! Quick delivery! Big commissions advanced. Experience unnecessary. Largest cut display. Outfit and business stimulator free. Northwestern Printing 2002 Division, Chicago.

FASTEST Selling advertising lead pencils. Matz Pencil Company, Reading, Pa.

SALESMAN Wanted for new hand soap. Must have car for deliveries. Work near home, not house to house. No experience needed. Connecticut Can Co., Hartford, Conn.

STATE Mgr. Marvelous invention seals 3,000 envelopes hourly! Sells \$4.50 only; equals work expensive electric machinery. Offices buy 1-100. Exclusive territory. Opportunity earn \$7,000 yearly. Free trial offer. Write quick! Redo, 28 Winthrop Bldg., Boston.

YOU Are wasting time working for other people. Let us show you how to control your own business and make \$100 a week. Capital unnecessary; immediate profits. American Products Company, 2512 Monmouth, Cincinnati, Ohio.

IOWA Salesman made \$78.00 first day selling new hot dog machine at \$18.50. Commission \$6.50; direct factory connections. Leonard E. Dickerson, Dept. E-9, Springfield, Mo.

EARN \$20 A day. Establish income for life selling for \$1 a year, \$1,500 accident policy. Write W. C. Stone, 11 So. LaSalle, Chicago.

BIG Pay every day, showing Nimrod's all-year sellers! Dress and work shirts, overalls, pants, sweaters, hosiery, underwear, pajamas, playsuits, etc. \$10-\$25 daily. Experience unnecessary. Big outfit free. Nimrod Co., Dept. 65, 4922-28 Lincoln Ave., Chicago.

ADVERTISING Salesmen. \$100 weekly sideline! Television movie-cards. Latest advertising novelty. Snappy pictures actually move. Whirlwind seller. Vestpocket sample free. Advertising Dept. 1113-M Noble, Chicago.

FASTEST Selling necessity on market. Good pay. Astounding bonus. Finest selling equipment. Lowest prices. Big demand. A repeater. No money or experience required. Business grows bigger steadily. Write today for first consideration. Spencer Mead Company, Harrison and Throop, Dept. B-817, Chicago.

SALESMEN: If you are an average salesman and willing to work 5 days a week, we have a proposition that will net you \$100 to \$150 per week constantly. Credit on repeat business. 4911 Lincoln Ave., Chicago.

"SHAKE-EM-UP"—And other new, sensational vending machines. Dealers waiting. Advance cash commissions. Best men \$250 weekly. Box 927, Cedar Rapids, Iowa.

BANG-UP Good new sideline! Sells everywhere, all merchants, banks, mfrs. Big comms. advanced daily. Pocket outfit free. Carroll, 319 N. Albany, Dept. 346, Chicago.

SELL Nothing! \$170 weekly empty handed. Punchboard headquarters announce amazing new plan. No investment. We even pay express. K&S Sales Co., 4397 Ravenswood, Chicago.

SALESMEN Wanted. No experience necessary. Fine profit earning business on part time basis or otherwise. Everbrite Products Company, Kansas City, Mo.

ALL-YEAR-ROUND Profitable business selling wonderful new water softener and cleaner. Removes grease, oil, ink and dirt quickly. Every home and business place a live prospect. 100% profit. Big repeat orders. Exclusive territory. Write for free sample. Seacoast Laboratories, Sea Bright, N. J.

\$60-\$200 A WEEK. Genuine gold letters for store windows. Easily applied. Free samples. Liberal offer to general agents. Metallic Letter Co., 438-A North Clark, Chicago.

ADVERTISING Salesmen in every state. Year around position, selling merchants and manufacturers, booklets, calendars, novelties. Commissions weekly. Plenty repeat business. Matson Pub. Co., Main St., South Whitley, Ind.

PUNCHBOARD Men! Sideline salesmen! Sensational merchandise catalog just added to famous "Lincoln Line"! No more closed territory! \$200 weekly. Easy repeat commissions paid daily. Smashing color catalog free. Samples unnecessary. Best season now. Get busy! Lincoln Sales, 9 So. Clinton, Chicago, Dept. D.

SALESMEN—Become independent. Own your business; experience unnecessary selling our \$10,000 Accidental death, \$50; accident, \$25. Sick weekly benefits—\$10.00 yearly. Other amounts proportionate. Guaranteed steady income from renewals. \$250,000 deposited insurance department. Universal Policy, Dept. A-40 Clinton St., Newark, N. J.

This "Crazy Scheme" Made Me Independent

Learn the secret of my success. Be a Real Estate Specialist. Start at home in spare time. Use my successful system. Free Book shows how.

"IT'S a crazy scheme," said some of the old-time real estate men. But with this "crazy scheme" I made a net profit of \$100,000 in less than five years—enough to make me independent for life.

So, no matter where you live, or what you are now doing, or what your sex or present age may be, if you want to learn all about my "crazy scheme"—if you want to do as I did—if you want to make big money—right at home—in your spare time—mail coupon at once for a free copy of my beautiful, new, illustrated book, which contains the biggest and best money-making business opportunity you ever heard of.

Use My Money-Making Method

When I started in real estate, I turned my back on all the ancient, threadbare, moss-covered methods of the past, and used a simple, scientific system of my own which is as far superior to the old-time methods as the radio is superior to the old-style music box.

With little education—no real estate experience, no money, no pull, I started a new kind of real estate business which met with overwhelming success.

If you want to follow the trail I blazed—if you want to use my amazingly successful system—write for my free book now. It tells how I won success, how I have helped other men and women succeed, how you, too, can succeed, how you can have a high-



A well-known cartoonist's conception of my idea

class business of your own and make more money than you ever made before in your whole life.

A Remarkable Business

The real estate business—in my way—is a wonderful business. It is as permanent as Mother Earth itself. And it is constantly increasing as our great country grows. It does not require years of study like most other trades, businesses or professions. And it pays big profits to ambitious men and women. Users of my methods report earnings of \$1,000, \$2,000, \$5,000—and more—on single deals; as much as the ordinary man or woman gets for months and years of hard work. And the

business is practically unlimited. Ten million properties are always for rent, sale or exchange. And you can start with little or no capital—right at home—in your spare time. I did. So did others. So can you. My free book tells you how.

What Others Say

Read the following record of results achieved by a few users of my remarkable system.

Anthony C. Maurell, Paterson, N. J., (former barber) reports earnings of more than \$4,100 his first three months in my kind of a real estate business. Kate Luke (65-year-old widow) says she has averaged \$200 a week for the past 6 months. W. E. Shoop, Bloomsburg, Pa., (former weaver), earned \$6,000 in one deal. A. D. Perkins, Forestville, Conn. (former wood worker), reports earnings of \$1,252 in one month. J. W. Randolph, Elizabeth City, N. C. (former grocery clerk) reports 3 sales in 2 weeks that paid him \$510. W. C. Campbell, Wichita, Kans. (former druggist), made real estate sales amounting to \$22,875 in one day.

These are a few samples of the successes you will learn about in my free book. Get it. Read it. Follow its instructions. Make big money my way.

Send For Free Book

My free book, "How to become a Real Estate Specialist," is filled with astounding facts about my kind of a real estate business. It tells what I have done—what others are doing—what you can do in this big field of opportunity.

Mail coupon at once and get all of this valuable money-making information free. For although this book costs you nothing, it may be worth more to you—in actual dollars and cents—than any other book you have read. So, mail coupon now and learn all about the "crazy scheme" that made me independent for life. Address President, American Business Builders, Inc., Dept. B-44, 18 East 18 Street, New York.

\$1,000 Reward

Here's the proof that this is the biggest money-making opportunity of all: ONE THOUSAND DOLLARS IN GOLD will be paid to anyone who shows us any other business course of any kind that has helped as many men and women make as much money in as short a time as our remarkably successful Real Estate Course.

AMERICAN BUSINESS BUILDERS, INC.

President, American Business Builders, Inc.,

(Authorized Capital, \$500,000.00)

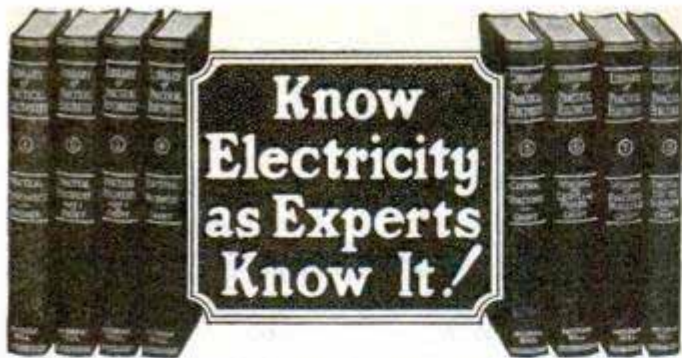
Dept. B-44, 18 East 18 Street, New York

Please send me—without cost or obligation—your new, illustrated book, telling how you will help me make big money in real estate, without capital or experience.

Name.....

Address.....

City..... State.....



Know Electricity as Experts Know It!

THIS is the electrical age, with unlimited opportunities for the man who has educated himself in the finer points of electrical practice.

Fit yourself for a big-pay job by knowing electrical practice complete, including inside and outside work, central stations, and the whole subject. With the aid of the Croft books you can know electricity as experts know it and put yourself in line for an expert's pay.

The Croft Library of Practical Electricity

A reference library and self-training course in eight volumes. 3000 pages—2100 illustrations

In these volumes Croft teaches you electrical practice complete. He takes you in quick, easy steps from the simplest principles to the complete and economical operation of a great central station. He tells you all that he has learned in twenty years of shirt-sleeve practice. With these books at his elbow a man can learn as much about electricity in six months—good practical "bread and butter" stuff—as he would ordinarily learn in a lifetime of practice.



Flexible binding for easy handling

**59,000
Croft
Sets
NOW
IN USE**

The Standard in Practical Electrical Training

The Croft Library is a complete electrical educator. It is founded on practice—on work as it is actually done. It is jammed from cover to cover with the kind of hard-headed facts you want. Written so that the beginner can easily understand it, yet so sound, so thorough, that it is the daily guide of 59,000 highly paid electrical workers and engineers.

Croft tells you the things you need to know about motors, generators, armatures, commutators, transformers, circuits, switchboards, distribution systems—electrical machinery of every type—wiring for light and power—wiring of finished buildings—underwriters and municipal requirements—illumination in its every phase—the latest and most improved methods of lighting—lamps and lighting effects, etc.—how to do a complete job, from estimating it, to completion. Make no mistake about it—there are big jobs in electricity ready for you when you're ready for them. Thousands of men who have the Croft Library know that to be a fact. The Library itself, on a **FREE TRIAL BASIS**, will prove it to your own absolute satisfaction.

NO MONEY DOWN SMALL MONTHLY PAYMENTS

Fill in and mail the coupon attached and we will send you the entire set of eight volumes for ten days' Free Examination. We take all the risk—pay all charges. You assume no obligation—you pay nothing unless you decide to keep the books. Then \$1.50 in ten days and the balance at the rate of \$2.00 a month. Send the coupon NOW and see the books for yourself.

**10 Days
FREE
TRIAL
Just Mail
the
Coupon**

FREE EXAMINATION COUPON

McGraw-Hill Book Co., Inc., 370 Seventh Ave., New York

Send me for 10 days' free examination the Croft Library of Practical Electricity. If satisfactory I will send you \$1.50 in 10 days and \$2.00 monthly until the special price of \$19.50 is paid. If not wanted, I will return the books at your expense. (To insure prompt shipment write plainly and fill in all lines.)

Name.....

Address.....

City and State.....

Position.....

Company..... P. M. 2-29



Make \$75 a Week as Expert SIGN and SHOW CARD WRITER

I teach you quickly at home in spare time. New, easy method. No experience needed. Qualify in short time for a big pay job. Employers everywhere want men at \$50 to \$75 a week. Experts always in demand. Making more money today than ever before. My Employment Service helps you land a good job in your locality. Or I'll equip you to start a shop of your own.

Big, Complete Outfit For You

If you're making less than \$75 a week, don't miss this chance. It means real money. No materials to buy. I offer big, complete Show-Card Writing Outfit with my Course. Write today for amazing new money-making facts.

Bert L. Daily, Dept. C, 126 E. Third St., Dayton, Ohio

Learn to Dance

This New Easy Way

You can learn all the modern dances—Charleston, Black Bottom, Valencia, Canter, French Tango, St. Louis Hop, Latest Waltzes, Fox Trots, etc., at home easily and quickly. New chart method makes dancing as simple as A-B-C. No music or partner required. Learn anywhere, anytime. Win new popularity. Be in demand at parties. Same course of lessons would cost \$20 if taken privately.

Send No Money

Just send your name and address. We'll ship the complete course—323 pages, 49 illustrations—with-out one cent in advance. When package arrives, hand postman only \$1.98, plus delivery charges, and this wonderful course is yours. Try for 5 days. Money back if not delighted. Send your name NOW.

FRANKLIN PUB. CO., 800 N. Clark St., Dept. 9420, CHICAGO



ACCOUNTING

How to
learn
Accounting

THOUSANDS of ambitious men are earning more money today because they know Accounting. Send for our 80-page book, "How to Learn Accounting," and the first lesson. Both will be sent free.

International Accountants Society, Inc.

A Division of the
ALEXANDER HAMILTON INSTITUTE

Dept. 14 3411 So. Michigan Ave., Chicago, Ill.

Prepare for Big-Pay Jobs in Aviation

Complete, practical EASY-TO-GRASP Home Study Course in Aviation qualifies you for big pay jobs. Motors, Wings, Design, Flight Principles, Aviation and 100 other subjects. Diploma given. Free Employment Service. If you are 16 or over, write for **FREE BOOK** on "Aviation" giving details of Course. **FREE BOOK**

NATIONAL AVIATION TRAINING

Dept. 112, 1031 So. Broadway Los Angeles, Calif.

BIG NOVELTY BARGAIN! 10c



Throw Your VOICE

Into a trunk, under the bed or anywhere. Lots of Fun fooling the Teacher, Policeman or Friends. **Barrels of Fun.**

THE VENTRILLO—

a little instrument, fits in the mouth out of sight, used with above for Bird Calls, etc. Sent with full instructions; anyone can use it. NEVER FAILS. Also a 32 PAGE BOOK ON VENTRILLOISM. Formula for Secret Writing, 12 Money Making Secrets and the marvelous



NOVELTY X-RAY WONDER

With it you can apparently see the bones in your fingers, lead in pencil, etc.; lots of fun with this outfit. Also 10 Big Magic Tricks Free with every order. All the above Novelties \$1.00 by prepaid mail for 10c



Ventrilo Company, Dept. 611, Norwalk, Conn.

LARGEST and OLDEST Mail Order House in Connecticut



Easy Steps

to "Easy Street"

You Can Get There In 1929

It's all very well to say that when a star salesman makes \$25,000 or \$50,000 a year, it's a streak of luck, or due to some mysterious quality you do not possess.

But when you see HUNDREDS of men no smarter than you, with no more education or ability, suddenly break into the selling game and within a year's time increase their earnings from \$30 or \$40 a week to \$3000, \$5000 and even \$10,000 a year—then, I say, if I were you, I'd look into this pretty quick.

Some of these men were ordinary office clerks. Some mechanics, some store-keepers, some even farmers and laborers. They were up against the same spirit-crushing hard work, small pay and HOPELESS OUTLOOK you face today. Wouldn't you like to know *just how* they were able to say "good-bye" to it all—by what magic they have been able to double and treble their pay so quickly?

1. Get Free Book!

2. READ! —Secrets of Successful Selling

3. Spare-time Selling Jobs Provided—while learning

4. Free Employment Service helps you get well-paid, permanent position

Now—Definite Increase in Earnings GUARANTEED! (or you pay nothing)

This million-dollar Salesmen's Association now offers every man who wants to earn bigger money, a remarkable CONTRACT that assures you a definite addition to your income, within three months after you complete the training, or no cost. This daring offer is made possible by the unequalled earnings in SALES WORK, and by the astonishing success of our members during the past 22 years. Mail coupon now for full details of this agreement which permits you to break into selling without risking a penny of your money.

Well-paid Jobs for you—while learning

N.S.T.A. is the first and only sales-training organization to include actual selling (for which you are well paid) in its course. Some of the biggest companies in many different lines of business now employ our members in their spare time. Find out about this astonishing feature which permits you to earn more than the cost of the training before you finish.



Amazing Free Book Brings You Your Big Chance!

"The Secrets of Modern, Dynamic Salesmanship" will tell you how to get a well-paid city or travelling sales job in a hurry. It will open your eyes to the opportunities within your easy reach in the one branch of business where earnings of \$5000 and \$10,000 are common. It will show you in detail, the four easy steps by which so many other men JUST LIKE YOU have become star salesmen. It will take you only 19 minutes to read it, but it will make 1929 the turning point in your life. Send for your Free Copy right now.



\$7,286 as Salesman
"I was a clerk earning \$1,000 a year when I enrolled. Last year I made \$7,286. I now own my home, drive a nice car and am able to give my family the things I always wanted to."—F. J. Walsh, Box No. 1586, Springfield, Mass.

\$8 to \$125 a Week
"When I came to America I started as a dishwasher at \$8.00 a week. By using a dictionary I mastered the N. S. T. A. Course. Secured a selling position at \$50 a week through the N. S. T. A. Now earning \$125 a week."—M. Barichievich, 3 Carl St., San Francisco, Calif.



Average Men Make Enormous Increases

From time-clock drudgery to independence and security. From penny-pinching to prosperity. From Hard Times to Easy Street. In 4 easy steps, the first of which you can take right this minute. For all these men STARTED by reading our amazing book, "The Secrets of Modern Dynamic Salesmanship"—free to any man who asks for it. And it points the way, step by step, by which YOU can duplicate their quick success.

National Salesmen's Training Assn. Dept. 101-X, N.S.T.A. Bldg., Chicago, Ill.

Without cost or obligation, send me your free book "The Secrets of Modern Dynamic Salesmanship." Also include a free copy of the new N. S. T. A. money-back bond that assures me a definite addition to my income within three months after completing training—or a complete refund of tuition fee.

Name.....
Address.....
City..... State.....
Age..... Occupation.....

NATIONAL SALESMEN'S TRAINING ASSOCIATION

Decorate these Giftwares and Make Money



Earn money at home,
this fascinating new way,
in spare time

We Show You How

THIS is the most delightful work you could imagine; you will enjoy every minute you devote to it. Many people do it solely for the artistic pleasure they get in creating beautiful things. But it also pays surprisingly well, for there is an enormous demand for giftwares. Many of our members make \$10 to \$25 a week, and have built up profitable businesses from small beginnings. Think of decorating a Hanging Shelf, for example, requiring only 3 hours' work, and realizing a profit of \$10.50. What other work could be so interesting, and pay so well?

No Special Ability Needed

The national association of homeworkers known as Fireside Industries now has openings for new members. This is your opportunity. Find out how you can secure a membership. The work is easily learned, and easy to do. You have only to follow the simple directions given by Gabriel Andre Petit, the Art Director, and you can easily learn the latest methods of decorating wooden toys, parchment lamp shades, painted furniture, book-ends, greeting cards, batik and other objects of art. You are furnished a complete outfit of materials, worth \$10.00 without extra cost. You can start making money almost at once.

Money-Back Offer

What thousands of others are doing in Fireside Industries, you also can do. So sure are we of your success in this fascinating work that we refund your money in full if, after completing your instructions, you are not entirely pleased. You take no risk whatever.

Beautiful Book FREE

The beautiful Book of Fireside Industries, illustrated in color, explains all about this new way to earn money at home. It will be sent you, absolutely FREE and without obligation. Just mail the coupon, or write, enclosing 2c stamp for postage. But do this at once, while openings for new members are being offered.

FIRESIDE INDUSTRIES
Dept. 66-B, Adrian, Mich.

Fireside Industries, Dept. 66-B
Adrian, Michigan

Please send me, Free, the book on Fireside Industries, which explains how I may earn money at home. I enclose 2c stamp.

Name.....

Address.....

City.....State.....

(Write in pencil—ink will blot)

get into **AVIATION**

TRAIN ON
The VERY LATEST EQUIPMENT

Learn to Earn \$80.00 a Week and Up

You can't learn aviation without training on the newest, most up-to-date equipment. Here you get actual work on all the big leading planes of the world. The most thorough, practical ground school course possible. Real flying and solo in up-to-minute planes. This is the training that will make you MORE VALUABLE—MORE IN DEMAND—CAPABLE of making from \$80.00 a week to \$15,000 a year.

Write for big free book "Airways".

AVIATION SERVICE AND TRANSPORT, Inc.
203 N. Wabash Ave. Dept. 13-52 Chicago, Ill.

HIGH SCHOOL EDUCATION

at home

Only
\$19.85

New, fascinating question and answer way to get the education you missed. In spare time at home. Every high school subject covered. Endorsed by 12,000 High School Teachers. Certificate awarded. Write for free book "New Way to Get a High School Education at Home." TODAY. High School Home Study Bureau, Dept. 252, 31 Union Square, N. Y. C.

DEVELOP YOUR MIND

An instructive book which explains an amazing system of mind training already used by more than 650,000 people.

Let us send you a free copy of "Scientific Mind Training". It will show you how and why Pelmanism is the *only* system of teaching for developing all the mental powers at the same time. Endorsed by such distinguished men as Judge Ben B. Lindsey, Sir Harry Lauder, Jerome K. Jerome, Prince Charles of Sweden and hundreds of others.

Write TODAY to

THE PELMAN INSTITUTE OF AMERICA
71 WEST 45th STREET DEPT. 62 N. Y. C.

SHOWCARD CARTOONIST

A New Book just chock full of ideas, better methods, short cuts,—shows you how to make cartoons and comics that give show cards and posters a real selling punch. You'll use it.—write now for Show Card Cartoonist, \$1.25 postpaid. Another good one!—"Their Best Stunts," by 25 successful chalk talkers, \$1.25 postpaid. Two new catalogs: A—Art Supplies, S—Show Card Supplies.

BART SUPPLIES, 515 EUSTIS BLDG., MINNEAPOLIS, MINN.

I'LL PAY YOU \$40.00 A DAY!



To Show This Sensational Pocket Lighter
Value To Men!

Agents, here is the greatest value and most sensational money maker you ever came across. The popular one hand Master Pocket Lighter—regular \$5.00 value—now sells for only \$1.00. Does everything \$10.00, \$20.00 and \$50.00 lighters do. Lights instantly, never misses—a masterpiece of mechanical perfection. Genuine leather covered with gold initial shield—fine gold working parts, extra flint. The ideal all year round gift.

**Sells for Only \$1.00—
You Make Over 100%**

Dealers and consumers everywhere buy on sight. Williams sold 48 in one day. Only one day's sales to dealers nets you \$40.00 profit. No experience necessary. Spare time workers make \$4.00 to \$12.00 an hour. Our sure fire selling plans show you many ways of making big money.

SAMPLE 50c TO AGENTS ONLY

This lighter in your pocket will pay you big profits daily. Just show it and make sales and profits on sight. Send 50c for sample and selling plans, or \$6.00 for a dozen. (Send \$1.00 deposit—will ship C. O. D. for balance.) The dozen comes packed in a colorful self-selling display box. You make \$6.00 profit selling to consumers, or use sample box to take orders from dealers. Your money refunded if you do not find them quick sellers. Send today!

Masterlite Mfg. Co., Dept. B P 19, 110 E. 23rd St., New York, N. Y.



Pilots and air mechanics needed!

The future of aviation is tremendous—is assured. **But what about your future in it?** What do you see in the skies for yourself? A career of thrilling work with big pay and a glorious future can be yours in the **world's fastest growing industry!**

We have just promised to furnish a \$2,000,000 St. Louis aircraft factory now building right on Perks Airport, with a minimum of 200 pilots and 200 airplane and engine mechanics **this spring!** Do you want one of these jobs?

Whether you want to work in St. Louis, New York or Los Angeles, the first question your employer will ask is **"Where were you trained?"**

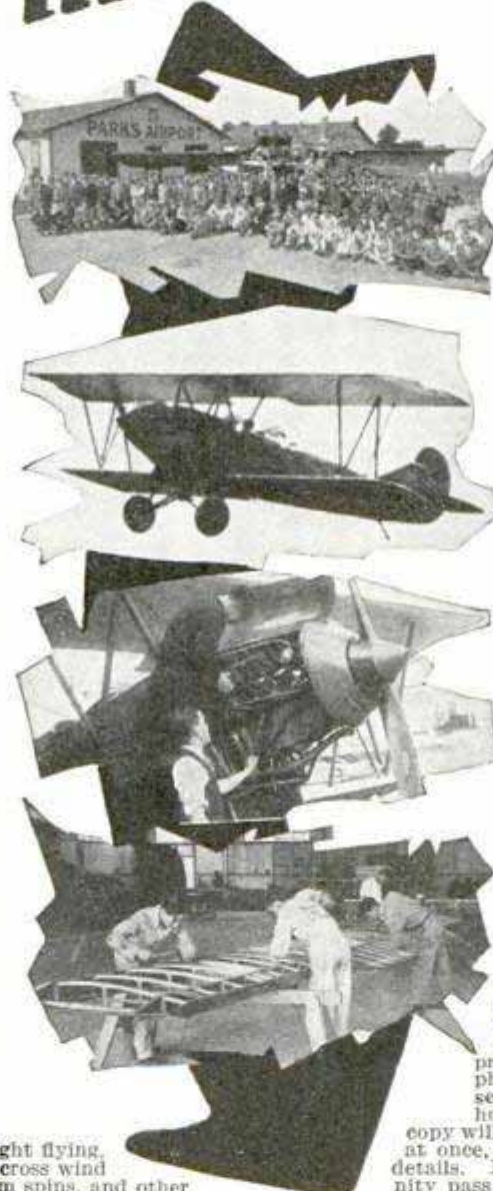
Because only thoroughly trained men are wanted and these are paid huge salaries. It costs you **no more** to receive your flying and ground instruction at the Parks Air College with 26 new training ships, nearly \$200,000 worth of special training equipment, 15 Government licensed transport pilots as instructors and our own airport equipped with 12,000,000 candle-power beacon, floodlights and other illumination for night flying, hangars, classrooms, Recreation Hall, restaurant, etc.—Parks is like a great University!

The photos on this page give you just a few glimpses of Parks Air College. Located in St. Louis, the recognized center of aviation in America, Parks Air College has facilities and opportunities undreamed of until you see them with your own eyes.

You get flying instruction every day on brand new training planes equipped with OX5 and Whirlwind engines, fitted with stick and wheel control—thorough flying instruction that turns you out a real pilot ready for success.

Thorough Training

At Parks Air College you are taught straight flying, aerobatics, forced landings, vertical banks, cross wind landings, cross country flying, recovery from spins, and other flight details, by nationally known transport pilots.



And in addition to flying, a pilot must know aerial navigation, meteorology, aerodynamics; be familiar with such famous engines as Whirlwind, Caminez, OX5, Velle, Wasp and others. You must know how to take care of your ship! All this is included at Parks Air College!

Aero Mechanics

In the Airplane and Engine Mechanics division of Parks Air College, we have Whirlwind, Caminez, OX5, Liberty, Hispano-Sulza, Velle and other latest motors. You tear these down, repair them, build them up, and test them.

You learn all about airplanes and engines. You actually build airplanes complete piece by piece.

You learn factory production methods; become qualified for field duty, factory jobs, foreman's and superintendent's positions!

You get field duty on the flying line where you are entrusted with the responsibility of keeping a certain number of airplanes in the air. The Parks job-way system gives you training under actual factory and transport conditions!

No wonder students have come to Parks from every state in the Union and from Canada, Panama and South America! No wonder they are now coming from Honolulu, Europe, even Africa!

Special Price

There are over 130 airplane factories and over 1500 registered airports in the United States. New dealers, distributors, factories, airports are opening up daily! Where are all the pilots and mechanics coming from? To supply them we are offering a special rate now that saves you nearly half.

Free Catalog!

Get all the details. Send the coupon below for your free copy of "Skyward Ho!" our new 32 page catalog profusely illustrated with photographs, so you can see with your own eyes how Parks excels. A copy will be sent free if you write at once, together with all other details. Don't let this opportunity pass you by. **Mail the coupon at once!**



Parks Air College, Inc.
234-M Mo. Theatre Bldg.,
St. Louis, Mo.

Please send me a free copy of "Skyward Ho!" and full details of your school, jobs available, etc.

Name.....

Address.....

234-M Missouri Theatre Bldg., St. Louis, Missouri

I'll Refund your R.R. Fare to Chicago

Learn Electricity

Men Wanted

I can help place 20 TO 40 men a day, in JOBS, while learning and after. Never before such unusual opportunities. Get my free book now. Learn about the big pay in ELECTRICITY—the Big Pay BUSINESS of today. That's why GREER College selected this Great Field. Coupon brings you amazing facts.

Earn up to **\$150.00** a week

A Great Profession

ELECTRICITY now pays hundreds of Greer trained men up to \$200 A WEEK. Here is a most wonderful business. One hundred million is spent annually to keep it going. Get your share—clip the coupon.

Greer trained men are NEEDED. I HAVE MADE hundreds of \$10,000 A YEAR MEN. 90,000 in the last 26 years have come to Greer.

Only 3 Months

Learn in ONLY 3 MONTHS in GREAT GREER SHOPS on large live equipment. I'LL PAY YOUR FARE HERE Free of extra cost, then help you to a job while learning. Then I not only FIT YOU to GET the big pay job, but I'll help YOU HOLD IT. Young and Old, Educated and Uneducated, Inexperienced and Experienced have found GREER SHOPS training easy, fascinating and valuable.

COUPON BELOW BRINGS YOU BIG FREE BOOK

Don't let money hold you back. Get my Free Book. Find out NOW how I PAY YOUR FARE HERE, let YOU ATTEND either days or evenings and help you find DAY OR EVENING WORK to PAY YOUR EXPENSES while learning. Then when trained we help you find the real big pay job. Learn about amazing opportunities in Electricity, and GREER COLLEGE. Right now, if you act quick, I can make you a most unusual short time offer. Address me personally

Erwin Greer, President, GREER COLLEGE
Dept. 201E, 2024 So. Wabash Av., Chicago.

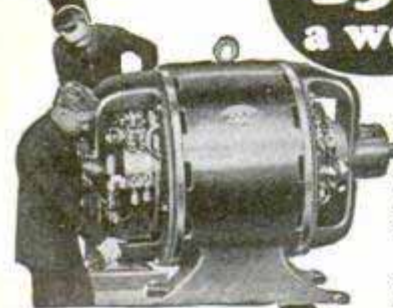
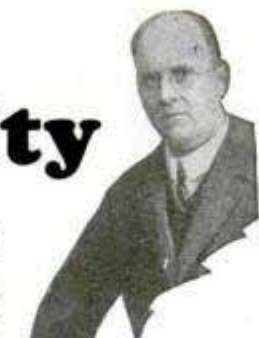
FREE BOOK

Erwin Greer, President
Dept. 201E, 2024 So. Wabash Avenue, Chicago, Illinois

Send Free Electrical Book and details of Special offer without obligation to me.

Name.....

Address.....



Study Flying NOW!

ABC of AVIATION

Gives complete flying foundation in simple language. By Major V. W. Page, America's leading instructor and engineer, 160 pages. Illus. Sent C. O. D., if desired. Only \$1.00.

3 new BOOKS

MODERN AIRCRAFT

Veritable encyclopedia of well-written explanation of everything in connection with planes and flying. Used in schools everywhere. Also by Major Page. \$55 pages. 500 costly illustrations. Sent C. O. D., if desired. Only \$5.00.

The One Authority

EVERYBODY'S AVIATION GUIDE

Major Page, famous instructor, asks and answers 600 questions. Covers everything you should know about planes and flying. 256 pages. Illustrated. Sent C. O. D., if desired. Only \$2.00.

CATALOG Free!

Get our FREE catalog covering all Henley books on more than fifty different practical and scientific subjects. Books shipped to any U. S. address C. O. D. plus postage, or postpaid if you enclose remittance. Order now.

Norman P. Henley Co., Dept. 6
2 West 45th St. New York, N. Y.

GET THE SECRET OF ORGANIC VIGOR AND SUPER STRENGTH

At No Cost

No obligation, entirely at my expense. Send for my big illustrated free book "NERVES OF STEEL, MUSCLES LIKE IRON."

It will show YOU how to get big, powerful, steel-like, shapely muscles. Fill in the coupon NOW while the opportunity is before you.



THE JOWETT INSTITUTE OF PHYSICAL CULTURE

422 Poplar St., Dept. 4P, Scranton, Pa.

Dear Mr. Jowett:

Send, at no cost to me, your wonderful illustrated book "Nerves of Steel, Muscles Like Iron."

Name.....

Address.....

Keep on ailing and you'll! KEEP ON FAILING!



STRONGFORT
Builder of Men

make yourself over into a vigorous specimen of vital manhood with 100% pep, power, and personality. It doesn't mince words. It will show you how to be true to the best that is within you—teach you how to be a real fellow. It is a man-builder—a success-maker, and a life-saver. Just check the subjects on the free consultation coupon on which you want special confidential information. Send for your copy of this book right now—TODAY!

STRONGFORT INSTITUTE
LIONEL STRONGFORT, DIRECTOR.
Physical and Health Specialist for over 27 years.

Dept. 664, NEWARK, NEW JERSEY, U. S. A.

DEFFECTIVE vitality, disease and chronic ailments drag you down to the lowest depths. Weakness of body robs you of every chance of a life of happiness and success. Your physical defects stick out all over you—tell on you wherever you go—mark you as a misfit and a weakling! You find yourself a reject in social circles—a nuisance in your home, with your constant ailing and complaining. Your sallow complexion, your anaemic look, your nauseating breath, your nervous fidgeting all contribute to make real men and women shun you wherever you try to mix with them.

Take a Look at Yourself

Look in the mirror. Look inwardly at your conscience—ask yourself if you believe you are a manly man who deserves any success, or favor, or friendship in the world. Ask yourself if you are getting the joys out of life that healthy and red-blooded, vigorous men get out of it. If in your own timid soul you know you don't deserve a thing—you know you are worthless because you are one who has neglected and abused the powers that Nature gave you—who has, by excesses, late hours, dissipation, booze-fighting or drugs and dope acquired physical ailments that keep dragging you down physically and mentally until you feel dejected and hopeless—Notwithstanding all you have been guilty of, no matter what your condition, I hold out a helping hand to you—I CAN PUT YOU ON YOUR FEET.

STRONGFORTISM

Science of Health and Strength—

has helped thousands overcome the vitality-sapping disorders that afflict so many. It will by natural methods, without the use of drugs or apparatus of any kind, enable you to develop your muscular system internally and externally, and banish weakness and the results of neglecting your body, and to again feel the thrill of vigorous life, buoyant health and cheerful mentality. It will build you up speedily. There isn't any doubt about this. You will realize the truth almost from the moment you start, in the privacy of your own room, following my easily understood directions.

You Won't Get Anywhere

so long as you go on snuffing, coughing, ailing, aching and complaining. You won't score until you've banished weakness and stood up straight and looked men and women square in the face. If you are suffering from nervousness, constipation, indigestion, weak heart, catarrh, colds or other afflictions, write me frankly and I will tell you how, in the privacy of your own home, you can rid yourself of these horrors and become a real he-man—vigorous, energetic, strong, magnetic. You can't afford to drag through life, half dead, wretched! I will help you out of this pit of despair if you will just tell me your trouble.

Send for My Book

*It's FREE—and Will
Prove A Revelation*

I've packed the experience and research of a lifetime of physical and health building into my startlingly interesting book, "LIFE'S ENERGY THROUGH STRONGFORTISM." IT IS PRICELESS!

In it are plain facts that will astonish you and help you out of your sorry plight. It will tell you frankly how you can

—Clip and Send this Coupon—

CONSULTATION COUPON

ABSOLUTELY CONFIDENTIAL

Mr. Lionel Strongfort, Strongfort Institute, Dept. 664, Newark, N. J.—Please send me copy of your book, "LIFE'S ENERGY THROUGH STRONGFORTISM," without obligating me or sending a salesman. I have marked (x) before the subjects in which I am most interested.

<input type="checkbox"/> Catarrh	<input type="checkbox"/> Rheumatism	<input type="checkbox"/> Weak Heart
<input type="checkbox"/> Colds	<input type="checkbox"/> Nervousness	<input type="checkbox"/> Great Strength
<input type="checkbox"/> Asthma	<input type="checkbox"/> Constipation	<input type="checkbox"/> Lung Troubles
<input type="checkbox"/> Headache	<input type="checkbox"/> Weak Back	<input type="checkbox"/> Poor Circulation
<input type="checkbox"/> Rupture	<input type="checkbox"/> Weak Eyes	<input type="checkbox"/> Round Shoulders
<input type="checkbox"/> Thinness	<input type="checkbox"/> Flat Chest	<input type="checkbox"/> Skin Troubles
<input type="checkbox"/> Pimples	<input type="checkbox"/> Despondency	<input type="checkbox"/> Stomach Disorders
<input type="checkbox"/> Insomnia	<input type="checkbox"/> Emaciation	<input type="checkbox"/> Increased Height
<input type="checkbox"/> Overweight	<input type="checkbox"/> Short Breath	<input type="checkbox"/> Muscular Development

Other Allments

Name

Age Occupation

Street

City State

Become a Trained RADIOTRICIAN



in
**90
DAYS**

RADIO INDUSTRY PLEADS for "Registered" Radio Experts



MICHAEL ERT,
Pres. Michael Ert,
Inc., and Pres.
Wis. Radio Trade
Assoc. and First
V. Pres. Federated
Radio Trade Assoc.

Opportunity beckons as never before in the Radio industry. Good-paying positions, interesting work, a chance to become independent—radio offers all this and more to ambitious men who seize the opportunity NOW! Last year the radio industry took all our graduates and clamored for more. Thousands of trained men are needed for Radio Service, Radio Engineering, Radio Broadcasting, Television, Station-operation, and Radio Merchandising. And still radio is in its infancy. Great expansion is ahead. Get in this wonderful fast-growing field NOW!

Radio Trades Association Approve S. of E. Radio Graduates

The Wisconsin Radio Trades Ass'n now compels every radio service man to pass severe examinations, and become registered. Dealers are tired of expensive incompetent help. Radio trade associations the country over are planning to follow Wisconsin's example. The School of Engineering is the only institution in the country whose course is approved by a radio trade association. Graduates of the S. of E. are "registered" without examination.

Most Thorough Practical Radio Course in America

Here in this big splendidly equipped electrical school (from which Station WISN is operated) you can secure in three months the most thorough, the most compact and practical radio training offered anywhere. Covers entire field of radio! Complete Course includes Radio Laboratory Practice, Radio Telephony Theory, Radio Transmission, Code Instruction, Electrical Mathematics, Service and Installation, Radio Sales & Merchandising. Daily broadcasting from WISN. All training is 100% PRACTICAL. You learn everything in three short months!



TELEVISION INCLUDED

Complete Radio Course also includes study of fundamentals of Television and latest developments in that gigantic new field. Enables anyone to keep up with progress of this new industry.

EARN WHILE YOU LEARN

Not only do we help place our men after graduation, but we can arrange for part-time employment that will cover part if not all of your living expenses while you are taking the Radio Course at the School of Engineering.

Send for FREE BOOK

Send today, without obligation, for FREE catalog describing the wonderful opportunities in radio, the three month Radio Course, and details of our Earn While You Learn Plan.



School of Engineering of Milwaukee,
Dept. PM 229A.

Without obligation, please send me FREE Book describing your 3-months "Radiotrician" course and full details of your "Earn While You Learn Plan."

Name..... Age.....
Address.....
City..... State.....



Choose as Your Profession Electrical Engineering

Electricity offers a brilliant future to the young man who is about to choose his career. Never before has there been such a wonderful opportunity in this great field. Big paying positions in electrical work the world over are open to trained men—men who possess specialized, practical knowledge. Come to the School of Engineering of Milwaukee—the foremost and best equipped electrical school in America. Here you are trained in both theory and practice by a faculty of experts. You learn in large, completely equipped laboratories. If you have 14 high school credits or equivalent, you can become an Electrical Engineer with a Bachelor of Science degree. Any credits you may lack can be made up in the short intensive course, covering Electricity and technical high school subjects.

B.S. Degree in 3 Years

A Complete, Practical, Electrical Education

Learn by the thorough, approved scientific methods which our 24 years of specializing enable us to give you. In addition to Electrical Engineering, the following complete courses are given: A. C. and D. C. Armature Winding—Wiring and Testing—Commercial Electrical Engineering—Automotive Electricity—Radio Sales Service and Broadcasting—Electrical Refrigeration.

Earn While You Learn

By our special system you may earn part of your way while learning. Our Employment Men will secure you a position to which you may devote a part of each day, spending the remainder at the school. Co-operation with large Milwaukee electrical industries affords Students splendid opportunities. Low tuition fee. Board and room reasonable. Daily Broadcasting. School Orchestra. Fraternities.

New Term Begins Now

Write for FREE Catalog

Write today for our free, illustrated catalog. Read about this wonderful institution and the great opportunities that lie before you. Find out about our specialized method of training and the details of our "Earn While You Learn" Plan.



School of Engineering of Milwaukee,
Dept. PM-229, Milwaukee, Wis.

Without obligating me in any way please mail free Photostory book, "Rise to Success Through Electricity" (just off the press), and NEW Bulletin regarding the course I have marked with an X.

- | | |
|--|---|
| <input type="checkbox"/> Commercial Elec. Eng. for High School Grad. 1 year. | <input type="checkbox"/> Elec. Refrigeration. |
| <input type="checkbox"/> Commercial Elec. Eng. others 1 to 2 years. | <input type="checkbox"/> Radio. |
| <input type="checkbox"/> Elec. Eng. B. S. Degree 3 yrs. | <input type="checkbox"/> Armature Winding. |
| <input type="checkbox"/> Automotive Elec. | <input type="checkbox"/> Light, Heat & Power. |
| <input type="checkbox"/> I am interested in your Earn While You Learn Plan. | <input type="checkbox"/> Practical Electricity. |
| | <input type="checkbox"/> Home Lab. Service. |

Name..... Age.....
Address.....
City..... State.....
Education.....

He Left His Calling Card

—*Telltale Finger Prints!*



Written In Blood!



THREE bloody finger prints on the cash register! He might as well have left his calling card—his doom was already written! These silent witnesses told the story—identified him—convicted him! Live through these thrilling adventures right with Detective McDonald as he gets Arizona's first finger print conviction. Mail the coupon below and get this gripping story **FREE**, with 12 others just as exciting!

13 True Detective Stories—**FREE!**

Gripping Mysteries! Gruesome Tragedies! Daring Deeds! Hair-Raising Climaxes! Every story will thrill you—grip you! You won't be able to lay it down until you have finished.

Think of it! Real Secret Service Operators give you "inside dope" on real crime cases. They reveal their secret workings—how they solved big crimes that baffled the police all over the country—how they won handsome rewards! These stories are **YOURS FREE!**—if you act quick! You would pay a good sum for them at a bookstore or news-stand. Here they are yours **FREE!**—for the asking. Mail the Coupon **NOW!**

Big Demand for Trained Men
Make \$2500 to \$10,000 a Year

Finger Print Experts solved every one of these weird, blood-curdling crimes! Finger Print Experts gathered in the great big rewards—were appointed to high official positions for their work! Every day more and more trained men are needed. New Bureaus of Identification, new positions are opening up all the time. The field is uncrowded! Opportunities are unlimited!

YOU can learn Finger Print Identification easily, in a short time—in your spare time—at home! **YOU** can make \$2500 to \$10,000 a year as a Finger Print Expert. Find out how you can enter this most thrilling, adventure-some profession and make big money fast!

The Knock of Opportunity

Is the knock of the postman as he brings this book, "Finger Prints," to you. It brings you fascinating true detective stories. And more! It tells you how **YOU** can learn Finger Print Identification quickly and easily—at home, by mail—and at a very small cost—made still easier by our liberal Easy Terms. Mail that coupon **NOW!**

University of Applied Science
 1920 Sunnyside Ave., Dept. 13-52 Chicago, Ill.

Send for this Free Book!



Mail This NOW for Free Book

University of Applied Science,
 1920 Sunnyside Avenue, Dept. 13-52 Chicago, Ill.

Without any obligation whatever, send me your new, fully illustrated, **FREE** book of authentic detective tales, "Finger Prints"; also full details of your low prices and easy payment plans.

Name.....

Address.....

City and State..... Age.....

Step INTO A BIG-PAY HOTEL JOB



Earn \$2,500 to \$10,000 a Year

IN America's 3rd Largest Industry. Hotels, Clubs, Restaurants, Institutions, Schools, Colleges, Hospitals, etc., are daily calling for Lewis Trained Men. Over 70,000 high-class positions paying \$2,500 to \$10,000 a year open annually in hotels alone. Salaries up to \$3,500 to start.

We Put You in Touch with Positions

Without cost let us show you how big pay, fascinating work, quick advancement can be yours in the great hotel industry. Age is no obstacle—young and old alike have equal chance for success. A common school education is all you need with the amazing Lewis System of Sparetime Training in Hotel Operation.

Previous Experience Unnecessary

Hundreds of Lewis students are winning success. Totally unacquainted with hotel work before taking the Lewis Course, N. Frank Hills is now Assistant Manager of a \$250,000 Apartment House in Los Angeles, Cal. Elwood V. Matlack rose from Elevator Boy to Manager of an Akron, Ohio, Hotel, in less than two years due to the training he received from the Lewis Schools. YOU can do as well. Low cost—easy terms—money back agreement. Write today for Free Book, "Your Big Opportunity," and complete details, mailed without obligation.

These Lewis Students "Made Good"

D. A. Robinson—"I am Manager of a Country Club in Teaneck, Ont., at double the salary I earned before taking the Lewis Course. One of my dearest regrets is that I didn't know about the Lewis Schools twenty years earlier."

Julius M. Windsor—"Now Assistant Manager of a 15-story hotel in New York City. I knew nothing of hotel work until I began your course 6 months ago."

Earnest Crowder, Indianapolis, Ind.—"The Lewis Schools are entirely responsible for my appointment as Assistant Manager."

1000 HOTEL POSITIONS OPEN

**Lewis Hotel Training Schools
Room BH-339
Washington D. C.**



LEWIS HOTEL TRAINING SCHOOLS, Room BH-339, Washington, D. C.

Send me the Free Book, "Your Big Opportunity," without obligation.

Name.....
Address.....
City..... State.....

OPPORTUNITY COUPON

Very Special COMPLETE ART COURSES Only \$4.98!

Learn QUICK—Right at Home—to Make \$50 to \$200 a Week!

For the first time YOU can have complete training in any branch of Commercial Art—from this 14-year old, nationally famous Art School—for only \$4.98, or your Money Back! NOW you can learn right at home; get ready quick to make Big Money. No previous training needed. We start you at very beginning, give you everything you need.

Thousands have succeeded with these Same Complete, Easy Courses

These same Courses have started thousands toward \$50, \$100 and more a week! Our students arrive. See list of fine, up-to-date Courses at right—choose the one you want—send \$4.98 check or money order AT ONCE to

**WASHINGTON SCHOOL OF ARTS
1115-15th St. N. W., Dept. A, Washington, D. C.**

Choose your Career; Plan Your Future. Any one of these 5 Courses ONLY \$4.98!

- Commercial Art
- Cartooning
- Fashion
- Illustrating
- Fashion Designing
- Show Card
- Writing

—and MONEY BACK if not delighted after trying Course for one whole week!

LEARN MECHANICAL DENTISTRY

SEND FOR FREE BOOK

Your Success

Earn up to \$5,000 a year

You can EARN WHILE LEARNING this modern money making business and become Your Own Boss. Big demand. Age no barrier and no previous experience required. You learn by doing actual work in rubber and gold. Easy terms. Individual instruction. Day and night school. Write NOW for Catalog P. Railroad fare allowed—no extra charge.

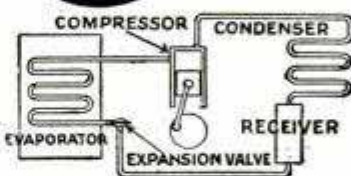
**NEW YORK SCHOOL OF MECHANICAL DENTISTRY
147 W. 33rd Street NEW YORK**



MEN NEEDED FOR RAILROADS

Nearest their homes—everywhere—to train for Firemen, Brakemen; beginners \$150-\$250 monthly. Promoted to Conductor or Engineer—\$3,000-\$4,000 yearly—highest wages on railroads. Also clerks. Railway Educational Association, Dept. D-1, Brooklyn, N. Y.

BIG Money IN ELECTRIC REFRIGERATION



AMERICA'S biggest new industry — electric refrigeration — needs men to fill jobs paying \$200 to \$1,000 a month. General Motors, General Electric, and others are investing billions. Millions of machines are being sold to homes, theaters, factories, stores, etc. Thousands of jobs are open in production, installation, service and sales which ordinary mechanics can't fill without special training in electric refrigeration.

Easy to Learn at Home

Learning electric refrigeration is now amazingly simple thru a new easy home training endorsed by authorities. Highly praised by Serval, Kelvinator, and others. GET FREE BOOK. Utilities Engineering Institute, 3120 N. Clark St., Dept. 12, Chicago.

Utilities Engineering Institute, 3120 North Clark St., Dept. 12, Chicago, Ill. FREE!

Without obligation, send me free information book.

Name.....
Address.....
City..... State.....

The "PICTURE WAY" Replaces Old-Fashioned Methods

**DRAFTSMEN
PAID
\$60 to \$100 a week**

Get Into This
WORK

BIG PAY with my new
amazingly simple
PICTURE-METHOD



At last—a quick, complete, fascinating way to learn Drafting, and learn it **right!** Experts acknowledge my new, simple, easy "Picture Method," to be the first new idea in teaching Drafting in 30 years. It's the most easily-grasped, sound and sensible plan ever devised for Home Study instruction,—so clear, so interesting, so practical that almost before you know it, you're through—have finished—and are ready to go to work on a Big Pay Job.

Learn to Earn—\$60 to \$100 a Week

That's what the expert draftsman gets. And he's never out of work the year 'round—for he's the King-Pin of Industry—the man they've got to have. Not a wheel can turn, not a brick can be laid, not a wire can be strung, until the job has first been planned and drawn on paper by a draftsman. Why don't you get into work like that? Why don't you be a man they can't get along without—a Big Pay Man with a year 'round Big Pay Job? You can—it's easy—I'll show you how!

I'll Quickly Prepare You for Drafting

With my new copyrighted "Picture Method," I'll help you get ready for a Big Pay Draftsman's job so quickly you will be astonished. Spare time only needed. With my method—you just watch my hands in the pictures—you see how it's done, and you do it yourself almost **automatically.** It's amazingly simple—yet so thorough and complete you learn Drafting from A to Z—learn it so you can sit in with the best of them on the Jobs that pay Big Money.

Sample Lesson FREE

Don't sign up for any Drafting Course until you've investigated my amazing new "Picture Method." Mail coupon for Big FREE Book and Sample Lesson. See my great Earn-while-Learning Plan—see the big Professional Drafting Outfit you get at no extra cost—learn about my Nation-wide Job Service—my positive Money Back Agreement. Mail coupon NOW!

MAIL COUPON FOR FREE BOOK

K. M. Boyd, Chief Drafting Engineer
L. L. COOKE SCHOOL OF DRAFTING
Dept. 12, 2132 Lawrence Ave., Chicago, Illinois.

Send me your book "Draw Big Pay in Drafting" and some sample lessons and tell me more about your "Picture Method." This does not obligate me in any way.

Name.....

Address.....

City..... State.....



This Professional Outfit given without extra charge

Associated with the **L.L. COOKE SCHOOL of ELECTRICITY** in helping the Working Man earn More Money

LEARN AUTOS IN LOS ANGELES

Jobs Open Now—\$40 to \$100 a Week

You are urgently needed to help repair the one and a half million autos in California. Trained auto repair men are also needed badly in every other state. The rapidly increasing number of cars means prosperity and big pay for auto men—more garages, tire shops, battery stations are needed. You can be one of the highly paid men in this fastest growing industry—if you get

**YOU CAN BE
An Auto
Expert!**

the right training. National Automotive special, practical Shop Training makes it easy for you to become an Auto Expert. In a quarter century this great institution has trained

20,000 men for bigger pay. It will help YOU make more money by giving you individual instruction on repairing Packards, Buicks, Cadillacs, Fords, etc., all types of electrical equipment, machine shop equipment, etc. You learn everything RIGHT at National.

**Paul Briggs Earns
\$4000 a Year**

"I want to thank you for the big part National has played in helping me to success in auto work. I am now assistant sales manager and made \$4,000 this year—which is more than I would have made in three years at my former work."—Paul Briggs, Portland, Ore.

**Money-Making
Book—FREE**



**Earn
While You Learn**

Free employment service. Spare time jobs help pay expenses while training. All tools included. No extras. Send for big free illustrated catalog explaining how National trains you for bigger pay. Learn the opportunities for you in California. Mail coupon now.

**Million Dollar
Training Head-
quarters for
Auto Ex-
perts**



**NATIONAL AUTOMOTIVE, Dept. 719,
4006 Figueroa St., Los Angeles, Calif.**

Send me, absolutely free, your big illustrated catalog of Automotive Opportunities showing how I can train for a Big-Pay Auto Job.

Name.....
Address.....
Age..... City..... State.....

Boys a Bicycle for You

You can earn it easily in YOUR spare time



Do you want this beautiful bicycle? This is just one of many prizes Crowell Junior Salesmen are given. They are a group of peppy go-getters who deliver The American Magazine, Woman's Home Companion and Collier's, The National Weekly.

You need no experience to start. We tell you how to locate readers of our magazines and furnish all material. Hundreds of boys are winning prizes and earning their own spending money. You can do the same—just mail the coupon now.

Mail this →

**Mr. Jim Thayer's Dept. 82
The Crowell Publishing Company,
Springfield, Ohio.**

Dear Mr. Jim:
I sure want one of your bicycles. Start me off as a salesman and send me full instructions.

My Name.....
Address.....
Town..... State.....

I Want YOU for My Next MIRACLE in MUSCLE!

New — Sensational — Extraordinary!
The greatest demonstrations of muscle-building known to the world of physical culture! You can be next! Almost overnight I'll transform you into a marvel of muscular power—give you astounding new health, strength and vitality. Read how!

MIRACLES IN MUSCLE! You hear everybody talking about them. Physical culture authorities are amazed.

Think of it! Men made over—almost overnight! Puny, sickly weaklings transformed into superb specimens of MANHOOD! Strong men made STRONGER. This astounding new method works its wonders for ALL—young or old, sick or well.

Incredible? Yes! But this is an age of marvels. We speed across continents by airplane, where once we plodded by stage coach. We talk through the air by radio, where once we depended upon slow-footed couriers. And now Titus brings to physical culture the greatest advance of the century.

Titus, the pioneer—the first in the field—today, as a'ways, is years ahead of his time. Titus Training—the original, the genuine—the system that has built the world's great strong men—still sets the pace. Startling new developments make it the most modern system of body-building in the world. Titus Training accomplishes almost overnight what other systems can never accomplish in months and years.

I'll Make You Feel ALIVE!

I'll give you a new and wonderful THRILL! I'll put glorious new LIFE into every cell, nerve and organ of your body. Man, things happen when I start working on that body of yours! And they happen FAST. Floods of vitality surge through you; your vital organs tune up and start hitting on all six; your muscles begin to GROW. In 30 days you're a changed man. You feel better and look better than you ever did in your life. Your body has been completely rebuilt—you'll wonder where those big, beautifully proportioned muscles came from!



Wear This Medal

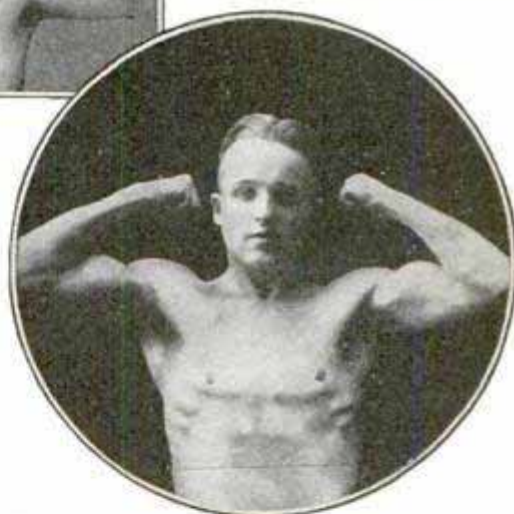
Strong men all over the world wear it. Made of solid statuary bronze and given to you free. Mail Coupon for full details.



BEFORE

The picture at the left shows how Wesley Webb used to look—a weak, sickly man, undersized, underdeveloped—soft as butter. He had no energy, no vitality.

ONLY 30 DAYS AFTER



Now look at Wesley Webb after 30 days of Titus Training. Titus built that wonderful body, developed those big, rippling muscles, changed the puny weakling into a magnificent specimen of MANHOOD. My FREE BOOK tells how.

I Don't Promise Anything

I Guarantee: to put 2 inches of solid muscle on your arms; to increase your chest five inches; to develop your neck to a size larger collar; to add three inches of powerful development to your thighs; two inches to your calves; to give you a slim, trim waist line that will make you take in your belt a notch or two. And I don't ask you to take my word for it—I don't promise anything—I back every statement with an ironclad, written GUARANTEE. I've done all this for others. I can do it for you. Get the PROOF.

**TITUS, Dept. M135
105 East 13th St.,
New York, N. Y.**

Dear Titus: Yes, I want to read your big new illustrated book, "MIRACLES IN MUSCLE." Please send it absolutely FREE, and without obligation to me.

FREE—AMAZING BOOK

Every man with an ounce of red blood in his veins should read my book. Whether you're interested in training or not—regardless of what other systems you have tried—regardless of how weak or how strong you may be—you need this book. It's packed full of information vital to every MAN. Rush your name and address—use the coupon, a postcard or a letter. But do it NOW.

The One and Only TITUS 105 East 13th Street
New York, N. Y.

Name.....

Address.....

Town..... State.....

The real money is in these professional fields

DRAFTING-ARCHITECTURE

ENGINEERING-ELECTRICITY

A real salary—a steady five-figure income—a dignified out-of-the-trades class position or a business of your own. That, briefly, is what Engineering, Architecture, Electricity or Drafting can mean to you. For in these fields, billions are spent annually. Millions go to those men specially trained to lay out and superintend construction work. Industry needs trained Draftsmen,

Engineers and Architects. Everywhere big salaries and bonuses are being paid. Men are at a premium. You're needed—and wanted if you're trained.

Chicago Tech Gives You That Training

For 26 years one institution—the Chicago Technical College—has been developing trained specialists in drafting and engineering. Its graduates are in great demand. Its courses represent the last word in tested and proved practical training for young men.

3 Easy Plans

You need not be without this training. 3*Plans make it easy for you no matter what your circumstances.

Come to Chicago if you can. Enter our resident school in either the 2 year Diploma or 3

year B. S. Degree Course. Either of these courses give you the maximum in thorough, up-to-the-minute and practical training. Mark *Plan No. 1* on the coupon if interested in these courses. It brings you our free 80 Page Blue Book and all the facts.

If your time is limited, consider our 4 months' course in Drafting—just mark *Plan No. 2* on coupon.

And finally, if you can't come to Chicago, then study at home—earn while you learn—and mark *Plan No. 3* on the coupon.

But get the coupon going now—for you can't afford to be without the facts that show you how to get into these 4 Big billion dollar fields.

Earn While Learning

Chicago offers opportunities for part time work to help defray expenses. The College assists students in making desirable employment connections.

Mail Free Book Coupon

Chicago Technical College, Dept. B-77, 118 E. 26th St., Chicago

Please send me your Free Book and other information about plan of training marked below.

Name.....

Address.....

City.....State.....

Check plan in which you are interested.

- No. 1.—Complete College Training (2 yr. Diploma —3 yr. Degree) Engineering or Architecture at the College in Chicago.
- No. 2. 4 months' Special Drafting Course at Chicago Tech. Earn while learning.
- No. 3. Home Study—College-Training-At-Home in Drafting. Your spare time is enough.

CHICAGO TECHNICAL COLLEGE



Dept. B-77, Chicago Tech Bldg., 118 East 26th St., Chicago, Illinois

FOREMEN!

FACTORY WORKERS AND ALL MECHANICS



\$1.98 (Worth \$2.50)
Lecture Course Complete in 1 Volume

SEND NO MONEY

Every foreman, factory worker, manager and ambitious mechanic will find a gold mine of inside information in "The Modern Foreman" by Robt. Grimshaw. The 28 chapters of this great work are shop talks pointing the way to success, efficiency, better pay and the job higher up. A complete study course in leadership; a handy, daily reference and guide.

SUBJECTS COVERED INCLUDE:—The Magic Wand of Efficiency, The New Type of Foreman, Teamwork, The Kicker, The Agitator, Bonus Plans, Self Improvement, How to Handle Men, Hiring and Firing, Assigning Men to Jobs, How to Keep Records, How to Cut Out Waste of Time and Materials, New Inventions, Modern Methods, The Inspector, Health and Character Requirements, What the Foreman Should Know, Mathematics, Business Law, The Foreman as "Top Sergeant," Factors of Success, Leadership, What is "Labor"? Time and Idleness, Knowledge is Power, "Morale," The Value of Mistakes.

"The Modern Foreman" has 297 pages, quick reference index, many tables, diagrams, illustrations and forms; big type, easy to read and understand; rich binding, gold stamped. Size 6 x 9 x 1 1/4. Reg. price \$2.50. Our special sale price \$1.98. Send no money. Satisfaction guaranteed. Mail this coupon TODAY!

GREGG PUBLISHING CO., 20 W. 47 St., New York, N. Y.

Send me "The Modern Foreman." I will pay postman \$1.98 and postage on arrival. My money is to be refunded if I am not satisfied.

Name.....

Address.....

Join an ASPA FLYING CLUB

Airplane FREE!

By enrolling as a member of The American Society for Promotion of Aviation, you can help us—with the aid of the country's most prominent "air-minded" individuals—to influence Congress to follow the lead of Canada by appropriating \$40,000,000 to supply gratis airplanes to every Flying Club of fifty members. We have already organized over 500 Flying Clubs. Will you help us organize one in your community? All ASPA members receive special courtesies at Airfields and Factories and secure practically 25% discount on all aeronautical books and equipment purchased through National Headquarters.

ASPA Home Study Course Complete for \$1.00

This Course is endorsed and recommended by America's leading airmen and leading students of aviation, as the most complete, the soundest, clearest and most informative of any Course ever prepared. It teaches you the fundamentals of aviation and materially cuts down the number of hours necessary before qualifying as a flier. Membership in the ASPA, including Silver Wings (pictured below) is but \$1.00. The Complete Home Study Course, including Blue Print of a Model Airplane, is also \$1.00. Show your spirit and patriotism by lending support to this national determination to "Make America Supreme in the Air." Use Coupon below—TODAY!



SECRETARY, ASPA, Dept. PM-2, 522 Fifth Ave., New York.

- I enclose \$1 for Membership in ASPA, including Silver Wings, Membership Card and literature of the Society.
- I enclose \$1 for ASPA Complete Home Study Course in Aviation, including Blue Print of Model Airplane.
- I enclose \$2 for both Membership and Course.

Name.....

Address.....

City.....State.....



Ain't Life Wonderful!

By Mason



NO HE CAN'T PLAY GOLF WITH US, HE'S RUPTURED POOR FELLOW

WHEN YOUR BARRED FROM AN ACTIVE LIFE BECAUSE YOU'RE STRAPPED DOWN WITH A TRUSS



YOU'RE SO GROUCHY SINCE YOU'VE BEEN WEARING THAT TRUSS-WHY DON'T YOU TRY SOMETHING THAT WILL RELIEVE YOU?

- AND CONSTANT DISCOMFORT SOURS YOUR DISPOSITION



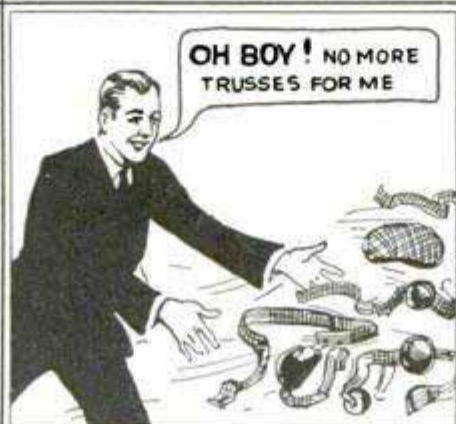
POOR OLD JOE IS LOSING HIS GRIP SINCE HE'S BEEN RUPTURED

- AND YOUR AILMENT BEGINS TO AFFECT YOUR WORK AND BUSINESS SUCCESS



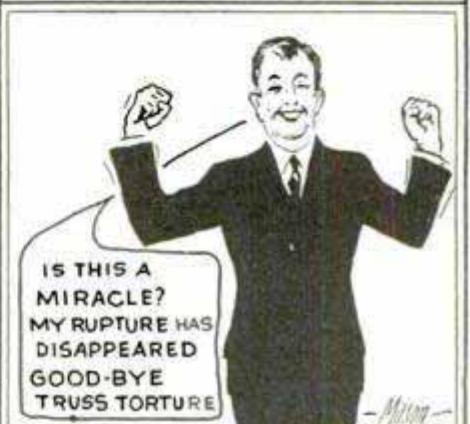
JOE-HERE'S WHAT YOU OUGHT TO GET

THEN- SOME KIND FRIEND TIPS YOU OFF ABOUT MAGIC DOT



OH BOY! NO MORE TRUSSES FOR ME

- AND YOU'RE AMAZED TO FIND IT SUPPORTS RUPTURE WITHOUT STEEL SPRINGS, LEG STRAPS OR HARD, GOUGING CUSHIONS



IS THIS A MIRACLE? MY RUPTURE HAS DISAPPEARED GOOD-BYE TRUSS TORTURE

- AND TWO MONTHS LATER YOU FEEL TWENTY YEARS YOUNGER - AIN'T LIFE WONDERFUL!

Button Rupture Newest Way (Without Pressure!)

SCIENCE now advises discarding cruel steel springs, barbarous leg straps, and other harness that press against the rupture and thus prevent nature from healing it. A new sensible method has been perfected, after experience of more than 40,000 cases, called Magic Dot—entirely different from any other way. Instead of "pressing" it "seals" rupture, and of course, allows users to run, jump, bend and cough in safety.

Rupture Help Breathes Air

With this 1/25th oz. device is a new kind of pad, air-porous and washable. It actually "breathes" air and cannot slip off the rupture—a feature you'll frankly admit that is lacking in your present appliance. In fact, it is so superior and different that it is praised by physicians as "an entirely new departure." Users report they have

forgotten they are wearing it. But don't buy it yet.

Ruptured? See It First!

By a special arrangement you can now have it sent to your home. Don't send a penny or order it now. Just mail the coupon for full description of "Magic Dot" and details of this unusual offer. Act now for quick relief. Write your name and address on the coupon and mail it today!

NEW SCIENCE INSTITUTE
2157 Clay St., Steubenville, Ohio

FREE SAMPLE

NEW SCIENCE INSTITUTE, 2157 Clay St., Steubenville, Ohio. Please send me free your illustrated book, sample of Airtex material that "breathes" and full details of the amazing new way to button rupture. Include also your offer which permits me to see the New Science System without cost or obligation.

Name.....
Address.....
City..... State.....
(Be sure to write or print very plainly.)



End Truss Torture Now or Never

Pay-Raising BOOKS

SENT FREE!



We offer you here the opportunity to see these books before deciding to buy them—to judge for yourself how they will increase your earning capacity and help you smash your way to the top. But you must mail coupon immediately if you wish to get the benefit of the reduced prices and easier terms shown below. "Aviation Guide" free for a limited time only with all sets listed (except Drafting).

Drafting and Design

Mechanical and Architectural Drafting, 4 volumes, 1578 pages, 1000 illustrations, blue-prints, etc. Thousands of men have learned Drafting quickly with these books and have gone into positions paying \$40 to \$100 a week afterward. \$1.80 after 15 days' free trial, then \$2 a month until \$14.80 has been paid. "Modern American Homes" free, see coupon. (Aviation Guide not included.)

Electrical Engineering

Great 8-volume reading course, 4400 pages, 3200 illustrations, charts and diagrams. Formerly sold at much higher price. If you act quick you may secure this complete, revised Electrical Engineering training for only \$2 after 15 days' free trial, then \$3 a month until \$34.80 has been paid. "Aviation Guide" free—see coupon.

Contracting—Building

2500 pages in 5 big deluxe volumes, just off the press. Over 2000 plans, blue prints, charts, diagrams and illustrations. Compiled by 24 noted engineers. Covers every branch of building construction, architectural and carpentry. 15 days' free trial. Then if wanted, \$2 down, \$3 a month, until \$24.80 is paid. "Aviation Guide" free—see coupon.

Auto Engineering

5 volumes, 2400 pages, over 2000 wiring diagrams, charts and illustrations. Most complete and up-to-date cyclopedia of ignition, engine, maintenance, trouble-starting, repairs, etc., ever published. 15 days' free trial. Then if kept, \$2 down and \$3 a month until \$24.80 is paid. "Aviation Guide" free—see coupon.

Machine Shop Practice

Both Machine Shop and Foundry methods and management. Production, Drafting, etc. 2300 pages, 2500 illustrations, 6 deluxe volumes. Latest edition sent on 15 days' free trial. If kept, \$2 down, \$3 a month until \$24.80 is paid. "Aviation Guide" free while this reduced price offer remains in effect.

Practical BUSINESS Administration

\$150 reading course at less than one-third the cost and on easy terms! 12 volumes by noted business executives covering the newest practice in Finance, Advertising, Sales, Accounting, Management, Production, etc. 13th volume free contains 80 lessons, quiz-questions and answers. 15 days' free trial. Then \$2 down, \$3 a month until \$39.80 is paid. "Aviation Guide" Free.

Civil Engineering

9 volumes, covering Steel Structures, Railroads, Public Works, Drafting, Surveying, etc. 4000 pages, 2000 illustrations. A great 2-year course offered at about 1/4 price. 15 days' free trial to prove its completeness and simplicity. Then if wanted, \$2 down and \$3 a month until \$34.80 is paid.

"AVIATION GUIDE"—FREE

Major Page's famous book on flying, design, aeronautics, ground-work, etc., called one of the finest books on aviation ever published. 250 pages, profusely illustrated. Never sold for less than \$2, now given free with any set of books offered at publisher's reduced rates above, (except Drafting), for a limited time only.

**American Technical Society, Dept. X-219
Drexel Ave. and 58th St., Chicago**

**American Technical Society, Dept. X-219,
Drexel Ave. and 58th St., Chicago, Ill.**

I accept your offer to use as my own for 15 days, 1 set of books marked X above entitled.....

..... which I have the privilege of keeping if I wish, on terms of \$2 down and \$3 a month. "Aviation Guide" will be sent free when you receive my down payment (not given with Drafting books) and notice that I prefer to keep books. I will pay few cents Express charges when books are received, and you agree to pay Express charge if I decide to return them.

Name.....
Address.....
Employer's Name.....
Employer's Address.....
103-N



Special Offer! Big Show-Card Writing Outfit



DON'T buy an Outfit. I include one with my new, easy Course in Sign and Show-Card Writing. I teach you at home in spare time. No experience needed. Quickly qualify for a big pay job. Employers everywhere want men at \$50 to \$75 a week. More jobs than men to fill them. Experts always in demand. Making more money today than ever before. My Employment Service helps you land a good job in your locality.

Make \$50 to \$75 a Week

If pleasant work at \$50 to \$75 a week looks good to you, just let me know. I'll show you how to succeed in this fascinating, big pay field. Write today—sure.

Bert L. Daily, Dept. D, 126 E. Third St., Dayton, Ohio

Earn money AT HOME

Men or women earn \$25 to \$50 a week at home. All or part time. Fascinating work. Nothing to sell. We teach you at home. Furnish all tools and materials. ARTCRAFT STUDIOS, Dept. 80, 427 Diversey Parkway, Chicago.

Learn art EARN MONEY

Our method of Oil painting Portraits, Landscapes, Miniatures, requires no experience. Painting Outfit and Employment service included. Write for booklet. Pictorial Art Studios, Inc., Dept. M.P., 2926 Broadway, Chicago.

I'll Start You in a Big Paying Steady Repeat Business OF YOUR OWN OVERNIGHT!

You Collect **\$20 a Day PROFITS**



Yes, \$20 a day every day—\$140.00 a week clear profit—that's what you or any live wire can earn by simply placing these astonishing new "Automatic Salesmen" of newly patented Master Key Cases. The world's smallest and handiest Key Case.

Works on a new principle: holds six keys on a clever screw-rod. Opens like a jack knife—each Key always in the same position. Comes in genuine Cowhide leather in attractive colors, packed 13 Key Cases to a beautiful display card. Notice, it retails for only 25c and you make 100% profit selling to dealers, and over 200% profit selling to consumers in full or spare time.

It Sells Everywhere—IT'S NEW!

Auto owners and everyone who has keys to carry BUY ON SIGHT. You can place the Master Key Case Display with automobile and auto accessory dealers, drug stores, hardware stores, grocers, novelty shops, cigar stores, men's furnishing stores—hundreds of different places where the dealer is glad to accept your unusual offer.

A LIFETIME OPPORTUNITY WITH THIS AUTOMATIC PROFIT MAKER!

Our amazing selling plans show you many ways of making big money selling to dealers outright or on consignment. You can easily place 20 cards with dealers every day—60 cards every 3 days. Your cost in lots of 50 is only \$1.00 per card. Selling to dealers at \$2.00 per card, you make 100% profit or \$20.00 a day, and just think of the tremendous repeat business that you are building.

Get Started At Once in This Big Paying Business! A \$1.50 Investment Pays You \$1.75 Clear!



For Auto

Send 25c for Sample Master Key Case or \$1.50 for sample card of 13 Master Key Cases. You make \$1.75 clear profit selling to consumers or use it to take orders from dealers.



For Pocket

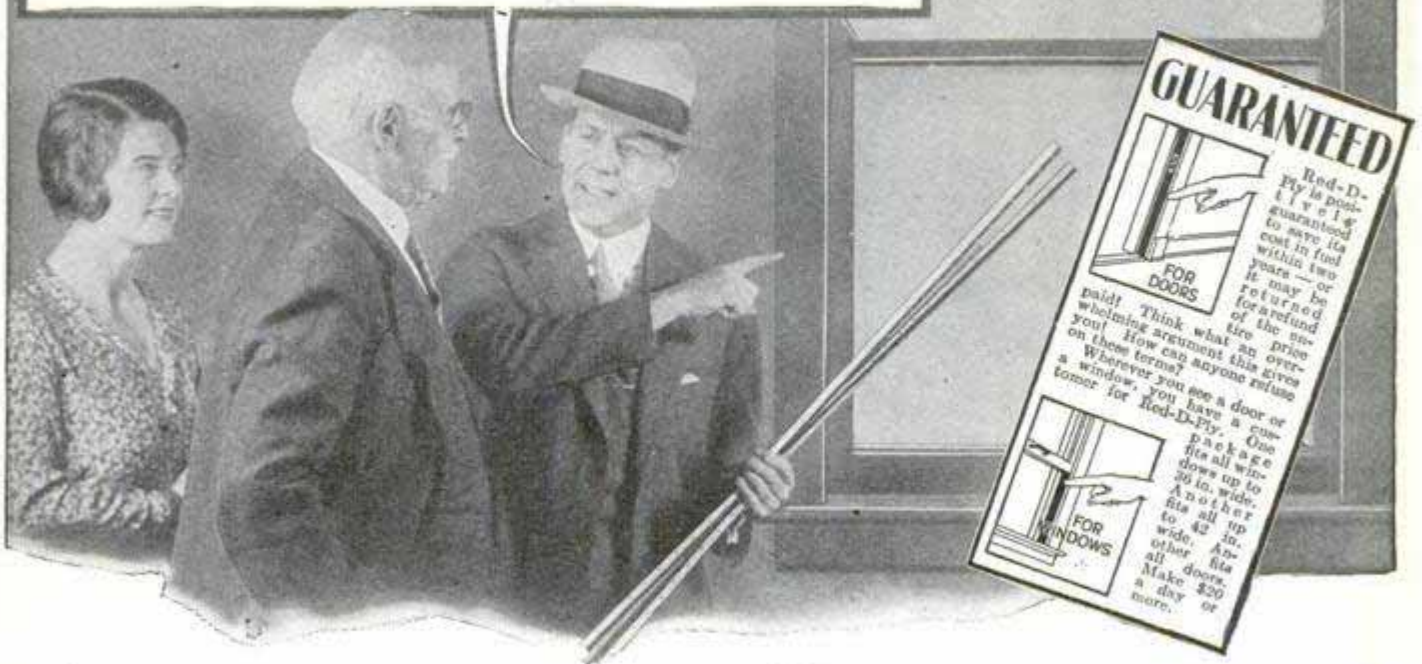
I Guarantee You Sales—You Can't Lose!

I guarantee that you will sell these Key Cases and make \$20.00 a day or refund your money absolutely. You will receive full details and selling plans with your order for single sample or sample display card of 13. Act At Once And Reserve Your Territory!

GORDON MFG. CO.
Dept. KP-19,
110 E. 23rd St.,
New York, N. Y.



"\$3.00 Spent on This Room NOW... Will Save You \$100!"



Amazing Strips of Lifetime Bronze

Save Home Owners \$30 to \$60 a Year!

NO More Big Fuel Bills! No More Cold, Draughty Rooms! No More Dust, Soot, and Smoke! Amazing New Invention Is Creating Thousands of Big Money Opportunities for Live-Wire Representatives, Red-D-Ply, New Kind of Metal Weatherstrip That Anyone Can Apply to Any Door or Window in a Few Minutes Does the Trick. Keeps Cold Draughts Out, Heat In! Guaranteed to Save Its Trifling Cost in Two Winters! Snap Up This New Money-Maker Now!

"Our coal bills cut in half!" "Saved \$50 in a single winter!" "Not a luxury—a real investment." Folks have hitherto thought of metal weatherstripping as expensive, and difficult to install. Imagine their delight when you show them Red-D-Ply! Each package contains material to completely weatherproof any door or window in half an hour, with no experience and no tools but a tack hammer and scissors! Slides into position without removing sashes or doors. Completely closes chinks and cracks where cold draughts sneak in to steal heating dollars, besides causing endless discomfort and sickness. Red-D-Ply also keeps out rain, dust, and soot. Makes windows slide easier and banishes rattles! Does away with storm windows and doors. Is it any wonder Red-D-Ply offers such amazing profits to representatives?"

A Double-Barreled Money-Maker for Agents
\$400 to \$600 a Month
The Year Round!

Just Count Windows and Doors!

A single block, even in small towns, may yield you as much as \$200 or \$300 in quick commissions! Just count the outside doors and windows in any home, figure up the fuel savings Red-D-Ply will give, and your sale is already half made! For Red-D-Ply is GUARANTEED to save its cost in two winters—and ordinarily does it in one! The cost averages about the price of an auto tire. And the saving goes on year after year—for no matter how windows and doors swell or shrink Red-D-Ply AUTOMATICALLY adjusts itself to suit.

Repeat Business—Installation Profits

The repeat business is simply enormous! Even if you don't sell a complete installation on the first call, make a test installation of one room or so—then come back for order after order, and

make the same or greater profit every time! Make extra money through installations.

Territories Going Fast—Act at Once!

Red-D-Ply offers such surprising profits in a new non-competitive field that hundreds are dropping everything to take over territory. Exceptionally generous proposition, with ready-cut selling plan absolute proof against failure. It insures repeat business. New buildings alone furnish a wonderful field—112,754 new homes built in 1928 need Red-D-Ply. We furnish everything to start a permanent, profitable business. This is only half the story. Will you risk a 2c stamp to hear the rest, if it means \$5000—\$7500 a year to you? Then mail the coupon for full particulars and a FREE SAMPLE of Red-D-Ply. No obligations. Get the facts and judge for yourself if this is not the proposition you have waited for all your life.

Red-D Manufacturing Co.

Dept. B-10, 3711-15 Parnell Ave., St. Louis, Mo.

GET FREE SAMPLE
Mail Coupon

RED-D MFG. CO., Dept. B-10
 3711-15 Parnell Ave., St. Louis, Mo. Send Free Sample of Red-D-Ply and full details of your proposition to Representatives. I am not obligated by this request.

Name.....
 Address.....
 City..... State.....

Red D Ply

The Universal Weatherstripping—Anyone Can Afford it... Sell it... Install It



You Can Learn HYPNOTISM ... or No Cost Try FREE 5 Days!

DON'T be unpopular, lonesome, or unhappy a minute longer. Now you can make your life what you want it to be—now you can win admiration, success and big money—through the strange power of hypnotism. I'll show you how to use this great force to help you master every situation or *The Five Day Trial is FREE!*

In just a few hours I'll teach you the hidden secrets of Hypnotism—the methods used by the great operators—the amazing things you can accomplish once you understand this mighty power. You can use it to overcome obstacles, achieve your fondest ambitions and become MASTER of yourself, friends and acquaintances—either sex. See for yourself how Hypnotism can banish fear, worry and opposition—improve your memory—increase your earnings—and force others to give you the good things in life you deserve!

In his startling NEW book, *The Science of Hypnotism*, the world famous hypnotist—Prof. L. E. Young—reveals the most carefully

guarded secrets of this fascinating subject. He not only explains the methods of noted hypnotists, step by step—but tells clearly all about the nine stages of hypnotism, the Hypnotic Mirror, Mental Telepathy, how to select your subjects, magnetic healing, methods of hypnotizing, how to waken the subject, how to make money out of hypnotism!

**Try 5 Days FREE—
Send No Money**

So confident are we that Prof. Young and his great book will quickly teach you the science of hypnotism, that we will send you a copy without one cent in advance! Simply clip and mail the coupon below. When the book arrives pay the postman the special low price of \$2.50 plus few cents postage. Then test the powers of Hypnotism 5 days! If not amazed and delighted return the book and money will be refunded at once! Mail the coupon now.

**FRANKLIN PUBLISHING CO.
Dept. B-70, 800 N. Clark St., Chicago**

Mysteries of Hypnotism Revealed

How to Hypnotize at a Glance
Susceptible Subjects
How to Hypnotize by Telephone
How to Give an Entertainment
How to Make Others Obey You
Overcoming Bad Habits
How to do Duzens of Hypnotic Feats
Use of Hypnotism in Operations



Franklin Publishing Co., Dept. B-70,
800 N. Clark St., Chicago

Please send me your amazing new book—*The Science of Hypnotism*—by Prof. Young. When the book arrives I'll pay the postman only \$2.50 plus postage. If I am not satisfied after 5 days' trial, I may return the book and you are to refund my money.

Name.....

Street and No.....

Town..... State.....

If you are likely to be out when postman calls, send \$2.50 with coupon and we'll pay delivery charges. Customers outside U. S. must send cash with order.

DYNAMIC STRENGTH



**SEND
ONLY
25
CENTS
for a
Sample**

STRENGTH-O-METER

The most unique, powerful chest developer ever made. Easily adjusted on the chest. Full directions on how to use. Will accurately register your muscular strength and lung power as it builds. Will daily show your chest growth. Inside of 30 days you can put 4 to 6 inches on your chest and increase your lung power 600 lbs. A fascinating form of chest development. Compare your chest strength with your friends. Test them. Build chest size via the pleasure and profit route.

This is a special offer. The regular price is one dollar. Take advantage of this great opportunity and send 25c today. This offer is good for only 30 days. With it I will give

FREE

My magnificent illustrated book "The Thrill of Being Strong," full of famous strong men and splendidly built pupils, who tell you the true secret of how to get great strength and a shapely body with big, powerful muscles.

A knockout offer. Grab it Right Now.

Fill in the Coupon and mail immediately to

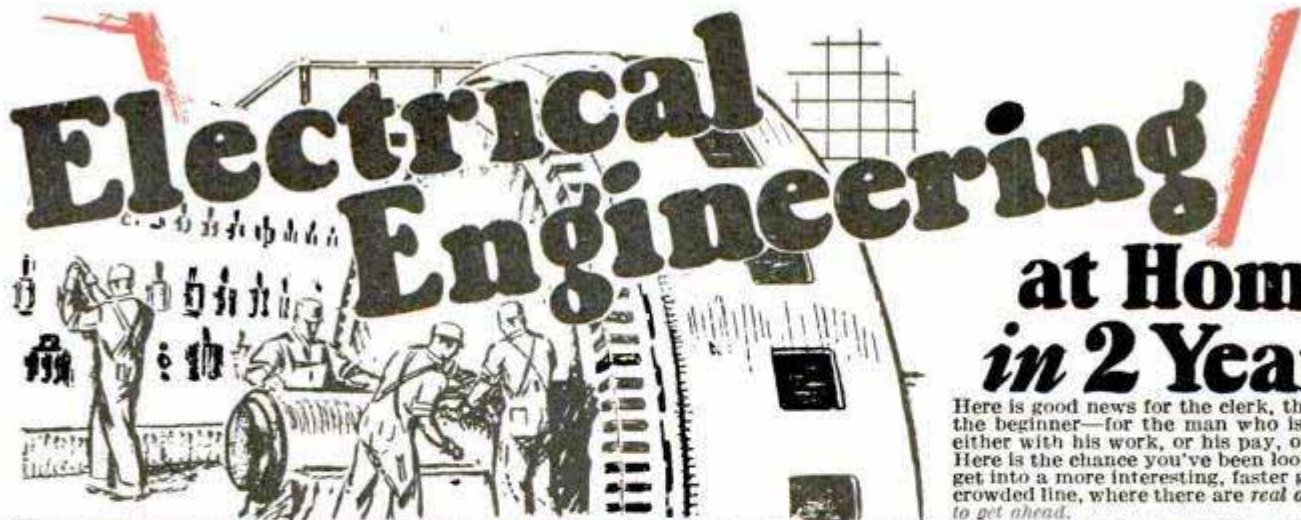
**The Jowett Institute of Physical Culture
422 Poplar St., Dept. 4PP, Scranton, Pa.**

Dear Mr. Jowett:

Enclosed find 25 cents to cover your special offer for a sample Strength-O-Meter and a copy of "The Thrill of Being Strong."

Name.....

Address.....



at Home in 2 Years

Here is good news for the clerk, the mechanic, the beginner—for the man who is dissatisfied either with his work, or his pay, or his future. Here is the chance you've been looking for—to get into a more interesting, faster growing, less crowded line, where there are *real opportunities to get ahead.*

A Real Job for You

There's a lot more to Electricity than the average man imagines. You probably do not realize that Electricity has become the *chief interest* of a hundred million people. That it is *first* in the home, supplying light and radio and many labor saving appliances. First in office conveniences. First in manufacturing, because the most economical and flexible power. Of course first in telephone, telegraph. A vital factor in transportation by autos, airplanes, railways. Altogether, a hundred giant industries, not one, employing *millions* of men and *billions* in capital.

A Good "Move" for Office and Factory Men

No matter if you work in store or office or factory or outdoors—no matter if you are a beginner or handicapped by lack of schooling. Being just a "clerk" now, may mean small pay and slow progress and a hopeless outlook. But if you're an Electrical engineer with only a clerk's business experience you've got something big employers will pay real money for. Same difference for the mechanic. Add Electrical Engineering to his equipment and he can step into a highly paid position and be set for quick and steady promotion.

Let me make this plain: Learn Electrical Engineering and you can take your choice of office of factory jobs, drafting or power jobs—sales or building jobs—Learn Electrical Engineering and you can double your pay and multiply your opportunities many, many times.



Chief Engineer DUNLAP, assisted by 29 Noted Engineers, GETS YOU READY for Positions Paying \$40 to \$100 a Week

This training prepared by engineers, executives and educators from leading corporations and universities including General Electric Co., Commonwealth Edison Co., Westinghouse Electric & Mfg. Co., Western Electric Co., Cutler-Hammer Co., Allis-Chalmers Co., Mass. Institute of Tech., Columbia University and other leading corporations and universities.

in ELECTRICITY



Manufacturing Jobs

Men now engaged in mechanical work of any kind will find a new world of opportunity open to them when they know Electrical Engineering. Your present experience, plus Electrical training, is a winning combination.



Office-Drafting-Sales Jobs

There are wonderful office jobs, Drafting jobs, Sales jobs, Store jobs—paying twice and three times what you earn today—waiting for you when you finish this Electrical training.



Power Jobs, etc.

The list of fine Electrical positions open everywhere today is almost endless. Here is the line to get into.

A Job and a Raise

With the cooperation of some of the biggest Electrical Corporations and Engineers in America, we have worked out a plan to prepare you for one of these fine positions—right in your own home, in spare time, by which we help you to a fine Electrical position and a substantial increase in pay, or *no cost*. This daring guarantee has been made possible by the amazing opportunities in Electricity —by the big demand for trained men, and by the success of the men we have trained. Get in touch with me and I'll tell you all about this remarkable offer.

Commonwealth Edison Co., Chicago

Dear Sirs: I take this occasion to assure you that many years of experience in the employment of your students and graduates has convinced me that your institution very effectively supplies the educational needs of many young men, who would otherwise be deprived of facilities for equipping themselves for advancement into well-paid, responsible positions. We have employed hundreds of your students and graduates, and could use more of them if they were available.

Very truly yours, Ernest F. Smith,
Supt., Sub-Stations

Electrical Lessons Actually FREE to show you how easily you can become an Electrical Engineer

You don't have to enroll to see this material taken bodily from our course. We are glad to send it to you on request, because that will prove to you, better than anything we can tell you, how EASY and SIMPLE this training has been made and how intensely interesting it is. Mail coupon without obligation.



THE AMERICAN SCHOOL, Dept. E-274, Drexel Ave. and 58th St., Chicago, Ill.

- Please send me free and without obligation:
- 1—Your plan of a job and raise.
 - 2—36-Page Book about opportunities in Electricity.
 - 3—Job tickets and lessons.

Name.....
Street No.....
City..... State.....
Age..... Occupation.....



Dept. E-274, Drexel Ave. and 58th St. Chicago, Ill.

Let Me Start *you* in this ~ Amazing new Business of your Own ~ Now!

\$5.00
DOWN STARTS
YOU

MAKE \$5,000 TO \$15,000 A YEAR in Your Own Home, Basement, or Garage Charging and Repairing Batteries

Here's your great opportunity to get into a Big Pay field that's growing by leaps and bounds—charging and repairing batteries. A \$5 deposit brings all the tools and equipment to get started in a real business of your own that brings you \$5,000 to \$15,000 a year. Clip coupon below and get complete facts.



\$950 in 5 Weeks for Trego
"I never dreamed money was so easy to make. Your charger has given me independence I never before enjoyed."



\$425 in 18 Days for Whalen
"I am now making money easier than at my job. Thank you for the wonderful prosperity your charger has given me."

Pocket 90c Clear Profit On Every Battery

I have invented a new Service Station Charger which saves 40% to 60% in electric current, yet handles 50% to 70% more batteries than similar outfits. Millions and millions of batteries in daily use by auto owners everywhere. Amazing new principle of my Service Station Charger simply scoops up all the business in town for you. My Free Book tells you how to get started.

No Experience or Education Required

Why go along at \$25, or \$30 a week when the battery field holds out an opportunity for you to make upwards of \$5,000 a year? Easy to get started with my charger. When the outfit

arrives, you're all ready to begin business. Simply let the business roll in. Charger is automatic and requires no attention during operation. Profits go into your pocket without effort on your part. Free Book tells how.

\$5.00 is All You Need to Start

Clip coupon and get your Free copy of my book "Big Profits". Read how hundreds of other fellows like yourself have established themselves in their own business. See the description of my amazing Service Station Charger. Find out about my plan for establishing you in this Big Pay field for only \$5. Along with the charger goes my complete outfits of tools, supplies, testers, advertising—in fact everything that you need to do business—you can take in \$20 a day or more right from the start. Get your copy of this book quick.



I help you make big money quick. C. F. H.



\$85 a Week for McDermott
"You are the best company I ever dealt with. My own station is now bringing me in plenty of money, with practically no effort."

Free Advertising, Tools, and Working Outfits

As an owner of my charger you get the benefit of my advertising. When you open up, customers come right to your door. No soliciting—no plugging for business. Everybody is more than anxious to give you their trade.

Operate in Full or Spare Time At first you can still work on your regular job. Go to your job in the morning and your batteries will be fully charged when you come home. You can make more money in this way during your spare time than at your job. Free book explains just how to do it.

Get Your Copy of "Big Profits"—Over 100 Illustrations

Find out the facts for yourself without one cent of expense. Read what the other fellows are doing. Let me show you how easy it is to get started—with only \$5.00 and how quickly you can build up your own business netting you \$5,000 to \$15,000 a year. Clip and mail coupon now.

Address Me Personally **C. F. HOLMES, Chief Eng.**
Independent Electric Works, Dept. 73
5116 Ravenswood Ave.
Chicago, Ill.

7 BIG FREE OUTFITS

for Quick Action



Clip Coupon Quick ~ ~

C. F. Holmes,
5116 Ravenswood Ave., Dept. 73,
Chicago, Ill.

Rush me by return mail a copy of your Free Book "Big Profits."

Name

Address

If you are earning Less than \$90.00 a week mail Coupon

FREE!

MEN! Here's the dope you've been looking for

HOW TO GET INTO THE RADIO BUSINESS~

J.E.S.

Many Earn \$50 to \$250 a Week in Work That is Almost Romance

If you're earning a penny less than \$50 a week, clip coupon now for FREE BOOK! New 64-page book pictures and tells all about the Radio business, hundreds of opportunities—in work that is almost romance! YOU can learn quickly and easily at home, through my tested, proved methods to take advantage of these great opportunities! Why go along at \$25, \$35, or \$45 a week when you can pleasantly and in a short time learn how to hold the big-pay jobs?

Clip Coupon for Free Book

Don't envy the other fellow who's pulling down the big cash! My proven home-study training methods make it possible for you, too, to get ready for better jobs, to earn enough money so you can enjoy the good things of life. One of the most valuable books ever written on Radio tells how—interesting facts about this great field, and how I can prepare you in your spare time at home, to step into a big-pay Radio job. GET THIS BOOK. SEND COUPON TODAY.



J. E. SMITH, Pres.
National Radio Institute
Dept. 9NPP, Washington, D. C.

**I
Have Trained
Hundreds of
Men at Home
for Big Radio
Jobs.
My Book Proves
I Can Do the
Same for
You.**



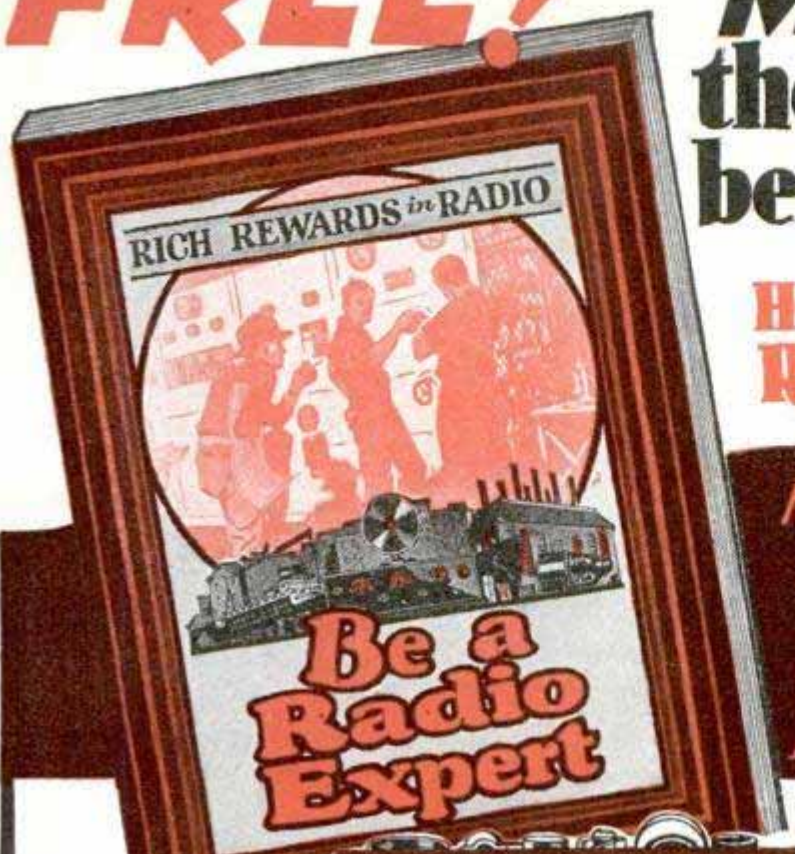
J. E. SMITH,
President
NATIONAL RADIO
INSTITUTE
Dept. 9NPP
WASHINGTON, D. C.

Dear Mr. Smith:
Without obligating me in any way, send me your big FREE BOOK, "Rich Rewards in Radio," and all information about your practical home-study Radio Course.

Name..... Age.....

Address.....

Town..... State.....



I Give You 6 Big Outfits of Radio Parts

With them you can build 100 different circuits—learn the "how" and "why" of practically every type of Radio set. This kind of training fits you to step into the good jobs—sends you out an experienced Radio expert. When you complete, my Employment Department will help you get a big Radio job like Graduate Edward Stanko, Chief Operator of Station WGR, or Frank M. Jones, 922 Guadalupe St., San Angelo, Tex., builder and operator of Station KGFI and Manager of the best equipped Radio shop in the Southwest, or help you start a Radio business of your own like Richard Butler, 1419 No. 17th St., Phila., Pa., who made around \$500 a month compared with a job as motorman when he enrolled.

The Famous "Course That Pays for Itself"

Spare time earnings are easy in Radio almost from the time you enroll. G. W. Page, 1807 21st Ave. S., Nashville, Tenn., made \$935 in his spare time while taking this course. Al Johnson, 1409 Shelby St., Sandusky, O., \$1,000 in four months, and he didn't know the difference between a condenser and a transformer when he enrolled. I'll give you a contract, backed by N. R. I. pioneer and largest home-study Radio school in the world, to refund every penny of your money if you are not satisfied, upon completing, with the lessons and instructions received. Find out what Radio offers you. Mail coupon.

ACT NOW~COUPON BRINGS MY

FREE BOOK



“He saves \$100 a month”

“See that man at the receiving teller's window? That's 'Billy' King, Sales Manager for The Browning Company. Every month he adds \$100 to his savings account.

“Three years ago he started at Browning's at \$25 a week. Married, had one child, couldn't save a cent. One day he came in here desperate—wanted to borrow a hundred dollars—wife was sick.

“I said, 'Billy, I'm going to give you something worth more than a loan—some good advice—and if you'll follow it I'll let you have the hundred too. Take up a course with the International Correspondence Schools and put in some of your evenings getting special training. The schools will do wonders for you, I know. We've got several I. C. S. men here in the bank.’

“That very night Billy wrote to Scranton, and a few days later he had started studying at home. Why, in a few months he had doubled his salary! Next thing I knew he was put in charge of his department and two months ago they made him Sales Manager. It just shows what a man can do in a little spare time.”

* * * * *

Employers are begging for men with ambition—men who really want to get ahead in the world and are willing to prove it by training themselves in spare time to do some one thing well.

Prove that you are that kind of man! The International Correspondence Schools are ready and anxious to help you prepare for something better if you will only make the start. Do it now! At least find out what the I. C. S. can do for you.

Mail the coupon for Free Booklet

INTERNATIONAL CORRESPONDENCE SCHOOLS

“The Universal University”

Box 5598-F, Scranton, Penna.

Without cost or obligation, please send me a copy of your booklet, “Who Wins and Why,” and full particulars about the subject before which I have marked X in the list below:

BUSINESS TRAINING COURSES

- | | |
|--|---|
| <input type="checkbox"/> Business Management | <input type="checkbox"/> Salesmanship |
| <input type="checkbox"/> Industrial Management | <input type="checkbox"/> Advertising |
| <input type="checkbox"/> Personnel Management | <input type="checkbox"/> Business Correspondence |
| <input type="checkbox"/> Traffic Management | <input type="checkbox"/> Show Card and Sign Lettering |
| <input type="checkbox"/> Accounting and C. P. A. Coaching | <input type="checkbox"/> Stenography and Typing |
| <input type="checkbox"/> Cost Accounting | <input type="checkbox"/> English <input type="checkbox"/> Civil Service |
| <input type="checkbox"/> Bookkeeping | <input type="checkbox"/> Railway Mail Clerk |
| <input type="checkbox"/> Secretarial Work | <input type="checkbox"/> Common School Subjects |
| <input type="checkbox"/> Spanish <input type="checkbox"/> French | <input type="checkbox"/> High School Subjects |
| | <input type="checkbox"/> Illustrating <input type="checkbox"/> Cartooning |

TECHNICAL AND INDUSTRIAL COURSES

- | | |
|---|--|
| <input type="checkbox"/> Electrical Engineering | <input type="checkbox"/> Architect |
| <input type="checkbox"/> Electric Lighting | <input type="checkbox"/> Architects' Blueprints |
| <input type="checkbox"/> Mechanical Engineer | <input type="checkbox"/> Contractor and Builder |
| <input type="checkbox"/> Mechanical Draftsman | <input type="checkbox"/> Architectural Draftsman |
| <input type="checkbox"/> Machine Shop Practice | <input type="checkbox"/> Concrete Builder |
| <input type="checkbox"/> Railroad Positions | <input type="checkbox"/> Structural Engineer |
| <input type="checkbox"/> Gas Engine Operating | <input type="checkbox"/> Chemistry <input type="checkbox"/> Pharmacy |
| <input type="checkbox"/> Civil Engineer <input type="checkbox"/> Mining | <input type="checkbox"/> Automobile Work |
| <input type="checkbox"/> Surveying and Mapping | <input type="checkbox"/> Airplane Engines |
| <input type="checkbox"/> Plumbing and Heating | <input type="checkbox"/> Agriculture <input type="checkbox"/> Navigation |
| <input type="checkbox"/> Steam Engineering | <input type="checkbox"/> Mathematics <input type="checkbox"/> Radio |

Name.....

Street Address.....

City..... State.....

Occupation.....

Persons residing in Canada should send this coupon to the International Correspondence Schools Canadian, Limited, Montreal, Canada

I'll Refund Your R.R. Fare to Chicago

Auto Experts Get BIG PAY!

Men Wanted

I can help place 20 TO 40 men a day, in JOBS, while learning and after. Never before such unusual opportunities. Get my free book now. Learn about the big pay. AUTOS lead WORLD'S BUSINESS. That's why GREER College selected this Field. Coupon brings you amazing facts.

Be Your Own BOSS

Earn up to \$150.00 a week

AUTOS now pay hundreds of Greer trained men up to \$200 A WEEK. Here

is a most wonderful business. BILLIONS—not millions, but BILLIONS of dollars are spent in it every year.

Greer trained men are NEEDED. I HAVE MADE hundreds of \$10,000 A YEAR MEN. 90,000 in the last 26 years have come to Greer.



Learn to Boss the Job

Only 3 Months

Learn in ONLY 3 MONTHS in GREAT GREER SHOPS on large live equipment. I'LL PAY YOUR FARE HERE Free of extra cost. Then help you to a job while learning. Then I not only FIT YOU to GET the big pay job, but I'll help YOU HOLD IT. Young and Old, Educated and Uneducated, Inexperienced and Experienced have found GREER SHOPS training easy, fascinating and valuable.

COUPON BELOW BRINGS YOU BIG FREE BOOK

Don't let money hold you back. Get my Free Book. Find out NOW, how I PAY YOUR FARE HERE, let YOU ATTEND either days or evenings and help you find DAY OR EVENING WORK to PAY YOUR EXPENSES while learning. Then when trained we help you find the real big pay job. Learn about amazing Auto opportunities and GREER COLLEGE. Right now, if you act quick, I can make you a most unusual short-time offer. Address me personally

Erwin Greer, President, GREER COLLEGE
Dept. 201 AT, 2024 So. Wabash Ave., Chicago

FREE BOOK

Erwin Greer, President
Dept. 201 AT, 2024 So. Wabash Avenue, Chicago, Illinois.

Send Free Auto Book and details of Special offer without obligation to me.

Name.....

Address.....



Clamp this Lamp On Any Door



IT BENDS . . . IT TILTS
IT HANGS . . . IT CLAMPS



Agents Make \$5 to \$15 An Hour!

NOW comes an amazing invention that is revolutionizing lamps! At last, a lamp that is adjustable—that ends eye strain and poor light caused by stiff-necked lamps. Already thousands of homes, work shops and offices have installed this sensational lamp that is almost human.

So powerful is its demonstration that agents' profits are leaping sky-high. And now the inventors are distributing samples and demonstrating outfits to agents and spare time workers; backed by the most unique direct selling plan ever offered. So quickly does this plan make money for agents that even inexperienced demonstrators are making \$35 to \$100 a week in spare time. Mail coupon for full details!



Nineteen Lamps In One

There are nineteen places in the home where this new-type lamp serves the purpose better than a stiff-necked lamp, dim overhanging bulb or flashlight. The base unscrews and clamps anywhere—on a work bench, radio set, desk, bed, or bathroom mirror. A gentle touch bends the stem and tilts the shade to throw a powerful close-up light for sewing, shaving, reading, garage, kitchen or shop work. Note the illustrations.

The Falcon Lamp has a complete line to suit every taste. Two metal lamps (bronze or ivory finish lamp and base) and four choices of Parchmentex shades (painted in genuine oils and up to 7 or 8 colors). The prices are amazingly low—made possible by the huge volume of a well-



established company. Size, 11 1/2 inches high. Fully guaranteed.

Get Agents' Introductory Offer

Mail coupon now—without obligation—for the Falcon sample-distributing offer and wonderful \$5 to \$15 an hour money-making plan. Also get full color reproduction, agents' prices, big commissions, territory proposition. Tear out coupon now before you forget. Address Dept. B-90.

FALCON MFG. CO.
2550 SULLIVAN AVE. ST. LOUIS, MO.
Falcon Lamps
ADJUSTING

Made \$80 in 8 Spare Evenings!

H. M. Oehken writes that he has made \$80 in eight evenings. Miss Mabel Adley made \$22 in two hours, demonstrating in one office. Hartman made \$19 in one day. Zinn has sold half the people in his county. Other agents are making even more, selling to church bazaars, and at carnivals, county fairs, etc.

Falcon Mfg. Co., Dept. B-90,
2550 Sullivan Avenue, St. Louis, Mo.
Without obligation, send full color reproduction of Falcon lamps. Also include your liberal sample-distribution offer.

Name.....
Address.....
City..... State.....
() Check here for agents' money-making plan.

Do You Like to Draw



Learn Commercial Art — There's Good Money in it.

Don't have the mistaken idea that you have to be a genius to earn a good income as an artist—if you like to draw, it shows that you may have talent that can be easily developed. The Federal Course, which is the result of 25 years experience, brings right to your home the very kind of instruction and training you need. Leading artists of the country have contributed to this course, and you get personal criticism on your work.

Federal Students Are Successful—Through Practical Training!

Many Federal Students, both men and women who were no better than YOU when they started, are making GOOD INCOMES this pleasant way. Just read what some of them say:—

Never Less Than \$70 Per Week

"The Federal methods have certainly taken a high place in my estimation . . . I am doing nothing but commercial art and making as high as \$300 per week—never less than \$70. My work is no better than many of the other students, I imagine."
M. O. HOLST.

The Federal Schools Made Me

"I conduct my own studio, do wash drawings, mechanical, from blue prints, general photo retouching and also creative work such as folders, etc. My approximate income from drawing is \$75 per week. The Federal Schools made me!"

PAUL HOLSING.

\$300 A Month Income

"I am working as Art Director and do free lance work besides. My monthly income from drawing is approximately \$300.00 and I give the Federal Schools quite some credit."

MILT ROTH.

Test Your Ability to Draw, FREE

Here is an easy way to find out if you have talent. Send for our Art Questionnaire, which will tell your sense of proportion, color, design, perspective, etc. We will tell you frankly if you have talent that can be developed. It is the first step to a successful art career—it is the way successful Federal Students got their start. Send in the coupon NOW!

The School Famous for Successful Students

Start Now!

The hundreds and hundreds of advertisers throughout the country are always in the market for art work—illustrations, designs, booklets, posters, etc. They will pay good money for what they want. Many concerns are on the lookout for well trained commercial artists. Here is a BIG OPPORTUNITY for YOU—get started at once. Mail the coupon today for Art Questionnaire and book, "YOUR FUTURE."



Federal School of Commercial Designing

640 Federal Schools Bldg.,
Minneapolis, Minn.

Please send me Art Questionnaire and book "YOUR FUTURE."

Name.....

Age..... Occupation.....

Address.....

This announcement has brought new vision and inspiration to ambitious thousands who hungered for wider, deeper culture.

A Background that Will Broaden Any Mind

Fascinatingly Told in Narrative Form

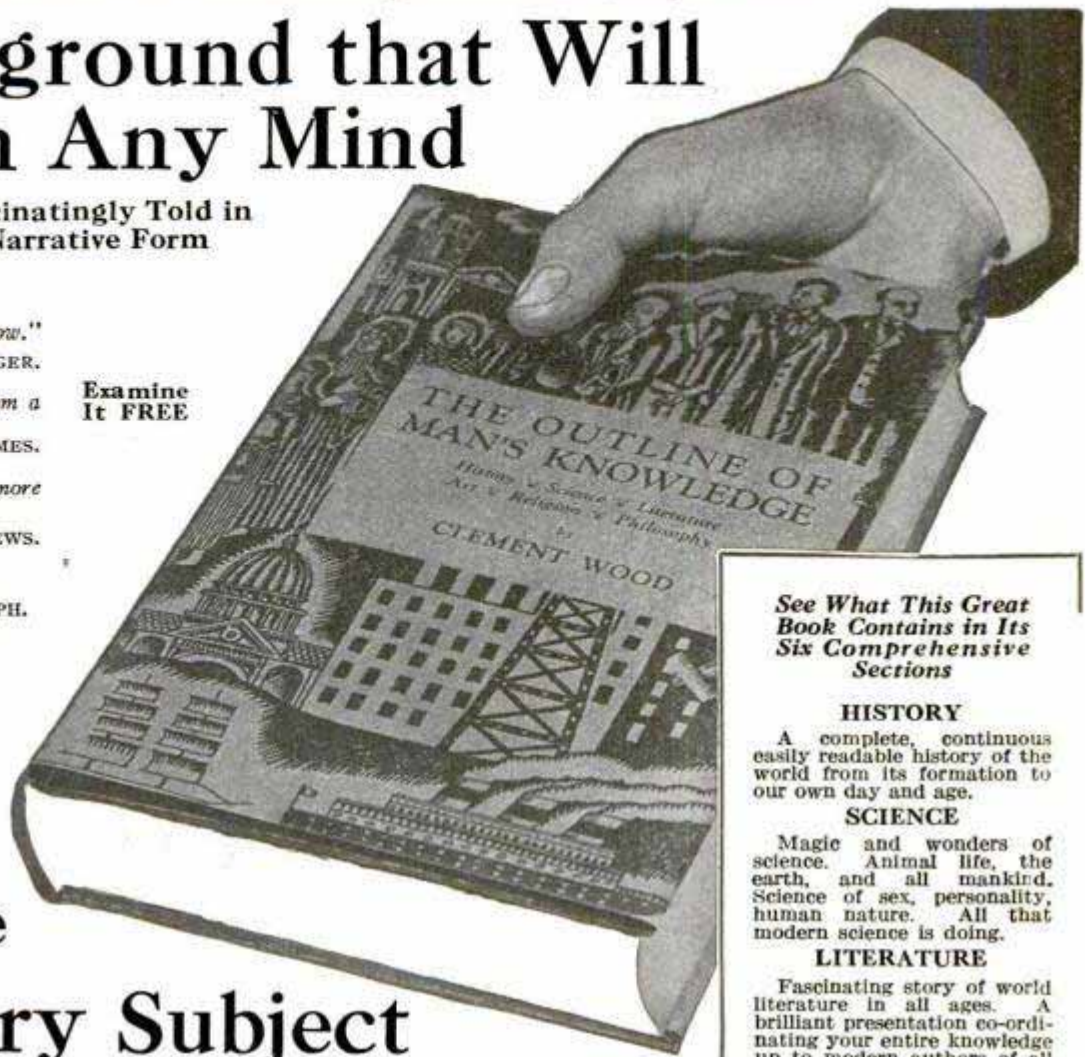
"The ONE book to read and know."
—PHILADELPHIA PUBLIC LEDGER.

"Like viewing the universe from a hilltop."
—TOLEDO TIMES.

"More dramatic than drama, more interesting than fiction."
—BIRMINGHAM NEWS.

"A university in itself."
—PITTSBURGH SUN-TELEGRAPH.

Examine It FREE



Brings YOU Up-to-date On Every Subject

NOW you can have at your command what man has learned in the six greatest branches of human knowledge and culture. Six great romantic outlines, six comprehensive sections that will bring you—compressed into one 700-page volume—the thrilling story of the world's HISTORY down to date—the stirring march and trends of RELIGION—the thought and wisdom of man's PHILOSOPHY—the intriguing beauty of the ARTS—the all-embracing survey of every branch of SCIENCE—and a complete panorama of the world's LITERATURE from the first Neolithic scribbles to the work of modern authors of all nations.

A Liberal Education in Narrative Form

THE OUTLINE OF MAN'S KNOWLEDGE, by Clement Wood, is the ONE book, the only book, that gives you the fascinating story of what man has learned and accomplished from the world's birth in a flare of meteoric splendor up to the arrival of radio, aviation and television. Here is the whole story—all of it—Science, Art, Literature, History, Philosophy and Religion—in one large, beautiful volume that you can actually BORROW for a week at our expense.

The Essence of ALL Knowledge Complete in Only One Volume

Clip and mail the convenient coupon and it will bring you, prepaid, a copy of THE OUTLINE OF

MAN'S KNOWLEDGE, by Clement Wood. Examine it. See for yourself how fascinating is the story of knowledge. Read it freely for a week. See how much you have missed in the realm of things you OUGHT TO KNOW. If you are not completely satisfied send the book back within seven days. Otherwise, keep it as your very own and remit the astoundingly low price of only \$1.50 and two dollars a month for two months. But don't decide now.

Send No Money—BORROW It at Our Expense

See this all-absorbing work first. You can do that at our expense. Send no money. Just clip and mail the coupon. Lewis Copeland Company, Dept. 71, 119 West 57th St., New York, N. Y.

See What This Great Book Contains in Its Six Comprehensive Sections

HISTORY

A complete, continuous easily readable history of the world from its formation to our own day and age.

SCIENCE

Magic and wonders of science. Animal life, the earth, and all mankind. Science of sex, personality, human nature. All that modern science is doing.

LITERATURE

Fascinating story of world literature in all ages. A brilliant presentation co-ordinating your entire knowledge up to modern authors of all nations.

ART

Entire story of the Arts: Painting; Sculpture; Architecture, Music, Dancing. Brings you a new appreciation of all arts.

RELIGION

Man's first spiritual aspirations. Mysteries of religious beginnings up to the story of all modern sects and their beliefs.

PHILOSOPHY

The story of Philosophy and Philosophers. The wisdom of the ages.

ALL in THE OUTLINE OF MAN'S KNOWLEDGE. Send this coupon and examine it FREE.

TEAR OFF ALONG THIS LINE AND MAIL TODAY

Lewis Copeland Company, Dept. 71,
119 West 57th St., New York City.

Kindly send me THE OUTLINE OF MAN'S KNOWLEDGE, by Clement Wood, 700 pages, illustrated, handsomely bound. Within 7 days I will either return the book or remit \$1.50 as first payment, and then \$2.00 per month for two months, a total of \$5.50. [Ten per cent discount for cash with order. Same return privilege.]

Name

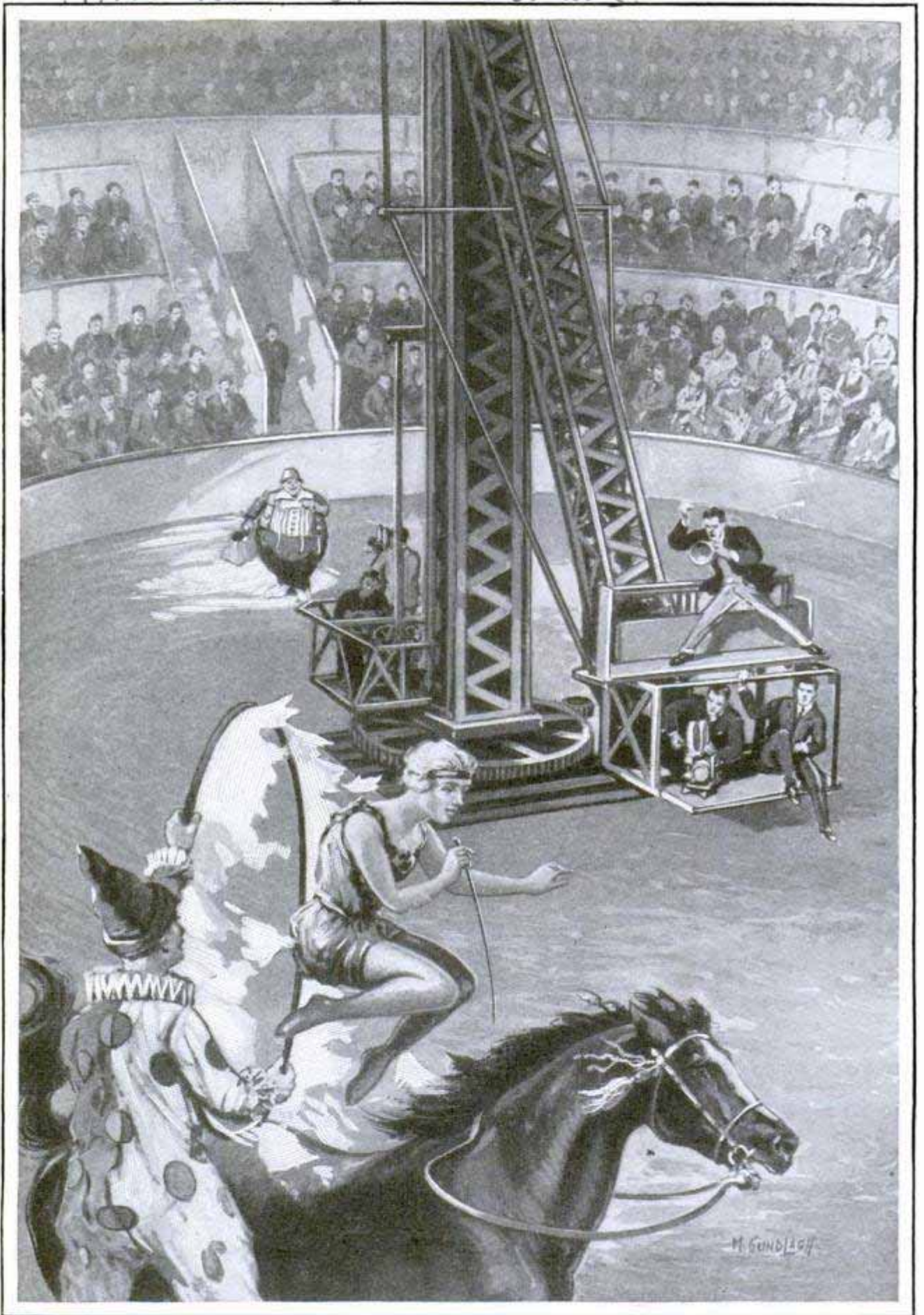
Address

City State

(If outside limits of Continental U. S., enclose cash with order.)

1387

U.S. Gov. Dept.
Interior F. W. Thurman



7:45:30
The film
Mechanism

Twenty Tons of Steel, Driven by a 200-Horsepower Motor, Was Used in a Recent Film of Circus Life, Although It Did Not Show on the Screen; the Huge Revolving Arm Carried the Director and Cameramen around and around the Ring, and Could Be Swung Up or Down as the Action Required

Popular Mechanics Magazine

REGISTERED IN U. S. PATENT OFFICE

WRITTEN SO YOU CAN UNDERSTAND IT

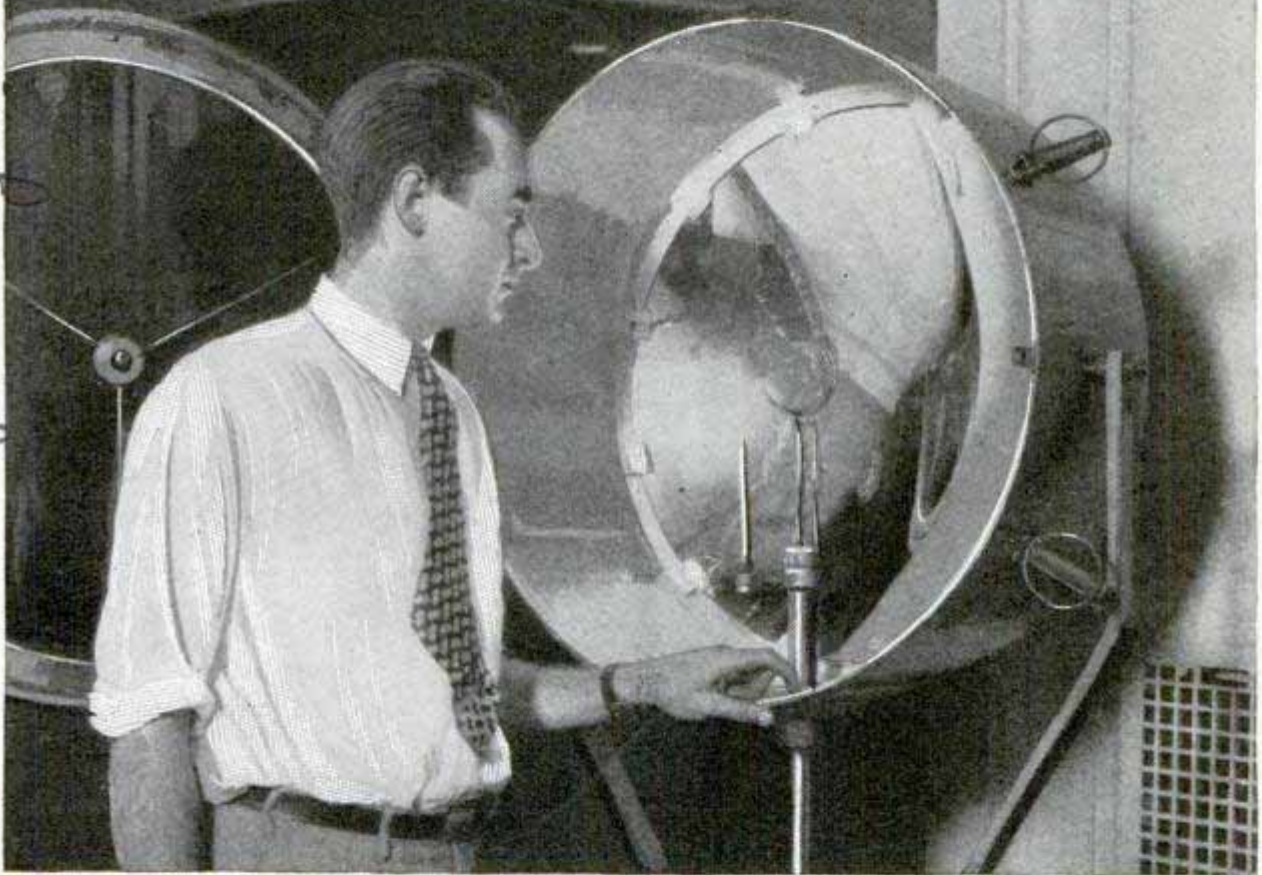
Vol. 51

FEBRUARY, 1929

No. 2

1846

Wireless Light Next?



175-5 St. Ave. New York City

Neon-Gas Beacon Recently Exhibited in New York; the Glass Ball in the Center Contains Only Neon Gas and Has No Electrodes; Energy Is Imparted from a Wire Coil

By Dr. E. E. Free

By WALTER RALEIGH

before New York Electrical Society

MORE light! The home, business, industry, aviation, are shouting for brighter, bigger and better lights.

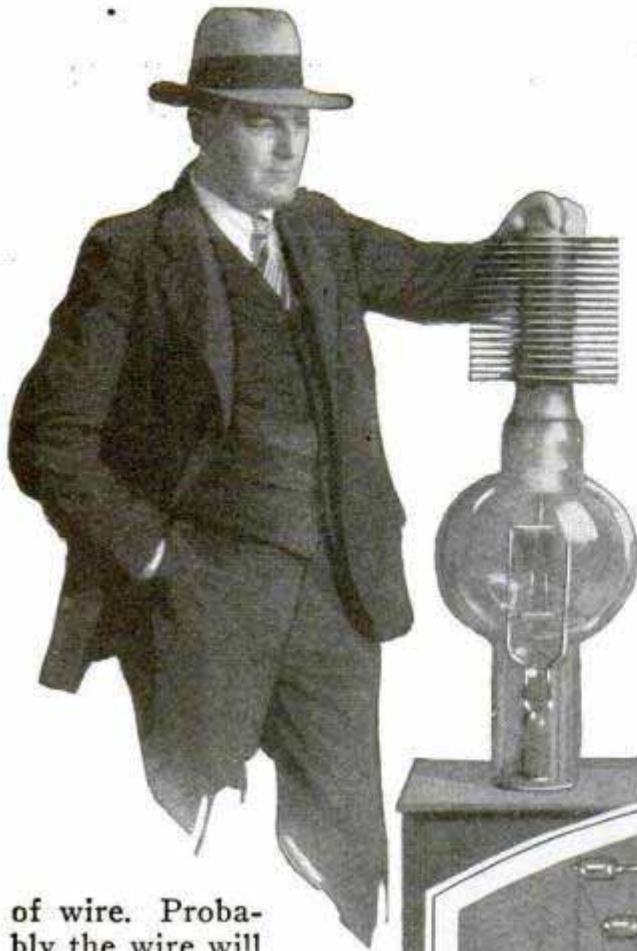
Lighting engineers are hard at work seeking daylight brightness for the dark hours, but, as yet, they are a long way from that ideal. To prove it, pull down your blinds during the brightest day, turn on all the lights your room affords, then go out in the street for a few moments and return. Inadequate? Very much so.

What is needed to be done has been all

but done. For one thing, we are soon going to stop using hot-filament electric-light bulbs with fine wires to burn up and break and metallic vapor to blacken the glass. We are soon going to have glass globes absolutely free from metal inside or out. When they are not lighted, they will look like crystal spheres, beautiful as reflecting soap bubbles.

These spheres will contain gases that can be rendered highly luminous by a high-frequency current in a near-by coil

Cont. Ethnai ...
center no. ...
177

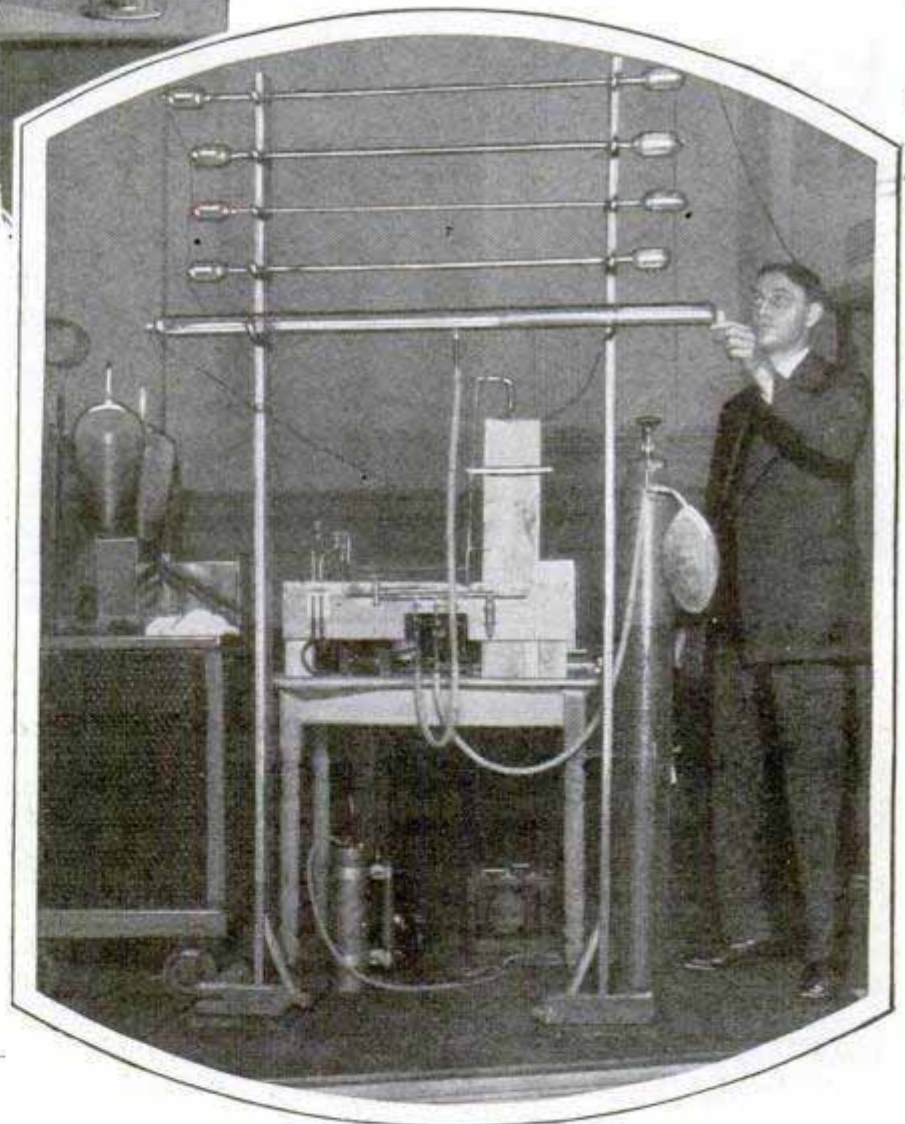


of wire. Probably the wire will be buried in the wall, with no signs of any outlet, or there may be a little recess in the wall in which the sphere can rest. This new magic of lighting already has been produced. Such lights are now in use. In fact their action is really not so very different from that of the large glow signs used for advertising purposes. These reddish, or sometimes bluish, white signs contain the rare gas argon, frequently mixed with mercury vapor. In each end is sealed a piece of wire, an electrode, and a rapidly alternating current at about 6,000 volts is applied.

But the same effect can be produced without a single wire. Utilizing the principle of the door-bell where, by pressing a

button, the current is sent through a coil which repeatedly pulls a soft-iron hammer over to ring the bell, scientists discovered that in the neighborhood of a rapidly changing magnetic field the electrons in a gas-charged bulb are started first one way and then another, and light is produced. Thus it was evident that these new lamps needed only to be in proximity of the changing magnetic coils. These latter might be buried in a wall leaving no external evidence.

Such magic lamps are practically indestructible. The hidden wiring would no more wear out than any wiring in a wall of today would wear out. The lamps, in whatever shape they might be, would have to be broken by some hard blow in order to render them useless. They would cost less to manufacture because there would be no intricate internal wires to arrange



D. K. Wright beside a 50,000-Watt Lamp with Chimney to Prevent Its Melting, and Lighting Gas-Filled Bulbs by Exposure to High-Frequency Current

and support. Such lights would be cool, throwing out very little heat, efficient and cost little to operate.

A lamp of this type and kind has been made. A large one, wireless or radio style, was mounted on a tower in Schenectady, N. Y., and gave sufficient light so that a newspaper could be read at a distance of two miles.

The fact of the matter is that the night-flying birdman more than anyone else has stimulated the lighting engineer to do his best to meet the demands made for safely operated and equipped landing fields.

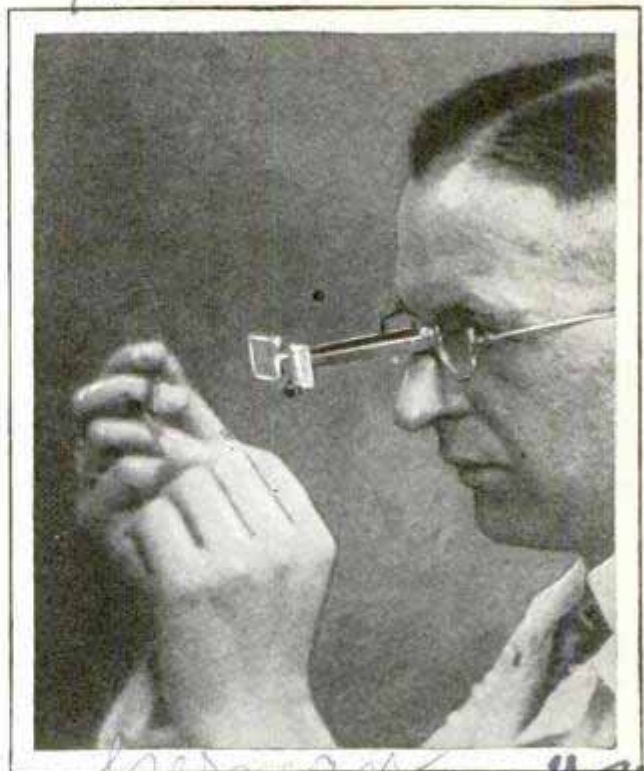
First came the narrow and powerful beam of light revolving slowly. This as a beacon helped. By timing a chain of such lights to make revolutions at various speeds, the aviator could tell one town from another. For a hundred miles such lights could be seen when weather conditions were good and for ten miles if poor.

But the neon light was the greatest help. These excited atoms, inclosed in glass, stirred up by high voltage, could be made to give out a reddish color, and a red light can be seen much farther through a fog or mist than any other color.

Experimentation is now seeking to produce them for domestic use. Here, however, the problem of eliminating the red glow or the too bluish glow will have to be solved.

Aviation's second problem relating to lighting had to do with illuminating the landing field and included boundary markers, with direction indicators. The red neon light has no special advantage here, since the ground would best reflect its own color. Giant lamps were tried to solve this problem. One of these is a new seventy-five horsepower lamp, being the largest ever built.

The electric lights in our homes are but as insects compared with this giant. So powerful is this lamp that a special chimney arrangement had to be designed for it, so that it would not melt from its own heat. It gives 125,000 candlepower.



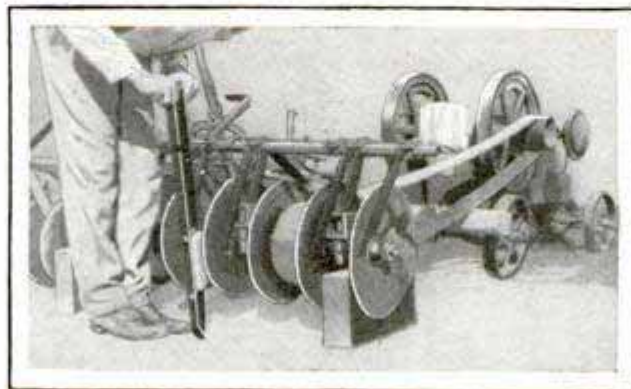
Microscope Lenses Attached to Spectacle Frame, to Leave Both Hands Free

MICROSCOPES ON SPECTACLES HELD BY CLIP

Attached with a clip to the frame of the spectacles, special magnifying lenses have been introduced for watchmakers, doctors and others who require a microscope. The glasses are focused simply by sliding them along the attachment by which they are connected to the spectacles. They leave both hands free and are adapted to work not requiring lenses of high power.

MOTOR DRIVES HARROW BLADES FOR RAPID SHARPENING

Disk-harrow blades are sharpened quickly and thoroughly with a special whetstone which is held against them as they are turned rapidly by power from a gasoline engine. All that is necessary is to jack up the harrow and hitch it to the engine with a pulley arrangement. The whetstone rests on the ground, giving great leverage.



Sharpening Disk-Harrow Blades with Engine Rig and Stone Held against Them as They Revolve

21st • Locust. East Omaha, Neb

*The Microscope Inactor
Esude Co. 1200 1st and
Neb*



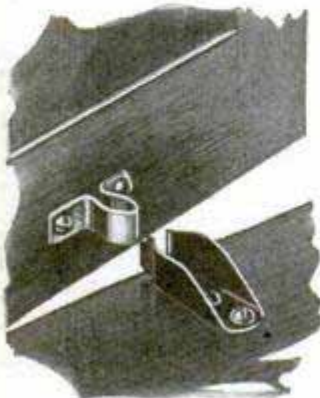
Mixer Connected for Operation; the Handy Electric Set Includes a Juice Extractor, Buffer and Emery Wheel

ELECTRIC SET MIXES CAKES AND SHARPENS KNIVES

Several useful kitchen aids are combined in a single electric set that is operated by current from a lighting circuit and is intended to save time and labor. Among the articles are a dough and batter mixer, a cream whipper and egg beater, juice extractor, buffer, rotary scratch brush for cleaning pots and pans, and an emery wheel for sharpening knives. The entire outfit is compact and simple.

CATCH TO HOLD DOORS SHUT PREVENTS SLAMMING

Quickly attached with but two screws, a steel catch holds all kinds of doors and windows shut and also acts as a buffer to prevent violent slamming. The device operates by friction, holding the door firmly shut, but not so tight that there is difficulty in opening it. It is especially useful on windows that have a tendency to open accidentally from the top, thus exposing the interior to harmful drafts.



barbed wire is wrapped about the poles to keep the animals away from the cables. Several feet of each pole, at a considerable distance from the ground, are protected with the wire.

SWING ASH TRAY SAVES ROOM AND PREVENTS DIRT

Clamped to the edge of a table or other convenient place, a deep ash tray can be swung out of the way when it is not in use. This saves room on the table for card or other games, the tray cannot be knocked over, and ashes are kept from spilling. The clamp has rubber protectors to prevent marring.



INVENTORS BREAK OLD RECORDS IN NUMBER OF PATENTS

About 3,000 more patent applications were granted during the last fiscal year than in the year previous, according to reports from Thomas E. Robertson, commissioner of the patent office. This is an increase of 17,000 over the number for 1924. The total for the last year amounted to 116,951.

POWER-LINE POLES OF METAL DEFY ANT ATTACKS

Engineers encounter many problems not met elsewhere in erecting power lines in Africa: For instance, the poles are made of metal to resist the white ants, or termites, that devour almost anything made of wood by eating it from the inside until it collapses. A further difficulty is found in that monkeys and baboons sometimes climb the poles and short-circuit the wires. To prevent this,

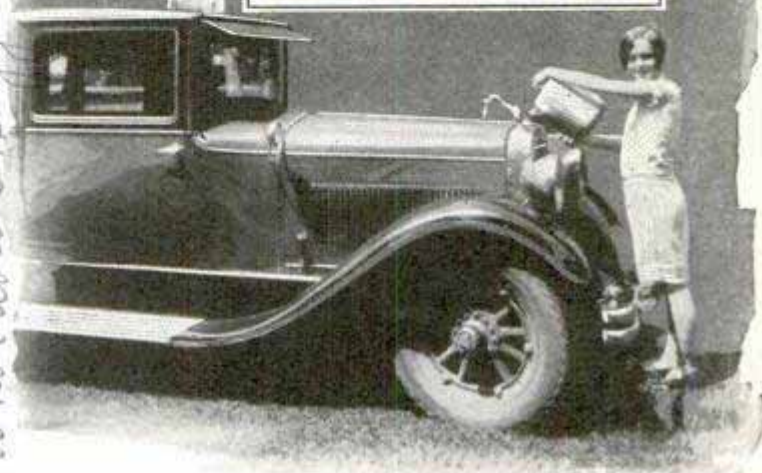
18
1834
Chicago
Logan, Box 335
Burlington
Southern Rhodesia
Chicago
W. Ontario
Co. 355
Chicago
54
54
Chicago 55
Co.
Christian Science Monitor 11/24/28

NEW BUTTON MATERIAL GIVES LONG WEAR

Plastic albumen, a recent product of chemistry, has been introduced for the manufacture of buttons and is said to have greater strength, more uniform wearing quality and a more enduring color than some of the other materials used for this purpose. The innovation marks another step in the long and interesting history of the button, first used as an ornament, then as a support for clothing. They have been made from metals, glass, celluloid, and many other substances and have played a part in history. During the Civil War, when both the northern and the southern states were supposed to be dependent upon England for their supplies, quantities of them were manufactured in the north and smuggled to the south on the Potomac river, together with other articles. The button has been a favorite with collectors, and research workers have used it to confirm historical facts. A brass military button discovered at Nulato, in Alaska, apparently is a relic of a massacre which took place at that town in 1851, when the military post maintained there by Russia was destroyed and its inhabitants massacred.

Chicago H. L. Price, 1111 Jackson Blvd.

12/9/28
cannot locate suggest
Carroll Corp. 2129-444
Bryant City Ill



Filling Radiator from Special Sprinkler; Using It to Spray Car, and a Close View Showing Oblong Nozzle

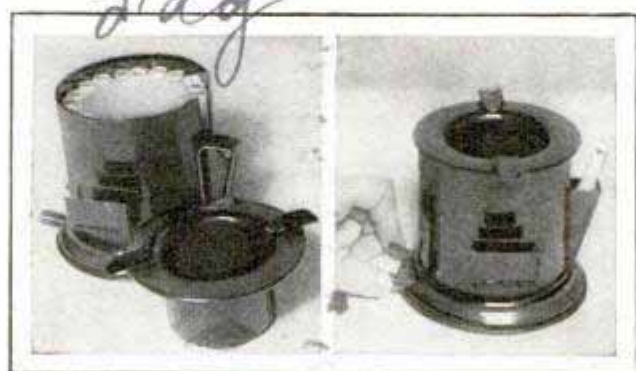
NOVEL SPRINKLING CAN USED TO FILL RADIATOR

A novel sprinkling can, which has several uses, including filling the automobile radiator, has been invented by a Chicago man. Instead of the usual spout and small round sprinkler head of the conventional can, the new one has a broad oblong sprinkler which will wet a much larger area. The can also can be used to spread liquid fertilizers or insecticides. An extra spout, rising above the handle, is provided for filling the auto radiator. Because of its location, the can does not have to be lifted as high as the ordinary type would. It is also useful as a minnow pail or for washing the automobile. When filling the radiator with it, the hands do not obstruct the view of the opening.

Chicago

ASH TRAY DELIVERS CIGARETS AT PRESS OF LEVER

Ash tray and cigaret holder have been combined in a single article for the convenience of the smoker. The container holds twenty cigarettes, delivered one at a time through an opening on the side by pressing levers. More than one kind of cigarettes may be distributed, a second pressing of the levers taking back the cigaret already ejected and delivering another.

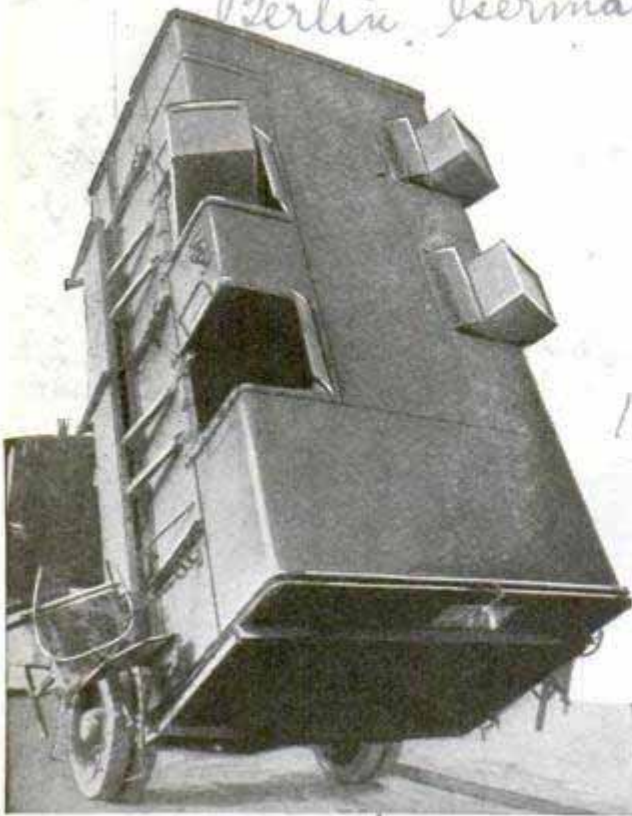


Cigaret Dispenser and Ash Container in One; Levers Shown at the Side on the Right

Keiter Co. Chicago Brokerage
1310 St. Van...
12/9/28

No information received

Berlin, Germany



Refuse Truck on End for Quick Dumping; Side Openings for Filling Are Fed from Small Cans

SELF-EMPTYING AUTO TRUCK SPEEDS STREET CLEANING

Loaded at the sides through openings that have separate lids, and emptied by being elevated at a steep angle so that the contents will run out at the rear, a special automobile truck used in Berlin, has been found of aid in street cleaning and similar jobs. It eliminates extra handling of the material and also prevents dust from spreading.

MORE WOMEN THAN MEN FLY ON ENGLISH AIR LINE

Shopping trips to Paris apparently explain why so many more women than men cross the English channel from London by the Imperial Airways lines. In a recent six-month period, more than 14,000 women were carried and every week end, hundreds make the air journey. The average weekly business is about 2,000 passengers. In all, the lines have flown 3,800,000 miles without a fatal accident. But human cargo is only part of the traffic. Gold, silver, precious stones and silks are included in the air shipments, while live animals are carried frequently. Not long ago, one plane arriving from Rotterdam

held fifty parrots, a small bear, a monkey and a tank of tropical fish. Pets, pigs and chickens are commonly carried and recently, a full-grown lion was taken in a special cage from London to Paris. Because of the safety of the traffic, insurance companies are charging lower rates on some goods by air than by land transport.

POLICE DOG TRAINED TO PICK COIN FROM MANY OTHERS

In a recent police-dog field trial held near London, one of the contestants was so well trained that it could pick out of a pile of coins one which had been held by its master for only a few seconds, and could still locate and retrieve the coin after it had been handled by several other people. The dogs were required to lie quiet in a field for fifteen minutes after their masters had walked away and left them on guard; to refuse meat offered by strangers; stop at a signal when running full speed, lie down or return and retrieve articles hidden 300 feet away; and to pick out a "criminal" from among a crowd and hold him at bay.

ORNAMENTS GLUED TO WOOD DECORATE FURNITURE

Ornaments of a composition wood material, pressed into attractive patterns, are now on the market for decorating furniture and other articles. They are to be glued on and colored as desired. A spe-



Samples of Composition Ornaments Which Are Used as Substitutes for Carved Decorations

cial adhesive makes them stick firmly to metal, paper, glass, or wood.

1882

International

Daily Mail

809

10 cent each

554-2679

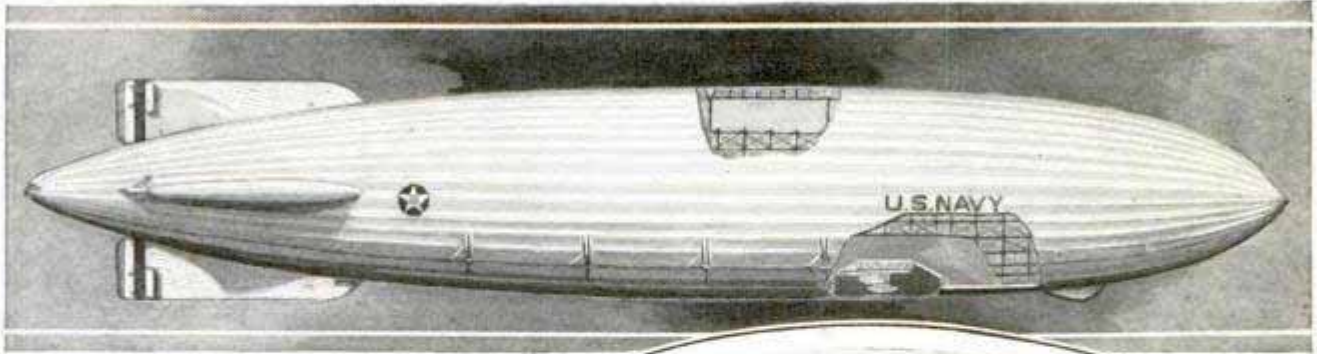
firmly cement

when

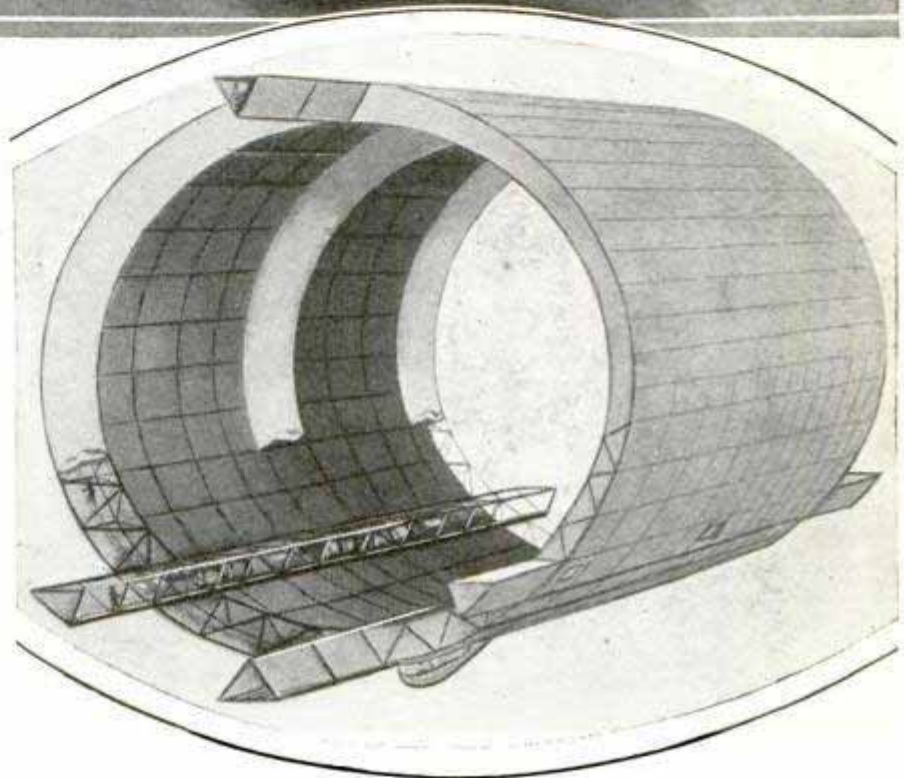
New York Times 12/2/28

Decorative Specialty Co. Cleveland, Ohio

AIRSHIPS TO HAVE TRAPEZE FOR CATCHING PLANES



Five scouting airplanes will be carried in each of the two huge dirigibles planned for the United States navy, and to provide the best equipment for handling the planes, interesting tests are being conducted with the "Los Angeles" and an observation plane. The latter unit has been fitted with special hooks over its wings for suspending it from a triangular trapeze attached to the frame structure of the dirigible. In actual practice, the plane would fly under the big ship, and the hooks would be attached to the trapeze,



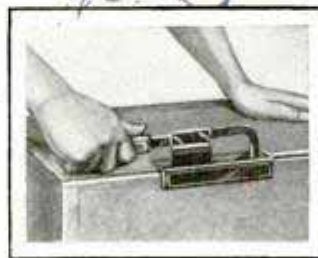
Drawings of Proposed Dirigible for the Navy; Note Airplane Compartment and the "Cat Walks" the Full Length of Ship

which would then be used to swing the plane up into its hangar in the framework of the dirigible. To launch the airplane, the locks that hold it when it is finally in place, would be automatically released, allowing the plane to drop down in position for flight. The two new dirigibles, the "ZRS-4" and the "ZRS-5" will each have a gas volume of 6,500,000 cubic feet, will be 785 feet long and, at fifty knots, can cruise 9,180 miles without refueling. Each will have eight motors with a total capacity of 4,480 horsepower. An interesting feature of the engines is that they will be housed inside the body of the ship to decrease wind resistance and to give greater safety. The propellers will be driven through transverse shafts and their axles can be turned into the vertical position to exert an up or down thrust to assist in taking off and landing. Access

to all parts of the ships will be afforded through three passageways.

KNIFE TO OPEN PAPER CARTONS PREVENTS DAMAGE

Paper containers are opened easily and quickly with a special knife that prevents damage to the contents and leaves the box in such shape that it may be used for reshipping. The cutting blade is held in a guide or shoe which keeps it from penetrating far into the carton, as sometimes happens with an ordinary knife. The blade may be removed for sharpening, and the tool is safe and strong.

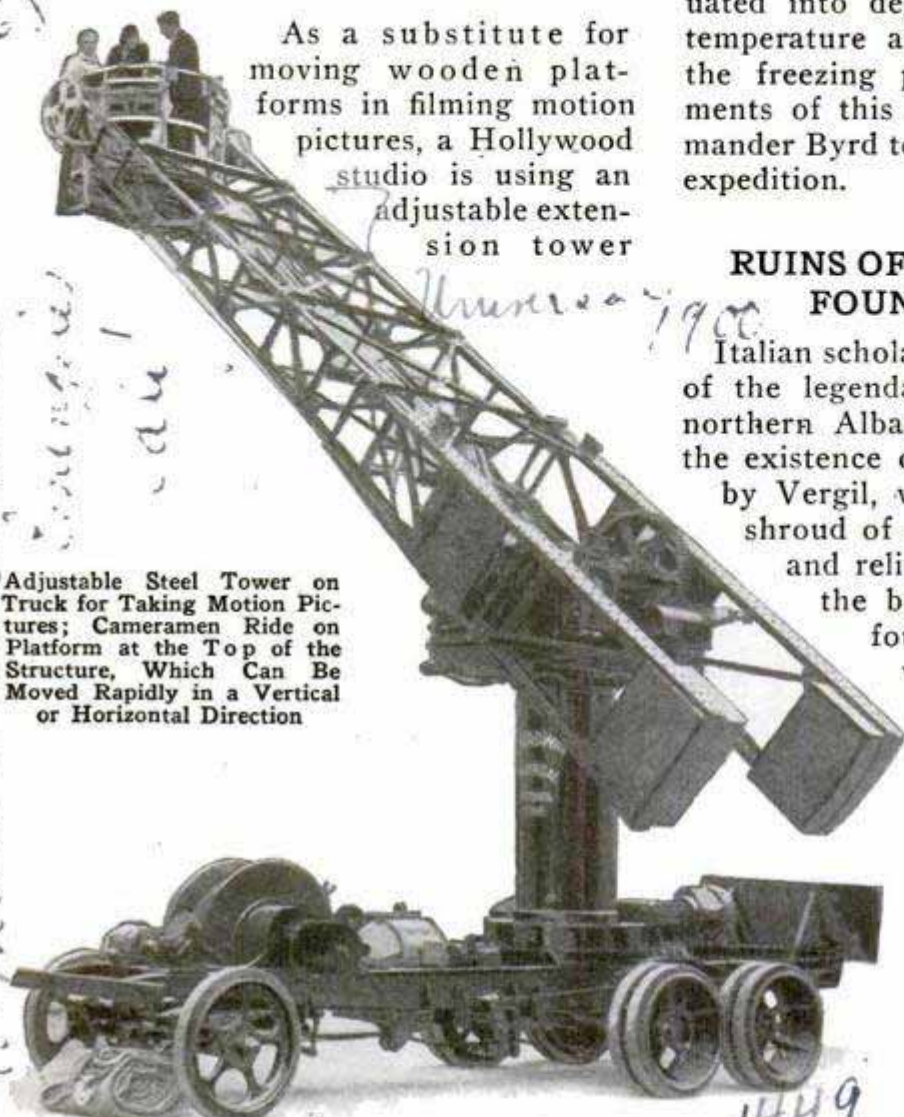


Handwritten notes:
 1748
 \$2.25
 Stanley Clark Mfg Co
 ...

TRAVELING TOWER FOR MOVIES AIDS CAMERAMEN

As a substitute for moving wooden platforms in filming motion pictures, a Hollywood studio is using an adjustable extension tower

Adjustable Steel Tower on Truck for Taking Motion Pictures; Cameramen Ride on Platform at the Top of the Structure, Which Can Be Moved Rapidly in a Vertical or Horizontal Direction



that can be moved 600 feet a minute horizontally and 400 feet per minute in a vertical direction. It can be swung to almost any angle and at any height within its range and has special adjustments so that the operators of the cameras can be actually going in eight different directions at once, according to reports. This permits unusual "shots," saves time, and makes possible unique effects in the finished films. The tower weighs 1,000 pounds.

PILOTS ARE GIVEN WARNING OF ICE ON WINGS

To inform the pilot when ice is about to form on the wings of his plane, a special thermometer has been devised. It consists of a bulb attached to the leading edge of the wing or one of the struts. A

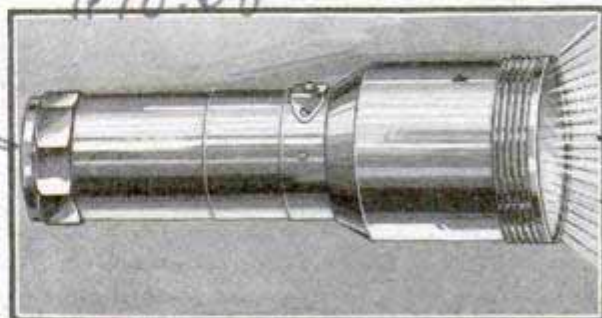
tube leads from it to the instrument board, where a hand, moving over a dial graduated into degrees, records the outside temperature and warns the pilot before the freezing point is reached. Instruments of this type were made for Commander Byrd to be used on his South Pole expedition.

RUINS OF MYSTERIOUS CITY FOUND IN ALBANIA

Italian scholars recently found the ruins of the legendary city of Buthrotum in northern Albania. Until this discovery, the existence of such a place, mentioned by Vergil, was doubted, but now the shroud of mystery has been removed and relics that date back as far as the bronze age have also been found on the site, together with the statues, baths and other evidences of Greek and Roman times. In the middle of a laurel grove a sacred well was found. Elaborate mosaics indicate that the citizens of Buthrotum were worshippers of Neptune.

FLASHLIGHT HAS OWN DYNAMO

Current is generated by a spring dynamo in a flashlight that requires no batteries. Electricity is supplied from revolving magnets simply by turning a spring in the handle. No oiling, adjusting or brushes are required. The light is especially suitable for service where dependa-



Flashlight Which Supplies Its Own Current from Spring Dynamo Inside

bility at all times is important and where batteries are difficult to obtain.

1961
built by Albin... of Iron Works
1. Main... of... of... of...

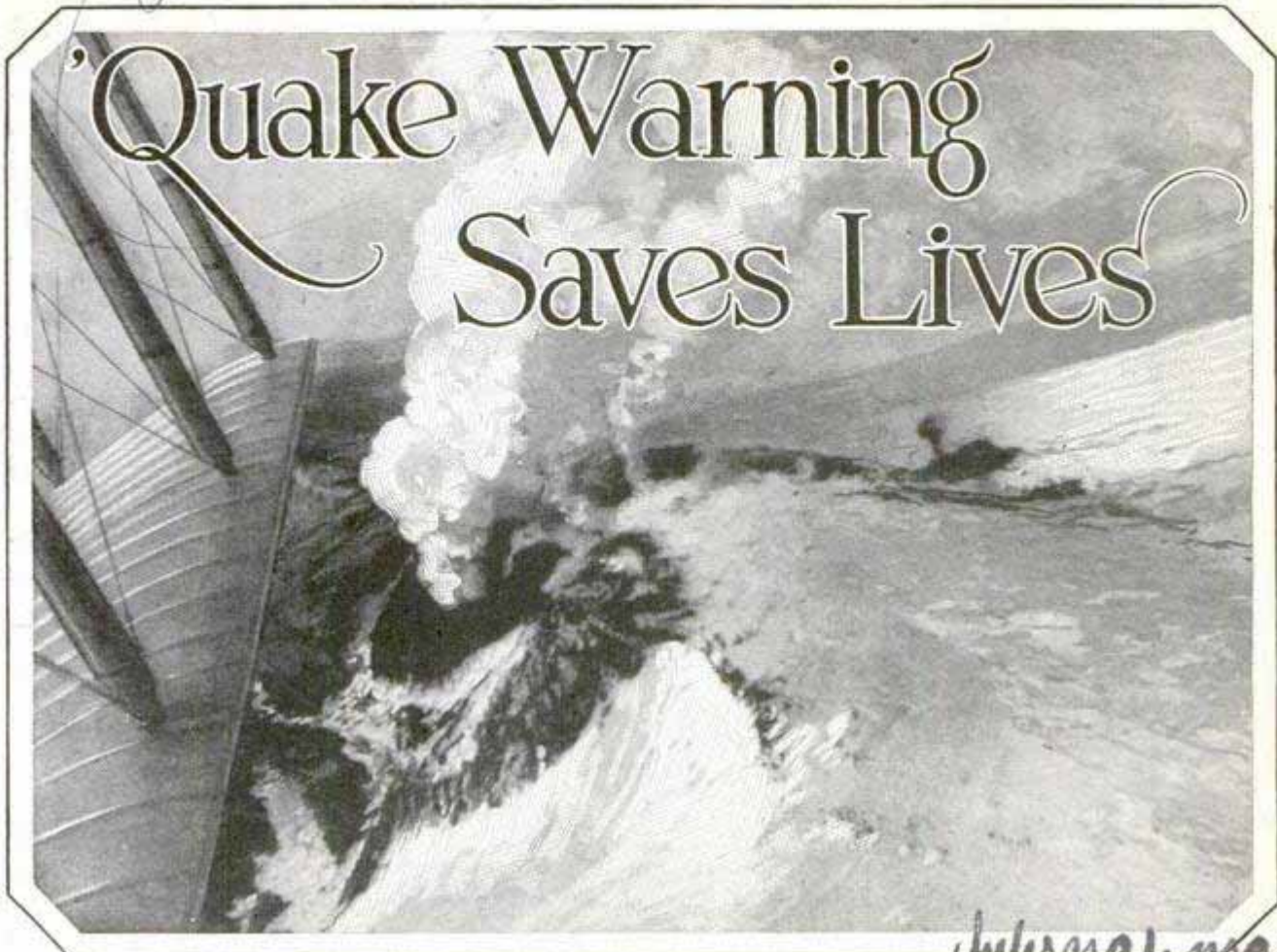
Luigi M. Golinò
near Lake Varese

1998
Motor Meter Co.
220 W. 42nd St

1449
\$10.00
Motor dynamo
MS - battery
05 11 24 37
Campbell Mfg Co.
Direchold

Quail

International News Service Corp



International

Aerial View of Mount Etna, Sicily, While the Crater Was Pouring Streams of Molten Lava down the Mountainside to Blot Out Villages Clustering beneath the Volcano

By ORVILLE H. KNEEN

FOR more than 2,400 years men have fled in terror from Etna's fiery outbursts. Records show that from 115,000 to 145,000 lives have been lost on the slopes of the volcano—sacrifices to the lure of its extremely rich soil.

But, in its latest eruption, not a single life was lost as it was predicted two years in advance.

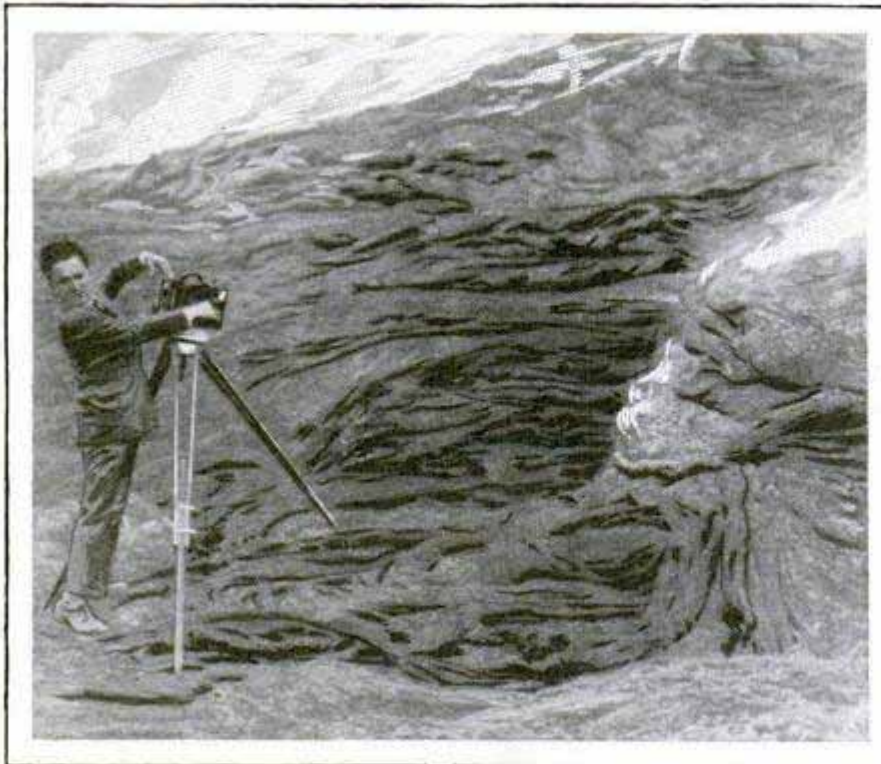
When a new mouth opened some 6,000 feet above sea level a short time ago, a broad river of white-hot molten lava, a mile in width, started for Sicily's fertile fields below. As the residents began a hurried retreat by motor, railroad and every form of conveyance, volcanologists and engineers mobilized their forces. For the first time in history, they determined to wage war on Europe's greatest volcano.

Rapidly into the beautiful Pietrafucile-Vallonazzo valley swept the river of molten rock, fourteen feet deep. So intense was its heat that houses and trees a hundred yards in front burst into flames. Another crater opened violently, lower

down the slope. Straight toward the villages of Mascali and Nunziata crept the torrent, leaving destruction in its flaming wake. Mascali, a town of 10,000, was soon seen to be doomed.

But other villages might be saved. With high explosives engineers began to dynamite the railroad bridge, to turn the flow southward. Soon it poured over another bridge, melting iron rails like butter. Power lines and aqueducts were cut in two. As one fiery river slowed its flow, another branch would reach out deadly tentacles. One of these began a threatening advance on Giarre.

To save this city now absorbed the efforts of thousands of soldiers, engineers and workmen. As fast as they could be planted, hundreds of mines were exploded around the northern and western outskirts, to create a great stream bed and thus divert the lava river into the sea. A huge earthen wall quickly was erected. Three streams were now advancing from the crater, with half a dozen villages in



Making Movies on the Still Warm Lava beneath Mt. Etna, Top, and Prof. Alfonso Sennino Studying an Eruption of Vesuvius

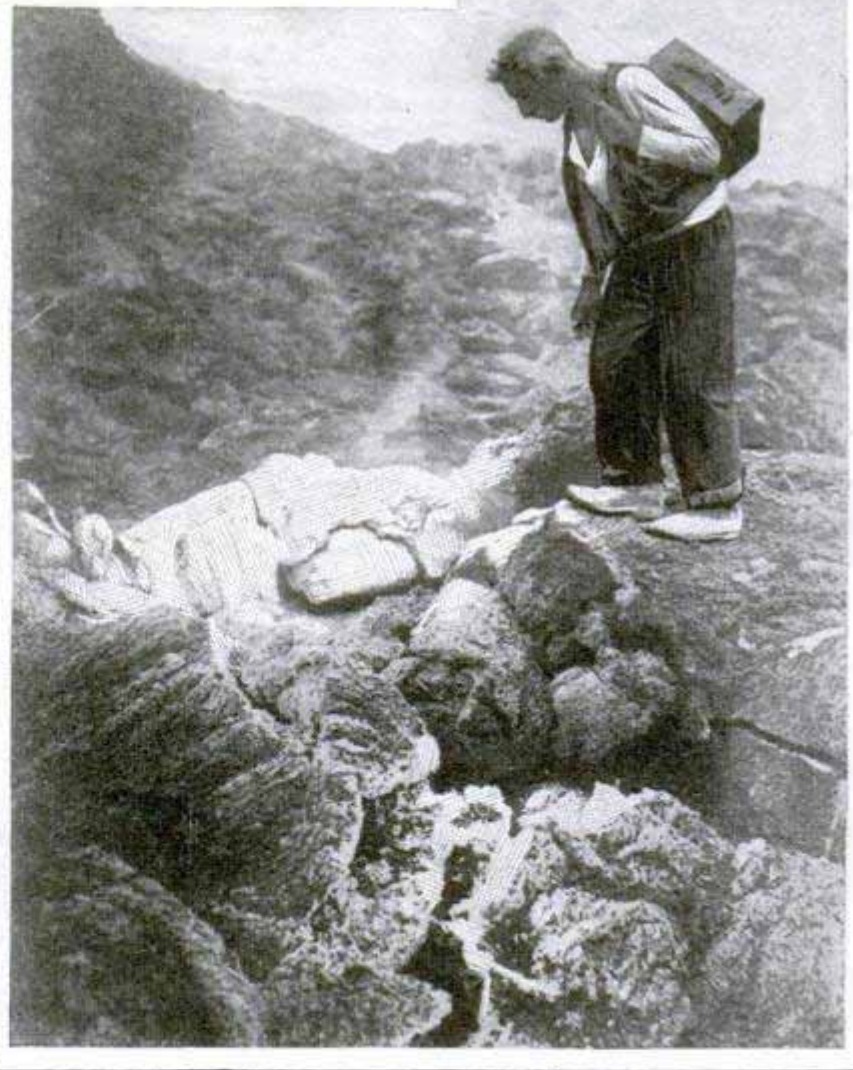
their path. Enormous clouds of steam and dust arose, while the earth shook from internal disturbance. In seventy-two hours the streams had traveled over six miles, over five times as fast as in 1923, the year of the last notable outbreak.

It was then that Prof. G. Ponte, head of the Etna volcanology institute, a lifetime watcher of the fire-breathing giant, determined to inspect the crater closely. He asked for an airplane, and at the risk of his life, soared over the peak. From a great height, above the clouds of smoke and fumes from craters and burning forests and towns, he saw liquid lava rising steadily from the main craters.

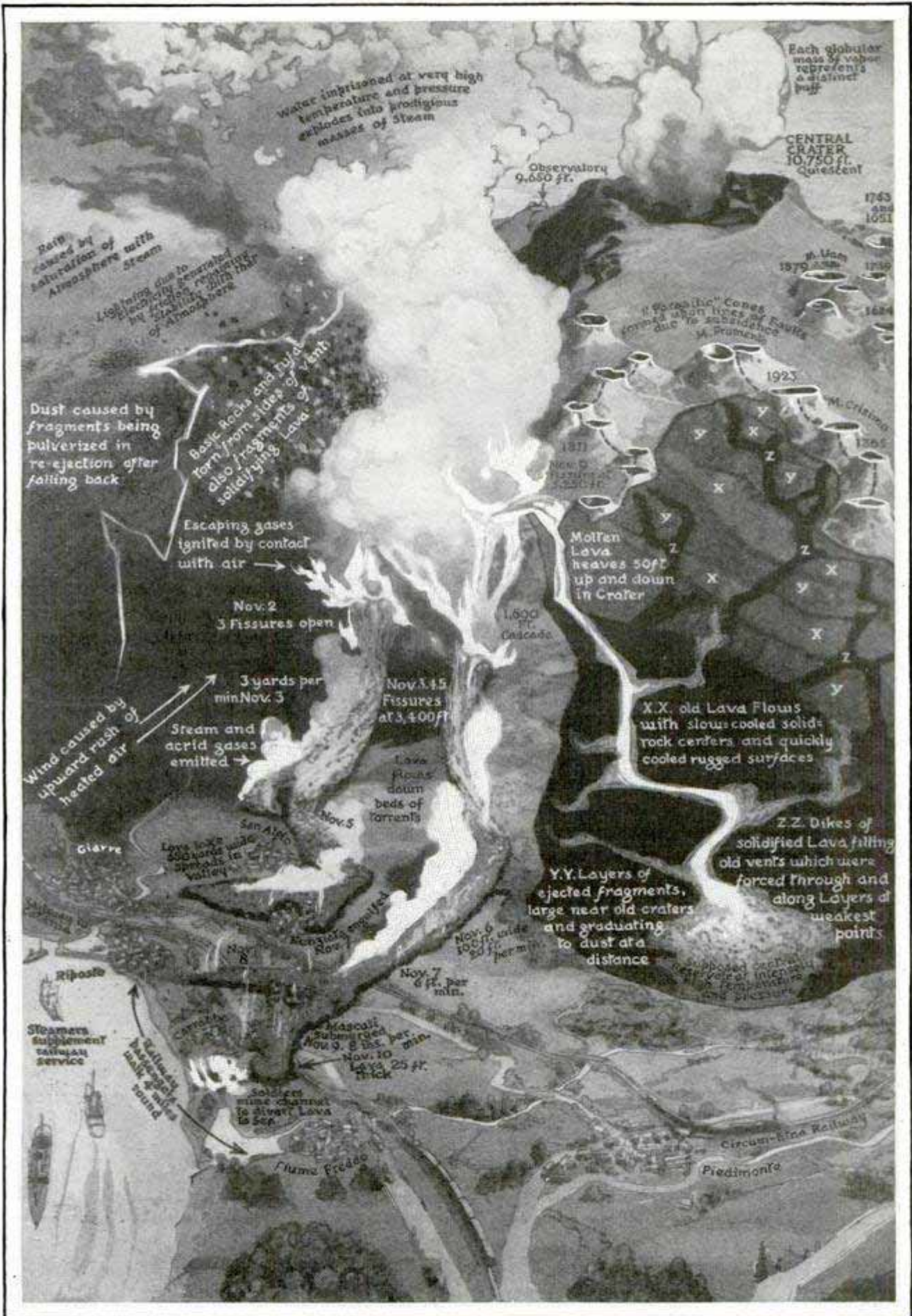
No electric lights remained in the whole area of many square miles, for power lines and plants had been destroyed. But at night the sweeping river could be traced

almost to its source, a sullen stream of dull red, winding down the mountain like a fiery dragon. Above it, the sky glowed fitfully as the crater boiled and opened its white-hot jaws. For miles, burning trees flamed like giant torches, and man-made explosions were answered by detonations of gas pockets, as the terrible heat distilled subterranean materials.

On November 12, Professor Ponte noted the

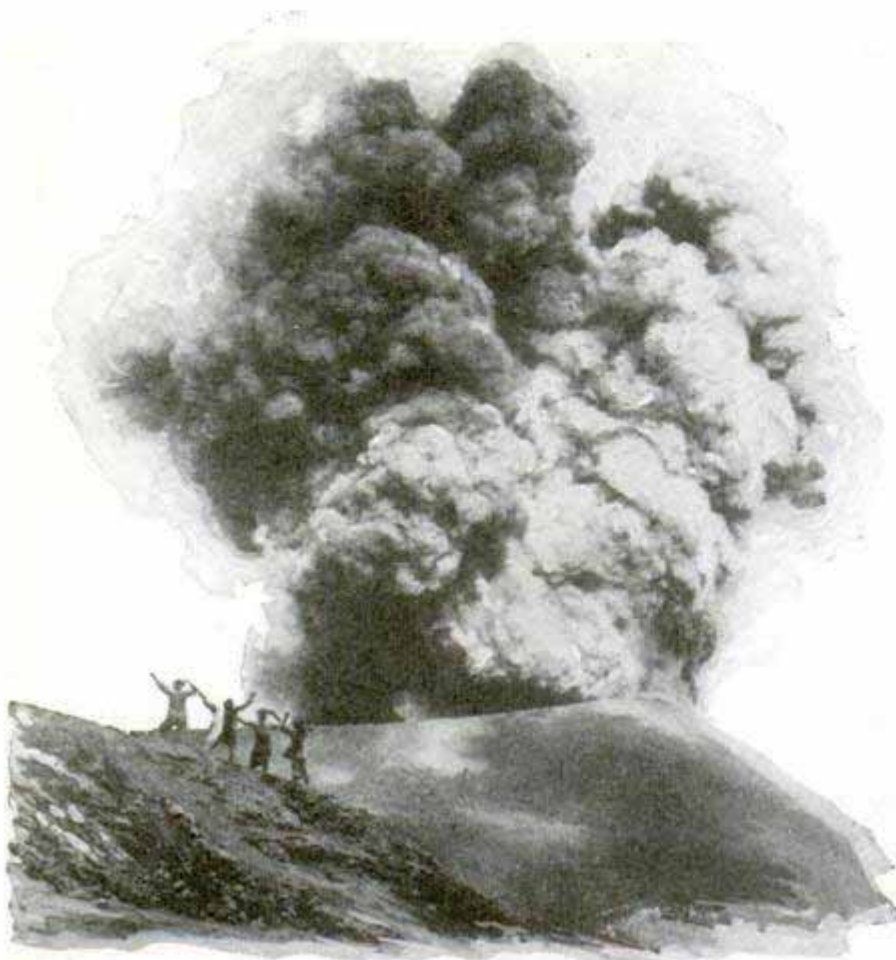


beginning of Etna's armistice. The quantity erupted was decreasing, he observed. Thus he brought reassurance of an early cessation, though warning that activity



© S. W. Clatworthy

Artist's Drawing of a Cross Section of Mt. Etna, Showing Many of the Cones through Which Past Outbreaks Occurred, and, in the Background, the Huge Central Crater



Close-Up of the Smoke and Dust Cloud Hovering over Vesuvius during a Recent Eruption of the Famous Volcano

was still possible. But it was now ten days, and, as expected, Etna did begin to subside. Steam-and-ash clouds from the main crater, as in former eruptions, heralded the advent of peace, unless fresh material should enter the great subterranean reservoirs.

Once more Professor Ponte soared over the peak, finding all lava streams and branches slowly blocking themselves by solidifying heads. Only by the push of interior lava, still fluid, did they advance a few yards an hour. "This eruption," Professor Ponte predicted confidently, "will not delay in showing its final phases and in extinguishing itself."

Another observer, Professor Platania, who has seen many previous outbursts, predicted alternate renewals of activity with the advent of the new moon. This brings the greatest ocean tides, and also, some believe, earth tides, which Professor Platania has found to affect eruptions from "the inferno of the earth."

The total damage done by Etna, in this last outburst, will run from ten to twenty

million dollars. Land worth up to \$2,500 an acre has been destroyed for centuries, until the lava decays to form the richest of all soils. Buildings, roads, railways, bridges, telegraph and telephone lines, power lines and plants and aqueducts destroyed by the three lava streams will require millions and years to replace.

Yet, in all this destruction, not a single life was directly lost. To scientists who are giving their lives to mastering the habits of volcanoes, future generations will owe their safety and that of their property. It was predicted that the 1928 eruption would coincide with the year of maximum sunspots.

From the beginning of an eruption, through its most violent phases, to

the period when sulphurous gases foretold the end, scientists like Prof. Alessandro Malladra are constantly on guard.

Close to 100 eruptions of Etna have been recorded, some very violent. From the depths of the earth, the spouting mouths, of which several hundred are still visible, have emitted white-hot lava, sulphur, sulphuric-acid gas, vapors of ammonia salts, hydrochloric-acid gas, and enormous clouds of steam and ashes. Such ash is by far the richest fertilizer known.

Prediction of eruptions is undoubtedly close at hand. Dr. T. A. Jaggar, world's most eminent volcanologist, has gathered a mass of data as to tilting of the earth cover near the bases of volcanoes, notably those of Hawaii. From scores of holes, ten feet deep, bored through the rock crust of Kilauea, he expects to be able to foretell eruptions when temperatures suddenly increase.

Earthquakes have been found to precede eruptions of some volcanoes, and seismograph studies have proved of value in predictions of disaster. Long-range



The Walls of Mascali, Sicily, Crumbling under the Millions of Tons of Molten Rock Poured into the Village by Mt. Etna; the Town Was Buried a Hundred Feet Deep

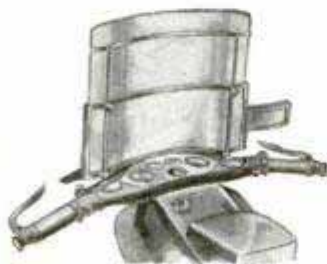
predictions may become possible through further study of sunspots and earthquakes.

We also are closer to making the volcanic cone work for mankind. Volcanic steam is used in several places for producing power and heat, notably at Larderello, Italy, and near Sonoma, Calif. Scientists speculate on the possibility of tapping reservoirs of molten rock, or the zones of great internal heat, for power plants.

But the taming of volcanoes is still far distant. And of the 400 or more active cones, Etna bids fair to continue as one of the most restless and destructive.

HYDRAULIC-BRAKE MOTORCYCLE HAS AUTO FEATURES

"An auto on two wheels" is the description given a motorcycle of recent British manufacture. It has a hydraulic braking system, a combined dash and handlebar, surmounted by a telescoping screen shield, and special plungers



that can be lowered by pressure on a knob to hold the machine upright when no wall or curb is handy. Over the handlebar is mounted an instrument board such as would be found in the ordinary automobile.

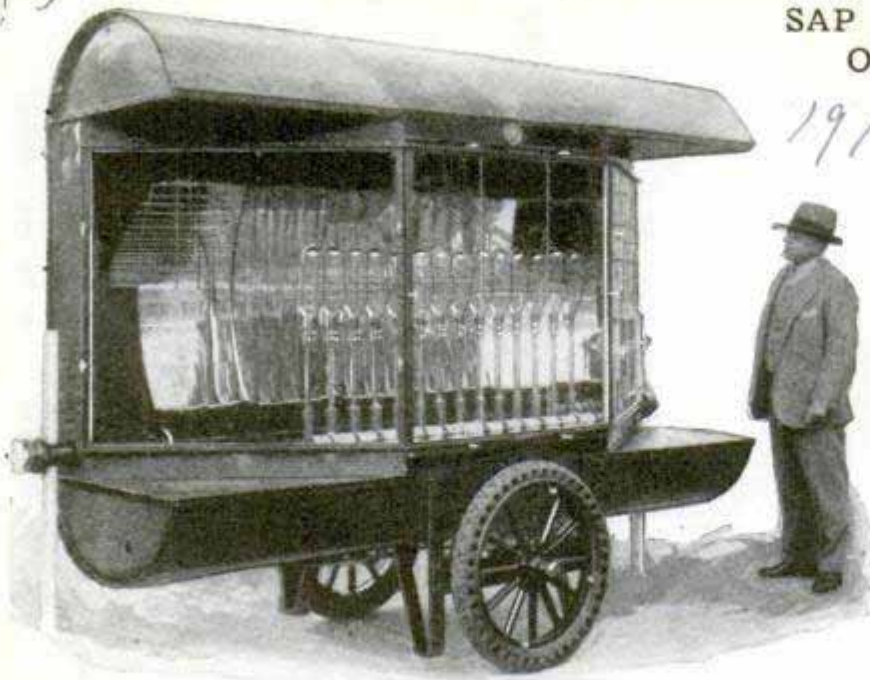
TOWER BUILT TO STUDY EAGLES IN FLIGHT AND ON NEST

Excellent motion pictures of eagles have been obtained from an eighty-foot tower erected near Vermilion, Ohio, where a nest, only forty feet away, offers many opportunities for such photography. The location is one of the few places on the eastern half of the continent where the study can be made, and the present tower, a steel structure, is the second to be built. The first was blown down in a storm. The nest, which also crashed at that time, was about fifty years old and enabled naturalists to determine much of the food habits of the birds. The eagles never clean house and this particular nest, with all its debris, weighed about two tons. Prof. Francis H. Herrick of Western Reserve university has been conducting the eagle research since 1922.

1699
Chas. C. Sullivan
etcher

laboratory
MacDougal
1911

Wagner - P. A. B. Walroon - 8 175



Airport Landing Light, Equipped with Fourteen Incandescent Globes Generating Three Billion Candlepower

BIG LIGHT FOR LANDING FIELDS SHIELDS PILOTS' EYES

Rays from a 3,000,000,000-candlepower floodlight for airplane-landing fields are directed downward, close to the ground, so that they will not shine in the eyes of the pilots as they descend. The big light has fourteen powerful lamps, and is said to be so brilliant that a person can read a newspaper in its light at a distance of one mile.

(Chw. Fuller)

HUMIDIFIER FOR AIR FURNACE HELPS GUARD HEALTH

Keeping the air inside rooms properly moist is highly important to health and comfort and, to aid in this, an automatic humidifier for the hot-air furnace has been introduced. Its most interesting feature is that the tendency of wood to expand and contract under varying moisture conditions has been utilized to insure the proper amount of water for evaporation over the furnace. When the fire is started and hot air rises, a staff of cross-grain wood contracts, the action causing water to drop into the pan over the furnace where it is evaporated. When the air becomes saturated, the wood expands, closing a valve which shuts off the water. The device is said to be reliable and easily installed.

Perfect Humidifier Co. East St. Louis, Ill.

Agent - J. E. Bauck Chemical Bldg

SAP IS PULLED TO TOPS OF TREES BY TENSION INSIDE OF TRUNK

A solution of the mysterious manner in which sap rises to the tops of trees has been offered by Dr. D. T. MacDougal, who has conducted extensive experiments with the phenomenon. He declares that the liquid is drawn up through tension caused by evaporation on the surface of the leaves and transmitted through the leaf stems, twigs and branches until it reaches the trunks and spreads down to the roots. He also found that

air confined in dead vessels of a tree trunk, forms a single connected system, just as the sap does. This was shown by applying pressure instruments to different parts of the tree. Change in pressure at one point was rapidly transmitted to others.

STEAM HEAT BY ELECTRICITY LATEST HOME COMFORT

In localities where low current rates are enjoyed, an electric radiator has been used successfully. Each is an independent unit and functions for about three months with but one pint of water. Steam is generated by contact of the water between the poles of an electrode instead of an element. This allows automatic shut-off of the cur-



Electric Steam Radiator Which Requires No Piping; Water Is Vaporized between Two Electrodes

rent if the water evaporates or is lost by leakage. A switch gives full heat control, and little current is consumed.

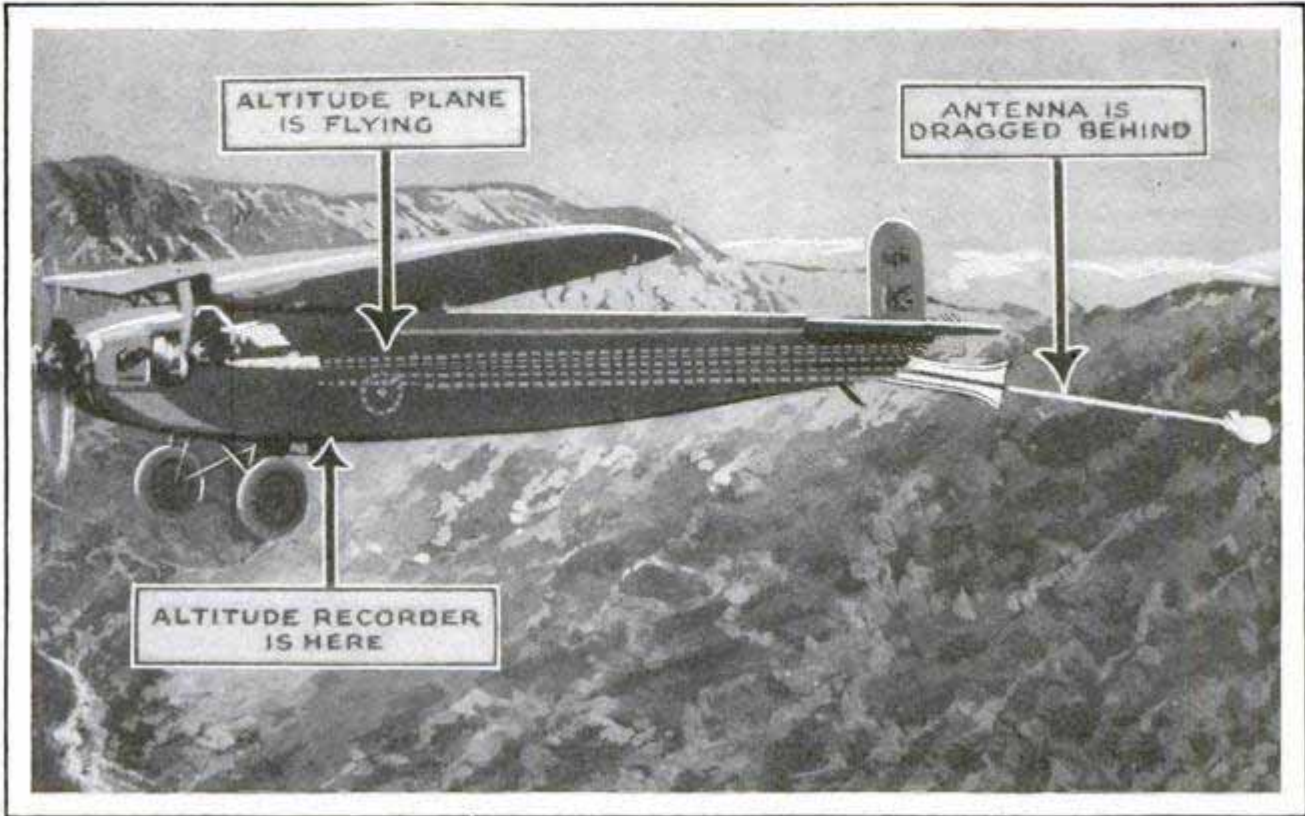
you Electric Heating Canada

ad
11
in
re
two
city
feet

1864

of Boston Sunday Post
POPULAR MECHANICS
Boston Mass

RADIO SQUEALS MAY SAVE AIRPLANES IN FOGS



Tri-Motored Plane Used by Doctor Alexanderson in Tests of New Radio Altitude-Finder; an Antenna of Unusual Design Is Dragged behind the Ship to Transmit Signals

Utilizing the squeal which annoys the radio listener when a neighbor overworks his regenerative receiver, to save airplanes from flying into the ground in a fog, is the latest development of science suggested by Dr. E. F. W. Alexanderson, famous television inventor and consulting engineer of the General Electric company. Professor Alexanderson has been experimenting for some time with an airplane altitude indicator designed to show the exact height of a plane above the ground. A signal, corresponding to the squeal of a regenerative set, is sent out from a transmitter in the plane, and the "echo" of its return from the ground picked up by a receiver. If the plane is 100 meters above the ground and a 100-meter wavelength is used, one full wave, like a letter "S," would carry the signal to the ground, and another full wave, completing a figure "8," would bring it back. The problem, however, is much more complicated than that. As a result of the experiments with recording apparatus, Dr. Alexanderson suggests it may be possible to get a continuous chart of the distance above the ground, or, by using two transmitters with an-

tennas adjusted for slightly different wavelengths, obtain a variation in signals which will reach their maximum at certain specified points, so that a descending plane can check its height at regular intervals, down to within a few feet of the ground.

SPONGE-NOZZLE AUTO WASHER PROTECTS FINISH

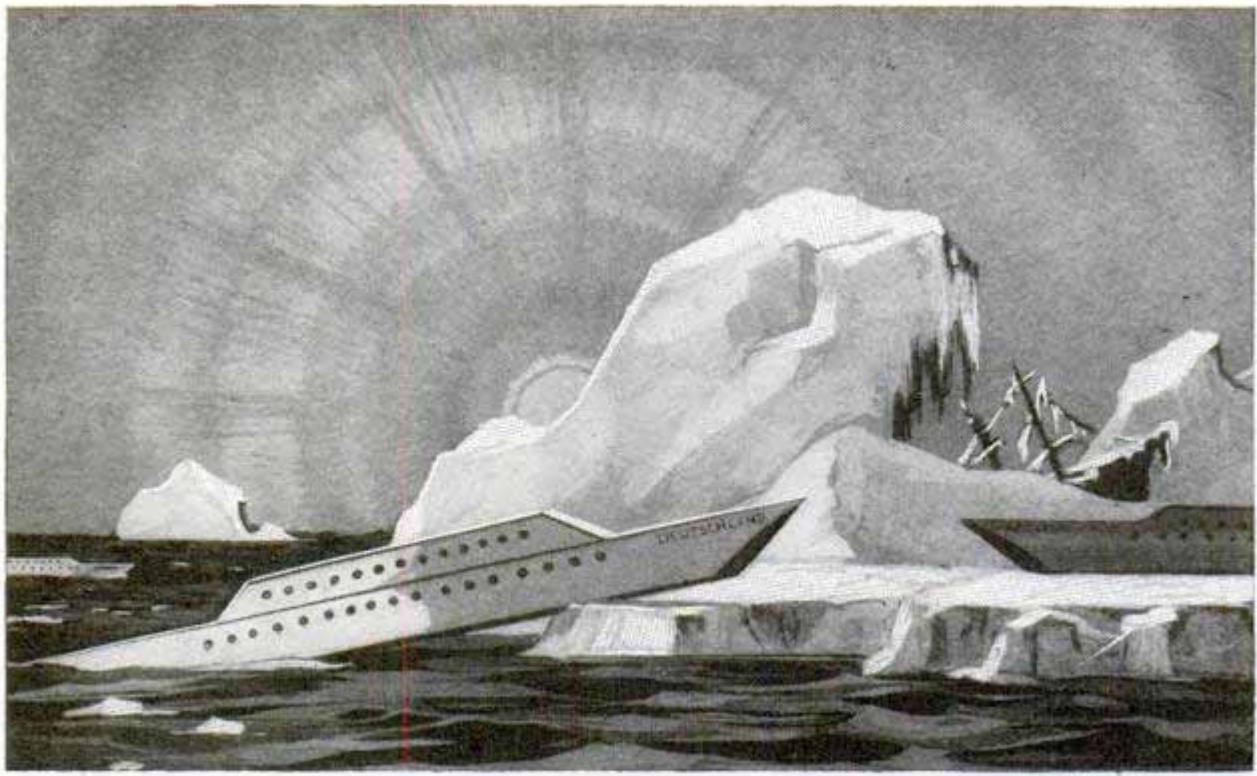


To save time and work in washing the automobile, a special nozzle attachment for the hose has been introduced. It contains a large sponge and is made of rubber to prevent damage to the finish. The user may handle it with less likelihood of scratching the car, and it saves bending over and wetting the feet and clothing, as spattering is eliminated.

Chicago Spectacle

An excellent trick

Chicago Spectacle Co.



Proposed for Journeys in the Frozen Seas; the Turbine-Propelled Steel "Water Sled" Intended to Withstand Severe Pressure and to Slide over Icebergs

STEEL BOAT FOR ARCTIC TRAVEL RUN BY AIR TURBINES

Constructed of heavy armor steel and propelled by wind-pressure turbines, a special boat has been designed by a German engineer for travel through the ice fields of arctic regions. It is shaped somewhat like a giant sled.

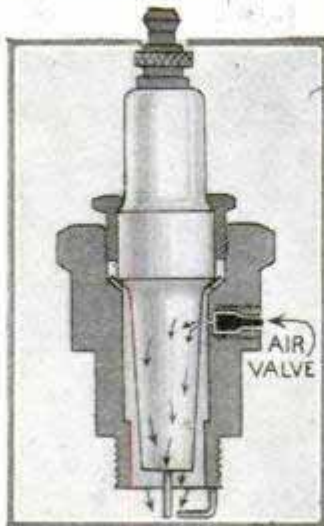
is said to increase the pick-up and decrease the hazards of poison gases from the exhaust.

TYPE IS SET BY TELEGRAPH TO SPEED NEWS

Two newspaper type-setting machines were operated by telegraph wire in a recent test. Dispatches were sent on a punched tape which was duplicated at the receiving end, and as this second ribbon passed through a small unit, the holes were translated into electrical impulses which actuated an apparatus roughly resembling a human hand. Metal fingers released letters and characters into the type setter as accurately as though a human operator had pressed the keys. The demonstration was made in a newspaper office, the sending set being on one side of the room and the receiver on the other, but the wire was made the equivalent of a distance of 140 miles by resistance coils. Should the innovation prove practical, news dispatches would appear in print much more rapidly than is now possible, as the type could be set directly from a central office. The system is essentially like the electric-typewriter way of duplicating what is written far away.

SPARK PLUG WITH AIR INTAKE HELPS SAVE GASOLINE

Better combustion, fuel economy and cleaner firing points are among the advantages claimed for a spark plug with a patented air valve, which allows air to pass into the cylinders. The unit is so constructed that the suction stroke of the piston opens the valve and the compression stroke closes it. Operating automatically, it requires no attention, and



Air Valve
3331 Superior Ave
Cleveland, Ohio

is said to increase the pick-up and decrease the hazards of poison gases from the exhaust.

Built by Ingersoll-Rand Corp

12/2/28

1828

HOMESTEAD LAND STILL AVAILABLE

According to government reports, there are about 300,000 square miles of free land in this country, still open to the home seeker. Practically all of it is in the west, although some tracts are available in Florida. That the frontier has practically disappeared, however, so far as agriculture is concerned, is seen in the statement that the "remaining vacant public lands, not mineral in character, are chiefly valuable for grazing purposes, though some tillable land may be found." Of all the land that is left, there is but little upon which a farmer could make a living even if conditions were more favorable than they now are, persons who have investigated the areas declare. Special offers have been made to ex-service men to file on certain tracts that have been held up to the present time for ammunition depots and for the Indians. More than 70,000 persons have made entries for homesteads upon which final proof has not yet been presented.

TOP OVER AUTO RUMBLE SEAT HAS SIDE CURTAINS

Top and side curtains of a cover for the automobile rumble seat, roll into one piece that fits into a metal container attached to the back of the car. When only a sunshade is needed, the side curtains are folded under the top. The canopy can be adjusted even when the car is running.



Rumble-Seat Top with Side Curtains Offers Complete Protection from Sun and Storm



Weather Bulletins Posted in Spaces Opposite Towns on Large Map, Give Motorists Aid in Planning Tours

International

GUIDE MAP TELLS WEATHER TO AID MOTORISTS

So that motor tourists will know what sort of weather to expect in different parts of the country, a London automobile association has devised a special guide map. Instead of the usual waving lines and other technical details of a weather chart, this one shows conditions by small printed bulletins inserted under the names of important cities. The blanks can be changed to conform with the latest reports and the map can be read and understood by anyone.

Carrier pigeons habitually fly only in the daytime.

H.C. Quick, Jr. 1844

*1591
Cant. Leitch, Leland S. Jamieson
Kelly Field, San Antonio, Texas*



Flying

protection of his windshield, searched the ground for a field sodded enough so that he could land the ship without nosing it over. But the only fields he saw had water standing in the furrows. The passenger a moment later cut the throttle.

"Turn around and head back about forty degrees from the way you've been coming," he said pointing, and again bent his head over the map.

The pilot turned around and headed back. His compass was pointing southeast after the turn was made. It had been pointing south before.

It told him nothing. "Gosh," he muttered. "This is the third time I've been lost in the last two weeks."

Suddenly the passenger pointed off into the rain to the left and signaled for a slight turn. The pilot headed into the blur of mist from a new tangent. Within a few minutes he saw the landing field.

"I don't see how I get lost so often," he complained, when they were on the ground.

"I don't see how you ever find the way home," was the reply.

"It's these strip maps I'm using. It's easy to run off of 'em. They ain't very wide."

"Only about fifty miles on each side of your course. The trouble with you is that you don't see anything when you fly over it; you don't make things on the ground

Shooting the Sun with a Special Sextant, Which Carries Its Own Horizon, for Aerial Work

By *Leitch* LELAND S. JAMIESON

Kelly Field, San Antonio, Texas
"WHERE are we?" yelled the pilot as the roar of the motor died away after he cut the throttle. "I'm lost!"

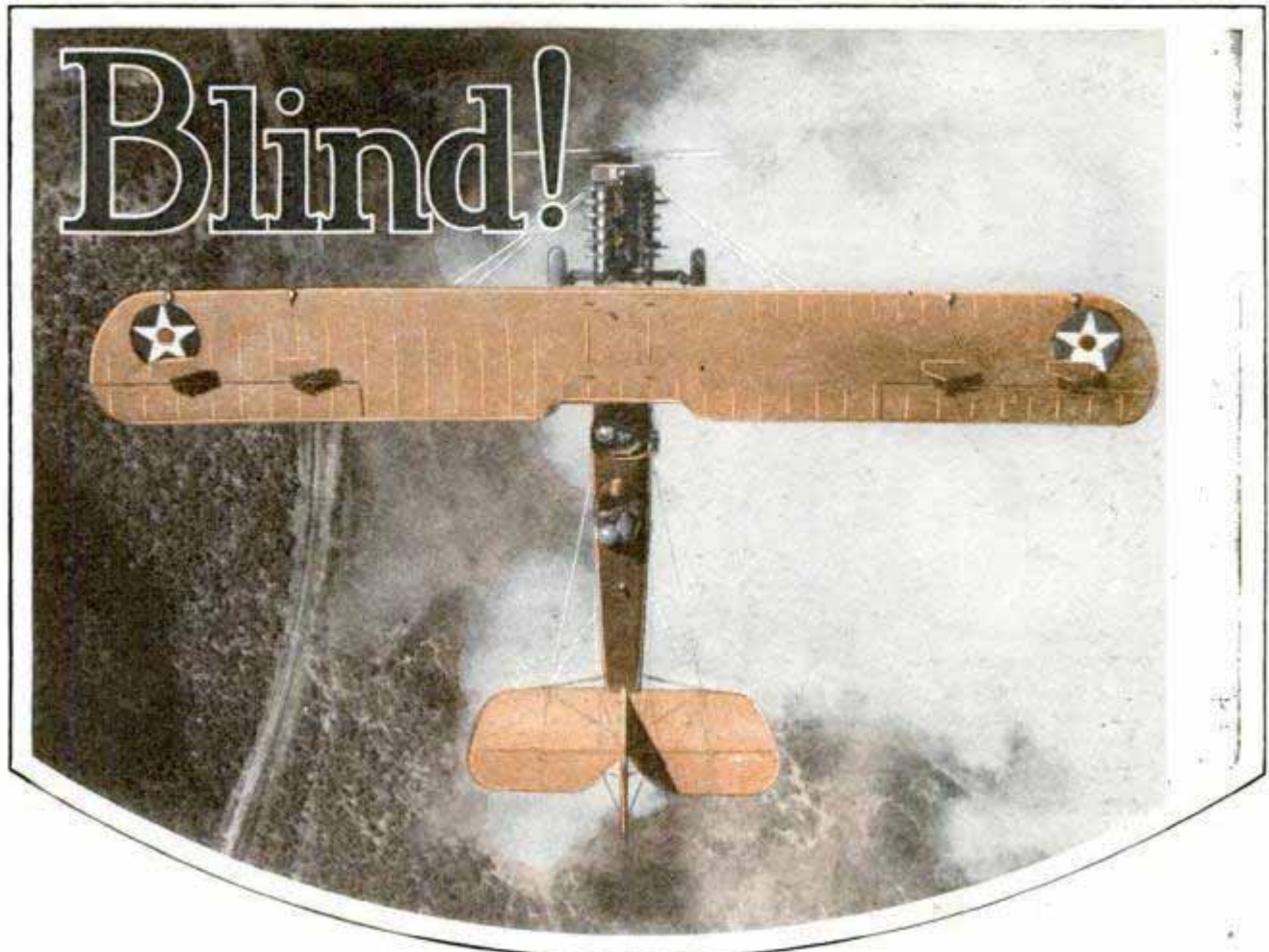
The passenger looked around in all directions at the haze of rain that shut off the horizon. He looked down 200 feet at the fields that were black and glistening with standing water. He held up his hands and shrugged his shoulders.

"How much gas we got left?" he asked.

"About an hour. We should have been home thirty minutes ago, but we're off the map and I don't know where we are."

"Let me see that map!" commanded the passenger, himself a pilot and a skilled cross-country flyer.

The pilot handed the map forward, then crouched down in his cockpit and, from the



As the Airman Sees the Country While Flying above Broken Clouds; the Railroad Track on the Left Serves to Check Position and Insure the Accuracy of the Compass Course

match up with your map. And you might get your compass fixed so you can tell which way you go," said the passenger.

The easiest and simplest way to fly an airplane cross-country is to sit up above a railroad and watch the ties flow away behind you until you get home, but that method has disadvantages. The railroad may not go in the direction you want to fly; it isn't the straightest line between the two points, and you therefore lose time by following it. Then, too, if you are flying over an area where there is a network of railroads you never can be quite certain that you follow the right one.

The experienced pilot, then, usually draws a line on his map that connects the two places between which he expects to travel, and tries to follow that line, which is called the "flight line." If a wind is blowing across the line of flight, it will produce drift, and the pilot must turn slightly into the wind in order to maintain the correct path, or track, over the ground. In the vernacular of flying, the course of the ship is the direction in which

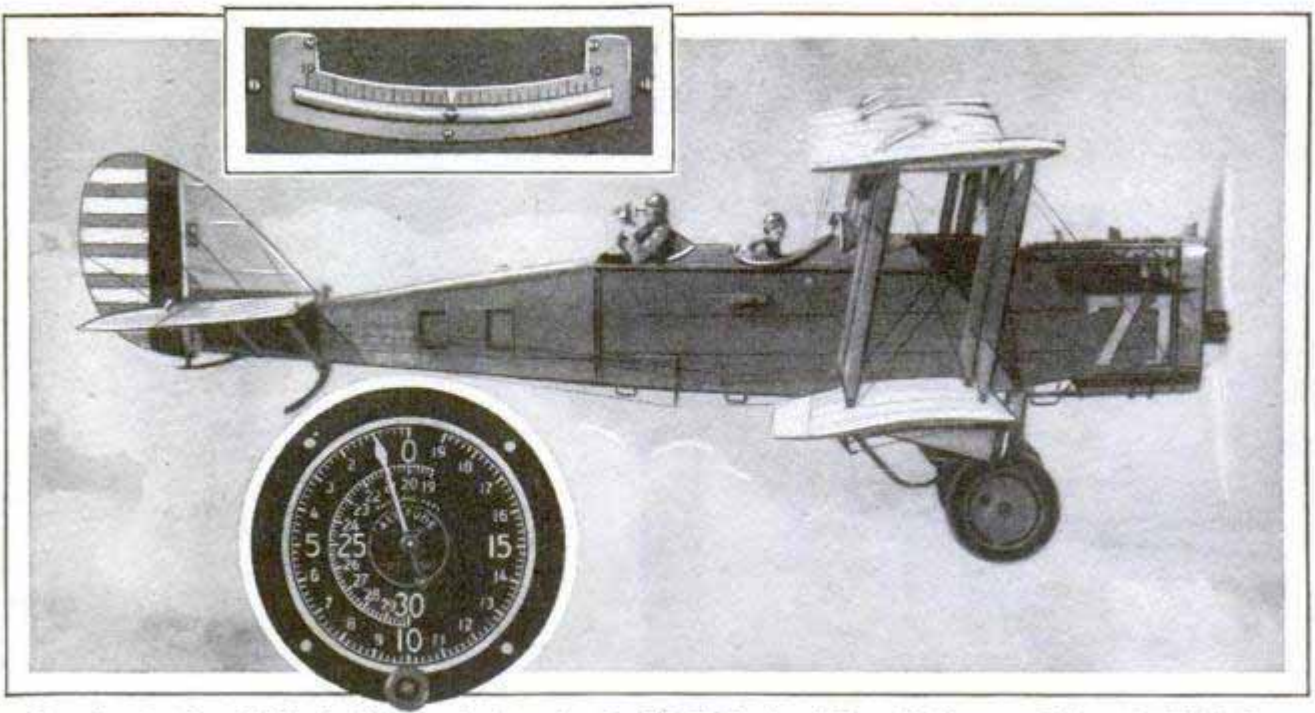
it is flying, regardless of its track due to crosswinds.

Thus, in case a pilot is about to fly from one point to another directly north of him, he draws a line on his map between the two points and tries to follow a corresponding imaginary line over the ground.

Maps are made to be read, just as books are read, but they have signs and symbols of their own. It is as essential that an airplane pilot be able to read a map as it is that he read his oil-pressure gauge or his altimeter. A good map is a very small replica of the area it covers, except that it shows only the main features of the ground below, such as railroads, towns, rivers, paved highways and other similar prominent landmarks. To get the idea of how a good map for aerial use looks, imagine one that shows all the railroads and towns that are marked on an ordinary map, all the roads on a highway map; all the contours, hills and rivers as on an engineering map, and other less pertinent data, such as electric transmission lines.

In Lindbergh's flight to Paris he flew

1591



Shooting the Sun While in Flight, and, Top, the Steel-Ball Bank-and-Turn Indicator; Below, the Dial of an Airplane Altimeter; the Knob at the Bottom Rotates the Dial for Different Ground Levels

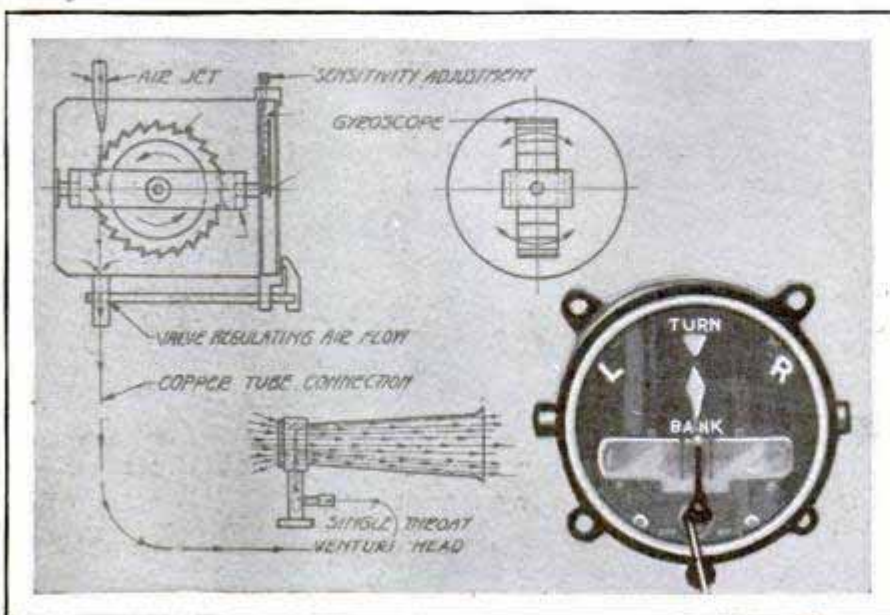
by dead reckoning from Nova Scotia to the western coast of Ireland. He had no check points or landmarks by which he could tell his location over the Atlantic, but, before leaving land on the western coast of the Atlantic, he had check points all along the coast from New York, and before he pushed out to sea, he had a point of departure that served as a check point in determining his correct course.

In cross-country flying the pilot relies upon two main check points: the initial check and the final check. The initial check is one which he may use a few

minutes after taking off to determine whether he is headed in the right direction. The final check is one which tells him definitely that he is at his destination, or nearing it.

Suppose that a pilot started to fly from Dallas, Tex., to Oklahoma City, Okla. Before the trip, he would draw a flight line on his map connecting the two cities, then he would measure the direction in which that line extended, beginning at true north and counting around the points of the compass in a clockwise direction. Oklahoma City is roughly thirty-three degrees west of north of Dallas,

but the pilot, instead of saying it in that way, says that the direction of Oklahoma City from Dallas is 327 degrees. Now, if there is no wind blowing across his course, the pilot can take off, turn his ship so that the compass reads 327 degrees, and, if the compass is correct, fly in that direction until he gets to Oklahoma City. To check against possible crosswinds in the air, he will look down along his fuselage and sight at objects on the ground as he



Diagrams Showing the Working of the Gyrostatic Turn Indicator and the Flight Guide, or Inclinometer

passes them. In this way he can tell whether the ship is traveling over the ground in the direction it is flying through the air or is drifting.

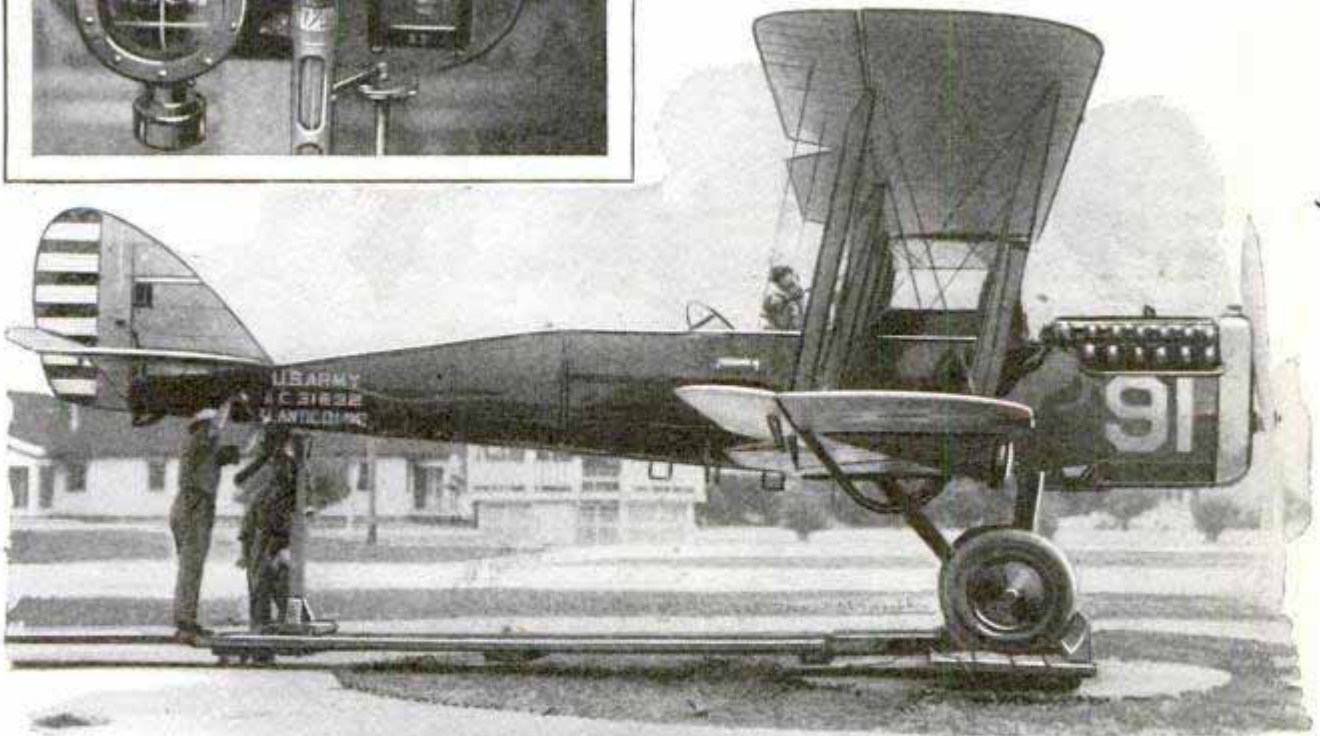
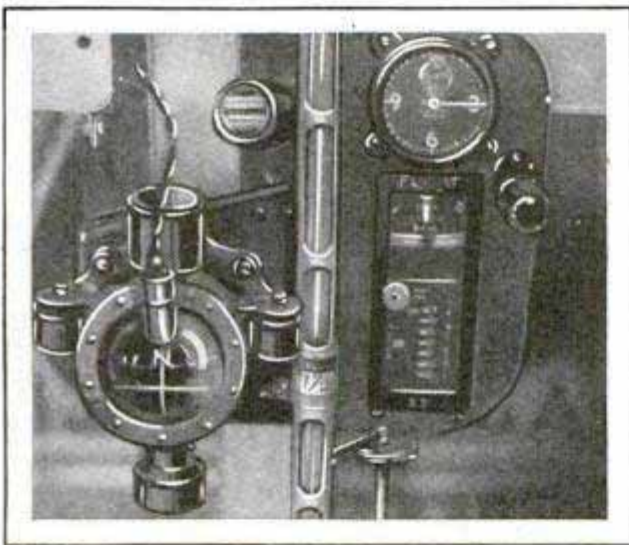
About twenty-five miles northwest of Dallas is a small lake, and the pilot's flight line passes about three miles to the east of it. It is the initial check point on the route, and after flying about seventeen minutes, if he finds himself opposite this lake at a distance of three miles, he knows that he is directly on his route, and making approximately 100 miles an hour over the ground. On this particular flight there are check points at intervals of about fifteen miles and unless the pilot runs into low clouds, rain or fog, there is little excuse for his becoming lost.

Yet getting lost is just as common among young pilots as it ever was. Experience seems to be the only way in which

a man can learn to recognize from the air the points along his route of travel that will guide him accurately. He may mistake railroads for highways; he may pass up a small river for a creek, or a swollen stream for a river that is a key check point on his route. He may perhaps go above the clouds in search of a more favorable wind and, striking a crosswind, come out of them miles from his course. Instantly the thought arises: "Was my last check correct? Has the wind changed? Has my compass 'gone out'?" Sometimes he may discover his position, but usually he lands and asks a farmer where he is.

Flying at 2,000 or 3,000 feet on a clear day and flying at a hundred feet under misting clouds offer the two extremes in finding one's way across the country by air. From 3,000 feet it is possible to see towns and prominent objects thirty miles away, and there is small chance of having trouble; but from a hundred feet, even in clear weather, the field of vision is cut to three or four miles.

Cross-country flying over nearly any part of the middle west is quite easy because of the abundance of towns and highways and systematically laid-out section lines, but there are some parts of the United States where a pilot can fly for as



Correcting an Airplane Compass on a Revolving Stand and, Inset, a Group of Airplane Instruments, Including Compass, Gasoline Gauge, Clock, and, Below It, Bank-and-Turn Indicators

Mr. W. Starkweather
Mr. O. O. O.

much as two or three hours without seeing anything by which he can tell his whereabouts. It is then that the pilot becomes a navigator. Such areas show on the map as blank spaces, sometimes with a tiny line threading along where a stream is supposed to be, but often when the stream is reached it is nothing but a dry wash, inaccurately placed upon the map, and therefore useless as a check for locating one's position.

In flying over country of that kind, the initial check point is of the greatest importance, for only in that way is the pilot able to tell whether he is correct or in error in choosing his course. After leaving the flying field and passing the first check point, he must trust entirely to his compass. If he starts out in the proper direction and watches carefully for crosswinds, he will have no trouble in arriving at his destination, but if he is as much as

**HELIIUM LEAKS THROUGH GLASS
YEAR'S TEST SHOWS**

Although glass is popularly considered as a fairly leak-proof material, helium gas seeps through it in small quantities after a time. Workers at Harvard university stored about a quart of it in a container of special glass and left it there a year. At the end of that time, about one per cent of the original contents had escaped by seepage, measurements showed, although the bottle was carefully sealed.

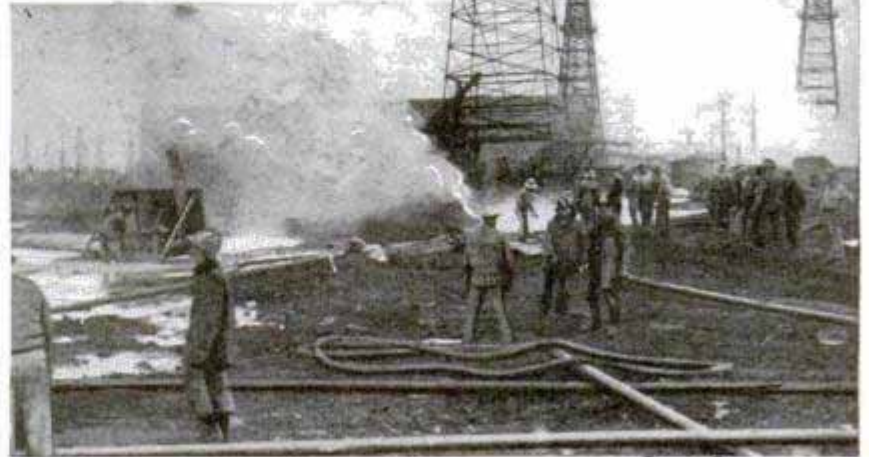
**SNUFFER PUTS OUT OIL FIRE
BURNING TWO MONTHS**

After a battle of almost two months' duration, engineers finally succeeded in extinguishing an oil-well fire that had cost more than \$1,000,000, in the California fields at Santa Fe Springs. An im-

portant aid to the final victory was an adaptation of the old-fashioned candle snuffer. In this case, it was a big steel cap which was applied with the aid of a derrick on wheels. Several lines of hose, charged with steam, mud and water, helped subdue the raging pillar of fire.



five degrees or more in error, he will find himself, at the end of a two-hour flight, so far away from his correct route that he will have great difficulty in locating it. And if there happens to be no definite final check point he may "overshoot" and continue on, believing that a headwind has delayed him. So the final check is almost as important as the initial one.



Huge Snuffer Built to Extinguish Blazing Oil Well, and a Scene at the Fire Before Cap Was Put On

1743
1743
Creely 11/17

308 W. Plum St.

1843 Britzies Hwy Co

Centralia, Wash
WAR TANKS WRECK OLD PRISON
TO SAVE HAND LABOR 1802

Lever. Minn

West
Union St
Draincraft Co. 33
New York

Ten tanks engaged in a peace-time "battle" recently when they were directed against the walls of an old prison at Fort Lewis, Wash. The structure, about 100 feet square, was surrounded by two lines of barbed wire, but the tanks passed through these with little difficulty and soon reduced the prison to ruins. To make the attack seem more realistic, machine guns fired a volley as the tanks started.



WHEEL THAT WELDS SHOES
SPEEDS PRODUCTION 1819

Popcorn in Thin Paper Cones Can Be Eaten without Soiling Fingers; Squeezing Bottom Forces Corn Up

PAPER CONES FOR POPCORN
KEEP FINGERS CLEAN

Shoe soles and uppers are welded together instead of tacked, on a wheel apparatus now being used successfully in several American factories after its appearance in Germany. The machine has turned out as many as 900 pairs in a single day, and its essential function is to force the sole and upper together by compressed air. A special glue is employed, eliminating the need of tacks or thread. The wheel holds thirty pairs, that number being made at each revolution. Simplicity of operation, as well as a saving of time commends the process to the manufacturer. More than 60,000,000 pairs have been made by this method in Germany.

Cones of transparent paper have been introduced for holding popcorn, to keep the fingers free from butter and to simplify eating. The cone is held in one hand and pinched slightly at the bottom to force the corn upward.

HOW TO BEAR UP IN A GALE

TIRE CHANGED IN FEW SECONDS
WITH IMPROVED TOOL 1815

How strong the wind must be to blow a person off his feet has been calculated by an English scientist, who found that in an eighty-mile-an-hour hurricane the wind pressure equaled thirty-two pounds to the square foot. A bulky person, presenting ten square feet of area to the wind, would have to stand up against a pressure of 320 pounds. In an average strong wind, blowing thirty miles an hour, the wind pressure is four and a half pounds to the square foot. In a forty-mile wind, it becomes eight pounds; at fifty miles, twelve and a half pounds, and at sixty miles eighteen. This gives some idea of the enormous pressure which often wrecks signs and plate-glass windows. In a sixty-mile gale a window only ten feet square is subjected to a pressure of 1,800 pounds.

Tires on the model-A Ford can be changed in a few seconds and with little difficulty, it is said, by using a lever device now on the market. The wheel is laid flat on the floor or ground. In putting the tire on, the hooked end of the tool is placed around the tire and rim. A slight forward pressure on the leverage bar against the hub, permits the tire to slip on while the operator steps on the section not already in the rim. The tool will also pry the tire off.



Tire Tool for Fords; It Is Hooked over the Rim and Leverage Applied from the Hub

Pioneer Specialty Co. Chic.
5130

Leary Express
11/21/25

1806
Comp. C. The ...
St. NW, Washington D.C.



Two Hours

achines which have been in use for many years, and the stock exchange had arranged to install them as fast as they could be turned out.

Invention and mechanics play a large part in the operation of the stock exchange. Without the telephone and the telegraph, a six-million-share day would be a physical impossibility, both because distant investors from all parts of the country could not be in instant touch with their New York brokers and because the brokerage offices themselves could not handle the sales.

Follow the route of a sale from the time the order is given until it is filled and the customer notified, and you find the biggest part of the work is being done by electricity. Take the case of a man in, let us say, Seattle, who wants to buy one hundred shares of U. S. Steel. In his local brokerage office a trans-lux machine is throwing the image of the ticker

© New York Stock Exchange
Page Telephoning Quotations from a Trading Post to the Quotation Room, New York Stock Exchange

AT 5:42 o'clock on a recent afternoon, the ticker service pounded out the last 700 shares of a 6,458,700-share day on the New York stock exchange—a sale that had occurred two hours and forty-two minutes before—and came to rest. Taking the estimate that the average price of all stocks traded in on the “big board” is \$84, a \$546,000,000 business had been done between 10:00 a. m. and 3:00 p. m., which explains why the overworked ticker bogged down and finished up nearly three hours after the bell rang as a signal to cease trading.

Anticipating just such a breakdown, inventors had already developed a new type of ticker that can write 900 characters instead of the 300 per minute on the ma-

tape on a screen, so that every occupant of the room can see the latest sales quotations, telegraphed direct from the New York stock exchange just as they are made—that is, on days when the ticker has not fallen behind.

The customer watches Steel quotations, decides to buy, and writes out his order to buy “at the market.” The blank is handed to a telegraph operator and the order dispatched by electricity over a private telegraph wire to the firm’s New York office. There it is telephoned, again by electricity, to one of the firm’s telephone men seated in one of the many booths that line the edge of the trading floor. The order taker presses an electric button and a number panel flaps down on a big call board high on the wall, signaling a floor trader that he is wanted at his telephone booth. He rushes over, gets



Getting the Market Report in a Broker's Office; at the Right Is the Board and in the Background the "Trans-Lux" Screen on Which the Moving Tape Is Reflected

the order, dashes out to the trading post at which U. S. Steel is listed and listens a moment for an offer to buy or sell, to get the market quotation. Some trader offers a block, the buyer with the hundred-share order nods or says, "Take it"; both buyer and seller note the deal on slips of paper—no written agreement is exchanged between them—and the deal is closed. The buyer notes his purchase and the price on a slip, hands it to a messenger to be telephoned back to the office, and his part is completed.

Again the telephone and telegraph are used, and within a matter of minutes after the order was written, the customer in far-away Seattle is informed he owns a hundred shares of Steel and the price he paid for it.

Before 2:00 o'clock of the following afternoon, the seller in New York will deliver the stock certificate to the broker representing the buyer, it will start westward, probably by air mail, and will be paid for on the coast.

That, in brief, is the history of every stock sale. If the buyer is in New York,

the telegraphing will be eliminated, and if his order is for less than one hundred shares, instead of going to a floor trader it will be dispatched from the telephone booth by pneumatic tube to an "odd lot" broker at the trading post, but those are minor differences.

The business of the stock exchange is chiefly to provide a place for traders to congregate and make their deals, and a system of reporting all sales as promptly as possible so that not only the floor traders, but brokers and customers all over the country, can be kept informed of current quotations. The exchange also makes rules that govern the conduct of business and sees that every member lives up to his contracts.

Business opens at 10:00 each morning, when the chief reporter, in a lookout tower, taps a big brass gong, and continues without break until 3:00 p. m., when another boom of the gong suspends business for the day.

Between those hours the floor below is a bedlam in which nearly a thousand men move and shout. There are brokers who

1806



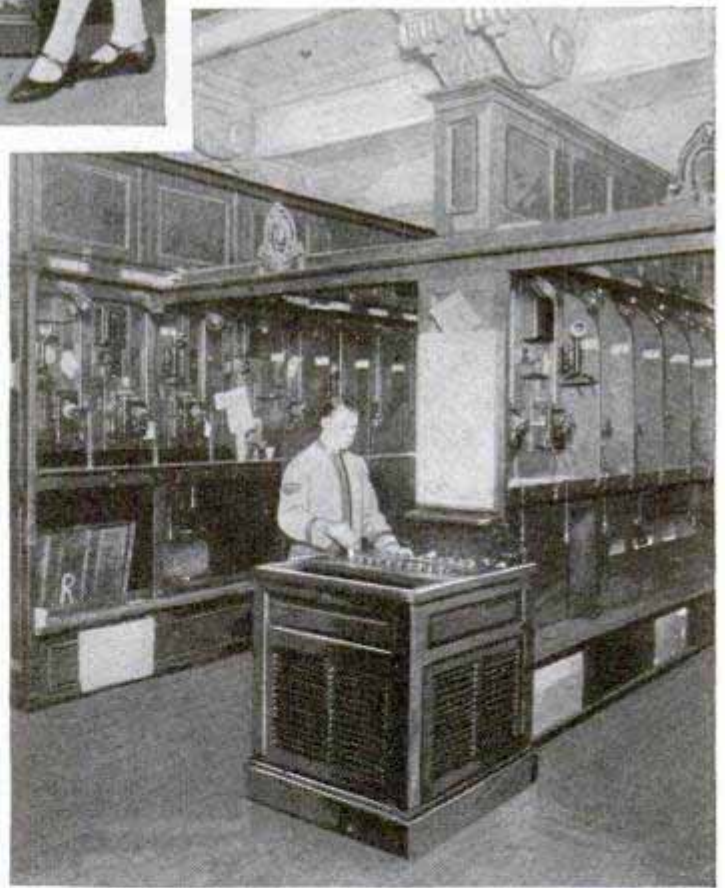
call. Every one of the 1,100 members of the exchange has an individual call number.

The same day the market was handling nearly six and a half million shares, a "seat" on the exchange sold for \$525,000. A seat is one in name only, for the holder is too busy to sit down from the time the opening bell rings until trading closes in the afternoon.

His business centers during the day about the twenty trading posts in the main room, the ten in an adjoining chamber, and the money desk, where offerings of money to lend on collateral security are received by the money clerk from the various banks. Here the brokers who desire to borrow money are accommodated.

buy and sell on commission for others. Dealers and traders who buy and sell for themselves, "Two-dollar brokers," the free lances of the floor, who got their name in the old days when \$2 was their customary share of the \$12.50 fee then paid as commission on the purchase or sale of each hundred shares of stock. Telegraph and telephone operators, reporters, pages, messenger boys and guards fill in the gaps. There are 1,100 telephone clerks alone, sitting in front of a total of 1,600 telephones. The clerks wear headsets, with transmitters strapped about their necks, like telephone operators, to leave both hands free for their work.

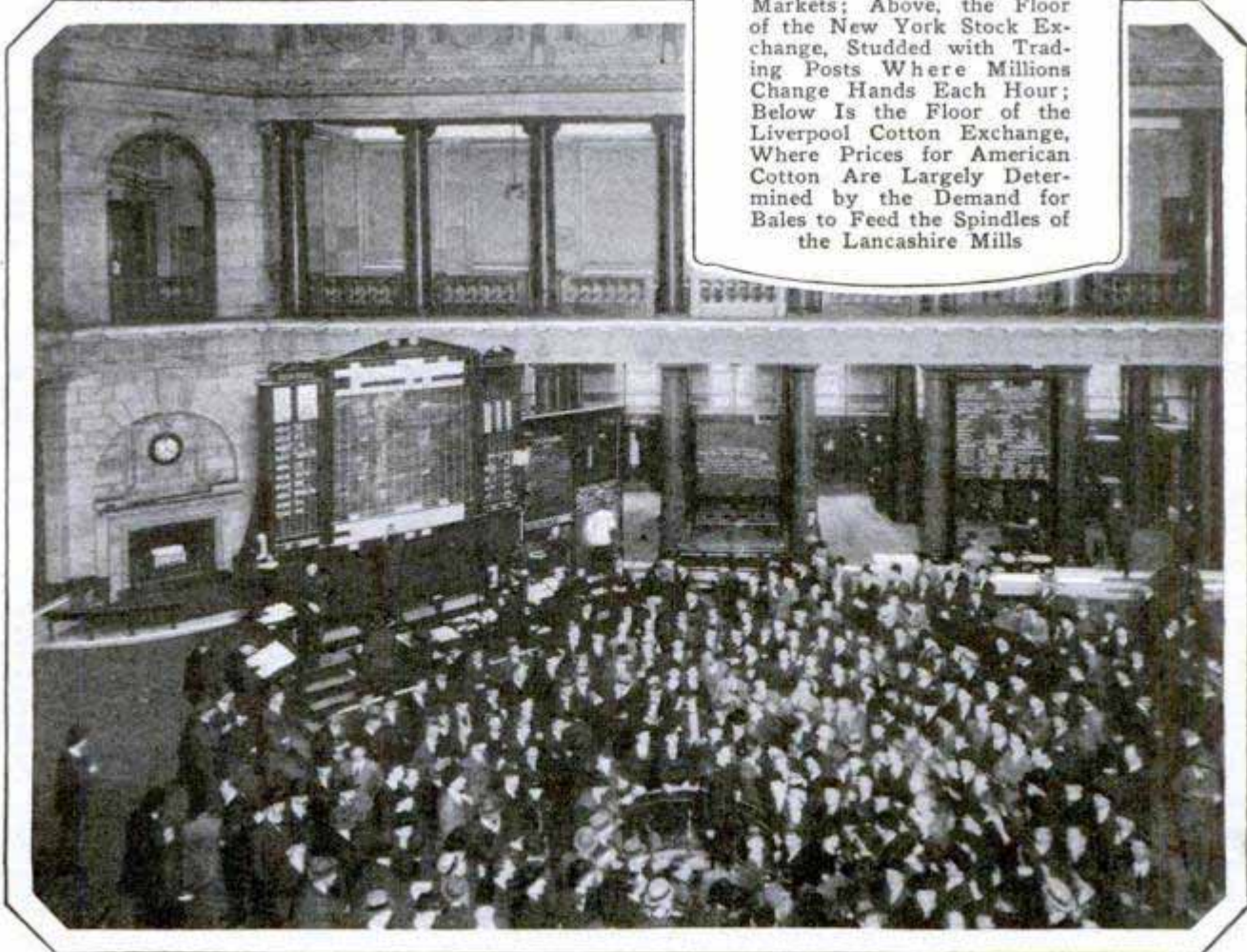
High on the wall at one end of the room are big black frames, twenty feet square—the annunciator call boards. When a clerk takes an order he presses a button, and a number plate, as big as an automobile license, flaps down and remains visible until the floor man assigned that number answers the



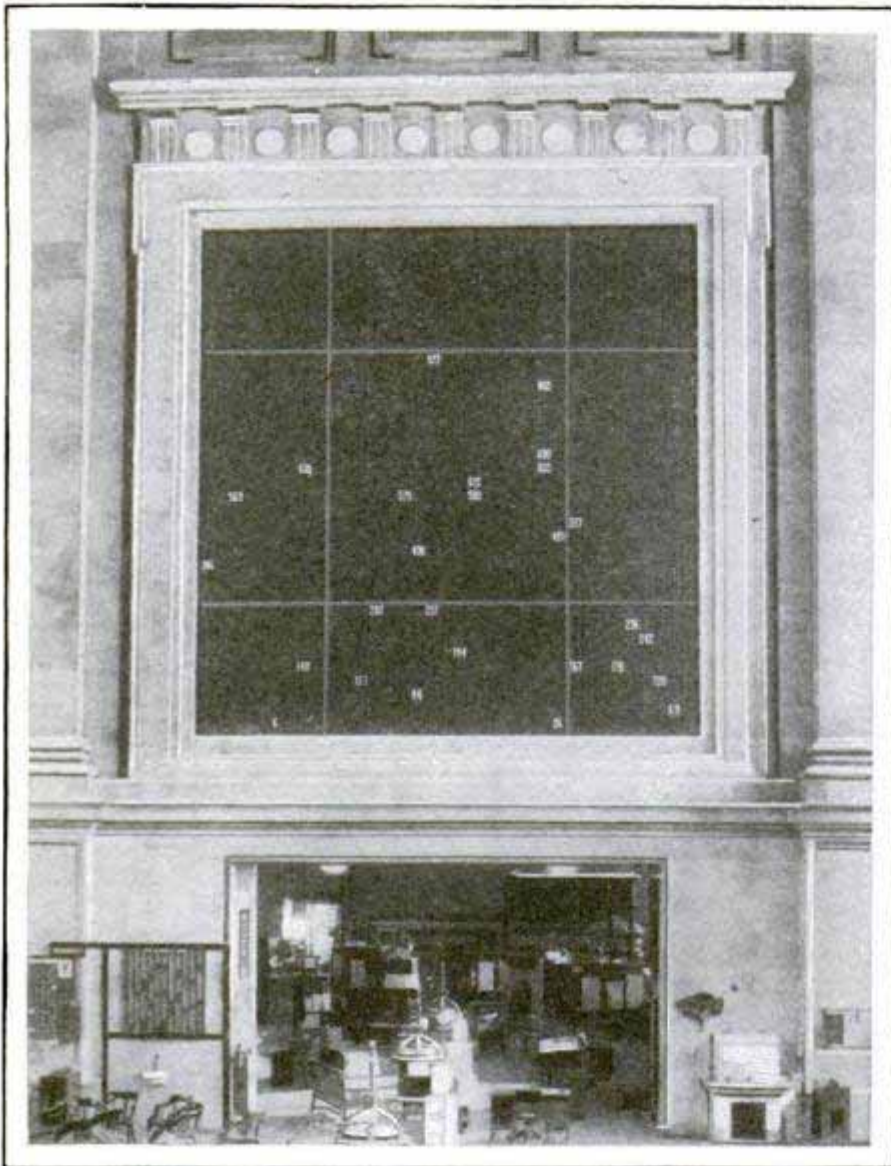
Trans-Lux Screen and Ticker. Top, and a Stock Exchange Page Dispatching Orders through Pneumatic Tubes to Trading Posts

The trading posts themselves are circular booths some ten feet in height. Their upper portions have twelve faces, each decorated with a list of stocks, followed by movable figures to show the last

1806



Two of the World's Greatest Markets; Above, the Floor of the New York Stock Exchange, Studded with Trading Posts Where Millions Change Hands Each Hour; Below Is the Floor of the Liverpool Cotton Exchange, Where Prices for American Cotton Are Largely Determined by the Demand for Bales to Feed the Spindles of the Lancashire Mills



When a Broker Is Wanted at His Telephone Booth to Receive an Order, His Number Appears on One of These Huge Annunciator Boards

price at which a sale was made. Below each stock there is a record of its movements for several weeks back. On one side of each post are pneumatic tubes for the so-called specialists—men who deal in some specific stock or stocks alone, and the odd-lot men, who handle sales of less than one hundred shares.

The ticker transmitters are out on the floor, with an operator at each to tap out, on a typewriterlike keyboard, the record of each sale as it is brought to him by one of the reporters. When sales start, the reporters are gathered around each post, ready to listen in on the trades made, note the stock, the number of shares sold and the price paid, and rush the slip to a ticker operator to be transmitted to every brokerage office in the country.

When sales passed the six-million mark in November, the exchange met the dif-

ficulty temporarily, until the new ticker equipment could be installed, by dropping the number of shares from the report, noting only the name of the stock and the price paid. A car load of special telegraph printers was rushed from Chicago to New York on the Twentieth Century limited and within a few hours lines had been rigged into every newspaper and press-association office in the city to carry the sales figures, so that newspaper tables could be compiled as usual.

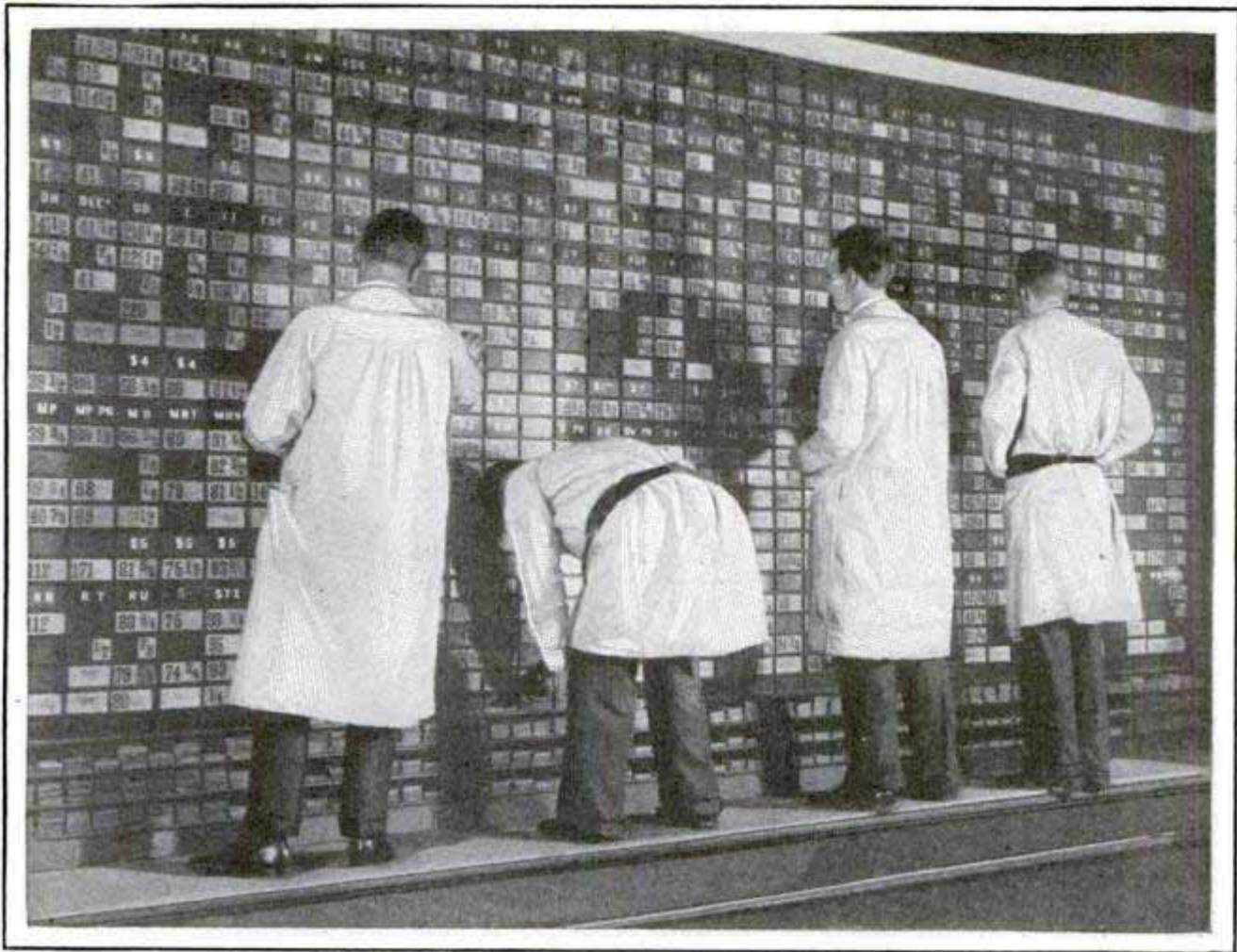
The amazing thing about the stock exchange is that such a vast business can be conducted without the exchange of even a written memorandum. When a broker sells or buys in the morning at one price, and later in the day discovers a much larger profit could have been made or a loss averted by postponing the deal, there may be a

desire to "welch," but such a thing is unknown. The exchange irons out differences between members, but, considering the vast business handled, differences are few and far between.

Normally, business is conducted almost entirely on the basis of the ticker reports, as brokerage offices and customers alike depend on them to show the state of the market. When the ticker falls an hour, two hours, or even more, behind, the sales orders to "buy at the market" are entered blindly, for the customer has no means of knowing what the market may be, or a "bear" movement may have started and forced it down far below the recorded price.

It is for this reason that a better ticker service has been so urgently needed.

The floor telephones alone carry an enormous volume of business, for more



Clerks Posting Quotations on the Board in a Broker's Office; from Ten to Three They Labor to Keep the Board Up with the Ticker, in Order That Customers May Have Latest Figures

than a million phone calls, it is estimated, are made on a busy day. Control of vast industrial empires may change in those five hours of activity, and thousands of people may be enriched or made poorer. Business has increased thirtyfold on the exchange since 1900. Fifteen million people, it is estimated, own stock in American industries, with an investment of something like \$350,000,000,000.

And the whole business is sealed with a nod of the head or two words—"Take it."

The procedure on the stock market differs notably in at least one particular from that used on Chicago's famous Board of Trade, where the bulk of the nation's grain crops are handled. Under the stock-market rules, only oral sales can be made, whereas the grain traders of Chicago have a complicated system of finger signals to supplement their voices. The wheat or corn pit on a busy day is even more of a bedlam than a trading post of the stock exchange, with hordes of brokers shouting and waving their hands, alternately

extending and closing their fingers as they indicate the prices at which they will buy or sell.

The grain pits get their name from their construction. Instead of a trading post, a huge circular pit is provided for each grain dealt in. The pit is formed by building up three steps from the main floor, and three down into the center pit, giving an amphitheater for the traders, who not only can fill the center, but, by standing on the surrounding steps, see over the heads of those below.

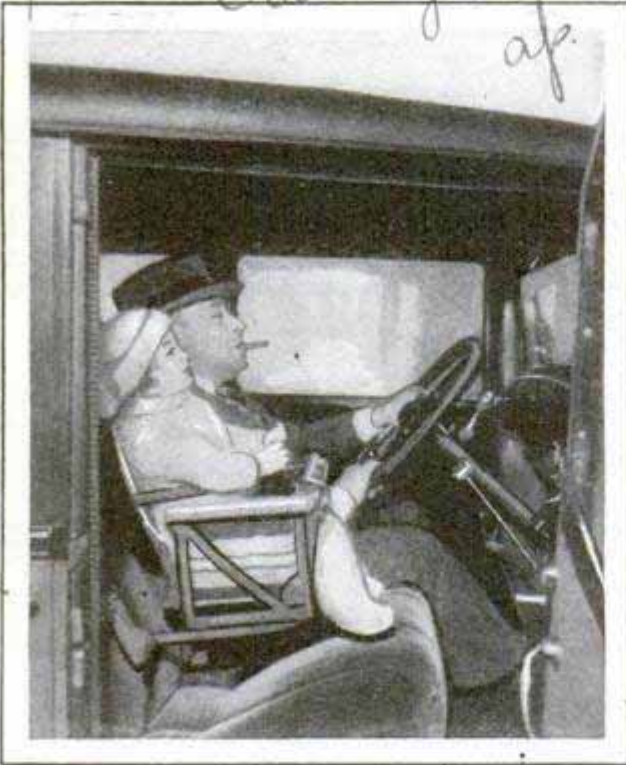
GEARLESS TWO-SPEED AUTO HAS VALVE CONTROL

1835 A gearless motor for automobiles has been developed by a California inventor. Its basic principle is a controlled valve inclosed in an oil-filled cylinder. There are only two speeds with an unbroken range of power between the two. The speed at which the engine may run depends upon the degree of valve opening.

Alameda, Calif.
Dr. A. A. Kuttles,
 2053 Pacific Ave

Ben Koral Co.
363 E. Ohio
Chicago.

183



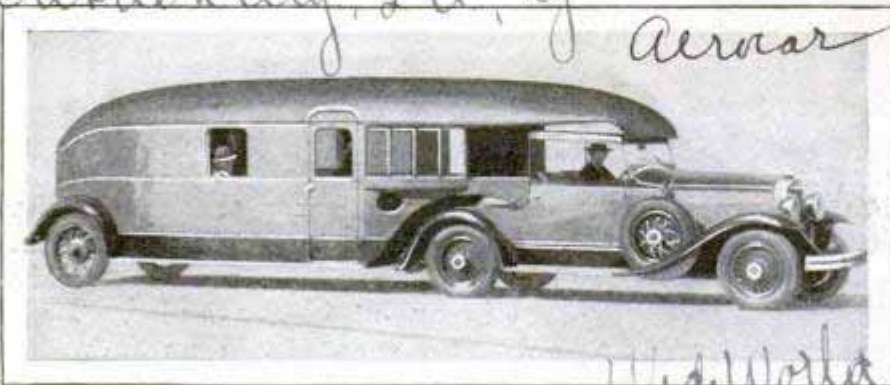
A Safe and Comfortable Auto Seat for the Baby; It Can Quickly Be Converted into a Crib

AUTO CHAIR AND CRIB IN ONE INSURE INFANT'S SAFETY

For the safety and comfort of a small child while riding in an automobile, a combination chair and crib has been introduced. It hangs over either side of the front seat and can be revolved in any direction desired. Parts that come in contact with the upholstery are covered with rubber to prevent damaging the fabric.

COMBINED BUS AND TRAILER DEVELOPS HIGH SPEED

For comfortable cross-country touring, a combination motor coach and trailer has been designed by Glenn Curtiss, pioneer aviator. He has incorporated lines of air-



For Fast and Luxurious Travel by Motor Bus; the Combined Coach and Trailer Designed by Glenn Curtiss

craft in its form and has reduced the weight below that of other vehicles of this size and capacity. The long wheelbase affords ease in riding, and the coach develops high speed. On a recent run from Florida to Detroit, it averaged more than forty miles an hour.

MEASURE OCEAN BY ECHOES FOR SAFER SHIPPING

How man is utilizing echoes to realize greater safety on the seas is one of the romances of modern scientific progress. For the first time in history, adequate marine charts have been prepared for Pacific coast shipping by this method, and the work is being extended over other areas where mariners need reliable guides to avoid the menace of hidden reefs and shoals. The plan is simple, in the light of modern knowledge, but would have been considered little short of miraculous just a few years ago. A sound is sent from the survey ship. It speeds to the bottom of the ocean at the rate of about 4,800 feet a second, for sound travels much more rapidly through water than through air. It bounces back. Sensitive recording apparatus registers the elapsed time between the sending of the sound and its receipt back at the ship in the form of an echo. The computation of the depth at that point, thus becomes a simple problem in mathematics. But the ship can do more than merely measure the depth. It also charts the location of the spot at which the sounding was made with respect to the shore, and this is exceedingly important to the mariner. Other important advantages of the method are that it can be carried on at night and in fogs, and is rapid and effective even at great depths.

The Popular Mechanics' Bureau of Information offers its free service to all readers of our magazine. Names and addresses of manufacturers and dealers in articles described, and any other details in our possession, will be promptly furnished.

Carl of Rockies \$9.60
W. \$10.00
See also Seph 1929-457

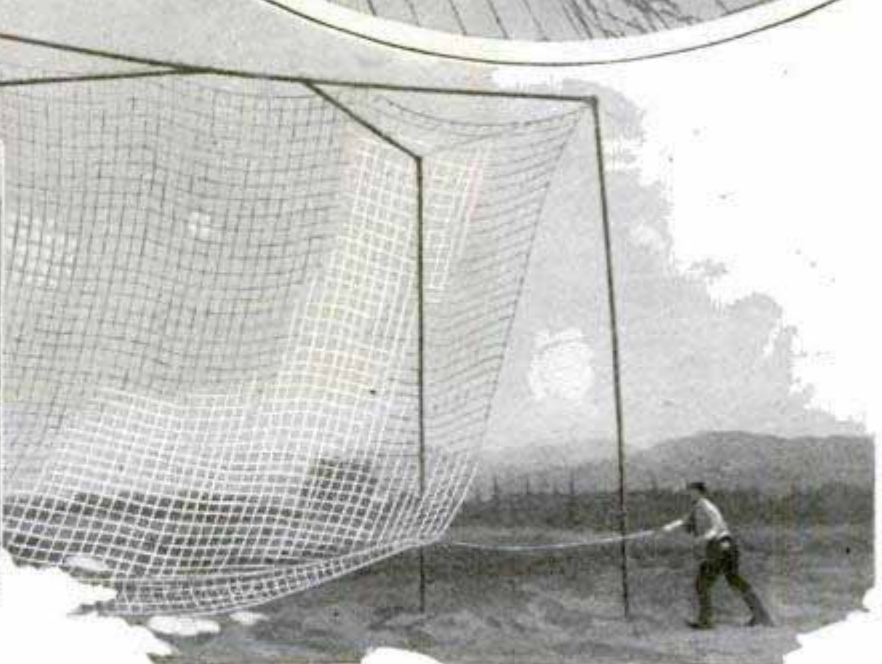
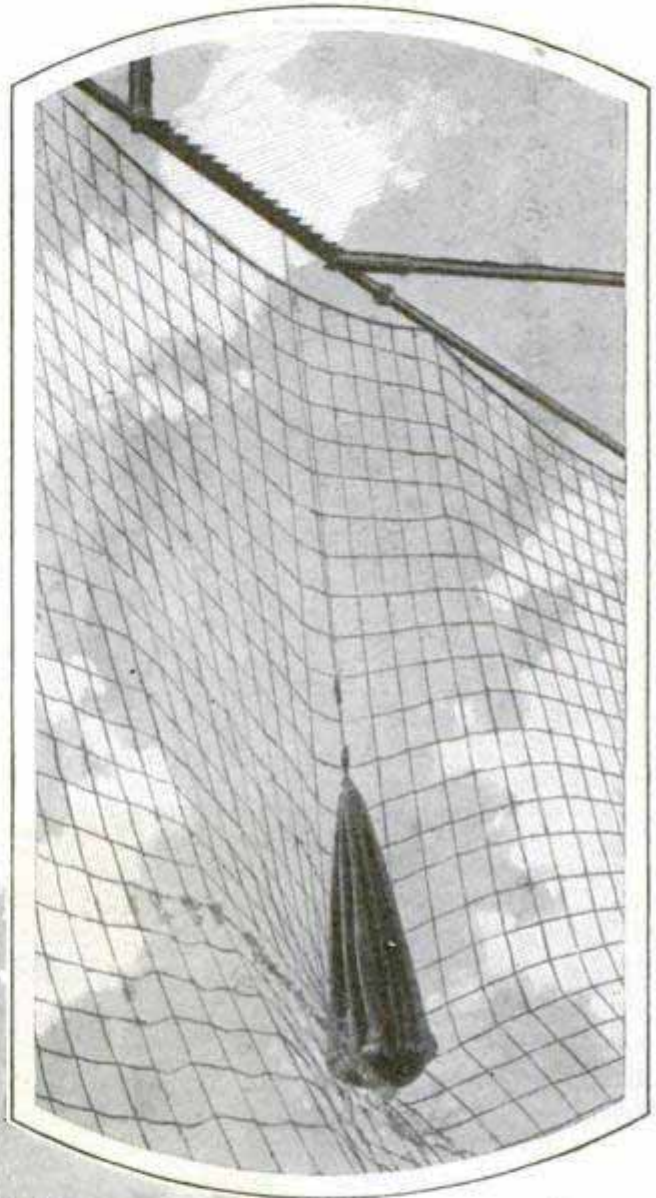
1862
Wash 11/24/28
Aerocar
W. W. W. W.

Curtiss Aerocar Company of Florida, Inc.
also Links File

*Whittier
Calif. 207.*

AIR MAIL DELIVERED ON FLY INTO NET WITH TEETH

Successful tests have been made with a special landing net for the delivery of mail bags and other parcels from moving airplanes. The bag, attached to a rope, is lowered from the plane and as the ship moves over the net, which is stretched on uprights, the rope is severed by sharp teeth on one of the crossbars of the cage. The bag is let down from a reel controlled by the pilot, and is kept from falling forcibly to the ground by the net. This is considered an advantage over some other methods proposed for delivery of packages from planes while in motion and is an improvement over the parachute idea, as no time is lost in recovering the bundle. There is an ample supply of rope on the reel so that the pilot does not have to descend to a perilously low altitude to make delivery. The cage is strongly braced and can be set up or taken down in a few moments.



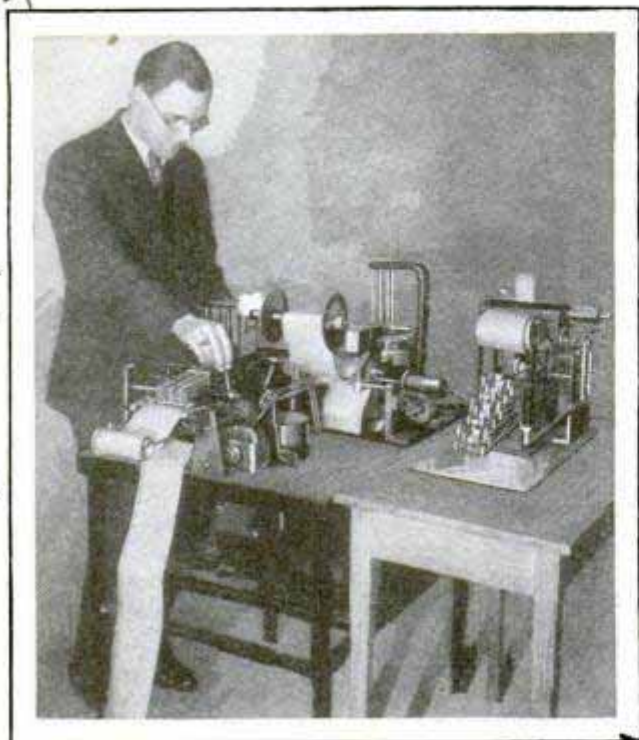
Bag in Cage Showing Teeth That Cut the Rope; the Lowering Reel on Side of Fuselage near the Pilot and Net Ready for Catching a Bag from Approaching Plane; the Trap Can Be Set Up in Any Part of the Field and Is Taken Down or Assembled in a Few Moments; Side Arms Direct Rope against the Knife

This
Airplane
easiest
A recent
vertical
the pow
lines, co
roadsters
and carry

CURT

CUR

MACHINE HELPS CHOOSE CAREER BY SHOWING TALENTS



Mechanism for Measuring a Person's Fitness for Different Careers; It Tabulates Results of Tests

To help a person determine his life's work according to his abilities, Dr. Clark L. Hull, of the University of Wisconsin, has devised a machine that correlates the results of various written and oral tests on the subject and summarizes the findings. Data from thirty or forty examinations as to the person's character, temperament and other qualities are represented by perforations on a paper tape which is run through the machine. As the strip passes along, it automatically records on a length of metal, the individual's bent as regards several of forty or fifty occupations. As the choices are made, they are noted by the machine on a card which is inserted at the same time as the paper tape. By examining the card, the subject can determine his natural fitness for certain lines of work or those in which his chances for success seem best.

BETTER LIGHTS FOR SUBMARINES TO REDUCE ACCIDENTS

Changes in the methods of lighting submarines to make them more easily seen when running on the surface, are among the recommendations to be made to the navy department by the submarine safety

board. Other improvements include a new type of door designed to facilitate the isolation of a punctured compartment, better equipment for the crews, comprising a special boot which can be easily removed, diving helmets, a system of valves, one on each side of each compartment, to which a diver might quickly attach lines to give fresh supplies of air, and sets of lifting eyes or pads built into the outer walls of the submarines to facilitate raising. The board had more than 5,000 suggestions from which to choose in making their recommendations and also sought the advice of submarine officers. Many of the ideas sent in were the result of the tragedies of the "S-51" and the "S-4."

TALKING MOVIES FOR THE HOME LATEST ENTERTAINMENT

Synchronized sound and moving pictures are now available for the home as well as the theater in a simple outfit recently introduced. It consists of a small projector, geared to a turntable with tone-arm and electric pick-up which connects the sound from a radio loud speaker. Special films and records are provided each month for a fresh supply of entertainment. The unit is operated by electric current from a lighting socket. Films or records may be run separately if desired.

HAMMER AND WRENCH IN ONE SIMPLIFIES TIRE CHANGE



Hammer and socket wrench are combined in a useful tool for changing auto tires. It is made of forged steel, and the wrench side is furnished in a ratchet type, or with a hexagonal shank, for mounting interchangeable

socket-wrench caps. The handle is marked to serve as a gasoline gauge and the tip is tapered for prying off rims.

There are more dairy cows in India than in any other country.

Ent. Walter H. Doremus
341 W. Dayton St
Madison Wis

Professor of Psychology

Cine Tone \$185.00
10.70
55.80
The The Very Corp 411
Chicago
825
Hammer & Wrench \$8.00
Grip

Christian Science
11/26/28

Griffith Cool Works
500 Commerce St

new 11/20/28
Cheaply
cheaply

ALUMINUM SUITS TO RESIST TEARING

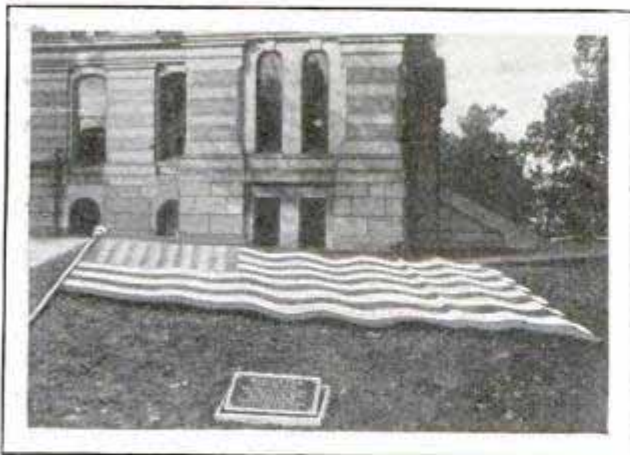
1816

Clothing made of aluminum will be in vogue within the near future, a German metallurgist predicts. He points out that the material is already being used successfully to cover shoes, pocketbooks and vanity bags and is also being employed in the interior decoration of airplanes. The metal, in the form of thread, can be stretched through layers of cellulose superimposed upon it and subjected to pressure, and is not likely to tear or crumple, the expert declares. Considerable quantities of aluminum brocades, for women's garments, are being exported.

WAVING CONCRETE FLAG IS WAR MEMORIAL

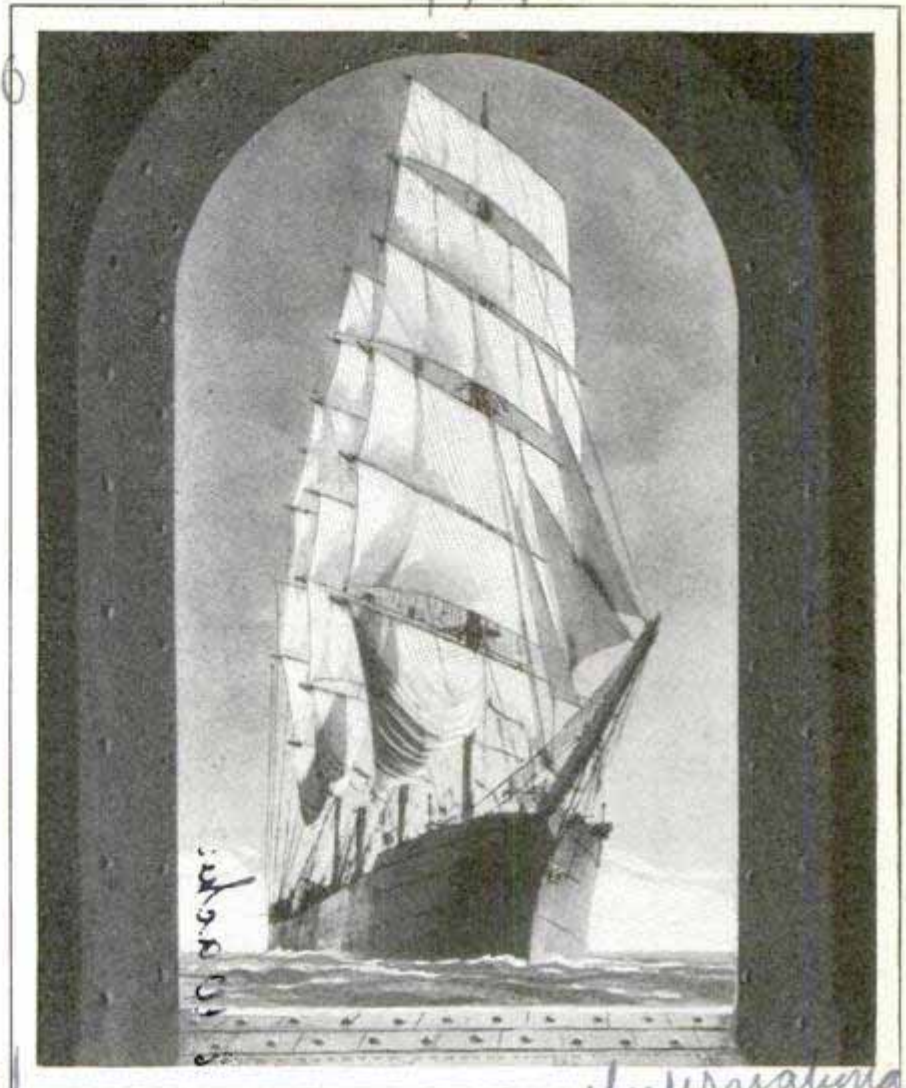
174

Concrete has been used successfully as a substitute for fabric in fashioning a large replica of a United States flag for a war memorial at Quincy, Ill. The surface has been designed to give the appearance of being blown by the wind, while the stripes and



Concrete Flag as War Memorial at Quincy, Ill.; It is in True Colors and Appears to Wave

field are colored in the true shades of the national emblem.



Photograph of the Four-Master "Parma," One of the Few Surviving Ships of Its Kind, Taken from Another Vessel

SAILING SHIP IS PICTURE QUEEN IN OCEAN TRAVEL

Although steam and motor vessels are far more efficient commercially than sailing ships, the latter still hold the popular appeal from the standpoint of majestic beauty. The accompanying photo of the four-master "Parma," was taken after its 100-day voyage from Hamburg to Chile.

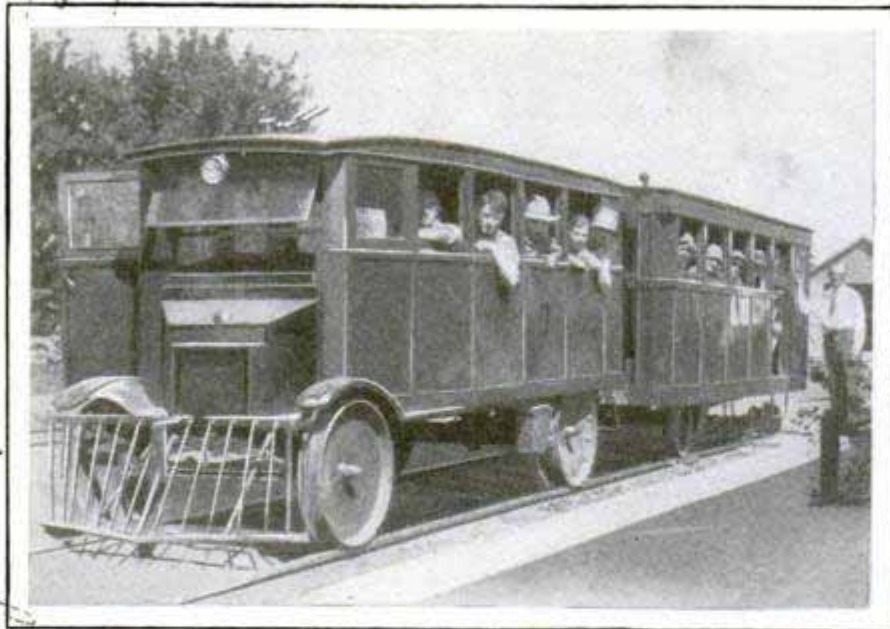
DEEP-SEA WATER "IMPORTED" FOR AQUARIUM FISH

1997

More than 100,000 gallons of sea water, pumped from the Atlantic far beyond the oil-contaminated area around New York city, was poured into the reservoir under Battery park recently for the aquarium specimens that thrive best in water free from pollution. A constant stream of fresh sea water flows from the reservoir to the tanks where the fish are kept.

Cons. Bureau of Boston, Nat. Herald
9250 Gates Ave.

6-1. Staircase, Tabor, Iowa



Typical Train on the One-Man Railroad in Iowa; It Is Powered with a Small Automobile Engine

TRAIN ON ONE-MAN RAILROAD RUN BY AUTO ENGINE

What is said to be the shortest railroad in the country is the eleven-mile line running between Tabor and Malvern, Iowa. It is owned and operated by one man, and the trains of special cars are powered with small automobile engines. These units are operated during the slack season. The road has a value of \$135,000, according to the interstate commerce commission, and serves a farming district which, on account of its productivity, is known as the "Bread Basket of the World."

are discovered, he endeavors to purchase the articles, but if the owners wish to keep them, he advises the finders as to their probable value and the best means for preserving them. Bits of precious metals, broken jugs, urns, coins, tiles and skulls are among the articles which the "champion building watcher" has found. Recently, excavators stumbled upon the remains of a medieval wine cellar. All but one of the jugs were broken and that was empty. The steam shovel and the

pneumatic drill have increased the difficulty of the museum expert's task, for many relics are carried away or destroyed by these machines.

SHEEP-FOOT TAMPER ROLLERS PRESS SOIL FIRMLY

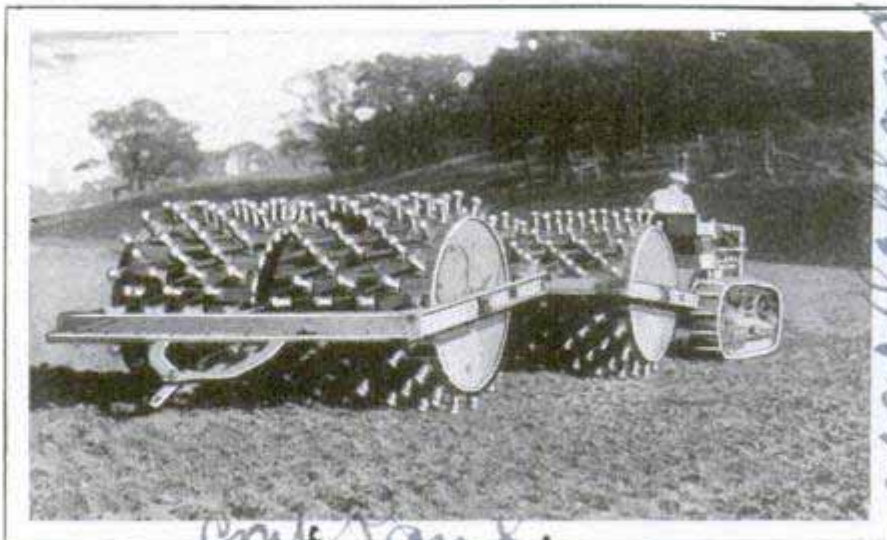
1678

Fitted with extensions shaped like sheep's feet, a roller used for heavy work in California is said to tamp the soil more firmly than is possible with the usual style of roller. The feet help break up the clods and press more deeply into the ground than a flat surface will do. The rollers themselves are weighted with water and are emptied after the machine has done its work in a field, in order to facilitate transportation on roads and elsewhere.

EXCAVATION WATCHER ON HUNT FOR RELICS OF PAST

1798

Stealing a moment or two from work to watch excavators dig the foundations for big buildings, is the daily pleasure of thousands of city dwellers, but London has a man whose business is to do what others regard as an idle amusement. Wherever a building is being torn down or a new foundation being dug, he is on hand to find, if possible, relics of Roman days for the city museum. When such things



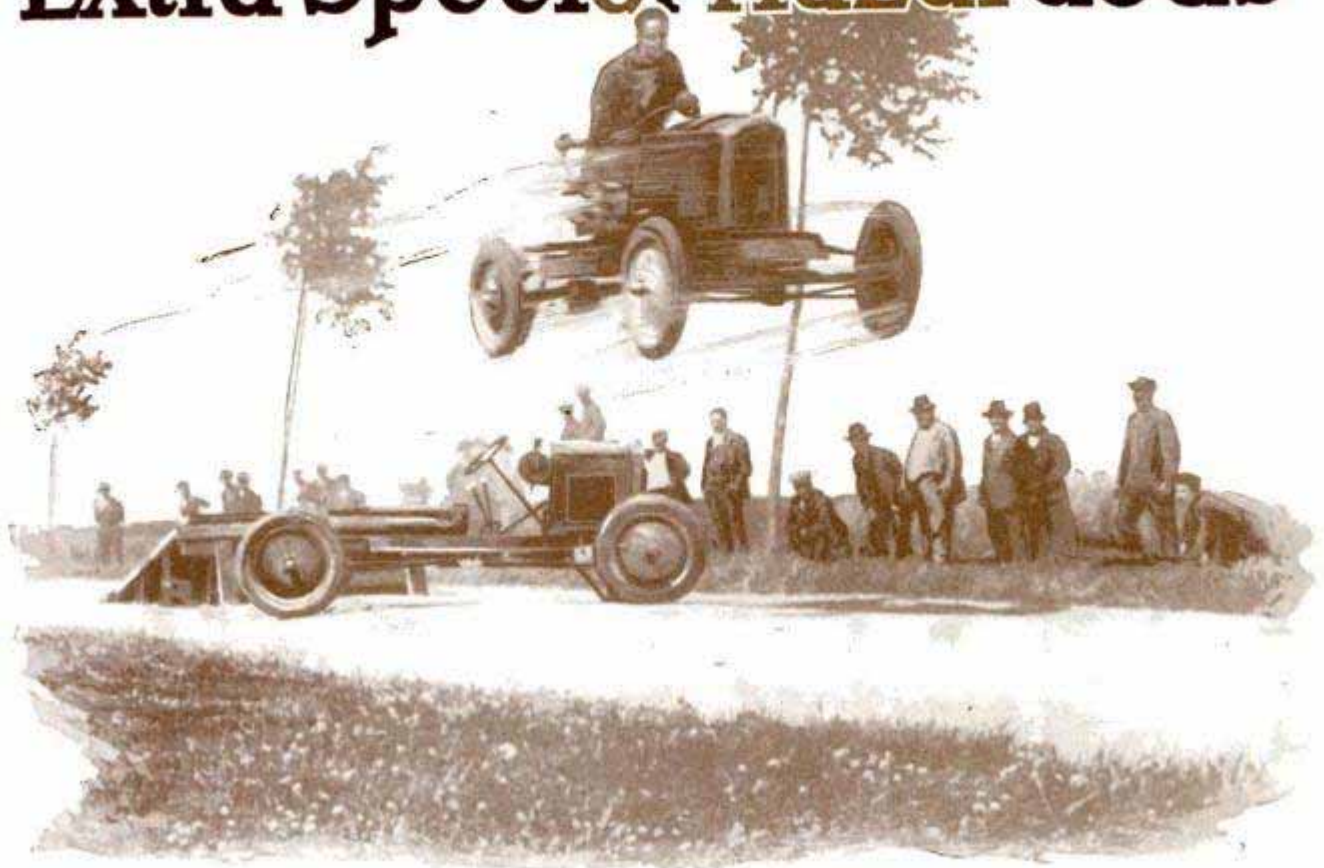
Roller with Feet That Help Tamp the Soil and Break Up Clods; the Rollers Are Weighted with Water

near Oakland Cal

Lafayette Steam of East Bay Municipal

ny 11/18/28

Extra Special Hazardous



Jumping over One Automobile in Another Makes the Jumper a Poor Insurance Risk; No Accident Company Will Solicit His Business and, If He Asks for a Policy, Limits the Amount

“YOURS,” says the insurance agent to whom the prohibition agent has applied for an accident policy, “is an extra-special hazardous occupation. Our company limits accident insurance policies on enforcement agents to a principal sum of \$500 and weekly benefits of \$2.50.”

That, with a change in occupation and the insurance that may be written, is the answer a wide variety of people get when they seek an insurance agent and solicit a policy—for such occupations are never visited and asked to buy insurance.

Insurance, whether it is life, health or accident, ranges through a variety of risks from preferred, ordinary and medium, to the hazardous, special hazardous occupations, and so to the elite of dare-devils, who rank as extra-special hazardous.

Take the animal trainer who wrestles with the lion in the steel-barred cage of the mammoth shows. He’s a poor insurance risk—“Ex. Spl. Haz.,” the manual says. The dainty aerialist swinging from a trapeze overhead, along with all other circus performers and animal trainers, gets the same rating.

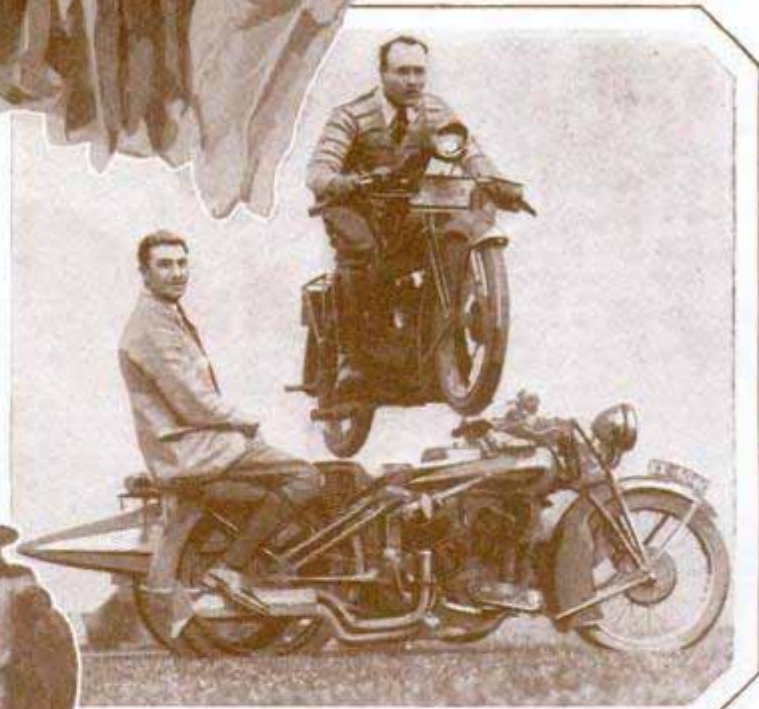
Out in the woods, the loggers, hewers, choppers and sawers are in the same class, and, at sea, submarine crews and common sailors on the surface share the rating.

Aviators are poor risks and must pay extra premiums to get even limited insurance. Most of the bigger companies have no such thing as prohibited risks in the accident department, insuring everything from flyers, through railroad freight brakemen and steel-construction workers to nitroglycerine makers and users—four of the world’s most dangerous occupations. They even have rates for steeplejacks. Even city firemen and policemen riding motorcycles come in the extra-hazardous and special-hazardous classes, though neither ranks as Ex. Spl. Haz. Not all of the dare-devil occupations which are listed are things that thrill the public, acid makers, for example, or mining prospectors.

1653



The Dainty Aerialist of the Circus, Swinging from Her Rings High in the Air, and the Lowly Canvasman on the Ground, Alike Are under the Insurance Ban, Because Their Work on the Lot and the Constant Traveling by Train Render Them Liable to Accident

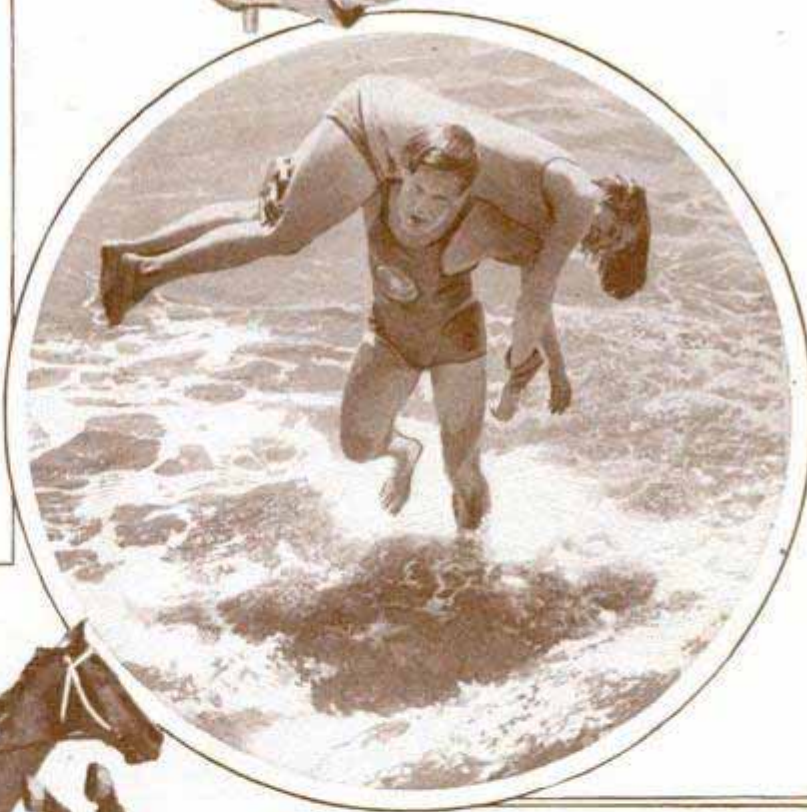


Another Poor Risk Is the Motorcycle-Stunt Man and the Motorcycle Racer; Professional Athletes of All Sorts Are in the Hazardous-Occupation Class; at Left, an Easy Way to Get Injured or Killed Is Riding Outlaw Horses in a Rodeo; This Indian Was One of the Performers in the Fourteen Tribes' Ceremonies in N. Mex.



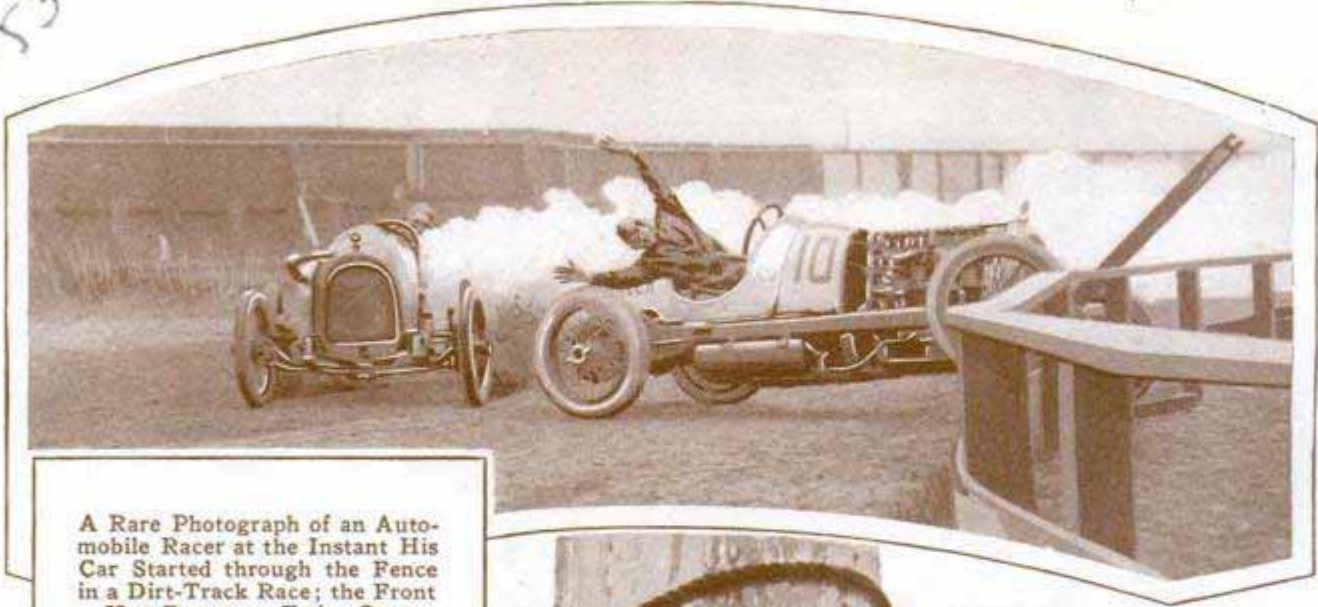
Photo, Ewing Galloway

The Man Who Paints Structural Steelwork Has to Be a Human Squirrel, and Is Entitled to His Place in the Gallery of Dare-Devs; at Right, Stubby Kruger, Who Quit as World's Back-Stroke Champion to Become a Professional and a Life Guard at a Long Beach, Calif., Pool, Demonstrates His Ability at Rescuing Fair Swimmers; Insurance Men Look Askance at Life Guards Because of Their Work. Their Small Number, Too, Makes Them Poor Risks, for Successful Insurance Depends Largely on Spreading the Risks over a Great Number of People in the Same Occupation

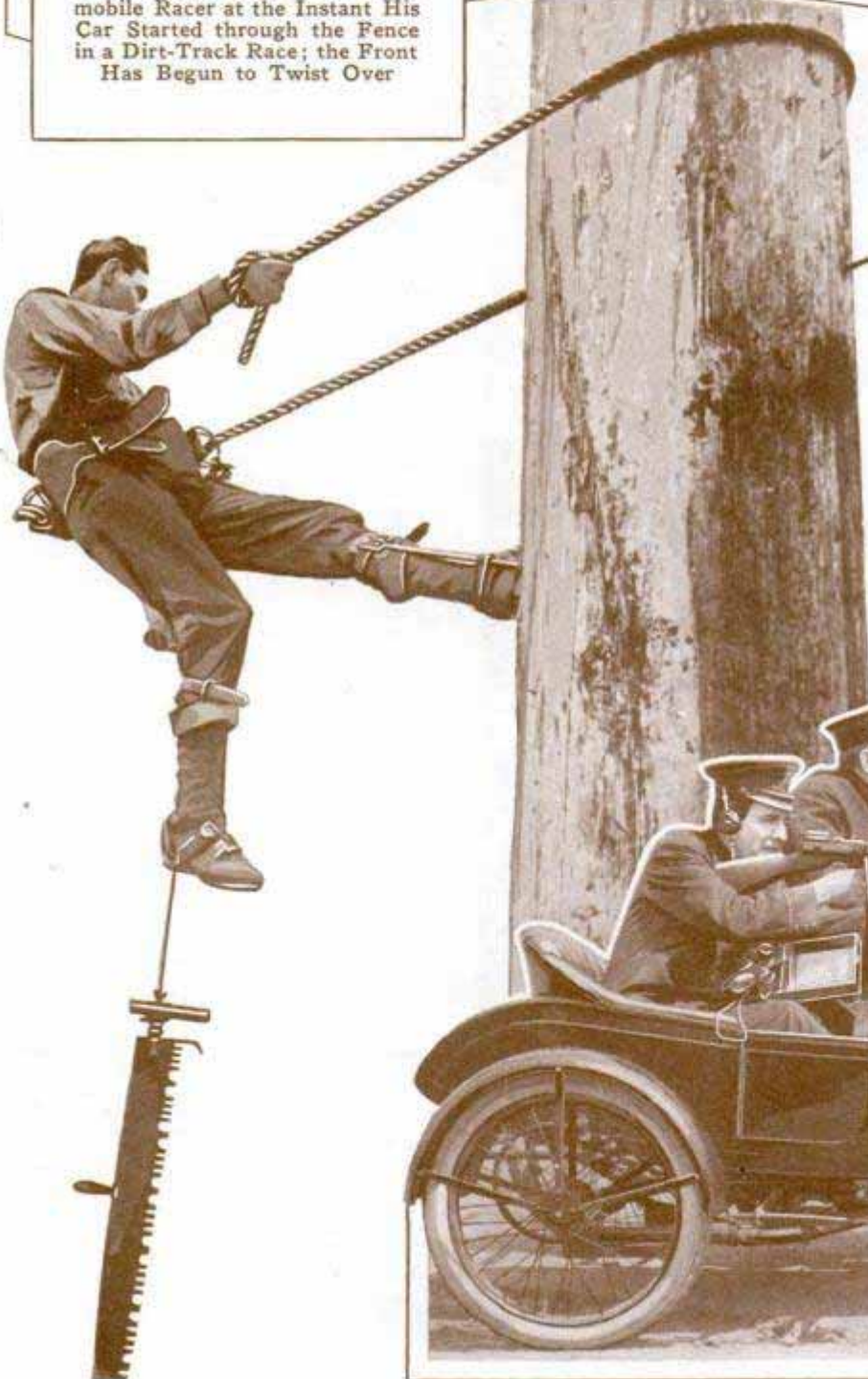


Jockey McKinney Caught in the Act of Acquiring a Broken Collar Bone in a Fall with His Mount "Mayflower" in the Oaklands Hunt Cup Race in Melbourne, Australia; Accidents and Riding Go Hand in Hand, and a Jockey's Life Is One of Constant Exposure to Crippling Injuries, If Not Fatal Accidents

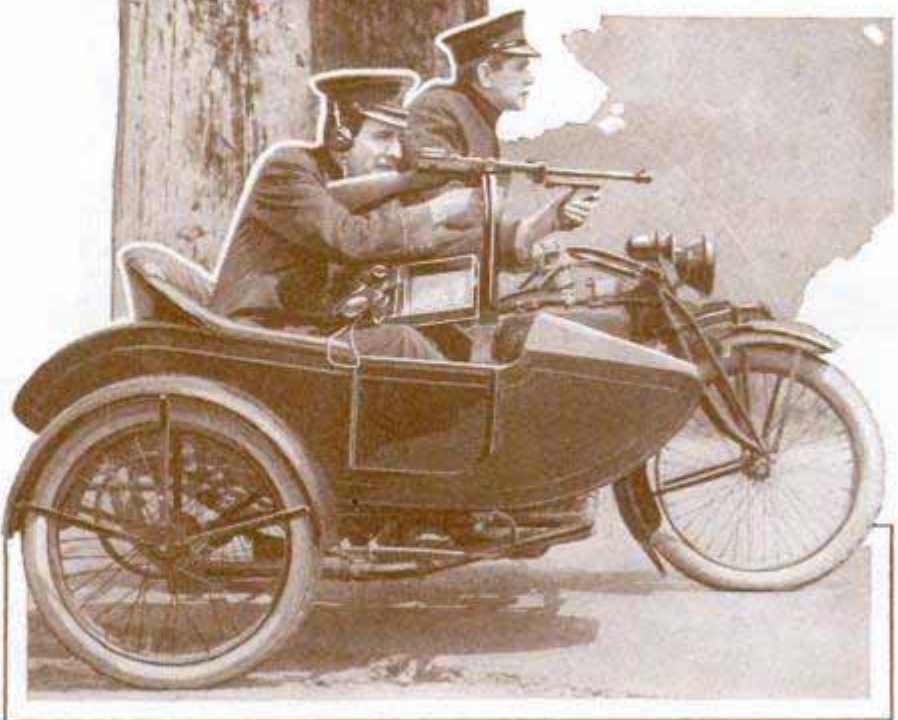
1653

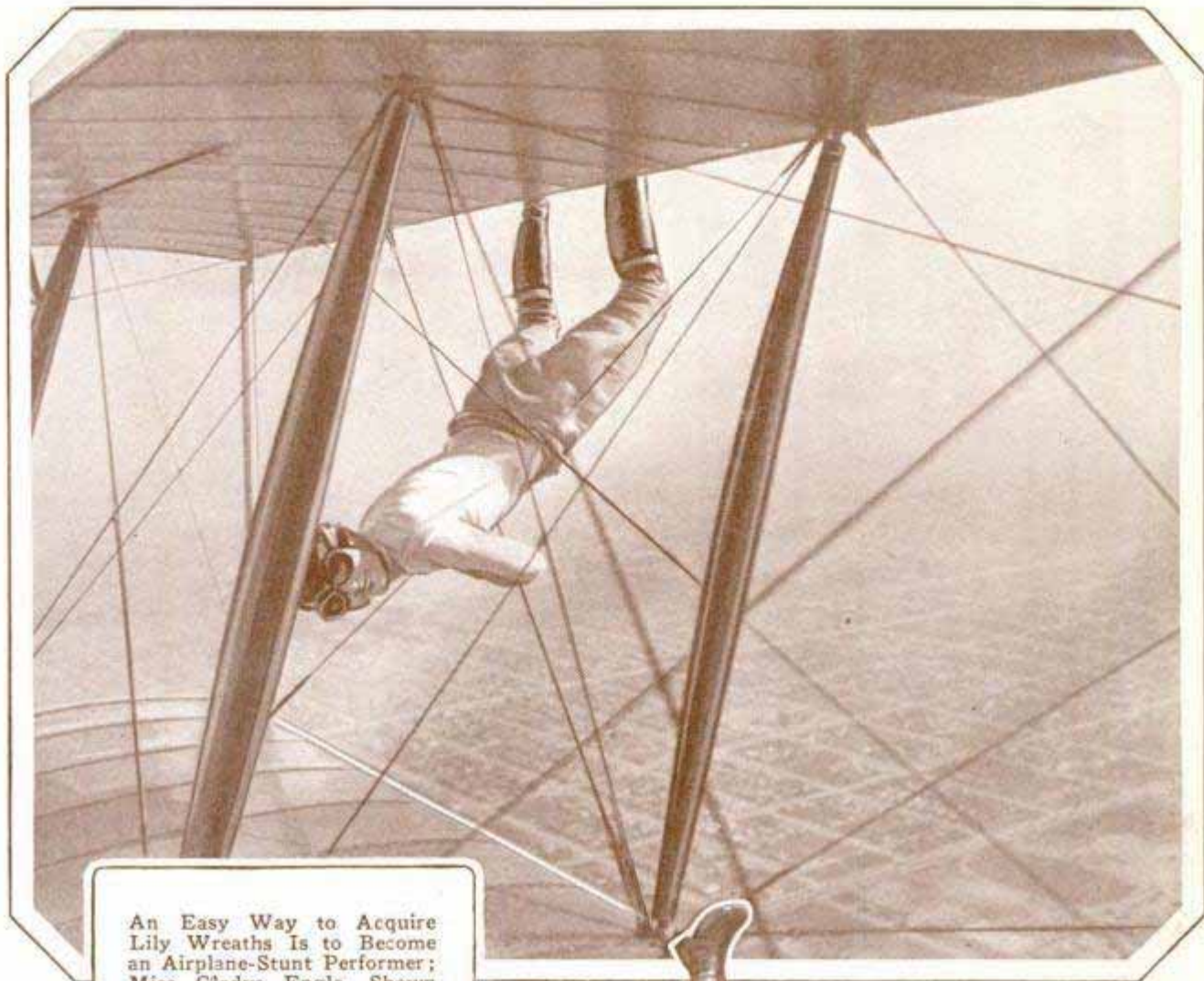


A Rare Photograph of an Automobile Racer at the Instant His Car Started through the Fence in a Dirt-Track Race; the Front Has Begun to Twist Over

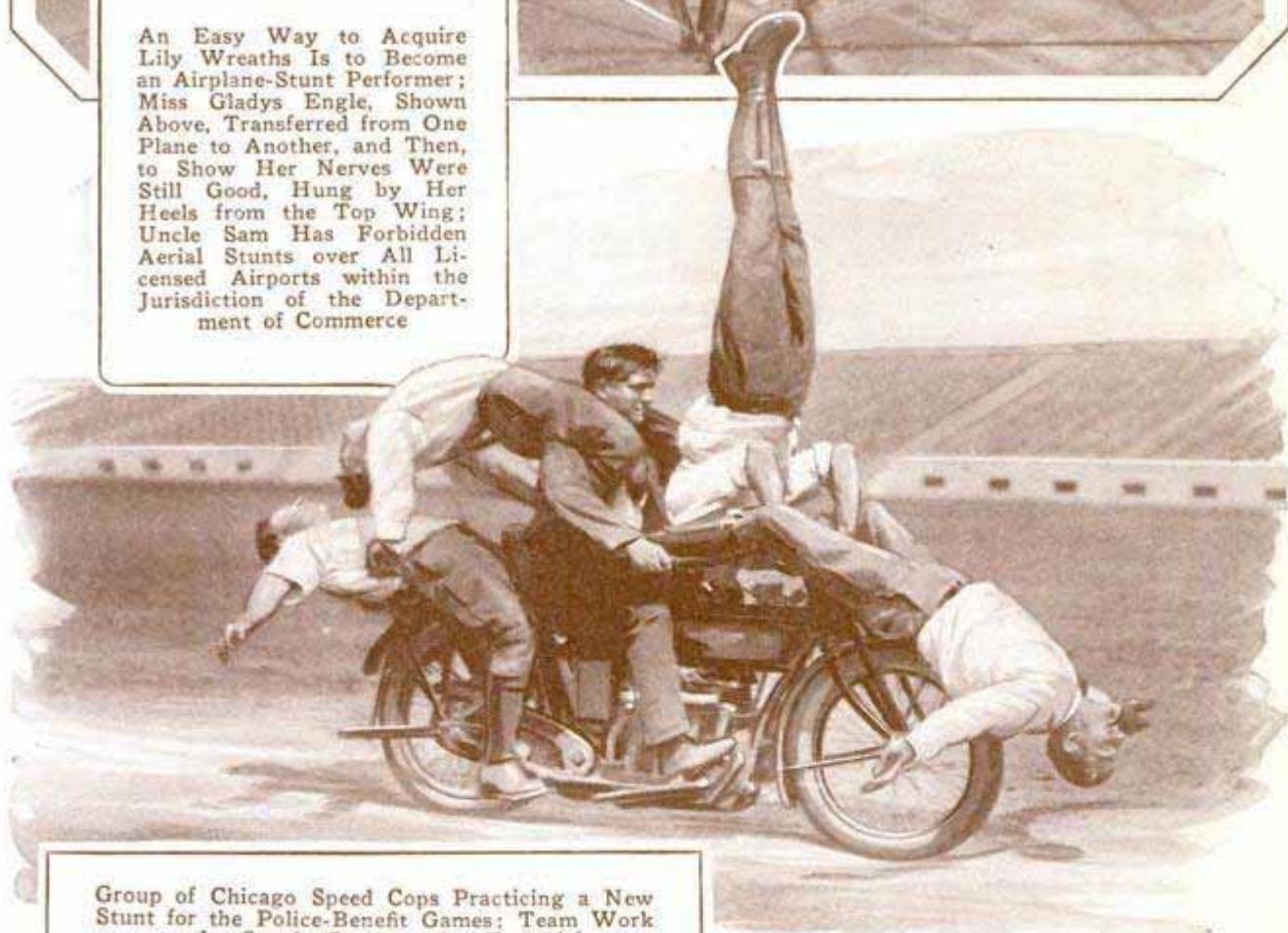


The "High Topper," Who Ties a Saw to His Foot, Passes a Rope around a Giant Douglas Fir, and Climbs 200 Feet in the Air to Cut Off the Top and Prepare the Bare Trunk as a Derrick Mast, Is a Real Daredevil; His Moment of Greatest Danger Comes When the Severed Tree Top Breaks Free, For a Back-Kick of the Huge Mass May Hurl Him off His Lofty Perch; Below, One of the Most Dangerous Jobs in Police Work Is Riding a Motorcycle or Sidecar, and the Men Who Are Assigned to Them Are Adjudged Poor Accident Risks; This Outfit Is One Used by the New York Police Department; the Sidecar Carries a Portable Radio Receiver, Tuned In on Police Headquarters, and the Armament Is a Thompson Submachine Gun, Capable of Firing 120 Shots a Minute



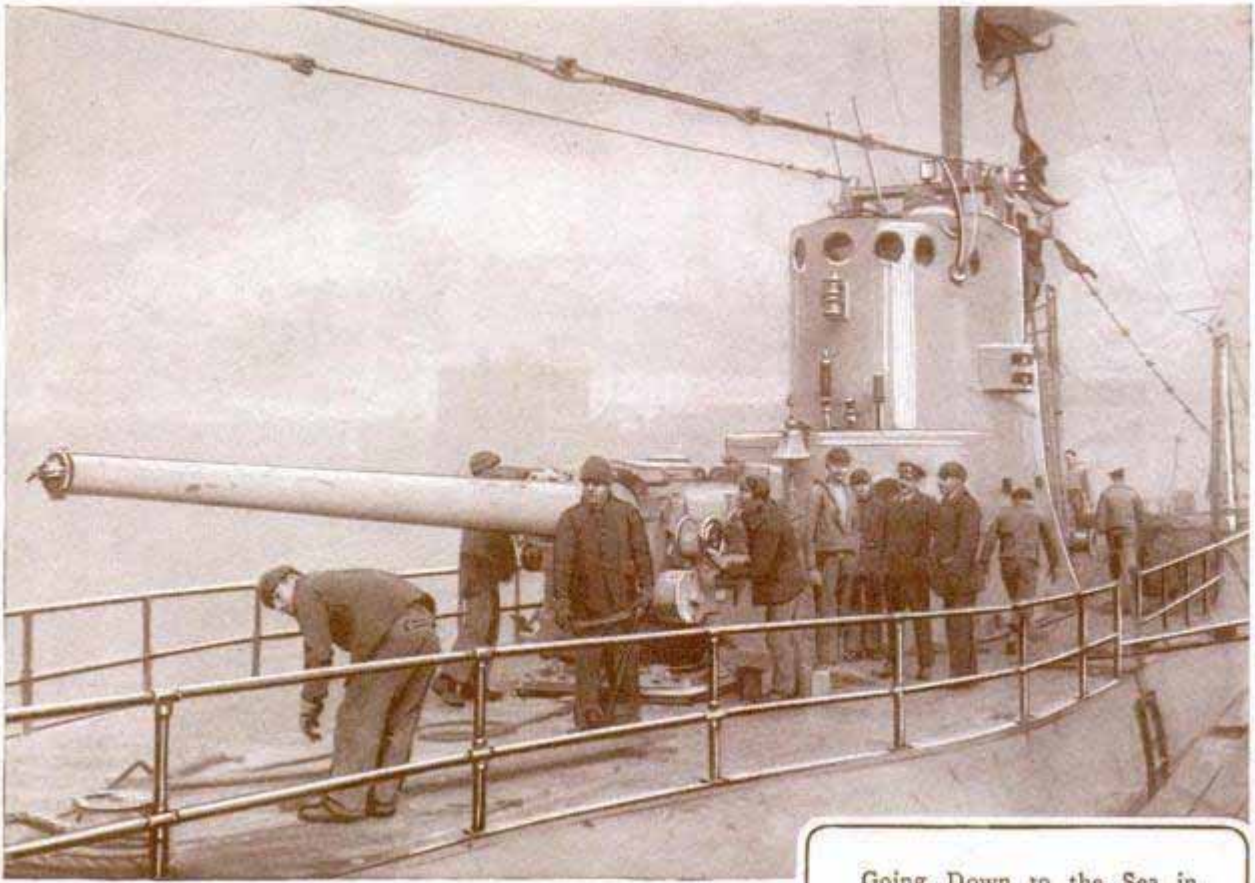


An Easy Way to Acquire Lily Wreaths Is to Become an Airplane-Stunt Performer; Miss Gladys Engle, Shown Above, Transferred from One Plane to Another, and Then, to Show Her Nerves Were Still Good, Hung by Her Heels from the Top Wing; Uncle Sam Has Forbidden Aerial Stunts over All Licensed Airports within the Jurisdiction of the Department of Commerce



Group of Chicago Speed Cops Practicing a New Stunt for the Police-Benefit Games; Team Work and a Steady Operator Are Essential

1653



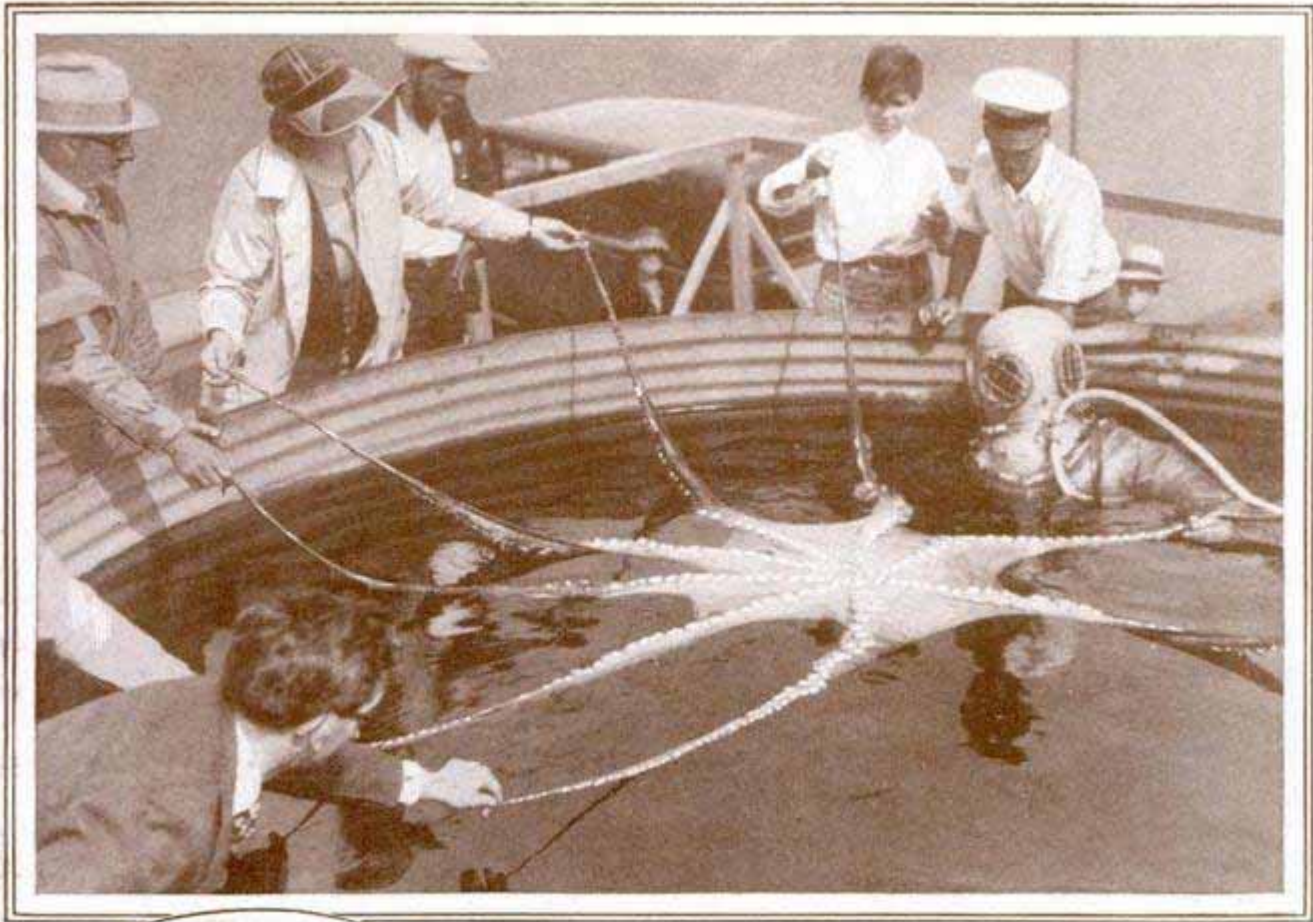
Going Down to the Sea in Submarines Is Not Favored by the Insurance Agent; Above, the Crew of the New "V-1," First of Uncle Sam's Largest-Type Fleet Submarines, Taking the Air on Deck after the Trial Trip; Below, Handling Dynamite and Other High Explosives, and Also Making Them Are Other Dare-Devil Occupations; These Men Are Stamping Dynamite for Identification



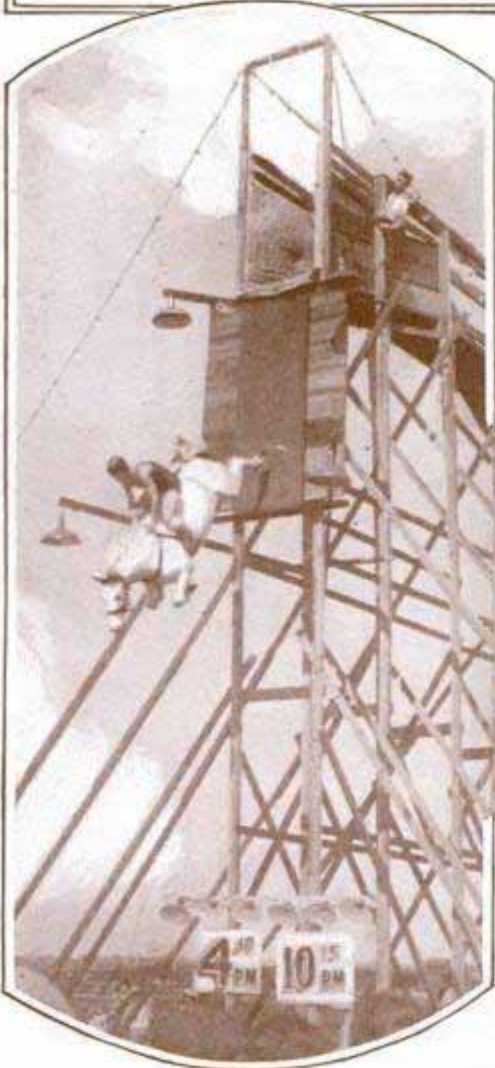
Something New in Thrillers; the Driver Loops the Loop in His Tiny Car; Then the Bottom of the Track Collapses, and He Drops into a Padded Basket, Out of Sight of the Audience



105



Capt. William Tucker, Deep-Sea Diver, Captured This Giant Octopus and Brought It Alive to Shore, to Be Exhibited with Himself; Perils of Deep-Sea Diving Suffice to Make Any Insurance Agent Shudder If He Is Asked to Underwrite the Diver's Life

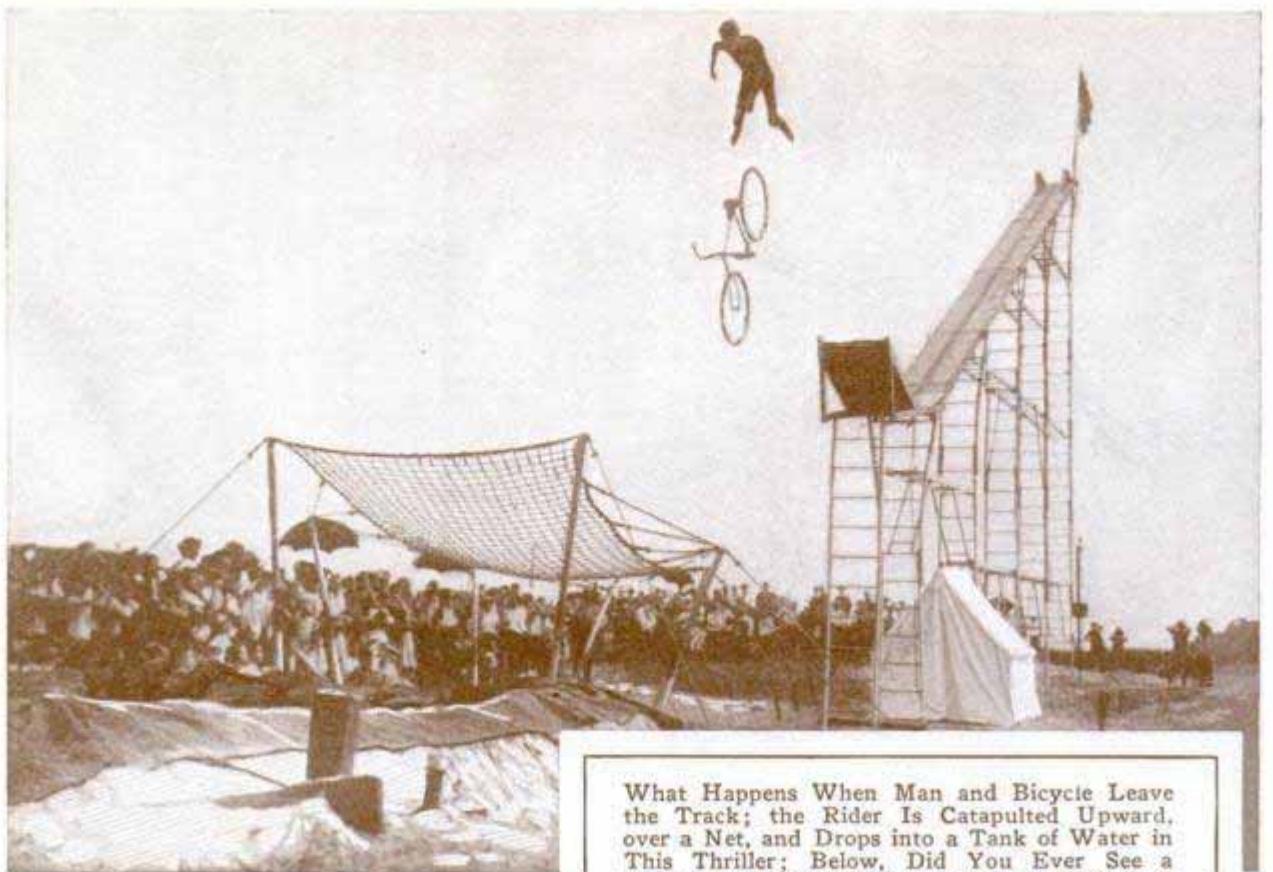


The Girl Rider of the Diving Horse, Plunging from a Sixty-Foot Platform, Takes Her Life in Her Hands Twice Daily to Thrill the Spectators; Above, Ace Hudkins and a Sparring Partner, Wearing Padded Helmets to Cut Down the Risk of Injury during a Training Bout Preparatory to the Fight with Micky Walker; the Work of a Professional Boxer Exposes Him Constantly to the Chance of Injury or Death

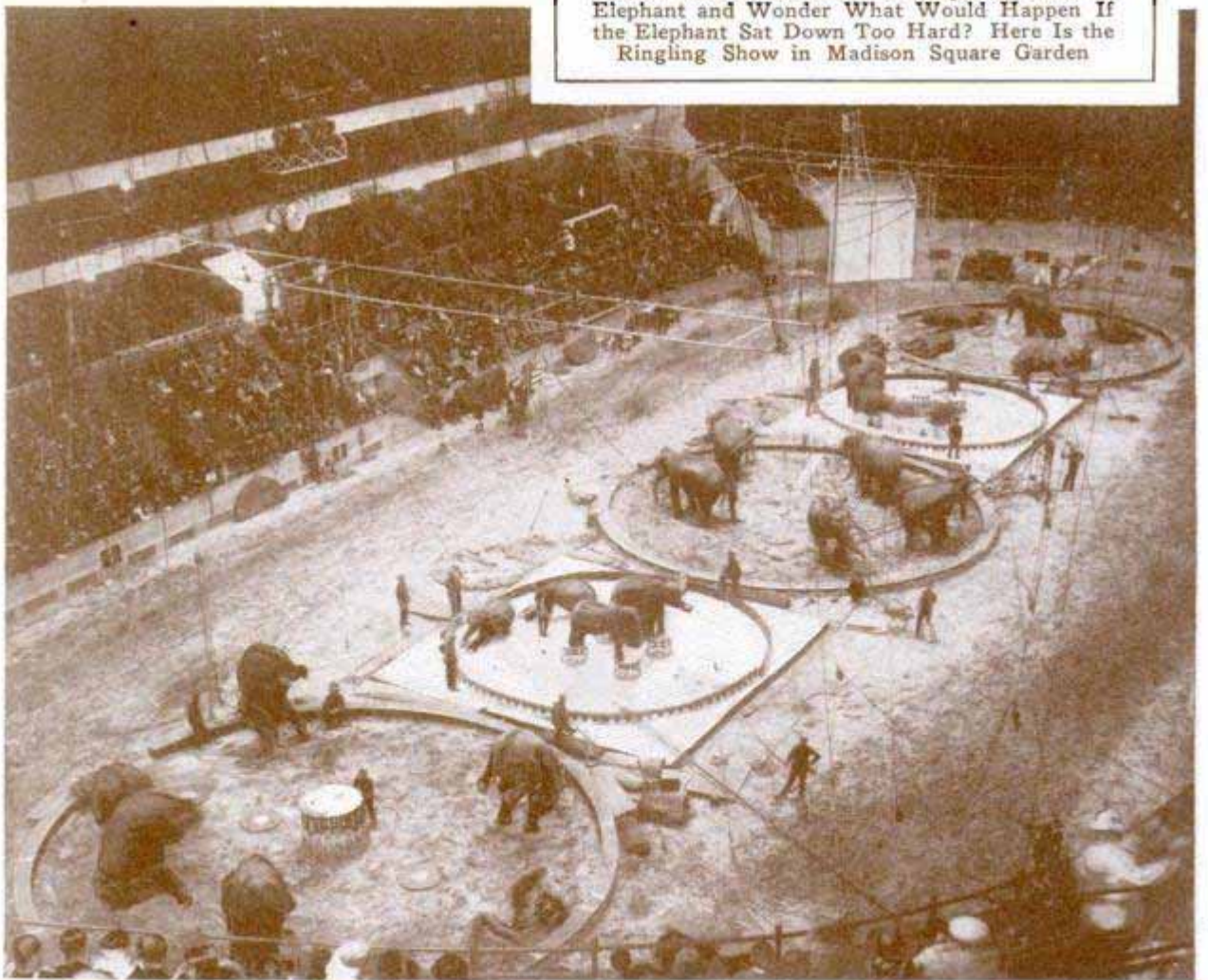
New York City

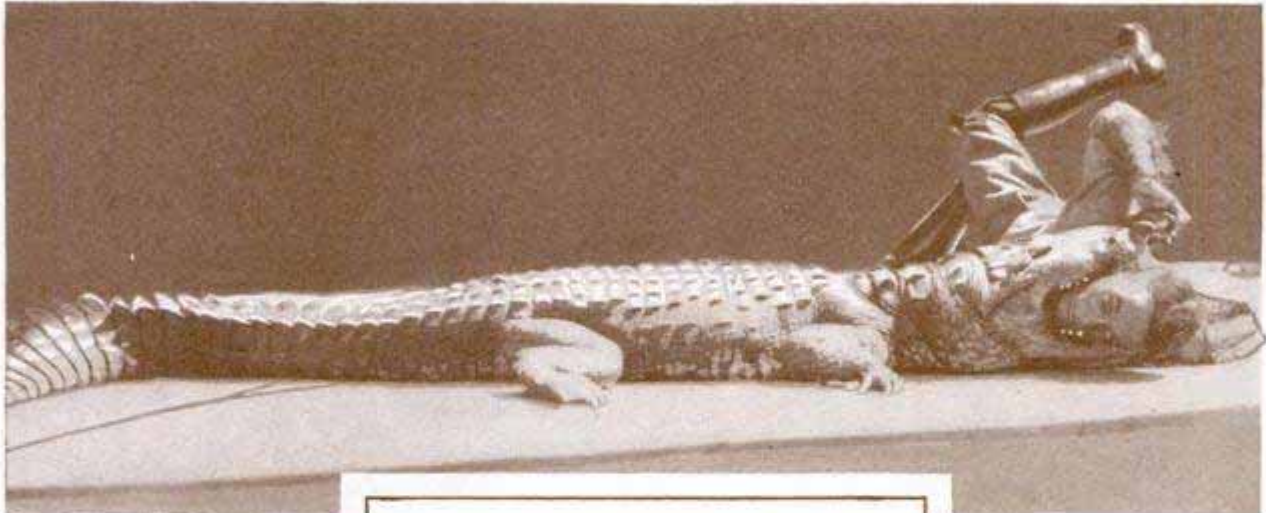
Everlast Sporting Goods

1653

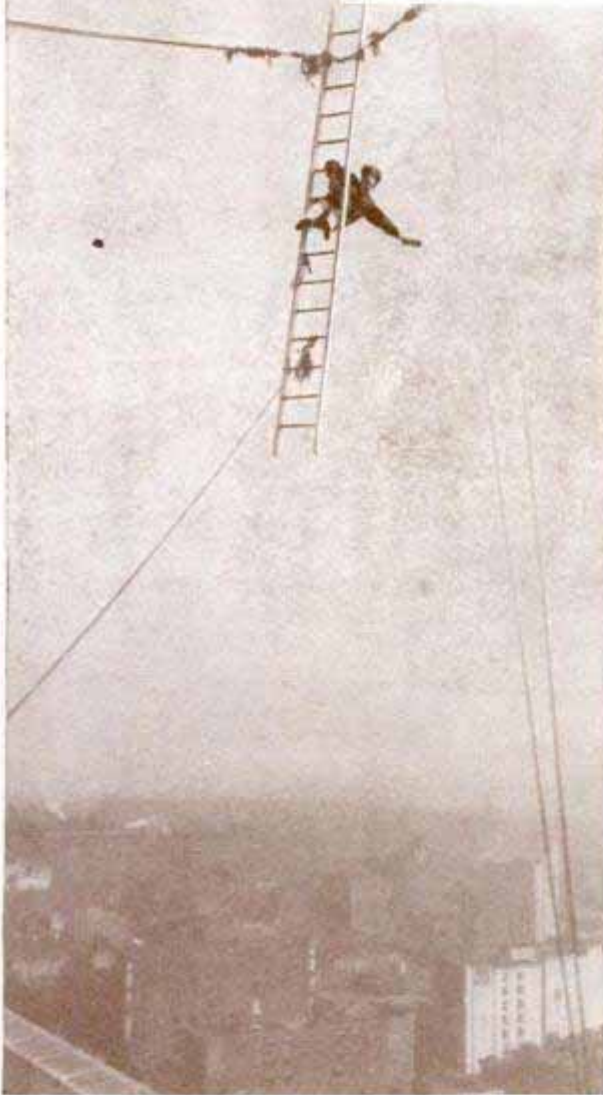


What Happens When Man and Bicycle Leave the Track; the Rider is Catapulted Upward, over a Net, and Drops into a Tank of Water in This Thriller; Below, Did You Ever See a Trainer Lie Down under a Couple of Tons of Elephant and Wonder What Would Happen If the Elephant Sat Down Too Hard? Here is the Ringling Show in Madison Square Garden





El Guarany Demonstrates His Hypnotic Power over Alligators by Inserting His Head in the Monster's Jaws



Hanging from a Ladder Suspended between Two Towers 400 Feet above New York Streets, Sig Smith Performs a Few Feats



Fighting Fires Is a Dangerous Business, and Many Men Have Been Killed under Falling Walls; This Is a Paint-Factory Blaze



Buddy Mason Demonstrates His Bicycling Skill by Riding around the Cornice of a Twelve-Story Building in Los Angeles; All Movie-Stunt Men, and Even Stars Who Perform Their Own Stunts, Such as Fairbanks and Harold Lloyd Do, Are Listed in the "Extra-Special Hazardous" Class

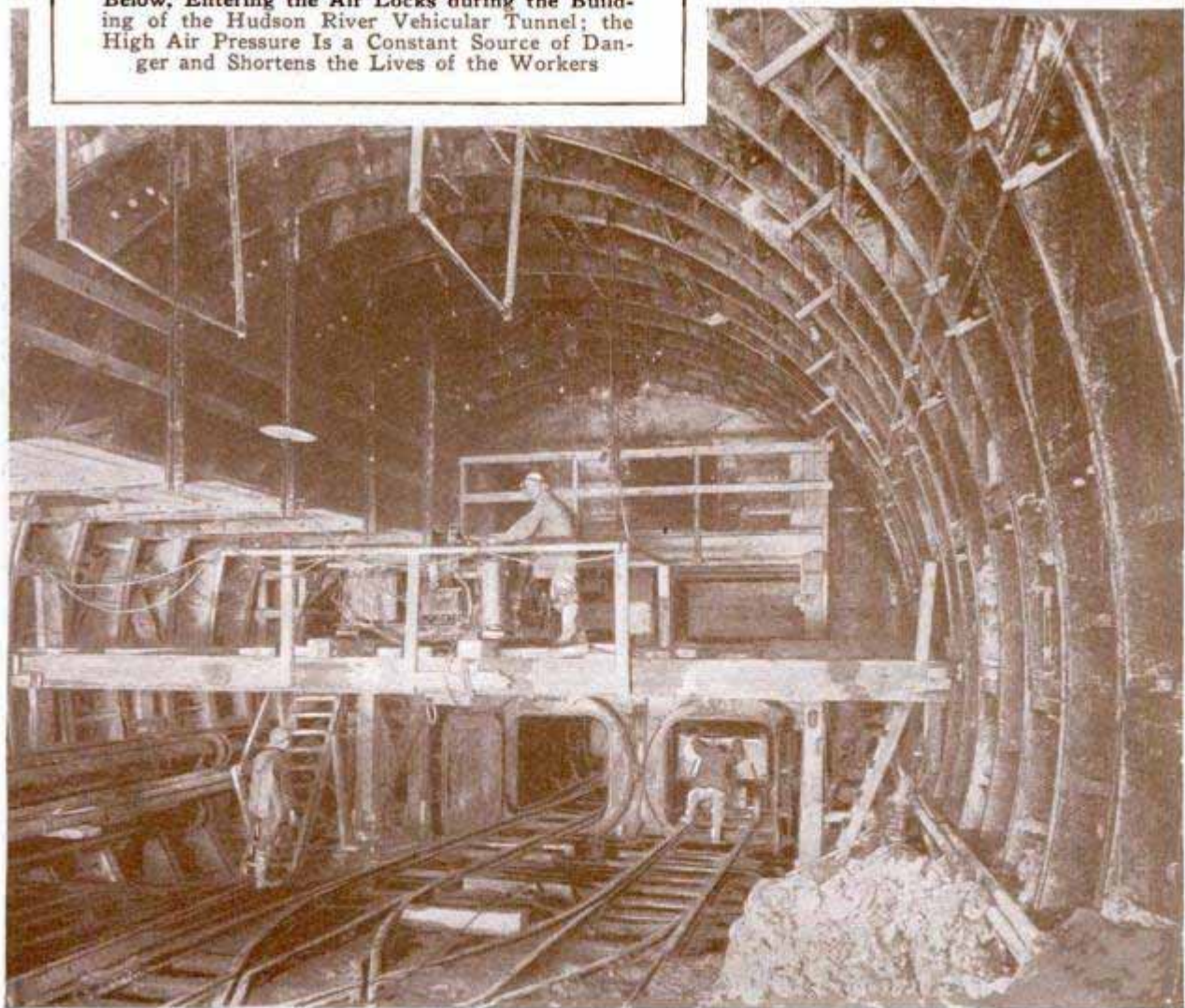
Pointing Up the Cracks in the World's Tallest Building; John Moore and Thomas Thom Were Snapped from a Tower Window of the Woolworth Building at Their Annual Task



Want to Wrestle with a Bengal Tiger, or a Human Opponent? Both These Jobs Are Classed as Too Exciting to Thrill an Insurance Agent; the Lady Above Wears a Leather Suit and Helmet to Protect Her against Accidental Scratches from Her Playmate's Claws, but If He Really Decided to Scratch in Earnest, They Would Be Poor Guards; the Gentleman at the Right with His Feet in the Air Is L. W. Muegge, About to Be Dropped by B. A. Shively as Part of the Practice Work of the Wrestling Team at the University of Illinois; Such Bone-Cracking Holds Do Not Put a Man in the Preferred List

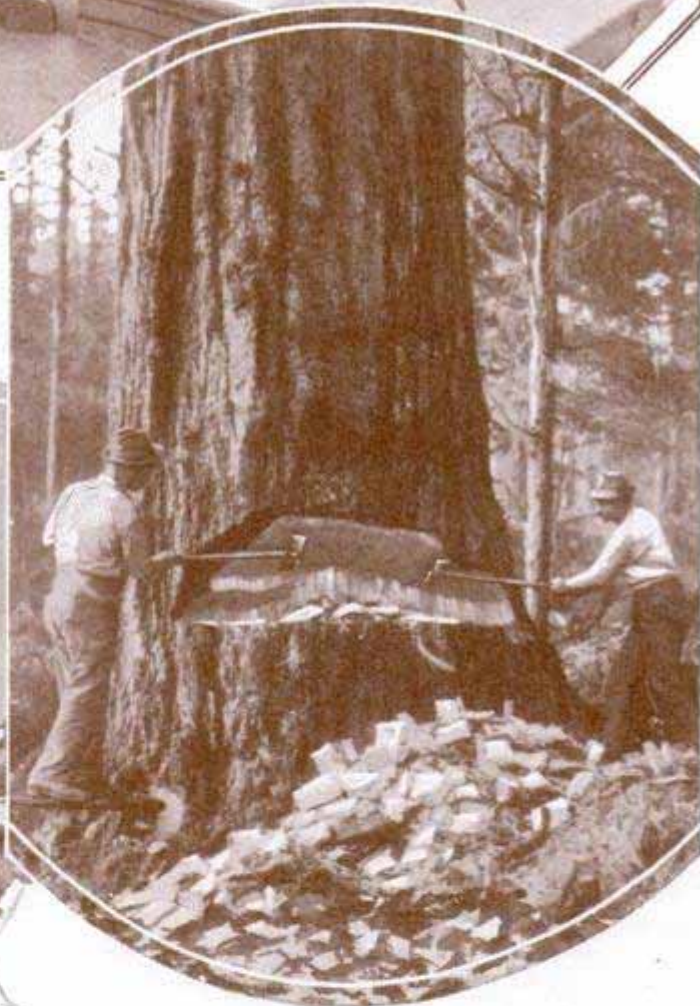


"Cross-O Baldy," a Bad Horse from Montana, Attacking Bill Montgomery, a Canadian Rider, after Throwing Him; Beaten and Stepped On, the Rider Went to the Hospital; Tunnel Workers, Below, Entering the Air Locks during the Building of the Hudson River Vehicular Tunnel; the High Air Pressure Is a Constant Source of Danger and Shortens the Lives of the Workers





Prohibition-Enforcement Agents and Bootleggers, Too, Have Been Added to the Lists of Dangerous Occupations; Above, a Gunner's Mate of the Dry Navy Trying Out His Machine Gun aboard One of the Fast Patrol Boats Used to Drive Rum Runners off the Atlantic Coast



Loggers in the Woods Live a Dangerous Life, Not Only from the Perils of Handling Sharp-Edged Tools, but Also from the Kick-Back of Fallen Forest Giants; River Drives in the Spring and Log Rafting Also Are Classed as Hazardous Occupations; at Left, Sailors on the Nova Scotia Schooner "Blue-nose" Hoisting Sail for a Race with the America-Cup Challenger; Sailors Are Poor Insurance Risks Because of the Dangers from Accidents and Storms



**SOUNDPROOF ROOM DEvised
WITH NEW MATERIALS** 1727

How materials of recent manufacture are being applied to meet the needs of special tasks is well illustrated in radio broadcasting and the making of talking movies, where the construction of soundproof rooms is an essential. A building stuff, consisting chiefly of the refuse of sugar cane when all the sugar has been squeezed from it, has helped greatly in insulating the rooms, and engineers have devised special methods of construction to keep out sounds. For instance, to make a room practically proof against noise, it is built with walls of brick, four inches thick and covered on both sides with a hard cement plaster that tends to reflect sounds. The doors are of steel plates with an air space between them, and they are trussed to eliminate vibrations. A continuous air cell inside the masonry wall separates the inner room, which is suspended on wooden blocks and is lined with three or more layers of insulating material. These are glued on, as nails would make small openings and would also act as conductors for sound. Flexible electrical connections are used. The problem of ventilating such a room required special study, but was solved satisfactorily by equipping it with a system of ducts, arranged in labyrinth fashion and built on the same plan.

WHY WE WALK IN CIRCLES 1736

Persons lost or blindfolded naturally walk in circles or spirals, not because one leg is shorter than the other, but because of a special "steering mechanism" that takes control when the eyes are unable to function as directing agents. This is the opinion of a British professor who has been studying the movements of many different kinds of animals. He noticed the curving path made by a single-celled organism "swimming" in a glass of water, and concluded that this tendency is practically universal.

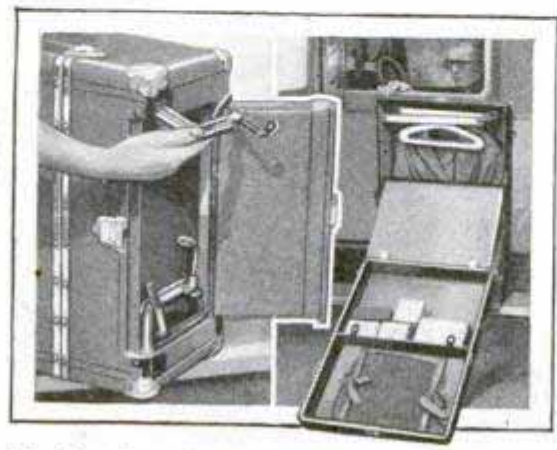


Combination Banjo and Ukulele, Which Is Really One Instrument; Interchange Is Made by Shifting Pick

**BANJO AND UKULELE IN ONE
PLAYED WITH FELT PICK**

Banjo and ukulele are combined in a single instrument with one set of strings. To produce the banjo tones, the strings are struck with a felt pick, which is placed under the bridge to eliminate the banjo sound, when the instrument is to be played as a ukulele.

**TRUNK ON AUTO RUNNING BOARD
SAVES EXTRA LUGGAGE** 1680



Showing How Trunk Is Attached to the Running Board, and View of Roomy Interior

Quickly attached with self-contained clamps to the running board of any auto, a wardrobe trunk saves carrying extra baggage, holds many articles and is covered with a washable fabric. The trunk may be used as a separate piece of luggage, and brackets that secure it to the running board are easily concealed.

B. Horenstein & Sons,
 42 W. 18th St. New York
 Model # 35-35 "high" \$35.00
 # 350-30 "high" \$33.50

J. J. ... 11/10/25

W. A. A. Schaeffer
 113 1/2 E. ...

Alenco Trunk Co.
 118 W. ...

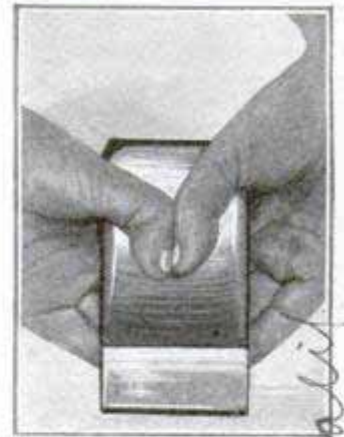
Peterson
Kalamazoo, Mich
CHEMICAL COOLER FOR AUTOS

A chemical cooling system, working like a home refrigerating plant, has been developed by a Michigan inventor to take the place of water cooling for automobile and airplane motors. A thermostat control will hold the temperature within five degrees of the most efficient operating temperature for the engine. Sulphur dioxide, which absorbs heat five times as rapidly as water, is used as a refrigerant. A small pressure tank with pump carries the chemical supply under twenty-five to thirty pounds' pressure. When the engine reaches the desired temperature after starting, the thermostat admits small quantities of the refrigerant into coils surrounding the cylinders. The system is expected to prevent freezing troubles. The apparatus eliminates radiator, water and pump, and weighs about sixty pounds.

Arctic Chemical Cooler
218 W. Walnut St.
SCRAPER HAS HOOKED BLADE

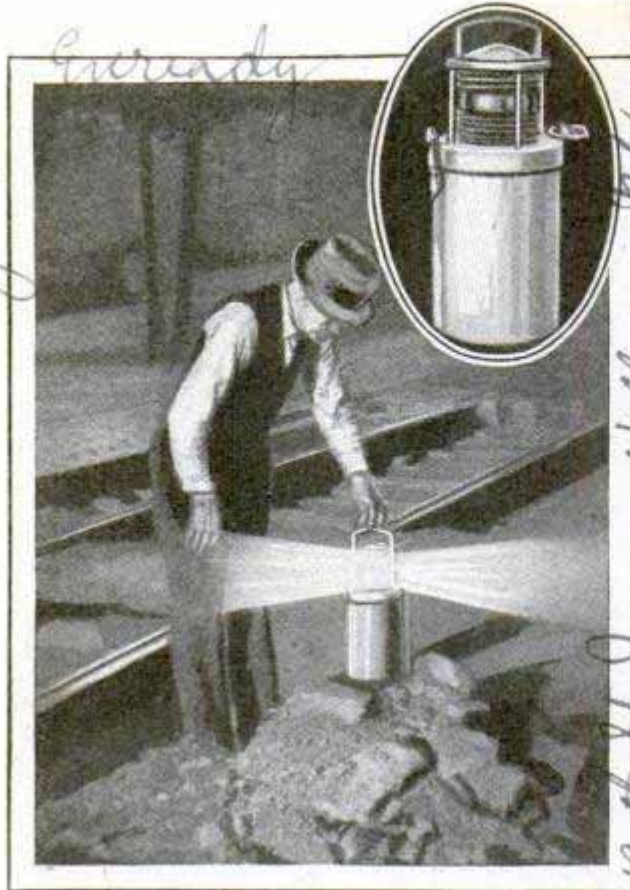
TO DO BETTER WORK

To scrape floors, remove paint, and perform other similar tasks, a scraper now on the market has hooked blades that can be removed and sharpened. The holder is shaped for comfortable and secure gripping, and, by varying the pressure and holding the tool at different angles, in accordance with the task, better results are obtained than with an ordinary instrument, it is asserted.



IMPROVED PUMP OF FEW PARTS INVENTED BY INVALID

While confined to a hospital, a western man devised a pump which is said to be much simpler than types now in use. It employs a suction principle which the inventor developed while making experiments on a model flying machine. He utilized a two-hour rest period in the afternoons to work on his miniature pump and discovered that his first model operated successfully without alterations.



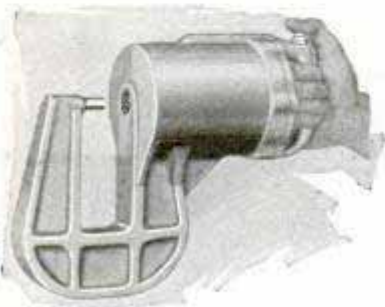
Setting the Electric Flasher Lantern, and a Close View Showing Battery Compartment and Lens

ELECTRIC FLASHER REPLACES SIGNAL LANTERN

As a substitute for the usual warning lantern that burns oil, a portable electric flashing beacon, supplied with current from batteries, has been introduced for construction work and all other places where warning lights are to be set at night. Economy, ease of operation, safety and dependability, as well as greater visibility, are a few of the advantages claimed for the unit. A year's upkeep expense is estimated at about ten dollars.

RIVETER FOR MOTOR CARS WEIGHS FIFTEEN POUNDS

Capable of exerting tremendous pressure but weighing only fifteen pounds, a portable riveter has been introduced. It is adapted especially for work on the bodies, hoods and instrument panels of automobiles, etc.



Natural Carbon Co.
30 E. 42nd St. New York

Hook & scraper Co. 96 - 219th St. Queens Village, N.Y.

Kalamazoo, Mich
W. W. Abbott

San Francisco
Stanislaw
Hachenburg

Havina Engineering Works
1765 Elston Ave

Stanislaw
Hachenburg

German Dye Trust
Leina

FOOD AND FUEL FROM COAL

1799

German chemists are obtaining soap fats, edible fatty foods, lubricating oils and an anti-knock motor fuel of high value from coal. Their results are of great importance to Germany, and of almost equal interest to the United States, for it has been revealed that various dye processes, controlled by the Standard Oil company in America, can be used effectively in the refining of crude oil. At one of the German plants an annual production of 70,000 tons of synthetic gasoline has been achieved, and by the end of this year, it is expected to reach 250,000 tons.

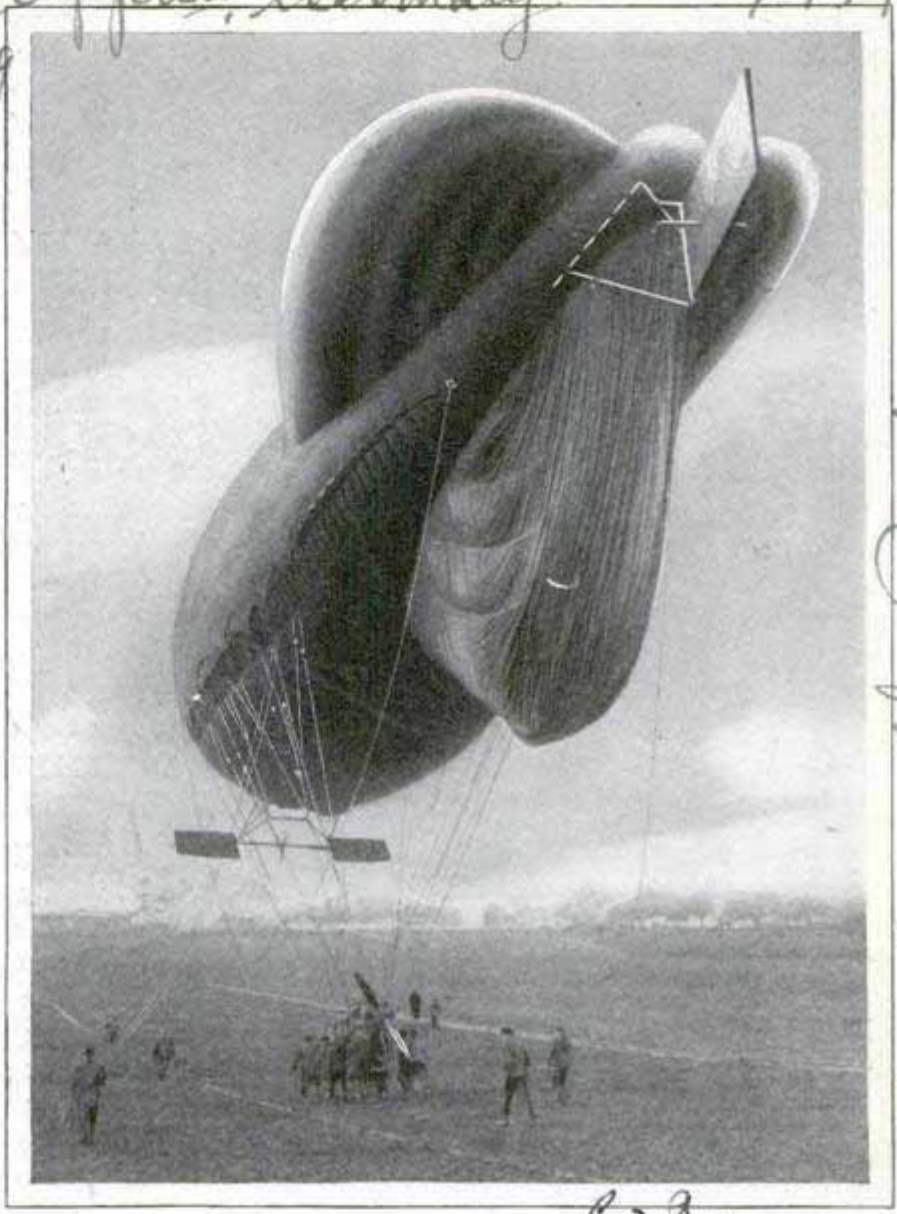
FORCE VENTILATOR FOR MOTOR CARS IS DRAFTLESS

1694

Motion of the automobile draws air into a ventilator and out again so that the interior of the car is always supplied with healthful air without opening the windows and without a draft. The unit fits all models of closed cars and is installed without bolts, clamps or screws. It is said to be especially effective in drawing tobacco smoke from the inside of the car, and is a safe-



Ventilator Attached to Car; the Auto's Forward Motion Draws Air Inside without Causing Drafts guard against any injurious fumes from heaters in the automobile.



With a Rudder at the Tail, Elevators Forward and an Outboard Motor and Propeller on the Basket, the Balloon Becomes a Dirigible

OBSERVATION BALLOON EASILY TURNED INTO DIRIGIBLE

An observation balloon of the sausage type developed during the world war, but which can be changed into a dirigible and navigate as an airship, has been produced by a German balloon factory. Stabilizing planes are fitted, and the power supplied by an outboard engine driving a propeller. The motor is attached to the basket swung beneath the gas bag.

The Popular Mechanics' Bureau of Information offers its free service to all readers of our magazine. Names and addresses of manufacturers and dealers in articles described, and any other details in our possession, will be promptly furnished by addressing the bureau.

Built by The Riedinger Works, Augsburg, Germany. No U.S. Reg.

Chicago 1150 W Jackson

Chicago Sales Corp

\$2.00 for two

W. H. ... 4/11/31

1754

P. A.

1949

cannot be located.



As Wearer Raises His Hands at Bandit's Order, a Stream of Bullets Issues from Gun in Center

BULLET-PROOF VEST HAS GUN FIRED IN RAISING HANDS

Installed at the center of a special bullet-proof vest is a machine gun that starts firing when the wearer's hands are raised. The unit therefore gives offensive and defensive service, and is intended to be especially effective against holdup men.

TUNING FORK TO GUIDE PLANES FLYING THROUGH FOG

Another aid to safer flying was announced by the bureau of standards recently in the form of a tuning-fork device to guide planes at night and while passing through fogs. The unit consists chiefly of two vibrating reeds, mounted on the instrument board in a shock-proof case. Electromagnets, operating these reeds, are connected to the plane's radio set. When a beacon signal is received, the reeds vibrate. Since their tips are white, each produces a white line when moving and, if the lines are of equal length, the pilot knows he is on his course. The reeds are so adjusted as not to be affected

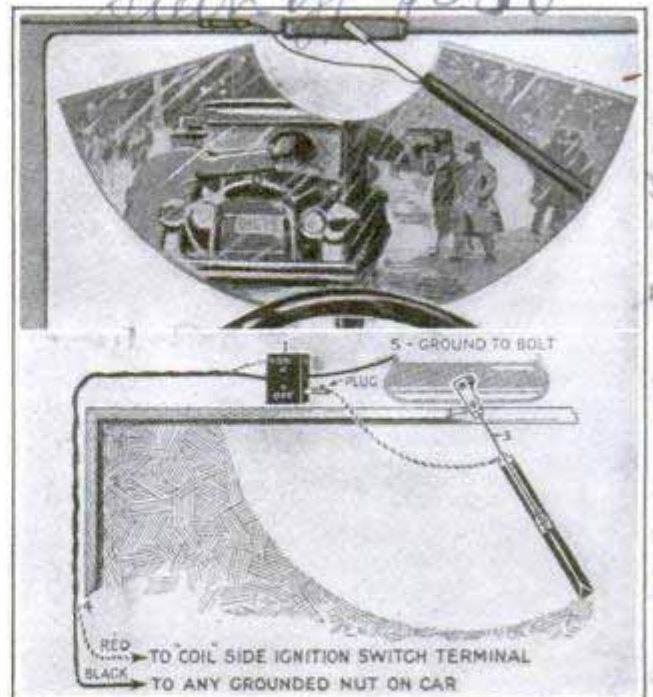
by interference unless it is great enough to block the tubes in the receiving set. The use of a visible signal eliminates headphones and the constant annoyance of an audible code signal drumming in the ears.

LAVA FLOW FORMS RICH SOIL FOR GROWING GRAPES

The slopes of volcanoes afford the best vineyard lands the world knows, according to Dr. Henry S. Washington, of the Carnegie Institution, who gives that as the principal reason why inhabitants of such districts as surround Mt. Etna, where recent eruptions have occurred, cling to their homes in spite of the danger. The famous grape districts of northern France and southern Germany are in ancient volcanic areas which have long been inactive.

WIPER HEATS AUTO WINDSHIELD TO KEEP IT CLEAR

For installation inside or outside the windshield, a wiper is supplied with electric current from the ignition-switch terminal of the car and, by warming the glass, helps in the removal of sleet and mist. It is easily connected and, when not needed during the warm months, is quickly detached from the circuit. The current is automatically switched off whenever the motor is stopped.



Drawings to Illustrate the Effect of the Heated Windshield Wiper and the Method of Connecting It

1996

Herald Examiner 11/18/28

The Greb Co 193 State St.

1508



Do Some Foods Poison You?



Any of These Ordinarily Wholesome Foods May Cause Violent Symptoms in Certain People Who Are Sensitive to Some of the Many Forms of Hay Fever and Asthma

By FREDERIC DAMRAU, M. D.

*400 Clinton Ave
Brooklyn, N.Y.*

"SUPERSTITION!"

That is the remark that used to be made to the person who said that lobsters, bananas or some other food always made him sick, or that he became asthmatic whenever he went near a horse or a cat. But physicians now have found that such complaints explain the nature of many diseases which were not at that time understood.

One of the most remarkable medical discoveries of recent years is that certain foods and inhaled particles, which are ordinarily harmless, may cause serious illness in the case of susceptible persons. One in every seven, it is now known, may inherit or acquire more or less sensitiveness to common articles of diet or substances carried in the air.

An attack of asthma may sometimes be precipitated by fondling a pet cat or taking a horseback ride. Many a person has been cured of severe asthma by the simple expedient of replacing the horse and buggy with an automobile, or getting rid of the cat. In such cases, it has been proved by skin tests that the patient is sensitive to horse or cat dandruff, as the case may be. The smallest amount inhaled into his lungs promptly produces the suffocating attacks, although it is entirely harmless to the average person.

Hay fever is another trouble of a similar nature, the difference being that it is due to the inhalation of plant pollens instead of animal dandruff. Many victims suffer every August with violent sneezing, nasal congestion and irritation of the eyes because they are sensitive to ragweed pollen. Other pollens, which may cause hay fever in different sections and at different seasons, include timothy, lamb's quarters, wormwood and many others.

The remarkable fact about the dandruffs causing asthma and the pollens causing hay fever is that they are entirely harmless when inhaled by most people. It is only when some one who is sensitive to the particular dandruff or pollen breathes it that symptoms follow.

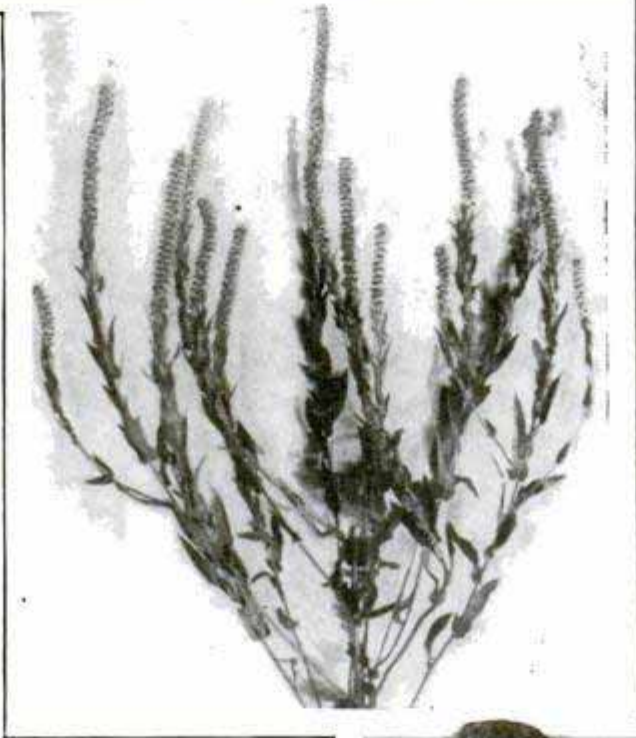
This condition of specific sensitiveness is called "allergy," a term that is used whenever one suffers from the introduction of an ordinarily harmless substance into the body. For example, whether the symptoms follow an injection of diphtheria antitoxin, the inhalation of ragweed pollen or the eating of a banana, the term allergy may be used. All of these substances do not hurt the average person, but may be dangerous to those who are sensitive to them. And the substances which are capable of causing allergy in sensitive persons are called "allergens."



Hives, a very common trouble, can usually be traced to a condition of sensitiveness to one or more articles of diet; that is, to food allergy. I recall the case of a young woman, who was found to be sensitive to oatmeal, carrots and apples. When, without any medical treatment, she simply eliminated these articles from her diet, the relief seemed like magic. In some

cases, especially in children, sensitiveness to some particular food, ordinarily not harmful, may be so extreme as to cause instant death. Dr. Von Starck, of Germany, relates the case of a boy who suffered from eczema after eating peas in any form. When peas were excluded from the diet, the eczema vanished. This experience certainly proves that what is food for one person may be poison to another.

Dr. Warren T. Vaughan, of Richmond, Va., recently reported twelve cases of migraine in which sensitiveness to certain foods played a part in causing the attacks. Unfortunately, different foods are responsible in individual cases and the same person may be sensitive to half a dozen or more substances. It is usually necessary



to go through the whole scale of skin tests to find out which foods are at fault.

Perhaps the most marvelous feature of this whole subject is the accuracy with which the physician can perform skin tests and pick out the foods that are causing the trouble. By simply scratching the skin and rubbing in a tiny quantity of protein extract, it is possible to determine to which of them the patient is sensitive.

To be subjected to seventy-two skin scratches, as would be required if each of the proteins were tested singly, would be decidedly unpleasant. For this reason, various allergens have been grouped. For

example, one group contains clam, oyster, crab, lobster, scallop and shrimp proteins; another, kidney-bean, lentil, lima-bean, navy-bean and pea proteins. If no hive forms after the group protein has been rubbed into the skin, it may be concluded that the patient is not sensitive to any of the members of this group.

Let us assume, however, that a large hive appears



Making Hay-Fever Tests to Find Out Which Pollen Is Responsible; One of the Pollen Producers, and, Bottom, Injecting Serum in a Guinea Pig

ten minutes after the shellfish group of proteins has been rubbed into the scratch. Then it is necessary to perform individual tests with clam, oyster, crab, lobster, scallop and shrimp allergens in order to determine which member or members of the group are the source of the trouble.

When the doctor has "spotted" the foods to which the patient is sensitive, his problem with regard to treatment begins. If the allergens should be unusual articles, such as almonds, garlic and tuna fish, all that is required is to forbid them. But suppose the skin tests should be positive to eggs, wheat or milk? These are staple foods which cannot very well be taken away.

If a food cannot be eliminated, the patient must be desensitized to it. This is another marvel of medical science. It is brought about by injecting or feeding the very protein substance that causes the harm, but in such a very small dose that there is no reaction at all. These injections, or feedings, are repeated again and again in gradually increasing doses, until finally it is possible to give much more than would originally have produced violent symptoms. Then desensitization is complete, and the patient may eat eggs, or whatever the allergen happens to be, as freely as anyone else.

Experiments on guinea pigs help us to understand the nature of allergy, or protein sensitiveness. Let us take two of these animals and inject only one of them with a small amount of horse serum. Ten days later, let us repeat the injection, this time giving it to both animals. The guinea pig receiving the serum for the first time will not be affected. But the other animal will soon show signs of uneasiness, gasp

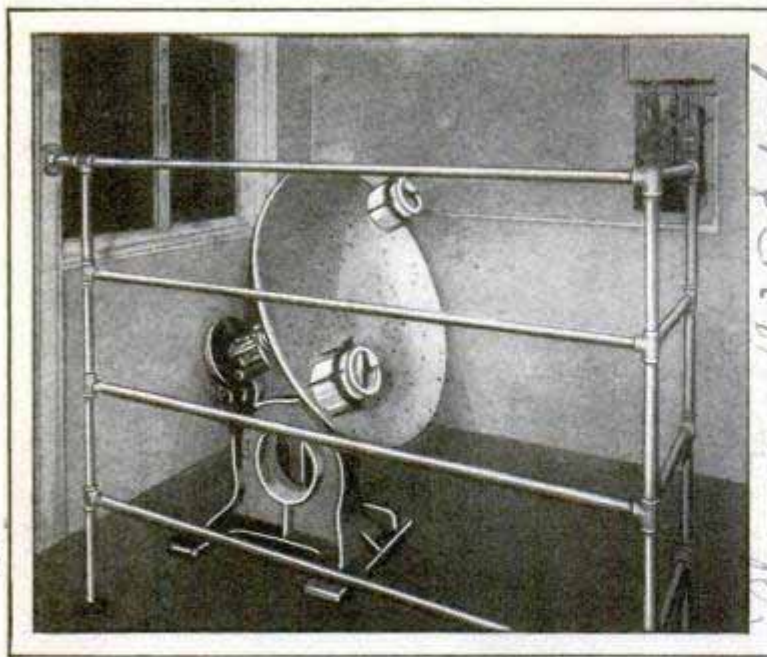


Some Children Are Sensitive to Dog or Cat Dandruff and Suffer from Asthma Until the Cause Is Found and Pets Banished

for breath, go into convulsions, and die with its lungs inflated like a pair of bellows. In fact, a very much smaller dose of horse serum would have produced the same result.

What has happened? Briefly this: The first injection of horse serum, a substance foreign to the guinea pig, has caused a very remarkable change in all the cells of the little animal's body. It has set them to manufacturing millions of little chemical substances, called "antibodies," whose sole duty is to rid the body of the obnoxious horse serum.

What occurs when the second dose of horse serum is given ten days later? It is immediately met and destroyed by the flood of antibodies. But this destruction is fraught with dangerous results. The proteins in the horse serum are very complex chemical substances. When they are



Curious Revolving Machine Used in Manufacture of Pollen Extracts at a Detroit Hay-Fever Laboratory

1508
H. R. McJorg Co, Broad & Wallace, Phila

Chicago - 125 S. Dearborn

Man as well as the guinea pig may show unfavorable symptoms after injections of horse serum, but they are always milder and seldom produce death. This is what sometimes occurs when diphtheria antitoxin is given to persons who are sensitive to horse serum, because this substance forms the basis of antitoxin.

Horse serum is but one substance of a class. Very many proteins, which are so plentiful in almost all of our foods, may act as allergens and produce violent symptoms in sensitive persons. Man is not so fragile as the guinea pig and does not succumb to the chemical explosion resulting when he eats a food to which he is sensitive; but what takes place in his

broken down, various poisonous compounds may be formed. That is just what occurs in the guinea pig receiving the second injection. The antibodies are so numerous and powerful that they tear the protein molecules of the horse serum apart, as it were, and in doing so flood the body with poisons coming from these broken-down molecules. And these poisons instantly kill the poor little guinea pig.

body is probably much the same, differing only in degree.

The complete outfits of protein extracts now available enable the physician to determine which food, pollen or animal dandruff is responsible in a given case of allergy; to protect the patient from further symptoms by asking him to avoid these proteins, if possible, and to desensitize him to the harmful proteins, if necessary.

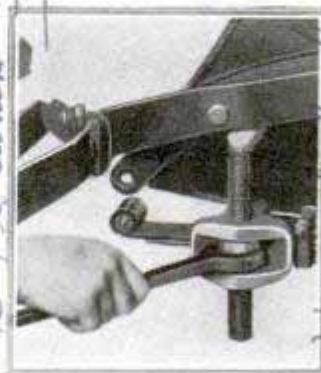
DIAMOND FIND IN INDIANA TRACED TO CANADA

1145

That a diamond field may exist in Canada is the belief held by geologists following the discovery of several diamonds of commercial size in Morgan county, Indiana, about fifty miles south of Indianapolis. The diamonds were discovered by vacationists who were panning for gold in small streams that flow through the lateral and terminal moraines where three separate glaciers dropped their debris. All three, moving southward in the glacial age, are supposed to have originated somewhere in the territory between James bay, and a line drawn northward from Lake Michigan. The fixing of the probable western boundary is based on the fact that copper nuggets have been found near Danville, Ill., a few miles west of the Indiana-Illinois state line, and, as the copper must have come from the Lake Superior

region, the glaciers which covered Indiana apparently originated farther east. Microscopic diamonds have been found in the township of Rheame, northern Ontario, but their source has not been located.

AUTO JACK FOR SPRING REPAIRS HELPS STRAIGHTEN FRAMES



Replacement of shackle bolts at both ends of front and rear auto springs is simplified with an improved jack that also has several other uses. It may be employed with a section of tubing

or pipe to spread or straighten frames, as a vise for holding spring leaves and as a tool for pressing in bushings.

1649
June 13, 1928

Handy Jack

Science Service News
Publication 3480 11, 9, 28

Trampson Products
Ltd 2196 Clarkwood

Stanley Wills of Santa Monica Outlook, Santa Monica Calif



Photographing the Players' Faces in a Movie Poker Game; the Camera Turntable Was Operated by a Long Arm Extending over the Actors' Heads, and the Camera Was Motor-Driven

MOVIE "MERRY-GO-ROUND" FILMS CARD GAME

In a recent movie film a panorama was shown of the faces of the six card players. To obtain it, the camera was mounted on a revolving "merry-go-round" arm, the base of which was glued to the center of the game table. A long wooden arm, extending over the heads of the players, made it possible to move the camera and also served as a support for the wire supplying current to the camera motor.

WATER SHIELD FOR HOUSES TO FOIL GAS ATTACK

To protect persons from poison-gas raids during a war, a French expert has suggested a plan for covering houses by a shield of water, released from pipes on the roof. The blanket, he asserts, would neutralize the effects of the gas and spare the occupants of the buildings. Ob-

jections have been offered to the scheme on the basis of its expense and because of the fact that many houses would have to be remodeled. Another student of the problem has recommended the enlargement of underground railroad stations to serve as gas-proof refuges.

AUTO LIGHT FOR HAND SIGNAL GUARDS NIGHT DRIVING



So that the hand signals can be easily seen at night, a small electric light is fastened above the door, where its rays will shine directly upon the driver's arm when extended. It does not interfere with

the operator and also has two colored lights, one green and one red, at the front and rear respectively.

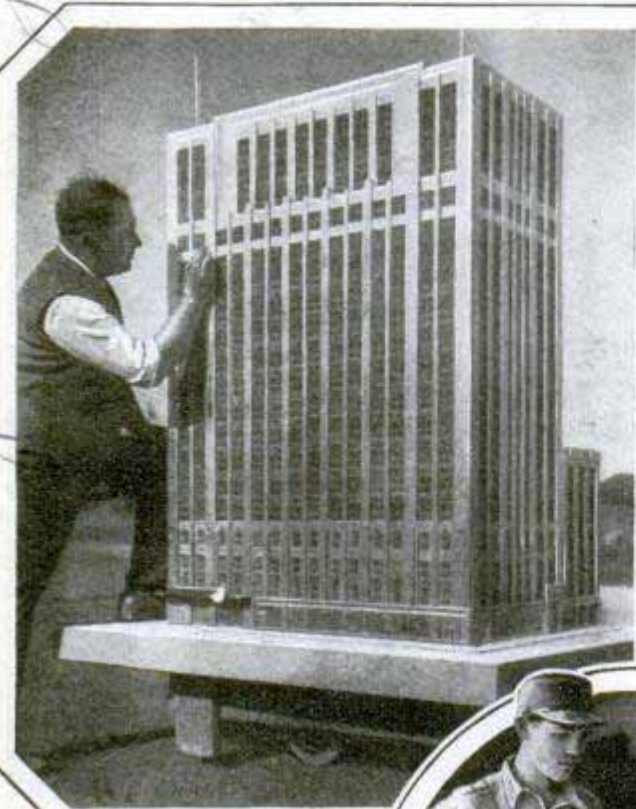
Inspector General, Chief French

C. Birnie, Ltd Co, Santa Monica, Calif

1700

ADD NEW BEAUTY TO BURNED EARTH OF ANCIENTS

Terra Cotta; Bureau of Ceramic Technology; 309 N. Michigan Ave. Chicago



Model of Terra-Cotta Building, Showing the Shaded Effect of Different Colors; Preparing Clay Model for Large Piece, and Spraying Three Colors at Once

Terra cotta or "burned earth," is one of the oldest building materials known, but modern demands for novel color effects and for production in increased quantities have changed the methods of manufacture until the process has little in common with that practiced centuries ago. A spray gun that applies three different colors at one time, to produce the interesting "spatter" and other effects on the blocks, is used at a manufacturing plant near Chicago. The unit is like other sprayers of its kind except that it has three nozzles and three supply lines, each flowing with a liquid of a different color. The nozzles are alternately opened and shut off by means of an electrically operated set of stoppers. This saves separate applications of color and affords a wide variety of finishes. The color materials are applied before the terra-cotta blocks are burned. The burning process has also been greatly improved in recent times. A tun-

nel kiln, heated by gas or by oil burners, is used in several large plants, the terra cotta being slowly drawn through it on small cars. The burning takes a week or so by this method, whereas from two to three weeks are allowed in the usual kiln. A powerful press, operated by compressed air, to force the clay into the molds and special reflectors for the lights used in inspecting the blocks are other modern developments in the craft. The reflectors make it easier to discover defects present in the blocks.

DEPOSIT MONEY FROM AUTOS IN CHUTE OUTSIDE BANK

Patrons of an Oakland, Calif., bank may deposit money without leaving their cars. They drive up to a lock box at the curb and slip their deposit through a chute. The plan is expected to relieve congestion and be of great service after hours.

Patrol Inspection Co. Photo Bank and maker

Central material

Bureau of Labor Statistics, Wash. D.C.

Alpert + Kennedy, 1924 Los Angeles, Calif

AVERAGE ONE-FAMILY HOUSE COSTS FIVE THOUSAND

Interesting figures show that the average cost of houses is higher in cities of 500,000 population and over than in smaller centers, and that there is a considerable difference in construction costs in different cities, greater in some instances than the average citizen would suppose. In fourteen cities of more than half a million, the average cost of one-family dwellings was \$5,169 during the first half of 1928. Such houses, however, were built for an average cost of \$3,619 in St. Louis, while the same general type of dwelling cost, on an average, \$8,534 in Washington, D. C., a difference of more than 100 per cent. It was not determined whether this increase was due to better houses in Washington or to higher construction costs or both. Multi-family dwellings in the fourteen cities averaged \$4,214 per family. In twenty-two cities surveyed, less than half of the population were housed in one-family dwellings. In the smaller cities, those having a population of 200,000 to 500,000, the average cost per family of the one-family dwelling was \$4,601. The costs listed did not include the cost of the land.

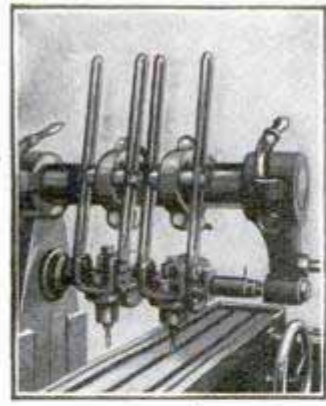


Removing Ice Cubes from the Tray That Freezes Them in an Ordinary Refrigerator

ICE CUBES FORMED IN TRAY OF SPECIAL METAL

Ice cubes can be made in refrigerators that are not electrically or chemically operated, with the aid of a mold which resembles a muffin pan and is made of a special alloy. It has twelve compartments and is simply laid on the block of ice, upside down, and in two hours or so, it melts its way down into the block until the up-turned bottom is on a level with the surface of the ice. The cubes are formed in the compartments of the tray and are easily removed with the aid of an icepick or other tool.

VERTICAL MILLING HEAD FITS ALL TYPES OF MACHINES



To save time and costs on various tool-making operations, a high-speed vertical milling-machine head has been introduced for use on all types of these machines without the need of bolts, clamps or other fixtures.

A special feature of the device is that one or more units may be set up, as production demands dictate. The head is easily handled and may be hung on a wall when not in use.

SPARK-PLUG CONTACT MAKES CHANGES EASY

Doing away with the nut usually employed to fasten the cable terminal to a spark plug, an English device is claimed to cut down roadside and repair delays to the minimum. The nut is replaced by a spring connector, between the coils of which the end of the cable wire is held. Pressure on the sides of the connector frees or grips the wire.

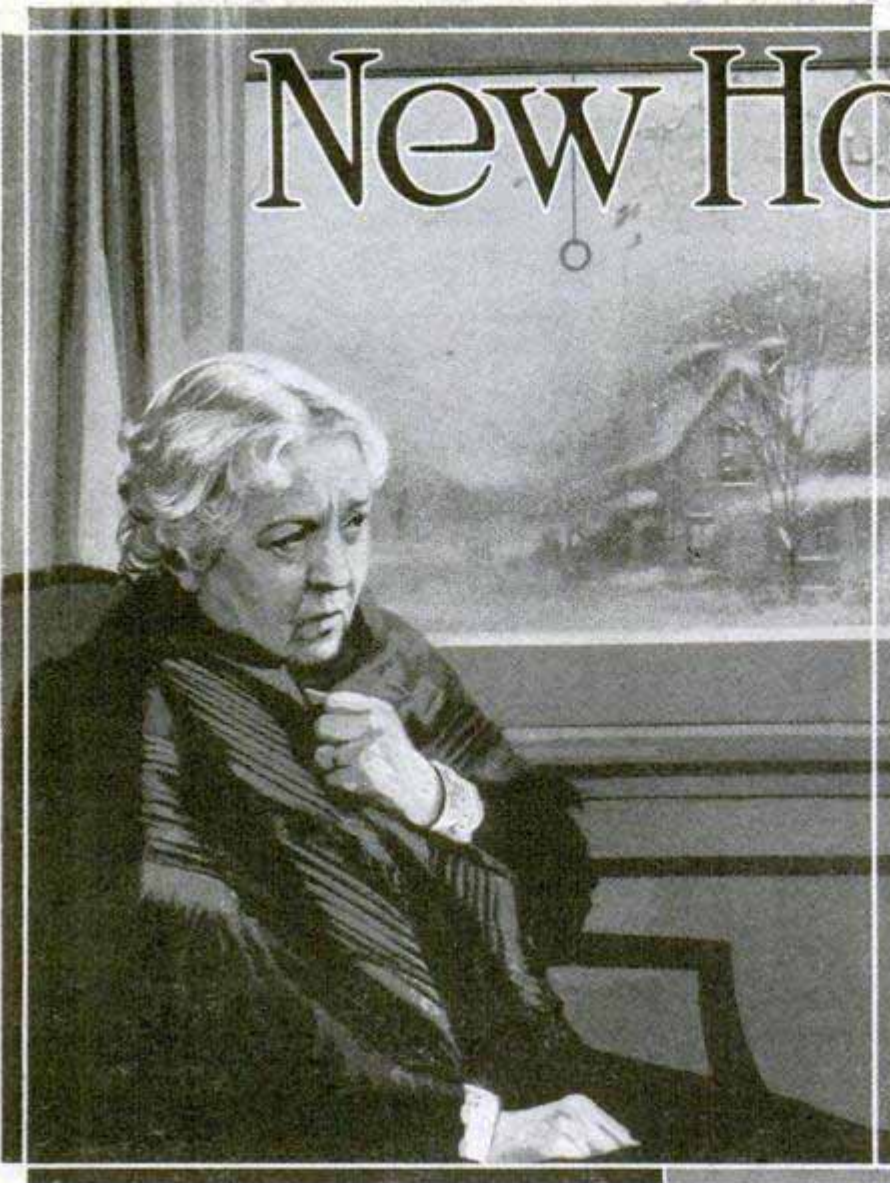


No. 10 Sargent & Greenway

Write our Bureau of Information, if you wish to know who makes or sells any article described in this magazine. Send no postage; the service is free.

H. G. Hayes, 1000 Courtney St., Washbrook Road

New Homes



Think that over if you own an old house. The chances are you do, because Walter Kohler, head of the national home-modernizing bureau, says, "more than 16,000,000 houses in the United States are out of style."

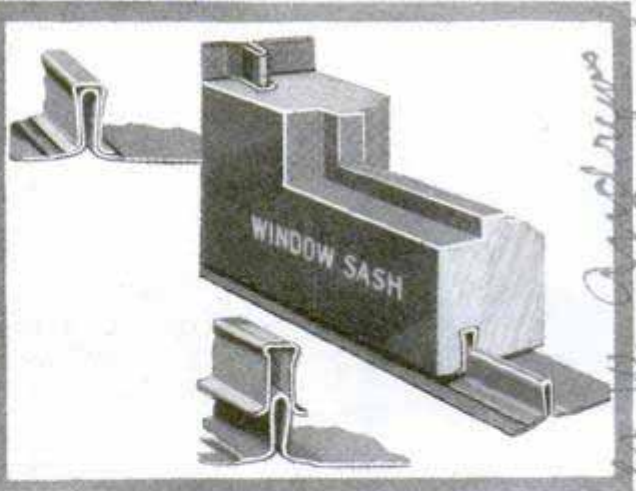
It seems incredible that every other house in all the land is out of date. Yet those are the figures. You know the kind of house I mean. Built for shelter but with no special attention paid to style or beauty. Small cut-up rooms, windows badly placed, no weather stripping, no insulation, sinks too low, splintery floors, paint in bad repair, bath room out of date—per-

By MAURICE I. FLAGG

A LITTLE money wisely spent in bringing an old house up to date can pay larger dividends than the same amount of money invested in gold securities.

If that sounds like a get-rich-quick proposition and glitters like a gold-brick promise, then read how the Nelsons spent \$2,500 to convert the old house shown on page 239—hardly more than a shack to start with—into the charming modern small Colonial home at the bottom of the page and made more than 100 per cent on their investment.

According to appraisers, modernizing this down-and-outer increased the value from \$600 to \$6,000. What is more, the owners say the house can now be rented furnished for a sum large enough to pay off the cost of the entire job in a comparatively short time.



Adequate Weather Stripping, When the Old House Is Rebuilt, Can Eliminate Drafts; This Is a Metal Strip

haps no bathroom at all. And a long list of other aches and pains. Houses that are literally "homesick."

Hardly more attractive than a packing box to start with, the Nelson house survived a major home-modernizing opera-

W. A. & N. Co. is also

The Heenan Mfg. Co. Newark N.J.

From Old



tion. It is a splendid example of how the imagination and skill of a trained designer, when applied to even an almost hopeless case, can bring it back to life with all the charm and fine qualities of a spick-and-span dwelling, modern inside and out.

Timbers were structurally sound. The framework or backbone of the old house was in good shape. A remodeling plan was drawn by an architect. The following changes were made in the old house:

A basement was put in to accommodate a modern heating plant. But notice how cleverly it has been camouflaged. You are not aware of it at all. Why? Because in this type of house it is best to preserve that low-down close-to-the-ground appearance. Somehow you feel this house grows out of the landscape. There's a snuggle-up, homey, intimate quality about cottages that do not show too much of their basement walls.

The roof was next raised to provide two gables. Four feet were

added to the living room. This gave the necessary space for the recessed front porch. New wood trim and new floors were installed. A bedroom and breakfast nook were added. That's about all the story except to tell you of the construction.

Cedar shakes laid with copper nails were used for the side walls and roof. Shakes are becoming popular as exterior wall coverings. They are modern shingles, patterned after the early hand-hewn Colonial shingles. Split toward the center of the tree, the crude early



Courtesy Weatherbest

Before and After; a Typical Example of What Can Be Done in Rebuilding Even an Old Shack by Adding a Porch and Dressing Up the Exterior with Stained Shingles

Chicago - L. W. Andrews
12 28 N. La Salle

Chicago - L. W. Andrews
12 28 N. La Salle



new life to an old house. A new sun porch, new dormers, new entrance door, new floors, a new bathroom, new side-wall covering of stucco, shingles or siding, new roofing, a fresh paint job, constitute the average improvements to an old house. Individually and collectively, such changes are not expensive. And you need not move out of the house while the work is under way. A job like the Nelson house might require living elsewhere during the process of ripping, slashing and moving partitions.

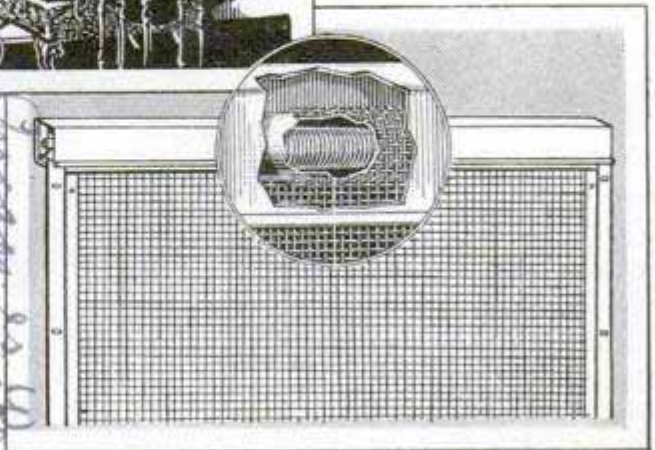
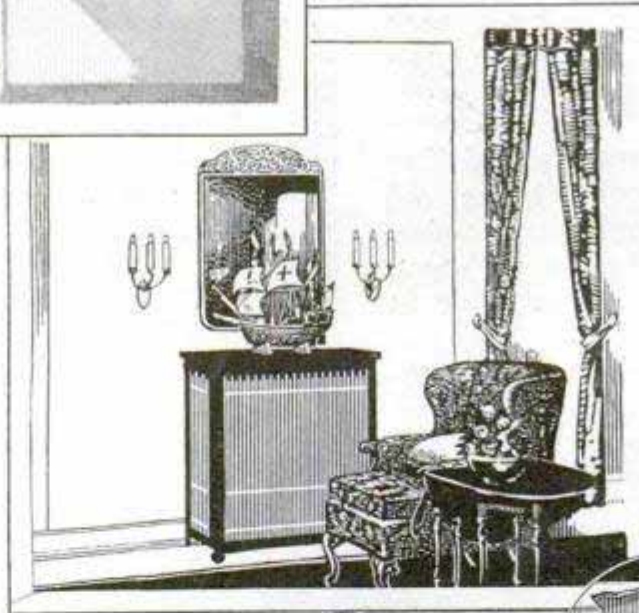
Even when a major operation is not performed, there are many little things that can be done to make an old house more attractive and more livable. An old bathroom with plaster walls can be brightened up and made the equal of the best of modern baths by covering the walls with tile or one of the tile substitutes that come in the form of wallboard. There is a tile panelboard on the market which comes in sheets of four by eight

feet, so that it can be used either for a four-foot-high tile strip up to the wainscot line, or placed on end for walls of double that height. And it is finished in pale greens and other shades, to introduce that touch of color which manufacturers are putting in the newest bathroom fixtures.

shingles, or shakes as they were called, had thick butts. Shakes gave enduring service and the thick butts cast shadows producing light and shade textures to roofs and side walls. Architects desire the same qualities in modern designs.

The side walls of the Nelson house are stained cream. The roof is terra-cotta in color. Windows and doors are trimmed green. Green blinds or shutters are to be added soon. This delightful color scheme adds a fresh, crisp appearance to the house and is in keeping with the spirit of the modernizing plan.

Few people will want to go so far as did the Nelsons in order to modernize an old house. Generally, small additions and minor alterations work wonders in giving



Metal Plate, Flush with Wall, Covers Pipes and Can Be Papered Over or Painted; Center, Modern Radiator Covers Save Walls and, Bottom, Roller Screens End a Source of Trouble

The Higgin Mfg Co
New York N.Y.

Chicago - 106 E 42nd St. New York
 POPULAR MECHANICS

Exposition
 228 N La Salle
 Chicago

The same panel tile boards can be used to brighten up the kitchen. They look and feel like tiles, and are washable.

Wallboards have a multitude of uses in remodeling an old house. With them, it is easy to create an additional room or two in the attic, or convert part of the basement into an attractive playroom. Decorated with the plastic wall finishes, a wallboarded room is the equal, if not superior, to the best of painted or papered plaster.

One of the newest boards, made by a process recently imported from France, is an asbestos product grained to imitate wood. The imitation is so good, and the molding, of special designs, imitation carvings and molding strips so excellent, that it is being used for fine paneled libraries and dining rooms.

A visit to a building exhibition, where the manufacturers display all their newest products, is a revelation in what can be done to make an old house better. There are metal radiator covers, worth their cost for the protection they afford to wall finishes or paper, and equipped with concealed humidifiers which not only keep the air properly moist to ward off colds, but protect furniture and woodwork from drying out and cracking.

There are window screens which roll up like shades, and are left permanently installed, instead of being taken down each fall and put up in the spring. The screens are of lasting copper.

There are bathroom cabinets, fitted with Venetian-mirror doors, which can be installed in place of an old-type cabinet with wooden door and frame, or fitted between the studs in a bathroom which has had no cabinet.



It Cost \$801.49 to Remodel This Old House, and the Valuation Was Increased by \$3,700; at Left, New Wall Tile Which Comes in Four-by-Eight-Foot Sheets, and Especially Suitable for the Bathroom or Kitchen

There are all kinds of weather stripping, wood, fabric and metal, to keep out the drafts around shrunken and badly fitted doors and windows.

There is a new casement window which not only opens on hinges, but slides up and down like an ordinary window. It gives a wide range of ventilation, makes it possible to draw the curtains at night and still have fresh air, which can't be done with an ordinary casement, and solves the washing problem, as both sides can be cleaned from the interior of the house.

And for the modernized kitchen, there are sinks with built-in dishwashers, low sinks at which the housewife can sit while she washes the dishes, and a wide range of enameled metal kitchen furniture in standardized units, so that any desired arrangement of space can be assembled.

What about modernizing costs? That is a difficult question to answer. No two jobs are alike. Location and choice of

Chicago Panel Stone Co
 2456 George St.
 Chicago

American Casement
 228 N La Salle
 Chicago

Morton Lugo Co.
 5105 W Lake Chicago

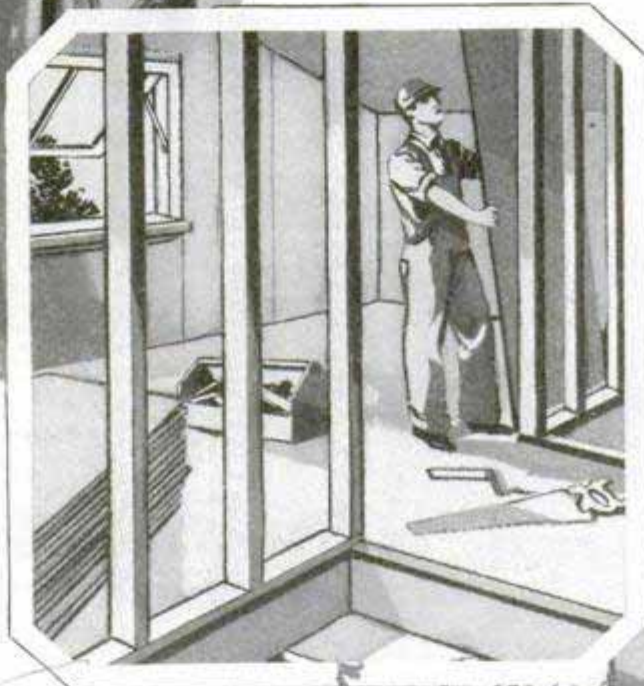
Chicago



for worry about money, provided your house is located in a good neighborhood and structurally sound. You can pay off home-modernizing loans on the easy-payment plan, and the rates of interest are quite reasonable.

Experienced builders say that your remodeling estimates should not exceed fifty per cent of the total cost of a new house offering you the same equipment and accommodations that you demand of the old house made over. Be sure to investigate the probable increase in value. It is a good plan to talk over all these points with local money lenders and tradesmen before you make your decision.

From a practical point of view, it is best to have your house inspected by an expert before you even contemplate spending a penny. Give it a fine-tooth combing. Investigate the condition of the footings, the framing, bracing, side walls and all exposed construction. Be sure it is sound and actually deserves rehabilitation.



materials enter into final costs. For example, a new sun porch on an average small house may run between \$600 and \$1,000. Insulation for the attic roof between \$75 and \$100. Dealers everywhere can give approximate cost information almost instantly.

There has never been a time when money could be obtained more easily for home modernizing than now. Loan associations everywhere are co-operating with building-material manufacturers and with others, to make it easy for anyone to dress up the old house. I am told that millions of dollars are awaiting owners to use for home improvements. These dollars can be had almost for the asking.

Frequently all you need to show for a loan is title to your property. Often the increased value of the house due to contemplated improvements is sufficient security for a loan. There is really no need



Venetian-Mirror-Front Medicine Cabinet Which Can Replace Old Style; Making an Attic Room with Wall-board, and, Bottom, a Comfortable Sink

*W.A. Thinger Sanitary
Mfg. Co. 1900 Lucas St.*

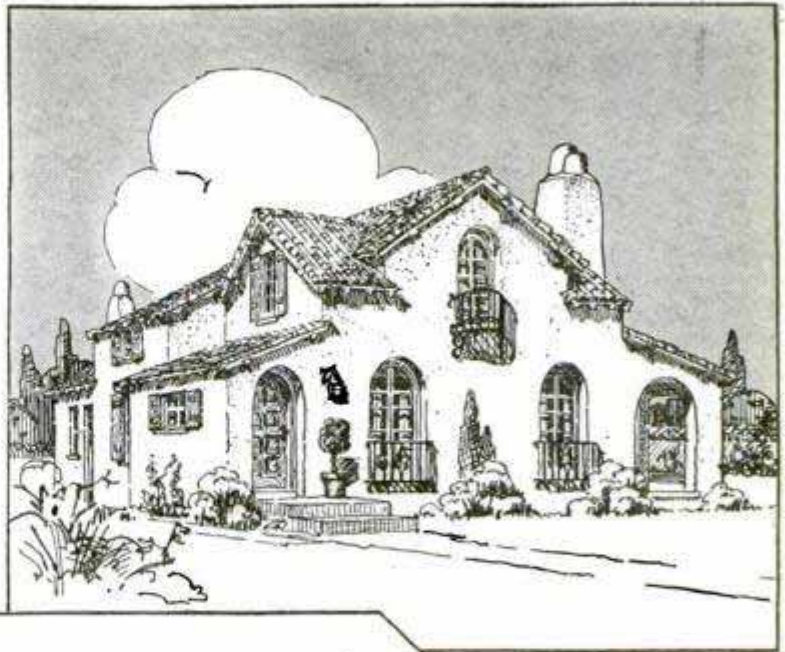
*Williamson Mason Fibre Co. Chicago
111 W. Washington St.*

Washing

Elco.

There is this to be said in favor of old houses. Many were built ten, fifteen and twenty years ago when materials were less expensive, labor less costly and in some cases construction better than today. In other words, the stuff was in 'em. They may have grown a bit down at the heels, lack style, but the framework and structure of the house may still be as sturdy as the rock of Gibraltar. In such cases you may be justified in spending considerable money on home modernizing.

I know of one builder who has worked up a profitable business buying old houses in good locations. He remodels them and finds a ready market, for the reason that, in almost every case, the completed house is brimful of individuality and little unexpected things. He tells me that the successful mingling of worthwhile old features with new altera-



tions adds a certain charm you seldom find in a brand-new house.

Finally, dealers of building materials, loan associations, bankers, and many other agencies, are waiting to help you. Some manufacturers have opened service departments and, at no cost, supply highly attractive modernizing suggestions di-

rect from photographs of the old house. Many fine results have thus been achieved.

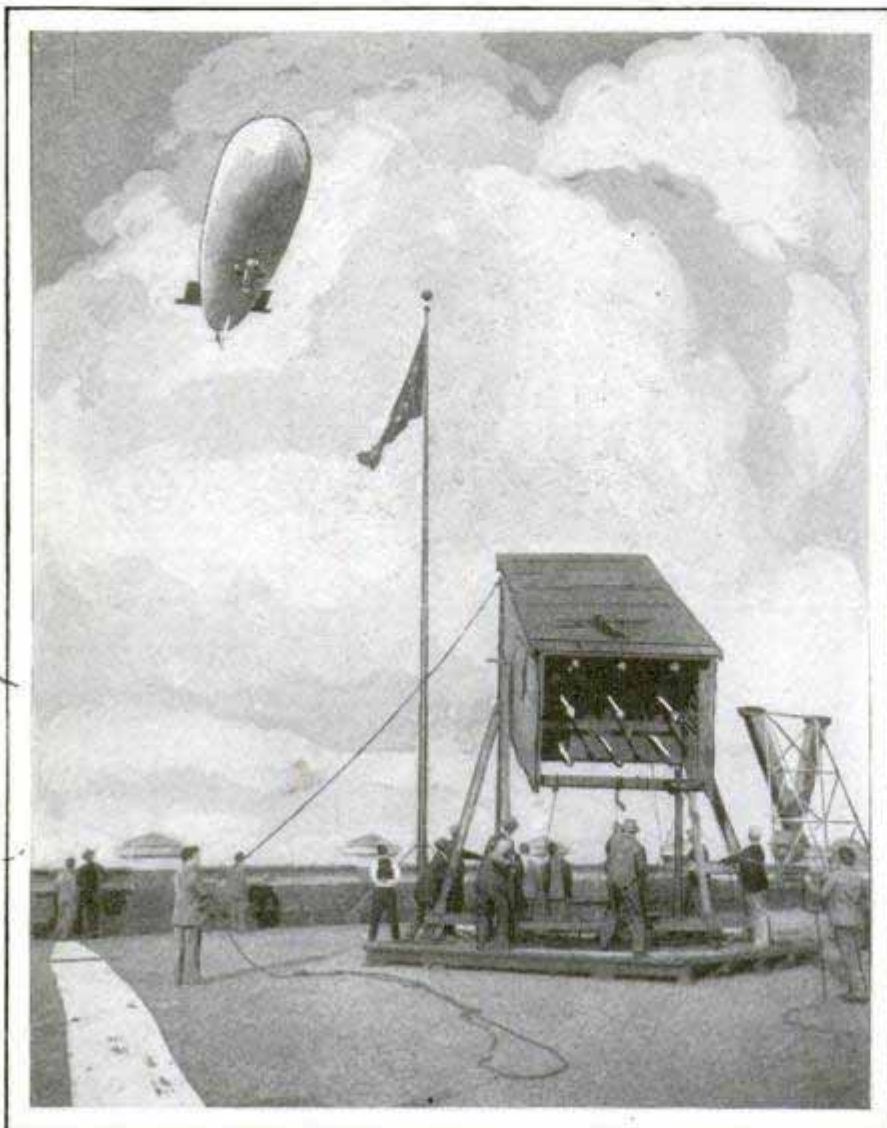
Home modernizing is a thrifty move any way you figure it. You take your shoes to the cobbler for new soles provided the uppers are in good shape. You replace old piston rings and give your car a new-paint and renickel job because you can see many a good mile ahead and more service from your original investment. Popular Mechanics home building department will be glad to help readers plan their remodeling.



A Colonial Home with Quaint Dormer Windows, or a Spanish Stucco Type, Can Be Had by Remodeling the Old House in the Center Illustration

Our Bureau of Information will answer all questions regarding articles appearing in this magazine

95-2 N. Vincennes



Special Horn That Projects a "Beam of Sound" for the Guidance of Aircraft; It Is Effective at 1,500 Feet and More

HORN HELPS GUIDE AIRSHIPS THROUGH DENSE FOGS

Instead of diffusing the sound waves, a horn recently tested in the east, directs a "beam of sound" at a definite point. It has been used in aiding an airship to land from an altitude of 1,500 feet, and engineers believe that it will be of great help in guiding aircraft through fogs.

FRUIT-JAR SEED-CORN TESTER TELLS GRAINS' GROWTH

A simple test to determine the fitness of corn for planting has been devised by the agricultural extension service of the University of Wisconsin. On half of a mat of old newspaper pages, or those of practically any circular not printed on glazed paper, about ten inches wide and ten and one-half inches long, fifty seeds are spread

so that no two grains touch each other. This is done after the paper has been thoroughly soaked and crumpled in water. The other half of the mat is then folded down over the grains, and the entire paper rolled up to form a compact bundle. Each end is tied with a string or rubber band, and the roll is placed in a two-quart fruit jar, a small hole is punched in the lid and the cover screwed on securely. In about a week, after the jar has been kept undisturbed in a moderately warm place, the roll is opened and the seeds examined. All sprouted seeds should have both shoots and roots. Those without sprouts are dead; those having roots and no shoots or those with shoots and no roots, should be accounted dead as well as those that have weak-looking sprouts compared with the

others. The seeds rated as dead are then counted, the number multiplied by two and the result subtracted from 100. This gives the percentage of germination.

HAND ENVELOPE SEALER HAS NO WICKS OR SPRAYS

A hand-operated envelope sealer, provided with an inverted jar of water, is now on the market. The envelope flaps are passed through a feed which moistens the gum and folds the flap. A companion machine is a stamp container which moistens and affixes stamps, and also keeps count of the number used. It works on the same principle as a date stamp.



Special Circular

Handmade Machine Co

NEON SIGNAL SAVES CURRENT ON ELECTRIC APPLIANCES

no 4 is urgent to man

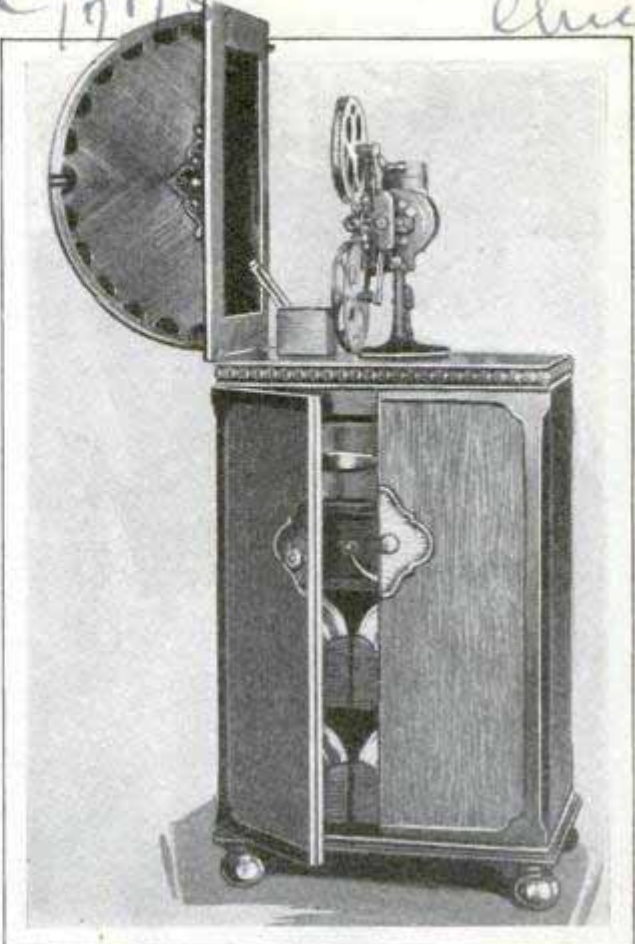
To show whether or not various electric appliances in the home are connected, a neon indicator has been introduced to help save current. It consumes but a fraction of the amount of electricity required by ordinary lamps now used for that purpose, and its glow is easily seen both in daylight or under strong artificial light. The device is simply a small glass cylinder filled with neon gas and having electrodes through which the gas is made to glow when the appliance on the same circuit as the indicator is turned on. The unit is also useful on switchboards in theaters, factories and other places having elaborate lighting systems. A glance at the board so equipped will tell the operator which lamp or group of lamps are lighted, when the position of the switches is not so easily interpreted.

RADIO SET BUILT ON BICYCLE ADDS FUN TO TRIPS

With a homemade radio set which he has fashioned, an eastern bicycle enthusiast enjoys music and other programs from various stations while riding through the country. The receiver, with loop antenna, is compactly built, weighs but a few pounds, and does not interfere with the normal operation of the bicycle.



He Has Radio Music Wherever He Rides; Receiving Set Attached to Handlebars Entertains Bicyclist



Cabinet for the Home Motion-Picture Projector and the Films; the Hinged Top Fits Down over Machine

HOME MOVIE-MACHINE CABINET HOLDS REELS AND PROJECTOR

Projector, films and other parts of a home motion-picture outfit are contained in an attractive cabinet with a dome-shaped top to cover the projector. The article forms what corresponds to the projection booth in a theater. The cover protects the projector from dust and damage when it is not in use and saves extra handling of it.

OIL FROM SHIPS KILLS BIRDS BY WEIGHTING WINGS

Alarmed at the number of birds that are killed by oil from ships, a British society has started a campaign to correct the evil. The oil weights the birds' wings and clogs their feathers so that they either cannot fly or become exhausted quickly. Eighty were found dead from these causes recently. The wider use of oil separators on ships has been recommended in order to do away with the necessity of discharging the material upon the water, as is still the prevalent practice.

W. James 11/18/24

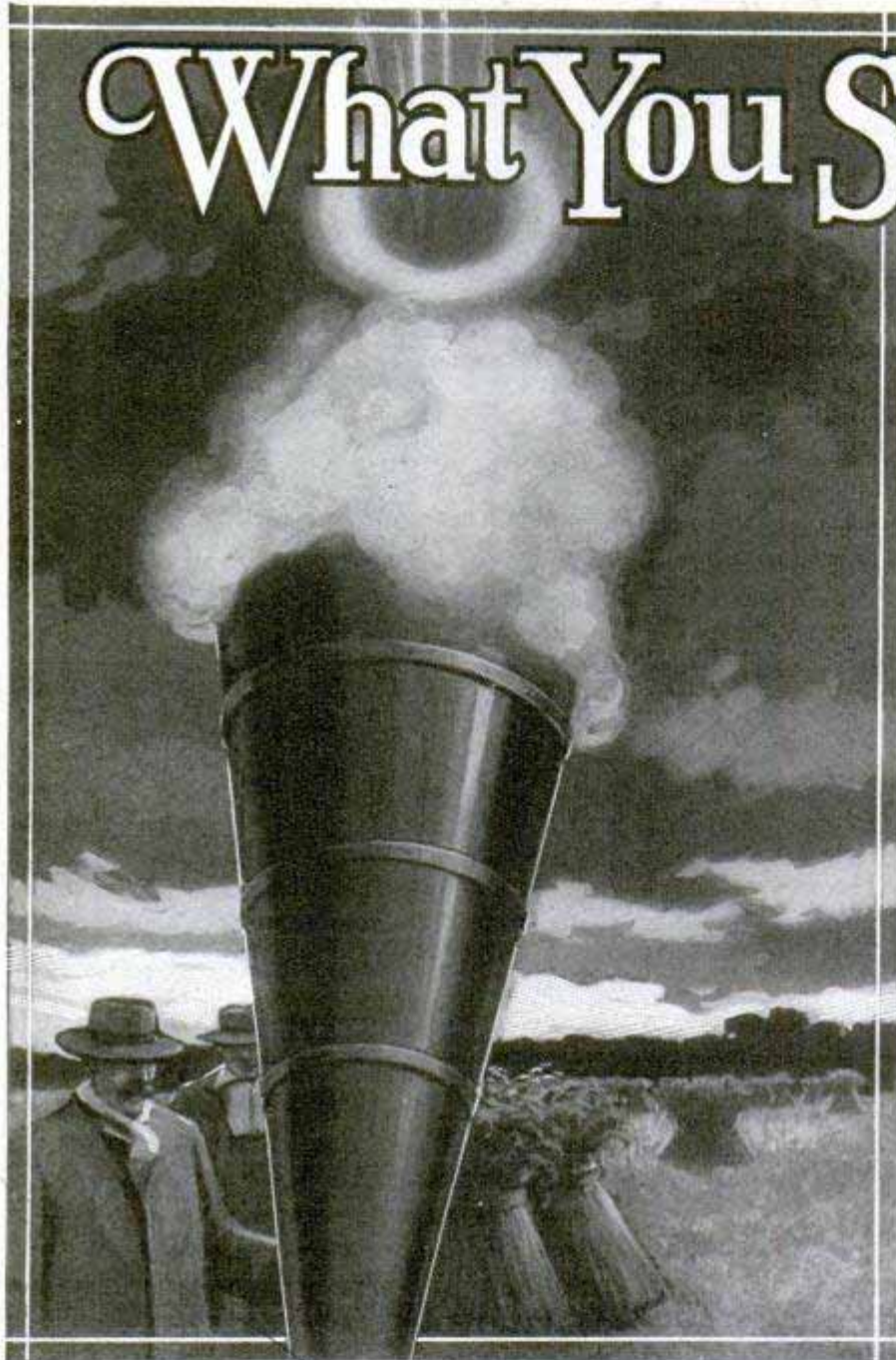
Royal Society for Protection of Birds

Mysses Masoth

1603

223 Spring St. New York

What You Should



taining more than 47,000 books.

Big as it is, the weather bureau library cannot supply answers to all the questions addressed to the weatherman. Many cannot be answered because science itself has not yet found the answers. Plenty of weather mysteries still await solution. Some are unanswerable for other reasons. The bureau is often asked, for example, why there were no rainbows before the flood. The other day a letter came from a correspondent who wanted to know the difference between a cyclone and a volcano. The bureau assumed that the writer meant tornado, and replied accordingly.

What kinds of questions does the public ask the weatherman? There is almost no end to their variety. There are, however, certain questions that are asked over and over again. Some of these relate to the dates and other particulars of memorable storms, cold winters, floods and other outstanding weather events.

Courtesy Everybody's Magazine
Bombing Clouds with a "Hail Cannon," an Old Idea with No Scientific Standing; Smoke Rings Were Fired Instead of Projectiles

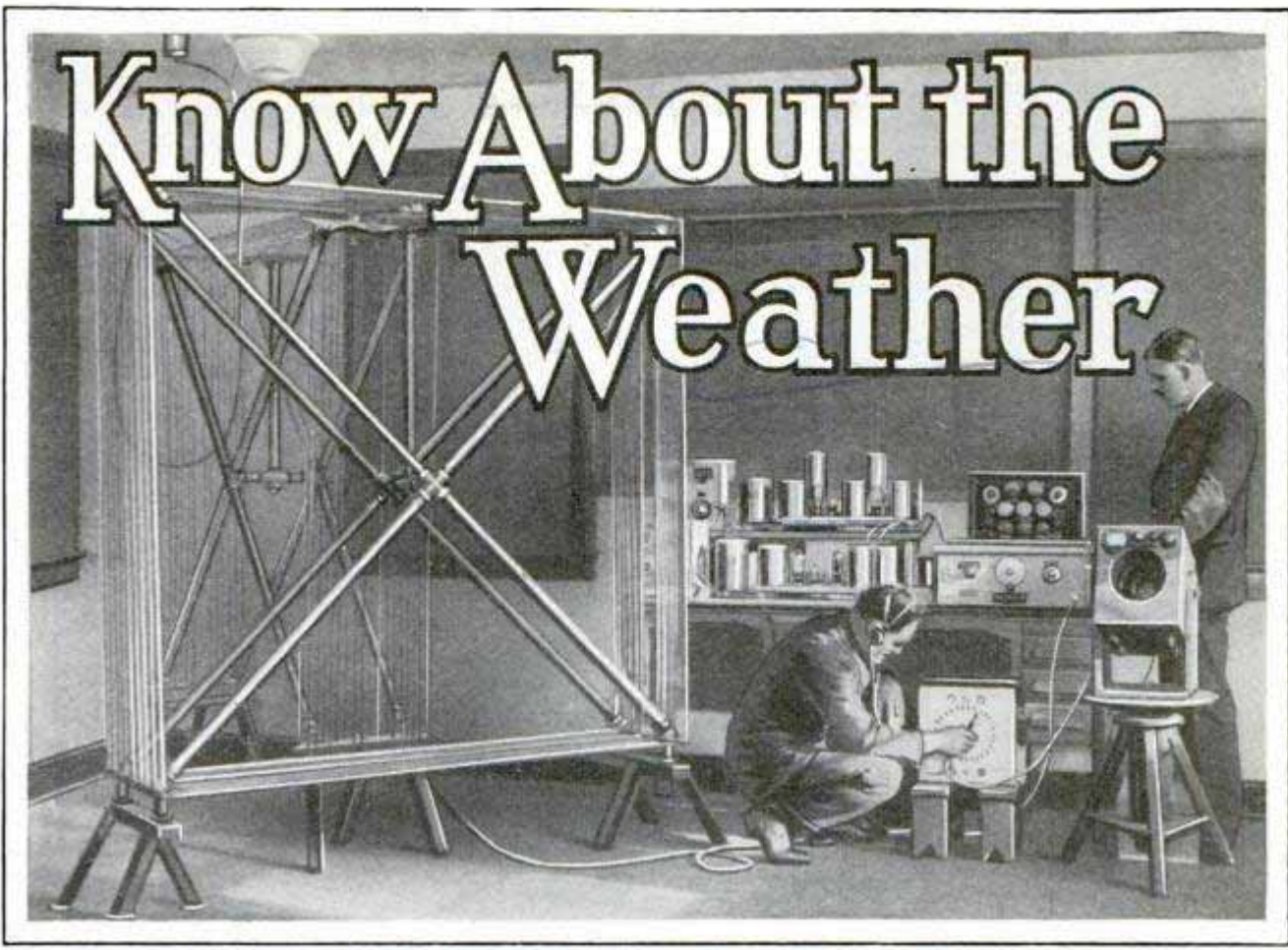
By CALVIN FRAZER

Photo-gram Co. Box 840, Washington DC
THE WEATHERMAN has several jobs on his hands besides those of recording and predicting the weather. One that takes up a great deal of his time is answering questions.

Every year, thousands of inquiries are received by the United States weather bureau, at its central office in Washington and at its stations throughout the country. As an aid in answering these inquiries the bureau has assembled in Washington the largest library in the world devoted to the subject of weather, con-

At least three or four times a year, somebody asks for information about the "Big Wind in Ireland." This name is applied to a violent tempest that swept over the British isles in January, 1839, causing great destruction by land and sea. Strange to say, though it is almost completely forgotten in the old country, it is frequently heard of in America. It was a recent event at the time Irish emigration to this country was at high tide, fol-

Know About the Weather



Said to Aid in the Prediction of Storms; an Automatic Static-Recording Device at the Naval Air Station in Washington; Direction of Signals Is Determined by the Loop Antenna

lowing the terrible famine of 1845-46, and the memory of it has been preserved among the descendants of the Irish who came over at that period.

Other famous weather events that people often inquire about are the two Galveston hurricanes (especially the one of 1900), the two St. Louis tornadoes, the Samoa hurricane of 1889, in which American and German warships were lost, the Johnstown flood, the New York-New England blizzard of 1888, and—last but not least—the “Year without a Summer” (1816).

The public is always much interested in record-breaking extremes of weather. There are many questions as to the highest and lowest temperatures ever registered in the United States or elsewhere, the places having the greatest and least rainfall, the strongest winds ever observed, and so on. Statistics on such subjects necessarily vary somewhat from year to year. Several places, for instance, have successively held the blue ribbon for hot weather. For many years this distinction was enjoyed by Wargla, a town in the

Algerian Sahara. Then, in 1913, Death Valley, California, established a new world record, with a reading of 134 degrees. This held good until 1922, when it was surpassed by two degrees at the village of Azizia, in the Italian Sahara. The low-temperature record has been held since 1892 by Verkhoyansk, Siberia, close to the arctic circle, with an official reading of 90 degrees below zero.

There has been much uncertainty as to which of the world's weather stations has the greatest average annual rainfall. The latest figure for Cherrapunji, in Assam, is 428 inches. This is rivaled at certain stations having shorter series of observations, including another place in Assam, Manoyuram, where measurements were made for only five years and then discontinued. The average for this period was 499 inches a year. Another notoriously wet spot, the summit of Mount Waialeale, in Hawaii, is so difficult of access that measurements are made there only once a year with an enormous rain gauge—the largest in the world—designed to catch and store the rainfall of an entire year.

1603
244



The average yearly rainfall at this station, up to date, is 427 inches. The driest known spot in the world is Iquique, Chile, with an average annual rainfall of only two-tenths of an inch. To the frequent question, "Are there any rainless places in the world?" the weather bureau replies in the negative.

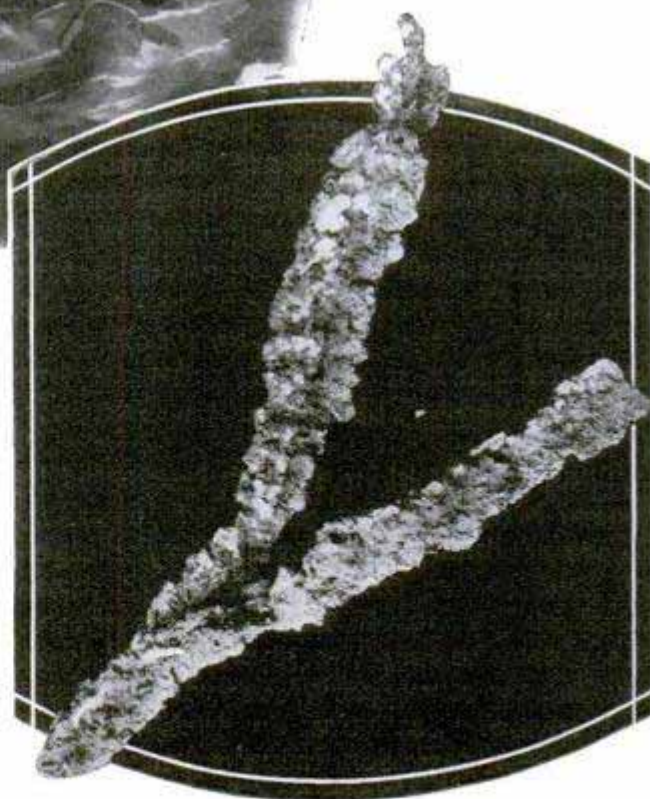
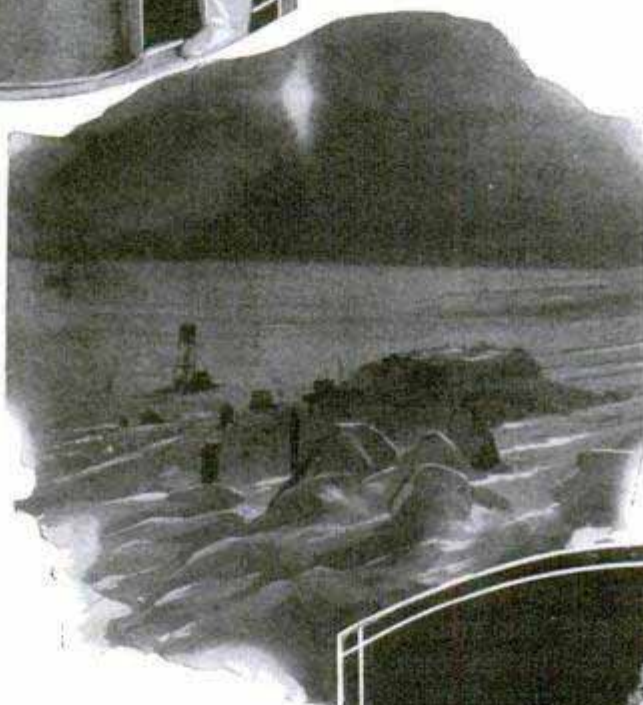
The rainiest known place in the United States is Glenora, Tillamook county, Oregon, where the rainfall averages 131½ inches a year, and the driest is Death Valley, where it averages a little over one and one-half inches a year. Whether the heaviest snowfall of the United States occurs in the high Sierra of California or on the upper slopes of Mount Rainier, Wash., is an unsettled question.

Chicago's nickname, "the Windy City," raises the question whether the city is actually windier than others. The answer is that the wind measurements in Chicago show a higher average than in any other large city of the United States (only slightly higher than in New York), but are surpassed at many smaller towns on

both the Atlantic and Pacific coasts. The strongest wind ever measured in this country was nominally 186 miles an hour, registered on the summit of Mount Washington, N. H., Jan. 11, 1878, but certain necessary corrections reduce this figure to about 140 miles an hour. Far stronger winds occur in tornadoes, but they have never been measured.

"How large are the biggest hailstones?" is a perennial question. Huge masses of ice have sometimes been found after hailstorms, but they were doubtless the result of several hailstones freezing together while lying in a heap on the ground. The greatest possible size of a single hailstone cannot be stated with any certainty. In

August, 1925, a hailstone, weighing four and one-half pounds, fell through the roof of a house at Heidgraben, Schleswig-Holstein. This stone was nearly ten inches long. There have been several reports of even bigger hailstones, but they

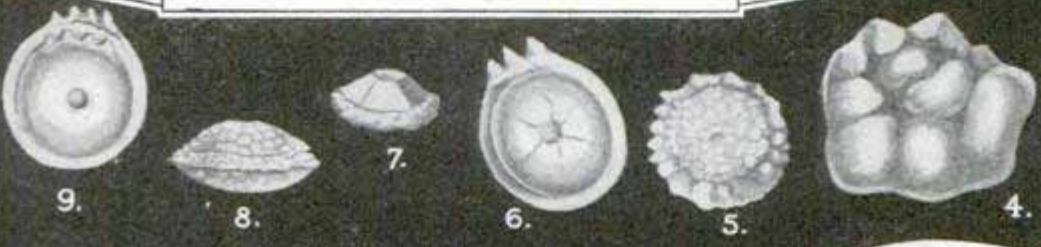
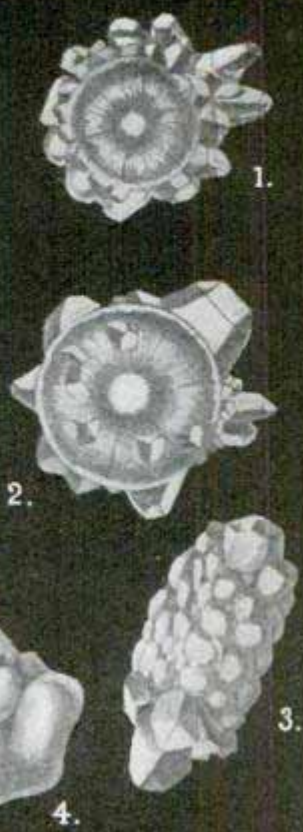


Big Rain Gauge; Weather Post in Greenland, and Record of Lightning Bolt in Fused Sand

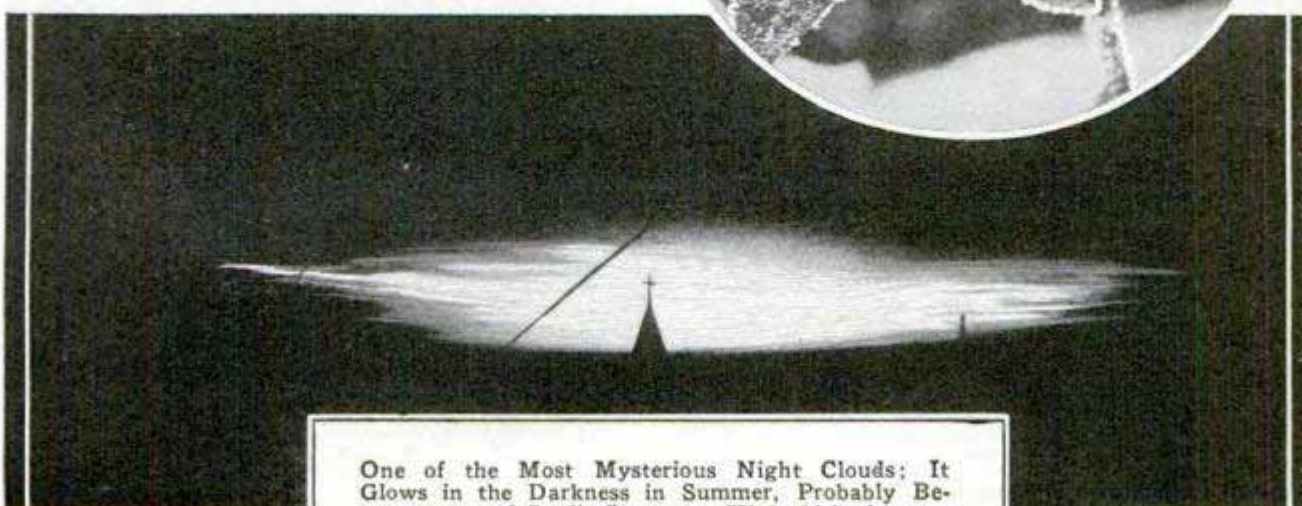
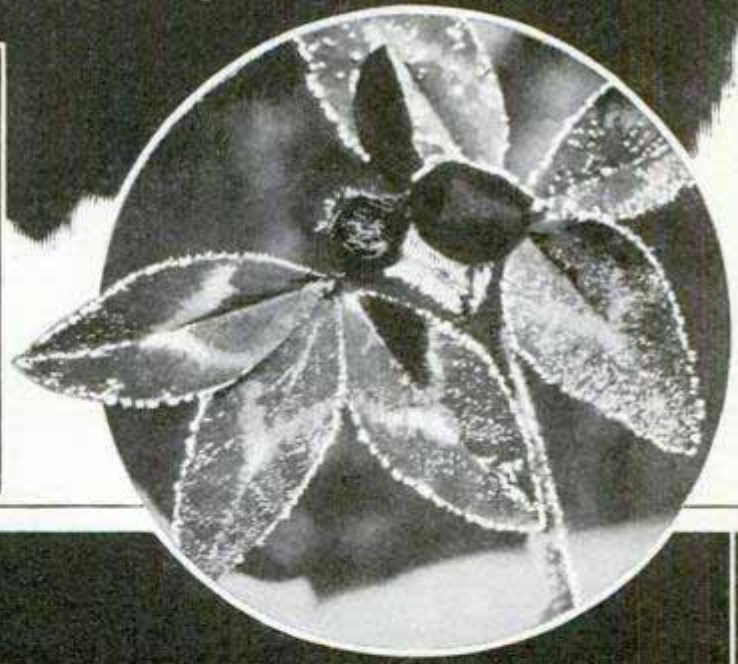
160-



Excellent Photograph of a Lenticular Cloud with Thin Edges That Often Are Iridescent; These and Other Clouds of Curious Aspect Inspire Many Queries



Hailstones of Curious Shapes Gathered after a Storm in Central Europe, and False Dew on Clover, Drops Exuded by the Plant Itself and Not Condensed from the Atmosphere; How Large Are the Largest Hailstones, Is a Frequent Question; One, Weighing Four and One-Half Pounds and Ten Inches Long, Fell through the Roof of a House in Germany in August, 1925; Other Larger Stones Have Been Reported but Are Not So Well Authenticated; the Various Layers of the Stones Are Formed by the Irregular Fall of the Lump from the Sky to the Earth



One of the Most Mysterious Night Clouds; It Glows in the Darkness in Summer, Probably Because of Sunlit Dust at a High Altitude



were not so well authenticated.

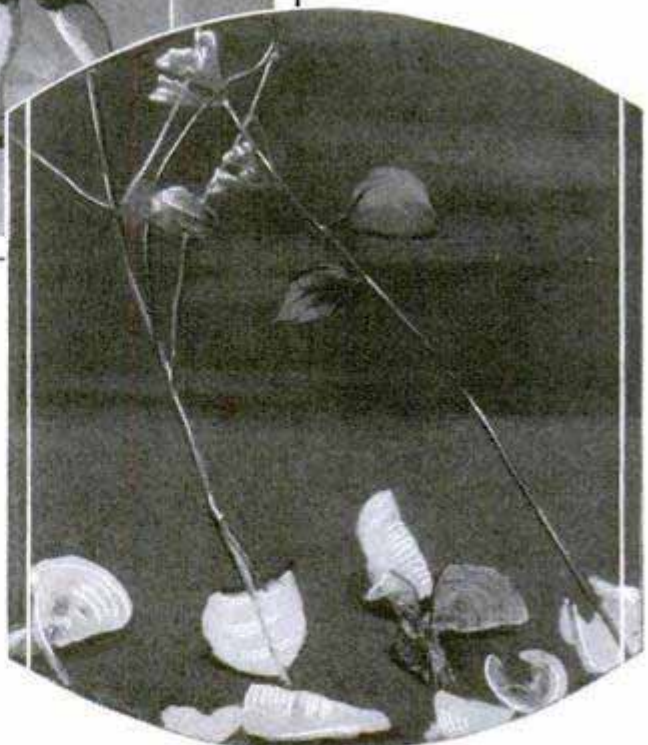
"Why," the weatherman is asked, "is a hailstone built up, like an onion, of successive layers?" Hail is formed in the violent updraft of air at the front of a thunderstorm. In this turbulent region the hailstone, first frozen at a high level, makes several journeys alternately up and down as it encounters stronger or weaker rising currents; at one time gathering a coating of snow aloft, and at another a coating of ice from rain below, until finally, on account of its large size or on account of a weakening of the upward blast, it falls to the ground.

The weather bureau is often consulted about the merits of two expedients for averting hailstorms that have been tried on an extensive (and expensive) scale in Europe, viz., "hail-shooting" and the "hail rod." The former consists in bombarding the clouds with funnel-shaped mortars, which discharge no projectile but send out smoke rings like those often seen over the

funnel of a locomotive. The hail rod, in its latest form, is merely an overgrown lightning rod, erected on a steel tower or at the top of a high building. Neither of these devices rests on any scientific basis, and both have lost much of their once unbounded popularity in the Old World.

In times of drouth, the bureau is besieged with appeals for information about methods of making rain. The feat is not impossible, but all known methods are vastly more expensive than the results would justify. One proposed scheme is to

set up a barrier packed with ice in the path of moisture-bearing winds; an idea inspired by the familiar "sweating" of an ice pitcher. Dr. W. J. Humphreys, of the weather bureau, has figured up the expense of operating such a contrivance under average conditions in a western state where the yearly cost of water for irrigation is now two dollars an



Fanciful Shapes Formed by Frozen Fog; Ball of Lightning Killing Professor Richmann, and Ice Fringe on Dead Plant



Like Jellyfish in the Sky; a Good Example of Alto-Cumulus Clouds with Tentacles and Streamers the Weathermen Call "Fallstreifen"

acre. He finds that the thing would cost about \$20,000 an acre per annum!

One of the endless tasks of the weatherman is explaining the difference between the various kinds of solid and liquid moisture condensed from the atmosphere. Here are some of the facts in a nutshell: Hailstones are part ice and part snow and are a product of thunderstorms. Sleet consists of small fragments or balls of clear ice formed by the freezing of raindrops. Graupel (sometimes called soft hail) is a granular form of snow, consisting of miniature snowballs. Glaze is a coating of clear ice formed by rain that freezes as it falls. A heavy coating of glaze constitutes an ice storm, such as may cause great destruction of trees, wires, etc. Rime is a deposit of ice from drifting fog. Both glaze and rime are dangerous to aircraft. Hoarfrost is a deposit of ice crystals on cold surfaces, generally by direct condensation of atmospheric water vapor without passing through the liquid form. When a cold surface condenses water vapor in liquid drops, the result is dew. The drops seen on vegetation in the early morning are not always dewdrops. Many—especially the big ones—consist of water exuded by the plants themselves and are called "false dew."

Several phenomena of the atmosphere are so uncommon that each occurrence of one of them calls forth letters of inquiry from the public. Among these rarities are the muff-shaped masses of snow known as "snow rollers," which are sometimes found by the thousand lying on snow-covered fields and lawns. They are formed by the wind when the temperature is just right to give the snow the necessary cohesion, and each lies at the end of a long trough marking the path along which the snow has been rolled. Then there are the delicate curved ribbons of ice that grow out from the dry stems of certain plants. Their mode of origin is not well understood. They are called "ice fringes."

Two other rare phenomena that the weatherman cannot explain to his own satisfaction, much less to that of the layman, are ball lightning and will-o'-the-wisp.

St. Elmo's fire—a harmless brush discharge of electricity from pointed objects—is something that most people have read of but few have seen. It is commonest on high mountains; less common at sea.

Widespread dustfalls, sometimes covering thousands of square miles, call forth many queries and thus make work for the weatherman, who can generally trace the

1603 248

dust to its source by consulting current weather maps. There was a case of this kind last April, when fully 2,000,000 tons of dust, blown up from the soil of southern Russia, fell over countries to the westward. Rain, reddened with dust blown from the Sahara, explains the showers of blood that have occurred many times in southern Europe, where they no longer arouse such superstitious terrors as they did in former ages. The "sulphur" sometimes said to fall from the sky is pollen blown from pine trees.

Ask me another is a game that most people play for amusement, but it is part of the weatherman's everyday business.

SEE SAFER PLANE LANDINGS WITH NEW ALTIMETER

Much of the guesswork and hazard of landing an airplane will be eliminated, experts predict, with the aid of a sensitive altimeter that shows the elevation of the plane with great accuracy even when it is but a few feet from the ground. In fact, the closer the ship approaches earth, the more accurately is the altitude registered, for the instrument operates by reason of the ground's electrical capacity. Few altimeters of the usual kind can be depended upon for accurate readings below 1,000 feet. The new altimeter, at fifteen feet, for instance, shows the altitude within a few inches, regardless of the speed of the plane, and this is an important service, for many serious accidents have occurred in crashes as low as this. The principle of the device, which is the invention of Dr. Ross Gunn, of the naval research laboratory, is familiar to physicists, but heretofore it has not been suc-

Dr. Ross Gunn in Arch Suppl. Light and Aircraft Div. Naval Research Laboratory

Chicago Beach

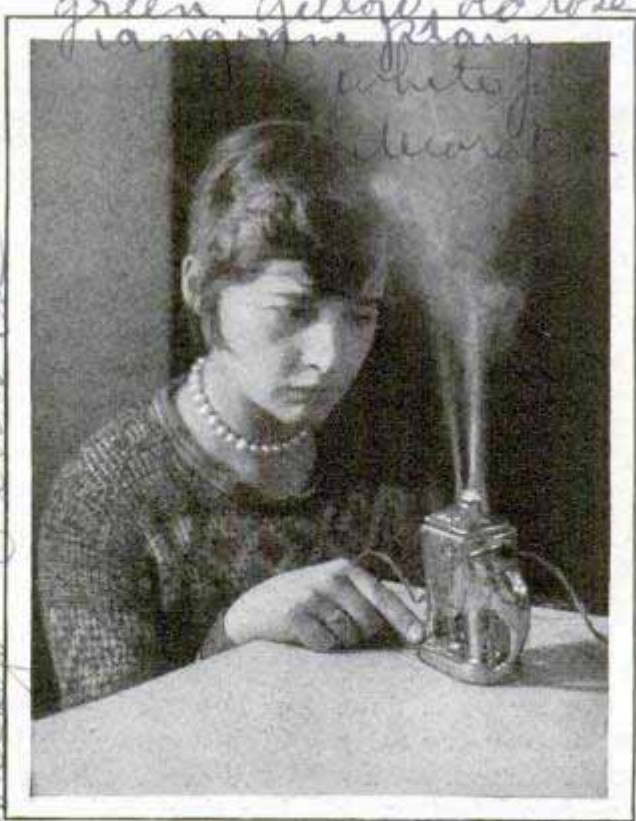
cessful with an altimeter under normal plane operations, because, at high altitudes, the changes in the electrical capacity are extremely small.

COUNTS SMALLEST SEEDS

A counter which not only counts small seeds in lots of one hundred, but then plants them evenly spaced in test boxes for germination has been built by the department of agriculture. One hundred holes, in ten rows of ten each, are drilled in a brass plate. The plate is mounted over an air-tight box, connected to a vacuum pump. An excess of seed is spread over the plate, the pump valve is opened, and the box gently shaken, then turned upside down. One hundred seeds remain, held to the holes by the vacuum, while the rest fall off. The box is then placed upside down over the test bed, the valve closed and air admitted, when the seed drop into place, properly spaced.

ELECTRICAL INCENSE BURNER ELIMINATES MATCHES

Incense burners equipped with electric heating units, to eliminate the use of matches, have been invented by a Madison, Wis., manufacturer. The burners are fitted with an extension cord to plug into any light socket, and have a small turn switch in the base. The incense cone is placed directly on the heating element, the switch turned for a few seconds, and the incense then burns from the bottom up, instead of the top down, which creates, it is claimed, a better smudge. The burners are made of both brass and porcelain, the latter style coming in colors, or white, to be decorated by the purchaser.



The Turn Button on the Base Operates the Electric Lighter and Starts the Incense Burning

Electra Incense Burner

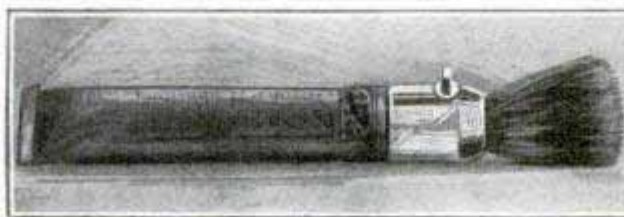
2314 Keyis Ave

IMPROVED "POLICE" WATCH RADIO STATIONS

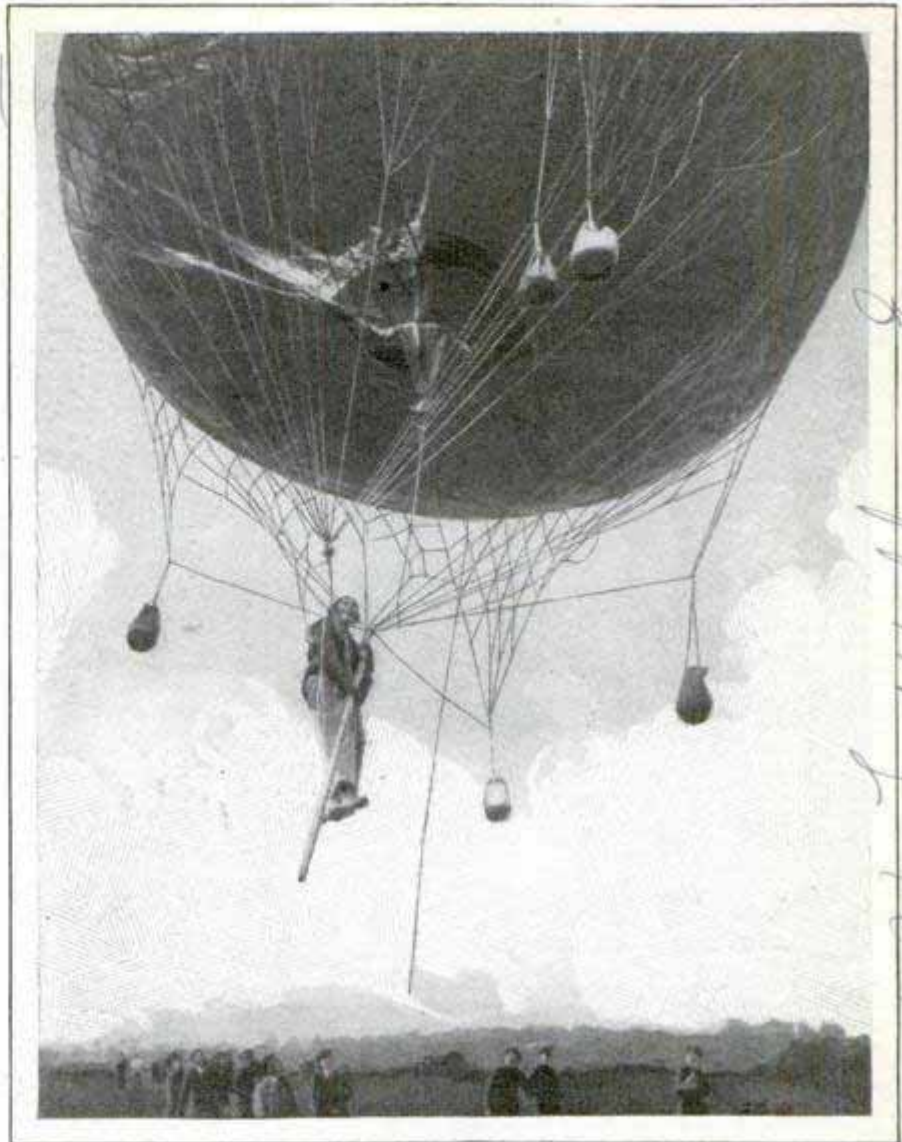
A better means of policing the air lanes, to determine when broadcasting stations wander from their assigned wavelengths, has been devised in the form of a central monitor station and sixteen secondary measuring units to be installed in motor cars and at points in various parts of the country. With this improved apparatus, which has been worked out by the radio division of the department of commerce, it will be unnecessary for the inspectors to go to the different stations in their areas. They can make a complete and accurate check-up in their own offices. The central monitor station is planned for some place in the middle west. It will maintain a higher degree of accuracy than the other units and will be more elaborate in character. Ten of the secondary depots are to be located in radio-inspection offices, and the other six installed in motor cars. The monitor apparatus consists of a high-class selective and sensitive receiving set which will cover the entire range of radio frequencies.

SHAVING-CREAM TUBE SERVES AS BRUSH HANDLE

Convenience and simplicity are afforded in a shaving brush which has a tube of cream for its handle, saving room in the traveling kit. To apply cream to the bristles, all that is necessary is to turn a valve and squeeze the tube.



Shaving Brush with Tube of Cream for Handle



Courtesy The London Daily Mail
Balloon Jumping Is Made Easier and Safer with Aid of Pole to Help Clear Ground and Avoid Obstructions

POLE AIDS BALLOON JUMPER IN TAKING OFF

To help get off the ground and to rise over obstructions, a long pole has been found effective by persons who follow the sport of balloon jumping in England. The pole can be used in many ways as, for example, to push away from the tops of trees and houses, and is employed in much the same manner as a vaulter uses his pole in clearing a bar. Perhaps most important of all, it is a safety aid to prevent landing on electric wires. To help relieve the weight, the pole may be attached to the balloon rigging.

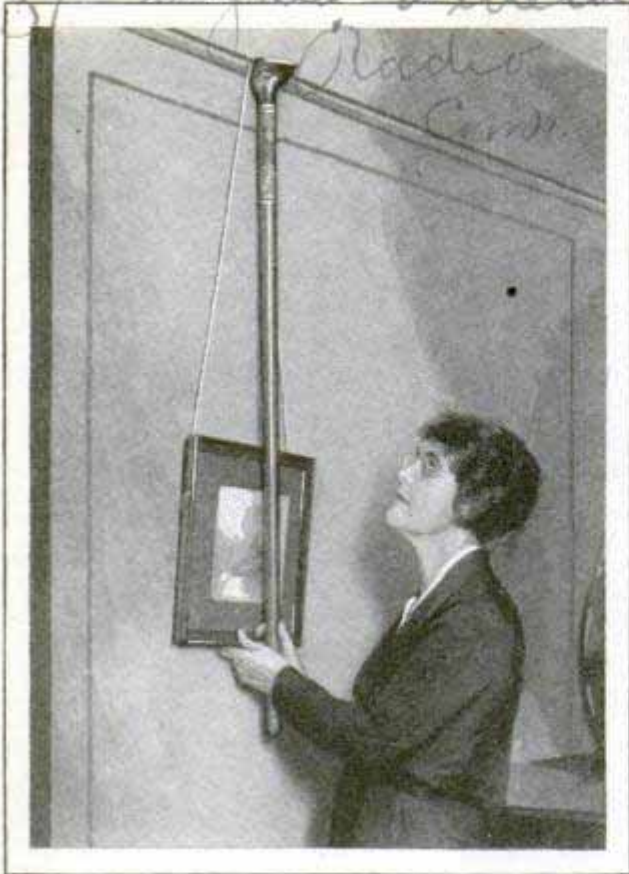
*Com. H. J. Watkins
Colombie, Ore. a r. h. e. r. e. l. o. o. a.
U.S. Army, Wash. D.C.*

*Com. H. J. Watkins
3206 Winton Ave.*

Albion, Miss

*National Club: my
Albion, Miss
11/11/1914*

*Dykes, wife of Judge
Dykes, Denver
and name Club
Boulder, Colo*



Hanging Pictures without a Ladder; the Pole Slips Wire and Hook over the Molding

POLE FOR HANGING PICTURES SAVES USING LADDER

To hang pictures without the need of a ladder, a woman has invented a special pole and holder arrangement which places the wire and hook over the molding while the user stands on the floor. It is designed to keep the picture from falling off, is quickly adjusted, and is long enough to be of service in all rooms.

COWLING FOR AIRPLANE MOTOR INCREASES SPEED

Resembling a large bowl, a cowl for radial air-cooled airplane motors cuts down wind resistance, helps assure proper functioning of the engine and increases the plane's speed, tests with an army pursuit ship have shown. Without the cowl, a test ship made 118 miles an hour with the propeller at 1,900 revolutions per minute, but with the cowl, the same ship attained 137 miles an hour, other factors being the same. The attachment is inexpensive and is expected to effect great savings in the operation of this kind of airplane. In operation, the bowl lets in sufficient air at

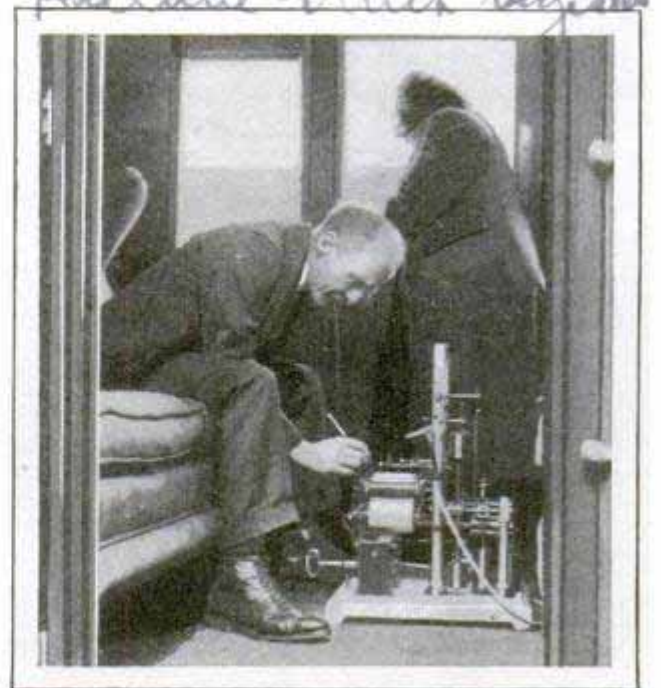
the front to cool the cylinders, and the flow issues from the rear in a smooth stream around the fuselage.

FISH IN HATCHERY POOLS GROW LARGER UNDER LIGHTS

By hanging electric lights over trout pools at a Colorado hatchery, a way has been found to provide the fish with an extra supply of food on which they thrive and grow larger than in pools without the lights. The rays of the lamps lure mosquitoes, moths and other insects which fall into the water and are devoured. The plan has reduced the cost of feeding the fish, and the benefits reaped from the system are reported to be such that they more than offset the expense.

JOLT RECORDER FOR RAILWAY AIDS SMOOTHER RIDING

To record jolts and jars while a train is in motion, a unit employed by an English railroad registers sideways motion, backward and forward action and upward jerks. These are indicated by graphic lines made by three pointers while the apparatus rests on the floor of a car. On the basis of these graphs, it is possible to make improvements in the track and roadbed, as well as in other equipment, and thus bring about smoother operation.



How Smooth Is the Ride? This Gauge Tells by Waving Lines When the Railway Car Sways

*Port. - Eastern Ry.
Winds Installed*

75
1
Capt. John A. ...
714 Jefferson St. N.W.
Washington, D.C.

Exploring the Earth

under the Sea

An "S" Boat, Similar to the One Used in Measuring the Force of Gravity under the Sea; the Submarine Is Just Emerging after a Dive during Maneuvers with the Fleet

A FEW weeks ago the secretary of the navy took the unprecedented step of turning an American submarine, complete with crew, over to a foreign scientist to use for two months. The visitor from overseas, Dr. F. R. Venin Meinesz, member of the Dutch geodetic commission, sailed away from Hampton Roads on the "S-21," cruised down to Key West and around to Galveston by way of the Sigsbee Deep, one of the holes in the sea, sailed out to St. Thomas, in the Virgin islands, Guantanamo bay, Cuba, and, after visiting the Nares Deep and the Porto Rican coast, returned to his starting point.

Dr. Meinesz was no stranger to submarine travel, for he had already been around the world in a Dutch submarine, traveling most of the way under the surface. That is undoubtedly the longest trip a civilian ever made in an undersea boat, and it was the reason why the American navy was glad to give him an S-boat to use for two months. For Dr. Meinesz is traveling under the waves to measure the thickness of the earth's crust, reweigh the earth, and also learn more about the great undersea earthquakes from which new islands are born, or old ones engulfed, tidal waves originated, the sea bottom changed, and readjustments started that have a reflection later in earthquakes affecting populated lands.

Since the theory was first advanced,

some years ago, that the earth's crust weighs virtually the same in every part of the globe, though it may tower five or six miles above sea level in one place and be five or six miles under sea level in another, scientists have been busy gathering evidence to prove their case. It was this work that has taken Dr. Meinesz around the world under the sea.

The scientific name of the theory he is seeking to prove is isostasy. It is based on the fact that the solid outer crust of the earth rests on an inner ball of plastic material, just like the arctic-ice sheet rests on the waters of the polar sea. The crust, scientists agree, must be composed of lighter material than the central ball, and, in order that equilibrium may exist—iso-static condition—the density of the crust in various parts of the globe must vary.

As Dr. Meinesz describes it, if the surface of the globe, down to the bottom of the crust, which is judged to be about sixty miles thick, was cut in squares of 100 miles each way, and all the squares weighed, it should be found that the weights were practically the same, despite the fact that the crust of continental portions would be, in some cases, ten miles or more thicker than sections taken from the depths beneath the sea.

To prove that point, he set out to measure the attraction of gravity at the deep holes in the sea, to determine if it was



The Naval Observatory at Washington, Where Dr. Meinesz' Pendulum Apparatus Was Checked with American Equipment, to Insure Both Would Give the Same Readings

really true that the density of the material there was sufficient to exert the same attraction as the material composing continents and mountain ranges.

In 1923, he started out from Holland for the Dutch colony of Java, sailing in a submarine by way of the Mediterranean, Red Sea and Indian ocean. Two years later, with improved apparatus, he made another experimental trip from Holland to Port Said, and in 1926 started again from Europe and went to Java, by way of the Panama canal and across the Pacific, so his voyages completed the circumnavigation of the world.

On these voyages he determined the force of gravity at more than 200 points, his observations showing in a general way that isostasy exists in the crust under the sea. As there are 140,000,000 square miles of ocean area, however, many more observations are needed to check the theory.

It was for that reason that the Carnegie Institution invited him to America, and the navy hydrographic office arranged to place a submarine and an escort of two "eagle" boats at his disposal. The trip was planned to include the Nares, Sigsbee

and Bartlett deeps. The first, lying north of Porto Rico, has a depth of 5,000 fathoms, or 30,000 feet.

The observations are all made from a depth of about 175 feet or more under the sea, to eliminate the pitching and tossing due to the waves, the factor that always prevented experiments from a surface vessel. The apparatus used consists of three pendulums swung in a brass box, some two and a half feet square. The box rests in a frame, mounted on a universal joint, so that it will remain vertical despite any rolling of the ship. A chronometer and electrically driven photographic roll to measure the pendulum swings complete the apparatus.

~~\$12.00~~
REFLECTOR ON SADDLE STIRRUP
327 GUARDS NIGHT-RIDERS

Attached to the left stirrup, a red-glass reflector gleams under the rays of automobile headlights and other sources, so that equestrians can be more easily seen. The device is put on in a few seconds and, when not in use, fits into a leather case which can be attached to the saddle.

teruphite Co
156 Paratoga

POPULAR MECHANICS \$6.00
Society of Mechanical Engineers
Main Branch 701

KEEP SPECIMENS BY FREEZING FOR RUSSIAN MUSEUM

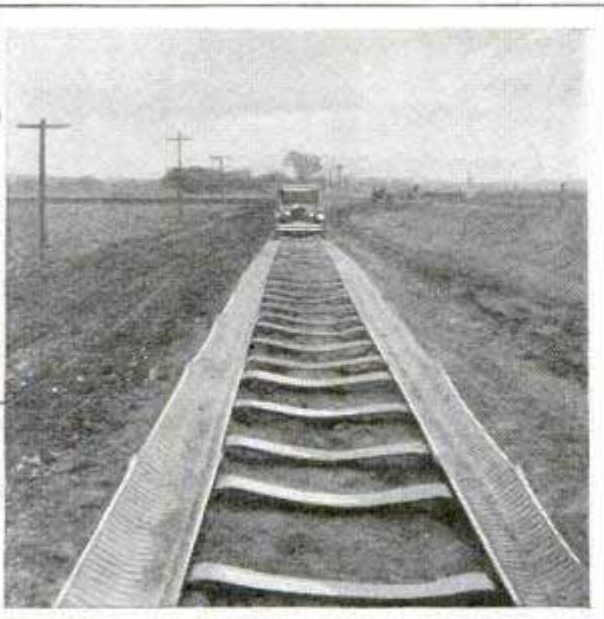
Human and animal specimens can be preserved for centuries in a huge "refrigerator" museum which a Russian society is planning for Moscow. It is proposed to spend about \$5,000,000 on the scheme, and justification for the idea is seen in nature, where the bodies of monster animals, such as the mammoth, have been found preserved in ice in such good condition that the flesh is fit for food. The plan has had a curious political expression in Moscow, where two professors have embalmed the body of the dictator, Lenin. It is not mummified, but is preserved in a moist atmosphere so as to lose no water and remain lifelike. Pamphlets have been printed, explaining to the peasants, who still are inclined to be superstitious, that the body has been kept in its present condition, not by a miracle, but by science.

1908

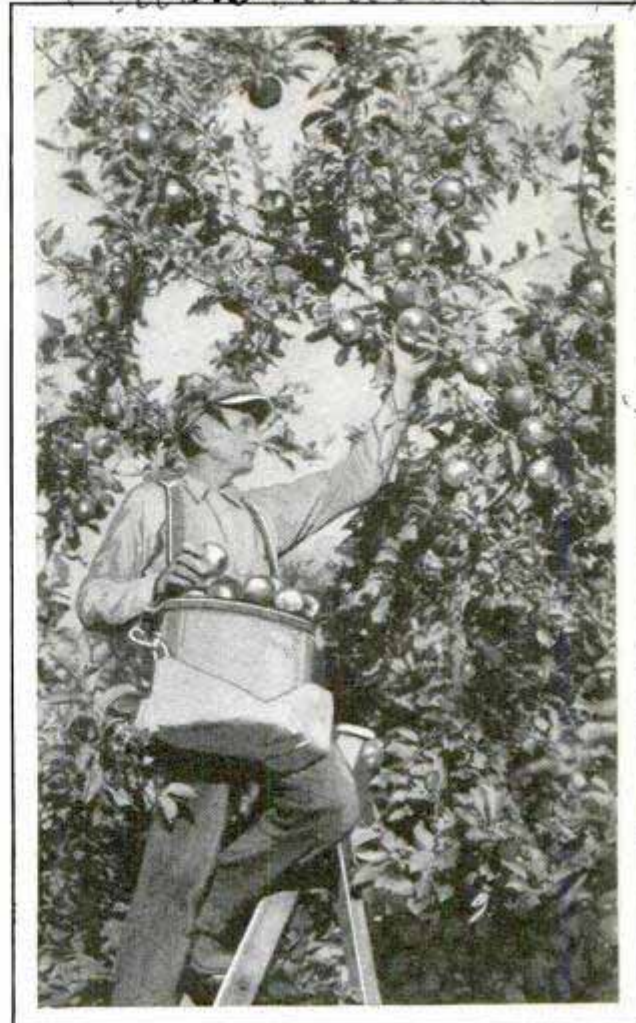
PIPE TRACK FOR AUTO TRUCKS AIDS CONSTRUCTION WORK

To run heavy truck loads of materials over soft dirt roads, an Iowa contractor employs a track made of sections of fifteen-inch pipe, tied together with strips to prevent spreading. The pipe is corrugated in order to afford extra traction, and the plan has proved a saver of both time and expense in the construction of roads and on other jobs.

1910



Pipe Track on Soft Road for Hauling Heavy Loads of Materials without Miring Down



Gathering Fruit in Basket That Has Removable Bottom, to Prevent Bruising

DUMP-BOTTOM FRUIT BUCKET SAVES PICKERS' TIME

Faster picking, better protection for the fruit and greater convenience for the workers are among the features claimed for a fruit-picking bucket that is emptied through the bottom instead of in the usual way. This is accomplished simply by operating a cord fastener which releases the canvas flaps that constitute the bottom. Fruit may be placed gently in the box and the bucket lifted from around it, thus eliminating needless and rough handling. Being equipped with soft, broad straps, the bucket is worn by the picker in comfort and ease. It is protected on the inside to prevent bruising the fruit.

Popular Mechanics Magazine does not publish the name of the maker or seller of any device described in its pages, but this information is kept on file and will be furnished free upon application to our Bureau of Information.

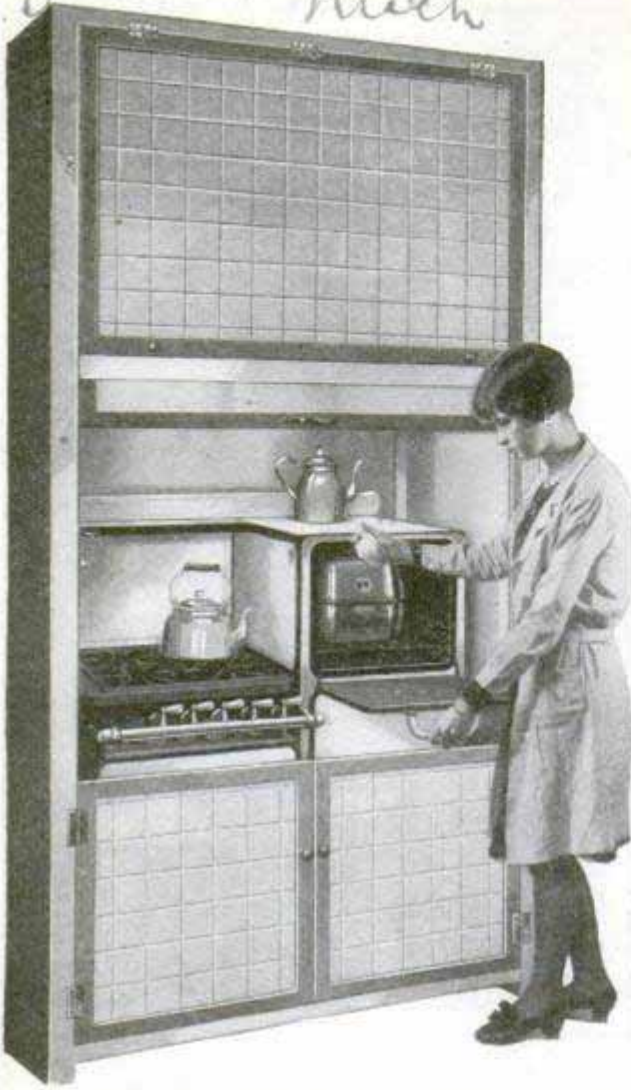
Details from U.S. Bureau of Public Roads

View of bucket in orchard, which

Used in Federal Highway Project 276 B

No foreign orders.

157. U. Mich



Kitchen Alcove for the Stove Has a Sliding Glass Door That Shuts Out Heat and Odors •

GLASS-DOOR CABINET FOR STOVE STOPS SMOKE AND ODORS

To promote cooking comfort, a cabinet with a sliding glass panel to inclose the gas range has been introduced. It carries off smoke and unpleasant odors, helps to keep the kitchen cool and also provides storage space for pots and pans. When the glass panel is down, the cook can watch the progress of foods on the range. In the dome of the cabinet is a blower to carry off the fumes through the stove flue. The inclosure is made of steel, finished in a number of different tints in order that the selection of one harmonizing with the decorations of the kitchen may be an easy matter.

□ We want all our readers to write us freely and often whenever they wish additional information on articles published in this magazine. Address Bureau of Information, Popular Mechanics, Chicago.

PHOTOGRAPHING SOUND HELPS IMPROVE BUILDINGS

Photographing sound waves set up in models of public halls, may enable architects to correct acoustical errors before they build. The national physical laboratory at Teddington, England, has developed a process which has met with considerable success. Models of the proposed auditoriums are built to scale and tested in two ways. In one, the models are placed on their side, filled with water and a plunger operated at the point where the speaker will stand. The ripples in the water correspond to those which would be produced by sound waves in the air. In the second method, a combination of sound wave and light wave is used to give a visible photograph of the path the sound will travel. The drawings on the opposite page explain some of the lessons learned. In No. 1 a smooth vaulted ceiling proves bad for acoustics when its radius is less than twice the height of the hall. In No. 2 the fault has been corrected by introducing deep paneling to break up the reflections of the waves. No. 3 shows how the hall of the House of Commons was improved by building in a false ceiling of glass to reduce the height of the room. No. 4 shows how skillful design in the famous Leipzig Gewandhaus breaks up sound waves. The last four show the movement of a sound wave through a complete cycle in the lecture hall of the Royal Institution, in London, where hearing is very good.

LEVER THAT BLOWS AUTO HORN FITS ON STEERING WHEEL



Blowing the horn is simplified by an extension lever fitted to the steering wheel. It is easily attached and saves removing the hands from the wheel when the signal is to be sounded.

Western Auto Supply Co. 11.00 d

CONTROLLING WAVES OF SOUND TO AVOID ECHOES

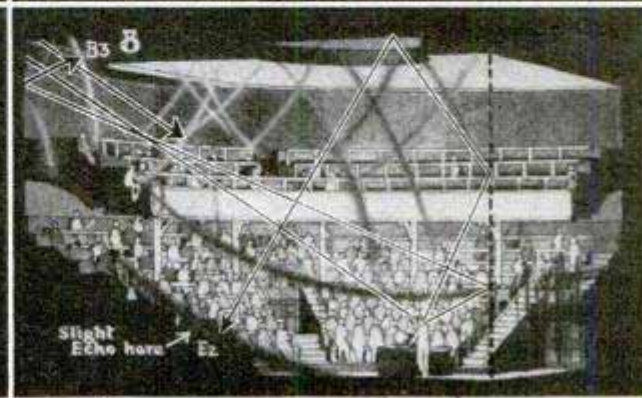
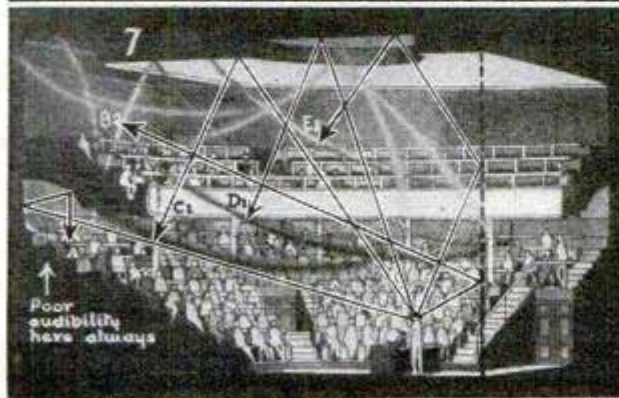
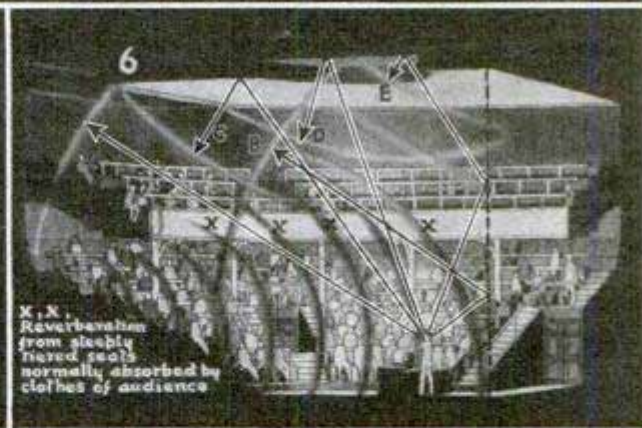
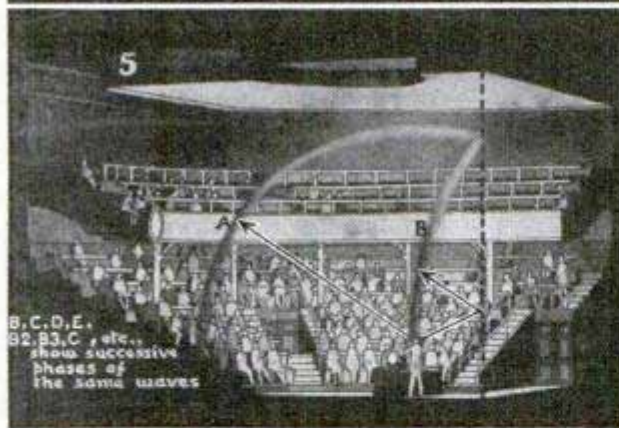
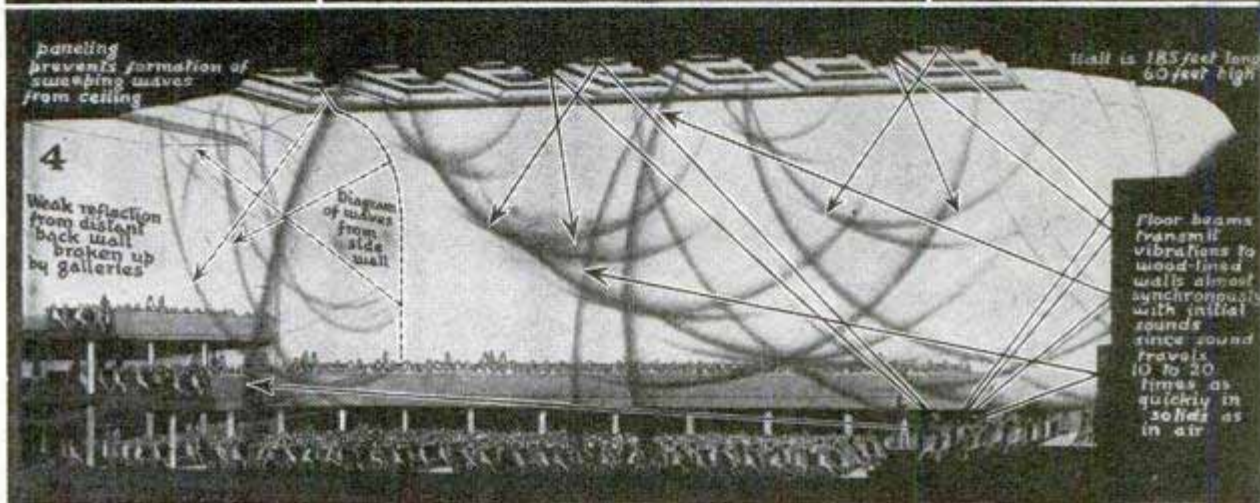
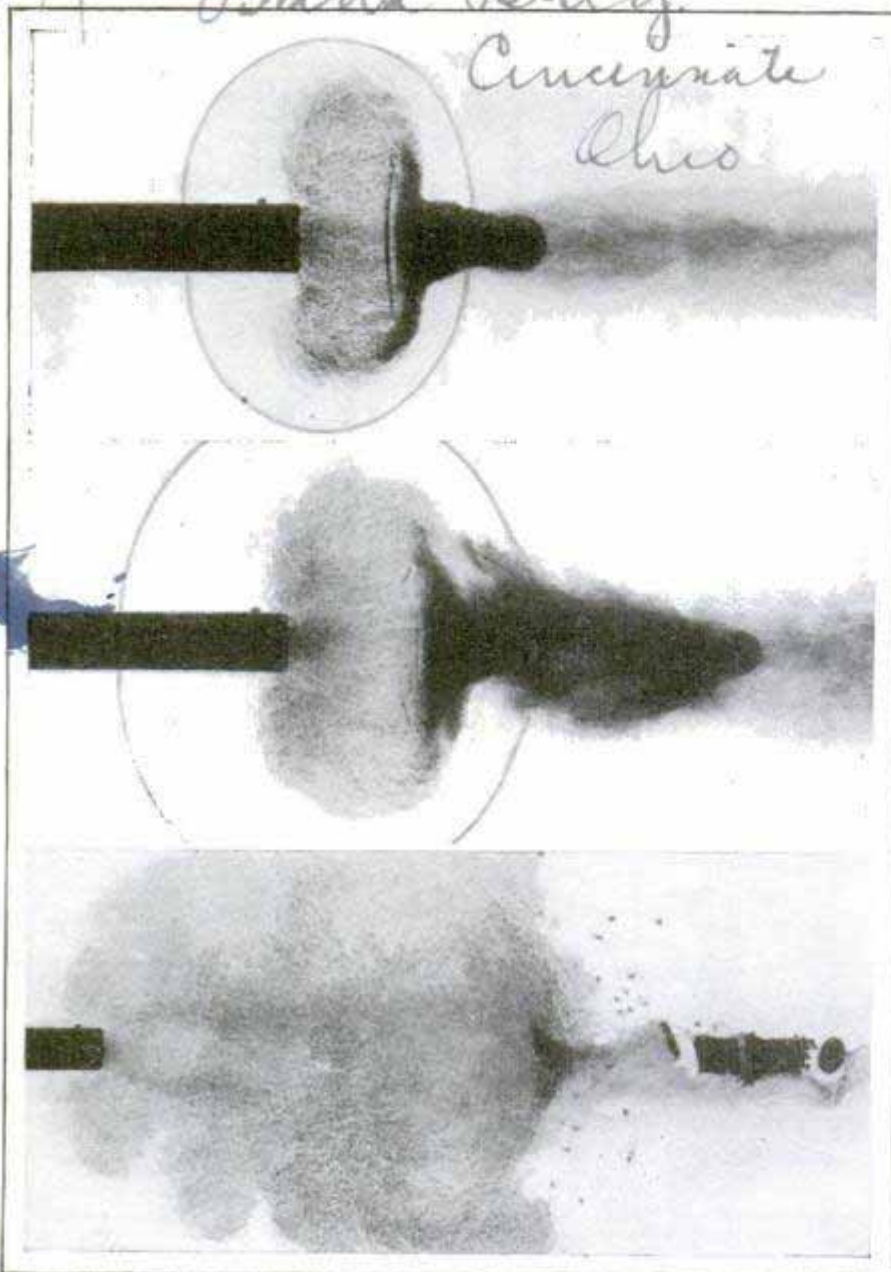


Fig- 18, Shakespeare Road, Herne Hill, London



Remarkable Photographs of a Shot Charge Emerging from Muzzle of Gun; Note the Wads and Shot in Bottom Illustration

SPLIT-SECOND SHOTGUN PHOTOS SHOW FIRING RESULTS

What happens when a shotgun is fired? Spark photography, which permits exposures of one-millionth of a second, supplies the answer with a graphic and accurate record of practically every stage from the time the trigger is pulled until the charge is well away from the muzzle of the gun. Three such photographs are shown here. The first is of the shot and wads just after leaving the muzzle. The charge is still being accelerated by the out-rushing gases. The heavy dark line inclosing the gas at the end of the gun, is a sound wave. The top-shot wad is seen blown from the head of the charge. In

the next photograph, the shot is approximately four inches from the muzzle and, in the next, about fifteen inches. Note how the shot are beginning to spread. Pictures such as these are especially valuable to ballistic engineers. Among other things, they show what a large gas leakage there is before the shot reach the muzzle.

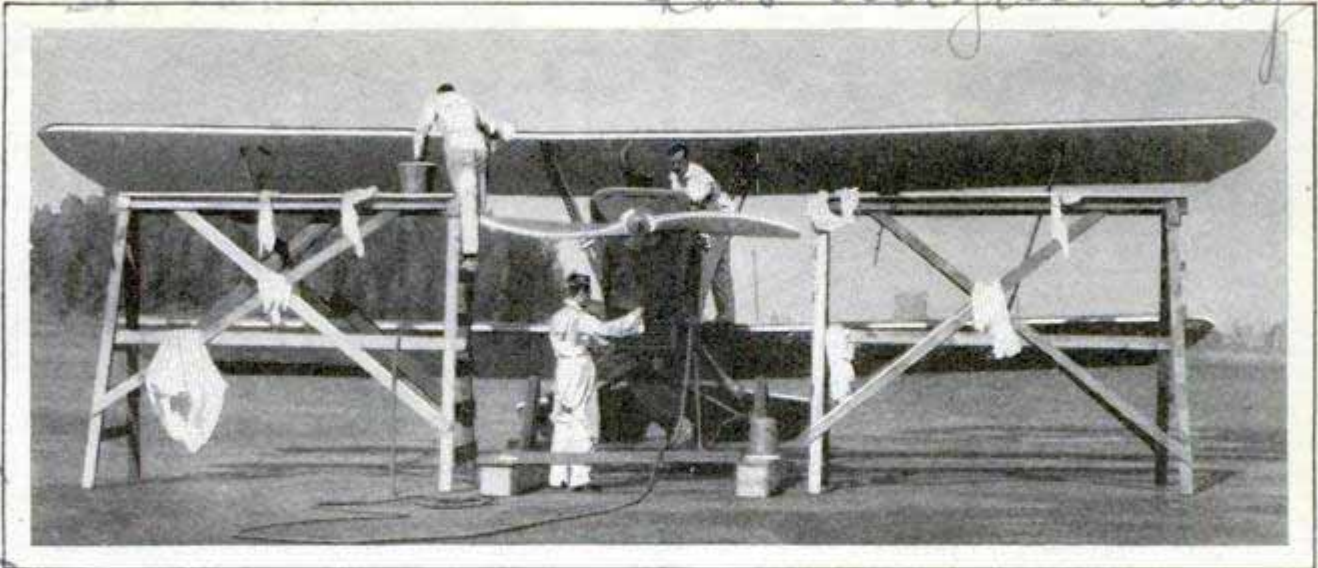
CHINESE IDEAS AID WESTERN WORLD

1813 China is generally regarded as being far behind the western world in many respects, but the nation has given other countries many valuable ideas. For instance, the United States army signal corps recently adopted the plan of tying whistles to carrier pigeons to frighten away hawks—a custom practiced in China centuries ago. Groceries in this country sold quantities of "potsai," or Chinese cabbage, this year; large red Chinese persimmons were found in many mar-

kets, while an essential ingredient in many salves and ointments sold by drug stores, has been used for centuries in the Orient. Chinese producers furnish us about 100,000,000 pounds of tung oil every year; our cotton growers have adopted one of their methods of distinguishing fertile from infertile cotton seeds by placing them all in water and planting only those that sink, and the Chinese are generally regarded as the discoverers of gunpowder. India ink is really Chinese ink. Dominoes, silk, tea, playing cards, dice, wood and rice paper, lacquers, artificial pearls, goldfish, Chinese lanterns, jade and many fruits are among other articles of great variety with the origin of which the Chinese people has been accredited.

My James 11/10/28

801 ... of Aero Corporation
Los Angeles Calif



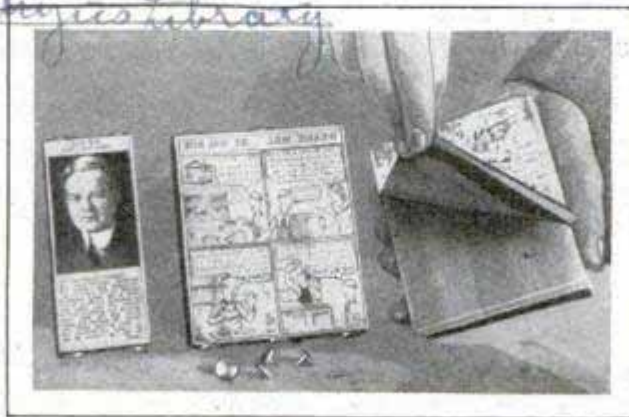
Plane at the Washing Rack, Which Permits Several Men to Work at the Same Time and Helps Protect the Wings and Fuselage from Damage While They Are Being Cleaned

RACK FOR WASHING PLANES SAVES WORKERS' TIME

Airplanes can be washed in a few minutes with the aid of a rack introduced at a western flying field. It consists principally of scaffoldlike platforms, equipped with water and air-drying hose, soap mixtures and all other necessary articles. The pilot may taxi up to the rack and depart in fifteen minutes or so with a spotless ship. The rig is large enough to accommodate four men at one time, two to clean the wings, one for the motor and the fourth to clean the fuselage. It can be set up quickly and is easily stored away.

BOOKS AT THREE CENTS EACH SEEN IN CAMERA PROCESS

Copies of costly books at three cents each may be enjoyed as a result of a photographic process Prof. E. E. Moran, of the University of Southern California, has developed. With a reducing camera, the pages of a fairly large book can be reproduced on a plate a few inches square and in not more than ten minutes. Copies of the plate can be made at three cents each and then shown, page by page, on a screen in any size



New Kind of Plate for Printing; It Can Be Sent Cheaply by Mail Because of Light Weight

desired. The shift from leaf to leaf is made simply by pressing a button. The camera and projector can be furnished at moderate cost. The method is expected to have special application in the recording of rare and expensive volumes, and will enable libraries to file many books in a small space.

LIGHTWEIGHT PRINTING PLATE SUBSTITUTE FOR METAL

Composed of a special material which is so light that it may be sent cheaply through the mails, plates from which illustrations, text and other matter may be printed in newspapers, have been introduced as a substitute for the metal kind. The plate is ready for use on the presses except for tacking it to a type-high wooden block. This eliminates the need for casting, and so will enable plants that have no facilities for this work, to receive and publish material that they otherwise could not handle. The composition plate is said to be fully as durable as metal and produces satisfactory impressions. In the process of manufacture, the material is subjected to a pressure of 4,500 pounds. Numerous publications are now using these plates.

Prof E. E. Moran, 3918 Wisconsin St. Los Angeles Calif

803

Grand Central Palace

Independent News Service Box 247

of ... notes

Hudson Bay Railroad.
1636 Part of Canadian National RR
360 McGill, Montreal Que

Steel Rails to



The Forerunner of the Muskeg Express, a Handcar and a Pair of Dogs, Provide Transportation on the Hudson Bay Line between the Arrivals of the Weekly Trains

By J. EARLE MILLER

SOME time next spring, along about May 15, a golden spike will be driven into a cedar crosstie on the shores of bleak Hudson bay, and all the United States, Canada and Mexico will have direct railroad service to the Arctic and the land of the midnight sun.

For the first time in the history of North America, a two weeks' summer vacation may include an arctic trip into the land where the sun never sets all summer long, a trip rivaling the European journey to the famous fjords of Norway. It will pass through the land of the Crees, over the Height of Land and down through the Great Barrens, where no trees can grow, and out to the land of the Eskimo, on the shores of the great bay.

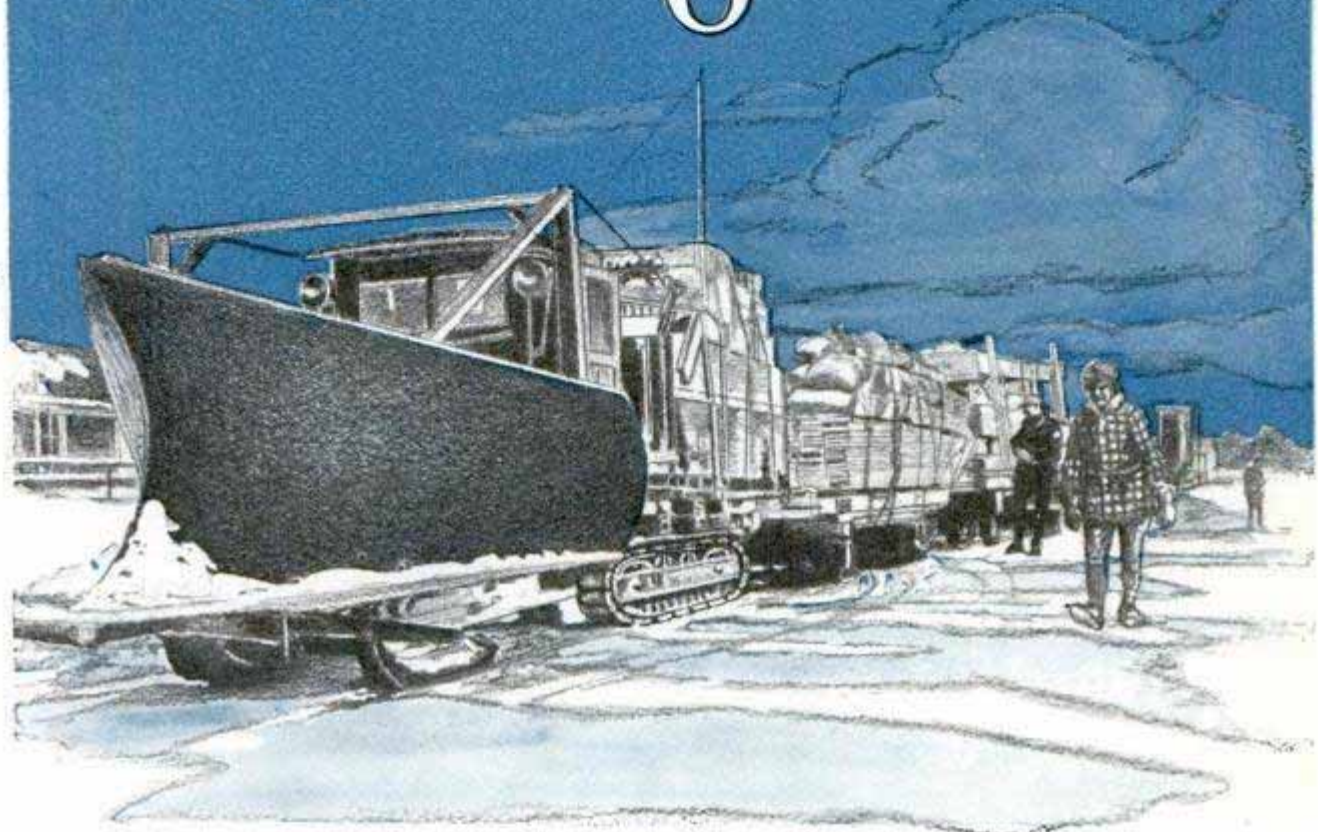
To get the steel rails to the inland sea the famous navigator found, and where he died when cast adrift by his mutinous crew, the weirdest, strangest railroad job

ever undertaken in North America has been going forward across the frozen north in winter, with temperatures of fifty below zero, and over the oozing muskeg swamps in summer, when the thermometer rises to the nineties.

From the war-time trenches of Europe came an idea that made the work through the swamps possible—duck boards, as the soldiers called their wooden sidewalks. Twenty-one thousand of them were built in the winter of 1927-28, freighted out on sleds ahead of the end of steel, and distributed in caches every ten miles. Placed end to end, they would have made a wooden sidewalk of some twenty-nine miles in length.

Instead of steam shovels, graders, tractors and horses—all the modern equipment usually associated with railroad building—the contractors went back to the days when the first transcontinental

the Midnight Sun



Freighting Supplies for the Flin Flon Branch; the Giant Tractors Hauled Forty to Sixty Tons and Never Stopped Running Day and Night for Week after Week Last Winter

line was pushing across the plains and built their railroad through the wilderness with wheelbarrows, picks and shovels, for nothing heavier could navigate the muskeg in safety.

A muskeg swamp is nothing but reindeer moss and decayed vegetation. In places, the railroad engineers found the perpetual-frost line only six inches under the surface. A few feet away, the gathering of water might draw the frost during the summer to a depth of six feet or more. The frost itself is in many places twenty feet or more in depth. To get a permanent water supply for the tanks supplying the locomotives, huge wells were dynamited down below the frost line to reach seepage water from near-by lakes and streams, covered over with triple-insulated roofs, and the water tanks themselves are surrounded by houses and heated throughout the winter, with the stovepipes passing up directly through the tank of water.

Wheat, and not tourists, sent the steel

to Hudson bay. From Saskatoon, in the center of the Alberta and Saskatchewan prairies, to Liverpool by way of Hudson bay is only 3,791 miles, whereas it is 5,213 miles by way of the Great Lakes and the St. Lawrence, the present rail-and-water route. That difference of 1,422 miles doesn't tell half the story. From Fort Churchill, the terminus of the Hudson bay railroad, to Liverpool is almost exactly the same distance as from Montreal, where the wheat now goes on ocean liners to Liverpool, so the two sea hauls will be virtually the same length. But from Saskatoon to Fort Churchill is only 845 miles, while from Saskatoon to Port Arthur, at the head of Lake Superior, is 1,142 miles. Wheat loaded on cars in the prairie provinces can be delivered direct to the elevators on Hudson bay without rehandling, and with a shorter rail journey than that to the head of the Great Lakes. Wheat shipped via Port Arthur must be reloaded into lake grain carriers, sent down to the



Welland canal, reloaded into canal barges, sent on to Montreal, transferred to the elevators, and from them to the deep-sea ships.

That is why, more than fifty years ago, Canada began surveying its outlet to the northern seas.

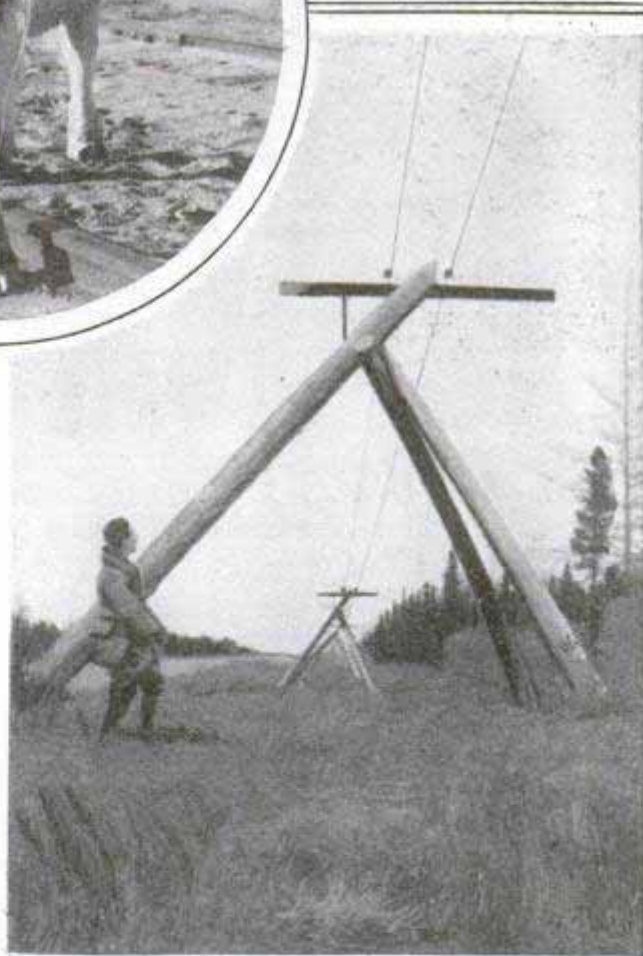
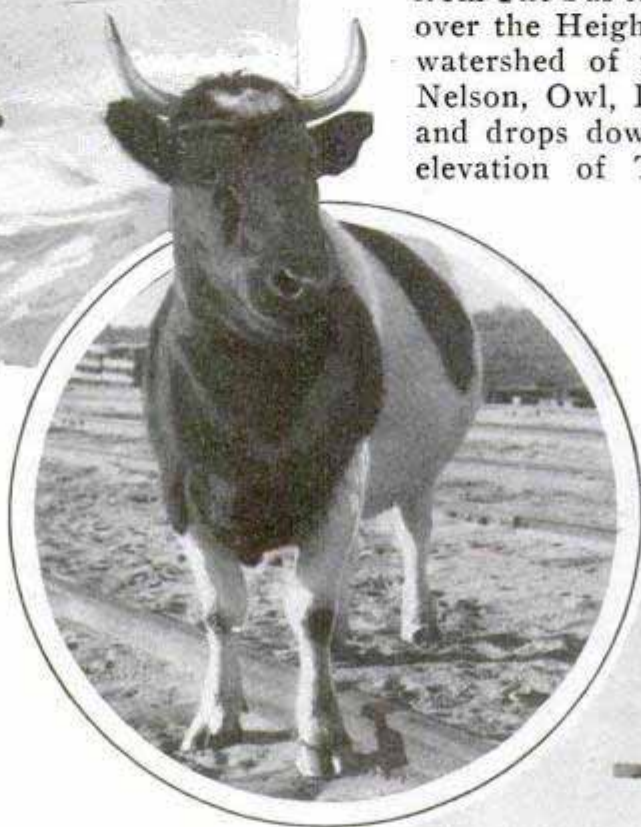
Work didn't get started until 1906 and 1907, when the first stretch from Hudson Bay Junction, in northeastern Saskatchewan, was built in to The Pas, on the banks of the Saskatchewan river. In 1911, contracts were let for the road to the bay, then designed to go to Port Nelson, at the mouth of the Nelson river, and 330 miles actually built to the Kettle Rapids on the Nelson. The war and business depression stopped the work, and for fifteen years the twin streaks of rust through the muskeg swamps slowly sank into ruins. In 1926, Canada was ready to rehabilitate the line already built and push the steel on to the bay, but in the meantime there was a growing opinion that Port Nelson was a poor terminus.

Frederick Palmer, a famous English engineer, was brought over and rushed to

the north by seaplane. He surveyed the work done at Nelson, where an artificial harbor had been started, and also visited Fort Churchill, a natural harbor in a well-protected bay. As a result, he recommended that the road go to Churchill, a hundred miles farther north, and that the \$6,000,000 worth of development already undertaken at Port Nelson be abandoned.

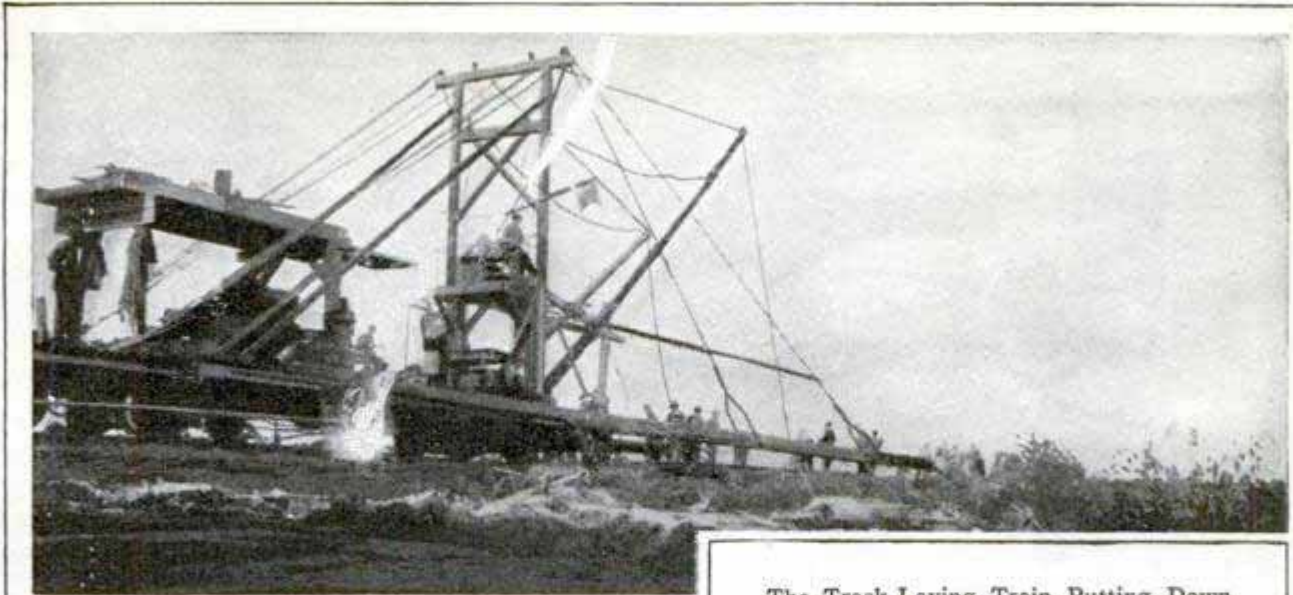
Although the railroad over the swamps, which stretch for most of the 512 miles from The Pas to Fort Churchill, passes over the Height of Land, crosses the watershed of four great rivers—the Nelson, Owl, Limestone and Wier—and drops down from the 1,190-foot elevation of The Pas to ten feet above sea level at Churchill, the greater part of it leads through flat, undrained country.

All construction supplies had to be

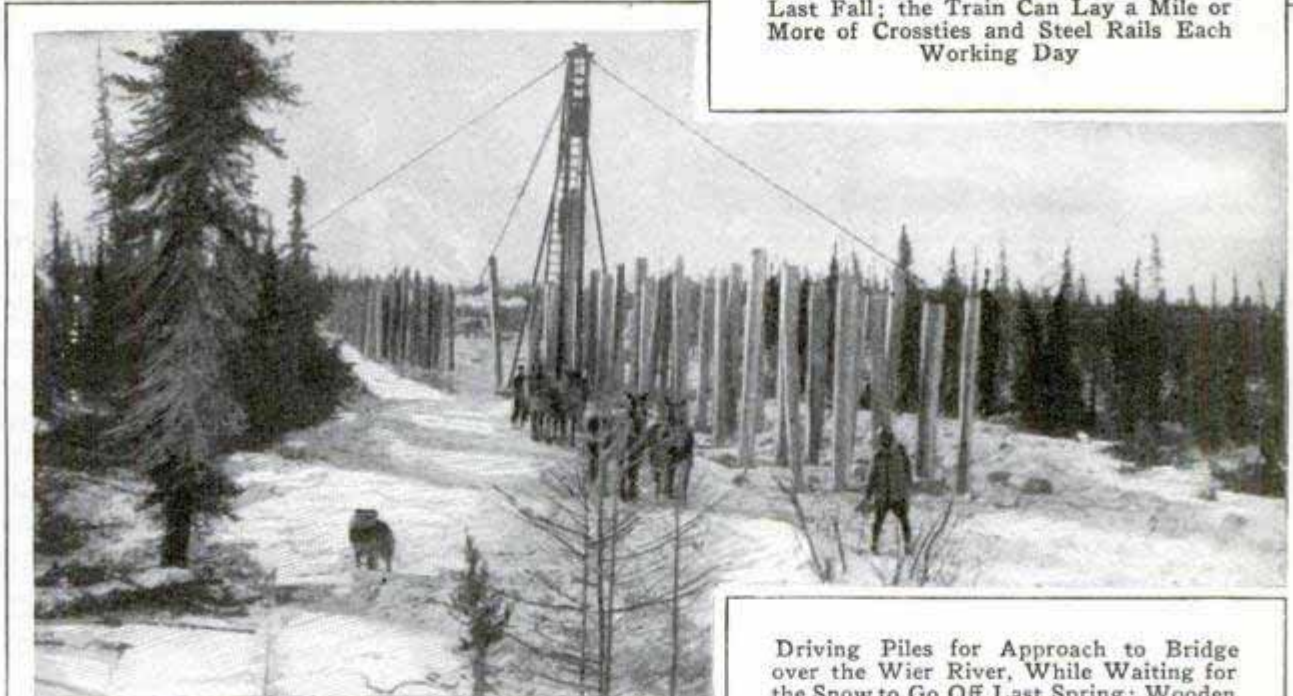


Claude Johnson, Railroad Engineer, in Charge of Construction at the End of Steel, the "Farthest North" Cow at Mile 347 and Frost-Proof Telegraph Poles

7636

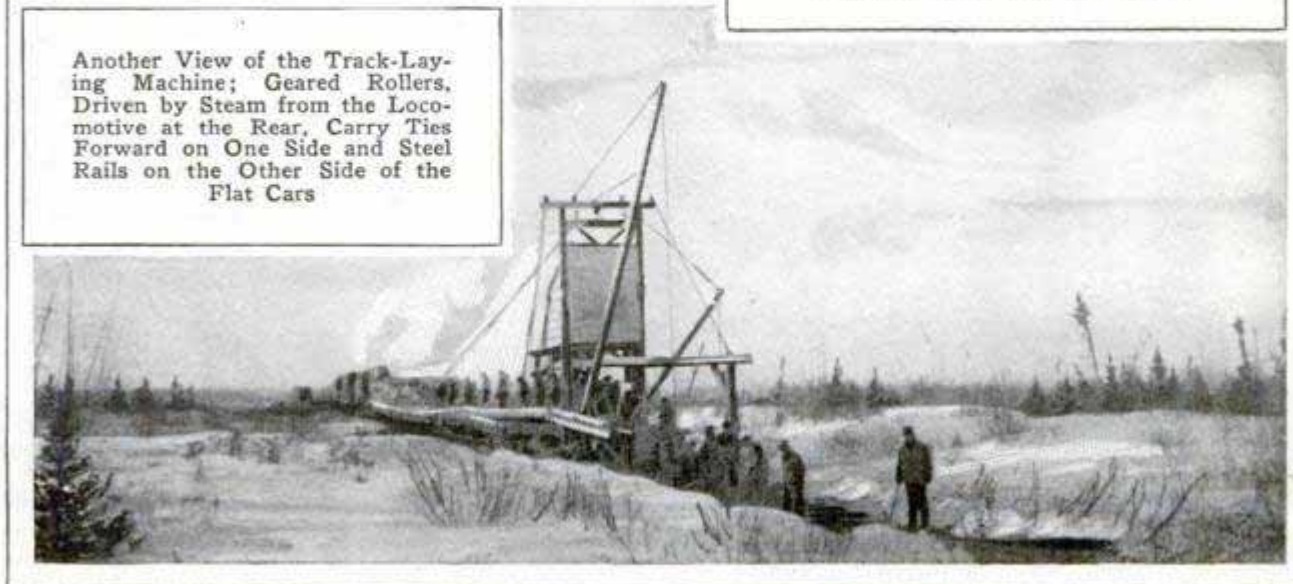


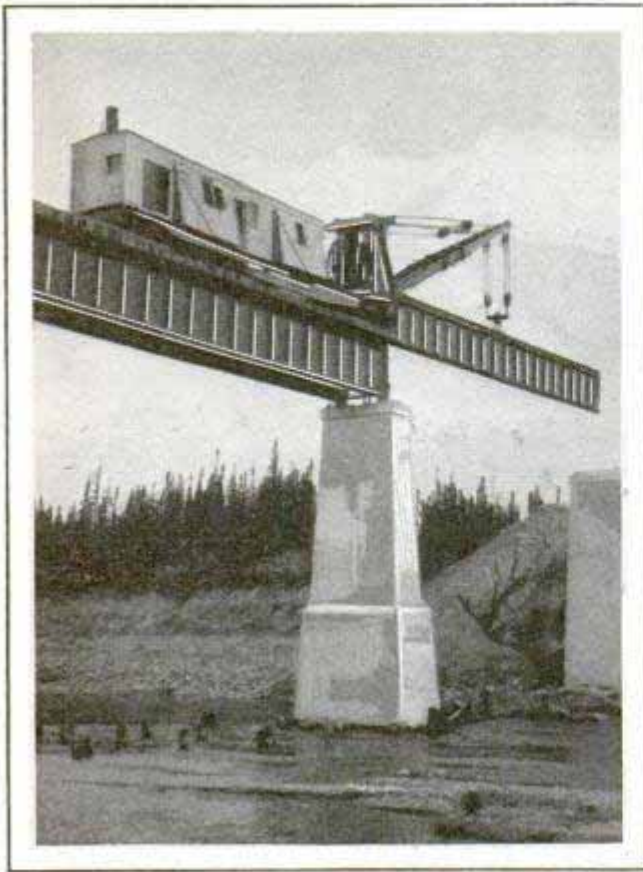
The Track-Laying Train Putting Down Steel at the Edge of the Great Barrens Last Fall; the Train Can Lay a Mile or More of Crossties and Steel Rails Each Working Day



Driving Piles for Approach to Bridge over the Wier River, While Waiting for the Snow to Go Off Last Spring; Wooden Bridges Are Replaced by Steel When the Track Catches Up with Builders

Another View of the Track-Laying Machine; Gearing Rollers, Driven by Steam from the Locomotive at the Rear, Carry Ties Forward on One Side and Steel Rails on the Other Side of the Flat Cars





expenses. To do that, though, they worked sixteen, eighteen and even, in some exceptional cases, as much as twenty hours a day, which is easier to do in a land where the sun sets around eleven o'clock at night and rises about 1:30 in the morning.

The Hudson bay railroad differs from all others not only because of the difficulties overcome, but in the way the work was done. For one thing, there was neither liquor nor camp followers in the north. In a land where every pound of food is freighted in at immense cost, camp followers, sight-seers and other visitors are not wanted, and the Royal Canadian Mounted Police established a liquor dead-line at the Saskatchewan river, at the edge of The Pas. Manitoba has govern-

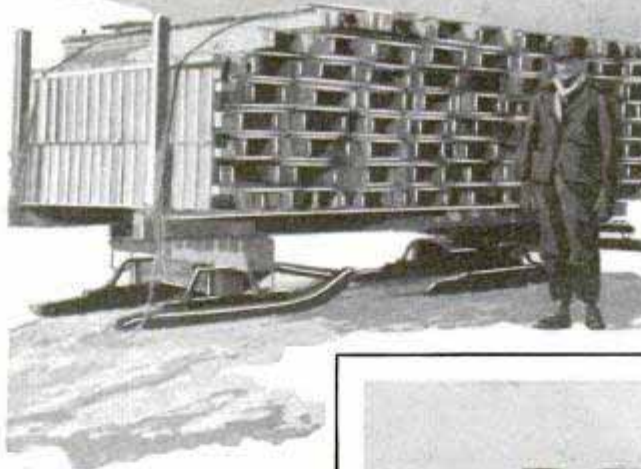
ment liquor stores, the one farthest north being at The Pas, but all the northern part of the province is unsurveyed crown land, not yet opened to homesteaders, and here the rule of the red-coated mounties is the law.

The ministry of railroads itself controls three miles on

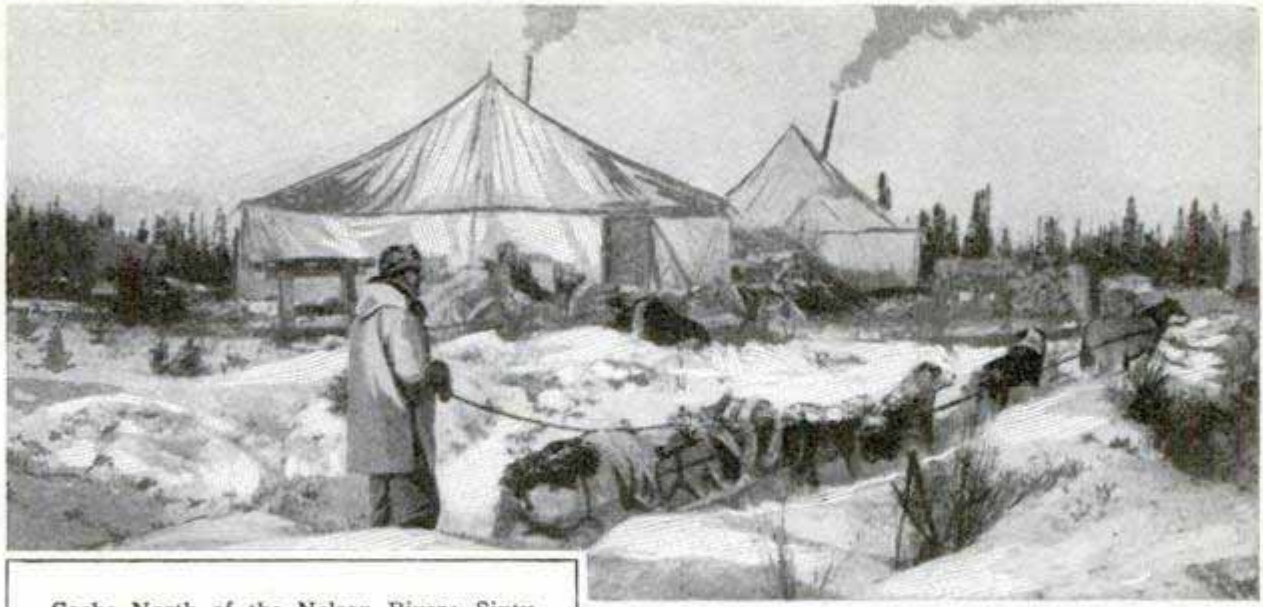
freighted into place during the winter months, using sleds drawn by either horses or tractors. Every ten miles a construction cache was placed in a log and canvas camp. Each cache, to supply the workers for five miles in either direction, contained sixty tons of supplies, forty tons being food, and twenty tons, wheelbarrows, picks, shovels, tents, bedding, clothes and other articles.

The workmen themselves were brought in over the snow before the spring break-up of ice. The workers were mostly Belgians, Finns, Russians and Swedes. Each man was an individual contractor, working under subcontract from the construction company. Sometimes eight or ten would band together, buy a tent and food supplies in common, and take a contract for a mile of grading.

The workers who went in last spring and spent eight or nine months in the north, averaged \$5 to \$6 a day above their



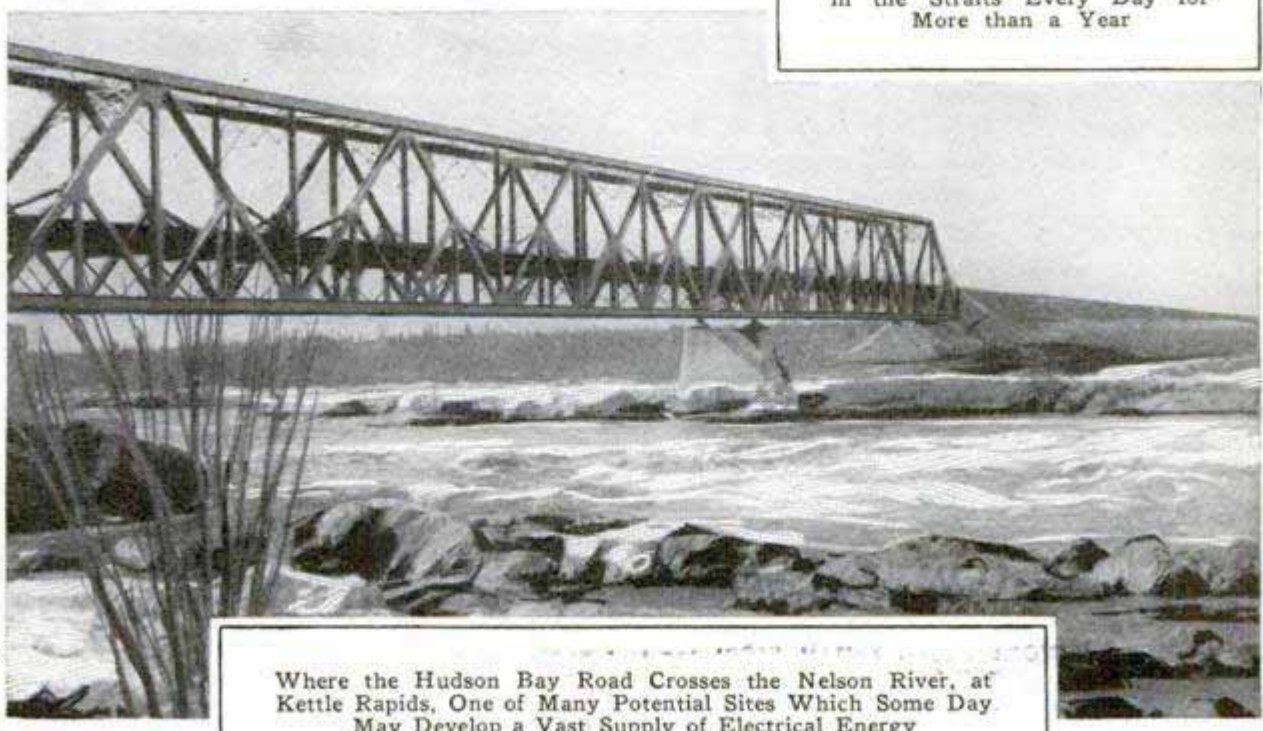
Placing Steel Beams of the Limestone River Bridge; a Sled Load of Duck Boards for the "Front Line," and, at Bottom, a Modern Ditching Machine



Cache North of the Nelson River; Sixty Tons of Supplies Were Placed Ten Miles Apart to Last through the Summer



Flying Boat Loading Supplies to Be Flown to Fort Churchill; the Air Patrol Also Has Charted Ice Conditions in Hudson Bay and in the Straits Every Day for More than a Year

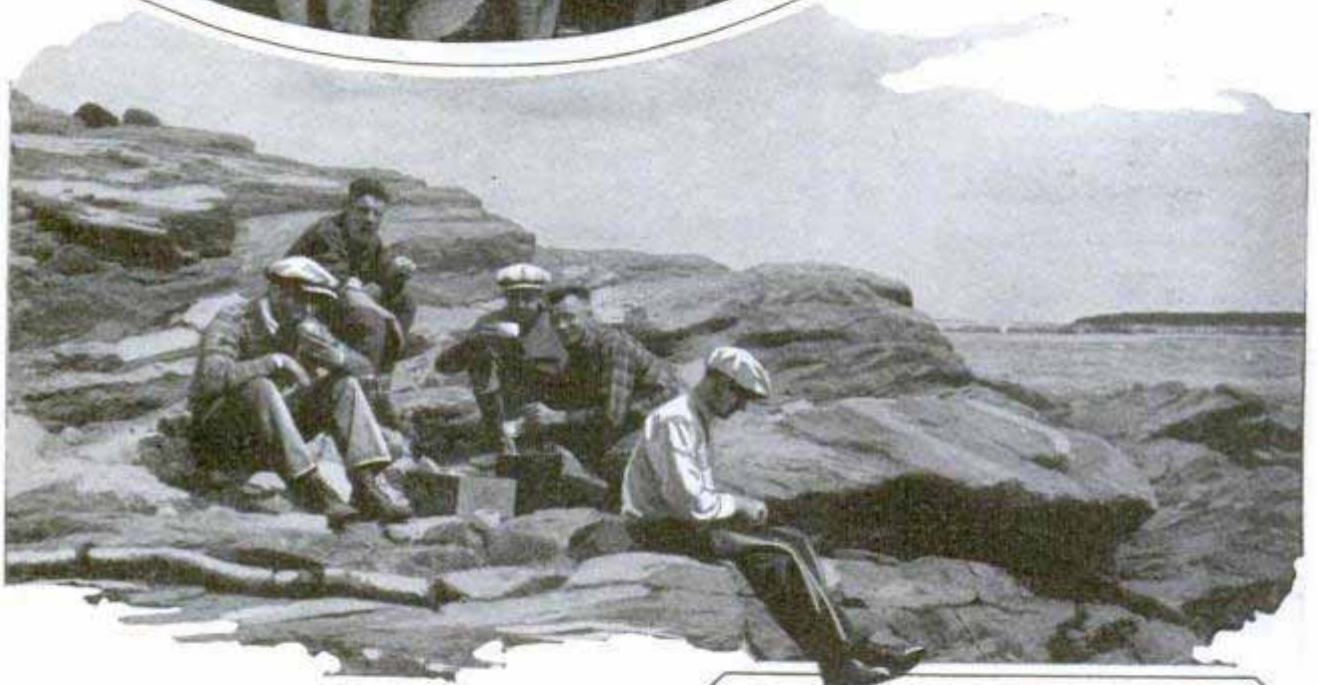


Where the Hudson Bay Road Crosses the Nelson River, at Kettle Rapids, One of Many Potential Sites Which Some Day May Develop a Vast Supply of Electrical Energy

1636
264



again on March 15, in an effort to reach Fort Churchill two months later. From about Mile 420, north of The Pas, to within three miles of the terminus, at Mile 512, in Churchill, the route lies over the Barrens. Churchill itself will be a deep-sea port within a few months. A vast quantity of material gathered at Port Nelson nearly fifteen years ago has been moved 150 miles up the



either side of the Hudson bay line, and not even a trader can build a store along the right of way without a permit from the engineers, who fix the site and control the operations of the storekeepers.

The north country probably will not be ready to welcome tourists and settlers before 1930, as all the coming summer will be required to get the final miles of railroad in shape for traffic. Maj. J. G. MacLachlan, the engineer in charge at The Pas, and Claude Johnson, his assistant at the end of steel, plan a steel-laying drive over the snow this winter. The road reached the edge of the Barrens in the late fall, and from there north steel was pushed ahead on the frozen ground without any grading. Work was discontinued December 15, at Mile 442, but will start



Group of Railroad Engineers beside Their Office Car; Scene at Fort Churchill, on the Bay, and the Break-Up of the Ice at Big Limestone Rapids on the Nelson



Freighting of the Railroad Is Largely Done by Air; in Winter, Portable Houses on Sled Runners Are Pulled over the Engines, to Keep Them Warm and Enable Mechanics to Work

bay; dredges and tugs brought around from the St. Lawrence, temporary docks built, and, probably during the coming summer, work will be started on the grain elevators.

Churchill is a natural harbor, with a narrow entrance between rocky headlands, one of which is crowned by the eight-foot-thick stone walls of ruined Fort Prince of Wales, and the other by the ruins of Merrey Battery, both noted defenses in the early days when all the Hudson's Bay company posts in the northland drew their supplies through the rivers leading west and south from the bay.

There is a Hudson's Bay company whaling station at Churchill, a Canadian Mounted Police barracks, and there was a settlement of traders and others on privately owned land. When it was decided to make Churchill the railroad terminus, the government expropriated all the private lands on the port side of the harbor to keep speculators out. The Canadian parliament is considering some form of town development which will eliminate private ownership entirely, and limit settlers to those actually needed at the port.

Built primarily as a wheat carrier, the railroad is opening up not only a sportsman's paradise, but a vast mineral belt. Last summer a ninety-mile branch was pushed through to the Flin Flon mines, where New York capitalists are spending \$30,000,000 to develop a great deposit of copper, zinc, lead and gold. A few miles away, \$10,000,000 is being spent on development of the Sherritt-Gordon mines.

Gasoline played a big part in the building of the Flin Flon branch last winter and spring, and is again playing a big part in the drive to Churchill. The ninety-mile branch was built in just eight months. To make it possible, all supplies were freighted in over the snow. Huge tractors, capable of carrying eight tons of freight on their own bodies while hauling a string of loaded sleds, were used. A tractor train averaged from forty to sixty tons at a load, and made a round trip of 120 miles in from seventeen to eighteen hours. The motors never stopped, running day and night.

Contrary to the accepted belief, the weather is not particularly bad in the north, and the camper and tourist season may stretch into the middle of October. There is little snow up to that time, and even at the edge of the Barrens, overcoats are not necessary, a wool shirt and "wind-breaker" being enough for comfort. At Mile 352, beside the Big Limestone rapids of the Nelson, some forty miles west of Port Nelson, on the bay, the temperature chart for the last year showed forty-six below zero on Dec. 9, 1927, and thirty-eight below on January 13 and February 2—the only three really cold spells. On the other hand, the thermometer reached seventy-eight above as early as May 12, eighty-eight on May 24, ninety-two on June 6, and ninety-two and a half July 9.

For a month or six weeks, man-eating flies and mosquitoes make life miserable, but the fly season is usually over by the end of July, and headnets and tents can be discarded.

*Manitoba
na The Pass*

*Flin Flon Branch
C.P. & N.W.*



Testing Motorcycle Propelled on the Rocket Principle; Fuel Supply Is Carried in the Sidecar Rack

MOTORCYCLE RUN BY ROCKETS PLANNED FOR HIGH SPEED

Interesting tests with a motorcycle propelled on the rocket principle, developed in Germany, have been made in New York by an American inventor. He hopes to attain a greater speed than is possible with existing types of cycles. One of the disadvantages of the idea, which, engineers assert, will have to be overcome before the rocket principle can be used satisfactorily in everyday life, is the large volume of smoke developed. Improvements to insure greater safety are also necessary.

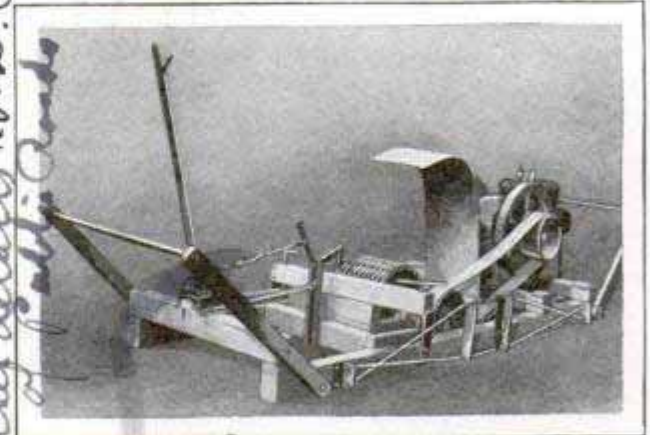
HEAT PROCESS TO RECOVER OIL FROM SAND STRATA

To obtain greater quantities of oil from sand that has been drained by usual methods, Ben E. Lindly, of the bureau of mines, has proposed to subject the strata to heated natural gas under pressure. His idea is based on the theory that, if the oil is raised to a high temperature, virtually all of it can be vaporized and forced out of the sand. According to his findings, not more than fifteen per cent of the oil is recovered by present methods.

Gasoline is said to be neutralized so that it will not form poison gases at the automobile exhaust by a process an Illinois man is reported to have discovered. In a series of tests, he directed fumes from the treated fuel into a small compartment containing a rat. The animal was alive and apparently none the worse for its experience after forty minutes' exposure to vapors from the treated gasoline, while another rat was killed in a little more than two minutes after breathing fumes from ordinary gasoline burned in an engine. The treated fuel is said to give as much power as the usual kind, does not injure the motor, and is even said to give the engine a little quicker pick-up.

WAVES IN CONCRETE PAVEMENT REMOVED WITH CUTTER

Waves and other irregularities in the surface of concrete pavements are removed with a rotary cutter that has 342 steel wheels which dress the material down to a depth of half an inch or more. The



Rotary Cutter with Many Steel Wheels Used to Smooth Out Irregularities on Concrete

smoother is moved along the highway on casters, grinding and cutting as it goes.

Kansas City Times

Used on Federal Highway

Capit. George White

Experiment station at Bartlesville Okla.

New York City

NEUTRALIZED GAS STOPS DANGER OF DEADLY FUMES

Gasoline is said to be neutralized so that it will not form poison gases at the automobile exhaust by a process an Illinois man is reported to have discovered. In a series of tests, he directed fumes from the treated fuel into a small compartment containing a rat. The animal was alive and apparently none the worse for its experience after forty minutes' exposure to vapors from the treated gasoline, while another rat was killed in a little more than two minutes after breathing fumes from ordinary gasoline burned in an engine.

Dr. C. Howard Williams, Ill.

C. Howard Williams, Ill.

1777

31

186

U.S. Bureau of Public Roads

3-34

SEA ANIMALS PRODUCE MOSS TO DECORATE HATS

For years, most of the sea moss used to decorate hats, and for similar purposes, was imported, but fishermen have discovered a closer source of supply in Chesapeake bay, where superior varieties are found in water from ninety to 150 feet deep. In reality, the material is not moss but a plantlike growth formed by tiny animals. It is torn from the rocks, shells and other objects to which it becomes attached, saturated with a nondrying substance that keeps it from becoming hard and brittle, and is then dyed and combined with artificial flowers.

near Richmond with water in

no such use known

OUTBOARD MOTORBOAT RACERS TO HAVE OWN-TRACK

English outboard motorboat racers are to have their own private speed track as the result of the purchase of a lake for their exclusive use. A grandstand seating 5,000 people, refreshment stands, automobile parking space, marine garage and slipways are to be established, and a branch canal dug to connect the lake with a near-by navigable canal, which links with an extensive system of rivers and canals, so motorboats from distant points can come direct to the race track by water.

slady 11 mile

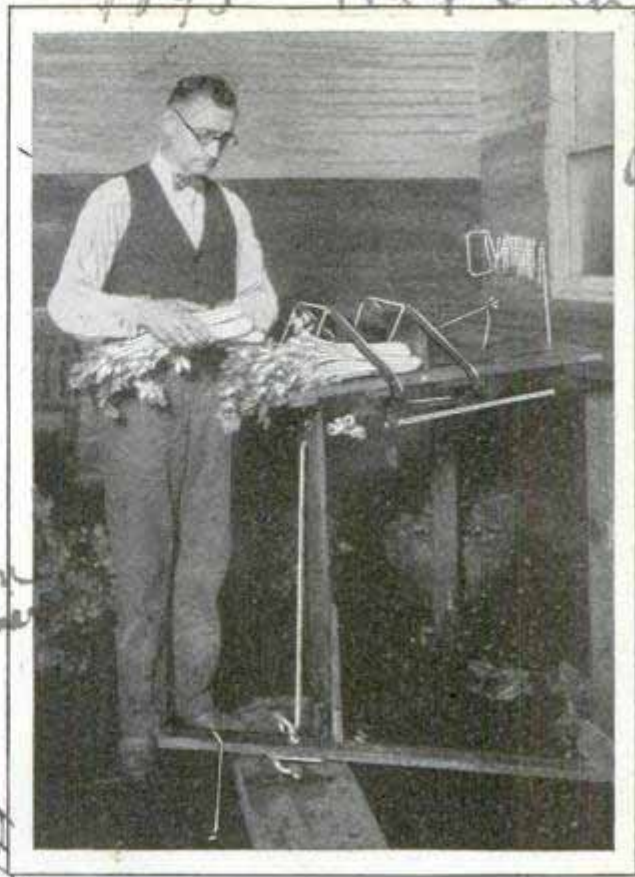
SMALL SAFE CARRIED IN AUTO GUARDS LICENSE PAPERS

Jewels, small articles of many kinds and auto license and registration papers or club cards are effectively protected in a small combination safe that may be attached to any convenient place inside the car. It is attractively nickelplated on heavy brass and cannot be opened unless the combination is known.



Groundhogs are sometimes found as far north as the Arctic.

Groundhog is 2465 miles



Tying Bundles of Celery with Rubber Bands Prepared from Inner Tubes

PACKAGE TYER USES BANDS CUT FROM INNER TUBES

Bundles of celery and similar articles are quickly tied with rubber bands cut from inner tubes. The bands do not cut or otherwise injure the celery and can be adjusted in a fraction of the time required for tying a package with string by hand.

BOTTLE DRIFTS MANY MILES ON OCEAN CURRENTS

One of the longest "bottle voyages" ever recorded has just been entered in the finding of a bottle on the shore of a small island near Japan. According to the form it contained, the phial was thrown from a ship about 250 miles west of Mexico, Nov. 14, 1926. It has thus traveled at least 6,500 miles, according to the drift of the ocean currents, and probably much farther. These bottles are set adrift by the hydrographic office with instructions that the finder return the paper inside after it has been marked to tell the place and date of its recovery, so that data may be obtained as to the direction and speed of the sea currents.

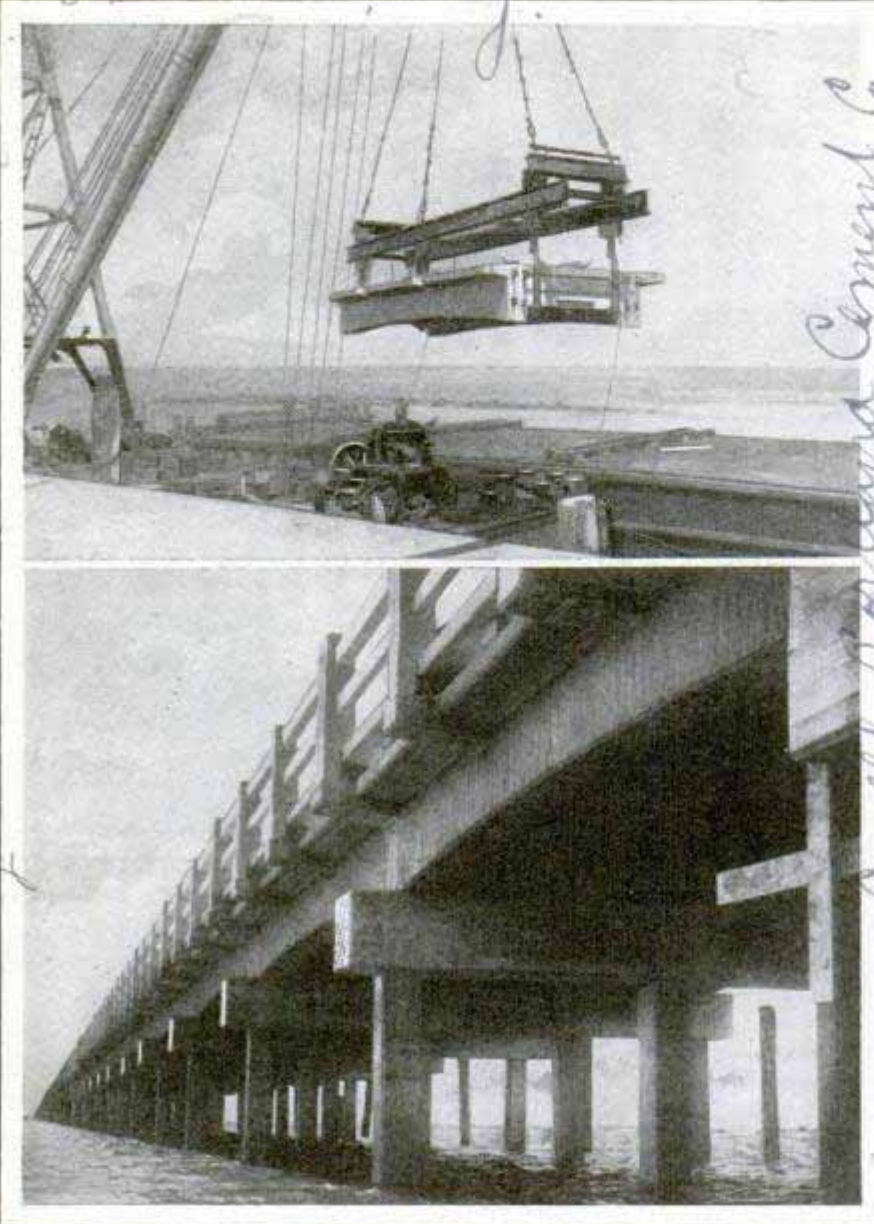
Trinidad Calif.

1845 1129.6 th St n.w. Canton Ohio

White Mt. 4

Materials Co. 849. 11 11
Sacramento, Calif

San Francisco Toll Bridge Co
1964
San Francisco, Calif



Swinging a Load of Bridge Sections into Place, and View of Part of the Structure, Showing Method of Assembly

BRIDGE IS BUILT IN SECTIONS OF PRECAST CONCRETE

To save time in constructing the long concrete bridge across San Francisco bay from Mt. Eden to San Mateo, deck sections, piles, roadway curb, handrails and other portions are being precast and then assembled after being shipped from the casting plant in barges. Thirty days are allowed for the piles to dry and eleven for the deck sections. More than 300 men are employed in the casting operations. In all, 1,100 precast deck sections, each thirty feet long and weighing forty-six tons, and 232 sections, thirty-five feet long and weighing fifty-five tons each, will be needed. For the entire project, which will cost \$7,500,000, 79,000 cubic yards of con-

Western Ave
1266

crete, 10,000 tons of reinforcing steel and 2,500,000 feet of lumber for the forms will be required.

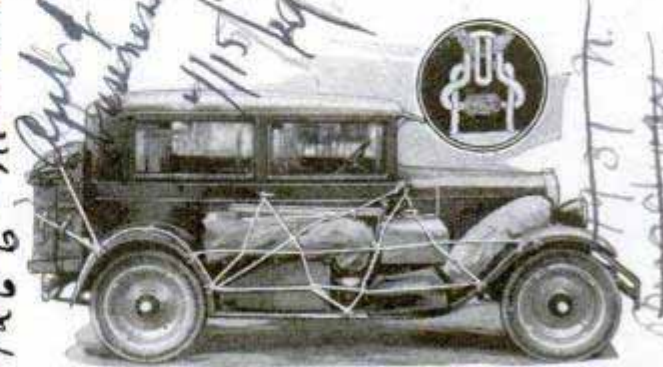
MIXED COAL DUST AND CEMENT FOR FUEL

Small blocks of coal dust, mixed with cement to hold the grains together, have been prepared by a western company as a way of utilizing coal too small for sale. Only two bags of cement are used to a ton of coal, and as little water as possible. The briquets are pressed in molds and each weighs about five pounds. They are said to burn readily and leave but little ash.

CLAMPS HOLD AUTO LUGGAGE ON CAR ANYWHERE

To tie luggage securely to the automobile, clamps, padded with rubber to prevent scratching the car, are quickly adjusted to the running board, fender or other parts.

They provide ties for the ropes that may be woven about the load to hold it on. The clamps are easily put on or taken off, and as many may be used as is necessary. Since several may be employed at once, secure roping of the load and distribution of strain are possible.



Ropes Tied to Clamps and about Luggage, and Close View of One of the Clamps

1266 N. Western Ave
11/15/19
Ropes Tied to Clamps and about Luggage, and Close View of One of the Clamps
1266 N. Western Ave

RUBBER TOP PROTECTS TABLE AND HELPS REDUCE NOISE

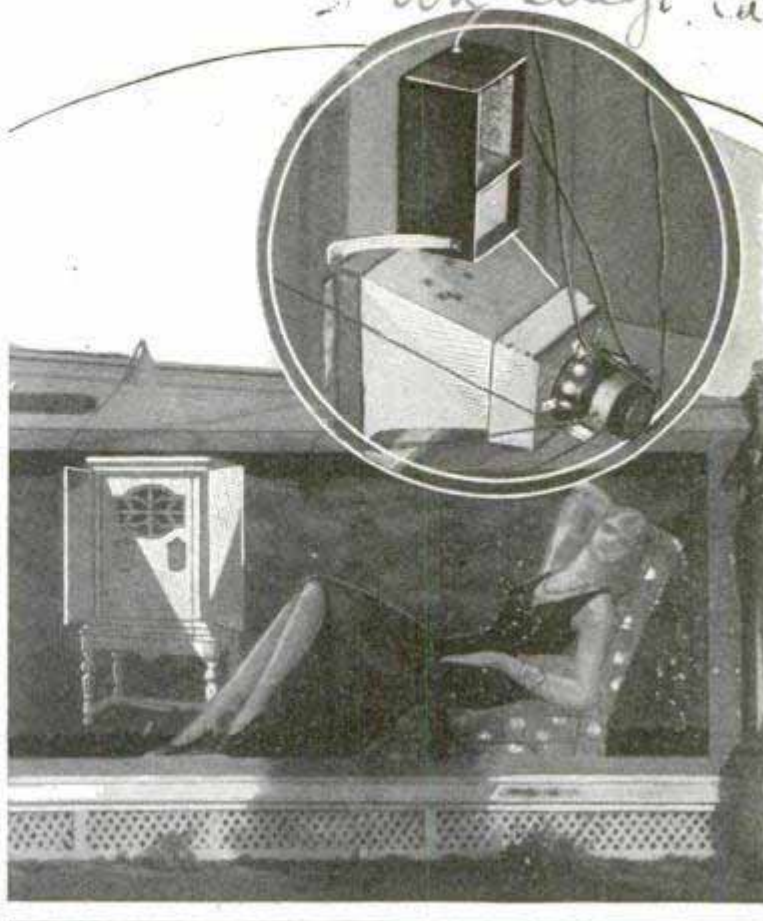
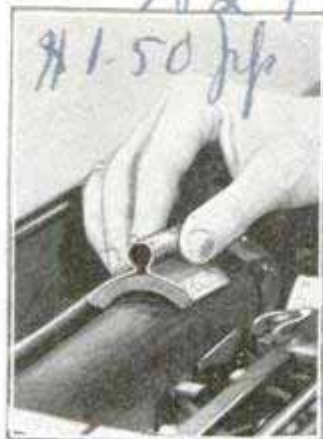
Adapted especially for a kitchen breakfast table, a rubber top, that slips over the edges and snaps into a groove on the underside, makes it easy to keep the table clean, stops noise and also protects the dishes. The corners are reinforced, and the top edges of the leaves and the center of the table are slightly raised to prevent spilled liquids from running off, thus guarding the floor. The table also has rubber tips on the legs.

NATURAL LIGHTING AIDS SARDINE FISHERS

Night is the best time for sardine fishing, for it is then easier to locate the fish. In swimming through the water, they disturb myriads of microscopic organisms which glow like fireflies and so enable the fishers to detect the presence of their prize. Along the California coast, a special net is used to take advantage of the phosphorescent glow. Its center is of extremely fine mesh, but the borders are much coarser to make it easier to haul. The fish are frightened to the center of the net, where they cannot escape, by the glow on the water.

TOOL ROUGHENS TYPEWRITER ROLL TO PREVENT SLIP

When the rubber on the typewriter roller wears so smooth that the paper slips, it is easily roughened with a small buffer that does not injure the material. The unit is furnished in three sizes for different makes of machines, and is curved to fit the rollers evenly and effectively.



Signboard as It Appears from the Street, and Close View of the Loud Speaker Concealed behind the Cabinet

RADIO SIGNBOARD THAT TALKS WORKS AUTOMATICALLY

An outdoor signboard, advertising radio equipment, has been made doubly effective by installing a dynamic speaker behind the painting of a cabinet. Radio and phonograph programs are broadcast through it at different times of the day, an automatic timing device turning the set, which like the speaker is concealed, on and off without the need of an attendant. The representation of the cabinet is outlined by means of neon-gas light tubes to attract further attention.

PAPER DETECTS GAS LEAKS TO AVOID ACCIDENTS

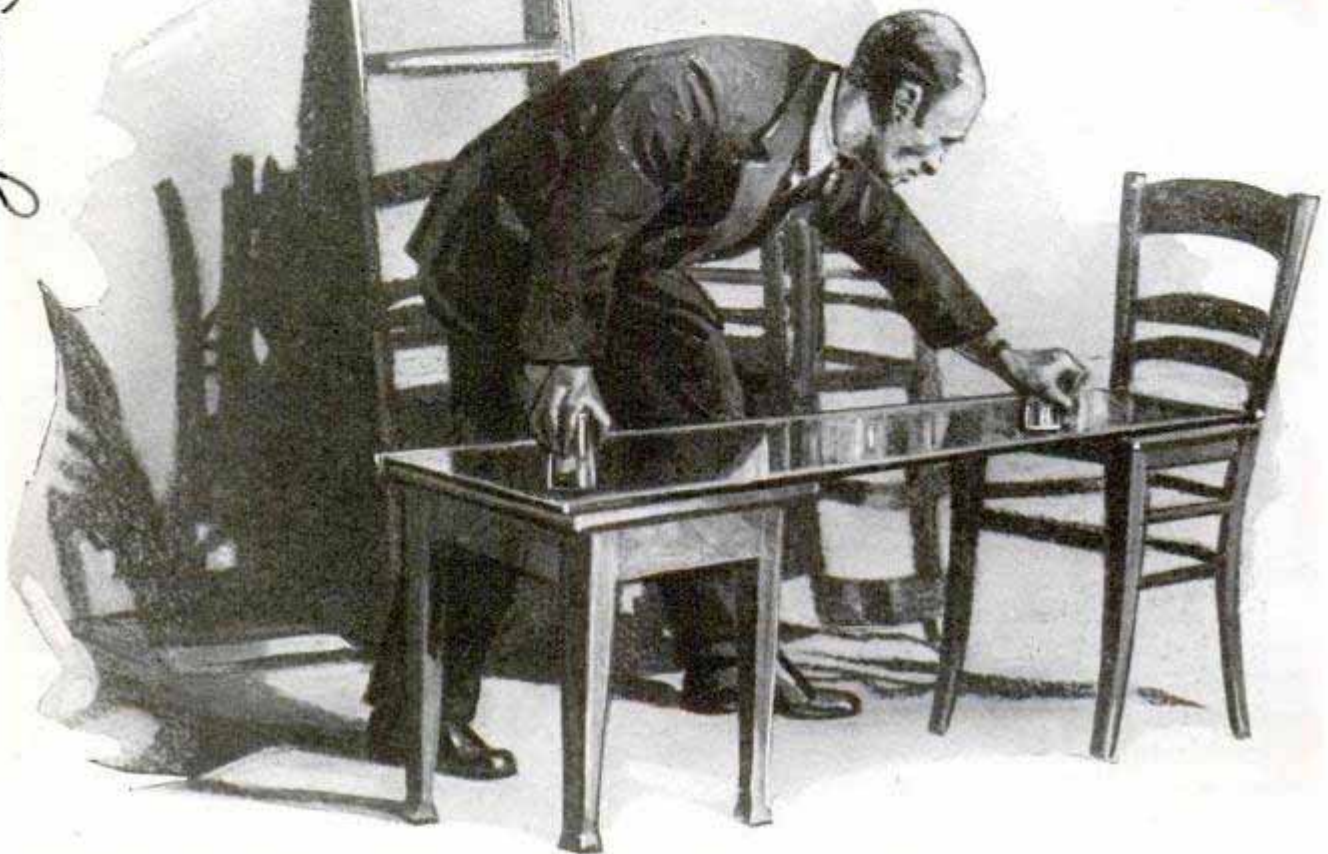
Testing house pipes and street mains for gas leaks is expected to be safer and more effective with the aid of a specially prepared, sensitive paper. It is of an absorbent variety like filter or litmus paper, and is chemically treated so that when a flow of gas comes in contact with it, its color is conspicuously changed.

*W. W. ...
Milford, ...
an Ikeji ...
Clyde ...
Barrel ...
Pino ...
Norman ...
Japson ...
14 ...
Holloway ...
The Secretary ...
Vicova Appliances*

*Typewriter tracing ...
135 ...*

Experiments made at Western Electric Co. 195 Broadway New York. 1911

The Art of Noise Making



Reproducing the Squeaking of a Train's Brakes from Off-Stage by Drawing a Pair of Tumblers across a Sheet of Plate Glass; One of the Effects in a New German Play

MAKING realistic sounds for the talking movies, the radio and the mystery plays of the stage is rapidly becoming both an art and a profession. The rise of a radio-play broadcast, calling for a variety of noises, focused attention several years ago on the fact that what goes into a microphone isn't always the same thing as what comes out of the reproducer at the other end.

The radio-play producers were mostly concerned with opening and closing doors to signal the arrival or departure of an unseen actor, with pistol shots, thunder, lightning, footsteps and the rustling of papers—all more or less simple noises.

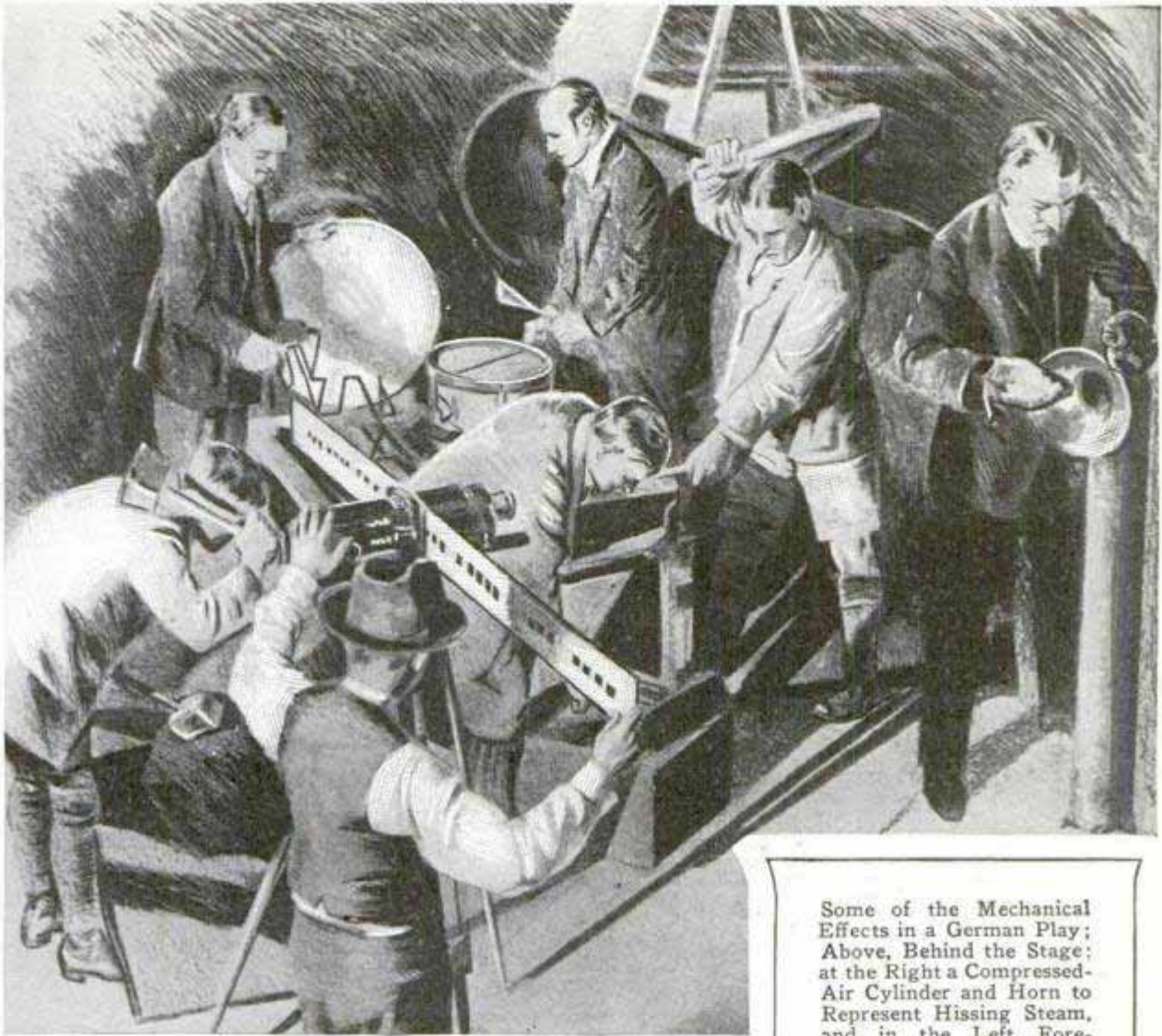
The talking movies, however, are troubled not only to produce the realistic sounds they want, but to keep from producing the sounds they don't want. A heroine, for example, can't faint in a taffeta-silk dress, because taffeta silk is altogether too noisy. She must wear crepe

de Chine to do her fainting in. A dancer can't wear a pearl or bead-bedecked frock, for every swish of such a dress would sound something like a violent hailstorm on a tin roof.

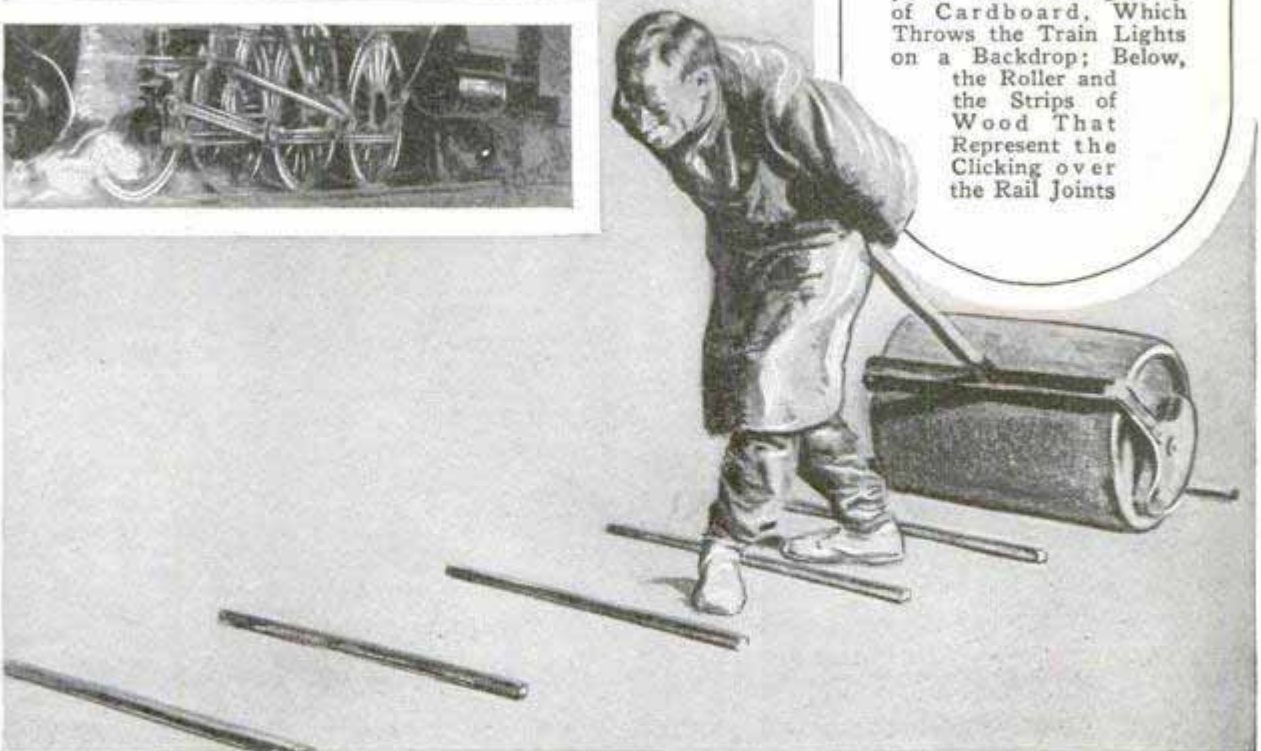
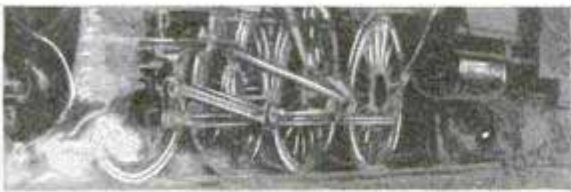
The trouble of sound in the films lies in the distortion of the noises in the electrical apparatus. Most talkies so far have lisped—their most noticeable defect. The reason for the lisp is the fact that the letter "S" is a high-frequency sound; in other words, one of extremely short wavelength. "O" on the other hand is a low-frequency note, of long wave and easy to reproduce.

The same electrical reason that makes the letter "S" difficult to reproduce is behind all the trouble in finding the wrong sound to reproduce the right effect. Roy J. Pomeroy, sound expert of the Paramount-Famous Players-Lasky studios, describes one typical difficulty. In the film "Varsity," Chester Conklin was required to rustle a newspaper. To the people of

1911



Some of the Mechanical Effects in a German Play; Above, Behind the Stage; at the Right a Compressed-Air Cylinder and Horn to Represent Hissing Steam, and in the Left Foreground the Light Projector with Moving Strip of Cardboard, Which Throws the Train Lights on a Backdrop; Below, the Roller and the Strips of Wood That Represent the Clicking over the Rail Joints



the studio it sounded quite natural, of course, for he just rustled the paper. But when the sound came back from the recording apparatus, the newspaper sounded like a machine gun in rapid fire. Mr. Pomeroy experimented until he discovered that the correct way to rustle a newspaper for the talkies is first to wet your paper.

A police whistle gives the same trouble, in a different way, as the letter "S." It is far too piercing for the reproducing apparatus to handle. Sometimes a soprano's high note, on your radio, "freezes" the diaphragm of the reproducing unit. That's what the police whistle did to the sound recorder. Mr. Pomeroy solves the problem by putting the whistle blower behind

a heavy curtain, to subdue the sound. A fire-engine siren had to be similarly blanketed to get it down to the right volume.

In a recent play produced in Germany, "The Phantom Train," all the off-stage sounds of a train were made by a half dozen men, using the ordinary stage-sound equipment. The clicking of the wheels over the rail joints was imitated by a man dragging a heavy garden roller over a series of cleats nailed to the floor, each little bump being one rail-joint click. The screech of brakes came from two tumblers rubbed over a sheet of plate glass. A cylinder of compressed air, released through a megaphone, represented escaping steam.

**PUSH-BUTTON TRAFFIC SIGN
AIDS PEDESTRIANS**

1853

Pedestrians act as their own traffic police with the aid of a press-button street signal introduced in Los Angeles. When

twenty-five seconds the signal may be operated again for another pedestrian. The device is intended especially for intersections where the traffic is intermittently light and heavy.



Pressing Button Raises the "Stop" Flag, Which Stays Up for Fifteen Seconds

a person wishes to cross an intersection, he presses a little knob on the sign post. That raises a "Stop" flag which stays up for fifteen seconds and then falls back to neutral position. After a lapse of

**GUARD MYSTERY DIAMOND MINE
TO PREVENT SMUGGLING**

1866

Workers in one of the more recently developed diamond mines in South Africa are confined in a barbed-wire inclosure which they cannot leave except by official permission. They must remove their shoes before they go to meals or off duty for the day, and those who help sort the gravel at the final washing are not allowed to put their hands in their pockets. These, and other stringent regulations have been established to prevent smuggling the gems out of the field. The area is an exceedingly productive one. While digging recently, workers removed a stone and found 148 diamonds lying together in a heap. The greatest secrecy has been maintained in regard to the yield of the mines, but it has been reported that if the full production were immediately released for sale, it would result in a slump in the industry. The mine is owned by the South African government and will provide profitable yields for at least fifteen years, according to engineers. In spite of all the precautions taken, there is smuggling of diamonds, although it is believed some of the "bootleg" stones come from fields that the natives themselves operate secretly.

The Daily Mail

11/17/28

Designed by Ralph Moray, City Traffic Signal Engineer,
 Los Angeles, Calif.

1711

4/13/28

WONDERS OF MODERN HOTELS SHOWN AT EXPOSITION

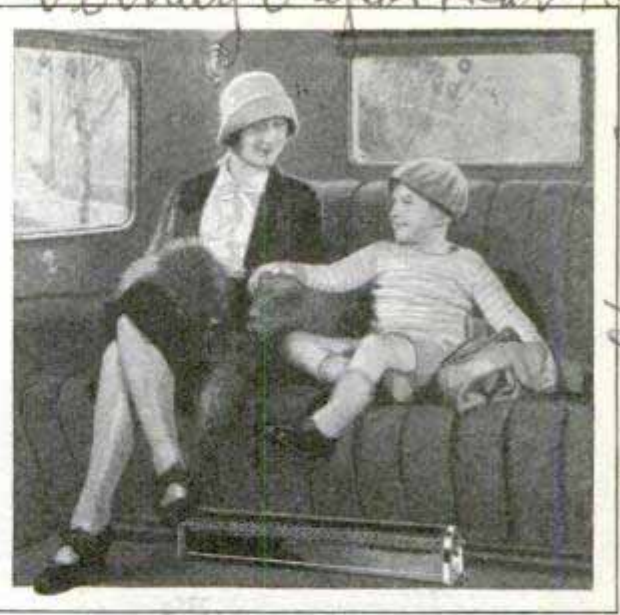
Machines that wash 25,000 dishes an hour, cash registers that can ring up \$9,000,000, electric toasters that can brown 900 pieces of bread in an hour—these and many other marvels were shown in New York recently to illustrate what goes on behind the scenes in a large modern hotel. Among the kitchen aids was a machine that shells a bushel of peas in three minutes and a mixer that prepares the ingredients for 1,200 loaves of bread in six to seven minutes. A washing machine cleans a bushel and a half of vegetables in one and a half minutes.

RANGE GUN FIRES STEEL BALLS IN TARGET PRACTICE

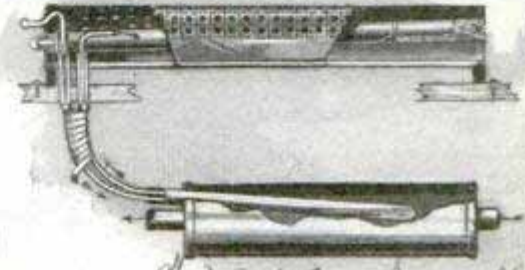
A range gun to be used in teaching gun laying and pointing has been invented by Capt. E. H. Stillman, assistant professor of military science and tactics at the University of California. The gun, a wooden affair worked by a spring, fires quarter-inch steel bearing balls. The spring tension is so adjusted that one inch on the range used equals fifty yards. The steel projectiles fall on a sand table eight by fourteen feet in size, and tiny bursts of sand mark the shell puts. Small wooden model battleships are used for targets, on ranges equivalent to 24,000 yards. A small screw controls the muzzle velocity, and trajectory, firing tables and probable error of the miniature gun are almost the same as for a modern fourteen-inch coast defense gun, and it cost less than \$1.50 to build.



Wooden Gun That Fires Steel Bearing Balls, to Aid in Target Practice at Less Expense



Verway Vapor Heat 1693



Large \$22.50. Small \$15.00
Automobile Heater Installed, and Drawing to Show Its Construction and Method of Connection

*Laminated Shum Co
14th St. & Cooper St. Place, N.Y.
Long Island City*

STEAM-HEAT SYSTEM FOR AUTO EASILY INSTALLED

Steam from a special liquid is produced by the exhaust heat in a warming system for the interior of the car, easily installed and capable of regulation simply by turning a small knob. It fits close to the back seat, gives off no fumes or odors and requires but little attention.

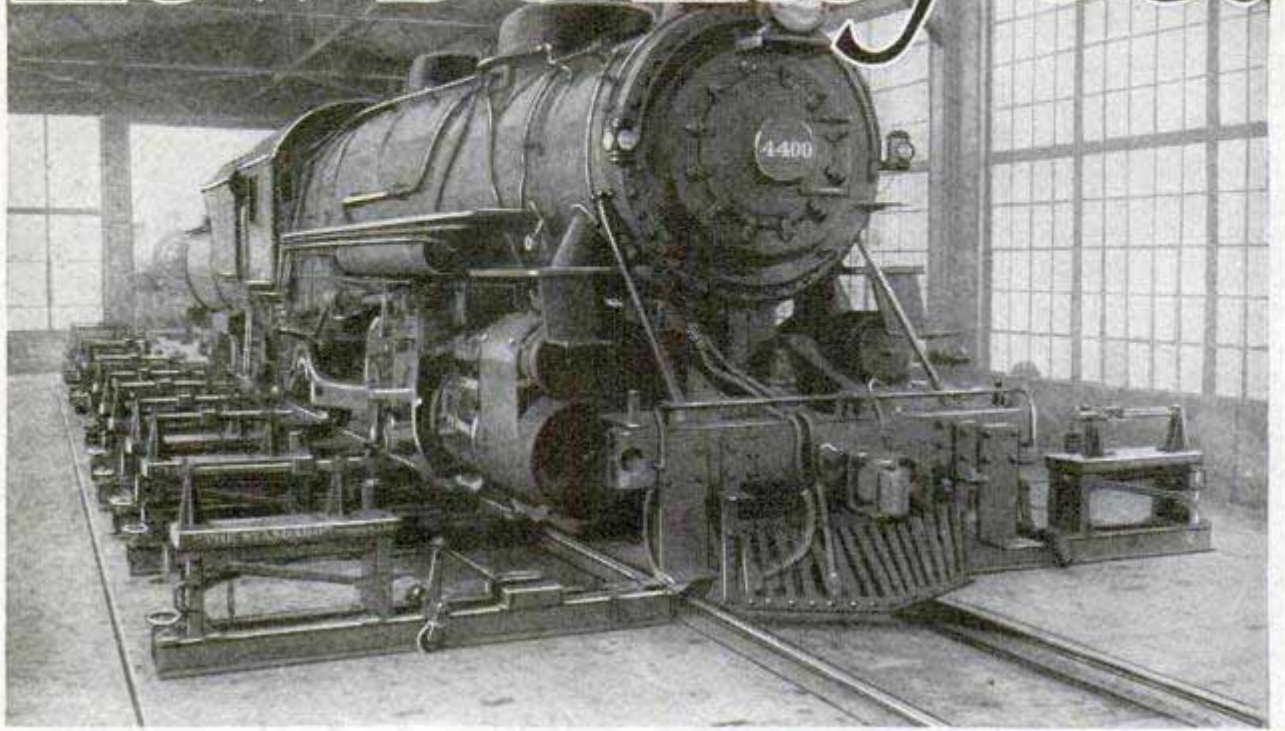
LOST ISLAND IN SOUTH PACIFIC SOUGHT-FOR EIGHTY YEARS

For nearly eighty years, mariners have told of a mysterious island, a lonely reef-guarded spot in the south Pacific, first reported in 1859, a year before the United States sailing vessel "Levant" disappeared on her way from Hilo to Panama. It is believed that the ship may have searched for the island, as her officers had talked with merchant captains about its probable location. Some persons regard the island as a myth. Others believe that it may be one of the floating islands not uncommon in tropical waters, and still others hold that it lies so low in the seas that it is difficult to find.

*New York Times
1928*

1612

How Do They Get



Weighing a New Locomotive in the Shops of the Baldwin Locomotive Company, at Philadelphia; Separate Track Sections and Scales Catch the Weight on Various Parts

A SECTION of steel railroad rail, several feet long, some six inches high and weighing ninety pounds to the yard, is mounted in a new museum in New York. The visitor is invited to push the rail and see how far he can bend it. He presses a button and looks in an eyepiece which discloses a series of light-interference rings. As he pushes, the interference fringes increase in number. A man of average strength can bend the huge rail as much as the width of seven or eight light waves.

That is something new in weighing, a demonstration of a process that may revolutionize the science of obtaining the exact weight of infinitesimal objects. A good laboratory precision scale will weigh a lead-pencil mark on a sheet of paper, but a weighing mechanism so delicate it can measure the force exerted by the human hand against a huge steel rail is so unbelievably delicate and sensitive that it can be used, perhaps, to measure the activity of an unseen atom.

Scales of all kinds, regardless of type, are alike in one thing, for they all are

basically systems of measurement in which a fixed proportion is used to determine quantities. This is true regardless of whether the fixed proportion is the tension of a spring, a weight of predetermined size, or the deflection of a beam of light. But what the average scale user knows about weighing mechanisms, and what the experts of the bureau of standards and the department of agriculture know are different things entirely.

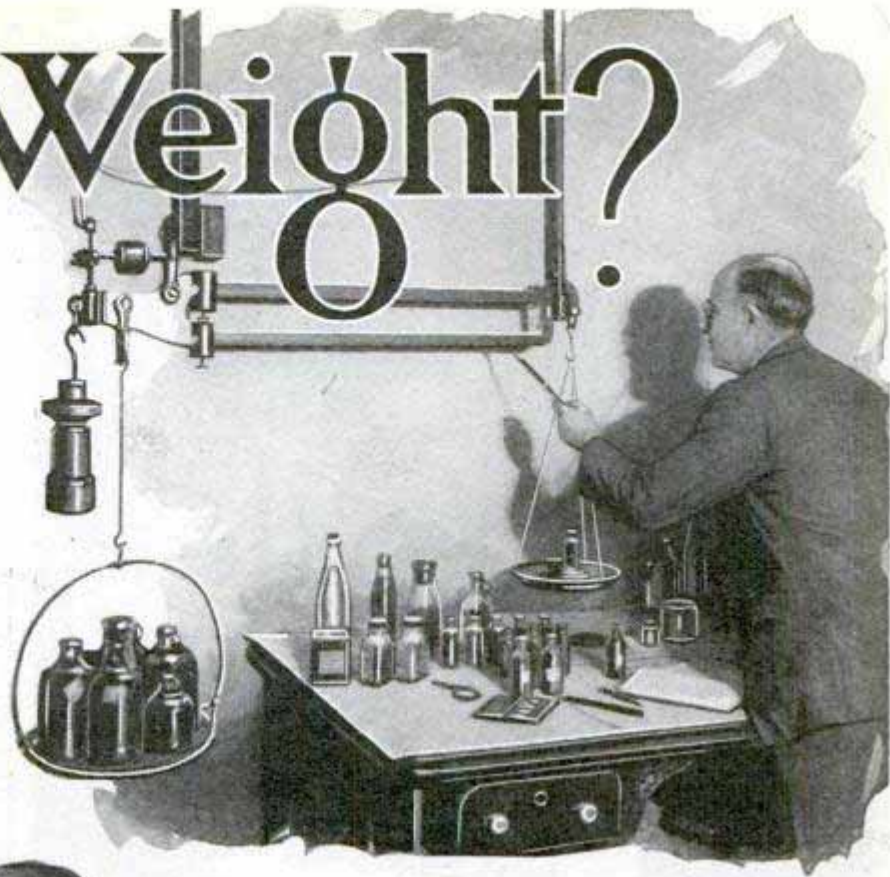
For example, sensitivity is not a sign of accuracy, popular belief to the contrary, for an extremely sensitive scale may be far from accurate, according to C. A. Briggs, government expert. Nor is accuracy a sign of correctness or inaccuracy a sign the scale will weigh wrong, for, paradoxical as it may seem, an accurate scale can be made to weigh wrong, and one that is way off in its weighing can be used in such a manner as to give a fairly accurate result.

When the butcher of popular legend rests a finger on the scale pan while weighing out the roast, he may or he may not be playing fair, for it is quite possible

That Weight?

according to Mr. Briggs, to poise a finger against the scale without affecting the result, and just as possible to exert pressure without betraying it.

There are countless curious and little-known facts about scales which the government experts are trying to clear up. They come in such a variety of sizes—from laboratory instruments that weigh the millionth part of a thousandth of a gram to track scales that weigh



Comparing Home-Made Test Weight with Metal Standard, at Left, and, Above, the Final Accuracy Test

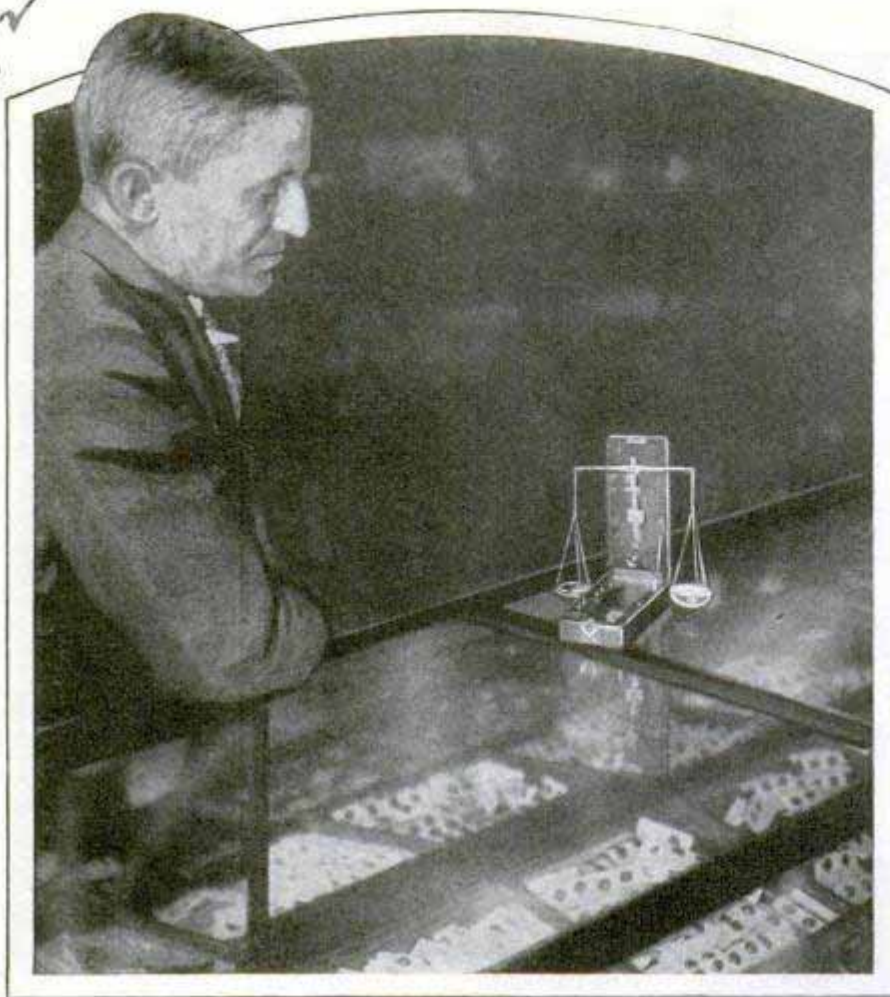
an 800,000-pound locomotive—and are used in such a variety of ways that keeping them accurate presents a real problem. The only means of telling whether a scale is maintaining its accuracy in use is to check

it against a test weight which in turn has been checked with the master weights of the bureau of standards.

Test weights of known accuracy are rather valuable, so Mr. Briggs has invented a new form, which promises to bring down the cost of keeping scales accurate. His new test weight is simply a bottle filled with lead shot and sealed with cork and sealing wax. A set of such test weights, calibrated to check with the government standards, has varied less than one grain per pound in two years of use. When it is remembered there are 7,000 grains in a pound, the accuracy of these bottle weights is apparent.

Anyone with access to a standard weight can make his own bottle weights by filling a container with shot or nails until it balances the standard. The cork and enough sealing wax to seal it are placed on the pan during the filling of the bottle, and the wax then melted into place. By changing the quantity of wax, an accurate final balance can be made, either adding or scraping off a bit of wax as required. As most platform balance scales in use employ cast-iron weights, which become nicked and battered with use, they require periodical checking against test weights to insure accuracy.

Briggs, Expert on Scales 275
... of ... agriculture



Weighing Diamonds with a Precise Type of Jewelers' Scales; Accurate Weighing Is Usually Done with Balance-Type Scales

It is a fact, Mr. Briggs points out, that an accurate weight can be obtained from an inaccurate scale, if occasion demands it. The system is known as substitution weighing. A large scale, used for weighing heavy objects, will not be accurate normally if used to measure small masses. To get around that drawback, a container, such as a bucket, can be placed on the platform and a weight equal to the amount to be weighed placed in it, and the lever balanced accurately. The weight is then carefully removed, without changing the position of the container, and the latter filled with the material to be measured, until the lever is again balanced. As the errors of the scale, whatever they may be, are constant, the substitution has produced an accurate weight.

Did you ever hear of weighing a heavy object in sections on a scale too small to weigh all of it at once? That is done regularly in checking the weight of motor trucks to determine whether they are loaded past the limit allowed on modern

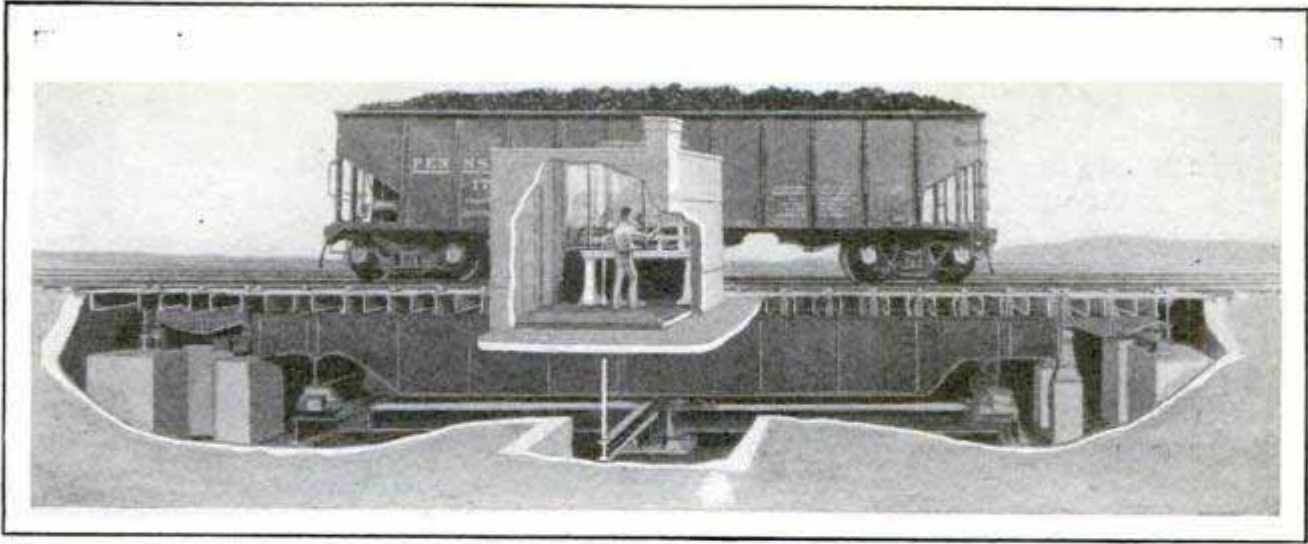
highways. The highway inspector carries one or two small scales which are placed under the rear wheels of the truck. If only one is used, a dummy block, the same height as the scale, is placed under the opposite wheel, to avoid disturbing the center of load. Of course there is a slight shifting of the fore-and-aft load center when only the rear wheels are elevated, but, as the wheel base is considerably longer than the tread of a car, the shifting is not as great as it would be if only one rear wheel was elevated at a time.

If all four wheels are placed on scales simultaneously, the combined weight shown by the four scales would be an accurate total for the truck and its load. Locomotives are weighed in much the same way in

the builder's plant to determine the proportion of weight on pilot wheels, driving wheels and trailing truck. Each group of wheels rests on a separate track section built on a scale platform. A similar system is used in weighing airplanes at the army experimental field at Dayton. Three platform scales are used, two under the landing wheels and one under the tail, the combined weight on the three being the total for the plane.

Weighing has been adapted to industry and merchandizing in some peculiar ways. In the big mail-order houses and department stores the orders received during the day or the day's sales checks are placed on scales and weighed. Knowing the weight of a given number of such slips of paper, a close count of the total volume can be obtained in an instant by weighing. Also, as the law of averages shows the average order or sale will be about a given sum, it is possible to estimate the day's business, in dollars and cents, by weighing the sales checks or order blanks, find-

1612



Weighing a Car Load of Coal on the Giant Balance of a Pennsylvania Railroad Fulcrum Track Scale; the Cut-Away Scale House Shows the Operator Adjusting the Balance

ing the approximate total number and multiplying it by the average size of a sale in the past.

Similarly, factories using large quantities of small parts, such as screws, or stores selling such small parts in quantities, habitually use scales to count them. Knowing the weight of a given number of the objects to be counted, it is easy to count any multiple of that number by weighing them. Or, with a balance, it is possible to get a direct count by placing a known number in one pan, and balancing them against a larger number in the other. With a ten-to-one balance arm, ten of the objects in the pan of the long arm will balance 100 in the opposite pan, and the hundred, shifted to the other side, will then balance a thousand, and so on.

Railroads are one of the largest users of scales, and the users of the largest scales, in the country. The plum for size goes to the new track scale of the Pennsylvania railroad at Altoona, which can weigh an 800,000-pound locomotive, when one is built. So far, the biggest locomotive weighed on it tipped the beam at 613,000 pounds. Scales are of importance in the operation of a railroad because all its freight revenue is calculated by them. The Pennsylvania handled 230,000,000 tons of freight in 1926, a measuring operation that required 6,000 scales, including 250 track scales for weighing entire cars with their loads. The 6,000 scales determine a revenue of well over a half billion dollars in normal years, and one track scale in the Juniata yard at Altoona fixes freight charges of about \$50,000,000 annually.

To keep so many scales accurate is a big task. The railroad companies employ one master scale, which is checked at frequent intervals against government standards. On this scale test cars are weighed and then sent out over the line to be reweighed on the other track scales. Freight cars are weighed on the track scales while in motion, the weight of each car being caught as the train passes over the scale platform. In one of the busier yards, the track scale has a record of having averaged one and a half cars every minute, day and night, throughout an entire month.

Despite their tremendous capacity, these track scales are so accurate that they can determine the weight of a person within five pounds. In some yards humps have been installed to start the cars down by gravity over the scale platform. A locomotive pushes a train to the top of the hump, and then, one by one, the cars roll down to the weighing track. In order that the cars may always pass over the platform at a uniform speed, to which the scale is adjusted, the hump is built so it can be raised and lowered at different seasons of the year.

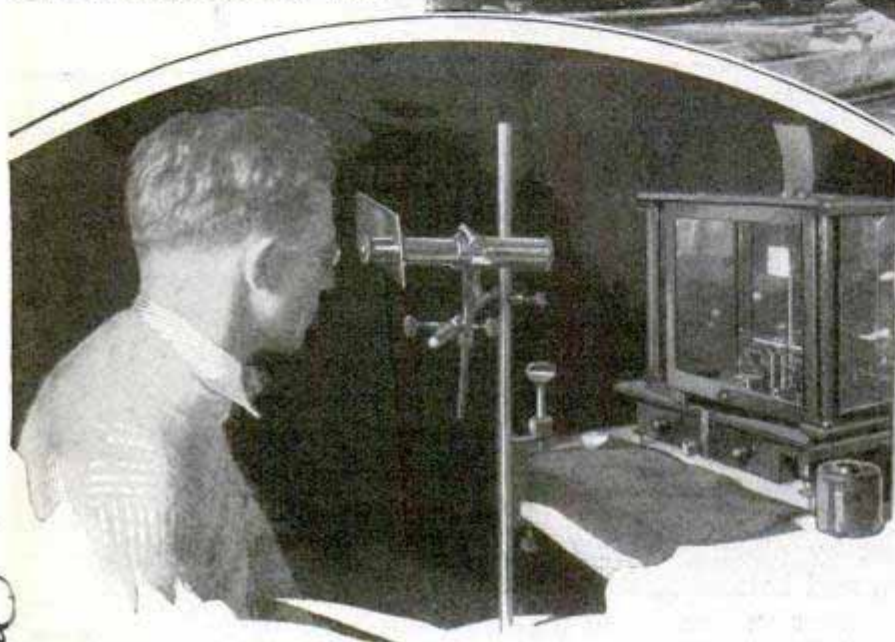
Jewelers' scales have always been supposed to be very accurate. Actually they may not be, according to A. T. Pienkowsky, one of the scale experts of the bureau of standards. The value of a precious stone would hardly be changed if the scale was wrong by as much as a fraction of one per cent, he points out.

The relation of sensitiveness to accuracy, or rather the lack of their relation, is easily demonstrated, according to Mr.

Briggs. Nearly all good compound-lever scales are far more sensitive than accurate. In one test of a large grain scale, with a 20,000-pound hopper and 120,000 pounds of wheat as the load, he found that the addition of as much as a tenth of a pound of grain was shown by the scale, whereas its accuracy was



Lowering the Seventy-Five-Foot Fulcrum-Scale Bridge into a Scale Vault on the Pennsylvania Railroad; the Completed Scale Bridge, Including Rails and Ties, Weighs 143,000 Pounds; at Left, Examining at Close Range the Cabinet-Inclosed Precise Test Scale at the U. S. Bureau of Standards; This Machine Will Weigh Objects Down to the Thousandth Part of a Milligram; Some Laboratory Scales Weigh the Millionth of a Milligram

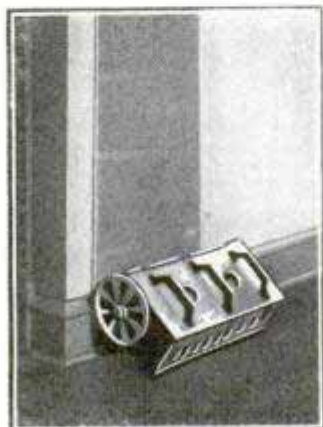


no greater than an error of twenty pounds in 120,000. There was a ratio of 200 to one in the relation of sensitiveness to ac-

curacy, yet there could just as easily have been an error of 400 pounds in the scale without affecting its sensitiveness.

MACHINE FOR PAPERING WALLS REQUIRES LITTLE SKILL

With the aid of a roller machine that applies paste and lays paper on the wall or ceiling, even a novice can paper a room, according to the manufacturers. After the paste is put on with revolving brushes in the machine, soft rubber rollers press the strip firmly to the wall. Only a few adjustments are needed for ceiling work, and the unit has



handles at the top for easy manipulation. Before applying, the paper is threaded into the machine.

HOW HEAT AFFECTS TREES

That the rate of growth and the survival of forest areas are largely dependent upon the temperature, has been established in a series of interesting tests performed in northern Idaho. Seedlings of the western yellow pine, gathered from twenty-one localities, were planted and careful measurements made as to their growth in the experimental area. Some lots grew slowly, while others developed five or six times as rapidly. Soil and other conditions were the same for all, the temperature evidently being the determining factor in speeding or delaying the growth.

New York World 11/9/28

R. J. Payne 564 Fairborne Ave. Coon Borough, Phila. no.

and shipping
June, 1929

STRAIGHT-LINED SHIPS REDUCE SEASICKNESS

1783

Ships with berth cabins and public rooms designed on straight lines, like those on shore, are less likely to cause seasickness than those where slightly curved lines prevail. At least, such seems to be the experience of a British railway company with two cross-channel vessels, exact duplicates, except that one was constructed in the ordinary manner with cambered decks, state-room bulkheads and other partitions following the form of the ship's sides, while the other had flat decks and partitions at right angles throughout. This ship proved to be more popular with the traveling public, and it was intimated that the reason was that seasickness was less frequent among persons occupying the square, flat-topped and flat-floored rooms. The explanation was that such lines had a less irritating effect upon the mind, while the irregular lines, in some cases, annoyed the observer and so helped upset his physical well-being, although unaware of the real source of his irritation. In support of this theory is the well-authenticated report of a hardy foreman on a railroad who became ill after only fifteen minutes' work in a baggage car that had been tipped at a slight angle during a wreck. Several other members of the crew were affected in the same manner. The out-of-plumb lines evidently helped cause nausea.

☛The Cuban humming bird is the world's smallest bird.

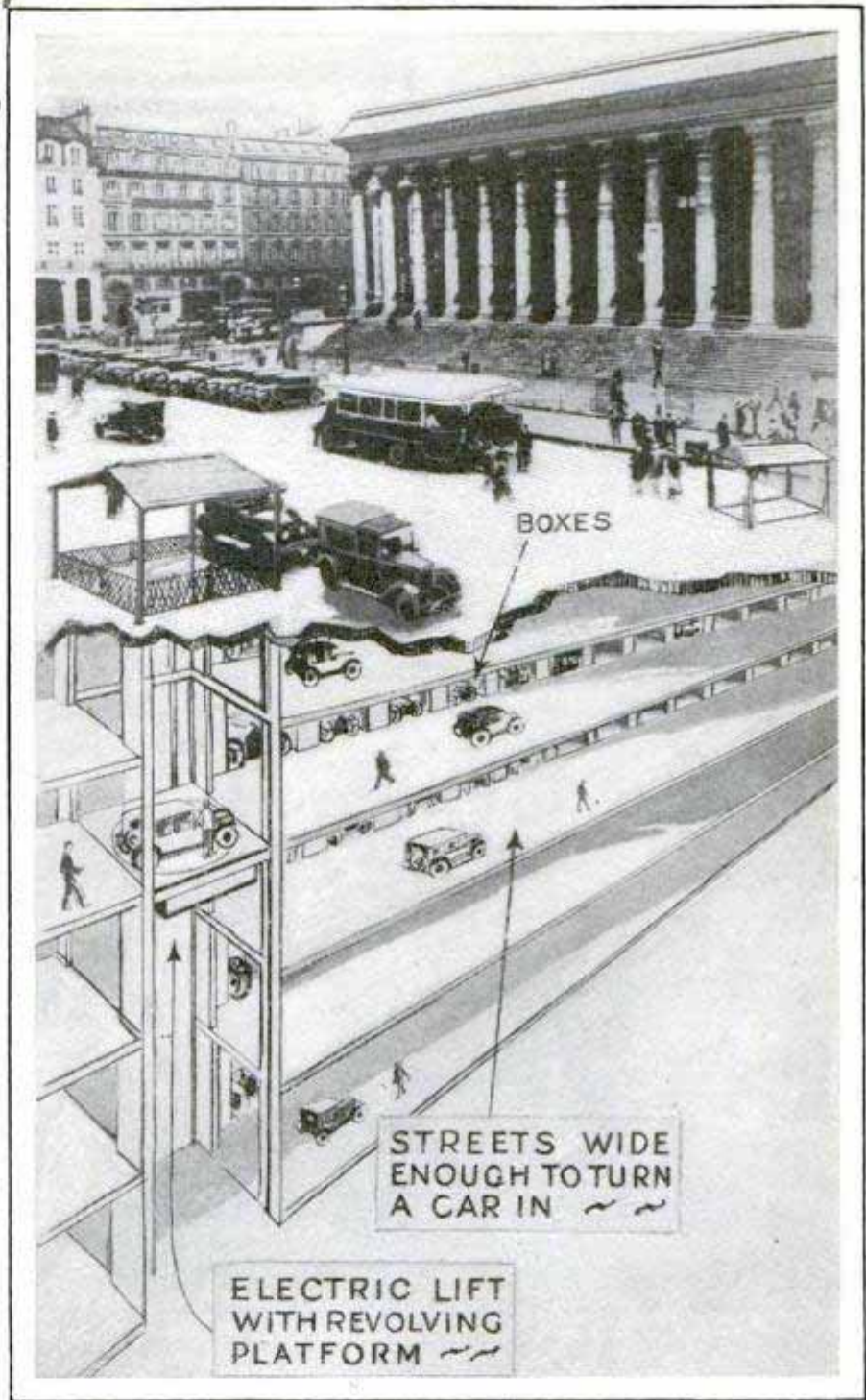


Photo-Diagram Showing How Paris Traffic Authorities Are Planning to Solve the Auto-Parking Problem in Busy Streets

PLAN UNDERGROUND AUTO PARK TO RELIEVE PARIS TRAFFIC

7690

Thousands of cars will be parked under the streets beneath the Place de la Bourse in Paris, if present plans materialize. A shaft for an electric lift will be sunk many feet below the surface and the autos parked in substreets at various levels. The passageways are wide enough for a car to be turned around, and will be thoroughly ventilated to eliminate fumes from the exhaust.

COLOR IS FOUND TO AFFECT DEMAND FOR FOODS



Testing Colors of Various Foods in Government Laboratory with Special Apparatus That Exactly Measures the Shades

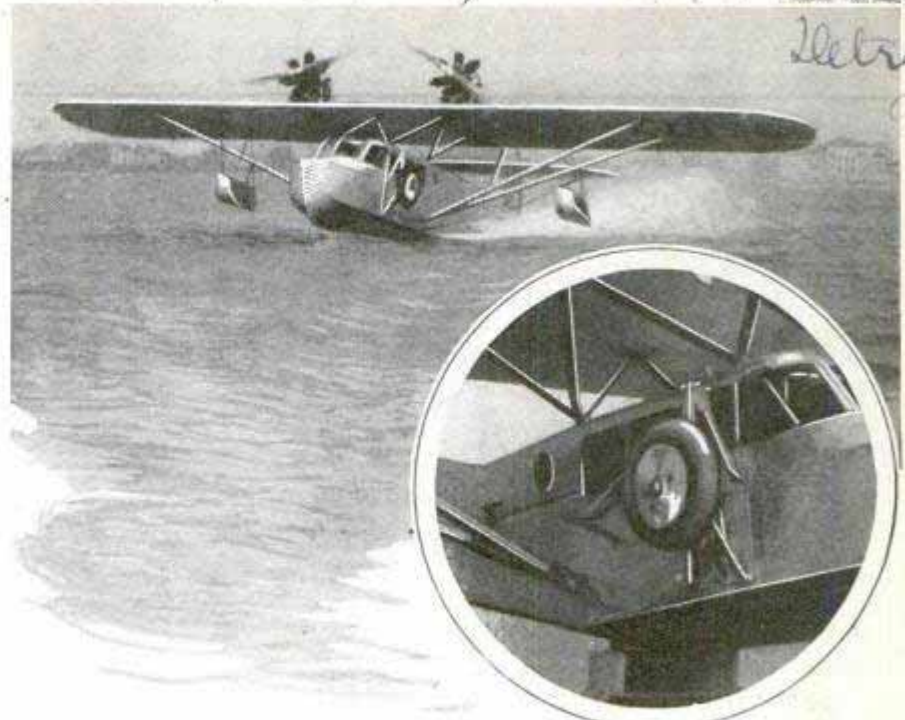
The color fad has struck the food industries. Consumers, it has been learned, have preferences for color in their foods as in house furnishings, clothing and automobiles. They want solid colors in the things they eat; red tomatoes, white corn, red apples for eating raw and green apples for cooking, purple grapes, yellow squash, meats with a deep-red coloring. As a result, studies are now being made by the department of agriculture to measure the color elements in farm products. Specially designed color apparatus is used to determine precisely the various tones of color in foods, such as apples, tomatoes,

beans, peas, celery and other products. On the basis of these and similar studies, recommendations are made to producers for harvesting crops at a time calculated to place the products on the markets at the exact stage of maturity to bring out the desirable colors. Nothing is so discouraging to variety in the human diet, say the food specialists, as the washed-out appearance of soggy vegetables on the dinner table. In fact, prejudices

against certain important vegetables are directly traceable to this cause. Preservation of the natural color goes hand in hand with proper cooking. The first is an appeal to the eye, the second tickles the palate, and both satisfy the requirements of the human body. Also, food quality standards have been issued by the department of agriculture for forty different fresh fruits and vegetables, meats, butter, eggs, poultry and canned tomatoes, corn and peas. It has been found that a food may be fit for consumption but is not necessarily of high quality. The consumer, to be sure, is not a food specialist and can

1677
Aviation Marine
Aircraft-Engineering
Co., 484 Card Ave
 281

judge quality only according to whether a food is pleasing to the eye and palate. Canners' organizations are co-operating in this work to assist consumers in their purchases and to give assurance of uniformity in the quality of products, and as a result a system has been developed in which "Grade-A" corresponds to what is known as fancy; "Grade-B" to choice or extra standard and "Grade-C" to standard. The investigations have shown that high price is not always the equivalent of high quality. Thus, it was found in one of the tests that the highest-priced can was really second in quality, whereas a medium-priced can, nineteen cents cheaper than the highest-priced product, was of better quality.



Detroit Mich

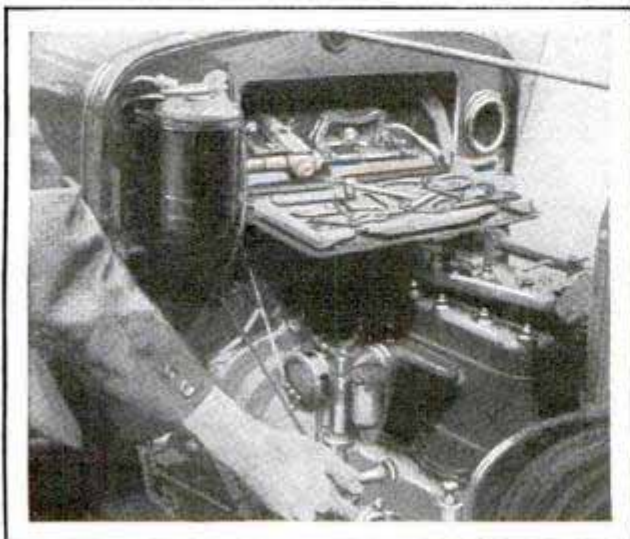
Flying Boat Skimming over Water, and a Close View of the Cabin, Showing Landing Wheel Drawn Up on Side

TWIN-MOTORED SEAPLANE HAS HIGH SPEED

A new type of amphibian plane, with twin motors mounted above the monoplane wing, in the manner of usual flying-boat practice, has been produced by a Detroit designer. The landing wheels are drawn up alongside the boat hull when not in use. Carrying six passengers, the ship, with two 150-horsepower motors, has a speed of 115 miles an hour.

DASHBOARD HOLDER FOR TOOLS SAVES TIME IN REPAIRS

Small tools for automobile repairs are quickly accessible in a convenient holder in the dashboard. The rack tips back on hinges, saving the task of lifting seat cushions, is easily installed, and holds the tools where they are not likely to jar loose.



Tool Kit Open for Easy Access; Its Installation Does Not Interfere with the Wiring

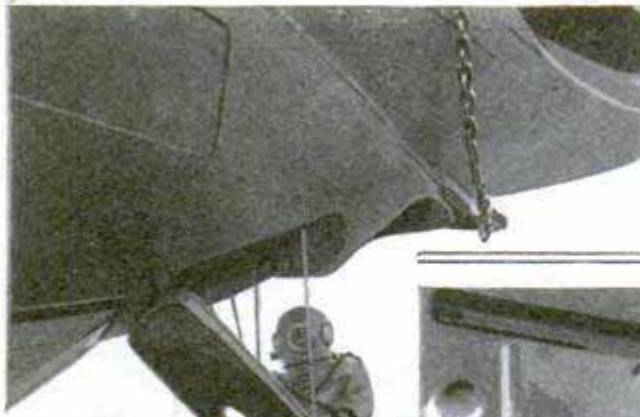
ESKIMO ICE CREAM IS MADE FROM OIL OF FISH

Eskimos of Alaska have one unexpected winter dish, ice cream made from fish oil, snow and sugar. The dish has a strong odor, but tastes, it is claimed, better than it smells. The eulachon, a species of smelt, is also known as the candlefish, because it contains so much oil that it can be burned to furnish light. The Eskimos catch vast quantities of the fish, place them in holes lined with heated rocks, and, after they are cooked, press out the oil by putting the fish in a covered basket on which the women tread with bare feet. During cold weather, the oil has much the appearance and consistency of butter. To make the ice cream, it is melted, and sugar and snow, then stirred in.

Cruxton & Co. Inc.
Cruxton, Montreal, Canada
210 Home Assurance

World
 1411 **RESCUE SUBMARINE HAS AN UNDERWATER EXIT**

a lost submarine has been located, drop to the bottom, lie alongside the damaged hull, and send divers over to work or rescue the crew, regardless of the weather on the surface. To make this possible, an air lock has been built into the forward underside of the "Defender's" hull, with



A submarine designed to rescue trapped crews of other submarines is rapidly nearing completion at the Bridgeport yards of Simon Lake, famous submarine inventor and builder. The new craft, rebuilt from the little ninety-two-foot seven-inch submarine "Defender," produced by Lake in 1906, is shortly to be given a trial by the navy, working in conjunction with the recently rebuilt "S-4," which was sunk a year ago in a collision with the coast-guard destroyer "Paulding." As a memorial to the "S-4's" dead, the navy reconditioned the boat especially to carry out tests of submarine-rescue apparatus. The unique feature of the rebuilt "Defender," in which Lake and Capt. Sloan Danahower have collaborated, is an underwater exit door enabling divers to enter and leave the ship. The great difficulty in all rescue work in the past has been that the divers had to work from surface ships, which could only be anchored in fairly calm weather. With the new boat, the rescue crew can, after



Diver Trying the Sea Door of the "Defender" and Preparing to Leave the Air Lock Which Admits to the Sea

a trapdoor for exit, and a ladder down which the diver can walk to the sea bottom. In operation, the diver enters the air lock, the door into the submarine is closed, and water is gradually admitted until the pressure within the lock equals the pressure of the sea outside. When the two are equal, the diver can open the outer door and lower his ladder, climb down and walk across to the damaged ship. When his work is finished, he re-enters the lock,

closes the sea door, and the pressure is then gradually reduced, or, by raising it slightly by forcing in air, the water can be blown out and the air pressure then reduced until all danger of the "bends" is past. With the ability to work alongside a damaged craft, it is believed air or oxygen lines can be attached much more quickly than from the surface, to supply air to the crew, and, using the rescue boat's pumps and motors, water can be blown out of the damaged boat to help it rise to the surface.

MAGNET TEST ON BRIDGE WIRE REVEALS DEFECTS 1742

Every inch of the wires that are being woven into the big cables for the Ambassador bridge, to connect Detroit, Mich., with cities in Ontario, is subjected to an interesting magnetic test to reveal any departures in the standard of requirements for the metal. The method is a simple one, and its principle is well known. The wire is passed along from the last operation in the mill to the reels on which it is wound for shipment, and as it moves, it acts as the core of a transformer, the primary winding of which is energized by alternating current. Any irregularity in the current generated in the secondary winding of this transformer, indicates some irregularity in the physical properties of the wire, and any fluctuation beyond the high and low limits established, is cause for rejection of a portion of the wire. The test does not show just what is wrong, but serves as a signal for a further inspection and is applied in addition to a number of other trials which the metal must pass before it is allowed to be used in the big cables that will support the span.

Whenever you wish to know more about any article in this magazine, write our Bureau of Information.



Work Track in Small Sections to Simplify the Removal of Rails or Laying a Curve

FLEXIBLE WORK-RAIL TRACK SIMPLIFIES CURVES

Construction of narrow-gauge track lines in work yards and other places is simplified with the use of a section in segments of small units, especially useful in laying a uniform curve. The rail sections rest in saddles mounted on steel cross-ties. This arrangement also lightens the task of moving the track to either side.

FAN VENTILATOR FOR MANHOLE HELPS PREVENT EXPLOSIONS 1730

To insure adequate ventilation for the workers in manholes, and to drive out gases that might cause explosions, a Minnesota public-utility concern has developed a fan blower and pipe which is placed in the hole to provide fresh air. Used before men are allowed to enter the passage, it removes all dangerous vapors and then can be employed to furnish a supply of fresh air as long as the men are at work.



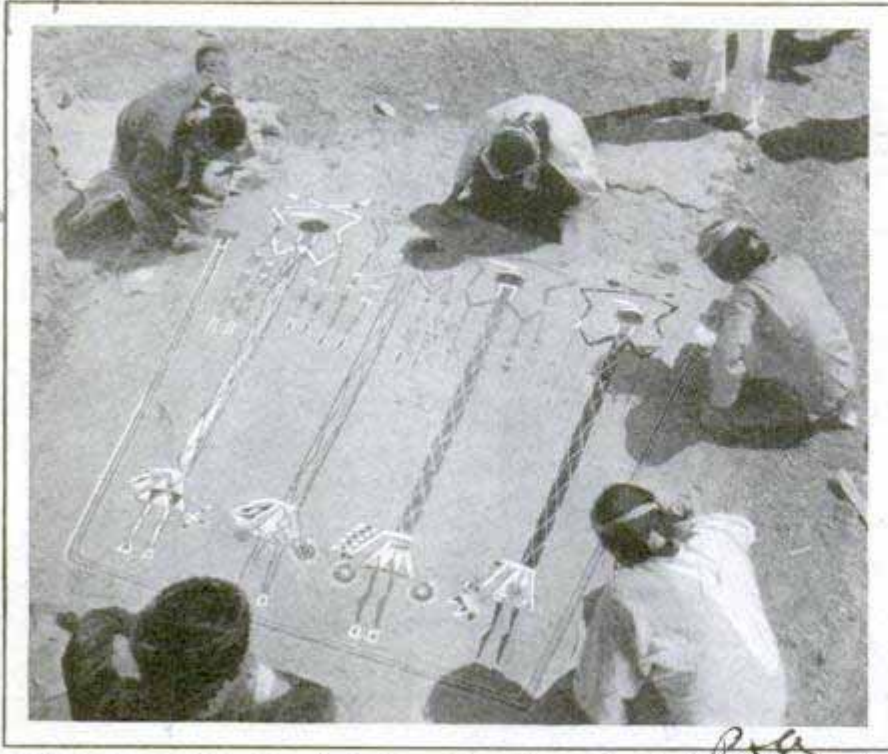
Ventilating Manhole with Pipe and Blower

Power Shovel Co. Nashville, Tenn.

Interstate Power Co. A. H. ...

1494

Chin Lee, Aug



Medicine Men of the Navajo Indians Executing a Mystic Sand Painting for Use in Their Religious Rites

INDIAN SAND PAINTING SHOWS DANCE OF FOUR SEASONS

Navajo medicine men recently demonstrated their skill at one of their oldest and strangest ceremonies, the preparation of mystic paintings on sand. Colored rocks and mineral ores are crushed to a fine powder and used as the "paint" to form the designs, which are traced on a smooth bed of light-colored sand. The figures in the accompanying photograph represent the four seasons, each dancer holding the "snakes of creation."

SUGAR FROM CORNSTALKS SEEN AS FUTURE FOOD

Sugar may be extracted from cornstalks or the waste wood of lumber camps and sawmills, according to Dr. Friedrich Bergius, famous German chemist, who recently visited the United States. He has developed a process in Germany for extracting glucose from waste wood to provide

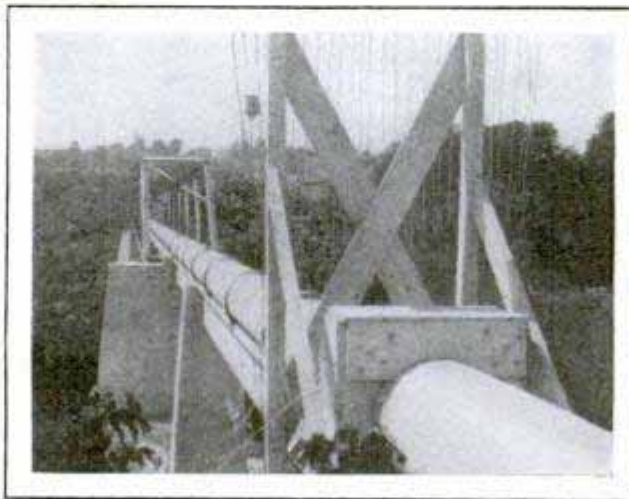
cattle food. With further refinement of the product, it may be made useful as a food for humans. Agriculture, he says, has only developed, over a period of thousands of years, comparatively few species which yield carbohydrates in suitable form for human or cattle food. Other forms of plant life, notably rich in this concentrated form of sun energy, provide food only for lower forms of life, including insects and microbes. As at least forty per cent of the material is wasted in producing lumber, a vast amount of possible food is sacrificed.

In this process, one hundred parts of wood, when treated with hydrochloric acid at a high temperature, yield seventy-five parts of glucose, and of the latter substance something like eighty parts are carbohydrates fit for human consumption.

CITY'S AERIAL SEWER LINE SUBSTITUTE FOR TUNNEL

Engineers at Sioux Falls, S. Dak., solved a problem in sewage disposal by building a concrete pipe line on a trestle instead of digging a tunnel under the river. The latter method would have been impossible because of the depth to which the bore would have had to be excavated. The

cement tubing is of special construction, two feet in diameter at upper end and increasing to forty-two inches toward the lower section, to accommodate the inflow from the laterals. Concrete piers and a suspension framework along the section that crosses the river, provide the means of support.



Aerial Sewer, Built of Concrete, Suspended across a River, Found Better Than Tunnel beneath Stream

Cont. George R. Harrison
218 W. 1st St. Philadelphia

Bulletin
Service
398
11/19/28

LATEST STUNTS THOUGHT UP BY CIRCUS CLOWNS



Some of Al Bruce's Most Effective Laugh Makers. Always Popular with Circus Crowds; the "Patent Cigar Lighter" Was Especially Effective

Thinking up new ideas for clown stunts is one of the important duties of producing experts who help give the circus its popularity, and one of the leaders in this profession is Al Bruce, with the Ringling Bros. and Barnum and Bailey combined shows. One of his most amusing devices this past season was the automatic cigar lighter, operated on the complicated principles of a cartoon and failing to light about as often as it was successful, thus arousing laughs from owners of pocket lighters who had experienced the same difficulty. Bruce also has arranged a vacuum cleaner to operate a set of Scotch bag

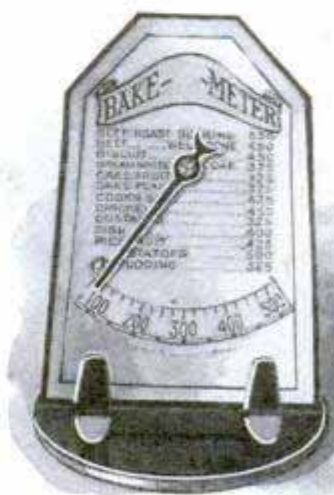
pipes and play music, while the weather joke is manifest in a set showing a clown seated on a stove while smoke pours from the stove pipe and steam issues from a tea kettle on the clown's head. "Will Summer Ever Come?" is the natural question this arrangement inspires. A school "persuader" consists of a large hand that paddles a boy as he walks along, thus inducing him to attend his classes. Many of the clown acts receive rehearsal at the circus' winter quarters at Sarasota, Fla., where new ideas are developed for the coming season, while the performers and animals make ready for another tour.

1374

To Save Work



Rotary Ironer Saves Time and Labor on Flat Work and Is Said to Leave a Sheen Superior to That Afforded by Hand Methods; Unit Occupies Little Space When Not in Use; Operator Remains Seated

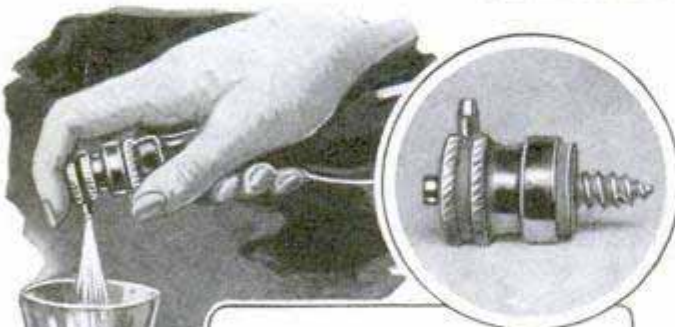


For Any Kind of Oven, This Meter Shows Right Temperature for Baking Different Kinds of Food; It Responds Quickly, Is Accurate and Portable; It Also Serves as a Check for Automatic Heat Controls, to Show if They Are Functioning



This Hand Hot-Pan Lifter Also Opens Jars and Bottles When Turned Upside Down

To Line the Garbage Bucket, Keeping It Clean, a Paper Bag Is Easily Lifted Out and May Be Discarded with the Rubbish

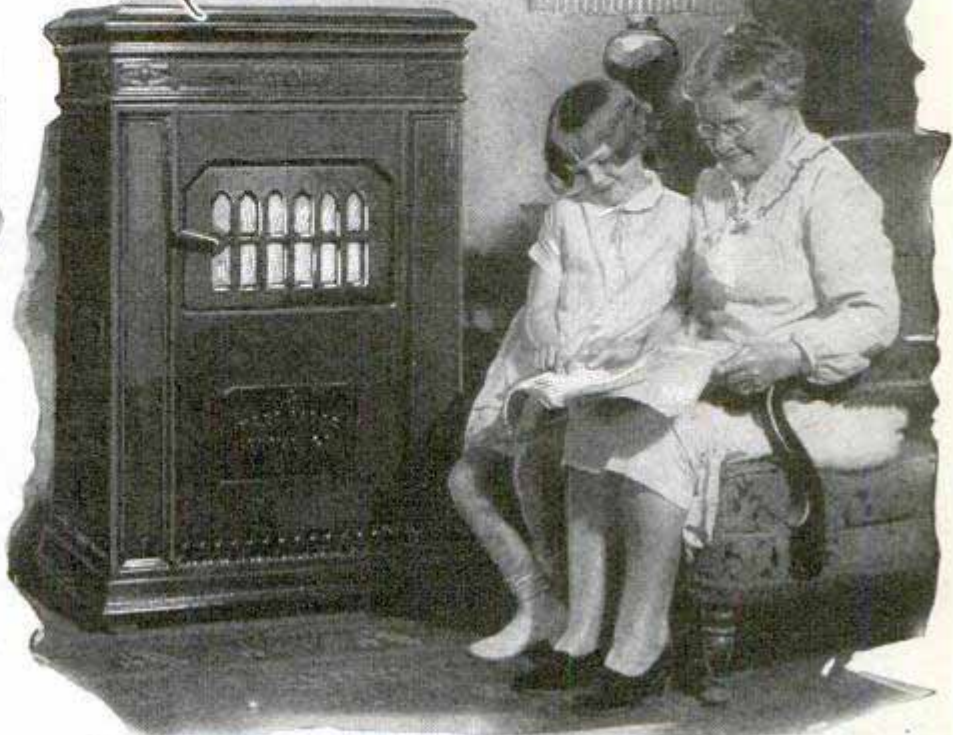


Fizz Top for Beverage Bottles Is Screwed through Cap and Operated by Simply Pressing a Button

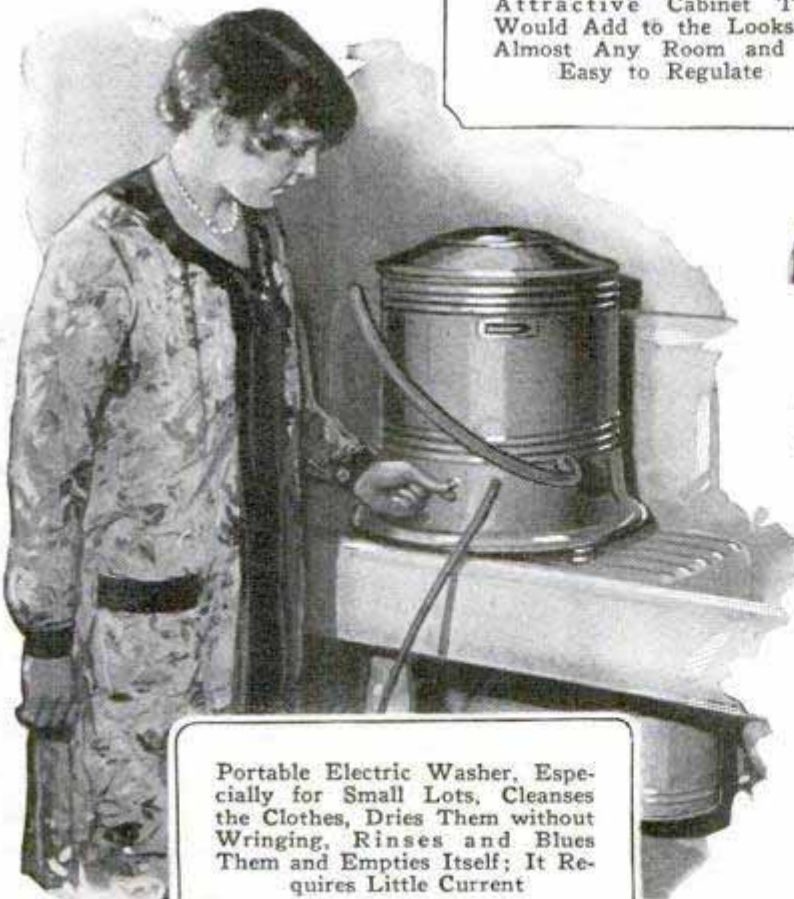
in Your Home



For Opening or Closing Bottles and Cans of Many Sizes; Simple Wrenchlike Tool Affords a Strong Grip, Is Easy to Operate and Requires No Adjustments; the Teeth Prevent Slipping and Notch on Side Takes Caps Off



Illustrating the Changes in Appearance of Stoves; This Heater Is Fashioned as an Attractive Cabinet That Would Add to the Looks of Almost Any Room and Is Easy to Regulate

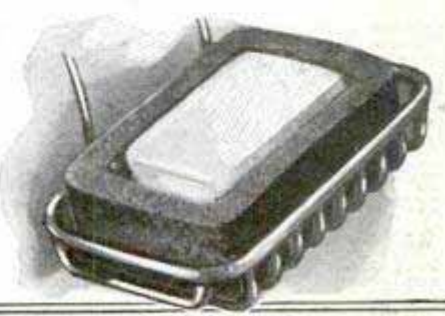


Portable Electric Washer, Especially for Small Lots, Cleanses the Clothes, Dries Them without Wringing, Rinses and Blues Them and Empties Itself; It Requires Little Current



Iron with Gasoline Heater Attached Is Quickly Warmed as No Preheating or Generating Is Necessary

To Keep the Soap Dish Clean and the Cake from Slipping Out; a Rubber Inset for the Holder



*all in a day's work
in a stroke*

1614



Plane About to Hook Bag from Cable between Poles Which Are Held by Men in Pick-Up Test

PLANE PICKS UP MAIL ON FLY BETWEEN TWO POLES

Snatching a mail bag with a grappling hook between two poles held by men, was the method successfully demonstrated at an eastern flying field to show how the air-mail service may be extended to places that have no airport facilities. The bag is dropped at its destination by parachute. During the tests, the hook did not once fail to catch the line to which the bag was attached, so that it could be hauled aboard the plane. The poles are of bamboo and are easily managed.

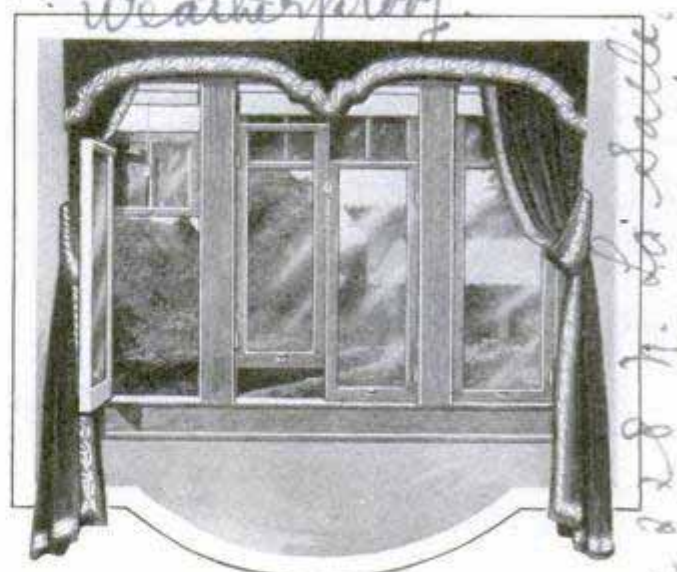
WAX COAT ON BOOK BINDINGS PROLONGS THEIR LIFE

By coating leather book bindings with wax, oils or grease of special kinds, the bureau of chemistry has helped to preserve some of the volumes in the congressional library. Impurities in the air, and the action of both natural and artificial

light and of gas fumes, have been found injurious to leathers. The backs of books, infrequently used and standing on exposed shelves, often are reduced to a state of powdery decay while the covers are but little damaged. Chemical analysis of this decayed leather has shown that it has a high degree of acidity, a high sulphate content and water-soluble nitrogen compounds. Part of this deterioration is believed to be due to the harmful sulphurous and acid impurities taken up in destructive quantities from a polluted atmosphere. Other [redacted] of the decay are [redacted] ods used in tanning [redacted] and injurious [redacted]

SLIDING SASH SWINGS IN TO AID CLEANING

Windows that slide up and down as do ordinary sash, but also swing inward on hinges so that the outside of the pane may be reached from the inside, have been introduced. They are designed to afford security against the weather, may be installed in old frames, and the transom sash across the top may be lowered to the bottom to form a protecting rail to guard children. The window can be held at various angles, when swung inward, by means of adjusters on the sill.



Sash at Left Swung Inward to Show How Pane May Be Washed from the Interior

1675

1412

New York Times 11/4/28

American Casement Window Hardware

*Weatherproof
J. S. H. Co. Sales*

OLD MOVIES FEATURE CIRCUSES TRAVELING IN FRANCE

Motion-picture films, long out of date, are shown in small and remote villages in France, at the "cine-circuses" as they are called, traveling shows that visit out-of-the-way places as the small street carnivals sometimes do in this country. The films are purchased for a small sum, and an outfit consisting, perhaps, of four wagons, hauled by a tractor and carrying its own electric generator, a small troupe of performing animals and a magician, will travel a wide circuit in a single season. A tent is pitched and a man is sent around with a drum to advertise the performance. An old phonograph is played with the reel. A recent show advertised a "new drama," which, however, proved to be taken about eighteen years ago.

1760

2-20-1917

1685

110 E 17 St. Los Angeles, Calif.

PORTABLE CUTTING MACHINE MAKES MANY DESIGNS

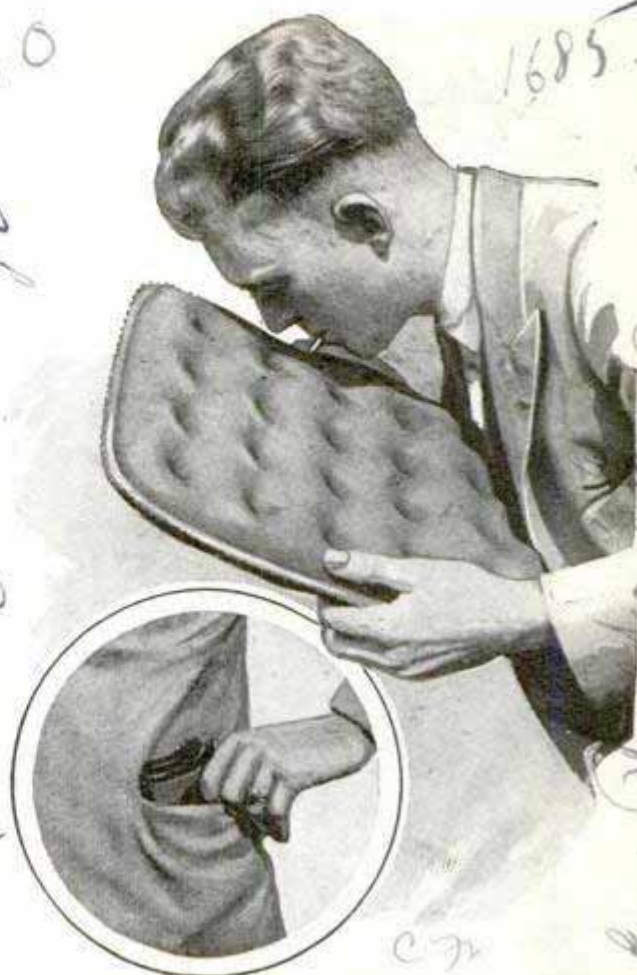
1705

An improved portable cutting machine to cut the intricate designs used by window decorators, model makers, and in similar work, has been developed. An older machine was swung from an extension arm and the work moved past under it, while the new one slides along the work so that it is possible to cut a design in a strip of wallboard or similar material of any length. It works something like a sewing machine. Instead of a needle, there is a small chisel, striking 2,000 blows a minute, which is mounted on a swivel so that, as the machine is



moved, the chisel turns and follows the pattern line. The length of the chisel stroke is adjustable for various thicknesses of work. The new model also is provided with tiny saw blades for work that is too hard or thick to be cut by a chisel. The machine is turned upside down and attached under a small metal saw table. As the saw blade swivels freely in any direction, it is possible to cut an intricate design without turning the work.

International Register Co. 15 E. Chicago



Inflating the Cushion, and Slipping It into Pocket; It Is a Valuable Aid to the Bleacher Fans

INFLATED PAD FOR HARD SEATS FITS IN POCKET

Hard seats at football or baseball games hold no terrors for the person equipped with a small pneumatic cushion now on the market. It can be blown up in a few seconds and, when deflated, fits in the coat or trousers pocket.

DRY-GAS SOLDERING TORCH NEEDS NO GENERATOR

1606

Schmidl \$23.50

Ready for quick service at all times, a gasoline torch now on the market burns dry gasoline gas, requiring no generating. It gives a clean, hot flame of different sizes suitable for soldering jobs of all kinds. The torch is operated on air-tank pressures of five to 200 pounds.



Miner - Cota Foundry & Mfg Co. 201-2nd St.

175

Easy Escape Tricks



With Hands Bound and a Rope Threaded between Them, It Is Still an Easy Matter to Escape by Pulling the Rope Down between the Wrists and Pushing It Over the Left Hand

By SAM BROWN

*151 Carhart St
Marion, Ohio*

HI, HO, ho, and a rope. Let's go! The performer's wrists are securely bound together with a large handkerchief, and a length of rope is looped over it, as shown. A spectator holds the ends of the rope. Looks as if the performer was hitched for life, doesn't it? But no; he turns his back for a moment, and—presto!—there stands our hero, wrists still bound, but entirely free from the rope.

And how does he do it? Simple! Tie yourself as illustrated, and loop the rope between your wrists. To free yourself is but a matter of pulling the rope down between your wrists and over either your right or left hand, as shown.

In the next one, the performer is bound to a chair, the rope running under the chair seat from one wrist to the other. A screen is placed around the performer.

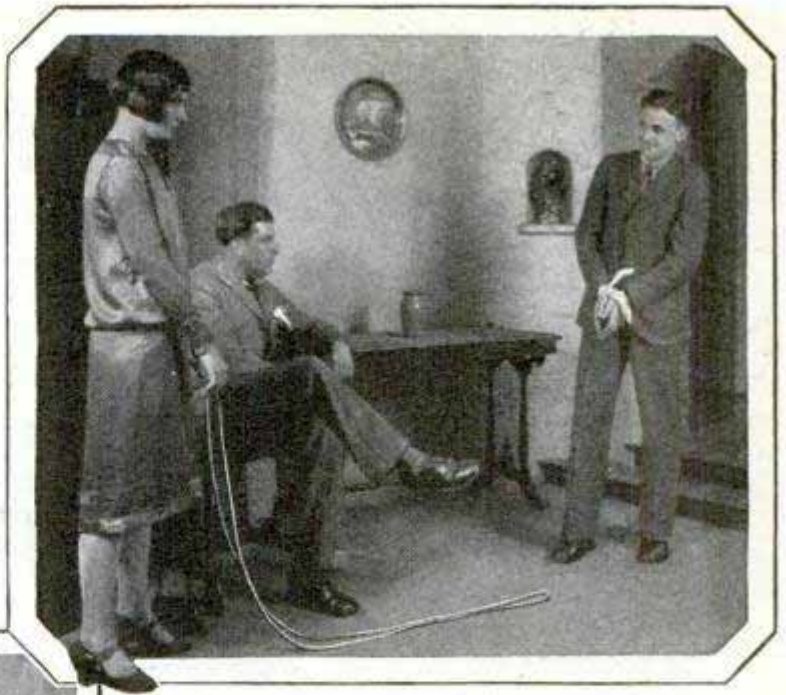
Well, you know what happens.

The secret of this tie depends on the fact that knots made with a free end around a tightly stretched rope can be nothing but slipknots. That's what happens when the performer's right wrist is tied, after the rope has been stretched under the chair seat from his left hand. To free himself, he bends over, as pictured, and with his left hand pulls the slipknot on his right wrist until he can free his hand. Simple, isn't it?

If you want comedy, try this one. But—and this is important—pick a good-natured man to work with.

The idea is to take off a man's vest without removing his coat. Like this: Unloosen the buttons on the vest, also the adjusting strap in back. Then reach down inside your victim's coat, and pull the vest

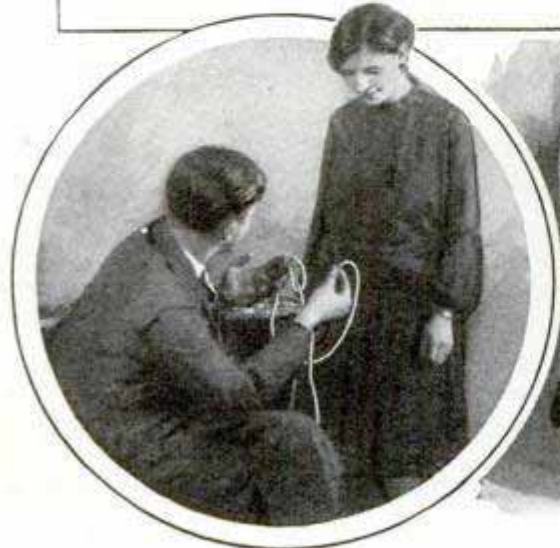
well up over his head as illustrated. Slip both shoulders out of the vest. Now, taking the vest in your left hand and inserting your right hand up the victim's sleeve, you pull the left sleeve of the vest (whatever that is) down until it can be slipped over his hand, as shown. That's the hardest part of the trick and it will take some experimenting until you can do it without an undue amount of "wear and tear." After that, it is a simple matter to push the vest around the victim's back, and remove it from his right coat sleeve. But pick your man.



Three Stages in the Chair Tie and Escape; and, Top, the End of the Handkerchief Tie, When the Rope Is Shed

This one is with a sack. The performer is placed in the sack, and the drawstring is tightly pulled and tied. A screen is placed around the performer. A moment later he appears, with the still tightly tied sack hanging over his arm.

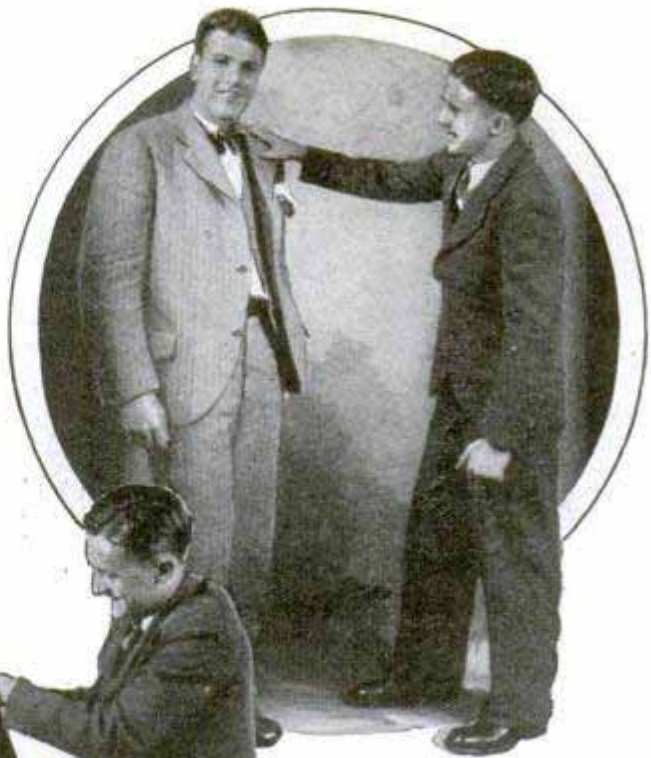
The hardest part about this trick is getting the sack. Usually you have to make your own. Make it plenty big, and sew a one-inch hem around the top, through



which you thread the drawstring. A small portion of the seam is left unsewn, so that you can easily get at the drawstring from the inside of the sack. And that's the whole secret. While you are standing, waist-deep, in the sack, you hook one finger onto the string through this small opening, and pull about a yard of it down into the bag. To release yourself, then, is simply a matter of letting go of the slack. The original knots are then untied and retied, while the added length of drawstring is cut from the end of the rope and stuffed into your pocket.

Another comedy effect: The performer's hands are tied behind his back. He then requests one of the spectators to tie his ankles together, and while this is being done, he calmly releases his hands, and, pointing to the knots around his ankles, gurgles, triumphantly, "Now, Helen, tie 'em tight!"

This tie is easy. The first stage is shown in the pictures. Notice that there is but a single knot on the right wrist, and that the hands hang straight down, and are uncrossed. When the spectator goes to make the final knots, the performer raises his hands high behind his back



and crosses them, as illustrated. And what have you? Nothing more nor less than a two-inch piece of slack, twisted up between your wrists. By returning your hands to the position shown, the left hand can be easily removed.

For the next one, the performer's wrists are securely bound with a piece of light cord, with about twelve inches of slack between them. A spectator hands the performer a ring. The performer turns his

back. When he turns around again, the ring is found securely tied onto the string, and it cannot be removed without untying the performer's wrists.

Oh, it's all very simple. When the performer turns his back, he threads the ring on the string as shown. He then pulls the loop up over his wrist as illustrated, and there you are—the ring is on the string, and the fair spectator just can't imagine how it ever got there.

For those who want something more complicated than rope escapes, handcuffs

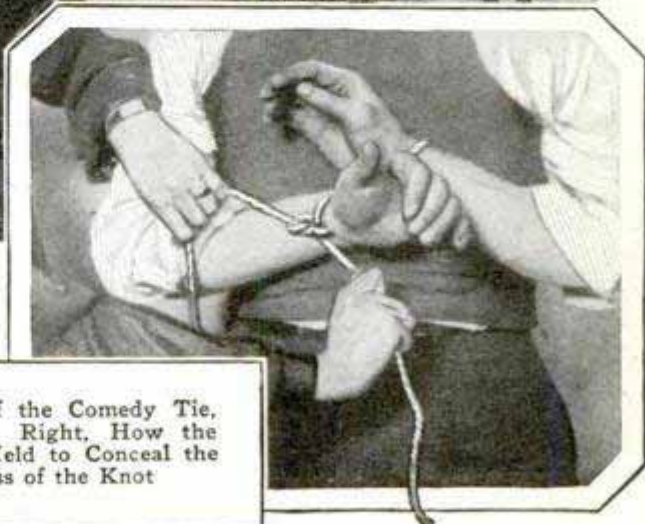
10/5



The Performer Is Tied in the Sack, at the Right, and a Few Seconds Later Steps Out with the Sack over His Arm, at Left

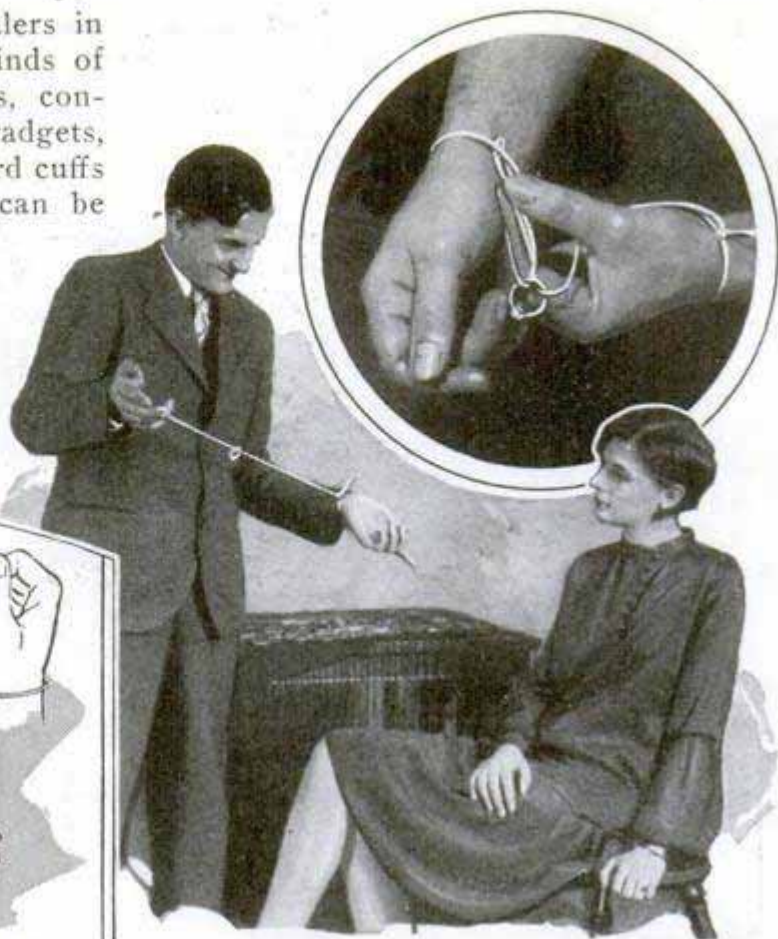
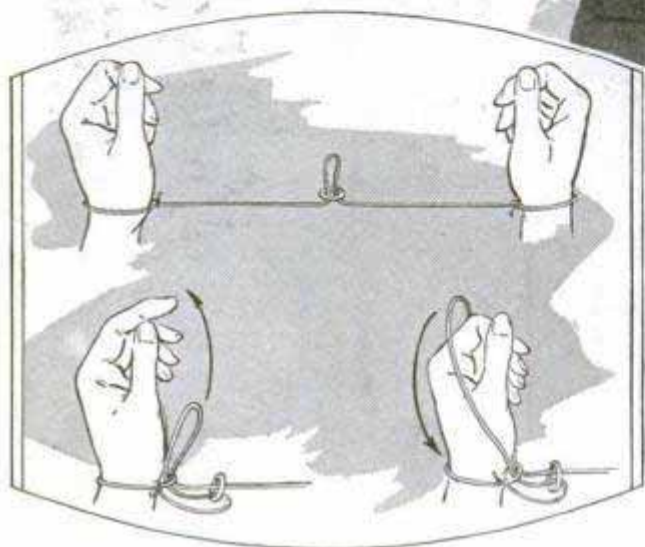


The Comedy Tie, Below, Is Always Good for a Laugh; After a Spectator Has Tied the Hands and Starts Tying the Feet, She (or He) Finds the Performer Using His Freed Hands to Point With



The Secret of the Comedy Tie, at Left, and, Right, How the Hands Are Held to Conceal the Looseness of the Knot

have always exerted a lure. Dealers in magicians' supplies sell various kinds of handcuffs, some with trick locks, concealed release buttons or other gadgets, and others which are simply standard cuffs made for police use, but which can be picked with ease, if you know how. One of the trick cuffs widely used by stage magicians has a clever lock which operates in certain sequences, locking perfectly for a certain number of times, and then releasing auto-



Slipping a Ring onto a Cord, Tied between the Hands, and Knotting It There So Securely It Can Only Be Removed, Apparently, by First Untying the Cord

matically. The usual arrangement is to exhibit the handcuff, unlock it, lock it again, pass it to the audience, which finds the lock secure, then unlock and place it on the wrists. The last operation brings the hidden release into action and the cuff can be removed instantly by pressing a button.

Stage performers who use strange handcuffs have to be lock experts, and also well equipped both with keys and lock picks. There is one make of handcuff used by many police departments which is easily picked with a piece of watch spring. The cuff belongs to the type in which one bar, with a series of teeth, passes through the other, so that an effort toward moving it only causes the handcuff to become tighter on the wrists. However, with a small piece of watch spring filed down very thin, it is possible to escape by simply slipping the pick between the lock and the bar, lifting the latch and holding it up while the bar is slid out. With such a pick, which can be concealed between the fingers or about the

clothing, the handcuffs can be removed, with the hands behind the back, in less than thirty seconds.

WICK CLEANER FOR OIL STOVES GIVES BETTER FLAME

Oil stoves cook more efficiently when the wicks are in good condition, and to keep them so, a cleaner has been devised that scrapes off the charred part through three slots, the flanges of which serve as blades. With this cleaner, the wicks can be trimmed so that they will have either a sloping or a chisel edge to give the most effective flame.



Oil of the Japanese peppermint is one of the sources of menthol.

Chicago. 323 Park St.
Perfection Stove Co
119 E. Platt Ave.

**ELECTRIC CHIMES
RUNG THRICE
A SECOND**

By means of an improved electric installation for ringing chimes, blows may be repeated on the same bell at the rate of three times per second, the manufacturers declare. This has been made possible by a system of magnets. The playing is done on a keyboard, which can be installed at any convenient place, and the control wiring is usually connected to the lighting circuit. It operates at low voltage. An installation at Dartmouth college has, in addition to the keyboard, a machine like a player piano which automatically rings long changes of the bells when released by the tower clock.



Ripping Brush from the Deserts with Tractor Armed with Knives That Cut Growth Close to Roots

**TRACTOR ARMED WITH CUTTER
HELPS RECLAIM DESERT**

Sagebrush and greasewood are cut and torn from the soil by a tractor used in reclamation work in the southwest and other sections. It is fitted with a deep-set knife blade that separates the growth at the roots. The tractor illustrated here is being used to clear 18,000 acres in a desert.

**RAZOR BLADES SERVE AS KNIFE
IN HOLDER FOR ALL SIZES**

What to do with your old safety-razor blades is no longer a perplexing problem since the introduction of a holder that makes an efficient knife and scraper out of them and that takes blades of any make. It is essentially like a pocketknife, is flat for convenient carrying in the vest pocket, the blades are easily inserted or taken out, and the holder locks when closed or open, thus preventing the blade from slipping or tearing the pocket. The case is shaped to form a good gripping handle. The cutter has wide application for clipping newspapers, cutting threads and seams, for scraping paint off windows and for practically all purposes where a strong, sharp knife is needed.



Opening Razor-Blade Holder, and Blade Samples

**LIGHTED PLANES AS BIRD LURE
LATEST AVIATION PERIL**

Flying lighted airplanes at night has met with a hazard from an unexpected quarter. Not long ago, several army planes, flying in formation over Washington and with searchlights turned on, encountered flocks of birds, lured by the lights. One of the birds collided with a wheel, and the aviators spent a few anxious moments as their planes passed through several flocks. Had one struck against a propeller, serious consequences might have followed.

Steel & Securities Mfg Co

35

Education Co

525 Bridge Bldg

Kansas City, Mo

Washington D.C.

Copy of magazine 7/18/29



Three-Octave Piano, Which Never Needs Tuning, Aids in Music Lessons When Instruments Are Impractical

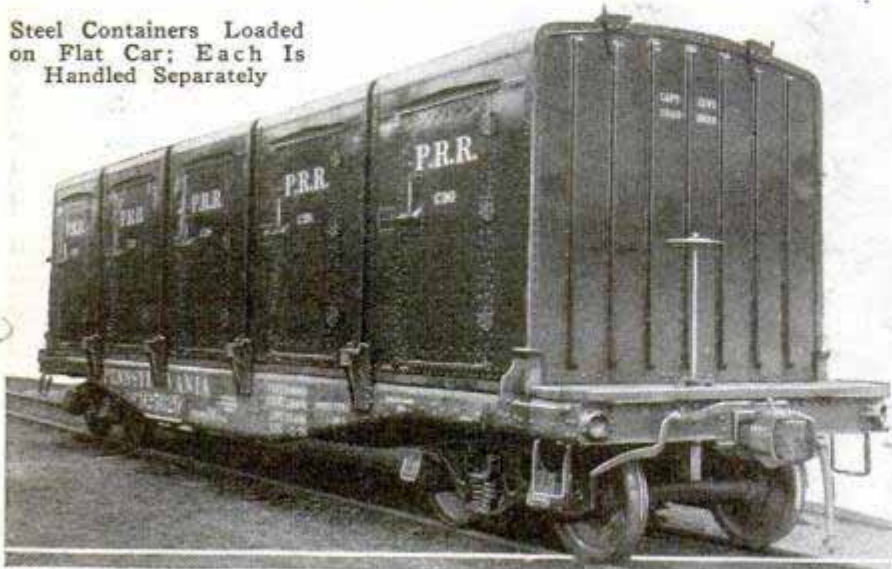
TINY PIANO WITH FEW OCTAVES AIDS MUSIC BEGINNERS

To help teach small children, a tiny piano with but three and one-half octaves, has been introduced. It is considered an improvement over charts and other devices of the kind, as it has the true piano action, aiding in the development of touch, and produces tones like those of a full-sized instrument. The small piano never needs tuning.

STEEL-CONTAINER FREIGHT CAR SERVES SMALL SHIPPER

For less than carload lots, portable steel containers of a carrying capacity of five tons each, which can be moved directly from the freight car to an automobile truck, have been introduced. They sim-

Steel Containers Loaded on Flat Car; Each Is Handled Separately



P. R. Ry. Co.

plify the task of delivering goods to the consumer from the terminal, eliminate extra handling and have also made lower rates possible, as the railroad company does not have the responsibility of loading and unloading the goods. For patrons who desire the service, a car-loading and distributing company collects articles, places them in the containers and then loads the big steel holders on the railroad flat cars.

SHEEP DIP KEEPS DEER AWAY TO PROTECT ORCHARDS

To keep deer from eating the foliage of fruit trees in certain parts of the west where the animals are protected by the game laws, growers are hanging a small piece of woolen cloth saturated with sheep dip on each tree. The odor is unpleasant to the deer and keeps them away. One soaking is sufficient for about six weeks. The method is said to be as effective as spraying and is less expensive.

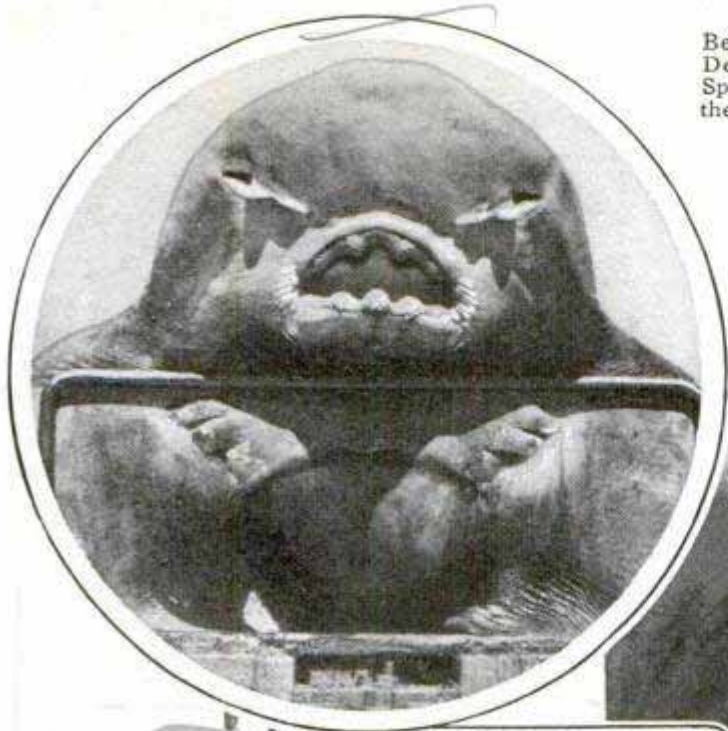
RADIO "ECHOES" LOCATE SHIPS AT NIGHT OR IN FOGS

Methods of locating a ship's position by means of automatic radio signals have reached a high degree of dependability, according to Col. E. Lester Jones, director of the United States coast and geodetic survey. A sound is produced which travels from the ship through the water to two or more stations which automatically send wireless signals back to the vessel as soon as the sound arrives. This gives a measure of the distance of the ship from each station. Knowing the location of the two stations from previous surveying, the three sides of a triangle are known from which the ship's position can easily be computed. The method is essentially like that employed in making depth soundings by sending a sound wave to the bottom of the ocean and observing the time required for the echo to be reflected back and registered on the vessel.

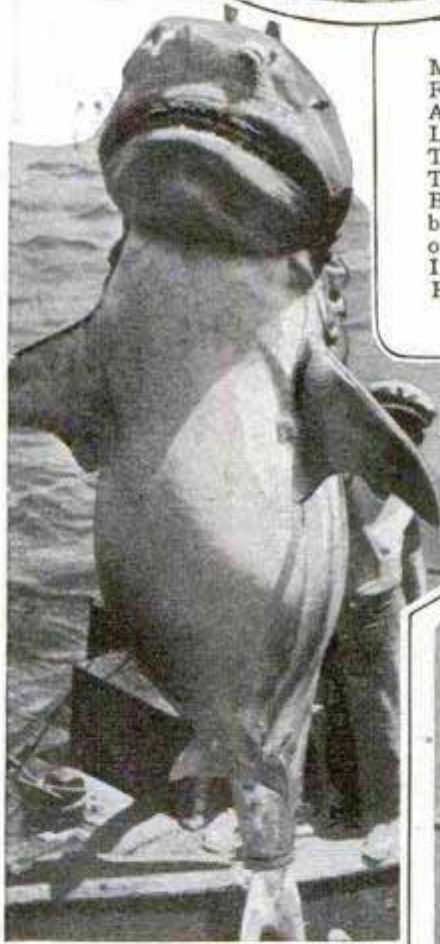
off Northwest Australia

STRANGE FACES TO BE FOUND ONLY IN DEEP SEAS

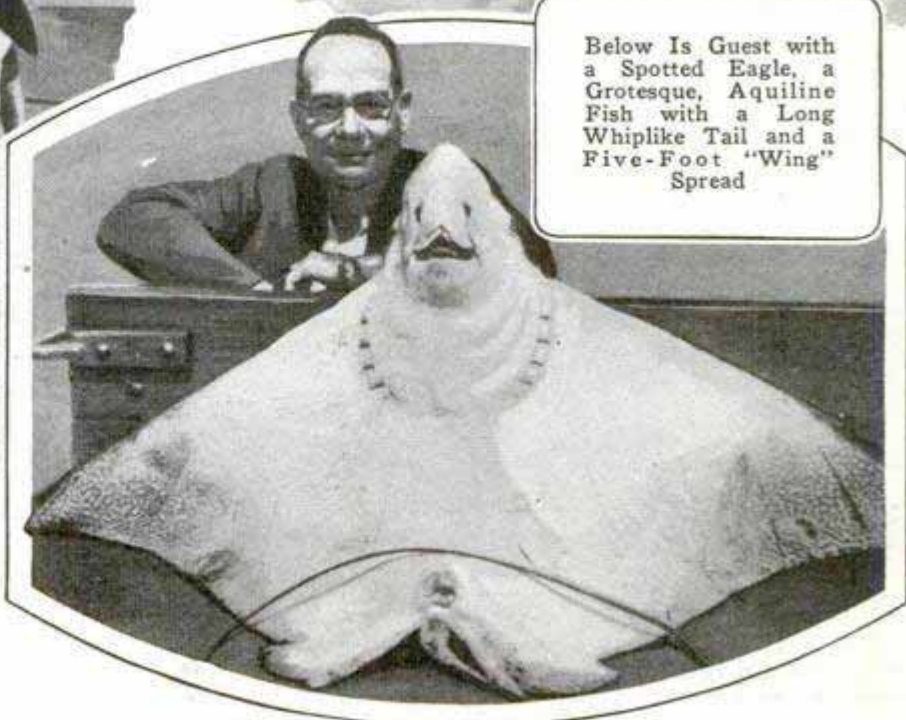
Below Is the Head and Peculiar Armored Back of a Devilfish, Caught by L. Haden Guest, a London Sportsman, While Collecting Deep-Sea Specimens in the Teeming Waters off the South Sea Island Continent



Meet the Devilfish Face to Face, as It Appeared When Loaded on a Hand Truck Ashore; the Two-Ton Monster Bears a Close Resemblance to Old Statues of the God Moloch; It Came from Waters Full of Queer and Ugly Creatures



Below Is Guest with a Spotted Eagle, a Grotesque, Aquiline Fish with a Long Whiplike Tail and a Five-Foot "Wing" Spread

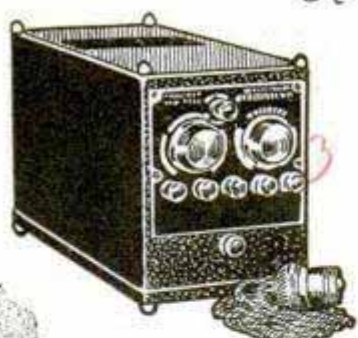


Above Is a Tiger Shark, One of the Larger Species of Deep-Sea Man-Eaters, Which Sometimes Attains a Length of Twenty-Five Feet in the Waters of the Coral Barrier Reef

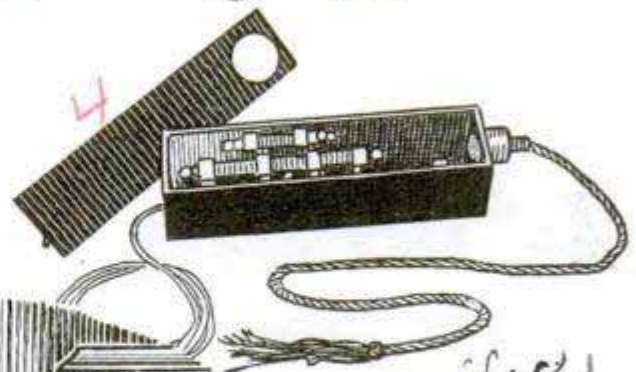
*507 E Pearl
Cincinnati Ohio*

*Super Radios
Laboratories, Inc.
3109 W. Montrose
Chicago*

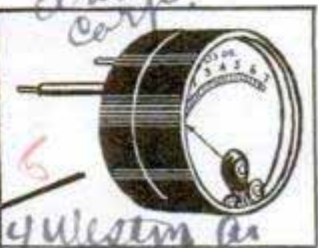
New Things Seen



Left, New A. C. Power Pack Makes Possible A. C. Operation of D. C. Sets without Changing the Set Wiring or Tubes; No Harness or Adapters Are Required; Right, a Power Supply and Converter for A. C. Tubes of the Arcturus Type



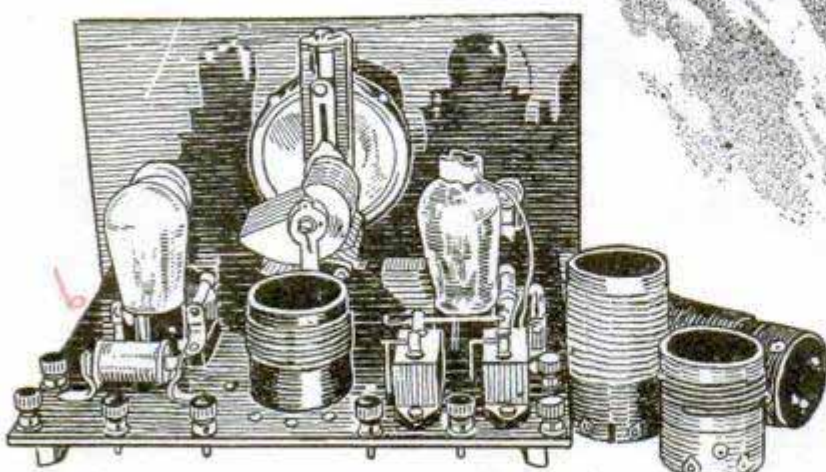
Above, Attractive Thirteenth-Century Shield, Fitted with Bronze Sword and Battleaxes, Conceals an Efficient Cone-Type Speaker Making a Useful as Well as Novel Decoration



Above, Pin-Jack Voltmeter, Designed for Standard A-Eliminator Units, When Equipped with Suitable Jacks Makes Possible Voltage Regulation for Maximum Tube Life; Below, Art-Moderne Radio Installation to Harmonize with the New Popular Style of Furniture



New Tuning Control Is Designed to Automatically Tune in the Station When the Correct Wavelength Number Is Turned Up in the Slot



A Simple Short-Wave Receiver Now Available in Kit Form for Long-Distance Broadcast Reception and Experimental Television Signals; Easily Assembled from Standard Parts, This Receiver Employs a Screen-Grid Tube and Specially Designed Plug-In Coils



*National Radio & Electric Co. Inc.
Chicago, Ill.
Walden, Mass.*

*Arborphone the
Consolidated Radio
Corp. and Arbor*

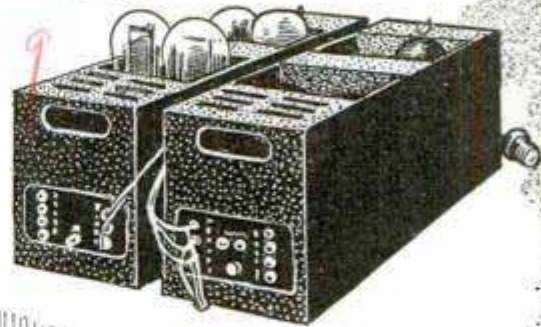
*Near 8 av r Co,
4612 Woodward Ave
Electron Tech
Radio Corp
106 7th Ave
New York*

Along Radio Row

*Tur
1-
Co
Jr
2
A.
50
Po
at
4
Pi
Ne
5
Sh
6
Ca
Ra
7*



Left, an A and B-Eliminator Which Supplies All Required Voltages from D. C. Supply Lines, Ranging from 110 to 250 Volts, and Is Suitable for Sets Employing from 1 to 14 Tubes; Right, a Powerful Three-Stage Push-Pull Audio Amplifier, for Radio Set, Phonograph Reproducer or Microphone, Employs the New 250-Type Power Tubes



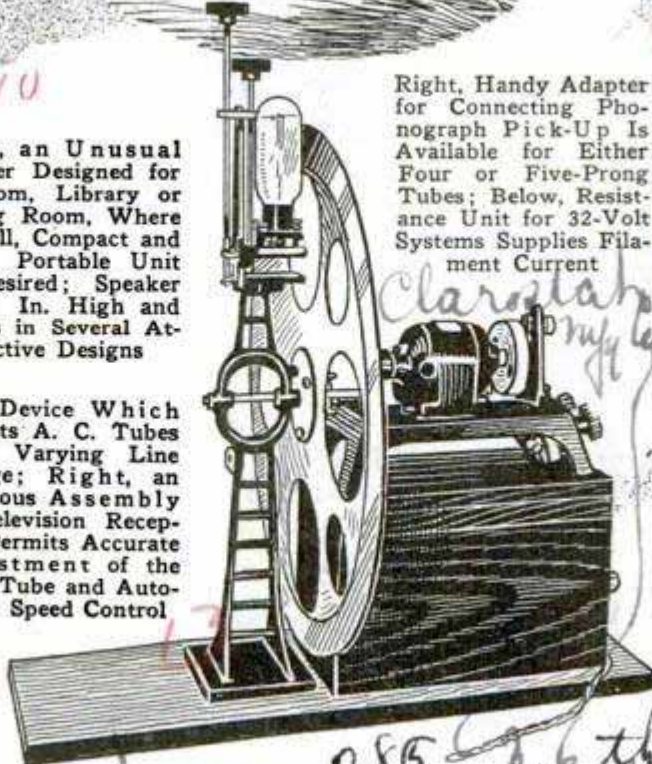
*Similar
to
18
41
type*



Above, an Unusual Speaker Designed for Bedroom, Library or Dining Room, Where a Small, Compact and Easily Portable Unit Is Desired; Speaker Is 5 1/2 In. High and Comes in Several Attractive Designs



Left, Device Which Protects A. C. Tubes from Varying Line Voltage; Right, an Ingenious Assembly for Television Reception Permits Accurate Adjustment of the Neon Tube and Automatic Speed Control



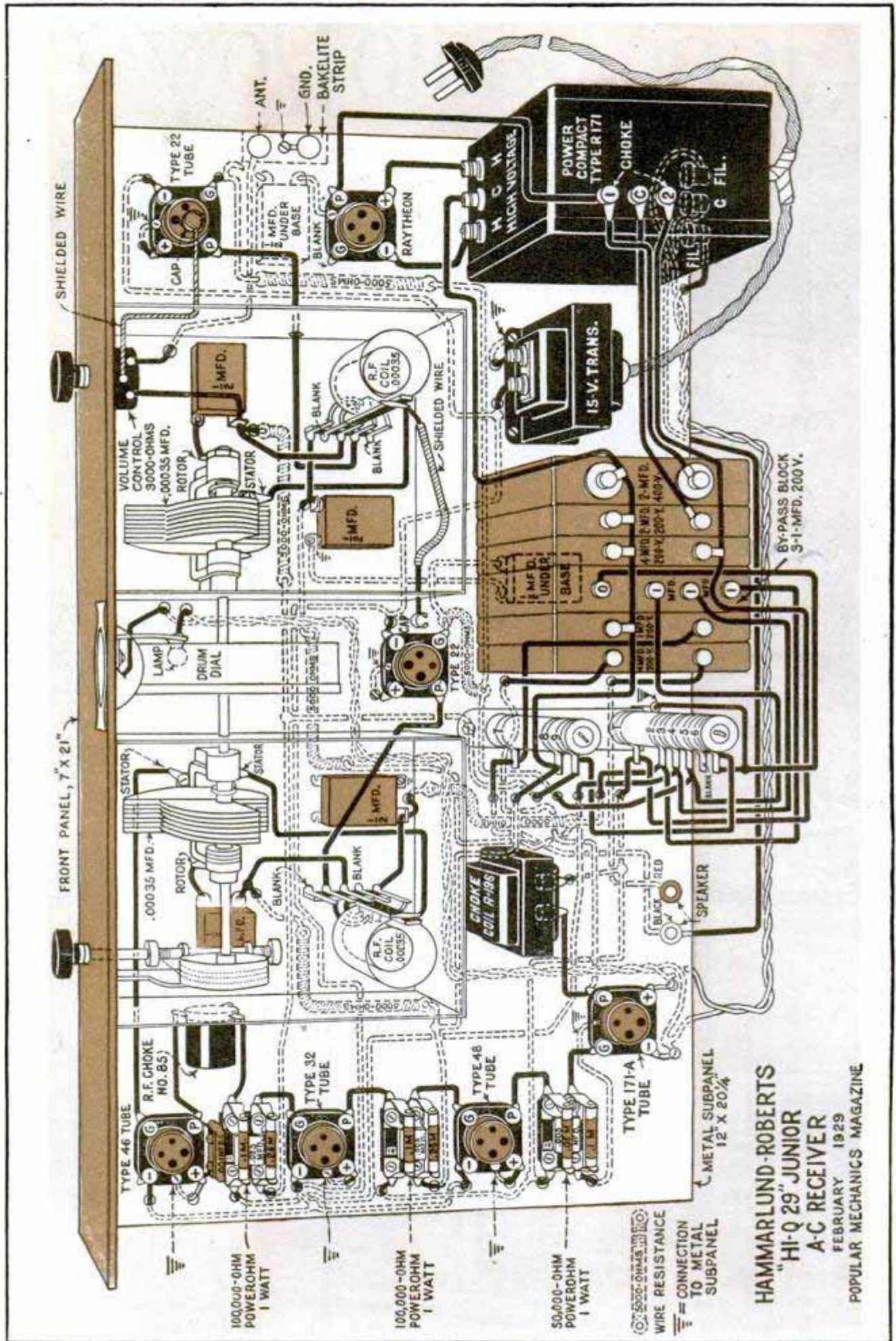
Right, Handy Adapter for Connecting Phonograph Pick-Up Is Available for Either Four or Five-Prong Tubes; Below, Resistance Unit for 32-Volt Systems Supplies Filament Current



*The Parson's Elec Co
91-7 4th Ave New York*

*Clarostat
Amplite Elec
Co.
Farl
Wayne
Ind*

*Ward Leonard
Electric Co
285 1.6th
Brooklyn
N.Y.*



HAMMARLUND-ROBERTS
"HI-Q 29" JUNIOR
A-C RECEIVER
 FEBRUARY 1929
 POPULAR MECHANICS MAGAZINE

The New **HAMMARLUND-ROBERTS A-C RECEIVER**



DESIGNED especially for those who wish a complete a.c. receiver of the latest type at a moderate price, the new Hammarlund-Roberts Hi-Q-29 Junior a.c. model described and illustrated in this article will please the most exacting set builder. It is a true single-control six-tube set employing a screen-grid antenna-coupling tube, a screen-grid tuned r.f. stage, a detector and three stages of high-quality audio amplification. The A, B and C-power apparatus is mounted directly on the steel chassis, making the receiver an entirely self-contained unit ready to plug into the light socket. The a.c. tubes used are of the Arcturus type.

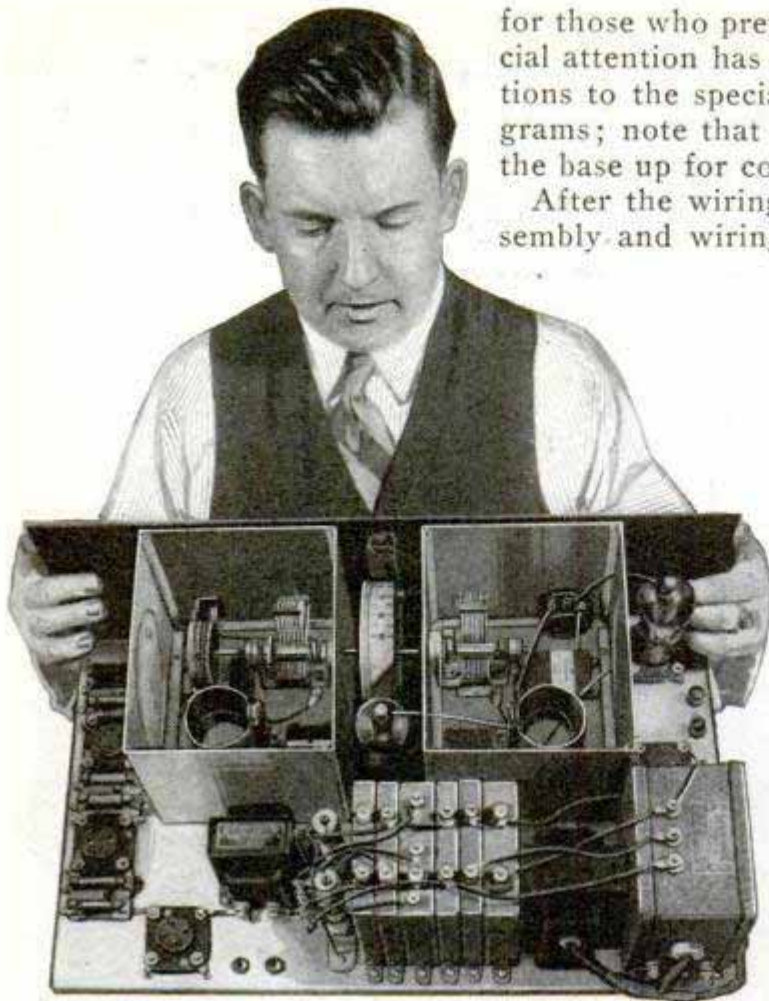
The screen-grid coupling tube is used to isolate the antenna from the first tuned circuit, making possible efficient simultaneous control of both the detector and tuned r.f. stages, without necessitating any separate means of compensating for different types of antennas. The coils used in the r.f. amplifier employ primaries especially designed for screen-grid use, being small in diameter and consisting of a large number of turns of very fine wire.

This design tends to equalize the amplification over the broadcast range.

The shielding of the screen-grid tubes has been handled in an unusual manner, the tubes being placed between the stage shields in such position that the control-grid and plate leads are very short. In ordinary practice, the tubes are placed within the stage shields and seldom properly shielded from the coils and tuning condensers.

Control of volume is accomplished by the use of a 3,000-ohm specially tapered potentiometer, connected between antenna and ground. The slider of this instrument is connected to the grid of the antenna-coupling tube, thus permitting any desired part of the signal voltage to be impressed on the grid, and resulting in a smooth, continuous control of volume.

The circuit employed is not new, as the basic principles involved in its design are well-known and have been proved sound in practice. The claim to superiority lies in the fact that all the details have been carefully worked out with a view to securing the utmost efficiency, at the same time



for those who prefer it to the simplified form, and special attention has been given to clarifying the connections to the special Hi-Q-29 resistor unit in both diagrams; note that the posts have been numbered from the base up for convenience.

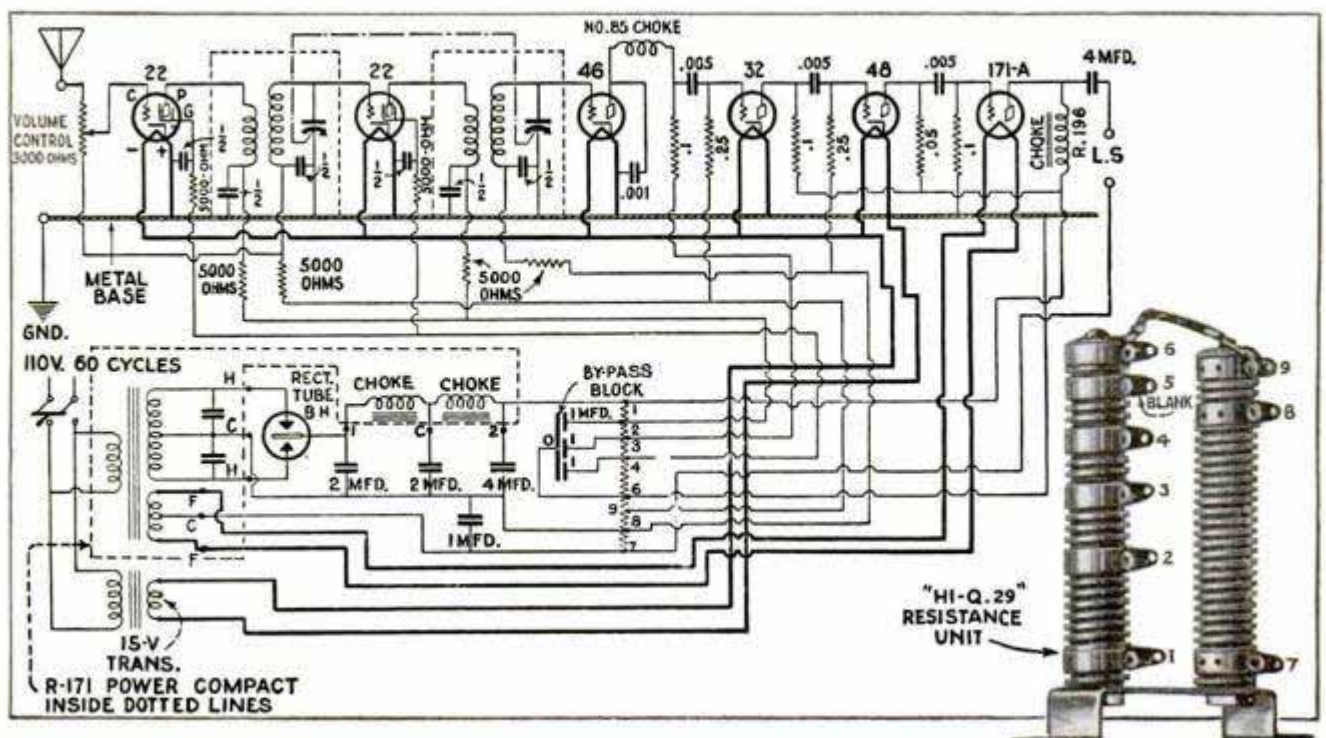
After the wiring has been completed, check the assembly and wiring carefully.

To test the power supply, a good voltmeter of the 1,000-ohm-per-volt B-eliminator type, reading up to 200 or 250 volts, must be employed. It should be of the double-reading type, unless a low-reading meter is also available, such as an 0 to 7 or 0 to 10-volt type. Place the Raytheon rectifier tube in its socket, leaving the other tubes out for the time being. The power end of the set may be checked as follows: Place the six resistors in the audio stages in their clips as shown in the diagram. Connect the negative terminal of the 250-volt meter to the chassis at any convenient point and turn on the 110-volt 60-cycle a.c. supply. Upon touching the P-terminal of the 171-A tube socket, a reading of over 200 volts

taking full advantage of the desirable characteristics of the screen-grid tubes.

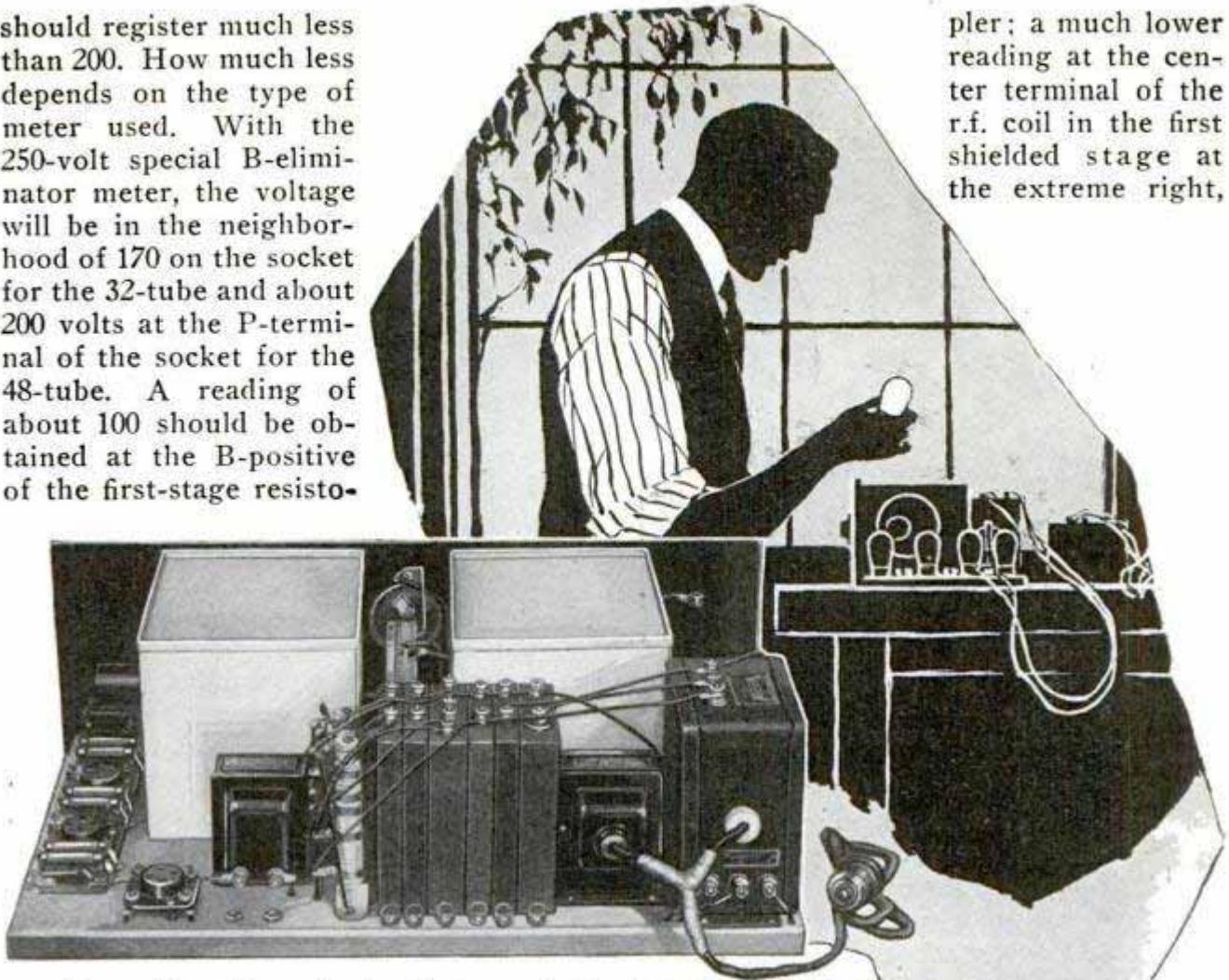
The parts are all standard and readily available in kit form, and the assembly is simple, as shown in the various illustrations. The schematic diagram is given

should be obtained. The same reading should also be obtained upon touching the B-positive terminals of the second and third resisto-couplers. The P-terminals of the sockets for the 32 and 48-type tubes may now be touched, and the voltmeter



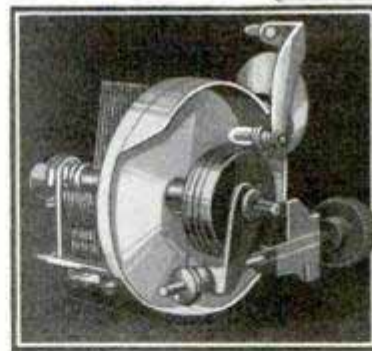
should register much less than 200. How much less depends on the type of meter used. With the 250-volt special B-eliminator meter, the voltage will be in the neighborhood of 170 on the socket for the 32-tube and about 200 volts at the P-terminal of the socket for the 48-tube. A reading of about 100 should be obtained at the B-positive of the first-stage resisto-

pler; a much lower reading at the center terminal of the r.f. coil in the first shielded stage at the extreme right,



coupler. The P-terminal of the socket, for the 46-tube, should show about 70 volts. The P-terminals of the screen-grid-tube sockets should show about 135 volts, and the G-terminals of the same sockets should show about 45 volts. These readings must be taken with a high-resistance voltmeter especially designed for use with B-eliminators.

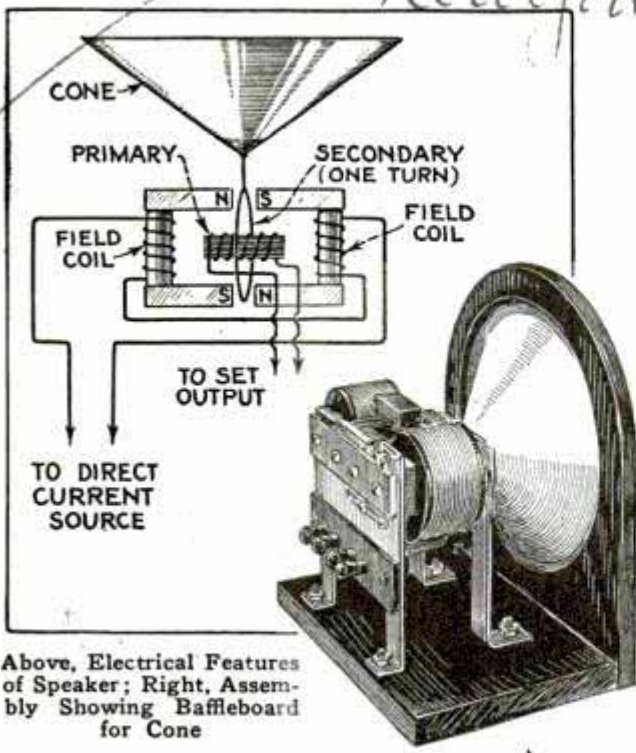
If these tests are satisfactory, it is a good indication that the B-circuit wiring of the receiver and B-power supply are correct. If no voltage, or insufficient voltage, is indicated at any point, test back along the faulty circuit until the trouble is located. Check the C-voltages by connecting the positive terminal of the low-reading voltmeter to the chassis. When the negative terminal of the meter is touched to the F-terminal of the resisto-coupler in the second a.f. stage, you should obtain a reading of about $4\frac{1}{2}$ volts. A much lower reading should be obtained at the center terminal of the r.f. coil in the shielded stage at the right. A reading of about 1 volt should be obtained at the F-terminal of the first-stage resisto-cou-



and the same reading at the left-hand terminal of the volume control. The above instructions apply when the operator faces the set from the rear.

Now place all the tubes in their sockets, and connect the aerial and ground. The aerial should be about 75 ft. long, including the lead-in wire, for average conditions.

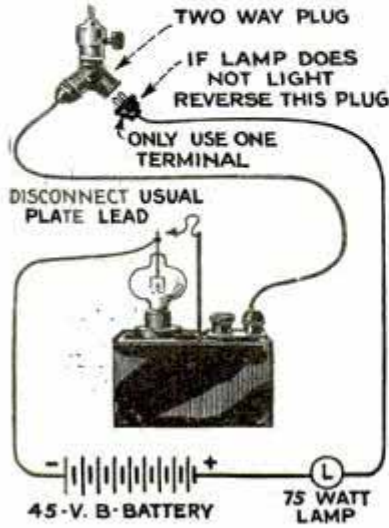
A large blueprint of the special simplified wiring diagram may be obtained from Popular Mechanics Magazine radio department, 200 East Ontario St., Chicago, for 15 cents to cover cost and packing. A copy of the material list will be mailed free to any address upon request.



A Simplified Dynamic Speaker

A dynamic speaker of unusually simple design has recently been put on the market. It differs from the usual dynamic speaker in that the moving or "voice coil," which consists of a single turn, acts also as the secondary winding of the output or impedance-matching transformer. Thus the entire circuit between the transformer and speaker is one turn, consisting of a metal ring supported by flexible springs and fastened to the cone apex. The combining of the moving coil and the secondary into one unit is said to provide great mechanical simplicity and, at the same time, improved electrical efficiency.

Charging Wet B-Batteries

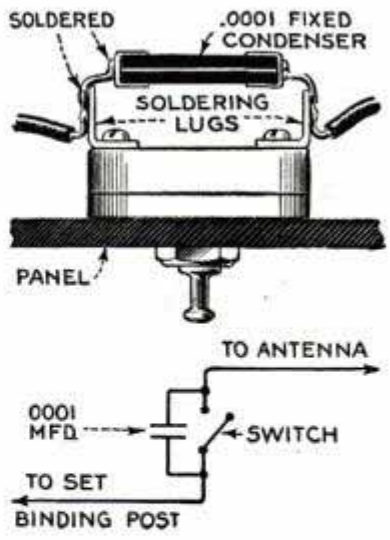


Wet B-batteries may be safely charged with the old-type standard 2-amp. tungar charger, if connected as shown in the sketch. Disconnect the plate lead from the terminal at the top of the

tungar bulb and run a flexible lead from this terminal to the negative terminal on the B-battery. The positive terminal of the battery is then connected to one side of an ordinary procelain lamp socket, and from the other side of this socket a lead is taken to one side of a socket plug, as shown. Place a 75-watt lamp in the socket, and the battery is ready for charging. Use a two-way socket plug at the lighting fixture, and plug the 110-volt supply to the charger in one side. The other plug connection, carrying the single wire, is then plugged into the other outlet. If the 75-watt lamp does not light, reverse this plug. If more than one B-battery is to be charged, connect them in parallel.

Switch for Short and Long Antenna

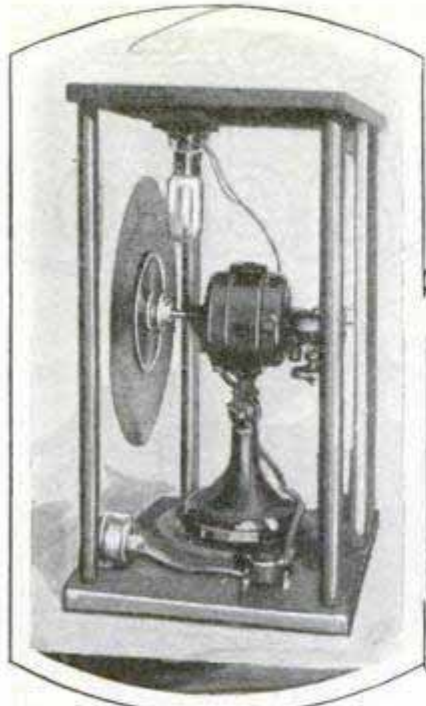
A simple means of obtaining the equivalent of a short and long antenna by means of a fixed condenser and switching device is shown in the sketch. In order to increase the selectivity of a standard set, a short antenna is usually recommended. As it is not always convenient or possible, however, to have two antennas, a fixed condenser is placed in series with the long antenna to secure the short antenna effect. Since it is desirable to have the advantage of a long antenna at times, the condenser may be shunted out by means of the filament switch. The same idea can be applied wherever a fixed condenser is temporarily required for testing purposes or for shunting across transformer or speaker windings to improve tone and pitch.—



Popular Mechanics' radio department offers its information service free to all readers of our magazine. We will be glad to help you with your problems, and will promptly answer all inquiries.

2044-2 International Newsreel

Television Receiver Run by Fan Motor



Left, Homemade Television Receiver Showing Fan Motor in Position; Right, Front View of the Apparatus Showing Radio Receiver and Loud Speaker Mounted Above



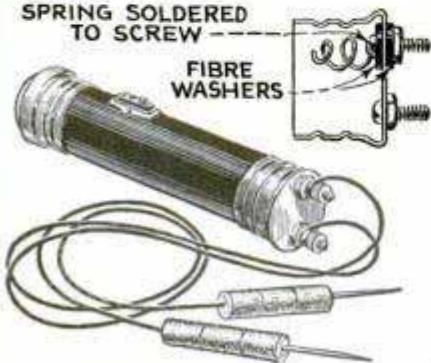
An ordinary fan motor supplies the power for revolving the television disk in the homemade receiver shown in the photos. The fan motor is already equipped with a suitable stand high enough for disks of the 24-aperture type; if larger disks are to be used, the stand will, of course, have to be placed on a shelf to obtain the necessary height for centering the disk. Two boards, cut from $\frac{7}{8}$ -in. material, are used for the top and bottom of the supporting frame. The length of the uprights, which may be made of wood or gas pipe, depends on the size of the disk. If of wood, each should be braced by means of angle irons at top and bottom. Gas pipe, cut down to proper lengths and threaded by the local plumber, can be obtained at small cost and, when screwed into deck sockets which are in turn screwed to the top and bottom boards, will make a sturdy framework that will support the ordinary broadcast receiver. Paint the framework a dull black and mount the motor and neon tube as shown, an ordinary X-type tube socket for the neon tube being screwed to the underside of the top board behind the upper edge of the disk. Mount the socket so that the plate of the tube is directly behind the perfora-

tions in the disk. A variable resistance with a suitable push-button shunting device, such as the Clarostat television-motor control unit, is connected in series with one side of the 110-volt supply line to the motor. The television disk may be homemade, but as this is difficult, the builder had better purchase one of the standard disks now available. The radio receiver for picking up and amplifying the television signals may be any of the standard short-wave or broadcast types employing two stages of a.f. amplification, but the resistance-coupled type is preferred for television reception. A d.t.d.p. switch is used to throw the output of the receiving set from the loud speaker to the neon tube for picture reception. If the receiver is of the standard broadcast type and the television signals are transmitted on short waves, a short-wave adapter may be employed. A suitable adapter was described in the March, 1928, issue. This number, as well as a blueprint of the layout and wiring diagram are available from Popular Mechanics radio department, at 25 cents each.

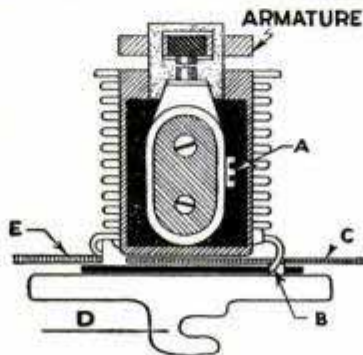
Hints and Radio



SPRING SOLDERED TO SCREW



Circuit Tester; Insulate Spring Post; Lamp Lights When Circuit Is Completed; Posts Shorted Restore Lamp

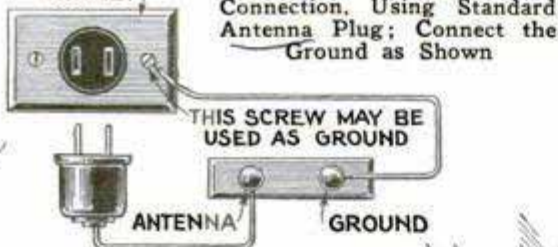


Automatic B-Eliminator Switch Made from Ford Cut-Out; It Is Mounted on a Bakelite Base; See Page 309 for Details



Ship and Moon Cut-Out on Loud Speaker Illuminated by Bulbs at Back, Lit by Bell-Ringing Transformer; Parchment Covers Holes

CONVENIENCE OUTLET



Combined Aerial and Ground Connection, Using Standard Antenna Plug; Connect the Ground as Shown

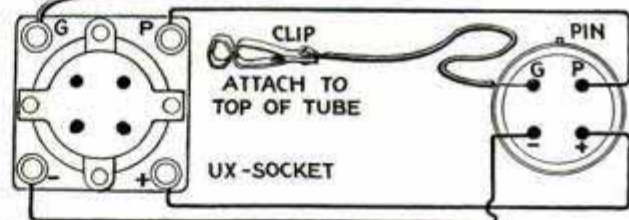
THIS SCREW MAY BE USED AS GROUND

ANTENNA GROUND

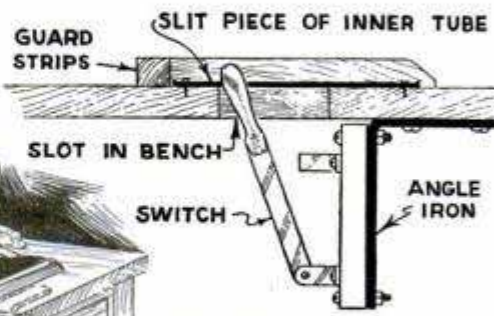
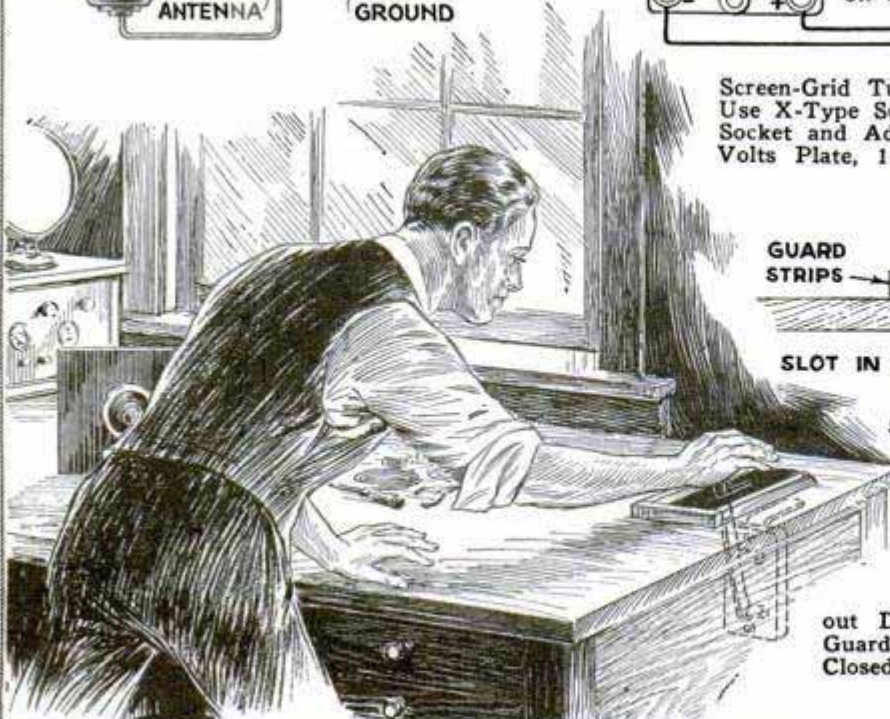
CLIP

ATTACH TO +45 VOLTS

301-A-BASE



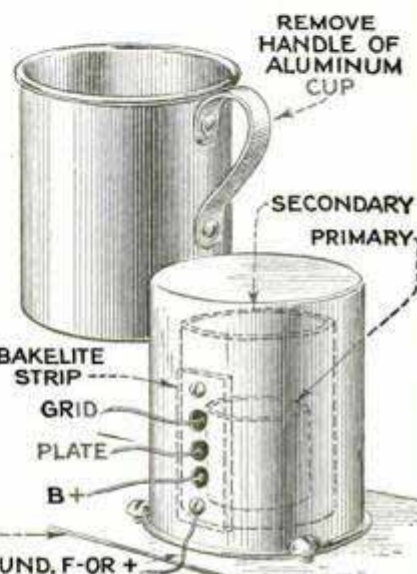
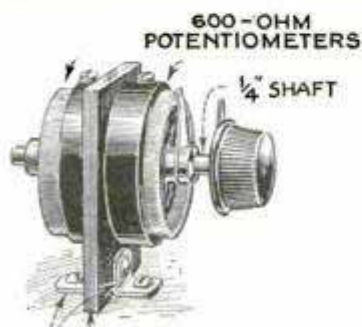
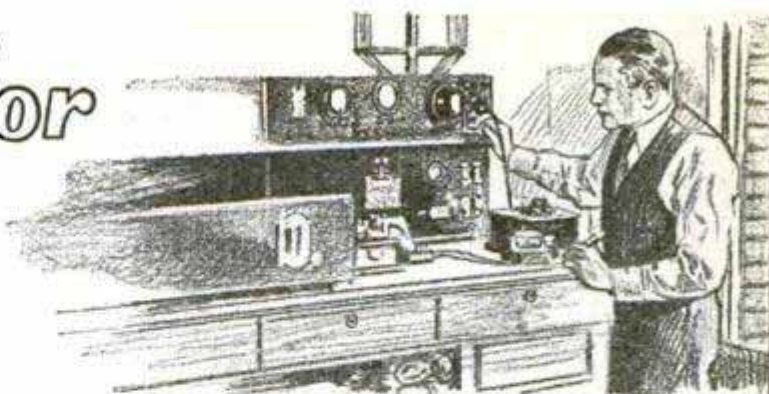
Screen-Grid Tube Adapter for Tube Tester; Use X-Type Socket and Base; Plug Tube in Socket and Adapter in Set; Use 90 to 135 Volts Plate, 1 1/2 Volts Negative-C and 3.3 Volts Filament



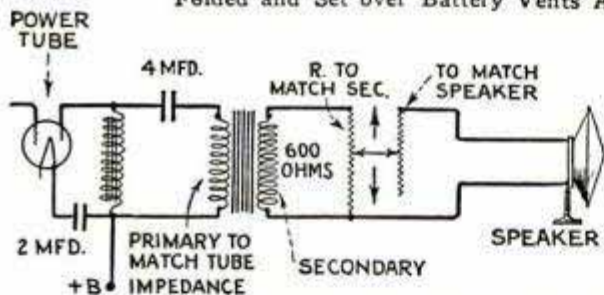
High-Voltage Switch, Mounted as Shown, Is Worked Conveniently without Danger of Accidental Shocks; Guard Strips Prevent Switch Being Closed by Objects on Bench Pushed against It

Carroll 11/9 to A. Brooklyn, N.Y. 275 N. 6th St.

Kinks for Fans



BAKELITE Two Potentiometers, Mounted Back to Back on Same Shaft, as Above, Make a Volume Control for the Speaker without Changing Resistance or Impedance; Circuit Is Given Below; Shaft Forms Connection between Potentiometers; Right, Blotter Folded and Set over Battery Vents Absorbs Spray

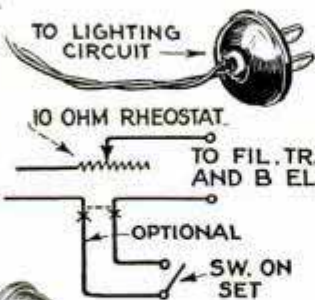
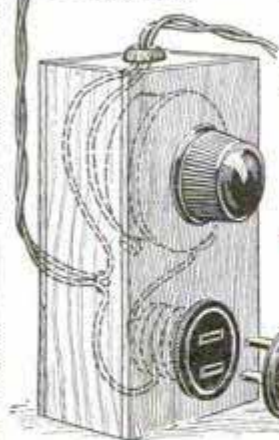


1/16" SHEET ALUMINUM

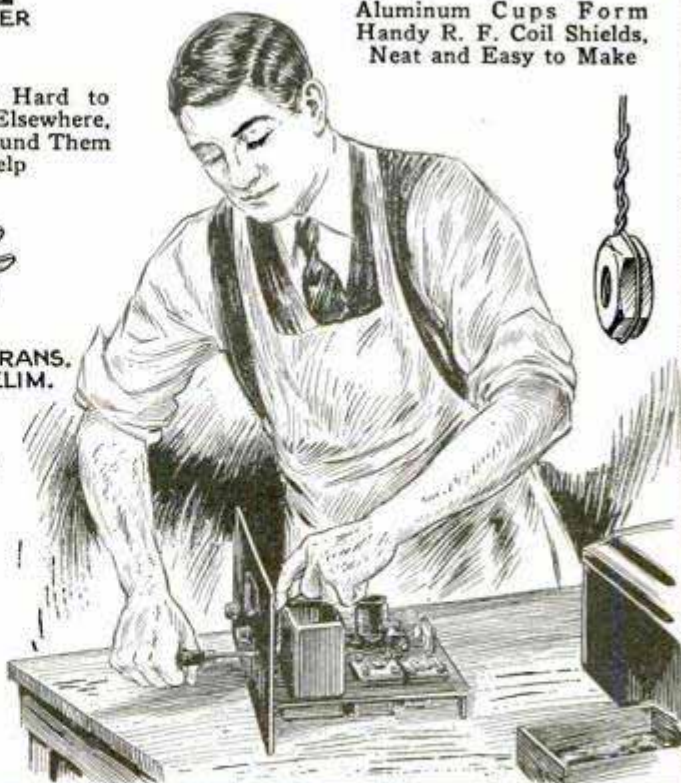
Aluminum Cups Form Handy R. F. Coil Shields, Neat and Easy to Make

TO FIL. SWITCH ON SET.

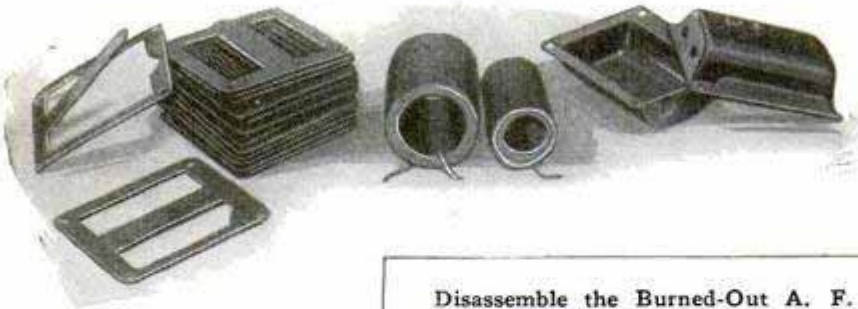
Right, When Nuts Are Hard to Start behind Panels or Elsewhere, a Bit of Wire Twisted around Them as Shown Will Help



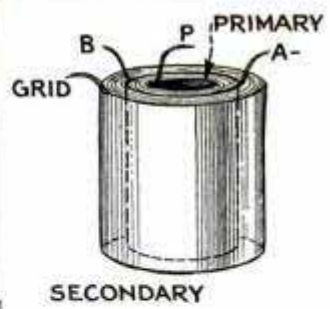
Voltage Control Protects A. C. Tubes; Set Rheostat for Trial with Set On; Turn Set Off Till Tubes Cool; Turn On; Tubes Should Take 30 Seconds to Heat; If Not, Readjust Rheostat Right or Left



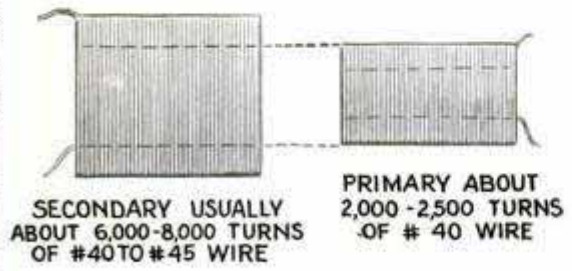
Rebuilding Burned-Out Transformers



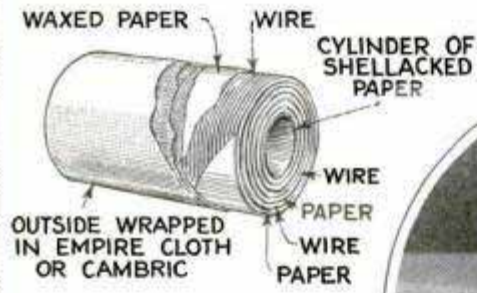
Disassemble the Burned-Out A. F. Transformer as Shown Above; the Parts Are Laminations, Secondary, Primary and Shield



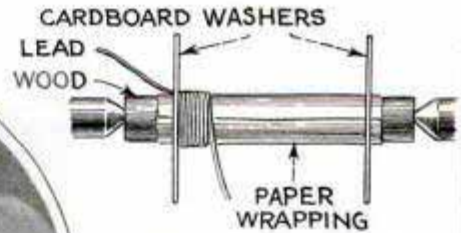
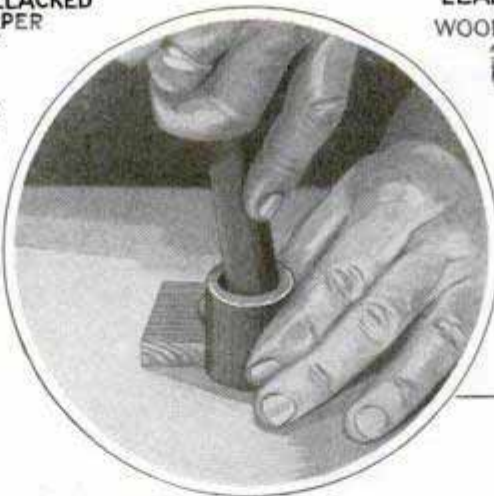
Above, Primary and Secondary Assembled; P and B Are the Primary Leads, a Negative and Grid the Secondary



Above, to Separate the Coils, Hold in Boiling Water Until the Paraffin Softens, Then Remove the Primary by Pushing It Out with a Round Stick as Shown in the Photo Below

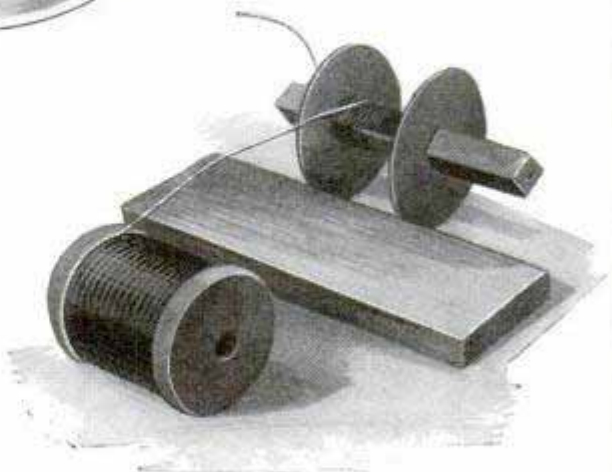


The Coil Construction Is Clearly Shown in Sketch Above; Rebuilding a Primary Coil Is a Simple Matter; a Burned-Out Secondary, However, Is beyond the Average Experimenter, Owing to the Large Number of Turns of Fine Wire



Above, Coil Mounted for Winding; Count Turns on First Layer and Multiply Layers for Total Count; Cover Each Layer with Paraffin Paper; Dry Coils in Slow Oven before Re-assembling

Measure the Inside Diameter of the Old Primary Coil and Cut a Stick of Wood the Same Thickness; Wind Several Layers of Well-Shellacked Paper the Width of the Coil, and Mount Cardboard Disks to Form Retainers; Thread the Starting End of the Winding through One Disk, as Shown at Right



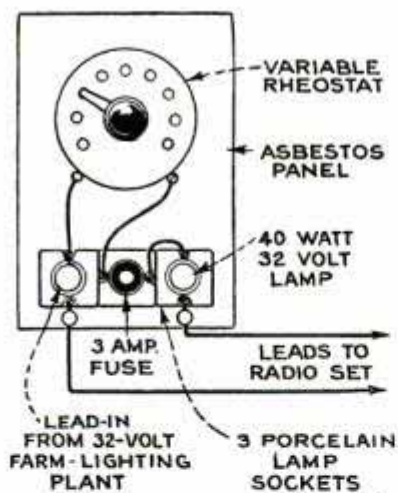
GAUGE	TURNS PER LINEAR INCH	RESISTANCE PER 1,000 FT.
40	130	1,069. OHMS
42	168	1,667 "
44	210	2,655. "
30	64	105.25 "

Automatic Switch from Ford Cut-Out

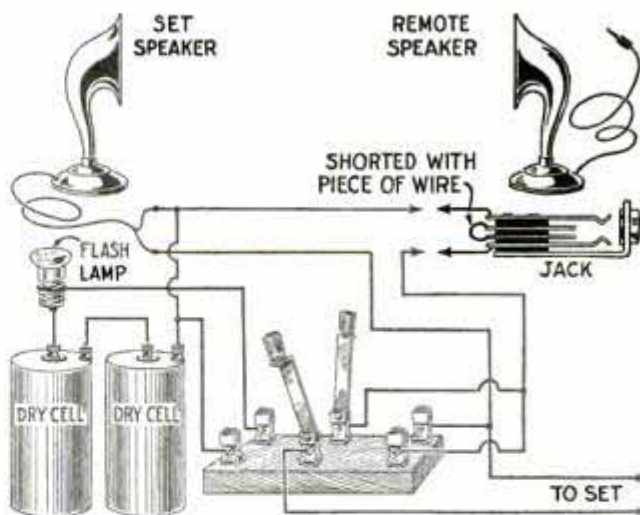
The automatic switch for B-eliminators, shown on page 306, needs a little explanation. Disconnect the fine wire from B (see diagram). Then disconnect the heavy wire from A and solder it to B. Break one of the wires leading to the eliminator, and connect one of the severed ends to A and the other to C. Cut one of the A-battery wires, and connect one of the ends to D, the other to E. Adjust the armature spring at the back of the cut-out by bending, so that the contacts will come together when the A-battery filament switch is closed. By bending the ears on the bottom of the cut-out straight, it can be mounted on a bakelite or hard-rubber base.

A-Supply from Farm Plant

After considerable experimenting, I finally hit upon the idea shown in the sketch for obtaining the necessary 6-volt A-battery supply for the radio set from the 32-volt farm-lighting plant. The control panel consists of three ordinary porcelain lamp sockets and rheostat, mounted on an asbestos panel and wired as shown. The line voltage is reduced by means of the lamp, which is connected in series with one side of the line, and the filament current to the set is then regulated with the rheostat. This device supplies the necessary filament voltage without placing a drain on any individual battery in the bank, which is preferable to the common practice of taking it from one 6-volt unit.—Marion J. Teachout, Martville, N. Y.



When three or more stages of intermediate-frequency amplification are employed in a superheterodyne receiver, the set will work best if the filament supply is kept at minimum; sensitivity is often increased in these stages by reducing the B-voltage.



Remote-Speaker Control, Showing the Jack and Lamp Arrangement for Checking the Distant Speaker

A Handy Speaker Hookup

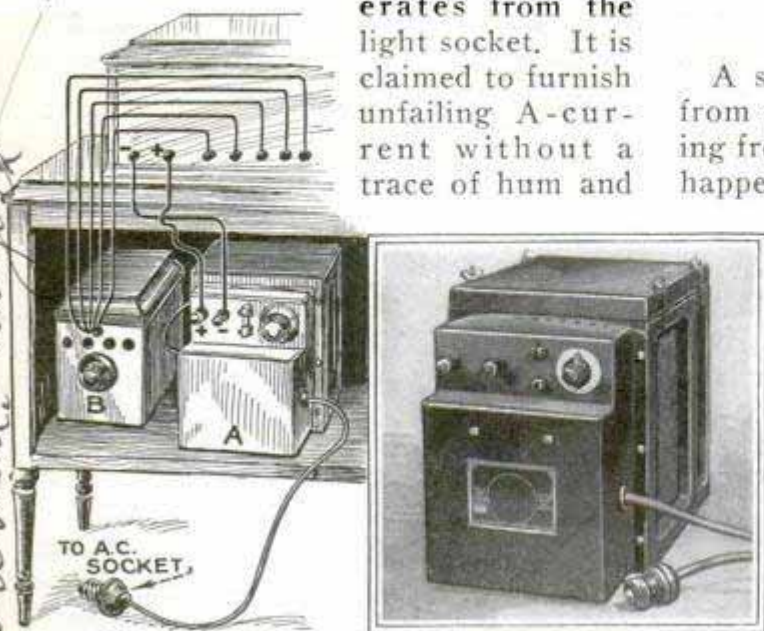
When two or more speakers are to be used and one of them is at a distant point, the hookup shown will prove practical. It enables the operator to use the set speaker alone, both together, or the remote speaker alone, as desired. If the listener at the distant point wishes to cut off his speaker, he can do so without disturbing the speaker at the set. The operator at the latter point can tell whether the remote speaker is in use by the signal lamp, which, when switched across the line to the distant speaker, will not light, owing to the resistance of the speaker winding. If that speaker is disconnected, the lamp will light.

Heavy-Duty Chokes for New Power Units

The increasing power requirements of high-power amplifiers has resulted in greater attention to the current-carrying capacities of chokes, resistors and connecting wires. While 60 milliamp. filter choke coils were more than sufficient to carry the current needs of the average receivers employing one or two of the 171 or 210-type tubes in the last stage, the new 250 or 350-type power tube requires heavy-duty low-resistance choke coils capable of carrying from 100 to 150 milliamp. When designing the filter system for this tube, the high-voltage tap can be taken from the connection between the chokes. With this arrangement, the heavy current flows only through the choke of the first stage of the filter so that a lighter-duty choke can be used in the second stage if desired.

Automatic A-Power Unit

The automatic A-power unit shown in the illustration has a built-in relay and operates from the light socket. It is claimed to furnish unflinching A-current without a trace of hum and



Left, A-Power Unit, Showing Installation with B-Eliminator, for Complete A.C. Operation of D. C. Sets

consists simply of a storage battery and trickle charger with which is combined an automatic relay switch of some good design. The installation sketch shows the simple connections necessary to place the unit in operation. The storage battery is of a long-life design claimed to outlast several ordinary batteries. The noiseless charging unit provides four graduated charging rates, and, in addition, one booster rate of 1½ amp. for an emergency charge, which enables it to take care of all sizes of sets and conditions of operation. The unit is designed to operate on 110 to 120-volt, 50 to 60-cycle a.c. current.

Advantages of Push-Pull Amplification

Before power tubes were introduced, when the standard 201 and 301A-types were the only ones available for the last audio stages, push-pull amplification was depended upon to give the best possible reproduction. By connecting two of the A-type tubes in push-pull arrangement, a greater output plus the advantage of freedom from harmonics was obtained, resulting in better reproduction. The advent of power tubes, such as the type 112 and 171 and the still higher 310 and 350-types made push-pull amplification unnecessary

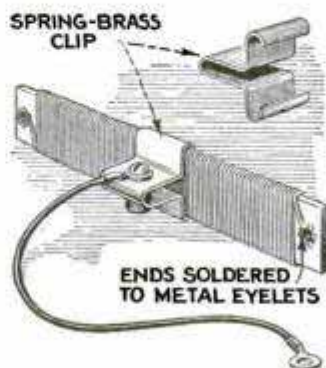
from the standpoint of providing the required power output. However, the push-pull arrangement permits simpler design.

A Sensitive Circuit Tester

A sensitive circuit tester can be made from a milliammeter having a scale reading from 0 to 1.5 milliamp., if such a meter happens to be among the odds and ends on your test bench. Remove the secondary winding from an old a.f. transformer and connect the coil in series with the ammeter and a C-battery. The remaining terminal from the battery and the coil form the test leads. Vary the battery voltage until full-scale deflection is obtained by a short-circuit connection. This voltage will depend on the resistance of the coil and will be somewhere between 4 and 8 volts. The increased sensitivity of the meter will afford better results than the battery and voltmeter combination usually employed. The tester is suitable for locating high-resistance leaks and defective fixed condensers of the low-capacity, bypass and filter types.

A Handy Resistance Clip

Requiring a small amount of easily variable resistance in the circuit of one of my test-bench meters, and desiring to hold the reading when once adjusted, I resorted to a variable sliding resistance made as shown in the sketch. A strip of ¼-in. fiber is boiled in paraffin and the resistance wire from an old rheostat is wound on the strip.



Either eyelets or Fahnestock clips are employed as terminals for each end of the strip. The clip was made of spring brass, bent as shown above, so as to slide easily, and may be permanently held at the desired resistance value

on the strip by means of the machine screw.—Charles H. Willey, West Concord, N. H.

Taken over by American Sales Co. Warren, New York

1688-112
 201 Park
 New York City

Should Katharine Thompson

Ballotini { Dennis Mfg Co. of Framingham, Mass. Chicago 62 E Randolph St.

AMATEUR MECHANICS



Ballotini Inlays for Boxes

By H. C. McKAY

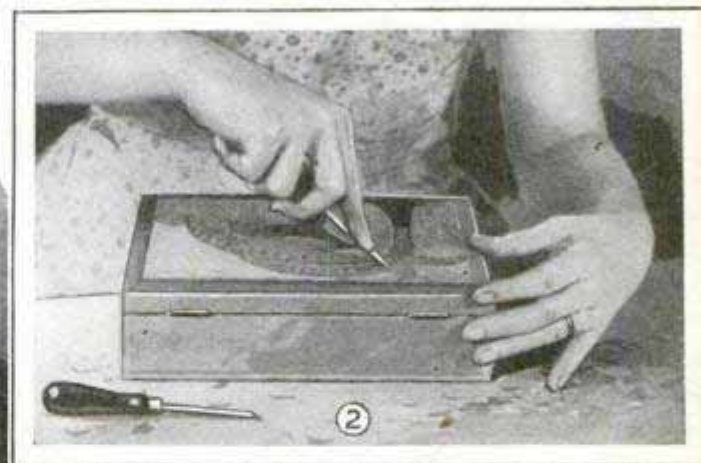
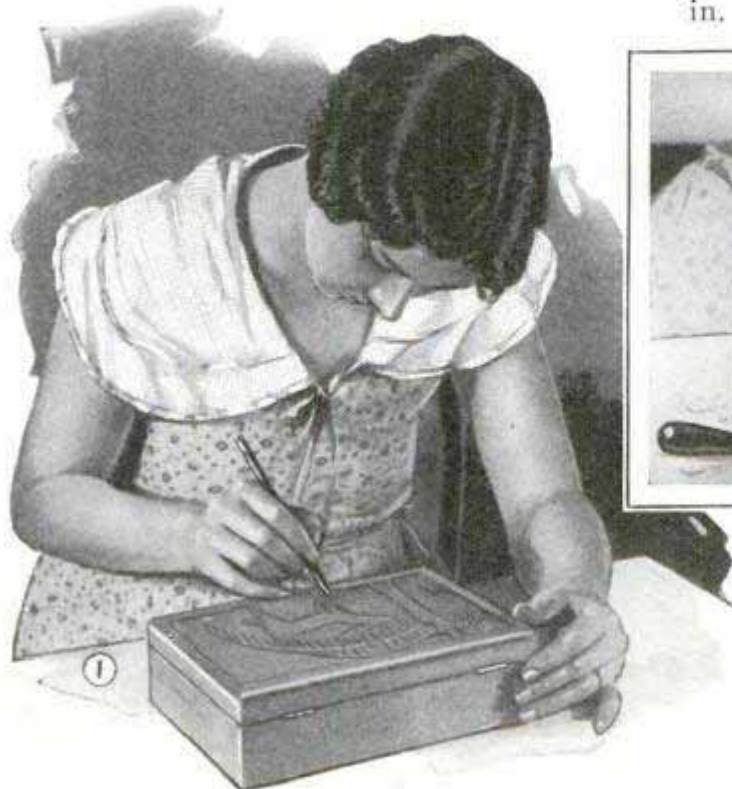
THERE is use in every household for small boxes of various sizes, such as glove boxes, jewel cabinets, etc.—containers that should be ornamental but which are rarely so. These boxes can be easily decorated in a novel and very attractive manner by the use of “ballotini” or tiny glass beads used for ornamenting of lamp shades and similar articles.

The boxes used may be those of white-wood made for gesso decoration or such simple containers as heavy “natural cedar” cigar boxes.

The first step is the selection of an appropriate design. The nature of this work lends itself to the modernistic patterns which are now in vogue, and there are few mediums that so well express the spirit

of this trend as does ballotini. The design should be chosen with regard to the size and shape of the box, unless one is experienced in drawing to an extent which will permit a free-hand reproduction. In any case, the design should be completed upon paper and then transferred to the box by means of carbon paper.

When the design has been transferred to the box, it is carefully strengthened with a heavy pencil, Fig. 1, to prevent obliteration during the carving process. It is then carved in relief in the usual manner followed in wood carving, as illustrated in Fig. 2. The texture of the cigar-box wood lends itself admirably to carving with sharp tools. The design is outlined with a deep single stroke. After this, the background is removed to a depth of about $\frac{1}{16}$ in. This may be done roughly, as the inlay



will cover all rough surfaces. Care must be taken in cutting the background that a deep grain is not caught which might result in splitting the wood and the removal of an entire piece of the top.

When the background has been re-

manufacture discontinued 1/24/36.

moved, all outlines are carefully inspected, and all rough edges trimmed. It is quite important that all edges be practically vertical, sharply defined, and that they run to the entire depth of the cut. This will take a little time. In trimming the edges, be careful not to lift splinters from small isolated portions of the design which are left in relief.

When this is done, the entire design is given a coat of shellac, Fig. 3, the orange variety being quite satisfactory. This shellac coat is a filler coat. It is allowed to become perfectly hard and dry before proceeding with the work. Then a sheet of tinfoil is selected which will cover the top of the box. If a variety of tinfoil can be secured which has an embossed geometrical design, the novel appearance of the work will be enhanced. The foil is laid over the design, as in Fig. 4, and carefully pressed and rubbed down upon it, taking care to see that every detail is fully outlined upon the foil. The foil is then carefully lifted from the box and placed

The raised portion of the design is now given a second coat of shellac. When the shellac becomes slightly tacky, the foil design is carefully lifted and placed upon the carved design. (See Fig. 5.) It is carefully adjusted to cover the design exactly and then pressed down to give a perfect contact. This is the most difficult operation in the whole work, as the foil persists in sticking to the design in the wrong place, but with a little care, it can be placed in proper position, and smoothed down until the design shows up clearly and distinctly in the foil. The box is then allowed to dry a second time. The foil is watched during this drying to see that the edges do not loosen and curl up. The foil should extend over the edges of the design and down to the bottom of the cut.

When this is done, the box is ready to receive the background. For this purpose two tubes of ballotini are needed, one of gold and one of iridescent mixture. The background of the design is given a coat of shellac and immediately thereafter a



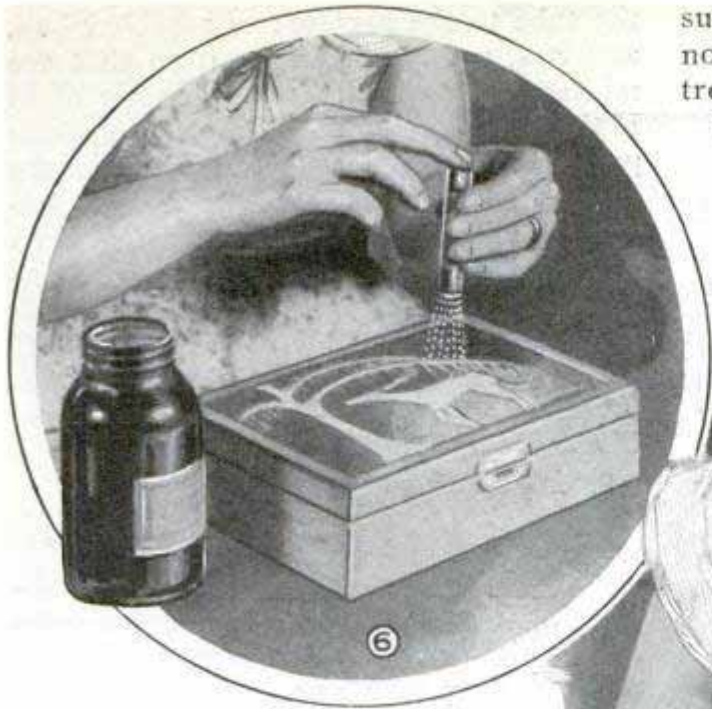
upon a smooth board. With very sharp scissors, the outline of the design is followed, leaving an oversize border, extending about $\frac{1}{16}$ in., all around the design.

When this is done, you will have a duplicate of the design, but, due to the fragility of the foil, it must be handled very carefully.



coating of gold ballotini is sprinkled upon the wet surface. (Fig. 6.) This is allowed to set for about ten minutes and then the box is tilted upon its side and sharply rapped against the table top to dislodge all beads which are not firmly held by the shellac.

As the shellac should be really wet when the ballotini



is applied, the top is done in small sections. After completion of the whole top, a period of ten minutes should suffice to insure the adherence of the necessary number of beads. When this is done, the design will be shown in silver relief against a gold background. At this stage the box is set away for twenty-four hours.

The next step is to apply a second coating of shellac by means of an atomizer such as is used by artists for applying fixative to pencil and charcoal drawings. In applying the shellac from the atomizer, it is necessary to protect the design by means of a paper mask, otherwise the iridescent ballotini would adhere alike to background and design. When the box is thoroughly wet with the sprayed shellac, the iridescent ballotini is applied thinly. This kills the harsh appearance of the gold, leaving the box with a colorful background with gold predominating.

The top design forms the principal part of the box decoration. The box is finished by painting any desired modernistic or conventional design upon it and bronzing this design with decorative bronzes in any desired color. Then, a final coat of white shellac is lightly sprayed over the entire box. This is a protective coat intended to prevent the beads from dropping from the box. The completed box is illustrated in Fig. 7.

This type of decoration may be applied

successfully to any wood object, and the novel appearance will well repay the slight trouble encountered in making them.

The materials needed are: the box or



other object to be decorated; 1 bottle best white shellac; 1 tube gold ballotini; 1 tube iridescent ballotini; 1 sheet tinfoil; oil colors and decorative bronzes in any shades that may be desired.

Simple Cap Remover

When no bottle-cap remover is at hand one can easily be made in a few moments by drilling a hole through a 6-in. length of wood, about 1 in. from one end, and inserting a round-head screw, letting the



head project about $\frac{1}{4}$ in. below the wood. A nut is driven on the other end of the screw to hold it.
—S. A. Gortner, Lancaster, Ohio.



Improvement on an Ordinary Wrecking Bar to Facilitate Removing Siding

Bar for Removing Siding

After having had considerable difficulty in removing siding and roofing boards with an ordinary wrecking bar, without breaking any wood, I devised the bar shown in the illustration. It helped do the work quicker and with less damage, as it is pressed against the board from both sides of the studs. It was made from a wrecking bar and a fork with two tines, about 5 in. apart, which was welded to one end of the bar.—Lovell Cook, Bloomington, Mich.

What to Do When an Inner Tube Gets Porous

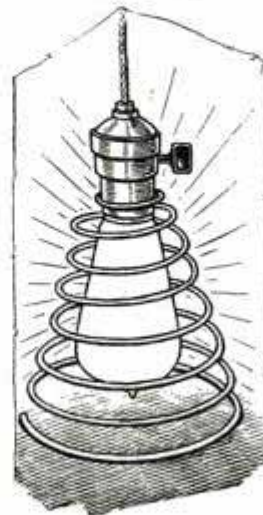
Every auto owner knows that inner tubes sometimes get more or less porous. This is due to acids forming in the material, especially when the tires have been standing for a long time. To neutralize the acids causing this trouble, wash the tube with a solution of ammonia and water. Take a tablespoonful of French chalk and three tablespoonfuls of the ammonia solution and mix thoroughly, remove the valve and introduce the mixture into the tube by means of a fountain-pen filler. After this has been done, inflate

the tube to the pressure of a rubber ball, and coil, rather than fold, it so that the mixture may circulate freely inside of it. If the tube is to be used immediately, this procedure is not necessary. The mixture will not only prevent the tube from becoming still more porous, but it will even seal small punctures for several days. Unlike many preparations often used for this purpose, this mixture will not work itself under existing patches and has no harmful effect on the tire.—George H. Holden, Chesterfield, England.

Short-Stopping Photographic Prints

One of the most difficult problems confronting the amateur photographer who makes his own prints is to give each one the same time in the fixing bath. Usually prints are transferred directly from the developer to the fixer, one by one, as they are printed, and allowed to accumulate there. The result is that the first ones are overfixed and the last ones underfixed, causing yellow discolorations and lack of permanency. The use of a short-stop solution, which stops the action of the developer but has no other effect on the prints, will be found handy, as the prints can be allowed to accumulate in this solution before they are put in the fixing bath. A good short stop, which has been found entirely satisfactory, is a solution of $\frac{1}{2}$ oz. of acetic acid in 8 oz. of water.—Norval Ballard, Virginia City, Nev.

Improved Lamp Guard



When you need a guard for an electric lamp in the garage, workshop or basement, and have none on hand, an ordinary helical spring, of the kind used in overstuffed furniture and auto seats, is a good substitute. Fasten the spring around the light socket, as shown, and screw in the bulb.

Then pull the spring out until it extends beyond the lower end of the lamp.—W. C. Thomas, Chicago.

False Bottom in Pan Prevents Burning Biscuits

My wife had trouble when baking biscuits, as the underside would scorch and burn before the top was properly browned. To eliminate this, I made a false bottom for the pan. It is merely a piece of tin, cut the same size as the bottom and indented with four rows of punch marks so that there would be a slight separation between the two. There were no more burned biscuits after that.—James E. Noble, Toronto, Can.

Advertising Feature on Closed Auto

It is possible to use your pleasure car for business purposes, without marring its appearance, by the application of painted signs. Just paint the advertisement on ordinary window shades and substitute these for the shades of the car, the roller of the window shade being removed and the roller of the car shade being used in its place. Remove the ratchet from the roller and drive a screw eye into the stick in the hem of the shade. The latter is slipped over a screw hook driven into the window sill, and the absence of the ratchet allows the spring to keep the curtain taut all the time. The stick in the hem should be a trifle longer than the width of the curtain so that it will be impossible for it to roll around the roller under the tension of the spring.—C. Neiper Bruce, New Castle, Pennsylvania.



Painted Window Curtains Used in the Closed Car for Advertising Purposes



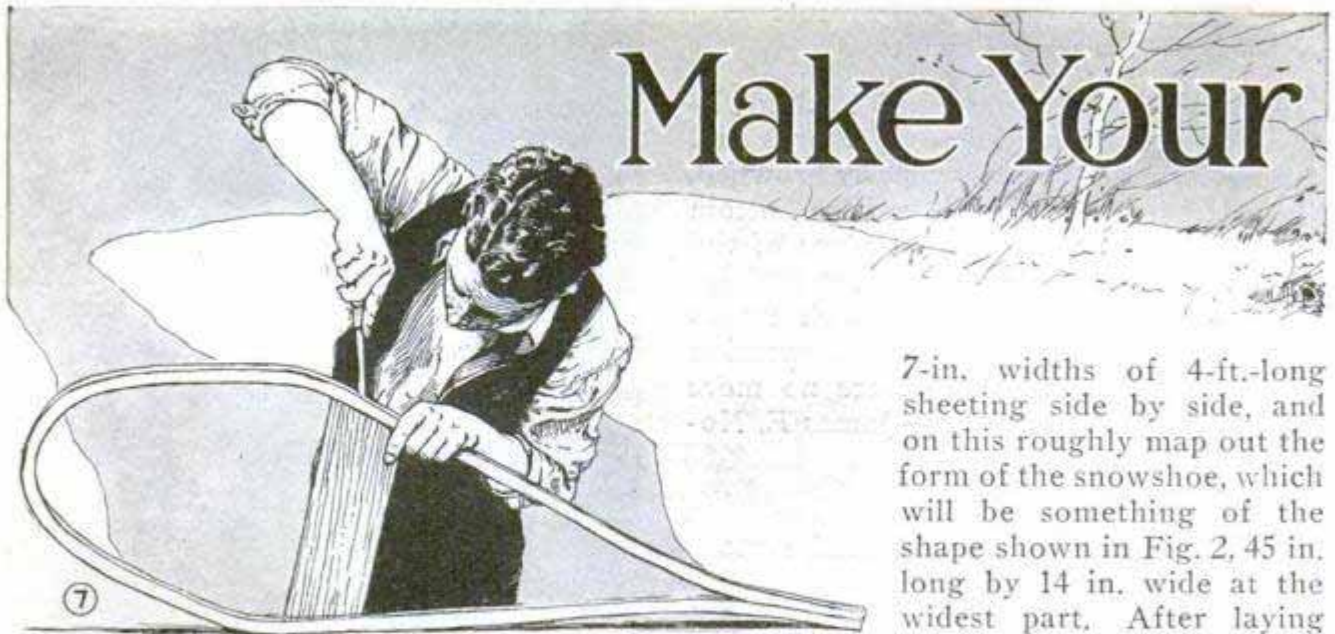
Old Truck Tire with Tread Removed Makes a Good Swing for the Children

Truck Casing Makes Novel Swing

A large truck casing that has been discarded can be used to advantage for making a swing for the children. All you have to do is to cut away all the tread except a portion about 18 in. long. The bead of the tire is, however, left intact. Turn the tire wrong side out, bringing the tread on the inside, and tie it to the limb of a tree with a length of strong rope, as shown in the photo.

To Prevent Accidents on Cellar Stairways

Many serious accidents are due to poor lighting of cellar stairways. This is something which no one seems to improve as the building goes on. Places where no consideration has been given to this feature may be made safer by coating the last two steps or treads with white paint, so that they can readily be seen.



Make Your

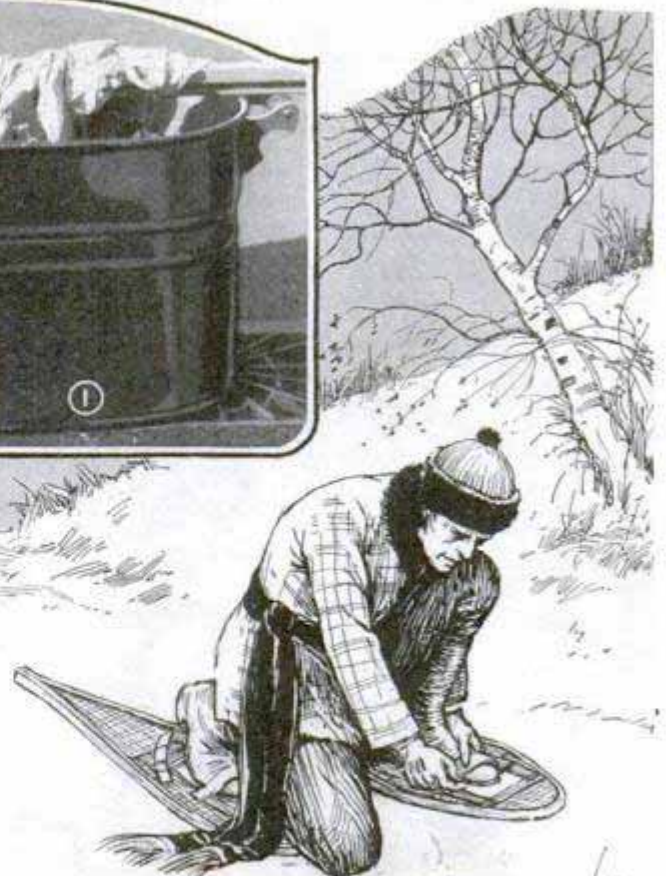
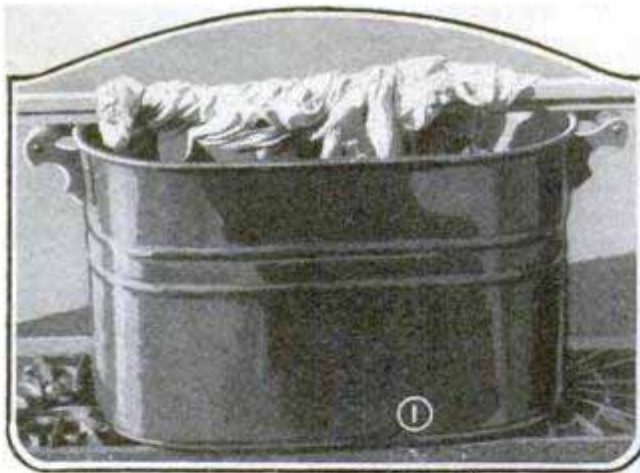
7-in. widths of 4-ft.-long sheeting side by side, and on this roughly map out the form of the snowshoe, which will be something of the shape shown in Fig. 2, 45 in. long by 14 in. wide at the widest part. After laying out the pattern, nail tin cans

MANY persons, even those experienced in home mechanics, look upon the task of making a pair of snowshoes as something very intricate and difficult; a fit job for an Indian or woodsman, but quite outside the capabilities of the average person. Of course, making snowshoes of the traditional rawhide variety is a difficult piece of work, but by substituting $\frac{1}{4}$ -in. galvanized screening (hardware cloth) for rawhide and screws, and bolts and nails for binding, the task becomes comparatively simple.

The first thing to do is to procure two 8 ft. 4-in. lengths of $\frac{1}{2}$ by $\frac{5}{8}$ -in. second-growth ash, hickory, mulberry, or some other pliable wood. Place these two lengths over the top of an old boiler filled with water. Turn on the gas. Wrap the wood with old rags, as shown in Fig. 1, and let it steam over the boiling water, wetting the rags occasionally until the pieces are pliable throughout their entire length. This initial step—the steaming of the wood—is quite important, for if the pieces are not properly treated, the wood will splinter or break in the bending process.

While the wood is steaming, nail two

and 2 by 4-in. wood blocks to the base to hold the wood to the proper course, as shown in Fig. 3; then remove the steamed lengths of wood and bend them around this form, as shown in Fig. 4. Use large spikes, driving them into the wood base, to check any tendency toward bulging. Bend the second piece over the first one, and set them aside to dry. This takes about one



Joe caps, straps - 6 p. 03 uru
Mirror Lake, N.H.

Own Snowshoes

by Sam Brown

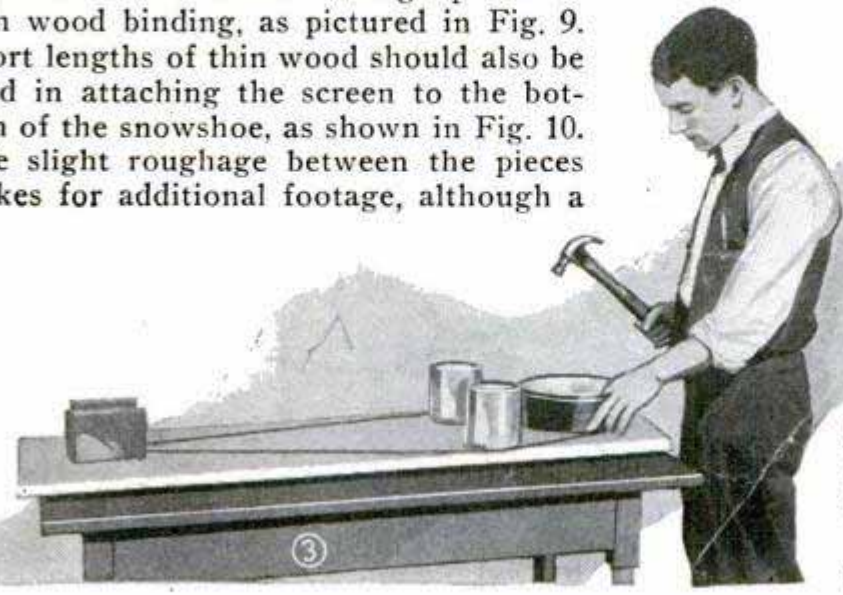
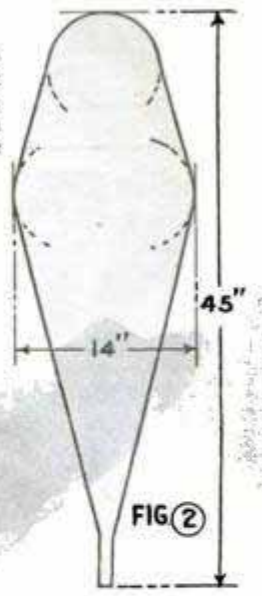
week. If removed from the forms before that time, the pieces will not hold their shape for any length of time.

After removing the pieces from the form at the termination of one week, fasten the ends together with two short bolts, as shown in Fig. 5. Now, cut a length of wood, 4 in. wide and $\frac{1}{2}$ in. thick, and screw it into position $15\frac{1}{2}$ in. from the tip of the snowshoe, as shown in Fig. 7. This is the "heel rest." With nails and screws, attach another length of wood 8 in. from the tip of the snowshoe, and, between these two crosspieces, nail two pieces of $1\frac{1}{4}$ by $\frac{5}{16}$ -in. ash with a distance of 5 in. separating them, as shown in Fig. 6. The rectangular opening thus formed is known as the "toe hole."

Now for the easy job which is to take the place of the intricate meshing of rawhide. Simply get a piece of $\frac{1}{4}$ -in. mesh screening and cut it to conform to the shape of the snowshoe, as shown in Fig. 8. The screening should also be cut down the center of the toe hole and the sides bent back and fastened to the sidepieces with short nails driven through pieces of thin wood binding, as pictured in Fig. 9. Short lengths of thin wood should also be used in attaching the screen to the bottom of the snowshoe, as shown in Fig. 10. The slight roughage between the pieces makes for additional footage, although a

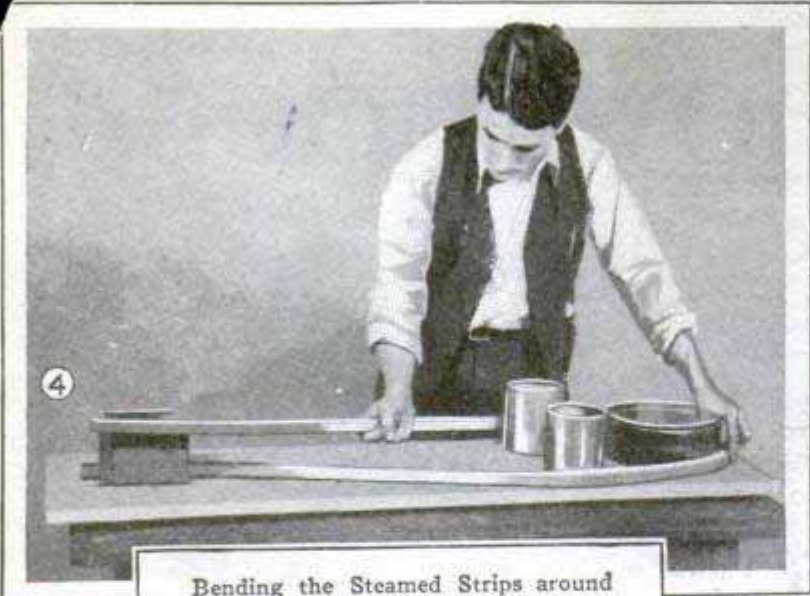


Fig. 2. How the Shape of the Snowshoe Frame Is Laid Out on the Boards; Fig. 3, Tin Cans and Wood Blocks Make the Form around Which the Frames Are Bent



single over-all piece, bent to shape, can be substituted if you desire a neater job.

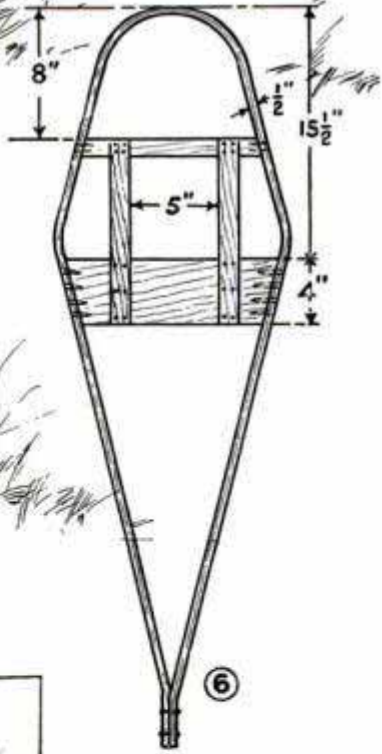
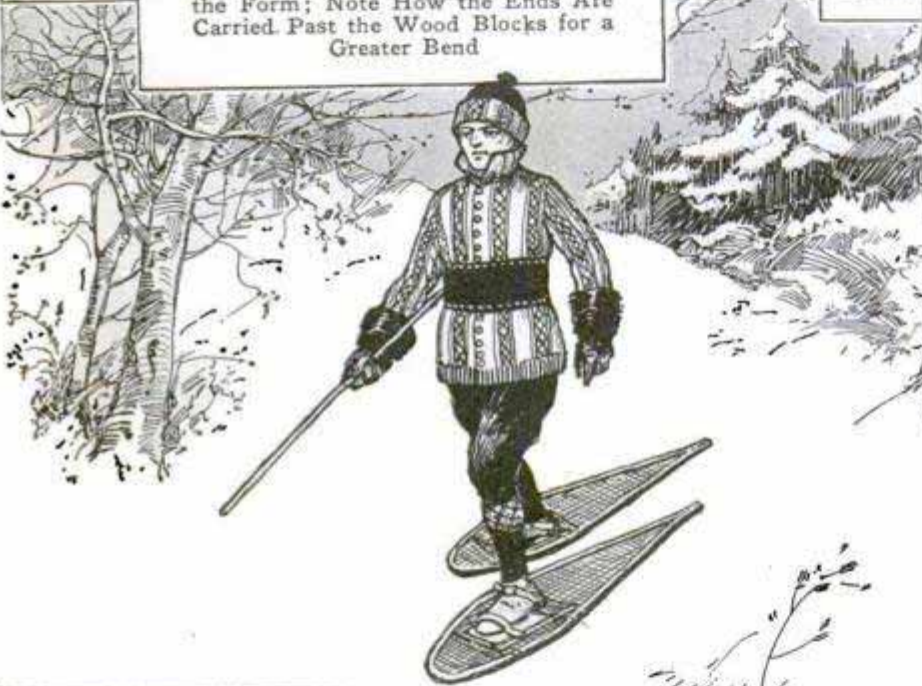
For foot binding, take a heavy loop of canvas web-



Bending the Steamed Strips around the Form; Note How the Ends Are Carried Past the Wood Blocks for a Greater Bend

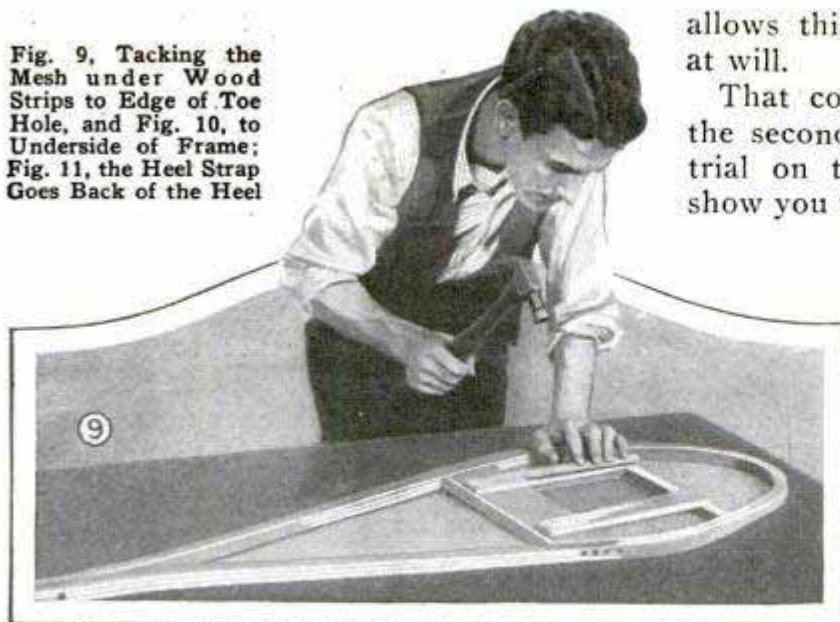


After the Wood Has Been Left in the Form for a Week, the Frames Are Removed and Drilled and the Ends Are Bolted as Shown Above



The Rawhide of the Traditional Snowshoe Is Replaced by Galvanized Screening, or So-Called "Hardware Cloth," Cut to Shape with Tin Snips and Tacked in Place

Fig. 9, Tacking the Mesh under Wood Strips to Edge of Toe Hole, and Fig. 10, to Underside of Frame; Fig. 11, the Heel Strap Goes Back of the Heel



bing of a size just sufficient to accommodate the toe, and nail it across the toe hole, as shown in Fig. 11. A secondary heel strap is then nailed into place. A buckle

allows this to be tightened or loosened at will.

That completes one snowshoe. Make the second one in a similar manner. A trial on these modern snow boots will show you that they serve practically every

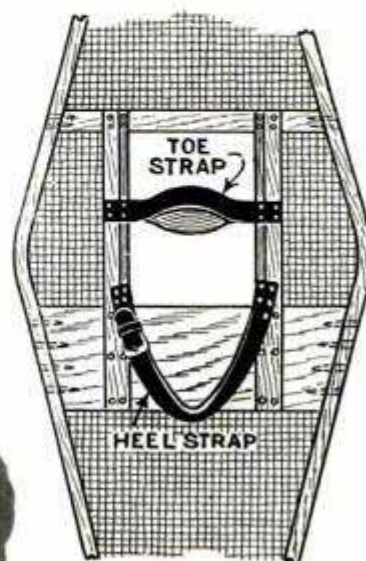
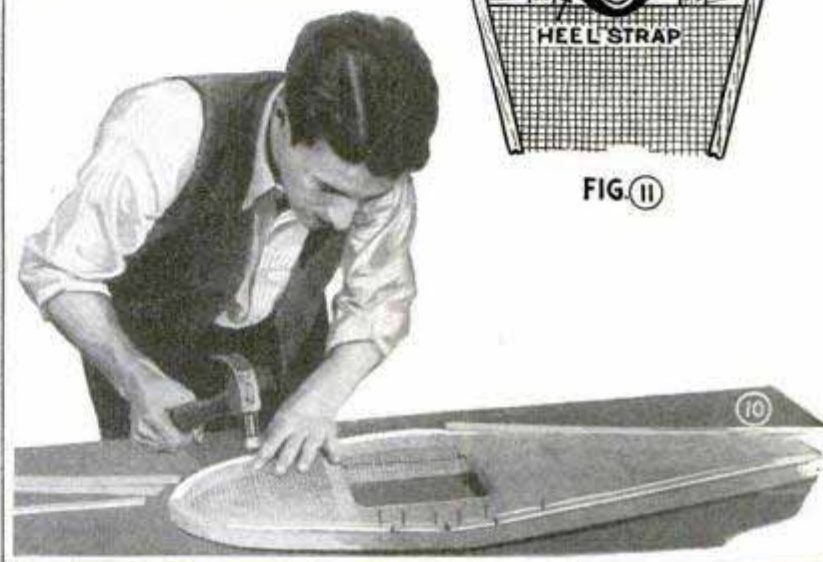


FIG. 11

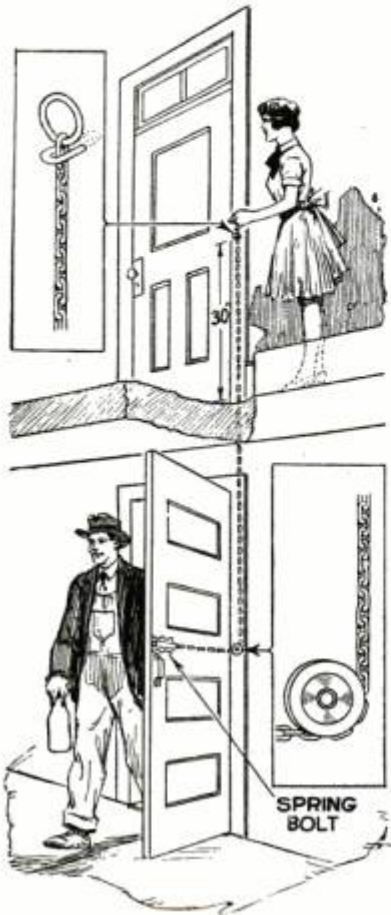


purpose of the more intricate snowshoes of the Red Men. The toe hole has been purposely made a trifle large because of the fact that it is surrounded by a rigid framework. It should be made smaller or larger, depending on the size of your shoes, but it must be of a sufficient size to allow the foot to sink down into the snow when taking a forward step.

Preventing Penetration of Paste

Stains on wall paper, caused by the penetration of paste, are highly objectionable, especially if the paper has a light color. An effective method of preventing them is to mix 2 oz. of powdered crystal alum in each bucket of paste of the 12-qt. size. Paste so prepared will not soak through the paper and consequently there will be no spotting.

Arrangement for Opening Basement Door



To do away with walking downstairs to open the basement door for the gas, electric and coal men, or others who occasionally have to be let in, I devised the arrangement shown in the illustration, by means of which I could unlock the door from the kitchen. The lock is of the spring-draw-bolt type, such as is often used on garage doors. A length of furnace chain is attached to the handle of the bolt, is run over a pulley on the door casing, and through the floor to a clip on the casing of the kitchen door, which happened to be directly above the basement door. Pulling the chain is all that is necessary to withdraw the bolt. The clip for the upper end of the chain may be fastened to the baseboard, if it is desired not to disfigure the door frame.—M. J. Stair, Chicago.

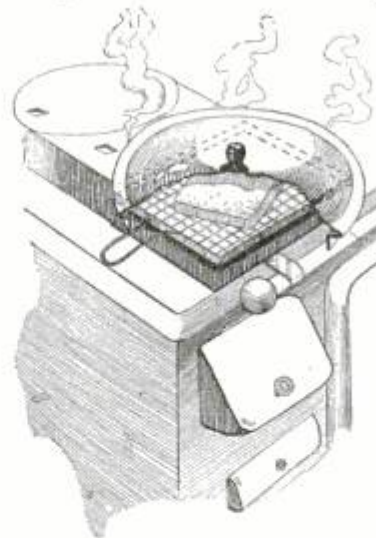
Suggestions for Your Aquarium

Most aquarium fish die from parasites and diseases, and not from old age. By taking proper care of your aquarium you will have fewer fatalities. The first thing to remember is not to overcrowd it. Two strong, active fish in a 5-gal. tank will thrive, where five fish in a 2-gal. tank may become sluggish and sickly. Pretty stones placed in the bottom of the tank are more or less objectionable, as particles of unconsumed food settle between the stones and decay, which pollutes the water and causes sick fish. It is much better to use

sand as uneaten food can then be siphoned off without disturbing or uprooting any of the plants. Siphoning is the proper method of removing water from an aquarium. Fish should be fed only once a day, preferably in the morning. Use a feeding ring and always put this in the same location. The aquarium should be kept in a place where it can get plenty of daylight. However, it should be kept away from the direct rays of the sun, especially during the summer months. Under normal conditions the water in a large tank aquarium need not be changed oftener than once every five or six months. Add only enough water every week to replace that lost by evaporation. A pinch of salt should be added to the water about once a month. This is beneficial to the fish and helps keep down parasites. At least one snail (red ramshorn) should be provided to every gallon of water, to keep the water clean. For goldfish, plants known as swimming arrow-wort should be used, and for tropical fish giant water weed is recommended. Both of these plants can be purchased at any fish store.

Toasting on Coal Stove

When an ordinary square, flat toaster is placed over an open hole in the cook stove, the admission of air at the top checks the fire, which is not always desirable. To

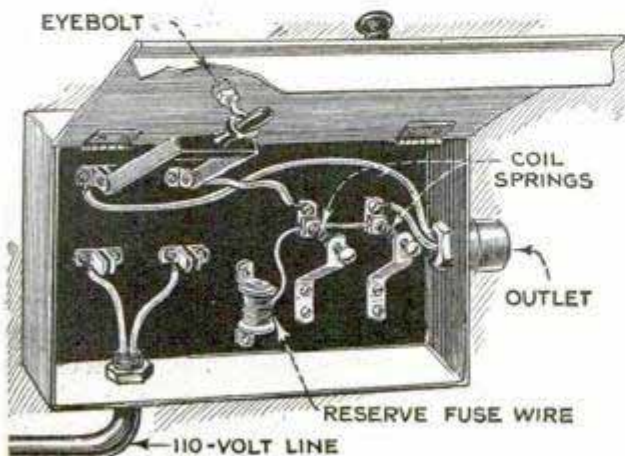


prevent this, place a large pot cover over the toaster, so that it completely covers the hole in the stove as shown. This simple trick is found very effective in keeping up the fire.—Albert E. Jones, Nova Scotia, Can.

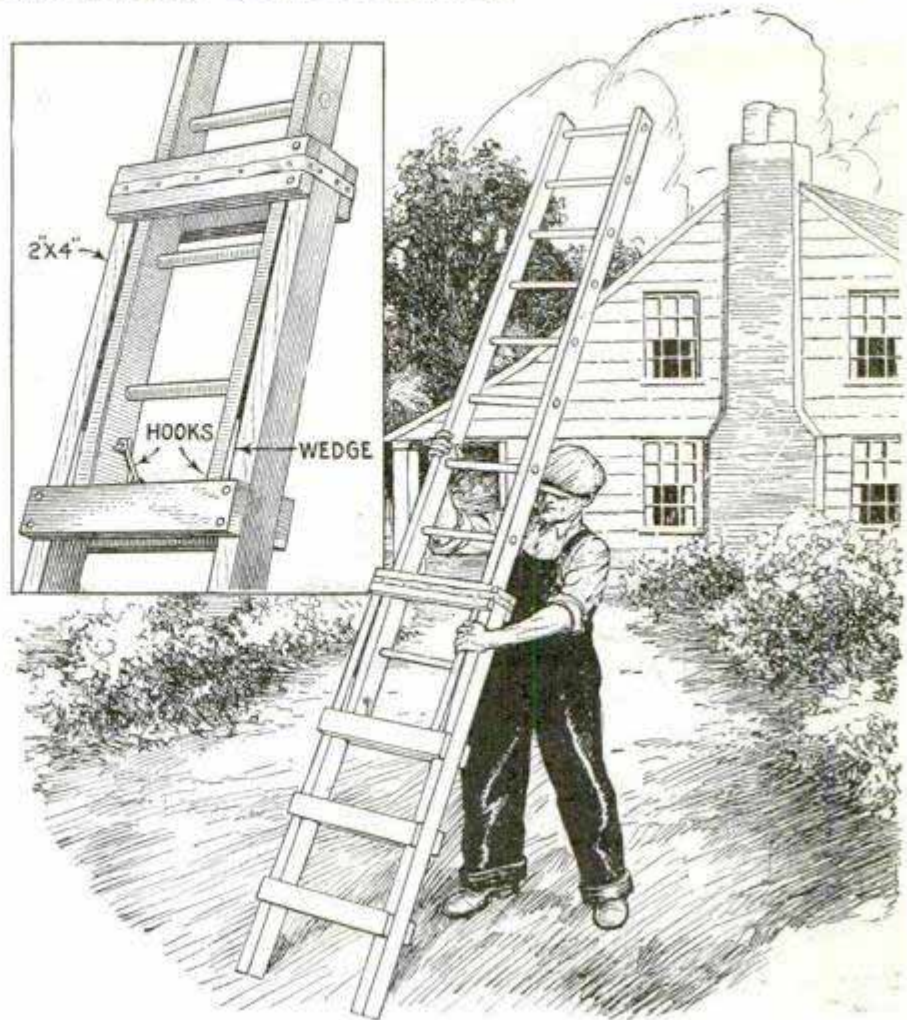
☞ A durable pouch for carrying silver can be made by cutting a circular piece of soft leather, 1 ft. in diameter, and punching holes every 2 in. around the outer edge; a drawstring of leather is run through these to close the pouch.

Fuse Box That Throws Switch Automatically

A safety switch and fuse box, which throws out the switch automatically when the cover is raised and contains a roll of fuse wire to facilitate renewal, is shown in the drawing. It is made of sheet metal except the bottom, which consists of slate, bakelite or other insulating material. The cover is hinged to the top edge as indicated, and has an apron which fits over the lower side to prevent anyone from reaching into the box before it is fully open. A d.p.s.t. knife switch is arranged inside, on the slate or bakelite bottom, so that the blades must be pulled up to disconnect them. The handle of the switch is slipped through an eyebolt attached to the cover in the open position. This causes the switch to be opened and closed with the opening or closing of the cover. A spool of fuse wire is mounted inside, on the bottom, so that it can be drawn between the ends of two pairs of copper plates, which are tightened or loosened by means of screws, held by clamps also attached to the bottom. When the section of fuse wire between the two copper plates blows, a new piece is inserted.



Safety Switch and Fuse Box Which Throws Out the Switch Automatically



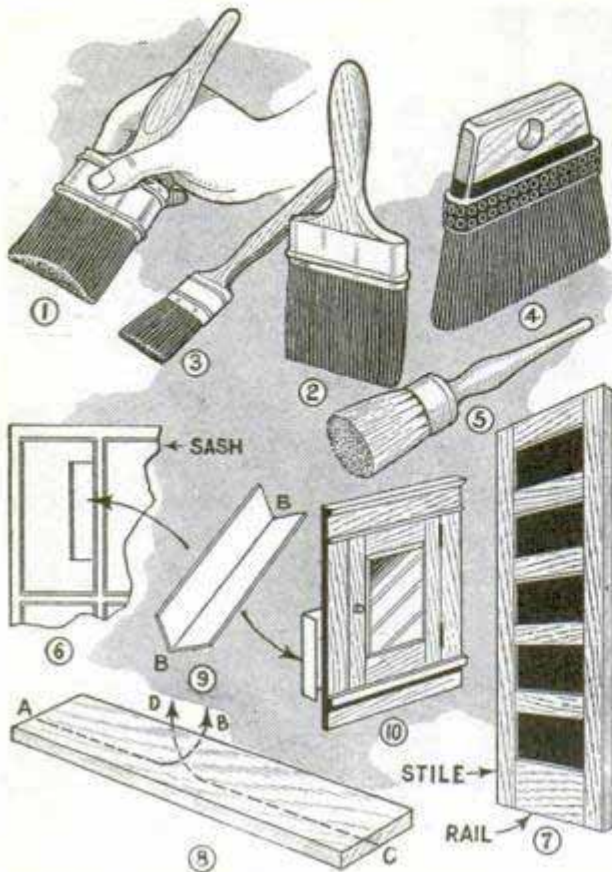
Five-Foot Extension for the Ladder Which Permits the Worker to Reach Otherwise Inaccessible Places

Making the Ladder Longer

When a ladder is just a few feet too short for the job on hand, the 4 or 5-ft. extension, shown in the drawing, will be found handy. It is made of two lengths of 2 by 4-in. stock with 1 by 2-in. cross-pieces nailed on both sides. The ladder is slipped between the crosspieces and held firmly by wedges nailed to the sides, hooks being provided to hold the extension on the ladder while the worker carries it from place to place. Strap iron is tacked around the upper crosspieces to prevent them from loosening, as they are subjected to most of the strain, and as many rungs are added below the crosspieces as may be necessary to give the extended ladder the desired reach.—Leon I. Thomas, Oak Park, Ill.

☐ A pencil will not fall out of the vest pocket while one is in a stooping position if a rubber band is wound tightly around the lower end; the ball of rubber thus formed clings to the cloth.

Paint Brushes and How to Use Them



Every Home Owner Should Know What Kind of Paint Brushes to Have and How to Use Them Properly

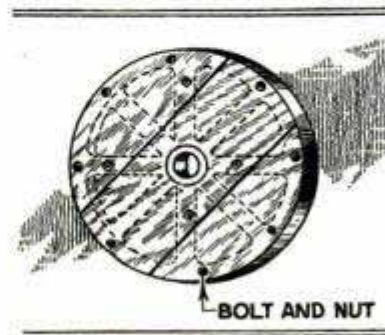
Every home owner should know something about paint brushes and how to use them, as there will be a time when he wishes to repaint the ceiling, walls, interior woodwork or perhaps some furniture. In the illustration, Fig. 1, is shown the proper way of holding a brush. This method may seem rather difficult and clumsy to the novice, but long practice has proved it to be the best, as it gives the user perfect control of the brush. For general use, the home owner should have a 3½ or 4-in., and a 1 or 1½-in. brush; with these he can do almost any kind of painting on woodwork. For walls and ceilings, a 6-in. flat brush, Fig. 2, is used, and for applying paste to wallpaper, the type of brush shown in Fig. 4 should be purchased. When you do wall-papering you should remember to dust off the wall thoroughly before applying the paper, and for this purpose a round dusting brush, Fig. 5, will be found handy.

When paint is applied to a surface by an amateur, "laps" are often evident. These are caused by stopping the brush abruptly on the surface and thus leaving a deposit of paint at this point. To prevent this,

apply the paint as indicated by the dotted lines in Fig. 8, brushing in the direction shown by the arrows. When painting paneled doors, first cover the panels, then the crosspieces or rails, and lastly the stiles. To prevent daubing paint on a finished wall when it is applied to sash or wall trim, take a piece of cardboard, about 6 in. long and 5 in. wide, and fold it lengthwise as indicated in Fig. 9. Hold this shield against the wall and the woodwork as in Fig. 10, and you will have no trouble in painting the wood without getting any paint on the wall. Turpentine cleans brushes that have been used for paint, varnish and stain. Lacquer is made of entirely different ingredients and turpentine will not clean brushes used with these materials. Alcohol or lacquer thinner will serve for cleaning lacquer brushes. After cleaning, the brushes should be washed out thoroughly with soap and water and set away to dry, after which they are wrapped in paper to prevent them from collecting dust.—Francis W. Henry, Pottsville, Pa.

Boxed Wagon Wheels for Mud Roads

In some parts of Mississippi, where logs and lumber are hauled through marshes, wagon wheels are boxed up to prevent the mud from lodging between the spokes, which, of course, makes it extremely hard for the horses to pull the load. The boards used for this purpose are thin and light. They are fastened to both sides of the wheels and are held in place securely by means of screws, nails or bolts driven into the spokes and the rim, the use of bolts being preferable if the spokes are heavy enough to take them without being weakened.



It is also advisable to locate the bolts in the spokes as near the hub as possible. Use round-head bolts to fasten the boards to the rim of the wheel, as square-head bolts are likely to catch in stumps encountered in hauling.—Bunyan Kennedy, McCool, Miss.

The Magic Ballroom

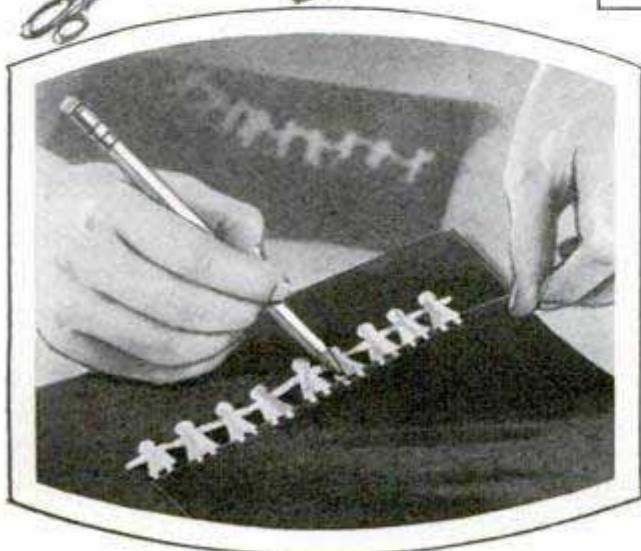
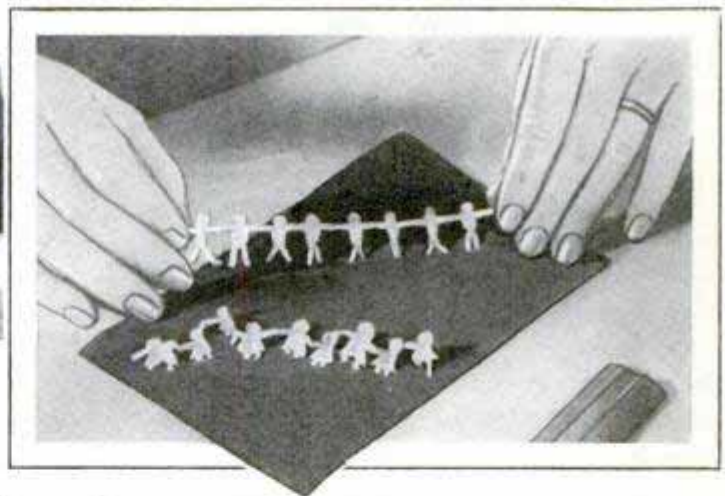
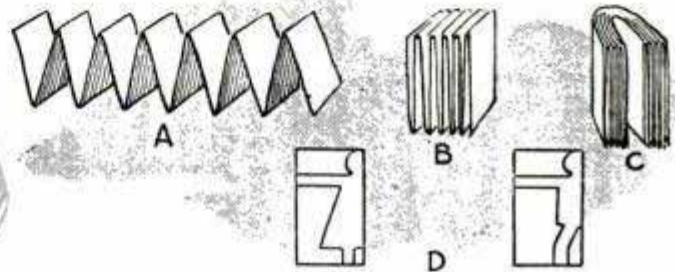
THE MAGIC ballroom is a simple toy which will provide endless enjoyment to children, and to some of the grown-ups also. The device is based upon principles of static electricity well known to all of us.

The ballroom proper is a shallow box. One of the cedar cigar boxes intended for 25 cigars makes an excellent box for this purpose. In addition, all that is needed is a small quantity of tissue paper, some thin card, a sheet of celluloid as large as the box, paste and tacks.

Two strips of tissue paper are cut about

$\frac{3}{4}$ in. wide and 4 or 5 in. long. These strips are folded back and forth as shown in the illustration, at A. When both strips have been thus folded, the resulting square packets B are folded in the center, as at C, and one each cut as shown in the diagrams at the right and left of D. When the strips are unfolded, you will have two rows of tiny tissue-paper dolls holding hands. These will be of the two shapes shown, one strip of boys and one of girls.

One edge of the thin card (black has been used in this case, in order to show up better in the illustrations) is given a coat of paste, and the feet of one strip of dolls



Upper Left, Folding the Tissue; Above, the String of Dolls after Cutting Out; Left, Pasting the Dolls to the Edge of the Thin Card

pasted upon this card, the feet extending over the card about $\frac{1}{8}$ in. This is to provide the feet with a certain amount of weight to hold the figures upright.

With sharp scissors, cut this narrow strip from the edge of the card. Then the card is carefully cut along the outlines of the feet. When this is done, each foot will have a piece of cardboard about $\frac{1}{8}$ in. square pasted upon its extremity. The strip is now held above the box and the hands of the dolls cut apart, allowing each



Upper Right, Cutting the Dolls from the Strip; Below, Tacking the Celluloid Cover in Place; Left, How the Dolls Are Made to Dance in Their Ballroom

doll to fall into the box. This is done because the dolls are so fragile that they are handled only with difficulty.

About five boy and five girl figures will be enough for the box. The sheet of celluloid is now fastened to the top edges of the box with fine tacks or nails. This completes the toy, unless the constructor desires to ornament the outside of the box. The simplest way to do this is to stain the box, then glue on a cut-out of a couple dancing, and give the box a coat of varnish or clear lacquer.

If the finger tip, or a piece of silk held in the fingers, is rubbed across the celluloid once or twice, the dolls will jump up-

right, and if the box is then tapped gently with the fingers, the dolls will dance about in a lively manner. As the charge of electricity generated becomes dissipated, the dolls will waver and drop to the floor of the box, but a single stroke of the finger will bring them upright again, some of them leaping up and hanging suspended by their heads.

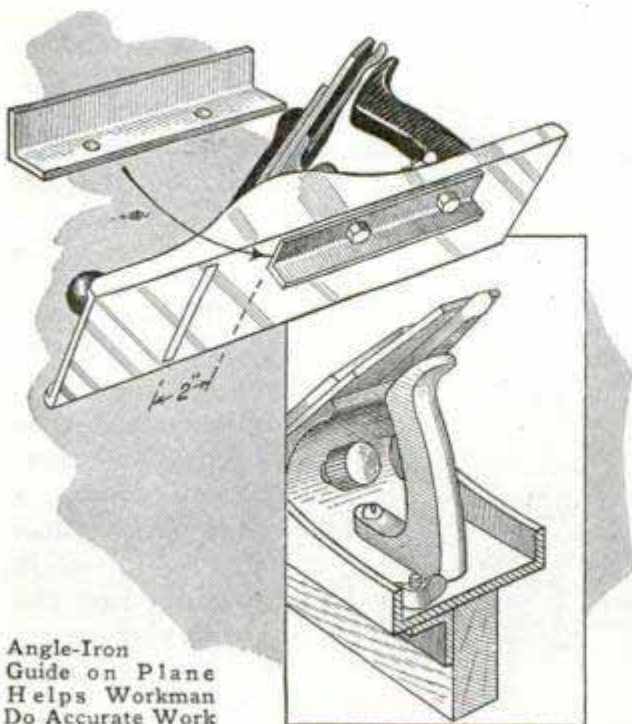
Thawing Out Frozen Auto Radiators

The quickest way to thaw out a frozen auto radiator is to pour hot water on the outside. Do not make the mistake of pouring the hot water into the radiator, as this will have little or no immediate effect. Pour the water around the tubes after having opened the drain cock. If steam is available, it can be used to greater advantage in the same way, but if there

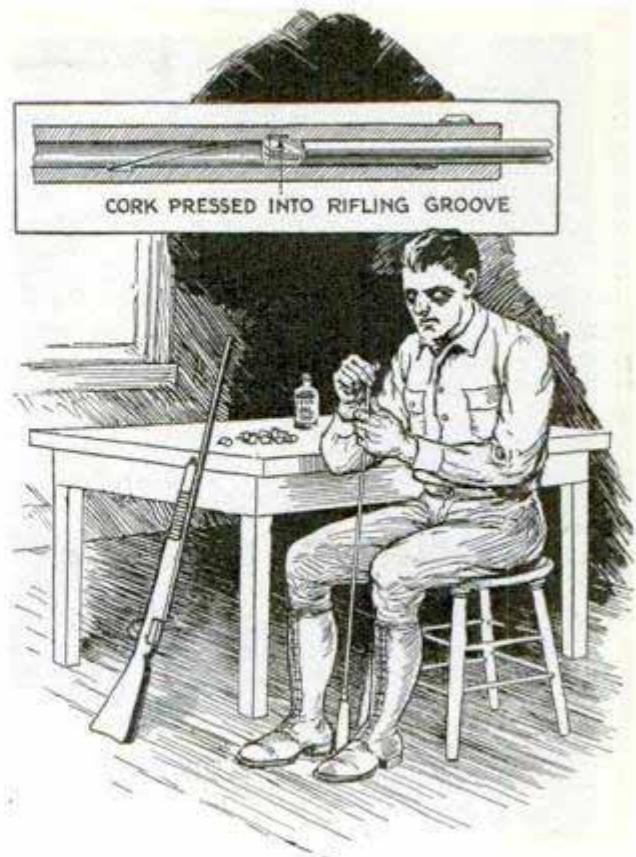
is no steam or hot water, throw a heavy blanket or cloth over the radiator and run the motor slowly, preferably with the fan disconnected. Take care, however, that the motor does not get too hot, or serious damage may result. If the sediment bulb under the gasoline tank becomes filled with water and freezes, soak a heavy piece of cloth in hot water and wrap it around this part until it thaws out. If water collects in the carburetor and freezes, the carburetor should be treated in the same way. Trouble of this kind causes difficult starting in cold weather, and a hot bath, such as just described, will sometimes do a lot more good than hours of cranking.—Glen F. Stillwell, Collinsville, Ill.

Detachable Plane Guide Aids in Squaring Work

In order to plane the edge of a piece of wood at perfect right angles to its face, the guide shown in the illustration will be found useful. It consists of a length of angle iron attached to the underside of the plane and parallel to its edge. Two holes are drilled through the guide and through the bottom of the plane to accommodate screws, which are held in place securely with wingnuts. The ends of the guide are slightly rounded to prevent marring the work. By tilting the blade the edge of the work can be cut at a slight bevel.—Albert Armyn, Astoria, N. Y.



Angle-Iron Guide on Plane Helps Workman Do Accurate Work



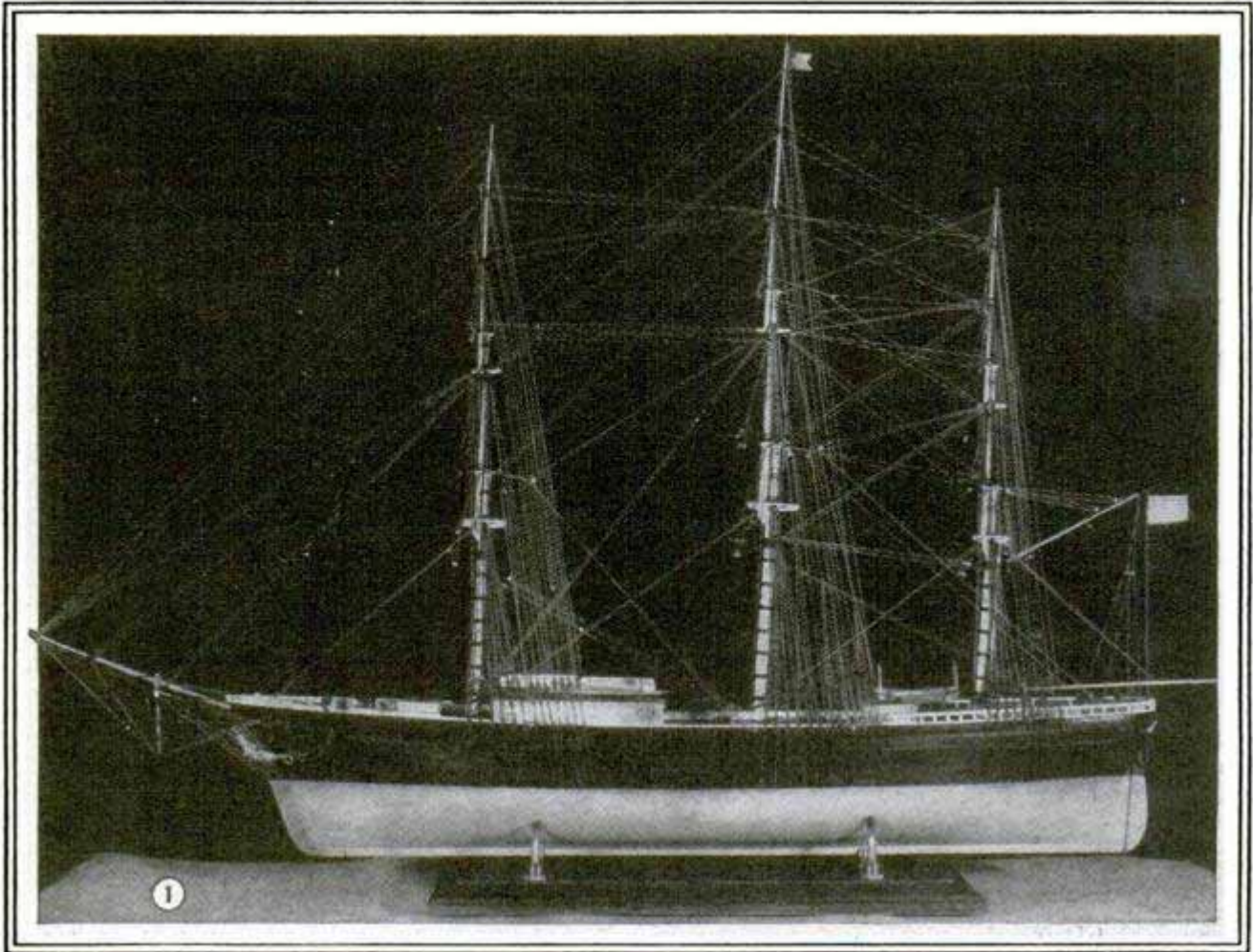
Rifles Can Be Thoroughly Cleaned by Pushing Corks through Them

Small Corks Used for Cleaning Rifle Barrel

Small corks make an excellent cleaner for rifle barrels. They should be slightly larger than the bore of the rifle and the larger end is pushed in first. The pressure of the ramrod against the cork will expand it slightly so that the rifling groove will be cleaned too. It has been found best to enter the cork at the breech end of the gun if its design permits. Small corks that are suitable for .22-caliber rifles, can be bought for a few cents, and larger ones for larger-size guns do not cost much more at groceries or drug stores.—Dick Cole, Los Angeles, Calif.

How to Clean an Electric Percolator

It is an easy matter to clean the inside of an electric coffee percolator. Put four heaping tablespoonfuls of salt in the coffee compartment, and fill the percolator with about as much water as when making coffee. Then put on the fire to boil and let the percolation go on for some time. This will remove the deposit on the interior and it will be found also that any grains of coffee which may have lodged in crevices have been loosened.



The "Flying Cloud" Contest

THE OUTCOME of the "Flying Cloud" contest was highly gratifying, as well as surprising. Surprising because of the general high quality of the models entered, and gratifying because of the large number of entries received. It may seem rather strange that the judges were surprised at the quality of the models, but, when it is considered that over ninety per cent of the contestants lived in inland towns, and had never seen a ship of any type, except in pictures, the reason for the reaction may be understood. Out of a total of 263 entries that arrived before the closing date, only

four models could be considered as poorly executed. The remainder, of course, fell into several classes: excellent, good and fair. Even the fair models, however, were excellent examples of the modeler's craft, as compared with the models one sees offered for sale in the stores, or compared

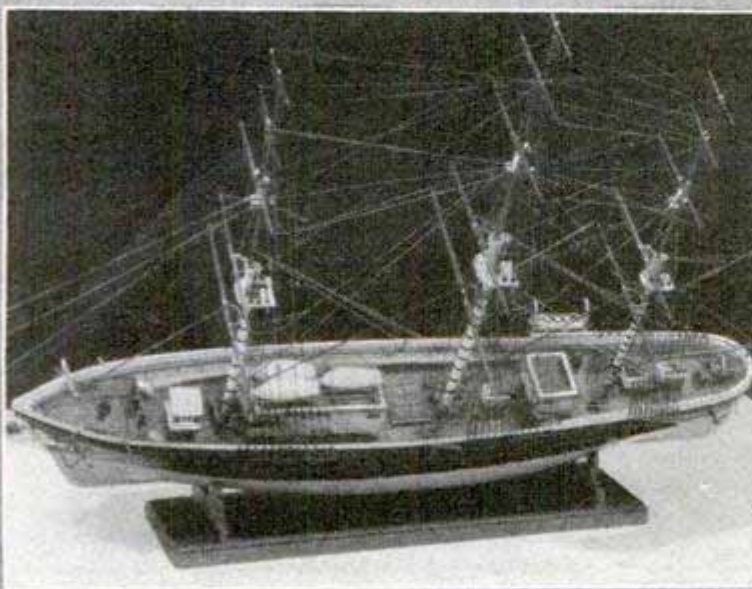
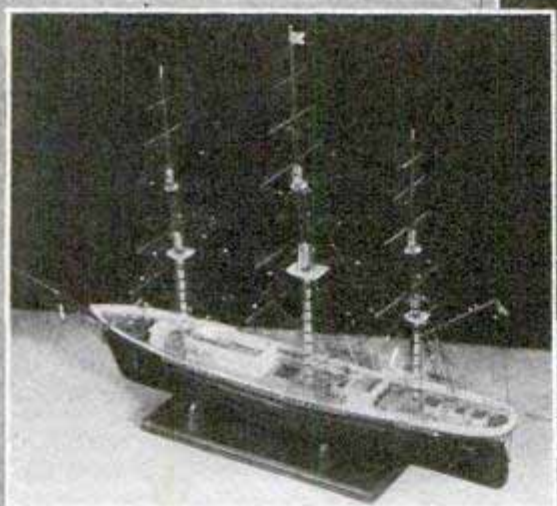
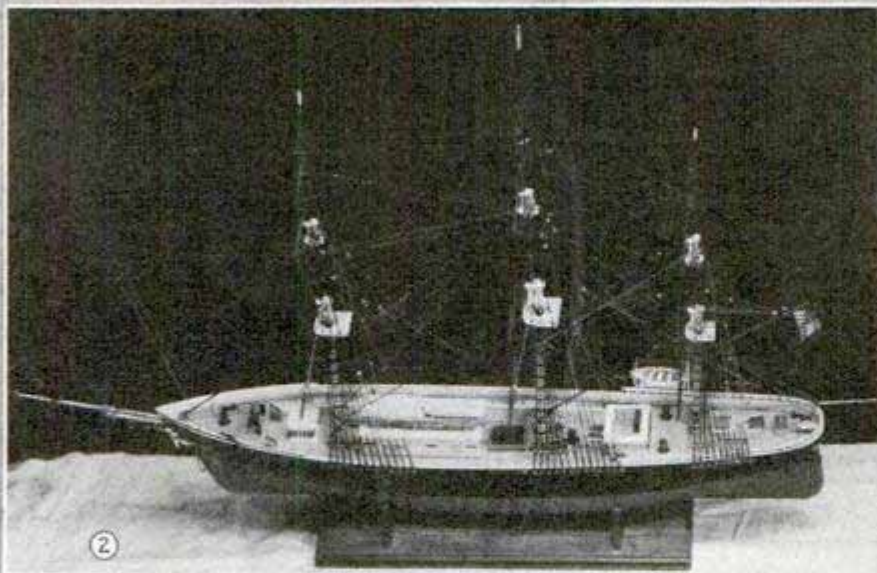
with the models one occasionally sees exhibited as the work of an "old salt."

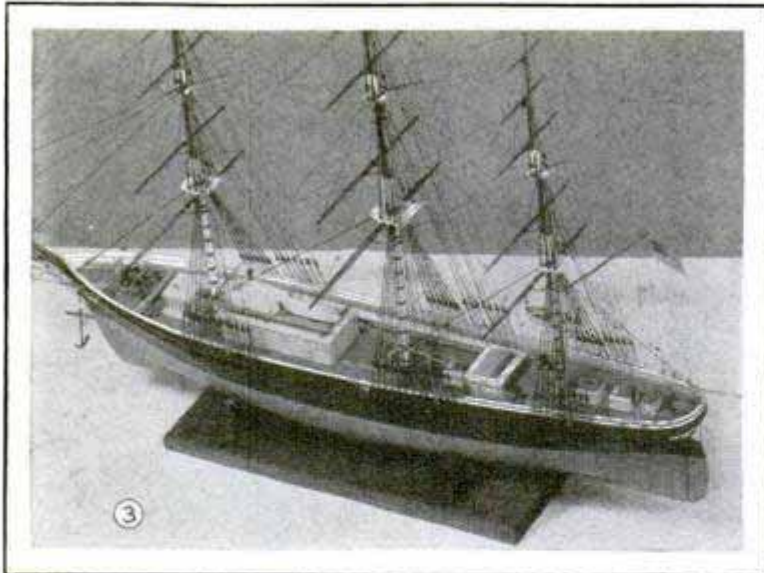
In judging, all small negatives were enlarged to a standard size, so as to give all contestants as equal a chance as possible, and the models were judged on the following scale: Accuracy, 30 points; general ap-

PRIZE WINNERS

1st, D. P. Brown, Dorchester, Mass.
2nd, Ivar Nordstrom, Falconer, N. Y.
3rd, L. J. Pitcher, Chicago, Ill.

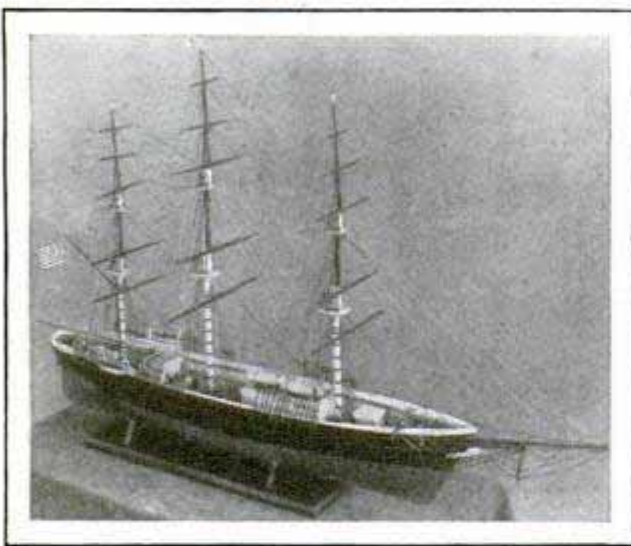
E. A. Gahl, Wauwatosa, Wis.
Dr. M. L. Rush, Meridian, Wis.
A. E. Warren, Burlington, Vt.
J. R. L. Hughes, Brownsburg, Ind.
G. F. Umpleby, Baltimore, Md.
W. G. Ahlers, Lansing, Mich.
Aug. Nelson, Portland, Oreg.
Fred. A. Craven, LaPorte, Ind.
E. R. McCarthy, Seattle, Wash.
W. F. Hillier, Lowell, Mass.
R. M. Johnson, Kansas City, Kans.
Oliver I. Ryon, Higganum, Conn.
A. C. Rymer, Washington, D. C.
Marshall M. Davis, Plainfield, Ill.
C. E. Marshall, Rockland, Me.
W. J. Herz, Reno, Nev.





pearance, 20 points; workmanship in deck fittings, 20 points; rigging, 20 points, and masts and spars, 10 points. The workmanship on the hull was considered in judging for accuracy, since the quality of the hull depended on the fidelity of the hull lines.

The faults most frequently found in the hull lines were the following: Too much or not enough sheer; line of sheer not smooth from end to end; line of bulwark curve uneven and bumpy; not enough flare at bow; bow cut down too sharp; stem inaccurately shaped; curves under counter too abrupt; stern too pointed or too square; too much "daylight" between rudder and sternpost, in other words, a



poor fit; hull curves not smoothly blended; a few photos showed the stem lines out of plumb. In the deck fittings, the main faults found were with the capstans, which were usually too clumsy;

paneling on deckhouses unevenly done and streaky, and occasionally one or two deck fittings were misplaced. The workmanship on the fittings, on the whole, was of a very high order.

The rigging was uniformly good. The faults found here were: Halyards improperly led; lanyards twisted; sheer poles omitted; upper stays slack; brace purchases twisted; backstays set up too tight, pulling masts out of line; lead of headstays wrong; chain ties too heavy; some lower stays were not doubled. Masts and spars were usually excellent,

the commonest fault found being that the spars were apt to be a little too much tapered. No attention was paid to yards that had been slewed around out of line, as the judges realized how easily this can be done accidentally while photographing. Some photos showed bad alinement of the masts, but mast and yard fittings, crane irons, jackstays, etc., showed that most of the builders were expert with the soldering iron.

The original list of prizes consisted of three major awards of \$100.00, \$50.00 and \$25.00, with gold, silver and bronze medals, respectively, followed by five awards of \$10.00 and five of \$5.00, with bronze medals, a total of thirteen prizes. When the number of models remaining in the contest had finally been reduced to nineteen, the real hard task of judging began. All were first-class examples, and it required careful, painstaking scrutiny to find the slight flaw in each one that relegated it to the background until the three winners were left. Then these had to be weighed and compared closely, point by point, until they were placed in the order of their merit. After the first three had been picked, it was found that there was nothing to choose between the remaining sixteen entries, so, in fairness, all were awarded \$10.00 and the bronze medal. A few of the prize-winning models are shown here, the first three being numbered in the order of the awards. It is unfortunate that the pictures do not begin to do justice to the excellence of these beautiful models, the makers of which may well be proud of their splendid workmanship.

*Wale Ob. Van Horne
420 Federal Bldg
Lincoln
nebr*

Keeping Brooder House Free from Rats

One of the best methods of keeping rats out of a brooder house is to break old pieces of glass into pieces about $\frac{1}{4}$ in. in size, and lay these on the ground outside of and next to the brooder house. The strip of ground covered with glass should be about 12 in. wide. Rats will not cross the glass barrier as they cut their feet in doing so, and I have found that they will not dig under it. Be sure not to trample the glass into the earth. When no longer needed, the glass can be swept up and put away until its use is again necessary.—Luther Strosnider, Onaga, Kans.



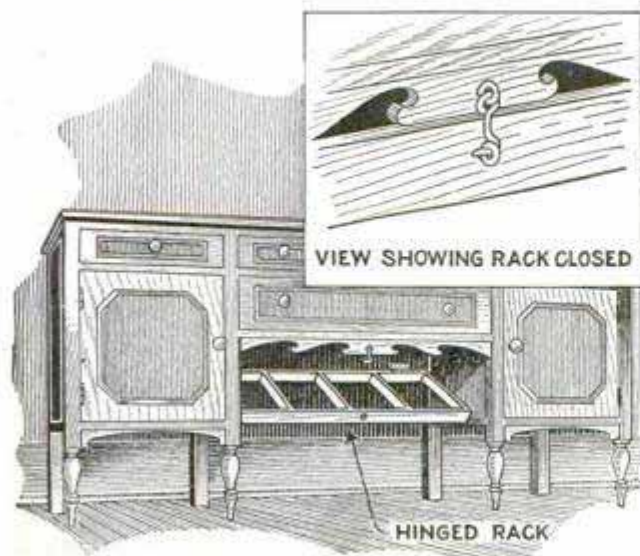
Old Tractor Wheel Belted to Small Generator Provides Electricity for the Farm House

Power Plant from Old Tractor Wheel

Used in conjunction with a concrete dam, an old tractor wheel makes a good water wheel, and has been found capable of delivering enough energy to supply electric current for a farm home, tests showing that approximately $\frac{1}{2}$ hp., or about 350 watts of electrical energy, are generated. The wheel is 5 ft. in diameter, and the blades, twenty in number, are 10 in. high and 20 in. long. Each blade is braced with lengths of light strap iron, both being held by small bolts. A turned steel shaft of suitable length runs through the hub, the shaft being keyed in place, and rests in two babbitted bearings. A pulley, 3 ft. in diameter, is keyed to one end of the shaft, and this is belted to a 1-in. pulley on the generator shaft. When the water wheel makes one revolution per second, the speed of the generator is 2,000 r.p.m. The latter is housed to protect it from the weather, and is set high enough so that occasional flood water will not reach it. Storage batteries are used to "float on the line" in order to supply a steady current and to provide a reservoir for slight overloads. The flume, made of concrete, is a little wider than the wheel, so that all the energy possible is obtained, which would not be the case if the flume were narrower than the wheel. A spillway is provided at the other end of the dam.

Storing Asbestos Table Mats

Asbestos table mats can be conveniently stored, out of sight, on a light wooden rack hinged to the back of the buffet, a few inches below the center drawer, as shown in the illustration. The rack is made of 1 by $\frac{1}{4}$ -in. hardwood strips, and a small hook, attached to the underside of the drawer, holds the rack in position when the mats are stored on it.—S. A. Pease, Wauwatosa, Wis.



VIEW SHOWING RACK CLOSED

HINGED RACK

Hinged Rack under Buffet Drawer Makes Storage Place for Table Mats



In the Absence of Regular Stretchers, the Curtain Can Be Mounted on the Side of the House

Improvised Curtain Stretcher

One woman who wanted to wash her lace curtains but had no stretcher, solved the problem in a very simple way. She merely tacked a bed sheet to the side of the house and pinned the curtains to it as shown. After they had dried, the curtains were just as good as though a regular stretcher had been used. Of course, the bed sheet is not essential; any large piece of clean cloth will do, provided it is larger than the curtains.

Spark Plugs Often Cause of Missing Motor

When your auto misses determine first of all whether the miss is steady or irregular. An irregular miss had best be left for an expert to find and remedy, but a steady miss is usually easy to find, and it should be remedied at once as uneven running soon damages the motor. When the miss is steady, short-circuit the spark plugs one by one while the engine is running slowly. Use a screwdriver to do this, being sure to hold the blade against the cylinder wall or against any metal part of the motor, and then, while keeping this metal contact, swing the blade over so that it almost touches the top of the spark plug to be tested. When the gap between

the screwdriver blade and the end of the spark plug is about $\frac{1}{8}$ or $\frac{3}{16}$ in., a spark should arc across it regularly. If no spark is noticed, the spark plug is most likely short-circuited inside and should be removed and cleaned thoroughly, or replaced with a new plug. If the blade of the screwdriver is actually touched to the end of the spark plug while testing the latter, it will prevent the spark plug from functioning at all. When you touch a plug in this way and you notice that the motor runs still more unevenly, the spark plug is evidently in good condition. But if it makes no difference in the running of the motor, the plug is defective or dirty, or the valves in that cylinder are not properly seated. If, after the above tests, you are still in doubt as to what plug is causing the trouble, remove all the plugs, and their condition will betray them. If they are wet with oil and gasoline or heavily carbonized, they cannot perform perfectly. It is a good idea to keep an extra plug on hand so that when trouble is experienced a spare plug can be installed until there is leisure to clean the dirty one.—Glen F. Stillwell, Collinsville, Ill.

Repairing Bath Spray



To prevent a bath spray from coming off the end of the rubber tubing, as it often does when the water is turned on full force, try the remedy shown in the illustration; simply cut off a $\frac{3}{4}$ -in. piece of the tubing and slip it over the end of the latter, as shown. Then a double thickness of rubber will hold the spray securely.—R. B. Ware, Wadsworth, Ohio.

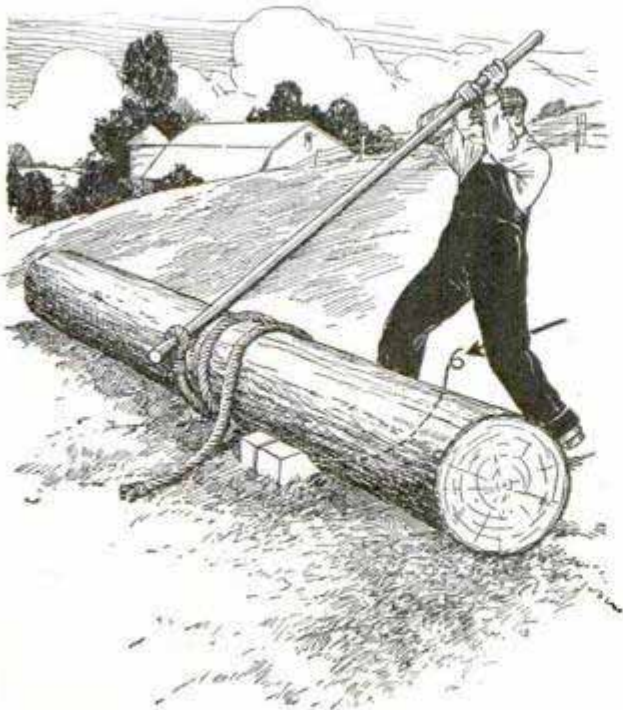
Eliminating Bedbugs

When bothered with bedbugs, rub the slats and joints of the bed with a mixture consisting of equal parts of turpentine and kerosene. Where there are many bugs

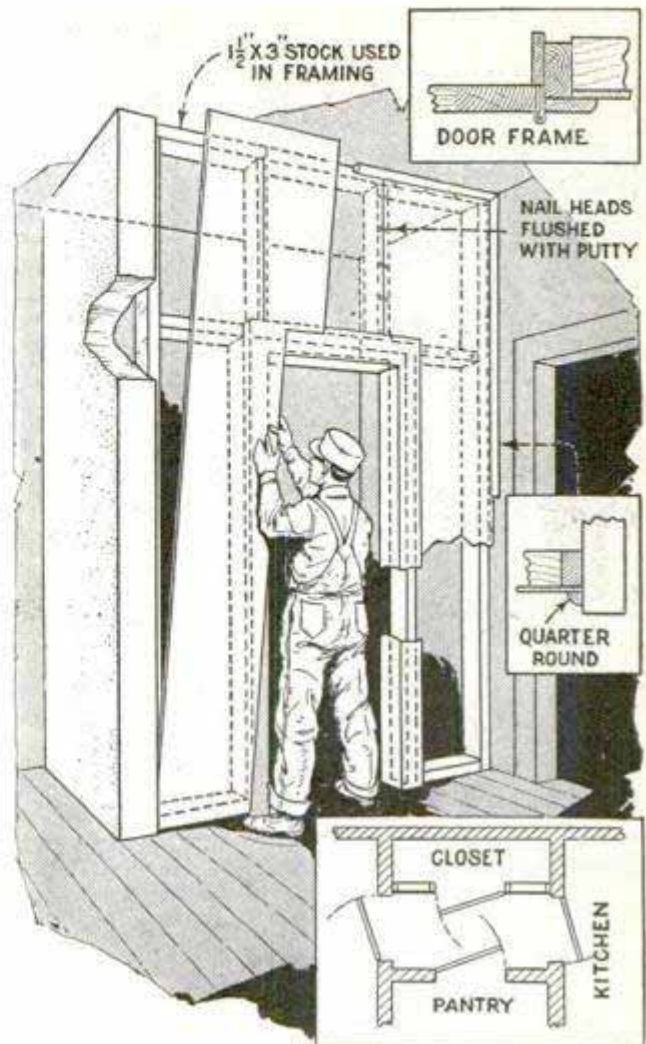
squirt the mixture into every crack in the room. An oilcan is useful for this purpose. To prevent more bugs from invading the bed after the treatment, set the legs in fruit-jar lids containing some of the mixture.—A. T. Bowden, Ottawa, Kans.

Rolling Heavy Logs Single-Handed

You can roll a heavy log single-handed on level ground or up a slight grade by the method shown in the illustration. The device used for this purpose consists of a stout pole or iron pipe, about 2 in. in diameter, a length of heavy rope, about 15 ft. long, a block, and a length of light rope such as sash cord. The heavy rope is snubbed a few times around the log so that the pole, which is slipped through a loop made at the end of the rope, is in the position indicated. Pulling down on the pole will roll the log toward the worker. After the pole has been pushed down as far as possible, the block is pulled up against the log to prevent it from rolling back again. In order that the worker may be able to pull the block up every time the log is rolled forward, the light rope is tied to the block, this rope being slipped under the log before starting the work. For the second and subsequent "bites," the heavy rope must, of course, be readjusted.—Sam Weidman, Lowell, Wash.



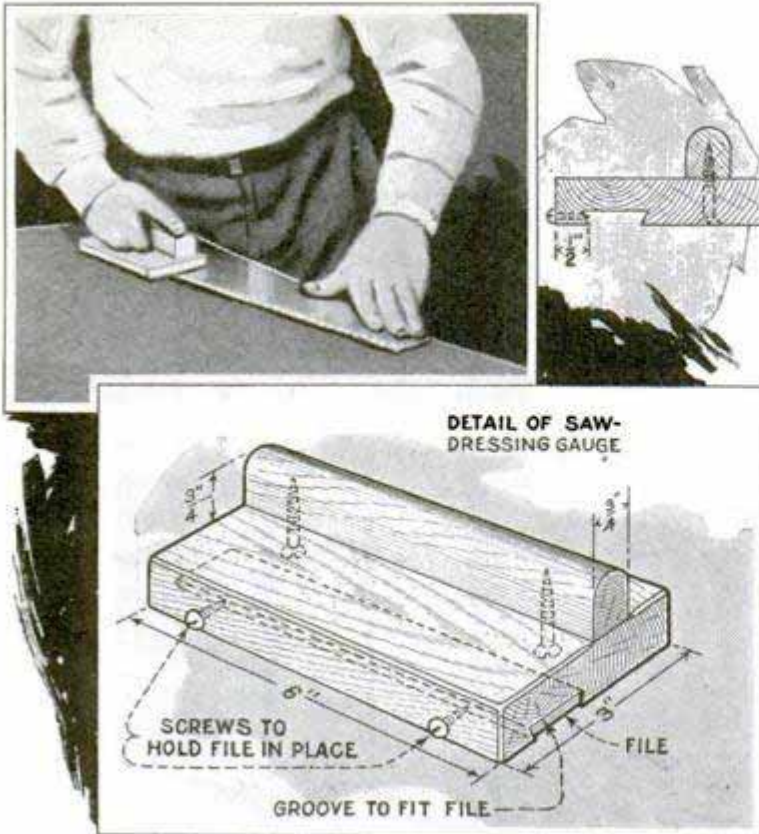
One Man Can Roll a Heavy Log Uphill or on Level Ground by This Method



Closets Made of Wallboard and Light Studs Are Cheap and Easy to Put Up

Wallboard Used for Making Closets

The owner of a Washington home requested several contractors to give estimates on closets in some rooms of his residence. One of them offered to make them at \$15 each, and this figure was about one-third the estimates of the others. The reason for this was that the use of wallboard was suggested by the low bidder, and the construction of the closets was so simple that every home owner who is handy with tools can build them himself. The framing consisted of 1 1/2 by 3-in. studs, widely spaced, but nevertheless making a rigid structure for the purpose, and resulting in less wasted space than would be the case if 4-in. studs were used. The doors were bought secondhand. In mounting the wallboard two sections were cut out to make one side, the joint being made over the door as shown in the illustration. The corners at the wall were finished with quarter-round stock. No interior finishing was desired.



Easily Made Device Which Will Be Found Helpful in Properly Side-Dressing Handsaws

Gauge for Side-Dressing Handsaws

Ordinarily the sharpening of saws is a difficult task for the amateur. The accuracy and smoothness with which the sharpened saw cuts depends as much on the operation of side dressing as it does on the filing of the teeth. A slight variation in the setting of the teeth causes the saw to cut roughly and to "run," and it is therefore necessary to side-dress them with a slightly worn file. Doing this by hand is not likely to produce an accurate job as it tends to dress the teeth unevenly. It is much better, therefore, to use the gauge shown in the illustration. It consists of a hardwood block, with a groove plowed on one side to receive a file or a piece of a file, which is held in place by means of two brass screws inserted in the edge of the block at right angles to the groove. A handle is attached parallel to the groove which holds the file. Tilting the gauge so that the block does not ride on the saw destroys its efficiency. The difference between the depth of the groove and the thickness of the file represents the amount of set that will result. In case the gauge is to be used for saws needing varying degrees of set, simply cut the groove deep

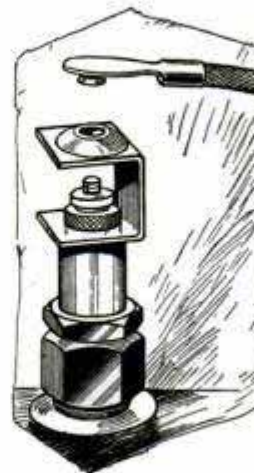
enough to take care of the greatest set, and use shims to raise the file for the smallest set. Saws to be used in dry hardwood require very little set, while saws that are to be used in soft, wet wood need more set, besides having coarser teeth.—K. L. Julson, Butte, Mont.

Phonograph Crank for Winding Spring of Movie Camera

The writer makes extensive use of a small movie camera in which the film is drawn through the shutter by means of a coiled spring similar to a clock spring. It is necessary to rewind the spring at the end of each 40 ft. of film exposure, and for this purpose a small hand key is provided. Rewinding the spring with this key is a slow procedure and rather tiresome on the wrist. A phonograph crank, altered to fit the

socket of the movie camera, was substituted, and the rewinding can now be done in about one-tenth of the time otherwise required. To make the phonograph key fit the winding socket, the threaded end of the key was cut off and filed square to the same size as the regular winding key of the camera.—John Edwin Hoag, Honolulu, H. T.

Snap Terminals for Spark Plugs



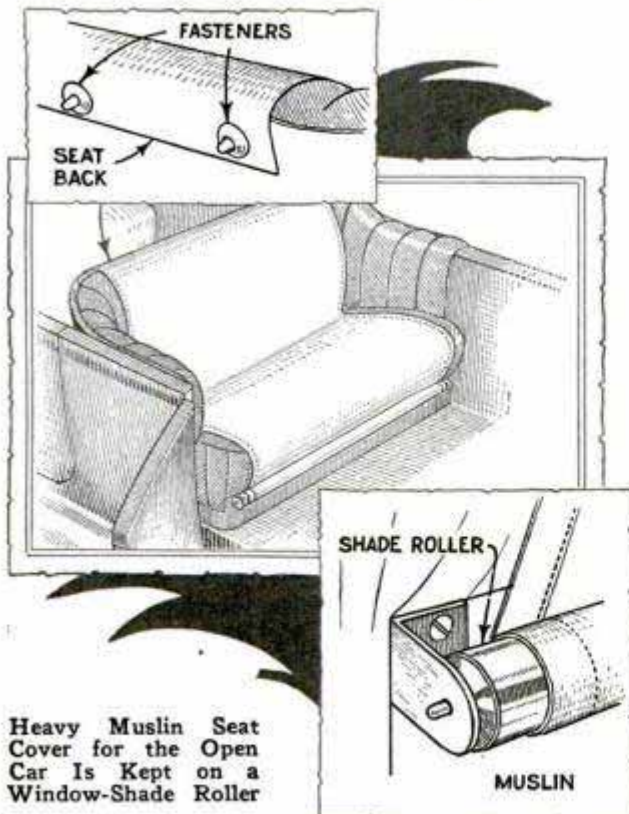
Auto-curtain snaps can be used to make terminals for spark plugs as shown in the drawing. Besides being quickly attached or removed, these terminals are especially useful as they do not loosen under heavy vibration. One part of the snap is soldered onto the wire terminal of the plug, while the other part is soldered to a small piece of brass, which is bent to the shape indicated and securely attached to the spark plug.—H. H. Hoover, Chickasha, Okla.

Screen Keeps Gravel Out of Roof Gutters

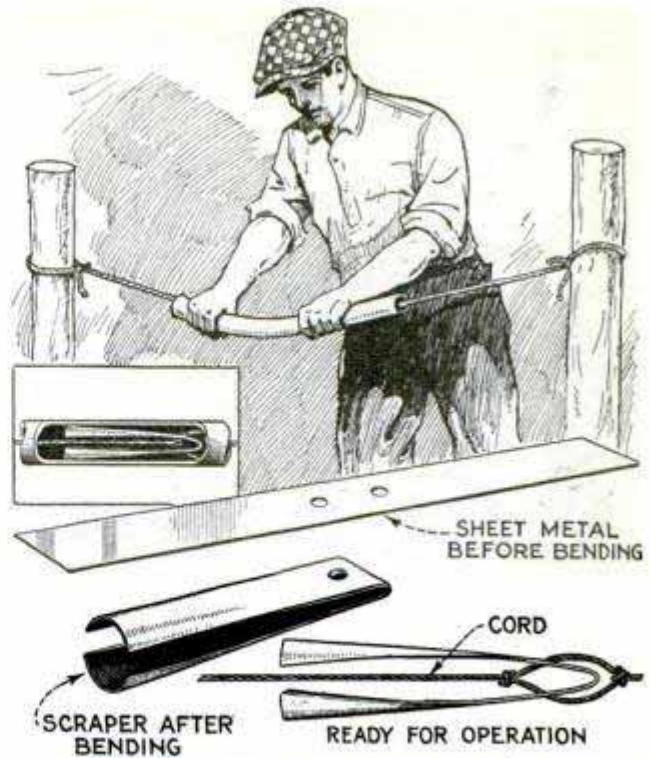
Roofs on many factories and homes have very little pitch, and in many cases the heavy tar paper is covered with a combination of slag and pitch. Although this makes a good roof, the slag often gets loose and is carried down into the gutters, clogging the entrance into the downspouts. The result is that the rain runs over the edge of the gutter and down the side of the building, often entering it and causing damage to the interior. We overcame this trouble by providing a screen guard on the lower edge of the roof to prevent the slag from getting into the gutter. A collection of slag against the screen, however, did not prevent the rain from seeping through it into the gutter.—O. S. Sprout, Lancaster, Pa.

Shade Roller Holds Auto-Seat Cover

To provide clean and dry seats for the open car the roll-away cover shown in the drawing will be found convenient. It consists of a piece of heavy muslin, large enough to cover the seat. One edge is tacked to a shade roller which is mounted on brackets attached to the front, lower part of the seat, as indicated. The other edge has eyelets to fit snap fasteners attached to the back near the top.



Heavy Muslin Seat Cover for the Open Car Is Kept on a Window-Shade Roller



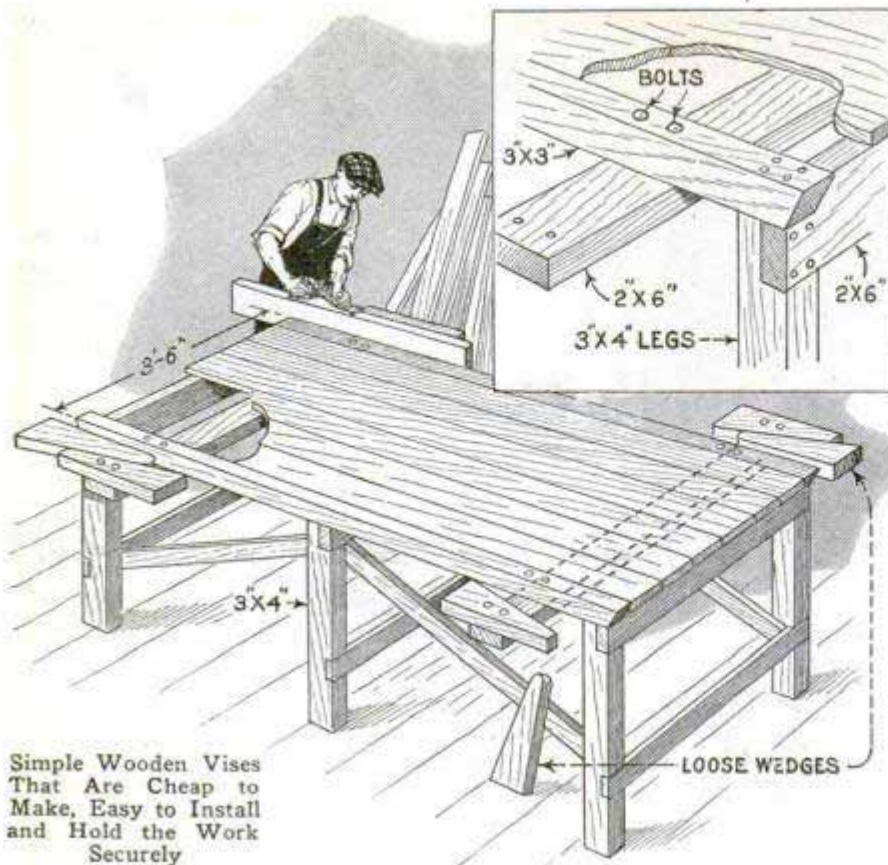
Clogged Automobile Exhaust Pipes Can Be Easily Scraped Clean on This Handy Device

Simple Device for Scraping Carbon from Exhaust Pipes

Cleaning out an automobile exhaust pipe from end to end, removing all the carbon, can be readily done by means of the device shown in the drawing. A strip of sheet iron is bent to a U-shape, the free ends being curved to fit the inside of the pipe. Holes drilled through the scraper, near the bend, provide for tying it securely in the center of a length of rope as indicated, the ends of the rope being fastened to suitable supports. In use, the exhaust pipe is slipped over the rope and the scraper, and by moving the pipe back and forth, the carbon will be removed in a short time.—G. A. Luers, Washington, District of Columbia.

A Good Silverware Polish

Powdered chalk is the principal ingredient in nearly all semiliquid polishes, as the chief purpose of a polish is to act as a gentle abrasive. A good silver polish consists of equal parts of powdered chalk and hyposulphite of soda, well mixed in distilled water. First add just enough water to the powder so that the mixture makes a sort of mortar, then gradually add more water until it reaches the consistency of a paste. In this form it is most suitable for the purpose.



Simple Wooden Vises That Are Cheap to Make, Easy to Install and Hold the Work Securely

Simple Vise for Workbench

In my manual-training department, I have met the need for simple vises on the workbenches as shown in the illustration. A similar vise can be installed on almost any home owner's bench at almost no expense. Each vise consists of a crosspiece projecting from the side of the bench top about 8 in. or 1 ft., the crosspiece being nailed or bolted on the underside. In case two vises are used, one on each side of the bench, a single crosspiece will do for both. A 10-in. length of 2 by 6-in. wood is sawed in half diagonally, one-half being nailed to the end of the crosspiece as indicated and the other piece being used as a wedge.—L. B. Rogers, Toungoo, Burma.

Trimming Saxophone Reeds

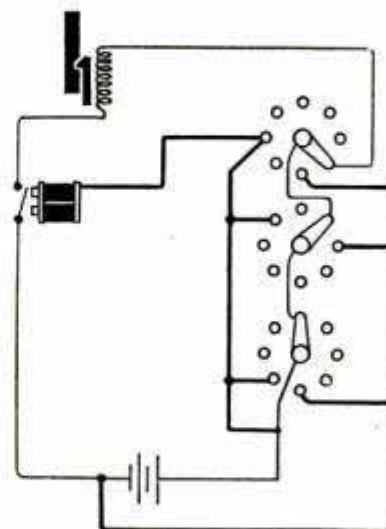
Players of the saxophone, clarinet, oboe and other reed instruments often find difficulty in preventing the cane reeds from splitting during the process of trimming them with a pair of scissors or a knife. To avoid this splitting, trimming by burning the edge off will be found highly satisfactory. Take a small metal disk and hold it against the reed with a pair of pliers, letting the portion to be trimmed off

project over the edge. With the disk on the underside, hold a lighted match below it so that the flame burns off the projecting part of the reed.—Thos. Goudie, Kirkcaldy, Scotland.

Fool-Proof Door Lock

On page 328 of the August, 1928, issue of Popular Mechanics was described an electric door lock operated by inductance switches set at a certain combination to complete a circuit. However, this lock is not fool-proof, as it can be opened by using three pieces of bare copper wire and putting them against each of the three dials so that

they touch every contact point and also the switch lever. A complete circuit is then established and the lock will operate. To overcome this trouble a device might be used to prevent opening the lock by causing the circuit to break when any two of the contacts are connected. Get an old electric bell, remove the coil lead that is grounded to the frame and connect it to one of the contact points as shown in the diagram. This contact point is connected to any contact on each of the other switches, and to one side of the



battery. The armature is then connected in the circuit as shown. If the contacts on any one of the switches are short-circuited, the coils on the re-connected bell attract the armature and the circuit to

the lock will be broken.—E. F. Seaman, Birmingham, Ala.

SHOP NOTES



All Shop Notes published in 1928, in book form—Fifty Cents—from our Book Department

Dadoing on Small Power Saws

A SIX-INCH dado head, cutting grooves from $\frac{1}{8}$ to $\frac{5}{8}$ in. wide, will be found a very useful addition to the equipment of the small power saws and "home workshops" now so deservedly popular, as it saves a lot of hand work. On narrow stock, the crosscut guide furnished with the ma-

chine forms a convenient and sufficiently accurate guide for use when cutting across the grain, but, when the worker finds it necessary to dado across boards of 8 or 10-in. width, the ordinary crosscut guide is useless. The tongue of the guide is so short that it barely enters the groove in

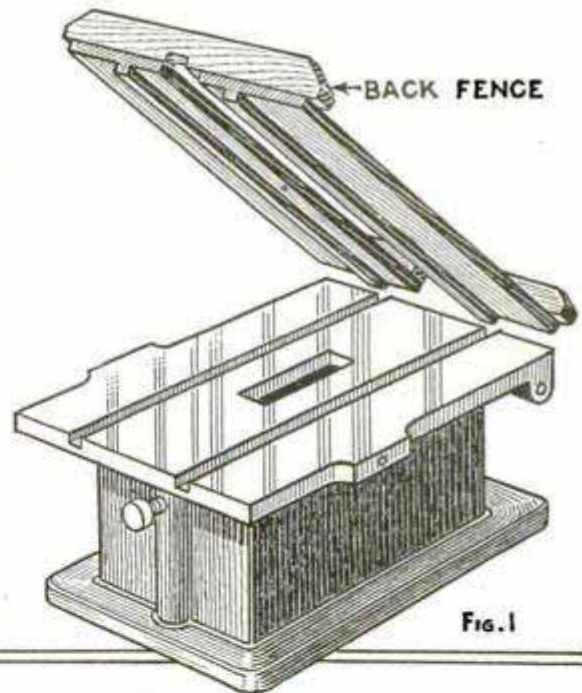
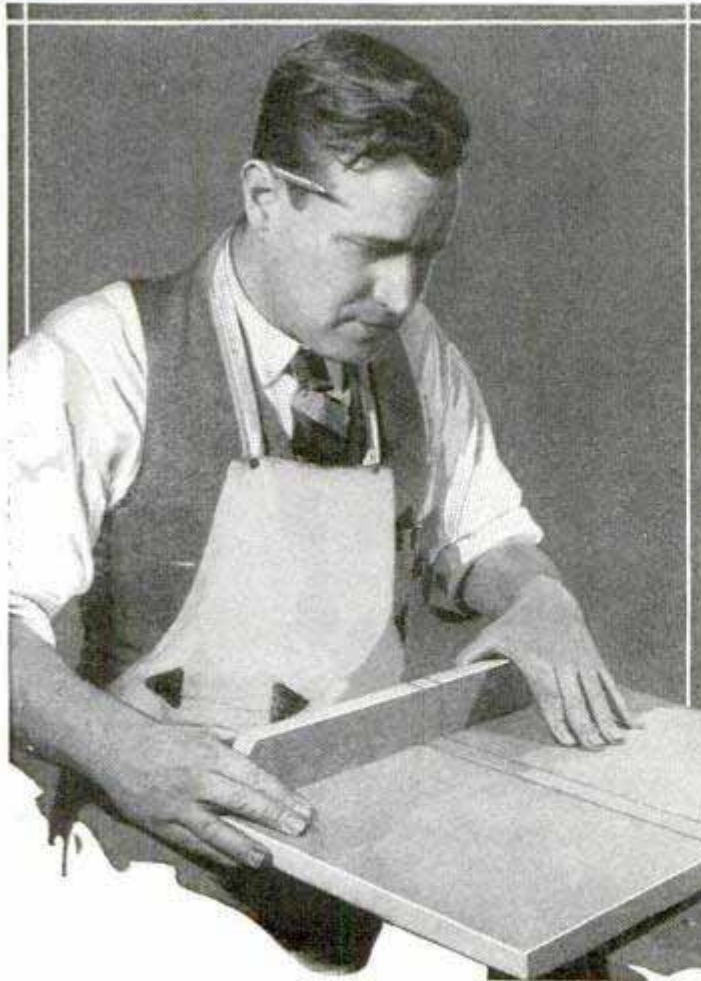
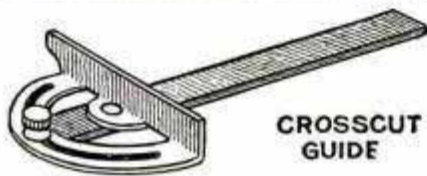


Fig. 1. Saw Table with Finished Auxiliary Table above It; Left, Dadoing with the Table; Note the Lines Squared across the Work

the table, and consequently it is almost impossible to guide the work properly to insure a square cut. It is, of course, easy enough to fit a longer tongue, but a better attachment for the purpose is the auxiliary table shown in the illustrations.

From a piece of well-seasoned hardwood, $\frac{1}{2}$ or $\frac{3}{4}$ in. thick by 11 in. wide, rip out two pieces $16\frac{1}{2}$ in. long. These sizes are given for a 12 by 16-in. saw table, and may be increased or decreased to suit. Plane the pieces true and out of wind. Cut two fences out of the same material, one $2\frac{1}{2}$ in. wide, the other 2 in., 16 and 12 in. long, respectively. Cut two hardwood strips, the same width and thickness as the guide grooves in the saw table,

clamp the work and drive home the remaining screws; next screw on the narrow fence at the other end of the table; this need not be squared with the saw.

Put the dado head on the machine, set for the widest groove it will cut; set the auxiliary table in place, and run the dado head through both fences, so as to cut a groove, about $\frac{3}{4}$ in. deep. In line with the right-hand edge of the groove in the wide fence, looking from the saw side,

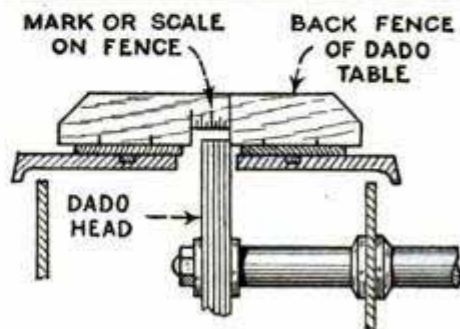
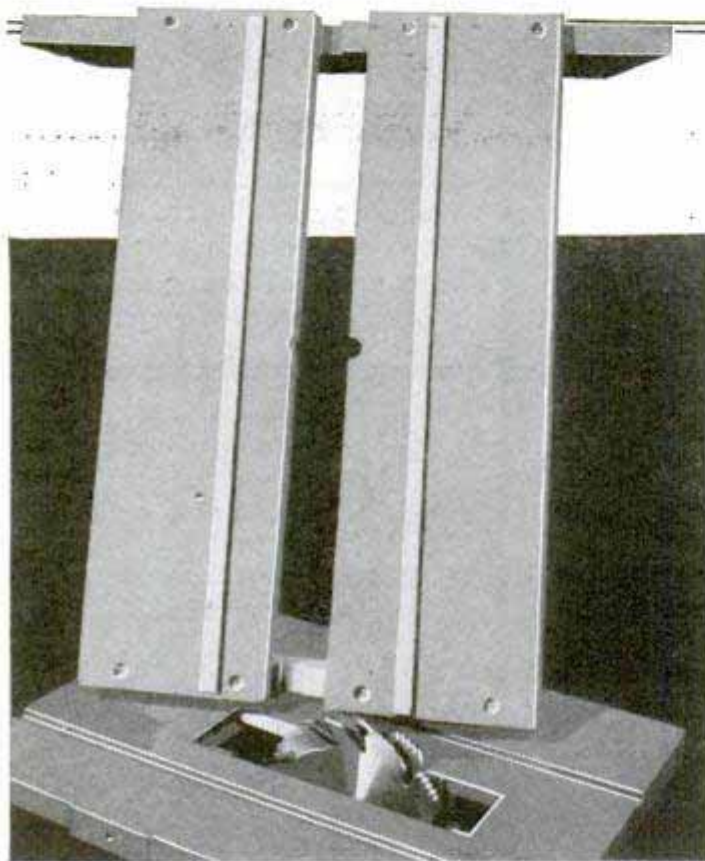


Fig. 2

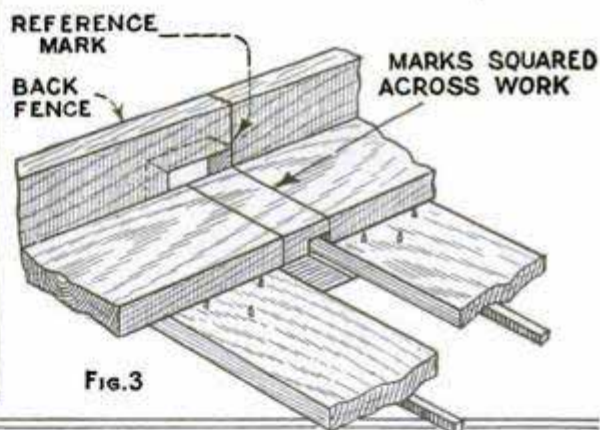
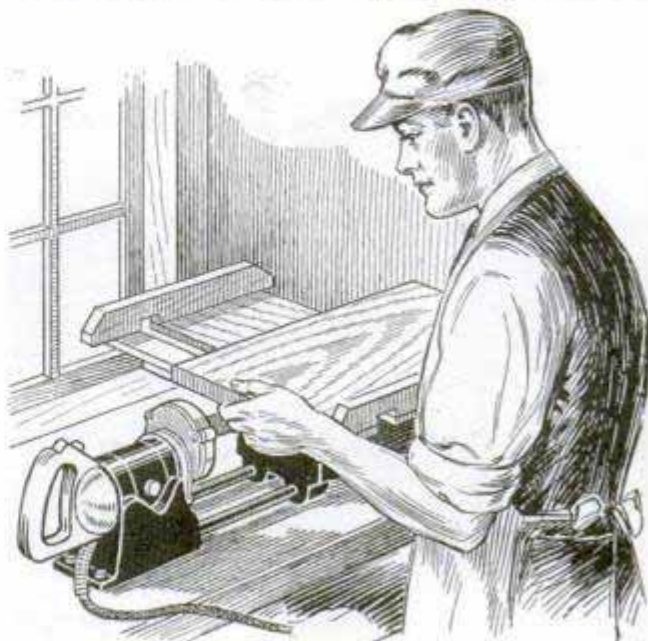


Fig. 3

Fig. 2. Section through Saw Table, Showing Relation of Dado Head to Fence; Fig. 3. Cutting a Wide Dado in Two Sections

and make them a good fit in the grooves. Lay the strips in the grooves, with the $5\frac{1}{2}$ -in.-wide pieces on top of them. Keep the latter pieces 1 in. apart and parallel to the saw, and mark the position of the strips. Glue and brad the strips to the underside of the pieces. (See Fig. 1, and photo to the left of Fig. 2.)

Drill the pieces for No. 12 screws to hold the fences, and counterbore on the underside for the screw heads. Center the wide fence on the table pieces, at the front end, and set one screw, making it fairly tight. Set the assembly on the saw table and square the fence carefully with the saw. Tighten the screw when square, then



run a knife and pencil mark across the fence to serve as a reference mark. Drive a few small brads into the surface of the table pieces, cut off the heads, and file to points, as shown in Fig. 3. These are not essential, but are an aid in holding the work.

When marking off for dados, the lines must be squared across the side opposite to that on which the dado is to be cut. Then, if the work is set against the back fence with the line to the reference mark on the fence, the dado will be cut in the proper place and square across the work. If wider dados are to be cut than the largest groove for which the dado head can be set, the reference mark is useful again, as, after the work has been run over the dado head once, cutting out part of the groove, the work may be shifted endwise and run over again, measuring to the reference mark for the second and succeeding cuts. An improvement on the simple reference mark would be a portion of an old rule let into the fence, with one of the inch marks on the edge of the groove, but the simple mark will serve well enough for occasional work.

A reference to the accompanying illustrations will make the construction and use of the table clear. A little alteration in design may be necessary for different saws; for example, on some home workshops, the saw is set near the left-hand edge of the table, as in the illustration below Fig. 3, and there is a single groove in the table. In that case, one wide and one narrow strip are used for the table, and a



Squaring Up the Back Fence with the Dado Head before Screwing It Fast; This Is Important

single guide strip. Other tables have no grooves at all, and on these the auxiliary table may be guided on the edges of the saw table. The most important thing to observe is to make the back fence, against which the work is pressed, exactly square with the dado head or saw. The attachment is also of use for crosscutting wide boards, when the usual guide is also somewhat of a nuisance.

Cardboard Tweezer for Holding Balls

For handling steel balls of the smaller sizes a pair of tweezers can readily be made as shown in the photo. Take a fairly stiff piece of thin cardboard, bend it over to the shape of a pair of tweezers and slip a paper clip of suitable size on each end. It is a good idea to bend the ends double to give a firm support for the clips. The circular ends of the clips will fit the balls and when one is picked up,



it will be held securely. Such a pair of tweezers has been found very handy for sorting balls or dropping them down into places where it is difficult to do this with the fingers. A third clip, used as shown, will keep the balls from rolling about the bench.

☛ A starting-crank spring of a model-T Ford, applied to the front-wheel brake expander of a model-A, will keep the expander from jumping up and down on rough roads.



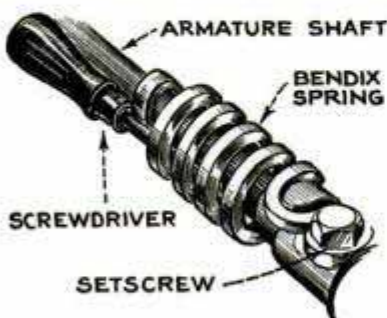
Homemade Floor Wiper Facilitates Janitor's Work of Cleaning Floors

Handy Floor Wiper for Janitors

In a large office building, the janitor uses the simple device shown in the drawing for wiping down the corridor floors. There are fifteen floors in the building, and with this device he has been able to handle alone all the work, which was formerly done by two persons using ordinary methods. The frame of the wiper is made of 2 by 4-in. stock, a swivel section being provided for the attachment of a broom handle. The frame, weighing about 20 lb., is set on an old folded blanket which is then pushed over the floor.

Preventing Kink in Bendix Spring

When installing a Bendix spring, the end of the spring tends to become twisted

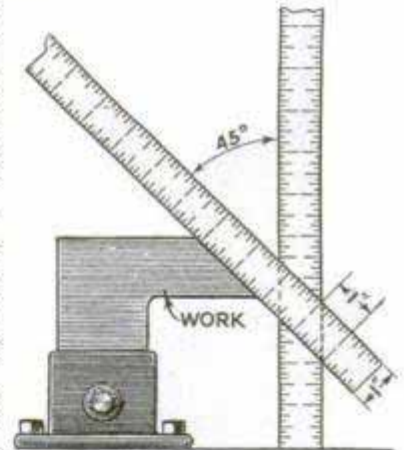


to the right as the screw is tightened. The spring is then pulled to one side and does not follow the armature shaft. The inner setscrew is more likely to cause this twist than the outer. This screw and spring end should be straight when installed, as they need be removed only when a spring is broken.

The spring can be kept straight while tightening the screw, by placing a screwdriver between the spring and shaft, on the left side when seen from above and facing away from the starting motor.

Improved Protractor Is Made from Two Scales

As the 45° angle is used most in machine shops, it is handy to know how it can be laid off accurately with two rules in the absence of a regular protractor. To do this, I use two standard 12-in. scales, which are exactly 1 in. wide. A line drawn from an inch mark on one side of the scale to the next inch mark on the opposite side, as indicated by the dotted line, would be at a 45° angle to the side of the scale. The second scale is laid across the first in this way and then both sides of the scales will lie at a 45° angle to each other. A scale $\frac{3}{4}$ in. in width can also be used, but in this case the edge of the second scale is laid across the first so that it runs from an inch mark to the $\frac{3}{4}$ -in. mark in the next higher inch division, or to the $\frac{1}{4}$ -in. mark in the next lower inch division. It is, of course, advisable to clamp the scales together when in use, to avoid slipping.—Harry Moore, Hamilton, Can.



Curing Efflorescence on Brick

Efflorescence, or white deposit on brickwork, has been a source of trouble and worry to builders and architects for years. It was long held that this deposit was caused by salts within the brick and that alternate wetting and drying of the wall caused the salts to be drawn to the surface and deposited in the form of crystals. A large brick-manufacturing company in the east has found a practical remedy for the trouble, and, incidentally, proved that it does not lie in the bricks at all, but in the mortar. If, instead of the ordinary

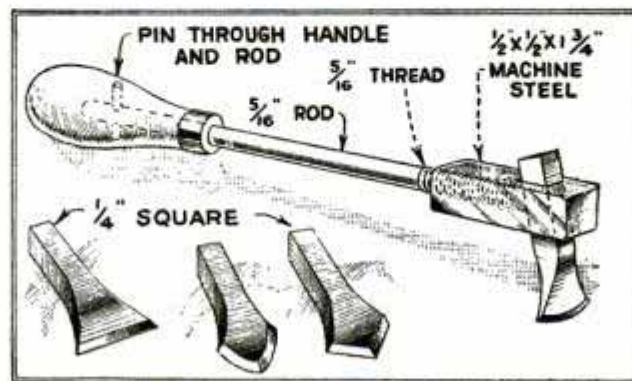
portland-cement mortar, the following formula is used, no efflorescence will appear on the masonry: 1 part cement, $\frac{3}{4}$ part lime and 4 parts sand. If a stronger mortar is required, use 1 part cement, $\frac{3}{4}$ part lime and 3 parts sand. The lime changes the soluble salts in the cement into insoluble calcium salts, which are fixed in the mortar and, therefore, cannot dissolve and discolor the masonry.

Grouting Small Machines

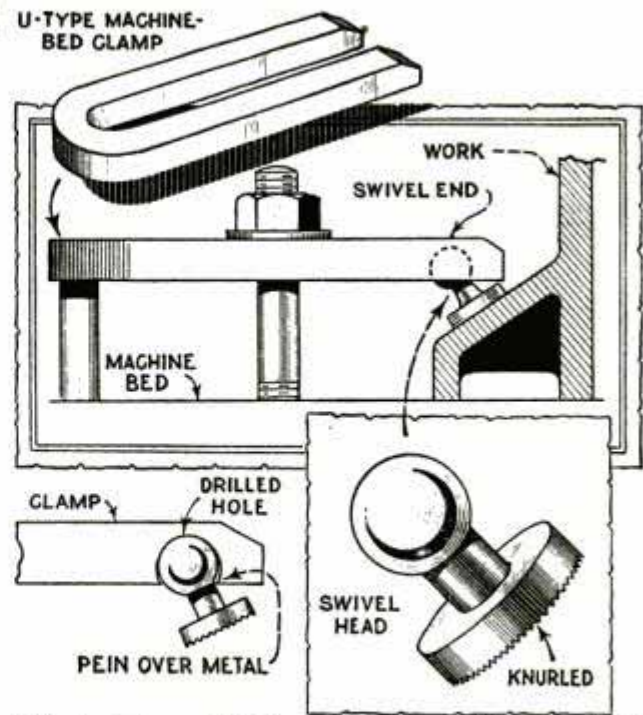
There are only a few substances that are suitable for grouting small machines after they have been set level. It will probably surprise many to know that plaster of paris can be used to great advantage for this purpose, as it will dry quickly and, if given time, have greater load capacity than would be supposed possible. When mixed in the proportion of one-half its weight in water, it will sustain a load of 500 lb. per sq. in. after setting only one hour. When 24 or 30 hours have elapsed, its strength rises to 1,000 lb. per sq. in., and after a few days, it will be 2,300 lb. per square inch.—L. H. Georger, Buffalo, N. Y.

Adjustable Carbon Scraper

For removing carbon from the cylinder heads of motors, for scraping out bearings, or for other purposes, I have found the adjustable scraper shown in the drawing very useful. A suitable handle is pinned to a $\frac{5}{16}$ -in. rod, and a piece of machine steel, $\frac{1}{2}$ by $\frac{1}{2}$ by $1\frac{3}{4}$ in. in dimensions, is screwed on the other end, the rod being threaded and the piece of steel tapped for this purpose. A $\frac{1}{4}$ -in. square hole is cut at an angle in the steel endpiece, as shown, to receive the scraper. The rod is then screwed against the scraper to hold it in place. It is a good idea to provide a number of scrapers with edges of different shapes, as shown in the illustration.—Henry S. Laraby, East Haven, Conn.



Adjustable Scraper with Tips of Different Shapes Facilitates Carbon Scraping



Swivel End on Machine-Bed Clamp Helps to Hold Non-Parallel Work Securely

Swivel Ends Improve Machine Clamps

When work is not parallel to the bed of a machine, the usual U-shaped machine-bed clamps are not entirely satisfactory, as frequently only the extreme ends of the clamp bear against the work, with the possibility of their loosening under a heavy cut. A much better clamp, as worked out by the machinists in a large shop, is shown in the illustration. It is a regular clamp except that inverted swivels have been fitted at one end, the heads of the swivels being knurled to grip the surface of the work. The drawing shows exactly how the clamp is constructed and used.

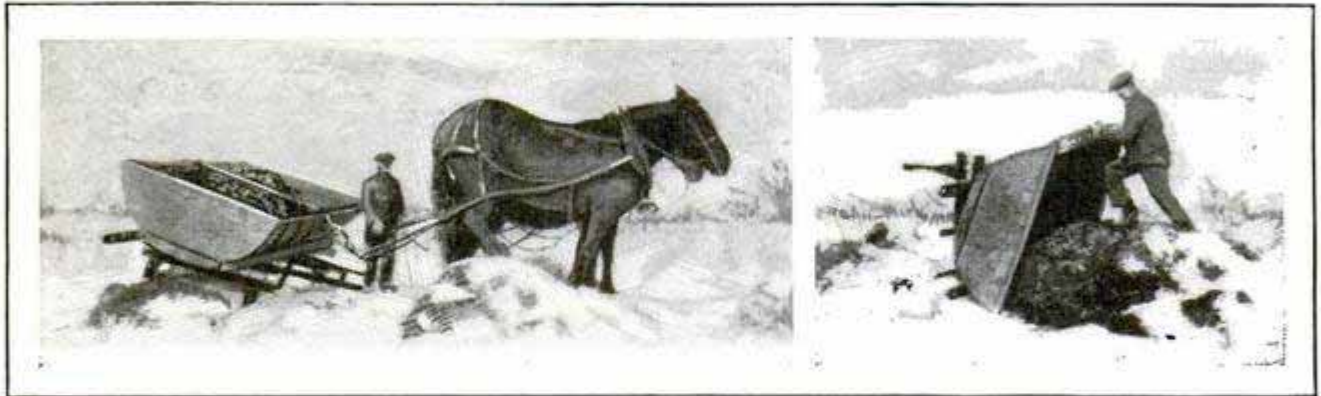
Holding Tacks in Furniture Webbing

Tacks that hold the heavy webbing of overstuffed furniture are often pulled loose by the strain, and some of them even come out entirely. To overcome this trouble, I screwed lengths of $\frac{1}{16}$ -in. strap iron, 1 in. wide, over the tacks, which were first driven down securely. Wood screws are used for this purpose.—Carl N. Furay, Paterson, New Jersey.

Hauling Manure in Winter

During the winter months when snow lies deep and drifted, the ordinary manure

on a set of old sleds fitted with a wooden cradle. Dumping a load of manure is a simple matter: On each side of the tank is a large ring securely bolted in place



You Can Easily Haul and Dump Manure with This Handy Tank Sled, Instead of Letting It Accumulate in the Barnyard during the Winter Months

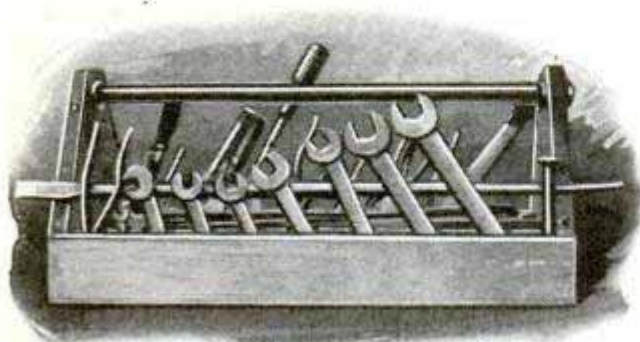
spreader cannot be used. Meanwhile, the barnyard manure pile grows, and when spring arrives and the farmer is busy with other chores, the manure must be hauled. Sometimes other work is sidetracked to make time for the hauling, or the plowing is delayed until the pile has been hauled and spread. To get around this state of affairs and to make better use of idle winter hours, a Wisconsin cattle and sheep raiser devised a handy manure hauler that other farmers will find equally serviceable. It consists of an old water tank of the flat-topped semi-cylindrical kind used to haul water for threshing machines. It is placed

close to the upper edge and midway of the length of the tank. To unload, the team is unhooked from the sled tongue and brought around to the side of the sled. A 12-ft. chain, with a hook at each end, is attached from the evener to the ring in the tank. When the team is started pulling, the tank rolls over and the load is dumped quickly. Rolling the emptied tank back into place is done easily by leaving the log chain attached to the tank but reversing the direction of pull. Thus the team does most of the hard work, and the man does only the guiding.—Joe H. H. Alexander, Madison, Wis.

Improvement on the Tool Box

By inserting a thin, tough board at each side of the tool box, leaving a $\frac{3}{4}$ -in. space between it and the side, a handy place is provided for holding wrenches, chisels, pliers and other tools on end, so that they can readily be seen and picked up. This

arrangement is only intended to hold the tools while the worker is busy on the job, and when finished they are laid flat.



This Tool Box Keeps the Tool with Which You Are Working in View

Compound for Drilling Hard Spots in Steel

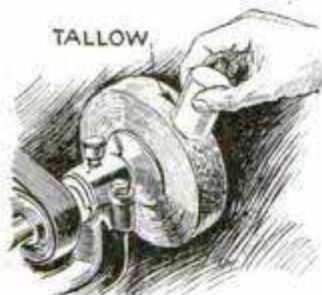
Our repair department had done an electric-welding job on a broken rack, and when the workmen tried to drill two holes through the metal at the welding point, it was too hard for drilling. As there were machined surfaces to be taken into consideration, annealing the part was out of the question. All the cutting compounds, such as turpentine and a few other combinations, were tried without success. One of the older men suggested the use of the following compound: powdered sulphur, 1 part; cylinder oil, 1 part, and castor oil, 2 parts. This was found effective.—Frank N. Coakley, Buffalo, N. Y.

Space for Milk Bottle in the Ice Box

In the average ice box the space between the shelves is not sufficiently high to accommodate a quart milk bottle, and it is therefore customary to transfer the milk to a pan or dish which can be set on any shelf. However, by cutting the netting away from the corner of the lower shelf, you can make space for the bottle. It is set on the bottom of the cooling compartment and the neck is pushed up through the hole in the shelf above.—Harold E. Benson, Denver, Colo.

Two Grinding Kinks

Ordinarily copper cannot be ground on an emery wheel because the metal particles get into the pores of the wheel and glaze it so that it will not cut. This trouble can be prevented by keeping the wheel smeared with tallow during the grinding. The tallow will not interfere seriously with the grinding of other metals on the wheel after the copper job has been completed. Soft rubber cannot be ground on an emery wheel satisfactorily, but can be nicely worked on a wheel having square

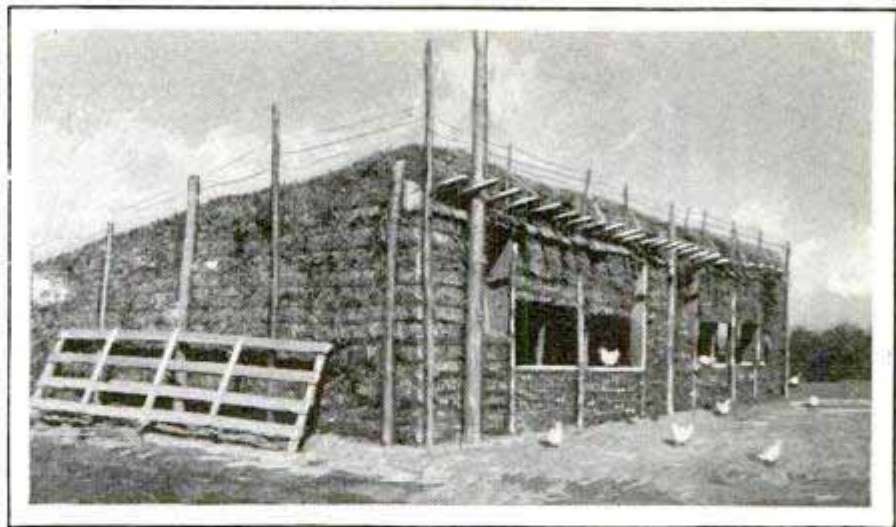


FOR GRINDING COPPER



teeth cut in its periphery. The pitch of the teeth should be about 1 in., which makes each tooth $\frac{1}{2}$ in. wide. Soft-rubber rolls can be neatly finished by swinging them in a lathe and inserting a center grinder in the tool post.—Herbert A. Freeman, Willimantic, Conn.

☛ The broken shank of an old drill can be made into a good screwdriver.



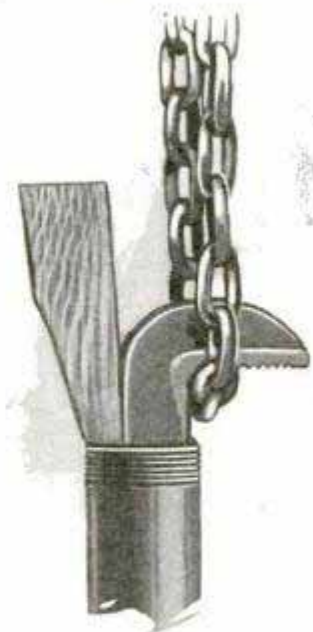
Poultry House Made from Bales of Straw Which Has Proved Satisfactory to Farmer in Arid West

Poultry House Made of Straw

In the arid west where rain seldom falls, a farmer found that a poultry house made of straw was entirely satisfactory. Bales of straw were piled to make the walls, suitable openings being left for the doors and windows. Poles set in the ground on the outside formed supports for wire mesh, which was stretched over the straw to strengthen the walls. The roof was made of timber covered with roofing paper. The poultry house is warm in the winter and cool in the summer.

Lifting Pipe with Wrench

When you have to pull out or lift a length of pipe and cannot get hold of it with a chain, clamp or other tool, try the simple method shown. Take the front jaw of a pipe wrench, the shank of which can be slipped inside of the pipe, driving a wedge in as shown. This will cause the coarse



threads on the shank to take hold of the pipe so securely that you can pull on the wrench jaw as hard as you like.



Nailing Studs to Plates on the Ground Saves Time and Much Unnecessary Labor

Saving Time in Building

Ordinarily the lower plate of a wall is laid down and nailed in place and the studs, nailed to the top plate, are then raised and toenailed to the lower one. This involves unnecessary labor and improper nailing is often the result. The drawing shows an improved method. The lower and upper plates are laid side by side and are marked off with a square for the location of the studs, which are then placed between the plates and nailed in place securely. The window headers are next fitted in place and nailed, and finally the cripples. The section is then ready to be raised, after which the lower plate is nailed down.

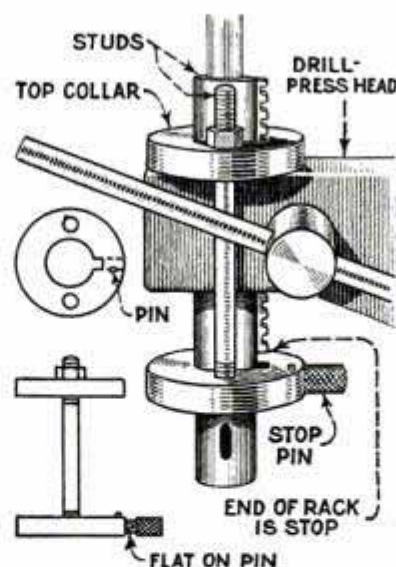
Auto Valves in Irrigation Standpipes

After installing an underground cement-pipe irrigation system in his apple orchard, the owner of a mountain ranch found that he had to cement caps on the top of each standpipe to keep the water from overflowing. In his particular case, there was such a drop from the wells back in the mountain that the water came through the irrigation pipe with considerable force,

compressing the air in the tops of the standpipes and occasionally causing the cement caps to blow off. To overcome this trouble, he got a number of old auto-valve stems and set them in the caps. These allowed the air to escape, relieving the pressure inside. Of course, the valve stems also allowed some of the water to run out, but this did not matter.

Drilling Holes of Varying Depths

It is often necessary to drill two holes of different depths in a piece with the same drill. With the use of an ordinary stop this cannot easily be done. A special stop of the kind shown in the drawing, when used in conjunction with the regular stop on the machine, allows the drilling of two such holes, and, if necessary, also a through hole. Two collars are drilled to fit the rack spindle, and keyways are cut in them to clear the rack. Both collars are drilled and tapped for studs, one on each side, and the lower one is drilled into the slot to take a knurled stop pin. The pin is kept from coming out by means of a small retaining pin which bears against a flat on the stop. In use, the regular stop of the drill press controls one depth and the stop just described the other depth. When feeding down to the regular stop, the pin



is pulled out and pushed in again for the next depth. It will be seen that the end of the rack is used as a stop surface, and that, when the pin is pulled out, the spindle is free to move down to drill a through hole. The nuts on the studs

are used to adjust the stop.—Harry Moore, Hamilton, Can.

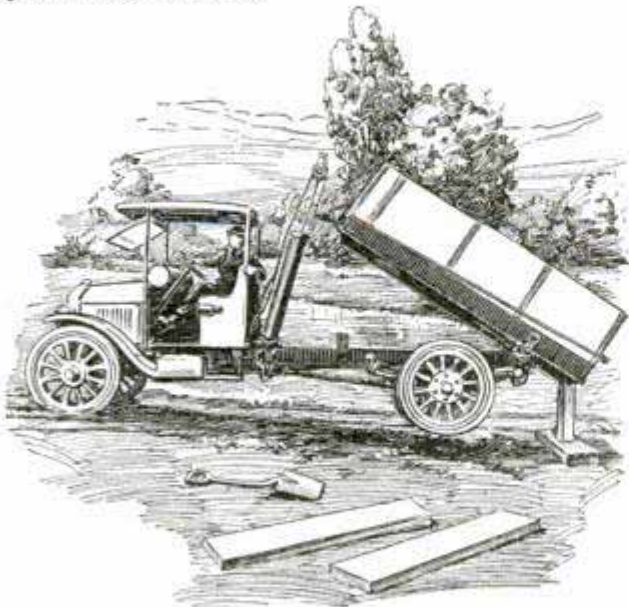
Starting a bolt in places hard to get at is much simplified if the head is slotted with a hacksaw so that the bolt can be turned with a screwdriver.

Vacuum Cleaner Useful in the Workshop

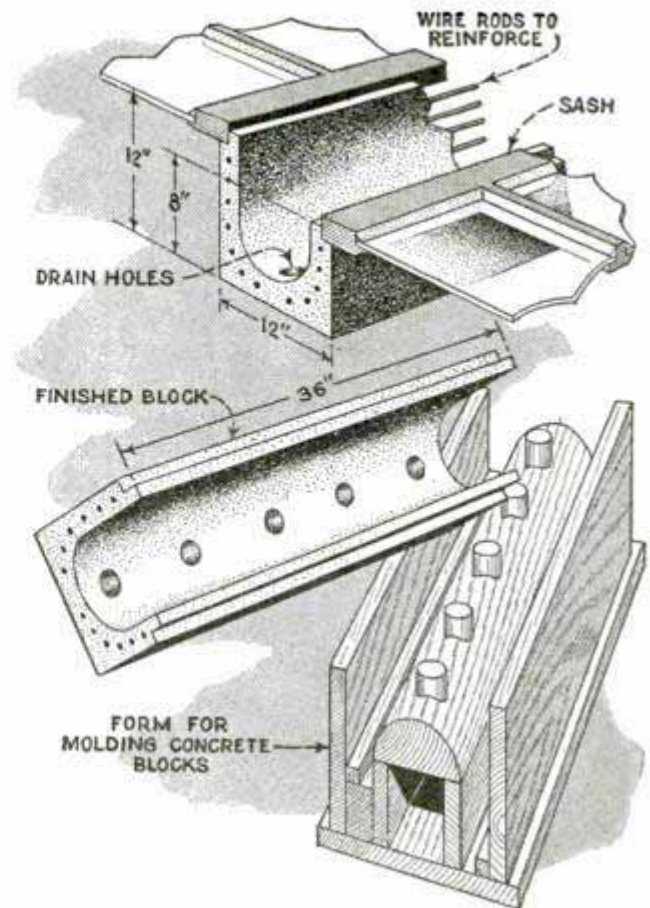
I have a workshop in which there are always so much sawdust and shavings on the floor that I use a vacuum cleaner to pick them up. At first I had considerable difficulty with this method, as the cleaner also picked up nails and bits of metal, which chipped the aluminum fan. To prevent this, I magnetized a length of iron rod which was cut to the length of the bell of the cleaner. I then soldered two short pieces of steel wire to the ends of the rod, after which the wire was bent to clip into the bell. The magnetized rod picks up all nails and other iron and steel chips. The attachment can be removed without difficulty.—Eugene K. Goodwin, Los Angeles, Calif.

Getting Trucks Out of Mud Holes

On a job in Central America, where a number of self-dumping trucks were used, some of the drivers have a novel and effective method of getting themselves out of mud holes. They merely let the power hoist of the truck do the work. The dump body overhangs the rear point of support so that when the front part of the body is raised for dumping, the rear end goes downward. Taking advantage of this, the drivers put timber struts under the body as indicated in the drawing. The body, bearing down on the struts, thrusts the wheels out of the mud, permitting the drivers to lay planks under them.—R. C. Hardman, San Jose, Costa Rica.



Novel Method of Raising Self-Dumping Trucks Out of Mud Holes



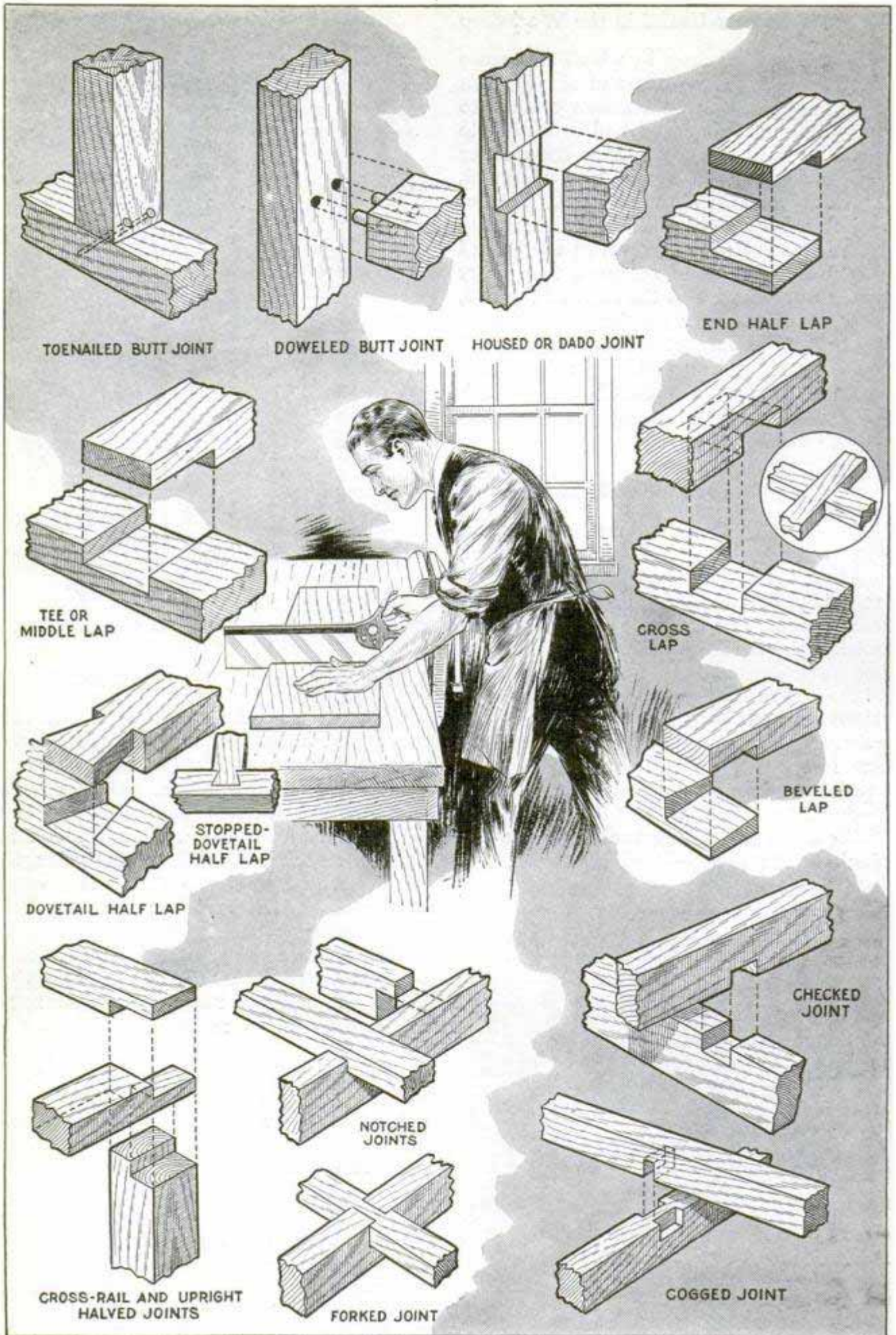
Concrete Frames for Hotbed Sashes Are Easy to Make and Neat in Appearance

Form for Making Concrete Hotbed Frame

Concrete frames for hotbed sashes are more permanent and look much neater than wooden ones. The illustration shows a form for molding blocks that are used to make hotbed frames, and also how the sashes are laid on them. Each block is made 3 ft. long, which is a handy length for use with 3 by 6-ft. sashes. One edge of the block is lower than the other, so that the sashes will be at a slight angle, allowing water to drain off easily. Holes in the blocks drain the water into the earth. In making the blocks, wire rods are used to reinforce them.

Lard Removes Tar Spots

I got some tar spots as large as quarters on my silk shirt. To remove them, I put a piece of white lard on each spot and left it on the shirt overnight. The next morning I washed the shirt in clean soap-suds. Every trace of tar disappeared. After this experiment, I tried lard for removing tar spots on my auto and found this, too, entirely successful.—C. Latour, Jr., Plattsburg, N. Y.



TOENAILED BUTT JOINT

DOWELED BUTT JOINT

HOUSED OR DADO JOINT

END HALF LAP

TEE OR MIDDLE LAP

CROSS LAP

BEVELED LAP

STOPPED-DOVETAIL HALF LAP

DOVETAIL HALF LAP

CHECKED JOINT

NOTCHED JOINTS

CROSS-RAIL AND UPRIGHT HALVED JOINTS

FORKED JOINT

COGGED JOINT

Wood Joints for the Amateur

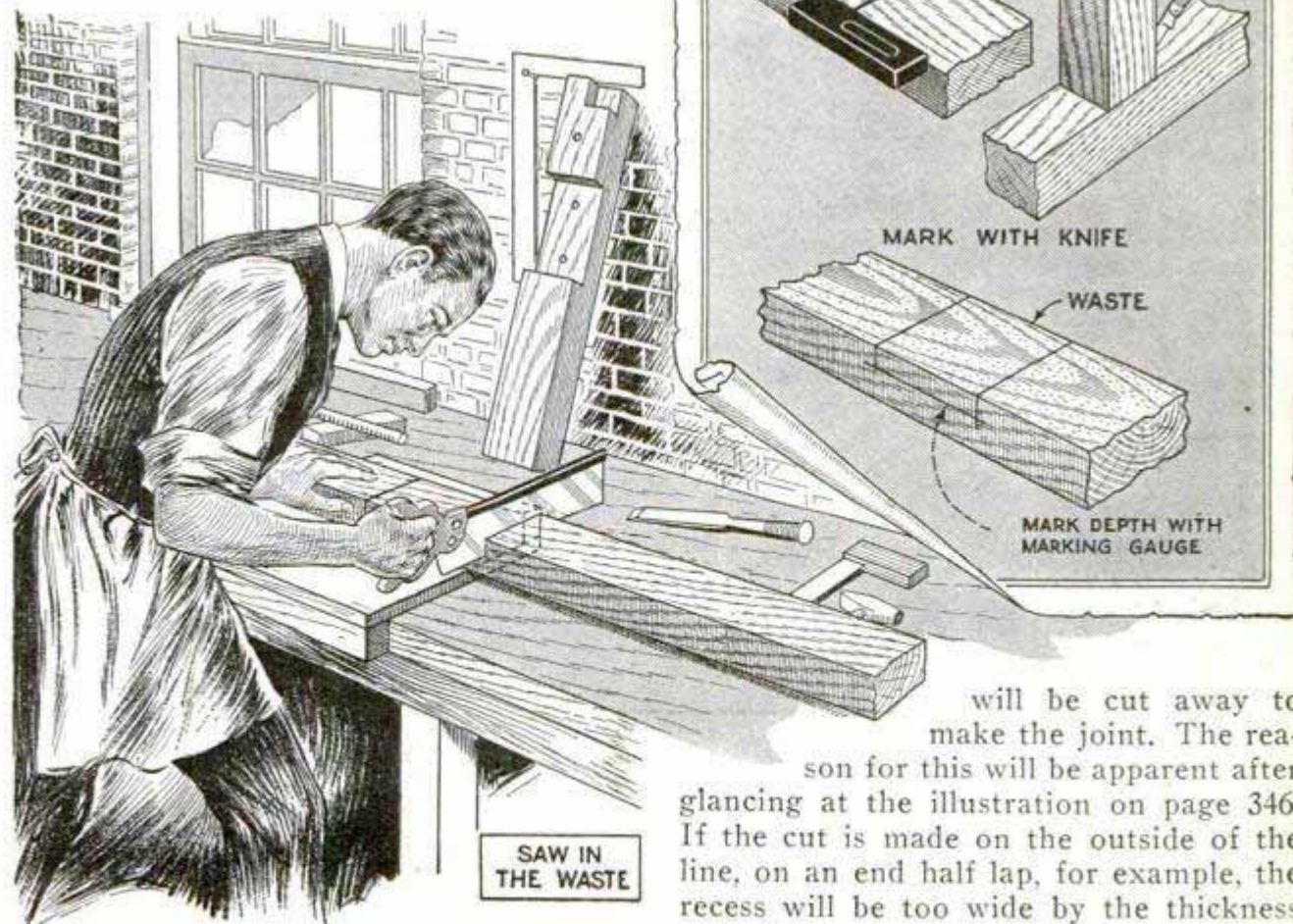
PART I

THE FIRST problem encountered by the amateur woodworker, after he has unpacked his new "home workshop," and is all set to "make things," is "what shall I make?" That problem disposed of, he is immediately confronted by another, and, to the average amateur, a much more formidable one, "How shall I put it together?" The answer to that problem is the purpose of these articles to supply.

To the man who has a flair for making things, woodwork joints present a fascinating subject for study. To many amateurs, and some tradesmen also, a joint is merely a means of fastening two or more pieces of wood together. It is more. There are a number of ways, for example, in which to joint two boards edge to edge, but, for any particular purpose, there is usually one way that is much better than the others, and therefore the amateur should not only know how it is done, but also why.

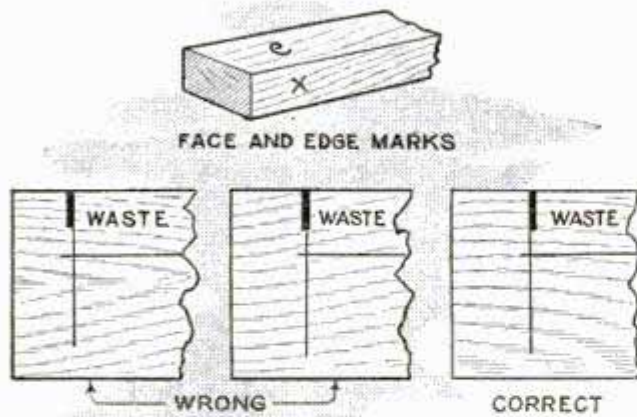
The first joints to be described are framing joints, and the first things to be learned

about these, as with all joints, are: Mark always from the face side or edge; mark with a knife; saw in the waste. When setting out the pieces that are to be joined, first plane up one face straight and true, then one edge, and mark them, the face with the conventional glorified comma that the tradesman uses, and the edge with a cross. All measuring and gauging must thereafter be done from the prepared faces and edges. A moment's thought will show why this is necessary. Next, whether the marking off be done with the square or by laying one piece on top of the other, use a sharp knife, not a pencil. Third, and very important, always saw or cut in the waste, or the part of the wood that



will be cut away to make the joint. The reason for this will be apparent after glancing at the illustration on page 346. If the cut is made on the outside of the line, on an end half lap, for example, the recess will be too wide by the thickness

of the saw kerf; on a middle lap, if both cuts are made outside the line, the joint



will be too wide by two saw kerfs. When the cuts are made just inside the line, the recess will just fit the mating piece.

The simplest framing joint is the toenailed butt joint, but where more strength is necessary, the doweled or the housed joint is used. The first-named joint is used in nothing but the roughest work. Where two pieces come together at right angles the half-lap joints are good. The dovetail half lap is used where there is an end strain on one of the parts that might pull it out from the other, and the stopped-dovetail half lap is used where it is not desired that the end grain of the mating piece show on the piece in which the socket is cut. The beveled lap is not often used, but is a good joint occasionally, where there is end strain on one of the pieces. Sometimes halved joints are used to join crossrails and uprights, and the making of this joint is therefore shown.

The notched, cogged, forked and checked (cheeked) joints are met with more frequently in carpentry than in cabinetmaking, and are used on joists and rafters where it is important to keep one member from moving endwise, without materially weakening the pieces. Where, in the halved joints, the pieces are let into one another until the faces coincide, in the checked, cogged and notched joints, the notches are merely cut deep enough to keep the members from moving.

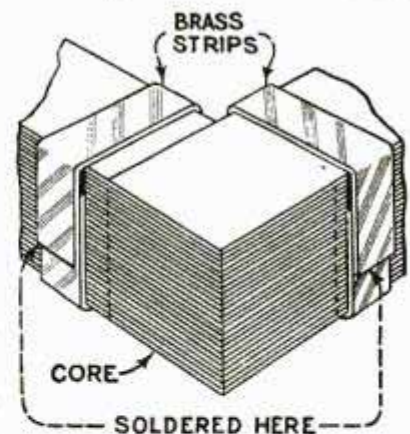
Circuit Breaker for Testing Auto Wiring

In the absence of a regular outfit for testing the electrical circuits of an auto, you will find a Delco overload circuit breaker, provided with leads and test

prods, to be a good substitute. This method eliminates the dangers of short circuits attendant upon the use of a single length of wire for making such tests. If the circuit is in good condition, the breaker will start clicking.

Clamping Transformer Laminations

Magnet and transformer cores made of layers of sheet iron are usually bound with tape, fastened with clamps or machine screws passed through holes drilled through the core. Tape makes an insecure assembly, and the use of clamps involves too much extra work for the experimenter, besides making a bulky job. Drilling holes through the core is not advised, as this reduces the effective cross section of the core and develops eddy currents. The writer has devised a simple method of keeping the laminations together tightly, which is illustrated in the drawing. The laminations, after being stacked up, are clamped tightly in a vise. Then a thin strip of tin or sheet brass is bent around the core, allowing a small overlap. The inner surfaces of the overlap are wiped with solder, after which a hot soldering iron is held on the overlap for a few moments until the solder melts. After cooling, the core is removed from the vise and is clamped in some other position, and another strip is soldered around it in the same way. If done carefully, this method insures a very tight and immovable assembly, and if the core is to be magnetized from an a.c. source, no perceptible hum



will be noticed. This form of core assembly has been used on small a.c. magnets, motor fields and transformers. The width and thickness of the strip must be governed by the size of the laminations to be bound. Sheet metal from tin cans, cut about $\frac{3}{8}$ in. wide, has been found satisfactory for ordinary work.—Emil J. Schau, Elizabeth, N. J.

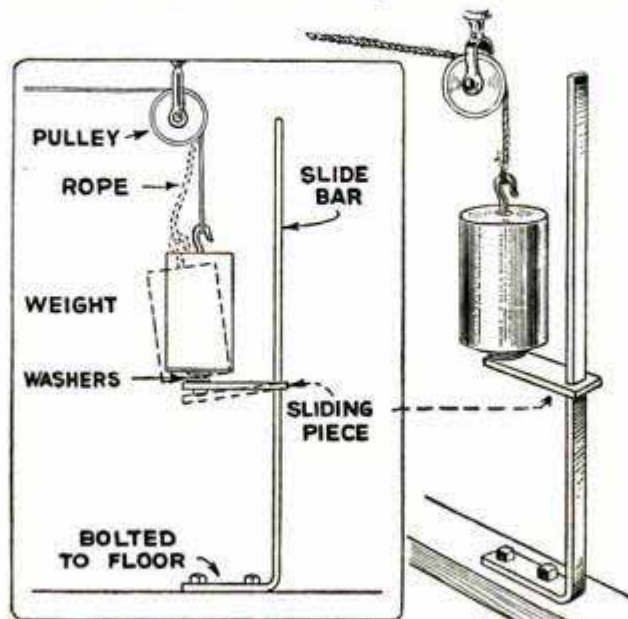
Safety Oil-Hole Covers

In a small woodworking shop, $\frac{3}{4}$ -in. capped pipe nipples were used as oil cups on some of the machines. Several times the caps of the nipples were accidentally dropped into the running machines, causing considerable damage. In the junk pile, a length of heavy cardboard tubing was found that fitted on the nipples snugly. This was cut into 3-in. lengths, plugged at one end with a short wooden peg and then shellacked. These covers were slipped over the oil cups, and if one happened to fall into the machine little or no damage resulted, except to the paper cover.

Catch for the Counterweight

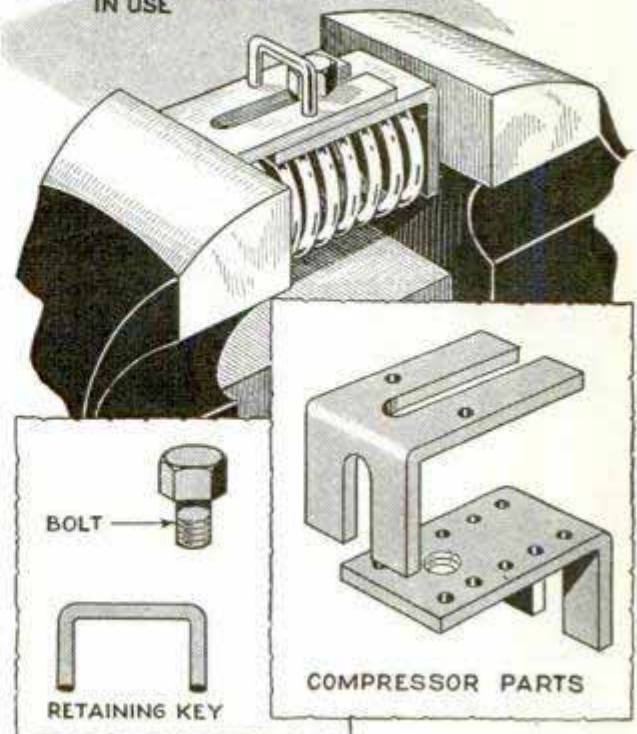
A counterweight suspended in a position where it might injure someone in case it fell, is always a source of danger. Often it is possible to adopt the illustrated device, which will check the fall of the weight. A length of flat iron is bent at right angles near one end, which is drilled for screws used to attach the piece to the floor as indicated. A slide bar made to slip on the bracket, is bolted to the underside of the counterweight so that, in ordinary use, when the latter is moved up or down, the slide bar will not bind on the bracket. However, if the rope or chain breaks, the counterweight suddenly bears down heavily on the slide bar and causes it to bind on the bracket, checking the fall of the weight. The handiest kind of weight for this purpose is a round one, drilled lengthwise through the center for a long bolt, which has the upper end bent to the shape of a hook. The lower end, which is threaded, slips through a hole drilled in the slide bar, and a nut is used to keep the assembly together.

☛ To find the distance between centers of two gears, add the number of teeth, divide by two and then by the diametral pitch.



Device for Arresting the Fall of a Counterweight in Case the Rope Breaks

SPRING COMPRESSOR
IN USE

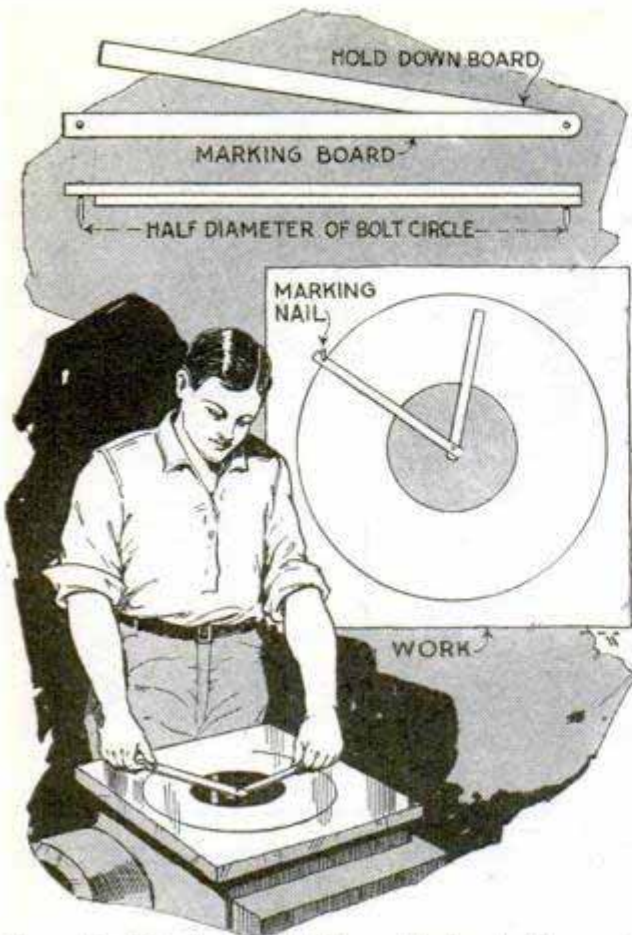


Practical Adjustable Holder for Keeping Coil Springs Compressed

Adjustable Holder for Compressing Coil Springs

For keeping coil springs compressed, the adjustable holder shown in the drawing is a great improvement over the ordinary method of wiring the spring and then cutting the wire after the retaining nut is adjusted. The holder consists of two angle clips, one fitted with a screw and the other having an elongated slot to slip over the screw. Holes are drilled in the two pieces as shown, and a retaining key, bent to a U-shape to fit the holes, is provided. In use, the holder is slipped over the spring and both are compressed in a vise as shown. The key is slipped into the proper holes and the screw is tightened to lock the holder on the spring, after which it can be removed from the vise.—G. A. Luers, Washington, D. C.

For keeping coil springs compressed, the adjustable holder shown in the drawing is a great improvement over the ordinary method of wiring the spring and then cutting the wire after the retaining nut is adjusted. The holder consists of two angle clips, one fitted with a screw and the other having an elongated slot to slip over the screw. Holes are drilled in the two pieces as shown, and a retaining key, bent to a U-shape to fit the holes, is provided. In use, the holder is slipped over the spring and both are compressed in a vise as shown. The key is slipped into the proper holes and the screw is tightened to lock the holder on the spring, after which it can be removed from the vise.—G. A. Luers, Washington, D. C.



Improved Device for Scribing a Circle, the Center of Which Is over a Hole

Centerless Circle Marker

It is sometimes necessary to scribe a circle around a hole that cannot be plugged. In such cases the method shown in the drawing will be found successful. Get two pieces of wood, one a little longer and the other a little shorter than the radius of the circle to be scribed. Tack the pieces together with a brad as indicated and drive another brad in the end of the longer piece, the distance between the brads being exactly equal to the radius of the circle. To use this marker, place the brad on which both pieces pivot in the center of the hole, which can be determined accurately by means of a rule. Hold the shorter piece down securely and revolve the longer one so that the brad scribes the circle.

Plaster of Paris Purifies Gasoline

Usually gasoline used for dry-cleaning garments at home is thrown away, but this is not necessary, for it can be purified and used again. Strong soda or acid solutions have been recommended to do this, but, although they may cause the dirt to

settle, there is some risk of the dirt mixing again with the fluid when it is poured off, with consequent damage to garments cleaned in it. By using ordinary plaster of paris as a settling agent, all possibility of such a risk is eliminated. The powder, when thoroughly mixed with the dirty gasoline, will cause the dirt to settle within twenty-four hours, leaving a pure, amber-colored liquid that can be used for cleaning the finest fabrics.

Clip for Catching Screw-Machine Work

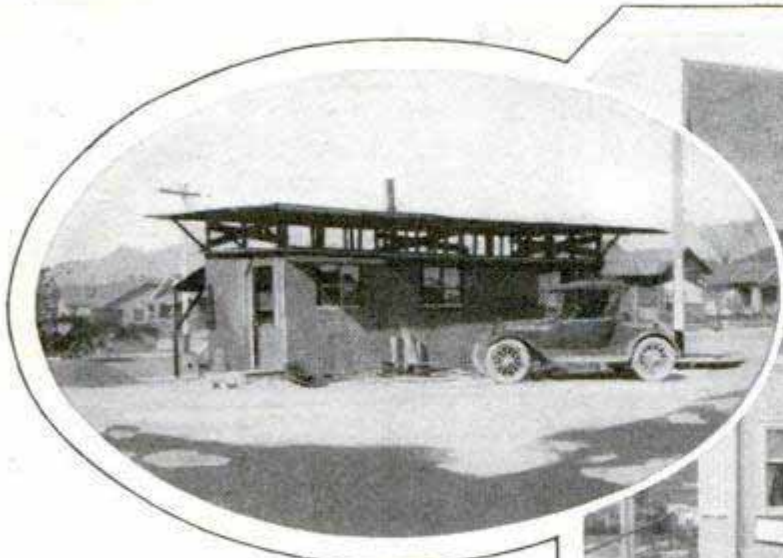
A screw-machine operator made the spring clip shown in the photo to save his fingers when catching work parted from the rod. The particular work shown is finished with a pointed end, and to prevent the end from being damaged in falling, it was necessary to grasp it with the fingers a moment before the separation from the rod. Threaded work, however, is apt to cut the fingers no matter how lightly the piece is touched, and, in any case, the fingers soon become sore from continued contact with the running work. This device, therefore, is a sensible precaution. It is made of flat spring steel, bent to form a nest for the work. Just above this point a hole is drilled so that a short length of wire can be inserted and bent over at both



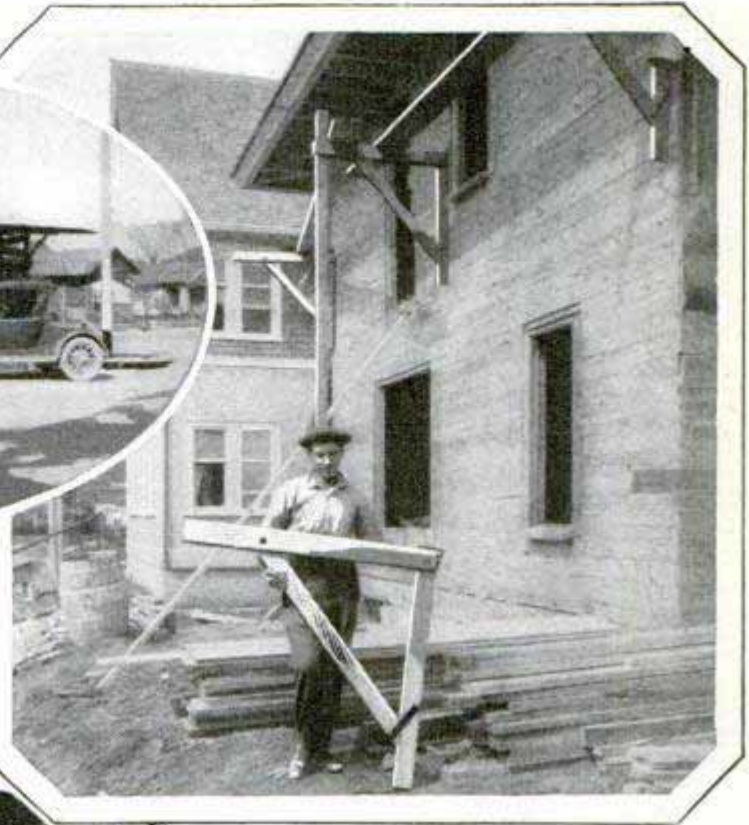
ends. This causes the clip to snap over the work easily and prevents its being accidentally pushed too far over the work. In use, the clip is held in the right hand, while the parted tool is being operated by the left, and snapped over the work a moment before it is cut off. The clip acts as a brake on the work and stops

it from revolving immediately it is cut off.
—Harry Moore, Rosemount, Can.

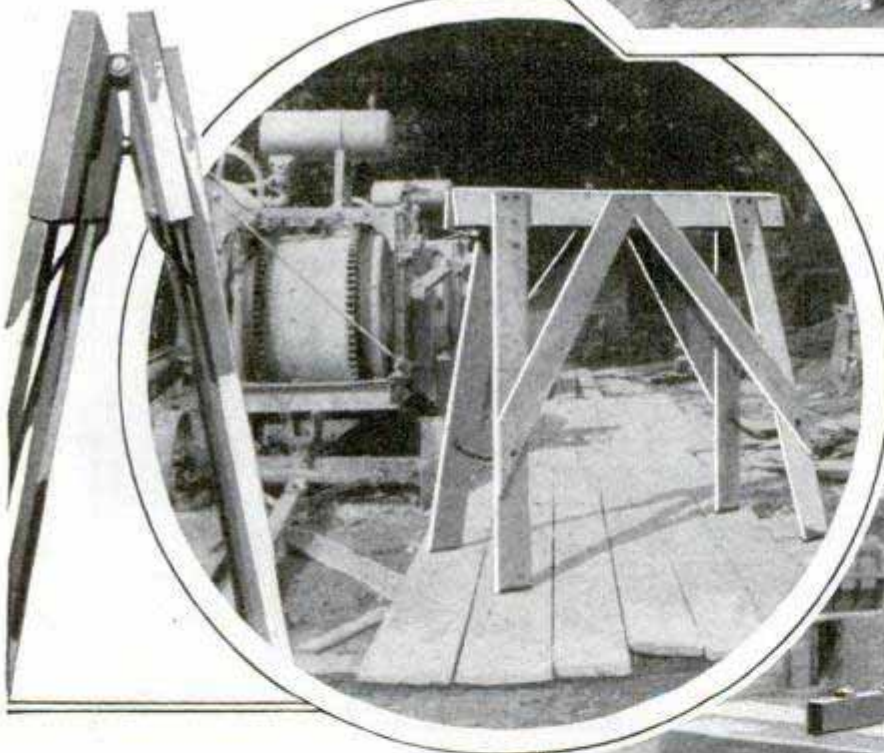
Helpful Hints for Builders



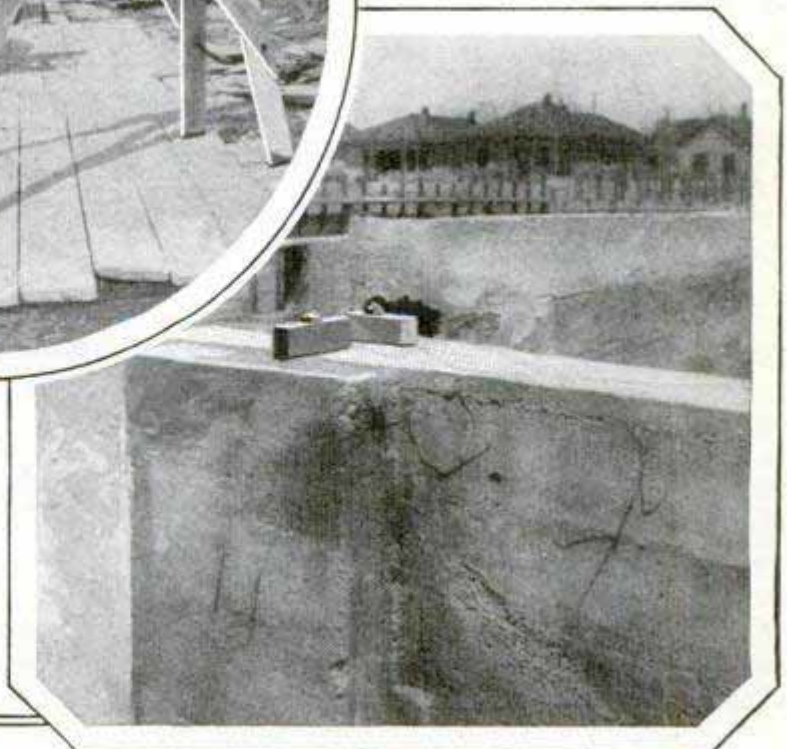
In Sections Where the Usual Flat-Top Construction Office Gets Too Hot for Comfort, a False Roof Will Help Make Working Conditions More Bearable; Circulation of Air between the False and True Roofs Keeps the Building Cool

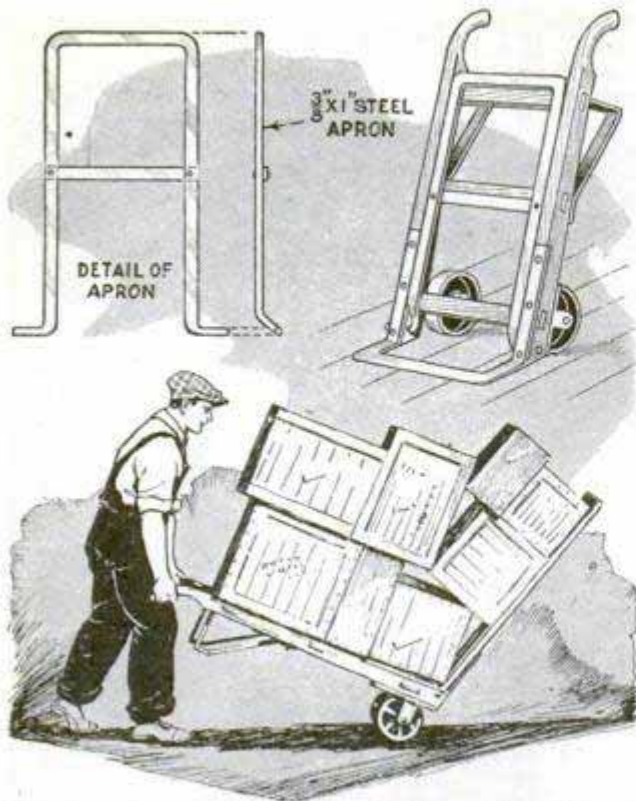


Above, a Well-Built Scaffold Bracket That Is Easily Moved About; the Doubled Horizontal Arm Measures Four Feet and the Vertical One Three Feet Six Inches; the Brace Is Haunched into the Vertical Arm and Fastened by Straps; Other Joints Are Bolted; a Hook on the Horizontal Arm Engages with the Frame Timbers



Above, These Hinged Scaffold Horses Are Easily Stored and Moved, and, Braced by Chains at the Bottom, Are Quite Rigid When in Use; Right, Where Bolts for Sills Are to Be Imbedded in Concrete Foundations, They May Be Hung in Drilled Blocks Nailed to the Foundation Forms





Flat-Iron Apron, Attached to Ordinary Hand Truck, Increases Its Capacity

Attachment for the Hand Truck

The ordinary hand truck, for moving boxes, barrels and freight of all kinds, is not of much use for moving light, bulky packages, which form the greater part of express shipments today. I have devised an attachment for the hand truck which more than doubles its capacity without interfering with its ordinary use. It consists of a hinged apron made of 1 by $\frac{3}{8}$ -in. steel bar. It is attached by drilling a hole in each side of the truck and springing the offset ends into the holes. When not in use, it is folded against the truck and held by a simple latch on the top crossbar of the truck.—J. Joseph Alpine, South Amboy, New Jersey.

Power Shears Made in Small Shop

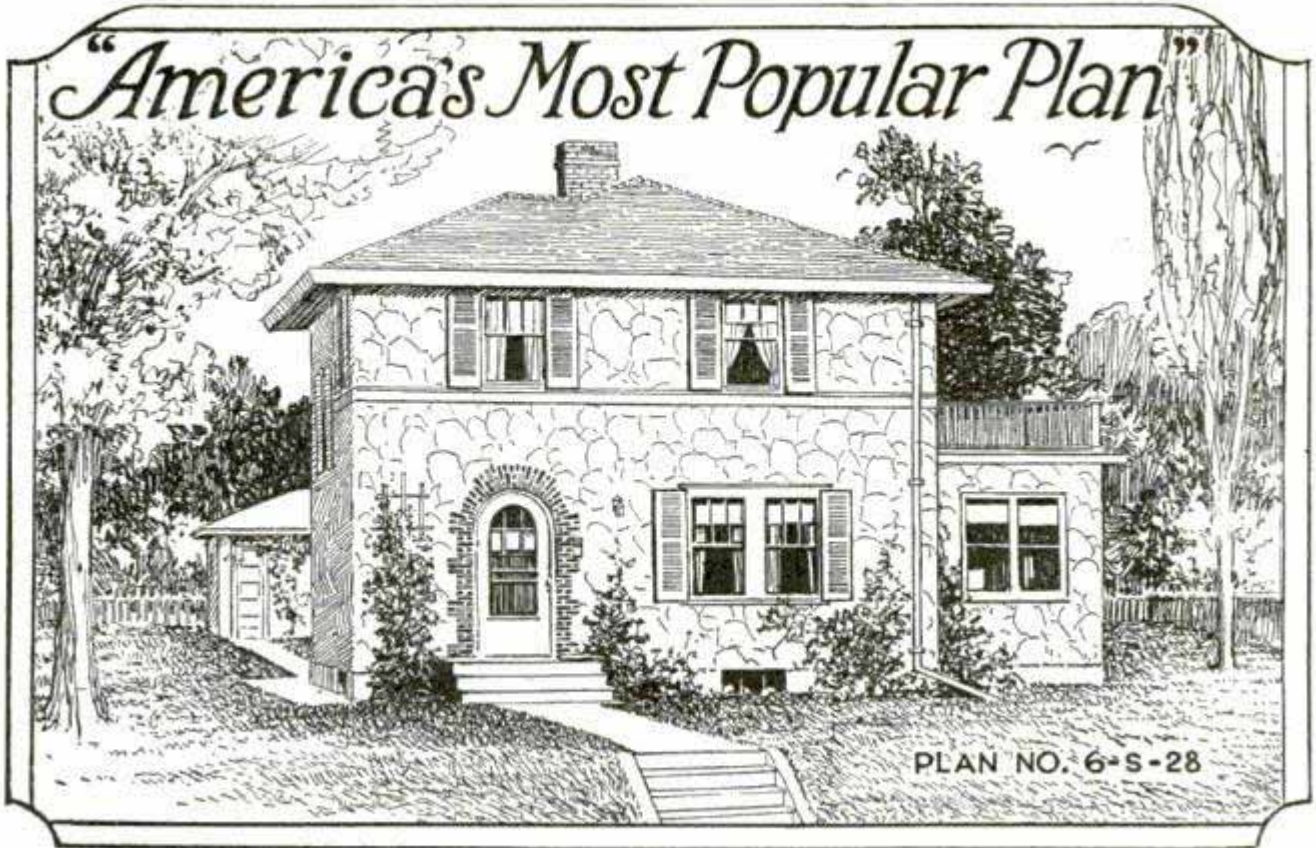
We occasionally have to cut numerous pieces of band iron and steel-sheet stock, from $\frac{1}{16}$ to $\frac{1}{8}$ in. thick, and in order to eliminate hand work, we made the power shears shown in the photo. The supporting frame is of angle iron, the lower member of the frame being a piece of 1 by 6-in. cold-rolled steel, while the upper member was made of 3-in. mild steel, although a somewhat heavier piece might be preferable. The throat depth is 7 in. the shaft

is $\frac{1}{8}$ in., and the travel of the lower ram $\frac{1}{4}$ in., an eccentric turned on the end of the shaft being the means of operating the ram. The flywheel is 14 in. in diameter and weighs about 20 lb. Both the upper and lower rams are made of 1-in. cold-rolled square steel, and the guides of $\frac{1}{2}$ -in. cold-rolled stock, fastened with capscrews. The center tie of the frame is made of two pieces of $\frac{1}{2}$ by 2-in. mild steel, welded top and bottom to pieces of 1-in. square cold-rolled stock. The tie is brazed to the lower frame member, but is not rigidly fastened to the upper member, an adjustment on top of the frame being provided for setting the knives as desired. The latter are pieces of self-hardening steel, such as is used in lathe cut-off tools, and are set in slots cut in the ends of the rams where they are held by means of two setscrews. One of the knives should have a rounded end and the other a cutting edge, from $\frac{1}{2}$ to $\frac{5}{8}$ in. long and straight. An eccentric, operated by a handle, provides a release for the upper ram and knife when it is desired to start a cut in the center of a sheet and stop cutting before reaching the edge. The shaft speed is about 500 r.p.m., and the bearings are made from steel tubing welded to pieces of flat steel. The bearings are large enough to permit babbitting the shaft in place. There is a screw adjustment on the connecting rod between the eccentric and the lower ram to set the knife at the right height. A $\frac{1}{4}$ -hp. electric motor is used to drive the shears.—Edwin Kilburn, Spring Valley, Minn.



Two blocks of wood, fastened between the jaws of a small clamp, will be found convenient for holding newly applied patches on an inner tube while the cement is setting.

"America's Most Popular Plan"



Copyright, Popular Mechanics Magazine

A VOTE taken among speculative builders, contractors, architects and home owners would no doubt show the plan for this house leads in popularity. Why? Because like an automobile that promises "most miles per gallon," so, too, houses built from this plan may be described as "most house per dollar."

You see this house with variations in almost every city and town. It appears in brick, stucco, wood siding, shingles and cement. Sometimes the sun porch is built to the rear. Again it is built to the side, as shown in the picture. Frequently it is placed at the front of the house. But always the same general plan for room arrangement is followed.

The reasons for this nation-wide popularity are worth looking into, provided you are planning to build or buy and want to make your dollars count. What are those reasons?

In the first place, the house is practically square, twenty-five feet wide by twenty-five feet six inches deep. Square

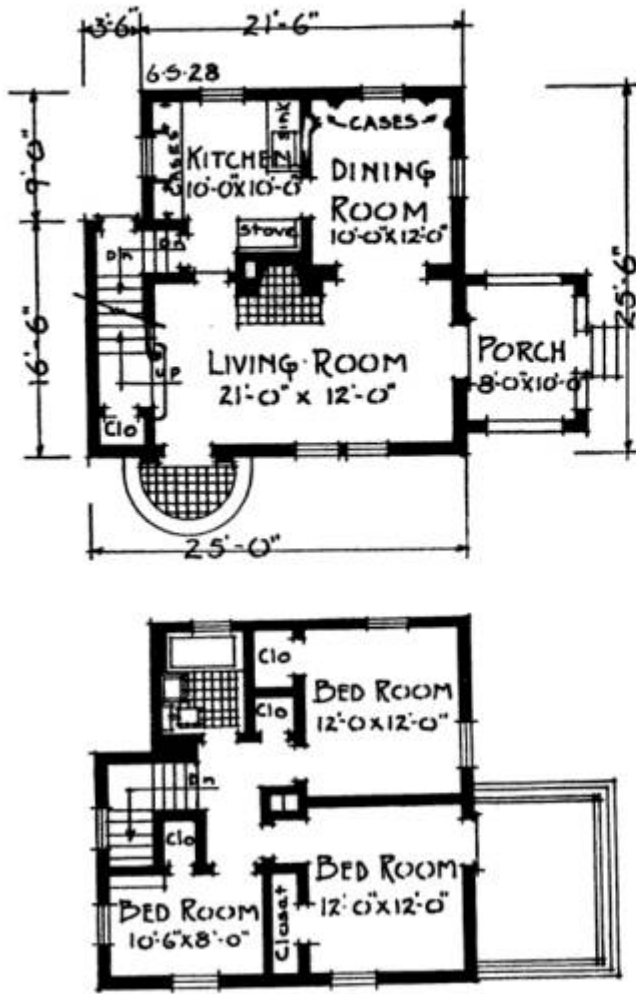
houses are the most economical to build. There are no crooks, turns, set-offs and no complicated roof to require extra time and labor by workmen. Labor usually amounts to around fifty per cent on nearly every job. If you can save on labor, you keep down building costs. This is also true in the saving of materials.

In the second place, the house is a two-story dwelling. The second story gives it size and impressiveness. That is important because, if at any time you wish to sell, you will find impressiveness a desirable sales factor. Buyers usually want an "eyeful" for their money.

Third, the house contains the minimum number of rooms demanded by the average family. What are those rooms? At least three bedrooms or three bedroom equipments. In addition, a living room, dining room, kitchen, bath and sun room. In passing, it is well to remember that even though breakfast nooks have replaced the dining room, nevertheless most

A SPECIAL OFFER

To help our readers get started on one of life's most glorious experiences—building and owning a home—Popular Mechanics Magazine will supply readers a one-sheet blueprint of "America's Most Popular Plan" for \$1 (regular price \$2), if ordered before Feb. 1. This blueprint does away with the necessity of first purchasing a complete set of plans to find out whether you can afford to build. It contains floor plans, elevations, a section, detail, size of joists, studs, etc., and also a brief specification. Submit it to tradesmen and dealers for building estimates.



people want a dining room as well. People who build houses to sell know this and usually include both a breakfast nook and a dining room.

Fourth, the arrangement of rooms in this house is as compact as sardines in a can. There is practically no unused space. Note how the lower floor opens up into one large living area. The sun porch adds extra length to the living room. Direct communication between front door and kitchen is a feature. All bedrooms have outside exposure. The inside fireplace is a stroke of economy by the designer. It accommodates a flue for the kitchen range. While no vestibule is provided, the owner can easily add one if he lives in a climate where vestibules are essential.

Search as hard as you may for waste space, you will find every inch of floor space in this house is working all the time. In fact, the plan is a model of economy both in construction and use of space.

The house can be placed on a lot forty-five feet in width if the sun porch is built as shown. If, however, the sun room is built to the rear, adjoining the dining

room, you can place the house on as narrow a lot as thirty-five feet.

Now add up all the space and money-saving features in this house, and you have the answer to why this plan is often said to be America's most popular design. The plan, style and equipment are all in line with the average pocketbook. Resale value is high according to people who build houses to sell. What more can you ask for?

As shown, the house is planned to be built of wood frame with stucco on metal lath for outside walls. Siding or shingle exterior would look well. The roof is wood shingle, although composition shingles may be laid in variegated patterns. The house is fully insulated.

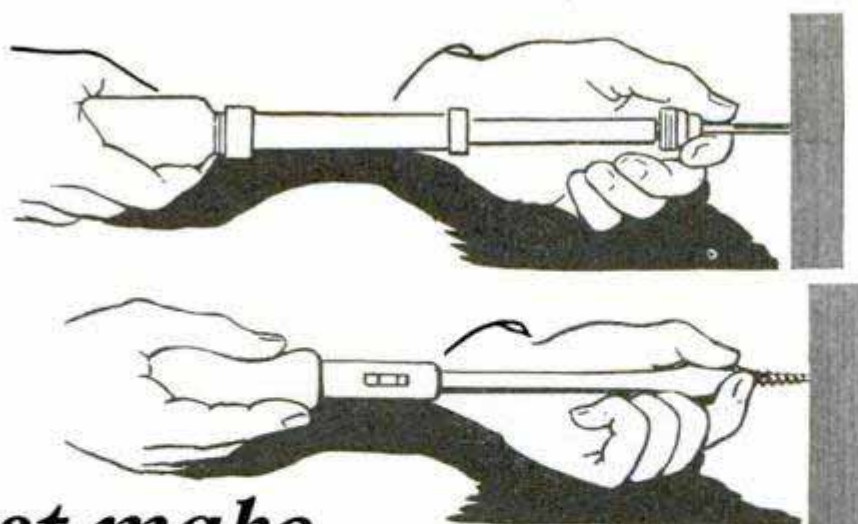
The illustration shows a detached garage to the rear of the lot. If, however, the sun porch is built off the dining room, it is possible that a one-car garage can be placed beneath the porch. This might require some excavation or a lot with a drop in grade.

The plan lends itself to several simple changes to meet individual tastes. The sun porch is easily converted into a library or den with only slight alteration, or, by replacing the wall between it and the living room with a wide alcove, it becomes an attractive music room and greatly enlarges the apparent size of the living room.

The roof of the porch, shown with a balcony railing, can be changed into an attractive sleeping porch, either at the time of building or later. The conversion may be permanent, or done with a framework of iron pipe, with canvas roof and side walls, easily removed if the sleeping porch is not to be used in cold weather.

And now about the cost to build. The house has been erected complete for \$5,000. Costs, however, vary with location, equipment and materials used. In some localities the cost may be more; in others, perhaps, savings can be made.

EDITOR'S NOTE: Popular Mechanics Magazine has prepared a new plan book, "Twenty Popular Low Cost Homes and Ten Commandments for Home Builders." These are selected homes and show labor, space and time-saving ideas. They are \$5,000 homes and less. Send 10 cents in stamps to cover postage. Address Building Editor.



First make a Hole with "Yankee" Push Drill

THERE'S one right way to do a screw-driving job. And,—the right way is the speedy, easy way!

Skilled mechanics always bore holes for screws. They use the "Yankee" Automatic Push Drill: because it is quick and sure! Makes the right-size hole for the screw. Doesn't split the wood. Operated simply by pushing. A spring brings handle back for next push; revolving drill-point backward to clear chips.

Eight "YANKEE" Drill-points, $\frac{1}{16}$ " to $1\frac{1}{64}$ ", supplied in magazine in handle and arranged for quick, easy selection. Every drill-point individually tested.

"YANKEE" No. 41 — Companion tool to "Yankee" Spiral Screw-driver, in the hands of good workmen the world over. Price, \$2.60.

"YANKEE" No. 44 — Adjustable Tension regulates pressure for boring in hard or soft woods, with large or small drills. Price \$3.15.

Ask dealer for "YANKEE" Push Drill. The genuine is always marked with the name. Use coupon to get "YANKEE" Tool Book, Free.

"YANKEE" TOOLS

Make Better mechanics



North Bros. Mfg. Co., Lehigh Ave., Philadelphia, U. S. A.

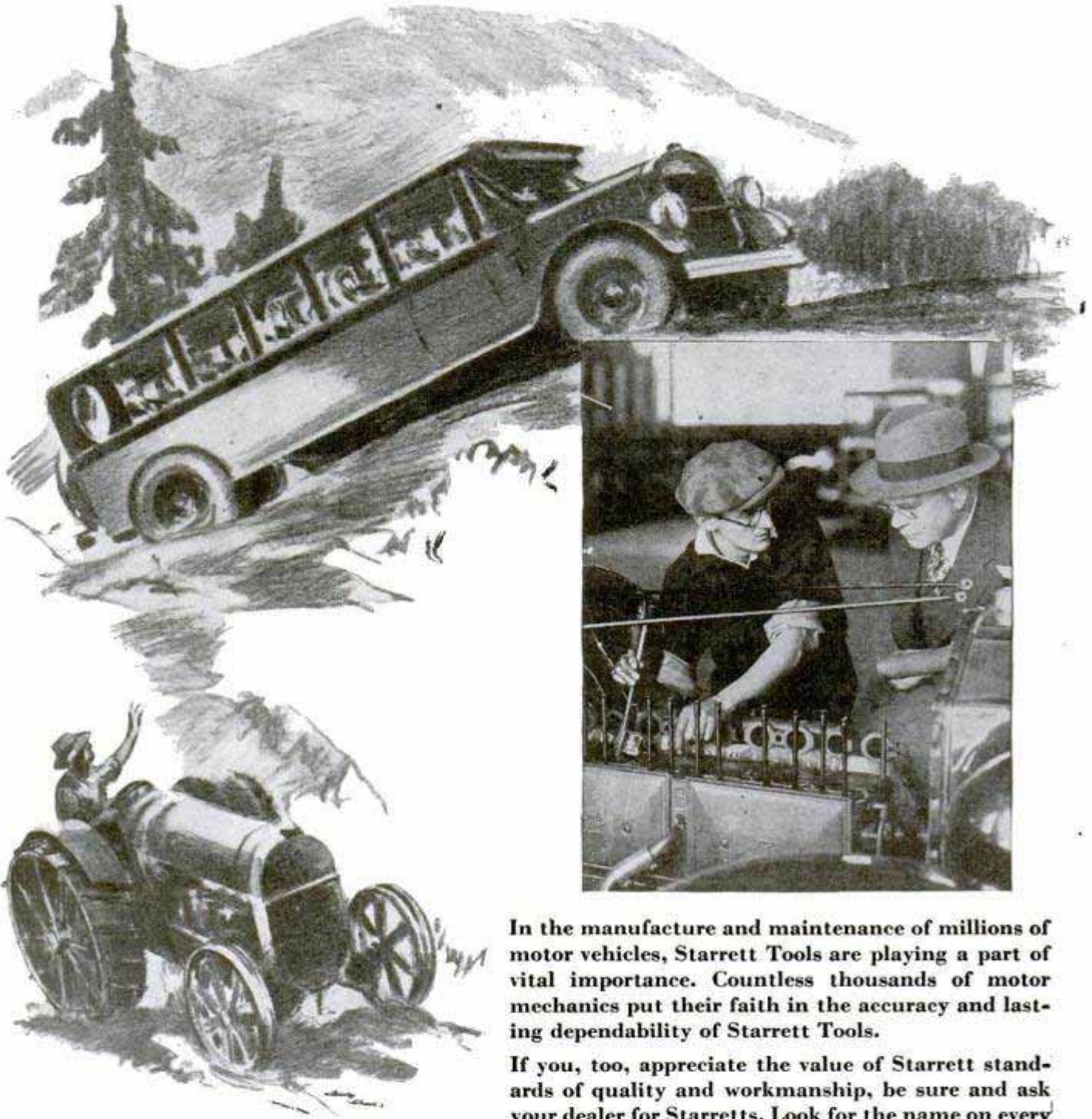
I want to know about labor-saving tools: send book showing Quick-Return Spiral Screw-drivers, Hand Drills that save burring and jamming, home-shop Automatic Bench Drills, Etc.

Name.....

Address.....



They, *too*, need Starrett Accuracy



In the manufacture and maintenance of millions of motor vehicles, Starrett Tools are playing a part of vital importance. Countless thousands of motor mechanics put their faith in the accuracy and lasting dependability of Starrett Tools.

If you, too, appreciate the value of Starrett standards of quality and workmanship, be sure and ask your dealer for Starretts. Look for the name on every tool. Ask us to send you Starrett Catalog No. 24 "AP" containing full descriptions and prices of over 2500 tools.

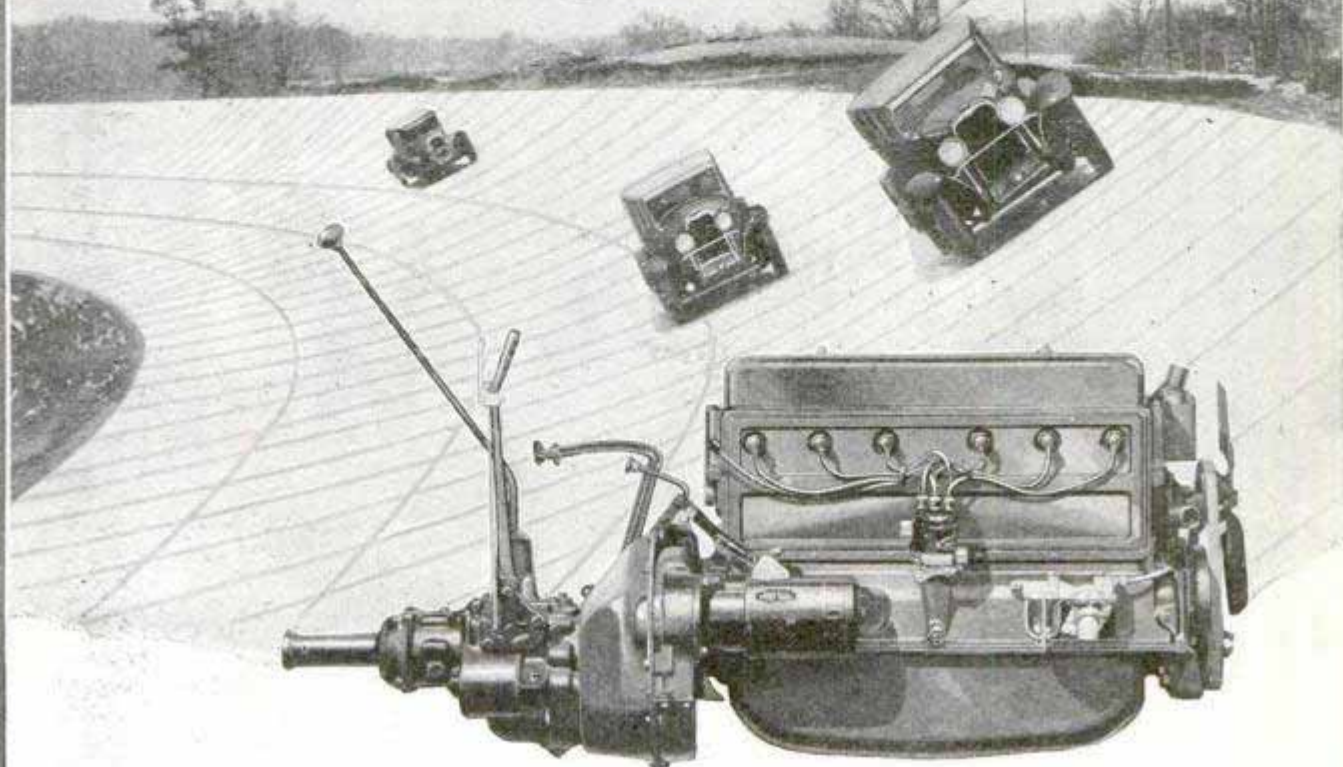
THE L. S. STARRETT CO.

World's Greatest Toolmakers
 Manufacturers of Hacksaws Unexcelled
 Steel Tapes—Standard for Accuracy
 ATHOL, MASS., U. S. A.



Use Starrett Tools

for Economical Transportation



4 Years of Grueling Tests

to achieve the Outstanding Chevrolet

-a six in the price range of the four!

Years ago the first experimental model of The Outstanding Chevrolet was taken to the General Motors Proving Ground to undergo one of the greatest series of tests ever given an automobile.

From time to time other experimental models were built and taken to this great General Motors outdoor laboratory—and after exhaustive tests, were torn down for inspection, analysis and improvement.

In this process of development, more than a hundred motors were built and tested in a period of four years!

Finally, the design and material specifications were approved. But still the tests went on—hundreds of thousands of additional miles to prove and reprove the quality, stamina and correct design of every part.

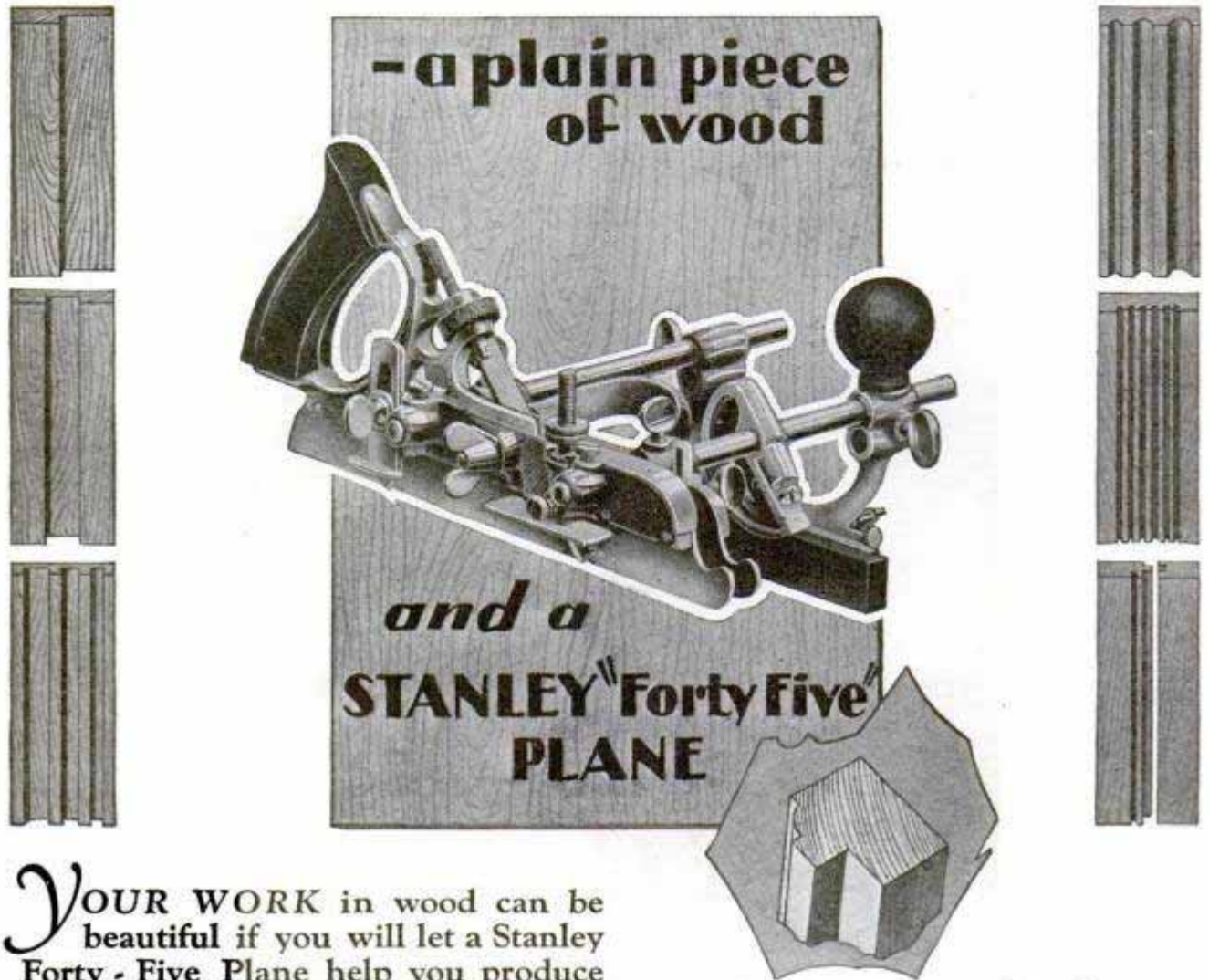
Visit your Chevrolet dealer today. Learn from him the full and significant details of this greatest of all Chevrolets!

The Roadster, \$525; The Phaeton, \$525; The Coach, \$595; The Coupe, \$595; The Sedan, \$675; The Sport Cabriolet, \$695; The Convertible Landau, \$725. All prices f. o. b. Flint, Mich.

CHEVROLET MOTOR COMPANY, DETROIT, MICHIGAN
Division of General Motors Corporation

Q U A L I T Y A T L O W C O S T

For Decorative Woodwork



YOUR WORK in wood can be beautiful if you will let a Stanley Forty - Five Plane help you produce flutes, beads, reeds, rounded corners and other finishing touches.

This remarkable plane combines seven planes in one in a convenient and practical form. Furnished with a large number of cutters, it cuts rabbetts, dadoes and fillisters; and also does a great deal of work which ordinarily must be done in a woodworking shop.

No. 1d—Book Rack
No. 2d—Candle Stick
No. 3d—Pipe Rack
No. 4d—Flower Box
No. 5d—Table Lamp
No. 6d—Toy Automobile
No. 7d—Sconce
No. 8d—Dinner Gong
No. 9d—Bird Houses

No. 10d—Dog House
No. 11d—Book Stand
No. 12d—Smoking Cabinet
No. 13d—Kitchen Cabinet
No. 14d—Sewing Cabinet
No. 15d—Cedar Chest
No. 16d—End Table
No. 17d—Tea Wagon
No. 18d—Model Sailboat

No. 19d—Combination Sail and Row-Boat
No. 20d—Combination Kitchen Seat and Step Ladder
No. 21d—Garden Seat
No. 22d—Garden Trellises
No. 70d—Small Tool Chest
No. 71d—Large Tool Chest
No. 72d—Work Bench

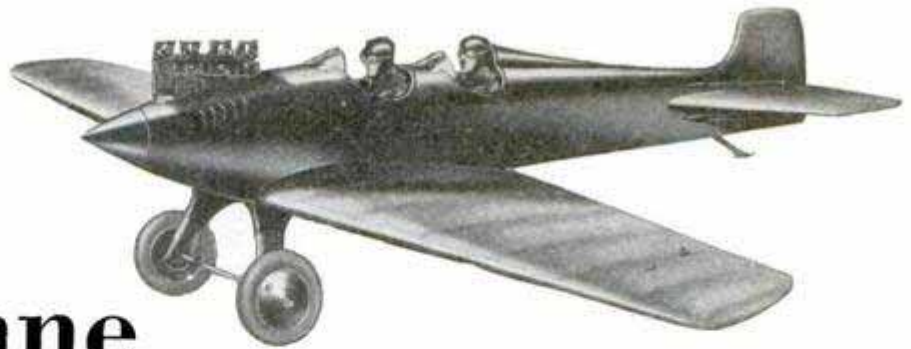
Stanley Plans and Books

Stanley offers you a complete series of Plans giving step by step instructions for making 25 useful articles, also a book "How to Work with Tools and Wood" which is invaluable to the amateur for instructions in woodworking, finishing, etc.

Your hardware dealer can supply you with Stanley Plans and Books. If he does not have them, write us. The plans cost only 10 cents each, Books \$1.00. Address The Stanley Rule & Level Plant, New Britain, Conn.

STANLEY TOOLS

Build Yourself a Lightplane



and save over \$1500!

IF you buy a commercial-production light airplane today, you'll pay well over \$2500 for it. You can build a Guardian—this fast, handy practical ship designed by famous aeronautical engineers—for \$275 to \$325, exclusive of motor. Total cost, motor and all, will show you a saving of over \$1500.

The Guardian Lightplane has been developed by an American Aeronautical Engineer from one of the most famous and successful lightplanes in Europe. This famous engineer was for four years with one of the largest factories in America. He has a record of eight years' designing, building, and flying success behind that! He has taken a successful European lightplane and developed it for American needs.

The Guardian is rugged, powerful, safe. Its design is simplified. It has a safety factor of 8! It is the simplest and lowest-powered practical airplane in America.

Working Drawings, only \$5

It has been especially designed so it can be built by any mechanically inclined young man who will follow the instructions and plans furnished.

Think of building an airplane yourself—from easy-to-understand plans prepared by a graduate aeronautical engineer with 12 years' experience! Think of equipping this with a low powered engine and flying it yourself! Think of an airplane strong enough for stunting, with a ceiling of over 10,000 feet, a speed of over 80 miles an hour—that you can build yourself for only a few hundred dollars!

Build Now for Spring Flying

Send \$5.00 today for a complete set of working drawings showing all details and dimensions of this practical, safe, speedy lightplane, with full instructions for building it, a list of kinds and types of motors recommended, complete price list of all parts needed, and suggestions for obtaining flying time for a commercial or transport license.

You can build it in a few weeks at home with simple tools. The Guardian has a modern steel tube fuselage and simple, strong fittings especially designed for the amateur builder. You can build a Guardian complete, and get in enough flying time for a license, for a fraction of the cost of attending a flying school! Send \$5.00 now for a complete set of plans and all particulars, and get started before your friends beat you to it! Satisfaction guaranteed, or money refunded.

Send Your Order Today!

Specifications

Span: 30 feet.
Length: 20 feet.
Weight empty: 400 pounds.
Top Speed: 85 m.p.h.
Landing Speed: 32 m.p.h.
Capacity: Pilot and passenger.
Type: Low-wing monoplane.
Power: As single seater, 25 h.p.; as two-seater, 35-40 h.p.

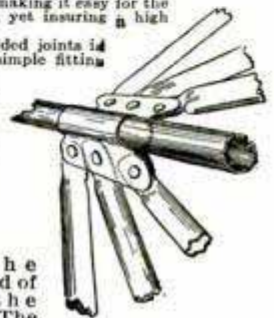
GUARDIAN AIRCRAFT COMPANY

Dept. C, 3008 S. Jefferson Ave., St. Louis, Mo.

Easy to Build!

All details of the Guardian have been simplified, making it easy for the amateur builder, yet insuring a high factor of safety.

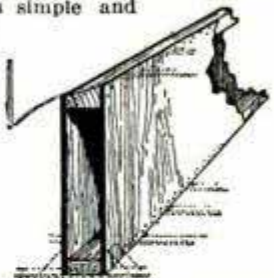
Instead of welded joints in the fuselage, a simple fitting is used which clamps around the longrons. Steel tube struts and bracers are flattened at the ends and bolted to this fitting.



Note the simple method of hinging the elevators. The front elevator beam is a steel tube. Simple metal straps slip around this beam with the ends bolted to the rear stabilizer spar.



The main wing beams are of box-type, made of two small beams of spruce covered with plywood as shown below. This type is simple and widely used.



These and other construction details are clearly shown in the set of large working drawings sold for \$5.00. Building instructions are sent with the plans. The design and all construction features have been approved by two nationally-known aeronautical engineers.

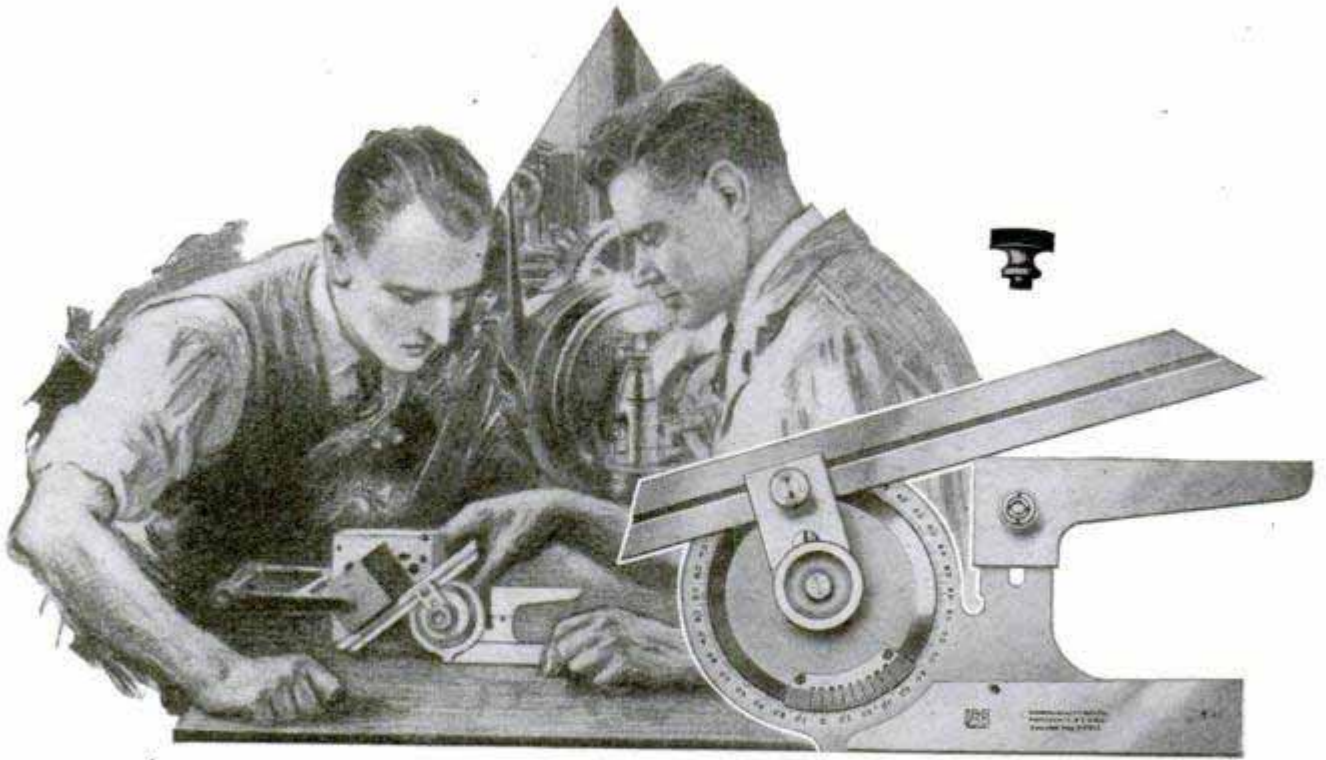
Mail This Coupon

Guardian Aircraft Co.,
Dept. C, 3008 S. Jefferson Ave.,
St. Louis, Mo.

I enclose \$5. Please send me post-paid a complete set of working drawings of the Guardian Lightplane, building instructions, and other material and suggestions as advertised in Popular Mechanics.

Name.....

Address.....



Accuracy Grows More And More Important

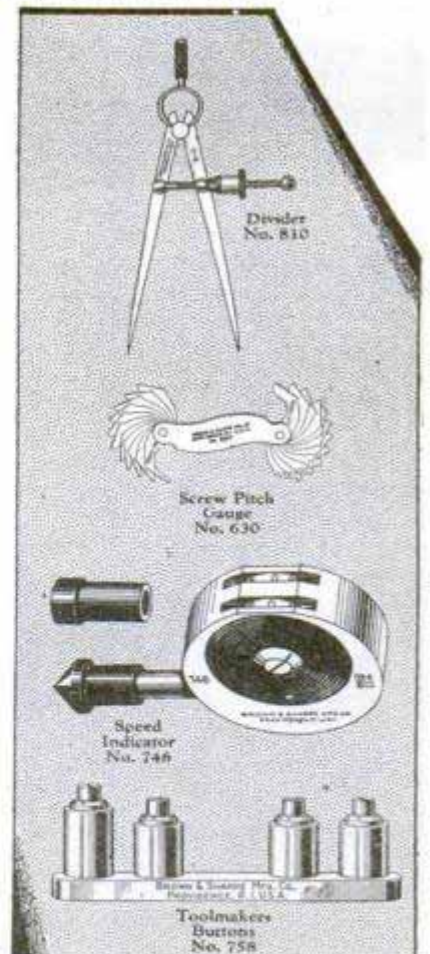
In many cases, today's product must be held to limits closer than one thousandth of an inch where yesterday's passed muster at less exacting standards. Why? Simply because today's manufacturer has learned that faster and more profitable production follows close in the wake of smaller tolerances, or working limits.

All along the line, fine measuring tools are needed to make high precision standards possible. Manufacturers, tool-makers, and mechanics everywhere rely for this work on Brown & Sharpe Tools, known the world over for their quality and unfailing accuracy.

The tool shown above is Bevel Protractor No. 496. Get a copy of Catalog No. 30, describing this and over 2300 other Brown & Sharpe Tools, from your hardware dealer. Or write us for one. Address Dept. P.M., Brown & Sharpe Mfg. Company, Providence, Rhode Island, U. S. A.



WORLD'S STANDARD OF ACCURACY

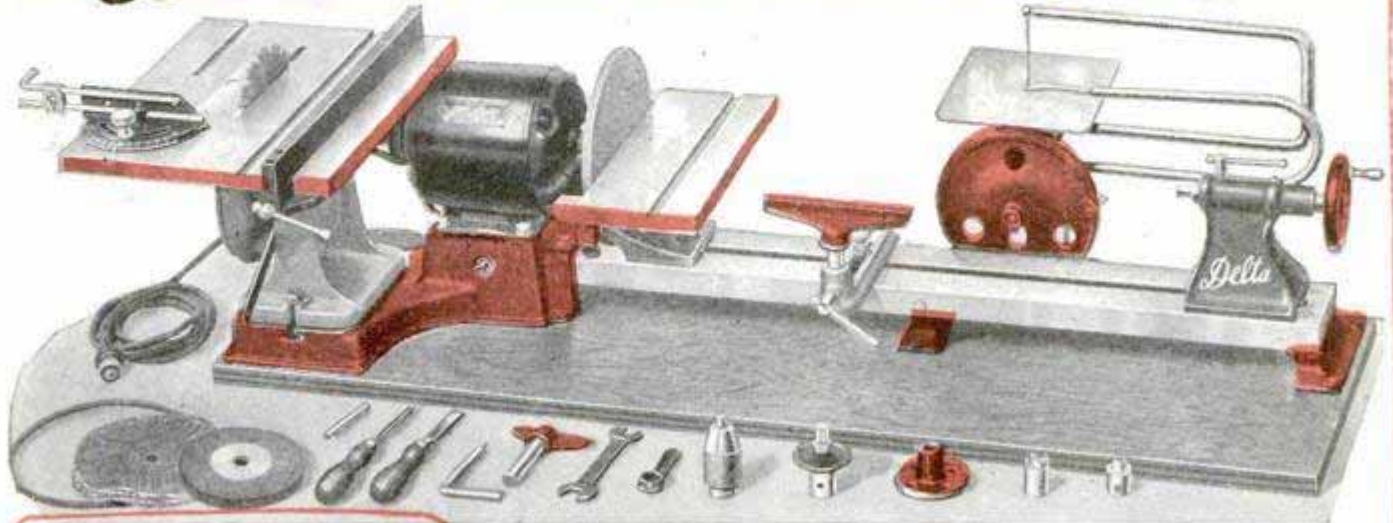


BROWN & SHARPE TOOLS

Here is a Husky Man-Size Workshop

The New 1929 Model-Complete, Practical

"Delta" Electric Handi-Shop



New Features of 1929 Model

found exclusively in the "Delta" Handi-Shop, in addition to the many regular advantages, include:

- New Delta Miter-Gauge (with many new features)
- New Circular Saw Adjusting Lever
- New Delta Adjustable Rip Gauge
- Larger Circular Saw Table
- One-third H. P. Motor
- Larger Triple Foundation Lathe Bed
- ½-in. Capacity Drill Chuck

For full details, send coupon below.

Make the Things You Have Always Wanted to Make

It's so easy and so quick with the Handi-Shop. Save money on repair work. Earn money in your spare time. Complete instructions and Blue Prints furnished. A few of the hundreds of articles you can make with the "Handi-Shop" shown below.

Blue Prints Included



Does Everything from Building Full-Sized Furniture to Turning 36" Table Legs



Note the two-shaft motor that permits two or three operations at one time—the heavy Triple Foundation U-Shaped Lathe Bed (no rods)—the practical arrangement of the Circular Saw that permits the cutting of large lumber without interference—the Improved Tilting Tables on the Circular Saw, Sanding Disc, and Jig Saw. Has automatically oiled bronze bearings and is completely assembled on heavy veneered wood base.

This combination of advantages, plus many more, IS FOUND EXCLUSIVELY IN THE "DELTA" HANDI-SHOP! And now, with the many additional exclusive features of the new 1929 model, this shop is in a class by itself—above all comparison—at a new price that is surprisingly low.

10-DAY TRIAL IN YOUR OWN HOME

without obligation. See how PRACTICAL, how EFFICIENT is this sturdy, full-sized machinery under actual working conditions. Study its many exclusive advantages. You will find the Handi-Shop complete with all necessary equipment for Circular Sawing, Wood-turning, Jig Sawing, Sanding, Drilling, Grinding and Buffing.

Easy Terms

Then if you decide to keep the Handi-Shop, you can have your choice of three convenient methods of payment.

Send Coupon

at once for FREE beautifully illustrated literature giving complete description of the New 1929 Model "Delta" Handi-Shop, and full details of the 10-day Trial Offer and Convenient Payment Plans.

Delta Specialty Company
Dept. A. 29

1661-67 Holton St., Milwaukee, Wis.



The TWO-SHAFT motor is the practical motor for the workshop. Permits you to carry on two or three important operations at one time without continually dismantling set-up.



Heavy Triple Foundation U-Shaped Lathe Bed (not rods or rails) is guaranteed not to spring or chatter.

Write for Valuable Book

crammed with practical information on how to construct useful and decorative objects. Illustrated.

If you want this book, enclose 10c to cover mailing cost. See Coupon.



Delta Specialty Company, Dept. A. 29
1661-67 Holton St., Milwaukee, Wis.

- Please send FREE illustrated literature on new Delta Handi-Shop. Also full details of 10 Day Trial Offer and Easy Payment Plans.
- Please send me copy of "How to Make Things with a Workshop." I enclose 10c to cover cost of mailing.

Name.....

Address.....

This is your car— and you don't have to park it



WHEN you have an errand down town, the street car takes you there and brings you back; you don't have to worry about whether it has gas and oil and water, you don't have to watch out for the traffic lights, and you don't have to search for a place to park. It's the safest and the least expensive form of transportation, and it's always running.

More and more, city automobile owners are finding the street car a satisfactory *individual* solution of the traffic problem; and every individual solution of this kind relieves the congestion of the city streets. A street car passenger requires an average of only six square feet of street space; an automobile passenger requires eight times as much.



The efficiency of street car operation has doubled during the last decade. This is due in a considerable degree to improved electric equipment bearing the General Electric monogram. The same mark on time- and labor-saving appliances for the home is your assurance of electrical quality and dependability.

Transformed in the comfort of its appointments as well as in the efficiency of its operation, the modern street car is bidding successfully for the patronage of all. Even in this age of the automobile, the street car is entering a new era of public recognition and service.

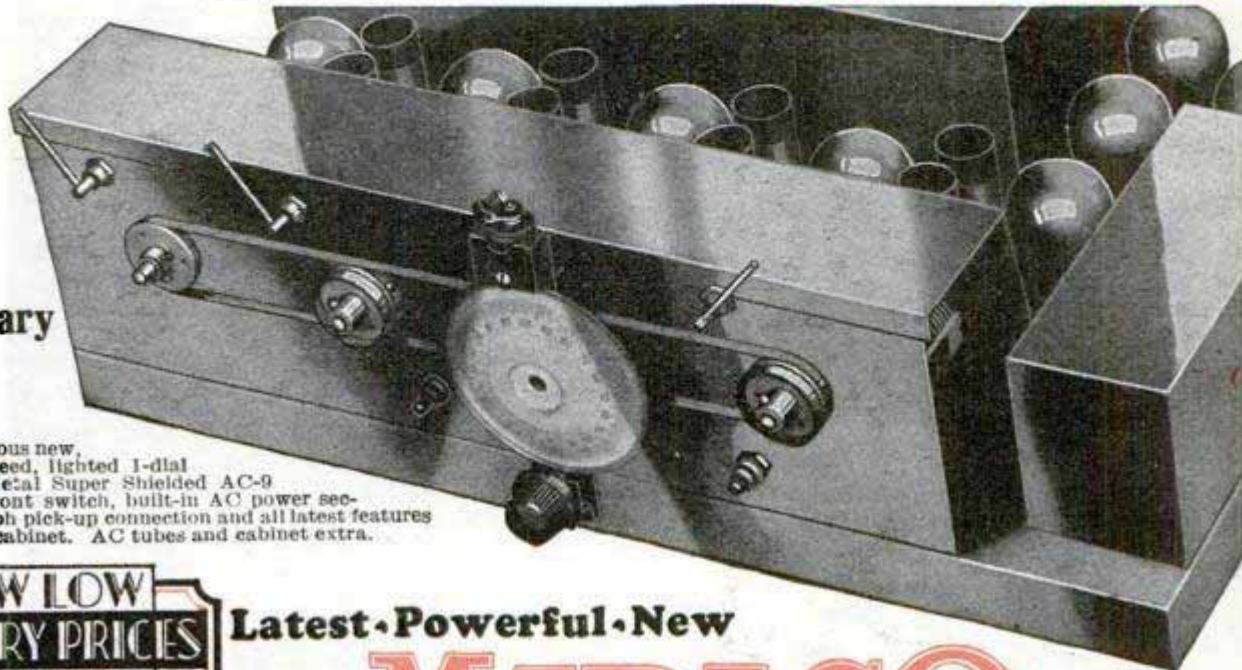
GENERAL ELECTRIC

FACTORY TO YOU—SAVE 50%—COMPARE WITH COSTLIEST OUTFITS BEFORE YOU BUY

Enjoy a powerful new Miraco ^{set or complete outfit} 30 DAYS FREE

AC Electric or Battery

Get Our
Send No
Money
9th
Anniversary
Offer!



View of marvelous new, 3-year guaranteed, lighted 1-dial control, All Metal Super Shielded AC-9 chassis with front switch, built-in AC power section, phonograph pick-up connection and all latest features removed from cabinet. AC tubes and cabinet extra.

NEW LOW FACTORY PRICES
SAVE 50%

Choice of Cabinets AC or Battery Sets
30 Days' Trial

Richly designed genuine walnut console of finest type. Electro-dynamic or magnetic power speaker

Graceful Spinnet console, genuine walnut. Choice of speakers. Also comes in Radio-Phonograph Comb'n.

A Lo-Boy Console that costs little. Dynamic Power speaker.

Popular inexpensive combination. Set on table speaker.

New-type armchair console of genuine walnut—latest speakers.

MIRACO Radio gets 'em Coast to Coast

Latest • Powerful • New

MIRACO

TRADE MARK REGISTERED

Cathedral Toned, Super Selective, Long Distance Getters

Battery or Electric AC Sets

Celebrating its 9th successful year, America's big, old, reliable Radio Corporation springs a genuine sensation in high-grade sets. With its latest, Super-powered, 1-dial Miracos—the All Electric wholly self-contained, hum-free, AC-8 and AC-9, using AC tubes or the new 8-tube Ultra for batteries or Eliminators—you are guaranteed the greatest values and savings in the fine set field.

Compare a Miraco with highest-priced radios, for 30 days in your home. Surprise and entertain your friends—get their opinions. Unless 100% delighted, don't buy it! Return everything—the complete outfit—at our expense. Your decision is final—absolutely!

Only exceptionally fine radios, of the very latest approved type, at rock-bottom prices, could possibly back up so liberally unconditional a guarantee. Send coupon now for *Amazing Special Factory Offer!*

Don't Confuse with Cheap Radios
With its rich, clear Cathedral tone, hum-free operation, tremendous "kick" on distant stations and razor-

edge selectivity—with its costly sturdy construction, latest features, including phonograph pick-up connection, ease of tuning, beauty, and economy—a Miraco will make you the envy of many whose radios cost 2 to 3 times as much!

Many thousands of Miracos—bought after 30 day home comparisons—are cutting through locals and getting coast to coast, Canada, Cuba, Mexico, with the tone and power of costly sets. Miracos are laboratory-built with finest parts, and embody 9 years' actual experience in constructing fine sets. Approved by Radio's highest authorities.

Deal Direct with Big Factory

Everything reaches you splendidly packed and rigidly tested to insure your instant enthusiasm. Enjoy the outfit 30 days—then decide. Liberal 3-year guarantee on each set. Play safe, save lots of money, and insure satisfaction by dealing direct with Radio's old, reliable builders of fine sets—9th successful year

Ultra 8
\$49⁸⁸

Electric AC-8
\$71⁵⁰

Electric AC-9
\$83⁷⁵



Metal or wood compact style cabinets. Wood cabinets in walnut or new shaded silver-chrome finishes. Cathedral Electro-dynamic or Magnetic-Power Speaker to match!

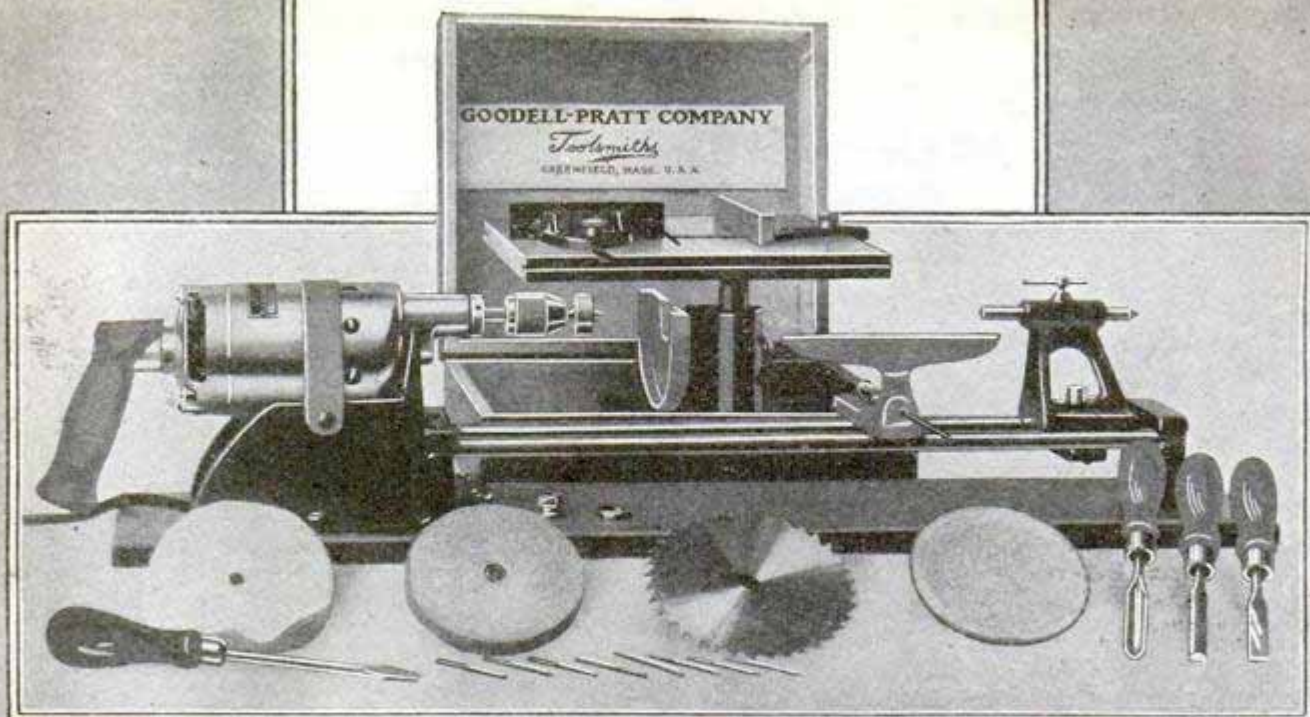
MIDWEST RADIO CORP'N, 407-RF Miraco Bldg., Cincinnati, Ohio, U. S. A.
BEAUTIFULLY ILLUSTRATED CATALOG, AMAZING SPECIAL FACTORY OFFER
Testimony of Nearby Users—All the proof you want—of our honesty, fairness, size, financial integrity, radio experience and the performance of our sets—including Amazing Factory Offer—sent with catalog.

Free!

MIDWEST RADIO CORPORATION
Pioneer Builders of Sets—9th Successful Year
407-RF Miraco Bldg., Cincinnati, Ohio

THIS COUPON IS NOT AN ORDER

WITHOUT OBLIGATION, send free catalog, Amazing Special Factory Offer, testimony of nearby users, etc. User Agent Dealer
 Check here if interested in an EXCLUSIVE TERRITORY PROPOSITION
NAME ADDRESS



*You can SEE this
BEFORE you Buy it!*

Ask your local dealer to show it to you. He probably has it in stock. Examine it. Its quality stands out. Made by a maker of good tools since 1888, you take no chances. Your dealer will guarantee it. We'll back him up. Note these features:

Power Unit

A No. 1040 1/4 inch Electric Drill: easily removable for use as a portable drill.

Lathe Unit

Practical and sturdy. Used for years on our foot power lathes. Adjustable Tee Rest and Tail Stock can be locked at any desired points. Capacity, 12 inches between centers; 5 inch swing.

Saw Table

Adjustable to cut from 0 to 1 inch. Made of wood, 9x10 inches, with steel inset and guard. Two Saw Guides--for ripping and for cross-cutting or mitering.

Polishing and Grinding

A 4 inch Grinding Wheel with 1/2 inch face and a 4 inch Buffing Wheel. Can be used either in lathe or portably.

Disc Sanding

Sanded Disc, with 4 inch face. Emery Cloth may be substituted for polishing or grinding.

Accessories

Three Wood Turning Chisels. Screw Driver, eight Drill Points--1/16 to 11/64 inch.

LIST PRICES

No. 1070	110V, complete	\$50.00
No. 2070	220V, complete	\$52.00
No. 3070	32V, complete	\$52.00

If your local dealer hasn't one of these in stock, write us.

For
Sawing
Drilling
Polishing
Buffing
Grinding
Wood Turning
Model Making
Cabinet Making



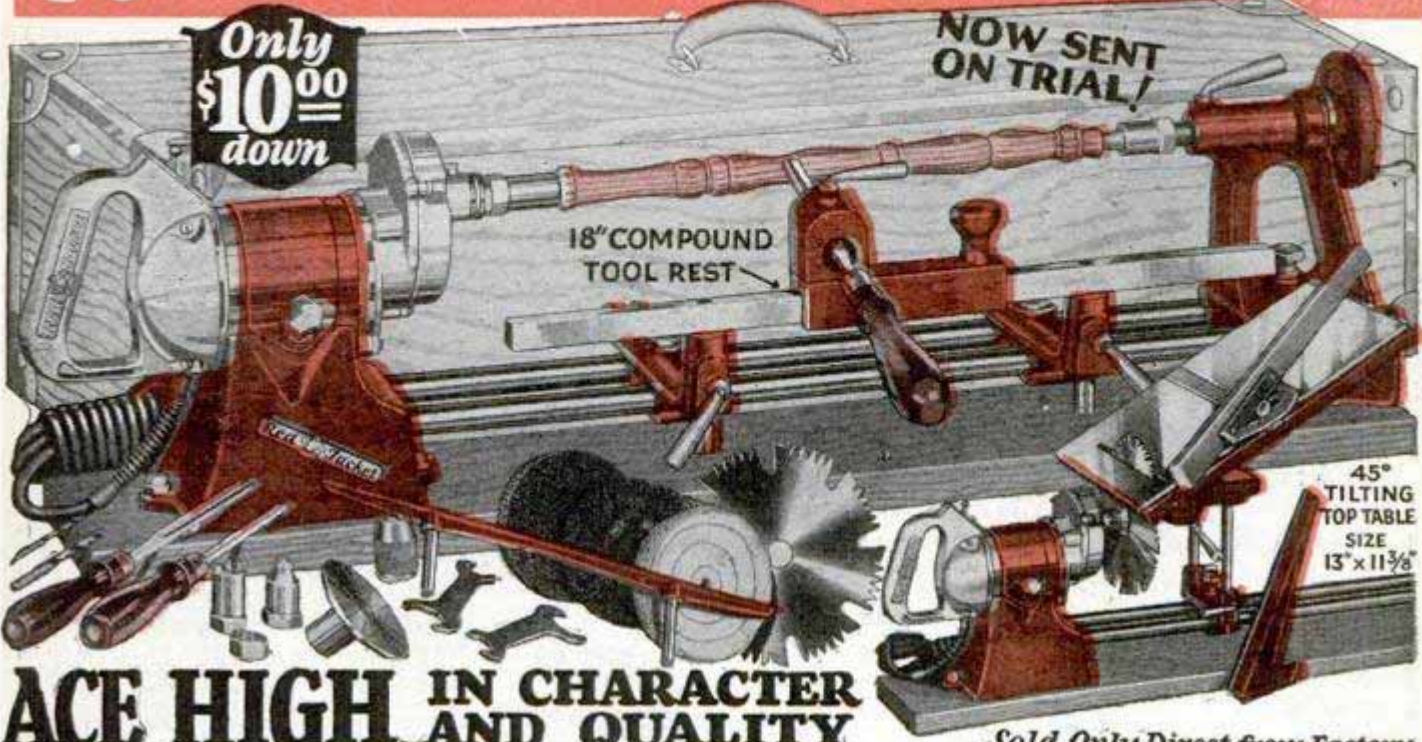
*The Mark of a
Complete Line of
Super-Performance
Electric Drills*

GOODELL-PRATT COMPANY *Toolsmiths*, GREENFIELD, MASS. U.S.A.

GOODELL-PRATT

1500 GOOD TOOLS

Now - Make Things at Home with this Wonder Working Shop



ACE HIGH IN CHARACTER AND QUALITY

Sold Only Direct from Factory



45° Tilt Top Table

3 years of testing, experimenting and improvement is wrapped up in each new Red Jacket Home Work Shop. The finest tools and accessories that can be made go with each assembly order. Red Jacket equipment is designed, tested, approved and guaranteed by Wm. L. Aylward, a nationally known craftsman and manufacturer, who has developed his hobby into a co-operative association of thousands of craftsmen.

Portable — Interchangeable — Complete RED JACKET Home Work Shop

The new Red Jacket Combination of Electric tools brings you a Red Jacket Band Saw and in addition the powerful Red Jacket Master Drill Motor with direct drive to the Waco Craftsman's wood turning lathe (capacity 9"x36"), also compound and 18" rests, a tilting top mitre saw with both depth and side gauges, scroll and jig saw, and all accessories for both portable and stationary power drilling, buffing, grinding and cleaning. Attaches to light socket and converts your work bench into a complete private tool and machine shop. It is a complete chest full of electrically driven tools designed for the private use of tool lovers and men who create, repair and appreciate handy tools at home.

Make It Yourself!

Exclusive Features with WACO—

- All Aluminum Master Drill Motor
- Perfect Tilting Saw Table 13 x 11 1/2 in.
- Patented Compound Tool Rests
- Finest Quality Hand Tools
- Unconditional Guarantee
- Unlimited Service

—Read Our Code of Business Ethics—
Ask 7000 Happy Waco Owners

Mail Coupon for Interesting FREE Literature

Send coupon at once for information valuable to those interested in beautiful handiwork. It is FREE. It tells you how easy it is to operate a Red Jacket set of tools and lists the advantages and privileges that are free to member craftsmen. Don't miss knowing all about Waco. You are invited. **Look out for imitations.** There is only one Red Jacket—one Waco—you will not find WACO TOOLS sold by retailers. All sales made direct from factory.

The WACO Guarantee
If it is not what you want when you get it—send it back.

SPECIAL CRAFTS COURSE FREE
SPECIAL CRAFTS COURSE and blueprint service is free to Red Jacket Shop owners—all there is to know about handicraft methods, raw materials, woods, carving, sawing, turning, designing, carpentering, decorating, is taught by special correspondence.

BUY ON YOUR OWN TERMS Only \$10.00 down. Liberal discount for cash. Easy monthly payment plans. It is no hardship to own a Red Jacket.

SEND THE COUPON—Interesting Literature Free You will be surprised with all it contains. Beautiful, Instructive, Fascinating, Interesting. Fill in and MAIL TODAY.



Loving Cup Won by Waco Grand Prize of American Master Craftsmen's Assn.



Red Jacket MASTER DRILL

The most elaborate and unusual drill motor ever designed for driving power.



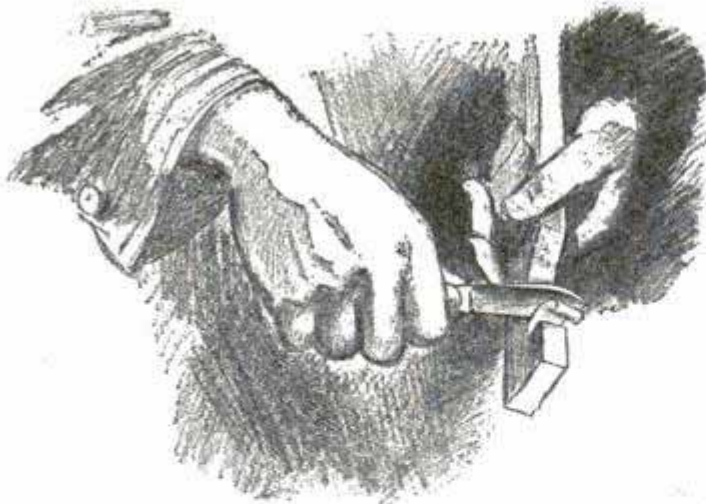
free BLUE PRINTS



This Headstock furnished where no electricity is available.

WACO TOOL WORKS, Inc.,
5216 W. Kinzie St., Chicago
Manager, Dept. 102. Please send me all free information and literature on Red Jacket Assemblies and FREE Services.

Name.....
Address.....



A WORK KNIFE

THE man or boy who wants a knife to do things with, will not find a better one than this. It belongs in the car, garage, tool kit, or work shop. Hunting, fishing, camping or touring you'll want this knife. You'll need it working around the house, garden or farm.

The cutlery blades are sharp—hand-honed at the factory. The fine, high-carbon steel will hold its biting edge. The screw-driver is a practical tool—made to fit average household screws. The can-opener works and doesn't slip. The punch, or reamer blade is solid-forged and can be easily resharpened when necessary. The cork-screw is onto its job.

Beautifully finished—reinforced brass linings, nickel-silver bolsters and shield, stag handle.

See one of these knives at your dealer's or, if he hasn't one in stock, send us his name and \$4.00 for R3843. It will be mailed to you promptly.

REMINGTON ARMS COMPANY, INC.

25 Broadway, N.Y.C.

Established 1816



R-3843
PRICE \$4.00

Remington

© 1929 R. A. Co.

2492



THIS MODERN
6 ROOM HOME
NOW ONLY \$1024

PAY ONLY
\$15.65
Per Month

Why not live in a modern new home of your own instead of in an old and shabby rented house that is costing you a fortune every year? You can build a new home on the STERLING PLAN and pay for it with your rent-money—as low as \$8.10 per month for a 6-room house. We even advance cash to help you build, if you own a well located city lot.

Build Now and Save Money!

We ship you any home you select, ready to erect—lumber cut to fit, FREIGHT PAID TO YOUR STATION. No high interest or financing charges. Lowest prices in the history of our company. Send 25c in coin today for beautiful Color Book of Sterling Home Plans and select the home that you want us to ship you.

International Mill & Timber Co.
924 S. Wenona Ave., Bay City, Mich.



New
Sepia
Prints

A BEAUTIFUL FINISH

that improves kodak pictures. Send 8¢ and negative for sample and catalog of specialties.

FRANK SCOBIE, 43-S, SLEEPY EYE, MINN.

SILVER ACE

Flying Models

Build a Tri-motor Fokker, Spirit of St. Louis or cabin models of the Ryan, Stinson or Fairchild types. Thousands of model builders have learned how sensibly SILVER ACES are made, and how they fly. Yet they have beauty, strength, light weight, and no metal except small wire parts. Ask your dealer for a SILVER ACE and play safe.

SILVER ACE supplies also are the best quality you can buy. Carefully tested by our engineers for our own use and yours. Special Balsa Veneer, Aero Glue, Rubber, Dope, Silk, Wheels, Propellers, etc.

Catalog—10 cents

THE AERO MODEL COMPANY
329 Plymouth Court Chicago, Illinois

This Man's Income is \$700⁰⁰ A Month *and it's* GETTING BIGGER

You can get into
his profession—
CLARKE
FlorKraftsmanship
—and Earn
as Much!

IF you are earning less than \$25.00 a day at your present job, this message is for you. It's a plain statement of the facts about FlorKraftsmanship—facts that have made thousands of men financially independent—that can raise *your* income to from \$500 to \$1000 a month.

Clarke believes in talking straight. Let's leave out the bunk. Read every word here,—it's the record of what men are actually doing today, and what they get paid for it, as Clarke FlorKraftsmen.

**No Schooling—
No Tuition**

You don't have to go to school to become a Clarke FlorKraftsman. Go into this work right from your present job—whether you're a clerk in an office, a mechanic or a carpenter; whether you are 25 years old or 50 years old.

There's no tuition for you to pay. A day's work teaches you to surface new floors smooth as glass or to sand off old varnished floors so they look like new. One day's practice—that's all. The Clarke does the work—your job is as easy as running a vacuum cleaner.

**OVER 1000
Popular Mechanics
Readers are now
FlorKraftsmen**

Among Popular Mechanics readers are over one thousand men who



have already grasped this opportunity. Clarke FlorKraftsmanship has raised their pay till they're making from \$25 to \$75 a day. And they're busy all the time.

The same opportunity that brought success to them is offered to you in this advertisement. Stop and think what this big pay will mean. A better car—a home of your own—financial independence! No boss who can fire you! A business of your own.

\$25 to \$75 a Day

With the Clarke Vacuum Portable Sander you can do the work of eight men sanding floors the old back-breaking way. 800 to 2000 square feet of new floor in 8 hours is the speed at which the Clarke works. The price paid for sanding new floors is 2 to 5 cents a square foot.

Then on refinishing old varnished floors, the Clarke sands 300 to 1000 square feet a day—without the use of varnish re-

**CLARKE SANDING
MACHINE CO.**

Dept. T-22
3831 Cortland St., Chicago, Ill.
*Originators and, for 12 years, Manu-
facturers of Portable Sand-
ing Machines.*

*Read what
others are
Earning*

A. E. Sweeney, Alturas, Calif., says: "I have had the machine almost a week and want to say it has paid me \$76.00. That is doing pretty well, I call it—two months payment in one week."

mover. You get 7 to 15 cents a foot on this work. Think what these prices mean! There's no material for you to buy except a little sandpaper. Your income is nearly 100 per cent *velvet*.

Full Facts FREE

Remember you don't need to be a carpenter or a painter to use the Clarke Sander. Men just like you are making these big incomes with it. They've read these ads in Popular Mechanics just like you are reading this one now. They've written for the facts and gone into the business just as you can.

Get the facts. Every day's delay is money out of your pocket. Write direct to Clarke, using the coupon placed here for your convenience. No cost to you to find out what others are doing in this business. You're under no obligation. Tear out this coupon and mail it today.

**POWERFUL - FAST CUTTING -
CLARKE
VACUUM PORTABLE SANDER**

**CLARKE SANDING MACHINE
COMPANY,**
Dept. T-22, 3831 Cortland St.,
Chicago, Ill.

Tell me, without obligation, how I can make \$25 to \$75 a day as a FlorKraftsman.

Name.....

Address.....

City.....State.....



-take it!
It's Bayer

The nurse tells you to take Bayer Aspirin because she knows it's safe. Doctors have told her so. It has no effect on the heart, so take it to stop a headache or check a cold. For almost instant relief of neuralgia, neuritis, rheumatism; even lumbago. But be sure it's Bayer—the genuine Aspirin. All druggists.

ASPIRIN

Aspirin is the trade mark of Bayer Manufacture of Monoaceticacidester of Salicylicacid

NEW AUTOMATIC WINDOW WASHER

Washes-Cleans-Dries-Polishes in ONE Quick Operation.



Amazing new invention completely revolutionizes window washing. Carries its own water supply! It eliminates all the drudgery and unpleasantness, five times as fast as old methods! No pail. No brush. No sponge. No chamols. Your hands never touch water with the NEW AUTOMATIC. Can be used with or without pole. Every housewife, auto-owner, storekeeper and factory owner a live prospect. Sensational demonstration. Sells at sight. Big repeat business. Year 'round seller.

MAKE \$90 TO \$150 A WEEK!

Agents coin tremendous profits. Going like wild-fire. Sells for only \$1.95. Liberal profits for agents. \$10 to \$25 a day easy; \$200 to \$300 a week possible.

WRITE FOR OUR FREE SAMPLE OFFER

You risk nothing. Don't delay. Write for money making proposition today.

NATIONAL INDUSTRIES, Wrigley Bldg., Dept. 152, CHICAGO

An Amazing Offer!

only \$1⁰⁰ DOWN

Brings You This 21 JEWEL Extra Thin STUDEBAKER

Just \$1.00! The balance in easy monthly payments. You get a famous Studebaker 21-Jewel Watch direct from factory at a saving of thirty to fifty per cent.

Your choice of 80 new Art Beauty cases and dials. Latest designs in white gold, yellow gold and green gold effects. 8 adjustments, including heat, cold, isochronism and 5 positions. Insured for lifetime. Ladies' Bracelet Watches, Men's Strap Watches, Diamonds and Jewelry, too. All sold on easy monthly payments. Your credit is good! Write today for free book of Advance Watch Styles or Jewelry Catalog.

Watch Chain FREE! For a limited time we are offering a beautiful Watch Chain free. This special offer will be sent to everyone who writes at once. Don't delay! Get this free chain offer today—while it lasts.

STUDEBAKER WATCH COMPANY

Directed by the Studebaker Family—known for three-quarters of a century of fair dealing

Dept. C103 South Bend, Indiana

Canadian Address: Windsor, Ont.

BIG MONEY

easily made by floor surfacing contractors who average \$40 per day. The New "American High Production" Machine does the work—makes you the money and builds you a business of your own. No dull seasons—no large capital nor experience required, complete information free without obligation—write today.

THE AMERICAN FLOOR SURFACING MACHINE COMPANY
523 So. St. Clair St. TOLEDO, OHIO

A Down Payment of \$27.50 —and monthly installments of \$10 for seven months will give you ownership of The Workshop Special.

The WORKSHOP SPECIAL
"Yours From The Bench Up"

A complete woodworking machine, fully guaranteed.

KORNAU MACHINE CO.
4020 Gulow St. Cincinnati, Ohio

RADIO LATEST CATALOG OF NEWEST SETS AND KITS **FREE**

Fresh from the press. Shows all the newest standard parts, sets, kits at big savings. Most complete line in America. Big discounts to set builders. Send name and address at once.

BARAWIK COMPANY 102B Canal Sta., CHICAGO, ILL.

Direct at Factory Prices

Sample \$1.18 3 for \$3.00 Postpaid

A Genuine \$2 Knife for \$1.18 Postpaid

Handy shaped Blade makes this knife best for mechanics, sportsmen and farmers; light but strong; re-sharpened easily. Stag handle. German silver finish; blades file tested, hand forged from razor steel and warranted.

Maher & Grosh Co.
106 A St., Toledo, Ohio

"THE HUDSON"

Six room shingle house; bath; fire-place; built-in conveniences. Materials Plan-Cut.

\$2661



*You
Can
Build
Your
Own
Home!*

Buy Direct from Mills!

If interested in building, write for 100 Home Plans!!

We ship direct from mill all framing lumber and sheathing, sawed, cut and fitted; complete blue prints and full, easy-to-follow erection instructions. No extras!

Easy to build as swinging a hammer! Every part numbered according to plan. All the figuring, measuring, roof-pitches, angles, already done for you. No cutting of heavy floor-joists, rafters, or timbers. Even the doors are mortised for locks. You can build your own home and save \$2000!

Save 1-3 Labor

Hand-sawing is the costliest item in building. By our Plan-Cut method you save 3940 hand saw cuts and 18% lumber waste, in addition to factory prices.

Guaranteed Prices

The price you pay us includes all lumber, lath, shingles, beautiful doors, windows, hardwood floors, trim, stair-work, hardware, paint, tin-work, nails, varnish, and enamels. Cement and brick work you buy locally.

Permanent Construction

Machine accuracy insures tight, solid fit of all joints. You get a stronger, stouter, and tighter house. Guaranteed for 20 years.

Insulation Saves Fuel

Our warm quilt insulation reduces fuel costs 1/4; warmer in winter, cooler in summer; comfortable and healthful.

Plan-Cut homes are designed by skilled architects—planned for beauty, practical arrangement, and correct height of rooms. Many built-in conveniences to save steps and lighten housework. Highest quality material throughout—guaranteed!

5000 Bargains in Building Material

- Lumber
- Lath
- Windows
- Roofing
- Furnaces
- Paints
- Shingles
- Flooring
- Doors
- Screens
- Glass
- Varnish

Gordon-Van Tine

Established 1865

PLAN-CUT Homes

DAVENPORT, IOWA

GARAGES

\$90 UP

All material complete. Lumber is Plan-Cut, bundled and marked. Build yourself and save money.



ROOFING

Jan-a-Top slate surfaced roofing. Green or red. 90 lbs. to the roll. Nails and cement included. Fire-resisting. \$2.20 per roll.



PAINT

Guaranteed quality house paint; all colors. \$2.40 per gal.

Before you Rent, Buy or Build, Send for 100 Home Plans!



Write

Gordon-Van Tine Co.
1286 Case Street
Davenport, Iowa

Satisfaction guaranteed or money back. Please send me catalogs. I am interested

In

Name

Address

Only \$188.00

A Complete Machine Shop 5 Machines in ONE

LATHE-DRILL-UNDERCUTTER-VALVEGRINDER-GRINDER

With this new and practical machine, you can handle all jobs of turning, grinding, drilling and repairing in metal and wood. Fast, accurate, sturdy and guaranteed by the makers of the famous C-O Garage Tools and Shop Equipment, known the world over.

Without Valve Grinder \$158.00

USED BY

- Garages
- Electric Shops
- Small Machine Shops
- Builders
- Inventors
- Model Makers
- Home Mechanics
- Farmers
- Storekeepers
- Radio Shops
- Battery Stations
- Air Ports, etc.

Operates from any Electric Light Socket

Weight, 200 lbs.
Size, 38" long,
27" high,
12" wide

Lathe—6" swing, 14" between centers. Adjustable tail stock. 1/2" Universal chuck, 3" face plate, center plate, tool post, 3/8" chuck dog, cutting tools, special wrench to fit all nuts and screws. 2 speeds, 500 and 1000 R. P. M.

Drill—Drills holes 0 to 3/8". Adjustable head with 7 1/2" travel on column. Drills to 9" circle and has 2 1/2" up and down spindle run. Speed is 1100 and 2200 R. P. M. 3-jaw chuck furnished with 1/2" chuck wrench. 3/16", 1/4", 5/16" and 3/8" bits.

Undercutter—Instantly adjustable and does accurate work. Equal to any separate and more expensive undercutter.

Valve Grinder—Grinds valves with 45 degrees up to and including 3/4" diam. stem.

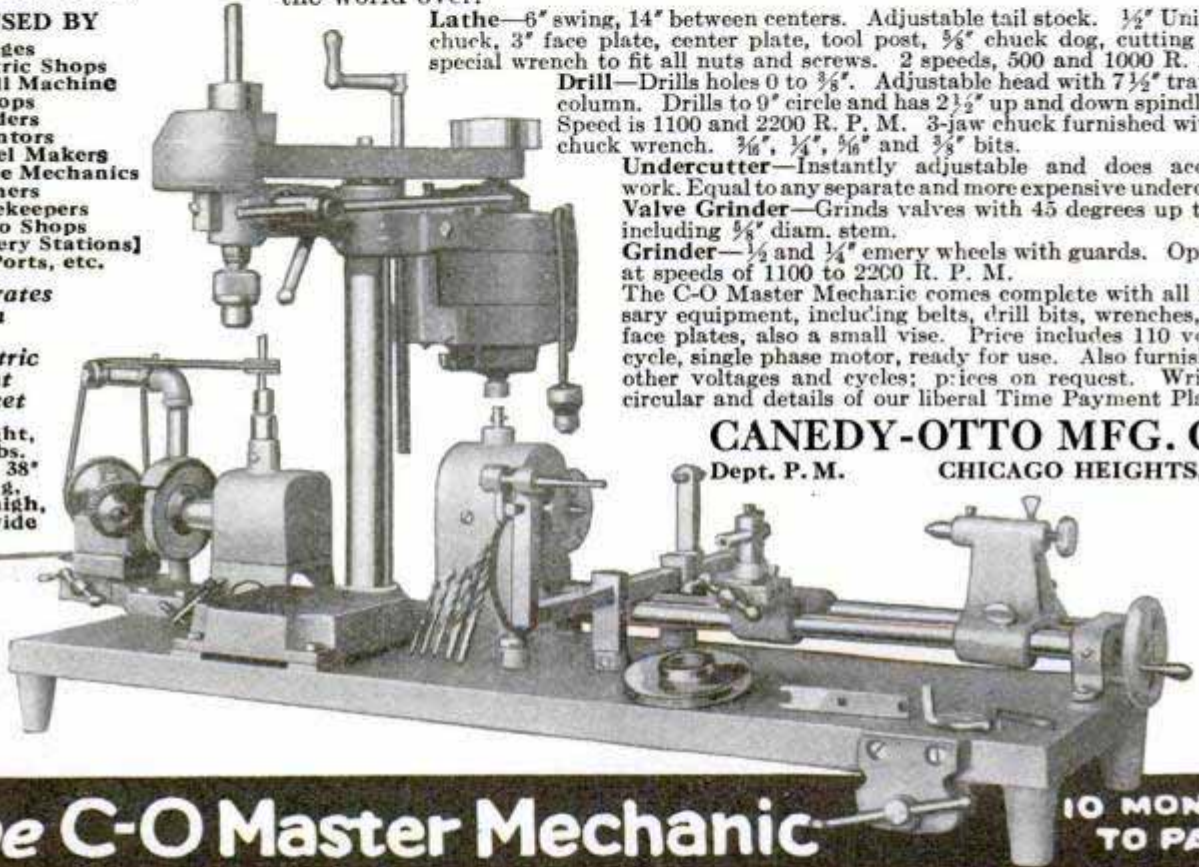
Grinder—1/2 and 1/4" emery wheels with guards. Operates at speeds of 1100 to 2200 R. P. M.

The C-O Master Mechanic comes complete with all necessary equipment, including belts, drill bits, wrenches, dogs, face plates, also a small vise. Price includes 110 volt, 60 cycle, single phase motor, ready for use. Also furnished in other voltages and cycles; prices on request. Write for circular and details of our liberal Time Payment Plan.

CANEDY-OTTO MFG. CO.

Dept. P. M.

CHICAGO HEIGHTS, ILL.



The C-O Master Mechanic

10 MONTHS TO PAY

SELL EGGS BY MAIL

If you are interested in making individual shipments of eggs to high class city and town trade no better article was ever made for carrying eggs with absolute safety than this famous crate with its metal edge filler. Lasts for years. Known everywhere. Sizes 1 doz. to 15 doz. Write for free circular giving prices, postage rates, instructions on how to build highly profitable business, etc. **METAL EGG CRATE CO., 507 Wolfe Street, Fredericksburg, Va.**

NO JOKE TO BE DEAF — EVERY DEAF PERSON KNOWS THAT



I make myself hear, after being deaf for 25 years, with these Artificial Ear Drums. I wear them day and night. They stop head noises and ringing ears. They are perfectly comfortable. No one sees them. Write me and I will tell you a true story how I got deaf and how I make you hear. Address



GEO. P. WAY, Artificial Ear Drum Co. (Inc.)
80 Hoffman Bldg., Detroit, Mich

Cal. 30-40 Six Shot



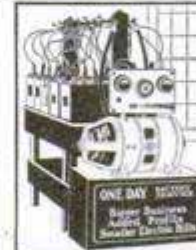
KRAG CARBINE

Price **\$9.75**

All the qualities of a high price rifle. In fine used condition, all working parts guaranteed for one year. Send today for our Free 50-page illustrated catalog of money saving values; Guns, Ammunition, Cutlery, Sports and Gov't goods. Deposit required on all orders. Money refunded if not satisfactory.

W. Stokes Kirk, 1627 No. 10th St., Dept. A-1, Philadelphia, Pa.

\$150 to \$300 Monthly Profit Charging Batteries—Start NOW!



HB One Day Charging starts you making big money recharging auto and radio batteries. \$150 to \$300 monthly profits easily made. **Only \$35 cash brings complete HB One Day Battery Charging Outfit.** Easy payments. No experience needed. Lowest-Priced complete One Day Charging Outfit on the market. **30 days' trial on money back guarantee.** Write for free bulletin.
HOBART BROS., Box M-291, Troy, Ohio

SPORS LATEST No. 1 FOUNTAIN PEN

SELLS FOR \$1.25 SEND ONLY 8 Different Colors Money Back If Not Pleased.

39¢ (SENT POST-PAID)

"Writes Like a \$7 Pen."



WRITE FOR FREE WHOLESALE CATALOG SHOWING OVER 400 ARTICLES.

F. SPORS & CO., 1227 Main St., LESUEUR CENTER, MINN.

**AMAZING
NEW
IDEA!**



Bath Room Outfits \$55.75
COMPLETE UP

Furnaces
\$42.95
UP

**BIG BOOK
FREE**



Sinks \$18.75
UP

**Save 1/2 on Material
Save ALL Labor Cost**

**We Show How You Save Hundreds
of Dollars Installing Your Own**

PLUMBING and HEATING



6 Room
Steam Heating
Plant
\$165.00
Complete

MAIL the coupon today and get this wonderful, Big FREE Book that lists 4000 great bargain offers and shows every little detail for installing your own plumbing and heating. Nothing like it ever printed before. Everything new, modern and up-to-date. Homes everywhere follow our instructions and save hundreds of dollars. You can do it too!

New, Low Factory Prices

You get the rock-bottom, wholesale, factory price on absolutely everything including fittings, accessories, supplies and tools. You make enormous savings here. No reliable firm ever undersells us. If our prices go down after you get catalog, we apply credit on your orders.

HIGHEST QUALITY GUARANTEED

Everything Sent On Approval

You never run the slightest risk buying from us. Not only do we guarantee highest quality and lowest prices but you are the sole judge. Your money always sent back at once if you are not completely satisfied.

**Startling Plan Explains How You Can
"Be Your Own Plumber"**

If you can use a wrench you can be your own plumber. Our amazing, simple and easy plan explains everything. No experience necessary. We help you in every way possible. Thousands of our customers do their own plumbing and heating work.

Small, Easy Payments

Many offers in our Big Catalog sold on small, easy payments. Goods shipped in 24 hours. We carry largest stock and variety in U. S. covering two solid acres of floor and shelf space.

MAIL THIS COUPON · TODAY

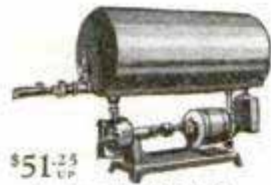
Don't delay! Don't wait another minute to investigate the most successful home savings, plumbing and heating plan ever devised. Mail the coupon—now!

BURKE (4) BROS., 423 Liberty Ave., Pittsburgh, Pa.

Largest Stock of
Accessories, Sup-
plies and Fittings
in the U. S. A.



**GET
FREE
BOOK
Now**



\$51.25
UP
Automatic Electric
Water Systems



Boiler
Tanks
\$6.40
UP



\$9.75
UP
Laundry Tubs



Hot
Water
Heaters
\$4.60
UP



Parlor
Heaters
\$39.00
UP



Pumps
\$1.45
UP



Lowest Prices on
Every Kind of Tools



Steel,
Copper, Brass
and Lead Pipe

Paints and Varnishes
Remarkably low prices on
all kinds of Paints, Enamels,
Varnishes, etc.



- Bathroom Outfits
- Steam and Hot Water Heating Plants
- Pipe & Pipeless Furnaces
- Pumps and Septic Tanks
- Plumbing Supplies

Burke (4) Bros.,
423 Liberty Ave., Pittsburgh, Pa.

Send your Big FREE Catalog of 4000 Wholesale Bargains explaining how I can install my own plumbing and heating. (Check subjects in which you are specially interested).

Name.....

Address.....

City.....State.....

NEW MODEL SOUTH BEND

LATHE BUILDERS FOR 22 YEARS

*For the
Manufacturing
Plant*

Tool Room
General Repair
Shop
Machine Shop
Service Station
Electrical Shop
Engineering Shop
and
Laboratory

*Used by
Manufacturers
of*

Automobiles
Electrical Parts
Machinery
Aircraft
Textile Machines
and
Government De-
partments
National and
State

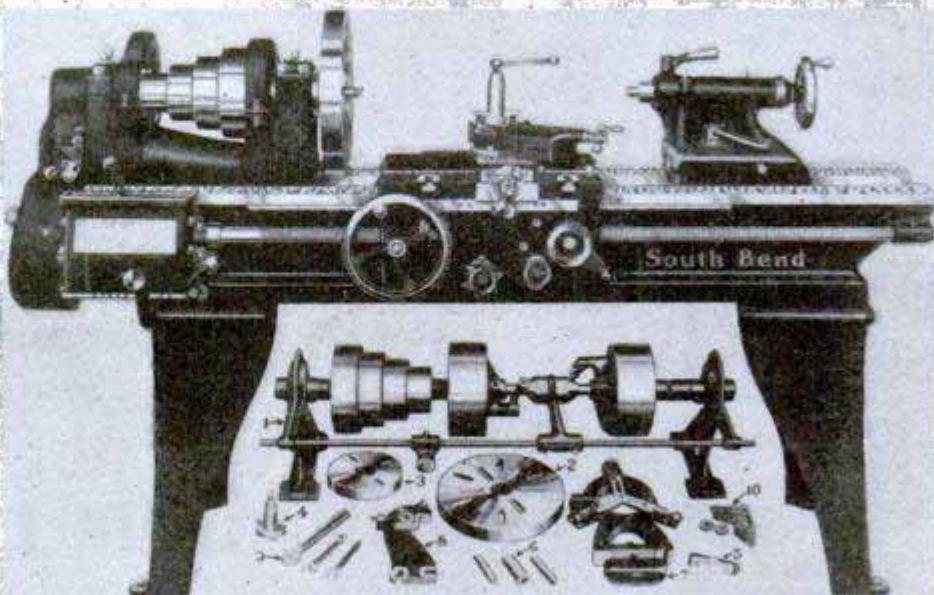
*96 Sizes and
Types*

Countershaft
Driven Lathes
Motor Driven
Lathes
Quick Change Gear
Lathes
Standard Change
Gear Lathes
Tool Room Lathes
Gap Bed Lathes
Brake Drum Lathes
Bench Lathes

All illustrated
and described
in

Catalog No. 89-A

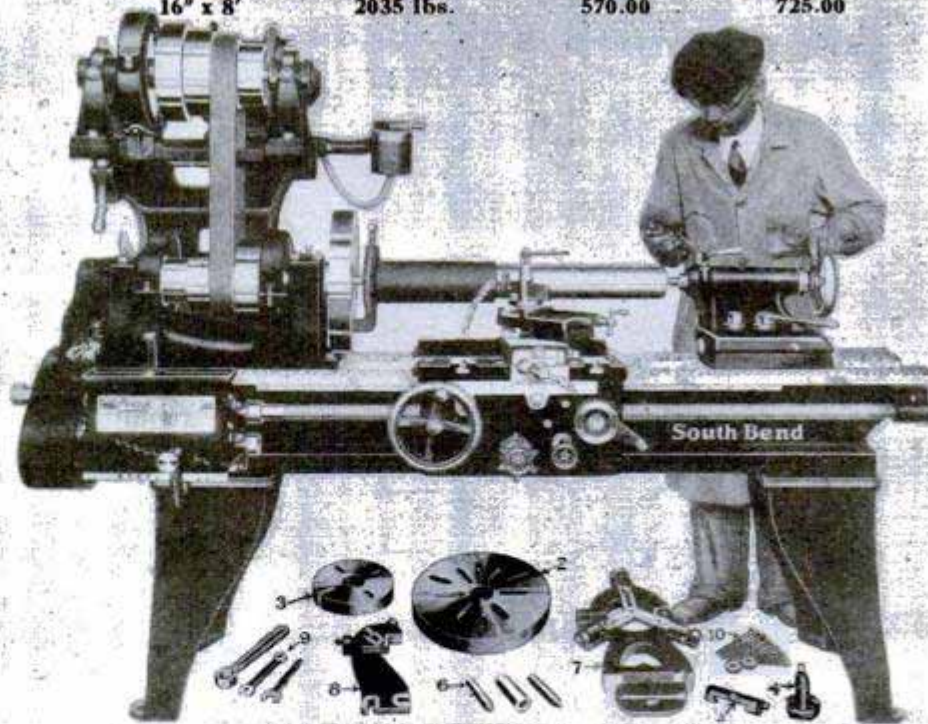
Write for
Free Copy.



16" x 6' Quick Change Gear New Model
South Bend Lathe.....\$540.00

Prices of Popular Sizes of Quick Change Gear Lathes

Size of Lathe	with Lathe Equipment Shipping Weight	Countershaft Drive	Silent Chain Motor Drive
9" x 3'	490 lbs.	\$270.00	\$371.00
11" x 4'	725 lbs.	335.00	455.00
13" x 5'	1110 lbs.	402.00	537.00
15" x 6'	1550 lbs.	490.00	643.00
16" x 8'	2035 lbs.	570.00	725.00



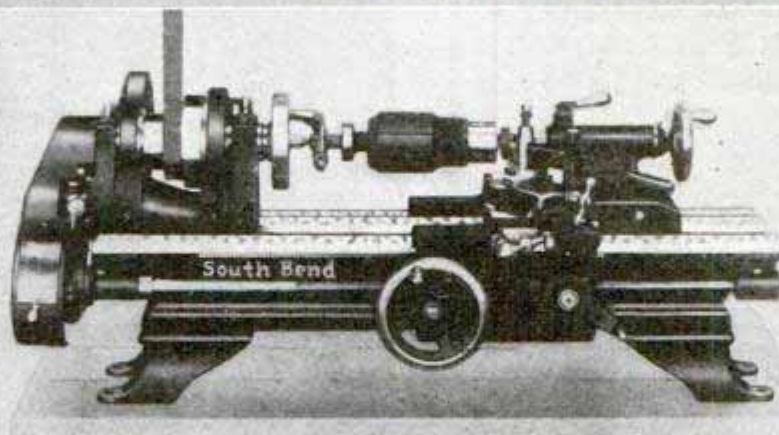
18" x 8' Quick Change Gear Silent Chain
Motor Driven Lathe.....\$908.00

SOUTH BEND

602 East Madison Street
New York City, J. E. Beggs Co., 183 Center Street

SCREW CUTTING LATHES

OVER 43,000 LATHES IN USE



Weight
375 Pounds

9" x 3' Junior New Model
South Bend Bench Lathe **\$155**
with Countershaft and Equipment

Easy Payments as low as \$12.40 a Month

Our Easy Payment Plan allows you to install a South Bend Lathe in your shop, by making one payment with the order; the balance to be paid month by month, the amount depending upon the size of the Lathe.

Write today for Catalog No. 89-P, which describes the Easy Payment Plan. Mention size of lathe desired.

The New Model South Bend Lathe is a remarkable tool and is practical for handling the finest and most accurate work. 96 sizes from 9" to 18" swing are available in various types and drives.

These New Model Lathes are used in the plants of the Western Electric Co., General Electric Co., Victor Talking Machine Co., Packard Motor Co., Oldsmobile Co., International Harvester Co. and thousands of other plants.

Operates from
Light Socket



Other 9-inch Junior Lathes

The Prices include Lathe Equipment

Size of Lathe	Shipping Weight	Counter Shaft Drive	Horizontal Motor Drive
9" x 2 1/2"	350 lbs.	\$150.00	\$221.00
9" x 3"	375 lbs.	155.00	226.00
9" x 3 1/2"	400 lbs.	160.00	231.00
9" x 4"	425 lbs.	165.00	236.00
9" x 4 1/2"	450 lbs.	170.00	241.00

Write for this 20-page booklet, illustrating and describing the 9-inch Junior New Model South Bend Lathe in all sizes and types. A copy mailed free on request.

9" x 3' Junior New Model South Bend Horizontal Motor Driven Bench Lathe complete, \$226.00.



LATHE WORKS

South Bend, Indiana, U. S. A.

Chicago, Ill., C. B. Burns Mach. Co., 541 Wash. Blvd.

SOUTH BEND LATHE WORKS
602 E. Madison Street, South Bend, Ind., U. S. A.
Gentlemen: I would like your net factory price on a Screw Cutting Lathe, Size _____ for (check kind of work)
 Manufacturing Machine Shop Garage Work
 Electrical Work Catalog 89-A Catalog 89-P Catalog 23.
Name _____
Address _____
City _____
State _____

The Old Reliable Credit Jewelers

LOFTIS BROS. & CO. EST'D 1858

Dept. K-894
108 N. State St.
Chicago Ill.

DIAMONDS CASH OR CREDIT
Genuine Diamonds Guaranteed
Bigger Diamond Ring Values!

Newer styles, finer quality, bigger values. We import our Diamonds from Europe—that's why we can sell to you for less. Our rings are solid 18-k white gold, magnificently engraved, and set with gorgeous blue white Diamonds of exceptional beauty. Order now!

No. 871 \$200 \$5 a wk.
No. 872 \$125 \$3.25 a wk.
No. 873 \$50 \$1.25 a wk.
No. 874 \$100 \$2.50 a wk.
No. 852 \$37.50 \$1.00 a wk.
No. 887 \$100 \$2.50 a wk.
No. 847 \$150 \$3.75 a wk.

No. 857 Ladies' Wrist Watch
Solid 14-k white gold case, 15 Jewels. \$275.00. \$2.75 down \$27 a month

Satisfaction guaranteed, or money back. Goods sent for your free examination on request. Credit terms: Pay one-tenth down; balance weekly, semi-monthly, or monthly at your convenience. All goods delivered on first payment.

Send for Free Catalog
Big 132-page book, illustrating our Diamonds, Watches, Jewelry, Silverware, and gift articles for all occasions, sent absolutely free. Write today.
"To Be Successful, Look Successful!"—own and wear a genuine Diamond!

Men's Diamond Rings
Two exceptional values in men's Diamond rings. Each ring is solid 18-k white gold, hand carved and engraved, set with a magnificent blue white Diamond. Order yours today!

Wedding Rings
No. 824—The "Elite" \$80.00
Solid 18-k white gold.
Set with 3 Diamonds, \$22.50;
5 Diamonds, \$32.50; 7 Diamonds, \$42.50; 9 Diamonds, \$52.50; 12 Diamonds, \$67.50.
All platinum, \$25.00. With 3 Diamonds, \$32.50; 5 Diamonds, \$42.50; 7 Diamonds, \$52.50; 9 Diamonds, \$62.50; circled by Diamonds, \$200.00.

17-Jewel Elgin No. 14 Thin Model
White gold filled, 20-Year Quality Case; 12 size; silver dial; assorted patterns, \$23.50. \$2.35 down and \$2.35 a month.

Railroad Watches — Guaranteed to Pass Inspection
HAMILTON No. 992. 21 Jewels. Adjusted to 6 Positions. Gold filled 25-Year Quality Case . . . \$55
ELGIN'S LATEST RAYMOND. 21 Jewels, 8 adjustments. Runs 40 hours one winding. Gold filled 20-Year Quality Case . . . \$55
ILLINOIS "BUNN SPECIAL." 21 Jewels. Adjusted to 6 Positions. Gold filled 25-Year Quality Case. 60 hours 1 winding . . . \$50

CREDIT AT CASH PRICES

BUCHSTEIN'S FIBRE LIMB
is soothing to your stump—strong, cool, neat, light. Easy payments. Braces for all deformities.
D. BUCHSTEIN CO., 610 3rd Ave., So., MINNEAPOLIS, MINN.

Send for Catalog Today

SNOW—ICE—MIST VANISHES "SLEETOFF"
works inside automatically. Simply attached to your present windshield wiper.

TEN DAYS' TRIAL If your dealer does not carry "SLEETOFF," send us \$3.50. Try it ten days. If not satisfactory, return it to us, and we will refund the money.

Pat'd WINDSHIELD WARMER

THE GREB COMPANY, 193 State Street, Boston, Mass.

Extra Income
Spare time—Part time—Full time profits

200 to 500% Profit

Cleared \$2,700 Invested \$97.00
H. G. Young of New Jersey invested \$97.00 in Utility Molds and made \$2,700 profit in spare time. A Michigan man sold \$2,000 worth to one concern. Hundreds of others are earning big money making these ornamental products. Send for FREE catalog at once. We show you how.

Write Your Own Pay Check!
In a manufacturing business of your own making brick, block and tile. Unlimited opportunity. Big future. Write for machinery catalog—it's free.

CONCRETE EQUIPMENT CO.
570 Oltawa Ave., Holland, Mich.

UTILITY CONCRETE EQUIPMENT

Send for Catalog

FLY THIS ARMY PURSUIT SHIP!

Light and fast, this one-foot model is a realistic copy of a single-seater military pursuit plane. Will rise from ground by own power and fly 60 ft. Can be used indoors or out. Has air service insignia on wings. Inexpensive. Construction set includes a ready-made aluminum propeller, shaft, rubber band motor, stream-line wood wheels, pre-cut balsa wing ribs and all other parts, with clear directions. Can be assembled in 2 hours by average 14-year old boy, without tools. Complete set, packed in unbreakable mailing tube, only 75c, postpaid in U. S. Send check or money order today (no stamps). Print address plainly. Satisfaction or money refunded.

LOGAN TOY WORKS, 35 E. Gay St., COLUMBUS, O.
(We cannot make C. O. D. shipments. No retail catalogue issued)

ONE-MAN SAW MILL — \$39 BRINGS IT TO YOU

Makes boards, strips, shingles, lath, casing, etc., from logs or lumber shorts.
Splits blocks in firewood.

Hundreds of uses. Needed by every farmer, timber owner, contractor. Pays for itself in week, or on one job. Guaranteed. Sold direct from factory. Write today for Special Offer and Free Book "How To Make Lumber."

BELSAW MACHINERY CO.
Box 104-B, Pleasant Hill, Mo.

CAN YOU USE \$100 A WEEK AND UP

Make \$100 a week and up selling our fine made-to-measure all-wool suits at \$23.50 — \$29.50 and \$36.50 retail, direct to wearer. Biggest values — positively sell on sight. Biggest commissions paid in advance. We attend to delivery and collections. New style outfit of large cloth samples — 100 styles — furnished FREE. Write at once.

SPENCER MEAD COMPANY, Chicago, Ill.
Harrison and Throop Sts., Dept. 8816

\$23.50 ALL WOOL SUITS

Here's An Easy Way To Start Your Own Business—

GET into this fine-paying business and be independent—it's an easy and sure way to build up a substantial income and a steady, all year 'round business. The beauty of it is that you do *not* need a lot of money to start—no stock to carry and practically no overhead expense to pay. We give you FREE plan. Work only in your spare time while getting started, and you'll see every Foley-filed saw you turn out bring you more customers. The FOLEY AUTOMATIC Saw Filer has put other men on the road to SUCCESS and they are independent—in business for themselves.



Make Good Money—No Canvassing

Our FREE PLAN shows you how to get all the saw-filing business you can handle from carpenters, factories, schools, woodworking plants, lumber yards, hardware stores, farmers and many other sources. No house to house canvassing. You get 50c for filing an ordinary saw and it only takes about 10 minutes. The Foley files hand, band, and circular saws. And it does the work AUTOMATICALLY even better than the most expert hand-filing. Foley-filed saws cut better and stay sharp longer, too.

Easy and Simple to Operate FOLEY^{AUTO}_{MATIC} SAW FILER

No special experience required. Many young men and boys only 14 years old are running Foleys. Simple instructions are easy to follow. Anyone, with a little practice, can operate the Foley and get first class mechanically accurate work.

New Customers Every Day

"Every day I get new customers and keep my old ones, which shows my Foley Filer is doing what you said it would. I am pleased with it."

E. H. SWAN,
San Leandro, Calif.

All the Filing I Can Do

"I have all the saw filing I can do in my spare time, and then some. I have been hiring a man to take my place one day a week, and then I can hardly keep up."

BEN L. ABRAHAM,
Monroe, Wisc.

Has Regular Customers

"I have regular customers that I am filing for. Five of them are printing shops, others carpenters, all satisfied customers."

W. T. POGUE,
Monroe, La.

Get Started NOW—Mail Coupon

Don't delay—get complete information and FREE PLAN on how to start a saw-filing business, at once. Write your name and address in coupon below and mail TODAY.

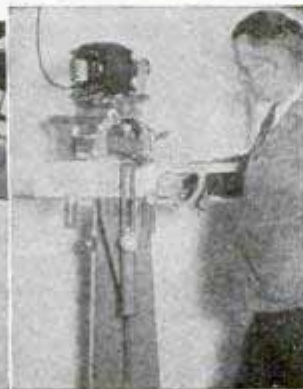
Foley Saw Tool Co., Inc.
236 Foley Bldg., 11 Main St., N. E.
Minneapolis, Minn.

Please send me FREE PLAN on how to start a saw-filing business with the Foley Filer.

Name.....

Street.....

City.....State.....





Ask your barber
for a free appli-
cation of Murine

CLEAR EYES are a business asset

Clear, bright eyes make a far better impression than do those which are dull and bloodshot. A few drops of harmless Murine will quickly clear up bloodshot eyes resulting from over-use, late hours or exposure to wind and dust.

MURINE FOR YOUR EYES

PLUMBING-HEATING
YOU SAVE HALF

Send for **FREE BOOK** of Guaranteed Plumbing and Heating. Everything cut-to-fit. 50 yrs. in business. Thousands of customers. "You saved me \$400.00," says Mr. Edw. Borkosky of N. J. Write today.
HARDIN-LAVIN CO., 107-17 C Pershing Rd., CHICAGO

Cut the Family Barber Bills

Belle City Home Electric Hair Clipper

Anyone can trim or bob hair, shorten bangs, clip neck or underarms in a shape almost impossible with hand clippers or shears. Operates on direct and alternating current. Will not clog or cut the skin, and cuts as cleanly as a razor. Thousands in use. Rigidly guaranteed.

TEN DAYS' FREE TRIAL

If your hardware or electrical dealer can't supply you, write for interesting booklet, or order from this ad. Send no money—pay postman \$8.75. Return it in ten days if not satisfactory. State whether 110, 220 or 32 volt current is used.

Dealers and Representatives Wanted
Belle City Appliance Co., 1022 12th St., Racine, Wis.

Fits Any Light Socket

ALL STEEL HACKSAW

An all steel, unbreakable hacksaw with perfect balance. The newly designed pistol grip fits the hand comfortably. A rugged fast cutting tool handsomely finished in heavy nickel plate. Sold with a money-back guarantee by hardware dealers.

CRESCENT TOOL CO.
Jamestown, N. Y.

\$1.25

Other saws, with wood, steel and composition handles. 60c to \$1.25.

CRESCENT and Smith & Hemenway TOOLS

Write for Catalog

Earn \$300 Monthly With 20 Minute Car Washing

Shops everywhere are adding pressure car washing. Washes cars easily in twenty minutes with unusually large profits for you. Satisfied customers advertise your business. Installed with practically no expense to you—

COSTS ONLY \$20 MONTHLY

the extra profits easily pay for it. Boltless, Ball Bearing, single unit construction insures long life and trouble free operation. Write for Details. No Obligation.

Hobart Bros., Box M293, Troy, Ohio

CRESCENT WOOD WORKING MACHINES

Turn out more work, more accurately at lower cost. Simple, easy to operate, highly efficient, carefully guarded, thoroughly modern. Many kinds of portable machines to operate from lamp socket. Also big line of heavy equipment for factories. Send for free fully illustrated circulars.

THE CRESCENT MACHINE CO., 93 Columbia St., LEETONIA, O.

Send for **FREE BULLETINS**

Get Into The Shoe Business Without Investment!

We start you, Inexperienced workers earn \$5,000 yearly with our direct to wearer plan. Easy to take orders. Just show the famous Tanners line of shoes and hosiery for Men, Women and Children. We tell how and where to sell. Patented measurement system insures perfect fit. Big facilities guarantee prompt deliveries. You collect your pay daily. We furnish \$40.00 outfit containing actual shoes and actual hosiery—a larger variety of styles and sizes than any store. Send for free book "Getting Ahead" and full particulars. No obligation. Write now!

Experience Unnecessary!

Tanners Shoe Manufacturing Co.
512 C Street Boston, Mass.

The Same
Fast, Accurate

COMPLETE OUTFIT

for home use and
profitable commercial work including
planer, saw, lathe
and electric motor
and many useful
attachments

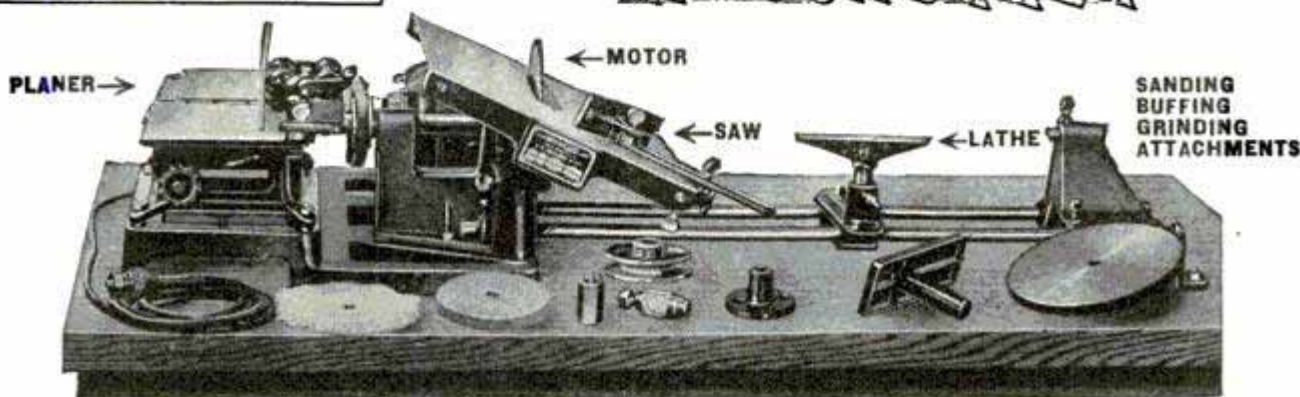
Every kind of woodworking operation

Make everything out of wood with the famous

WORKACE

Electric

WOODWORKER



Amazing low price includes everything

This complete all-electric shop costs less than most other outfits and gives you the **biggest value per dollar!** You can prove it at home by actually using the Workace in every kind of woodworking operation, making furniture or other useful and decorative things for your own home and to sell at a handsome profit. The Workace is fast, accurate and easy to work with. Planing, sawing, turning, drilling, grinding, sanding or buffing—you save time on every operation, do better, cleaner work, too!

There's ample power, strength and capacity in The Workace Woodworker to do any job quickly and economically . . . mitering, tapering, rabbeting, beveling, slotting, cross-cutting, ripping—anything! Every unit works from the G. E. motor. All parts are sturdy and well fashioned. The regular Wallace UNQUALIFIED GUARANTEE assures replacement of defective parts for one year. This is a simple straightforward offer—no exaggeration, no red tape—just plain facts that you yourself can prove. If you want to make woodworking your real hobby—or a real source of income—send this coupon for all details of this unusual proposition.

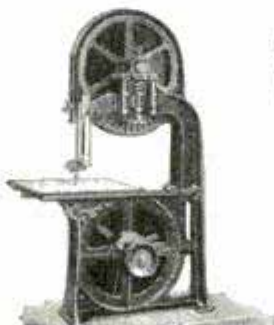
EASY TERMS

Our terms are all in your favor, a new and revolutionary method of purchase. Many pay for their Workace Shop out of the profits it makes A small down payment brings the Workace complete and ready to set up for immediate use. The monthly payments are so small you'll scarcely miss the money Send the coupon now—today—and we'll see that you get full details and a complete description by return mail!

\$89

Includes all this:

- 4' Planer
- 8" Circular Saw
- 6"x36" Lathe
- 8" Disc Sander
- 6" Buffing Wheel
- 5" Emery Grinder
- 1/4" Drill Chuck
- 1/2 H.P. G.E. Motor, 110-Volt, A.C., 60 Cycle.
- Endless V-Belt, two 4' and one 2 1/4" V-Belt Pulleys, Cast Iron Sub Base and 10 ft. Cable with separable Plug.
- The Planer and Circular Saws are each complete units and may be purchased separately at the correspondingly low price of \$25.00 each.



WORKACE 14' BAND-SAW. Speedy, accurate, economical. Price, \$75.

Wallace
PORTABLE MACHINES

SEND TODAY GET OUTFIT RIGHT AWAY

J. D. Wallace & Company,
Adams St. and California Ave.,
Chicago, Illinois.

That Workace Electric Woodworker sure looks good to me. I want to know ALL about it, including your easy terms, right away.

Name
Kind of Business
Address
City State

LUMINOUS PAINT

Make Your Watches, Clocks, Etc., Visible by Night The very latest discovery in the scientific world. Hitherto, practically unobtainable except at an exorbitant price, we have at last succeeded in producing this remarkable LUMINOUS PAINT, which, applied to the surface of any article, emits rays of white light, rendering it perfectly visible in the dark. THE DARKER THE NIGHT, THE MORE BRILLIANT IT SHINES. Quite simple to use. Anyone—you can do it. A little applied to the dial of your watch or clock will enable you to tell the time by night. You can coat the push buttons or switch plates of your electric lights, match boxes, and innumerable other articles; make your own Luminous Crucifixes, Luminous Rosaries, etc. Small bottle, price 25c. Larger sizes, 50c and \$1 postpaid. **JOHNSON SMITH & CO., Dept. 832 RACINE, WIS.**



CIGARETTE MAKER

Roll your own and save money. Better and quicker; saves more than half. Use your favorite brand of tobacco. Neat, useful, handy. Pocket size, weighs 1/2 lb. Made entirely of metal, nickel plated. 25c, 3 for 65c postpaid anywhere.



GOOD LUCK RING

Very striking, quaint and uncommon. Silver finish; skull and crossbones design, two brilliant, flashing gems, sparkle out of the eyes. Said to bring good luck. Only 25c ppd.



Exploding Cigarettes

JUST LIKE ORDINARY CIGARETTES. BUT SUCH REAL STARTLERS! The box contains ten genuine cigarettes of excellent quality. They appear so real, but when each cigarette is about one-third smoked, the victim gets a very great surprise as it goes off with a loud BANG! A great mirth provoker yet entirely harmless. Price 25c box.

NOVELTY BADGES



Kissing Permit 10c. Two very novel metal badges, nickel plated, that you can wear, giving you fun out of all proportion to your trifling cost. 10c, each badge, 3 for 25c, or 75c per doz. postpaid anywhere.

SURPRISE MATCHES

More fun than fighting with your wife. Look just like ordinary matches. Put up in boxes just like regular Safety Matches. As the victim tries to light one he gets quite a surprise. Price 10c per box, 3 boxes for 25c, 12 for 75c.

MIDGET BIBLE

GREAT CURIOSITY Smallest Bible in the World. Size of a postage stamp. 200 Pages. Said to bring good luck to the owner. A genuine work of art. Must be seen to be appreciated. Make good money selling them to friends, church acquaintances, etc. PRICE 15c each, 3 for 40c, 12 for \$1.35, 100 for \$7.50. Also obtainable in Leather Binding, with gold edges. Price 50c each, 3 for \$1.25, \$4.50 per doz. Magnifying Glass for use with Midget Bible 15c.

STAGE MONEY

With a bunch of these bills, it is easy for each person of limited means to appear prosperous by flashing a roll of these bills at the proper time and peeling off a genuine bill or two from the outside of the roll, the effect created will be found to be all that can be desired. Prices, postpaid: 40 Bills 20c, 120 for 50c, or \$3.50 thousand postpaid.

MAGIC NOSE FLUTE

The Magic Nose Flute, or Humastone, is a unique and novel musical instrument that is played with nose and mouth combined. There is just a little knack in playing it which, when once acquired after a little practice, will enable you to produce very sweet music that somewhat resembles a flute. There is no fingering, and once you have mastered it you can play all kinds of music with facility and ease. When played as an accompaniment to a piano or any other musical instrument, the effect is as charming as it is surprising.

JOHNSON SMITH & CO. Dept. 832 RACINE, WIS.

A De Luxe Edition of our new 1929 CATALOG mailed on receipt of 25c. Handsome binding. Bigger and better than ever. Only book of its kind in existence. Nearly 600 pages of all the latest tricks in magic, the newest novelties, puzzles, games, sporting goods, rubber stamps, unusual and interesting books, curiosities in seeds and plants, etc., unobtainable elsewhere. Remit by Coin, Money Order, Check or unused U. S., Canadian and Foreign Stamps for all articles listed above.

BLANK CARTRIDGE PISTOL

Protectio- against Burglars, Tramps, & Dogs. Special Offer 1 Blank Cartridge Pistol 100 Blank Cartridges 1 560-page Novelty Catalog ONLY \$1.50



Well made and effective, modified on latest type of Revolver; appearance alone is enough to scare a burglar. When loaded it may be as effective as a real revolver without danger to life. It takes standard 22 Cal. Blank Cartridge—obtainable everywhere. Special cash with order offer: 1 Superior quality Blank Cartridge Pistol, 100 Blank Cartridges, and our new 560 page De Luxe Catalog of latest novelties; all for ONLY \$1.50. Shipped by Express only. Cannot go by parcel post. Extra Blank Cartridges 50c per 100. Special Holster (Cowboy Type) for pistol 50c. No C. O. D. shipment.

LOOK 35c LOOK Wonderful Instrument.

Greatest thing yet. Nine separate articles in one. Everybody delighted with it. Odd, Curious and interesting. Lots of pleasure as well as very useful. It is a double Microscope for examining the wonders of nature. It is also an Opera Glass, a Stereoscope, a Burning Lens, a Reading Glass, a Telescope, a Compass, a pocket Mirror, and a Laryngoscope—for examining eye, ear, nose and throat. It is worth all the cost to locate even one painful cinder in the eye. Folds flat and fits the pocket. Something great—you need one. Don't miss it. Sent by mail. Only 35c or 3 for \$1.00. **JOHNSON SMITH & CO., DEPT. 832, RACINE, WIS.**



It is made in the shape of and looks like a regular Automatic Pistol. No one is likely to stop and ask you whether it is real or not. Thus it is likely to prove itself very handy in an emergency. On pressing the trigger it opens up as shown in the illustration at the right, revealing nine most useful articles—Opera and Field Glass, Telescope, Mirror, Magnifying Glass and Burning Lens, Reading Glass, Sun Dial, Sun Compass, etc. In the handle of the revolver there is a place for various pocket necessities, such as First Aid Articles, Buttons, Pins, etc. The Pistol is of sheet metal, blued finish, that can be carried comfortably in pocket. PRICE \$1.00 postpaid.

Watch Charm Pistol \$1.75

Exact reproduction of a real pistol; actually fires REAL BLANK CARTRIDGES of miniature size. Illustration is a actual size, 1 1/4 inches long, with ring at end for attaching to watch chain. Loads like a regular pistol. Pull the trigger and it goes off with a loud bang. Pistol is break open type; illustration shows position for loading. Made entirely of high grade steel, nickel plated, octagon barrel, handomely engraved handles, complete in box with cleaning rod. PRICE \$1.75. Also furnished with pearl handles, \$2.50. **BLANK CARTRIDGES, 50c per box of 25.** **JOHNSON SMITH & CO., Dept. 832, RACINE, WIS.**

MICROPHONE TRANSMITTER BUTTON



You can easily make a highly sensitive telephone by using this Transmitter Button to collect the sound waves. You can build your own outfit without buying expensive equipment. It is simple and inexpensive. You can install an outfit in your home and hear conversations being held all over the house. You can connect up different rooms of a hotel. This outfit was used by secret service operatives during the war. It is being used on the stage. It is ultra-sensitive and is the greatest invention in micro-phones. You can mount the button almost anywhere—card board boxes, stove pipes, stiff calendars, on the wall behind a picture frame, etc. Button is so light and small it cannot be detected. Persons can be overheard without suspecting it. You can listen in on conversations in another room. A deaf person in the audience can hear the speaker. Connected to phonograph, piano or other musical instrument, music can be heard hundreds of feet away. Button may be used to renew telephone transmitters; often makes an old line "talk up" when nothing else will. The ideal microphone for radio use; carries heavy current and is extremely sensitive. Amplifies radio signals. Countless other similar uses will suggest themselves. Experimenters find the button useful for hundreds of experiments along the lines of telephones, amplifiers, loud speakers, etc. Many fascinating stunts may be devised, such as holding the button against the throat or chest to reproduce speech without sound waves. PRICE \$1.00. **JOHNSON SMITH & CO., DEPT. 832, RACINE, WIS.**

Keyless Lock

These clever locks cannot be opened unless you know the combination. No key necessary. For your locker, bicycle, tool chest, mail box, thousands of uses. Buckle and tumblers nickel plated. Weighs trifling over one ounce. Small yet strong. Secret and full instructions with each lock. Price 25c or 3 for 65c postpaid.

Wonderful X-Ray Tube

A wonderful little instrument producing optical illusions both surprising and startling. With it you can see what is apparently the bones of your fingers, the lead in a lead pencil, the interior opening in a pipe stem, and many other similar illusions. A mystery that no one has been able to satisfactorily explain. Price 10c, 3 for 25c, 1 dozen 75c. **JOHNSON SMITH & CO.**

NOSE BLOWER

When some men blow their noses it sounds like a trombone. Now the NOSE BLOWER has come to torment us. It is a starter! It is ingeniously concealed in the handkerchief. Proceed to blow your nose and your friends will think they heard a steam engine or something. You can blame the hideous noise to your having a very bad cold and keep up the fun as long as you like. PRICE 10c, 3 for 25c, or 75c doz. postpaid.

Serpent's Eggs

Box contains 12 eggs. When lit with a match, each one gradually hatches itself into a snake several feet long, which curls and twists about in a most life-like manner. Price per box, 10c postpaid, 3 for 25c.



BOYS! BOYS! BOYS! Throw Your Voice

Into a trunk, under the bed, under a table, back of the door, into a desk at school, or anywhere. You get lots of fun fooling the teacher, policemen, peddlers, and surprise and fool all your friends besides.

THE VENTRILO

is a little instrument that fits in the mouth out of sight. Cannot be detected. It is used in connection with the above, and with the aid of this wonderful **DOUBLE**

THROAT, or VENTRILO, you can imitate many kinds of birds, animals, etc. Remember you get everything for **ONLY TEN CENTS**—a booklet giving you full instructions how to become a ventriloquist and throw your voice, the **Double Throat, or Ventrilo**, and our big 600 page catalog of novelties, tricks, puzzles, masks, books, etc., **ALL SENT POSTPAID TO ANY ADDRESS FOR ONLY 10 cents**



Rubber Chewing GUM



Price 10c Pkge. 3 for 25c P.Pd.

It is just like a regular package of chewing gum and looks so real that it fools everybody. Of course no one suspects it is not genuine until they start to chew it. There's a world of fun in this rubber chewing gum—5 sticks to the package. Price, 10c Pkge.; 3 for 25c; 12 for 75c postpaid. **JOHNSON SMITH & CO.**

INVISIBLE INK

The most confidential messages can be written with this ink, for the writing makes no mark. Cannot be seen unless you know the secret. Invaluable for many reasons. Keep your postals and other private communications away from prying eyes. Great fun for playing practical jokes.



Only 15c a Bottle; 3 for 40c. **JOHNSON SMITH & CO.** Dept. 832 RACINE, WIS.

MAGICIAN'S BOX OF TRICKS

Apparatus and Directions for a Number of Mysterious Tricks, Enough for an Entire Evening's Entertainment..... \$1.00

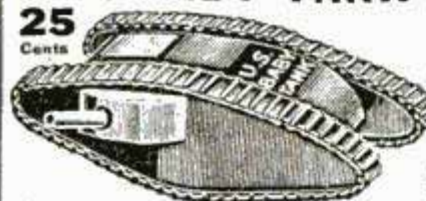
ANYONE CAN DO THEM

It is great fun mystifying your friends. Get this Conjuror's Cabinet, and you will be the cleverest fellow in your district. It contains the apparatus for ten first-class tricks, including THE MAGIC BALL, AND VASE TRICK (a wooden ball is placed inside, and upon replacing the lid has disappeared and is found in someone else's pocket); THE HINDOO TRICK CARDS (can be made to change completely no less than five times); DISAPPEARING COIN BOX (a coin, placed in the wooden box, vanishes entirely or changes into a coin of another denomination); THE GLASS GLOBE TRICK (a coin is dropped into a glass of water and when the water is poured out the coin has vanished and is found somewhere else); THE RIBBON FACTORY FROM THE MOUTH TRICK (a seemingly endless supply of colored paper ribbons comes out of your mouth); the DISAPPEARING HANDKERCHIEF (a handkerchief held in the hand mysteriously vanishes); the WIZARD'S RING COIN TRICK; the ENCHANTED BOTTLE (no one but yourself is able to make it lay down); the GREAT HAT AND DICE TRICK (a large dice is placed on top of a hat, disappears, and is found underneath yet no one has touched the hat), and last, but not least, the GREAT PHANTOM CARD TRICK, or two from five leaves nothing. Full instructions are sent for performing each trick. In addition to the above, a number of other fonts and illusions are fully explained for which you can easily make or procure the necessary apparatus. Price complete \$1.00 postpaid. **JOHNSON SMITH & CO.**



U. S. BABY TANK

25 Cents



toys, yet this tank will keep plodding along ten times longer than the ordinary run for toys. It will perform dozens of the most wonderful stunts. 2 1/2 inches long. Price only 25c prepaid. Stamps accepted. **JOHNSON SMITH & CO.**

It goes with real Yankee Pep—by its own power

Most remarkable toy ever invented. By drawing the Tank backward, either with the hand or over the floor or table and then placing it down, it will crawl along, overcoming all obstacles, in the same life-like manner as the larger Tank that proved so deadly in the great war. What makes it go is somewhat of a mystery, for there is no mechanism to wind up as is usually understood, with mechanical toys, yet this tank will keep plodding along ten times longer than the ordinary run for toys. It will perform dozens of the most wonderful stunts. 2 1/2 inches long. Price only 25c prepaid. Stamps accepted. **JOHNSON SMITH & CO.**

RESURRECTION PLANT

Great curiosity. Place in water, plant opens up and starts to grow in few minutes. Taken out it dries up and goes to sleep until put in water again. PRICE 10c, 3 for 25c, 75c dozen, postpaid.



15c POSTPAID Card Sailer Pistol



It shoots small squares of cardboard, sending them spinning and sailing through the air to great distances. Length 8 1/4 inches. Wood barrel, metal handle, heavy rubber band. Plenty of ammunition and extra rubber with each gun in neat box. More ammunition can be made as desired. Can use without the ammunition as a fly killer. PRICE ONLY 15c each, 3 for 40c, or \$1.35 per doz. postpaid. Stamps accepted. **JOHNSON SMITH & CO., Dept. 832, RACINE, WIS.**

DISSOLVING VIEWS

50c You may have a lot of fun with this little peep show. A dissolving view viewer. Made entirely of metal, having a microscope lens fitted into one end. While the victim is absorbed in admiration of the pretty picture, and turns the buttons in the confident expectation of seeing something interesting, a spring syringe is brought into action, and the observer experiences a very great surprise. 50c p.p. **Johnson Smith & Co., Dept. 832, Racine, Wis.**



Comical Motto Rings

Lots of harmless fun and amusement wearing these rings. Made in platinumoid finish (to resemble platinum), with wording on enameloid, as illustrated. Price only 25c Postpaid.

Great Fire Eater

A great trick by which you can apparently breathe fire from mouth, to the horror and consternation of all. Quite harmless. All apparatus necessary necessary sent complete in box for ONLY 30c. p. pd. **JOHNSON SMITH**

SEEBACKROSCOPE

Place this clever instrument to your eye, you see what is going on behind your back. Very interesting things sometimes occur when no one thinks you are looking. Just like having eyes at the back of your head. PRICE 25c POSTPAID



SQUIRT ROSE

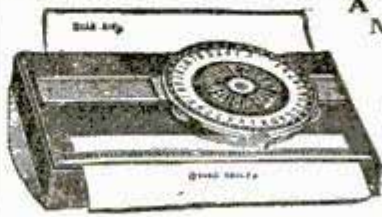


A REAL STARTLER. This is the most popular of all squirt tricks. The flower in your coat looks so fresh and sweet that everyone is tempted to inhale the delightful perfume. Then is the moment to press the bulb. Geeshillikens. Don't they jump? There is a very long rubber tube that easily reaches to the pocket of your coat or trousers, and the bulb is large enough to make a dozen shots with one loading. PRICE 25c each, or 3 for 65c postpaid.

The "Little Giant" Typewriter

A First Class Writing Machine For \$1.50

A perfect little typewriter for \$1.50. There are thousands of persons who would like to use a typewriter but whose needs and business do not warrant the expense attached to the purchase and use of a fifty or seventy-five dollar machine. To such persons we confidently recommend our Little Giant. It is strongly made, but simple in construction, so that anyone can quickly learn to operate it, and write as rapidly as they would with pen and ink. The letters of the alphabet most frequently used are so grouped as to enable one to write rapidly, the numerals 1 to 10, and the punctuation marks being together. With this machine you can send your best girl typewritten love letters, address envelopes, make out bills, and do almost any kind of work not requiring a large, expensive machine. With each typewriter we send a tub of ink and full written instructions for using the machine. Price complete \$1.50 by mail postpaid to any address in the world.



JOHNSON SMITH & CO. Dept. 832 Racine, Wis.

Send remittance (Postage Stamps accepted) for all articles listed above also in our other ad on previous page

GET THIS BIG GREEN BOOK NOW!

New!
AERO KITS 1929!

The Big Green Book gives the very latest details on Aero Coils and Kits, Short Wave Radio, newest broadcast radio receivers, short wave converters, telephone transmitters, coil kits, adapters and a host of new wrinkles for 1929.

24 Different New Kits Shown for 1929

The kits everyone is talking about are fully described in the new 1929 Aero Green Book—Aero 7-29, Aerodyne 6-29, Chronophase, Metropolitan, Trio, International, Standard, Radiophone—in Shield Grid, A.C. and D.C. models. Be sure to send for your copy of this 25c Big Green Book—worth \$25.00 to anyone who wants to keep up with the latest radio wrinkles.

Mail coupon for your copy today—NOW!

AERO PRODUCTS INCORPORATED

4611 E. Ravenswood Ave., Dept. 411
CHICAGO, ILL.

----- MAIL THIS COUPON NOW -----
AERO PRODUCTS, INC. Dept. 411
4611 E. Ravenswood Ave., Chicago, Ill.
Send me your Big Aero Green Book, 25c, giving the latest information on What's New in radio, short wave, etc.
Name _____
St. and No. _____
City _____ State _____

Get England every day, Australia on Thursdays, Holland on Fridays. Gets everything on the Air

FREE RADIO CATALOG

Since the dawn of Radio, Barawik has been known the world over as headquarters for radio set builders and fans. Here, under one roof, is everything you need—sets, parts, supplies—thousands of products—ready to ship to you the same day your order arrives. Barawik prices save you money. Barawik service saves you time. Barawik merchandise always pleases. A quarter million satisfied customers say, "Barawik is Best." Let us send you the Big Barawik Book free and prove it to yourself.

BARAWIK CO., 102A Canal St., CHICAGO, U. S. A.

LATEST RADIO GUIDE

Mail This Coupon Now for Free Radio Guide

Name _____
Address _____

COMPLETE RADIO \$10.90

Just what millions of homes have been waiting for. 300,000 already sold. Write today for life size picture and folder number 18

LEON LAMBERT MFG. CO., Wichita, Kans.

FREE to You

1929 RADIO BOOK

New Hook-ups. This book shows how to make Short Wave Receivers and Short Wave Adapters. How to use the new screen grid tube in D. C. and A. C. Circuits. How to build Power Amplifiers, and ABC Eliminators. Up to the minute information on all new radio developments. Set Builders, Fans, Dealers, send for it today.

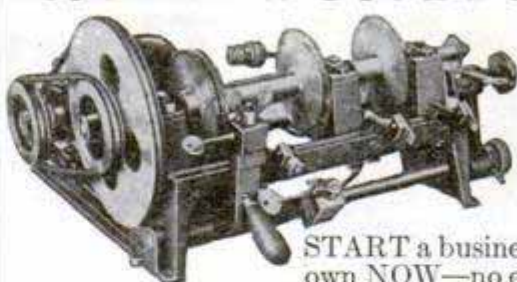
KARAS ELECTRIC COMPANY
4028B-N. Rockwell St., Chicago, Ill.
Please send me your free book

Name _____
Address _____
City _____ State _____

Write for it!

Establish a Good Future

DON'T BE A SHOP WORKER



START a business of your own NOW—no experience necessary. The only key machine that cuts ALL kinds of keys. No hand-filing. Make first keys by number without taking locks apart. Instructions furnished free.

WRITE TODAY.

BEISSER KEY MACHINE COMPANY
407 Fort St. East Detroit, Mich., U. S. A.

This 260 Page Wholesale Radio Catalog

A Liberal Radio-Education Within Itself!

FREE

Containing 75 radio hook-ups, 1,000 illustrations, 6,000 articles.

Build your own with Rasco parts. Positively lowest prices in the country.

Radio Specialty Company

98E Park Place NEW YORK, N.Y.



New 1929 Edition

FREE CHI-RAD'S NEW 1929 RADIO CATALOG

Includes complete parts for HFL ISOTONE New TYRMAN "80." MADISON-MOORE "AC." New THOR-DARSON Power Amplifier. Also write for Special Circular on the World's Finest DYNAMIC SPEAKER. Discounts for Set Builders.

CHICAGO RADIO APPARATUS CO.
415 S. Dearborn Street Dept. PM CHICAGO, ILL.

30 Days' Free Trial

New Models now ready for delivery direct from our factory. Astonishing low prices and terms. Do not buy until you get them.

RIDER AGENTS WANTED to ride and exhibit sample. Make big money. Many models \$21.50 up. Guaranteed \$1.50 each, wheels, tires, lamps, horns, equipment at half usual prices. Send No Money. Write for our marvelous prices and terms on RANGER Bicycles.

Mead CYCLE CO. Dept. 0-109 CHICAGO



Send for WESTERN RADIO

New 1929 Catalog

THE NEW 1929 Catalog is crammed full of the FINEST, NEWEST, Nationally known A. C. sets, consoles, cabinets, dynamic speakers, kits, eliminators and accessories at Lowest Prices. Largest stock of radio parts. Prompt delivery. Write for our Free catalog.

WESTERN RADIO MFG. CO.
128 W. Lake St. Dept. PM-2 CHICAGO

FREE ACWESTRAD 3485

WESTERN RADIO

The Big Friendly Radio House

PUT THIS WORKSHOP IN YOUR HOME

FREE For 10 Days—No Deposit!

A New and Improved Workshop

Here is a workshop built to a standard of perfection—accurate in operation—most durable in construction—easy to operate. It is absolutely dependable and will withstand severe constant service. Try it for ten days at our expense and you will be convinced of its superiority.

Suitable for Carpenters, Home Workers, Pattern Makers, Etc.

Furniture manufacturers use MAC—the Popular Mechanic Workshop—for making furniture models. Manual Art Schools use it for instruction. Home workers use it for pleasure and profit. Carpenters use it for making repair parts, spindles, chair legs, cabinets. It is ideal for making all kinds of furniture.



The Lowest Price for Such a Sturdy, Complete Workshop

MAC, THE POPULAR MECHANIC, represents the utmost in value and dependability. Now you can have an accurate, practical workshop at a big saving. Once you use MAC you will be convinced of its superior qualities. That's why we want you to try it for 10 days at our expense.

NO DEPOSIT

A YEAR TO PAY

GET DETAILS QUICK

MIDLAND APPLIANCE CORPORATION
Dept. 210—219 N. Michigan Ave.
CHICAGO, ILL.



MODEL NUMBER 70

Wagner 1/4 H. P. Motor, 8 1/4 inch Sander Disc, Circular Saw, Jig Saw, 30 inch Lathe with 9 inch swing, Black & Decker 1/4 inch Drill, Electric Glue Pot. Accessories include 6 inch Dia. Face Plate, Spur and Cup Type Wood turning Centers, 1/2 inch Three-jaw Geared Chuck, Arbor and Flange, 6-inch Cotton Buffs, 6 inch Wire Brushes, 6 inch Emery Wheel, Adjustable Tool Rest and Tool Supports with Bed Clamp, Two Turning Tools and Socket Wrenches.



Match Your Coat and Vest With New Trousers. FREE SAMPLE

DON'T DISCARD YOUR OLD SUIT. Wear the coat and vest another year by getting new trousers to match. Tailored to your measure. With 90,000 patterns to select from we can match almost any pattern. Send vest or sample of cloth today, and we will submit FREE best match obtainable.

AMERICAN MATCH PANTS CO.,
Dept. E. N. 6 W. Randolph St., Chicago, Ill.

AGENTS AND SIGN MEN

Now Making \$50.00 to \$100.00 and Up Per Week Selling Our **GOLD LEAF SIGN LETTERS**

R

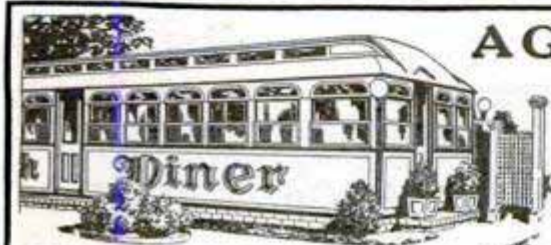
For store and office windows, board signs, trucks and glass signs. We also make to order script signs and business emblems singly or by the thousands. A permanent business. No capital or experience required. Big demand in every city. *Samples and Literature Free.*

CONSOLIDATED SIGN LETTER CO. 71-X W. Van Buren CHICAGO, ILL.

A Good Profit—365 days in the year!

Rain or sunshine, hard times or good, summer or winter, is all the same to the man who owns a **JERRY O'MAHONY LUNCH CAR**. These attractive, business-getting Dining Cars have all the conveniences of the modern restaurant and cost far less. They can be shipped anywhere by rail. Business good every day of the year. Many owners are making \$10,000 a year profit and over. Only small cash payment down. We help you finance and tell you how to start. Write today for our big illustrated catalog showing profits others are making.

JERRY O'MAHONY, Inc.—Dining Car Manufacturers
983 W. Grand St. Elizabeth, New Jersey



Shoot the Best Gun

The NEW BENJAMIN is the finest air rifle ever made. Unlike all others. Has amazing accuracy—shoots hard and far. It's the original American genuine AIR operated rifle. One to six pump strokes compress air to any desired degree of power. Same force as in air drills and air hammers except you control the shooting force. Never loses force—no springs or levers to get out of order. Makes crack shots quickly, inexpensively. Gives years of delightful recreation with utmost safety. At your dealer's, or sent postpaid for \$5.00.

Shoot 5 Days FREE

We give you five days, ammunition supplied, to test the NEW BENJAMIN. If in this time you don't believe it to be the finest air rifle you've ever seen or used, and if you don't believe it is the one and only air rifle for you, return it, postpaid, and your money will be refunded at once.

The NEW BENJAMIN AIR RIFLE

America's Original Air Rifle

\$5 at your dealer's or sent postpaid direct from factory on FREE Trial as above if dealer does not handle it—write for our wonderful offer.

Get This Book and Details FREE

BENJAMIN AIR RIFLE & MFG. CO.
645 N. Broadway, St. Louis, Mo.

Please send your amazing offer and free copy of "The Shooter's Art," telling how to become a crack shot, how to hold, aim, and handle guns and guide others in use of guns.

Name _____

Address _____



The man who studies gets ahead. Popular Mechanics Press will advise you what books to read to advance in your trade. 200 East Ontario Street, Chicago, Illinois.



ARTISTIC PORTRAIT ENLARGEMENTS

only **98¢** each

FROM ANY PHOTO or SNAP-SHOT~ SIZE 16 x 20 INCH

(or smaller if desired)

The usual price of this work is \$5.00 but by taking advantage of this Special Offer you can get a beautiful life-like enlargement of that favorite picture of mother, dad, sweetheart, baby or any friend for only 98 cents.

SEND NO MONEY—Just mail us the photo—any size (Full figure, bust or group) and in about a week you will have your enlargement guaranteed never to fade. It comes to you C.O.D. On arrival pay postman 98¢ plus a few cents postage, or send one dollar cash with order and we pay postage. Money back if not delighted. You can send us your most treasured photograph, it will be returned to you unharmed.

FREE In order to advertise this remarkable offer we send free with every enlargement ordered, a **Highly-Glazed Hand Painted** miniature reproduction of the photo sent. These miniatures alone are worth the whole price charged for the enlargement. Take advantage of this really Amazing Offer and send your order today. **DO IT NOW.**

ALTON ART STUDIO, Dept. 46
5654 West Lake St., Chicago, Ill.

Please enlarge artistically the enclosed photo. Return enlargement and FREE Hand Painted miniature, C.O.D. 98¢ plus postage. (If \$1.00 is enclosed you are to send postage paid.)

Name _____

Address _____

Town _____

State _____

Check Size

Wanted

16x20 in.

10x 16 in.

11 x 14 in.

8 x 10 in.

FREE New Book

FACTORY PRICES

Save $\frac{1}{3}$ to $\frac{1}{2}$

New FREE book quotes **Reduced Factory Prices. Lower terms—year to pay.** Choice of 5 colors in New Porcelain Enamel Ranges. New Circulating Heaters—



\$33.75 up. 200 styles and sizes. Cash or easy terms. 24-hour shipments. 30-day FREE trial. 360-day test. Satisfaction guaranteed. 28 years in business. 750,000 customers. Write today for FREE book.

Ranges **\$37⁷⁵** up

Furnaces \$54⁹⁵ up
KALAMAZOO STOVE CO.
391 Rochester Ave.
Kalamazoo, Mich.

"A Kalamazoo Direct to You"
Trade Mark Registered

Own This Better H & A Saw Table



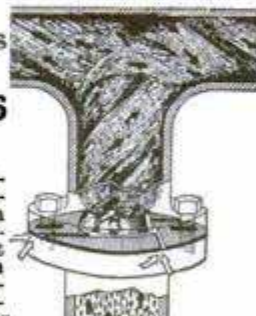
A sturdy, powerful, large capacity machine that will handle wide material. Accurate, speedy, reasonably priced. Use it for ripping, cross-cutting, mitering, grooving, rabbeting or dadoing. Equipped with tilting fence for bevel sawing; $\frac{3}{4}$ or $\frac{1}{2}$ H. P. motor; ball bearing spindle. Write for catalog of wood-working tools.

HESTON & ANDERSON, 602 Market St., Fairfield, Iowa

Is Your Car..... A Gas Eater

New Invention Increases Mileage on Auto Gas Eater from 13 $\frac{1}{2}$ to 34.6 Miles on a Gallon

An astonishing new device has been perfected that is amazing car owners everywhere. Goerzen reports increase from 13 $\frac{1}{2}$ to 34.6 miles on his Dodge. Thousands have been installed and users report 30-40 and more miles on a gallon of gas. In addition power is increased, instant starting and flashy pick-up is noticed and carbon formation disappears. Every car owner in the country needs this new invention. Its cost is so trivial it pays for itself in a few days' time, yet it will save hundreds of dollars for its owners in gasoline.



\$100 a Week Territory Open

\$5.00 an hour for spare time. Men are needed in every locality to take care of the tremendous local demand. Sales ability is not required. Every car owner will buy on sight. **Ideal for spare time workers.**

FREE Offer enables our workers to obtain this marvelous Whirlwind gas saver for their own cars without cost. Quick action is necessary. Be the one in your locality to cash in on this device which every auto owner will buy. Send today for full particulars and free sample offer.

Whirlwind Mfg. Co., MILWAUKEE, WISC. 999 844 Third Street

Northland Skis

rank first among men who live in the open winter. You can depend on Northlands. Speed, quality, durability are unexcelled. Look for the deerhead trademark. "How to Ski" booklet sent free.



Largest Manufacturers of Skis in the World

Northland Ski Mfg. Co.
95 Merriam Park, St. Paul, Minn.



Build a CLOCK for Pleasure or PROFIT!

FREE BOOK shows how YOU can Make Fine Clocks Right at Home

Check full of Clock-Making and Money-Making ideas. Gives full details, descriptions, prices of movements and parts. Write NOW for your copy.

THOUSANDS of men have built our Clocks. For their own use—or to sell at money-making prices. It's easy, fascinating. Only ordinary tools needed. We furnish plans, instructions, parts. Works all assembled, ready to install, as low as \$1.65; others with chimes at all prices. You make the case, or simply assemble knock-down parts. Cash-in on the demand for craftsman-built Mantel Clocks, Banjo Clocks, Grandfather's Clocks. Here's a hobby that **PAYS**—in pleasure, in ownership and in spare-time or full-time PROFITS!

Write for FREE Catalog and Special Blue Print Offer

American Chime Clock Company
1678-B Ruffner St., Philadelphia, Pa.

SPIRIT OF TIME BANJO CLOCK



DEAFNESS IS MISERY

Multitudes of persons with defective hearing and Head Noises enjoy conversation, go to Theatre and Church because they use Leonard Invisible Antiseptic Ear Drums. Tiny Megaphones fitting in the Ear entirely out of sight. No wires, batteries or head piece. They are Unseen Comforts and inexpensive. Write for booklet and sworn statement of the inventor who was himself deaf.

A. O. LEONARD, Inc., Suite 699, 70 5th Ave., New York

MOTORCYCLES



Price \$10 and up purchased through our Co-Operative Plan for as low as \$1.00 down and \$1.00 per week
Indians Harley-Davidsons Ace Henderson and Clevelands
Send ten cents for Bulletin A.
Motorcycles shipped to all parts of the world

WALKER-INDIAN CO., 78 Brookline Ave., BOSTON

BASHFUL?

"Shame on you!" Are you nervous, embarrassed in company of the other sex? Stop being shy of strangers. Conquer the terrible fear of your superiors. Be cheerful and confident of your future! Your faults easily overcome so you can enjoy life to the fullest. Send 25c for this amazing book.
RICHARD BLACKSTONE, 8-472, FLATIRON BLDG., NEW YORK

I'll Start You at \$15 a Day

taking orders for Ced-O-Bags and Butterfly Moth Bags. Hundreds making big daily profits. You can too. No experience needed. No investment. No risk. Keep present job and sell in spare time. Lewis, spare time worker, cleared \$15.30 first day. Act quick. This means money. Write today for big free outfit.
COMER MFG. CO., Dept. W-5139, DAYTON, OHIO

Mail Coupon Below for details of the \$5 to \$50 a day "Brown Bobby" Plan.



You Can Make \$50 to \$200 a week AT HOME SPARE TIME...

WANTED—a reliable man or woman in every community to make nationally advertised "Brown Bobby" greaseless electric doughnuts to fill orders for wholesale and retail trade. Chas. Minch, Fla., cleared \$3,000 in 3 months; Iota Blanton, Ia., \$400 in 26 days; H. G. Landroth, Ia., \$60 a day. Inexperienced but ambitious men and women everywhere are cleaning up by the "Brown Bobby" plan.

No Training Needed We Furnish Everything

No experience or baker's skill needed. You simply add water to the prepared "mix" we send; marvelous doughnut maker does the rest. You can start making doughnuts at home by the "Brown Bobby" process; later on you can rent floor or window space, or open shop. Small investment required to show you mean business. We will help you sell your entire output!

Typical Successes

Mrs. A. J. Miller, N. Y., cleared \$24 a day, buys a hotel with "Brown Bobby" profits.

Mr. F. D. Morrow, Ill., rents grocery window, clears \$40 a day.

Mrs. J. H. Toulouse, N. M., from her home builds \$12-a-day profit business in 4 weeks.

Mr. J. D. Hecker, Ill., sells 400 dozen daily at profit of 12c per dozen.

INVESTIGATE This Proven Plan

For the sake of your future, write for details now! Learn what others are doing, what you can do, how in a few weeks you can be earning up to \$1,000 a month. Now is the time to get started. Don't wait.

Mail Coupon NOW!

GEORGE HARDT, Director of Distribution.
Food Display Machine Corporation,
Dept. 1352, 500-510 N. Dearborn St., Chicago
Gentlemen: Please send me without cost or obligation the "Brown Bobby" plan by which I can make \$50 to \$200 a week.

Name.....
Address.....
City..... State.....

One Year To Pay



No. A40—\$62
\$2 Deposit—\$1.25 Week

This exquisite, diamond ring is considered extremely handsome. A fine quality, full cut, genuine blue-white diamond full of fiery brilliance and sparkling colors, is set in this lady's, popular 18 Kt. white gold mounting. It makes a wonderful engagement ring or friendship ring. Your friends will think you paid \$100 for it. Everyone will admire it. The gift case is free. Sold on written guarantee.

18 KARAT

No Red Tape 10 Days Trial

SEND NO MONEY When you get the ring, pay only \$2.00 to the postman. If you keep it, pay only \$1.25 a week for one whole year. All credit dealings kept strictly confidential—No orders accepted from persons under 20 years of age.

PRICE CUT TO \$62.00—WORTH \$100.00

You can now buy this gorgeous ring at the wholesale price. Compare it with similar rings at \$100. We guarantee it to stand any test or comparison. Greatest bargain offered by any Diamond Importer. We allow 8% annual increase in exchange for a larger diamond ring.

Write for FREE Illustrated Catalog

It brings our large Jewelry Store right into your home. Gives weights, grades and complete description so you can buy diamonds like an expert. Gives you information other jewelers dare not tell.

Genuine Blue-White Diamonds as low as \$197.00 a Carat.
AGENTS WANTED—EARN \$100 WEEK. Write for details.

STERLING DIAMOND CO. INC.
DIAMOND IMPORTERS—\$1,000,000 STOCK—ESTABLISHED 1879
1540 BROADWAY DEPT. 2586 NEW YORK

MODEL AIRPLANE MOTOR

Only motor of kind on market. Compressed air. Tanks, blueprints. The only motor for model aircraft builders. A powerful little job and a real beauty. IDEAL CHRISTMAS GIFT. Send for descriptive circular.

Amalgamated Sales & Service Corporation
542 West Jackson Boulevard Chicago, Illinois

\$4.90

A BIG MACHINE at a LOW PRICE!

DOES 20 DISTINCT WOODWORKING OPERATIONS

TURN YOUR HOBBY INTO INCOME!

No trick at all with this amazingly low price Woodworker, which you may try, and pay for, on terms, to turn idle hours into profit. Does 20 wood-working operations. Ideal size, capacity for shop, home or the job. Economical to operate. The best buy in the market!



just \$25.00 BRINGS IT TO YOU FREE TRIAL

COMES COMPLETELY EQUIPPED!

Comes complete with 8-in. Cross Cut, 8-in. Rip Saw; 12 in. Band Saw; Jointer, Lathe, Borer, Sander, Guides, Electric Motor. Investigate it!

60 Working Drawings of Items You Can Make

SEND FOR FULL DETAILS!

A. S. ALOE CO.
1831 Olive St., St. Louis, Mo.

Without obligation, send me details on the Woodworker, and the Free Trial and Easy Terms Plan.

EDFF with Saw

NAME.....
ADDRESS.....

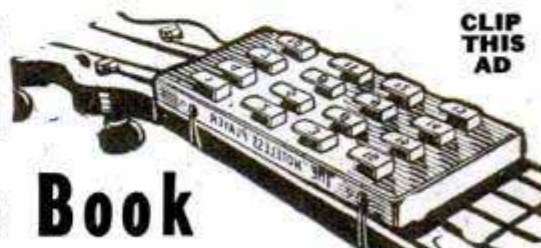


"Be the Life of the Party"

Play a Tune in 10 Minutes

Anyone can play the Ukulele, Tenor Banjo, Guitar, Banjo Uke or Mandolin with an amazing new invention. NO knowledge of music required. Play tunes from the start by numbers instead of notes, or by notes if you wish. Simple as 1-2-3, "just press the keys and play."

Astonish your friends by playing latest "hits" and old favorites. NO more costly lessons! NO weeks of tiresome practice! So simple a child can use it. Over 50,000 delighted Users—young and old, men and women now playing.



CLIP THIS AD

Free Book

Send for free book telling the amazing story of this marvelous device. Contains letters from hundreds now playing who could never play before. E-Z Player can be attached to your own instrument in a jiffy. Or we'll send you choice of instruments with Player attached on easy payment terms. Satisfaction guaranteed. "No play, no pay!" Have more fun, popularity, money-making chances, more friends—send today for free book. No obligation.

FERRY & CO., Manufacturers
1750 N. Robey St. Dept. 1772 Chicago, U. S. A.

Get Half Your Gasoline Free

Amazing invention gives from 25% to 100% Increase in Gas Mileage. 9 other valuable results guaranteed.

AGENTS Make \$250 to \$750 a Month

in profitable territories. Get new p'an and Free Test Offer. Act Quick. Write **Blanche Auto Devices Co.**, Dept. 805-88, 154 E. Erie St., Chicago

LIGHTING FIXTURES

Ready to hang

Direct from the manufacturer. Completely wired, including glassware. Send for new catalogue No. 29. Just Reduced Prices. *Special Proposition to Dealers.*

Erie Fixture Supply Company, Inc.
Station A ERIE, PA.

MAKE A MOTORCYCLE

OUT OF YOUR BICYCLE with a **STEFFEY MOTOR ATTACHMENT**. RELIABLE—ECONOMICAL—EFFICIENT. Easy to attach. Fits any wheel. Send 10 cents for circulars.

STEFFEY MFG. CO. Dept. P. 5040 Westfield Ave. Merchantville, N. J.

BOYS! BOYS! BOYS!
THROW YOUR VOICE

Into a trunk, under the bed or anywhere. Lots of fun fooling the teacher, policeman or friends.

THE VENTRILO

a little instrument, fits in the mouth out of sight, used with above for Bird Calls, etc. Anyone can use it. Never fails. A booklet on Ventriloquism, the Ventrilo, and big catalog of novelties, **ALL FOR 10c.**




World Novelty Co., Dept. 1, 929 Main St., Racine, Wis.



Bald Men! Free



One Full Ampoule of my amazing hair fluid which I discovered myself and which grew hair on my head. This Ampoule is absolutely free. Don't send any money. There is no C.O.D. No charge whatsoever. All I want is an opportunity to show you how easily I grew hair on my own and hundreds of other men's heads. Merely mail coupon below for Free Ampoule.

Here is How I Used to Look

I was just as bald as this picture. It is a true photograph without any tampering or retouching. It is exactly like I used to look. Then look at the full head of hair I have in the picture on the left! As I have stated so often, I don't know whether I am the first man who discovered this great secret, but I do know I have it, that I grow my own hair and that I am growing hair on the heads of other men all the time.



Bald Men Grow Hair Quick!

What I accomplished on my own head and on other heads I can do for you, provided you are under 45 years of age and loss of hair was not caused by burns or scars. Anyhow, I must succeed or you pay nothing. No apparatus. My home treatment is simple, quick, inexpensive.



Here is Brennan Brennan while he was bald. And Brennan after Vreeland grew his hair. Write and I will tell you Brennan's story and give you his address.



Mail This Free Coupon

Mail the coupon today—Right Now—I will send you, immediately, one full Ampoule of my marvelous fluid which I discovered, of which I hold the secret and which grew my own hair on my own bald head. Besides the Free Ampoule of Fluid, I will send photographs, names and addresses of men and women who successfully used my Wonder Fluid for Dandruff, Falling Hair and Baldness.

Here is Wiseman Wiseman was bald like this. But Wiseman grew this head of hair with my wonderful hair growing fluid. All about Wiseman and how he did it, if you write. You will get his address, too.



VREELAND
1352 Euclid-Windsor Building
Cleveland, Ohio

FREE COUPON

VREELAND 1352 Euclid-Windsor Bldg. CLEVELAND, O.
Please send me, entirely free, one full Ampoule of the same Wonderful Hair Fluid which grew your hair.

My Name.....
My Address.....
State.....

ATKINS SILVER STEEL SAWS



ATKINS makes "Silver Steel" Circular Saws in sizes and types for every use.



ATKINS Groover or Dado Heads, in eight sizes.

for Home Workshops,
Factories and Mills

In your home workshop, ATKINS Saws and Tools add to your pleasure and profit, in making things and doing repairs.

In the shop, mill or factory, ATKINS Saws and Tools save time, material and money, in cutting and working wood or metal.

The name ATKINS means longer service and more value for your money. The ATKINS products you want should be at your hardware dealer's or mill supply house. If not, write us.

Write for "SAW SENSE," "SAWS in the HOME," or free booklets on whatever ATKINS Saws or Tools you require.

E. C. ATKINS & CO., Est. 1857
426 S. Illinois St., INDIANAPOLIS, IND.

Leading Manufacturers of Highest Grade Saws for Every Use: Saw Tools, Saw Specialties, Plastering Trocels, Machine Knives, Grinding Wheels and Files



ATKINS "400," finest saw made. Blade is "Silver Steel," ship point. Perfection handle.



Junior Mechanic: handiest, high grade saw for boys, or light work. 20-in. blade.



Thin-Rim Mill Saws with cut-off or rip teeth.



No. 10 Hack Saw Frame. Nickered steel; adjustable. Non-breakable or "Silver Steel" Blade.



"Silver Steel" Files and Rasps; "Finest on Earth."



ATKINS Aerolite and Ferrolite Grinding Wheels.

MOVIES AT HOME



Many models of genuine MOVIE MACHINES, some as low as \$3.75, all using standard size big theatre films. Our stock of films is the most complete and lowest in price—with an exchange service. Films of leading stars and religious subjects are available. DON'T DELAY. WRITE FOR FREE INTERESTING CATALOGUE NOW!

PARAMOUNT MFG. CO.
Dept. G-11 BOSTON, MASS.

Portable ELECTRIC Light Plant

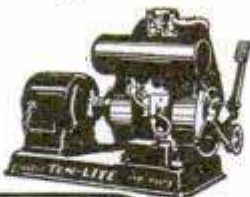
110 Volt — Complete with all wiring, fixtures and lamps for seven rooms \$147.50

for Farms, Camps and Summer Homes

Install it yourself. Write for direct to you prices. Immediate delivery.

D. W. ONAN & SONS

2 Royalston Ave., Minneapolis, Minn.



Flying Cloud Model

Miniature model finishes 20" long. Complete in details. Set consists of Hull Block, 30-1/8" S. P. Blocks, Steering wheel, Anchor, Bell, Capstan, Bitts, Flag, Spar materials, Rigging Brass wire, Pins, etc., also all materials for Deck Houses and rails. Complete set with instructions. \$10.00 plus postage for 5 lbs. Hull shaped and sanded, \$1.00 extra. Figure head 50c. Order one today. Or send Dime for our big Ship Model Supply catalog.

ROY HANCOCK

323 Douglas Ave. Portsmouth, Va.

Gentlemen: Send me your illustrated catalog.

Enclosed is 10c. Enclosed find \$.....

Send above set.....

Name.....

Street.....

City..... State.....



Free Trial!

Motorize Your workshop!

SPEEDWAY SHOP Easy to make things at home with this big new metal and wood-working shop. Attaches to any lamp socket. \$10.00 down—easy payment. Make money in your spare time. Big free illustrated book gives full particulars, including free trial offer. Send 25c for instructions for making attractive magazine basket. Write Electro Magnetic Tool Co., Dept. 2F, 1830 S. 52nd Av., Cicero, Ill.

Start Your Own Business

Own a Welding or Lead Burning Outfit

Sold on the payment plan
Write for particulars

Lead Burning and Soldering Outfits. \$8.00 to \$25.00
Welding Outfits..... \$25.00 to \$69.20

The Superior Oxy-Acetylene Machine Co.
Box 285 Hamilton, Ohio

DO YOU

WANT a new business profession of your own, with all the trade you can attend to? Then become a foot correctionist, and in a few weeks earn big income in service fees,—not medical nor chiropody—easy terms for home training, no further capital needed, no goods to buy, no agency. Address


Stephenson Laboratory, 1 Back Bay, Boston, Mass.

COLD AUTOS START IN 60 SECONDS

Amazing invention provides heat in the right spot at touch of switch. No more starting struggles, even in freezing temperature. **SURE-FIRE** a'so averages 20% saving in gas. Helps prevent carbon. **AGENTS**—New liberal distributors proposition pays big profits.

GET ONE FREE—Just write at once for full details and our Free Offer.

THE SURE-FIRE COMPANY
Dept. 805-B, 4308 Sheridan Rd., Chicago, Ill.



CHEMCRAFT

There's No Fun Like Chemistry!

BE A BOY CHEMIST!

GET a CHEMCRAFT outfit; that's all you need for real fun! Work hundreds of fascinating and useful chemical experiments; make soap, dyes and ink; test foods, water and soil; perform tricks of chemical magic and surprise your friends. CHEMCRAFT is the original and best chemistry set; contains more chemicals; more and better experiments—the most for the money! Seven fine outfits:

Sold in all Toy Stores

No. 1—\$1.00	No. 3—\$3.50	No. 8—\$ 8.00
No. 2—\$2.25	No. 7—\$5.00	No. 12—\$12.00

Laboratory Work Bench—\$35.00

Every set complete with chemicals, apparatus and Manual of Instruction. Ask for yours by name—CHEMCRAFT—and get the best outfit!

Try Chemistry for 25c
Get CHEMCRAFT JUNIOR; just right for boys who want to try chemistry. Performs lots of fine experiments. Sent postpaid for only 25 cents.

Free Magazine for Boys
CHEMCRAFT Chemist Club Magazine; full of fine ideas, stories, chemical stunts and information about the best Chemistry outfits. Ask for your Free copy right away.

The PORTER CHEMICAL COMPANY
113 Summit Avenue Hagerstown, Md.

AGENTS 500% PROFIT

GENUINE GOLD LEAF LETTERS

S guaranteed to never tarnish. Anyone can put them on stores and office windows. Enormous demand, large profits. Paul Clark says: Smallest day \$28.70. R. L. Reel made \$920 in two months. Write today for free sample and liberal offer to general agents.

METALLIC LETTER CO. 433-B N. Clark St., CHICAGO

I Offer You \$8.00 a Day
~and a

Write quick for new proposition. We offer \$8.00 a day and a new Chevrolet Coach, for demonstrating and taking orders for Comer All-Weather Topcoats and Raincoats. Spare time. No Experience required. Sample outfit free. Write now.

COMER MFG. CO., Dept. W-5138, Dayton, O.

Do Your PRINTING

Cards, stationery, circulars, tag, labels, paper. **Complete Outfits, \$8.85 up, Job Presses \$11 up, Rotary \$1.49.** Card Cutters, \$3. Save money. Print for others, big profits. All easy rules sent. Write for catalog presses, type, paper, cards, ink etc. **THE KELSEY CO., T-37, Meriden, Conn.**



The Musical Sensation ACCORDEON
Played by Music Rolls

Without any knowledge of Music or Notes you play in a few minutes, perfect like an artist, latest hits, songs and dances. No study or practice. Nobody can see the arrangement. Musical Entertainers wanted everywhere, making easy money. Three models. Every instrument guaranteed. Interesting circular No. 1 and roll list mailed free.

TREASURE SALES COMPANY, 1690 Boston Road, New York



Where's the can of PLASTIC WOOD?

(Reg. U. S. Pat. Off.)

Cracks around a built-in tub. Water slopping through. Seal up the cracks with Plastic Wood, or Plastic Wood White Waterproof Tile Cement (which dries to a hard flat white).

Not only for bathroom cracks, but for gouged or broken furniture, loose handles, rotted wood, mouse holes and other household repairs or depreciation, Plastic Wood is invaluable. It is an inexpensive, practical, household repair product that often saves many dollars and anyone can use. It handles like putty, hardens into wood, is waterproof and grease-proof, and takes paint, lacquer or varnish perfectly.

Plastic Wood Solvent

When working with Plastic Wood, keep a can of Plastic Wood Solvent on hand to soften it if it hardens too rapidly, thin it if necessary, and clean the hands and tools after using. At dealers, in 25 and 50 cent cans.

Handles Like Putty



Hardens Into Wood

1 lb. can \$1.00

¼ lb. can 35 cts.

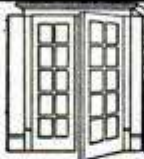
At Hardware and Paint Stores

ADDISON-LESLIE CO., 412 Bolivar St., Canton, Mass.

Going to Build Remodel or Repair?

DON'T think of building a new home or repairing an old one without a copy of our free woodwork catalog.

To those who contemplate building or remodeling, this book is a valuable work of reference. In it are found the latest ideas and most advanced styles for everything in millwork. It illustrates and describes windows and sash of all kinds, including porch and storm sash, doors, frames, mouldings, screens, porchwork, stairwork, hardwood flooring, interior finish, cabinet work—in fact, practically everything in manufactured millwork.



Every article in the book shows a low money-saving price direct to you.

FREE ESTIMATES

Send us your lumber and millwork bills for a free estimate. Let us quote prices on your material and tell you the exact amount of freight. Then compare our prices with others. This service costs you nothing and places you under no obligation whatever.



CHICAGO MILLWORK SUPPLY CO., 1444 W. 37th St., Chicago, Ill.
PLEASE SEND ME YOUR FREE BOOK

Name _____ St. No. _____
Town _____
State _____
Occupation _____

Book is Free

CORNWELL QUALITY TOOLS

in Convenient Kits

A KIT of "CORNWELL" tools is a prized possession of the expert mechanic. Valued not alone for their high quality but because they do better work in less time than any other tools. 65 different tools for almost every purpose. Their remarkable performance in difficult work is simply amazing.

There Is No Substitute for CORNWELL QUALITY

Every CORNWELL tool is hand made under our exclusive CORNWELL processes from Swedish or Chrome Molybdenum steels.



Tools of Amazing Strength

No other tools are like them. They withstand the most severe tests to which any tools can be put. Try them at our risk.

Let Us Demonstrate

Ask for salesman to call and show you many startling demonstrations of CORNWELL QUALITY TOOLS. Or send for free catalog, order tools, and make these tests yourself.

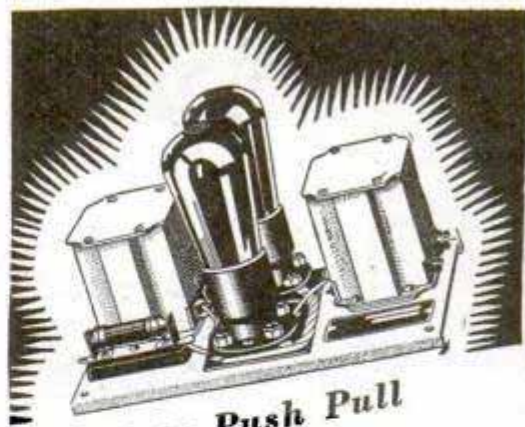


COUPON BRINGS CATALOG-FREE

The Cornwell Quality Tools Co., Dept. G, Mogadore, Ohio. (Formerly at Cuyahoga Falls, Ohio)

Send me new illustrated catalog with prices on full line of CORNWELL Hand-made Tools.

..... Where Employed
Name.....
Address.....
City..... State.....



Complete Push Pull Power Stage

Completely assembled and mounted—ready to install in any set. Most flexible as it consists of a standard input transformer and is supplied with just the output transformer and you need for 210 or 171 type tubes operating magnetic or dynamic speaker. Four types, one of which will be just what you want for your particular problem.

Price (East of Rockies) \$36.00

American Transformer Company
50 Emmet St. Newark, N. J.

AMERTRAN

KINKADE GARDEN TRACTOR AND POWER LAWNMOWER

A practical, Proven Power Cultivator for Gardeners, Suburbanites, Truckers, Florists, Nurserymen, Fruit Growers, Poultrymen.

AMERICAN FARM MACHINE CO.
1058—33rd Ave. S. E., Minneapolis, Minn.



Catalog Free



AIRPLANE

12-inch scale model of Lindbergh's Spirit of St. Louis. Scientifically designed and very realistic. Rises from ground by own power and flies 30 ft. or more. Stays in air 8 to 10 seconds.

Easily built in 2 or 3 hours. No tools needed. Construction set, with all parts and full directions postpaid in U.S., only 50c. (no stamps). Satisfaction or money back. Send today. Mann & Benton, Box D, Chillicothe, O.



MASONS



Latest style genuine selected leather, gold trimmings; 5 window card case, Masonic emblem stamped in heavy gold.

Who would be without for only

Send for \$1 to help cover cost, just to get our catalogue in the hands of Masons. The case is a beauty.

Your name or other stamping 35c a line extra. Pin a dollar to this. Money back if not entirely satisfied. Larger and better cases from \$2. up to \$5. Masonic Books, Monitors, Jewelry and Lodge Supplies for over 69 yrs.

REDDING MASONIC SUPPLY CO. INC.
200 Fifth Ave. - Dept. P.M., New York

\$1



Have You Seen this?



We want every reader of Popular Mechanics to get *this* book

EVERY man who uses edge tools will find in this new 40-page illustrated booklet "How to Sharpen Wood-Working Tools," real helpful information on the art of sharpening edge tools. Out of the background of long experience and full knowledge Emanuel E. Ericson has written a book that earns a place in every man's tool box.

Sign and mail the coupon below and we will send you a copy free. If you have an interested friend let's have his name. We will be glad to send one to him too.

Carborundum Sharpening Stones for your

- GOUGES HATCHETS DRAW KNIVES
- WOOD CARVING TOOLS
- CABINET SCRAPERS FLOOR SCRAPERS
- AUGER BITS CHISELS KNIVES

Carborundum
REG. U. S. PAT. OFF.
SHARPENING STONES

{ Carborundum is the Registered Trade Mark of The Carborundum Company for its Silicon Carbide and is its exclusive property }

THE CARBORUNDUM COMPANY, NIAGARA FALLS, N. Y.
Send me the 40-page booklet "How to Sharpen Wood-Working Tools." P. M. F. 9

Name _____
Address _____

PARKS

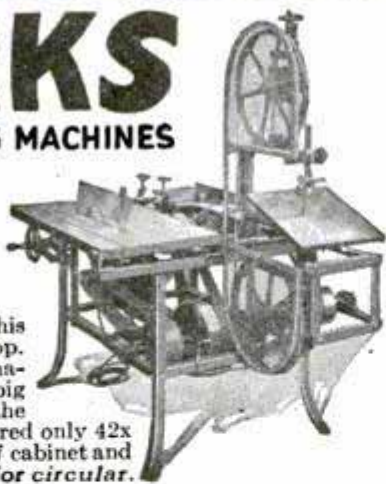
WOODWORKING MACHINES

Cabinet Shop Special No. 10

\$290

With Motor

You ought to have this handy Parks in your shop. Compact, complete machine designed like a big production outfit at 1/2 the cost. Floor space required only 42x72 in. Does any kind of cabinet and joinery work. *Write for circular.*



The Parks Woodworking Machine Co.

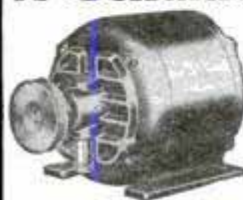
1500-40 Knowlton St. Cincinnati, Ohio
Canadian Factory: 338 Notre Dame East, Montreal

A Genuine Robbins & Myers

1/4 H. P. Electric Motor

for 110 V., 60 Cycle light circuit at the low cost of \$9.50. A tool that will lighten your chores, connected to your lathe, grinder, pump, washer, etc. Always ready for service.

ROBBINS & MYERS, Inc.
Department A, Springfield, Ohio



Makes Old Ford a Tractor

Now you can convert that old Ford car into a useful farm tractor without altering any Ford parts. We furnish the traction wheels, drive gears and auxiliary axle and mountings, ready to clamp on to the Ford frame. Pulls 16" plow.



We supply a Belt Pulley also

Write for Free Particulars.
Shaw Mfg. Co., Dept. PM2, Galesburg, Kan.

"Interlox"

MASTER SLIDE RULE

Speeds up all measuring. Slides in and out—no folding. Direct-reading for instant inside measurements, as well as outside. Any length, 2 to 3 ft., 20¢ linear ft. If not at dealers, sent postpaid.



MASTER RULE MFG. CO., 813 E. 136th Street, NEW YORK
Dealers and Agents: Write for attractive proposition.

Beautiful HOUSES \$900 and BUNGALOWS

CAN BE BUILT FOR AND UP

This and many others in my new book, Building Plans for Modern Homes, will save you hundreds of dollars. One of the most complete and comprehensive books of plans ever published by any architect. New edition just off the press. Nearly 600 floor plans and photographs of Colonial houses, bungalows, etc., costing from \$200 up; gives sizes and cost to build. Sent postpaid for \$3.00.



FREDERICK H. GOWING
ARCHITECT
101 Tremont St., BOSTON, MASS.

OTTAWA LOG SAW

only **\$39**

GREATEST OFFER EVER MADE

PUTS THIS OTTAWA TO WORK FOR YOU

Make Money! Wood is valuable. Saw 15 to 20 cords a day. Does more than 10 men. Ottawa easily operated by man or boy. Falls trees—saws limbs. Use 4-hp. engine for other work. **30 DAYS TRIAL.** Write today for **FREE** book. Shipped from factory or nearest of 10 branch houses.

OTTAWA MFG. CO., 1741-W Wood Street, Ottawa, Kansas



BIG BOOK FREE



Obviously!

You need fine tools for fine work. For operations that require skill and craftsmanship, choose tools that combine exact balance with the best of material—Pexto Tools. You will find them dependable and long lived. Look for the Pexto trademark when you buy—a mark of worth while tools.

Popular tools in the Pexto Line include Braces, Bits, Pliers, Wrenches, Snips, Squares, Hammers, Chisels, Pruning Shears, Screw Drivers, Draw-knives and Calipers.

Send for booklet "M."

THE PECK, STOW & WILCOX CO.
Southington, Conn., U. S. A.

PORTABLE SAWS

(MOTOR DRIVEN)

Only \$48⁰⁰

Never before and never again will you be able to purchase a genuine guaranteed portable power saw at such a price! (Limited time only.) Direct drive—no gears. Fastest saw on the market. Light and easily handled. Two models—one has totally enclosed guard and 2" cutting capacity, other cuts up to 1 3/4" with depth adjustment for grooving, slots, etc. Every saw guaranteed and made with precision by machine tool builders. Give up backbreaking costly hand-sawing by taking advantage of this amazing offer. Pays for itself. Your choice for only \$48.00. Money refunded if not satisfactory, within ten days.



Be sure of getting one by ordering to-day.

Porter-Cable Machine Co.
1704-10 N. Salina St.
Syracuse, N. Y.



TOOLMAKERS and MACHINISTS FIND GERSTNER Tool Chests

desirable. They keep tools in order and save them from loss and damage. *Catalog Free.*

Gerstner & Sons

462 Columbia St., Dayton, Ohio

\$19⁸⁵ CONCRETE MIXER ON SKIDS



Or \$6.85 down and \$5 a month for three months. Improved for easy, speedy, quality work. Hand crank or engine. Order now or write for particulars.

BADGER KWIK-MIX CO.,
1074 Cleveland Ave. Milwaukee, Wis.

Walsh Garden Tractor and Power Mower



Plows, Seeds, Cultivates, Mows Lawns & Hay For Gardeners, Florists, Fruitmen—Walk or ride

SPECIAL FACTORY PRICE

Single & Twin Engine-Belt Jobs. *Catalog Free.* **WALSH TRACTOR CO.** Minneapolis, Minnesota 3328 Talmage Av., S. E.



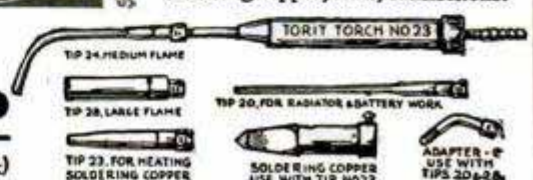
For the Handy Man!

TORIT TORCH No. 23

Uses acetylene only from a Presto auto tank. Finest thing you ever saw for Radiator and Battery Repairing, Soldering, Light Brazing, Heating, etc. Complete with 4 tips, soldering copper, hose, connections.

PRICE \$7⁵⁰

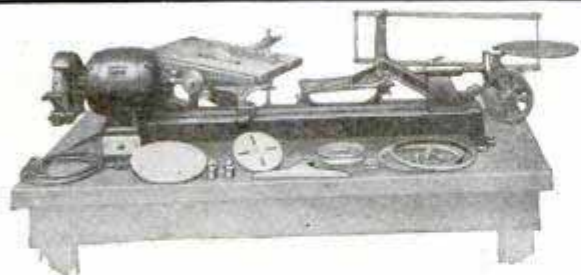
(Except tank)



ST. PAUL WELDING & MFG. CO., 177 W. 3rd, St. Paul, Minn., U. S. A.

AIR-CON UTILITOO

THE KING OF THEM ALL



Acclaimed by Those Who Know

The best proof that thousands were waiting for a sturdy, powerful, quality-built workshop such as the Ar-Con Utilitool lies in the character of the inquiries which have flooded us since its announcement, and in the enthusiastic commendations of men who know tools.

Ar-Con Utilitool is not a plaything to become tired of when limitations are revealed; it is a dependable, efficient outfit that is a never-ending source of delightful, constructive recreation—and, if you wish, of profit as well.

You owe it to yourself to learn about this super-efficient home workshop. Just write your name and address in the margin, tear out and mail to

THE AR-CON TOOL COMPANY
500 Fassett Street TOLEDO, OHIO

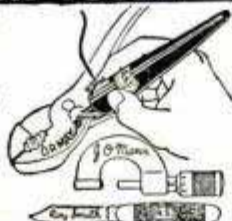
BURN YOUR NAME ON TOOLS

WITH THE ARKOGRAF

PROTECT YOUR TOOLS FROM THEFT

Write with electricity any name or design on the hardest and finest tools and instruments, or any metal, like writing on paper with pen or pencil. Complete outfit \$3.50—Prepaid Anywhere. Interesting illustrated circular free. Write today. Agents wanted.

ARKOGRAF PEN CO., 1171 E. Stark St., Portland, Oregon



\$25 To \$50 Make \$25 to \$50 per day and be Your Own Boss! Per Day Drilling Wells!

Cash in on demand for good wells in every community! Any man with mechanical turn of mind can easily operate one of our drills, make big money, be independent, work the year 'round! A few hundred dollars starts you in this big paying business—pay balance out of earnings! Write for FREE CATALOG describing ARMSTRONG ALL STEEL WELL DRILLS—gasoline traction or non-traction models.

Write now—today—Armstrong Mfg. Co., 810 Chestnut St., Waterloo, Iowa.



\$1500 WITHOUT MOTOR

SCHROETERS No. 15 Motor Driven SCROLL SAW for Home or Small Shop

The saw is mounted on a neat wood base and has a 7 1/2-inch nickel plated tilting table which is essential for inlay work. The work which can be accomplished is marvelous. Has a range of work from the finest inlay up to 7/8-inch white pine. A practical machine for sawing Radio panels such as bakelite, sheet brass, hard rubber, bone, fibre, etc. Has 16-inch swing. Weight only 21 pounds without motor. We supply a catalog of 250 miniature scroll saw designs with each machine.

Add \$500

when boring attachment is wanted

For More Information Write for Our Scroll Saw and Tool Catalog
SCHROETER BROS. HARDWARE CO.
810 Washington Ave., ST. LOUIS, MO.

—depend on SIMONDS HACK SAW BLADES



"Hacksawology"
a booklet of information about the care and use of blades will be mailed free on request.

To hold a keen cutting edge

IF you want hack saw blades that aren't afraid to tackle the toughest metal, that keep a biting edge throughout an unusually long service life—specify Simonds.

The reason for the long-wearing qualities in Simonds Hack Saw Blades lies in the special heat-treated Tungsten steel from which they are made. This steel has been developed exclusively by Simonds in Simonds plants. No other steel can add so much toughness to cutting tools—so much wear-resistance, so much dependable service.

It pays to keep a supply of Simonds Hack Saw Blades on hand at all times. The keenest judge of tool quality—the experienced craftsman who knows the finest cutting tools—will tell you that for real economy and satisfaction it pays to use Simonds. Ask your dealer.

SIMONDS

SAWS FILES KNIVES STEEL

SIMONDS SAW AND STEEL COMPANY
"The Saw Makers" Fitchburg, Mass. Established 1832

BRANCH OFFICES AND SERVICE SHOPS IN PRINCIPAL CITIES

Now! Do Your Own Electric Nickel Plating



For Plating
Nickel, Brass,
Copper, Silver,
Gold, etc.

Make \$150 to \$500 a Week

New Scientific Invention Enables Anyone to Nickel-Plate Anything, Anywhere

This Marvelous New Scientific Invention enables anyone to do his OWN Electro-Plating in the Home, Garage, Office, or Place of Business. Electrically Deposit Metal—Nickel, Brass, Copper, Silver, or Gold. You can Successfully do all the plating on your Automobile, Bathroom and Electric Fixtures, Faucets, Spoons, Forks, Knives, Chandeliers, Tools, Coffee Urns, Surgical and Dental Instruments, Utensils large or small, Iron Stoves, Music Instruments; recondition Old or Worn plating or plate New Work; do it at any time and Instantly with the

ALADDIN PORTABLE ELECTRO-PLATER

without removing the parts to be plated. Easy, Simple, and Economical to operate. Not a toy, but a practical Electro-Plating Outfit with which Perfect and Durable Work can be done. Positively Guaranteed to do as we claim. **BE YOUR OWN BOSS!** Build up a Profitable Aladdin Electro-Plating Business of Your Own. Big Easy Money-Maker for Agents and Dealers. Thousands in Service. Write for FREE Booklet and Testimonials Today.

P. J. F. BATENBURG

DEPT. 63 RACINE, WISCONSIN



DEALERS AND AGENTS WANTED

Eight Instruments In One!

The new Regal Octofone can be tuned and played like a "uke," tenor banjo, mandolin, tenor guitar and other plectrum instruments.

\$15.00

OCTOFONE

"Uke Players"

Pick up the Octofone and play it right off! No lessons or relearning. The Octofone tunes and plays like a uke, but you get a finer, more mellow tone than a "uke" gives. The Octofone has the harmony qualities of eight instruments in one!

FREE Instruction Booklet with Each Instrument

REGAL MUSICAL INSTRUMENT CO. CHICAGO

Regal Musical Instrument Co.
3207 W. Grand Ave., CHICAGO.

I am interested in the Regal Octofone. You may send FREE complete information.

Name.....

Address.....

only \$100 DOWN

10 Day FREE Trial

You can have a genuine L. C. Smith (the world's only ball bearing typewriter) for \$1 down. Lowest price ever offered! Easiest terms. All the 1928 operating attachments. Re-newed. **GUARANTEED FOR FIVE YEARS.** \$1 down and we ship. No delay. No red tape. 10 day Free Trial. Free Typewriter Course, Tools, Waterproof Cover if you act now. Write for \$1 down offer and free manual.

Smith Typewriter Sales Corp., 112-380 E. Grand Ave., Chicago, Ill.

\$4.99 22 Cal. Blank Automatic

WITH 100 shot Automatic. Use for CART- fun or self-defence. keeps away tramps, RIDGES. Frightens thieves, scares away dogs— a real home protector. Fool your friends. Same as an expensive automatic in construction, finish, appearance, durability; automatic magazine loading and ejection of cartridges. Instantly and powerful report. Guaranteed absolutely safe. Send no money. Pay expressman \$4.99 for automatic with 100 cartridges. JENKINS, 621 Broadway, New York, Dept. 23-J-2

No Permit Required

6 SHOT

STANDARD GARDEN TRACTOR

Plows Seeds Cultivates Mows Hay and Lawns

A Powerful Tractor for Small Farms Gardeners, Florists, Nurseries, Fruit Growers and Poultrymen

DOES 4 MEN'S WORK

Walking & Riding Equipment
Free Catalog. Does Belt Work

STANDARD ENGINE COMPANY
3221 Como Ave. Minneapolis, Minn.

\$450 PROFIT IN ONE DAY

Without experience, A. L. Bradley made that much showing amazing new 38,000 candle power automobile light. Easy to install. Sells instantly. 300% to salesmen. Write today.

Aerial Electric Co., 329 West Ohio Street, Chicago, Ill.

I Offer You \$60 a Week-Steady



Pocket big daily profits taking orders for No-Frost—the amazing new preparation that keeps rain, snow, frost, mist and steam off auto windshields, show windows, mirrors, etc. Auto owners, bus drivers, store keepers, housewives buy on sight. Be your own boss. Work when you feel like it—full or spare time—and make \$48 to \$60 a week—steady and sure. Wonderful opportunity for men and women everywhere.

ANYONE—ANYWHERE—CAN MAKE BIG MONEY

No capital or experience needed. We furnish everything. Earnings start at once. Don't miss this chance. Write quick for Profit-Sharing Offer.

AMERICAN PRODUCTS CO., 1098 Monmouth Ave., CINCINNATI, OHIO

\$351⁰⁰ CLEARED IN ONE DAY

So writes W. H. Adams of Ohio. Letter from California man reports \$11275 sales in three months; New Jersey \$4000 profits in two months; Pa. \$3000 profits in four months. Ira Shook \$365 sales in one day. Bram bought one outfit April 5 and 7 more by August. Iwata bought one outfit and 10 more within a year.



J. R. Bert says "only thing I ever bought that equaled advertisement." John Culp says: "Everything going lovely. Crispette wrappers all over

town. It's a good old world after all." Kellog, \$700 ahead end of 2d week. Wholesale or retail. Big profits either way. No town too small. Business is pleasant, fascinating and dignified. You manufacture a food product.

WE START YOU IN BUSINESS

Furnish secret formulas, raw material and equipment. Little capital required; no experience needed.

Build a Business of Your Own

No limit to the sale of Crispettes. Everybody likes them. It's a delicious food confection. Write for facts about a business that will make you independent. Start now, in your own town.

PROFITS \$1000 MONTH EASILY POSSIBLE

Send postal for illustrated book of facts. It contains enthusiastic letters from others—shows their places of business, tells how and when to start, and all information needed. Free. Write now!

LONG-EAKINS COMPANY

228 High Street

Springfield, Ohio

DO YOU WANT \$100 WEEKLY

Ambitious men! Here is an opportunity to enter the big money class by showing Gibson all wool made-to-measure tailoring. Sell direct to wearer at \$23.50 and \$31.50 regular \$40 and \$50 values. Money back guarantee of satisfaction with every suit. Orders come quick, easy. Big commissions in advance. Complete outfit with over 100 large cloth samples, Style Book and Supplies sent FREE. Write for territory now! Dept. B-516

W. Z. GIBSON, Inc. 500 Throop St. Chicago



MAKE YOUR FORD Into The "LARK"

\$5⁰⁰ Red-i-Kut life size patterns Class—Snap



Famous sure-fit RED-I-KUT life-size patterns and picture instructions show how you can easily convert your Ford into this Fast, Saucy, Sport-Car as thousands have done with easily obtained materials. No need to lay up the car. Rear seat folds, making 4-passenger car. Send 10c coin for actual body photo

and new manual of other distinctive sport body patterns from \$3.80 up—"RKO" Steel "Swing-Lo" irons, Tons and Windshields. ORDER RIGHT NOW

KUEMPEL COMPANY, 105 Kuempel Bldg., GUTTENBERG, IOWA



BARGAIN! ONLY 39¢ GUARANTEED RADIO TUBES

Why pay \$2.00 for new radio tubes? Get guaranteed high quality 201A type Barawik tubes for only 39¢ each. Send check or money order. These and thousands of other bargains are shown in Barawik's Big Radio Guide. Newest coast-to-coast radio sets, speakers, parts, short wave and television supplies, etc.—all at lowest prices. Send for free copy today—NOW

BARAWIK CO., 102 Canal St., Chicago, U. S. A. Mail This Coupon Now for Free Radio Guide



Name..... Address.....



FREE! This Nerve Chart

If you will mail the coupon below, this nerve center and vertebrae chart, showing how the nerves radiate from your spinal column to all organs of the body, will be mailed to you without one cent of expense. It is a chart which should be in every home.

Where is that PAIN?

It may be in the neck, back, hips, stomach, liver, legs or arms—wherever it is the chart will help to show you the location and cause of your ailment.

Stop that Pain

By Relieving the Cause with

Violet Ray – Vibration Ozone – Medical Electricity

The Four Greatest Curative Powers Generated by This

Great New Invention!



Elco Health Generators at last are ready for you! If you want more health—greater power to enjoy the pleasures and delights about you, or if more beauty is your desire—write! Ask for the book on these inventions which has just been prepared. It will be sent to you without cost. It tells you how Elco Health Generators aid you in leaving the lethargy and hopelessness of bad health and weakness behind forever. Re-vitalize yourself. Bring back energy. Be wholly alive. Write today!

Here's What Elco Users Say—

"Wouldn't take \$1000 for my Elco." "Has done me more good in 2 weeks than doctors did in three years." "Cured my Rheumatism." "My Eczema gone." "Cured my stomach trouble." "Cured my weakness." "Now I sleep soundly all night." "Thanks to Elco my strength and vigor are back." "No more pain." "Colds never bother me now." "Chronic Constipation banished."



These great new inventions generate Violet Ray, Vibration, Electricity and Ozone—combined or separate. They operate on the electric light in your home or on their own motive power at less than 50 cents per year. Elco Health Generators are positively the only instruments which can give you in one outfit Electricity, Violet Ray—Vibration and Ozone—the four greatest curative agents. Send the coupon below. Get the Free Book NOW!

MAIL COUPON for FREE BOOK

Do not put this paper down without sending the coupon. Don't go on as you are with pains and with almost no life and energy. You owe it to yourself to be a better man or woman. You were put here to enjoy life—not just to drag through it. So do not rest another day until you have put your name on the coupon here. That will bring the whole story of these great new inventions. Do it today—now.



Lindstrom & Co. [Makers of Therapeutic Apparatus since 1892.]
2322 Indiana Avenue Dept. 93-52 Chicago
Please send me your free book, "Health—Power—Beauty" and full information of your 10-day Free Trial Offer.

Name..... Address.....



"Lava-clean" hands are clean!



Men—you who love to tinker—here's just the soap you need. Cleans quickly and thoroughly the toughest-looking pair of hands that ever fussed around a work bench. Makes more lather in 15 seconds than ordinary soap in 60, and even hard or cold water won't discourage it. Millions use it. "Good old Lava," they call it. Gets hands *clean!* Not just "surface clean," but clean 'way down deep. As easy on your hands as fur-lined gloves—because it's made from the finest of vegetable oils. All grocers sell it.

Full size cake of Lava Soap FREE!

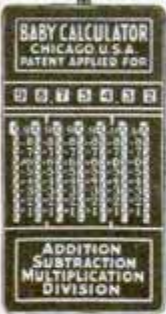
Mail this coupon

Procter & Gamble (Dept. W-229)
Cincinnati, Ohio

Please send me, FREE, a full size cake of LAVA, the hand soap that removes *all* the dirt and grease.

Name.....
Street.....
City.....
State.....

NEW VEST POCKET ADDING MACHINE



ADDS, SUBTRACTS, MULTIPLIES, DIVIDES
Does work of \$300 machine. Guaranteed 5 years. NOT A TOY.
Made of steel and indestructible. Million dollar capacity. Fits in pocket. Will not make mistakes. So simple child can operate it. Instructions furnished. Everybody should carry one for figuring.

FREE TRIAL \$2.50 Total Cost

SEND NO MONEY—Just name and address. We will ship Calculator immediately. On delivery pay postman \$2.50 (Plus few cents Postage). (If outside U. S. send cash) 10c additional in Leatherette Case. If not satisfied after 10 days trial you get your money back. **THOUSANDS OF SATISFIED USERS.**
This is lowest priced practical calculator made. "Why pay more for inferior imitations?" Order from this ad.

Guaranteed **Mail Coupon Today**

BABY CALCULATOR SALES CO., (MANUFACTURERS)
Dept. 41, P. O. Box 1118, CHICAGO, ILL., U. S. A.
 I am enclosing \$2.50—send adding machine prepaid.
 Send Adding Machine C. O. D. \$2.50 plus postage. (10c additional in Leatherette Case)

Name.....
Address.....
City..... State.....

AGENTS Write for big commission and territory proposition.

OLD MONEY and stamps WANTED



POST YOURSELF! It pays! I paid J. D. Martin, Virginia, \$200 for a single copper cent. Mr. Manning, New York, \$2,500 for one silver dollar. Mrs. G. F. Adams \$740 for a few old coins. I want all kinds of old coins, medals, bills and stamps. I pay big cash premiums.

WILL PAY \$100 FOR DIME
1894 S. Mint; \$50 for 1913 Liberty Head Nickel (not buffalo) and hundreds of other amazing prices for coins. Get in touch with me. Send 4c for Large Illustrated Coin Folder. It may mean much profit to you. Write today to

NUMISMATIC COMPANY OF TEXAS
Dept. 324 FORT WORTH, TEXAS
(Largest Rare Coin Establishment in U. S.)

Spinning Auto Light
SPINS WITH THE WIND NIGHT or DAY



\$3.00 Complete

The Flying Ace

Spinning airplane windmill rainbow auto light. Beautiful color combinations. The most beautiful light in the world. The Daddy of them all. Red, White & Blue—Blue, White & Orange—Red—Green—Yellow for Taxis—Special colors for colleges, etc. Anyone can install to any part of auto, truck, motorcycle, boat or air plane quickly. Ideal chromium plated radiator ornament—spins night or day. Just patented. Furnished complete. Order today Pay mailman \$3 plus postage or prepaid on receipt of \$3. Money back guarantee. Go Light Co., 19 Liberty St., N. Y. C. Dept. 100, Agents Wanted.

MOTORCYCLES

Direct to you at wholesale prices Send 10c today for the latest Illustrated Bulletin and Confidential Price List of Guaranteed Indians Harleys Hendersons SuperX etc. (Sold on easy terms if desired)
CRANDALL CYCLE CO. 826-28 State St. Shipments to all parts of the world
Motorcycles Since 1905 Springfield, Mass.

SPORT BODIES FOR FORDS



at FACTORY PRICES
This Model in Grey Prime **\$38.50**

Hi-compression heads, underslung parts, 3:1 gears, headlights, cowl lamps, etc. for Fords. Seat Covers for all cars.
SPORT FACTORIES, Dept. A-3, AURORA, ILL.

MOTORCYCLES

WE WILL TRUST YOU
Pay As Low As \$2.00 per Week
Hendersons, Harley-Davidsons, Indians
Slightly used and rebuilt. Hundreds to select from.
Send 10c for list today.
MYEROW BROS. CO., 15 Berkeley St., Boston, Mass., U. S. A.

Catch Fish!

Eels, Mink, Muskrats with our new folding galvanized **STEEL WIRE TRAP.** Write for our **FREE TRAP OFFER** and Bargain Catalog. **\$1 Box** of our famous Fish Bait **FREE** to introduce our traps.
WALTON SUPPLY CO., 3502 JUNIATA AVE., ST. LOUIS, MO.

CLASS PINS 35¢
FREE CATALOG SHOWING 200 DESIGNS
EITHER DESIGN SHOWN. SILVER PLATE 35¢ EA.; 12 OR MORE, \$3.50 DOZ.; STERLING SILVER OR GOLD PLATE, 50¢ EA.; 12 OR MORE, \$5.00 DOZ.; 1 OR 2 COLORS ENAMEL, ANY 3 LETTERS AND DATE.
BASTIAN BROS. CO., 893 BASTIAN BLDG. ROCHESTER, N. Y.

Thompson BEATS the World on BOATS
THOMPSON BOATS
CATALOG FREE!



OUTBOARD MOTOR BOATS—A complete line of strictly up-to-date racing models. Also some entirely new models for general pleasure use with speed of a racer. Built strong, staunch and durable, and absolutely safe.

Rowboats \$44.00 and up—

The most complete line ever offered, at real money-saving prices.

Canoes \$48.00 and up—

Some all wood, others canvas covered. Light, swift, safe, strong and durable. Choice of many distinctive color combinations.

Motor Boats—

With or without Engine. Fast, handsome craft at money-saving prices.

CATALOG FREE — SAVE MONEY — ORDER BY MAIL
 Please state the kind of boat you are interested in (30)

TWO LARGE FACTORIES

THOMPSON BROS. BOAT MFG. CO.

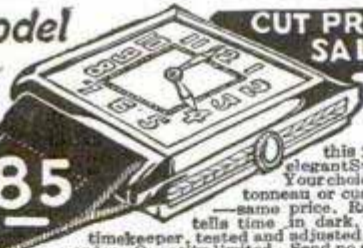
213 Ann St.
PESHIGO WISCONSIN

(Write to
 Either Place)

113 Elm St.
CORTLAND NEW YORK

New Model Men's Strap Watch

\$3.85



CUT PRICE SALE

Two years written guarantee given with this full jeweled elegant Swiss watch. Your choice in square, tonneau or cushion shape—same price. Radium dial, tells time in dark. Accurate timekeeper, tested and adjusted. Rush your order. Quantity limited. Send no money, pay postman \$3.85. **JENKINS**, 621 Broadway, New York, Dept. 23-F-2

Boils 50 Gallons In Less Than Hour

No Other Compares With This

Improved Oil Burner

Use Ordinary Kerosene or Coal Oil

[Burns Outdoors as Well as Indoors]

THE most remarkable Kerosene Burner ever built. Boils down apple cider, maple syrup, molasses, etc., in half the ordinary time. Ideal burner for dairies, butchers, indispensable on the farm.

PRODUCES TERRIFIC HEAT WITH SILENT BLUE FLAME

**NO NOISE
 NO SMELL
 NO SMOKE
 NO SOOT**

So efficient it produces twice the amount of heat of City gas at half the cost. So simple anyone can install and operate. Double generator assures continuous operation without shut-downs. Nothing to wear out, starts in a jiffy, will last a life time. Every burner guaranteed fully. Write for special introductory price and free catalog of outdoor utility and kitchen stove oil burners.



HOME MFG. CO., Dept. 2813, 20 E. Kinzie St., CHICAGO

WURLITZER
 REG. U.S. PAT. OFF.



**"Bill Carola"
 Landaus
 Serenaders**

Couldn't Play a Note—Now Makes

\$100 a week

"When I sent for your catalog, I didn't know a note of music. A few months after I bought my Wurlitzer instrument, I had taken my place in a professional orchestra. Now I am making \$100 a week, three times what I made as clerk. I wish everybody knew how easy it is—anyone who can whistle a tune can learn to play a musical instrument."
 —Bill Carola

Free Trial Easy Payments

You may now have any Wurlitzer instrument for an ample free trial in your own home. Examine the instrument, note the fine workmanship, the full, rich tone value and especially how easy it is to play. No obligation to buy—no expense for the trial. We make this liberal offer because we want you to try for yourself a genuine Wurlitzer instrument, the result of 200 years' experience in musical instrument building.

Easy payments are arranged to suit your convenience. This is your opportunity to try a famous Wurlitzer instrument in your own home. Send for

Free Book

Illustrates and describes every known musical instrument—more than 3000 articles, many of them shown in full colors. All genuine Wurlitzer instruments—buy direct from Wurlitzer and save money. Special offers on complete outfits.

We also give you our Free Trial, Easy Payment Plan. No obligation.

Send Coupon Today!

The Rudolph Wurlitzer Co., Dept. 1772

117 E. 4th St., Cincinnati

Send me your Free Book on musical instruments. Also your Free Trial, Easy Payment Plan. No obligation.

Name

Address

City State

Instrument

Copyright, 1929, The Rudolph Wurlitzer Co.

PATENT

Protect Your Ideas

Take the First Step Today

If you have a useful, practical, novel idea for any new article or for an improvement on an old one, you should communicate with a competent Registered Patent Attorney AT ONCE. Every year thousands of applications for patents are filed in the U. S. Patent Office. Frequently two or more applications are made for the same or substantially the same idea (even though the inventors may live in different sections of the country and be entirely unknown to one another). In such a case, the burden of proof rests upon the last application filed. Delays of even a few days in filing the application sometimes mean the loss of a patent. So lose no time. Get in touch with me at once by mailing the coupon on the opposite page.

Prompt, Careful, Efficient Service

This large, experienced organization devotes its entire time and attention to patent and trade mark cases. Our offices are directly across the street from the U. S. Patent Office. We understand the technicalities of patent law. We know the rules and requirements of the Patent Office. We can proceed in the quickest, safest and best ways in preparing an application for a patent covering your idea. Our success has been built on the strength of careful, efficient, satisfactory service to inventors and trademark owners located in every state in the Union.

NO CHARGE for Information On How to Proceed

The booklet shown here contains valuable information relating to patent procedure that every inventor should have. And with it I will also send you my "Record of Invention" form on which you can sketch your idea and establish its date before a witness. Such evidence may later prove valuable to you. Simply mail the coupon and I will send you the booklet, and the "Record of Invention" form, together with detailed information on how to proceed and the costs involved. Do this NOW. No need to lose a minute's time. The coupon will bring you complete information entirely without charge or obligation.

My Patent Law Offices
Just Across
Street From
U.S. Pat. Office



Above is a view of my drafting and specification offices where a large staff of experienced experts are in my constant employ. All drawings and specifications are prepared under my personal supervision.

NEWS

Inventors Write for these Free Books

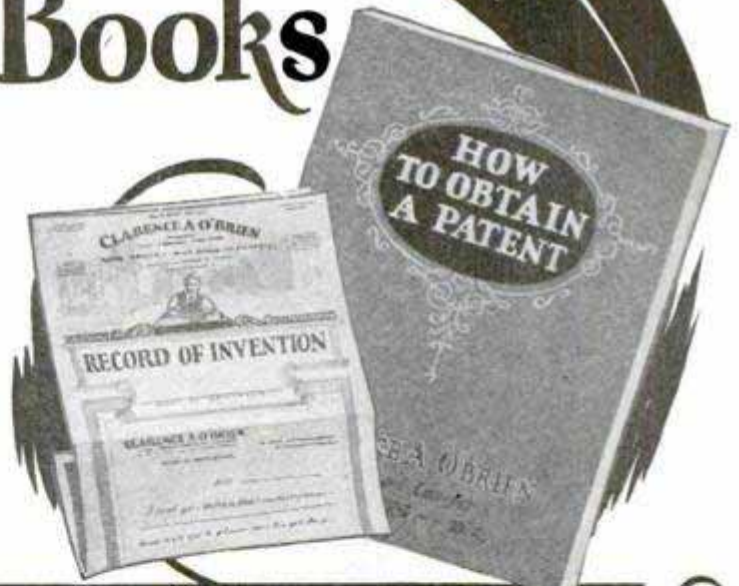
Strict Secrecy Preserved

All communications, sketches, drawings, etc., are held in strictest confidence in strong, steel, fireproof files, which are accessible only to authorized members of my staff. Feel free to write me fully and frankly. It is probable that I can help you. Highest references. But **FIRST**—clip the coupon and get my free book. Do **THAT** right now.

Clarence A. O'Brien

Registered Patent Attorney

Member of Bar of: Supreme Court of the United States; Court of Appeals, District of Columbia; Supreme Court, District of Columbia; United States Court of Claims. Practice confined exclusively to Patents, Trade marks and Copyrights



Clip this Coupon and Mail it Now!

CLARENCE A. O'BRIEN, Registered Patent Attorney

70-K Security Savings and
Commercial Bank Bldg.,
Washington, D. C.

OR

Suite 1106 Woolworth Bldg.,
New York City

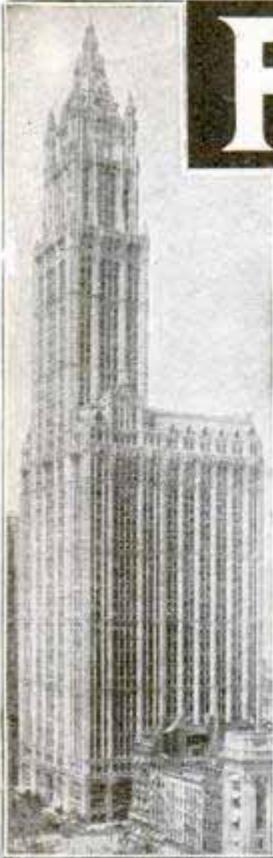
Please send me your free book, "How to Obtain a Patent," and your "Record of Invention" form without any cost or obligation on my part.

Name.....

Address.....

(Important—Write plainly and address office nearest you)

PATENTS TRADE MARKS COPYRIGHTS



Our New York Office
Suite 1007 Woolworth Bldg.



Our Philadelphia Office
Suite 518-519 Liberty Bldg.



Our Washington Office, Victor Bldg.



Have You An Idea ?

Our Offer: FOR THE PROTECTION
OF YOUR INVENTION

YOUR FIRST STEP

The inventor should write for our blank
form

"RECORD of INVENTION"

This should be signed and witnessed and
returned to us together with model or
sketch and description of the invention for

INSPECTION AND ADVICE

No Charge for the Above Information

**Our Five Books Mailed
Free to Inventors**

Our Illustrated Guide BOOK

How to Obtain a Patent

Contains full instructions regarding U. S. Patents,
Our Methods, Terms, and 100 Mechanical Move-
ments illustrated and described.

Our Trade Mark Book

Shows value and necessity of Trade Mark Protec-
tion. Information regarding *Trade Marks and un-
fair competition in trade.*

Our Foreign Book

We have Direct Agencies in Foreign Countries, and se-
cure Foreign Patents in shortest time and lowest cost.

Progress of Invention

Description of World's Most Pressing Prob-
lems by Leading Scientists and Inventors.

We Regard a Satisfied Client as our best advertise-
ment, and furnish anyone, upon request, lists of clients
in any state for whom we have secured patents.

**Highest References—Prompt Service
—Reasonable Terms**

VICTOR J. EVANS & CO.

Patent Attorneys, Established in 1898
Main Offices: 789 9th St., N. W., Washington, D. C.
Opposite U. S. Patent Office

DELAYS ARE DANGEROUS IN PATENT MATTERS

IMPORTANT! To Avoid Delay!

YOU SHOULD HAVE YOUR CASE MADE SPECIAL IN OUR OFFICE to save correspondence, secure protection and early filing date in the Patent Office. To secure **special preparation** of your case send \$25.00 on account with model or sketch and description of invention.



MAIN OFFICE, VICTOR J. EVANS & CO.—VICTOR BUILDING, WASHINGTON, D. C.

Our Lawyers Practice in all U. S. Courts and defend Clients in Suits involving Patents, Trademarks and Copyrights

All Communications and Data Strictly Confidential. Interference and Infringement Suits Prosecuted

OUR ORGANIZATION OFFERS PERSONAL SERVICE By Experienced Patent Lawyers, Solicitors and Draftsmen

**FREE
COUPON**

VICTOR J. EVANS & CO.
PATENT ATTORNEYS *Established in 1898*

NEW YORK OFFICES
1007 Woolworth Bldg.

CHICAGO OFFICES
1110 Tacoma Bldg.

PHILADELPHIA OFFICES
518-519 Liberty Bldg.

PITTSBURGH OFFICES
514 Empire Bldg.

SAN FRANCISCO OFFICES
1010 Hobart Bldg.

MAIN OFFICES: 789-9th Street, N. W., WASHINGTON, D. C.

Gentlemen: Please send me *Free of Charge* your books as described on preceding page.

Name

Address



Our Chicago Office
Suite 1110 Tacoma Building



Our Pittsburgh Office
Suite 514 Empire Building



Our San Francisco Office
Suite 1010 Hobart Building

PATENTS

Booklet Free **Highest References**
Promptness Assured **Best Results**

Send drawing or model for preliminary examination of Patent Office records.

ALL BUSINESS GIVEN PROMPT AND PROPER ATTENTION

Listed Patent Lawyer in the latest editions of the Rand-McNally Directory of Bankers and Bonded Attorneys, published by Rand-McNally & Co., Chicago, Ill.; The Baggott & Ryall Directory of Guaranteed Attorneys, published by the Ryall Legal Directory Company, New York City; Flugel's List, published by the Legal Directory Publishing Co. of St. Louis, Mo.; the American Lawyers Annual, published in Cleveland, Ohio; Eyre's Law List, Bush Terminal Building, New York City.

WATSON E. COLEMAN,
REGISTERED PATENT LAWYER

Victor Building, 724 Ninth Street, N. W.
WASHINGTON, D. C.



\$300,000 For This Invention

That's what Eastman Kodak paid for the Autographic idea. Thousands of other inventions are needed and offer enormous opportunities for earning fortunes. If you are of an inventive turn of mind why not concentrate on things that are really NEEDED. Get

Raymond Yates's new book

"1000 NEEDED INVENTIONS"

Costs only \$1.25 and may start you thinking along the right lines. You'll get nowhere just fussing around. Concentrate on what the industries need, and on what the public wants. Mr. Yates's book tells you what these things are. Send no money. Just write postal. Pay mail man \$1.25 plus postage when book arrives. Your money back if you want it. This offer limited. Write now and get on the right track. (Outside U. S. \$1.45, cash with order.)

BUREAU OF INVENTIVE SCIENCE
Dept. 32, Wisner Building, Rochester, N. Y.

Make Much Money

Making and Selling Your Own Goods. Formulas by experts. Manufacturing Processes. Trade-Secrets. All Kinds. All Lines. Send for interesting catalog, special circulars, free.
W. THAXLY CO., Washington, D. C.



PATENTS

Send us sketch or model for advice and exact cost of patent. Our book "How to Obtain a Patent" sent free. It tells how to apply for Patents, Trade Marks, Foreign Patents, Copyrights, etc.; gives information on Patent Procedure; tells what every inventor should know. Thousands of inventors, who are our clients, are our reference.

CHANDLEE & CHANDLEE, 25 Years' Experience
410 Seventh St. Washington, D. C.

PATENTS

Trade Marks, Copyrights, Patent Litigation Handbook with illustrations, 100 mechanical movements. Sent free on request.

ALBERT E. DIETERICH
formerly member Examining Corps U. S. Patent Office

REGISTERED
PATENT LAWYER and SOLICITOR
621-A, Ouray Bldg.
30 Years' Experience Washington, D. C.



GEARS ALL KINDS SMALL

The most accurate made and prices reasonable. We carry a complete line of gears in stock for immediate shipment. Can also quote on special gears of all kinds. Send us your inquiries.

WRITE FOR CATALOGUE 10
CHICAGO STOCK GEAR WORKS
105-109 S. Jefferson St., CHICAGO

Filters a Gallon Every 4 Minutes



Low Priced—Guaranteed

Amazing new invention—patented Home Filter for fruit juices and beverages. Nothing like it. Removes all sediment, pulp, fibres. Filters a gallon every 4 minutes. **Perfect results guaranteed.** No moving parts. Simple. Practical. Low priced. Lasts a lifetime. Thousands already in use.

FREE HOME TRIAL—Agents Wanted

Try free at our risk and return if not satisfied. Send name and address TODAY for full particulars of this liberal offer. Act NOW. AGENTS WANTED.
HOME FILTER CO., 422 CENTRAL AVE., BAY CITY, MICH.

INVENTORS PROTECT YOUR IDEAS

Send for our Guide Book, **HOW TO GET A PATENT**, and Evidence of Invention Blank, sent Free on request. Tells our terms, methods, etc. Send model or sketch and description of your invention for INSTRUCTIONS. No charge for the above information.

RANDOLPH & CO.
301 Victor Bldg., WASHINGTON, D. C.

NAME.....

STREET.....

CITY..... STATE.....

PATENTS

TRADE-MARKS & DESIGNS
FOREIGN PATENTS

MUNN & CO.
PATENT ATTORNEYS

Associated since 1846 with the Scientific American

SCIENTIFIC AMERICAN BUILDING
24 W. 40th St., New York City

SCIENTIFIC AMERICAN BUILDING
Washington, D. C.

TOWER BUILDING
Chicago, Ill.

VAN NUYS BUILDING
Los Angeles, Cal.

HOBART BUILDING
San Francisco, Cal.



Books and Information on Patents and Trade-Marks by Request.
Associates in All Foreign Countries.

MASON, FENWICK & LAWRENCE PATENT LAWYERS

600 F St., N. W., Washington, D. C.

Estb. over sixty years. Send sketches.

Electrical and Chemical Inventions carefully handled.
Practice before the U. S. Courts and the Patent Office.
Prompt and careful service. WRITE US.

TRADE MARKS REGISTERED

PATENTS Write for FREE Instructions. Send
Drawing or Model for Examination.
CARL MILLER, Patent Attorney
former member examining corps U. S. Patent Office
260 McGill Building Washington, D. C.

BLUE BOOK ON PATENTS

AND PRIORITY RECORD BLANK GRATIS.

MONROE E. MILLER, PATENT LAWYER
411-2 Ouray Building, WASHINGTON, D. C.
ELECTRICAL AND MECHANICAL EXPERT

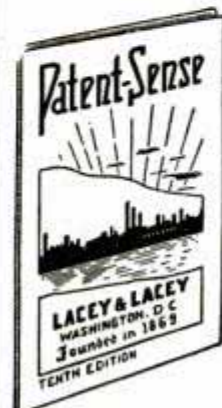


PATENTS TRADE-MARKS

**Don't Lose Your Rights
To Patent Protection**

Before disclosing your invention to anyone send
for blank form "EVIDENCE OF CONCEPTION"
to be signed and witnessed.

LANCASTER & ALLWINE
480 Ouray Bldg. WASHINGTON, D. C.
Originators of forms "Evidence of Conception."



Patents

Inventors who derive largest deserved profits know
and heed certain simple but vital facts **BEFORE**
applying for patents. Our book **PATENT-
SENSE** gives these facts. Sent **FREE**.

LACEY & LACEY

WASHINGTON, D. C.

ESTABLISHED 1869

Please send me your **FREE** book **PATENT-SENSE**.
Name.....
Address.....
City.....
State.....
Lacey & Lacey, 646 F St., N. W. Washington, D. C.

Old Cars Made NEW in 30 Magic Minutes



KOTAL gives the BEAUTY and LUSTRE of an Expert Paint Job at 1/20th the Cost!

NOT A POLISH—NOT A PAINT

This Amazing New Liquid, discovered in a famous industrial research laboratory, has startled the Motor World. Just flow *KoTal* on with a cheesecloth pad as easy as wiping a car with a chamol. *NO Rubbing—NO Hard Work. Results are Amazing*—with one sweep of your hand you restore *BOTH the COLOR and Original Mirror-like FINISH to Dull—Drab—Faded Cars*. Gives a glass hard protective coat that does not hold dust and the *Lustre Lasts for months*. Makes shabby *OLD* cars look like the day they were driven *NEW* off the dealer's floor. Words cannot describe the startling transformation. Warranted harmless to any finish. Manufactured by a long established highly rated, financially responsible concern and sold under the **STRONGEST GUARANTEE** ever put on any product.

AGENTS
EARN

\$5 to \$10

Every Hour You Work

\$200 a Week

is Easy Money

\$1000 Would Not Buy the Start We Give You FREE. Get the Facts

We furnish **FREE** every sales help conceivable. We back you to the limit. *Man Alive!* Here is the *Biggest* thing in the motor industry today—it's going over like a house afire. Everybody claims big money—*KoTal*, men *actually* make it. Hustlers laugh at \$100 per week. Millions of cars need this Quick—Economic—Magic finish which adds 25 to 40% to resale values. *Demonstrates itself instantly*. No Talking Needed. Men who have tried to sell everything on earth and failed are making good with *KoTal*. Even inexperienced country boys make money hand over fist. *Strike while the Iron is Hot. Get the facts and get them now.* We will send you our **FREE BOOK** illustrated in colors, and Agents' **FREE TRIAL OFFER**. Good territory is going fast. *Act NOW—Act at once. Send TODAY.*
E. RICHWINE & CO., 17 W. Jackson Blvd., Dept. 140, Chicago



OXO GAS

Blue Flame Oil Burners for Cook Stoves—Heaters and many other purposes.

The fastest growing industry of the times offers the opportunity to become branch manager; men of character and responsibility will be furnished with complete demonstrating outfits for themselves and sub-distributors.

DORAN OIL BURNER CO.
112-2 No. May Street CHICAGO

FRENCH and SPANISH Demonstration Record



A condensed lesson. Printed text furnished with the record. A practical demonstration of how easily you can learn a language by this new conversational method. Endorsed by French and Spanish Embassies. Mail only 25¢. Check language wanted French Spanish. International Correspondence Schools, Box 5599-F, Scranton, Penna.

only
25¢



Happiness Incorporated!

BOB—Bill—and Mary
B—a Pan-American
Trombone and Trumpet
with Mary at the piano.
Here's sure happiness—and

within your reach! You can have a Pan-American band instrument, saxophone, clarinet, or any other now, **FREE TRIAL** and if you decide to keep it—small monthly payments.

Pan-Americans Lead

Because of their superior quality—factory guarantee, and moderate price. Ask any band master, music teacher or superior. They'll recommend Pan-American.

You can play popular melodies in a few short weeks. Mail coupon today for beautifully illustrated catalog, **FREE TRIAL** offer and details of **EASY TERMS**.

Pan-American Band Instrument & Case Co.
Dept. G-25 Elkhart, Ind.

Gentlemen: Please send me your catalog and also details of your Free Trial Offer and Easy Payment Plan.

Name.....

Address.....

City..... State.....

My Music Dealer is.....

TYPEWRITERS
ALL STANDARD
10 Days FREE Trial at 1/2 PRICE
SENT WITHOUT 1¢ DOWN
Underwood, Remington Royal, etc. ONLY 14¢ A DAY
All late models, completely refinished brand new. **GUARANTEED** for ten years. Send no money—big free catalog shows actual machines in full colors. Get our direct-to-you easy payment plan and 10 days' trial offer.
International Typewriter Ex., 186 W. Lake St., Dept. 294, Chicago, Ill.

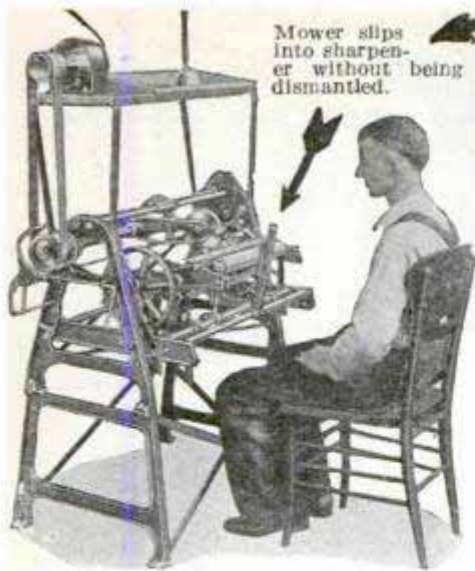
PATENTS

To the Man with an Idea

PATENTS Procured. Trade Marks Registered. —A comprehensive, experienced, prompt service for the protection and development of your ideas. Preliminary advice gladly furnished without charge. Booklet of information and form for disclosing idea free on request.

IRVING L. McCATHRAN, Patent Lawyer
Formerly with and successor to **RICHARD B. OWEN**
704 International Bldg., Washington, D. C.
41-E Park Row, New York City

**TRADE-MARKS
REGISTERED**



Mower slips into sharpener without being dismantled.

THIS MAN IS MAKING \$4⁰⁰ to \$6⁰⁰ an hour!

Sharpening Lawnmowers in Spare Time With the "IDEAL" Lawnmower Sharpener

Man, Why Don't You Do That? You've got the chance—the same chance as W. T. Moore, Twin Falls, Idaho, who made \$1200 net profits in 90 days—the same chance as Walter Wever, Middletown, N. Y., who made \$1000 in 4 months—the same chance as hundreds of others who have reaped rich rewards with this amazingly efficient lawnmower sharpener.

Use Your Spare Time. If you work at a trade, put an Ideal in your basement and earn \$4 to \$6 an hour evenings and Saturday afternoons. E. W. McCormick, Saginaw, Mich., writes: "Five years ago I bought an Ideal Sharpener on which I have ground over 5,000 lawnmowers. In the last few weeks I worked at my trade, machinist, full time 9 hours a day. I also ground 97 mowers which netted me \$114.10 clear gain."

You Make Money Right Away—Geo. E. Kearney, Stillwater, Minn., writes: "We set the machine up 2 weeks ago Friday; since that time have sharpened 102 mowers." That's close to \$200 in Kearney's pocket for 2 weeks' work.

Our Free Book Tells You How—these men and many others have made themselves independent—built substantial permanent BIG PAYING businesses with this Ideal Grinder. Send for this book today—It's Free.

The Fate-Root-Heath Co., 918-944 Bell St., Plymouth, O.

SIGN THIS AND MAIL TODAY

FREE BOOK TELLS HOW OTHERS DO IT!

The "Ideal" Lawnmower Sharpener is a wood-fully simple machine that sharpens all makes of mowers perfectly, scientifically, without taking the mowers apart. Just pick up the mower, set it in the "Ideal", make a few simple adjustments and proceed to sharpen. In 15 minutes the mower is ready for the lawn, and you have made \$1.50 to \$2.00—depending upon the charge you fix. No training required, and machine set up in a few minutes. Plug into light socket and start to sharpen. Hundreds of dull mowers in your locality are waiting to be sharpened. Owners are looking for a place to get them sharpened. No town too small. R. S. Newcomer, Vinton, Ia., writes: "People come from miles around and other towns to get their mowers ground." The Ideal earns money the year 'round, too. Sharpens skates—all kinds—perfectly. C. S. Coburn, Little Rock, Ark., writes that his "Ideal" sharpener earned enough in 18 months to pay for itself and \$157 worth of additional machinery.



The Fate-Root-Heath Co.
918-944 Bell St.,
Plymouth, Ohio.

Send me the book that tells me how I can make my spare time worth \$4 to \$6.00 per hour.

Name.....

Address.....

POCKET BEN—The Westclox Watch

Built by the makers of Big Ben and other Westclox.

Sold everywhere. \$1.50



\$15 A Day Making Doughnuts Men or women. No experience needed. Put dough in hopper—turn crank—out drop delicious golden doughnuts. Machine in store window attracts crowds. You take in money fast. Or start at home, spare time. Sell to grocers, restaurants, homes. Use Prepared Doughnut Flour. (Simply mix with water.) This machine also makes delicious potato chips. Write for FREE plan. C. A. BUTLER, 233 N. Taylor Ave., Oak Park, Ill.

Still Greater Bargains in Boice Machines

Boice-Crane, the world's largest builders of small bench machines, now offers you the very greatest bargains in their 14 years' experience. Fifteen different Boice-Crane Machines. Unsurpassed quality and capacity. Seven choices of 2, 3, 4, or 5 machine workshops completely motorized and with individual machines. Practical, fully capable, no attachments to change. Astonishingly low priced at \$48, \$70 and up.



4" Handi Jointer

Tables 20" ground and polished. Planes 1 1/4"x4". Fence tilts 45 deg. both ways. Improved rabet arm. Bronze bearings. Safety guard \$3. **\$25**



12" Band Saw

Table 10"x12", tilts 45 deg. Cuts 4 1/2" deep. Bronze bearings. Copied after our famous 14" band saw. Guards, \$8. Sturdy construction. (Without motor or guards.) **\$35**



Universal Handisaw

Table 15"x17", tilts 45 deg. 8" saw cuts 2". Elevates for dadoing. Always accurate. Pulley between bronze bearings. Attachments for dadoing, jointing, disc & drum sanding, boring, thickness planing, grinding. Wgt. 60 lbs. Big value. **\$30**



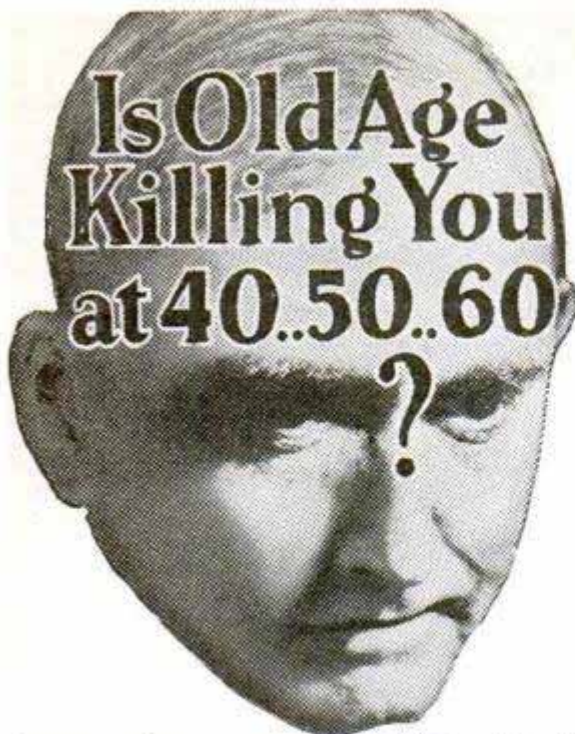
Jig Saw

Table 8" dia., tilts 45 degrees. Ground smooth. Vertical stroke 1 1/2". Capacity 10" to frame. 6 sizes of blades, 1/2" to 3/4". Speed 600 R.P.M. **\$12**

5 Models of Lathes
for turning wood and metals
\$13.50 and up

W. B. & J. E. Boice
Toledo, Ohio Dept.
P.M. 2-E

Send 10c for Boice-Crane's new 1929 catalog of 80 pages. Describes books of designs and instructions containing 450 designs of furniture, toys and puzzles. Investigate Boice-Crane bargains in machines and workshops before you buy.



Are you aging too soon . . . getting up 5 to 10 times at night . . . is vitality ebbing steadily away . . . are you definitely on the down grade, half-living, blue, depressed, subject to chronic constipation, chronic fatigue, backache, foot and leg pains? Then look to the vital prostate gland.

New Facts About the Prostate Gland

In men past 40, do you know that these symptoms are often the direct result of prostate gland failure? Are you aware that these symptoms frequently warn of the most critical period of a man's life, and that prostate trouble unchecked usually goes from bad to worse . . . that it frequently leads to years of fruitless treatment and even surgery . . . that it even threatens life itself?

FREE to Men Past 40

No man past 40 should go on blindly blaming old age for these distressing conditions. Know the true meaning of these symptoms. Send for a new, illustrated booklet, "Why Many Men are Old at 40," written by a well-known American Scientist, and see if these facts apply to you.

Natural Method

There is little or nothing that medicine can do for the prostate gland. Massage is annoying, expensive and not always effective. Now this scientist has perfected a totally different kind of treatment that you can use in your own home. It employs no drugs, medicine, or violet rays. It stimulates the vital prostate gland in a new natural way, and it is as harmless as brushing your hair. 50,000 men have used it with remarkable results.

Swift Natural Relief

Now physicians and surgeons in every part of the country are recommending this non-medical treatment. So directly does this new safe treatment go to the prostate gland that noticeable relief often follows overnight. So remarkable are the results that you can test it under a guarantee that unless you feel 10 years younger in 6 days you pay nothing.

Scientist's Book Free

Send now for this Scientist's free book and learn these new facts about the prostate gland and old age ailments.

Simply mail the coupon to W. J. Kirk, president, 2114 Morris Ave., Steubenville, Ohio.

[If you live West of the Rockies, mail your inquiry to
The Electro Thermal Co.
303 Van Nuys Building, Dept. 21-P
LOS ANGELES, CALIF.]

W. J. Kirk, Pres., 2114 Morris Ave.,
Steubenville, Ohio.

Without obligation, kindly send me a free copy of "Why Many Men are Old at 40."

Name

Address

City State



VEST POCKET FLASHLIGHT

(Size: Height, 2 3/4" — Width, 1 3/8" — Depth, 11/16")
A dainty, exquisite and caseless flashlight that is durable and practical. Lasts an amazingly long time. Lights as top snaps open. Go to the nearest dealer and buy one today.


Silvery and
Sparkling
Designs in:
Red Blue
Green
Brown
Black

A COMPLETE FLASHLIGHT
39¢
NOTHING ELSE TO BUY

Sold in these
Stores:
Drug
Hardware
Electrical
Automotive
Department
and many
others

BURGESS BATTERY COMPANY
General Sales Office: Chicago
Manufacturers of Radio, Ignition and Flashlight Batteries

BURGESS SNAP LITE FLASHLIGHT

Keds At \$1.00, \$1.25, \$1.50,
\$1.75 and up to \$4.00. 
United States Rubber Company

NEW DISCOVERY Grows Hair Quickly!

Noted surgeon has discovered amazing way to grow hair called Dermo-Ray. Employs Infra-Red Rays. In thirty days no more dandruff. Scalp tissues given new life. Then within a few weeks luxuriant new hair! Two years ago the discoverer was himself bald. Today his hair is full and thick. Sent on Free Trial. Results or no pay. If you have electricity in your home write at once for Free, startling, thirty-two page booklet. Address the **LARSON INSTITUTE 216 North Wabash Ave. Dept. 438 Chicago, Ill.**



"Height Increasing"

Is Report of Hundreds

Results have been remarkable. Letters from all over tell of decided height increase gained in a few months. They tell of improved health, more pep and life, greater efficiency, more joy in living because of better physical condition. Nothing like our course. Based on sound, proven, scientific principles.

No Drugs—No Dope

We have no magic medicine to sell. Only a system of simple exercises and special diet, assisted by a simple apparatus. Takes but a few minutes each day. The Glover system helps overcome the flattening of the vertebrae and the sagging of the supporting muscles. Permits cartilage cushions in spinal column to expand. Strengthens muscles. Stimulates nerves. Results have been permanent because based on true physiology. Unusually successful in under-developed young men and women.

EASY—INEXPENSIVE—CERTAIN
Write today for FREE Information
GLOVER INSTITUTE — Dept A17
508 S. Dearborn St. Chicago, Illinois



A \$100 SHIP MODEL FOR \$4⁹⁸



You can put a beautiful Ship Model together in a few hours of pleasant pastime

Let the World's Largest Builders of Ship Models supply you with all the necessary parts cut to fit and ready to put together for the models, Santa Maria, Mayflower, or LaPinta. You need not know anything about ship building to assemble one of these models. If you have never seen a ship model you can put one of these models together in a few hours by following our diagram and instruction sheets which explain and show you exactly what to do with each part. All you need is a small tack hammer to tap the parts in place. The diagram making it impossible for you to go wrong. These models when completed are exact in every detail of the famous old ships they represent, and when completed will add a distinctive touch to your home. We also have parts for the model for the Constitution at \$6.98; all other models listed at \$4.98 each.

\$ **4⁹⁸**

SANTA MARIA

25" High; 11" Wide; 27" Long

Write for our beautiful illustrated booklet containing photos and information on all of our models.

Miniature Ship Models, Inc.,
Dept. PP-3, 3818-24 BARING STREET
PHILADELPHIA, PA.

MINIATURE SHIP MODELS, INC., Dept. PP-3,
3818-24 Baring Street, Philadelphia, Pa.

Please send me the complete parts cut to fit and ready to put together for the Model.....
I will pay postman..... plus a few cents postage.
Please print name and address plainly to avoid delay.

Name.....
Street or R. F. D.
City.....
State.....




HB PAINT SPRAY DOES THE WORK OF FIVE MEN

"Paint Spraying Brings Quick Easy Profits"

HB does the work of five brush painters. One man can do the work of five painters with brushes with an H B Portable Paint Spray. Does automobile painting, furniture refinishing, house painting inside and out, at prices no one can touch, with high profits for yourself. **Pays for itself—Only \$30 monthly.** Easy payment terms brings it to you with practically no investment. **Thirty Days' Trial.** Write for valuable booklet, Hobart Bros. Co., Box M292, Troy, Ohio

EASY TERMS. 30 DAYS TRIAL. QUICKLY PAYS FOR ITSELF.



A PERFECT LOOKING NOSE
Can Easily Be Yours

Trados Model No. 25 corrects now ill-shaped noses quickly, painlessly, permanently and comfortably at home (excepting cases caused by improper bone structure). It is a safe and guaranteed patent device of precise adjustment that will actually give you a perfect looking nose. Over 90,000 satisfied users. For years recommended by physicians. 16 years of experience in manufacturing Nose Shapers is at your service. **Model 25 Junior** for children. Write for testimonials and free booklet, which tells you how to obtain a perfect looking nose.

M. TRILETY, Pioneer Noseshaping Specialist
Dept. 3070 Binghamton, N. Y.



AGENTS! SELL SHIRTS

Bostonian

Start without investment in a profitable shirt business of your own. Take orders in your district for nationally-known Bostonian Shirts. **\$1.50 commission** for you on sale of 3 shirts for \$6.95—Postage Paid. \$9 value, guaranteed fast colors. No experience needed. Complete selling equipment **FREE!**

GOOD PAY FOR HONEST WORKERS

Big earnings for ambitious workers. Genuine broadcloth in four fast colors. Write for money-making plan, free outfit, with actual cloth samples and everything needed to start. Name and address on postal will do. Write **TODAY! SURE!**

BOSTONIAN MFG. CO., Dept. B-126, 89 Sackford Street, Boston, Mass.



Play Tunes the First Day

Prove It Yourself

WITH an easy-playing Conn instrument and new instruction methods, you play tunes very first day. No long drudging over scales and exercises. **You begin to enjoy the instrument from the start!**

Prove this yourself. It has been done by thousands of others. Select the Conn instrument which interests you most—any one used in the band or orchestra. Then get it for a free trial in your own home.

EASY PAYMENTS, if desired, when you decide to buy. Remember, Conns are world-famous for easy playing and for their musical quality. Yet they cost no more. Send the coupon today. No obligation.

CONN BAND INSTRUMENTS
WORLD'S LARGEST MANUFACTURERS

C. G. Conn, Ltd. 231 Conn Bldg, Elkhart, Ind.
Send free literature and details of trial offer on.....[Instrument]

Name.....
St. or R.F.D.....
City.....
State, County.....



T. R. F. CIRCUIT

5 TUBE SETS \$14⁹⁰

IN BEAUTIFUL CABINETS

THE MOST ASTOUNDING OFFER EVER MADE IN RADIO

Guaranteed for Tone Quality and Selectivity

If, after trying out one of these sets, you do not feel that this is the MOST WONDERFUL BUY you ever saw in a radio set, we will cheerfully refund your money in full. These sets were taken in trade by dealers for all electric sets. The dealers, having been loaded with these used battery operated sets, Liquidated. We purchased them for spot cash at a tremendous sacrifice. Therefore, the reason for the ridiculously low price we quote. All sets tested before we ship, and guaranteed perfect. Orders will be filled in the order that we receive them. **ACT AT ONCE**

Complete Equipment for 5 tube sets \$14.75 more. This includes tubes, speaker, batteries, and aerial kit.

Used 5 tube sets, \$9.90. In table model cabinets. T. R. F. circuit. Require slight repairs. Crosley cone units, \$2.00. UX226 A. C. tubes, \$1.00. UX227 tubes, \$1.75. Fully guaranteed UX280 eliminator tubes, \$1.75. 201A tubes, \$.60. Glo dials, \$.85. Radiola loop antennas, \$1.65. 2 Mfd. Western Electric condensers, \$.65. 30 henry chokes, \$.90. Battery cables, \$.25. Panels, 6 x 10½, \$.25. Speaker plugs, \$.20. Rheostats, \$.25. Condensers, \$.50. Transformers, \$.75.

Send money order with order.

CHAS. HOODWIN CO., Dept. H, 4240 Lincoln Ave., Chicago, Ill.
DEALERS IN BANKRUPT STOCKS

Makers of High Quality
Condensers and
Resistors

AEROVOX

Built Better
TOM WASHINGTON ST. BROOKLYN N.Y.

Write for
THE RESEARCH
WORKER—A FREE
MONTHLY PUBLICATION.

SOLDERALL

METAL IN PASTE FORM

The
only
convenient
metal
solder



Every Electrical
Connection needs
Solderall for perfect reception
25¢
The SOLDERALL CO., NEWARK, N.J.



Ford Owner Stop that ruinous chatter on your ear. **MAKE THIS TEST**—take out your floor boards, pull your emergency brake back and forth. If you notice play at the ball joint, you need Bredar's Ball Shim. Price \$1.50. Ask your Dealer or order direct. Demand Bredar's Shim.
NIC BREDAR'S SON MFG. CO., Rock Island, Ill.

FREE 1929 WHOLESALE RADIO CATALOG

Dealers—Set-Builders—Write today for this 1929 Wholesale Catalog containing hundreds of money-saving "specials". Over 2,000 items. Complete lines of Radio Sets, Cabinets, Tubes, A & B Eliminators, Speakers, Parts at prices that mean **BIG SAVINGS!**

Complete Television Section

Latest television equipment. A. C. Sets, Short Wave Receivers, Dynamic Speakers also listed. Write Now—Dept. 34

BENSON-ALLEN, Inc., 456 So. State St. CHICAGO, ILL.



64
PAGES
OF
BARGAINS

SCORES OF MONEY SAVING BARGAINS

Devitt's eight-inch Combination **Circular Saw Outfit \$30.00**

F. O. B. Philadelphia. Before buying elsewhere write for descriptive circular and 136-page builders' hardware and tool catalog.

Paul J. Devitt, 1104 S. Second Street, Philadelphia, Pa.

Build Your Scale Model Airplane the IDEAL way!

IDEAL Models are accurate, scale-reduction copies of famous Airplanes; perfect duplicates in appearance and construction details, with many realistic parts and fittings not found on other models. They make long, perfect flights and are controllable by movable ailerons, elevators and rudder. Build an IDEAL Model—it's the easiest, quickest and safest way to construct a strong, reliable Model that is guaranteed to fly correctly.

"SPIRIT OF ST. LOUIS" shown at left. 3 ft. Model. \$7.50
Complete Construction Outfit

Also Models of FOKKER, DEHAVILLAND, CURTISS and other aircraft. Ask Your Dealer for IDEAL Model Airplanes, or send for our catalog.

Plans for Model Airplanes—25c Each

Accurate, ¼-size Plans, with Building-Flying Instructions for any one of the following: New York-Paris; FOKKER; DeHavilland; Curciss; NC-4 Seaplane; Bleriot, Taube or Nieuport Monoplanes; Cecil Peoli Racer—25 cents each. Catalog Free with Plans.

64-page Catalog—5c

Biggest, best listing of everything for building all kinds of Models; also much other Aviation information. Send for yours now!

IDEAL AEROPLANE & SUPPLY CO., Inc.

Headquarters for 18 Years!

26 West 19th Street

New York City



WE PAY FREIGHT

PRICE INCLUDES

all highest quality lumber cut to fit, doors, windows, stairs, interior woodwork, lath, shingles, hardware, glass, paints, nails, etc., complete. Plans FREE. Materials fully guaranteed. Monthly payments if desired. Freight paid east of Mississippi River and north of Mason-Dixon line, also to Minnesota, Iowa, Missouri.

BUY AT WHOLESALE!

Get all materials direct from mill and save \$300 to \$1,500 on your home! Mill-cut lumber saves you 40% labor, 30% on materials. Not portable. Sturdy, substantial, permanent homes. 32 years' square dealing behind Liberty guarantee. Amazing new plan—examine materials 5 days on your own lot before you pay!

"I Saved \$1,000 on House and Garage"

says Mrs. Coombs. "Believe I saved \$500 by buying from you," writes B. A. Anderson. Mr. Davis saved "between \$1,000 and \$1,500" on his Liberty home. You can do as well. Get new Book of Homes with full details. Address:

LIBERTY HOMES
LEWIS MFG. CO.
Dept. 122 Bay City, Mich.

The Lafayette: 6 rooms, bath, 2 closets, hall. Price \$895. Others at \$386 to \$1536.



ONLY \$895

Complete

NO EXTRA CHARGES

FREE Handsome Big Book of Homes

37 plans—full color photographs—amazing values from \$386 to \$1536. Practical—Beautiful. Mail Coupon Today.



Liberty Homes, Lewis Mfg. Co., Dept. 122, Bay City, Mich.

Please send me your new book of Liberty Homes, also complete details of your plan, FREE.

Name.....
Address.....
City..... State.....



Is Tobacco Harmful? FACTS AMAZING!

It Kills Thousands, Physicians Say

Prominent physicians who have studied the effect of tobacco on the human system, over a period of years, tell us that thousands of men and women die prematurely because of the use of tobacco. As Dr. D. H. Kress states: "Tobacco is a deadly poison. It kills its user slowly. Some may live to old age in spite of its use, but none because of its use."

Look, Feel and Sleep Better By Stopping the Use of Tobacco

If tobacco is a deadly poison, as medical scientists say, then common-sense tells you that once this poison is eliminated from your system you will be healthier and stronger, and in better shape mentally and physically. No question about it! Today is the time to stop this injurious habit.

Keeley Treatment Successful for More Than 50 Years

It is the safest and most reliable, for it is the only one that has been tried and tested for over half a century. Heavy, inveterate tobacco users are amazed at the ease with which it enables them to stop the use of tobacco—without inconvenience or unpleasant effects. It is wonderful, simply wonderful. Will you try it?

Your Treatment Is the Best, Easiest, Quickest and Surest, Users Say

The Keeley Treatment is a scientific medical treatment that acts directly upon the nervous system. It stops, quickly, the irresistible craving of the nerve cells for tobacco—tends to restore to these cells their natural condition before they had been poisoned by tobacco.

Thousands Have Taken Keeley Treatment

The Keeley Treatment seldom fails. That's why we can guarantee it without qualifications. If it does not work in your case, the treatment costs you nothing. You get your money back at once, without quibble, question or red tape.

Investigate! Get the Facts

If you use tobacco in any form, by all means find out what The Keeley Treatment has done for many, many thousands of men and women. Send for Free Booklet and Special Offer at once. Write today... This very instant.

THE KEELEY INSTITUTE, Dept. A-918 Dwight, Illinois

FREE BOOKLET!

This booklet contains facts and facts only. It tells you of the conclusions reached by not one physician, but scores of medical authorities, who have studied the effects of tobacco upon the human system.

Tells You Everything

If you use tobacco in any form, by all means get this booklet. It is free. Let us send you a copy at once, also our special money back guarantee offer. Write today without fail.

No Tobacco Since

1921—"I am writing you in regard to your Tobacco Treatment, which I have taken and which your records of the year 1921, October will show. I am absolutely cured and have been recommending it to my friends, and have given all the literature I had to them. Several would like to take it (The Tobacco Treatment), so I am sending you their names and trust they will be your future customers."

1924—"I took your treatment in 1924 and am more than pleased that I did so. I had used tobacco for over 20 years, and your treatment was certainly well worth what I paid for it."

1925—"You will find enclosed P. O. Order for which send the Tobacco Treatment to address below. I took your treatment for tobacco four years ago, and have never used any since, and also through my influence, Harvey Holmes, and Olen Brown took it, and they have never used tobacco since." The following letter is also typical of many thousands in our files: "About 18 months before I sent for your Home Treatment, I bought a treatment from another Company, and it didn't help me any. So have been trying different tobacco medicines, until I found out about yours. I've used yours and it was the only one that has cured me."

TOBACCO HABIT STOPPED

or MONEY BACK - write Quick for Special Offer



On a new principle—keeps both needle and lead vertical—no digging in the paper. Accurate settings right on the beam. Makes circles up to eight inches across—yet fits easily in your vest pocket.

Only 50c—at your stationer's, or direct prepaid, from Esterbrook Pen Company, Camden, New Jersey.



CAMPBELL'S

INFRA-RED RAY LAMP

Have You Some Troublesome Ailment?



Infra-Red Rays relieve congestion or troubles causing aches and pains in the body. The Campbell Infra-Red Ray Lamp concentrates a mild beam of Infra-Red Rays upon any part of the body.

These rays penetrate deeply into the tissues. As they penetrate they create an active circulation of the blood. Most ailments are due to congestion—relieve the congestion and you relieve the ailment. Nature herself does the healing by active, normal blood circulation.

Why Suffer Needless Pain?

If you or some friend have a troublesome ailment, a lamp like this is a blessing. May be used safely by anyone.

Relieve bronchial trouble, Neuralgia, Neuritis, Rheumatism, Lumbago, Flu and many other ailments.

Tell Us Your Trouble

Get Our Book on Infra-Red Rays

Quotes leading authorities as well as users Infra-Red Rays have brought wonderful results for others. Let us send you their letters. Write today for our book giving details.

THE WILLIAM CAMPBELL COMPANY
1040 Union Avenue • Alliance, Ohio

STARTLING INVENTION → **ADDING PENCIL** ←
MONEY MAKER Turn spare time into money just showing it to friends. Get sample and literature now
ADD-O-GRAPH CO., Dept. 24. SALTILLO, MISS.

"Blue" the Harmonica "No-hands"
 Be a "one-man-band!" Play harmonica "no-hands" with ukulele, banjo or guitar! Amaze your friends! 50¢ (Money Order) brings instruction book and songs, blues etc.
HARRY MONICA, Box 252, Dept 3, WOONSOCKET, R. I.

BUICK 4door SEDAN **4 CARS GIVEN**

Puzzle fans attention: J. C. Long, Charles Vogtmann, Mrs. J. E. Fields, Viola Javins, Alvin Smith, Mrs. John Gillies, Jacob Brancher, each won sedans in our last auto puzzles. Over 800 prizes awarded in one year. Over \$11,000.00 in prizes paid by us in October, 1928. In next few months will award between 300 and 400 prizes through our puzzles. Here's the new one for you.

FIND THE "DIFFERENT" AUTO

The cars in the oval all look exactly alike at first glance. They are not all alike. One is different from all the others. There is a real difference. Something is purposely left off all the other cars but this one. The difference may be in the fenders, bumper, nameplate, radiator or top. The one that is "different" is the real Buick Sedan I am giving away in addition to three other cars in my great friendship advertising campaign. If you can find the different careful instructions will be sent you.

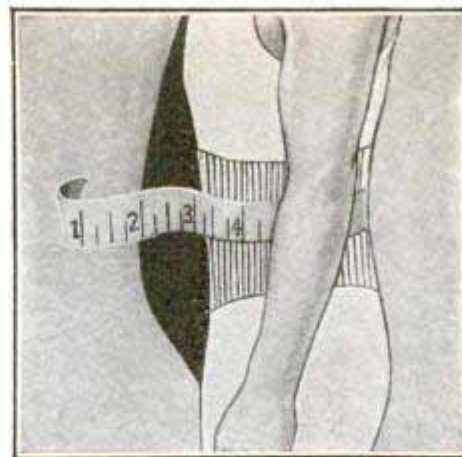
WIN BUICK SEDAN OR \$1800.00 CASH

4 sedans and 28 other prizes totaling over \$5,000.00. 32 prizes and duplicate prizes paid in case of ties. Immediate quick action—no delay—we send certificate for \$480.00 to add to the first prize at once if you win and directions for getting Buick Sedan. We spend over \$150,000.00 this way each year to advertise our products locally.

NO MORE PUZZLES TO SOLVE. No lists of words to make or write or any other puzzles. This is all. Everyone rewarded if actively interested. No cost. Nothing to buy now, later, or ever. Just send the number of the "different" auto in a letter or on a post card. That's all, send no money.

B. H. France, Dept. 498
500 N. Dearborn St.,
Chicago, Ill.

Send No Money! Reply to-day! **\$480.00 for Promptness!**



Free Proof That WAISTLINE FAT Can Be Quickly Reduced —without drugs, diets or exercises

INSTEAD of wasting your time—instead of risking your health by weakening diets, exhausting exercises and pill-taking, in an effort to get rid of bulging waistline fat—try the popular Weil Reducing Belt for 10 days—at our expense.

Made of scientifically treated rubber it causes a gentle, unnoticed massage action as it comes in contact with flabby flesh. So that with every move you make unwanted fat is being moulded away—and kept away for good—and at a fraction of the price charged by expert masseurs.

Look Thinner Instantly!

Take your waist measurement before and after this Free 10-Day Trial. Note the difference in inches. Feel the improvement in your general condition. According to the terms of our absolute guarantee, you must be thoroughly satisfied with the results secured—or you pay nothing.

Coupon Brings Free Details

Write us at once and you will receive our Special 10-Day Trial Offer—a detailed description of this most successful reduc-

ing method, the principles of which are highly endorsed by leading physicians and professional athletes everywhere. For the sake of your health and appearance take advantage of this offer at once. Send no money. Write now. The Weil Company, 92 Hill Street, New Haven, Conn.

THE WEIL COMPANY,
92 Hill Street, New Haven, Conn.

Gentlemen: Please send me complete description of the Weil Scientific Reducing Belt and also your Special 10-Day Trial Offer.

Name.....

Address.....

City.....State.....

UP-TO-DATE HOME CRAFTSMAN SHOP

For the handy man or boy who enjoys working with well equipped electrically driven wood working machinery!

The Up-to-Date Home Craftsman Shop is complete in every detail and is exactly such an equipment. It is driven by a Super-Power $\frac{1}{2}$ H. P. Electric Drill. The lathe, circular saw, and jig saw are all well constructed and real wood working

tools. Each purchaser of a Craftsman Shop is given free of charge a 12 month course in Wood Craftsmanship, and 27 well designed blue prints of various pieces of furniture, toys and models.

Full details and illustrations sent without obligation. A 10 day free trial is given. Can be purchased on Monthly Payment Plan—Write to-day!

12" Band Saw

Perfection in design and construction, this wonder working band saw is positively the greatest value ever presented to the home or shop mechanic. Send for details. May be purchased on Time Payment Plan.....\$39.00

\$35.00

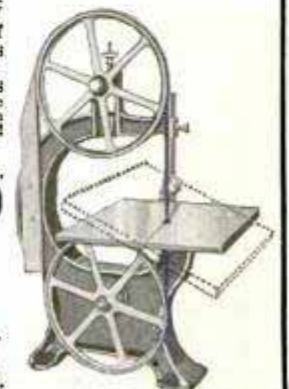
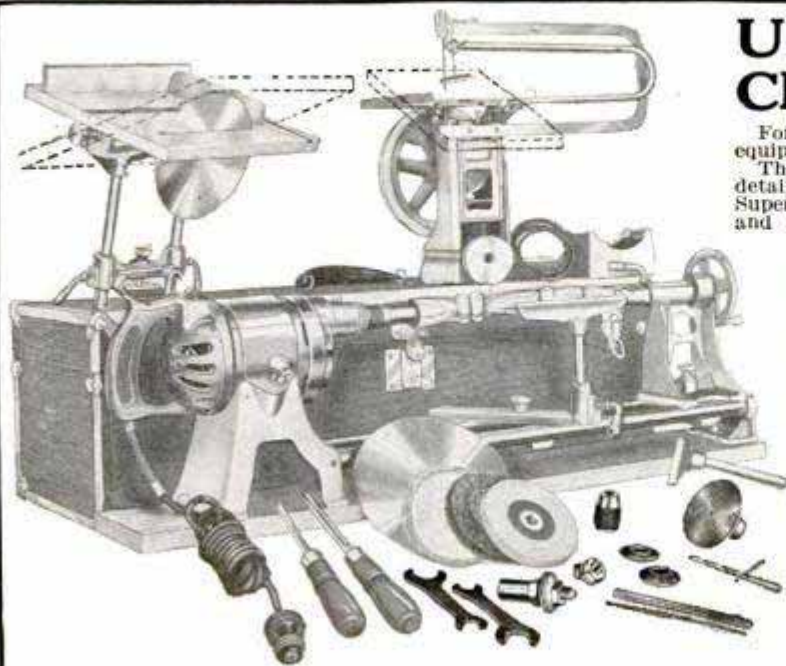
F. O. B.

Chicago

Write NOW!

To Manager Department No. 30.

UP-TO-DATE MACHINE WORKS
2915 So. Wabash Ave. Chicago, Ill.



Ring Up \$150 to \$300 MONTHLY PROFIT

With an
HB
8-Hour
Battery
Charger



Mechanics, garages, battery shops and filling stations are all adding tremendous profits this season with this new 8-Hour Battery Charging Business. Practically no expense or investment required. No special experience necessary. 8-Hour Service gives you a big advantage over other shops; saves 30% to 50% on electric bills over rectifiers. Find how easily you can have these profits by checking No. 1 below.

Only \$16 Monthly Easily Paid by Increased Profits

FREE AIR SERVICE



For only \$12 Monthly for a few months you can have the advantage of Automatic Air Service bringing customers to your door. Beltless, Silent, Ball Bearing. Lowest prices for such quality equipment. Get full details without obligation by checking No. 2 below.

HB TEST BENCH

Best paying equipment for automotive electrical work. Tests starting, lighting, ignition systems. Brings you business from other shops. Priced \$100 to \$150 below similar quality outfits. Write today for full information without obligation. Check No. 3 below.



PAINT SPRAY



Does the work of five men with brushes. Paints cars, furniture, houses, barns, garages. You can do better, quicker work at lower prices, yet make far more money than old time painters. No experience necessary. Investigate—Check No. 4 below.

HOBART  **BROTHERS**
Successful manufacturers ~since 1893~

BOX M29

TROY, OHIO

Tear off Coupon and Mail Today

HOBART BROTHERS CO.
Box M29, Troy, Ohio.

Send me complete information on the items I've checked with your 30 day trial offer, easy payment terms, and information on how HB equipment will increase my earnings.

1. One Day Battery Service Profits
2. Better Automatic Air Compressor
3. Electrical Test Bench Opportunities
4. Portable Paint Spray Business

Name.....

Address.....

CAMPBELL'S Electro- Magnetic Health Pad Will Purify Your Blood Stream



Pain is Nature's warning—don't ignore it. Such troubles as Arthritis, Rheumatism, Catarrh, Neuritis, Anemia, Lumbago, Backache, Run Down Condition and other diseases caused by impure blood—or any congestion—will be quickly relieved.

Campbell's Magnetic Health Pad when attached to an electric light outlet becomes a magnet and magnetizes the iron in your blood, making it able to transfer or absorb more oxygen and oxygen is recognized as a life-giving essential.

It Seems Like Magic

—but it isn't! It is simply Nature's way of purifying the blood. No drugs, no electricity touches you. It is Nature's way of starting the red corpuscles to work by supplying them with more oxygen from the air.

Let Us Send You Full Information—FREE

Write for free folder on Campbell's Magnetic Health Pad and tell us your trouble. It gives full description, instructions for use, how to order, etc. Also explains 30-day free trial. Get my special introductory offer.

THE WILLIAM CAMPBELL COMPANY
304 Union Avenue Alliance, Ohio

"Don't Shout"



"I hear you. I can hear now as well as anybody. 'How?' With the MORLEY PHONE. I've a pair in my ears now, but they are invisible. I would not know I had them in myself, only that I hear all right."

The MORLEY PHONE for the

DEAF

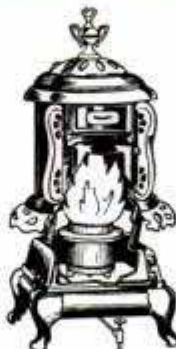
to the ears what glasses are to the eyes. Invisible, comfortable, weightless and harmless. Anyone can adjust it. Over 100,000 sold. Write for booklet and testimonials.

THE MORLEY CO., Dept. 781, 10 S. 18th St., Phila.

Enjoy the Convenience of

OIL HEAT

in Your Stove or Range



So easy, so safe, so dependable. A LACO No. 2 Oil Burner will give unsurpassed service in heating-stoves, parlor-furnaces, cooking-stoves or ranges. No soot, smoke or odor. Will not clog. Manufactures its own gas from liquid fuel.

LACO Oil Burners are Low in Cost

DEALERS

The New LACO No. 2 Natural Draft Burner can be used wherever you have a good draft. Has the patented LACO indestructible mineral wick, and many other mechanical advantages. Thousands in use. LACO No. 2 sells for only \$18.00. Other sizes proportionately low. Order direct from ad or write for descriptive literature.

LACO GAS BURNER CO.

116 Union Str.

GRISWOLD, IOWA

—FREE—
\$5.00 Book of Blue Prints
Showing 46 PRIZE PROJ-
ECTS with \$35 Outfits.

The S & B "Wonder" Famous Outfits

Money Back Guarantee

12" Band Saw

Sent to You on 15 days approval

Positively
a Sensation

S & B 8" Combination Saw

The only machine that
you can tilt the table to
45° without removing
insert. Big advantage on
pattern work.

18 TOOLS IN ONE

\$35
F. O. B.
CHICAGO

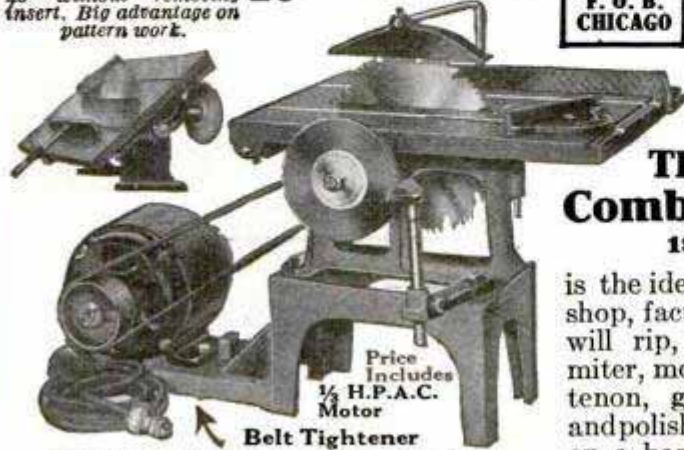
and at this LOW PRICE
you can NOW do the 1001
things you wanted quick
and easy. This 12" BAND
SAW has a tilting table,
with Miter and stur-
dily built. Ideal for
the shop or home.



\$35.00 F. O. B. Chicago
without Motor

The S & B 8-in. Combination Saw 18 Tools in One

is the ideal machine for the
shop, factory or the home;
will rip, cross cut, bevel,
miter, mortise, groove, drill,
tenon, grind, rabbet, buff
and polish. Motorismounted
on a base that is a part of
the machine proper. Run
from any light socket, also
provides power for other
purposes when the saw is not in use. Complete with attachments
and price includes 1-3 H. P. Motor, 60-cycle, 110-Volt A. C. **Price**
\$35.00 F. O. B. Chicago. Shipping Weight 100 lbs.
(Planer attachment to fit on table top will smooth pieces up to 2 in. wide, \$9 extra)



Price Includes
1/2 H.P.A.C. Motor
Belt Tightener
[1/3 H. P. Motor—40%—100% overload]
Double Shaft Extension

Greatest Machine You Ever Saw

Scroll Saw



Delights
Every
Boy

\$15.00

F. O. B.
CHICAGO
1/2 H. P. A. C.
Motor \$15 extra

Here is the outfit of practical
usefulness. Will cut wood and light
metal true to marks. Table top
tilts to 45 degrees, making it con-
venient and easy to cut at proper
angle. Thousands of jobs can
NOW be done by any man or boy
with the accuracy of a real me-
chanic. This S & B WONDER SCROLL
SAW is free from vibration.

S & B "Wonder" Lathe

The S & B "Wonder" Lathe Outfit is the biggest value in lathes you can find. Built
in our own shop we know it is right! Heavy channel iron bed makes lathe rigid and
prevents vibration. Head and tail stock in perfect alignment permits of fast and
accurate work. This lathe is built for long service and hard use. It carries the same
guarantee that our other machines do. Accessories to complete the S & B "Wonder"
Lathe (as illustrated) \$16.60 extra.

Write for Complete
Illustrated Folder—
Dealers Wanted

\$35
F. O. B.
CHICAGO

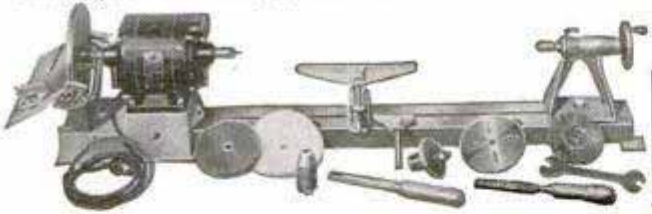
—MAIL TODAY—

Scott-Bansbach Machinery Co.,
130 So. Clinton St., Dept. 101, Chicago, Ill.

Please mail free particulars about your "Wonder"
Outfits.

Name.....

Address.....



SCOTT-BANSBACH MACHINERY CO.
130 So. Clinton St., Dept. 101, CHICAGO, ILL.

Don't Guess!

Radio success or failure is largely a matter of
knowing or guessing. And where all factors—
voltage, tubes, circuits, etc.—are not precisely
measured, you are guessing unless you supply
hand-fitted resistance.

CLAROSTATS take the guess out of radio. The Grid Leak
Clarostat is typical. It provides the precise grid leak value for
best results, particularly in short-wave reception.

And in obtaining correct resistance values for grid-biasing
and plate voltages, the Duplex Clarostat is a great favorite. It
has two resistances, with center tap, each adjustable by
means of ordinary screwdriver blade.

There are many other types of Clarostats for every radio pur-
pose, in many designs, mounting, and resistance ranges.

WRITE for literature describing
the complete Clarostat line.

CLAROSTAT MFG. CO., Inc., 286 N. 6th St., Brooklyn, N. Y.

CLAROSTAT
Reg. U. S. Pat. Off.

- M—Ships
- O—Power Boats
- D—Steam Engines
- E—Sail Boats
- L—Supplies



**SHIP
MODEL
MAKERS
H'DQUARTERS**

We can supply special construction sets, semi-finished hulls,
and all sorts of fittings such as anchors, blocks, deadeyes, belay-
ing pins, figureheads, guns, bells, ventilators, binnacles, bits,
chocks, davits, flags, etc., for Flying Cloud, Constitution,
Sovereign of the Seas, Half Moon, Spanish Galleon,
Mississippi River Steamboat and many others. Also construc-
tion sets for model power boats and model sail boats. Steam en-
gines, boilers, blow torch, propellers, couplings, etc. Special
materials such as 3-ply veneer, celluloid, rigging line, model
makers tools, etc. Our large 48-page, photographically illustrated
Booklet contains valuable information and hints for building
ship models in addition to prices and full descriptions of the
above articles. The finest ship model booklet published. A
copy will be sent postpaid upon receipt of 15c. (coin preferred).

Model Ship Supply Co. Dept. B Mineola, N. Y.



When Food Sours

Lots of folks who think they have "indigestion" have only an acid condition which could be corrected in five or ten minutes. An effective anti-acid like Phillips Milk of Magnesia soon restores digestion to normal.

Phillips does away with all that sourness and gas right after meals. It prevents the distress so apt to occur two hours after eating. What a pleasant preparation to take! And how good it is for the system! Unlike a burning dose of soda—which is but temporary relief at best—Phillips Milk of Magnesia neutralizes many times its volume in acid.

Next time a hearty meal, or too rich a diet has brought on the least discomfort, try—

PHILLIPS Milk of Magnesia



BABY STANDARD

MOVIE CAMERA

Make your own action movies of events, trips, parades, etc. Takes **\$13⁵⁰** F.O.B. Phila. 25 feet of standard film. Equipped with F.5 universal lens. Loads in daylight. Films developed free. Film can be projected from any standard projector.

Send 10c in stamps for illustrated booklet.

VICAM PHOTO CO. 1224 Belmont Ave. PHILA., PA.

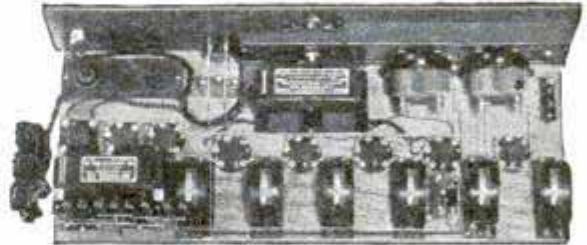
“Standard of the World”

A fitting title for

VICTOREEN

Super Receivers

The New Victoreen Circuit for 1929 eclipses all past achievements. It combines unparalleled sensitivity, selectivity and tone quality.



Perfected A. C. Operation

Until you have heard and used a 1929 A. C. Victoreen you cannot realize what a wonderful receiver it is. Stations that you have never heard before, together with all the old favorites, are at your instant command.

The heart of this master circuit is the Victoreen Super Transformer, vastly improved for 1929, tuned and matched to a precision of $\frac{1}{2}$ of one per cent. In addition, the Victoreen Circuit itself contains improvements far ahead of its time.

Complete Kits Available

Either A. C. or D. C.

You can assemble a Victoreen yourself, in a few pleasant hours. Write us for complete information. **Blue Prints and Assembly Instructions are FREE.** State whether you wish A. C. or D. C.

Victoreen Power Amplifier and “B” Supply

for Best Results from Any Receiver

FREE BLUE PRINTS, with list of parts and complete assembly instructions, will be sent upon request.

The George W. Walker Company

Merchandisers of Victoreen Radio Products
2825 Chester Ave., Cleveland, Ohio

EASY
\$100
a
Week



FUGO

FIRE EXTINGUISHER

Unusual opening for live agents in every locality. Make \$5000 or more a year—easily. Fugo—the instantaneous automatic fire extinguisher—is needed and wanted in every home, store, theatre, garage, shop, school, automobile, etc. Cheapest fire protection available today. Within reach of all.

1 Qt. Size \$5.00 2 Qt. Size \$7.50

Recharged in a jiffy
Amazing 30-second demonstration clinches sale—each one sold sells others. Territory going fast. Write at once for wonderful proposition that will make you big money.

THE NATIONAL FORMETAL CO.

6535 Metta Ave., N. E. Cleveland, Ohio

Will You Pay **\$95⁰⁰** a Year
for a **\$15,000⁰⁰** a Year
BUSINESS?



“From Nothing to \$15,000 a Year!”

No dream—but an actual fact! L. E. Berry, Barnesville, O., writes—“Have built a business up from nothing to \$15,000.00 a year. I owe my success to your Haywood plan.” Haywood proved plan has made over 16,000 men independent. Free training. Write at once for free book, “Steps to Success.”
J. A. Schreiber, Pres. HAYWOOD TIRE
EQUIPMENT CO., 2330-B Ogden Ave., Chicago



Enjoy the Thrill of Electrified RADIO at Small Cost!

Why discard your present good set when you can electrify it for only \$6.85, and also banish forever all the annoyance and expense of buying new "B" Batteries?

HEAR IT! TEST IT! COMPARE IT!



ONLY \$6.85 Complete

RESULTS

Eliminator bought from you more than eighteen months ago is still giving first class service, and I haven't had to touch it since I connected it to my set. It has given me the best radio programs I ever received on my five year old set and I wouldn't swap for the best all electric set made.
RALPH DUNHAM,
 Portland, Maine.
 Eliminator is just fine. Have had much better service than with batteries.
MRS. F. S. PARTRIDGE,
 Maryville, Mo.
 Your Eliminator has given excellent and satisfactory results. Also increased volume and improved tone.
E. J. LUKEN,
 Louisville, Ky.
 Your Eliminator has saved me \$20.00 in "B" batteries already.
THEODORE OLSEN,
 Ogden, Utah.

Electrified radio is what everyone wants now. Forget noisy, interrupted reception. You will see how easily you can electrify your set when you write us for proof and the truth about all electric radio.

OVER 100,000 TOWNSEND "B" POWER UNITS NOW IN USE

Hooked up in a few minutes. Use same tubes—No changes. You will be amazed at the improvement in reception. Pure, even tones. Crystal clarity. Plenty of volume. Surprising distance. Freedom from hum and line noises. New radio enjoyment.

TRY IT FREE!

We are so sure the Townsend will do all we claim for it that we give you the privilege of testing it out for ten days at our risk. A new radio joy awaits you. Don't put up with second rate reception any longer. You don't have to—when you can have electric reception with a Townsend "B" Power Unit for the astounding low cost of \$6.85. Mail coupon for complete information TODAY!

Approved and passed by the rigid laboratory tests of Radio News, Popular Radio, and Other Authorities.

TOWNSEND LABORATORIES, 2/29 Dept. 15, 713 Townsend St., Chicago, Ill.

Please send me full information on the Townsend "B" Power and Free Trial Offer.

Name.....
 Address.....
 City.....State.....

TOWNSEND LABORATORIES, Dept. 15, 713 Townsend St., Chicago, Ill.



BIG VALUE FOR 10 Cts.

6 songs, words and music; 25 Pictures Pretty Girls; 40 Ways to Make Money; 1 Joke Book; 1 Book on Love; 1 Magic Book; 1 Book Letter Writing; 1 Dream Book and Fortune Teller; 1 Cook Book; 1 Base Ball Book, gives rules for games; 1 Toy Maker Book; Language of Flowers; 1 Morse Telegraph Alphabet; 12 Chemical Experiments; Magic Age Table; Great North Pole Game; 100 Conundrums; 3 Puzzles; 12 Games; 30 Verses for Autograph Albums. All the above by mail for 10 cents, and 2 cents postage.
ROYAL SALES CO., Desk 319, Norwalk, Conn.

Save Your Feet

When all else fails, end your suffering with the **Heefner Arch Support No Metal**



Fully patented. Itre-adjusts the entire foot. Write for free book and statements from doctors and users.

Heefner Arch Support Co. 668 M. E. Taylor Bldg. Louisville, Ky.

Freed from Rupture

By a New Invention



TEST IT FREE

A new invention, so small that it cannot be detected beneath the closest fitting clothes, has been perfected; it retains rupture safely and with comfort and heals the rupture.

Dancers, athletes, sportsmen, society women and people who do hard, tiring work have been healed in this new way. It is so comfortable that regardless of the position you assume, it does not hamper the body movement.

Constructed of sanitary, non-irritating materials and assures absolute freedom from skin irritations. Send for Free Trial Offer, sent in plain, sealed envelope.

Brooks Appliance Co., 107-B State Street, Marshall, Mich.

10 Inches Off Waistline In 35 Days

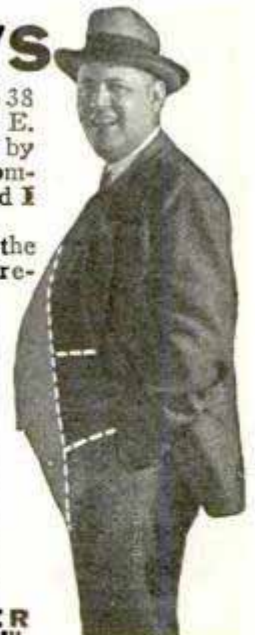
"I reduced from 48 inches to 38 inches in 35 days," says R. E. Johnson, of Akron, O., "just by wearing a Director Belt. Stomach now firm, doesn't sag and I feel fine."

The Director Belt gets at the cause of fat and quickly removes it by its gentle, kneading, massaging action on the abdomen, which causes the fat to be dissolved and absorbed. Thousands have proved it and doctors recommend it as the natural way to reduce. Stop drugs, exercises and dieting. Try this easy way.

Sent on Trial

Let us prove our claims. We'll send a Director for trial. If you don't get results you owe nothing. You don't risk a penny. Write for trial offer, doctors' endorsements and letters from users. Mail the coupon NOW!

LONDON & WARNER
 332 S. La Salle St., Chicago, Ill.



Landon & Warner, Dept. M-2, 832 S. La Salle, Chicago

Gentlemen: Without cost or obligation on my part please send me details of your trial offer.

Name.....
 Address.....

Choose *the* Instrument the Big Professionals Use



"I am happy to say that all the musicians in my present band use Buescher True Tone Instruments."

If you're interested in a musical instrument, you should choose the kind used by famous professionals--

BUESCHER

True-Tone

Musical Instruments

It is just as important that you have the right instrument as it is for the professional. Buescher instruments are the very finest it is possible to buy and have improved features no other instruments possess, yet cost no more.

The Buescher Saxophone is equipped with patented Snap-on Pads—easy to replace, with no more cementing. This is a great improvement for beauty of tone and a great convenience. Found only on the Buescher.

Easy to Play—Easy to Pay

Besides being unusually easy to play, we make it easy for you to pay for any Buescher Instrument, by our Partial Payment Plan arranged to suit your convenience. It enables you to play and earn while you pay.

6 Days' Trial in Your Own Home

on any Buescher Saxophone, Cornet, Trumpet, Trombone or other instrument. Fill out and mail coupon for full information. Mention instrument in which you are interested.

Buescher Band Instrument Co.

2708 Buescher Block

Elkhart, Indiana

BUESCHER BAND INSTRUMENT CO. (508)

2708 Buescher Block, Elkhart, Ind.

Gentlemen: Without obligating me in any way please send me your free literature.

I am interested in the following instrument.....

Name.....

Address.....

Open Your Own Auto Glass Shop

\$6000 TO \$15000 A YEAR

New specialized business. You can make \$1,000 a month by starting your own Auto Glass Shop, replacing broken glass in cars. Accidents increasing. Garages send you work. You continually get new customers. Big profits are easy. All you have to do is open your shop.

We Furnish Everything

You don't need to be an experienced garage man or a mechanic. We have compiled a series of special charts and instructions and complete information on how to open and operate your own Auto Glass Shop. You can learn at home and make money while learning. Don't miss this opportunity. Write at once for **FREE** Auto Glass Book and complete information.

AUTO-GLASS SHOPS, INC., Dept. 10
862 Teutonia Avenue MILWAUKEE, WISC.

Photos ENLARGED

Size 16x20 inches
Same price for full figure or bust, groups, landscapes, or pet animals etc., enlargements of any part of group picture. Safe return of your own original photo guaranteed.

98c

SEND NO MONEY Just mail photo or snapshot (any size) and within a week you will receive your beautiful life-like enlargement size 16x20 in., guaranteed fadeless. Pay postman 98c plus postage or send \$1.00 with order and we pay postage. **SPECIAL FREE OFFER** With each enlargement we will send FREE a hand-tinted miniature reproduction of photo sent. Take advantage now of this amazing offer -- send your photo today.

UNITED PORTRAIT COMPANY
1652 Ogden Ave. Dept. B-369 Chicago, Ill.



SPRAYIT

ELECTRICALLY New Agitator Type

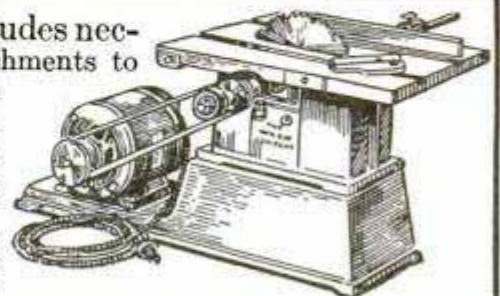
Revolutionizes paint spraying performance and results. Constant fluid agitation, instantaneous control of spray, many other new features. Hold 1-lb. gun only—put rotary compressor unit on floor or ladder. Price, \$39.50. Write for complete details.

THE ELECTRIC SPRAYIT CO. Inc.
202 East Colfax Avenue
South Bend, Ind.

8" COMBINATION SAW OUTFIT \$35

F.O.B. Phila.

Outfit includes necessary attachments to rip, cross-cut, bevel, grind, mitre, groove, sand, mortise, tenon, and polish. Table tilts to 45°



angle. Base for saw and motor makes it portable. Complete ready to plug into any light socket. Send for free folder of full details.

THE WILBAR CO., Inc. 2020 E. Arizona St.
PHILA., PA.

Charge It By Mail

SENT FOR \$1

NO C. O. D. TO PAY

Wear this standard American watch and take a full year to pay—Send \$1 with order and this watch comes to you prepaid --no C.O.D. to pay on arrival

FREE A FULL YEAR TO PAY

After examination and 10 day free trial, pay balance in 12 equal monthly payments. No interest. No extras. All transactions strictly confidential. You take no risk—satisfaction absolutely guaranteed or money back.

Established 1895

ROYAL DIAMOND & WATCH CO.

ADDRESS DEPT. 11-P 170 BROADWAY, N.Y.

BR1
Elgin or Waltham movement, hand engraved 20 year guaranteed gold filled case. \$2.12 a month. **\$26.50**

10 DAYS FREE TRIAL

Buy Later

First Make This Remarkable Test for 7 days . . .
Prove This Unique Shaving Cream's Supremacy . . .
Buy Only if Convinced. Mail Coupon Now.

Never Before a Motor Like This!

4 cylinders bring new thrills to outboard motoring. The Super Elto Quad drives racers better than 35 miles per hour — comfortable runabouts at 25 miles — cabin cruisers at 15 miles. Brings luxurious motor boating within reach of all. Send for catalog of Quad and other Super Elto models. Address, ELTO OUTBOARD MOTOR CO., Ole Evinrude, President, Mason St., Department AA, Milwaukee.

The Super Elto
Quad

GENTLEMEN:

Most manufacturers clamor for immediate sales. But we have found success in urging men not to buy. Rather, to find out at our expense if they like our product.

The great majority of men who make our test become regular users. Remember they, like you, were wedded to some other shaving cream before.

The coupon is for your convenience. Please send this one in. In fairness to yourself and to us.

How it was discovered

We asked 1000 men what their wishes were. They gave us four objectives.

To the 4 things men asked, we added a fifth. Today we believe Palmolive Shaving Cream is supreme for shaving comfort. Men tell us no other compares.

These 5 Things

The things you get in your 7-day test of Palmolive, are things you long sought:

1. Multiplies itself in lather 250 times.
2. Softens the beard in one minute.
3. Maintains its creamy fullness for 10 minutes on the face.
4. Strong bubbles hold the hairs erect for cutting.
5. Fine after-effects due to palm and olive oil content.

Now we ask a test

No doubt your present shaving preparation suits you—still there may be a better way. If there is you want to know it. So won't you let us prove, on your face, how excellent this unique product is? It's up to us to prove our point, you've lost nothing if we fail. Please mail the coupon now.

PALMOLIVE RADIO HOUR—Broadcast every Wednesday night—from 9:30 to 10:30 p. m., eastern time; 8:30 to 9:30 p. m., central time; 7:30 to 8:30 p. m., mountain time; 6:30 to 7:30 p. m., Pacific Coast time—over station WEAJ and 39 stations associated with The National Broadcasting Company.

With the new unbreakable Bakelite top

4240

7 SHAVES FREE

and a can of Palmolive After Shaving Talc

Simply insert your name and address and mail to Dept. B-1597, Palmolive, 3702 Iron St., Chicago, Ill. Residents of Wisconsin should address Palmolive, Milwaukee, Wis.

.....

.....

(Please print your name and address)

Chesterfield

The MILD cigarette that SATISFIES

RADIO CATALOG FREE!

WHOLESALE PRICES on standard radio equipment! Also special proposition on Lafayette Receivers. Get this latest 64 page book - a valuable radio guide - Absolutely Free! Nothing to compare with it. Confidential price list for dealers, agents and fans. All merchandise fully guaranteed. Write To-day for your Free catalog. **WHOLESALE RADIO SERVICE CO.** 6 Church St., Dept. 205, New York City

ITALIAN ACCORDIONS

Best in the world. 10-year guarantee, lowest prices. FREE instruction, ask for FREE catalog. RUATTA, SERENELLI & CO., 1014 Blue Island Ave. Dept M Chicago, Ill.

New! Wonderful!

Super-Eight (Coast-to-Coast) 100% Electric

8 TUBES—SINGLE DIAL RADIO

Shipped Direct from Our Factory on

30 Days Free Trial

Metrodyne

SUPER-EIGHT ELECTRIC

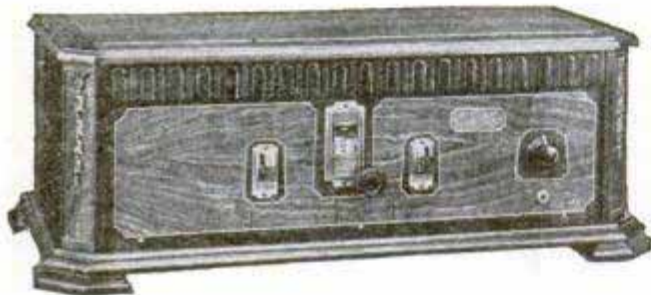
Metro's latest achievement—the world's greatest electric radio set. Powerful long distance 8 tube receiver—clearness of tone that is astounding—ultra-selective. Radio engineers pronounced it the ultimate for all-around perfection. To prove our claims we will send this marvelous set to you direct from our factory on **30 days' free trial**. Compare its quality, beauty and price with any other radio on the market, and decide to keep it only after you are satisfied that the new 1929 Metrodyne Super-Eight is the peer of them all.

Super Quality Throughout

Eight powerful tubes. Highest quality low loss parts. Illuminated single dial. Positive switch control—simply turn a knob and it's on. Select your stations with accuracy at any desired volume. Beauty of tone unsurpassed. Console and table cabinets are handsomely grained genuine walnut, hand rubbed, in two-tone effect—artistically carved trimmings. All metal parts finished in two-tone gold. Seeing is believing. **YOU WILL BE THE JUDGE.**



Gorgeous console with newest type, built-in sonorous speaker.



Metrodyne Radio Sets are Equipped for Battery or Electric Operation

Write Today!

Agents and Dealers

The 1929 Super-Eight line offers great money making opportunities. Nothing like them for high quality—nothing near them in price. Let us prove this by shipping you a **DEMONSTRATION SET** on

30 Days' Free Trial

Test it—compare it—demonstrate it to prospective radio buyers. Get our liberal discounts—exclusive territory—newspaper and billboard advertising offer that will help sell Metrodyne radios quickly.

Thousands of Metrodynes have been bought on our liberal free trial basis. We will send you hundreds of letters from owners who acclaim the Metrodyne as the greatest radio set in the world. A postal or letter brings complete information, testimonials, wholesale prices and our liberal **30 days' free trial offer**.

Metro Electric Company

2161-71 North California Avenue
Dept. 26, CHICAGO, ILLINOIS

Remarkable Metal Tile Offers Big Money

Beautiful tiled bathrooms and kitchens are now within the reach of all. Chromite, the astonishing tile wall covering, slashes all previous costs to one-third. Has all the glow, beauty, luster and permanence of clay tile. Greeted by exclamations of surprise and praise wherever shown. The sensation of the building material industry. No other product like Chromite ever offered before through direct selling. Homes, stores, institutions are eager buyers. A big money-making opportunity for a live, aggressive salesman. Write today for Free sales plan.

CHROMITE COMPANY

278 N. LaSalle St., Dept. P. M., CHICAGO

Write Now!



Looks Like Clay Tile

" COSTS 1/3 AS MUCH "

FREE

This handsome selling kit of actual samples is given Free to men who qualify as Chromite representatives.



SAVE 1/2

on plumbing, heating, hardware, paint, roofing and millwork supplies. Large quantity buying enables us to offer Grade "A" merchandise at great savings. Send today for free catalog—over 120 pages of enormous bargains.

STANLEY PLUMBING SUPPLY CO., Inc.
400 N. 12th St. Philadelphia, Pa.



Let us recommend the best books to study on any subject. Popular Mechanics Press, Chicago, Illinois.



Deafness OVERCOME

And perfect hearing restored in cases of deafness and poor hearing resulting from Flu, Scarlet Fever, Catarrhal Troubles, Blows, Explosions, Defective Ear Drums, Discharges, etc. Relief comes from the use of the tiny, invisible

Wilson Common-Sense Ear Drums

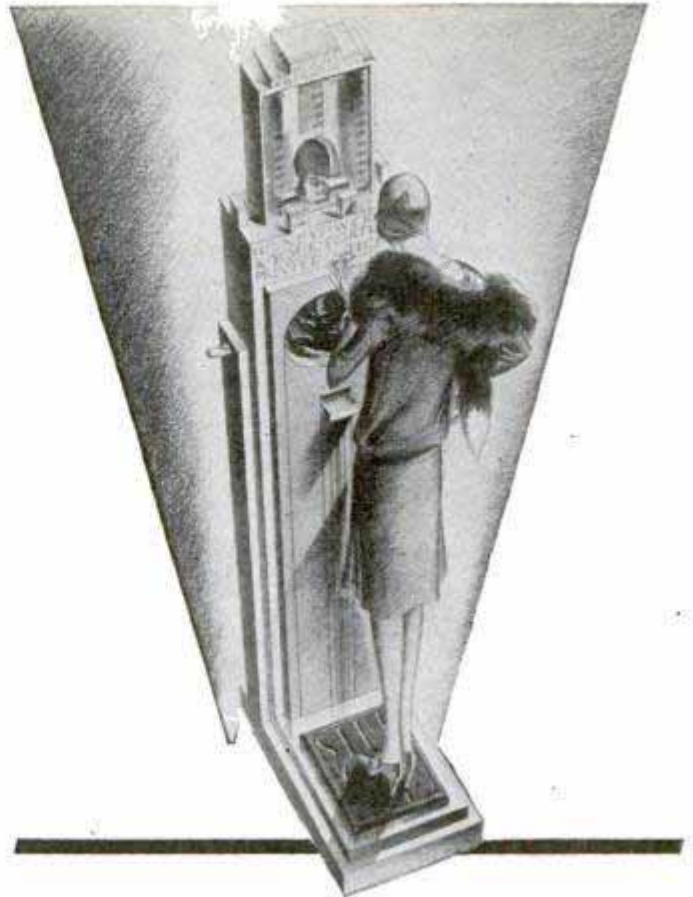
In use for 36 years by hundreds of thousands, the world over. They replace what is lacking in the natural ear drums, without medicines, operations, or being seen or felt. Easy for wearer to put in and remove without any discomfort.

FREE BOOK on deafness and copies of voluntary letters from many of the thousands of grateful users, will be sent postpaid by the **WILSON EAR DRUM CO. Inc.** 423 Todd Building, Louisville, Ky.

POINTING THE WAY TO FINANCIAL INDEPENDENCE

An amazing investment opportunity for those with a little money and some spare time.

This is the first opportunity for private individuals to participate directly in a proposition of this kind. It makes possible what is to all intents and purposes an investment, yielding a return of 25% annually the first two years, during which time the principal is enhanced 200%, and yielding 125% annually thereafter for years to come. • This investment is in the ownership of a chain of ticket-printing-personal-weighing-scales. You put out to work for you 50 or 100 or 1000 highly developed mechanical servants. They neither eat nor sleep. They take no days off. Day and night they work and serve you, smiling at interested passersby, holding their coats, while they step on inviting platforms, and then give them printed on a neat ticket their weight and fate for a small copper penny. • These mechanical marvels are the new International Ticket Scales—the modern personal weighing machines, and the fruit of 20 years experience in the manufacture and operation of penny operated scales. On location in drug and cigar stores and other places that others have determined are the places where people pass or



congregate in the greatest numbers, they earn and earn and earn, while you sleep or play. • We have prepared a booklet which outlines in detail, step by step, the way in which a chain of these new International Ticket Scales can be acquired and operated on a very unusual franchise plan. It tells how you, if you have the necessary qualifications, can with the greatest ease, assure your financial future. It is a booklet for those with a little money and some spare time; for the capitalist; for the individual or group who can control capital. Write for it today. The coupon below is for your convenience. • International Ticket Scale Corporation, 17 East 45th Street, New York, N. Y.

International

TICKET SCALE CORP., Department 101
17 East 45th Street, New York, N. Y.

Please send me your proposition.

Name _____

Address _____

To Chain Store Executives: An International Ticket Printing Scale in each of your stores will add a substantial amount to your net profits. For full information, write the Chain Store Manager of the International Ticket Scale Corp., 17 E. 45th St., New York, N. Y.



Build a "HiQ-29" Junior and Enjoy REAL RADIO

THE finest in radio receivers is exemplified in the new Hammarlund-Roberts Junior "HiQ-29" Models, for A. C. or D. C. operation.

The coils, condensers, chokes and foundation units are of Hammarlund design and manufacture—which means QUALITY, clear through.



Your dealer can supply the Foundation Unit and all parts. Send 25c for "HiQ-29" Manual.

HAMMARLUND MFG. CO.
424-438 W. 33rd Street, New York

For Better Radio
Hammarlund
PRECISION
PRODUCTS



CONTROLS THE TRAFFIC THRU YOUR TUBES

Like the corner cop directing traffic, AMPERITE controls tube voltage. Self-adjusting, dependable, accurate. A type for every tube—A. C. or D. C. \$1.10 with mounting (in U. S. A.) at all dealers.

This symbol in a radio diagram means—



AMPERITE
REG. U. S. PAT. OFF.
The "SELF-ADJUSTING" Rheostat.

Radiall Company
56 FRANKLIN ST., NEW YORK
FREE "Amperite Blue Book" of modern circuits and valuable construction data. Write Dept PM 2.



Complete
Outfit
\$9.65

PAINT WITH AIR

New Simplified Easy Way!

with improved Payntgun! Quickest, easiest way to paint ever discovered. Anyone can put perfect smooth brilliant surface on car, furniture, woodwork, etc., with lacquer, varnish, paint or enamel. No experience needed—years of painting skill built into the Payntgun. New exclusive features cut painting time in half. Sturdily built—compact—convenient. Powerful spray specially designed for easy sure control. Turns painting jobs into play. Fully guaranteed. Sent on ten-day trial. Get special offer.

FREE Folder on Skillful Home Painting—Write for yours today!

HAYWOOD EQUIPMENT COMPANY
2345-B Ogden Avenue, CHICAGO, ILL.



**AGENTS
WANTED**

RUSH-ABSOLUTELY FREE!
THIS E-F ANGLE SCREWDRIVER—of tempered crucible Spring steel—has 7 powerful edge-cutting edges for large & small screws. Works under obstructions where others won't—101 other uses. Carries like pen-knife—often more valuable.

Name _____
Route No., St. _____
P. O. _____
City State _____

Interested in Factory Representative Proposition!
 In User Literature!

THE FLASH SALES CORPN
B P m - 4809 N. Ashland Ave., CHICAGO, ILL.

CLIP HERE—MAIL TO

Also **FREE** ON COUPON—the "\$5,000" CIRCULAR giving amazing 125-Picture story of **The "Pocket Machine Shop!"**

with its 1-TON POWER-GEAR
It Outgrips a 40-Lb. Vise!



The 'hand-grip' of a tiny Rubber band holds the Hardest-to-Hold thing known against a 300-Pound Pull!

Its 10-to-1 ratio Power-Gear Transmission gives YOUR hands the 1-TON GRIP of 20 Hands, yet —YOU CAN GRIP A HAIR.

An Automatic Lock-Grip Ratchet Wrench



Speed VISE
Parallel
PLIERS
Plus

No. 3—for all Wire, chain, spring-making, fence work, etc.
No. 2—for all Pipe work, "chewed" nuts in tight places, etc.
No. 1, Universal—for ALL Pliers, Nut Wrench, Vise and Clamp, Spring-making Work, etc.

EIFEL-FLASH PIERRENCH KIT

(Say "Eye-fel-Flash") "The T.N.T. of Tools"

You get the amazingly Quicker, Better, Easier, Universal Tool Service of Nos. 1, 2 & 3—Convertible in 1/5 second—in this new 24-Ounce Master Tool Kit—for the Price of One Good Tool; yet it Does the Work of the best other tools Weighing 60 pounds and Costing \$50.00!

Hundreds of Thousands of Men and Women are using these wonder Kits to make Homes and Estates more comfortable—Farms, Shops, etc., more profitable; to get more and better service from Auto's and all mechanical devices with a huge saving in money, time and energy!

Used by the U. S. Army and Navy. Just try a PierRench Kit Once, and you'd no more go back to other tools than to the ancient Ox-cart!

With each Kit a 64-page Manual of Mechanics

[A GUARANTEED] SUPER-QUALITY PRODUCT (©'29 J.E.)

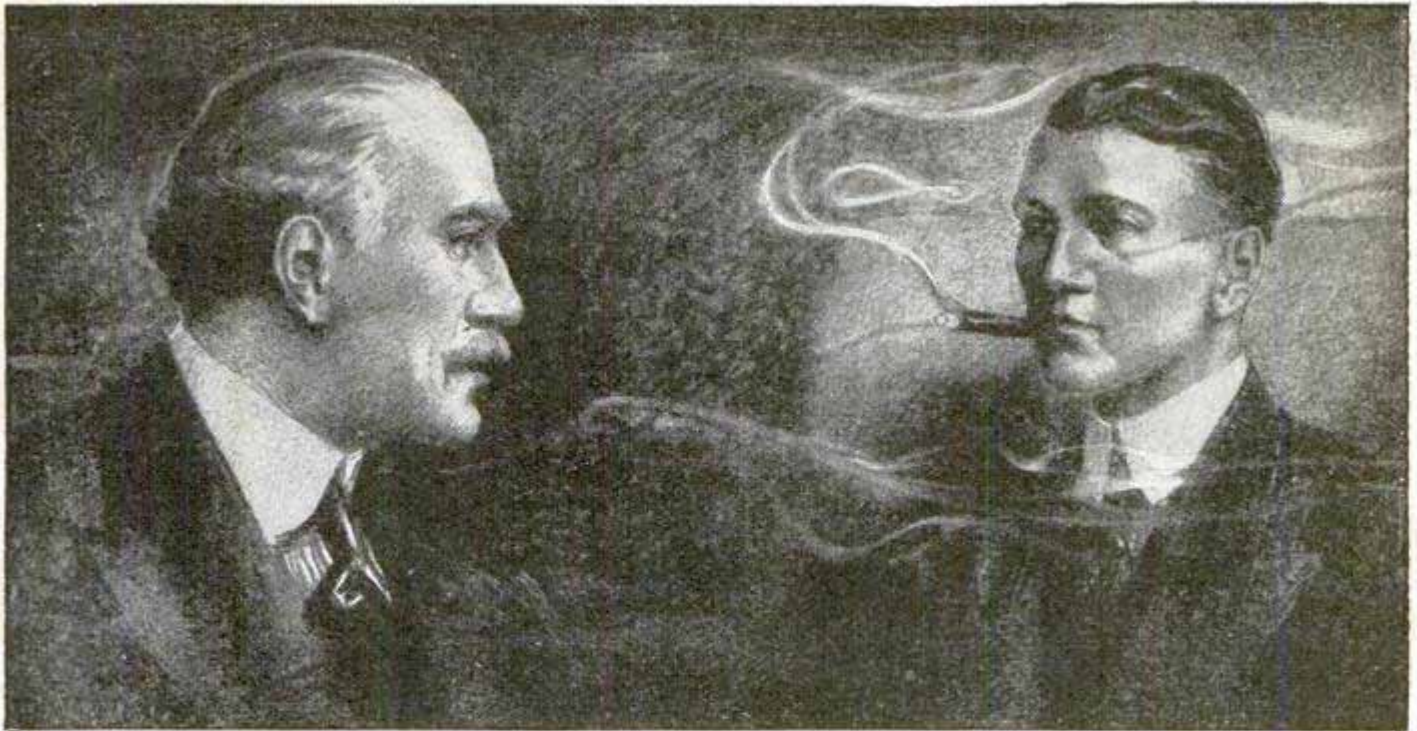
Also Big Winter and Spring Money Maker

for PierRench Factory Representatives—Full or Part Time. Amazing Demonstr'n sells at sight—makes \$75-\$200 weekly all year 'round. Seasonal Demand Doubles Profits. A Ga. Repr. made \$97 in 20-Min. Group Sale; a Mich. Repr. \$368 in 12 days; another \$379 in 5 days. Everybody wants the KIT!

Mail Valuable Coupon Above NOW!

PLANS for Poultry Houses

All styles, 160 illustrations; secret of getting winter eggs, and copy of The Full Egg Basket. Send 25 cents. INLAND POULTRY JOURNAL, Dept. 514 Indianapolis, Ind.



Tobacco Is Hurting You

Look at the facts square in the face, Mr. Tobacco User. You may think tobacco is not hurting you.

That is because you haven't as yet, perhaps, felt the effects of the nicotine poison in YOUR system. For you know that nicotine, as absorbed into the system through smoking and chewing tobacco, is a slow working poison. Slow, yes—but sure.

Tobacco is lowering your efficiency. It slows a man down. Makes it harder for you to concentrate your mind on your work. You haven't near the amount of "pep" and energy you would have if you stopped using it. There's many a man twice as old as you in years who's twice as young in energy, simply because he lets tobacco alone.

Some day you will realize to what an alarming extent tobacco has undermined your system.

When your hands begin to tremble—
and your appetite begins to fail—
and your heart seems to "skip a beat" now and then—
and slight exertion makes you short of breath—
then you have a right to suspect that
TOBACCO is getting the upper hand.

Any well-informed doctor will tell you that these are only a few of many symptoms of tobacco poisoning.

And YOU know that the use of tobacco in any form is an expensive, utterly useless habit. You know you ought to quit.

Tobacco Habit Banished Let Us Help You

It doesn't make a particle of difference whether you've been a user of tobacco for a single month or 50 years, or how much you use, or in what form you use it—whether you smoke cigars, cigarettes, pipe, chew plug or fine cut or use snuff—**Tobacco Redeemer** will positively remove all craving for tobacco in any form in a very few days. Not the slightest shock to the nervous system. Your tobacco craving will usually begin to decrease after the very first dose—there's no long waiting for results.

Tobacco Redeemer contains no habit-forming drugs of any kind and is marvelously quick, scientific and thoroughly reliable.

It is in no sense a substitute for tobacco. After finishing the treatment you have absolutely no desire to use tobacco again or to continue the use of the remedy. It helps to quiet the nerves and make you feel better in every way.

Results Guaranteed A single trial will convince you. Our legal-binding, money-back guarantee goes with each full treatment. We will refund every cent you pay for the treatment if after taking it according to the easy-to-follow directions, it should fail to banish the tobacco habit completely.

SEND Coupon for Free Proof Let us send you our free booklet on the deadly effects of tobacco, together with testimonial letters from men all over the country telling how they have been absolutely freed from the tobacco habit by this simple home treatment. You could not ask for stronger proof that **Tobacco Redeemer** will free you from the habit than the evidence we will gladly send on request. Just mail the coupon—or a postal will do.

NEWELL PHARMACAL CO.

Dept. 300 Clayton Station St. Louis, Mo.



Free Book Coupon


NEWELL PHARMACAL CO.
Dept. 300 Clayton Station St. Louis, Mo.

Please send, without obligating me in any way, your free booklet regarding the tobacco habit and proof that **Tobacco Redeemer** will positively free me from the tobacco habit or my money will be refunded.

Name

Street and No.

Town..... State.....



Let the Motrola wind your phonograph

Takes the place of the winding crank on any phonograph. Consists of a specially designed fully enclosed electric motor. By simply pressing a button the Motrola quickly winds your phonograph, and automatically shuts off when fully wound. Absolutely foolproof. Uses either direct or alternating current, and is supplied to you for 110-125 volts; 200-250 volts or 32 volts.

Can be installed in 5 minutes with a screw driver. No parts to wear out, and needs no adjusting. Costs only a cent a month to operate. Comes fully equipped with 10 ft. of cord and plug. Sold with our unlimited guarantee. Thousands already giving dependable service.

Jones Motrola Sales Co.
Dept. 102, 370 Gerard Ave., N.Y.

IF
you prefer to buy direct, we will ship post-paid anywhere in the U. S. A. In ordering give voltage used.


Special Price
\$25

Write us today for illustrated folder.

Miller's American Poultry Guide FREE

Tells all about chick's-care, feeding and raising for profit. Also describes Hot Water & Electric "Ideal" Incubators \$11.50 Up With Original Patented EGG TURNING TRAYS "Ideal" Brooders - - \$6.90 Up Coal, Oil, and Electric Brooders, Poultry Supplies, Baby Chicks. Special LOW PRICES! Write Today!

J. W. MILLER CO., Box 12, Rockford, Ill.



70 BREEDS Chickens, ducks, geese and turkeys.


Pure bred hardy, northern raised and most profitable. Fowls, eggs, baby chicks, incubators; low prices. America's great plant. 36th year. Valuable new 100 page Poultry book FREE.

R. F. Neubert Co., Box 908, Mankato, Minn.



RAISE CHINCHILLA AND NEW ZEALAND WHITE FUR RABBITS

Make Big Money We Supply Stock and pay you following prices for all you raise: Chinchillas average \$3 each - New Zealand Whites \$2 each. 32-page illustrated book, catalog and contract, also copy of Fur Farming magazine, tells how to raise rabbits for big profits, all for 10c. Address **OUTDOOR ENTERPRISE CO., Box 1021 Holmes Park, Missouri**



SQUAB BOOK FREE

Breed squabs and make money. Sold by millions for more than chickens. Write at once for free 48-page book beautifully printed in colors telling how to do it. You will be surprised.

PLYMOUTH ROCK SQUAB CO.
634 H Street Melrose Highlands, Mass.



WONDERFUL POULTRY BOOK FREE

The Nation's Great Poultry Manual; tells about mammoth hatchery, 52 BREEDS pure tested poultry. Feeding, Housing, Diseases and Remedies. LOWEST PRICES, best Fowls, Eggs, Chicks, Brooder Houses and Stoves. Stamps appreciated.


BERRY'S POULTRY FARM, Box 29, Clarinda, Iowa



FOY'S BIG BOOK, in Colors

A complete guide to successful Poultry and Squab Raising. Low prices on CHICKS, Breeding Stock and PIGEONS. Write Today! FREE!

FRANK FOY, Box 18, Clinton, Iowa



68 BREEDS Valuable New Poultry Book Free—100 Pages

Fine Pure-bred Northern raised chickens, ducks, geese, turkeys, eggs, baby chicks, incubators & brooders at lowest prices. America's great industry. My 47th year.

W. A. Weber, Box 28, Mankato, Minn.



INCREASE YOUR POULTRY PROFITS!

By proper Breeding, Feeding, Housing, Culling and Marketing **AMERICAN POULTRY JOURNAL** tells how to do it, and in addition a series of **COLORED PICTURES** with explanatory text tell and show many things you should know. They are not just colored pictures of birds but pictures of an educational nature, something never before shown by a poultry paper. **12 Issues of American Poultry Journal contain about 1000 pages—Price 25c a year—5 years for \$1.**

AMERICAN POULTRY JOURNAL, 14-536 S. Clark St., CHICAGO

WIN \$3,500.00!




Here's news for puzzle fans: C. W. Francis, Matilda Hikens, A. F. Holt, Miss Leola Markus, Alvin Smith won from \$1,400.00 to \$3,500.00 each in some of our last puzzles. Over 800 cash prizes awarded within a year. In Oct. 1928 alone we paid over \$11,000.00 in prizes and in the next few months will award between 300 and 400 cash prizes in our puzzles. Here's a new puzzle for you.

Find the "Different" Picture

Here are twelve pictures of Charlie Chaplin, the world famous United Artists star. No, they're not all alike, even though they look alike. Eleven of them are exactly alike, but one and only one is different from all the others. That's the real Charlie Chaplin. Can you find him? The difference may be in the hat, shirt or tie.

300 CASH PRIZES duplicate prizes in case of ties. If you can find the "different" figure, Complete instructions will be sent you.

CERTIFICATE FOR \$1,000.00 TO APPLY ON GRAND PRIZE SENT AT ONCE AS BELOW IF YOU FIND "DIFFERENT" FIGURE

If you find the real Charlie Chaplin we will send, as soon as correct answer is received, certificate for \$1,000.00 to add to the first prize of \$2,500.00, if you win, and directions for getting largest prize. We spend over \$150,000.00 this way each year to advertise our products locally. No cost or obligation. Nothing to buy now, later or ever. Everyone rewarded if actively interested. Just send the number of the "different" Chaplin in a letter or on a postcard. That's all. Send no money.

F. A. HARRE, ADVERTISING MGR., DEPT. 512, 510 N. DEARBORN ST., CHICAGO, ILL.










I Want to send you a Santa Fe Special Watch

for your
Examination
21
Jewels
Approval



Watch Sent on 30 Days Free Trial **Send No Money**

In addition to our New Low Price, I will send for your approval one of these Standard Watches, guaranteed for a lifetime of satisfactory service, not only by the Santa Fe Watch Company, but by the Great Illinois Watch Factory. They are found in the pockets of men in the service on every railroad in this country. Senators, Congressmen and Governors keep their official appointments by "Santa Fe Special" time. Army officers and privates carried them all through the Greatest War in history—thousands of these splendid watches are in use all over the World. If you want one on my liberal new **LOW PRICE PLAN**, you had better write for my Free Watch Book today and make your selection without delay. I will send the Watch for you to see **WITHOUT ONE PENNY DOWN**—I will even allow you to wear the Watch 30 days **FREE**—then sell it to you on a binding money-back guarantee.

Why Not Own A 21 Jewel Watch

You will never miss the few cents a day that will make you own one of these watches—**SEND FOR WATCH BOOK**—illustrating in beautiful colors hundreds of designs and combinations in cases in the **POCKET WATCH, MEN'S STRAP WATCH and LADIES' WRIST WATCH**. You can have your name or monogram and any emblem you may desire engraved in the Case to suit your own ideas.

New Case Designs

I want you to see the new models and wonderful case design in the Santa Fe Special, the Santa Fe Mogul, the Santa Fe Strap Watch and the Petite Santa Fe Princess Watch. No matter what your choice of a watch may be there is a Santa Fe Watch to please you. Send coupon for our beautiful **FREE** catalogue showing hundreds of designs and models in watches and newest creations in Diamond Rings and Jewelry.

WRITE FOR SPECIAL CASH OFFER — GOOD FOR 30 DAYS

Mail **SANTA FE WATCH COMPANY**
Dept. 26 **THOMAS BUILDING, TOPEKA, KANSAS**
Coupon

for Beautiful
FREE Watch
and
Diamond Book

Santa Fe Watch Company,
Dept. 26, Thomas Building, Topeka, Kansas.
Please send prepaid and without obligation your Watch Book Free, explaining your "No Money Down" Offer on the Santa Fe Special Watch.

Name

Address

City..... State.....

FREE A limited offer! With every Santa Fe Special, a beautiful gold chain or strand of exquisite pearls. Write today.

STOP THAT LEAK WITH SMOOTH-ON No. 1



YOU can apply Smooth-On with radiator full or empty, hot or cold, without removal from the car and without putting inside anything that clogs the circulation.

Merely roll the Smooth-On into a stiff putty, press it against and into the leak with your thumb or pack it into the defect with a knife blade or screw-driver, and scrape off the excess. The leak will stop instantly, and the repair is permanent. For a few cents and in a few minutes you will have avoided all the delays and expense of a professional repair job that couldn't be any better.

Cracked Water Jackets. Water jackets of automobile, stationary or marine gas engines which have developed long or short cracks or have even had pieces broken entirely out from freezing can be made thoroughly and lastingly serviceable by similar repair, or by applying Smooth-On under straps or a plate.

Smooth-On No. 1 can be used in a hundred ways in the household, and it often saves from \$50.00 to \$100.00 on the first job.

Keep a can of Smooth-On No. 1 with your tool kit and some day when caught with a repair job you will thank yourself for your forethought.

Get Smooth-On No. 1 in 7 oz., 1-lb. or 5-lb. tins at any hardware store or if necessary direct from us.



Write for
FREE BOOK



Do it with SMOOTH-ON

SMOOTH-ON MFG. CO., Dept. 37,
574 Communipaw Ave., Jersey City, N. J.
Please send the free Smooth-On Repair Book.

Name.....

Address.....

2-29.....

FREE

This booklet tells how to stop not only water leaks in radiators, cracked water jackets, and at loose hose connections, but also how to stop gas leaks from the tank, gasoline lines and exhaust system, and oil leaks at gaskets and at cracks in crank or gear case. It also tells how to make headlight posts, nuts, hub caps and bolts and grease cups stay tight, and shows dozens of simple money saving Smooth-On repair jobs.

Sent free if you return the coupon
SMOOTH-ON MFG. CO.
Dept. 37, 574 Communipaw Ave.
JERSEY CITY, N. J.

The Newest, Absolutely Successful



Pleasurable riding in all Weathers

Cheapest "Kleensweep" Windshield Wiper

Patented 1928

A Clean Sweep Across The Windshield

Gives the driver a completely unobstructed view the whole length of the windshield, as it works with one blade only. No longer is it necessary to "take a chance" on what is coming. You have the whole front clear.

What is more, your passengers, those at the rear as well as the one on the front seat, can get a good front view, and enjoy riding in spite of the worst rain or snow.

The New "Kleensweep" Windshield Wiper (patented) fits any make of car, works on the vacuum principle. It has plenty of power to sweep off the heaviest rain or snow. The vacuum principle is that used on the latest brakes which have proved so powerful and efficient.

When not working, the blade is pushed right to one side, and cannot obstruct the front view. No part of it covers the windshield; it leaves you absolutely your full windshield view.

The "Kleensweep" Wiper is simplicity itself, nothing in it to go wrong. It is guaranteed for one year, and is offered on a 10 day free trial basis. Installed in a few minutes.

Kleensweep Wiper A, Full Price Only \$7.50 Postpaid
(Best Duco Finished)

Kleensweep DeLuxe \$11.50 Postpaid

Larger, more power, silver nickel plated, making a beautiful addition to finest cars.

SAFETY FIRST: Avoid danger by ensuring a good, unobstructed view, whether raining or not. You owe it to your safety and that of your passengers to install this very necessary accessory.

SEND NOW CHECK OR MONEY ORDER TO
Kleensweep Windshield Wiper Co.,
Dept. 1, Suite 860, 508 South Dearborn St., Chicago, Ill.

The "Kleensweep" Windshield Wiper will be sent C. O. D. if desired.

Special Notice to Dealers

If you do not already stock this new Patent KLEENSWEEP WINDSHIELD WIPER, which is becoming so popular, you should write to us immediately.

SALESMEN WANTED—Liberal Commission

Are You Driving a gas Hog?

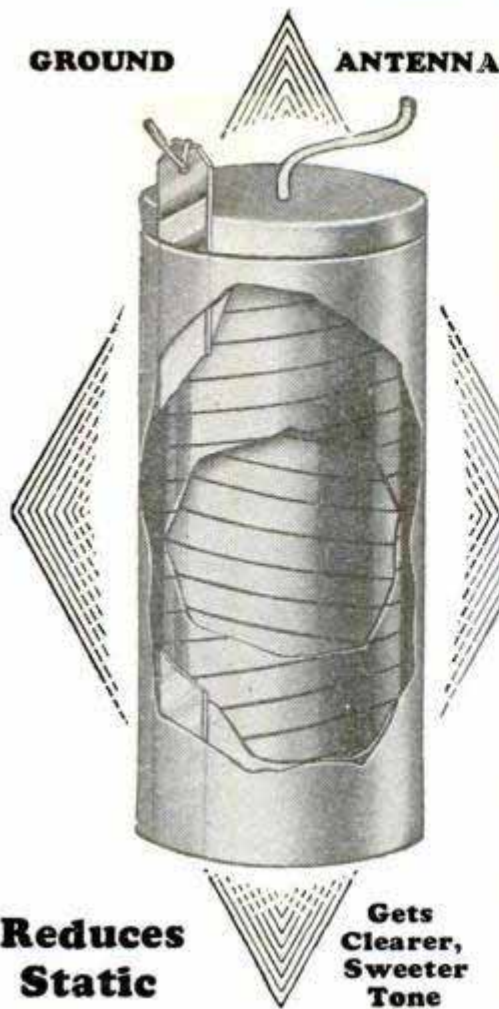
**NEW WAY TO
SAVE 1/4 to 1/2
YOUR GAS**

Now you can cut your gas cost with a new Vapor Moisture Humidifier or it COSTS YOU NOTHING. Uses vapor moisture from radiator. Gives engine that wonderful night driving effect ALL THE TIME. Eliminates hard carbon—gives ADDED POWER—MORE pep—QUICKER pickup—SMOOTHER running—HIGHER topspeed—GREATER mileage.

FREE TRIAL Try this New Principle Humidifier AT MY RISK

Try it on your car. See for yourself what Vapor Moisture will do. If you don't say it does MORE than I claim, return it and it COSTS YOU NOTHING. I also want County and State Representatives everywhere who can make \$350 to \$1,500 per month. Write today for my free trial and big money-making offer.

WALTER CRITCHLOW, Inventor & Manufacturer
4K-805 Street
Wheaton, Ill., U. S. A.



NEW

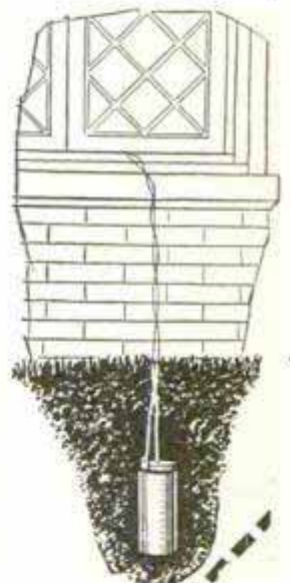
ANTENNA and GROUND *Combined in one convenient Unit*

A wonderful thing has happened in radio! Convenience never before dreamed of! Clearer, sweeter-toned reception! Radio pleasure with less interruption! These things are brought to you by the amazing, tested, approved EARTH ANTENNA.

Many set owners have come to realize the importance of using a dependable antenna, also the value of perfect grounding in getting good reception. Now science has gone a step further; it says that the LOCATION of the antenna is an equally important factor in getting best results. Because the radio wave goes right into the earth—where obviously there is less atmospheric disturbance and interference—it is claimed the logical place for the antenna should be the EARTH, not the air. This important conclusion allowed Radio Engineers to work out the EARTH ANTENNA.

SHIELDED ANTENNA GETS BETTER RECEPTION

The antenna is insulated or "shielded" against electro-static disturbances as are the most advanced, expensive receivers and their various parts. Science declares that the earth itself "shorts" the electro static capacity before it reaches the Antenna. This acts as another shield. The ground element is constructed of copper, undisputed as the most effective material for obtaining a perfect ground connection. This section of the unit is separated from the antenna by the insulation which shields the antenna. So in the EARTH ANTENNA you have a scientific ground and an antenna of modern shielded construction combined in one compact unit. You can test it yourself right now at our risk. Hear the wonderful results!



Reduces Static

Gets Clearer, Sweeter Tone

The new Scientific successful EARTH ANTENNA is designed to give you clearer, better, more dependable reception—and it costs no more than the old inefficient aerial—in fact less than many.

EARTH ANTENNA is so easy to install that soon people will wonder how they ever put up with the old, dangerous, slow methods. You simply dig a small hole only two feet below the surface of the ground, drop the EARTH ANTENNA into it and attach the lead-in wires to your set.

Now you are ready to listen to earth-clared, sweeter toned ground wave reception. You never need to touch the EARTH ANTENNA again.

Test EARTH ANTENNA at Our Risk

Don't remove your old aerial and ground until you've compared the old and modern methods and hear the vast improvement with the new. If possible pick a time when static is bad. Then if you are not convinced that EARTH ANTENNA is the greatest discovery you've ever found for your radio—if not enthused over the improvement—you don't pay us a cent. The thrilling details of this important development—illustrated—will be sent immediately on receipt of this coupon. Mail it NOW!

The Modern Antenna Co.,
Dept. 805-B.E.
St. Clair Bldg.,
cor. St. Clair and
Erie Sts.,
Chicago, Illinois

Rush literature of
EARTH ANTENNA and
Free Trial Offer. No obligation.

THE MODERN ANTENNA COMPANY

Dept. 805-B.E., St. Clair Bldg., cor. St. Clair and Erie Sts.,
CHICAGO, ILLINOIS

Name.....

Address.....

City.....

State.....



Be A Kid Again!



Rupture Curable

WHY put the joys of youth out of your mind? You, too, can play and be young again, after you—

—Throw Away Your Truss

Let medicated Plapao-Pads nourish those weakened muscles. The tissues having knit together almost magically, you will note the hernial orifice gradually become smaller—then disappear completely. Soon you will forget you ever had a rupture!

Thousands Profit

Mr. M. R. Newton's letter is typical when he says: "Myself and other friends were likewise cured." Naturally the Plapao-Pads were awarded Gold Medal, Rome, Grand Prix, Paris, and Honorable Mention at Panama Pacific Exposition—unparalleled endorsement by International juries of Award!

FREE TEST

You do not have to buy anything—simply mail the coupon below and we will send you a *free* 10 days' test of the essential remedial factor called "Plapao." Make a start TODAY. Mail Coupon below.

FREE TRIAL PLAPAO

PLAPAO CO., 929 Stuart Bldg., St. Louis, Mo.
Send me Trial Plapao and 48 page Book—No charges for it now or ever.

Name.....

Address.....



BOYS! Make Big Money

BUILD BIRD HOUSES

Boys! Here's a real money maker. With my simple instructions any boy can build and erect Grandpa Bird Houses. They sell at \$2 to \$30 each. \$2,000 worth sold in Oak Park, Ill., in one year. Send \$1 for 16 Blue Print Drawings showing correct building plans so you can build my famous bird houses. Valuable book on song birds with tips and advice on making sales included free.

GEO. J. BREIDERT, 1040 N. Elmwood Ave., Oak Park, Ill.



BOW LEGS?

THIS GARTER (Pat'd)
Makes Trousers Hang Straight
If Legs Bend In or Out
Free Booklet—Plain Sealed Envelope

THE T. GARTER CO., Dept. E
South Bend, Ind.

Skin Troubles

Cleared Up—Often In 24 Hours

Pimples, Blackheads, Acne Eruptions on the Face or Body, Barbers Itch, Eczema, Enlarged Pores, Oily or Shiny Skin. "Clear-Tone" has been tried and tested in over 300,000 cases. Used Like Toilet Water. It is simply magical in prompt results. At All Druggists, with proven directions.

ASK YOUR DRUGGIST—You Can Rely On

Clear-Tone

TRADE MARK REC.

FOR THE SKIN AND COMPLEXION

GIVEN

THIS Large Size Movie Machine operates on same principles as expensive professional models, uses standard size films same as big theatres. Imported double Convex Lenses show large, clear pictures. Complete outfit furnished—enough for a full hour's show, including Tom Mix film, etc. Easy to operate, guaranteed for life. Just send for 12 large Bottles *Saint D'Amour* Perfume that sells at 25 cents each. This is a real bottle size 3 x 2 inches. We also send 12 Perfume Novelties which you give away free of charge and Easy Plans for obtaining MOVIE Machine. Send no money. We trust you.

TREVAUX Perfume Co.
Dept. 7E78 CHICAGO



FREE TRIAL BOTTLE OF Marvelous New Discovery for Gray Hair

Amazing new discovery—REVA—restores hair to a youthful natural color. No need to fuss with messy dyes. REVA is a clean, colorless liquid. Same bottle used for all colors. No samples of hair are needed. Applied to scalp—not to hair. Anyone can apply easily at home without skill or outside aid. Restore so naturally your friends cannot notice change. Does not streak or crack hair. Will not wash off or fade. Hair keeps uniform color. Does not get gray at roots. REVA also acts as hair tonic. Overcomes dandruff. Thousands have used successfully. Satisfactory results guaranteed. Test FREE a full sized bottle in your home. Ask for particulars.

REVA CORP. 4242 Lincoln Avenue, Dept. 312, CHICAGO



Beautify your NOSE

to shapely
proportions—
while you sleep!



Gold Medal
Won 1923

ANITA NOSE ADJUSTER
is SAFE, painless, comfortable. Speedy, permanent results guaranteed. Doctors praise it. No metal to harm you. Small cost.



Write for FREE BOOKLET
ANITA INSTITUTE, B-12 Anita Bldg., NEWARK, N. J.

MAKE THINGS AT HOME—SAVE MONEY



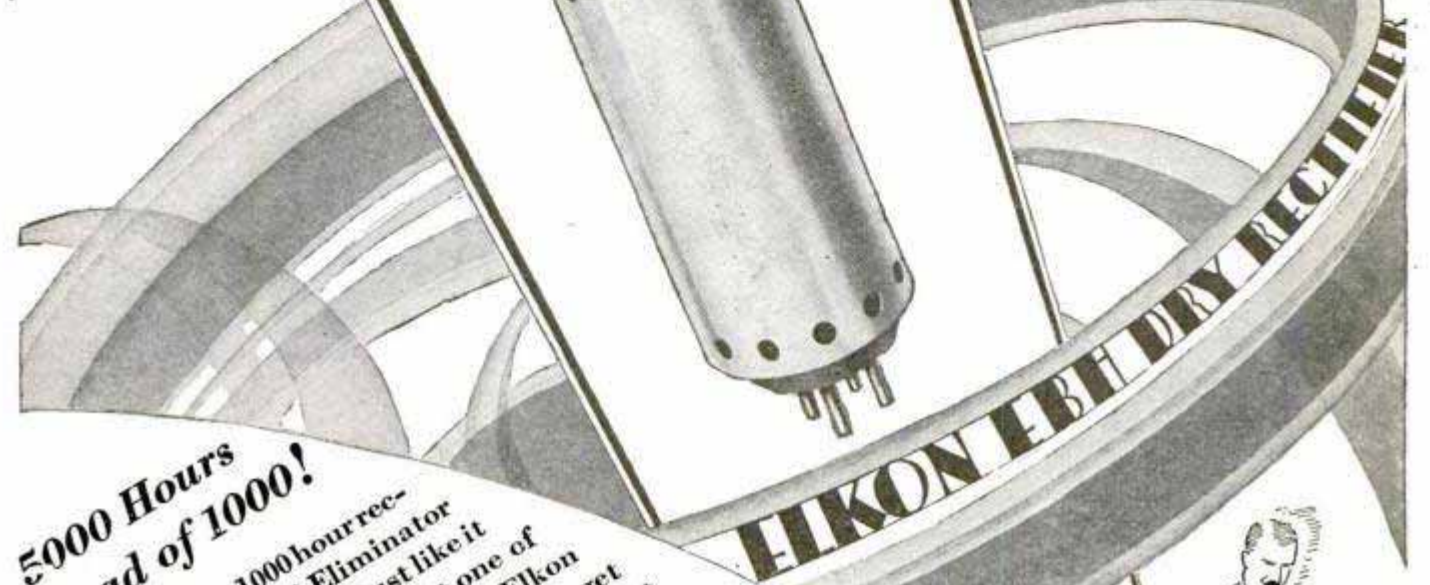
Only
PARTRIDGE WOOD TURNING LATHE \$16⁵⁰
Buy the finished completely assembled lathe. Build bed at home. A real tool. 6-inch diameter capacity. Shipping weight 21 lbs. Make radio parts, floor lamps, toys and numerous other practical and valuable articles. Also made in sizes to swing 8, 11, 13, and 16-inch diameters. f.o.b. Chicago

AN IDEAL LATHE FOR FATHER OR SON

Send today for descriptive circular.

E. O. PARTRIDGE, Dept. F-29, 2039-49 W. Lake Street, CHICAGO, ILL.

A LIFE PRESERVER FOR YOUR "B" ELIMINATOR



**5000 Hours
Instead of 1000!**

When your fragile 1000 hour rectifier tube in your "B" Eliminator "blows", don't put another just like it in the socket—be modern—get one of the husky, solid, all dry 5000 hour Elkon EBH rectifiers from your dealer and forget your rectifying troubles for 5000 hours, at least.

The new Elkon EBH replaces all BH type rectifiers—no changes in wiring—simply take out the trouble-causing gas tube and plug in the smooth, powerful, trouble-free Elkon—that's all there is to it.

Other Elkon Replacement Rectifiers, too

Ask your dealer about the new dry Elkon rectifier which replaces the wet jar Philcatron type A and type AA in all Philco power units—trickle chargers, "A" Eliminator and A combinations. For the Philco "A" Eliminator equipped with Elkon rectifiers, use the Elkon M-16 for replacement. Eleven "A" Eliminator have used the M-16—be sure you get the M-16 in the red, black and yellow box.

The Elkon V-4 is used for 6 makes of trickle chargers, and the Elkon is the only authorized replacement rectifier for the Balkite Power Units, types N, K and J.

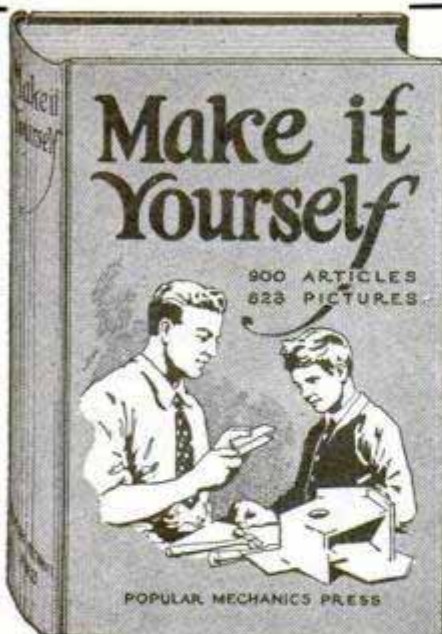
ELKON, Inc.
Division of P. R. Mallory & Co.
350 Madison Ave., New York

ELKON, Inc., Dept. E-7
350 Madison Ave., New York City
Kindly send me complete information
on Elkon Radio Products.

Name _____
Address _____



Elkon rectifiers are tested with receiving sets



Do You Enjoy Making Things?

If so, you should have a copy of this new book just published by Popular Mechanics entitled

Make It Yourself

The home mechanic, whether young or old, amateur or professional, will take pride and delight in making many of the things described therein.

Both father and son will find fascination and an association of interest in making useful and ornamental articles for mother to admire upon their completion.

900 Articles All Different

There are attractive ship models, a great variety of toys that operate themselves by means of an ingenious application of mechanical principles, novel amusement devices for indoors and outdoors, for both water and land, unique designs in furniture for children, scores of useful appliances for the home, things of beauty and utility for lawn and garden, etc.

Special articles instruct the amateur mechanic in the care and use of tools, special tools for special purposes, how to read and use plans, how to solder, the making of a handy work bench, cuts, joints and methods in woodworking, automobile repairing, installing radio equipment, house wiring, fixture hanging, working in glass, leather, metal, celluloid, lathe work, utilizing parts of old machines to make equipment that would be expensive to buy, etc.

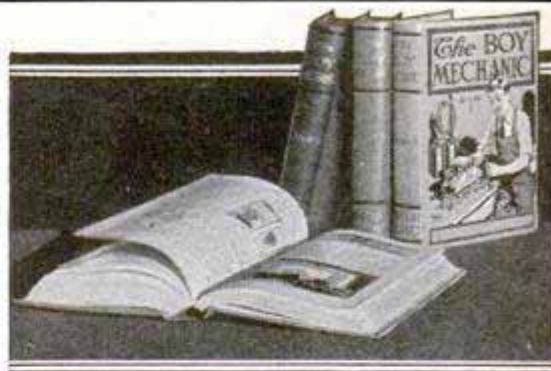
Some of the Articles:

Tools for the Home Mechanic	Monorail Coaster
Ship Model Maker's Tools	Writing Cabinet
Build Your Own Ship Model	Workbench
Ship Model Plans	Tea Wagon
Water Sprite	Radio Apparatus
Puzzles	Lawn Canopy
Crazy Clown	Camp Car
Walking Wampus	California Cooler
Winter Toboggan Slide	Musical Instruments
Colonial Bric-a-Brac	Hedge Trimmer
Merry-Go-Twist	Homemade Baseball Game
Wiggling Pup	Small Turbine Motor
Black Cat Bench	Tools from Sewing Machines
Christmas Toys	Small Valves
Skating Whirligig	Bench Lathe
Venetian Swing	Auto Glare Shield
Bird Houses	Seesaw Merry-Go-Round
	Ferris Wheel

480 Pages—823 Illustrations. Size 7x10x1 1/2 in. Cloth Binding **Price \$3.00**

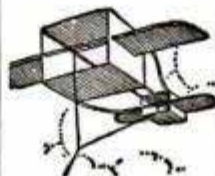
Mailed Postpaid upon receipt of price anywhere in the world. If you reside in U. S., Hawaii, Porto Rico, Alaska or Mexico, we will send the book by mail C. O. D. if you prefer. Simply pay postman when he delivers the package.

POPULAR MECHANICS PRESS (ROOM P-1)
200 East Ontario St. Chicago, Ill.



BOYS

It's Fun to Make Things



Let the other boys wonder how you can make so many interesting things. Make your own automobile. Make your own radio. Make your own kites and gliders. You can learn how to make almost anything that any boy could want by following the pictures and the simple directions in

The Boy Mechanic Library

And just think of it, there are nearly 4,000 separate articles in the four beautiful volumes! Some of the most fascinating subjects are listed below:

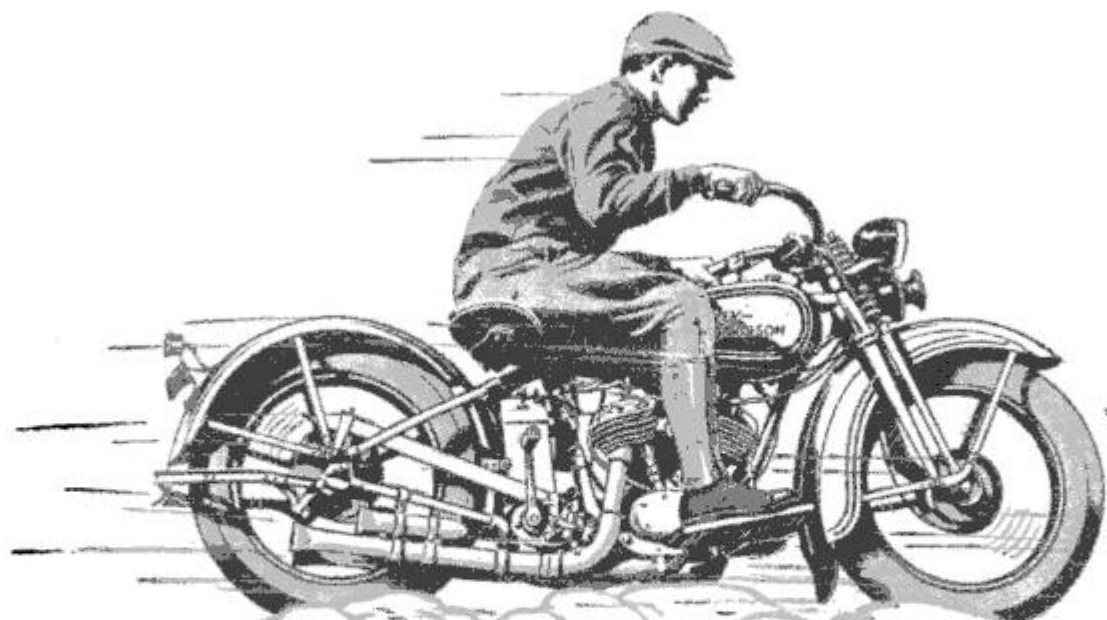
How to Make Things

Boats	China painting
Winter sports	Decorative metal work
Camping	Furniture making
Ice boats	Farming
Water sports	Poultry
Toboggans	Models
Tents	Laboratory helps
Skis	Household helps
Indian snowshoes	Wood working
Skating	Electrical devices
Gymnasium	Photography
Wind wagons	Music
Motor sleds	Outdoor games
Radio	Stoves
Magic	Furnaces
Trapping	Wireless
Pets	Tricks
Leather work	Puzzles
Carpentry	Bicycle
Painting	Flowers
Toys	Hunting
Fishing	Kites
Fruit growing	Metal working tools
Entertainments	Secret locks
Automobile	Swings
House decorations	Sleds
Drafting	Power devices

Buy the complete library, including Book 1, Book 2, Book 3 and Book 4 for \$7, thus saving \$1 as single volumes are \$2. If you want individual books at \$2 each order by number 1, 2, 3 or 4.

When the postman delivers the books to your door, pay him the price of the books and the postage. That is all. If outside U. S. remit when ordering and include 28 cents per volume extra for postage.

POPULAR MECHANICS PRESS
200 E. Ontario St.
Room P-1 CHICAGO, ILL.



Like Floating on a Cloud

THAT tingling rush of air in your face, that lightning response to the throttle, the buoyant speed, and the feeling of perfect control of your mount

— they give to motorcycling the sense of glorious freedom that no other sport offers. Flying a plane is tame by comparison!

Motorcycling at its best is yours for small cost—in the Harley-Davidson "45". This newest Twin is a wonderful performer—smooth, quiet, speedy, economical—and it costs only \$290 f. o. b. factory.

See it at your local Harley-Davidson Dealer's. Ask him about his Pay-As-You-Ride Plan. Mail the Coupon for illustrated literature.

HARLEY-DAVIDSON

Motorcycles

HARLEY-DAVIDSON MOTOR CO., Dept. P., Milwaukee, Wis.
Interested in your motorcycles. Send free literature.

Name.....

Address.....

On the trail of the "KNOCK"

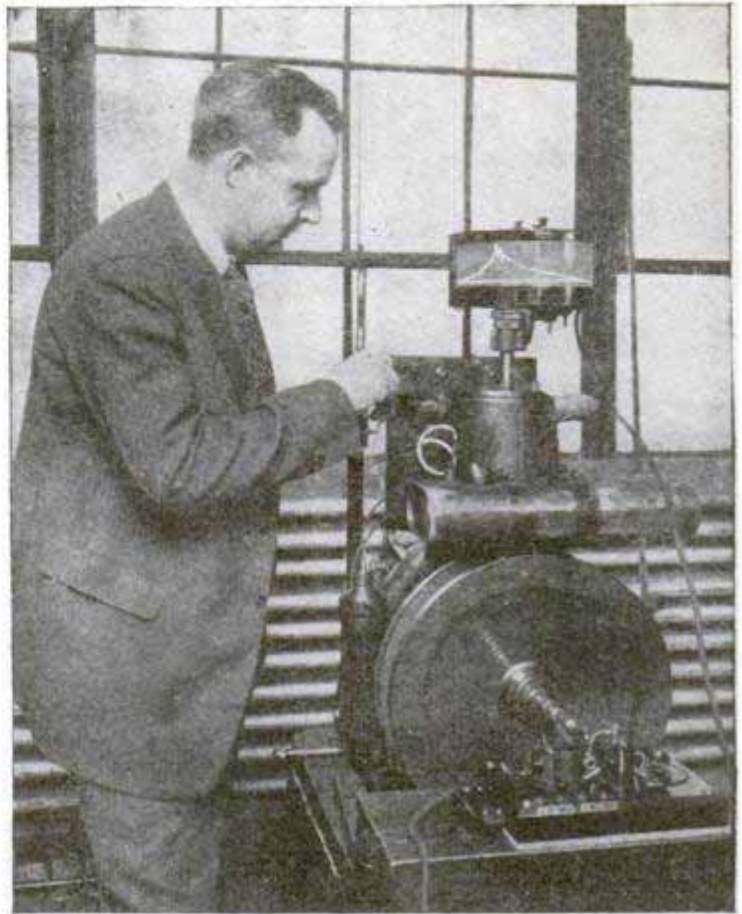
*(The indicator
hound)*

WHEN you hunt a wild animal, you usually take along a dog that can follow the animal's trail. So when the scientists in General Motors' Research Laboratories started to trail the elusive and annoying "knock" in the gasoline engine, they had to develop a sort of scientific dog that could show them where the knock was and what sort of thing it was.

It is rather disrespectful to call the Midgley Indicator a "scientific dog." It is a most ingenious mechanism that records the pressures in the cylinder of a gasoline engine while it is running. By studying these pressures the scientists found out what was happening when the engine knocked. In fact, they found that it was the *fuel* that knocked, not the engine.

It was all part of the long trail of investigation that led to the discovery of tetraethyl lead as an "anti-knock." To-day leading oil companies add Ethyl Fluid (containing tetraethyl lead) to gasoline. As Ethyl Gasoline, this better fuel is now available all over the country.

But Ethyl Gasoline has done much more than eliminate the "knock" in gasoline engines. It



This is Thomas Midgley, Jr., the inventor of Ethyl Gasoline, and the Midgley Optical Indicator, the machine which played such an important part in the development of Ethyl. The Midgley Optical Indicator, mounted on an engine, took a picture of what occurred inside the combustion chamber and enabled Mr. Midgley and his associates to establish the cause of the "knock."

has made possible the construction of high compression engines. With these it has introduced a new era of motoring comfort and efficiency.

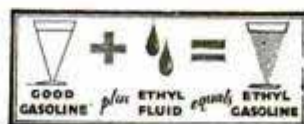
The millions of cars of ordinary compression run better on Ethyl too—for carbon formation automatically raises their compression. Have *you* tried Ethyl?

ETHYL GASOLINE CORPORATION

25 Broadway, N. Y.

56 Church St., Toronto, Can. 36, Queen Anne's Gate, London, Eng.

ETHYL GASOLINE



Knocks out that "knock."



“This free book saved us \$200”

MORE than 130,000 car buyers have saved money by sending for this valuable book, “How to Judge a Used Car.” Filled with new pictures and new information, this book tells you how to judge a used car’s condition, what speedometers tell; what code prices mean, how the Studebaker Pledge protects your investment.

A better car for fewer dollars — a finer car you can drive with pride at a price lower than you believe possible — how 2,000,000 motorists saved money for themselves last year — this free book tells you all these money-saving facts, and many more.

Don’t let false pride prevent you from enjoying a good six or eight this summer. The cost is small when you learn how to take advantage of big savings on today’s market. This practical book, offered you for a 2c stamp, may easily, *safely*, save you \$200 this Spring!

Mail the coupon now.



Pledge to the Public on Used Car Sales

- 1 Every used car is conspicuously marked with its lowest price in plain figures, and that price, just as the price of our new cars, is rigidly maintained.
- 2 All Studebaker automobiles which are sold as CERTIFIED CARS have been properly reconditioned, and carry a 30-day guarantee for replacement of defective parts and free service on adjustments.
- 3 Every purchaser of a used car may drive it for five days, and then, if not satisfied for any reason, turn it back and apply the money paid as a credit on the purchase of any other car in stock—new or used. (It is assumed that the car has not been damaged in the meantime.)

© 1928 The Studebaker Corporation of America

THE STUDEBAKER CORPORATION OF AMERICA
Dept. 152, South Bend, Indiana

Please send me my copy of your valuable free booklet, “How to Judge a Used Car.”

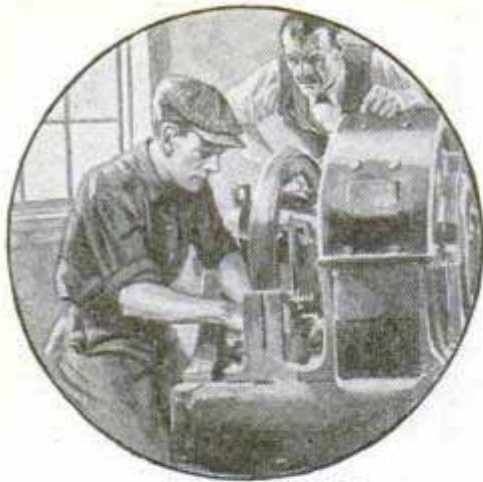
Name.....

Street.....

City..... State.....

STUDEBAKER

Builder of Champions



ELECTRICAL EXPERTS IN DEMAND

Good positions await trained men. Salaries of \$12 to \$30 a day are paid many experts in this field.

THE Electrical field needs men. It needs them badly. Hardly a month or a year passes but what some new use for electricity is discovered. Each new use means new positions—*better positions*—for men who have trained themselves as experts in this wonderfully fascinating work.

Why don't *you* study electricity and prepare for a good position at a good salary?

You can do it right at home in spare time through the International Correspondence Schools. Home-study courses endorsed by Edison and Steinmetz. Successful students everywhere.

Mark and mail the coupon today for Free Booklet

INTERNATIONAL CORRESPONDENCE SCHOOLS
 "The Universal University"
 Box 5593-F, Scranton, Penna.

Without cost or obligation, please tell me how I can qualify for the position, or in the subject, before which I am marking X:

- | | |
|--|---|
| <input type="checkbox"/> Electrical Engineer | <input type="checkbox"/> Salesmanship |
| <input type="checkbox"/> Electrician | <input type="checkbox"/> Show Card and Sign Lettering |
| <input type="checkbox"/> Electric Wiring | <input type="checkbox"/> Railroad Positions |
| <input type="checkbox"/> Electric Lighting | <input type="checkbox"/> Illustrator |
| <input type="checkbox"/> Telegraph Expert | <input type="checkbox"/> Industrial Management |
| <input type="checkbox"/> Practical Telephony | <input type="checkbox"/> Secretarial Work |
| <input type="checkbox"/> Mechanical Engineer | <input type="checkbox"/> Business Correspondence |
| <input type="checkbox"/> Mechanical Draftsman | <input type="checkbox"/> Accounting and C.P.A. Coaching |
| <input type="checkbox"/> Toolmaker | <input type="checkbox"/> Bookkeeper |
| <input type="checkbox"/> Machine Shop Practice | <input type="checkbox"/> Stenographer and Typist |
| <input type="checkbox"/> Gas Engineer | <input type="checkbox"/> Traffic Management |
| <input type="checkbox"/> Civil Engineer | <input type="checkbox"/> English |
| <input type="checkbox"/> Surveying and Mapping | <input type="checkbox"/> Common School Subjects |
| <input type="checkbox"/> Reading Architects' Blueprints | <input type="checkbox"/> Civil Service |
| <input type="checkbox"/> Metallurgy <input type="checkbox"/> Architect | <input type="checkbox"/> Railway Mail Clerk |
| <input type="checkbox"/> Architectural Draftsman | <input type="checkbox"/> Textile Overseer or Supt. |
| <input type="checkbox"/> Plumbing and Heating | <input type="checkbox"/> Agriculture |
| <input type="checkbox"/> Sheet Metal Worker | <input type="checkbox"/> Spanish |
| <input type="checkbox"/> Automobiles | <input type="checkbox"/> Navigator |
| <input type="checkbox"/> Airplane Engines | <input type="checkbox"/> Mathematics |
| <input type="checkbox"/> Chemical Engineer | <input type="checkbox"/> Poultry Raising |
| <input type="checkbox"/> Pharmacy | <input type="checkbox"/> Radio |

Name.....
 Street Address.....
 City..... State.....
 Occupation.....

Canadians should send this coupon to International Correspondence Schools Canadian, Limited, Montreal, Canada



3 to 45 M.P.H.

WORLD'S greatest sport — "Evinruding!" More fun than flying. More thrills at 30 than from a car at 60 M.P.H. Evinrude — world's fastest twin last year and winner of most endurance runs, offers still more power, more speed, more features for 1929.

Four "twin" models—2½, 6, 14 and 20 H.P., with light weights of 44, 58, 75 and 95 lbs. A size for every craft, from canoe to small cruiser. Waterproof ignition, easy starting made still easier, torpedo streamline, pressure vacuum cooling (no moving parts), ball and roller bearings, self steering.

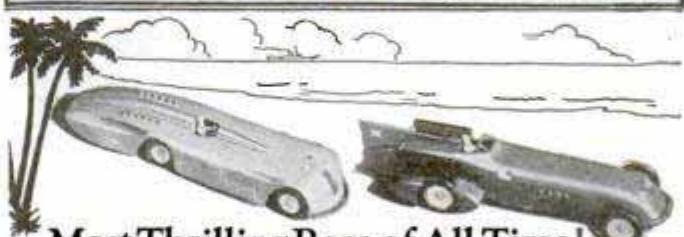
Easy time payments as low as \$31.10 down. Write for new free Evinrude Year Book.

EVINRUDE MOTOR CO., 2425 27th St., Milwaukee
 Division of Briggs & Stratton Corporation—World's largest builders of portable gasoline engines.



\$10.00 PER MONTH BUYS Fibre-Life Limbs
 NEXT TO NATURE. BRACES MADE TO ORDER. AGENTS WANTED. FREE FIBRE SAMPLE **WORMAN CO.** 252-P HENNEPIN AVE. MINNEAPOLIS, MINN.

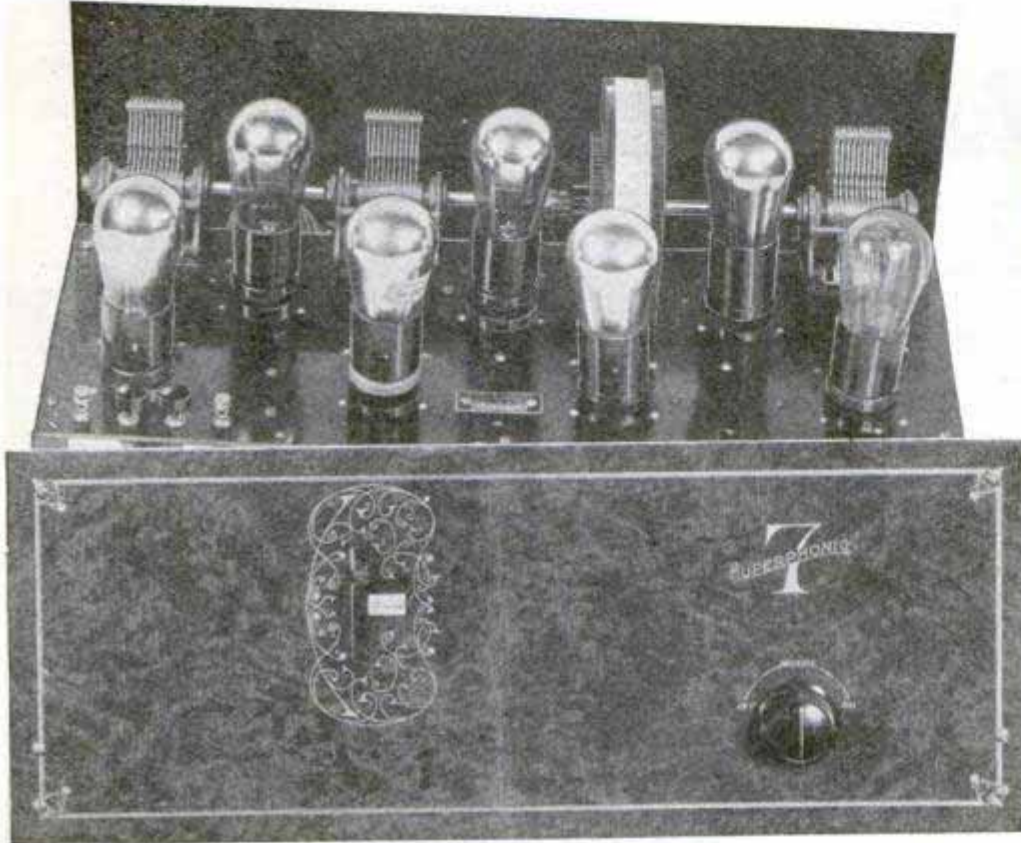
\$15 a Day EASY
 The NEPCO Electric Iron Cord Coiler is the only practical device for keeping the cord out of the way. Women are wild over it and buy on sight. Cannot kink or snarl. AGENTS making BIG MONEY. Write for FREE particulars.
National Electric Prod. Co.
 3947-K Armitage Avenue, Chicago



Most Thrilling Race of All Time!
 PICTURE two monster racing cars—one brilliant red, one shining blue—side by side, thundering down an endless stretch of sand at more than 200 miles an hour! That's what would happen if those two famous racers the "Sunbeam" and the "Blue Bird" could be raced together at Daytona Beach, where they made their world speed records. You can race the Sunbeam and the Blue Bird in toy form! Exact copies beautifully made, all of steel, with clock-spring racing motors. If your dealer hasn't these exciting Kingsbury Toys in stock, order direct from us. Either toy \$3, both \$6. (West of Miss. \$3.30 and \$6.60) Toy Catalog Free. Kingsbury Mfg. Co., 83B Myrtle St., Keene, N. H.
KINGSBURY Motor Driven TOYS
 SPECIAL: Send 10¢ for novel Eraser made from a Kingsbury disc wheel.

Radio's
greatest
value!

7
SUPERPHONIC



Only
\$16.95
COAST
to COAST
RECEP-
TION

7
TUBES
SINGLE
DIAL

Superphonic 7 is a world beater! An exceptionally high grade receiver that is amazing the Radio World. Latest 7 tube tuned radio frequency circuit, using 4 radio frequency amplifiers, detector and 2 stages of audio. Power tube can be used in last audio stage. Extremely selective, marvelous sensitivity. Single drum dial control. Straight line wave length condensers permit accurate, equally spaced tuning over entire wave band. All sockets spring cushioned to eliminate microphonic noises. Bakelite subpanel [8 1/4 in. deep] insures minimum dielectric losses. Clear and realistic reception guaranteed. An exceptionally beautiful, walnut finish, metal front panel 7 in. x 18 in. Complete chassis. No extra parts to buy. All parts mounted ready to wire. No special tools needed. All hook-up wire and colored battery cable included. Value \$60.00; our price **\$16.95.**

SIMPLE WIRING DIRECTIONS

Very easy to wire this set with the instruction we furnish. Just connect a few wires. **All you have to do is to follow numbers. Simple as adding 2 and 2.** Can be wired in a few minutes by anyone. No radio knowledge needed. Make money by wiring these sets in your spare time and selling them to your friends.

COMPLETELY WIRED

If you would rather receive Superphonic 7 completely wired, we will be glad to have it wired for you at an additional charge of only \$2.00. Please indicate on your order whether or not you want Superphonic 7 wired.

RADIO EQUIPMENT COMPANY
Dept. 10-B, 551 S. Wells St., Chicago, Ill.

TESTED AND APPROVED

Severe laboratory tests have proved the remarkable efficiency of this set. Owners everywhere are sending us letters praising its wonderful receptive qualities. E. Richmond, Detroit, Michigan, writes: "Tried out my Superphonic first night with weak batteries. Was surprised to get all local and 7 other long distance stations loud and clear. This is some record. I expect to get even better results tonight with full power. A friend heard it and wants one too. Please ship me another outfit immediately." B. J. Gillis, Denver, Colorado, says: "Wired set in short order. Getting stations all over the country. Plenty of volume. The set is a dandy." M. A., Syracuse, N. Y., sends telegram: "Rush at once 2 more Superphonics." M. Madsen, Chicago, Ill.: "Don't know anything about radio. Got it wired up in a little while and it works great." C. Drysch, Chicago: "First night set was up got 12 out of town stations. Everything came in clear as a bell and nice and loud."

SEND NO MONEY

Fill in the coupon and mail it today. We will ship you this great outfit immediately. Upon arrival pay only \$16.95 (ready to wire) or \$18.95 (completely wired) plus a small delivery charge. Foreign countries send \$19.50 (ready to wire) or \$21.50 (completely wired) with order. We pay shipping charges.

RADIO EQUIPMENT CO.,
551 S. Wells St.,
Dept. 10-B, Chicago, Ill.

Gentlemen:

Please send me at once Superphonic 7.

Check set desired.

(ready to wire) \$16.95

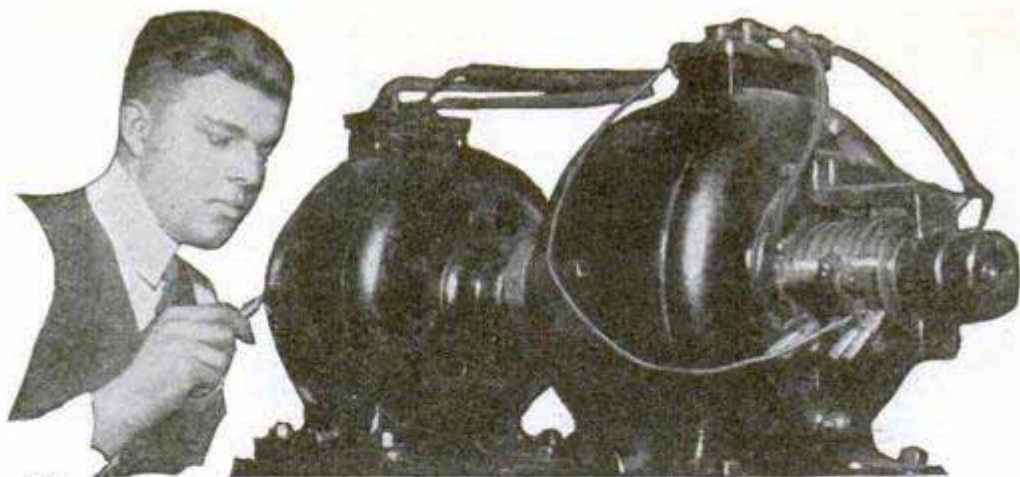
(completely wired) \$18.95.

Upon arrival I will pay the above price plus a small delivery charge.

Name.....

Address.....

City.....State.....



AMAZINGLY EASY WAY TO GET INTO ELECTRICITY

Let me tell you in my big Free book how I can quickly train you for jobs leading to salaries of 6000 a week and up. NOT BY CORRESPONDENCE. NOT BY BOOKS. But, on real electrical machinery in 90 DAYS.

you don't need advanced education or electrical experience. EARN WHILE YOU LEARN. Free employment service for life as often as you want it.

AVIATION ELECTRICITY COURSE

For a short time I will give you at no extra cost my big new aviation course and also my Radio course.

GET MY BIG FREE BOOK

mail coupon today and I'll send you my big Free book. It tells you an amazingly easy way to get into a big pay field.

COYNE ELECTRICAL SCHOOL
Founded 1899 H.C. LEWIS, Pres.
500 S. PAULINA ST., Dept. 29-98 CHICAGO, ILL.

FILL IN MAIL TODAY

H. C. LEWIS, Pres.
COYNE ELECTRICAL SCHOOL, Dept. 29-98
500 S. Paulina Street, Chicago, Illinois

Dear Mr. Lewis:

Without obligation send me your big free catalog and all details of Free Employment Service, Aviation, Radio and Automotive Courses without extra cost, and how I can "earn while learning."

Name

Address

City..... State.....

Start to Play Very First Day

Give Yourself
Lifelong Fun
Profit and
Popularity



THINK of the best gift you have ever received. Multiply the pleasure it gave you by ten, and still you have only an idea of the joy you can give yourself right now if you act at once!

PARENTS!

What greater gift can you confer on your children this year than lifelong fun and entertainment?

Love of music means love of home, an appreciation of the finer things in life. Here is a chance to give your boy or girl that love without the tedious practice that most instruments require. The Xylorimba is easy to play. No teacher is needed. Practice is actually a joy.

Remember, the Xylorimba is the guaranteed product of a company established nearly half a century ago—a company that stands back of every promise it makes.

Start to Play the Very First Day!

Haven't you, like millions of others, envied the fellows who "bring down the house" with snappy xylophone or xylorimba numbers? Haven't you longed to create your own music, to be looked up to wherever you go, to be able to make real money in spare time? If you have, this ad spells O-p-p-o-r-t-u-n-i-t-y. The xylorimba—wonderful for home, in demand at dances and gatherings—is nevertheless the *easiest of all instruments to play*. In fact, on the very day you get yours you play simple melodies, even if you can't read a note of music right now. In a few weeks you astonish your friends and family. *All your life* you have the joy that comes to those who can entertain.

Plays 20 Minutes; Gets \$20!

Ralph Smith, Chicago, played twenty minutes at wedding; his "pay" was \$20. Altho only 12, Turk McBee, Jr., plays big-time vaudeville exclusively. Harry Breuer, New York, has

made thousands of friends thru his xylophone selections on the radio. L. E. Hallman, Reading, Pa., writes: "Made \$300 in 5 weeks—spare time."

And now J. C. Deagan, Inc., (world's largest manufacturer of xylophonic instruments) has made it so easy to own a xylorimba that nothing stands in your way. Sizes and styles to fit every age and pocketbook. A five-day free trial that eliminates risk. Free, easy lessons that make teacher unnecessary—and, best of all, such easy payments that they are hardly noticed.

Will You Investigate?

Everyone wants to be popular. Everyone wants to make extra money. Everyone wants to be *center of attraction* at gatherings. But these advantages don't come by themselves. Opportunities must be seized. This is *your* opportunity—will you pass it up without investigation? The accompanying coupon will bring our big FREE book to your door. It tells all about the Deagan line, the free trial, the easy payments. Remember, no cost or obligation! Simply fill in and mail the coupon—but do it before it slips your mind. Today is as good a day as any. Do it NOW!

YOUR
MAGIC

to Popularity

KEY

Mail
Now!

Send for
BIG FREE
Book!

Please send me full details on the Free Trial offer and easy payment plan of the Deagan Xylorimba.

J. C. DEAGAN, Inc.
Dept. 1452, 1770 Bertness Avenue, Chicago

Name _____ Address _____
City _____ State _____

This
CROSLLEY

AC Electric
GEMBOX

\$**65.**

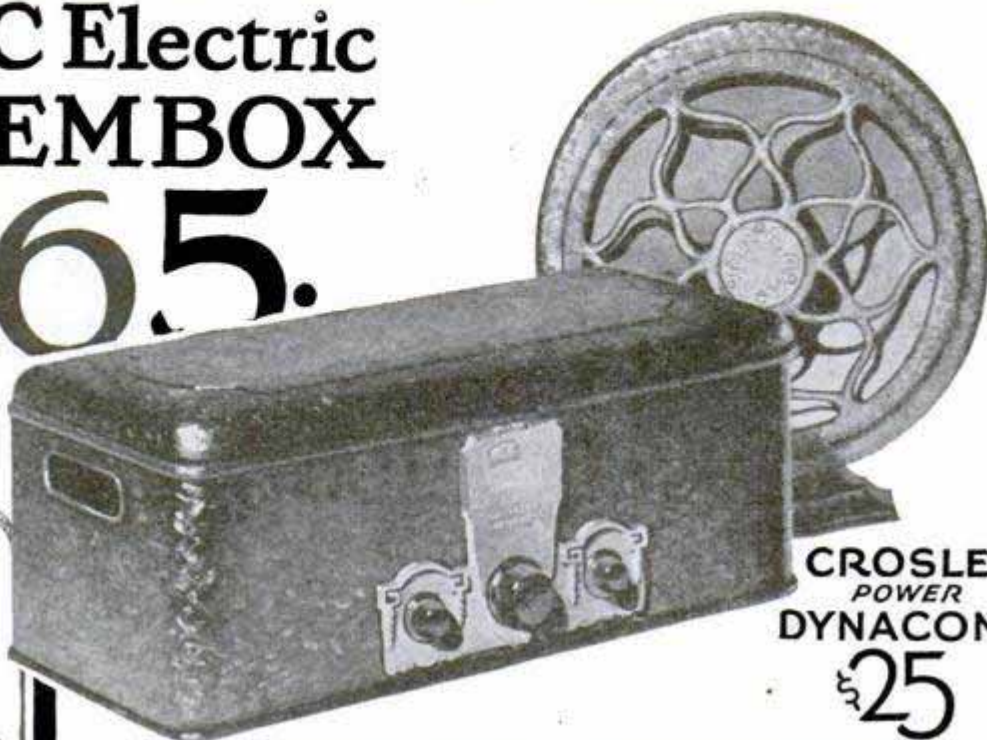
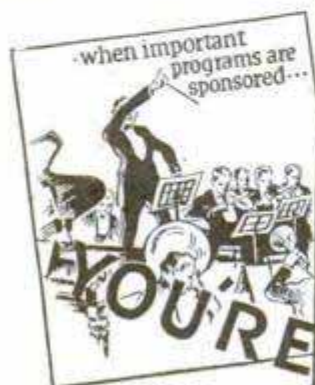


The 8 tube AC Electric
SHOWBOX—\$80

Genuine Neutrodyne circuit—push-pull audio amplification with two 171 power tubes on last stage—trouble proof Mershon condenser supplying full 180 volts CONSTANTLY—modern illuminated dial—(7 tubes, radio, detector, audio stages and 1 rectifier, 8 in all)—operating dynamic type power speaker—unbeatable in performance and value offered—\$80.



Crosley Battery Type Sets embody superior advantages of new AC models. The 6 tube **BANDBOX** operates the **DYNACONE**, new Crosley dynamic typespeaker. Price \$55. The 5 tube **BANDBOX Jr.**, is a dry cell set very easy on batteries and operates loud speaker. Price \$35.



CROSLLEY
POWER
DYNACONE
\$**25**

..gives no condenser trouble

The higher the voltage the better the reception. Crosley has designed this set to stand maximum power supplied CONTINUOUSLY. Celebrated Mershon Condensers used in the power supply section do NOT BREAK down. If they should be punctured they are self-healing. Paper condensers constantly break down and the only safeguard is to reduce power which reduces enjoyment of your radio.

..operates power speaker

The popular dynamic quality of radio reception is attained in the new power **CROSLLEY DYNACONE**. This speaker like its predecessor has created a tremendous demand because of its wonderful performance at so low a price. The range of true notes on this new speaker has been greatly increased over accepted standards.

..uses famous Neutrodyne circuit

This well known and preferred radio circuit is introduced into this inexpensive radio that you may possess the BEST possible apparatus for receiving radio programs. This with other Crosley features permits you a degree of selectivity and sensitivity that many a radio at twice and three times the \$65 price of this set will never have.

..embodies latest radio improvements

Modern illuminated dial for dark corners—is easy to read especially these days of hunting about for station reallocations. The rich gold highlighted brown case is both an attractive container and an efficient shield. Everything about this amazing set is **NEW, UP-TO-DATE!** Enormous demand—mass production—straight line assembly—enables Crosley to top the radio world with this unmatched value this season!

THE CROSLLEY RADIO CORPORATION

Department 15

POWEL CROSLLEY, JR., Pres.

Cincinnati, Ohio

THERE WITH A CROSLLEY

Prices quoted are without tubes. Montana, Wyoming, Colorado, New Mexico and West, prices slightly higher.



JIMMIE, THIS THING WILL SELL! LET ME BORROW IT FOR THIS AFTERNOON

THAT'S WHAT THEY CALL A KRISS-KROSS STROPPER- IT GIVES THE SLICKEST SHAVES EVER INVENTED



JIMMIE, THAT KRISS-KROSS STROPPER YOU LOANED ME A YEAR AGO - WAS THE START OF A \$15,000 BUSINESS

I SHOULD HAVE KEPT IT AND GONE INTO THE KRISS-KROSS BUSINESS MYSELF

How I Started Making \$5300 A Year

With a Borrowed Kriss-Kross Stropper

BY B. G. LOUGHREN



\$200 the first week! \$1000 in a single month! And over \$5300 cash profits in a year! When I sit down and look at those figures in my bank book, I can't help marveling at the strangeness of fate. It was Chance—and Chance alone — that thrust this money-making opportunity into my path at the very moment I needed

it most! I had been in the real estate business in Florida, when suddenly the "boom" collapsed. The immediate future looked gloomy, until one day when I dropped in to talk things over with a friend.

When I went into his office, he was at the wash bowl just finishing shaving, so I sat down at his desk where my eye fell on a little nickel-plated contrivance about half the size of my hand. There was something about it that aroused my curiosity.

NEW, REVOLUTIONARY INVENTION

"What's this thing?" I asked.

"That's one of those KRISS-KROSS razor stropers," said Jimmy. "You've read about it in the magazines. I've only been using it a month but I'm getting the keenest shaves of my life, all from the same blade. Look here, I'll show you how it works."

Well, it certainly was a mechanical marvel. I hadn't seen anything as ingenious in years!

"I wish I could invent something like that," I said. "I'll bet the company that puts it out is coining money hand over fist."

"They are," said Jimmy. "Furthermore, they only sell through agents and demonstrators,—and those agents are making plenty, too! I sent for their proposition the other day just out of curiosity."

He handed me a letter with some sample order blanks attached. I read it through and then read it all over again.

"Jimmy," I said at last, "this thing sure will SELL—and they certainly give their men a generous split! Let me borrow your stropper this afternoon and see how many orders I can take!"

ASTONISHING PROFITS

That afternoon I got the surprise of my life. The first man I walked up to had read all about KRISS-KROSS in The Saturday Evening Post and

said "Send me one" before I got half-way through my demonstration. By 4:30 I had 9 orders—and the next morning I got 11 more!

That sure convinced me—and I wrote the company that although they were not aware I was working for them, the only way they could stop me was by wire!... They wrote back—"Good work. Go to it."... Needless to say, I "went to it" in earnest and the end of the week found me with exactly \$200 cash profit in my pocket!

A \$15,000 BUSINESS ALMOST OVERNIGHT

The money I made that first week came easily enough—but after I got well started it became easier and easier. And then, before I knew it, I found that I was actually clearing as high as \$1000 in the single month!

Today I figure that I did a \$15,000 gross business that first year—with profit of over \$5000. And it all came from getting started with the right kind of a proposition. Success comes from giving the public what it wants and they surely have shown that they WANT KRISS-KROSS! Personally, I believe that it is the greatest direct-selling item of all time! * * *

Mr. Loughren's experience is typical of the surprising successes of KRISS-KROSS representatives in all parts of the country. Practically every man finds himself making money faster and easier than he ever dreamed possible. Right now, due to our heavy Fall advertising program in Liberty, The Saturday Evening Post, Collier's, etc., there is room for more KRISS-KROSS representatives—to earn \$30 a day and up. Find out about this opportunity today. No obligation. Just clip the coupon and mail it at once!

RHODES MANUFACTURING CO.
Makers of KRISS-KROSS

Dept. B-373, 1418 Pendleton Ave., St. Louis, Mo.



Why KRISS-KROSS Pays Agents Such Astonishing Profits

KRISS-KROSS actually reproduces with mechanical precision the intricate diagonal stropping stroke of a master barber. Strops any make blade (except Durham Duplex), giving the keenest cutting edge that steel can take! Just insert blade and turn the crank for 11 seconds.

How can anyone help but be interested in such an amazing device, especially since it means cool smooth shaves forever with no more blades to buy!

Rhodes Mfg. Co., Dept. B-373,
1418 Pendleton Ave., St. Louis, Mo.

Please send me details of KRISS-KROSS Stropper with generous commission proposition you offer to representatives and agents, working full or spare time.

Name.....
Address.....
Town..... State.....

New!



Just a Twist of the Wrist

Banishes Old Style Can Openers to the Scrap Heap

and Brings Agents \$5 to \$12 an Hour!

WOMEN universally detest the old-style can opener. Yet in practically every home cans are being opened with it, often several times a day. Imagine then, how thankfully they welcome this new method—this automatic way of doing their most distasteful job. With the wonderful little Speedo can opener you just put the can in the machine, turn the handle, and almost instantly the job is done.

may seem almost incredible to you. I'll grant you that the profit possibilities are so tremendous that it's impossible to give more than a mere hint of them here. So I've worked out a plan by which you can examine the invention and test its profit possibilities without risking one penny of your own money.

Mail the Coupon Today

All I ask you to do is to fill out and mail the coupon below. You do not obligate yourself in any way whatever. I'll rush you the details. Get my FREE TEST OFFER while the territory you want is still open—I'll hold it for you while you make the test. I'll send you all the facts about \$75 to \$150 a week with Speedo. I'll also tell you about another fast selling item in the Central States line that brings you two profits on every call. All you risk is a 2c stamp—so grab your pencil and shoot me the coupon right now.

READ!

One of my prospects told me she could get along with her old can opener. Two weeks later her husband ordered a can opener from me saying his wife had cut her hand badly.—W. L. Godshalk, Pa.

AGENTS!



**\$265
in a
Week**

"Here is my record for first 30 days with Speedo:

June 13,	60	Speedos
June 20,	84	Speedos
June 30,	192	Speedos
July 6,	288	Speedos

Speedo sells to 9 out of 10 prospects."

M. Ornoff, Va.

PART TIME

14 Sales in 2 Hours

J. J. Corwin, Ariz., says: "Send more order books. I sold first 14 orders in 2 hours."

SPARE TIME

Big Money Spare Time

Barb, W. Va., says: "Was only out a few evenings and got 20 orders."

A "Million Dollar" Can Opening Machine

The Speedo holds the can—opens it—flips up the lid so you can grab it—and gives you back the can without a drop spilled, without any rough edges to snag your fingers—all in a couple of seconds! It's so easy even a 10-year-old child can do it in perfect safety! No wonder women—and men, too—simply go wild over it! And no wonder Speedo salesmen often sell to every house in the block and make up to \$10 an hour either spare or full time.

Generous Free Test Offer

Frankly, I realize that the facts about this proposition as outlined briefly here



Patented Household Specialties

CENTRAL STATES MFG. CO.

Dept. B-702

4500 Mary Ave. (Est. over 20 years) St. Louis, Mo.

Central States Mfg. Co.,
4500 Mary Ave., Dept. B-702,
St. Louis, Mo.

Yes, rush me the facts and details of your FREE OFFER. And tell me how I can make \$75 to \$150 a week.

Name

Address

City

State

() Check here if interested only in one for your own home.