

DECEMBER

25 CENTS

REGD. TRADE MARK, GREAT BRITAIN No. 410430 REG. U.S. PAT. OFF.

# POPULAR MECHANICS

## MAGAZINE

WRITTEN SO YOU CAN UNDERSTAND IT



SEE PAGE 1021

M. GUNDLACH



# ATKINS

## SILVER STEEL SAWS



### ATKINS SILVER STEEL HACKSAW BLADES

Economical because they last longer

WILL LAST AT LEAST SIX TIMES AS LONG AS ANY OTHER HACKSAW BLADE

25 TO EACH INCH OF EACH

Will Not Snap

Keep Their Teeth

THE RIGHT NUMBER OF TEETH FOR YOUR WORK



Mr. Happy Man Says

## “They Cut TWICE as Fast”

YOUR Hardware Dealer can show you the wonderful new ATKINS “Silver Steel” Hack Saw Blades for hand use. They revolutionize metal cutting—cut *twice* as fast, and last at least *six times* as long, as any other hack saw blade you ever used.

Think what a saving of time, money and effort this means. What it means to do a metal-cutting job in *half* the usual time—to have a hack saw blade that will outlast *six* ordinary blades! “Silver Steel” blades keep their teeth and will not snap.

You should be using these new blades NOW. Ask your hardware dealer for them. If he cannot supply you, write and tell us what kind of metal you are cutting, enclosing 25c, and we will send you a sample “SILVER STEEL” blade.

E. C. ATKINS & CO., Est. 1857, 426 So. Ills. St., Indianapolis, Ind.

Leading Manufacturers of Highest Grade Saws for Every Use; Saw Tools, Saw Specialties, Plastering Trowels, Machine Knives, Grinding Wheels and Files.



# At Your Hardware Store



LEAVE IT TO THE YOUNGER CROWD TO KNOW THE BEST!



**I**T is characteristic of this younger set to settle the cigarette question exactly as they settle their hard-fought games—on the sporting principle of “may the best win!”

**F A T I M A**



*A few cents more—for the best that money can buy!*





for  
Christmas

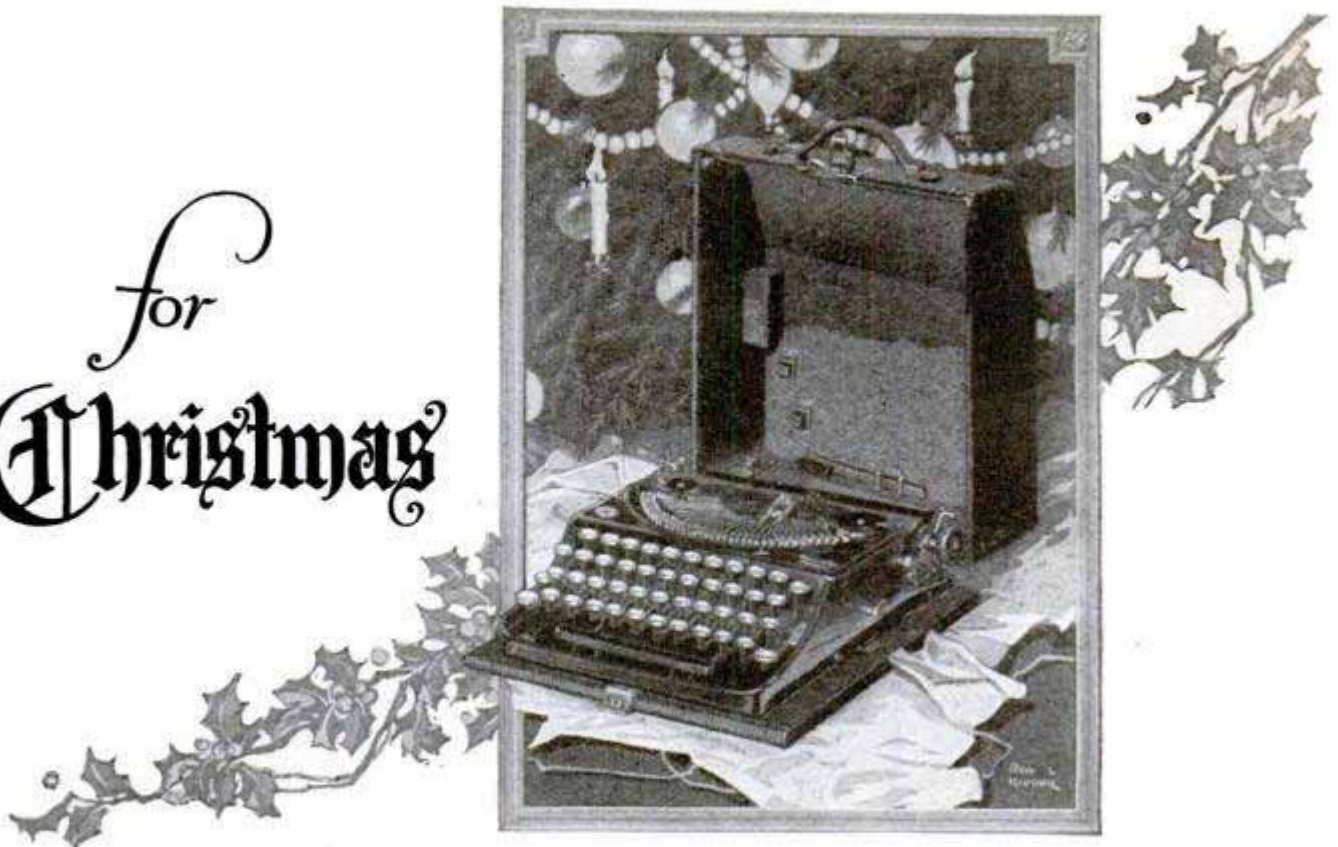

**A**RE you searching for a helpful, useful, practical Christmas present—for son, or daughter, for brother or sister, for wife or husband, for dearest friend?

Here it is! The Remington Portable is a gift that always inspires gratitude, for it provides its owner with the modern, time-saving way to write.

Remember that the Remington Portable is the world's smallest and lightest typewriter with standard keyboard—weighs only 8½ pounds net and fits in a case only four inches high. But it is complete in every feature—strong and durable—simple and easy to operate—the recognized leader—in sales and popularity.

Terms as low as \$5 monthly. Sold by Remington branches and dealers everywhere. Send for our booklet "For You—For Everybody." Address Dept. 12 Remington Typewriter Company, Division of Remington Rand, 374 Broadway, New York.

# Remington Portable



OVER FOUR MILLION REMINGTON TYPEWRITERS BUILT AND SOLD



# Popular Mechanics Magazine

200 E. Ontario Street, Chicago, U. S. A.

H. H. WINDSOR, Founder

H. H. WINDSOR, Jr., Editor and Publisher

London: Hachette & Cie.,  
16-17 King William Street, Charing Cross, W. C. 2

Paris: Hachette & Cie.,  
111 Rue Reaumur

Melbourne: Gordon & Gotch  
509-513 Little Collins St.

ISSUED MONTHLY

SUBSCRIPTION:

SINGLE COPY, 25 CENTS

In United States and its possessions, also Canada, Cuba, and Mexico, per year, postpaid - \$2.50

To all other countries in the Postal Union - 3.00

All subscriptions are discontinued at expiration. Please examine the date printed on your wrapper.

Entered as Second Class Matter Sept. 15, 1903, at the Post Office at Chicago, Illinois, under Act of March 3rd, 1879.

Entered as Second Class Matter at the Post Office Department, Canada.

Published monthly by POPULAR MECHANICS CO.

Copyright, 1927, by Popular Mechanics Co.

Copyright in Australia. Copyright in France

Vol. 48

Contents for December, 1927

No. 6

Advertising			
big toothpaste tube gives bathers ride	987		
statue of cow advertises city creamery	927		
Airplanes			
midget high-speed, has 80 horsepower motor	1000		
seven passenger, supported by one man	895		
without wing struts may have greater speed	984		
Animals—in first balloon flight honored	897		
Archæology—ancient toy soldier found in burial mound	913		
Architecture			
beauty of city increased by color of buildings	890		
Russians plan bomb and gas proof cities	924		
Astronomer—Danish honored by marble monument	906		
Astronomy			
color photos of Mars result in new riddles	987		
the world's largest eye	970		
where a pint weighs 25 tons	962		
Automobiles			
speed of pocket-size car 18 miles an hour	891		
truck wheels of rubber reduce tire expense	953		
Automobiles—Accessories			
disappearing bed latest camping comfort	968		
heater eliminates back pressure	906		
heater unit helps start car and saves gasoline	993		
self-dimming light penetrates fog	936		
tin traffic officer in car helps prevent accidents	896		
Automobiles—Repairs			
pedal depressor aids in brake adjustments	961		
vertical lift elevator saves garage space	999		
Automobiles—Tires—casing spreader helps prevent punctures	955		
Automobile Trucks—demountable body for loading	992		
Aviation			
are ocean flights worth the price?	885		
carrier holds eighty planes	989		
deliver papers by airplane with small parachute	968		
Barrels—easily pulled up stairs	883		
Baseball—indoor, played in box	946		
Bicycle—flying to have speed of 50 miles an hour	982		
Birds—secret of flight sought by science	929		
Boats and Boating			
birds' wings emulated in new sailing yachts	986		
small boat run by windmill built to cross Atlantic	999		
speed boat of rubber won't get water-logged	1000		
Bowlders—artificial, protect river bed from erosion	928		
Boxing—in barrels	884		
Bridge, Japanese—shows progress	883		
Bullets—that leave track of fire aid target practice	998		
Bump Meter—insures smoother roads	961		
Cable—protecting shore ends of	957		
Cards (Playing)—black-backed show fewer stains	890		
Chair—locking joint increases life of	975		
Chimney—cleaner and draft combined	978		
Circus—It's a simple life for children of the	948		
Clock—starts furnace	947		
Concrete Form—wall tie for, saves work and cost	987		
Crime—fingerprints enlarged to aid identification of criminals	973		
Electricity			
high-voltage tester guards against accidents	960		
splendor of oriental palace magnified by lights	969		
Electric Wires—tester for, simplifies repairs	920		
Elephant—stone, as billboard in China	960		
Engraving Block—of cellulose composition	976		
Fire Fighting			
auto changed into fire engine to help save forests	956		
extinguisher like pistol	969		
Fire Station—like residence beautifies city	910		
Fish—guarded from road oil by curtain on bridge	922		
Food and Nutrition—how Uncle Sam's food testers help you	995		
Foundry Ladle—sliding-grip, guards hands from heat	998		
Furnace—gas, for home has many advantages	997		
Garage—Accessories			
merry-go-round wash rack quickly cleans autos	895		
valve grinder that fits hand	923		
Gardening—"collars" speed plant growth	938		
Gas Masks—tested to prevent accidents	890		
Gauge—to place door hinges	982		
Gems—mysteries of, puzzle scholars	985		
Golf—ball branding stamp prevents loss	913		
Gun—coast-defense, has range of 27 miles	912		
Handcuffs—like steel mittens prevent use of gun	976		
Horse Racing—the horse or the jockey?	916		
Household Devices	990		
House Plan	1056		
Ice Cream			
frozen with tablets	904		
special scoop for cones	923		
Insomnia—bed rocked to imitate train as cure	889		
Library—on wheels serves rural readers	895		
Life Saving			
electric pump to restore blood circulation	992		
throwing out life lines from airplanes	907		
Lightning—artificial, studied in laboratory	891		
Lock—door knob has cylinder for added protection	969		
Lumbering—aided by amphibian tug	937		
Mail			
air-mail letters identified with label tape	957		
growth of air, sets aviation record	955		
slot machine that cancels letter eliminates stamps	914		
tracking down the robbers	898		
Meat Packing			
needle branding device identifies grade of meat	985		
steel gloves for packing-house butchers	943		
Memorials—foreign monuments to American heroes	958		
Mirages—weird phantoms of the air	979		
Models—plane flies backward or poises in air	945		
Motor Bus—tilted windshield eliminates reflection	911		
Motorcycle			
contortions of passenger help win race	905		
trailer cuts outing cost	914		
twin sidecars carry two children	904		
Motor Sled—run by cogwheel	942		
Moving Pictures			
cameramen ride on engine to film rail movie	894		
hair tests with color chart to improve	911		
show romance of industry	937		
traveling theaters for Italian towns	905		
Music—scales measure power needed to play piano	983		
Oil—wells tamed by cement applied by novel process	998		
Package Tier—portable, saves time and expense	927		
Paints and Painting			
airline from paint sprayer supplies worker's mask	923		
hand sprayer for lacquering	953		
Paving—motor driven pounder lays blocks	912		
Physical Culture			
leg exerciser keeps runner in trim	955		
mechanical wrestler develops arms and back	897		
Plumb Line—self-chalking saves worker's time	913		
Police			
"Iron Philip" helps train German	943		
traffic, have heater and protecting shield	978		
traffic, use periscope to trap speeders	989		
Pontoon Bridge—profits from, reward builder	983		

[Continued on Page 4]



Poultry—chicken farm on city roof	947	Automobiles—Driving	
Radio		anti-glare cap for motorists	1030
cabinet table built for less than five dollars	1001	fence from old wheels guards ditch	1031
tone filter made from Ford coil	1010	instructing beginners	1020
weakened by light shining on aerial	912	Automobiles—Equipment and Supplies—leather strap	
Radio—Aerials		adds safety to coach	1029
cleaning insulators	1013	Automobiles—Repairs	
on apartment houses	1011	oiling the springs	1018
Radio—Applications		repairing radiator leak	1031
Scotland Yard enlists radio to help catch thieves	936	Birds	
street lamps in eastern city controlled by	978	ornamental dovecote	1017
tanks equipped with direct British maneuvers	910	winter feeder for	1035
Radio—Batteries		Curtains—weights to prevent whipping	1029
handy tester	1013	Diamonds—bathing to check yellow tinge	1029
new charger is dry	1004	Door Lock—protected by receptacle plate	1016
trickle charger from full-current charger	1011	Electric Toaster Stove—lid for	1029
Radio—Broadcasting—time card	1004	Fireproofing—Christmas tree ornaments	1017
Radio—Coils—small electrically driven winder	1011	Fish and Fishing—kink for fishermen	1030
Radio—Condensers—testing	1004	Furnace, Hot-Air—automatic valve for water pan	1018
Radio—Installation—oscillator for testing and calibrating	1014	Hangers—hat, for closet shelf	1019
Radio—Loud Speaker—built in globe form	1014	Milk Pail—clean bottom for	1017
Radio—Receiver		Motor—outboard, removes water from basement	1020
loop set built in for cabinet speaker	1005	Mucilage—bottle corks that won't stick	1018
shielded units feature new infradyne	1012	Screen Door—cork prevents hook marring	1031
Radio—Tubes—booster works on B-battery	1013	Scrubber—electric floor	1017
Railroads		Shelves—fitting to odd corners	103
air jack speeds transfer of car wheels	944	Ship Models—build the "Flying Cloud"	1021
engine location board aids efficiency	946	Skating—flaming beacon for night	1019
fair of the iron horse celebrates 100 years of	892	Sled—single runner for narrow track	1032
most difficult covers seventy miles	922	Steel Wool—as furnace repair	1035
rail-laying device operated by one man	989	Toothpaste—cleaning out tubes	1030
shields on open observation car	984	Toys—two homemade, for Christmas	1033
testing giant of the rails over mountains	896	Trees—protecting young fruit	1030
Refrigeration—refrigerating unit operates on cook stove	956	Violin—restoring tone quality of	1019
Rivet—cutter shield reduces labor and aids safety	994	Water Pipes—thawed with brick torch	1036
Roosevelt—house returns to the family	884		
Saws and Sawing—electric for butchers	935		
Service Station—like teapot	985		
Ships—building in backyard is profitable hobby	993		
Ships and Shipping			
electric beam penetrates fog to find ships	974		
floating service stations for liners	914		
just one more trip	930		
modern Vikings prove Ericson's feat possible	988		
Shoe Pad—air cushion, relieves foot ills	975		
Skyscraper—X-ray picture of shows structure	944		
Smokers' Accessories—air and water pipe	894		
Snow—fighting on Pikes Peak simplified by tractors	945		
Spectacles—bow on top gives wearer clearer view	897		
Spiritualism—tricks of the ghost hunters	939		
Sports—putting zip and speed into winter	915		
String—seven mile ball of	922		
Structural Engineering—buildings tested in wind tunnel	920		
Sunburn—fancy, with stencils	921		
Swimming—dog-disguised swimmers add sport to race	975		
Taxidermy—paraffin bath for specimens	977		
Temperature			
fat men can stand more heat than thin	891		
regulated by automatic valve on radiator	911		
Traffic			
light cells as policemen to regulate	994		
sign in silhouette is more easily read	973		
Singapore policemen carry signs on backs	928		
Transportation—from stagecoach to the latest plane	936		
Trees			
change fruit of walnut, by grafting	953		
dwarf, a possible substitute for briar	947		
Typewriters—folding cover prolongs life of	911		
Vision—affected by overeating	989		
Warfare—cavalry horses to be dyed to combat air attacks	927		
Weed Cutter—for railroad right of way	983		
Whales—a fat cure from	881		
Wires—tested by apparatus which measures billionth of inch	904		
Woodpeckers—harm power lines' poles	974		
Yosemite Falls—framed in high hotel window	938		

## SHOP NOTES

Automobiles—canvas apron prevents overheating	1038
Automobiles—Driving—cautions in use of anti-freeze solutions	1048
Automobiles—Equipment and Supplies—serviceable spring bumper	1052
Automobiles—Repairs—mirror useful when working behind instrument board	1041
Baggage Truck—rubber tired	104
Boxes—carrier for two	107
Building Construction	
advantages of air space around foundation	1040
driving long rods into the ground	1047
homemade loader saves time for contractor	1041
Can Handle—detachable	1054
Casting Dies—cleaning on linotype	1044
Ceilings—repairing cracked	1037
Chute—substantial built-in, for barrels and boxes	1053
Corn Crib—improving construction of sill	1043
Cultivators—plow pins for	1044
Cutters—clearance of milling	1052
Drawing Board—improving	1042
Factory Trucks—locking wheels to back straight	1055
Furnace—pipeless, made from old heater	1049
Garage—Accessories—clamp to hold auto hood	1051
Glass—fluids for drilling	1043
Guide—for cutting knife	1041
Hammer—for armature winders	1055
Handcar—windshield for	1048
Heater—for small shop floor	1055
Hydraulic Ram—curing a waterlogged	1047
Irrigation Canal—most economical shape found by experiment	1052
Junk—new uses for old	1045
Lawn—homemade water-ballast roller	1043
Linoleum—heating, facilitates laying	1039
Linseed Oil—to bleach	1055
Magnet Wire—removing insulation from	1039
Oilcan—handy and economical spout	1042
Paints and Painting—effective white paint cleaner	1039
Piano Stool—used as tool holder	1051
Pipe—handy rack for	1047
Poultry—improved whitewash disinfectant	1043
Sawhorse—folding, for small repair work	1048
Screws—to make hold in soft wood	1040
Tack—radium-headed shows door	1047
Tools—holder makes gauge of scales	1040
Traffic—mirror prevents auto accidents at gateway	1042
Wagon—effective brake	1046
Water Gauge—old culvert pipe makes inexpensive	1044
Wax—for filling pits in varnish on piano	1048
Wheelbarrow—rubber tired	1044
Wood Rot—preventing in posts	1042

## AMATEUR MECHANICS

Alum—household uses for	1036
Automobiles	
grease cup helps prime vacuum tank	1032
how to prevent a frozen oil pump	1032
turnbuckle on Ford fender brace	1036
Automobiles—Accessories	
canopy for rumble seat	1018
plug and jack for trouble lamp	1035
windshield warmer	1018

Specimen, paraffin bath 977



# DRAKE'S PRACTICAL MECHANICAL BOOKS

## THEY WILL RAISE YOUR PAY—

### ORDER ON 5-DAY TRIAL

The books listed below will perfect you in your chosen trade—pave the way to the big positions. Written in non-technical language—easy to read and understand. Every book covers its subject completely. An entire course of instruction condensed into one volume. Your choice sent postpaid—you benefit 5 days—money refunded in full if not entirely satisfactory. Order direct from this page.

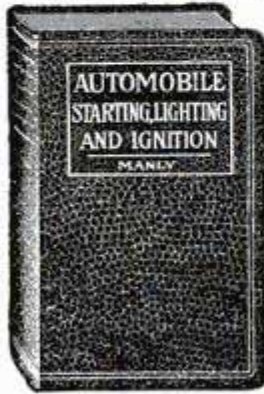

#### Automobile Books

- Automobile Starting, Lighting and Ignition, by Manly... 700 pp. \$3.00
- Books' Automobile Handbook... \$2.00
- Ford Motor Car, Truck and Tractor, by Manly... Cloth \$1.50
- Automobile Battery, Care and Repair, by Manly... Leatherette \$2.00
- Motorcycle Handbook, by Manly... \$1.50

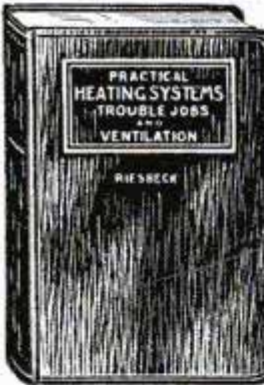

#### Shop Practice Books

- Practical Heating Systems, Trouble Jobs and Ventilation... \$4.00
- Sheet Metal Workers' Manual... \$2.00
- Oxy-Acetylene Welding and Cutting... Cloth \$1.25
- Slide Rule and Logarithmic Tables... \$2.00
- Handbook for Millwrights... Cloth \$2.00
- Machine Shop Practice... Cloth \$2.00
- Mechanical Drawing and Machine Design... Cloth \$2.00

### ORDER DIRECT FROM THIS PAGE—ON OUR MONEY-BACK PLAN

The books listed above are only a few of the many in our catalogue, which you will receive promptly after filling out and mailing us the attached coupon. For quick action order direct from this page—cross name of each book wanted and send in with price quoted. We prepay postage and send the books on our money-back plan.

## FREDERICK J. DRAKE & CO.

Publishers

1008 Michigan Ave. CHICAGO  
Drake Books Are For Sale at All Book Stores

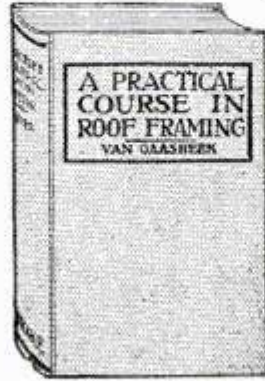

#### Carpentry Books

- Cloth Binding
- Modern Carpentry, 2 vols. \$3.00
  - The Steel Square, 2 vols. \$3.00
  - Modern Estimator... \$1.50
  - Timber Framing... \$2.00
  - Builders' Architectural Drawing... \$2.00
  - Concrete... \$1.50
  - Practical Bungalows... \$1.00
  - Roof Framing, by Van Gaasbeek... \$1.50

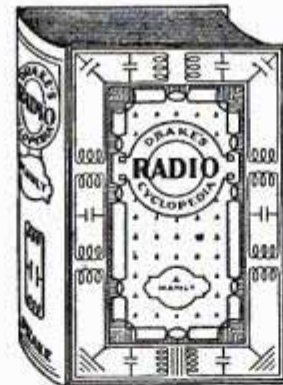

#### Drake's Radio Cyclopedia

By H. P. Manly

870 Pages, 985 Illustrations, 1700 Subjects, arranged alphabetically. For Service and Repair Men, Dealers, Salesmen, Experimenters and Designers. Bound in Art Buckram. Price... \$6.00



#### Painting and Decorating

- Furniture, Furniture Finishing, Decoration and Patching... \$5.00
- Ross Crane Book of Home Furnishing and Decoration... Cloth \$3.00
- House Painting Methods with the Brush and Spray Gun, by Vanderwalker... Cloth \$2.00
- Interior Wall Decoration, by Vanderwalker... Leatherette \$4.00
- The Mixing of Colors and Paints, by Vanderwalker... Cloth \$2.00
- Studio Handbook—Letter and Design... \$3.00
- A Show at Sho' Cards... Cloth \$4.00
- Sign Painting, by Atkinson... Cloth \$4.00
- Strong's Book of Designs, Leatherette \$4.00
- Modern Painters' Cyclopedia, Cloth \$2.00
- Automobile Painting... Cloth \$1.50
- New Hardwood Finishing... Cloth \$1.50
- Wood Finishing, Plain and Decorative... Cloth \$2.00
- Owen's Paint Guide... Cloth \$1.00

#### Steam Engineering

- Swingle's Handbook for Steam Engineers and Electricians... Leatherette \$4.00
- Examination Questions and Answers for Marine and Stationary Engineers... Leatherette \$2.00
- Steam Boilers... Leatherette \$2.00
- Swingle's Catechism of Steam, Gas and Electrical Engineering... Leatherette \$1.50

#### Modern Languages

- By Prof. P. S. Allen, U. of Chicago
- French without a Teacher... Cloth \$1.25
- Spanish without a Teacher... Cloth \$1.25
- German without a Teacher... Cloth \$1.25
- Everyday French... \$1.25
- Everyday Spanish... \$1.25

**FREDERICK J. DRAKE & CO.**  
1008 Michigan Avenue  
Chicago, Ill.

GENTLEMEN:—Please send me free, postage paid, your illustrated catalogue which lists and describes 200 Practical Mechanical Books for Home Study.

My name is .....

and my address .....

Mail Coupon For Free Catalogue  
Your Guide to Home Study



# "Were You Born a Money-Maker?"

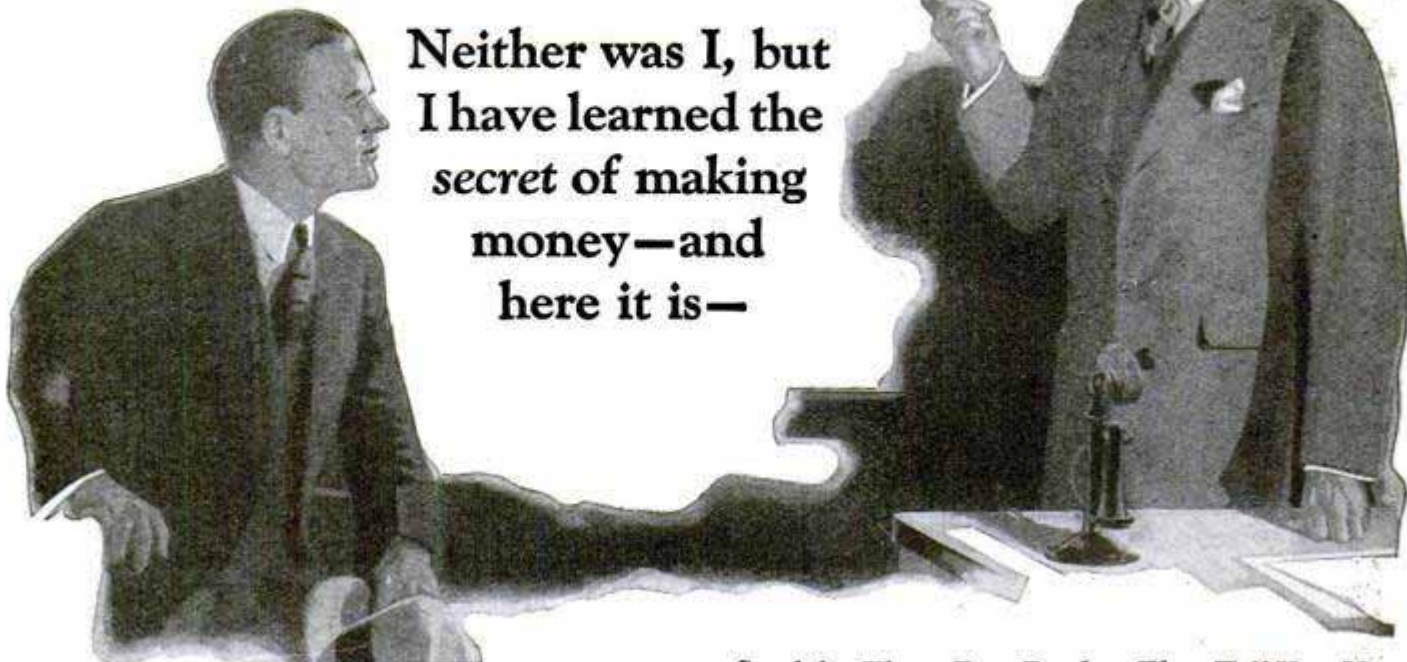

Neither was I, but I have learned the secret of making money—and here it is—

I'M going to let you in on a little secret, Tom. It ought to be worth at least \$5,000 a year to you, and I'm not going to charge you a single penny—

"When I was your age, I was always wondering why the boss never seemed to take much interest in me. Every six months or so I would hit him for a 'raise'—and once in a great while I would get an extra \$5 a week. But the big jobs—the jobs that paid real money—always went to someone else.

"Then something happened that set me thinking—

"Bob Harris, who had started at the same time I did, was promoted to the very job I had picked for myself—salary \$6,500. I knew Bob didn't have any more natural ability than I had—yet the fact remained that he got the place. And I had to admit he was better able to swing it!

"Well, I took myself aside, and for the first time in my life I looked the situation squarely in the face. That night I clipped and mailed a LaSalle coupon.

## How He Landed the Big Job

"And now came the big surprise—for me, at least.

"I had always looked upon home-study business training as drudgery. Inside of three weeks, however, I actually got to *looking forward* to those different lesson assignments. You see, instead of reading a lot of heavy, theoretical stuff, I took up case after case that represented *actual business problems*. I was shown the principles that governed them; *then I worked them out for myself*. It fascinated me, because I could actually see myself grow.

"First thing I knew, I received my first real 'raise'—then a better job—and a better one yet—

"I told you I was going to let you in on a little secret. Well—the secret is this: Always give a little more than you're paid for. And—so that you can be *sure to give more, first get more to give!*"

## Send for These Free Books—They Tell You How

You want to make more money—as soon as possible—with the least lost effort.

Then there's one thing you should do immediately—you should send to LaSalle Extension University and find out how you can turn that secret into cash.

During only six months' time—as a direct result of putting that secret into practice—as many as 1,248 LaSalle members reported definite salary-increases totalling \$1,399,507—an average increase per man of 89 per cent. **Find out how you can duplicate or even exceed this record.**

To aid you in this purpose, LaSalle has prepared two very interesting and helpful books and will send them to you without cost or obligation. One is a 64-page book outlining the opportunities in the business field that most appeals to you—telling you exactly how you can turn them to your own advantage. The other has marked the turning point for thousands. It is entitled, "Ten Years' Promotion in One."

Face your problem—decide the field in which you want to make a big success—then fill in, clip and mail the coupon NOW.

— — — — Find Yourself Thru LaSalle — — — —

## LaSalle Extension University

The World's Largest Business Training Institution

Dept. 1264-R

Chicago

I would welcome an outline of the LaSalle plan, together with a copy of "Ten Years' Promotion in One," all without obligation.

- Business Management
- Modern Salesmanship
- Higher Accountancy
- Traffic Management
- Railway Station Management
- Law: Degree of LL. B.
- Commercial Law
- Industrial Management Efficiency
- Modern Business Correspondence and Practice

- Banking and Finance
- Modern Foremanship
- Personnel Management
- Expert Bookkeeping
- Business English
- Commercial Spanish
- Effective Speaking
- C. P. A. Coaching
- Stenotypy



Name.....

Present Position.....

Address.....



# BUILDERS

## TRADE GUIDES



### AUDELS CARPENTERS AND BUILDERS GUIDES—4 VOLS. \$6

Inside Information for Carpenters, Builders, Joiners, Building Mechanics—all Woodworkers. **1600 pages; 3700 diagrams; flexible; pocket size.** Short-cut instructions, new methods, ideas, solutions, plans, systems—money saving suggestions. An easy progressive course for the apprentice. A practical daily helper and Quick Reference for the master worker. A Helping Hand to Easier and Better Work and Better Pay. To get this aid for yourself, simply fill in and mail the FREE COUPON below.

#### INSIDE TRADE INFORMATION ON:

How to use steel square; How to file and set saws; How to build furniture; How to use mitre box; How to use chalk line; How to use rules; How to make joints; Carpenters' arithmetic; Mensuration problems; Estimating strength of timbers; How to set girders and sills; How to frame houses and roofs; How to estimate costs; How to build houses, barns, garages, bungalows, etc.; How to read and draw plans; Drawing up specifications; How to excavate; How to use settings 12, 13 and 17 on the steel square; How to build hoists and scaffolds—skylights; How to build stairs; How to put on interior trim; How to hang doors; How to lath—lay floors; How to paint.

"Audels Guides worth four times their price—in a day too as I carry them in pocket for reference." **W. J. Bates, Knoxville, Pa.**



### AUDELS PLUMBERS AND STEAMFITTERS GUIDES—4 VOLS. \$6

A new set—just out! A practical, illustrated, Reference Library and Study-Course for Master Plumbers, Journeymen and Apprentice Steamfitters, Gas Fitters and Helpers, Sheet Metal Workers, Draughtsmen, Master Builders, Engineers and all Building Trade Students. **1670 pages; 3642 diagrams; flexible; pocket size.** Guides explain all the principles, advances and short cuts of the Plumbing and Heating trade. Contains instructions on how to figure and estimate jobs. Use FREE COUPON below to examine, without obligation, this valuable work.

#### INSIDE TRADE INFORMATION ON:

Soldering, tinning, joint wiping, bending, beating. Pipe—iron—steel, threading. Mathematics, tables, physics. Materials—iron, steel, copper, brass, lead, tin, antimony. Sheet metal—galvanized—plate. Sanitation, syphonage, tanks. Drainage, sewage, purification. Fixtures—bath—kitchen. Pipe fittings, soil pipe, tools. Laying out work. Roughing. Screwed fittings, flanges, joints. Pipe bending, examples. Elbows. Heating, ventilation, refrigeration. Water supply, mains, wells, tanks. Gas-fittings. Underwriters. Sheet metal work, problems, methods, brazing, heating, lead burning. Welding, various welds, methods. Blacksmithing, forges, tools.

"Audels Guides are practical, easy to understand, reliable. Cover the field in plain language." **W. F. Arminger, Annapolis, Md.**

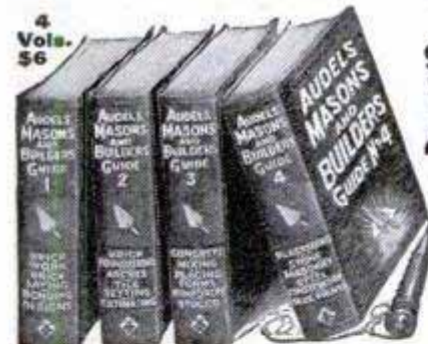

### AUDELS MASONS AND BUILDERS GUIDES—4 VOLS. \$6

A new, complete, illustrated trade reference library, for Bricklayers, Cement Workers, Plasterers, Tile Setters and Stone Masons, including a practical outline of Steel Construction. **1100 pages; 2067 diagrams; flexible; pocket size.** A practical Trade Assistant explaining modern methods of masonry construction. Easy to understand and apply. A reliable and authentic reference work and study-course for Master Journeyman and Young Mechanic. Use FREE COUPON below and find out for yourself, without obligation, whether this set will benefit you.

#### INSIDE TRADE INFORMATION ON:

Bricklaying, tools, materials; Brick designs, patterns, bonds; Setting frames and foundations; Mortars, scaffolds, estimating; Mortars and mortar mixing; Tile setting, mosaic, hollow tile; Straight edge test, trowelling; How to figure brick work; Safe loads, piers, chimneys; Boiler settings, anchors, fire stops; Labor tables; Concrete, forms; How to figure concrete work; Stucco—on old and new buildings; Plastering—wood lath—metal; Plasterers agreement; Plastering on various surfaces; Stonemasonry; Cutting, finishing, estimating stone; Derricks, rigging; Steel construction; Fire proof; How to read blue prints.

"Audels Masons Guides are the best books on the subject. Have laid brick 12 years and am able to judge." **H. A. Sonnett, Corlies, Pa.**



### PRACTICAL ELECTRICITY — 1 VOL. \$4

Audels Handy Book of Practical Electricity is a simplified Ready Reference and Study Course in one pocket size, leather bound volume—for Engineers, Professional Electricians and Students. **1040 pages; 2600 diagrams; flexible red leather bound.** A reliable authority and handy helper for every electrical worker. Contains important and valuable wiring diagrams, calculations, machine sketches, helps on maintenance and repair. Use this FREE COUPON today and find out, without obligation, how this handy book will help you in your daily work.

Complete in one handy, red leather bound volume

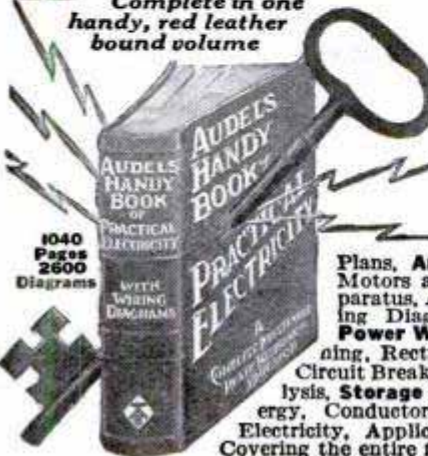

#### INSIDE TRADE INFORMATION ON:

Electro-Therapeutics, X-Rays, Shocks, Welding, Brazing, Radio Hook-ups, Motion Pictures, Telephone, Telegraph, Cranes, Bells, Elevators, Pumps, Tools, Ship Drive, Railways, Vehicles, Automobile Electric Systems, Ignition, Generation, Lighting, Plant Management, Power Plans, Armature Winding, Repairing, A. C. Motors and Apparatus, D. C. Motors and Apparatus, Alternator Construction, Dynamos, Wiring Diagrams, Sign Flashers, Cable Splicing, Power Wiring, Outside Wiring, Switches, Lighting, Rectifiers, Converters, Transformers, Fuses, Circuit Breakers, Rheostats, Electro Plating, Electrolysis, Storage Batteries, Magnetism, Electrical Energy, Conductors, Insulators, Static, Dynamic, Radio Electricity, Applications, Ready Reference and Index Covering the entire field of Modern Electricity.

### Learn More and You Will Earn More!

Know your job and you'll never be without one. The skilled man is always in demand. Knowledge is power. Learn your trade thoroughly by easy reading. This coupon is your opportunity for advancement and better pay. You risk nothing in sending for Audels Guides for free examination. Send it NOW!

FREE EXAMINATION COUPON

**THEO. AUDEL & CO., 65 W. 23 ST., NEW YORK CITY**

Please mail me for free examination the books marked (x) below. If I find them satisfactory, I agree to mail \$1 in 7 days, on each set ordered, and to further mail \$1 monthly on each set until I have paid the purchase price.

- 4 CARPENTERS GUIDES \$6
- 4 PLUMBERS GUIDES \$6
- 4 MASONS GUIDES \$6
- 1 ELECTRICIANS HANDY BOOK \$4

NAME .....

ADDRESS .....

OCCUPATION .....

EMPLOYED BY..... 12T30



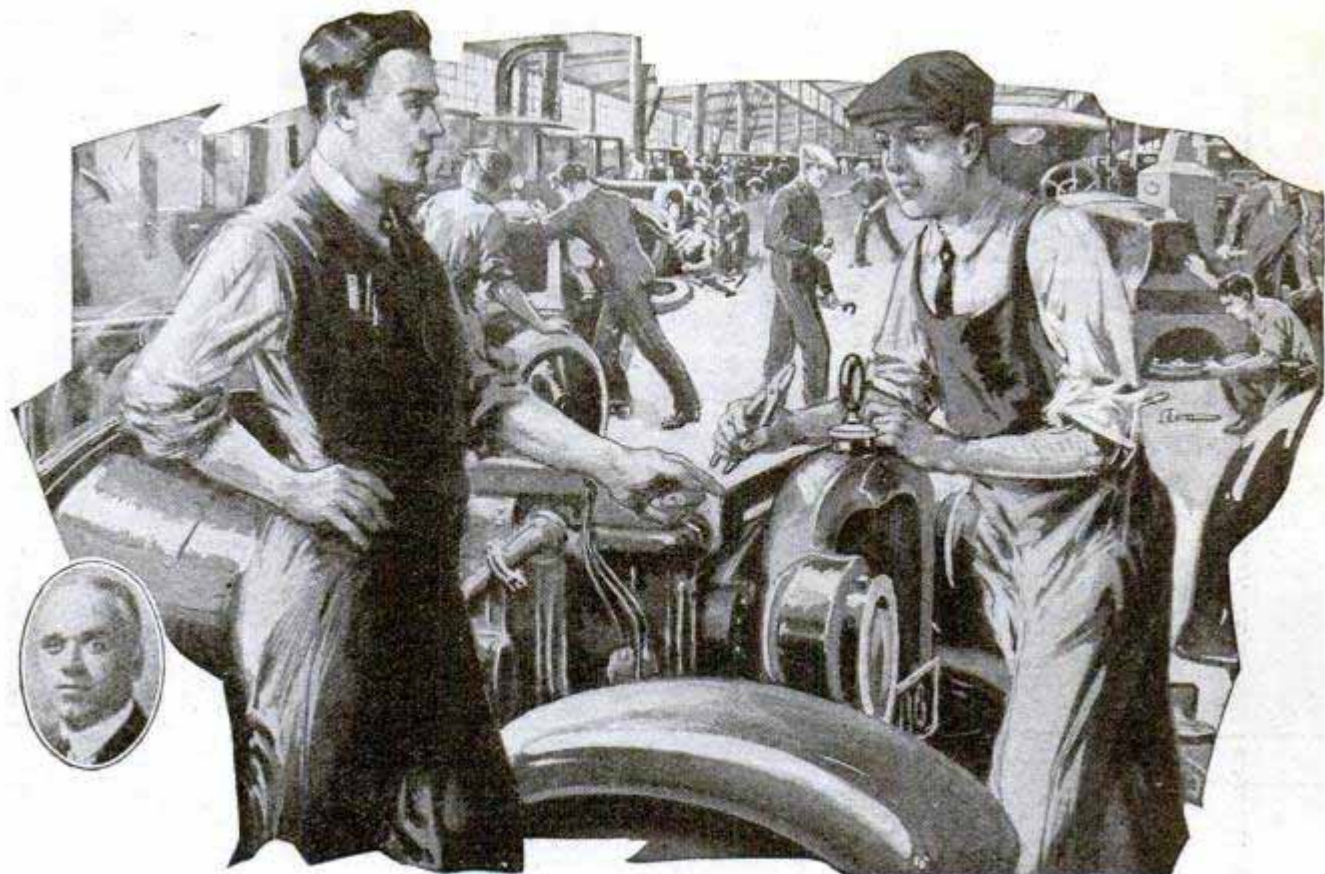

# "I Used to Earn Only \$25 a Week— But it's \$50 to \$75 Now!"

"BEFORE starting your course," writes Mr. James T. Summers of Statesville, N. C., "I knew nothing about auto repair work. I have only a common school education but find your training so clear and easy that a child could understand them. I now own a good, paying business. Before taking your course, I made only \$25 a week. Now I make \$50 to \$75 and have good prospects for the near future."

## GET ALL THE FACTS!

If you're earning a cent less than \$60 a week, get my Free Book now! See the amazing opportunities for **QUICK RAISES IN PAY** in Automotive Field! See how men like W. S. Yancy, Perla, Ark., can have their salaries boosted from \$30 a week to \$90 a week!

## LEARN HOW I TRAIN YOU AT HOME

Don't sell your time for low pay! *You don't need to.* Get my Free Book. Find out how you can become a Big Pay Auto man in **QUICK** time! Keep your present job. Stay home. You don't have to leave your doorstep. Master every Branch of Auto Work *right in your own home.* See how I train you **QUICKLY** and **EASILY** to **BOSS** the Job, or **GO INTO BUSINESS** where Big Pay comes **QUICK**—and up to \$10,000 a year can be made!

The **World's BIGGEST BUSINESS** Need You!

Get into this gigantic Auto Business! **IT NEEDS YOU!** Think of it—*5 Thousand Million Dollars* paid to Auto Men *every year* for upkeep alone! That's why there are so many Opportunities for **Big Raises in Pay QUICK** for the trained Auto Man—opportunities waiting for YOU! If you want to **boost your pay QUICK, clip coupon now.** Common schooling all you need. I help you do it. I give you Lifetime Employment Service—Lifetime Consultation Service too!

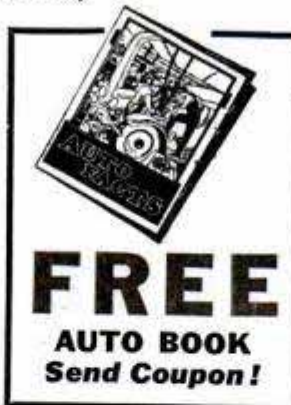

## CLIP COUPON NOW!

Send for this amazing **FREE BOOK** *right NOW!* See how hundreds of men who never had a day's previous Auto experience before writing for my book—and others who had years of experience—are **boosting their salaries, making Big extra Spare-time money,** and getting into **Money-Making Businesses** of their own **QUICK!** Get all the facts! Send coupon now!

**B. W. COOKE, Directing Engineer, Chicago Motor Training Corp., 1916 Sunnyside Ave., Dept. 916, CHICAGO**

B. W. COOKE, Directing Engineer,  
Chicago Motor Training Corp.,  
1916 Sunnyside Ave., Dept. 916, Chicago

Send me FREE Auto Book and proof that you will put me in line for a good job as an Electrical and Mechanical Auto Expert. Also send your 4 Outfits Offer. It is understood that this obligates me in no way.

Name.....

Address.....

City..... State.....

Get the Full  
Details of My  
4 **WORKING  
OUTFITS  
OFFER**

Includes Tools, Tool  
Bag, Electrical Test  
Bench, also Special  
Electrical Exper-  
imental Outfits. Also  
303 Wiring Diagram  
Charts.





## J. G. Vincent was once a toolmaker!

*Today he is Vice-president in charge of Engineering of the Packard Motor Car Co., and one of the big figures in the automobile field*

TWENTY-SEVEN years ago, J. G. Vincent, the farmer boy of Little Rock, Arkansas, was working as a toolmaker.

He loved to tinker about and he had a natural aptitude for the work of the machine shop. But he knew that wasn't enough. Fortunately he realized in time that he needed specialized training in order to make the most of his natural ability. So he enrolled for a course in Mechanical Engineering with the International Correspondence Schools.

Such a combination could not fail. In 1902 Mr. Vincent was made head of the toolmaking department of the Universal Adding Machine Co. In 1903 he was engaged by the Burroughs Adding Machine Co., first as tool designer and then as Superintendent of Inventions. In 1910 the Hudson Motor Car Co. engaged him as Chief

Engineer. Today J. G. Vincent is Vice-president in charge of Engineering of the Packard Motor Car Co.

Jesse G. Vincent is only one of many prominent men in the automobile field who got their early training through spare-time study with the International Correspondence Schools.

Walter P. Chrysler, Chairman of the Board of the Chrysler Corporations, also studied with the I. C. S. So did J. R. Hall, Vice-president and Factory Manager of the Chandler Motor Car Co., and Hiram Walker, the Chief Engineer.

E. V. ("Eddie") Rickenbacker, America's flying ace and Vice-president of the Rickenbacker Motor Car Company, and Max H. Thoms, Supervisor of Inspection of the Marmon Motor Car Company, are other prominent men who once studied with the International Correspondence Schools.

If the I. C. S. can help these men to succeed, it can help you. If it can help other men to win advancement and more money, it can help you too. At least find out how.

### MAIL THE COUPON FOR FREE BOOKLET

#### INTERNATIONAL CORRESPONDENCE SCHOOLS, Box 5687-E, Scranton, Penna.

*"The Universal University"*

Without cost or obligation, please send me a copy of your booklet, "Who Wins and Why," and full particulars about the course before which I have marked X:

- |   |  |   |                                     |  |
|---|--|---|-------------------------------------|--|
| <input type="checkbox"/> Business Management              | <input type="checkbox"/> Private Secretary                       | <input type="checkbox"/> Illustrating           | <input type="checkbox"/> Cartooning | <input type="checkbox"/> Architect                                   |
| <input type="checkbox"/> Industrial Management            | <input type="checkbox"/> Spanish <input type="checkbox"/> French | <input type="checkbox"/> Electrical Engineering |                                     | <input type="checkbox"/> Blueprint Reading                           |
| <input type="checkbox"/> Personnel Organization           | <input type="checkbox"/> Salesmanship                            | <input type="checkbox"/> Electric Lighting      |                                     | <input type="checkbox"/> Contractor and Builder                      |
| <input type="checkbox"/> Traffic Management               | <input type="checkbox"/> Advertising                             | <input type="checkbox"/> Mechanical Engineer    |                                     | <input type="checkbox"/> Architectural Draftsman                     |
| <input type="checkbox"/> Business Law                     | <input type="checkbox"/> Business Correspondence                 | <input type="checkbox"/> Mechanical Draftsman   |                                     | <input type="checkbox"/> Concrete Builder                            |
| <input type="checkbox"/> Banking and Finance Management   | <input type="checkbox"/> Show Card Lettering                     | <input type="checkbox"/> Machine Shop Practice  |                                     | <input type="checkbox"/> Structural Engineer                         |
| <input type="checkbox"/> Accountancy (including C. P. A.) | <input type="checkbox"/> Stenography and Typing                  | <input type="checkbox"/> Railroad Positions     |                                     | <input type="checkbox"/> Chemistry <input type="checkbox"/> Pharmacy |
| <input type="checkbox"/> Nicholson-Prouty Cost Accounting | <input type="checkbox"/> Good English                            | <input type="checkbox"/> Gas Engine Operating   |                                     | <input type="checkbox"/> Automobile Work                             |
| <input type="checkbox"/> Bookkeeping                      | <input type="checkbox"/> Civil Service                           | <input type="checkbox"/> Civil Engineer         |                                     | <input type="checkbox"/> Airplane Engines                            |
|   | <input type="checkbox"/> Railway Mail Clerk                      | <input type="checkbox"/> Surveying and Mapping  |                                     | <input type="checkbox"/> Navigation                                  |
|   | <input type="checkbox"/> Common School Subjects                  | <input type="checkbox"/> Metallurgy             |                                     | <input type="checkbox"/> Agriculture and Poultry                     |
|   | <input type="checkbox"/> High School Subjects                    | <input type="checkbox"/> Steam Engineering      |                                     | <input type="checkbox"/> Mathematics <input type="checkbox"/> Radio  |

Name.....

Address.....

Present Position.....

Canadian address—International Correspondence Schools Canadian, Limited, Montreal



# Step Into Aviation

**Adventure...  
Thrills...  
Big Money!**

## The Game for Daring Young Men

**G**ET away from the dull, prosaic grind of humdrum work—the narrow restrictions of petty, uninteresting jobs! Break into one of the most fascinating, most thrilling occupations since time began—Aviation—the virile, exciting, romantic game for men of sporting blood!

Many of the big men of the coming generation will be men with the foresight to get into Aviation now—while opportunities abound. They can see that the Golden Age of Aviation has just begun—that the future is almost too stupendous to be imagined.

What other occupation offers you more amazing opportunities? Thrills such as you never had before—the praise and plaudits of the multitude—and a chance to get in on the ground floor where rewards may be unlimited.

Aviation is growing so swiftly that one can hardly keep track of all the astonishing new developments. The skies are dotted with daring young men—from every country come stories of new feats—new victories—new heroes! Everything is set for one of the greatest booms in history. Big fortunes came out of the automobile industry and out of motion pictures. Big fortunes will also come out of Aviation! The development of Aviation as an industry is bringing with it a call for trained men. Those who qualify quickly should find themselves on the road to undreamed of money—success—popularity—and prominence!

### Easy to Become an Aviation Expert!

Get into this thrilling business at once while the field is new and uncrowded. Now—by a unique new plan—you can quickly secure the preliminary training necessary to get a start in the Aviation Industry, either flying or ground work, at home during your spare time. Experts will teach you the secrets—give you the inside facts

that are essential to your success. And, the study of Aviation by our method is almost as fascinating as the actual work itself. Every Lesson is chock-full of interest—and so absorbing that you actually forget you are studying. But best of all are the ultimate rewards you are fitting yourself to gain!

#### PICK YOUR JOB!

Flying  
Airplane Instructor  
Airplane Engineer  
Airplane Repairman  
Airplane Assembler  
Airplane Mechanician  
Airplane Inspector  
Airplane Builder  
Airplane Salesman  
Exhibition Manager  
Airplane Contractor  
Airplane Motor Expert  
Airplane Designer

#### Send for FREE Book

Send the coupon for our new, free booklet—**Opportunities in the Airplane Industry**. It is vitally interesting, reads like a romance and tells you things about this astonishing profession you probably never even dreamed of. You owe it to yourself at least to read it. We offer you a free copy now, no obligation. Mail the coupon for yours, today.



#### American School of Aviation

Dept. 1359  
3601 Michigan Ave.  
CHICAGO, ILLINOIS

American School of Aviation,  
Dept. 1359, 3601 Michigan Ave.  
Chicago, Ill.

Without any obligation please send me FREE booklet **Opportunities in the Airplane Industry**. Also information about your Course in Practical Aviation.

Name.....Age.....

Address.....

City.....State.....



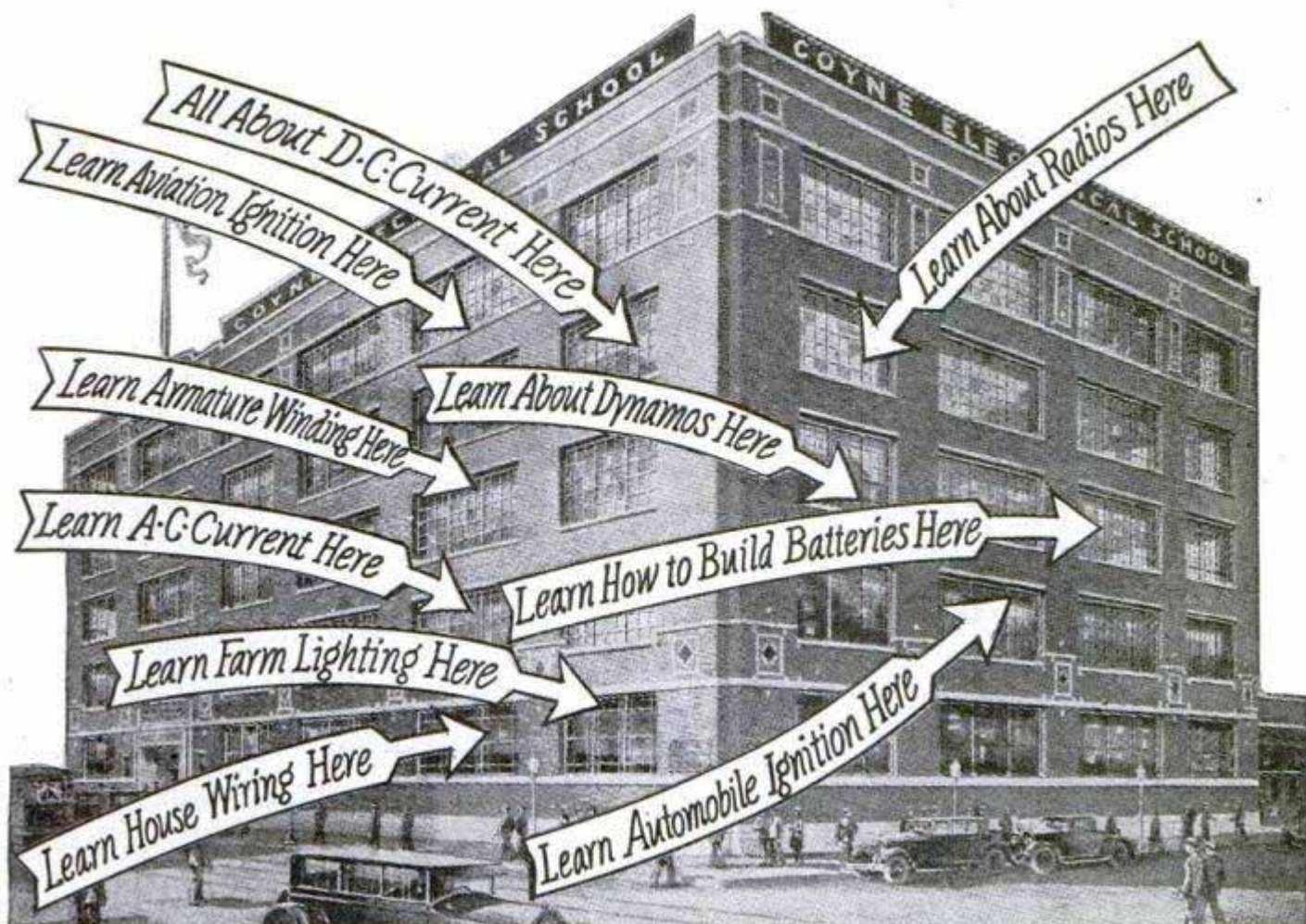

# Learn Electricity

## In This Big New \$2,000,000 School

### in 12 WEEKS

**No Books**  
**No Lessons**

**Amazingly Easy Way to Get Into Electricity -  
Mail Coupon for Big Catalog Which Tells You How**

Even if you have not had an advanced education, or know nothing about electricity, I can make you a master of practical Electricity in 90 days. Don't let lack of funds worry you. Send for my big 56-page book, with 150 illustrations showing how Coyne Students learn by actual work in my shops. You work on real dynamos; you wind real armatures; you build real batteries; you wire real houses. Everything real, with an instructor by your side. Get into the big pay class. Coyne graduates get positions leading to \$50 a week and up—many go into business for themselves and become independent.

**Act NOW! Send for My Big Book—Absolutely FREE!**

My Course Includes **Aeroplane Electricity**  
Training in

**COYNE Electrical SCHOOL**

*Not a Correspondence School*

H. C. LEWIS, Pres., Dept. 97-72 Established 1899  
500 South Paulina Street, Chicago

Mr. H. C. Lewis, Pres.  
COYNE ELECTRICAL SCHOOL, Dept. 97-72  
500 S. Paulina St., Chicago, Ill.

Dear Mr. Lewis: Without obligation send me your big free catalog and all details of Free Employment Service, Radio, Aeroplane, Automotive Courses that are included and how you will help me "earn while learning." I understand I will not be bothered by any salesman.

Name .....

Address .....

City ..... State .....



# The Auto Painter



## Is "Sitting on Top of the World" Today!

You men, looking for something better—**MORE MONEY!** You can make the most money in Auto Painting. Here is the biggest uncrowded field in the world today. Prove it to yourself by the next 20 cars you see. Yes, sir, 17 out of 20 need painting.

**I will have you ready in a few months**

Now—how many auto painters do you know? . . . I thought so. Well, who's going to do the work? You are—after you get the right training and you're going to make more money than you ever dreamed of! The world is looking for trained auto painters. Cash in on this big demand!

### You Can Own Your Own Business!

Yes you can! With the information I supply you, you can make your dream come true. You can be the head of your own establishment. In auto painting it's no trick to be your own boss—own your own business and be independent! You don't have to start out with the biggest building

on the busiest corner. You can begin small with little or no capital, but I don't know of another business where you can get big so fast. We show you how to open your own shop.

**Now—Make 60 to 90 Dollars a Week!**

Why plod? There are jobs that pay real money waiting for men that know what I have to teach you. After you get my training you can get a job anywhere. You can travel and know at your destination there will be a job waiting for you that pays big money. Remember—I don't forget you when you complete the course. I help you get a real job. You also get a life consultation service without extra charge. 17,000,000 cars need painting. Just imagine! There are t-w-e-n-t-y f-i-v-e m-i-l-l-i-o-n cars in the U. S. alone—and 17 million need priming, surfacing, painting, ducoing, varnishing, stripping and the whole works—and take it from me, I teach you the whole works so you can get in on the **BIG MONEY**—or I'll refund every penny of the small price you pay.

**PROOF**

Chicago Duco says: "Skilled Duco men are scarce. We can place many at \$1.00 to \$1.25 an hour." Binks, one of the largest auto equipment manufacturers, says: "The big auto manufacturers are insisting that their dealers repaint all used cars." Stockton, Illinois, says: "No shop here. All work must go to Freeport. Believe plenty of work to make paying business." Nash says: "This is a big field and splendid opportunities for your graduates in repainting cars." Many, many more like these.

I realize that you are up against quite a problem in deciding what field to enter, but on my say-so, and my guarantee to you, just come into auto painting with me and you'll be glad of it all your life. Men like yourself who have taken my advice are now making \$5,000 to \$10,000 a year.

## Send Coupon for FREE BOOK

G. King Franklin, Supt., American Auto Painting School, Dept. 901, 425 S. Ashland Ave., Chicago.

Send sample shop-tickets free and information on how I may learn auto painting and Duco at home in spare time.

Name.....  
 Street No.....  
 City.....  
 State.....

**FREE BOOK**

## LEARN at HOME!

And the beauty of my proposition is that you can learn at home in your spare time—evenings—and keep your present job while learning. By my **SHOP-TYPE METHOD** you learn quickly and easily—the greatest advance in home study training assures you success—no car needed—work on wood and metal panels which we furnish you! 13 big outfits of standard tools and materials given without extra charge—Get information now! Don't wait. Get my big illustrated booklet **FREE**—you will not be obligated—



**G. KING FRANKLIN, Supt.**  
**American Auto Painting School**  
 Dept. 901, 425 So. Ashland Avenue, CHICAGO



# Guaranteed Twin Service for Ambitious Men!

**T**  
Training  
Preparing  
you for a  
better job  
and a Raise  
in Pay - - -

**E**  
Employment  
—then help-  
ing you get it,  
or money  
refunded!



O. C. MILLER  
Director Extension Work

**The American School** is the first in the home-study field to recognize the need of guaranteeing its courses with a money-back contract, if the training fails to accomplish the benefits you expect. Thus all risk and doubt are eliminated—either the training will help you to a better job and a raise in pay or it will cost you nothing. To better carry out this important service, we maintain a National employment department which keeps in touch with the employers of Draftsmen all over the U. S. All this without extra charge to our students and graduates.

## Professional Outfit Given!

You will naturally expect the American School to give you the best kind of instruments and tools with the best kind of training. This outfit is good enough to use professionally after you finish your training. Mail coupon for description.



# Come into Drafting!

Learn drafting—how to *make* and *read* plans, and the doors of opportunity in all mechanical, building, and engineering lines swing open for you! There are more well-paid Drafting jobs open today than in any other one profession or trade. There's a variety, a fascination to Drafting that will grip you. No other work is so interesting, *so well paid*—no other field offers equal opportunities for quick promotion.

## If You Are Now Earn- ing \$40 a Week or Less

I guarantee to *prepare* you for a fine drafting position, right in your home, in your spare time; then I guarantee to help you find such a position at a substantial increase in pay, within 60 days after you complete this training, or I will refund small amount you pay for tuition. We make this agreement to prove this instruction *will* make you a *real Draftsman*. Back of this guarantee are the entire resources and reputation of this million dollar institution.

O. C. Miller

O. C. MILLER  
Director Extension Work

## The Draftsman is the Boss of the Works!

Destroy blue-prints and *plans*, and the wheels of all Industry will stop until new ones can be made. Every move of every workman on the job is *controlled* by the Draftsman through his plans. Railroads, public works, buildings of a hundred sorts, machinery, electricity, automobiles—all manufacturing and construction *start* on the Drafting table! That's the kind of work to get into, friend. Where you have the same chance as anybody else to make a *quick success!*

# 3 DRAFTING Lessons FREE!

—to prove you can learn at home in spare time!

You'll be surprised how *quickly* you can learn Drafting by our new one-step-at-a-time method. We start you off by doing actual Drafting room jobs from the very beginning. Before you know it, you are *batting out* professional plans like a veteran. Get the first three lessons—the coupon brings them. *Do them.* Test your ability to master Drafting at home. Without cost or obligation.

**The American School**

Dept. D-974A, Drexel Ave. and 58th, Chicago

O. C. MILLER, Director Extension Work  
American School, Dept. D-974A, Drexel Ave. and 58th St., Chicago.

Your offer to send me three lessons free and facts about the opportunities in Drafting and about your course, looks good to me. It is understood I am not obligated in any way in making this request.

Name .....

Address .....

Occupation ..... Age .....

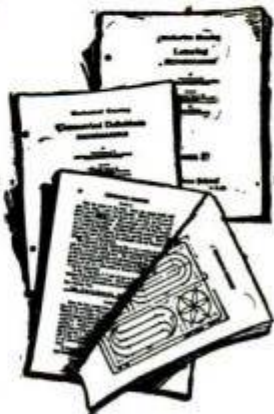



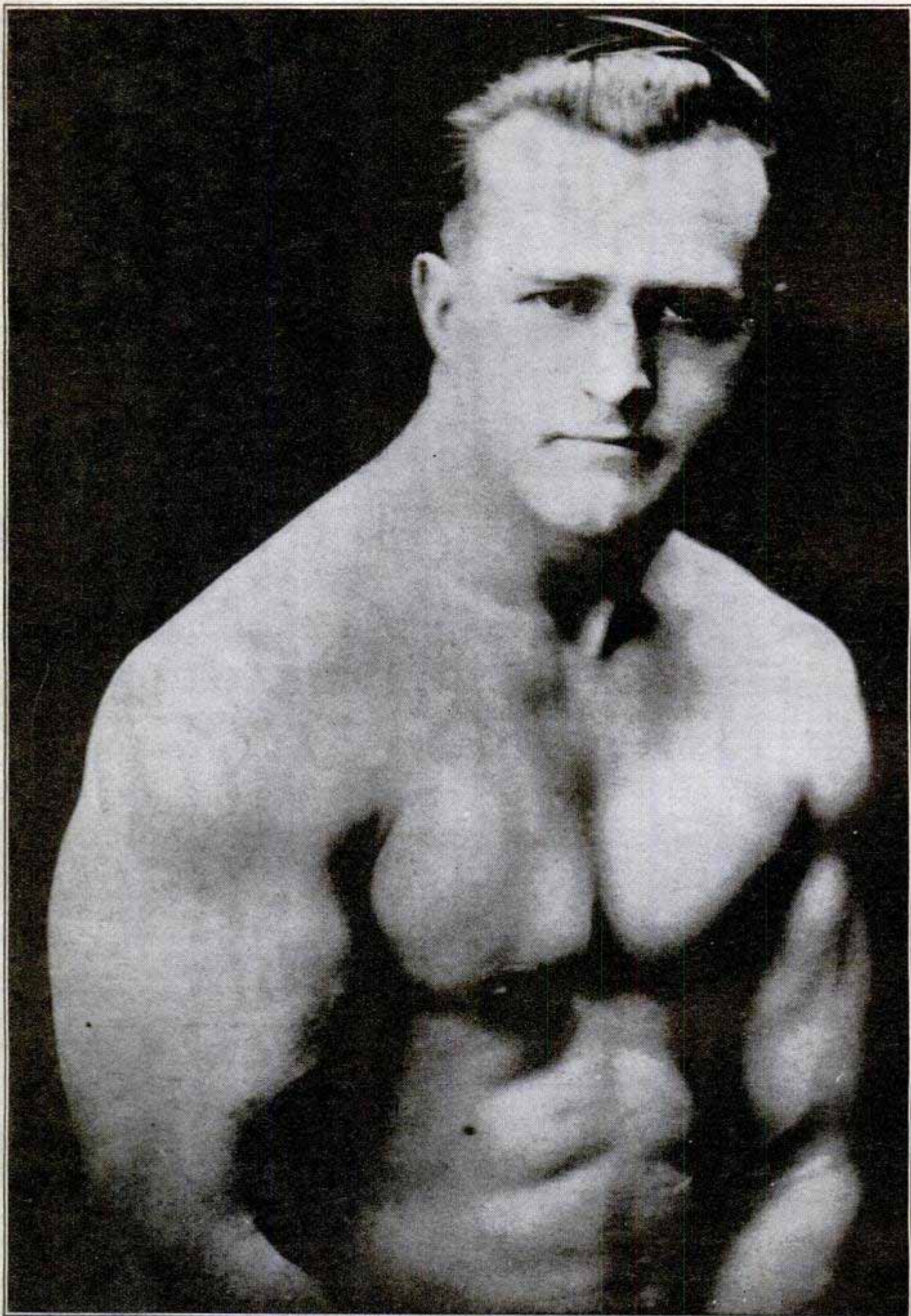

**EARLE E. LIEDERMAN, *The Muscle Builder***

*Author of "Science of Wrestling," "Muscle Building," "Secrets of Strength," "Here's Health," "Endurance," etc.*



# If You Were Dying To-night

and I offered something that would give you ten years more to live, would you take it? You'd grab it. Well, fellows, I've got it, but don't wait till you're dying or it won't do you a bit of good. It will then be too late. Right now is the time. Tomorrow or any day, some disease will get you and if you have not equipped yourself to fight it off, you're gone. I don't claim to cure disease. I am not a medical doctor, but I'll put you in such condition that the doctor will starve to death waiting for you to take sick. Can you imagine a mosquito trying to bite a brick wall? A fine chance.

## A RE-BUILT MAN

I like to get the weak ones. I delight in getting hold of a man who has been turned down as hopeless by others. It's easy enough to finish a task that's more than half done. But give me the weak, sickly chap and watch him grow stronger. That's what I like. It's fun to me because I know I can do it and I like to give the other fellow the laugh. I don't just give you a veneer of muscle that looks good to others. I work on you both inside and out. I not only put big, massive arms and legs on you, but I build up those inner muscles that surround your vital organs. The kind that give you real pep and energy, the kind that fire you with ambition and the courage to tackle anything set before you.

## All I Ask Is Ninety Days

Who says it takes years to get in shape? Show me the man who makes any such claims and I'll make him eat his words. I'll put one full inch on your arm in just 30 days. Yes, and two full inches on your chest in the same length of time. Meanwhile I'm putting life and pep into your old back-bone. And from then on, just watch 'em grow. At the end of thirty days you won't know yourself. Your whole body will take on an entirely different appearance. But you've only started. Now comes the real works. I've only built my foundation. I want just 60 days more (90 in all) and you'll make those friends of yours who think they're strong look like something the cat dragged in.

## A Real Man

When I'm through with you you're a real man. The kind that can prove it. You will be able to do things you had thought impossible. And the beauty of it is you keep on going. Your deep, full chest breathes in rich, pure air, stimulating your blood and making you just bubble over with vim and vitality. Your huge square shoulders and your massive muscular arms have that craving for the exercise of a regular he-man. You have the flash to your eye and the pep to your step that will make you admired and sought after in both the business and social world.

This is no idle prattle, fellows. If you doubt me, make me prove it. Go ahead, I like it. I have already done this for thousands of others and my records are unchallenged. What I have done for them, I will do for you. Come then, for time flies and every day counts. Let this very day be the beginning of new life for you.

Send For My New  
64 Page Book

*"Muscular Development"*  
IT IS FREE

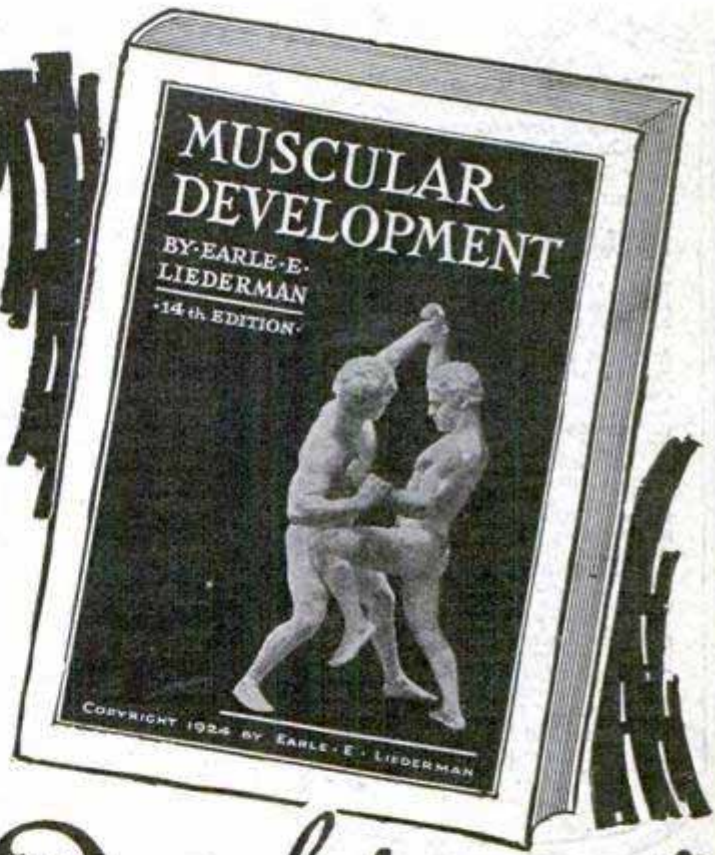

It contains over four dozen full-page photographs of myself and some of the many prize-winning pupils I have trained. Some of these came to me as pitiful weaklings, imploring me to help them. Look them over now and you will marvel at their present physiques. This book will prove to be an impetus and a real inspiration to you. It will thrill you through and through. And it's all yours. I don't ask a cent. This will not obligate you at all, but for the sake of your future health and happiness do not put it off. Send today—right now before you turn this page.

**EARLE E. LIEDERMAN**

Dept. 2012 305 Broadway, New York City

<b>It Is F R E E</b>	<b>DON'T SEND ONE PENNY</b>	<b>EARLE E. LIEDERMAN</b>	
	—	Dept. 2012, 305 Broadway, New York City	
	<b>YOUR NAME AND ADDRESS</b>	Dear Sir: Please send me, without any obligation on my part whatever, a copy of your latest book, "Muscular Development." (Please write or print plainly.)	
	<b>ON A POSTAL WILL DO</b>	Name.....	Street.....
		City.....	State.....





**WILLIAM CLAYTON**  
*McCarrie Graduate*  
And His Own Dental Laboratory

# From \$30 a Week Bookkeeper to \$150 A Week as Owner of Dental Laboratory

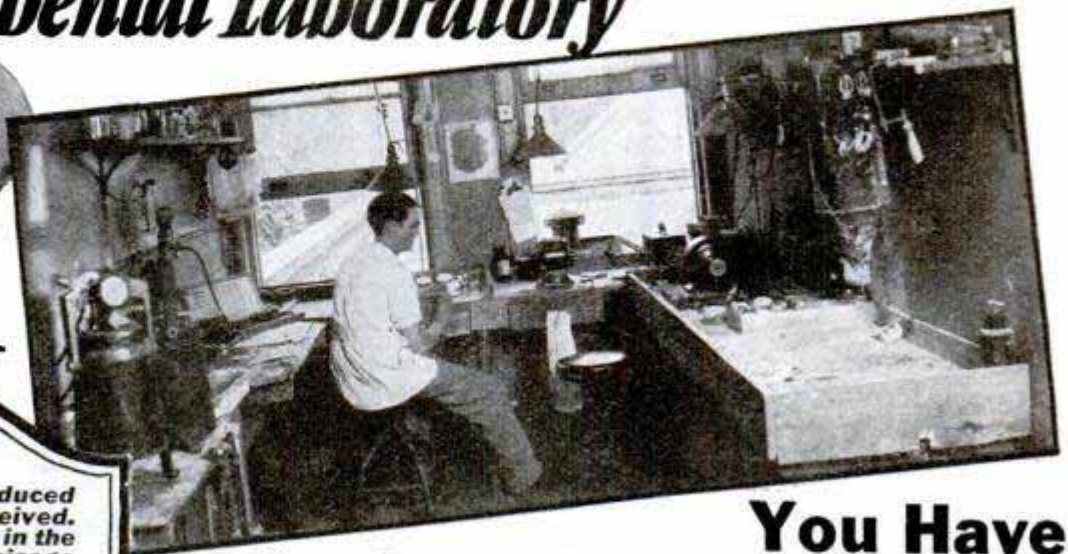

The following is reproduced from a letter we received. The original is on file in the McCarrie School in Chicago

Dear Mr. McCarrie:

I was bookkeeping up until January, 1924, at \$15.00 per year, and while having lunch one noon, I picked up a "Popular Mechanics" and ran across your ad, which fascinated me very much. Although making a good living at the time, I was not entirely satisfied, so I wrote for your literature.

Upon receipt of the above, and having read it very thoroughly, I could not help but admit I was quite enthused. Two weeks later I arrived at your school. Completing the course in August, I returned home where I received a position in a laboratory. After a few months experience, I got connected with Dr. L. . . . . with whom I stayed two years, resigning my position to open a laboratory of my own, October 15, 1926. I have ten dentists on my list which net me about \$150.00 of business per week, with business increasing rapidly.

Thanking you hardly expresses my appreciation of your most thorough course. Your promises were more than fulfilled, and in closing I want to state that there is a large field open for your graduates. I remain,

A Successful McCarrie Graduate.

(Signed)  
William H. Clayton.

## You Have the Same Opportunity— Learn Mechanical Dentistry

Follow in Clayton's footsteps! Read his inspiring letter telling how he jumped from \$30.00 a week to \$150.00 a week! Many McCarrie graduates are doing the same! Larson writes, "Our laboratory has averaged about \$800.00 a month profit since first of year—not bad for two of your boys who have been in business for only a year." Ostrander says, "I earned as high as \$45 profit in a single day." Another McCarrie man sends us this message: "No trick for me to make \$20.00 a day." Our free book tells many more amazing success stories like this—write for it today!

### Day or Night Schools—All Personal Instruction —No Books—No Classes—Work Your Way Thru School—We Help You To Spare Time Job

Enter this fascinating profession—assure yourself steady employment the year round—work that is highly congenial and dignified! Associate with a fine class of people! Earn a splendid income! We have hundreds of testimonial letters on file from enthusiastic McCarrie men who have made good.

Will you accept this big opportunity? The dental profession needs you. It has grown so fast that the demand for mechanical dentists far exceeds the supply. Here is specialized training of the finest sort! No mechanical skill necessary—no special educational requirements—and a quick, sure reward!

### SEND FOR INTERESTING BOOK

Read absorbing facts about mechanical Dentistry—the laboratory bench work that the dentist turns over to the laboratory worker, the making of plates, crowns, bridges, etc.—why 64,000 dentists need laboratory work—how we train you in a few months, day or night, for this uncrowded, moneymaking field!

McCarrie Schools are located in Chicago, Detroit, Cleveland, Philadelphia and Boston.

### MAIL COUPON TODAY

No obligation—no cost! Mail coupon today and get your free copy of this handsomely illustrated, interesting book. Complete details of our special offer—low rates—easy terms. Send coupon today!

**McCARRIE SCHOOL OF MECHANICAL DENTISTRY**  
Dept. 148 1338 S. Michigan Ave. CHICAGO, ILL.



**FREE BOOK**

McCarrie School of Mechanical Dentistry,  
1338 S. Michigan Ave.,  
Dept. 148 Chicago, Ill.

Without obligation, please send me your free Book with complete information about how I may become a Mechanical Dentist, how you will help me open a Laboratory, how you will help me find a job while I take my training, etc.

Name.....

St. No. or R. F. D.....

City.....State.....

Work Your Way Thru School. We Help You Get Spare Time Job.



**NOW!  
FREE!**

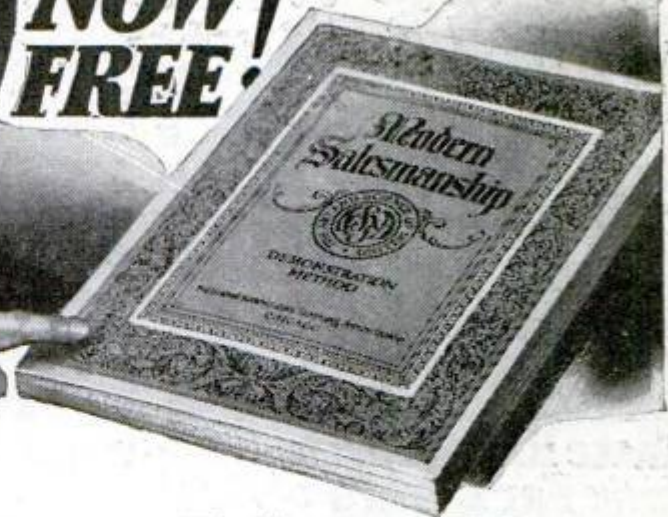

# Raised My Pay 700%

## This Amazing Book Showed Me How

**This is Perhaps the Most Remarkable Book Ever Printed. It Has Proved the Turning Point in the Careers of Thousands Who Were Ambitious for Bigger Pay! If You Ever Aspired to Earn \$10,000 a Year or More—Read It Without Fail!**

CAN you imagine how a man feels when his earning capacity quickly jumps 700% in a few months? Can you imagine how you would feel if your salary suddenly became seven times greater than ever before?

That is exactly what happened to O. A. Jones of Charleston, Missouri, after reading the amazing book pictured above. Between its covers, he discovered something he had never even dreamed of before—a certain force that lifted him out of the routine rut and set him on the road to \$10,000 a year!

Unusual? Not at all. This surprising book has done the same for hundreds of others. For example, F. N. Hiatt of California read it and quickly saw the way to raise his earnings 625%! It led Robert Ellis of Massachusetts into three promotions and trebled his former salary. Sending for this remarkable book was the first step that elevated M. J. Ebeling of St. Louis from a clerkship to the presidency of a large manufacturing company!

### THE SECRET OF BIG EARNINGS

How did they do it? What did the book show them? Just this: Every one of these men realized that a knowledge of salesmanship and the ability to sell brings bigger rewards than anything else in modern business today! But until they saw the contents of this book—"Modern Salesmanship"—they had no idea that they, too, could win quick success through salesmanship. They believed that this golden field of endeavor was forever barred to them. But they were wrong—and this unusual book opened the way to the success that they had formerly despaired of attaining!

### SALESMEN ARE MADE—NOT BORN!

Yes! Any man of ordinary intelligence can become a successful salesman! Just as you learned the alphabet, you can master the secrets of selling as taught by the National Salesmen's Training Association.

Reason it out for yourself. Salesmanship is governed by rules and laws. There are certain ways of saying and doing things to make men act as you want them to: certain ways of getting exactly what you go after! Once you have mastered these fundamental rules, your success is governed only by your energy and ambition!

### BIG DEMAND FOR TRAINED SALESMEN

City and traveling sales positions are open in every line all over the country. For years, thousands of leading firms have

called on the N. S. T. A. to supply them with salesmen. Employment service is free to both employers and members and thousands have secured positions through this service.

### FREE TO EVERY MAN

If we were asking two or three dollars a copy for "Modern Salesmanship," you might hesitate. But it is now FREE. We cannot urge you too strongly to take advantage of this opportunity to see for yourself what salesmanship has done for others—and what the National Salesmen's Training Association stands ready and willing to do for you. No matter what your opinion is now, "Modern Salesmanship" will give you a new insight into this fascinating and highly-paid profession.

Mail the coupon now!



Dept. W-100, N. S. T. A. Bldg.  
Chicago, Ill.

**National Salesmen's Training Association**  
Dept. W-100, N. S. T. A. Bldg., Chicago, Ill., U. S.

Please mail me FREE your illustrated book, "Modern Salesmanship" and particulars of membership in your association and its Free Employment Service.

Name.....

Address.....

City.....State.....

Age.....Occupation.....



# See the World FREE!



## Taste Romance and Adventure In the Far Lands of the Earth.

How often you've longed to see for yourself the awe of Egypt's pyramids—the beauties of the gorgeous Mediterranean sunset—the squalor of China's ancient cities!

Spend a few years, or the rest of your life, tasting high adventure on the seven seas and in all the world's great ports—roving the earth's highways and byways! You can do it FREE—all your expenses paid—and earn a good salary besides!

Only one profession will carry you around the world at will, travelling like a gentleman, but that's the most interesting and pleasant work there is—Radio Operating! Easily and quickly learned, there's no other profession like it for the man who wants the experiences and pleasures of world-travel. Radio operators are needed—all sea-going ships like the one shown here must carry from one to half a dozen or more.



## Take a Look Beyond the Skyline Without a Pennys Expense

Radio operators aboard ocean liners live luxuriously—they rank as officers of the ship. Meals, a private cabin, all other living needs are furnished free, and besides the operator draws a good salary. You can learn quickly and easily at home in your spare time to be a Radio operator through our practical training methods. Take a look at the FREE BOOK which tells how—mail coupon below.

This U. S. Government-recognized school has been training successful operators since 1914. Our graduates are all over the world. We maintain an Employment Department to help put you on your own ship. The world-famous NATROMETER, our own patented invention, obtainable only by students of this Institute, is recognized as the best and easiest way to learn the Radio code. A few short months, with the aid of the famous Natrometer and our quick home training, and you too can be a fully qualified Radio operator, sitting in your cabin like the one shown above, bound out for Liverpool or Nagasaki!

Read the Free Book that tells all about this fascinating profession and our practical Government-recognized methods of training you for it. Send coupon TODAY—no obligation. Special tuition offer now on, includes world-famous Natrometer free of extra cost with your course! Act at once.

**NATIONAL RADIO INSTITUTE  
WASHINGTON, D. C.**

### SPECIAL OFFER COUPON

National Radio Institute,  
Dept. PP-85, Washington, D. C.

Gentlemen: Without obligating me in any way send me your free book and information about your offer of Natrometer with course.



World-Famous Natrometer

Name.....

Address.....

# \$25.00 DRAWING COURSE for \$2.98



Haven't you often wished that you could draw cartoons, illustrate some idea, sketch some pretty face, etc.? You can do all of these things. One of America's most famous Cartoonists and Illustrators has developed a great, simple system for success in all branches of Commercial Art. This system has revolutionized the entire theory of drawing. It means that drawing can be as easy for you as writing—much simpler than learning shorthand, bookkeeping or typewriting. We are now placing this original system for learning Drawing, Art and Cartooning, consisting of 34 lessons with over 500 illustrations, within reach of every one. If you will devote a few hours each week to the Course WE ABSOLUTELY GUARANTEE that you will learn to draw and draw well before you have half finished the Course. If we fail to make this claim good, we will refund every cent paid us. By eliminating a large office force for answering correspondence, expensive catalogs, etc., we are enabled to make a price of \$2.98, the cheapest price ever known for a high-grade, home study course. Many have sent us letters similar to that of Rob't P. Davis of Detroit, who wrote: "I can't see how you ask so little. It is more than I expected." Learn to draw. It is a big asset, no matter what field you are in.

## Send No Money

Just order the course and **\$2.98** on arrival pay postman plus a few cents postage, payment in full for the entire Course and Drawing Outfit. If not entirely satisfied, return within five days and we will Refund Money. Address:

If you order the course at once, we will include a drawing outfit, consisting of artist's pencils, pens, paper, erasers, thumb tacks, etc., enabling you to go to work without any additional cost.

**LEDERER SCHOOL of DRAWING, Dept. 5318-F, Chattanooga, Tenn.** Orders from outside the U. S. A. are payable \$3.28 cash with order.

## Learn to Mount Birds



Learn at home by mail, to mount birds, animals, game heads; tan furs, make rugs and robes. Complete lessons. Easily and quickly learned by men, boys and women.

### FREE

Write today for Free Taxidermy Book. Tells all about it. Every Sportsman, Hunter, Trapper and Nature lover should know this wonderful fascinating art. Save your trophies. Big profits. Success guaranteed. Our school is 20 years old—100,000 graduates. Investigate today. Write for Free Book.

Northwestern School of Taxidermy 9379 Elwood Bldg., Omaha, Neb.

# YMCA TRADE SCHOOL

Learn Auto Mechanic, Auto Electrical, Battery, Machine, Electrical, Radio Mechanic, Tiling, Bricklaying, Plastering, Plumbing, Welding, Drawing, Estimating, Show Card, Sign Painting, Window Dressing, Fine And Commercial Art.

Write for Catalog 50.  
**BROOKLYN ENGINEERING INSTITUTE**  
(Operated by Bedford Br. Y. M. C. A.)  
1125 Bedford Ave., Brooklyn, New York City.

# STAMMER

Write for my free book "Millard's Advanced Natural Corrective Course" and a free copy of my speech magazine. 10,000 cases successfully treated. Est. 24 years. Largest school for stammers in world. Millard Inst. of Normal Speech, 2317 Millard Bldg., Milwaukee, Wis.



## BECOME A RAILWAY POSTAL CLERK

Men—Boys 18 up—Examinations coming. \$1900 to \$2700 a year. Steady life-time job. Common education sufficient. No "pull" necessary. Mail coupon for Catalog.

**A. R. PATTERSON**

Civil Service Expert  
**PATTERSON SCHOOL**  
Dept. 812A, ROCHESTER, N. Y.

SIRS: Send me without charge your Catalog, describing this and other U. S. Government positions.

Name.....

Address.....

**A. R. PATTERSON**  
Civil Service Expert

Patterson School  
Dept. 812A  
Rochester,  
N. Y.



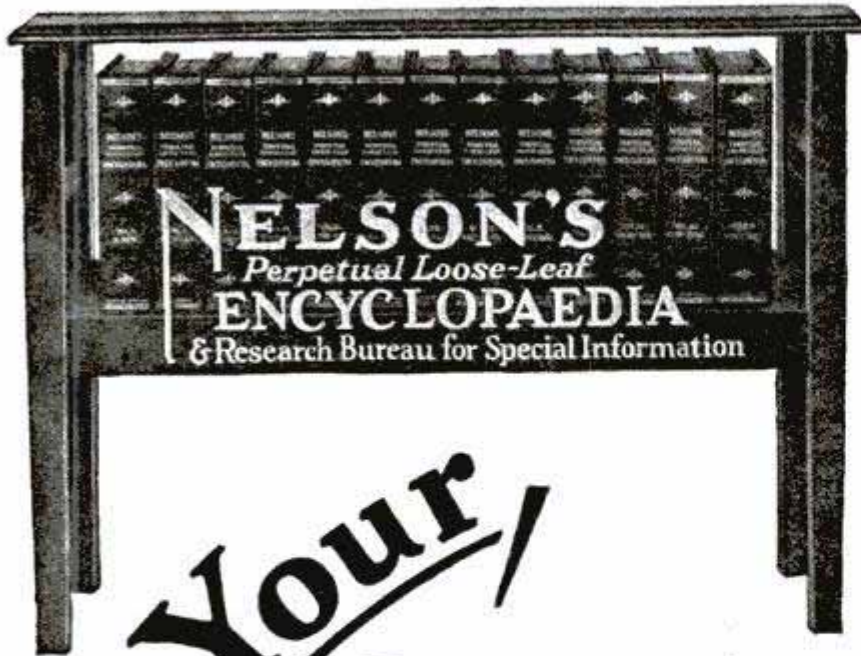

**Your**

*Progress depends upon  
Your use of Your spare time ★*

**What You Get in  
Nelson's Loose-Leaf  
Encyclopaedia:**

A handsomely bound, beautifully printed encyclopaedia that is new now and will always be up-to-date. More profusely illustrated than any other encyclopaedia.

Authoritative articles on every conceivable subject. . . . Biographies of prominent men and women—both of today, and the past. . . .

A complete Atlas of the world, including up-to-date maps and population data.

New information that can always be substituted for obsolete matter—by means of the loose-leaf binding device.

An Index Volume, containing over 200,000 references—so exhaustive that every item, relating to any subject, can be found instantly.

Nelson's FREE Reader's Guide—33 full-study college courses on as many subjects.

FREE Membership in Nelson's Research-Library Service-Bureau—for special information on any subject.

**THE ENCYCLOPAEDIA  
FOR A LIFE-TIME**

**U**SE your spare time—if only a few minutes a day—acquiring valuable information to know the world in which you live. Don't guess—know the facts!

Knowledge of facts means time saved and mistakes avoided. Facts are the keynote of every truly successful career—wisdom in a larger sense is founded upon facts!

Get *your* facts from Nelson's—and know that every one is correct, *right down to date!* Remember, the value of an encyclopaedia depends on its up-to-dateness; and fast-bound encyclopaedias must necessarily be *out of date always*. Nelson's *Perpetual Loose-Leaf En-*

\* Let Nelson's help improve your leisure hours. The habitual use of this wonderful Encyclopaedia means a broadened intellect—wider and deeper knowledge upon every subject investigated—skill in discriminating between facts and theories—the development and strengthening of a logical mind which enables you to grasp larger things in life! In all your daily undertakings, "BE SURE YOU ARE RIGHT—THEN GO AHEAD." Check up your facts with Nelson's!

Because of the patented Loose-Leaf binding device, every fact you get from Nelson's is not only authoritative, but *always up-to-date*. The ONLY encyclopaedia of which this is true.

encyclopaedia is ALWAYS UP-TO-DATE—it never grows old!

This great American Encyclopaedia is considered an authority—in the Library of Congress, U. S. Senate, U. S. Supreme Court; in libraries, universities and schools in every State in the Union; and in thousands of homes.

From the dawn of history to the present day, every field of knowledge is covered. Every article is clear, concise, authoritative—prepared by an expert. And Nelson's patented *Loose-Leaf* binding device keeps every article—every individual fact—correct, *right down to date*. Nelson's is the only encyclopaedia with this vital feature—it changes and grows as the world progresses—it LIVES!

**THOMAS NELSON & SONS**

*Publishers Since 1798*

Originators of the Loose-Leaf Reference System  
P.M.—Dec. 381 Fourth Ave., New York City

Send me FREE your Book of Specimen Pages with full information of your offer telling how I can own Nelson's Loose-Leaf Encyclopaedia on the Small Monthly Payment Budget Plan.

Name.....

Street.....

City..... State.....

(Adv. Copyright, 1927, by Thomas Nelson & Sons)

***This Coupon  
puts you un-  
der no obliga-  
tion. Mail it  
TODAY!***





## "I'm going to raise his salary"

"I've had my eye on him for some time and I know he can handle bigger work."

"He studies those I. C. S. textbooks every chance he gets, and I want to tell you it has made him a valuable man for this business."

"I'm going to raise his salary and give him that new job we were talking about. I wish we had more men like him."

How do you stand when your employer checks up his men for promotion? Does he pass you by as just a routine worker, or does he think of you as a man who is ambitious to get ahead? Won't you be far more likely to get the promotion if he knows you are studying at home and are really preparing yourself to handle bigger work?

Think it over. Then act. It takes only a moment to mark and mail the coupon and find what the International Correspondence Schools can do for you, yet that one simple little step may be the means of changing your whole life.

### Mail the Coupon for Free Booklet

#### INTERNATIONAL CORRESPONDENCE SCHOOLS

"The Universal University"  
Box 5690-E, Scranton, Penna.

Without cost or obligation, please send me a copy of your booklet, "Who Wins and Why," and full particulars about the course before which I have marked X in the list below:

#### BUSINESS TRAINING COURSES

- |  |   |
|--|---|
| <input type="checkbox"/> Business Management                     | <input type="checkbox"/> Salesmanship                                     |
| <input type="checkbox"/> Industrial Management                   | <input type="checkbox"/> Advertising                                      |
| <input type="checkbox"/> Personnel Organization                  | <input type="checkbox"/> Better Letters                                   |
| <input type="checkbox"/> Traffic Management                      | <input type="checkbox"/> Show Card Lettering                              |
| <input type="checkbox"/> Business Law                            | <input type="checkbox"/> Stenography and Typing                           |
| <input type="checkbox"/> Banking and Finance Management          | <input type="checkbox"/> English  |
| <input type="checkbox"/> Accountancy (including C.P.A.)          | <input type="checkbox"/> Civil Service                                    |
| <input type="checkbox"/> Nicholson Cost Accounting               | <input type="checkbox"/> Railway Mail Clerk                               |
| <input type="checkbox"/> Bookkeeping                             | <input type="checkbox"/> Common School Subjects                           |
| <input type="checkbox"/> Private Secretary                       | <input type="checkbox"/> High School Subjects                             |
| <input type="checkbox"/> Spanish <input type="checkbox"/> French | <input type="checkbox"/> Illustrating <input type="checkbox"/> Cartooning |

#### TECHNICAL AND INDUSTRIAL COURSES

- |   |  |
|---|--|
| <input type="checkbox"/> Electrical Engineering                     | <input type="checkbox"/> Architect                                       |
| <input type="checkbox"/> Electric Lighting                          | <input type="checkbox"/> Architects' Blueprints                          |
| <input type="checkbox"/> Mechanical Engineer                        | <input type="checkbox"/> Contractor and Builder                          |
| <input type="checkbox"/> Mechanical Draftsman                       | <input type="checkbox"/> Architectural Draftsman                         |
| <input type="checkbox"/> Machine Shop Practice                      | <input type="checkbox"/> Concrete Builder                                |
| <input type="checkbox"/> Railroad Positions                         | <input type="checkbox"/> Structural Engineer                             |
| <input type="checkbox"/> Gas Engine Operating                       | <input type="checkbox"/> Chemistry <input type="checkbox"/> Pharmacy     |
| <input type="checkbox"/> Civil Engineer                             | <input type="checkbox"/> Automobile Work                                 |
| <input type="checkbox"/> Surveying and Mapping                      | <input type="checkbox"/> Airplane Engines                                |
| <input type="checkbox"/> Metallurgy <input type="checkbox"/> Mining | <input type="checkbox"/> Agriculture <input type="checkbox"/> Navigation |
| <input type="checkbox"/> Steam Engineering                          | <input type="checkbox"/> Mathematics <input type="checkbox"/> Radio      |

Name.....

Street Address.....

City..... State.....

Occupation.....

Persons residing in Canada should send this coupon to the International Correspondence Schools Canadian, Limited, Montreal, Canada

## Electrical Engineering

Course for men of ambition and limited time. Over 5000 men trained. Condensed course in Theoretical and Practical Electrical Engineering including the closely related subjects of Mathematics and Mechanical Drawing.

Students construct motors, install wiring, test electrical machinery. Course designed to be completed in one college year. Prepare for your profession in the most interesting city in the world. Est. 1893. Catalog on request.



## Bliss Electrical School

122 Takoma Ave., Washington, D. C.

## MUSIC LESSONS IN YOUR HOME



Write today for our **FREE** booklet. It tells how to learn to play Piano, Organ, Violin, Mandolin, Guitar, Banjo, etc. Beginners or advanced players. Your only expense about 2c per day for music and postage used. **American School of Music, 51 Manhattan Bldg., Chicago**



## "BECOME A LIGHTNING TRICK CARTOONIST"

Send \$1.00 for Laugh Producing Program of 23 Trick Drawings with Instructions. Catalog of Chalk Talk Supplies Free. **BALDA ART SERVICE, Dept. 1, Oshkosh, Wis.**

## LEARN WATCHMAKING

and become independent. We help you secure a position.

Easy to learn. Send for **FREE CATALOG.**

**ST. LOUIS WATCHMAKING SCHOOL,**

**Dept. 5.**

**ST. LOUIS, MO.**

## LEARN PHOTO-ENGRAVING

Earn \$200 to \$500 monthly. Photo-Engraving and Photography taught by largest college of its kind in the world. Established 1893. Big demand for graduates. **Write for free book. Illinois College of Photography, Box 4127, Effingham, Ill.**

## A GREAT BOOK FREE WITH THIS LIBRARY!

For a short time only we will give every subscriber to the New Library of Machine Shop Practice a copy of French's Engineering Drawing—the greatest book on mechanical drawing ever written. This book makes drawing as plain as day—tells you all about instruments, plans and methods—and prepares you to handle any drawing job you will ever have to do. It comes to you absolutely free with

## Machine Shop Practice

**9 volumes—3065 pages—3608 illustrations**  
(A combined home-study course and reference library)

The New Machine Shop Library is written for practical men. It gives you the best methods for every kind of machine shop work. It explains machine tools and their operation, drawing and design, tool work, gears and grinding, jigs and fixtures, automatic screw machines and their tools and all of the mathematics you will ever have to use. It is plainly written, completely illustrated—the very best kind of help to the machine-shop man who wants to advance himself.

Sent

**FREE**



No money down—  
only 7c  
a day

## FREE EXAMINATION COUPON

**McGraw-Hill Book Co., Inc., 370 Seventh Ave., New York**

Send me for 10 days' free examination the New Library of Machine Shop Practice. If satisfactory, I will send you \$2.50 in 10 days and \$2 monthly until the special price of \$22.50 is paid. If not wanted, I will return the books at your expense.

On receipt of my first payment of \$2.50, it is understood that I am to receive, free of charge, a copy of French's Engineering Drawing.

Signed.....

Address.....

City and State.....

Position.....

Employer..... P.M. 12-27





# Suddenly I Broke Away and Held Them Spellbound

As I review that tense dramatic moment when I electrified that meeting, it all seems strange and weird to me. How had I changed so miraculously in three months from a shy, diffident "yes" man to a dynamic, vigorous he-man? How had I ever dared give my opinion? Three months before nobody ever knew I held opinions!

ALL my life I had been cursed with a shy, timid, self-conscious nature. With only a grammar school education I could never express ideas in a coherent, self-confident way. But one day my eye fell upon a newspaper article which told about a wonderful free book entitled *How to Work Wonders With Words*,—a book that was causing widespread comment from coast to coast—a book that was being read not only by millionaires, but by thousands of others. It discussed men like me and explained how we could overcome our handicaps.

At first I was skeptical. I thought these defects were a part of my natural makeup—that I would never be able to overcome them. But some subtle instinct kept prodding me to send for that free book. I lost no time in sending for it, as I was positively amazed at being able to get cost free a book that made absolutely plain the secrets that most successful men have used to win popularity, distinction, money and success.

As the weeks wore on, and I absorbed the principles of this remarkable method, I became conscious of new physical and mental energy, a new feeling of aggressiveness, and a resurrected personal power that I never dreamed I possessed. Then came that day in the general meeting when the president called on the assembled department heads and assistants for suggestions on the proposed new policy.

boss and associates. And I noticed with silent exultation the rapt, intent look on my audience as my story unfolded itself smoothly and eloquently.

To-day the men whom I used to greet deferentially I now meet with an air of cool equality. I am asked to conferences, luncheons, banquets, etc., as a popular after-dinner speaker. And my talents are not confined to business matters but have made me an interesting conversationalist at social affairs. I am meeting worth-while people, I own a good job, a good home, a good car. I am the happiest man that ever lived.

And I frankly and candidly admit that I owe all of these blessings to that wonderful little free book *How to Work Wonders With Words*.

### Send for This Amazing Book

This new method of training is fully described in a very interesting and informative booklet which is now being sent to everyone mailing the coupon below. This book is called *How to Work Wonders With Words*. You are told how to bring out and develop your priceless "hidden knack"—the natural gift within you—which will win for you advancement in position and salary, popularity, social standing, power and real success. You can obtain your copy absolutely free by sending the coupon.

Now Sent  
FREE

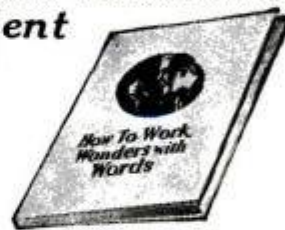

North American Institute,  
3601 Michigan Ave., Dept. 1359  
Chicago, Illinois

NORTH AMERICAN INSTITUTE,  
3601 Michigan Ave., Dept. 1359, Chicago, Illinois

Please send me FREE and without obligation my copy of your inspiring booklet, *How to Work Wonders With Words*, and full information regarding your course in Effective Speaking.

Name.....

Address.....

City.....State.....

#### WHAT 20 MINUTES A DAY WILL SHOW YOU

- How to talk before your club or lodge
- How to address board meetings
- How to propose and respond to toasts
- How to make a political speech
- How to tell entertaining stories
- How to make after-dinner speeches
- How to converse interestingly
- How to write better letters
- How to sell more goods
- How to train your memory
- How to enlarge your vocabulary
- How to develop self-confidence
- How to acquire a winning personality
- How to strengthen your will power and ambition
- How to become a clear, accurate thinker
- How to develop your power of concentration
- How to be the master of any situation

Three months previously, the forces of indecision, timidity, and inability to talk in public would have held me to my seat. But suddenly that new power took possession of me and drove me to my feet. That wonderful 20-minute daily training at home had taught me to forget myself and think only of my subject. Almost automatically the ideas which had heretofore lain dormant in a mental jumble, now issued with a vigor, clearness and enthusiasm that astounded me no less than my





## IN DRAWING CARTOONS

Why spend your time doing work that is drudgery, and get little money for it when you may be able to draw cartoons for Big Pay? Learn cartooning at home with this simple, tested method. Many students earn money while learning.

Become a high-salaried cartoonist—one of the easiest, most pleasant, and best paid of all businesses. Millions of dollars spent last year on serious, comic, sport and animated cartoons—and the demand for cartoons increases every day! Hundreds of cartoons now used by big national advertisers.

### Learn Cartooning at Home In Spare Time—Simple, Tested Method

There is a knack about learning cartooning which you can master in your spare time with this simple home study method. It starts you at the very beginning—on simple fundamental principles—then takes you through every branch of humorous and serious cartooning. You will be surprised how quickly you can draw cartoons that will sell. Many earn even while learning.

#### Send for Free Book

Get this handsomely illustrated booklet which gives the details of this remarkable home study course in Cartooning. Gives thorough outline of the cartooning field and market for cartoons. Shows how to become a cartoonist. No obligation. Send for it today. (No salesman will call.)

**Washington School of Cartooning**  
Room 3012E, 1113—15th St., N. W., Washington, D. C.

**Washington School of Cartooning**  
Room 3012E, 1113—15th St., N. W., Washington, D. C.

Please send me without obligation, your Free Booklet on Cartooning and special offer to new students.

Name..... Age.....  
(Write Name Plainly.) (State whether Mr., Miss or Mrs.)

Address.....

City..... State.....

## LOOK!

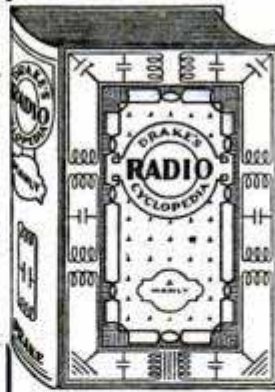

### The Last Word in RADIO

Radio is an exact science, yet so new there is still much that is incorrect and unscientific in present equipment. The results are faulty reception and complaints.

To meet this need we have compiled the exact facts covering the entire scope of radio science and every type of receiver into one big, fine, new book. With it you can now **Be The Man Who Knows!**

### DRAKE'S RADIO CYCLOPEDIA Solves the Dealer's Service Problems

If you design, build, repair or service radio receivers you need this book. All subjects alphabetically arranged, with hundreds of cross references so you quickly find what you want. 1672 headings, 985 illustrations, 871 pages. Nothing else like it. It is **the** book of radio, just out. **SEND TODAY.** \$6.00 postpaid. Also for sale at all bookstores.

Big catalog of useful books sent free.

### FREDERICK J. DRAKE & CO.

*Publishers*

1010 S. Michigan Blvd.

Chicago

### LEARN PIANO TUNING AT HOME

Send for **FREE** copy of the 30th ANNIVERSARY EDITION of our book, "Winning Independence". Read how students master tuning with our **TUNE-A-PHONE**, and **WHY** our graduates head the profession in all parts of the world. With Bryant's patented devices, tools, charts and lessons, one learns quickly and easily. Low tuition; easy terms. Diploma granted. **MONEY-BACK** if not satisfied. \$10.00 to \$25.00 a day, exceptional opportunities and an ideal profession awaits you.

**BRYANT SCHOOL OF TUNING, 31 Bryant Bldg., Augusta, Michigan.**

## MEN WANTED

TO LEARN

### Motion Picture Projection

\$2,000 to \$4,000 a Year

Quickly learned. Short hours, big pay. Best equipped school in Michigan. Projectionists for Movie Houses and Road Shows.

#### MOVIE OPERATORS SCHOOL

61 Sproat Street,

DETROIT, MICHIGAN

### LEARN WATCHMAKING AND ENGRAVING



#### BY OUR PROFIT-SHARING PLAN OUR GRADUATES SUCCEED

One of our Iowa students started in a very small way—now doing over \$30,000 a year. Another in Wisconsin, over \$10,000 the first year. Day or night classes. Call or write for **FREE BOOK**

**Chicago School of Watchmaking, Dept. 3501, 4844 Lincoln Avenue, CHICAGO**

RADIO

## ACCESSORIES at WHOLESALE

Radio Sets, "B" Eliminators, Chargers, Tubes, Kits, Parts—everything new in Radio at lowest wholesale prices. Thousands of nationally advertised bargains. All listed and illustrated in my Big New Catalog and **FREE** Cash Book.

132 Pages of valuable Radio information—trouble finding, set building—Radio knowledge of all kinds. Write today. **HARRY SCHWARTZBERG PRES.**

**AMERICAN AUTO & RADIO MFG. CO.**  
Dept. 264 American Radio Bldg.  
Kansas City, Missouri

**FREE  
BIG  
BARGAIN  
CATALOG**



# ELECTRICITY

## Complete Study Course and Pocket Library \$10



### SHIPPED FREE

A set of **HAWKINS GUIDES** is a true friend to the electrical worker. It tells you how to do any job the right way—without guessing or taking chances.

Hawkins Guides put all the facts about modern electrical engineering at your finger tips. Therefore your chances for advancement in the electrical field are unlimited.

### HAWKINS GUIDES DOUBLE YOUR VALUE



Electricity is king! It is the ruling force of today—transportation, communication, light, heat, power—indeed every modern activity is dependent on electricity. Industry is crying for electrical men that know their jobs!

Hawkins Guides teach you all you need to know about electricity in easy, step-by-step lessons. Daily spare time reading of the Guides will greatly increase your value to yourself and your employer in a few weeks. Hundreds of our friends have written us and told us this!

### READERS OF HAWKINS GUIDES KNOW HOW



"You can't stump him on an electrical job." "He certainly knows his business." "Certainly have to hand it to him for knowing how."—These are the things employers say about our friends who are readers of Hawkins Guides. No matter what question or problem comes up the Ready Reference Index enables you to give an expert answer at once.

### HAWKINS STARTS YOU WHERE OTHERS LEFT OFF

Why should you work at low wages when easy reading of HAWKINS GUIDES will give you the money-making knowledge of the expert? Easy daily reading of the Guides will teach you in a few months what it has taken the expert a lifetime to learn!

With HAWKINS GUIDES in hand you have a running start to success in the electrical field. You will actually begin where others left off!



## NOW!

This coupon is your golden opportunity. Tear it out—send it now!

## FOR EXAMINATION!

### REAL ELECTRICAL EDUCATORS

"Hawkins Guides at \$10 is the best investment I have ever made. Am able to take up almost any electrical job and have never gone to an electrical school."—B. Roessler, Oenaville, Texas.

### AS EASY AS A. B. C.

"Everything in Hawkins Guides is very plain and anybody can read and understand them as easy as A. B. C."—J. Knight, Tobyhanna, Pa.

### OTHER ENTHUSIASTIC READERS SAY

"Worth ten times their price." "Helped me to two raises in four months." "Better than a school of instruction." "Studied them when I was laid up and got further ahead than if I had been on the job."

### Hawkins Guides Explain These Points So You Can Easily Understand:—

Magnetism—Induction—Experiments—Dynamo—Electric Machinery—Motors—Armatures—Armature Windings—Installing of Dynamos—Electrical Instrument Testing—Practical Management of Dynamos and Motors—Distribution Systems—Wiring—Wiring Diagrams—Sign Flashers—Storage Batteries—Principles of Alternating Currents and Alternators—Alternating Current Motors—Transformers—Converters—Rectifiers—Alternating Current Systems—Circuit Breakers—Measuring Instruments—Switch Boards—Wiring—Power Stations—Installing—Telephone—Telegraph—Wireless—Bells—Lighting—Railways. Also many Modern Practical Applications of Electricity and Ready Reference Index.

### Hawkins Guides—10 POCKET SIZE NUMBERS

Each number easy to carry around and read in spare time. Big type and clear diagrams. Easy to study and learn. Durable, flexible binding—gold edges. 3,500 pages—4,700 illustrations. Shipped free for examination. Pay only \$1 a month if satisfied. Price of set, complete, \$10.



### EXAMINE GUIDES FREE! \$

Let the Guides themselves demonstrate their practical value to you—as a study course, reference work and complete electrical library. You are the judge. Simply send this coupon. No obligation unless you are entirely satisfied. Tear out on dotted line—fill in—mail it NOW!

\$1 PER MO.

### FREE EXAMINATION COUPON

Theo. Audel & Co., 65 W. 23rd St., New York City

Please send me (postpaid) for my approval Hawkins Electrical Guides, 10 numbers (price \$1 each). If satisfactory I will mail you \$1 in 7 days and further mail \$1 monthly until purchase price of \$10 is paid.

Name.....

Address.....

Occupation.....

Employed by..... 12T30



# Play the HAWAIIAN GUITAR and be Popular!

Play all the latest hits just as the Hawaiians do. Be the most popular member of your set. Get in on all the good times. Entertain your friends—or play professionally. Be in demand everywhere. We will help you.



**\$15**  
**HAWAIIAN GUITAR**  
with Genuine Seal Grain  
**Fabrikoid Cover**  
**GIVEN**  
when you enroll



This sweet-toned, mellow Hawaiian Guitar would cost you at least \$15 in any music store without the Genuine Seal Grain Fabrikoid Case. We can afford to give you the entire outfit free when you enroll, including picks, steel playing bar, etc., because we make them in huge quantities in our own factory. Nothing to buy—everything is furnished.

### Learn in Spare Time at Home

You study in spare time—when you like—as long as you like. And even if you don't know one note from another, our method is so simple, plain and easy that you can begin a piece your first lesson. In half an hour you can play it!

### Famous Native Hawaiians Teach You

You receive expert instruction from such world famous players as Kolomoku, Kalaluki, Ferrara and Seville. They quickly teach you the secrets of this fascinating instrument.

**Complete Conservatory Course.** You get 52 complete printed lessons. Nothing is omitted. Pictures explain every move. And no matter how little you know about music when you begin, no matter if you have never touched a musical instrument, you can positively learn to play by our plain, easy, picture method.

### Only 4 Motions to Learn

Then you can play any music—popular songs, classical, old-time melodies, native Hawaiian airs—or real jazz—separately or with accompaniment. You'll never be lonesome after you learn to play on this beautiful Hawaiian Guitar.

### Pay as You Play

We make it easy for you. You start any time—with a small first payment—then pay while learning. Write for liberal offer.

### Our Written Guarantee

We guarantee in writing to teach you. 45,000 successful students. And we coach and advise you after graduation—no extra cost.

### Tenor Banjo

and other courses—Violin, Tiple, Tenor Guitar, Banjo Ukulele, Ukulele—under well-known instructors. Write for information.

### FIRST HAWAIIAN CONSERVATORY OF MUSIC, INC.

9th Fl., Woolworth Bldg., Dept. 448, New York, N. Y.

Approved as a Correspondence School Under the Laws of the State of New York

**ACT! Mail This Popularity Coupon NOW!**

FIRST HAWAIIAN CONSERVATORY OF MUSIC, Inc.  
9th Fl., Woolworth Bldg., Dept. 448, New York, N. Y.

Please mail full information about your 52-lesson Hawaiian Guitar Course. I am not obliged to enroll unless I want to.

Name \_\_\_\_\_

Address \_\_\_\_\_

City \_\_\_\_\_ State \_\_\_\_\_

Learn to Write

## I Teach by Mail

I CAN make a good penman of you at your home during spare time, no matter where you live or how poorly you now write. My simplified system has shown thousands of others the way to good penmanship during the past twenty years—it can and will do the same for YOU!

Beautifully Illustrated Book  
"How to Become a Good Penman"

It contains general information, with testimonials and beautiful specimens of penmanship showing what others have accomplished by the Tamblin System. (Your name elegantly written on a card if you enclose stamp for postage.) **WRITE TODAY.** Address

F. W. TAMBLIN

418 Ridge Bldg., Kansas City, Mo., U. S. A.

F. W. Tamblin



## Be a drummer!

Trap Drumming made easy in a short time. Our free instruction course furnished with genuine Ludwig Trap-Drum Outfit. Develop your natural sense of rhythm. Go to your nearest dealer or write for full details.

LUDWIG & LUDWIG, 1611 North Lincoln Street, Chicago

## Learn to PAINT SIGNS and SHOW CARDS

We quickly teach you by mail, or at school, in spare time. Enormous demand. Big future. Interesting work. Oldest and foremost school. **EARN \$50 TO \$200 WEEKLY**  
John Vasson, N. Y., gets \$25 for single show card. Crawford, B. C., writes: "Earned \$200 while taking course." Don't delay. Send today for complete information, samples and guarantee.

**DETROIT SCHOOL OF LETTERING**  
154 Stinson Ave. Est. 1899 DETROIT, MICH.



## LAW High-Grade Instruction By Correspondence Prepares You for the Bar—Est. 1892

University Methods. Standard Text-Books. Approved by Bench and Bar. Graduates practicing in every state. Send today for Free Catalog and Rules for Admission to the Bar. CHICAGO SCHOOL OF LAW, 802 Reaper Block, Chicago, Ill.



## LEARN WATCH REPAIRING



You can learn by our modern and original system of instruction every part of the **Watch Repairing Trade** at home as good or better than at a shop. You can earn money while learning and secure a well paying position or start in business after completing our course of instruction. Good watch repairers are always in demand and earn from \$50 to \$75 per week. For particulars apply to the **Wisconsin School of Watch Repairing**  
166 Mason St., MILWAUKEE, WIS.



# A Challenge Made Me Popular!

**"A** BOX of cigars says you don't dare dance with her—Wallflower!" That was the challenge they flung at me! My sporting blood boiled! "All right, I accept!" I responded. And I started across the floor.

**I** NEVER was much of a dancer. But when our club gave this affair I couldn't stay away. Even now, I should have been sitting safely on the "sidelines"—if the fellows hadn't made that sarcastic remark.

"Show them you can do it! Show them you can dance as well as they!" my pride whispered. And I would!

But halfway across the hall my courage died. I was nearly paralyzed with fright. There she was, waiting expectantly—Marion Blake, an exquisite dancer—graceful, poised, at ease. Suppose she should refuse? Suppose she should leave me in the center of the floor? Oh, wouldn't the fellows chuckle then!

## The Unexpected Happens

"I'm—I'm sorry"—I stammered. "I guess——"

"Why, of course, I'll be glad to dance!" she interrupted. And before I realized it we were swallowed up in the dancing throng.

What a terrible ordeal it was for me! And twice as bad for her. I stumbled through the steps. I trod on her toes. I tried desperately to keep in time with the music. Yes, my dancing was inexcusable—hopelessly out-of-date!

Suddenly she suggested that we sit out the rest of the number. I blushed furiously "Now, it's coming!" I thought. "Now, she is going to tell me what she thinks of my nerve!"

But I was in for the surprise of my life. "Jim," she began softly. "I'll be frank. You're not the best dancer in the world. But you're certainly not the worst. What you need is 'brushing up' on the latest steps. Why don't you get in touch with Arthur Murray?"

"Arthur Murray! Arthur Murray!" I repeated. "He teaches dancing by mail. You can't learn that way!"

"No?" and Marion arched her eyebrows. "The truth is, that's *exactly* the way I learned—even though no one *does* suspect it!"

Naturally I was astounded, but the next evening I found one of Arthur Murray's ads and clipped the coupon. Then I mailed it, asking for his free booklet and five free lessons. If Marion could become a wonderful dancer that way it was certainly worth investigation—especially since I didn't risk a penny.



But halfway across the hall my courage died. I was nearly paralyzed with fright. There she was, waiting expectantly—Marion Blake, an exquisite dancer—graceful, poised, at ease. Suppose she should refuse? Suppose she should leave me in the center of the floor?

## I Find the Secret!

The booklet and free lessons came promptly. What a revelation! They showed me how many mistakes I had been making—how utterly ignorant I was of the modern style of dancing, yet in a few evenings I had learned the modern Waltz—the modern Fox Trot and many delightful variations of the *very latest* steps—without music, partner or teacher!

## I Turn the Tables

A week later I attended a dance. The old crowd was there. "Here he is again!" they chorused. "Give him the cigars! He earned them!" Imagine how surprised they were when I asked Marion to dance! They stood open-mouthed as I glided around the floor like an expert! Now girls are always delighted to dance with me. I laugh when I think how scared I was that terrible evening—for everywhere I go I am welcomed as an accomplished dancer!

## Will YOU Accept These 5 FREE Lessons?

No matter how poorly you dance now—no matter if you've never even been on a dance floor in your life—Arthur Murray's method makes you a finished dancer in 10 days, or you don't have to pay a penny. To prove it he is willing to send you five lessons from his remarkable course *absolutely free!* Just mail coupon (with 10c to cover cost of printing and mailing) and these valuable lessons will be forwarded at once. Also a free copy of his new book, "The Short Cut to Popularity." Mail coupon *NOW!*

Arthur Murray, Studio 749, 7 East 43rd Street, New York City.

Arthur Murray, Studio 749,  
7 East 43rd Street, New York City

To prove that I can learn to dance at home in ten days you may send the FIVE FREE LESSONS. I enclose 10c (stamps or coin) to pay for the postage, printing, etc. You are to include free "The Short Cut to Popularity."

Name.....

Address.....

City..... State.....

See how easy it is to learn the Arthur Murray way!



Learn



24th Year

# DRAFTING

## ENGINEERING, ELECTRICITY

### and ARCHITECTURE

## CHICAGO TECHNICAL COLLEGE

One of "America's oldest and largest schools of specialized engineering" offers you a maximum of practical training in a minimum of time, here at Chicago, the country's building and engineering center. Technical training of college standard for men who have neither the time, money nor preliminary education to attend a university. Each year more than 1000 men and women enroll in day and evening classes.

### Short, Intensive Training

practical in every respect, puts you quickly into a high salaried position. Many of our students are assisted to responsible positions before graduation . . . they earn while they learn.

#### In Spare Time At Home

If you can't come to Chicago, learn Drafting at home. Your spare time is enough. Same practical course. Quick, easy—yet thorough.

#### Trial Lesson FREE

Test yourself and see how easy you can learn Drafting by the Chicago Tech. method. Trial lesson sent free if interested in home study. Address Dept. R-209.

COURSES are arranged to suit your needs—2 year diploma; 3 year B. S. degree; special 3 and 4 months' short courses adapted to the individual. Expert instructors actively at work in the very professions they teach.

Tuition low, terms easy. Enter any time. Day and Evening Classes.

## Write for FREE 84 Page Blue Book

It tells about all the courses . . . fully describes them; about the great demand for Chicago Technical College trained men; about college athletics and other interesting facts you'll want to know. Gives you a vivid picture of what you may expect at this leading technical college. There is no obligation. Send for this free Blue Book today . . . now!

Address Registrar R-75

Chicago TECHNICAL College  
Dept. R-75 118 East 26th St., Chicago

# Wrestling

Learn at Home

# Book 10c



Secrets of expert wrestling revealed by world champions—Farmer Burns and Frank Gotch. Be a great athlete—a winner. Every man and boy needs this wonderful book. Send for it today. This school teaches expert wrestling, jiu-jitsu, physical culture. Learn in your own home by mail to be an all-round athlete. Train to win in all sports—football, baseball, running, walking, boxing. Handle big, strong men with ease. Have a beautiful attractive body that all admire. Surprise your friends, and the "bully" with your great ability. Learn to protect yourself, your mother, sister or sweetheart. You can be a great athlete if you'll try. Develop the great ability that is within you.

Send only 10c, coin or stamps, for this wonderful 32 page, illustrated book that tells you how to become a real man. Don't be a weakling—be a leader—a winner. This valuable book tells how! Tells the secrets of the big champions; gives many truths, holds and other valuable information. A costly book which we send for only 10c—the cost of packing and postage. Grasp this opportunity now. Send today. State age.

**Farmer Burns School** 3379 Railway Exchange Bldg. OMAHA, NEB.

## EARN PROMOTION AND COLLEGE CREDIT

through the HOME-STUDY COURSES

in 40 different subjects given by

The University of Chicago

207 Ellis Hall, University of Chicago, Chicago, Ill.

## PIANO JAZZ

By Note or Ear. With or without music. Short Course. Adult beginners taught by mail. No teacher required. Self-Instruction Course for Advanced Pianists. Learn 259 styles of Bass, 684 Syncopated Effects, Blue Harmony, Oriental, Chime, Movie and Café Jazz, Trick Endings, Clever Breaks, Space Fillers, Sax Slurs, Triple Bass, Wicked Harmony, Blue Obligato, and 247 other Subjects, including Ear Playing. 133 pages of REAL Jazz, 25,000 words. A Postal brings our FREE Special Offer.

Waterman Piano School, 1826 W. Adams St. Los Angeles, Cal.

## "STAMMERING

### Its Cause and Cure"

You can be quickly cured if you stammer. Send 10 cents, coin or stamps, for 288 page cloth bound book on Stammering and Stuttering. It tells how I cured myself after Stammering and Stuttering for 20 years. BENJAMIN N. BOGUE  
11100 Bogue Building, 1147 N. Ill. St. Indianapolis



WHY NOT spend Spring, Summer and Fall gathering butterflies, insects? I buy hundreds of kinds for collections. Some worth \$1 to \$7 each. Simple outdoor work with my instructions, pictures, price-list. Send 10 cents (not stamps) for my illustrated Prospectus before sending butterfly.  
MR. SINCLAIR, DEALER IN INSECTS,  
Dept. 6, Box 1424. San Diego, Calif.

## BE AN ARTIST

WE CAN TEACH YOU DRAWING in your own home during your spare time. Twenty-five years of successful teaching proves our ability. Artists receive large salaries.

Write Today for Art Year Book

SCHOOL OF APPLIED ART  
ROOM NO. 2 BATTLE CREEK MICH.





# -You Pledge

Yourself to Secrecy  
I will Teach You  
the Secrets of  
Real Professional

# Magic

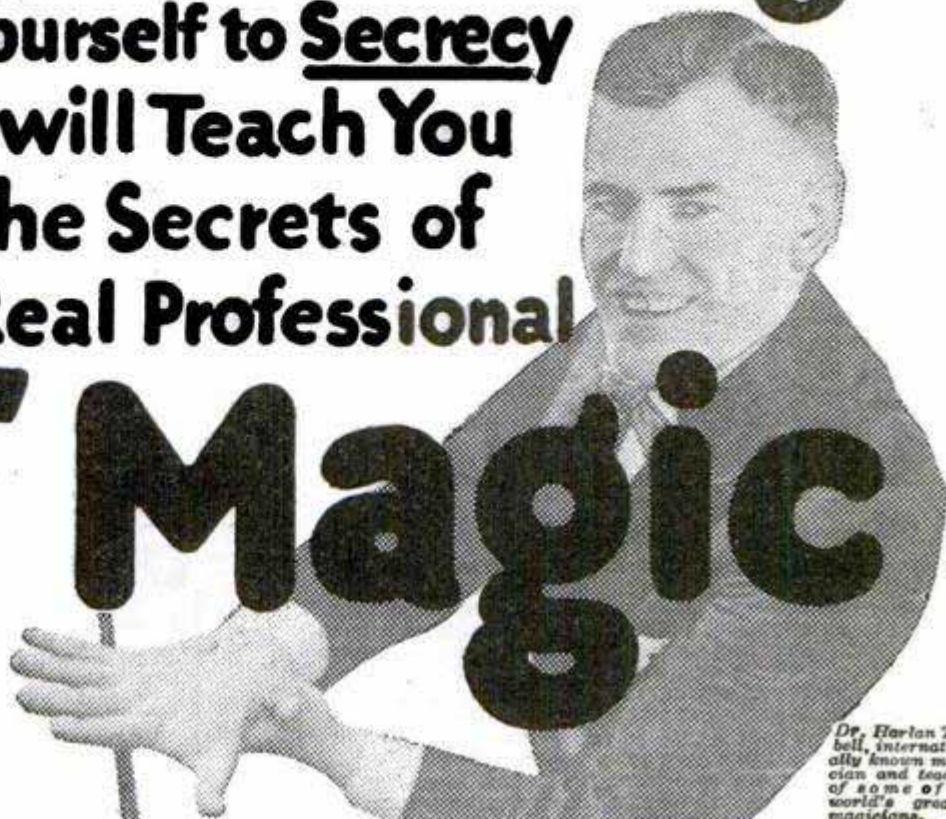

*Dr. Harlan Tarbell, internationally known magician and teacher of some of the world's greatest magicians.*

## Astonish Your Friends with your *Magic Art*

For the first time in the history of Magic the old-age, sacredly guarded secrets of the Mystic Art are being revealed. Now at last you can learn to be a Real Professional Magician. Yes, and you can learn this wonderful art *easily and quickly* AT HOME. You are taught the mysterious *Principles* by which the Professional Magician works. You are taught everything from wonderful improptu effects to massive stage illusions.

But before you can study, you must sign the Magician's Solemn Pledge of Secrecy. This means that you are getting the *guarded secrets* of the Magic Profession. Think of that!

**Earn \$250 to  
\$1000 a Month**

There's a big demand for Magic entertainment. Magicians get big money. Dr. Tarbell gets as high as \$250 for a half hour's work. Unlimited opportunities for you!

### Special Limited Offer!

Clubs, Lodges, Charity and Social affairs—all will pay high fees to the man who knows Magic. Dr. Harlan Tarbell really gets as high as \$250 for a half hour's work right now. Opportunity everywhere to make money on the side. Salesmen find it a tremendous asset. The coupon brings full details without any obligation. Mail it TODAY.

*Mail  
this Coupon  
Now!*

**Tarbell System, Inc., Studio 13-59  
1920 Sunnyside Avenue, Chicago, Illinois**

Gentlemen: Without any obligation send me your free literature and information all about your wonderful "Tarbell Course in Magic." Also tell me about your great Special Price Offer and Easy Payment Plan—offered NOW for limited time only.

Name .....

Address .....

Age .....





## High School Course in Two Years!

### You Want to Earn Big Money!

And you will not be satisfied unless you earn steady promotion. But are you prepared for the job ahead of you? Do you measure up to the standard that insures success? For a more responsible position a fairly good education is necessary. To write a sensible business letter, to prepare estimates, to figure cost and to compute interest, you must have a certain amount of preparation. All this you must be able to do before you will earn promotion. Many business houses hire no men whose general knowledge is not equal to a high school course. Why? Because big business refuses to burden itself with men who are barred from promotion by the lack of elementary education.

### Can You Qualify for a Better Position

We have a plan whereby you can. We can give you a complete but simplified high school course in two years, giving you all the essentials that form the foundation of practical business. It will prepare you to hold your own where competition is keen and exacting. Do not doubt your ability, but make up your mind to it and you will soon have the requirements that will bring you success and big money. **YOU CAN DO IT.**

Let us show you how to get on the road to success. It will not cost you a single working hour. Write today. It costs you nothing but a stamp.

### American School

Dept. H-974, Drexel Ave. and 58th St., Chicago

### American School

Dept. H-974, Drexel Ave. and 58th St., Chicago

Send me full information on the subject checked and how you will help me win success.

- |                              |                            |
|------------------------------|----------------------------|
| .... Architect               | .... Business Law          |
| .... Building Contractor     | .... Lawyer                |
| .... Automobile Engineer     | .... Machine Shop Practice |
| .... Automobile Repairman    | .... Mechanical Engineer   |
| .... Civil Engineer          | .... Shop Superintendent   |
| .... Structural Engineer     | .... Employment Manager    |
| .... Business Manager        | .... Steam Engineer        |
| .... Cert. Public Accountant | .... Foremanship           |
| .... Accountant and Auditor  | .... Sanitary Engineer     |
| .... Bookkeeper              | .... Surveyor (& Mapping)  |
| .... Draftsman and Designer  | .... Telephone Engineer    |
| .... Electrical Engineer     | .... Telegraph Engineer    |
| .... Electric Light & Power  | .... High School Graduate  |
| .... General Education       | .... Wireless Radio        |
| .... Vocational Guidance     | .... Undecided             |

Name .....

Address .....

# ELECTRICITY

M  
A  
D  
E

REAL WORK with REAL TOOLS on REAL EQUIPMENT

COLEMAN SYSTEM never fails when student means business

All Electrical Subjects Taught

Armature Winding; Electric Welding; House Wiring; Electric Refrigeration; Farm Lighting; A. C. and D. C. Motors and Generators; Power and Light Switchboards, Dynamos and Transformers; Radio; Storage Batteries; Automotive Electricity.

All Electrical Trades need Skilled Men—Electrical Skill is in Demand at \$200.00 to \$600.00 a Month.

FREE—Automobile Training—FREE.

Real Cars to Work On—and No Extra Charge

LET COLEMAN TELL YOU HOW—

WRITE FOR FREE BOOK

COLEMAN ELECTRICAL SCHOOL

1628 J Main Street

KANSAS CITY, MO.

E  
A  
S  
Y

## LEARN PIANO AT HOME

TRIAL LESSONS FREE

Learn in minutes by our method what took hours. To prove you can do it, we will send you free the first two lessons. No previous training necessary to become an accomplished musician. Lessons are so easy a school child can master them. **PLAY FROM NOTES IN SIX LESSONS.**

Write for details and free lessons

BOSTON ACADEMY OF MUSIC

Suite 13, Regent Circle, Boston (46) Mass.



## Anyone CAN LEARN

No talent or experience necessary. Fascinating work. Pays big money. Complete instruction book tells about: Alphabets, Colors, How to Mix Paints, Show Cards, Window Board and Wall Signs, Ready made letters, Gliding, Tricks of the Trade, also gives 100 Alphabets and Designs. Book bound in flexible imt. leather—gold edges, and four half bearing Show Card Pens. Sent postpaid \$3.00, (C.O.D.) 10c ex. Ogilvie Pub. Co., 57 Rose St. Dept 20, N.Y. City

**EARN MONEY IMMEDIATELY— WE FURNISH EQUIPMENT TO START !!**

## Learn to Dance

You can learn all the modern dances—Charleston, Black Bottom, Valencia, Canter, French Tango, Latest Waltzes, Fox Trots, etc. at home easily and quickly. New chart method makes dancing as simple as A-B-C. No music or partner required. Don't be a wallflower. Learn to dance. Complete course—323 pages, 49 illustrations only \$1.00. Equals \$20.00 course. Satisfaction Guaranteed. Bargain Book Catalog FREE.

FRANKLIN PUBLISHING COMPANY  
186 N. LaSalle St., Dept. 9409 CHICAGO



## MINSTRELS

Musical Comedies and Revues, with full instructions for staging. You can stage your own show with our books. Full line of plays, stage songs, crossfire monologues, afterpieces, vaudeville acts and make-up. CATALOGUE FREE.

T. S. DENISON & CO., 623 So. Wabash, Dept. 19, Chicago

## Learn Advertising at HOME

Many of the highest paid men in the world are advertising men. You can learn easily and quickly at home during your spare time. We guarantee satisfaction. Bigger opportunities now in advertising than ever before. Constant demand for our graduates at splendid pay.

Send for FREE Book, giving interesting information and vital facts—just what you want to know about advertising. Write today.

PAGE-DAVIS SCHOOL OF ADVERTISING  
Dept. 1359 3601 Michigan Ave., Chicago, U. S. A.



# They Thought I Was Bluffing



## *When I Told Them I Learned Music Without a Teacher*

You could have heard a pin drop in the room! I had just finished playing Rubinstein's "Melody in F." My friends were actually dumfounded. At last I was the center of attraction instead of a mere onlooker! It was just like a dream come true!

"Why, you didn't know a single thing about music not so long ago, Bob"—"How in the world did you ever do it?" A note of half envy, half admiration crept into their voices. "Yes," said Jim, "what sort of trick have you played on us—I thought you weren't musically inclined." "Oh, he's been taking lessons for years and has kept it a secret"—followed Betty and Sue in rapid-fire succession. "You can't fool us though, you never learned to play that well without a teacher."

They were all wrong, though. At first I didn't believe it was possible to learn music by mail. I thought I needed special "talent." But, thanks to a startling new simplified method, I soon discovered my mistake. It was simple as A-B-C, and actual

FUN learning. Each new lesson was better and easier than the last. Everything about them was so simple that a child of eight could understand it. Now I can play any piece of music—classical or jazz—and play real notes! I never have to refuse when I'm called upon to entertain. Now my life is just a joyous round of gay parties and admiring friends.

### Play Any Instrument

You, too, can now teach yourself to be an accomplished musician—right at home—in half the usual time through

this startling method, which has already shown almost half a million people how to play their favorite instrument. Forget that old-fashioned idea that you need special "talent." Just read the list of instruments in the panel, decide which one you want to play and the U. S. School will do the rest. And bear in mind no matter which instrument you choose, the cost in each case will be the same—averaging just a few cents a day.

### Send for Our free Booklet and Demonstration Lesson

If you are in earnest about wanting to play your favorite instrument—if you really do want to gain the proficiency in music that will add to your happiness, increase your popularity, and open the way to greater income—ask at once for the free booklet and valuable demonstration lesson. Getting them will cost you nothing and place you under no obligation.



Now—before it's too late—sign and send the convenient coupon. Instruments supplied when needed. Cash or credit. U. S. School of Music, 712 Brunswick Bldg., New York City.

U. S. SCHOOL OF MUSIC,  
712 Brunswick Bldg., New York City

Please send me your free book, "Music Lessons in Your Own Home," with introduction by Dr. Frank Crane, Demonstration Lesson and particulars of your offer. I am interested in the following course:

..... Have You Instr? .....

Name.....  
(Please write plainly)

Address.....

City..... State.....

### Pick Your Instrument!

- |                                     |                              |
|-------------------------------------|------------------------------|
| Piano                               | Harmony and Com-<br>position |
| Organ                               | Sight                        |
| Violin                              | Singing                      |
| Drums                               | Ukulele                      |
| and Traps                           | Guitar                       |
| Banjo                               | Hawaiian                     |
| (Tenor,<br>Plectrum<br>or 5-String) | Steel<br>Guitar              |
| Mandolin                            | Harp                         |
| Clarinet                            | Cornet                       |
| Flute                               | Piccolo                      |
| Saxophone                           | Trombone                     |
| 'Cello                              |                              |
| Voice and Speech Culture            |                              |
| Automatic Finger Control            |                              |
| Piano Accordion                     |                              |



# \$100 for One Good Commercial Drawing



## Become An Artist This Tested Way

Thousands who never dreamed they could draw can now become artists at home, in spare time, by amazingly simple way. Students write telling us they never realized that learning to draw could be so simplified. Many are able to earn good money making drawings before completing our training. Miss Hartleigh made \$235 after 12 lessons. David Gould made \$225 on one job while still just a student. E. V. Fritsch wrote, "I earn \$10 to \$15 a day."

### Big Money in Commercial Art

Millions of dollars are being spent this year on advertising and story illustrations, commercial designs, and cartoons. And even more will be spent next year. Commercial art is a tremendous field—and a field where very big money is gladly paid anyone who can produce good art work. Advertisers, magazines, newspapers, printing houses, business concerns all need trained artists. Competent artists easily earn from \$50 to over \$250 a week. Why don't you too enter this fascinating, big pay business?

### Learn to Draw by This Simple Method

You will be delighted with the fascinating method—and you will be amazed at your rapid progress. You start at the very simplest fundamentals, yet almost before you realize it, you are taught how to produce salable work. It's actual fun learning to draw this way. You learn at home yet your work receives the personal attention and criticism of competent Art Instructors. Many students actually sell enough work during their training to pay for it many times over!

### Mail Coupon for FREE BOOK

A new handsomely illustrated book has just been printed, which gives all the most up-to-date information on the thousands of wonderful opportunities in Commercial Art and shows how this startling, simple method enables you to enter this field. It tells about our students—their successes—what they say—actual reproductions of their work—how they made big money while studying. This attractive book will be sent without cost or obligation. Send for it. Mail coupon NOW. (No salesman will call).

WASHINGTON SCHOOL OF ART, Inc.  
Room 3012-E, 1115-15th Street, N. W., Washington, D. C.

Washington School of Art, Inc.  
Room 3012-E, 1115-15th St., N. W., Washington, D. C.  
Please send me without cost or obligation your book "Quick, Easy Way to Become an Artist" and your offer to new Students.

Name.....  
(Write name plainly and state whether Mr., Mrs., or Miss)

Address.....

City.....State.....

Age.....

## Don't Envy The Plumber BE ONE!

**\$11.00-\$16.00 PER DAY** and work **EVERY day**, is the Plumber's wage.

Every skilled workman will tell you that Plumbers have the best of it. WINTER and SUMMER the Plumber is busy at top wages. No skilled Plumber is ever out of a job—compare his opportunities with any trade, plus the opportunities of having your own shop.

We teach you Plumbing with **TOOLS** (not books) under Licensed Master PLUMBERS in one of the finest equipped schools in America. We make you a Plumber, every branch is taught thoroughly—Lead Work—Blue Print for plan reading—all other tricks.

**LEARN IN 8 to 12 WEEKS** without previous experience.

If you are making less than \$60.00 a week you owe it to yourself to investigate. Get **FREE** catalog that tells in pictures and words how we teach this trade. Special rates now.

**UNIVERSAL PLUMBING SCHOOL**  
2030 Troost Ave. KANSAS CITY, MO.

## Play Piano BY EAR

**-IN 90 DAYS!**



Play anything—jazz to classical! Even if you know nothing about piano music—I'll have your fingers dancing over the keyboard with confidence in 90 days. If you can hum or whistle a tune you can play it! My students are broadcasting—making money. **MAKE ME PROVE IT!**

Without puzzling notes! Without practicing tedious scales! I've found the way to bring out your musical instinct. New and original system does away with years of work. **YOU WANT THE PROOF!** I'll send it. Write me now.

D. M. SUTTLE, Director  
ILLINOIS SCHOOL OF MUSIC  
215 Hunter Bldg., Chicago, Ill.

**Send NOW for PROOF!**

Home of the International Correspondence Schools



## Go to High School at Home

You can secure a high school education right at home by studying the splendid new courses recently prepared by the International Correspondence Schools.

These courses are equivalent to the courses given in resident high schools. They have been specially arranged for men and women who wish to meet college entrance examinations, to qualify for a business position, or to make up the education they missed when forced to leave school too soon. A diploma is awarded at graduation.

### Mail Coupon for Free Booklet

INTERNATIONAL CORRESPONDENCE SCHOOLS  
Box 5693-E, Scranton, Penna.

Without cost or obligation, please send me full particulars about the course before which I have marked an X:

- College Preparatory Course
- High School Commercial Course
- High School English Course
- High School Vocational Course

Name.....

Address.....



Join Dobe's Draftsmanship Army. March to Success!

Turn Spare-Time into Profit—learn Drafting!

**\$600**  
Monthly. I refused that salary because I'm making more.  
*Earl H. Smith*

**\$130**  
a week. That's my income as a Draftsman.  
*C. E. Cornack*

**\$400 a Month**  
I average that!  
*W. H. Smith*

**\$1000 a Month**  
is what I make.  
*J. H. Brown*

**\$7000-9000**  
Yearly. That's what I earn.  
*W. H. Smith*

**\$475 a Month**  
—I make that from drafting.  
*S. C. Stroop*

**\$43,400 a year!**

Yes, Drafting pays these six Dobe-trained Draftsmen \$43,400 a year! They learned Drafting at home in their spare time after reading my Free Book—Successful Draftsmanship. YOU should write for it now! You must take that step first. Do it today. Mail the FREE Coupon at the bottom.

Learn a Fundamental, Basic Profession—Drafting!

These 6 Successful Draftsmen wrote for my Free Book. Will you?

# You, Too, Can Learn Drafting At Home

Before Dobe's "Easy Drafting Training at Home" it was almost necessary to go away to college to learn drafting. But now you can stay home, hold down the job you've got, keep on earning money and easily and quickly equip yourself to enter the drafting profession. All the men you see pictured here did just that. Get into drafting. It is a big, appealing field! Drafting is growing bigger and more important every

year. Before any house or machine or factory can be built there must be a PLAN.

That plan must be DRAWN. A draftsman must DRAW it. Learn how now. Be ready when the time comes. It is smart to choose a profession that has always been and always will be. A profession which is standard and essential. A profession which the world must have. Mail Coupon. Do that Now.



**WRITE! FOR FREE BOOK—**  
**Successful Draftsmanship!**

Read this book! After you have read it, make up your mind whether you want to be a draftsman! But write for it today. Certainly reading the book can't hurt you. Mr. Dobe will tell you about other men besides those pictured above who have been successful—many—many of them. No matter what you are making now ask for the book today.

**DOBE EASY DRAFTING**  
1951 Lawrence Ave., Div. 13-59 Chicago

**DOBE EASY DRAFTING**  
1951 Lawrence Ave., Div. 13-59 Chicago

Please send me free your book, "Successful Draftsmanship", and names of other big money earning draftsmen you have trained.

Name..... Age.....

Address.....

Post Office..... State.....





## Learn Piano **JAZZ** Quickly by Ear

Beginners and advanced students learn quickly at home—in spare time. Wonderful Niagara Method clearly shows you how. Complete course 20 lessons. 10 years successful teaching.

By R. C. JAMES

How I used to wish that I could sit down at the piano and pour out the golden syncopation of American melody, like the jazz piano players I had heard. How I used to wish that I could be the popular one in every crowd. But I could not play a note.

### Niagara Method Showed Me The Way

Then somewhere—just as you are reading this—I read of the Niagara Method which makes piano playing wonderfully simple. I sent for Director Wright's book "The Niagara Secret." I read the book, and I knew it was right.

I followed Director Wright's principles, and in no time I had caught on to his ideas.

### So Simple—So Easy—So Delightful

And the best part of it all is that there is nothing hard about the Niagara Method. In a short time, by following Director Wright's principles and by devoting a part of my spare time to the practical application of his course, I soon learned to play.

No tiresome scales—no arpeggios to learn—no weary hours of practice—no do-re-mi—no meaningless exercises. If you know the Niagara Method, you can sit down and reel off any popular song which the high-priced orchestra leaders play in cabarets, clubs, hotels, dance halls, or theaters.

### Clip Coupon Now—Play In Few Months

If you have never played a note, or if you do play—no matter how well—you too may become a master of jazz and melody by learning the simple, wonderful Niagara Method.

### FREE BOOK

Don't wait another day. Send the coupon now for the "Niagara Secret." This book is yours absolutely FREE. If 10c (coin or stamps) is enclosed, you also receive wonderful booklet "How to Entertain at Piano"



Ronald G. Wright, Director  
Niagara School of Music  
226 Cleveland Ave., Niagara Falls, N. Y.

### CLIP THIS COUPON NOW!

NIAGARA SCHOOL OF MUSIC, 226 Cleveland Avenue  
Niagara Falls, N. Y.

Without obligation mail me your book "The Niagara Secret." I enclose 10c for book "How to Entertain at Piano"

Name \_\_\_\_\_

Street \_\_\_\_\_

City \_\_\_\_\_ State \_\_\_\_\_

# ELECTRICITY

## Practical-Technical TRAINING

Great demand for practical-technical electricians and engineers. A brilliant future awaits you. A high salaried position or a profitable business of your own; these may be yours through our PRACTICAL-TECHNICAL courses. Opportunities unlimited.

Finlay condensed method now in 25th successful year trains head and hand. Thousands of high salaried graduates throughout the world testify to the success of Finlay training. Extensively equipped laboratories and shops. Faculty of recognized experts. One and Two Year courses in Electrical Engineering

SEND  
FOR  
FREE  
CATALOG

12 Weeks courses in Practical Electricity and Power Plant Operation open at any time. Degrees, diplomas and certificates of efficiency awarded. Students assisted to positions.

## FINLAY ENGINEERING COLLEGE

126 Finlay Bldg.

Kansas City, Mo.

### PREPARE FOR AN

# ART CAREER

—thru the only art school operated as a department of a large art organization, who have actually produced over a quarter million drawings for leading advertisers. Where else can you get so wide an experience? Home study instruction. Write for illustrated book telling of our successful students.

## MEYER BOTH COMPANY

Michigan Ave. at 20th St. Dept. 16, Chicago, Ill.

## LEARN WATCH REPAIRING

Be a watchmaker—you can learn this profitable trade by correspondence in a few weeks in your own home by the DeSelms Chart System. After you complete the course you will know a watch from A to Z. You will know just what the matter is and how to repair one. When you graduate you will be a practical watchmaker and repairer and competent to fill any position. Positions for our graduates. Ask for our Free Book. It explains our system and terms.



THE DeSELMS WATCH SCHOOL  
LOGANSPORT, INDIANA

No Joke to  
**STAMMER**  
Be successful. Master perfect speech. Win happiness. Send for full information and special phonograph record. Dime covers postage.  
153 Stimson, The Lewis Institute, Detroit



## Strength

is not so much muscle as skill. Police Captain Wallander's illustrated "Physical Training Manual" explains fine points of Jiu Jitsu, Boxing and Wrestling. Makes you invincible. A complete course in physical culture, astounding police secrets and simple health rules. Sent C. O. D. for \$1.97 plus postage. Siebel Press, 34-O W. 20 St., New York, N. Y.

## LEARN MECHANICAL DENTISTRY

SEND FOR  
FREE BOOK

In 3 months Earn up to \$5000 a year

FREE EMPLOYMENT SERVICE

enables you to earn while learning this new money making Profession. Age no barrier and no previous training required. You learn by doing actual work in rubber and gold. Easy terms. Individual instructions. Day or night sessions. Railroad FARE allowed—no extra cost. Write Secretary for FREE BOOK P.

NEW YORK SCHOOL OF MECHANICAL DENTISTRY  
147 W. 33rd Street  
New York





# This Singular Book Wields a Strange Power Over Its Readers

*Giving them a MAGNETIC PERSONALITY almost instantly!*

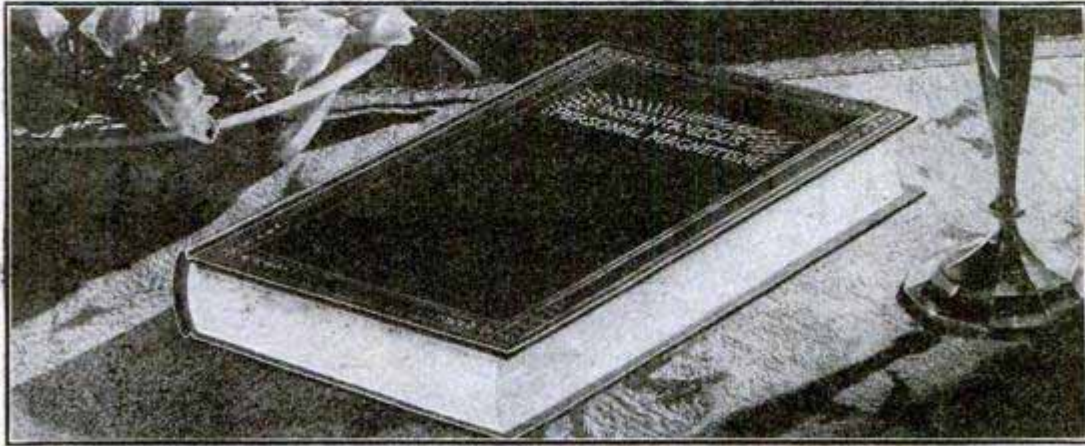

## Will You Read It 5 Days FREE—to Prove It Can Multiply Your Present Income?

A STRANGE book! A book that seems to cast a spell over every person who turns its pages!

A copy of this book was left lying on a hotel table for a few weeks. Nearly 400 people saw the book—read a few pages—and then sent for a copy!

In another case a physician placed a copy in his waiting-room. More than 200 patients saw the book—read part of it—and then ordered copies for themselves!

Why are people so profoundly affected by this book?—so anxious to get a copy? The answer is simple. The book reveals to them for the first time how any one can develop a Magnetic Personality *instantly!* It explains how to gain *overnight* the personal charm that attracts countless friends—the self-confidence that insures quick success in any business.

It tells how to draw people to you at once, irresistibly—how to be popular in any society—how to overcome almost at once any timidity you may have—how to be a magnet of human attraction, well-liked wherever you go!

Best of all it tells you how to accomplish these results *instantaneously!*

### Whence Comes This Uncanny Volume?

Forty years ago, Edmund Shaftesbury, student of the human mind, set out to discover the secret of Personal Magnetism. He applied his discoveries to his friends. Results were astonishing! His methods seemed to transform people into *entirely new beings!* Shaftesbury's fame spread. Great men came to him. His students and friends embraced such names as Gladstone, Queen Victoria, Edwin Booth, Henry Ward Beecher, and Cardinal Gibbons.

Until recently, Shaftesbury's teachings have been available only to people who could pay \$25 or \$50 each for instruction books. Now, his wonderful teachings have been collected into a single volume, at a price *within the reach of all!* And furthermore, Shaftesbury has consented to reveal hundreds of new discoveries never before put into print.

### Strange Effect on Readers

Readers of this book quickly become masters of a singular power to influence men and women around them. Not by force—not by loud argument. But rather by some subtle, insinuating power that sways men's emotions. They are able to play on people's feelings just as a skilled violinist plays upon a violin.

Is it any wonder that thousands of men and women say that they are overjoyed with the results they have received? One enthusiast said of this volume, "Things I have read there I would never have dreamed of." Another wrote, "I would not give up what Shaftesbury has taught me for \$100,000!"

In your everyday life—in social life—you will find this book of immense value. You will learn to fascinate people you meet—to attract new friends—to gain speedy promotion in business.

### Read This Book 5 Days Free

Merely mail coupon below and this remarkable volume, with cover in handsome dark burgundy cloth, gold embossed, will be sent you for free examination. If you aren't stirred and inspired in the 5-day free period, return it and it costs you nothing. Otherwise keep it as your own and remit the Special Price of only \$3 in full payment. This volume was originally published to sell at \$5—but in order to reach many readers—it is being offered at reduced price. You risk nothing—so clip and mail this coupon NOW. Ralston University Press, Dept. 13-W, Meriden, Conn.

RALSTON UNIVERSITY PRESS  
Dept. 13-W, Meriden, Conn.

All right—I'll be the judge. You may send me the volume "Instantaneous Personal Magnetism" for 5 days' FREE EXAMINATION in my home. Within the 5 days I will either remit the special low price of only \$3, in full payment, or return it without cost or obligation.

Name.....

Address.....

City.....State.....

### Book Tells You

How to develop a Magnetic Personality  
How to use certain Oriental Secrets  
How to gain perfect nerve control  
How to read people's feelings by watching their mouths  
How to read people's thoughts by watching their eyes  
How to develop a magnetic eye  
How to make your face appear 20 years younger  
How to control others by a glance  
How to use Magnetic Healing  
How to end awkwardness and timidity  
How to attract the opposite sex  
How to get ahead in your business or profession  
How to make your subconscious mind work wonders  
And dozens of other vital topics



# MORE MONEY

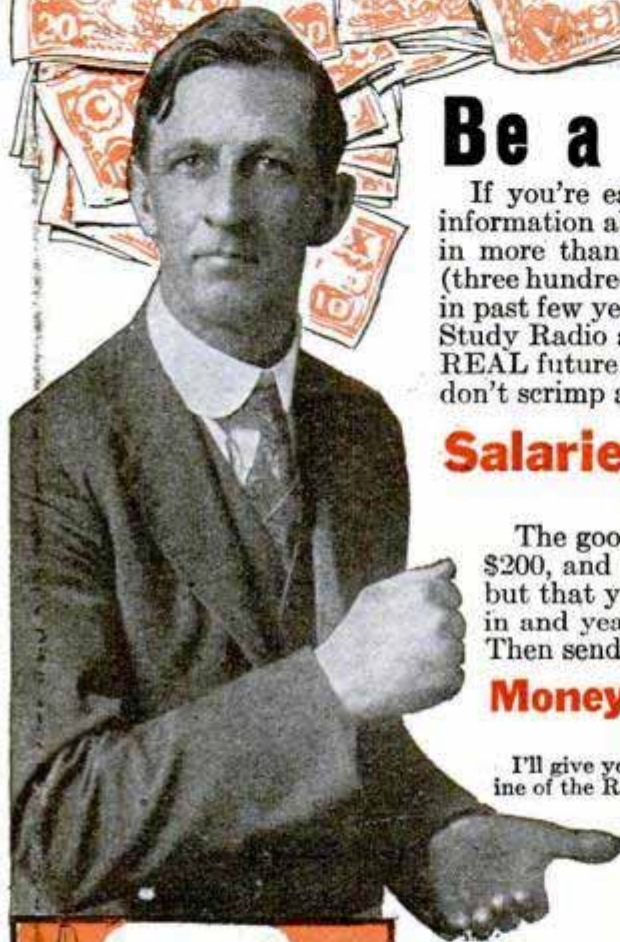

## Be a Trained Radio Expert

If you're earning a penny less than \$50 a week, get my free book of information about the Radio business. Trained Radio Experts are needed in more than twenty different lines of this new and growing profession (three hundred thousand new openings created by the swift growth of Radio in past few years). Why go along at \$25 or \$35 or \$45 a week all your life? Study Radio and after only a short time land yourself a REAL job with a REAL future! Be a man who has money in his pocket and in the bank—don't scrimp and scrape for the rest of your days.

## Salaries of \$50 Up to \$250 a Week Not Unusual in Radio

The good positions in Radio pay all the way from \$50 on up to \$150, \$200, and even \$250 a week. Suppose you don't climb to the very top but that you do advance to a position that pays you \$125 a week, year in and year out. Any chance to make that much where you are now? Then send for my free book, and learn about a field where there's some

### Money Back If You Aren't Fully Satisfied

I'll give you all the training you need to get into any line of the Radio business. And I back up this training by a signed agreement to refund every penny you pay me if I don't give you exactly the training you need. After you finish my training, you'll be the judge, if you think I've earned my tuition fee. I keep it. If not, ask for it and you'll get it right back.

### Six Big Practical Outfits Given You To Help You Learn

I teach you both the "why" and the "how" of Radio. You learn to DO a thing, and you learn WHY it's done. I send you, WITHOUT EXTRA COST with your course, six big practical outfits of material to experiment and work with. These outfits are the real thing—not toys. The parts they contain will build approximately one hundred different Radio circuits. With all this material you do practical work from start to finish of your training. You get your hand in, and you get confidence in yourself. Then when you run into a Radio problem later on, on the job, you KNOW you can do it because you've already done it with these six outfits of practical material. With me you don't learn to be a "paper Radio Expert"—you learn to be the kind of expert that shows his worth on the payroll. Full details in my big book—sent free.

real opportunity. Where good men, if they have the right training, can work their way into really big salaried jobs!

### Get Book!

Find out for yourself about bigger pay waiting for you in Radio! From \$2,000,000 in 1920 to \$504,000,000 in 1926—that's the record of the Radio industry! Plenty of big Radio jobs are waiting for the man who KNOWS. John Fetzer sent for my free book—now he's Chief Engineer at WEMC and designs and builds broadcast stations. T. M. Wilcox sent for the book—now he's in his own Radio business and reports profits as high as \$70 in one day! All information will be sent to you free, without obligation—just mail coupon on opposite page.



Broadcasting and commercial Radio and station work appeal to a lot of men—it's a big, growing field and fascinating work. My course prepares you thoroughly to get into this field and make good.



Radio manufacturing has grown faster in the last six years than any other big business ever did. It's two hundred and fifty times as big as it was. That means lots of good chances for the trained Radio Expert.

Six million Radio receiving sets in use in the United States means millions of dollars are going to Radio Service and Repair men everywhere. For this work you must be trained.



Radio operators on board ship go everywhere—see everything. You sail the world over, all your expenses paid, and draw a good salary besides. It's the life of Reilly.

### Send For Free Book of Information

see coupon next page



# for you in Radio

## Learn Quickly, Easily

### Train at Home In Spare Minutes

Stay home! Hold your job! I'll bring your Radio training to you, and you can learn in your spare time after work. No need to go to a strange city and live for months on expense when you learn my way. You study in the quiet of your own home. As for this training—it's written just as I would talk—in straightforward, every-day, understandable language. You'll get it, and you'll get it quickly—in a few months' spare time—because I've made it so clear and interesting! No particular education needed—lots of my successful students didn't finish the grades.

### Earn \$15, \$20, \$30 Weekly Right Away "On the Side"

Deloss Brown, South St., Foxboro, Mass., made \$1,000 from spare-time Radio jobs before he even finished my course. H. W. Colbentz, Washington, averaged \$45 a week; Leo Auchampaugh, 6432 Lakewood Ave., Chicago, made \$500 before graduation; Frank Toomey, Jr., Piermont, N. Y., made \$833 while taking the course. All this done IN SPARE TIME away from the regular job, while these fellows were still studying the course—and they're only a few of hundreds. As soon as you start this training I begin teaching you practical Radio work. Then a few weeks later, I show you how to make use of it in spare time, so you can be making \$15, \$20, \$30 a week "on the side," all the while you're learning.

### 64-page Book Sent Free For the Asking

My big book of Radio Information won't cost you a penny, and you won't be under any obligation by asking for it. It's put hundreds of fellows on the way to big pay and brighter futures. Sending for it has been the turning-point where many a man has made his start toward real Success. Get it. See what it's going to mean to you. Send coupon TODAY!

Address: **J. E. SMITH, President,**  
National Radio Institute,

Dept. P-85

Washington, D. C.

## Send No Money

J. E. Smith, President,  
National Radio Institute,  
Dept. P-85, Washington, D. C.

Dear Mr. Smith: Kindly send me your big free book "Rich Rewards in Radio," giving all information about the big-money opportunities in Radio and how you will train me to take advantage of them. I understand this places me under no obligation, and that no salesmen will call on me.

Name.....

Address.....

Town.....State.....

### JOBS WAITING!

In seven short years—three hundred thousand new jobs in Radio! Lots of jobs open right now, for those who have the training. The Radio industry has grown by leaps and bounds—so fast it has had to take whatever sort of men it could get. Such men, if they haven't trained themselves in the meantime, are losing out and will keep on losing out. They'll be replaced by men with the KNOW-HOW. But it's trained men ONLY that are needed.

### Over 1,000 Openings For Trained Men NOW!

One great Radio manufacturing concern alone has over one thousand openings to give my graduates this year. These men will be needed all over the United States. Any graduate of mine who stands well in his home town is eligible for this work. The head of the above mentioned concern, one of the biggest Radio organizations in the country—is a graduate of mine. He knows what my training did for him. When he wants new men for his organization he wants men with the same training.

I can't possibly graduate enough men this year to fill these openings. So there will be more openings with this one concern than there will be graduates to accept them.

But there are other openings to choose from, too. My school has trained more Radio Experts than any other school in the world. It's the oldest and largest Radio home-study school in the world. There are N. R. I. trained men in almost every Radio concern of any importance in this country. Many Radio employers are themselves my graduates. That's where you get your "stand-in" as an N. R. I. graduate yourself.

Every graduate of my course is entitled to Life-Time Employment Service, without a penny's charge, from my helpful Employment Department.

### Full Information Sent With Free Book

My Free Book contains full information about the Radio employment situation, and the advantages I'm in a position to give you. Also about my Life-Time Employment Service, and Life-Time Consultation Service, too.

### Mail Coupon Today!

## RICH REWARDS IN RADIO



This big 64-page book, printed in two colors crammed with interesting facts and photos about money-making opportunities in Radio, sent free to everyone who clips the coupon. No obligation by sending for the book—it's absolutely free. One of the most valuable books about Radio ever written.





# THERE'S MONEY IN \$ H C C £ \$ \$

For Any Man who likes Mechanical Work the Shortest Way to Financial Independence is **Making Crowns, Plates, Bridges, Inlays, Etc. for Dentists.** Steady Earnings up to \$5,000 a year—some earn far more in this Profitable Professional Trade.

### THREE MONTHS TRAINING

will qualify one to enter this most rapidly growing professional trade—Mechanical Dentistry. Best opportunity for men who like to use tools—dignified work, steady income, rapid advancement, no 'slack seasons' as in other trades.

### LEADING THE FIELD

Bodee training is recognized by dentists everywhere, owing to our 35 years' experience at this work—established 1892—the oldest school. Bodee-trained men make good. After only a few years you find them prominent in this profitable trade—on good salaries or conducting their own laboratories. There's room for many more—think it over! We conduct a Placement Bureau to select suitable positions, and, should you desire to open your own laboratory, we assist you in securing a location and equipping your laboratory.

### LEARN BY "DOING"

Individual instruction—No classes whatever—Practical work. You use regular standard tools and learn to do exactly the kind of work which will later be required of you by Dentists.

### EARN WHILE YOU LEARN

Lack of money need not stop you. We assist in securing whole or part time positions to help our students pay expenses.

### JUST COMPARE!

Compare this trade with what you are now doing, or with the best you can find in any other line! Compare our unexcelled training—step by step—every point thoroughly covered—no time wasted! Consider also the very reasonable cost of this exceptional training.

Send for Catalog No: 2



### FOUR EXCEPTIONAL OFFERS WITHOUT ADDITIONAL COST

- 1—R. R. Fare to Our Nearest School.
- 2—10% Reduction of Tuition.
- 3—\$50 Outfit of Standard Tools.
- 4—Post Graduate Instruction.

## BODEE DENTAL INSTITUTE

NEW YORK  
1755 Broadway

PHILADELPHIA  
1305 N. Broad Street

BROOKLYN  
85 Court Street



# Want Some Money?

Here's a wonderful way to get it

OUR beautifully illustrated book tells how. It tells all about our new methods of art decoration, art treatment and how anybody can learn without previous training or experience. It contains page after page of handsome color illustrations of what you can make and sell.

### Make Good Money—Book is FREE

Our system is amazingly easy to learn and the profits are larger than in almost any other business. You can produce beautiful finished art objects almost from the beginning. You don't have to know how to draw or have any experience. Begin making money now.

All supplies are sent by us with the instructions and many have made \$25 the first week. Some men and women have taken up this work for their own amusement. Either way, pleasure or profit, it's the most delightful home work you can imagine. Write Now for your copy of this valuable book; it's FREE.

## Fireside Industries

DEPT. 66-W

ADRIAN, MICH.



# TRAVEL - for 'UNCLE SAM'

**RAILWAY POSTAL CLERKS  
MAIL CARRIERS—POSTOFFICE CLERKS  
\$1700 to \$3300 a Year for Life**

No "lay-offs" because of strikes, poor business, etc.—sure pay—rapid advancement. City and country residents stand same chance. Common sense education sufficient—no political influence.

### STEADY WORK

Cut coupon and mail it before turning the page.

## MEN—BOYS 18 to 45

Use Coupon Before You Lose It

### COUPON

FRANKLIN INSTITUTE, Dept. P175, Rochester, N. Y.  
Rush to me, entirely free of charge, (1) A full description of the position checked below; (2) 32-page book, with list of positions obtainable; (3) Particulars telling how to get the position checked.  
 Railway Postal Clerk (\$1900 to \$2700)  Customs Positions (\$1140 to \$1860)  
 Postoffice Clerk (\$1700 to \$2300)  Prohibition Agent (\$1800 to \$3000)  
 City Mail Carrier (\$1700 to \$2100)  Rural Mail Carrier (\$2100 to \$3300)

Name .....

Address .....



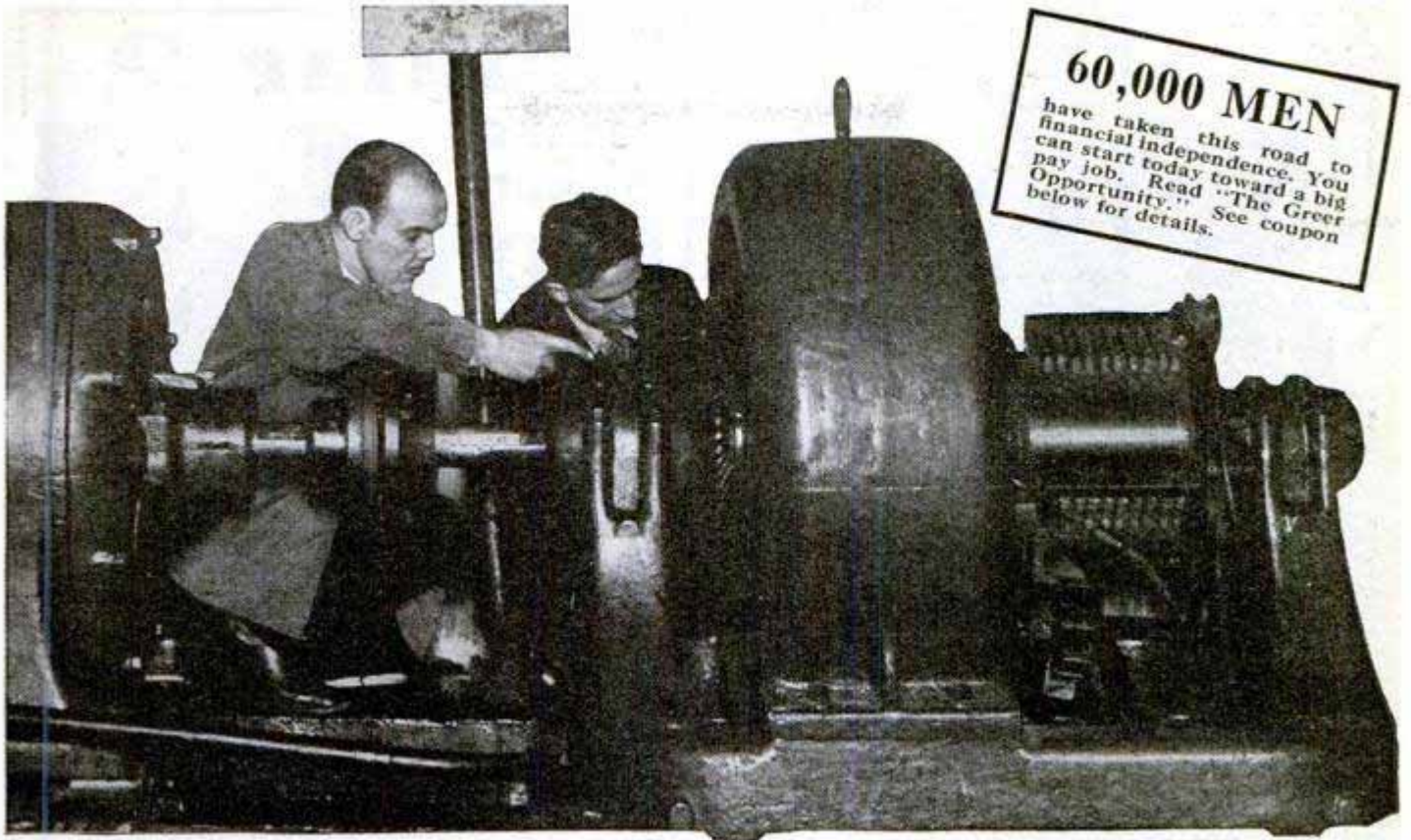

**60,000 MEN**  
 have taken this road to  
 financial independence. You  
 can start today toward a big  
 pay job. Read "The Greer  
 Opportunity." See coupon  
 below for details.

**"I was a \$30 a week clerk  
 —but electricity now pays  
 me \$10,000<sup>00</sup> per year"**

**That's what happened when  
 I stepped out for a big-pay  
 job—Greer paid my fare to  
 Chicago**

What this man did you can do. Five years ago he clipped a coupon like that on this ad. He didn't have much money. He was slave to a clerical job that paid starvation wages.

I paid his way to Chicago. When he got here I got him a part time job and found him a place to live.

In my shops he learned by actually working on motors, dynamometers—all the costly equipment I've gathered. My friendly instructors guided his work until he knew more than many highly paid electricians. Now he's independent—connected with a big company, drawing big pay.

### Like Electricity?

**—Make it Pay You Big Income**

If you like to fool with the "juice" that runs our industries you can get into this big pay class. I've trained over 60,000 others. I'll turn you out fit for the work big corporations need high paid men to do. They are searching

**GREER COLLEGE OF ELEC-  
 TRICAL ENGINEERING**

Dept. 1201 • 2024 S. Wabash Ave. • Chicago

for these men. Those from Greer College, because they've learned by actual experience on the newest equipment, pick the desirable positions.

There isn't room here for further details, but send for my book, "The Greer Opportunity." It tells full facts about the course, how I get you a part time job, find you a place to live—and even pay your fare to Chicago.

### Take Automobile Course at Same Time

By learning automobile—another big opportunity—at the same time you save considerable money. Or you can learn Electricity only. Just which to go into you will know better when you have all the facts.

### Act Promptly

To get anywhere in life you have to act. Don't put off sending for "The Greer Opportunity." It costs nothing.

Write your name and address on the coupon, and mail it direct to me. Then see just what you will learn—look over the photos of the Greer shops—study the facts about both Electrical and Automobile courses.

Do this at once. It is time to enroll now. Mail coupon today.

ERWIN GREER, President, Greer College  
 Dept. 1201 2024 S. Wabash Ave. CHICAGO.  
 Please send me your FREE BOOK and offer for Electrical  course  
 It is understood I am not obligated in any way Automotive  course

Name .....

Address .....







# LICKED!

Yes, licked! Twenty-five years old and still working in a small job at a small salary.

Why? Well, chiefly because he felt he didn't need special training. And now that he realizes the need, he still keeps putting it off—and off—and off. He'd rather shoot pool or stand around the corner than spend an hour each night in money-making spare-time study.

And the pity of it is that he has just as much natural ability as most of the men who have gone ahead of him. He could be earning three times his present salary if he only had special training.

Are you like that? Are you going to work for a small salary all your life? Or are you going to get the special training that employers everywhere are looking for? It is for you to decide.

Nobody can force you to mail this coupon to the International Correspondence Schools. That's a matter entirely in your own hands. But remember this—the sooner you send it in, the sooner you are going to get a better job and a better salary.

## INTERNATIONAL CORRESPONDENCE SCHOOLS

"The Universal University"

Box 5688-E, Scranton, Penna.

Without cost or obligation, please send me a copy of your booklet, "Who Wins and Why," and full particulars about the course before which I have marked X in the list below:

### BUSINESS TRAINING COURSES

- |  |   |
|--|---|
| <input type="checkbox"/> Business Management                     | <input type="checkbox"/> Salesmanship                                     |
| <input type="checkbox"/> Industrial Management                   | <input type="checkbox"/> Advertising                                      |
| <input type="checkbox"/> Personnel Organization                  | <input type="checkbox"/> Better Letters                                   |
| <input type="checkbox"/> Traffic Management                      | <input type="checkbox"/> Show Card Lettering                              |
| <input type="checkbox"/> Business Law                            | <input type="checkbox"/> Stenography and Typing                           |
| <input type="checkbox"/> Banking and Finance Management          | <input type="checkbox"/> English  |
| <input type="checkbox"/> Accountancy (including C.P.A.)          | <input type="checkbox"/> Civil Service                                    |
| <input type="checkbox"/> Nicholson Cost Accounting               | <input type="checkbox"/> Railway Mail Clerk                               |
| <input type="checkbox"/> Bookkeeping                             | <input type="checkbox"/> Common School Subjects                           |
| <input type="checkbox"/> Private Secretary                       | <input type="checkbox"/> High School Subjects                             |
| <input type="checkbox"/> Spanish <input type="checkbox"/> French | <input type="checkbox"/> Illustrating <input type="checkbox"/> Cartooning |

### TECHNICAL AND INDUSTRIAL COURSES

- |   |  |
|---|--|
| <input type="checkbox"/> Electrical Engineering                     | <input type="checkbox"/> Architect                                       |
| <input type="checkbox"/> Electric Lighting                          | <input type="checkbox"/> Architects' Blueprints                          |
| <input type="checkbox"/> Mechanical Engineer                        | <input type="checkbox"/> Contractor and Builder                          |
| <input type="checkbox"/> Mechanical Draftsman                       | <input type="checkbox"/> Architectural Draftsman                         |
| <input type="checkbox"/> Machine Shop Practice                      | <input type="checkbox"/> Concrete Builder                                |
| <input type="checkbox"/> Railroad Positions                         | <input type="checkbox"/> Structural Engineer                             |
| <input type="checkbox"/> Gas Engine Operating                       | <input type="checkbox"/> Chemistry <input type="checkbox"/> Pharmacy     |
| <input type="checkbox"/> Civil Engineer                             | <input type="checkbox"/> Automobile Work                                 |
| <input type="checkbox"/> Surveying and Mapping                      | <input type="checkbox"/> Airplane Engines                                |
| <input type="checkbox"/> Metallurgy <input type="checkbox"/> Mining | <input type="checkbox"/> Agriculture <input type="checkbox"/> Navigation |
| <input type="checkbox"/> Steam Engineering                          | <input type="checkbox"/> Mathematics <input type="checkbox"/> Radio      |

Name.....

Street Address.....

City..... State.....

Occupation.....

Persons residing in Canada should send this coupon to the International Correspondence Schools Canadian, Limited, Montreal, Canada

# Popular because he can Play

and  
earn  
**\$75.00**  
to  
**\$200.00**  
each week



## LEARN AT HOME

With a nationally famous artist as your teacher you can learn to play classical or popular music. We guarantee our personal teaching method. Both advanced and elementary courses on all instruments.

Write for catalogue

**CONN NATIONAL SCHOOL OF MUSIC INC.**  
506 So. WABASH AVE., DEPT. 516 CHICAGO

# LAW

**STUDY AT HOME**  
Become a lawyer. Legally trained men win high positions and big success in business and public life. Be independent. Greater opportunities now than ever before. Big corporations are headed by men with legal training. Earn **\$5,000 to \$10,000 Annually**. We guide you step by step. You can train at home during spare time. Degree of LL.B. conferred. LaSalle students found among practicing attorneys of every state. We furnish all text material, including fourteen-volume Law Library. Low cost, easy terms. Get our valuable 108-page "Law Guide" and "Evidence" books FREE. Send for them NOW. LaSalle Extension University, Dept 1264-L Chicago. The World's Largest Business Training Institution

## Learn Watchwork, Jewelrywork and Engraving

A fine trade commanding a good salary, and your services always in demand. Address: **Horological**, Dept. P. Bradley Institute, PEORIA, ILLINOIS, for our latest catalog.

# Big Money in Poultry

**Eggs Turn into Dollars FAST!**

### Make \$1,000 a Year in Spare Time—Easy

Lots of room for YOU in the poultry business. 85% of the people of this country live in cities. EVERYBODY eats eggs and poultry meat—but only 15% produce them. Why not let the "other fellow" pay YOU the fancy prices? Easy to get started in back yard, on vacant lot, or farm. We GUARANTEE success if you follow our methods. We show you how to feed for eggs, in winter, when eggs are high in price; how to cut feed bills; how to keep flocks healthy; how to tell laying hens, PAY-BIRDS, from loafers. Our course, produced by eighteen famous experts, endorsed by 30 leading agricultural schools, gives you thousands of sure, proved, tested methods that make PROFITS CERTAIN. FREE book tells what we're doing for others—and what we can do for you.

### Others Say:

"You have opened up to me a pleasant and profitable way of gaining an independent living."  
Seldon Anderson, R. I.  
"When I enrolled for your course, I knew nothing about poultry keeping. I am now successfully operating a commercial poultry farm."  
W. J. Warthen, Conn.  
"Your course was a splendid investment. I recommend it for both beginners and experienced poultrymen."  
Y. W. Ow, Hawaii.

Mail Coupon Today

## Mail this now

The National Poultry Institute  
Washington, D. C. Dept. 411-D

I am interested in your plan on "How to Raise Poultry for Profit." Send me your FREE book, without obligation on my part.

Name.....

Address.....



# 5 ELECTRICAL Job Tickets actually FREE!



**to prove this home-training will prepare you for a good job and a raise in pay!**

Get these five job-tickets. Look them over. Test your own ability to master Electricity at home in spare time. See for yourself how every fact has been simplified. See what thousands of men have paid millions of dollars for, to help them earn **BIGGER PAY**. Uncover some of the mysteries of Electricity, and see why millions of men are so fascinated by it. Don't send a penny, don't enroll — just mail the coupon.

## Go Into ELECTRICITY!

Thousands of jobs open at \$60 to \$125 a week. My training prepares you to fill them. Superintendents of Power Plants Wanted. Chief Electricians Wanted. Electrical Experts Wanted in Radio, Electrical factories, Auto Plants, Telephone and Telegraph Systems, etc.

**Training Built by 29 Noted Engineers**

This is not a one-man, one-idea school. 29 famous Engineers and Executives of the following corporations and universities helped me make Dunlap-training complete and up-to-date.

1. General Electric Co.
  2. Commonwealth Edison
  3. Crocker-Wheeler Co.
  4. Cutler-Hammer
  5. American Tel. & Tel. Co.
  6. Westingh. El. & Mfg. Co.
  7. Western Electric Co.
  8. Underwriters Lab., Inc.
  9. Columbia University
  10. Dartmouth College
  11. Massachusetts Inst.
  12. Lehigh University
  13. University of Vermont
- AND MANY OTHERS





**AMERICAN SCHOOL**  
—the Million Dollar Educational Institution

Your name here.....  
When you enroll for my home-training in **ELECTRICITY** I agree to give you:

1. Complete training, including Electrical Engineering, Ignition; Radio, etc.
2. Seven outfits of standard tools and materials, including a \$10 motor.

3. I WILL HELP YOU GET A GOOD JOB AND A RAISE IN PAY, —or I will refund every cent of your money.

By *Chief Engineer Dunlap*

**I Will make this Contract with You!**

Read it. This million dollar institution stands back of this agreement to **PREPARE** you to fill a well-paid Electrical Job, and then to help you **FIND** the job—or to refund the small amount charged for your training!

**7 Costly Electrical Outfits Given!**

I send you absolutely without extra cost, as a part of this training, 7 costly outfits of standard size tools and materials, so you learn Electricity **BY DOING** actual Electrical jobs. One of these outfits is a \$10 Electric Motor—a real motor and generator, the same type as the big fellows in a power plant. I send it to you "knockdown" and have you wind the field and armature and assemble it. *That's the way I teach every branch of Electricity!* House-wiring, Electric Light, Radio, and Motor outfits included.



\$10 Motor Given

## Free Job Service!

for **STUDENTS** and **GRADUATES**. This **JOB SERVICE** keeps in touch with great Electrical employers all over America. The day you enroll, this Job-Service Department registers you, finds out what kind of job you want, where you want to work, etc. And when you apply for the job you want, we back you with our recommendation and help you make good in it after you get it.

## WRITE Me Immediately!

If you have reached the point where you realize YOU **MUST** train and specialize to get anywhere, *write me immediately!* I will show you the wonderful opportunities, the enormous salaries, the many openings waiting in this billion dollar industry. I'll tell you about our sensational combination **TRAINING-AND-JOB** offer which practically assures your success. Mail coupon and get 5 Free Electrical Job-Tickets and complete information.

**CHIEF ENGINEER DUNLAP, Electrical Division**  
**AMERICAN SCHOOL** Drexel Avenue and 58th Street  
Dept. E-974 CHICAGO

## 5 Job Tickets actually FREE!

Chief Engineer Dunlap, Electrical Division  
**AMERICAN SCHOOL**  
Drexel Ave. & 58th St., Dept. E-974 CHICAGO

Send me your combination **TRAINING-AND-JOB** offer, 5 Free Job-Tickets, facts about opportunities in Electricity, etc.

Name \_\_\_\_\_  
Address \_\_\_\_\_  
Occupation \_\_\_\_\_ Age \_\_\_\_\_



# Hawaiian Guitar

## GIVEN

Worth  
\$18

### When You Enroll

This Hawaiian Guitar expert and professor wants the opportunity to welcome you as a student so you will quickly learn how to play a Hawaiian Guitar—yes, you will be able to play just like the native Hawaiians. To get you started and help your musical success, which will bring you popularity, you will receive a beautiful Hawaiian Guitar, the same as the one pictured, when you enroll. Our short cut method of instruction will enable you to play a piece almost from the first lesson. Rush coupon for full particulars today and we will reserve a Hawaiian Guitar for you.



### Play Quickly

With our short cut method of instruction you will quickly learn how to play Hawaiian Guitar, which will bring you popularity and social success. You will learn to play from notes. If you never had any musical training, you will quickly get on, because our nine experts have perfected a course of home instruction which is as simple as learning A, B, C's.

### Picture and Photograph Record Method Easy

We don't depend upon printed lessons only for your success, but we also furnish pictures of our professors playing, diagrams, charts and phonograph records for each lesson. This practically brings our professors from our studio to your own home and enables you to listen to their playing just as if they were actually in front of you. To prove this is easy, we will send you your first lesson free. Rush coupon now.

HAWAIIAN STUDIO No. 5212  
of New York Academy of Music  
100 Fifth Avenue, New York, N. Y.

Please rush your Free book, "How to Learn Hawaiian Guitar," and my first free lesson. Also reserve a Hawaiian Guitar for me. This obligates me in no way whatever.

Name.....  
Address.....  
City..... State.....

## You can get a promotion like this

"Due to the training I received from your course, I have been promoted from the shop to the drafting room. I have completed only 11 lessons but have been able to satisfactorily draw up all the jobs I have been given." (Name on request.)

### Ornamental Iron Draftsmen

Get Big Pay! Beginners as high as \$60.00 a week — experienced men up to \$500 a month in executive positions. Learn while on your present job. We'll help you get a position as soon as you qualify. Write for free book telling all about the opportunities in this line.

American Institute of  
Ornamental Iron and Bronze  
3048 Hennepin Ave., Minneapolis, Minnesota



## LAW Free Book

Write today for FREE 128-page book, "THE LAW-TRAINED MAN," which shows how to learn law in spare time through the Blackstone home-study course prepared by 80 prominent legal authorities, including law school deans, lawyers, and U. S. Supreme Court justices. Combination text and case method of instruction used. All material necessary furnished with the course, including elaborate 25-volume law library, which is delivered immediately upon enrollment. Many successful attorneys among our graduates. LL. B. degree conferred. Moderate tuition, low monthly terms. Money-Back Agreement.

Write for free book today

BLACKSTONE INSTITUTE, 4753 Grand Boulevard  
Dept. 59 Chicago



## 1,000 Hotel Positions Open!

HOTELS, restaurants, clubs, apartments, hospitals, institutions, schools and colleges everywhere need trained men and women. Over 70,000 high-class positions paying \$2,500 to \$10,000 a year open annually in the hotels of the United States. Nearly one and three-quarter billions of dollars' worth of NEW HOTELS, CLUBS AND INSTITUTIONS being built this year will need over 200,000 trained men and women. Hotels start you at salaries up to \$3,500 a year, with living usually included. At any time there are over 1,000 hotel positions open.

### Previous Experience Unnecessary

You can have one of these fascinating, big-pay positions. The Lewis Schools guarantee to give you the valuable knowledge that it has taken some of the most successful hotel men years to obtain. Age is no obstacle—young and old alike have equal chance for success. Past experience absolutely unnecessary. A common school education is all you need. We train you in your spare time with the Lewis Simplified Study Plan and put you in touch with big opportunities. All of your training under the personal supervision of Clifford Lewis, Managing Consultant for over 225 hotels throughout the United States. Our students employed by leading hotels everywhere. Send coupon today for Free Book, "Your Big Opportunity," showing how we can train you for one of these splendid positions and explaining our Money-Back Agreement.

### FREE BOOK COUPON

LEWIS HOTEL TRAINING SCHOOLS,  
Room AO-385, Washington, D. C.

Send me without obligation the Free Book "Your Big Opportunity."

Name.....  
Address.....  
City..... State.....





# Now he **DRAWS** the things he wants

**L**OOK at drawing No. 1 above. Then compare it with No. 2 and note the improvement Federal School training has made in the work of Art Nelson. Before he studied drawing with the Federal Schools, he worked as a surveyor's assistant at \$18.00 a week. Today he has a fine position in the work he enjoys at \$75.00 a week. He says, "The Federal Schools made this possible through their training and cooperation, as I had only average ability before enrolling as a student." Mr. Nelson is just one of hundreds of young people making good money because of Federal training.

Opportunities for artists have never been better. Magazines and newspapers buy millions of dollars' worth of illustrations every year. If you like to draw, let your talent make your living.

The Federal School of Illustrating has taught hundreds of successful students. That is because its methods of instruction are right. Over fifty famous artists such as Sid Smith, Neysa McMein, Clare Briggs, Charles Livingston Bull, Norman Rockwell and many others contribute exclusive lessons and drawings to the Federal Course. They tell you their methods in a clear understandable way. The subjects include illustrating, cartooning, lettering, poster designing, window card illustrating, etc. They are easy to learn the "Federal Way"—at home in your spare time.

## Have Your Drawing Talent Tested

If you like to draw, you may have the free criticism and analysis of your work by sending for our free Vocational Test Chart. We will send with it our free book, "A Road to Bigger Things," which explains illustrating as a profession. Nelson got his start sending for it. This is your opportunity—grasp it. Fill out the coupon now.



# Federal School of Illustrating

Federal School of Illustrating,  
12137 Federal School Bldg., Minneapolis, Minn.

Please send your free book, "A Road to Bigger Things."

Name.....

Occupation..... Age.....

Address.....





## From \$1,800 to \$10,000 in Four Years

### Thanks to Higher Accountancy

"LaSalle training in Higher Accountancy has enabled me in four years to increase my business more than 500 per cent." So writes John H. Lansing, Public Accountant, Income Tax Specialist, and prominent citizen of Amsterdam, New York, who deliberately resigned as purchasing agent for a large carpet manufacturing company to start on his own as a Public Accountant.

Mr. Lansing was 43 when he enrolled with LaSalle, and at the time was earning from his newly adopted profession less than \$2,000 a year.

Today, the firm of which he is head is auditing the books of 100 business houses, including 20 corporations; and his Income Tax Department has more than 500 clients. Each year his business shows a healthy increase.

"When you consider that the average bookkeeper does not receive over \$40 a week," writes Mr. Lansing, "it is obvious that \$10,000 a year has advantages well worth the consideration of any ambitious man or woman. I shall always be grateful to LaSalle for the help it has given me in building a greater income."

### Send for This Book—It's Free

Do you appreciate what Accountancy means in the business world? Do you realize that it constitutes the indispensable foundation for success in any business undertaking? Would you seriously fit yourself for positions paying \$3,000, \$5,000, \$10,000 a year and even better?

LaSalle has prepared a 64-page book entitled "Accountancy, the Profession that Pays." The information it contains is of very real and definite value. It will pay you well to read it. And—LaSalle will send it to you free.

Balance the two minutes that it takes to fill out the coupon against the rewards of a successful career—then clip and mail the coupon—NOW.

— — — Find Yourself Thru LaSalle! — — —  
**LA SALLE EXTENSION UNIVERSITY**  
The World's Largest Business Training Institution

Dept. 1264-HR Chicago

I would welcome details of your salary-increasing plan, together with copy of "Accountancy, the Profession that Pays," also a copy of "Ten Years' Promotion in One," all without obligation.

### Higher Accountancy

Training for positions as Auditor, Comptroller, Certified Public Accountant, Cost Accountant, etc.

### Other LaSalle Opportunities

LaSalle opens the way to success in every important field of business. If more interested in one of the fields indicated below, check and mail now.

- |   |  |
|---|--|
| <input type="checkbox"/> Business Management        | <input type="checkbox"/> Personnel Management                        |
| <input type="checkbox"/> Modern Salesmanship        | <input type="checkbox"/> Banking and Finance                         |
| <input type="checkbox"/> Traffic Management         | <input type="checkbox"/> Modern Business Correspondence and Practice |
| <input type="checkbox"/> Railway Station Management | <input type="checkbox"/> Expert Bookkeeping                          |
| <input type="checkbox"/> Law—Degree of LL.B.        | <input type="checkbox"/> C. P. A. Coaching                           |
| <input type="checkbox"/> Commercial Law             | <input type="checkbox"/> Business English                            |
| <input type="checkbox"/> Industrial Management      | <input type="checkbox"/> Commercial Spanish                          |
| <input type="checkbox"/> Factory Management         | <input type="checkbox"/> Effective Speaking                          |
| <input type="checkbox"/> Modern Foremanship         | <input type="checkbox"/> Stenotypy                                   |

Name.....

Present Position.....

Address.....



## Free—Send for This Amazing Book

It will tell you how you can quickly and easily learn to play beautifully right in your home and in your spare time.

### The Open Door to Popularity

Music will open wide the doors of social success—make you the center of popularity everywhere. You will be surprised and delighted to find how easily you can learn with the famous National Academy Method. 200,000 successful students. Low cost, easy terms.

Courses in Piano, Violin, Trumpet, Voice, Banjo, Tenor Banjo, Organ, Spanish Guitar, Hawaiian Guitar, Mandolin. Write Today.

**NATIONAL ACADEMY OF MUSIC**  
Dept. 26 702 East 41st Street, Chicago

## Write and Speak MASTERLY ENGLISH



Learn correct English with Sherwin Cody's new invention. No rules to memorize. Like a fascinating game. Spare-time study, 15 minutes each day, quickly gives you command of English. Send for free booklet "How to Speak and Write Masterly English." Write today.

Sherwin Cody School of English, 512 Searle Bldg., Rochester, N.Y.

## FREE 352-Page Catalog Books of all Publishers

Save time and money when buying books. Here is one central source carrying books of all publishers. Quantity buying permits lowest prices to you. Send for our 33rd Annual Illustrated Catalog describing over 25,000 books; used by public, private and school libraries and individuals everywhere. It is free. Write today.

**THE BOOK SUPPLY COMPANY, Dept. 13**  
231-233 West Monroe Street Chicago, Illinois

## Learn Photography at HOME

Make money taking pictures. Prepare quickly during spare time. Also earn while you learn. No experience necessary. New easy method. Nothing else like it. Send at once for free book, OPPORTUNITIES IN MODERN PHOTOGRAPHY and full particulars.

**AMERICAN SCHOOL OF PHOTOGRAPHY**  
Dept. 1359 3601 Michigan Ave. Chicago, U. S. A.

## Learn Watchwork, Jewelrywork and Engraving

A fine trade commanding a good salary, and your services always in demand. Address **Horological**, Dept. P. Bradley Institute, PEORIA, ILLINOIS, for our latest catalog.

## BIG NEW CATALOG FOR RADIO BUILDERS

**FREE** My big 1928 Radio Catalog, Call Book and Trouble Finder. 132 pages about Radio. Chock full of newest circuits—kits, transmitter parts, short wave outfits, eliminators and speakers. Thousands of bargains at lowest wholesale prices. A regular Radio Encyclopedia—Free. Write today.

**American Auto & Radio Mfg. Co.**  
HARRY SCHWARTZBERG, PRES.  
Dept. 265 American Radio Bldg., Kansas City, Mo.





# FREE How to Read Blue Prints

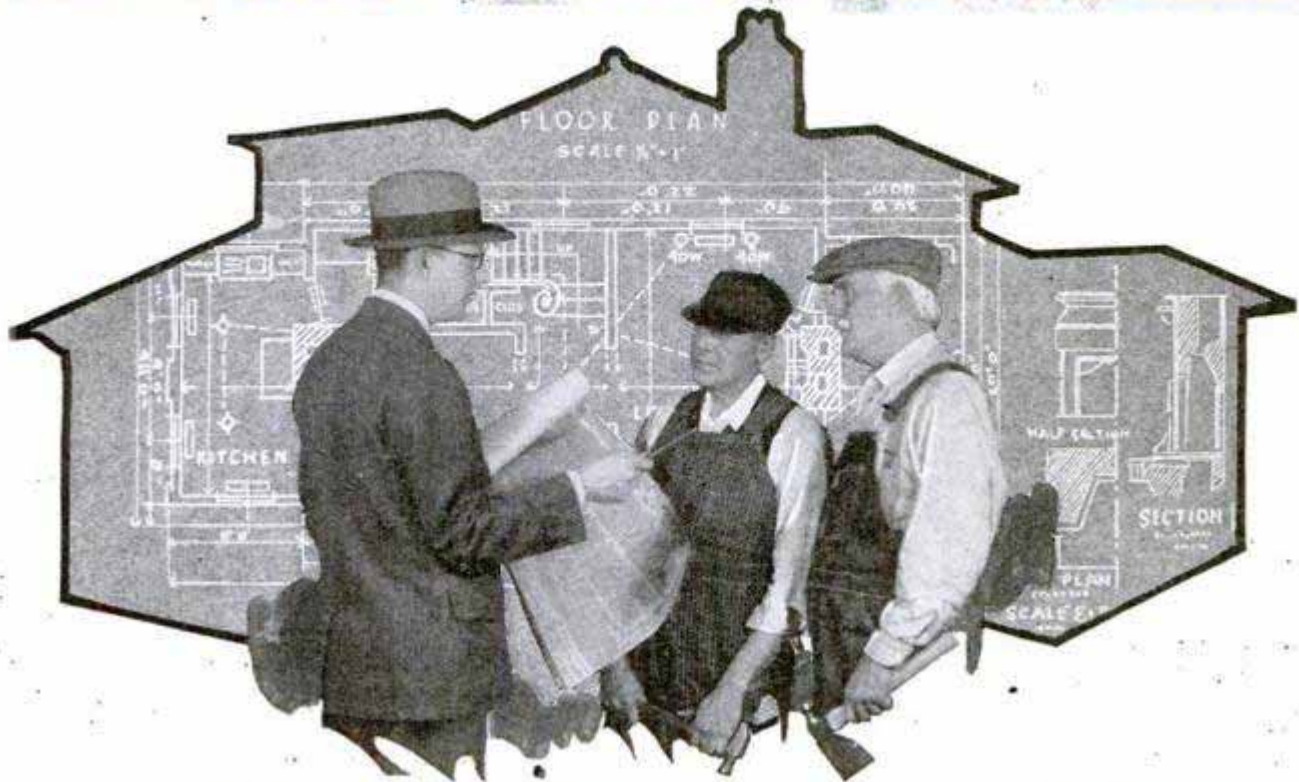

## New Easy Practical Way

**Leads Quickly to \$4,500 to \$12,000 a Year**

Thousands of Men From All Walks of Life Have Discovered an Altogether New Way to Double and Triple Their Incomes! Surprising, Yes—But True! Almost Over Night They Have Taken Their Choice of 9 Interesting, Big-Pay Jobs—Become Foremen, Superintendents, Estimators, Real Estate Experts—or Are Making Big Money in Business for Themselves. The Same Wonderful Opportunity Is Now Offered You. Don't Send One Penny. Just Mail the Coupon for Full Set of Valuable Blue-Print Plans, Big Free Book, and Complete Details.

**B**IG pay jobs by the score, yes, by the hundreds, are waiting for you in the world's richest industry—Building. There is a constant never-ending call for trained men—and still more trained men—men who have practical headwork training and can read Blue Prints and run jobs.

Many men think the only way they can get this practical "headwork" training is on the job. But thousands of Chicago Tech. graduates have proved that the idea is all wrong. In fact, a man can spend 5 or 10 years working with his tools and never get a real chance to learn the things he must know, if he is ever to get into the big-pay class. Anyhow, it's a long, hard, slow process—on the job.

### Amazing, New Kind of Training

But it's all different—the new Chicago Tech. Builders' Course way—amazingly different! It's quick, easy, certain. Right at home you get real Blue Prints used on actual jobs to examine and keep for reference. In language you can understand, as plain as A-B-C, everything is told you and worked out for you in concise, practical home lessons—no textbooks to study—you

are taken by experts right through every step of Plan Reading, Estimating, and Superintendence so simply and easily it is just like play. You don't need even a grade school education to understand every word and absorb every fact.

### Big Pay in 3 Months

Consider what this quick, practical Chicago Tech. training has done for others. Woodside, in less than three months, rises to foreman, then makes big money in contracting business for himself. In a few months McAvoy goes from bricklayer on the wall to foreman in charge at a big increase in pay. Marchand says, "Ten days after completing course my pay was raised 100%." Hundreds—yes thousands of others say the same. Chicago Tech. has helped them to bigger jobs or a business of their own. It is ready right now to help you.

### Blue Print Plans — FREE

We want you to see for yourself how easily you can learn to read Blue Prints and do Estimating this new quick way—how easily you can double and triple your income. Test this yourself. Don't send one penny. Just mail the coupon. We will send you absolutely FREE a full set of practical, working Blue Prints, also valuable book, "How To Read Blue Prints." Act at once as this Free Trial opportunity may not be offered again.

### FREE BOOK



### READ!

"Since starting the Builders' Course I have been raised to Superintendent and my pay raised 100%." P. F. Blair, Okla.

"I owe a lot of credit to your course. Am now listed as a Brick Contractor and made about \$3,800 clear money this summer." E. F. Baker, Ohio.

### If You Live in or Near Chicago

Visit our day or evening classes which over 1,000 Builders attend. You can get the same training by mail—same Plans, Lessons and Instructors. Mail the coupon for details.

## CHICAGO TECHNICAL SCHOOL FOR BUILDERS

Dept. R-140 118 East 26th Street CHICAGO, ILL.

Blue Prints, also valuable book, "How To Read Blue Prints." Act at once as this Free Trial opportunity may not be offered again.

**CHICAGO TECHNICAL SCHOOL FOR BUILDERS, Dept. R-140, Chicago Technical Bldg., 118 E. 26th St., Chicago, Illinois.**

Please send your Free Books and Blue Prints which I understand are mine to keep without obligation. It is also understood that no salesman will call on me.

Name.....  
Address.....  
City..... State.....  
Occupation.....



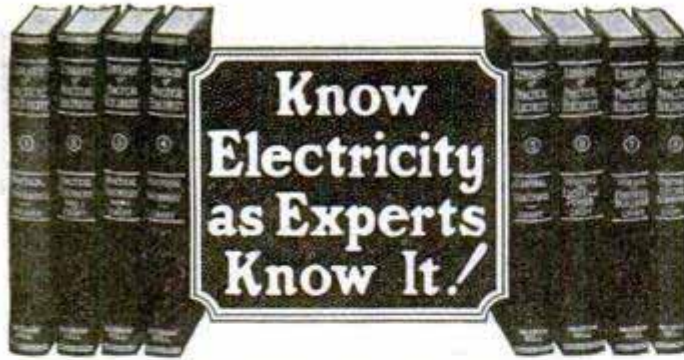

**Know  
Electricity  
as Experts  
Know It!**

**T**HIS is the electrical age, with unlimited opportunities for the man who has educated himself in the finer points of electrical practice.

Fit yourself for one of the really big jobs by knowing electrical practice complete, including inside and outside work, central stations, and the whole subject. With the aid of the Croft books you can know electricity as experts know it and put yourself in line for an expert's pay.

## The Croft Library of Practical Electricity

A reference library and self-training course in eight volumes. 3000 pages 2100 illustrations

In these volumes Croft teaches you electrical practice complete. He takes you in quick, easy steps from the simplest principles to the complete and economical operation of a great central station. He tells you all that he has learned in twenty years of shirt-sleeves practice.

With these books at his elbow a man can learn as much about electricity in six months—good practical "bread and butter" stuff—as he would ordinarily learn in a lifetime of practice.



Flexible binding for easy handling

**59,000  
Croft  
Sets  
NOW  
IN USE**

### The Standard in Practical Electrical Training

The Croft Library is a complete electrical educator. It is founded on practice—on work as it is actually done. It is jammed from cover to cover with the kind of hard-headed facts you want. Written so that the beginner can easily understand it, yet so sound, so thorough, that it is the daily guide of 59,000 highly paid electrical workers and engineers.

Croft tells you the things you need to know about motors, generators, armatures, commutators, transformers, circuits, switchboards, distribution systems—electrical machinery of every type—wiring for light and power—wiring of finished buildings—underwriters and municipal requirements—illumination in its every phase—the latest and most improved methods of lighting—lamps and lighting effects, etc.—how to do a complete job, from estimating it, to completion.

### No Money Down Small Monthly Payments

Fill in and mail the coupon attached and we will send you the entire set of eight volumes for ten days' Free Examination. We take all the risk—pay all charges. You assume no obligation—you pay nothing unless you decide to keep the books. Then \$1.50 in ten days and the balance at the rate of \$2 a month. Send the coupon NOW and see the books for yourself.

**10 Days  
FREE  
TRIAL  
Just Mail  
the  
Coupon!**

#### FREE EXAMINATION COUPON

McGraw-Hill Book Co., Inc., 370 Seventh Ave., New York

Send me for 10 days' free examination the Croft Library of Practical Electricity. If satisfactory I will send you \$1.50 in 10 days and \$2 monthly until the special price of \$19.50 is paid. If not wanted, I will return the books at your expense. (To insure prompt shipment write plainly and fill in all lines).

Signed.....

Address.....

City and State.....

Position.....

Employer..... P.M.-12-27



## LEARN WATCHMAKING

**Earn up to \$100<sup>00</sup> a week**

Great shortage of watchmakers, watch and clock repair men! Grasp this amazing opportunity. Steady employment in any section of the country. Uncrowded money-making field. We help you get big-pay job. Or you can own your own repair shop—easy to start—we show you how—fine income right from the beginning. NOW is the time to start—employers are writing us for trained men. Greatest opportunity of your life!

### WE TEACH YOU QUICKLY

Takes but a few months to learn. Day or night school, no books, all personal instruction. Our profit-sharing plan helps you earn tuition. Work your way through school. We help you get part-time job.

**FREE BOOK** Write today for interesting book on watchmaking. It shows you the tremendous growth of the watch and clockmaking industry, the need for expert watchmakers and the wonderful money making prospects for men who are trained by our competent instructors. **Write Today. NO OBLIGATION.**

**NATIONAL SCHOOL OF WATCHMAKING**  
1340 South Michigan Avenue, Dept. 15, Chicago, Ill.



### \$20 Musical Instruments

Your choice of a Violin, Tenor Banjo, Hawaiian Guitar, Banjo, Cornet, Ukulele, Banjo Ukulele, Guitar, Mandolin or Banjo Mandolin. You will be proud to own any one of these instruments and we will give you one without cost. A few cents a day for lessons is your only expense. Our system of teaching is so easy that you can play several pieces by note with the first four lessons. We guarantee success or no charge. Instrument and lessons sent on one week's free trial. Write for booklet today, no obligation. Over 200,000 satisfied pupils.

**CHICAGO CORRESPONDENCE SCHOOL OF MUSIC, INC.**  
1632 North Halsted Street, Dept. 413, Chicago, Illinois.



Wonderful, new device, guides your hand; correct your writing in few days. Big improvement in three hours. No failures. **Complete outline FREE.** Write C. J. Ozment, D-34, St. Louis, Mo.

**ALWAYS Ask For DENISON'S—52 Years of Hits**  
Comedy-Dramas, Farces, Musical Comedies, Revues, Musical Readings, Blackface Skits, Make-up Goods. Catalog FREE.  
**PLAYS** Vaudeville Acts, Monologs, Dialogs, Entertainments.  
T. S. DENISON & CO., 623 S. Wabash, Dept. 9 CHICAGO

## WANT THIS JOB?

**\$1700 to \$2300 a Year**  
**MAIL CARRIERS—POSTAL CLERKS**  
Men 18 up  
**Steady Work Paid Vacation**  
Write immediately for FREE list of positions and full particulars telling how to get a position.  
**FRANKLIN INSTITUTE**  
(Not connected with U. S. Government)  
Dept. 5-306 Rochester, N. Y.





# It's Your Job, Young Fellow, To Run That Body of Yours!

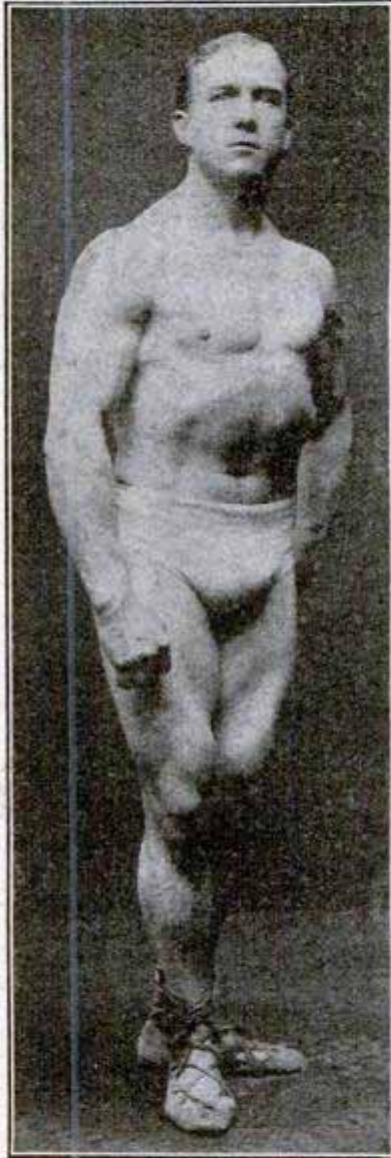

**Lionel Strongfort**  
Pronounced by Dr. Sargent, of  
Harvard University, the finest  
specimen of physical develop-  
ment he had ever seen.

This book of many pages and dozens of pictures tells of my wonderful experience. It tells what I have done for others, what I can do for you. It doesn't mince words. It tells plain truths. "Promotion and Conservation of Health, Strength and Mental Energy," points the way from disease and weakness to health and strength. It is priceless. I'll send it to you on request—FREE. Write for your copy today.

**STRONGFORT INSTITUTE**  
LIONEL STRONGFORT, DIRECTOR.

Physical and Health Specialist  
DEPT. 409 NEWARK, NEW JERSEY, U. S. A.

You can make it a body to be proud of—a dynamic, powerful machine, capable of performing wonders that will make others marvel at you. Nature gave you a wonderful human organism and she equipped it with intricate machinery for you to run it with. Your job is to take care of that body—to operate the machine **WITH YOUR MUSCLES!** It's up to you, young man, to give your body at least as good care as you'd give an automobile or any ordinary piece of machinery. Give it a square deal! It's easy enough if you'll only be man enough to do your part.

## Take Up the Science of **STRONGFORTISM** For Building Up Bodies

STRONGFORTISM works wonders with run-down, weakly, skinny fellows. It builds them up to health through internal muscular development, then rounds them out into robust physical specimens, by bringing into play every muscle and making every muscle **do its work** as Nature intended. You'll be astonished how quickly you'll feel the benefits of this best of all health and strength courses. You'll feel like a new man almost from the first day you start under my instructions—and you'll look like a new man!

### It Wakes You Up

You'll be surprised at the lazy muscles you wake up when you begin, and they'll wake you up in turn. You'll quickly realize that a new day has dawned for you as you feel the red blood coursing through your whole body like a bounding mountain stream. The old, stupid, sluggish feeling will disappear like magic. That gloomy outlook will vanish as though a heavenly hand had brushed it away. Oh, it's a great feeling! **Great to feel like a man!** And you surely will when you adopt Strongfort as your instructor and guide—STRONGFORT, "The builder of men."

### Strongfortism Restores Power

by ridding the human organism of distressing ailments and irregularities that have clogged its normal action and thrown its delicate machinery out of gear. Strongfortism strengthens the vital organs; brings back health, strength, vigor, vitality—the ability both to do things worth while and to enjoy to the fullest the good things of life. You can banish Constipation, Indigestion, Dyspepsia, Catarrh, Nervousness, Insomnia, Mental Depression, Timidity—most of the common ailments men complain of—by this system of gaining health and strength and stamina by natural methods within the reach of every man who has enough manhood left to listen to my words of instruction and advice.

**I Want to  
Send You  
My Free Book**

**Send This FREE Consultation Coupon**  
ABSOLUTELY CONFIDENTIAL

Mr. Lionel Strongfort, Strongfort Institute, Dept. 409, Newark, N. J.—Please send me absolutely free my copy of your book, "PROMOTION AND CONSERVATION OF HEALTH, STRENGTH AND MENTAL ENERGY." I have marked (X) before the subjects in which I am most interested.

- |             |                 |                         |
|-------------|-----------------|-------------------------|
| .. Catarrh  | .. Overweight   | .. Great Strength       |
| .. Colds    | .. Constipation | .. Lung Troubles        |
| .. Asthma   | .. Weak Back    | .. Round Shoulders      |
| .. Headache | .. Weak Eyes    | .. Stomach Disorders    |
| .. Rupture  | .. Rheumatism   | .. Increased Height     |
| .. Thinness | .. Nervousness  | .. Muscular Development |
| .. Pimples  | .. Short Breath |                         |
| .. Insomnia | .. Weak Heart   |                         |

Other Ailments.....

Name.....

Age..... Occupation.....

Street.....

City..... State.....





**“I’m making real money now”**

“SEE that coupon? Remember the day you urged me to send it to Scranton? It was the best thing I ever did.

“Mr. Carter called me in today. Said he’d been watching my work for some time—ever since he learned I was studying with the International Correspondence Schools.

“Then he asked me if I thought I could take over Bill Stevens’ job. I told him I was sure I could—I’d had that goal in view ever since I started my I. C. S. course.

“I start tomorrow, Mary, at an increase of \$60 a month. It’s wonderful how spare-time study helps a man to get ahead.”

For thirty-five years, the I. C. S. has been helping men to win promotion, to earn more money, to get ahead in business and in life.

You, too, can have the position you want in the work you like best. Yes, you can.

All we ask is the chance to prove it. Without cost or obligation, just mark and mail this coupon.

*Write for Free Booklet*

**INTERNATIONAL CORRESPONDENCE SCHOOLS**

*“The Universal University”*  
Box 5691-E, Scranton, Penna.

Without cost or obligation, please send me a copy of your booklet, “Who Wins and Why,” and full particulars about the course before which I have marked X in the list below:

**BUSINESS TRAINING COURSES**

- |  |   |
|--|---|
| <input type="checkbox"/> Business Management                     | <input type="checkbox"/> Salesmanship                                     |
| <input type="checkbox"/> Industrial Management                   | <input type="checkbox"/> Advertising                                      |
| <input type="checkbox"/> Personnel Organization                  | <input type="checkbox"/> Better Letters                                   |
| <input type="checkbox"/> Traffic Management                      | <input type="checkbox"/> Show Card Lettering                              |
| <input type="checkbox"/> Business Law                            | <input type="checkbox"/> Stenography and Typing                           |
| <input type="checkbox"/> Banking and Finance Management          | <input type="checkbox"/> English  |
| <input type="checkbox"/> Accountancy (Including C.P.A.)          | <input type="checkbox"/> Civil Service                                    |
| <input type="checkbox"/> Nicholson Cost Accounting               | <input type="checkbox"/> Railway Mail Clerk                               |
| <input type="checkbox"/> Bookkeeping                             | <input type="checkbox"/> Common School Subjects                           |
| <input type="checkbox"/> Private Secretary                       | <input type="checkbox"/> High School Subjects                             |
| <input type="checkbox"/> Spanish <input type="checkbox"/> French | <input type="checkbox"/> Illustrating <input type="checkbox"/> Cartooning |

**TECHNICAL AND INDUSTRIAL COURSES**

- |   |  |
|---|--|
| <input type="checkbox"/> Electrical Engineering                     | <input type="checkbox"/> Architect                                       |
| <input type="checkbox"/> Electric Lighting                          | <input type="checkbox"/> Architects’ Blueprints                          |
| <input type="checkbox"/> Mechanical Engineer                        | <input type="checkbox"/> Contractor and Builder                          |
| <input type="checkbox"/> Mechanical Draftsman                       | <input type="checkbox"/> Architectural Draftsman                         |
| <input type="checkbox"/> Machine Shop Practice                      | <input type="checkbox"/> Concrete Builder                                |
| <input type="checkbox"/> Railroad Positions                         | <input type="checkbox"/> Structural Engineer                             |
| <input type="checkbox"/> Gas Engine Operating                       | <input type="checkbox"/> Chemistry <input type="checkbox"/> Pharmacy     |
| <input type="checkbox"/> Civil Engineer                             | <input type="checkbox"/> Automobile Work                                 |
| <input type="checkbox"/> Surveying and Mapping                      | <input type="checkbox"/> Airplane Engines                                |
| <input type="checkbox"/> Metallurgy <input type="checkbox"/> Mining | <input type="checkbox"/> Agriculture <input type="checkbox"/> Navigation |
| <input type="checkbox"/> Steam Engineering                          | <input type="checkbox"/> Mathematics <input type="checkbox"/> Radio      |

Name.....

Street Address.....

City..... State.....

Occupation.....

Persons residing in Canada should send this coupon to the International Correspondence Schools Canadian, Limited, Montreal, Canada

**Learn How to BOX**

**JIMMY DeFOREST BOXING COURSE**

Teaches by mail the Same System he taught Champion JACK DEMPSEY

In 20 weeks, under the System of Jimmy DeForest, WORLD’S GREATEST TRAINER AND MAKER OF CHAMPIONS, you will master the priceless knowledge that made Jack Dempsey his millions, and fortunes for a host of other Jimmy DeForest-trained ring stars. Boys who were once rank amateurs are today earning big money; weaklings have been made strong, courageous; men have learned the art of self-defense. Send today for the now famous book, “THE GOLDEN AGE OF BOXING,” greatest book of its kind ever written; full of valuable information, photos of great fighters and pupils who became successes over night. Enclose 10c to cover cost of mailing, etc. WRITE NOW.



**JIMMY DeFOREST BOXING COURSE**

347 Madison Avenue, Box 125, New York City

**Become a PHOTOGRAPHER**

Attractive money making opportunities in Portrait, Commercial and News Photography, or Get Into Motion Picture Photography. Camera Men Earn \$50 to \$250 a Week. Fascinating Work; in big demand. You can learn at Home or in our N. Y. Studios.

**FREE BOOK Tells How—**  
How to prepare for High Salaried position.

How to start your own business.

How to make money in spare time.

Write for this big illustrated Book and Job Chart today—FREE.

**N. Y. INSTITUTE OF PHOTOGRAPHY, Dept. 49**  
10 West 33rd Street, New York, N. Y.



**Learn to PAINT SIGNS and SHOW CARDS**

We quickly teach you by mail or at school, in spare time. Enormous demand. Big future. Interesting work. Oldest and foremost school. **EARN \$50 TO \$200 WEEKLY**

John Vassos, N. Y., gets \$25 for single show card. Crawford, B. C., writes: “Earned \$200 while taking course.” Don’t delay. Send today for complete information, samples and guarantee.

**DETROIT SCHOOL OF LETTERING**

150 Stinson Ave. Est. 1899 DETROIT, MICH.



**Book on Law Free**

Write today for this new book. It tells you how a law training will shorten your road to success. It also carries a vital and inspiring message to every ambitious man. Find out about the opportunities that await the law trained man. Find out how you can learn law right in your own home. No obligations. The book is absolutely FREE.

**Write Today—now—while low tuition fee is in force.**  
American Correspondence School of Law  
3601 Michigan Ave, Dept. 1359 Chicago, Ill.

**TELEGRAPHY**

(Morse and Wireless) and RAILWAY ACCOUNTING taught thoroughly. Big salaries; great opportunities. Oldest, largest school. Endorsed by Telegraph, Railway, Radio, and Government officials. Expenses low—opportunities to earn large portion. Catalog free. **DODGE’S INSTITUTE, Jones St., Valparaiso, Ind.**

**Skin Troubles**

Cleared up—often in 24 hours. To prove you can be rid of Pimples, Blackheads, Acne Eruptions on the face or body, Barbers’ Itch, Eczema, Enlarged Pores, Oily or Shiny Skin, simply send me your name and address today—no cost—no obligation. **CLEAR-TONE** tried and tested in over 100,000 cases—used like toilet water—is simply magical in prompt results. You can repay the favor by telling your friends; if not, the loss is mine. **WRITE TODAY.**  
**E. S. GIVENS, 428 Chemical Bldg., Kansas City, Mo.**



# AUTO

## 5 AUTO BOOKS SENT FREE!



Mail the coupon and we'll send you a set of these remarkable auto books, just off the press. Whether you are mechanic or helper, expert or student, auto owner or driver, if you're interested in autos, by all means take advantage of this opportunity to see the latest and most complete work on autos we have ever published. Built by eighteen of America's greatest automotive engineers. Simple enough for men with little schooling to understand, yet in daily use by hundreds of engineers, service-station superintendents and foremen as an authoritative REFERENCE Cyclopedia. This new edition includes straight-eights, 4-wheel brakes of all types and other features of the 1928 models.

**Put the JIFFY INDEX**  
to work for you!

## Can You FIX IT?

Can you take out "play" in differential? Can you kill the "Shimmy" in steering? Can you reset TIMING? Can you put your finger on engine trouble without guessing or tinkering? Can you pull the starter off and fix it? Can you adjust and repair transmission, engine, rear axle, bearing?

### These Books Tell How!

They bring the answer to any auto problem instantly. And they show the best, quick, professional way to do EVERY repair and replacement job you will ever need. Auto owners say the cost is saved over and over again by showing how to make adjustments and emergency repairs on the road.

### 5 Big De Luxe Volumes just off the press!

2400 pages, over 2000 illustrations, wiring diagrams, equipment charts, etc. De Luxe edition with gold-stamped flexible binding. Sent FREE for 15 days' use. If not wanted return express collect. If kept, send only \$2 after 15 days, then \$3 a month until special advertising price, \$24.80, is paid.

### A Year's Consulting Membership FREE!

Privilege of consulting engineers of million-dollar American Technical Society on any automotive problem for one year without charge, if you mail coupon immediately.

American Technical Society



Dept. A-919, Drexel Ave. & 58th St.,

CHICAGO, ILL.

The billion-dollar auto industry offers rich prizes to men with gumption enough to really learn all branches of automotive mechanics. A better job, bigger pay—a chance to go into business and get a share of the huge profits, are waiting for any man who even half tries to improve his ability to deliver service. And here's the shortest, easiest way: No tedious studying, no memorizing, no lessons or examinations. Just LOOK UP the fact you seek. You'll find the answer to any auto problem literally at your finger-tips, in the famous JIFFY INDEX. No need to "carry it in your head," at all.



"Was garage hand—now have Shop of my own," writes W. Sidle of Toboso, O.

J. H. Gelse of Detroit says: "I received \$50 worth of information out of them the first 5 days."

"I got a raise," says P. Ervin of Yarmouth, N. S., shortly after getting his books.

And D. S. Reid of Siluria, Ala., was offered \$4000 for invention worked out with these Auto Books.

## Don't Send a Penny!

AMERICAN TECHNICAL SOCIETY,  
Dept. A-919, Drexel Ave. and 58th St., Chicago, Ill.

I would like to see the new 5-volume edition of your AUTO BOOKS, but without obligating me to buy them. I will pay the few cents delivery charges only, but if I choose to, I will return them express collect and owe you nothing. If after 15 days' use I prefer to keep them, I will send you \$2 and pay the balance at the rate of only \$3 a month, until \$24.80 is paid. Please include free membership.

Name.....

Address.....

Employed by.....

Address.....





**\$4.00 AN HOUR**  
 Dear Mr. Cooke:  
 Just finished four electrical jobs in 11 hours, making \$41 -- almost \$4.00 an hour. Wouldn't take a million dollars for your wonderful Course.  
 Peter J. Terlesky  
 Exceter Row, P. O.  
 236 Orchard Street  
 Pittston, Pa.

**\$15 A DAY**  
 Dear Mr. Cooke:  
 If I hadn't taken your Course, I would be like the helpers here, getting \$3.60 a day, instead of the \$15 a day I am getting.  
 E. B. Gaskell  
 P. O. Box 142,  
 Greystone Park, N. J.



**WHY** earn \$15 or \$20 or \$30 a week, when in the same six days as an Electrical Expert, you can make \$70 to \$200 — and do it easier — not work half so hard. Why, then, remain in a small-pay, no-future job that offers no chance for big promotion — no chance for big income? Fit yourself for a real job. **Get into Electricity.** That's where the big money is being made, and always will be made.

**Electricity — The Big Pay Field**  
 Today even the ordinary Electrician — the "screw driver" kind — is making money — big money. But it's the trained man — the Electrical Expert — who makes the really big money — \$12 to \$30 a day — \$70 to \$200 a week. Be a Big-Pay man, yourself. Get in line, now, for one of these "Big-Pay" Jobs.

**I'll Train You At Home**  
 I'll train you at home — in your spare time. You work just as you are working now — at your same job. My now famous "Work-Sheet and Job-Ticket" method, guarantees you simplified, practical training along work-shop lines. In a few short months you can step out of your old job into a new job — into electrical work where you can be a Big-Pay man in this Big-Pay field.

**You Earn As You Learn**  
 To learn Electricity my way you don't have to be a College man, or even a High School graduate. You can read. You can write. That's enough. With me, you get experience as you go along and make good money while learning. I'll show you how — and I'll give you, without extra cost, tools and apparatus to work with — 6 Big Outfits in all.

**Money Back If Not Satisfied**  
 That's what I agree to do. And back of me in this agreement stands the Chicago Engineering Works, a \$2,000,000 Illinois Corporation. There's nothing like "Cooke" Training, anywhere. It's the Training that big Electrical men are praising; it's the Training that employers recommend; it's the Training that one of our greatest Engineering societies, has endorsed 100 percent. **It's the Training for you.**

**6 BIG OUTFITS NO EXTRA COST**



**If Not Earning \$70 A Week — Investigate**  
 Don't wait a minute! Find out today why "The Cooke Trained man is the Big-Pay Man", everywhere! Find out how "Cooke" Training will help you boost your pay! Mail coupon right now for my Big FREE Book of Facts. See the Six Big Working-Outfits I give you without extra charge. See the hundreds of pictures, the proofs, the Big-Pay letters of other "Cooke" Trained Men. Get this great free Book. Send for it today. Clip, sign, and mail coupon, **RIGHT NOW!**

**L. L. COOKE,**  
 Chief Instruction Engineer  
**L. L. COOKE SCHOOL OF ELECTRICITY**  
 Dept. 19  
 2150 Lawrence Ave.  
 Chicago, Ill.

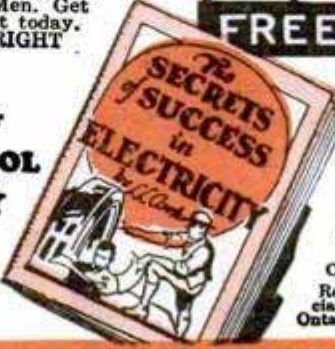

**LEARN TO EARN \$70 to \$200 A WEEK**

**If you earn less than \$70 a week INVESTIGATE NOW**

**I'll train you at home in a few short months. L. L. COOKE**

**FREE BOOK COUPON**

**L. L. COOKE, Chief Instruction Engineer**  
 Dept 19, 2150 Lawrence Ave., Chicago, Ill.  
 Send me FREE and prepaid, your Big Book "Secrets of Success in Electricity" with all details about your Home Study Course in Electricity.

Name \_\_\_\_\_  
 Address \_\_\_\_\_  
 City \_\_\_\_\_ State \_\_\_\_\_

Residents of Canada send coupon to R. A. Farrow, Special Representative, 7 Medbury Lane, East, Windsor, Ontario, Canada.

**The "Cooke" Trained Man is the "Big Pay" Man**



# Classified Advertisements

## WORLD'S BEST WANT AD MEDIUM

Advertisements in this section, 30 cents per word, each insertion, minimum 10 words, payable in advance. To be inserted under proper classification in January issue, copy should be in our office November 18th.

### ADVERTISING AGENCIES

**SECURE and Increase Your Business** by going after out of town trade. Our Service department guides you on every detail. Copy and literature composed free. Your 24-word ad (4 lines) inserted in the following 10 leading Sunday papers for only \$10.00. Circulation 1,500,000. Gazette, Little Rock; American, Atlanta; Star, Indianapolis; Journal, Minneapolis; Star, Kansas City; World-Herald, Omaha; Courier, Buffalo; Enquirer, Cincinnati; Gazette Times, Pittsburgh; Banner, Nashville. Proof of insertion guaranteed or money refunded. 56 page rate Book and Atlas sent free. Frank W. Lenhoff Advertising Agency, 600 North Michigan Blvd., Chicago. (Established 1897.) Chicago's Most Progressive Advertising Agency.

A TEN Dollar Ad may put your proposition over. \$10 pays for a 4 line 24 word classified ad one Sunday in 8 of the largest newspapers. Reach over 6 million readers. Minneapolis Tribune, Buffalo Courier, Detroit Free Press, Kansas City Star, Pittsburgh Press, Indianapolis Star, Atlanta Journal, Cincinnati Enquirer. Free catalogue showing other lists of newspapers and magazines sent on request. Ankrum Advertising Agency, 22 West Jackson Blvd., Chicago. Largest classified advertising agency in the world.

**ADVERTISE in 24 Big Sunday Newspapers**, 24 words \$15.00. Excellent for securing Agents, Salesmen, and Business Opportunities. Catalog listing 1,000 leading Dailies, Weeklies, Mail Order Magazines. Everything. Free. Wade Advertising, Baltimore Bldg., Chicago.

**ADVERTISERS!** Get hold on 4,000,000 men readers at 50c a word. Circular free. Cervene System, Box 4, Buffalo, N. Y.

**ADVERTISE 50 magazines \$4.00 inch**, three \$8.00; circulation proven. King, Box 672-P, Wilmington, Del.

**LOWEST Rates.** New Catalog. Owl Agency, Times Bldg., New York.

**NEWSPAPER — Magazine advertising**—Classified, mailorder, Catalog. Martin, 276B West 43rd, New York.

**SIX Word Line—355 rural weeklies \$3.55.** Admeyer, 4112-M Hartford, St. Louis.

### FOR ADVERTISERS

**ADVERTISERS—Your 24 word ad in 24 metropolitan dailies \$5.00; 40 words, 50 magazines, \$3.00.** Try our guaranteed fresh name mailing lists—1,000 names of agents, salesmen, M. O. buyers, \$1.00; housewives, 1,000 for \$3.00. We do better printing for less money. Get our free catalog and 2 advertising magazines. Don't wait. Write today. The Waring Advertising Co., Dundee, Mich.

**ADVERTISE in 275 country newspapers**, 28 words, \$10. Keator, Hartford Bldg., Chicago.

**CUTS, Drawings \$1.50. Window Cartoons, 6. \$1.50. GPO, Bx471, New York.**

**40 WORDS insert 50 magazines \$2.00.** Empire Agency, Shawano, Wis.

**28 WORDS in 200 rural newspapers, \$7.50.** Roberts Agency, Forreston, Ill.

### AUTOMOBILE SUPPLIES

**AUTOMOBILE Clock:** Most Ideal Christmas Gift. "Prak-ti-ka!" is the last word in automobile clocks. Very neat appearance, durable and attached to dashboard in two minutes. Ask nearest jeweler, accessory or hardware dealer or order direct from us. \$2.25 with white dials, 50c extra for radiolite. If stops running before two years, return with 25c for exchange. If you have watch to spare, order the Prak-ti-ka! Automatic Watch holder. Fits any size pocket watch. Black finish \$1; Nickel \$1.50. Territorial agencies, jobbers, retailers ask for our proposition. Practical Specialty Co., Inc., 7th and Sanson Streets, Phila., Pa.

**YOU are Wanted to Resilver Mirrors** at Home. Immense profits plating auto parts, ta-bleware, etc. Write for information. Sprinkle, Plater, 77, Marion, Ind.

**EVERY Automobilist, Mechanic and Sportsman**, needs the "Hands Free" flashlight. Has adjustable belt to fasten around chest, two standard flashlight batteries placed side by side in beautiful case. Ideal Xmas present. Complete \$2.50. Was originally \$5.00. Fremco Products, 177 New York Ave., Newark, N. J.

**FORD Gas Saver Free.** To advertise. Fits any auto. Enormous mileage increase. Critchlow, G1-805, Wheaton, Ill.

**JUNK auto tires cost \$10 per ton.** Our Hoxie converts them into demandable, saleable Mds. that sells anywhere for \$200 a ton. \$200 starts you, investigate. Address Hoxie, 106 East 11th St., Los Angeles, Calif.

**VULCANIZING Auto Tires is a Paying Business.** We have plants near you, \$50 up. Catalogue free. Equipment Exchange, 108 East 11th, Los Angeles, Calif.

**NEW Generators, Magnetos, Carburetor, Electrical Equipment, Bearings, and everything in Automotive Equipment and Parts.** Write for 150-page illustrated catalogue of bargains. Leterstone Sales Company, 2515 Wabash Ave., Chicago, Ill.

**RADIATORS at wholesale prices.** All standard makes. Satisfaction guaranteed. Send for prices, stating make and model. Independent Radiator Co., 1119 S. Wabash Ave., Chicago.

**AT Last! Reasonably priced Auto Emblems for every Lodge.** Sells for only \$1.25. Write for attractive selling proposition and free Sample Case offer. North Central Distributors, Dept. 9, Ashland, Ohio.

**MAKE Money!** Complete Tire and Battery Shop equipment for \$129.74. Wholesale only. Investigate. Adams-Barr, Columbus, Ohio.

**FAMOUS Dyke's Automobile Encyclopedia—Just out, 15th edition.** Fully revised to include all latest facts regarding newest developments. Information on repairing and adjusting every part of all motor cars. How to find trouble and fix it. 1,250 Pages, 4,200 Illus. Price, cloth, \$6. Flexible Morocco \$7.50. Will be sent C. O. D. anywhere in U. S. Pay postman price and postage when he delivers book. Popular Mechanics Press, Room 912, 200 E. Ontario St., Chicago.

### SALES PROMOTION

**\$50 TO \$50,000 Daily Sales Developed** During 28 years for clients by our direct mail plans, copy, campaigns. One product, 1923, an idea; this year \$100,000 orders booked. Fifty year old concern desired 50 national representatives in 1925; we produced 40 in three months. 700 dealers in 10 months at \$3 each, for another. Ten years Sales Promotion Manager Larkin Co. Submit sales problems for Free diagnosis. James C. Johnson, 118A Woodbridge Ave., Buffalo.

**SALES Promoters, Attention:** Desire contracting, territorial or national, reliable sales organization, who specialize in introducing new articles by personal calls, upon jobbers, r-tallers, mail-order houses, chain-stores, and direct selling to consumers. Our meritorious Specialty is for automobile dashboards, sold by auto accessory, hardware, and novelty stores. Write Box PSC, % Popular Mechanics, Chicago, Ill.

### LETTER SPECIALISTS

**LETTERS—\$5.** Murphy, Lost Creek, Pa.

### AUTOMOBILES

**PATENTS.** Time counts in applying for patents. Don't risk delay in protecting your ideas. Send sketch or model for instruction or write for free book "How to Obtain a Patent" and "Record of Invention" form. No charge for information on how to proceed. Communications strictly confidential. Prompt, careful, efficient service. Clarence A. O'Brien, Registered Patent Attorney, Security Bank Building (directly across street from Patent Office), Washington, D. C. See pages 156 and 157.

### AUTOMOBILE SERVICE EQUIPMENT

**BATTERY Service pays big profits.** Get my low prices and easy terms on latest 8-hour charging equipment. Also used outfits in first class condition. Write quick for bargains. I. C. Helmick, Box M-1273, Troy, Ohio.

**BIG Money in complete auto electrical service** and practically no investment required. Test and repair starting—lighting—ignition. Easy to learn with new low-priced test bench. Shipped on trial. Small monthly payments. E. C. Galbreath, Box M-1274, Troy, Ohio.

**START A money making business of your own** with low-priced equipment for servicing automobiles. Every car owner a prospect. Write for new illustrated catalog of car washers, air compressors, battery chargers, paint sprayers, electrical testers, etc. The Hobart Industries, Inc. Box M-1275, Troy, Ohio.

### FOR AUTO OWNERS

**FORD Gas Saver Free.** To advertise. Fits any auto. Enormous mileage increase. Critchlow, G2-805, Wheaton, Ill.

**UNDERSLUNG with "RKO" Swing Lo Irons.** See "Red-i-Kut" ad page 142.

**FORD Electrical Equipment Troubles—** Locate and remedy them easily yourself with the aid of our book "Ford Standard Electrical Equipment." Why pay big garage bills? Battery, Ignition, Starting and Lighting covered. Order to-day. When postman hands you the package pay him \$1.98 and the postage. Popular Mechanics Press, Room 908, 200 E. Ontario St., Chicago, Ill.

### MOTORCYCLES, BICYCLES AND SUPPLIES

**GOOD used parts for Indian, Harley Davidson, Excelsior, Henderson and others** at one-half of new prices or less. New parts for all makes. Quick service; expert repairing; prices right. J. B. Dahl, 3661-63 Archer Ave., Chicago, Ill.

**MONEY Saving Motorcycle Bargains—** Large stock of Used Harley-Davidson—\$50 and up. Send for Free bargain bulletin—Now! Motorcycle Parts, accessories, repairs. Knuth's Harley-Davidson Agency, 2525 Fond Du Lac Ave., Milwaukee, Wis.

**MOTORCYCLES at Reduced prices.** Save 25% to 50%. Send for our Bargain Bulletin. American Motor Cycle Company, 2041-2047 Chicago Ave., Chicago.

### AVIATION

**LEARN to Fly; \$100.00 including Solo.** We guarantee to solo you regardless of the number of flying hours required. Our instructors are ex-army aviators and air-mail pilots with wide experience. Our training equipment is the best obtainable. Our course requires about two weeks, depending on the individual. No bond required, no charge for breakage. Eight years without an accident. 76 students graduated in 1925. Commercial aviation is a rapid growing industry. Don't delay! Enroll now in one of the oldest and best known flying schools in America. Write for booklet. Robertson Aircraft Corporation, operators of the United States Air Mail, St. Louis-Chicago, Lambert-St. Louis Airport, Anglum, Mo.

**THOROUGH Instruction in flying and building airplanes** can only be had in a well equipped school. We offer our students the combined facilities of a real aircraft factory, excellent flying equipment and experienced instructors. Learn to fly in five weeks for \$100 with one of America's oldest pilots; 20 years in business. Employment given to students who are short of funds or who wish to take our special winter and spring evening course. Work in our own factory guaranteed to day students. Special agency offer to students to represent our airplanes in their territories. The only offer of its kind in existence. Heath Airplane Company, Chicago, Ill.

**YOUNG Men:** If you want to learn to fly free, write us immediately. Dept. 1, Pearson Aviation Co., Coalwood, W. Va.



**PATENTS.** Time counts in applying for patents. Don't risk delay in protecting your ideas. Send sketch or model for instruction or write for free book "How to Obtain a Patent" and "Record of Invention" form. No charge for information on how to proceed. Communications strictly confidential. Prompt, careful, efficient service. Clarence A. O'Brien, Registered Patent Attorney, Security Bank Building (directly across street from Patent Office), Washington, D. C. See pages 156 and 157.

**OPPORTUNITY** is calling. Be a Wallace Trained Man. We teach you to fly, build and design airplanes. Low rates to students. Salary to qualified men. Wallace Aircraft Co., Builders of "Wallace Mohawk." Dealers wanted in every state. 4710 Irving Pk. Blvd., Chicago, Ill.

**BUILD! Fly!** Scale models Ace E. Z. system! 39 inch Lindbergh monoplane construction set \$7.00. List of model supplies for stamp. Ace Aeroplane, 131 Prospect St., Jersey City, N. J.

**LEARN** To fly this winter—Special 15 hour course and Ground School by French and U. S. Army trained instructors only \$250.00. Prepare here for Government license and a good job. Unique Savings plan and Home Study Course for future students. Write for descriptive folder. Porterfield Flying School, 2330 Harrison, Kansas City, Mo.

**HEATH** Propellers represent the most efficient method of aerial drive. Each propeller individually designed for the particular work to be done, as laid out by America's oldest aeronautical engineers. Propeller catalog 4c. Heath Airplane Company, Chicago, Illinois.

**AEROPLANE** Engines in Theory and Practice by Rathbun, a 465-page book, illustrated, describes engines fully. For mechanic, builder and flyer. Price \$2.50. Will be sent C. O. D. anywhere in U. S. Pay postman price and postage when he delivers book. Popular Mechanics Press, Room 912, 200 E. Ontario St., Chicago, Ill.

**RE-BUILT** Twin cylinder motorcycle engines, for ice and snow sleds, or boats, complete with propellers and hubs. Price \$75 to \$50. Send dime or equal in stamps for latest catalog. Sensenich Brothers, Lititz, Pa.

**AIRPLANE** Motors, 28 to 200 H.P.—\$50.00 to \$300. Propellers \$5.00 to \$25.00. Good used leather coats \$7.50. Smith Machinery Co., P. O. Box 153, Houston, Texas.

**AVIATION'S** Primer (Original) 26c. Church, C. A., 1603 Golden Gate Ave., San Francisco.

**CLASSY** racing planes; 20", 75c; 24", \$1. Exceptional fliers. Marx Aircraft, 668 E. 8th South, Salt Lake, Utah.

87 M. P. H. Aerodrive Sled-Blueprints. Only 50c. Other sled and boat prints 50c each. Ostergaard Aircraft, 4305 North Nargansett, Chicago.

**SET** absolutely new covered wings for Heath Parasol monoplane crated \$20.00. If building one chance save money. Curtiss Jenny \$490.00. 2 pair army aviators' goggles \$1.00, postage paid. New unused Curtiss propeller, boxed, \$3.00 each. Gnome engine \$35.00. Midway Aero Co., Box 283, St. Paul, Minn.

**EAGLEROCK**, government certified safety airplane at \$2,475. Denver or may be purchased on time payments. Pilots pay as they earn. Low charge for student instruction. Write for new complete course Airplane operation "Modern Flight." One Dollar. Alexander Aircraft Company, 3333 S. Broadway, Denver, Colo.

**THE American School of Aviation** announces a new correspondence course in Mechanics of Aviation. A thorough training in Practical Aeronautics. American School of Aviation, Dept. 1861, 3601 Michigan Ave., Chicago, Ill.

**DICTIONARY** of Aviation, \$3.90. Languages Publishing Company, 15 W. 18th Street, New York.

**SEND** dime for 12 inch mounted propeller and circulars on free three foot model aeroplane. No selling. Aero Shop, 3059 Huribut Ave., Detroit, Mich.

**BIGGEST**, Best Catalog Model Airplanes, Parts Supplies; 5c postpaid. Ideal Company, 165½ Spring Street, New York.

**SPORT** Plane builders. Send one dollar for booklet on Nomenclature, Stability, Controllability, Design, Charts, Illustrations, etc. Donald Smith, 1247 Loma Vista Drive, Long Beach, Calif.

**AVIATION** Opportunities. How to earn while learning. Other information. Send \$1.00. Romby National Aeronautical Service, Box 43, Santa Monica, Calif.

**HERE** it is—the new revised edition of Rathbun's book Aeroplane Construction and Operation containing all the information about the latest models of planes including the ships flown by Lindbergh and Byrd. Also the latest engines such as the Wright Whirlwind, etc. Authentic data furnished by the manufacturers. Complete and right up to the minute. Price \$2.50, postpaid. Will be sent C. O. D. anywhere in the U. S. or possessions. Popular Mechanics Press, Room 912, 200 E. Ontario St., Chicago, Ill.

#### BOOKS AND PERIODICALS

1927, **THIRD** edition revised. "Radio Theory and Operating," by Mary Texanna Loomis, President Loomis Radio College; member Institute Radio Engineers, 886 pages, 700 illustrations. Used in all Government and private radio schools, many colleges and high schools. Comprehensive, up to date, the standard on radio. Price \$3.50, postage paid. At your book store, or order direct from Loomis Publishing Company, Dept. M., 405 Ninth, Washington, D. C.

**Old Money** Wanted. Do you know that coin collectors pay up to \$100.00 for certain U. S. cents? And high premiums for all rare coins? We buy all kinds. Send 4c for large coin folder. May mean much profit to you. Numismatic Co., Dept. H-2, Fort Worth, Tex.

**WHAT** Every home owner should know about the plumbing and heating system in the home. Over 360 illustrations; nearly 200 pages. Backed by 25 years of experience. \$1.00 postpaid, U. S. or Canada, C. O. D. 20c extra in U. S. Satisfaction guaranteed. Chas. Geiser, author and publisher, Box 1127, Chicago.

**"THE Personal Liberty Course"**—A clever combination of mirth, information and instruction for quickly overcoming fear, bashfulness and physical complexes in men. No drugs, no gymnastics. Full particulars free, sealed. Harry J. Gardener, P. O. Box 607, Station C, Los Angeles, Calif.

**THOUSANDS** of dollars added to your income. 10c brings our instructive booklet. Cervence System, Box 4, Buffalo, N. Y.

**HYPNOTISM** Wins health, wealth, fame, love. 25 easy lessons and 248 page reference guide \$2.00. Popular Science, 430, P.N., Milwaukee Ave., Chicago.

**LEARN** a trade. We have books that will show you how. Send 10c for catalogs. Goldman's Book Store, 424 So. Dearborn, Chicago.

**BOOK** of Luck, lucky numbers, superstitions, etc. 25c. Circulars, F. & R. Co., 87 Fourth Ave., New York City.

**CURIOUS** Books, Unique Novelties, Stunning Pictures. Samples, 10 cents Prepaid. Linds, 214 W. 34th Street, New York.

**PAINTERS, Decorators, Artists**—Books 10c up. Circulars free. King, Box 1482, Indianapolis, Ind.

**INDUSTRIAL** Alcohol, Wright's book. Full directions for making, fully illustrated. \$2.50. Spon & Chamberlain, 120 P.M. Liberty Street, New York, N. Y.

**FREE:** Valuable book telling the uses of roots and herbs. Box 29C, Station L., New York.

#### PICTURES AND POSTCARDS

**LUMINOUS** Pictures in darkness, very Curious. Samples for 50c, \$1.00, \$3.00, coins, bank notes. Paris-Picture Publishers, at Neuilly-Plaisance (S & O), France

**FREE—True-Blue** book. Exchange postcards, stamps. Ericson, Elroy, Wis.

**ART** Pictures, Books and Novelties. Catalog 10c. Howard Sales Co., Dept. 15, 1188 Folsom St., San Francisco, Calif.

**FREE**—Send address for beautiful 5x10 art print. C. C. Dry, 1112½ 21st N. W., Canton Ohio.

#### MAGIC TRICKS, BOOKS AND JOKER NOVELTIES

**NEW** 1927 "Fun—Magic—Mystery" now ready. 100 Pages, profusely illustrated. Over 750 Tricks—Illusions—Jokes—Puzzles—Books—European Novelties, at Reduced Prices. Postpaid 10c. Lyle Douglas, Station A, Dallas, Texas.

**MAGIC**—Tricks, Books and Supplies. For Amateurs as well as the great professionals. Anyone can learn through our instructions. Feature Acts in Mind-Reading, Spiritualism, Rope Ties, etc. Large illustrated Professional Catalog, 20c. Chicago Magic Co., 140 So. Dearborn St., Dept. B, Chicago, Ill.

**FREE** with \$25 order die box. Send 20c for our large catalogue of tricks, wigs, sensational escapes. Oaks Magical Co., Dept. 548, Oshkosh, Wis.

**ELECTRIC** Fun! Seventy stunts, 110 volts, \$1. TaCutting, Campbell, Calif.

**MAGIC** tricks, Card tricks, Coin tricks. Hypnotism, Ventriloquism, 64-page books. Complete guides. 10c each. Geo. Fenner, 2401 Jefferson, Louisville, Ky.

**ILLUSION** Catalog, 10c; Trick Catalog, 7c. Lynn's, 105 Beach, Jersey City, N. J.

**MYSTERIOUS** Peg Paddle; particulars how become Magician 10c. Swivel, 114 Huntington, New Brunswick, N. J.

**MAGIC** Trick Cards that are absolutely guaranteed; Bees, Bicycles, Steamboats. Free samples. C. D. Blankenship, Adrian, W. Va.

**SEVEN** Magical Delusions and Catalogs—25c. Gilmagico, Morgan Park, Ill.

#### GAMES, ENTERTAINMENTS AND PLAYS

**CHRISTMAS** presents, Novelties, Catalogue 10c. Refunded first order. Frank Anderson, 815 Twentieth Ave., Rockford, Ill.

**VENTRILLOQUISM** taught almost anyone at home. Small cost. Send 2c stamp today for particulars and proof. George W. Smith, Room S-217, 125 N. Jefferson Ave., Peoria, Ill.

**MYSTIFY** friends. Throw your voice anywhere. Fool everybody. Great fun! New Ventriloquism method easy. Send only \$1 for complete professional course. Guaranteed. Whittle Institute Ventriloquism, Dept. M, Bloomfield, N. J.

**PLAYS**, Musical comedies and revues, minstrel music, blackface skits, vaudeville acts, monologs, dialogs, recitations, entertainments, musical reading, stage handbooks, make-up goods. Big catalog free. T. S. Denison & Co., 623 So. Wabash, Dept. 11, Chicago.

**PUZZLE** catalogue and leader free. B. Z. Puzzles, Fairview, Mass.

#### STAMP COLLECTING

**NOW** on Sale. 1928 edition Scott's Standard Postage Stamp Catalogue. This edition is notable for many important price changes in many countries. Order your copy now. Bound in cloth, \$2.00; Cloth with thumb index, \$2.50. Shipping wt. 3 lbs. For sale at all dealers. 1928 edition Scott's Specialized U. S. Catalogue. Listings greatly revised, as well as the important New Listings of U. S. Revenues, first issue, Die and Plate Proofs, U. S. Postage, and Confederate States, General Issues. When you buy Scott's Catalogues subscribe to Scott's Monthly Journal. Scott's Monthly Journal is a monthly supplement to both the Standard Catalogue and the U. S. Specialized. It lists monthly price changes and new issues, keeping you informed up to the last minute. Stamp bargains it lists exclusively, will more than repay you the subscription price. It is the Live! Stamp Journal. \$1.00 per year, 12 issues. Any dealer will take your subscription or send to Scott Stamp and Coin Co., 1 West 47th Street, New York, N. Y.

**MYSTIC'S** "Queer Country" Packet! Contains scarce stamps from the following strange lands: San Marino, Antioquia, Congo, Cyprus, Fiji Islands, Gwalior Hyderabad, Iceland, Jhind, Kenya, Uganda, Lebanon, Monaco, North Borneo, Nyassa, St. Thomas Prince, Port. Guinea, Siam, Sierra Leone, Tanganyika, Trinidad Tobago, Ubangi, Upper Volta, Wallis Futuna, Zanzibar. Get this wonderful packet of "freak countries" and make your friends envious! Price only 10c to approval applicants! Write today. Mystic Stamp Company (Dept. 8), Camden, New York.

**\$1.00 FREE.** Black U. S. Postage. Given Away with each order. Pioneer Stamp Album with 500 illustrations, 150 different stamps from 40 countries, Syria, Lebanon, Hejaz, Liberia, New French Colonies, British, Portuguese Colonies, South Africa, Australia, 500 hinges, 36 page illustrated catalogue. All for 15c. Big Commission to Agents for the Best approval sheets of stamps ever offered. Write for sample outfit. Hussman Stamp Co., Dept. M, 620 Olive St., St. Louis, Mo.

**WONDERFUL** collection 205 different stamps from Gwalior, Haute-Volta, Kouang-Tcheou, St. Thomas, South Africa (Springbok), and other "hard" countries; fine triangle stamp; package hinges; millimetre scale, ruler; copy largest stamp in the world (China "Wild Goose," cat. 40c!); big illustrated lists. Total Value \$4.50. All for 10c! Also approvals. Indian Stamp Co., 103 Howard St., Bangor, Maine.

**FREE** 12 Diff. large, showy picture stamps for a request for my popular approvals. Premiums with every purchase. A. Bauer, Palmyra, N. J.



500 DIFFERENT Stamps for 25c! Big Collection 500 Different Stamps from Bosnia-Herzegovina, Crete, Epirus, Hong Kong, Iceland, Kenya and Uganda, Liberia, Malta, Nyassa, North Borneo, Orange River Colony, Siam, Wallis and Futana, and other "hard" countries. Catalogue value \$10.00. Price only 25c to Approval Applicants! Special Bargains, 1,000 different 79c; 15 triangle stamps 49c; 100 Africa 45c; 100 Asia 50c; 100 Balkan States 35c; 100 British Colonies 25c; 100 French Colonies 30c; 100 Portuguese Colonies 50c. All 8 packets for \$3.00! Illustrated Lists Free. Loma Stamp Co., 3926 32nd Street, San Diego, Calif.

ANCHERS \$\$\$ Outfit—only 12c! Fine triangle stamp; set German stamps with (pre-war) value forty million dollars (interesting!); perforation gauge, mm. scale; small album; airmail set; scarce stamp from smallest republic on earth; newspaper set; packet good stamps from Travancore, Malay, Dutch Indies, etc. Entire outfit for 12c to approval applicants! (Nice pocket stock book, value 25c, with every order!) Ancher Stamp Co., 148½ Clerk St., Jersey City, N. J.

LOOK, Boys! Nickel packets. All stamps different. 10 Australia; 10 Argentine; 10 Brazil; 4 Chad; 10 China; 4 Dahomey; 4 French Congo; 4 Guadelupe; 5 Gwallor; 5 Hyderabad; 4 Jhind; 26 Liechtenstein; 5 Malay; 2 Orange River; 5 Siam; 20 Spain; 5 South Africa. Any three 13c; any six 25c; any thirteen 50c. Premiums too. Illustrated lists free. Reimers, 3 Flatiron Bldg., Fort Worth, Texas.

70 DIFFERENT Foreign Stamps from 70 Different Foreign Countries, including Africa, Asia, Australia, Europe, West Indies, etc., for only 16c. Free with each order, our pamphlet which tells "How to Make a Stamp Collection Properly," together with our price lists of albums, supplies, and hundreds of bargains in sets, packets, etc. Queen City Stamp & Coin Co., Room 36, 604 Race Street, Cincinnati, Ohio.

LUCKY 13—13 sets 15c to approval applicants. Austria, charity; Azerbaijan, pictorial; 5 Russia; 7 Netherlands; Newfoundland, Caribou; Greece, charity; Austria, Karls Fund; 4 Dutch Indies; 2 Azores; 4 Boenia; 5 Finland; 5 Cuba; Hungary, charity. Joe Dennis, 7763 Logan, Detroit, Mich.

BEAUTIFUL Set Free with Bargain Approvals. Van's Stamp Co., Walla Walla, Wash.

1000 DIFFERENT genuine stamps, only \$1.00. Guaranteed to please or money back. C. E. Nickles, 213-F Seaton, N. E., Washington, D. C.

BEST one cent approvals in America. F. P. Hand, 1117 So. 60th St., Phila., Pa.

SWEDEN Packet, Attractive Stamps 5c to Approval Applicants. Harvey Teeple, Decatur, Ind.

1000—1000—1000—. 1000 ALL different stamps, 1000 hinges and album to hold 1000 stamps for only \$1.00 to approval applicants. Edgewood Stamp Co., Milford, Conn.

XMAS Gifts—Stamps—Sets—Packages, Tengs—Magnifiers. Albums—Hinges. Marney's, 400 Broadway, East St. Louis, Ill.

JUST Published! North American Philatelic Year Book, 162 large pages, illustrated, price \$1.00. Contains Canadian Precancel Catalogue and other fine articles and features. Indispensable as Scott's. Descriptive circular free. Year Book Publishing Company, 138 Gillard Avenue, Toronto 6, Canada.

BEAUTIFUL set to approval applicants. Lists, approvals, postage 4c. Noemus Stamp Co., 312 East 23rd Street, New York.

BARGAIN, 40 Stamps, 40c. William Grant, 6317-18th Avenue, Brooklyn.

UNIQUE Sale—Stamps for cash. J. E. Richards, 514 W. 44th St., Shadyside, Ohio.

100 STAMPS free to approval applicants. Rock Lake Stamp Co., Lake Mills, Wis.

BARGAIN offer. Packet of 48 different stamps, including two scarce Costa Rica (cat. 60c), Niger Coast, Gabon, etc., and large price list of bargains in sets. All for ten cents. Shaw Stamp Co., Bear River, Nova Scotia, Canada.

1,000 DIFFERENT, \$0.80; 2,000, \$3.50. Fred Onken, 630 79th Street, Brooklyn.

STAMPS—Must sell now. Wonderful bargains. 100 high-grade mixed—only 15c; 1,000 very good mixed—45c. Stamp Dept., 118 West 75th, New York.

150 GOOD mixed foreign stamps, 3 cents. Stanton, Niantic, Conn.

15 DIFFERENT Alpost and 5 Different Triangles—15c with Beautiful Approvals. The Stamp Mart, 943 Marshall Ave., St. Paul, Minn.

JUST Think! Colonial approvals of any country and big set 4c to applicants. Gopher Stamp Co., Canby Minn.

TRIANGLES: 75% discount special approval sheets with each 10c packet containing set triangles, 2 sets war tax; set airplane, U. S. stamp before 1880, etc.; over 100 different stamps. Murray Stamp Co., 515A Tower Bldg., St. Louis.

TRIANGLES: 2 different union South Africa 16c. F. Buffham, Lake Ave., Racine, Wis.

GREAT Hoodoo packet, 10c; monkey set, 10c; wonderful surprise packet, 10c. S. J. Frey, 527 E. Market St., York, Pa.

100 FOREIGN postage stamps, 4c; approvals 50% off, references, write for our big bargain lists of packets and sets. Palmer Stamp Co., 8221 Linwood Ave., Detroit, Mich.

GREECE-Turkey, 58 beautiful stamps 24c. Surprise. Vogan, Box 1566, Pittsburgh, Pa.

ROMANIA—25 varieties 10c postpaid. Lists free. Allion, Angola, Ind.

MAGNIFICARCIUS Packet foreign stamps, beauties from distant lands. (Many richly colored, unusual designs), free for 2c. Gray Stamp Company, Toronto, Can.

85 DIFFERENT U. S., including \$1.00 and many commemoratives, 25c; 215 different world, 25c. Mountain City Stamp Co., Box 335 Mannington, W. Va.

BOYS! A watermark detector with instructions, perforation and millimeter scale, and 100 different stamps all for 15c. Lakeview Stamp Co., 505 Commerce Guardian Bldg., Toledo, Ohio.

TRIANGLES: 10 different, 25c; 50 different, \$3.95; Luxembourg 25 different, 15c. Hanisch Stamp Co., Mountain, Wis.

FIFTEEN Newfoundlands, 10c to approval applicants. Prall, Semerville, N. J.

FREE—True-Blue book. Exchange stamps, postcards. Erickson, Elroy, Wis.

60 LIGHTLY canceled U. S., including 11c; 50c dues, 37c. Tausig, 2701 Ave. J, Brooklyn.

BEAUTIFUL set unused free to approval applicants. John F. Miller, 350 West 55th, New York.

PORTUGUESE Colonies, 25 Different 12 cents. Lufbery, Route 3, North Branford, Conn.

87 DIFFERENT countries!! Georgia, Indore, Jhind, Sudan, etc. Marvelous packet 87 different stamps from 87 different countries; many scarce. Only ten cents. But only with our approvals. Free premiums to buyers. Lists free. Reimers, 3 Flatiron, Fort Worth, Texas.

10 DANDIES, 15c. No approvals. H. Schaller, Medford, Wis.

FREE Pricelists unusual approvals, the best for the least money. References please. Yale Stamp Co., Back Bay, Boston, Mass.

UNITED STATES, 50 Different 10c. 100 Different 30c. Scott's Catalogue with Premium \$2. Elwood D. Weber, 1377 Park Ave., Plainfield, N. J.

FREE—British West Indies price list, postage 2c. Craven Stamp Co., Thompsonville, Conn.

GENUINE Z.R.H. Airmail cover, Catalogue \$1.00. Price 35c. Theodore Schreier, Plainfield, N. J.

COLOMBIAN Republic, 45 different, \$1.00. Inquiries invited. Doekray, 82 Richmond Ave., Worcester, Mass.

\$1.00 Lincoln memorial and 111 different 5c. \$1.00 Franklin and Spirit Packet 10c. Approvals. Golden Rule Stamp Co., Box 1248, Chicago.

1,000 HINGES and Confederate Bills 7c. Only to real buying applicants for approval sheets. Pettet Bros., 962 S. Boulevard S. E., Atlanta, Ga.

25 DIFFERENT British colonials to applicants for stamps on approval sending 20 postage and reference. Atlas Stamp Co., West Somerville, Massachusetts.

TIP-TOP Premium of 50 different, stunning stamps, pocket stamp book, perforation gauge, mm. scale, ruler, good stamp from Kenya & Uganda (cannibal land). Gold Coast Persia, all for 10c to applicants for Tip-Top approvals. Tip-Top Stamp Co., Colorado Springs, Colorado.

"STAMP Topics"—Six months subscription, 50c. 10 Nyassa free. Sample gratis. Topics, 423 West 42nd, New York.

FREE! Mammoth Illustrated Bargain Bulletin! Premium cataloging 40c for addresses two collectors. Penna. Stamp Co., Greensburg, Pa.

100 DANZIG 43c with approvals. References. Clarkson, Ridgewood, N. J.

FREE 25 U. S. only with approvals. 3c postage. Ref. please. F. E. Gaerte, Morton Grove, Ill.

FREE 50 Different stamps, illustrated lists of sets, postage 2c. Cincinnati Stamp Shoppe, Greenwood Bldg., Cincinnati, Ohio.

STAMPS Sent on approval. References please. Pine Tree Stamp Co., Box 150 Lewiston, Maine.

1000 MIXED Foreign Stamps 25c. Phil Lundsted, Cape Cottage, Maine.

\$6.50 FOR 12c. Fine packet 115 different stamps, including scarce Venezuela set, Cat. Val. (1923), \$2.79; beautiful set of 19 stamps from Jugo-Slavia, etc., etc., all for 12c to approval applicants. Ray Foss, 43 Hardy St., Methuen, Mass.

1000 ALL different stamps, catalog value \$25.00, for only 69c, to approval applicants only; or 500 cataloging \$10.00 for 19c. Free Price Lists. Rotnem Stamp Co., 809 Northwestern Building, Minneapolis, Minn.

1000 MIXED 25c. 100 Var. Precancel 20c. Charles Peugh, Elma, Wash.

ANNIVERSARY Offer! Six beautiful sets: "Commemorative," "Charity," "Airmail," "Eagles," "Prisoners," "Pictorial." Four following packets: (British, French, Dutch Colonies), (Precancels), (Bulgaria), (International) 15c to approval applicants. Deering, Fairmount, Marlborough, Mass.

STAMP Album Free—Spaces for 1,200 stamps, with purchase of 50 stamps from 50 different countries for 25 cents. B. Nagle, 1101 Marion, Reading, Pa.

48 COLORFUL French Colonials, 20c. Germain Bonneau, Bayside, N. Y.

1,000 DIFFERENT stamps and 1,000 hinges \$1.00. Lists free. A. Frisch, 83-47 Vlietor Place, Elmhurst, L. I., N. Y.

STAMP collector's outfit only 15c, includes 106 stamps from Cochon, Gabon, Sudan, Ubangi, etc. Illustrated album, 100 hinges, mammoth illustrated bargain lists; also trial approvals. Ioor, 802 State Life Bldg., Indianapolis.

24 VARIETIES Cuban stamps, 10 cents. List of 6,000 low-priced stamps free. Address Chambers Stamp Co., 111P, Nassau St., New York City, N. Y.

110 DIFFERENT Stamps, many unused, high values, free to collectors requesting our Net Approvals. Postage 2 cents. Christensen, Milwaukee, Wis.

ONLY 5c! 10 Airmail stamps, including scarce Esthonia triangle; Greece Red Cross set; packet fifty different stamps—all unused—from Guyane, Ubangi, etc. All for 5c! Approvals and free lists with each order. Curhan Stamp Company, Gloucester, Mass.

STAMPS, 100 all different. Postage 2c. Lists free. P. M. Quaker Stamp Co., Toledo, Ohio.

FREE! 110 different stamps to Approval Applicants, 2c postage. Paige Stamp Co., Oak Park, Ill.

200 DIFFERENT stamps 10c; 1,000 Hinges 10c. R. H. Carlton, 380 W. So. Temple, Salt Lake, Utah.

110 NEW Europe All Different, a wonderful collection cataloging several dollars, free to collectors requesting our Net Approvals. Postage 2 cents. Badger Stamp Co., Milwaukee, Wis.

FREE Hungary Charity No. 565 to 567 and a surprise packet given to those requesting for my 1, 2, and 3c approvals, and also my 50% discount. Chas. W. Schmidt, P. O. Box 4832, Frankford Station, Philadelphia, Pa.

FRENCH Colonies, 25 different, 5 cents. Big lists free. Challenge Stamp Company, 425 McDonough Street, Brooklyn, N. Y.

OUR Latest 20-page U. S. and Canadian price list free. Stanley Gibbons, Inc., 37 Ann St., New York City.

STAMPS, 100 varieties. Africa, Brazil, Peru, Cuba, Mexico, etc., 10c; 25 different U. S., 25c; 1,000 mixed, 40c; 1,000 hinges, 10c. List free. C. Stegman, 5941 Cote Brillante, St. Louis Mo.

LIBERIA Snake Triangle and two other triangles in our packet of 53 genuine foreign stamps for five cents. Crowder Company, Waverly, Baltimore, Md.

COVERTCO Packet, 250 varieties unused and used stamps 15 cents. Covert Stamp, 39 State, Rochester, N. Y.

BEAUTIFUL Picture Stamps Sent Free. Paul Cornish, Schenectady, N. Y.

292 DIFFERENT Germany, 60c; 25 Airmail, 15c; 16 Armenta, 12c; 25 Cuba, 16c; 40 Denmark, 12c; 20 Egypt, 10c; 20 Finland, 10c; 25 Japan, 8c; 25 Oceania, 10c; 50 Turkey, 30c. Frederick Jackson, Dos Rios, Calif.



**MOST** Sensational values; over 140 diff. Algeria, Alpranes, Azerbaijan, Barbadoes, Cameroun, Gabon, Guyane, Irish set, large French Colony packet, largest stamp, 40 year old U. S. gauge, etc., for 10c to approval applicants. List free. 100 diff. U. S. 25c—1,000 hinges 9c—50 Bavaria 7c. Hawkeye Stamp Co., Cedar Rapids, 39, Iowa.

**STAMPS** sent on approval at 70% discount. Reference required. Emory Renoll, Hanover, Pa.

**PENNY** Approvals that Satisfy. Neil Gronberg, Box 5441, Philadelphia, Pa.

**THOUSAND** Foreign Stamps, 50c; catalog free. Prof. McCreery, Chatham, Ontario.

**105 CHINA**, etc. 2c. Album (500 illustrations) 3c. Bullard, Sta. A, Boston.

**200 DIFFERENT** Stamps, Zanzibar; Album, 12c. Liberty, 3974 Arsenal St., St. Louis, Mo.

**FREE** 40 Czecho Slovakia Stamps to approval applicants. 2c Stamp. Lightbown's, Osborne Rd., Southsea, England.

**25 DIFF.** British Col. 12c; will catalog at least \$1.00, with a request for my popular approvals. Chas. Bushnell, 4728 Princeton Ave., Lacony, Philadelphia, Pa.

**100 DIFFERENT** U. S. stamps 40c; no cut squares. Approvals all countries; send reference to M. L. Cook, 527 West 46th Street, Chicago, Ill.

**FREE!** Loose Leaf Postage Stamp Album at rate of 8 pages each month given with subscription to monthly Journal. Send 2c stamp for prospectus. United Stamp Co., Marquette Bldg., Chicago, Ill.

**STAMPS** on approval 1/4c up. Premium 2c. Herbert Kelgwin, Middletown, N. Y.

**50 DIFFERENT** United States 10c. 60% approvals. Seidenberg, Baroda, Mich.

**REVENUES—Telegraphs—Every country.** Pretty—Intriguing—Cheap. Mint \$5.00 revenue free to applicants with references. Vanderhoof, 1114 Logan, Denver, Colo.

**CANADIAN** Confederation Jubilee stamp, 5 Newfoundland and bargain lists free with 25 different Canadian for only 10c if you ask for approvals. Victoria Stamp Co., London, Canada.

#### RARE COINS

**COMMEMORATIVE** Half Dollars, all uncirculated, for sale. Lincoln \$1.30, Maine \$1.45, Pilgrim \$1.25, Alabama \$1.75, Grant \$1.20, Concord \$1.00, Stone Mountain 95c, Sequi \$1.80, Vermont \$1.25, Postage Extra. Will buy United States Commemorative Coins Gold or Silver of any amount. Ambrose Brown, Box 203, Marblehead, Mass.

**SPECIAL** Prices on United States Commemorative Half Dollars in Uncirculated Condition. Columbian 69c, Lincoln \$1.29, Maine \$1.29, Pilgrim \$1.29, Grant \$1.39, Monroe \$1.29, Lexington \$1.19, Stone Mountain 99c, Norse American \$1.20, Oregon \$1.35, Bennington \$1.35, 2c Bronze and bargain Price List 10c. Arvy, Box 483, Muskogee, Okla.

**40 OLD** Coins all different, \$1.00; 20 different Silver coins, \$1.00; 100 different coins, \$3.00; Monroe Half-Dollar Inc., \$1.00; 50 different dates Small Cents, \$1.00. Claud Denney, Box 315, Dallas, Texas.

**CALIFORNIA** Gold 1/4, 27, 1/2, 53, 5c Copper Coins and Lists, 10c. Nickel 3c and 2c. 15c. 2 1861 Confederate and Wild Cat. Bills, 20c. Al E. Bonsall, Richmond, Indiana.

**25 DIFFERENT** foreign coins, 50c; 100 different foreign bills, \$1.00. Oddehon, Box 681, Kansas City, Mo.

**MY** Bargain 15c postcard packets sell big. Samples, prices, 12c. Durso, 25 Mulberry, New York City.

**CALIFORNIA** Gold quarter, 27c; half, 52c. Confederate \$500 \$1.00; Jackson cent, 25c. A. Wylie, Wheaton, Ill.

**OLD** Money Wanted. Will pay fifty dollars for nickel of 1913 with Liberty head (no Buffalo). We pay cash premiums for all rare coins. Send 4c for large coin folder. May mean much profit to you. Numismatic Co., Dept. H, Fort Worth, Tex.

**COINS**, 3 different foreign coins, 4 different foreign Notes and Catalog 10c. Geo. Best, Cedar Rapids, Iowa.

**OLD** Coins Bought and Sold. Rare Coin Book 65c, 700 illustrations. Send 10c for Coin collecting booklet. Gutttag Bros., 16 Exchange Place, New York.

**UNITED STATES** and Foreign Money; Military Decorations Catalogue and Greek coin 10c. Alexis Mengelle, Colorado Springs, Colo.

**UNITED STATES**, Large Cent, two-cent bronze, three-cent nickel and Bargain List, 2c. Fifteen dates large cents, \$1.00. George Coffin, Greenwood Mountain, Me.

**GET** Profit and Pleasure in collecting Old Coins. Send 10c for Large Illustrated Coin Catalogue. You'll be delighted with it. Send for it right now. B. Max Mehl, Numismatist, Mehl Bldg., Dept. F, Fort Worth, Texas. Largest Rare Coin Firm in the U. S.

**OLD** Coins, Large fall Selling catalogue of coins for sale free. Catalogue quoting prices paid for coins, ten cents. William Hesselein, 101A Tremont Street, Boston, Mass.

**CALIFORNIA** Gold—Quarter Size, 27c; 3/4 size, 53c; 3c Piece and Catalogue, 10c Norman Shultz, Box 746, Salt Lake, Utah.

#### FOR BOYS

**EARN** Christmas Money. Order 50 Sets Christmas Seals. Sell for 10c set. When sold return \$3.00, you keeping \$2.00. No Work—Just Fun. St. Nicholas Seal Co., Dept. 43PM, Brooklyn, N. Y.

#### CAMERAS AND PHOTO SUPPLIES

**PHOTOGRAPHIC** equipment and accessories of every description are listed and illustrated in our 228-page catalog. It will pay you to secure a copy which is issued free, as our prices are low. We also deal in used goods which are sold under the same guarantee as new goods. Ask for our Bargain Book. Central Camera Co., Dept. E124, 112 S. Wabash Ave., Chicago, Ill.

**TRANSFER** Photographs to metal, china, etc. Patented process. Makes beautiful miniatures. A real art. Lots of fun and profit. Anyone can do it. Outfit supplied to members only. Write about membership. Kyograph Photo System, 21-c W. 17th St., New York.

**HAVE** You a Camera? Write for Free sample of our big magazine, showing how to make better pictures and earn money American Photography, 116 Camera House, Boston, 17, Mass.

**EARN** big money with your camera in your spare time, using Haldorson Home Portrait Lamp. Write for booklet "Home Portrait Photography" and catalog—both free. The Haldorson Company, 4747 N. Western Ave., Chicago.

**MAKE** money in Photography. Learn quickly at home. Spare or full time. New plan. Nothing like it. Experience unnecessary. American School of Photography, Dept. 3432, 3601 Michigan Ave., Chicago.

**BIG** Money Saved on Photographic Lenses and Apparatus—goods exchanged; repairing done. Ralph J. Goisen, 1128 Argyle St., Chicago, Dept. P.

**FILMS** Developed. Special Trial Offer. Any Size Kodak film developed 5c, prints 3c each. Trial 6x10 Enlargement in handsome folder 40c. Overnight Service. Roanoke Photo Finishing Co., 209 Bell Ave., Roanoke, Va.

**ENLARGEMENTS** From your negatives, 8x10 size, 50c; 11x14, \$1. The Hobby Shop, Box 6, Traffic Station, Minneapolis, Minn.

#### MOTION PICTURES

**NEW** \$150 double spring movie camera, \$42; 80 foot spring motor camera, Zeiss lens, \$80; negative film, 2 1/2c foot; 16 millimeter spring operated camera, \$50; 16 millimeter negative film, \$5 postpaid; 100 foot complete 16 millimeter comedy or western, \$4.50. Cameras and projectors bought and exchanged. New twin are movie lamps, \$40; 3 1/4x5 1/2 kodak, \$9. Ray, 296 5th Ave., New York.

**\$1,250.00** FOR a Photoplay Story by an unknown writer and sold through our Sales Dept. We revise, copyright and market. Located in the heart of Motion Picture Industry, we know the demand. Established 1917. Send Manuscript for free criticism. Booklet on request. Universal Scenario Company, 206 Western and Santa Monica Bldg., Hollywood, Calif.

**WANTED** to Buy—Second-Hand Power's, Simplex and Motiograph Machines. Also extra mechanisms and stands. Must be bargains. P. O. Box 202, Birmingham, Ala.

**SEND** 10c in stamps for the 1928 edition of the famous Bass Book of Cinema Apparatus, greater than ever. Send \$2.00 for catalog and new book on "How to Make Motion Pictures," by Cameron, Bass Camera Company, 179 West Madison St., Chicago.

**MOTION** Pictures for home use. 1,000 foot rolls \$3.50. Send for list. Toy Film Company, 804 South Wabash Avenue, Chicago, Ill.

**NEW** and Rebuilt Projectors for Theaters, Schools, Churches, Traveling Shows. Supplies and Complete Theater Equipments. Bargain Prices. Free Catalog. Monarch Theatre Supply Co., Memphis, Tenn.

**FILMS:** \$3.00 per reel up. Comedy, Western, Cartoon, Drama, Serial, Educational, Special Features, Best Movie Stars. Free List. Toy Film 200 Feet Postpaid \$1.50. Dixie Film Co., Box 2042, Memphis, Tenn.

**FILMS** and Machines, dirt cheap. Stamp for lists. Box No. 5836, Westport Station, Kansas City, Mo.

**COMEDY** 100 feet, \$0.75. Send for sample. Hill, Beechwood, Cleveland Heights, Ohio.

**FILMS** for toy machines. Cheapest and best. List. Alton Films, 205 Brush Creek, Kansas City, Mo.

**FILMS** \$2.50 Reel. Cameras \$35.00-\$65.00. Stewart Marshall, Rome, Ga.

**1000** FEET of motion picture film, \$2.00. No lists. Sunset Film Exchange, 298 Turk St., San Francisco, Calif.

**HUNDRED** Feet Comedy Film and Rare lists Film Bargains, One Dollar. Film Classic, Fredonia, N. Y.

**BE** a movie exhibitor—big opportunity only moderate capital required—complete equipment at remarkably low prices. Write, Atlas Moving Picture Co., 624 So. Michigan Ave., Chicago, Ill.

**MOVIE** Films, 1,000 ft. reels, \$2.50 each; shipped anywhere on receipt of remittance. Particulars on request. Independent Films, 177 Golden Gate Ave., San Francisco, Calif.

#### SCENERY TO RENT

**WORLD'S** Most Beautiful Settings for operas, plays, minstrels. Amelia Grain, Philadelphia.

#### EDUCATIONAL AND INSTRUCTION

**U. S. GOVERNMENT** wants men. \$1,700-\$1,900 and up at start. Railway Mail clerk examination coming. Let our expert (former Government examiner) prepare you for this and also Rural Carrier, Post Office, Customs, Internal Revenue, and other branches. Write today for free booklet. Dept. 8, Patterson School, Rochester, N. Y.

**MEN, Boys**, 18 up. U. S. Government Jobs. \$1140 to \$2300 year. Steady pleasant work. Paid vacation. Short hours. Experience unnecessary. Common education sufficient. 25 coached free. Write today sure for list positions and full particulars. Franklin Institute, Dept. 8-14, Rochester, N. Y.

**BECOME** Automobile Mechanics. \$35.00-\$100.00 week. Particulars free. Franklin Institute, Dept. 8-400, Rochester, N. Y.

**FIREMEN**, Brakemen, Baggage men, (white or colored), sleeping car, train porters (colored), \$150-\$250 monthly. Experience unnecessary. 810 Railway Bureau, East St. Louis, Ill.

**\$10** AUCTION Course \$1. 393 Auctioneer Jokes \$1. Established 1906. Missouri Auction School, Kansas City, Mo.

**PROFESSIONAL** Bookkeeping Taught for \$0.85 by simpler, speedier more practical method. "Different"—that describes it! All phases. Write for folder. Kinman Morris Co., CPA's, Old National Bldg., Spokane, Wash.

**MEN** Wanted—prepare as firemen, brakemen, colored train or sleeping car porters, write for application blank; experience unnecessary first class roads. Good pay. Name position wanted. Railway Institute, Dept. 25, Indianapolis, Ind.

**BEGINNERS** prepared for positions in hotels, Carolinas, Bermuda, Florida. Fares paid. Write Lee Hotel Institute, Drawer 1568, Boston.

**USED** educational matter sold on repurchase basis. Also rented and exchanged. Money-back guarantee. Catalog free. (Books, etc. bought.) Lee Mountain, Elgah, Ala.

**BECOME** a Landscape Architect. Uncrowded profession; wonderful opportunity for money-making. Easily mastered by mail. Earn while you learn. Est. 1916. Write for details. American Landscape School, 56, Newark, N. Y.

**RAILWAY** Postal Clerks. Men 18 up. \$158.00-\$225.00 Month. Common education. 25 coached free. Write immediately for particulars. Franklin Institute, Dept. S-3, Rochester, N. Y.

**A. B., B. S.**, degree courses by extension. Business, engineering and industrial. Topical plan of practical teaching. Licensed and experienced instructors. Tuition low. Write for a free copy "Democracy in Education." The Central Scientific College, 1416 3 Ave., North, Fargo, N. Dak.



**STORY Ideas Wanted for photoplays, magazines.** Big demand. Accepted any form for revision, development and submission to markets. Established 1917. Send manuscripts for free criticism. Booklet mailed on request. Universal Scenario Company, 403 Western and Santa Monica Bldg., Hollywood, Calif.

**MEN To train for locomotive firemen on railroads nearest their homes—everywhere; beginners \$150-\$250 monthly; promoted, locomotive engineer, \$3,000-\$4,000 yearly. Best paying positions on railroads. Railway Association, Desk M1, Brooklyn, N. Y.**

**ELECTRICIANS, Mechanics.** 8 handy blueprints for connecting motors, starters, compensators, copies questions answers, aids examination, postpaid \$1.00. J. Rochi, 1301 Ave. O, Brooklyn, N. Y.

**DOUBLE Entry Bookkeeping mastered in 60 hours with 8 keys; guaranteed; diplomas. International Bookkeeping Institute, Dept. 8, Springfield, Mo.**

**WORLD-ROMIC System.** Masterkey 5,000 languages. Primers, \$1.98; Arabic, Chinese, French, German, Italian, Japanese, Russian, Spanish. Languages, 15 W. 18th St., New York.

**LEARN Barbering at home.** Practice on the family. Complete barber college instructions, home study, for \$1 bill or money order. Foster, Expert Barber, 6128 Michigan Blvd., Chicago, Ill.

**MECHANICAL drafting by mail.** Unusual opportunity to learn lucrative profession at low cost. Postal brings particulars. Wilsey, Box 401, Mt. Vernon, N. Y.

**EARN \$25 weekly, spare time, writing for newspapers, magazines.** Experience unnecessary. Details Free. Press Syndicate, 931 St. Louis, Mo.

**SILVERING Mirrors, French Plate.** Easily learned; immense profits. Plans free. Wear Mirror Works, Excelsior Springs, Mo.

**TURN to page 82 and read my display ad.** Hampton, Washington, D. C.

**FAMOUS Bailey Handbook—The book that prepares you to pass the examination for any grade of license for Stationary, Marine and Diesel Engineers, Firemen and Boiler Inspector in any state of the Union or any province of Canada.** Flexible cover. Handy Pocket Size. Pay Postman \$2.00 plus postage when he hands you the package. Popular Mechanics Press, Room 912, 200 E. Ontario St., Chicago, Ill.

#### RADIO OUTFITS AND SUPPLIES

**\$10.00—RADIO A Batteries—\$10.00.** Car Starting Batteries—6 Volts, 100 Ampere Hour. "Guaranteed." These batteries are manufactured from the very best of materials. Black rubber case 1/2 inch heavy duty positive and negative plates Douglas Fire heavy separators. Refund in ten days if not satisfactory. Please mention make of car or radio. Send Money Order. Velvet Chemical Company, 30 N. Michigan Avenue, Chicago, Ill. Will ship anywhere U. S. A. or Canada.

**300 MILE pocket radio, \$2.00.** No tubes nor batteries required. Useful and practical. Loud-speaker volume. Order direct today. Spencer Laboratories, 116 Atlas, Akron, Ohio.

**YOUR Radio 400% better.** Simple, non-adjustable Volumer attachment, \$1.00. Money-back guarantee. Radio Specialists, Le Mars, Iowa.

**LONG Distance Radio, \$2.95 postpaid.** Needs no tubes, batteries or electrical current. Over 300,000 homes have them. Picture and folder sent free. Crystal Radio Company, Wichita, Kans.

#### TRADE AND TECHNICAL SCHOOLS

**LEARN Telegraphy.** Pleasant, steady work. Operators earning big money. Always in demand. No experience necessary. Write Chief Operator, Illinois Telegraph, 1608 W. Madison, Chicago.

**GET a foreman's job in any trade.** You will earn more money. Become an expert blue print reader. You can do it in spare time. My training will advance you quickly. Write now—tell me what trade you want—I will send my plan at once. Carroll Rumsey, 265 Drexel Building, Philadelphia, Pa.

**TELEGRAPHY—Both Morse and Wireless—taught thoroughly and quickly.** Tremendous demand. Big salaries. Wonderful opportunities. Expenses low; chance to earn part. School established fifty years. Catalog free. Dodge's Institute, Fern St., Valparaiso, Ind.

**YOUNG Men may prepare at home for positions \$40 to \$100 weekly.** Write for particulars and catalog of our Extension Course. (It is not a correspondence course.) Loomis Radio College, Dept. 5-E, 405 Ninth, Washington, D. C.

#### BUSINESS OPPORTUNITIES

**EARN liberal second income, not interfering with your present work.** Build substantial paying business in comparatively short time making world's biggest selling specialties. Investment small. Profits great! Have others selling your goods. My free, valuable, enlightening literature explaining all, how its possible, without machinery for you to manufacture Loidiac, Instant Automobile Refinish; Acmolite, guaranteed radiator anti-freeze; Re-Nu-Shu, factory refinish for old stained shoes; Klerzit, assures clear windshield vision; Aluite, wonderful all-metals polish; catalog of popular priced, Apex guaranteed formulas for 500 necessities. 30 years' experience turning beginners into successful manufacturers. Highest references. Miller, Chemist, 1706-G Jetton, Tampa, Fla.

**FOR Sale by executive of corporation who wishes to retire from active business on account of his health a controlling interest in a very profitable chemical manufacturing business.** Plant running day and night and certain of its products contracted twelve months in advance. The company owes nothing, has good bank balances, earned 60% last year and paid income tax on this amount. Located in healthy town of 10,000 population where taxes are low and labor conditions and shipping facilities exceptionally good. Also wish to sell beautiful home. If interested and in a position to invest \$85,000.00, address Box T, care Popular Mechanics, Chicago, Ill.

**READ The Mail Order News—America's Pioneer Mail Trade Journal.** Quarter Century Old. Approximately 600 pages yearly of valuable information for beginners and established mail-order houses. Analyzes mail-order business, its opportunities. Practical mail-order ideas, legitimate money-making schemes, instructive articles. Tells how to start, what to sell. Published monthly. Subscription \$3.00 yearly. Send 25c for sample copy. None free. Mail Order News, 360 Bristol Bldg., New York.

**MANUFACTURER with sales organization reaching principal cities in U. S. and Canada, desires additional articles of merit to manufacture and sell—either on royalty or outright purchase—in Builders' Hardware and Electrical Appliances.** Letters and papers treated with confidence. Address H. L. Cook, Aurora, Ill.

**OPPORTUNITY for Machinist With Small Capital—Can buy Fifty Thousand Dollar Machine Shop and Foundry on Long Terms, Going Business.** P. H. Vandyke, Newport, Ark.

**MIRRORS Resilvered at Home.** Costs Less. 5 cents per square foot; you charge 75 cents. Immense profits plating like new; brassy, worn-off autographs, reflectors, tableware, stoves, etc. Outfits furnished. Details free. Sprinkle, Plater, 127, Marion, Ind.

**VALUABLE mail-order information free.** Tabory, 1838 West Fifth Street, Brooklyn, N. Y.

**DON'T sell for others.** Employ agents yourself. Make your own products. Toilet Articles, Household Specialties, etc. 500% profit. We furnish everything and show you how. Valuable booklet free. Write at once. National Scientific Laboratories, 1919 W. Broad, Richmond, Va.

**NEED More Money? Our method for mail order business offers unlimited opportunities.** Particulars for stamp. Zoll Bros., Box 1753, Los Angeles, Calif.

**MECHANICS, painters, carpenters, start furniture refinishing, painting, handyman shop on nearly nothing; winning plan brings customers quickly.** John Braceland, 1439 So. Ninth, Philadelphia, Pa.

**NEW system mail-order; big profits, instructions free.** King Company, Box 672-P, Wilmington, Del.

**SELL Fast-Selling Books By Mail.** Circulars supplied at cost. E. Kephart, 415 East 73rd, New York.

**MAKE Big Profits with a Fur Farm in your backyard.** Chinchilla Rabbits, Muskrat, Mink. Write for facts. 252 Conrad's Ranch, Denver, Colo.

**SELL by mail—Rubber Stamps!!! 1,000 per cent profit.** Our formula and full instructions \$1. Money back if not satisfied. Mid-West Stamp Works, Forrester, Ill.

**SELL by mail.** Wonderful opportunity. Particulars Free. Mason, 3902 Broadway—Room 5, Chicago.

**PLASTIC Wood; liquid leather; delicious ice cream for 50c a gallon; cider made over night.** Make them all yourself. Any formula \$1.00. Moscato, 757 East 107 St., Brooklyn, New York.

**OPPORTUNITY 23,000,000 autos, trucks need guaranteed nonevaporating, harmless, freezeproof solution.** Ingredients to make 100 gallons, \$19.50. Wholesale chemicals 18,000 varieties. Any formula \$1.00 or free with chemicals. Forex Chemical Works, Station CB6, Milwaukee, Wis.

**FURCRAFT at home.** Positively the finest, surest and easiest big profits at home in spare time for men and women. Investigate now. N. W. Fur Co., Dept. 37, Omaha, Nebr.

**ATTENTION! Establish for yourself new system real estate, brokerage and insurance agency; office at home; earn \$5,000 year.** Stamp free booklet. Hayes Realty Association, Cincinnati, Ohio.

**FEW Dollars starts one in worthwhile local and mail-order business.** May operate from home. Valuable descriptive booklet, agency proposition, etc., free. Address, Manager, Box 437, Seattle, Wash.

**\$ SPARE Time \$—Full set, plans and two \$1.00 articles extra for 25c coin.** You can't lose. Square Deal Co., 3108 Wentworth Ave., Chicago, Ill.

**EARN Independent Income at home; anywhere; spare time.** Coe, 129 East 59th St., New York.

**FOR SALE—Indian motorcycle and bicycle business, established for 39 years; only reason for selling is sickness.** A splendid opportunity for the right people. \$12,000 to \$14,000 required; stock taken at cost. Amos Shirley, 935 8th Ave., Bet. 55th and 56th St., New York.

**SELL by mail.** I'll show you how in my free plan. Write now. Donlon, Box 99, Floral Park, N. Y.

**BUSINESS profession of your own and earn big income in service fees.** See Stephenson Laboratories, display ad, page 150.

**LET us show you how to start small mail order business, with less than \$100, that will make you quick, big, positive income.** We furnish everything, with complete, detailed confidential information. The Ellis Company, Box 477, Desk 1, Stockton, Calif.

**OPERATE Profitable business of your own.** Selling by mail. Quick returns. Small investment. Our methods used in every successful mail-order business. Particulars free. Ray A. Yoder, Wadsworth, Ohio.

**NEW Ways for making money in every number of Porter's Magazine.** 5c copy; only 25c year, may make you successful. Porter's Publications, 9416a, 115th St., Richmond Hill, N. Y.

**MONEY in Dry Cleaning; we furnish instructions and machinery; experience unnecessary.** Potterf Manufacturing & Supply Co., 4723 Delmar Ave., St. Louis, Mo., U. S.

**MAKE Money with potato Malden-Flakes, \$10.00 starts you.** Sample and particulars 2 dimes. General Sales Co., Muncie, Ind.

**BUSINESS Men, collect over-due accounts yourself.** New system, sent on trial for \$1.00. Order today. Yorton, B-373-PM, Syracuse, N. Y.

**START in business.** Make and sell liquid for transferring pictures. Sample and formula, 25c. United Sign Co., 954 King Ave., Detroit, Mich.

**MAKE Toys, novelties, furniture; assorted patterns and instructions \$1.00.** Scroll saw Free with order. Wm. Bogren, 2264 Hermany Ave., New York.

**"SCHEMER," Alliance, Ohio, 36 p. monthly, prints Schemes, Tips, Formulas.** Subscriber reports \$25,000 from three; another \$10,000 from one. Try it! Year, \$1.00; 3 months, 50c.

**CHARTERS: Delaware; best, cheapest; free forms.** Colonial Charter Co., Wilmington, Del.

**YOU can have an independent business of your own, and I am here to show you the way.** Write at once! Wm. E. Heinemann, 2415 Montrose Ave., Chicago, Ill.

**ARTIFICIAL marble sanitary flooring instructions, covering wood or cement flooring 1/2 inch thick, fireproof, waterproof, all colors, low cost.** Ornamental casting, concrete, plaster, papier-mache decorations, garden furniture, statuary, flexible molds. 18 years instructing the public; particulars and illustrations free. Chris. Mahler, Huntington, N. Y.

**DELAWARE Incorporator. Charters; Fees Small; forms.** Chas. G. Guyer, 901 Market St., Wilmington, Del.

**LEARN the collection business.** Good income, quick results. Interesting booklet, "Skillful Collecting" free. National Collectors Assn., Long St., Newark, Ohio.



**PATENTS.** Time counts in applying for patents. Don't risk delay in protecting your ideas. Send sketch or model for instruction or write for free book "How to Obtain a Patent" and "Record of Invention" form. No charge for information on how to proceed. Communications strictly confidential. Prompt, careful, efficient service. Clarence A. O'Brien, Registered Patent Attorney, Security Bank Building (directly across street from Patent Office), Washington, D. C. See pages 156 and 157.

**MAKE Money Sparetime.** Hundreds of opportunities for the home worker. Big mail free. Mogensen, 1409 Cass, Omaha, Nebr.

**COMPOSITION Floor Making** earns industrious men \$12 and more daily if used as trade. Or make business of it with profits up to \$10,000 yearly. Openings everywhere. Semi-Tile, Dept. C, Hollis, N. Y.

**MAIL-ORDER Business** is your opportunity. Breniser's famous handbooks, for fifteen years have shown beginners practically how to get into this fascinating and profitable business. Continually revised, always up to date. Set of ten, \$3. One book and descriptive catalog 25c. None free. Breniser Publisher, 1607 P. Sanson, Philadelphia.

**START Mail Order Business.** Article costs 25c, sells for \$5.00. Folder free. Pitts, Amana, Iowa.

**A LITTLE manufacturing business**—Crispettes, delightful confection and big money maker. We start you. Adams says \$364 profit two days last summer. You might do as well this winter. Write, Long Eakins, 1960 High St., Springfield, Ohio.

**OPERATE chewing-gum machines.** Large profits. Small capital. Particulars Free. Robbins Company, 28 Dodworth Street, Brooklyn, N. Y.

**CAPITAL**—For copy of "The Promoters' Hand Book"—a leaflet on financing, send \$1.00 to Amster Leonard, East Orange, N. J.

**THOUSANDS of opportunities** to make money in spare hours, managing own business; mail-order or local. Particulars free. Publishers, 6652-J Gravois, St. Louis, Mo.

**A BUSINESS of Your Own Making**—Sparkling Glass Name and Number plates. Checkerboards, Signs. Big book and sample free. E. Palmer, 540, Wooster, Ohio.

**WE Start You in Business,** furnishing everything; men and women, \$30.00 to \$100.00 weekly operating our "New System Specialty Candy Factories" anywhere. Opportunity lifetime; booklet free. W. Hillyer Ragsdale, Drawer 4, East Orange, N. J.

**TASTE flavor of real money** selling Annie Blain Flavors, wholesale, retail; new system, samples; other unique methods. Geo. S. Parker, New Brunswick, N. J.

**PATENTS Procured;** Trade Marks Registered—A Comprehensive, experienced, prompt service for the protection and development of your ideas. Preliminary advice gladly furnished without charge. Booklet of information and form for disclosing idea free on request. Richard B. Owen, 30-Owen Bldg., Washington, D. C., or 41-R Park Row, New York.

**UNPATENTED Ideas Can Be Sold.** I tell you how and help you make the sale. Free particulars (Copyrighted). Write W. T. Greene, 810 Jenifer Building, Washington, D. C.

**CHEMICAL Expert** will furnish Formulas and Trade Secrets. All lines. Lists Free. W. L. Cummings, Ph. D., 228 Gordon Ave., Syracuse, N. Y.

**SELL by Mail!** Books, novelties, bargains! Large profits! Particulars Free! R-Effco, 525 South Dearborn, Chicago.

**BIG Bunch Mail Year 15c.** Catalogues, Magazines. Kentucky Agency, Covington, Kentucky.

**EARN \$10 daily** silvering mirrors, plating, refinishing metalware, chandeliers, head-lights, bedsteads. E. Decle Laboratories, 275 Varick St., New York.

**I MADE \$30 a Week Home.** French Breadmaking. 15 years' experience; Free Booklet tells. Ashbrook 67, Marengo, Ohio.

**75 WINNERS** for mail dealers. Successful sales plans. Everything supplied. K. Home, 3949 Metropolitan, Chicago.

**MONEY for working capital;** incorporate and sell shares in your business. 27 years organizing and raising money for businesses of merit. Terms reasonable. Prompt and confidential service. W. Harrison Cole, 507 5th Ave., Suite 510, New York.

**SUCCEED With Your Own Products.** Make them yourself. Formulas, Processes, Trade-Secrets. All lines. Catalog, circulars free. B. Thaxly Co., Washington, D. C.

**SIGNS and Showcards Easily painted** with Letter Patterns. Large variety of Styles and Sizes. Samples for stamp. John Rahn, a2129 Neva Ave., Chicago.

#### TELEGRAPHY

**TELEGRAPHY**—Both Morse and Wireless—taught thoroughly and quickly. Tremendous demand. Big salaries. Wonderful opportunities. Expenses low; chance to earn part. School established fifty years. Catalog free. Dodge's Institute, H St., Valparaiso, Ind.

#### CHEMISTRY

**YOUR Chemical or Industrial Problems Solved.** Fast and permanent dyes and colors for spraying, painting or dyeing on fabrics, leather, wood and novelties; also paints and lacquers of extra fine brilliancy for particular requirements; just phone "Chickering 9238" or write Malgo Products, Inc., 109-115 W. 26th Street, New York City.

**YOUR chemical problem solved** and working formula or process furnished for \$5.00. Write me. W. Stedman Richard, Industrial Chemist, Box 2402, Boston, Mass.

**CHEMICAL Analysis, Processes, Technical Information.** Robert Henderson, Laboratory, Madison, Maine.

**EXPERIMENTERS' Laboratory apparatus.** Chemicals. List 5c. Chemical Apparatus Co., 4402 West End, Chicago.

#### FORMULAS AND TRADE SECRETS

**DON'T sell for others.** Employ agents yourself. Make your own products. Toilet Articles, Household Specialties, etc. 500% profit. We furnish everything and show you how. Valuable booklet free. Write at once. National Scientific Laboratories, 1919W Broad, Richmond, Va.

**KANTLEAK Automatically Seals Punctures;** Formula 25c. Western Chemical, B1013, Rock Springs, Wyo.

**GOOD Formulas Cheap.** Lists Free. Arvyl Ellis, St. Albans, W. Va.

**SUPERIOR storage battery formula** and complete manufacturing information for starting and lighting batteries. A real business opportunity. Particulars free. Moline Laboratories, Moline, Ill.

**GUARANTEED Formulas** for world's largest selling specialties. Play safe, get my valuable lists, special formulas. Catalog describing Apex formulas, all lines. "Exclusive but not expensive" 30 years supplying particular people, with unequalled service. Miller, Chemist, 1706-H Tampa, Fla.

**CHEMICAL Consultation.** Manufacturing ideas made practical. Complete service, \$6. Valuable formulas with label copy. Long experience. Write Associated Chemists, Indianapolis, Ind.

**500 FORMULAS and Big Catalog 20c** Ideal Book Shop, Park Ridge, Ill.

**SUCCEED With Your Own Products.** Make them yourself. Formulas, Processes, Trade-Secrets. All lines. Catalog, circulars free. B. Thaxly Co., Washington, D. C.

#### AGENTS WANTED

**PRIVATE brand Toilet Articles,** Household Specialties, Perfumes, Soaps, Extracts, etc. We pack these goods for you under your private label. With your name on the goods you get all the repeat business. Don't sell for others, but build up a profitable business for yourself. Highest quality merchandise. Extremely low prices. Quick shipments on both large and small orders. Write immediately for lowest wholesale prices and complete information regarding our amazing offer. Address Supply Department, National Scientific Laboratories, 1904W Broad, Richmond, Va.

**AGENTS—\$13.80 Daily** in advance, introducing New Insured Hosiery for men, women, children. Must wear or replaced free. 57 styles, 39 colors including latest "Silk to the Top" Ladies' Hose. Nyland made \$595 in one month. Edwards, \$460.00. Mrs. Bone, \$425.45. Why not you? Even spare time should pay you \$3.00 an hour. No experience needed. We furnish samples. Silk hose for your own use free. New Plan. Write Quick. Maccoches Company, Road 25612, Cincinnati, Ohio.

**AGENTS \$240 month.** Bonus besides. Dri-Klean—It makes car look like new. Slickest thing you ever saw. Removes dirt, grease, road oil, all one operation. No soap or water used. Clean any car for 10c. Wonderful seller. Exclusive territory. Write for sample. American Accessories Co., Desk 1831, Cincinnati, Ohio.

**JIFFEX**—Pays all profit! Invest \$1.00, make \$20.00. Enclose \$1.00 bill, receive charge prepaid Jiffex for 10 gallons (80 pints) earning you \$20. Jiffex Amazing Glass Cleaner, cleans, polishes windows, windshields, showcases without water, soap or chamomile. Wonderful demonstrator. Everybody buys on sight! Receive also many other agent's profitable paying propositions. Satisfaction guaranteed. Miller, Chemist, 1706-F Jetton, Tampa, Fla.

**CASH Paid** for Butterflies, Insects. See Sinclair Display Advertisement on page 26.

**AGENTS**—Best seller; Jem Rubber Repair for tires and tubes; supersedes vulcanization at a saving of over 800 per cent; put it on cold, it vulcanizes itself in two minutes, and is guaranteed to last the life of the tire or tube; sells to every auto owner and accessory dealer. For particulars how to make big money and free sample, address Amazon Rubber Co., Philadelphia, Pa., Dept. 505.

**AGENTS**—\$6.00 hour earnings making four sales hour. Tremendous demand \$3.50 article, powerful selling plan. Fagley & Halpen, Dept. 40, Phila., Pa.

**AGENTS**—Everybody buys "Croff's Universal Metal Polish." Cleans and brightens all metals. 100% profit. Field unlimited. Particulars free. Orlando Products Co., Box 132, Milford, Mass.

**AGENTS**—America's greatest sensation. 6 new record-breaking sellers. Enormous demand; tremendous profits. Write quick for details. United Service, 500 Fifth Ave., New York.

**MEN**—Women, \$1.80 an hour. No less. Large Mfg. Co., established 30 years. Starting new medalion dept. Amazing new sales plan. First 22 agents average \$1.80 an hour steady. Only 1 agent wanted in locality. Your Own Photo Free as sample. Art Medalion Co., Dept. 61, Corner Campbell and Jackson, Chicago, Ill.

**HANDPAINTED Lingerie holders.** Samples 10c (Coin). E. Mack Company, 15 Mechanic, H. Canton, N. Y.

**MANUFACTURE Radiant glass name and number plates, mirrors, signs, etc.** Besides teach others! Investigate! Radiant Signs, 15905 Alden, Detroit, Mich.

**FASTEST Selling automobile seat covers;** Spanish trimmed; most successful and reliable; lowest prices; spot cash commissions. Write for complete outfit, colored folders, etc.—free. Elliott Textile, Dept.-K, 6301 South Park, Chicago.

**FORD Gas Saver Free.** To advertise. Fits any auto. Enormous mileage increase. Critchlow, G3-805, Wheaton, Ill.

**AGENTS**—Sell Apex needle threader, marvelous new invention makes threading easy. \$1 bill brings 7 threaders, retail \$1.75. Money back if not satisfied. Jos. McMennamin, 1129 Shelmire, Philadelphia, Pa.

**OHKAY Money maker.** Sample free. Osman, 1728 Seventh St., N. W., Washington, D. C.

**YOU Can sell every merchant** in your town. Write for proposition. Geo. Speere & Sons, 434 So. Dearborn St., Chicago.

**POLISHERS**—Simonizers, earn \$15 daily, full, spare time. Demonstrate amazing new polish proclaimed best by experts. Experience unnecessary. Liberty Chemical, 3557 W. 22nd, Chicago.

**SALESPEOPLE**—Men and women can earn \$1.50 or more an hour, selling our F. & M. Liquid Heater, which retails for \$3.50 each. For complete details, write to Francis T. Mantion, Sales Manager, F. & M. Liquid Heater Co., 1521 Maple St., Wilmington, Del.

**TWO Amazing new inventions;** one solves blurred windshield problem; one rub keeps glass clear 24 hours; other ends home window washing drudgery; eliminates ladders, buckets, sponges, rags; low priced; 150% profit. Security Mfg. Co., Dept. 1, Toledo, Ohio.

**AGENTS Wanted** to sell men's hats direct from factory. Send for catalog. Model Hat Mfg. Co., Dept. P-9, East Orange, N. J.

**AGENTS**—You can make big money working full or spare time selling our line of silk, silk and wool hosiery. Our new fall and winter line going strong. Your pay in advance if you want it. Write at once for particulars. Queen City Hosiery Co., Box 301, Bangor, Me.

**MAN in each town** to plate auto parts, reflectors, bathroom fixtures, refinish beds, mirrors, chandeliers; by new method. No capital or experience required. Simple plan of manufacturing at home starts you in big money-making business. Outfit furnished. Free particulars and proofs. Gun Metal Co., Ave. H, Decatur, Ill.



**AGENTS—\$100 a week for full time;** \$25 to \$50 spare time. Equipment and car free. Exclusive territory. Sound, permanent proposition. A rare opportunity, but you must act quickly. Write for particulars today sure. American Products Co., 9598 Monmouth, Cincinnati, O.

**AGENTS** become a regular established McCannon dealer; buy on credit, sell for cash or credit. 185 absolute household necessities; all repeaters. Enjoy a sure income 52 weeks per year, year after year. City or country trade. Capital, experience unnecessary. McCannon & Co., Dept. S35, Winona, Minn.

**AGENTS—Make Christmas money** selling our Luminous Crucifix which shines in the Dark. An ideal Christmas gift—Easily demonstrated—Big profits. W. G. Hannan Co., 2539 So. State St., Chicago, Ill.

**SLICKERS—Raincoats. Lowest prices, largest commissions.** Outfit free. Sample on trial, \$2.65. Hamilton Raincoats, 4111V Gladys Ave., Chicago.

**AGENTS, every Car Owner and Housewife** will buy Auto Mitten Dusters. Sample Offer and Particulars free. National Fibre Broom Co., St. Louis, Mo.

**REAL Money** selling a great new Health Invention generating Violet Ray, Vibration, Electricity and Ozone. Exclusive Territory now open. Write today. Lindstrom & Co., 30 W. Lake St., Dept. A, Chicago.

**AGENTS: Free Prize Auto Contest.** Sell smoking sets; Two Pipes, Cigar, Cigarette holder, beautiful lined Case, De Luxe Pen and Pencil set, velvet-lined case, marked \$10.00. Sell for \$2.75. Large commission each sale. Agent sending most orders wins Pontiac-Six Auto or \$850.00. Details Free. E. H. Sieg, Box 252, Red Wing, Minn.

**AGENTS—Big Seller—\$20 Daily Easy selling** Taylor Caps — made-to-measure — every man buys—some want 2 or 3 caps. Samples Free and Cap free to agents. Write quick for fast money-making proposition. Taylor Cap Manufacturers, Dept. C-17, Cincinnati, Ohio.

**MAKE \$25.00 daily** selling colored Raincoats and Slickers; Red, Blue, Green, Etc., \$2.95. Hat Free. Commissions daily. Outfit Free. Elliott Bradley, 241 VanBuren, Dept. AB-12, 1-S, Chicago.

**MAKE \$95 a week!** Sensationally new, different Self-Wringing Mop. Women buy at sight! Keeps hands out of dirty water. Practical—guaranteed. Amazingly low priced. Free samples offered. Delphos Mop Co., 10112 Washington St., Delphos, Ohio.

**SOMETHING New!** \$75 a week easy. "Self-Flex," finest leather belt, has hidden spring. Belt expands and contracts. No rubber. 100% more comfort. Initial buckles. Buyers everywhere. Free sample. Self-Flex Co., 220 W. Institute Place, Chicago.

**AGENTS: Special Radio proposition** taking the country by storm. Everybody buys. Big profits for hustlers. Catalog free. Harco Company, Dept. A3, 1251 Wabash Avenue, Chicago.

**DON'T sell for others.** Employ agents yourself. Make your own products. Toilet Articles, Household Specialties, etc. 500% profit. We furnish everything and show you how. Valuable booklet free. Write at once. National Scientific Laboratories, 1219W Broad, Richmond, Va.

**AGENTS—Make \$15 daily.** Show samples and distribute teas, coffee, spices, extracts; 200 products; things people eat. I go 50-50 and furnish Chrysler closed car. Offer made to first person answering in your locality. Write or wire Health-O-Quality Products Company, Dept. 101-P, Cincinnati, Ohio.

**SELL Radio antenna.** Big profit. Address Nolot Bros., 517 Franklin, Peoria, Ill. Dept. P.

**AGENTS—\$13.80 Daily in advance** (Sworn proof) Introducing New Insured Hosiery. Guaranteed one year. No capital or experience required. Your pay daily. Monthly bonus besides. We supply samples. Silk hose for your own use free. Milton Mathews, Road 58612, Cincinnati, Ohio.

**100 MORE active men to introduce** "Chieftain" Guaranteed Tailored Shirts 3 for \$4.95. Latest novelties, colors, styles. Dickman, Illinois, in 3 weeks made \$589; Sinton, Texas, in 12 days, \$219.60; Bend, Iowa, in 16 days, \$334.80. Why not you? No experience or capital needed. We deliver and collect. Full working outfit free. Cincinnati Shirt Company, Lane 15812, Cincinnati, Ohio.

**PLAID Slickers and hat, \$2.98;** also new aerotex and hidelike coats. Outfit free. American Waterproof, 724-P Roosevelt, Chicago.

**WOMEN—\$2 an hour spare time; 100% commission,** new idea sanitary necessity; sells on sight; every woman buys; new feature never before used; designed by physician; revolutionizes old uncomfortable methods; pay every day; no deliveries, no collections, no experience or capital required. Write Mary P. Coleman, Meriden, Conn.

**OUR 4 for 1 plan** sells our Foods fast. Big repeaters. Result getting helps. Outfit free to workers. Write F. Lingott, 558 Congress, Chicago.

**FLAVORING Extracts—Bottle Yourself!** Concentrated—add water! Free labels. Whirlwind Sellers! 500% Profit! Money-making opportunity. Write Thomas Manufacturing Company, Indianapolis, Ind.

**COMBINATION Leatherettes \$6.98.** Commission \$1.75. 6x9 swatches increase sales. Complete line raincoats, topcoats, slickers, \$2.68 up. Elaborate outfit free. Amazon, 1101 N. Robey, Chicago.

**LATEST Fad—Samples free—show them** to friends—make money. Castle Studios, Independence, Mo.

**AGENTS Make \$40 to \$80 weekly** selling typewriters re-manufactured like new by the "Young Process." Lowest prices and easiest terms ever offered. Big commission—no investment—real opportunity to start in business for yourself. Write today. Young Typewriter Co., Dept. 710C, 654 W. Randolph St., Chicago, Ill.

**NO Peddling.** Start own business. Home, Office. Big profits. Free particulars. Elite, 38H Elizabeth St., N. Y.

**AGENTS—200% profit.** New, highly practical, useful article for every home and office. Quick seller. Hydraulic Corporation, Roselle, N. J.

**WRITE Atlas Sign Works** for free working equipment. Beautiful window sign letters. Penny each! Any size. Wonderful offer to general agents, K1032 E. 55th St., Chicago.

**AGENTS, Big Money** selling perfect saw filers, \$12.50. Discount 40%. Circulars. Hoof Mfg. Co., Minneapolis, Minn.

**DON'T read this unless 300% profit** interests you. Everybody buys on sight. Free sample. Magic Products, Dept. 200, Oak & 31st, Kansas City, Mo.

**RELIABLE Man for Sale-Agency,** for "Dreadnaught" Greasebattler and Ace Hand Soaps. D. P. C., 3138 Southport Ave., Chicago, Ill.

**PENNANTS—Headquarter — Colleges — States—Cities—Sample: 25c.** \$1.75 dozen. Omama Pennant Works, 715 Baltimore Building, Chicago.

**RADIO Agents—Make big money—Easy!** selling marvelous new sets and accessories. Buy from factory at lowest prices. Get new catalog with thousands of nationally advertised bargains. Free Call Book. Write today. American Auto and Radio Co., Dept. 268, American Radio Bldg., Kansas City, Mo.

**MAKE \$100 weekly** supplying demand for new invention. Makes autos run on 7% gasoline. Free sample. Write Whirlwind Co., 999-492 E. Third St., Milwaukee, Wis.

**JUST Out—New Patented Apron.** No strings or straps—\$20.00 a day every day; over 100% profit; commissions daily. Write for free offer. Sta-Put Co., Dept. 212, St. Louis, Mo.

**\$50,000. PICTURE Man Friedman** made canvassing. Beginners can make \$100.00 weekly with my sales talk. Experienced men make more. Free book. "Profits in Portraits" explains. Sample Free. Picture Man Friedman, Dept. 8-B, 541 W. Lake, Chicago.

**NEWEST Invention!** Abolishes kinks and snarls. Automatically coils telephone, electric iron and lamp cords. Housewives, companies actually buying 5 to 50. Tremendous profits. Samples furnished all salesmen. Neverknot, Dept. 12-A, 4503 Ravenswood, Chicago.

**\$18 TO \$25 daily.** Biggest selling line of 2-piece suits, \$9.95 and \$12.50; 3-piece wool suit, \$17.95 (regular \$28.00 value). All-wool overcoat, \$18.50. Splendid raincoats, slickers and boys' suits. Biggest commissions. Free outfits. "Jim" Foster, Inc., Dept. 212, 2250 S. Spaulding Ave., Chicago, Ill.

**AGENTS, portraits, photo-pillow tops,** frames, sheet pictures, medallions, photo-jewelry, guaranteed hose laundry tablets, food products, toilet requisites, luminous crucifixes. Catalog 50 specialties free. 30 days' credit. Jas. C. Bailey, Dept. C-12, Chicago.

**WE pay \$50 a week and expenses and give** Ford Auto to men to introduce poultry and stock compounds. Imperial Co., D23, Parsons, Kan.

**AGENTS \$17.50 daily.** Bonus besides. Auto furnished. Introduce finest hosiery. Seven months guarantee. New selling plan gets business fast. No experience needed. Write for samples. Betterknit Textile Co., Silk, 1431, Greenfield, Ohio.

**AGENTS—Make two dollars hourly.** Sell new kind of Sharpens. Sharpens all knives, tools, quickly. Demonstrating sample free. Premier Mfg. Company, Dept. 74, Detroit, Mich.

**NEW INVENTION—400% profit.** Liquid quick mend for Fabrics and Hosiery. Stops runs. Every woman buys. Hundred other fast sellers. J. E. Johnson Co., Dept. 460, 6129 Wentworth, Chicago.

**AGENTS: Make \$500.00 monthly.** Pay daily. No investment. Rhinestone Initial buckles and Novelties. Sell easy everywhere. Exclusive territory. Chaton Novelty Co., 606 Blue Island, Chicago.

**AGENTS—Mosco Corn and Callous Remover** will build you a steady repeat business. Send today for Pocket-size trial outfit. The Moss Co., 396 Searle Bldg., Rochester, N. Y.

**NEW Household Device** washes—dries windows, sweeps, cleans walls, scrubs, mops. Costs less than brooms. Over half profit. Harpers, 132 Third St., Fairfield, Iowa.

**AGENTS make \$3.00 an hour** taking orders for our 40 fascinating kitchen specialties. No competition. Write quick. General Products Co., M-207, Newark, N. J.

**SUPERKEEN! Amazing New Patented** Magnetic Blade Sharpener! Sharpens All Razor Blades Instantly. Magically, By Powerful Magnetic Force! New! Absolutely different! Sensational Demonstration! Whirlwind Seller! Write for Pocket Sample! SuperKeen, Dept. B-12, Salisbury, N. C.

**MIRRORS Resilvered at home.** Costs less 5 cents per square foot; you charge 75 cents. Immense profits plating autoparts, reflectors, tableware, stoves, refinishing metalware, etc. Outfits furnished. Details Free. Write Sprinkle, Plater, 128, Marion, Ind.

**BIG Money for men and women** selling wonderful Whitehouse Stove Polish, Devil Dog, Walnut Flavoring, Beauty Creations, etc. Write quick. Blair Laboratories, Lynchburg, Va.

**"WHERE to buy half million articles** wholesale." 72-page directory offers unlimited opportunities for agents. Free particulars. Pruitt System, Brookfield, Ill.

**NOW Earn \$15 a Day Easy.** Take orders for shirts. Factory prices. Samples Free. Write quick. Fashion Wear Shirt Co., Dept. S-943, Cincinnati, O.

**MAKE \$50 to \$75 a week.** Everyone needs shoes. Sell Mason's all-leather shoes, amazingly low prices. 85 styles—men's, women's, children's. No experience needed. Big outfit free. Mason Shoe Mfg. Co., Dept. 2212, Chilpewa Falls, Wis.

**AGENTS \$72 a week—take orders** for Guaranteed Cutlery, Knives, Razors, etc. Big commission. Exclusive territory. Big money for spare time. Write quick. Novelty Cutlery Co., Desk 631, Canton, Ohio.

**AGENTS, Men Women, for Fast Sellers,** Good Profit. Write to Miller, Box 3, Treatment Station, New York City.

**AGENTS—Engraved name plates, signs,** numbers; profits large; samples free. Brett Bros., Roxbury Crossing, Boston, Mass.

**AGENTS: for big quick profits,** try our new adjustable waterproof aprons; 100% profit. B. & G. Rubber Company, Dept. 289, Pittsburgh, Pa.

**AMAZING Discovery Brillianite diamonds,** Baffle experts, rivals the genuine African diamond in dazzling brilliancy. Make \$100 weekly. Particulars Free. Brillianite Co., E5643 Prairie, Chicago.

**BIG Pay every day!** Complete guaranteed line direct to wearer. Dress shirts, work shirts, flannels, overalls, pants, leather coats, sweaters, playsuits, \$10-\$25 daily! Experience unnecessary. Big outfit free. Nimrod Co., Dept. 8, 4922-28 Lincoln Ave., Chicago.

**CHAMOIS-Ray, 200% profit, all-metal** polisher, latest invention. Le Soleil Company, 1454 Wellington, Chicago.

**AGENTS—Stamping names on pocket-key** protectors; sample check with your name and address, 25c. Stamping outfits. Emblem checks, Check fobs, name plates. Hart Mfg. Co., Desk 2, 303 Degraw St., Brooklyn, N. Y.



**CHECK** protection experts make \$120 weekly with ease. Free training now offered for this fascinating new profession. New checkwriter equals any machine on market at fraction of cost. Merchants, professional men, business men buy it at sight. Permanent, dignified position. Write quick for details and special offer. Arnold Checkwriter Co., Dept. W-10, Flint, Mich.

**AGENTS** \$240 month and auto to travel in. Bonus besides. Introduce new line guaranteed hosiery for men, women, children. 126 styles, colors. Beats store prices. Guaranteed to wear 7 months or new hose free. Finest line Silk Hosiery you ever saw. New sales plan. Credit given. Spare time satisfactory. Write for samples. Wilknit Hosiery Co., Dept. 3631, Greenfield, Ohio.

**DON'T** sell for others. Employ agents yourself. Make your own products. Toilet Articles, Household Specialties, etc. 500% profit. We furnish everything and show you how. Valuable booklet free. Write at once. National Scientific Laboratories, 1919W Broad, Richmond, Va.

**BIG Winner** for Agents. New patented cigarette case. Holds package cigarettes and box safety matches; beautiful, compact, flexible container; large profits; write for liberal proposition. All-in-One, Dept. A-12, 2510 Portland Ave., Minneapolis, Minn.

**\$100.00 WEEKLY!** Two Suits or Suit and Overcoat \$33.50. All wool—Made to Measure. Commission \$6.00-\$7.50. Outfit Free. Garfield Tailors, BD, 1557 Milwaukee, Chicago.

**FURNITURE** Refinishing, Polishing, painting, handyman shop; wonderful profits; start yours on nearly nothing. John Brace-Land, 1457 So. Ninth, Philadelphia, Pa.

**SELL** Handy wire stretcher, a simple, practical fence-repairing device. Hawbaker Stretcher Co., Elmore, Minn.

**CHRISTMAS** Novelty. Make \$25 daily selling every store, office and home. Day or Evening. Sample and literature free. Consolidated, 65-C West Van Buren, Chicago.

**AGENTS**, Big Opportunity to make money, easy. Men's fancy hosiery, imperfects. \$13.20 Gross Pairs; Rayon Silk \$10.80 Gross Pairs. Send \$25.00 for the above two gross pairs, Post Paid. Last opportunity. Lewis Hosiery Company, 12 N. 3rd Street, Philadelphia, Pa.

**NEW** tested sales plans gets orders from empty cars for new Suction Ash Receiver. One out of every 5 circulars distributed come back with dollar bill. 100% profit guarantees \$20 to \$50 a day. Territory going fast. Write immediately. Gordon Co., 110 East 23 St., New York.

**\$15 DAILY**, easy. Pay advanced. New two tone aviator style rain coats. Big selling outfit free. Fisk Warner, 443 So. Dearborn, Dept. M, Chicago.

**FORD** Gas Saver Free. To advertise. Fits any auto. Enormous mileage increase. Critchlow, G1-895, Wheaton, Ill.

**\$60-\$200 A WEEK**. Genuine Gold Letters for store windows. Easily applied. Free samples. Liberal offer to general agents. Metallic Letter Co., 438-B North Clark, Chicago.

**AGENTS**—Big Profits selling useful novelty. Good side line for any class of trade. Sample and circular free. Travella Sales Co., Dept. P, 123 Liberty St., New York.

**AGENTS**: Our gold-eyed Needle Cases are wonderful sellers; immense profits; \$50 to \$300 weekly; proof and particulars free; sample outfits 10c; factory prices. Paty Needle Co., 231 Davis Square, Somerville, Mass.

**AGENTS**—We start you in business and help you succeed. No capital or experience needed. Spare or full time. You can earn \$50-\$100 weekly. Write Madison Company, 566 Broadway, New York.

**\$31.00 PROFIT**—with \$1.50 Outfit—Big Money—Easy Work. Selling Gold Monograms for Automobiles, Luggage, Windows, Wagons. No experience. No license. "Samples Free." NuLife Monograms, Hartford, Conn.

**RELIABLE** People Wanted—place Eggine in stores and appoint agents. Used same way as eggs in baking and cooking, rate 9c dozen. Always fresh. Large package 10c postpaid, with particulars of our other fast sellers. Morrissey Company, 4417-25 Madison St., Chicago.

**AGENTS**, get our prices. Largest reliable line toilet preparations and home remedies, including valuable premium coupons. Prompt service. Established 1867. Valuable selling plans. Lab. 11, F. Ad Richter Co., Berry and S. 5th Sts., Brooklyn, N. Y.

**EVERY** Woman Wants a Sewing Set. Home Sewing Sets contain 142 useful sewing articles. \$4 an hour easily made with this 50c seller. Lee Bros., 128 E. 23rd St., New York.

**REAL** Whirlwind Seller—Nopolout Custom Shirt. Every man buys them. Patented—no competition. Liberal commission. Free selling kit. Make \$15 up daily taking orders direct from consumer at manufacturer's prices. District or local agents. Write Nopolout Shirt Co., Dept. Y, Hazleton, Pa.

**SELL** real necessity. Novelty Shirts, Hosiery, Neckwear. Colonial Novelty Co., Geneva, N. Y.

**REPRESENTATIVES** wanted by over 500 manufacturers, offering real money-making propositions. No need of being out of work. Write for Free copy. Opportunity Magazine, 750 N. Michigan, Service Dept., Desk 2, Chicago.

**ARVEO** Polishing Cloths offer big profits to salesmen. Sample and particulars free. Arveo Industries, Box F 147, Grosse Ile, Mich.

**AGENT** Repeaters cost 10c, sell 50c. List free. Thorn-Burr, Carthage, Ill.

**AUTO** owner tire agent wanted each locality to use and take orders for hand made Mellinger cord and balloon tires; guarantee bond 15,000 miles; shipped prepaid on approval; get your tires free; no capital or experience required; make \$100 to \$300 weekly. Write for wholesale prices and sample kit. Address Mellinger Tire Co., Dept. 400, Kansas City, Mo., or Dept. 400, Philadelphia, Pa., or Dept. 400, Oakland, Calif.

**PHOTO** Medallion Agents Earn \$20 Daily. Easy work collecting photos. Big line; quick sellers. Capital or experience unnecessary. Give you 4-day service on beautiful photo reproductions. Reserve your district today. Write Pudlin Corp., Dept. 103, 259 Bowery, New York.

**\$5,000 A YEAR**—Selling Perry Photo Medallions. Big demand. Ready sales. 400% to 600% profits. Any photo copied perfectly on Medallions, Mirrors, Compacts, Jewelry, etc. Guaranteed likeness. Investigate. Free catalog, full details on request. Write Today. P.M. Perry Photo Novelty Corp., 1793 Jerome Ave., New York.

**AGENTS**—Moseo Corn and Callous Remover will build you a steady repeat business. Send today for pocket-size trial outfit. The Moss Co., 387 Searle Bldg., Rochester, N. Y.

**SIMPLEX** Vaporizer—Wonderful invention; 25-60% increased mileage guaranteed; retails \$1; free trial; exclusive territory. American Fixture Co., 234 West Water, Milwaukee, Wis.

**SEND** name, address on postcard. Free introductory copy Salesology Magazine; contains 1,000 money-making opportunities. Offered by big reliable firms; no obligations. Salesology Magazine, Desk B-38, 500 No. Dearborn, Chicago.

**AGENTS** make \$100 week furnishing Cigar Lighters to merchants on free advertising plan. Particulars sent free, write at once. Drake Mfg. Co., Dept. M, Milwaukee, Wis.

**FREE** Sample, "Rain Shield Wiper." Retails \$1.00—Cost (25 cents). Sold Clear and Rainy Days. No Cloth—No Paste—No Attachment. (1) Rub keeps windshield clear 48 hours. Experience Unnecessary. NuLife Corporation, Hartford, Conn.

**PATENTS**. Time counts in applying for patents. Don't risk delay in projecting your ideas. Send sketch or model for instruction or write for free book "How to Obtain a Patent" and "Record of Invention" form. No charge for information on how to proceed. Communications strictly confidential. Prompt, careful, efficient service. Clarence A. O'Brien, Registered Patent Attorney, Security Bank Building (directly across street from Patent Office), Washington, D. C. See pages 156 and 157.

**NEW**: Just invented; Comb fastens anywhere. Send 10c for a 25c value. Never Lose Comb Mfg. Co., Lesneur Center, Minn.

**JUST** Out, new cigarette vendor. Positively the most beautiful high-class dependable Vending machine made. Practically Slug Proof. Built to last indefinitely. Agents make fortunes by acting quickly. Manufactured exclusively by the National Sales Machine Company, Dept. B, 1926 Chestnut St., St. Louis.

**SHOP** Agents or General Agents to sell new large cans of Paste Hand Soap—fine profits—quick sales. The Connecticut Can Co., Hartford, Conn.

**WE** Start You Without a Dollar. Soaps, Extracts, Perfumes, Toilet Goods. Experience unnecessary. Carnation Co., Dept 2480, St. Louis.

**AGENTS**—Make a dollar an hour. Sell Mendets, a patent patch for instantly mending leaks in all utensils. Sample package free. Collette Mfg. Co., Dept. 404, Amsterdam, N. Y.

**NO** Dull Times Selling Food. People must eat. Federal distributors make big money; \$3,000 yearly and up. No capital or experience needed; guaranteed sales; unsold goods may be returned. We furnish you with sample case, license and Free Samples for customers—Sure repeat orders. Exclusive territory. Ask now! Federal Pure Food Co., A2307 Archer, Chicago.

**POLMET**—The Wonderful Polishing Cloth that cleans all metals without liquid, paste or powder. Approved by "Good Housekeeping" and "Modern Priscilla"—sells fast at 25c. Sample free. Gale & Co., Inc., 15 Edinboro St., Boston.

**PHOTO** Medallion Men and Women, the largest line of Photo Novelties in the world. Lowest prices, quickest service. Send for catalogue showing over 200 money makers. Photo medallions, photo medallion clocks, photo mirrors, photo fountain pens, photo powder compacts, photo jewelry and photo buttons. Gibson Photo Jewelry Co., 608-614 Gravesend Ave., Brooklyn, N. Y.

**AGENTS**: 500% profit. "Happy Home Make Shampoo" builds your own big business. Martin of Indiana made \$75.00 in one day. Missouri man made \$750.00 one month. Exclusive territory. Geo. A. Schmidt & Co., Dept. P, 236 W. North Ave., Chicago.

**REPLATE** brassy worn-off Automobile parts. Reflectors, Bath Room Fixtures, Worn Spoons, Forks, etc., with pure silver. Looks like new. Use U-Kan-Plate Polish. Positively no mercury. \$1.00 half pints. Post Paid. Satisfaction Guaranteed. Agents wanted. Dept. A, U-Kan-Plate Co., Philadelphia.

**AGENTS** make \$10.00 Daily selling Non-Splash Water Filters on sight. Best canvasser's article on market. Investigate. Write for particulars, Desk 14, Seed Filter Company, 73 Franklin Street, New York.

**FIBRE** Brooms—detachable handles, fine finish. Good profits, repeat sales. The Fibre Broom People, 147-C New Jersey Ave., Brooklyn, N. Y.

**MONOGRAM** Automobiles. \$1.35 Profit ten minutes' work; every owner wants them; millions without; particulars free. Motorists Accessories Co., Mansfield, Ohio.

**ONE** of the biggest mails on earth. Sent to any address for 10c. Louisiana Distributing Service, Dept. PM, Harmon, La.

**PORTRAIT** Agents—Write for New Catalogue—Enlargements, Frames, Medallions, Sheet Pictures, Luminous Crucifixes. Adam J. Kroll & Co., 2539 So. State St., Chicago, Ill.

**WANT** Distributing Agent for Handlick, powdered hand soap; removes anything from hands; everybody a customer; sample free. Solar Products Co., J-2142 S. Troy, Chicago.

**ALL-YEAR-ROUND** profitable business selling wonderful new water softener and cleaner. Removes grease, oil, ink and dirt quickly. Every home and business place a live prospect. 100% profit. Big repeat orders. Exclusive territory. Write for free sample. Seacoast Laboratories, Sea Bright, N. J.

**GOLD** Leaf window letters and script signs. No experience; 500% profit. Samples free. Consolidated, 69-U West VanBuren, Chicago.

**REMNANT** Store, Bethel, Ohio. Greatest Dry Goods Bargains on Earth. Agents and Dealers.

**AGENTS**—Clever Invention! Inkspon makes every pen a fountain pen. Fast office seller; big profit, demand increasing everywhere. Exclusive territory offered. Sample free. H. Marni Company, Tribune Bldg., New York, N. Y.

**GET** Our Free Sample Case—Toilet articles, perfumes and specialties. Wonderfully profitable. La Derma Co., Dept. A, St. Louis, Mo.

**DON'T** sell for others. Employ agents yourself. Make your own products. Toilet Articles, Household Specialties, etc. 500% profit. We furnish everything and show you how. Valuable booklet free. Write at once. National Scientific Laboratories, 1919W Broad, Richmond, Va.

**AGENTS**—Art tapestry patterns in colors. Opportunity. Illustrated catalog free. S. Plock Suite 707, 58 East Washington St., Chicago, Ill.



**RELIABLE** aggressive agents needed to sell Holley Suction and Force Pumps. Used in clearing plugged plumbing fixtures. Sizes for every need. Readily salable, and show good profit to consistent workers. The Holley is priced below competition and offers, at the same time, exceptional quality. Worth-while for worth-while men. Alert Products, Inc., Dept. 50, Holley, N. Y.

**32 SECONDS** complete tire change by Detmer, Ohio, with Morey Quick Action Rim Tool. Sold, singly, 49 three days, cleared \$100. Anderson, Mont., sold 1400 in 14 weeks. Get details for good territory. Harvest time Now. M. Morey Rim Tool, Buffalo, N. Y.

**AT Last!** Diamond Rival Discovered! Amazing blue white Rajah Gem astounds jewelry world and deceives experts. Beautiful sample case free! \$100 weekly. Quick! Rajah Diamond Co., Dept. F20, Salisbury, N. C.

**SELL** men's neckwear; wonderful proposition. Astor, 318-M Broadway, New York.

**\$16 A DAY** Easy—I start you in auto accessory business; no investment; no experience necessary. Landin, 4206 Montrose Ave., Chicago.

**LAMB'SWOOL** Polishing Mittens, Brushes. Newhall, 358 Broad, Lynn, Mass.

**BIG Money** and Fast Sales. Every owner buys Gold Initials for his auto. You charge \$1.50; make \$1.35. Ten orders a day easy. Write for particulars and free samples. American Monogram Co., Dept. 40, East Orange, N. J.

**DON'T** sell for others. Employ agents yourself. Make your own products. Toilet Articles, Household Specialties, etc. 500% profit. We furnish everything and show you how. Valuable booklet free. Write at once, once. National Scientific Laboratories, 1919 W. Broad, Richmond, Va.

**FORD Gas Saver** Free. To advertise. Fits any auto. Enormous mileage increase. Critchlow, G5-805, Wheaton, Ill.

**GENUINE** Gold Leaf Letters anyone can put on store windows. Guaranteed to never tarnish. Large Profits. Enormous Demand. Free Samples. Write today. Metallic Letter Co., 438-D North Clark, Chicago.

**SUCCEED** With Your Own Products. Make them yourself. Formulas, Processes, Trade-Secrets. All lines. Catalog, circulars free. B. Thaxly Co., Washington, D. C.

**FREE** Sample of lace handkerchief. Lightning-quick seller. Big profits. Earn \$30.00 daily. Send 10c for mailing charges. Other flash sellers also. Lewis Importing Co., 143 Fifth Ave., New York.

**AGENTS** to distribute sample puzzles and catalogues, evenings. Catalogue for stamp. B. Z. Puzzles, Fairview, Mass.

**SELL** Wonderful Hand Adding Machine. \$1 wholesale. Retail, \$4.50. Typewriter Supply, 102 Hersch Bldg., Pittsburgh.

**RAINCOATS**—Full line, all prices. Also Sheeplined coats—shirts. Outfit free. Commission 25% with bonus. Hydro Raincoat Co., 718 Independence, Dept. 45, Chicago.

**\$100.00 WEEKLY.** Sell nationally known product and appoint agents. N-R-G Co., H234 W. Superior, Chicago.

**\$1,000.00 CLEARED** in 30 days by one agent. New Amazing Cleaner. Sample Free. Bestever Products Company, 4317-P, Irving Park, Chicago.

**AUTOMOBILE** Specialties. Guaranteed formulas for all latest money makers. Lowest prices. Write for free lists. Murphy, Chemist, Tujunga, Calif.

**BIG** profits distributing 5c candy specialties to dealers. Fast sellers. Exclusive territory. Universal Sales Company, 631-B Wilson Ave., Brooklyn, N. Y.

**AGENTS**—250% profit selling exclusive new process Artistic Signs. Finest selection of stock signs in the country, barring none. Details free. Sample 10c. Artistic Signs, 799-R Broadway, New York, N. Y.

**SEND** 25 cents for a one dollar Cigar Lighter, and learn how to make \$10 a day. Particulars free. Rapid Mfg. Co., 799 Broadway, New York City.

**EARN** \$10 daily silvering mirrors, plating, refinishing metalware, chandeliers, headlights, bedsteads. E. Decie Laboratories, 225 Varick St., New York.

**\$50.00 WEEKLY** easy. Applying Gold Initials on Automobiles. No experience needed. \$1.45 profit every \$1.50 job. Free samples. "Raleo Monograms," X1043 Washington, Boston, Mass.

**FREE:** Large wholesale Specialty catalog, showing latest best sellers from many parts of the world. Spors Co., Lesueur Center, Minn.

**A BUSINESS** of Your Own—Making Sparking Glass Name and Number Plates, Checkerboards, Signs. Big Book and Sample Free. E. Palmer, 512 Wooster, Ohio.

**SOMETHING** New. Every motorist a buyer of our electro-magnetic-emergency Wonderlamp; takes only one minute to demonstrate and make a sale; no experience necessary; \$5.00 an hour easily made; full time or evenings. Write for sample. Wonderlamp Co., 926 Flisk Bldg., Dept. 10-A, New York.

**CALIFORNIA** perfumed beads selling like hot cakes. Agents coming money. Big profits. Catalog free. Mission Factory P., 2328 W. Pico, Los Angeles, Calif.

#### HIGH-GRADE SALESMEN WANTED

**SALESMEN**—Manufacturer of established line guaranteed tools offers profitable connection to men with mechanical and some sales ability; part-time men considered; two average sales daily net \$50 weekly; advance against commission. Write for free catalogue and money-making plan. J. G. Woods, Inc., Dept. 112, 37 W. 20th St., New York, N. Y.

**BIG** Season Just Ahead. Advertising pencils most popular every day—every business prospect. Our line repeats. Big commissions. Established in 1902. North American Pencil Works, 126 So. Clinton, Dept. 55E, Chicago.

**MEN**—Sell dependable shrubbery, fruit trees, etc. Steady demand. Complete co-operation. Commissions paid weekly. We deliver and collect. Write Perry Nurseries, Dept. R-12, Rochester, N. Y.

**DON'T** sell for others. Employ agents yourself. Make your own products. Toilet Articles, Household Specialties, etc. 500% profit. We furnish everything and show you how. Valuable booklet free. Write at once. National Scientific Laboratories, 1919 W. Broad, Richmond, Va.

**WALKER** Made \$165.00 First Day selling Collection System to Doctors and Merchants. Retail \$6.50. Collects \$65.00. Costs \$1.50. Adjustment Bureau, Mobile, Ala.

**LIVE** Salesmen can easily make \$15.00 or \$20.00 a day selling Utility Stools direct to the home. 200% profit. Send for full information today. If you will send money order of fifty cents we will send you sample stool. If you are not satisfied with its sales value return to us at our expense. This is not an ordinary offer but is a real opportunity. Nappanee Lbr. & Mfg. Co., Nappanee, Ind.

**EASY** to sell groceries, auto oils, to consumers from samples. Big pay in advance. Liberal credit. We pay freight. Capital or experience unnecessary. Loverin & Browne, K-1500 So. State, Chicago.

**EARN** \$20 a Day. Establish income for life selling for \$1 a year. \$1,500 accident policy. Write W. C. Stone, 11 So. LaSalle, Chicago.

**PUNCHBOARD** Salesmen. Amazing new line worth \$100 up weekly—Boards, Vending Machines. Iowa Novelty Co., Dept. 18, Cedar Rapids, Iowa.

**SALESMAN**—Calling on the radio trade to sell Orthocone speakers—nationally famed for their wonderful tonal qualities. Low price, liberal discounts to dealers. Big commissions. An unusual moneymaking opportunity for you. Sample furnished. References required. Write immediately to Orthocone Speaker Co., 2728 St. George Court, Chicago, Ill.

**SELL** printing. Big commissions. Outfit Free. Atlas, 2622G East Tenth, Indianapolis, Ind.

**ANTIFREEZE** prevents radiators freezing. Dricleen, the combined auto cleaner, polisher. Radiator, internal cleaner. Hand soap. Write for free shipment long-profit auto specialties. Mickman Co., St. Paul, Minn.

**MAKE** \$25.00 daily selling colored Raincoats and Slickers; Red, Blue, Green, Etc., \$2.95. Hat Free. Commissions daily. Outfit free. Elliott Bradley, 241 VanBuren, Dept AB12-S, Chicago.

**SALESMEN**—Just out, \$8.88 for men's suits; commission \$3.00 in advance; free selling kit. The 888 Company, Dept. 121, K. Ft. Wayne, Ind.

**MR. BRUSH** Salesmen—Old Established New York Brush Manufacturers require services of men in all territories to sell their extensive line of Sanitary Twisted Wire Brushes. We pay larger commission than any other Brush House in the country. Write immediately for proposition. Wise Grip Sanitary Brush Corporation, 15 Mercer Street, New York.

**NO** high-pressure salesmanship necessary selling Luminare, our Magic Electric Window and Outdoor Salesman. Demand established. Color, light, motion gets 'em. Greatest quick-change letter system and snappy two-color posters land orders on demonstration. Hustlers collecting \$100 weekly, easy. Protected territory. Display Products Co., A407-9 East 31st St., Kansas City, Mo.

**WONDERFUL** Invention Seals Fifty Envelopes minute. Sells on sight at \$3.50. Exclusive territory. Kendall Sealer Co., E20, East Jaffrey, N. H.

**SELL** Collection Comics to merchants, manufacturers, professionals. They get the money. Big profits. Sample assortment 10c. Collection Comics, 548 Van Cortland Park Ave., Yonkers, N. Y.

**NEW** Invention automobile shutter. Retail \$1.50. Real winter proposition. Make \$150 weekly easy. Jones, 804 N. Clark, Chicago.

**AMAZING** Invention pays agents \$150 weekly! Unique combination gear shift ball-ash tray. 250% profit. Lifetime guarantee. Free particulars. Fisher, 7730 So. Chicago Ave., Chicago.

**REPRESENT** Auto Seat Cover Manufacturer. Make \$125 weekly. Biggest commission paid daily. Lowest prices. Highest quality. Elaborate outfits free. Marvello, 333 South Paulina, Chicago.

**TO** Market 3A garage door holders, simple automatic action, quickly installed. Instantly attracts garage owners, builders, dealers. Write for exclusive territory proposition. Knowlson-Stevenson Co., 1118 Packard, Ann Arbor, Mich.

**EARN** \$10 daily silvering mirrors, plating, refinishing metalware, chandeliers, headlights, bedsteads. E. Decie Laboratories, 225 Varick St., New York.

**SALESMEN**—Become Independent. Own Your business, experience unnecessary. Selling our \$7,500.00 Accidental Death; \$50 Accident; \$25 Sick Weekly Benefits—\$12.50 Yearly. Other Amounts proportionate. Guaranteed steady income from renewals. \$250,000 Deposited Insurance Department. Universal Policy, Dept. A, 30 Clinton St., Newark, N. J.

**PUNCHBOARD** Salesmen—making small towns. One sale a day nets you \$105 weekly. Full commission on repeats. K&S Sales Co., 4395 Ravenswood Ave., Chicago.

**ANY** Salesmen Can Sell Them! Merchants everywhere use punchboards. Someone sells them, why not you? Collect big commissions daily. Newest, largest, elaborate catalog sent upon request. Lincoln Sales Co., 9 So. Clinton, Chicago, Dent. D.

**\$60-\$200 A WEEK.** Genuine Gold Letters for store windows. Easily applied. Free samples. Liberal offer to general agents. Metallic Letter Co., 438-A North Clark, Chicago.

**SEND** name, address on postcard. Free introductory copy Salesology Magazine; contains 1,000 money making opportunities. Offered by big reliable firms; no obligations. Salesology Magazine, Desk B-39, 500 No. Dearborn, Chicago.

**DOUBLE** Spark Plug—Two spark gaps; bigger, hotter spark on weaker current and leaner mixture. Guaranteed to be better than other plugs or money refunded. 50% Commission. Agents and side-line men wanted. Affinity Spark Plug Co., Box P-329, Omaha, Neb.

**COLLECTS** Money from the Dead-Beats. Retail \$5.00. Cost—\$1.00. Profit \$4.00. "New Method." Every Storekeeper, Doctor buys quickly. Wonderful Money Getter. Federal Association, Hartford, Conn.

**GOLD** Leaf window letters and script signs. No experience; 500% profit. Samples free. Consolidated, 69-V West Van Buren, Chicago.

**PUNCHBOARD** Salesmen. 2 hours daily. \$100 every week. New line. Lowest prices. Full commission on repeat business. Catalog free. Puritan Novelty Co., 1409 Jackson, Chicago.

**MAKE** More money selling exclusive line of engraved personal Xmas cards. Largest commission paid. Art Craft Engraving Co., Dent. C, 117 N. Wells, Chicago.

**SHOP** Representative. Sell Reed Micrometers to shop friends. Liberal commission. Reed Small Tool Works, 35 Hermon St., Worcester, Mass.

**SALESMEN**—Sell men's Rayon Swiss and Jacquard ties—new startling features; highest commissions. Wonder outfit free. National Service Mills, 2054—83rd St., Brooklyn, N. Y.



**TRAVELING Salesmen Calling on Retail Stores** wanted by large manufacturer of fast-selling specialties entirely different from the average. Year-round sales, main or sideline. Big commission paid immediately on original and repeat business. Opportunity for well paid and permanent connection with old-established firm. If not making \$150 weekly, write today. Union Specialty Works, Dept. 222, Boonville, N. Y.

**TAKE orders** for coffee, flour, dried fruits, canned goods, meat, staple groceries, toilet articles, paints, tires, auto and tractor oils. No capital or bond required. We deliver and collect. Permanent business. Big pay. Write at once. Hitchcock-Hill Co., Dept. 50, Chicago.

**PUNCHED** Salesmen Take Notice: New, fascinating game excitement. Can be used all states. \$200 weekly easy. One-minute sales talk. Pay daily. Cigar Stores Novelty Co., Dept. G, Peoria, Ill.

**40% COMMISSION** selling printed business stationery at knock-out prices. Part or full time. Free outfit. L Process Service Minneapolis, Minn.

**FOUR \$7.50** sales to merchants net you \$20.00 daily. Sayers Systems, 2813 Sheffield Ave., Chicago, Ill.

### HELP WANTED

**WHY** not sell us your spare time? \$2 an hour, \$19.70 daily easy Full Time, introducing New Style Guaranteed Hosiery for Men, Women, Children. Silk hose for your own use free. No capital or experience required. Your pay daily. Monthly Bonus Extra. We furnish samples. Macochee Hosiery Company, Road 26012, Cincinnati, Ohio.

**MAKE \$25.00** daily selling colored Raincoats and Slickers; Red, Blue, Green, Etc., \$2.95. Hat Free. Commissions daily, outfit free. Elliott Bradley, 241 VanBuren, Dept. AB12-M, Chicago.

**SEND** name, address on postcard. Free introductory copy Salesology Magazine; contains 1,000 money-making opportunities. Offered by big reliable firms; no obligations. Salesology Magazine, Desk B-40, 500 No. Dearborn, Chicago.

**WE Start You in Business**, furnishing everything; men and women. \$35.00 to \$100.00 weekly operating our "New System Specialty Candy Factories." Few dollars start you home or small room anywhere. Booklet free. W. Hillyer Ragsdale, Drawer 350, East Orange, N. J.

**OBTAIN Employment!** 70 Jobs offered one person! Get work quickly, using our methods, or we'll promptly return your money. Complete instructions 50 cents. Better Yourself! New Idea Service Co., Box 39-A, Station K, New York.

**REPRESENTATIVES** wanted by over 500 manufacturers, offering real money-making propositions. No need of being out of work. Write for Free copy. Opportunity Magazine, 750 N. Michigan, Service Dept., Desk 3, Chicago.

**MR. MAN!** Big Money Refinishing Furniture, Radio-Cabinets, etc. Spare-time. Full-time. Experience unnecessary. Valuable information free. F. Jackson, 716 W. Exchange, Owosso, Mich.

**WANTED** 10,000 men at once. Wonderful opportunity. Full particulars and sample free. Big Four Co., 509 Ashland, Ohio.

**CASH** Paid for Butterflies, Insects. See Sinclair Display Advertisement on page 26.

### MAILING LISTS

**99% GUARANTEED** Mailing lists. Accurate. Reliable. Guaranteed. The kind that produces business; compiled for every possible business or individual. Lists of every kind of any business or individuals compiled for your individual needs anywhere. Catalog and information on request. National List, 817 Broad, Newark, N. J.

**500 NAMES** rural families; first time offered, \$1.00. Frame, Rockland, Ohio.

**1,000, 1927 WOMEN'S** names, \$1.00. W. Sheagreen, PM1427 North Penn, Minneapolis, Minn.

### CIRCULAR MAILING

**WE** mail to a definite class—opportunity seekers, active agents, small mail dealers, spare-time workers—First Class Mail, \$3.00 thousand. Free Circular. Mid-West Mailing Bureau, Forreston, Ill.

### BUSINESS SERVICE

**REPRESENTATION** in Washington, D. C. Information. Anything, Anytime. Service, Victor Bldg.

**EXECUTIVES!** Proven business analysis forms assure fewer leaks—greater 1928 profits. \$1.00 Standard Cost, PM1427 North Penn, Minneapolis, Minn.

**INCORPORATE.** Low cost. Chas. W. Barrick, New Martinsville, W. Va.

### INFORMATION

**HEIRS** Wanted. "Lost Heirs"—A 92-page book filled with names for lost heirs and missing kin from different parts of the world. Chancery Court of England, Ireland and Bank of England lists included. Price one dollar. International Claim Agency, Dept. 189, Pittsburgh, Pa., U. S. A.

**753 TIME, Labor and Money Saving** Ideas for all who own, drive or repair autos. These practical kinks are based upon the actual experiences of hundreds of owners and repairmen. Three books, Auto Owners', Auto Repairman's and Auto Tourists' Handbooks, regular \$1.50 value will be supplied at 98c plus the postage C. O. D. for a limited time only. Send your order today to Popular Mechanics Press, Room 912, 200 E. Ontario St., Chicago.

**CARBURETOR** Supplement to Dyke's Auto Encyclopedia—Just Out—Deals with every make of carburetor. Just what every auto service man has long been in need of. 106 pages, 246 illus. Price \$2.00. Send for your copy today. C. O. D. if you prefer. Popular Mechanics Press, Room 912, 200 E. Ontario St., Chicago.

### TYPEWRITERS AND SUPPLIES

**UNDERWOOD** Typewriters—only \$3.00 down. Easy monthly payments. Low prices at less than manufacturers. 10 days' free trial. Rebuilt, all worn parts replaced. Just like a new machine. 5-year guarantee. Write for a big free catalog. Shipman-Ward Mfg. Co., 1519 Shipman Bldg., Chicago, Ill.

**SIMPLEX** Typewriters \$3-\$5; Remingtons \$12.00; catalog 5c. Dimeo, 114 Ford St., Prov., R. I.

**TYPEWRITERS**—All standard makes, \$6 to \$36. Fully guaranteed. Free trial. Free catalog. Typewriter Bargain House, Ada, Okla.

**ALL** makes, lowest prices, 5-year guarantee. Several specials. Free illustrated catalogue. Henry Typewriter Co., 217 West 125th St., New York, N. Y.

**100 TYPEWRITERS** Free. Overstocked. Rent Rebuilt Underwood or Remington \$3.00 month. If you pay its value in rental, we give machine free. Particulars free. Pittsburgh Typewriter Exchange, 945 Hersch Bldg., Pittsburgh, Pa.

**TYPEWRITERS**, all standard makes. \$10 up. Fully guaranteed. Free trial. Write for complete illustrated lists. Northwestern Typewriter Exchange, 121 N. Francisco Ave., Chicago.

**TYPEWRITERS**, Radios, Motorcycles \$3 to \$45. Knights, 1512 Locust, St. Louis, Mo.

### PRINTING, ENGRAVING AND MULTIGRAPHING

**"NEARGRAVURE"**—"Neargravuremboso" "Litogravure" printed stationery, if particular. Samples, stamp. Solldays, Knox, Ind.

**CIRCULARS**—3½x8, \$2.50; 6x9, \$4.00; folders, \$5.25, thousand. Andrews, Box 1051, Fargo, N. Dak.

**5,000 LETTERHEADS**, \$10.00, 20 lb. bond. Publications, catalogs big savings. Anville Printing Company, Anville, Pa.

**250 BOND** Letterheads, 250 envelopes, \$3.00 delivered. Satisfaction guaranteed. Curtis, 811 Harrigan, Kalamazoo, Mich.

**5,000 LOTS** 3½x8 folders, \$13.75; envelope slips, \$5.00; 5½x8½ circulars, \$10.00. Samples free. Christmas cards, colored embossed designs, paneled, name engraved style, 10, \$1.00. Good's Printery, Harrisonburg, Va.

**GOOD** Printing pays. 100 envelopes, 100 full sized letterheads, bond paper, neatly printed, \$1.25 postpaid; 500 each, \$4.00. Write copy plainly. Samples. Peerless Press, Wytheville, Va.

**200 HIGH-GRADE** Bond Letterheads, Envelopes, \$1.00; other printings. Ask for samples. De Toledo Printing Co., 455 N. 51st Street, Philadelphia, Pa.

**100 PERSONAL** Cards Printed, \$1. Samples. Stanley Ladage, Camden, N. J.

**12 CHRISTMAS** Greeting Cards—Copperplate Engraved—your name on each card for only \$1.00. American Printery, 83 Sheridan St., Wilkes-Barre, Pa.

**RAISED** Letter Printing, 100 6x7 Ripple paper, 100 envelopes, \$2.00. Krafts, Ames Station, Omaha, Nebr.

**CIRCULARS**, 5,000—5½x8½—\$11. 3½x6—4-page folders \$14. All printing lowest prices. Samples. Garrison Press, Harrisonburg, Va.

**500 WATERMARKED** letterheads, note-heads or billheads \$1.90. 1000 \$3.25. Mirror, Gilmer, Texas.

**MULTIGRAPHED** Letters \$1.75 Thousand. Samples. Profit, Box 1071B, Knoxville, Tenn.

**250 LETTERHEADS** and 125 envelopes, \$1.50 postpaid. Commercial Printing Co., Allendale, S. C.

**MULTIGRAPHING** business correspondence, two dollars thousand. Hammermill letterheads, four dollars. Miscellaneous printing. Mayera Corporation, Monmouth, Ill.

**250 BOND** Letterheads, Envelopes, Billheads, Cards, \$1.35 each. Economic Press, Leonia, N. J.

**QUALITY** Printing! Reasonable Prices! Send for Free Standardized samples and prices. Folders. Circulars. Catalogs our specialty. Earnest Fantus, 525 South Dearborn, Chicago.

**PRINTED** Personal Stationery. Ideal for Christmas Presents. Samples. Austin Press 722 Clifton Ave., Newark, N. J.

**1,000—6½** WHITE envelopes printed, \$2.35; 5,000—\$8.85. Letterheads, 1,000—\$2.95. Spors Printery, Lesueur Center, Minn.

**\$3.00 DELIVERED**, 500 watermarked bond letterheads 8½x11 and 250 envelopes. Cash. Catalog free. Printing bargains. National Printing, Goshen, Ind.

**PUBLISH** Your Own Magazine or House Organ. Our standardized service at one-fifth ordinary prices. Samples and particulars free. Evans Printing Company, Grand Rapids, Mich.

**DISTINCTIVE**—Artistic Business Stationery that Creates Confidence. 1,000 Letterheads or Envelopes \$3.00. Samples. Moulton Printing Company, 1410-P East 8th, Kansas City, Mo.

**WE** print Stationery, Booklets, Catalogs, Circulars. Samples. Commercial Press, Batavia, Ohio.

**GUMMED** labels, 500 name, address, 2 lines 35c. 3—55. Catalog. Eastern Label Co., B., Clintonville, Conn.

**1000 BUSINESS** Cards, Envelopes, or Letterheads, \$3.00, 300, \$1.00, 108 Eureka, San Francisco.

**150 BOND** Letterheads, 8½x11, and 150 Envelopes printed to order, \$1.50; 100 Lined Calling Cards, 75c. J. Ferreira, 249 Eugenia St., New Bedford, Mass.

**PRINTING**—Stationery, Circulars, Booklets. Fine work; prices right. Battlefield Press, Gettysburg, Pa. Free battlefield souvenir.

**200 LETTERHEADS** and 100 envelopes, \$1.00 postpaid. Oberman Company, Box 1268, Chicago.

### PRINTING, OUTFITS AND SUPPLIES

**PRINTING** Presses, type, supplies. List 2c stamp. Bargains. Geo. Foster, 4342 North Robey, Chicago.

**PRINTING** Outfits—Presses, type supplies, type novelties. Send stamp for catalogue. Model Press, York, Penna.

**PRINT** Your Own Stationery, cards, bookplate, Christmas cards, circulars, book pamphlets, etc.; complete outfits, \$8.85; larger, \$11, \$29 rotary \$149. Print for others. Easy and interesting rules sent. Write for catalogue presses, type, paper, etc. Kelsey Company, K-11, Meriden, Conn.

### GUMMED LABELS

**1,000 PRINTED**; Name, Business, Address, 50c. JBS Co., Box 93, Holyoke, Mass.

### RUBBER STAMPS

**RUBBER** stamps!!! Name, address, two lines 35c; 15c additional line. 24 hour service. Mid-West Stamp Works, Forreston, Ill.

**RUBBER** Stamps—First line 15c; additional lines 10c. Newman & Son, Desk 44, Auburn, Neb.

**ILLINOIS** Rubber Stamp Works, manufacturers. Send for circular. 2913 No. Rockwell St., Chicago.

### DUPLICATORS AND DEVICES

**STENCIL** Duplicator — \$2.00 — Larger \$3.00, \$3.50, \$4.00. Returnable. Samples. Circular. Primos Specialty Co., Primos, Pa.



**STENCIL** Duplicating machine (Postcard Size) prints 500 copies of postcards, blot- ters, notices, etc., with or without illustrations, for 15c. Simple, speedy, guaranteed. Sent on trial. Send for literature and actual samples of printing. Complete outfit \$10.50. Keller Manufacturing Company, Pasadena, Calif.

YOU can make 50 to 100 copies of a letter, notice, etc., at a cost of three cents on a Heyer Quality Duplicator. Write for free trial offer. The Heyer Duplicator Co., 909 Jackson Blvd., Chicago, Ill.

#### ADDING MACHINES

**NEW \$3.50 Automatic Adding Machine.** Adds, subtracts, multiplies absolutely accurate. Capacity \$999,999.99. Fully guaranteed. 75,000 pleased users. Makes adding easy, positive, quick. Eliminates mistakes. Saves time. Postpaid \$3.50. Bassett Co., 1458-H Hollywood Ave., Chicago.

#### FOR SMOKERS

**HOMESPUN Tobacco**—guaranteed, good flavor. Chewing, 5 pounds, \$1; 10, \$1.75. Smoking, 5 pounds, 75c; 10, \$1.25. Pay when received. Farmers Union, Mayfield, Ky.

**TOBACCO:** Kentucky Sweetleaf. Smoking, Chewing, 15 pounds \$2.25. Kentucky Farmers, Wingo, Ky.

#### FOR THE HOME

**PHENOMENAL New Finish** gives all the waterproofness and weatherproofness of Valspar yet dries in 30 minutes! In addition, Valspar Brushing Lacquer is amazingly durable and not easily scratched. Ideal for wood, metal and composition surfaces indoors or outdoors, especially where wear is hard and quick drying is desired. Anything you make or use about your home can be protected and beautified by a coat of Valspar Lacquer and be ready for use a few minutes later. Try it on furniture, toys, bicycles, radio apparatus, floors, trim, lighting fixtures—anything about the home, shop, office or farm. Send 25c for 45c sample stating color: Java Brown, Coral Sand, India Ivory, Nile Green, Palm Green, Italian Blue, Cardinal Red, Peacock Blue, Jonquil Yellow, Persian Lilac, Chinese Red, Oriental Green, French Gray, Holland Blue, Argentine Orange, also in Black, White and Clear. Valentine & Company, Dept. 4, 456 Fourth Avenue, New York, N. Y.

**MEN! Women! Make \$1 An Hour at Home.** Weaving special-to-order Colonial Rugs on Union Looms. Big demand, no house-to-house selling, no store competition. You learn fascinating new craft in 30 minutes, we guarantee it. New looms at lowest prices ever. Liberal Pay-As-You-Weave terms. Write for Free Loom Book today. Union Loom Works, 480 Factory St., Boonville, N. Y.

**DOES your radiator leak?** Send 25c for trial package Stop-Leak. Canteen Oil Co., Box 212, R. R. 3, East St. Louis, Ill.

**GRANDFATHER'S Clock Works.** \$5.00. Build your own case: Instructions free; make good profits selling your friends. Clock works with chimes for old or new cases. Write for full particulars. Clock Co., Ruffner St., Philadelphia.

**CEDAR chests only \$11.65—"Red-i-Kut"** complete with rich copper trim—your assemble and save half—send for pictures. Kuempel Furniture Company, Guttenberg, Iowa.

**FINE old maps and Colonial prints**—the newest thing for lampshades or framing. Interesting catalogue 6c. Sea Arts Guild, 730-X Winnebago St., Milwaukee, Wis.

**WONDOR Sewing Board \$2.00.** Instructions 50c. Schryer, 5402 Train Ave., Cleveland, Ohio.

**THAT Concrete Job.** Don't be afraid to tackle it. With the instructions found in Popular Mechanics Concrete Handbook you can make 173 articles of utility and beauty ranging from ordinary steps to garden furniture. This book with our Home Mechanics Handbook that contains 329 helps about jobs that come up about the home will be sent for only 98c plus postage C. O. D. Send your order today to Popular Mechanics Press, Room 908, 200 E. Ontario St., Chicago, Ill.

**HOW to Make and How to Mend.** 1000 articles telling how to repair almost everything in use or needed about a home or farm. Many illustrations; formulas and trade secrets. Send no money. Just ask for "How to Make and How to Mend." Pay postman postal charges and \$1.00. Popular Mechanics Press, Room 908, 200 E. Ontario St., Chicago, Ill.

**THIS is the season for making repairs** about the home. Easily done with instructions in our new book. Tells exactly how to use tools, sharpen tools and cutlery, repair furniture and cabinets, upholster, work metal, solder, work glass, paint, stain, varnish, hang paper, repair plumbing, furnace, electrical equipment, shoes, harness, gloves and concrete work. Send no money. Just write and ask for "The Practical Book of Home Repairs." When postman hands you the book, pay him \$2.50 and the postal charges. Popular Mechanics Press, Room 908, 200 E. Ontario St., Chicago, Ill.

#### RAZORS AND BLADES

**WE Hollow grind and recondition old** Razor Blades like new 12 for 30c or 4 dozen \$1.00. Wm. Betken, 7740 Rhodes Ave., Chicago, Ill.

**FREE**—10,000 hollow-ground blades given away. Clean and save your blades, we buy and recondition blades, manufacturing commercial sharpening machines. Velvet Edger, 6001 Gramercy, Los Angeles, Calif.

**GILLETTE Style Blades.** Guaranteed new. Dozen 38 cents; 3 dozen \$1.00. Wallace Kutz, 132 Chambers, Phillipsburg, N. J.

#### FOR MEN

**DO you like to make things?** If so, you should have a copy of Popular Mechanics new book entitled "Make It Yourself." A large book of 480 pages describing how to make 900 different articles. 823 illustrations. Price \$3 postpaid. A full description will be sent upon request. Popular Mechanics Press, Room 912, 200 E. Ontario St., Chicago, Ill.

**YOU Need a better grip on mathematics?** Tell us to send you a copy of "Mathematics for the Practical Man," only \$1.50. By common sense methods it removes the mystery and difficulties so algebra and calculus are made simple. Assuming your knowledge is limited to arithmetic you quickly and easily gain a working knowledge of algebra, geometry, trigonometry and calculus. Simply pay postman when he hands you the package. Address Popular Mechanics Press, Room 908, 200 E. Ontario St., Chicago, Ill.

#### BOATS AND LAUNCHES

**BUILD Your Own Boat** using our Knock-Down ready cut materials. 55 models, outboard motor speedsters, runabouts, cruisers, sail, or row. Send 25c for catalog. Brooks Boat Co., Inc., Rust Ave., Saginaw West Side, Mich.

**HUBBELL Marine Coolers** convert Ford engines into marine motors. Booklet free. Ford speedboat, easily built, large blue-print and directions one dollar. C. C. Hubbell, Perry Ave., Norwalk, Conn.

**PROPELLERS,** Stuffing boxes, rudders, etc.; also used equipment bought, sold, exchanged. Wm. H. Baker, Pond St., Quincy, Mass.

**NEW Boat Book** telling how to make 21 kinds of boats. Also many other helpful ideas on boating. Profusely illustrated. With this we include the big book, "Outdoor Sports the Year Round." Directions for making all sorts of devices for outdoor recreation. Send no money. Simply pay the postman \$1.98 plus postage when books are delivered. Popular Mechanics Press, Room 908, Popular Mechanics Building, Chicago, Ill.

**SHIP Models**—Worth while. Easy to make. Decorative Ships Picturesque Barbary Pirate Felucca and Beautiful Spanish Treasure Galleon (both 17th century). Instructions so simplified that any handy person can make these models with a few household tools almost without expense. No personal knowledge of ships or naval architecture required. New book only one of its kind. Pay postman \$2.50 plus postage when book is delivered. Popular Mechanics Press, Room 908, 200 E. Ontario St., Chicago, Ill.

#### WATCH REPAIRING

**ALL makes of Watches** repaired by experts. Write International Watch Service, Box 5P, Fordham Station, New York.

#### ANTIQUES, WAR RELICS AND INDIAN GOODS

**OLD Money Wanted.** Will pay \$100.00 for 1894 dime, S. Mint., \$50.00 for 1913 Liberty head nickel (not Buffalo). Big premiums paid for all rare coins. Send 4c for large coin folder. May mean much profit to you. Numismatic Co., Dept. H-3, Fort Worth, Tex.

**INDIAN Bead and Horse-hair work,** Necklaces and War Bands 50c each. Belts \$2.50 and \$3.00 Hat Bands \$1.50. Laura Kendall, Gig Harbor, Wash.

**INDIAN eagle feather war bonnets** only \$10.00. Indian silver bracelets \$5.00. (Send 25c for arrow head, foreign coin and catalogue.) Indiancraft P. Company, 466 Connecticut, Buffalo, N. Y.

**FOR Dens.** Relics and medals from Europe's Battlefields. Illustrated catalogue, 25c. International, 1889 Albany Avenue, Brooklyn, N. Y.

**100 GENUINE Indian arrowheads** from Arkansas \$4.00 postpaid. H. Daniel, Lamar, Ark.

**SEND 5c** for fine new list Indian relics, antique firearms. F. E. Ellis, Webster Groves, Mo.

**INDIAN Stone relics.** Catalog 2c. Grutzmacher, Mukwonago, Wis.

#### PHONOGRAPHS AND RECORDS

**BUILD Your own phonograph.** Catalog and instructions to build new type horn mailed for 10c. American Phonograph Co., 4115 West 24th Place, Chicago.

**RECORDS,** latest selections, thirty cents each. Write for catalogue. Pleasing Sound Phonograph Company, 204 East 113th Street, New York, N. Y.

#### MUSIC AND MUSICAL INSTRUMENTS

**"WOODWIND"** Clarinet and Saxophone Steel Ebouite - Mouthpieces (scientifically faced with an accuracy of 1/2000") are being sold by over 200 dealers in America, Australia, New Zealand and Europe. For particulars, write The Woodwind Company, 131 West 45th Street, New York, N. Y.

**MAKING a Violin**—If perplexed, ask me. William Mullen, Duff Building, New Bedford, Mass.

**"LIKENU"** perfectly rebuilt saxophones, trumpets, trombones, clarinets, baritones, sousaphones, etc. Conn. Buescher, Holton, King—all makes. Tremendous stock. Prices right. Beautiful four-colored folder, bargain list 10c. Musical Agents wanted. Waltersdorfs, Rebuilders, Creston, Iowa.

**WE'LL remanufacture your old musical instruments** like new. Latest methods, finest workmanship. Price list. Waltersdorfs, Rebuilders, Creston, Iowa.

**PIANO Jazz:** Teaches negro harmony, player effects, chimes, blues, etc. Five courses to choose from. Write for Booklet 18. "Piano Bill," Toronto, 3, Ontario.

**SONGWRITERS:** Submit poems. Expert Preliminary-Publication services. Brennen, Dept. L-1658 Broadway, New York.

**SONG-POEM Writers:** Address Monarch, 236 W. 55th, Dept. 104, New York.

**SONG Poem Writers,** Write Sequoia Songwriters' Service, Sherman Branch, Los Angeles, Calif.

**VIOLINS,** Deep, Mellow, Soulful—on credit. Easy terms for wonderful instrument. Get details today. Gustav F. Henning, 2424 Gaylord St., Denver, Colo.

**"MUSIC Composed"** to words. Bauer Bros. (formerly of Sousa's Band), Oshkosh, Wis.

**I WANT Song Poems.** Casper Nathan, 3544 N. Racine, Chicago.

**SHEET-MUSIC,** 10 for \$1.00. For Amateur Teacher or Student. Catalog free. Ferd. Zarb, P. O. B. 18, Sta. D., New York.

**WRITE Songs.** Big money and reputation. Write for information. J. Gordon Pub. Co., 201 N. Hoyne Ave., Chicago.

**CORNETISTS**—Trombonists—Saxophonists—Clarinetists. Get "Free Pointers." Name instrument. Virtuosi School, Buffalo, N. Y.

**MUSICAL Merchandise,** instruments, plating, repairing. Guaranteed work. Sternberg's, 59 E. Adams St., Chicago, Ill.

**POEM or Melody Writers**—real proposition. Hibbeler, D1, 2104 N. Keystone Av., Chicago.

**MUSIC Composed** to words. Art Melody Co., Art Theater Bldg., Kansas City, Kans.

#### PATENT ATTORNEYS

**PATENTS.** Time counts in applying for patents. Don't risk delay in protecting your ideas. Send sketch or model for instruction or write for free book "How to Obtain a Patent" and "Record of Invention" form. No charge for information on how to proceed. Communications strictly confidential. Prompt, careful, efficient service. Clarence A. O'Brien, Registered Patent Attorney, Security Bank Building (directly across street from Patent Office), Washington, D. C. See pages 156 and 157.

**PATENTS**—Write for Instructions. Carl Miller, Registered Patent Attorney (former Patent Office examiner), McGilly Building, Washington, D. C.



**PATENTS** Procured, Prompt Service. Personal, careful and efficient service. Highest references. Moderate fees. Send sketch or model for actual search and advice. George P. Kimmel, Master of Patent Law, 54-N Legal Bldg., Washington, D. C.

**BROCHURE** "How to Get a Patent," free. Send rough ideas or sketch. No obligation. Prompt, expert cooperation. A. L. Applebaum, Registered Patent Attorney, 41 Park Row, New York. Formerly Assistant Examiner U. S. Patent Office.

**INVENTORS** having ideas to patent: Write for Booklet explaining Co-operative Plan for handling your applications. Tells how to sell and safeguard your inventions at lowest cost. Ralph Burch, Patent Lawyer, Jenifer Bldg., Washington, D. C.

**MILLIONS** spent annually for ideas! Hundreds now wanted! Patent yours and profit! Write today for free book—tells how to protect yourself, how to invent, ideas wanted, how we help you sell, etc. American Industries, Inc., 500-Victor Bldg., Washington, D. C.

**INVENTORS**—Write for our Guide Book, "How to Get Your Patent" and Evidence of Invention Blank. Send model or sketch of your invention for our prompt examination and instructions free. Randolph & Co., Dept. 430, Washington, D. C.

**PATENTS, Trade-marks, Copyrights.** Reliable services by an experienced practitioner devoting personal attention to each case. Inquiries invited. References furnished. B. P. Fishburne, Patent Lawyer, 525-A McGill Bldg., Washington, D. C.

**PATENTS.** Booklet free. Highest references. Best results. Promptness assured. Send model or drawing for preliminary examination. Watson E. Coleman, Patent Lawyer, 724 Ninth St., Washington, D. C.

**PATENTS** That protect. Prompt service. Send sketch for free information and opinion. Ehrlich, Garrick Bldg., Chicago.

**"INVENTORS' Guide"** sent free on request; this book contains illustrations of patented inventions and gives valuable information and advice for all who have original ideas or improvements. Frank Ledermann, Registered Attorney and Engineer, Woolworth Bldg., 1712, New York.

**PATENTS** Procured: Trade Marks Registered—A comprehensive, experienced, prompt service for the protection and development of your ideas. Preliminary advice gladly furnished without charge. Booklet of information and form for disclosing idea free on request. Richard B. Owen, 30-Owen Bldg., Washington, D. C., or 41-R Park Row, New York.

**PERCY S. WEBSTER,** 203 Saving and Loan Building, Stockton, California. Long established organization. Patent booklet free.

**LANCASTER** and Allwine, 221 Ouray Bldg., Washington, D. C. "Originators of the Form Evidence of Conception." Before disclosing your invention to anyone send for blank form to be signed and witnessed. Form and patent information bulletin free.

**MONROE E. MILLER,** Ouray Bldg., Washington, D. C. Patent Lawyer; Mechanical, Electrical Expert. Booklet and Priority Record blank gratis.

**PATENTS** obtained under Cooperative Payment Plan. Write for particulars. W. E. Beck, Registered Patent Lawyer, 951 Jenifer Bldg., Washington, D. C.

**RICHARD E. BABCOCK,** Patent Lawyer, Washington Loan & Trust Bldg., Washington, D. C. Booklet.

**SELL** your invention before patenting. Write for free particulars. W. T. Green, 801 Jenifer Bldg., Washington, D. C.

**PATENTS**—Free advice. Confidential, prompt personal service of Registered Patent Attorney, former Patent Officer Examiner. Booklet. Albert Jacobs, 727 Barrister Bldg., Washington, D. C.

**PATENTS, Trade-Marks, Designs.** This firm has 27 years' experience and gives expert personal service at reasonable rates. We properly protect your invention. Write for free information and exact cost of procuring patent before proceeding. John B. Thomas & Co., 902 F St., N. W., Washington, D. C.

**UNPATENTED** Ideas Can Be Sold. I tell you how and help you make the sale. Free particulars (Copyrighted). Write W. T. Greene, 806 Jenifer Building Washington, D. C.

**PATENTS**—Write for our free book, "How To Obtain A Patent" and Record of Invention Blank. Send model or sketch of inventions for inspection and instructions Free. Terms Reasonable. See advertisement on page 159. Victor J. Evans & Co., 934 Ninth, Washington, D. C.

**INVENTORS:** Send sketch or model for advice and exact cost of patent. Ask for our Free book: "How to Obtain a Patent." Tells what every inventor should know. Established twenty-eight years. Highest references. Prompt service. Reasonable charges. Chandler & Chandler, 414 Seventh, Washington, D. C.

**ESTABLISHED 1864.** Milo D. Stevens Company. Free Booklet. Patents, Trade-Marks, Copyrights. Offices, Monadnock Block, Chicago; Barrister Building, Washington, D. C.

**LACEY'S Patent Sense.** Valuable book free. See ad page 160.

#### FOR INVENTORS

**PATENTS.** If you have an invention which you wish to patent you can write fully and freely to Munn & Co., for advice in regard to the best way of obtaining protection. Please send sketches, or a model of your invention and a description of the device, explaining its operation. All communications are strictly confidential. Our Hand-Book on Patents is sent free on request. This explains our methods, terms, etc., in regard to Patents, Trade Marks, Foreign Patents, etc. "Scientific American" contains Patent Office Notes, Decisions of interest to inventors and particulars of recently patented inventions. Munn & Company, Solicitors of Patents, 1523 Scientific American Building, 24 W. 40th St., New York City; 524 Scientific American Bldg., Washington, D. C.; 1313 Tower Bldg., Chicago, Ill.; 666 Hobart Bldg., San Francisco, Calif.; 521 Van Nuys Bldg., Los Angeles, Calif.

**PATENTS**—Write to B. P. Fishburne (a South Carolinian), Registered Patent Lawyer, 525-E McGill Bldg., Washington, D. C.

**PATENTS** obtained under Cooperative Payment Plan. Write for particulars. W. E. Beck, Registered Patent Lawyer, 950 Jenifer Bldg., Washington, D. C.

**PATENTS** Procured: Trade Marks Registered—A comprehensive, experienced, prompt service for the protection and development of your ideas. Preliminary advice gladly furnished without charge. Booklet of information and form for disclosing idea free on request. Richard B. Owen, 30-Owen Bldg., Washington, D. C., or 41-R Park Row, New York.

**INVENTORS** Universal Educator—contains 900 mechanical movements; 50 perpetual motions. Tells how to obtain and sell patents. Suggests new ideas. Explains how to select your attorney and avoid patent sharks. Price (revised edition) \$1.00 postpaid. Albert E. Dieterich, 621-Ouray Bldg., Washington, D. C.

**GET** your own patents. Legal blanks, complete instructions \$1. Cutting Sons, Cambell, Calif.

**INVENTIONS** Designed, Developed and Marketed; Inventors' Advisory Service; Experienced Since 1906. C. J. Williams, Patent Engineer, American Bank Bldg., Oakland, Calif.

**I AM** in touch with hundreds of moneyed men and manufacturers who wish to buy good inventions. Write Hartley, 38 Court St., Bangor, Me.

**PATENTS** wanted by manufacturers. Send description, Box 126, Dowagiac, Mich.

**INVENTORS** wishing to commercialize their patents safely should write "International Inventors Service Bureau," Box 252-B, Racine, Wisconsin, for advice.

**I SELL** Patents. A personal, experienced Service, your patent may be worthy of. Established in 1900. Charles A. Scott, 773PM Garson Ave., Rochester, N. Y.

**INVENTIONS** Developed—Your crude ideas developed into practical form for your patent application. Model not necessary. Send rough sketch and description for estimate of cost and advice. 27 years' experience. Albert E. Dietrich, Engineer and Registered Patent Attorney, 621½ Ouray Building, Washington, D. C.

**IF** you have a patented article of merit, will furnish capital for manufacturing. Write Robert Hammond, Milwaukee Athletic Club, Milwaukee, Wis.

**PATENTS.** Time counts in applying for patents. Don't risk delay in protecting your ideas. Send sketch or model for instruction or write for free book "How to Obtain a Patent" and "Record of Invention" form. No charge for information on how to proceed. Communications strictly confidential. Prompt, careful, efficient service. Clarence A. O'Brien, Registered Patent Attorney, Security Bank Building (directly across street from Patent Office), Washington, D. C. See pages 156 and 157.

**INVENTORS**—Write for our free book, "How To Obtain A Patent" and Record of Invention Blank. Send model or sketch of inventions for inspection and instructions Free. Terms Reasonable. See advertisement on page 159. Victor J. Evans & Co., 157 Ninth, Washington, D. C.

**LACEY'S Patent Sense.** Valuable book free. See ad page 160.

**SELL** your invention before patenting. Write for free particulars. W. T. Greene, 802 Jenifer Bldg., Washington, D. C.

**UNPATENTED** Ideas Can Be Sold. I tell you how and help you make the sale. Free particulars (Copyrighted). Write W. T. Greene, 807 Jenifer Building, Washington, D. C.

**WE** will buy suitable inventions, write Martin Laboratories, Gap, Pa.

**INVENTIONS!**—Have you conceived one? There is a long, winding road to travel before your vision of rewards can be realized. Send for the new book "Inventions and Patents, Their Development and Promotion" by an eminent authority. It is designed to guide the inventor on his way and help him avoid pitfalls. Will be sent C. O. D. Pay postman \$2.50 plus postage when he hands you the package. Popular Mechanics Press, Room 912, 200 E. Ontario St., Chicago.

#### PATENTS FOR SALE

**OUTRIGHT** Or Royalty basis, to a very reliable manufacturer interested in automobile accessories, my newly patented Handy Andy automobile accessory. Nothing like it on the market. Not an experiment, but a proven success. Easily attached to steering post and is very attractive. Fits any make car, truck or tractor. Contract cost twenty-five cents. Retail for two dollars. Handy Andy is a real serviceable, attractive and useful accessory, and if handled properly should be a big money getter. H. C. Schrell, Terry, La.

**OUTRIGHT**—Automobile parking means. Car can be readily and quickly moved into and out of position. Floyd Palmer, 400 W. 17th St., Jacksonville, Fla.

**OUTRIGHT**—new improvements in Valve-actuator device. A set throttle valve regulates opening to very fine degree. M. H. Lucas, Box 4, Moshannon, Pa.

**FOR SALE,** outright cash between \$50,000 and \$100,000, on an alleged new and useful improvement in Galley-slug adjusters—No. 1643540. Rodney T. Bunn, % The Register & Bee Publishing Co., Danville, Va.

**UNITED STATES** Patent, No. 1,567,859. Means for utilizing Power from Streams. A Device for running Dynamos. E. C. Co., Inc. Interested parties may join or acquire right to manufacture the invention. Write J. W. Ornell, Box 865, Philadelphia, Pa.

**OUTRIGHT** or Royalty—sun and headlight shield and side shade that works automatically when doors are opened. Simple, durable and manufactured at very low cost. J. J. Killip, Stokes Bldg., Astoria, Ore.

**PATENT**—Fortune in Stop-Direction Signal on Autos visible all around. Sale of royalty. F. Cox, 536 Rush St., Chicago.

**HOUSEHOLD** article—Inexpensive—every home a prospect. Geo. Jentzen, 772 40th St., North Bergen, N. J.

**INVENTIONS** and Patents for Sale. Order your inventions, Patents and Trade-marks from Hip, 722 Mace Street, Greensburg, Pa.

**NEW** Tool holder for planers and shapers for metal working. Pronounced success by leading manufacturers. Bergman Machine Co., 811 E. Main St., Merrill, Wis.

**OUTRIGHT**—Improved household faucet with lead disc and rotatable stem. A big money maker. S. C. Caldara, 627 Morris Park Ave., New York.

**WHY** let your patents lie idle? Tell our two million five hundred thousand readers about it! The majority of our readers are especially interested in new ideas and inventions. Ask me to tell you how other inventors successfully sold their patents. M. L. Rund, Mgr., Classified Advertising, Popular Mechanics Magazine, Chicago.



**INVENTION** for handknitting machine (transfer stitches automatic), outright or royalty. John Jensen, Saskatoon, Sash., Can.

### ELECTRICAL

**ELECTRICIANS** And Helpers, send Dollar for Questions and Answers. Learn these; receive more pay. Hinman, 2938 W. Hancock, Detroit, Mich.

**LATEST** and Best House Wiring book—just published—This new book of over 250 pages and 600 illustrations represents 15 years of work in perfecting the material for the best House Wiring manual it is possible to produce. The work of two men high up in the fields of mechanical arts and electricity. Price \$2.50 postpaid. Sent C. O. D. anywhere in the U. S. or possessions. Popular Mechanics Press, Room 912, 200 E. Ontario St., Chicago, Ill.

**"BLUEPRINT Reading"** is a compact book telling how to read machine blueprints. Send no money. Just pay postman postal charges and \$1. Popular Mechanics Press, Room 908, 200 E. Ontario St., Chicago, Ill.

**MAKE Things Electrical.** Complete instructions for making medical coil, buzzer, rheostat, sign flasher, electric toaster, heater, electric grill, soldering copper, crystal receiver, transformer, Tungar rectifier, Duram receiver, motor and other things in fine illustrated book costing \$1.25. Pay postman price and postage when he hands you the package. Address Popular Mechanics Press, Room 908, 200 E. Ontario St., Chicago, Ill.

**SAVE Money on Electrical Books**—While they last we will supply the following books: Practical Electrics, Electrical Circuits and Diagrams, Electric Bells and Alarms, Induction Coils, Experimenting with Induction Coils, Experiments in Static Electricity, Wimshurst Machine, Small Accumulators, your choice of any four books for \$1, postpaid. Regular price 35 cents per volume. Popular Mechanics Press, Room 908, 200 E. Ontario St., Chicago, Ill.

### SURVEYING INSTRUMENTS

**LARGEST** stock of new and used surveying instruments in the country direct from factory. Satisfaction guaranteed or money refunded. Wissler, 619 N. Broadway, St. Louis, Mo.

### MODELS AND MODEL SUPPLIES

**MODEL** Steam Engines, Boilers and Model Pipe line fittings. Model Making Supplies. Send 20c for this year's illustrated catalogue and hand book. Batho Mfg. Co., Dept. D, 5214 Woodland Ave., Philadelphia.

**CANADIAN** Modelmakers. Blocks. Dead-eyes, ship-fittings. Stamp brings circular. Anderson, 44 Butterworth Ave., Toronto, Ont.

**EVERYTHING** for Ship Models. Catalog, Dime; also complete line of Books for Yachtsman's Library, including Boatbuilding, yacht and Naval Architecture. Gasoline Engines, Marine Engineering, Navigation, Model Yachts. Complete line of Boatbuilding Blueprints. Both catalogs, 25c each. Roy Hancock, 323 Douglas Ave., Portsmouth, Va.

**PATTERNS** and models made. Light manufacturing. H. W. Hathorn, Mason City, Iowa.

**LET** our experience be your guide. Models that are models; tools and equipment for economic manfg. Patterns of all types; manufacturing in all branches. Satisfaction guaranteed. United Machinery Company, Cincinnati, U. S. A.

**SHIP** Models: Complete Parts and Blueprints for Chinese Junk, Venetian Sailboat, Nile Boat, or Viking Galley. 60c Postpaid. Casson-Craft, Dept. B, Framingham, Mass.

**SHIP** Model Fittings: Send stamp for booklet. A. J. Fisher, 1002 Etowah Ave., Royal Oak, Mich.

**SPECIAL** machine builders, tool and die makers, inventor's models production work of all kinds. Dept. L. Quality Hardware & Machine Co. Ravenswood and Thorndale Avenues, Chicago, Ill.

**WE** make working models for inventors and do experimental work and carry a complete stock of brass gears and model supplies. Send for catalogue. The Pierce Model Works, Tinley Park, Ill.

**MODELS, Tools, Dies and General** manufacturing. Logan Machine Co., 652 W. Lake, Chicago, Ill.

**MODEL** and Experimental Work at lowest cost. Wagar Model & Machine Works, 115 So. Clinton Street, Chicago.

**SHIP** model plans, supplies, books, fittings. Interesting catalog of Sea Things, 6c. Sea Arts Guild, 730-M, Winnebago St., Milwaukee, Wis.

**PATENTS.** Time counts in applying for patents. Don't risk delay in protecting your ideas. Send sketch or model for instruction or write for free book "How to Obtain a Patent" and "Record of Invention" form. No charge for information on how to proceed. Communications strictly confidential. Prompt, careful, efficient service. Clarence A. O'Brien, Registered Patent Attorney, Security Bank Building (directly across street from Patent Office), Washington, D. C. See pages 156 and 157.

**THE** Modelmaker, a magazine for all interested in making working models, boats, etc. Sample 10c. Modelmaker, 122 Liberty St., New York.

**MODEL** steam engines and boilers. Boat and boiler fittings. Send 10c stamp for catalog. Refunded with first order. Model Machine Shop, 212 Price St., Rahway, N. J.

**FUN** making things. Four large profusely illustrated books telling how to make almost everything from a sail boat to a toy automobile propelled by a motorcycle engine. Now \$2 per book or \$7 for the four if ordered at once. Send No Money. Just write a postal saying, "Send the Boy Mechanic Library." Pay postman \$7 and postage. For single books, specify either Book 1, Book 2, Book 3, or Book 4. Popular Mechanics Press, Room 908, 200 E. Ontario St., Chicago, Ill.

### MANUFACTURING

**COMPLETE** Manufacturing. Dies and stampings and Special Machinery. Our Engineering department will design and perfect your article; our tool room will tool it for production. Our shop will make any quantity you may need. Models made if necessary. Barth Stamping & Machine Company, 3816 West 34th St., Cleveland, Ohio.

**CONTRACT** Manufacturers—Dies, Stampings, Models, Castings and Forgings Machined. Automatic Screw Machine Product. Screw Machine Specialty, Susquehanna Street, Pittsburgh, Pa.

**SPECIAL** Machinery or parts, dies, tools, metal specialties, models, special gears, stock gears and model supplies. Send for Catalogue. The Pierce Model Works, Tinley Park, Ill.

**PATTERNS,** wood and metal. Models, tools and dies. Brass, bronze, aluminum and iron castings. Screw machine work, production work of all kinds. Write Modern Machine & Pattern Co., Terre Haute, Ind.

**WANTED** to manufacture on royalty basis—some mechanical appliance or automobile accessory. Cincinnati Automatic Machine Co., Cincinnati, Ohio.

**LITTLE** Jobs: Machine work, small machine, parts, single pieces, repairs, nothing too small. Buzzell Co., 200 Congress St., Boston.

**WE** Will pay royalty for any item that we can manufacture and sell in volume. Waco Tool Works, Inc., 542 No. Parkside, Chicago.

**INVENTIONS**—Specialties—Developed—Manufactured—Commercialized—Foreign—Domestic. Pacific Products, Inc., 135 Tehema St., San Francisco.

**LET** us figure on your requirements for special machine work and manufacturing. Automatic machines developed to reduce production costs. York Electric & Machine Co., York, Pa.

**WANTED,** to manufacture special Truets and Machinery. Get our prices. Gallagher Bros., Uhrichsville, Ohio.

**INVENTIONS** developed, manufactured and packed ready for market. Models, dies, special machinery. Established 20 years. Swanberg, 5124 N. Kildare Ave., Chicago.

**MANUFACTURING** Models, Dies, Stampings, Brass Work, one or thousands. Baum's Metal Specialties, Kansas City, Mo.

**WIRE** goods made to order. Cooley Mfg. Co., 530 N. Western Ave., Chicago.

### MACHINERY, TOOLS AND SUPPLIES

**WANTED**—Your old Electric motors or surplus stock. Universal, 1018 W. Lake St., Chicago.

**TOOL** Boxes—Second Quality Tool Chests. Low Prices. Get list sizes, description. H. Gerstner & Sons, Dept. M, Dayton, Ohio.

**NO. 60** Heald Cylinder Grinder, \$375.00; Marvel Cylinder Boring Machine, \$115.00; 16x9" Chard Engine lathe, latest type, \$325.00; No. 41 Becker Milling Machine, \$165.00; No. 1 Cincinnati Milling Machine, with dividing heads, \$285.00. Terms if desired. Send for catalog. Cincinnati Machinery & Supply Co., 27 West Second St., Cincinnati, Ohio.

**START** business of your own, small investment required, doing nickel, copper and silver plating. This work in big demand. Information free. Electro Platers Supply Co., 547 Considine Ave., Cincinnati, Ohio.

**HERE** is your opportunity to obtain a real good buy on electric grinders and buffers, which are, full 1/4 HP, 110 volt, 60 cycle, single phase, AC, enclosed dust-proof motor with cord and plug, emery wheel on one side and buffer on the other, at a low price of \$19.75 each. General Distributing Co., Duluth, Minn.

**OTHERS** have successfully sold their machinery through our columns—so can you. Ask me for proof. M. L. Rund, Manager, Classified Advertising, Popular Mechanics Magazine, Chicago.

**CONCRETE** Building Block Machine and Molds. Catalogue free. Concrete Machine Co., 5 N. Main St., St. Louis, Mo.

**WOODWORKERS.** Multiple Tenenor, for circular saw. Wonderful results. One dollar. Clayton's Woodshop, Port Huron, Mich.

**ELECTRIC** Welders, oxy-acetylene torches, welding supplies. Progressive Welder Sales Co., St. Louis, Mo.

**FOX** Lathe, Turret Lathe, Hex Nut Miller, 10 H.P., D. C. motor, \$100 each. Keystone Electrotype, Erie, Pa.

### ENGINES, MOTORS AND DYNAMOS

**A. C. WASHING** Machine motors \$5.00 each. Satisfaction Guaranteed. Elle & Co., 1018 W. Lake, Chicago.

**STEAM** Engines—One H. P. \$18.00; 1/2, \$12.00. James Chambliss, Bessemer, Ala.

**MAKE** your own—half and one horse-power electric motors. A. C. Induction motor model shows winding connections plain sight. Quick easy way. Gaines Bros., Box 481, Gainesville, Texas.

**FOR** Sale: 1/4 and 1/6 H.P. Motors, 110 Volt, 60 Cycle A.C. Slightly used—Good running condition, \$5.00 each while they last. Cash with order. Maytag-Chicago Co., 237 W. Madison St., Chicago, Ill.

**GOVERNORS** for all auto engines where used for power plants. Send for circulars. A. C-S Governor Co., Springville, N. Y. or 215 W. Manchester, Los Angeles.

**ALTERNATING** Current, new single phase 1/4-h.p. motor complete with cord, plug and pulley, \$10.75. Same motor with buffering and grinding wheels, \$14.25. All motors in original factory packages. No shopworn, repainted or rerated motors. Hyre Electric Co., 615 H.X. So. Dearborn St., Chicago.

**FOR** SALE—3 H.P. Steam Engine \$25. Governor, Lubricator \$15. Geo. Doebert, 77 Landon St., Buffalo, N. Y.

**WRITE** for bargain catalogs on electric motors, generators, electric drills, etc. Do not buy, consult us first. General Distributing Co., Security Bldg., Duluth, Minn.

**MOTORS**—New GE 110 or 220 volt 60 cycle Single Phase 1/4 HP, \$11.90; 1/2 HP, \$28.50; 1 HP, \$38.50. Mail \$3 check or money order. We will ship COD anywhere. Motor Specialties Co., Crafton, Penna.

**NEW** 1/4 horse 110-volt alternating motors \$5.50 each. Also other bargains all sizes direct and alternating. Write for prices stating size and kind of current. Queen City Electric Co., 1736 Grand Ave., Chicago.

### BLACKSMITHS

**BE** a Master Mechanic Blacksmith and Expert Tool Maker and Dresser with colored tempering charts. Price \$1.00. Valuable samples free. W. M. Toy, Sidney, Ohio.

### BENDING MACHINES

**THE** Famous Hossfeld "Wrenchless" Universal Iron Bender is the last word in bending machines. Bends metal, cold or hot, into most any conceivable shape, including Eye Bolts and Automobile Spring Eyes. Bends up to 1" bars or 1 1/2" pipe cold. Thousands in use by all classes of trade, from the smallest shops to the largest railway systems. Write for circular and prices. Hossfeld Mfg. Co., Winona, Minn.



## FOR SALE—MISCELLANEOUS

QUICK Action boilers and dry steam generators from small garment press boilers up to the largest building, heating and commercial use, a boiler for every need. Produces steam in 32 seconds from cold water, stood the test for 5 years. Saves fuel, time, space and repairs. Mercer Sales Company, 4723 Delmar, St. Louis, Mo.

ADDRESSOGRAPHS. Letter Folders. Multigraphs, Envelope Sealers, Duplicators, less than half price. Guaranteed. Pruitt Co., 117 No. Market, Chicago.

DYKE'S Automobile Encyclopedia. Latest 14th edition. Information on repairing and adjusting every part of all motor cars. How to find trouble, and fix it. Send No Money. Pay postman the postage and \$6. Popular Mechanics Press, Room 908, 200 E. Ontario St., Chicago, Ill.

RADIO "trouble shooting," also easily followed directions for constructing, testing, repairing and remodeling all kinds of radio apparatus. All in the book "Practical Radio Construction and Repairing." Discusses radio as it is today. Price \$2. Book will be sent C. O. D. Pay postman price and postage when he delivers same. Popular Mechanics Press, Room 912, 200 E. Ontario St., Chicago, Ill.

## WANTED—MISCELLANEOUS

MAIL us your discarded Jewelry, Gold, Crowns and Bridges, Watches, Diamonds, Silver, Platinum and old False Teeth. Money promptly mailed. Goods returned if offer refused. United States Smelting Works (The Old Reliable), Dept. 71, Chicago.

CASH For your discarded jewelry, diamonds, watches, gold crowns, etc. Articles returned if offer refused. Petersen's Jewelry, 2010 Division, Grand Rapids, Mich.

## REAL ESTATE, FARM AND ORCHARD LANDS

154 ACRES. Only \$750 needed. 325 Poultry, 3 Cows, 25 T. Hay, Horses, also corn, buckwheat, potatoes, fruit; beets, carrots, onions, cabbage, squash, equipment and tools; winter's living, substantial income; comfortable 5-room house, markets nearby. Price \$2,200; easy terms. Details pg. 5 illus. fall bargain catalog. Copy free. Strout Agency, 255-P, 4th Ave., New York City.

FLORIDA Farm absolutely free to some man or woman; no obligation; will grow three crops yearly; interesting particulars free. Dept. PM, Paver & Wright, Realtors, Deland, Fla.

ATTENTION! Get acquainted, cash for your property, farm, hotel or retail store, no matter where located; confidential service. Hayes Business Agency, Cincinnati, Ohio.

BARGAIN—10 lots Oilway, Canada, near steel mills. Hayes Business Agency, Cincinnati, Ohio.

SEVEN-ROOM Suburban home; also a ten-acre lot at Houston, Texas. Mrs. Hiram Harrison, 611 Birch, Anaconda, Mont.

EASY to Buy "Pineview Farm" in sunshine southwest Georgia. Investigate. Herbert W. Elder, Sandersville, Ga.

\$10 IS all I ask down on 20 acres in Mich. Potato Belt. Very easy terms. Near Markets, lakes and streams. Write for particulars now. G. W. Swigart, P1276 First Nat'l Bank Bldg., Chicago.

SELL your property quickly for cash, no matter where located. Don't pay big commission. Particulars free. Real Estate Salesmen Co., Desk B, Lincoln, Nebr.

PECAN-Orange-Fig Groves "On the Gulf" Monthly payments. Guaranteed care. Big, quick returns. Suburban Orchards, Dept. M, Biloxi, Miss.

OZARKS—10 acres near White River and proposed power dam, \$100, \$5 monthly. Alvin Zimmerman, 1802 N. 5th, Kansas City, Kans.

## SEEDS, PLANTS, TREES, ETC.

BIG money growing Ginseng. Booklet on Golden Seal 10 cts. W. N. Long, Florence, Ky.

## ROOTS AND HERBS

OVER 1,000 varieties Roots, Herbs, Barks, Flowers, etc. Imported and domestic. Dime brings valuable recipe book and complete information. Shawnee, 145 West 112th St., Chicago.

HERB Doctor Book—10 cents. 250 receipts for making herb medicine. Hazard Company, Box 1, Vanderveer Park, Brooklyn, N. Y.

## DOGS AND PETS

60 HIGH-CLASS registered English, Irish, Gordon Setters, Pointers and Cocker Spaniels. Trained and Young Dogs. Sales list free. Golden West Kennels, Dundee, Minn.

SAVE your Puppies and Grown Dogs. Carbon Tetrachloride Capsules expel worms, stop fits. One Dollar per box, delivered anywhere. Specify size, puppy or grown dog. Curtis Pharmacal Co., 1900 So. Broadway, Denver, Colo.

ST. BERNARDS, Champion bred pups, registered prizewinning stock. Scientifically raised to develop size, beauty, intelligence. Reasonably priced. Photos 10c. Brockington, 181-P McKenna Avenue, Montreal.

HUNTING Hounds Cheap; Trial Dixie Kennels, A7, Herrick, Ill.

FOR Sale—Guinea pigs for breeding or laboratory purposes. \$1.00 each. G. D. Affleck, Columbus, Ga.

ENGLISH Setter Puppies. Robert Lewis Weis, Saylesville, R. I.

BEAUTIFUL Fox Terriers. Collies, Shepherds, Ed Barnes, Clay Center, Nebr.

FOR Sale—My A1 Coonhound Lead. "Good as goes into the woods." Priced right for trial. C. Hicks, Sedalia, Ky. (B120).

FOR Sale. Minks, squirrels, raccoons, foxes, ferrets, muskrats, ginseng, rabbits, skunks, wolf pups, opossums. B. Tippman, Caledonia, Minn.

HUNDRED Hunting hounds cheap. Supplies. Catalog. Kaskaskennels, N19, Herrick, Ill.

## RABBITS

MAKE big profits with Chinchilla Rabbits. Real Money-makers. Write for facts. 852 Conrad's Ranch, Denver, Colo.

COMMERCIAL Poultry Raising can be made a profitable venture, yet certain well established rules must be followed. Avoid pitfalls by getting our reliable 572 page book of the latest and best practice. It will increase your profits. Order today and pay postman \$3 plus the postage when he hands you the book. Money back if not satisfied. Popular Mechanics Press, Room 908, 200 E. Ontario St., Chicago, Ill.

## PERSONAL

THE "Sanatory Physician" an 80 page book teaching natural laws of health, also suggests reliable self-treatment of disease. Appreciated by every reader. Mrs. S., Denver, Colo., says: "I owe my regained health to that dear little book." Postpaid 20c, address, Author, Box 437, Seattle, Wash.

BACKWARD children trained and cared for. Wilson Schools, Dayton, Ohio.

GYPSY Oracle Fortune Teller and Dream Book (pocket size) 10c. G. Elsen, Bowling Green, Ohio.

DRAKE'S Radio Cyclopedic—Most complete radio book in print; covers the whole field of radio receivers and reception, construction, repair, testing, care and operation for repair men, builders, experimenters, students, salesmen and operators. 871 pages, 985 illus. Price \$6. Will be sent C. O. D. Pay postman price and postage when he delivers book. Popular Mechanics Press, Room 912, 200 E. Ontario St., Chicago, Ill.

1,000 DOLLARS health secret. Guaranteed. Cures and prevents sickness without drugs. Price, \$1. Shine, 1817 Ingram Ave., Richmond, Va.

FREE. Valuable book telling the uses of roots and herbs. Box 29, Station L, New York.

TOBACCO or Snuff Habit Cured or no pay. \$1.50 if cured. Remedy sent on trial. Superba Co., N3, Baltimore, Md.

WE answer your questions, 25c coin. Fred Klotz, Reading, Pa.

10,000 FORMULAS. A real gold mine of money-making ideas. Tells how to make almost everything under the sun. You can make and sell cosmetics, mucilage, anti-freeze solutions, battery solutions, beverages, cheese, chewing gum, cleaning preparations, extracts, hair preparations, inks, blueing, leather polish, mirrors, perfumes, polishes, typewriter ribbons, carbon paper, washing powders, liquid soap, and hundreds of other profitable articles. Send no money. Just write a postal for "Henley's 20th Century Book of Formulas." Pay postman postage and \$4. Popular Mechanics Press, Room 908, 200 E. Ontario St., Chicago, Ill.

MAGIC Incense, personality perfume, occult books, catalog 10c. Hindu Publishers, Garlick Building, Chicago.

## MISCELLANEOUS

FLYING Squirrels—Handsome pets as Christmas suggestion. Safe delivery guaranteed; express paid; booklet; \$5.00 pair. Wildwoods Fur Farm, Woodville, Texas.

TATTOOING supplies direct from manufacturer, Catalogue. "Waters," 965 Putnam, Detroit.

YOU are wanted to resilver mirrors at home. Immense profits plating auto parts, tableware, etc. Write for information. Srinkle, Plater, 288, Marion, Ind.

CRYSTAL Gazing Globes, all sizes. Waldmann, 1450 First Ave., New York.

HOMEOPATHIC and Biochemic preparations sent postpaid to all parts of the world. Manual and booklets free. Halsey Bros. Co., 645 St. Clair St., Chicago, Ill. Established 1855.

WEEDS—Cut them with cutter bar on Shaw Garden Tractor. Also plows, cultivators and runs belt machinery. Low prices. Immediate delivery. Shaw Manufacturing Company, Department C, Galesburg, Kans.

CUTS anybody can make. Simple, cheap process. \$1. Specimens, particulars. 2c stamp. M. Day, Windfall, Ind.

FUN making things. Four large profusely illustrated books telling how to make almost everything from a sail boat to a toy automobile propelled by a motorcycle engine. Now \$2 per book or \$7 for the four if ordered at once. Send No Money. Just write a postal saying, "Send the Boy Mechanic Library." Pay postman \$7 and postage. For single books, specify either Book 1, Book 2, Book 3, or Book 4. Popular Mechanics Press, Room 912, 200 E. Ontario St., Chicago, Ill.

YOU can emboss your stationery as needed. Perfect work guaranteed. Simple—inexpensive. Miller Sales Company, Dept. E, Lexington, Ky.

PRINT 250 Signs or pictures an hour without press, type or machinery. Sample and particulars 10c. Straco, 1013, Springfield, Ohio.

THE Charleston Flapper, newest joke novelty with a real kick, 10c. Bowman Novelty Co., Racine, Wis.

FLEROCAN Set on car for running water in camp, heat on stove for shower, collars for car packet. 2 gallon size, \$2.75, with 6 ft. 3/4 tubing, \$3.25. Phelps, 96 So. 10th, San Jose, Calif.

FREE Printed stationery, 100 each, or cards, with small order for Listerine Tooth Paste. Samples free. Address Printing Department, 8113 Linwood Ave., Cleveland, Ohio.

SHOP Notes for 1927. Get your copy now. Only a limited edition. Contains all the articles published in the Shop Notes department of Popular Mechanics Magazine during 1926. Send no money. Just write a postal and we'll send 1927 Shop Notes and any one of the other following numbers, 1908, 1912, 1913, 1914, 1915, 1916, 1917, 1919, 1920, 1921, 1922, 1923, 1924, 1925, 1926. Pay the postman 98 cents and the postage when he hands you the two books. Popular Mechanics Press, Room 908, 200 E. Ontario St., Chicago, Ill.

CASH Paid for Butterflies, Insects. See Sinclair Display Advertisement on page 26.

VIRGIN Wool yarn for sale by manufacturer at bargain. Samples free. H. A. Bartlett, Harmony, Maine.

ATTENTION Builders and Cement Workers—Diamond granite a new invention. Sparkles like diamonds. Harder than genuine granite. Cheaply manufactured. Sample 24c—Complete instructions \$2.00. Guaranteed. F. D. Gibson, 8 Eden Park Terrace, Cincinnati, O.

AMATEUR Cartoonists: Make money in spare time with new cartoon selling plan. Write Smith's Service, PM1194, Wenatchee, Wash.

MEXICAN Made pistol holsters, cartridge belts, lariats, horse hair articles; rattlesnake belts; list free. Tex-Mex Leather Co., 309 Esperson Bldg., Houston, Texas.

TELL an army of 3,000,000 live readers all about your offer! If you have anything to sell, buy or exchange, or if you have any reasonable proposition, tell our readers all about it—they'll respond quickly. Our booklet "How to Create More Business" contains some very interesting, helpful facts. Write today for your copy—it's free. M. L. Rund, Manager Classified Advertising, Popular Mechanics Magazine, 200 E. Ontario St., Chicago, Ill.



Everybody Needs  
this  
**MIRACLE  
INVENTION!**



Retailer



Contractor



Bookkeeper

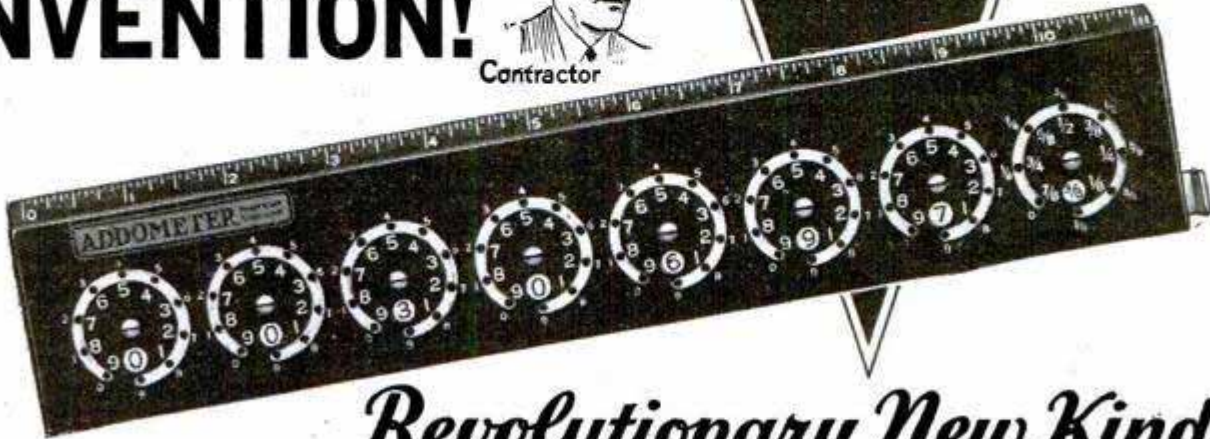

# Revolutionary New Kind of ADDING MACHINE!

... Does all the work of bulky \$300 machines, yet costs only

Here's a startling invention worth twenty times its cost to everybody who works with figures! A new kind of adding machine, called the ADDOMETER, that's truly a wonder! A thoroughly practical and efficient machine that does every kind of figuring swiftly and with perfect accuracy—at a price of only \$10!

Just think! A real honest-to-goodness adding machine capable of doing all the work of bulky, expensive \$300 machines, at no more than the cost of a good fountain pen! Why, it seems almost impossible! But it's not—it's a FACT! And we're ready to prove it by sending you a machine FREE for 10 days' trial without the payment of a single penny!

### A Mechanical Marvel

Undoubtedly the most ingenious invention in 25 years. ADDOMETER is much more than just an adding machine. It ADDS—clear up to \$99,999.99— $\frac{1}{4}$  quick as a flash! SUBTRACTS instantly with the same speed, agility and ease of operation as it adds! Even adds and subtracts FRACTIONS in units down to  $\frac{1}{4}$ ! And it MULTIPLIES and DIVIDES just as easily and quickly as the most costly machines! You can use it to total invoices, take inventory, balance ledger accounts, figure discounts or perform 1001 other useful everyday computations. ADDOMETER always gives you the right answer every time—in a jiffy!

### Operates on New Principle

Revolutionary in principle as well as in price, ADDOMETER has been acclaimed by experts as the neatest, most compact and remarkable adding machine ever invented. It

works entirely without the use of keys or awkward levers. Yet it is lightning fast and never makes a mistake. Shows the total visible at all times. Clears by a flick of the finger. Every action is simple—direct—positive. But that's not all! ADDOMETER is also radically new and different in design. It is made entirely of metal—and guaranteed for 2 years! Embodies a host of features that have long baffled the best mechanical designers. Only  $11\frac{1}{2}$ " long,  $2\frac{1}{2}$ " wide, and  $\frac{3}{8}$ " thick, and weighing but 14 oz., it can be carried anywhere right in your coat pocket—the only adding machine made that really "goes to the work." Being flat, it fits right over the sheet of figures being computed, keeping your place, preventing troublesome eye-strain, and speeding up your work. And the upper edge of the machine is cleverly formed into a handy graduated rule!

### AMAZING TEST

In a recent demonstration an inexperienced boy totaled 22 items on the ADDOMETER in 29 seconds. It required 28 seconds for an expert operator to get the same answer on a \$350 electric adding machine! THAT'S SPEED!

### A Machine Everybody Needs

ADDOMETER performs a useful, practical, necessary service in the daily life of almost everybody. Does all your figuring for you quickly and accurately. Eliminates mental strain, prevents costly errors, saves you time and money every hour of the day. Even if it sold for \$100 or more you shouldn't be without it! At only \$10 you

### SALESMEN—A WONDER!

ADDOMETER is the biggest selling sensation in years! Sells on sight to everyone who uses figures! Every territory jammed with buyers! Write TODAY for details of our astounding Money Making Plan whereby you can easily make profits of \$15 to \$45 A DAY!

couldn't buy anything that would be such a handy helper. Yet that's all ADDOMETER costs—and you don't pay a single cent until you've had a chance to use it for 10 days!



### TEN DAYS' FREE TRIAL!

We want you to have an ADDOMETER for 10 days' FREE TRIAL in your home or office. So we are offering it to anyone on our famous "No Risk" Plan. We ask NO money in advance—NOTHING on delivery—NO deposit of any kind. Simply fill out and mail the coupon and we'll send you a machine postpaid. Try it! Test it! Use it for 10 days! Then if satisfied, remit only \$10 in full payment. Otherwise return the machine. That's all we ask. By all means mail the coupon for your machine NOW—TODAY!

THE ADDOMETER CO., Dept. 49,  
(Div. Reliable Adding Machine Corp.)  
184 W. Washington St., Chicago, Ill.

Gentlemen: Please send me an ADDOMETER for 10 days' FREE TRIAL on your special "No Risk" Plan.

Name.....

Address.....

Clip and mail this coupon NOW. Please accompany coupon with your business card or letterhead, or give name of one reference. This is important. THANK YOU!

(P. M. 12-27)

The Addometer Company Dept. 49 184 W. Washington St. Chicago, Ill.





**"Gee, I'd give anything if I could only play something"**

How often have you said it? How often have you found yourself sitting heavy-hearted, blue—on the edge of the crowd—disturbed at your awkwardness?

Before joining the New York Academy of Music—before mastering the world's most popular instrument, the Tenor Banjo—most of our students were in exactly that position. Most of them were definitely lacking that most of all social assets, the ability to "play something."

Most of them, before joining us, had never, touched a string—never read a single note. But look! Reports like these are typical: Alfred Biron, Manchester, N. H., wrote: "My Tenor Banjo came safely just a few days ago and I can already play a few tunes." Leon G. Sessions, Lumbertown, N. C., wrote: "When I received my first lesson, I did not know one note from another, but in just a short while I could play very well. Now every night I have somewhere to go and best of all I get \$15 to \$25 for every night I play."

**The Best Instrument of All to Learn—  
And the Best Way to Learn It**

No other instrument is so handy to use and carry, so adaptable and so universally popular as the Tenor Banjo. It's the ideal instrument for the average man or woman. And the best place to learn to play it is right in your own home, in one to three months' spare-time. Our remarkable, new, easy, scientific short-cut method—"The Play-Way"—can positively make you socially. And professionally, too, if making more money has any appeal.

**Read All About The Play-Way**

The only course of Tenor Banjo instruction which includes phonograph demonstration records of every selection in the course—fifty-five selections in all. Also includes the handsome big Tenor Banjo, shown here, together with Tuner, Pick, Extra Strings. Course itself has fifty-five easy, interesting lessons, illustrated with hundreds of pictures, charts and drawings, that positively assure your quick success.

**Why Others Are So Successful**

In the book shown below, we give you FREE all the facts that have brought boundless pleasure, real popularity and financial success to hundreds of others. You'll be astounded to discover how quickly, easily and inexpensively you can master this matchless, money-making instrument. Find out how easily you can set your course straight for the things that make life worth living. Get this big, FREE book at once. Tell us TODAY that you want it!



**Big Tenor Banjo comes with Course**

**Get Big Free Book**

A. F. Bloch, President,  
New York Academy of Music,  
Studio 112, 100 Fifth Ave.,  
New York City.

Send FREE Book telling how I can master the Tenor Banjo at home, in one to three months. Also all about the big Tenor Banjo outfit and demonstration phonograph records. No obligation, understand.

Name.....  
Address.....



**"I would not part with it for \$10,000"**

So writes an enthusiastic, grateful customer. In like manner testify over 100,000 people who have worn it.

**The Natural Body Brace**

*Comfortable and Easy to Wear*

Overcomes Weakness and Organic Ailments of women and men. Develops erect, graceful figure, brings restful relief, comfort, health and strength.

**Not Sold in Stores—**

**Made to Measure—**Makes work easy and walking a pleasure; replaces and supports misplaced internal organs; reduces enlarged abdomen; straightens and strengthens the back; corrects stooping shoulders; develops lungs, chest and bust; relieves backache, curvatures, nervousness, ruptures, constipation.

**Get Well—Stay Well** Write today for illustrated booklet, measurement blank, etc., and read our very liberal proposition.  
**HOWARD C. RASH, Pres., Natural Body Brace Co.**  
223 Rash Building • • SALINA, KANSAS



**30 Days Free Trial**

**NO JOKE TO BE DEAF**

**—EVERY DEAF PERSON KNOWS THAT**



I make myself hear, after being deaf for 25 years, with these Artificial Ear Drums. I wear them day and night. They stop head noises and ringing ears. They are perfectly comfortable. No one sees them. Write me and I will tell you a true story, how I got deaf and how I make you hear. Address



**GEO. P. WAY, Artificial Ear Drum Co. (Inc.)**  
80 Hoffman Bldg., 2539 Woodward, Detroit, Mich.

**FREE TRIAL Grows Hair**



**AMAZING NEW ELECTRICAL DISCOVERY**

A noted surgeon has discovered an amazing way to grow hair, called Dermo-Ray. In 30 days no more dandruff. Scalp tissues are given new life. Then within a few weeks, luxuriant new hair! The startling discovery of the almost magic effect of Infra-Red Rays on the hair-growing tissues was made by a leading surgeon. Two years ago he was himself bald. Today his hair is full and thick.

**FAMOUS SURGEON'S DISCOVERY**

Here is his own personal, home treatment, called Dermo-Ray. At last a home method endorsed by science. Guaranteed to bring you these same results in 30 days—or you pay nothing. You can use Dermo-Ray in any home with electricity. The warm, soothing Infra-Red Rays vitalize the scalp while you rest—a few minutes each day is all the time required.

**SEND NO MONEY** Complete facts about this astounding new scientific discovery, opinions of authorities, incontrovertible evidence, and details of special trial offer sent free, if you mail the coupon below. To end your scalp and hair troubles, act at once. Print your name and address plainly—and mail the coupon NOW!

**-----FREE TRIAL OFFER-----**

**The Larson Institute**  
216 North Wabash Ave., Dept. 143, Chicago, Ill.  
Send me at once, without obligation, full particulars—in plain envelope—of your 30-day Free Trial of DERMORAY.  
Name.....  
Address.....  
City.....State.....







**RYAN  
WHIRLWIND  
MONOPLANE**

Sister Ship of Col. Lindbergh's Spirit of St. Louis.

One of several of our planes now in service.

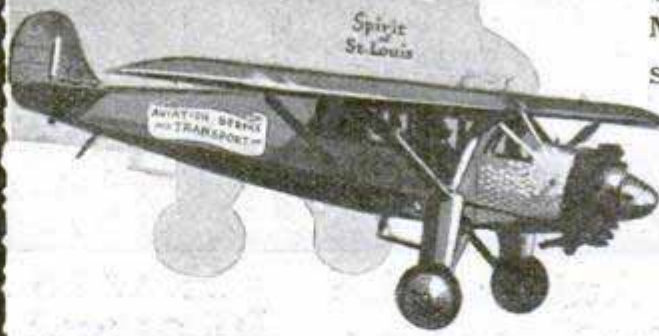

**COMMERCIAL AVIATION CALLS YOU!**

Tremendous expansion is rapidly following the dawn of this new era of air transportation. Train to fly and to make the most of today's possibilities for you with a large transport company, actively engaged in flying—passenger, express, freight, aerial photography, surveying, etc.

**COMPLETE ARMY AND NAVY GROUND WORK AT HOME—  
COURSES—U. S. LICENSED MEN ACTUAL FLYING IN CHICAGO**

This organization gives Army and Navy School courses in aero-dynamics, plane construction, motor mechanics, practical navigation, parachute operation and actual flight training, as well as the commercial branches of the industry.

You can start with your ground course at home through correspondence and finish intensively in Chicago at the million-dollar municipal airport on which our hangars, shops and classrooms are located—or you can come to Chicago at once.

**\$300 TO \$1000 A MONTH—  
FREE EMPLOYMENT SERVICE**

A five-year employment service free to our students and graduates. Earn while you learn and prepare for a \$300 to \$1000 a month position. Eight places on the ground for every pilot to be filled. Our Guarantee: "The latest and most advanced training with one of the largest organizations of its kind in the world."

**Act! Now!** "The Airway," full of interesting facts about requirements, methods and opportunities is yours for 10c. coin or stamps. Worth many dollars to any interested man or woman whether 20 or 50 years of age. Use the coupon.

**AVIATION SERVICE AND TRANSPORT, INC.,  
203 N. Wabash Ave., Dept. P. M. 12, Chicago, U. S. A.**

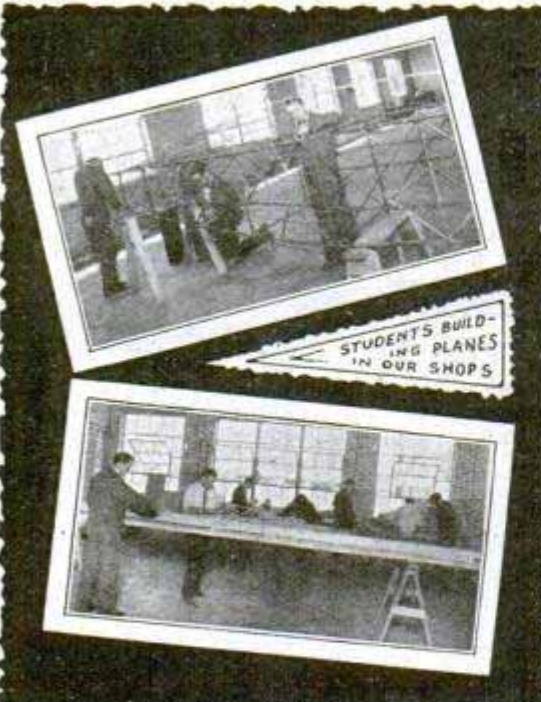

**AVIATION SERVICE AND TRANSPORT, INC.,  
203 N. Wabash Ave., Dept. P.M. 12, Chicago, U. S. A.**  
Send me your new book on commercial aviation, "The Airway."

Enclosed is 10c in { currency stamps

Name.....

Address.....

Age.....

**THESE BOOKS MAKE PROMOTION SURE!**

**H**ERE in seven handsome volumes is a complete education in power plant practice. Under the editorship of Terrell Croft, a staff of engineering specialists have put into the books everything the power plant man needs to know in order to get to the top.

**Power Plant Practice 7 Volumes—2795 Pages  
3706 Illustrations**

With the aid of this library hundreds of ambitious men have stepped into bigger jobs. You have the same opportunity. With a little spare-time reading you can have the identical knowledge possessed by the highest paid engineers.

With these books to guide you, you can fit yourself for the big-pay jobs in the power plant field.

The library covers the entire field—boilers—valve setting—engine operation—turbines—injectors—foundations—electrical machinery—combustion—refrigeration—fuels—governors—boiler stresses—fire tubes—feed water treatment—selection of boilers and engines—pumps and pump governors—steam traps—condensers—piping, etc.

Every page is packed with the kind of information that the power plant man needs in his daily work.

If you want to get ahead in your work—if you want to pass an examination for an engineer's license—if you want the big pay that comes with increased knowledge—get these books.

**Free Trial—No Money  
Down—7c a Day!**

**FREE EXAMINATION COUPON**

**McGraw-Hill Book Co., Inc.  
370 Seventh Ave., New York**

Ship to me, charges prepaid, the seven volumes of the POWER PLANT LIBRARY, price \$16.00. If satisfactory, I will send \$2.00 in ten days and \$2.00 a month until the special price of \$16.00 has been paid. If not wanted I will return.

Name.....

Home Address.....

City and State.....

Occupation or Position.....

Firm or Employer.....

PM-12-27

**BE AN OFFICER  
in the U.S. Coast Guard  
\$1700 Up to \$7,500 Yearly**  
\$780 yearly at the U. S. Academy while training. You rank Ensign to Captain in service. Age requirements 18 to 22. Write Dept. P, for information.  
**COAST GUARD PREPARATORY SCHOOL  
4000 Ga. Ave., N. W. Washington, D. C.**

**HYPNOTISM**  
Learn the secrets of Hypnotism—that strange subtle power which enables you to make others love you; overcome bashfulness; strengthen your memory, mind and will power; realize your ambitions; develop a strong magnetic personality and gain control over others. These magic secrets explained in 25 easy lessons. Complete Course, \$1.00. Satisfaction Guaranteed. Bargain Book Catalog FREE.  
**FRANKLIN PUB. CO., 186 N. LaSalle St. Dept. 9419 CHICAGO**

**NOTHING SHALL SEPARATE YOU**  
Be the first one to get a Radio-X-Ray in your home, school, office, shop or camp. Always causes every one to marvel from the youngest to the eldest. You seem to see through everything with the Radio-X-Ray, an illusion which proves materiality is not so real and opaque after all.

**RADIO-X-RAY**  
Finished in pleasing colors. Very neat and attractive and fits nicely in your pocket. Serviceably constructed, will stand lots of rough use. **SEND NO MONEY!** Send postcard or letter with your name and address saying you saw this ad. When Radio-X-Ray is delivered pay postman \$1.55 plus postage. Satisfaction guaranteed or money refunded. Send today. Be first to have one. Enter-tain your friends. **The Principia Co., E. Cleveland, O.**





## Make the Same Discovery John Harned Did

**AT LAST** A Dead Sure, Intensely Interesting,  
Quick Way to Test Your Mental Powers

### Can You Score 75%?

It's only a few months ago that John Harned overheard his worst enemy at the office talking with the chief engineer of the Company.

"Yes," agreed the chief. "John Harned is too backward."

Still, he felt that he was away above the average in mechanical brains. But he had no way to prove it even to himself. If he could only find some conclusive test—a private one—he knew he would be a changed man. Then he could "kill" that sub-conscious doubt that was making him "too backward." He would absolutely know, then, that study and work would bring him big success.

#### A Cigar and—

By a strange coincidence, when he stopped for a cigar that night, the druggist showed him a new pocket size, wood block PUZZLER.

He worked it for Harned, rapidly, once. "Now," he challenged Harned, "how long will it take you to solve it?"

"How long?" exclaimed Harned. "About a second. Why, man—you've just showed me how!"

"You're going to make a big discovery," said the druggist.

#### Late for Supper

Half an hour later Harned was still at it. The druggist smiled.

"Here," said Harned. "Sell me this. But I'll bet you a cigar I'll work it right after supper."

"Then you have the best mechanical brains in the world."

"How's that?"  
"It's really a mental test. The latest craze in New York. One man, woman or child in a hundred thousand people may work it in half an hour. They are 100% mechanical geniuses."

#### How to Score

"Work it in three hours, for instance, and you score 97%. You lose 1% for every hour or fraction longer than the first half hour. Good brains may solve it in several days. Below the average people cannot solve it at all."

John Harned was delighted. Here was just what he had wanted. He would have two hours and a half after supper to score 97%. If he succeeded, he would be "too backward" no longer. IF—

#### Racing Time

After supper he told his family—made his young son timekeeper. John Harned worked. He studied. Never had time raced so fast.

Finally, his son told him he had five minutes more. Then four minutes. Three minutes. Wife and family gathered around him excitedly. He failed.

Fifteen minutes later he let out a great shout. "Solved!" 96%.

His son solved the PUZZLER in seven hours. His wife did it in ten.

But Harned's biggest delight came at the office, where everybody wanted to try the PUZZLER. The chief struggled with it fourteen hours. Best of all, Harned's enemy never could work it. It was all John Harned needed. The chief has boosted him twice since that.

#### Dad's Puzzler

Is the name of the handsome, pocket size, wood block mental test with which John Harned found himself. Since then he has made a score of 83% with MA'S PUZZLER, and 91% with THE FLYING PUZZLER—both handsome, pocket size sequels.

#### Tremendous Popularity

When you can solve these PUZZLERS, you are "cock of the walk," the center of the crowd. A certain famous resort hotel man of the East entertains many jurists, big divines, actors. He does the PUZZLER for them once, then bets them fifty cents they cannot do it in half an hour. They all fail, laugh, snort, and refuse to be stumped.

A man holds the record. Twenty minutes. But perhaps you are a woman who can beat that.

Everybody wants them. More than a million have been sold in less than a year. A drug store next to Grand Central Terminal in New York has sold 35,000 in the last six months.

#### Christmas Presents

One—or a nest of three—make the Christmas remembrance of the hour. Cheap as engraved greeting cards, but different. More novel. People want them. Children of school age are wild about them. And they train young minds to concentrate.

#### Sold Everywhere

Many drug, novelty, tobacco, chain, book and department stores sell them now. Merchants may write for proposition, or they are stocked by Butler Bros., Liggett, and other large distributors.

If not in your town, order by mail. We send, postpaid, the introductory nest of DAD'S, MA'S and FLYING PUZZLERS, attractively boxed, with mental scoring card in each PUZZLER, for only \$1.00. Clip coupon, enclose dollar bill or check. Mail NOW.

PUZZLER DEPT.,  
STANDARD TRAILER COMPANY,  
CAMBRIDGE SPRINGS, PA.

Enclosed find \$.....for..... nest of handsome, pocket size, wood block MENTAL TESTS, which you will send postpaid.

Print Name.....

Address.....

City.....State.....

Each nest of three, \$1.00. Any one PUZZLER, 50c, postage and packing included. If only 50c enclosed, send the pocket size mental test checked.

DAD'S PUZZLER. Move largest block from upper to opposite lower corner. Open space in box only ¼ size of largest block.

MA'S PUZZLER. Ma and her boy are separated by sickness, discouragement, no money, etc. Reunite them.

FLYING PUZZLER. Hop off from New York and land in Paris in spite of storms, fog, air pockets, breakdowns, etc.

Everybody eventually buys all three. Better send the dollar now and save time and fifty cents.

**DAD'S PUZZLER • MA'S PUZZLER • FLYING PUZZLER**



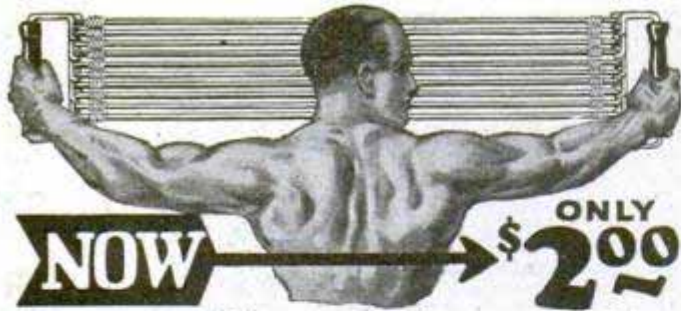

**NOW** → **ONLY \$2.00**  
**Giant Chest Expander**

**and**

**Progressive Exerciser**

Be a muscular marvel. Have the muscles of a superman. Become strong for your health's sake or to astound your friends with extraordinary feats which only men of giant strength can do. In a few short weeks you will easily do stunts which now seem difficult—then real

**Send No Money Use This Money Saving Coupon**

muscles and strength will be yours—and yours to keep. If you want exercise to just keep in good shape you can reduce the strength of the Progressive Exerciser by eliminating as many cables as you wish. If you want great resistance so as to build up big solid muscles then use the full strength.

**How the Giant Chest Expander and Progressive Exerciser Is Made**

The Giant Chest Expander and Progressive Exerciser is made with new live, springy rubber so as to give it long wearing and great resisting qualities. Do not pay more for an exerciser that has forty or less rubber strands to each cable. Get the best and most durable. The Giant Progressive Exerciser has **50 strands** of the finest rubber procurable to each cable.

**Free Instructions**

We do not think it enough to send you an exerciser worth double what we ask, so for a limited time, we will also include instructions absolutely free. These instructions are interesting and simple to follow—they show you the short cut to health and strength. Order today before this wonderful offer is withdrawn.

**Your Guarantee**

The Giant Chest Expander is sold with a guarantee that you will say it is the finest you ever saw or your money back.

**5 Cables or double 10 Cables for strength for \$2**

**\$4** The double strength exerciser has resistance of over 200 lbs.

**How to Order—Send No Money**

Sign your name and address to coupon below and get your Giant Exerciser at the present low introductory price by return mail. The price is made low because we want everyone to enjoy muscles and strength at the lowest possible cost. Don't pay more—order from us—get the most for your money. Use coupon now.

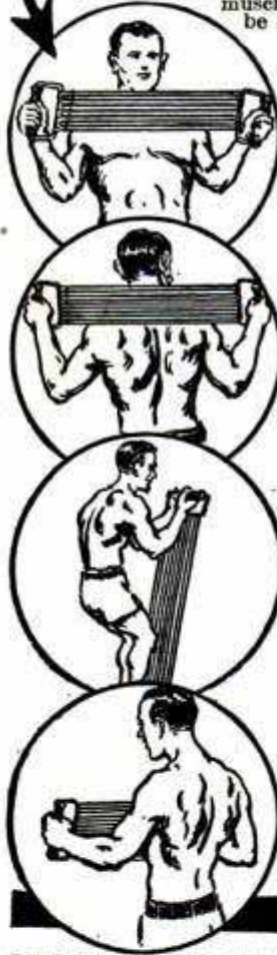

**PROGRESSIVE EXERCISER CO.,**  
 4012 Langdon Bldg.,  
 Broadway and Duane Street, New York

Please send  Your 10 cable Progressive.  
 Your 5 cable Exerciser.

Check the Exerciser you want, and it will be sent you by return mail. Pay postman introductory price, plus few cents postage on arrival. It is understood that if you are not entirely satisfied with your exerciser you may return it within 5 days and get your money back.

Name.....

Street.....

City..... State.....

If you live outside the United States, send cash with order.

**LEARN BY DOING**

Every phase of all branches of

**ELECTRICITY**

taught by

**Actual Practice**

In one of America's foremost institutions for trade training

ESTABLISHED 1902

**No Books Used**

Individual Instruction Start Any Day

Write for FREE 64-page catalog

**THE NEW YORK ELECTRICAL SCHOOL**  
 44 West 17th St., New York City

STATEMENT OF THE OWNERSHIP, MANAGEMENT, CIRCULATION, ETC., REQUIRED BY THE ACT OF CONGRESS OF AUGUST 24, 1912, of Popular Mechanics Magazine, published monthly at Chicago, Ill., for October, 1927. State of Illinois, County of Cook, ss. Before me, a notary public in and for the state and county aforesaid, personally appeared H. H. Windsor, Jr., who, having been duly sworn according to law, deposes and says that he is the editor and business manager of the Popular Mechanics Magazine and that the following is, to the best of his knowledge and belief, a true statement of the ownership, management, etc., of the aforesaid publication for the date shown in the above caption, required by the Act of August 24, 1912, embodied in section 411, Postal Laws and Regulations, printed on the reverse of this form, to wit: First, That the names and addresses of the publisher, editor, managing editor, and business manager are: Publisher, Popular Mechanics Co., 200 East Ontario St., Chicago, Ill. Editor, H. H. Windsor, Jr., 200 East Ontario St., Chicago, Ill. Managing Editor, L. K. Weber, 200 East Ontario St., Chicago, Ill. Business Manager, H. H. Windsor, Jr., 200 East Ontario St., Chicago, Ill. Second, That the owner is: (If owned by a corporation, its name and address must be stated and also immediately thereunder the names and addresses of stockholders owning or holding one per cent or more of total amount of stock. If not owned by a corporation, the names and addresses of the individual owners must be given. If owned by a firm, company, or other unincorporated concern, its name and address, as well as those of each individual member, must be given.) L. H. Windsor, 200 East Ontario St., Chicago, Ill.; H. H. Windsor, Jr., 200 East Ontario St., Chicago, Ill. Third, That the known bondholders, mortgagees, and other security holders owning or holding 1 per cent or more of total amount of bonds, mortgages, or other securities are: (If there are none, so state.) None. Fourth, That the two paragraphs next above, giving the names of the owners, stockholders, and security holders, if any, contain not only the list of stockholders and security holders as they appear upon the books of the company but also, in cases where the stockholder or security holder appears upon the books of the company as trustee or in any other fiduciary relation, the name of the person or corporation for whom such trustee is acting, is given; also that the said two paragraphs contain statements embracing affiant's full knowledge and belief as to the circumstances and conditions under which stockholders and security holders who do not appear upon the books of the company as trustees, hold stock and securities in a capacity other than that of bona fide owner; and this affiant has no reason to believe that any other person, association, or corporation has any interest direct or indirect in the said stock, bonds, or other securities than as so stated by him. H. H. WINDSOR, Jr., Editor and Business Manager. Sworn to and subscribed before me this 28th day of September, 1927. J. GRAHAM, Notary Public. (My commission expires June 17, 1928.)

**GOV'T. POSITIONS**  
 \$35 TO \$75 WEEKLY

- ( ) Railway Mail Clerk ( ) Special Agent
- ( ) P. O. Clerk ( ) (investigator)
- ( ) File Clerk ( ) Stenographer-Typist
- ( ) Matron ( ) Immigrant Inspector
- ( ) General Clerk ( ) City Mail Carrier
- ( ) Chauffeur-Carrier ( ) U. S. Border Patrol
- ( ) Skilled Laborer ( ) Typist
- ( ) Watchman ( ) Seamstress
- ( ) Postmaster ( ) Steno-Secretary
- ( ) RFD Carrier ( ) Auditor
- ( ) Meat Inspector

Mr. Ozment, Dept. 111, St. Louis, Mo.  
 Send me particulars about positions marked "X"—salaries, locations, opportunities, etc.

NAME.....  
 ADDRESS.....



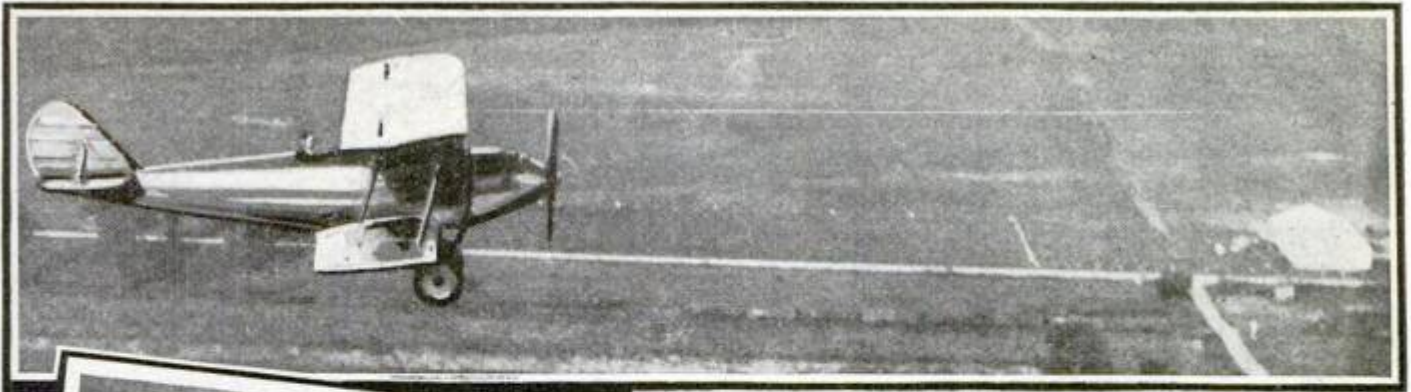

Fuselage & Assemble



Working on Motors



Covering Wings

# The Sweeney School

With planes, equipment and instructors under U. S. Govt. inspection, the million dollar Sweeney School, with its 150 acre private flying field, club house, hangar and thousands of dollars worth of latest tools, machinery and equipment for aviation, offers young men the most efficient, economical and practical method of getting into this great business. Picture above shows Dr. Brock, a Sweeney flyer, in the air over the Sweeney Air Port. Hangar at upper right.

## Pilot or Ground Course

YOU can select either the pilot course or ground mechanics course or combine the two courses. All the flying with dual controls and later solos to qualify you. All the ground work in motors, ignition, wings and construction qualify you to become an expert and five men are needed on the ground for one man in the air. The cost of tuition is extremely low and living conditions are pleasant and economical. Many men just out of the army come here to take up this work. Student body very high class. No previous experience required. We use tools, not books.

## Col. Lindbergh Advises You

"Aeronautics in the U. S. today are in a position no other industry has ever been in. It is probable the great transcontinental air lines of the future will pass thru Kansas City. Kansas City is naturally located to become this hub."

**FREE** Send name today for full details. Illustrated catalog shows pictures of students at work in shops and in the air. Everything you want to know about aviation. Lists of jobs and high pay offered aviators and mechanics. No colored students accepted.

**SEND THIS NOW**

**EMORY J. SWEENEY, President**  
4406 Sweeney Bldg., KANSAS CITY, MO.

Please send me full information about your Aviation Course.

Name..... Age.....

Address.....

Town..... State.....

**LEARN TO FLY BY FLYING**  
**Sweeney**  
SCHOOL of AVIATION  
4406 SWEENEY BLDG, KANSAS CITY, MO.



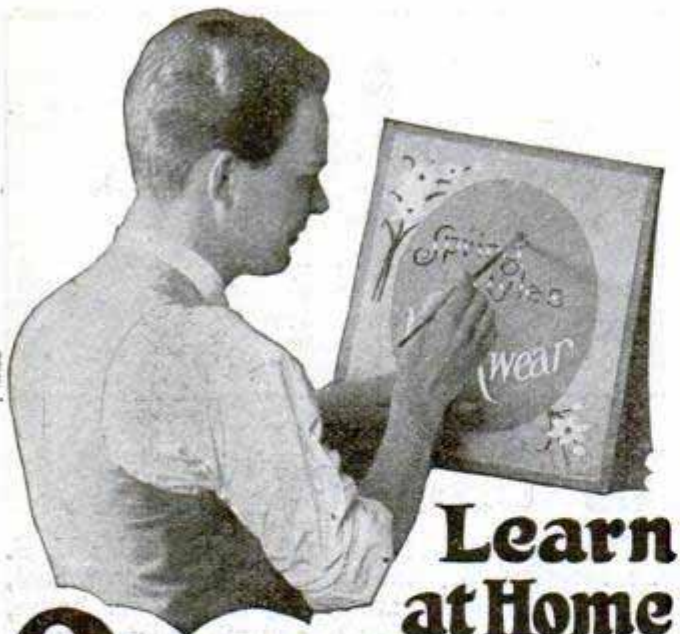

# Learn at Home to Make Clever SHOW CARDS

A profitable Business of Your Own for full or spare time. Earn \$25 or more a week in spare time. Double your full time pay. This practical method of home instruction has simplified everything.

Why work for low pay? Clever "sales-increasing" display material is always needed by progressive business enterprises of every description. \$10 to \$20 is often paid for a single attractive show card. Skilled Show Card Writers command high salaries—right from the start.

Prepare now. No special ability needed. Learn at home in spare time through this most complete, practical method. Student R. A. Hart writes: "I make not less than \$2.00 an hour making show cards in spare time." Ray Underwood (while still a student) wrote: "Am with a large sign company. People ask me to do work after regular hours and I clear \$25 to \$35 a day." Many others have learned Show Card Writing by this method. So Can You if you will simply apply yourself as they did.

Take advantage of the money-making opportunities open in the Show Card field. Make Show Cards for your present employer or for several merchants at one time. Have a profitable business of your own. Earn up to \$100 a week—more if you're ambitious.

**Send for FREE Book**

Get busy. Boost your pay. Don't delay another hour. Send coupon now for big, Free Illustrated Book and full information. Mail coupon now. No obligation. No salesman will call.

Washington Show Card School, Dept. 3012-E  
1117-15th Street, N. W., Washington, D. C.

Washington Show Card School, Dept. 3012-E  
1117-15th Street, N. W., Washington, D. C.

Please send me FREE and without obligation, a copy of the new 32-page book, "Quick Success in Show Card Making," and special offer to new students.

Name.....  
(Write name plainly and state whether Mr., Mrs., or Miss)

Address.....

City..... State.....

Age.....



There is a Santa Claus! He will help you win for yourself a bicycle, radio, sled, football or any one of 300 other prizes. You won't have to wonder how to get a present for Dad, Mother, Sister and the other members of the family.

Hundreds of boys are earning their own spending money and winning dandy prizes. They never wonder where their Christmas money will come from. They are Crowell Junior Salesmen who deliver three of the best known magazines to regular customers. They had no experience to start. We taught them how to get their customers. They work only a few hours of their spare time each week.

You can, also, be a Crowell Junior Salesman and always have ready spending money. Send today the attached coupon and learn how easily you can earn money and win prizes.

Mr. Jim Thayer, Dept. 39  
The Crowell Publishing Co., Springfield, Ohio.

Dear Jim: I want to be my own Santa Claus. Start me off as a salesman.

My Name.....

Address.....

Town..... State.....



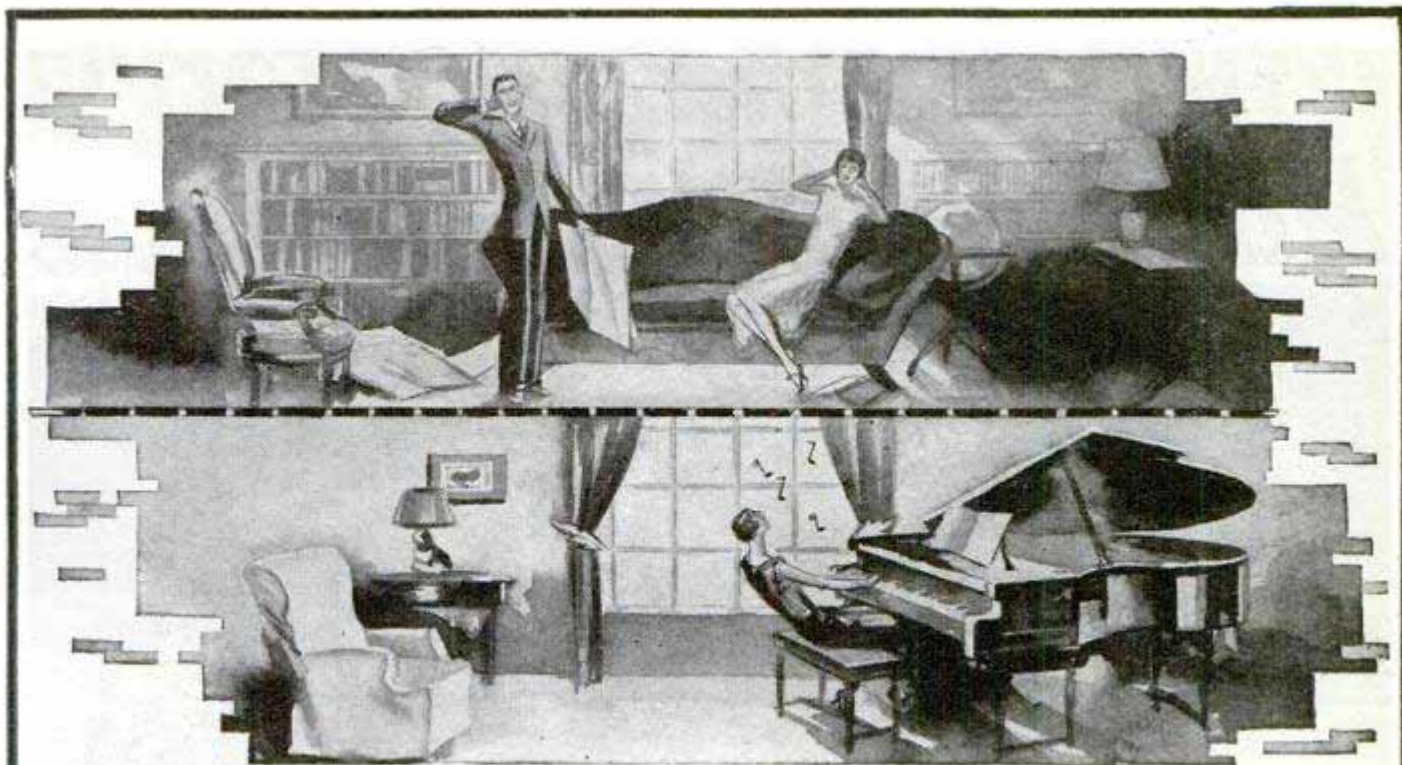

# Don't Sing Scales -Use Silent Method

**S**URPRISING! Yes, unheard of perhaps to you. Entirely revolutionary to all usual methods of teaching voice. But 30,000 pupils acclaim this new *silent* method and 30,000 pupils tell of astonishing improvements. You will recognize Prof. Feuchtinger's method as based on sound scientific *facts*. Don't take a chance of ruining your voice by straining at monotonous and tiresome scales. He will teach you to build up the strength and elasticity of your vocal organ through scientific muscular exercise. These exercises are *silent*. You may practice them in the privacy of your room. With surprising rapidity you will notice that your voice is becoming stronger, richer, more beautiful every day.

## 100% Improvement Guaranteed!

Prof. Feuchtinger is a voice teacher who actually guarantees *results!* To you, as to every one of his pupils, he says: "I will improve your voice 100% or refund your tuition." Nothing involved about that guarantee. It is so simple and direct that it is astounding. You are to be the judge. If you, yourself, do not think, after completing the course, that your voice has been improved 100%, back comes your money. Send the coupon and get the most inspiring book ever written about voice—actual *true stories* of those who have won fame and money as a result of Prof. Feuchtinger's training. The book is *free*—it is yours to keep without obligation of any sort. He can do for you what he has done for many thousand others. Send the coupon right now while you are reading these words and you have made the first step toward the voice you've longed for.

**Perfect Voice Institute** Eugene Feuchtinger, A. M.  
Director  
1922 Sunnyside Ave., Studio 13-59 Chicago, Ill.

Perfect  
Voice  
Institute,

Studio 13-59,  
1922 Sunnyside Ave.,  
Chicago, Ill.

Gentlemen: Send at once, free and without obligation, your beautifully illustrated book, "Physical Voice Culture," and full information regarding your home study method of voice building. It is understood that I do not have to pay a cent for this book, either now or later, and that I do not have to return it.

Name.....

Address.....



# The Whole Amazing Story of "Miracles Worked in Muscle"

**NOW FREE TO READERS OF POPULAR MECHANICS**

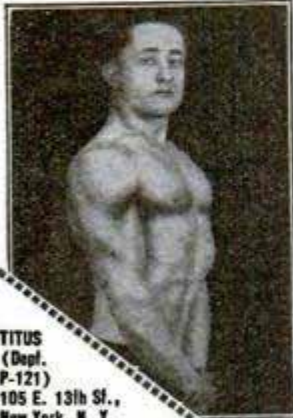

TITUS (Dept. P-121) 105 E. 13th St., New York, N. Y.

EVERY reader of Popular Mechanics Magazine is familiar with the extraordinary muscle-building feats of TITUS, the famous pioneer in the field of physical training. Many photographs have appeared in these pages of men re-built by TITUS—photographs taken before and after. These pictures show real miracles worked in muscle—amazing transformations from puny, flat-chested weaklings into giants of strength—all in the short space of 30 days!

How is it possible? What magic does this man Titus possess? What is his startling secret of building muscle?

Now it can be told! A wonderful book has been written—a book that reveals the inside secrets of Titus Training—a book crowded from cover to cover with sensational facts about strength, power and endurance.



## RUSH COUPON FOR YOUR COPY OF THIS ASTOUNDING BOOK

This book is yours FREE—if you rush the coupon. The demand will be overwhelming—every reader will take advantage of this remarkable opportunity. Don't lose a minute. You want this book, you must have it. You will eat up every word it contains. You will marvel at the dozens of photographs—every one a sensational demonstration of Titus RESULTS. Stories of champion strong men, stories of invalids transformed into marvels of physical perfection, first-hand tips from the Master Trainer of them all. Mail the coupon TODAY! First come, first served. No cost, no obligation, no strings of any kind. This book is yours, free and clear, for all time. Send NOW.

Yes, I want my copy of the Titus book disclosing his secrets of building the most powerful muscles ever put on the human body. Send it to me by return mail—FREE.

Name .....

Address .....

Town ..... State .....

The One and Only **TITUS** Address: Dept. P-121 105 E. 13th St. New York City

## COMMAND A LARGE, STEADY INCOME!

The Technical man always wins. Technically trained men are in constant demand. Become independent by using your spare time at home to master any of the crafts listed opposite. The St. Louis Technical Institute is one of the most thorough institutions for Technical home study to-day. Our methods and lesson material are so plainly and clearly defined that you will be astonished at your rapid progress. Check the subject in which you are interested and we will send you complete information. Special drafting courses arranged.

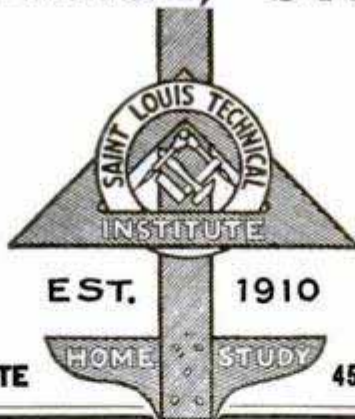

- ... Drafting { .. Architectural .. Machine .. Electrical .. Structural Steel
- ... Heating & Ventilating Engineering
- ... Plumbing & Sanitary Engineering
- ... Sheet Metal Designing & Drafting
- ... Boiler Maker Laying Out & Inspection
- ... Steel Ship Laying Off & Plan Reading
- ... Contracting & Estimating
- ... Mathematics & Slide Rule Reading

ST. LOUIS TECHNICAL INSTITUTE

4545 CLAYTON AVE., ST. LOUIS, MO.

## CHEMISTRY—Learn at home

The Chemical Industry now ranks fourth among the industries of the United States and it offers a splendid opportunity for ambitious men.

One of the best ways to prepare for a good position in this fascinating field is through the home-study courses in Chemistry offered by the International School of Chemistry.

These courses are complete and practical because they were prepared by some of the best-known chemists in this country, including ALLEN ROGERS, B.S., M.S., Ph.D.

—Head of Department of Industrial Chemistry, Pratt Institute;

L. M. TOLMAN, Ph.D.—Formerly Chief Chemist, Wilson & Co. Now Vice-president, United Chemical and Organic

Products Co.; BRADLEY STOUGHTON, B.S.

—Head of the Department of Metallurgy,

Lehigh University, and OWEN L.

SHINN, Ph.D.—Professor of Applied

Chemistry, University of Pennsylvania.



Mail coupon for Free Booklet

INTERNATIONAL SCHOOL OF CHEMISTRY

Associated with the

International Correspondence Schools Dept. 5692-E, Scranton, Penna.

Without cost or obligation, please send me full details of your home-study course in CHEMISTRY

Name .....

Address .....



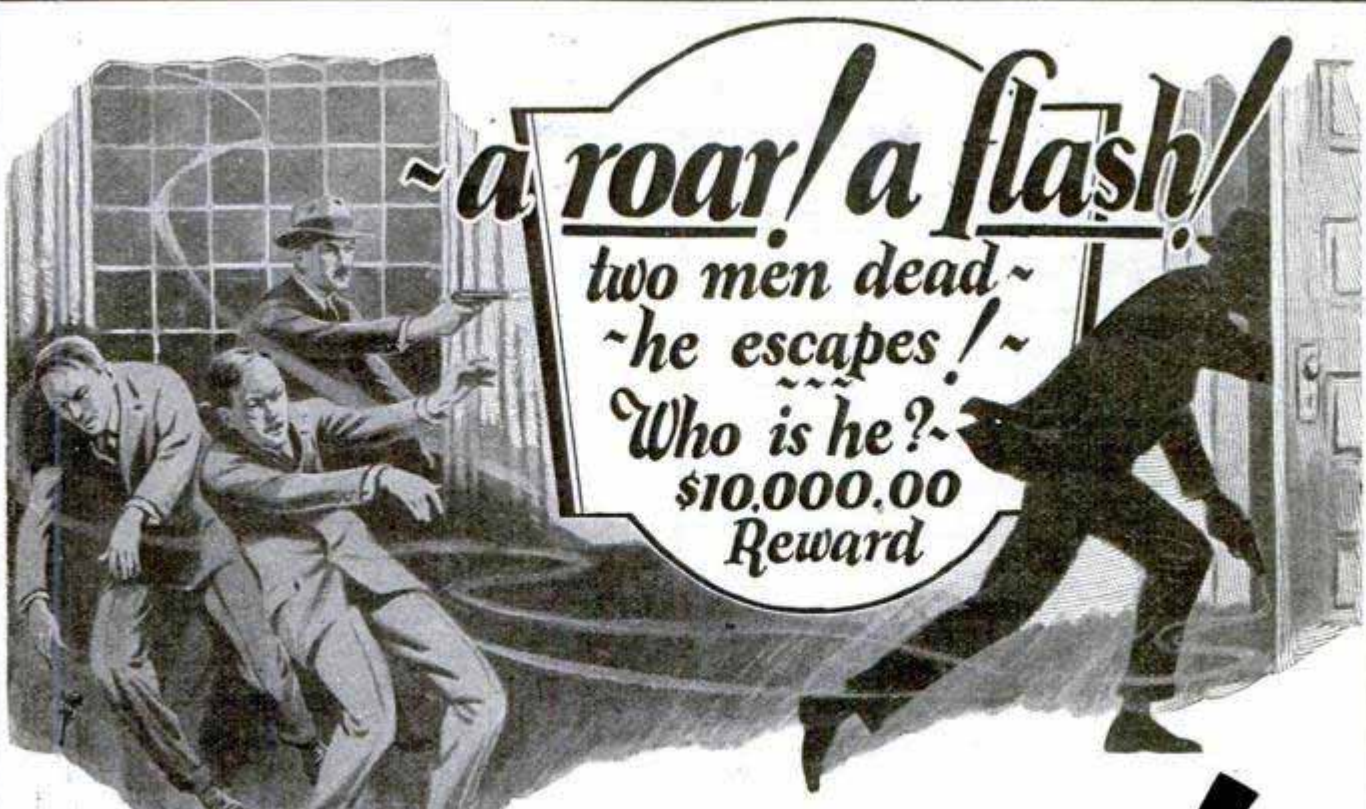

**~ a roar! a flash!**

two men dead ~  
 ~ he escapes! ~  
 Who is he? ~  
**\$10,000.00**  
 Reward

# Follow Him!

- PARTIAL LIST**  
 Graduates U. of A. S.  
 Recently appointed  
 Finger Print Ex-  
 perts of these  
 States, Cities and  
 Institutions.
- State of Iowa
  - State of Idaho
  - State of Colorado
  - State of Washington
  - State of Michigan
  - Duluth, Minn.
  - Detroit, Mich.
  - St. Paul, Minn.
  - Pittsburgh, Pa.
  - Lincoln, Nebr.
  - Birmingham, Ala.
  - Columbus, Ohio
  - Havana, Cuba
  - Calgary, Ala., Canada
  - Pensacola, Fla.
  - Houston, Texas
  - New Haven, Conn.
  - Great Falls, Mont.
  - Galveston, Texas
  - Albany County Peniten-
  - Albany, N. Y. (Itary)
  - Waterloo, Iowa
  - Wilkes Barre, Pa.
  - El Paso, Texas
  - Everett, Wash.
  - Schenectady, N. Y.
  - Alhambra, Calif
  - Livingston, Mont.
  - Saginaw, Mich.
  - Tampa, Fla.
  - Fort Collins, Colo.
  - Windsor, Ont., Can.
  - Tulsa, Okla.
  - Fueblo, Colo.
  - Idaho Falls, Idaho
  - Lorain County, Ohio
  - Ogden, Utah
  - Lansing, Mich.
  - Galveston, Texas
  - Walla Walla, Wash.
  - Indiana Reformatory
  - Jeffersonville, Ind.
  - St. Joseph, Mo.
  - Mingo Junction, Ohio
  - Oklmulgee, Okla.
  - Hazleton, Pa.

**I** M AGINE the keen thrill that would be yours following some case like this: The escaping desperado is a notorious international character with a long record. He's wanted in five countries. Rewards range from \$5000 to \$25000 for his capture. He loots a palatial mansion. Kills two men. Escapes. Disappears. Changes his entire appearance. Pulls a clever "dead" fake and is recorded as "Dead" on all police records. Dead to all records except ONE—the Inevitable Finger Print.

For ten years he deceives the world. Prospers. Becomes a social lion. And then—Bang!—the Finger Print Expert nabs him. Society is shocked. They can't believe that this social Prince is the famous Mr. "X" of criminal

fame 10 years ago. But finger prints do not lie. Never! The Finger Print Expert always wins. Glory, fame, rewards are always his.

## Thrills! Rewards! Await YOU!

Imagine the thrill, mystery, glory, fame and reward that would be yours if you were this Finger Print Expert. You can make them yours if you will. You can learn the secrets of this great science at home in your spare time. Any man of ordinary ability who can read and write can become a Finger Print Expert in a short time at a small cost.

A brilliant career and a handsome income with world-wide opportunities awaits you. Act Now. Don't let the other fellow enjoy what is rightfully yours. Mail that coupon now and learn the great things that are in store for you.

# FREE Course in Secret Service

If you mail us that coupon now you will get in on a special free offer we are making for a limited time of a professional finger print outfit free, and a Free Course in Secret Intelligence without extra cost. No obligations. You have everything to gain and nothing to lose! Act NOW! Write for handsome FREE BOOK.

**UNIVERSITY OF APPLIED SCIENCE**  
 1920 Sunnyside Ave., Dept. 13-59 Chicago, Ill.  
 Gentlemen:—Without any obligation whatever, send me your new, fully illustrated Free book on Finger Prints and your offer of a FREE course in Secret Service Intelligence and the Free Professional Finger Print Outfit.

Name.....  
 Address.....  
 Age.....

**University of Applied Science**  
 1920 Sunnyside Avenue, Dept. 13-59 Chicago



# Automobile Mechanics are needed!

Prepare yourself now for a big-pay auto job!

THE demand for trained men in the automobile field is far greater than the supply. More than 15,000,000 automobiles are in use in this country now, and every week the figures grow larger.

There are not enough trained automobile service and repair men to keep up with this steady growth.

If you are not satisfied with your present earnings, look into this proposition NOW.

**Just Published!**

## PRACTICAL AUTOMOBILE LIBRARY

Four Books—\$1.50 in 10 days and \$2 monthly for 6 months—only \$13.50 in all!

These four practical books, written by five well known teachers of automobile practice, will teach you, right in your own home during your leisure time, just what you need to know about automobile troubles and repair. They will teach you automobile construction, maintenance and repair as experts know them and will help you to earn an expert's pay.

### Your Big Chance—Get Ready for it!

Hundreds of question-answering diagrams—hundreds of clearly-marked illustrations—make the books plain and readily understandable to any man with the mechanical instinct. All the explanations and descriptions are clear, simple, direct. Every chapter is packed with definite, step-by-step, how-to-do-it information.

### Examine This New Library Free

No money down Small monthly payments

These books were written specially for self-instruction by men who have trained thousands of automobile operators and garage men. Examine the library for 10 days free. Just fill in and mail the attached coupon.

If you find the books what we say they are, send us \$1.50 in ten days and \$2 monthly for only six months. If you do not want the books, send them back at our expense. It costs you only a postage stamp to take a look at the books. Act now!

7c a day pays for these books!



### FREE EXAMINATION COUPON

McGraw-Hill Book Co., Inc., 370 Seventh Ave., New York

Send me for 10 days' free examination the New Practical Automobile Library. If satisfactory, I will send you \$1.50 in 10 days and \$2.00 monthly until the special price of \$13.50 is paid. If not wanted, I will return the books at your expense.

Signed.....

Address.....

City and State.....

Position.....

Employer..... P. M.—12-27



Win a NASH Sedan

or \$1400.00 in cash

Someone who answers this ad will receive a fully equipped De Luxe Model Nash Sedan, or full value in cash if preferred (\$1,085.00). In addition to this Nash Sedan we give away, a latest model Chevrolet Coach or its cash value (\$595.00), a Brunswick Panatrophe Phonograph, a Six Tube, Single Dial Freshman Radio, a Corona Portable Typewriter—many other valuable prizes and Hundreds of Dollars in Cash.

### Solve This Puzzle

The numbers in the squares to the right spell two words. The alphabet is numbered. A is 1, B is 2, C is 3, etc. Can you make out what the two words are? When you do this, send me your answer right away. It may mean winning the Nash Sedan or \$1,400.00 in cash.

### \$315.00 Cash For Promptness

In addition to the two automobiles, the many other valuable prizes and Hundreds of Dollars in Cash, we are also offering a Special Prize of \$315.00 in Cash for Promptness. First prize winner will receive \$1,400.00 in cash, or the Nash Sedan and \$315.00 in cash. In case of ties duplicate prizes will be awarded each one tying. Get busy right away. Solve the puzzle and send me your answer together with your name and address written plainly. EVERYBODY REWARDED. Address

M. L. BOEING, Dept. 1779  
323 So. Peoria St., Chicago, Ill.

14
1
19
8
19
5
4
1
14



# DRAFTING

BOOKS SENT FREE!

### For Beginners 4 Big Volumes

Written so you can understand every word, by 18 famous Engineers and Architects, De Luxe, flexible binding. 1750 pages, 1050 blue prints, charts and diagrams. Prepares you for a good Drafting job in mechanical or architectural lines. Sent for 15 days' free use, if you mail coupon immediately.

Only fifteen minutes a day with these WONDER BOOKS will prepare you for a good Drafting job in less than a year! Mechanical and Architectural Drafting from simple straight lines to important, complex plans, a step at a time! Built especially for beginners, for men with only grammar schooling. Drafting room practice plus engineering made easy and clear!

### Big Field—Big Demand—Big Pay!

Competent Draftsmen are urgently needed right now in all building and manufacturing lines at \$50 to \$100 a week. That's just the beginning—for draftsmen have the best chances for advancement! Pleasant, fascinating work, easy to learn and do. Learn quick with these books—send coupon for a set FREE, and see for yourself!

A year's Consulting Membership in the American Technical Society now given free to all readers of this famous Cyclopaedia of Drafting. Many say that's worth more than cost of books.



# Modern American Homes FREE!

American Technical Society  
Dept. D-919, 58th & Drexel Ave., Chicago

Send for 15 days' free use 4-volume set of DRAFTING. In return for mailing this coupon promptly send absolutely FREE "Modern American Homes," 112 plates, exteriors, interiors and plans. I will pay the few cents delivery charges. If I wish I may return books in 15 days and owe you nothing. But if I prefer to keep them I will send \$1.50 after 15 days, then \$2.00 a month until \$14.50 (special reduced price) is paid.

Name.....

Address.....

Employed by.....

Address.....



# "ASPA" WANTS YOU



*As a Member of*

## AMERICA'S GREATEST AIR SOCIETY

The American Society for Promotion of Aviation was organized by 12 ex-service aviators at the Army and Navy Club, New York City, in 1925.

Our objects as incorporated are to "arouse and maintain interest in aviation" and eventually to

### "Make-America-Supreme-in-the-Air"

We can accomplish our objectives by having a landing field or air port in every town, and by training red-blooded Americans in the art of flying.

FLYING CLUBS WILL BE ORGANIZED IN EVERY COMMUNITY.

THIS WORK ENDORSED AND SUPPORTED BY AMERICA'S LEADING AIRMEN.

You can participate in this great movement by becoming a member of THE A. S. P. A., and, as our representative, work for aviation in your community.

### Join Aviation's Great Fraternity — ENROLL NOW!!!

MEMBERSHIP fee ONE DOLLAR which covers the cost of silver wings, membership card and literature of the A. S. P. A.

Silver Wings



Actual Size

Secretary, The ASPA  
522 5th Avenue  
New York City, N. Y.

Yes, I am interested in aviation! Please enroll me in the American Society for Promotion of Aviation. I enclose membership fee of One Dollar. Please send me my wings.

Name..... Dept. X

Address.....

City..... State.....



# BOYS

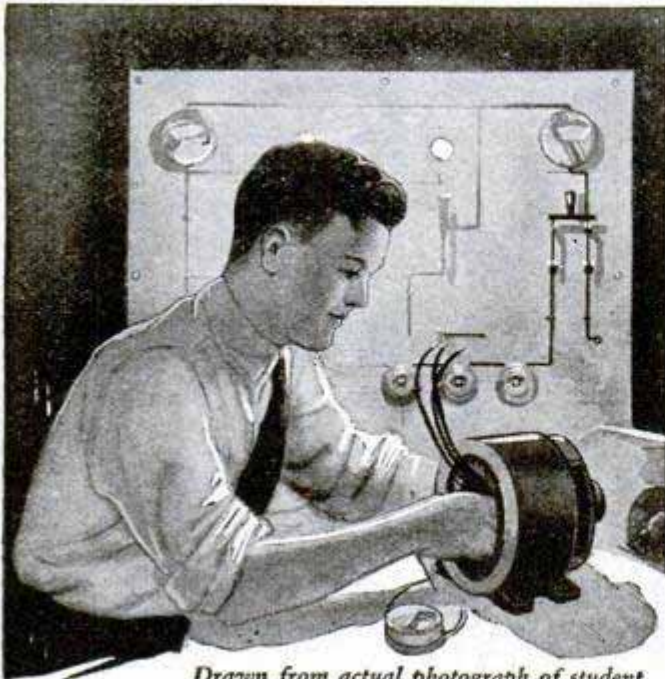

Drawn from actual photograph of student doing spare time electrical work

## Learn Electricity Make Big Money

How would you like to earn two or three dollars every evening after school and prepare yourself for a fine big job at the same time? Here's the opportunity of a lifetime for you fellows who like Electricity. Begin right now to prepare yourself for a regular man's size job in this fascinating field. Your chances for a big success are simply wonderful—the pay is big (thousands of men earn \$70 to \$200 a week) and advancement comes swift and sure.

### I Will Train You at Home

With my easily learned, spare time Electrical Course I will train you at home like I have trained hundreds of other boys who are now big successful men. It will not interfere with your school work and you can earn more than the small cost of the course doing odd electrical jobs in your spare time. The Course pays for itself. I will show you how to get this work and how to do it. Some of my boy students make \$10 to \$15 a week this way.

### Tools, Apparatus and Radio Course —Given Without Extra Charge

Send me the coupon below and I will tell you all about the big outfit of tools, apparatus and instruments and a new Radio Course that I am giving to my students for a limited time. I will send you my big interesting Electrical Book and a sample lesson, too—all Free. You will be tickled with the things I will send you Free. Mail the coupon right now.

L. L. COOKE, Chief Instruction Engineer

L. L. Cooke School of Electricity  
Dept. O19 CHICAGO

### Look What This Boy Is Doing

"Although the School term is coming to a close, and I am pretty busy with my examinations, I manage to keep up with my electrical studies and work."

"I guess I forgot to tell you I am now in business for myself. Am doing fine, but owe it all to you. If it had not been for your Course, I, being under age, could not have secured my license in this town. But I got it, and now have all the work I can do, averaging \$20 to \$30 a week, thru spare time work."

"I went out on a job tonight after school, on which I made \$3 and brought home another on which I made \$2.50—\$5.50, for 4 hours' work and no material furnished by me."

ROBERT SMITH,  
1215 Chestnut St.  
Greenville, N. C.

### Use This "FREE BOOK" Coupon

L. L. COOKE, Chief Instruction Engineer,  
L. L. Cooke School of Electricity,  
Dept. O19 2150 Lawrence Avenue, Chicago

Send me your big Electrical Book, Sample Lesson and particulars of your Electrical Course and Extra Radio Course. This will not obligate me in any way.

Name .....

Address .....

This Coupon only for use of boys 15 years old or more.



## Air Commerce Needs Men!

Don't envy the Highly Paid Air Man—Be One! Air Men are in demand. Beat the other fellow to the High Salaried Jobs in Aviation. Western training will qualify you to enter Aviation. Learn how through our catalog, sent on request.

Write for Free Catalog  
"Airplanes and Flying"

Aeronautical Training Division

WESTERN AIRPLANE CORPORATION

Dept. M-12 Monadnock Block Chicago, Ill.





### BART SUPPLIES

Special 48 p. catalog "S"—Show Card and Sign Writer's supplies. Also catalog "A"—Art Supplies. Save Money—write—  
**BART SUPPLIES, 503 Euclid Bldg., MINNEAPOLIS, MINN.**

## FREE BOOK ON MIND TRAINING

An instructive book which explains an amazing system of mind training already used by more than 650,000 people. Let us send you a free copy of "Scientific Mind Training". It will show you how and why Pelmanism is the *only* system of teaching for developing all the mental powers at the same time. Endorsed by such distinguished men as Judge Ben B. Lindsey, Sir Harry Lauder, Jerome K. Jerome, Prince Charles of Sweden and hundreds of others. Write TODAY to

THE PELMAN INSTITUTE OF AMERICA  
71 WEST 45th STREET DEPT. 612 N. Y. C.

## EXTRA

# Look at the BARGAIN

# McFADDEN!

## Gives You.

Now Only

# \$1.98

### FREE

Course of Instruction! Given to you with your McFadden Exerciser, physical culture, complete system of your body. Develops every muscle in and endurance. Biggest bargain ever—only \$1.98 for this world-famous Exerciser and Instructions.



## SMASH Goes the Price on this Famous Muscle-Builder

The champion muscle-making Exerciser of the world! Develops GIANT muscles in 30 days. Big, powerful cables made of genuine live Para rubber. Your choice of 5, 10 or 15 cables. Satisfaction GUARANTEED. Money back if you can match it at THREE TIMES the price.

McFADDEN INSTITUTE  
Dept. R-121  
840 Broadway  
NEW YORK CITY

### Rush Coupon

First come, first served. Take advantage of this sensationally reduced price NOW. If you want health, vitality a superb physical development, get this bargain of a lifetime.

Send Exerciser checked. I enclose special low price. My money back if I want it after one week's trial.

- 5 Cable Exerciser \$1.98
- 10 Cable Exerciser \$3.98
- 15 Cable Exerciser \$5.87

Name .....

Address .....

City .....

State .....

Check here for C.O.D. shipment. Post, extra.



# Men Wanted in Auto Trades

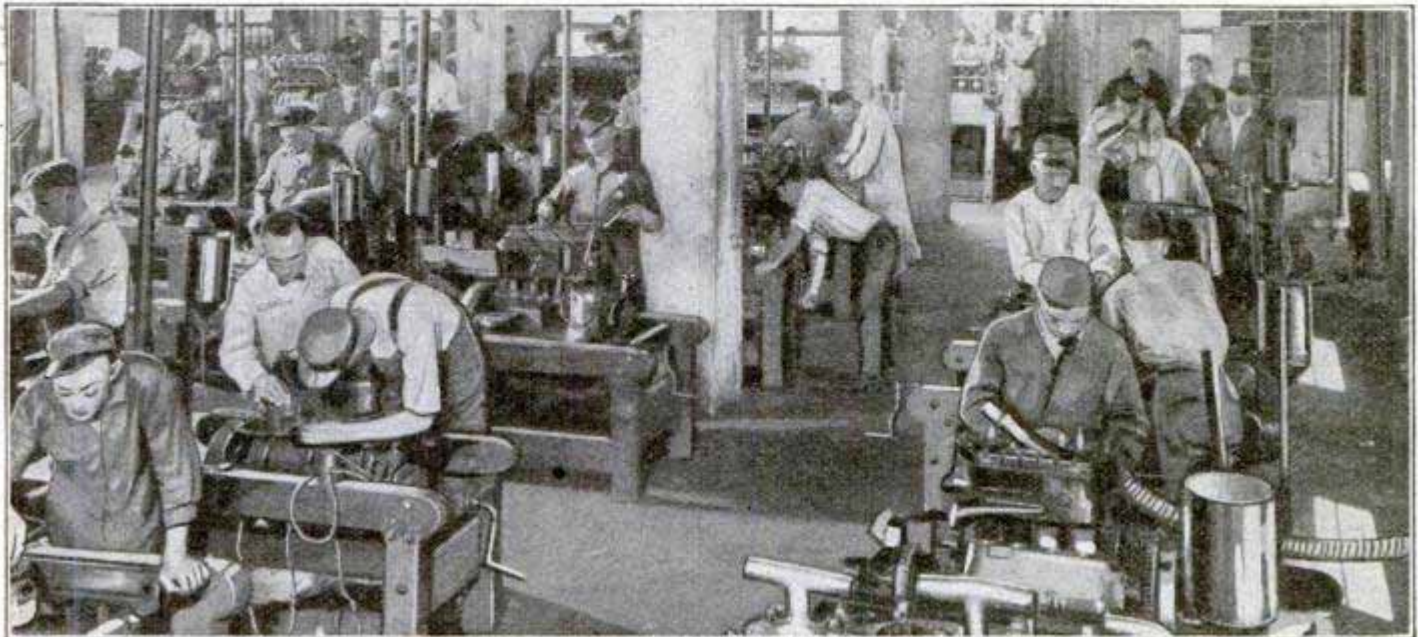

Battery and Ignition Dept.

Young man, if you are mechanically inclined, this is the most important month of your life. Now is the time when you should come straight into the Sweeney Auto School and learn in a few short weeks the automobile trades and fit yourself for a sure-fire big pay job doing work you like. You can send for a catalog but that isn't necessary. 70,000 men have gone through this school and you can just write or wire when you are coming and all will be ready for you. Don't worry about previous experience or any scholarship; no experience is necessary and we have even made good mechanics out of men who could barely read or write. We teach with tools, not books. Right now you want to know all about the NEW FORD CAR and thousands of jobs are open for men who can handle the new Ford. You will learn this at Sweeney's. Many old mechanics now coming in for this special work. Yes, my EMPLOYMENT DEPARTMENT helped L. W. Kelley to a job at \$18.00 A DAY — IT helped J. H. Miller to a job at \$10.50 A DAY — IT helped Gordon Shyroek to a job at \$10.50 A DAY, and it, also, is helping dozens of other Sweeney Graduates to fine jobs at \$10 to \$18 a day, IMMEDIATELY after finishing ONLY A SHORT COURSE OF SWEENEY TRAINING.

## The Sweeney System

Teaches by practical, personal experience. You work with tools, not books. You learn by doing. Million dollar school with complete equipment. You need no previous experience. If you are looking for success in life and working at a trade you like write me today. Drivers, mechanics, repair men, testers, garage owners, painters, welders, demonstrators—thousands more are needed and opportunities are everywhere. If you are mechanically inclined simply send name today for my big free book how to fit yourself for steady high paid employment in the auto business.

**LEARN A TRADE—**  
**Sweeney**  
**AUTOMOTIVE & ELECTRICAL SCHOOL**  
**4431 SWEENEY BLDG. KANSAS CITY, MO.**

## FREE CATALOG AND SPECIAL OFFER

Get my big FREE 72-page catalog. It shows hundreds of actual photographs of men at work in my magnificent new school. Tells all about wages, profits, opportunities in auto business. Explains step by step how you learn. Interesting letters from graduates telling how they made good. Shows how men come from all over the world to this big school. Makes you want to join the crowd. Tells everything you want to know. I will gladly send you a copy beautifully illustrated. I'll tell you how to get into business for yourself. No colored students accepted.



**E. J. SWEENEY**  
 President

To save time, write or wire when you'll arrive and we'll be looking for you! No need to delay—Just come along!

**EMORY J. SWEENEY, President**  
**4431 Sweeney Building, Kansas City, Mo.**

Send me free, without any obligation, your catalog and Special Offer!

NAME.....

P. O.....

STATE..... AGE.....





This illustration shows the main building of the McCleary Sanitarium and Clinic at Excelsior Springs, Missouri—the largest institution in the world devoted to the treatment of piles and other rectal troubles. (Only curable cases are accepted.)

## A Serious Affliction Cured Without Surgery

THE old theory that piles can be cured only by surgery has been wholly disproved. This treacherous affliction which slowly but surely undermines the health of its victims can be cured—totally and successfully—without the dangers of a surgical operation.

### Patients From All Parts of United States and Canada

For 27 years, Dr. A. S. McCleary and his associates have made an exhaustive study of rectal diseases. During that time, more than 13,000 patients from all parts of the United States, Canada and foreign countries have been successfully cured. Scores of these had been given up as incurable and many others were chronic cases of long standing.

### Absolute Relief or No Pay

No matter how long you have been troubled—  
No matter how distressing your case may be—  
No matter how many treatments you have had without avail, if your case has not been neglected so long as to be incurable, we can promise you absolute relief or no pay.

If you or any of your relatives or friends are interested, we will gladly mail you our free book, "Piles Cured Without Surgery." This book fully describes the McCleary methods of diagnosis and treatment of all rectal troubles, and tells you exactly what is offered here at a very nominal cost.

## The McCLEARY CLINIC and SANITARIUM

254 Elms Boulevard  
EXCELSIOR SPRINGS, MO.

McCleary Clinic and Sanitarium  
254 Elms Blvd., Excelsior Springs, Mo.

Please send me book fully describing the McCleary Method of Treating Piles Without Surgery.

Name.....

Street Address.....

Town or City..... State.....



## Showing Car Owners How to SAVE GASOLINE!

New invention bringing big profits to agents. Herick made \$157 in one day showing new way to save gasoline and end carbon trouble. Unique demonstration plan brings sales quickly on proved results. National advertising helps you. Over two million now installed. Fits any car, truck or tractor.

**FREE!** To introduce in every locality, inventor will send samples to car owners and distributor<sup>s</sup>. No sale if it doesn't show results. Write for details to J. A. Stransky, W-10 Stransky Block, Pukwana, S. D.

## NO MORE BALD HEADS



WHEN our VACUUM CAP is used a few minutes daily. We accept no pay until you have tried the Cap 60 days and are satisfied. The Vacuum Cap is an appliance that draws the blood to the Hair Roots and starts a new healthy crop of hair. It stops Dandruff, stops the hair from falling out.

Bought by Doctors and men who know that it is the only reasonable HAIR GROWER known to science. No Drugs Used. Write for application blank, testimonials and booklet on "HAIR," sent sealed in plain envelope, FREE.

**THE MODERN VACUUM CAP CO.**  
559 Quincy, Denver, Colo.

## Save Your Feet

When all else fails, end your suffering with the Heefner Arch Support



No Metal  
Fully patented. It re-adjusts the entire foot. Write for free book and statements from doctors and users.

Heefner Arch Support Co. 658 M. E. Taylor Bldg. Louisville, Ky.



### BUCHSTEIN'S FIBRE LIMB

is soothing to your stump—strong, cool, neat, light. Easy payments. Braces for all deformities. D. BUCHSTEIN CO. 610 3rd Ave., So. MINNEAPOLIS, MINN.

Send for Catalog Today

## STOP USING A TRUSS



Reduced Fac-Simile Gold Medal

STUART'S PLAPAO-PADS are different from the truss, being mechanico-chemico applicators made self-adhesive purposely to hold the distended muscles securely in place. No straps, buckles or spring attached—cannot slip, so cannot chafe or press against the pubic bone. Thousands have successfully treated themselves at home without hindrance from work—most obstinate cases conquered. Soft as velvet—easy to apply—

inexpensive. Awarded Gold Medal and Grand Prix. Process of recovery is natural, so afterwards no further use for trusses. We prove it by sending Trial of Plapao absolutely FREE

Write name on Coupon and send TODAY. **PLAPAO CO., 733 Stuart Bldg., St. Louis, Mo.**

Name.....

Address.....

Return mail will bring Free Trial Plapao.



Grand Prix



# Button Rupture Newest Way [Without Pressure]



I take pleasure in informing you through the use of the New Science System my rupture is entirely relieved. At the time I ordered your System I had been ruptured 20 years.

*M. P. Brumbough,  
Juanita, Pa.*

I am writing to let you know that my rupture does not trouble me any more and I think in a little while it will be gone. Your appliance has all you claim for it. Before I got it I could work only part of the time. Now I can do almost anything.

*Mrs. C. W. De Leno,  
Gilboa, N. Y.*

**S**CIENCE now advises discarding cruel steel springs, barbarous leg straps, and other harness that press against the rupture and thus prevent nature from healing it. A new sensible method has been perfected, after thousands of test cases, called Magic Dot—entirely different from any other way. Instead of “pressing” it “seals” rupture, and of course allows users to run, jump, bend and cough in perfect safety.

## Breathes Air

With this 1-25th oz. device is a new kind of pad, air-porous and washable. It actually breathes air, and cannot slip off the rupture—a feature, you’ll frankly admit, that is lacking in your present appliance. In fact, it is so superior and different that it is praised by physicians as “an entirely new departure.” Users report they have forgotten they are wearing it. But don’t buy it yet.

## See It First

By a special arrangement you can now have it sent to your home without obligation to wear it. Don’t send a penny or order it now. Just mail the coupon for full description of “Magic Dot” and details of this unusual offer. Act now for quick relief. Write your name and address on the coupon and mail it today!

**NEW SCIENCE INSTITUTE**  
2143 Clay St. Steubenville, O.

New Science Institute,  
2143 Clay St., Steubenville, O.

Please send me free your illustrated book and sample of Airtex. Include also your offer which permits me to see the New Science System without cost or obligation.

Name.....

Address.....

City..... State.....





## “How I got the job that 34 others were seeking”

THIRTY-FIVE men applied for the position as Advertising Manager of a big department store in New Orleans. But Sam D. Reeks was selected above all these other men because he was trained.

He says: “My I. C. S. course enabled me to put my facts before the proprietor of this business in such a way as to prove that I knew what I was talking about. I was just as well equipped to discuss his advertising with him as if I had been at the work for years and years.”

Mr. Reeks was given the position—and he made good in a big way after he got it—because his International Correspondence Schools course had prepared him to take advantage of his Opportunity when it came. Just a few years ago he was elected president of the Advertising Club of New Orleans—another tribute to his personality and ability.

Why don't you study, as Mr. Reeks did, and prepare to get a better position and a larger salary? You can do it if you really try.

At least make the start by marking and mailing the coupon printed below and find out what the I. C. S. can do for you. It doesn't cost you a penny or obligate you in any way to get the facts, but that one simple little request may be the means of changing your whole life. “Do it now.”

Mail the Coupon for Free Booklet

### INTERNATIONAL CORRESPONDENCE SCHOOLS Box 5689-E, Scranton, Penna.

Without cost or obligation, please send me a copy of your booklet, “Who Wins and Why,” and full particulars about the course before which I have marked X in the list below:

#### BUSINESS TRAINING COURSES

- |  |   |
|--|---|
| <input type="checkbox"/> Business Management                     | <input type="checkbox"/> Salesmanship                                     |
| <input type="checkbox"/> Industrial Management                   | <input type="checkbox"/> Advertising                                      |
| <input type="checkbox"/> Personnel Organization                  | <input type="checkbox"/> Better Letters                                   |
| <input type="checkbox"/> Traffic Management                      | <input type="checkbox"/> Show Card Lettering                              |
| <input type="checkbox"/> Business Law                            | <input type="checkbox"/> Stenography and Typing                           |
| <input type="checkbox"/> Banking and Banking Law                 | <input type="checkbox"/> English  |
| <input type="checkbox"/> Accountancy (including C.P.A.)          | <input type="checkbox"/> Civil Service                                    |
| <input type="checkbox"/> Nicholson Cost Accounting               | <input type="checkbox"/> Railway Mail Clerk                               |
| <input type="checkbox"/> Bookkeeping                             | <input type="checkbox"/> Common School Subjects                           |
| <input type="checkbox"/> Private Secretary                       | <input type="checkbox"/> High School Subjects                             |
| <input type="checkbox"/> Spanish <input type="checkbox"/> French | <input type="checkbox"/> Illustrating <input type="checkbox"/> Cartooning |

#### TECHNICAL AND INDUSTRIAL COURSES

- |   |  |
|---|--|
| <input type="checkbox"/> Electrical Engineering                     | <input type="checkbox"/> Architect                                       |
| <input type="checkbox"/> Electric Lighting                          | <input type="checkbox"/> Architects' Blueprints                          |
| <input type="checkbox"/> Mechanical Engineer                        | <input type="checkbox"/> Contractor and Builder                          |
| <input type="checkbox"/> Mechanical Draftsman                       | <input type="checkbox"/> Architectural Draftsman                         |
| <input type="checkbox"/> Machine Shop Practice                      | <input type="checkbox"/> Concrete Builder                                |
| <input type="checkbox"/> Railroad Positions                         | <input type="checkbox"/> Structural Engineer                             |
| <input type="checkbox"/> Gas Engine Operating                       | <input type="checkbox"/> Chemistry <input type="checkbox"/> Pharmacy     |
| <input type="checkbox"/> Civil Engineer                             | <input type="checkbox"/> Automobile Work                                 |
| <input type="checkbox"/> Surveying and Mapping                      | <input type="checkbox"/> Airplane Engines                                |
| <input type="checkbox"/> Metallurgy <input type="checkbox"/> Mining | <input type="checkbox"/> Agriculture <input type="checkbox"/> Navigation |
| <input type="checkbox"/> Steam Engineering                          | <input type="checkbox"/> Mathematics <input type="checkbox"/> Radio      |

Name.....

Street Address.....

City..... State.....

Occupation.....

*Persons residing in Canada should send this coupon to the International Correspondence Schools Canadian, Limited, Montreal, Canada*

# DOUBLE PROFITS



## \$544.00 IN A MONTH



Here's something startling, new! A revolutionary "Twin" plan of selling that pays men everywhere double profits. So read the Free Test Offer Below. Then act!

One of the most sensational chapters in the history of direct selling has been written in the past 4 months! For, almost incredible as it may sound, in that short time over 2,000 men have discovered the secret of double profits on 4 out of 5 sales.

### TWIN INVENTIONS—NEEDED EVERYWHERE

This unique plan is made possible by two revolutionary patented inventions. A new kind of can opener, absolutely automatic, holds the can, cuts the top out (not off) inside the rim, leaving it smooth, slick and clean—all in a couple of seconds at the turn of a crank—ends forever all stabbing and hacking with old-style can openers. A twin invention, an equally revolutionary knife, scissors and tool sharpener—operating on new, patented "magic groove" principle—sharpens automatically at a twist of the wrist.

Every home feels an instant need for at least one of these amazing new devices. Four out of five buy both because of unique interchangeable feature, both operating from same tiny wall bracket. There is not room for all the sensational details here. Our plan includes practical sales training course. We furnish everything. Exclusive territories. Write today for Free Test Offer and proof of \$68 to \$150 a week.

**\$544.00 First Month**

"Speedo sells to 9 out of 10 prospects. Here's the result of my first month's work, June 13—84 Speedos; June 20—192 Speedos; June 30—288 Speedos." M. Ornof, Va.

### CENTRAL STATES MFG. CO.

Dept. W-701 4500 Mary Ave. St. Louis, Mo.

CENTRAL STATES MFG. CO., Dept. W-701, 4500 Mary Ave., St. Louis, Mo.

Rush me details of your double profits plan and Free Test Offer.

Name.....

Address.....

Town..... State.....



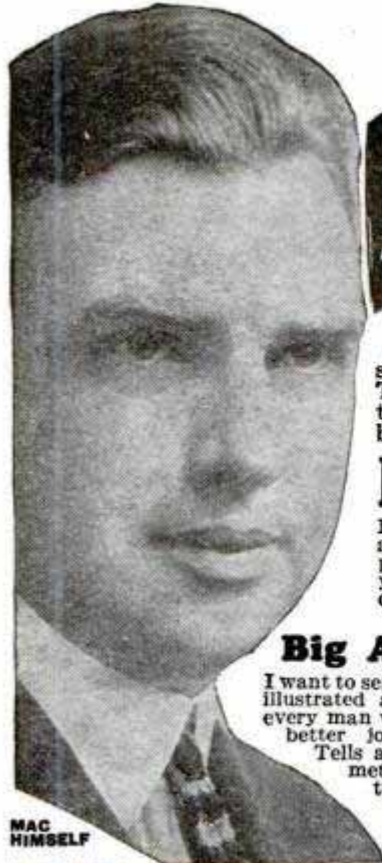

MAC HIMSELF

# Auto Mechanics Make Big Money

I have trained thousands of men to be auto and tractor mechanics, and I can train you. 8 weeks is all it takes. No previous mechanical experience necessary. Very little schooling required. With my simple, practical, work-while-you-learn methods anyone can quickly fit himself to go into the auto and tractor business or work for others at big pay. Hundreds of McSweeny trained men are making \$75 to \$125 a week. And there is room for thousands more. Big pay jobs all over the country are begging for skillfully trained men.

**This is Your Opportunity** to get out of the rut and learn a trade where you can make real money. Write at once for my big special Fall and Winter tuition offer which includes

## R. R. FARE and BOARD While Learning

I am prepared to handle thousands of students this season and I am making the most liberal offer you ever heard of. You'll be surprised how little it will cost to fit yourself for a big pay job. I promise you satisfaction or money back. After you have completed my course, if you are not satisfied that I have done everything possible to fit you for a big job, I'll refund your tuition. Hurry! Mail the coupon now. Get liberal tuition offer and details of electrical course FREE.

**FREE**  
of extra cost  
General  
Electrical Course  
House wiring, armature winding, motor work and all general electrical training. Both alternating and direct current work.

**Big Auto Book**  
I want to send my big, beautifully illustrated auto book FREE to every man who is interested in a better job and bigger pay. Tells all about my training methods and big opportunities in auto and tractor repairing.



McSweeny Auto, Tractor and Electrical Schools, Dept. 11-T-2, Cincinnati, O., Cleveland, O.

Without cost or obligation, send me your big FREE book on Autos; also, full details of your big offer including R. R. Fare and Board Paid, and FREE electrical course.

Name.....  
Street.....  
Town..... State.....

**MC SWEENY**  
AUTO, TRACTOR and ELECTRICAL SCHOOLS  
Dept. 11-T-2 CINCINNATI, OHIO; CLEVELAND, OHIO

**LEARN AVIATION AT HOME**  
Under Lieut. Walter Hinton  
AVIATION INSTITUTE OF U. S. A.  
1115 Connecticut Ave., N. W. Washington, D. C.

**Learn Watchwork, Jewelrywork and Engraving** A fine trade commanding a good salary, and your services always in demand. Address **Horological**, Dept. P, Bradley Institute, PEORIA, ILLINOIS, for our latest catalog.

# LEARN CARTOONING AT HOME DURING SPARE TIME



from the School that has trained hundreds of successful cartoonists of today. The Landon Picture Chart Method of teaching ORIGINAL drawing by mail makes cartooning easy to learn. Write today for sample picture chart to test your ability and examples of the work of successful students now earning from \$75 to \$200 and more per week. Please state your age.

**THE LANDON SCHOOL, 2838 National Bldg., Cleveland, Ohio**

# LEARN TELEGRAPHY AT HOME



**TEACH YOURSELF** in half usual time, at trifling cost, with the wonderful Automatic Transmitter, **THE OMNIGRAPH**. Sends unlimited Morse or Continental messages, at any speed, just as an expert operator would. Adopted by U. S. Government, and leading Universities, Colleges and Telegraph Schools. Catalog 6 cents. **OMNIGRAPH MFG. CO., 13-19 Hudson St., NEW YORK**



# ★ WORK FOR UNCLE SAM ★

**MEN 18 TO 45**  
**City and Rural Mail Carriers**  
**\$141.67 to \$275.00 Month**

Many Other U. S. Government Jobs Now Obtainable  
Steady Work. Paid Vacation. Common Education Sufficient. Pull Unnecessary.  
**MAIL COUPON—TODAY SURE**

**Franklin Institute**  
(No connection with U. S. Government)  
Dept. R306, Rochester, N. Y.

Rush to me, WITHOUT CHARGE, (1) Your 32-page Illustrated Book. (2) Send full particulars on how to get a position as City or Rural Mail Carrier at \$141.67 to \$275.00 a month.

**COUPON**  
Name.....  
Address.....



# Learn Electricity in Los Angeles

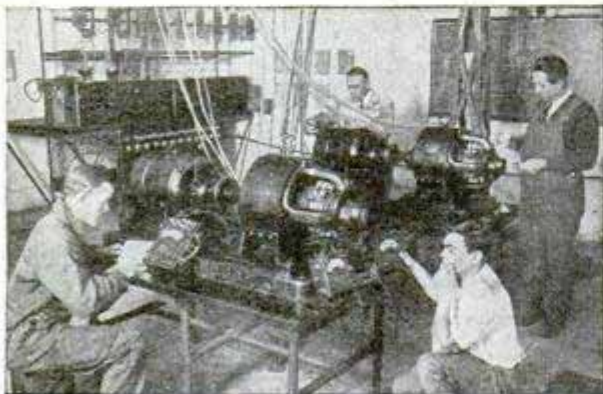

## Earn \$50 to \$200 Week As Electrical Expert

Train at National, Los Angeles, in the center of California's \$100,000,000 electrical development program.

The tremendous increase in development of enormous electrical projects has created a big demand for trained men with practical knowledge. YOU can quickly get into this fascinating industry and earn \$50 to \$200 a week.

National training will qualify you. Actual work on modern electrical equipment helps make you a skilled expert in Power House Operation, Motors and Controls, Central and Sub-station Operation, Armature Winding, Motor Building, Electrical Fundamentals, Drafting, Illumination, Commercial Radio, Radio Construction, Battery Manufacture, Automotive Electricity, etc. Expert instructors; million-dollar shops; liberal "no-time-limit" training plan assure success. Over 17,000 successful graduates of this quarter-century-old institution.

### L. W. Bell Gets Two Promotions in 19 Days

"After leaving National Electrical School, I obtained employment with the So. Cal. Edison Co. as apprentice operator, and after working at this job for 10 days was promoted to asst. foreman at the Laguna Bell Sub. I worked here for 9 days and was transferred to Saticoy Sub, a switching center, as asst. operator."  
(Signed) L. W. Bell,  
Saticoy, Calif.

### Free Employment Service

National graduates are preferred by many big electrical employers. We help you get the kind of job you want upon your graduation. We also assist you to get part-time jobs to pay living expenses while training. Mail the coupon now for big free electrical book. Explains everything. Make your start to win success today.

# NATIONAL ELECTRICAL SCHOOL



Dept. 513 4006 Figueroa St., Los Angeles, California

Please send me your Free, illustrated National Electrical Book describing opportunities in the electrical industry and illustrating National training methods.

Name \_\_\_\_\_

Address \_\_\_\_\_

City \_\_\_\_\_ State \_\_\_\_\_



# Learn To Fly in 5 Weeks



## From Winner of National Air Races

Let champion aviator, E. B. Heath, winner of the National Air Races at Spokane in 1927 and at Philadelphia in 1926, teach you how to fly. Heath has been building and flying aeroplanes for 20 years. Learn aviation, aeroplane building and flying from this veteran flyer. Learn in the oldest and best-equipped flying school in the country—no books, no mere theory, you learn by actual practice. Learn in a real air craft factory with latest and best flying equipment and experienced instructors. Big flying field in connection. Complete instruction in motors, ignition, and aeroplane construction.

### Heath Parasol Aeroplanes

Aeroplanes manufactured by Heath have been the national champions for the past two years. The Heath Parasol won first place in two events at the National Air Races at Spokane. Heath "Tomboy" won first place at Philadelphia in 1926.

Write for illustrated catalog describing Heath made aeroplanes. Send only 10c to cover partial cost. Agents wanted to represent us in their home territory. Write for full details.

### Employment Service

Employment service to all students enrolled in our day courses. Our tremendous aeroplane factory needs men. We help you get a job, while learning. Special employment service for evening students in need of additional funds.

### Big Money in Aviation

No need to tell you that every year sees bigger demands for trained flyers. You know big money awaits you in this fascinating work. We offer our graduates the agency for our famous aeroplanes in their own territory. You can make big money not only flying but selling Heath made planes.

Write for Catalog Write today for full information regarding America's oldest flying school. Read how you can learn to fly in 5 weeks. Get full details, prices and terms of our complete day and evening courses in aeroplane building and flying. See employment offer. No obligation. Write today. A postal will do.

HEATH SCHOOL OF AVIATION, Dept. 3379, 2856 Broadway, Chicago, Ill.

## YOU CAN OIL PAINT

Amazing new method teaches men or women to earn after first lesson. OIL PAINT photos—portraits, landscapes or art subjects. Earn \$18 to \$50 and more a week. OIL PAINT OUT-FIT GIVEN. Send now for free illustrated book. PICTORIAL ART STUDIOS Inc. Dept. MP, 2926 Broadway, Chicago, Ill.

**GET GOV'T JOB!** Thousands of appointments made yearly. Good salaries—short hours—liberal vacations. Common education usually sufficient. Hampton will help you prepare to pass next Civil Service examination with high mark. Write for free booklet.  
L. HAMPTON, BOX 1818-X3, WASHINGTON, D. C.



## BE THE LIFE OF THE PARTY Learn to Whistle

I'll teach you in 24 hours to whistle the latest songs and imitate bird calls using your tongue and lips—new method. Amaze your friends, whistle solos at parties, over radio, earn extra money, be popular. FREE with order. In-Visible Bird Call. Complete with instructions 25c.

JACK THE WHISTLER, Box 262, Dept. 1-X, New Haven, Conn.



## Physical Training for Height Increasing

My scientific physical training Course and apparatus have for their special object the increase of height. They have been remarkably successful, beside giving buoyant "pep," abundant health, and improved appearance. To be of full height means more efficiency and ability to increase your earning power.

Course is easy, inexpensive, and results sure. Satisfaction guaranteed on money back basis.

Write today for Free and Complete information, stating present height.

L. GLOVER, Dept. A48, 70 Bulkley Avenue SAUSALITO, CAL.



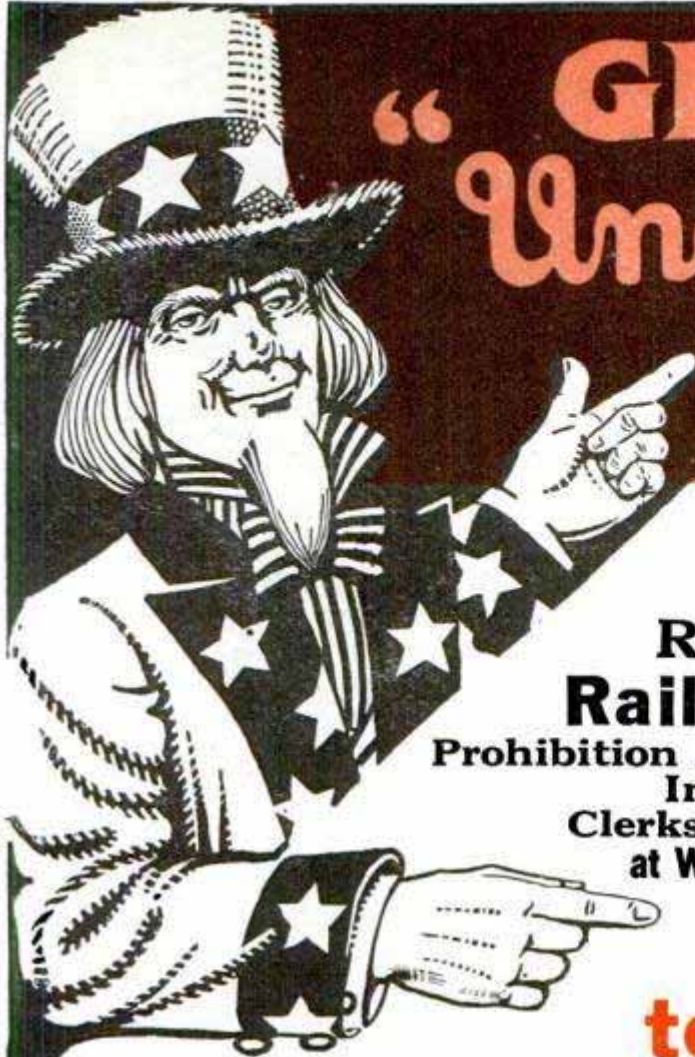

# “GET ON” “Uncle Sam’s” PAYROLL

**Post Office Clerks  
City Mail Carriers  
Rural Mail Carriers  
Railway Postal Clerks  
Prohibition Agents                      Stenographers  
Income Tax Auditors  
Clerks in Government Offices  
at WASHINGTON, D. C., and ELSEWHERE**

**\$1140<sup>00</sup>  
to \$3300<sup>00</sup> a year**

These are steady positions. Strikes, poor business conditions, lockouts or politics will not affect them, U. S. Government employees get their pay for full twelve months every year. There is no such thing as “HARD TIMES” in the U. S. Government Service.

### RAILWAY POSTAL CLERKS

Railway Postal Clerks now get \$1900 the first year regular, being paid on the first and fifteenth of each month. \$79.16 each pay day. Their pay is quickly increased, \$100 and \$150 a year, the maximum being \$2700 a year. \$112.50 each payday. They get extra allowance for hotel expenses when away from home.

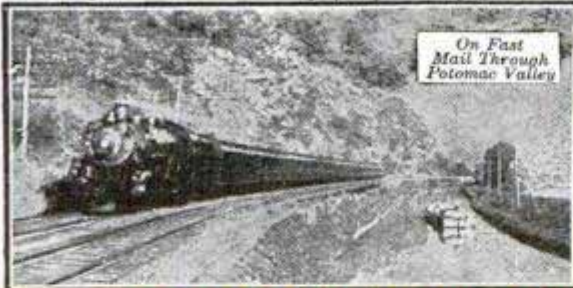

### PAID VACATIONS

Railway Postal Clerks, like all Government employees, have a yearly vacation of 15 working days (about 18 days). On runs they usually work three days and have three days off duty, or in the same proportion. During this off duty and vacation, their pay continues just as though they were working. When they grow old they are retired with a pension. As Railway Postal Clerks are continually traveling, they have an excellent chance to see the country.



### CITY MAIL CARRIERS—POST OFFICE CLERKS

Clerks and Carriers get \$1700 the first year regular, and automatically increase \$100 a year to \$2100 with further increase to \$2300. They also have 15 days vacation. Examinations are frequently held. City residence is unnecessary.

### GENERAL CLERK

(Open to men or women 18 or over)

Salary \$1140 to \$1860 a year. Pleasant clerical work in the various departments and offices at Washington, D. C., and elsewhere throughout the country.

### WHAT WILL YOU EARN 5 YEARS FROM NOW?

Compare these conditions with your present or prospective condition, perhaps changing positions frequently, no chance in sight for PERMANENT employment; frequently out of a position and the year's average salary very low. DO YOU EARN \$1900 EVERY YEAR? HAVE YOU ANY ASSURANCE THAT A FEW YEARS FROM NOW YOU WILL GET \$2700 OR MORE A YEAR, EVERY YEAR?

### GET FREE LIST OF POSITIONS

Fill out the coupon. Tear it off and mail it today—now, at once. DO IT NOW—This investment of two cents for a postage stamp may result in you getting a U. S. Government Job.

FRANKLIN INSTITUTE  
Dept. S-173  
ROCHESTER,  
N. Y.

(Not connected with U.S. Government)

Rush to me, entirely free of charge (1) a full description of the position checked below; (2) Send particulars telling how to get appointment; (3) Free copy of 32-page illustrated book, “U. S. Government Positions and How to Get Them,” with list of positions now obtainable.

- Railway Postal Clerk..... (\$1900-\$2700)
- Post Office Clerk..... (\$1700-\$2300)
- City Mail Carrier..... (\$1700-\$2100)
- Rural Mail Carrier..... (\$2100-\$3300)
- Clerk in Government Offices..... (\$1140-\$1860)
- Prohibition Investigator..... (\$1800-\$3000)

Name.....

Address.....

Use This Coupon Before You Mislaid It—Write or Print Plainly.

MAIL COUPON TODAY



# Pains

Vanish Almost Instantly

with Violet Ray

Scientific, Painless Treatment Used by Doctors, Hospitals, Sanitariums—Now Offered to Every Home



Thousands of men and women suffering from rheumatism, paralysis, neuritis, bronchitis, skin diseases, headaches, constipation, sprains, prostate trouble, goitre and many other ailments, even hay fever and asthma, have found quick relief, new health and vitality with this marvelous scientific invention. Try it.

**Violetta** **10 Days FREE Trial**  
For Health—Beauty—Vigor

Every home should have one. Saves hours, days, months of suffering. No medicine. Painless, pleasant treatment. Violet Rays penetrate to every nerve affected. Also generates pure oxygen—wonderful for pulmonary troubles. Simple, safe—anyone can use VIOLETTA. Don't suffer pain and poor health when you can now try VIOLETTA 10 days FREE.

**This Book Free** Tells all about violet rays—how this remarkable discovery of Nikola Tesla, the electrical wizard, now brings this mysterious curative power to all. Contains many astounding testimonials from our thousands of satisfied users. Send for all the facts and our liberal trial offer.

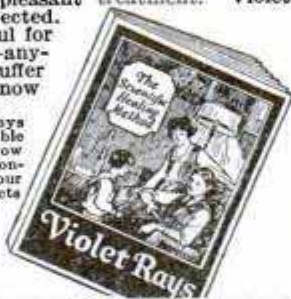

**VI-REX CO., Dept. 1231,  
2304 Warren Avenue, Chicago**

VI-REX COMPANY  
2304 Warren Ave., Dept. 1231, Chicago.

Please send me your free book on Violet Rays and details of your 10-day free trial offer.

Name.....  
Address.....  
City..... State.....  
Ailment.....



Young men needed by Davey Tree Expert Co.

Interesting, vigorous outdoor work in a growing organization where merit wins advancement. Good starting wages. Permanent positions and a real future for men who make good. Our present field force of Davey Tree Experts cannot meet the increasing demand. So we are selecting now, to enter our employ, a few sturdy, clean young men, thorough Americans, single, between 20 and 30 years old, free to travel, industrious, with good practical education, and able to give good references. Write for qualification blank to serve in place of personal interview. The Davey Tree Expert Co., Inc., 841 Federal Bldg., Kent, Ohio.

**Learn to FLY**  
Learn Right at Marshall

Get into the great, growing business—Aviation! Tremendous demand for well-trained pilots and ground men. Thrills—Romance—BIG PAY!

Personal instruction from men of long experience qualifies you for Department of Commerce license. Flying in new training planes. Ground instruction in modern airplane factory. **FREE Catalog**—Send for finest, most complete school catalog ever issued. Answers all questions. Write today.

MARSHALL FLYING SCHOOL, 270-A North St., Marshall, Mo.

## Pocket Drawing Board

T-square, triangles, etc., with book on mechanical drawing. All for **50c.**

VOCATIONAL PUBLISHING CO., Box 255, ST. LOUIS, MO.

## TELEGRAPH-RADIO

Operators earn \$150 to \$350 month and up. Learn in Chicago or at home. Chance to work while training. We furnish operators to U. S. Govt., Railroads, Com'l Cos., Broadcasting Stations and Sh'ps. CHICAGO TELEGRAPH INSTITUTE, Dept. 1-12-7, 1338 So. Michigan Ave., CHICAGO, ILL.

## WANT WORK AT HOME?

Earn \$18 to \$60 a week **RETOUCHING** photos. Men or women. No selling or canvassing. We teach you and furnish **WORKING OUTFIT** given with each enrollment. Limited offer. **Write today.** Artcraft Studios, Dept. 50, 3900 Sheridan Rd., Chicago

**10c** NEW SCIENTIFIC WONDER  
**3 for 25c** "X-RAY" CURIO

**BOYS** You apparently see thru Clothes, Wood, Stone, any object. See Bones in Flesh. **FREE—PKG. RADIO BIG FUN PICTURE FILMS.** Takes pictures without camera. "You'll like 'em." 1 pkg. with each 25c order.

MARVEL MFG. CO. Dept. 31 NEW HAVEN, CONN.







**YOU  
TOO CAN BE**

# Promoted!



*From Repair Man to  
Auto Factory Official  
OR HAVE A BUSINESS OF YOUR OWN*



High grade training means real success for automobile men. *Every day* we enroll men who have had from two to five years' experience in automobile work—men who were working in garages all over the

country but were not getting the big money that is earned by real skill. These men are going *higher up*, because when they leave the "Michigan State," they will have what the other fellows haven't got—*knowledge in their heads and skill in their hands*. This combination earns the big money.

## BIG BUSINESS Wants Trained MEN

We have standing orders from auto manufacturers and their dealers, to send them men who qualify for advancement as service executives. Good men are *always* wanted by big business.

Men are coming here daily to take the great MASTER COURSE of Automobile Training—here at Detroit's big Trade School, the "Michigan State."

They are aiming at *big jobs*—aiming at big business! *And they get it!* Our graduates of a few years ago now are Service

Managers, Superintendents—owners of their own shops—managing bus or truck transportation—or climbing high in aviation, that great new branch of the motor industry.

A real course is what you want—real training—six to eight months of it—practical, intensive work—work that puts knowledge in your head and skill in your hands! That is the "Michigan State" Master Course.

Small starts lead to big futures if you *know your business*. Don't be half-baked in any trade! You must know it all to climb to the top. Take time now to learn,—then start real strides toward a job with real money. That's becoming independent!

### THOROUGH Six to Eight Months' Training

Including Auto Service, Electricity, Batteries, Machine Shop, Welding, Tires, Service Management, Business Course. Catalog gives detailed outline of full course. It's free. (Write for it today.)

*Other Courses:* Straight Auto Service Course, 10 weeks. Also short courses in batteries, tires and other auto branches. Day or Night Classes. Earn while you learn, if necessary. Also Home Study Courses to start on for those who can't come now.



*Leads To Air Transport Management*—The skilled auto man becomes the skilled aviation leader. Another big-money opportunity. Even Lindbergh was a garage mechanic. In flying and in management of aeronautics, auto men are showing the way!

**A. G. Zeller, President**

**MICHIGAN  
State Automobile School  
312 Auto Bldg., Detroit, Mich.**

The Auto Repair Man is sitting on Top of the World Today.

### DETROIT — Now More Than Ever The Auto Center

Detroit and vicinity makes four-fifths of all the autos in the world. The engineering and business brains of this mammoth business are centered here. Here you can learn most—under the expert guidance of our experienced instructors you advance beyond your greatest hopes.

*Come To Detroit Now*—Get in this steady, year-round business—the big pay business with no strikes, no lay-offs. Get thorough training at this world famous school. Jump on the train for Detroit now. Or, send for full particulars about factory-endorsed Detroit-training for real success. Write, or come now!

**THIS WILL BRING YOU THE FACTS**

Michigan State Automobile School,  
312 Auto Bldg., Detroit, Michigan.

I want to know about Detroit training to make the most money.

Name.....

Street Number or R. F. D.....

City.....State.....

I am interested in:

- ( ) 30 weeks' Master Course.
- ( ) 12 weeks' Auto Course.
- ( ) Home Study Course.
- ( ) Aviation.



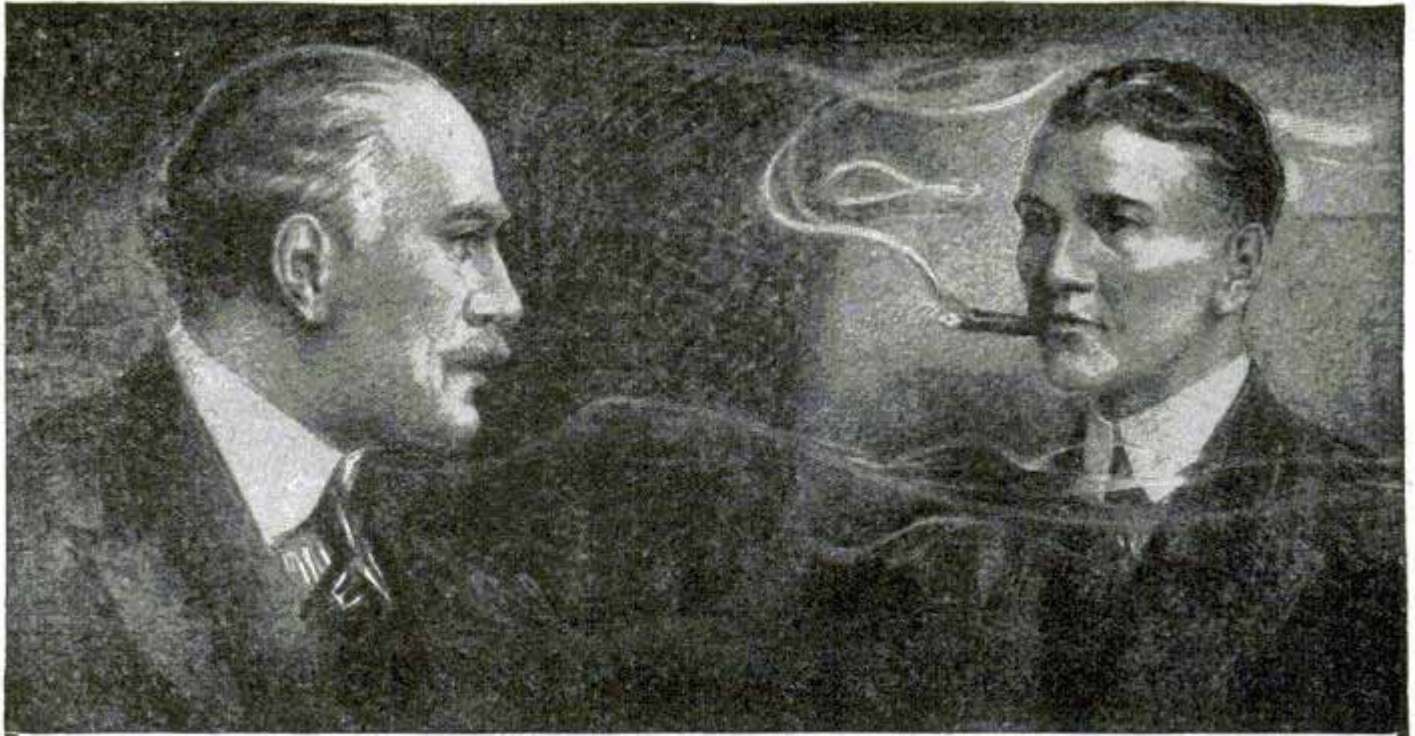

## Tobacco Is Hurting You

Look at the facts square in the face, Mr. Tobacco User. You may think tobacco is not hurting you.

That is because you haven't as yet, perhaps, felt the effects of the nicotine poison in YOUR system. For you know that nicotine, as absorbed into the system through smoking and chewing tobacco, is a slow working poison. Slow, yes—but sure.

Tobacco is lowering your efficiency. It slows a man down. Makes it harder for you to concentrate your mind on your work. You haven't near the amount of "pep" and energy you would have if you stopped using it. There's many a man twice as old as you in years who's twice as young in energy, simply because he lets tobacco alone.

Some day you will realize to what an alarming extent tobacco has undermined your system.

When your hands begin to tremble—  
and your appetite begins to fail—  
and your heart seems to "skip a beat" now and then—  
and slight exertion makes you short of breath—  
then you have a right to suspect that  
**TOBACCO** is getting the upper hand.

Any well-informed doctor will tell you that these are only a few of many symptoms of tobacco poisoning.

And YOU know that the use of tobacco in any form is an expensive, utterly useless habit. You know you ought to quit.

## Tobacco Habit Banished Let Us Help You

It doesn't make a particle of difference whether you've been a user of tobacco for a single month or 50 years, or how much you use, or in what form you use it—whether you smoke cigars, cigarettes, pipe, chew plug or fine cut or use snuff—Tobacco Redeemer will positively remove all craving for tobacco in any form in a very few days. Not the slightest shock to the nervous system. Your tobacco craving will usually begin to decrease after the very first dose—there's no long waiting for results.

Tobacco Redeemer contains no habit-forming drugs of any kind and is marvelously quick, scientific and thoroughly reliable.

It is in no sense a substitute for tobacco. After finishing the treatment you have absolutely no desire to use tobacco again or to continue the use of the remedy. It helps to quiet the nerves and make you feel better in every way.

**Results Guaranteed** A single trial will convince you. Our legal-binding, money-back guarantee goes with each full treatment. We will refund every cent you pay for the treatment if after taking it according to the easy-to-follow directions, it should fail to banish the tobacco habit completely.

**SEND Coupon for Free Proof** Let us send you our free booklet on the deadly effects of tobacco, together with testimonial letters from men all over the country telling how they have been absolutely freed from the tobacco habit by this simple home treatment. You could not ask for stronger proof that Tobacco Redeemer will free you from the habit than the evidence we will gladly send on request. Just mail the coupon—or a postal will do.

**NEWELL PHARMACAL CO.**  
Dept. 300 Clayton Station St. Louis, Mo.



## Free Book Coupon

**NEWELL PHARMACAL CO.**

Dept. 300 Clayton Station St. Louis, Mo

Please send, without obligating me in any way, your free booklet regarding the tobacco habit and proof that Tobacco Redeemer will positively free me from the tobacco habit or my money will be refunded.

Name .....

Street and No. ....

Town..... State.....



# LEARN AUTOS IN LOS ANGELES

**Jobs Open Now—\$40 to \$100 a Week**

You are urgently needed to help repair the one and a half million autos in California. Trained auto repair men are also needed badly in every other state. The rapidly increasing number of cars means prosperity and big pay for auto men—more garages, tire shops, battery stations are needed. You can be one of the highly paid men in this fastest growing industry—if you get the right training.

**YOU CAN BE An Auto Expert!**

National Automotive special, practical Shop Training makes it easy for you to become an Auto Expert. In a quarter century this great institution has trained

16,000 men for bigger pay. It will help YOU make more money by giving you individual instruction on repairing Packards, Buicks, Cadillacs, Fords, etc., all types of electrical equipment, machine shop equipment, etc. You learn everything RIGHT at National.

**Paul Briggs Earns \$4000 a Year**

"I want to thank you for the big part National has played in helping me to success in auto work. I am now assistant sales manager and made \$4,000 this year—which is more than I would have made in three years at my former work."—Paul Briggs, Portland, Ore.



**Earn While You Learn**

Free employment service. Spare time jobs help pay expenses while training. All tools included. No extras. Send for big free illustrated catalog explaining how National trains you for bigger pay. Learn the opportunities for you in California. Mail coupon now.

**Million Dollar Training Headquarters for Auto Experts**



NATIONAL AUTOMOTIVE, Dept. 705, 4006 Figueroa St., Los Angeles, Calif.

Send me, absolutely free, your big illustrated catalog of Automotive Opportunities.

Name.....  
Address.....  
Age... City..... State.....



**Money-Making Book**



## DRAW CARTOONS

**TURN YOUR TALENT INTO MONEY**

Cartoonists earn from \$50 to \$250 per week—some even more. Remarkable *Circle System of Drawing* teaches you in half the usual time. Students from all parts of the world are enrolling for this exceptional instruction. *Personal criticism service* and up-to-the-minute instruction make it easy for National students to attain success. Send for interesting **BOOKLET** and **SAMPLE LESSON PLATE** explaining full details of the Course and what National students are accomplishing. No salesman will call.

The National School of Cartooning, 623 Penton Bldg., Cleveland, Ohio



### ANY BOOK IN PRINT

Delivered at your door. We pay the postage. Standard authors, fine editions, new books, all at biggest savings. Be sure to send postcard for Clarkson's catalog.

**FREE** Write for our great book catalog. This catalog is a short course in literature and is so used by some of America's leading universities; 300,000 book lovers buy from it. Free if you write now.

**DAVID B. CLARKSON THE BOOK BROKER**  
1221 CLARKSON BLDG. CHICAGO, ILL.

### TEN MAGAZINES for 10¢

**10¢ NOW**

The smartest, most interesting, entertaining and instructive Magazine in America! *10 weeks for only 10c.* Special introductory offer. No magazine like it. Full of important facts, pictures and the best, most popular fiction. For all members of the family. Send name, address and 10c immediately!  
**THE PATHFINDER, Dept. K-82 Washington, D. C.**

**Make a Six Pointed Star**  
Just Draw Six Straight Lines With Four Dots on Each Line

I will give away four sedans and 30 other big prizes making a total of \$5,000.00 in prizes. We have already given over \$42,000.00 in prizes to advertise our business—including 9 Buicks and many other cars. Now YOU can get YOUR Buick Sedan or \$1,800.00 in cash. **GET BUSY!**

**and WIN NEW 1928 BUICK or \$1800.00 CASH!**

**4 New Autos Given!**



1st prize, Buick Sedan, 2nd prize, Nash Sedan, 3rd prize, Essex Sedan, 4th prize, Chevrolet Sedan. 28 other valuable prizes, total \$5,000.00.

**Send No Money** Just your answer—it costs nothing! Draw each line making a six-pointed star with a Buick in center. Draw the lines—cut out the ad, send your name and address; that's all and I'll tell you all about this offer. It may mean your winning a Buick Sedan or

**You Can Win \$1800.00 Cash**

Any winner can have cash instead of prize won. First prize winner can have Buick Sedan worth \$1295.00 and \$505 in cash, total \$1,800. You do not risk one cent, now! later, or ever! Leola J. Markus of Virginia, Minn., received \$2,500.00 check. H. A. Andrews, Horse Creek, Wyo., received Buick Sedan. Big list of former prize winners sent you. Everyone doing good work is rewarded. Act quick.

**T. W. KELLY, 500 N. DEARBORN ST. DEPT. 67 CHICAGO**

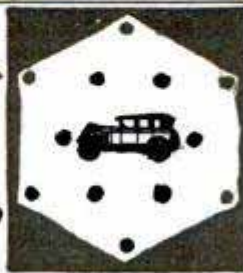

*Puzzle Fans Here's a Brand New One!*

**\$505 EXTRA for promptness**



# Sensational Typewriter Offer



## The World's Only Ball Bearing Typewriter

NEVER has there been such a typewriter bargain on as easy terms! A genuine Silent Ball Bearing L. C. Smith at a 40% savings!

**Only the L. C. Smith has all these features:** Ball bearings (636 of them) at all points of wear. All the writing visible all the time. Non-shift carriage. 2-color ribbon. All the latest operating conveniences. Beautiful—renewed.

If you decide to keep it only **\$3<sup>00</sup>** DOWN BALANCE EASY TERMS

## Guaranteed 5 Years

Money cannot buy a better typewriter. U. S. Government bought 50,000. The choice of railroads, big corporations like the Standard Oil Co., etc., because of its exclusive ball bearing feature. Easiest running, longest wearing of typewriters.

## Send No Money!

Just mail coupon. Without delay or red tape, typewriter will be shipped you. Use it 10 days. See how speedy and easy it runs—the perfect work it turns out. If not delighted, return at our expense. You'll want to keep it. You can, for \$3 down and \$5 monthly. Now is the time to buy. \$3 worth of extras free. Send coupon now before offer is withdrawn.

**40% SAVED by Using this Coupon**  
SMITH TYPEWRITER SALES CORP.  
11C-360 E. Grand Ave., Chicago

Ship me the L. C. Smith, F. O. B. Chicago. On arrival I'll deposit \$3 with express agent. If I keep machine, I'll send you \$5 a month until the \$68.70 balance of \$69.70 price is paid; the title to remain with you until then. I am to have 10 days to try the typewriter. If I decide not to keep it, I will repack and return to express agent, who will return my \$3. You are to give your standard 5-year guarantee.

Name.....  
Address.....  
City..... State.....  
Employed by.....

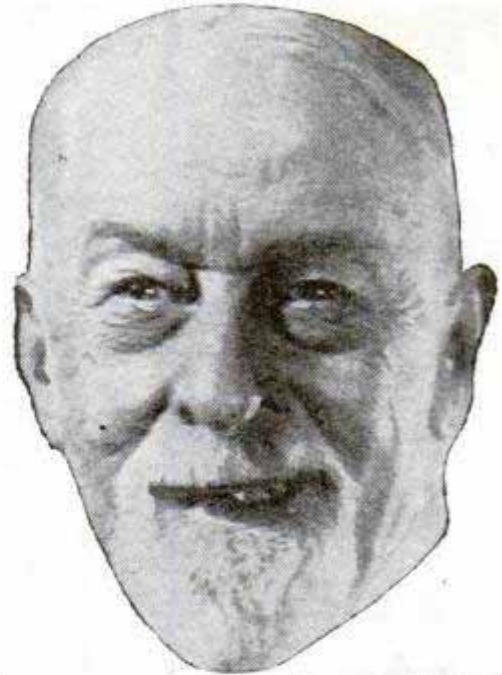

# Triumph Over Wretched Old Age!

Noted Doctors Endorse This New-Type Treatment for Men Past 40!

Now, in your own home, you can use a new type of drugless gland stimulation endorsed by noted doctors and sanitariums throughout the world. Thousands of men, some of them even as old as 90 years, have used the method successfully.

**DO YOU SUFFER THESE DISTRESSING SYMPTOMS**  
Prostate Trouble . . . . Weakness . . . .  
Nightly Risings . . . . Foot Pains?

Do you know how a disordered prostate gland causes a myriad of pains in legs, back, feet, disturbed sleep, debility, lack of pep? Medical science says that about 2 men out of 3 past a certain age are victims. Often the trouble is confused with bladder or kidney disorder. If you are a sufferer you should act immediately to learn the details of this new drugless gland stimulation that has already proved a godsend to so many thousands of men. To many it has been the means of avoiding serious operations. Other men, some as old as 90 years, report that through its use they are now living youthfully.

## FREE Book—Mail Coupon

This new method is described in an outspoken book, "Why Many Men Are Old At 40." Send for this book and learn these amazing new facts about old age. Simply fill out and mail the blank today to

**The Electro Thermal Co.**  
2176 Main Street,  
Steubenville, Ohio

If you live west of the Rockies, mail your inquiry to The Electro Thermal Co., Suite 21-V, 303 Van Nuys Building, Los Angeles, California.



**THE ELECTRO THERMAL CO.**  
2176 Main St., Steubenville, Ohio

Please mail at once a FREE copy of your booklet, "Why Many Men Are Old At 40," and details about the new treatment. I am not obligated.

Name.....  
Address.....  
City..... State.....



# Pick the JOB you want!

**—we'll help you land it!** Follow the example of other ambitious men, who are going after better-paid jobs by systematic reading of these wonderful books. Only 15 minutes a day will do the trick. Written so you can understand every fact instantly, even if your schooling is limited.

**"LOOK IT UP" Try the REFERENCE Way!** —no studying, no memorizing

The JIFFY INDEX places the answer to any problem right at your finger tips. That's better than trying to keep it all in your head.

Without lessons or examinations you can gradually acquire the expert knowledge which pays top salaries. Big opportunities today in Electrical, Auto, Building and Manufacturing industries for men who take the trouble to really learn the work.

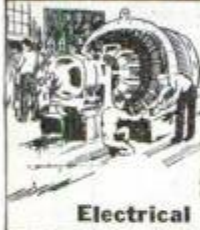

Electrical



Building



Auto



Civil Engineering

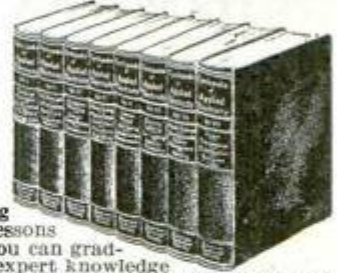

**A Year's Membership FREE!**

With privilege of consulting Engineers of American Technical Society. This service has often helped men win promotion and increased salary. Free with books.

**Pay-raising Books SENT FREE!**

Not a penny in advance. If not wanted after 15 days' free use, return charges collect and you owe us nothing. But if you prefer to keep them pay only \$2, then the balance at the rate of only \$3 a month. Coupon brings any set you wish.

Mail Coupon—Send No Money—Order by Number

	Total Price
1. Electrical Engineering, 8 vols., 4000 pages, 32,000 illustrations.....	\$34.80
2. Architecture, Carpentry & Building, 5 vols., 2500 pages, 2000 blueprints, etc.....	24.80
3. Civil Engineering, great new, 9 vol. edition, 3000 pages, 3000 illustrations.....	34.80
4. Auto Engineering, 5 big volumes, 2400 pages, 2000 charts, diagrams, etc.....	24.80
5. Business Management & Commercial Law, new 9 vol. set, richly illustrated.....	29.80
6. Modern Shop Practice, raises mechanics to experts, 6 vols., 2300 pages.....	24.80
7. Drafting—4 volumes, complete home instruction, 1578 pages, 1000 blueprints, etc. 14.80	14.80
8. Steam & Gas Engineering, 7 vols., 3300 pages, 2500 illustrations, new DeLuxe edition. 24.80	24.80
9. Great Library of LAW, complete in 13 big volumes, 6000 pages plus 24 case texts... 49.80	49.80
10. Fire Prevention and Insurance, 4 volumes, 1500 pages, green & black binding.....	14.80
11. Sanitation, Heating, Ventilating, 4 volumes, 1450 pages, 1400 illustrations.....	14.80
12. Employment Management, 7 volumes, 1810 pages, flexible American Morocco.....	24.80

**American Technical Society Dept. X-919, Drexel Ave. & 58th Street, CHICAGO**

## Send No Money

**American Technical Society, Dept. X-919, Drexel Ave. & 58th St., Chicago**

Send free for 15 days' use:

name of set..... No.....

I will pay the few cents delivery charges, and have the right to return the books, charges collect in which case I owe you nothing. But if I prefer to keep them I will pay \$2 after 15 days and the balance of your special advertising price at the rate of only \$3 a month. Please send FREE MEMBERSHIP as offered above.

Name.....

Address.....

Employed by.....

Address.....



# —Be a Railway Postal Clerk

**Get \$1900 to \$2700 a Year**  
**EASY WORK—LONG VACATIONS**

Why work hard for small pay? Uncle Sam offers you a fine position as a Railway Postal Clerk. Travel on fast trains sorting mail. Travel expenses paid. \$1900 a year TO START. \$100 RAISE EVERY YEAR until you reach TOP PAY.

**FREE Information About These Fine Jobs**

Let Arthur R. Patterson help you qualify for a position as a Railway Postal Clerk or in Customs, Internal Revenue, Departmental, Immigration, Postmaster, Postoffice, and Rural branches. He trained thousands now in Civil Service. Write for FREE BOOK. Tells how Mr. Patterson coaches you to pass exams. Also read his Money Back Agreement. Mail coupon now.

**ARTHUR R. PATTERSON, Civil Service Expert**  
**PATTERSON SCHOOL, Dept. 812, Wisner Bldg., Rochester, N. Y.**

Arthur R. Patterson, Civil Service Expert  
Patterson School  
Dept. 812, Wisner Bldg.  
Rochester, N. Y.

Sir: Send me without charge your catalog describing Railway Postal Clerk and other Civil Service positions.

Name.....Age.....

Address.....City.....State.....

# Show Card Lettering

HERE is the very course you need if you want to get a good paying position as a Show Card Letterer or Sign Letterer, or have a business of your own. This course is complete and practical and especially arranged to meet the needs of the student who studies at home. It was written by E. L. Koller, Principal of the International School of Art, member of the American Federation of Arts, and The National Society of Craftsmen.

H. L. Wood, a clerk, made more than \$700 "on the side" before he had completed this course. Harry Lord writes that he has more than doubled his salary. William Whitman is earning three times as much as he did before enrolling with the International School of Art.

**INTERNATIONAL SCHOOL OF ART**

Associated with the International Correspondence Schools  
Dept. 5694-E, Scranton, Penna.

Without cost or obligation, please send me full details of your home-study course in  
**SHOW CARD LETTERING**

**Learn at Home**

**Mail Coupon for Free Booklet**

Name.....

Address.....





**WE ARE GIVING AWAY THIS FULL STRENGTH 5-CABLE EXERCISER**  
with one year's "STRENGTH MAGAZINE" subscription to  
**AT ITS REGULAR PRICE OF \$2.50**

We (the Milo Publishing Co.) believe that we are not exaggerating the least bit when we say that, "Never before was so much value given for the small sum of \$2.50 in the physical training field." You simply cannot equal it and consequently you cannot afford to miss it.

**12 Big Monthly Issues of "Strength"**  
and This Powerful 5-Cable Exerciser Complete with Instructions

**ALL MAILING CHARGES PAID BY US**

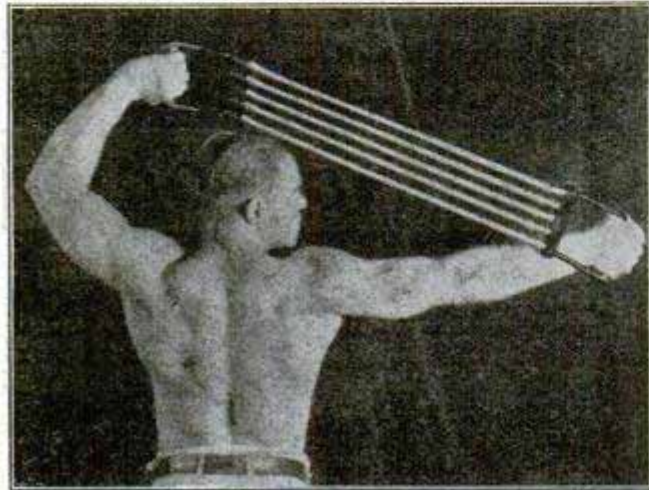

A Strong 5-Cable Exerciser like this, with Course "STRENGTH" is the HEALTH and STRENGTH SEEKERS' MAGAZINE

If you want to become healthy, strong and shapely or remain healthy, strong and shapely, you need "Strength" and with this Exerciser and course the value is doubled. It's an opportunity of a lifetime to get these two big muscle developing mediums at the price of only \$2.50. There are no extra charges not even for postage.

"Strength" contains articles each month on muscle strength and health culture by men who are experts—Men who write from experience and not from theory—Men who have the strength and physiques that prove their teachings. Also Sports articles on wrestling, boxing, swimming and all other sports are included and written by practical writers.

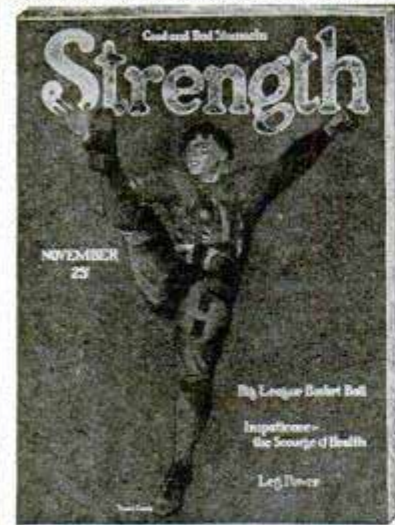

Whether you are always ailing or not you will profit by and enjoy "Strength" each month.

**You Know This is a Big Offer**

Just think of 12 big issues of "Strength" delivered right to your door each month for less than the newsstand price. Add to that this strong 5-strand exerciser and course and what have you got?—the best offer of its kind ever brought before your eyes. You are not asked to pay even the postage on the 12 magazines or exercisers.

**TEAR THIS COUPON NOW and GET IT OFF**

**THE MILO PUBLISHING CO.** P. M. 12-27  
2747 N. Palethorp St., Philadelphia, Pa.

Gentlemen: Enclosed you will find \$2.50 for which please enter my name for a year's subscription to your "Strength Magazine" and send me free of extra charge, whatsoever, the complete 5-STRAND EXERCISER and COURSE.

Name.....  
Street.....  
City..... State.....

**QUIT TOBACCO**

No man or woman can escape the harmful effects of tobacco. Don't try to banish unaided the hold tobacco has upon you. Join the thousands of inveterate tobacco users that have found it easy to quit with the aid of the Keeley Treatment.

**KEELEY TREATMENT STOPS Tobacco Habit**

Quickly banishes all craving for tobacco. Write today for Free Book telling how to quickly Free yourself from the tobacco habit and our Money Back Guarantee.

**THE KEELEY INSTITUTE**  
Dept. A904 Dwight, Illinois

**AMERICAN POULTRY JOURNAL**  
OLDEST, LARGEST AND BEST. EST. 1874

**1 Year 25c** Can. 50c **5 Years \$1** Canada \$2.00

Averages over 100 pages per issue—tells how to feed, house and breed; how to secure high egg production; how to hatch and rear poultry successfully. 25c 1 year. 5 years \$1.00.

**AMERICAN POULTRY JOURNAL, 14-536 S. Clark St. CHICAGO**

**FREE Book HOW TO FEED AND CARE FOR CHICKS**

Gives Money Making Secrets of Poultry Raising. Tells how to hatch, care for and feed chicks until fully grown. Gives plan of Poultry and Brooder Houses. Describes Miller's "IDEAL" INCUBATORS with Patented Egg Turning Trays. Oil and Coal Burning BROODERS. Eggs for hatching—Baby Chicks—BARGAIN PRICES. WRITE TODAY!

**J. W. MILLER CO., Box 12, Rockford, Ill.**

**RAISE BELGIAN HARES**  
NEW ZEALAND REDS—Chinchillas—Flemish Giants

**MAKE BIG MONEY—We supply stock and pay you** following prices for all you raise: Belgian Hares \$2 each—New Zealands \$3 each—Chinchillas \$4 each—Flemish Giants \$5 each. 32-page illustrated book, catalog and contract, also copy of Fur Farming magazine, tells how to raise skunk, mink, fox, etc., for big profits, all for 10c. Address

**OUTDOOR ENTERPRISE CO., Box 25, Holmes Park, Mo.**

**SQUAB BOOK FREE**

Breed squabs and make money. Sold by millions for more than chickens. Write at once for free 40-page book beautifully printed in colors telling how to do it. *You will be surprised.*

**PLYMOUTH ROCK SQUAB CO.**  
634 H Street Melrose Highlands, Mass.

**FOY'S BIG BOOK, in Colors**

A complete guide to successful Poultry and Squab Raising. Low prices on CHICKS, Breeding Stock and PIGEONS.

Write Today! FREE!

**FRANK FOY, Box 18, Clinton, Iowa**

**PLANS for Poultry Houses**

All styles, 150 illustrations; secret of getting winter eggs, and copy of "The Full Egg Basket." Send 25 cents.

**INLAND POULTRY JOURNAL, Dept. 514 Indianapolis, Ind.**

**WOLF COYOTE, FOX AND SKUNK EXTERMINATOR CAPSULES.** Got 9 coyotes one night. Brought \$121.50.

Free Circular. Free Formulas and Instructions.

**GEORGE EDWARDS, Livingston, Montana**

**\$10.00 PER MONTH BUYS Fibre-Lite Limbs**

NEXT TO NATURE. BRACES MADE TO ORDER. AGENTS WANTED. FREE FIBRE SAMPLE.

**WORMAN CO.** 252-P HENNEPIN AVE. MINNEAPOLIS, MINN.

**DEAFNESS IS MISERY**

Multitudes of persons with defective hearing and Head Noises enjoy conversation, go to Theatre and Church because they use Leonard Invisible Antiseptic Ear Drums. Tiny Megaphones fitting in the Ear entirely out of sight. No wires, batteries or head piece. They are Unseen Comforts and inexpensive. Write for booklet and sworn statement of the inventor who was himself deaf.

**A. O. LEONARD, Inc., Suite 699, 70 5th Ave., New York**



# Learn Auto Repairing the Sure, Easy Way

McSweeney training methods are simple, practical, effective—the work-while-you-learn system. No books, dry lectures or mere theories. You are shown how to do everything and you know WHY you do it. When you have completed the McSweeney course you know the "ins and outs" of every make of pleasure car, truck and tractor. You have the necessary knowledge and training to fit you to open a shop of your own or accept a responsible position. McSweeney has trained thousands of successful auto mechanics and now offers you the complete course at a specially attractive figure—not by correspondence, but by a sound method of teaching that makes you an auto and tractor mechanic in only eight short weeks.

**Earn  
\$75 to \$125  
Weekly**

## Complete Course in 8 Weeks

Don't let lack of money or mechanical experience hold you back. Most of the men at the McSweeney Schools have no more money than you have. And age makes no difference. My simple, practical, easy-to-learn methods will make you a competent auto mechanic in eight weeks, no matter whether you are 16 or 60. You work with real tools on real equipment. You DO the jobs you will have to do after you complete the course. McSweeney men know their tasks thoroughly—that's why they are in such big demand.

## Plenty of Good Jobs Waiting— or Start a Business of Your Own

When you complete the McSweeney course you will be competent to handle any and all kinds of auto and tractor repairing. You can start a garage and repair shop of your own, or accept one of the splendid jobs that are just begging for skillfully trained men—McSweeney men. Good auto mechanics make \$50, \$60, \$75 a week on up to \$100 a week, and more.

D. M. Collins, West Va., started as manager of a garage at \$300 a month after completing the McSweeney course.

George Smith of West Alexandria owns an auto agency and repair shop and makes \$200 a week and more.

C. E. Gillespie earns a nice fat salary as supervisor of a large fleet of trucks and tractors for the State Highway Commission.

Other McSweeney-trained men are doing as well and better. Thousands have started on the road to success through the McSweeney Schools.

## Begin Any Time

So great is the demand for McSweeney-trained men that both schools are in constant operation. No waiting for the end of a term—start any time—come tomorrow, if you like. Right now is the best time to begin, because owing to the popularity of closed cars, repair work is about as heavy in winter as in spring and summer. Don't lose any more time. Fit yourself for a big job at once. Write immediately for my special fall and winter tuition offer which includes

**Start  
NOW!**

## R. R. Fare and Board While Learning

Your railroad fare to Cincinnati or Cleveland and your board included in this special offer. One lump sum covers everything. No extras to buy—no books to pay for. If you act promptly, I will include a course in electricity absolutely without extra cost. Write me today. Get my big, complete, beautifully illustrated auto book. It's FREE. Just send me your name and address in the coupon below.



**McSweeney Auto, Tractor and Electrical Schools,  
Dept. 11-T-1, Cincinnati, O. Cleveland, O.**

Without cost or obligation, send me your big FREE book on Autos; also, full details of your big offer including R. R. Fare and Board Paid, and FREE electrical course.

Name.....

Street.....

Town..... State.....



"MAC"  
Himself

One of America's Foremost Trainers of Auto  
and Tractor Mechanics

## YOUR LAST CHANCE TO GET ELECTRICAL COURSE

**FREE**

OF EXTRA COST

House wiring, armature winding, motor work and all general electrical training, both alternating and direct current work.

This is positively the last time I am going to offer the course in electricity to those who enroll in the Auto and Tractor School without extra cost. After January First, 1928, the electrical course will cost extra—at least \$200.00 or more. So you can make a big saving by enrolling at once.

Get into the Auto and Tractor repair business NOW. Don't be satisfied with a small pay job. If you're making less than \$50 a week, you can afford to quit any job you've got and rush to the nearest McSweeney School. The future in auto and tractor repairing looks bigger and brighter every day. Don't wait until all the good jobs are filled. Get started now while you have unlimited chances for big earnings.

*Mac's Shop Plan Makes  
the Big Pay Man.*

**MC SWEENEY**  
AUTO TRACTOR  
and ELECTRICAL **SCHOOLS**  
Dept. 11-T-1  
CINCINNATI, OHIO  
CLEVELAND, OHIO



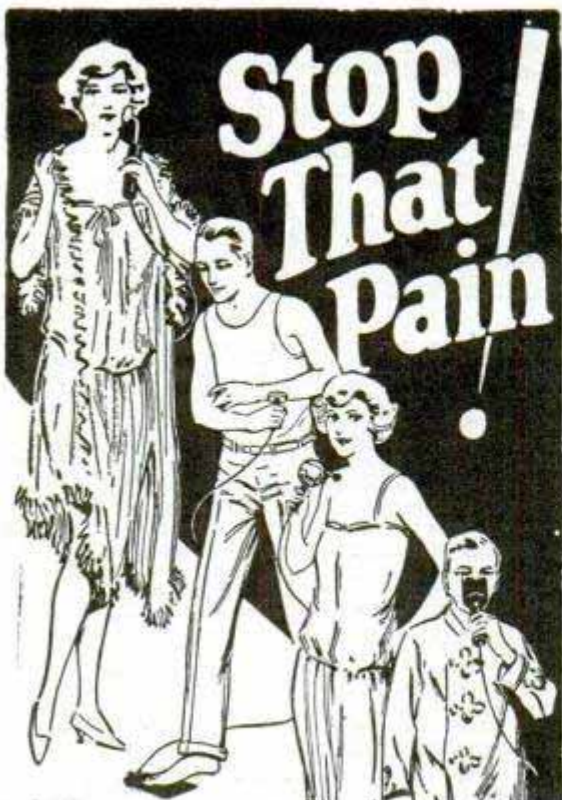

**With Violet Ray Vibration  
Ozone Medical Electricity**

*The Four Greatest Curative Powers  
Generated by This*

**Great New Invention!**



Elco Health Generators at last are ready for you! If you want more health—greater power to enjoy the pleasures and delights about you, or if more beauty is your desire—write! Ask for the book on these inventions which has just been prepared. It will be sent to you without cost. It tells you how Elco Health Generators aid you in leaving the lethargy and hopelessness of bad health and weakness behind forever. Re-vitalize yourself. Bring back energy. Be wholly alive. Write today!

**Here's What Elco Users Say—**

"Wouldn't take \$1000 for my Elco."  
"Has done me more good in 2 weeks than doctors did in three."  
"My Eczema gone."  
"Cured my stomach trouble."  
"Cured my weakness."  
"Now I sleep soundly all night."  
"Thanks to Elco my strength and vigor are back."  
"No more pain."  
"Colds never bother me now."  
"Chronic Constipation banished."



These great new inventions generate Violet Ray, Vibration, Electricity and Ozone—combined or separate. They operate on the electric light in your home or on their own motive power at less than 50 cents per year. Elco Health Generators are positively the only instruments which can give you in one outfit Electricity, Violet Ray—Vibration and Ozone—the four greatest curative agents. Send the coupon below. Get the Free Book NOW!

**Free Trial**

**MAIL COUPON  
for FREE BOOK**

Do not put this paper down without sending the coupon. Don't go on as you are with pains and with almost no life and energy. You owe it to yourself to be a better man or woman. You were put here to enjoy life—not just to drag through it. So do not rest another day until you have put your name on the coupon here. That will bring the whole story of these great new inventions. Do it today—now.



**Lindstrom & Company**

30 West Lake St. Dept. 13-59 Chicago  
Please send me your free book, "Health—Power—Beauty" and full information of your 10-day Free Trial Offer.

Name.....  
Address.....



Edgar E. LaParle, Chief Pilot—will teach YOU the many things HE knows about flying. 30 actual flying lessons in the air is only part of your training. He teaches you to be both Pilot and Mechanic. Send for FULL INFORMATION. Write Edgar E. LaParle, Chief Pilot.

**Chicago Aeronautical Service, Inc.**  
608 So. Dearborn St. Chicago, Ill.



**Deafness**

Perfect hearing is now being restored in all cases of deafness caused by Catarrhal troubles, Relaxed or Sunken Drums, Thickened Drums, Roaring or Hissing Sounds, Perforated, Wholly or Partially Destroyed Drums, Discharge from the Ears, etc.

**Wilson Common-Sense Ear Drums**

require no medicine but effectively replace what is lacking or defective in the natural ear drums. They are simple devices, which the wearer easily fits into the ears where they are invisible.

**Free Book  
on Deafness**

Soft, safe and comfortable. Write today for 168-page book on deafness giving full particulars and many testimonials. The hearing of thousands of grateful users has been restored by these "little wireless phones for the ears."

**WILSON EAR DRUM CO., Incorporated**  
722 Todd Bldg. LOUISVILLE, KY.



**How to Straighten Bow and Knock-kneed Legs!**

Improve your personal appearance by using the new patent "Lim-Straitner," Model 18. Corrects now Bow and Knock-kneed legs safely, quickly and permanently at home. No costly operation or discomfort. Is worn at night. Easy to adjust; its result will save you soon from further humiliation and will improve your personal appearance 100 per cent. Write today for copyrighted Physiological and Anatomical book and experience of others without obligation. Enclose a dime for postage.

**M. TRILETY, Specialist** Dept. 1524L BINGHAMTON, N. Y.

**Free Your Skin**

of pimples, boils, etc., with KLEERSKIN! It purifies the blood and rids it of the poisons that cause skin disorders. KLEERSKIN is wonderful also for treating carbuncles, blackheads and similar skin infections. KLEERSKIN is made after the formula of a celebrated German physician who, after many experiments and clinical trials, has proved it to be the remedy par excellence. Write today. Medco Medicine Co., 503 Ridge Bldg., Kansas City, Mo.

**What Will Tomorrow's Weather Be ?**



This marvelous weather prophet forecasts the weather 8 to 24 hours in advance. Never fails. Scientific, and accurate. Warns against coming rain, frost, storm or change. Invaluable to fruit growers, gardeners, farmers. Useful in every home. Built just like the picture. Size 6 1/2 x 7 1/2. Perfect miniature cottage. Boy and girl appear when weather is to be fine. Old witch comes out to warn of storm or change. Beautiful, valuable, useful, instructive.

Send 25c for years subscription to our Monthly publication Everyday Life and 75c extra or \$1.00 in all and we will send our publication one year and Weather Prophet, all for \$1.00.

EVERYDAY LIFE, 91 W. P., 337 W. Madison St., Chicago

**DON'T WEAR  
A TRUSS**

**BE COMFORTABLE—**

Wear the Brooks Appliance, the modern scientific invention which gives rupture sufferers immediate relief. It has no obnoxious springs or pads. Automatic Air Cushions bind and draw together the broken parts. Nosalvesor plasters. Durable. Cheap. Sent on trial to prove its worth. Beware of imitations. Never sold in stores nor by agents. Every appliance made to special order and sent direct from Marshall. Full information and booklet sent free in plain, sealed envelope.



MR. C. E. BROOKS

**BROOKS APPLIANCE CO., 107A State St., MARSHALL, MICH.**



*Electrical Experts are in Big Demand!*  
—L.L. Cooke!

# I Will Train You at Home to fill a Big-Pay Job!



**L. L. COOKE**  
Chief Engineer

It's a shame for you to earn \$15 or \$20 or \$30 a week, when in the same six days as an Electrical Expert you could make \$70 to \$200—and do it easier—not work half so hard. Why then remain in the small-pay game, in a line of work that offers no chance, no big promotion, no big income? Fit yourself for a real job in the great electrical industry. I'll show you how.

## Be an Electrical Expert Earn \$3,500 to \$10,000 a Year

### Your Satisfaction Guaranteed

So sure am I that you can learn Electricity—so sure am I that after studying with me, you, too, can get into the "big money" class in Electrical work, that I will guarantee under bond to return every single penny paid me in tuition, if, when you have finished my Course, you are not satisfied it was the best investment you ever made. And back of me in my guarantee, stands the Chicago Engineering Works, Inc., a two million dollar institution, thus assuring to every student enrolled, not only a wonderful training in Electricity, but an unsurpassed Student Service as well.

### Get Started Now — Mail Coupon

I want to send you my Electrical Book and Proof Lessons, both Free. These cost you nothing and you'll enjoy them. Make the start today for a bright future in Electricity. Send in Coupon—NOW.

L. L. COOKE, Chief Instruction Engineer

### L. L. COOKE SCHOOL OF ELECTRICITY

Dept. 519

2150 Lawrence Av. Chicago



**L. L. COOKE, The Man Who Makes "Big-Pay" Men**  
Dept. 519  
2150 Lawrence Ave., Chicago

Send me at once without obligation your big illustrated book and complete details of your Home Study Course in Electricity, including your outfit and employment service offers.

Name .....

Address .....

Occupation .....

### Look What These Cooke Trained Men are Earning



#### Makes \$700 in 24 Days in Radio

"Thanks to your interesting Course I made over \$700 in 24 days in Radio. Of course, this is a little above the average but I run from \$10 to \$40 clear profit every day; you can see what your training has done for me."

FRED G. McNABB,  
843 Spring St., Atlanta, Ga.



#### \$70 to \$80 a Week for Jacquot

"Now I am specializing in autoelectricity and battery work and make from \$70 to \$80 a week and am just getting started. I don't believe there is another school in the world like yours. Your lessons are a real joy to study."

ROBERT JACQUOT,  
2008 W. Colorado Ave.,  
Colorado Springs, Colo.



#### \$20 a Day for Schreck

"Use my name as a reference and depend on me as a booster. The biggest thing I ever did was answer your advertisement. I am averaging better than \$500 a month from my own business now. I used to make \$18 a week."

A. SCHRECK,  
Phoenix, Ariz.



#### \$3500 A Year For Beckett

"When I began with you I was just a common laborer, going from one job to another, working for anything I could get, and that wasn't much. Now my salary is \$3,500 a year and the Company furnishes me with an automobile."

C. O. BECKETT,  
108 Maple Heights,  
New Lexington, Ohio

Today even the ordinary Electrician—the "screw driver" kind—is making money—big money. But it's the trained man—the man who knows the whys and wherefores of Electricity—the Electrical Expert—who is picked out to "boss" the ordinary Electricians—to boss the Big Jobs—the jobs that pay \$3,500 to \$10,000 a Year. Get in line for one of these "Big Jobs." Start by enrolling now for my easily learned, quickly grasped, right-up-to-the-minute, Spare-Time Home-Study Course in Practical Electricity.

### Age or Lack of Experience No Drawback

You don't have to be a College Man; you don't have to be a High School Graduate. As Chief Engineer of the Chicago Engineering Works, I know exactly the kind of training you need and I will give you that training. My Course in Electricity is simple, thorough and complete and offers every man, regardless of age, education or previous experience, the chance to become, in a very short time, an "Electrical Expert," able to make from \$70 to \$200 a week.

### No Extra Charge for Electrical Working Outfit

With me, you do practical work—at home. You start right in after your first few lessons to work at your profession in the regular way and make extra money in your spare time. For this you need tools, and I give them to you—5 big complete working outfits, with tools, measuring instruments and a real electric motor.

**5 big outfits given to you — no extra charge**



MAIL COUPON FOR MY FREE BOOK

The "Cooke" Trained Man is the "Big Pay" Man



# BE A RAILWAY TRAFFIC INSPECTOR



**NO HUNTING FOR A POSITION AFTER COMPLETING YOUR TRAINING**

Read what Ed. Grogan says—  
Dear Mr. Jarrell:  
You will recall that I took a Correspondence Course in your school and was placed in a position a year ago. I am not going to try to say what the School and the Employment Department has done for me, but it is so much beyond my expectation that it would sound to a reader of this letter beyond reason, but I was placed in a position at \$110 per month, was raised to \$135 at the expiration of one month, and am now getting \$150 per month and like the work fine.  
I find the men who are my superiors to be pleasant generally to meet and to work for, and they are invariably favorably impressed with your school. I am indeed grateful to you and your Institution. You have been a stepping stone to my future and I cannot thank you sufficiently. I wish I could tell some of the under-paid who are dragging along in a tough rut about your Institution. Again let me thank you.

(Signed) Ed. Grogan

**STANDARD BUSINESS TRAINING INSTITUTE**  
Division 2 Buffalo, New York

EARN UP TO  
**\$250 per month SALARY**

**PLUS EXPENSES**  
Our students never worry about a position as one will be offered them within a few days after completing the Traffic Inspection course. You start at \$120 or more per month plus expenses. Our contract shows why you take no risk.

As a Railway Traffic Inspector, you are practically your own boss, see new faces and places each minute, report only to high officials, are rapidly advanced. It's healthful outdoor work with regular hours.

**Hundreds of Satisfied Graduates**  
During the last nine years, hundreds of our graduates have found satisfaction and increased incomes in Traffic Inspection. They took no chance—started on a definite salary. You can do the same. Write today for our free booklet, and contract agreeing to refund your money if position is not offered after graduation.

# Be a REAL ESTATE Specialist

Learn my amazingly successful system—right at home—in your spare time. Let me train you for real success. Let me put you in touch with big business. Let me do for you what I have done for other wide-awake men and women. D. H. Garrett says: "Made \$630 in one week before I was half through your training." Mrs. J. H. Hastings says: "Have sold two lots, receiving two hundred and forty-eight dollars in commissions. Have fine business lined up." M. I. Stokes says: "Made \$900 in three months in my spare time." Send your name and address at once for my new, free book, "How to Become a Real Estate Specialist," giving full facts about my remarkable Home-Study Course, my Free Business Service and positive proof of big success. Address DIRECTOR, Dept. 44-NN, American Business Builders, Inc., 18 East 18 Street, New York, N. Y.



SOLITAIRE \$1.98	AQUAMARINE \$3.72	MAN'S RING \$4.93	ONYX INITIAL RING \$3.79
---------------------	----------------------	----------------------	-----------------------------

**Send 10c Take Your Choice**

These beautiful rings are all the vogue in New York and Hollywood. Words can't do them justice. They are Reproductions of \$500 Gems and have all the flash and dazzling beauty of genuine diamonds. Mounted in Genuine Sterling Silver with a Platinum Finish. Experts even have difficulty in distinguishing them from genuine jewels. The Aquamarine is an ideal friendship ring and has a very rare color found only in the most perfect gems.

**Send Only 10c Now!** When ring arrives, deposit \$1.00 with postman and pay balance in easy installments of \$1.00 a week. **WE TRUST YOU.** No red tape! No references asked for. Simply tell us which ring to send and enclose 10c with ring size. Satisfaction guaranteed. Canada, cash with order. **THE JEWELRY IMPORTING CO., Dept. 3600 Arlington Heights, Ill.**

# GET INTO AVIATION

**20 MECHANICS NEEDED TO EVERY FLYER**

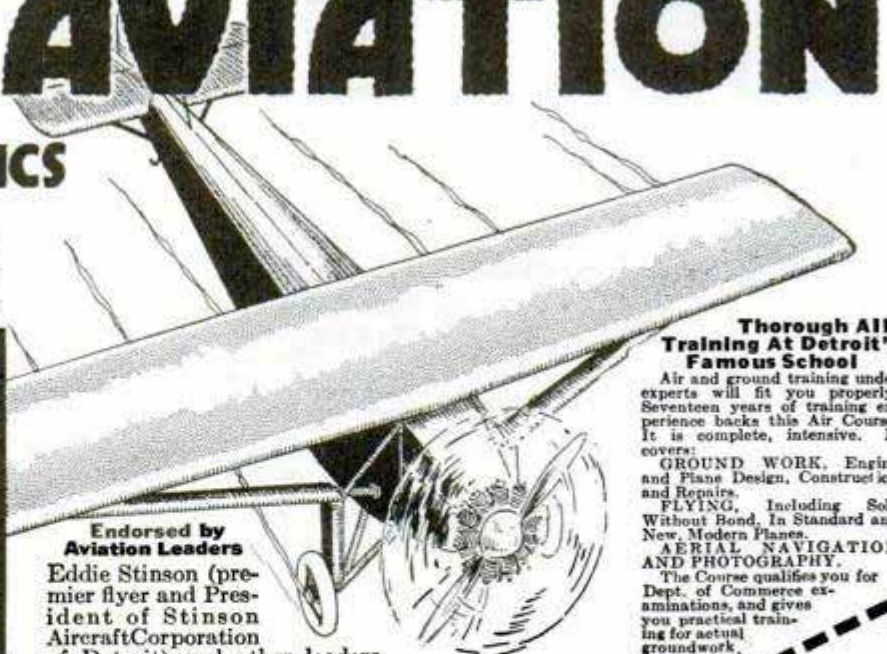

**Thorough AIR Training At Detroit's Famous School**

Air and ground training under experts will fit you properly. Seventeen years of training experience backs this Air Course. It is complete, intensive. It covers:

**GROUND WORK,** Engine and Plane Design, Construction and Repairs.

**FLYING,** Including Solo Without Bond, In Standard and New, Modern Planes.

**AERIAL NAVIGATION AND PHOTOGRAPHY.**

The Course qualifies you for Dept. of Commerce examinations, and gives you practical training for actual groundwork, and flying.

**Endorsed by Aviation Leaders**

Eddie Stinson (premier flyer and President of Stinson Aircraft Corporation of Detroit) and other leaders, endorse "Michigan State" training. They say the need of trained men is great and growing bigger fast. Aviation is just entering on its stage of business success. Marvelous futures and profits await the men who learn this thrilling business thoroughly NOW.

Write today for complete details of Opportunities in Aviation and practical "Michigan State" training.

**Get the Facts TODAY**

A. G. Zeller, President  
Michigan State Aviation School  
3712 Woodward Ave., Detroit, Mich.

Send me at once the details of your Aviation Ground and Flying Course. I expect to come to Detroit about.....

Name.....

Street and No. or R. F. D.....

City and State.....

**MICHIGAN STATE AVIATION SCHOOL**  
Affiliated with Michigan State Automobile School  
Established 17 Years A. G. ZELLER, Pres. 3712 Woodward Ave., Detroit, Mich.



# Silent Magic



Here is the Eveready Layerbilt "B" Battery No. 486, Eveready's longest-lasting provider of Battery Power.

TURN your radio dial, and presto! you turn your home into a theater, a concert hall, a lecture room, a cabaret, a church, or whatever you will. Turn the dial and your attentive ear does the rest. That is all there is to this magic of radio.

Or almost all. If a radio set is to work at its very best, attracting no attention to itself, creating for you the illusion that can be so convincing, you must pay a little attention to the kind of power you give it. There is but one direction, a simple one—use Battery Power. Only such power is steady, uniform, silent. It is called by scientists pure Direct Current. Any other kind of current in your radio set may put a hum into the purest note of a flute, a scratch into the song of the greatest singer, a rattle into the voice of any orator.

Don't tamper with tone. Beware of interfering with illusion. Power that reveals



## Radio is better with *Battery* Power

its presence by its noise is like a magician's assistant who gives the trick away. Use batteries—use the Eveready Layerbilt "B" Battery No. 486, the remarkable battery whose exclusive, patented construction makes it last longest. It offers you the gift of convenience, a gift that you will appreciate almost as much as you will cherish the perfection of reception that only Battery Power makes possible.

NATIONAL CARBON CO., Inc.  
New York San Francisco



Unit of Union Carbide and  
Carbon Corporation

Tuesday night is Eveready  
Hour Night—9 P. M., East-  
ern Standard Time

WEAF—New York	WOC—Davenport
WJAR—Providence	KSD—St. Louis
WEEL—Boston	WCCO—{Minn.
WFI—Philadelphia	{St. Paul
WGR—Buffalo	WDAF—Kansas City
WCAE—Pittsburgh	WRC—Washington
WSAI—Cincinnati	WGY—Schenectady
WTAM—Cleveland	WHAS—Louisville
WWJ—Detroit	WSB—Atlanta
WGN—Chicago	WSM—Nashville
	WMC—Memphis

Pacific Coast Stations—  
9 P. M., Pacific Standard  
Time

KPO—KGO—San Francisco
KFOA—KOMO—Seattle
KFI—Los Angeles
KGW—Portland

**EVEREADY**  
**Radio Batteries**  
—they last longer

The air is full of things you shouldn't miss



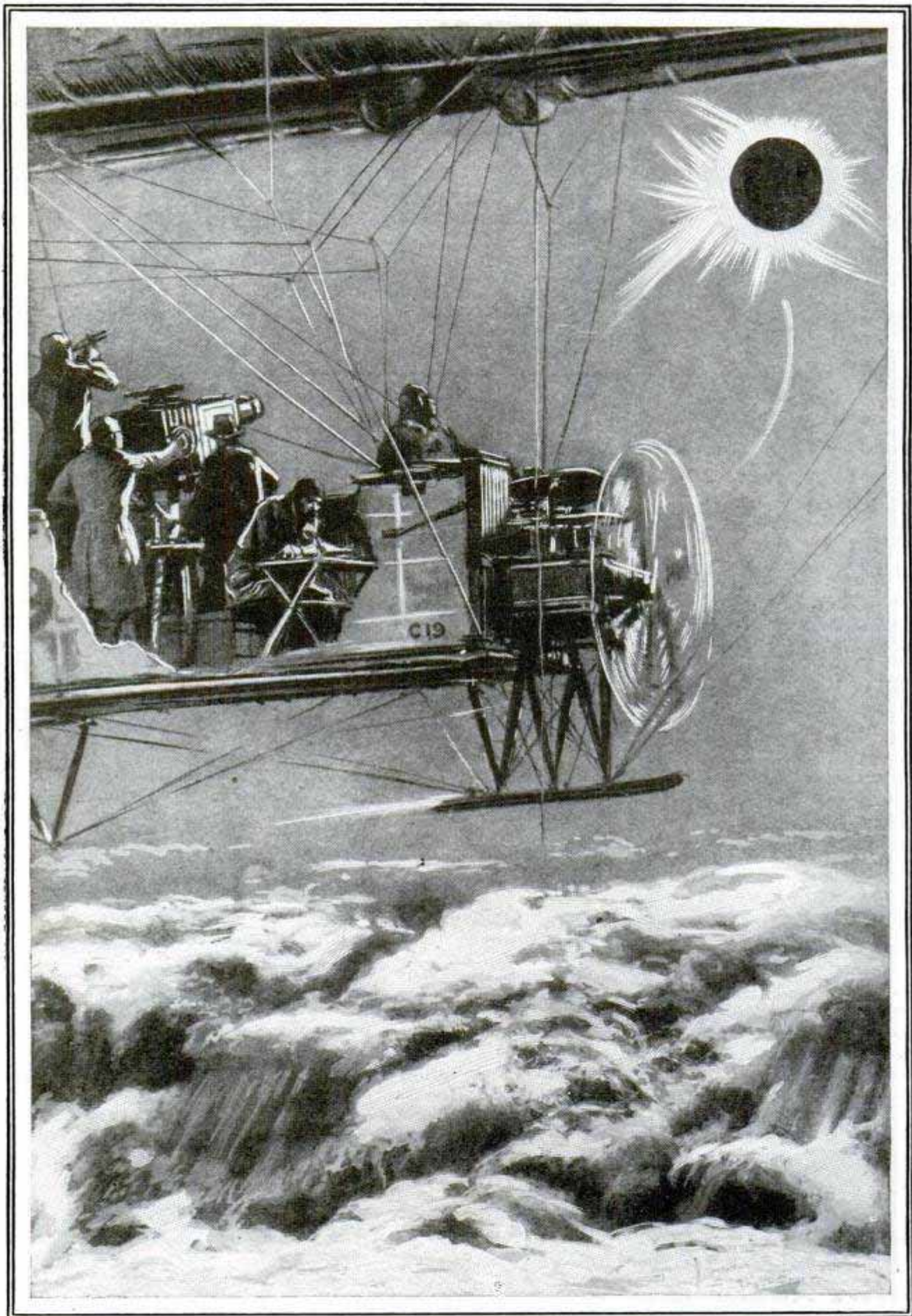

Airplanes and Dirigibles Have Rendered the Astronomer Independent of Clouds and Rain, Enabling Him to Take His Cameras Aloft to Cover Such Events as an Eclipse—See Page 962



# Popular Mechanics Magazine

REGISTERED IN U. S. PATENT OFFICE

WRITTEN SO YOU CAN UNDERSTAND IT

Vol. 48

DECEMBER, 1927

No. 6

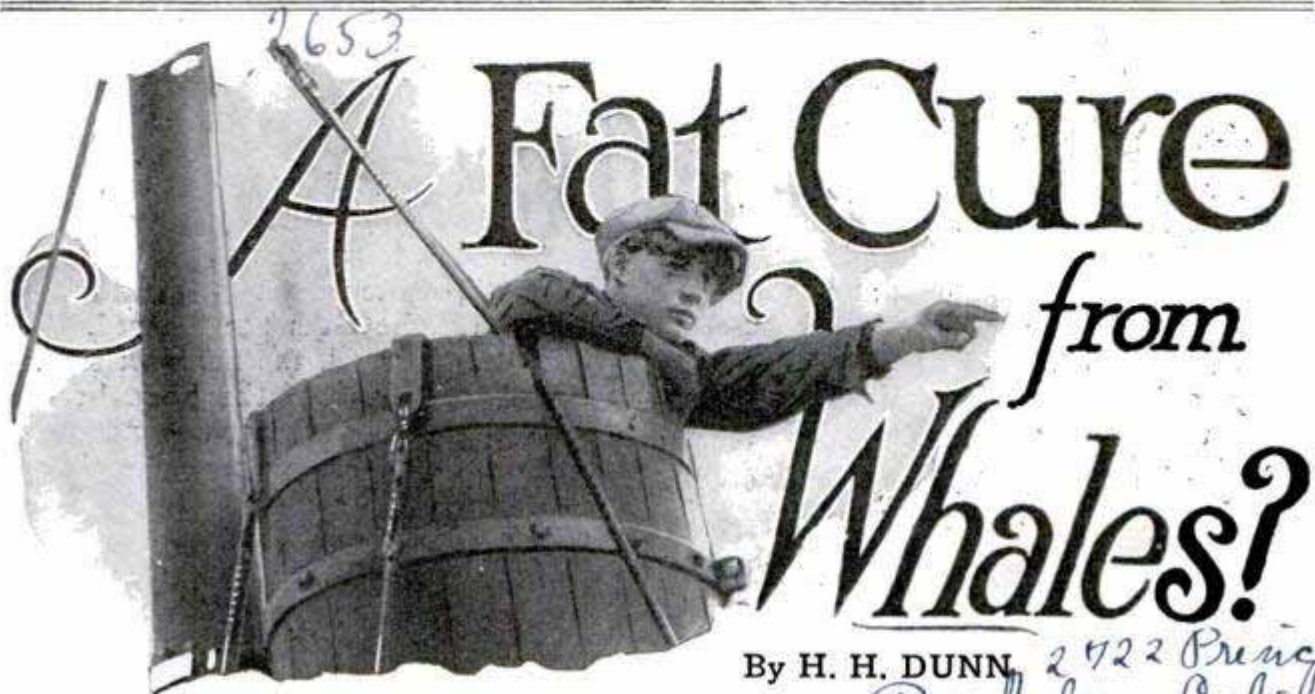

## A Fat Cure

from

## Whales?

By H. H. DUNN,

2722 Prince St  
Berkeley, Calif.

**T**WO scientists from the University of California are trying to learn the cause of extreme obesity in man, and the reason for the huge size to which whales grow. They believe, if they find the one, they will be on the trail of the other.

It is thought that whales, which are among the largest creatures which ever lived on earth, attain their great length and weight, and produce their thick layers of fat, because of the absence, or deterioration, of the pituitary and thyroid glands. It is known that failure of these glands to function properly in human beings produces either giants or dwarfs, excessively fat persons or exceedingly thin ones.

Whales range from the twenty-foot length, of a small variety found in New Zealand waters, to the ninety to 100-foot sulphur bottoms, or bluebacks, of the north Pacific. They weigh an average of one ton for every foot of length. Scientists say that, while the whale is admirably adapted to the element in which it lives, there is no apparent reason for it to attain such size; that, in fact, the size is a handicap in its feeding, migrations and general success in life. They believe

the whale during its development in past generations lost its pituitary and thyroid glands, either in whole or in part, or they became so altered that development of the mammals to their present size resulted.

If this condition is found to exist, and examination of hundreds of whales shows it to be general, similar experiments will be carried on with elephants and other large animals. The condition also will add another chapter to the scientific history of the influence of these two glands on human life, since the whale is as much of a mammal as man, whom it greatly resembles in structure, save for size.

If, on the other hand, the whale is found to possess the pituitary and thyroid glands, it is believed they will be of such large size as to form a new and valuable source of supply for the extracts, now used in the treatment of obesity and of excessive leanness in man.

The whales used in the experiments were hunted in the most modern manner, mechanical devices produced during the past ten years having brought an end to the old-time year-long voyages in sailing ships, and reduced the adventure and gam-

Information obtained will be turned over to the Max S. Linn



ble of whaling to an exact business. The small iron steamers—none of them more than 100 feet long, and many not so large as the whales they hunt—put out of Ensenada or Guaymas each morning, seldom proceeding more than twenty to forty miles from shore. A lookout goes into the crow's-nest on the mainmast of the little steamer, and watches for the "spout" of vapor which betrays the whale newly risen to the surface. At his cry, the steamer, which has a speed of twenty knots, as compared with the whale's maximum of fifteen, sets out in pursuit.

There is no lowering of longboats, with hours of pulling at the oars, as in the old days of whaling, and there is no danger to men or vessel, unless some huge and crusty old sulphur bottom decides to charge the steamer. The gunner takes the tarpaulin off the three-inch harpoon gun, set well forward in the bow, puts the charge of black powder in the breech, fits the 150-pound harpoon in the muzzle, and stands by his lanyard.

The head of the harpoon carries a killing charge of high explosive, with a time fuse, set to explode four seconds after the harpoon leaves the gun. Leading from the harpoon is twenty to thirty feet of heavy steel chain, rove into 3,000 fathoms (18,000 feet) of three-inch Manila cable, running to a steam winch below decks, and feeding through a slot and pulley in the very tip of the bow. This winch has an automatic arrangement, whereby it releases and picks up this great cable as

easily and in the same manner as an automatic fishing reel takes care of the slack in a thin silk or linen line.

The wheel by which the steamer is steered is located in such a position that the helmsman, usually the captain, has an unobstructed view of the gunner and the sea ahead. As he approaches within shooting distance of the whale, he "lays" the ship "dead on" the quarry, just as a gun-pointer might lay his cannon on a target. The gunner then, so long as the captain holds the ship on her "point," attends to the depression or elevation of his piece, considering the roll of the ship and the roll of the whale. When the two rolls coincide, he pulls the lanyard.

If his aim is good, the harpoon strikes about ten feet back of the great head—whales have no visible necks—and penetrates to such a distance that the charge of explosive wrecks the heart before the monster can "sound." If all goes well, the whale is dead in a few minutes, the winch takes in the line and the thirty to 100 tons of flesh and bone and blubber are pulled alongside. A man, armed with a long, hollow-stemmed steel lance, connected with an air compressor, leaps to the back of the floating whale, drives the lance deep into its vitals and the body is pumped full of air. A flag bearing the name of the ship making the capture is stuck on a steel rod in the whale's body, which is

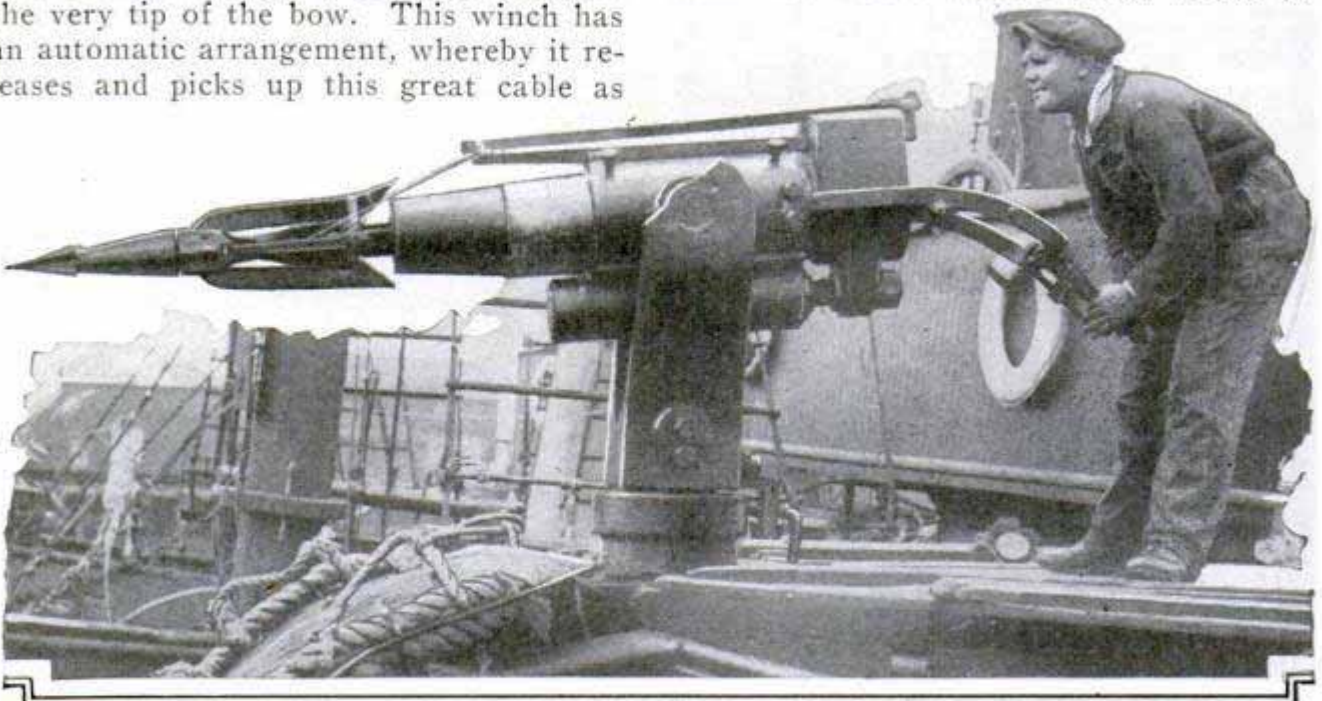

When the Lookout in His Barrel on the Masthead Cries, "There She Blows," the Gunner in the Bow of the Whale Ship Swings His Harpoon Around, Ready to Fire



*Arise Sumida River*

3309

then cast loose while the steamer goes after another, returning later to pick up its earlier kills.

If, however, the harpoon does not strike true, or the explosive fails to go off, the whale almost immediately sounds—that is, rears its huge flukes ten to thirty feet in the air, and dives. Contrary to whaling fiction, the whale seldom goes down more than 500 to 600 feet. A whale is able to remain under water not more than five minutes, being compelled to return, at the end of that period, to the top for air.

But the whale may come up half a mile from the whaler, whose three miles or more of cable still holds fast. Then pursuit is taken up again, the cable, drawn taut, making a drag of the ship against the strength of the whale. Now and then, one of the large whales, rising close to the little steamer, will charge the vessel blindly, and such a collision is fraught with danger to both men and boat. Sometimes, the whale will rise a mile or two away, but the weight of that length of cable, if the harpoon is well "sunk," soon wears down the big mammal's strength until it can be overtaken easily. The whales so taken are towed like so many barges or rafts, to a mother-ship, or, as in Monterey and Eureka, Calif., to shoreside cooking stations, where they are cut up and every bit of the carcass utilized.

The oil, however, is the principal product, being worth today around \$1.40 a gallon, as compared with eighty cents at the height of the whaling industry in the late seventies and early eighties.

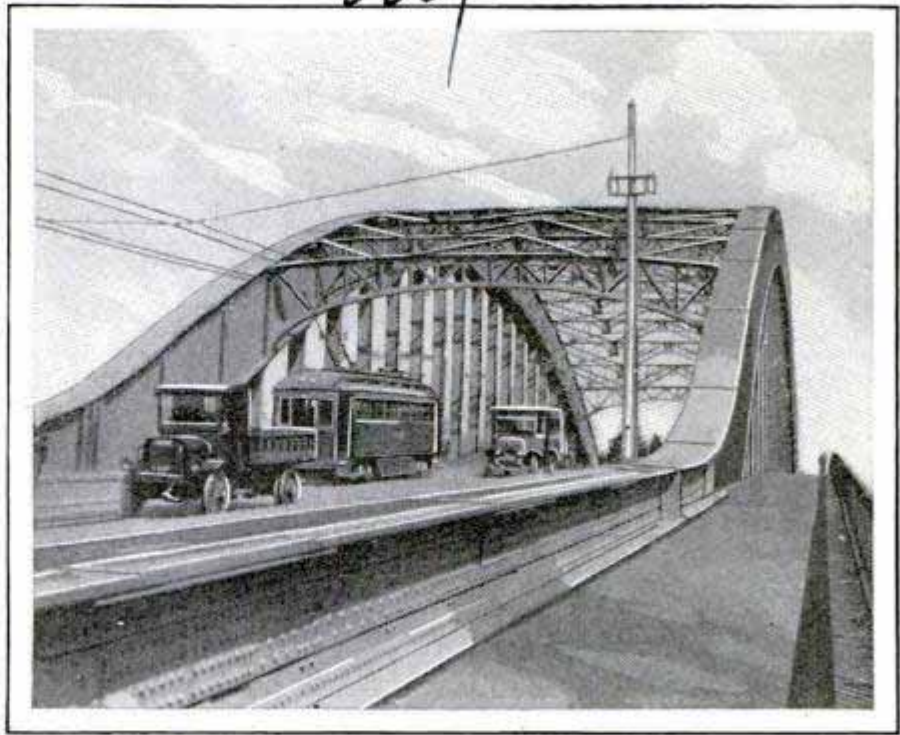

The Yantai Bridge in Tokyo, Illustrating How Japan Is Keeping Abreast of the Times in Steel-Construction Methods

**BUILDING PROGRESS IN JAPAN SHOWN BY STEEL BRIDGE**

That Japan is keeping abreast of the times in construction methods is shown by the Yantai bridge in Tokyo. It weighs more than 4,000 tons, is 600 feet long and eighty-four feet wide. The distinguishing features are the wide arched girders that support the lower part of the viaduct. At one place, these are fifteen feet wide. Steel bands replace the usual cables.

**PULLING BARRELS UP STAIRS IS MADE EASY**

3354



To Simplify the Task of Hauling Barrels up Stairs; the Apparatus in Working Position

Pulling heavy barrels up stairs or taking them down is made safer and easier with a tackle apparatus introduced in France. It consists chiefly of a cable sling which is passed around the barrel and a geared drum by which the ropes are wound up or let out. By turning a crank, the load is easily drawn up the stairs and releasing the cables permits the barrel to descend.

is easily drawn up the stairs and releasing the cables permits the barrel to descend.

*Denri. Marechal  
Neuville-au-Bois,  
France*

*no U. S. agent known.*



3358



Where Body Blows Mean Little; Barrel Boxers in Action

**BOXERS BATTLE IN BARRELS FOR NEW RING THRILLS**

Wearing barrels suspended from their shoulders, boxers at the Oregon agricultural college furnished spectators amusement by their grotesque tactics. The "protectors" eliminated such difficulties as hitting below the belt and tested the ability to attack and protect the head.

**AIR MOSS REALLY AN ANIMAL ALTHOUGH SOLD AS PLANT**

3379

Among the interesting specimens in nature are those that lie close to the borderline between plants and animals, sometimes confusing scientists and almost always a riddle to the layman. One of these is the air moss, which is dredged up from the sea, dyed a brilliant green and sold in conveniently sized bunches. The material is not vegetable but animal, being built up by the secretions of a vast number of minute creatures living in a close and harmonious colony. Each animal has long tentacles to sweep food into its mouth. The colonies grow at moderate depths.

**"CAFETERIA" HOTEL HAS NO CLERKS OR BELL BOYS**

You write your name on a blackboard, go to your room, where you find the key on the inside of the door, and next morning, you slip a dollar in a slotted box at the entrance, as you leave. These are the chief formalities at a Texas hotel which is run strictly on the self-service idea, without clerks or bell boys. Each room is supplied with abundant stocks of linen and other necessary

articles, and the proprietor asserts that he has had few patrons who have attempted to evade payment. The hotel has proved especially popular among auto tourists.

**OLD ROOSEVELT FAMILY HOUSE RETURNS TO FAMILY**

3275

Still in good repair, a wooden house at Brooklyn, Conn., built by Col. Daniel Tyler, great-great-grandfather of Mrs. Theodore Roosevelt, has been purchased recently so that the Roosevelt family may retain possession of it. The dwelling was built in 1765. A tomb and statue near it were erected in memory of Gen. Israel Putnam, revolutionary-war hero.

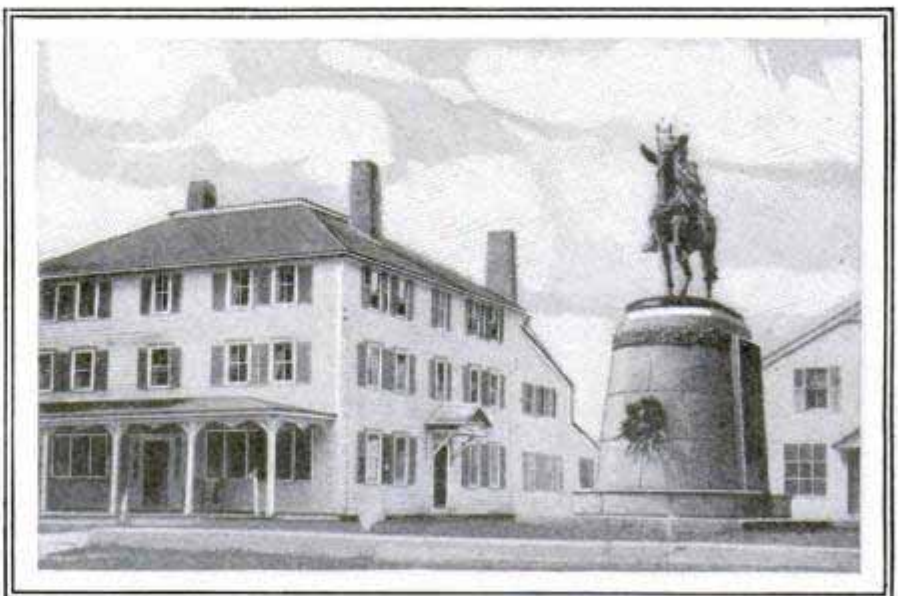

Tyler House in Brooklyn, Conn., Built in 1765, and Recently Acquired by the Roosevelt Family

The Mentor



# Are Ocean Flights



# Worth The Price?

Atlantic Air Liner Designed by M. Louis Bleriot, First Man to Fly across the English Channel; He Provides Four Engines and a Detachable Fuselage Built like a Boat

**T**WENTY people, including two women, missing and presumably drowned at sea; seven lives snuffed out in preparing for long-distance flights. That is the toll of aviation's biggest, most spectacular year in all the twenty-four years since Orville Wright took the first plane into the air at Kitty Hawk, N. C., on December 17, 1903. And the whole world is asking whether transoceanic flying is worth the price in lives and material.

The answer is important, for throughout the world well-meaning people are initiating movements to put a stop to such flying. Whether such a ban would work is doubtful, but three of the eight men who succeeded in crossing the Atlantic this year have declared their opposition to it. Col. Lindbergh says it would put a stop to scientific progress; Clarence Chamberlin declares it would retard the advance of aviation, and Commander Byrd believes the step unnecessary because the pressure of public opinion alone will deter further needless risks by eliminating possible financial backers.

No one can say whether the lives sacrificed will be paid for by the lessons taught, but it is probable that the benefit to aviation of the failures will be equally great as the benefits of the successes. Lindbergh showed the Atlantic could be crossed by an airplane. Chamberlin showed it was possible to cross it and carry a passenger. Byrd demonstrated that a multimotored plane could not only make the crossing but carry four men, the last word in scientific navigating equipment and a complete radio installation to keep in touch with the rest of the world all the way.

And the failures that followed showed that once those facts had been proved it was foolish to keep on attempting the feat with single-motored ships, without radio and navigating equipment, and with airplanes incapable not only of landing on the sea, but of remaining afloat in moderately rough weather.

In the final analysis it is probable that the lessons of failure will do more to speed up the building of the right kind of planes for long-distance flying than all





Major Coli, Left, and Captain Nungesser in Their "White Bird," Decorated with Nungesser's Grim Wartime Insignia

the enthusiasm aroused by the successful flights. The automobile has been built on the lessons of its own faults when driven to destruction, and the same is true of every other piece of machinery that has reached a high state of evolution. So it is reasonable to assume that the lessons of disaster may, in the end, outweigh the rewards of success, and in that sense even the heavy toll of life be made to pay.

Aviation leaders are generally agreed on a number of the lessons learned, including:

Abolishing the use of land planes for long flights over water.

The necessity for multimotored planes, capable of carrying on with at least half their engines out of commission.

Complete radio-sending and receiving equipment for every long-distance flyer,

with a competent radio operator in charge.

Improvement of both navigation and flying instruments, and competent aerial navigation for every long flight.

Better weather reports covering conditions along the sea routes.

Charles A. Levine, of New York, who hopped bareheaded into Chamberlin's plane and flew to Europe as the first transatlantic aerial passenger, is planning a regular Atlantic air service. Announcing the details in London, he said he planned to build ten planes, each with a capacity of fifty passengers, besides its crew. Each plane would have seven engines, of which only four would be in use at any one time, leaving three in reserve. The ships would be monoplane flying boats, capable of landing at sea, if necessary.

Their great size, with fifty passenger seats and berths, would mean economical operation. With a ship like the one he flew to Europe, the fare would have had to be at least \$2,500 per passenger, whereas his proposed seven-motored airplane would bring the overhead down, by dividing it among so many people, to the point where aerial liners could compete on favorable terms with ocean steamers.

Levine isn't alone in planning mammoth air liners. Prof. Junkers, Rumpler and other German designers are already building them, and Louis Bleriot, the first successful sea flyer in history, for he crossed the English channel, has prepared designs for two. Both are monoplanes, each driven by four engines, placed in tandem fashion, two on either side of the fuselage, driving a pulling and pushing propeller. One of the designs calls for 2,800 horsepower. The passengers would be housed in





Part of the Long Honor Roll of the Brave; at the Left Is Lieut. Col. Minchin, Famous British Airways Pilot, Who Was Lost with Princess Lowenstein-Wertheim When Her Plane, the "St. Raphael," Disappeared in the Atlantic; at the Right Is Capt. William P. Erwin, Who Went to Sea on a Rescue Mission in His "Dallas Spirit" and Fell in a Tailspin Somewhere West of San Francisco, as His Radio Reported Before the Ship Hit the Sea



Ike Eichwaldt, Navigator of the "Dallas Spirit," at Left, Sent the Final Radio S.O.S. That Told the World Their Rescue Mission Had Failed; in the Center Are J. D. Hill, Left, and Phillip Payne, Right, Respectively One of the Pilots and the Passenger in the "Old Glory"; Hill Sent the Radio S.O.S. Just Before They Fell; at the Right Is Paul Redfern, of Georgia, Who Circled a Freighter Off South America and Then Disappeared into the Blue



Lloyd Bertaud, the Pilot Who Took "Old Glory" on Her Last Flight, at Left; He Learned to Fly More Than Twenty Years Ago by Building a Glider from Popular Mechanics Plans; the Smiling Pair Are Gordon Scott and Jack Frost, Navigator and Pilot of the "Golden Eagle." One of the Two Planes Lost in the Dole Flight, and for Whom the "Dallas Spirit" Was Searching When She, Too, Sent Her S.O.S. and Plunged into the Pacific Ocean





the wings as well as in the central body. The other ship, a smaller model, would have four engines developing a total of 900 horsepower—motors the same size as the ones Lindbergh, Chamberlin and Byrd used—and the fuselage would be a detachable lifeboat, capable of being released from the wing and driven over the waves under its own power.

Equally important with bigger and better ships, powered with several engines and fitted with boat hulls, is the need for better weather service. The shortest air routes do not follow the usual steamer routes at sea, for the latter are diverted by the necessity of keeping away from land and other obstructions. Yet the only sea-weather reports available are those wireless by ships. They are supplemented, in part, by predictions based on the known speed of storms checked while they moved across land, but, at best, predictions for weather over the sea remain inadequate.

Several inventors have proposed huge landing stages, to be anchored at intervals of 500 miles across the ocean. They would

be enormous harbors to shelter seaplanes, have vast landing decks for land ships, and provide hangars, machine shops, mechanics, and hotels for the passengers. Their cost would run into the millions.

It is possible that a half dozen stanch lightships, anchored at similar intervals, and equipped with powerful radio to report weather conditions hour by hour, might be more useful, at less cost.

There is a growing field for aerial navigators capable of guiding a plane to any part of the world. They must know more than the captain of a surface ship, for the latter's field is limited to the surface of

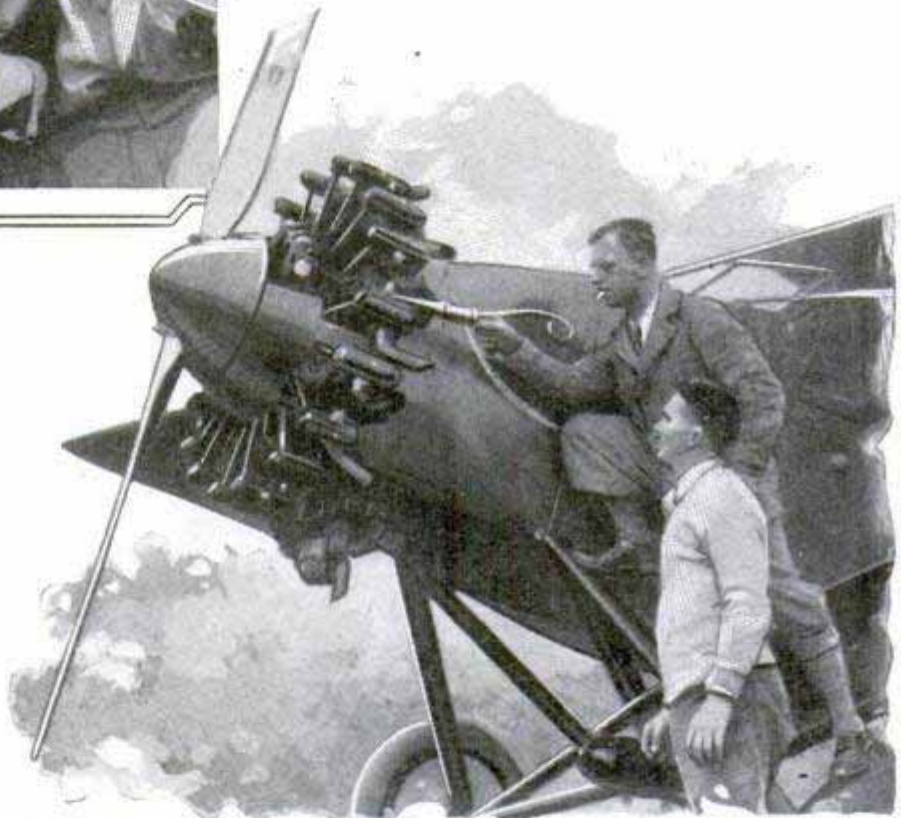

John Pedlar, Miss Mildred Doran and Lieut. V. R. Knope, of the "Miss Doran" Plane, and Capt. Tulley and Lieut. Medcalf, of the "Sir John Carling"

the sea and the storm winds immediately above it. The air pilot, on the other hand, must be not only a competent navigator by sun and stars, but must be an expert meteorologist, versed in the air layers for miles above the earth, and capable of finding the most favorable layer in which to fly his course.

Better navigators and better weather reports are essential before round-trip flights to and from Europe become practical. The westbound trip has never been made by a heavier-than-air machine, and only twice by gas-filled ships. The first was the British "R-34," which made the



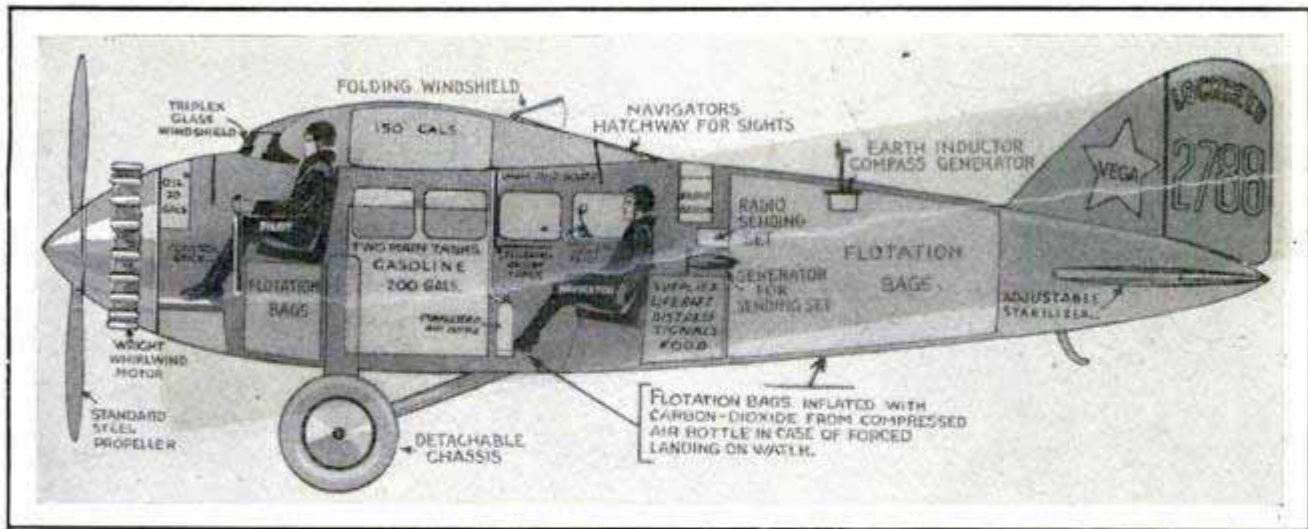

The Type of Ship Used on Most of the Ocean Flights This Year, Big Monoplanes, Single-Engined, Equipped with Some Provision for Floating on the Water; This Is the "Golden Eagle"

round trip to the United States just after the war, and the second was the German-built airship "Los Angeles," which was flown from Germany by a Zeppelin crew and delivered to the U. S. navy.

Two French, two German, one English and one Irish plane have started the westward trip. Nungesser and Coli disappeared at sea, and all the rest turned back safely when they found the weather out over the Atlantic was worse than the weather reports had led them to expect.

The westward flight is not going to be accomplished, nor is a regular air line going to be established, without taking more chances. If the attempts are made in haste, without proper preparation and equipment, in order to win a prize donated by some well-meaning person anxious to have his name connected with aviation and the tremendous amount of publicity such a connection brings, it may end in failure and further loss of life.

To aviators, however, that loss is considered part of the game, which is why they resent any suggestion of forbidding hazardous flights. They point out that when Orville Wright made his first flight at Kitty Hawk he took chances far beyond those faced by any ocean flyer. He didn't know how to fly, nor did he know that his ship would fly, and the ocean racers knew the answer to both. His homemade engine was so weak it could barely keep the ship in the air at thirty-five to forty miles an hour, and every flyer knows that safety lies in speed, for the slow, lumbering plane is at the mercy of every air gust and every air pocket.

A regulation against hazardous flying would have kept Wright, Santos Dumont, Bleriot, Glenn Curtiss, and all the rest of the pioneers out of the air.

If aviation profits by the lessons of disaster, as it is preparing to profit, then it may be said that the price, however great, was not too much.

## BED ROCKED TO IMITATE TRAIN AS INSOMNIA CURE 2838

Discovering that he could sleep much better in moving trains than in a stationary bed, Sir Alfred Yarrow, a British marine engineer, devised a rocking apparatus for his bed to reproduce the motions of a sleeper berth. It is operated by electricity and controlled by a button.

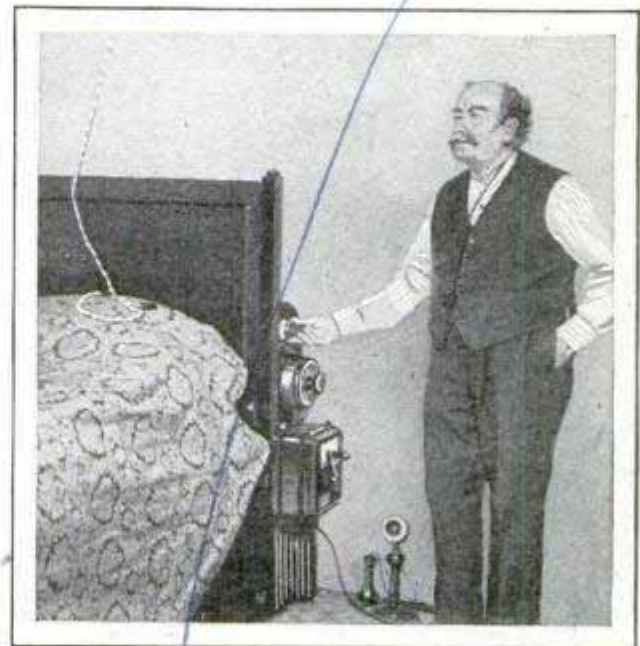

To Imitate the Rocking of a Train; Electric Shaking Apparatus Connected to Bed, to Induce Slumber

*Hindhead  
Lancashire England*



Testing Gas Masks in the Experiment Chamber; the Men Are Breathing Fumes from Inner Compartment While Attendant Keeps Careful Watch and Checks the Time



*International*  
**GAS-MASK TESTERS RISK LIVES TO PREVENT ACCIDENTS**

To make sure that gas masks issued for service are in working order, they are tested under conditions somewhat perilous to the demonstrators at a London laboratory. Men wearing the masks breathe fumes from a poison chamber, while an observer carefully watches them for signs of trouble. The air which they exhale is also analyzed to determine the effects of wearing the protectors.

**BUILDINGS' COLOR TO SUIT SUN INCREASES CITY'S BEAUTY**

Greater attention to color effects in skyscrapers and other buildings is doing much to beautify cities in the opinion of Henry Boehm, New York architect, who points out the importance of studying the quality of the sunlight and the atmosphere

*587 2 1/2 St Ave*

in each locality in order to apply the right colors. The reason for this is that what appears to be bright and attractive under an Arizona sun, for instance, may be dull and unsuited to use in a city like Boston, where the air is frequently moist. Color is merely reflected light, certain pigments absorbing part of the rays and allowing others to "bounce back" to the eye. Since the sunlight is affected by the quality of the atmosphere through which it passes, the result is certain to be manifested to some degree on exterior colors especially. Thick, heavy air filters some of the color out of light; hues are intensified in rare air and the angle at which the sunshine strikes an object during different parts of the day, often has an effect on the shade and colors. All these things must be taken into account by the

"color architect." The introduction of a wide range of building materials, such as terra cotta in various colors, makes possible a far greater emphasis to the color scheme than builders were able to achieve when ordinary brick, stone and stucco were the principal materials available.

**BLACK-BACKED PLAYING CARDS SHOW FEWER STAINS**



Playing cards with black backs have been introduced to ease the eyes and to conceal stains. Hearts are in red, clubs green, diamonds white and spades yellow against the black back-

ground, the color scheme making it easier to distinguish and sort the cards.

*Charles Stevens & Bros. Chicago - 75 cent*  
*Chicago*  
*3284*  
*Ontario*  
*Canada*  
*Chicago*  
*Menzies & Co. Ltd. Toronto.*  
*439 King St.*

*330 41*

*336*



**FAT MEN CAN STAND THE HEAT BETTER THAN THIN ONES**

Tests by the Bureau of mines show that fat men can stand high temperatures better than thin ones. They lost more weight but were less exhausted after the experiments were over. The trials revealed that high pulse rate rather than the mere increase in bodily temperature, is the important factor that brings discomfort under high heat and humidity. In a state of rest and in still air, the experiments revealed that the human body cannot endure indefinitely a temperature higher than ninety degrees Fahrenheit, with 100 per cent relative humidity. Subjects became extremely uncomfortable when the pulse rate reached 135 beats a minute, and unbearable symptoms were manifested at 160. The highest rate recorded was 184.

**SPEED OF POCKET-SIZE AUTO EIGHTEEN MILES AN HOUR**

One of the smallest motor cars ever constructed was introduced at a recent show in France and attracted considerable attention because of the excellence of its workmanship and its efficiency. It was an exact duplicate of the larger cars, developed a speed of eighteen miles an hour and was just roomy enough for a small child to operate it.



No Bigger Than a Toy, but It Runs like Larger Autos and Carries a Child

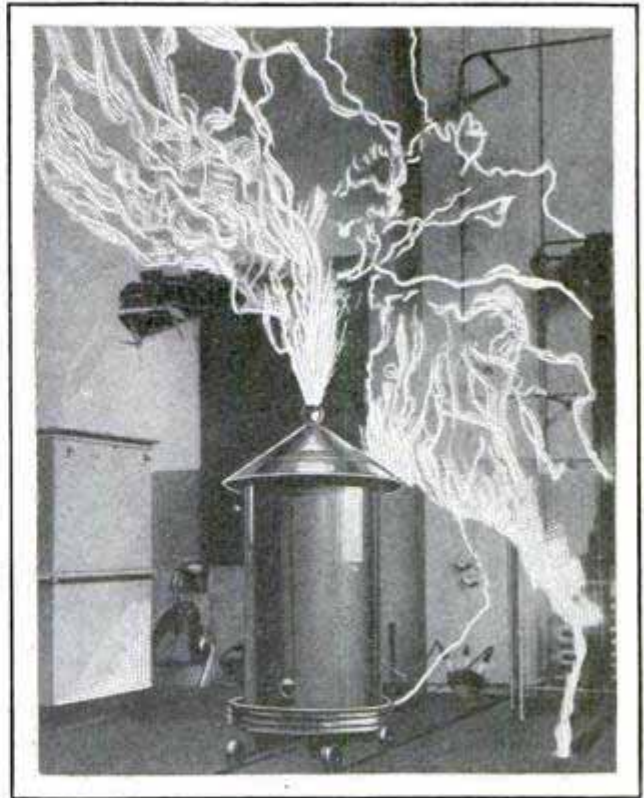

Studying a Thunderstorm in the Laboratory; Flashes of Lightning during Discharge Measurements

**FIRE OF ARTIFICIAL LIGHTNING AIDS STORM STUDY**

Reports like those of gun fire and sheets of artificial lightning resembling a miniature conflagration are produced in a laboratory of the General Electric company, in Berlin, where special studies are being conducted on electrical discharges during thunderstorms. A transformer of particular type is one of the important units employed in the investigation.

**ORIGIN OF BUTTER IS TRACED TO SWAY OF CAMEL**

Had it not been for the camel in Arabia, the world might never have discovered butter. The National Dairy council, after considerable research, has traced the origin of butter to the Arabians' habit of carrying sour milk in skin bags across the desert. The swaying motion of their camels caused the contents of the bags to turn to butter, which was first used as a skin lotion. Later, they discovered the trick of making it by tying the bags to fast horses and racing the steeds up and down for several hours. They also laid the sacks of milk on the ground and beat them. With the invention of the first churn, these methods were discarded.

Chicago Daily News  
9/26/27



3319

## FAIR OF THE IRON HORSE CELEBRATES HUNDRED

When the Iron Horse Was Just a Colt, the "DeWitt Clinton," Below, Hauled This Train over the Rails of the New York Central; Now the Historic Engine Has Run Again in the Baltimore and Ohio's Centenary Fair, Celebrating a Hundred Years of Railroading in America

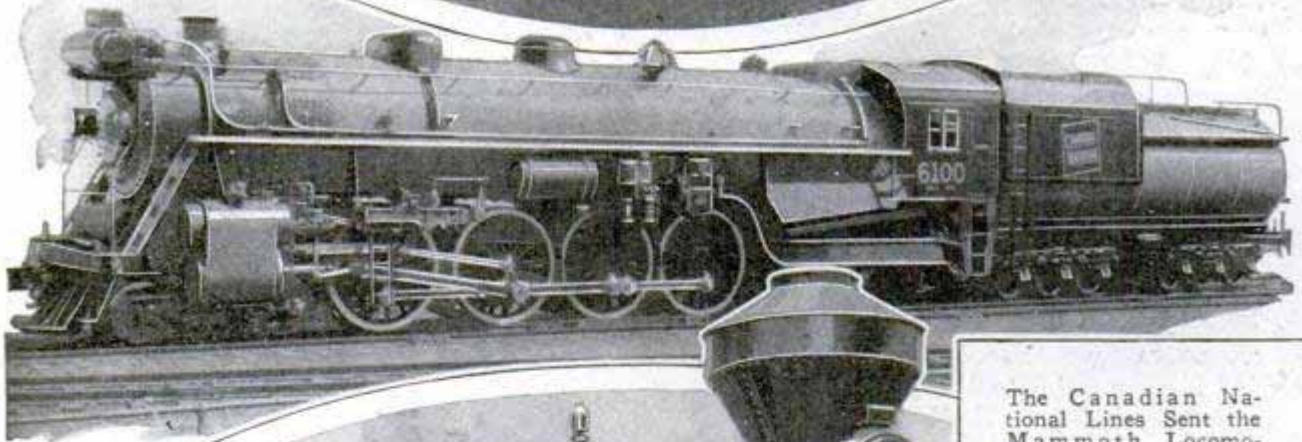
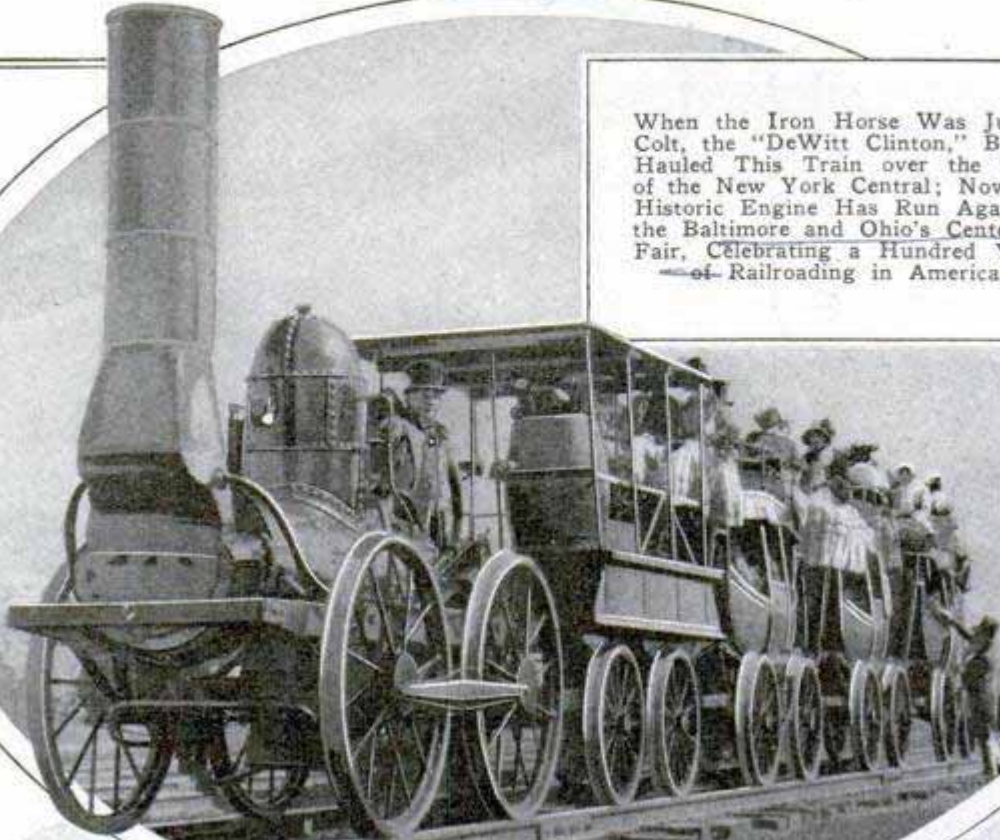

The Canadian National Lines Sent the Mammoth Locomotive, Above, to Baltimore for the Fair; the Giant Is Nearly Ninety-Four Feet Long and Develops 3,200 Horsepower; It Is Used in a 511-Mile Run from Montreal to Sarnia

Henry Ford's Relic Collection Yielded the "Satilla." Above, a Quaint Survivor of the Spreading - Smokestack Days of the Civil War

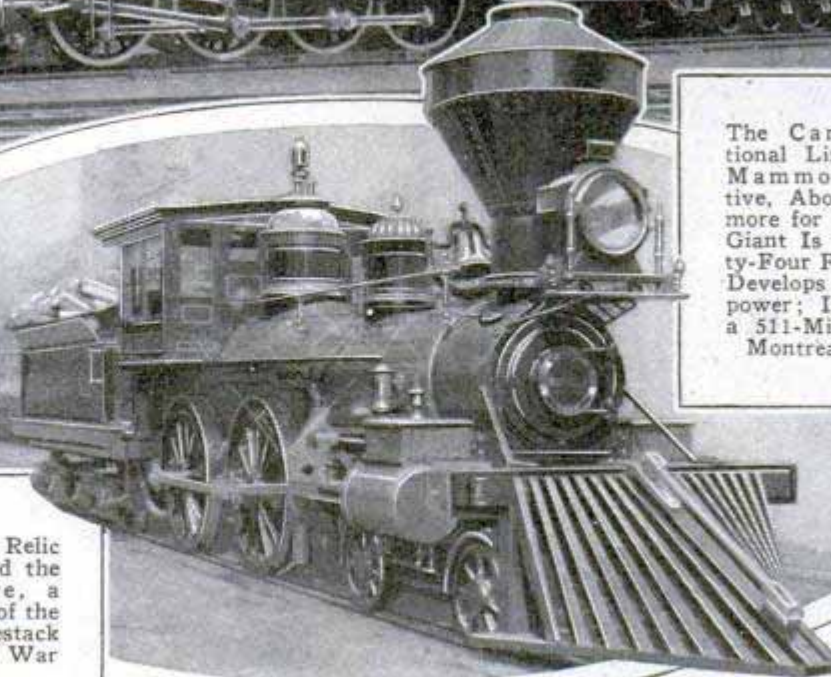



5319

YEARS OF RAILROADING IN THE UNITED STATES



PETER COOPER'S "TOM THUMB" 1829-30 BALTIMORE & OHIO R. R.

Peter Cooper's Famous Locomotive, "Tom Thumb," Was One of the First Engines to Operate over America's Oldest Railway, Succeeding the One-Horsepower Hay Burner Which Pulled the Original Passenger Coach, Seen at the Right; the First Horsepower Line Is Interesting Because the Rails Were Attached to Stone Bedplates, as Cross-ties Had Not Yet Been Invented; Now, after a Hundred Years, Railroads Are Experimenting with Artificial Stone Ties

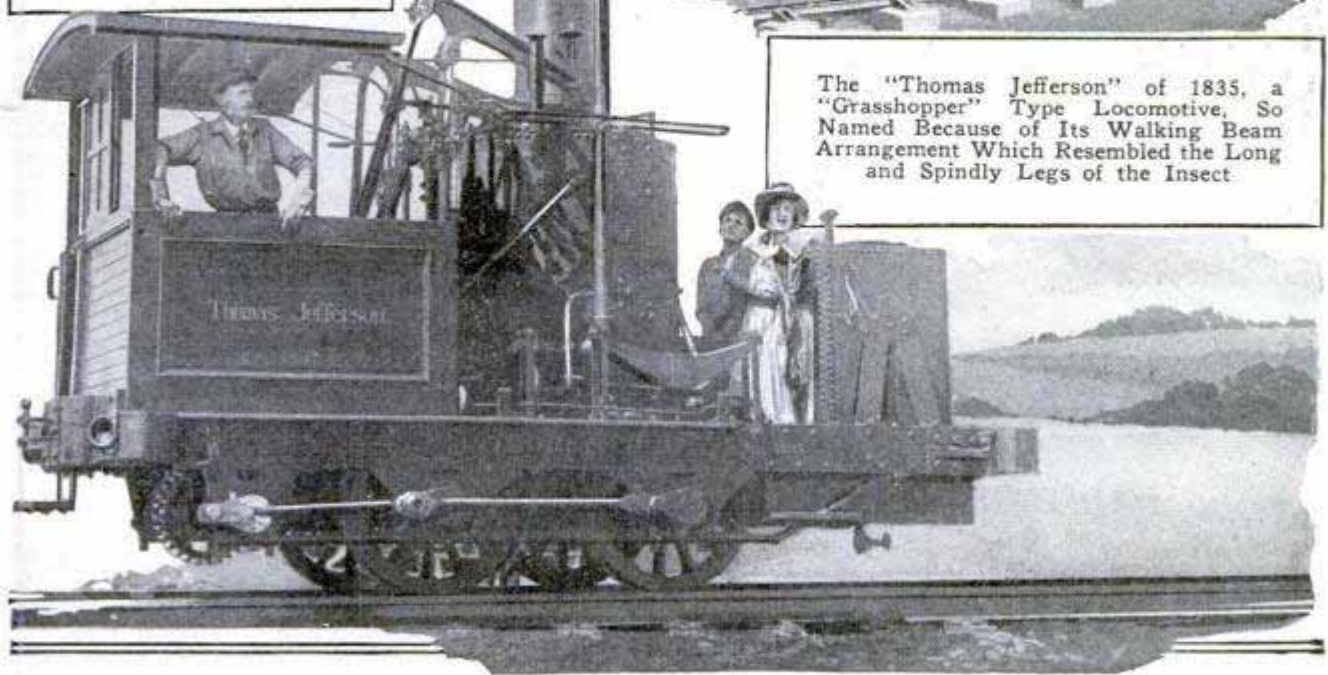
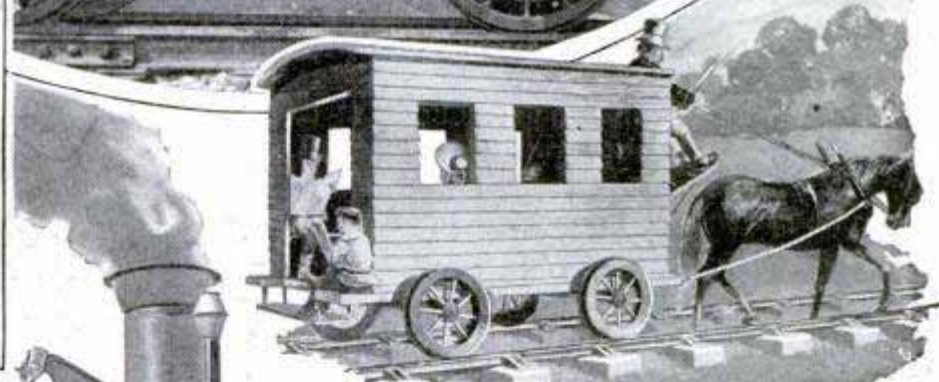

The "Thomas Jefferson" of 1835, a "Grasshopper" Type Locomotive, So Named Because of Its Walking Beam Arrangement Which Resembled the Long and Spindly Legs of the Insect.



326 Metro-Soldwyn-Mulvey

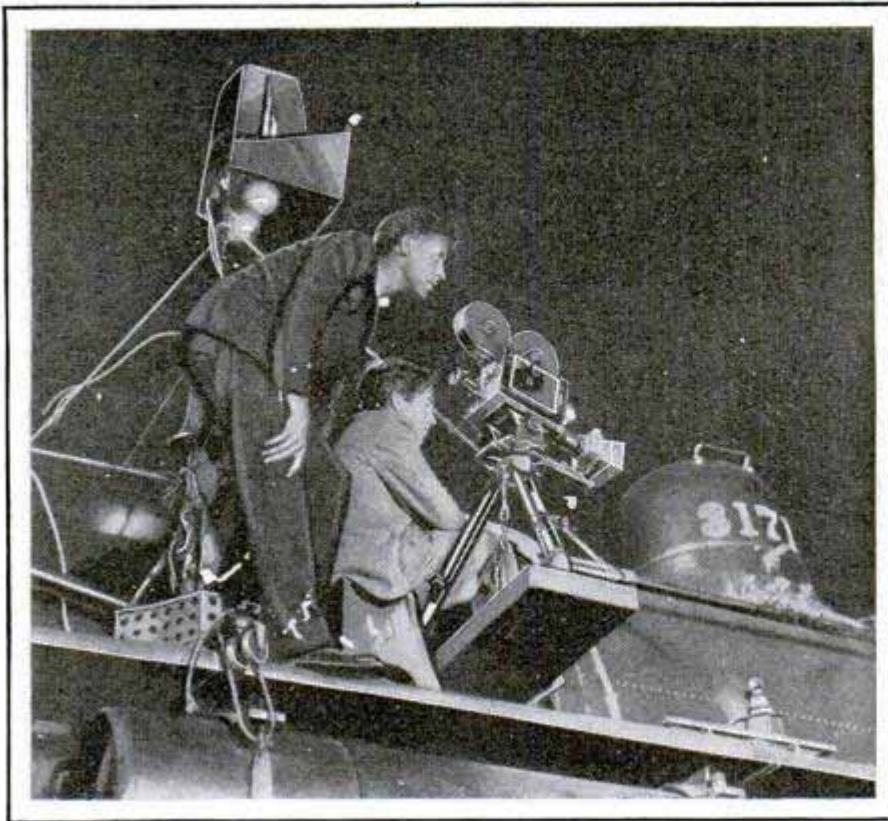

Locomotive as a Traveling Motion-Picture Studio; Photographers and Cameras on Running Board for Realistic Views

### CAMERAMEN RIDE ON ENGINE TO FILM RAIL MOVIE

To film realistic railroad scenes for a motion picture, photographers attached their instruments to the running board of a locomotive so that they could get "shots" of their own engine and the track ahead. Special lighting equipment was provided and, although the cameras were securely fastened, the swaying motion was recorded sufficiently to add, in large measure, to the realism of the effect.

### AIR AND WATER TOBACCO PIPE GIVES COOL SMOKE

A more enjoyable smoke and greater freedom from injurious substances are two of the advantages claimed for a tobacco pipe now on the market. It has an inner section of disks which is removable for immersion in water to cleanse the smoke.

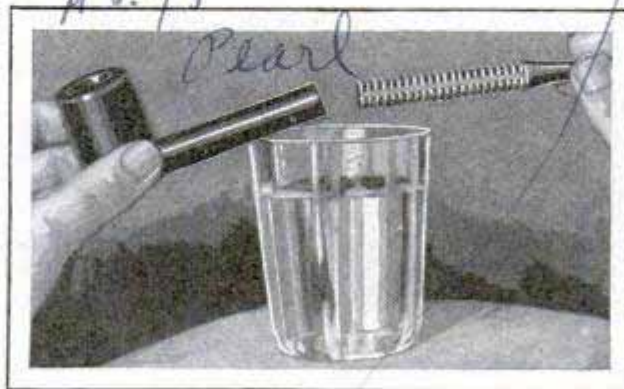

Inner Section of Pipe Removed, to Show the Disks That Hold Water and Help Cleanse the Smoke

### WASTE OF ENERGY IN LIGHT SUGGESTS IMPROVEMENTS

Only a small percentage of the electrical energy that flows through the filament in a light bulb, goes to the production of visible light. The rest passes off as heat or rays that cannot be seen by the eye. In some bulbs as much as ninety-four per cent of the current is unused for actual light, leaving the unit only six per cent efficient so far as illumination is concerned. Improvements are being made, but electric engineers point out that inventors still have a tremendous field in the line that Edison opened up, in producing an electric-

light bulb that will give more brilliance without an increase in current or other expense. One expert estimates that if a light only two per cent more efficient than the present common house type could be devised, it would save the country \$100,000,000 a year.

Charles Green Coyne

### DISCOVERIES CHANGE THE MAP OF NORTH AMERICA

A map is a romantic index of adventure which is being changed by recent discoveries. Reports of the Putnam Baffin island expedition, off the coast of Labrador, show a new range of mountains, and evidence that the island was once a part

of the mainland. From Africa comes news of the finding of snow fields within fifty miles of the equator, at an altitude of more than 15,000 feet in the Ruwenzori mountains. Natives have feared to approach this range, in the belief that the snows would kill them.

Ernest A. Cadzow, Ethnologist

3188 Kober & Co., Inc., 594-26th St.

Electrical School, 500 S. Paulina Chicago



3333 *respective by use of*

*Prudden - San Diego Airplane Co,  
2001 of Juniper St.  
San Diego, Calif.*

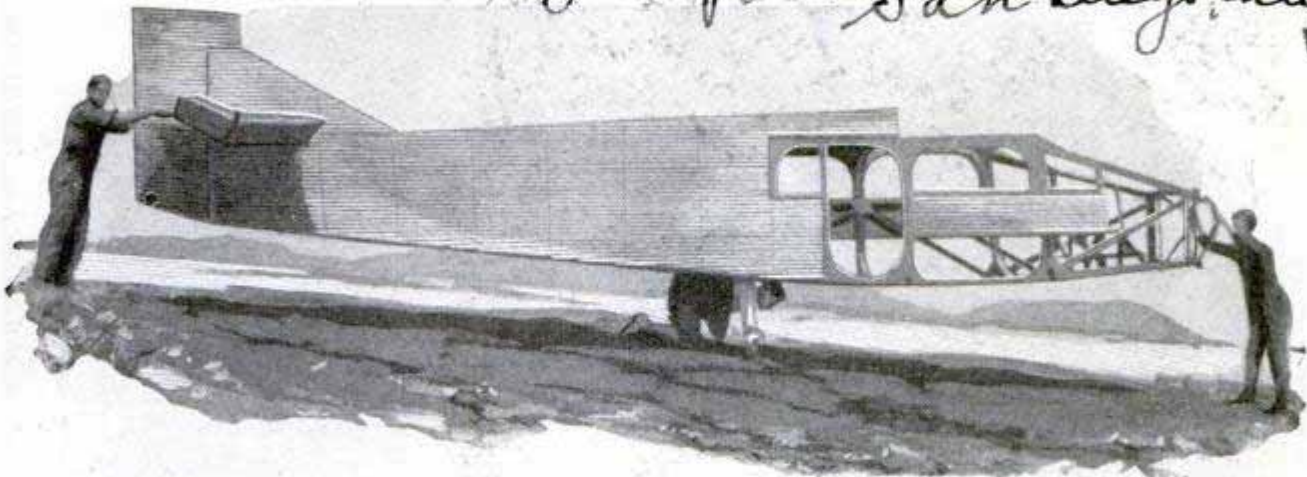

Full Weight of the Fuselage Is Resting on the Man in the Center, the Others Are Merely Balancing the Load; the Plane Body Is Constructed of Light Duralumin

**ONE MAN SUPPORTS AIRPLANE THAT CAN CARRY SEVEN**

How successfully designers of airplanes have secured light weight without sacrificing the strength of the craft is shown in the accompanying illustration of one man supporting the full weight of a large plane's all-metal fuselage while two others steady it. The material used in this ship was duralumin, which is being developed for increasing use in aircraft because of its light weight and strength. The fuselage is thirty feet long and five feet high, inside, with a capacity of seven passengers.

*3377*

**MERRY-GO-ROUND WASH RACK QUICKLY CLEANS AUTOS**

Automobiles, instead of gaudy animal figures, ride a merry-go-round in Los Angeles, but the unit is built for service instead of pleasure. It is a washing rack to save time in cleaning automobiles. Cars are placed on a moving platform and go past the workers, who perform the various operations, thirteen in all, while the owner stands in the center to inspect the cleaning and make suggestions if he desires. The platform is ten feet wide and moves

about a circumference of 287 feet. Powerful lights help the cleaners inspect all parts of the car. A machine is cleaned without and within in fifteen minutes.

**PUBLIC LIBRARY ON WHEELS SERVES RURAL READERS**

*3218*

Persons living in the country near Cincinnati, Ohio, may enjoy the advantages of a circulating library, for one of the branches of the main department is housed in a specially constructed motor truck, which tours the rural sections, distributing books and collecting those that have been read. Counters on each side of the truck permit inspection of the volumes. An attendant keeps a record of the books that are taken out and returned.



Where the Library Goes to the Readers; the Motor-Truck Reading Room on Location, near Cincinnati

*advertised in  
B. K. Bulletin*

*Cont. J. R. Schmidt  
3557 St. Charles Place  
t. 10*



3262

# TESTING GIANT OF THE RAILS OVER MOUNTAINS

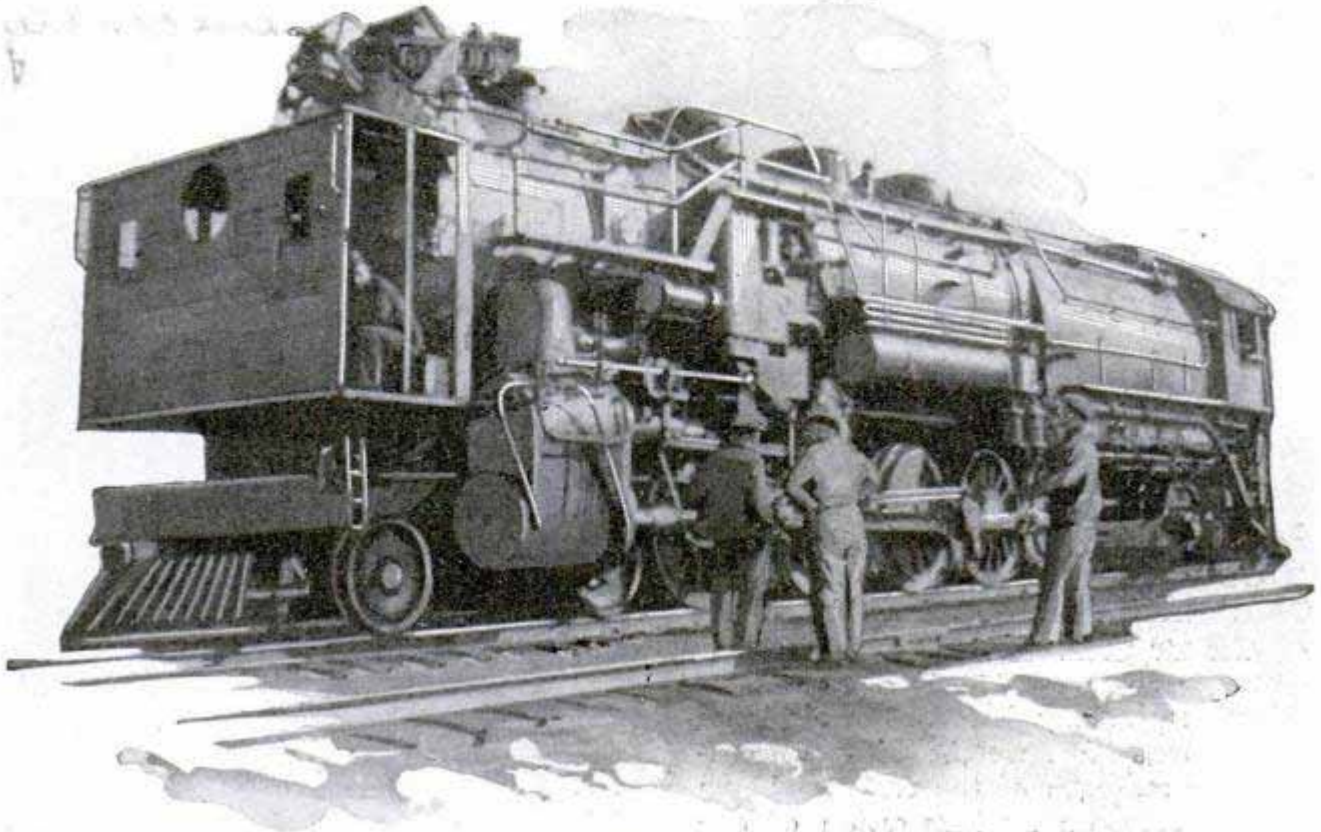

Testing Apparatus, Installed in Booth on Front of Engine, Enabled Mechanics to Obtain a Complete and Accurate Record of the Locomotive's Performance on Trial Run.

*500 N. Broad St. Phila*

Engine "60,000," one of the latest products of the Baldwin works, made a chart of its own movements during a test run over the Sierra Nevada mountains recently. Recording apparatus, installed at the front of the huge locomotive, registered practically every quiver of the monster as it toiled over steep grades and around curves. Besides the engineer and firemen, eleven mechanics were required to help in the test. The locomotive is equipped with an interesting arrangement to prevent sparks setting fire to the wooden snowsheds. By means of a lever, operated from the cab, the smoke is kept from passing out of the stack in the usual manner and is forced back over the engine and discharged behind so that the sparks cannot strike the roof.

The boiler maintains a working pressure of 350 pounds, about 125 pounds higher than the usual engine making mountain runs. No. "60,000" is nearly eighty-seven feet long, its driving wheels are sixty-three inches in diameter, and it weighs 457,500 pounds. The engine is of compound type.

3285

## TIN TRAFFIC OFFICER IN AUTO HELPS PREVENT ACCIDENTS

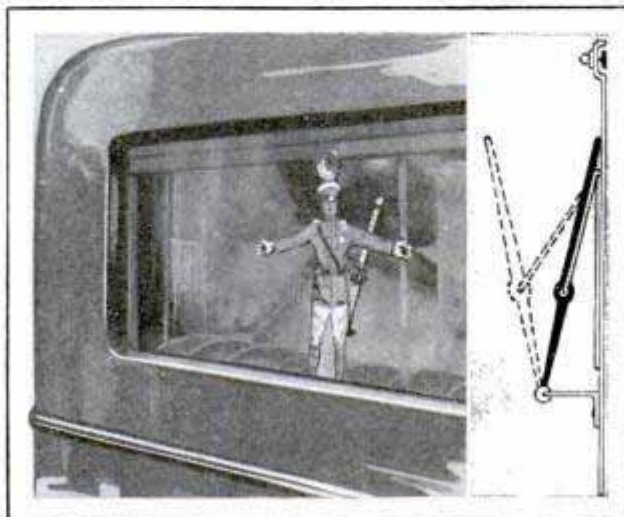

Policeman Figure in Rear of Car, and Drawing to Show How the Arms Are Moved

Attached to the rear window of the automobile with vacuum cups, a miniature tin "traffic policeman" gives a signal when the car is about to slow down. This he does by raising the arms to right angles. The motion of the car causes the action and, when speed has been again attained, the arms fall to the sides.

*Traffic Cop  
24 of Chrysler M.  
13*



Physics Lect. 3320.

DUST GENERATES ELECTRICITY

Fine particles of sand and dirt flying through the air during the dust storms common to parts of the west, often generate electric current. Measurements with the aid of a radio antenna wire and spherical electrodes indicated potentials of over 40,000 volts. The tests were made at the Texas technological college, and the investigators, as a result, were inclined to give greater credence to reports that shocks were suffered from radio antennae during such storms as well as from fence wires and automobiles. The dryness of the air prevents the dissipation of the electricity accumulated. Similar experiments have shown that dust and smoke commonly become charged, a volcanic eruption in Alaska, in 1912, being attended with such continuous thunder and lightning that the natives were terrified. By study of the behavior of dust, scientists believe they may gain further clues as to the weather and so aid aviation and radio communication, as dust is present in greater or less degree all the time practically everywhere.

SPECTACLE-BOW ON TOP GIVES WEARER CLEARER VIEW 2994

The bows are near the top of the lenses instead of at the center in an improved



spectacle frame introduced by an Ohio oculist. This is said to permit the wearer to turn his eyes to either side without encountering the bows and the frame is rigidly and comfortably adjusted.

TYPEWRITERS TO MATCH DRESS LATEST FASHION FAD 3280

Typewriters in brilliantly lacquered colors have appeared, to match various schemes of interior decoration. The innovation indicates the increasing popularity of the instruments for personal correspondence among women.

Corona.



"Wrestling" with the Arm and Back Stretcher; This Unit Can Be Adjusted to Give Different Degrees of Resistance

BOUT WITH SILENT WRESTLER DEVELOPS ARMS AND BACK

To take the place of a human antagonist, a western athlete has devised a mechanical wrestler to aid him in his training. It consists principally of two handles or arms, adjusted to a standard, and which are pushed or pulled against resistance that can be regulated to various intensities. The exercise is said to be especially beneficial to arms, shoulders, neck and back.

COAT OF ARMS HONORS ANIMALS IN FIRST BALLOON FLIGHT 2881

According to tradition, a duck, a sheep and a rooster were the first passengers in a balloon ascension in France, more than 140 years ago. Honor has been paid to these pioneer air travelers on the coat of arms recently adopted by an army balloon corps. Figures of the animals are prominently displayed on the shield.



Mr. Levett Commercial Club of Southern California, 1106 S Broadway Los Angeles, Calif



2788

Mr. D. C. Winters, suspect  
National Bank Bldg  
Washington, D. C.

# Tracking Down

By J. EARLE MILLER

**F**OUR years ago, three brothers out in Oregon dynamited a mail car, killed four trainmen and escaped, leaving behind a piece of burlap foot covering coated with pitch to throw bloodhounds off the scent. Under the microscope, a criminologist discovered three tiny grains of salt in the burlap, and with that slender thread named the three slayers. More than three years later, one was arrested in the

Philippines, where he had joined the army under an assumed name. Three years and eight months after the crime, the other two were caught near Steubenville, Ohio, where one had married and the two were living quietly on a farm. The three confessed and were sentenced for life.

Like the Canadian mounted, the postal inspectors who form the man hunters that guard Uncle Sam's mails, never quit a



The Brutal Murder of Several Trainmen in an Attempted Mail Robbery Has Just Been Avenged by the Capture and Conviction of Three Brothers, Caught by a Scientific Sleuth



# Mail Robbers

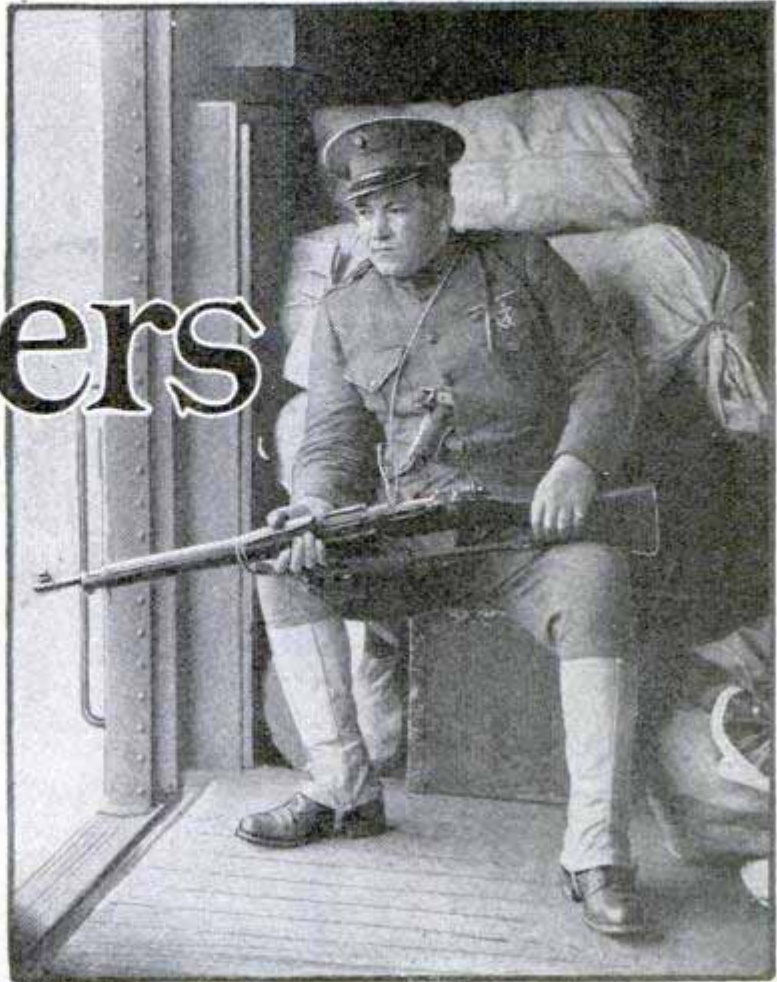
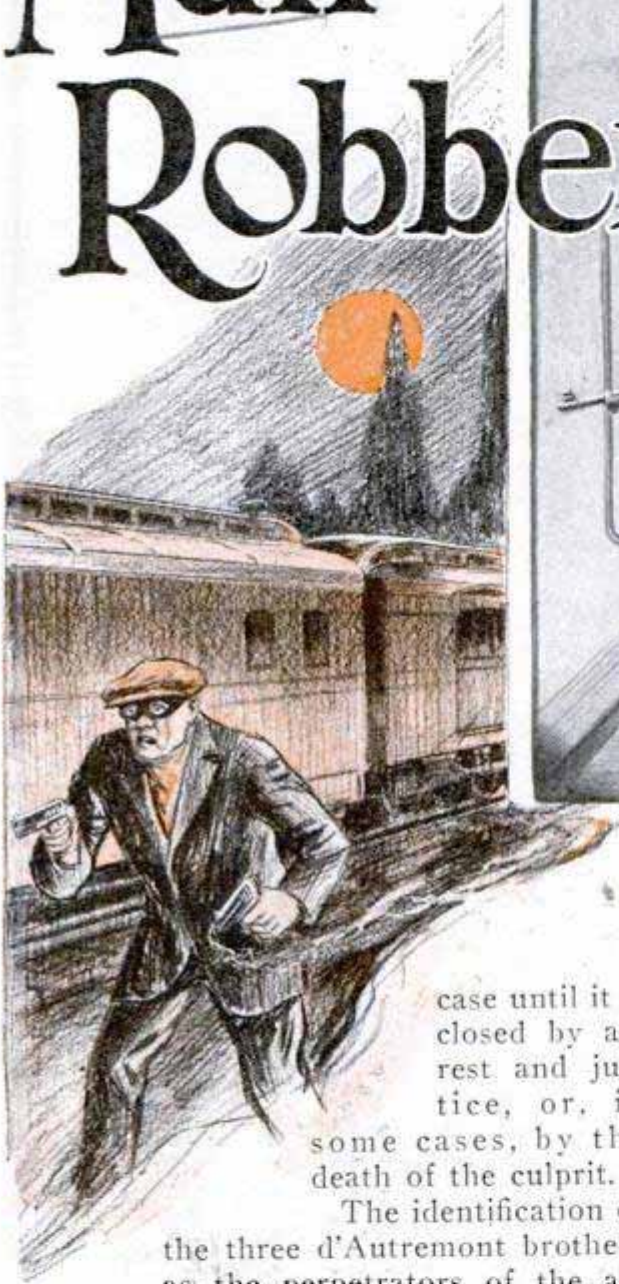

One of the Marine Mail Guards with Rifle Ready and Pistol Tucked into His Tunic

case until it is closed by arrest and justice, or, in some cases, by the death of the culprit.

The identification of the three d'Autremont brothers as the perpetrators of the attempted mail robbery at Siskiyou, Oreg., on Oct. 11, 1923, is a story that outdoes anything Sherlock Holmes ever dreamed of. Their arrest years later is a story of dogged perseverance and unrelenting chase. Every resource of the government backed the postal inspectors in their long pursuit. Two million pamphlets, with the pictures and descriptions of the three slayers, were printed and spread broadcast. Every post office under the American flag was decorated with posters carrying the pictures and offers of \$15,900 in rewards.

C. W. B. Long, postal inspector, who

led the chase for more than three and a half years, closed it when he flew by airplane from San Francisco to Steubenville, Ohio, to identify the two brothers arrested there in June. The real story of the capture, however, goes back to a few days after the attempted holdup, when Prof. Edward Oscar Heinrich, of the University of California, found the three grains of salt and built up the chain of evidence that fixed the crime on the three d'Autremonts.

In their flight, one of the brothers lost the burlap foot covering which had been designed to shake off pursuit by bloodhounds. Prof. Heinrich found the three grains of salt adhering to the burlap and put them under his microscope. They were revealed to be grains of a form of rock salt used in salting cattle. A survey of the dynamiting scene, in which the engineer, fireman and a brakeman had been shot down in cold blood and the mail clerk killed in the dynamiting of his car—the blast at the same time destroying



the mail, so that the robbers got nothing—disclosed only one place near by where salting was done. Near it was a cabin, in a grove of Douglas firs. The home-made pitch on the burlap had been extracted, the microscope showed, from the same species of tree.

In the cabin, Prof. Heinrich found a towel on which a razor had been wiped, and, under the microscope, removed from the towel hairs from the beards of three men, along with pieces of skin scraped from their faces while shaving. After examining them carefully, he announced the three men who had used the towel were of French-American descent, blond in complexion, and between eighteen and twenty-five years of age. Further search of the cabin revealed more burlap saturated with the pitch, both material and coating corresponding to that found near the railroad.

Convinced he had found the robbers' hangout, the professor returned to the railroad and, on hands and knees, quartered the ground for 100 yards around. At length, buried under leaves and dead wood in a clump of thorny brush, he found a pair of overalls. In the pockets were other grains of the same type of rock salt, and one pocket still sagged in the shape of a heavy revolver, while another yielded three hairs, evidently scratched from the head of the one-time wearer. The hairs, under the microscope, proved to have come from the head of one of the three who had used the cabin towel after he had shaved himself.

Circling the scene farther, the revolver was found which had bagged down the overall pocket. The gun had evidently fallen into a badger hole while the disguising overalls were being removed. Identification marks on the gun had been filed and burned off with acid, but inside the mechanism, where the owner had for-

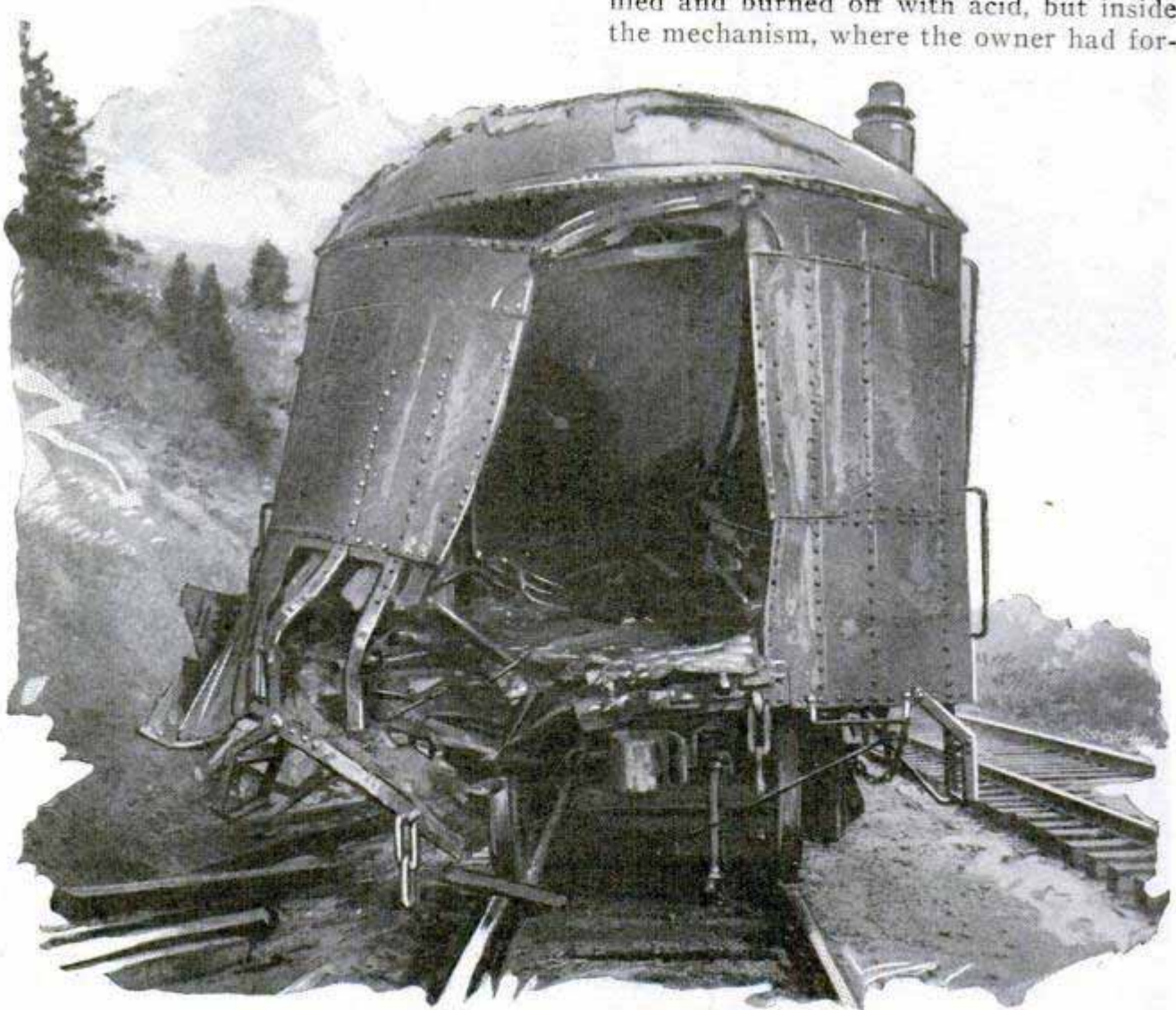

The Ruins of the Mail Car Dynamited by the Three d'Autremont Brothers, Showing How an Excess Charge of Explosive Defeated Them by Wrecking the Car and Killing the Messenger





Postmaster-General New and the Commanding General of the Marines inspecting the Mail Guard at the Post Office in Washington; at the right, Prof. E. O. Heinrich in his laboratory with microscope that convicted the d'Autremonts

gotten to look, was the manufacturer's serial number. Through that the gun was traced to the dealer, and from his records to a man giving the name of William Elliott. The purchaser's description was obtained, and it tallied with the height, length and waist measurements of the overalls. That detailed description fitted one of the three d'Autremonts.

The French-American descent and the blond complexion fitted all three of them. They had disappeared from their usual haunts a week before the robbery attempt, and their father admitted they frequently stayed at the cabin on the range, so the world-wide search for them was actually started within a few days after they had committed the crime and fled from the dynamited train.



The 535 postal inspectors annually solve more than ninety per cent of the cases of mail theft, according to Grant B. Miller, chief of inspectors. Last year, they sent sixty-six men to penitentiaries in major holdup cases, while over 3,000 were apprehended on minor theft charges. In 1926, of fourteen major crimes against the mails, in which \$1,408,340 was stolen, the inspectors recovered

\$760,634. The year 1924 was a high-water mark for mail bandits, their loot totaling \$2,509,157, but of this \$1,467,444 was recovered.

That was the year of the Rondout robbery a few miles out of Chicago, probably the most daring mail robbery in history, and the largest in point of loot taken. Planned with the connivance of a postal inspector who went wrong—the only case, incidentally on record in which that has happened—the Rondout robbers intro-



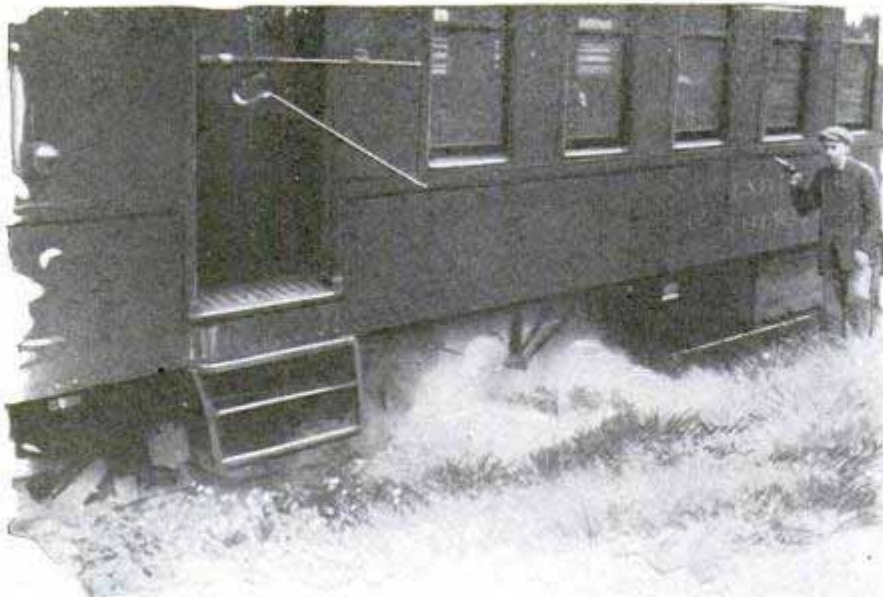

Testing a New Bandit-Proof Mail Car, Built to Withstand Bullets and Gas and Well Armed Within

duced the latest thing in bandit technique, forcing the mail-car crew to open the doors by throwing tear-gas bombs through the windows, while the robbers came provided with gas masks to enable them to do their work. They got away with \$2,200,000. Eight men were involved, including the postal inspector.

The Rondout holdup was followed by drastic changes in postal routine. Marines were called out to ride the trains and orders were placed for bullet-proof steel mail coaches by hundreds, while the clerks were given increased armament, gas masks to resist tear gas and provided with

gas equipment of their own, so the fumes could be released along the sides of the cars. Special portholes turned the cars into serviceable forts.

Under such conditions attacks on mail trains are almost impossible of success, and the major banditries nowadays usually take the form of an attack on a postal truck, or some isolated station just after a factory payroll or a bank shipment has been received.

Miller, who personally has run down sixty-two bandits, sent them to prison for combined terms of more than 2,000 years and recovered from them more than \$3,000,000 in loot, participated in unraveling one such crime in 1926 just before he was made chief inspector.

On April 14 of last year, a mail truck, bringing a load of registered mail to the post-office in a Chicago suburb, found a touring car blocking the entrance to the rear door. The driver got out, apparently to see why his car wouldn't run, drew a revolver, seized two pouches of registered mail, then ordered the postal



New Type of Mail Truck; the Armed Driver Rides in a Bullet-Proof Cab, Ready to Meet Bandit Guns with a Shower of Lead, While Steel and Bullet-Proof Glass Guard Him



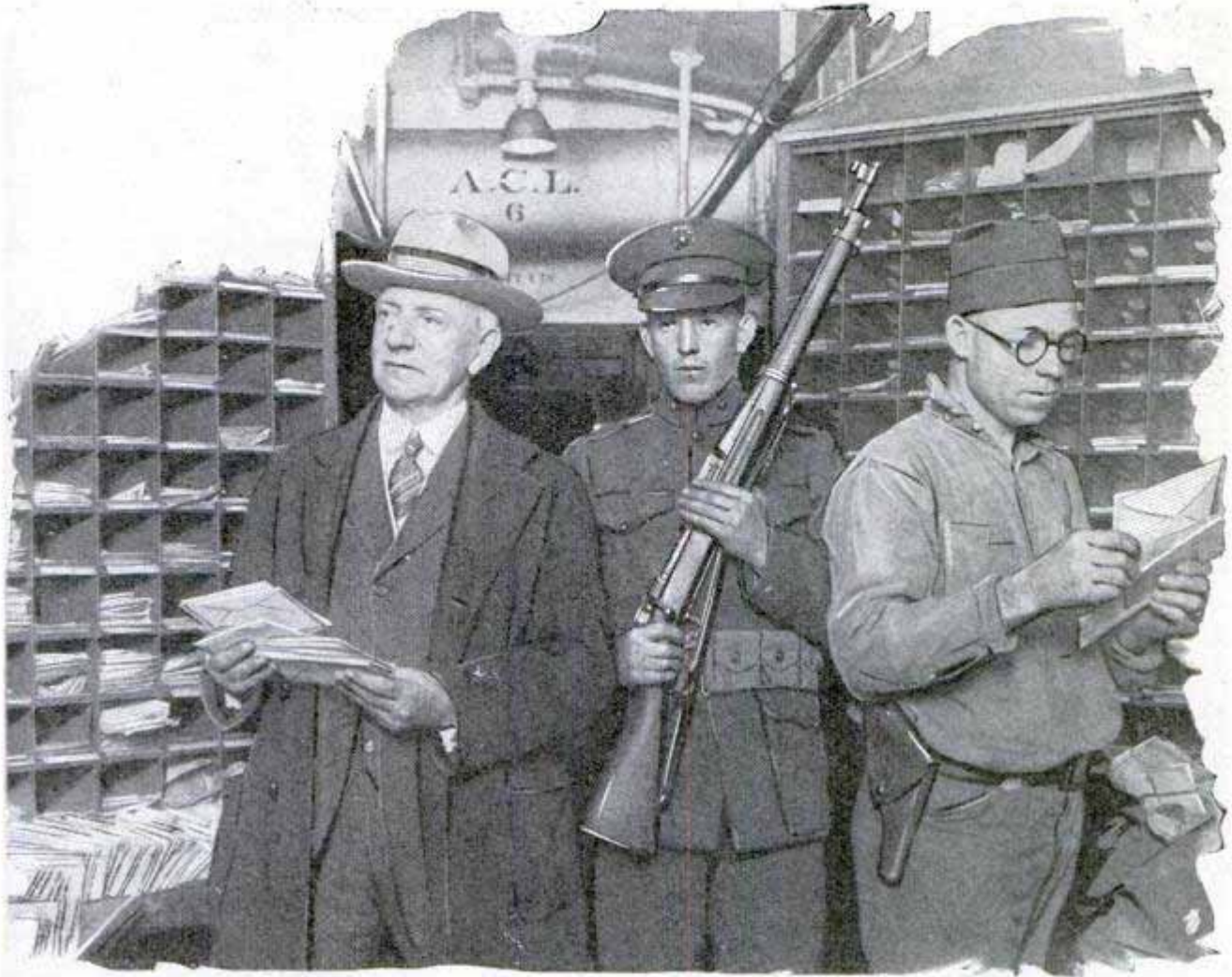

An Assistant Postmaster-General at the Sorting Rack of a Mail Car, with a Marine Marksman and an Armed Postal Clerk, Who Carries a Gun While Distributing the Letters

employe into the touring car and forced him to drive it to Joliet, Ill. The bandit sat in the rear seat and searched the pouches during the drive, extracting \$37,000 in cash.

Just outside of Joliet, the bandit's car stalled on a slight incline. Though threatened with death, the mail driver, a boy of nineteen, was unable to make the grade, and even the bandit, who took the wheel, couldn't negotiate it, so he decided to back to a garage and have the clutch fixed. He tried to keep the driver covered with a revolver in his coat pocket while the garage man worked on the car, but the driver succeeded in getting the car between them and ran to a farm house to telephone for the sheriff.

The bandit, becoming nervous, got the two mail pouches, walked out the garage door and disappeared—and then enters the one unsolved mystery of the case. The Joliet police blotter shows the boy reported the robbery at 10:10 in the morn-

ing, and at 10:25 a physician in a village twelve miles away reported he had been held up by an armed man who stole his car. Later it was shown the bandit was the auto thief, though how he traveled the twelve miles in not more than fifteen minutes continues to be a mystery, for he refused, when captured, to explain it.

At any rate, a deputy sheriff from the doctor's village started in pursuit, driven by a garage man, and overtook the bandit, who shot him dead, but not before the official had fired one shot through the windshield of the stolen car, the flying glass cutting the bandit's face. A taxicab chauffeur was found later in the day who recalled a passenger bleeding from cuts on the face, and carrying two bags, the first intimation that the mail robber and the sheriff's slayer were one and the same person.

Various clues fixed the bandit's identity, and his home was searched, but it had been abandoned. Confident the man



2780

had not left Chicago, the inspectors arranged with a friendly newspaper reporter to publish an item saying the sheriff had been killed by a foreigner whose body was found near by, and that the post office inspectors believed the foreigner was the mail robber and that he had hidden the loot.

That item inspired the bandit with a

false sense of security, and, six days later, the inspectors, who had been following every clue, tracked him down in his room in a Chicago hotel, where he had been living in the belief that no one was looking for him. He got life for the killing and twenty-five years more for the mail robbery, and all the loot, with the exception of \$148, was recovered.

2912

**TWIN SIDECARS ON MOTORCYCLE CARRY TWO CHILDREN**



Room for Most of the Family in This Double-Sidecar Motorcycle; Children Balance the Load and Are Protected by Shields

*in Wimbledon*

Instead of having a single car on one side, a motorcycle owned by an English rider has a small car on each side, affording individual compartments for his young son and daughter, who often accompany him on his trips.

**MEASURE BILLIONTH OF INCH TO TEST WIRES**

To find out how much wires of different composition expand or contract when magnetized, a scientist of the Bell Telephone company laboratories has developed an apparatus that measures a billionth of an inch. It will also register a millionth of a degree in temperature. It is the most refined measuring apparatus in existence today, surpassing the interferometer, a delicate unit that splits distances into tiny gaps of light waves, by about 100 times in

*P.P. Cioffi*

0296

sensitivity to changes in length. When the temperature varies as much as one-thousandth of a degree, a spot of light races across the scale. The instrument was devised for research into the nature of magnetism. No one knows exactly what magnetism is, but it is of prime importance to a telephone company because it plays an essential part in the transmission of sound waves in telephoning. That is the chief reason why permalloy, a special mixture of nickel and iron, became so valuable for cables. It proved extremely sensitive to magnetization and was rapidly put in place of pure iron in loading coils and other devices for transmitting sound. A gauge was wanted to help study the atomic changes which take place in different alloys as they expand or contract under magnetic forces. P. P. Cioffi, a laboratory scientist, was put to work on the problem. In a month, he had devised a plan for the instrument, but many months were required to perfect it.

**ICE CREAM FROZEN IN GLASS WITH COLD TABLETS**

2893

Patented refrigerating tablets may be used as a substitute for ice in a freezer that quickly prepares small quantities of ice cream with little work. The cream itself is held in an inner aluminum container and agitated with a crank-operated scraper. The outer chamber is of glass for the ice and salt or the special tablets. It is said that the cream can be frozen in about ten minutes



*Leiberg, U.S. 31, Esarman.*

*Seisler, Krosch Co. Naumburgerstrasse 11*



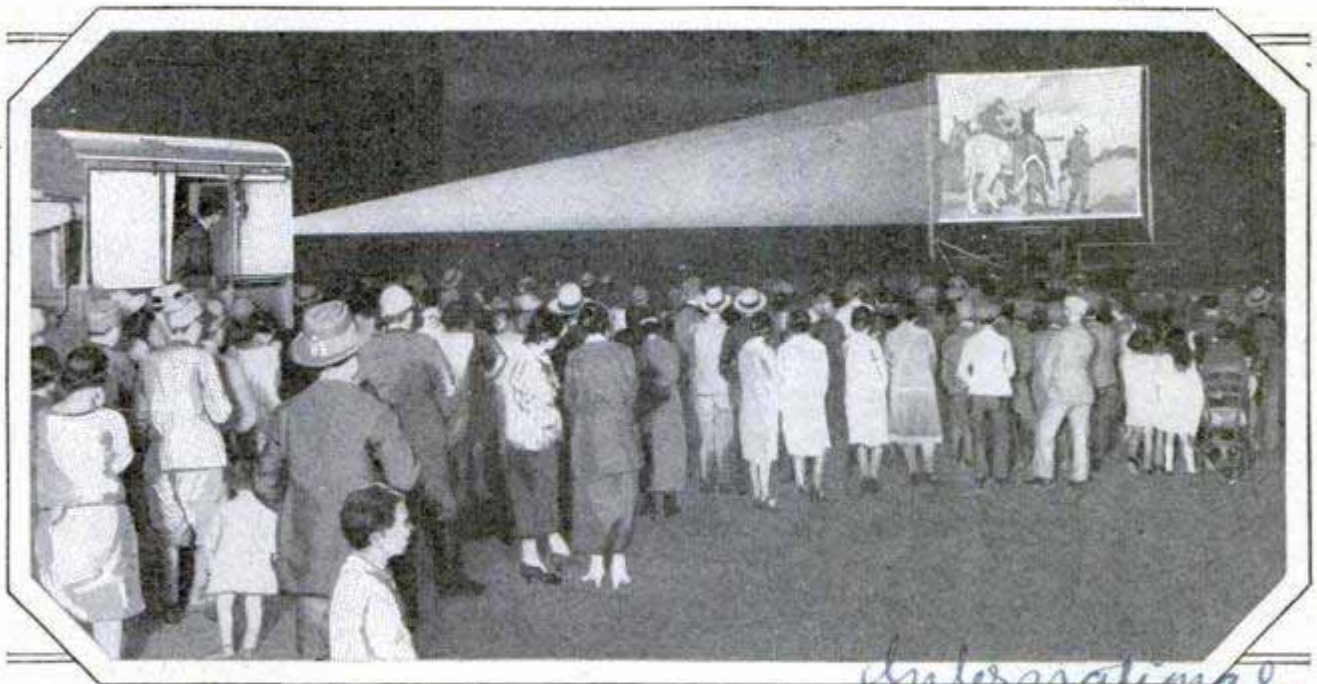

Outdoor Movies in Italy; Projector and Screen Are Carried in Auto Trucks to Remote Towns, and, Besides Giving Entertainment, the Plan Is Helpful in Spreading Propaganda

*International*

**MOVIE THEATERS ON WHEELS  
SERVE ITALIAN TOWNS**

Mussolini is making use of the motion-picture screen in a special way to transmit word to the inhabitants in small Italian towns. Several auto trucks, with projectors and a screen that can be quickly set up outdoors and taken down for packing, constitute a fleet of traveling motion-picture theaters which spread propaganda.

*John*

**RAILROAD INSIDE ARCTIC CIRCLE  
334 HAULS IRON ORE**

Threading its way through ice-clad mountains, the Arctic railroad taps a rich deposit of iron ore 150 miles within the Arctic circle, to supply the blast furnaces of Europe with material for the manufacture of special steels. The demand for Sweden's remarkable supply of magnetic iron ore is the reason for the construction of the railway which runs from the Swedish town of Lulea, near the head of the Gulf of Bothnia, to Victoria Havn on the Ofoten

Fiord in Norway. Special precautions have been taken to prevent landslides and the fall of avalanches along the road.

**HIS CONTORTIONS HELP TO WIN  
MOTORCYCLE RACE 3/40**

Credit for winning a motorcycle race in London recently was divided between the driver and the occupant of the sidecar, much of the honor going to the latter. By his clever contortions on curves, he permitted sharper turns than could ordinarily have been made, thereby cutting down time and distance.

*Eda Norchi*

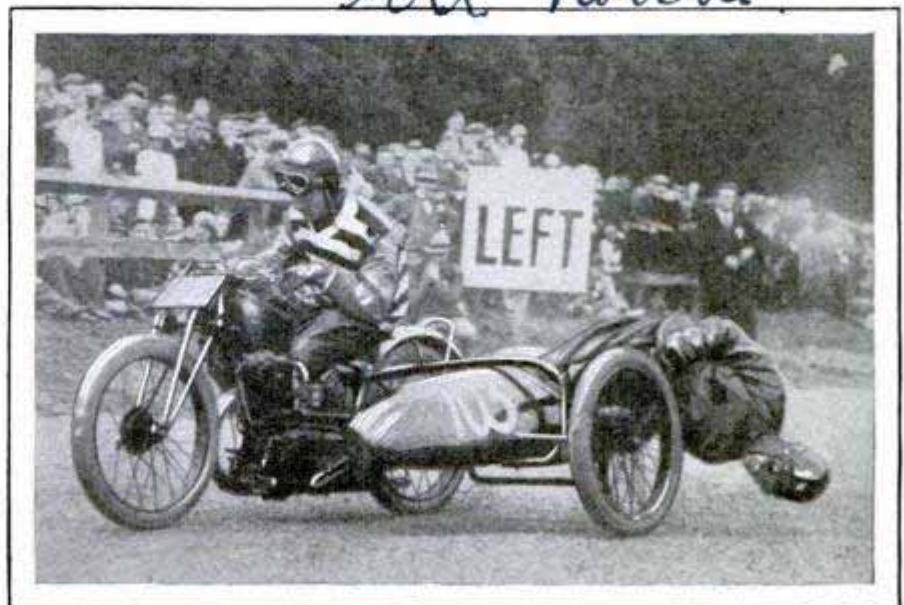

Helping to Balance the Racer at a Sharp Turn; the Pilot's Passenger in the Sidecar Prevented Upsets

*Cmd. H. Journeux,  
Thundersten*

*at Crystal Palace  
London Eng*





Honor to a Pioneer Explorer of the Skies, Tycho Brahe, the Danish Astronomer; This Monument Was Recently Unveiled in Sweden

**HONOR TO EARLY ASTRONOMER  
IN MARBLE MONUMENT**

Tribute was paid recently in Sweden to the Danish astronomer, Tycho Brahe, by the erection of a celestial globe of bronze on a white marble base. The monument was unveiled in Helsingborg by Crown Prince Gustav. Brahe lived during the latter half of the sixteenth century, his interest in astronomy being excited by the punctual occurrence of an eclipse of the sun on Aug. 21, 1560, at the predicted time. He regarded the phenomenon as "something divine" and straightway read all he could find on the subject of astronomy and began studies with globe and compasses, although he was supposed to be fitting himself for the law. He gained the support of the king of Denmark in a few years, and is credited with doing a

vast amount of valuable work in correcting the errors of earlier observers and computing instrumental inaccuracies.

**"BLOODY SWEAT"  
OF THE HIPPO  
RED PIGMENT**

The "blood-sweating behemoth" of the circus display, does not really sweat blood at all, the red fluid on its skin being an oily substance, excreted when the animal is excited or in pain. The color is due to a peculiar carmine pigment in the skin, which is two inches thick in some places.

**HEATER FOR AUTO  
ELIMINATES THE  
BACK PRESSURE**

Prevention of back pressure on the motor and an abundant supply of fresh, hot air, free from fumes, are cited among the advantages of an automobile heater which utilizes the warmth of the exhaust gases. The system consists of an air-intake pipe, directly behind the fan and in front of the motor, and a series of steel tubes where the air is warmed as it comes in contact with the pipes, heated from the exhaust. The warm current is delivered through a register in the bottom of the car. The only moving part of the installation is a valve to control the fresh air, and the heat is regulated from the dash.

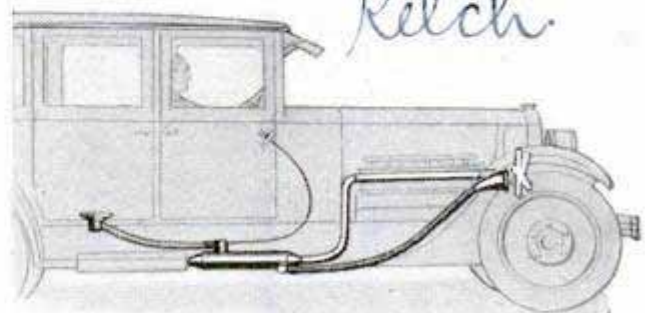

Installation of Heating System for the Auto, Utilizing the Warmth of Exhaust Gases

*Robert J. Brass mfg Co.  
Harlan Marshall*





Coast-Guard Flyer Preparing to Drop the Trailing Gear to Pick Up the Life Line as His Plane Races Out to Sea above the Shore Masts Which Replace the Life-Saving Cannon

## Throwing Out Life Lines from Airplanes

New Method of Rescuing Crews of Wrecked Boats Is Adopted  
by the Coast Guard after Successful Tests

**A**MPHIBIAN planes, capable of taking off from or alighting on either land or water, are being used at two American coast-guard stations instead of life guns to carry rescue lines to wrecked ships off shore. Developed as the result of five years of experimenting by Lieut. Comm. C. C. Van Paulsen, of the coast guard, the aerial life-saving service is able to establish breeches-buoy connection with ships a mile or more off shore, instead of being limited to a few hundred yards, as is the case with lines thrown by the small harpoon cannon. The record distance for a cannon-shot-carried line is 695 yards, whereas the planes are effective at several times that distance.

The problem of taking a line out to sea by air was complicated by the fact that the

plane could not take off while burdened with a trailing rope, so must pick up the life line after it was actually in the air. Comm. Paulsen solved the difficulty by attaching the end of the line to a cross rope swung between two masts placed 200 feet apart. The plane, after getting under way, circles about and passes over and between the two masts, while the observer lowers the weighted end of a light rope, carried on a reel in the airplane. The weighted rope tangles with the line between the masts, jerks it free and carries it out, trailing the life line after it. The airplane flies straight out and over the ship in distress, and the observer then cuts the rope and allows the line to fall across the deck.

From then on the procedure is the same as in the usual rescue work with breeches-



buoy tackles. The first light line is used to pull a somewhat heavier tackle out to the ship. After it is made fast, the coast-guard crew ashore attaches the still heavier rescue cable and it is hauled out. After the ship's crew has made the end fast, the original light tackle is used to pull the trailing pulley of the breeches buoy back and forth along the big line.

Cape May, N. J., and Gloucester, Mass., are the first two stations to be equipped for aerial life-saving. They were chosen because they had already been provided with Loening amphibian planes, of the type used by Comm. Byrd in Greenland and in the flight around South America. The planes were purchased originally for the aerial patrol against rum ships off Boston, New York and New Jersey shores.

The life line used is so light that the powerful planes can take the end a mile or more to sea before the dragging weight becomes too great. No reels are used for coast-guard lines, as the friction would quickly stop the line, whether fired from a gun or trailed from an airplane. Instead, the line is coiled in a complicated pattern about pegs set in a wooden frame

laid out something like a chessboard. The pegs are then withdrawn, leaving the line "faked," as sailors say, in such a way that it will run out without tangling, and without friction.

The Lyle gun, which has saved thousands of lives since its invention by Lieut. David A. Lyle, of the U. S. army, has been the chief reliance of the coast guard for a half century. It is a small bronze cannon, weighing, with its eighteen-pound projectile to which the line is attached, slightly more than 200 pounds. Once the line is made fast to a ship, it can be used either for the breeches buoy, a pair of canvas trousers, knee-length, in which the rescued person is suspended and dragged through the waves, or for a water-tight life car, built like a small submarine and capable of holding a number of people at each trip. The Lyle gun is the successor of one of the oldest forms of rescue apparatus, a powerful crossbow, mounted on a wheeled carriage and bent by turning a crank, which, with an arrangement of cogs and line, brought the bowstring back until it could be caught by the trigger.

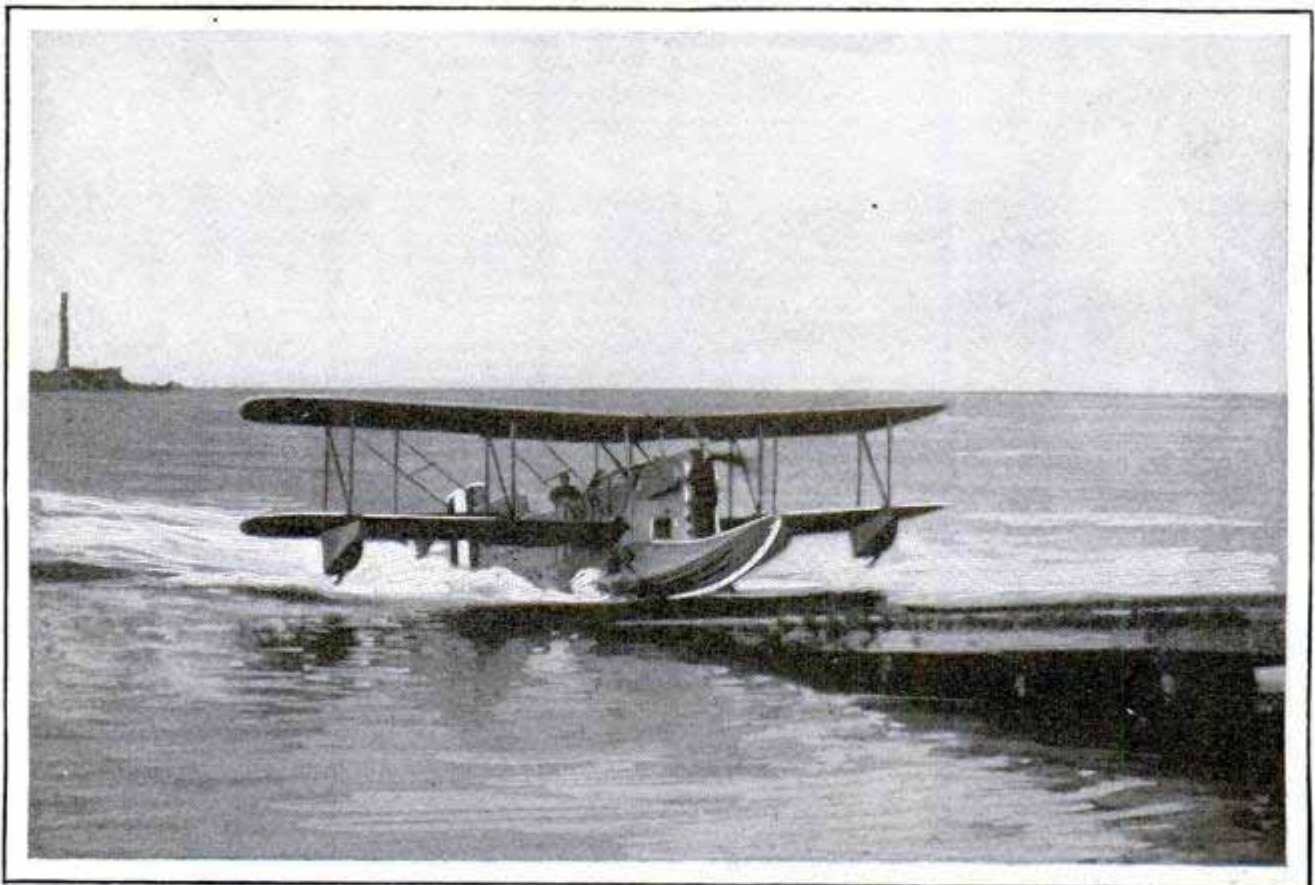

Coast-Guard Amphibian Airplane Coming Back to Land and Mounting Its Own Runway; the Planes Are Equipped with Both Boat Hulls and Wheels for Land or Sea



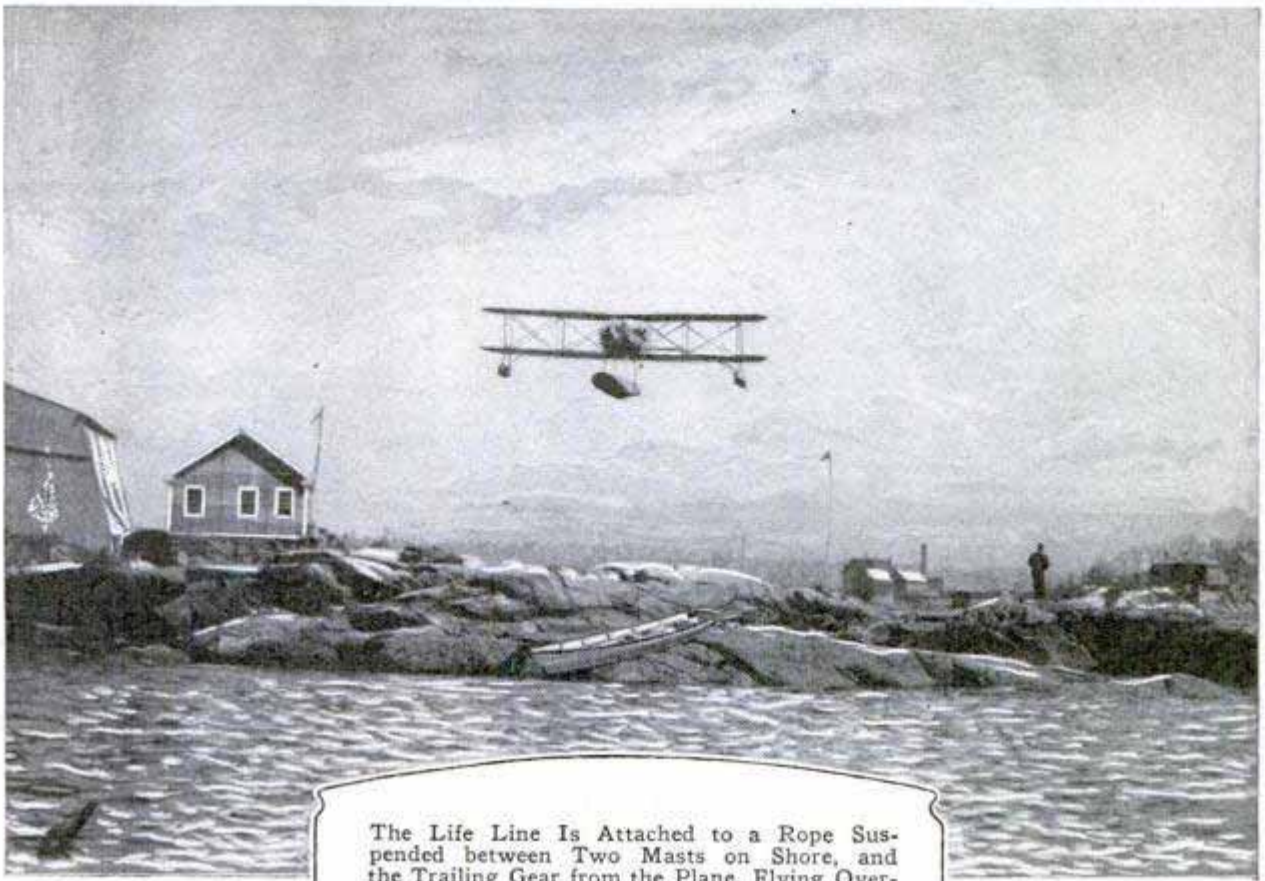

The Life Line Is Attached to a Rope Suspended between Two Masts on Shore, and the Trailing Gear from the Plane, Flying Overhead, Picks It Off and Carries It Out to the Distressed Ship

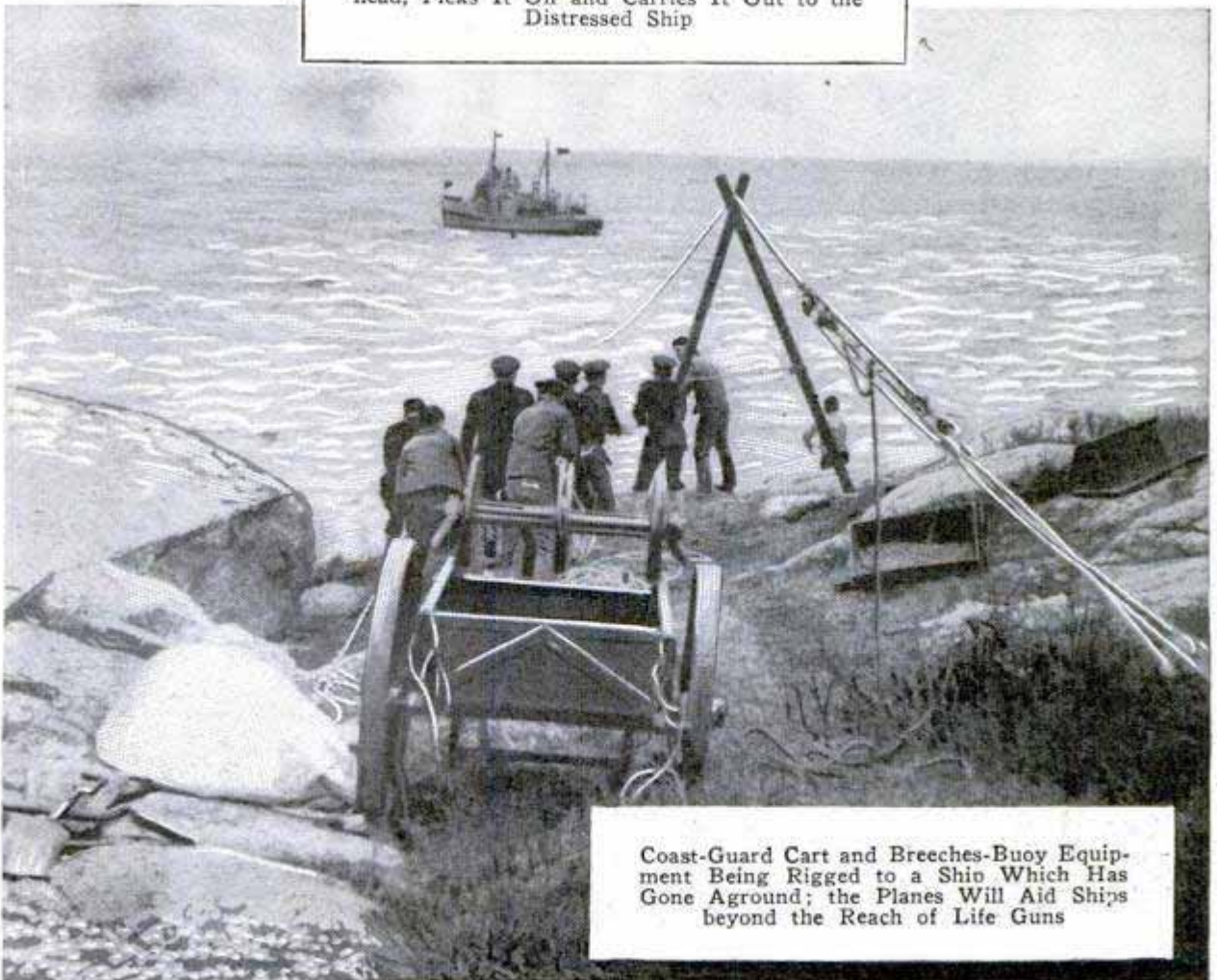

Coast-Guard Cart and Breeches-Buoy Equipment Being Rigged to a Ship Which Has Gone Aground; the Planes Will Aid Ships beyond the Reach of Life Guns



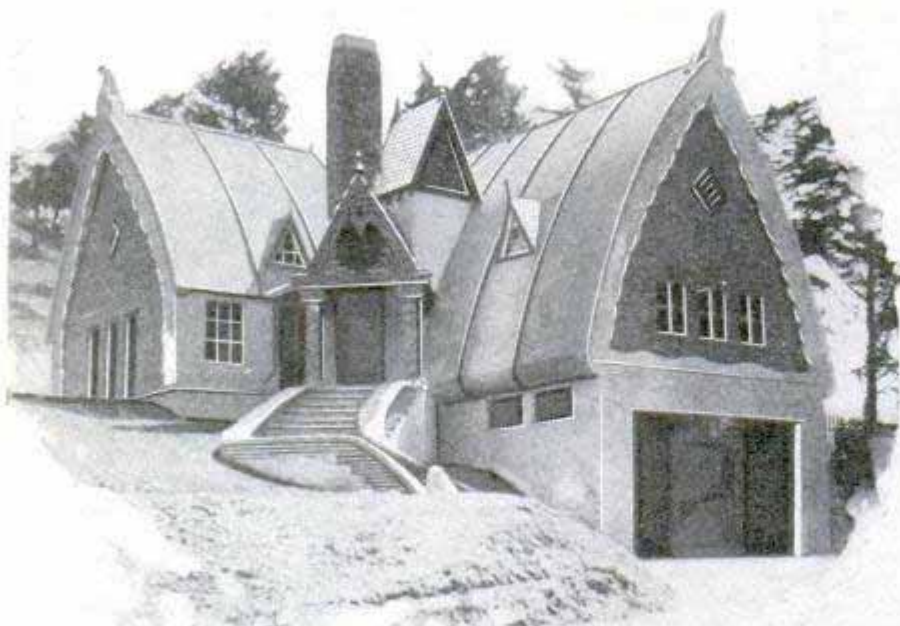

Home for One of the Oakland, Calif., Fire Companies; the Engines Are Housed in Garage Space in Basement

**FIRE STATION LIKE RESIDENCE BEAUTIFIES CITY**

The city of Oakland, Calif., has introduced a different style in fire stations. Instead of the usual garagelike structure, its latest unit is patterned after the plan of a residence, with space for the engines in the first story and men's living quarters above. It is made of brick and concrete.

**RADIO-EQUIPPED ARMY TANKS DIRECT MANEUVERS**

An army of "robots," mechanical monsters carrying gas-masked men, was mobilized recently when the British army held five weeks' maneuvers for the mechanical force, which corresponds to the American tank corps. Little two-passenger tanks, mounting a driver and a machine gunner behind steel breastworks, sped across the fields on endless treads, or switched in a twinkling to rubber-tired wheels and dashed down clear roads. Four-passenger tanks, with guns in conning towers, huge

battle tanks mounting small field artillery, heavy anti-craft guns on tractor mounts, and tanks equipped with wireless rumbled after them. Overhead attack and pursuit airplanes soared and dipped while they sprayed the advancing steel army with bursts of machine-gun fire. The maneuvers continued day and night under conditions as nearly like those of actual war as could be produced on Salisbury Plain.

"The roar of the great engines used in the tanks and tractors, the sharp crackle of machine-gun fire, and the crashing of eighteen-pounder quick-firers were nerve-racking," said one of the correspondents who covered the maneuvers. "The army on wheels traversed a rugged country in the robot maneuvers.

"The engagement was like an evil dream, with mythical gray monsters spitting flames and death. Noise, smoke and unceasing clatter lasted nearly an hour while deadly single-seater fighting planes swept the crews of tanks and motor cars with accurate fire.

"'Road bombed out of existence,' was

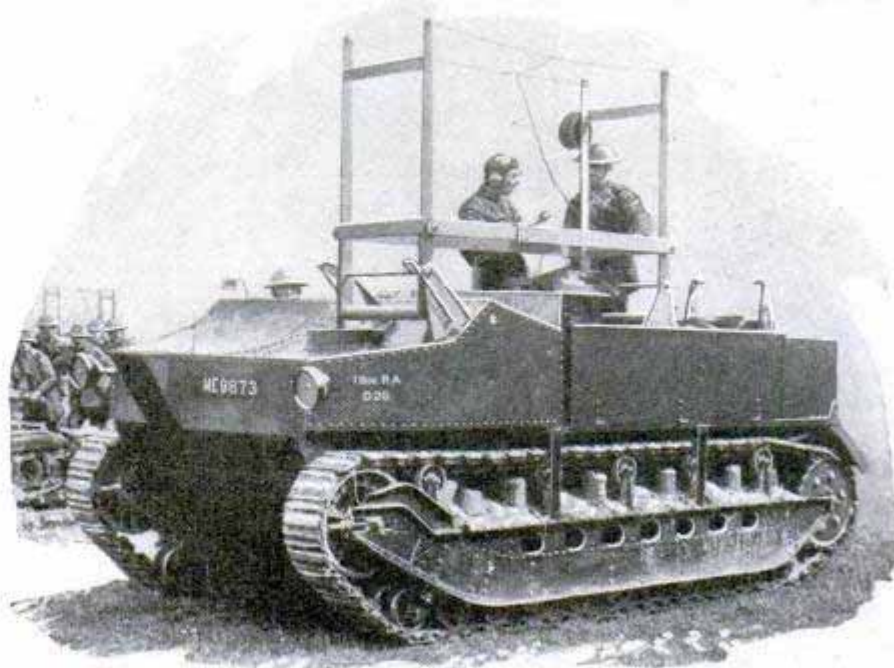

Radio-Equipped Tank Used to Direct Battle Operations in British Maneuvers of the Mechanical Army

*322,  
n Salisbury Plain*



the message flashed back from the wireless scouts. 'Make your own way across country,' came the command.

"Then the mechanical army moved, the sluggish pace quickened; one-man tanks bustled hurriedly over the banks on the side of the road on their scouting duty. The 'dragons,' with their wheels within wheels, scuffled at dangerous angles into the open country, the crews clinging perilously to their seats. Heavily armored beasts, on tracks, wallowed lustily through ditch, over bank, and among brushwood. The land liners—the eighteen-pounder quick-firer guns on self-propelled mountings—swept into position, the gun crews jumping to stations.

"Suddenly three airplanes, like falcons, dropped out of the bank of leaden clouds. It was a startling moment. The unprotected vehicles out in the open field, balancing precariously as their speed increased, hurried for the shelter of the trees. Men in the dragons opened fire with their rifles as the falcons swooped down."

2738.

**FOLDING COVER ON TYPEWRITER PROLONGS MACHINE'S LIFE**



To keep dust and dirt from the intricate parts of the typewriter, a collapsible cover now on the market locks securely when in place, fits down over the machine like a bellows, and is easy to open or close.

It is proof against dust, is permanently attached to the machine and is equipped with an adjustable copy holder.

**TILT STOPS GLASS REFLECTION IN BUS WINDSHIELD 3312**

By tilting the windshield of the motorbus forward from bottom to top and painting the ceiling over the driver's seat black, an eastern company has found an effective way to eliminate reflection from the lights inside. The plan is said to contribute to the safety of night driving.



Anita Loos, Testing the Color of Helene Millard's Hair with the Shade Chart

**HAIR TESTS WITH COLOR CHART TO IMPROVE MOVIES**

The actress for the motion-picture part may be beautiful and "screen well," but is her hair the proper color? The question is a very important one in the minds of the moving-picture photographers, and to answer it, a special color-testing chart has been devised. The candidate's hair is quickly and easily compared with the samples on the card, all of which have been photographed to determine their values in the finished picture. In this particular case, the performer's hair had to be as light or lighter than color No. 5 on the chart.

**AUTOMATIC VALVE ON RADIATOR REGULATES TEMPERATURE**

Direct control of room temperature is said to be afforded through a thermostatic valve attached to the radiator. It requires no power or special piping as it is self-contained, and there are no difficulties due to leaks, lodgment of dirt or other troubles, the manufacturers claim. The temperature may be varied.



412 1/2 5th Ave. New York

3144  
 Direct Control Valve Co., 332 S. Michigan

General Electric Co.  
 on buses of Public Service



3054

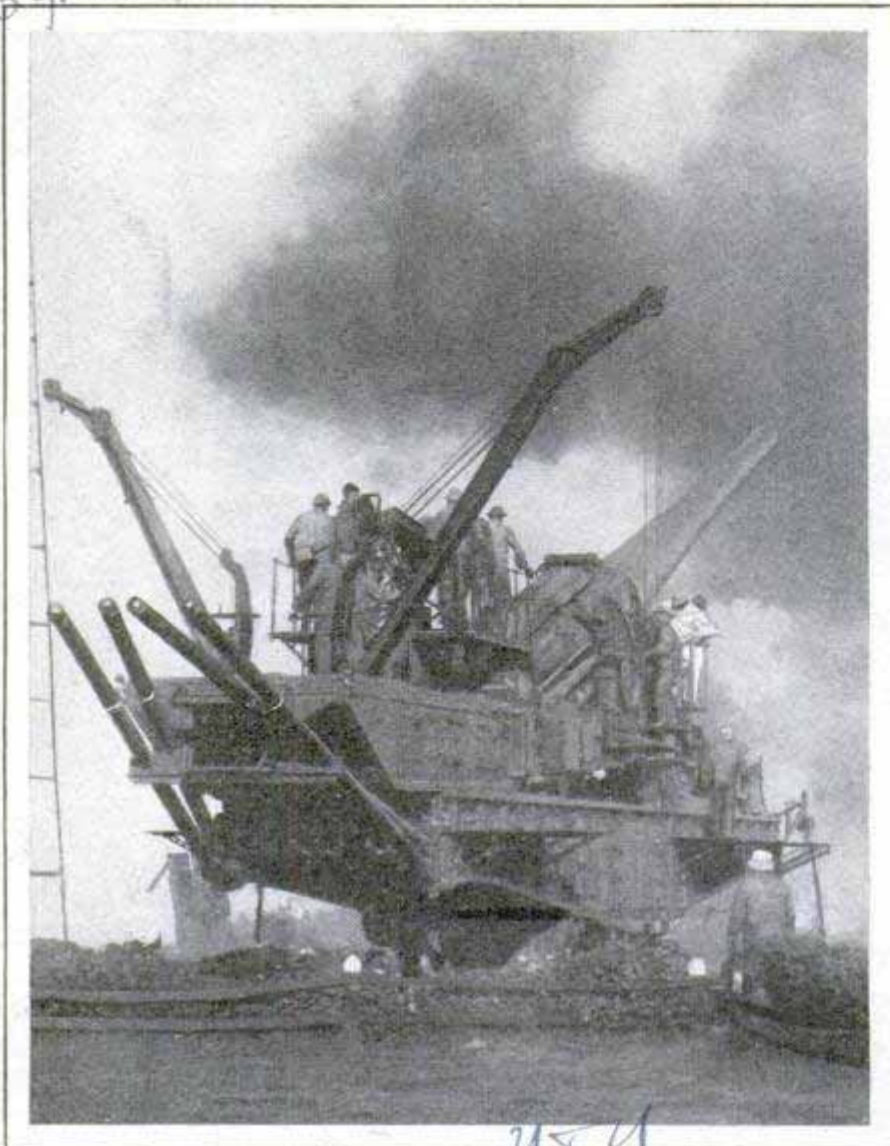

Big Coast-Defense Rifle in Action during Marksmanship Test; the Gun Is Mounted on Railway Carriage for Easy Transportation

**SHOOTING TWENTY-SEVEN MILES TESTS COAST GUN**

Marksmen were given an opportunity to test their skill recently when the giant coast-defense rifle at Fort MacArthur, Calif., was given its first service firing. This huge piece, mounted on a railway carriage, so that it can be transported to points of vantage quickly, has an effective range of over twenty-seven miles.

**RADIO IS WEAKENED BY LIGHT SHINING ON AERIAL**

Operators of radio station WLWL, in New York city, were mystified not long ago to discover that the signals perceptibly weakened and then grew stronger during the broadcast. Examination showed that a powerful searchlight was

being played from a statue near by and, in its path, swept across the station's antenna. Whenever this occurred, the signals grew weaker. The phenomenon is in harmony with the fact that radio reception is usually better at night than during the day, for light rays and radio waves, apparently "clash" in some mysterious way to the disadvantage of the latter. It has been suggested that the bright illumination in the cities near radio broadcasting stations is one reason why better reception at distant points is not accomplished. A weak searchlight probably would have no appreciable effect, however.

2560 ———  
**PAVING-BLOCKS LAID WITH MOTOR**

In laying street paving blocks in Denmark, a motor-driven pounder has been employed with success. It is said to do the work of several men at a saving of time and expense and also performs the task more thoroughly. The outfit is somewhat like a small pile driver and the force of the blows can be easily regulated.

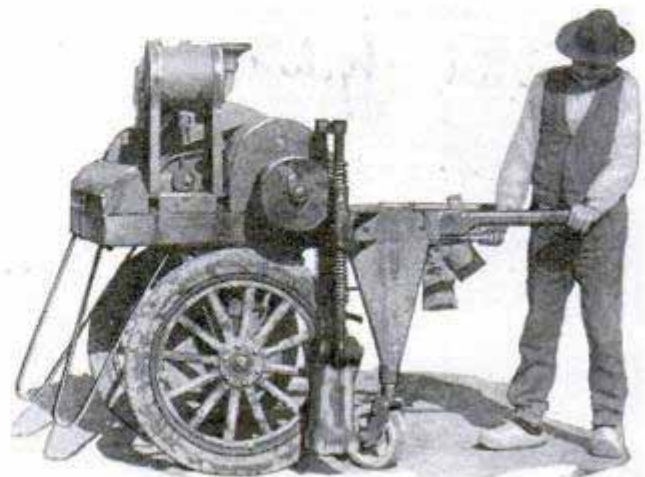

Placing Paving Blocks with the Portable Pounding Outfit Operated by a Motor

Paulist League on 59th St. ...

Handwritten notes on the right margin, including a large '3' and other illegible scribbles.



9/23/29

Mexico 1915

2710

### WATER-SOAKED LOGS SALVAGED FOR LUMBER PROFITS

Minnesota lumbermen are realizing profits from the wasteful methods of their predecessors, in salvaging logs which long have been under the waters of woodland lakes in the old timber districts. Millions of eighteen and twenty-foot cuts, entire rafts and other timbers in an excellent state of preservation, have been pulled from the lakes with big cranes and cut into boards. Much of the wood is of superior quality and it does not warp like green timber. More than 3,500,000 feet of lumber was taken from one lake last year and like quantities from others. Removal of the logs is also an aid to users of canoes and motor boats.

525 W. Willow St

3357

### SELF-CHALKING PLUMB LINE SAVES WORKER TIME

For carpenters, contractors, masons and others who use a chalk line, a self-chalking cord on a reel that fits into the pocket, saves time and trouble. There is a chamber at the top which is filled with powdered chalk and a patented device prevents the contents from spilling. The reel is quickly wound or unwound, keeps the line from tangling and knotting, and can be folded out of the way.

Always Ready Chalk Williamsport Pa



Williamsport Pa 2998

### GLASS FUSE PLUG DISCOLORS WHEN IT BLOWS OUT

Detecting blown fuse plugs of the usual type is not always easy, but can be done at a glance with a glass plug recently introduced, the manufacturers claim, as it discolors at an overload or short circuit. The effect can be seen in the center of the top of the plug, and the unit is installed in practically the same manner as it is in the ordinary ones.

54 W. Lake St

2761

Royal Electric Co, Chelsea Station



Did Aztec Children Play with Toy Soldiers? This Figure, from Burial Mound, Indicates That They Did

### TOY SOLDIER CENTURIES OLD FOUND IN BURIAL MOUND

Interesting pottery images, believed to antedate the days of the Aztecs, were uncovered from a burial mound in Mexico recently. Among them was a figure of a warrior, indicating that toy soldiers may have been popular even then. Small statues of dogs were also found.

### GOLF-BALL BRANDING STAMP AIDS IDENTIFICATION

Golf balls are quickly identified with the owner's initials in indelible ink by the use of a marking stamp specially adapted to fit the contour of the sphere and to hold the letters so that they cannot slip out. The outfit includes the stamp, pads and a supply of ink.



Waterproof, indelible. 2 sub & alphabets.

P. H. Swisher Mfg. Co, 411 S. Clinton St.



2722 Prince St  
Berkeley Calif



Trailer and Sidecar Fit This Motorcycle for Carrying the Camping Party and Equipment

**CAMP TRAILER ON MOTORCYCLE CUTS OUTING COSTS**

Vacation and its camping trip at less cost was the object of an English motorcyclist who rigged a trailer for his cycle. An advantage of the outfit was that it could be taken to places difficult to reach by automobile so that more secluded camping spots could be enjoyed, time saved and expenses reduced.

**SLOT MACHINE CANCELS LETTER ELIMINATING STAMPS**

Use of a cancel permit for letters as a substitute for stamps is made available to the public in a slot machine introduced in England. The envelope or card is placed in a slot, a coin inserted in another and the mark is stamped on by turning a handle. After the envelope is canceled, it passes into a compartment where it is later collected by the postman.



Slot Machine That Cancels Letters, Saving the Use of Stamps; It also Serves as Mail Box

**FLOATING SERVICE STATIONS FOR LINERS**

Fifty miles outside the Golden Gate, a trans-Pacific liner rolled, power in her engines only sufficient to hold her head to the seas. Her wireless crackled the story of her battle with winds and waves, telling in dots and dashes that her tanks were drained until she had not enough fuel to reach San Francisco. Five hours later, what seemed a submarine riding on the surface, noiseless as a floating shadow, swung in a wide circle until she lay alongside the pitching steamer. A great hose was lifted, passed inboard, and a hum as of a swarm of giant bumblebees arose from the small boat. In half an hour, the submarine had become a monitor, rising as she poured her own contents into the liner's tanks, showing herself for what she is—a floating service station for deep-water steamships. The general idea of a tanker is that of a huge, sluggish vessel, stored with thousands of barrels of oil, bound on long voyages. But up and down the Pacific coast, the oil-refining corporations have devised toy tankers, small craft, few of them more than 150 feet long, many of them much less, carrying from 1,000 to 2,500 barrels of crude oil, devoted to the servicing of ships. They also force their streams of liquid fuel over thousands of feet of land lines, supplying gas-manufacturing establishments, truck tanks, for road builders, factories where oil is burned

under steam boilers, and, in times of storm on the bays and harbors, flooding the waters with oil, so that other and larger ships may make their berths of protected anchorages in perfect safety.

Write our Bureau of Information if you wish to know who makes or sells any article described in this magazine. Send no postage; the service is free.

Dr. Frederich Wilkerson, London, England.

2341

International



PUTTING ZIP AND SPEED INTO WINTER SPORTS

*All article on making sail  
January 1928*



Even a Discarded Automobile Tire Can Provide Thrilling Sport on a Snow-Covered Hillside, If the Rider Is Young and Flexible Enough to Curl Up Inside



Sail-Skating Is a High-Speed Sport; the Old-Time Square Sail, That Carried the Skater Only Before the Wind, Is Being Displaced by This Cat-Boat Rig, So as to Permit Higher Pointing



Ski-Joring, with the Riders Pulled behind a Horse, Was Introduced Abroad, but American Sport Enthusiasts Have Improved on the Game by Using Automobiles and Motorcycles, and Even Airplanes; the Automobile System Is Particularly Good, Because Either Rider Can Fall Out without Danger to the Other, as Is the Case When All Hold a Long Rope





30 4 3

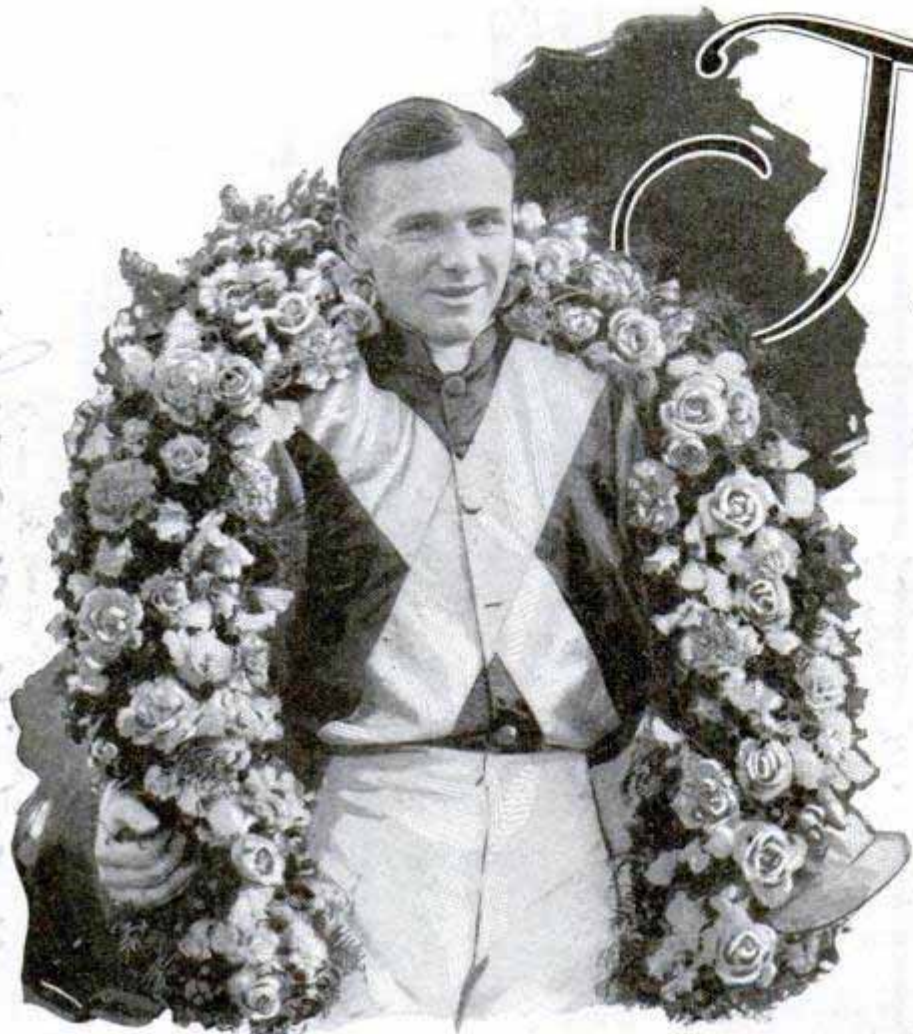

# THE

the field as soon as we made the first turn. Then I eased off a bit to give 'Mars' a breather and, when I was ready to spurt through, the colt was right with me.

"The thrill of shooting down the home-stretch past 'Black Maria,' to beat that filly by a length and a half, was one I shall never forget."

"In that particular race, Mr. Sande, who was it that won, you or the horse? Is the race between the jockeys or the horses?"

"It's both," he responded. "It is that combination I was telling you about which is struck up

*daily news*

when the jockey gets on good terms with the horse. Then the two of you are made one. The one cannot win without the other."

"I think you are known to be a hand rider, Mr. Sande."

"You bet. That's just what I want to be known as. I never use a whip on a horse. I don't believe in it. Horses slow up and swerve when whipped. I have seen many instances where jockeys have lost races they might have won if they hadn't resorted to the whip.

"Race horses are almost human in that respect. You are their friend. They resent it very much when you welt them with a whip. Sometimes I think their feelings are hurt. Instead, I kind of like to jolly a horse along.

"That is something few riders can do. I think I have developed the knack to perfection. I actually talk to my horses. I give them baby talk. At the same time I

Earl Sande, America's Premier Jockey, Wearing the Floral Horseshoe after a Victory on "Sarazen"

By A. A. ALBELLI,

"THE chief thing about winning a race," declares Earl Sande, America's highest-paid jockey, "is to know your horse. I don't mean being acquainted with the horse, but knowing it—knowing its disposition and its temperament. Horses are as temperamental as prima donnas. You and the horse have got to be buddies."

"Taking it for granted that you know your horse well, how do you manage to push him out in front during a race?" he was asked.

"The best way I can explain that," he replied, "is to take the first day of the races here this season when I won the Saratoga handicap with 'Mars,' son of 'Man o' War.' 'Mars' is just like the rest of his kind, a fine mount. That was one of my typical races. I got my good start. I left it to somebody else to be the pace maker. But the good start is very important. Ground lost at the start is hard to make up. I made it my business to get the measure of



*Row*

# HORSE or the JOCKEY?



Fourteen Youngsters Thundering down the Track in a Race for Three-Year-Olds at Belmont; the Picture Was Taken 150 Yards from the Start, with the Field Still Bunched

paw them with my hands, sort of slap them gently to spur them on. But I never lose my head and abuse them. Horses are honest, usually, and they'll always give you the best that's in them if you only treat them right.

"'Mad Hatter,' which I rode in 1924, used to be a good one for that. This riding racket requires masterful strategy. No two races are the same, no two horses are the same. I used to have 'Mad Hatter' so trained that he knew when the cue came to overhaul the bunch. We'd be riding a little behind two leaders, then all of a sudden I would crouch over and barely whisper to 'Mad Hatter.'

"I used to say, 'Whoa boy! Easy now! We're winning,' and sort of pet him. I would keep a light pull and keep talking to him, then suddenly I'd jerk and give him free rein and he was off like a bullet."

"Is the horse aware of the fact that he is running a race?"

"If I can help it, I keep my horse from being race-conscious. I don't let him notice the pace. Naturally a horse does

not know he is running for a rich purse, though he is usually aware of the glory that awaits a victory.

"Then, when the horse finds that the track ahead of him is cluttered up with other horses, he just naturally lets out and runs around them. But that doesn't always work. There are different types and different temperaments. The nip-and-tuck variety of race, with quick thinking on the part of the rider, is the most common. The rider has got to be keen and ready to take advantage of any opening. Being on the alert and grabbing off the chances when they loom, is one of the strong points.

"For instance, I have been credited with an uncanny knack of starting a winning drive with a stolen length or two before my rivals realize that I have thrown myself heart and soul into the race. I always try very hard to win every race. I think that my self-confidence—untainted by vanity, mind you—together with my experience in riding most often carry me through to victory."



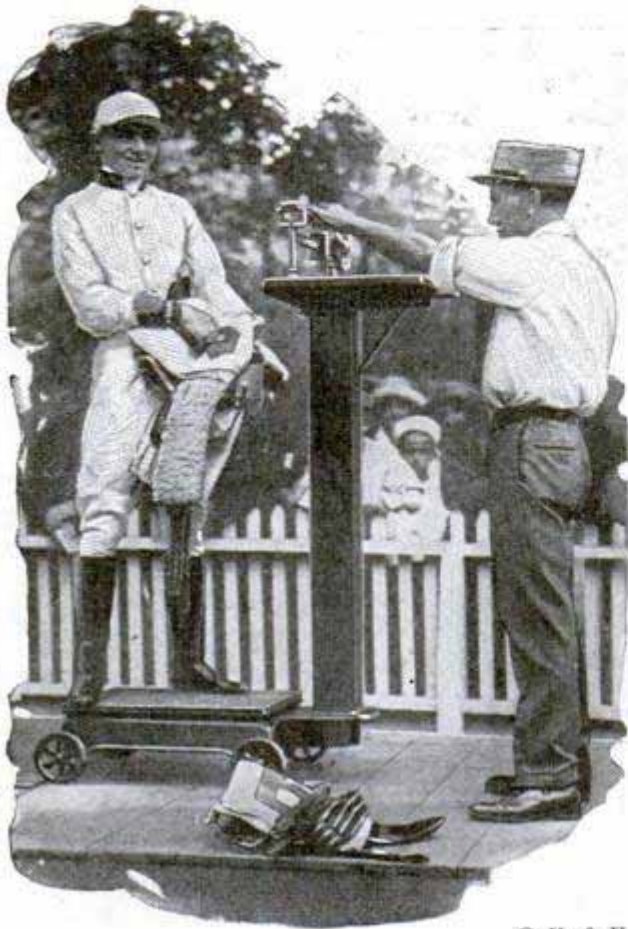

© U. & U.  
Weighing in Jockey Sande with All His "Tack," Including Saddle and Lead Weights

"Is there any money for the jockey in the horse-race business?"

"A good jockey will always find fair compensation. At the present time I am not under exclusive contract to anyone. Joseph E. Widener, the Philadelphia millionaire, has first call on me to ride his horses. He pays me \$15,000 a year for

that privilege. Otherwise I am entirely a free lance.

"Take that Saratoga handicap. 'Mars' was owned by Walter M. Jeffords. The purse was \$8,000, of which I received \$1,000. The rate is usually ten per cent of the purse to the winning jockey. I didn't figure that bad pay. Doing the mile and a quarter in 2:07 $\frac{3}{4}$  I brought the owner about \$63 a second, while I was earning about \$8 a second for myself. Not bad pay, eh?"

"What do you earn annually?"

"I make about \$50,000 a year."

"When did you first start riding?"

"Gosh," said this blond-haired youth, who doesn't look his twenty-nine years, "it goes so far back I can't remember."

"Well, what is the first horse-riding experience you remember?"

"That goes back to the time my family lived in American Falls, Idaho. I was fourteen then. At that time we were very poor. My father was boss of a section gang on the Milwaukee railroad.

"Without letting my mother and father know anything, I traded some ducks and my father's shotgun for a little roan named 'Babe.' My parents nearly went crazy when they found out what I had done. I thought they were going to kill me. But it was done and couldn't be undone.

"I started to ride 'Babe' in some of the pick-up races around the ranches. Then a cowboy of varied fortunes, who had seen me ride 'Babe,' wanted me to ride his 'cold-bloods,' which is a half-thorough-

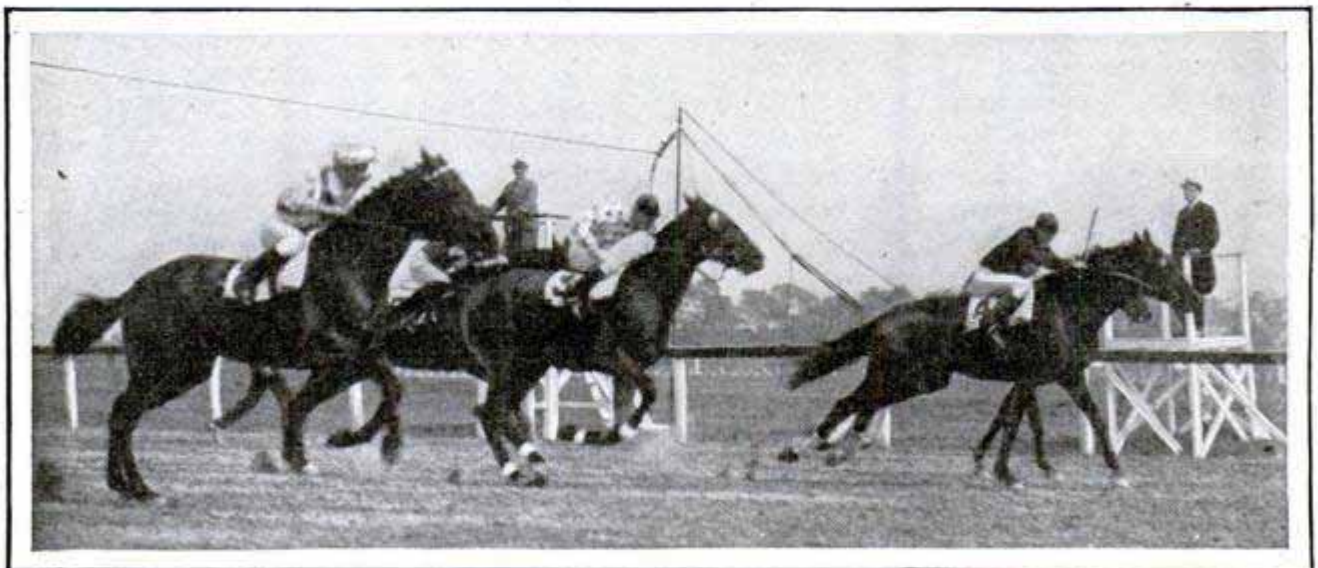

Start of the Race at Jamaica, in Which the Colt "Sting" Set a New World's Record for the Distance of a Mile and Seventy Yards; the Barrier Is Seen above the Horses' Heads



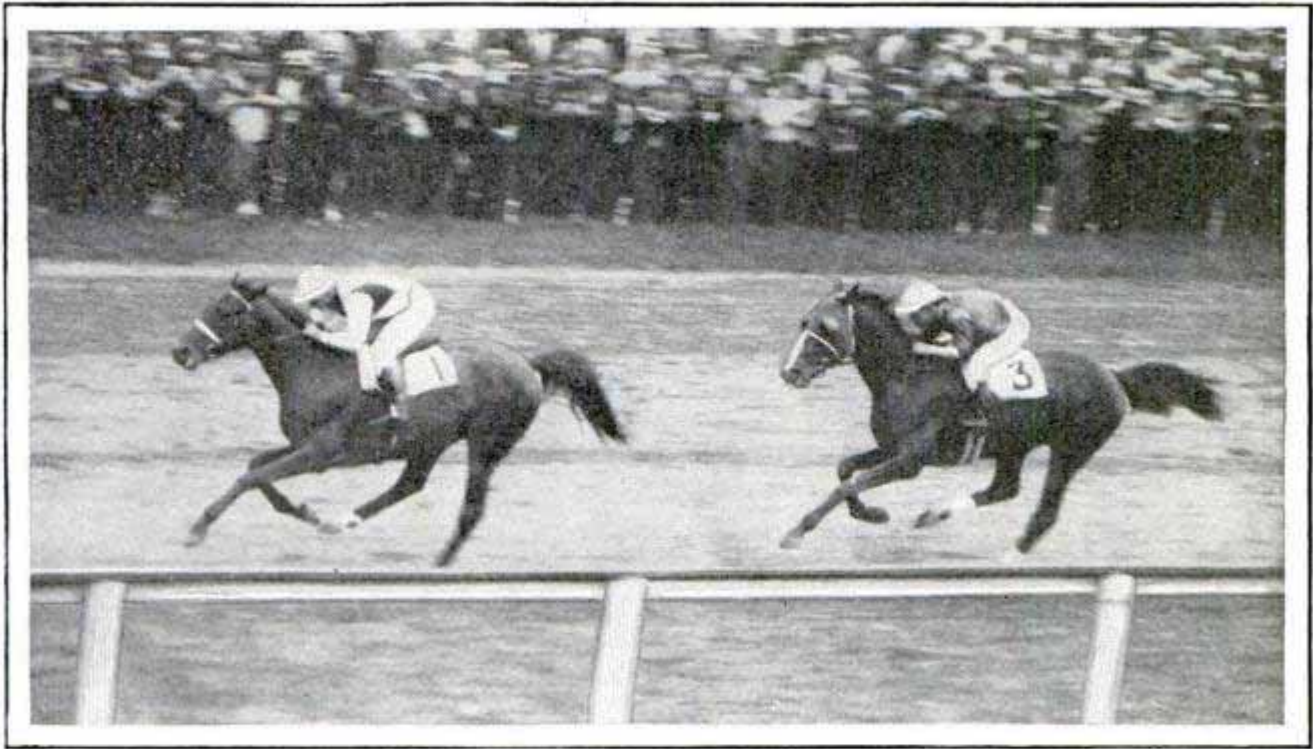

"Peanuts," a Great Handicap Horse, Winning the Empire City Handicap, with "Sanford" Two Lengths Behind; Note the Jockeys' Crouch, Developed by Tod Sloan

bred, in some sprints. There was a sort of rodeo and carnival in town that summer. I got \$2 for riding that man's horses. His name was Burr Scott.

"That winter I returned to school. One day Scott sent in a note to the teacher, stating he wanted to see me. He said he liked my way of riding and wanted me to go with him to Phoenix, Ariz., where he said I could make a lot of money as a jockey. So I ran away.

"We didn't do so well, and Scott got discouraged and quit the game. I started galloping horses for \$25 a week. At the age of nineteen I struck out for New Orleans. Here I won my first professional race with one of Joe Goodman's horses."

From that time forward, Sande began to win. He took the Kentucky Derby, the blue-ribbon event of the American turf, twice, once with "Zev" and again with "Flying Ebony." He won the historic Belmont stakes four times, the Suburban handicap three times, the Metropolitan handicap twice with "Mad Hatter" and he was second in the Futurity thrice.

Sande has won so many races he has lost count. In 1925, he went through with 718 winners out of 2,680 starts. He says his average has been about the same since. Harry Sinclair, of the Rancocas stables, whose horses Sande rode one year, has earned more from Sande's services than

anybody else. In that one year Sande netted Sinclair \$564,000.

"In the old days," commented Sande, "I used to ride the whole card of six races a day for \$10."

The life of a jockey, however, is not all clover. It is perilous. There are hardships to endure. One must fight against mental hazards and depression which might grow out of adversity. In 1924, Sande was badly injured at Saratoga while trying to edge through an opening next to the rail. He suffered a broken thigh. The wiseacres said he was through. Later he came back by winning the Derby with "Flying Ebony."

The jockey permits himself no dissipation, no matter how slight. Sande neither drinks nor smokes. Then there is the weight to think about. Every morning Sande takes to the road and jogs along for several miles. He is heavily clothed so as to knock off weight. He says when he can't make the weight, about 115 pounds, any longer, and the muscles begin to harden, he'll become a trainer. "But that's over ten years off," he said.

"What are the opportunities for young men in the jockey field?" he was asked.

"Well," he said, ponderingly, "well, I've told my story. Now if you were a young man what do you think? Would you want to do it? It's a matter for the in-



dividual to decide. Only one thing I say, the young man who contemplates the jockey game wants to be sure he can stand the gaff, there's an awful lot of ups and downs in the game. It takes a brave heart to fight it out."

### BUILDINGS "EXPLODE" IN WIND TUNNEL TESTS SHOW

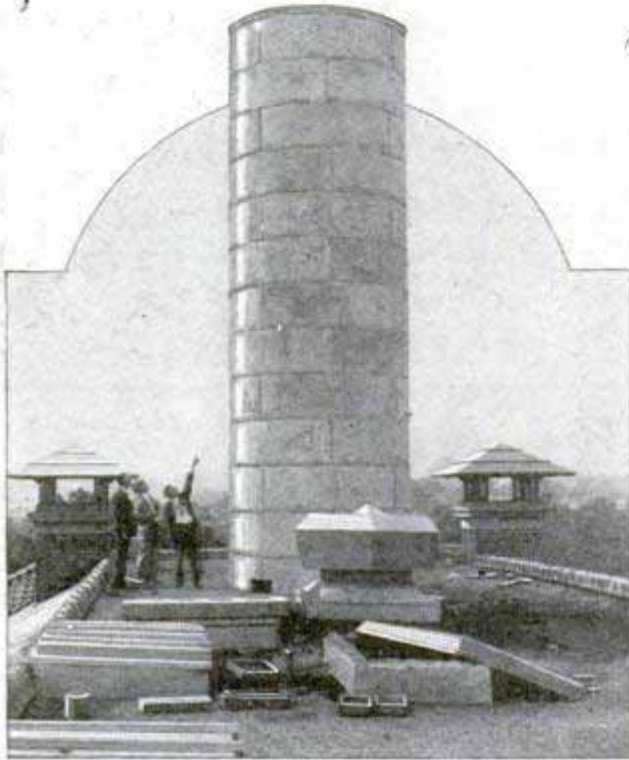

Model Smokestack on Bureau of Standards Laboratory  
Which Is Studied for Wind-Stress Data

Interesting data concerning the behavior of structures of different kinds in severe winds are being gathered by tests at the bureau of standards. One of the units employed is a model of a typical factory building, erected within a giant wind tunnel through which strong air currents are forced. Preliminary results seem to show that suction rather than pressure tends to cause the building to explode outward rather than collapse inward. Another test involves a chimney, ten feet in diameter and thirty feet high, on top of one of the laboratory buildings. It is punctured with twenty-four holes in a circle, each hole connected with a pressure gauge so that experts can measure the amount of suction and pressure for each direction of the wind every fifteen degrees around the stack. Information obtained from this test will be arranged for the benefit of builders seeking to construct

the strongest stacks within the range of efficiency and economy. Other experiments are staged to determine how much of a motor car's power is used to push the air aside and how aircraft behave in currents of varying velocities manufactured in the "cave of the winds," the bureau's big testing tunnel.

### EARTH CRUST SIXTY MILES DEEP ACCORDING TO SCIENTISTS

327 *William B. Bowie*  
Data gathered by the coast and geodetic survey indicate that the earth's crust is more than sixty miles thick, but that does not mean that the interior below is necessarily a molten, flowing mass. By "crust," the geologists mean the outer layer of the earth within which certain densities may be maintained, and their estimate as to its thickness was obtained by mathematical analysis of various earth movements. The crust is believed to be comparatively weak in order that internal adjustments may be made as readily as they are, after quakes, for instance. The investigators hold that the earth is solid throughout. Shifting of materials horizontally at the surface or below the crust, sets up stresses which express themselves in earth tremors. These occur almost every day as the seismographs prove.

### TESTER FOR ELECTRIC WIRING SIMPLIFIES REPAIRS

3034  
Broken places in insulated electric wires can be located, without the necessity of extensive removals, with a novel tester recently introduced. It is constructed like a pair of pliers, the upper jaw being lined with old phonograph needles of metal. When these are pressed into the wire, the live side is quickly revealed on contact with the needles, but the tester is insulated to prevent injury to the user. It is said that the instrument does not damage the insulation on the wire.

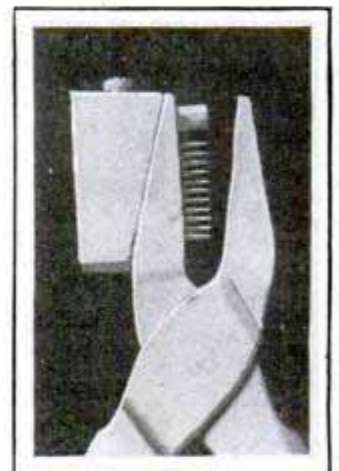

*Clarkson Co.,  
1273 Curtis St.*



*237 Mrs. M. ...  
2619 B. ...  
Seattle Wash.*

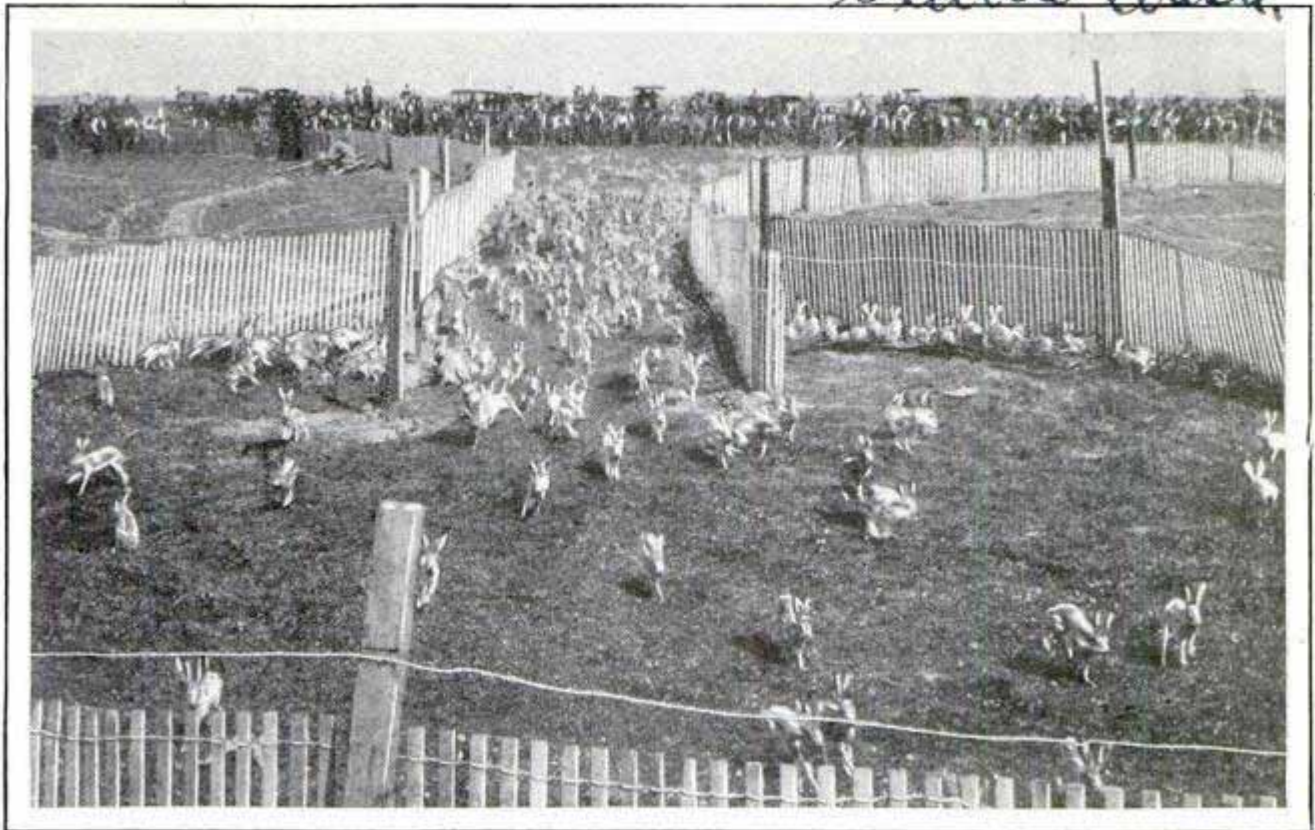

Nearing the End; the Rabbits Have Been Rounded Up over a Wide Expanse of Country, Driven into the Corral and Will Be Killed; Drives like This Are Needed to Save Crops

**RABBITS SLAIN BY THOUSANDS  
— IN MONSTER DRIVES**

Owing to the decreasing numbers of wolves, coyotes and other natural enemies, the jack rabbit is prospering in many parts of the west and, some years, infests the fields in such large numbers that wholesale slaughter is necessary. This is accomplished by a drive in which ranchers and townsmen over a wide area participate. The brush is beaten for miles around, the drivers advancing on foot, horseback, buckboard or auto, until the herds of rabbit are driven into a corral through a V-shaped barricade. They are then killed. Twenty thousand or more may be destroyed in a drive of this kind, and, for a few

seasons, the rabbits do not cause such great damage. In California, losses caused by the animals have run as high as \$600,000 a year in one county.

**FANCY SUNBURN WITH STENCILS  
LATEST FASHION FAD 3083**



Removing the Stencil Protectors After Skin around Them Has Been Sunburned to Produce Designs

Stencil papers, cut in various patterns and applied to the skin, leave lighter areas when they are removed after exposure to the sun, so that an "artistic" sunburn is produced. The method proved popular last season at swimming beaches. Fruit growers have used this system for some time on apples and other products, initials of the orchard owner and elaborate designs being made on the fruit in the same manner.

*cm. lso. F. Paul R. 8 09  
537 J. Dearborn*



9/21/27

An Oregon State Highway



Screen along Roadway, in Oregon, to Prevent Oil from Dripping into the Stream and Killing the Fish

### FISH GUARDED FROM ROAD OIL BY CURTAIN ON BRIDGE

Oil splashing from a motor road into a trout stream in Oregon has injured the fish and marred the paint on the bridge, but the highway commission has found a way to end the nuisance by stretching a tar-paper curtain along the guard rail. It is securely fastened and placed high enough to protect the bridge, while the barrier below keeps the oil from trickling in from the road.

### THE MOST DIFFICULT RAILWAY COVERS SEVENTY MILES

3338

Twisting through a mountainous country between Mack, Colo., and Watson, Utah, the Uintah railroad is officially recognized as the most difficult line to operate in the United States. It is seventy miles long and is used principally for hauling a mineral employed in the manufacture of shellacs, varnishes, lacquers and insulation for high-tension electrical apparatus. In thirty-five miles, the road climbs from an altitude of 4,541 to 8,437 feet, and along another stretch there are nearly twenty curves to the mile. A specially constructed engine was necessary for this road in order to negotiate the sharp curves and the steep grades. In places, the bends attain a curvature of sixty-six degrees.

### WHAT THE AIRMAN SEES BELOW

3349

If the skies are clear, an aviator at a height of 6,000 feet can see more than eighty miles. How flying has pushed back the horizon is apparent when it is realized that a man five feet six inches tall, standing at sea level, can see but two and one-half nautical miles over the ocean. Ascending but 100 feet increases the limit of his vision to more than ten miles, at 3,000 feet he can gaze more than fifty-eight miles before the horizon interferes and at 6,000 feet, he

can command a circular area with a diameter of 167.76 nautical miles, the horizon being half this distance away. A nautical mile is slightly more than 6,000 feet as compared to the usual 5,280 feet.

### SEVEN-MILE BALL OF STRING AN EXAMPLE OF THRIFT

3359

As an example of thrift, employes in the post office at Loomis, Calif., saved bits of string salvaged from packages, and before long had an enormous ball containing nearly seven miles of twine. The sphere, measuring five feet in circumference, was sent to the post office department in Washington.



Seven Miles of String, the Result of Saving Bits from Post-Office Packages at Loomis, Calif.



3343

WINTER REFUGE FOR WILD ELK  
GIVEN TO GOVERNMENT 3352

Deed to 1,760 acres of land in the Jackson Hole country of Wyoming recently was given to the government by the Izaak Walton league, as an additional refuge and feeding ground for wild elk that are driven out of the high portions of Yellowstone park and near-by country with the approach of winter snows. The land was purchased by popular subscription, more than \$40,000 being raised from as many contributors. Between 8,000 and 10,000 elk are fed there each year. Two men are retained to grow and harvest the hay, which is distributed to the animals throughout the winter until they can return to their usual feeding grounds.

SCOOP FOR ICE-CREAM CONES  
SAVES TIME AND TROUBLE 3286

Filling ice-cream cones with the ordinary dipper or disher is often attended with waste, loss of time and breakage of the cone. These difficulties are said to have been eliminated in a special scoop that shapes a serving of the cream to conform



with the cone and permits dropping it in, point down, so that it fills the container and does not drip from the sides. An outward movement of a small thumb piece on the scoop allows the cream to fall into the cone.

The unit may also be used for jelly, puddings or other dishes for the home table.

FARMYARDS AT SEA 3337

Installation of flower gardens on some of the ocean liners, from which come decorations for the dining tables, recalls a queer craft that once plied between England and Ireland. It was operated entirely by women and was the sole means of livelihood of two elderly sisters. They had a well-kept kitchen garden and a poultry yard on the deck, and supported themselves by selling the products.

Set Bits 9/17/27



Painter Wearing Mask While Spraying; Note the Line Connected to Main Supply Pipe

AIRLINE FROM PAINT SPRAYER  
SUPPLIES WORKER'S MASK

Extra protection is afforded against the danger of inhaling poison fumes while spraying paint in a mask that utilizes air pressure from the line to the paint nozzle. A length of braided tubing leads from a valve on the main supply line to the mouthpiece so that a current of air is constantly available to the wearer without exposure to the fume-laden atmosphere. The mask is easily adjusted and the valve can be regulated to suit the operator.

VALVE GRINDER THAT FITS HAND  
EASES MECHANIC'S WORK 2819

Reconditioning the auto valves is simplified by a grinder that is shaped to fit the mechanic's hand, so that he can obtain a strong grip and work with greater accuracy and increased comfort, instead of having merely a knob at the top or an awkward, cumbersome tool to grasp. There are no parts to get out of order.

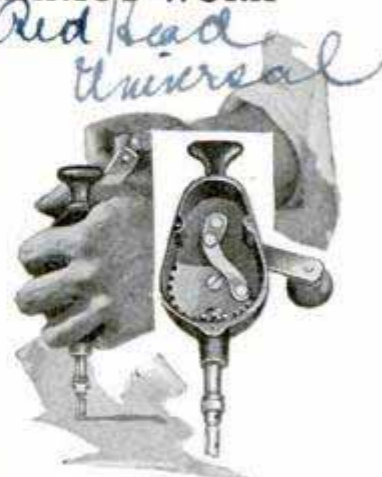

Red Head Universal  
Duro Metal Products Co.,  
2649 W. Kildare Ave

Oregon Specialty Co. 705 Lehigh Bldg Portland, Or.

Pulmonon Safety Equipment Corp. 356 1st St. Philadelphia, Pa.



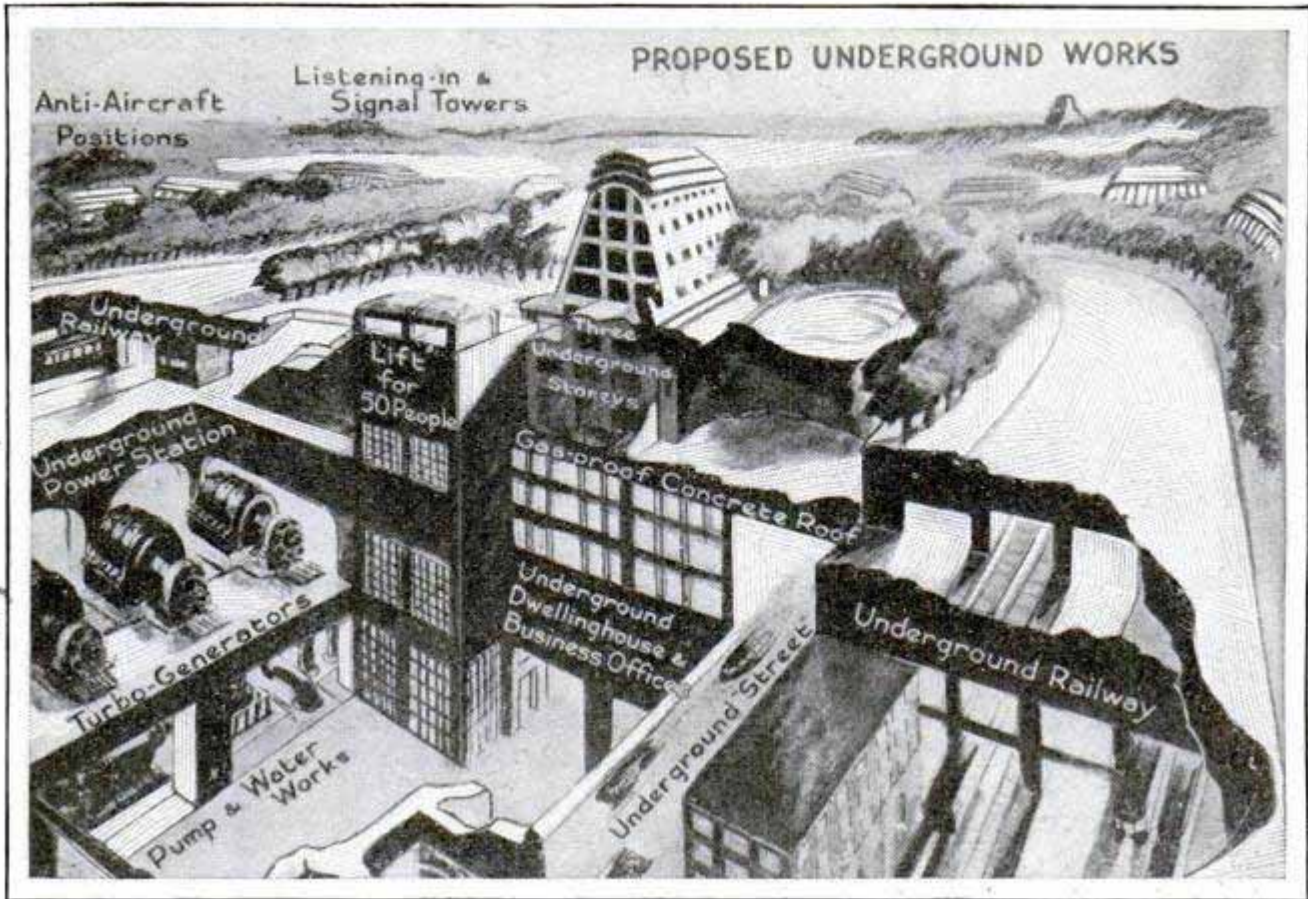

Sectional View of Underground City, Proposed by Russian Architects as Protection against Bombs and Gas; Note the Above-Ground Building with Sloping Walls and Multiple Roofs

## Bomb and Gas-Proof Cities of Future

Russians Plan Weird Architecture to Save Civilian Population against Possible Attack by Fleets of Giant Air Raiders

**M**EN may have to go back to their cave-dwelling ancestors and live a large part of their lives underground; big cities may have to be decentralized and spread, in low-lying buildings, over vast areas, broken up by parks and open spaces, if the threatened horrors of aerial warfare really materialize.

Those are the conclusions reached by soviet officials in Moscow, who are busy at work planning a gas and bomb-proof city capable of resisting attack from the air. The soviet architects featured a recent anti-war "Scare Week" with plans for such a city. The plans called for vast subterranean cities, covered by reinforced-concrete roofs, which in turn were buried under many feet of sod and earth. Railways and streets, as well as sidewalks, would also be placed underground.

Such buildings as would be permitted above ground would be limited to four

stories in height. The outer walls would taper, to offer the smallest possible target from above, and they would be surmounted by triple reinforced-concrete roofs, with honeycomb air spaces between to take up the shock of an exploding bomb. The roof idea is similar to the blister plan used as a submarine defense for warships, an outer shell or blister exploding the torpedo on contact, and the inner space taking up the shock before the main hull is reached. Not all bombs explode on contact, but the triple roofs would offer sufficient resistance to stop even a penetration type and explode it before the interior of the building could be reached.

Every outlet to the air, including all doors and windows, would be rendered gas-proof, while the underground passages and refuge rooms would be protected against poison gas by double doors,



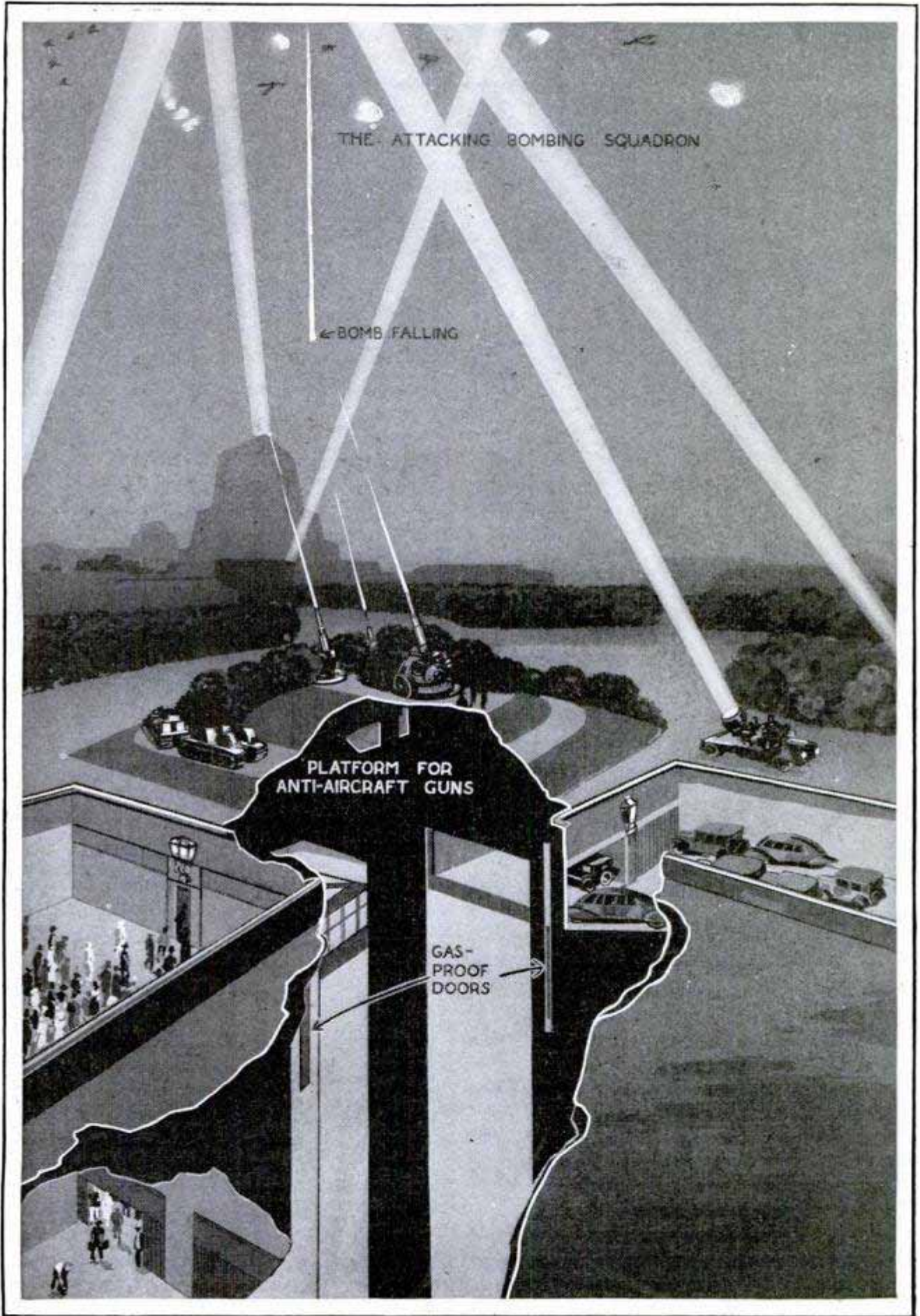

Night in the City of the Future, as Russian Designers Imagine It; the Civilian Population Finds Refuge behind Gas-Tight Doors Underground, While Bombs Rain on Broad Parks and Dissipate Their Force without Harm; Only Searchlight and Listening Posts and Battery Positions Are Manned above Ground



3056  
926

**PROPOSED  
"ARMOURED"  
BUILDINGS**

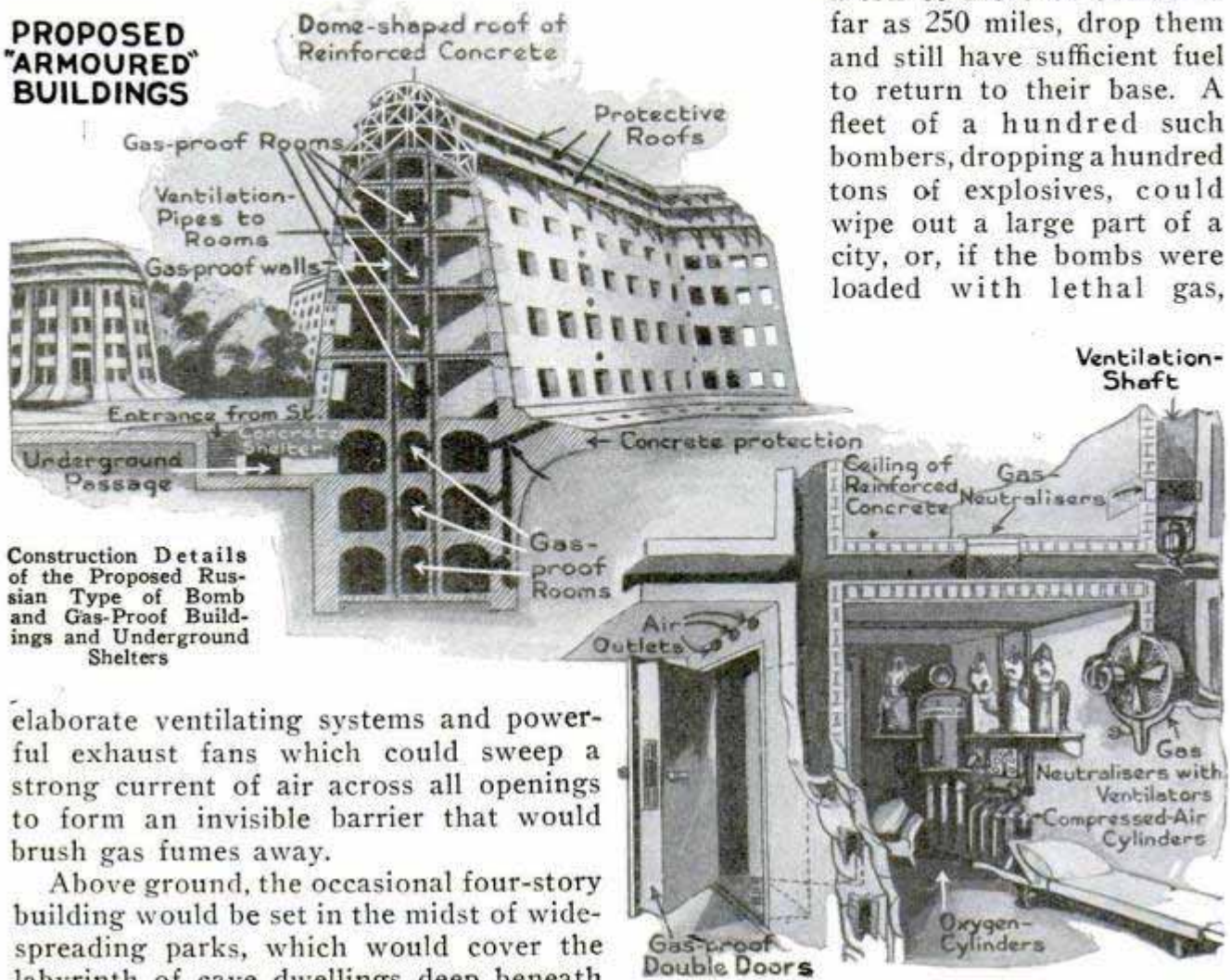

Construction Details of the Proposed Russian Type of Bomb and Gas-Proof Buildings and Underground Shelters

elaborate ventilating systems and powerful exhaust fans which could sweep a strong current of air across all openings to form an invisible barrier that would brush gas fumes away.

Above ground, the occasional four-story building would be set in the midst of wide-spreading parks, which would cover the labyrinth of cave dwellings deep beneath the surface. Occasional listening and signal towers and platforms for anti-aircraft guns would be interspersed among the scattered houses.

Another idea advanced by the Russians is the building of powerful gas neutralizers, which would draw the gas-laden air through water spray and chemicals and release it as pure air again.

The possibility of horrors in the next war beyond anything hitherto dreamed of is being given consideration throughout Europe, especially in Russia, Germany and England. A German magazine, *Die Woche*, recently pointed out that in the next war a city such as New York, with its tremendously tall buildings and enormous concentration of millions of defenseless people in a restricted area, would be "a giant with feet of clay, a veritable man trap." Bombing planes, the writer pointed out, have risen two miles into the air carrying a load of six and a half tons of bombs, besides the weight of the crew and their supplies. Modern bombers can carry

a ton or more of bombs as far as 250 miles, drop them and still have sufficient fuel to return to their base. A fleet of a hundred such bombers, dropping a hundred tons of explosives, could wipe out a large part of a city, or, if the bombs were loaded with lethal gas,

spread a curtain of death over a vast area. A 225 to 525-pound bomb would demolish a big building, and the larger sizes, weighing from 1,640 to 3,280 pounds, as used in bombing tests, would each wipe out an entire city block.

Lord Halsbury, former assistant inspector of high explosives in the British ministry of munitions, writing in the *London Daily Mail*, recently said:

"In a war of any magnitude there will not merely be armies engaging armies, but whole nations mobilized against nations. It inevitably follows that the old demarcation between the military forces and civilian population will cease to exist. The first conclusion that emerges is that an attack will be made upon the civilian population. From the dislike of facing unpleasant truths, an answer comes readily to many. 'London,' it is said, 'was bombed during the war, and not much damage was done after all.' The answer omits one very serious consideration. London was attacked with incendiary



and explosive bombs. Since then great strides have been made in chemical warfare. The only other answer that may be made is that it would be impossible to drop sufficient gas. Some two years ago, I pointed out that, in the vital triangle including the Thames docks and Clapham junction, 2,000 tons of gas would create a lethal atmosphere over all that area to a height of forty feet."

**TIRE HEATER FOR LOCOMOTIVES SIMPLIFIES REPAIRS**

3236

When the big tires on the driving wheels of a locomotive become worn enough to require replacement, it is necessary to remove them by expanding with a heater. An improved unit for this work has recently been devised by a Pennsylvania railroad employe. While similar to others, it is said to eliminate the danger of burning varnish off the engine-wheel centers, jacket and cab, thoroughly heats the tire in about twelve minutes and is used in placing new tires on the wheel. It is so arranged that ignited gas from preheated oil makes a blazing ring around the wheel except six inches at the bottom.

**STATUE OF COW ADVERTISES CITY CREAMERY**

2019

Statues of a cow were placed at several localities near Los Angeles, recently, to advertise a local creamery. The first figure was prepared from a live model, the artist keeping the cow near his studio.



Art for Advertising; Statues of Cow and Dairy Maid along California Highways Celebrate Creamery

3128



Package Tier in Operation; String Is Easily Passed over Entire Bundle and Machine Is Movable

**PORTABLE PACKAGE TIER SAVES TIME AND EXPENSE**

For manufacturing plants producing merchandise in boxes, a package tier, recently introduced, can tie 45,000 boxes a day in approximately 2,500 bundles with but one operator required. It is said to wrap the twine about the parcel at even tension, preventing cutting or damaging the boxes, and eliminates the need of corner cards. Little skill is necessary to operate the unit, and it can be moved about to any convenient place in the shop.

**PLAN TO DYE CAVALRY HORSES TO COMBAT AIR ATTACKS**

3243

Dyed horses and "shineless" saddles are under consideration at the cavalry school at Fort Riley, Kans., as a means of protecting mounted units against low-flying airplane attacks. It has also been suggested that a "flock" formation be adopted to keep the men scattered and so decrease the likelihood of heavy casualties in case of assault from the air. Tests have shown that the glint of the polished saddle-seat leather is easily visible to observers in the planes.

Herald Examiner  
9/8/27

Burns Co, 7329 Vincennes Ave. Chicago, Ill



2440

RABBIT FUR GIVEN MANY NAMES

According to David C. Mills, general director of the national association of the fur industry, at least seventy-five names have been given to rabbit pelts in efforts to make the product more appealing to the purchasers. Among these are "Russian Leopard," "Moline," "Nutriette," "French Sable" and "Visionette." The fur is disguised by the skillful use of special dyes.

POLICEMEN CARRY TRAFFIC SIGNS

ON BACK

Traffic policemen in Singapore carry rattan signs with red disks at each end, to direct autos. The disks reflect the light of approaching cars so that the drivers can easily see if the signal is set against them. To indicate a change in traffic, the police-

Straits Settlements



Singapore Policeman with His Lighted Rattan "Arm" That Helps Him Direct Traffic

man has but to turn the signal through an angle of forty-five degrees.



Boulders in Stream Bed to Prevent Water from Tearing Out Bottom and Banks by Breaking Force of Flow

ARTIFICIAL BOWLDERS IN RIVER PROTECT BED FROM WEAR

A western irrigation district has found that river or creek beds, subjected to unusually high velocities, can be protected from erosion by scattering artificial concrete boulders irregularly over the channel bottom. Those shown in the illustration proved effective where velocities were as high as thirty feet a second, and were made to contain two cubic yards of concrete.

VILLAGE SMITHY STILL HERE DESPITE AUTOMOBILE

That the "cough" of the motor has not completely displaced the clang of the anvil was shown at a horseshoers' convention in Jersey City recently, when it was announced that there are 70,000 blacksmiths in the United States today and prediction was made that the number would increase. In New York city alone, there are 65,000 horses, enough to keep many smiths' fires burning, and wise men of the craft have fitted their shops to do automobile repair work so that cars have contributed to their business instead of diminishing it.

3350

New York Times 9/20/27



Je Sais Tout August 1927

SECRETS OF BIRDS' FLIGHT SOUGHT BY SCIENCE

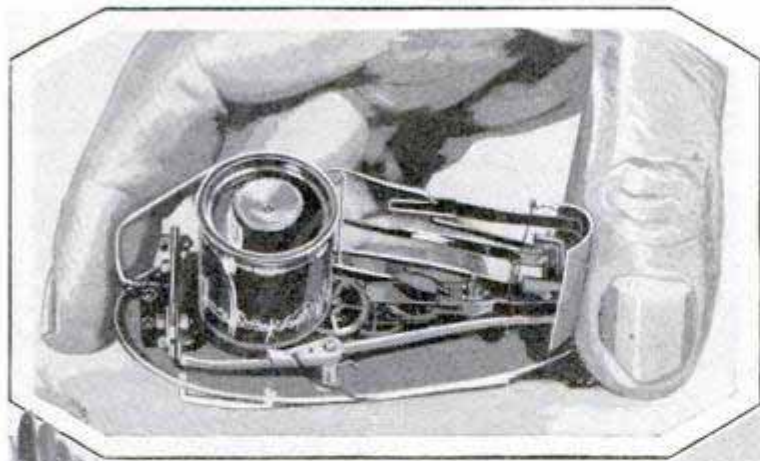

Close View of the Flight-Recording Apparatus; Drawing to Show How It Is Adjusted to the Bird, and Reproduction of the Record Made

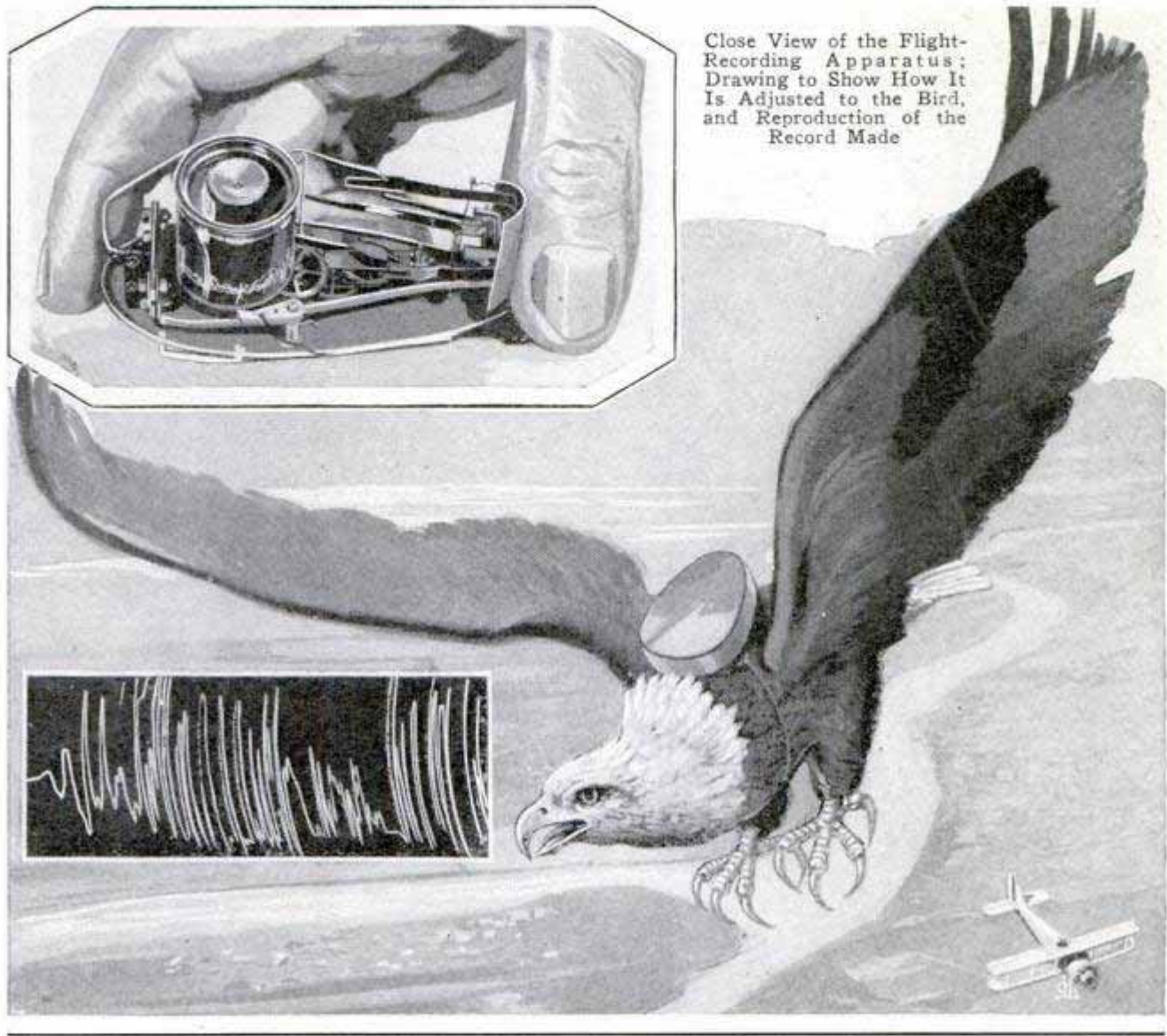

Courtesy Je Sais Tout

While the secrets of a bird's flight are not yet wholly solved, with an apparatus devised by two French scientists, accurate measurements have been made as to the amount of flying energy expended, the number of wing beats, speed, and other factors. The bird registers its own record of its flight on the instrument, which is essentially a small revolving drum actuated through a system of levers and strapped to the bird's back in such a way that wings, feet, neck and tail are left free. The drum makes a revolution every six seconds, starts automatically when the bird is released, and shows the flight record as a wavering line on the drum. The curves illustrated here represent the flight of a pigeon. They show that the bird started slowly and beat its wings at

the rate of six to eight times a second at the beginning, sufficient to sustain four times its own weight. A complete "report" of a pigeon's performance from the time it was started until it returned to its loft has been made with the unit. One of the interesting facts revealed is that a bird flies on an almost negligible expenditure of energy because it takes advantage of both natural air currents and those created by itself for support and motion. The problem is: To what extent can these forces be applied to future flying machines? Experts do not hesitate to state that means of making such application soon will be found and among them are some who even presage from the experiments the realization of man flight by his own muscular power.

Huguenard and Planiol.



1397

and a to the laughing  
 Sunday Feature Dept.  
 Detroit News, Detroit, Mich

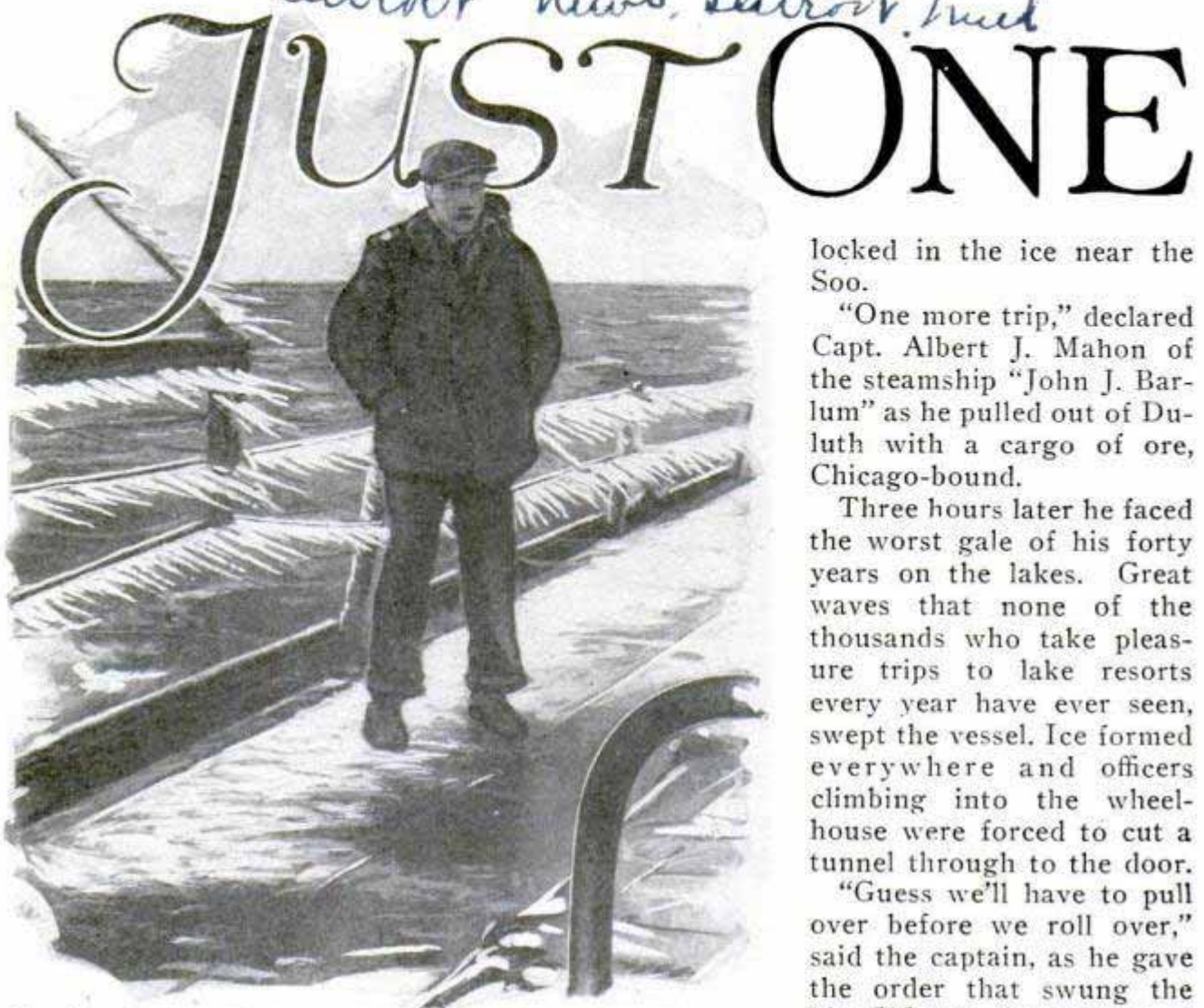

The Gales Blow So Hard That the Icicles, Clinging to Life Lines and Rails, Stick Out at Weird Angles.

By EDWARD BERNARD

A RACE with death and disaster, with \$150,000,000 as a side bet, is run every year on the waters of the Great Lakes, in the effort of several hundred vessels to make "just one more trip."

Ships of the lakes that sail through placid waters during the calms of spring and summer, become places of fear when the order comes for that one last trip.

Captains, ever watchful, knowing that an accident means wrecked ambitions, spend sleepless nights and foodless days when the time of year comes for the one extra voyage, the last of the year's cargoes.

Insurance companies will not take a chance on the last trips. Owners may make their bets with the Storm King each year if they will, but after midnight, Nov. 30, the underwriters declare hands off. They refuse to wager. Last year \$150,000,000 in ships and cargoes remained

locked in the ice near the Soo.

"One more trip," declared Capt. Albert J. Mahon of the steamship "John J. Barlum" as he pulled out of Duluth with a cargo of ore, Chicago-bound.

Three hours later he faced the worst gale of his forty years on the lakes. Great waves that none of the thousands who take pleasure trips to lake resorts every year have ever seen, swept the vessel. Ice formed everywhere and officers climbing into the wheelhouse were forced to cut a tunnel through to the door.

"Guess we'll have to pull over before we roll over," said the captain, as he gave the order that swung the big 505-foot freighter at right angle to her course, a point off Michipocoten island. Down the opposite

shore of Lake Superior the steamship rolled by Copper Mine Point, within a few hours of the time when another "last tripper" had gone ashore.

This was the steamship "Cottonwood." Her crew got ashore. No more desolate spot could be found in the entire lake country. Suffering from exposure and lack of food, volunteers chose to risk the lake in a small boat to bring relief to their fellows. Those on shore waited through a long night, fires being kept burning to ward off hungry wolves heard near the miserable camp.

Neither ship was equipped with wireless, said Capt. Mahon, and the "John J. Barlum" knew nothing of the "Cottonwood" disaster until hours later.

Tacking back and forth across the greatest of the lakes, the steamship acted as did the sailing vessels of years ago and



# MORE TRIP

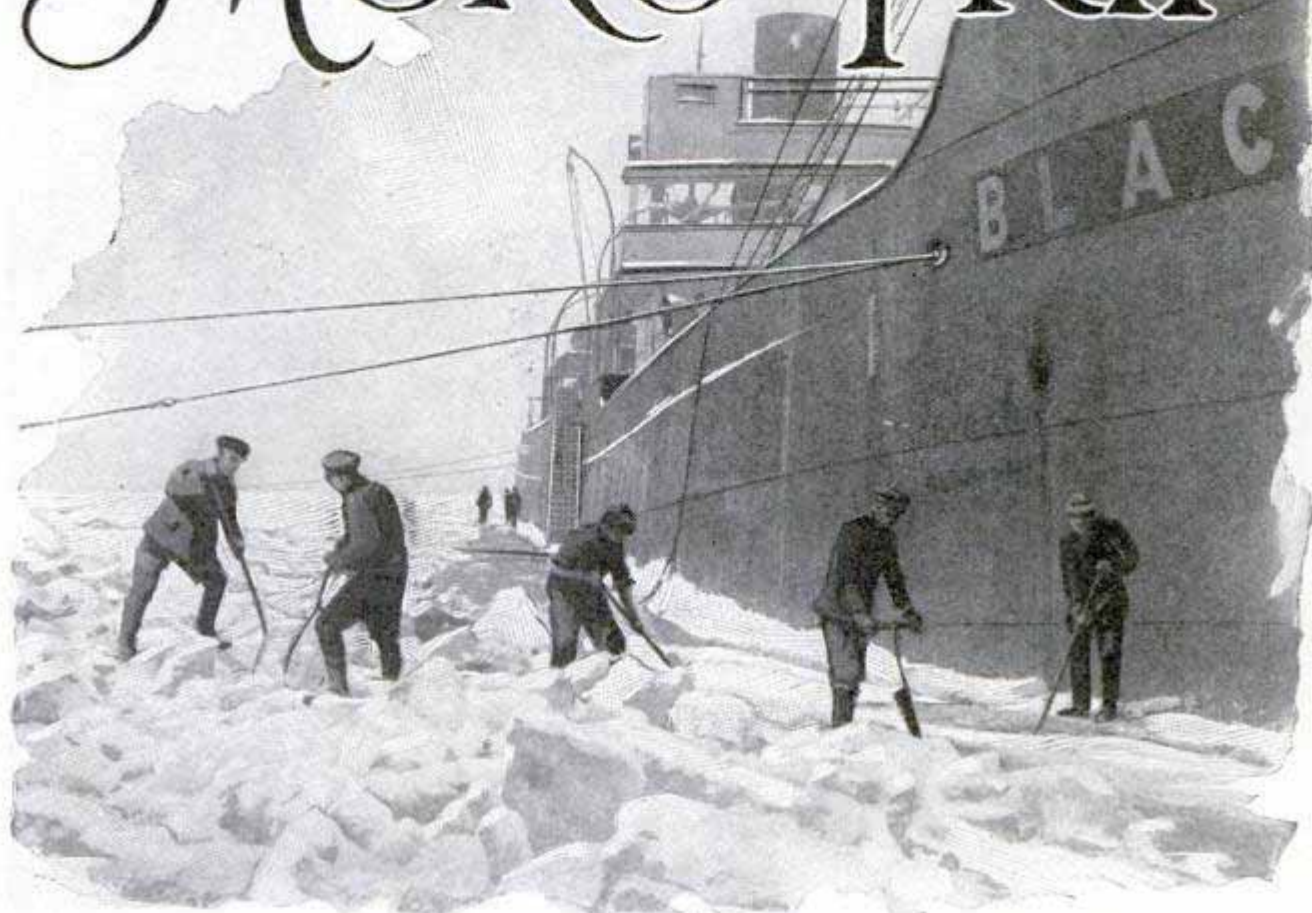

Crew of a Big Grain Carrier Working to Chop a Lane in the St. Lawrence, to Give the Boat Room for a Short Run, So That She Could Ram the Ice Pack and Split It Apart

yet such navigation saved the \$1,000,000 boat and her \$1,000,000 cargo of ore.

Forty-three hours Capt. Mahon stood at the window of the wheelhouse, staring into the gale. Once he lunched on sandwiches and tea, never once attempting to make the galley. Men forward dared not venture aft for meals. Many went hungry for hours rather than attempt passage over a wave-swept deck.

Down Lake Michigan, the storm continued and when the big vessel nosed her way down the Calumet river to the docks of the Wisconsin steel company, all hoped that the last trip of the year had been made.

"Ashland for cargo of ore," came the crisp order over the wire. Captain and crew who had weathered the worst storm of the year were again off on "one more trip."

Out on Lake Michigan that night, steaming along in ballast, the captain soon

learned that the elements knew no mercy. Straight north the ship headed into another gale, the wind growing in volume each hour, bringing another sleepless night for the skipper. Lights ashore told their story of snug Chicago apartments, warm homes, gay dinners in palatial hotels. Aboard the "John J. Barlum," what a contrast! In the wheelhouse the captain and J. McCarthy, first mate, got the vessel on her course and through the darkness discussed the fury of the gale just passed and the possibility of the one brewing.

At the Soo warnings were out and when the "John J. Barlum" passed Whitefish Point, headed due north, twelve ships were anchored behind the shelter.

During the day the captain told of disasters that came upon ships of the past that ventured one last trip.

"Caribou island, to the port," he began, "was the scene of a sad wreck. The famous Minch family of Cleveland built



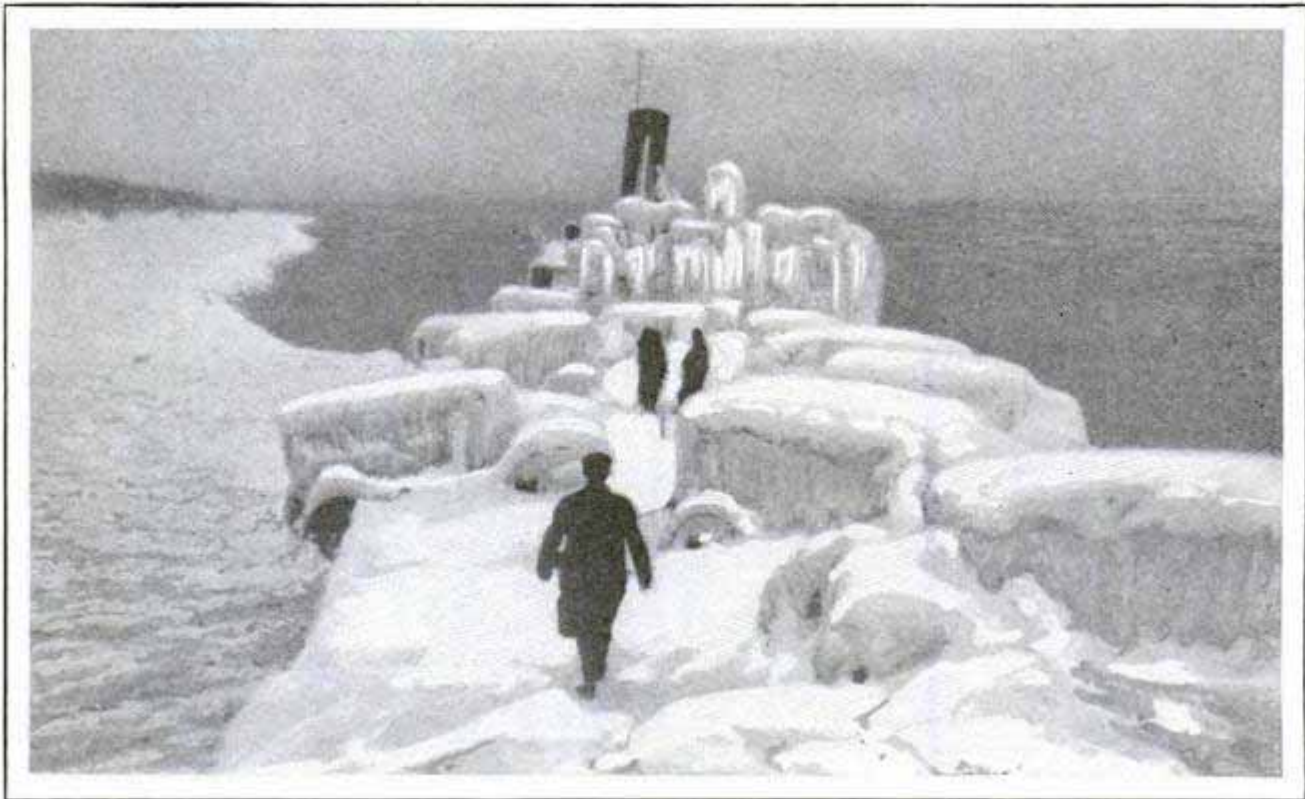

With Hold Full of Automobiles and Hundreds Lashed to Her Decks, "The City of Bangor" Was Driven Ashore in Lake Superior by a Winter Gale; Note the Ice-Covered Cars

what was then the largest steel vessel on the lakes. Five members of the family came along with the captain on what actually proved to be the ship's last trip. During the night, the steward started forward to bring some food to the owners. Amidships he saw a great crack in the vessel—she was breaking in two. Only time enough remained for him to grab a life preserver and sound a warning. But, it came too late. All were lost, except the steward. He was picked up twenty-four hours later."

The year 1926 will go down in history as the year of the big winds on the lake, declared the captain. "Worse than 1913," he maintained. "That was the year of the many wrecks—the 'Charles S. Price,' 'Isaac M. Scott,' 'Henry B. Smith,' 'John A. McGean,' the 'Argus,' 'Hydrus,' 'James Caruthers,' 'Waxford,' 'Regina,' 'Leafield,' all gone.

"It was along here, probably further back near Whitefish Point, that the 'Orinoco' and her tow were wrecked two years ago. The towline was cut and the captain ordered the crew of twenty off in boats. He was Capt. Lawrence—a fine fellow—and, with the chief engineer, Joseph Wurtz, and wheelman Hugh Gordon, remained on board. All three were lost.

Twenty hours later the crew made Montreal island, two of them having died from exposure.

"O, I tell you, sailing at this time of the year is no pleasure business."

Officer McCarthy was on duty when the first blizzard on the trip north was encountered. One could see it miles away, and the ship rushed into a dense wall of gloom—one minute sunshine, the next darkness. Immediately the whistle started its fog warning and just in time. Out of the darkness appeared another ship.

A man on the bridge with a megaphone meant a message. It was caught as the two vessels rushed by. "Five inches of ice in Ashland harbor," the voice said.

The next day, after another sleepless night for the skipper, Apostle islands were sighted. "Too bad we can't see Isle Royal, way over there to the port," said Capt. Mahon. "It's the scene of the lakes' worst disaster. It's where the 'Algoma' was sunk with more than 200 aboard.

"Funny thing, too, about the 'Algoma' wreck. Years-ago I had a wheelman, who, despite his 35 years, was white-headed. I liked him very much. Once when passing Isle Royal I remarked about it being the scene of the wreck. The wheelman turned to me and said, 'yes, captain, I



was the man at the wheel in that wreck.' His premature white hairs were explained."

Docking a 505-foot freighter in the dark, through a solid sheet of five-inch ice formed just one of the many incidents of the "John J. Barlum's" trip. A tug came to assist.

"We'll go in stern first," said the captain. "Ice will form during the night and I don't want to chance the rudder."

That night the crew worked tirelessly. Holds, after they were filled with ore, must be covered. Each hatch must be covered with canvas—no small job when the canvas is frozen stiff. Winter came to Ashland early and hands were frozen, ears nipped. But, throughout it all came the piping tunes of the "John J. Barlum" ditty:

"If you only knew there are men in the crew  
From Amherstberg to Harlem,  
When your work is through, there's nothing to do,  
On the good ship 'John J. Barlum.'"

The next morning the "Barlum" cut through six instead of five inches of ice. Then came a nor'wester and, when Whitefish Point was sighted, the gale registered fifty-two miles an hour.

"On the ship ahead of us coming down on the last trip, the men stayed forward two whole days, not daring to cross the

decks for their meals," declared the captain. "You see, heavy seas were breaking over the decks and ice formed about the life line to such thickness as to make it useless. One of the men, declaring he would rather drown than starve, made a dash for his dinner. But, he was caught amidships and went overboard. Of course his body was never recovered."

Cheerful talk, this! Spray, by this time, freezing as it fell, had completely covered the decks with a coating of ice. True, it had been the means of decking the steamship in Thanksgiving holiday attire, fringing the cables with pearl and polishing the decks with a gleaming surface.

Throughout the night, the fog continued. Throughout the day the storm roared on. Even the narrow channel leading into Port Huron brought no relief from the wind. Lake St. Clair, usually calm, misbehaves on the last trips of the lake vessels. "One could shut his eyes and imagine he's in the middle of Lake Superior," remarked the captain, as



Captain Mahon of the "John J. Barlum"

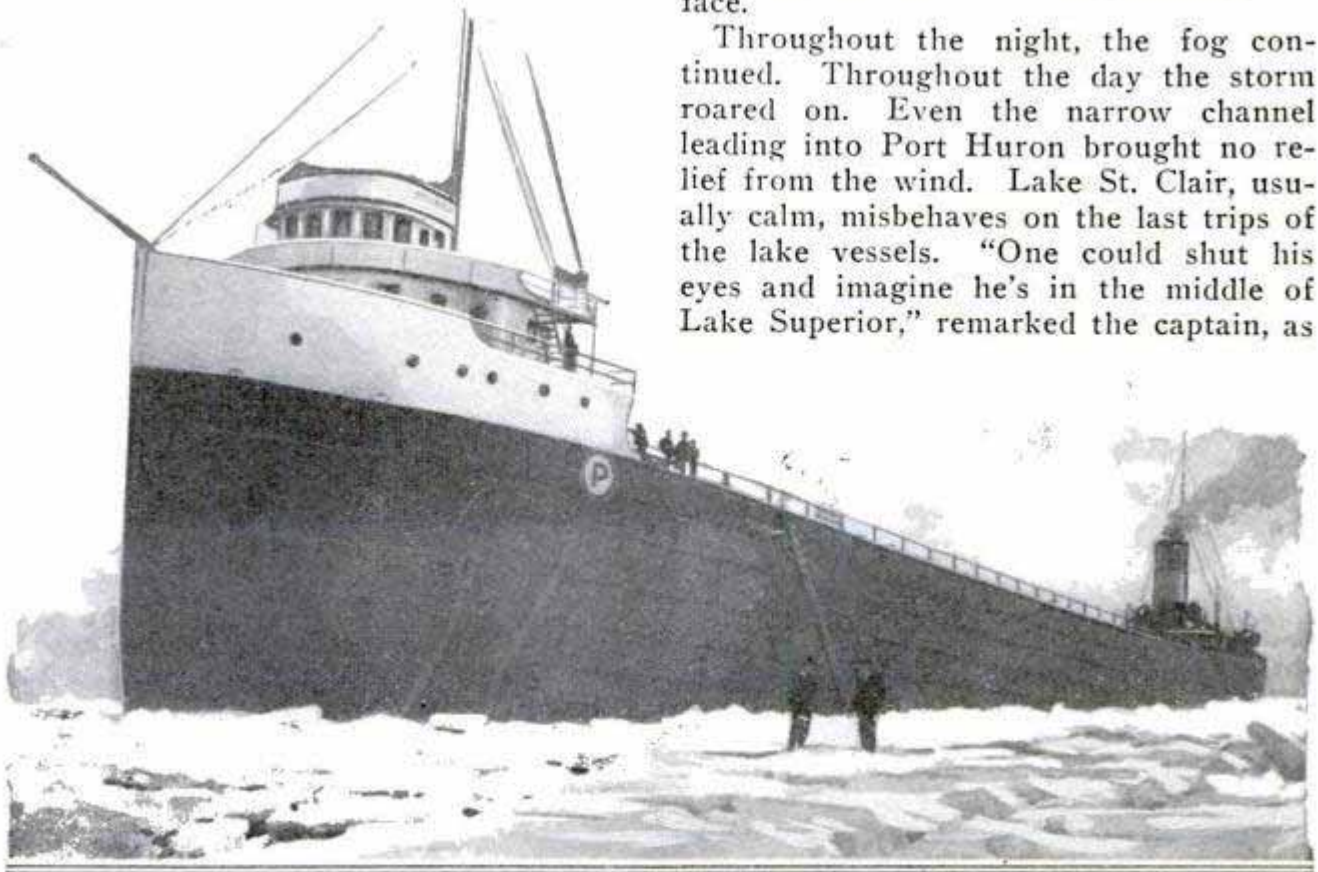

The Steamer "John J. Barlum," Caught in the Ice of the St. Marys River, below the Locks at Sault Ste. Marie, on Her Last Trip of the Year up the Lakes for a Final Cargo



the ship plunged on toward the rosy glow that indicated Detroit.

Lake Erie meant more wind and Cleveland was welcomed by captain and crew.

"Do we tie up here?" the question was asked of man to his officer, the officer to the captain.

The owner answered. It was an order to make "one more trip." This time to Chicago with a cargo of coal.

Midnight of November 30 had passed and when on the first day of December the "John J. Barlum" started on her "one last trip" she contributed to the annual \$150,000,000 bet made by lake ship owners.



For insurance ceases. Owners may take a chance. Crews may ship aboard vessels in the danger season. Skippers may follow orders that mean sleepless nights and double worries. But, insurance companies say, "nothing doing."

Once again started, the "John J. Barlum" began her last trip. Through gales and fogs she gamely fought her way into the St. Marys river, where with more than 100 of her kind, she succumbed for a time to the onslaught of winter. For days her men stayed aboard, waiting for the laboring tugs to clear a passage. None dared leave the boat to make shore, for the lake ice was treacherous. One man attempted it from another vessel and his life was the forfeit.

Then the day came when passage was cleared. The "John J." headed for Chicago. One of the winners in the \$150,000,000 bet, she berthed into a snug haven and when the orders came to "tie up for the winter," the "John J. Barlum" had made her "one last trip."

Less fortunate was the freighter "The City of Bangor." With holds and deck loaded with a consignment of automobiles from Detroit en route to Duluth, she was driven ashore near Keweenaw Point in the Upper Peninsula of Michi-

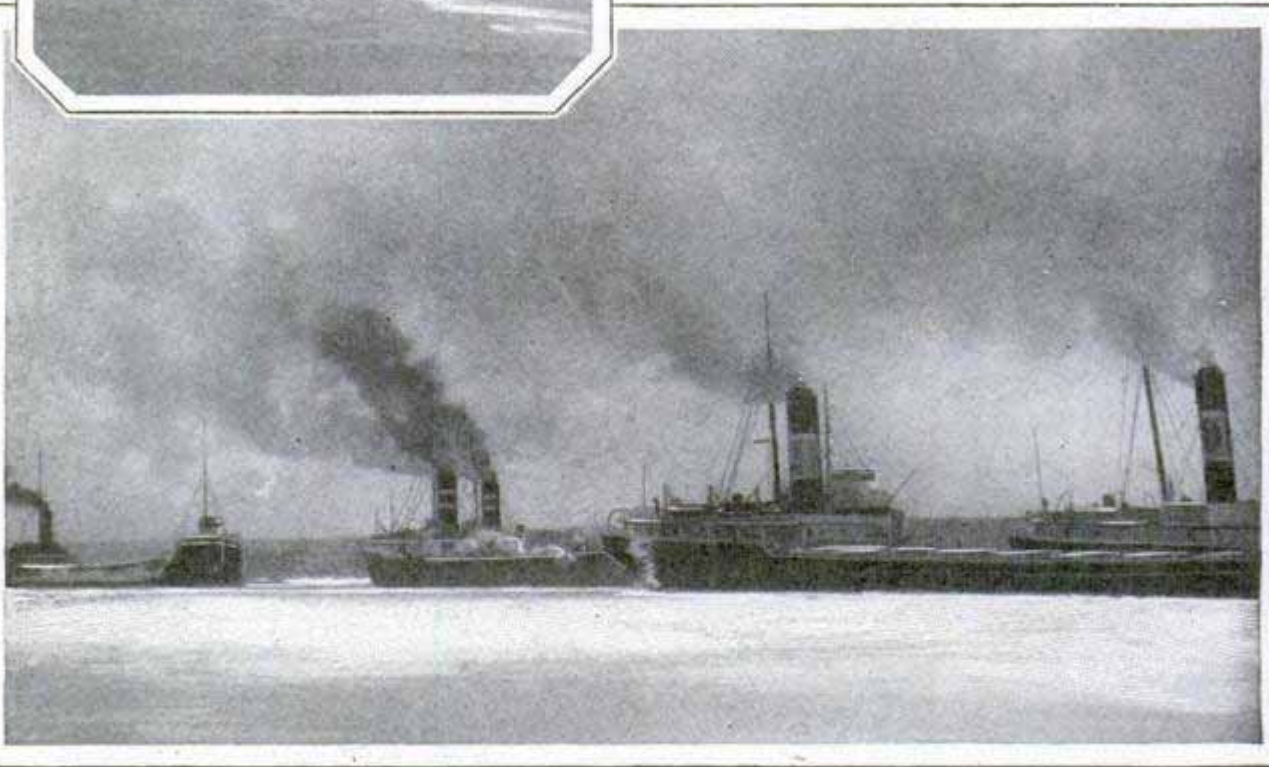

Ice-Breaking Tug Opening a Road for the Ore and Grain Carriers, Top, and Part of the Ice-Bound Fleet in the St. Marys Waiting Their Turns to Be Released



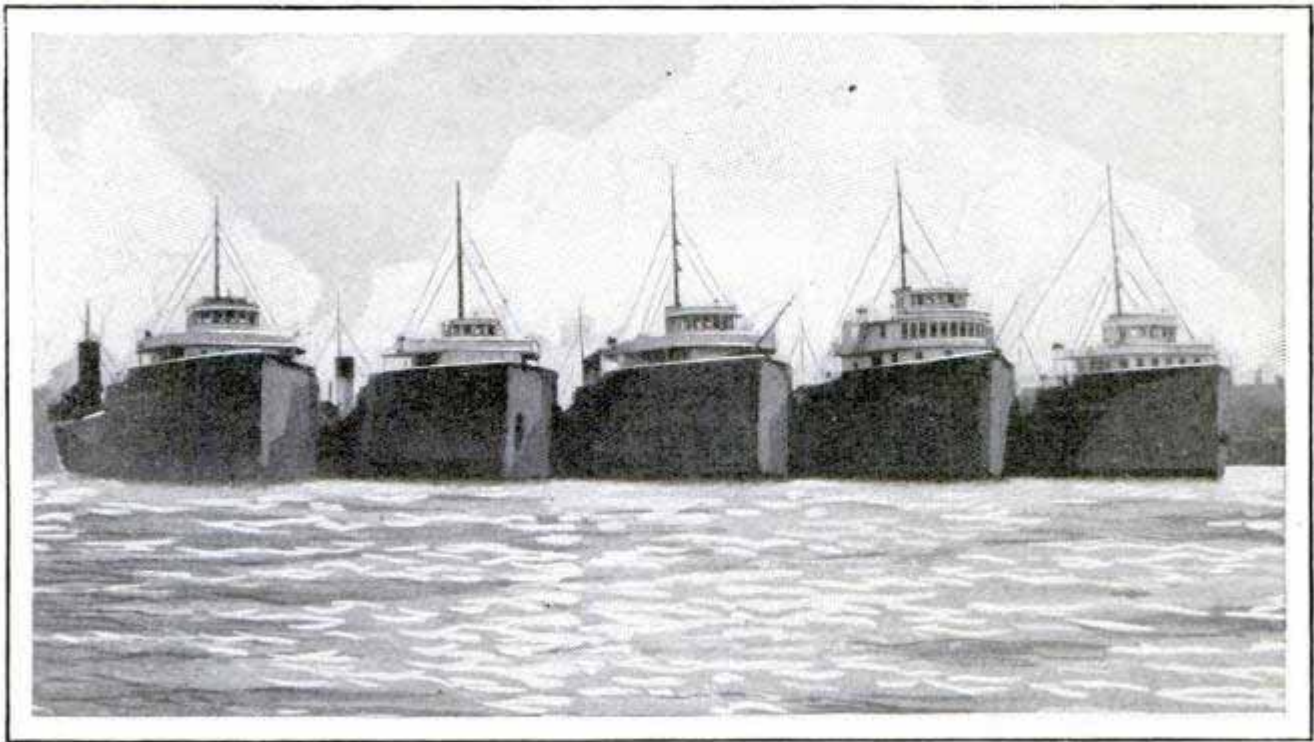

Tied Side by Side, Five of the Low-Lying Ships, Each with Its Ten or Twelve Thousand Tons of Ore, Wait for the River Passage to Be Opened for the Dash to Safety

gan. There she remained where help could not reach her and slowly she became ice-incased, which was all that saved her from being dashed to pieces.

A constant watch had been kept on board the ship but it was finally decided that all efforts to salvage the boat itself were useless, so the insurance underwriters turned to the salvaging of the cargo. Two hundred automobiles is too valuable a cargo to let Lake Superior claim, and a firm of wreckers were given the task of removing the cars. The task was not an easy one, requiring the building of a road for a distance of several miles through a heavily timbered country on shore before any communication could be established with northern Michigan towns not isolated by snow.

The majority of the cars were stored below the decks and were hoisted with block and tackle to the improvised ice road leading to shore. Those on deck were ice-incrusted and were pried from their firm footing by jets of steam.

3116

### ELECTRIC SAW FOR BUTCHERS SAVES TIME AND WORK

Swung from a shaft attached to the ceiling, an electrically operated circular saw for butchers is adapted to a wide variety of work, saves time and effort and

requires practically no attention except an occasional oiling. The outfit is so arranged that the current is automatically shut off when the saw is released, preventing waste, and is turned on simply by lowering the blade into working position. The saw is so balanced that the blade is raised out of the way, so that it cannot injure the operator, at the same time he lets go of the handle. Power is supplied through a lighting socket.

Cutting Meat with the Electric Saw; It Is Suspended from the Ceiling for Easy Manipulation and Swings Out of Way When Not in Use



*Innarch Electric Saw Co. San Francisco  
519 California St.*



FROM STAGECOACH TO THE LATEST EXPRESS PLANE

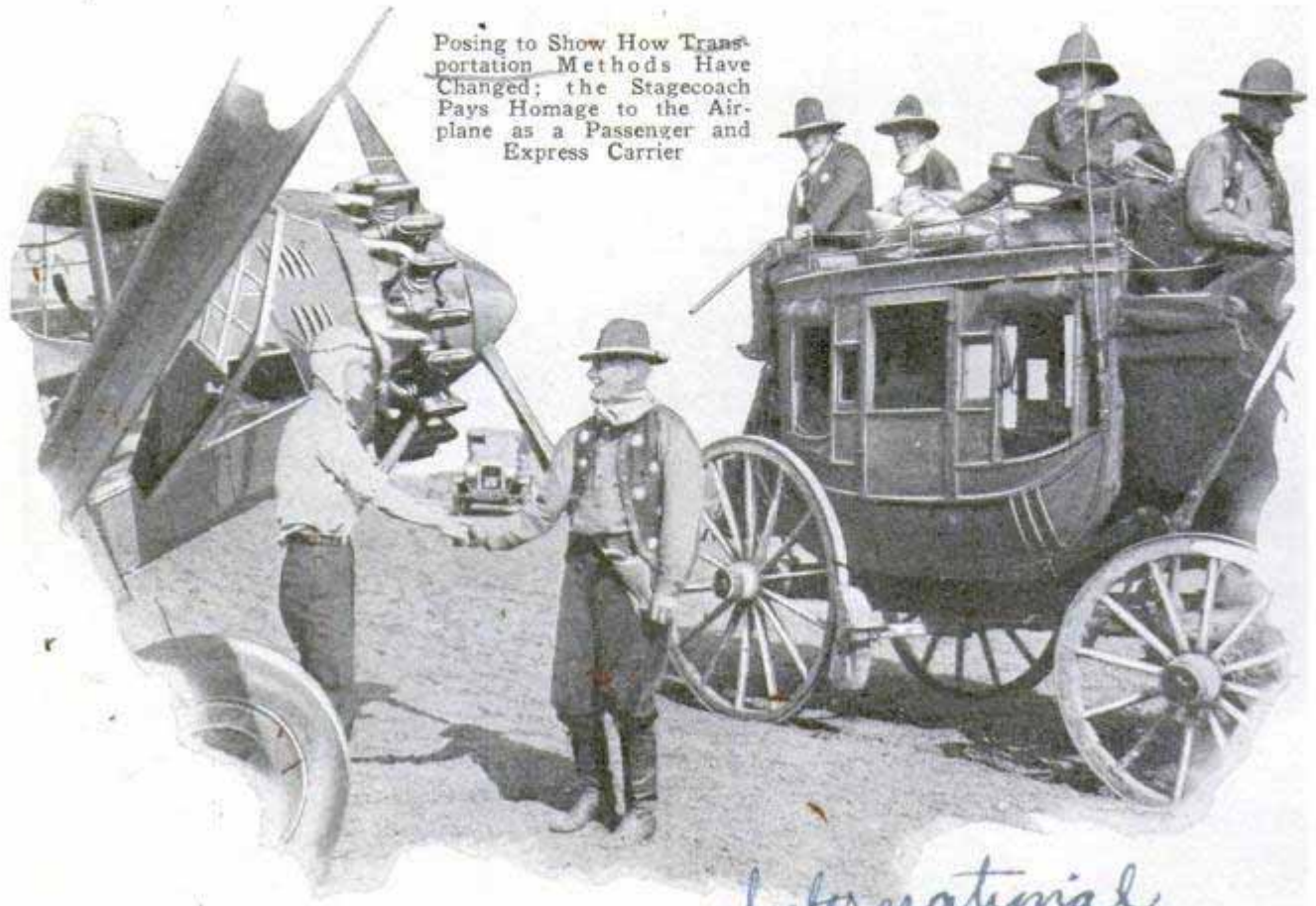

Posing to Show How Transportation Methods Have Changed; the Stagecoach Pays Homage to the Airplane as a Passenger and Express Carrier

*International*

What will be the next mode of travel? The question cannot be answered, but changes in the past justify replies that may seem fanciful, for who, in the days of the stagecoach, would have believed that travel by air would be common in a few decades? Old and modern methods of transportation were illustrated recently in Chicago when a stagecoach was drawn alongside an express and passenger airplane for the Chicago-Dallas service.

range, due to the special design of the bulb, although it affords the operator a constant illumination ahead. The units fit any type of automobile lamp.

**SCOTLAND YARD ENLISTS RADIO TO HELP CATCH THIEVES**

3288

Scotland Yard's recently organized radio squad has been doing effective work with specially designed sets by which quick communication is established between units touring the city districts and the central office. The detail has proved especially useful in frustrating automobile thefts. In a recent three-month period, only one attempt at auto stealing out of 100 was successful. When riots were threatened during the Sacco-Vanzetti disturbances, a squad of detectives in a motor car heard that a march was proposed on Buckingham palace. The squad immediately radioed the word to Scotland Yard and, before the procession could get under way, 500 police, mounted and on foot, were in readiness to disperse the demonstrators. A window-smashing gang had planned to steal a quantity of diamonds

**AUTO LIGHT IS SELF-DIMMING AND PENETRATES FOG**

Fifteen per cent more light on the road ahead and greatly increased fog penetration are claimed for an automobile head-lamp bulb that dims itself without attention from the driver. To approaching motorists it appears to grow less bright and almost vanishes at closer

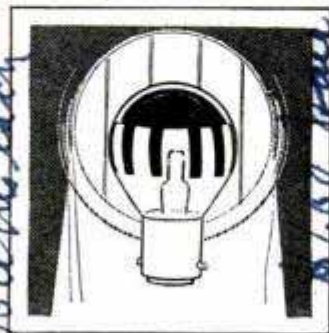

*The Siba-Lite Corp.  
Meriden Conn 27*

*The Siba-Lite Corp.  
Meriden Conn*



displayed in Cartier's famous shop in Bond street. The Yard heard of the plot, within a few moments the store was surrounded by detectives and, when the thieves drove up in their luxurious automobile with chauffeur attending, they were promptly arrested. The catch was made ten minutes after Scotland Yard had been tipped off.

**LUMBERING AIDED BY AMPHIBIAN TUG**

Lumber companies in Ontario, Can., are utilizing a land-going tug in districts where booms of logs have to be towed on lakes and rivers to the mills. The craft is scow-shaped and driven by two propellers when in the water. It can pull itself out of a stream and travel across country to the next body of water where there is work for it to do. This is accomplished by means of a steel cable, anchored to a tree or other solid object and wound up on a drum on the tug. Portages of five to ten miles are often made by these craft, which are solidly built and fitted on the bottom with iron-shod oak runners.

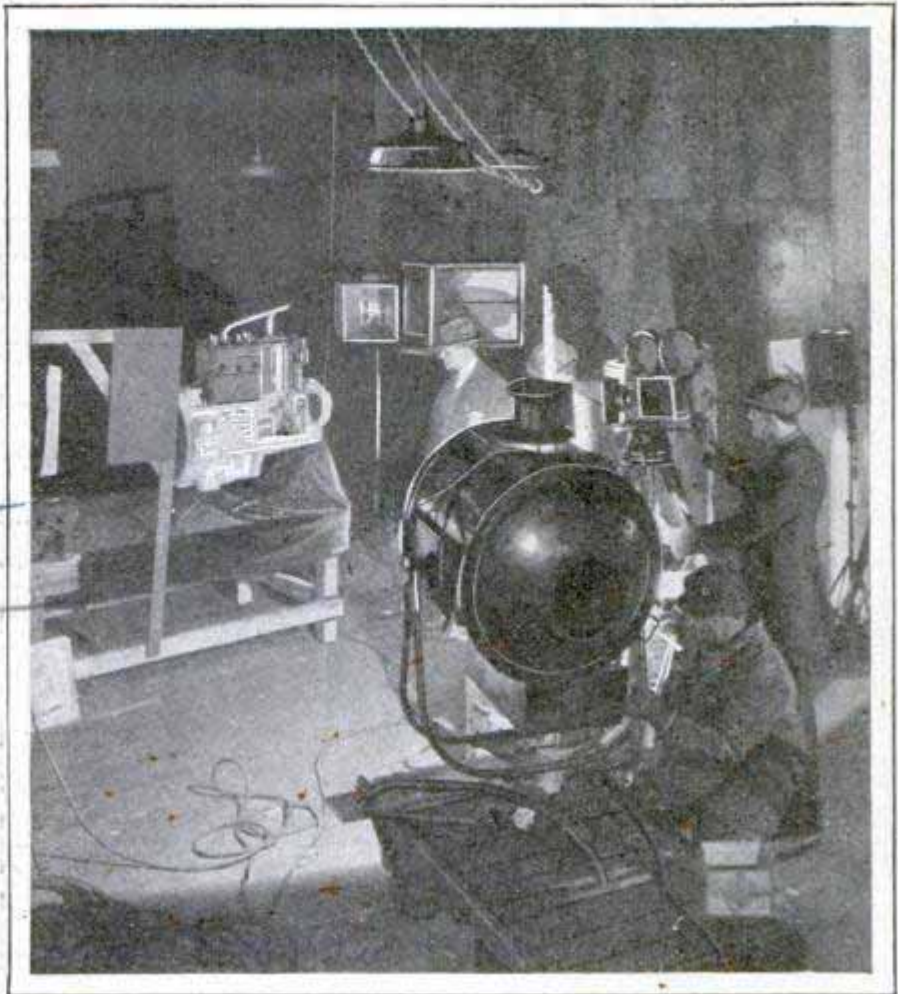

In the Bureau of Mines Motion-Picture Studio, Showing One of the Big Lights for Filming Interiors

**ROMANCES OF INDUSTRY TOLD IN MOVIE LIBRARY**

More than sixty subjects involved in the romantic task of taking wealth from underground are depicted in a series of motion pictures prepared by the bureau of mines. The work has been going on for eight years, and elaborate equipment, including portable lighting facilities that furnish 12,000,000 candlepower, has been devised for the task. One of the illuminating units is a huge searchlight somewhat like that used on airplane-landing fields. Fifty trunks of lighting apparatus are employed. In filming the "Story of Copper," many of the reels were taken 8,000 feet below the surface.

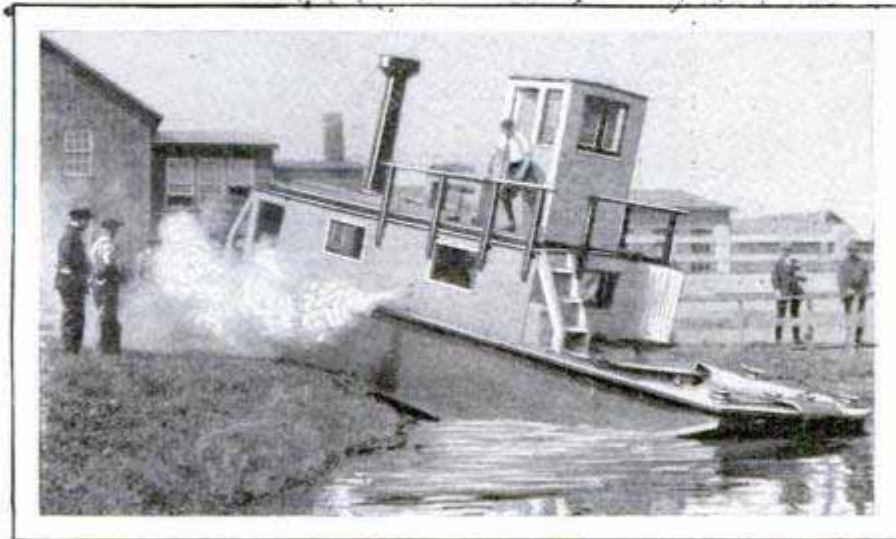

It Can Travel on Land as Well as in Water; Lumbering Tug Which Propels Itself between Streams

*West and Peachy, Canada*



John  
Cafisch, 1628 Ward Ave  
Detroit, Mich.

3261

"COLLARS" SPEED  
PLANT GROWTH

Switzerland  
St. Gall  
Papierwerk AG

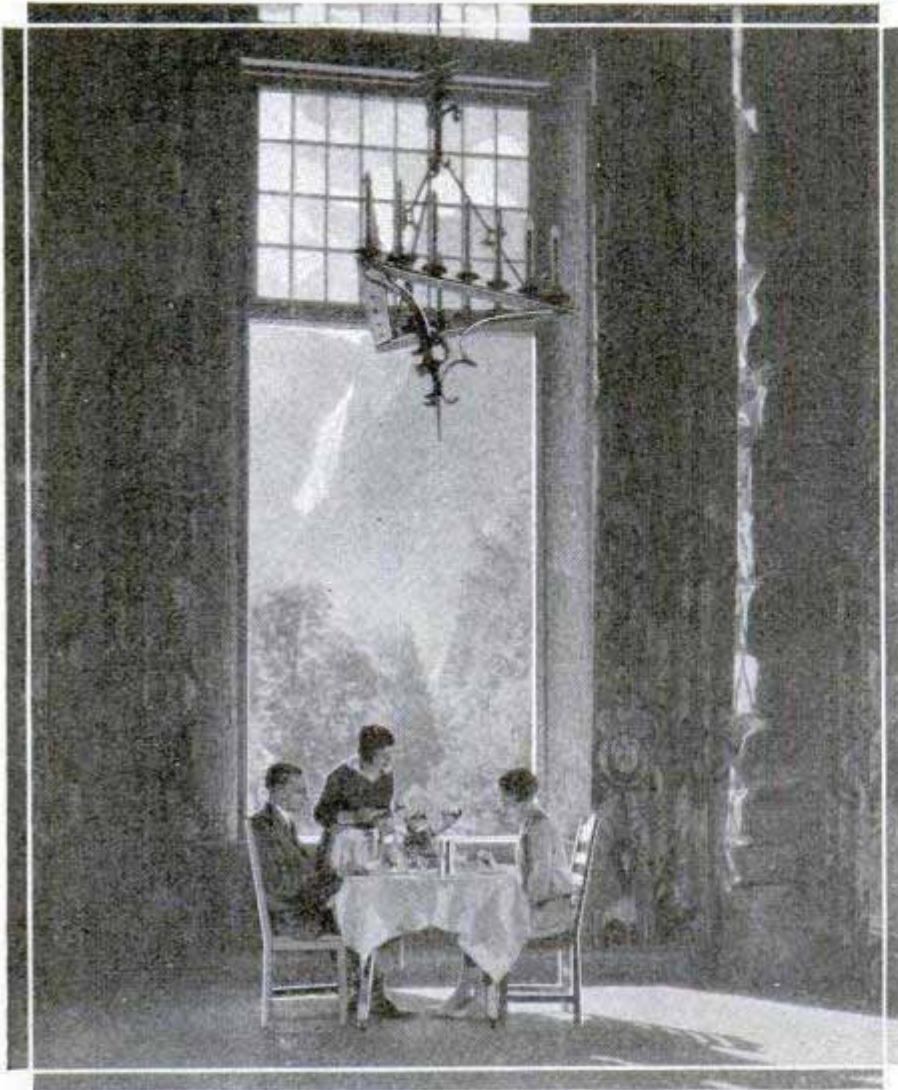

In the Dining Room of the Ahwahnee Hotel in the Yosemite; the Huge Window Makes a Frame for the Distant Falls

HIGH WINDOW FRAMES FALLS  
IN YOSEMITE HOTEL

One of the features of the Ahwahnee hotel in the Yosemite valley is a dining-room window, thirty-five feet high and fifteen feet wide, that forms a frame for the falls, not far away. The effect is that of a huge moving picture and greatly adds to the novel decorations of the room. The building is made of natural rock rolled down from the cliffs above, the color scheme of the exterior follows the tones of the pine needles and valley sides, and Indian and Spanish influences are carried out in various parts of the hotel. Of special interest is the men's lounge, which has been decorated to suggest early days in California with red-and-blue checkered curtains like a miner's shirt, oil lamps, buffalo and black-bear skins on the floor and other mementos of the gold-rush period worked into the decorative scheme.

Swiss gardeners are credited with the introduction of a simple unit that is said to stimulate the development of seeds and plants, resulting in quicker germination and better products. It is simply a disk-shaped collar which is placed about the seed or the plant, to attract and retain the heat of the sun, acting as a sort of miniature hot-house. There is a hole in the center and the disk is shaped to convey water toward the middle so that the plant receives additional benefit from showers, and evaporation is reduced because of the covering. The task of weeding is likewise simplified and there is less likelihood of uprooting the plant, since foreign growths do not spring up close to the stalk. Tests are said to have shown

that tomato plants grew to nearly twice their usual size when protected by the collar, and tobacco and cotton showed equally marked development. The disks will last for five years, it is claimed.

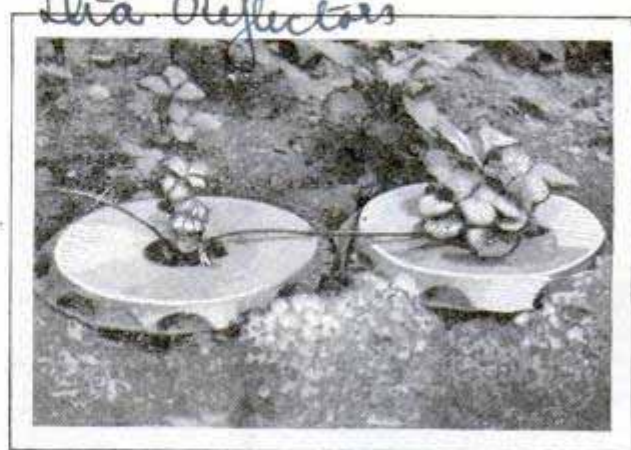

Plants Wearing Their "Collars"; These Units Attract Sunshine and Help Retain Moisture

(About 100 tornados occur in the United States every year.

To be sold by Sears  
Roebuck in every Ward



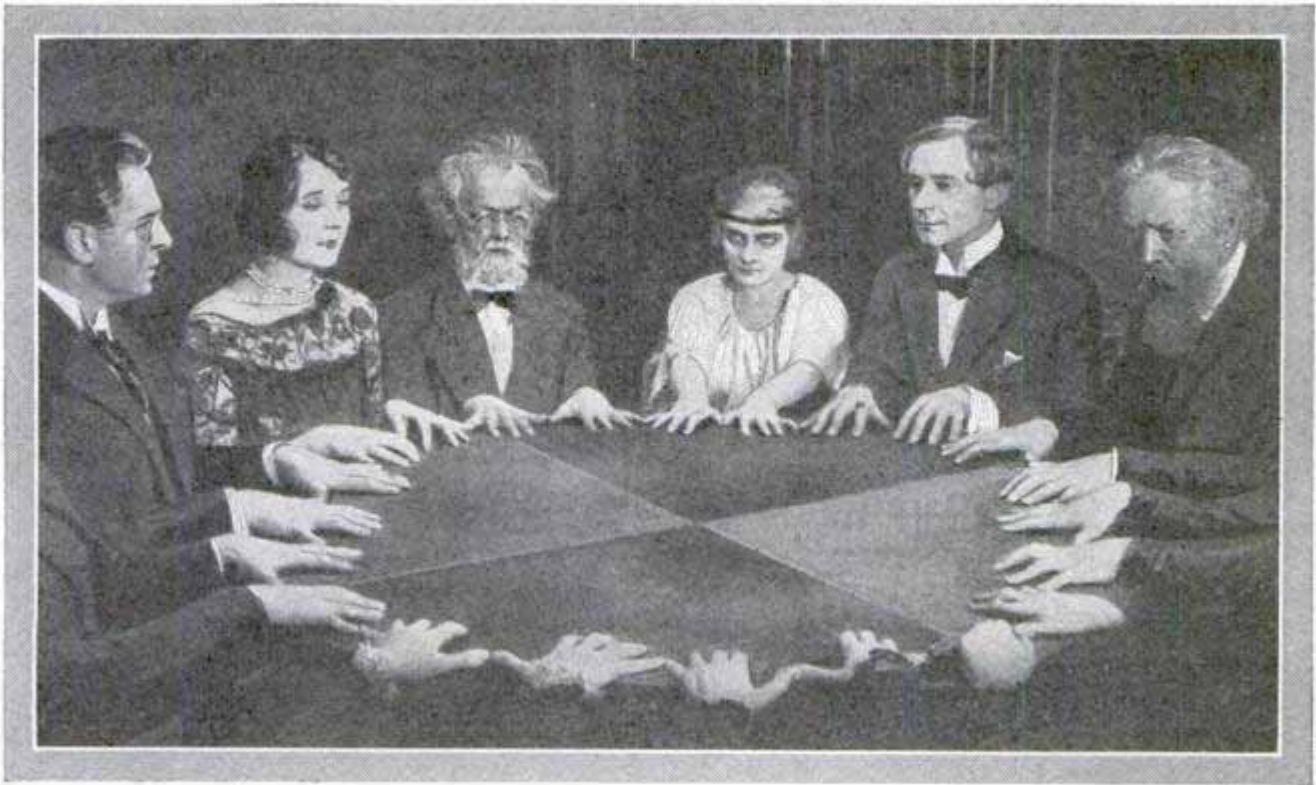

## The Tricks of the Ghost Hunters

How Fake Spirit Manifestations, Which Often Deceive Even the Most Skeptical, Are Produced

By WALTER B. GIBSON, *Concord Hall,*  
*45th St. & Spruce - Phila*

HEREWARD Carrington, who has for many years endeavored to establish certain psychic phenomena as genuine, declares that "ninety-eight per cent of the physical phenomena are fraudulently produced."

The purpose of this article is to give an insight into the methods by which fake spirit manifestations are performed, and to show that the means employed by fraudulent mediums are like those used by magicians. The important distinction lies in the fact that the magician's work is justifiable, as he claims no supernormal power, whereas the fraudulent seance is nothing more than a swindle.

Spirit slate writing, or the production of messages on blank slates, has been performed for many years and still flourishes. Some of the methods used today are remarkable for their ingenuity. Take, for example, the bolted slates. Two slates are shown to contain no writing, and are bolted firmly together at all four corners.

The slates are marked for identification. The lights are turned out for a few minutes, then they are turned on; the slates are unbolted, and a message is found written upon the inner surface of either of the two.

Special slates are used. Close attention will show that the frame of the average slate is made in four sections. One of the special slates is constructed so that the end is removable. When the end of the frame is pulled, the slate slides out with it, and the medium is free to write on the inner surface of either slate, or to write on a card that may be between the slates.

Slate writing also may be performed with a single slate. The slate is shown blank on both sides, and is placed in a paper bag. When the slate is withdrawn, a message is found upon it. In this case, the writing is already on the slate, but is concealed beneath a layer of thick black paper or very light cardboard, which appears to be the surface of the slate. When





EVEN BOLTED SLATES MAY BE OPENED EASILY

the slate is taken from the bag, the paper covering is dropped off and remains in the bag.

The exchanging of slips of paper is one of the most undetectable of all the tricks of fraudulent mediums, some of whom rely upon it alone. It is called the "billet switch," and is performed in various ways.

In one system, the original question is folded and placed on the table so that it stands with the creased edge upward. The medium holds the dummy slip edgewise between the middle fingers of his right hand. He places the hand around the original question, and as he slides it toward him along the table, he pushes the dummy up with his right thumb and, at the same instant, his fingers bend in and press the original slip into the palm of the hand. To all appearances, the hand has merely picked up the original question and moved it to another part of the table.

In utilizing the billet switch alone, the operator asks that a question be written on a slip of paper, which must be folded. He picks up the slip, making the switch, and presses the dummy question against his forehead. He changes hands, which enables him to place the original question in his lap, and quietly unfold it.

Then, looking slyly downward, he reads the original question and starts to answer it. He folds the original slip, and when he has answered the question, he drops the dummy on the table. He picks it up immediately, making the switch once more, and hands the original slip back to the writer. Strangely enough, this test often works more smoothly when the

medium is blindfolded, because, with a loose blindfold, he can look downward easily and read the question in his lap.

Some mediums have methods whereby they can learn what the sitter has written without exchanging slips at all. This may be accomplished by the use of carbon paper. If the sitter is given a pencil that contains hard lead, and is told to place his slip upon a piece of cardboard, the medium may obtain a copy of the question by having a sheet of carbon paper on the cardboard, covered with a thin sheet of paper of the same color as the board.

Another and more elaborate method involves the use of a special table, which has a top covered by parchment or thin leather. Under the table covering is a sheet of carbon paper and beneath this a piece of thin white silk. The sitter writes his question on a paper on the table, which, of course, is transcribed on the silk. A string runs down the table leg,

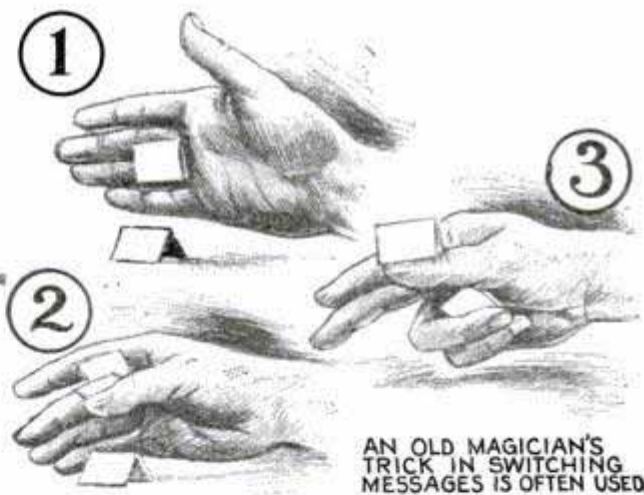

AN OLD MAGICIAN'S TRICK IN SWITCHING MESSAGES IS OFTEN USED

and, when an assistant pulls the string, the piece of silk goes through the floor, where the confederate reads the question.

Then there is a form of pencil reading that may be compared to lip reading. A person skilled in this art can learn what another person is writing, without seeing the paper, or being close enough to read the written words. The medium stands at a distance and carefully watches the top of the writer's pencil. The movements of the pencil indicate the letters which are being written, and a keen observer can identify many words in this manner. This system is generally used only when the sitter is told to write the name of a departed friend, from whom he or she



wishes a message. The medium can often learn either the first name or the full name by watching the top of the pencil.

When a medium insists that a question be written, that, in itself, is an indication of trickery. All sorts of pretexts have been given why the sitter or spectator should write a question, for instance, to "concentrate his thoughts," to "check up the spirit answer," or some such reason. Nevertheless, when a medium insists that questions be written, it is a sure sign that he or she has some method of learning what is being written.

Sealed-letter reading has been employed by self-styled mediums for many years. The old reliable method depends upon a sponge soaked in alcohol. When the face of an envelope is rubbed with the sponge, the paper becomes transparent, and the medium can read the question inside. But this method has been broadly exposed.

There is a form of sealed-letter reading in which the medium holds up an envelope, and answers a question written by a confederate. Then he tears open the envelope, and reads off the confederate's question aloud, but at the same time reads the writing which is actually on the question which he holds in his hand. Thus he learns somebody's question. He holds up another envelope, and answers the question which he has just learned. He opens the envelope and reads aloud the question which he has just learned, at the same time reading the new question to himself.

ONE OF THE SIMPLEST OF MEDIUM TRICKS. POINT BOTH FOREFINGERS AT THE SUBJECT AND THEN —



ONLY USE TWO FINGERS ON ONE HAND, LEAVING THE OTHER HAND FREE TO RING BELLS OR TAP SUBJECT'S HEAD

This is an old method; it can be performed as an impromptu trick with good effect, but most magicians think the trick is too well known. Nevertheless, it is used constantly by a certain medium whom the writer has seen in action, and this man performs it so artfully that the trick is never detected. As he finishes reading a question aloud, he holds the slip of paper so his audience can see it, and calmly says:

"There is your question; you wrote it hastily, but that was all the same."

The person who wrote the question is seated too far away to observe that the medium is showing him a question written by someone else, and he takes the medium's statement in good faith.

In dark seances, where the medium is bound, but still manages to produce certain manifestations, the principal trick lies in the method whereby the medium temporarily frees himself. Many of these tricks have been exposed, but new ones constantly replace them. Here is a method which is virtually unknown:

The medium has two metal rings, each with a chain attached. He slips one hand in each ring, and a person on his right holds the end of one chain, while another on his left holds the end of the second chain. Obviously, one person controls each of the medium's hands; yet when the lights are turned out, some startling phenomena take place.

The trick is easily accomplished. The medium simply slips his left thumb into the ring which encircles his right wrist.

ALCOHOL REVEALS THE SECRET MESSAGE IN A SEALED ENVELOPE



IF THE MEDIUM USES RINGS IT'S A GOOD SIGN OF TRICKERY, AS SHOWN





TABLE TOPS  
MAY CONCEAL  
CARBON PAPER  
AND TABLES OFTEN  
HAVE HOLLOW LEGS

Then he removes his right hand which is free to do its appointed task. When he calls for the lights, he can instantly slip his right hand back into its ring. In fact, the operation is so quick that the medium can meet any emergency.

A story is told of a fraudulent "trumpet medium," who customarily freed his right hand and used it to manipulate a trumpet through which he talked. At one seance, the investigators insisted that the medium fill his mouth with water. Despite the handicap, the voices talked through the trumpet. The medium accomplished this very artfully. Among his paraphernalia was a bell. As soon as the lights were out, he released his hand, inverted the bell and raised it to his mouth. He deposited the water in the bell, and set the bell carefully between his knees. He was free to proceed with the trumpet manifestations, and when he had finished, he filled his mouth with the water from the bell again.

There is a clever little trick which demonstrates how easily a hand may be freed without anyone knowing it. This can be performed for one person only. The operator places the tips of his forefingers against the spectator's eyelids. Feeling both fingers, the spectator knows that the operator's hands are occupied, and he is greatly astonished when he feels a hand

tap him on the head or brush his shoulder. The operator immediately removes his fingers, and the spectator is free to look around in an effort to discover whence came the spirit touch.

The method is interesting. As soon as the spectator shuts his eyes, to receive the tips of the operator's extended fingers, the operator merely extends the first two fingers of one hand, placing one finger tip on each of the sitter's eyelids. This leaves one of the operator's hands free for action. The operator should have both hands close together when he removes his fingers from the person's eyelids.

The trick is simple enough; but it is no simpler than numerous methods of release that have been adopted by fraudulent mediums, past and present. Simplicity is the keynote of some of the most effective tricks, whether they are performed fairly by magicians or unfairly by fakers.

2017

### MOTOR SLED RUN BY COGWHEEL NINETEEN MILES AN HOUR

Winter sport for the person who likes to drive a motor is afforded in a sled introduced in Germany. It is propelled by a cogwheel turned by a one and one-half horsepower gasoline motor. The wheel is also used for steering. A speed of nineteen miles an hour is attained on level surfaces when the snow is in the right condition. On down grades, the drivewheel can be disconnected and the sled coasts. An

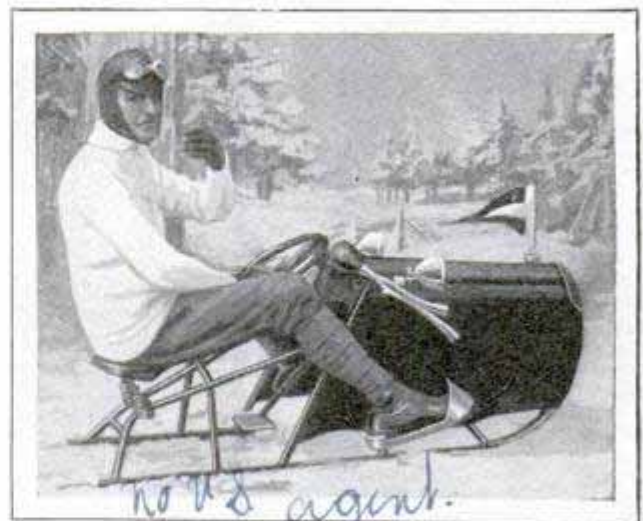

Motor Sled with Footrests Heated by Gases from the Engine; the Latest Unit for Winter Sports

additional feature is that the footrests are heated by exhaust gases from the engine.

Inventor, Carl Jegler,  
Fr. Augsburg, Bavaria



"IRON PHILIP" HELPS TRAIN GERMAN POLICE

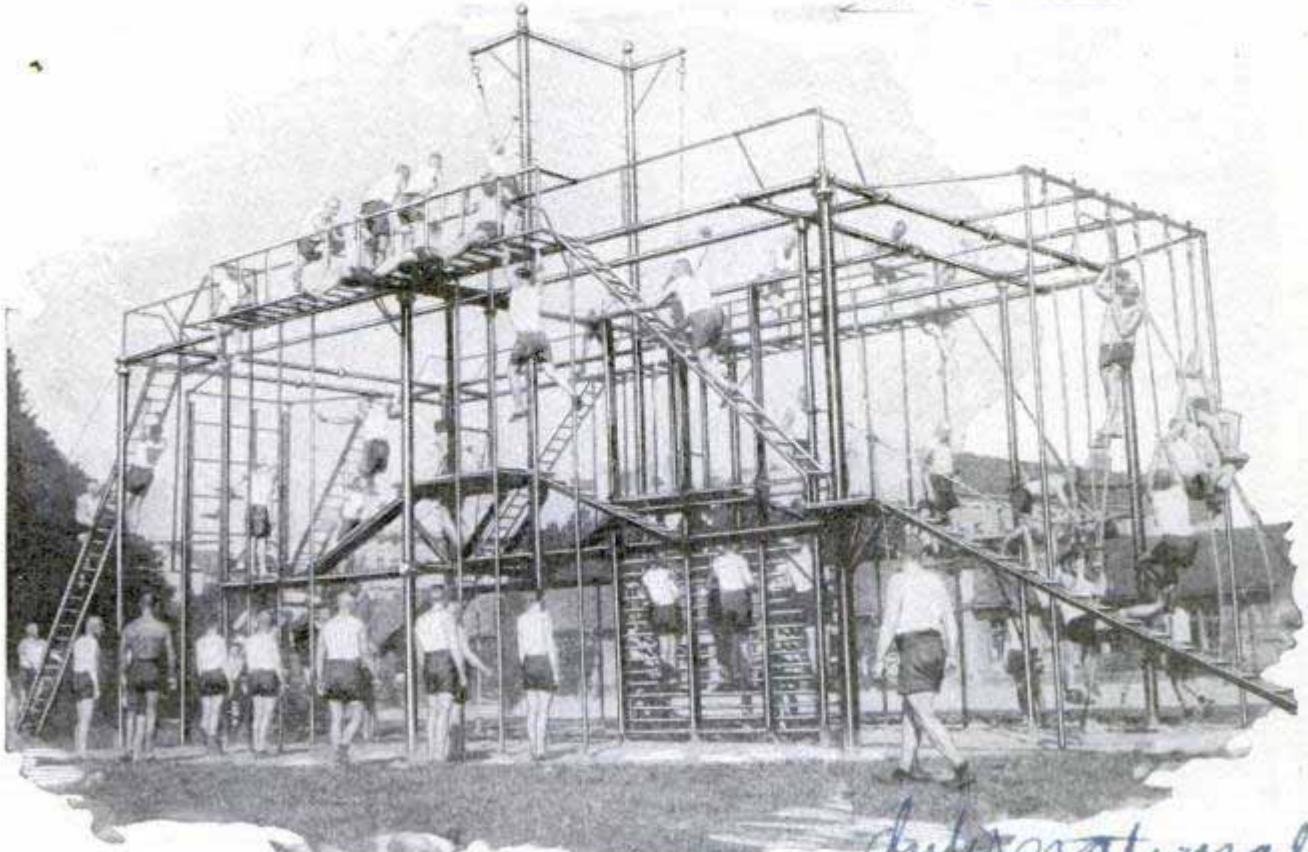

Where German Policemen Keep Physically Fit; Outdoor Gymnasium at Which 100 Men Can Exercise at One Time and Perform a Wide Variety of Stunts

One hundred men can exercise at the same time on an outdoor gymnasium unit installed for the Berlin, Germany, police force. It has horizontal bars, trapezes, ladders, swinging rings and other attachments and is well fitted for individual or group work. Stanchly constructed of metal, the gym has been named "Iron Philip" by members of the department.

remote from the seas that the effect of the ocean tides is not registered in the similar movements of the world's crust. It has been shown that the tides in the Atlantic have an appreciable effect at Williams Bay, Wis., about 800 miles away.

<sup>3294</sup>  
TIDES IN SURFACE OF EARTH LIKE THOSE OF OCEAN

Like the seas, the earth's crust rises and falls in tides as a result of the attraction of the sun and moon, Dr. Walter D. Lambert, scientist of the coast and geodetic survey, asserts. These movements have never been measured because instruments for the task have not yet been devised and complicated computations are involved, but scholars have established the existence of such movements beyond all reasonable doubt, he declares. These earth tides are affected by the ocean tides, according to Dr. Lambert, who says that there is probably no place on earth so

STEEL GLOVE FOR BUTCHERS REDUCES HAND INJURIES 3162



Designed especially for packing-house butchers, a glove of steel mesh protects the hand that does not wield the knife. The guard is the invention of a physician who was called upon to dress the injuries of men

working in a large packing plant. As many as thirty cut hands daily led him to design the glove, which has proved effective in preventing injuries of that kind and yet does not interfere with work.

*Inventor. Dr. Earl Love, South St. Paul, Minn.*

*Inventor. Dr. Earl Love, South St. Paul.*

*International*



3246

*W. Jefferson, head  
Fuel Conservation Section  
U.S. Shipping Board*

**COAL PULVERIZER  
CUTS STEAMERS'  
FUEL COST**

3215

Marked reduction of the fuel costs on steamers is predicted with a special coal pulverizer for marine use. The outfit not only crushes the fuel, but forces it into the furnaces with compressed air, eliminating the necessity of firing by hand. Since the powdered coal has greater heating efficiency, there is an added advantage besides the saving in labor.

**AIR JACK SPEEDS  
TRANSFER OF  
CAR WHEELS**

3238

Time and labor are saved at the Pennsylvania yards in Chicago in handling car wheels with a compressed-air jack. It is placed in the center of the junction of two tracks, one leading to the shop and the other to the repair yards. As the wheels come from the

cars, they are raised for easy transfer to either track simply by depressing a pedal. To lower them, another pedal is depressed. The top of the jack is shaped to keep the axle from falling off.

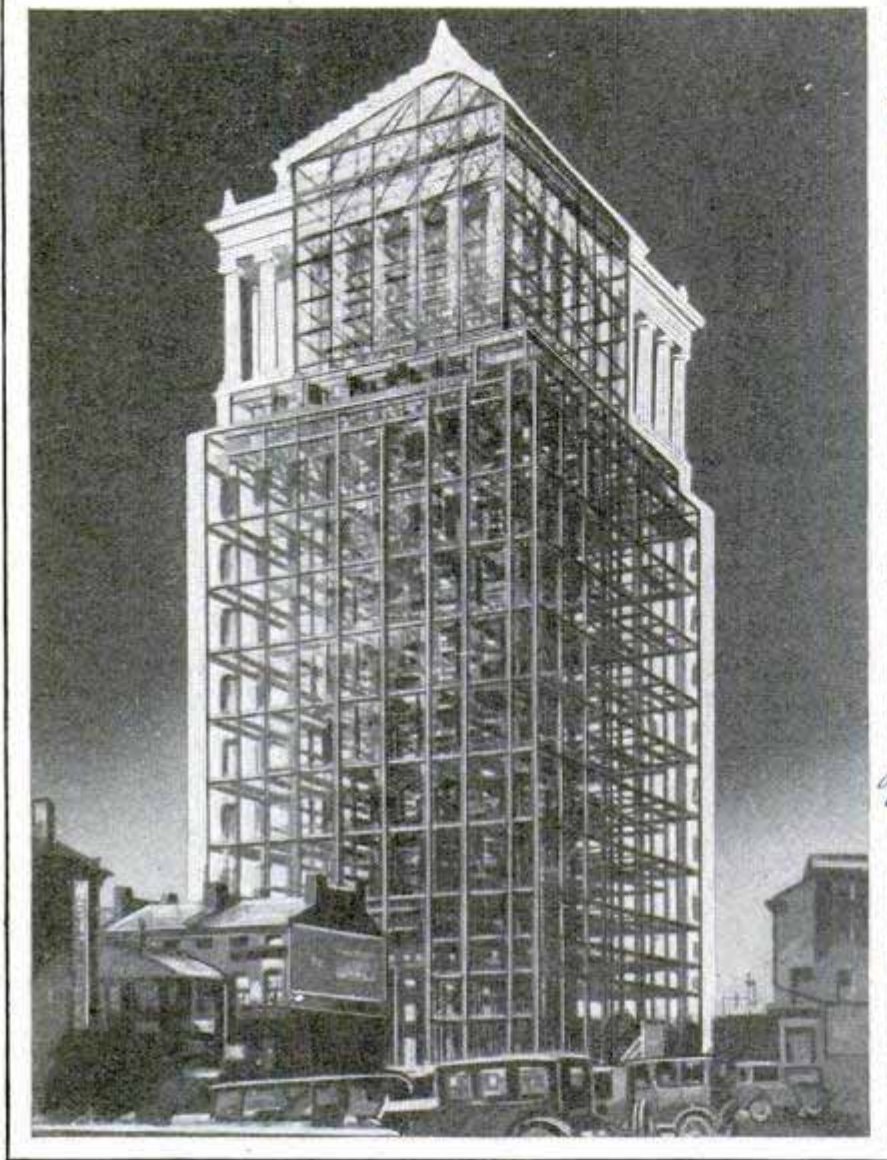

Composite Photograph Which Produces X-Ray Effect, Showing Steel Skeleton of the New St. Louis Courthouse

**"X-RAY" PHOTO OF SKYSCRAPER  
SHOWS ITS STRUCTURE**

By means of a composite photograph, producing the effect of an X-ray, an interesting study has been made of the new \$5,000,000 courthouse in St. Louis, Mo. The result was obtained by making a photograph of the steel work and printing it through another photo of the building itself as it appeared in a four-foot plaster model. The double exposure shows at a glance how much of the building is steel and how much is stone and reveals other data concerning its construction. The courthouse is nearly 380 feet high and has the equivalent of thirty-three stories. The architects combined classical forms with the lines of the modern skyscraper in achieving the design.

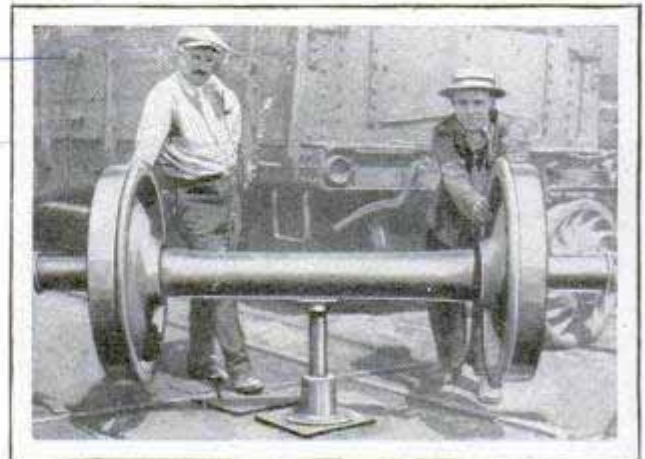

Air-Operated Jack Which Raises Car Wheels So They Can Be Shifted to Different Tracks

*Perfected by C. A. Haas  
Pennsylvania R.R.*



3247

Union League Club.

San Francisco Calif.



Pinwheels in Snow! Rotary Plow Cutting Its Way through Drifts up Pikes-Peak Motor Road; in Places Surveys Had to Be Made to Find the Hidden Highway

### FIGHTING SNOW ON PIKES PEAK SIMPLIFIED BY TRACTORS

*caterpillar*  
Tractors and rotary plows that cut their way through deep drifts and hurl the snow far to either side, have been successfully enlisted in the annual battle to clear the toll road up Pikes Peak. Where from thirty-five to forty days were once required for the work, it is now done in seven and with fewer men. The highway twists and winds about the mountain, affording many "pockets" for the snow to accumulate, and, in places, the road is entirely obscured so that maps and surveys are necessary to guide the workers. Should their machines stray from the right course, equipment and men might be tumbled down the steep peak. Because of the intense cold at altitudes of 13,000 feet and more, special precautions

have to be taken to prevent the water in the tractor radiators from freezing. Drifts eighteen feet high are encountered in many places.

### MODEL PLANE FLIES BACKWARD OR POISES IN AIR 2693

To demonstrate a helicopter plane he expects to finish in serviceable size, a California inventor has prepared a working model with a one and one-quarter horsepower motor to operate the blades. The model is said to fly straight up or down, backward as well as forward and can remain stationary for a time while aloft. The large-size ship will have a wing spread of thirty-four feet and will be driven by a 600-horsepower motor.



Model Helicopter Plane Which Flies Up or Down and Can Remain Stationary for a Time in Air

Coins dating from about 700 B. C., have been unearthed.

*Valentine Neubauer, Los Angeles, Calif. 1909 & 1910*



*San Francisco Calif*  
*Cannal locate*

*3278*

*3226*

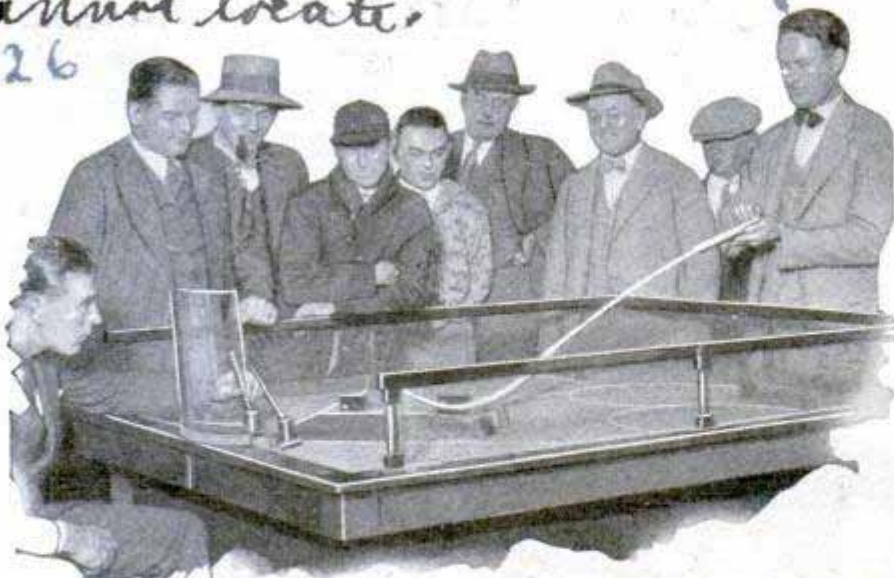

An Exciting Game on the Indoor Diamond; the Ball Is Rolled Down the Incline to Opposing Player at Swivel Bat

### FOODS REPRESENT ONLY FRACTION OF SUN'S HEAT

To release as much energy as is contained in the sunlight captured annually through the production of plant foods, it would be necessary to burn about 8,900 times as much coal as the whole world produces in a year, scientists estimate. But of this huge total, the human race uses less than two-tenths of one per cent, according to Dr.

### BASEBALL GAME PLAYED IN BOX LATEST INDOOR SPORT

Devised originally for the amusement of disabled war veterans, an indoor baseball game is becoming popular among others. It is said to afford some of the thrills of the real game, requires considerable skill and is interesting to the spectators as well as to the players. A tiny ball is rolled down an incline, the object being to have it hit the backstop and so score a strike on the opposing player, who is at bat with a tiny small stick adjusted to a swivel. He endeavors to hit the ball with this miniature bat, to score a hit, homerun or other credit, according to the place where the ball lands.

John M. Arthur, of the Boyce Thompson Institute for plant research. Human beings are dependent on the process by which the plant uses the sunlight to produce energy in the form of various foods, of which each person consumes about 2,000 calories every day.

### ENGINE-LOCATION BOARD AIDS RAILROAD EFFICIENCY

Devised by an engine-house clerk, a location board tells at a glance where locomotives on the division are, whether in shops, in service, borrowed or available for duty. It saves consulting more complicated records and is easy to operate, metal-bound tags being placed on hooks to indicate the status of the engines. It saves time and aids the locomotive dispatcher in making accurate reports and quick assignments.

### PAPER PRODUCT SETTLES DUST ON SWEDISH ROADS

Use has been found in Sweden for one of the by-products of the paper mills. It is sulphite lye, that heretofore has gone to waste, but is now being employed to sprinkle the roads for settling the dust. The material, which is mixed with other substances for this purpose, also reduces maintenance costs on the roads and increases their surface durability, according to reports.

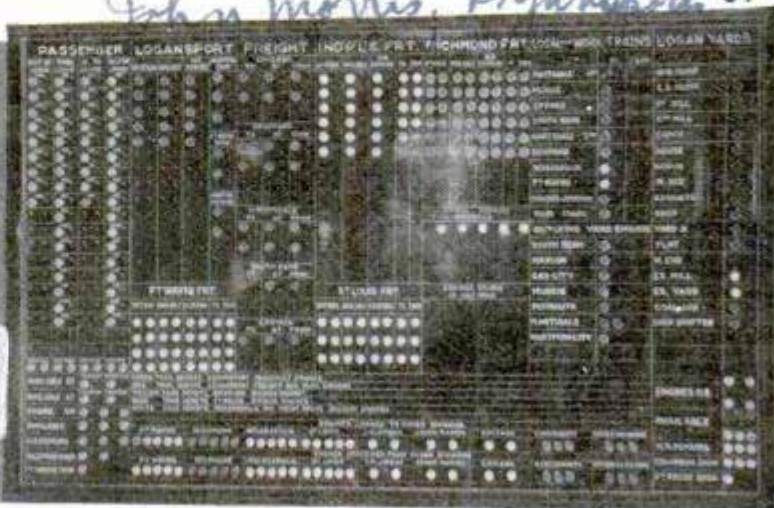

Keeping Track of the Railroad's Engines; This Wall Chart Shows Where Every Locomotive Can Be Found

*Robert Karlberg, Sweden*  
*Norrköping*

*Composition found by Robert Karlberg, Norrköping.*



Operated by L. Eugene Walker  
 3257 on roof of Providence Biltmore  
 POPULAR MECHANICS 947  
 Hotel Providence, R.I.

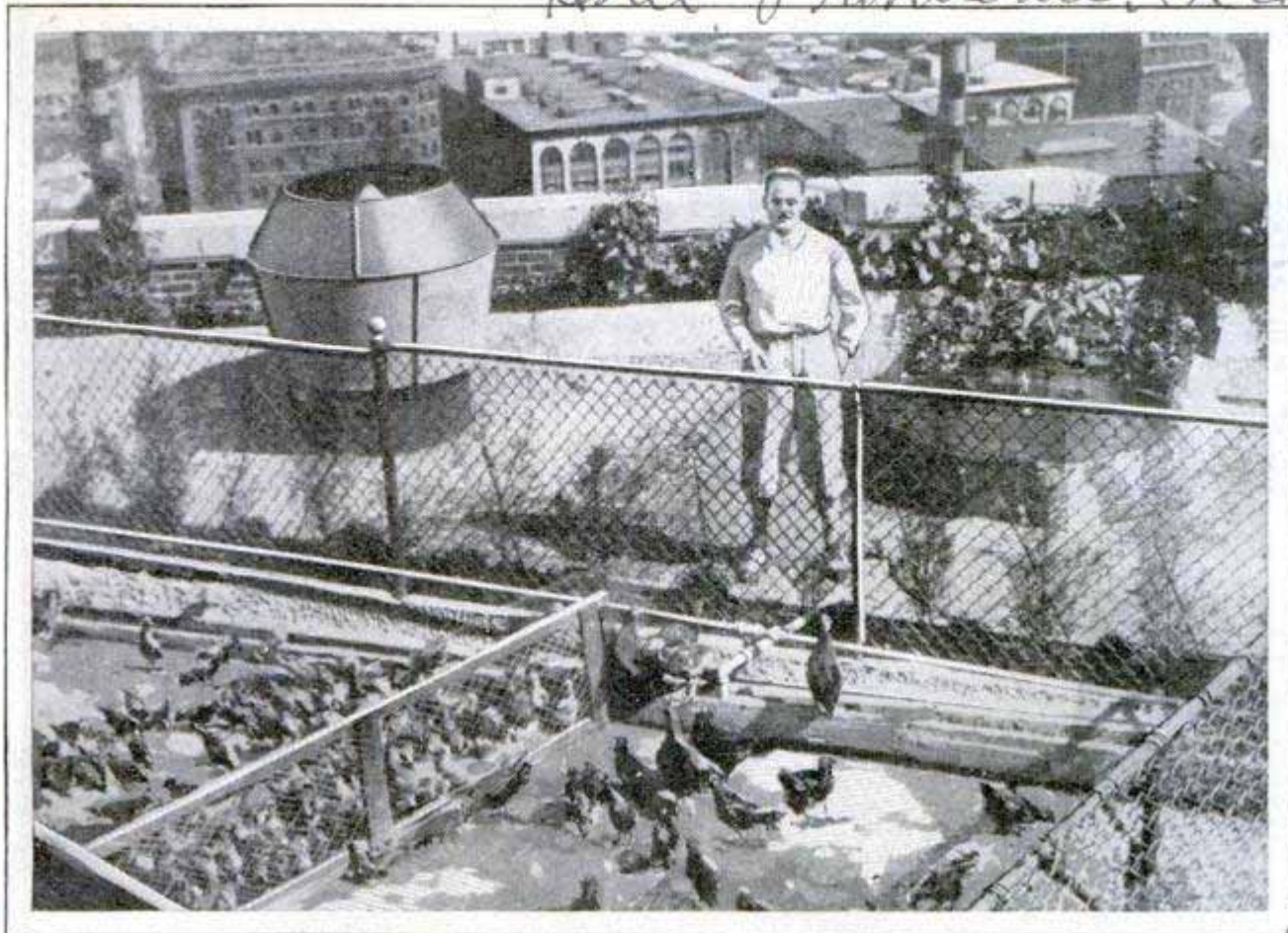

Happy and Thriving Although They Have Never Been on the Ground; Chickens on Roof Farm of Providence, R. I., Hotel; They Enjoy Plenty of Fresh Air and Sunshine

### CHICKEN FARM ON CITY ROOF SERVES BIG HOTEL

The chickens shown in this illustration have never seen the ground, and probably never will, for they have been raised on an aerial farm on top of a large hotel building in Providence, R. I. They have pens, watering fountains, and dirt to scratch in, just as their country cousins have, and seem to thrive on their elevated location. Besides making use of space that otherwise would go to waste, the plan assures the hotel fresh poultry and eggs.

### DWARF TREES ONE FOOT HIGH SUBSTITUTE FOR BRIAR

A possible substitute for briar, in the manufacture of pipes and other articles, is reported to have been found in a peculiar wood that grows in Africa. The trees sometimes have trunks four feet in diameter but are not more than one foot high. There are but two leaves to a tree, and these attain a length of six feet and a breadth of two feet. The roots are tough

and of a beautiful shade. The wood is successfully worked in a lathe and does not easily fracture, so that waste is reduced to a minimum.

### CLOCK STARTS UP THE FURNACE ON COLD MORNINGS

Discomforts of arising on cold mornings to start the furnace fire are avoided with a clock arrangement that opens the drafts at any time specified. It is easily adjusted to any type of furnace and functions chiefly by releasing a weight at a certain predetermined time, to lift the drafts. This is done gradually to prevent damage to castings. The clock is set like an alarm and is specially constructed for service in a dusty cellar.

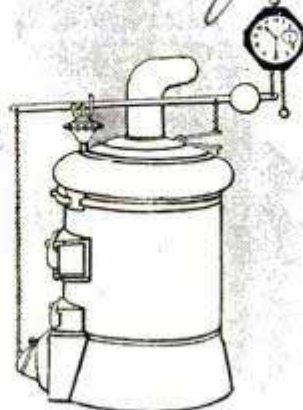

The American Anulo Co.  
 1003 K St. N.W.  
 Washington, D.C.

Com. George H. Holden, Esq.  
 1400 1/2 View Park Road



# It's a Simple

By EARL CHAPIN MAY  
*Sharon Conn*

These youngsters of the tights, spangles and tented world come, almost always, from circus stock. They are "born into the business," to use a circus phrase, and are raised as tenderly as any sons or daughters of college professors or merchant princes. About the only difference between the way they are brought up and the way the children of "towners" or "gillipins" are raised is that "trouper" children are taught the virtues and rewards of discipline. Their lives are circumscribed by duties. These little troupers learn from infancy to respect their parents and their wishes or commands, which sets them apart from most offspring of non-trouping stock. But they take a wholesome delight in circus life. They rejoice in it. Why shouldn't they? It's one long life of camping out.

Spring has come and with it a tented city grows up some morning on the grass-grown field that is your local circus grounds. If you are among the hundreds of towners who are early birds, you are in your railroad yards in time to see the Nelson family descend the steps of a yellow Pullman car, which is part of a long and heavily loaded circus train.

Mother and father Nelson first appear and are followed by seven children ranging from Rosina, aged thirty, to little Paul, in his fourteenth year. As they walk or ride in taxi or trolley car from the train to circus grounds, you'd hardly guess that the motherly looking



Harriet Hodgini, Twelve-Year-Old Daughter of the Circus, Shows Her Skill at Riding High School Horses

**T**HE children of the modern circus family, the budding riders, aerialists and acrobats of the future, lead simple, sane and happy lives.





woman in gingham dress and the kindly man in plain gray suit are conveying a group of the world's most famous acrobats. You might not notice them at all. Certainly you would never recognize them as circus people if you did not see them in connection with the gaudy train or tall white tents.

Once on the lot, the younger ones may romp a bit. They may play leapfrog among themselves. But they pay no attention to those who do not belong to their fraternity. Their own company satisfies them. They hunger for just one thing more—breakfast in the cookhouse or circus tent. As each Nelson enters the long canvas room, above which a small flag is flying to indicate that food is being served, he pauses to purchase from the circus steward a quart of milk for his own use. This extra is ordered by the parent Nelsons three times each day, for breakfast, noon-day lunch or dinner and five-o'clock supper. Fruit, cereals, jam, bread, butter and a little fish complete the daily menu.

Between breakfast and dinner the Nelsons visit with their circus friends, clean and repair wardrobes and, occasionally, practice some new trick. Then comes a

The Cinderella Story. Starring a Circus Child, and Bertie Hodgini Taking a Ballet Lesson



session of lessons with mother Nelson as teacher. This time may be devoted to mathematics, physics, chemistry or almost any subject except geography, for, as the





Nelsons have been traveling with some circus since infancy and in almost any year can show a mileage of at least 20,000, they have learned their geography from contact with many countries in many climes. Like other troupers, they work twice each weekday, but, all told, are in the circus ring less than thirty minutes daily, including the matinee and night performance.

Of course, there are thorns along the circus path. I've seen the Nelson girls, clad only in low bodices and silk tights, stand, unprotected from chilling rain, while awaiting their turns to enter the big top and do their stunts. But the weather did not bother them.

"They've lived outdoors most of their lives," the mother proclaims proudly. "They take a cold sponge bath every day. Of course, they get plenty of exercise, and all the food that's good for them. There are plenty of blankets in their berths and I

can heat our private dressing tent if I think best."

Among the well-known circus families are the Hobsons, riders of the first rank. Mr. and Mrs. Homer Hobson, Sr., have, like the Nelsons, been featured in the circus ring for more than forty years, but you'd never guess it unless the family chieftain told you so. Homer Hobson, Jr., and Herbert, his youngest brother, have been trouping since infancy. In one of the Hobson riding acts, young Homer, while clowning it, is dragged face downward around the ring clinging to the tail of a galloping horse, which frequently kicks cinders or gravel into the clowning equestrian's mouth. I've seen the boy's lips bleed many times, but he thrives on rough work of that kind. You would hardly recognize in

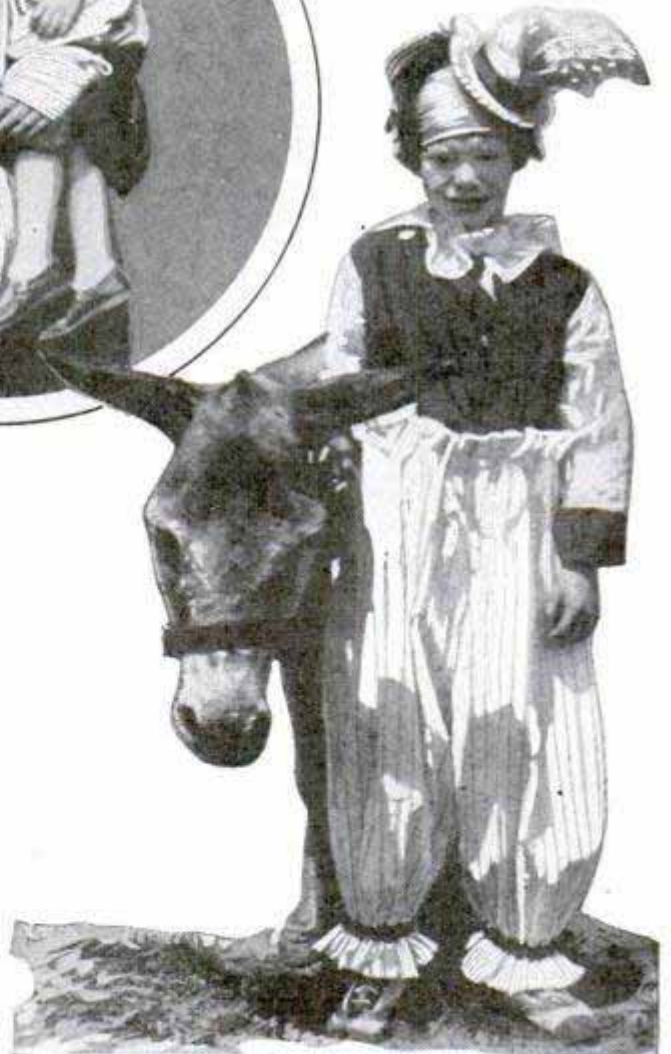

Madge Fuller as an Elephant Trainer, Georges Carpentier with a Circus Daughter, and Bertie Hodgini Trying a Clown Role



the pink-faced, sturdy lad the buffoon who "steps off" a racing "finish" horse. The "step-off" is a difficult trick. While one foot is on the hindpart of the moving horse, the other foot must touch the ground. But the second foot must follow rapidly, or it would be painful for the Hobson boy.

Herbert, who works with Homer, Jr., made up as a girl, also doubles with the other Hobsons in an Indian riding act. Herbert likes that Indian "double" best, because he has a strong leaning toward the Wild West stuff.

For several seasons, when not in school, he has practiced cowboy tricks, until he has become so proficient with the lariat that he does rope spinning in the circus after-show or concert as a product of our western plains, although the Hobsons have long been legal residents of



Chicago's west side. Which shows that one professional boy regards circus-ing as a bully game.

Performers take their work seriously, yet they look upon their work as play. The biggest

event in the Sells-Floto show during the season of 1925 was one in which outsiders had no part. They didn't even look in on it because it was a burlesque on the big-top performance, given in the backyard by riders, acrobats, clowns, jugglers, contortionists and aerialists. Acrobats came out on hobby horses. Aerialists "took off" the so-called funny clowns. Clowns made fun of the aerialists, and the hundreds of circus executives, musicians and laboring men, who paid their money to see the mimic show, had the time of their lives, and helped create a fund for a performer laid up in a hospital. Birthdays and weddings are celebrated in the backyard, and the clown band often stages its own impromptu shows.

The discipline which young circus people accept as the most important part of



The Two Hodgini Children in Some of Their Favorite Playtime Stunts, Harriet as a Cowgirl and Bertie as Equestrienne and Clown



the daily life doesn't spoil the fun for them. Although they must be through their breakfast by nine o'clock and, on smaller shows, be ready for parade when the second bugle blows, at ten or thereabouts, and must be through their dinner and supper before the cookhouse flag falls, because when that flag falls it means that meals are no longer being served; although they must sleep in the same berths each night, usually doubling up with some one of their sex; although they must sit on the same hard plank in the same place at the same table at each meal; although all their circus and street wardrobe must be in the same little square-topped trunk in the same place, close to other trunks, in the dressing room each day, and everything must be packed and unpacked methodically, and although they must never be late a second or disobey or ignore any order referring to their appearance in the ring, they lead a simple, easy life.

Not only do they get plenty of fresh food and air and just enough exercise to keep them hard and fit, they also are protected by the traditions of the circus lot. Even on the wettest days, when wind and weather are against all trouser folks and the canvassmen are struggling with hostile elements, rough language seldom meets

their ears. They are taught to take care of themselves whenever possible. They are not pampered or petted. But day in and out, the circus family is never separated. If the parents do not keep their children in plain sight, they know exactly where those children are.

The circus company is one great family and some of its members are always close at hand. The young folks have no opportunity to take long rides in motor cars by themselves. Such rides as they take between the lot and circus train are in the company of other troupers. So circus parents do not wonder where Tom or Sally may be at night. The children are either in or near the lighted tents, on the way to or in the circus train.

This sounds as though young circus lives were pretty limited. They are, but I've never heard a word of discontent. Sometimes Harriet Hodgini, from the wisdom of her twelfth year, will grumble because she is not allowed another ice-cream cone. Bertie, her ten-year-old brother, may look vainly at a lollypop. But fatness is fatal in the circus business, unless one wants to be a sideshow freak. They are trained to restrain themselves even when they are sorely tempted by the circus steward.



All Ready for the Grand Entry in the Opening Spectacle; the Circus Families Gather in Gorgeous Costumes, Ranging from Oriental Splendor to the White Paint of the Clowns



Last Fourth of July, at New Bedford, Mass., Harriet and Bertie sat through a dinner which included sweet relish, Little Neck cocktail, celery, young onions, radishes, chicken gumbo soup, broiled salmon with tartar sauce, young Vermont turkey with oyster dressing and cranberry sauce, baked Virginia ham and corn fritters, new potatoes in cream, green peas, combination salad, asparagus tips on toast, strawberry shortcake, watermelon, ice cream, salted nuts and coffee. Yet Harriet and Bertie did not sample half of it. Meats and sweets are seldom given them because they are destined to follow their mother and father in the ring.

They have been preparing for their careers since babyhood. They are skillful school riders now. But they look long years ahead. Some day they are going to be principal riders. A principal rider is one who stands, pirouettes and somersaults on the rosined back of a loping steed. As that steed goes round and round the ring and the circus band plays its fastest tune, the rider kisses his or her hand to the thousands of applauding towners.

**HAND SPRAYER FOR LACQUERING SAVES USING BRUSH**

Special nozzle adjustments in a hand sprayer now on the market are said to adapt the instrument to the successful application of lacquer to a wide variety of surfaces, resulting in a better job than could be done with a brush and at a saving in time.

By taking care to have the liquid of the proper consistency and holding the sprayer at an angle of about forty-five degrees to the face of the work, spots and runs can be avoided, it is asserted. The tool is easily kept in order and, when not in use, is held in an upright position so that the contents will not spill.



The United States has one-third of the world's telegraph lines.

*The E. C. Brown Co., 244 Maple*

**CHANGE FRUIT OF WALNUT TREE BY GRAFTING OPERATION**

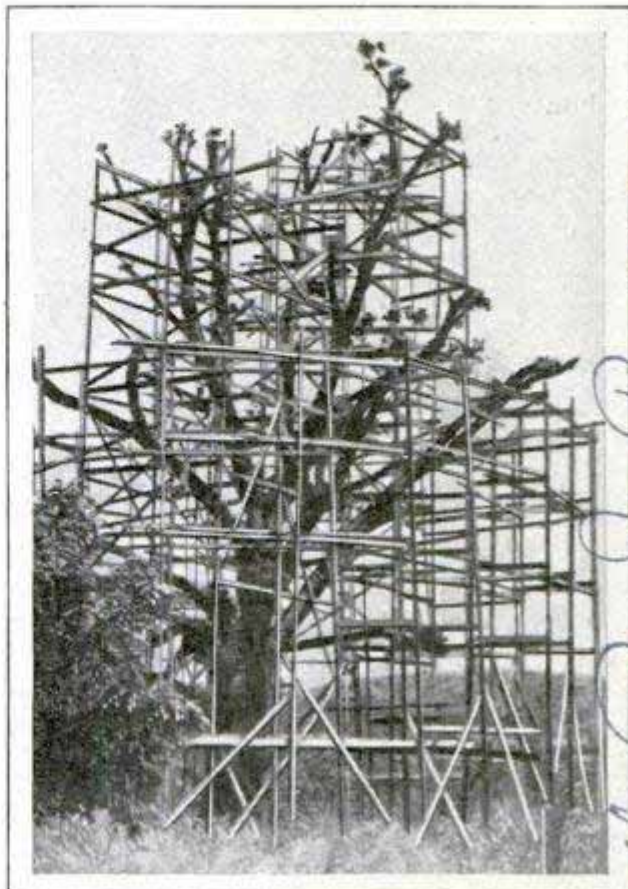

Black-Walnut Tree Transformed into Bearer of the English Variety and Scaffold Used in Grafting

Although it has yielded black walnuts for many years, a huge tree in California will produce only the English variety from now on, for it has been altered by one of the most extensive grafting operations on record. Tree surgeons erected a huge scaffolding about the limbs in order to reach all parts of them. The tree is more than 100 years old and, in a few seasons, it is expected to produce nearly a ton of English walnuts.

**AUTO TRUCK WHEEL OF RUBBER REDUCES TIRE EXPENSE**

Auto truck wheels made of compressed rubber have been introduced to replace the usual disk and tire type. They are resilient and noiseless, do less damage to surfaces and may be obtained in varying degrees of hardness, depending upon the maximum expected load. Maintenance is low, as there are no punctures, retreading costs or breakages, and the wheels are unaffected by hot, cold or damp climates, it is asserted.

*Rochester, N.Y.*

*2077*  
*the C. H. Burgess place at Walnut Creek, Calif.*  
*on*  
*Compressed Rubber Products, Ltd. 221 W. 42nd St. New York, N.Y.*

*Tr.  
 fr.  
 il  
 g.*



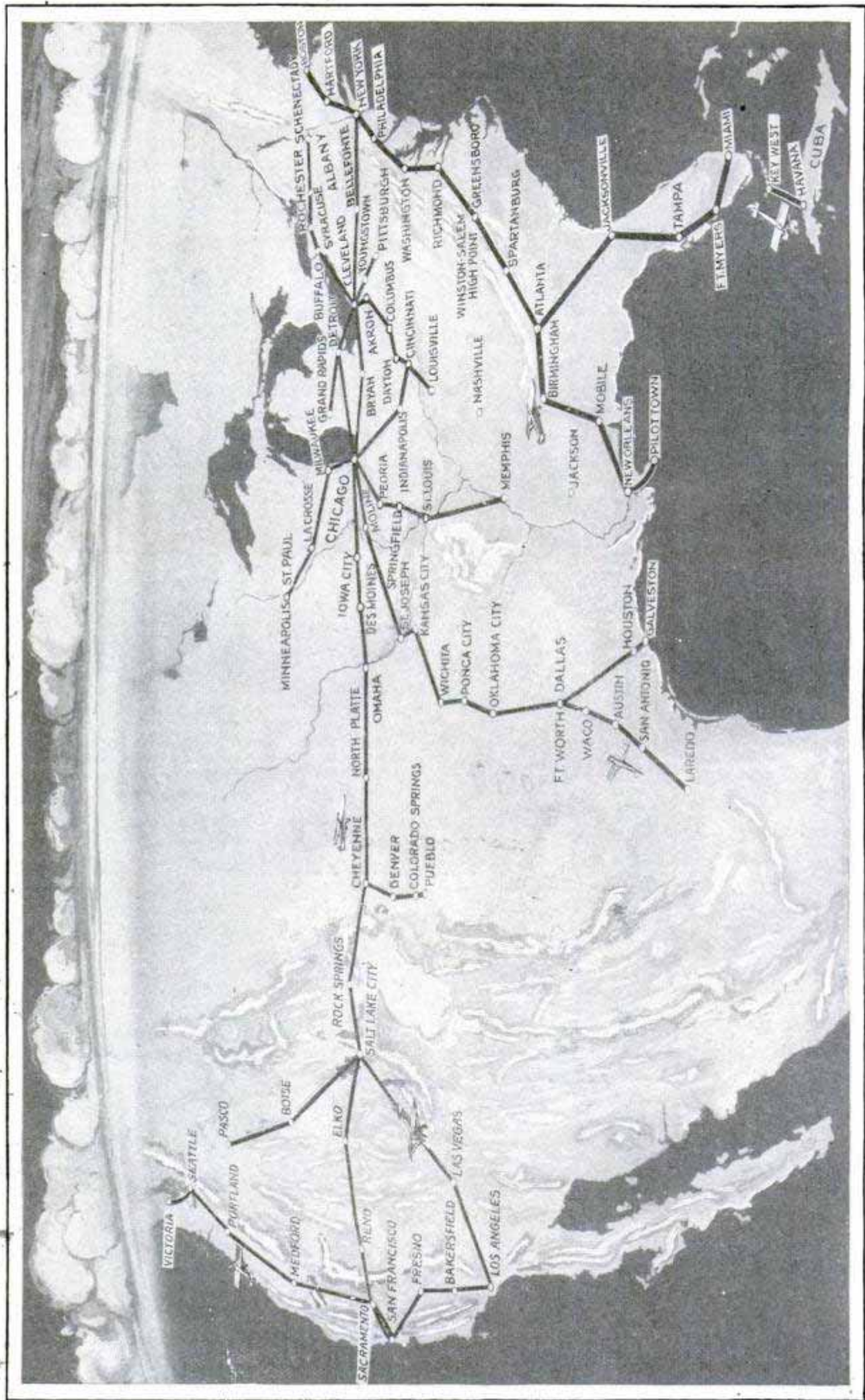

The Air Mail as It Will Be As Soon as Additional Routes, for Which Bids Have Been Received, Get in Operation; the Rate Is Ten Cents a Half Ounce Anywhere, Except on the Three Foreign Routes, New Orleans-Pilottown, Seattle-Victoria and Key West-Havana, Where Regular Two-Cent Postage Applies



*E. Hall, Box 411*

**AIR MAIL'S AMAZING GROWTH  
SETS AVIATION RECORD**

With the greatest air-mail and aerial-express system in the world, the United States has quietly taken the lead in self-supporting commercial aviation, so quietly that few people realize the extent of the air lines in actual operation. While European countries, with their government-subsidized air lines, are still ahead in passenger carrying, the United States is rapidly forging to the front in this field, too, since the mail lines built up by the post office department have been turned over to private operation. For a fare of \$200, it is now possible to go from Chicago to San Francisco by air in twenty hours, instead of three days by train, and shorter passenger routes are in operation on many of the other air lines. The elimination of the old zone system, with various rates for different sections, has done much to popularize the air mail, as it is no longer necessary to study a map before sticking the stamp on an air letter. The new rate is ten cents a half ounce, regardless of where the letter is going. Air letters do not require an extra two-cent stamp, as is the case for special-delivery mail, the ten cents being the only charge. While the actual flying has been turned over to private contractors, who furnish their own planes and landing fields and carry the mail at a fixed price per pound, the government system of night-flying beacon lights has been taken over by the department of commerce, and placed under the lighthouse service, which guards ships at sea and ships over land now. The lights are being extended on new mail routes, to permit night flying, and eventually every part of the country will have its blazing trail of beacons to mark the main air routes. The department also is developing radio-compass beacons, and already has installed the first one at the Bellefonte, Pa., field, the center of the worst flying zone in the country. While the domestic air mail has been growing apace, the post office recently let a contract for its third foreign mail route, a ninety-mile jump from Key West to Havana.

Some kinds of goldenrod are cultivated as garden flowers.

"Running Sitting Down"; Barsi, Hungarian Athlete, Doing Road Work on the Leg Exerciser

2702

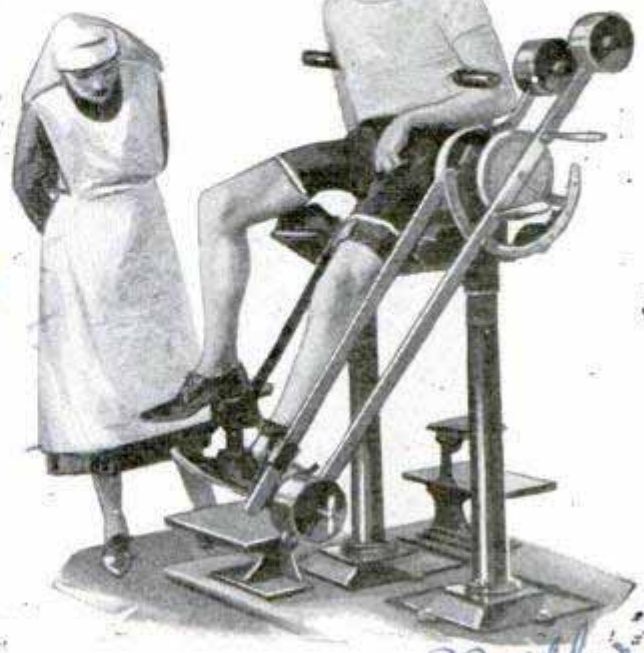

**LEG EXERCISER KEEPS RUNNER  
IN TRIM FOR RACES**

To strengthen his leg muscles and keep in training for the races, Barsi, a Hungarian middle-distance runner, practices on a special exerciser. It permits the operator to stand in approximate running position and manipulate pedals which turn weights to give the necessary resistance. The outfit is especially useful when the weather does not permit outdoor training.

**TIRE-CASING SPREADER HELPS  
PREVENT PUNCTURES 3109**

Thorough examination of the inside of the auto-tire casing and removal of small articles, such as tacks and nail points, likely to cause puncture, can easily be accomplished with a simply operated spreader now on the market. It forces the sides of the casing far apart, and the entire surface is exposed, by means of a corrugated roller and two disks, as the casing is rotated with a hand lever.



*Ans. H. S. Blackman,  
9/4 Central Vulcanizing*



Placing the Refrigerating Unit in Cabinet, and Closer View, Showing the Two Balls and Cube Freezer

3/84

**CHANGE AUTO INTO FIRE ENGINE TO HELP SAVE FORESTS**

By the addition of high and low-pressure pumps, a small automobile has been changed into an efficient fire engine for fighting blazes in the California forests. It carries 500 feet of hose, tools and other equipment and can hurl a two-and-one-half-inch stream of water eighty feet, at a pressure of eighty pounds to the square inch. The low-pressure pump is employed for forcing water to the other from a considerable distance, a feature that many other auto units have not had. This is important, for often the available source of water is far from the actual scene of the fire. Both pumps are portable and quickly taken from the auto for use in any convenient place. The car is fitted with a variable-gear axle and, since it can be turned within a short radius, it is especially adapted to service on narrow, winding mountain roads. As many fires occur near the highways, owing to carelessness of campers, it is believed that the auto unit will be especially effective in curbing blazes before they have a dangerous start. In a recent test, the converted car beat regular fire-fighting equipment to a blaze and had water on the fire within a short time, although the supply was half a mile up the road. A ditch and the low-pressure pump solved the problem.

*Chicago - 2758 N. Clark*  
*not sold in foreign countries, can be purchased*  
*140.00 per*  
*yearly*

*but must be part of the original*  
*no guarantee for foreign country*

*dayball*

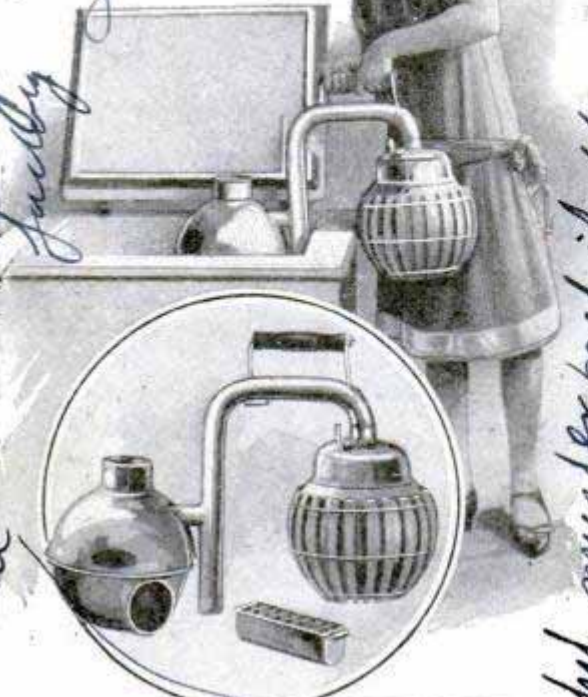

**ICE IS MADE WITH COOKSTOVE FOR REFRIGERATING**

Artificial refrigeration is now available even to homes that are not supplied with electricity in a recently introduced unit, operated on almost any kind of a stove. It consists principally of two large balls, connected by a peculiarly bent tube. A refrigerating liquid, introduced into one of the balls, is heated on the stove while the other is submerged in a tub of water. The heat evaporates a portion of the liquid which passes into the cold ball and condenses. A small whistle warns when the heating has been continued long enough; the unit is then lifted off the fire, the hot ball submerged a few moments in water and the outfit placed in the refrigerating cabinet. The liquid in the cold ball has started to evaporate and pass slowly back into the other chamber, the process chilling the cold ball to a temperature of zero or below, it is said. This action is continued and is said to maintain a cold, dry temperature for twenty-four to thirty-six hours, depending upon the outside atmosphere. An ice tray is supplied with the unit and is placed inside the cold ball for freezing cubes for salads, deserts or cooling liquids.



Pump in Action on Front of Auto, Which Has Been Converted into Fire Engine to Guard Forests

Ⓜ A five-speed outboard motor is being built for small boats.

*Developed by Emil*  
*Los Angeles.*



PROTECTING THE SHORE ENDS OF LATEST CABLE



Completing the "Cable Handclasp" between England and Belgium; Placing the Shore End of the Big Line; Special Coverings Have Been Used to Protect the Wires from Corrosion

A new link between England and Belgium, an iron handclasp across the English channel, has been completed recently. It is the British post-office cable, an international bond that will mean better and quicker communication between these two countries. Every new cable contains improvements designed to make it better than its predecessors. If corrosion damages a cable, it is very expensive to fish up the ends and repair them. In fact, any kind of work would be difficult, because of the strong current in the English channel and the prevalent stormy weather. The worst corrosion usually takes place on the shore ends of the cable because of decomposed matter near the surface of the water. Even the thick composi-

tion coating used does not always resist such severe conditions, and cables sheathed with ordinary steel wire have failed quickly. So it was decided to use rust-resisting pure iron to cover this latest cable.

AIR-MAIL LETTERS IDENTIFIED WITH LABEL TAPE

For easy identification of letters intended for the air mail, a special label tape carried in a handy roll has been devised.



Simple Means of Identifying the Letter for Air Mails; Applying Tape from Holder

The tape comes as a continuous strip, gummed on one side, and the holder is designed to prevent the edges from curling up and for removing the tape with a slight movement of the thumb. Each label is detached at a perforation in the strip.

Inventor - The American Rolling Mill Co. Buddington, Ohio.  
 Patent - Capt. Raymond S. Jewell, 100 Madison Ave., New York City.  
 International Corp. 64  
 Victoria St.  
 London  
 S.W. 1, Eng.

Handy Roll Co. No 2  
 100 Madison Ave. New York



BATTLE MONUMENTS TO AMERICAN HEROES

*574 Woodward Bldg  
Washington DC  
World War*

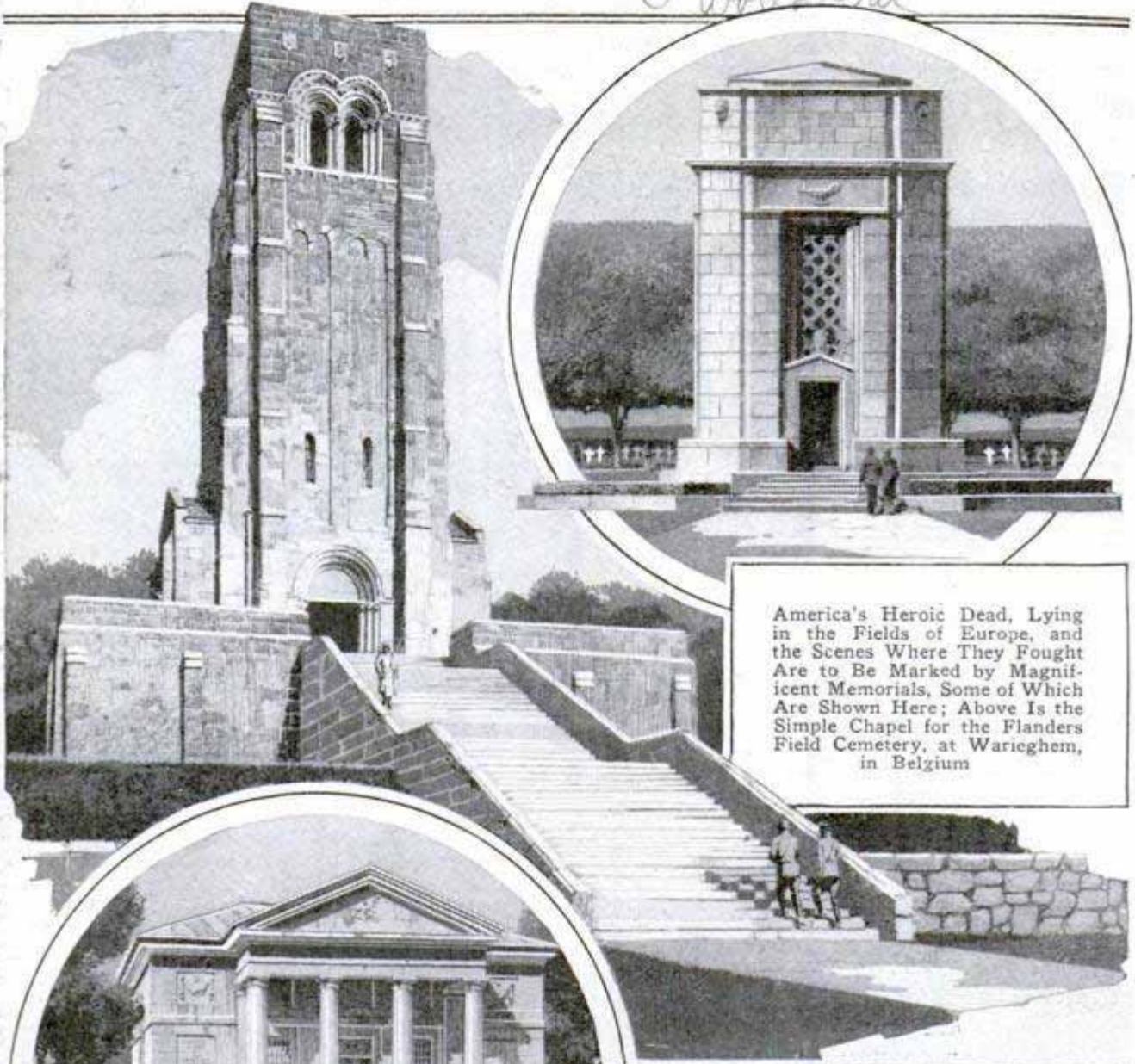

America's Heroic Dead, Lying in the Fields of Europe, and the Scenes Where They Fought Are to Be Marked by Magnificent Memorials, Some of Which Are Shown Here; Above Is the Simple Chapel for the Flanders Field Cemetery, at Warieghem, in Belgium

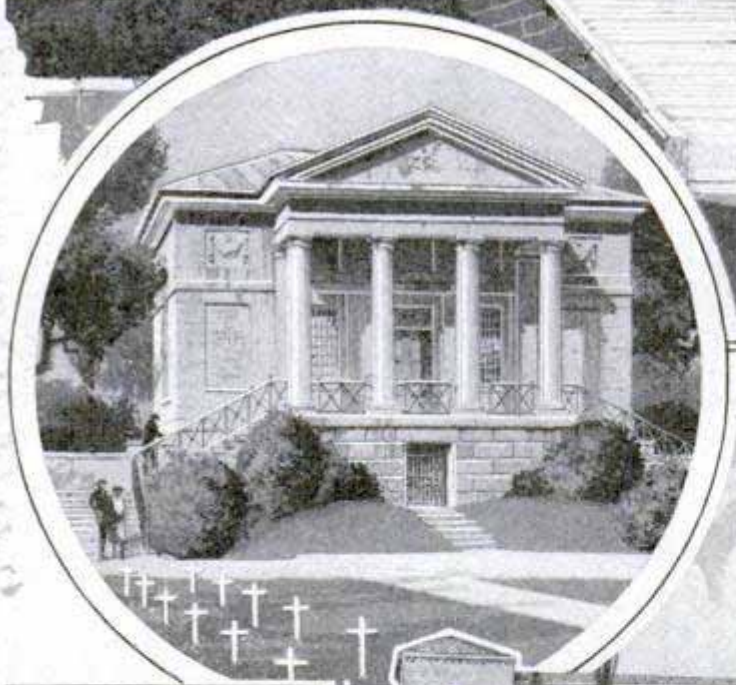

The Chapel for the Cemetery at Suresnes, and, Top, the Great Gothic Tower to Stand Guard over the Dead in the Aisne-Marne Cemetery. Situated near Belleau Wood

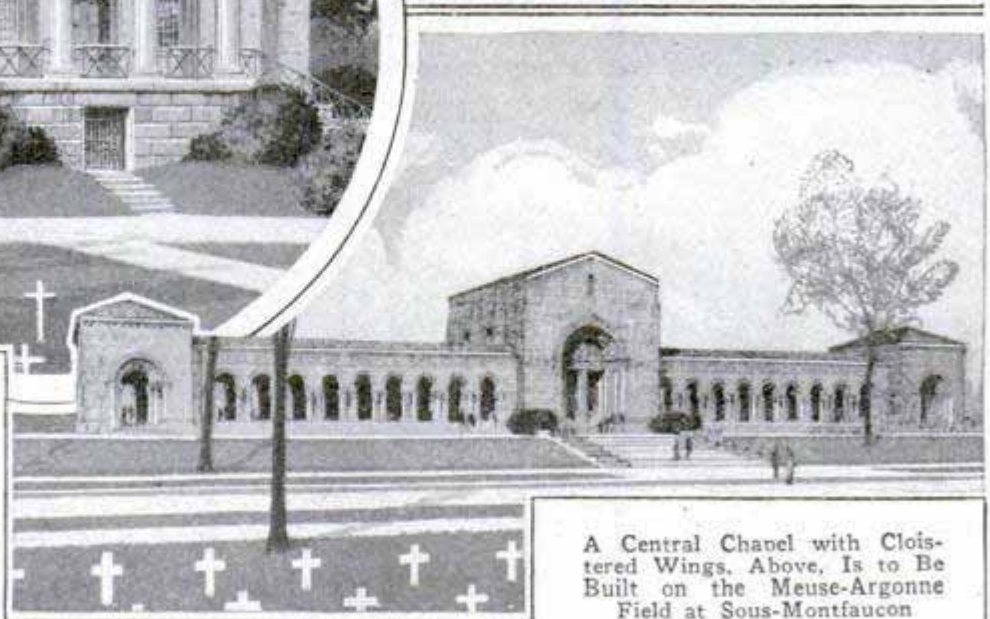

A Central Chapel with Cloistered Wings. Above, Is to Be Built on the Meuse-Argonne Field at Sous-Montfaucon



TO MARK MAJOR ENGAGEMENTS IN FRANCE

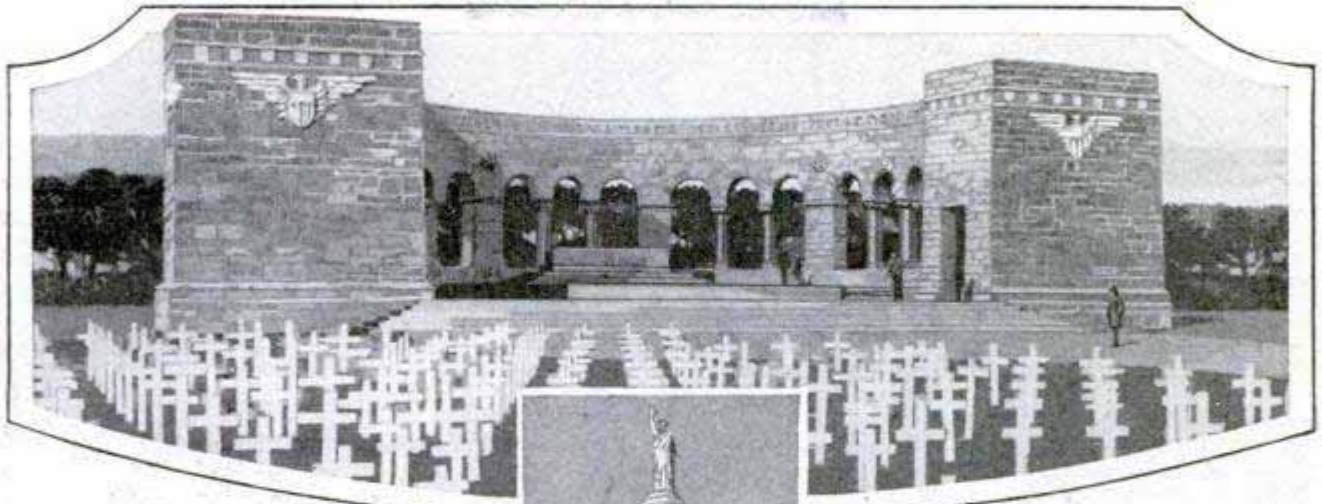

Eagles and Shields Are the Simple Ornaments for the St. Mihiel Cemetery Chapel

At Left Is the Tall Column to Mark the Meuse-Argonne Battle Site at Montfaucon

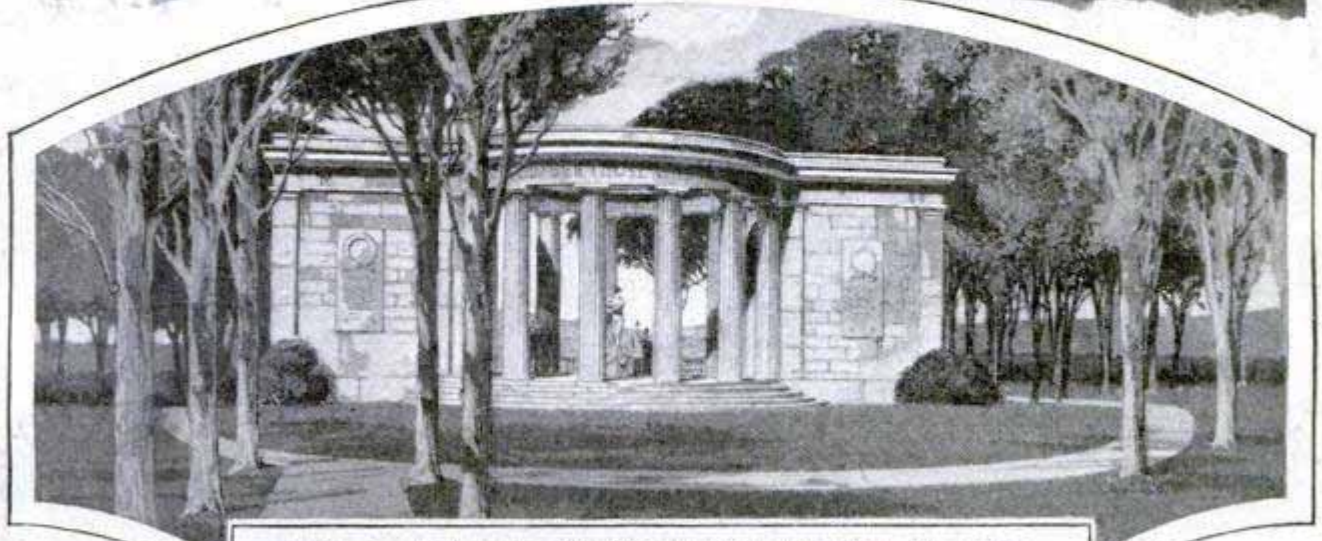
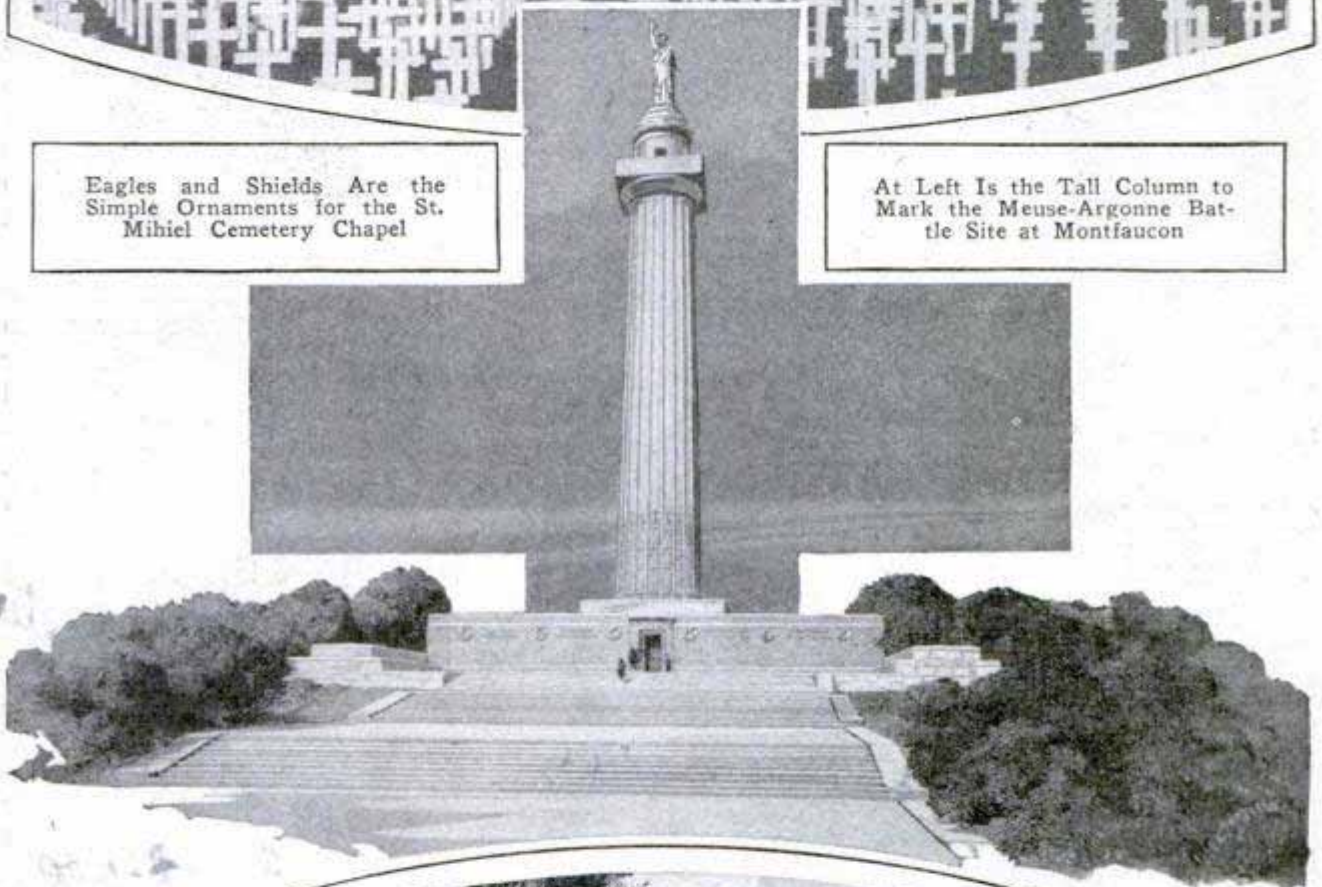

A Circular Colonnade with Chapel Wings Has Been Planned by Gen. Pershing's Monument Commission for the Oise-Aisne Cemetery near Fere-en-Tardenois



9/10/27

3043

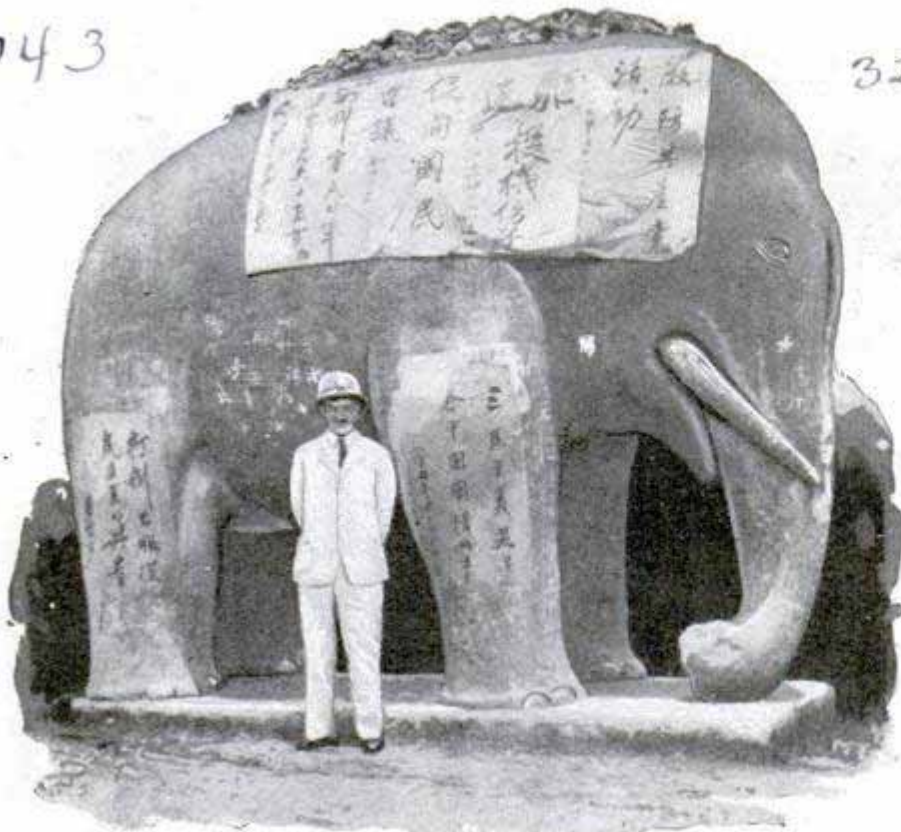

Superstition and Modern Advertising Meet on Chinese Stone Elephant; Ming Tomb Figure Is Billboard and Shrine

**STONE ELEPHANT AS BILLBOARD SHOWS CHANGES IN CHINA**

That modern China is recognizing the importance of advertising, even to the extent of trampling on the traditions of the past, is shown by the accompanying illustration. The nationalists have used a stone elephant near the Ming tombs as a billboard on which to display posters urging citizens to put down communism and attend the nationalist-party conference. In striking contrast to this modern note are the stones on the back of the elephant. They were tossed there by women following an ancient superstition, signifying that, if the stone lodged on the monument, good luck would reward the thrower and her next child would be a boy, but if it fell off, a girl child would be born.

**GOLD IS BROUGHT BY PLANES FROM SIBERIAN FIELDS**

Gold is delivered in a few hours instead of several days from the rich Aldan fields of Siberia, by airplanes. The mines are several days' travel from a railroad, but the airplane has stimulated development.

3260

New York Sun 9/7/27

**"PADDED CELL" FOR MACHINERY**

3277

A huge flywheel is spinning at terrific rate. There is the sudden crash of hurtling metal, and one side of the big wheel collapses and is thrown against the wall. Anyone standing in the path of the missile would have been killed or severely maimed, but the men who have been watching the wheel are safely outside, peering through telescopes, and the concrete walls that guard them from the spinning giant are nine feet thick. This is a test chamber or "padded cell," an English electric company uses for trying out flywheels and other machine parts subjected to high speeds.

Fast camera lenses, at guarded openings in the walls, record the results of the tests which would be impossible were it not for the safety room.

in Manchester

**HIGH-VOLTAGE TESTER GUARDS AGAINST ACCIDENTS**

2766

Electrical workers handling installations involving currents of 1,000 volts or more, are provided with a tester intended to reveal parts of equipment still connected to the high voltage with a minimum of danger and great certainty. It consists chiefly of an indicator filled with neon gas which glows brightly when electric current passes through it. On voltages of 3,000 or more, it registers simply by being placed in the electrostatic field, without contact with the wire. For use on parts difficult to reach, it is mounted on a pole.

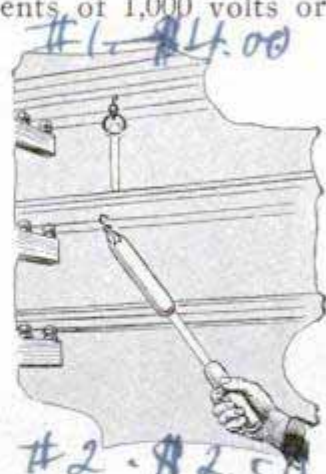

Radio Electrical Works, 23 Union



3189

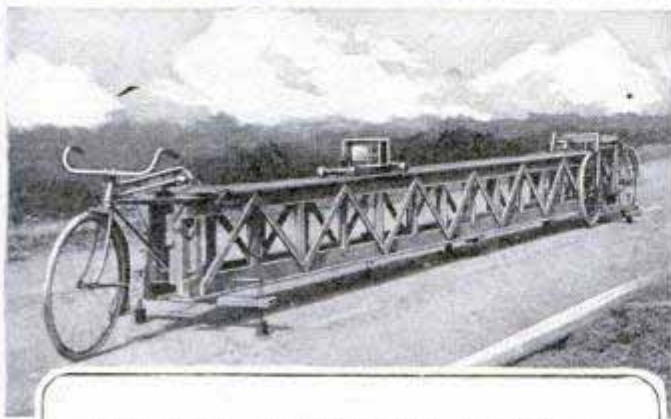
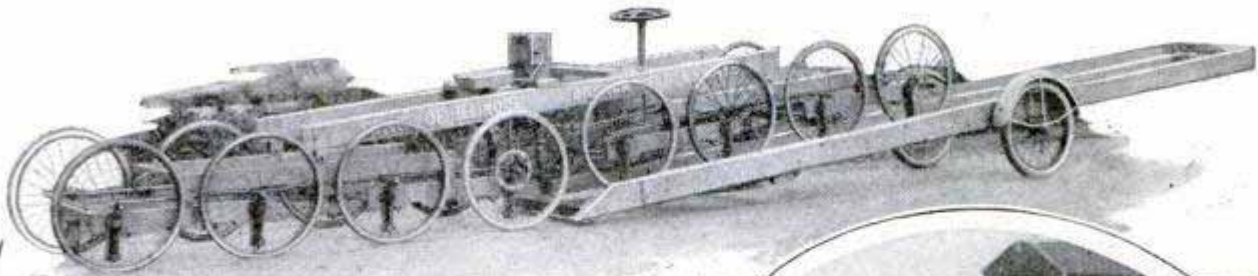

Two Types of Meters That Register the Bumps in Cement Pavings, and, at Right, Illustration of the Familiar Straightedge for the Same Purpose



**METER THAT MEASURES BUMPS INSURES SMOOTHER ROADS**

To determine the smoothness of concrete roads, the bureau of standards has developed a special measuring instrument which writes an accurate record of the bumps as it moves along the highway. The outfit has sixteen wheels, each adjusted to react to the irregularities on the surface in such a way that the motion is transmitted to the delicate recording apparatus.

**MAGIC METAL LIKE ALUMINUM TO IMPROVE AIRPLANES**

Airship frames and automobile pistons of beryllium, or its alloys, a metal about a third lighter than aluminum and much harder, may be introduced in the near future, experts predict. The substance has been known for a long time but, until recently, its production in quantities large enough to be industrially practical has been impossible because of inadequate refining methods. In many ways, beryllium is suited to the service of man. It offers high resistance to corrosion, is four times as elastic as aluminum and expands under the influence of heat at about the same

rate as cast iron. This property makes it peculiarly adapted to use in engine pistons. Some of the difficulties of the present types of light pistons arise from the fact that they expand at a different rate from that of the iron cylinders in which they are inclosed.

**AUTO-PEDAL DEPRESSOR AIDS IN BRAKE ADJUSTMENTS**

The need of an extra man is eliminated in making adjustments of the auto's brake, clutch and stop light with a depressor for the pedal. It fits against the edge of the front seat and holds the pedal in a steady grip at unvarying pressure.



Brake Depressor Attached to the Pedal Showing How It Serves as a Helper in Making Adjustments

*Beryllium Corp. 119 W. 57 St. New York*

*Hoote Mineral Co. 1610 Summer St. Phila*

*Mather Mfg. Co. Boston, Mass.*

*Dr. H. S. Coaker, 90 Kernel Laboratories 12337 Cedar Road*  
*Industrial Chemist*



# Where a PINT

"A PINT'S a pound the world around," says an old proverb, but the author of it had never heard of a star, which astronomers have weighed and measured, where a pint weighs twenty-five tons.

The star is one part of the twin body which we know as Sirius, the dog star. It is so far away that it appears to the eye as a single star, but actually it is two bodies, revolving about a common center. The two stars are of unequal size, the larger being thirty-three times brighter than our sun. The other isn't much larger than the earth, but weighs as much as our

sun, which is why the two bodies will revolve about a point between them.

If you imagine compressing such a pile of lead into a pint cup you can get some idea of the solidity of the matter of which the small half of Sirius is composed. What that material is, so far has defied analysis. If this material could be classified and then reproduced on earth, science would have a new tool that would revolutionize our life. For one thing, such a metal would make an almost perfect electrical conductor. With it the power of Niagara could be wired around the world.

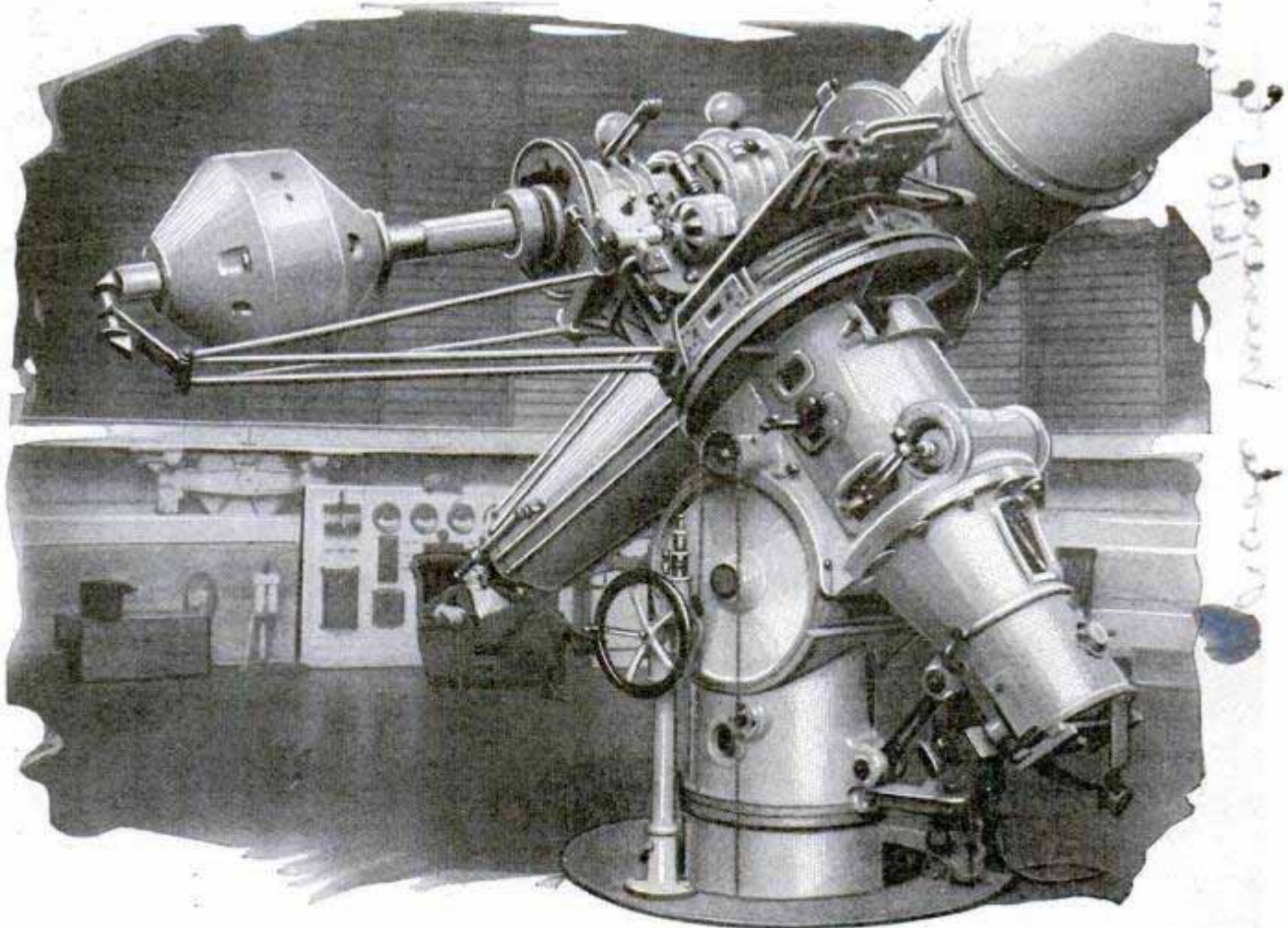

1910  
George Prentiss

Seated in His Comfortable Armchair, This German Astronomer Views the Heavens through His Giant Telescope, Moving the Ponderous Mass at Will with the Controls behind Him



# Weights 25 TONS



Gaseous Nebula and, at the Right, the Huge Bright Disk of Orion; Our Sun, Earth and Planets Would Be Only a Small Bright Spot in This Enormous Nebula, Billions of Miles Away

without appreciable loss in the round trip.

The star is far too close to the tremendous heat of its big neighbor to support life, though its size, practically the same as our world, is sufficient to hold together an atmosphere. That life does exist in some of the thousands of universes outside our own was the belief expressed recently in a lecture by Sir Oliver Lodge. He only gave voice to the opinion held by many astronomers, when he pointed out that the distribution and arrangement of matter throughout the many worlds which we can see is such as to be entirely suitable for the growth of life.

"I think it reasonable to infer the existence of innumerable habitations on which life in its various grades may have developed as it has on this earth," said Sir Oliver. "It seems absurd to suppose that this earth is the only habitable world merely because it is the only one of which we are certain.

"What we find here is that life, vegetable and animal, makes its appearance wherever conditions allow. We may reasonably suppose that the same sort of thing would happen elsewhere and that amid the hosts of worlds there must be multitudes in which those conditions, whatever they may be, are satisfied.

"The universe is a sort of law-abiding organism or organization, the parts of which are worlds. It affords evidence of design and planning. There is great variety, but nothing haphazard. It is rather like looking at a workshop full of running machines. The machines appear self-working and complete, but they are full of evidence of design to accomplish a certain object.

"From what we know of details here, it is legitimate to surmise that the object of all worlds in space is to provide opportunity for life and mind to develop, and that the arrangement of matter in the



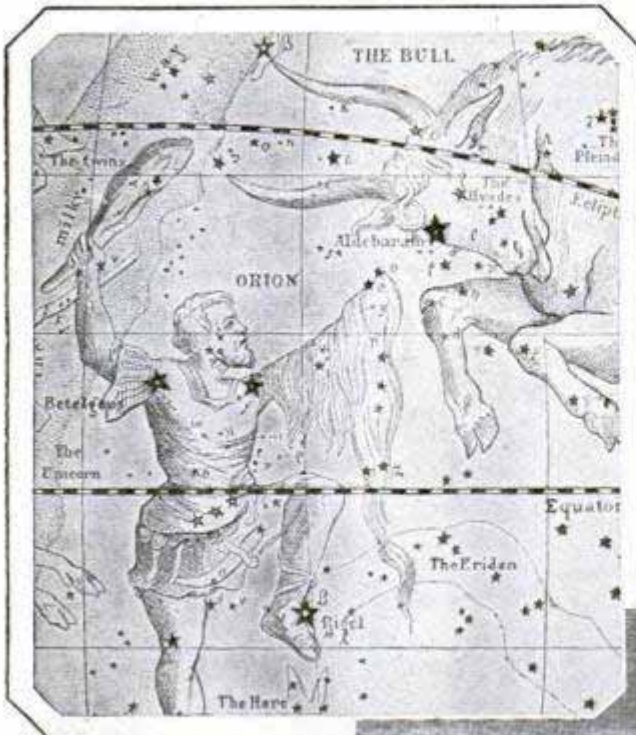

Many of Our Star Names Come Down from Ancient Folk Lore and Superstition, That Ascribed Fanciful Forms to the Heavenly Groups, as in the Old Drawing Above; at Right, Druid Sun Worshipers Are Depicted at Their Orisons at Stonehenge in Ancient England

universe is subsidiary to that important end."

The study in recent years of innumerable far-distant nebulae, as the astronomers call them, has revealed that, far outside the farthest stars which we see as part of our own universe, are thousands of vast groups, each forming a complete world in itself. Every solid nebula studied has presented exactly the same form—a cartwheel, thicker in the middle than at the edges. The most powerful telescope can photograph these nebulae only as blurs of light, though each is probably composed of millions of stars as large or larger than our sun.

The distance to some of the nearest of these world groups almost defies the imagination. Despite the immensity of our own solar system—the orbit of Neptune

is almost 5,000,000,000 miles across—it takes light, traveling 186,000 miles a second, or about 11,000,000 miles a minute, slightly over eight hours to traverse the distance. Yet distant stars and nebulae have been measured which are so far away that it takes a beam of light 11,000 years to reach the earth, and there are others still farther away.

The hundred-inch telescope at Mt. Wilson observatory is capable of picking up about 300,000,000 stars and nebulae. The latter include not only such near neighbors as those 11,000 light years away, but, way beyond that, float a million more spiral nebulae, whose distances are said to range from 500,000 to 10,000,000 light years.

Some of the distant star clusters which are visible to the naked eye are quite well known, the Pleiades, for example. But to fly to them at 11,000,000 miles a minute, the speed of light or of a radio signal, would take 325 years, and when you arrived, you would find them to be a group of about 500 stars, as big as, or bigger than, our sun.

How the distance to these stars is

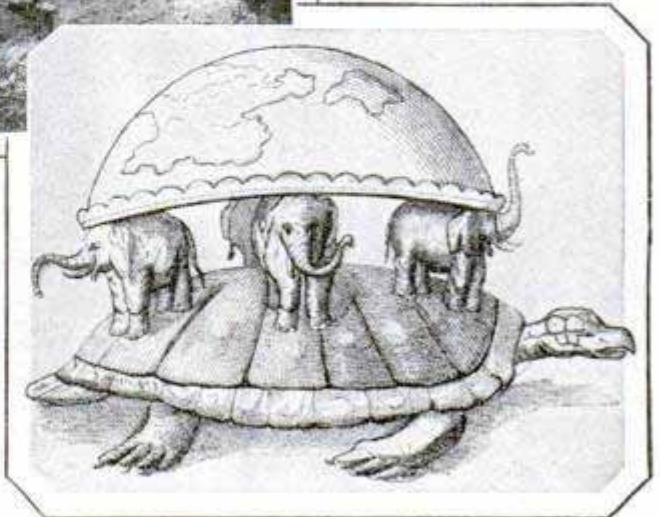
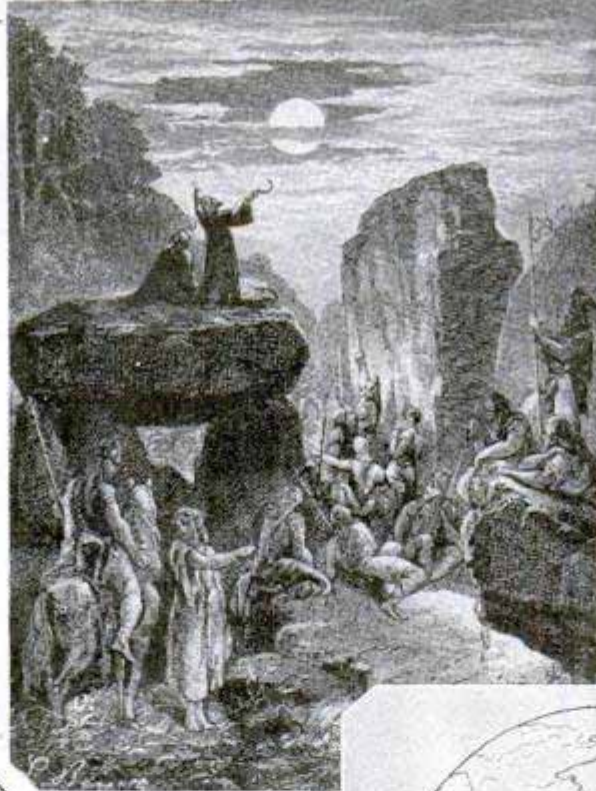

The Hindus in Olden Times Pictured the Earth as a Hemisphere, Supported by Elephants Standing on a Turtle's Back



890

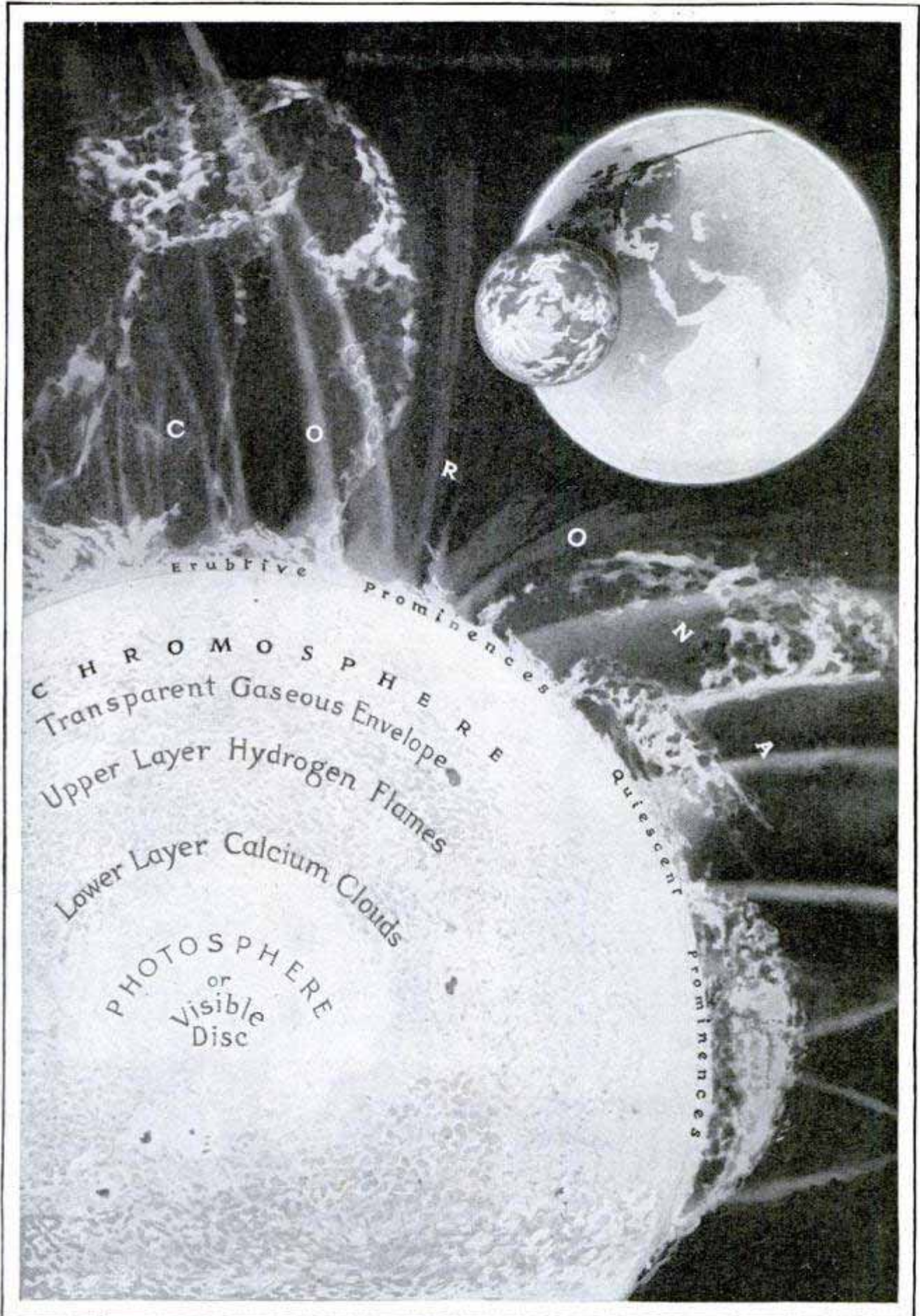

Copyright, S. W. Clatworthy

Cross Section of the Sun's Corona and Flaming Layers Which Surround the Real Molten Sphere; Above Is a Sketch Showing How the Moon Casts a Small Shadow on Part of the Earth





Spiral Nebula Unwinding, Above, and, Right, Series of Photographs of a Number of Stars Taken at Fifteen-Minute Intervals; the Variations in Intensity Proved One Was Really a Double or Twin Star, the Two Revolving around Each Other

measured is a marvelous story of human ingenuity. When the distance to the moon, a matter of some 250,000 miles, is measured, observations from two points as far apart, say, as France and America, are sufficient. If a sight is taken from France and the angle measured, and a similar sight taken from America, it is as easy to calculate the point where the lines meet—the length of the base line between the two observatories being known—as it is for a surveyor to work out a similar problem in triangulation on an open prairie. For some of the close planets, the diameter of the earth itself is a sufficient base line, giving angles of sufficient size to be readily and accurately measured.

But in 1838, when Bessel undertook the first measurement of the distance to a star, he was faced by an infinitely more complicated problem. Imagine constructing a triangle with a one-inch base and two sides eight miles long, and then try to measure the angle of the sides to the

base. Yet that was the proportion of his angles, though his base line was the earth's orbit itself, a distance of 186,000,000 miles. After years of calculation, he figured that the star known as 61 Cygni, in the constellation of the Swan, was forty trillion miles away.

The use of the earth's orbit as a base line was a clever idea, but made the work rather slow, for it was necessary to make one observation and then wait six months for the earth to reach the opposite side of its orbit before making the second. In fact it was so slow, with the necessary calculations, that only sixty stars had been fixed up to 1900.

Then Yerkes observatory, at Williams Bay, Wis., undertook to take over the task, using a photographic method. The idea was as clever as Bessel's. If you hold your pencil in front of your eyes and look at a picture on the wall, and then close first one eye and then the other you will see that the apparent position of the pencil, in relation to the picture, shifts from side to

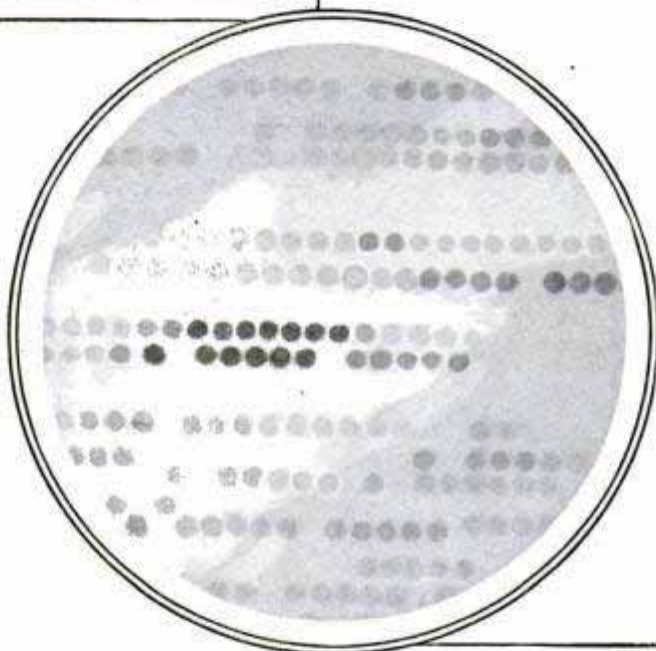

The Familiar "Falling Star," Really a Meteor, Sometimes Crosses an Astronomer's Plate, Leaving a Perfectly Straight Mark



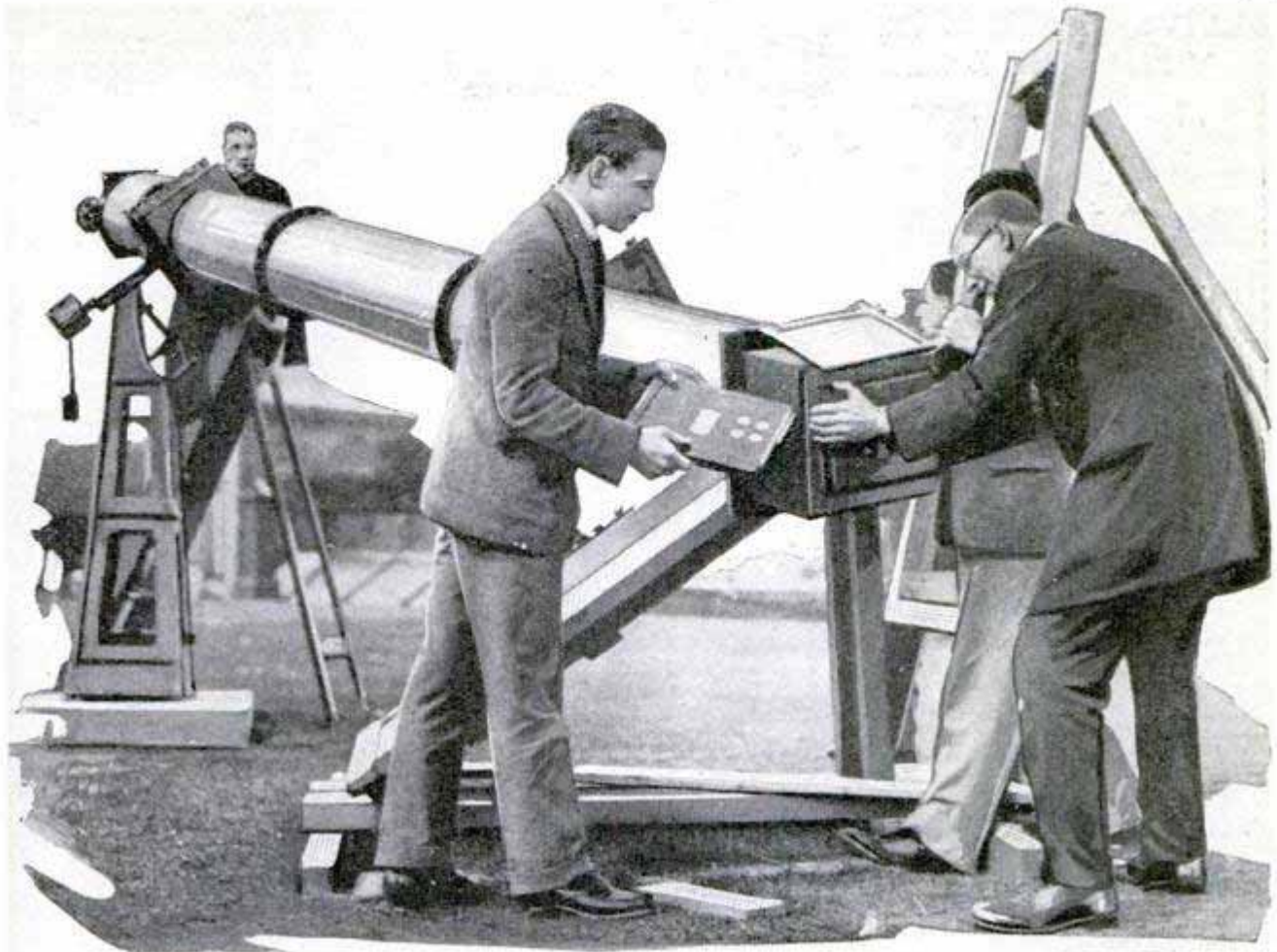

Students of an English College Helping Their Professor Place a Plate Holder on a Nineteen-Foot Camera to Photograph Recent Eclipse of the Sun, Visible Only Overseas

side. The Yerkes astronomers used a near star instead of a pencil and the distant star as a picture, and took photographs six months apart, on opposite sides of the earth's orbit. The result was that the near star had shifted in its apparent relation to the distant one, and the seeming shift could be measured and angles and distances calculated. In this way stars as much as 375 trillion miles away have been accurately located.

That, though, was about the limit of even that method, so another had to be found for stars still farther away. The sun and its planets are moving toward Vega at the rate of twelve miles a second. In twenty years this movement gives a base line forty times as long as the diameter of the earth's orbit, so observations made at twenty-year intervals, recording changes in the position of Vega in relation to inconceivably remote ones, are correspondingly larger, and the distance can be calculated. The work is made possible by the fact that vast multitudes of the stars are what is known as "fixed," mean-

ing they show no apparent change in position. Actually they are hurtling through space at tremendous speed, but the distance to them is so great that their motion is not apparent. A passenger in an airplane high above the earth, speeding at 100 miles an hour, does not feel that he is going any faster than in an automobile at a quarter of that speed, or less. The reason is that his view ranges so much farther, and there is nothing near by to help him judge his speed. Similarly, the observer on the ground does not appreciate the great speed of the airplane because of its distance. Enlarge the plane to the size of a star, but move it a few trillion miles away and you will see why the stars appear to be fixed in space.

One odd thing about distant stars is that what appears as a single one often is two, as Sirius, or more. The presence of such plural stars was first disclosed by measurements made of the light emitted by one of them, revealing the fact that the star was both approaching the earth and going away from it at the same time.



*J. J. Hamigan, Chief Asst. Editor*  
*for San Diego Aircraft Corporation*  
 968  
 3228  
**POPULAR MECHANICS**  
**DELIVER PAPERS BY AIRPLANE**  
**WITH SMALL PARACHUTE**



Delivering Papers by Airplane; the Bundle Attached to Its Parachute, Settling to the Ground

Commercial application of the airplane has been somewhat restricted because of landing and take-off difficulties, but recent experiments at delivering goods from moving ships by means of special parachutes, indicate that the number of landings may be reduced to a minimum. Shipments of typewriters have been unloaded in this way, and, a few days later, bundles of newspapers were dropped from a monoplane in California and reached the ground gently after a quick fall of but a few feet to give the parachute time to open. The chute and newspaper pack weigh but five pounds. They are released when the pilot pulls a cord.

**HOW SALVAGING FARM TOOLS HELPED RESTORE SOUTH**

3347 Following the disastrous floods in Mississippi, Arkansas, Louisiana and Tennessee, relief agencies were faced with the immediate problem of saving human lives and then putting farms into operation

again as quickly as possible. A detail of that task involved a gigantic salvaging plan which saved millions of dollars and enabled growers to plant crops before the season was too late. Officials of the International Harvester company consulted their records, and wherever they found a tractor or other farming implement they had sold, whether it was paid for or not, they went to the owner with this proposition: "Get your wrench and oilcan and come with us. We stay with you until your tractor is running and the service will not cost you a cent." In a few weeks, more than 2,000 farming implements, that had been under water, were in working condition again and the owners were spared the expense of buying new equipment and the cost of delays that would have resulted otherwise. With the encouragement of Secretary Hoover, farmers were induced to plant corn, alfalfa, oats, soy beans and other crops that had never been raised before in these sections.

**DISAPPEARING BED INSIDE AUTO LATEST CAMPING COMFORT**

2906 Concealed behind the rear auto seat when not in use, a spring bed with felted mattress, four feet wide and over six feet long, is quickly extended and saves carrying extra luggage on the running board. It clears the seats, the cushions are not used as supports or removed, and, hence, it does not damage the upholstery.

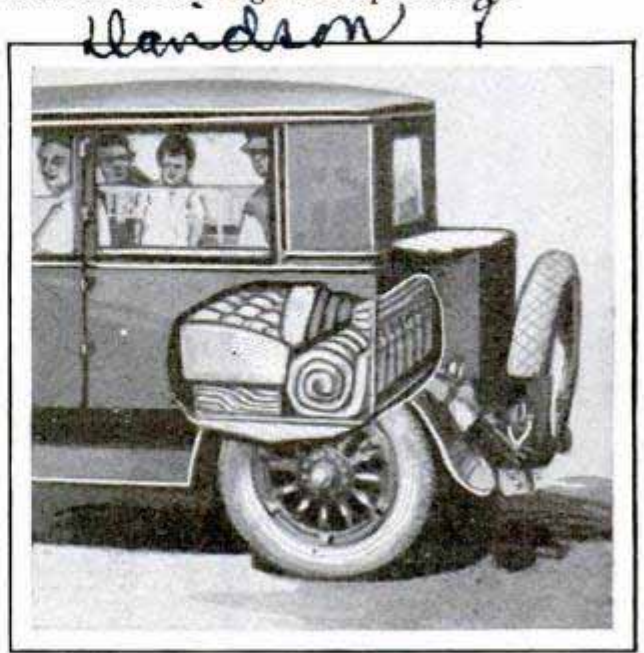

Drawing to Show How the Bed Folds Up under the Rear Auto Seat When Not in Use

*Davidson In. A. Car Bed Co. 1231 Hill St*



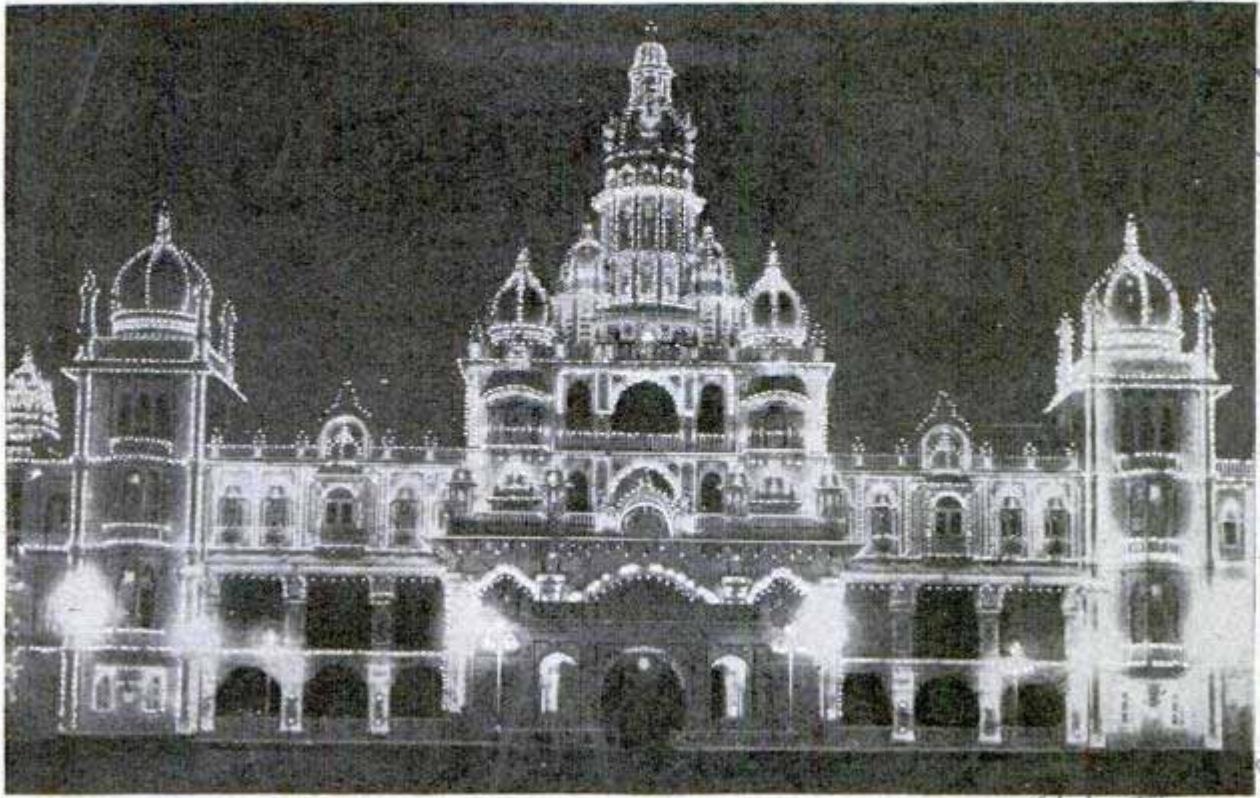

Palace of the Maharajah of Mysore as It Appeared under Electric Illumination; the Display Reveals the Intricate Details of Indian Architecture

### SPLENDOR OF ORIENTAL PALACE MAGNIFIED BY LIGHTS

How modern genius can be applied to emphasize the wonders of bygone days is well illustrated in the use of electric lights on famous buildings. Architectural details are thus more clearly revealed and the beauty of the structure heightened instead of lost in the night. When the maharajah of Mysore entertained the viceroy of India recently, he spared no pains in lavish hospitality, a feature of the occasion being the illumination of his palace, which glowed like luminous lace.

### FIRE EXTINGUISHER LIKE PISTOL WORKED WITH ONE HAND

To operate a hand fire extinguisher now on the market, you simply pick it up, point it at the fire and pull a trigger. An effective stream of flame-smothering liquid is projected from the barrel of the pistol-shaped unit to a distance of thirty-five feet. The extinguisher is easily reloaded, and working



parts are not subjected to corrosion by contact with the chemical. The article is also serviceable as a substitute for a revolver in repulsing attacks, and, as only one hand is needed to use it, the other is left free for aid in defense or putting out fires.

### CYLINDER LOCK IN DOOR KNOB GIVES ADDED PROTECTION

A door knob that locks and simply spins around when it is secured, without opening the door, is one of the most recent accessories for protection. It is quickly attached in place of the ordinary knob and fits any door. When unlocked, the knob operates the latch in usual fashion, but when the key is turned and the door locked, the outside knob merely turns, without engaging the latch.



Write our Bureau of Information if you wish to know who makes or sells any article described in this magazine. Send no postage; the service is free.

*Liverpool & Metropolitan  
Pittsburgh, Pa.*

*2699 mfg Co,  
The Kinney*

*Junior 1 1/2 pts \$10.00  
Senior 2 pts \$12.00*

*3143.*

*\$2.50*

*Chicago - D. W. Randolph*

*Battle Fire Extinguisher Co,*



2890 Cont, Ulene Waache,  
1823 Q St. Washington  
J.C.C.

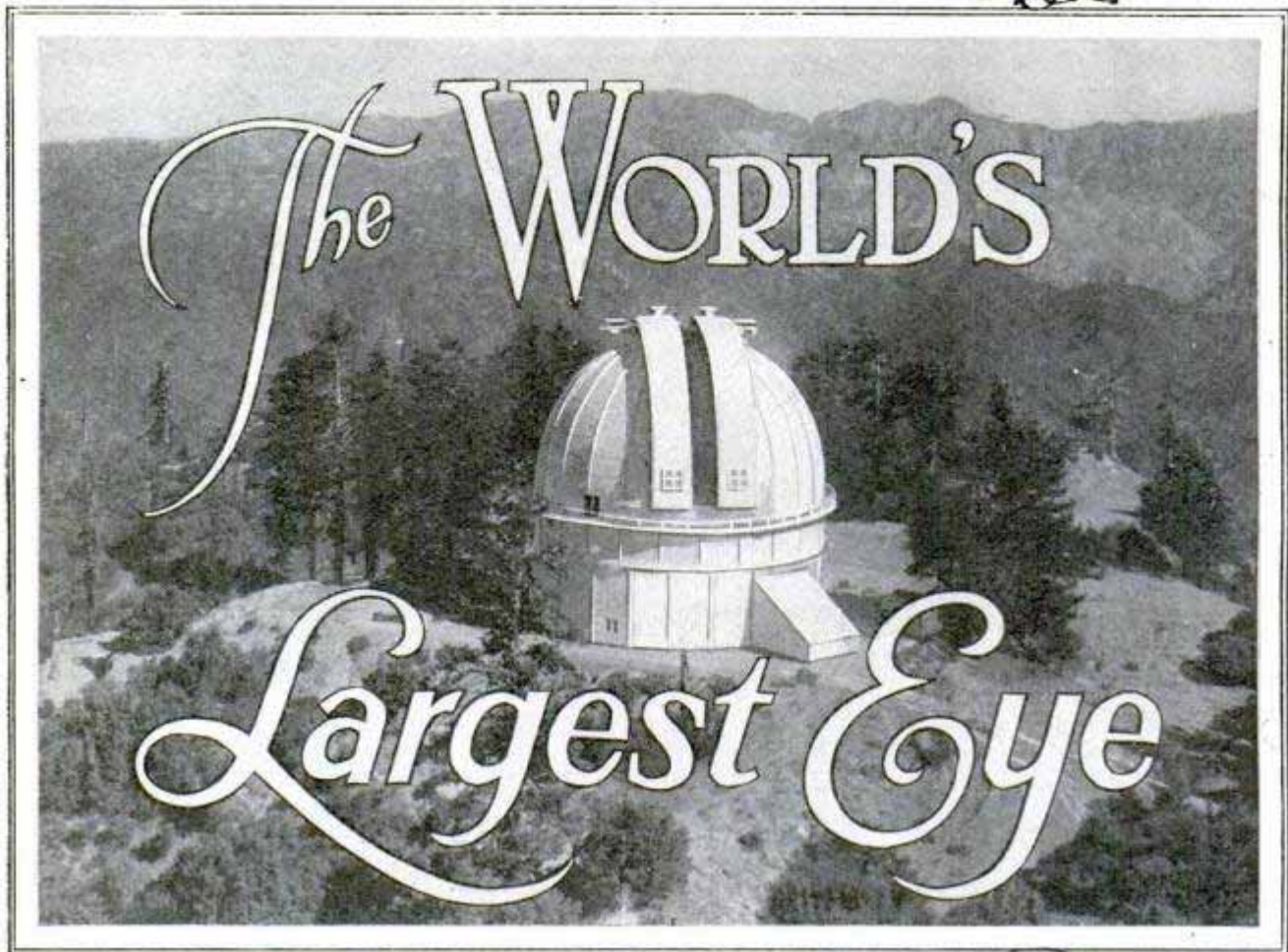

Mount Wilson Observatory, in California, Which Houses the Only Hundred-Inch Telescope in the World; It Is a Reflector, Employing an Eight-Foot-Four-Inch Polished Mirror

**T**HE largest eye in the world is planned for southern California. It will be ten feet in diameter.

A reflecting telescope it will be called. It will be set upon the summit of Mount Wilson, and its chief purpose will be to photograph celestial objects.

Nothing could better illustrate the ambition of man to extend the range of his knowledge and to overleap the limits of the faculties with which nature has endowed him. In the development of aids to vision lies one of the greatest of all human achievements. Yet the earliest telescope dates back only to 1608, and spectacles were not known until near the end of the thirteenth century.

Their invention is attributed to an Italian, Salvino degli Armati, and for a long time nobody thought of any other way to use them than by holding them on the nose with one hand while reading or writing. Pictures of the fifteenth and sixteenth centuries show people using them in that way. Later, when the supporting "bow" had been adopted—at first of

iron or leather, and then a spring—Nuremberg manufactured spectacles in enormous quantities, distributing them to all parts of the world.

Right there was the beginning. The telescope gave to man supersight, and the climax of its development will be represented by the gigantic ten-foot eye at Mount Wilson.

The astronomical observatory already there has the largest reflecting telescope in the world, with a mirror lens 100 inches in diameter; but the reflector of the contemplated instrument will be nearly half again as big, gathering a proportionately greater number of light rays from a celestial object viewed.

Reflecting telescopes are a relatively new invention. For a reason presently to be stated, they can be made much larger than those of the more familiar kind, which are called refracting telescopes. They are constructed on a wholly different principle.

Thus the huge one planned for Mount Wilson will be a tube that is a mere skel-



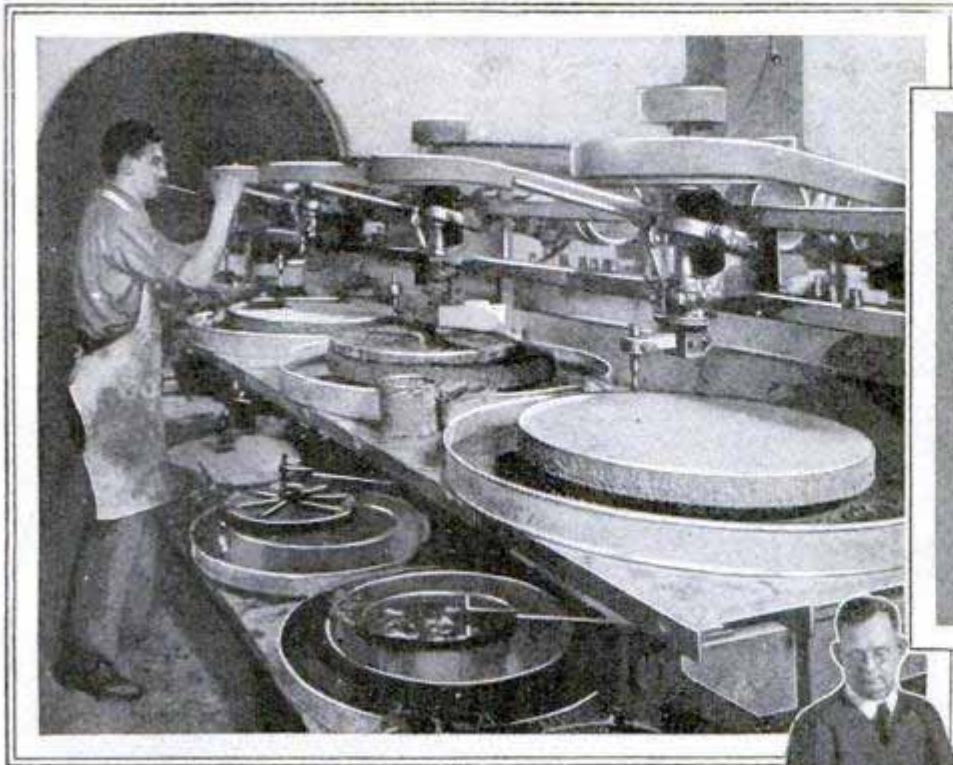

Twenty-Six and a Half Inch Object Lens for a Big Refracting Telescope, Ground and Mounted Ready to Be Installed; the Workman Gives a Comparison to Show the Size of the Big Glass

Grinding Big Telescope Lenses for Refractor Instruments, Which Are Similar in Design to Opera Glasses or Binoculars, the Light Being Focused by a Series of Lens Groups; Right, Optical Glass Fresh from the Melting Pot

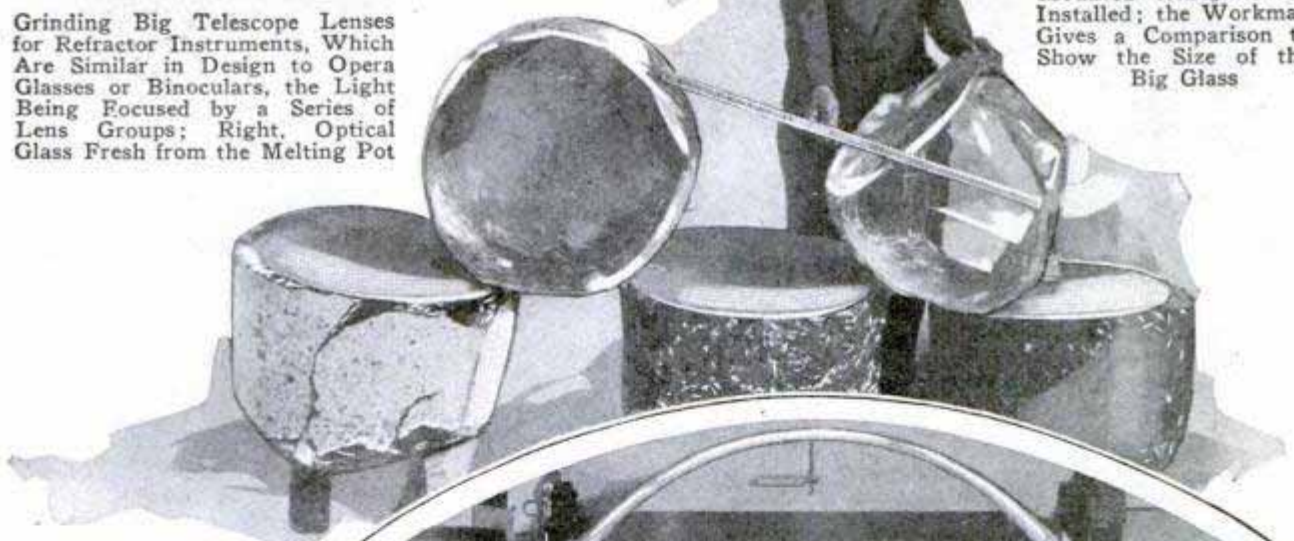

The Mirror of the Hundred-Inch Reflecting Telescope at Mount Wilson; the World's Largest Refracting Instrument Is the Forty-Two-Inch Lens at Yerkes Observatory, Williams Bay, Wisconsin

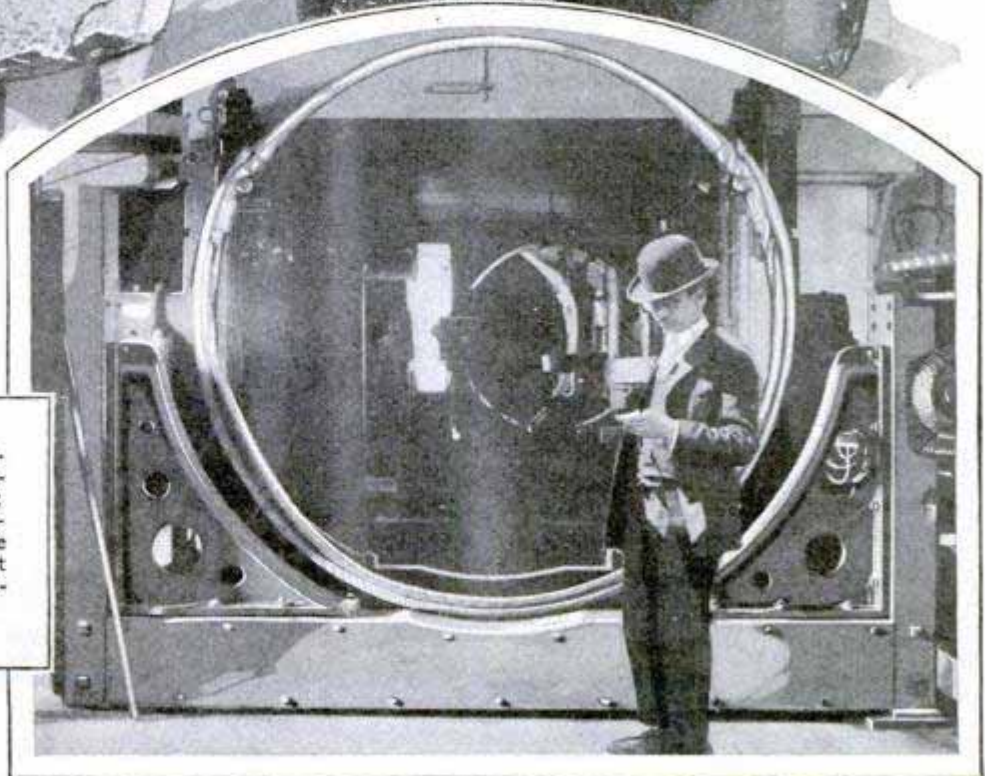



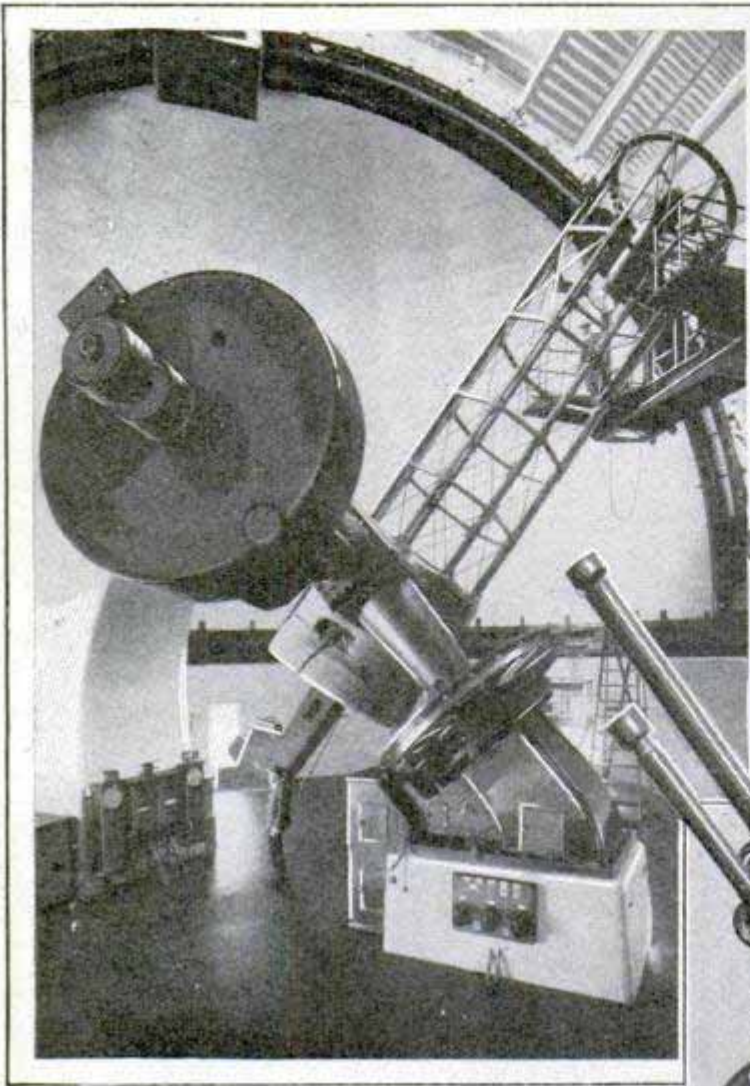

Seventy-Two-Inch Reflecting Telescope in the Astrophysical Observatory, Victoria, B. C., and a Portrait of Galileo, with Two of His Tiny Telescopes

eton, built for lightness, without any "object glass." At the bottom of it will be set the disk-shaped glass mirror, ten feet in diameter, a reflecting lens concaved and ground with mathematical accuracy. When observations are to be made of a star, the moon, or what not, the skeleton tube will be covered with a cylindrical envelope or canvas.

The light rays that come from the celestial object pass through the length of the tube to the mirror disk, which reflects them back in the shape of a cone, thereby concentrating them and bringing them to a focus upon a prism. The prism diverts the focused rays at right angles to an eyepiece at the side of the tube. The observer, looking through the eyepiece, sees the image of the star or other object. Or his eye may be replaced by a camera specially designed for making astronomical photographs.

The new mechanical eye at the Mount Wilson observatory will be an enormous affair, its construction requiring no little engineering skill. A solid-steel counterweight of many tons will be used to facilitate the moving of the great tube, rendering its



balance so perfect that a child can easily change its position and make it point to any desired quarter of the heavens.

The huge reflecting lens will be silvered, but not on the back like an ordinary mirror. The silver will be on the outside of the lens, on top of the glass, so that light rays will be reflected directly from the bright metal. That in itself seems odd, for silver soon tarnishes, and one might suppose that its usefulness as a reflecting surface would thereby soon be spoiled. Undoubtedly that would be the case, were it not for the fact that the disk will get a fresh coat every two weeks, being lowered for that purpose into a tank of molten silver. In order that changes of temperature may not affect its shape, a specially contrived refrigerating apparatus will be used in summer to keep it cool.



In making an object lens for a large refracting telescope, the chief difficulty is to get a piece of glass big enough that is of the requisite purity and flawlessness. That is what puts a limit on the size of ordinary telescopic lenses. But there is no such limitation where reflecting telescopes are concerned, because a few flaws more or less in the glass do not matter. It is covered by a silver coat anyway, and the main requirement is that it be ground to a concavity that is perfectly true.

The most important recent advances in astronomical knowledge have come through the invention of the reflecting telescope. It is particularly well adapted for celestial photography. Pictures taken at Mount Wilson, with the 100-inch instrument, of landscapes on the moon, the surface of the sun with its whirling storms of fire, so-called "spots," and distant nebulae which are believed to be universes distinct from ours, are marvelously beautiful, far surpassing any heretofore produced.

It is a far cry from the telescope of Galileo to the monster sky-searching instruments of today. The invention, like many another, was an accident. In October, 1608, an apprentice in an optician's shop at Middleburg, in Holland, playing with some lenses, found that by holding two of them in certain relative positions, he obtained an enlarged inverted view of objects. His master, Hans Lippertuy, having his attention called to the phenomenon, fixed a couple of lenses in a tube and showed the device as a toy in his window. It could see a man two miles away!

Galileo, then residing in Venice, chanced to hear about this curious "spyglass," in June of the following year. He made several telescopes. With his fifth he discovered Jupiter's moons, opening new worlds for human discovery.



Studying an Enlarged Reproduction of Fingerprints for Better Identification; Minute Marks Are Preserved

**FINGERPRINTS ENLARGED TO AID IDENTIFYING CRIMINALS**

For more accurate comparison and study of the fingerprints of criminals and suspects, a means of magnifying them without spoiling or altering the distinguishing marks has been devised. Some of the prints are enlarged as much as 500 times. In this size, they are effective as courtroom exhibits in presenting evidence and accentuating telltale features.

**TRAFFIC SIGN IN SILHOUETTE IS MORE EASILY READ**

1955

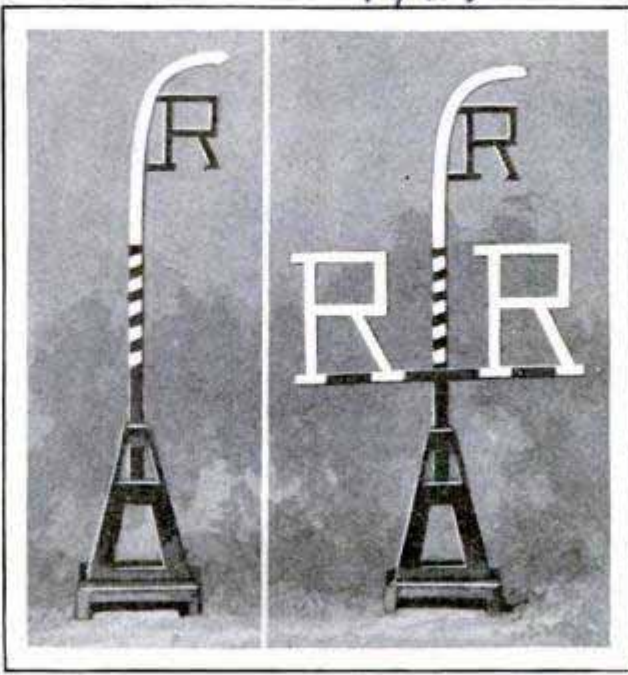

Easily Read in Frost or Storms; the Silhouette Traffic-Signal Posts for Highways

For greater visibility, auto-traffic signs along the highways are written in silhouette lettering, with conspicuous markers near by. Tests have shown that this style does not become obscured after frosts or storms so readily as printed ones. The plan may be adapted for directing airplane traffic as well, for the letters may be laid out on top of roofs or on a landing field.

Finger print is best. Los Angeles Police Dept. H. L. Carroll

cmd. P. J. Bachus



3049

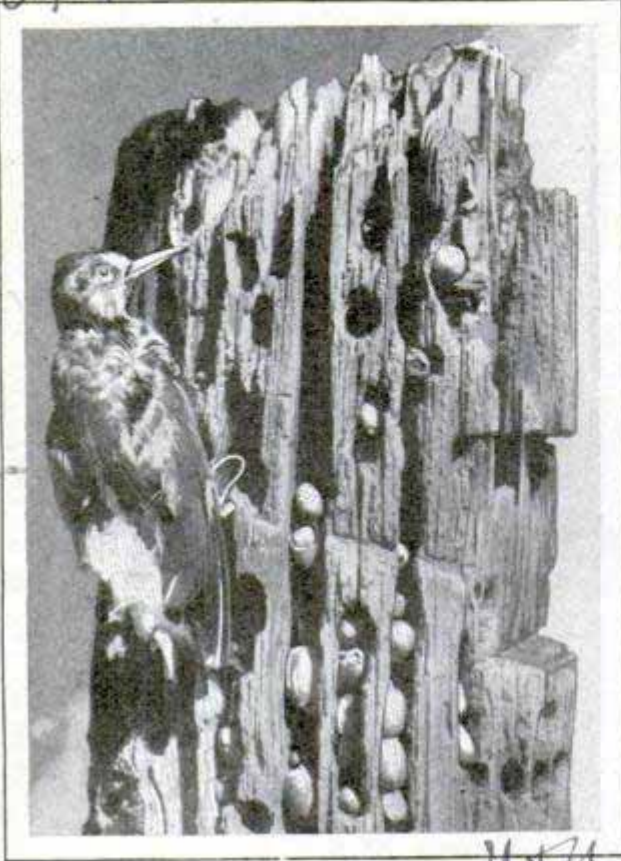

Niches in the Wood Afford the Bird Convenient Storehouse for Food but Are Disastrous to the Timber

**THRIFT OF WOODPECKER HARMS POWER LINES' POLES**

Woodpeckers devour many harmful insects, but also do considerable damage to wooden power-line poles by using them as storehouses for their food. As the accompanying illustration shows, the birds have a habit of drilling holes in the wood and inserting acorns and other morsels. The acorns decay and sometimes harbor worms, which the bird relishes. Holes in the pole weaken it and expose it to rot. Along some of the lines that pass through extensive wooded territory special patrols are maintained to keep the woodpeckers and other birds away.

**UNDER WATER LIGHTS IN POOL HELP PROTECT SWIMMERS**

To eliminate shadows and enable the swimmers to see the bottom of the pool more clearly, lights have been installed under the water in an outdoor pool at Jefferson Barracks, Mo. They cause no glare and eight lighting units are sufficient for the tank, which is 130 feet long and fifty feet wide. The lights are inclosed in specially constructed projectors.

*Large Marine Service  
Transportation Bldg  
Washington D.C.  
NO SHORTAGE OF TIMBER IN U.S.  
ASSOCIATION DECLARES*

Contrary to public opinion, there is an abundance of timber in the United States at the present time, according to the National Lumber Manufacturers' association, and the problem of a future supply is one of sufficient consumption now rather than overuse. In other words, the body points out that it is not economical to preserve "ripe" trees indefinitely, for only by marketing those that are ready for use can the industry be assured of reasonable profits from the work of growing trees.

3269 **FIND SHIPS HIDDEN BY FOGS WITH ELECTRIC BEAM**

Will the smoke screen, laid down to protect battleships, become obsolete and useless? Possibility that it may, is suggested in a recent invention by John L. Baird, television expert, whereby an electric beam is made to penetrate smoke and mists and produce a sound whenever it meets an obstruction. The nature of the obstacle is determined by focusing the beam upon a screen attached to the apparatus. Tests with the outfit on a coastal steamer, running between Dundee and London, indicate that the electric eye will be of great help in locating vessels in fogs, thus resulting in a decrease in maritime accidents with a possible reduction of insurance rates as a consequence.

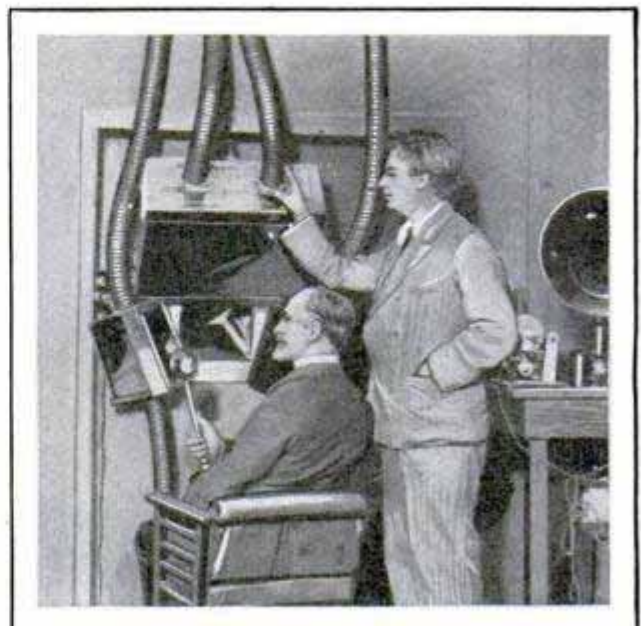

John L. Baird, Standing, with Sir Arthur Keith at the Electric Apparatus Which Penetrates Mists

*General Electric Co. Schenectady*

*Reserve Officer Civilian*

*London, England*



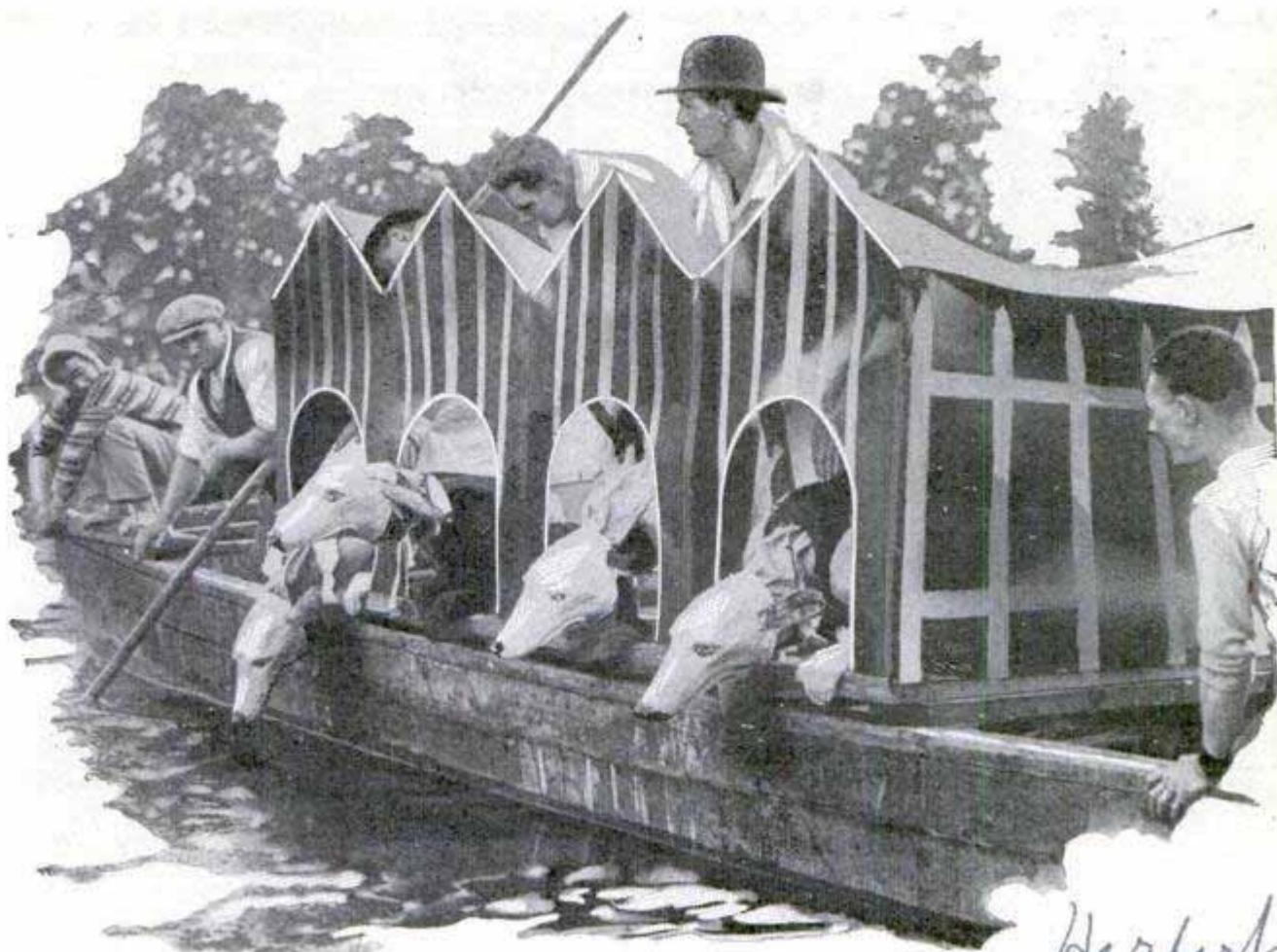

Swimmers in the Dog Masks Starting the Race from the Punt Disguised as a Row of Kennels; the Event Proved an Interesting Novelty at an English Meet, Due to Popularity of Greyhound Racing

**SWIMMERS IN DOG DISGUISE  
— ADD SPORT TO RACE**

The popularity of greyhound racing was reflected at an English resort recently when swimmers donned papier-mache dog masks and leaped from a punt disguised as a starting box for a race. The masks were adjusted so as not to interfere with the swimmers' vision or breathing and, being of light weight, caused little, if any, discomfort to the wearers.

**AIR-CUSHION PAD INSIDE SHOES  
RELIEVES FOOT ILLS** 3300

Adaptable to the form of the feet, an inflated air cushion fitted inside the shoes, is said to provide a helpful support to the arch, does not change the shape of the shoe and keeps the foot from sliding off, a common trou-



ble with many styles of supporters. It is light in weight and, since it can be inflated to different degrees, solves the problem of raising the arches gradually.

**CHAIR WITH LOCKING JOINTS  
HAS LONG LIFE**

Parts of a chair now on the market are held together by a patented mortise-and-tenon lock joint as well as glue. This joint is so adjusted that the harder a member is pulled, the more securely it holds, as the pronglike extensions of the joint become more firmly imbedded in the wood.

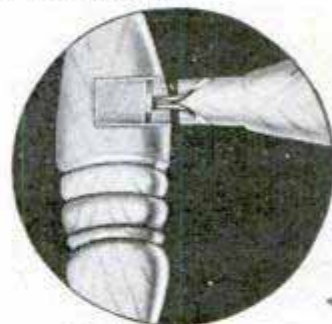

Experts have estimated that the average American breathes as much as five times his own weight in soot and dirt every twelve months.

*Herbert*

*Colonial Furniture Co., Wash. D.C.*

*Pneumette, Inc. 64 Water St. 108 40th St.*



Standard Cell Company of New Jersey, 26 Broadway New York  
over chair rights in 3340

Mr. A. de Jacobo, 2460 Deepwell St.  
2106 Denver Colo.

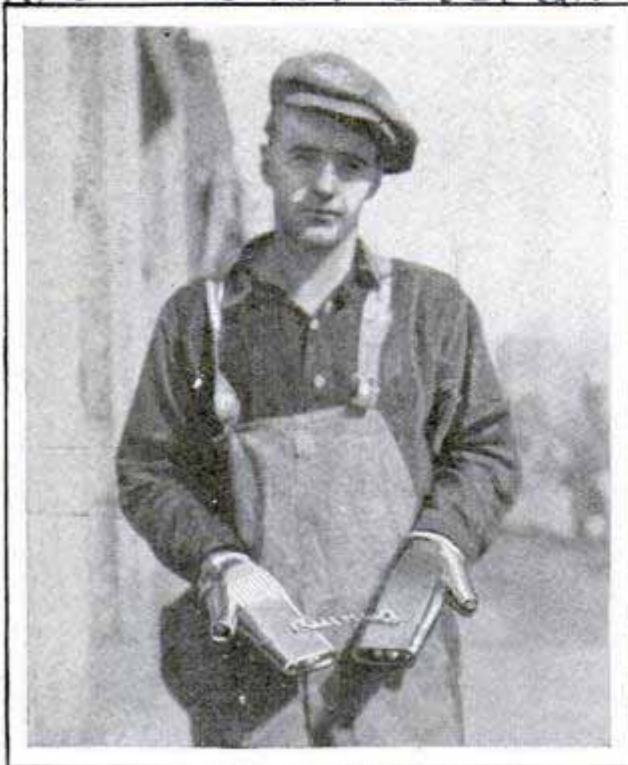

For Added Protection against the Dangerous Captive; Steel Mittens That Prevent Using Gun

### STEEL MITTENS AS HANDCUFFS PREVENT USING GUN

To restrain prisoners from using knife or gun, steel-mitten handcuffs have been devised by a western man. They are hinged in the palms so that the hands may easily be inserted.

### GASOLINE FROM COAL AVERTS THREATENED OIL SHORTAGE

After fifteen years of toil, a synthetic gasoline, the invention of Dr. Friedrich Bergius, has been placed on the market in Germany. The introduction of the product in this country is not expected for some time. At the present time chemists are at work on the process which may greatly reduce the price of gasoline. The new fuel is produced by combining hydrogen gas with coal by means of high heat and pressure. The coal is pulverized and then mixed with a heavy oil to a pasty mass. This is then placed into a light steel retort and heated to about 800 degrees Fahrenheit under a pressure of some 3,000 pounds per square inch. A complex mixture of gases is obtained, as most of the carbon unites with the hydrogen. And then there are the liquid and solid compounds similar to those extracted from

natural wells. Through the principles of the Bergius process, as much as 90 per cent of the carbon in lignite, a low-grade coal, is transformed into such oil products. A ton of common bituminous coal, experiments have shown, will yield 300 pounds of gasoline, 400 pounds of heavier oils available for Diesel internal-combustion engines, 120 pounds of lubricating oils and 160 pounds of fuel oils. From these figures, scientists point out, it can be seen that any threatened oil shortage within the next century will be averted. It will seem a crime, they say, within the next few years to burn coal for fuel when it contains such valuable ingredients.

### PRINTING PICTURES MADE EASY BY COMPOSITION BLOCK

3119

An engraving block, built up of a cellulose composition, which is easy to cut in any direction, as it has neither the grain of wood nor the fiber of linoleum blocks, has been patented by an Omaha engraver, who is marketing the blocks in any desired size, as well as tools for cutting anything from a simple poster to the finest of line work. The block is said to be durable, and will stand up under press runs of 20,000 or more without showing appreciable wear. It is suitable for all forms of work, from simple monograms to large advertisements, and, as its surface is colored, it is easy to engrave. The outline of the drawing can be placed directly on the block with pen or pencil.

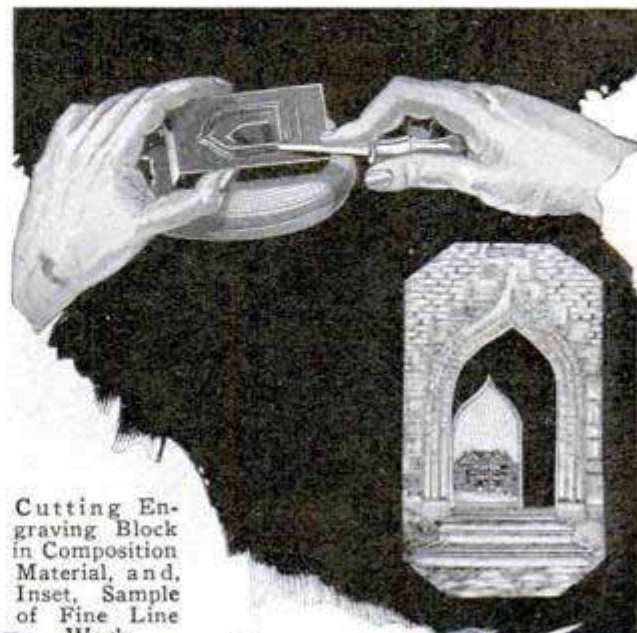

Cutting Engraving Block in Composition Material, and, Inset, Sample of Fine Line Work

Bab Printing Block Co  
2307 407 Omaha Neb



itudes.  
 ey are pla  
 quefied. para  
 mass. The p  
 emoved from  
 rom the surf  
 product of st  
 pheric influ  
 yet to deter  
 process.  
 of anima.  
 "Mo  
 by t"

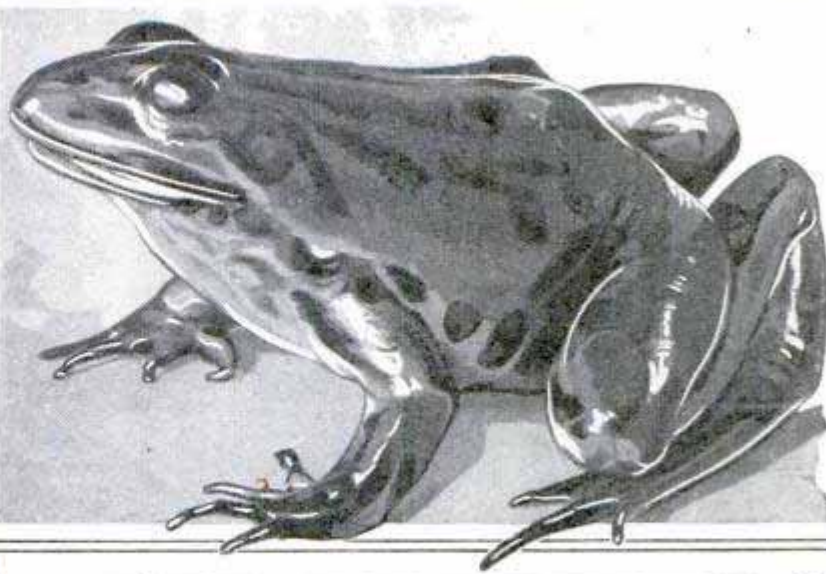
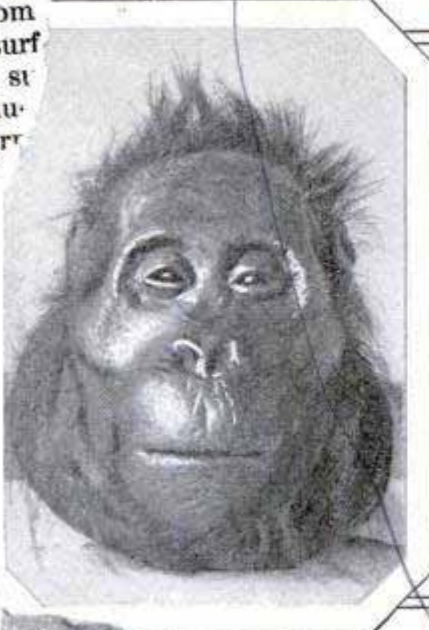

ir.  
 dev  
 of  
 Vie  
 is  
 para  
 quef  
 thei  
 ing  
 bath  
 from  
 once  
 The  
 mic

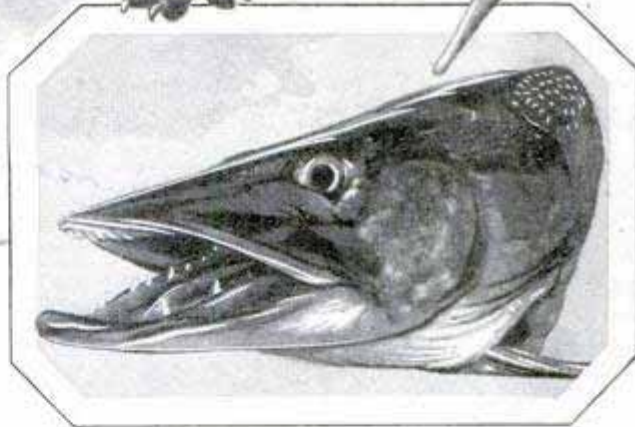

From specimens Which Have Been Preserved by the Paraffin-  
 with Treatment, Making Use of Alcohol or Other  
 liquids Unnecessary; Some Animals Can Be Kept  
 without Removing Internal Organs.

**PARAFFIN BATH FOR SPECIMENS PRESERVES NATURAL FORM**

Animal and vegetable specimens are said to be preserved in their natural form and colors more faithfully than can be done by other methods through a process developed by professors at the university of Vienna. Because the samples are kept dry, making the use of alcohol or other liquids unnecessary, the system promises great aid to biology and botany students. A first step is treatment with a special fixing liquid which prevents deformation and shrinking. Following this, the specimen is subjected to a paraffin and preserving bath, during which it absorbs the substance, becoming stiff, and the water content is driven out. The fixing preparation is applied as soon after the death of the specimen as possible. It is said

that the process can be performed without first removing an animal's organs. In the field of botany, it promises aid, as the natural colors and form of flowers and leaves are preserved.

**SHOWERS OF "VOLCANIC ASHES" PROVE TO BE POLLEN**

3240 Botanists rather than geologists were required to solve a recent mystery in Alaska—the appearance of a fine yellow dust that was at first supposed to be ash from a distant volcano. Examination showed that the substance was pollen from spruce trees.

*W. H. S. Cooper*

*such as used in microscope -  
 Williams Brown Earle*

*Herald 9/11/27  
 Los Angeles*



978  
1675

*Advertisement by  
Adirondack Power  
Light Corp*

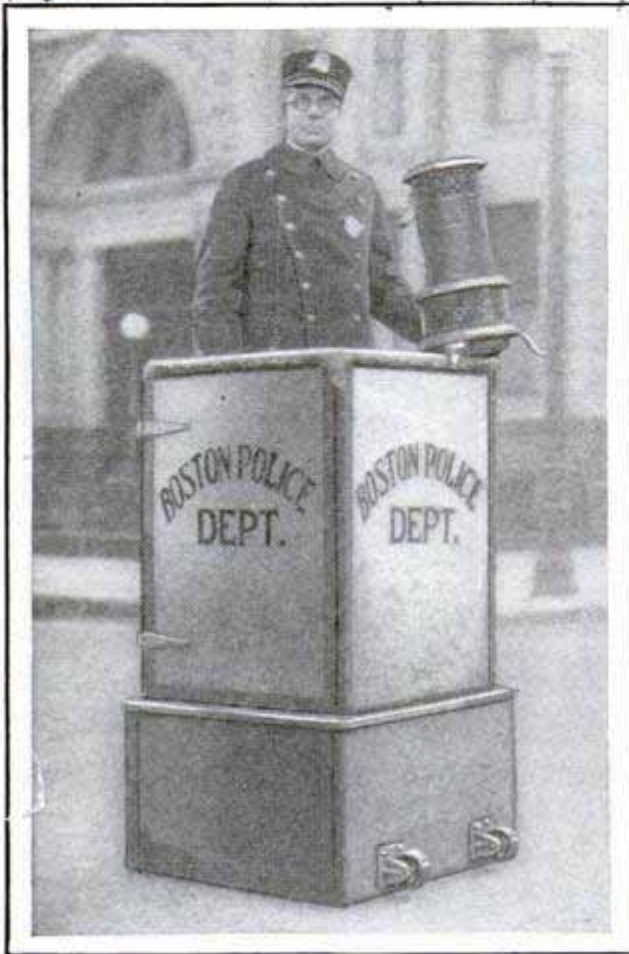

Comfort for the Traffic Policeman While on Duty; Booth and Oil Heater Keep Feet Warm

### HEATER FOR TRAFFIC POLICE MAKES WORK EASIER

With an oil heater and a protecting shield about his post, a traffic policeman in Boston is guarded from chill winds and dampness while on duty. The walls about the station help retain the warmth from the heater and protect the officer's feet.

### LIGHT STREET LAMPS BY RADIO IN EASTERN CITY

Similar in many respects to the familiar radio transmitter, a long-wave, low-powered vacuum-tube sending set, operated for a few seconds daily, controls all the street lights in the city of Glens Falls, N. Y. The system, developed by engineers of the General Electric company, marks the first commercial application of radio to such a function, and is so regulated that instead of spreading out in all directions as they do in radio broadcasting, the impulses are confined to the wires to receiving stations. There switches are tripped, relays operated and lights turned

on or off. Only five seconds are required to illuminate them; when the operator turns the "off" button in the power house, the transmitter automatically operates for ten seconds and cuts off the lights. Among the advantages claimed for the system are the following: existing circuits are used for transmission of control energy; the usual distribution of power is not affected in any way; interference with telephone and radio space is avoided, and the system is equally applicable to grounded and ungrounded distribution installations. Lightning, switching surges or stray currents do not operate it, and since the "on" and "off" operations are distinctive, there can be no doubt as to the condition of the circuit at the remote point of control.

### CHIMNEY CLEANER AND DRAFT 2252 COMBINED IN ONE

Better regulation of the furnace draft and a means for quickly cleaning the chimney are afforded in a patented installation introduced by a western inventor. It consists of a brush, operated on an endless chain by a crank, to scrape off soot and dust inside the flue. The door to the brush chamber, which opens at the base of the chimney, is hinged and has a chain leading to the front of the furnace for easy adjustments affecting the draft. The outfit is said to give protection against fires, reduce fuel consumption and improve the operation of the heating plant.



A Turn of the Crank Helps Clean the Chimney, as Brush on Endless Chain Inside Is Drawn Along

*Advertisement by  
Ambro Chimney Cleaning Machine Co  
Wauzau Wis*



247 Uene Wache  
18232 St.  
Washington, D.C.

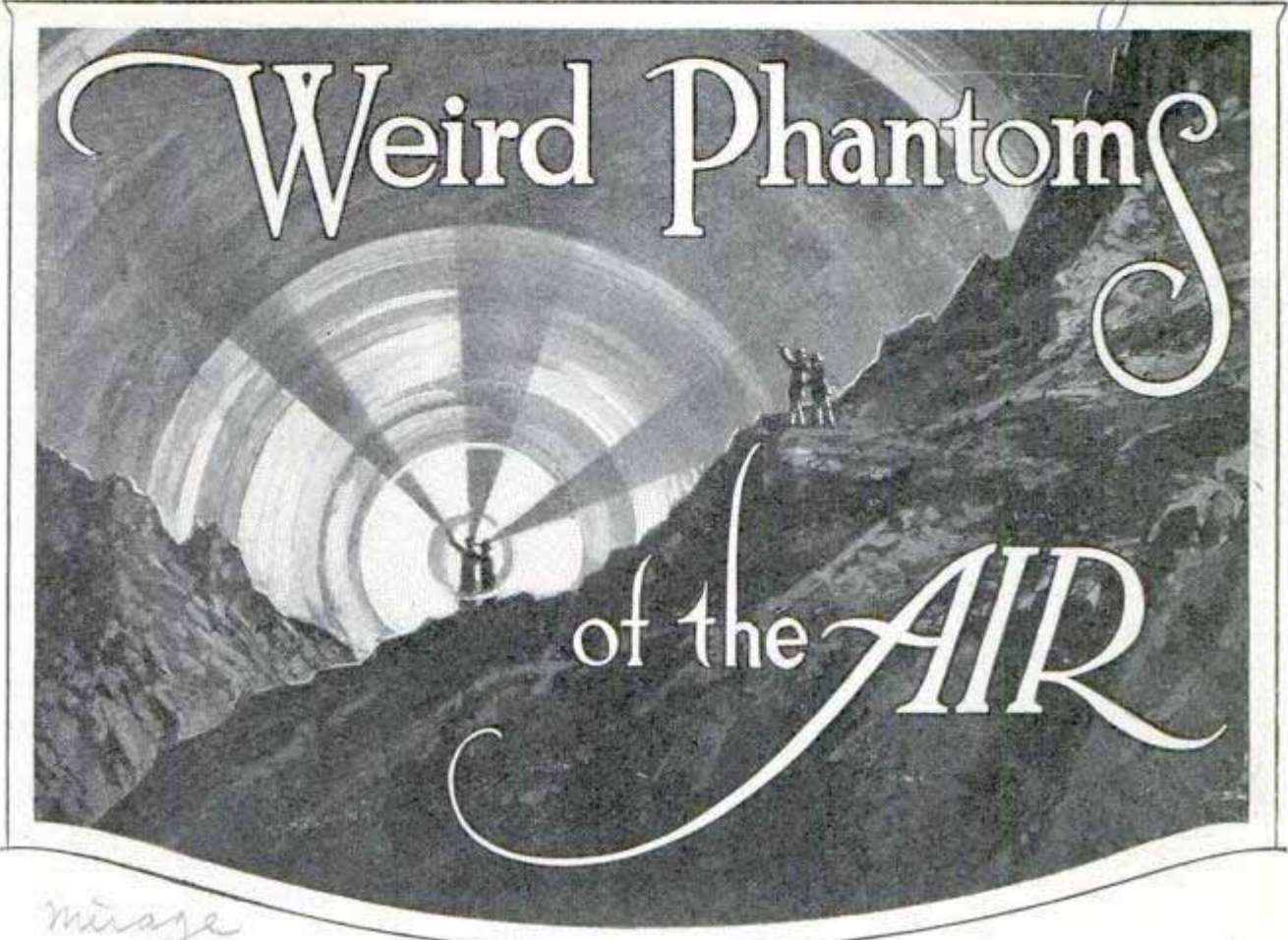

The Specter of the Brocken as Seen on the Top of the Famous German Mountain When the Setting Sun Throws the Explorers' Shadows against a Rainbow-Marked Bank of Clouds

**F**LYING across the Pacific, bound for Honolulu, Smith and Bronte, pilots of the "City of Oakland," sighted a number of islands where no islands were. When they finally reached the leper colony of the archipelago on the last drop of gas in their tanks, they believed, at first, it was only another mirage, and hesitated about picking out a place to land.

Col. Charles A. Lindbergh, on his flight to Paris, encountered the same sort of mirage, several hundred miles before he reached the Irish coast. Ahead of him he saw mountains, valleys and grassy glades that looked so real it was difficult to reconcile them to the fact, which he knew, that he was still some hours from the nearest land.

Mirages are not at all uncommon, though aviation has made it possible for anyone who cares to go up to have the chance of seeing at least one. The world's most famous optical illusion, the Fata Morgana of the Straits of Messina, has recently succumbed to modern photo-telescopic cameras and been reduced to paper.

The Fata Morgana is a mirage seen oc-

asionally from the Italian side of the straits, which lie between Italy and Sicily. For hundreds of years it has been famous as the mysterious city, popularly believed to be built on a submersible island, and home of the Fairy Morgan, sister of King Arthur of the Round Table. She, according to the superstitious Italians of the neighborhood, is an immortal princess, possessed of magic powers, and at her will the island rises or sinks beneath the sea. They tell stories of mariners lured to the misty city, cast away on its shores, and never seen again.

The phenomenon is actually an illusion—a distorted image of Messina, far away on the Sicilian side of the straits, and not, under ordinary conditions, visible to the watcher in Italy, for, because of its distance, it lies far below the horizon.

But occasionally, on the afternoon of a hot day, when the sea is unusually calm, a layer of air, cooled by the water, overspreads the sea, with a warmer layer just above it. This juxtaposition of two layers of different densities causes a bending of light rays toward the observer, and he act-



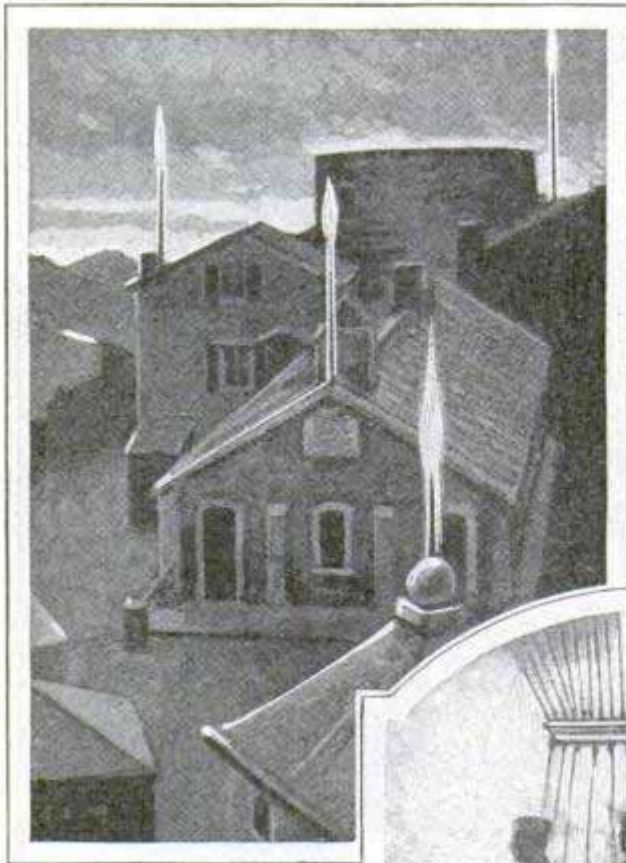

ually sees objects which are below the horizon. The appearance of the mirage is always preceded by the forming of a streak of mist along the horizon where the two layers of air meet, due to the condensation of moisture in the calm air by the coolness of the sea. Presently the mist dissolves, and the magic city begins to uplift itself in the distance, its towers and palaces taking form with all the seeming of reality, only to melt away, become indistinct, and disappear after a little while.

The image is not a true picture of the hidden city across the straits, but is made up of indistinct and wavering lines, the distortion accounting for the fact that the superstitious natives never connect the vision with its actual cause.

Occasionally the atmospheric conditions may be reversed, with the cool air above a warmer layer, and then the vision is reversed, and the fairy isle of Fata Morgana is apparently seen beneath the surface of the sea. That is the form of the true mi-

rage seen on the desert, while the city in the air is technically ascribed to "looming."

The most common desert mirage takes the form of a cool lake of water, which appears miles ahead of the thirsty traveler. Actually, the mirage is due to the bending of light rays in such a way that a portion of the sky appears below the horizon, giving the impression of a blue lake. Looming also is fairly common in the desert, the mud walls, towers and minarets of far-distant villages appearing in the sky. The soldiers of Napoleon on the Egyptian campaign were so awe-struck by the spectacle that they fell down and prayed.

Alaska and Greenland both are famous

for their aerial phantoms. Seamen sailing along the east coast of Greenland see amazing spectacles, due to the air over the icecap being chilled, while warmer currents lie above it. Then the light rays are bent downward and the distant cliffs, viewed through a telescope, appear as

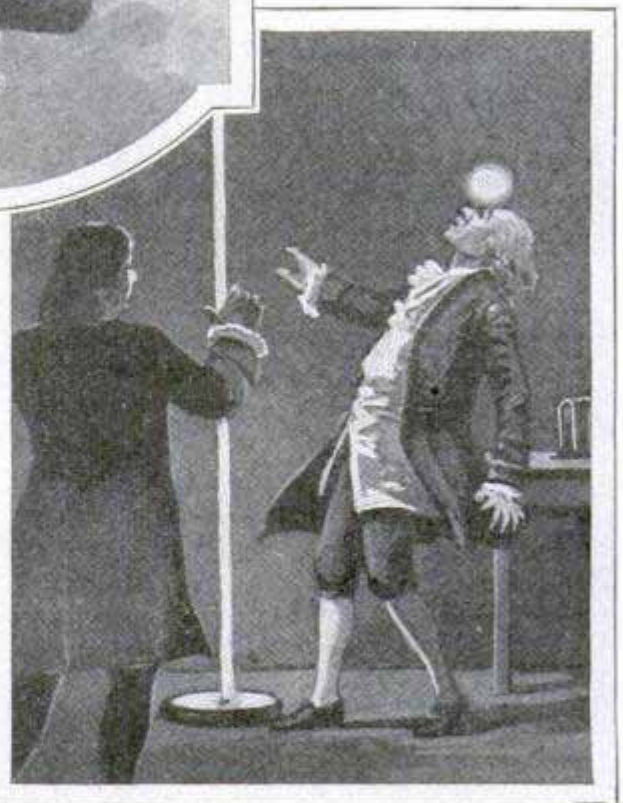
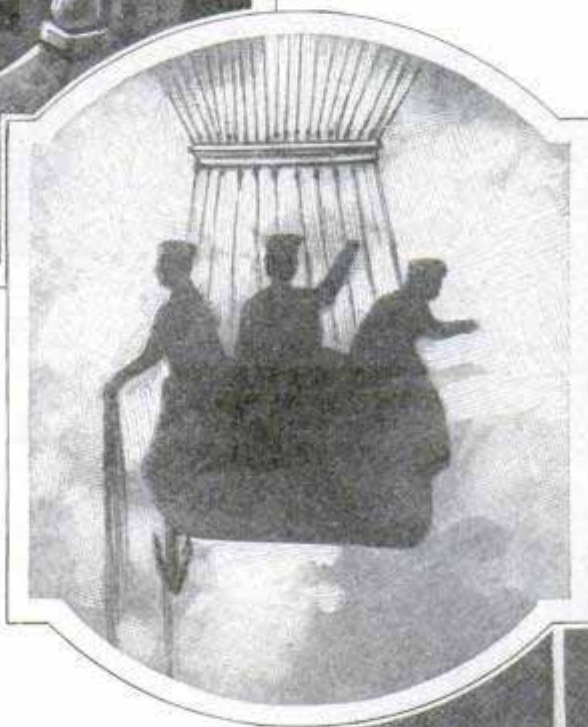

St. Elmo's Fire, Top; an Actual Spectral Image Photographed on a Cloud, and the Death of Prof. Richman, a Russian Scientist, from Lightning



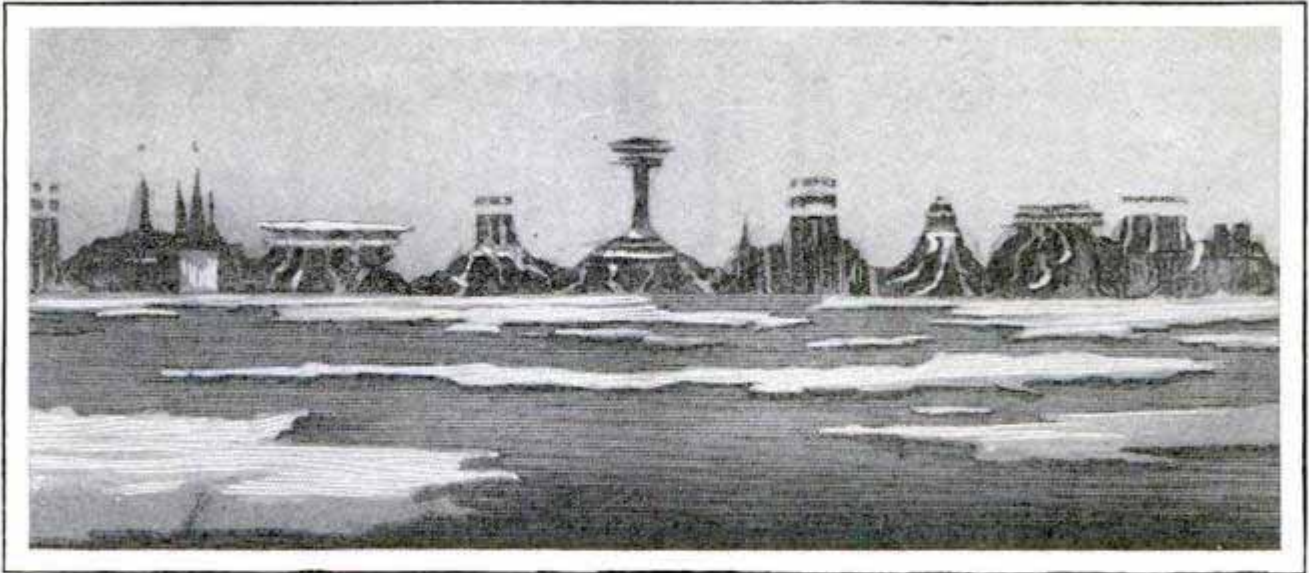

Spectral Image Sketched from a Ship off the Coast of Greenland, Showing the Spires and Towers Produced by Distortion of Light Rays in Two Currents of Hot and Cold Air

huge cities, with domes, minarets, obelisks and medieval fortifications. The structures have all the appearance of being substantial, save that their forms are constantly changing.

The Silent City of Alaska occasionally seen above the great Muir glacier, is a similar phenomenon. It looks so much like an ancient fortified city that spectators have often sworn they saw people walking in the streets. Actually both the visions are due to distortion of icy pinnacles and peaks.

It isn't necessary, however, to go to the desert or the arctic wastes to see mirages, for aviators encounter them regularly in flying through clouds. Drops of moisture in the atmosphere break up the light and form marvelous rainbows, which, unlike the bows seen on land, are complete circles, as the eye is not limited by the horizon. Instead of the single or occasional double rainbow on the ground, there may be many of them, one inside the other, and, if the position of the sun is right, in the exact center of the concentric bows will be the image of your airplane. The image is simply the shadow of the plane, thrown by the sun on a near-by cloud.

The famous Brocken specter of Germany, and similar illusions seen by mountain climbers, are due to the same cause. The phenomenon was first observed on the Brocken, a noted German mountain, when an explorer was startled to see what he described as an enormous giant walking along through space. The sun was

behind him at the time and threw his shadow on the cloud bank, greatly magnified, and as the mountaineer walked, the shadow appeared like some advancing giant. Around the specter is often seen one or more rainbow circles.

Not all mysterious phenomena are as easily explained. No one, for example, has ever been able to account for ball lightning, first recorded when the pious worshipers of Tours, France, saw a huge ball of living flame hover over the head of Bishop Martin while that prelate, afterward made a saint, was dedicating a cathedral. Yet, the appearance of these huge balls during thunderstorms is not at all unusual, and many have been startled by seeing them hovering in the air, rolling through a house or across the ground, sometimes striking the earth and rebounding into the air, and again bursting with a terrific thunderclap.

Dazzlingly bright, they are sometimes white, sometimes blue, and again red. Some who have seen them have described a peculiar hissing, humming sound as they moved, and their speed may be fast or slow. They apparently have an inclination toward entering houses, floating in through open doorways or windows or coming down the chimney. Now and again they set fire to buildings: occasionally they kill people. In one recorded instance, a lightning ball killed a dog in a girl's lap without harming her.

In size, they may be anything from that of a golf ball to several feet in diameter.



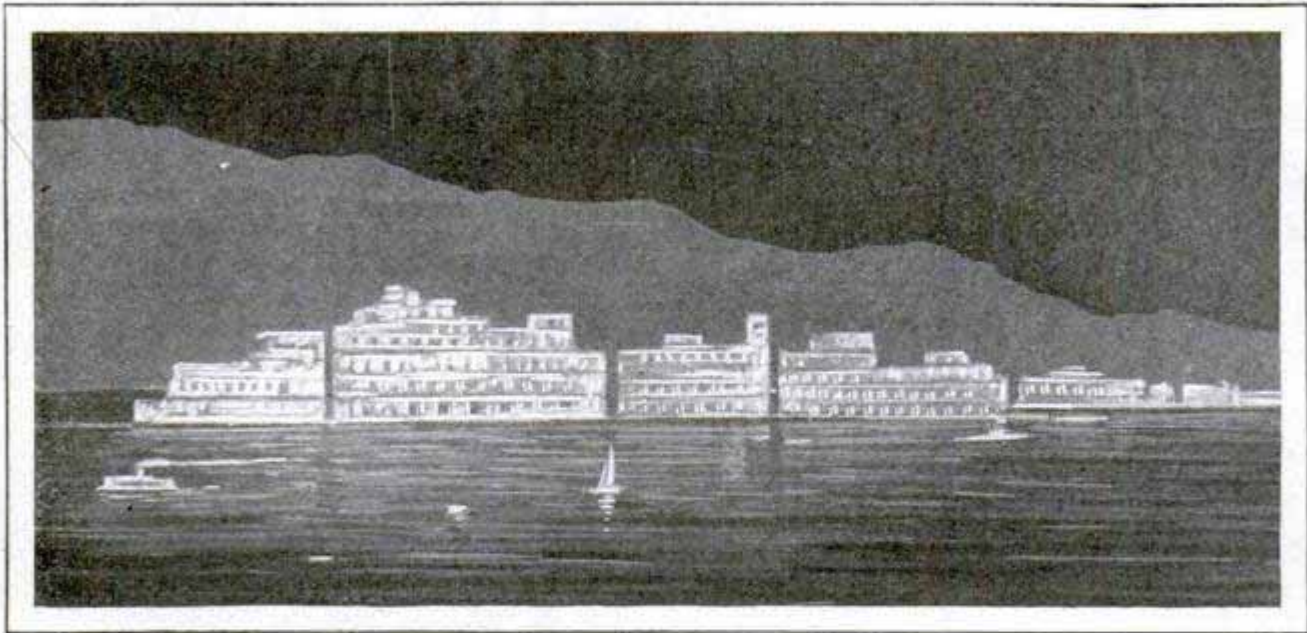

Photograph of the Fata Morgana, the Illusion Which Brings the Picture of the Distant City of Messina over the Curvature of the Earth, to Make It Visible from the Italian Shore

During the progress of the tornado that struck Louisville, Ky., in March, 1890, numerous balls of living fire, the size of oranges, added to the fright of the terror-stricken victims. In the darkness, all of the lights of the city having been put out, they rolled about the streets and along telephone wires and the cornices of buildings, and finally exploded with tremendous reports.

A Russian scientist, who tried to duplicate Benjamin Franklin's kite experiment, failed to take proper precautions. A ball of lightning ran down his kite string, blew up, killed him and knocked his assistant unconscious.

On high mountain tops, tufts of light often appear about persons' heads. At sea the same thing is seen on the mast-heads and rigging of vessels. It is known as St. Elmo's fire. It may sometimes be seen springing from church steeples or other prominent points. It is not at all mysterious, being merely a static discharge such as the familiar "brush discharge," seen about high-tension electrical apparatus when operated in the dark.

**FLYING BICYCLE TO HAVE SPEED OF FIFTY MILES AN HOUR**

Revival of the bicycling craze is seen as a possibility in the invention of a Viennese engineer who has added wings and a propeller to the unit for travel through the

air. He hopes that the rider will be able to attain a speed of forty to fifty miles an hour, rise from the ground at will, reach altitudes of 3,000 feet, and all with practical safety. Tests with a quarter-size model of the machine have justified his predictions, he asserts. The propeller is sufficiently high above the bottom of the rear wheel not to interfere with travel on the ground; the entire outfit is to weigh not more than 100 pounds. The wings and guiding planes are controlled by moving the handlebars.

2049

**GAUGE TO PLACE DOOR HINGES SAVES TIME AND ERROR**



To simplify the task of fitting hinges, a gauge is hung from the top of the door and the size and positions of the hinges indicated on the wood by adjustable cutter heads. A rap of a hammer on each of the three marking units is sufficient to outline the places to be chiseled out.

Repeating the operation against the jamb, insures accurate matching.

3213

Michael Rosehard no. Thomas  
Wilmington, Pa.



**PROFITS FROM PONTOON BRIDGE  
REWARD BUILDER** 3279

Ability to serve the community in an emergency has put dollars into the pocket of an Oregon man and prevented serious delays in travel. A flood wrecked the steel bridge over the Rogue river at Galice, but one of the enterprising citizens quickly secured a franchise from the county court and constructed a pontoon bridge, on four anchored scows, at a total cost of not more than \$700. Tolls have paid for the bridge, and more besides, while the steel viaduct was being rebuilt on higher piers to prevent a repetition of the washout.

**RAILWAY KEPT FREE OF WEEDS  
WITH PUSH-CAR CUTTER** 3047

From an ordinary flat push car, and at an expense of about \$18, a Pennsylvania railroad foreman has constructed an efficient weed cutter to keep the right of way free from growth that damages ballast and ties. The cutter itself is like that of a farm mowing machine, and the outfit has cut more than twenty-five tons of weeds on a stretch of over six miles, doing

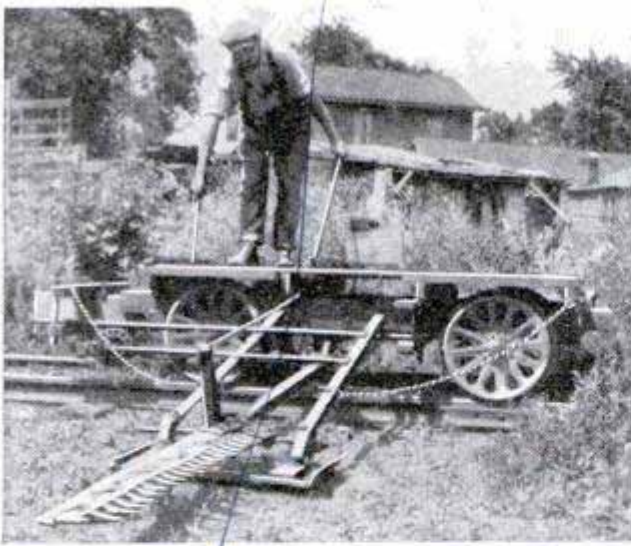

Mowing Weeds along Railroad Tracks with Push-Car Cutter, Made by Foreman at Little Expense

in four hours what would have taken six men about five days with hand tools. Only one man is required to operate it, the cutter is adjustable to different heights, makes a swath four feet wide and, when not in use, can be elevated to an upright position. A small motor car furnishes the necessary power.

*C. A. Nehren  
Columbus, Ind.*



Boguslawski with the Scale Used in Weighing Hand Pressure He Exerted in Playing Selection

**POWER NEEDED TO PLAY PIANO  
MEASURED BY SCALES**

Moissaye Boguslawski exerts hand and finger pressure of more than four tons while playing Rubinstein's "Staccato Etude," making as many as 540 chord strokes to the minute. Three pounds to a chord is about the average pressure, as shown by scales which are used as the piece is played to record the effort required. In one performance, he finished the number in six minutes with a total pressure of 9,720 pounds.

*Robert*

**CARRY LOCOMOTIVE ON MULES  
FOR MEXICAN MINE** 3202

Since many mines in Mexico are located far back in the mountains and accessible only by narrow trails, it is necessary to transport the machinery on the backs of mules. This has been successfully done with units as large as locomotives, which are thus transported, piece by piece, across the rugged country and reassembled at the mines.

Ⓢ A radio loud speaker has been successfully used in a German orchard to frighten away birds.

*Emr. A. W. Allen, 1452  
Scenic Ave.  
Berkeley, Calif.*



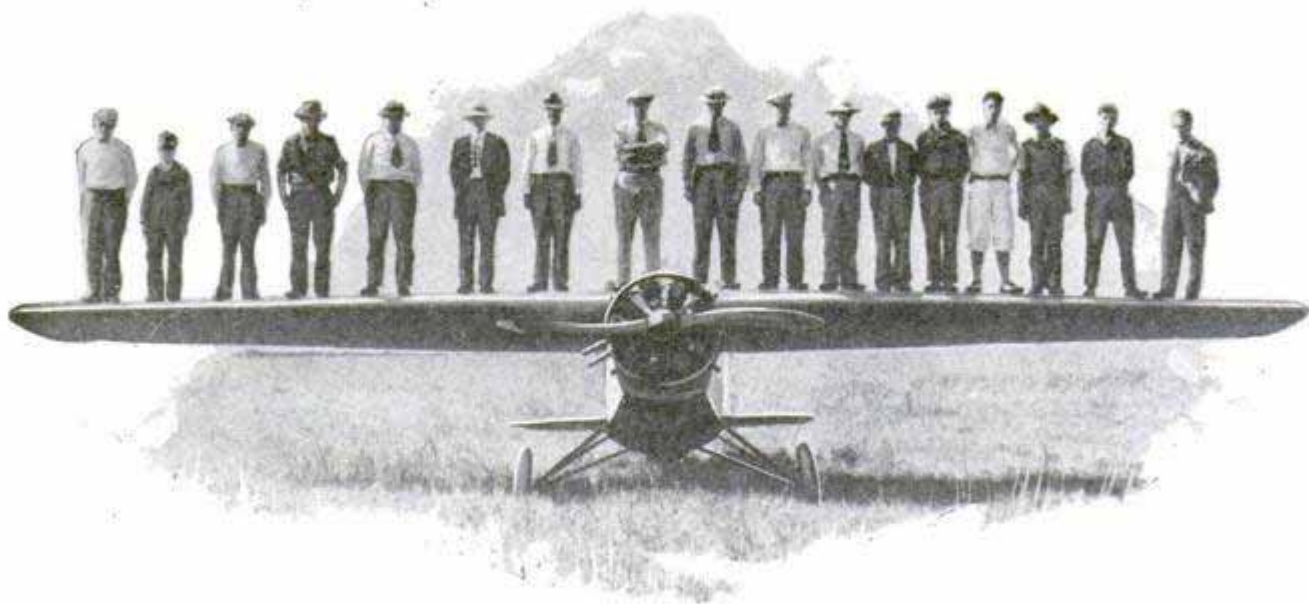

Absence of Braces under This Monoplane Wing Is Calculated to Make Greater Speed Possible; Support Is Obtained by Cantilever Construction of the Wing Itself

### PLANE WING WITHOUT STRUTS SUPPORTS SEVENTEEN MEN

To test the strength of the unstrutted wing of a monoplane recently constructed, seventeen men stood on the ship, and careful measurements showed that it suffered no damage and did not sag under the weight. The wing bracing is entirely concealed within the outer fabric and is constructed on the cantilever principle. Absence of the struts outside will afford possibility of greater speed.

son enjoyed further comfort as each seat was protected by a glass windshield, breaking the force of the breeze and warding off smoke and cinders. The protectors were designed and adjusted so as not to obstruct the view.

### RADIOMEN MAKE OWN WEATHER TO TAME STATIC

Radio manufacturers have called in the "air-conditioning engineer" to aid them in making tests on the effect of weather on reception and broadcasting. In their laboratories, temperatures from zero to 100 degrees, or higher, can easily be created and a wide range of humidity percentages produced to determine any significant reactions. Another problem of

### SHIELDS ON OBSERVATION CARS ADD TO TRAVEL COMFORT

Travelers riding on the roofless observation cars of a western railroad this sea-

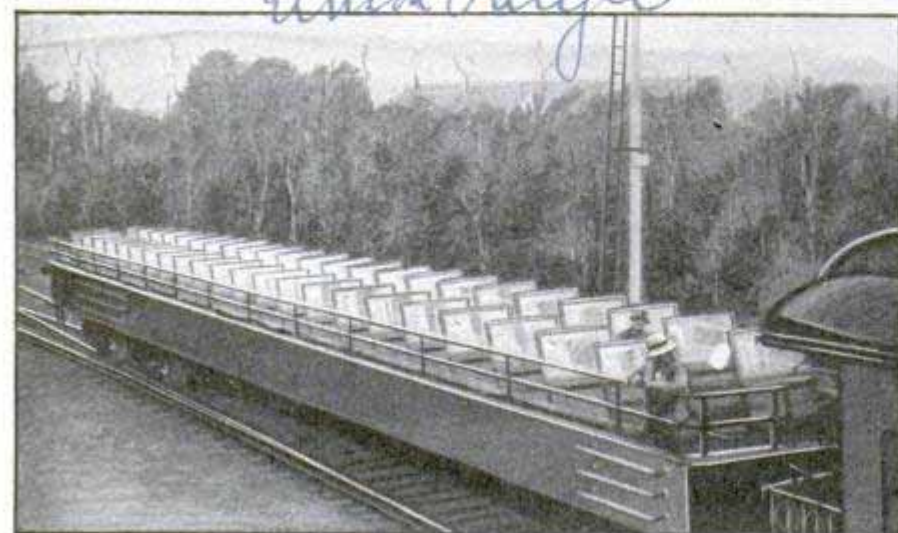

New Observation Car of Western Railroad with Seats Having Separate Windshields to Keep off Smoke and Dust

the weather-radio question is more definitely studied, namely, what the interior temperature and moisture should be to keep the set in the most satisfactory working condition. Will air that is too dry warp and damage the set as it does the piano and other furniture? What is the result of too hot and dry air on batteries? Tests have shown that dry air frequently causes the acids in batteries to creep out of the boxes upon the

Sept. 1927

Chicago Tech. news  
118 E. 6th

2647



Highfield View, Sapton View Road  
 Chesterfield, Eng. 3/83

reque:  
 W  
 as our

floor, and that is why some radio users find the best place for the batteries in the basement. A suitable mixture of moisture with air in the house is better for the radio as well as for health, the experiments have shown. In the broadcasting rooms, improved ventilating and air-conditioning apparatus has been installed, to insure more comfort for performers and better quality of the music.

**MYSTERIES OF PRECIOUS GEMS  
 PUZZLE SCHOLARS** 3259

What becomes of a diamond when it is burned up? It leaves no ash and when it finally blazes itself out, there remains not even so much as would dust the point of a needle. Sapphires are shrouded in mystery. In the Orient, there is a species of spider which dies suddenly when placed in a box along with the gems. According to one scholar, this jewel "feels with the air," sympathizes with the heavens and does not shine equally when the sky is cloudy or bright. Opals also present a number of riddles. They are comparatively soft when taken out of the earth, but grow harder after exposure to the air. Plunged into water, they disengage small bubbles of gas while their warm tints are sometimes emphasized by the heat of the hand. Turquoises are noted for their peculiar color changes. Often they are pale, then turn spotted and may change from blue to white. Their original value may double or treble in a single night because of these mystifying changes. One of the rare and costly stones, Alexandrite, has not yet been satisfactorily imitated. This gem is emerald by day and amethyst by night. Genuine rubies contain little bubbles and have a silky sheen. Experts have found such successful ways to imitate them that extensive research into the genuine stones, which are worth about twelve times as much as diamonds, weight for weight, has been dropped.

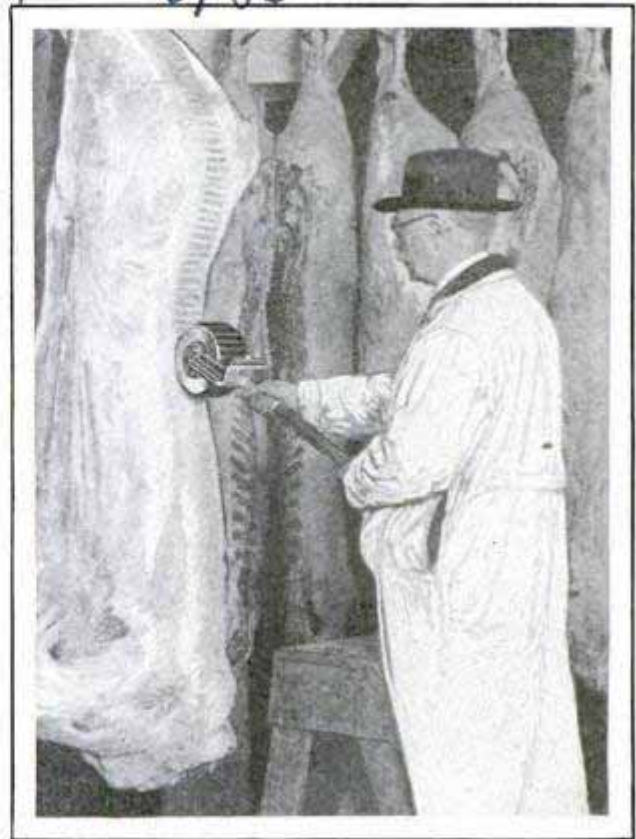

Branding Beef with the Needle Marker; Stamp Is Imbedded beneath the Surface for Permanence

**NEEDLES BRAND FRESH BEEF  
 TO IDENTIFY GRADE**

The two best grades of its fresh beef are being stamped with a needle-branding device by a packing company. The marker is constructed of phonograph needles that prick the design on the meat as the unit is rolled over it. The sign is repeated quickly, and little time is required to register the identification. It is said that 60,000 needles were required to make it.

**SERVICE STATION LIKE TEAPOT  
 USES SPOUT FOR CHIMNEY** 3198.



Teapot Service Station Attracts Attention and Proves Practical; the Spout Serves as Chimney

Novelty is the chief feature of a service station resembling a huge teapot, but the spout is also useful, for in the winter time it serves as a chimney. With the handle, it is made of clay and plaster of paris, while the outside of the building is of shingles.

N.S.U.



# BIRDS' WINGS EMULATED IN NEW SAILING YACHTS

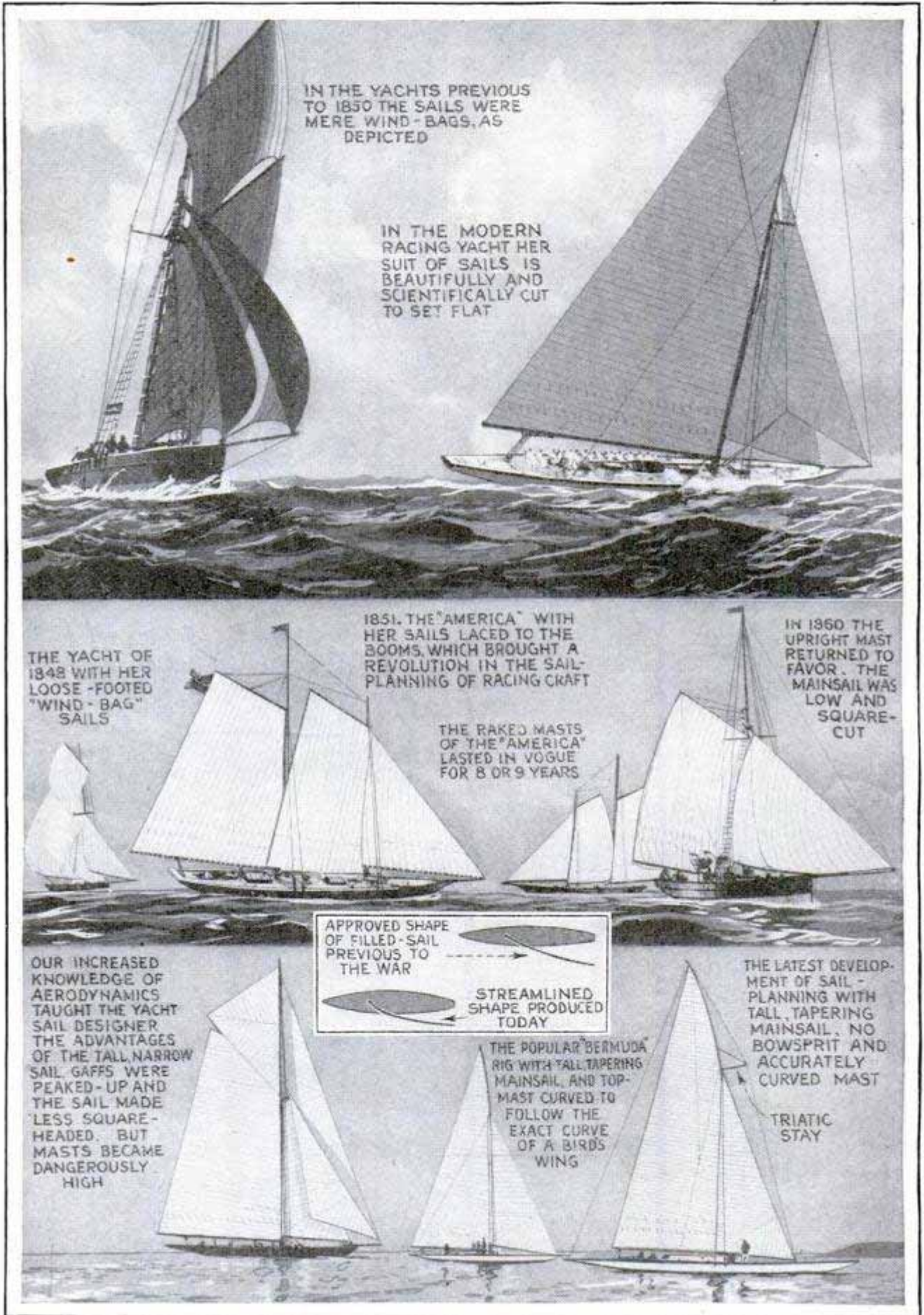

IN THE YACHTS PREVIOUS TO 1850 THE SAILS WERE MERE WIND-BAGS, AS DEPICTED

IN THE MODERN RACING YACHT HER SUIT OF SAILS IS BEAUTIFULLY AND SCIENTIFICALLY CUT TO SET FLAT

THE YACHT OF 1848 WITH HER LOOSE-FOOTED "WIND-BAG" SAILS

1851. THE "AMERICA" WITH HER SAILS LACED TO THE BOOMS, WHICH BROUGHT A REVOLUTION IN THE SAIL-PLANNING OF RACING CRAFT

IN 1860 THE UPRIGHT MAST RETURNED TO FAVOR. THE MAINSAIL WAS LOW AND SQUARE-CUT

THE RAKED MASTS OF THE "AMERICA" LASTED IN VOGUE FOR 8 OR 9 YEARS

OUR INCREASED KNOWLEDGE OF AERODYNAMICS TAUGHT THE YACHT SAIL DESIGNER THE ADVANTAGES OF THE TALL NARROW SAIL. GAFFS WERE PEAKED-UP AND THE SAIL MADE LESS SQUARE-HEADED, BUT MASTS BECAME DANGEROUSLY HIGH

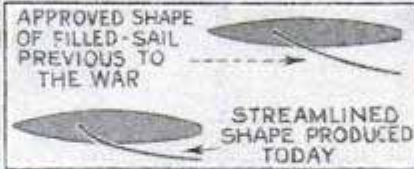

THE POPULAR "BERMUDA" RIG WITH TALL TAPERING MAINSAIL, AND TOP-MAST CURVED TO FOLLOW THE EXACT CURVE OF A BIRDS WING

THE LATEST DEVELOPMENT OF SAIL-PLANNING WITH TALL TAPERING MAINSAIL, NO BOWSPRIT AND ACCURATELY CURVED MAST

TRIATIC STAY



*W. A. ...  
and  
O. J. ...  
Univ. of California*

3086

**COLOR PHOTOS OF  
MARS RESULT IN  
NEW RIDDLES**

2255

Color photos have been enlisted on a large scale at the Lick observatory in an effort to solve some of the riddles of Mars. While new data have been gathered, still greater perplexities have resulted, for, among other things, the color pictures reveal that the Martian atmosphere contains a type of blue cloud with a composition that so far defies analysis, and this atmosphere probably extends more than fifty miles from the surface of the planet. The photographs were taken through the thirty-six-inch refracting telescope, enlarged and carefully studied, the use of ultraviolet and infrared lights enabling the photographers to show the planet with its atmosphere surrounding it like a blanket or "peeled away," reducing the interference. It has been established that the planet's atmosphere supports water-vapor clouds similar to those found above the earth and by means of the infrared-light photos, which penetrate the atmosphere, it has been determined, in the opinion of the scholars doing the work, that the "canals" on the surface of Mars are not optical illusions but are growths of vegetation and that the planet is some seventy miles less in diameter than was formerly supposed. More than 1,700 photographs were taken and enlarged in such a way as to increase the size of the observed planet about 800 times. The astronomers have made a new map of the body, using 150 photos, and propose to study it with the aid of motion pictures.



Riding the Paste "Bottle"; Replica of the Dentifrice Container Used for Amusement Purposes at Beach

**BIG TUBE GIVES BATHERS RIDE AND ADVERTISES PASTE**

At a German seacoast town, an anchored tube, representing the container of a brand of toothpaste, afforded bathers amusement. It was placed where it would float at high tide and be visible to everyone at the beach when the waters receded.

**WALL TIE FOR CONCRETE FORM SAVES WORK AND COST**

Cut-to-fit wall ties for binding concrete forms together have been placed on the market. The tie is essentially a piece of wire with lugs that fit over the edge of the form, saving the task of unrolling the wire, bending it around timbers and cutting it to the right length. With the ties, the studding can be alternated so that fewer uprights are needed. Since nails do not have to be driven into the forms, the life of the lumber is prolonged.

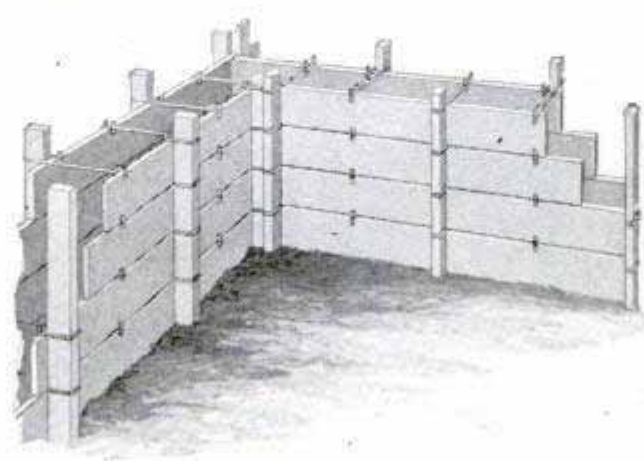

Concrete Form Fastened with Wall Tie That Is Quickly Adjusted and Saves Labor

*Ed. George Dr. Paul, O. Fog  
639 S. Washburn - Chicago*

*5th - Harwood, Dayton, Ohio.*

*Layton Sure Grip - Shore Co,  
Power Bldg*



3113 Com. Co. J. W. Hansen  
Chicago.

## MODERN VIKINGS PROVE ERICSON'S FEAT POSSIBLE

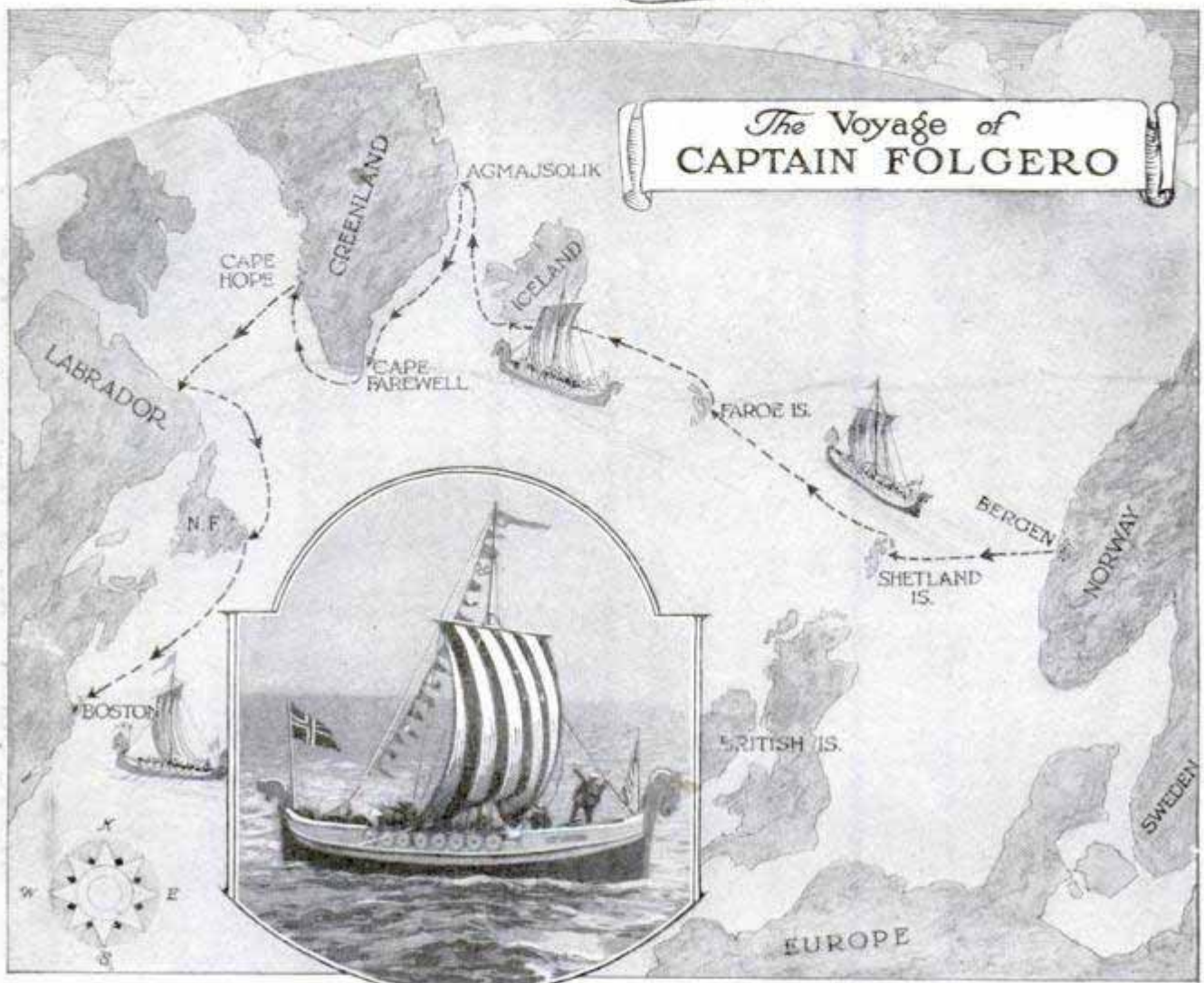

Voyage of the "Leif Ericson" across the Atlantic in the Path Followed by the Famous Son of Eric on the Voyage of Discovery That Brought Him to America

Two Viking ships, a Norse longboat of slightly more than eighty feet, constructed to the same size as one dug up in Norway fifty years ago, and a half-size replica met in Chicago recently as a result of a modern Viking's desire to prove not only that Leif Ericson's voyage of discovery to America was quite possible, but that it could have been done in a much smaller boat. The longboat was one built by Norway and sailed across the Atlantic many years ago for the World's Columbian exposition at Chicago. The half-size boat, forty-two feet over all, twelve feet nine inches wide, and drawing four feet of water, was sailed from Norway for the Philadelphia exposition, and then followed the route of its earlier and bigger prototype in a tour of the Great Lakes. Capt. Gerhard Folgero and three companions brought the little ship, with its single mast,

its oars for calm weather and its rows of painted battle shields, across the western ocean by way of the Shetland and Faroe islands, Iceland, Greenland, Labrador and Newfoundland in twenty-nine days, battling gales and ice fields for a large part of the way. A sea anchor and a supply of oil bags, to smooth the worst seas, fresh water and provisions for three months constituted their chief equipment. From Bergen, Norway, they sailed to the Faroes, by way of the Shetland group, and were given a ceremonial welcome by the Norse community. Then they bore northwest to Iceland, where Eric and Leif, his son, lived, the small boat almost foundering in a terrific hurricane on the way. It took five days to reach Iceland, and after a one-day stop to replenish the oil supply, they set sail for Greenland. After reaching it and sailing



3052

around its southern end, they crossed to Labrador, but ice blocked them, so eventually they had to go on to St. John's, N. F., before they could reach a harbor to rest and repair.

**RAIL LAYER IS RUN BY ONE MAN**

3237

Operated by only one man, a rail-laying device, constructed by a section foreman of the Pennsylvania railroad, is said to do the work of twenty men. The outfit weighs but 400 pounds and was made from odd materials taken from the railroad yards. It is especially adapted to the placing of new rails where small crews are available. It is reported that, with the outfit and six men, the inventor has laid as many as eighty-two rails in a day.

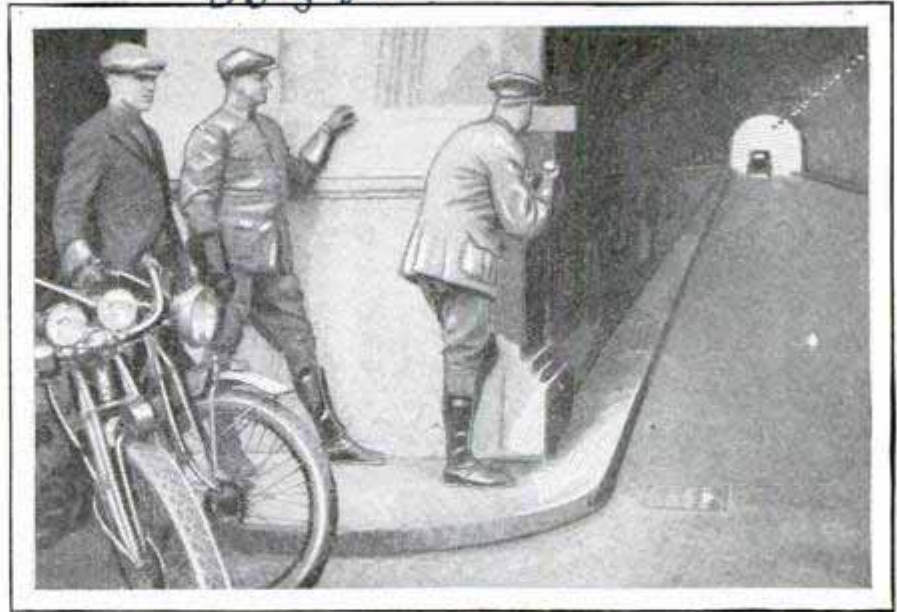

Police Timing an Autoist with Aid of Periscope as He Drives through Tunnel; Speeders Are Pursued

**PERISCOPES TO TRAP SPEEDERS AID TRAFFIC POLICE**

Small periscopes, similar to those used in the trenches during the war, have been adopted by the Los Angeles police in a campaign against automobile speeders who persist in exceeding the limits while driving through tunnels in the downtown district. Concealed, the police can check the speed of the car through the instrument and pursue it, if necessary.

2641  
**CARRIER HOLDS EIGHTY PLANES AND COST FIFTY MILLION**

Eighty airplanes will be accommodated on the carrier "Lexington," which is expected to be finished next January. It is 888 feet long, displaces 35,000 tons, will carry a crew of 1,700 men, and the cost is approximately \$50,000,000.

3254  
**OVEREATING AFFECTS THE EYES STOMACH BALLOON SHOWS**

By swallowing a stomach tube to which a small balloon was attached and inflated, a subject at the Rush medical college recently demonstrated to physicians how overeating affects the vision. Distention of the stomach produced results similar to those arising after eating a large meal. Within a few moments after the balloon was blown up the subject became drowsy and extra effort was required to read. Examination of the eyes showed that vision was distinctly impaired.

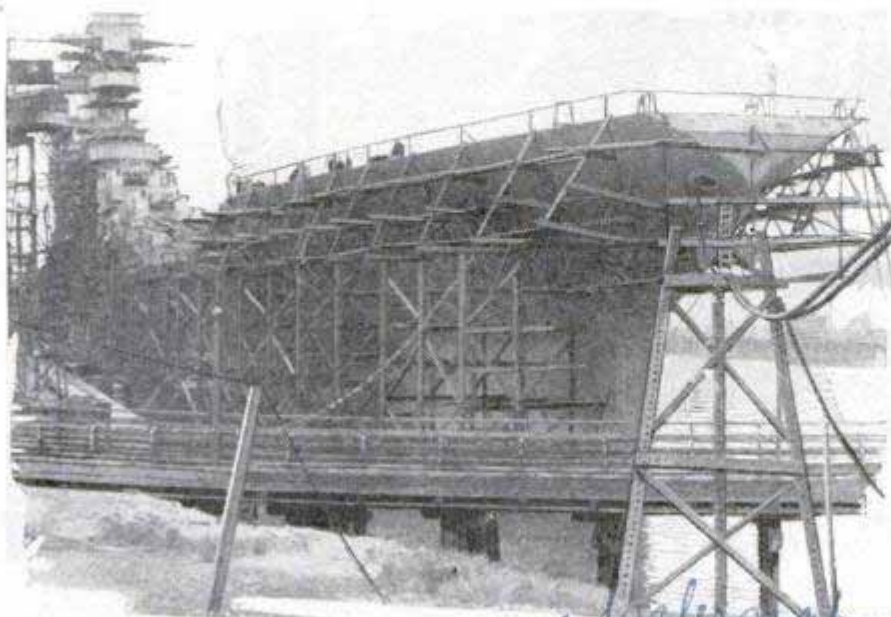

Part View of the Airplane Carrier "Lexington," Which Will Have Room for Eighty Planes and 1,700 Men

*Rush Medical College*  
*Dr. Thomas Dyer Allen*  
*Ophthalmologist*

*J. Frank Percy*



# TIME and MONEY

## Saving Things

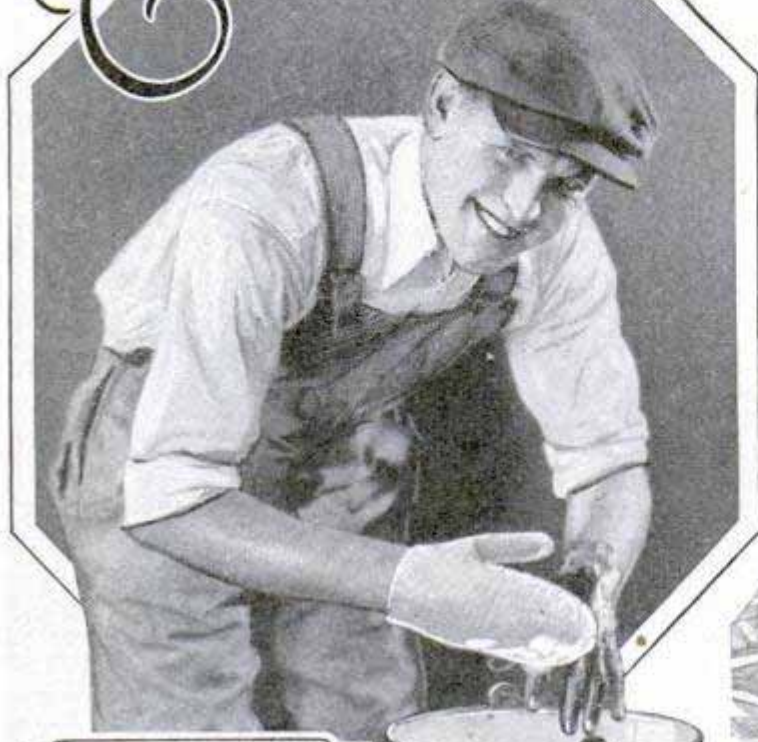

It Saves Towels and Laundry Bills; Cleaning Glove for Dirty Hands Helps Remove Grease and Paint

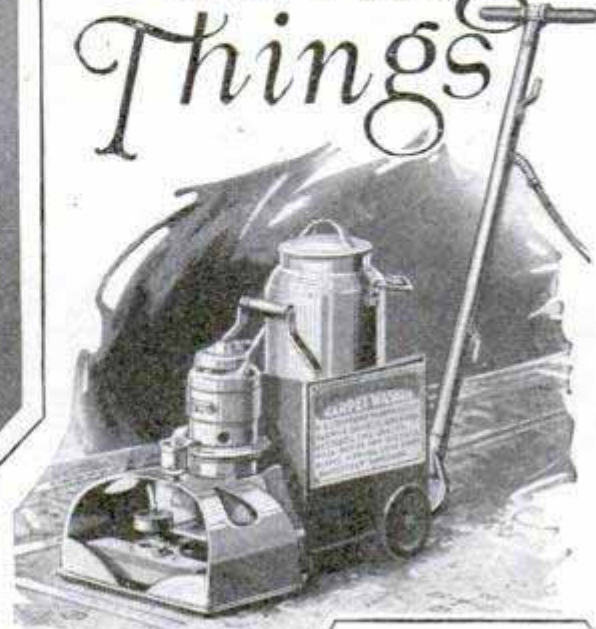

Carpet Washer for Your Home; It Scrubs and Dries the Nap



Glass Clothes Sprinkler Distributes Water Evenly



Loom for Weaving Small Articles Is Easily Set Up for Different Sizes



Cotton-Tape Mop Head Will Not Drop Threads

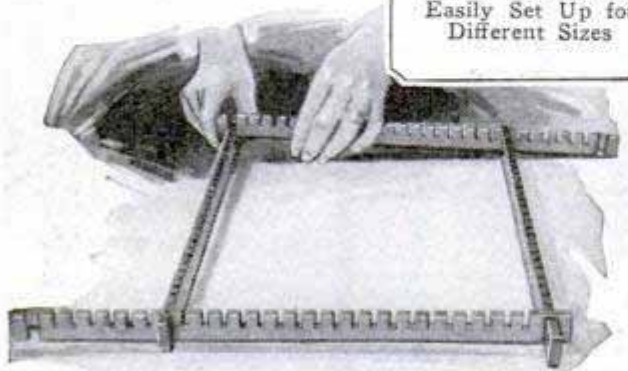

For Small Washings, Spring Outfit on Tub Does Work Thoroughly and Easily



Ca  
Hand for your  
Gas  
Pup  
Glov  
Glas  
Car  
Cot  
Loc  
prop  
Spri  
El  
Hou  
**HOME**

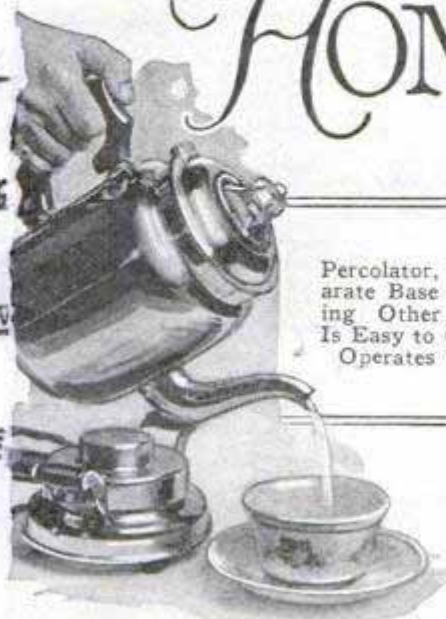

Percolator, with Separate Base for Heating Other Liquids. Is Easy to Clean and Operates Quickly



Safe and Clean. This Household Incinerator Has a Spark Arrester at the Peak of the Stack, Is Lighted from the Top and Burns Contents Thoroughly



Something New in Candles for Tablecloth or Other Location; It Needs No Stick

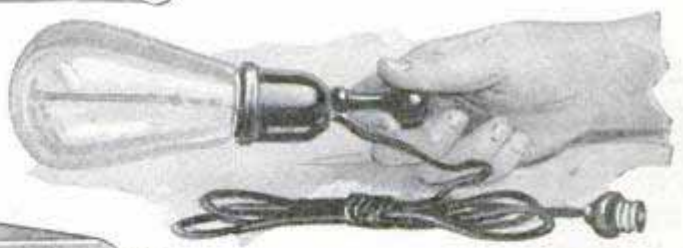

Handle on Extension Electric-Light Bulb Simplifies Searching in Dark Closets and Promotes Safety



Inside This Attractive Cabinet Is a Five-Burner Gas Stove with Generous-Sized Oven and Broiler Space Underneath; Control Handles Are Back of Grill Work and Doors Open Downward

Puppy Purses with Quick-Closing Runner Clasps Please the Children; Pinch the Tail and the Doggie Whines





*Los Angeles, Calif*  
*1620 W. 47th St*

*Lee Ulee Automatic Body Loader*  
*Company being organized.*  
*9/15/28*

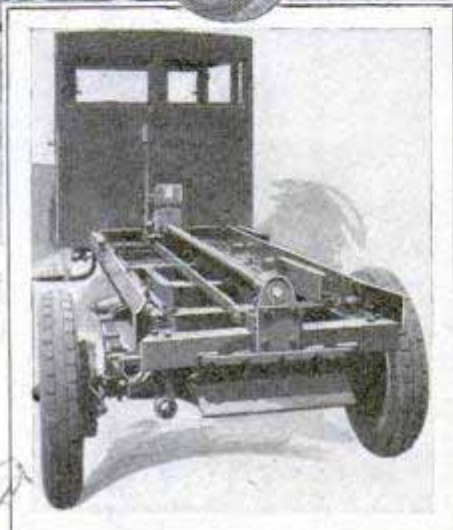
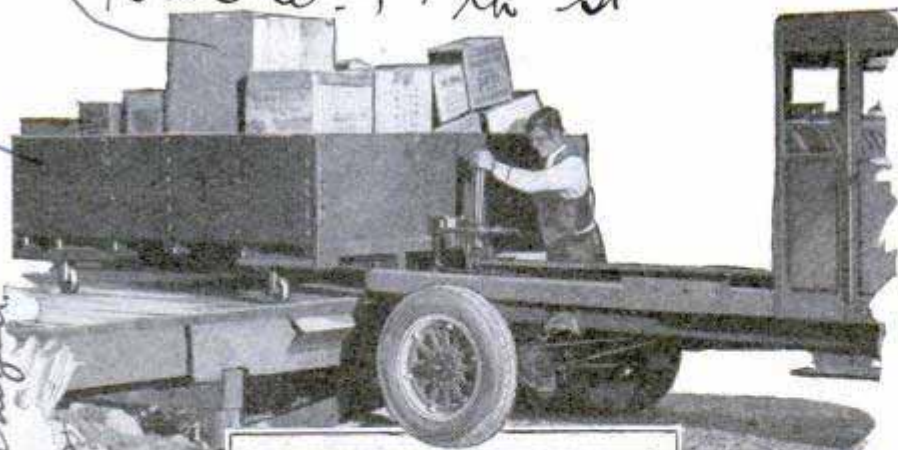

Sliding Body from the Auto Truck for Easy Unloading, and Rear View Showing the Gear That Moves the Body

### AUTO-TRUCK BODY SLIDES OFF TO SIMPLIFY LOADING

To save time and make trucking easier, a California inventor has introduced an easily demountable body for motor units, somewhat like those now in use on freight and express trains. The power of the truck itself is utilized to slide the body, loaded or empty, upon a platform and readjustment is made by reversing the process. Small wheels on the body permit moving it around for ease in removing the contents or filling it and thus save hand trucking. Only a few seconds are required to remove the body or haul it on.

### COCOA-ODOR FERTILIZER LATEST GARDEN AID

Fertilizers with unoffending odors have been prepared recently by the bureau of soils from the by-products of cocoa and other materials. Some 20,000 tons of the cocoa substance are pro-

duced annually in the United States. It is said to contain considerable quantities of nitrogen and is easily applied. Other fertilizers have been made from dried-crab waste, shrimp waste and bran.

### ELECTRIC PUMP TO RESTORE BLOOD CIRCULATION

By means of an apparatus which circulates the blood artificially, a Vienna specialist has provided an effective unit, already successfully demonstrated in cases of drowning, heart failure, nervous shock and like instances of temporary cessation of normal life functions. It is said to overcome one of the chief difficulties that has defeated previous attempts in this direction, that is, getting the blood back into the heart. In the new apparatus, this is accomplished by simultaneous mechanical stimulation of the abdomen, the lungs and the heart resulting in restoration of the activity of the heart, arterial system and lungs at one and the same time. The outfit is portable and may be operated by electrical current from regular circuits or by a special motor. It has been designed especially for life-saving units of all kinds and has been successfully demonstrated.

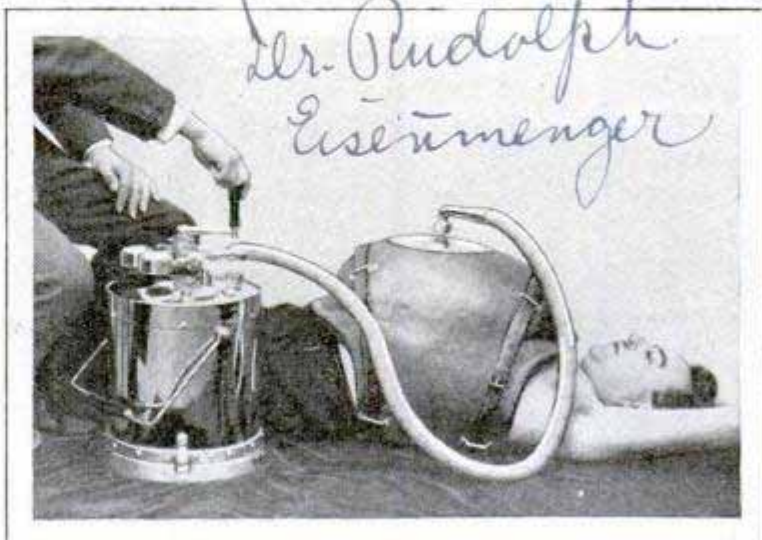

Using the Pump Which Circulates Blood Artificially, to Aid in Reviving Persons Nearly Dead

*3196*  
*78th St*  
*Ellenka*  
*New York*  
*P. W.*  
*U.S.*

*3214*



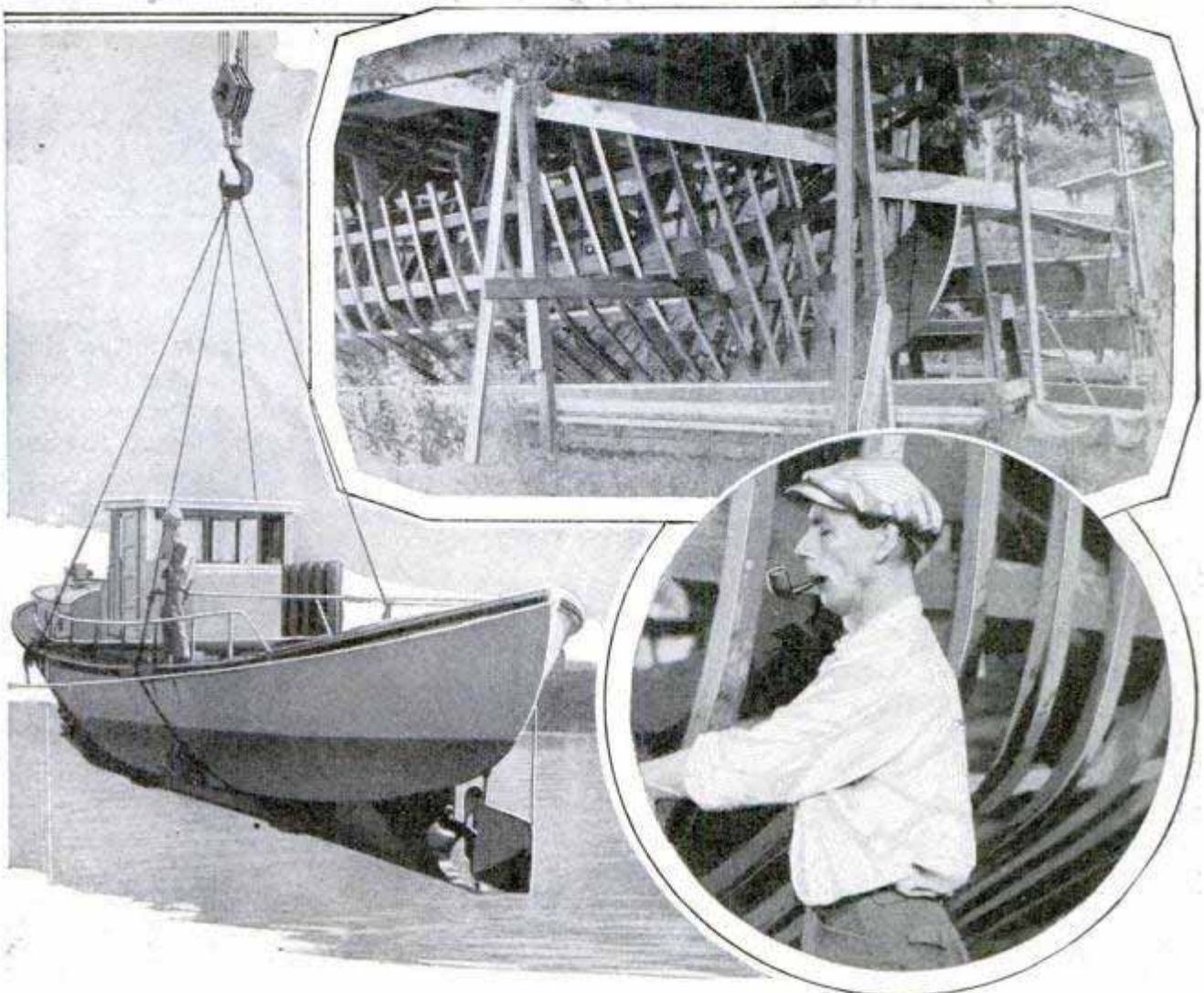

Views of the One-Man Shipyard and Its Operator; Part of an Unfinished Ship, Launching One of the Craft, and Mr. Hoffman at Work; Seagoing Vessels Are His Specialty

### MAKING SHIPS IN BACKYARD PROVES PROFITABLE HOBBY

A backyard in the outskirts of a large city is not the place you would expect to find a shipbuilding plant, but such is the location of one at Portland, Oreg., which has turned out four seagoing motor fishing boats and has construction of the fifth under way. The enterprise is conducted wholly by one man, Samuel Hoffman, who has been building ships as a hobby for fifteen years. A carpenter by trade, he gives his spare time only to the boats and thinks nothing of devoting two or three years to a single ship. The trawler he is now building will have cost approximately \$10,000 when it is finished. Its ninety ribs are of eastern white oak, the boat is forty-two feet long, with an eleven-foot beam, and will be equipped with a thirty-horsepower motor. When the boats are finished, they are taken by house movers to

*93rd + Halsey,  
Portland Ore.*

the Willamette river, a distance of five and one-half miles, and launched by crane for the journey to the Columbia river and out to the sea.

### HEATER UNIT HELPS START CAR AND SAVES GASOLINE

1274.

Adaptable to all makes of automobiles, or to other combustion motors, a heating system forces an air current at some 300 degrees Fahrenheit into the intake manifold to simplify starting the engine. It consists of a small motor and fan, the air being driven over an electrically heated coil through a flexible tube into the manifold. The necessary energy is derived from the storage battery.

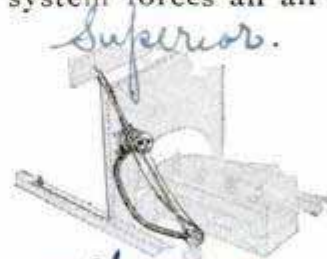

*221 Erie St. Council  
Patent Model Co, Buffalo  
731 W. Broadway*

*for sale on cash and royalty basis.*



1639

*E. Washington St. Steel Car Shop  
Pennsylvania R.R. Indianapolis Ind*

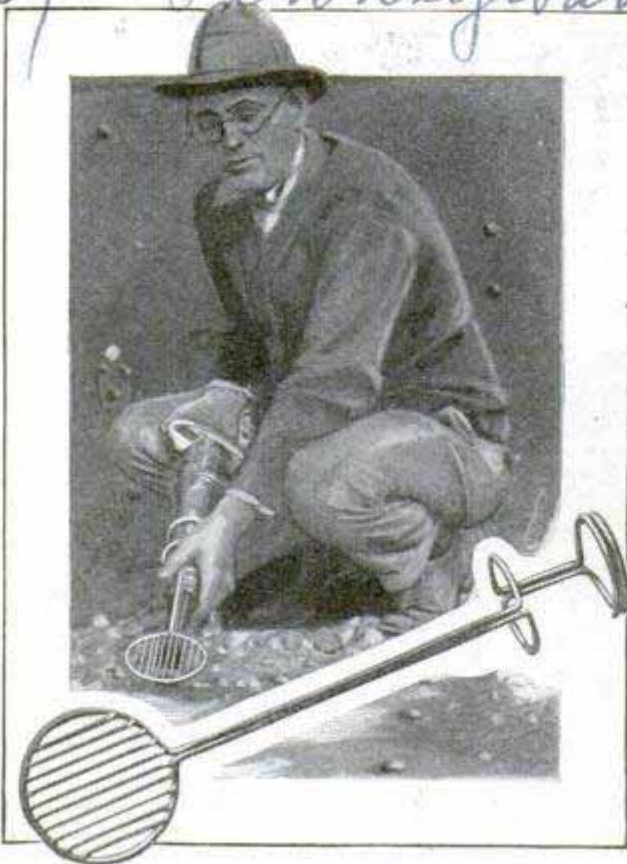

Removing Rivets with Cutter That Has Shield Attached, and Close View of the Guard

### RIVET-CUTTER SHIELD REDUCES LABOR AND AIDS SAFETY

In removing rivets from steel cars and other units, two men generally are required, one to shield and catch the rivet head while the other operates the cutter. With a wire net, which fits on the end of the cutting hammer, the danger of flying heads is eliminated and only one man is needed, an additional advantage being that workers can operate directly opposite each other without danger.

### "POCKET" BALLOON CARRIES MAN 300 MILES

3208

Weighing but fifty pounds, a twenty-foot balloon recently carried a man from New Jersey to the Adirondacks on a 350-mile overnight trip. He landed near a railroad station, emptied the bag of its 4,000 cubic feet of hydrogen, packed the bal-

*Editor read*

loon on his back and walked to a train. He had sufficient gas and ballast to have gone 250 miles farther, he declared. The pilot's car was just large enough to hold one man and carried him standing.

### 3146 LIGHT CELLS AS POLICEMEN TO REGULATE TRAFFIC

As a substitute for the usual system of stop-and-go lights to regulate automobile traffic, an attache of the bureau of standards has developed a means whereby the cars themselves actuate the signals to eliminate unnecessary delays and clear the road which is open to traffic at the proper time. An essential unit of the installation is a light-sensitive cell in the center of the street, not far from the intersection, and exposed to rays from a spotlight shining directly opposite to it. An automobile passing between the cell and the spotlight, and thereby interrupting the rays, would cause the cell to operate a relay controlling the traffic signal. For instance, a car approaching the sign would set the stop signal, halting traffic on the intersecting highway. The sign remains on for a few seconds to allow the following cars to pass, so long as they intercept the light beam on the sensitive cell in time to prevent the signal from changing against them. An advantage claimed for the system is that no one street is favored over another but both are controlled according to the actual demands of the traffic.

*John P. Buckley*

*Head, Electrical Research Dept.*

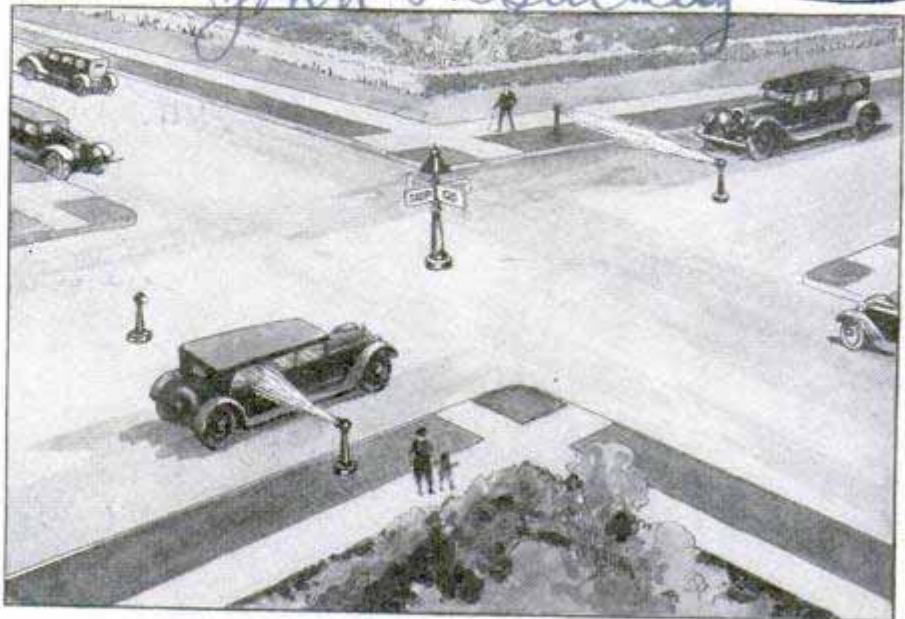

Drawing to Illustrate Operation of the "Light Cell Policemen" at Intersections; Cars Interrupt Beams from Beacons to Actuate the Signal

*A. Leo Stevens, 612 W. 144th St. New York*





Government Food Tasters Putting On an Ice-Cream Eating Contest, and Getting Paid for It; Their Jobs Require Acute Development of the Senses, and Few Can Qualify

## How Uncle Sam's Food Testers Help You

Glass Stomachs and Rats Also Are Used to Determine Nutrition Value of Different Table Products

By C. MORAN

UNCLE Sam now has a staff of official food tasters at Washington whose job it is to determine the palatability of foods cooked in the experimental kitchens of the department of agriculture. Glass stomachs are used to determine digestibility of foods and rats to demonstrate body-building factors, but only the human palate can determine palatability, which is regarded now by the government scientists as of high importance in food-value determination.

Food tasters are department officials who score the food for taste, tenderness, flavor and other palatability factors. Ice-cream tests were made recently in which the officials were required to eat their fill of ice creams made in different ways. There was a decided preference for rich, sweet and firm ice cream.

Another-tasting experiment recently was

of 100 legs of lamb from animals commonly bred in the western range states. These animals had been produced at the government sheep-experiment station at Dubois, Idaho; they were fattened at Purdue university, and slaughtered at the government experiment farm at Beltsville, Md.

Twenty-five legs from each of four different breeds were cooked in the department's experimental kitchens, in lots of eight, in temperature-controlled ovens. Five judges scored the cooked meat, the tests resulting in specific recommendations as to better production methods to satisfy consumer demands, and in a standard method of cooking lamb with a maximum of palatability and a minimum of labor and fuel consumption.

Department experts say there has been an unfortunate tendency among students



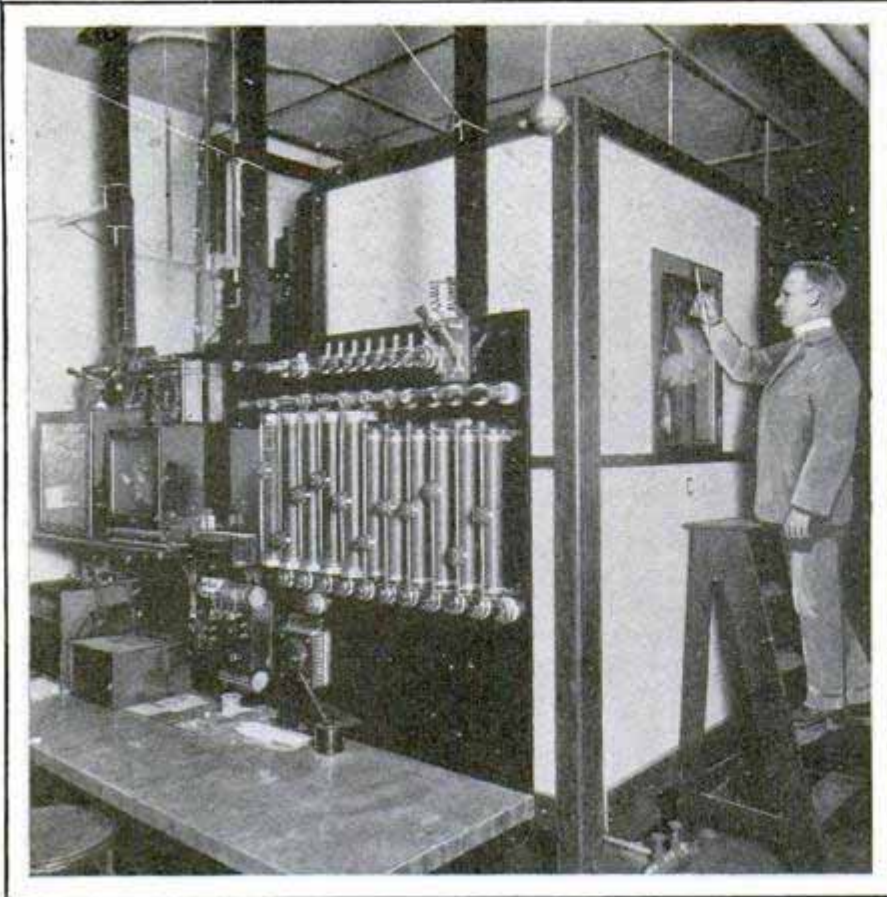

In This Air-Tight Chamber, the Body Heat and Energy Developed by Measured Amounts of Food Products Are Determined

of nutrition to underestimate the importance of palatability, individual preferences and family customs, but the question of how foods go together, from the standpoint of taste as well as from that of body building and health, must always be kept in mind. The human palate seeks variety of flavor and also differences of texture.

Many food customs have been formed in response to instinctive requirements of the body. In early days, people gathered wild herbs and greens of various kinds, but not until very recently was it known that these foods provide an important dietary principle necessary for health. The instinctive demands of the human body, in a less fertile and prosperous country, might have led finally to the custom of satisfying body needs by means of simple, palatable meals, but, as a matter of fact, it is not unusual for a meal to provide several starchy foods, several animal protein foods and several fat foods, which means waste of materials and labor.

The so-called "vegetable plate" has received much attention in the government food kitchens, where a "panning" method has been developed, consisting in cutting

the vegetables into small pieces and cooking them in a flat pan on top of the stove with a minimum of water, to which a little fat has been added to prevent the vegetables from sticking to the pan. The water tends to evaporate and it is often unnecessary to pour any of it off.

Many new recipes and new cooking methods have been developed by the food tasters. They found in beef-tasting experiments that successful results in roasting beef are obtained by a preliminary searing at 250 degrees Centigrade, and then lowering the temperature to 125 degrees Centigrade for the remainder of the cooking period. The time of cooking may be shortened by cooking at 150 to 175 degrees, but

the evaporation and dripping losses increase and there is less uniformity of "doneness" as compared with meat cooked at the lower temperature.

The results of the food-tasting experiments are being related by the department to production and marketing problems. Food habits in this country have changed markedly in the last few years, consumption of wheat and meats having decreased with a corresponding increase in consumption of fruits and vegetables. Department figures show that the consumption of the latter commodities in New York city alone has increased more than twenty per cent in the last five years, whereas the city's population increased less than four per cent during the same period.

An official tea taster for many years has been employed by the department. His job is to brew tea from samples taken from imports. This official now is making a series of experiments to determine whether the flavor of tea is affected by the type of containers in which it is packed. The department also has a corps of butter tasters who inspect and grade creamery products.

The palatability tests are a part of the



department's recent activities to determine consumer preferences for different food products and grades of foods. Nationwide surveys have been made of the consumer demand for milk, meats, fruits and vegetables, the latest survey dealing with prunes. The investigators interviewed housewives in scores of cities and learned, among other things, that housewives

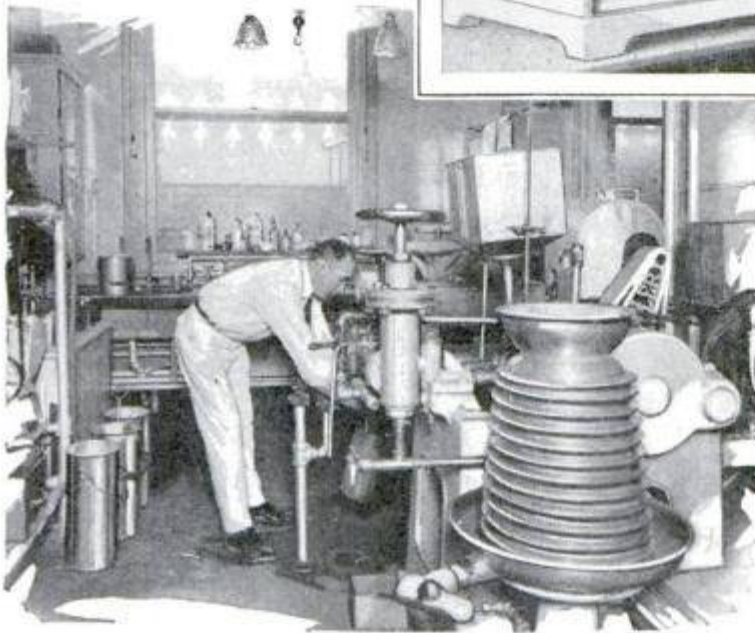
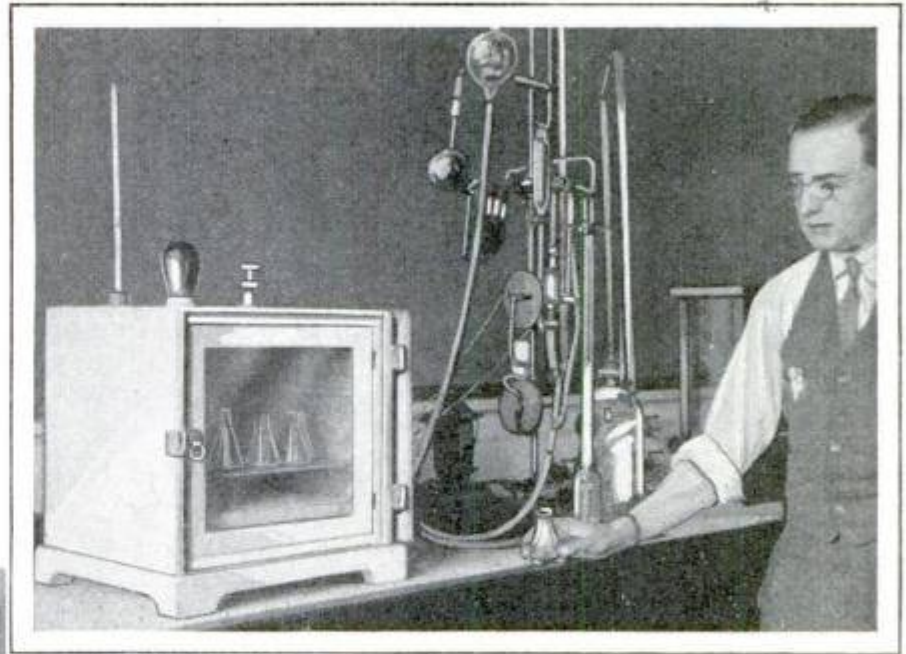

At the Top Is a Glass "Stomach," in Which Government Chemists Test the Digestibility of Foods, and at the Left, Below, the Ice-Cream Plant

do not know there is more than one kind of prune. The survey dealt with the so-called Italian prune, which is a sour product grown in the northwest.

The department's survey of meat consumption revealed that housewives know only two or three cuts of meats, whereas an animal carcass provides a dozen or more.

**SPEED GROWTH OF MUSHROOMS WITH ARTIFICIAL "STORMS"**

"Synthetic" electrical storms are produced in Pennsylvania cellars to speed the development of mushrooms. The disturbance creates ozone in the air which is favorable to the rapid maturity of the growths. A public-service company recently found that there are 8,400 uses to

which electric current has been put. It is employed to operate delicate measuring instruments at the government aeronautical testing laboratories, in Virginia; it is harnessed to churn butter which is unchurned again by electricity to make cream; orchardists and gardeners are using it to lure insect pests which are trapped in pans of oil under electric lights; beauty experts run reducing machines with it and the dentist makes use of it to run his drills.

**GAS FURNACE FOR HOME REDUCES COST**

The many advantages of gas for heating purposes long have been recognized and, to utilize it still further, a special furnace has been devised. Burners are of the Bunsen type and air, heated to a high degree, passes through large steel chambers on each side of the combustion area to extract every usable degree of heat from the gas consumed. A horizontal



flue at the top leads into the chimney. An additional feature is thermostatic control to regulate the flow of gas and maintain a more even temperature.

*The Favorite Store  
Orange Co.*

*Shore drive  
Lake  
May 536*

3216



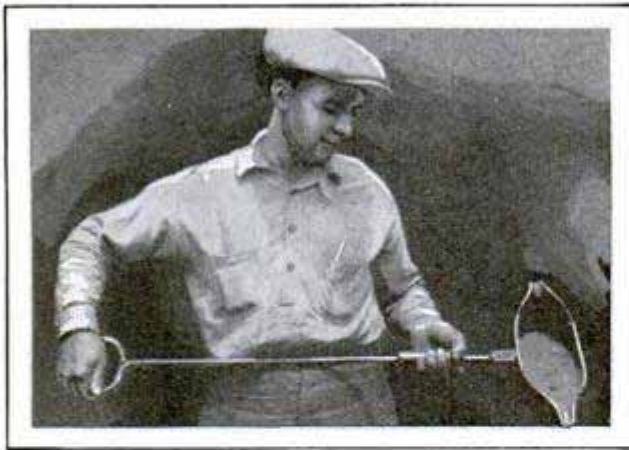

To Protect the Foundryman from Burns; Pouring Ladle with Sliding Wooden Handle

### SLIDING-GRIP FOUNDRY LADLE GUARDS HANDS FROM HEAT

Equipped with a sliding wooden grip, a ladle used for skimming the slack from molten iron in foundries, enables the user to avoid discomfort and possible burns by having the hand too close to the metal. The handle is quickly adjusted to any position and permits obtaining a firm hold.

### BULLETS LEAVE TRACK OF FIRE TO AID TARGET PRACTICE

With bullets that leave a glowing mark to indicate their path, successful machine-gun practice has been conducted by army

units. The tracers showed the rebound as well as the path to the target, as illustrated in the accompanying photograph.

### OIL WELLS TAMED BY CEMENT APPLIED BY NOVEL PROCESS

*3217* Back of the vast oil industry lies an interesting story of a young man's victory over one of the most perplexing problems of well construction, the task of properly reinforcing the deep holes to support the casing and keep out water. Credit for one of the most effective ways of doing this is given to Erle Palmer Halliburton, who, in the last seven years, has patented many devices to simplify and improve engineering methods in the oil fields and who has treated 12,000 wells without a single failure. The feature of Halliburton's scheme is that he virtually makes the oil well "cure" itself. How to introduce cement between the earth walls of the well and the casing—a string of pipe from a quarter to a mile in length, often times presenting obstacles forbidding the mere pouring of the material between the sides—was his problem. He devised two wooden plugs. One was forced into the casing and cement "slush" pumped on top of it. As the weight increased, the plug slid down inside the pipe and finally fell into the "dead

*3695*



Night Photograph of Target Practice with Glowing Bullets; Course of Projectiles to the Mark Is Plainly Indicated and One Bullet Registered as It Glanced Away from the Surface

*17th Infantry U.S.A.  
Fort Bliss*



3158

end" of the hole when the bottom of the casing was reached. This allowed the cement to pour in upon the oil sand, which has the peculiar characteristic of resisting any such intrusion, forcing the foreign material upward between the casing and the walls of the earth. The rising mass of cement, carried ahead of it the mud and water accumulated between the pipe and the earth. To introduce the necessary quantity of cement quickly, Halliburton invented a combination pump and cement mixer mounted on a four wheel-drive truck that could be taken anywhere about the oil fields, in all sorts of weather. A mechanical measuring device was also adapted to determine, to a fraction of an inch, the exact quantity of cement that had been forced between the casing and the earth.



Windmill Boat for Trip across the Atlantic; the Wheel Is Geared to a Small Propeller

**SMALL BOAT RUN BY WINDMILL BUILT TO CROSS ATLANTIC**

To cross the Atlantic in fifty days, or less, is the object of two English adventurers who propose to make the journey in a twelve-foot boat without steam, sails or oars. Propulsion will be afforded by a windmill geared to a propeller and the wheel is to be turned by the wind.

*E. O. Tierney, Salford, Eng.*

**QUARRY IS MADE INTO GARDEN AROUND CEMENT PLANT 320**

One of the sights in the suburbs of Victoria, B. C., is a limestone quarry changed into a lawn with shrubs and rock gardens. As an example of landscape architecture, it well illustrates the possibilities of decorating commercial-plant grounds.

**VERTICAL-LIFT AUTO ELEVATOR SAVES GARAGE SPACE 3102**

Several desirable features are claimed for an electrically operated elevator for repairing or servicing autos. It requires no special foundation and raises the car vertically, saving space. It may be stopped at any height desired, suspends the auto at four points and lifts it by the axles, leaving the wheels free. The hoist has a capacity of 6,000 pounds, and may be raised to a height of four feet or lowered to seven and one-half inches. Controls prevent accidental dropping of the load.

*\$445 - \$560.00*

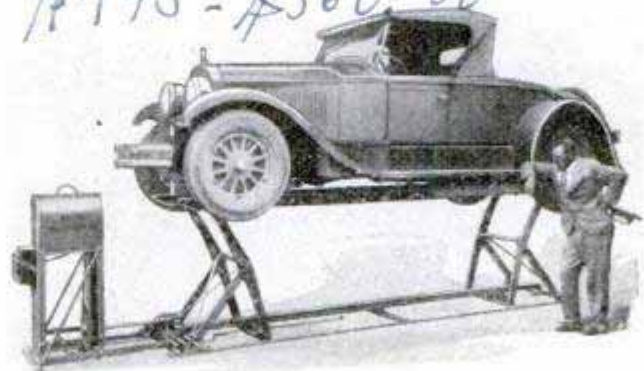

Car on the Vertical Hoist Showing How It Stands in Convenient Position for Repairs

*Manley Mfg. Co. (no longer in business) 6/5/28*



*Concrete Company of America, 522 Fifth Ave New York*

which have 400-horsepower engines. Its performance emphasizes the fact that much of the excess power of big engines for planes is utilized in carrying their own weight.

**SAWDUST-CEMENT MIXTURE MAKES LIGHT LUMBER**

Chemically treated sawdust and cement are mixed together to form a material which is said to weigh about half as much as ordinary concrete, has a better wearing surface, high fire-resistance and insulation properties and can be sawed, nailed or screwed, and painted or polished like wood. It

is being successfully employed in precast units for many purposes, and numerous tests have showed that it has great strength and durability in this form.

*at Columbia University*

**SPEED BOAT MADE OF RUBBER WON'T GET WATER-LOGGED**

Successful tests are reported with an all-rubber speed boat, the hull of which is constructed of the recently introduced "rubber lumber," devised especially for airplane use. This material consists of thin sheets of hard rubber with a central core of sponge rubber. A fabric or metal covering may be added if desired.

The boat was lined on the outside with a soft-rubber cushion, fastened to the hull by a special process, to make it water-proof and resistant to shocks. Since the craft cannot become water-logged, it has the advantage of greater speed over boats of similar size, type and power.

*Chicago - 1925 - Michigan*

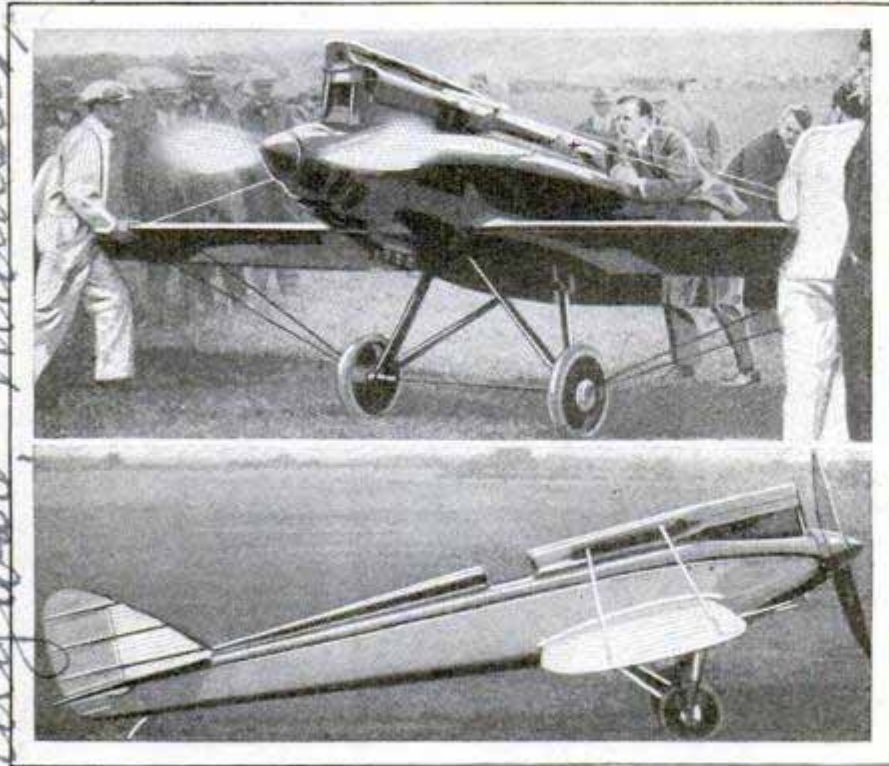

Nicknamed the "Flying Pencil" Because of Its Unusual Streamlined Appearance, a New Light Plane Produced in England

**MIDGET HIGH-SPEED AIRPLANE HAS EIGHTY-HORSE MOTOR**

A plane with an engine of only eighty horsepower, yet capable of making 175 miles an hour, was given its first trial in the recent King's cup races in England. Designed by Maj. DeHavilland, whose ships were standard equipment in the U. S. army and air-mail service for some years after the war, it is a low-wing monoplane, the wing being placed below the body instead of above it, as is the more common practice. Built to carry a single passenger, its appearance is unusual

because of the way in which the streamlining of the body has been carried out, even the projecting head of the pilot being streamlined through a projection tapering back to the tail. Because of this design, the little craft is thirty to forty miles an hour faster than the British army's single-seat fighting planes,



Rubber Speed Boat Carries Four Persons with Ease and Does Not Lose Its Buoyancy

*B. F. Goodrich Co. Akron, Ohio*

*1000  
3104  
Aircraft Co. Ltd  
Edgware, Middlesex, Eng*

*De Havilland  
Aeroplane  
Works*







Mark the length and width for the blind mortises to fit the tenons on the ends of the stretchers and also the notches to receive the bottom board for the cabinet. The two back legs have grooves,  $\frac{1}{4}$  by  $\frac{1}{4}$  in., to take the back panel. The shelf and corner-block details are shown on page 1003. To bore the holes for the screws in the corner blocks, use a drill a trifle larger than the smooth shank of the screws. The holes in the legs are drilled

smaller than the threaded part of the screw; use washers, and soap the screw threads before inserting. To fasten the cabinet top to the rails, bore several holes on the inside of the rails, as shown in the sketch at upper right. These holes are located an inch or so from the top and slant down for the screws.

To put on the top, lay it face down on the bench, as shown in the same sketch, place the rails in the proper position, and

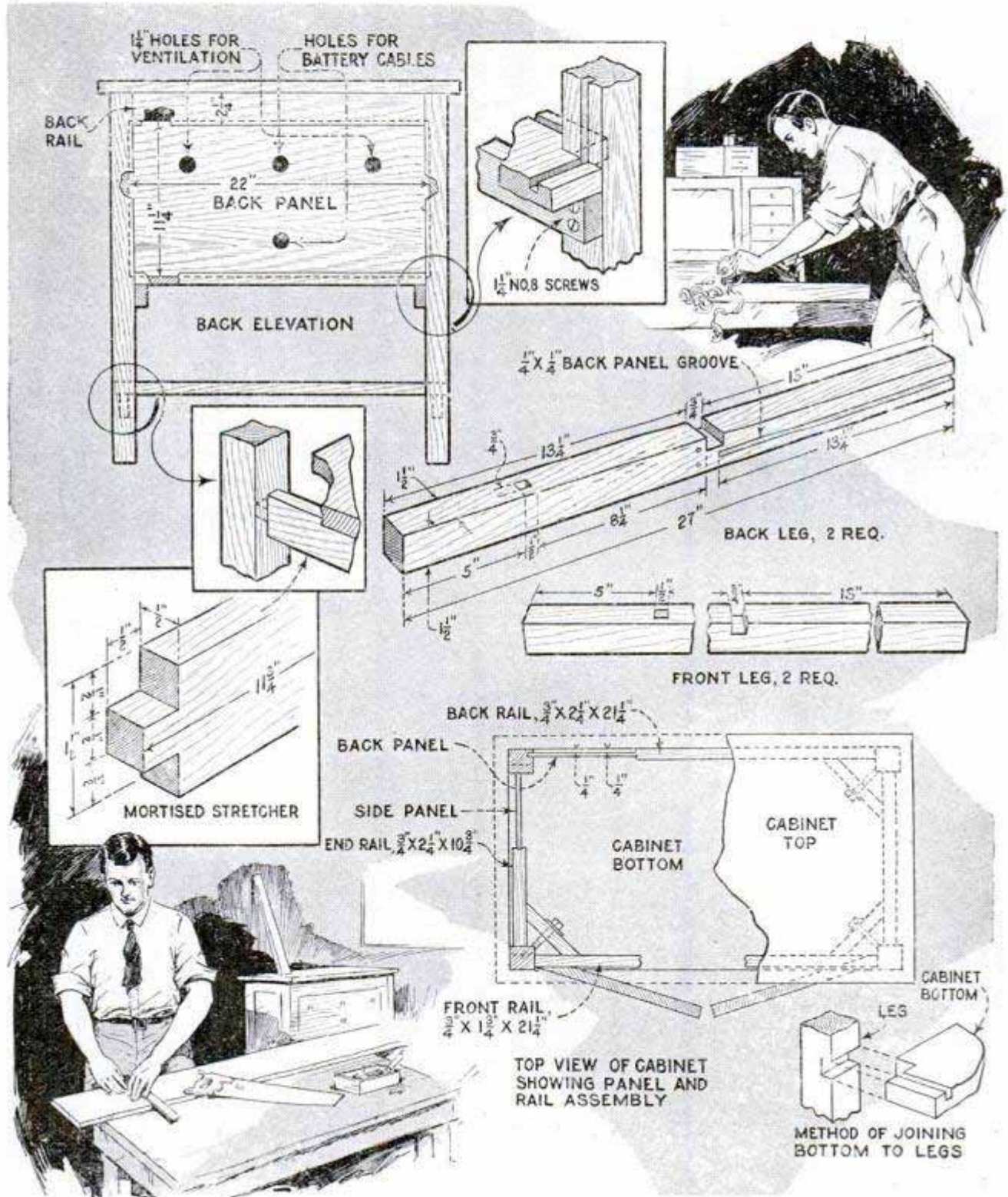



screw them to the underside of the top. Do not overlook the two supporting rails under the cabinet bottom, as they help to brace the legs and add strength to the cabinet bottom.

The two doors,  $10\frac{5}{8}$  by  $11\frac{1}{4}$  in., shown in the front elevation on page 1001, may be ornamented by grooves or carved de-

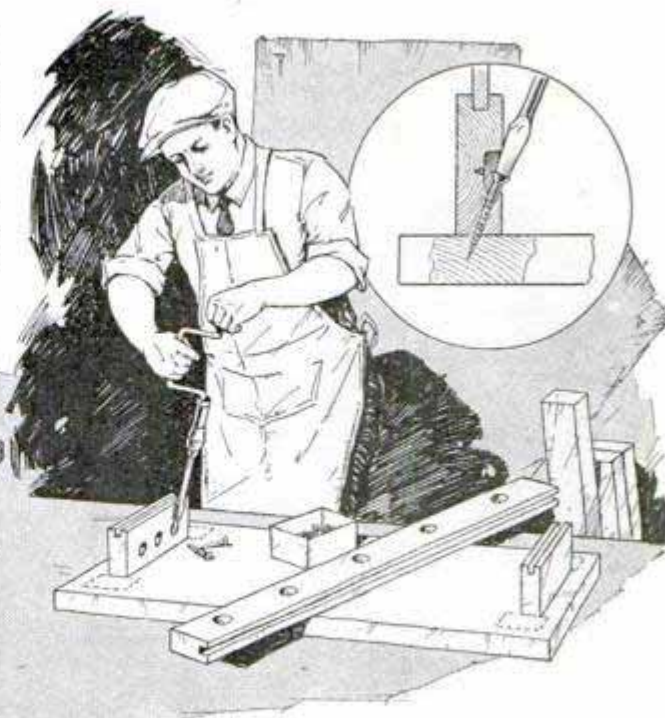

Above, Method of Drilling Holes for Screws to Fasten Cabinet Top to the Rails; Left, Details of Shelf

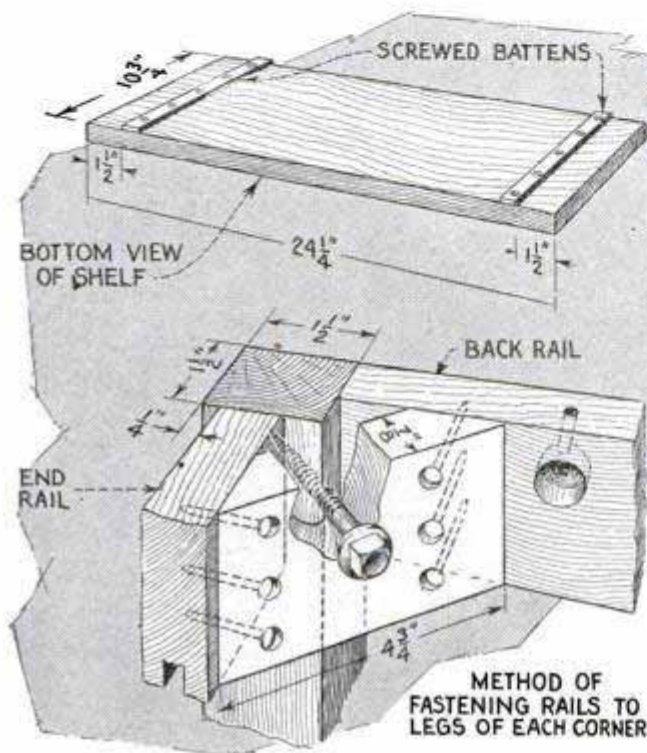

of the color selected, and let it dry at least 24 hours, then sand the surface. It is best to try out the stain on a piece of wood of the same kind as the cabinet first, as some stains change their color on different woods. Use mahogany glaze color for the next coat, and let it dry overnight. Finish with fine sandpaper or rottenstone, and apply a number of coats of any good standard varnish, sandpapering each coat after it has thoroughly dried. For a dull effect, rub down the last coat with rottenstone, wipe carefully and apply furniture polish.

signs if desired. Inexpensive "carved" designs, made of pressed wood, for the doors may be obtained from your local cabinetmaker and glued in the center of the doors, or if the lacquer finish is used, suitable transfer designs are very effective. Ventilation holes and battery cable outlets, shown at the upper left on page 1002, are drilled in the back panel of the completed assembly. The entire surface should then be well sanded. For those who prefer the wood stain, the directions given in the May, 1927, issue of Popular Mechanics Magazine, on page 842, can be followed with good effect. If a dark or red-mahogany finish is

#### MATERIAL LIST

- 1 piece,  $\frac{7}{8}$  by  $15\frac{3}{4}$  by 78 in.
- 5 pieces,  $1\frac{3}{4}$  by  $1\frac{3}{4}$  by 27 in.
- 1 piece,  $\frac{7}{8}$  by  $2\frac{1}{4}$  by 20 in. (hardwood, for corner blocks).
- 1 piece of sheathing board, for rails. (When dressed on two sides it should measure  $\frac{3}{4}$  by  $2\frac{3}{4}$  by 66 in., and one edge should be grooved  $\frac{1}{4}$  or 5-16 in. deep and  $\frac{1}{4}$  in. wide to take the panels.)
- 1 piece, three-ply,  $\frac{1}{4}$ -in. stock,  $22\frac{1}{2}$  by  $21\frac{1}{2}$  for panels.
- 1 piece,  $\frac{3}{4}$  by  $11\frac{1}{4}$  by 22 in., for doors.
- 3 doz.  $1\frac{1}{4}$ -in. No. 8 flat-head wood screws.
- 4  $\frac{1}{4}$ -in. square-head lag screws,  $2\frac{1}{2}$  in. long, with four washers.
- 2 small round-head door knobs with screws.
- 4 1-in. brass or steel door hinges with screws.
- 2 door catches with plates.

#### Rate of Drop in Idle Batteries

Both dry and wet batteries will run down when permitted to remain idle. The rate of discharge is about one-third that of the discharge when in active use. B-batteries are now stamped with a date limit, like films, to guarantee fresh stock, and the buyer should look for this date to protect himself.



Unit Ready for Use and with Front Removed; Right, Rectifying Unit About One-Half Actual Size

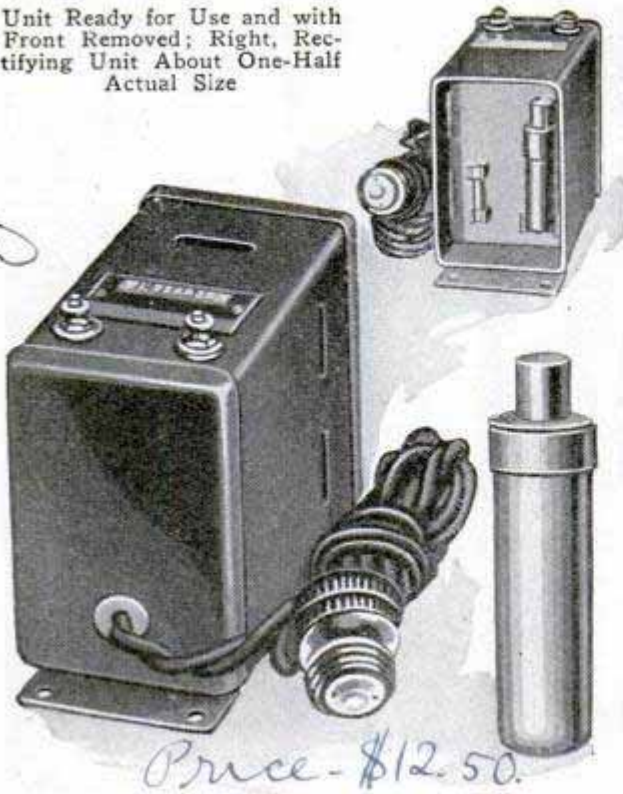

**New Battery Charger Is Dry**

A new battery charger using no vibrating parts or liquid is now available, the current being rectified through an electrochemical process. With this type of charger, no hazard to rugs or woodwork is possible, as there is no acid to spill. The charger is so designed that the tubes are safe even if turned on when the charger is in operation. Only 2¾ in. wide, 5¾ in. long and 4¾ in. high, the charger fits into the battery compartment of the usual console. The rectifying element, shown in capsule form, is held in spring clips like a cartridge fuse and can be easily replaced. The rectifying unit is guaranteed by the manufacturer for 750 hours of full-load operation, or approximately one year's service, while the transformer will last indefinitely. The charging rate is two amperes.

**Testing Transformers and Condensers**

Audio transformers and condensers can be most accurately tested with a voltmeter; the use of headphones for transformer testing often leads to false impressions owing to the inductance between two parts of a broken coil. Connecting the voltmeter in series with a transformer winding and a B-battery, the

reading will be lower than the battery voltage because of the resistance of the winding. If there is a break in the coil, no reading will be obtained. The primary and secondary windings of a transformer which is not marked at the terminals can be determined by means of the voltmeter and battery. The secondary winding will cause a greater voltage drop than the primary, due to its greater resistance. To determine the amount of charge a condenser is capable of holding, connect the condenser directly across a battery to charge the plates, remove the battery connections and connect the voltmeter across the condenser. The degree of the needle's deflection, which will immediately drop back to zero as the charge is dissipated, indicates the comparative charge-retaining capacity of the condenser. To test a condenser for a short circuit, connect the voltmeter in series with the battery and condenser terminals; a sustained deflection of the needle indicates a shorted condenser. If the condenser is efficient, the needle will swing over and return to zero immediately.

**Broadcasting Time Card**

Time and trouble are saved by condensing the usual radio programs on the time card shown in the illustration. A piece

RADIO PROGRAM	
1:00 WGN	7:00
1:15	7:15 WHT
1:30 WMAQ	7:30
1:45 WQJ	7:45
2:00 KYW	8:00 WGN
2:15	8:15
2:30 WGN	8:30
2:45	8:45
3:00	9:00 WMAQ
3:15	9:15
3:30	9:30 WQJ
3:45	9:45
4:00 WJJD	10:00
4:15	10:15
4:30 WGN	10:30 CNRC
4:45	10:45
5:00	11:00 KFI
5:15 WMAQ	11:15
5:30	11:30
5:45	11:45 WSB
6:00 WLS	12:00
6:15	12:15 WLW
6:30	12:30
6:45	12:45 WDAF

of cardboard, about the size of a postal card, is ruled as shown and the time divided into fifteen-minute intervals from 1:00 p. m. to 12:45 a. m. The features you wish to listen to are selected from the newspaper programs and the call letters entered on the card opposite

the time given. The dial settings may be substituted for the call letters if desired.

Thordarson Electric Co., 500 W. Huron St. Chicago



# Loop Set Built In for Cabinet Speaker

Power Amplification, Simplicity of Control, Splendid Tone and Volume Make This Set Ideal for the Music Lover

By FRANK L. BRITTIN

**E**XAMINATION of one of the new exponential horns, housed in a console cabinet, suggested the installation shown in the photo below. There is ample room in the cabinet for storage battery, charger and combination B-eliminator and power amplifier, and even with this, there is still sufficient space for a compact three-tube receiver. The same general arrangement may be adapted to a phonograph console if desired, or built up in separate units for use with speakers of any type. In designing this set no attempt was made to obtain long-distance reception; it is simply a local broadcast receiver employing only high-class parts, and devoted to tone quality, selectivity and simplicity of control. Easily adjusted from a whisper to volume sufficient to fill a large auditorium if desired, this set is for the music lover located near any of the large broadcasting stations.

Equipped with "powerizer" for power amplification and

B-elimination, and automatic relay switching over to trickle charger when the set is turned off, it is practically an electric receiver, and as it is operated on a standard three-tap loop, the receiver is very selective and comparatively free from static and local interference. The circuit is very similar to the one described in the December, 1926, issue which has been very popular with our readers and is especially suitable for this type of installation. The detailed wiring diagram and several photos show the extremely simple arrangement of the various instruments on the panel and subpanel. The wiring should be run as nearly as possible like that shown in

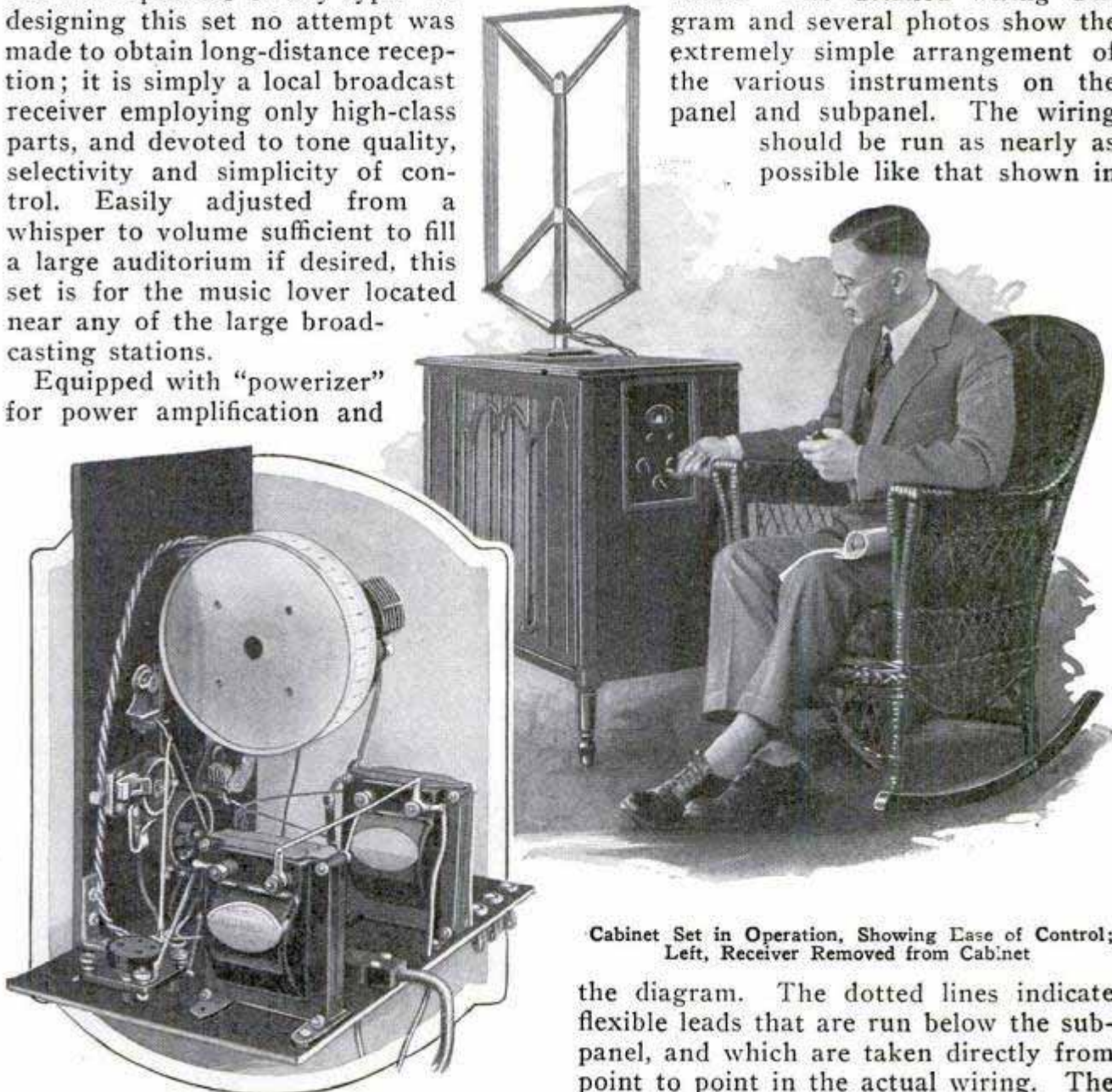

Cabinet Set in Operation, Showing Ease of Control; Left, Receiver Removed from Cabinet

the diagram. The dotted lines indicate flexible leads that are run below the subpanel, and which are taken directly from point to point in the actual wiring. The



sockets are of the spring-suspended type, and this is especially important at the detector tube. High-grade heavy a.f. trans-

inet, and provides ample room for all controls. Either drum or standard dial for the .0005-mfd. variable condenser may be

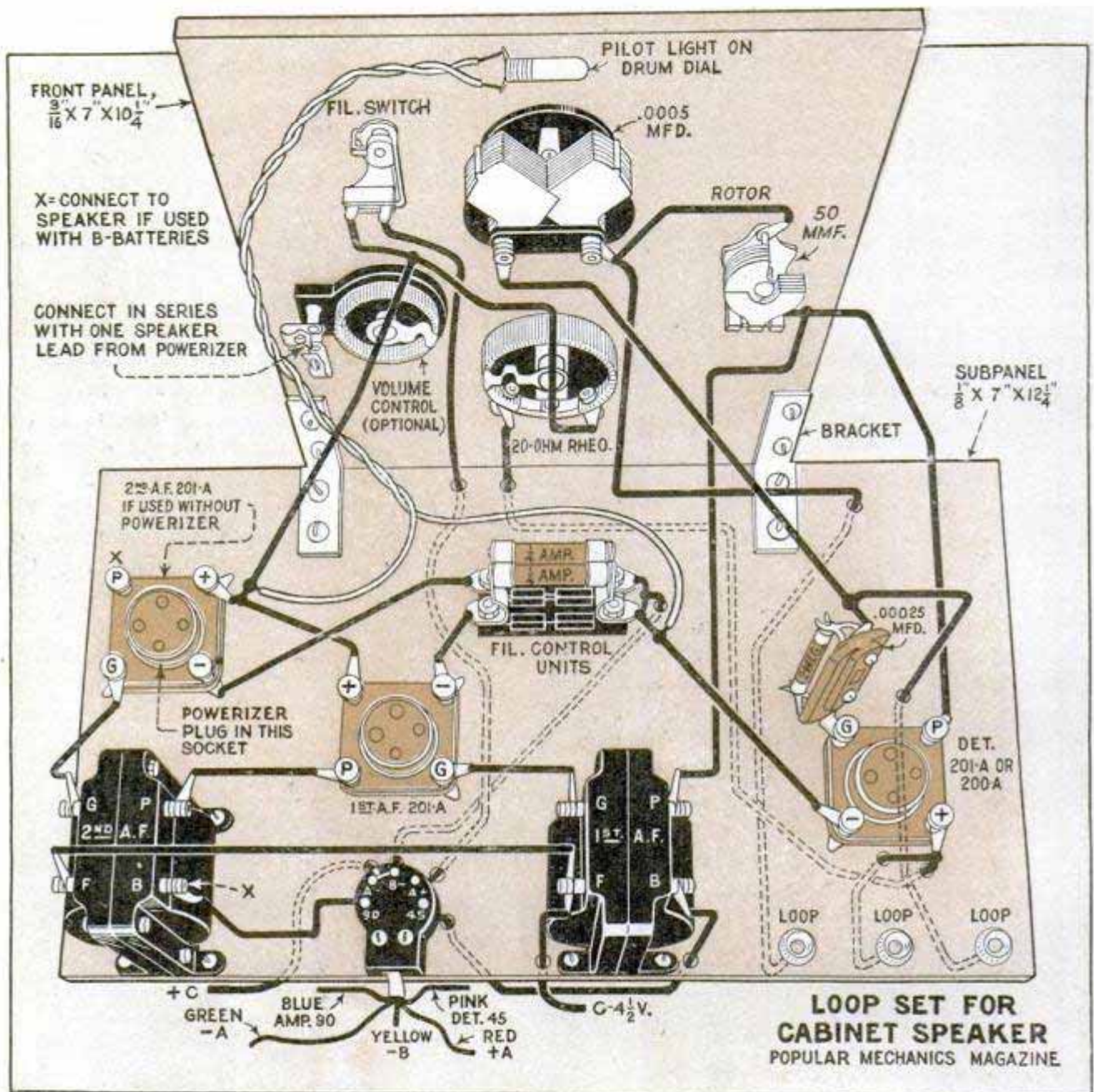

formers are used, the filaments of the amplifier tubes being controlled by automatic units. The set is complete in every way for use without powerizer, if desired, and with standard B-batteries.

The front panel is mounted on the subpanel by means of two angle brackets, and the entire set is supported inside the speaker cabinet on two black japanned shelf brackets, screwed to the underside of the subpanel. The front-panel assembly is very simple, and may be arranged to suit the builder. Assembling the instruments the long way of the panel makes a neat appearance at the side of the cab-

used; on the detailed wiring diagram the drum-dial mount was omitted, to simplify the layout. However, the mounting details are shown at the upper left on page 1008. The 50-mmf. midget condenser at the right is rotated by means of a small knob and, when once set, needs very little readjustment. The volume-control device, shown at the left, is optional and consists of a special variable resistance. At this point it will be well to explain that if the set is to be used without the powerizer and with standard B-batteries, an open-circuit jack may be mounted in the position occupied by the volume control.



Extra leads run from the P-post marked X, on the second amplifier-tube socket, and the B-post marked X, on the second a.f. transformer. They are soldered to the jack terminals, and the speaker is plugged in at the front. If an inside connection from the speaker is desired, the leads may be taken to two extra binding posts which may be mounted at any convenient point at the rear of the subpanel. If the combination power amplifier and B-eliminator is used, no extra leads are required at the points marked X, as these connections are all automatically taken care of by the plug from the powerizer unit, which is plugged into the second a.f.-tube socket, and the loud-speaker connections are taken directly from the powerizer unit, as shown in the lower diagram on page 1008. In this case, note that one of the loud-speaker leads is cut and the volume-control device inserted in series. Rather than cut the speaker lead, which is difficult to connect if this is done, use an extra phone cord of the single-phone type. Metal tips are

provided on both ends, and the extension may be made by means of extra double

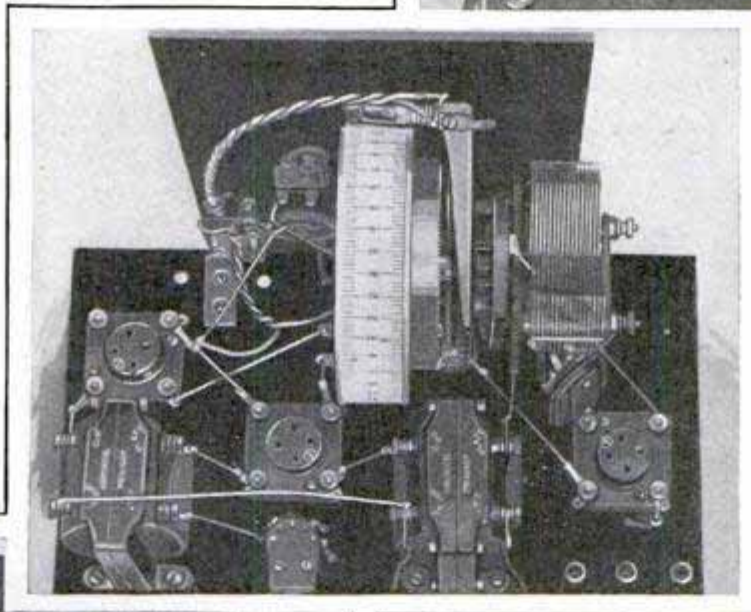
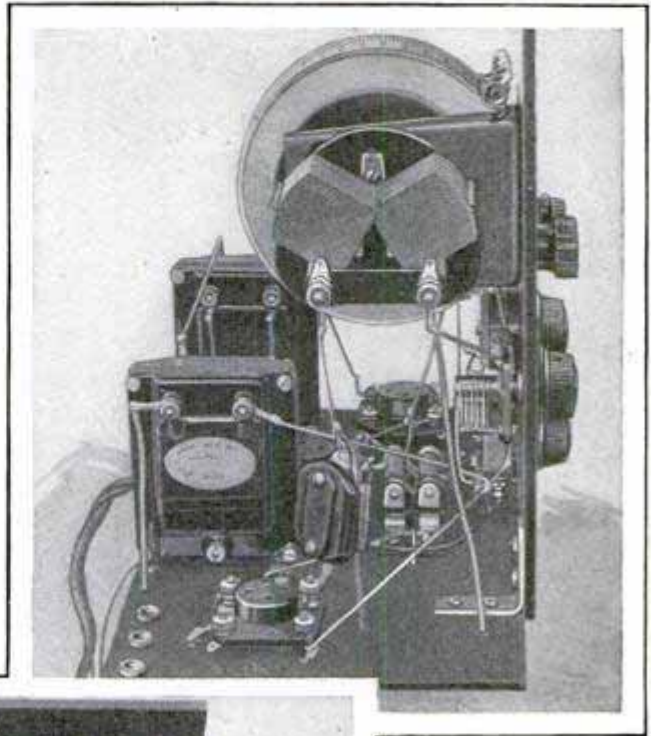

Above, Side View, Showing Location of the Detector Tube and Loop Jacks; Left, Rear View; Below, Front View of Panel

Fahnestock clips screwed to the inside of the cabinet at any convenient point. These clips are also used on the volume-control unit for quick

connection. The speaker lead from the powerizer through the volume control is run through to two holes drilled in the subpanel directly below the volume-control unit, not shown in the detailed wiring diagram.

The B-battery cable terminates in a bakelite lug mounted at the rear edge of the subpanel; each terminal connection is identified by a color corresponding to the colored wire leads running to the various batteries. Note that the A-negative and B-negative terminals of the lug are connected, and that an extra lead is taken to the positive of the  $4\frac{1}{2}$ -volt C-battery from the same negative connection. The

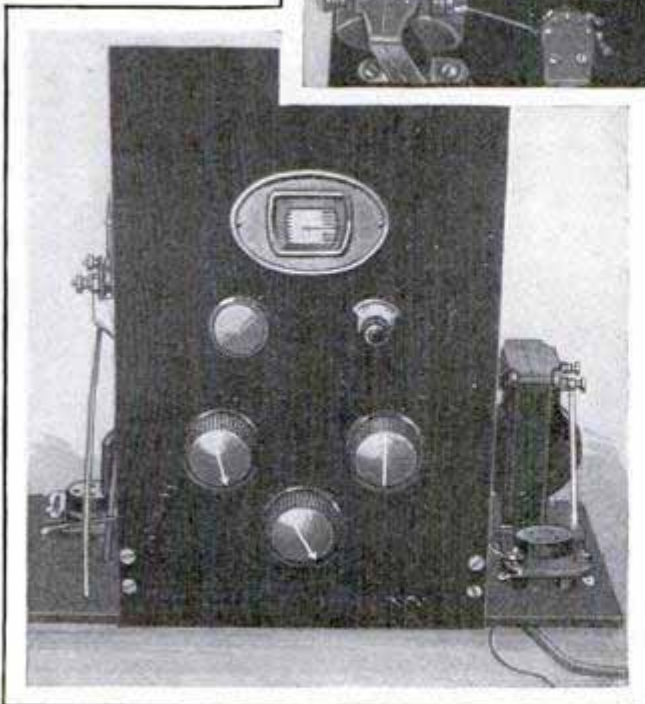



negative terminal of the 4½-volt C-battery is connected to a flexible lead and taken to the two F-posts on the a.f. transformers; this is the only connection independent of the battery-cable lug. Individual binding posts may be used instead of the battery cable and lug, but the builder will find this device very convenient. Carefully note the three loop jacks at the rear of the subpanel in the detailed wiring diagram; the center loop jack must always be connected to the center lead from the loop, or the set will not work efficiently. The photos on page 1007 give the reader a clear idea of what the finished set looks like from various angles. The lower photo of the front panel shows the

neat arrangement of the controls; this bakelite panel is finished in imitation walnut so as to match the cabinet as nearly as possible.

Mount the finished set on small wooden blocks and connect the A and B-batteries or powerizer for a thorough test before the instruments are finally placed in the cabinet. The detailed diagrams for making these connections are shown on this page; turn on the filament switch and place one tube of the 201-A type in each socket in the set successively to test the filament circuit. If the tube lights correctly in each socket, it is safe to proceed with the test. Then insert the tubes in the detector and first a.f. sockets and plug

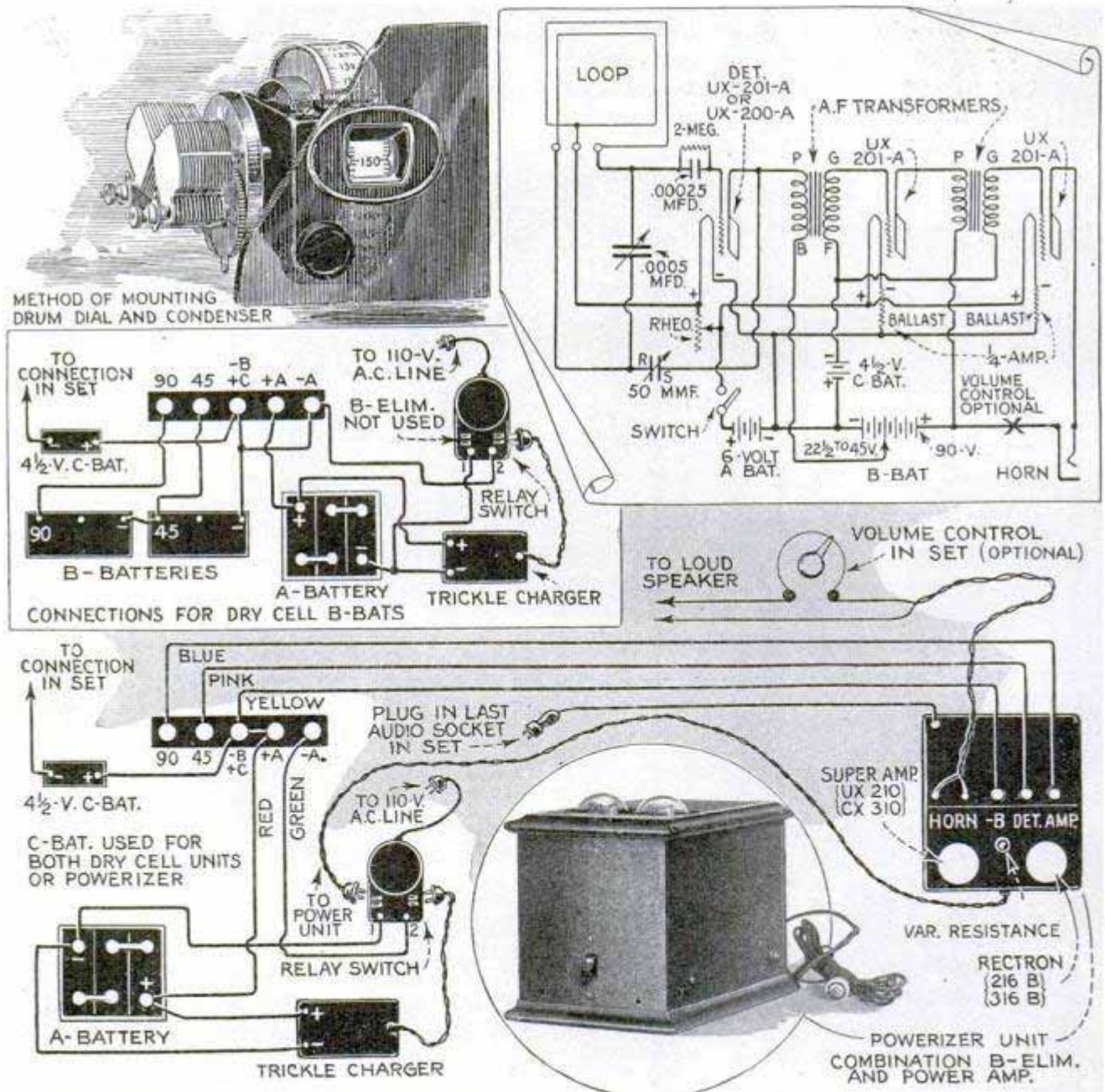

Above, Schematic Diagram of Receiver Circuit; Below, Detailed Hookup with Combination Power Amplifier and B-Eliminator, Automatic Switch and Trickle Charger, All Controlled by Filament Switch on Front Panel



the signal lead from the powerizer in the second a. f. socket, making sure the super-amplifier and rectifier tubes are in the sockets designated for them in the powerizer. If the lower hookup on page 1008 is used, plug the relay switch into the 110-volt 60-cycle house-lighting supply, and turn on the switch at the front of the powerizer. The switch on the front panel of the receiver will then alone control the entire installation.

Now, with the loop leads plugged into the small jacks at the rear of the subpanel and the center lead in the center jack, rotate the large condenser dial slowly and adjust the detector-tube rheostat. The plates of the midget condenser should be about half out for the initial test, and, as soon as a station is picked up, the large dial and the midget condenser should be adjusted for the loudest and clearest signal. Volume may then be controlled by the variable resistance as desired. For loudest signals, the edge of the loop should point directly toward the transmitting station. This directional effect of the loop is put to good use in cutting out undesired stations and similar interference. The set is very selective, separating stations in Chicago when other larger and more expensive sets fail to do so.

After you have familiarized yourself with the operation of the set, disconnect the various apparatus and prepare the cabinet for the installation. The photo of the rear of the cabinet, with the back re-

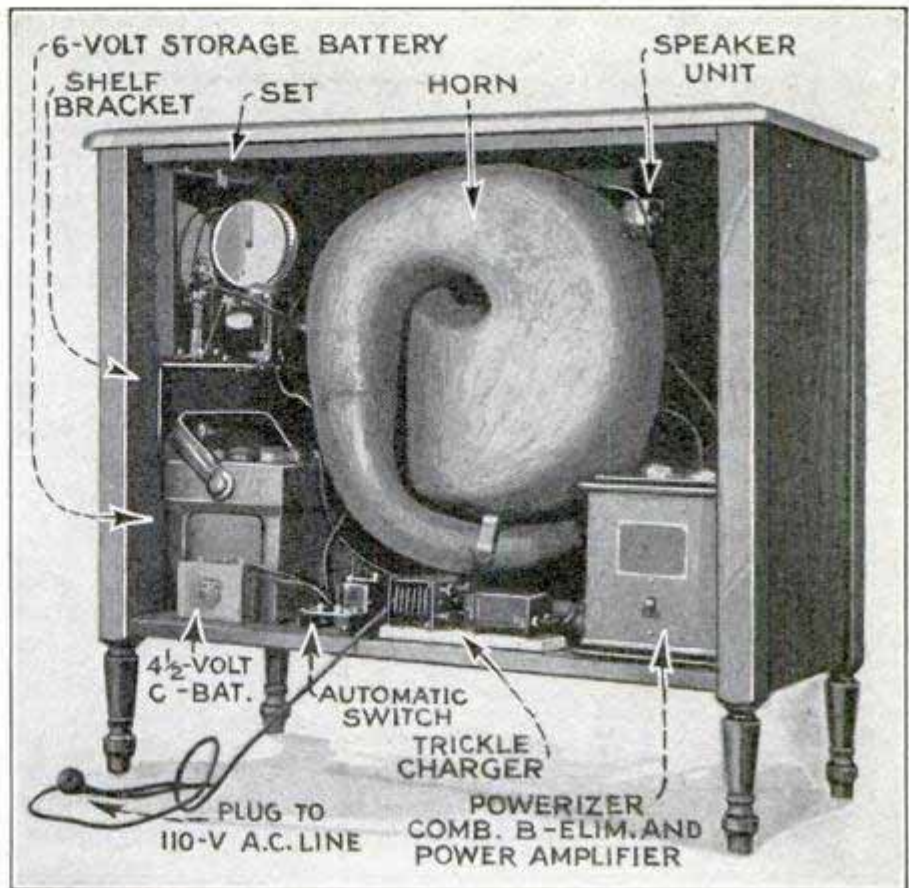

View of Cabinet Speaker with Back Removed, Showing the Location of the Various Instruments

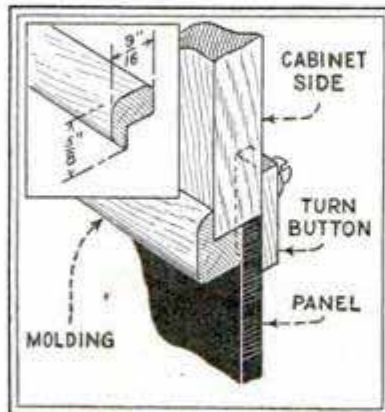

moved showing all apparatus in position, appears on this page; the large exponential-type horn is seen at the center with the apparatus grouped about it. This photo shows everything in detail and requires little explanation. Plenty of room is available for the apparatus without crowding. The set is mounted on shelf brackets at the upper left, as viewed from the rear; the square hole in the side of the cabinet for the instrument panel must be carefully measured and cut so that the panel fits into it neatly. Walnut picture-frame molding is then mitered to fit the hole and glued and pinned in position. The detailed sectional sketch shows the method of fitting and framing the instrument panel. A small wooden turn button is screwed to the inside of the cabinet directly above the instrument panel to hold it in position and facilitate easy removal of the set. The back of the loudspeaker cabinet should be drilled with a number of holes to provide free air circulation, and the powerizer should be kept as far as possible away from the A-battery. The loop leads are held by insulated cleats along the inside of the cabinet at



top and brought out through slots, cut in the back cover at the upper rear, to the loop placed on top of the cabinet.

The finished installation is neat, efficient, and leaves little to be desired for the music lover who insists on real tone quality and is satisfied with the local broadcast and

chain-station programs in the large cities.

Large blueprints of the diagrams have been prepared and may be obtained from Popular Mechanics Radio department, 200 E. Ontario st., Chicago, Ill., for 25 cents to cover postage and packing. Specify blueprint No. 124.

#### MATERIAL LIST

- |   |  |
|---|--|
| <ul style="list-style-type: none"> <li>1 front panel, 3-16 by 7 by 10¼ in. (Exact size optional.)</li> <li>1 subpanel, ⅝ by 7 by 12¼ in. (Exact size optional.)</li> <li>1 Remler condenser No. 649, .0005 mfd.</li> <li>1 Remler drum dial No. 110.</li> <li>1 midget condenser, either 50 or 55 mmf. (Hammerlund or similar type.)</li> <li>1 rheostat, 20-ohm, Frost, Yaxley, Electrad or similar type.</li> <li>1 Electrad Tonatrol (variable resistance).</li> <li>1 filament switch, Yaxley or similar type.</li> <li>2 Amperites or ballasts, ¼ amp. each, complete with mountings.</li> <li>3 X-type tube sockets, Benjamin or similar spring-suspended type.</li> <li>1 grid condenser, .00025 mfd., with gridleak clips.</li> <li>1 gridleak, 2 meg.</li> <li>2 a.f. transformers, Ferranti, Amertran, Silver-Marshall, or similar heavy type.</li> <li>1 Jones Cabelug.</li> </ul> | <ul style="list-style-type: none"> <li>3 midget jacks and plugs, Carter or Yaxley.</li> <li>2 small angle brackets.</li> <li>2 6-in. shelf brackets.</li> <li>22 round-head brass machine screws, 6-32, ½ in. long.</li> <li>9 round-head brass machine screws, 6-32, 1 in. long.</li> <li>2 doz. soldering lugs, long round-hole type.</li> <li>4 lengths of round tinned-copper busbar wire.</li> <li>12 ft. rubber-covered hookup wire.</li> <li>2 pieces ¾-in. walnut picture-frame molding, 22 in. long.</li> </ul> |
|---|--|

#### SUGGESTED EQUIPMENT

- 2 UX 201-A, or similar type, tubes.
- 1 C-battery, large size, 4½ volts.
- 1 6-volt storage battery, 80 or 100-amp. type.
- 1 Automatic relay switch, Yaxley No. 444, or similar type.
- 1 trickle charger, Kuprox, Balkite, or similar type.
- 1 Powerize P-1, with tubes specified.
- 1 Newcombe-Hawley cabinet speaker No. 55.

### Tone Filter Made from Ford Coil

With the new power tubes, some device is necessary to keep the high voltage out of the loud speaker, in order to prevent the speaker windings from burning out. A very efficient filter for this purpose can be made from an old Ford spark coil. This is cheap and does the same work as a more expensive filter especially designed for the purpose. The spark coil is taken apart, care being used not to break the end leads of the secondary coil. The primary, or inside, leads are not used and are cut off. The iron core is left in place. A small wood or bakelite base, about 3 by 5 in., is made, and the condenser taken from the coil box is placed on this base. The coil is then put on top of

the condenser and held by a strip of brass or tin, as shown in the illustration. Holes are drilled at both ends of the base for binding posts, two on each side. The filter, now complete, is connected as shown, only three wires being required; these should be soldered to the terminals and care should be taken that the condenser is in good condition and is not punctured or blown out. The entire filter

may be placed inside the receiver cabinet or outside. The input is connected to the loud-speaker terminals on the set and the speaker to the output side of the filter. The secondary, or choke coil, as it now is, permits the d.c. of the battery to reach the plate of the amplifier tube while the condenser keeps it out of the speaker, thus protecting the windings.

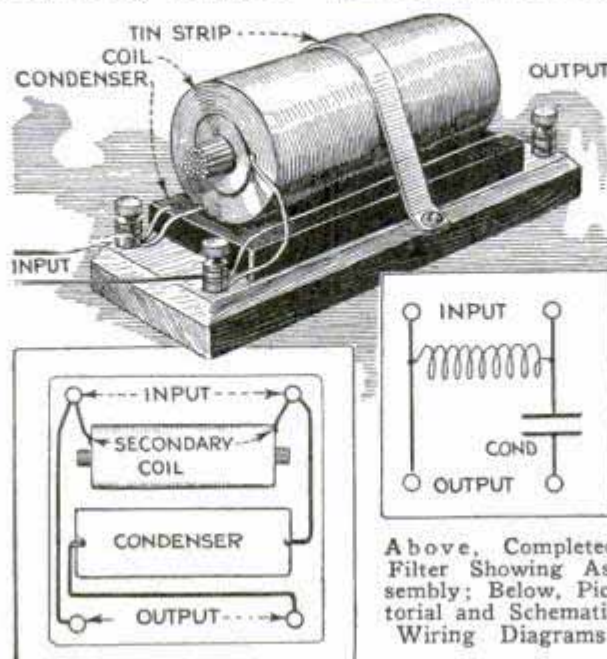

Above, Completed Filter Showing Assembly; Below, Pictorial and Schematic Wiring Diagrams



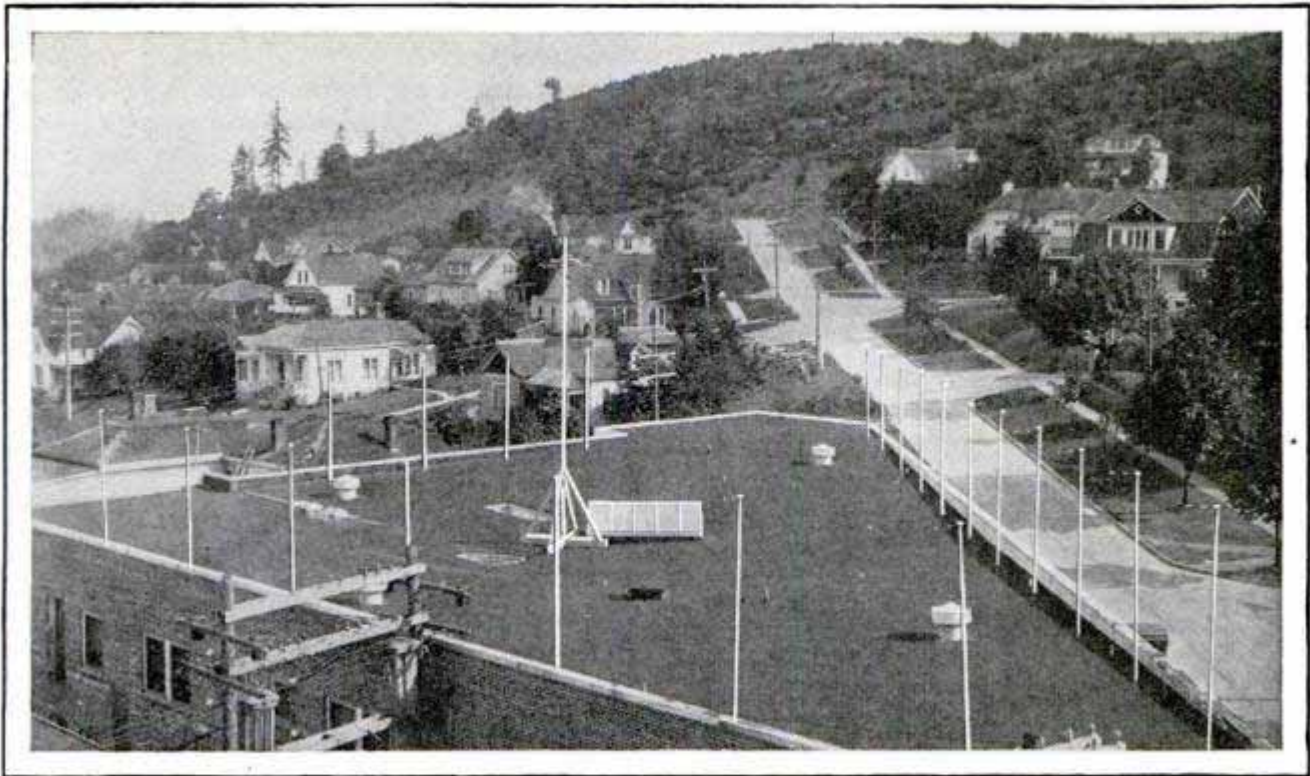

Washington Apartment House Has a Neat Installation for 32 Aerials, Consisting of a Large Central Mast and a Number of Small Masts

### Aerials on Apartment House

Rather than have a maze of aerials criss-crossing each other and running in all directions, a neat installation of 32 aerials was devised for a Washington apartment house. It consists of one large mast erected in the center of the roof and 32 smaller ones at the edges, the aerials radiating from the central mast. The lead-in wires were, of course, attached to the aerials at the end near the short masts. This installation has the advantage of preventing the aerials from touching each other.—Carlton Groat, The Dalles, Oreg.

### Trickle Charge from Full-Current Charger

The effect of a trickle charger for radio batteries is accomplished by connecting an ordinary charger of full current rating, such as the 2-amp. type, to a circuit containing a lamp that is in definite periodic use. This lamp should be one that is normally used a little while each day, so that the battery will be charging whenever the lamp is in use; for example the cellar light, used each day during attention to the furnace and other jobs. Experience has shown that this gives the battery almost enough charge to meet ordinary needs; at least it comes near enough

to doing this in the average household so that the battery requires a regular charge only at rare intervals. A little observation will enable the average set owner to select some lamp in the house that will greatly assist in keeping up the required charge. When putting this plan in operation, the charger is, of course, constantly connected to the storage battery.

1402. G

### Small Electrically Driven Coil Winder

For the small manufacturer, the coil winder shown in the photo will be of considerable utility. It is driven by means of a small universal motor, which will operate either on a.c. or d.c., and from 2,000 to 3,000 coils can be made in a week by one



operator. Various sizes of wire can be used, and the turns are counted automatically. The speed can be varied by means of a foot-operated rheostat. The entire machine is made of bronze with steel shafts, and is portable.

Wichawakee Electric  
Mfg. Co. 1402 G



## SHIELDED UNITS FEATURE NEW INFRADYNE

Efficient shielding and compact construction make the new model of the infradyne receiver, shown in the accompanying illustrations, of special interest.

pletely inclosed copper box and the instruments are assembled in this box. The three-in-line condenser, three coils and three sockets, with each stage isolated by shielding, make up this assembly. These units, with the necessary tubes, constitute two stages of r.f. amplification and detector. The three-in-line condenser employs three small balancing condensers, by means of which capacities introduced by the wiring and tubes may be compensated for at the time the amplifier is put into service. Referring to the center photo, we find the infradyne amplifier mounted at the rear of the base; this is the same amplifier as that used during the past year and has been described in a

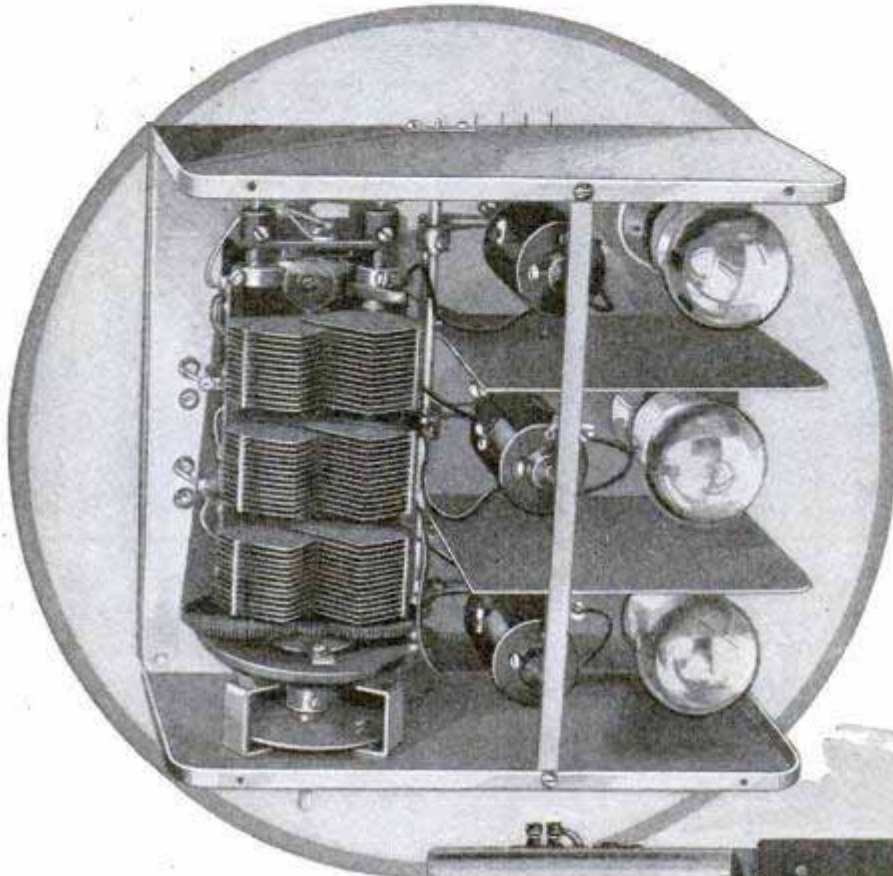

Above, Radio-Frequency Amplifier and Detector Unit Removed from Copper Box; Right, Complete Assembly as Viewed from Above; Below, Installed in Metallic Cabinet Showing Compact Arrangement of Controls

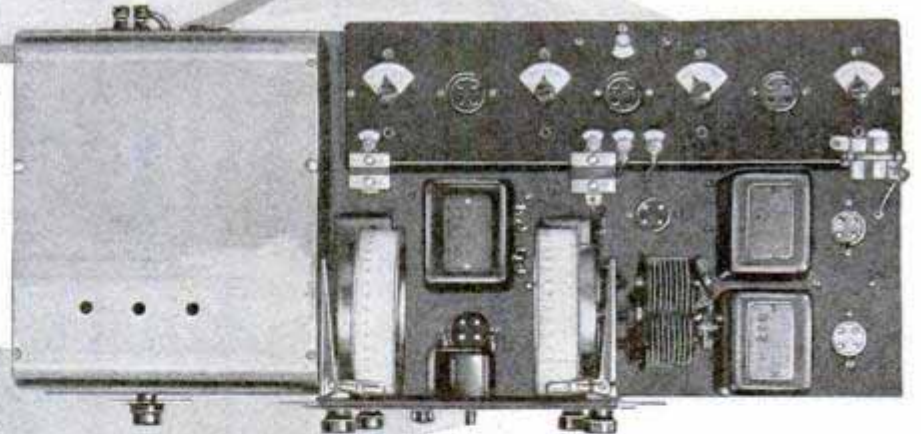

All units are supported on a pressed-steel base, heavily enameled in black and drilled to accommodate all mounting screws and wiring. The shaft from the left-hand drum dial extends into a com-

previous issue, its ability to sharpen tuning and to build up volume without increasing background noises being well known to the home constructor. Back of the bronze panel carrying the instrument controls is a pressed-steel panel upon which are mounted the voltmeter, infradyne amplifier rheostat, two drum dials and the oscillator-tuning condenser. Behind the drum dials, and supported on the pressed-steel base, are the volume and sensitivity-control rheostats, connected respectively in the r.f. tube-filament circuit



*Master 3803 N. Clark Chicago*  
*1368 Tube Booster Works on B-Battery*

and, in series with a blocking condenser, between the positive-B and negative-A in-fradyne-amplifier leads. These rheostats are operated through extension shafts from the front control panel. The tube sockets, two a.f. transformers and output transformer complete the assembly. The lower photo of the completed set in the attractive sheet-copper cabinet shows the controls grouped at the center. The cabinet is finished in two-tone brown enamel, and is mounted on a decorative wooden base. All controls, except that for an antenna compensator, are mounted on an etched bronze panel, set off in red enamel, and the control knobs are of brown molded bakelite.

A tube rejuvenator of very low cost, that will boost any type of tube on the batteries of the radio set has recently made

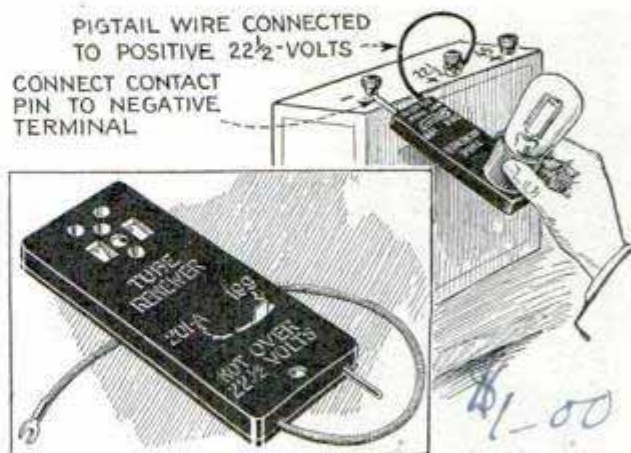

**Power Sets Require Full Line Voltage**

While the radio fan, having a powered set, is usually correct in assuming that his line delivers 110 volts, a check with a good a.c. voltmeter will often show that the voltage is 100 volts or even less. The failure of some power units to give satisfactory results may often be traced to deficient line voltage. This is especially true in rural districts, where transmission lines are long and the voltage is not so carefully regulated as in the more thickly populated districts.

its appearance on the market. Tube renewal is thus made available to every owner, regardless of the type of lighting current in his district. The renewal of a 201-type tube takes less current from the batteries than the average set uses in one hour of operation, and the 199-types require a still smaller amount. This cheap and simple device adds many useful hours to the life of the tube.

**Cleaning Aerial Insulators**

Soot accumulation on aerial insulators should be removed at least once a year if good continuous reception is to be expected. They may be cleaned with carbon tetrachloride. Also, the connections should be tightened and resoldered if necessary. The slack in the aerial and lead-in wire should be taken up, since the weight of the wire itself and the sway due to wind pressure will gradually loosen any aerial in time. These attentions may bring back stations you have not heard for some time.

**Handy Battery Tester**

The handy battery tester shown in the photo is intended to be permanently connected across the storage battery terminals by means of two special clamps. When a reading is desired, a push button on the side of the voltmeter is pressed. The scale is divided into three sections, marked "Start Charging," "OK" and "Stop Charging," respectively. Battery tests are made when the set is turned off and when the charger is not in operation.

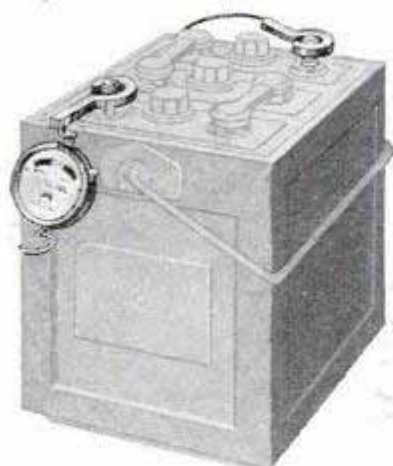

**Following Specifications Important**

Good results are seldom obtained by the set builder unless he follows exactly the specifications of the designer. The latter has usually tried all the possible combinations before he has approved a description for publication. Small changes in the set may seem practical, but they frequently interfere seriously with proper functioning at some other point.

*Beede Electrical Instrument Co., Pensacola, Fla.*



1295. R

Loud Speaker Built in Globe Form

Different from the various types of loud speakers now on the market, the instrument shown in the photo



is a hollow globe with the reproducing unit inside. A map of the world is printed on the outside and it is covered with a transparent finish which can readily be cleaned with a moist cloth. It is claimed that this speaker gives exceptionally good reproduction and good tone quality, besides its feature of utility.

Recharging Dry B-Batteries

It has been generally assumed that it is impossible to recharge dry batteries, and in the case of dry ignition or radio A-batteries, it is. But it has been found by recent experiments that any ordinary B-battery can be recharged as easily as the storage type. This should be welcome news for the many fans to whom replacing B-batteries represents one of the chief items of maintenance expense, particularly since the advent of power tubes with their heavy drain on the B-supply. To recharge a set of dry B-batteries, simply proceed as in the case of storage batteries. Many A-chargers are equipped with a tap for charging B-batteries and this can be used with good results. If such a means is not available, one of the simple electrolytic B-chargers can be rigged up in a few minutes; or, if something permanent is desired, a charger designed especially for use with dry batteries, now on the market, can be used. Only one or two precautions are necessary. First, keep the charging rate low, to prevent the batteries from heating, which will drive off the active material and shorten their life. A current as small as from 40 to 50 milliamp. is usually satisfactory, though, if no means of measurement is at hand, it will

be necessary to determine the correct rate by experiment, keeping in mind the size of the battery being recharged. Also, be sure that all batteries in a series are of the same size (capacity, not voltage). Otherwise, a charging current which would not damage a large heavy-duty battery would cause a small battery to become seriously overheated. Next, let the charging continue for some time—even several days, if the batteries are badly run down. A long-continued charge every few months will give better results than briefer charges at more frequent intervals. To check the progress of the charge it is, of course, not possible to take hydrometer readings as with storage batteries. Instead, voltmeter readings must be relied on, and these should be taken with the charging current turned off. If they are not, the voltage of the charging current, not of the battery, will be shown. It is not claimed, of course, that dry batteries can be recharged as often as those of the storage type. After several repetitions, the active material in the cells gradually becomes exhausted to the point where repeated charging is not practicable. But from four or five to as many as a dozen times it can be done, with a saving that makes the small trouble and consumption of lighting current required, well worth while.

Oscillator for Testing and Calibrating

Signals at any wavelength from 200 to 575 meters can be radiated by means of

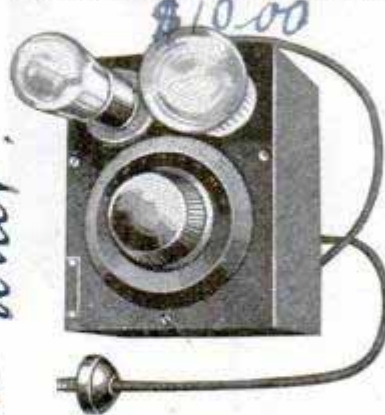

the simple oscillator shown in the accompanying photo, and these can be picked up by the average receiver at any distance not over 50 feet away. Such a

device is especially useful to service men for neutralizing and calibrating receivers. It is provided with a cord and plug, so that it can be connected into a light circuit. There is no buzzer, and no batteries are required for its operation.

Hanscom Radio  
 Sales, Worcester

\$05.00

1339 R

brush  
 buffer



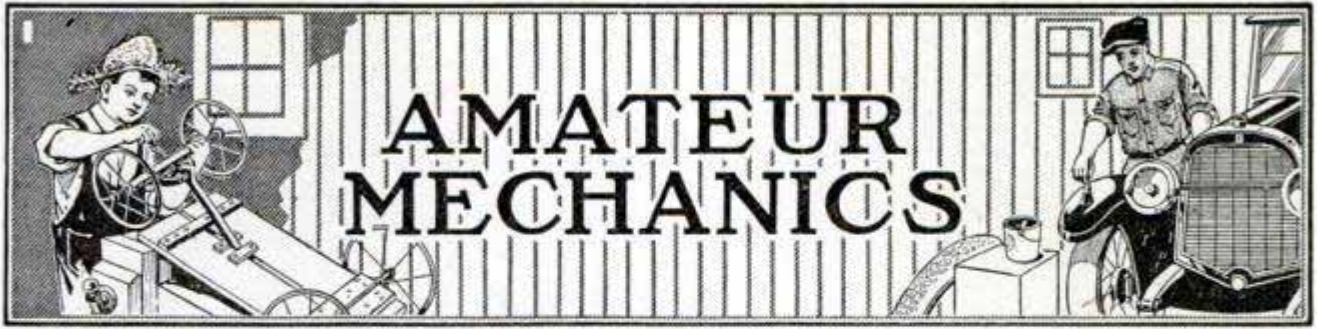

## An Electric Floor Scrubber

By ARTHUR N. CAPRON

WHERE it is necessary to do quite a bit of scrubbing, the electric outfit shown in the drawing will be found to be a great convenience and labor saver. It consists essentially of a metal casing of cylindrical shape, inside of which a brush is arranged, while a motor is attached on top by means of a bracket, which also serves as a pivot support for the handle. The casing consists of a cast-iron sauce pan, about 10 in. in diameter and 6 in. high. The center is accurately scribed, a  $\frac{1}{2}$ -in. hole drilled through it, and two 1-in.

pipe flanges are then riveted or bolted to the bottom, one on each side, and centered over the hole.

The inside of the flanges is babbitted to receive a length of  $\frac{1}{2}$ -in. steel shaft, which must be at right angles to the surface of the flange. A rubber ring,  $\frac{1}{2}$  in. thick, is fastened all around the edge of the casing, as shown, being held in place securely by means of a steel strip,  $\frac{1}{8}$  by  $\frac{3}{4}$  in. in dimensions, which is screwed to the casing, holes being drilled and tapped to receive the screws. The rubber ring should extend  $\frac{1}{2}$  in. from the end of the casing and serves as a water-tight packing when it is in contact with the wetted floor, preventing the water from splashing outside of the casing. The shaft is a 5-in. length

Floor Cleaning Is an Easy Task with This Electric-Driven Scrubber, Which Carries Soapsuds over the Floor and Does Not Splash

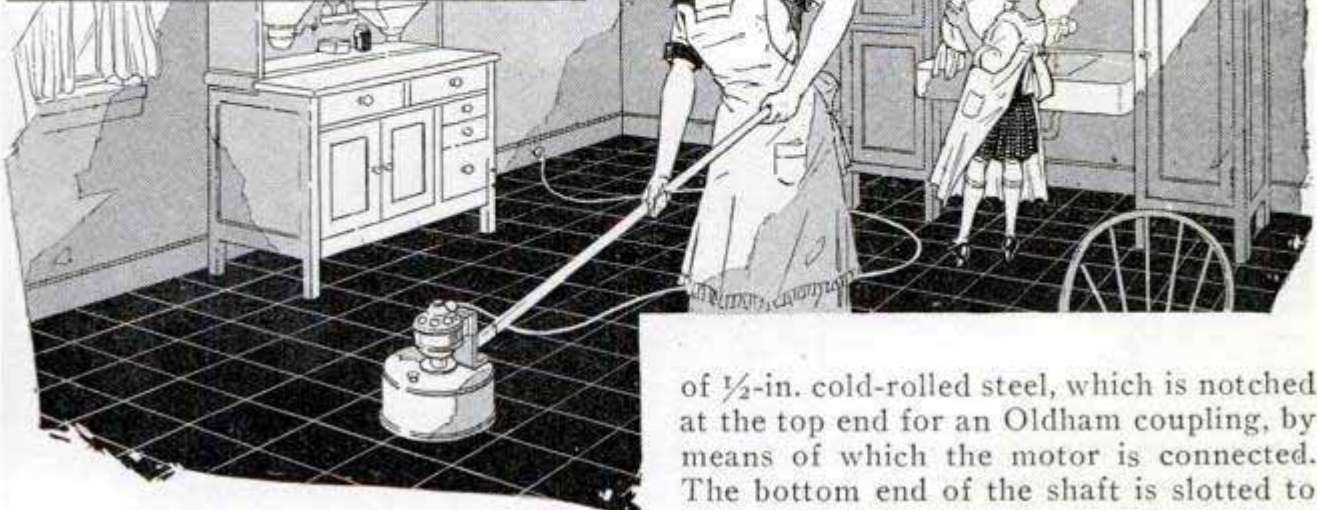
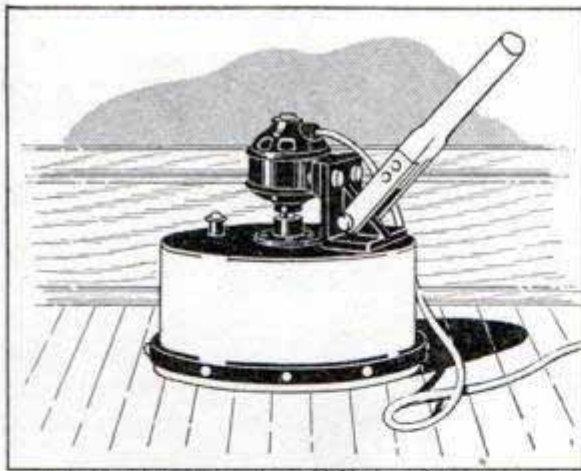

of  $\frac{1}{2}$ -in. cold-rolled steel, which is notched at the top end for an Oldham coupling, by means of which the motor is connected. The bottom end of the shaft is slotted to



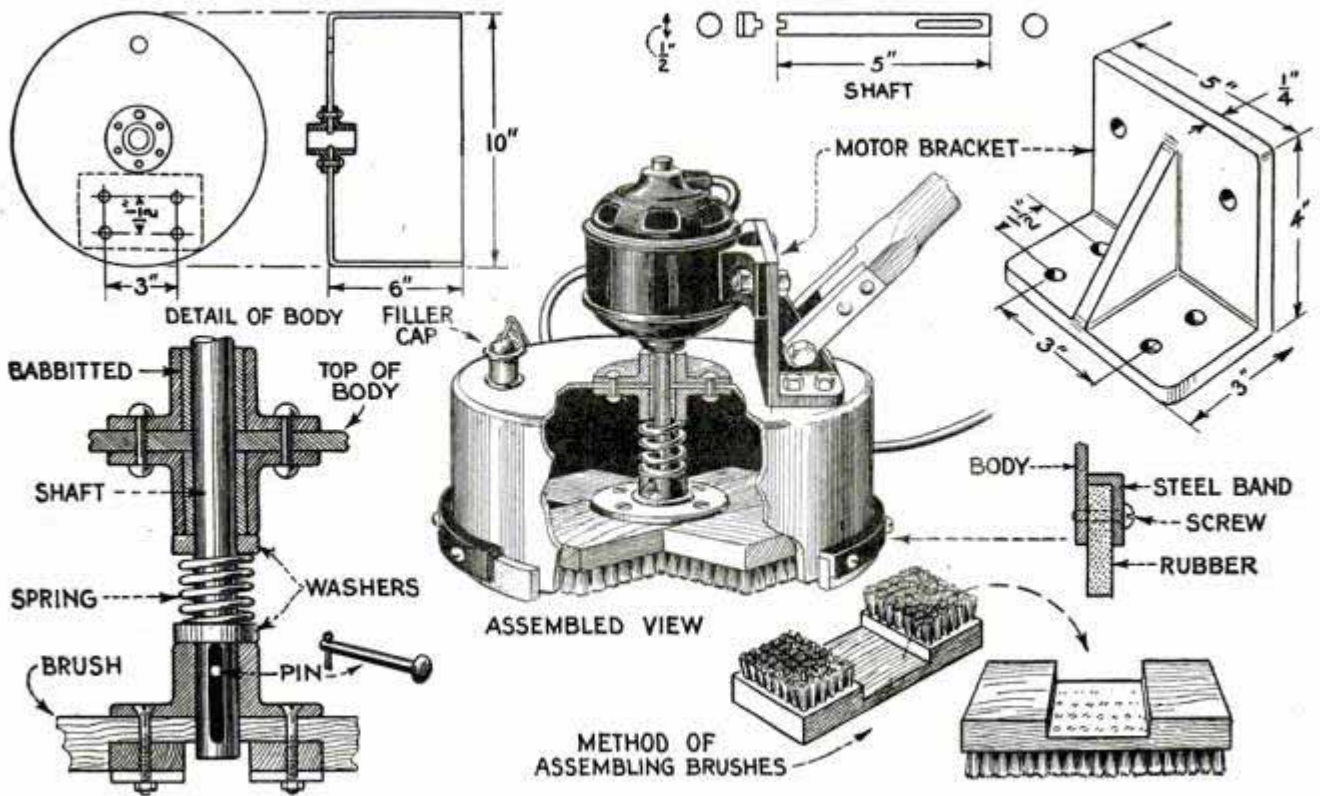

Constructional Details, Showing the Casing, Shaft, Scrubbing Brushes and Motor Bracket, and an Inside View of the Assembled Scrubber

permit attachment of the scrubbing brush. This consists of two ordinary floor brushes, assembled as indicated, and a pipe flange screwed on top securely. The inside of the pipe flange is reamed out to make a sliding fit on the shaft, and a pin is driven through both flange and shaft to hold the brush to the shaft yet permit vertical movement. A coil spring and two washers are provided on the shaft, to keep a downward pressure on the brush, forcing it against the floor. However, this spring must not be so strong that it will tend to raise the casing from the floor. A heavy angle bracket, of the shape and size shown, is provided to hold the motor in position securely and furnish a support for the handle. It is bolted or riveted to the casing, so that the motor is located centrally over the shaft. The end of the motor shaft is shaped to fit the notched upper end of the brush shaft. A filler cap is also provided, as indicated, through which a quart of hot soapsuds is poured for scrubbing. This will not leak out if the rubber facing is even and held tightly against the floor. The brush, revolving against the surface of the floor in the hot soapsuds, cleans it thoroughly. By moving the scrubber over the floor, the suds are carried along, and therefore very

little of the suds is required. The brush can be removed by merely taking out the cotter pin.

### Receptacle Plate Protects Door Lock

It is sometimes difficult to open locks of the pin-tumbler type if a few grains of sand have become lodged inside. This trouble is especially likely to occur in locks on summer cottages, where sand is blown about by the winds. An ordinary

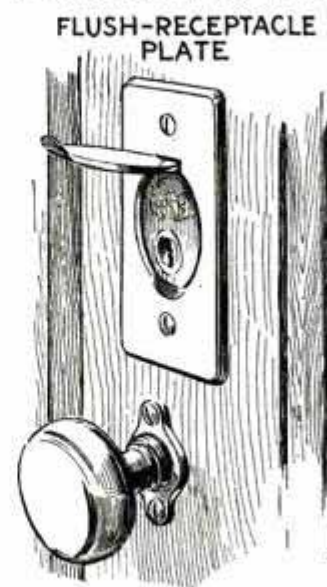

flush-receptacle plate of the kind shown in the drawing, obtainable at any electrical store, will be found effective in keeping dirt out of the lock. Some types of locks will permit fastening the plate directly to door while other types necessitate the use of a block of wood through which a hole is drilled to fit over the lock, and on which the plate is then screwed down.



### Reducing Christmas-Fire Hazard

Serious accidents caused by Christmas-tree fires could be avoided to a great extent if proper precautions were taken to render the ornamental decorations fire-proof. Cotton wool, in the majority of cases, is used to give the appearance of a snow-covered floor and is also scattered over the tree. In its natural state it is a most dangerous and highly inflammable material, but with proper treatment it can be made reasonably safe for use. Make a solution of  $\frac{1}{2}$  lb. of alum to 2 qt. water, or any quantity of the same proportions. Hot water must be used to dissolve the alum; when the solution has cooled, soak the cotton wool in it and hang it up to dry thoroughly. When it is quite dry it must be pulled apart to renew its original appearance. The solution can be used for other decorations constructed of light materials. Tissue-paper ornaments can be made practically fireproof by a solution of 10 parts of ammonium sulphate, 4 parts of boracic acid, and approximately 3 parts of common borax, with 100 parts of water. Dip the paper in the solution and carefully dry it, to retain its original shape.

### Clean Milk-Pail Bottom

To clean milk pails and utensils well is the endeavor of every good dairymaid,

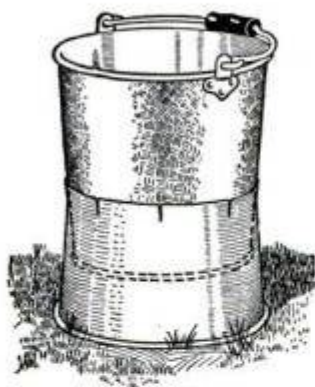

but when the milking is done in the feed lot or in the pasture, the bottom of the pail often becomes so soiled that the washing is a very disagreeable task. One farmer, however, eliminated this trouble by cutting the bottom half off a discarded feed pail and using the upper portion in an inverted position to hold the milk pail. The latter is gently forced into this holder and the two cling together so that they can be carried about without further attention. After the milking is finished and the pail is emptied, a slight blow against the side of the holder dislodges it.—G. E. Hendrickson, Argyle, Wis.



Keg, Ornamented with Pebbles and Seashells, Makes an Artistic Dovecote

### Ornamental Dovecote

A highly artistic and attractive dovecote may be seen in the park grounds of the municipal zoo at Surabaya, Java, in the Dutch East Indies. It is beautiful in spite of the fact that it is constructed from the cheapest kind of materials, and its cost was practically nothing except the labor of the zoo keeper, who built it during his spare time. It consists of an old barrel having holes cut in it to permit the entrance of the birds, a wooden roof, a shelf and a pedestal. It is coated with cement and covered with pebbles and seashells. It would be a very simple matter to modify this form of construction for native wild birds in this country, swallows, wrens, bluebirds, martins and others, and it would make a good squirrel house for parks or private estates. Such a bird house is attractive and weather-resisting.



### Canopy for Rumble Seat in Car

A person riding in the rumble seat of a roadster has no protection against the weather, unless a portable canvas canopy

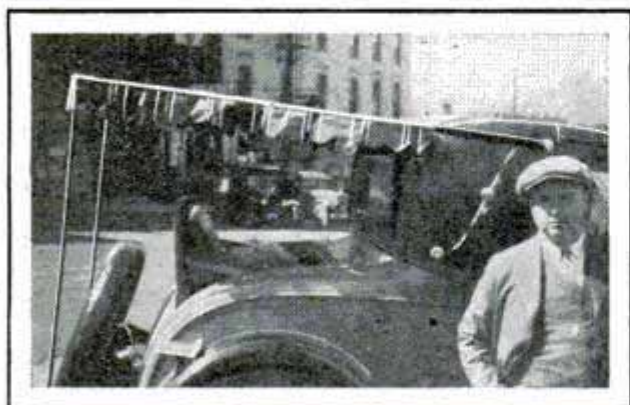

Homemade Canopy over Rumble Seat of Roadster Protects Occupant from Weather

of the kind shown in the photo is provided. This is a homemade affair and consists of a set of pipe and fittings, which is fastened to the car securely, the canopy being attached to it.

### Windshield Warmer

A length of flexible metal tubing, led from the heater to the portion of the windshield just ahead of the steering wheel, will deflect the heat entering the car so that ice on the outside of the windshield will melt, and, with the aid of the automatic wiper, the glass in front of the driver can be kept clear, even during sleet and freezing rain. The tube can be permanently installed, as the deflection of the warm air does not make any appreciable difference in warming the car.

### Automatic Valve Fills Water Pan

Most hot-air furnaces are equipped with a water pan for adding moisture to the dry, hot air. Usually it is necessary to refill this box every day as the water evaporates quite rapidly. To eliminate the



trouble of doing this, one home owner installed an ordinary float valve on the pan; as soon as the water drops to a certain level the valve opens, and the pan is filled automati-

cally. The float is attached to the valve on a rigid arm and closes the valve when the pan is nearly filled.—C. E. Weibezahl, Syracuse, N. Y.

### Corks in Mucilage Bottles

Ordinary corks, in glue or mucilage bottles, stick badly after being removed a few times, so that the user does not put the cork in securely, with the result that the mucilage soon dries out. The trouble can be avoided by dipping the cork in fresh paraffin or tallow before replacing it in the bottle. If neither of the above substances can be obtained, rub the cork with vaseline, which will have the same effect, but is more easily rubbed off than paraffin or tallow, and is also objectionable because it is greasy. This kink will save many a bottle of mucilage.

### Oiling the Auto Springs

When the oiling of the auto springs is neglected, squeaks and chirps soon develop, and the riding qualities of the car suffer. Overoiling, on the other hand, brings conditions that are just as bad, and, in any event, the job of oiling the springs is an awkward one. The simple device shown in the illustration not only makes the task an easy one, but it feeds oil to the springs in just the right amount to make them ride easily and to keep down the squeaks. It consists of a few turns of felt wound around the spring, near the end, as indicated, and fastened in place with wire ties. The felt is soaked with oil once every two weeks or oftener, depending on the use of the car and the weather conditions.

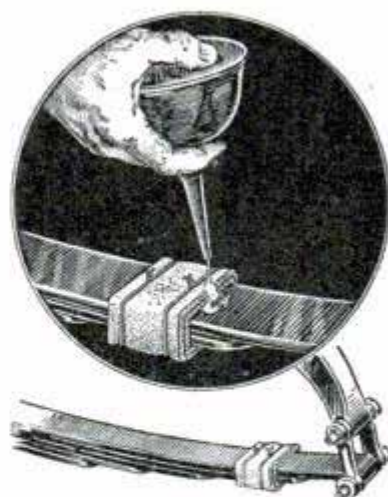

☛ A little fresh developer added occasionally to old developing solutions will bring them up in speed and intensity.



### Flaming Beacon for Night Skaters

This beacon will be found useful for skating or coasting parties, as it is easily moved about and will give light for a long

runners can be used instead of wheels. These can be made of light material,  $1\frac{1}{2}$  in. thick, 4 or 5 in. wide and about 14 in. long. Drill holes for the ends of the axle 1 in. from the top and 2 in. ahead of the

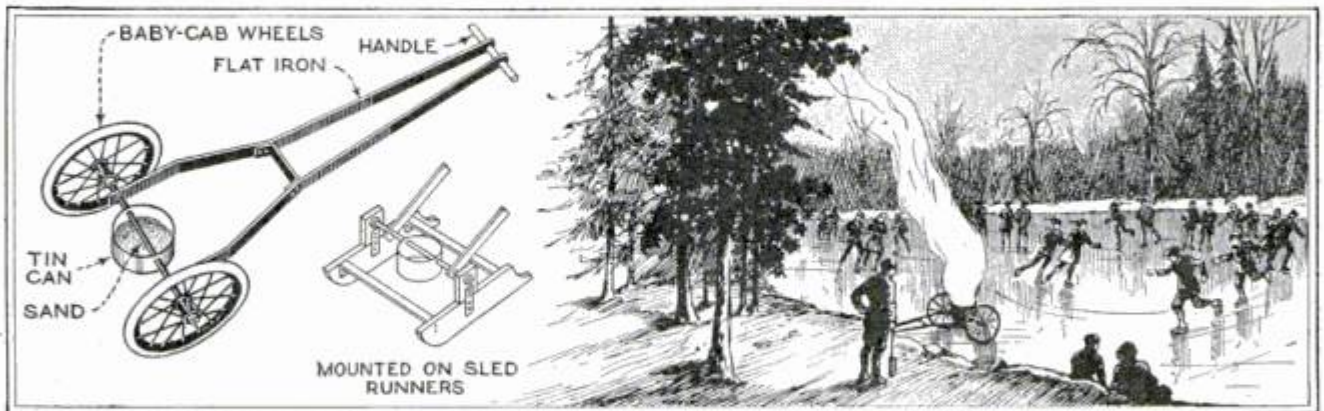

You Can Have Much More Enjoyment from Skating or Coasting at Night, If You Provide Yourself with a Flaming Beacon to Give Light

time. When set on top of the coasting hill, it will cast its beams for miles. It consists of two wheels with a metal can mounted midway on the axle that supports them. The handle is fashioned from two lengths of flat iron with a rod or broom handle set through holes in the front end. If desired, only one length of flat iron of double length, bent sharply in the middle, can be used. Besides the rod, two wheels, such as can be salvaged from an old baby cab, are needed, together with the axle. Holes are punched through the side of the can just above the middle and the axle is run through them. After drilling the ends of the lengths of iron, fit them over the axle, drill the front end and insert the handle. If the holes at the rear end are a tight fit, the "pinch" on the handle at that point will hold it in place securely. Before starting out, fill the can with dry sand and pour over it some kerosene to which a small amount of gasoline has been added. When it is lighted, the beacon will burn for several hours. When facing the wind, draw the light behind you and, if the wind comes from behind, push the light in front of you. If desired,

center, and the runners will ride rough spots with ease.—Dale R. Van Horn, Walton, Nebr.

### Restoring Tone Quality of Violin

A novel method of quickly restoring the tone quality of a violin, which has become sluggish and impaired in this respect, due to long periods of disuse, consists in placing the instrument with its sound holes in close proximity to a radio loud speaker. It has been found that new violins can be "aged" in the same way.—Luke Mattera, Brooklyn, N. Y.

### Hat Hangers for the Closet Shelf

In closets where the space is limited a simple device can be used to keep hats in place and entirely out of the way. It is made of No. 10 galvanized-iron wire,

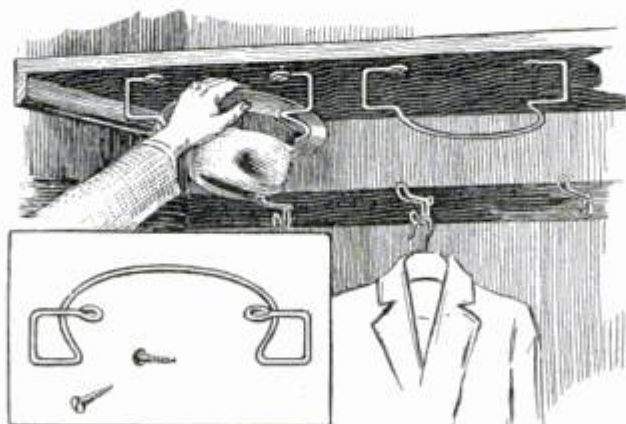

Easily Made Wire Hat Hangers Attached to the Under-side of a Closet Shelf

which is bent to the shape shown in the drawing, two "eyes" being provided at the ends, as indicated. The hanger is then fastened to the underside of a shelf with two wood screws through the eyes. A number of these hangers can be used in most closets.



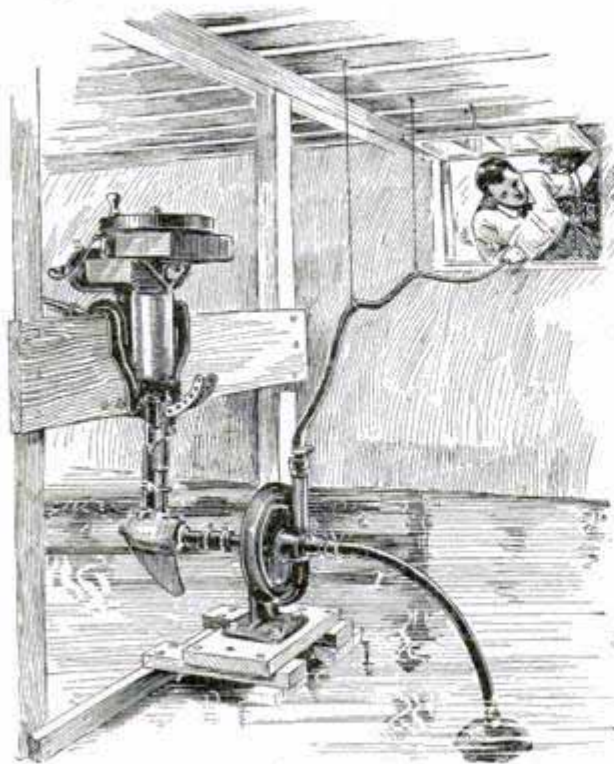

Outboard Motor Connected to a Small Rotary Pump Removes Water from Flooded Basement

### Outboard Motor Removes Water from Flooded Basement

Owing to the breakage of a water main, a resident of an eastern town found his basement flooded to a depth of nearly 2 ft., with no means of draining it after the main was repaired. He solved the problem by using his outboard motor and a small centrifugal pump borrowed from a near-by supply house. A heavy plank was spiked across the basement a short distance above the water level, and the motor was clamped to it solidly and in a vertical position. The propeller was removed from the driving shaft and the latter was fitted to a piece of pipe, about 1 ft. long, in which holes were drilled and tapped for two setscrews. The pulley was removed from the pump shaft and the pump was bolted to a heavy piece of timber, which was blocked up from the cellar floor until the pump shaft came in exact line with the propeller shaft on the motor. The two were then clamped together with a pipe coupling. The blocking and the motor were thoroughly braced in all directions so that they could not work out of line by vibration. The intake hose was fitted with a bilge strainer which the houseowner had on hand, although any other strainer could be used for this purpose. The motor was started, and, when

thoroughly warmed up, its speed was reduced to 300 r.p.m. so that the pump would work efficiently. The water intake of the motor was piped to the bottom of the cellar by means of a rubber hose so that the motor would be kept cool at all times. The discharge hose was led overhead by tying it to the beams with cord, and the water was discharged through a window where it flowed down a grade. The open window also carried off the gasoline fumes. This outfit did the work in a few days, with only three "rests" for slight adjustments of the engine.

### Holes Punched in New Overshoes

When you buy a pair of galoshes or overshoes at a price lower than usual, and you find a hole punched in the back at the upper part, the article has some defect. By this method manufacturers of rubber goods, who make galoshes and other rubber footwear, inform their customers of the quality of the product. All such goods containing minor defects in manufacture are designated as "seconds" by the hole.—J. S. Hagans, Chicago, Ill.

### Instructing Beginners to Operate Autos

For use in instructing beginners to operate automobiles, the following idea is of much assistance and enables the instructor to acquire control of the car quickly and completely, as, for example, when the pupil becomes confused and steps on the

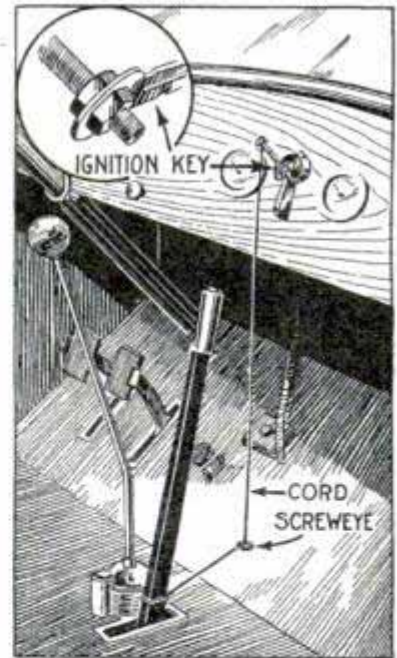

accelerator instead of the brake, as often happens. The drawing is self-explanatory, the ignition being automatically shut off, releasing unnecessary strain on the drive system and brakes, as soon as the emergency brake lever is pulled back.



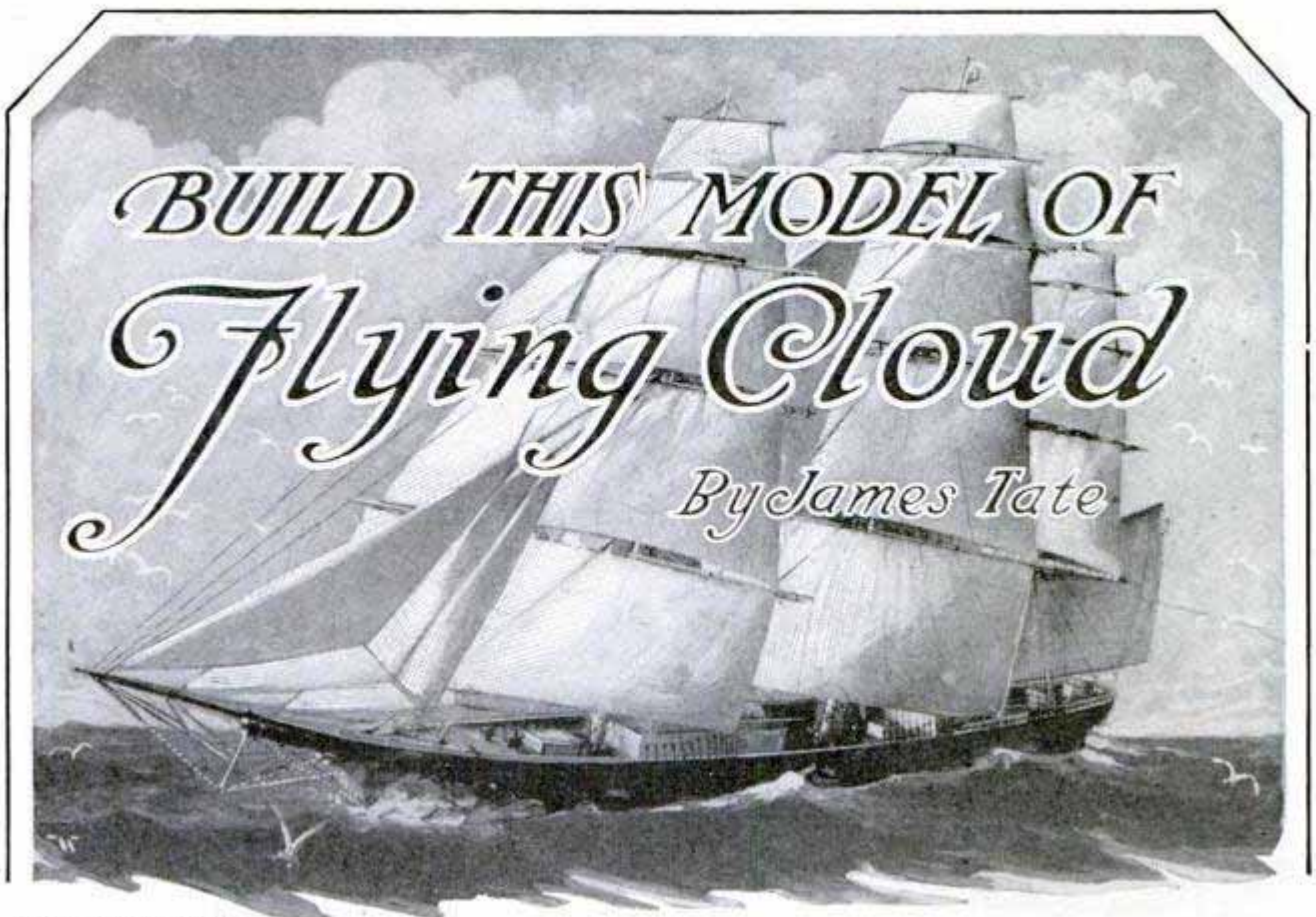

Photo © Edw. Levick

OF all the clippers built by that master shipbuilder, Donald McKay, the "Flying Cloud" was considered the most notable. According to Samuel E. Morrison, author of "The Maritime History of Massachusetts," McKay "built faster clippers and larger clippers; but for perfection and beauty of design, weatherliness and consistent speed under every condition, neither he nor anyone else surpassed the 'Flying Cloud.' She was the fastest vessel on long voyages that ever sailed under the American flag." Her very name breathes the spirit of the golden age of sail, and her fame endures even in this age of steam and oil.

Built for McKay's friend, Enoch Train, she was sold on the stocks to Grinnell,

Minturn & Co. of New York, a sale that Train regretted for the rest of his life. Her dimensions were 229 ft. length on deck, 40 ft. 8 in. breadth and 21 ft. 6 in. depth; registered tonnage 1,783. Her commander was Capt. Josiah Perkins Cressy (pronounced Creecy), of Marblehead, Mass.

On June 3, 1851, the "Flying Cloud" slipped out past the Hook on her maiden voyage. Before it ended, she had established a new record for the voyage to San Francisco, eighty-nine days, and this was only twice equaled; once by herself in 1854, and once by the "Andrew Jackson" in 1860. On this voyage she

made a day's run of 374 miles, and logged 1,256 miles in four consecutive days.

### SHIP-MODEL PRIZES

FEW hobbies enable the amateur to produce such beautiful work with so few tools and such inexpensive material as ship-model building. To encourage such a worth-while and pleasant pastime, Popular Mechanics Magazine offers the following awards for the best models of the "Flying Cloud" made from plans published in this and subsequent issues:

First, \$100 cash and gold medal.

Second, \$50 cash and silver medal.

Third, \$25 cash and bronze medal.

Five awards, \$10 cash and bronze medal.

Five awards, \$5 cash and bronze medal.

Bronze medals also will be awarded for excellence in workmanship.

The contest is open to everyone, regardless of age or sex. The conditions are very simple, and full details will be supplied to every reader addressing the Editor, Amateur Mechanics department, Popular Mechanics Magazine, 200 E. Ontario st., Chicago.



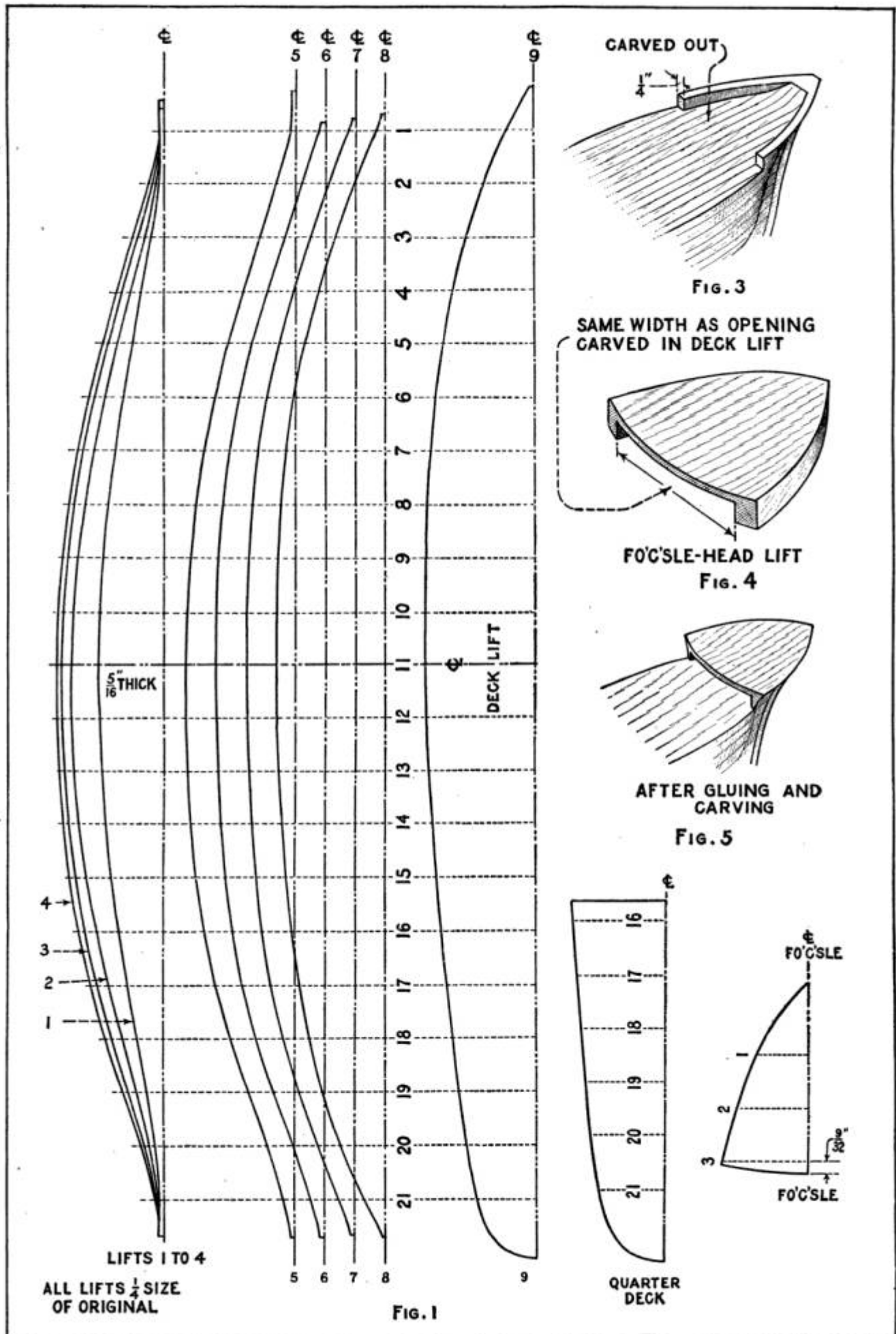

Quarter-Size Drawings for Making Hull, Deck, Quarterdeck and Fo'c'sle Templates



No other clipper, except, perhaps, the famous English "Cutty Sark," makes such an appeal to the imagination, and this was

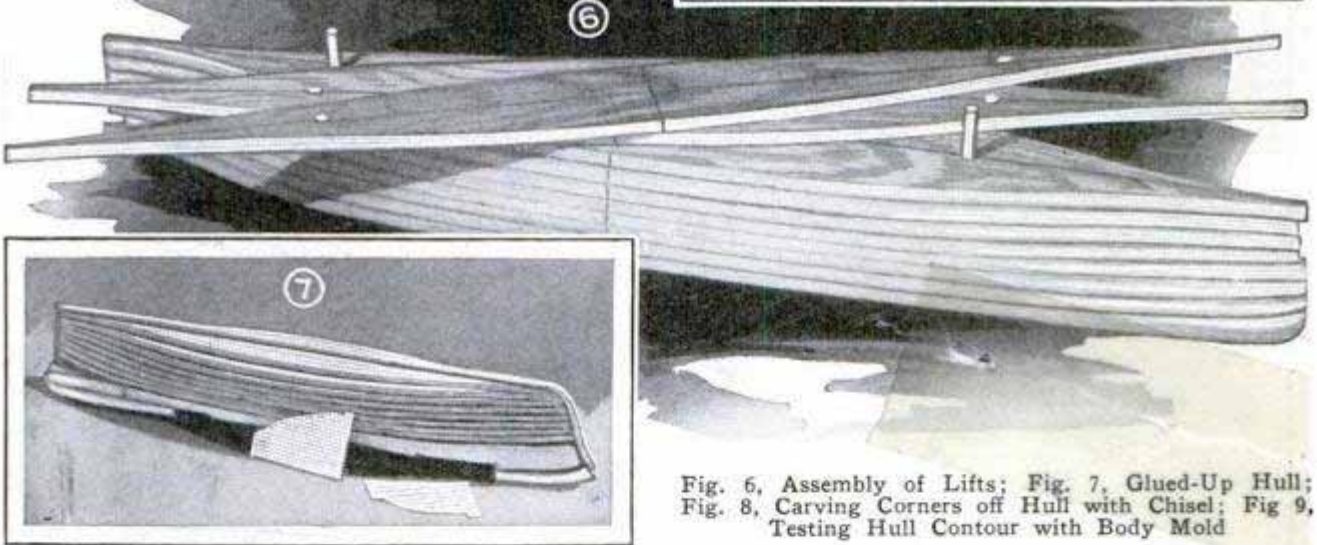
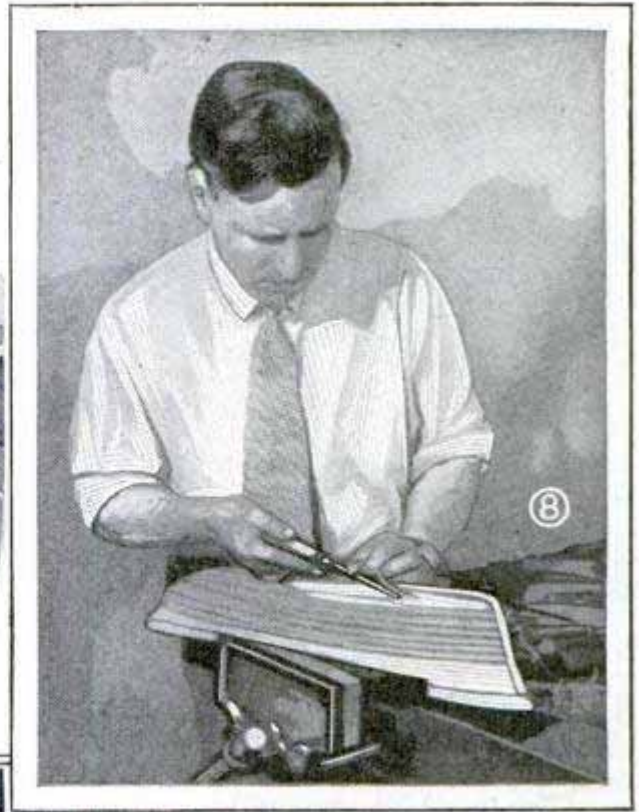
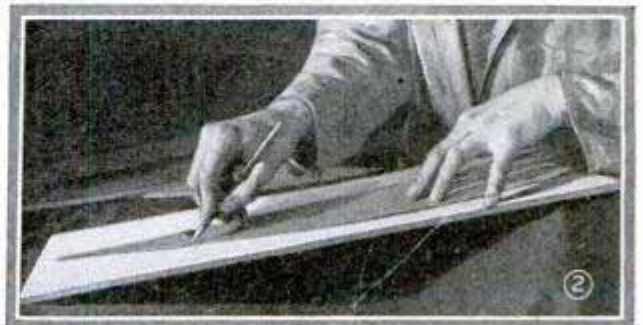

Fig. 6, Assembly of Lifts; Fig. 7, Glued-Up Hull; Fig. 8, Carving Corners off Hull with Chisel; Fig. 9, Testing Hull Contour with Body Mold

the reason "Flying Cloud" was selected as the subject of our model.

While there is a great deal more detail in a model of a clipper than in our previous model of Hudson's "Half Moon," the construction is not a bit more difficult. Owing to the character of the ship, the detail in the deck fittings, etc., is finer, and the smaller parts must be made with more care; this, however, does not demand more skill, but merely a little more patience. The method of building up and carving the hull is exactly the same as with the "Half Moon," with the exception that, as the lines are finer, body molds or templates are employed to insure that they will be correct.

Arrangements have been made with a well-known firm of ship-model supply makers to furnish a complete set of parts for building the model, in order to save the reader time and trouble in assembling



Marking Off One of the Lifts from the Wrapping-Paper Template



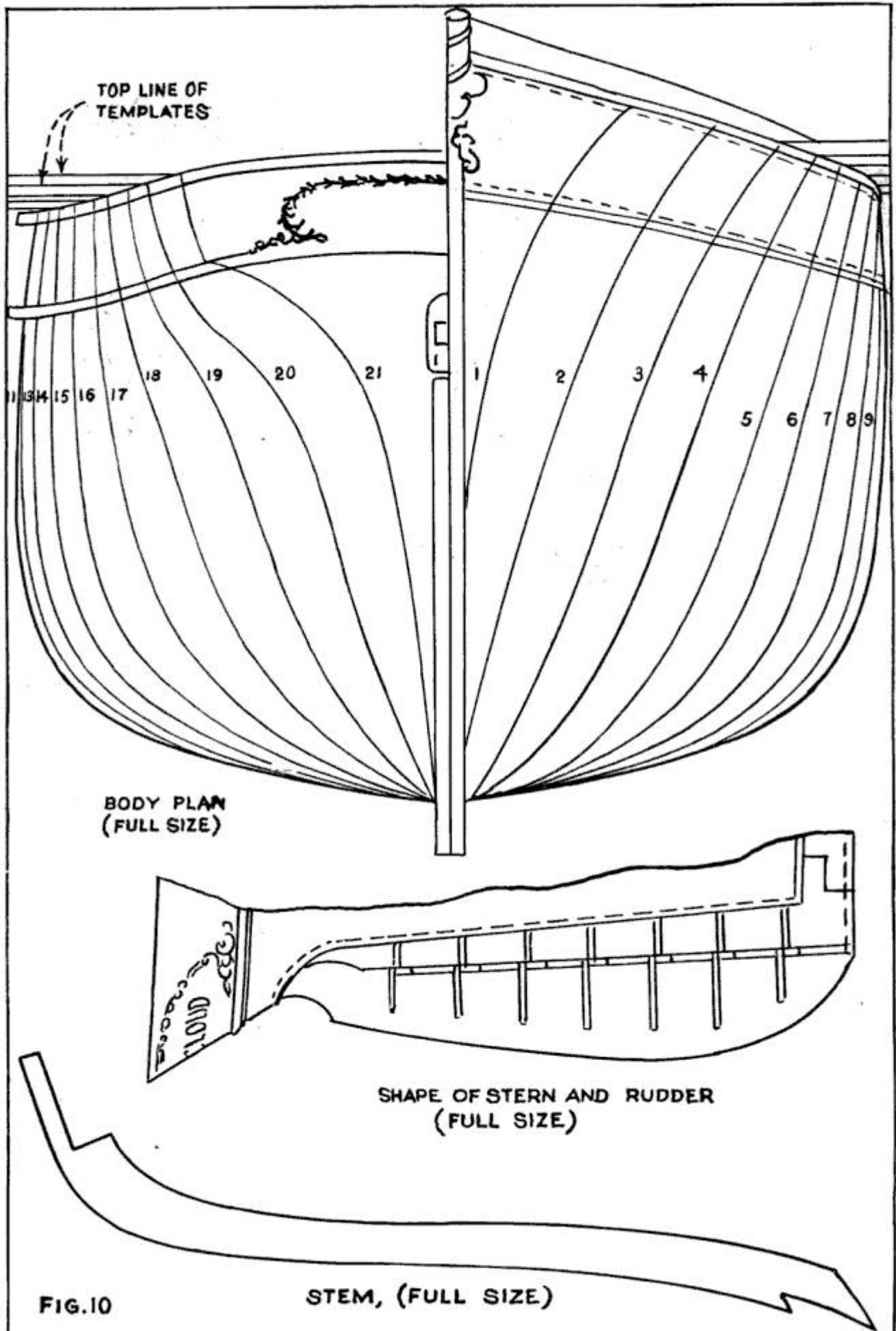

Full-Size Drawings for Making Body Molds, Stem and Stern Templates



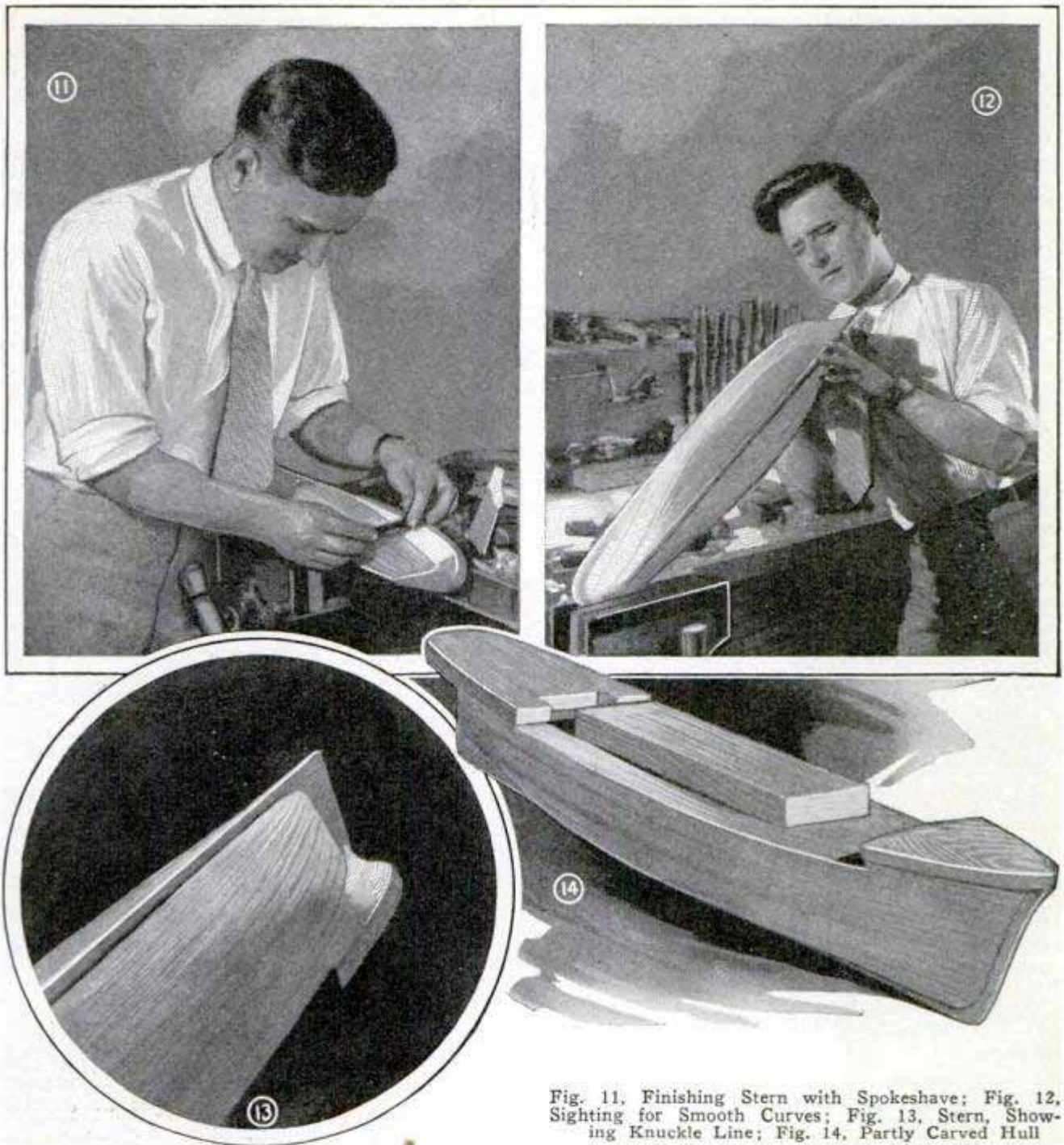

Fig. 11. Finishing Stern with Spokeshave; Fig. 12. Sighting for Smooth Curves; Fig. 13. Stern, Showing Knuckle Line; Fig. 14. Partly Carved Hull

them. These will include lifts cut to shape, wood for bulwarks, deck fittings, etc., rough blocks and deadeyes, anchors, bitts, capstans, etc. Full information about these sets will be furnished on request.

The first step in making the model is to lay out the templates for the lifts, or planks, that are glued together in "bread-and-butter" fashion to form the rough hull. Get some sheets of stout brown wrapping paper, 30 in. long, and cut it into strips, 8 in. wide. Draw a line down the center of each strip and erect perpendiculars to this line all along its length,  $1\frac{1}{4}$  in. apart. Number these from 1 to 21, as

in Fig. 1. The drawings for the lifts given therein are exactly one-fourth the size of the original, so, taking lift No. 8 as an example, measure with a pair of dividers the distance from the center line to the curved line representing the outer edge of the lift, along line No. 1, and step this distance off four times along line No. 1 on the wrapping paper. Do the same with lines Nos. 2, 3, and so on, until you have a series of points on the paper through which a smooth curve can be drawn, and which will look exactly the same as lift No. 8 in Fig. 1, but four times the size. Use a French curve in drawing



the line through the points marked, and make the curve "easy" from end to end. Now fold the wrapping paper exactly along the center line and cut through the doubled paper along the curved line. When cut and opened, you will have a template for lift No. 8 on which both sides will be exactly alike. Lay out the remaining templates in the same manner. Templates 1 to 4 are shown with a common center line, to save space, and 5 to 9 are separated, to avoid confusion in measuring. Mark the exact position of line No. 11 on all templates, squaring a line right across the paper. The templates will be found to fold easily along the center line if the rounded point of a pair of scissors is drawn along the line before the paper is removed from the board for cutting.

The lines given are for lifts  $\frac{5}{16}$  in. thick. There are eight of these, and one deck lift  $1\frac{3}{16}$  in. thick. It is practically as satisfactory to make the lower lifts  $\frac{5}{8}$  in. thick, and to cut only four of them, and, if this is done, templates need only be made for lifts Nos. 2, 4, 6 and 8. In some cases it may be easier to get lumber planed to  $\frac{5}{16}$ -in. thickness and in others  $\frac{5}{8}$ -in. lumber, so lines for both thicknesses are given here. Make templates for the quarterdeck and fo'c'sle (forecastle) in the same way as for the others. Mark all templates for bow and stern; in Fig. 1 the bow ends of all lifts are at the top of the page.

In order to simplify the construction, blueprints have been prepared giving the lines full size. These may be obtained, at 50 cents for the set of three, from the Amateur Mechanics department, Popular Mechanics Magazine, 200 E. Ontario st., Chicago.

The lumber used for the hull lifts is white pine, or sugar pine,  $\frac{5}{16}$  or  $\frac{5}{8}$  in. thick, well seasoned and free from knots. Eight pieces of the  $\frac{5}{16}$ -in. size or four of the  $\frac{5}{8}$ -in., will be required, 27 in. long, and one piece,  $1\frac{3}{16}$  in. thick and 29 in. long, for the deck lift. Also a short piece of  $\frac{1}{2}$ -in. pine, 9 in. long, for the quarterdeck, and one piece  $\frac{1}{2}$  by 4 by 5 in., for the fo'c'sle head. All pieces, except the last, are 6 in. wide. It is difficult to give an exact material list for a job of this kind, since so many of the smaller fittings are made from scraps. For example, the

keel, stem, sternpost and rudder in the original model were ripped from a scrap piece of birch chair rail, and the bulwarks were cut out of the scrap left over from the deck lift.

The templates having been made, take No. 1, or No. 2, as the case may be, and pin it down on one of the boards, stretching it so that it lies flat, then run a pencil around the edge as in Fig. 2, to lay out the curves on the board. Transfer the center lines to the board also. Do the same with all lifts, then cut them out with a compass saw, fretsaw or frame saw, as convenient, cutting just outside the line. After sawing, clamp the lifts in the vise individually, and trim them down to the line with a spokeshave. Mark the bow and stern on all pieces, so that they do not become reversed when gluing; also mark the center line down the middle and at each end and line No. 11 square across each piece at the proper place. Line No. 11 is after this called station No. 11. All lines at right angles to the center of the lifts are stations. Cut a notch,  $\frac{7}{8}$  in. deep,  $2\frac{1}{8}$  in. wide, out of the center of the forward edge of the quarterdeck, as in Fig. 16.

Lay lift No. 8 down on the bench with the center marks uppermost, coat this side, and the plain side of No. 7, with glue, set No. 7 on the lower one, lining it up in position by means of the center marks and with station 11 on No. 7 exactly over station 11 on No. 8. (See Fig. 6.) Drive in a couple of short brads to keep the lifts from shifting, and glue and set all the other lifts in the same fashion. You will have to work fast here. When the assembly is complete, clamp it firmly, so as to force all the lifts into good contact, and set aside for 24 hours to set. If desired, before gluing, the lifts can all be assembled and drilled for two  $\frac{1}{2}$ -in. dowels, as indicated in Fig. 6. This makes it easier to assemble the lifts when gluing, but the dowels must be a trifle shorter than the combined height of the lifts, or they may interfere with the clamping. If large enough clamps are not at hand to take in all the lifts at once, the hull may be glued up in two or more sections. Now lay the deck lift flat on a board or on the bench, mark the position of each station on the edges, and with a pair of dividers, and measuring from the bottom edge of



the lift, lay off the sheer line from the measurements given in Fig. 15. The positive sign behind some of the figures indicates that the distance is "just a hair" more than the measurement given, and the negative sign behind others that the distance is a trifle (not quite  $\frac{1}{64}$  in.) less. In other words, one measurement is "full"; the other "scant." Lay off all

the edge of the fo'c'sle, on the forward end of the deck, and carve out between the marks as shown. Clamp the fo'c'sle lift in place temporarily on the deck lift, placing it according to the station lines, and mark the curve of the fo'c'sle deck from the dimensions given at stations 1, 2 and 3 in Fig. 15. Cut the deck down to this line, then carve out the underside to

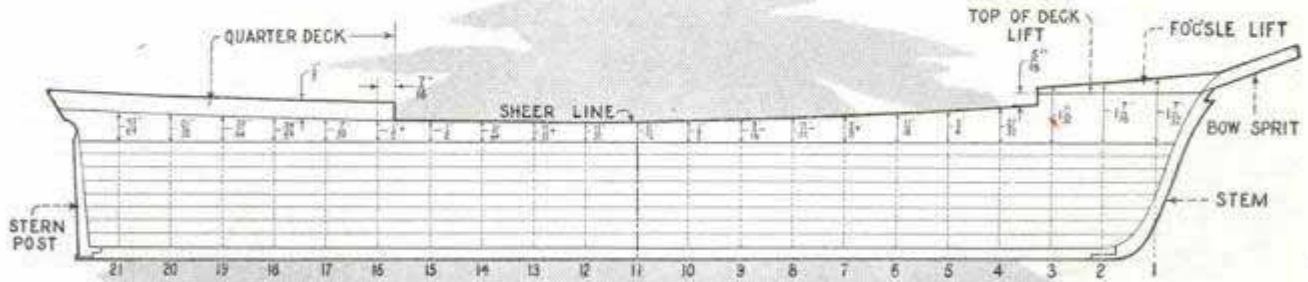

FIG. 15

these points, on both sides, from station 4 clear back to the stern, then draw the sheer line on both sides, through these points, continuing the curve forward from station 4 for a distance of  $\frac{7}{8}$  in.; at this point draw a vertical line from the sheer line to the upper edge of the lift, on each side, and connect the two by a pencil line drawn square across the lift. This represents the after edge of the fo'c'sle. A saw cut is made down this line to meet the sheer line, then the remainder of the lift is cut away, with chisel and drawknife, down to the sheer line. Leave the deck "crowned," or  $\frac{1}{8}$  in. higher along the center line than at the edges. Square and smooth the after end of the lift and glue on the quarterdeck,  $\frac{1}{2}$  in. in thickness. To make a good joint between the two, lay a sheet of sandpaper, abrasive side up, over the after end of the deck, place the quarterdeck over the sandpaper, and move it back and forth over the abrasive until the underside of the quarterdeck fits the deck perfectly. See that the station marks on the quarterdeck line up with the corresponding lines on the deck lift when gluing, as indicated in Fig. 15, above.

Mark, as in Fig. 3, a line  $\frac{1}{4}$  in. inside

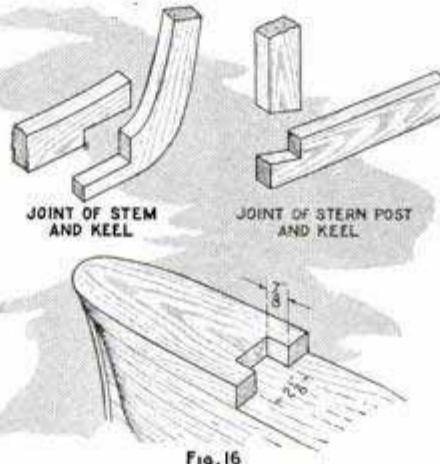

FIG. 16

the same size as the opening carved in the deck, leaving the fo'c'sle deck  $\frac{1}{8}$  in. thick, and glue the fo'c'sle head in place. When the glue has set, glue the deck lift to the remainder of the assembly. Crown quarterdeck and fo'c'sle deck  $\frac{1}{8}$  in., like the main deck.

Now make up a set of body templates or molds from the body plan, Fig.

10. The lines in this plan represent what each section of the hull would look like if it were sliced like a loaf of bread at each station line. The lines on the left represent sections of the hull as viewed from the stern; those on the right, sections as sliced and viewed from the bow. Trace each line separately on a piece of stout bristol board, or heavy cardboard, then cut out carefully along the curve, and leave enough of the cardboard to enable it to be handled easily, as shown in the photo, Fig. 9. Taking mold 1 as example, it is cut along the curved line, straight down the stem, down to the bottom of the keel, then across to the center of the keel, and cut off at this point. Note the molds in the photo, Fig. 7. Number the molds as they are drawn and cut. Make a stem template from the full-size drawing in Fig. 10, also a template for the shape of the stern, inside



the sternpost, and one for the sternpost. Cut a temporary stem and sternpost out of  $\frac{3}{16}$ -in. wood, and carve and file the stern and bow of the model until the stem



"Crowning" the Surface of the Fo'c'sle Deck; Note Improved Cradle Holding Hull

and sternpost fit correctly, then cut a temporary keel from  $\frac{3}{16}$  by  $\frac{1}{4}$ -in. wood and tack all in place. These pieces help a lot in carving the hull, and the reason for using temporary ones is that, in carving near the ends, it is almost impossible to avoid digging slightly into the stem and sternpost, so that if permanent pieces were fitted they would be badly marred. Mark the station points on the keel and stem, where station 1 runs through the latter, then fasten a block to the deck by means of a couple of screws, so that the hull can be held in the vise while carving, and you are ready for the next operation. When drilling the screw holes in the holding block, place these so that one screw will come  $5\frac{1}{4}$  in. from the forward edge of the quarterdeck and the other the same distance aft of the edge of the fo'c'sle head, on the center line of the deck. In this position, the screw holes in the deck will afterward be covered by deck erections, so they will not have to be filled.

Now, starting at station 11, begin carving the hull down to the outline given by

mold 11. The corners of the lifts can be carved off with the chisel, but when the contour of the hull begins to approach that of the mold, it is well to supplement the chisel with a small spokeshave, set to take a very fine shaving. Always work one or two molds ahead of the station you are finishing; that is, when working on station 11, and carving toward the bow, carve stations 10 and 9 roughly to shape also. This helps to indicate the sweep of the curves in the hull. Also, be sure to keep the mold, when trying it against the hull, as in Fig. 9, exactly at right angles to the center line of the hull, not at right angles to the hull surface. Proceeding from the center station to the ends, carve each station point until the mold for that particular station fits exactly, and the curves of the hull, when viewed from any angle, as in Fig. 12, are "sweet" and true, showing no humps or hollows. Be particularly careful when carving at stem and stern. The bow on this ship has a pronounced flare or outward curve, and if the carver is not careful at this point, there is a tendency to destroy the true shape of the fo'c'sle deck. Also, at the stern, you will notice that mold 21 flares outward from the keel until it meets a molding; from there it runs up in an almost straight line to the deck. The line where the curve changes is called the "knuckle," and the way it looks when carved is shown in Fig. 13. From this knuckle to the deck, from a point about midway between stations 20 and 21 on one side, right around to the same point on the other side, this part of the hull is practically straight in the vertical plane, although the angle of the straight part changes rapidly as it approaches the stern, when it becomes as shown in the stern template, Fig. 10. The knuckle shows as a decided line all around the stern, following the line of the deck, and about  $1\frac{1}{16}$  in. below it. "Fair up" all the curves in the hull with spokeshave and sandpaper, until they are sweet and sweeping when viewed from any angle. A mold is not shown for station 12, to avoid confusion in the drawing, but the change of section from 11 to 13 is slight, and the hull is easily carved by eye at this point.

Now drill a  $\frac{5}{16}$ -in. hole in the bow for the bowsprit, at the angle indicated by



the top of the stem; drill this about 2 in. deep. Make a permanent stem, keel and sternpost from  $\frac{3}{16}$ -in. birch or similar hardwood, glue and pin these in place and sandpaper them, but do not take too much off the sharp edges. Leave the rudder until later.

(To be continued)

### Bathing Diamonds to Check Yellow Tinge

A diamond expert claims to have discovered a method of checking the discoloration of diamonds during storage, the cost of the treatment being less than 5 cents per hundred stones. They are immersed in any solution of a blue tint, which is the complementary color of the natural yellow tinge of a diamond. The result of this immersion is that a thin film of blue coloring matter adheres to the stone and quenches the yellow light, making the gem look as if it were of the first water. When the gem is required for sale, all that is necessary to bring back the native color is to wash the stone in clean cold water and then dry it carefully. Diamonds that are slightly discolored after being worn for some time can also be improved by this treatment.

### Weights for Window Curtains



invented this trouble by providing weights to hold the curtains down. A small chain, sewn into the lower hem, allows the curtains to drape as usual but is heavy enough to prevent whipping about in a stiff wind.

A strong breeze through an open window frequently causes damage to expensive curtains by whipping them about on the sills until they become badly soiled and perhaps frayed. One housewife has eliminated

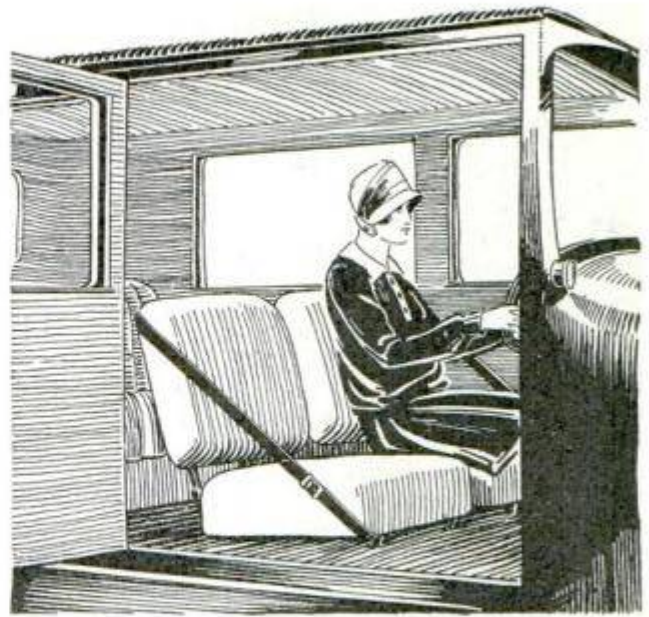

Strap Attached to Coach Seat Prevents Occupant from Falling Out, if Door Is Opened Suddenly

### Leather Strap Adds Safety Feature to Coach-Type Auto

Leather straps placed on the front seat of a coach-type closed car are an advantage in holding the occupant in the seat if the door is suddenly opened. The drawing shows how the strap is arranged. If it is fitted with a buckle, it is possible to tilt the seat back for the most convenient position of the occupant. The strap should be of strong leather, and the ends held with washers and screws.

### Lid for Electric Toaster Stove

Electric toaster stoves of the kind shown in the photo have many kitchen uses, but the heat cannot easily be controlled. It is often necessary to keep the contents of a pan simmering and for these occasions I keep a large tea-can lid handy. Placing this

on the stove and the pan on the top of it, I find that it acts much like a stove lid over an open fire, giving just the right heat for a slow simmer. —Nellie May Moore, Hamilton, Can.







GREEN CELLULOID  
STRIP SEWED ON BAND  
AND SLITTED FOR BUTTON

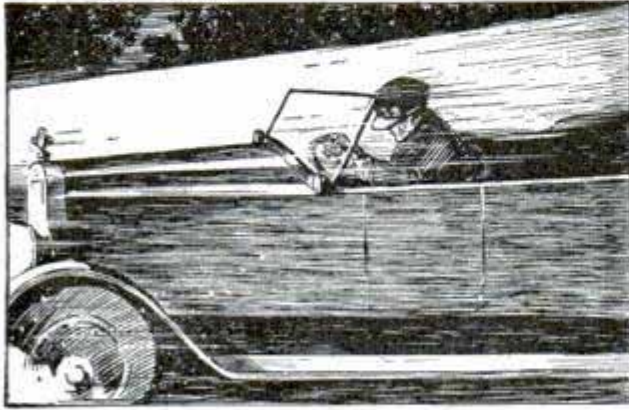

Piece of Green Celluloid in Cap Makes Good Anti-Glare Shield for the Motorist

### Anti-Glare Cap for Motorists

Instead of having a separate pair of goggles to wear as a glare protector at night, the motorist will welcome the idea shown in the illustration, where the goggles are incorporated in the cap and, therefore, always at hand. Cut out a piece of the cap just above the visor and replace this with a piece of green celluloid. Of course, the cap must be large enough to permit this. The band of the cap is cut and a button and buttonhole are provided, as indicated. When the goggles are needed, simply loosen the button and pull the cap over the eyes so that you can see through the celluloid.—William C. Thomas, Chicago, Ill.

### Protecting Young Trees

During the fall and winter months, it is necessary to put protectors around young fruit trees. A very good protection can be made at almost no cost and with very little work, by getting a large Russian thistle, and placing it around the base of the young tree. With the use of a little twine the thistle will prove to be a superior all-purpose protection. It will keep the rabbits away and the body of the tree shaded, thus preventing the continual thawing and freezing which kills so many

young fruit trees throughout the central west every winter. If the Russian thistle does not grow wild in your section of the country, as it does in the west, you will find that it is very profitable to raise a few of them in your yard. They are real life-savers for young trees. Another advantage gained by using this protector is that, if it is not taken off from the tree in the spring, it makes an excellent mulch and prevents the ground from baking around the roots.

### Kink for Fishermen

Game fish usually bite best when the surface of the water is somewhat rough. However, under such conditions the anchor often drags. This is due, not so much to the direct force of the wind, as to the pitching or "bobbing" of the bow of the boat, giving intermittent but powerful jerks to the anchor rope and shifting the anchor along the bottom. This trouble can be prevented by connecting a 3 or 4-ft. strip of rubber, cut from an old inner tube, between the boat and the end of the anchor rope.

### Cleaning Out Toothpaste Tubes

Everything from toothpaste to stove polish seems to be handily put up in tubes. Quite often it is necessary to get all we can of the contents of a tube when we run short. To do this effectively, stick the end of the tube between the legs of a clothespin and turn it. The fingers can tightly

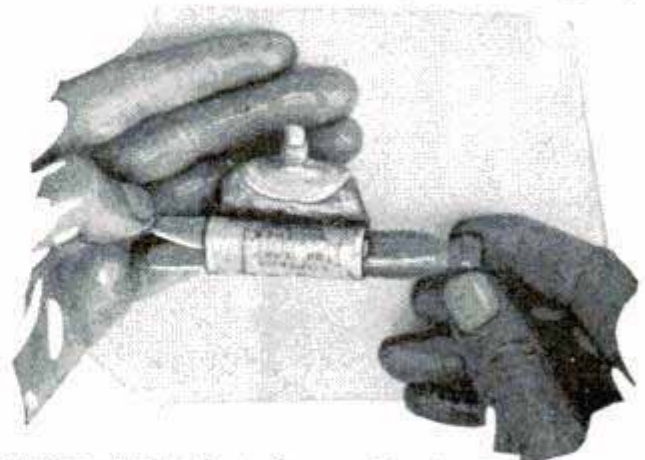

Using a Clothespin to Squeeze Out the Contents of a Toothpaste or Other Tube

press and follow the tube as it winds up. When you get to the end, the contents of the tube will be entirely removed.



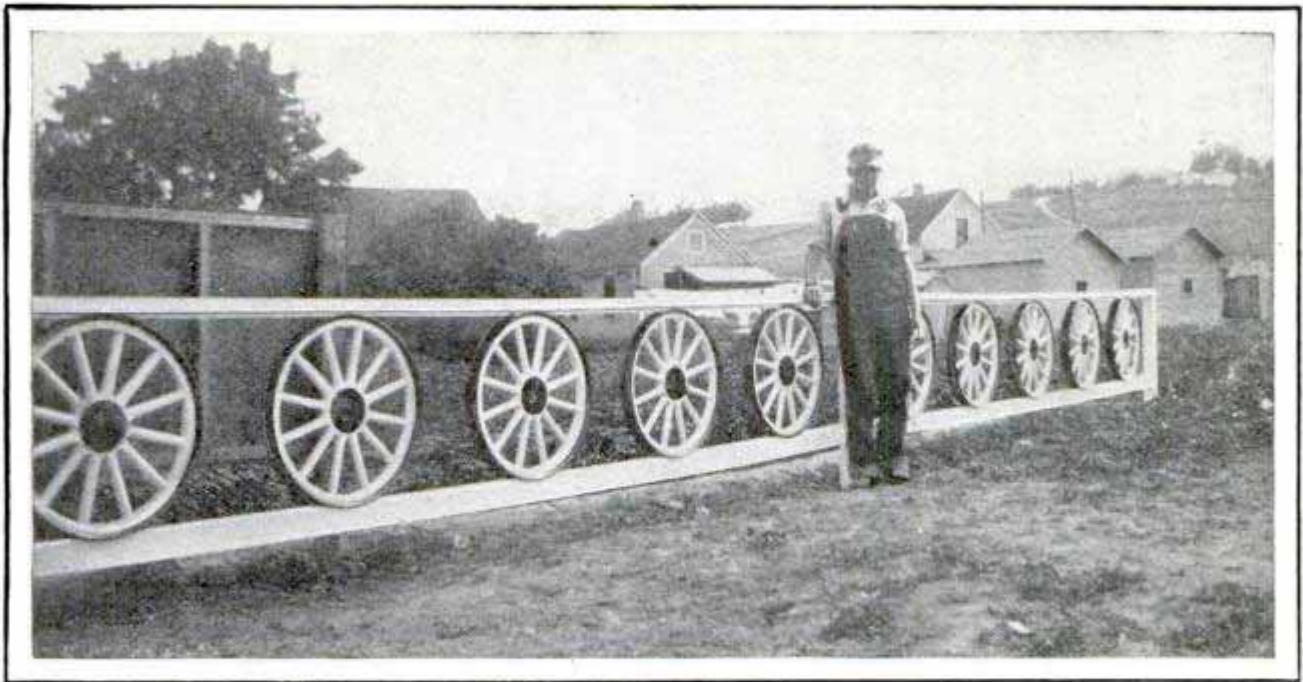

Omaha Garage Man Sets Up Useful and Novel Fence Consisting of Discarded Automobile Wheels, Painted White and Red, to Guard against Accidents at Ditch

### Fence Made from Old Auto Wheels Guards Deep Ditch

To protect motorists from accidentally backing into a deep ditch just beyond his parking place, an Omaha garage man provided a fence made from old auto wheels, as shown in the accompanying photo. Besides being useful, the fence is novel and has attracted much notice. The wheels were taken from a junk pile and the spokes were painted white, while the centers and rims were in bright red. The wheels were held in place by the upper and lower rails of the fence over which the rims of the wheels fit snugly.—Geo. R. Harrison, Council Bluffs, Iowa.

### Shelves for Odd Corners

Shelves for odd corners may be accurately fitted by following the method shown in the drawing. A small board, with a sheet of paper fastened to it by means of thumbtacks, is held in the corner. A short piece of wood, having one end pointed and a hole through it, as shown, is used to trace the contour of the corner on

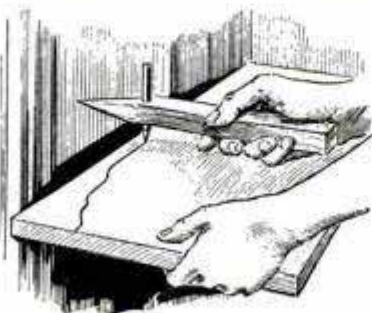

the paper. The paper, of course, is afterward cut and used as a template.—Charles I. Reid, New York City.

### Cork Keeps Hook from Marring Screen Door

When screen-door hooks drop down, they often mar the paint of the door, and gradually cut disfiguring grooves in the wood. To prevent this, force a thin cork from a pop-bottle cap over the hook, as shown in the accompanying photo. The cork will prevent the metal from touching the door.



### Repairing Auto-Radiator Leak

Some time ago the radiator on my car sprang a bad leak where the horn wires passed through it. As it was necessary to use the car immediately, a temporary repair had to be made. The leak was quite large, but a white potato, cut to fit around the hole, and a wooden brace, propped up against it, stopped the leak long enough to drive three miles to a garage.—Edward H. Buckley, Philadelphia, Pa.



### Sled for Narrow Track Has Single Runner

When we wanted to visit our aunt and the cousins a mile away, it was necessary to go through a woods. During the win-



One-Runner Sled Solves the Problem of Transporting Children over Narrow Forest Path

ter months there is usually a single path to walk over, but our two little girls were too small to walk the entire distance. The use of a regular sled was also impossible as the path was too narrow, and therefore I made a single-runner "ski-boggan" as shown in the photo. Both youngsters could be comfortably seated in it, and the sled was held securely by means of a handle rigidly attached to the body.—J. J. Brindos, International Falls, Minn.

### Some Dry-Cleaning Tricks

Often, when cleaning, it will be found that the color of a material will be slightly lightened. If the bleaching is not too noticeable, the color may be restored by rubbing the fabric with a piece of cloth, barely moistened with neat's-foot, cottonseed or olive oil. Before brushing over the light spot, rub the moistened cloth on another cloth several times to remove most of the oil. This is done after the dry-cleaning process, and must be repeated each time the garment is cleaned. To give crepes and other silk materials new luster, dip them in carbon tetrachloride, or gasoline containing 4 or 5 drops of one of the above oils. This is also done after they have been cleaned. Water stains on silks generally can be removed by scraping the edges gently with the finger nail or rub-

bing carefully with a rather stiff brush, such, for instance, as a new toothbrush.—A. T. Bawden, Belton, Tex.

### How to Prevent a Frozen Oil Pump

Water forms in the crankshaft case of automobile motors through condensation. The inside of the case warms up before the outside, thus creating small drops of moisture. This moisture naturally flows to the lowest point in the crankcase, which is around the oil-pump mechanism. Then the pump freezes every cold night, which means grave danger to the motor or expense and bother to thaw it out. To remedy the trouble, pour two tablespoonfuls of wood alcohol into the crankcase every two weeks in the winter time. The alcohol will not mix with the oil nor impair its efficiency. It simply sinks to the bottom of the crankcase, where it mixes with the water and prevents it from freezing. This is the only practical solution to the oil-pump freezing problem that I have ever come across.—Rolla H. Waffle, Walla Walla, Wash.

### Grease Cup Helps Prime Vacuum Tank

When the vacuum tank is drained or the fuel supply is exhausted, difficulty is sometimes experienced in priming the tank, but by substituting a small grease cup for the pipe plug at the top, this difficulty can readily be overcome. As the hole in the top of the tank is tapped with a  $\frac{1}{8}$ -in. pipe tap, the grease cup is easily screwed on. It is then a simple matter to pour in gasoline without spilling.—G. A. Luers, Washington, D. C.

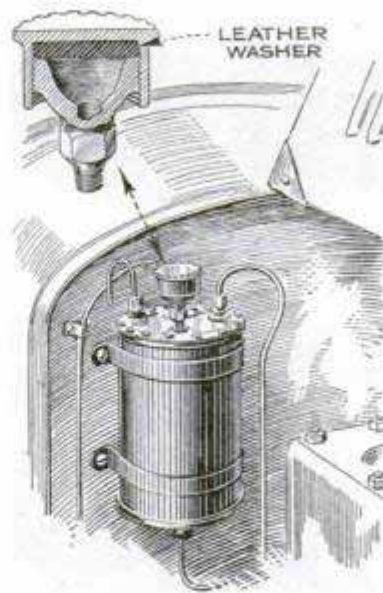

☐ An ordinary curling iron makes a good finger stretcher for kid gloves.



# TWO HOMEMADE TOYS

for

# CHRISTMAS

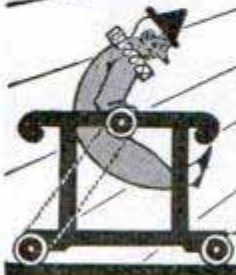

BY HERBERT C. MCKAY

A TOY, that will be a delight to the youngsters, is the tumbling clown, shown in the illustration below. It consists essentially of a cart, the back wheels

blowing a clown being mounted on the shaft. When the cart is pulled, the shaft is turned and the clown swings head over heels, apparently holding onto the shaft.

The clown body is cut from a piece of  $\frac{1}{2}$ -in. wood according to the design given in the drawing, each division measuring  $\frac{3}{8}$  in. square. When com-

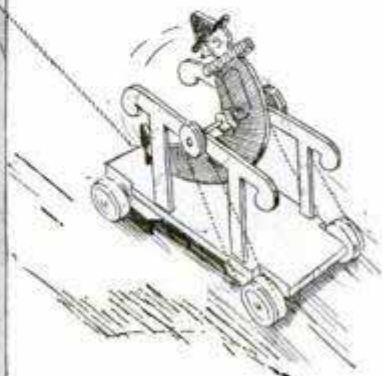
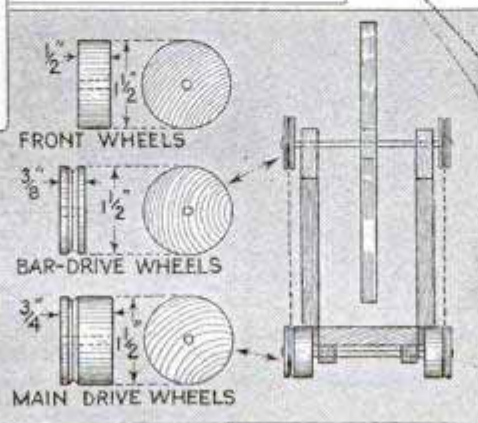
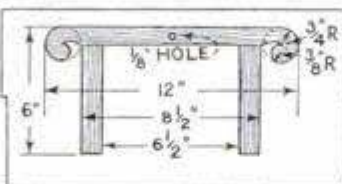
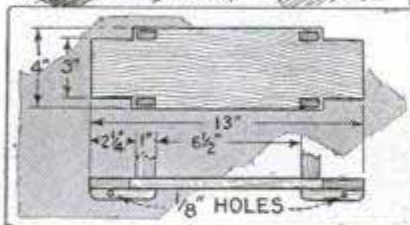
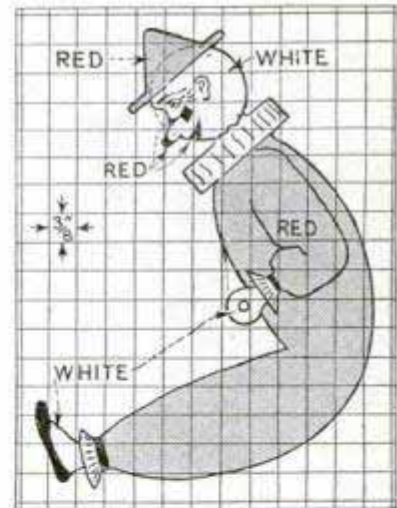

Tumbling Head over Heels As the Cart Is Pulled Along, the Clown Offers Constant Amusement to the Youngsters

of which are belted to a shaft supported on the frame of the cart, a wooden figure resem-



pleted, the figure must be carefully balanced and the accuracy with which this is done determines the success of the toy. The whole action depends on the balancing, for there is not enough power to turn the clown if it is seriously out of

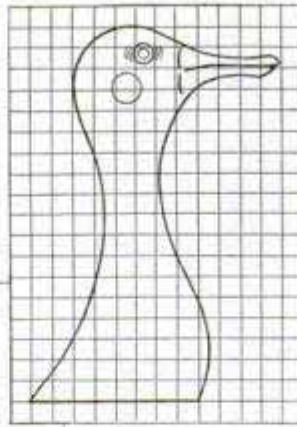

are attached securely, glue being used for this purpose. The side supports which serve as bearings should, of course, be reamed out so that the axles fit in them loosely. The clown is similarly

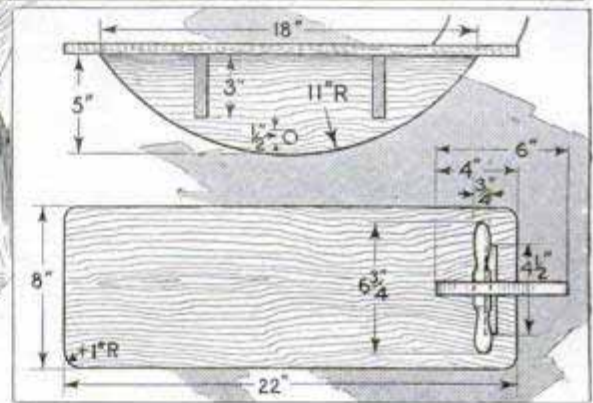
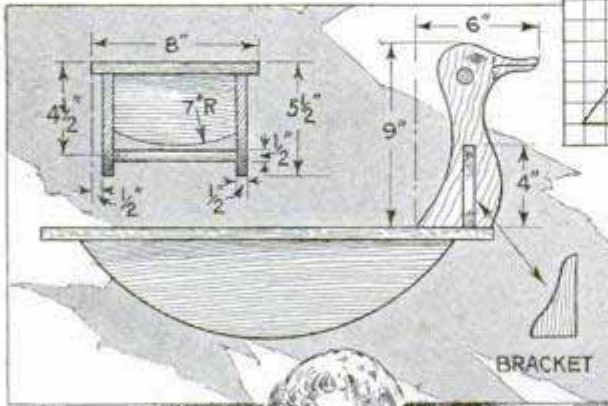

A Rocking Duck Is a Strong Wooden Toy Which Can Readily Be Made by Anyone, and Is Convenient for Children to Mount

balance. The center of balance lies somewhere in the hands and the exact point can be determined by driving two small pins into the hands, directly opposite each other, and testing the balance by suspending the clown from a string looped over the pins.

The wheels may be cut from a wooden curtain pole, the exact diameter being of little importance as long as sufficient clearance is provided for the base and the axle boxes. The drivewheels are  $\frac{3}{4}$  in. thick, while the front wheels are  $\frac{1}{2}$  in. thick. A groove, about  $\frac{1}{16}$  in. in width and depth, is cut in the former to hold the drive belt. The parts are enameled and, after it has become thoroughly dry, the toy is assembled. The wheels are drilled in the exact center to receive the axles on which they

glued to the shaft. The grooved wheels must be in line and rubber bands are used for belts.

Rocking toys will always be popular with small children, but the trouble with most toys of this kind is that the small child finds it hard to get in or out of them unaided. The rocking duck, shown in one of the illustrations, is not subject to this drawback. It consists of a seat, rocker, duck-head handle and the necessary braces. All the pieces, except the handle and one cross brace, are cut from  $\frac{3}{8}$  or  $\frac{1}{2}$ -in. plywood. The seat measures 8 by 22 in., and the corners are rounded. The two rockers are 18 in. long, have a maximum width of 5 in., and are cut on a 11-in. radius. The seat is fastened to the rockers by nailing and gluing, and two braces, of the shape shown, are provided between the rockers. All parts are then



screwed together securely. A  $\frac{1}{2}$ -in. round or square rod forms an additional brace at the bottom, as indicated. The duck's head is cut according to the pattern, each square being  $\frac{3}{8}$  in. in size. A handle is provided on the head as shown. This consists of a  $6\frac{3}{4}$ -in. length of  $\frac{3}{4}$ -in. wood driven through a hole in the head. The latter is securely fastened to the seat with three wood screws, and two braces are used to support it, one on each side of the head. The head may be painted white or yellow, the bill yellow and the features outlined in black. All the screw heads in the body are sunk below the surface, and the holes filled with putty. The surface of the wood is sanded and given a coat of flat white paint. After this has dried thoroughly, a coat of enamel may be applied, if desired.

### Winter Feeder for Birds

When the ground is covered with snow, birds often find it difficult to get food enough to sustain life. They eat suet and chunks of fat meat, and the feeder shown in the drawing is designed to hold this kind of food so that the birds can get at it at any time. It consists of a wide board nailed to a post in the vicinity where the birds congregate. A shelf should be built below it, upon which the birds can sit and eat the chips of fat, while other birds may cling to the poultry wire, which is nailed over the fat or suet on the vertical board.



Use large-mesh wire and fasten it by means of flat-head nails, around which are wound all the loose ends of the wire, to prevent these from injuring the birds while perched on the feeder. The poultry wire holds the suet in place and protects it from stray cats and dogs. Raise the feeder as high as possible from the ground.

### Plug and Jack for Auto Trouble Lamp

A plug and jack, such as used in radio sets for phones and loud speakers, can be installed in the car for use with a trouble

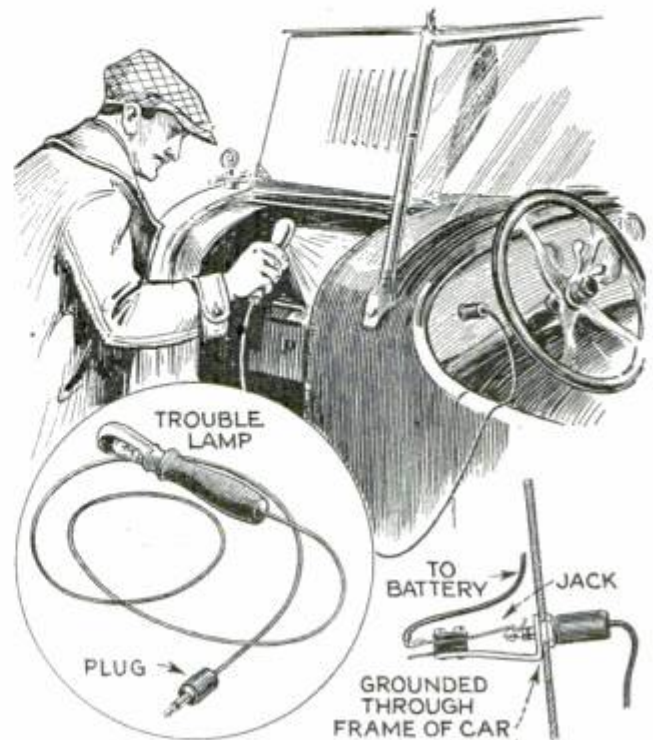

Radio-Plug and Jack Installation on Auto Makes Handy Trouble-Lamp Arrangement

lamp. A jack of the single-circuit type is obtained and is installed on the dashboard, or any other handy place on the car. Two or three jacks can be mounted at other points. A small hole is drilled and the jack is fastened with the large nut. This nut serves as one connection to the battery through the metal parts of the car. The other connection is made with a single wire to the battery. A phone plug is connected to the trouble lamp with an extension cord. Pushing the plug into the jack immediately lights up the lamp. When finished using it, pull out the plug.—Herman R. Wallin, Brooklyn, N. Y.

### Steel Wool as Furnace Repair

It sometimes happens that a poker or shovel is pushed through the lower casting around the ash pit in a hot-air furnace, making a hole that causes excessive draft. A satisfactory repair may be made by pushing some steel wool, soaked with iron cement, firmly into the hole, and smoothing over with the same cement. Stove lining may also be used, but it is not so permanent.—R. C. Tarr, Gloucester, Mass.



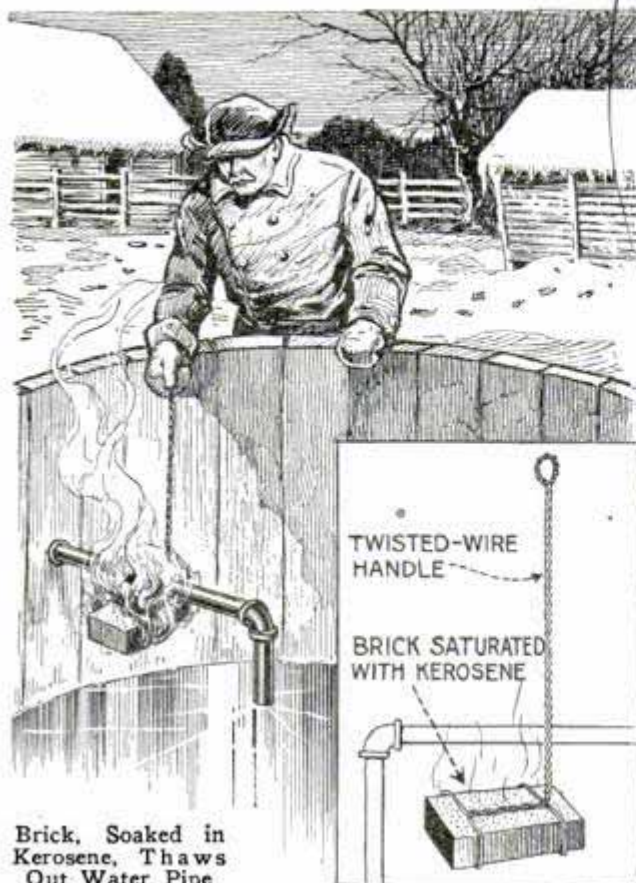

Brick, Soaked in Kerosene, Thaws Out Water Pipe

### Brick Torch Thaws Out Water Pipes

For thawing out frozen water pipes in cisterns, tanks and other places where an open flame will do no damage, a brick and wire torch will be useful. A dry brick is wrapped with several strands of heavy wire, the strands being drawn together at one side and twisted to form a convenient handle, as shown in the drawing. The brick is immersed in a can of kerosene and is allowed to remain there until thoroughly saturated. After that it may be lighted and used as a torch, as indicated. If the brick is dry when placed in the kerosene, it will cause numerous air bubbles to rise to the surface and, when these discontinue, it may be assumed that the brick is "saturated" and will burn long enough to thaw out the pipe.

### Uses for Alum about the House

Alum is used rather widely in the form of crystals to stop the flow of blood from small cuts after shaving, on account of its astringent properties, which also make it useful in the form of a solution as a non-perspirant and deodorant. A weak solution may be used as a gargle in case of a sore throat. A two-per-cent so-

lution of alum makes an excellent spray for plants, as it kills aphids, plant parasites, and insects, but is harmless to the most tender plants. Powdered alum, poured in places frequented by insects, will keep them away effectively. It can also be sprinkled on carpets to eliminate fleas. A solution of alum will bleach ivory handles, but do not use it for celluloid, as it yellows that material. Many colors, particularly yellows, are brightened by the application of a solution of alum, and for this reason carpets are improved in appearance when brushed with it. Blacks, browns, grays, reds, pinks, greens and blues are set by alum. If brushed over flaky ceilings, a solution of alum will remove superfluous lime and will whiten them. Alum is also used as a size in whitewash and calcimine. A mixture of plaster of paris and alum makes an excellent cement. It is used in liquid form mixed with water. Powdered alum, melted in an old spoon and applied to the heated edges of broken glass and chinaware, will hold them together after it cools. Alum is also added to glues and paperhangers' pastes to improve them. Dresses, curtains, etc., can be fireproofed by soaking them in a solution consisting of a tablespoonful of alum to each quart of water. The durability of rubber can be increased by soaking it in a solution of alum occasionally.

### Turnbuckle on Ford Fender Brace

Many Fords are fitted with a brace running across the front fenders to hold them in place and prevent them from loosening. However, by the installation of a turnbuckle, the brace can be made adjustable. The rod is prepared in the usual way, flattening the ends and bending them to conform to the top of the fenders, and then sawing the rod in half. About an inch of the rod is sawed off both lengths, and the ends are threaded for a turnbuckle, with which the brace can be tightened.

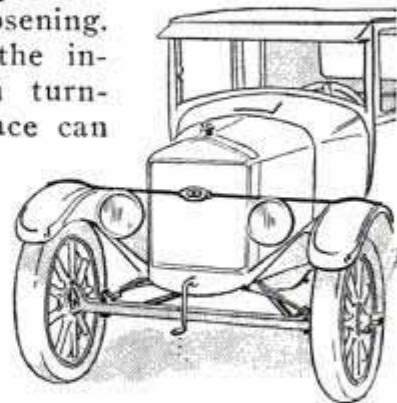



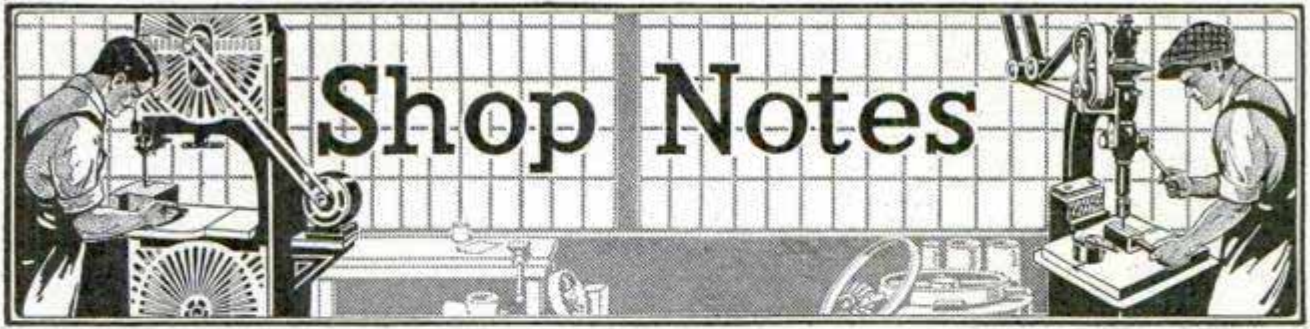

All Shop Notes published in 1926, in book form—Fifty Cents—from our Book Department

## Repairing Cracked Ceilings

By R. L. WALES

**C**RACKED or sagging ceilings are not uncommon experiences to the average householder. As the customary method of repair—battering off the broken plaster and patching—involves clouds of dust which penetrate everywhere, as well as a considerable bill for labor, the following simple, quick and effective substitute will

ble suggests the remedy; replace the clinches. The manner of doing this is illustrated in the accompanying drawings.

If portions of the plaster have begun to settle, it is necessary first to force them back into their normal positions and to support them there. For this purpose, a lattice of thin boards, like a section of a

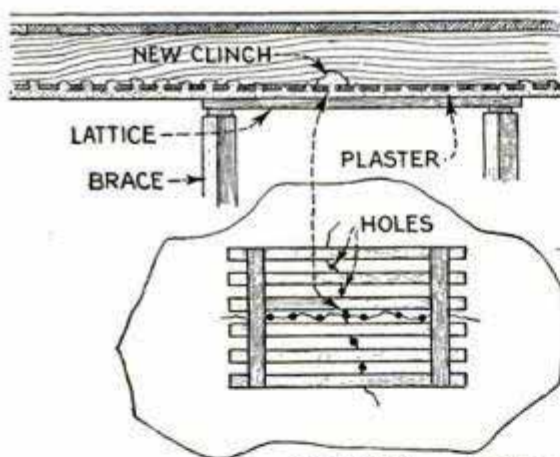

Patching and Re-Anchoring of a Cracked and Sagging Ceiling May Easily Be Done by This Simple Method without Dirt or Fuss

be of interest to him. It is not an untried "scheme," but has been used by the writer with very satisfactory results.

Ceilings crack and sag because the "clinches," formed by forcing the soft plaster through the spaces between the laths, have broken and no longer support the portions below. The trou-





picket fence, may be placed against the plaster, the lattice being forced upward and held in position by pieces of studding from below. The lattice supports the plaster at many points, thus preventing further cracking, and at the same time exposes enough of the ceiling for work.

After the broken plaster is forced back, a series of holes, about 6 in. apart, is made with a  $\frac{3}{8}$  or  $\frac{1}{2}$ -in. twist drill along the entire length of the cracks, and at other spots where support is apparently needed. Some of these holes will come between the laths, thus penetrating the plaster only; in other cases, the drill will pass through the lath, or perhaps even the furring. Through these holes is introduced the material for the new clinches.

For the latter purpose, so-called "rock plaster" is sifted, to remove its content of wood fiber, and mixed with water to a very light consistency, so that it will flow fairly easily from the mixing spoon. This mixture is poured into an ordinary grease gun and forced through the holes prepared. The mix must be wet for several reasons; it must not choke the gun; it must be able to flow out over the laths and into the spaces between them, and it must carry sufficient excess of water to wet thoroughly the dry and powdered

plaster with which it comes in contact and make a good bond with it. Charges of about one cupful each have been used with success. Of course, the plaster should be mixed in small quantities, and just previous to its use, as it begins to set within a short time. No difficulty has been experienced with the plaster running back through the holes on the removal of the gun, as "plugging" takes place quickly.

It remains simply to patch the holes and cracks with more of the plaster, using a putty knife and being careful to scrape off all excess from the surface. This is an important detail. After setting for twenty-four hours, the supports may be removed and the calcimine touched up.

If it is attempted to apply such materials in the usual way, with a brush, difficulty may arise due to the old coating "rolling up" and making it impossible to do a smooth piece of work. This may be avoided, and much time saved, by applying the material with an atomizer. For this purpose, the calcimine is mixed somewhat thinner than for ordinary use and is sprayed directly upon the patched spots and cracks without disturbing the rest of the field in any way. A simple and effective atomizer, suitable for small jobs, is shown in the lower left-hand detail.

### Canvas Apron Prevents Overheating

A man who used to make daily round trips of 80 miles in one of the California valleys with a truck, noted that, on the return trip, when running light, the radiator water almost invariably would boil. Neither tightening the fan belt, changing the pitch of the blades, checking the circulation system nor fitting new hose connections remedied the trouble. At length, the source of the overheating was found to be a strong tail wind that

blew up the valley every day. The wind would blow under the truck into the mud pan, "backing up" the hot air radiated by the exhaust pipe and engine itself, and preventing free circulation of air through the radiator core.

To remedy this, a canvas apron was made and laced snugly to the rear end of the mud pan and to the cross member of the frame back of the gear box. A slot was cut for the drive-shaft and holes in the mud pan, as shown, to let out the heated air, where it would not be driven back.

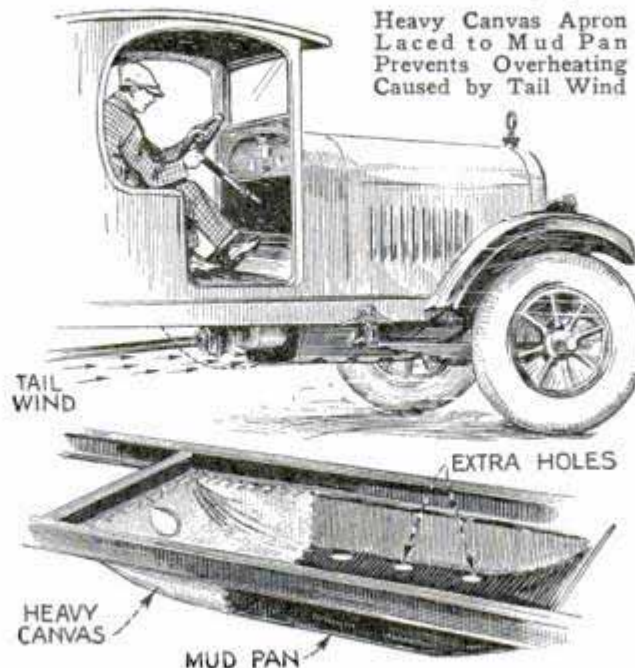



### Removing Insulation from Magnet Wire

A good method of removing enamel or other insulation from magnet wire, especially when a lot of ends have to be cleaned for soldering, is to take a fine-tooth hacksaw blade, hold the blade in one hand and draw the wire over the teeth, holding it between the thumb and the saw teeth. This method is very rapid. The fine teeth will remove both cotton and enamel insulation in one operation, leaving the wire bright for soldering.

### Heating Linoleum Facilitates Laying

An Illinois merchant, who makes a specialty of selling linoleum, contracting to cut and fit it to the floors, claims that success in laying it depends partly on its pliability, and therefore he makes a practice of heating it before attempting to lay it in place. A small oil stove is fitted with a large furnace-pipe elbow. While the room is being made ready to receive the linoleum, the latter is loosely rolled and supported on bucks, and the lighted stove is placed at

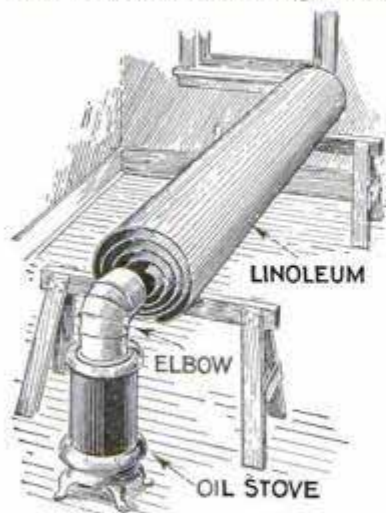

one end, with the elbow directed to throw the heat into the roll. As soon as the heat from the lighted stove has penetrated the linoleum, and it is sufficiently pliable, the work of cutting and fitting is begun. With this method much of the usual guesswork is eliminated, and the floor covering is free from cracks.

In Stores and Small Shops This Double-Box Carrier with Pivoted Handle Will Be Found Very Useful

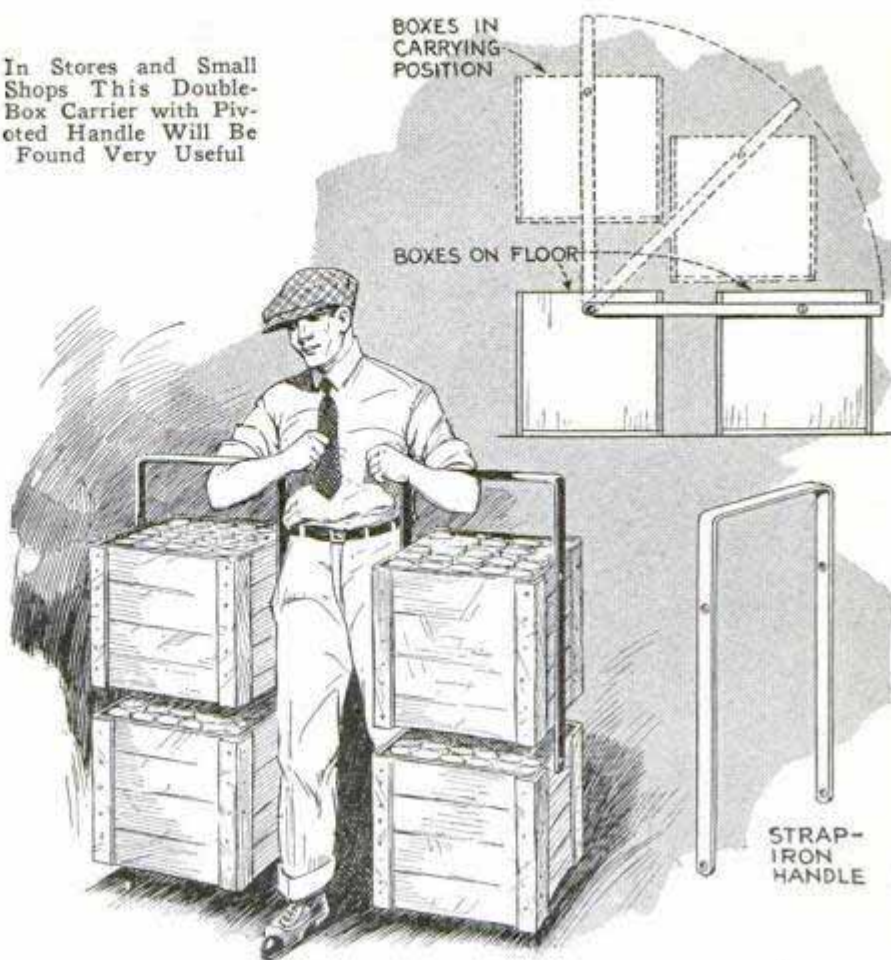

### Double-Box Carrier

When boxes filled with light material have to be carried around the shop, it is possible to double the number that can be moved by one person by using a single handle for two boxes, as shown in the drawing. The arrangement is convenient, and when the boxes are being filled or emptied, the handle is entirely out of the way. To make a carrier of this kind place two boxes a proper distance apart, so that the top of one will clear the bottom of the other when the handle is raised to a vertical position. The handle is made of strap iron and is attached to each box with two screws, as indicated, to serve as pivots. With these handles one person can easily carry four boxes.

### Effective White-Paint Cleaner

Place three small onions in a pan of water and boil them for some time until they are soft. Strain the liquid and use it as a cleaner for white paint. Neither powder nor soap is required, and the application does not need much rubbing.



### Holder Makes Gauge of Scales

A handy addition to a tool kit is a holder like the one shown in the drawing. It is used for clamping two scales together, forming a useful gauge that can be adjusted to suit many types of work. For

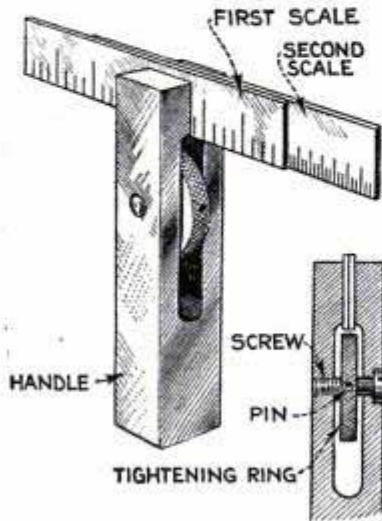

example, when turning shoulders in the lathe, it is much easier to measure from one shoulder to the other by using the ends of two scales suitably clamped at the proper dimensions than by the use of one

scale, in which case the lines must be located with the eye. Similarly, two scales are handy for setting collars the proper distance apart, or for cutting off lengths of stock, and for many other uses that will readily occur to the machinist. The type of holder shown is a good one, because it leaves one side or edge of the scales free to be laid flat on the work and also because it is neatly arranged so that there are no unnecessary projections. Take a piece of square or round stock, slot it for the scales and drill out a clearance slot beyond it. Drill and tap it through for a tightening screw and make a knurled ring to fit the screw shank. Assemble the parts as shown, with a pin through the ring and the screw. To measure the distance between two shoulders, which must be finished, for instance,  $8\frac{3}{4}$  in. apart, use two 6-in. scales. Set one of them out  $2\frac{3}{4}$  in., and by turning the knurled ring, clamp them together at this distance. The clamp, of course, is a handle as well and will facilitate the work.

### Making Screws Hold in Soft Wood

When wood screws are driven into soft-wood articles, that are in constant use, the screws often work loose. This trouble can be eliminated in the following way: Melt a small quantity of rosin in a

metal pot and apply some of it, while hot, on the screw about half of its length, just before driving the screw home. This method is better than the use of a rosin-coated nail, driven in cold.

### Mirror Useful When Working behind Instrument Board.

When a fuse blows out, a wire becomes disconnected or any other trouble develops behind the instrument board of an auto, it is a difficult task to see and reach the part to be fixed. It means lying on the back in a cramped position in the car with your head in darkness so deep that it is almost impossible to see. It is a good idea to use a small mirror, holding it in the hand or resting it so that the light will be reflected up behind the board. The parts will then be illuminated and the work can be seen in the mirror.—L. B. Robbins, Harwich, Mass.

### Air Space around Foundation Has Advantages

Provision of an air space around a foundation, as shown in the illustration, has several points of advantage.

Greater warmth is assured as the frost will not penetrate the wall and leave a coating within. It is also a guard against dampness. Likewise, stucco applied to the lower section

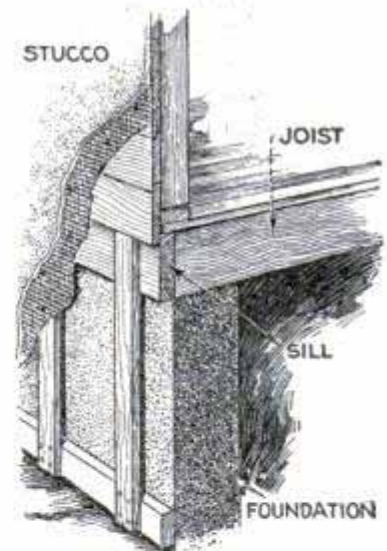

will not crack, as is often the case where it is used on the flat wall. The drawing shows how the sill comes outside of the foundation edge and the joists are flush with the edge of the foundation. A piece of 2-in. material runs along the foundation at the bottom, and furring strips are nailed from the sill to the bottom piece. The wire lath covers the whole of this and continues up the wall without interruption.



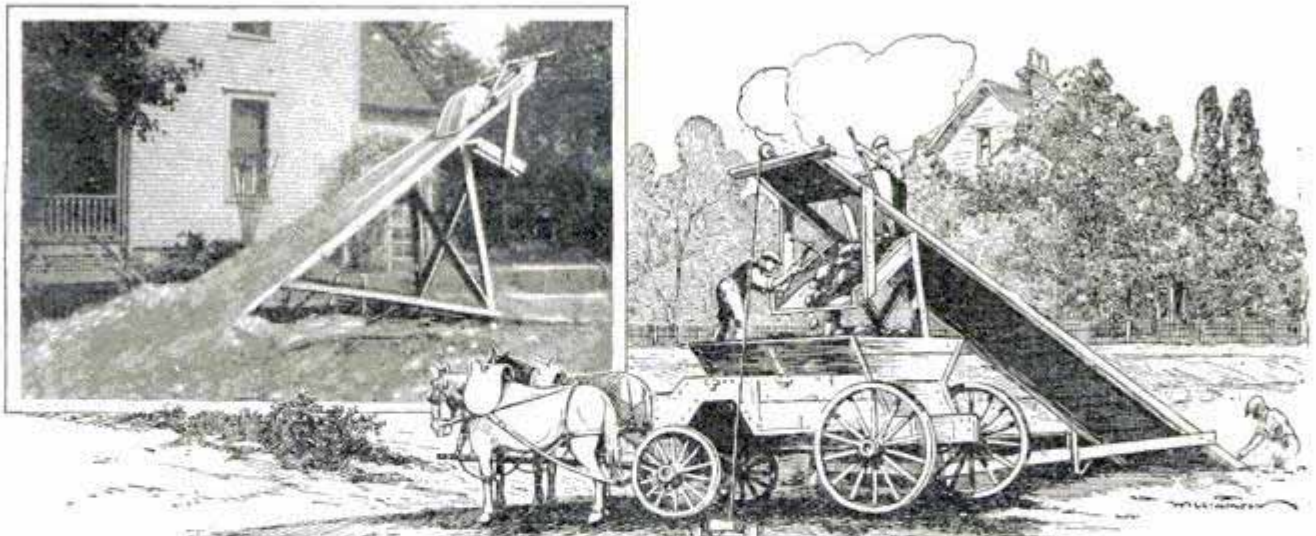

Dumping Incline for the Small Contractor Is Useful for Excavations and Saves Considerable Time and Labor

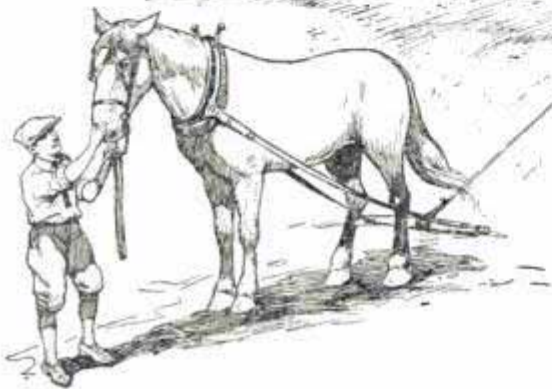

Homemade Loader Saves Time for Contractor

One contractor, who had a number of basements to excavate, decided to build his own dirt loader and save time and labor. The soil is first loosened up as usual with a plow. This is then scooped

up in a scraper, and by means of a long cable, running on a pulley at the top of the loader, is drawn up an incline. The scraper is tripped at the top of the incline, the dirt falls through an opening and slides down a slanting trough directly into the truck or wagon waiting beneath. Two 4 by 4-in. timbers are used for the uprights that support the incline, and are cross-braced by 2 by 6-in. planks. The incline itself is made from 2 by 6-in. planks with 2 by 4-in. joists for reinforcement. As soon as one excavation is completed, the timbers are quickly knocked down and removed to the next field of operation.— J. Coohon, South Bend, Ind.

### Attachment Guides Cutting Knife

To make it easier to slice long straight lengths of leather, rubber or similar material, a guide for the knife will be found useful. The one shown in the drawing does away with the need for a straightedge, which is a difficult thing to hold while running the knife along. With this attachment it is only necessary to use a straightedge for the first couple of inches

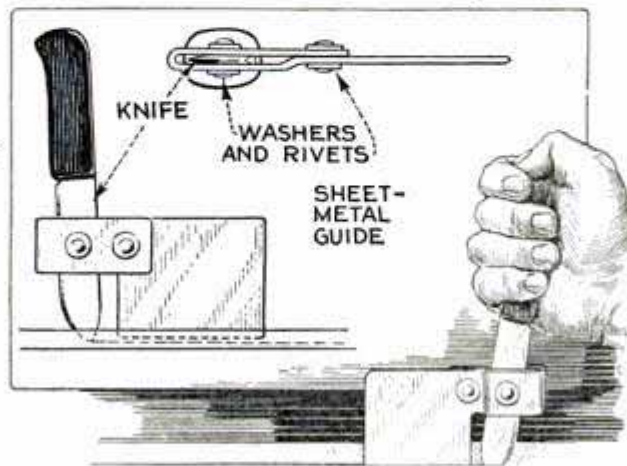

Simple Guide on Knife Helps to Cut Straight

or so, when it is discarded and the slicing continued after placing the guide in the initial cut. To make this handy attachment, a piece of sheet steel is cut out and bent around the knife. A lap is left to be riveted to the guide proper. In use, the guide piece is placed in the first cut, and the slicing can be continued in a straight line. It is best to hold the guide in the cut lightly with one hand, and not to cut the material quite through at first.



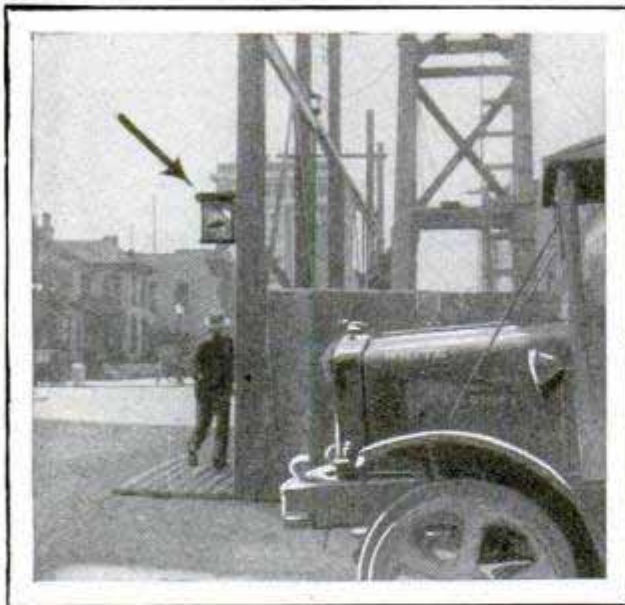

Mirror at Gateway Permits Truck Drivers to See Passing Autos and Avoid Accidents

### Mirror Prevents Auto Accidents at Gateway

In the construction of a large office building in Denver, Colo., it was necessary to make a gateway in the high board fence surrounding the building site, to allow the passage of the material trucks. As the fence took up a large portion of the already narrow street, the trucks, emerging frequently into the stream of traffic, were a source of considerable danger to passing cars. The danger was eliminated by placing a large mirror on a post at the right side of the gateway, which enabled the truck drivers to see approaching cars before driving outside.—Jos. C. Coyle, Denver, Colo.

### Improving the Drawing Board

When large drawings or maps are to be made, the draftsman often has trouble from the drawing creasing at the edge of the drawing board. A simple remedy is shown in the illustration. A semicircular strip of wood, such as a broomstick planed down, is screwed to the front end of the board. This rounded edge allows the drawing paper or map to hang over it without creasing.

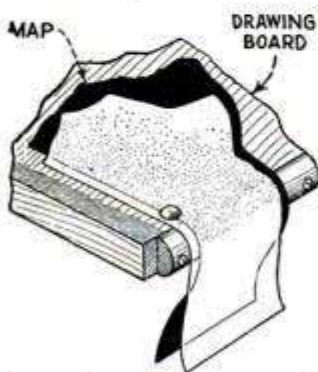

### Effective Method for Preventing Wood Rot in Posts

Paint does little good to prevent wood rot in posts, which are placed sufficiently deep to be rigid. A method has been discovered, which is highly effective, as it practically covers the end of the post with stone. Mix in an iron pot 50 parts of rosin, 40 parts chalk and 4 parts linseed oil. After these ingredients have been thoroughly mixed, add first one part cupric oxide and then, very carefully and slowly, one part of sulphuric acid. Stir this until it is well mixed. Apply the warm mixture to the post ends with a brush. The coating dries very hard, and posts so treated will not be affected by wood rot. Another advantage is that the work can be done more quickly than in other ways.—L. H. Georger, Buffalo, N. Y.

### Handy and Economical Oilcan Spout

The writer has never encountered an oilcan of a practical size for the bench having a spout opening which would drip oil on a stone exactly right, that is, drop by drop. The openings are always a little too large. When the light oil used for such a stone is warm, it gushes from the can, no matter how careful one may be. The trouble can

readily be remedied in the following way: Clip the small three-pronged retainer from the end of an old tire-valve core and force it snugly over the end of the oilcan spout. There is a small hole in these little pieces which just allows the oil to flow in drops as you want it to. It is very quickly taken off if the can is wanted for oils of different nature and purpose. This method saves oil and the stone is never flooded.—Frank W. Bentley, Jr., Missouri Valley, Iowa.

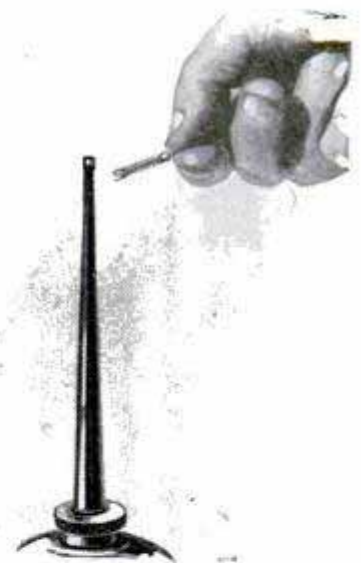



### Fluids for Drilling Glass

Several fluids are used for drilling or filing glass, of which vaseline oil and a solution of camphor mixed in spirits of turpentine are the most common. A French scientist recommends a solution of 30 gr. of camphor and  $\frac{1}{2}$  fl. oz. of sweet-almond or olive oil in 7 fl. oz. of benzine. This mixture will not deteriorate, renders filing and drilling easy, and can be removed from the glass by simply dipping the latter into benzine. The vaseline oil is more or less objectionable because it leaves the glass greasy, and the solution of camphor in spirits of turpentine is unpleasant to use because of the disagreeable smell.

### Whitewash Makes Breeding Places for Chicken Mites

When an ordinary mixture of whitewash is used to disinfect the interior of a poultry house, it usually leaves minute scales or blisters. Millions of mites may breed and multiply in these blisters, safe from subsequent sprayings of insecticide. To overcome this, mix about 2 per cent or more of sizing glue with the whitewash. This will serve as a binder, and a thick coat of whitewash will dry smooth without scales or blisters.

### Improving Corn-Crib Sill Construction

The sill construction of a slatted type of corn crib shown in the drawing will add years to its service. The lower board is a wide one, and is nailed on at a slant so that it extends over the box sill. This prevents water from dripping on the sill, and as the life of the sill really determines that of a crib, safeguarding it against rotting is highly desirable. The construction also simplifies the joining of studdings and sills.—Louis Schneider, Clinton, Mo.

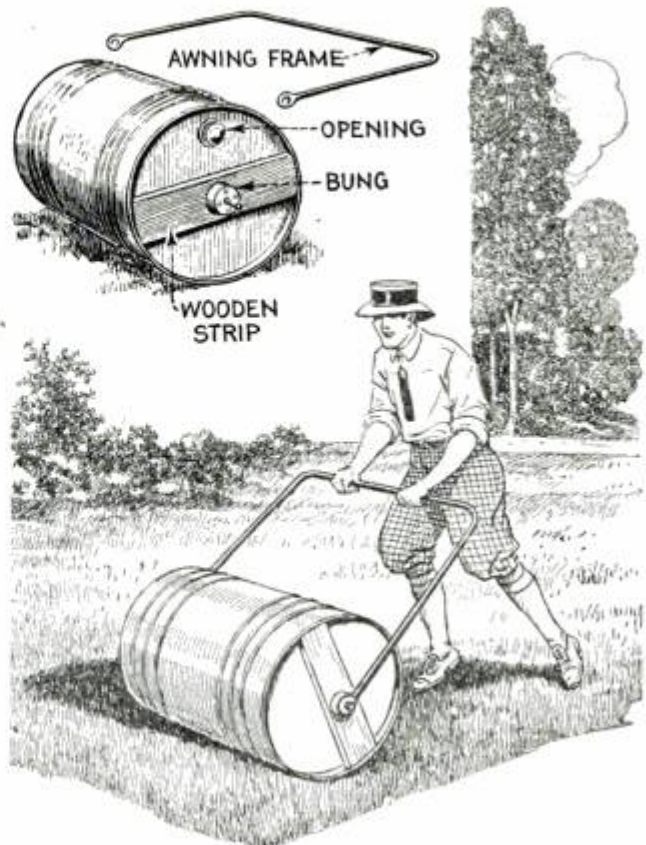

Efficient Lawn Roller Made from Old Oil Drum Filled with Water

### Homemade Water-Ballast Lawn Roller

A water-ballast lawn roller may be readily made at little or no expense. The writer obtained a discarded 15-gal. oil drum, on each end of which a piece of  $\frac{5}{8}$ -in. wood, about 5 in. wide, was snugly fitted inside of the rim. Holes were drilled through the center of two wooden barrel bungs and  $\frac{1}{4}$ -in. bolts were fitted through these holes. The bungs, nailed to the strips of wood attached to the drum ends, served as hubs and axles for the shafts of the handle. A discarded awning frame was used for the handle, the "eyes" on each end of the frame being placed over the axles and fastened with washers and nuts. If an awning frame is not available, a suitable handle may be made either of wood or by using a length of pipe, bent at right angles, and running a piece of heavy galvanized wire through it. An eye is twisted on each end to fit the axles and the handle is fastened with washers and nuts. The roller may be filled with water or sand.—David W. Murdock, Brooklyn, N. Y.

☞ Cotter pins rubbed in graphite will not rust and are more easily removed.



### Rubber-Tired Wheelbarrow

A motorcycle wheel on a wheelbarrow makes it easy-running and noiseless. When

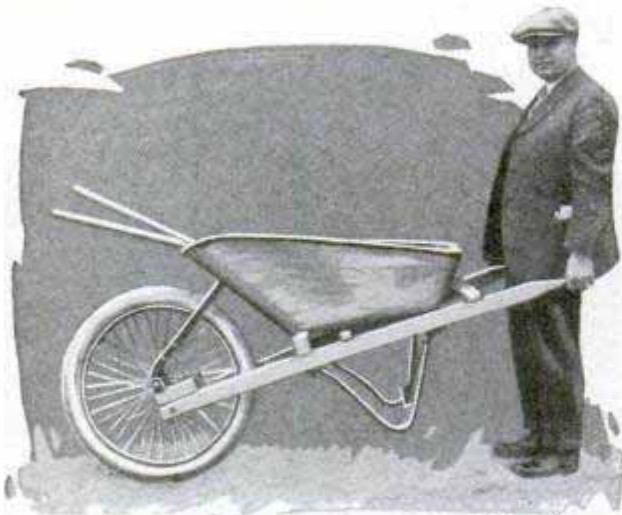

Pneumatic Motorcycle Wheel Attached to Wheelbarrow Provides Comfort for Worker

a bump is hit, it does not jar the user like the ordinary iron wheels. Such a wheel is easy to attach.—Carlton Groat, The Dalles, Oreg.

### Old Culvert Pipe Makes Inexpensive Gauge Chamber

The accompanying photo shows how old culvert pipe can be used to advantage in the installation of a water-stage recorder. The gauge mechanism is mounted in the upper end, where it is protected from the weather by a conical sheet-iron roof, riveted or bolted to the pipe, and easily reached through a swinging door cut in the side. The float moves up and down in the lower portion of the pipe as the water rises and falls, the bottom being left open to admit water from the stream. Circular iron straps, bolted to the timber heading, dam, or bridge pier, as the case may be, hold the pipe rigidly

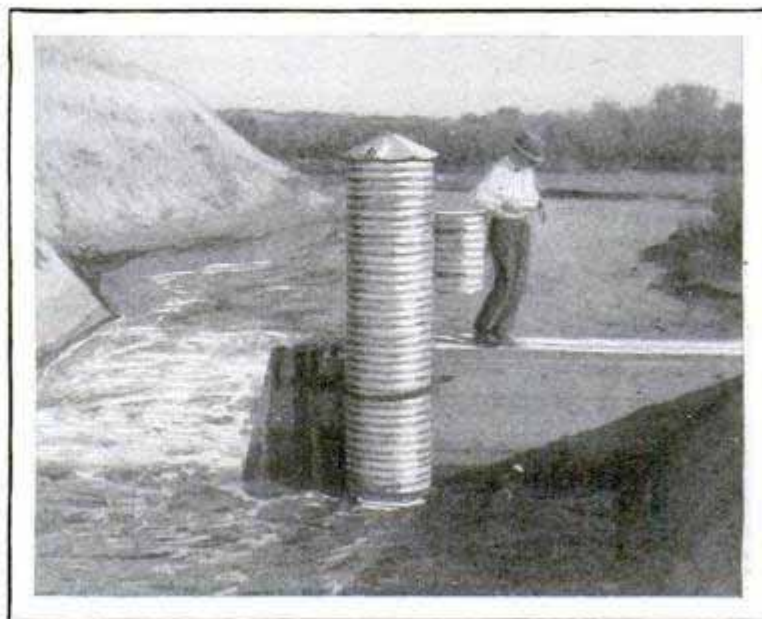

Water-Stage Recorder Mounted in a Section of Old Culvert Pipe

in a vertical position. Such installations are inexpensive and can be used on irrigation, drainage, power, or navigation canals; on small creeks or rivers, or on swamps, lakes and reservoirs.

### Cleaning Casting Dies on Linotype

When the casting dies on a linotype become clogged, they can be cleaned very quickly by coating them with blue ointment, letting them stand for a while, then rubbing off the ointment with a clean cloth and brushing with a stiff brush. Blue ointment is a compound of mercury and can be purchased at any drug store. When it comes in contact with type metal it softens this, or forms an amalgam, which is easily brushed off, taking the dirt with it. Operators of linotype machines will find that this method saves a lot of time and hard work.

### Plow Pins for Cultivators

Most cultivators have wooden pins to hold the plows. This is to protect the plows in case they hit a rock, in which case the pins break. The pins are usually cut or split from a hardwood block. As they are then square they must be made round to fit the plow. Heretofore I have used a knife for this purpose, but it is a hard job and takes time. One day, when out in the field without any knife, I found that there were several holes in the cultivator frame. By driving the square pin through one of these, a neat round pin could be made. Of course, a hole of the right size must be found. In case there is not such a hole, a piece of flat iron with the right-size hole drilled in it, should be bolted at some place on the frame.—Wilfred Sorensen, Humboldt, Ia.



# New Uses for Old Junk

In  
melt  
in c  
can

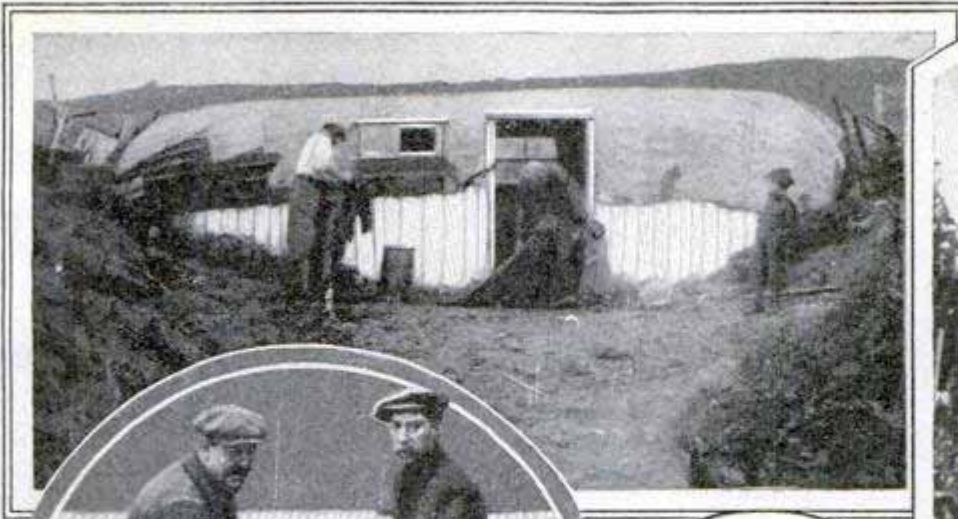

Above, Old Fishing Boat Makes a Good "Sea House"; Right, Effective Scarecrow Made from Dress-makers' Form



Old Tin Cans, Melted and Run into Molds, Make Paving Blocks

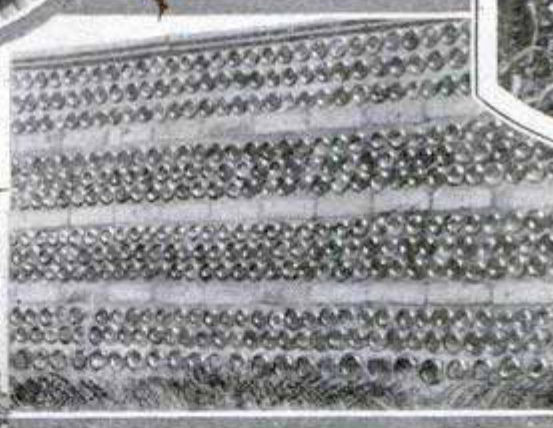

Left, Old Bottles Built into Concrete Wall Reduce Cost

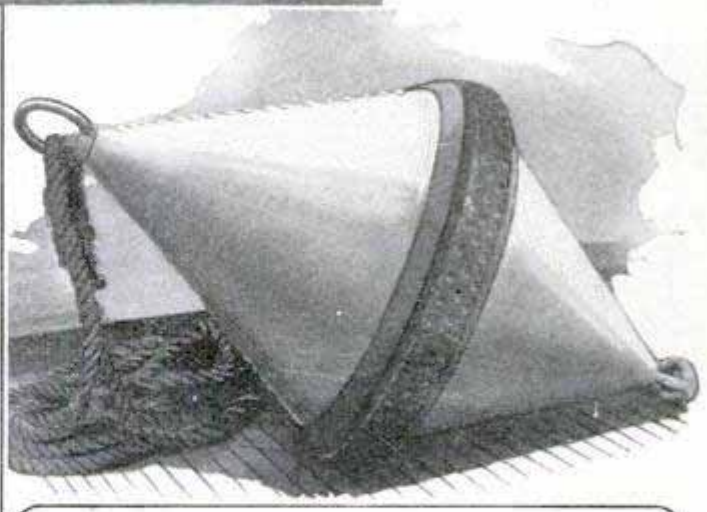

Left, a High Horseshoe Pile Advertising the Village Blacksmith; Above, Old Auto Tire Makes Effective Bumper for a Motorboat Buoy



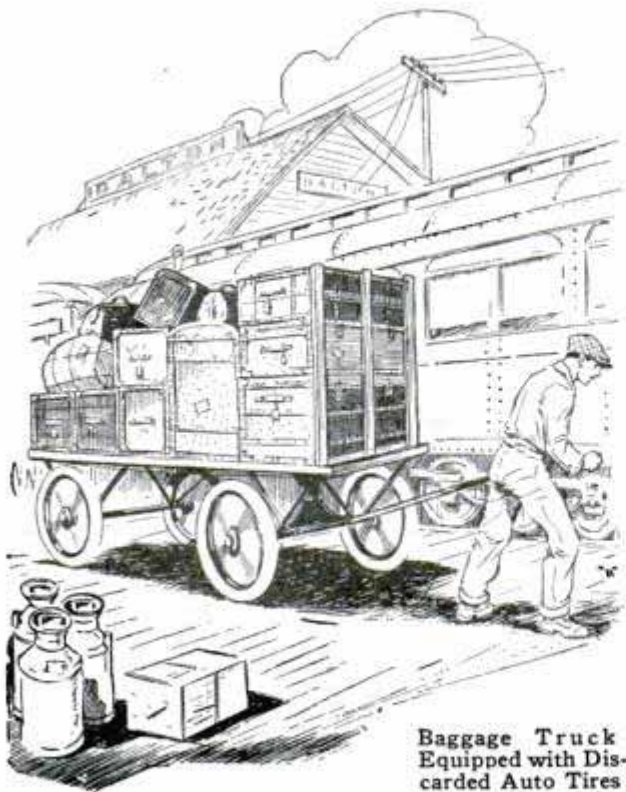

Baggage Truck  
Equipped with Dis-  
carded Auto Tires

### Rubber-Tired Baggage Truck

To prevent jarring of baggage, one baggage agent uses discarded auto tires on the wheels of the trucks. Equipped in this way, the trucks can handle greater loads with less danger of the baggage falling off. A test was made on a load of milk cans and not a drop of milk was spilled. The rubber-tired trucks are also silent and can be drawn past a sleeping car without disturbing the occupants.—W. N. McCoy, Little Rock, Ark.

### Effective Wagon Brake

A general outline of a simple but effective wagon brake is shown in the illustration. Its construction is such that a slight pull on the lever causes the brake blocks to press tightly against the wagon tires. The lever is quite short, occupying only a little space, and the whole fixture requires less room than the average homemade brake. No pole projects upward above the level of the bolsters or above the wagon box, to be in one's way while loading the wagon. A rope, tied to the rear end of the lever, extends to the front end of the wagon, where it is accessible to the driver, who can operate the brake equally well for either running gear or wagon-box hauling. The rope is tied to the right-

hand standard, to keep it at a point where the driver can readily reach it.

None of the materials required for the construction of this brake are hard to obtain. The hardwood used is 2 in. thick and 3 in. wide. Four iron bars,  $\frac{3}{8}$  by  $1\frac{1}{2}$  in., are required, two of them being used on top and two beneath, to keep the brake-block holders in the desired position. Two thin iron bars, bent to the shape shown in the illustration, are used as a support for the brake lever, and also to connect the brake-block holders, and they provide a sort of rack for the lever when it is idle. These pieces are attached to the short block holder by means of a U-shaped bolt, and to the longer one with a lag screw. The timber into which the lag screw is driven is banded at the end to prevent it from splitting. The block holders are further connected by means of two bolts and two short straps at a point near the center of the wagon. Pieces of an old casing should be nailed to the brake blocks, to prevent wear of the wood. The illustration does not show the detailed construction of the brake, and few of the dimensions are given, but

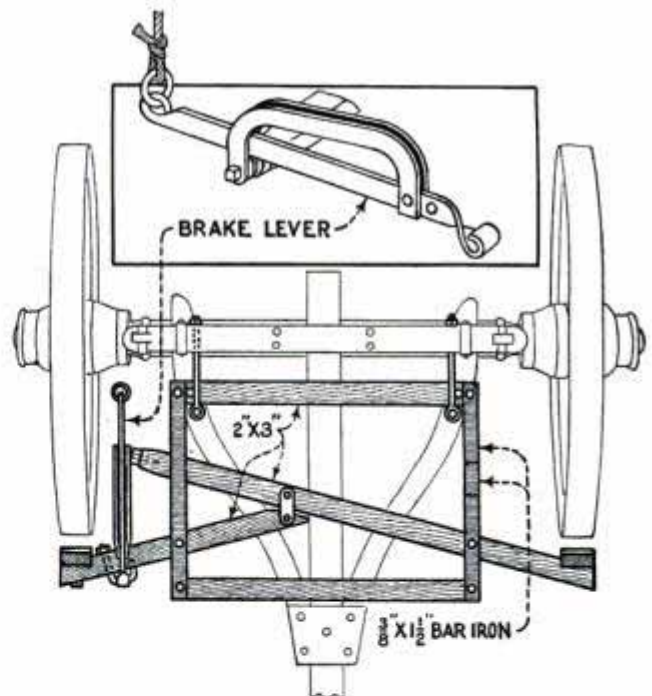

Homemade Brake for Heavy Wagons Which Has Been  
Found Very Effective

one should be governed by the size and kind of wagon, when determining the sizes of the parts to be used. The brake can be made adjustable by drilling more than one hole near the front end of the lever, where it is given a quarter twist.



Pulling the lever forward causes the brake-block holders to come close together at the lever end of the brake, and thus makes the blocks bear against the wagon tires. Be sure that the brake blocks are close enough to the wagon tires before deciding the location of any holes, as these will influence the size of the openings between the blocks and tires.—Bunyan Kennedy, McCool, Miss.

### Curing a Waterlogged Hydraulic Ram

Many farmers have difficulties with hydraulic rams after a short period of operation. The ram seems to lose its efficiency and finally the flow of water stops almost entirely. This, in many cases, is due to the stopping of the snifting valve—a plug usually found screwed into the base of the ram with a very small hole drilled through it. This admits air to the air chamber of the ram at each stroke and, if it becomes clogged, the ram will not operate. It is also possible that the waste water from the ram, running past the plug, will cover the hole, and this would have the same effect as plugging the hole with refuse. Keep it clear, and you will find that the ram will work satisfactorily.—L. B. Robbins, Harwich, Mass.

### Handy Pipe Rack

Odd lengths of usable pipe and stock rod often lie around in the small shop, where they may roll over the floor and get in the way. I took a number of discarded old-style brake-band lugs from Fords and spiked them to the wall, as shown in the photo, making several tiers. In this way the pipe and rod were separated so that I could find what I wanted without any trouble, and the material was also entirely out of the way.—Frank W. Bentley, Missouri Valley, Iowa.

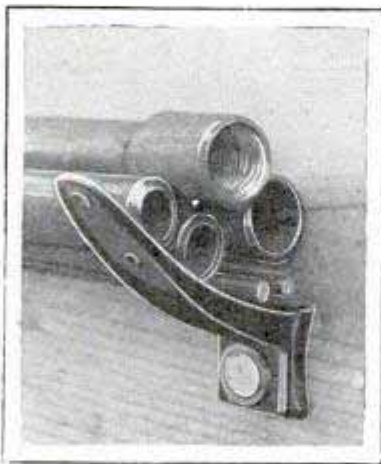

Simple Method of Driving Long Pipes or Rods with the Aid of a Block

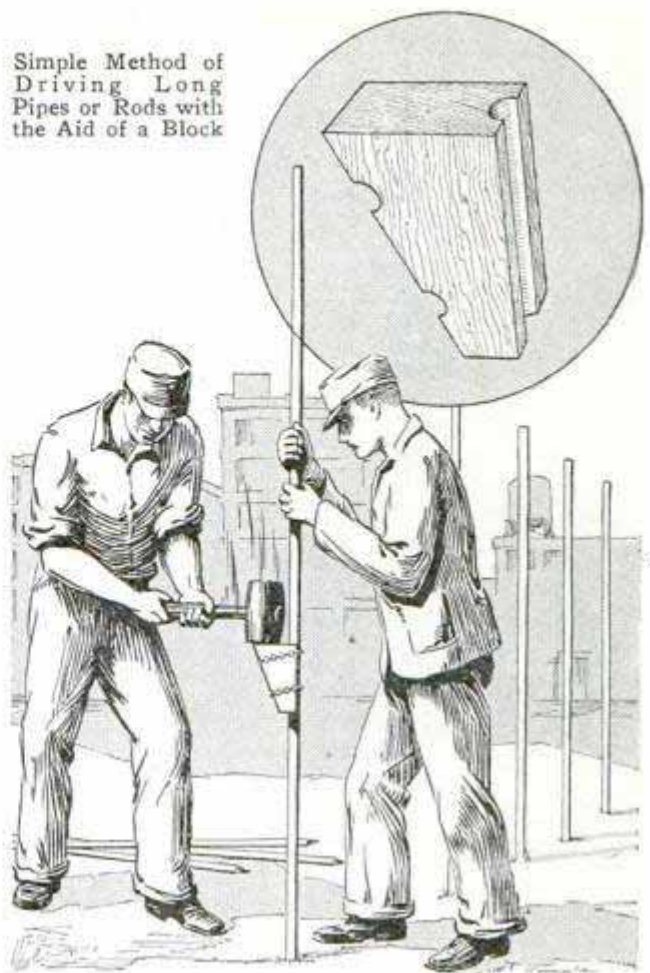

### Driving Long Rods into the Ground

It is almost impossible to drive long poles into the ground from the top of a ladder; sometimes the pole breaks, the top is badly marked up or the rod bends. A simple method of driving long poles or rods into the ground without such effects, consists in using a block of hardwood, cut and grooved to fit the pipe, rod or pole, as shown in the illustration. The block is slipped on the pipe or rod from the bottom. Moving it up does not cause the chains to bind, but as soon as a downward force is applied, the block is wedged tightly against the pipe, which can then be driven down by striking the block as shown.—L. H. Georger, Buffalo, N. Y.

### Radium-Headed Tack on Door

Half-open doors may cause considerable injury when one walks against them in the dark. After several painful hurts, I placed a radium-headed thumbtack on the edge of the door, at eye height. This can readily be seen and will prevent collisions.—Leon I. Thomas, Oak Park, Ill.



*Denver Colo*

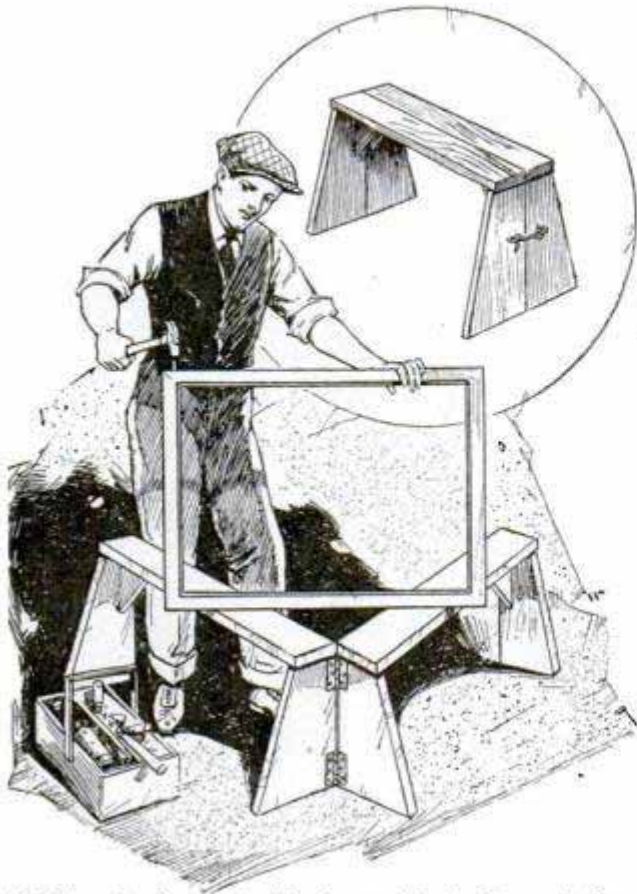

Folding Sawhorse Is Handy to Work On and Easy to Carry Around

#### Folding Sawhorse for Small Repair Work

For general repair work, especially on jobs away from the shop, a Wisconsin carpenter employs a sawhorse of hinged construction, so that it serves the purpose of two. The horse is made as shown in the accompanying illustration, and may be opened or closed to accommodate the size of work being done on it, and to facilitate moving it from place to place.

#### Cautions in Use of Anti-Freeze Solutions

Cold weather to the car owner means replacing the water in his car with some form of anti-freeze solution. While alcohol was once the main stand-by, every winter sees a number of new preparations placed on the market as substitutes, claiming various advantages. One thing that seems to be common to the majority of them is that they will leak out of a radiator that is water-tight, and to prevent this, some form of radiator liquid is often used to seal the leaks if they cannot be stopped in any other way. In such a case, however, much trouble can be prevented if the two liquids are tested chemically before the mixture is placed in the ra-

diator. One motorist was not only stalled many miles from home, but had to replace an expensive aluminum cylinder head because the solution had so corroded the metal during a few hours' standing, that it broke down as soon as the car was run, and flooded the cylinders with liquid. Both liquids were safe in themselves, but combined chemically to the detriment of the aluminum.—Harold E. Benson, Denver, Colo.

#### Special Wax for Filling Pits in Varnish on Pianos

If the varnish on a piano has pitted, fill the pits with a wax made as follows: Melt  $\frac{1}{2}$  oz. of carnauba wax, 2 oz. japan wax, or white beeswax, and 2 oz. of ceresin wax in a suitable vessel. A good method is to place one vessel inside of another, place hot water in the outside one and the wax in the other, then set them both on a stove. When melted, add enough kerosene to form a mass like petroleum jelly, when cool. This may be tested by placing some of it on a piece of glass and letting it cool. If it seems too hard, add a little more kerosene. Rub in on the piano with a wool pad, giving two or more applications until the pits are filled.

#### Windshield for Handcar

A windshield for a handcar will give the men working in railroad yards much comfort during the cold winter months. It is simple and inexpensive to make and should be of interest to section hands in

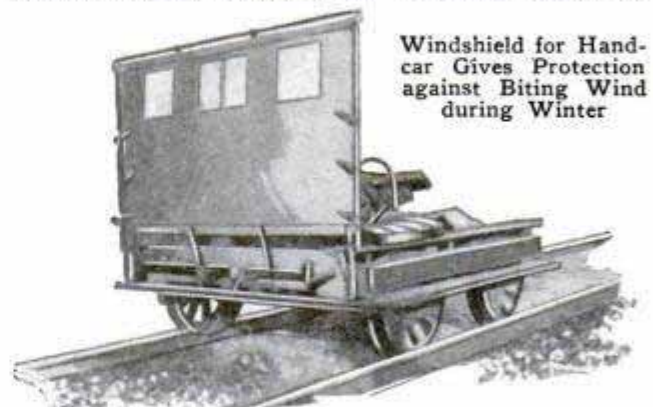

Windshield for Handcar Gives Protection against Biting Wind during Winter

railroads working in the open. It is made of either canvas or light wood, and has celluloid or glass panes to permit a clear view of the track ahead.—W. H. Soames, Minneapolis, Minn.



# Pipeless Furnace Made from Old Heater

By L. B. ROBBINS

UNABLE to heat his house properly with an old-type of hot-air furnace, the writer, with little work, changed it into a pipeless furnace, which has given entire satisfaction. The same firepot and stove castings were used, but the casing was altered in order to eliminate the individual pipes to the different rooms. The converted furnace has heated the house to a normal 70° and higher, even during extremely cold weather.

It is not necessary to tear out the old heater entirely. If the firepot is large enough, you should have no difficulty in heating your home either to normal temperature on less coal or higher on the same amount. The advantage of the new installation is that all the heat is discharged into the house through one register, and that the return pipes conduct the air back to the furnace for reheating, establishing continuous circulation.

isters were taken out and the holes boarded up to match the floors. The casing around the firepot and the radiator casting was disengaged by removing the bolts which held it in place. As each piece was taken off, it was chalked with an identifying mark to avoid mistakes when reassembling. Next, the sections of the stove were taken down and the joints thoroughly cleaned of old cement and soot. The proper location for the heater must then be determined. In my case, the register was put on the west side of the house, midway between the north and south ends, because the prevailing winds are from the west and thus strike the warmest side of the house and spread the heat evenly through the entire building. Always a spot should be chosen that will promote even radiation and ready ascent of the heat to the second floor. My old furnace had an 18-in. firepot, and I found that a



Old-Style Hot-Air Furnace Converted into an Efficient Pipeless Furnace, Which Heats the Entire House; the Cost of the Furnace Amounts to Only Fifty Dollars

The pipes to the various rooms were removed from their registers and the collars on the casing dome. The reg-

30-in. register, with an 18-in. central grating, would be the correct size to use. A 30-in. square hole was, therefore, cut in the floor directly over the new location for the furnace and the register was set in posi-



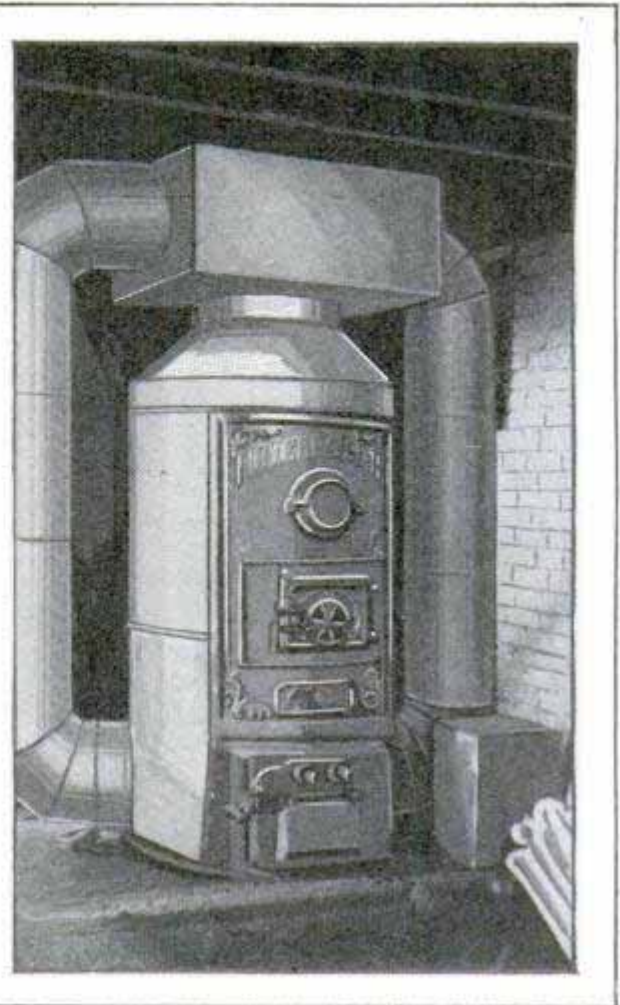
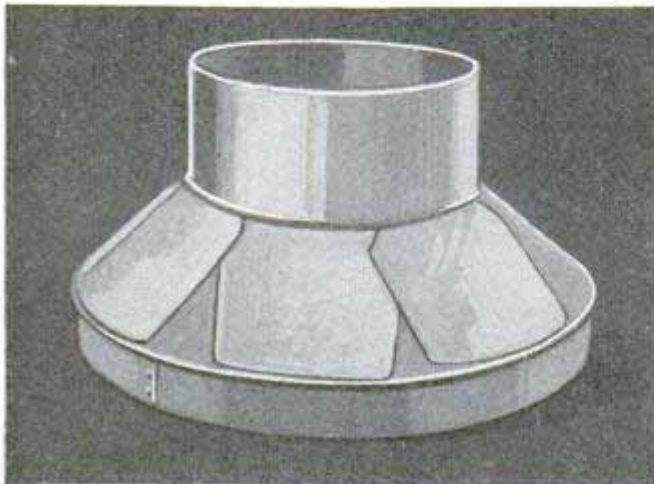
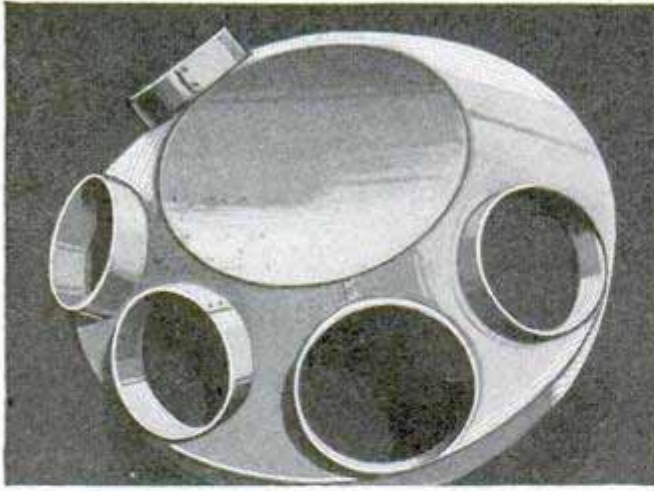

Left, How the Pipe Collars on the Dome Are Closed by Pieces of Sheet Iron; Right, Completed Installation, Showing the Pipes That Return the Air for Reheating

tion. The castings were then reassembled under the hole. Plenty of furnace cement was used in all the joints, and any suspicious crack was also filled with cement to prevent gas leakage. The exact center of the stove was determined by dropping a plumb bob from the center of the register. The collars were then removed from the casing dome. The edges of the holes were hammered smooth, and square pieces of galvanized sheet iron were cut to cover each with a 1-in., or wider, overlap on all sides. A couple of slits were made in two opposite sides of each piece to form lugs which were slipped under the edge of the hole and pressed up from the inside. These held each piece securely. Just before this was done, however, the underside of the piece of sheet iron was well smeared with cement. When the job was done and the piece clamped in place securely, the cement hardened and made a perfectly gas-tight joint. The detail drawing and the two photos show how this part of the work was done.

Lastly, the entire circular top of the dome was cut out and a collar was attached. This measured 18 in. in diameter, the same as the diameter of the firepot. An 18-in. galvanized sheet-iron stack was riveted together and left long enough to fit closely against the register when the rest of the furnace was completed. With this done, the casing was replaced with new bolts, and the dome put on as before. Short pieces of wire were wound about the bolts at the front and chicken wire was wrapped about the casing tightly and held by the short wires. This was for the proper support of an asbestos plaster, which was later applied.

To complete the arrangement, a galvanized sheet-iron box was constructed, 30 in. square and 18 in. deep. The drawing illustrates the box in detail. The upper end was left open, but the bottom was closed by a sheet pierced in the exact center by a round hole, 18 in. in diameter, which was intended to fit over the heater stack. In each of two opposite sides a



12-in. round hole was cut and fitted with a collar. The box was slipped down into the register hole and the top edges of the box were nailed to the inside edges of the opening, about  $\frac{1}{2}$  in. below the floor level. The heater stack was then inserted through the hole in the bottom of the box and fitted over the 18-in. collar on the top of the furnace dome. A length of 12-in. pipe and the necessary elbows connected the 12-in. collars on the sides of the box to corresponding 12-in. collars on the bottom of the furnace. The finished assembly is clearly shown by the photo and drawings. The entire furnace casing, as far up as the bottom of the box, but not including the 12-in. pipes, was covered with a 1-in. layer of asbestos plaster, mixed to a paste form in water and applied with a trowel. When it dried, it was given a coat of white cold-water paint. The smoke pipe was fitted with a check damper that could be operated by a chain from above for regulating the draft without going down into the basement.

The drawing shows the circulation of the air, which compares very favorably with the double-casing system of the typical pipeless furnace. The heated air rises directly into the rooms and, when cooled, flows along the floors, down the outside edges of the register into the box and, through the 12-in. pipes, to the bottom of the casing where it is reheated and again rises into the house. This action continues as long as there is fire in the furnace. The cost of making this installation was less than \$50 and has well repaid the trouble. Practically all the heat generated in the firepot is utilized and the fuel cost is reduced considerably.

☐ All metal patterns should be thoroughly cleaned with a stiff brush having plenty of beeswax on it and dipped in powdered plumbago, to draw easily.

### Piano Stool Handy as Tool Holder

By utilizing a piano stool for a tool holder, as shown in the drawing, a garage man found that tools can be kept handy with less risk of losing them. The stool is fitted with a rim separated from the top by a 1-in. space. This was done by nailing four 1-in. blocks equidistantly about the edge of the seat and nailing a barrel hoop to the blocks. The tools were hung in this slot, and the seat could be turned to bring any one of them within easy reach. The stool could also be used by the repair man as a seat, if desired, by pushing some of the tools together on one side.



### Clamp Holds Auto Hood

When working about the engine of a car, most garagemen prefer to remove the hood entirely to eliminate the necessity of raising and lowering the sides as occasion demands. An Illinois mechanic improvised a simple holder by means of which both sides of the hood can be kept open without danger of falling while the repair work is being done. It is simply a length of  $\frac{1}{4}$ -in. steel rod, bent to the shape shown and having lengths of rubber tubing slipped over the "legs," to avoid scratching the hood. In use, the sides of the hood are raised and the tool is slipped down over them like a huge clothespin.

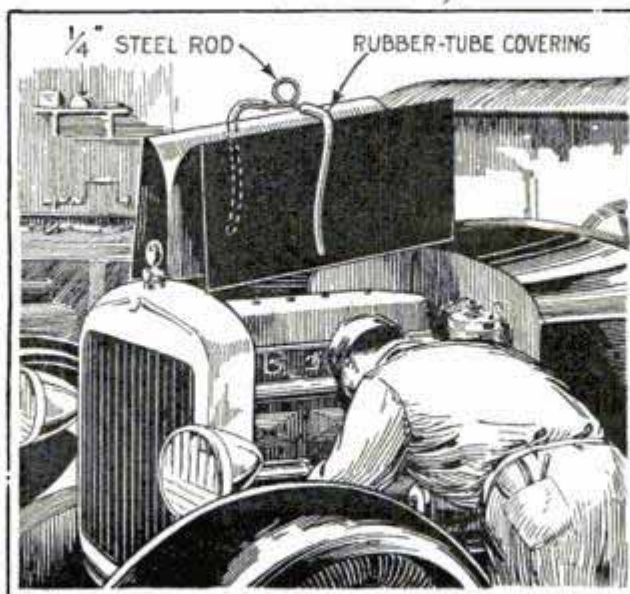

Simple Device Holds Both Sides of Auto Hood Up Securely without Marring Finish





Drainage-Canal Banks Built at an Angle of 45 Degrees Are Most Economical

### Most Economical Shape of Canal Found by Experiment

A western irrigation district recently concluded that the most economical shape for a concrete-lined canal is one with the banks sloping at a  $45^\circ$  angle. Such a shape allows the concrete lining to be built without forms, while the operation of the canal is fully as satisfactory as it is in canals of other shapes. This was determined after observations on the experimental canal shown, which was built with banks of different slopes.

### Clearance of Milling Cutters

In grinding the clearance on the cutting edge of milling cutters, sufficient attention is usually not paid to the angle or exact amount of clearance the cutter will have on the work. This is a very important matter, as too much one way or the other will result in failure of the job. If the clearance is too great, the cutter will have a tendency to chatter and make a rough finish, to say

nothing of the disagreeable noise, and the loosening up of the bolts and clamps on the machine will cause the heel of the land to drag, making an uneven surface, and is liable to break the teeth. The angle depends, to a great extent, on the diameter of the cutter and also on the material it is to cut, although, in general, milling cutters are used on almost anything that can be cut, making regular shapes, while in those that are made up for a special job and used for that purpose only, more attention must be given to the kind of material to be cut.

Generally soft materials will machine better with more clearance than tool steels, and the like.

Usually, for cutters up to 4 in. in diameter, from  $6$  to  $7^\circ$  will be found ample on the outside diameter. Over and above this diameter, the angle may decrease, say  $\frac{1}{4}^\circ$  for each 1 in. in diameter, until  $4^\circ$  is reached. The clearance on the teeth of end mills should be from  $2$  to  $3^\circ$ , when the cutters are used for roughing and finishing. If used for roughing alone, a little more clearance is better.

### Serviceable Spring Bumper

An efficient and sturdy spring bumper can be made from a 12-in. section of old tire casing filled with a tightly rolled section of inner tube. This is strapped over the spring, as shown in the illustration. This style of bumper is usually adaptable

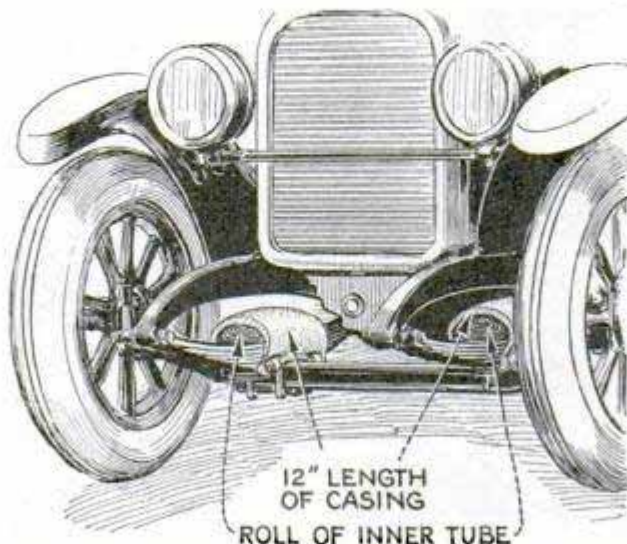

Old Tire Casing and Inner Tube Make Effective Bumper on Auto Spring

to both rear and front springs, and should find favor with tourists, who frequently overload their cars with camping equipment, and encounter bad detours and rough roads. In the case of a broken spring, this bumper makes an excellent cushion between the axle and the frame, enabling the car to be driven home.



# A Substantial "Built-In" Chute for Barrels and Boxes

By ROY M. SINGER

A CHUTE that will handle both barrels and boxes with ease is exceptionally useful. All the necessary details for building such a combination chute are shown in the illustrations accompanying this article, enabling anyone to build it without trouble. The particular feature of advantage of this type of chute is that the barrels can be controlled so that they will not slide off the chute on the way down. The slides are made of angle iron such as can be obtained at almost any place where structural iron is available. It is quite possible that secondhand pieces of suitable size can be picked up in a junk yard. The proper size of angle iron to use is 4 by 4 by  $\frac{1}{2}$  in., the length of the slides, of course, depending on the particular installation. If extremely heavy

so that a barrel will slide easily between them, and the third is placed so that the chute will have sufficient width of bearing for the largest box it is expected to handle.

The method of anchoring the slides at the top and bottom is important, for upon this depends the stability of the entire installation. The leg at the top should be flush with the surface of the concrete, and the bottom leg should be imbedded in the concrete floor, as indicated in the details. At the top, the slides are held with anchor bolts fixed in the concrete, the heads of the bolts being set in countersunk holes in the slides, so that these heads will not interfere with boxes and barrels sliding over the surface. Flat washers, 4 by  $\frac{1}{2}$  in., are used to set the bolts in the concrete. At the bottom, the slides are

held in the concrete floor by anchors, made as shown in the detail. One leg of the angle is cut away and the other is bent into the concrete floor so that the anchor can be slipped through it. Throughout the

Strong Chute of Angle Iron for Advantageous Handling of Both Barrels and Boxes

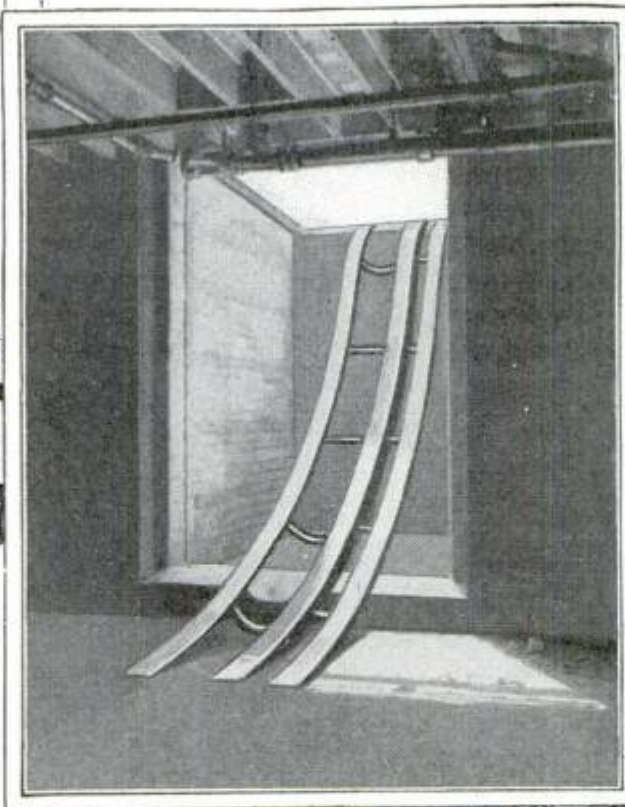

boxes and barrels are to be handled, it is advisable to use 6 by 4 by  $\frac{3}{4}$ -in. angle iron, placed so that the 6-in. side is vertical. The slides must first be cut to the proper length and are then bent to the desired curve. Three of them are required, as shown in the photo. Two of the angles are placed far enough apart



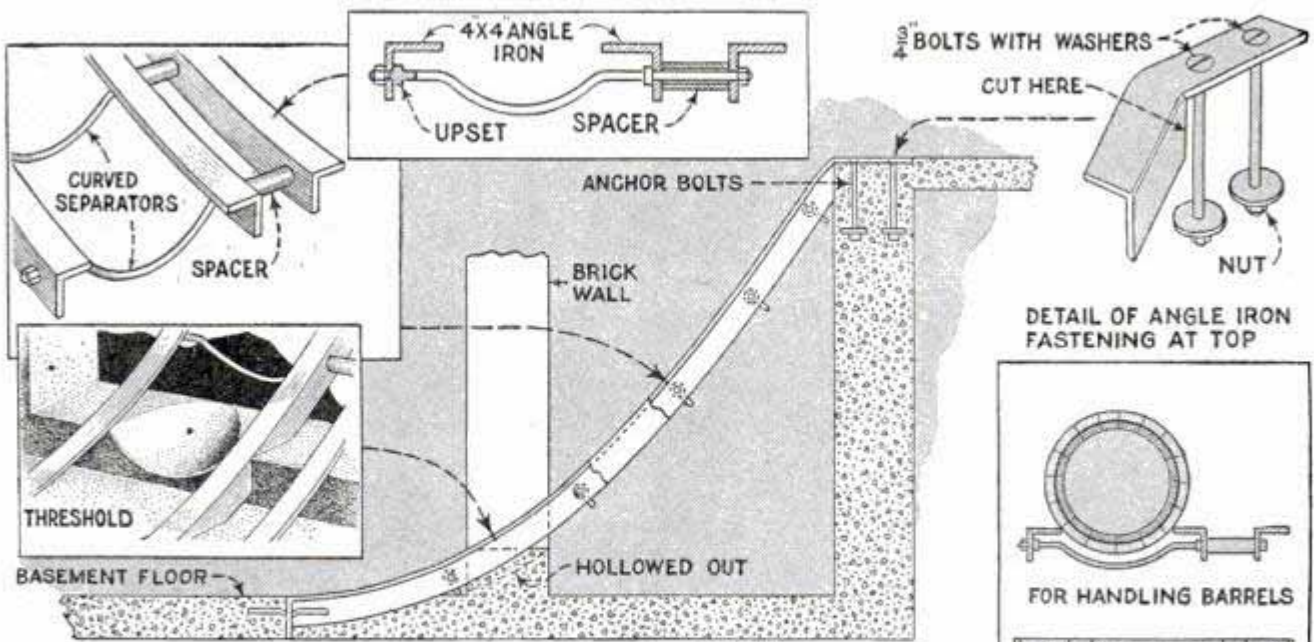

Constructional Details of the Chute, Showing Method of Anchoring and Supporting the Slides

length of the chute, the slides are kept apart by separators, placed at intervals of about 3 ft. The separators are curved between the two left-hand slides, so that they will not offer any obstruction to the barrels sliding down the chute. In case the chute is carried past a threshold, as in the case shown in the illustrations, the threshold should be cut out so that the barrels will not hit it. The separators are made as follows: A length of 1-in. iron rod is cut into proper lengths. Each of these is bent to the shape shown, and collars are welded on in the positions indicated in the detail. Each separator is threaded on both ends and short pieces of pipe are cut to a length equal to the distance between the two right-hand slides. The pieces of pipe are held between the two slides and the separators are slipped through. If the collars have been correctly placed, there will be just room enough for a nut to be screwed on each end. The slides are held so that they cannot work away from each other, and the entire arrangement is considerably strengthened.

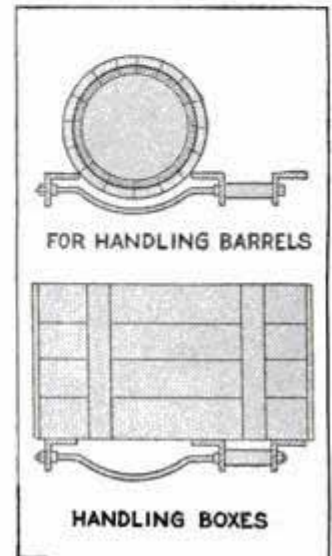
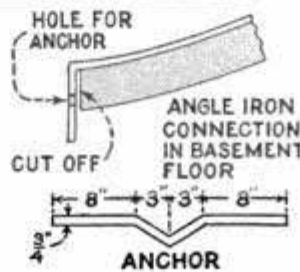

ened. If it is not desired to weld collars on the separators, the screw threads could be cut farther on the ends and inner nuts and washers used instead of collars.

### Detachable Can Handle

Welding flux used by one shop comes in large cans without handles. The cans must of necessity be carried around a good deal, and therefore the shop operator made a handle, which could be taken off or replaced quickly on a can. It is made of wire and stout cord, the former having looped ends through which the cord is threaded and knotted. To attach the handle, the looped cord is placed on the can, and the handle is wound around to twist the cord until it is tight enough to hold the can. Once this is done the handle will not come off, as the can

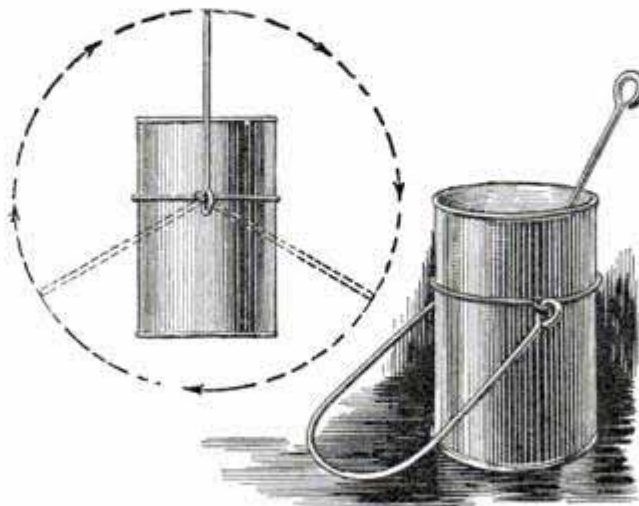

Quickly Improved Bail on Large Cans Facilitates Carrying Them



is always either resting on the bottom, as shown in the drawing, or carried by the handle. The twisted cord tends to unwind itself, and as soon as the can is set down, the handle snaps back out of the way. When the contents of the can have been used up enough to decrease its weight, the handle is unwound a turn or so to make the can hang straight.

### Bleaching Linseed Oil

If it is desired to bleach linseed oil for some special purpose, mix it with some five per cent of peroxide of hydrogen in a tin or glass vessel and shake it from time to time. It will require only a few days to bleach the oil, which then may be poured off, the peroxide having been reduced to oxide of hydrogen—water. There are other ways of bleaching linseed oil but they require about a month in making the change, and this is the simplest and quickest method.—A. A. Kelly, Frazer, Pa.

### Armature Winders' Hammer

Armature winders, and other mechanics who work on electrical machinery, often need to force wires into their slots by tapping them

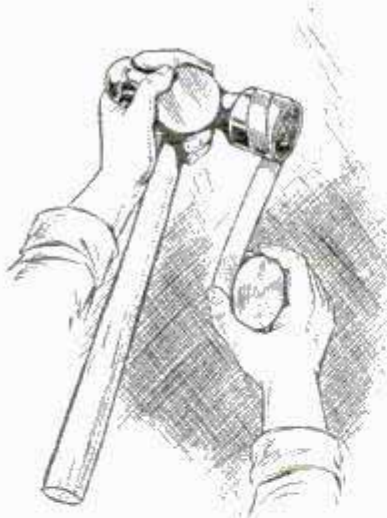

down with a hammer. To do this without damaging the insulation requires considerable skill, unless a hammer having a resilient face is used. An ordinary mechanics' hammer can be provided with

a resilient face by wrapping friction tape over it, as shown in the illustration. The tape is coiled into a tight roll equal to the diameter of the hammer head. It is then placed against the face and bound to it by a dozen layers tightly drawn over both the hammer head and the extending roll. This will provide effective cushioning for the blow and protect the insulation from damage.—Eugene Emerson, Brooklyn, N. Y.

### Locking the Steering Wheels on Trucks Used in Factory

It is often necessary to back a factory truck a considerable distance down an

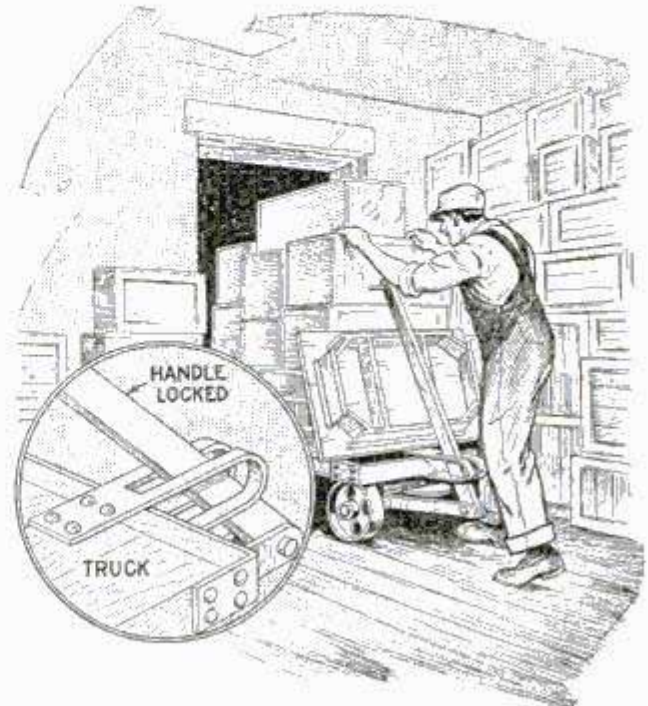

Sheet-Metal Device on Factory Truck Locks the Steering Wheels

alley having very little clearance, and this is an awkward task, as it is difficult to back it up in a straight line. By fixing a simple lock on the truck, we overcame this difficulty. The lock consists of a piece of strap iron, bent double and fixed to the top and bottom of the truck floor in the center. It is slotted to receive the truck handle. When the truck has to be backed any distance, we first set the rear wheels straight, then push the handle back into the slot to lock the front wheels.—Harry Moore, Montreal, Can.

### Floor Heater for a Small Shop

The brick floor in my shop is very cold in winter, and to make it more comfortable, I removed the brick and dug a hole, 36 in. long, 18 in. wide and 18 in. deep, in front of the lathe where I stood most of the time. An old two-burner oil stove was procured and set in the hole. I then covered the hole with a board, made to fit tightly, and bored a number of 1/2-in. holes near the center. A large hole was also cut at each side for draft. I was surprised at the results of this little heater.—J. H. Priestly, Lawrence, Mass.



## Is This Your Home?

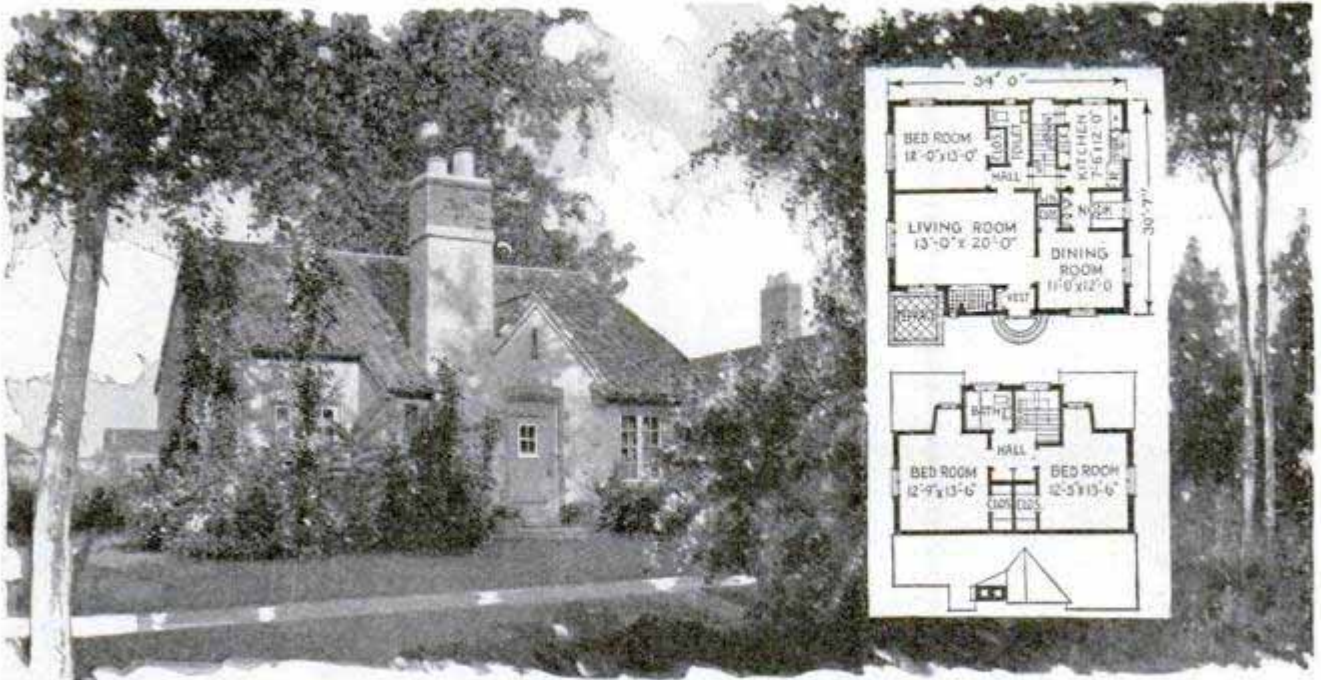

Copyright, Architects' Small House Service Bureau

Plan No. 6B27

**Q**UESTIONS regarding home building addressed to this magazine will be answered by The Architects' Small House Service Bureau of the United States, Inc., controlled by the American Institute of Architects and endorsed by the United States Department of Commerce. Please inclose 10c in stamps or coin. Blueprints, specification forms, and material lists for the house shown here may be obtained from The Architects' Small House Service Bureau for a small fee. If further information is desired, literature describing the plan service and publications of The Architects' Small House Service Bureau will be sent you upon request. A booklet entitled "50 Ways to Lower Home Building Costs," illustrated by ten Bureau homes actually lived in and showing how as much as \$1,000 can be saved on a home, may be obtained for 20c.

**W**HAT sort of result issues from the architect's alchemy? He mixes together walls, roofs, windows, chimney stacks in his paper crucible. From it must come order, direction, beauty. The more skillful he is the more beauty he gets. Here then, in this plan, is an expression of the alchemy of architecture by which gross materials have been transmuted into pure beauty—in a word, into architecture.

To this six-room house, four on the first floor and two on the second, have been added vestibule, breakfast room, terrace, inglenook with gorgeous fireplace, and closets in profusion.

Going over the plans we find many details of interest. For example, there is a first-story bedroom and toilet, a grade entrance, coat closet in the vestibule and three linen closets.

The living and dining room, and the kitchen, occupy a position which is detached from the first-story bedroom. The separation of kitchen and dining room by

the breakfast alcove is an arrangement which has its particular advantage.

The placement of the dining alcove makes of this feature, which has come to be the standard equipment of the small house, a somewhat more formal affair than the usual dining space that appears as part of the kitchen proper. Yet its convenience is practically as great.

The interesting details are not confined to the plan alone. Perhaps the prospective home builder is more inclined to give the exterior most of his attention.

There is a contrast of materials here which lend vivacity from color and texture as well—plastered walls, variegated tile roof, brick insets about the doorway, iron-bound door. The bricks at the stoop and at the chimney stack, complete a variety which is wholly bounded by good taste.

Construction: Hollow tile walls, exterior finish stucco, brick trim; window frames may be of metal if desired; lot size, forty-five feet; face, east or south.



# Drive Screws the Quick, Easy Way

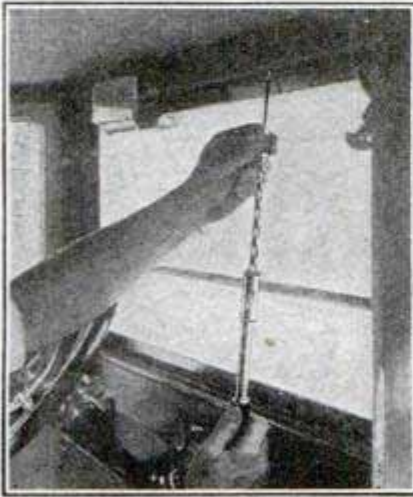

Up or Down is the same to this world-famous "Yankee" Spiral Screw-driver.

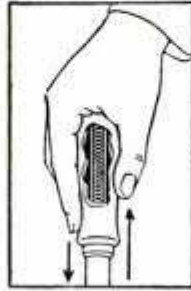

The Live Spring in the Handle makes "Yankee" No. 130-A the Quick-Return Spiral Screw-driver.



One-handed you can quickly drive (or draw) screws in tight places.

## Use "YANKEE" No. 130-A

Wherever there is a hard screw-driving job — that's where you want "Yankee" Quick-Return Spiral Ratchet Screw-driver No. 130-A. For, in any position, driving screws is surprisingly easy and speedy.

The live spring in handle keeps blade in screw slot, and brings handle back ready for the next push—without a second's loss. Just push! The Spring and "Yankee" Spiral do the work for you and save your time. The long reach prevents barked knuckles.

Right-hand Ratchet, Left-hand Ratchet and Rigid. Three sizes of bits. No. 130-A, standard size; No. 131-A, heavy pattern; No. 135, light pattern. Without the Quick-Return feature, No. 30-A, No. 31-A, No. 35.

### "YANKEE"

#### Christmas Suggestions

- No. 1530—Ratchet Hand Drill
- No. 1435—Two speed Hand Drill
- No. 41—Automatic Push Drill
- No. 1555—Ratchet Breast Drill
- No. 90 or 95—Plain Screw-drivers
- No. 1992—Vise with Swivel Base
- No. 2100—Ratchet Bit Brace
- No. 10 and 15—Ratchet Screw-drivers
- No. 130-A—Spiral Screw-driver

Dealers Everywhere Sell "Yankee" Tools

*"Yankee" on the tool you buy means the utmost in quality, efficiency and durability.*

NORTH BROS. MFG. CO.

Philadelphia, U. S. A.

# "YANKEE" TOOLS

*Make Better mechanics*



**FREE**  
"Yankee" Tool Book for all lovers of fine tools. Write for it.





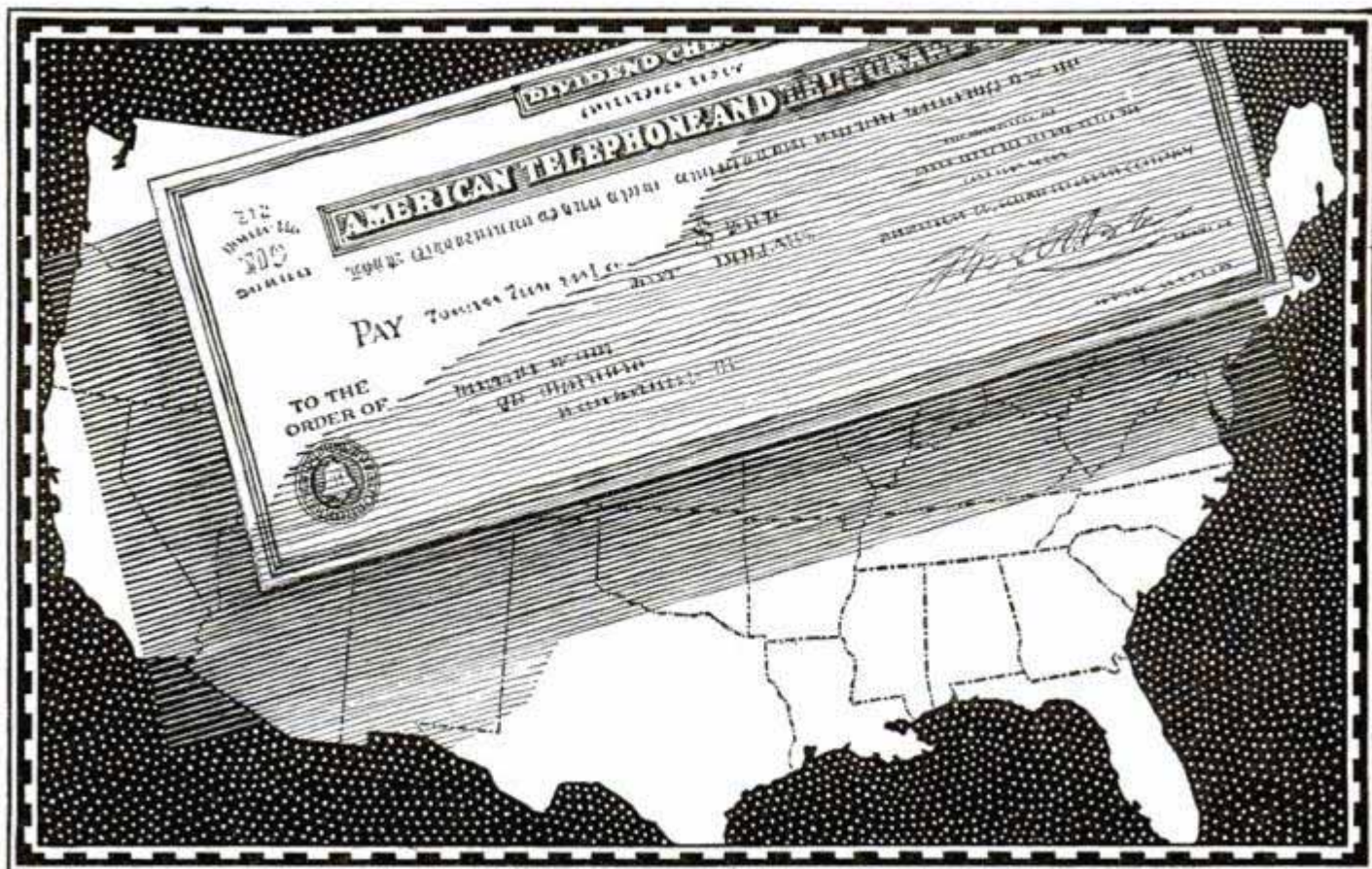

## How many are 421,000 stockholders?

*An Advertisement of the  
American Telephone and Telegraph Company*

ON OCTOBER 15th, American Telephone and Telegraph Company checks representing the 152d dividend were mailed to its 421,000 stockholders. That is the largest number of stockholders of any company in the world.

The American Telephone and Telegraph Company is owned by a great investment democracy.

Its dividend checks are cashed at banks in every state in the Union, by people representing all trades, stations and professions.



No institution is more nationally or publicly owned than the American Telephone and Telegraph Company, which in turn owns more than 91% of the common stock of the operating companies of the Bell national System. The average holding is 26 shares, and no one person owns as much as 1% of the total stock.

The Bell System was developed in the interest of telephone users and is owned by the public that it serves.



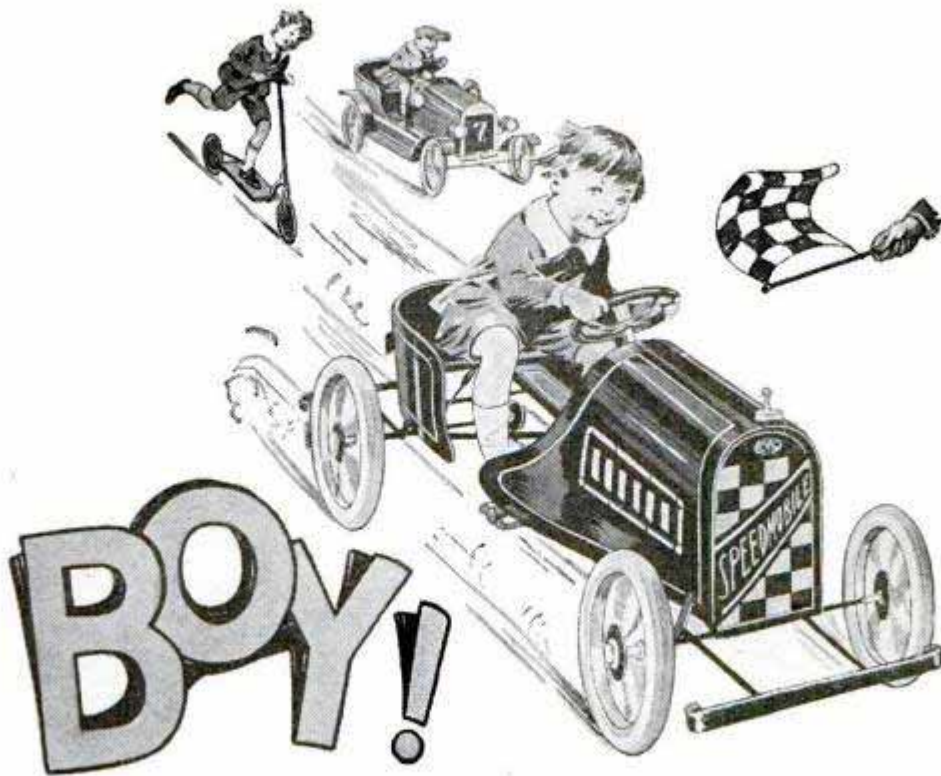

This wonderful new **SPEEDMOBILE** makes you a faster racer than you ever dreamed!

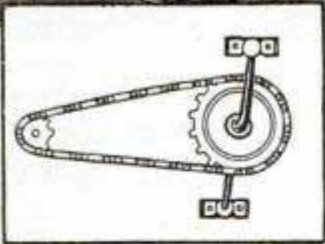
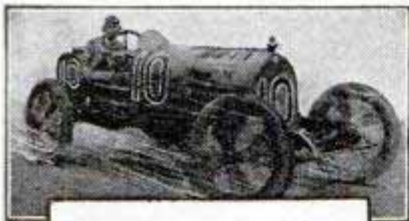

**CHAIN DRIVE**

like famous racing cars

THE new Speedmobile chain drive is the greatest improvement ever made in boys' automobiles. It has a chain sprocket like famous racing cars with bicycle-type rubber cushioned pedals. It's a cinch to win with this new snappy racer. It is adjustable for boys from 4 to 10 years old.

**YOU'LL** leave the bunch way behind when you step into this speedy little racer. The Speedmobile boy is always the envy of the neighborhood.

This shiny red speedster has real class. It is built just like an honest-to-goodness racer, slung low, balloon tires and everything. Not only is it a winner as a racer but it coasts too. Simply keep the pedals still and let 'er go! Has the famous patented "Speedorcoast" sprocket, that speeds ahead, reverses, brakes and coasts.

**SAFE because under control**

THE Speedmobile has double precautions for safety. Besides an emergency brake the boy's feet are always free to act as brakes because his legs aren't enclosed by side boards. The chain is guarded too, so he can't possibly catch his legs or clothes in it.

Send for **FREE** racing poster

THIS poster tells you all about famous races and drivers; about the "Sunbeam," the fastest car in the world; and other interesting things about automobiles. Send the coupon now for your free poster. It will tell you how to conduct a thrilling Speedmobile race yourself. Children's Vehicle Corporation, Dept. F-1, East Templeton, Mass.



**\$19.75**

West of the Mississippi  
**\$21.50**

MAIL THIS COUPON

**CHAIN  DRIVE**  
**SPEEDMOBILE**  
**"FASTEST JUNIOR BUILT"**

CHILDREN'S VEHICLE CORPORATION,  
Dept. F-1, East Templeton, Mass.

Please send me a free copy of your Racing Poster'

Name.....

Street.....

City..... State.....

I am..... years old, going on..... years.



# LIONEL - The Father

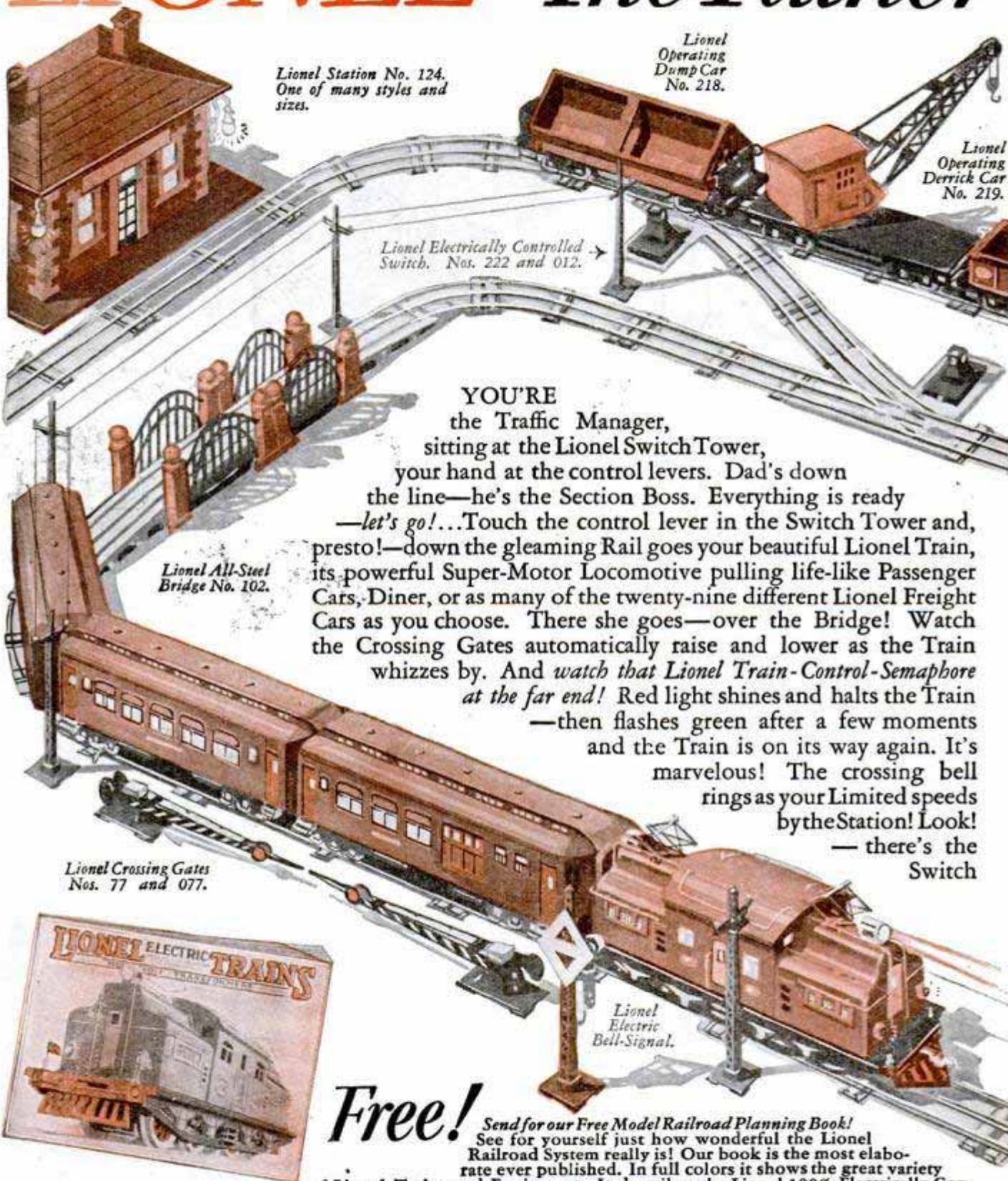

Lionel Station No. 124.  
One of many styles and sizes.

Lionel  
Operating  
Dump Car  
No. 218.

Lionel  
Operating  
Derrick Car  
No. 219.

Lionel Electrically Controlled  
Switch. Nos. 222 and 012.

Lionel All-Steel  
Bridge No. 102.

Lionel Crossing Gates  
Nos. 77 and 077.

Lionel  
Electric  
Bell-Signal.

YOU'RE  
the Traffic Manager,  
sitting at the Lionel Switch Tower,  
your hand at the control levers. Dad's down  
the line—he's the Section Boss. Everything is ready  
—let's go!... Touch the control lever in the Switch Tower and,  
presto!—down the gleaming Rail goes your beautiful Lionel Train,  
its powerful Super-Motor Locomotive pulling life-like Passenger  
Cars, Diner, or as many of the twenty-nine different Lionel Freight  
Cars as you choose. There she goes—over the Bridge! Watch  
the Crossing Gates automatically raise and lower as the Train  
whizzes by. And watch that Lionel Train-Control-Semaphore  
at the far end! Red light shines and halts the Train  
—then flashes green after a few moments  
and the Train is on its way again. It's  
marvelous! The crossing bell  
rings as your Limited speeds  
by the Station! Look!  
— there's the  
Switch

**Free!**

Send for our Free Model Railroad Planning Book!  
See for yourself just how wonderful the Lionel  
Railroad System really is! Our book is the most elabo-  
rate ever published. In full colors it shows the great variety  
of Lionel Trains and Equipment. It describes the Lionel 100% Electrically  
Controlled Railroads for "0" Gauge and "Lionel Standard" Track. This great 46-page  
book shows the supreme quality and built-in excellence of all Lionel Products.  
Sets from \$5.75 to \$300. Send for the book today!

"STANDARD OF THE WORLD SINCE 1900"

# LIONEL ELECTRIC TRAINS

MODEL RAILROAD ACCESSORIES

# "MULTIVOLT" TRANSFORMERS



# and Son Railroad

—real enough for a man to enjoy—simple enough for a boy to operate.

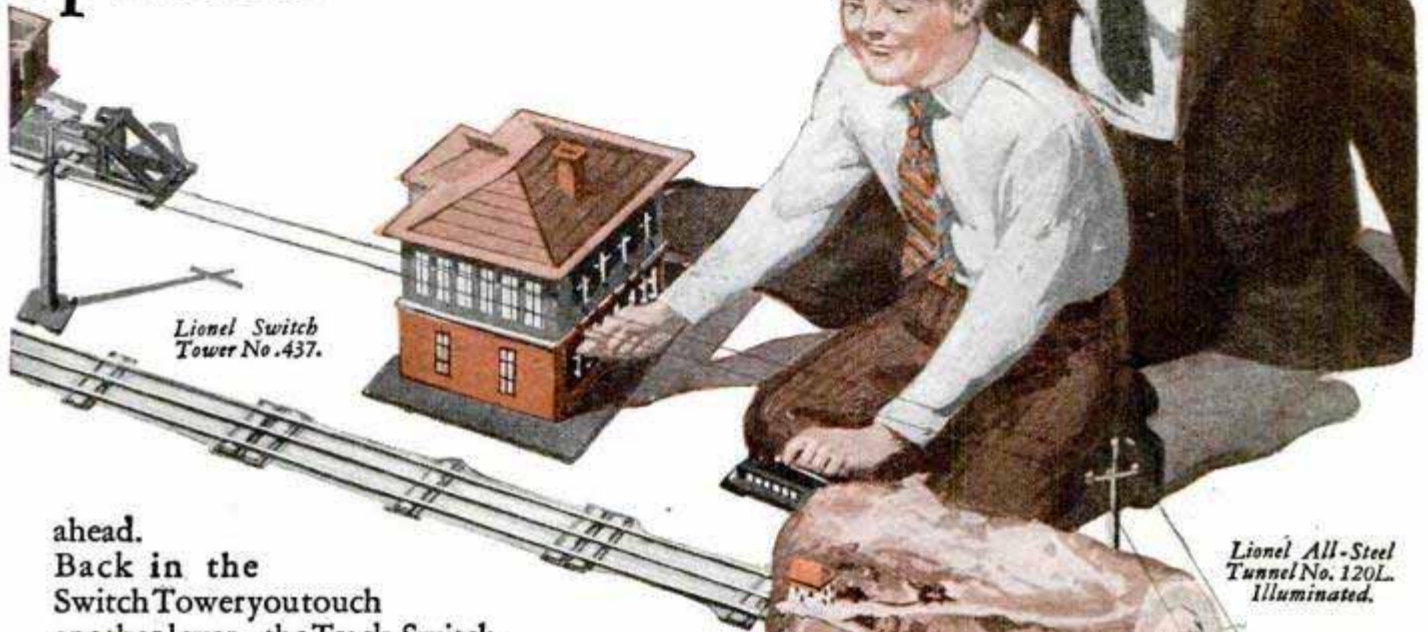

Lionel Switch Tower No. 437.

Lionel All-Steel Tunnel No. 120L. Illuminated.

ahead.

Back in the

Switch Tower you touch

another lever—the Track-Switch

is thrown, the Train glides into a Siding—

touch another lever and the Train stops. But

—wait! You are building a freight yard down

the line. You call to Dad—he couples on the new Lionel

Derrick Car with operating boom and tackle, and the new operating

Dump Car filled with sand! Again you touch a lever—your Train backs

out onto the main line. Throw the Switch again and she's off on her way!

Just think! You can do all this at any distance from the track... It's amazing

—almost magical—the way a Lionel Railroad operates. So real!—*all* the

Equipment, Locomotives, Cars, Stations, Semaphores—*everything* is real!

The only difference between Lionel Trains and real trains is the size.

See Lionel Products demonstrated at the leading department stores, toy, hardware, electrical, sporting goods and furniture stores.

## THE LIONEL CORPORATION

Dept. G

15-19 E. 26th St., New York, N.Y.

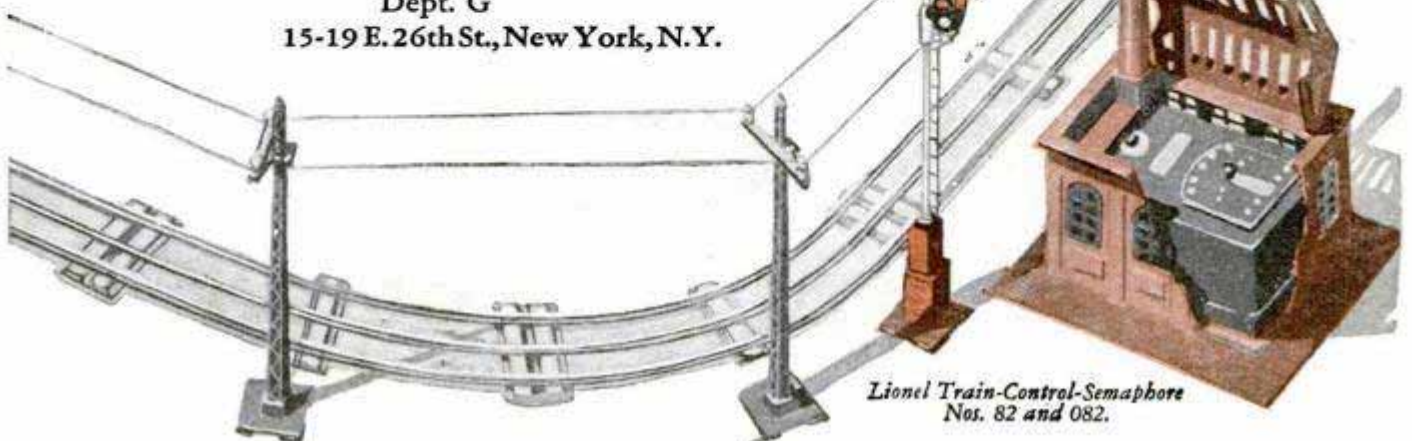

Lionel Power House Nos. 435 and 436.

Lionel Train-Control-Semaphore Nos. 82 and 082.





Set No. 904  
12 tools—oak cabinet  
Price \$15.00

## The three most important Xmas questions

They are: (1) What gift gives the most lasting pleasure? (2) What gift offers most for the money? (3) What gift is offered at a range of prices that permits selection according to the amount you wish to spend?

These three questions are answered by Stanley Tool Sets. Stanley Tools are known the country over as the

most complete line of fine wood-working tools. Stanley Catalog Sd35 shows 18 Tool Assortments costing from \$5 to \$95. Your hardware dealer has these sets or can easily get them. Ask him for Catalogs Sd35 and Sd50. If he cannot supply you write us for free copies. The Stanley Works, New Britain, Connecticut.



Set No. 907—7 tools in cardboard box—  
Price \$5.00. This set includes plans for  
making a tool cabinet.

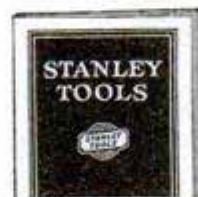

Set No. 902—20 tools—oak chest  
Price \$25.00

# STANLEY TOOLS



# Colored CORONAS FOR CHRISTMAS

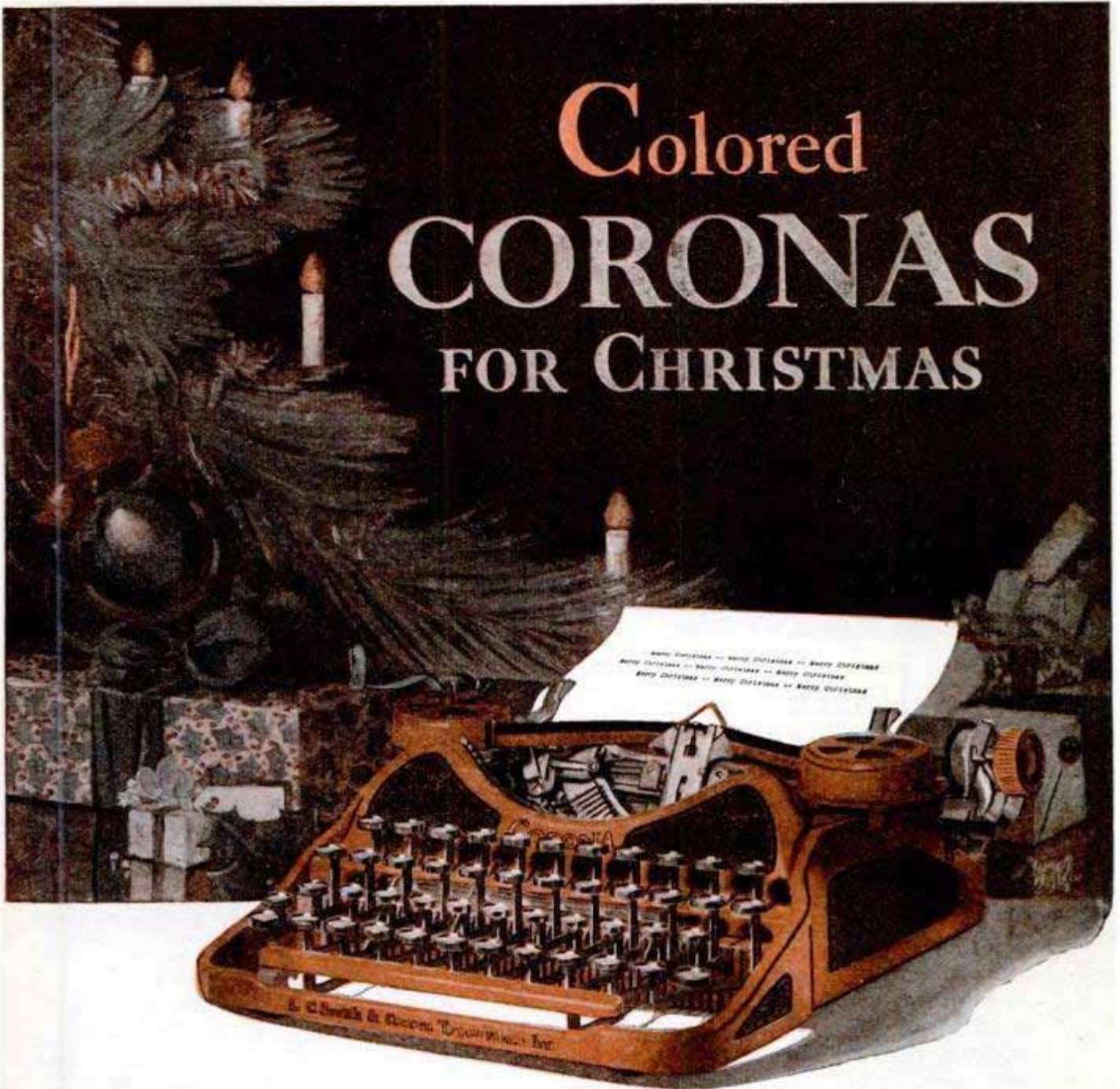

WHAT a delightful Christmas gift! Corona, the finest portable typewriter money can buy, finished in durable Duco to blend inconspicuously with the color scheme of your room, or to lend a vivid spot of contrasting color.

There is a color for every taste—red, green, maroon, blue, cream, lavender.

All metal parts not finished in Duco are either brightly nicked or given a satin finish. No care has been spared to make this the most beautiful typewriter ever built.

Write us for illustrations of Duco finished Coronas in actual color, or if convenient, stop in at the nearest Corona store.

## L C Smith & Corona Typewriters Inc

Sales offices in principal cities of the world

Established 1903

1212 E. Washington Street, Syracuse, N. Y.

Also manufacturers of the L C Smith Typewriter, the Ball-Bearing Office Machine



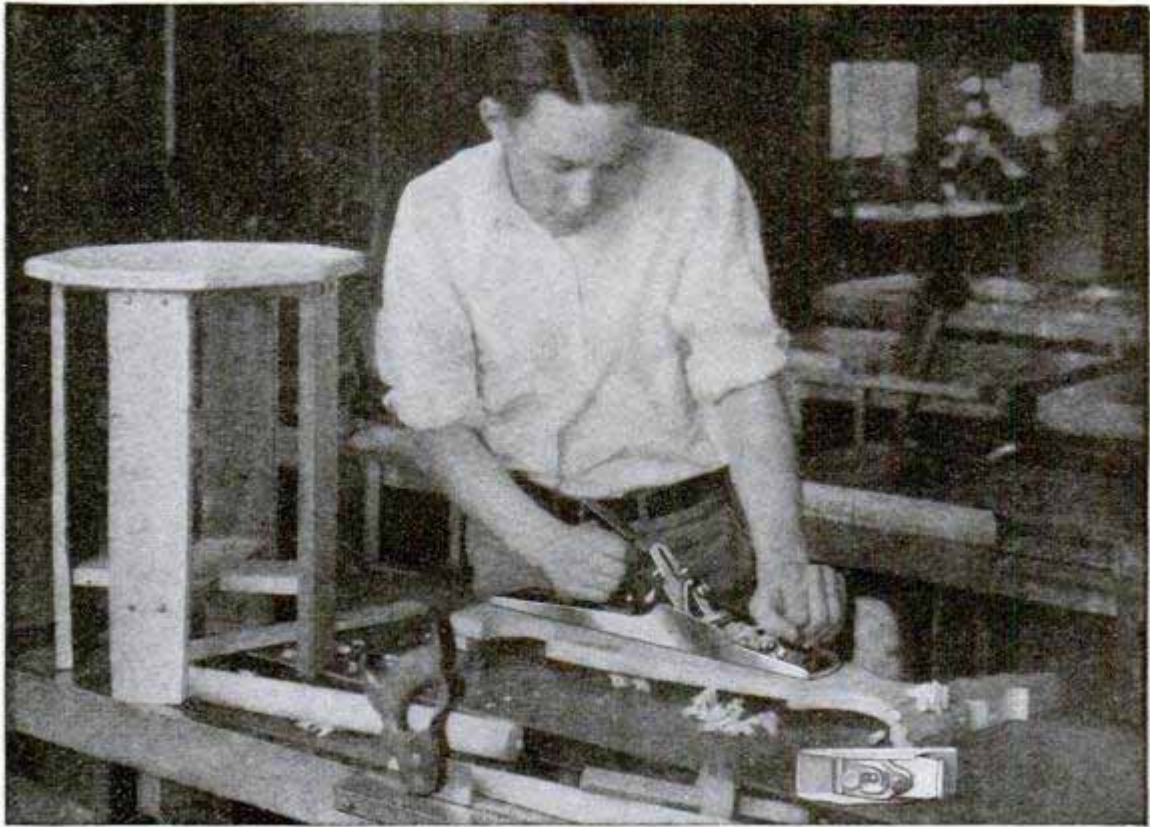

## As lean and as fleet as a greyhound—the Sargent Auto-Set

THERE'S not one gram of excess weight on the Sargent Auto-Set Bench Plane. It's the ideal tool for the home or school work bench. There's an exclusive feature which permits the chromium steel cutter to be removed, sharpened, and put back in a jiffy—right where it was, without disturbing the original adjustment. This feature is a time and trouble saver, as any of the many carpenters and wood-workers who use the modern Auto-Set will

tell you. The Auto-Set is handsome, roomy around the grips for freer handling, and lastingly built.

For the smaller jobs or for use in close quarters you couldn't own anything better than the Sargent Steel Block Plane. It is small, but mighty sturdy and dependable. Ask your dealer to show you these long-lasting economical planes and write to us for free booklet. Sargent & Company, *Manufacturers*, 49 Water Street, New Haven, Conn.

# SARGENT

## PLANES

*Sargent Steel Block  
Plane No. 5206*



*Sargent Auto-Set  
Bench Plane  
No. 714*



**30  
DAYS  
FREE  
TRIAL**

# 7 Tube Set

## Single Dial Radio



**Metrodyne  
Radio Sets**  
Are Equipped For  
**BATTERY or  
ELECTRIC  
operation**

*The* **Metrodyne**  
ONLY ONE DIAL TO TUNE

**Retail Price**  
**\$75<sup>00</sup>**  
**COMPLETELY  
ASSEMBLED**  
BIG DISCOUNTS to  
Agents and Dealers

Wonderful offer direct from the factory! The world's greatest radio! A perfect working, single dial control, 7 tube receiver! And just to prove our claims, we will ship it to your home for 30 days' free trial. Test it under all conditions. Test it for distance, volume and tonal quality—and if you are not convinced that it is the best single dial set you ever heard, return it to the factory. We don't want your money unless you are completely satisfied.

**BIG PROFITS TO  
AGENTS AND DEALERS**  
Our Agents and Dealers make big money selling Metrodyne Sets. You can work all or part time. Demonstrate the superiority of Metrodynes right in your home. Metrodyne Radios have no competition. Lowest wholesale prices. Demonstrating set on 30 days' free trial. Greatest money-making opportunity. Send coupon, letter or postal for our agent's proposition.

### Three Year Guarantee

## Metrodyne Super-Seven Radio

A single dial control, 7 tube, tuned radio frequency set. Tested and approved by Popular Science Institute of Standards, Popular Radio Laboratory, Radio News Laboratory and by America's leading Radio Engineers. Designed and built by radio experts. Only the highest quality low loss parts are used. Magnificent, two-tone walnut cabinet with beautiful, gilt metal trimmings. Very newest 1928 model.

Easiest set to operate. Only one small knob tunes in all stations. The dial is electrically lighted so that you can log stations in the dark. The volume control regulates the reception from a faint whisper to thunderous volume, 1,000 to 3,000 miles on loud speaker! The Metrodyne Super-Seven is a beautiful and efficient receiver, and we are so sure that you will be delighted with it, that we make this liberal 30 days' free trial offer. You to be the judge.



30 Days' Free Trial—3 Year Guarantee

### Metrodyne Super-Six

New 1928 model Metrodyne 6 tube, two dial, long distance tuned radio frequency receiver. Approved by leading radio engineers. Highest grade low loss parts, completely assembled in a beautiful walnut cabinet. Easy to operate. Dials easily logged. Tune in your favorite station on same dial readings every time—no guessing.

Mr. Howard, of Chicago, said: "While five Chicago broadcasting stations were on the air I tuned in seventeen out-of-town stations, including New York and San Francisco, on loud speaker, loud and clear."

We are one of the pioneers of radio. The success of Metrodyne sets is due to our liberal 30 days' free trial offer, which gives you the opportunity of trying before buying. Thousands of Metrodynes have been bought on our liberal free trial basis.

**6  
Tube Set**  
**\$48<sup>50</sup>**  
RETAIL PRICE  
Completely  
Assembled

**MAIL THIS  
COUPON**

or send a postal or letter. Get our proposition before buying a radio. Deal direct with manufacturer—SAVE MONEY—WRITE NOW!

### Mail COUPON Below!

Let us send you proof of Metrodyne quality—our 30 days' free trial offer and 3 year guarantee

MRS. WM. JEFFINGWELL, WESTFIELD, N. J., writes: "The Metrodyne Radio I bought of you is a wow! This is as good as any \$225 machine I have ever seen." N. M. GREENE, MAYWOOD, ILL., writes: "My time is up and the Metrodyne works fine. I got Havana, Cuba, Oakland, Calif., Denver, Colo., Toronto, Canada, all on the loud speaker."

J. W. WOODS, LEADVILLE, COLO., writes: "Received the 7-tube Metrodyne in fine condition. Had it up and working same day received. Was soon listening to Los Angeles, San Diego, Oakland and other California points; also St. Louis, Kansas City and other east and south stations—all coming in fine. Am more than pleased. Sure enjoying it."

We will send you hundreds of similar letters from owners who acclaim the Metrodyne as the greatest radio set in the world. A postal, letter or coupon brings complete information, testimonials, wholesale prices and our liberal 30 days' free trial offer.

**METRO ELECTRIC COMPANY**  
2161-71 N. California Ave., Dept. 45, Chicago, Illinois

**METRO ELECTRIC COMPANY**  
 2161-71 N. California Ave., Dept. 45, Chicago, Ill.  
 Gentlemen:  
 Send me full particulars about Metrodyne 6 tube and 7 tube sets and your 30 days' free trial offer.  
 Name.....  
 Address.....  
 If you are interested in AGENT'S proposition, place an "X" in the square



# What About Your

**A  
L  
C  
O  
H  
O  
L**

**This Winter  
?**



## The ZeroMeter

Takes the worry out of winter driving. A permanent instrument. Install one now!

Is a constant and accurate check upon the amount of alcohol present in the cooling system of your car. Always working.

**TOO MUCH** alcohol is sheer waste, for it evaporates out on the first mild day.

**NOT ENOUGH** alcohol means a frozen radiator and cracked cylinder block.

**JUST RIGHT** means economy and no worry,—“The ZeroMeter Way.”

The all aluminum ZeroMeter makes a handsome attachment on any car. Easily installed on the radiator hose by any one. Saves its cost in alcohol. Once installed, it can be taken apart in a moment—without affecting the water in the radiator.

—SENT ON APPROVAL—

Fill in the coupon below and get a ZeroMeter on approval. If you are not satisfied with it, your money will be refunded.

**CHRISTIE-COUSE CORPORATION**  
2928 Migel Pl., Bronx, N. Y.

Please send me a ZeroMeter on approval. I will pay the postman \$3.50 and postal charges on receipt of the Meter. I can return the Meter within 10 days and my money will be refunded.

Name .....  
Street and No.....  
City..... State.....

- (Please print)
- Sent postpaid if \$3.50 check or money order is enclosed.
- Canada, \$4.00 postpaid.



## Get Ready to Join a Harmonica Band!

**Y**ES, you can learn to play as well as the next fellow. All you need is a Hohner Harmonica, our free instruction book, and a little practice — and first thing you know, you'll be reeling off the tunes like a veteran!

Pretty soon you'll be looking round for some other chaps to join you in a harmonica band—and that's when you'll really appreciate what fun there is in being able to play this “miniature orchestra.”

There are harmonica contests, too, in which thousands of boys take part—and some mighty handsome prizes waiting for those who win!

### The NEW Way to Learn



A special orthophonic Victor Record (No. 20377) “How to Play the Harmonica” is now available for those who wish to learn by listening to the living voice of the instructor,

and following the notes as they are sounded on his harmonica. Illustrated instruction sheet also included. Reverse side reproduces “Old Black Joe” as rendered on harmonica with piano accompaniment. At all dealers selling Victor Records . . . . complete 73c

### FREE Instruction Book

Anyone can learn to play the harmonica by following the clear, simple, illustrated instructions given in our booklet “How to Play the Harmonica.” Free at your dealer's — or write to M. Hohner, Inc., Dept. 508, 114 East 16th Street, New York.





Your dealer has a full line of Dorfan wide and narrow gauge trains, bridges, tunnels, semaphores, tracks, switches and stations. Be sure you see them all today.

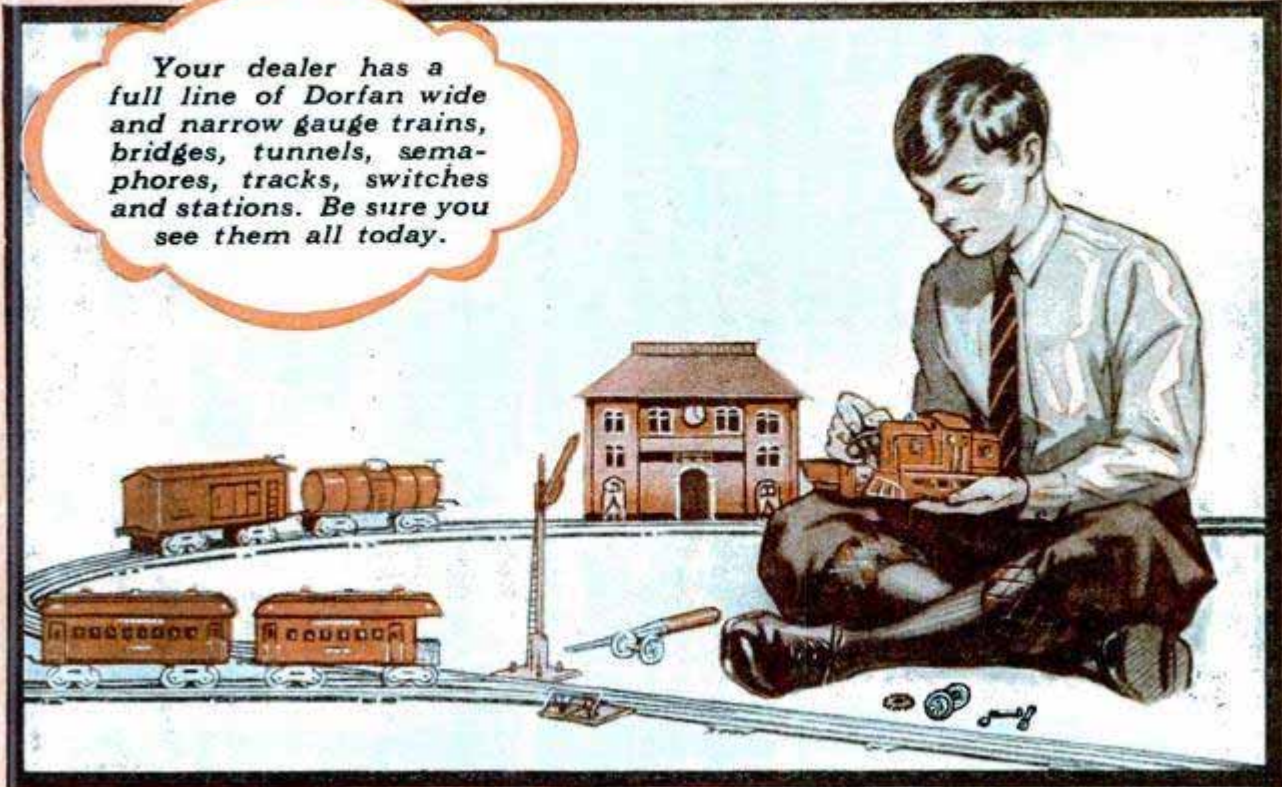

## The Only Electric Engine You Can Take Apart and Rebuild

It's a Dorfan Loco-Builder—the fastest and most powerful electric engine made. Think of the fun there is in being able to take apart your engine and put it together again! How this develops skill and a genius for things mechanical and electrical. This "Take-apart" feature is found only

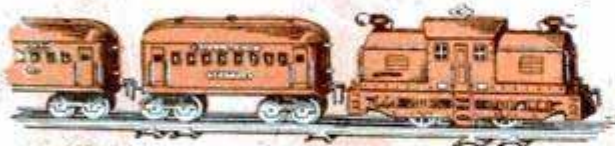

in Dorfan electric engines. Dorfan engines and trains are handsome and powerful—copies of famous transcontinental flyers! Thousands of American boys say—"there's no train like the Dorfan!" Priced from \$6.00 to \$38.50.

Ask your dealer today for a catalog. If he does not have the new catalogs yet, send us his name and he will receive a supply for you and your friends. **THE DORFAN COMPANY, 137 Jackson Street, Newark, New Jersey.**

# DORFAN

TAKE-APART ENGINES

ELECTRIC TRAINS





# IF YOU CAN USE AN EXTRA \$20.00 BILL

write for this

# FREE BOOK



You can save \$20.00 in no time by using

## SMOOTH-ON No. 1

to do your own household repairing—and in addition you will have that proud "I-did-it-myself" feeling.

Here is what one enthusiast did with two 35 cent cans:—A \$25 lamp stand loose in base, two big leaks in heating furnace smoke pipe, loose hammer handle, and three loose hooks in tiled bath room wall were all put into good usable condition at an average cost of 10 cents each for the seven repairs—and \$20.00 easily saved over what would have been paid to professional fixers or for new parts.

By using Smooth-On to make dozens of the simple repairs necessary in every home, you can save enough to pay your radio upkeep, buy yourself or your wife a camera, a bull pup or some other pleasure-giving article that you would otherwise hate to spend the money for.

The free Smooth-On Repair Book will show you how an astonishing number of home and automobile repairs are as easy for you to make as for somebody else, also how you can make cellar walls, concrete floors, etc., water and damp proof with Smooth-On No. 7.



Mail the coupon for a free copy and get Smooth-On No. 1 in 7-ounce or 1 or 5-pound can from any hardware store.

**SMOOTH-ON MFG. CO.**  
Dept. 37, 574 Communipaw Ave.  
JERSEY CITY, N. J.

Do it with **SMOOTH-ON**

SMOOTH-ON MFG. CO., Dept. 37,  
574 Communipaw Ave., Jersey City, N. J.

Please send the free Smooth-On Repair Book.

Name.....

Address.. ..

12 **Return this coupon for a**  
27 **FREE copy of Booklet**



**Ranks High!**



## New Model Pocket Ben

The New Model Pocket Ben ranks high among good watches. That's because it combines good looks with correct time-keeping.

Sold everywhere for \$1.50. With night-and-day dial \$2.25.

*Built by the makers of Big Ben and other Westclox*

**WESTERN CLOCK COMPANY**  
La Salle, Illinois





*Delta*  
Handi-Shop

Here is the workshop you have been waiting for! The DELTA Handi-Shop, a practical outfit for practical work. Big, sturdy, oversize attachments and accessories, and plenty of them. A trial will prove its true value.



# Dry-Permanent! Radio Power!



No Acids, Liquids  
or Charging Bulbs

Maximum Attention!





The famous New Model "American Giant" Scroll saw, 12-inch throat cuts up to 1 1/2-inch thick. (Patented August 21, 1923.) Table tilts 45 degrees to left, 15 degrees to right.

Cutting groove with dado head, either straight or at an angle, with table raised for depth of cut. It's easy with the Delta Handy-Shop.

Cutting a 1-inch by 12-inch board at an angle. No interference, floor and ceiling are only limits to length of board handled.



Sanding proper draft on pattern, and sizing and squaring electrotype—two of the many possible operations with this attachment.



Showing special frame for holding real fine jewelers blade for delicate marquetry, jewelers or inlay work. Takes standard 5-inch long jewelers blades. Note table is tilted fully 45 degrees to the left. Blade is always securely supported by hardened guide underneath table, an exclusive Delta feature.



Showing small flexible shaft attachment. Note the delicate work possible. Uses standard burrs, easily obtainable everywhere.

# Different? SURE! - Here's Why-

**W**E set out to produce a really practical and efficient work shop. After long and careful study and experimenting, we scrapped all of the old, conventional designs and ideas, and decided upon using a sturdy, quiet-running motor of special design, with two shaft extensions—right there we had a valuable feature that offered unusual, and practically unlimited possibilities.

While the much-used Circular Saw is driven from one shaft, the Lathe, with its many attachments, can be driven from the other shaft. There are always two tools ready for work and easily controlled by a conveniently placed switch. Simply throw off the Special Rubber V-belt and the saw is disconnected. In a jiffy any one of the many full-sized, sturdy, practical accessories is in place and you are ready to go. Simple, isn't it? You never saw anything so easy—so quick—so convenient as the interchanging of attachments. You must try it to thoroughly appreciate its many advantages—its outstanding superiority.

The Delta Handy-Shop consists of the following—all specially designed—all sturdily built from the finest materials obtainable.

**MOTOR**—Specially designed 1/4 H. P. fully enclosed, 1750 R. P. M., constant speed, with two shafts.

**LATHE**—has capacity of 9-inch diameter by 24 inches. (Can be furnished up to 36 inches at small additional cost.) Steel bed of 4-inch U-Section—will not chatter or spring. Ballbearing Tailstock, 4-inch face plate, spur center, cup center, and wide and narrow tool supports.

**Lathe Attachments**—6-inch diameter, fast-cutting emery wheel, adapter flange, 6-inch buffer, 5-inch wire brush, all of finest quality—all oversize. 3/4-inch capacity Jacobs chuck that fits both motor and tailstock spindles; two turning tools.

**Sanding Attachment**—8 1/2-inch diameter "Man Size" sanding disc. Takes standard sheet of sand paper. Novel design sanding table 5-inch by 12-inch, tilts 45 degrees down, 10 degrees up. An exceptionally valuable and useful attachment, quickly attached and easily adjusted.

**Flexible Shaft**—Can be furnished in two sizes, with hand pieces to take standard burrs. Ideal for carving, metal pattern and die work, etc.

Make these beautiful things, and hundreds of others; there is practically no limit to the work the DELTA HANDI-SHOP will do.

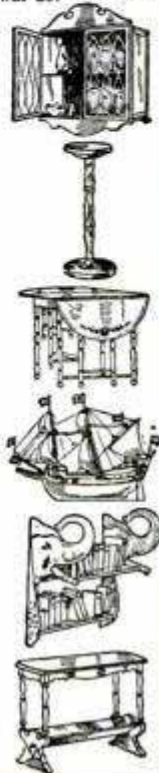

## NOW—Give Yourself a Treat!

Make all those wonderful, attractive things you want around the house. Develop your ideas and inventions. Get started in business—earn money on full or spare time. Let the DELTA HANDI-SHOP be your never-failing and faithful servant. Lack of space does not permit a full description here, so act now—send for it and judge for yourself.

## 10 Days FREE Trial

A small down payment brings this complete workshop to you. Use it. Do those unusual things that only Delta Handy-Shop can do. You can do even the simple things easier and quicker, too. Let us send you our beautiful, illustrated folder that describes in detail every novel feature of the DELTA HANDI-SHOP. See how much you get for so modest an outlay of money.

## Mail Coupon NOW!

## FREE Blue Prints

DELTA SPECIALTY CO.

Dept. MP-1227—858 3rd St., Milwaukee, Wis.

Send me your illustrated color folder describing Delta Handy-Shop. Tell me about your Free Trial offer and easy payment plan.

Name.....

Street Address.....

City..... State.....



**KUPROX "A" TRANSIFIERS**—Batteryless, noiseless, electric "A" power. Dry, dependable, needs no attention. Operates any receiver. 4-volt or 6-volt, \$28.50 and up.



**KUPROX A & B TRANSIFIERS**—All radio power from a single unit. Controlled from set switch. Absolutely dry, requires no attention. \$57.50 and up.



**KUPROX "B" TRANSIFIERS** — Dry, permanent, free of hum. Guaranteed voltage at rated output. Models for all sets and circuits, \$14.50 and up.

**KUPROX Radio Power Devices** make any set entirely electric!

Now, no more of the bother and worry of batteries ... none of the troublesome watering and attention. KUPROX is absolutely dry ... all metal ... it requires no watching or watering ... no attention of any kind. Simply install KUPROX Radio Power Devices on

your set and forget them. A mere snap of a switch gives you all the power you need without a bother of any kind.

Your radio dealer has the complete line of KUPROX dry Power Devices, from trickle chargers to the mighty A & B Combination Models that supply all radio power from a single compact unit.

**{ FREE BOOKLET FOR YOU: "The Secret of Successful Battery Elimination," describing KUPROX Devices, will be mailed free on request. Write for it. }**

**THE KODEL RADIO CORPORATION, 517 E. Pearl St., Cincinnati, O.**

# KUPROX

## RADIO POWER DEVICES



**KUPROX REPLACEMENT UNIT**—For replacing the acid jar on all standard trickle chargers and power units. Eliminates all watering and attention. \$4.50.



**KUPROX TRICKLE CHARGERS** — Absolutely dry; 1-amp. rate. Large model gives 2½-amp. booster charge. \$10.50 and \$18.50.



# BUILD YOUR OWN SHIP MODEL

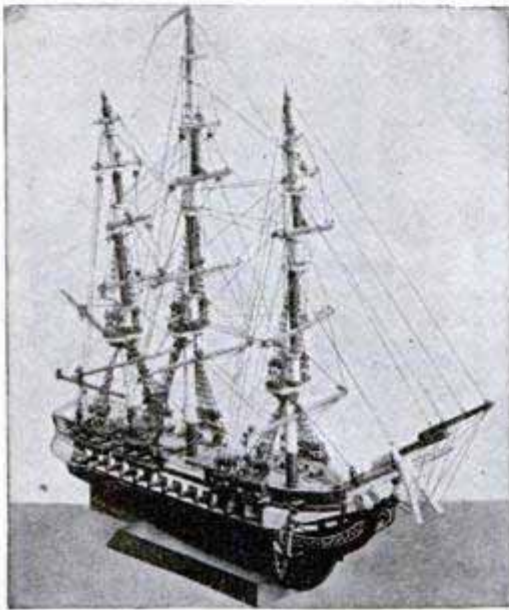

**CONSTITUTION**

Size: 30' high; 32' long; 10' wide (overall)

We will supply the parts for the Constitution (Old Ironsides) cut to fit and ready to assemble for \$6.98. This price includes every part necessary for constructing the complete model. Full instructions for assembling Old Ironsides are included with each kit. A diagram of parts, showing the number of the parts and just exactly how to piece together the model, make it impossible for you to make a mistake. Other beautiful ship models can be built from our cut to fit and ready to assemble parts. We have kits for the Santa Maria, the La Pinta and the Mayflower at \$4.98 each.

*You can build a beautiful Ship Model as low as \$4.98 or a Loud Speaker Ship Model for \$12.50 with your own hands in a few hours of pleasant pastime from parts, cut to fit and ready to assemble, supplied by the largest builders of ship models in the world.*

A fifteen year old school boy won first prize in a model building contest with a Constitution model built from our kit of parts. More than 1,000 models were entered in this contest.

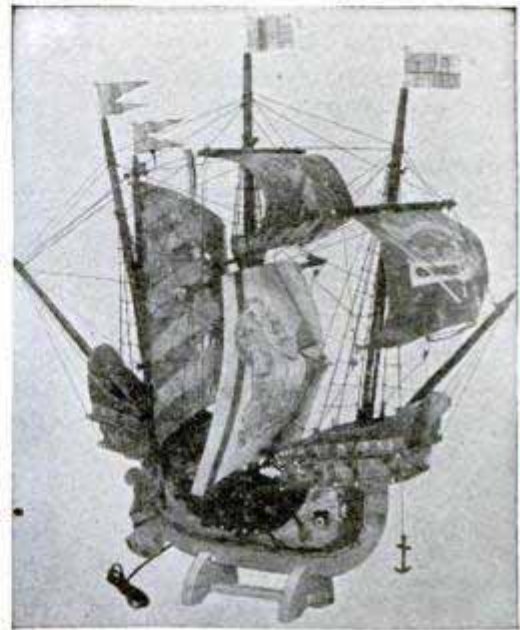

**LA PINTA**

A Ship Model Loud Speaker. Size: 26' high; 27' long; 12' wide (overall)

This is the most beautiful loud speaker on the market. We will supply you with all parts necessary and complete instructions for building this beautiful loud speaker ship model. The price of \$12.50 also includes the melody sail and loud speaker unit. The unit is of the Electro Magnet type and does not require power amplification to bring out the low notes as it gives faithful reproduction at all frequencies. The mainmast is deeply imbedded in the solid wood hull and the unit is attached to this mast, making it impossible for counter-vibrations to affect reproduction.

## A Useful and Ornamental Home Decoration

No doubt you have often admired ship models and yearned to possess one but could not do so because the price was too high. Let the WORLD'S LARGEST BUILDERS OF SHIP MODELS AND SHIP MODEL LOUD SPEAKERS supply you with all the necessary parts, cut to fit and ready to assemble from which you can build a beautiful model.

You need not know anything about ship building or carpenter work in order to build one of these ships. No special knowledge of ship model building is necessary either. We will supply all the parts, from the hull down to the smallest piece, all cut to fit and ready to assemble. You cannot go wrong. Diagrams and plans of parts that are included with each kit tell exactly what to do with each part.

These plans show you step by step just how the model is constructed. Everything is made so simple that even a small child can build a beautiful model.

All you need is a small hammer to tap the parts into place. Here is a part of the instructions copied word for word from the diagram and instruction sheet that goes with the kits. "Take part No. 57, place it in front end of part No. 56 and tap lightly with a hammer. Next take part No. 58 and place it up against No. 57 and tap it with a hammer to bring it into place."

Easy! Nothing simpler. The instructions are like that from beginning to end. Do this and that and before you realize it a beautiful ship model has grown before your eyes.

Write for our free, beautifully illustrated catalog, which contains photographs of all our models together with complete details and price of each. We will send this catalog without obligation to you. Fill in the coupon below and we will act upon it immediately.

**If, after assembling the model according to our instructions, you do not think it worth many times the purchase price, return it to us in good condition and we will gladly refund your money.**

MINIATURE SHIP MODELS, INC., DEPT. P3  
3818-20-22-24 Baring St., Phila., Pa.

Please send me complete parts, cut to fit and ready to assemble for the Constitution, \$6.98 ; Santa Maria, \$4.98 ; La Pinta, \$4.98 ; Mayflower, \$4.98 ; Melody Ships: La Pinta, \$12.50 ; Santa Maria, \$12.50 ; Mayflower, \$12.50 . I will pay postman purchase price plus postage (a few cents). Check which model you want shipped.

PLEASE PRINT NAME AND ADDRESS PLAINLY

Name.....  
Street or R. F. D.....  
City.....  
State.....

**MINIATURE SHIP MODELS, Inc.**  
3818-20-22-24 Baring St., Philadelphia, Pa.

Canadian Branch: 1485 Bleury St., Montreal, Canada

Canadian Prices Slightly Higher. Send all Canadian Orders to Canadian Office



# BUY AT WHOLESALE PRICES

## AGENTS MAKING \$100 PER WEEK

### Selling Our Guaranteed Spors Pens and Other Specialties

The special polished points and sponge in cap make the points write as smooth as a lead pencil, looks and writes like a \$7 pen. Cannot blot or clog, ideal ruling pen. No dull season. Money refunded if not pleased.

### PROSPECTS WORTH \$15 A DAY TO YOU!

Business men, students, professional men, stenographers, teachers, merchants, salesmen, farmers, bookkeepers, and express agents, in fact anybody that writes, is a prospect.

**SELLS FOR \$1.25**

**AGENT'S SAMPLE 65¢**

IDEAL XMAS GIFT, COMES IN HOLLY BOX

# FREE

Handsome roll, pen case with your first order of \$6.42 worth of our famous Spors pens.

The pens come in 8 assorted colors, ladies' or men's style.

SIZE 66 x 80

RETAIL PRICE \$3.45  
WHOLESALE SAMPLE \$2.45

## PART WOOL INDIAN DESIGN BLANKET

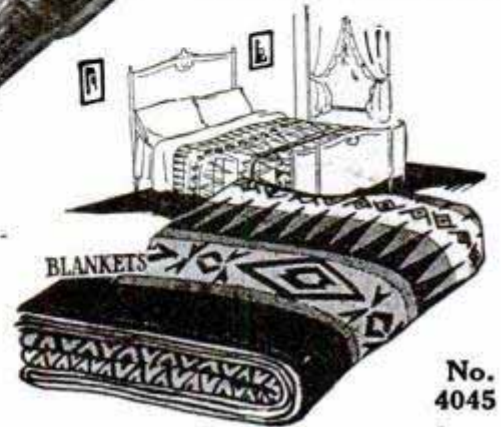

No. 4045

## PLIERS

No. 311. Drop forged steel.  
RETAIL PRICE 35¢.  
WHOLESALE SAMPLE 20¢



## Indestructible La Patee Pearls



No. 55P. PEARL CHOKER with Silver Clasp, without box. Retail price 50c. Wholesale price, Sample 19c, dozen \$1.95.

MEN'S DRESS SHIRT. No. D87. Retail price \$1.48. Wholesale Sample 98c.

MEN'S HOSE. No. 260. Retail price 55c. Wholesale Sample pr. 29c. Dozen \$3.45.

DANCING RABBIT. No. 125. Retail price 35c. Wholesale Sample 19c. Dozen \$1.98.

# F. SPORS & CO.

1027 Main St.

Le Sueur Center, Minn.

**FREE!** UPON REQUEST this large wholesale specialty catalog, showing over 300 fast selling specialties, from many parts of the world.

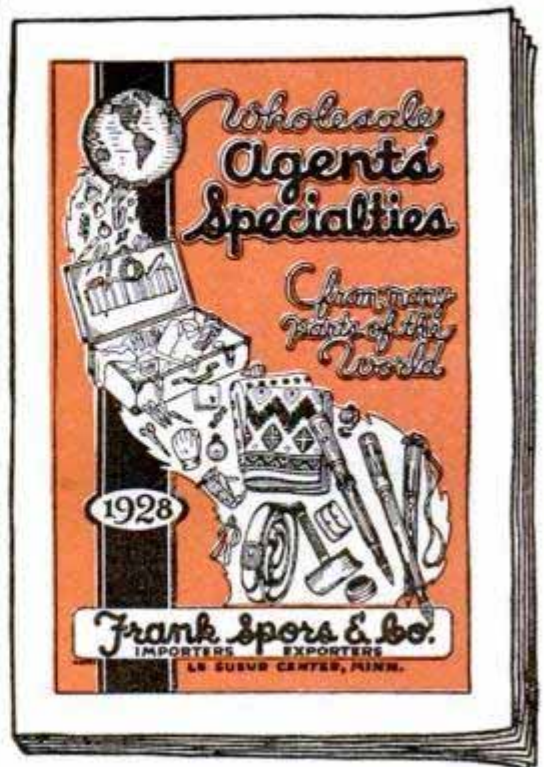



*Hello boys!*

Send for this free book which tells all about my **NEW 1927 ERECTOR**

*with these sensational new features*

- 1-Complete Unit Control (New assembled Trumodel Construction equipment parts)
- 2-New Erector Trumodel 3 Drum Hoist
- 3-New Erector Trumodel Tip Bucket
- 4-New Erector Trumodel Clam Shell Bucket

- 5-A great assortment of New Feature Parts
- 6-Erector Complete Unit Accessory Sets
- 7-Udyline — the rust-proof finish (some parts)
- 8-The new Brass Perfect Gear standardization

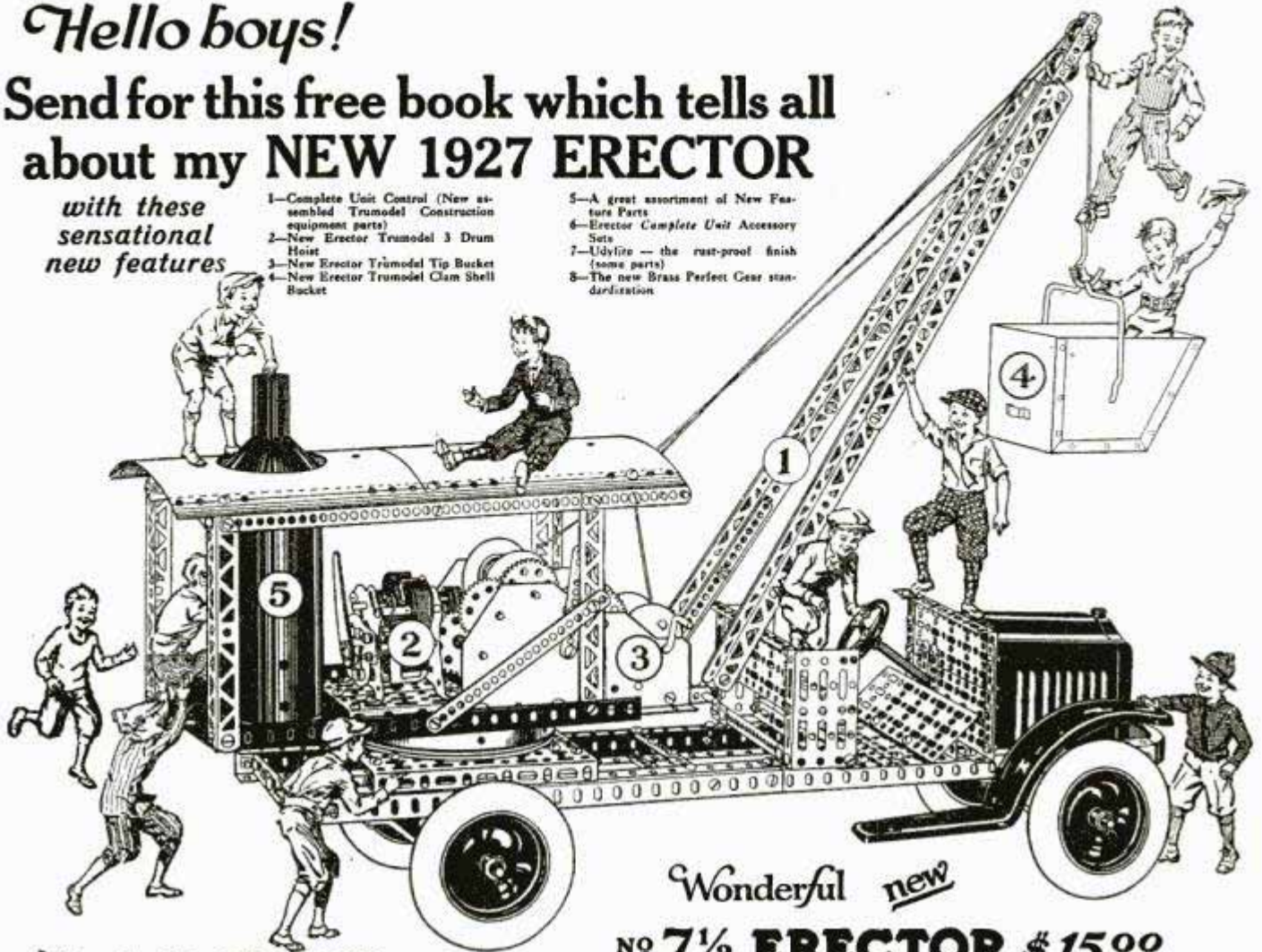

*Why the New ERECTOR is the world's greatest toy*

**Trumodel Features:**

- 1 ERECTOR SQUARE GIRDER.** This big, exclusive Erector feature makes Erector so sturdy and strong. They are real girders just like engineers use in making skyscrapers and bridges. (In all Erector Sets.)
- 2 ERECTOR MOTOR.** You can make 27 interesting experiments with the Erector Motor alone. The motor shaft is the same diameter as all other shafts. You can hitch pulleys to both sides of the motor. (In the Famous No. 4 Erector and up.)
- 3 3-DRUM HOIST.** Completely assembled operating unit. New exclusive Erector feature. (In the No. 8 Erector and up.)
- 4 TIP BUCKET.** An exclusive Erector feature. (In the No. 8 and up.)
- 5 ERECTOR STEAM BOILER.** There is no end to the models that this exclusive Erector feature makes possible. Hoisting engine, steamboats, fire engine, horizontal engine, locomotives. The Erector motor furnishes power to make these models go. (In the Super No. 7 and up.)



Wonderful *new*  
**No 7 1/2 ERECTOR \$15 00**  
 With Automobile Chassis

Here's the set I know will give you the greatest thrill you ever had. Fun! Oh, Boy! It's the real thing, and there's a thrill packed in every one of its 627 parts. Boys, in this great outfit there are hours of real sport waiting for you building automotive models. From this great assortment of distinctive, important and feature Erector parts you can build 554 models—wonderful automobile chassis, tractors, scooters, service cars, fire engines, hook and ladder, are only a few. Packed in a cabinet and includes a complete assortment of automotive parts, many in color; also a 92-page manual, powerful electric motor, big red steel disc wheels with oversize balloon tires, fenders, radiator hood, bumper, springs, steering wheel, truck body, heavy truck axles, cab top, boiler, digger scoop—in fact, everything to make this set a world's standard.

**Boys! Here's the greatest book I ever compiled**

In this book you will find the final story of my years of experience since I first invented Erector—the construction set which other engineers have been kind enough to call "the world's greatest toy"—and which they consider one of the most astonishing mechanical phenomena of the age.

In this book I tell you how with Erector's new Construction Parts you can build and operate (one after the other) over 1000 actual working models of Aeroplanes, Submarines, Ocean liners, Light houses, Machine guns, Automobiles, Ship cranes, Trains, Steam shovels, Traveling crane, Wrecking hoist, Trench diggers, Locomotives, Hoisting derricks, Cantilever bridges, Suspension bridges, Well drillers, Power plants and Hoisting engines.

Think what a thrill you'll get making these wonderful working models while and hum with the powerful Erector electric motor. The day you get your Erector (Christmas or any other day) will be the biggest of your life. Send for my new book "Engineering Thrills" today and then tell your Dad. Don't miss this chance. Make him realize what you really want by showing him the book and then taking him to the nearest toy store to see for himself. He'll want to build models with Erector too. Just fill out the coupon below.

*A.C. Gilbert*

THE A. C. GILBERT COMPANY,  
 210 Blatchley Avenue, New Haven, Conn.

Please send me free my copy of the book "ENGINEERING THRILLS."

Name .....

Street .....

City ..... State .....

Send for it—  
**FREE**



**Other Erector Features**

- 1** Erector contains more parts and builds more models than any other construction toy.
- 2** The New Erector Steam Shovel—an exclusive Erector feature. (In Super Erector No. 7 and up.)
- 3** The New Erector Dredge Bucket—an exclusive Erector feature. (In the New No. 10.)
- 4** Curved Erector Girders. An exclusive Erector feature. (In all sets.)
- 5** Giant Fly Wheel. An exclusive Erector feature. (In the No. 10 set.)
- 6** Perforated Strips — four holes to the inch
- 7** New brass perfect gear standardization. The New Erector contains a great assortment of brass and die-cast gears, including pinion, crown gears, flat gears, mitre gears, and a large 72-tooth gear.

**ERECTOR**

Buy one today—At all stores where toys are shown



*Make this a Musical Christmas*  
THIS YEAR  
with  
**PAN AMERICAN**

This Christmas—your boy, your girl, or yourself—would prize a PAN-AMERICAN trumpet, clarinet, saxophone or other wind instrument. Order now a PAN-AMERICAN, which leads the world in medium-priced, factory guaranteed band and orchestra instruments. You can learn to play a PAN-AMERICAN in three lessons. Free trial offer from now to Christmas. Easy payment plan. Send coupon today for beautifully illustrated catalog.

**Send No Money—Mail Coupon**

**Pan-American Band Instrument & Case Company**  
Dept. G-13, Elkhart, Indiana

Send me PAN-AMERICAN catalog of medium-priced band and orchestra instruments by return mail. I am interested in (Name instrument here).....

Name.....

Street or R.F.D. Address.....

City..... State.....

**This New Book Will Save You \$100.00**

This new Hi-Q Construction-Manual shows you how simply you can save at least \$100, or how easily and quickly you can make large profits through building the advanced CUSTOM-BUILT "Hi-Q Six"—the new receiver that is astonishing experts with its remarkable performance. Prepared by ten of America's leading manufacturers, this 48-page comprehensive manual gives you practical, thorough and com-

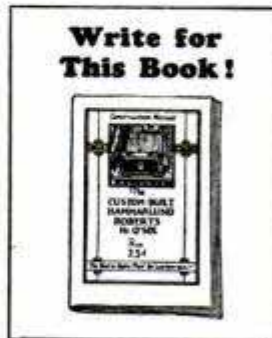

**Hammarlund ROBERTS Hi-Q SIX**

plete instructions with charts, diagrams, photos and A. B. C. descriptions. Also includes full instructions for building the Hi-Q Power Supply Unit. Used with equal success by professionals and novices alike. If you want to save at least \$100 on your own set or if you want to make big profits building the nationally-advertised Hi-Q Six CUSTOM-BUILT receiver, send 25c immediately before first edition is exhausted.

**Associate Manufacturers**

- |                  |                         |                          |
|------------------|-------------------------|--------------------------|
| Carter Radio Co. | Hammarlund Mfg. Co.     | International Resistance |
| Samson Elec. Co. | Benjamin Elec. Mfg. Co. | Co. (Durham Resistors)   |
| Sagamo Elec. Co. | Acme Wire Co. (Parvot)  | Radical Co. (Amperite)   |
| Yasley Mfg. Co.  | H. H. Eby Mfg. Co.      | Westinghouse Micarta     |

**Hammarlund-Roberts, Inc., 1182-X Broadway, New York City**

**THIS 100 PAGE RADIO CATALOG FREE**

Contains "Hook Ups" 75 Radio 500 Illustrations Over 1,000 Articles

*"Build your own with 'RASCO' Parts"*

**RADIO SPECIALTY CO., 98 E Park Place, New York, N. Y.**

**Sport Express**

Make a utility express out of your Ford chassis at a small cost.

Write for circular E-1 showing this and other models.

**SPORT FACTORIES, Aurora, Illinois**

**CAN YOU SELL GAS at 5c PER GAL.?**

If so write me quick. My Distributors make as high as \$3,000.00 per month. Let me show you how.

**SEND FOR FREE TRIAL**

Proof of astounding success and my \$15.00 a day Guarantee to Distributors.

**Frank Andrews, Dept. 805-T, 154 E. Erie St., Chicago, Ill.**

**The Super-Elto** **WRITE FOR CATALOG!**

Address Dept. AA

**ELTO OUTBOARD MOTOR CO., MILWAUKEE**

**Fansteel Products Company, Inc.**  
North Chicago, Illinois

**No. 6132**

**\$25**

This Reg. Trade Mark guarantees you genuine diamonds

**SEND NO MONEY**  
*Genuine Full Cut Diamonds—No Chips*

**Terms: 6 Months to Pay**

**No. 6132.** Solid Gold Men's Initial or Emblem Ring. 2 Genuine Diamonds 4-100 each. 14-Kt. White Gold Top. Emblem (any lodge) or any initial (Old English) Yellow or White Gold Inlaid in Genuine **Hope Ruby or Black Onyx**. Mention if desired in solid White Gold or Green Gold, same price.

**No. 6746.** Genuine Double Head Cameo (raised hand carved heads); 1-piece stone. **Heavy Shank** in White Solid Gold or Green Gold. Genuine Stone—onyx, nicely shaded. Send number of ring, size of finger, initial or emblem desired, and ring will be sent for inspection.

**BUFFALO JEWELRY MFG. CO., "The Mail Order House"**  
Dept. P (or at your Jeweler's)  
**501 Washington St. BUFFALO, N. Y.**

**No. 6746** **\$24**

Exact size of ring.

*Ask for Free Jewelry Catalog*



# BIG-NEW SpeedWay Shop

only \$10<sup>00</sup> down

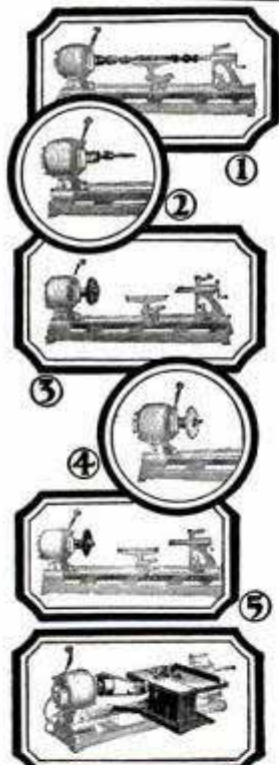
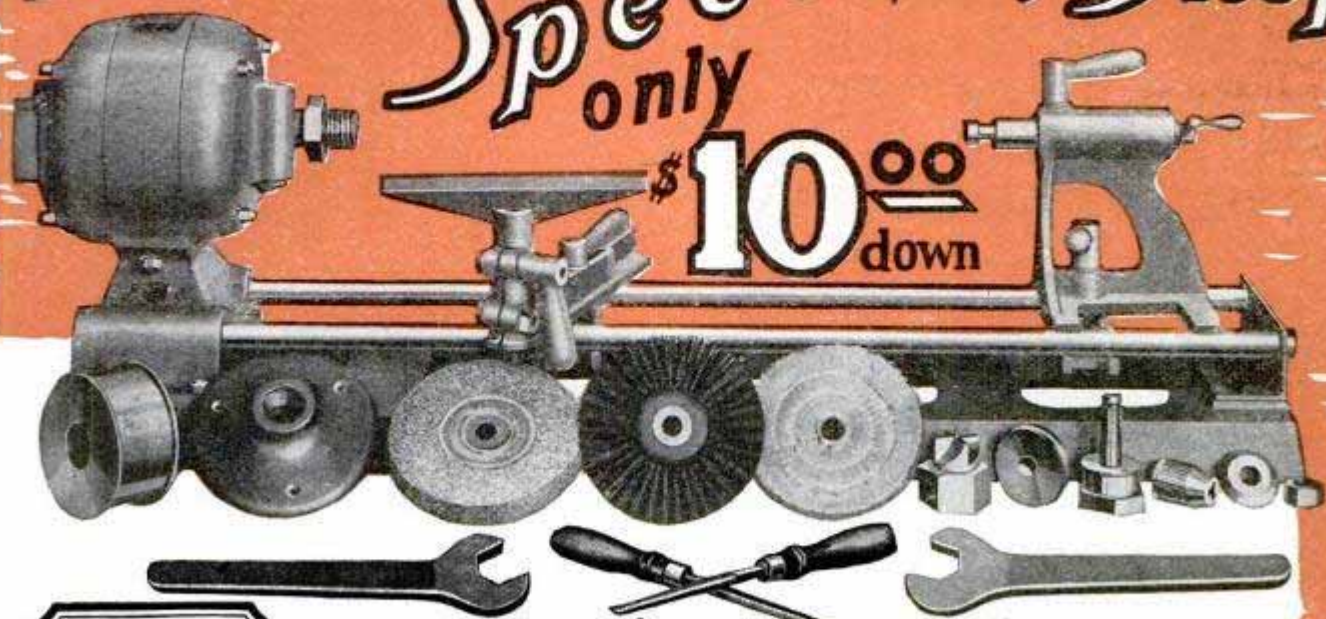

## Completely Motorizes Your Work Bench

A big, efficient, practical workshop for regular commercial or home use; operates from any lamp socket. The kind used by carpenters, small manufacturers, machine shops, home craftsmen—yet costs no more. Contains—

### Seven Heavy Motor Driven Tools

- 1—Motor Driven Lathe on heavy cast iron base; takes up to 10 in. diameter and 18 in. length.
- 2—SpeedWay Bench Drill, 1/4 in. in steel or 1/2 in. in wood.
- 3—Bench Saw with 6 in. blade; rips, cross-cuts, mitres, grooves.
- 4—Patternmakers' Jig Saw with 10 in. throat.
- 5—Motor Driven Grinder, 5 in. emery wheel.
- 6—6 in. Metal Scratch Brush.
- 7—6 in. Buffer and Polishing Wheel.

All necessary parts supplied, including two chisels, jig-saw blades, etc.

### 10 Days' Free in Your Own Home! Have Fun or Make Money

To work with the Super SpeedWay Shop is fascinating! Intriguing! Profitable, too. You can make almost anything—attractive, odd furniture, toys, home and garden improvements, radio manufacturing, consoles, bric-a-brac, book shelves—countless useful articles which will bring you an easy, neat profit.

### \$10.00 Down! Pay While You Use It

Our terms are very liberal—we want every man who can use a SpeedWay to order it for 10 Days' Free Trial in his own shop. If you like it you pay the balance a little at a time.

### Act Quickly!

Don't hesitate! We want you to know more about the SpeedWay Shop. Write today to this big factory and benefit by our 20 years' experience in making electrically driven tools. We have Sales and Service Stations in most of the leading cities. Your copy of our new, big catalog, showing the complete SpeedWay line of combination shops for the home is waiting for you. Send in the coupon at once.

**ELECTRO MAGNETIC TOOL CO.**  
Address Dept. 2-D, 1830 S. 52nd Avenue,  
CICERO, (Adjoining Chicago) ILLINOIS

*Remember, this is the only company in the world making a complete line of Portable Electric Saws, Hammers, Drills and Grinders.*

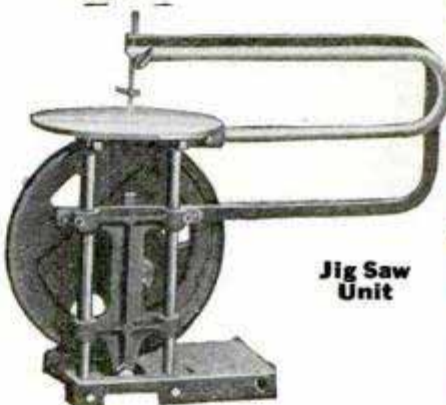

Jig Saw Unit

### A Combination to Suit You

For the man who wants a Shop for special uses there are various combinations. Even the \$42.50 Shop is built to the same high standards as the one shown above. Send for catalog describing them all.

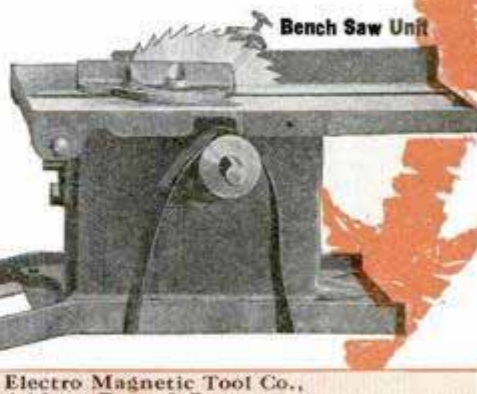

Bench Saw Unit

**6 LOOK! Wood Turning**  
The SpeedWay Lathe shown with work in place. Note firm grip and sturdy appearance of this assembly.

**Drilling**  
Shows drill chuck with 1/4-inch bit. Tail stock may be run up on rods to provide pressure feed, drill press.

**Grinding**  
Use your SpeedWay Shop for all kinds of grinding. Photograph shows 6-inch grinding wheel fitted on to accessory arbor. Direct drive, no vibration.

**Polishing and Buffing**  
The illustration above shows buffing wheel as used on the accessory arbor. May be used for all kinds of polishing and finishing.

**Scratch Brush—Bench Saw**  
Double metal scratch brush. Removes rust from metals. Photograph above shows No. 260 Bench Saw Drives at 4000 R.P.M. Note simple supporting arrangement. No nuts to tighten. Lifts on and off.

**24 FREE BLUE PRINTS**

24 working blueprints of tools, furniture, etc., are furnished free with each SpeedWay Shop.

Electro Magnetic Tool Co.,  
Address Dept. 2-D,  
1830 S. 52nd Ave., Cicero, Ill.

Dear Sirs: Please send me full particulars about 10 Days' Free Trial, Free Blue Prints, and your Easy Payment Plan on SpeedWay Shops.

Name.....  
Address.....  
City.....State.....



# XMAS GIFTS



Send Only \$1

Send Only \$1

10 Days Free Trial

A FULL YEAR TO PAY

Royal's terms make buying easy. Just send \$1 with order and selection comes to you on 10 DAYS FREE TRIAL. Pay postman only \$1 more on delivery. After free trial, pay balance in 12 easy, equal monthly payments. Satisfaction absolutely guaranteed or your money back. All Dealings Strictly Confidential. Order today. Wear while paying.

FREE! Royal's latest "BOOK OF GEMS" Write now for copy.



**AK3**—Extraordinary value; attractively hand engraved **18k solid white gold** lady's ring; set with genuine radiant blue white diamond. Special **\$22.50**. \$1.71 a month.

**AK10**—Striking value! 3 fiery genuine blue white diamonds; new style, richly hand pierced **18k solid white gold** lady's mounting. Specially priced. **\$36.75**. \$2.89 a month.

**AK5**—Extraordinary value; lady's hand engraved and pierced **18k solid white gold** mounting; dazzling genuine blue white diamond. Bargain. **\$37.50**. \$2.96 a month.



**AK7**—Ultra fashionable lady's ring. **18k solid white gold**; finest genuine blue white diamond in patented octagon top; looks like  $\frac{3}{4}$ ct. **\$79.50**. \$6.46 a month.

**AK4**—Exquisite. Latest style lady's dinner ring; 3 genuine blue white diamonds; richly engraved and pierced **18k solid white gold** mounting. **\$29.75**. \$2.32 a mo.

**AK11**—Exquisite new creation! A dazzling cluster of 7 fiery genuine blue white diamonds set to resemble a \$750.00 solitaire; **18k solid white gold** lady's ring. **\$49.75**. \$3.98 a month.



**AK14**—Latest style, engraved, rectangular shape, lady's wrist watch, **14k solid white gold case**, highest grade 15 jewel, ruby and sapphire movement; lifetime guarantee. **\$22.00**. \$1.67 a mo.

**AK18**—Smart looking and inexpensive! Lady's **14k solid white gold** engraved ring; genuine imported black onyx set in center with sparkling blue white diamond. **\$19.75**. \$1.48 a month.

CREDIT AT CASH PRICES

USE YOUR CREDIT



**AK17**—Newest model **Waltham** or **Elgin** nationally famous, gentleman's strap watch, 20 year guaranteed green gold filled case; radium dial, dependable time-keeper. Specially priced **\$24.50**. \$1.87 a mo.

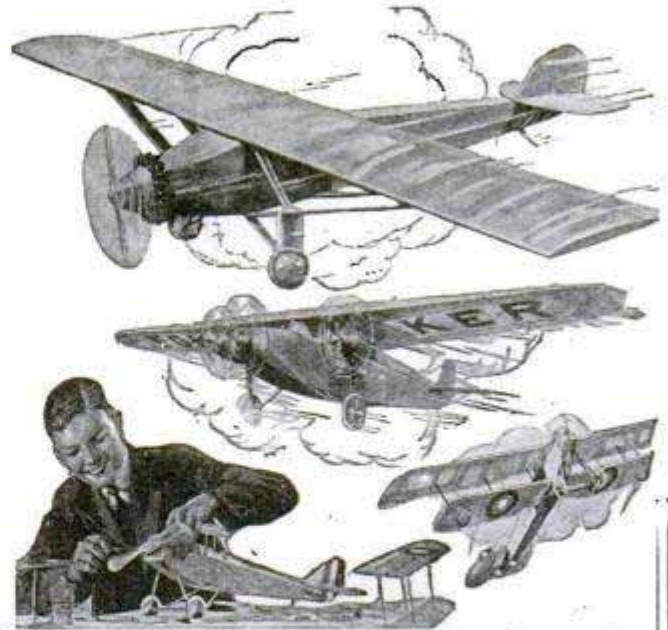

## Build Flying Models of Famous Airplanes!

THERE'S fun and useful interest in Building and Flying Model Airplanes; shows you, in the best and easiest way, all the parts of real planes, what each part does, how they are constructed, what makes them fly and many other things licensed pilots must know. IDEAL Models are wonderfully accurate copies of large Airplanes, designed in accurate proportions, with structural features, parts and fittings like real ones; and guaranteed to fly when correctly constructed. They are easy to build; IDEAL Complete Construction Outfits contain everything needed, including Plans, Diagrams, Building-Flying Instructions and all parts, fittings and materials. Here are several famous models; choose yours now and get it for Christmas:

- LINDBERGH'S "Spirit of St. Louis"** (Shown at top above). Complete Construction Outfit, 3 ft. size. \$ 7.50
- FOKKER Monoplane, "America"** (Shown in Center above). Complete Construction Outfit, 3 ft. size. . 8.50
- JN4D-2 Curtiss "Jennie" Training Biplane** (Shown on bottom above). Complete Construction Outfit, 3 ft. size. . . . . 7.00
- DeHAVILLAND Air Mail Biplane**, 3 ft. size. Complete Construction Outfit, 3 ft. size. . . . . 7.50
- NC-4 Naval Cross-Atlantic Seaplane**, 4 1/2 ft. size. Complete Construction Outfit, 3 ft. size. . . . . 10.00
- NIEUPORT French Scout Monoplane**, 3 ft. size. Complete Construction Outfit. . . . . 6.00
- BLERIOT or TAUBE Monoplanes**, 3 ft. size. Complete Construction Outfit, each. . . . . 5.00

Ask your Dealer for IDEAL Model Airplanes, or Order Direct if Unobtainable in Your Locality. West of Denver, Colo., and Outside the United States, add 50c to above prices.

### Plans for Model Airplanes      Catalog of Models & Supplies

For those desiring to build with materials on hand, or ordered as needed, we supply complete Plans with Building - Flying Instructions for any of the Models listed above. Price, including copy of Catalog: **25c EACH**

The most complete and instructive book on Model Airplanes obtainable. 48 pages of information, prices, etc., on Models, Parts, Fittings, Materials and Supplies. Every Model builder should have a copy. **5c POSTPAID.**

**IDEAL AEROPLANE & SUPPLY CO., Inc.**  
Established in 1911—16 years ago.  
408 WEST BROADWAY, NEW YORK CITY

**ROYAL DIAMOND & WATCH CO.**  
ADDRESS DEPT. 1897 -170 BROADWAY, N.Y.



# All Electric Radio



*The Randolph*

## 7 Tubes-Single Control

JUST plug this Randolph Radio into the electric light socket—and tune in. A powerful, selective radio that gives dependable coast to coast reception. **No batteries, chargers, eliminators, acids or liquids.** Easy tuning with one control brings on all stations. Illuminated drum allows you to operate the radio in the dark and has space for logging stations. Every detail of the Randolph is modern and perfected, unsurpassed regardless of price. It is this wonderful radio that you test and try for 30 days FREE before you buy. When it convinces you by actual performance it is the ideal radio—you can buy it direct at factory prices. Be sure you write for free descriptive literature today.

### Beautiful Ampliphonic Console



Made of the finest carefully selected heavy solid burl finish walnut. Has built-in genuine large cone speaker that compares with any on the market. Assures unlimited reception of high and low notes clear as a bell. Completely electric—uses no batteries of any kind. Be sure you send for fully illustrated, full color folder giving complete details.

### Genuine Walnut Cabinets

The finest of heavy, genuine, solid burl finish walnut is used in the making of all Randolph cabinets. No picture can do them justice. You must see them to appreciate them.

### 6-Tube Radio

Do not compare this set with old-style, 2-dial, 6-tube sets selling for about the same price. The Randolph 1928 Senior Six has also been tested and approved by the leading radio engineers. Beautiful solid walnut cabinet. Single control. Illuminated drum with space for logging. Very selective. Sent for 30 days free trial.

**All Sets Guaranteed**

**30 DAYS FREE TRIAL**

**6 Tube \$55 Retail Price**

**Biggest Discounts To Agents**



**Biggest Discounts to Agents**  
Work either full or part time and make big money. Sensationally big discounts to agents. No experience required. Randolph All-Electric Sets sell on first demonstration. Tremendous advertising campaign helps you. Men and women both make big money this way. Demonstrating set sent on 30 Days TRIAL. WRITE NOW for proposition.

**USE THIS COUPON TODAY!**

**Randolph Radio Corporation  
711 W. Lake St., Dept. 296  
Chicago, Illinois**

Send me full particulars about the RANDOLPH Six and Seven-Tube Electric and Battery Table and Console Sets with details of your 30 Day FREE Trial Offer.

Name.....  
Address.....  
City..... State.....  
Mark here  if interested in Agent's proposition.

**RANDOLPH RADIO CORPORATION  
711 W. Lake Street, Dept. 296 Chicago, Ill.**



# for Xmas



**The Complete Equipment consists of the powerful Red Jacket Drill Motor with direct drive to the Waco Craftsman's wood turning lathe (capacity 9 in. x 34 in.); a bench saw, that has depth and side gauges, scroll and jig saw; and all accessories for both portable and stationary power drilling, buffing, grinding and cleaning. Attaches to any light socket and converts your work bench into a complete private tool and machine shop.**

Turning  
Sawing  
Winding  
Spinning

Grinding  
Buffing  
Polishing  
Drilling

Cabinet  
Making  
Scroll  
Sawing

Repairing  
Dove  
tailing  
Pointing

Jointing  
Sharpening  
Sanding  
Scratching

Carving  
Successfu  
Master  
pieces

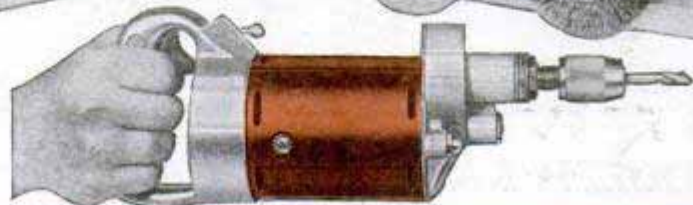
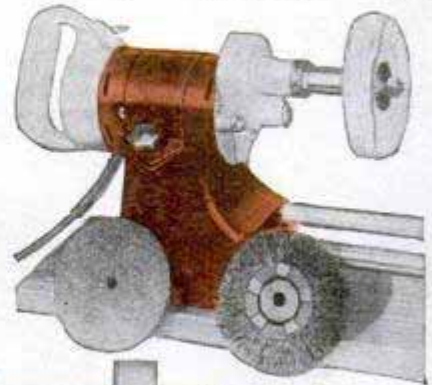
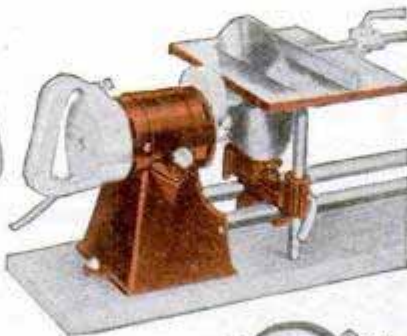
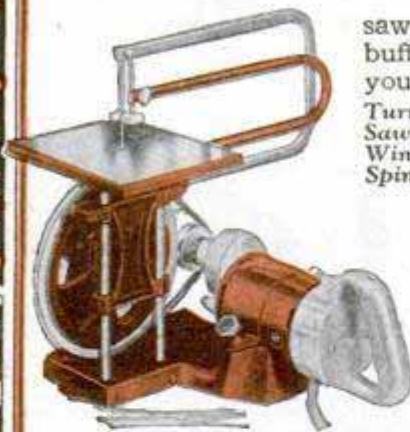

**ONLY**  
**\$10<sup>00</sup>**  
**DOWN**



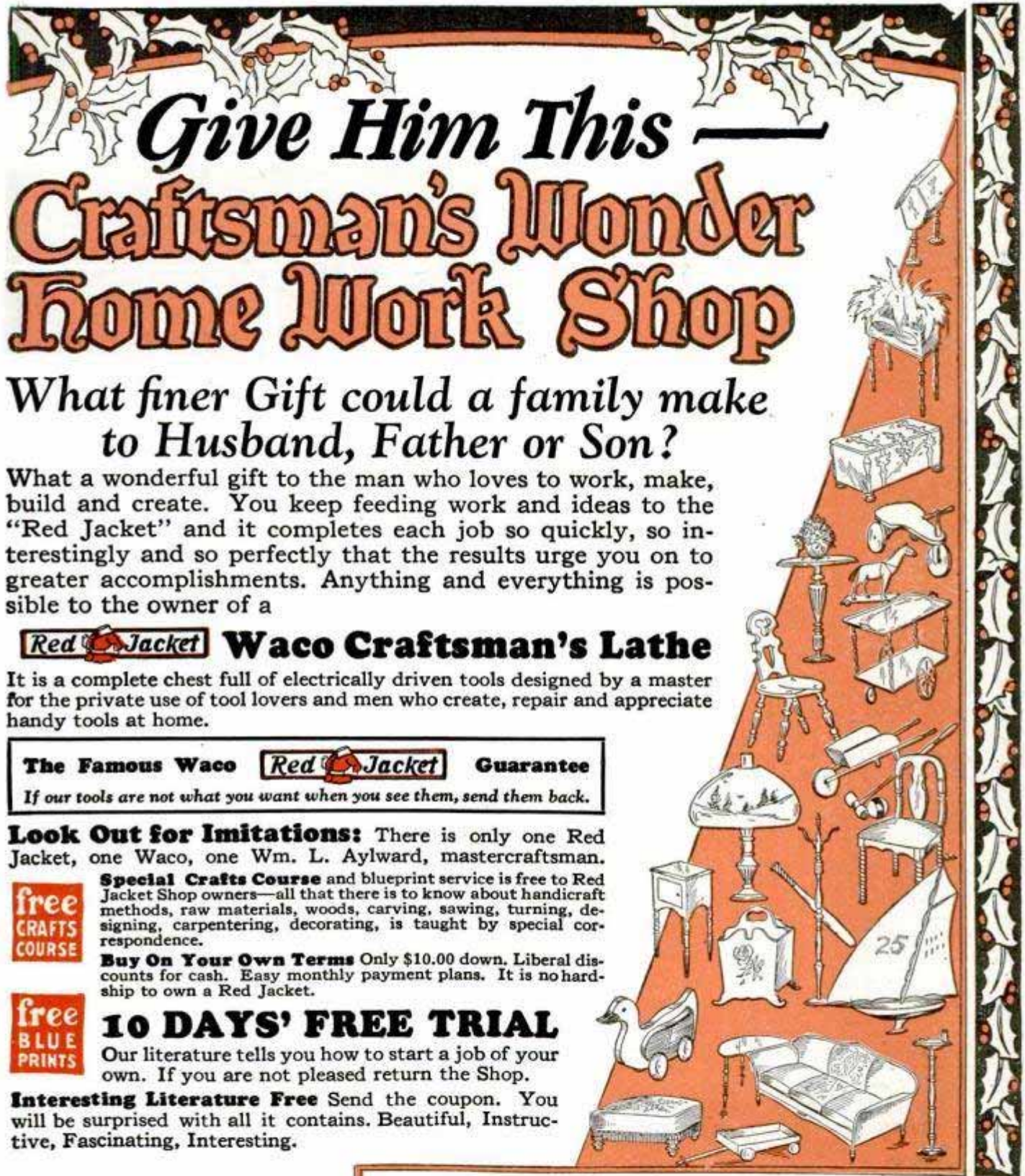

# Give Him This — Craftsman's Wonder Home Work Shop

What finer Gift could a family make  
to Husband, Father or Son?

What a wonderful gift to the man who loves to work, make, build and create. You keep feeding work and ideas to the "Red Jacket" and it completes each job so quickly, so interestingly and so perfectly that the results urge you on to greater accomplishments. Anything and everything is possible to the owner of a

## **Red Jacket Waco Craftsman's Lathe**

It is a complete chest full of electrically driven tools designed by a master for the private use of tool lovers and men who create, repair and appreciate handy tools at home.

**The Famous Waco Red Jacket Guarantee**

*If our tools are not what you want when you see them, send them back.*

**Look Out for Imitations:** There is only one Red Jacket, one Waco, one Wm. L. Aylward, mastercraftsman.

**Special Crafts Course** and blueprint service is free to Red Jacket Shop owners—all that there is to know about handicraft methods, raw materials, woods, carving, sawing, turning, designing, carpentering, decorating, is taught by special correspondence.

**Buy On Your Own Terms** Only \$10.00 down. Liberal discounts for cash. Easy monthly payment plans. It is no hardship to own a Red Jacket.

## **10 DAYS' FREE TRIAL**

Our literature tells you how to start a job of your own. If you are not pleased return the Shop.

**Interesting Literature Free** Send the coupon. You will be surprised with all it contains. Beautiful, Instructive, Fascinating, Interesting.

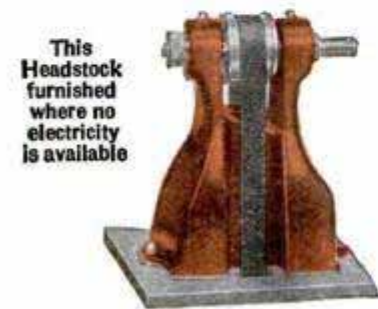

This Headstock furnished where no electricity is available

### Mail This to Waco

**WACO TOOL WORKS, Inc.**  
542-4 N. Parkside Ave., Chicago, Ill.

Manager, Dept. 112. Please send me particulars about 10-day free trial, free blueprints, and \$10 down payment.

Name.....

Address.....



# Perfect Radio Parts for Discriminating Set Builders

## The BRADLEYLEAK



A variable grid leak that provides perfect grid leak adjustment, thereby providing the best possible results with any tube.

## The BRADLEYSTAT



The ideal filament control. Gives noiseless, stepless control for all tubes. Can be easily installed in place of wire wound rheostats.

## The BRADLEYOHM-E

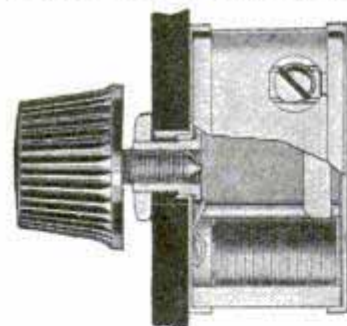

Standard equipment for accurate plate voltage control on many leading B-eliminators. Provides noiseless, stepless plate voltage control.

## The BRADLEYUNIT-A



A fixed resistor that is molded and heat-treated under high pressure. Not affected by temperature, moisture or age. The ideal fixed resistor for B-eliminator hookups.

When you build a set or B-eliminator, demand Allen-Bradley Perfect Radio Resistors to secure best results

# Allen-Bradley Co.

ELECTRIC CONTROLLING APPARATUS  
280 Greenfield Ave. Milwaukee, Wis.

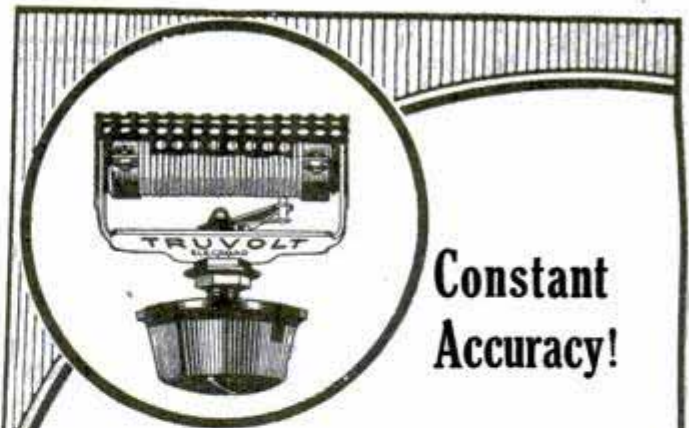

Constant Accuracy!

# TRUVOLT

An All-Wire Variable Voltage Control

Install Truvolt in your B-Eliminator and vary your voltage exactly. A new type wire variable high resistance kept cool by its greater radiation surface—like an air cooled motor.

Develops but 1/2 the temperature of other resistances of like size; hence is permanently accurate and lasts indefinitely. Positive metallic contact always and 30 exact readings of resistance.

Type	Resistance (Ohms)	Current (Milliamperes)
T-5	0 to 500	224
T-10	0 to 1,000	158
T-20	0 to 2,000	112
T-50	0 to 5,000	71
T-100	0 to 10,000	50
T-200	0 to 20,000	35
T-250	0 to 25,000	32
T-500	0 to 50,000	22.5

Eight stock types with resistances up to 50,000 ohms. All rated at 25 watts.

Price \$3.50 each.

Also a full line of Wire Fixed Resistances.

Write for free hook-up circular.

*"This Is An Eliminator Year"*

Dept. 17B, 175 Varick Street, New York

# ELECTRAD



**NEW TIMER FOR FORDS**  
MARVELOUS INVENTION  
FREE OFFER TO USERS **FORD DYNAMO**  
**60,000 MILES WITHOUT TROUBLE**

WRITE TODAY FOR FREE OFFER

Agents Wanted Everywhere

Eclipse Timer Co., 2933 Meinecke Av., Milwaukee, Wis.

**DENINGER WILL TRUST YOU**

SEND 30c INSTAMPS FOR CATALOGUES  
BIG MONEY SAVING FOR YOU

Used and rebuilt motorcycles \$25 to \$100,  
used bicycles \$9.50, tandems \$20.  
All machines fully guaranteed.  
New bicycles and motorcycles  
at factory prices, save dealers'  
profits. Motorcycle and auto-  
mobile tires \$3. Complete line  
frames, engines, supplies.

DENINGER PRICE CUTTER, ROCHESTER, N. Y.

**PAY AS YOU RIDE**

## Catch Fish!

Eels, Mink, Muskrats with our new folding galvanized **STEEL WIRE TRAP**. Write for our **FREE TRAP OFFER** and Bargain Catalog. \$1 Box of our famous Fish Bait **FREE** to introduce our traps. **WALTON SUPPLY CO., 3501 JUNIATA AVE., ST. LOUIS, MO.**

**MOTORCYCLES**

**WE WILL TRUST YOU**  
Pay As Low As \$2.00 per Week  
Hendersons, Harley-Davidsons, Indians

Slightly used and rebuilt. Hundreds to select from.

Send 10c for list today.

**MYEROW BROS. CO., 15 Berkeley St., Boston, Mass., U. S. A.**



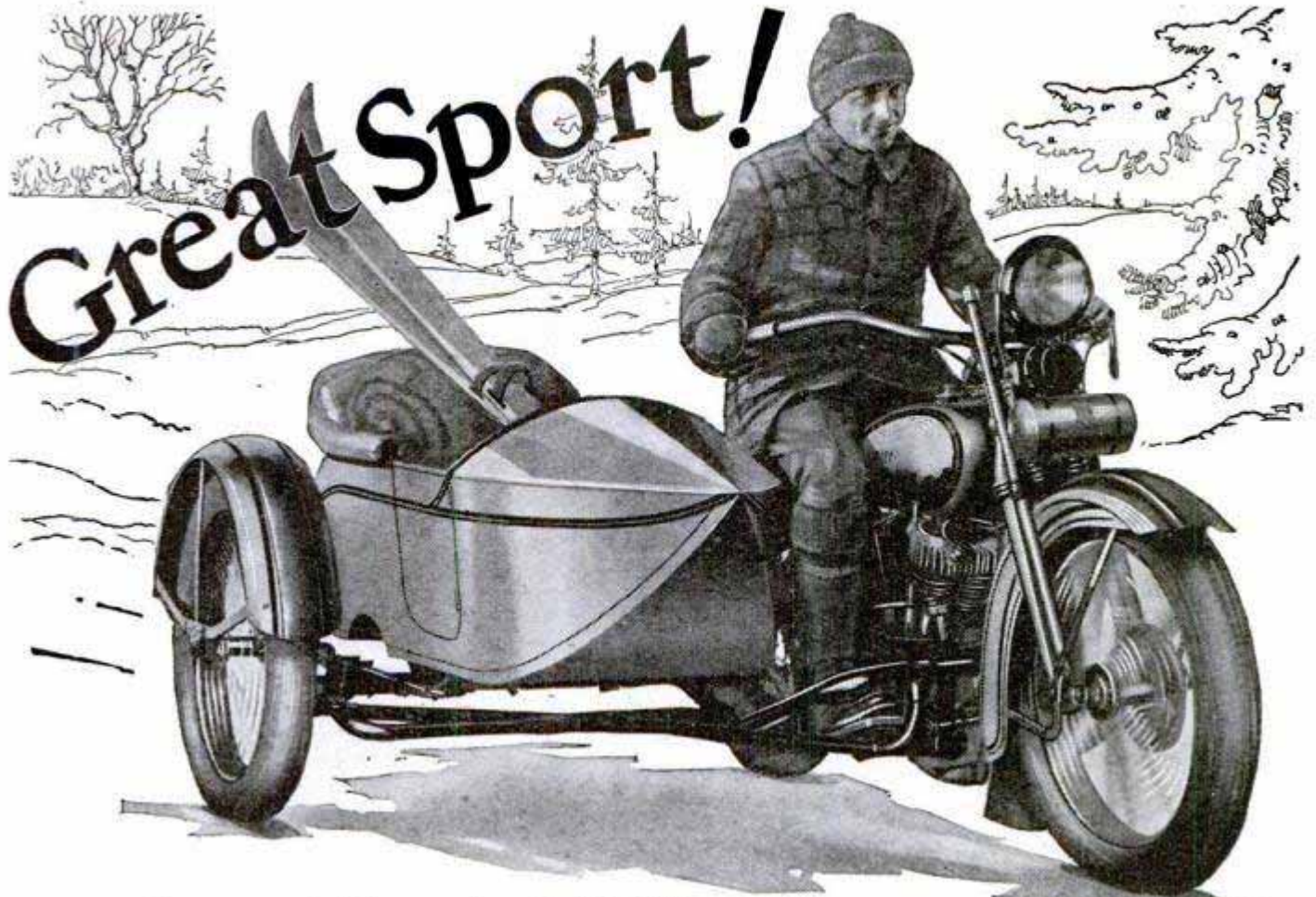

## Snow-Mantled Hills — Your Harley-Davidson — and the Great Outdoors

**M**EET old King Winter man to man. Ride a Harley-Davidson Twin out into the clean, crisp air that zips the red blood through your veins!

Harley-Davidson speed and getaway make cars seem logy. Its balance and comfortable springs carry you comfortably and safely. Plenty of room in the side car for a pal and your "plunder". And the running cost is only 2¢ per mile!

1928 models have both front and rear brakes, and many other improvements. Prices as low as \$310 f. o. b. factory. Ask your dealer about his Pay-As-You-Ride Plan. Mail the coupon for literature.

**HARLEY-DAVIDSON MOTOR COMPANY**  
Department P Milwaukee, Wisconsin

# HARLEY-DAVIDSON

## Motorcycles



The Single—our famous solo mount that travels "80 miles to the gallon" and is priced at only \$235 complete f. o. b. factory. All models have front and rear brakes and electrical equipment.

HARLEY-DAVIDSON MOTOR CO.,  
Dept. P, Milwaukee, Wis.

Interested in  Twin,  Single.  
 Interested in selling motorcycles.

Name \_\_\_\_\_

Address \_\_\_\_\_

City \_\_\_\_\_

State \_\_\_\_\_



# \$ Only 1 Down Brings You Either of These Guaranteed Eliminators

## Super-Power "A" Eliminator

This eliminator completely replaces "A" Batteries and the bother and expense of chargers with their disappointments. Here is constant, smooth, unvarying, humless current at 6 volts for any radio using 201-A and power tubes.

### Not a Battery-Charger Combination

Large capacity rectifier in this super-power "A" Eliminator changes alternating house-lighting current into direct current. Highly efficient heavy duty filter system then changes pulsating direct current from rectifier into smooth, even current for lighting of filament in radio tubes. By simply attaching this "A" Eliminator to your set and plugging in the electric light socket your set is instantly supplied with the correct amount of hum-free current. **Requires no attention, as there are no batteries to be charged.** Always reliable whether used once or a thousand times a year. Has no moving parts to wear out. Operates from light socket 110-120 volts, 50-60 cycle A. C., output 6 volts for all sets up to 12 tubes with power tubes.

### Test It for 30 Days

Just fill out the coupon below and send it to us with one dollar. We will send you this Super-power "A" Eliminator. Try it for 30 days before you pay another cent. If it fails to make good in any way return it at our expense and your money will be cheerfully refunded. Because of our great buying power we are able to offer you this "A" Eliminator

at  $\frac{1}{4}$  less than it is sold for elsewhere. It is offered complete for only **\$31.50** payable in easy installments after you test it.



**NO BATTERY—NO CHARGER  
NO BULBS  
NO HUM  
Nothing to wear out or replace**

ELECTRIFY ANY RADIO

## Super-Power "B" Eliminator

This eliminator permanently replaces "B" Batteries and the constant expense of getting new ones. Attached to your radio and plugged into light socket it delivers a steady flow of power. Hum, noise, distortion and all other disturbances are gone. **Used with any good "A" Eliminator it completely electrifies your set.**

### Complete with Raytheon Tube

This super-power "B" Eliminator can be used with any set up to 12 tubes. It comes complete with full wave rectifying 85 Mil. Raytheon tube, making possible the delivery of great current at a high voltage. This Raytheon tube has indefinite life as it has no filament to burn out. Delivers up to 180 volts.

The case is beautifully finished in olive green Duco with black panel etched in gold. Equipped with rubber-covered cord and socket plug. High voltage taps and variable adjustments enable the use of new power tubes. Operates from 110-120 A. C., 50-60 cycle current. Has tap for intermediate voltage, on which 67½ to 90 volts may be obtained. The detector tap will supply 22½ to 67½ volts. Variable adjuster will deliver any desired detector voltage. On and off switch and high and low voltage switch are integral parts of the eliminator. No additional switches or cords are necessary.

### Test It for 30 Days

We make you the same liberal trial offer with this "B" Eliminator as with the "A" Eliminator described in this advertisement. Ordinarily this "B" Eliminator ordinarily sells for the cash price of \$42.50. You can buy it on easy installments for only **\$29.50** after you have tested it.



**COMPLETELY REPLACES "B" BATTERIES  
Easy to attach  
Plug into electric light socket**

**AT REDUCED PRICES**

### Mail This Coupon NOW!

ELLIOTT RADIO CORPORATION, Dept. 392  
709 West Lake Street, Chicago, Illinois  
Attached find \$1.00 for which you agree to send me ( ) "A" Eliminator at \$31.50. ( ) "B" Eliminator at \$29.50. (Send \$2.00 if both are desired as described in ad.) Full particulars will be sent me by return mail and my money refunded if I do not accept your offer.

Name \_\_\_\_\_  
Address \_\_\_\_\_  
City \_\_\_\_\_ State \_\_\_\_\_



# WITH THAT DEGREE OF ACCURACY ASSURED BY REAL TOOLS



**SENT ON TRIAL**

**ONLY \$10 DOWN**

## HOME MECHANICS MADE EASY WITH THE NEW UP-TO-DATE HOME-CRAFTSMAN SHOP

**THIS OUTFIT IS A SUPERIOR DEVELOPMENT OVER ALL OTHERS**

Home Craftsmen, Cabinet and Pattern Makers, have found our shop invaluable in making the commodities of their business. Portable, compact and inexpensive, this shop can be afforded by any home or shop mechanic. \$10.00 down makes it possible to outfit your bench with this equipment, equal in efficiency and accuracy to any professional machine shop.

The Up-to-date Home-Craftsman Shop, shown above, which can be operated from any home electric light fixture, consists of a Superior 1/2 H. P. Motor, a Genuine Precision Lathe (10 x 34 inches), a six-inch Circular Saw, featuring the Tilting Table Bevel, Miter, Side and Depth Gauges, a Superior Jig Saw for scroll work, all accessories for buffing, grinding, etc., and all portable or stationary drilling and sawing.

Volumes of literature explaining the shop in detail may be had without any obligation by mailing the corner coupon.



**Our Educational and Blue Print Departments**

Under personal supervision of Master Craftsman Eugene E. Maurey offers special correspondence crafts course, giving in simple detail full information on home handicraft. Blue print service giving plans and details for making hundreds of pieces of wood handicraft included in this course FREE to our users.

**OUR LITERATURE GIVES ALL DETAILS** Send for it.

**YOUR OWN Terms On Purchase.** \$10.00 down—balance arranged to your convenience. Liberal discount for cash.

**4" Jointer**

Accessory to Up-to-Date Shop

**15" Band Saw**  
Accessory to Up-to-Date Shop



**GUARANTEE**

After receipt of the Up-to-date Home-Craftsman's Shop, if you are not satisfied, without question or delay every cent refunded and return express charges paid.

**10 DAY FREE TRIAL**

Use our shop for 10 days at our expense. If not satisfied—return—express collect.

**MAIL THIS** for full particulars to **Up-to-Date Machine Works** 2915 S. Wabash Ave., Chicago, Ill.

MANAGER, Dept. D. Without any obligation, please send me all particulars about your shop, 10-day free trial, free blue prints, free crafts course, also \$10.00 down payment offer.

NAME.....  
ADDRESS.....



# Most Smiles Per Dollar

Your happy face will smile right back at you when you begin to shave with Barbasol. No brush. No rub-in. No after-smart. Try Barbasol—3 times—according to directions.

"Mister, you're next!"



# Barbasol

For Modern Shaving

The Barbasol Company  
Indianapolis, Ind.

I enclose 10c. Please send trial tube.

Name .....

Address .....

P-M-12-27

## AGENTS!

*Improved Dubeledge Stropper Pays You \$100.00 Weekly*

Think of it! Over 500 clean, satisfactory shaves from a single razor blade. Tell men how to shave for over a year, with one blade, by stropping with new Dubeledge razor blade stropper. Make an easy \$100.00 a week. Sharpens all edges in one operation. Makes new blades out of old ones in a jiffy.

**Sensational Features get Quick Sales**

Nearly every stropper on the market sells for \$3.50 to \$5.00. Here's one with features the others do not have, yet it sells for \$2.00. Sharpens with true diagonal stroke all edges without removing blade. Easy to work—nothing to get out of order—guaranteed to last lifetime. Show these Dubeledge features and the sale is made.

**Read This Big FREE Offer**

We give free with every Dubeledge stropper our new patented pencil. Automatically feeds new leads, one after other by pressing top. Writes 48,000 words, or one year without refilling. Quick sales assured with this free offer.

**Write for Free Plan**

Get facts free. We show you how to make at least \$100.00 a week. Postcard will bring information.

**MORTON SALES CO.,**  
Dept. B12 10-15 46th Ave., Long Island City, New York

All Metal Chassis Shielded Ready to Wire

# 6 TUBE

## SUPERPHONIC

Radio ALL PARTS MOUNTED

Only \$16.95

**FREE!**  
6 TUBES  
UX 201-A TYPE  
Tested and Matched

Can be wired in a few minutes

**COAST to COAST RECEPTION**

An amazing value that can't be beat! Latest 6 tube tuned radio frequency circuit. Extremely selective, marvelous sensitivity. Two stages of radio frequency, detector and 3 audio amplifiers for improved tone quality. Two dial control. All metal chassis. Shielded. Clear and realistic reception guaranteed. Beautiful front panel, crystalline finish. Metal panel and sub panel; all parts mounted. Simply connect a few wires. No special tools needed. Vernier dials for fine tuning. New type UX sockets. All hook-up wire and colored battery cable included. Value \$60.00—our price \$16.95.

**NO RADIO KNOWLEDGE NEEDED!**

**Simple Wiring Directions**

Very easy to wire this set with the instructions we furnish. Just connect a few wires. That is all. Can be wired in a few minutes by anyone. No radio knowledge needed. Make money by wiring these sets in your spare time and selling them to your friends.

SEND NO MONEY

Just write your name and address on a post card and ask us to send you this great outfit together with 6 tubes. We will ship them right away. When they arrive, pay only \$16.95 plus a small delivery charge.

**RADIO EQUIPMENT CO.**  
Dept. PH 549 S. Wells St. Chicago, Ill.

**For Every Woodworking Job—H & A Equipment**

All machines portable, electric—sturdy, efficient, reasonably priced. Just check the machines in which you are interested, write your name and address in the margin and return this ad to us for complete information. Dealers in all principal cities.

**HESTON & ANDERSON** 612 Depot Street Fairfield, Ia.

### INCREASE YOUR PROFITS

Sell more Accessories, Gas, Oil, Tires, Batteries, Repair Jobs, Paint Jobs. You'll sell more of everything if you give a BETTER, MORE DEPENDABLE AIR SERVICE THAN THE OTHER FELLOW. Only \$12 Monthly pays for the dependable HB Ball Bearing, Silent Spiral Bevel Drive, Automatic Air Compressor. Try it in your shop for 30 Days At Our Risk—on absolute Money Back Guarantee.

A letter or card will bring complete details.

**HOBERT BROTHERS, Box M1272, Troy, Ohio**

## PLUMBING-HEATING

### Install Your Own—Save Half

Lowest wholesale prices on highest quality Grade A goods. Any Handy Man can install his own Plumbing and Heating BY OUR NEW EASY METHOD. Get the best and pay only a little each month.

**Send for FREE Book**

New bargain catalog just issued. With our cut-to-fit systems you save waste material and high labor cost. 50 years of economical service to home owners, farmers, builders and mechanics. Million Dollar Plants back up our Bonded Guarantee. FREE book gives you the whole story. Write for your copy today.

**OVER 50 YRS. HARDIN-LAVIN Co. EST. 1876**  
107-17 West Pershing Road, Chicago, Ill.





Sent for  
only

**\$1.00**  
down  
**DIRECT FROM FACTORY**

Here is the greatest buying opportunity today! Just \$1.00 down brings you the famous 21-Jewel Studebaker Watch direct from factory. Balance in easy monthly payments. Lowest prices ever named for equal quality. You save fully 30% to 50%. Your choice of 80 magnificent, new Art Beauty cases and dials. Latest case designs in yellow, green and white gold effects. Exquisite thin models. 12 Size and 16 Size. Send coupon for catalog of Advance Watch Styles and full particulars.

21 JEWEL ~ Extra Thin  
**STUDEBAKER**  
*The Insured Watch*

The Studebaker Watch Company is directed by members of the famous Studebaker family—known throughout the world for three-quarters of a century of honest dealing. Studebaker Watches have 21 Ruby and Sapphire Jewels, 8 Adjustments—for heat, cold, isochronism and 5 positions. Made so good we insure them for your life-time. Insurance policy free with every Studebaker Watch. Ladies' Bracelet Watches, Men's Strap Watches, Diamonds and Jewelry also sold at lowest prices and easy monthly payments. Send coupon for details.

**MAIL COUPON**  
**for FREE BOOK!**

Watch direct from the maker—save big money—and pay for it in easy monthly payments. Mail the coupon.

Let us send you a copy of our beautiful new 6-color catalog. It contains complete information on watch making. It tells how you can buy a 21-Jewel Studebaker Insured

**SPECIAL OFFER! Watch Chain FREE!**

For a limited time we are offering a magnificent Watch Chain Free. To all who write immediately we will include particulars of this astounding offer. Time is limited. Send the coupon NOW before this offer expires!

**STUDEBAKER WATCH COMPANY**  
*Directed by the Studebaker family—three-quarters of a century of fair dealing*  
Watches • Diamonds • Jewelry  
Dept. N-806 • South Bend, Indiana  
Canadian Address: Windsor, Ontario

Mail This  
Coupon

Our Diamond and Jewelry Catalog is just off the press. Your copy will be sent you FREE if you mail coupon.

**STUDEBAKER WATCH COMPANY**  
Dept. N-806, South Bend, Indiana

Please send me your free catalog of Advance Watch Styles and details of your \$1.00 down offer.  Please send me free catalog of Jewelry and Diamonds.

Name.....

Street or R. F. D. ....

City..... State.....

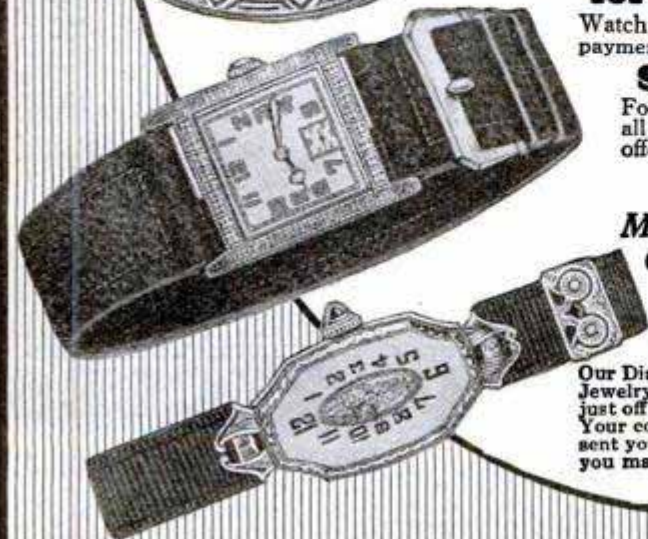
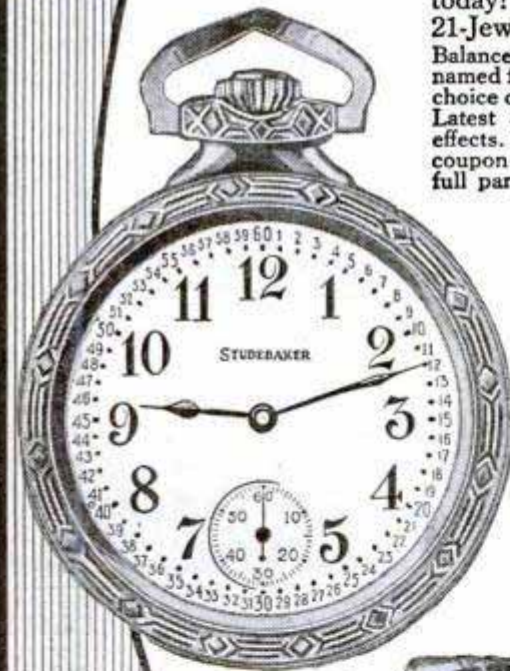



# DEVITT 8" COMBINATION SAW

8,000 IN USE!

**A SHOPFUL OF TOOLS WITHIN ARMS REACH!**

SAW TABLE RAISED SHOWING EMERY WHEEL, SAW GUARD AND DRILL ATTACHMENT



PLANER ATTACHMENT ON SAW TABLE

SHOWING SANDING DISC ATTACHED



TABLE TILTED FOR BEVELING

DADO HEAD ATTACHED FOR GROOVING

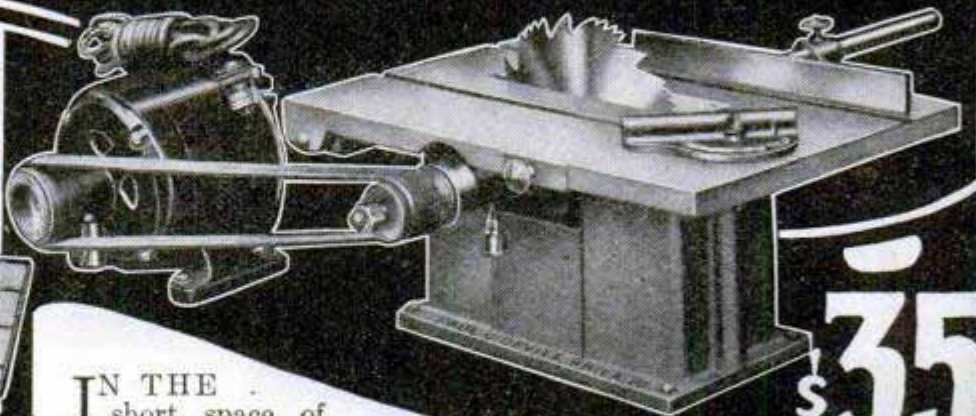

**\$35**  
F.O.B. PHILA

**I**n the short space of four years, the Devitt 8-Inch Combination Saw has become a practical necessity in thousands of shops, factories and households everywhere. Many imitators have sprung up, but Devitt leads them all. Think of the convenience and economy of this handy little machine that will rip, cross cut, bevel, miter, groove, mortise, tenon, drill, rabbet, grind, buff and polish. Attachments are easily and quickly adjusted. The saw and motor, when set up for work, occupy very little room. Saw is equipped with  $\frac{1}{4}$  H.P. 60 cycle, 110-volt A. C. Motor which can be attached to ordinary light socket, and provide power for other purposes when wanted. A cut up to  $2\frac{1}{4}$ " can be made without planing. Comes complete with following attachments—12"x16" table, 8" Combination Saw, iron pulley for saw table, 10" ripping fence, adjustable cut off miter gauge, motor-specifications as above,  $1\frac{1}{4}$ " endless leather belt, wood pulley, 8 ft. cord and plug, 6" buffing wheel,  $\frac{3}{8}$ " 3 jaw drill chuck, 5" emery wheel, 6" sander, saw guard, and 2" dado insert. \$35.00 F. O. B. Phila. Height  $7\frac{1}{2}$ ", shipping weight, 100 lbs.

(Only \$12 extra for Planer Attachment to fit on table top. Can smooth pieces up to 2 inches wide. Price, F. O. B. Phila.)

Send today for our attractively illustrated 4-page circular

## PAUL J. DEVITT

Dept. B 1102 SOUTH 2ND ST. PHILA., PA.

**Ask for Keds by name**

They are not Keds unless the name Keds is on the shoe

## Better Than A Brush



**The Lacquer-Well Spray Gun**

for all brushing lacquers including brushing Duco.

**Dozens of Uses**

Lacquer your auto. screens, etc. Make your old furniture like new. Change tanks and use it for oiling springs or touch up work, etc. Splendid as plant or disinfectant spray.

Sturdy, lasting service, quality made—Sent postpaid anywhere in U. S. upon receipt of only \$2.00, extra tanks 25c each.

**THE LACQUER-WELL SPRAY COMPANY**  
Dept. 2 2012 East 105th St. Cleveland, Ohio



**STOP Ford & Chevrolet CRANKSHAFT END-PLAY!**

**C-A ADJUSTABLE BEARING** corrects and prevents end-play without removing motor. Eliminates many troubles. Easy to install—simply drop pan. For Fords, \$3.75; for Chevrolets, \$4.25. Ask your dealer or sent prepaid by ADJUSTABLE BEARING CO., Dept. P, 405 Virginia Ave., Indianapolis, Ind.

**MAKE YOUR FORD Into The "LARK"**

\$5.00 Red-1-Kut life size patterns Class—Snap



Famous sure-fit RED-1-KUT life-size patterns and picture instructions show how you can easily convert your Ford into this Fast, Sassy, Sport Car as thousands have done with easily obtained materials. No need to lay up the car. Rear seat folds, making 4-passenger car. Send 10c coin for actual body photo

and new manual of other distinctive sport body patterns from \$5.50 up—'RKO' Steel "Swing-Lo" fenders, Tops and Windshields. ORDER RIGHT NOW.

**KUEMPEL COMPANY, 91 Kuempel Bldg., GUTTENBERG, IOWA**

## MOTORCYCLES

Price \$10 and up purchased through our Co-Operative Plan for as low as \$1.00 down and \$1.00 per week  
**Indians Harley-Davidsons Ace Henderson and Clevelands**  
Send ten cents for Bulletin A.  
Motorcycles shipped to all parts of the world  
**WALKER-INDIAN CO., 78 Brookline Ave., BOSTON**





# The World's Most Amazing Gun

## The Benjamin

**Any Shooting Force Desired**

One stroke of the pump gives light penetration. Two strokes a little more. Six strokes of the pump will drive the shot clean through a half inch plank. Note the tremendous controlled shooting force as illustrated below. Picture shows shot imbedded in 1-inch block.

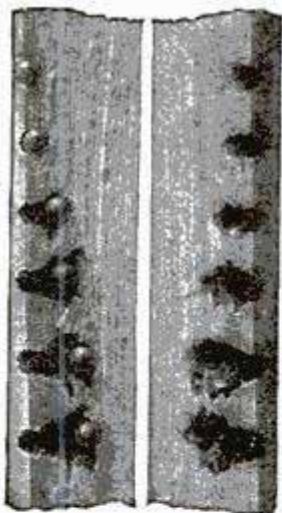

Showing power of penetration using from one to six strokes of the pump.

**Read These Letters**

"I am enclosing a photograph of me and my squirrel. I certainly recommend the Benjamin very highly. A few days ago I saw a squirrel in the top of a high tree. I fired and brought him down with a bullet in the back of the shoulder. For any boy that likes hunting like me, he ought to get a Benjamin. Norman Gile, Braintree, Mass."

Please send me two new valves for my Model E Benjamin. The gun has been in use for 12 years and this is the first repairs I have had on it. M. C. Dunsford Sullivan, Missouri."

"I take this opportunity to congratulate you on your Benjamin Air Rifles for they are the only make which gives such marvelous results. Albert Stins, Port au Prince, Haiti, W. I."

**No Springs to Break or Weaken**  
No cleaning required. The Benjamin is always ready to shoot. Accidental discharge impossible. Nothing to get out of order. No complicated mechanism to jam or springs to weaken and break. Retains its shooting force for years.

**Safe and Accurate**

**America's Original Genuine Compressed Air Rifle**

It's the straightest shooting, hardest hitting most accurate compressed air rifle you ever saw. Unlike all others. Shoots regular inexpensive air-rifle shot. Ideal for target practice or small game. Absolutely safe.

**For Young or Old**



The Benjamin is not a toy. Yet it is safe for boys to handle. It is the one and only gun for boys who have passed the pop-gun stage but who are not ready to own the more dangerous powder shooting gun. Take-down walnut stock. Nickel plated barrel. Guaranteed for one year from date of purchase.

Benjamin Air Rifle and Mfg. Co., 645 N. Broadway, St. Louis

**\$5.00** Postpaid or at your dealer's

**The Ideal Xmas Gift for Any Boy**

It is as natural for a boy to want a gun as it is for a girl to want a doll. Here is a gun for a Xmas gift that is absolutely safe, yet will delight any boy who loves to hunt and wants a real gun. If your dealer cannot supply you, order direct from factory. Satisfaction guaranteed. Use coupon.

**FREE TO BOYS**

Get your copy of the "Shooter's Art" a dandy book that tells all about shooting. Shows how to hold and aim your gun, how to hit moving objects and how to be a crack shot. It is FREE. Mail coupon for your's to-day.

**CLIP THIS COUPON AND MAIL TODAY**

BENJAMIN AIR RIFLE AND MFG. CO. 645 N. BROADWAY, ST. LOUIS, MO.

Enclosed find \$.....for which please send me

- 1 Benjamin Air Rifle for \$5.00
- 3 lbs. Air Rifle Shot for \$1.00
- 1 Free Copy of "The Shooter's Art" (Check Items Ordered)
- 1 Free Benjamin Target

Name.....

Address.....

Town.....State.....







**\$100**  
Brings Your Choice  
**10 MONTHS TO PAY**

A \$57.50 B \$50

For Christmas...

**WHAT YOU DO—**

Send one dollar with Name and Address, article desired and brief note telling us something about yourself. Simply state: (1) how long at address; (2) age; (3) married or single; (4) name and address of employer; (5) nature of work; (6) how long in employ. All information held strictly confidential—no direct inquiries to employer.

**WHAT WE DO—**

Upon arrival of your order, we will open a 10 month Charge Account and send selection for approval and 15 DAY TRIAL. If satisfied, pay balance in ten equal monthly payments; otherwise return and dollar will be refunded.

No Articles sold to persons under 20 years of age.



**A-AA-1 Blue-White Diamond** in ladies ring, 18-K White Gold, Patent design. **\$57.50**  
\$1. with order, \$5.65 a month.

**B-The May Flower** Beautifully carved in 18-K White Gold; AA-1 Blue-White Diamond. **\$50.00**  
\$1. with order, \$4.90 a month.

**C-Row Knot** design for ladies; 18-K White Gold; AA-1 Blue-White Diamond. **\$39.50**  
\$1. with order, \$3.85 a month.

**D-Engagement Ring-Motif** of love birds; 18-K White Gold; AA-1 Blue-White Diamond. **\$45.00**  
\$1. with order, \$4.40 a month.

**E-Dinner Ring** - 18-K White Gold, leaf and floral design; Three AA-1 Blue-White Diamonds. **\$39.50**  
\$1. with order, \$3.85 a month.

**F-Low price Solitaire**; 18-K White-Gold; AA-1 Blue-White Diamond. **\$32.50**  
\$1. with order, \$3.15 a month.

**G-14-K Green Gold** filled strap watch, engraved, guaranteed 15 Jewel movement, radium numerals and hands. **\$27.50**  
\$1. with order, \$2.65 a month.

**H** 4 Blue White Diamonds, 4 Blue Sapphires in 14-K Solid White Gold engraved wrist watch. Complete with ribbon and expansion bracelet, 15 Jewel movement. **\$45.00**  
\$1. with order, \$4.40 a month.

**E \$39.50**  
**F \$32.50**  
**G \$27.50**

Diamond and Sapphire Wrist Watch Combination

**L.W.SWEET Inc**

DEPT. 67-1  
1660 Broadway  
NEW YORK



To any adult interested in purchasing a diamond watch or other article of jewelry we will send free of charge and without obligations this booklet illustrated in colors - Masterpieces of the jeweler's art. 10 months to pay on everything.

Now! At last!  
**SUPERKEEN**  
Powerful  
Magnetic Sharpener!

\$3.50  \$3.50

Amazing New Scientific Invention!  
Sharpens All Razor Blades Instantly!  
By Powerful Magnetic Force!  
No Moving Parts! Nothing to Wear!  
Guaranteed a Lifetime!

**AGENTS WANTED!**  
The SuperKeen Co., Inc.  
Dept. S-6 Salisbury, N. C.



**\$10.00 DOWN**  
Brings this Lathe to You

Lathes \$6.00 to \$75.00. Largest line of small lathes in America. Send four cents for 24 page catalog of lathes, drill presses, bench saws, jig saws, band saws, etc.

**SYPHYER MANUFACTURING COMPANY**  
Dept. D Toledo, Ohio

**RADIO AGENTS**  
Make Big Money



EASY to sell American Radios and Supplies. Nationally advertised, high quality merchandise at wholesale. Big profit on every sale. No capital to invest. No stock to carry. Order direct from my huge warehouse as you sell. Get My Liberal Offer and also Big New 132-page Catalog and Guide—"How to Sell Radios"—Free. Full of Bargains—all latest in Radio. Write today.

**AMERICAN AUTO & RADIO MFG. CO.**  
HARRY SCHWARTZBERG, PRES.  
Dept 266 American Radio Bldg., Kansas City, Mo.

**FILMS**  
DEVELOPED AND PRINTED

GIVE YOUR FILMS A CHANCE!  
They deserve it. Send for Sample. See what good prints look like. Ask for prices.

FRANK SCOBIE, 43-D, SLEEPY EYE, MINN.

**\$10.00 to \$25.00 a Day!**



**Selling Freshly Roasted Peanuts**

Wherever you find a crowd, hot, savory peanuts and crisp, sweet popcorn are in demand. Set up a Kingery Machine anywhere—in stores, at ball games, races, fairs. Profits 250%. Machines take little room; are easy and inexpensive to operate. Barbecue machines, too. Write now for Free Catalog.

**The Kingery Mfg. Co.** Dept. P.M.12, 410 E. Pearl St. CINCINNATI, OHIO



The MODERN Blow Torch uses Prest-O-Lite Gas only . . . no compressed air or oxygen is required.

THE PREST-O-LITE COMPANY, Inc.  
New York INDIANAPOLIS San Francisco

In Canada, Prest-O-Lite Company  
of Canada, Ltd., Toronto, Ontario

Unit of Union Carbide and Carbon Corporation

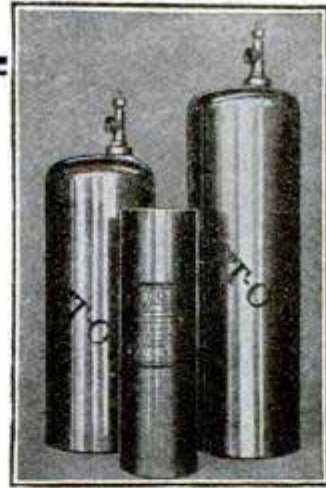

The Prest-O-Lite blow torch attaches to any Prest-O-Lite Gas tank. Write for descriptive literature mentioning the kind of work you do with blow torches.



## ITALIAN ACCORDEONS

We manufacture and import all kinds of first-class hand-made

ITALIAN ACCORDEONS,

the best in the world. Ten year guarantee. Our Prices are lower than any other maker's. Free Accordion instructions to buyers. Write for FREE catalog.



RUATTA SERENELLI & CO.

1014 Blue Island Ave., Dept. M Chicago, Ill.

## Makes Old Ford a Tractor

Now you can convert that old Ford car into a useful farm tractor without altering any Ford parts. We furnish the traction wheels, drive gears and auxiliary axle and mountings, ready to clamp on to the Ford frame. Pulls 16' plow.

We supply a Belt Pulley also



Write for Free Particulars.  
SHAW MFG. CO., Dept. S, Galesburg, Kan.



Price only  
**\$10.50**

Weight 20 lbs.  
Write for circular.

**THE ADRIAN SPEED LATHE**

for wood and light metal turning. 7' swing, 17' centers.

H. G. CRANE,

Adrian, Mich.

**\$5.00**  
**Down**  
buys a  
**WITTE Engine**

Write Me Today—for new FREE

Witte Book telling how you can buy a WITTE Engine for ONLY \$5.00 Down and small EASY Payments. No interest. Absolutely the greatest engine made. Guaranteed for a lifetime. Used all over the world—from the frozen wastes of Alaska to the burning sands of Arabia. Will increase your farm profits \$500.00 to \$1,000.00 a year. Runs on all fuels. Simple, sturdy. Gives most power at least expense. Sizes 1½ to 30 H. P. Engines; also 3-in-1 Saw Rigs and Pump Outfits. Write me today for FREE book and Easy Terms Offer.

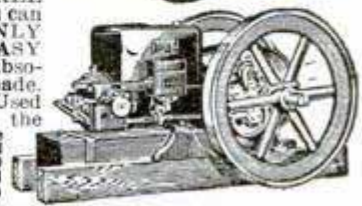

**Witte Engine Works**

1749 Witte Bldg., Kansas City, Mo.  
1749 Empire Bldg., Pittsburg, Pa.



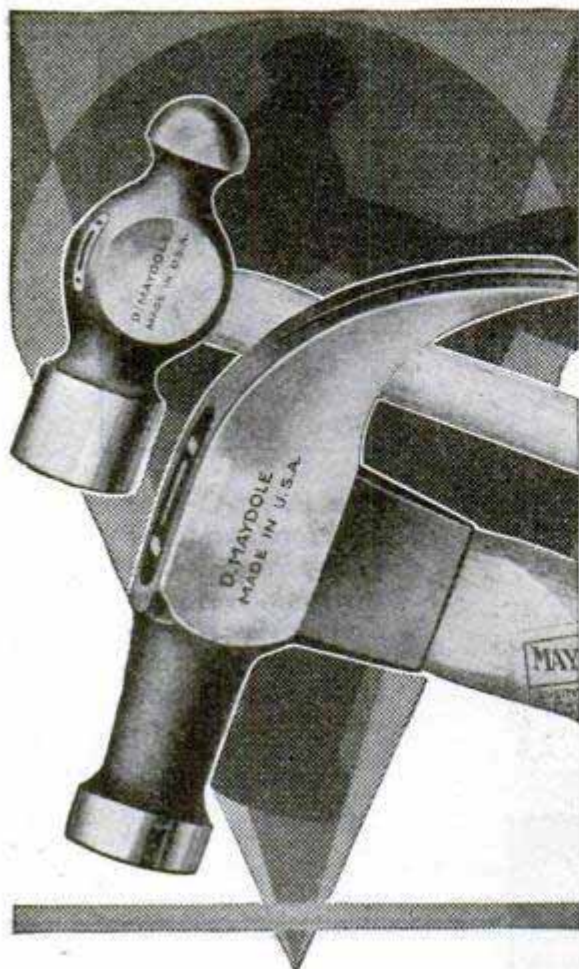

## Maydole Hammers

*The choice of three generations of skilled American craftsmen.*

Heads press-forged of finest tool steel. Handles of clear, second-growth, air-seasoned hickory — put on "for keeps." There is a style and weight of Maydole for every service—each with the unequalled Maydole "hang" and an in-built resistance to hard use and abuse that means true economy.

Write for interesting and useful Pocket Handbook 23 "L." It's free!

YOUR HAMMER SINCE 1843  
**Maydole  
Hammers**

The David Maydole Hammer Co., Norwich, N.Y.

1167

## A NEW DIAGONAL PLIER for heavy duty

For the man who uses a cutting plier and wants one that he can use day after day for heavy work and still be able to depend on it, this new plier is ideal. While it is just average in size, it is a giant in strength and no man can break it without mechanical assistance.

PRICE  
**\$1.50**

No. 742  
7-inch

### CRESCENT TOOL CO.

210 Harrison St., Jamestown, N. Y.

Wrenches—Pliers—Screwdrivers—Chisels—  
Punches—Hacksaws—Snips—Auger Bits—  
Nippers—Electrical Tools



## CRESCENT and Smith & Hemenway TOOLS

BURN YOUR NAME ON TOOLS

### WITH THE ARKOGRAF

PROTECT YOUR TOOLS FROM THEFT

Write with electricity any name or design on the

hardest and finest tools and instruments, or any

metal, like writing on paper with pen or pencil.

Complete outfit \$3.50 — Prepaid Anywhere

Interesting illustrated circular free. Write

today. Agents wanted.

ARKOGRAF PEN CO., 1171 E. Stark St., Portland, Oregon



## PARKS Manual Trainer

**\$35.00**

Without  
Motor



For your home shop! Combination 11-inch band saw and 11-inch wood lathe. If you have a knack for wood working you can turn out first-class bridge lamps, cabinets, furniture, ship models, etc., in fast time. Get one!

Write for specification circular

THE PARKS WOODWORKING MACHINE CO.  
1500-40 Knowlton Street Cincinnati, Ohio

CANADIAN FACTORY: 208 Notre Dame East, Montreal, Canada





# SIMONDS HACK SAW BLADES

WHATEVER THE METAL CUTTING JOB, A **SIMONDS HACK SAW** WILL DO IT **BETTER AND FASTER**

FOR both hand and machine work, Simonds Hack Saws are preferred by experienced mechanics. They know that Simonds Blades cut easier and faster—that the teeth will not shell—and that the high tungsten content gives longer life.

For power saw use, specify Simonds All-Hard Blades—for hand use, Simonds Hard Edge Blades. But be sure to specify "Simonds" and thus secure the advantages of a near-century's experience in the manufacture of fine cutting edges.

**SIMONDS SAW AND STEEL COMPANY**  
"The Saw Makers" *Established 1832*

Fitchburg, Mass.

BRANCH STORES AND SERVICE SHOPS IN PRINCIPAL CITIES



## Crescent Wood Working Machines

are neat in design, substantially built and are intended for hard, continuous service. Users of wood working machinery who appreciate quality always investigate Crescent machines before placing their orders.

Send today for circulars of Band Saws, Saw Tables, Self Feed Rip Saw, Shapers, Jointers, Variety Wood Worker, Planers, Planer and Matcher, Disk Grinders, Cut Off Table, Swing Saws, Borers, Hollow Chisel Mortisers, Tenoners, Universal Wood Workers.  
**The Crescent Machine Co.** 93 Columbia St., Leetonia, Ohio, U. S. A.

**\$6**  
FOR A REAL LATHE



17" Over all, 4" Swing, 11" Centers. Shipping weight 13 lbs. Largest line of small Lathes in America. Send 4 cents for 24 page catalog of Lathes, drill presses, bench, jig and band saws, etc.  
**SYPHER MFG. CO., Dept. L, Toledo, O.**

## The One-Profit WITTE Log and Tree Saw



**LOW PRICE EASY TERMS**

COMPLETE OUTFITS—everything you need for working in timber. Saws 15 to 40 cords a day! Change to tree saw in 3 minutes.  
**FREE** Simply send name for NEW CATALOG, new Lower Prices and offers. 3 Hours Shipping Service.

**WITTE ENGINE WORKS**

7749 Witte Building  
7749 Empire Building

KANSAS CITY, MO.  
PITTSBURGH, PA.

## Put These TOOLS to Any Test We Stand Behind Them



Tools of phenomenal strength and wearing qualities. You can drive rivet punch through auto frame. Cut shaving off axle shaft with bearing scraper. Lock our wrench with any other wrench and bring pressure until one breaks. Drive 3/8" chisel through 1 1/2" machinery steel. **Your money back if tools fail to meet these tests.**

## CORNWELL Quality Tools

Hand made of finest Swedish Charcoal Process Molybdenum Steel manufactured to our famous Cornwell formula. Forged, heat treated, hardened and tempered in oil. **NOT drop forged and case hardened.**

### Free Booklet—Mail the Coupon

Booklet describing amazing tests of these tools will be sent upon request. **Our Money Back**

Guarantee is your assurance that these tools will do everything we claim.

**The Cornwell Quality Tools Co.,**  
Dept. R, Mogadore, Ohio.  
(Formerly at Cuyahoga Falls, Ohio.)  
Send me new illustrated catalog with prices on full line of Cornwell Hand-Made Tools.

..... Where Employed  
Name.....  
Address.....  
City..... State.....



**NOW—**  
**GET MY**  
**GREATEST**  
**Log Saw**  
**Offer**



**Fastest Cutting**

**Saws 15 Cords a Day**

**ONLY \$39**

**Used by The United States Government**

It's easier, now, than ever before to own this fastest-cutting, easiest-moved, most powerful Log Saw. Now, you can make big money sawing firewood, stove-bolts, ice, shingle timber, etc. **WRITE TODAY FOR FULL DETAILS.**

**Try 30 Days**

—ONE WHOLE MONTH to use the OTTAWA at your own sawing. Every saw shipped on trial only—

**Backed by 10-Year Guarantee**

**FREE** Send me your name and address on a postcard today for my wonderful new edition of the "Wood Sawing Encyclopedia." Be sure to investigate—it will help you to make big money.

**HARRY OVERMAN, Pres., OTTAWA MFG. COMPANY**  
1745-L Wood St., Ottawa, Kans. 1745-L Magee Bldg., Pittsburgh, Penna.

**ONLY**  
**\$39**

**Puts the OTTAWA Working For You!**

**350 Cuts a Minute!**

Now you have a log—in a few seconds it's all sawed up—without any hard work!

**FREE**  
Wood Sawing Encyclopedia

For Real "Woodworking Efficiency"  
The handy man about the home can do many more jobs with our

**JUNIOR CABINET WORKER**

**\$156.00**

complete with motor

Your home shop is fully equipped when you have this machine. It's a whole workshop in itself. Nothing else to buy.

**KORNAU MACHINE CO.**  
Station A,  
CINCINNATI, OHIO



This machine does it all.

Write for details

**Making Big Money Is EASY**



when you are "on your own." Pocket all you earn—have steady, year 'round work—no lay-offs, no lost time. This is open to you in floor surfacing. Do you want it? The "American Universal" electrically driven floor surfacing machine surfaces new and old floors better and faster than any other method. It makes the most money for its owner.

YOU can get into this big paying business with almost no capital. No experience necessary. Big Field. Big Opportunity. Write quick for the facts.

**The American Floor Surfacing Machine Co.**  
523 So. St. Clair St.  
TOLEDO, OHIO

You can get yourself no Better Christmas Gift than

**A Gerstner Tool Chest**

Ideal for Toolmakers and Machinists

Write for free catalog

*Gerstner & Sons*

448 Columbia St., DAYTON, OHIO



Measure Hard-to-Reach Places with

**Interlox" THE SPEEDY RULE**

Indispensable for accurate inside and outside measurements. Slides—no folding.

**MASTER SLIDE RULE**

Any length, 2 to 8 1/2 - 200 lineal ft. If not at dealers, sent postpaid.

Dealers and Agents: Write for attractive proposition.

**MASTER RULE MFG. CO., 813 E. 136th Street, NEW YORK**

**BUILD YOUR OWN GRANDFATHER'S CLOCK**



We furnish blue prints, finishing material and instructions. Buy the works, dial, weights and pendulum from us at surprisingly low prices. You make a fine profit building artistic clocks for your friends.

Plain Works as Low As \$5.00. Others with Chimes At All Prices. Ask for Our Free Catalogue and Offer of Blue Prints.

**American Chime Clock Company**  
1670 Ruffner Street  
PHILADELPHIA

**RADIO AT WHOLESALE**

Write for my Big 1928 Radio Catalog—just off the press. Thousands of marvelous bargains in nationally advertised goods. All the LATEST IN RADIOS and equipment. Lowest wholesale prices. Agents Wanted.

**FREE**

It's a regular encyclopedia on Radio. All about trouble finding. **FREE Log and Call Book and Catalog.** Get your copy today. Send postcard now!

**American Auto & Radio Mfg. Co.**  
HARRY SCHWARTZBERG, PRES.  
Dept. 263 American Radio Bldg., Kansas City, Mo. 3

**DEALERS NEW 1928 CATALOG**

**Palmolive Shaving Cream**

"5 New Delights for Men"

**WADE AMATEUR MECHANICS, REPAIR SHOPS, INVENTORS, STUDENTS**

**BENCH LATHE**

A real machine tool for the home work bench—capacity 4" dia. x 12" length. For Metal—Wood—Composition Materials. Turning—Facing—Boring—Drilling—Winding—Thread Cutting. Accurate—Strong—Quiet—Compact. Slide-rest has travel entire length of bed. Leadscrew inside bed. No. 1 Lathe, plain headstock, \$28.00. No. 2 Lathe, back-geared headstock, \$38.00. Extra for lathes with 18 inches between centers, \$7.00. Complete line of accessories at equally low prices. Write for free catalog.

**THE GEROLD CO.** Dept. P-38 120 Liberty St. New York







Kingsbury Sedan No. 945  
Length 13 1/2 in. Price \$3.00. West of  
Miss. and in Canada slightly higher.

## REAL? TOY? WHICH?

THE picture certainly looks like a real car, doesn't it? And so does the toy itself, this up-to-date model of a modern sport sedan. Every detail is just like life—the coloring, accessories, spare wheel, trunk, bumpers, lamps, etc.—even the speed! For it is equipped with a strong swift spring motor that runs fast and long. Your toy dealer will be glad to show you this Kingsbury novelty. If he is not yet supplied, we will fill your order direct. Write for free catalog.

KINGSBURY MFG. COMPANY  
83 Myrtle St., KEENE, N. H.

## KINGSBURY MOTOR DRIVEN TOYS

Send 10c for this



Disc Wheel Eraser

DEALERS: Kingsbury toys are always "best sellers." Write for our Proposition.

## Beautiful HOUSES \$900 and BUNGALOWS

CAN BE BUILT FOR AND UP

This and many others in my new book, Building Plans for Modern Homes, will save you hundreds of dollars. One of the most complete and comprehensive books of plans ever published by any architect. New edition just off the press. Nearly 600 floor plans and photographs of Colonial houses, bungalows, etc., costing from \$200 up; gives sizes and cost to build. Sent postpaid for \$3.00.



FREDERICK H. GOWING  
ARCHITECT  
101 Tremont St., BOSTON, MASS.

FREE

1000  
Illus-  
trations

## ELECTRIC FIXTURE CATALOG!

Write today for your copy. Save 50% direct from Manufacturer. No Middleman's Profit. OUR SPECIAL: 8 Room Electric Set, ready to hang, \$24.50—Other bargains.



UNITED LIGHTING FIXTURE CO.  
83 Flatbush Ave., Dept. M, Brooklyn, N. Y.

## PIN A DOLLAR BILL TO THIS

and get this genuine leather 5-window-pass case. Holds Railroad Passes, Auto License, Lodge Cards, etc. Masonic or Shrine Emblem stamped on in gold free. Your name or other stamping 35c extra per line. Cash must accompany order.

We carry

## EVERYTHING MASONIC

Send for free catalogue No. 10 P. M., of Books, Monitors, Jewelry; No. 11 P. M., of Lodge Supplies.

We Have Been in Business 67 Years!

## REDDING & COMPANY

200 Fifth Ave., Desk P. M.

NEW YORK



DR. HARLAN TARBELL  
MASTER OF MAGIC

# I'll Teach YOU Real Professional MAGIC

*at Home ~ By MAIL*



## Big Stage Illusions Secrets of the Orient

Master Illusions from Europe, India, China, Japan. Guarded secrets of the Orient—over 150 tricks from small effects to Big Stage Illusions, with nearly 1500 illustrations, *that and more* is what you get in the Tarbell Course in Magic!

## Read This Great Endorsement

Dr. A. M. Wilson, Editor of the Sphinx, Official Organ of The Society of American Magicians, pays the Tarbell Course this tribute:

"The greatest work on Magic ever attempted and will mark an epoch in Magic greater than the revelations of Robert Houdini, Father of Modern Magic, 60 years ago."

## Money-Back Guarantee Protects YOU

The Tarbell course in Magic protects you with an Iron Clad Guarantee to refund your money if you are not satisfied. You can't lose. You have everything to gain.

## Get Started on the Road to Big Money

You need not give up your job. You don't have to be a "professional" to make big money. You can make nice money entertaining on-the-side as a semi-professional, or if you want to, you can become a big Magician, make big money and enjoy fame and glory. Learn all the great limitless opportunities that are in store for you. Mail coupon NOW!

The first  
and only  
Course in  
Magic

ever offered to the  
public teaching  
real professional  
Magic!

## Mail This Coupon NOW!

### Tarbell System, Inc.

1926 Sunnyside Ave., Studio 93-59, Chicago

Tell me about Dr. Tarbell's new and simple system by which I can learn the secrets of MAGIC. Also tell me about your Special Price and Easy Terms Offer. No obligation on my part.

Name.....

Address.....

Age.....



**The Old Reliable Credit Jewelers** **LOFTIS BROS. & CO.** EST'D. 1859 Dept. G-894 108 N. State Street Chicago Illinois

**DIAMONDS AS LOW AS \$100 A WEEK**  
**Genuine Diamonds Guaranteed CASH OR CREDIT**  
**Beautiful Diamonds for Christmas!**  
 Diamonds for Christmas at a great saving! Dazzling gems of fine blue white color—all special importations—exquisitely set in mountings of solid 18-k white gold. Buy direct from Loftis, the importer, and save what others pay to middlemen. Order now—direct from this ad!

Satisfaction guaranteed, or money back. Goods sent for your free examination on request. *Credit Terms:* Pay one-tenth down; balance weekly, semi-monthly, or monthly at your convenience. All goods delivered on first payment.

**Christmas Catalog Free!**  
 Big 132-page book, illustrating our Diamonds, Watches, Jewelry, Silverware, and gift articles for all occasions, sent absolutely free. Write today.

**No. 877 \$50 \$1.25 a wk.**  
**No. 878 \$100 \$2.50 a wk.**  
**No. 879 \$150 \$3.75 a wk.**  
**No. 864 \$37.50 \$1 a wk.**  
**No. 830 \$75 \$1.75 a wk.**  
**No. 887 \$100 \$2.50 a wk.**

**Rectangular Wrist Watch No. 868**  
 Solid 14-k white gold, 15 Jewels, Gold filled bracelet to match. \$35. \$3.50 down, \$3.50 a month.

**Cushion Strap Watch**  
 Nickel, 6 Jewels—high grade Leather strap. Special . . . . . **\$8.50**

**Railroad Watches—**  
**Guaranteed to Pass Inspection**  
**HAMILTON NO. 992, 21 Jewels, Adjusted to 6 Positions, Gold filled 26-Year Quality Case . . . \$55**  
**ELGIN'S LATEST RAYMOND, 21 Jewels, 8 Adjustments, Runs 40 hours one winding. Gold filled 20-Year Quality Case . . . . \$55**  
**ILLINOIS "BUNN SPECIAL," 21 Jewels, Adjusted to 6 Positions, Gold filled 26-Year Quality Case, 60 hours, 1 winding . . . . . \$50**

**Wedding Rings**  
 No. 824—The "Elite" solid 18-k white gold. Set with 3 Diamonds, \$22.50; 5 Diamonds, \$32.50; 7 Diamonds, \$42.50; 9 Diamonds, \$52.50; 12 Diamonds, \$67.50. All platinum, \$25. With 3 Diamonds, \$60; 5 Diamonds, \$70; 7 Diamonds, \$80; 9 Diamonds, \$100; circled by Diam' ds, \$200.

**Credit at Cash Prices**  
**Send for Free Catalog!**

**SHIP MODEL PLANS!**  
 fittings and supplies. Build and sell models. Plans and instructions for Viking Galley 40c; Chinese Junk 45c. Interesting catalog of Sea Things 6c.  
**SEA ARTS GUILD**  
 730A Winnebago St., Milwaukee, Wis.

**BOYS!**  
**Enter this Contest**  
**\$500.00 Cash 1st Prize**

EVERY boy will want our new, thrilling and beautifully illustrated book. It is a most interesting story and tells you all about the new Meccano. It fully explains the fun and ease with which you can build hundreds of wonderful working models in colors, such as steam shovels, wrecking cars, cranes, bridges, etc. These models are exact duplicates of the real engineering machines from which they are copied. With this book you will receive an entry blank for the great Meccano Prize Contest—first prize \$500 in cash. You may be the lucky boy. Write today. The book and entry blank will be sent to you free upon receipt of your name and address and the names and addresses of three (3) of your friends. Put No. H-2 after your own name for reference.



**MECCANO**  
 MECCANO COMPANY, INC. Div. H-2 Elizabeth, N. J.

**10 DAYS FREE TRIAL - MONEY BACK IF NOT SATISFIED**  
**THE NEW INKOGRAPH SELF FILLER**  
 IMPROVED GREATEST VALUE EVER OFFERED

Same size as \$7 and \$8.75 Fountain Pens  
 The Perfect Writing Instrument  
 Writes with ink easy as a lead pencil. Won't skip, blot, scratch, leak or soil hands. Its steady uniform flow of ink improves handwriting.  
 Makes three carbon copies with original in ink. Guaranteed—Send No Money. Pay postman \$1.50 plus postage.  
**INKOGRAPH CO., Inc.**  
 199-57 Centre St., New York City

A hard, round, smooth ball-like 14-kt. Gold Point.

**AGENTS** Send for Inkograph or write for Sales plan booklet which tells how to make big money

**Your Coat and Vest Can Be Matched with New Trousers**

Save the price of a new suit. We match hundreds of coats and vests satisfactorily every day. Each pair tailored to your measure. 80,000 patterns. We submit sample of cloth for your approval. Just mail your vest or a sample of the suit.  
 We employ no agents.  
**ACME PANTS MATCHERS**  
 Dept. BM-14, 20 W. Jackson, Chicago



**Do Your PRINTING**  
 Cards, stationery, circulars, tag, labels, paper. Complete Outfits, \$8.85 up, Job Presses \$11 up, Rotary \$149. Card Cutters, \$3. Save money. Print for others, big profits. All easy rules sent. Write for catalog presses, type, paper, cards, ink etc. **THE KELSEY CO., K-37, Meriden, Conn.**



**DO YOU** WANT a new business profession of your own, with all the trade you can attend to? Then become a foot correctionist, and in a few weeks earn big income in service fees,—not medical nor chiropody—easy terms for home training, no further capital needed, no goods to buy, no agency. Address  
**Stephenson Laboratory, 1 Back Bay, Boston, Mass.**

**Direct at Factory Prices**  
 Sample \$1.18 3 for \$3.00 Postpaid  
**Hand Forged Razor Steel Blades**  
 Send for our 100-page FREE List and "HOW TO USE A RAZOR."  
**Maher & Grosh Co.**  
 106 A St., Toledo, Ohio

**A Genuine \$2 Knife for \$1.18 Postpaid**  
 Handy shaped Blade makes this knife best for mechanics, sportsmen and farmers; light but strong; re-sharpened easily. Stag handle. German silver finish; blades file tested, hand forged from razor steel and warranted.







### Automatic Concertina Played With Inter- changeable Rolls.

Musical Entertainers wanted everywhere and earn big money at Moving Pictures, Vaudevilles, Cabarets, Restaurants, Inns, Lunch Rooms, Outings, Dances, Weddings, Fairs, Parties, or travelling with shows all year. Entertainers charge \$10.00 per evening. Our **AUTOMATIC CONCERTINA**, played with interchangeable **Rolls** offers opportunity, to make big money or steady side income. You play perfect in 30 minutes Songs, Dances, Operas, Marches, Waltzes, Fox Trots, One Steps, etc. without a faint idea of music or notes. Beautiful tone and melodious as played by artists. The **AUTOMATIC CONCERTINA** possesses a charm, which no one can escape. The player is actually playing, without any study or practice. Attractive professional cards furnished without charge, lead to an income for lifetime. **AUTOMATIC CONCERTINAS** are used in Song and Dance Acts on the stage. Three Models for Home, Concerts, and Paid Entertainers, from \$30.00 to \$60.00. Descriptive circular number 2 mailed free.

**TREASURE SALES COMPANY** 1690 Boston Road  
NEW YORK

### GENUINE FRENCH BRIAR PIPE SET



for Only **\$2.75**

Magnificent smoking outfit, beautifully polished and engraved, imported when the French franc was lowest. Manufactured to retail at the \$10 price stamped in each box, we are offering them to you direct from our wholesale dept. at only \$2.75. Set consists of two genuine French Briar pipes treated to require no breaking-in. Amberlite mouthpieces; fancy Amberlite cigar and cigarette holders. Each set is fitted in a beautiful strongly made plush and silk-lined case. Complete, \$2.75.

Send No Money Pay postman \$2.75 plus postage on delivery. Money refunded if not satisfied.

**H. & H. SALES CO.,** 81 Bowery, Dept. P 51, NEW YORK, N. Y.

### WHITE FLAME BURNERS

make your old kerosene lamps and lanterns give a brilliant white light better than electricity or gas. Doubles your light. Saves oil. **NO MANTLE TO BREAK.** Guaranteed Safe and Reliable. Delights every user. Send now for complete sample postpaid 50 cents, stamps or coin, 3 for \$1.25. **Money Back If Not Satisfactory.** Live Representatives Wanted. Exclusive Territory. **WHITE FLAME LIGHT CO.,** 68 Clark Bldg., Grand Rapids, Mich

### AGENTS 500% PROFIT GENUINE GOLD LEAF LETTERS

**S** guaranteed to never tarnish. Anyone can put them on stores and office windows. Enormous demand, large profits. Paul Clark says: Smallest day \$28.70. R. L. Reel made \$920 in two months. Write today for free sample and liberal offer to general agents. **METALLIC LETTER CO.,** 433-B N. Clark St., CHICAGO

# save 1/3 to 1/2

New FREE book quotes **Reduced Factory Prices. 5-Year Guarantee Bond** on Stoves, Ranges, Furnaces. 200 styles and sizes. Beautiful porcelain enamel ranges and combination gas and coal ranges. Mahogany porcelain enamel heating stoves. Cash or easy terms. 24-hr. shipments. 30-day free trial. 360-day test. Satisfaction guaranteed. 25 years in business. 650,000 customers. Write today for FREE book.

**Kalamazoo Stove Co. Manufacturers**  
391 Rochester Avenue  
Kalamazoo, Mich.

Ranges **\$49.95** Up  
**"A Kalamazoo Direct to You"**

# You can now Own a Typewriter!

**\$3.00 DOWN** and its yours *guaranteed for 5 years.*



Be up-to-date—know the pleasure and convenience of having one in your home. You'll be amazed at the uses everyone in your household will find for this real Underwood typewriter. Every member of the family will use and enjoy it! Don't send a cent—but do get our big special offer—our valuable book on typewriters and typewriting—FREE.

### Any One Can Learn to Operate a Typewriter!

You can learn to write on this standard-keyboard machine in one day; it's so simple that even a child can use it. A week after the expressman has brought it, you'd feel LOST without it. A trial will PROVE it—and doesn't cost you a penny!

### SPECIAL FREE TRIAL OFFER

We don't want a penny now. Nor any money at all unless this proves the typewriter bargain of your life. The trial is FREE. If you buy, our easy terms make it a pleasure to pay. There's no excuse now, for not owning a typewriter—and the finest make!

We include all tools, a cover, etc., all complete, all ready to write. Write us now. Deal direct; we are the largest factory of the kind.

Our plan gives you the opportunity of a thorough trial before you buy. You run no risk whatever. You start to pay for your typewriter AFTER you have found it the only machine for you!

But get the facts before this lot of machines is all in use. Clip the information coupon before you turn the page. It will pay you! Note the very useful book you will receive free! Write for full particulars at once.

### The Greatest Typewriter Offer Ever Made

If you know typewriters, you know the perfect work and the ease and speed of a Shipman Ward rebuilt Underwood typewriter.

New machines are guaranteed for only one year; WE GUARANTEE EVERY ONE OF OUR MACHINES FOR FIVE YEARS! If you have never owned a typewriter, start with the finest! You can try this one at our risk. But, the time to act is NOW. Don't miss out on this present bargain offer whereby you can get this genuine Underwood at a big savings. Don't do longer without the convenience of a typewriter.

**FREE!** Get our catalog free; lowest prices and terms. A manual free, too; valuable instruction for learning rapid typing.

## Mail Today!

Shipman Ward Manufacturing Co.,  
2129 Shipman Building, Chicago, Ill.

Please send me your Free Trial Plan and Typewriter Book, together with your special offer on prices, terms, free course in Touch Typewriting and also how I can make money with this typewriter, without obligation. This is not an order.

Name.....  
Street or R. F. D.....  
City.....  
State.....



# This Wonderful BANJO

THE Gibson Mastertone, with its brilliant, snappy, yet always musical tone, and exclusive easy-playing features, make it the choice of leading professionals and amateurs alike. YOU can learn to play it quickly, easily.

Send coupon now for new FREE Book, illustrating and describing Gibsons, today's most popular instruments. Easy Payment Plan enables you to enjoy a Gibson immediately. Get the facts now; no obligation. Mention instrument: Tenor-Banjo; Plectrum-Banjo; Guitar-Banjo; Mandolin-Banjo; Mandolin; Guitar; Ukulele.



GIBSON, Inc., 1203 Parsons Street, Kalamazoo, Mich.  
Please send details of easy payment plan on

**Gibson**

Name \_\_\_\_\_ (Instrument) \_\_\_\_\_  
St. or R. F. D. \_\_\_\_\_  
City, State \_\_\_\_\_

## Chemical Tricks for Boys



Surprise and puzzle your friends with magic chemical tricks; make ink, dye cloth, test water and soil; write secret letters with invisible ink; pour blue, brown and black liquid from a pitcher of water. All these and many more chemical stunts are easy with ChemCraft Junior. It's the best box of fun you ever had! Get yours now.

**ONLY 25c POSTPAID**

**FREE Magazine**

of the ChemCraft Club to every boy who writes for it now. Full of new ideas and chemical stunts. Ask for yours!

The Porter Chemical Co.  
113 Summit Ave. HAGERSTOWN, MD.

# EDWARDS WILL SAVE YOU MONEY ON METAL ROOFS

We own our own steel mills, roll our own sheets, make them into high-grade REO METAL SHINGLES, Sidings, Ceilings and Roofings of every type and style for every kind of building. We control every operation from the raw material to the finished roof and we sell direct from our factories to the user. Not a dollar to divide with anybody but the customer! You get better value for less money.

### OUTLAST THREE ORDINARY ROOFS

EDWARDS METAL ROOFS are weather-proof, lightning-proof, fire-proof! The galvanizing bends with the metal. No tools required.



### LOW-COST ALL-METAL GARAGES

Any size. Any style. Portable. Ready to erect. Complete with frames, doors, sash and hardware. Ornamental, durable, economical. Blue-prints and complete instructions FREE. Write today. Get our low prices and Free Samples. Ask for Roofing Book No. 150 or for Garage Book No. 150.



THE EDWARDS MFG. CO.  
1200-1250 Butler St. Cincinnati, O.

## Sport Bodies for Fords AT FACTORY PRICES!

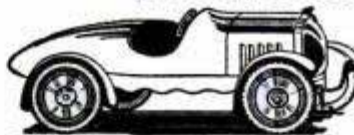

This Model in Grey Prime **\$39.50**

Write for Booklet A-2 Showing Other Models.

SPORT FACTORIES, AURORA, ILL.

## I made \$250<sup>00</sup> extra in 3 months with my TORIT handy Torch



THOUSANDS OF MECHANICS in the U. S. and Canada are doing the same—Cashing in on quick, easy profits. One man writes, "I received my Torit Torch in the morning and by night had made an extra \$7.50 on jobs I ordinarily turn down. The Torit has already paid for itself and is now the **HANDIEST TOOL IN THE SHOP.**" Beats anything you ever tried for soldering, lead burning, radiator repairing, etc.

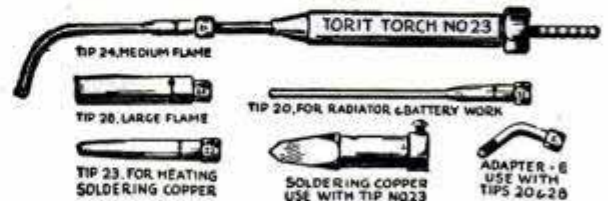

PAT. JAN. 5, 1926

Uses Acetylene Only. No oxygen or air pressure is required. Tips suck in air. Simply connect to Presto auto tank, light gas, and outfit is put to work. Consists of torch, 4 tips, soldering copper, 5 ft. rubber tubing, tank connection and instructions. Price **\$750**

ST. PAUL WELDING & MFG. CO., 177 W. 3rd St., St. Paul, Minn.





## RADIO SET BUILDERS

*Here's Information You Can Depend On*

Leading radio engineers have prepared authoritative design manuals

containing much original information of greatest practical value to those interested in improving the operation, bettering the quality of reproduction, or applying power equipment to their sets.

**Audio Amplification**, Sent upon receipt of 25 cts.

**B Eliminator and Power Amplifier Construction**. Send 10 cts.

**Make-Em-Better Sheet**, showing use of RF and AF Chokes in 17 popular circuits or your own receiver. Send 5 cts.

**Inductance Units Bulletin**, contains RF Amplifier and coil formulae. Send 10 cts.

All four sent on receipt of 50 cts.

**Samson Electric Co.**

MAIN OFFICE: CANTON, MASS.  
Manufacturers Since 1882  
Factories at Canton and Watertown, Mass.

## RADIO PANELS

### BAKELITE—HARD RUBBER

Cut, drilled and engraved to order. Send rough sketch for estimate. Our complete Catalog on Panels, Tubes and Rods—all of genuine Bakelite or Hard Rubber. Mailed on Request.

**STARRETT MFG. CO.** 524 S. Green St. Chicago, Ill.

# PRICES SLASHED

## On Standard Radio Products

Now ready! Harry Alter's price list for December. Saves you money on every requirement—not merely on a few "bait" bargains. Check and prove my unheard-of values. Test Alter's "Minute-Man" shipping service. Send for this big catalog—free.

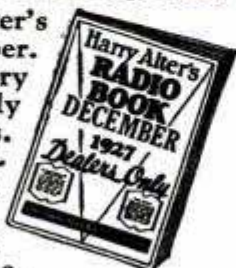

(NOTE: We Sell to Dealers Only)

**The Harry Alter Co.**

1790 Michigan Ave., Chicago, Ill.



You can candle an egg—but not a battery



THERE isn't much difference in the size or shape of batteries. And you can't tell how good they are before you use them. Q If you could, one element alone would win your preference for Burgess. That element is *Chrome*. Q *Chrome* is the preservative that maintains an abundance of unfailing energy in Burgess Batteries—long after most dry cells cease to function. The black and white stripes are individual marks for identifying Burgess *Chrome* Batteries. Buy them for long lasting, dependable performance!

*Chrome*—the preserving element used in leather, metals, paints and other materials subject to wear, is also used in Burgess Batteries. It gives them unusual staying power. Burgess *Chrome* Batteries are patented.

Ask Any Radio Engineer

**BURGESS BATTERY COMPANY**

General Sales Office: CHICAGO

Canadian Factories and Offices: Niagara Falls and Winnipeg

## BURGESS BATTERIES



RADIO • IS • BETTER • WITH • DRY • BATTERY • POWER



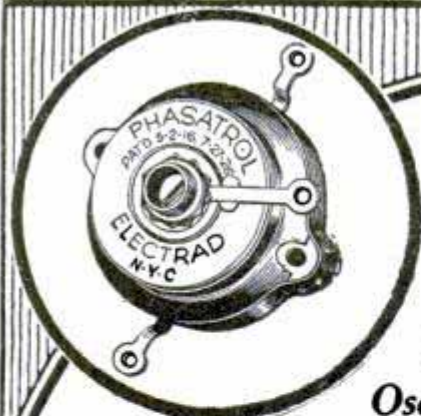

Licensed by  
Rider Radio  
Corporation  
Pats. Pending.  
Patented 5-2-'16  
Patented  
7-27-'26

**Don't  
Endure  
Oscillations!**

# Phasatrols

Reg. U. S. Pat. Off.

**A True Balancing Device for Radio  
Frequency Amplifiers**

**\$2.75**

If you are troubled with R. F. oscillations in your set, you can positively put an end to the squeals and howls they cause with Phasatrols.

PHASATROLS make tuning easier. Endorsed and used by experts. Very easy to install in any tuned, untuned or reflex R. F. set.

Write for free hook-up circular for any set or circuit.

Dept. 65C, 175 Varick St., New York, N. Y.

# ELECTRAD

The man who studies gets ahead. Popular Mechanics Press will advise you what books to read to advance in your trade. 200 East Ontario Street, Chicago, Illinois.

# TISIT

## COLD SOLDER

### No Heat or Soldering Iron Required



Repairs aluminum, iron, wood, and most household articles. Indispensable for radio or automobile owners. TISIT is a household necessity. It can be used for nearly any kind of a repair job. It is applied cold with a stick and dries in 30 minutes. Not affected by heat or acids. The most inexperienced person can use it with satisfaction. TISIT makes soldering a simple job. 50c at your dealer's. If he cannot supply you, send us 50c and we will ship you a bottle post-paid. Money back if dissatisfied.

**LETELLIER LABORATORIES, Inc.**  
185 Main St. E.  
ROCHESTER, N. Y.

# REMOTE CONTROL



**Mechanical Model \$18.00**  
**Electrical Model \$60.00**  
(Add 10% west of Rocky Mountains)

Write for illustrated descriptive circular

Imagine the pleasure of tuning your radio without having to get up once all evening! Turn set "on" or "off," tune, regulate volume—from your easy chair! Easily attached to any single, removable dial receiver in a few minutes.

**ALGONQUIN ELECTRIC COMPANY, Inc.**  
245 Fifth Avenue, New York City

The New *Algonquin*

TRADE MARK REG. U. S. PAT. OFF.  
**REMOTE CONTROL Radio Tuning Unit**

# BIG RADIO CATALOG

From the "Big, Friendly Radio House"

NEW 1928 Book offers finest, newest well-known sets; parts, eliminators, accessories at lowest prices. Dealers, set-builders, agents — WRITE for this CATALOG!

# Western Radio Mfg. Co.

132 West Lake St., Dept. 39—CHICAGO, ILL.

# Set Builders! Dealers!



## FREE

Standard parts and equipment at money-saving prices, with discounts that show you a real profit. Electrical Phonograph—pickups—latest kits! New A C tubes and transformers—parts for any circuit—power audio equipment—short wave supplies—they are all in our big new 1928 Catalogue. Write for it today, with discount sheet. 12-hour shipment guaranteed.

# Dan-Ashe Radio Co.

206 N. 10th St., St. Louis, Mo.



# HARRY ALTER'S *NEW* LOWER PRICES WILL AMAZE YOU!



Again Harry Alter challenges all competition by smashing prices that were already the lowest known in radio. Staggering values in sets and parts of standard quality. Get my new December catalog. Write for it NOW. We sell to retailers only.

**The Harry Alter Co.**

1792 Michigan Avenue CHICAGO

**6 TUBE RADIO**  
**ONE DIAL** Latest advanced circuit. All steel chassis totally shielded. Balanced parts of best quality. Marvelous power and selectivity. Gets the long range stations as clear as a bell. One dial single control. An unsurpassed value—just one of our many mighty bargains.  
**Only \$32.50**

**FREE Log and Call Book and Big New Catalog**—just off the press. Full of Radio Bargains. Send for your free copy now!  
American Auto & Radio Mfg. Co.  
HARRY SCHWARTZBERG, Pres.  
Dept. 262 American Radio Bldg., Kansas City, Mo. 2

**SOLDERALL**  
METAL IN PASTE FORM

The only convenient metal solder

Every Electrical Connection needs Solderall for perfect reception

**25¢**

The SOLDERALL CO., NEWARK, N.J.

**\$75 to \$125 Weekly**  
**Charging Batteries Starts You**

Let me show you how to make big money right from the start. I've prepared a FREE book explaining all details. First week's profit pays for all equipment. You can get all the battery charging business in your community with my Service Station Charger—it's years ahead of ordinary chargers—handles 50% to 70% more batteries. I explain everything—start you in a business of your own and put you on the way to big money. Write for FREE Book.

**C. F. HOLMES, Chief Engineer, Dept. PM**  
Independent Electric Works, 5116 Ravenswood Ave., Chicago

**FREE BOOK—Just Out**

TRADE MARK *REB*  
**WURLITZER**  
THE WORLD'S LARGEST MUSIC HOUSE



**200 Years Ago** in the little Saxon town of Shoeneck lived Hans Adam Wurlitzer, Master Violin Maker. His shop was a gathering place for musicians of the time, for he was a true craftsman.

When he died his shop passed into the hands of his eldest son, and for seven generations, down to the present day, the descendants of Hans Adam Wurlitzer have carried on his work.

Today in every Wurlitzer instrument you will find a quality, a character, that could not come from mere excellence of manufacture. It is the heritage of these seven generations of music craftsmanship.



# Try any Wurlitzer Instrument in your Own Home

YOU may now have any Wurlitzer instrument for a generous free trial in your own home. Examine the instrument, show it to your friends, play it as much as you wish. No obligation to buy—no expense for the trial. We make this liberal offer because we want you to try for yourself these wonderful instruments, the result of 200 years' experience in musical instrument building. Easy payments are arranged to suit your convenience. This is your opportunity to try a famous Wurlitzer instrument in your own home.

Send for  
**New Catalog**

The greatest musical catalog ever published. Over 3,000 articles—every known instrument described and illustrated; many of them shown in full colors. Gives you lowest prices and all details of Free Trial, Easy Payment plan. All sent FREE—no obligation.

Send this Coupon

**THE RUDOLPH WURLITZER CO., Dept. 1779**  
117 E. 4th St., Cincinnati

Send me absolutely free, your new illustrated catalog, with prices and description of every known musical instrument. Also tell me how I may try any instrument in my own home and pay for it in small monthly sums. No obligation.

Name .....

Address .....

City ..... State .....

Instrument .....

(State instrument in which you are interested)

Copyright, 1927, The Rudolph Wurlitzer Co.



# PATENT

## Protect Your Ideas

### Take the First Step Today

If you have a useful, practical, novel idea for any new article or for an improvement on an old one, you should communicate with a competent Registered Patent Attorney AT ONCE. Every year thousands of applications for patents are filed in the U. S. Patent Office. Frequently two or more applications are made for the same or substantially the same idea (even though the inventors may live in different sections of the country and be entirely unknown to one another). In such a case, the burden of proof rests upon the last application filed. Delays of even a few days in filing the application sometimes mean the loss of a patent. So lose no time. Get in touch with me at once by mailing the coupon on the opposite page.

### Prompt, Careful, Efficient Service

This large, experienced organization devotes its entire time and attention to patent and trade mark cases. Our offices are directly across the street from the U. S. Patent Office. We understand the technicalities of patent law. We know the rules and requirements of the Patent Office. We can proceed in the quickest, safest and best ways in preparing an application for a patent covering your idea. Our success has been built on the strength of careful, efficient, satisfactory service to inventors and trademark owners located in every state in the Union.

### NO CHARGE for Information On How to Proceed

The booklet shown here contains valuable information relating to patent procedure that every inventor should have. And with it I will also send you my "Record of Invention" form on which you can sketch your idea and establish its date before a witness. Such evidence may later prove valuable to you. Simply mail the coupon and I will send you the booklet, and the "Record of Invention" form, together with detailed information on how to proceed and the costs involved. Do this NOW. No need to lose a minute's time. The coupon will bring you complete information entirely without charge or obligation.



My Patent Law Offices  
Just Across  
Street From  
U.S. Pat. Office



Above is a view of my drafting and specification offices where a large staff of experienced experts are in my constant employ. All drawings and specifications are prepared under my personal supervision.

# NEWS

*Inventors*  
*Write for these* **Free Books**

**Strict Secrecy Preserved**

All communications, sketches, drawings, etc., are held in strictest confidence in strong, steel, fireproof files, which are accessible only to authorized members of my staff. Feel free to write me fully and frankly. Your case will have my personal attention. It is probable that I can help you. Highest references. But **FIRST**—clip the coupon and get my free book. Do **THAT** right now.

**Clarence A. O'Brien**

*Registered Patent Attorney*

Member of Bar of: Supreme Court of the United States; Court of Appeals, District of Columbia; Supreme Court, District of Columbia; United States Court of Claims. Practice confined exclusively to Patents, Trade marks and Copyrights

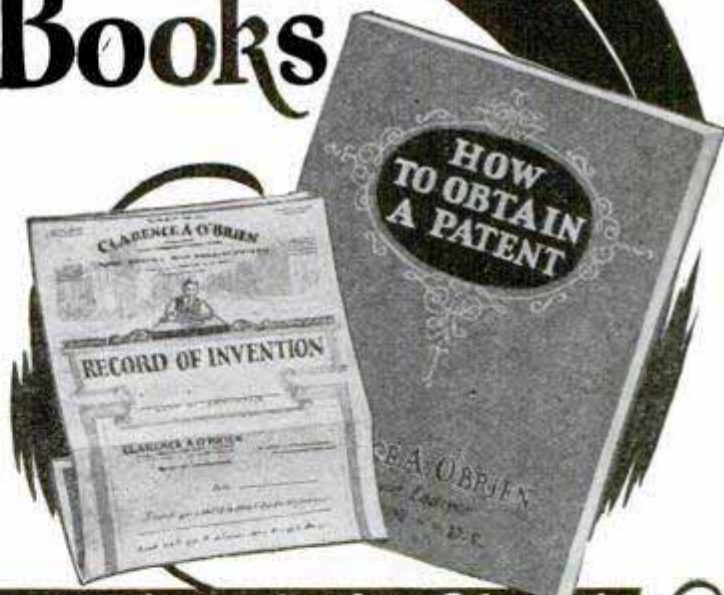

**Clip this Coupon and Mail it Now!**

**CLARENCE A. O'BRIEN, Registered Patent Attorney**

702 Security Savings and Commercial Bank Bldg., Washington, D. C.

Please send me your free book, "How to Obtain a Patent," and your "Record of Invention" form without any cost or obligation on my part.

Name.....  
*(Important: Write or Print name clearly.)*

Address.....



# PATENTS

TRADE-MARKS ·· DESIGNS  
FOREIGN PATENTS

MUNN & CO.  
PATENT ATTORNEYS

*Associated for 81 years with the Scientific American*

SCIENTIFIC AMERICAN BUILDING  
24 WEST 40th STREET  
*New York*

SCIENTIFIC AMERICAN BUILDING  
*Washington, D. C.*

TOWER BUILDING  
*Chicago, Ill.*

HOBART BUILDING  
*San Francisco, Cal.*

VAN NUYS BUILDING  
*Los Angeles, Cal.*



Books and Information on Patents  
and Trade-Marks by Request.  
Associates in All Foreign Countries.



# PATENTS TRADE-MARKS AND COPYRIGHTS



## OUR OFFER: FOR THE PROTECTION OF YOUR INVENTION

**YOUR FIRST STEP.** The inventor should write for our blank form—"RECORD OF INVENTION." This should be signed, witnessed and returned to us together with model or sketch and description of the invention for INSPECTION and INSTRUCTIONS FREE!

### Our Four Books Mailed Free to Inventors Our Illustrated Guide Book

#### HOW TO OBTAIN A PATENT

Contains full instructions regarding U. S. Patents, Our Methods, Terms, and 100 Mechanical Movements illustrated and described.

#### OUR TRADE-MARK BOOK

Shows value and necessity of Trade-Mark Protection. Information regarding *Trade-Marks and unfair competition in trade.*

#### OUR FOREIGN BOOK

We have Direct Agencies in Foreign Countries and secure Foreign Patents in shortest time and at lowest cost.

#### PROGRESS OF INVENTION

Description of World's Most Pressing Problems by Leading Scientists and Inventors  
All Communications and Data Strictly Confidential.  
Interference and Infringement Suits Prosecuted.

#### IMPORTANT

TO MAKE YOUR CASE SPECIAL AND AVOID DELAY YOU SHOULD HAVE YOUR CASE MADE SPECIAL IN OUR OFFICE to secure protection, save correspondence and obtain early filing date in Patent Office. To secure special preparation of your case send \$25.00 on account with model or sketch and description of your invention.

*Our Lawyers Practice in all U. S. Courts and defend Clients in Suits involving Patents, Trade-Marks and Copyrights*

### OUR ORGANIZATION OFFERS PERSONAL SERVICE By Experienced Patent Lawyers, Solicitors and Draftsmen

We Regard a Satisfied Client as our best advertisement, and furnish upon request, lists of clients in any state for whom we have secured patents.

*Highest References—Prompt Attention—Reasonable Terms*

WRITE TODAY

## VICTOR J. EVANS & CO.

Registered Patent Attorneys

MAIN OFFICES: 792 Ninth St., Washington, D. C.

New York Offices, 1007 Woolworth Bldg.; Philadelphia Offices, 518-519 Liberty Bldg.; Pittsburgh Offices, 514 Empire Bldg.; Chicago Offices, 1114 Tacoma Bldg.; San Francisco Offices, 1010 Hobart Bldg.

Gentlemen: Please send me FREE OF CHARGE your books as described above.

Name .....

Address .....

FREE  
COUPON



# PATENTS

**Booklet Free**      **Highest References**  
**Promptness Assured**      **Best Results**

Send drawing or model for preliminary examination of Patent Office records.

## ALL BUSINESS GIVEN PROMPT AND PROPER ATTENTION

Listed Patent Lawyer in the latest editions of the Rand-McNally Directory of Bankers and Attorneys, of Chicago, Ill.; The Baggott & Ryall Directory of Attorneys, New York City; The Lawyers Guaranteed Directory, Detroit, Michigan; The Lawyers and Bankers Quarterly, published by the Legal Directory Publishing Company of St. Louis, Mo.; the American Lawyers Annual, Cleveland, Ohio.

**WATSON E. COLEMAN,**  
REGISTERED PATENT LAWYER

Victor Building, 724 Ninth Street, N. W.  
**WASHINGTON, D. C.**

## 1000 NEEDED INVENTIONS!

Here is the most remarkable book ever offered to inventors. One Thousand needed inventions listed and described. Arranged as follows: General Problems; Automotive; Mechanical; Electrical; Chemical; Radio; Marine. Separate chapter on the Ten Most Needed Inventions. This book may give you one idea that will win you a fortune. Nothing else like it has ever been published. Compiled at enormous expense. Edited by Raymond Francis Yates, formerly Managing Editor of a leading scientific magazine. Over 100 pages, durably bound. Price \$1.00. Cut out this advertisement, pin \$1.00 to it and send it to us with your name and address, plainly written, and your copy of this remarkable book will be sent immediately. (Outside U. S. \$1.25.) Money back after 10 days' examination if desired. Limited edition. Write NOW.

**BUREAU OF INVENTIVE SCIENCE**  
Dept. 312      Rochester, New York

## PATENTS

### Don't Lose Your Rights To Patent Protection

Before disclosing your invention to anyone send for blank form "EVIDENCE OF CONCEPTION" to be signed and witnessed. As registered patent attorneys we represent hundreds of inventors all over the United States and Canada in the advancement of inventions. The form "Evidence of Conception," sample, instructions relating to obtaining of patents and schedule of fees sent upon request.

**LANCASTER & ALLWINE**  
480 Ouray Bldg.      WASHINGTON, D. C.  
*Originators of forms "Evidence of Conception."*

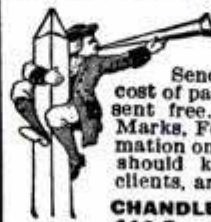

## PATENTS

Send us sketch or model for advice and exact cost of patent. Our book "How to Obtain a Patent" sent free. It tells how to apply for Patents, Trade Marks, Foreign Patents, Copyrights, etc.; gives information on Patent Procedure; tells what every inventor should know. Thousands of inventors, who are our clients, are our reference.

**CHANDLEE & CHANDLEE, 25 Years' Experience**  
410 Seventh St.      Washington, D. C.

## Will Finance Patents

Patents of commercial value financed on royalty basis without expense to inventor. Mail models and copies of patents or full details to

**KAMSTONE HOLDING CORP.**  
41 East 42nd Street      N. Y. C.

## PATENTS

Trade Marks, Copyrights, Patent Litigation Handbook with illustrations, 100 mechanical movements. Sent free on request.

**ALBERT E. DIETERICH**  
formerly member examining corps U. S. Patent Office  
**PATENT LAWYER and SOLICITOR**

621-A, Ouray Bldg.  
27 Years' Experience      Washington, D. C.

## PATENTS

As one of the oldest patent firms in America we give inventors at lowest consistent charge, a service noted for results, evidenced by many well known Patents of extraordinary value. Book, Patent-Sense, free. Lacey & Lacey, 646 F St., Wash., D.C. Estab. 1869.

## BLUE BOOK ON PATENTS

AND PRIORITY RECORD BLANK GRATIS

**MONROE E. MILLER, PATENT LAWYER**  
411-2 Ouray Building.      WASHINGTON, D. C.  
ELECTRICAL AND MECHANICAL EXPERT

# INVENTORS PROTECT YOUR IDEAS

Send for our Guide Book, **HOW TO GET A PATENT**, and Evidence of Invention Blank, sent Free on request. Tells our terms, methods, etc. Send model or sketch and description of your invention for **INSTRUCTIONS**. No charge for the above information.

**RANDOLPH & CO.**  
301 Victor Bldg., WASHINGTON, D. C.

NAME .....

STREET .....

CITY ..... STATE .....



# PATENTS

## To the Man with an Idea

I offer a comprehensive, experienced, efficient service for his prompt, legal protection and the development of his proposition.

Send sketch, or model and description, for advice as to cost, search through prior United States patents, etc. Preliminary advice gladly furnished without charge.

My experience and familiarity with various arts frequently enable me to accurately advise clients as to probable patentability before they go to any expense.

*Booklet of valuable information and form for properly disclosing your idea free on request. Write today.*

**Richard B. Owen, Patent Lawyer**  
9-303 Owen Bldg., Washington, D.C.  
41-E Park Row, New York City

## TRADE-MARKS REGISTERED

**MANUFACTURERS** If you have a machine that does not function properly we will redesign it or design a machine to increase your production and lower cost.

**INVENTORS** We develop inventions, perfect ideas and build beautiful Models. We have a national reputation, a staff of high-class Mechanical Engineers, operate our own machine shop and guarantee entire satisfaction. Write us for further information.

**R. G. CLYNE ENGINEERING CO.**  
3505 Page Blvd., St. Louis, Mo.

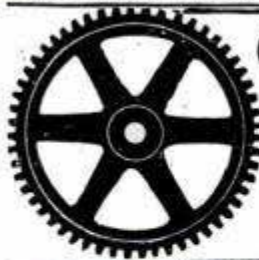

## GEARS ALL KINDS SMALL

The most accurate made and prices reasonable. We carry a complete line of gears in stock for immediate shipment. Can also quote on special gears of all kinds. Send us your inquiries.

WRITE FOR CATALOGUE 10

**CHICAGO STOCK GEAR WORKS**  
105-109 S. Jefferson St., CHICAGO



## LATEST SCIENTIFIC MOTOR Runs 10 Hours on 1 Gallon Wonderful Gasoline Engine

Operates Washing Machine, Cream Separators, Lathes, Etc. Also handle Castings for other Engines. Books and Supplies of every kind for **HANDY-MAN, MECHANICS and MODEL MAKERS.**

Complete Catalogue 25c which is allowed on first \$2 order.  
**AMALGAMATED SALES & SERVICE CORPORATION**  
327 R So. LaSalle St. Chicago, Ill.

## SAVE 30 TO 80% ON AUTO PARTS

Write us for prices on your requirements. Everything for the car at prices only Warshawsky can offer!

**WARSHAWSKY & CO.** 1915-35 S. State St. Dept. PM12, Chicago  
*World's Largest Replacement Parts House*

# GOVERNORS

FOR GAS OR AUTO ENGINES  
CANDEE SMITH GOVERNOR CO., SPRINGVILLE, N. Y.

# SEE MILES AWAY WITH Big 3 1/2 ft. Telescope

Has unusually powerful lenses—magnifying 8 times. Brings people and objects miles away close to your eyes. Brings new pleasures to home, farm, camp, travel, sport. See moon and stars as never before. New Ferry "Wonder" telescope has 5 sections—opens out over 3 1/2 ft. long, measures 12 inches closed. Brass bound with knurled edges. Sections made of special, smooth finish fibre, easy to slide in and out. Brass safety caps at each end to keep out dust.

**5 DAY TRIAL**



3 1/2 ft. long open  
12 in. long closed  
FIVE SECTIONS  
8-power Lenses  
Thousands of Delighted Users!

"I am delighted with the 'Wonder' telescope. Today I have been watching submarines 3 miles off the coast."  
—Philip Brush. "I can see across the Mississippi 3 miles and see people fishing."  
—M. L. Thorn. "I am nearly 80 years old and if I could not get another would not take \$10.00 for it."  
—A. R. Walker. "I can tell time on the church clock 5 miles away."  
—Edward Foster. "Could tell color of aeroplane 4 miles away."  
—Mrs. L. M. Yarbrough.

## Free!

**YES, ABSOLUTELY FREE!** Handsome Carrying Case, light, strong, complete with strap. Case is 12 in. long, 2 1/2 in. in diameter. Protects from dust and damage. Handy for farmers, auto tourists and hikers.

## Send No Money

Send coupon and Wonder 3 1/2 ft. Telescope with free Carrying Case will come by return mail. Pay postman special bargain price of \$1.85 plus postage. (Or send \$1.85 and we pay postage.) Two for \$3.50. Try for 5 days. Satisfaction guaranteed or money back. Send coupon today!

FERRY & Co., Chicago, Ill.

Ferry & Co., Dept. 1771, Chicago, Ill.

Send me 3 1/2 ft. Wonder Telescope and Free Carrying Case. I will pay postman \$1.85 plus postage on arrival. If, at the end of 5 days, I am not satisfied you will refund my money.

Name.....

Address.....

City..... State.....



**KICK**  
from  
**DAVEN TUBES**

**"KICK,"** the added power which means the difference between mediocre and excellent reception—between not quite bringing in that distant station and getting it strong, clear and undistorted.

Daven Tubes bring added "Kick" to your set—and in addition insure quiet, clear, tone perfect reception. Three types for any storage battery set.

#### The New Daven 201-A Amplifier and Detector

Try just one of these tubes in your set—the difference you will find in added power will make you replace the others. 5 Volt— $\frac{1}{4}$  Ampere.

#### The Mu-20—The Finest Detector Tube Made

On account of its unique characteristics the Daven Mu-20 is, we honestly believe, the finest detector tube ever designed. Quiet in operation, non-microphonic, amplification factor of 20 and exceptionally long life. Also the standard tube for resistance and impedance audio amplifiers. 6 Volts— $\frac{1}{4}$  Ampere.

#### The Mu-6—The Power Tube for All Storage Battery Sets

The special filament insures long life—its characteristics make it possible to use a stronger signal without overloading or distortion. 6 Volt— $\frac{1}{2}$  Ampere.

#### The New Daven AC Tubes

5 types to meet every requirement—the largest line on AC Tubes on the market. 4 Prong, platinum coated filaments, no hum, non-microphonic. Amplifier, High Mu, Detector, Power and Rectifier.

#### FREE CATALOG

Giving complete information about these and other Daven Products, at your dealer or direct from us.

*"The Sign of Merit"*  
**DAVEN RADIO CORPORATION**  
TRADE MARK *"Resistor Specialists"* REGISTERED  
154 SUMMIT ST., NEWARK, N. J.

12 MONTHS TO PAY  
BEGIN  
FEBRUARY

## DIAMONDS WATCHES & JEWELRY

### Buy From Diamond Importers

You save middleman's profits because we have been diamond importers since 1879—48 years. We sell only blue-white diamonds—no off color grades. Everything guaranteed as represented. Our money-back-if-not-satisfied guarantee protects your order. An old concern means safety.

No. V88 \$89



\$8 Down \$1.75 Weekly  
Dainty, 18 Kt. white gold wrist watch set with 12 blue-white diamonds, 4 sapphires in platinum. Guaranteed 15 jewel movement.

No. A169 \$62  
\$5 Down Weekly \$1.10



7 blue-white diamonds set in platinum, 2 sapphires, attractive 18 Kt. white gold mounting.

### Write For Illustrated Catalogue

Hundreds of bargains in Diamonds, Watches, Wrist Watches, Jewelry, Toilet Sets, Tableware, etc. Beautifully illustrated. It brings our large jewelry store right into your home. Buy Diamonds Like An Expert. Know grades, qualities and values before buying. Contains information other jewelers dare not tell, such as weights and grades of diamonds.

**STERLING DIAMOND & WATCH CO.**

1540 BROADWAY, Dept. 2377, N. Y.



No. A99—\$67  
\$5 Down—\$1.30 Weekly  
A large genuine blue-white diamond is set off by 4 smaller diamonds and 4 sapphires in solid white gold set in 18 Kt. formerly priced at \$100.

### XMAS SPECIALS

Jewelry makes the best Xmas gift because it lasts. All articles pictured here have been reduced in price for Xmas so as to offer the biggest value for the least money on convenient terms.

### Send Your Order 10 days Free Trial

Just send \$1 deposit or the full first payment. Pay postman on delivery the additional amount, if any, to cover down payment. Pay balance in equal weekly, semi-monthly or monthly payment beginning February. You have 10 days to decide. If not satisfied, return and we will refund every cent you paid.

### Open Confidential Credit Account

To open a charge account without delay, just give a little information about yourself and a few business references. Everything strictly confidential. No one will know what or from whom you are buying. If under age, have parents or guardian guarantee account or place order for you.

MAKES \$18.<sup>08</sup>  
In Few Hours

1000  
SAMPLES  
FURNISHED

Without experience E. Lube earned \$18.08 in one afternoon with our beautiful dress goods, silks and wash fabrics. No capital needed. We show you how to succeed. Write for samples and complete selling instructions.

The National Importing Company  
Dept. Z-6 569-573 Broadway New York City

**STOP  
CHECK  
FRAUDS**



**Amazing New Invention  
Brings Men \$100-\$150 a Week**

Be a check-protection expert—stop check frauds. Make big money quick. So new, practical and handy the Little Check Writer with the Big Protection sells easily on first sight. Quick and fascinating demonstration. Costs no more than good fountain pen yet fully equal to best \$100 check writers. More Factory Representatives Wanted. Permanent dignified positions; immediate earnings and brilliant future assured. Sweeter made \$500 last 10 days—Bache made \$3,000 in a month. Write today for details and start at once making splendid regular income.

**ARNOLD CHECK WRITER CO., Dept. W-14, FLINT, MICH.**



# THE NEW **Red Jacket** BAND SAW

**HERE IT IS:**

Five thousand craftsmen insisted that Waco produce the Red Jacket Band Saw. Now here it is: capable of doing all Band Saw work, powerful, efficient, dependable, and small enough to fit into the Waco Home-Workshop family of excellent tools.

Solid disc wheels giving 12-inch capacity on four-inch lumber. Saw table 9"x12" that tilts full 45 degrees for all miter requirements. Direct gear drive from the famous Red Jacket Motor. Unconditionally guaranteed.

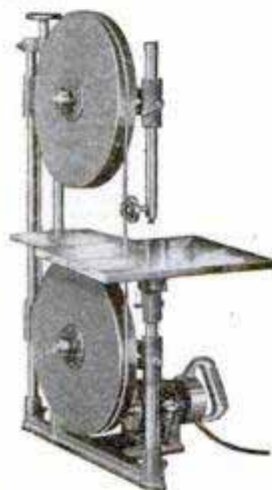

SENT ON  
10-DAY TRIAL

**ONLY**  
**\$35.00**

SEND THE  
COUPON

**WACO TOOL  
WORKS, INC.**

Waco Tool Works, Inc.  
542 North Parkside Avenue  
Chicago, Illinois

- I am enclosing \$31.50. This is the full price less 10% for cash.
- I am enclosing \$10.00 as down payment and if I keep this band saw, I will remit \$10.00 monthly. This band saw is sent on 10 days trial and may be returned for full refund.

Name.....

Address.....

City and State.....



## AUTO DESK

Fits steering post of any car. Holds 4x6 paper pad and pencil. Serves as holder for road maps or memoranda. Invaluable for doctors, salesmen, delivery men, taxi cabs, tourists. Well made, beautifully finished. An ideal Christmas present. Sent prepaid for \$2.50. State make of car when ordering.

LIVE AGENTS WANTED

Brainard Bros. Sacramento, Calif.

Build YOUR OWN BUZZ SAW with THIS 1/2" SAW ARBOR  
\$3.00 BRONZE BEARING—BALL BEARING \$5.00

Send in your order today

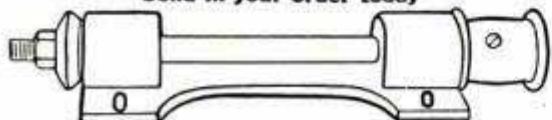

E. A. POPHAL MFG. CO. WAUSAU, WISCONSIN  
Builders of Bench Saws, Band Saws, Lathes, Jointers, Etc.  
ASK FOR CATALOG



# BANK

## \$150 to \$300

### More Each Month

Easily earned from HB 8-Hour Battery Service—with practically NO INVESTMENT on your part

Charging batteries in 1/2 the time required by other shops brings you the business. Costs less to operate, making you more net profit on each battery. Requires no special experience and PAYS FOR ITSELF on easy monthly payments WITH A PROFIT BESIDES. Now is the time to start to get the Big Fall and Winter Business.

**Costs Only \$16 Monthly**  
**Comes on 30 Days' Trial**

For full information without obligation, check No. 1 in the coupon below.



Complete Automotive Electrical Service is also a Big Moneymaker with an HB Universal Test Bench in your shop. ONLY \$20 MONTHLY brings you advantages previously to be had only with equipment costing \$100 to \$150 more. For full information check No. 2 in coupon below.



Get five men's profits for one man's work with an HB Portable Paint Spray. The wonderful new paint method you read so much about. Paint automobiles, houses, barns, garages, furniture, etc. Inexperienced men doing better work than old-time brush painters. Check No. 3 in coupon for full information.



Better air service than the other fellows will bring more customers to any Automotive Shop. HB Upright, Beltless, Twin Automatic Air Service now available for as low as \$11 monthly. Check No. 4 in coupon for full information.



Any HB Equipment may be had on 30 Days' Trial—and on easy monthly terms that let it pay for itself with a handsome profit besides. Investigate now. Mail the coupon below.

# HOBART **HB** BROTHERS

Successful manufacturers ~ since 1893 ~

BOX M127 TROY, OHIO  
**Tear off Coupon and Mail Today**

HOBART BROTHERS CO.  
Box M127, Troy, Ohio.

Send me complete information on the items I've checked with your 30 day trial offer, easy payment terms, and information on how HB equipment will increase my earnings.

- 1  One Day Battery Service Profits
- 2  Electrical Test Bench Opportunities
- 3  Portable Paint Spray Business
- 4  Better Automatic Air Compressor

NAME.....

ADDRESS.....



# CAN YOU SELL HEAT? IN WINTER?

# Hot Dollars All Winter!

Man, you don't have to sell heat. Everybody wants it. Everbrite agents cleaning up \$3000 to \$5000—no soliciting—no investment—no risk—just visiting prospects secured by our national advertising and leaving the heater for a night's trial.



**When It's 23 Below Zero** The Everbrite Radiant Oil Heater will keep you comfortable. Mrs. Senften, Genoa, Nebraska, writes: "23 below zero, but the Everbrite kept us warm and burned 25 hours on 1 filling." A portable heater for homes, stores, churches. Makes and burns its own gas from common kerosene. Pours out flood of pure, clean, intense heat at cost of 1 cent an hour.

**FREE** Just send name for amazing agents' offer. Clean up \$200 a week or more! Get a demonstration heater for your own use. Or if not interested in agency, write for special offer on heater. No wick—burns like city gas. Cleaner, cheaper, more comfortable than wood or coal. Low price.

**WRITE TODAY**

## The EVERBRITE Radiant Oil Heater **\$250 a Week**

J. O. Hand, California, made over \$250 a week last year. Knabb and Godwin of Florida both did better than \$200 a week. H. T. Rees of Kansas, averaged \$300 a week. F. W. Hubbel, Iowa, beat \$400 a month. So did Senften and Cassel, Nebr., Richie of Iowa, Shook of New Mexico, Webb of Arkansas, Wilson of Louisiana, and Alfred of Kansas.

**The EVERBRITE STOVE CO. KANSAS CITY, MO.** 6216 Gateway Sta.

## FOR BETTER RECEPTION

All radio programs, especially from distant stations, come in clearer with a firm roof aerial. Your aerial must be right. Poorly erected or makeshift clothes-line-on-the-roof aeriels are the cause of most faulty reception, no matter how good a set you have or the condition of the tubes and batteries.

**BEST ROOF AERIAL ONLY \$1.50**

The W-E-B-B new Ball and Socket Adjustable Aerial keeps firm and constant tension in your aerial wire. This permanent and extremely good looking aerial improves the appearance of any building.

**Sold by Radio Dealers Everywhere**

or sent direct, charges prepaid, upon receipt of price for the complete set. Circular FREE. Agents wanted.

**FITS ANY ROOF—**

**TIMING GEARS CORPORATION**  
272 N. California Ave.  
CHICAGO, ILL.

For Slant, Flat Roof or Wall:  
Model C—For 3/4" pipe.....\$1.50  
Model B—For 1" pipe.....\$3.00

For Gable Roof:  
Model D—For 3/4" pipe.....\$1.50  
Model A—For 1" pipe.....\$3.00

## A NEW RADIO LOUDSPEAKER

This Dual Tone Speaker Reproduces the High and Low Notes Perfectly

### BUILD IT YOURSELF FOR \$12.50

The COMPACTCONE is a thirty inch cone speaker, so arranged that it fits into a cabinet fourteen inches in diameter and seven inches deep. It has two distinct sound chambers, one being designed to reproduce the high notes and the other to carry the low notes of the tube and the base viol. It is damp proof and cannot be affected by weather conditions.

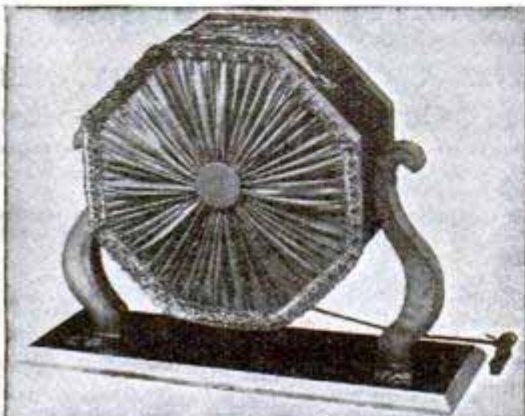

The usual thirty inch cone, while possessing wonderful tone value, occupies so much space that it is considered impractical. In the COMPACTCONE the diaphragm is full thirty inches but it is so arranged as to occupy a space but fourteen inches in diameter.

The COMPACTCONE may be had in the completed form and in knock down kits. In the knock down form we supply all the necessary parts, cut to fit and ready to assemble, with full directions for assembling. You can put one together in a very short time.

Write for our free beautifully illustrated catalog

### Miniature Ship Models, Inc.

Dept. PM  
3818-20-22-24 BARING STREET  
PHILADELPHIA, PENNA.  
CANADIAN BRANCH

1485 Bleury Street

Montreal, Canada



# Amazing, New Glass Cleaner

**Offers \$15 a Day-PROFIT!**



HERE'S an absolutely new, money-making proposition that will bring you big profits—easy profits—QUICK PROFITS! You can make \$50 a week in spare time—\$100 in full time—taking orders for JIFFY GLASS CLEANER—a new, pure, harmless liquid that easily and instantly cleans glass surfaces without water, soap or chamois. Think of it! Unequaled for cleaning windows, mirrors, windshields, show cases, eyeglasses, etc.

## Anyone, Anywhere, Can Earn Big Money

All you do is demonstrate to housewives, automobile owners, stores, garages, etc., and take orders. We do not sell dealers. All business from your locality must come through you, and you alone get the profit on every order. Every demonstration brings you two to four orders. Just moisten a cloth with Jiffy Glass Cleaner, rub over the surface of the glass and then polish with a dry cloth. Instantly removes all dust, dirt, grease and grime without streaking. After one application windows shine, gleam and sparkle like crystal—and stay clean twice as long.

# Albers Made \$47 in a Day!

Henry Albers, Ohio, made \$47 in one day and he says that \$100 a week is easy for him. Men and women everywhere are making amazing profits with Jiffy Glass Cleaner and my 350 other fast-selling products. Chris. Vaughn, Ohio, made \$125 in a week; L. C. Van Allen, Ill., averages more than \$100 a week; Mrs. K. R. Roof, S. C., earned \$50 in her first week's spare time; Mrs. B. L. Hodges, N. Y., earns \$18 to \$20 a day; H. C. Hanson, N. D., makes \$75 a week in spare time. You can make this big money, too!

## Send No Money

I don't want you to send me a cent. All I want you to do is let me show you how you can make \$50 to \$100 a week, without experience and without taking any course of training. I agree to furnish everything you need, to tell you what to do and say in this easy, fascinating work. You positively take no risk whatever. You can't lose a penny and yet you

have a wonderful chance to reap big profits quickly. You can make \$10 to \$20 a day right from the start.

## Mail Coupon NOW

Introduce Jiffy Glass Cleaner in your locality while it's new. This is your chance to make more money than you've ever made before. Send coupon for full details—without cost or obligation to you! Act quick for big profits. Send coupon TODAY!

THE JIFFY GLASS CLEANER CO.,  
3518 Monmouth Ave., Cincinnati, Ohio.

Please send me full details of your money-making proposition without cost or obligation.

Name.....

Address.....

(Print or Write Plainly.)

## MAKES A COMPLETE MACHINE SHOP

EVERY-USE ELECTRIC MOTOR ATTACHMENT

ONLY \$3.95

Fastens directly on motor shaft, no pulleys or belts necessary. Holds grindstones, buffs, saws, wire scratch brushes, drills, etc. Serves as pulley. Made to fit 3-8, 1-2 and 5-8 inch shafts. State size.



United Electric Motor Co., 178 C-1 Centre St., N. Y.

## Traffic Lite Reflector



Quickly Installed It Magnifies!

DAY-NITE REFLECTALITE

AGENTS: Thousands will be given as gifts. Send \$1.50 AT ONCE for sample (credited on first order) and full proposition. ACT QUICK.

G. D. CHICHESTER CO. 8212 Carnegie Ave. Cleveland, O.

## For Folks who refuse to be a Giraffe

Reflectalite brings overhead traffic signals right onto your instrument board. No stretching, nor craning. Full, clear 100-degree vision, day or night. Always in perfect focus. Outlasts car. For all makes.

### Ideal Xmas Gift

Beautiful chromium plated metal—will not rust or stain. Special Xmas package with gift card. Mailed ANYWHERE in U. S., postpaid for only \$1.50. Order NOW.

Makes \$1,000 a month



## Ending Auto Accidents

NO wonder Charles Hickey earned over \$6,000 in six months! He takes orders for an amazing new invention that prevents glaring headlights from blinding you—a device that would have prevented the thousands of glaring headlight accidents that occur every year. It is radically new. Shields your eyes without blocking view. Unique demonstration makes money fast.

Agents—Car Owners—write for free sample offer and territory. Right now is when car owners need glare protection most. Don't send money. Simply write name and address in space below, and mail to Face-A-Lite Mfg. Co., Dept. W-79, Mitchell, S. D.

Name.....

Address.....



# BIG MONEY in ROASTED "Red Hots"

Wonderful  
Sanitary  
Automatic  
Electric  
Machine

Just!  
Out!

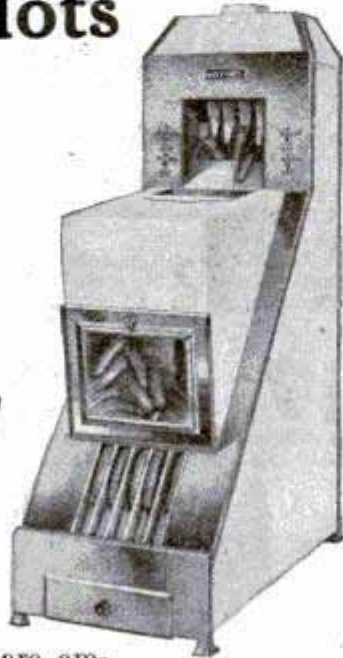

If you are already in the food business—OR, if you are ambitious to start a business of your own that brings in tremendous profits on a small investment—Find out at once about this new automatic electric way of Roasting "Red Hots" that makes them twice as appetizing as before.

**\$5000 to \$15000 A YEAR**

Fortunes in "Red Hots" are being made everywhere. Even bigger profits await you with the Wee-Nee Machine. Once a man tastes a roasted Red Hot he is done forever with the old, soggy, boiled "dog"—or the dried-up fried kind. Crowds flock to the place where Roasted Red Hots are served hot, deliciously browned, chock full of appetizing juiciness, as only the Wee-Nee Machine can cook them.

## Mail Coupon Quick!

Be the first to have the Wee-Nee Machine and Monopolize the Red Hot Business in your locality. You can do it with this machine whether you are now in business or wish to start into one of the sweetest profit producing lines imaginable. Coupon brings the full details that will open your eyes to what is in store for you. Mail it today!

**FOOD DISPLAY MACHINE CORP.**  
350 W. Huron St., Dept. 13-59, Chicago, Ill.

FOOD DISPLAY MACHINE CORP.,  
350 W. Huron St., Dept. 13-59, Chicago, Ill.

Send me without obligation full details of your new Wee-Nee Machine and facts concerning the big money to be made.

Name.....

Address.....

# The LOGICAL Filament Control

AMPERITE is the only self-variable filament control. Automatically does the work of hand rheostats and delicate meters. Proved for 6 years. Specified in every circuit. Entirely different from fixed filament resistors. Accept nothing but AMPERITE, FREE—"Amperite Book" of the season's best circuits and latest construction data. Address: cpt. P.M.-13 RADIALL COMPANY 50 Franklin St., New York



## AMPERITE

REG. U.S. PAT. OFF.  
The "SELF-ADJUSTING" Rheostat

SM

Do You Know the Secret of Quality Reproduction?

"The Secret of Quality" tells you simply and concisely how to get the most out of your amplifier—how to get quality. This 96 page booklet is yours for the asking—it's free. Write for your copy.

SILVER-MARSHALL, INC., 840 W. Jackson Blvd., Chicago, U.S.A.

## Be the Life of the Party



### Play a Tune in 10 Minutes

Popularity—new friends—money-making opportunities come to those who can play!

Now you can pick up your favorite stringed instrument and play a tune almost instantly. NO knowledge of music needed. NO expensive lessons. NO weeks of tiresome practice. Play tunes from the start. Play by numbers. Surprise and astonish your friends. Amazing new invention makes it easy to play Ukulele, Banjo Ukulele, Tenor Banjo, Guitar, Mandolin. Just press the keys and play.

Trixie Frigana, famous Vaudeville Star, wrote: "I played in 3 minutes and never touched a stringed instrument before." John A. Cruzer: "I was skeptical about anyone playing tunes instantly but have changed my ideas completely." W. B. Matthias: "Your advertisement didn't tell the half of it." Mrs. A. Kansen: "My friends and I play wonderful tunes. The more we play the better it gets."

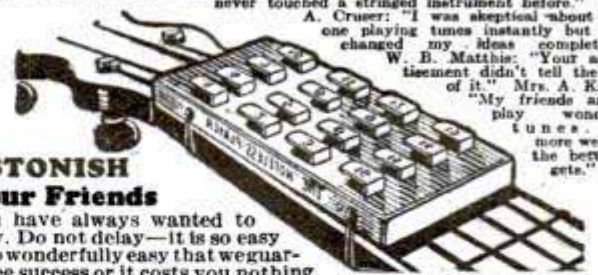

### ASTONISH Your Friends

You have always wanted to play. Do not delay—it is so easy—so wonderfully easy that we guarantee success or it costs you nothing.

## SEND FOR FREE BOOK!

More popularity—more fun from life—new friends—money-making opportunities. If you want to play tunes at once—send today for a free book about **Ferry E-Z Playing stringed instruments**. Soon, you, too, can know the joy of making your own music. "No play, no pay." E-Z Playing Instruments are sold complete or the E-Z Player can be attached to your own stringed instrument in a jiffy.

Mail Coupon Today!

**FERRY & CO., Dept. 9771, Chicago, U. S. A.**

Send free book telling how I can get more fun out of life, make more friends, have greater opportunities for getting ahead by learning to play my favorite stringed instrument in 10 minutes. No obligation.

Name.....

Address.....

City..... State.....



# \$351<sup>00</sup> CLEARED IN ONE DAY

So writes W. H. Adams of Ohio. Letter from V. A. Marini of California reports \$11275 sales in three months. Jacob Gordon of New Jersey "\$4000 profits in 2 months." Alexander of Penna. "\$3000 profits in four months." Ira Shook \$365 sales in one day. Bram bought one outfit April 5 and 7 more by August 28. Iwata, bought one outfit and 10 more within a year. Mrs. Lane of Pennsylvania says "sold 8000 packages in one day." J. R. Bert says "only thing I ever bought that equaled advertisement." John Culp says: "Everything going lovely.



## WE START YOU IN BUSINESS

Furnish secret formulas, raw material and equipment. Little capital required; no experience needed.

## Build A Business of Your Own

No limit to the sale of Crispettes. Everybody likes them. It's a delicious food confection. Write for facts about a business that will make you independent. Start now, in your own town.

## Profits \$1000 a Month Easily Possible

Send postal for illustrated book of facts. It contains enthusiastic letters from others—shows their places of business, tells how and when to start, and all information needed. Free. Write now!

### LONG-EAKINS COMPANY

1228 High Street

Springfield, Ohio

# Save Your Feet

When all else fails, end your suffering with the

## Heefner Arch Support

No Metal

Fully patented. It re-adjusts the entire foot. Write for free book and statements from doctors and users.

Heefner Arch Support Co. 658 M. E. Taylor Bldg. Louisville, Ky.

# AUTO RUNS 40 MILES ON GALLON OF GAS

Automobile engineers who worked for years in an effort to reduce gasoline consumption have found the solution in a marvelous invention that fits all cars. An actual test made by one of the engineers showed 40 miles on a gallon of gas. Thousands of car owners have already installed this new invention. They not only report amazing gas savings but are also surprised to find quicker pick-up, instant starting, smoother running motors and disappearance of carbon. E. Oliver, 999-151 E. Third St., Milwaukee, Wis., for a limited time is offering a free device to those who will help introduce it. He also needs men everywhere to make over \$100 weekly in their own territory taking care of local business. Write him at once for free sample offer and big money making offer.—Adv.



# NEVER TOO OLD to Learn

IS music one of the big things in life you've missed? Don't give up. It's never too late to start with a

## BUESCHER

### True Tone Saxophone

This is the one instrument you know you can learn to play. If you can whistle a tune you can't fail with a Buescher. You can learn to play quickly, with comparatively little effort.

#### Join the Home Town Band

With the aid of the 3 lessons given on request with each new Buescher, many learn scales first hour and play tunes first week. You can teach yourself, and in 90 days join the Band, or play with an orchestra, at good pay.

#### Only Buescher Assures Success

But only with a Buescher is this rapid progress assured. You don't have to fuss and favor for certain notes. Just open the key and blow normally. Every tone full, clear and true.

#### Six Days' Trial. Easy Terms

Take any Buescher Instrument home for 6 days' trial. If you like it, pay a little each month. Send coupon for beautiful catalog and details of this liberal plan. There will never be a better time to start. Write today.

### BUESCHER BAND INSTRUMENT CO.

Everything in Band and Orchestra Instruments

2183 Buescher Block

Elkhart, Indiana

BUESCHER BAND INSTRUMENT CO.		335A
2183 Buescher Block, Elkhart, Ind.		
Gentlemen:—Without obligating me in any way please send me your free literature. Mention instrument interested in.		
Age?.....	Name instrument.....	
Name.....		
Address.....		



**30 DAYS FREE TRIAL!**

**SEND NO MONEY FOR the CON-RAD SINGLE DIAL CONTROL** **6**

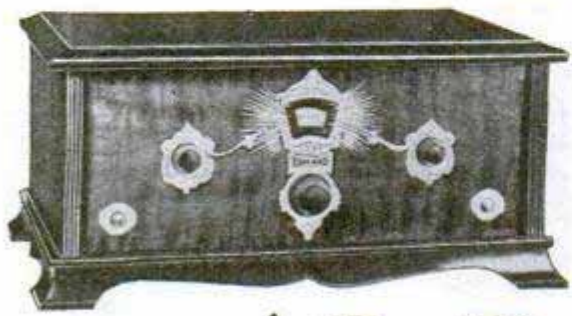

**6 TUBES 1 DIAL COMPLETELY ASSEMBLED RETAIL PRICE** **\$66<sup>66</sup>**

**Save 1/3 to 1/2!**

You can now buy at wholesale the famous Con-Rad sets—manufactured under license grants from Radio Corp. of America; Westinghouse Electric Mfg. Co.; General Electric Co.; and American Telephone and Telegraph Co. The Con-Rad Super Six—with single control and illuminated dial—is the ultimate in radio receivers. A 30 Day Free Trial will convince you of Con-Rad superiority. Latest 1928 Model—Walnut Cabinet—shielded chassis—can be operated by a child—and guaranteed to give complete satisfaction.

**A CON-RAD in Your Home Means Money for You**

Men and women making big profits selling Con-Rad Receivers through home demonstrations. Full or spare time. Low factory wholesale prices enable you to cash in on the radio sensation of the year. Write today for complete information.

**Another CON-RAD Success!**

Six tube model—single dial control—completely assembled in latest model table cabinet. Retail Price, \$34.75. Tremendous buying power enables us to sell this set at this low price. Con-Rad Radio Sets are sold exclusively by Consumers Radio Co. Our generous Free Trial offer makes it easy for you to hear a Con-Rad in your own home.

**CONSUMERS RADIO CO.**

**4725 Lincoln Avenue Chicago, Illinois**

Consumers Radio Co.,  
4725 Lincoln Ave.,  
Chicago, Ill.

Dear Sirs:  
Without obligation on my part, send me full details of the Con-Rad 30 Day Free Trial Offer.

Name.....  
Address.....  
City.....  
State.....

Also send me Home Agents Proposition.

**Majestic**

**Most Popular "B" Power Unit for radio sets in the world**

**IMPROVED RECEPTION**

Plugs into Light Socket. No Hum or Blast. Only fraction of cent cost per hour. Any good radio dealer will sell on approval.

The Super "B" illustrated below is only \$29.50, complete with Majestic Super-Power B-Rectifier Tube. Write for booklet on "Better Radio Reception."

**Grigsby-Grunow-Hinds Co.**  
4541 Armitage Ave., Chicago



**No Acids. No Liquids**

**RABBIT HUNTERS See and Try The "SCREW-BUG"**

A mechanical ferret, for hunting Rabbits, Ground Hogs, etc.

"It travels round the curves and bends, and gets 'em out of their holes and dens." Thousands of satisfied users in the past three years.

One trial will convince you of its merits. The "SCREW-BUG" is sold and shipped by the inventor, direct to you by U. S. Mail, allowing a five day trial, with an absolute. *If Not Satisfied Money back guarantee.* Price \$4.00 each with order in U. S. A. Prepaid, or C. O. D. plus postage. We have no Agents. Write for Free circulars.

**THE GRABOW CO., Dept. A, Franklin Square, L. I., NEW YORK**



**Model Ship Builders "FLYING CLOUD"**

Our special "Flying Cloud" construction set contains all necessary materials according to specifications. The model maker will be assured of an accurate model by purchasing one of these reasonably priced sets. Our new catalog containing reproductions of photos of various ship models, together with prices of all sorts of fittings, materials, tools, etc., sent postpaid upon receipt of 10c.

**MODEL SHIP SUPPLY CO., Dept. M, Mineola, N. Y.**



**HELD JAPAN!**

The thrill of receiving Tokio, Japan and Sidney and Melbourne, Australia on a Magnaformer 9-8 was experienced by K. G. Ormiston and party on the night of September 11, 1927—6,000 to 9,000 miles on the loud speaker with a world of volume. The thrill of great distance added to the sonorous, true-to-life tone quality for which the **Magnaformer 9-8** is famous, gives you a truly supreme entertainment combination. The Magnaformer 9-8, Creator of True Tone Quality, "Commander in Chief of the Air," is the finest and most powerful receiving set ever designed.

The secret lies in the perfect **Magnaformer Intermediate Long Wave R. F. Transformers** with which it is equipped. Prominent Radio Editors are giving these coils highest praise in editorial articles in Radio, Popular Radio, Radio Doing, Citizens' Call Book, Radio World and other magazines and numerous newspapers. Each coil is unalterably peaked at 69.73 Kilocycles (4300 meters). They are so securely and scientifically put together mechanically that nothing can change their electrical characteristics. **It is the greatest set in the world.** Build it from the fully illustrated official construction sheet 28x34 inches, both sides printed solid.

**Send at once,** right now while you have it in mind, for **FREE** illustrated Magnaformer story, wonderful testimonials and full account of K. G. Ormiston's unique experience—W. D. Scott's challenge and defeat. *Don't build a set 'til you hear from us in a day or two.*



**RADIART LABORATORIES COMPANY**  
19 S. La Salle Street Dept. 79 Chicago, Ill.





**Cut the Family Barber Bills**

**Fits Any Light Socket**



**Home Electric Hair Clippers**



Made by old, experienced manufacturers of barber clippers. Plugs into your light socket and anyone can use it successfully for trimming, bobbing, shortening bangs, clipping neck, in fact saves barbering bills for the whole family. Equally practical for removing superfluous hair under arms, on forearms or legs. Cuts clean as a razor. Does not clog, pull, nor cut the skin.

**Saves Its Cost**

The Home Electric Hair Clipper is a tried and proven appliance — now used in thousands of homes. Does work equal to the best barber clippers. Rigidly guaranteed. Takes the place of razors and dipilatories for women.

**A Valuable Christmas Gift**

Put a Home Electric Clipper on your Christmas shopping list for mother, father, brother, sister or a friend—a useful gift that will be highly appreciated.

**Ten Days' FREE TRIAL**

The Home Electric must sell itself to you. If your hardware or electrical dealer can't supply you, send today for interesting booklet or order from this ad. Pay postman \$8.75. Use it for 10 days, then if it doesn't prove a wonder, a money saver, return it in good order and your money will be refunded. State whether your current is 110, 220 or 32 volt.

**ALLOVER MFG. CO.**  
Dept. 30. Racine, Wis.

Dealers and Sales Representatives Wanted

A new practical and profitable line. Sells summer and winter to men and women. Write for plan.



ACME K-1A \$25

ACME K-3 Single Free Edge Cone \$14.50

**The Speaker that Deserves Such Broadcasting**

EVERYBODY KNOWS present-day broadcasting deserves a good speaker. But here's the speaker that **DESERVES** such broadcasting!

[ It took five years and 320 experimental models to produce the new Acme double free edge cone speaker! ]

Full orchestra volume without distortion. Takes full output of all power tubes without blasting and without additional apparatus. Beautifully designed. Richly finished in walnut.

Never until you actually hear and compare the Acme, can you fully appreciate the remarkable improvements that have been made in radio reproduction since your present loud speaker left its factory.

If your dealer does not carry Acme speakers, we will supply you direct. Send coupon for Acme booklets described below.



Look for the ACME head

**ACME**  
**-for amplification**

ACME APPARATUS CORPORATION  
Dept. PM-1, Cambridge, Mass.

Gentlemen:—Please send me a copy of booklet checked below. I enclose 10c for each copy.

- Amplification without Distortion—How to Improve Any Radio Set
- Power Supply for Radio Sets—The Story of Socket Operation

Name.....  
Street.....  
City..... State.....



**I'll Pay You \$40 A DAY!**

**To Show My Mysterious Cigarette Lighter to Men**

Quick, easy profits with this amazing invention. Lights cigarettes and cigars in strongest wind. New principle of ignition. Does work of expensive lighters. But sells for only 50c. Guaranteed 10 years. Elmers sold 48 in one day. Johnson cleaned up \$63.00 in two days. No experience necessary. Work full or spare time. Smokers and dealers buy on sight. Send \$3.00 for dozen lighters or 50c for agent's sample and rapid fire selling plans. Satisfaction guaranteed.



No wind can blow it out!

How does it work?

MASTERLITE MFG. CO., Desk M-23  
110 E. 23rd Street NEW YORK CITY



# POWERIZER

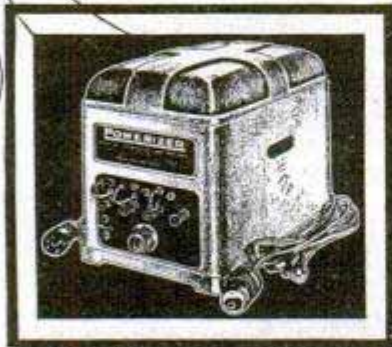
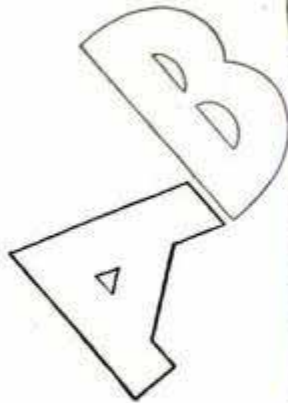

Model for Atwater Kent and other standard sets.....\$60  
Radiola "20" model without tubes.. \$59

Now you can make any good set a new \$500 type  
**A. C. Electric Receiver**

**A**NY Radio—equipped with a Powerizer—operates with the newest R.C.A. tubes which require no batteries—**B** eliminators or convertors.

The world's finest tone quality is yours. Powerized sets are real light socket sets perfected by pioneers in powerized amplification . . .

Have your set equipped with a Powerizer—you'll have a permanent source of power and a set that will be modern in 1938 . . .

Hear a Powerized Atwater Kent—a Powerized Radiola 20 or any good set with a Powerizer . . . Compare it with any other A. C. Receiver selling at \$500 to \$800 . . . The only difference will be in the saving you make.

*Write for literature explaining details of real A B C socket-power and tone quality.*

**RADIO RECEPTOR CO., INC.**  
106 Seventh Ave., New York

Licensed by Radio Corporation of America and Associated Companies

## Improve Your Radio With this R. F. Choke

The New  
**HAMMARLUND**  
R. F. CHOKE



*Distinctive  
in Principle;  
Superior  
in Performance*

In your radio are two kinds of currents—both necessary. But they must be kept in proper channels if you would have stable reception and good tone quality.

The new Hammarlund R. F. Choke puts a leash on radio-frequency currents and keeps them in their own "backyard." Your receiver is not modern without one or more. Ask any radio engineer. Two sizes—85 and 250 millihenries.

Write for Folder

**HAMMARLUND MANUFACTURING CO.**  
430 W. 33rd St., New York, N. Y.

For Better Radio  
**Hammarlund**  
PRECISION  
PRODUCTS

## COASTER WAGON GIVEN

HEAVY BUILT RUBBER TIRES  
SEND NO MONEY We Trust You



**BOYS!** Here is 16 x 36 inch Wagon 10-in. heavy disc wheels with roller bearings; 1-inch rubber tires. Specially made body of seasoned wood—heavily reinforced with steel braces. Send for 12 boxes famous UCA-MENTHO Healing and Vapor Salve which sells at 25¢ a box. We also send 12 packs perfume which you Give Away FREE (to help sell the salve), and easy plan for obtaining this Coaster Wagon. Don't send a penny. We are reliable.

**UCA MFG. CO.**  
Dept. 3A78, CHICAGO

## EXCEPTIONAL XMAS OFFER \$25<sup>50</sup>

Retail Price \$49.50—Limited Time ONLY



**Agents Make Big Profits Before XMAS**

X-Ray Electric Vacuum Cleaner Shipped C. O. D. Anywhere on **10 DAYS TRIAL**

Powerful Suction with Special General Electric Motor Fully Guaranteed

EVERY Convenient Attachment FREE

**The Morrow Co., Inc.**  
326 W. Madison St. CHICAGO

**AGENTS WANTED**

**STEEL BLUE Elite Diamond**  
IF YOU CAN TELL IT FROM A DIAMOND  
**SEND IT BACK!**

**\$389 C.O.D.**

1 Carat Elite Diamonds. Matchless for their dazzling rainbow brilliancy. You'll be delighted. Elite Rings surpass all others. Stand acid and other tests. Handsomely Engraved Ring, sterling Guaranteed. Looks like \$250.00. Proud owner offered \$85.00 5 minutes after buying one.

**COLLAR AND CUFF LINKS GIVEN**  
With each ring order, we give free beautiful Combination Set. Set with small Elite Diamonds. **SEND NO MONEY.** Just send name, address and finger size. On arrival pay postman \$3.89 and postage. Satisfaction Guaranteed. Write today. Cash with Canadian or foreign orders.

**ELITE JEWELRY HOUSE,** Dept. 376, 609 S. Paulina St. CHICAGO, ILLINOIS





**Radio  
\$5<sup>00</sup>**

Postpaid to any city in the U.S.A.

**No Tubes  
No Batteries  
No Static  
No Upkeep**

Guaranteed for one year. Brings to you, at a range of 10 miles, ALL PROGRAMS from local broadcast stations.

**Clarity of Tone Unsurpassed**

**BUY ONE FOR A "SHUT-IN"**

Special Light Weight Ear Phones \$2.50 Additional

APPROVED BY Popular Radio Laboratory, Radio Broadcast and thousands of others.

Described on Page 659 October Issue  
**POPULAR MECHANICS**

**FLASH RADIO CORPORATION**  
127 Federal Street Boston, U. S. A.  
**AGENTS WANTED**

# Amazing NEW Ground Antenna

**Gets Everything but Static**

**Brings in Faraway Stations Loud and Clear Regardless of Static Conditions**

Fans everywhere are replacing their troublesome and static gathering up-in-the-air aerials with the marvelous new **GROUND ANTENNA**—Aer-O-Liminator—Radio engineers and hundreds of users testify that Aer-O-Liminator gets better long distance reception, almost unbelievable freedom from outside noises, far greater selectivity and marvelously true, clear sweet tone quality.

John E. Christenson, radio engineer Chicago, writes: "I have tested and thoroughly approve the Aer-O-Liminator. I find it increases selectivity and volume without distortion, practically eliminates static, gives good clear tones, both on local and distant stations. I would recommend the use of the Aer-O-Liminator to every radio owner to get the best reception from his set."

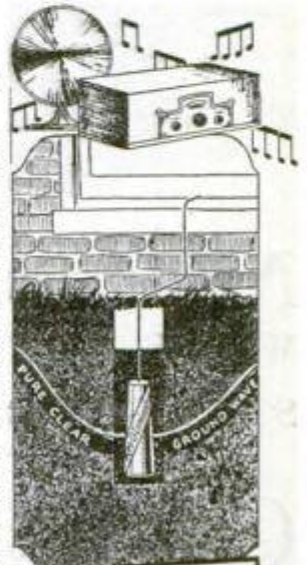

Easy to Install



**FREE TRIAL**

**Makes this thrilling test at our risk!**

Install an Aer-O-Liminator (Ground Antenna). Leave your old overhead aerial up. Try out on a night when static is bad. If you do not get a wonderful improvement in freedom from static, greater selectivity and clear sweet tone without interfering noises, if you can't get good reception on stations that are drowned out by static on your old aerial, you need not pay us a red cent for this test. Send coupon at once for scientific explanation of Aer-O-Liminator (Ground Antenna) proof of performance and our conclusive iron-bound guarantee and remarkable Free Trial Offer—Mail Coupon TODAY!

**Curtan Mfg. Co.,**  
154 E. Erie St., Dept. 805-T, Chicago, Ill.

**Aer-O-Liminator**  
(Ground Antenna)

**IS YOUR LOUD SPEAKER PARALYZED?**

If your Speaker is one of the majority which acts "Dumb" with no apparent cause, ask your Dealer for the Muter Clarifier, or write us for full particulars about this miraculous new Radio necessity which assures Full Tone, Clarity and Volume.  
**Leslie F. Muter Co., 76th and Greenwood, Dept. 805-T, Chicago, Illinois**



**MEN'S STRAP WATCH**  
DIRECT FROM SWITZERLAND  
**\$3.99**  
Radium Dial Jeweled Movement Silveroid, Cushion Shaped Case  
This fully guaranteed watch cannot be manufactured in America for less than \$12. Genuine leather strap. Accurate—durable—handsome. **SEND NO MONEY.** Pay on delivery \$3.99 plus postage. "FED CO."  
U. S. Swiss Agents, 561 Broadway, New York City, Dept. W-10

**MAKES RADIO STATIC UNHEARD**

A simple, amazing device has been invented by C. H. Geppert, W-207 Hewitt Bldg., Des Moines, Ia., which filters 50 to 90 per cent of static in radio receiving sets. Not only that, but when static is not bad, you can increase your volume tremendously, bring in more distant stations, save 30 to 40 per cent on batteries, eliminate local stations from running in, give your set at least one more stage of radio reception and greater selectivity. Works on all radios; can be attached instantly by anyone without change to set. Mr. Geppert wants agents and is willing to send a no cost sample. Write him today.

**Rush This Important Coupon**

Curtan Mfg. Co.,  
154 E. Erie St., Dept. 805-T,  
Chicago, Ill.

Please send me at once complete description of Aer-O-Liminator with details of guarantee, Scientific Proof and FREE TRIAL OFFER.

Name.....  
Address.....  
City.....  
State.....



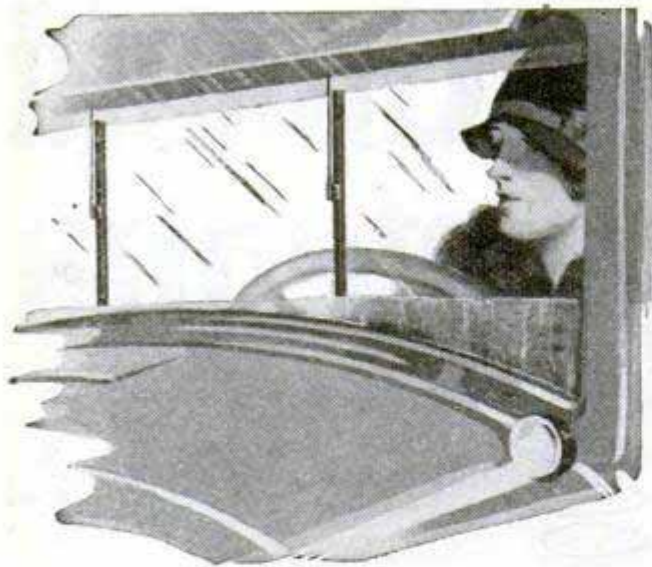

**NEW TWIN BLADE CLEANER  
WIPES YOUR WINDSHIELD  
STRAIGHT ACROSS . . . \$8.50**

**C**RYSTAL clear vision for driver and passenger! A powerful, noiseless motor, driven automatically by the well-known suction principle, equipped with two vertical blades which slide smoothly back and forth, clearing your whole range of vision.

The Visionall clears 254 square inches of glass—more than twice as much as the average cleaner!

Blades do not swing in a half circle, but wipe straight across, allowing the water to run freely down off the end of each blade. One model fits all cars. Easily installed.

If your dealer can't supply the Visionall, we will mail one postpaid for \$8.50. Trico Products Corporation, Buffalo, N.Y. *World's largest makers of windshield equipment.*

**TRICO  
VISIONALL**

TRICO PRODUCTS CORPORATION, BUFFALO, N. Y.  
As advertised in Popular Mechanics, please send me one Trico Visionall with instructions for installing. I enclose draft or money order for \$8.50. I have written my dealer's name in the space below.

Name .....

Address .....

Dealer's Name .....

**Protects  
Life and Home**

**NEVER-FAIL ALARM**

warns away prowler and sneak-thief from home, garage, barn or chicken house. Patented, guaranteed signal bell rings 2 minutes when doors or windows are tampered with. **NOT ELECTRIC.** No upkeep expense. Quickly installed. Mounts in small space. Handsomely finished in oxidized copper or nickel. Door or window style in either finish. **\$1.50**

**AGENTS MAKE BIG PROFITS DEMONSTRATING**

**THE AKRON ALARM CO., Dept. 14, Kenmore, O.**

Post Paid

Cal. 30-40 6 Shot **\$9.75**

**KRAG CARBINE—Why Pay More?**

All the qualities of a high price rifle. The choice of those who know. Fine used condition, all working parts guaranteed for one year. Send for our Free 50-page catalog of money saving values: Guns, Ammunition, Cutlery, Sports and Gov't goods. Outfitters for 50 years to leading Military and Society Organizations, Theatrical and Wild West Shows. Satisfied customers all over the world. Terms Cash. No C.O.D.

**W. STOKES KIRK, 1627-P. M. 10th St., Philadelphia, Pa.**

**BIG VALUE FOR 10 CTS.**

6 songs, words and music; 25 Pictures Pretty Girls; 40 Ways to Make Money; 1 Joke Book; 1 Book on Love; 1 Magic Book; 1 Book Letter Writing; 1 Dream Book and Fortune Teller; 1 Cook Book; 1 Base Ball Book, gives rules for games; 1 Toy Maker Book; Language of Flowers; 1 Morse Telegraph Alphabet; 12 Chemical Experiments; Magic Age Table; Great North Pole Game; 100 Conundrums; 3 Puzzles; 12 Games; 30 Verses for Autograph Albums. All the above by mail for 10 cents, and 2 cents postage.

**ROYAL SALES CO., Desk 919, Norwalk, Conn.**

**ENCYCLOPÆDIA BRITANNICA**

in the New Form—at a saving of 40%

Write for full details. Address Dept. PM

**THE ENCYCLOPÆDIA BRITANNICA, INC.**

342 Madison Ave., New York City

**Turn Your Spare Hours Into Real Money**

**H**AVEN'T you often wished for a spare-time way of making more money than comes in the regular pay envelope? Of the various ways which present themselves none is more pleasant or profitable than playing engagements in a Band or Orchestra.

**Send the Coupon**

For particulars of our easy Payment Plan that tells how you can "Pay While You Play."

**Free Trial**—We want you to try out a King in your own home, without obligation and if you do not find the King the very best instrument you ever played—return it.

**Trade-In Proposition**—Turn in the instrument you now own as part payment on a new King. Our latest catalogs show many new model Kings and tell why they are the best instruments to learn on and play on.

*Use the coupon to order your copy.*

**THE H. N. WHITE CO.**  
5211-88 Superior Ave., Cleveland, O.

Instrument .....

Name .....

Address .....

City .....

State .....



# LYNCH RESISTORS

## 5 Tube De Luxe Deck

Build any 5 tube circuit simply and inexpensively with this new deck. All mounted ready for wiring. Improves appearance and performance. Choose your own circuit and component parts. Price \$12.50.

## LYNCH Complete Resistance Line

Lynch Resistors have been specified by many leading experts for season's best receivers. Increasingly popular because of accurate, permanent, noiseless performance. When buying resistors say "Lynch."

## The LYNCH Book

"Resistance the 'Control Valve' of Radio" explains uses and value of resistance in radio. Interesting, simplified language and illustrations. Information worth dollars—for a quarter. Send for copy today.



Arthur H. Lynch, Inc.  
1775 Broadway at 57th Street  
General Motors Bldg., New York, N. Y.

**GOLD WAVE**



## Make this Amazing FREE TEST!

Will you prove at our risk that the famous GOLD WAVE AERIAL actually does the amazing things we claim? Will you test this triple gold-plated aerial 10 days and prove positively that it will GIVE YOU STATIONS YOU HAVEN'T BEFORE RECEIVED? BRING IN FAR GREATER DISTANCE! — IMPROVE TONE AND QUALITY MARVELOUSLY! This aerial of gold is filled with conductivity—it draws and is GUARANTEED to produce these remarkable results on any make radio set. 7 strands—gold triple plated—Aerial 100 feet long, installed in or outdoors like any other aerial.

## Send No Money

If your dealer can't supply, send name and address. Pay postman only \$4, plus few pennies postage. Use 10 days. If not amazed and delighted your money refunded at once. Learn at our risk why thousands of radio owners and even broadcasting stations use it with better results. All radio engineers recommend it. Now sold in all European countries. Don't wait!

**LUXEM & DAVIS MFG. CO.**  
Dept. J-12, 6229 Broadway CHICAGO  
**Distributors** JOBBERS—DEALERS

—AGENTS write for liberal discounts and generous proposition. Fastest radio seller in market. Exclusive territories.

### No More "Leaking!"

The wonderful TUF-GLASS ALL-WEATHER ANTENNA INSULATOR is sensation everywhere. Positively resists temperature changes. Cut out that grind and squeal! Stops leaking! Corrosion proof—element defying—91,000 volts high frequency resistance. Only 35 cent! Buy now and enjoy better reception than ever before possible.

# NOW ART MODELS Ensco

## 2 and 3 foot Cone Speaker Kits

The same famous "Ensco", the original and World's Finest Loud Speaker Kits, now dressed up with Art Models which will delight the heart of the most fastidious. Two and three foot models to suit every need and condition. Guaranteed the equal of any manufactured loud speaker, regardless of cost. Anyone can assemble in less than an hour, no mechanical or radio knowledge needed.



2 foot Pedestal

### The Three Foot Pedestal

Beautifully finished in polychrome, heavy metal base. Complete kit including pedestal. A practical, beautiful floor model.

Model F-175-36 - 17.50  
In Canada - - 22.50

### The Two Foot Pedestal

Equally as well made and as beautiful as the three foot model, but smaller. Ideal for use on top of set or on any other piece of furniture. Finished in Polychrome.

Model F-135-24 - 13.50  
In Canada - - 17.50

### Standard and Wall Kits

Wall Kits are supplied with hardwood frame for easy assembly, now available in either 2 or 3 foot sizes.

Standard Kits identical with the wall kits, but without hardwood wall frame (you can make your own wall frame if desired) for use in building console, wall or book type speakers. Fully described in illustrated book. Either 2 or 3 foot sizes.

Standard Kits 2 or 3 ft. - 10.00  
In Canada - - 11.50

Wall Kits 2 or 3 ft. - 11.00  
In Canada - - 12.50

Demand the "Ensco"—go to your dealer, ask to hear the "Ensco," you will have a surprise in store for you. If your dealer hasn't been supplied send the coupon—our money back guarantee protects you.



Wall Model

## ENGINEERS' SERVICE COMPANY

25 Church Street, New York 75 Cornhill, Boston  
28 E. Jackson Blvd., Chicago 331 Bay St., Toronto, Ont.  
144 Second Street, San Francisco

ENGINEERS' SERVICE CO. (Send to nearest address)

### Send me

	U. S. Prices	Canada Prices	I am enclosing
2 foot Standard Kit	10.00	11.50	Check
3 foot " "	10.00	11.50	Money Order
2 foot Wall Kit	11.00	12.50	Cash (registered)
3 foot " "	11.00	12.50	Send C. O. D.
2 foot Pedestal Kit	13.50	17.50	(All shipping charges paid on Standard and Wall Kits only.)
3 foot " "	17.50	22.50	
(Check which)			

Name.....

Address.....

City..... State.....  
P. M.



# The CROSMAN .22 RIFLE

## "Power Without Powder"

With what other rifle can you set up a target range in any room of the house or even fire it in the back yard within city limits? You can do it with a Crosman because it is noiseless and its power is adjustable, yet it is powerful enough for use with small game.

### Amazing Accuracy with Utmost Economy

For target and small game shooting the Crosman is the unanimous choice of knowing people because it is the most convenient and economical .22 calibre rifle they can use—THE CROSMAN RIFLE NEVER NEEDS TO BE CLEANED—and the ammunition is cheap—five shots for a penny.

Amateurs can soon become experts. The Crosman can be used so frequently with so little effort and so economically that it is in constant use. Continued regular practice makes the marksman.

### Get a Crosman for Christmas

The whole family will enjoy it. Or tell them about it and let it solve their problem of what gift to get you.

See the Crosman at your nearest dealer. If he has none in stock write us giving us your dealer's name, and we will see that he gets one to demonstrate to you.

### The New Crosman Pell



Greater accuracy and more killing power

Send for this Booklet NOW!

FREE Target and Game Shooting

**CROSMAN ARMS CO.**  
385 St. Paul Street  
ROCHESTER NEW YORK



Ethyl is best.

for cold weather, too

Your car needs Ethyl Gasoline this winter.

You need Ethyl's *extra* power to negotiate roads that are muddy and snowy and slushy... to keep in high and get away faster in winter traffic... to reduce engine strain... and, most of all, to "knock out that 'knock'."

The ingredient in Ethyl Gasoline—tetraethyl lead—which made Ethyl the best summer fuel makes it best for cold weather too. *It's the superior high-compression fuel for all seasons.* And if you have one of the new high compression engines, Ethyl will give you a still greater thrill.

Ride with Ethyl the year round. This improved motor fuel is on sale at thousands of pumps throughout the United States and Canada which display the "ETHYL" emblem shown above. Fill your tank today.

ETHYL GASOLINE CORPORATION  
25 Broadway, New York City

# ETHYL GASOLINE



Price includes New Brake Rods Made to Fit All Cars

FITS ALL CARS

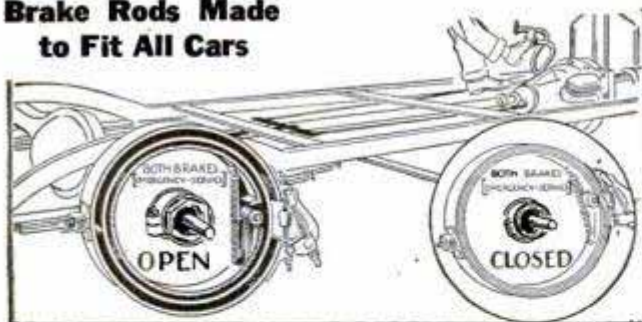

# Now "YOU" Can Put 4 Wheel Brake Power on "YOUR CAR"

Anyone Can Install in a Few Minutes on Any 2 or 4 Wheel Brake Car **POSITIVELY THE MARVEL OF THE AUTO AGE**

Wonders never cease—and here is the sensation of the year! JUST THINK—a simple idea that has been overlooked all these years and now is boiled down to a device that anyone can easily attach to their own car in a few minutes—and from that day on your car stops with a feeling of SAFETY—without undue strain—Stops your car almost on a straight line. Triples the Life of Brake Linings, as—

## The Super Brake Device Equalizes Pressure on Both Sides of Each Brake Drum

The SUPER BRAKE DEVICE puts real 4 wheel brake power on cars with 2 brakes and puts 6 wheel brake power on cars with 4 wheel brakes. The minute your foot touches the brake pedal you feel that security of good brakes without the continuous worry of damage to other cars and property as well as your own car—Then there is always that danger (with weak brakes) of hitting pedestrians mostly caused by brakes failing to respond promptly.

**LIMITED SPECIAL OFFER .. \$498**

### Stops Skidding — Acts Instantly

You must experience this NEW SUPER BRAKE DEVICE; that smooth yet forceful stop without skidding in all kinds of weather and wet streets—Relieves the pressure on the axle and shaft—The Greatest Brake Device Ever Invented—almost unbelievable stopping power on any level road; up or down grade; forward or backward—and if necessary will stop "on a dime."

**AGENTS \$1500 a Month**

**SUPER BRAKE DEVICE 1929-C, Straus Bldg., Chicago, Ill.**

**SUPER BRAKE DEVICE, 1929-C, Straus Bldg., Chicago, Ill.**  
Gentlemen:—Enclosed find remittance of \$4.98, kindly rush to me one SUPER BRAKE DEVICE for my..... Car, Model..... It is understood that my money will be refunded if I am not well pleased.  
 Mail me FREE particulars only.  
 My County is.....  
Name.....  
St. or R. F. D.....  
City..... State.....

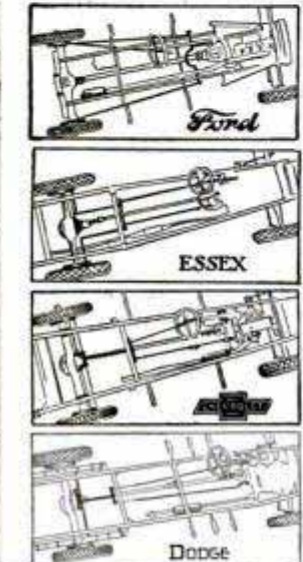

**FREE: Blue Prints**  
Show You How To Make Things For The Home

**NOW YOU CAN SAW EASILY and ACCURATELY**  
5 TOOLS IN 1: A Mitre, Saw Guide, T-Square, Protractor, and Precision Tool

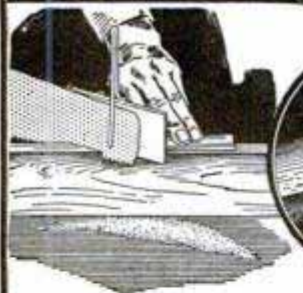

**The Harmak Saw Guide Shows You How.** Everyone can now do their own carpentry work—picture framing, garden seats and ornaments, shelving, cabinets, etc. No tool kit complete without one.

### Make Money at Home Doing Things

Don't ruin good lumber. Use a Harmak Guide. Operates anywhere. If your hardware or department store does not handle, order direct or write us for folders.

**\$30 Worth of Tools for Only (Special) \$2<sup>50</sup>**

**One-Half of any Carpenter's Outfit**

**HARMAK MFG. CO., 635-E Delmonte Way, St. Louis, Mo. Regular Price \$4.00**

## Still Greater Bargains in Boice Machines

**14' Band Saw**  
Table 12"x14" tilts 45 degrees. Saws 7" stock. Uses blades 3/4" to 1 1/2" wide. Bronze bearings. Ball bearing roller guides.

You can completely equip your shop with the latest Boice-Crane machines at their surprisingly low prices. Large capacity. Strong. Sturdy. Speedy. Economical.



**8' Bench Lathe**  
Does turning, drilling, sawing, sanding, grinding, and jig sawing in wood or soft metal. Swing 8". 19" center to center.

**Universal Handisaw**  
Table 15"x17" elevates for grooving. Tilts 45 degrees for bevelling. Swings 9" saw; cuts 2 1/2" stock. Guides always remain parallel to saw regardless of elevation or tilt of table. No other saw of equal cost has this indispensable and mechanically correct feature. Jointer attachment quickly fits on right of table. Other new low cost attachments will plane boards to thickness, mortise, shape, bore, tenon, drum sand, grind, disc sand, rout and make mouldings.



**JIG SAW BARGAIN AT \$11.00**  
Ideal for home shop, yet practical and sturdy enough for manufacturers use. Stroke 1 1/2". Saw to frame 8". Capacity 1 1/2" stock. Uses blades 1-8" to 3-8" wide. Net weight 18 lbs.

All Boice machines driven from light socket attachment. Send 10 cents for 64-page booklet, "Making It Easy to Build Things of Wood," which completely describes Boice-Crane Machines.



**W. B. & J. E. Boice, Dept. P.M. 12-C, Toledo, Ohio**



# DAVEN AMPLIFICATION



## Still the Superior Audio Amplifier

Use it in the Economy Nine  
and all other circuits

After three years, Daven Amplification is still the most faithful audio amplifier. No matter what your favorite circuit Daven Amplification will improve it. Only with Daven can you get absolutely straight line amplification over the entire audible range. No motor boating on good "B" Eliminators. Daven Amplification is now engineered for either AC or DC Tubes, for use with "B" Eliminators or Batteries. With AC operation, the new Daven AC-15 Tubes are used in the first two stages and an AC-10 or Mu-6 in last stage.



## GLASTOR

THE TRANSPARENT RESISTOR

Glastor, made only by Daven by secret process makes the glass itself conductive. Glastor cannot change in value, cannot become noisy while the glass remains intact.

**Make your last change**  
Replace your resistances now, it will be the last change as long as the set is in use. Glastor is made in a full range of values.

## The DAVEN BALLAST

Good for life

The Daven Ballast, the Standard Filament Control will not burn out. Good for life of the set. Made in 5 sizes to control from 1 to 5 volt tubes. Sold with or without special mounting as shown.

**Free Catalog** at your dealer or sent direct upon request.



*The Sign of Merit*

### DAVEN RADIO CORPORATION

TRADE MARK "Resistor Specialists" REG. U.S. PAT. OFF.

153 SUMMIT STREET

NEWARK, N. J.

## How do you do your work on WOOD?

—the same as your granddad did OR with a

# TAKE- ABOUT Sander

Here is a belt surfacing machine of only 14 pounds that will sand more than five times faster than is possible by hand. It does work that no machine has ever done before. Simple as a plane to use.

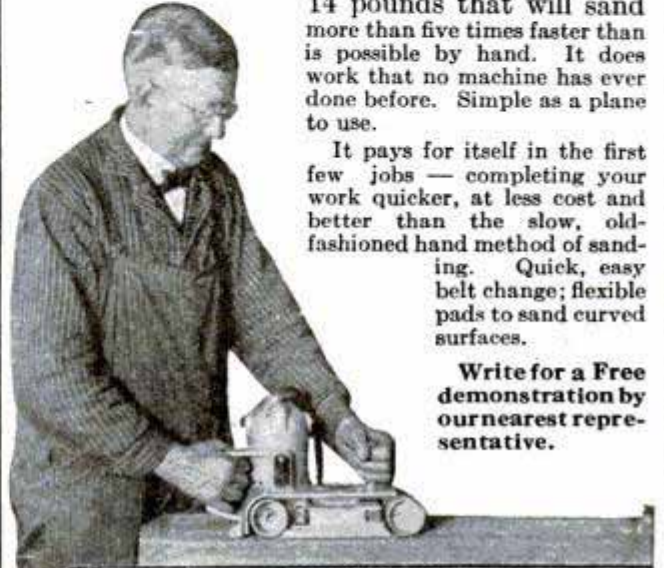

MADE ONLY BY THE  
PORTER-CABLE MACHINE COMPANY  
1704-10 North Salina St. SYRACUSE, N. Y.

It pays for itself in the first few jobs — completing your work quicker, at less cost and better than the slow, old-fashioned hand method of sanding. Quick, easy belt change; flexible pads to sand curved surfaces.

Write for a Free demonstration by our nearest representative.

## FROST-RADIO DE LUXE APPARATUS

Ask your dealer to show you the new Frost Metal Frame and Bakelite De Luxe Rheostats, with and without filament switches; the new Frost Variable High Resistance Units, with Bakelite shells and pointer knobs; the new Frost Gem Rheostats—they are GOOD small rheostats—and the new Frost Fixed Resistances. The latter cost but a few cents, but they make a tremendous difference in the operation of your set. Be sure to specify Frost Parts by name when ordering.

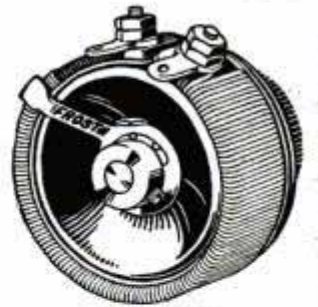

FROST-RADIO

### TWO NEW FROST BOOKS FREE

Write today for your copy of our two new books, just off the press: "What Set Shall I Build?" and "Better Reception." These books contain a great deal of valuable information on popular circuits, and on the use of Frost Parts in getting the utmost in high quality reception from any set you plan to build. These books are free—write for them today.



FROST-RADIO

## HERBERT H. FROST, INC.

Main Offices and Factory, Elkhart, Ind.

New York  
Boston

Philadelphia  
Pittsburgh

Chicago  
St. Louis

Los Angeles  
St. Paul



# This Marvelous Tool!

No other wrench like it! **Pays \$1000 a Month**

AN IDEAL XMAS GIFT

## The First and Only "One Hand" Monkey Wrench

No Thumb Screw Adjustment—That simple slide motion locks securely with a hold that resists over 750 pounds end pressure. Compare this with any other wrench. Does away with the old thumb screw idea that was always a handicap. In every sense a "One Hand Monkey Wrench."

### Slides Up and Down—Locks Automatically

The H&E Wrench creates a sensation wherever shown. Its simplicity, smooth action, strong grip and practical value arouses interest everywhere. In the Factory, Machine Shop, Garage, on the Farm, or in the Home; in fact, wherever tools are used—they all go wild over it.

#### This Is Your Opportunity

Think of the big sales possibilities right in your locality and surrounding territory—even if you never sold anything in your life before, we show you how to be successful. In fact, under our plan you even get your H&E Wrench FREE.

#### Praised by Big Concerns

The C. B. & Q. Railroad and many other large Corporations have acknowledged its value and endorsed it. Automobile Owners want it for convenience and our Agents tell us "It is the easiest selling article they ever tackled."

#### H&E WRENCH SALES CORP.

Dept. P. 228 No. LaSalle St., Chicago, Ill.  
Dept. P. 285 East 134th St., New York City

## Mechanics Wild Over It

Any mechanic readily appreciates the greater convenience and efficiency of the H&E Wrench and wherever shown they are anxious to own one. As one mechanic puts it, "I don't see how I ever could do without the H&E Wrench." That simple slide motion gets their eye and it locks with a better grip and releases instantly.

### 500 Agents Wanted at Once

Rapid sales with a handsome profit make this a very attractive proposition for Agents, and on account of this unusual demand we want agents everywhere and the opportunity is open to you NOW but you must ACT PROMPTLY.

Pressure 8000 Inch Pounds

All tests passed Government Specifications. Actual service and endorsement of Railroads assures High Class Practical Value.

GET YOURS FREE



H&E WRENCH SALES CORP.,  
Dept. P. 228 No. La Salle St., Chicago, Ill.  
Dept. P. 285 East 134th St., New York City.

Gentlemen:— Please mail me FREE particulars. This does not obligate me in any way.

NAME.....  
ADDRESS.....  
TOWN..... STATE.....

**SPEED LATHE \$10.50**  
complete as shown, 7' swing, 24" metal bed, 3 speed cone pulley. Longer bed \$1.00 per additional foot.

JEFFERSON MFG. CO., Fairfield, Iowa

### KNICKERBOCKER 4 The Wonder Set

#### 2-DIAL KARAS EQUAMATIC 5-Tube Receiver

These two famous receivers as well as scores of other well known sets owe no small part of their marvelous performance to the use of Karas parts. Karas Condensers, Transformers, Filters, Coils and Dials are the perfected products of a factory which has been building precision electrical apparatus for more than a third of a century. Write today for complete catalog of all Karas Parts, and details of the Knickerbocker 4 and the 2-Dial Karas Equamatic.

**KARAS Electric Co.** 4028-L No. Rockwell St., Chicago

## NEW VEST POCKET ADDING MACHINE

ADDS, SUBTRACTS, MULTIPLIES, DIVIDES

Does work of \$300 machine. Guaranteed 5 years. NOT A TOY. Made of steel and indestructible. Million dollar capacity. Fits in pocket. Will not make mistakes. So simple child can operate it. Instructions furnished. Everybody should carry one for figuring.

**FREE TRIAL \$2.50 Total Cost**

SEND NO MONEY—Just name and address. We will ship Calculator immediately. On delivery pay postman \$2.50 (Plus few cents Postage). (If outside U. S. send cash). 10c additional in Leatherette Case. If not satisfied after 10 day trial you get your money back. THOUSANDS OF SATISFIED USERS.

This is lowest priced practical calculator made. "Why pay more for inferior imitations?" Order from this ad.

Guaranteed

----- Mail Coupon Today -----

**BABY CALCULATOR SALES COMPANY**  
Dept. 41, P. O. Box 1118, CHICAGO, ILL., U. S. A.

I am enclosing \$2.50—send adding machine prepaid.  
 Send Adding Machine C. O. D. \$2.50 plus postage. (10c additional in Leatherette Case)

Name.....  
Address.....  
City..... State.....

**AGENTS** Write for big commission and territory proposition.

## MAKE THINGS AT HOME—SAVE MONEY \$13.50

### PARTRIDGE WOOD TURNING LATHE

Buy the finished parts completely assembled. Build bed at home. A real tool. 6' swing. Shipping weight 21 lbs. Make radio parts, floor lamps, toys and numerous other practical and valuable articles. Also made in sizes to swing 8', 11', 13', 16', diameters.

**IDEAL GIFT FOR FATHER OR SON**

Send today for descriptive circular.

**E. O. PARTRIDGE, Dept. 3, 2039-49 W. Lake Street, CHICAGO, ILL.**

f. o. b. Chicago



# Suppose You Were Offered Diamonds at 60% of Market Price



Suppose a reason you rarely think of makes possible here radically low prices, even for finest quality diamonds. Thousands of representative people, bankers, lawyers, merchants, others—continually reap this real advantage. Everything sent for Free Examination. This 3/4 century, oldest, largest diamond banking institution in the world, rated over \$1,000,000.00,—converts into cash the diamonds on which money was loaned and not repaid. Loan values, a fraction of market values, are the price basis. Diamonds too from big cash deals direct with European cutters. Must sell now

## Why Pay Full Prices

When Much Less Buys the Same See this 3/4 less 1/16 ct., snappy solitaire for \$69.50. Try to match at \$115.00. Examine free any bargain at our risk. Startling, legitimate offers here of diamonds at 60% of market price. Send now for full details. Diamonds of unusual qualities (also watches) from unpaid loans, offered at radically low prices based on mere loan values. Then, too, we have hundreds of diamonds from big, cash, European deals with diamond cutters, who sacrificed these gems away under the market. Send now for our latest offers of this internationally known cash headquarters.



## Unpaid Loan Listings Ready

### As low as \$60 a Carat

Radically different from a catalog. List accurately describes every diamond in full detail with guaranteed exact weight, color, quality, etc. Explains Guaranteed Cash-like Insurance Policy Loan guarantee. Also Unlimited Exchange privilege at price paid us. Gives full details of free examination offers. Don't wait, the very diamond you want may be in this very list at a price that will amaze you. Costs nothing to see. Write today. A postal will do, or—**Mail Coupon NOW!**



**Command Recognition a DIAMOND Does It**

**JOS. DE ROY & SONS**  
Only Opposite Postoffice  
1963 De Roy Bldg., Pittsburgh, Pa.  
Without obligation to buy, send me free in plain envelope, your latest Bargain List of Diamonds, Watches, and other Jewels.

Name \_\_\_\_\_  
Address \_\_\_\_\_  
City \_\_\_\_\_ State \_\_\_\_\_

References by Permission:—Bank of Pittsburgh, N. A.; Marine National Bank; Union Trust Co., Pittsburgh, Pa. Your bank can look us up in the mercantile agencies.

# CLAROSTAT



## IMPROVE YOUR RADIO SET!

In making your radio set better, or building a better radio set, you will generally find Clarostat specified. Radio authorities know that Clarostats provide the necessary resistance range, hold their settings, introduce no noises, and are dependable. There are three types of Clarostats—Clarostat Variable Control, for receiving circuits only; Standard Clarostat, for voltage control of radio B-power units; Power Clarostat, for series filament, line-voltage, and transmission controls. Don't substitute, intentionally or otherwise! The Clarostat, as the standard variable resistor, is widely copied in appearance, but hardly

in performance. Look for the green box. See that the name is stamped on the Clarostat itself.

Ask your radio dealer for Clarostats. Watch the radio columns for data on how to better your radio. Or write us direct for latest information.

**MEMBER RMA American Mechanical Laboratories, Inc.**  
Specialists in Variable Resistors  
285 North 6th St. Brooklyn, N. Y.



# Your Neighbors Will Pay You \$75<sup>00</sup> a week for Your Spare Time

You can easily sell them your spare hours for \$3 each by serving as "radio doctor," building them sets, selling them supplies at less than retail. A membership in the Association shows you how to cash in on Radio now and trains you for the \$3,000 to \$10,000 openings awaiting qualified men. The Association starts you in business if you wish. Investigate all it has done for others, all it can do for you. A MEMBERSHIP NEED NOT COST YOU A CENT.

## Earned \$500 in Spare Hours

Our members are making big money with Radio. Werner Eichler, N. Y., earns \$50 a week—Lyle Folliek, Mich., has earned \$500—F. J. Buckley, Mo.—makes as much as he receives from employer—all in spare time. Our members are starting radio stores, getting better positions, increasing their salaries, earning money spare time.

## ACT NOW—for No-Cost Membership

Send post card for details of Special Membership Plan that need not—should not—cost you a cent, and our book, "Your Opportunity in the Radio Industry." It will show you how you can cash in on Radio now—and later.

**Radio Association of America**  
4513 Ravenswood Ave., Dept. PM-12, Chicago, Ill.

## RADIO GREATEST RADIO BARGAIN \$18.45 in U. S. 5-Tube Chassis



Coast to coast reception. Certified circuit. Dealers write for special proposition. AGENTS WANTED. Write today for folder.

**A. J. MUSSELMAN, Inc.**  
240 Machinery Hall. CHICAGO, ILL.

## Here It Is Boys! Look It Over

R. O. Gorden of Michigan made \$321.05 in 9 days—sold 5 machines in 2 1/2 hours.

## THE EUREKA ADVERTISER (The Merchant's Friend)

Automatically prints the merchants' "ADS" on his wrapping paper in one or two colors. Costs only what it costs to have "AD" printed on twenty rolls of paper. Flint of New York sold four machines in two hours. You collect and keep your commission. We deliver. Every merchant a prospect. Many buy five or more machines—one for each paper rack they use.



**SALESMANAGER, Dept. A, 1201 Cortland Street, Chicago, Illinois**

# A & B Battery \$2 Charger ONLY

## SATISFACTION GUARANTEED



Charges any type of storage A or B battery, using a few cents worth of ordinary house current, either alternating or direct. Cannot injure battery. Complete directions enclosed. Anyone can operate. No expensive "extras" to buy. Why pay \$10.00 to \$15.00 for a charger when you can get this splendid GUARANTEED R. B. Charger by mailing us two dollars (bills, money order, check or stamps) plus ten cents in stamps or coin to pay mailing costs. Charger will be sent postpaid. If you are not satisfied, return within five days and we will refund your money. Order at once—TODAY.

**R. B. SPECIALTY CO.**  
Dept. 601-S East Third St., Cincinnati, O.





**FACTORY PRICES - SAVE 50%**  
Choice of beautiful cabinets offered

3 Year Guarantee

**TRY IT 30 DAYS FREE**  
BEFORE YOU BUY

**ALL METAL SHIELDED CHASSIS**

**8 tube - one dial**  
**MIRACO**  
TRADE MARK REGISTERED

Only **69<sup>75</sup>**  
Retail List Completely Assembled



**MAGNIFICENT TONE - SUPER SELECTIVE - POWERFUL DISTANCE GETTER**

**All Electric or Battery Set** *Big Discounts to User-Agents*

America's big, old, reliable Radio Corporation (8th successful year) **guarantees** in its big, powerful, latest 6, 7 and 8 tube Miraco sets "the finest, most enjoyable performance obtainable in **high grade radios.**" Unless 30 days use in your home fully satisfies you a Miraco is unbeatable at any price for beautiful, clear cathedral tone, razor-edge selectivity, powerful distance reception, easy operation, etc.—**don't buy it! Your verdict final!** Save or make lots of money on sets and equipment — write for testimony of nearby users and **Amazing Special Factory Offer.**

cathedral tone quality of costliest sets. Don't confuse Miraco's with cheap, "squawky" radios. Miraco's have finest parts, latest approved shielding, metal chassis, etc.—as used in many \$200 sets.

**DEAL DIRECT WITH BIG FACTORY**

Your Miraco reaches you completely assembled, rigidly tested, fully guaranteed. Easy to connect and operate. **30 days trial free.** 3 year guarantee if you buy. You take no risk, you insure satisfaction, you enjoy **rock-bottom money-saving prices by dealing direct** with one of radio's oldest, most successful builders of fine sets. 8th successful year.



MIRACO "Powerplus" sets—8 and 7 tube models—have magnificently beautiful, clear cathedral tone quality. Turn one dial for stations everywhere. Ultra-selective. Latest all-metal shielded chassis, illuminated dial. Fully guaranteed. Try one free for 30 days! Big selection of beautiful cabinets.

**7 tube one dial**  
METAL SHIELDED CHASSIS  
**49<sup>75</sup>**  
RETAIL LIST



**Dealers Write!** **USER-AGENTS!** Make big profits showing Miraco to friends. Get Our Special Wholesale Prices! **MID-WEST RADIO CORPORATION, Cincinnati, O.** **BEAUTIFULLY ILLUSTRATED CATALOG AND AMAZING SPECIAL OFFER** **Free!** SEND NO MONEY—30 DAYS' TRIAL, Special Wholesale Price Offer to User-Agents, Bank References, testimony of nearby Miraco users—all the proof you want—sent with catalog.

**mail coupon right now!**

**Electrify Any Radio** with **MIDWEST NO-BATTERY "AC" Light Socket Power Units**

"A", "B" and "C" power, direct from light socket, without batteries! Write for Midwest prices and discounts. Units are highest grade—lastingly dependable, quiet in operation, fully guaranteed. Mail coupon!

**Miracos work equally fine on "AC" electric house current or with batteries.** Take your choice. Many thousands of Miraco users—who bought after thorough comparisons—enjoy programs Coast to Coast, Canada to Mexico, loud and clear—with the magnificent



**MIDWEST RADIO CORP'N**  
Pioneer Builders of Sets  
407-G Miraco Bldg., Cincinnati, Ohio.

**THIS COUPON IS NOT AN ORDER**

WITHOUT OBLIGATION, send me free literature, AMAZING SPECIAL WHOLESALE PRICE OFFER, testimony of nearby users, etc.

NAME

ADDRESS



# LUMINOUS PAINT

## Make Your Watches, Clocks, Etc., Visible by Night

The very latest discovery in the scientific world... practically unobtainable in producing this remarkable LUMINOUS PAINT, which, applied to the surface of any article, emits rays of white light, rendering it perfectly visible in the dark. THE DARKER THE NIGHT, THE MORE BRILLIANT IT SHINES. Quite simple to use. Anyone—you can do it. A little applied to the dial of your watch or clock will enable you to tell the time by night. You can coat the push buttons or switch plates of your electric lights, match boxes, and innumerable other articles; make your own Luminous Crucifixes, Luminous Rosaries, etc. Small bottle, price 25c. Largest size, 50c and \$1 postpaid. JOHNSON SMITH & CO., Dept. 816 RACINE, WIS.



### CIGARETTE MAKER

Roll your own and save money. Better and quicker, saves more than half. Use your favorite brand of tobacco. Neat, useful, handy. Pocket size, weighs 1/2 oz. Made entirely of metal, nickel plated. 25c, 3 for 55c postpaid anywhere.



### GOOD LUCK RING

Very striking, quaint and uncommon. Silver finish; skull and crossbones design. Two brilliant, flashing gems sparkle out of the center. Said to bring good luck. Only 25c post.



### Exploding Cigarettes

JUST LIKE ORDINARY CIGARETTES. BUT SUCH REAL SHATTERERS! This box contains ten genuine cigarettes of excellent quality. They appear so real, but when each cigarette is about one-third smoked, the victim gets a very great surprise as it goes off with a loud BANG! A great mirth provoker yet entirely harmless. Price 25c box.

## NOVELTY BADGES



Keeping Permit 100. Garter Inspector 10c. Two very novel metal badges, nickel plated, that you can wear, giving you fun out of all proportion to their trifling cost. 10c, each badge, 3 for 25c, or 75c per doz. postpaid anywhere.

## MIDGET BIBLE



GREAT GENUINITY. Smallest Bible in the World. Size of a postage stamp. 200 Pages. Bound to bring good luck to the owner. A genuine work of art. Must be seen to be appreciated. Make good money selling them to friends, church societies, etc. PRICES 15c each, 3 for 40c, 12 for \$1.35, 100 for \$7.50. Also obtainable in Leather Binding, with gold edges. Price 50c each, 3 for \$1.25, \$4.50 per doz. Magnifying Glass for use with Midget Bible, 15c.

## STAGE MONEY



With a bunch of these bills, it is easy for each person of limited means to appear prosperous by flashing a roll of these bills at the proper time and peeling off a genuine bill or two from the outside of the roll, the effect created will be found to be all that can be desired. Prices, postpaid: 48 Bills 20c, 120 for 50c, or \$3.50 thousand postpaid.

## MAGIC FLUTE



The Magic Flute, or Humantone, is a unique and novel musical instrument that is played with nose and mouth combined. There is just a little knack in playing it which, when once acquired after a little practice, will enable you to produce very sweet music that somewhat resembles a flute. There is no fingering, and once you have mastered it you can play all kinds of music with facility and ease. When played as an accompaniment to a piano or any other musical instrument, the effect is as charming as it is surprising.

## SURPRISE MATCHES

More fun than fighting with your wife. Look just like ordinary matches. Put up in boxes just like regular Safety Matches. As the victim tries to light one he gets quite a surprise. Price 15c per box, 3 boxes for 25c, 12 for 75 cents.

## Keyless Lock



These clever locks cannot be opened unless you know the combination. No key necessary. For your locker, bicycle, tool chest, motor boat, thousands of uses. Sneak and tumbler design, nickel plated. Weighs trifling over one ounce. Small yet strong. Secret and full instructions with each lock. Price 25c or 3 for 65c postpaid.

## Wonderful X-Ray Tube



A wonderful little instrument producing optical illusions both surprising and startling. With it you can see what is apparently the bones of your fingers, the lead in a lead pencil, the inner opening in a pipe stem, and many other similar illusions. A mystery that no one has been able to satisfactorily explain. Price 10c, 3 for 25c, 1 dozen 75c. Johnson Smith & Co.

## Every Boy His Own Toy Maker

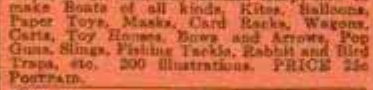

A great book for boys. It gives plain, practical instructions for making all manner of toys, machines and other articles, amusing and useful. Tells how to make a Steam Engine, a Photographic Camera, a Windmill, Microscope, Electrical Machine, Galvanic Battery, Electric Telegraph, Electrotyping Apparatus, Telephone, Kaleidoscope, Magic Lantern, Acoustic Harp; how to make Boats of all kinds, Kites, Balloons, Paper Toys, Masks, Card Tricks, Wonders, Cards, Toy Homes, Bows and Arrows, Pop Guns, Slings, Fishing Tackle, Rabbit and Bird Traps, etc. 200 illustrations. PRICE 25c Postpaid.

## Serpent's Eggs



Box contains 12 eggs. When lit with a match, each one gradually hatches itself into a snake several feet long which curls and twists about in a most life-like manner. Price per box, 10c postpaid, 3 for 25c.

# BLANK CARTRIDGE PISTOL



Protection against Burglars, Thieves, & Dogs. Special Offer: 1 Blank Cartridge Pistol, 100 Blank Cartridges, 1 550-page Monthly Catalog. ONLY \$1.50. The Lot shipped by Express Only. Cash With Order Only. Well made and effective, modified on latest type of Revolver; appearance alone is enough to scare a burglar. When loaded it may be as effective as a real revolver without danger to life. It takes standard .38 Cal. Blank Cartridge—obtainable everywhere. Special cash with order offers 1 Superior quality Blank Cartridge Pistol, 100 Blank Cartridges, and our new 550-page De Luxe Catalog of latest novelties; all for ONLY \$1.50, shipped by Express only. Cannot go by parcel post. Extra Blank Cartridges 50c per 100. Special Holster (Cowboy Type) for pistol 50c. No U.O.D. shipments.

# THROW YOUR VOICE



Into a trunk, under the bed or anywhere. Lots of fun fooling the teacher, policeman or friends. THE VENTRILO a little instrument, fits in the mouth out of sight, used with above for Bird Calls, etc. Anyone can use it. Never Fails. A 16 page course on ventriloquism, the Ventrilo, ALL FOR 10 CENTS.



PISTOL, OPERA AND FIELD GLASS. 9 In One. It is made in the shape of and looks like a regular Automatic Pistol. No one is likely to stop and ask you whether it is real or not. Thus it is likely to prove itself very handy in an emergency. On pressing the trigger it opens up as shown in the illustration at the right, revealing also most useful articles—Opera and Field Glass, Telescope, Mirror, Magnifying Glass and Burning Lens, Reading Glass, Sun Dial, Sun Compass, etc. In the handle of the revolver there is a place for various pockets necessary, such as First Aid Articles, Buttons, Pins, etc. The Pistol is of sheet metal, blood finish, that can be carried comfortably in pocket. PRICE \$1.00 postpaid.



Watch Charm Pistol. \$1.75. Exact reproduction of a real pistol; actually fires REAL BLANK CARTRIDGES of miniature size. Illustration is a natural size. 1 1/4 inches long, with ring at end for attaching to watch chain. Loads like a regular pistol. Pull the trigger and it goes off with a loud bang. Pistol is break open type; illustration shows position for loading. Made entirely of high grade steel, nickel plated, outside barrel, and decorated with engraved handles, complete in box with cleaning rod. PRICE \$1.75. Also furnished with pearl handles, \$2.50. BLANK CARTRIDGES, 50c per box of 25. JOHNSON SMITH & CO., Dept 816, RACINE, WIS.

## MICROPHONE TRANSMITTER BUTTON



You can easily make a highly sensitive detector-phones by using this Transmitter Button to collect the sound waves. You can build your own outfit without buying expensive equipment. It is simple and inexpensive. You can install an outfit in your home and hear conversations being held all over the house. You can connect up different rooms of a hotel. This outfit was used by secret service operatives during the war. It is being used on the stage. It is ultra-sensitive and is the greatest invention in micro-phones. You can mount the button almost anywhere—on board boxes, stove pipes, stiff calendars, on the wall behind a picture frame, etc. Button is so light and small it cannot be detected. Persons can be overheard without suspecting it. You can listen in on conversations in another room. A deaf person in the audience can hear the speaker. Connected to phonograph, piano or other musical instrument, music can be heard hundreds of feet away. Button may be used to renew telephone transmitters; often makes an old line "talk up" when nothing else will. The ideal microphone for radio use; carries heavy current and is extremely sensitive. Amplifies radio signals. Countless other similar uses will suggest themselves. Experimenters find the button useful for hundreds of experiments along the lines of telephones, amplifiers, loud speakers, etc. Many fascinating stunts may be devised, such as holding the button against the throat or chest to reproduce speech without sound waves. PRICE \$1.00.

# JOHNSON SMITH & CO.

Dept. 816 RACINE, WIS.

A De Luxe Edition of our new 1926 CATALOG mailed on receipt of 25c. Handsome binding. Bigger and better than ever. Only book of its kind in existence. 550 pages of all the latest tricks in magic, the newest novelties, puzzles, games, sporting goods, rubber stamps, unusual and interesting books, curiosities in seeds and plants, etc., unobtainable elsewhere. Remit by Stamps, Coin, Money Order, Check, etc. Unused U. S., Canadian and Foreign Stamps also accepted.



## THE EXPO WATCH CAMERA



The most wonderful and ingenious Camera made. It is but little larger than a watch, which it closely resembles. You can carry the Expo about in your pocket and take pictures without any one being the wiser.

**Less Than 2 Cents a Picture**

The Expo loads in daylight with 10 or 20 Exposure Films, costing 25c and 35c respectively, and thus the picture taking part of a whole day's outing may be had for a very nominal sum—Little more than one cent a picture.

**Easy to Manipulate**

Price \$3.60 Post Paid

It is simplicity itself to operate. Takes pictures through the lens, where the Rapid Fire Lens is located. The photos (5-5x7-6) may be enlarged to any size. Operated as quick as a Flash. Time and instantaneous shutters; weighs but 3 ounces; nickel plated. Endorsed by amateurs and professionals the world over. Thoroughly practical—printing and developing of films just the same as ordinary cameras—in daily use by the police, newspaper reporters, detectives, and the general public. Important hints have been secured with the Watch Camera by enterprising reporters. From duces clear, sharp negatives indoors or outdoors equal to any camera on the market, size or price notwithstanding. Sold Under a Positive Guarantee.

Expo Watch Camera \$3.60 FILMS, 10 Exposures 25c, 20 Exposures 35c Price Post Paid Leather Pocket Carrying Case, 35c



WATCH CAMERA

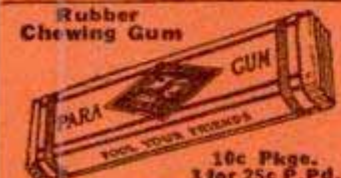

**Rubber Chewing Gum**  
10c Pkgs. 3 for 25c P. Pd.  
It is just like a regular package of chewing gum and looks so real that it fools everybody. Of course no one suspects it is not genuine until they start to chew it. There's a world of fun in this rubber chewing gum—4 sticks to the package. Price, 10c Pkgs.; 3 for 25c; 12 for 75c postpaid.

## INVISIBLE INK

The most confidential messages can be written with this ink, for the writing makes no mark. Cannot be seen unless you know the secret. Invaluable for many reasons. Keep your postals and private memorandums away from prying eyes. Great fun for playing practical jokes.

Only 15c a Bottle; 3 for 40c.



## POCKET CIGAR LIGHTERS

You may pay more, but these two Lighters will do the work as well as the most expensive. The "SIMPLEX" (Illustrated on the left) sells for but 20c; lights merely by giving the wheel a turn with the thumb. The "AUTOMATIC" (on right) lights automatically; press the button, the lid flies open and lights wick at same time. Better, safer and cheaper than matches. A light instantly available whenever you want it. Price: Simplex Lighter 20c; Automatic Lighter \$1.00; extra flints for either 5c each. All postpaid.

Simplex Lighter 20c

Automatic Lighter \$1.00

## RESURRECTION PLANT

One of the most wonderful plants known. Possesses the strange power of turning in a few minutes from an apparently lifeless, dry herb to a **BEAUTIFUL LIVING FERNLIKE PLANT** of a dark green color. Simply place the plant in saucer of water, it will open up and start to grow in 20 minutes. When taken out it will dry up and go to sleep until placed in water again. Fine house plant—summer or winter. 10 cents each or 3 for 25c., 75c per doz., postpaid.

## Great Fire Eater

With the Fire Eater in his possession any person can become a perfect salamander, apparently breathing fire and ejecting thousands of brilliant sparks from his mouth, to the horror and consternation of all beholders. Harmless fun for all times, seasons and places. If you wish to produce a decided sensation in your neighborhood don't fail to procure one. We send the Fire Eater with all the materials in a handsome box, the cover of which is highly ornamented with illustrations in various colors. Price of all complete only 30 cents, postpaid.

## SQUIRT ROSE 25c



**A REAL STARTLER.** This is the most popular of all squirt tricks. The flower in your coat looks so fresh and sweet that everyone is tempted to inhale the delightful perfume. Then in the moment to press the bulb. Gee-whillikens! Don't they jump! There is a very long rubber tube that easily reaches to the pocket of your coat or trousers, and the bulb is large enough to make a dozen shots with one loading. PRICE 25c each, or 3 for 65c postpaid.

## MAGICIAN'S BOX OF TRICKS

Apparatus and Directions for a Number of Mysterious Tricks Enough for an Entire Evening's Entertainment

**ANYONE CAN DO THEM \$1.00**

It is great fun mystifying your friends. Get the Conjuror's Cabinet, and you will be the cleverest fellow in your district. It contains the apparatus for ten first-class tricks, including THE MAGIC BALL AND VASE TRICK (a wooden ball is placed inside, and upon replacing the lid has disappeared and is found in someone else's pocket); THE HINDU TRICK CARDS (can be made to change completely no less than five times); DISAPPEARING COIN BOX (a coin, placed in the wooden box, vanishes entirely or changes into a coin of another denomination); THE GLASS GORGET TRICK (a coin is dropped into a glass of water and when the water is poured out the coin has vanished and is found somewhere else); THE RIBBON FACTORY FROM THE MOUTH TRICK (a seemingly endless supply of colored paper ribbons comes out of your mouth); the DISAPPEARING HANDBRECHIEF (a handkerchief in the hand mysteriously vanishes); the WIZARD'S RING COIN TRICK; the ENCHANTED BOTTLE (no one but yourself is able to make it fly down); the GREAT HAT AND DICE TRICK (a large die is placed on top of a hat, disappears, and is found underneath yet no one has touched the hat), and last, but not least, the GREAT PHANTOM CARD TRICK, or two from five leaves nothing. Full instructions are sent for performing each trick. In addition to the above, a number of other tests and illusions are fully explained for which you can easily make or procure the necessary apparatus. Price complete \$1.00 postpaid. JOHNSON SMITH & CO.



## U. S. BABY TANK

It goes with real Yankee Pep—by its own power. Most remarkable toy ever invented. By drawing the Tank backward, either with the hand or over the floor or table and then placing it down, it will crawl along, overcoming all obstacles, in the same life-like manner as the larger Tank that proved so deadly in the great war. What makes it go is somewhat of a mystery, for there is no mechanism to wind up as is usually understood with mechanical toys, yet this tank will keep plodding along ten times longer than the ordinary run for toys. It will perform dozens of the most wonderful stunts; it will go backward or forward at will; 2 1/2 inches long. Price only 25 cents prepaid.

Most remarkable toy ever invented. By drawing the Tank backward, either with the hand or over the floor or table and then placing it down, it will crawl along, overcoming all obstacles, in the same life-like manner as the larger Tank that proved so deadly in the great war. What makes it go is somewhat of a mystery, for there is no mechanism to wind up as is usually understood with mechanical toys, yet this tank will keep plodding along ten times longer than the ordinary run for toys. It will perform dozens of the most wonderful stunts; it will go backward or forward at will; 2 1/2 inches long. Price only 25 cents prepaid.



There is a great deal of wholesome fun and amusement to be derived from these handcuffs. Although merely a toy, they are well and strongly made, with extremely simple mechanism that can be slipped on and off in a moment. No key is required either to lock or unlock them. Just slip them over the wrists and you have your pal securely handcuffed. These Handcuffs stand for Law and Order and, in the hands of the boy, inspire him with respect for Civic Virtues. They are entirely nickel-plated all over. Price only 65c pair postpaid.

## Female SEX Indicator

Hold the MAGIC INDICATOR over a man's hand—instantly it moves in a straight line, backward and forward. Hold it over a woman's hand and it describes a complete and continuous circle. The same action can be obtained over a letter written by a man or woman, etc. It is fascinating; baffling. We have never been able to figure out how it's done—but we've never seen it fail. Many novel and entertaining tests may be performed with the Sex Indicator. For example, similar results can be obtained with animals, cats, dogs, rabbits, over birds, chickens, canaries, etc. Also used to predetermine the sex of chickens and birds, etc. In fact it is sold as a patented egg tester in Europe. Price 25c, or 3 for 65c, postpaid.



## The "Little Giant" Typewriter

A First Class Writing Machine For \$1.50. A perfect little typewriter for \$1.50. There are thousands of persons who would like to use a typewriter but whose needs and business do not warrant the expense attached to the purchase and use of a fifty or seventy-five dollar machine. To such persons we confidently recommend our Little Giant. It is strongly made, but simple in construction, so that anyone can quickly learn to operate it, and write as rapidly as they would with pen and ink. The letters of the alphabet most frequently used are so grouped as to enable one to write rapidly, the numerals 1 to 10, and the punctuation marks being together. With this machine you can send your best job typewritten love letters, address envelopes, make out bills, and do almost any kind of work not requiring a large, expensive machine. With such typewriter we send a tube of ink and full printed instructions for using the machine. Price complete \$1.50 by mail postpaid to any address in the world.



# For Christmas an Ingersoll

When you give an Ingersoll Watch you make a gift that is appreciated out of all proportion to its cost.

For there's no gift like a watch, nothing used so much, consulted so often, carried so long. And Ingersoll Watches, made for over 35 years, have a reputation for dependability and enduring service that is world wide and thoroughly deserved.

If your dealer hasn't just the model you want, write us giving his name.

INGERSOLL WATCH CO., Inc.  
New York · Chicago · San Francisco



### YANKEE

The new improved model. More closely cased, antique bow and crown. Always dependable and sturdy  
Yankee Radiolite, \$2.25. **\$1.50**



### WRIST

Everybody needs a wrist watch. The time's in sight—at a glance. Unusually dependable . . . **\$3.50**  
Wrist Radiolite, \$4.00.



## Free Trial on this New Conn Saxophone

A WHOLE LIFE-TIME of joy is packed in a Conn saxophone. You play tunes in a week. Conn's easy-playing features and new instruction methods speed you along.

Pleasure, popularity, increased income—all may be yours with a Conn. You're welcome everywhere when you play. Professional engagements pay big money.

FREE TRIAL; EASY PAYMENTS on any Conn instrument for band or orchestra—saxophone, trumpet, trombone, cornet, clarinet, flute, drums, violin, etc. Send for details, mention instrument.

C. G. CONN, *Qd.*  
1231 Conn Bldg, Elkhart, Ind.

**CONN**  
BAND  
INSTRUMENTS  
WORLD'S LARGEST MANUFACTURERS

## MOVIES AT HOME

Many models of genuine MOVIE MACHINES, some as low as \$3.75, all using standard size big theatre films. Our stock of films is the most complete and lowest in price—with an exchange service. Films of leading stars and religious subjects are available. DON'T DELAY. WRITE FOR FREE INTERESTING CATALOGUE NOW!



PARAMOUNT MFG. CO.  
Dept. 1371 BOSTON, MASS.

## You can earn BIG MONEY!



with this handsome sample case filled with Rawleigh Good Health Food Products, Flavors, Spices, Toilet Preparations, etc. Hundreds of families will buy from you. No experience needed

—we show you how. Low prices. Liberal terms. Advertising literature and sales helps free. Good locations for 1500 men and women. Write

**The W. T. RAWLEIGH Co.**

DEPT. 9 P P M  
FREEPORT, ILL.



# All Electric Radio

Single Dial 7 Tube Set—30 Days Free Trial

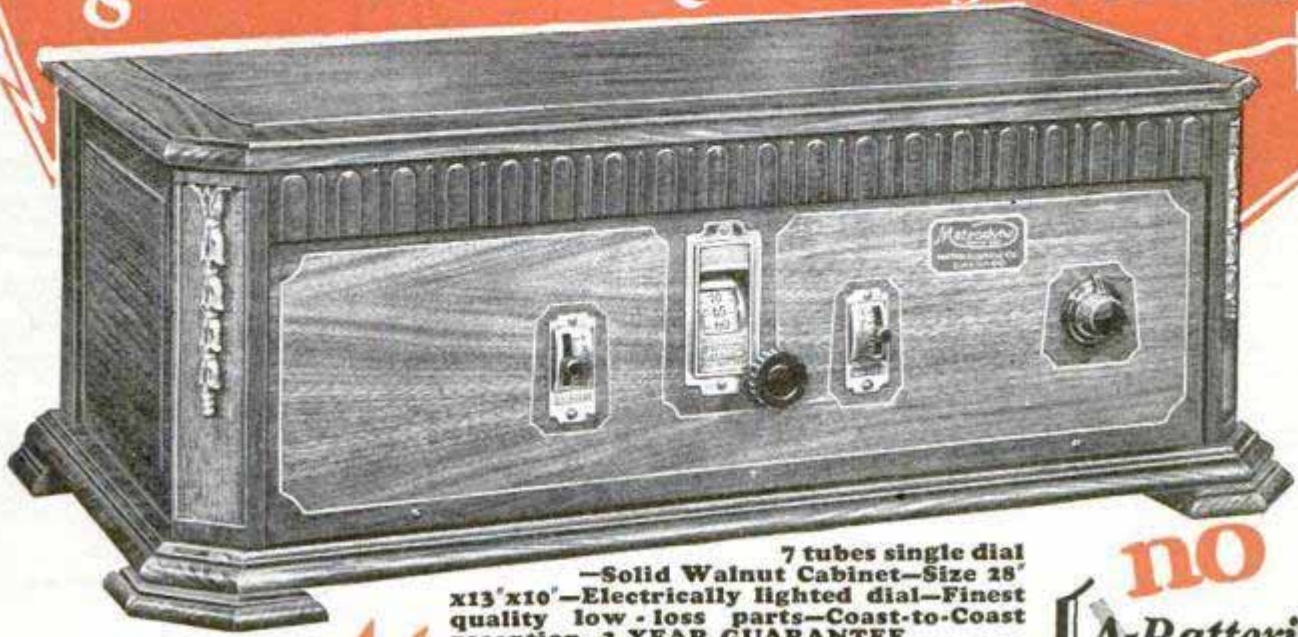

7 tubes single dial  
—Solid Walnut Cabinet—Size 28"  
x13"x10"—Electrically lighted dial—Finest  
quality low-loss parts—Coast-to-Coast  
reception—3 YEAR GUARANTEE.

“Simply  
press the  
switch button  
and it's on”

## Metrodyne

ALL ELECTRIC RADIO

**no**  
A-Batteries  
B-Batteries  
C-Batteries  
Eliminators  
Chargers  
Acids

**NOW! A real electric radio set! Costs less than most battery sets. No batteries—no chargers—no eliminators—no acids—no liquids! Shipped direct from our factory at rock bottom prices and on 30 DAYS' FREE TRIAL.**

**Agents! Dealers—Big Profits!**  
Make big money taking orders for Metrodynes. All or part time. Metrodyne All Electric Radios are in a class by themselves. Unequaled for quality, performance and price. Demonstrate at home and take orders. Lowest wholesale prices. Your demonstrating set on 30 days' free trial. Mail coupon below for details.

At last! The radio you've dreamed about! If you have electricity in your home you can now really enjoy coast to coast radio reception without the care, bother and muss of batteries, chargers, eliminators, etc. The Metrodyne All Electric is a real, genuine batteryless radio set. Simply insert the plug in the socket, press the switch button and “tune in.” You could not possibly buy a better radio set than the Metrodyne All Electric, no matter what price you paid.

**30  
DAYS  
FREE  
TRIAL**

### Costs Less Than Most Battery Sets

Do not confuse the Metrodyne electric radio with ordinary light socket sets. The Metrodyne is an all electric radio—uses less than 2c worth of power a day. Comes direct from factory. Its low cost brings it down to the price of an ordinary battery set. We are so confident that you will be delighted with this wonderful, easy-to-operate batteryless radio that we offer to ship it to you for 30 days' free trial—you to be the judge.

We are one of the pioneers of radio. The success of Metrodyne sets is due to our liberal 30 days' free trial offer, which gives you the opportunity of trying before buying. Thousands of Metrodynes have been bought on our liberal free trial basis. Write Today!

**Gorgeous Console Electric Radio**

Genuine walnut cabinet, in a beautiful two-tone finish. Has a built-in genuine Metro-Cone large size speaker. Brings in programs with great volume, reproducing the entire range from the lowest to the highest notes with remarkable clearness and distinction. All metal parts finished in old gold. Wonderful electric radio, in cabinet that will beautify any home.

Learn about the marvelous Metrodyne All Electric Radio before buying any radio set. Let us send you the proof of quality. Read the letters from thousands of owners. Get our rock bottom direct-from-factory prices and our liberal thirty days' free trial offer.

**MAIL THIS COUPON**



**METRO ELECTRIC COMPANY**  
2165 N. California Ave., Dept. 614  
Chicago, Illinois

Gentlemen:

Send me full particulars about Metrodyne All Electric Radio sets and your thirty days' free trial offer.

Name.....

Address.....

If you are interested in AGENT'S proposition place an "X" in the square.

## METRO ELECTRIC COMPANY

2165 N. California Ave., Dept. 614, Chicago, Illinois



**The Old Reliable Credit Jewelers** **LOFTIS BROS. & CO.** EST'D. 1858 Dept. G-894 108 N. State St. Chicago Ill.

**DIAMONDS CASH OR CREDIT**  
**Genuine Diamonds Guaranteed**  
**Diamond Jewelry for Christmas!**

Newer styles, finer quality, bigger values. We import our Diamonds from Europe—that's why we can sell to you for less. Our rings are solid 18-k white gold, magnificently engraved, and set with gorgeous blue white Diamonds of exceptional beauty. Order now!



No. 871 \$200 \$5 a wk.  
 No. 872 \$125 \$3.25 a wk.  
 No. 873 \$50 \$1.25 a wk.  
 No. 874 \$100 \$2.50 a wk.  
 No. 852 \$37.50 \$1.00 a wk.  
 No. 887 \$100 \$2.50 a wk.  
 No. 847 \$150 \$3.75 a wk.

**No. 857 Ladies' Wrist Watch**  
 Solid 14-k white gold case, 15 Jewels. \$27.50. \$2.75 down 2 month

Satisfaction guaranteed, or money back. Goods sent for your free examination on request. Credit terms: Pay one-tenth down; balance weekly, semi-monthly, or monthly at your convenience. All goods delivered on first payment.

**Send for Free Catalog**  
 Big 132-page book, illustrating our Diamonds, Watches, Jewelry, Silverware, and gift articles for all occasions, sent absolutely free. Write today.  
 "To Be Successful, Look Successful!"  
 —own and wear a genuine Diamond!

**Men's Diamond Rings**  
 Two exceptional values in men's Diamond rings. Each ring in solid 18-k white gold, hand carved and engraved, set with a magnificent blue white Diamond. Order yours today!

**Wedding Rings**  
 No. 824—The "Elite" \$750 solid 18-k white gold set with 8 Diamonds, \$22.50; 6 Diamonds, \$32.50; 7 Diamonds, \$42.50; 9 Diamonds, \$52.50; 12 Diamonds, \$67.50. All platinum, \$25. With 3 Diamonds, \$50; 5 Diamonds, \$70; 7 Diamonds, \$90; 9 Diamonds, \$100; circled by Diamonds, \$200

**17-Jewel Elgin No. 15 Thin Model**  
 White gold filled, 20-Year Quality Case; Accurate, silver dial; assorted patterns, \$23.50. \$2.35 down and \$2.35 a month.

**Men's strap watch, nickel, cushion shape, 6-jewel, high-grade movement, \$8.50 fine leather strap . . . . .**

**Railroad Watches — Guaranteed to Pass Inspection**  
 HAMILTON No. 992. 21 Jewels. Adjusted to 5 Positions. Gold filled 25-Year Quality Case . . . . . \$55  
 ELGIN'S LATEST RAYMOND. 21 Jewels, 8 adjustments. Runs 40 hours one winding. Gold filled 20-Year Quality Case . . . . . \$55  
 ILLINOIS "BUNN SPECIAL." 21 Jewels. Adjusted to 5 Positions. Gold filled 25-Year Quality Case. 60 hours 1 winding . . . . . \$50

**CREDIT AT CASH PRICES**

**LE PAGE'S GLUE** Handiest tool in your workshop.  
 In bottles, tubes and cans.

**AMAZING NEW ADDING PENCIL** TOTAL SHOWS HERE

Guaranteed Absolutely Accurate. Fountain pen size. Ends all mistakes. Send for yours Today. Great money maker. Everybody interested. Reserve territory immediately.

**AGENTS** HOUK ADDING PENCIL CO., Dept. 38 St. Louis, Mo.

**WANTED**

**RADIO CATALOG free**

**2000 Exceptional Radio Values**

**1928 WHOLESALE CATALOG of RADIO Sets, Kits and Everything in Radio**

**LOWEST PRICES to DEALERS**

**Economy Nine Super**  
 Retail price \$67.25.  
 This is the lowest priced Super kit of quality that the Radio market offers. Our extremely large discount makes your net price extremely low.

**EVERY SET BUILDER NEEDS THIS BOOK**  
 Every live dealer in radio, sets, parts, accessories, supplies, etc., should have a copy of this bargain catalog. You will be amazed at the thousands of money saving radio items illustrated and listed in this storehouse of everything you could possibly need in radio.

**The GUIDE BOOK to Bigger RADIO PROFITS FOR YOU**  
 The book contains all the latest and most popular kits—all the famous, nationally known radio parts, accessories and supplies—the very newest types and designs of table cabinets and consoles—everything at prices that mean bigger profits for you.

**Short Wave Section** Our catalog contains a section devoted to a showing of the highest grade short wave receiving and transmitting apparatus. Also the finest electrical appliances for use in the home.

**DEALERS Make More Money**  
 Tie up with a house that carries large, complete stocks, that gives you the highest quality radio parts, that insures speedy shipments and 100% satisfactory service. Our wholesale vest pocket price list and discount sheet and catalog will be sent to you on request. But Write Quickly.

**SHURE RADIO COMPANY** 341 D. West Madison Street CHICAGO, ILLINOIS

**Make a MOTOR CYCLE of your BICYCLE.** CASTINGS to build Motor or FINISHED MOTORS. Complete information, 10 cents. Blue prints of Drawings, 25 cents, coin. None free.

**STEFFEY MFG. CO.,** Dept. B, 3924 Fairmount Ave., Phila., Pa.

**TIRE REPAIRMEN—WRITE** for Booklet No. 22 "The Vulcanizing of Balloon and High Pressure Tires."

**The SHALER Co.** 2713 4th St., Waupun, Wis.

**SHALER VULCANIZERS**

**Boils 50 Gallons In Less Than Hour**  
 No Other Compares With This

**Improved Oil Burner**  
 Use Ordinary Kerosene or Coal Oil  
**[Burns Outdoors as Well as Indoors]**

**THE** most remarkable Kerosene Burner ever built. Boils down apple cider, maple syrup, molasses, etc., in half the ordinary time. Ideal burner for dairies, butchers, indispensable on the farm.

**PRODUCES TERRIFIC HEAT WITH SILENT BLUE FLAME**

**NO NOISE SMELL SMOKE SOOT**

So efficient it produces twice the amount of heat of City gas at half the cost. So simple anyone can install and operate. Double generator assures continuous operation without shut-downs. Nothing to wear out, starts in a jiffy, will last a life time. Every burner guaranteed fully. Write for special introductory price and free catalog of outdoor utility and kitchen stove oil burners.

**HOME MFG. CO.,** Dept. 1413, 18 E. Kinzie St., CHICAGO



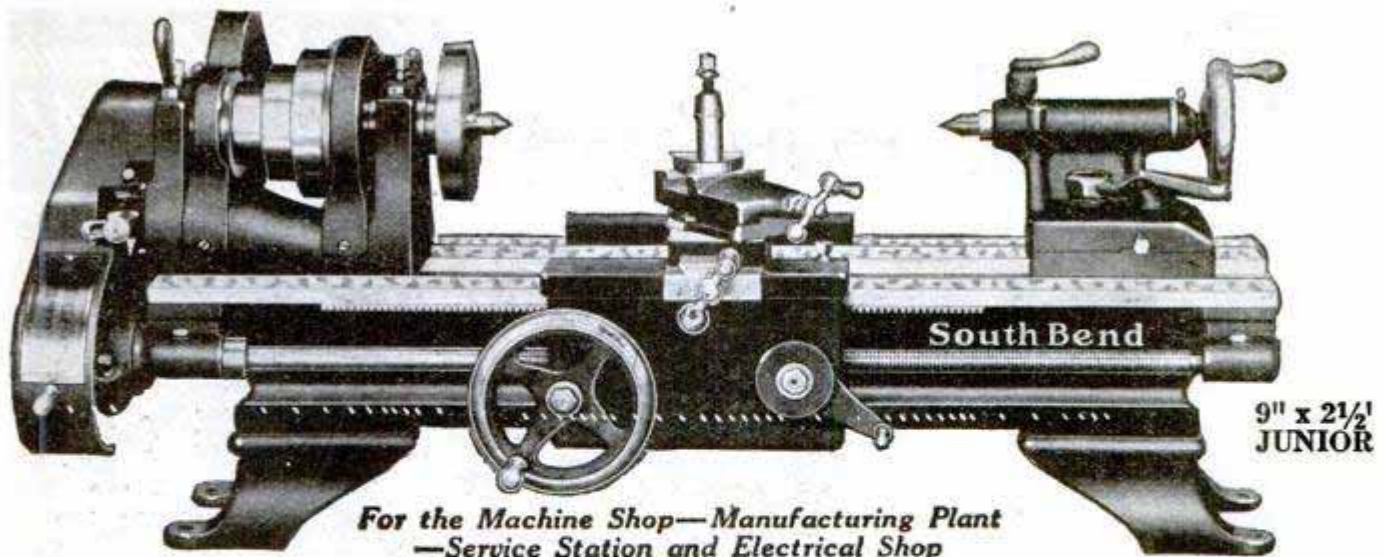

*For the Machine Shop—Manufacturing Plant  
—Service Station and Electrical Shop*

**Only \$150**

**The NEW MODEL—  
Back Geared—Screw  
Cutting Precision Lathe**

*Complete with Countershaft and Equipment*

**Easy Payments If Desired**

This New Model 9" Junior South Bend Lathe is built in the same plant where 38,000 other fine Precision Lathes have been manufactured for the United States Government, Ford, Westinghouse, Bethlehem Steel Co., U. S. Steel Corporation, and hundreds of other large industries in the United States and 32 Foreign Countries. It is the world's greatest Lathe value.

**Features and Specifications**

- Power Feed to Carriage
- Set-over for Taper Turning
- Hole through Spindle..... 3/4 in.
- Spindle Speed..... 48 to 714 R. P. M.
- Width of Belt..... 1 in.
- Maximum Draw-in Collet Size..... 1/2 in.

A number of attachments can be fitted to the Lathe for doing various classes of work.

**Small Down Payment**

**Balance in 10 Equal Monthly Payments**

A small down payment brings you the Lathe to use while you are paying for it. In this way it earns its own cost by the work it does and the savings it makes.

**OTHER POPULAR SELLING SIZES**

**Complete with Countershaft and Regular Equipment**

Size of Lathe	Shipping Weight	Standard Change Gear	Quick Change Gear
9" x 3'	490 lbs.	\$235.00	\$270.00
11" x 4'	725 lbs.	300.00	335.00
13" x 5'	1110 lbs.	352.00	402.00
15" x 6'	1550 lbs.	430.00	490.00
16" x 8'	2035 lbs.	510.00	570.00
18" x 10'	2840 lbs.	685.00	750.00

The complete line ranges from 9 to 24-in. swing, and from 2 1/2 to 16-ft. bed. Write for name and address of your nearest dealer.

**Free New Booklet 22-K and Complete Catalog No. 88**

Our new 20 Page Booklet 22-K describes the New Model 9" Junior South Bend Lathes in all types and drives—165 illustrations—sent free on request. Complete Catalog of all South Bend Lathes will also be mailed postpaid.

**South Bend Lathe Works** 632 E. Madison Street  
South Bend, Ind., U. S. A.  
New York City Salesroom, 183 Centre Street

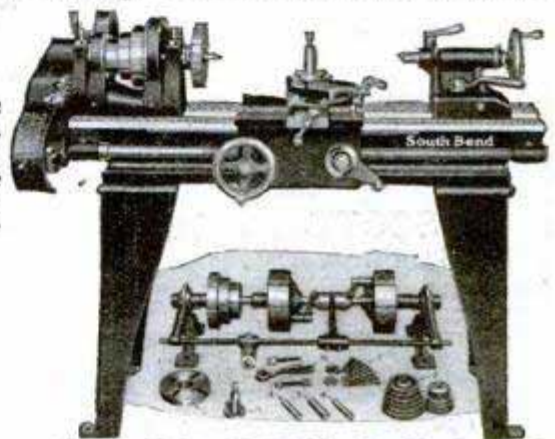

9" x 2 1/2" New Model Junior South Bend Lathe with floor legs, countershaft and equipment .....\$160

Operates from lamp socket—  
3/4 H. P. Reversing Motor  
connects directly  
to nearest lamp  
socket for  
power.

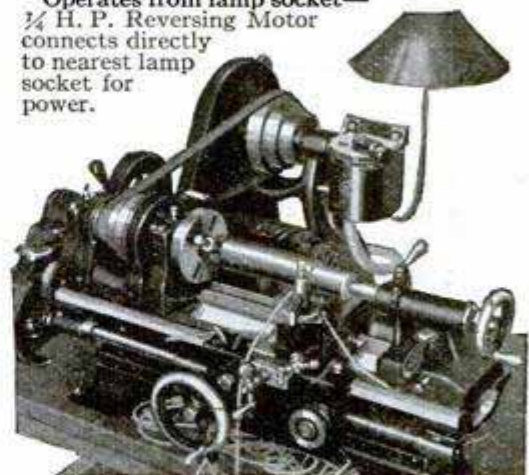

9" x 2 1/2" New Model Junior Self-Contained Motor-Driven Bench Lathe, complete as shown .....\$228

**SOUTH BEND LATHES**



# 18 Tools In One S & B SAW Money Back Guarantee 8" Combination S & B SAW 15 DAYS TRIAL

The S&B 8-in. Combination Saw (18 tools in one) is the ideal machine for the shop, factory or the home; will rip, cross cut, bevel, miter, mortise, groove, drill, tenon, grind, rabbet, buff and polish. The greatest machine you ever saw; no other machine so complete and efficient as the S&B—actually

**\$35**

**F. O. B. CHICAGO**

18 tools in one! You will marvel at the wonderful beveling, grooving, buffing, etc. All attachments are adjusted in a few seconds without any difficulty. Very little space is used and the motor is mounted on a base that is a part of the machine proper, this is an exclusive feature! The motor: 1/4-H.P., 60-cycle, 110-volt A.C., run from any light socket also provides power for other purposes when the saw is not in use. Complete with attachments: 12-in. x 16-in. Table, 8-in. Combination Saw, Iron Pulley for Saw Table, 10-in. Ripping fence, Adjustable Cut-Off Miter Gauge, Motor 1/4-H.P., 3-in. Iron Pulley, 6-in. Buffing Wheel, 5-in. Emery Wheel, 6-in. Sander, 3/8-in. 3-Jaw Drill Chuck, 1 1/4-in. Endless Leather Belt, 8-foot Cord and Plug, Saw Guard and 2-in. Dado Insert. Price \$35.00, F.O.B. Chicago. Shipping weight 100 lbs. (Planer attachment to fit on table top will smooth pieces up to 2 in. wide, \$12.00 extra. Flexible Shaft Grinder attachment, \$35.00 extra.)

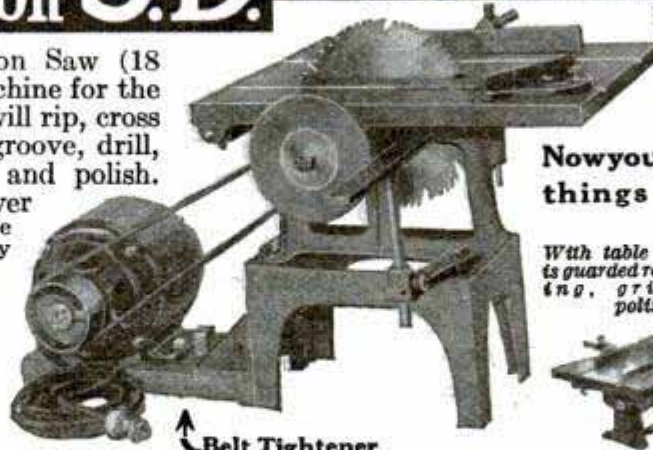

↑ Belt Tightener

**A Sensible XMAS GIFT**

Now you can make the things you wanted

With table raised—saw is guarded ready for drilling, grinding or polishing.



Ready for dado or planer head and special molding work—Table is adjustable.

Planer attachment—most practical ever adapted to a saw table.



Flexible shaft grinding attachment—especially good for metal patterns, routing, grinding, die-castings, etc.



The only machine that you can tilt the table to 45° without removing insert. Big advantage on pattern work.



Write for Complete Illustrated Folder

**SCOTT-BANSBACH MACHINERY CO.**

130 So. Clinton St.

Dept. 59

CHICAGO, ILL.

## "B" BATTERY ELIMINATOR

Only **\$4.95**

**New Improved 1928 Model Absolutely Guaranteed**

No more worry with "B" Batteries! Hook up a Perfect "B" Battery Eliminator and forget battery troubles forever. This wonderful new invention means better reception, sharper tuning. Gives you more real pleasure from your set.

No Tubes, No Harmful Acids, No "Extras" to Buy

Send **\$1.00**

Operates perfectly on direct or alternating current, giving up to 90 volts current, and using the full wave of the power supply. Simple directions enclosed—anyone can plug it into any kind of set up to six tubes. Constant voltage gives set more power. Costs no more than set of good "B" Batteries.

**SEND YOUR ORDER NOW**

Don't blame your set because run down "B" Batteries won't let it work right. Order your Eliminator NOW. Write name and address on a piece of paper, pin a dollar bill to it, and mail it TODAY. Pay postman balance (\$1.95 plus a few cents postage) when he delivers your Eliminator. Use it ten days. If not more than satisfied, return it and get your money back. 135 volt "B" Battery Eliminator \$7.95. Send \$3 with order. Pay postman balance on delivery.

**PERFECT ELIMINATOR CO.**

N-21 National Theatre Bldg., Cincinnati, O.



**Make Money SHARPENING SKATES**

**A FEW DOLLARS STARTS YOU**

**Universal and Keen Edge Skate Grinding Holders**

As used for Lengthwise and Cross sharpening of skates. Price \$5.00 and \$3.50 each. Particulars on request. The Original Makers of Skate Grinding Holders.

Ferodowill Mfg. Co. 202-214 W. Indiana Ave. ST. PAUL, MINN.

## COOKS BY BURNING AIR



**Does Away With COAL!**

Converts any ordinary stove into gas range. Produces clean heat much cheaper and is far more efficient than coal. Burns 96% air and 4% kerosene. Installed in few minutes.

Types for all heating purposes. Reliable distributor wanted. **GLORIA LIGHT CO., 111-12 N. May St., CHICAGO**

## CHRISTMAS NOVELTY

Salesmen and Agents wanted everywhere to sell our Christmas Novelty. Previous years' experience prove active men make \$25.00 daily, upward. Sold day or evening. Every store, office, and home is a prospect. Easy method of display. Cash sales; no order taking. Send quick for FREE sample and literature.

**CONSOLIDATED CO., 65-A West Van Buren St., Chicago, Ill.**

The man who studies gets ahead. Popular Mechanics Press will advise you what books to read to advance in your trade. 200 East Ontario Street, Chicago, Illinois.



## ALL GIVEN

10 year guar. Watch with chain and ring, large Eastman Roll Film Camera or 22 cal. Hamilton Rifle yours for introducing finest assorted liquid perfume at 15c a bottle. Send for 20 bottles and choose gift as per offer in our catalog. We trust you—just write to **BELL PERFUME CO., Dep. C 153 Chicago, Ill.**

## 22 CAL. RIFLE





# 30 Days Trial



## One Dial Westgale Radio Sets

NOW,—you can get the finest quality Radio, DIRECT FROM FACTORY on 30 Days' Trial and save almost half. Now you can put any of the new 1928 WESTGALE models in your home and use them to your heart's content for 30 days at our risk. Listen to the music, concerts, news, sports, market reports from all over the country. Test the Westgale Radio for distance, selectivity and REAL Tone value. Compare it for quality and price with any other Radio. Then if not convinced that Westgale gives you the biggest value for the money—YOU DON'T HAVE TO KEEP IT.

### Westgale Sets are Licensed Under R. C. A. and Associated Companies Patents

For the 4th consecutive year Westgale offers you the newest and latest in Radio at lowest prices. Our 1928 models are licensed under the basic patents of the Radio Corporation of America and Associated Companies. That assures you dependable service. Beware of an un-licensed Radio. Why not have the best? Why pay high prices? Why take chances when you can test out any Westgale model in your own home on 30 Days' Trial? Our retail prices are low factory prices. Our Agent's prices are lower. Send for our new 1928 catalog and see for yourself.

### 24 Styles to Choose From Table Styles—Consoles—De Luxe Cabinets

This season Westgale offers you 5 tube—6 tube—and 7 tube models in your choice of a beautiful array of table styles, consoles and period type Walnut cabinets.

Don't buy any radio until you send the coupon for our new catalog which pictures and describes our complete line in almost any size or style you could wish for. Don't wait,—a special introductory discount from retail prices for those who write quick. Mail the coupon today—get posted before you buy.

5-6-7  
Tube Sets  
\$47.00  
to  
\$72.00  
RETAIL PRICES

*The Last  
Word in  
Guaranteed  
Radio  
Sets*

### Why Not Be Our Agent?

Buy at cost. We want Agents and Dealers in every locality to demonstrate and take orders for these amazing new 1928 Westgale Models. This is your chance to get a Westgale Radio at a big discount and make it pay you big money. Millions of radios will be sold this season. Get a Westgale set on 30 Days' Trial—demonstrate to your neighbors and friends and get your share of these big radio profits.

### Your Own Radio FREE

Our new Catalog also explains a plan whereby you can put a Westgale Radio in your home on 30 Days' Trial—demonstrate it to your neighbors and friends in your spare time and get your own set without cost before the trial period is up.



6 Tubes—1 Dial  
Only  
\$87.00  
Retail Price  
Including Spesker

### Special Discounts to Agents and Dealers

To quickly introduce these wonderful new 1928 models we are offering for a limited time a big reduction, way below retail prices on the FIRST Westgale set placed in each community. So get busy now. Be first in your locality to mail the coupon for our FREE catalog and get full particulars of this special discount offer.

### Westgale Electric Co.

Dept. 112

1751 Belmont Ave. Chicago, Ill.

*and the  
Biggest  
Values  
Ever  
Offered*

**Mail Today—Don't Delay**

**WESTGALE ELECTRIC CO.,**  
Dept. 112—1751 Belmont Ave.,  
Chicago, Illinois

Please send me your FREE Catalog on the new 1928 Westgale Radio sets. Also full particulars of your Special Discount offer on the first outfit placed in each community.

Name.....

Address.....



# 12 Years of unfaltering Service

FOR twelve years Cunningham Radio Tubes have been providing dependable tube service in millions of radio sockets.

You, too, may enjoy unfaltering radio reception by equipping your set throughout with Cunningham Radio Tubes.

Don't use old or inferior tubes with new ones—use new tubes throughout.

To keep your set at peak performance, retube throughout with Cunningham Radio Tubes at least once a year. Your dealer will tell you the correct types for which your set is designed.

**E. T. CUNNINGHAM, Inc.**

New York

Chicago

San Francisco



## The Famous AERO SHORT WAVE KIT NOW IMPROVED

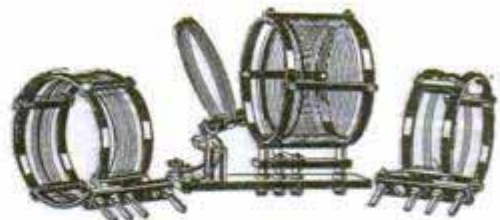

### AERO LOW WAVE TUNER KIT

Code No. L. W. T. 125 . . . . . Price \$12.50

Always the prime favorite of all experts and amateurs insistent upon the very best in short wave reception, the AERO Low Wave Tuner Kit for this season has been made even better than ever!

### Range 13 to 725 Meters

The AERO Low Wave Tuner Kit illustrated above is completely interchangeable. The kit itself includes 3 coils and base mounting covering U. S. bands 20, 40 and 80 meters. You can increase the range of this kit to 725 meters by use of AERO interchangeable coils No. 4 and 5 (Price \$4.00 each) or you can decrease the range to go as low as 13 meters by use of AERO interchangeable coil No. 0 (Price \$4.00).

By all means build the new AERO Short Wave Set. The AERO coils used in its construction can be procured from your dealer or direct from our factory. We have also arranged to furnish the Westinghouse Micarta drilled and engraved panel for this receiver direct from our factory. Write us at once for full information.

**AERO PRODUCTS, Inc., Dept. 107**

1772 Wilson Avenue

CHICAGO, ILL.

## PLUMBING - HEATING WATER SYSTEMS



### SAVE UP TO 40%

Wonderful bargains—everything guaranteed. Full line of plumbing and heating supplies. Hot water, steam heating plants and fixtures and water systems at big savings.

### Install Them Yourself

Finest materials all brand new and perfect. Tell us your wants and mail us a rough sketch of your rooms.

### SEND FOR PRICE LIST

800 S. KEDZIE AVE.

**B. KAROL & SONS CO. Dept. 20 CHICAGO**

## 30 Days' Free Trial

New Models now ready for delivery direct from our factory. Astonishing low prices and terms. Do not buy until you get them.

**RIDER AGENTS WANTED** to ride and exhibit sample. Make big money. Many models \$21.50 up.

**Tires** Guaranteed \$1.50 each, wheels, lamps, horns, equipment at half usual price. Send No Money. Write for our marvelous prices and terms on RANGER Bicycles.

**Mead CYCLE CO. Dept. A-108 CHICAGO**



Make \$100.00 a week and up, selling our fine made-to-measure, all-wool suits, direct to wearer. Biggest values—positively sell on sight. Biggest commissions paid in advance. We attend to delivery and collections. 6 x 9 cloth samples—over 100 styles—furnished FREE. Ambitious men write at once.

**W.Z. GIBSON, Inc., 161 W. Harrison, Dept. M516, Chicago**



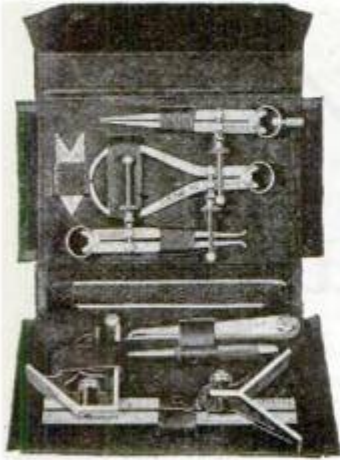

Starrett Set No. 900, in a handsome folding leather case, is made up of 6 inch Combination Square, complete; center punch, 6 inch flexible steel rule in pocket case, center gage, 4 inch inside and 4 inch outside calipers with solid nuts, and 4 inch dividers with solid nut.

Price \$8.75.



The Starrett Book for Machinists' Apprentices, Volume I of the famous Starrett Books, contains answers to the many questions the beginner will ask. Every apprentice should have this book. Ask your dealer for it.

Price 75 cents.



*"I hope to tell you that's a real present!"*

Any man who is mechanically inclined will appreciate a gift like this.

The Starrett No. 900 Set is a kit he will be proud to own. It contains just the tools he needs to get started on precision work—each one of them made with the accuracy and quality which has made Starrett Tools the standard for good workmanship the world over.

Your tool dealer will gladly show you the Starrett No. 900 Set. Ask him or write us for a copy of the Starrett Catalog 23 "AP" illustrating and describing more than 2500 fine tools.

**THE L. S. STARRETT CO.**

World's Greatest Toolmakers  
Manufacturers of Hacksaws Unexcelled  
Steel Tapes—Standard for Accuracy

ATHOL, MASS.

U. S. A.



**Use Starrett Tools**





## Transformers

An Amazing Achievement in Audio Amplification

The new C-16 and C-25 Transformers will work in any circuit and will improve any Radio Set. Endorsed by America's Leading Engineers. Guaranteed by the Manufacturers

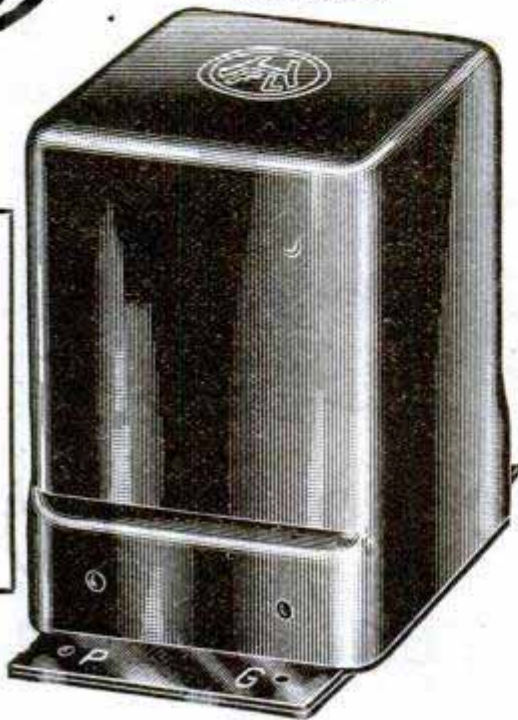

### Two additions to last year's Radio Sensation

H.F.L. C-16 is the most efficient Audio Transformer built. It carries signals at highest volume and lowest amplitude without blasting or developing harmonics. Operates with all power tubes as well as standard tubes.

H.F.L. C-25 Output Transformer handles the voltage output of power amplifying tubes, at the same time matches the impedance of the average speaker to the tubes. Protects loud speaker unit without reducing plate voltage.

Mechanical features of these two transformers are: A coil designed and treated to exclude moisture and withstand heavy electrical surges without breaking down—complete magnetic shielding to avoid inter-stage coupling—terminals brought out so as to insure short leads.



#### PRICES

H-210 Tran. \$8.00  
H-215 Tran. 8.00  
C-16 Transf. 8.00  
L-425 R. F. Choke... 5.50  
L-430 R. F. Transform. 5.50  
C-25 Output Transform. 8.00



**SET BUILDERS! Write Us for the Name of Our Nearest Distributor**

**HIGH FREQUENCY LABORATORIES**  
133K—North Wells St., Chicago, Ill.

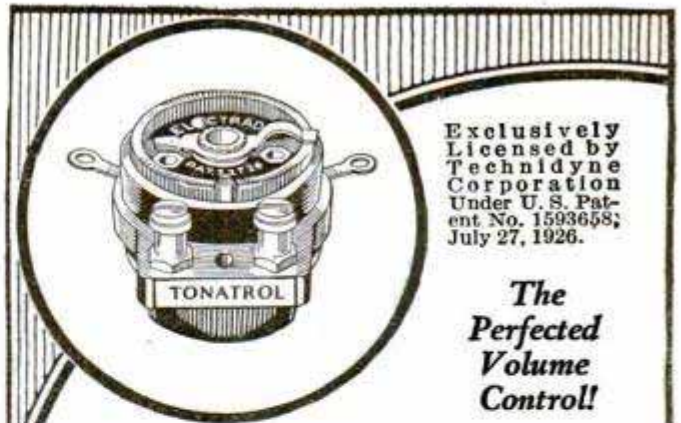

Exclusively Licensed by Technidyne Corporation Under U. S. Patent No. 1593658; July 27, 1926.

The Perfected Volume Control!

## "Tonatrol"

A True Tone and Volume Control

Your neighbors will envy the ease and convenience with which you secure every gradation of volume if you use "Tonatrol."

This new tone and volume control enables you to change from soft music, clear and sweet, to powerful house-filling volume a second after. A helpful addition to any receiver. Constructed to last with genuine bakelite. Very simple to install.

Tonatrol—Standard Volume Control \$1.50

Tonatrol—Type W. S. (with filament switch attached) \$2.00

Write for free installation booklet for the proper way to control volume.

Dept. 66C, 175 Varick St., New York, N. Y.

# ELECTRAD

## "RADIO DOCTORS" MAKE BIG MONEY

\$7 to \$10 a week spare time evenings. \$50-\$150 after short training period. THIS IS A NATIONAL RADIO SERVICE ORGANIZATION THAT NEEDS MEN. Send for booklet No. 27 now.

**CO-OPERATIVE RADIO DOCTORS**  
131 Essex Street Dept. L SALEM, MASS.

## LEARN TO Mount Birds

We teach you At Home by Mail to mount Birds, Animals, Heads, Tax Furs and Make Eggs. Be a taxidermy artist. Easily, quickly learned by men, women and boys. Tremendously interesting and fascinating. Decorate home and den with beautiful art. Make Big Profits from Spare Time Selling Specimens and Mounting for Others.

**Free Book**—Yes absolutely Free—beautiful book telling all about how to learn taxidermy. Send Today. You will be delighted. Don't Delay!

Northwestern School of Taxidermy 3379 Elwood Bldg. OMAHA, NEB.



## You—and This New Machine Can Earn \$500 a Month

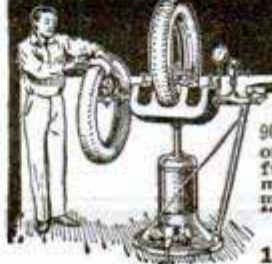

### Operate a Tire Repair Shop

90,000,000 Tires in use. America's greatest opportunity for men with small capital. We furnish everything—\$100 and up. Easy payments. We train you FREE right at home. Start making money at once. Write today for Free Book "Steps to Success."

**Haywood Tire Equipment Co.**  
1334 South Oakley Chicago, Illinois



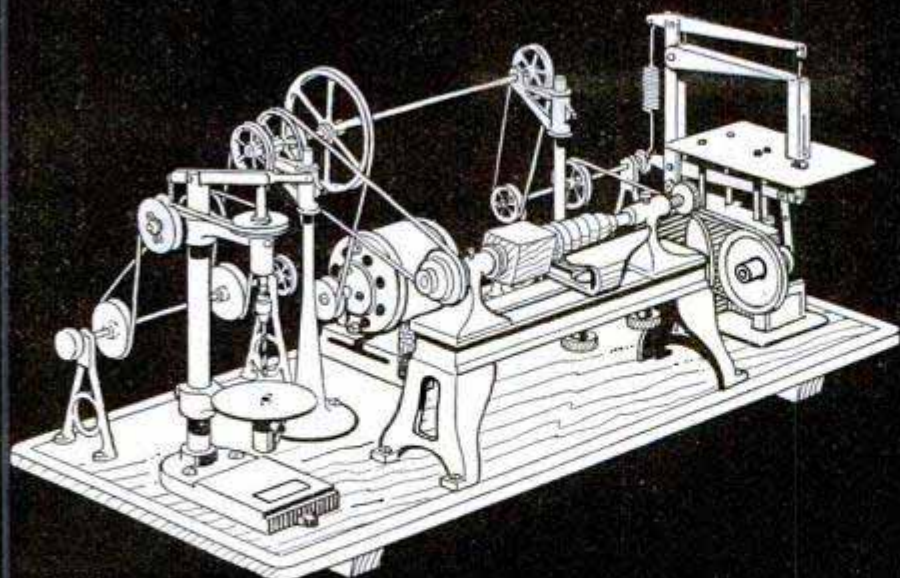

## KNAPP WORK SHOP

### All Who Love To Make Things!

**Model Makers, Amateur Mechanics, Experimenters, etc.**  
Study the specifications of this ultra-quality line of dependable machine tools, selling at prices you can afford.

You can easily see the great advantages of owning an outfit like this. It can accurately handle the small turnings and do saw work, that now take so much time doing by hand on ship models and other work, and at the same time it is big and sturdy enough to handle up to  $\frac{3}{8}$ " lumber in the saw, turnings  $2\frac{3}{8}$ " x 5" and will drill not only wood, but metals (iron, copper, brass, lead, aluminum), bakelite, celeron, slate, radio panels, etc.

It has been especially designed so that it can do not only the ordinary work but very small work as well.

It is operated by  $\frac{1}{35}$  h. p. 110 volt a. c., d. c. motor, the cutting

tools are the best tool steel, the drills and saw blades of high temper. Coming with the outfit is your first piece of wood for turning, wood stamped with design for sawing, and illustrated instruction book, belting, and all tools.

Outfit comes completely set up, ready to plug in to an electric light socket. Motor costs less to run than a 75 watt lamp. Or you may buy any of the tools separately.

This outfit is a worthy addition to any work room, and is handy in a hundred ways.

Go to your dealer and see a Knapp Work Shop—hardware, sporting goods stores, or department stores (toy dept usually), or send 10c. in stamps for full color catalogue fully describing Knapp American Industry in Miniature.

**Workshop No. 990 complete \$27.50**  
Denver West \$30.00

*If your dealer is out of stock we will send for price plus carrying charges.*

**KNAPP ELECTRIC CORPORATION, PORT CHESTER, N. Y.**

DEPT 69

Also Manufacturers of Knapp Electric Questioner

FOR SALE BY **T. EATON CO. LIMITED**  
CANADA



**KNAPP LATHE No. 930 AND TOOLS**

#### Knapp Lathe, No. 930

Turns wood up to 5 in. length,  $2\frac{3}{8}$  in. diameter. Tool rest, head rest, tail stock all fully adjustable. Complete with 3 step pulley, 3 high grade cutting tools, and instruction book.

**\$6.00 Denver West \$6.50**  
Shipping Weight 4 lbs.



Samples of work done on the Knapp Lathe with Outfit 935, consisting of 12 interesting and useful turning designs, and templates, 43 white pine blocks, 5 in. long, from  $\frac{1}{2}$  to  $1\frac{1}{2}$  in. diameter.

**Outfit 935, \$1.25**  
Shipping Weight 7 lbs.



**KNAPP JIG SAW No. 900**

#### Knapp Jig Saw No. 900

Capacity up to  $\frac{3}{8}$  in. lumber, also bakelite, celeron, etc. Handy for making radio panels, as well as jig saw and scroll work. Instruction book, wood with design laid out ready for cutting and 3 blades furnished.

**\$4.00 Denver West \$4.25**  
Shipping Weight  $3\frac{1}{2}$  lbs.

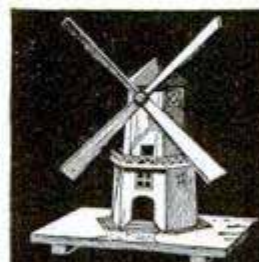

Sample of work done on Saw No. 900 from Outfit 902 which consists of 20 boards,  $4\frac{1}{2}$  x  $12$  x  $\frac{3}{16}$  in. and 12 designs for making everything from toys to practical household articles.

**Outfit 902, \$2.00**  
Shipping Weight 6 lbs.



# I Want to Send You a Santa Fe Special Watch

for You to see and examine

Our 21 Jewel Santa Fe Special Guaranteed for Life

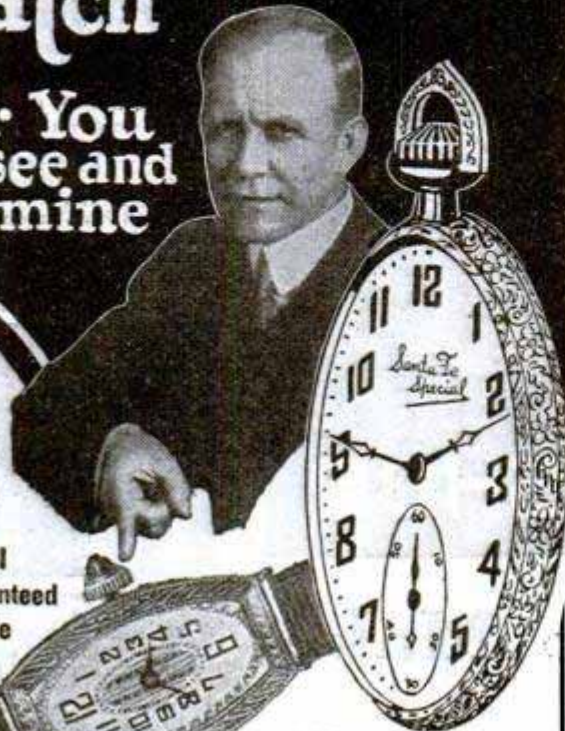

Send No Money

Watch Sent on 30 Day Free Trial

Santa Fe Special Watches are today being shipped to every civilized country in the world, and are probably the best and most favorably known watch in both Army and Navy.

In addition to our NEW LOW PRICE, I will send for your approval one of these Standard Watches, guaranteed for a lifetime of satisfactory service, not only by the Santa Fe Watch Company, but by the Great Illinois Watch Factory. So accurate, Government officials carry them; so perfect and beautiful, jewelers say they are worth 1-3 to 1-2 more than we ask for them. I will send you one to see WITHOUT ONE PENNY DOWN—allow you to wear it 30 days FREE—then sell it to you on easy payments.

**WHY NOT OWN A 21 JEWEL SANTA FE SPECIAL WATCH?**

You will never miss the few cents a day that will make you own one of these watches—SEND FOR WATCH BOOK—illustrating in beautiful colors hundreds of designs and combinations in cases in the POCKET WATCH, MEN'S STRAP WATCH and LADIES' WRIST WATCH. You can have your name or monogram and any emblem you may desire engraved in the Case to suit your own ideas. Write today for Free Watch Book, and make your selection at once, while this offer lasts.

**FREE** A limited offer! With every Santa Fe Special, beautiful gold chain or strand of exquisite pearls. Write today. Mail coupon for both Watch and Diamond Catalog

**WRITE FOR SPECIAL 30 DAYS CASH OFFER**

**SANTA FE WATCH COMPANY**

Dept. C.-6, Thomas Building Topeka, Kans.  
(Home of the Great Santa Fe Railway)

Mail coupon to-day!

**SANTA FE WATCH COMPANY**

Dept. C.-6, Thomas Building, Topeka, Kansas

Please send prepaid and without obligation your Watch Book Free, explaining your "No Money Down" Offer on the Santa Fe Special Watch.

Name.....

Address.....

City..... State.....



# HEAT LACO OIL BURNER

Economical Dependable

You won't care how cold it is this winter if you have a LACO oil burner in your furnace. LACO will give you automatic, clean, economical heat. Needs no attention; requires no adjustments and there's no dirty coal to handle. Made in five adaptable sizes—each the lowest price on the market—for any size home or building. LACO is safe as a gas range; doesn't bother radios; noiseless and it's as simple as the ordinary kerosene lamp. Guaranteed to heat the home or building to the maximum capacity of the heating plant. Write today for full details telling how LACO will give you trouble-proof, dependable, economical heat.

**DEALERS!**  
Write Today for Terms

**LACO GAS BURNER CO.**  
701 CASS STREET  
GRISWOLD IOWA

## How Does This Sound?

\$2.00 to \$3.00 an hour at home during spare time, or a good steady income in business for yourself! A clean, dignified business. No canvassing. Pleasant and easy work. No studying, no rent, no experience needed.

## FOLEY Automatic SAW FILER

The business is already waiting for you if you have a Foley. Practically every home has saws to be filed regularly. You can get the filing business from the manual training department of your school. Carpenters, contractors, factories and dozens of others will be your regular customers. You get \$.50 or more for each saw. The Foley does the work automatically. Files and joints all kinds of saws. Electrically driven. This is a real opportunity for the man who honestly wants to make real money. If you are that man, write for free instructions on how to build up a saw filing business.

**FOLEY SAW TOOL CO., Inc.**

222 Foley Bldg., 9 Main St. N. E. Minneapolis, Minn.



## THREAD CUTTING LATHE

A REAL Lathe. 9' swing; 30' between centers. Speedy and accurate. Special attachments and tools available. Write today for Circular and 12' Band Saw Powerful, practical. Not a toy. Prices on these Has tilting table. Saws 6" stock. and other machines. Rossbacher Machine Co., 1516 Fernwood Ave. TOLEDO, OHIO

## I Offer You \$8.00 a Day and a

Write quick for new proposition. We offer \$8.00 a day and a new Chevrolet Coach for demonstrating and taking orders for Comer All-Weather Topcoats and Raincoats. Spare time. No experience required. Sample outfit free. Write now.



Comer Mfg. Co., Dept. SW-5127, Dayton, Ohio

## 5 TUBE RADIO ONLY \$19.98

It's a wonder for power and selectivity. Famous ARL circuit. Coast to coast reception! Finely built of selected, tested parts. Thousands now in use. FREE Log and Call Book and New 132-p. Catalog with thousands of nationally advertised bargains. Latest in radio at big savings. Write for Free copy.

**AMERICAN AUTO & RADIO MFG. CO.**  
HARRY SCHWARTZBERG, PRES.  
Dept. 261 American Radio Bldg., Kansas City, Mo.





# 30<sup>D</sup><sub>A</sub><sup>Y</sup><sub>S</sub> FREE TRIAL

## Battery or All-Electric OPERATION

**T**RY this powerful seven-tube RANDOLPH RADIO for thirty days. After it brings in stations from coast to coast with amazing clearness—with easy one dial tuning—after it easily equals any other radio—after you are more than satisfied, then you can buy it direct at factory prices. Every RANDOLPH must make good before it is sold.

This RANDOLPH can be had for use with batteries or connected direct to the electric light socket—absolutely batteryless—no batteries, chargers or acids—just plug in and tune in. 100% efficient either way. Its construction and performance have been tested and approved by leading radio engineers and authorities—by leading radio publications and laboratories.

### 7 Tubes—Single Control Illuminated Drum

One drum dial operated by one simple vernier control tunes in all stations with easy selectivity to tremendous volume. No overlapping of stations. Illuminated drum permits operation in the dark. Volume control for finer volume modulation. This is a seven-tube tuned radio frequency receiver with power transformers and power amplification. Space wound solenoid coils. Full and completely shielded. Tremendous distance, wonderful tone quality, simple to operate.

### Beautiful Walnut Console Built-in Cone Speaker

The Randolph Seven-tube Ampliphonic Console illustrated above is housed in a genuine burl-walnut cabinet with two-toned hand rubbed finish giving it unsurpassed beauty. The same expert cabinet work has gone into the making of these consoles as in the finest furniture. Has built-in cone loud speaker that compares with any on the market. Accurately reproduces complete range of musical notes from the highest to the lowest pitch.

### What Users Say

I have logged more than 50 stations from coast to coast.—Lloyd Davenport, Littlefield, Texas. I have logged 52 stations from Cuba to Seattle, the set is a world beater.—J. Tampkinson, Detroit, Mich. Your set is a revelation, has all others tied to the post for distance and selectivity.—Waldo Powers, Vergennes, Vermont. On strength of its performance sold two more sets this week.—T. Scanlow, Orlando, Florida.

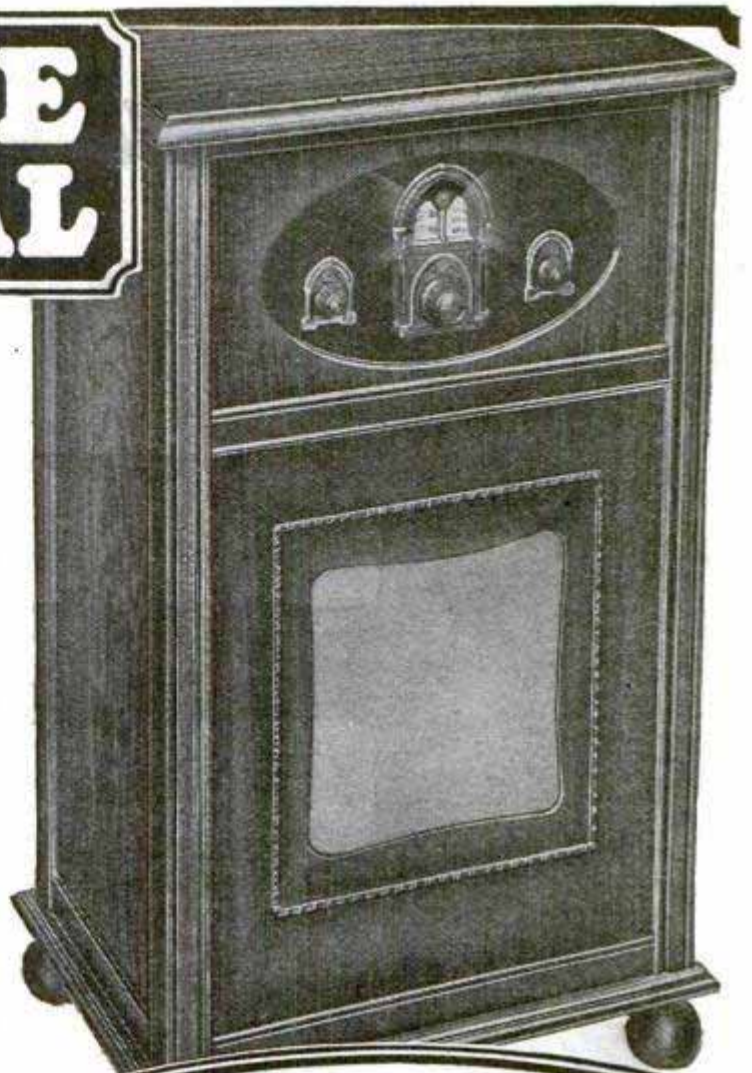

*The Randolph* \$ **99**  
7-Tube Console  
Single Control  
**RETAIL PRICE**  
Completely Assembled



**6-Tube**  
\$ **55**  
Retail Price  
Single Control

**The Senior Six**  
Do not compare this set with old style 2-dial 6-tube sets selling for about the same price. The Randolph 1928 Senior Six has also been tested and approved by the leading radio engineers.  
Beautiful solid walnut cabinet. Single control. Illuminated drum with space for logging. Very selective. Sent for 30 Day's FREE Trial.

**MAIL COUPON NOW!**

The Randolph Radio Corporation are pioneers in the manufacture of radios. Long and successful experience in the radio business makes us perfectly confident in sending Randolph Radio on trial. We know what it will do. Mail us the coupon for the greatest radio offer ever made.

**Sensationally Big Discounts to Agents**  
Work either full or part time and make big money. Tremendous advertising campaign helps you sell. Regardless of whether you have ever sold before, be sure to get our proposition. The Randolph sells on first demonstration. Men and women both can make money this easy way. Get your demonstration set for thirty day's FREE TRIAL.

**Use This Coupon NOW!**

**Randolph Radio Corporation**  
711 W. Lake St., Dept. 390  
Chicago, Illinois

Send me full particulars about the RANDOLPH Six and Seven Tube All-Electric and Battery Table and Console Sets with details of your 30 Day FREE Trial Offer.

Name .....

Address .....

City..... State.....

Mark here  if interested in Agent's proposition.

**RANDOLPH RADIO CORPORATION**  
711 West Lake Street Dept. 390 Chicago, Illinois



# A *reliable* BENCH LATHE at a price you can afford



No 125—\$40

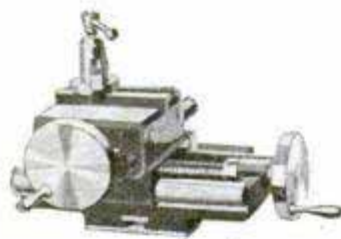

No. 132 Slide Rest  
List \$17.50



No. 194 Saw Table  
(saw not included)  
List \$17.50

**I**f you don't require ultra precision, but do want a reasonably accurate lathe, this one will serve your purpose and meet your pocket-book.

This lathe is sturdily built and dependable, and is designed especially for use in trade schools, repair shops and the home workshop.

It has Milled Bed and Tail Stock with Milled Base, both Screw and Lever Feed and 3-Step Cone Pulley. Capacity: 7" swing; 12" between centers. Live Spindle fitted with cone bearing. Measures 25" over all and is 11½" high.

No. 125 . . . List \$40.00.

No. 494 Bench Lathe is similar, but has larger T Rest and longer bed. Capacity 7" swing; 18" between centers. List \$44.00.

Either lathe can be driven by a ¼ H. P. motor.

Ask to see these Lathes and Accessories at your dealer's. Or write us for Lathe Booklet, which will be sent FREE on request.

GOODELL-PRATT COMPANY, GREENFIELD, MASS., U. S. A.

MAKERS OF *Toolsmiths*, MR. PUNCH



No. 128 Turret Attachment.  
List \$50.00



No. 130 Countershaft  
List \$12.00

## GOODELL-PRATT

1500 GOOD TOOLS



# Installation FREE!

On ANY  
**Radio Set!**

The Marvelous New Model

## PHILCO

Radio **(AB)** Socket Power

*Runs Any Radio from  
Your Electric Current!*

Yes, any Authorized Philco Dealer will connect the wonderful Philco AB Socket Power to your radio set—whether it is an old set or a new set—at no extra cost to you. Installation is FREE!

**No Matter What Set You Own—  
No Matter What Set You Buy—  
Philco Will Run It From the Light Socket!**

*It makes no difference whether you now have a dry cell or storage battery operated set or what kind of battery radio set you buy, the Philco AB Socket Power will run it from the electric lighting current. Here is your chance to do away with the ordinary "A" storage battery and all dry cell "A" and "B" batteries. Super-power for all power tubes! No hum! No distortion! No more recharging to do! No more batteries to replace!*



The Famous Philco AB  
Socket Power

Any Authorized Philco Dealer will make you a liberal allowance for your old "A" storage battery when you buy the brand-new Philco.

### Easy Payments!

You can buy the New Model Philco AB Socket Power from any Authorized Philco Dealer on Easy Payment Terms. Merely make a small first payment and pay the balance monthly.

### Trade In Your Old "A" Storage Battery

You won't need it with the Philco.



All In ONE  
Cabinet

Built for  
All Radio  
Power Tubes  
and  
Will Deliver  
**180 Volts**  
at 60 Milli-amperes

### Easy As Turning On Your Electric Light!

Merely snap ON your radio set switch when you want to listen in. Snap it OFF and your radio is silent. No fuss. No bother.

### Every Philco Guaranteed!

Each and every Philco AB Socket Power is covered by an ironclad factory guarantee and is built to conform to Underwriters' Laboratories Safety Specifications.

### Console-Cabinet Models

Console-Cabinet Models are built to fit inside the cabinets of practically all well-known radio sets, including:

Atwater Kent    Crosley    Pfanstiehl  
Freed-Elseman    Fada    Radio-28  
Victrola-Radiola    Brunswick-Radiola

Special Philco Units have been designed for Fada, Pfanstiehl, Freed-Elseman, Stromberg-Carlson, Brunswick-Radiola, Kink, Splittorf and Victrola-Radiola and are tested and approved by these companies.

**Clip and Mail Today!**

## Mail This Coupon NOW!

Just sign your name and address to this FREE Coupon, put it in an envelope and mail it to us. It does not put you under the slightest obligation. Then we will send you at once full descriptive literature on the New Model Philco AB Socket Power. We will also send you the full details of our liberal offer of Easy Payments, Free Installation and Trade-In Allowance.

**Philadelphia Storage Battery Co.**  
Ontario and C Streets  
Philadelphia, Pa.

### Special FREE COUPON

To Philadelphia Storage Battery Co.  
Ontario and C Streets  
Philadelphia, Pa.    Dept. 1439

I shall be pleased to receive your free illustrated literature describing the famous Philco Radio AB Socket Power; also the full details of your Easy Payment, Free Installation and Trade-In Allowance Offer.

Name \_\_\_\_\_  
Mail Address \_\_\_\_\_  
City \_\_\_\_\_ State \_\_\_\_\_



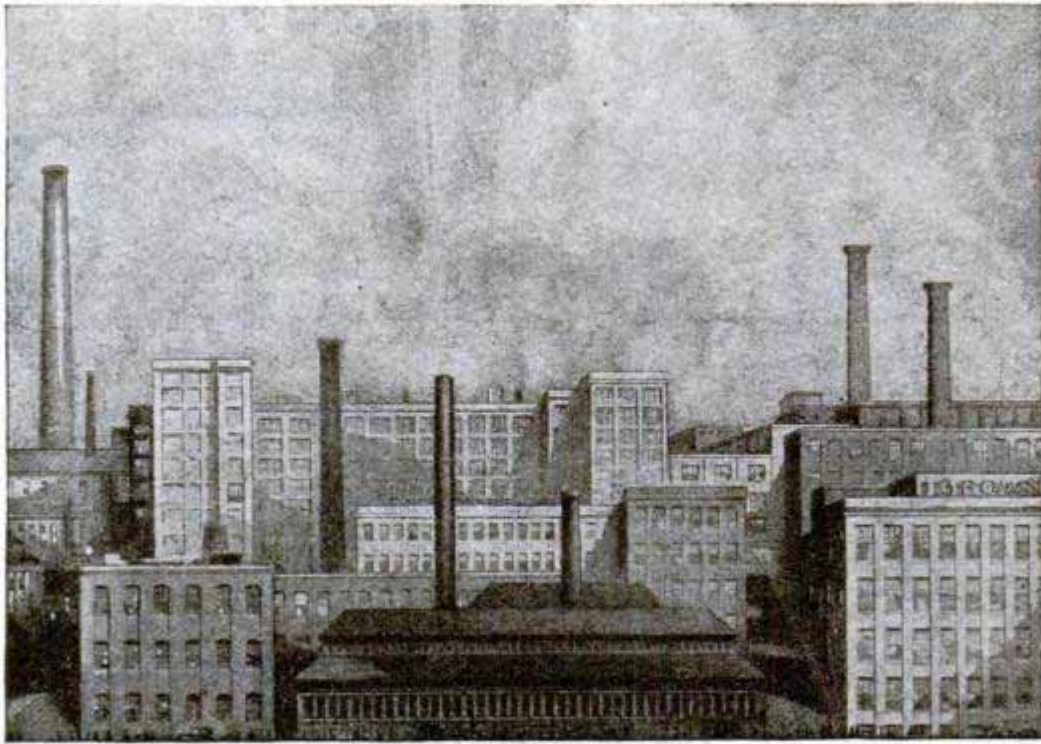

## A Mechanical World In Itself

Those who go through the Brown & Sharpe plant very frequently come out with the impression of having visited a mechanical world in itself.

Every facility exists in this plant for making Brown & Sharpe precision tools with almost unbelievable accuracy and for testing them with painstaking care.

This work is done so well that the performance of Brown & Sharpe

tools is recognized as setting a standard of accuracy by mechanics in shops all over the world.

Hardware dealers everywhere carry Brown & Sharpe tools. If, by chance, your dealer does not happen to have a copy of our catalog, we will send you one free on request.

DEPT. P. M.



**BROWN & SHARPE MFG. CO.**  
PROVIDENCE, R. I., U. S. A.

# **BROWN & SHARPE' TOOLS**

*"World's Standard of Accuracy"*

## **PLUMBING-HEATING** *Install Your Own - Save Half*



Lowest wholesale prices on highest quality Grade A goods. Any Handy Man can install his own Plumbing and Heating BY OUR NEW EASY METHOD. Get the best and pay only a little each month.

**Send for FREE Book**

New bargain catalog just issued. With our cut-to-fit systems you save waste material and high labor cost. 50 years of economical service to home owners, farmers, builders and mechanics. Million Dollar Plants back up our Bonded Guarantee. FREE book gives you the whole story. **Write for your copy today.**

**OVER 50 YRS. HARDIN-LAVIN Co. EST. 1876**  
107-17 West Pershing Road, Chicago, Ill.



## **LIGHTING FIXTURES**

*Ready to hang*

Direct from the manufacturer. Completely wired, including glassware. Send for new catalogue No. 28. Just Reduced Prices. *Special Proposition to Dealers.*

**Erie Fixture Supply Company, Inc.**  
Station A ERIE, PA.



## **QUICK, EASY PROFITS!**

Practically no investment. Small space required. Steady demand and **BIG PROFITS** refinishing autos, furniture—painting houses and barns with HB quick spray method. Spray equipment for Duco, Paint or Lacquer recommended by car manufacturers. One man does the work of five with brushes. Pays for itself on easy monthly payments. **30 DAYS' TRIAL.** Write today for details.

**Hebart Brothers Co., Box M1271, Troy, Ohio**



# Typewriter

Wm. F. Clausing  
Gen. Mgr.



## Prices Cut

## Bargains

Standard

Send for this New Catalog **FREE**

Writer Exchange  
Lake St. Chicago

# Save 1/2

## New Low Factory Prices Now Only

Our big new catalog—showing all standard make typewriters in full colors is ready. Reduced prices are in effect. Our 25,000 satisfied customers prove conclusively that we save you over one-half by our direct-to-you selling plan.

# Your Choice

Underwood - Remington  
L.C. Smith - Royals

# \$2 DOWN

### On 10 Days' Free Trial

Think of it—only \$2.00 down brings you your choice of these world-famous standard-make typewriters—direct from our factory, on 10 days' Free Trial. Balance of greatly reduced price on easy monthly payments. Our new direct-to-you sales plan saves you over 50% to 60% regular price. Quality the very highest—and prices the very lowest. Every typewriter carries a 10-year written guarantee of perfect satisfaction.

### Every Typewriter a Bargain

This amazing offer enables you to try your typewriter 10 full days Free before you buy. Every machine is full standard size—late model with all up-to-date improvements including back spacer, automatic ribbon reverse, tabulator, two-color ribbon, etc.—all completely rebuilt and refinished brand new. Every machine a real bargain.

### Why Pay Full Price

Send for this new book Now. Learn how International gives you your choice of any high-grade, standard-make typewriter, good as new in every respect, at less than half the regular price. Also explains our easy monthly payment plan,—over a year to pay.

**INTERNATIONAL TYPEWRITER EXCHANGE**  
184 W. Lake Street Dept. 1294 Chicago, Illinois

Famous  
Van-Sant  
Course in Touch  
Typewriting  
**FREE**

Just think what it means to get any one of these world-famous standard-make typewriters—regular \$100 to \$125 values—at less than 1/2 price and only \$2 down. That is what this remarkable offer means if you act at once.

### Special Limited Offer

For a limited time only we are offering the famous Van-Sant Home Study Course in touch typewriting. Free with any typewriter you select. This is the same recognized system as used and taught by many leading business colleges today. Send for beautiful big catalog and special offer at once—before it expires.

International Typewriter Exchange,  
184 W. Lake Street, Dept. 1294, Chicago.

Gentlemen:

Please send me your big Free Catalog showing reduced prices on all standard-make typewriters. Also your 10-day Free Trial, and Free Course in touch typewriting offer.

Name..... Address.....

Town..... State.....



# A Sensational Success!

### They are Enthusiastic

All three Eliminators received from you are working well and the owners are entirely satisfied to say the least. One is working on 60 cycle current, another on direct current, and the other is on 25 cycle current in Windsor, Canada. I am thoroughly convinced in your statement that they will operate on any lighting circuit or any frequency. J. G. Mullan, Detroit, Mich.

Wish to tell you I consider your Eliminator the best piece of radio equipment I have ever bought. I was surprised with the fine performance and construction. Ed Seager, Hamilton, Ont., Canada.

I could scarcely wait to report to you the fine results of your Eliminator. Since receiving it the house has been filled with fine clear music, the local stations tune very sharply and the increase in volume is remarkable. We never want to use noisy B Batteries again. It is the best bargain I have struck and I wish to compliment you on this Eliminator. Frederick Lyon, Seattle, Wash.

Have been using your Eliminator since last February and it certainly works fine. Fred A. Peters, Dallas, Texas.

### You will be enthusiastic, too!

# Townsend "B" Socket Power

Approved and passed by the rigid laboratory tests of Popular Radio and Radio News.

## Over 25,000 sold the first 6 months

Overwhelming evidence that VALUE is quick to be recognized and appreciated.

Unsurpassed quality is built into the Townsend "B" Socket Power Unit with money saved by unified production methods and lower merchandising costs.

You get more—you pay far less—for the most remarkable value in Radio today.

New thousands of Radio set owners are learning this daily by installing Townsend "B" Socket Power.

Sold on REAL GUARANTEE OF MONEY BACK IF NOT SATISFIED. Delivers up to 100 volts on any set, on D. C. or A. C.—any cycle. Full tone, clarity and volume.

**Send Order Today** Simply fill out the coupon and slip it into an envelope with only \$1.00 and mail it at once. Your Townsend "B" Socket Power Unit will be sent promptly. Deposit only \$5.85 plus postage with the postman. Try out for 10 days—then if it does not do everything we say, return it to us and purchase price will be refunded.

**10 Days FREE TRIAL**  
You are the Judge

**Townsend Laboratories**  
713 Townsend Street, Dept. 15  
Chicago, Ill.

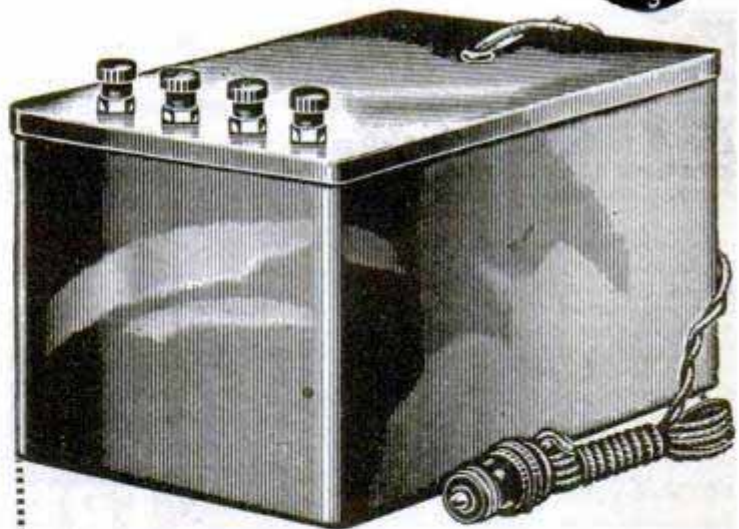

Complete  
**\$6.85**  
\$1.00 Down  
Balance C.O.D.

Attach only \$1.00 to this coupon

**TOWNSEND LABORATORIES,**  
713 Townsend St., Dept. 15, Chicago, Ill.  
Gentlemen: Attached find \$1.00. Kindly send at once Townsend "B" Socket Power Unit, C. O. D. for \$5.85, plus postage, on guaranteed 10-day free trial.

Name.....  
Address.....  
City..... State.....



# "Why-It's a Whole Machine Shop!"



**Its Grip Locks**

**AN APPRECIATED XMAS GIFT**

—that is what Users call the EIFEL-FLASH Plier-Rench KIT, because instead of using a dozen tools on One job they do a thousand jobs with the Plier-Rench KIT alone! And if this page could show "Mechanics" readers what this Kit can do for them, the Kits reserved for the Special Offer below would not last one day, but—space permits only "a word to the wise."

**Helped Win WORLD FLIGHT**

USED BY U. S. World Flyers; on U. S. S. Shenandoah, S. S. Leviathan, U. S. Army, Navy, and Mail Planes. By MAKERS of Buick, Chevrolet, Nash, Packard, Reo, Studebaker, etc., Automobiles; each with its employees buying from 200 to 1000 Kits.

Thousands of Housewives are using the Plier-Rench too, because it is the only tool giving a woman's hand a 1/2-TON grip and enabling her easily to do mechanical work difficult for a man using other tools!

**A SUPER PLIER-WRENCH-VISE WITH A 1-TON POWER-GEAR**

The Plier-Rench out-speeds, out-works and out-wears, dozens of best other tools in an incomparably superior way. In 1/4 second the Ratchet Gear-shift fits the Jaws to the work and the handles to the size of Your hand. The One-Ton POWER-GEAR automatically LOCKS and releases the grip on the Corners and "flats" of Any shape and in addition applies 1/2 to 1 TON Direct pressure—64 to 128 TONS per square inch! It is a Perfect Ratchet Turning Wrench!

**OUTGRIPS A 40-POUND VISE!**

The force of the 1-TON Plier-Rench Grip is beyond belief—it must be experienced. It Out-grips a 40-LB. VISE; twists round heads off 1/4-in. stove bolts and heads off 1/2-in. Bolts! It will easily, instantly, remove worn, chewed, and chiseled, nuts, broken taps, drills, studs, etc., in tightest places, with next-to-nothing to get hold of—when all other tools fail!

Its smooth Jaws with 4-Way V-Grooves will hold a hair, and all possible shapes from 0' to 1 1/2' diameter with a rigid, clinching grip that never chews or slips one bit. They coil 1/16" to 1' diameter springs of fine and heavy spring wire, and—do a thousand other "impossible" things quickly and easily.

**ALL TOOLS in a 24-Ounce KIT**

The Plier-Rench Kit is a Guaranteed, Time-perfected, Super-quality Master Tool, having a Universal Utility that defies imagination. "The Plier-Rench Way" Manual of Mechanics—64 Pages with 145 Pictures—shows most valuable uses and advantages!

HUNDREDS OF THOUSANDS of men are using these wonder Kits to make their Homes and Estates more comfortable—Farms, Shops, etc., more profitable; to get more and better service from Automobiles and all mechanical devices, with an enormous saving in money, time and energy!

JUST TRY a Plier-Rench Kit once, and you would no more go back to other tools than you would to the ancient Ox-cart!

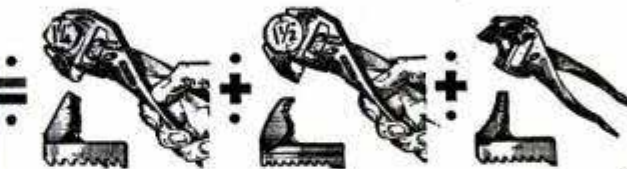
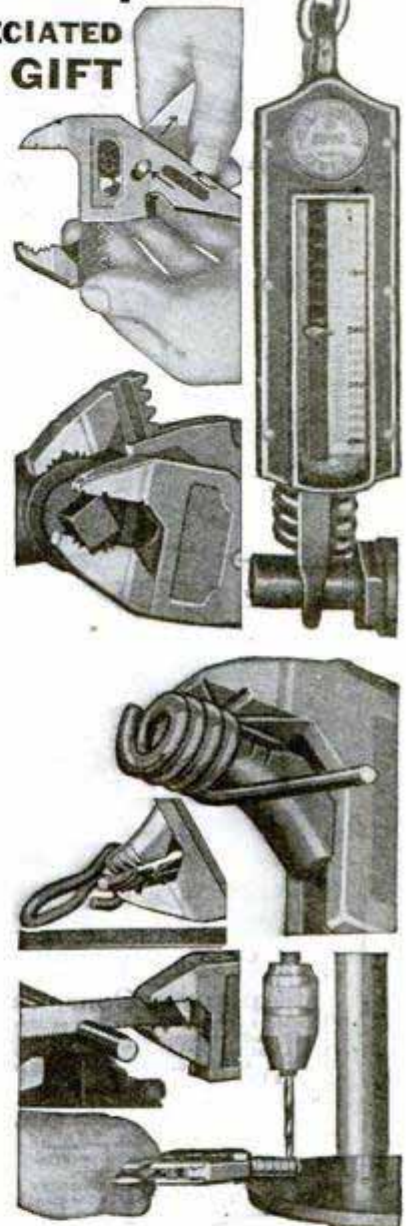
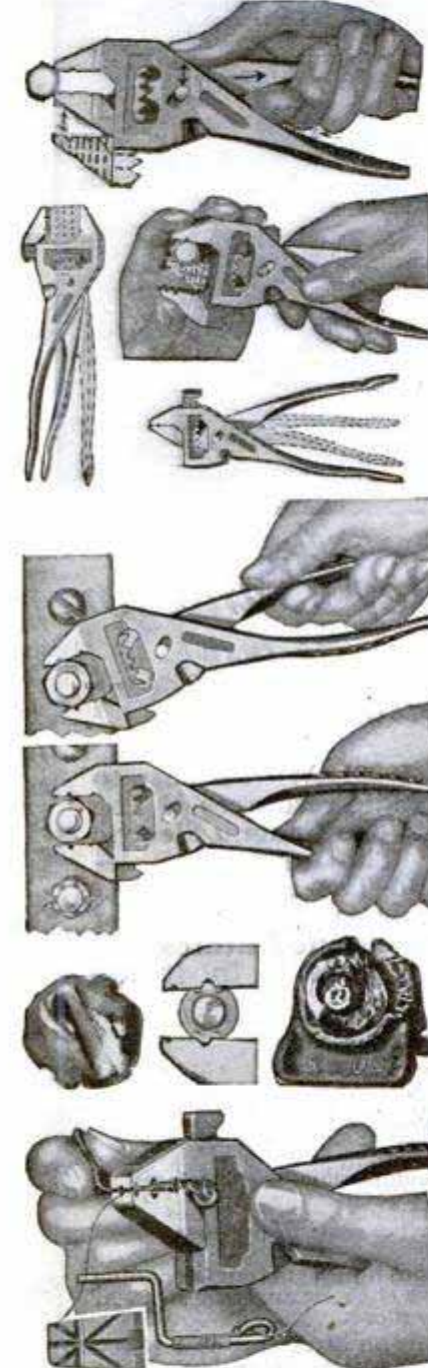

**Ltd. Special Introductory PRICE ONLY \$3.75**  
(Regular Price \$5.00)

The KIT has 3 Gear-Jaws. In 1/4 Second you convert the Universal Plier-Rench into the Pipe-and-Fitting Plier-Rench, or into the Wire-Chain-Cable Plier-Rench—each the Master in its field.

This \$5.00, 1 1/2-Lb., Kit will do the work of 40 Lbs. of other tools costing \$50.00—Quicker, better, easier.

**MAKES WONDERFUL GIFTS**  
Show on Coupon, Kits Wanted on 2-Weeks' MONEY-BACK OFFER—

**MAIL TODAY, SAVE \$1.25 PER KIT!**

**Agents: \$200 a Week**  
Plier-Rench representatives earn amazing incomes demonstrating this wonderful new tool. One man alone sold nearly 10,000 in just one state. Fastest seller known. Factories buy by hundreds. Every auto and home owner buys. We have wonderful special proposition to agents. Mail coupon for full details. Why not earn \$75 to \$200 and more a week, spare or full time!



**THE FLASH SALES CORP'N**  
LP-4809 N. Ashland Ave., CHICAGO, ILLINOIS

Plus—  
The Flash Sales Corp'n, LP-4809 N. Ashland Avenue, Chicago 40, Ill.  
If not delighted I may return within 2 weeks and deposit will be refunded at once.  
Send me only user literature.  
Am interested in Salesman's Big Proposition.

Name.....  
R.F.D. ....  
St.....  
P.O. City.....  
State.....



When the ball goes 'round the end for 40 yds.

**"You're there with a Crosley!"**

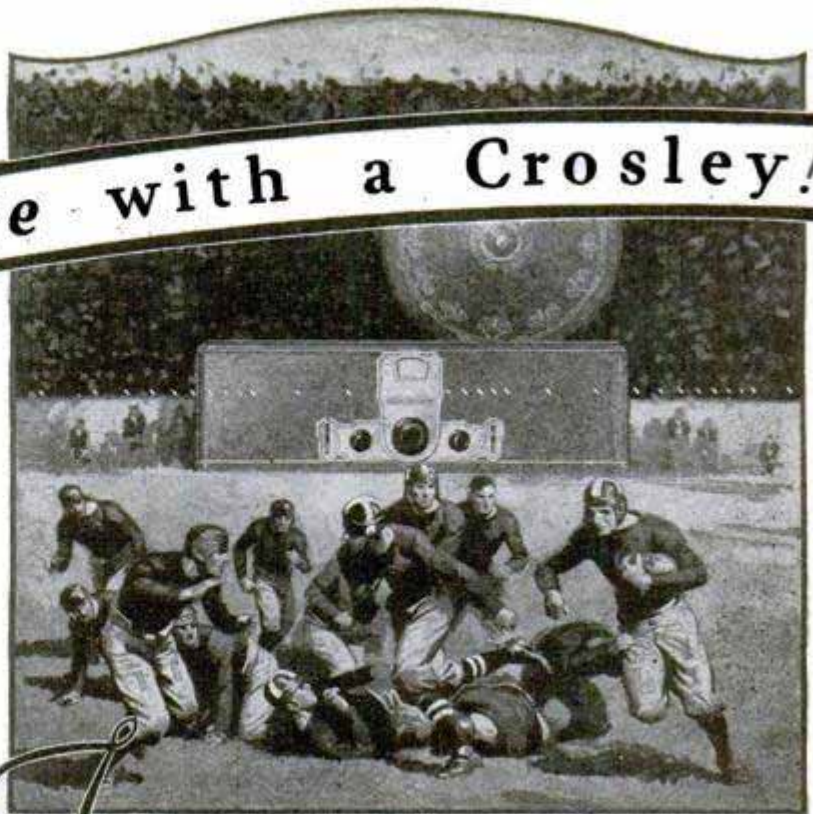

**Approved Consoles**

Selected by Powel Crosley, Jr., as ideal, acoustically and mechanically for the installation of the Crosley "Bandbox." Genuine Musicone built in. Crosley dealers secure them from their jobbers through

**H. T. ROBERTS CO.**  
1340 S. Michigan ave.,  
Chicago, Ill.  
Sales Agents for Approved Console Factories  
Showers Brothers Company  
The Wolf Mfg. Industries

\$65

\$85

\$35

**Approved Consoles**

Selected by Powel Crosley, Jr., as ideal, acoustically and mechanically for the installation of the Crosley "Bandbox." Genuine Musicone built in. Crosley dealers secure them from their jobbers through

**H. T. ROBERTS CO.**  
1340 S. Michigan ave.,  
Chicago, Ill.

Sales Agents for Approved Console Factories  
Showers Brothers Company  
The Wolf Mfg. Industries

**Improved Musicones**

Musicones improve the reception of any radio set. They are perfect affinities in beauty and reproductive effectiveness for Crosley Radios. A tilt-table model with brown mahogany finish stands 36 inches high, \$27.50—16-inch Super-Musicone as pictured above with "Bandbox," \$12.75—12-inch Ultra-Musicone, \$9.75.



***THIS new Crosley Bandbox***  
6 TUBE RECEIVER *de luxe*  
*is the national radio hit at \$55.*

The "All American" radio of 1928! With license to participate in the enormous radio resources of The Radio Corporation of America, The General Electric Co., The Westinghouse Co., The American Telephone and Telegraph Co., and The Hazeltine and The Latour Corporations, the Crosley Bandbox of 1928 is an "eleven" of super-efficient features and amazing co-ordinated performance. In it are incorporated:

1. The best idea of balancing.
2. The best ideas of shielding.
3. The best ideas of sharp tuning.
4. The best idea of controlling volume.
5. The best idea of station selection.
6. The best idea of finish and color.
7. The best idea of power tube use.
8. The best idea of console installation.
9. The best idea of power supply connections by enclosing all leads in a cable.
10. The best idea of AC tube operation.
11. The best idea of converting AC current to necessary radio DC.

Operation of the Bandbox receiver from house current is possible with the AC model at \$65, which uses the new amazing R. C. A. AC tubes. Power converter costs \$60 more.

These new Bandbox receivers are now on display at over 16,000 Authorized Crosley dealers. Their faultless reception of the many wonderful events constantly on the air is proving such a startling demonstration that a national enthusiasm sweeps the country in the natural exclamation—"You're there with a Crosley!" If you cannot locate the nearest dealer write Dept. 15 for descriptive literature.

**CROSLEY RADIO**

Crosley is licensed only for Radio Amateur, Experimental and Broadcast Reception.



**THE CROSLEY RADIO CORPORATION**  
Powel Crosley, Jr., Pres. Cincinnati, Ohio  
Prices slightly higher west of the Rocky Mts.



# Start to Play Very First Day

This Year Give Yourself  
*Lifelong Fun  
Profit and  
Popularity*



## PARENTS!

What greater gift can you confer on your children this year than lifelong fun and entertainment?

Love of music means love of home, an appreciation of the finer things in life. Here is a chance to give your boy or girl that love without the tedious practice that most instruments require. The Xylorimba is easy to play. No teacher is needed. Practice is actually a joy.

Remember, the Xylorimba is the guaranteed product of a company established nearly half a century ago—a company that stands back of every promise it makes.

THINK of the best Christmas gift you have ever received. Multiply the pleasure it gave you by ten, and still you have only an idea of the joy you can give yourself this Christmas if you act at once!

## Start to Play the Very First Day!

Haven't you, like millions of others, envied the fellows who "bring down the house" with snappy xylophone or xylorimba numbers? Haven't you longed to create your own music, to be looked up to wherever you go, to be able to make real money in spare time? If you have, this ad spells O-p-p-o-r-t-u-n-i-t-y. The xylorimba—wonderful for home, in demand at dances and gatherings—is nevertheless *the easiest of all instruments to play*. In fact, on the very day you get yours you play simple melodies, even if you can't read a note of music right now. In a few weeks you astonish your friends and family. *All your life* you have the joy that comes to those who can entertain.

## Plays 20 Minutes; Gets \$20!

Ralph Smith, Chicago, played twenty minutes at wedding; his "pay" was \$20. Altho only 12, Turk McBee, Jr., plays big-time vaudeville exclusively. Harry Breuer, New York, has

made thousands of friends thru his xylophone selections on the radio. L. E. Hallman, Reading, Pa., writes: "Made \$300 in 5 weeks—spare time."

And now J. C. Deagan, Inc., (world's largest manufacturer of xylophonic instruments) has made it so easy to own a xylorimba that nothing stands in your way. Sizes and styles to fit every age and pocketbook. A five-day free trial that eliminates risk. Free, easy lessons that make teacher unnecessary—and, best of all, such easy payments that they are hardly noticed.

## Will You Investigate?

Everyone wants to be popular. Everyone wants to make extra money. Everyone wants to be *center of attraction* at gatherings. But these advantages don't come by themselves. Opportunities must be seized. This is *your* opportunity—will you pass it up without investigation? The accompanying coupon will bring our big FREE book to your door. It tells all about the Deagan line, the free trial, the easy payments. Remember, no cost or obligation! Simply fill in and mail the coupon—but do it before it slips your mind. Today is as good a day as any. Do it NOW!

J. C. DEAGAN, Inc.  
Dept. 1459, 1770 Bertaux Avenue, Chicago

YOUR  
MAGIC  
KEY

to Popularity

Send for  
BIG FREE  
Book!

Mail  
Now!

Please send me full details on the Free Trial offer and easy payment plan of the Deagan Xylorimba.

Name \_\_\_\_\_ Address \_\_\_\_\_  
City \_\_\_\_\_ State \_\_\_\_\_





And Now  
**A MACHINE**  
 To Make Shaving 50% Easier  
 and 100% Cheaper!

Unique Invention Arouses a Whirlwind of National Interest! . . .  
 Achieves Amazing Records of Unbelievably KEEN, Cool Shaves . . .  
 Special Introductory Offer in Force Right Now!

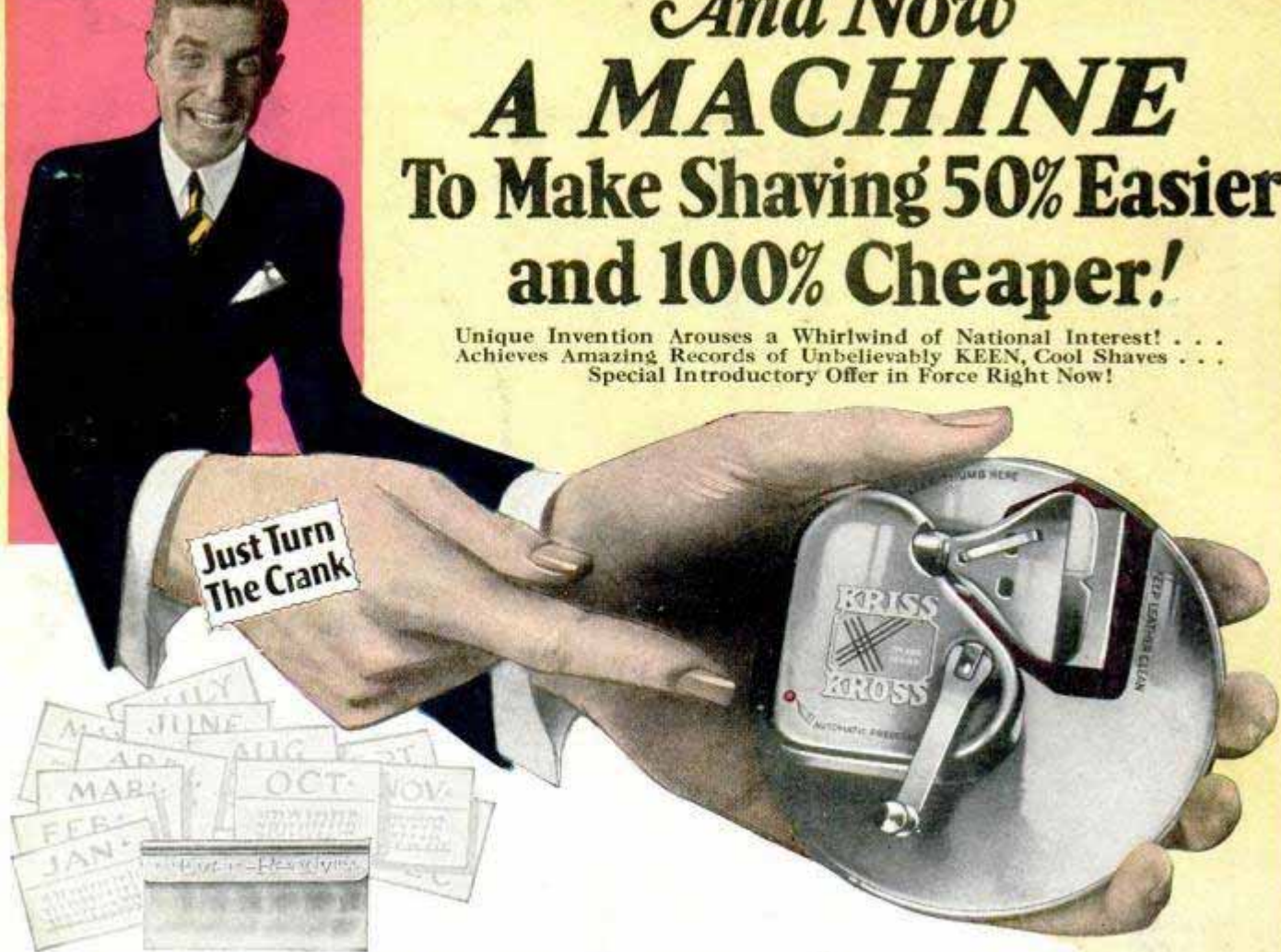

**MAKES ONE BLADE LAST 365 DAYS!**

**T**HIS is the age of amazing scientific discoveries. And now comes the most surprising invention of all;—a machine that absolutely revolutionizes shaving!

Just think of a device that can take any ordinary razor blade on the market and multiply its sharpness 50% to 100% in exactly 11 seconds! And just imagine what a slick, painless shave you can get when your blade is just about twice as keen as any you have ever tried before!

**No More Blades to Buy**

But that isn't all. KRISS-KROSS not only stropps blades to unbelievable sharpness—but it makes them last almost indefinitely! Day after day—week after week—you can keep using the same old blade and still get smoother, better shaves than you now get from a blade right out of a fresh package! Any number of cases are on record where one blade has lasted over a year and is still going strong. And M. T. Main of Kenosha, Wisconsin, has used one single blade for more than five solid years of the coolest shaves he ever got in his life!

**Rejuvenates All Makes of Razor Blades**

KRISS-KROSS is so remarkable that it is more a blade-rejuvenator than a stropper. It embodies 7 mechanical features that have long baffled inventors.

Works on all brands of blades except Durham. Reproduces the magic diagonal stropping-stroke of the master barber. Reverses blade automatically, first one side and then the other. Starts with strong pressure and finishes light. Nickel jig flies up to notify you when blade is ready with the keenest cutting edge steel can take!

**Generous Introductory Offer**

KRISS-KROSS is never sold in stores—but only through authorized representatives in each locality. Right now, we are making a generous offer and are giving a new kind of 3-way, adjustable razor FREE to introduce KRISS-KROSS. Use the coupon below to get details of this unusual invention and offer. See for yourself how ingenious KRISS-KROSS is and what undreamed of shaving comfort it holds in store for you. No obligation. Clip the coupon now. Mail it to-day!

**Agents!**  
**\$30 a Day** And More

KRISS-KROSS is an astonishing money maker and brings excellent profits to men who are willing to act as our representatives in their home territories. Many earn \$30—\$60 a day and others are making \$5000 and \$7500 a year clear profit. Spare-time agents often take in \$6—\$12 an evening and up to \$200 a month. We give you an extremely generous proposition and show you just how to get started the easiest way. Write for information and see just exactly what we offer. It will pay you to investigate. Check bottom line of coupon below and mail it to-day!

**Rhodes' KRISS KROSS STROPPER**

RHODES MFG. CO., Dept. W-372  
 1418 Pendleton Ave. ST. LOUIS, MO.

**Wonderful Xmas Gift!**

KRISS-KROSS makes a novel and unique Xmas gift that will be remembered for years to come. Attractively boxed in holly wrapper for holiday season. Inexpensive. Also ideal remembrance for business houses to give employees or special customers.

Rhodes Mfg. Co., Dept. W-372,  
 1418 Pendleton Ave., St. Louis, Mo.

Without obligation, please send me complete illustrated explanation showing how KRISS-KROSS rejuvenates all types of razor blades (except Durham). Also give me details of your special introductory offer and the Free 3-way razor you are giving away at present.

Name.....  
 Address.....  
 Town..... State.....