

POPULAR MECHANICS

MAGAZINE

WRITTEN SO YOU CAN UNDERSTAND IT

REG'D. TRADE MARK GREAT BRITAIN NO. 410428

REG. U.S. PAT. OFF.

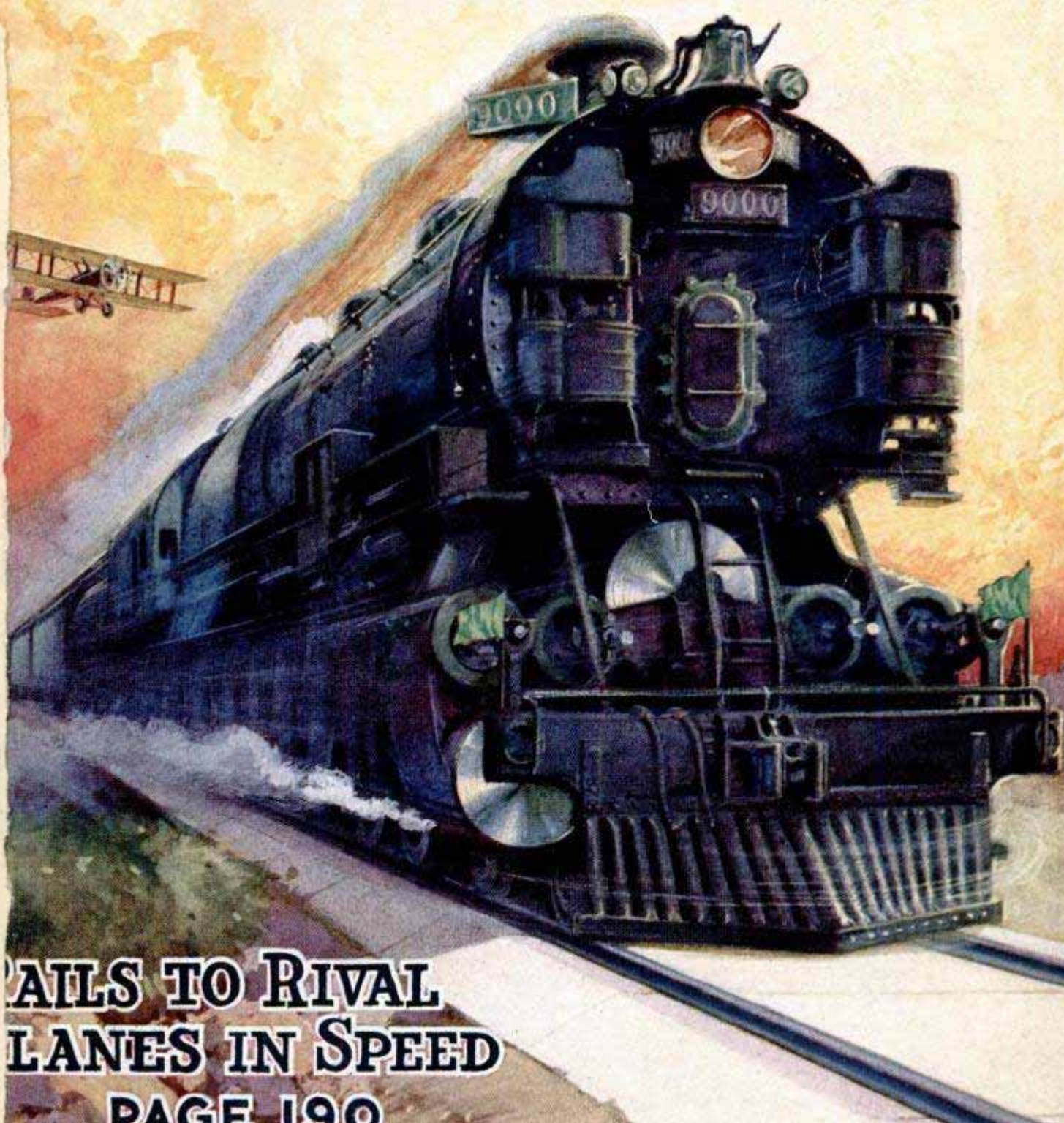

**RAILS TO RIVAL
PLANES IN SPEED
PAGE 190**

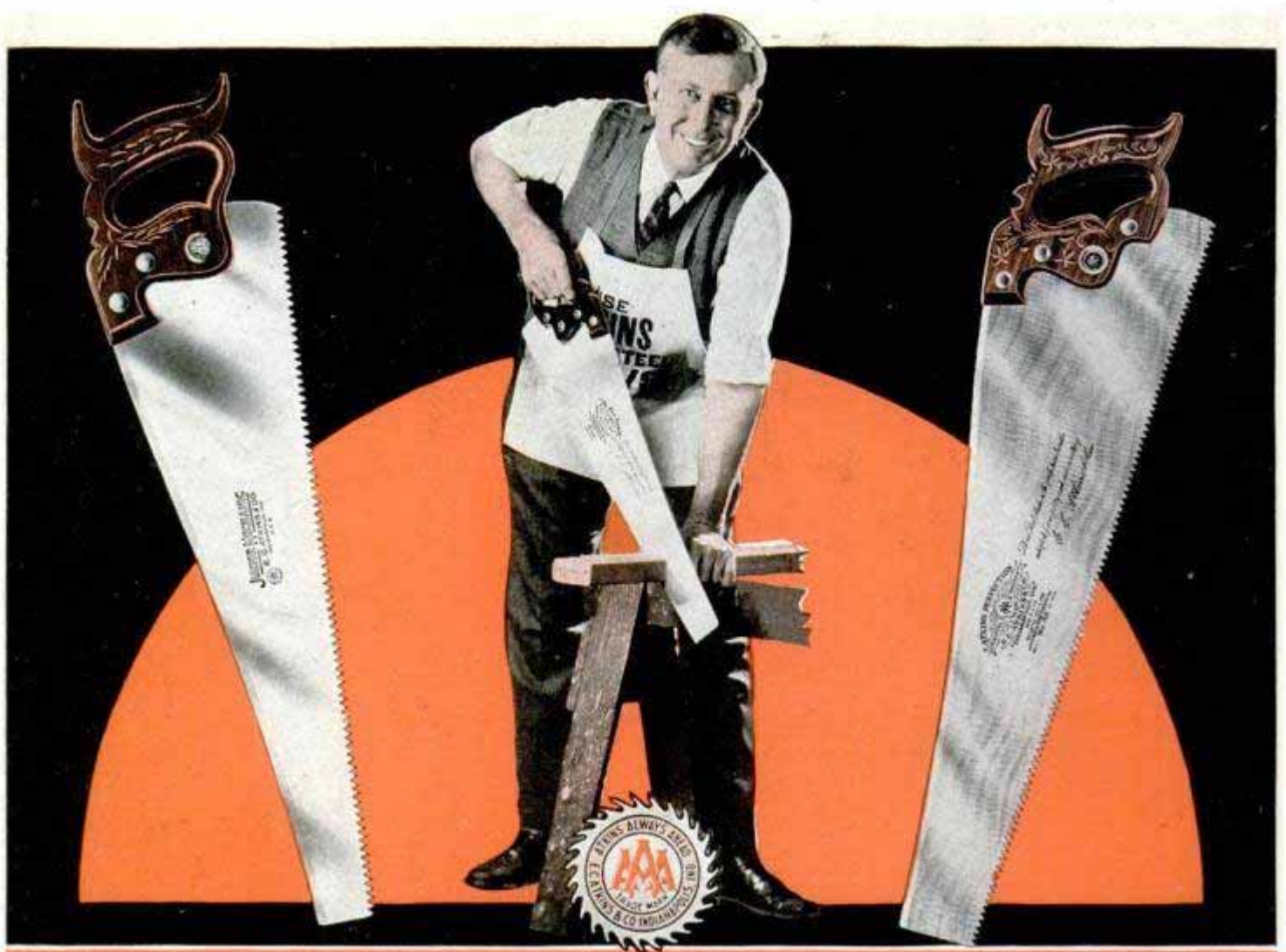

It Pays to Buy a Better Saw!

HERE are three popular ATKINS Saws — for the carpenter, home-worker or junior mechanic:

No. 400 hand saw, preferred by master carpenters everywhere—the finest saw in the world.

No. 53 hand saw, a lifetime saw for the millions of men who need a really good saw for home use.

Junior Mechanic hand saw, for the junior mechanic or Boy Scout. A handy saw for grown-ups, too.

ATKINS Saws are made of "Silver Steel"—the ATKINS exclusive steel that makes a saw hold its keen edge longer, and outlast two or three "cheap" saws. "Taper Grinding" makes ATKINS Saws cut faster, surer and easier.

When you buy a saw, look for the ATKINS name on the blade. Let us send you "Saws in the Home," an interesting folder on tools for the home — or "Saw Sense," a helpful booklet on saws and their use. **FREE.**

Write today.

E. C. ATKINS & CO., Estab. 1857

Dept. P, INDIANAPOLIS, U. S. A.

Leading Manufacturers of Saws for Every Use, Saw Tools, Saw Specialties and Machine Knives

ATKINS

SILVER STEEL SAWS

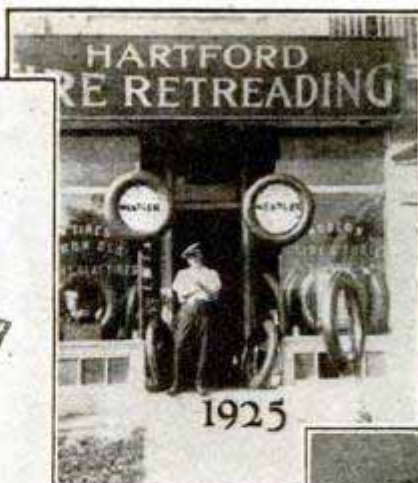

Read the facts about the amazing growth of Nestler Licensees. Make this success your own!



Emil Nestler, discoverer of the Nestler Rubber Fusing Process, is the recognized authority on tire retreading.

From \$780 year store to \$8200 year bldg. in one year

Your community, too, needs Nestler Service

WHAT these two Hartford men have done you, too, can do. In May, 1925, they secured a license to operate the patented Nestler Rubber Fusing Process in Hartford, Conn., and opened for business in a small \$65 a month store. In twelve months they built up the *largest tire servicing business in the state* with no previous tire experience. An \$8200 a year building has just been taken to give room to take care of a steadily increasing demand.

What is the Nestler Rubber Fusing Process and what does it do? Only a bare outline can be given here. It is a patented Process producing a de-vulcanization of rubber by which a positive fusion or welding of new and old rubber can be produced at will. Nothing like it has ever been employed before. It makes possible the first practical and successful method of retreading pneumatic auto and truck tires, doubles the mileage at one-third the price of a new tire and saves car owners 50 per cent of their tire bills. It is creating a brand new industry.

An Enormous Market

A thousand miles of use takes but a few ounces of rubber from the tread of your tires. A tire considered worn out because of tread wear has actually lost only 15 per cent of its cost. Of the more than 34 million tires which are now annually junked, a large proportion could be made to do

double duty with the Nestler Rubber Fusing Process. Since it was patented in 1920, the Nestler Rubber Fusing Process has been in practical use. Hundreds of thousands of tires are now being successfully Nestlerized annually.

Be President of Your Own Company

Think of the opportunity for a Nestler Rubber Fusing Station in your community. Previous experience unnecessary. Only moderate capital required. Earnings of \$4,000 to \$15,000 and more annually are now being made by Nestler Operators. Records of growth similar to the one in Hartford are being made all over the country!

The Nestler Rubber Fusing Process is not only a better method of tire servicing, but is also more simple, cheaper and faster than any other method on earth. Any man of average intelligence can master the Nestler Process in a few days time. Free instruction in the Nestler Rubber School or by mail is given all licensees. New plan makes it possible to *earn while you learn*.

The Nestler Plan

The Nestler Plan gives the full facts concerning the Nestler opportunity. It tells the methods used by the Hartford Tire Retreading Co., and hundreds of other successful Nestler Operators throughout the world in building prosperous businesses in their communities. Write for it today and we will also send you a copy of the Nestler catalog and a history of tire servicing methods which will show you the great advantages you will have. This is a proven, new and uncrowded field of business with an enormous demand and unlimited possibilities for growth. Present conditions are all favorable due to high tire prices. Write for the books today.



New Tires From Old. That is the Nestler Message in a nutshell.



Send for this book!

Nestler Rubber Fusing Co., Inc.

Dept. P8, 245 W. 55th Street, New York, N. Y.

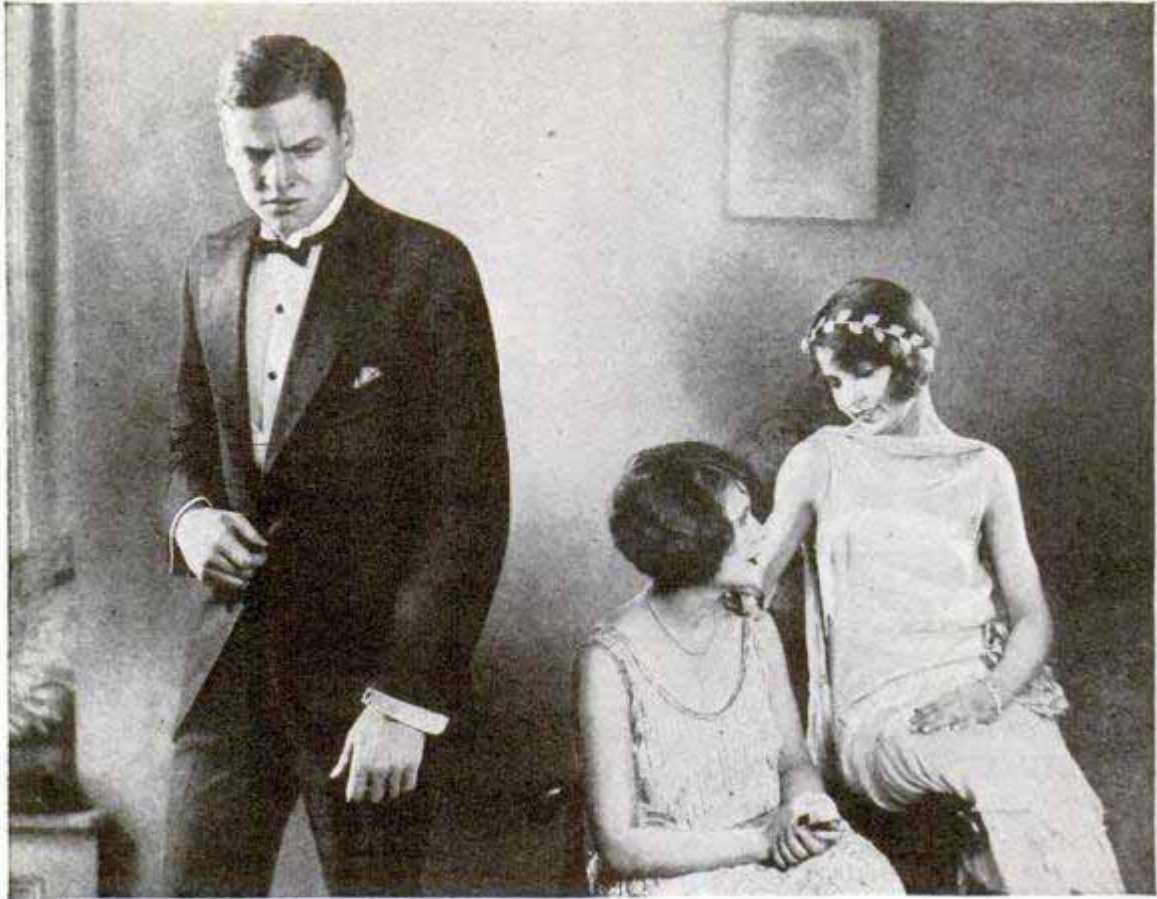

He *could* be so attractive

What was it that kept him socially submerged?

TALL—slender—good features. An interesting talker—an excellent dancer. Yet somehow he seldom held the interest of any girl for long. He was fairly popular with men—but girls would look him over carefully and then just as carefully overlook him.

* * *

A great many young men are inclined to have a grimy-looking skin spotted with blackheads and dull in appearance. Few realize that this hinders their success in life. Pompeian Massage Cream helps you overcome this handicap by giving you a clear, ruddy complexion.



Clears the Skin. Pompeian Massage Cream thoroughly cleanses the pores. It helps clear up blackheads and pimples by stimulating healthy circulation, and by keeping the skin clean and the pores open.

Easy to Use. After shaving or washing, rub the cream in gently. Continue rubbing and it rolls out, bringing with it all the dirt, grime, and skin impurities. Result—a clean, healthy skin.

Use Pompeian Massage Cream regularly at home—then you'll get the full benefit. At all druggists.

SPECIAL INTRODUCTORY OFFER

1/3 of 60c jar for 10c

For 10c we send a special trial tube containing one-third of contents of a regular 60c jar. Contains sufficient Pompeian Massage Cream to test thoroughly its wonderful benefits. Positively only one trial tube to a family on this exceptional offer.



The Pompeian Co., Cleveland, O., Dept. 81
Gentlemen: I enclose a dime (10c) for liberal sample of Pompeian Massage Cream.

Name _____

Street Address _____

City _____ State _____

Popular Mechanics Magazine

200 E. Ontario Street, Chicago, U. S. A.

H. H. WINDSOR, Founder

H. H. WINDSOR, Jr., Editor and Publisher

London: Hachette & Cie.,
16-17 King William Street, Charing Cross, W. C. 2

Paris: Hachette & Cie.,
111 Rue Reaumur

Melbourne: Gordon & Gotch
509-513 Little Collins St.

ISSUED MONTHLY

SUBSCRIPTION:

SINGLE COPY, 25 CENTS

In United States and its possessions, also Canada, Cuba, and Mexico, per year, postpaid - \$2.50

To all other countries in the Postal Union - 3.00

All subscriptions are discontinued at expiration. Please examine the date printed on your wrapper.

Entered as Second Class Matter Sept. 15, 1903, at the Post Office at Chicago, Illinois, under Act of March 3rd, 1879.

Entered as Second Class Matter at the Post Office Department, Canada.

Published monthly by POPULAR MECHANICS CO.

Copyright, 1926, by Popular Mechanics Co.

Copyright in Australia. Copyright in France

Vol. 46

Contents for August, 1926

No. 2

Alaska—origin of first American sought in	200	Fire Protection	
Animals—tigers more intelligent than lions	227	powder mixed with water for oil fires	285
Arctic Regions—the North Pole	177	rope fire escape	193
Athletics—Riff courier runs seventy miles overnight	273	Fireboat—with Diesel engine	273
Atmosphere—tropic heat fifty miles up	267	Fishing	
Automobile—auto tested standing still	251	automatic lure, with fishhook	209
Automobile Racing—racer sets record	234	Indians trapping for salmon	284
Automobiles—Design—auto run by air propeller	214	Flowers	
Automobiles—Equipment and Supplies—auto mats with padded slits	250	dried in sand	193
Automobiles—Safeguarding—bimetallic number plate on auto	276	hues of, due to sap	225
Automobiles—Shock Absorber—rubber disks	265	Fog—electrified air and sand to end fog menace	226
Aviation		Ford, Henry—antiques collected by	274
billion candlepower light for airmen near Dijon	240	Forest Fires—static aids against	238
winged words you should know	291	Garage	
Baggage—hatch on coach top	258	for small car, with spring-hinged roof	236
Beads—flexible, for dresses	257	portable, of metal	208
Bicycle—practice on rollers	244	Golf	
Birds		book shows movies of	282
storks' nests	183	guide on club	273
woman doctor treats birds	258	novel and useful accessories	252
Blindness—electrical eye for blind	222	zinc tee	215
Boats—land rowboats for children	201	Greenhouse	
Bridge—strain tested while in use	280	home, addition	234
Cave—Big Diamond, in Ozark mountains	236	of an eastern research laboratory	250
Chairs—boardwalk, on ship	272	Handicraft—in remote places	210
Chimes—tower, operated by electric keyboard	215	Health—easy to add life to your years	245
Cigaret Case—for swimmers	270	Horse Racing—jockeys train on rocking horse	227
Circus—flirting with fate	259	House Plan—is this your home?	352
Clocks—time from lighting socket	265	Household Devices—to save work in home	286
Colors		Ice Cream—molded in slices	233
coal tar yields many	256	Idol—unearthed in Florida	227
mystery of, reflects wonders of light rays	203	Insect—botfly flies thirteen miles a minute	234
Copper—poisoning from home brew	243	Inventions—latest achievements in world of invention	294
Coronium—gas found on sun sought here	236	Iron—shirt ironer	249
Cowboy		Lifeboats—skids for	188
rodeo	195	Light—heatless, secret sought	213
schoolboy champion roper	241	Loading and Unloading—bucket lift on refuse truck	296
Crane		Los Angeles—turning swamps into harbor	192
and pile driver in one	216	Lumber and Lumbering—pole road for motor trucks	212
picks up freight cars	221	Meter—thirty-inch electric	254
Cribbage—vest pocket, board	280	Mirror—reflector for feet	235
Crime—raising hands fires pistol	225	Model	
Dam—across Merced river	283	castle built of clay	296
Deaf—tiny phone for deaf	243	odd driftwood figures made hobby	241
Decoration and Ornament—woman's design for library wins	191	ships of turkey bones	181
Disease		Monument	
ephedrine, ancient Chinese drug	282	soldiers of four U. S. wars honored in memorial	257
measles' antitoxin	181	world war	181
Dog—cross eyes cured with glasses	225	Moon	
Dolls—from all parts of world	224	sky would be black on moon	221
Drawing Instruments—ruling pen without screws	289	temperature of its surface	248
Earthquake		Motor Boat	
all U. S. subject to quakes	208	boat runs on land serving as auto	192
studied	250	folds into pack	206
Egg—cushion pad for crates	281	Motor Bus	
Electric Iron—electric shoe for flatirons	293	electric bus for exposition	249
Electric Power—wind-driven electric plant	267	motor coach as dining car	290
Elevator		Moving Picture	
on trailer truck extends like telescope	289	in home shown without screen	206
rope basket, at monastery	254	sheet-iron horses pull coach	188
Eye—Eskimo eyeshade for movies	212	voice given to drama of silver screen	202
Fire—tests new extinguisher	255	Musical Instruments	
Fire Apparatus—engine's stream 200 feet high	205	double-neck banjo for jazz	227
		one man plays whole band	238
		Nature—facts on	276
		Ocean Currents—straying prove fatal to fish	244

[Continued on Page 4]

[4] *Wardmel, Electric 267*
 [Contents—Continued]

Order 194

Oceanography	
sea's bottom seen under lens	242
where oceans come from	258
Painting	
painters take climbing test to get bridge job	256
woman paints California scenes on stamps	295
Paper Money—how Uncle Sam makes your money last	204
Petroleum—seek prevention of oil tank fire by lighting	280
Photograph—that fits in handbag	216
Photography—studio in auto	277
Pictures—portrayed in rags	183
Picture Frames—metal corners	223
Plant	
grows in sealed bulb	221
that shrivels at touch	207
Postal Service—outdoor post office	251
Puzzles—pet brain twister	217
Radio	
ancient art helps improve your set	266
German radio fans pay fee	249
latest novelties	305
Radio—Aerial—raise mast alone	297
Radio—Apparatus	
“canned” units feature latest set	300
non-metallic subpanel brackets	304
rotor mounting easily made	309
Radio Application	
radio safeguard for miners	241
stenographers use radio for practice dictation	309
traveling radio musician	208
Radio Battery—metal strip for multiple dry-cell connection	310
Radio Broadcasting—stage plays for radio only	273
Radio—Jacks—one-inch jack needs small space	309
Radio—Loop—collapsible	310
Radio—Receiver	
for your car	301
on wheelbarrow	225
Radio Repairing	
cause of howling	310
forestalling radio troubles	304
what's wrong with your set	306
Radio—Tool—wire bender made from pliers	309
Radio—Transformer—making low-loss r.f. transformers	310
Radio—Tube—rejuvenator and tester	300
Raft—of logs rowed like boat	191
Railroad—train guide set by levers	265
Railroad—U.S.A.—railway trains to rival airplanes in speed	190
Rings—illustrate wedding rites of centuries	290
Roller Skate—on pole	284
Rotor Principle—airial rotor ship latest in aviation	243
Rotor Ship—liner with three rotors	209
Saws and Sawing Rigs—pole saw for trimming tree	223
Scales—for weighing eggs	189
Searchlight—as bandit alarm	267
Sewing Kit—fits in pocket	270
Ship—dummy funnels in motorized liners	278
Speed	
how fast can man travel on wheels and live	271
how limit of human speed is being measured	182
Sprayer—portable, has motor	289
Sprinkler—for lawn on roller	244
Stadium	
for sesquicentennial exposition	281
Northwestern university	189
Steam	
from wells harnessed	288
storage tanks for steam supply reserve	201
Steel—new heat resisting	235
Storage Batteries—railroad puts wind to work	193
Stove—folding, for campers	238
Street Traffic Regulations—optical illusion to aid auto safety	203
Submarine—fifteen years under the sea	228
Swimming—as easy to swim as walk	184
Telephone	
latest phone in one unit	203
loud-speaker phone system for car switching	270
Telescope—to show moon at ten miles	215
Theater—triple organ for six-thousand-seat theater	237
Tobacco—molded paper pipe	257
Tool—for cable workers, insures safety	255
Tornado—how to be safe in	295
Toy—wooden horse that “walks”	295
Turpentine—tree tapped for, saved by metal gutters	282
Vulcanizer—for balloon tire	285
Warfare—bullet-proof rotary shield	285
Washington, George—Washington's church restored	239
Watches—to run by radio	181

Water Sport—latest ball for	183
Weather—reports by radio to guide flyers	191
Window—washers rail cage	290
Yucatan—lost world found in	268

AMATEUR MECHANICS

Automobiles—Radiator—remedy for overheating auto	330
Automobiles—Tires—inner tube repairs	324
Barrel—saving rain water	316
Blowtorch—used for spraying	314
Boats and Boating—boat for outboard motor	311
Books—loose leaf binder	332
Boots and Shoes—slips of rubber to protect floor	331
Brick—painting foundations of	328
Camera—cork mount for lens	316
Canteen—campers'	315
Cleaning—electric coffee pot	315
Doll—novel house	316
Door—adjustable screen door hook	327
Fishing—hints for fishermen	317
Ford Car—curing elusive knock	322
Garden Tools and Appliances	
coil spring protects lawn hose	322
setting trellis work	327
split handle hoe	324
tool opens seed rows	314
Lighting—illuminating the camp	324
Linoleum—gluing to iron steps	326
Motor Truck—special truck body aids florist	331
Mower—bicycle lawn mower	316
Paint—drip catcher for paintpots	314
Pantry—convenience	323
Pests—getting rid of gophers and moles	324
Physics—puzzle in	332
Pole—non-slip clothesline	328
Puzzles—Chinese teaser	325
Seat—garden rocker settee	326
Shooting—indoor game for air rifle	326
Sign Painting—mirror helps painter	328
Tank—how to fix that leaky	323
Toys—“wiggle turk”	329
Typewriter—doubling life of ribbons	332
Vacuum Bottle—carrier for	330
Washboard—bathtub hook for	315

SHOP NOTES

Alarm—bell on scales	350
Asbestos—for annealing	340
Automobiles—Brakes—countersinking and drilling machine	351
Automobiles—Tires—test for leaky valve	350
Automobiles—Wheels—why your car shimmies	341
Blowtorch—starting gasoline	351
Centering—markers for short work	345
Concrete	
canvas bottom form for pouring concrete into	336
speeding up concreting	338
Dairy—two kinks for dairyman	338
Desk—portable for lumber yard	336
Door—construction	335
Electric Wiring	
doing your own conduit work	348
method of locating partition	340
Floor Sander—you can make	333
Hay—outside chute	345
Ladder—orchard	340
Lantern—large oil tanks on	344
Magnet—strengthening	345
Marker—rubber stamp attached to thimble	344
Oilcan—extension holder	335
Pipe—record form for checking fittings	351
Pumps	
binder heads make jack	339
remedy for run down	345
Putty—enameling over	344
Reamers—adjustable as mandrels	338
Saws and Sawing Rigs	
depth gauge for sawing	347
saw driven by auto	337
Street Traffic Regulations—converting driveways into walks	347
Swine—tattooing hogs	346
Telephone—making receiver comfortable	334
Typewriter—bicycle pump cleans	344
Welding—closed containers	336
Workbenches—for garages	339

DRAKE'S PRACTICAL MECHANICAL BOOKS

THEY WILL RAISE YOUR PAY—

ORDER ON 5-DAY TRIAL

The books listed below will perfect you in your chosen trade—pave the way to the big positions. Written in non-technical language—easy to read and understand. *Every book covers its subject completely. An entire course of instruction condensed into one volume.* Your choice sent postpaid—you benefit 5 days—money refunded in full if not entirely satisfactory. Order direct from this page.

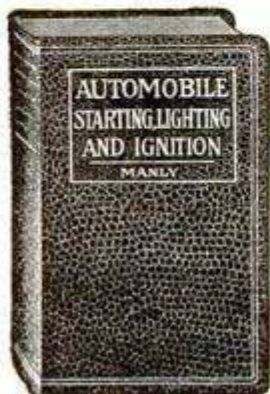

Automobile Books

- Automobile Starting, Lighting and Ignition, by Manly... 700 pp. \$3.00
 Bookes' Automobile Handbook. \$2.00
 Ford Motor Car, Truck and Tractor, by Manly... Cloth \$1.50
 Automobile Battery, Care and Repair, by Manly... Leatherette \$2.00
 Motorcycle Handbook, by Manly \$1.50

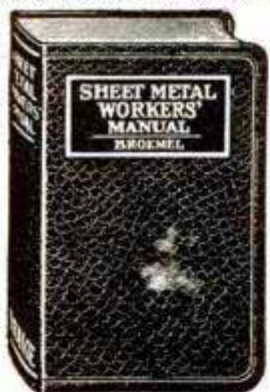

Shop Practice Books

- Sheet Metal Workers' Manual... \$2.00
 Acetylene Welding and Cutting... Cloth \$1.25
 Rule and Logarithmic Tables... \$2.00
 Book for Millwrights... Cloth \$2.00
 The Shop Practice... Cloth \$2.00
 Mechanical Drawing and Machine Design... Cloth \$2.00

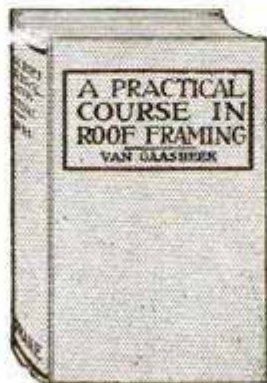

Carpentry Books

- Cloth Binding
 Modern Carpentry, 2 vols. \$3.00
 The Steel Square, 2 vols. \$3.00
 Modern Estimator... \$1.50
 Timber Framing... \$2.00
 Builder's Architectural Drawing... \$2.00
 Concrete... \$1.50
 Practical Bungalows... \$1.00
 Roof Framing, by Van Gaaabeek... \$1.50

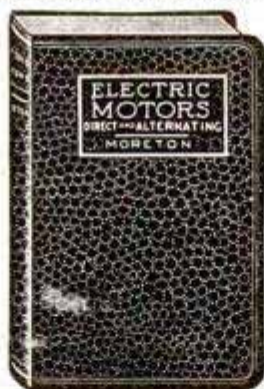

Electrical Books

- Telephony, Including Automatic Switching, by Smith, 450 pp. Leatherette \$2.50
 Practical Applied Electricity... \$2.00
 Wiring Diagrams and Descriptions... \$1.50
 Armature and Magnet Winding... \$1.50
 Electric Motors, D. & A... \$1.50



Painting and Decorating

- Ross Crane Book of Home Furnishing and Decoration... Cloth \$3.00
 House Painting Methods with the Brush and Spray Gun, by Vanderwalker. Cloth... \$2.00
 Interior Wall Decoration, by Vanderwalker... Leatherette \$4.00
 The Mixing of Colors and Paints, by Vanderwalker... Cloth \$2.00
 A Show at Sho' Cards... Cloth \$4.00
 Sign Painting, by Atkinson... Cloth \$4.00
 Strong's Book of Designs, Leatherette \$4.00
 Modern Painter's Cyclopaedia. Cloth \$2.00
 Automobile Painting... Cloth \$1.50
 New Hardwood Finishing... Cloth \$1.50
 Wood Finishing, Plain and Decorative... Cloth \$2.00
 Owen's Paint Guide... Cloth \$1.00

Steam Engineering

- Swingle's Handbook for Steam Engineers and Electricians. Leatherette... \$4.00
 Examination Questions and Answers for Marine and Stationary Engineers. Leatherette... \$2.00
 Steam Boilers... Leatherette \$2.00
 Swingle's Catechism of Steam, Gas and Electrical Engineering. Leatherette \$1.50

Modern Languages

- By Prof. P. S. Allen, U. of Chicago
 French without a Teacher... Cloth \$1.25
 Spanish without a Teacher... Cloth \$1.25
 German without a Teacher... Cloth \$1.25
 Everyday French... \$1.25
 Everyday Spanish... \$1.25

ORDER DIRECT FROM THIS PAGE —ON OUR MONEY-BACK PLAN

The books listed above are only a few of the many in our catalogue, which you will receive promptly after filling out and mailing us the attached coupon. For quick action order direct from this page—cross name of each book wanted and send in with price quoted. We prepay postage and send the books on our money-back plan.

FREDERICK J. DRAKE & CO.

PUBLISHERS

1008 Michigan Ave., Chicago

Drake Books Are For Sale at All Book Stores

Mail Coupon For Free Catalogue
Your Guide to Home Study

FREDERICK J. DRAKE & CO.
1008 Michigan Avenue
Chicago, Ill.

GENTLEMEN:—Please send me free, postage paid, your illustrated catalogue which lists and describes 200 Practical Mechanical Books for Home Study.

My name is

and my address



Foundry Man—then Office Man—at \$12 a Week His Salary in 1924—\$9,000!



COULSON B. HYDE
General Auditor
Eureka Vacuum Cleaner Co.
Detroit, Mich.



Plant of Eureka Vacuum Cleaner Co., Detroit, Mich.

And—as General Auditor of the Eureka Vacuum Cleaner Co.—he is still climbing!

COULSON B. HYDE, molder in a local foundry, was discontented. He checked the words "Higher Accountancy" on a LaSalle coupon, signed his name, and mailed it in.

It brought him a free book, but a book worth many times its weight in gold—for in it he found the opportunity that started him toward bigger things.

Today he is General Auditor of the Eureka Vacuum Cleaner Company; and in his letter of May 12, 1925, he writes: "My compensation for the past year was \$9,000, and I fully expect to double that the coming year."

Tremendously inspiring, Mr. Hyde's career! "I quit the job at the foundry," he writes, "for a position in the office of a local baking company—at \$12 a week—where I applied the principles of the accounting I was studying.

"Three years later I resigned the position as cashier to go into public accounting with a local accounting concern. This led to my connection with

the Eureka Vacuum Cleaner Company.

"Naturally I am a great booster for LaSalle and take pleasure in recommending it to anyone who is interested in doubling or trebling his salary. *It can be done.*"

Send for Free Copy, "Accountancy, the Profession that Pays"

The book that showed Coulson B. Hyde what he must do to go from \$12 a week to \$9,000 a year is yours for the asking. The title of that book is "Accountancy, the Profession that Pays."

If this 64-page book can place you on the direct path to greater earning power—as it has done for literally thousands of LaSalle-trained men—you'll agree that it would be cheap at \$100—even \$1,000 a copy... Yet LaSalle will send it to you free.

Balance the two minutes that it takes to fill out the coupon against the rewards of a successful career—then clip and mail the coupon NOW.



**Repeated Promotions—
Now General Auditor and
a Stockholder in Company**

"Since C. B. Hyde started with our company in 1919 as a bookkeeper, he has had several promotions, until today he holds the position of Manager of our Auditing Department.

"In reward for his faithful service we made him a stockholder in our company on January 1st of this year. His work is most satisfactory, and I only learned today that he acquired the basic principles of his auditorship thru the course he took with your University. If every student becomes as proficient as he in his work, then you are making it possible for many men to hold much better positions." (Signed)

FRED WARDELL,
President
Eureka Vacuum Cleaner Co.

LASALLE EXTENSION UNIVERSITY

THE WORLD'S LARGEST BUSINESS TRAINING INSTITUTION

FIND YOURSELF THRU LASALLE!

LA SALLE EXTENSION UNIVERSITY Dept. 864-HR CHICAGO

Other LaSalle Opportunities: LaSalle opens the way to success in every important field of business.

If more interested in one of the fields indicated below, check here:

- | | |
|---|--|
| <input type="checkbox"/> Business Management:
Training for Official, Managerial, Sales and Departmental Executive positions. | <input type="checkbox"/> Modern Foremanship and Production Methods. |
| <input type="checkbox"/> Modern Salesmanship. | <input type="checkbox"/> Personnel and Employment Management. |
| <input type="checkbox"/> Traffic Management—Foreign and Domestic. | <input type="checkbox"/> Railway Station Management. |
| <input type="checkbox"/> Industrial Management. | <input type="checkbox"/> Commercial Law. |
| <input type="checkbox"/> Law: Training for Bar; LL.B. degree. | <input type="checkbox"/> Expert Bookkeeping. |
| <input type="checkbox"/> Modern Business Correspondence and Practice. | <input type="checkbox"/> Business English. |
| <input type="checkbox"/> Banking and Finance. | <input type="checkbox"/> Commercial Spanish. |
| | <input type="checkbox"/> Effective Speaking. |
| | <input type="checkbox"/> C. P. A. Coaching for Advanced Accountants. |

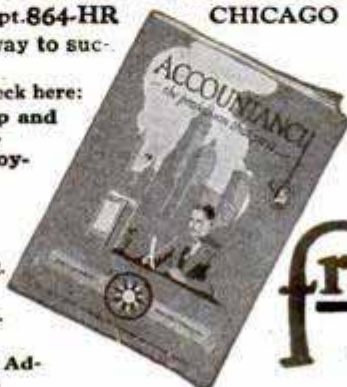

Opportunities in Accountancy—Check below and we will send you an outline of our salary-doubling plan, together with a copy of "Accountancy, the Profession that Pays," also copy of "Ten Years' Promotion in One," all without obligation.

Higher Accountancy:

Leading to position as Auditor, Comptroller, Certified Public Accountant, Cost Accountant, etc.

free!
mail coupon
NOW

Name

Address

Present Position

Age

BUILDERS TRADE GUIDES



AUDEL'S CARPENTERS AND BUILDERS GUIDES—4 VOLS. \$6

Inside Information for Carpenters, Builders, Joiners, Building Mechanics—all Woodworkers. **1600 pages; 3700 diagrams; flexible; pocket size.** Short-cut instructions, new methods, ideas, solutions, plans, systems—money saving suggestions. An easy progressive course for the apprentice. A practical daily helper and Quick Reference for the master worker. A Helping Hand to Easier and Better Work and Better Pay. To get this aid for yourself, simply fill in and mail the FREE COUPON below.

INSIDE TRADE INFORMATION ON:
 How to use steel square; How to file and set saws; How to build furniture; How to use mitre box; How to use chalk line; How to use rules; How to make joints; Carpenters' arithmetic; Mensuration problems; Estimating strength of timbers; How to set girders and sills; How to frame houses and roofs; How to estimate costs; How to build houses, barns, garages, bungalows, etc.; How to read and draw plans; Drawing up specifications; How to excavate; How to use settings 12, 13 and 17 on the steel square; How to build hoists and scaffolds—skylights; How to build stairs; How to put on interior trim; How to hang doors; How to lath—lay floors; How to paint.

"Audel's Guides worth four times their price—handy too as I carry them in pocket for reference." **W. J. Bates, Knoxville, Pa.**



AUDEL'S PLUMBERS AND STEAMFITTERS GUIDES—4 VOLS. \$6

A new set—just out! A practical, illustrated, Reference Library and Study-Course for Master Plumbers, Journeyman and Apprentice Steamfitters, Gas Fitters and Helpers, Sheet Metal Workers, Draughtsmen, Master Builders, Engineers and all Building Trade Students. **1670 pages; 3642 diagrams; flexible; pocket size.** Guides explain all the principles, advances and short cuts of the Plumbing and Heating trade. Contains instructions on how to figure and estimate jobs. Use FREE COUPON below to examine, without obligation, this valuable work.

INSIDE TRADE INFORMATION ON:
 Soldering, tinning. Joint wiping, bending, beating. Pipe—iron—steel, threading. Mathematics, tables, physics. Materials—iron, steel, copper, brass, lead, tin, antimony. Sheet metal—galvanized—plate. Sanitation, syphonage, tanks. Drainage, sewage, purification. Fixtures—bath—kitchen. Pipe fittings, soil pipe, tools. Laying out work. Roughing. Screwed fittings, flanges, joints. Pipe bending, examples. Elbows. Heating, ventilation, refrigeration. Water supply, mains, wells, tanks. Gas-fittings. Underwriters. Sheet metal work, problems, methods, brazing, heating, lead burning. Welding, various welds, methods. Blacksmithing, forges, tools.

"Audel's Guides are practical, easy to understand, reliable. Cover the field in plain language." **W. F. Arminger, Annapolis, Md.**



AUDEL'S MASONS AND BUILDERS GUIDES—4 VOLS. \$6

A new, complete, illustrated trade reference library, for Bricklayers, Cement Workers, Plasterers, Tile Setters and Stone Masons, including a practical outline of Steel Construction. **1100 pages; 2067 diagrams; flexible; pocket size.** A practical Trade Assistant explaining modern methods of masonry construction. Easy to understand and apply. A reliable and authentic reference work and study-course for Master Journeyman and Young Mechanic. Use FREE COUPON below and find out for yourself, without obligation, whether this set will benefit you.

INSIDE TRADE INFORMATION ON:
 Bricklaying, tools, materials; Brick designs, patterns, bonds; Setting frames and foundations; Mortars, scaffolds, estimating; Mortars and mortar mixing; Tile setting, mosaic, hollow tile; Straight edge test, troweling; How to figure brick work; Safe loads, piers, chimneys; Boiler settings, anchors, fire stops; Labor—ables; Concrete, forms; How to figure concrete work; Stucco—on old and new buildings; Plastering—wood lath—metal; Plasterers agreement; Plastering on various surfaces; Stonemasonry; Cutting, finishing, estimating stone; Derricks, rigging; Steel construction; Fire proof; How to read blue prints.

"Audel's Masons Guides are the best books on the subject. Have laid brick 12 years and am able to judge." **N. A. Sonnett, Corliss, Pa.**



PRACTICAL ELECTRICITY — 1 VOL. \$4

Audel's Handy Book of Practical Electricity is a simplified Ready Reference and Study Course in one pocket size, leather bound volume—for Engineers, Professional Electricians and Students. **1040 pages; 2600 diagrams; flexible red leather bound.** A reliable authority and handy helper for every electrical worker. Contains important and valuable wiring diagrams, calculations, machine sketches, helps on maintenance and repair. Use this FREE COUPON today and find out, without obligation, how this handy book will help you in your daily work.

\$1 PER MO.

Complete in one handy, red leather bound volume



INSIDE TRADE INFORMATION ON:

Electro-Therapeutics, X-Rays, Shocks, Welding, Brazing, Radio Hook-ups, Motion Pictures, Telephone, Telegraph, Cranes, Bells, Elevators, Pumps, Tools, Ship Drive, Railways, Vehicles, Automobile Electric Systems, Ignition, Generation, Lighting, Plant Management, Power Plans, Armature Winding, Repairing, A. C. Motors and Apparatus, D. C. Motors and Apparatus, Alternator Construction, Dynamos, Wiring Diagrams, Sign Flashers, Cable Splicing, Power Wiring, Outside Wiring, Switches, Lighting, Rectifiers, Converters, Transformers, Fuses, Circuit Breakers, Rheostats, Electro Plating, Electrolysis, Storage Batteries, Magnetism, Electrical Energy, Conductors, Insulators, Static, Dynamic, Radio Electricity, Applications, Ready Reference and Index Covering the entire field of Modern Electricity.

Learn More and You Will Earn More!

Know your job and you'll never be without one. The skilled man is always in demand. Knowledge is power. Learn your trade thoroughly by easy reading. This coupon is your opportunity for advancement and better pay. You risk nothing in sending for Audel's Guides for free examination. Send it NOW!

FREE EXAMINATION COUPON

THEO. AUDEL & CO.,
 65 W. 23 ST., NEW YORK CITY

Please mail me for free examination the books marked (x) below. If I find them satisfactory, I agree to mail \$1 in 7 days, on each set ordered, and to further mail \$1 monthly on each set until I have paid the purchase price.

4 CARPENTERS GUIDES \$6 | 4 PLUMBERS GUIDES \$6

4 MASONS GUIDES \$6 | 1 ELECTRICIANS HANDY BOOK \$4

NAME

ADDRESS

OCCUPATION

EMPLOYED BY.....S-T-30

NOW FREE



B. W. COOKE
Directing
Engineer

I WILL
TRAIN YOU
AT HOME

**EARN
up to**

\$150 a Week!

If you're earning a cent less than \$60 a week, *clip coupon now*. Get the **PROOF** that you can be on your way to **BIG PAY** as an Auto Expert **QUICK!** See for yourself how fascinating this training is—how easily you can master Auto Work right in your own home—and how **quickly** you can get in line for the **big Auto Jobs** that pay up to **\$150 a week and more**—or a Money-Making Auto Business of your own! Remember these Instruction jobs come to you **ABSOLUTELY FREE** and without obligation. *Clip coupon now.*

I'll train you AT HOME Get these free Instruction Jobs now. See how thorough, how complete "JOB-WAY" Training is—includes all Electrical work—Ignition, Starting, Lighting—all Mechanical, also Welding, Brazing, Vulcanizing—also Business Course, Salesmanship, Advertising—How to keep simple Books—also Students' Magazine, also 5 working Outfits. Nowhere else can you get this original genuine, copyrighted B. W. Cooke "JOB-WAY" Training.

This Big Auto Book Also FREE Coupon brings this startling, revolutionary Auto Book, too, absolutely Free! Shows how hundreds of men have reached Big Pay in amazingly quick time! Shows what you can do. Send for it now!

SEND ME LESSONS and BOOK FREE

B. W. COOKE, 1916 Sunnyside Ave., Dept. C16, Chicago
Send me absolutely FREE and without any obligation on my part, 6 Auto Instruction Jobs. Also your Auto Book FREE and full particulars of your 5 Outfits Offer.

Name
Address
Town State

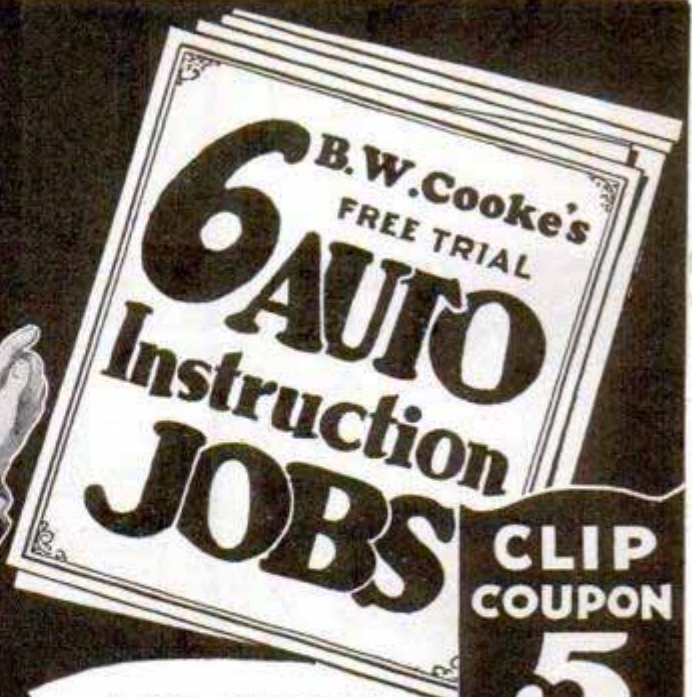

**CLIP
COUPON**
**5
BIG
OUTFITS
Free
OF EXTRA
COST**

TO PROVE
that "JOB-WAY" is
"PAY-RAISE" Training

Clip coupon now. I'll send you absolutely **FREE OF CHARGE**—with positively no obligation on your part—6 "JOB-WAY" Instruction Jobs! and my big book. I want you to *SEE for yourself* just why "JOB-WAY" Training is bringing so many men **Big Money** in such remarkably quick time. I want you to see how men without a day's previous auto experience—and only common schooling become Garage Owners, Superintendents, Managers, and earn up to **\$150 a week** and more! I want you to see why Hundreds of men have found "JOB-WAY" Training to be such interesting, most practical money-making training!

That's why I make you this unusual offer—with absolutely no strings on it and not a single penny's charge. Clip coupon now and I'll rush your jobs to you absolutely Free!

Be An Auto Expert

The World's Biggest Business Needs You!

There are so many tremendous Opportunities in this gigantic Auto Industry that I want every ambitious man who really wants to make more money, to have these 6 Instruction Jobs, just to see how easily and quickly I can boost his pay

way up. Just think! Seven thousand Millions of Dollars are paid to Auto men every year for *upkeep alone*—Nineteen Million Dollars a day! Think what that means to you—the Big Pay Opportunity open to you as a Cooke trained auto expert! It's the one field for the man who wants a **BIG** pay check! Learn all about it now!

Act Quick!

Don't delay a minute. Send coupon right now while I can still make you this special offer of 6 Auto Instruction Jobs absolutely free—as well as my Big Auto Book, free too! Act now!

B. W. COOKE Directing
Engineer
Chicago Motor Training Corporation
1916 Sunnyside Ave. Dept. C16 CHICAGO, ILL.

Coupon Brings Full Details of My 5 OUTFITS OFFER

Includes Tools, Tool Bag, Electrical Test Bench and Radio Receiving Set—all Equipment. Also 303 Wiring Diagram Charts, also Socket Wrench and Ignition Wrench sets.

The Warning of the Desert

By WILLIAM LAWRENCE



THIS is the story of Bill Andrews—plain Bill Andrews. He was twenty-seven years old—married—the father of as fine a baby boy as you have ever seen.

But Bill was just like thousands of other men. He had been forced to leave school and go to work when he was still young.

He had taken the first thing that came along and he had worked as hard as he knew how. But somehow or other, he didn't seem to be getting anywhere.

It was hard—terribly hard, sometimes—to make both ends meet. Sickness came—doctor's bills—the rent was raised—and all that sort of thing.

Above everything else in the world, Bill wanted to go home some night and tell his wife of a raise in salary—of a promotion that would mean a happier, better home.

I wonder if there is a man anywhere who hasn't had that same ambition, that same hope!

But that increase in salary and that promotion never came. Indeed, once or twice Bill came mighty near losing his job.

And then, one night, Bill came across an advertisement that told how men just like himself had gotten out of the rut and had gone ahead—how men with no more education than himself had studied at home in their spare time—how the International Correspondence Schools would come to him and help him to develop his natural ability.

Bill had seen that advertisement and that familiar coupon many, many times before. For two years he had been promising himself that he would cut it out and send it to Scranton. He knew that he ought to do it—that he should at least find out what the I. C. S. could do for him. But he never had.

And he might not have sent in the coupon this time, either, but for the few words under a picture called "The Warning of the Desert":

"On the Plains of Hesitation bleach the bones of countless millions who, at the Dawn of Victory, sat down to wait—and waiting, died."

Bill read that over two or three times. "The Plains of Hesitation!" "The Dawn of Victory!" These two phrases kept ringing in his ears. They worked their way into his very soul. So he clipped that coupon, marked it and mailed it to Scranton.

Bill told me the other day that he was surprised how interested he became in his lessons—of the personal interest the teachers at the I. C. S. took in him—how his employers learned about his studying and saw evidence of it in his work.

"The most important moment in my life," says Bill, "was that moment four years ago when I sent in that I. C. S. coupon. And the happiest moment of my life was when I went home with the news of my first real increase in salary and my first real promotion. If I hadn't sent in that coupon I'd still be working at a humdrum job and a small salary."

Won't you let the I. C. S. help you, too? Won't you trade a few hours of your spare time for a good job, a good salary and the comforts that go with it? Then mark the work you like best on the coupon below and mail it to Scranton to-day. That doesn't obligate you in the least, but it will be your first big step toward success. *Do it now!*

INTERNATIONAL CORRESPONDENCE SCHOOLS Box 5589-E, Scranton, Penna.

Without cost or obligation, please tell me how I can qualify for the position or in the subject before which I have marked an X:

BUSINESS TRAINING COURSES

- | | |
|--|---|
| <input type="checkbox"/> Business Management | <input type="checkbox"/> Salesmanship |
| <input type="checkbox"/> Industrial Management | <input type="checkbox"/> Advertising |
| <input type="checkbox"/> Personnel Organization | <input type="checkbox"/> Better Letters |
| <input type="checkbox"/> Traffic Management | <input type="checkbox"/> Show Card Lettering |
| <input type="checkbox"/> Business Law | <input type="checkbox"/> Stenography and Typing |
| <input type="checkbox"/> Banking and Banking Law | <input type="checkbox"/> Business English |
| <input type="checkbox"/> Accountancy (including C.P.A.) | <input type="checkbox"/> Civil Service |
| <input type="checkbox"/> Nicholson Cost Accounting | <input type="checkbox"/> Railway Mail Clerk |
| <input type="checkbox"/> Bookkeeping | <input type="checkbox"/> Common School Subjects |
| <input type="checkbox"/> Private Secretary | <input type="checkbox"/> High School Subjects |
| <input type="checkbox"/> Spanish <input type="checkbox"/> French | <input type="checkbox"/> Illustrating <input type="checkbox"/> Cartooning |

TECHNICAL AND INDUSTRIAL COURSES

- | | |
|---|--|
| <input type="checkbox"/> Electrical Engineering | <input type="checkbox"/> Architect |
| <input type="checkbox"/> Electric Lighting | <input type="checkbox"/> Architects' Blue Prints |
| <input type="checkbox"/> Mechanical Engineer | <input type="checkbox"/> Contractor and Builder |
| <input type="checkbox"/> Mechanical Draftsman | <input type="checkbox"/> Architectural Draftsman |
| <input type="checkbox"/> Machine Shop Practice | <input type="checkbox"/> Concrete Builder |
| <input type="checkbox"/> Railroad Positions | <input type="checkbox"/> Structural Engineer |
| <input type="checkbox"/> Gas Engine Operating | <input type="checkbox"/> Chemistry <input type="checkbox"/> Pharmacy |
| <input type="checkbox"/> Civil Engineer | <input type="checkbox"/> Automobile Work |
| <input type="checkbox"/> Surveying and Mapping | <input type="checkbox"/> Airplane Engines |
| <input type="checkbox"/> Metallurgy | <input type="checkbox"/> Navigation |
| <input type="checkbox"/> Steam Engineering | <input type="checkbox"/> Agriculture and Poultry |
| <input type="checkbox"/> Radio | <input type="checkbox"/> Mathematics |

Name.....

Street.....

Address.....

City..... State.....

Occupation.....

Persons residing in Canada should send this coupon to the International Correspondence Schools Canadian, Limited, Montreal, Canada.

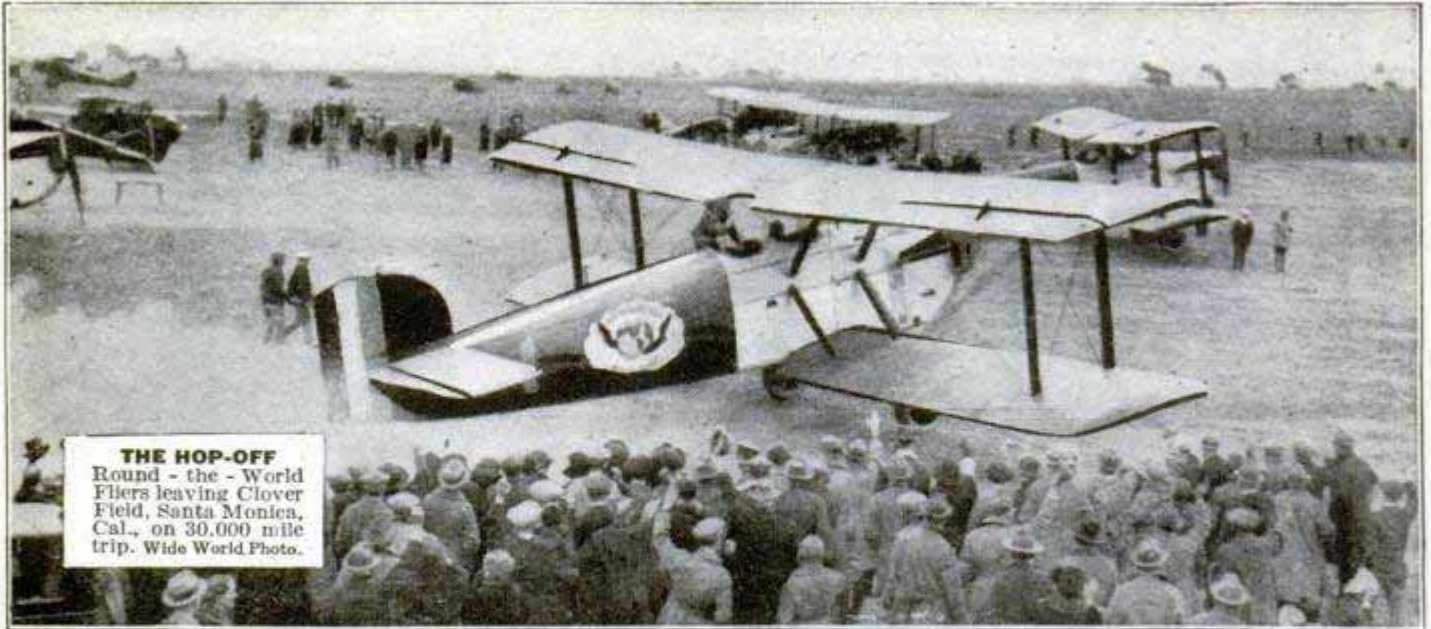

THE HOP-OFF
 Round - the - World
 Fliers leaving Clover
 Field, Santa Monica,
 Cal., on 30,000 mile
 trip. Wide World Photo.

Daring Young Men Needed in Aviation

THERE is no field of work in the world today which offers such amazing opportunities to young men of daring and who love adventure as does Aviation. Although still in its infancy, there is a crying demand in Aviation for young men with courage, nerve and self-reliance. For those who can qualify there will be thousands of highly paid jobs which will lead quickly and surely to advancement and success.

Big Opportunities Await The Trained Man

Look over the fields of work which are open to the young man today. You will find that Aviation is the ONE FIELD that is not overcrowded—the ONE FIELD in which there is plenty of room at the top. Think of it. Only 21 years ago Orville and Wilbur Wright made the world's first airplane flight. Now airplanes fly around the world. Yes, Aviation offers the same wonderful opportunities today that the automobile and motion picture industries did 15 and 20 years ago. Men who got in on the ground floor of those industries made fortunes before others woke up. AVIATION IS NEW! It clamors for nervy young men—and the trained man has the world before him in Aviation.

Easy to Become an Aviation Expert — \$50 to \$100 a Week

You can qualify now quickly for one of these exciting highly paid jobs through a new, sure, easy method of training. The study of Aviation is almost as interesting as the work itself. Every lesson is fascinating and packed full of interest. That's why Aviation is so easy to learn—you don't have to force yourself

to study—once you start, you can't get enough of it. Only one hour of spare time a day will give you the basic training in an amazingly short time.

One student, S. F. McNaughton, Chicago, says: "Your lessons are like a romance, and what is more, after one reading, the student gets a thorough understanding. One never tires of reading them." James Powers, Pa., another student, says: "I am indeed surprised that such a valuable course can be had from such practical men for so little cost."

PREPARE For One of These POSITIONS

- Aeronautical Instructor \$60 to \$150 per week
- Aeronautical Engineer \$100 to \$300 per week
- Aeronautical Contractor Enormous Profits
- Aeroplane Repairman \$60 to \$75 per week
- Aeroplane Mechanician \$40 to \$60 per week
- Aeroplane Inspector \$50 to \$70 per week
- Aeroplane Salesman \$5,000 per year and up
- Aeroplane Assembler \$40 to \$65 per week
- Aeroplane Builder \$75 to \$200 per week

Personal Instruction by Experienced Men

Men who have had actual experience in Aviation give you personal attention and guide you carefully through your training. They select the lessons, lectures, blueprints and bulletins. They tell you the things that are essential to your success. Every lesson is easy to read and quickly understood.

Big Book on Aviation FREE

Send coupon below for New Free Book, just out, "Opportunities in the Airplane Industry." It is interesting and instructive and will show you many things about Aviation which you never knew before. Only a limited number offered—get yours before the edition is exhausted.



American School of Aviation
 Dept. 135C, 3601 Michigan Ave., Chicago, Ill.

AMERICAN SCHOOL OF AVIATION,
 3601 Michigan Ave., Dept. 135C, Chicago, Ill.

Without any obligation, send me your Free Book, "Opportunities in the Airplane Industry," also information about your Course in Practical Aeronautics.

Name.....
 Street.....
 City..... State.....

FREE RAILROAD FARE



ELECTRICITY

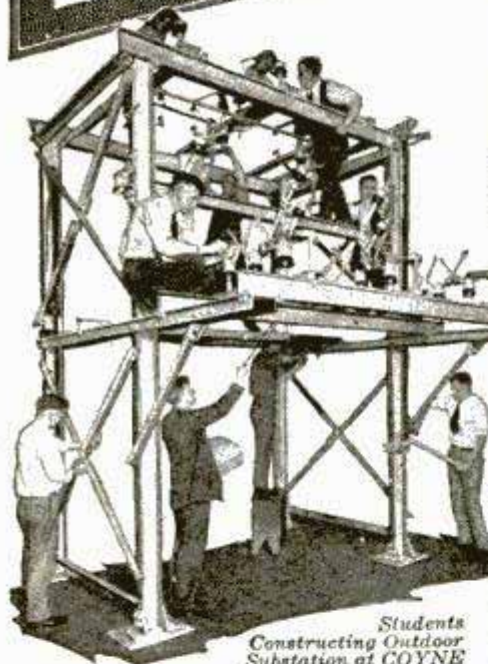

Students Constructing Outdoor Substation at COYNE

You Don't Need Advanced Education or Experience

Don't worry if you lack advanced education, knowledge of higher mathematics, or experience. My course is a *practical, LEARN-BY-DOING* Course. Every COYNE student receives **INDIVIDUAL and PERSONAL** instruction, on **COMPLETE** electrical apparatus, under **EXPERT INSTRUCTORS**, in the COYNE Shops at Chicago.

—Pays Big Money to Men Who Train the COYNE Way, on Real Equipment, in Great Shops!

If you are going to train for one of the thousands of **BIG-PAY** opportunities in the fascinating Electrical Field, why not train on real, gigantic electrical equipment such as you will find in the great Shops of COYNE at Chicago, the electrical center of the world? COYNE training is thorough but easy to understand, because **EXPERT** instructors guide you at every turn, as you work with your own hands on big, modern apparatus.

Hundreds of COYNE-Trained Men Earn \$60 to \$200 a Week



Students producing "artificial lightning" on Tesla coil in great shops of Coyne

Students operating large switchboard at Coyne

Earn While You Learn
My employment department helps you get a job to earn a good part of your expenses and assists you to a good job on graduation.

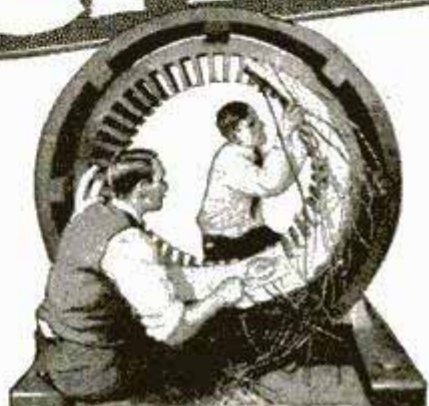

Student Winding Stator at COYNE

COMPLETE ELECTRICAL TRAINING

In 12 Happy Weeks at Coyne

My newly enlarged Electrical Course is the result of 27 years of experience, solving the needs of young men and of the Electrical Field. COYNE has been teaching Electricity in a **PRACTICAL** way since 1899.

My course is thorough, easy to master, and fits men for **BIG** Electrical jobs, the **HIGH-SALARIED** thrilling jobs.



H. C. LEWIS President, Coyne Electrical School

We Teach Electricity and Nothing Else

COYNE teaches only **ONE** thing—**ELECTRICITY**. We are **SPECIALISTS**. Our interests are not divided, nor is Electricity a sideline or merely an "additional" subject with us.

You Can Start Any Day of the Year at COYNE
—No Classes or Seasons

FREE RAILROAD FARE TO CHICAGO

For a limited time only, I will pay your Railroad Fare to Chicago and will include Free my Radio and Auto Truck and Tractor Electricity Courses.

I want to send you a copy of my big, attractive Electrical Book. It is 12 x 16 in size and contains 151 photos of electrical scenes, Tesla about dynamos, radios, autos, airplanes, farm lighting and power, etc. **Absolutely FREE, Remember.**

COYNE ELECTRICAL SCHOOL

H. C. LEWIS, President Established 1899
1300-10 W. Harrison St., Dept. C-135 Chicago

Not a Correspondence Course
All Practical, Personal Training

SEND COUPON NOW

H. C. LEWIS, President
COYNE ELECTRICAL SCHOOL
1300-10 W. Harrison St.
Dept. C-135, Chicago, Illinois
Dear H. C. — You can just bet I want one of those big, handsome **FREE** 12x16 books, with 151 actual photographs printed in two colors. Send it quick, before the supply is exhausted. Be sure to tell me all about Railroad Fare and Special Courses without extra cost.

Name.....
Address.....
Town..... State.....

Two Years' Engineering Course With Diploma and Degree

Civil Mechanical Electrical Chemical

Compact courses of essentials. Rich in higher mathematics, higher science, mechanical drawing and field work. Planned for those short in time and money, but strong in purpose. Courses distinguished alike for what is embraced and what is omitted. Adapted to

**Engineers with Practical Experience desiring a Degree
No Entrance Examination or High School Diploma Required**

Indispensable preliminary work provided for students with only elementary school education. Modern laboratories. Students may begin a course in September, January, March, or June. **Expenses low.** For catalog address

TRI-STATE COLLEGE OF ENGINEERING BOX M-86 ANGOLA, IND.

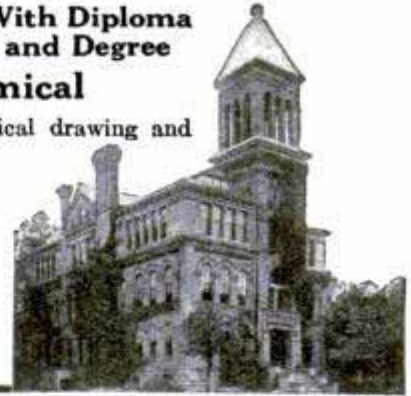

Whatever Your Question;—be it the pronunciation of Fascista, the spelling of a puzzling word, the location of Esthonia the meaning of soviet, realtor, vitamin, etc., this Supreme Authority—

WEBSTER'S NEW INTERNATIONAL DICTIONARY

contains an accurate, final answer. 407,000 Words 2700 Pages. 6000 Illustrations. Regular and India-Paper Editions. **G. & C. MERRIAM CO., Springfield, Mass.**
Write for specimen pages, prices, etc., and FREE Pocket Maps, per Popular Mechanics.



"THERE'S MONEY IN IT"

LEARN TELEGRAPHY AT HOME MORSE AND WIRELESS AT HOME

TEACH YOURSELF

In half usual time, at trifling cost, with the wonderful Automatic Transmitter, **THE OMNIGRAPH.** Sends unlimited Morse or Continental messages, at any speed, just as an expert operator would. **Adopted by U. S. Government, and leading Universities, Colleges and Telegraph Schools. 3 Styles. Catalog free.** **OMNIGRAPH MFG. CO., 13-19 Hudson St., NEW YORK**
If you own a Radio Phone Set—and don't know the code—you are missing most of the fun.



DO YOU LIKE TO DRAW?

It's Easy To Learn When Shown In The Right Way

Some of the cleverest cartoonists and comic artists in America today learned how to draw quickly—by following **CARTOONIST EVANS' SIMPLE AND EASY METHOD.** This school is recommended by foremost cartoonists because they know the students are handled right. If you like to draw, send 6c in stamps for **portfolio of cartoons and full details.** The course is **NOT EXPENSIVE.**

The W. L. Evans School of Cartooning 821 Leader Building CLEVELAND, OHIO



Learn to Mount Birds

Learn at home by mail, to mount birds, animals, game heads; tan furs, make rugs and robes. Complete lessons. Easily and quickly learned by men, boys and women.

FREE Write today for Free Taxidermy Book. Tells all about it. Every Sportsman, Hunter, Trapper and Nature lover should know this wonderful fascinating art. Save your trophies. Big profits. Success guaranteed. Our school is 20 years old—75,000 graduates. Investigate today. Write for Free Book.

Northwestern School of Taxidermy C-177 Elwood Bldg., Omaha, Neb.



Wonderful, new device, guides your hand; correct your writing in few days. Big improvement in three hours. No failures. **Complete outline FREE.** Write C. J. Ozment. D-34, St. Louis, Mo.

MUSIC LESSONS FREE

IN YOUR OWN HOME

You can read Music like this quickly

Write today for our FREE booklet. It tells how to learn to play Piano, Organ, Violin, Mandolin, Guitar, Banjo, etc. Beginners or advanced players. Your only expense about 2c per day for music and postage used. **American School of Music, 51 Lakeside Bldg., Chicago**

LEARN MECHANICAL DENTISTRY

Earn \$35 to \$125 a week. Taught by actual practice—day or night. Three months' course. Modern laboratories. No previous training required. Established 30 years. For 36-page catalog, write Dept. 2.

BODEE DENTAL INSTITUTE
NEW YORK 1785 Broadway
PHILADELPHIA 1305 N. Broad St.
BUFFALO 501 Washington St.
BROOKLYN 85 Court St.



WANT \$1900 A YEAR?

**RAILWAY POSTAL CLERKS—MEN—BOYS 18 UP
CARRIERS—POSTOFFICE CLERKS**

**Steady Work. No Layoffs
Paid Vacations**

Common Education Sufficient

TRAVEL—SEE YOUR COUNTRY

MAIL COUPON IMMEDIATELY

FRANKLIN INSTITUTE
Dept. W-176, Rochester, N. Y.

Sirs: Rush to me without charge, (1) Sample Railway Postal Clerk Examination questions; (2) List of government jobs now open to men and women, 18 up; (3) 32-page Civil Service Book.

COUPON

Name.....
Address.....

PRACTICAL EDUCATION IN ELECTRICITY Complete in Three Months

Great concerns want S. of E. men. Get ready in a few weeks of fascinating training for a big career in ELECTRICITY.

BOOK FREE—SEND COUPON

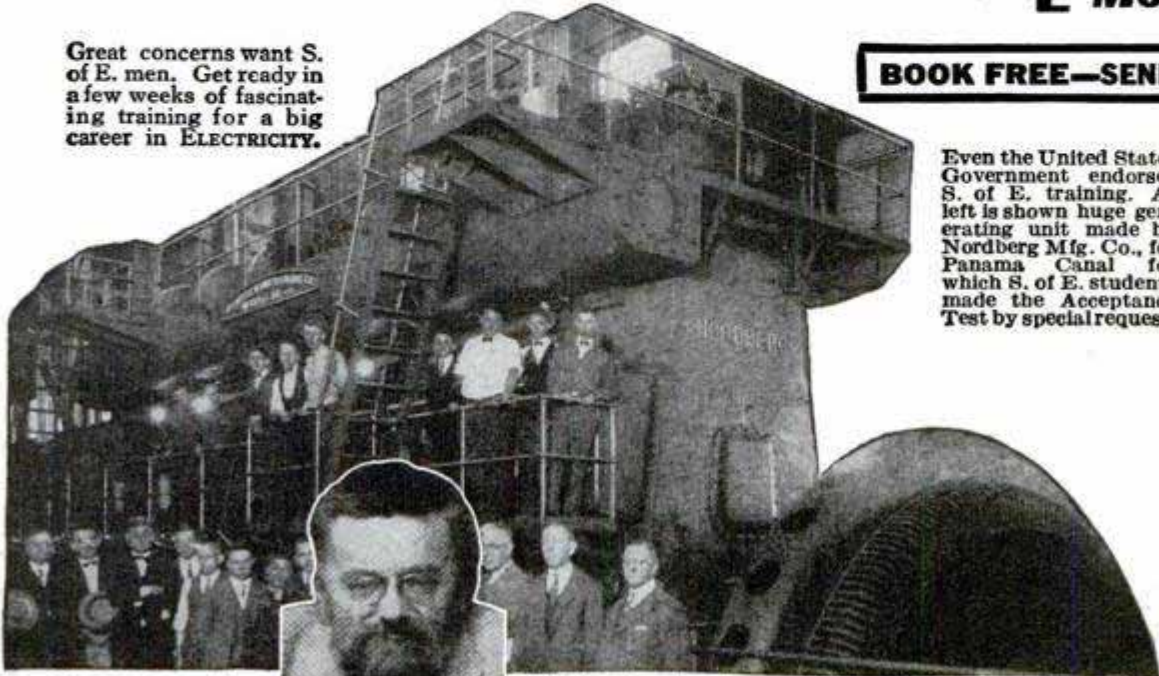

Even the United States Government endorses S. of E. training. At left is shown huge generating unit made by Nordberg Mfg. Co., for Panama Canal for which S. of E. students made the Acceptance Test by special request.

22 YEARS TEACHING THE ONE RIGHT WAY

DON'T WASTE another minute getting into the fascinating field of electricity. Never before has there been so many amazing opportunities. Electric refrigeration, radio battery work, central stations, power plants, are combing the country for men with electric training.



CHARLES P. STEINMETZ
"electrical wizard" of General Electric was for the last six years of his life on the Advisory Council of School of Engineering.

Steinmetz, the electrical wizard.

THREE MONTHS' FASCINATING training fits you to enter the big job with one of these concerns or go into business for yourself. Thousands of opportunities exist in every section for men with a little training to do house-wiring, operate battery service stations, to do automotive electrical work. In three months' time S. of E. training gets you ready for the amazing opportunity of a lifetime.

\$3200 AND UP with amazing opportunity for advancement awaits you in this most fascinating business of all. S. of E. training will prepare you in a few weeks' time to step into a fine electrical job in a big corporation like General Electric, Western Electric, Commonwealth-Edison, Harnischfeger Corporation.

THE BIG CONCERNS are the ones who offer the big opportunities. And they prefer S. of E. men because 22 years' experience has shown that they are the ones who succeed. The finest engineering talent available directs your work in classroom and laboratory. Our staff is not excelled. They are big men like our Chief Engineer John D. Ball, for three years assistant to Dr.

S. OF E. MEN GET PREFERENCE everywhere that men are hired for electrical work. For in nearly every electrical concern in America S. of E. men will be found holding

big jobs. They are on the lookout to help you succeed when you come in. In one of the 10 largest American cities the 3 biggest electrical jobs are all held by S. of E. men. To be an S. of E. man means prestige—preference!

ACT NOW BEFORE CLASSES FILL UP. Due to the enormous amount of personal attention given to each man, S. of E. classes fill up rapidly. Employers ask first for the S. of E. man. We suggest immediate action to avoid disappointment.

SPECIAL BOOK NOW FREE—Act! Clip and mail the coupon right away. A big 72 page book telling all phases of S. of E. training will be rushed to you. Get it by all means to help make up your mind. The most complete book on opportunities in electricity ever offered.

**CLIP AND MAIL COUPON NOW!
A PERSONAL CHALLENGE TO YOU**
"Whatever your previous education our training will make you successful in Electricity! Put yourself in my hands for a few weeks and the big job is yours."
OSCAR WERWATH, President



You will find and enjoy a different spirit among S. of E. students than you find in the "trade schools." Good times mixed with work. Fraternities, daily broadcasting from Station WSOE. Above is photo of the student parade. Below, one of Milwaukee's famous beaches. Enjoy a real summer in a real lakeside city. Boating, bathing, etc.



SCHOOL of ENGINEERING of Milwaukee

Founded 1905, Dept. 12-C 415-17 Marshall St., Milwaukee, Wis.

**SCHOOL OF ENGINEERING OF MILWAUKEE
Dept. 12-C 415-17 Marshall St., Milwaukee, Wis.**

Without obligating me in any way, please mail free 72-page illustrated book, "Electricity and the One Best Way to Learn It," and particulars regarding the course I have marked with an X.

- Commercial Electrical Eng.
- Electrotechnics
- Junior Electrical Eng.
- Automotive Electricity
- Radio Sales, Service and Broadcasting
- Armature Winding
- Light, Heat, Power Wiring, Testing
- Practical Electricity
- Home Laboratory Service

Name..... Age.....

Address.....

City..... State.....

Education.....

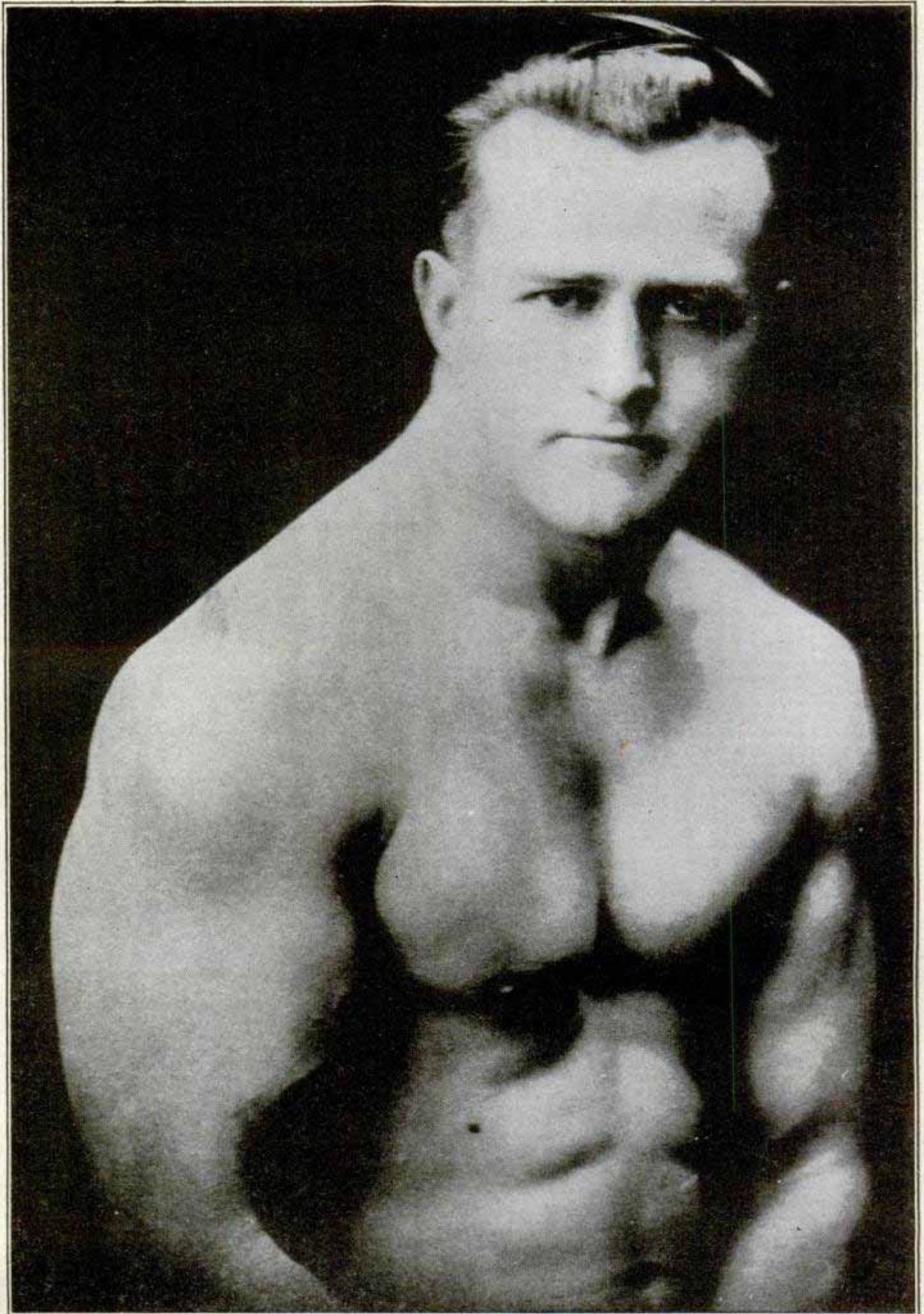

EARLE E. LIEDERMAN, *The Muscle Builder*
Author of "Science of Wrestling," "Muscle Building," "Secrets of Strength," "Here's Health," etc.

How Strong Are You? Can You Do These Things?

Lift 200 lbs. or more overhead with one arm; bend and break a horseshoe; tear two decks of playing cards; bend spikes; chin yourself with one hand.

CAN you do any of them? I can and many of my pupils can. It is remarkable the things a man really can do if he will make up his mind to be strong. It is natural for the human body to be strong. It is unnatural to be weak. I have taken men who were ridiculed because of their frail make-up and developed them into the strongest men of their locality.

I WANT YOU FOR 90 DAYS

These are the days that call for speed. It once took four weeks to cross the ocean—now it takes less than one. In olden days it took years to develop a strong, healthy body. I can completely transform you in 90 days. Yes, make a complete change in your entire physical make-up. In 30 days I guarantee to increase your biceps one full inch. I also guarantee to increase your chest two inches. But I don't quit there. I don't stop till you're a finished athlete—a real strong man. I will broaden your shoulders, deepen your chest, strengthen your neck. I will give you the arms and legs of a Hercules. I will put an armor plate of muscle over your entire body. But with it come the strong, powerful lungs which enrich the blood, putting new life into your entire being. You will be bubbling over with strength, pep and vitality.

A Doctor Who Takes His Own Medicine

Many say that any form of exercise is good, but this is not true. I have seen men working in the factories and mills who literally killed themselves with exercise. They ruined their hearts or other vital organs, ruptured themselves or killed off what little vitality they possessed.

I was a frail weakling myself in search of health and strength. I spent years in study and research, analyzing my own defects to find what I needed. After many tests and experiments, I discovered a secret of progressive exercising. I increased my own arms over six and a half inches, my neck three inches and other parts of my body in proportion. I decided to become a public benefactor and impart this knowledge to others. Physicians and the highest authorities on physical culture have tested my system and pronounced it to be the surest means of acquiring perfect manhood. Do you crave a strong, well-proportioned body and the abundance of health that goes with it? Are you true to yourself? If so, spend a pleasant half-hour in learning how to attain it. The knowledge is yours for the asking.

Send For My New
64 Page Book

"Muscular Development"

IT IS FREE

It contains forty-eight full-page photographs of myself and some of the many prize-winning pupils I have trained. Some of these came to me as pitiful weaklings, imploring me to help them. Look them over now and you will marvel at their present physiques. This book will prove an impetus and a real inspiration to you. It will thrill you through and through. This will not obligate you at all, but, for the sake of your future health and happiness, do not put it off. Send today—right now, before you turn this page.

EARLE E. LIEDERMAN

Dept. 2008, 305 Broadway, New York City

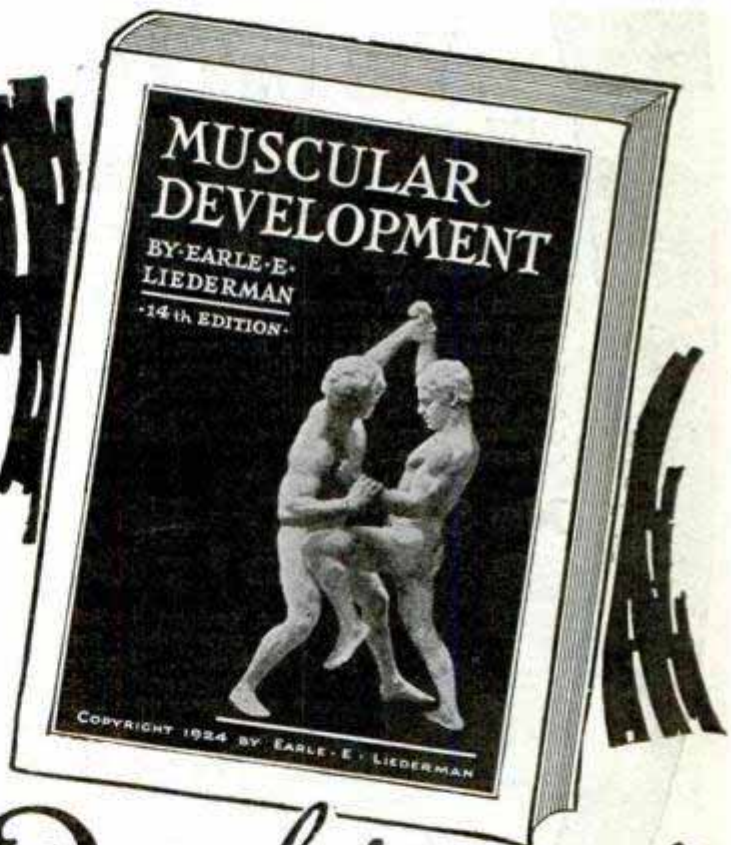

**It
Is
F
R
E
E**

**DON'T
SEND ONE
PENNY
—
YOUR
NAME AND
ADDRESS
ON A
POSTAL
WILL DO**

EARLE E. LIEDERMAN
Dept. 2008, 305 Broadway, New York City

Dear Sir: Please send me, without any obligation on my part whatever, a copy of your latest book, "Muscular Development." (Please write or print plainly)

Name.....

Street.....

City.....State.....

These Men Earn \$40 to \$125 a Week as Mechanical Dentists

These are actual pictures of dental laboratories owned by McCarrie graduates. This live, up-to-date profession offers any ambitious man the opportunity of a lifetime to become financially independent. Read the letters below. Many dental "labs" do a \$25,000 annual business. Mechanical Dentists earn \$40 to \$125 a week.

You Can Learn Mechanical Dentistry in a Few Months

Learn to make crowns, bridges, plates, etc., for dentists by our practical method of individual training. Many students complete the course in a few months. Day and evening instruction in all of our 5 big schools in Chicago, Detroit, Cleveland, Boston and Philadelphia. We help you secure spare time job while learning. No educational requirements for entering McCarrie School. No mechanical experience required.

No Classes — No Books Learn by Doing

Each student trained individually. You work with new set of tools and with precious metals. Training is practical, thorough and quick so that you can start your own laboratory after completion of course.



FREE

R-R-FARE

to any
McCarrie
School.
Send coupon
for details.

**FREE
BOOK**

**MAIL
COUPON
NOW**

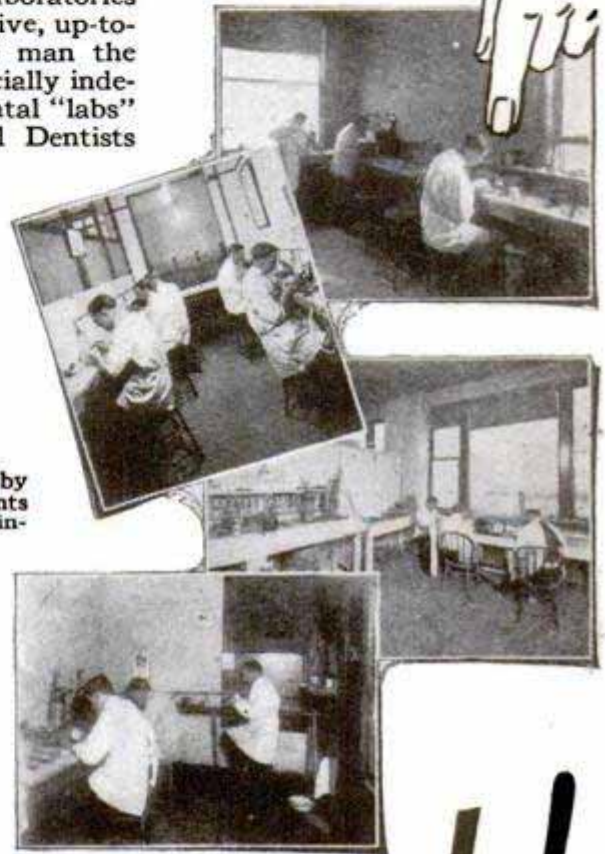

Read!

What Some McCarrie Graduates Write:

- A. K. writes: Am making good as manager of laboratory. Just turned down an offer of \$75 a week.
- C. M. writes: I am now doing laboratory work for D. N. M. at a salary of \$50 a week.
- S. K. H. writes: Some months I take in \$500. Last month I took in \$674.80.
- G. P. W. writes: Am making \$50 a week straight time turning out bridges, plates, etc.
- W. M. B. writes: I have an excellent business. I average \$75 to \$150 a week.
- R. W. B. writes: I secured one of the very best responsible positions immediately upon completion of my course.

These are specimens of hundreds of letters on file here from McCarrie graduates.

Facts About This Money Making Opportunity

There are 64,000 dentists in the U. S. Thousands of dental "labs" and expert mechanical Dentists are needed to handle the great volume of work required by dentists. *Mail coupon for free book that gives all details of this great opportunity and SPECIAL OFFER.*

McCarrie Schools of Mechanical Dentistry

**McCarrie Schools of Mechanical Dentistry
1338 S. Michigan Ave., Dept. 22, Chicago**

Without cost or obligation, send me your illustrated book containing complete information as to my opportunities in the dental laboratory profession and details of your special offer.

Name

Address.....

Does Your Present Job Offer You These Things?



Big Pay
Unlimited Opportunities
For Increasing Earnings
Permanent Employment
Your Own Boss
Promotion
Travel

Salesmanship Does!

Don't let the word "selling" scare you, for it is remarkably easy for any man of average intelligence to become a first class salesman. And then your future can be as big as you want to make it.

THE majority of men are shackled down to poorly paid positions because they are either afraid to strike out for better things—or they condemn themselves to a life of drudgery because of preconceived notions about what they can do.

Take salesmanship, for instance. To the vast majority, a salesman has to be "born" to his task. Nothing could be further from the truth. Possibly you think that selling is a "gift."

You cannot be blamed for what you think—but you are utterly to blame if you do not investigate as to the soundness of your thoughts. For what you may think may be the thing that is tying you down to deadly routine and poor pay.

Proof That You Can Be a Master Salesman

During the past eighteen years the National Salesmen's Training Association has taken men from all walks of life and made them into producing salesmen. There's a statement you should investigate—but look at a few typical examples of the thousands of success stories in our files and literature:

A. H. Ward, Chicago, earned better than \$1,000 a month within one year after he completed his training. Today he is an executive of Postl's, Chicago. J. H. Cash, Atlanta, Ga., increased his earnings from \$75 to \$500 a month. F. M. Harris, a telegraph operator, increased his earnings to \$6,000 a year—and is now a Sales Manager.

Why You Can Be Taught to Sell

You may think it remarkable that this Association can teach men at home during spare time to sell so quickly and easily. But there is nothing remarkable about it—for Salesmanship is governed by fundamental rules and principles. There are certain ways to attract attention, arouse interest and make prospects act—certain ways to overcome objections, batter down prejudices, outwit competition and get results. Once you know these secrets of master salesmanship, you can duplicate any of the successes this remarkable System of Salesmanship Training has been responsible for.

Exceptional Demand for Trained Salesmen

City and traveling sales positions are open in every line all over the country. For years thousands of leading concerns have called on the N. S. T. A. to supply them with salesmen. Employment service is free to both employers and members.

Free Book "Modern Salesmanship"

Naturally, you will want to investigate and find out for yourself what Salesmanship offers you, how it is taught by a method that gives you the equivalent of actual experience while studying, and what facilities are offered you by the Free Employment Bureau of the Association. Just mail the coupon below and we will promptly mail you a free copy of "Modern Salesmanship"—the book that has started thousands on the road to bigger pay.

NATIONAL SALESMEN'S TRAINING ASSOCIATION
 WORLD'S OLDEST AND LARGEST *Exclusive* SALES TRAINING INSTITUTION

Dept. K-12, N. S. T. A. Bldg., Chicago, Ill.

National Salesmen's Training Association,
 Dept. K-12, N. S. T. A. Bldg., Chicago, Ill.
 Send me FREE your book "Modern Salesmanship" and
 proof that I can become a Master Salesman.

Name.....
 Address.....
 City..... State.....
 Age..... Occupation.....

BUILDING TRADES NEED TRAINED MEN

Thousands of good positions at good salaries

THE building trades are still booming. Trained men are in demand at good salaries. Government experts estimate that billions of dollars will be spent for construction this year.



To-day the most vital need of this great building program is men—trained men—men who can step right in and do the skilled work that building construction requires.

There is a simple, easy, practical way by which you can prepare for a better position, at a bigger salary. You can do it right at home, in spare time, no matter where you live, through the International Correspondence Schools.

A recent investigation of 13,298 students enrolled in I. C. S. Building Trades Courses showed that 1921 had become Architects; 246 had become Designers; 494 had become Chief Draftsmen; 2827 had become Draftsmen; 1845 had become Contractors; 211 had become Assistant Foremen; 4030 had become Foremen; 2354 had become Superintendents.



You, too, can have the position you want in the work you like best; an income that will give you and your family the home, the comforts, the luxuries you would like them to have. No matter what your age, present occupation, or your means, you can do it!

All we ask is the chance to prove it. That's fair, isn't it? Then, mark and mail this coupon.

TEAR OUT HERE

INTERNATIONAL CORRESPONDENCE SCHOOLS

BOX 5590-E SCRANTON, PA.

Explain, without obligating me, how I can qualify for the position, or in the subject, before which I mark X.

- | | |
|---|--|
| <ul style="list-style-type: none"> <input type="checkbox"/> ARCHITECT <input type="checkbox"/> Architectural Draftsman <input type="checkbox"/> Contractor and Builder <input type="checkbox"/> Building Foreman <input type="checkbox"/> Concrete Builder <input type="checkbox"/> Structural Engineer <input type="checkbox"/> Structural Draftsman <input type="checkbox"/> Plumber and Steam Fitter <input type="checkbox"/> Heating and Ventilation <input type="checkbox"/> Plumbing Inspector <input type="checkbox"/> Foreman Plumber <input type="checkbox"/> Sheet Metal Worker <input type="checkbox"/> CIVIL ENGINEER <input type="checkbox"/> Surveying and Mapping <input type="checkbox"/> Reading Architects' Blue Prints <input type="checkbox"/> ELECTRICAL ENGINEER <input type="checkbox"/> Electric Lighting and Rys. <input type="checkbox"/> Electric Wiring <input type="checkbox"/> Telegraph Engineer <input type="checkbox"/> Telephone Work <input type="checkbox"/> MECHANICAL ENGINEER <input type="checkbox"/> Mechanical Draftsman <input type="checkbox"/> Toolmaker <input type="checkbox"/> Machine Shop Practice <input type="checkbox"/> CHEMIST <input type="checkbox"/> Pharmacy | <ul style="list-style-type: none"> <input type="checkbox"/> Navigation <input type="checkbox"/> SALESMANSHIP <input type="checkbox"/> ADVERTISING <input type="checkbox"/> Window Trimmer <input type="checkbox"/> Show Card and Sign Painting <input type="checkbox"/> BUSINESS MANAGEMENT <input type="checkbox"/> Private Secretary <input type="checkbox"/> Business Correspondent <input type="checkbox"/> BOOKKEEPER <input type="checkbox"/> Stenographer and Typist <input type="checkbox"/> Higher Accounting <input type="checkbox"/> COMMERCIAL LAW <input type="checkbox"/> Common School Subjects <input type="checkbox"/> Mathematics <input type="checkbox"/> GOOD ENGLISH <input type="checkbox"/> ILLUSTRATING <input type="checkbox"/> Railway Mail Clerk <input type="checkbox"/> CIVIL SERVICE <input type="checkbox"/> Mining Engineer <input type="checkbox"/> Gas Engine Operating <input type="checkbox"/> STATIONARY ENGINEER <input type="checkbox"/> Textile Overseer or Supt. <input type="checkbox"/> TRAFFIC MANAGER <input type="checkbox"/> AUTOMOBILES <input type="checkbox"/> AGRICULTURE <input type="checkbox"/> Poultry Raising <input type="checkbox"/> French <input type="checkbox"/> Spanish <input type="checkbox"/> Banking |
|---|--|

Name _____

Present Occupation _____ Business Address _____

Street _____

and No. _____

City _____ State _____

Persons residing in Canada should send this coupon to the International Correspondence Schools Canadian, Limited, Montreal, Canada.



Think of being able to offer a suit or topcoat made of the finest quality of pure Virgin Wool; fit, fabric and fashion guaranteed, at the powerfully attractive price of \$23.50! Can you sell such values? You can, if the experience of 2,500 other salesmen means anything. And you don't have to know anything about selling clothing. We'll take you, train and equip you to go out and make a success of this work if you are honest, ambitious and willing to work. If you are, write us. You'll hear from us promptly with the full facts. Address Dept. 914.

William C. Bartlett, Inc., 850 Adams St., Chicago
Gentlemen: I'm interested in the opportunity you offer. Please send the facts without obligation to me. 9.4

Name _____

Address _____

Town _____ State _____

LAW THIS BOOK

FREE!

Study at Home

Become a lawyer. Legally trained men win high positions and big success in business and public life. Greater opportunities now than ever before.

Earn \$5,000 to \$10,000 Annually!

We guide you step by step. Degree of LL.B. LaSalle law graduates practicing in every state. We furnish all text material, including 14-volume Law Library. Low cost. Easy terms. Valuable, interesting 96-page book free. Send for it NOW.

LaSalle Extension University, Dept. 864-L, Chicago

STAMMER

If you stammer attend no Institute till you get my large FREE book entitled "STAMMERING, Its Origin and The Advanced Natural Method of Treatment." Ask for special tuition rate and a FREE copy of "The Natural Speech Magazine," published monthly in the interest of those afflicted with stammering, stuttering and other speech impediments. Largest, best equipped and most successful school in the world for the cure of stammering. Established 20 years. No sing-song or time-beat. Write today. MILLARD INSTITUTE OF NORMAL SPEECH, 2317 Millard Bldg., MILWAUKEE, WIS. Branch Summer School, Philadelphia, Pa.

Rider Agents Wanted

Select from the 44 Styles, colors and sizes of Ranger Bicycles. Ride and exhibit sample Ranger and make money. Delivered free, express prepaid, on Approval. Factory-to-Rider bicycles \$21.50 up. \$5 a Month on any Ranger if desired. Boys and girls easily save the small monthly payments. Parents often advance first payment.

Tires best quality, at factory prices, express prepaid. Lamps, wheels and equipment, low prices. Send No Money, do business direct with makers.

Mead CYCLE COMPANY
DEPT. R-109 CHICAGO

Write today for free Ranger Catalog, factory prices and marvelous easy payment terms.

\$141⁶⁷ to \$275 Month

Mail Carriers

(City or Rural)

Steady—common education sufficient. Big chance for men, 18 up.

FRANKLIN INSTITUTE
Dept. W308
Rochester, New York

Rush to me, WITHOUT CHARGE, pointers on how to get a position as mail carrier or City Post Office Clerk and give full particulars.

Mail Coupon Today Sure

Name _____

Address _____

RADIO NEEDS TRAINED MEN!

I Will Train You At Home To Fill a Big Pay Radio Job

"I give you all this apparatus so you can learn quickly at home the *Practical Way*"

J.E.S.
FREE OF EXTRA COST

You Get All of This

All instruments shown here and others sent to all my students free of extra cost under short time special offer. Clip coupon now—find out all about this big unequalled offer while you still have time to take advantage of it. This training is intensely practical—these instruments help you do the practical



\$70 in one Day for T. M. Wilcox
"In business for myself—RECENTLY MADE \$70 in ONE DAY. I was an electrician of rich experience, occupying a splendid position as telephone superintendent when I enrolled with you, believing it would open up greater opportunities. Estimate Radio worth tens of thousands of dollars to me in next few years." T. M. Wilcox, Belle Island, Newfoundland.



If you're earning a penny less than \$50 a week, clip coupon now. Send for AMAZING FREE BOOK, "Rich Rewards in Radio." Why go along at \$25 or \$35 or \$45 a week, when you could earn \$50 to \$250 in the same six days, as a Radio Expert? Hundreds of N. R. I. trained men are doing it—why can't you?

Earn \$50 to \$250 a Week—Radio Experts in Big Demand

Radio needs trained men. Get into this new live-wire profession of quick success. It's the trained men, the Radio Expert, who gets the big jobs of this profession—paying \$75, \$100, \$200 a week and up. Every day N. R. I. trained men are taking good places in the Radio field—men just like you—their only advantage is TRAINING. You can prepare just as they did by new practical methods. Our tested clear training makes it easy for you. Big Free Book contains all the proof.

You Learn Quickly In Spare Time

So sure am I that I can train you successfully for a better future in this new Big-Pay profession that I guarantee your training with a money-back bond. Lack of experience or education won't hold you back—common schooling all you need to start. You can stay home, hold your job, and learn quickly and pleasantly in your spare time. My practical, helpful methods enable you to start RIGHT AWAY toward one of the bigger Radio jobs paying \$50 to \$250 a week. No delay, no losing time from work—no scrimping or scraping to get your training.



Operates WMAQ
"Accepted a position with the Chicago Daily News Station WMAQ. MY INCOME PRACTICALLY DOUBLED. I handle all consultation, also do operating. Your course taught me the theoretical and practical knowledge that makes my work easy." Keith Kimball, Station WMAQ, Chicago, Ill.

Get This FREE BOOK

Most amazing book on Radio ever written—full of facts and pictures—tells all about the great new Radio field, how we prepare you and help you start. You can do what others have done—GET THIS BOOK. Send coupon today—no obligation.

J. E. SMITH, President
NATIONAL RADIO INSTITUTE
Dept. HT7, Washington, D. C.

World Famous Training That "Pays for Itself"

My Radio course World-Famous as the training that "pays for itself." Make more money QUICK when you take up this practical course. Work on millions of antennae, receiving sets, offers you big chance to make spare time cash while you're learning. I'll show you how. My students don't wait a year to increase their income—they report QUICK INCREASES as a result of this course—often two or three weeks after starting. Howard Luce, Friedens, Pa., made \$320 in 7 weeks during spare time. D. H. Suitt, Newport, Ark., writes: "While taking the course I earned in spare time work about \$900. These records not unusual—these men a few of hundreds."

Your Satisfaction Guaranteed

We who know the results this practical tested training gets, stand behind it all the way with a signed guarantee bond that we give you when you enroll. Get started today! It's your big chance for one of the bigger Radio jobs—mail coupon NOW for my Big FREE BOOK and proof! No obligation.

Employment Service To All Graduates

Originators of Radio Home-Study Training



MAIL THIS COUPON TODAY

J. E. Smith, President
NATIONAL RADIO INSTITUTE
Dept. HT7, Washington, D. C.

Dear Mr. Smith—Without obligating me in any way, send me your free book, "Rich Rewards in Radio" and all information about your practical, home-study Radio Course.

Name.....Age.....
Street Address.....
Town.....State.....

Learn Electricity

by the



The American School

is chartered under the laws of Massachusetts, as an educational institution. Established 29 years. Over 200 Executives, Engineers, and Educators have prepared the text used in these wonderful home-study courses.

DUNLAP Job-Method Training

Dunlap Home-Training in Electricity is divided in two parts. The first, "Applied Electricity," 53 lessons and "Jobs," covers all the ground usually found in Electrical home-training. In the second part, containing 51 lessons and jobs, you get Electrical Engineering subjects. It is this second part which prepares you to step out of the mechanic class into the big-pay class of Electrical Experts who boss the important jobs in the Electrical industry.

Get my amazing GUARANTEE

When you put your time and money into home-training you want to know in advance WHETHER IT WILL EQUIP YOU TO FILL A BETTER JOB AT BIGGER PAY. The American School answers these questions in plain English. You owe it to yourself, before you enroll for home-training, to get my MONEY-BACK GUARANTEE. Coupon brings it.

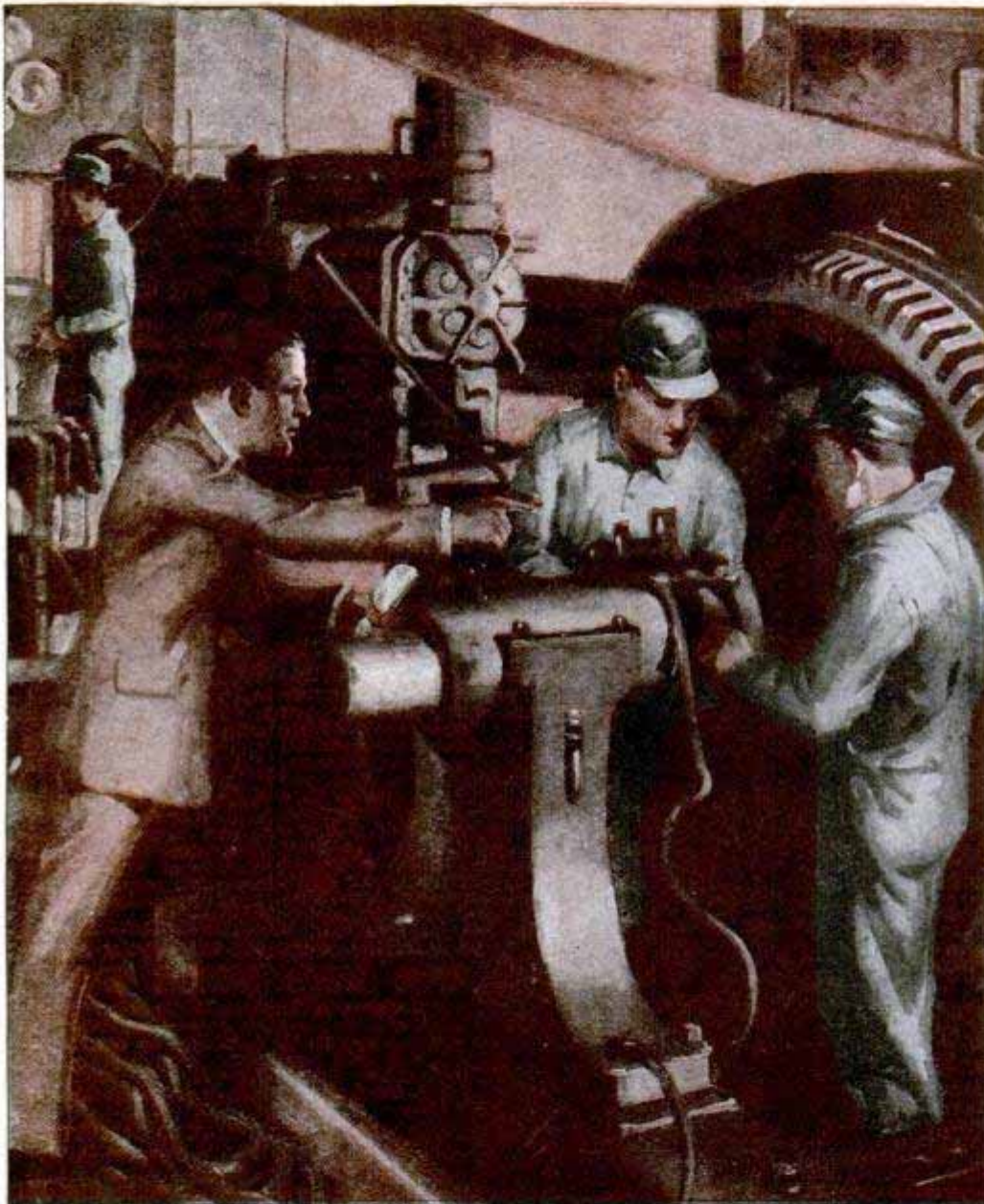

Electrical Experts Wanted!

\$60 to \$250 A WEEK!

FREE Job-Service for Students and Graduates

We have supplied thousands of jobs FREE, not only to graduates, but to STUDENTS also. This JOB-SERVICE keeps in touch with the great Electrical employers all over America. The day you enroll, this Job-Service department registers you, finds out what kind of job you want, where you want to work, etc. When the AMERICAN SCHOOL backs you for a fine BIG-PAY job, you are pretty sure to get it, and make good in it.



Go into Electricity—The Business of

At Home Job-Method

I train you for a fine Electrical JOB and a BIG RAISE in PAY!

If you are now earning less than \$40 a week, if you want to become an ELECTRICAL EXPERT, if you want to step quickly into the class of men who earn \$60 to \$250 a week—write me at once! This million-dollar training school guarantees you COMPLETE, thorough training, and guarantees to back you from one position to another until you are a success! My training easy to understand, rapid, practical, because you learn by doing actual Electrical jobs with all this standard material, tools and equipment which I send you without one penny of extra cost!

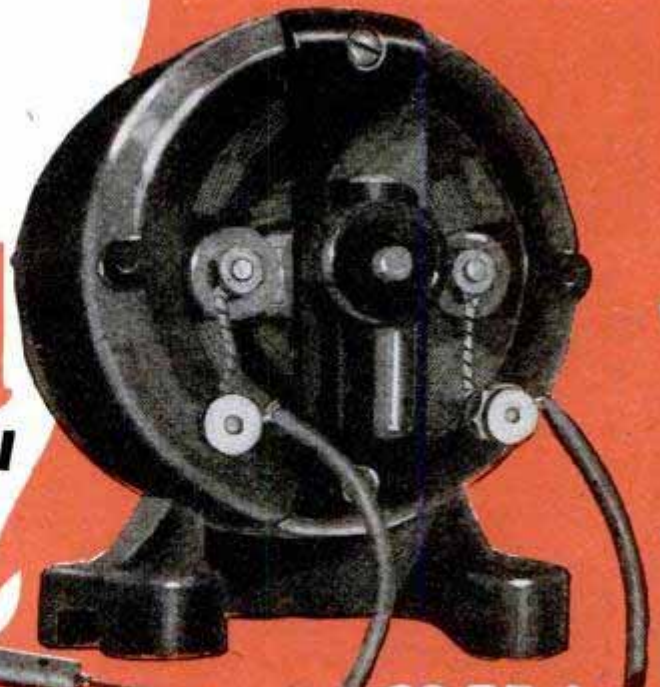

**\$10 Motor
4 Big Outfits
GIVEN!**

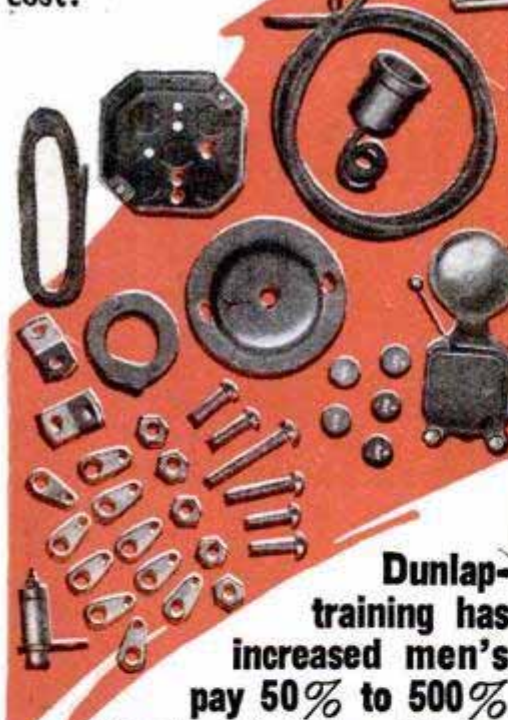

Dunlap-training has increased men's pay 50% to 500%

I have hundreds of letters which prove my training has doubled and trebled the pay of my students and graduates. You only need common schooling to go through with this—the ability to read and write simple English. If you haven't a high-school education, I will give you the mathematics you need later, without extra cost. My training includes Radio, Auto Electricity, Electrical Drafting, Business training, and Electrical Engineering subjects, all for one small price and on terms within reach of the fellow who needs this training.

Write Me Today! Get my catalog; my wonderful new guarantee, my sensational offers—quick! Get the facts about your opportunities in Electricity when you are Dunlap-trained, when you have the backing of the American School. Get the facts about my training. Get the real facts about my job service. Mail coupon today!

**CHIEF ENGINEER DUNLAP, Electrical Division
AMERICAN SCHOOL, Dept. EC-74, Drexel Av. & 58th St., Chicago**

a Million Opportunities!

Training built by 23 Noted Engineers

This is no one-man, one-idea school. 22 famous Engineers and Executives of the world's greatest Electrical corporations and leading Universities helped Chief Engineer Dunlap make this training complete and up-to-date:

- | | |
|--|---|
| 1. General Electric Co. | 8. Underwriters Laboratories, Inc. |
| 2. Commonwealth Edison Co. | 9. Columbia University |
| 3. Crocker-Wheeler Co. | 10. Dartmouth College |
| 4. Cutler-Hammer Mfg. Co. | 11. Massachusetts Institute of Technology |
| 5. American Telephone & Telegraph Co. | 12. Lehigh University |
| 6. Westinghouse Electric & Mfg. Co. | 13. University of Vermont |
| 7. Western Electric Co. | 14. Armour Inst. of Tech. |
| 15. University of Kansas and many others | |

Nearly 100 items included in 4 BIG Motor, Radio, and Electrical Outfits given to you without one penny of extra charge. Not a "premium," not something "FREE" to induce you to enroll. But costly, standard, full-size tools, materials, and equipment. As necessary a part of your instruction as the lessons and job-sheets. The man-size motor of the same type as the big-fellows in a power plant. Not a toy, but a regular power-motor. Runs on Alternating or Direct Current, or 32 Volt farm electric systems. Comes to you knock-down. It's part of your job to wind the armature and assemble it. That's the way you learn every branch of Electricity by the Dunlap Job-Method.

MAIL COUPON FOR SENSATIONAL OFFERS!

**CHIEF ENGINEER DUNLAP
AMERICAN SCHOOL, Dept. EC-74
Drexel and 58th, CHICAGO**

I want to be an Electrical Expert. Please rush guarantee, job-service facts, complete information, and money-saving offers.

Name

Street No.

City..... State.....

Play the HAWAIIAN GUITAR and be Popular!

Play all the latest hits just as the Hawaiians do. Be the most popular member of your set. Get in on all the good times. Entertain your friends—or play professionally. Be in demand everywhere. We will help you.



\$15
HAWAIIAN GUITAR
with Genuine Seal Grain
Fabrikoid Cover
FREE
when you enroll



This sweet-toned, mellow Hawaiian Guitar would cost you at least \$15 in any music store without the Genuine Seal Grain Fabrikoid Case. We can afford to give you the entire outfit free when you enroll, including picks, steel playing bar, etc., because we make them in huge quantities in our own factory. Nothing to buy—everything is furnished.

Learn in Spare Time at Home

You study in spare time—when you like—as long as you like. And even if you don't know one note from another, our method is so simple, plain and easy that you begin a piece your first lesson. In half an hour you can play it!

Famous Native Hawaiians Teach You

You receive expert instruction from such world famous players as Kolomoku, Kalatuki, Ferara and Seville. They quickly teach you the secrets of this fascinating instrument.

Complete Conservatory Course. You get 52 complete printed lessons. Nothing is omitted. Pictures explain every move. And no matter how little you know about music when you begin, no matter if you have never touched a musical instrument, you can positively learn to play by our plain, easy, picture method.

Only 4 Motions to Learn

Then you can play any music—popular songs, classical, old-time melodies, native Hawaiian airs—or real jazz—separately or with accompaniment. You'll never be lonesome after you learn to play on this beautiful Hawaiian Guitar.

Pay as You Play

We make it easy for you. You start any time—with a small first payment—then pay while learning. Write for liberal offer.

Our Written Guarantee

We guarantee in writing to teach you. 45,000 successful students. And we coach and advise you after graduation—no extra cost.

Other Courses

under famous teachers—Tenor Banjo, Violin, Mandolin, Banjo Ukulele and Ukulele.

FIRST HAWAIIAN CONSERVATORY OF MUSIC, INC.

9th Fl., Woolworth Bldg., Dept. 248, New York, N. Y.

Approved as a Correspondence School Under the Laws of the State of New York

ACT! Mail This Popularity Coupon NOW!

FIRST HAWAIIAN CONSERVATORY OF MUSIC, Inc.

9th Fl., Woolworth Bldg., Dept. 248, New York, N. Y.

Please mail full information about your 52-lesson Hawaiian Guitar Course. I am not obliged to enroll unless I want to.

Name _____

Address _____

City _____ State _____

Know
the
School



By
the
Emblem

Win Success in Business

Plainly, bluntly—but truthfully—the great opportunities of today are in business—that modern profession to which the brightest men and women of the age are turning.

The requirements for success in business are *training, ambition and industry*. If you have the ambition and industry, you can get *the training* in one of America's great schools of business—300 of which have been Accredited by this Association because of their outstanding merit.

If you look forward to a business career, get your education in an Accredited school. Write today for Booklet E, "The Sure Way to Success," with list of Accredited schools.

National Association
Accredited Commercial Schools
1618 Mallers Building, Chicago

LEARN WATCH REPAIRING



You can learn by our modern and original system of instruction every part of the **Watch Repairing Trade** at home as good or better than at a shop. You can earn money while learning and secure a well paying position or start in business after completing our course of instruction. Good watch repairers are always in demand and earn from \$50 to \$75 per week. For particulars apply to the **Wisconsin School of Watch Repairing** 166 Mason St., MILWAUKEE, WIS.

Become an Artist

EARN \$100 to \$250 A WEEK

You can quickly learn to draw pictures that sell through a remarkable simple home-study method. Earn money while learning and secure a well-paying position after completing course. Good artists are always in demand and earn from \$100 to \$250 a week. Write today for free book. No obligation.

Washington School of Art

Room 308-D

1115-15th St., N. W.

Washington, D. C.

BIG MONEY IN POULTRY

Get into the poultry business NOW. This fall eggs and fowls will jump way up in price. Easy to make \$1,000 a year in spare time; or \$5,000 a year for full time. Free book tells all about our new, up-to-date, money-making poultry course and our remarkable plan of close, careful, individual assistance. Thousands use our methods. Write for FREE copy today.

NATIONAL POULTRY INSTITUTE, Dept. 400-X, Washington, D. C.

PIANO JAZZ

By Note or Ear. With or without music. Short Course. Adult beginners taught by mail. No teacher required. Self-Instruction Course for Advanced Pianists. Learn 259 styles of Bass, 684 Syncopated Effects, Blue Harmony, Oriental, Chime, Movie and Café Jazz, Trick Endings, Clever Breaks, Space Fillers, Sax Slurs, Triple Bass, Wicked Harmony, Blue Obligato, and 247 other Subjects, including Ear Playing. 133 pages of REAL Jazz, 25,000 words. A Postal brings our FREE Special Offer.

Waterman Piano School, 1826 W. Adams St. Los Angeles, Cal.

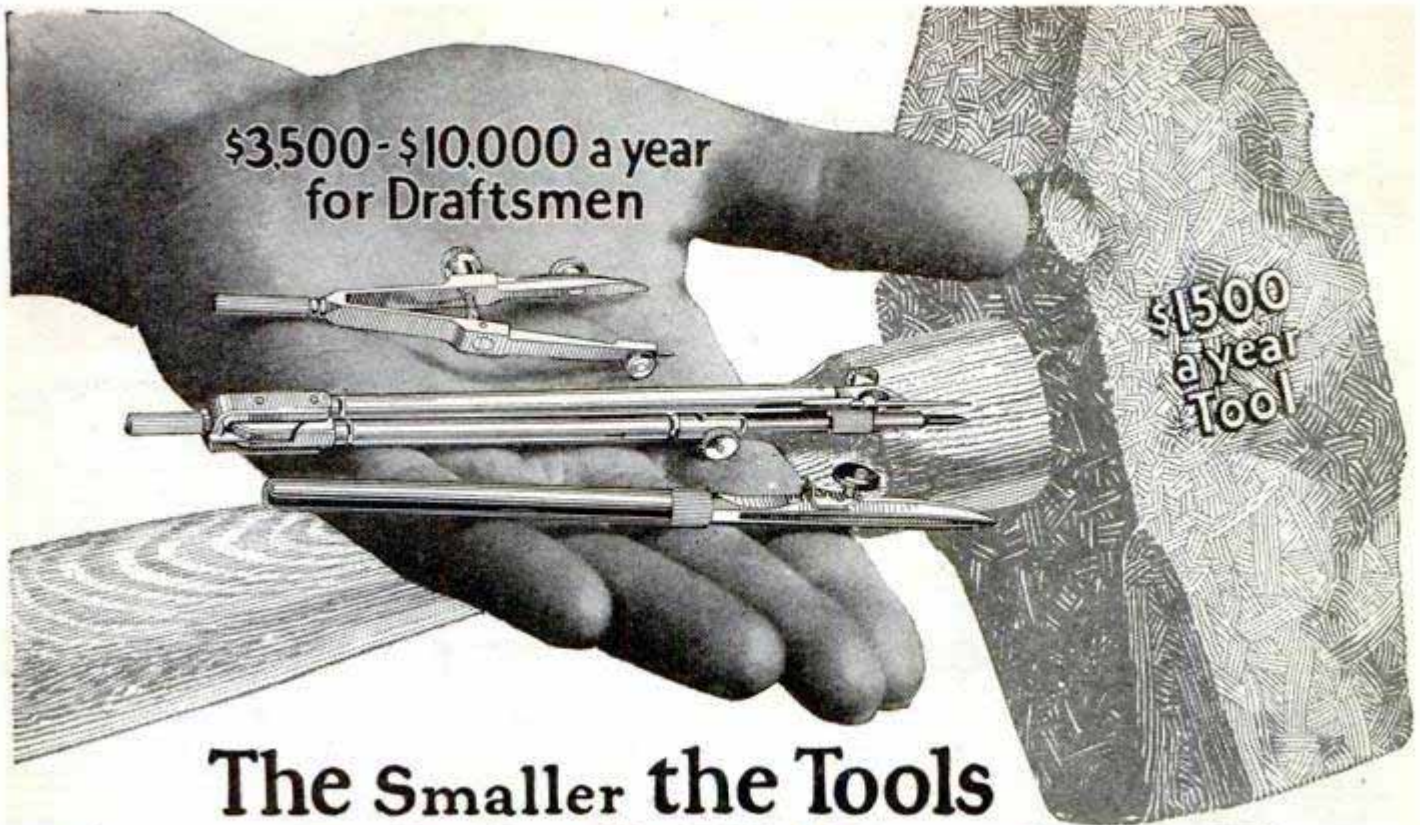

The Smaller the Tools the BIGGER the PAY DRAFTING PAYS BEST

\$3500 to \$10,000 a year

That's where the big pay is—in drafting. Even beginners earn \$50 and \$65 a week or more. Practical draftsmen earn \$400 or more a month. The chief earns from \$800 a month up. There is almost *no limit!* The draftsman is the most important man in any manufacturing or construction work. Ordinary workmen cannot begin their work until the draftsman completes the plans for their guidance. That's why the great demand for draftsmen is never ending. That's why the field is never crowded and constantly seeks men. That's why the pay is big, the work fascinating, the jobs plentiful, the working conditions ideal.

Special Talent Not Needed

Here is your chance to take up drafting. Learn practical draftsmanship at home—but under the daily personal direction of Chief Draftsman Dobe—the man who has made finished draftsmen of inexperienced men, young and old—men with *no previous training*, or even the average amount of schooling. Give him part of your spare time for only a few short months—then you'll be ready to tackle any drafting job that offers—then you'll get your share of the big money in this great uncrowded field.

Scores of engineering firms and manufacturing concerns constantly seek draftsmen from my classes. *I must have men—so I make this amazing offer to get action.* A beautiful lifetime set of imported drafting instruments—all the tools and rules a finished draftsman needs—and a *drafting table*, absolutely free of any extra cost whatever to those who join my class at once.

Earn and Learn

Accept my special limited offer before I must withdraw it. If a hundred dollars a week sounds big to you—yes, or \$150—you're not in the right line of business now. Amounts like that do not sound big to draftsmen! Investigate the field of drafting for yourself—know what trained men are earning—find out how very few had previous experience or any special schooling—learn of the tremendous opportunities it offers—hear how it is crying for men to fill important, big pay jobs! Do this—and you will *know* the great value of the offer made you here!

Big Jobs Waiting!

Almost as quickly as you are enrolled in a Dobe class, paying jobs will loom up before you. *Daily* come requests for junior men—men only partly through their Dobe training! "We'll take a *beginner*, so long as he is taking Dobe training and is *started right*," many write. I can't tell you here of all the wonderful opportunities drafting holds for you. Send the coupon now and get your copy of the big new book, "Successful Draftsmanship"—the book that has

Money Making Tools



This Set of Imported Instruments supplied without extra charge. Act now.

started thousands of ambitious men on the road to big pay and fascinating work. It's full of startling information, stories of the success of Dobe men—the biggest and most comprehensive book ever published on the subject! Send for it in time to get your complete lifetime drafting outfit *absolutely free of any extra cost whatever.*

GOOD FOR TOOLS!

CHIEF DRAFTSMAN DOBE, Div. CI-35
1951 Lawrence Ave., Chicago

Please send me FREE and POSTPAID, without obligation, your big new profusely illustrated book, "Successful Draftsmanship," complete information terms, etc., in time for free tool offer.

Name.....Age.....

Address.....



COME TO DETROIT

TRAINED AUTO MEN

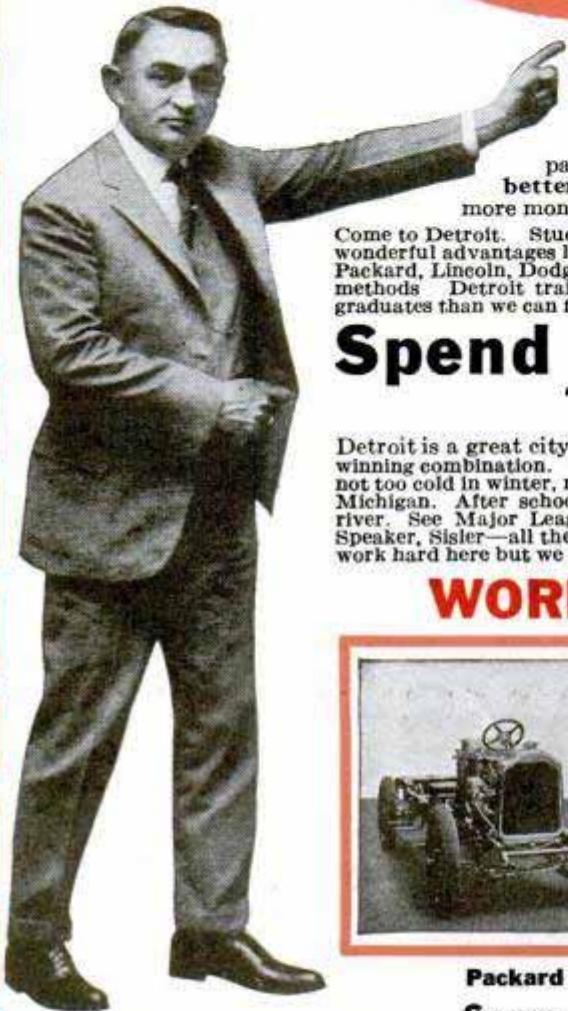

Automobiles are now increasing faster than repair shops and mechanics can't keep up with them. Thousands of trained men are needed right now. Why should you work for small pay? Why stick to a poor trade? Learn autos—how to repair them. **Get a better Job—NOW!** The auto business holds a wide open door to you, to earn more money. It offers you a better job or a business of your own.

Come to Detroit. Study autos where they are made. Three-fourths of all cars are built here. You have wonderful advantages learning in the center of the industry. Visit the great plants of Ford, Cadillac, Packard, Lincoln, Dodge, Hupp, Hudson, Paige, Studebaker, Rickenbacker, many others. Learn their methods. Detroit trained men are in demand by employers everywhere. We have more calls for our graduates than we can fill.

Spend the Summer in Detroit

The "Summer Resort City"

Detroit is a great city for business. And a mighty pleasant place. Weather is always fine. A sure winning combination. Detroit's location in the center of the Great Lakes district gives it ideal climate, not too cold in winter, not too hot in summer. Get away from the burning sun into the cool breezes and Michigan. After school hours, enjoy boat trips, swimming, fishing, sailing, canoeing on the lakes and river. See Major League baseball games—see Ty Cobb, Babe Ruth, Walter Johnson, Eddie Collins, Speaker, Sisler—all the stars. Spend a pleasant summer and **improve yourself at the same time.** We work hard here but we believe in some good times, too.

WORK ON THESE GREAT CARS

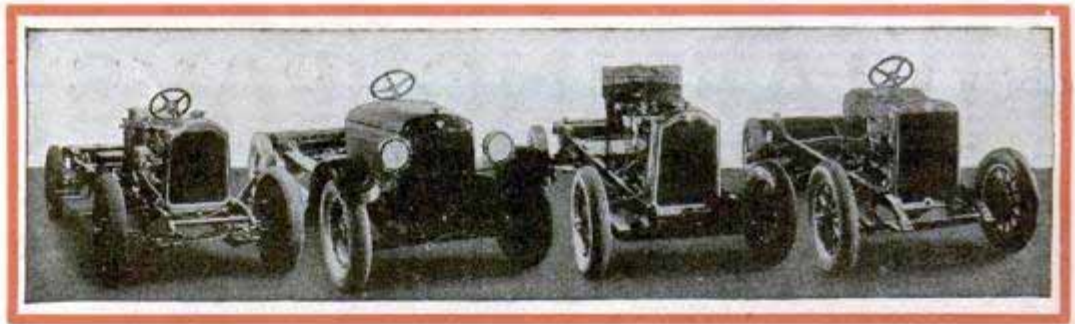

Packard

Reo

Buick

Rickenbacker

Some of the New (1926) Chassis Recently Received

Especially fine equipment is provided for our students. Hundreds of engines, electrical systems and parts, and many fine cars, are used in our classes and training shops. Equipment is up to date and in good condition. These two illustrations show a few of our complete chassis of 1926 models of different cars. These chassis

are supplied to us by the automobile manufacturers for use of our students, and are exchanged each year for the new models as they come out. Those shown in this picture are the Packard Straight Eight, Reo Six, Buick Master Six, and Rickenbacker Six—fine, wonderfully built cars. You study them thoroughly.

No Experience Needed

No experience is needed. A few weeks of real training will save you years of time. **Get into work you like and earn big money.** I can start you to success as I have so many others.

JUMP AHEAD OF THE CROWD

Some men think they can learn the business by starting in green as a helper in a garage. They are wrong. Years of dirty work will be wasted learning wrong methods from poor mechanics. Save all this by coming to the auto center for a few weeks. Learn right, under expert instructors. Learn the short cuts and best ways of doing electrical repairs, engine work, all about autos, trucks and engines. O. E. Parker, Buick dealer, Howell, Mich., writes:

"After finishing at the school I could locate any trouble and fix it, and in many cases quicker and better than men who had years of experience."

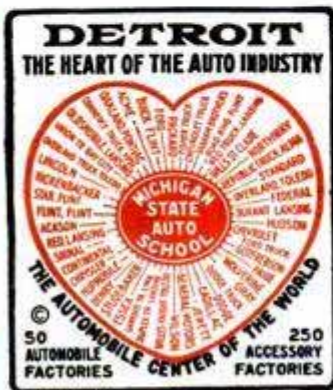

Learn at Detroit

The Auto Center

Without any previous experience—just a liking for mechanics—you can learn the auto business from A to Z in a few weeks at the Michigan State Automobile School in Detroit, the heart of the industry. Then step out, equipped with knowledge and training, to a future of certain, big money making. You have great advantages, learning the business here. It's the fountain head of the automotive industry. You are taught under factory endorsed methods. You learn both theory and practice on latest equipment. Go through the great Ford plants. Visit the other auto factories. Learn their methods first hand—and it all means greater opportunities and more certain success. The Michigan State Automobile School, in Detroit, the automobile center, is the logical place to learn the auto business.

MICHIGAN STATE

308 Auto Building Detroit, Michigan

Learn Autos Where Autos Are Made

THE AUTO CENTER

ARE WANTED!

20,200,000
Automobiles in U.S.

One Car to Every
6 People

269 Cars to Every
Repair Shop

Thousands more Trained
Men are Needed

Facts and Figures on the World's Biggest Business

Autos are increasing faster than repair shops or mechanics can keep up with them. 20 million cars are in use now. The auto industry leads all others in value of production. There are more autos than telephones. 269 cars to every service station. This shows as plain as A-B-C where the big chance is today. Walter Burk, Danville, Ill., writes: "I take care of 60 big trucks for the State of Illinois Highway Department, and have been with them since I graduated." What thousands of others have done, you can do, too. You have even a better chance than they had, because there is a bigger demand for trained men than ever was before. Service managers tell us that 100,000 new trained auto mechanics are needed every year. Not nearly enough are starting, and a trained man can get a good job any place and any time.

Get Into This Big Money Business

Does your pay envelope bring you a pitiful \$15 or \$20 a week? Are you in the hard-work-and-little-reward class? If you are it is because you are doing unskilled labor. Many men go through their lives at such work sticking in the rut. It's a dog's life. It's life imprisonment behind the bars of small wages.

Get away from that Now. Get into this great auto business. Here opportunities are miraculous. Think of the repair work to be done on 20 million cars. Trained men are wanted at good pay. It's interesting, pleasant work. A good auto man has high standing in his community and with his friends. Soon get in business for yourself.



Oldsmobile

Oakland

Jewett

Essex

Hudson

The chassis in this picture are the Oldsmobile, Oakland, Jewett, Essex and Hudson. These are also the latest 1926 models. Just received. Our location in Detroit, the Automobile Center of the World, and our reputation for giving Quality Training only, brings us the close co-operation and endorsement of the automobile

manufacturers. This means much to you. You always find the latest and most up-to-date equipment at the "Old Reliable" Michigan State. Our equipment is continually being improved and is now better than ever.

Complete Equipment—Expert Instructors

Here you learn on up-to-date, new equipment. All types of cars, engines, axles, transmissions, electrical systems. Some of the new cars and engines that you will find in our equipment are the new Packard Straight Eight with four wheel brakes, new Buick with four wheel brakes, Oakland, Cadillac Eight, Hupmobile, Reo, Oldsmobile, G. M. C. Truck, Hudson, Overland, and many others. Each instructor is a master in his line. Their knowledge is at your disposal.

GOOD POSITION OPEN

The demand for trained men is greater than the supply. We cannot fill all the calls we get. Look into any garage that is run by trained men—everybody is as busy as bees, have more work than they can do. Men working overtime, all at extra pay. That means big money for repairmen and boss. These money making opportunities can be yours too, with "Michigan State" training. Earn while you learn if necessary. Some students work evenings to pay their way. Others work days and take our evening classes.

AUTOMOBILE SCHOOL

3729 Woodward Avenue Detroit, Michigan

The Automobile Center

Home Study Course Free

For students who can not come to Detroit at once we have a fine Home Study Course. With this you can start to learn at home. If you come here later there is no extra charge for the Home Study Course. It will help you to get a garage job right away. Write for full information about this and explain your circumstances. Get all the interesting facts. Mail the coupon or send us a postcard today. Write now. We do not enroll colored students, except for our Home Study Course.

Send for NEW BIG Catalog

Mail the coupon today for Free Catalog of Courses, which gives all facts. It is just off the press and shows the complete outline of courses, automobile repair, battery, tire repair, welding, machine-shop. The business and management course is free. Mail the coupon Today.

Mail Coupon To Day

Michigan State Automobile School 308 Auto Building
DETROIT, MICH.

Send me free and without obligation complete information about Detroit-training to make the most money. Also send me your BIG NEW CATALOG.

Name.....

St. and No., or R. F. D.....

City..... State.....

I am interested in [] 12 Weeks' Auto Course.
[] 30 Weeks' Master Course
[] Home Study Course.



Men Needed in Electricity

NO PROFESSION offers greater opportunity to-day than Electricity. Salaries of \$12 to \$30 a day are not uncommon and the opportunity for advancement is unlimited.

As Forrest Crissey said recently in *The Saturday Evening Post*—"The demand for electrical work is increasing immensely and electrical contractors assert that the supply of electrical workers cannot overtake the demand for several years."

Now is the time to prepare for a good position in this profitable, interesting profession. You can study right at home in spare time through the International Correspondence Schools—just as so many other men have done. The I. C. S. Electrical Courses have been endorsed by Thomas A. Edison and Charles P. Steinmetz—the late electrical wizard of the General Electric Co.

Just mark and mail the coupon printed below and full information about Electrical Engineering, Electric Lighting, Electric Wiring, Electric Railways, Radio or any other work of your choice will come to you by return mail.

Mail the Coupon for Free Booklet

TEAR OUT HERE
INTERNATIONAL CORRESPONDENCE SCHOOLS
 BOX 5592-E SCRANTON, PA.

Explain, without obligating me, how I can qualify for the position, or in the subject, before which I mark X.

- | | |
|--|---|
| <input type="checkbox"/> ELECTRICAL ENGINEER | <input type="checkbox"/> CHEMICAL ENGINEER |
| <input type="checkbox"/> Electrician | <input type="checkbox"/> Pharmacy |
| <input type="checkbox"/> Electric Wiring | <input type="checkbox"/> SALESMANSHIP |
| <input type="checkbox"/> Electric Lighting | <input type="checkbox"/> Show Card and Sign Painting |
| <input type="checkbox"/> Electric Car Running | <input type="checkbox"/> RAILROAD POSITIONS |
| <input type="checkbox"/> Heavy Electric Traction | <input type="checkbox"/> ILLUSTRATOR |
| <input type="checkbox"/> Electrical Draftsman | <input type="checkbox"/> DESIGNER |
| <input type="checkbox"/> Electric Machine Designer | <input type="checkbox"/> BUSINESS MANAGEMENT |
| <input type="checkbox"/> Telegraph Expert | <input type="checkbox"/> Private Secretary |
| <input type="checkbox"/> Practical Telephony | <input type="checkbox"/> Business Correspondent |
| <input type="checkbox"/> MECHANICAL ENGINEER | <input type="checkbox"/> BOOKKEEPER |
| <input type="checkbox"/> Mechanical Draftsman | <input type="checkbox"/> Stenographer and Typist |
| <input type="checkbox"/> Toolmaker | <input type="checkbox"/> Cert. Public Accountant |
| <input type="checkbox"/> Machine Shop Practice | <input type="checkbox"/> Traffic Management |
| <input type="checkbox"/> Gas Engineer | <input type="checkbox"/> Commercial Law |
| <input type="checkbox"/> CIVIL ENGINEER | <input type="checkbox"/> GOOD ENGLISH |
| <input type="checkbox"/> Surveying and Mapping | <input type="checkbox"/> Common School Subjects |
| <input type="checkbox"/> Reading Architects' Blue Prints | <input type="checkbox"/> CIVIL SERVICE |
| <input type="checkbox"/> METALLURGY | <input type="checkbox"/> Railway Mail Clerk |
| <input type="checkbox"/> ARCHITECT | <input type="checkbox"/> STATIONARY ENGINEER |
| <input type="checkbox"/> Architectural Draftsman | <input type="checkbox"/> Textile Overseer or Supt. |
| <input type="checkbox"/> PLUMBING AND HEATING | <input type="checkbox"/> AGRICULTURE <input type="checkbox"/> Spanish |
| <input type="checkbox"/> Sheet Metal Worker | <input type="checkbox"/> Navigator <input type="checkbox"/> Math'm't's |
| <input type="checkbox"/> Automobiles | <input type="checkbox"/> Poultry Raising <input type="checkbox"/> RADIO |

Name _____
 Present Occupation _____ Business Address _____
 Street and No. _____
 City _____ State _____

Canadians may send this coupon to International Correspondence Schools Canadian, Limited, Montreal, Canada

Learn to Write

I Teach by Mail

I CAN make a good penman of you at your home during spare time, no matter where you live or how poorly you now write. My simplified system has shown thousands of others the way to good penmanship during the past twenty years — it can and will do the same for YOU!

Beautifully Illustrated Book
"How to Become a Good Penman"
FREE!

It contains general information, with testimonials and beautiful specimens of penmanship showing what others have accomplished by the Tamblin System. (Your name elegantly written on a card if you enclose stamp for postage.) WRITE TODAY. Address

F. W. TAMBLIN
 418 Ridge Bldg., Kansas City, Mo., U. S. A.

BE AN ARTIST

WE CAN TEACH YOU DRAWING in your own home during your spare time. Twenty-five years of successful teaching proves our ability. Artists receive large salaries. Write Today for Art Year Book

SCHOOL OF APPLIED ART
 ROOM NO. 2 BATTLE CREEK MICH.

LEARN PIANO TUNING AT HOME

Send for FREE copy of the 28th ANNIVERSARY EDITION of our book "Winning Independence." Read how students master TUNING with our Tune-A-Phone, and WHY our graduates head the profession in all parts of the world. With Bryant's patented devices, tools, charts, and lessons, one learns quickly and easily. Low tuition, easy terms, Diploma granted. MONEY-BACK GUARANTY. \$10 to \$25 a day, exceptional opportunities, and an ideal profession await you.

BRYANT SCHOOL OF TUNING (71) Bryant Bldg., Augusta, Michigan

Learn Photography at HOME

Earn \$3,000 to \$10,000 a year. Prepare quickly during spare time. Also earn while you learn. New easy method. Nothing else like it. Send at once for free book, "Opportunities in Modern Photography" and full particulars. Special offer open now. International Studios, Inc., Dept. 135C, 3601 Michigan Ave., Chicago, U. S. A.

Book on Law Free

Write today for this new book. It tells you how a law training will shorten your road to success. It also carries a vital and inspiring message to every ambitious man! Find out about the opportunities that await the law trained man. Find out how you can learn law right in your own home. No obligations. The book is absolutely FREE. Write Today—now while we are making a special reduced tuition offer.

American Correspondence School of Law
 3601 Michigan Ave. Dept. 135C Chicago, Illinois

Weak Men Strengthened

WHEN STRONGFORT TAKES HOLD

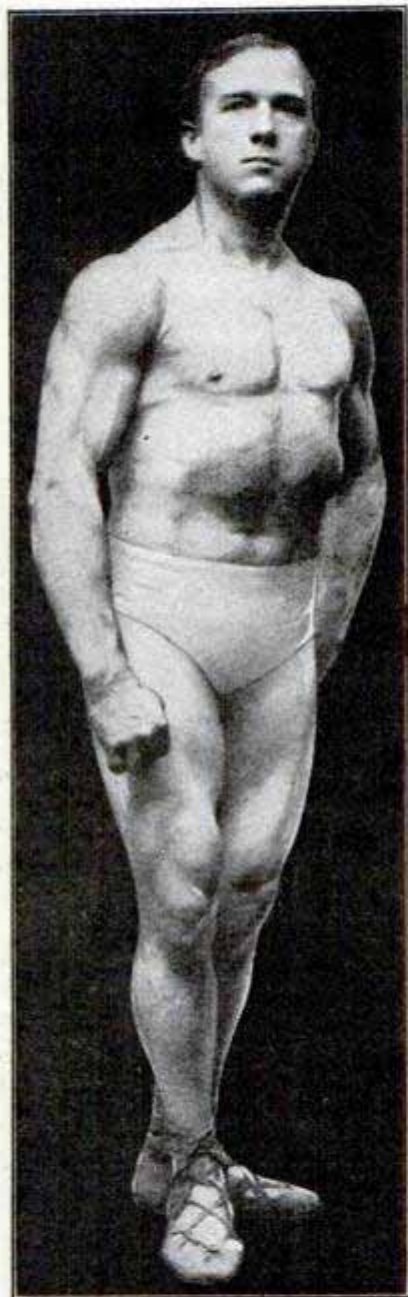

STRONGFORT
Builder of Men

men, a pleasing personality to women. My pupils and graduates in all parts of the world will back up every word I say—you'll find photos and letters from some of them in this book. What I have done for them I can do for YOU. I GUARANTEE IT.

SEND FOR THE FREE BOOK NOW. Fill out the coupon and mail it.

Don't delay. SEND IT TODAY.

LIONEL STRONGFORT
Physical and Health Specialist for over 25 Years

Dept. 185 NEWARK, NEW JERSEY, U. S. A.

YOU have no apology for being a weakling—a make-believe man—one who is laughed at, gossiped about, despised. You are to be pitied if you are discouraged and despondent and down with the blues; but who wants to be pitied? You don't. You want to be a manly man—a strong, healthy chap whom it is a pleasure to meet and associate with—a fellow that men like to call by his first name—one whose company is craved—a regular fellow. And you can be just such a man—no matter how far down the ladder you've slipped; no matter how you've neglected yourself; no matter what your excesses or your dissipation. You can be revitalized, regenerated, restored to the full flower of manhood—this I can promise you through

STRONGFORTISM

—The Science of Health and Strength

Throughout the years of my personal contact with thousands of men, so many who have been my pupils, I have been gathering facts about the human body and studying the relation of the muscular system to the health of the body. My experience has proved positively that I can overcome the physical ailments, disorders and weaknesses so common to humanity and restore strength, vital energy and health by natural methods, working through both the internal and external muscular systems. I use no drugs, no apparatus, no fakery—I help you to help yourself in the privacy of your own home.

When I Take Hold Of A Man

who is run down from any cause, from disease or neglect or excesses—I build him up by tuning-up his nervous system, improving his digestion, relieving him of the awful effects of constipation, catarrh, nervousness, or dyspepsia, and immediately life takes on a new beauty for him—he radiates buoyant health, cheerfulness and optimism. He feels and looks like a winner—and he soon becomes one—a star in athletics, a light stepping dancer, a strong swimmer, a good fellow in social circles—"the life of the party"—and above all he becomes a go-getter in business.

Thousands of Letters

tell this story over and over again; full of tears, full of sorrow for the past, but exulting and joyous, and overwhelming in praise of the revelation through Strongfortism that led to a higher realization of life, that implanted hope, that imparted strength and restored health. If you could read some of these letters—but act for yourself—get the proof yourself—learn what it means to be strong, healthy, happy, successful.

Send for My Book

This book will show you that Strongfortism should not be confused with the many advertised gymnastic and physical culture courses. It really is the Science of Living. My book shows you how to eliminate from your system, in a very short time, the distressing disor-

"Promotion and Conservation of Health, Strength and Mental Energy"

FREE CONSULTATION

Clip and Send this Coupon

ABSOLUTELY CONFIDENTIAL

Mr. Lionel Strongfort, Strongfort Institute, Dept. 185, Newark, N. J.—Please send me absolutely free my copy of your book, "PROMOTION AND CONSERVATION OF HEALTH, STRENGTH AND MENTAL ENERGY." I have marked (x) before the subjects in which I am most interested.

- | | | |
|---------------|-----------------|------------------------------|
| .. Colds | .. Weak Back | .. Weak Heart |
| .. Catarrh | .. Weak Eyes | .. Great Strength |
| .. Asthma | .. Flat Chest | .. Lung Troubles |
| .. Headache | .. Despondency | .. Poor Circulation |
| .. Rupture | .. Emaciation | .. Round Shoulders |
| .. Thinness | .. Rheumatism | .. Skin Troubles |
| .. Pimples | .. Nervousness | .. Stomach Disorders |
| .. Insomnia | .. Constipation | .. Increased Height |
| .. Overweight | .. Short Breath | .. Muscular Develop-
ment |

Name

Age Occupation

Street

City State

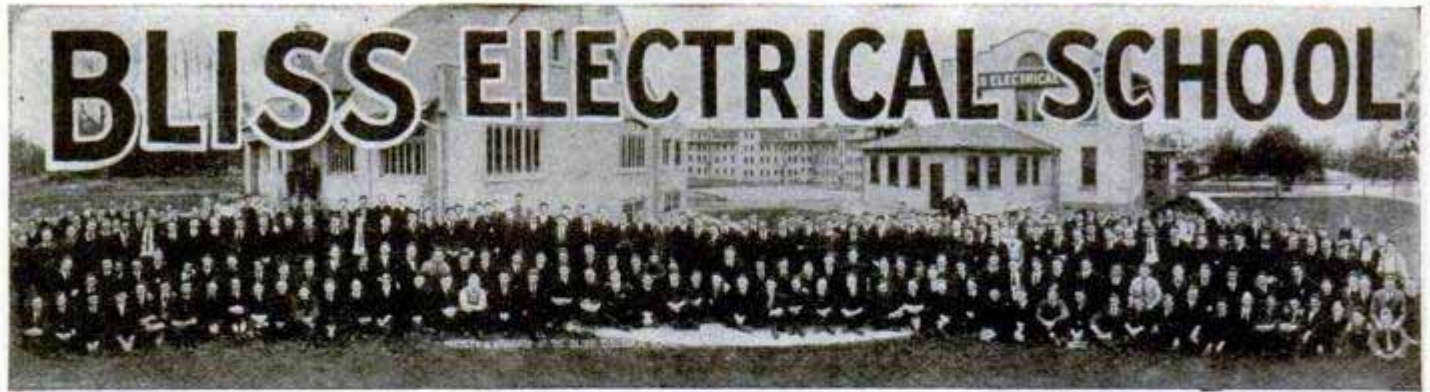

A special technical school with concise but comprehensive course in Electrical Engineering. Non-essentials eliminated. Thorough knowledge of underlying principles emphasized. Theory and practice closely interwoven.

Electrical Engineering in One Year



The course is designed for earnest, ambitious young men of limited time and means. Curriculum includes mathematics, mechanical drawing and intensive shop work. Students construct motors, install wiring, test electrical machines. Graduates are qualified to enter the electrical field at once.

Bliss men hold responsible positions throughout the world. Thoroughly equipped fireproof dormitories, dining hall, laboratories and shops. **Prepare for your profession in the most interesting city in the world.** Established 1893. Send for catalog. Address

BLISS ELECTRICAL SCHOOL,

418 Takoma Avenue

Washington, D. C.



LEARN CARTOONING At Home—It's Easy

Just think—\$50 to over \$250 a week paid to good cartoonists for work that's fun! And YOU can easily learn cartooning at home—no matter if you've never touched a drawing pencil. Write for interesting FREE Book describing our easy simplified method. Also details of special Outfit Offer! Send postcard today to Washington School of Cartooning, Room 308-D, 1113—15th St., N. W., Washington, D. C.

Deagan Free trial! Xylorimba



Become a crack Xylorimba player right in your own home. Easy to play. Learn in a few hours with our 14 free complete lessons. Earn \$80.00 to \$200.00 a week!
FREE LESSONS—A YEAR TO PAY
Free trial, easy payment plan. Earn while you learn. Write for details special free trial offer.
J. C. DEAGAN, Inc., Dept. C-135
1770 Berteau Ave. Chicago, Ill.

BE A PLUMBER and HEATING EXPERT

Here's the opportunity of a lifetime for men who want to learn a real trade. Thousands of trained plumbers making from \$75 to \$150 a week.

A few short weeks in our shops will fit you for any branch in the plumbing field. Here you learn lead wiping, building and construction work, jobbing, estimating, blue prints and specifications.

No books, all actual, practical work under the supervision of master plumbers.

Plumbers' opportunities are everywhere. In the cities, small towns and the country. Send for our free booklet on how you can earn your expenses while learning.

ILLINOIS PLUMBING WORKS SCHOOL
512-514 N. La Salle St. Dept. 5, Chicago, Ill.

Learn Watchwork, Jewelrywork and Engraving

A fine trade commanding a good salary, and your services always in demand. Address **Horological**, Dept. P. Bradley Institute, PEORIA, ILLINOIS, for our latest catalog.

WHY NOT spend Spring, Summer and Fall, gathering butterflies, insects? I buy hundreds of kinds for collections. Some worth \$1 to \$7 each. Simple outdoor work with my instructions, pictures, price-list. Send 10 cents (not stamps) for my illustrated Prospectus before sending butterflies.
MR. SINCLAIR, DEALER IN INSECTS,
Dept. 6, Box 1424, San Diego, Calif.



WANTED—RAILWAY MAIL CLERKS

\$158.00 to \$225.00 a Month for Life

Every second week off with full pay—no "lay-offs" because of strikes, poor business, etc.—sure pay—rapid advancement to higher positions. City and country residents stand same chance. Common sense education sufficient—no political influence.

TRAVEL—SEE YOUR COUNTRY
Many U. S. Government Jobs Open to Women

Mail Coupon today—sure. Every day's delay means so much less chance of appointment from the next examinations—so do it at once.



Take this First Step for a U. S. Government Job
Use Coupon Before You Lose It

COUPON

FRANKLIN INSTITUTE, Dept. W 174, Rochester, N. Y.
Kindly rush to me, entirely free of charge, (1) A full description of the position checked below; (2) Sample examination questions and coaching; (3) 32 page book with a list of U. S. Government Jobs now obtainable; (4) Tell me how I can get the position here checked.

- .. Railway Mail Clerk (\$1900 to \$2700)
- .. Customs Positions (\$1140 to \$1860)
- .. Postoffice Clerk (\$1700 to \$2300)
- .. Internal Revenue (\$1140 to \$1860)
- .. City Mail Carrier (\$1700 to \$2100)
- .. Rural Mail Carrier (\$2100 to \$3300)
- .. Income Tax Auditors..... (\$2040 to \$3000)

Name.....
Address.....

I Was Afraid of This New Way to Learn Music

— Until I Found It Was Easy As A-B-C

DON'T be silly, Mary. You're perfectly foolish to believe you can learn to play the piano by that method. You are silly to even think about it."

That is how my husband felt when I showed him an ad telling about a new way to learn music.

But how I hated to give up my new hope of learning to play the piano. Music had always been for me one of those dreams that never-come-true. Others could entertain their friends. But I was a mere listener.

For a week I resisted the temptation to look at the ad again, but finally, half-frightened, I wrote to the U. S. School of Music—without letting Jack know.

Imagine my joy when the lessons started and I found it was easy as A. B. C. A mere child could master it!

I quickly saw how to blend notes into beautiful melodies. My progress was so rapid that soon I was rendering popular and classic selections. For thru this short-cut method, all the difficult, tiresome parts of music have been eliminated.

Finally I decided to play for Jack. He was astonished. "Why... why..." he floundered. I simply smiled and went on playing. But soon, of course, Jack insisted that I tell him where I had learned... when... how? So I told of my secret. And what did Jack do but start learning the violin. Now our musical evenings are a marvelous success, and we are always flooded with invitations. Music has given us Popularity! Fun! Happiness!



Thousands of successful students never dreamed they had musical ability until it was revealed to them by our "Musical Ability Test." You, too, can learn to play your favorite instrument thru this short-cut method. Send now for booklet, "Music Lessons in Your Own Home," and free Demonstration Lesson. Instruments supplied when needed, cash or credit. U. S. School of Music, 78 Brunswick Bldg., New York City.

U. S. SCHOOL OF MUSIC,
78 Brunswick Bldg., New York City

Send me your amazing free book, "Music Lessons in Your Own Home," with introduction by Dr. Frank Crane; also Demonstration Lesson. This does not put me under any obligation.

Name.....
Address.....
Instrument..... Have you this Inst.?

Pick Your Instrument

- Piano Violin Organ
- Clarinet Ukulele Flute
- Cornet Saxophone
- Trombone Harp
- Piccolo Mandolin
- Guitar 'Cello
- Hawaiian Steel Guitar
- Sight Singing
- Piano Accordion
- Voice and Speech Culture
- Harmony and Composition
- Drums and Traps
- Automatic Finger Control
- Banjo (Tenor, Plectrum or 5-String)

WOULD YOU LIKE THIS TO HAPPEN TO YOU?

YOUR mail man is going to hand you this magazine "STRENGTH" soon after you send in this free coupon. Wouldn't you like to get a copy of this wonderful magazine when you know it isn't going to cost you a cent?



You Send No Money but Get "STRENGTH" Just the Same

Don't be afraid of it. There is no catch in it. Send that coupon NOW.

This magazine is for all those who are interested in their own health and the health of their families. It teaches the drugless healing methods—Nature's own way.

"STRENGTH" Is for Those Who Want to Reduce

and for those who want to be built up. Young men who are interested in athletics, strength feats, strong men, muscle building, boxing, wrestling, tumbling, etc., will find "STRENGTH" a happy hunting ground of information on these subjects. If you are ailing with one disease or another, send for "STRENGTH" now; it will show you the cause and the natural cure.

LAVISHLY ILLUSTRATED

"STRENGTH" is full of interesting pictures on the subjects above-mentioned. Its articles are written by experts.

The Milo Publishing Company,
2747 N. Palethorp St., Philadelphia, Pa.

P. M. 8-26

Gentlemen: Please send me immediately, and without any obligation on my part, a FREE COPY of your great magazine, "STRENGTH."

Name.....
Address.....
City..... State.....

96 Pages — Large Size

Don't Turn This Page Without Mailing This Coupon

The Milo Publishing Company

P. M. 8-26

2747 N. Palethorp St. Philadelphia, Pa.

O. C. Miller,
Director
Extension
Work

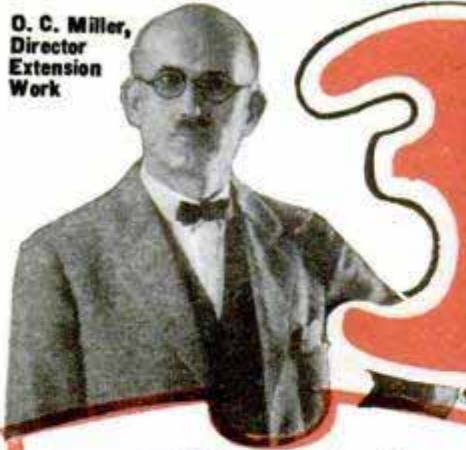

3 Drafting Actually

WHY I advised my best friend's son to go into Drafting.

"If you could go to a University, Bud," I told him, "it would be the making of you. But if you can't, go into drafting. Because, first, you can't get far in any engineering line without it. You must know how to make and read plans to succeed in Building, Electrical, Mechanical, Structural or Automotive work.

"Then, Drafting can be learned QUICKER than any other line of work paying equally large salaries. You can learn EASILY, at home in your spare time, without giving up your present job.

"Again, there are MORE Drafting jobs advertised than in any other well-paid field. In fact, Draftsmen are needed in ALL factories, in a hundred different industries.

"Finally, Drafting will appeal to you because you're ambitious. It leads to positions as Chief Draftsman, Superintendent of Construction, and other executive opportunities. Men go from Drafting into contracting on their own hook. Start with Drafting; it offers you BIG MONEY from the very beginning, and in the long run there's no limit to your progress."

I recommend Drafting to any ambitious fellow because it's the foundation of all industrial activity, because the DRAFTSMAN is the KEY-MAN in all building and manufacturing.

O. C. Miller
Director Extension Work



The American School

Chartered as an EDUCATIONAL institution in 1897. Not a dollar in dividends or profits has ever been paid out. Every cent received for tuition has been returned to our students in education and service. Over 200 noted educators, engineers, and executives have contributed to the courses we offer.



Building Draftsmen WANTED!

Architects and Contractors urgently need Draftsmen who have specialized in building construction, who can calculate and design ORIGINAL work. Beginners, trainers, detailers, or men with only general Drafting training will not do. We undertake, under guarantee, to supply this valuable training.



\$60 to \$125
a week

Mechanical Draftsmen WANTED!

There's an enormous demand for Draftsmen who have learned Mechanical Engineering subjects in addition to general Drafting practice. Naturally, Mechanical Drafting Experts earn larger salaries than those who have not specialized. Ours is the one home-training supplying advanced Mechanical Engineering and both to those who wish to specialize in this branch of the work.



First Time!

We could teach you the general principles of "Mechanical Drawing" in a few weeks. But that wouldn't prepare you for a GOOD DRAFTING JOB. If you tried to hold down a position as Mechanical Draftsman in a factory building machinery you would discover you needed to know how to calculate the size of parts, and how to design a machine to do a certain kind of work. The same would be true in a big Electrical or Auto plant. So now, for the first time in the history of home-training we give the advanced Engineering instruction you need to gain the BIG SALARIES, and fill the BEST positions.

"Fascinating as the Dickens!"

is the way one fellow describes Drafting work. And it's a fact, there's a gripping, thrilling fascination about Drafting that can't be described or explained. It may be white-collar work, but it surely attracts a fine, up-standing bunch of real HE-MEN. Fellows you'll be glad to associate with by day, and pal around with, by night.

O. C. Miller, Director Extension Work—

Lessons FREE



—to prove you can learn at Home!

Yes, Sir! With a guarantee in black and white, to get you ready for a fine Drafting job and a big raise in pay, or to refund every penny of your money. For 29 years we have turned clerks, mechanics, even laborers with only common schooling, into DRAFTSMEN—We've raised their pay from 50% to 400%—AND WE'VE FOUND THEM GOOD JOBS as soon as they were ready for it!

70,000 Drafting Jobs!

advertised in the past year. Salaries offered, \$35 to \$50 a week for men with little or no experience. \$60 to \$125 a week for Draftsmen capable of designing, calculating, and planning original work. \$5000 to \$12000 a year for Chief Draftsmen and Designers. Positions offered by practically every important industry. In all sections of the U. S. In cities of all sizes. That's the beauty of Drafting—it's the biggest, broadest, most varied and interesting field you can choose.

Electrical Draftsmen WANTED!
Electrical Draftsmen, capable of designing Electrical machinery and equipment, earn larger salaries and course, than the Electrical workers who usually do the job. After you have mastered general Drafting principles, you may choose this fascinating branch for advanced training, and we will give you Electrical Engineering instruction and Electrical Drafting Design, as definite preparation for the better paid positions in this important industry.



Easy to Learn
Automotive Draftsmen WANTED!

For the first time in the history of home-training in Drafting you may go farther than merely learning general Drafting principles. Now you may specialize! You may choose any one of the 5 great Engineering branches here mentioned. AUTOMOTIVE Drafting offers men interested in autos a wonderful field for advancement and profit.



Structural WANTED!

—to plan and design bridges, steel structures, steel and concrete buildings and public works, etc. Our students who decide to go into this field are given thorough training in Civil Engineering subjects and advanced Structural Drafting.

Draftsmen



Coupon Brings 3 Lessons FREE

JOBS!

for beginners and graduates

At enormous expense to us, but without extra charge to our students or graduates, we maintain a nation-wide Employment Service which keeps in touch with employers of Draftsmen everywhere. Frequently, we are able to place students after only a few months of training. Immediately after starting, our Employment Manager registers each student for his future job. The American School accepts all enrollments for Drafting instruction with a positive guarantee that it will lead to a better job and a big increase in pay, or money refunded.

American School Drexel Ave. & 58th St. Dept. DC-74, CHICAGO

3 Drafting Lessons FREE

O. C. Miller, Director Extension Work American School, Drexel Ave. & 58th St., Dept. DC-74, Chicago

I never realized the extent or possibilities of Drafting work. I am interested in getting the WHOLE story, and 3 Free Lessons to prove I can learn at Home in spare time.

Name.....
St. No.....
City.....State.....

Electrical Experts are in Big Demand!



It's a shame for you to earn \$15 or \$20 or \$30 a week, when in the same six days as an Electrical Expert you could make \$70 to \$200—and do it easier—not work half so hard. Why then remain in the small-pay game, in a line of work that offers no chance, no big promotion, no big income? Fit yourself for a real job in the great electrical industry. I'll show you how.

Be an Electrical Expert Earn \$3,500 to \$10,000 a Year

Today even the ordinary Electrician—the "screw driver" kind—is making money—big money. But it's the trained man—the man who knows the whys and wherefores of Electricity—the Electrical Expert—who is picked out to "boss" the ordinary Electricians—to boss the big jobs—the jobs that pay \$3,500 to \$10,000 a year. Get in line for one of these "Big Jobs." Start by enrolling now for my easily learned, quickly grasped, right-up-to-the-minute, Spare-Time Home-Study Course in Practical Electricity.

**I Will
Train You at
Home for a
Big Pay Job**
L.L.C.

5 Big Fine Outfits to work with No Extra Charge



With me, you do practical work—at home. You start right in after your first few lessons to work at your profession in the regular way and make extra money in your spare time. For this you need tools, and I give them to you—5 big complete working outfits, with tools, measuring instruments, and a real electric motor—5 outfits in all.

Age or Lack of Experience No Drawback

You don't have to be a College Man; you don't have to be a High School Graduate. As Chief Engineer of the Chicago Engineering Works, I know exactly the kind of training you need, and I will give you that training. My Course in Electricity is simple, thorough and complete and offers every man, regardless of age, education, or previous experience, the chance to become, in a short time, an "Electrical Expert," able to make from \$70 to \$200 a week.

Your Satisfaction Guaranteed

So sure am I that you can learn Electricity—so sure am I that after studying with me, you, too, can get into the "big money" class in electrical work, that I will guarantee under bond to return every single penny paid me in tuition, if, when you have finished my Course you are not satisfied it is the best investment you ever made. And back of me in my guarantee stands the Chicago Engineering Works, Inc., a two million dollar institution, thus assuring to every student enrolled, not only a wonderful training in Electricity, but an unsurpassed Student Service as well.

FREE Book on Electricity

I want to send you my Electrical Book and Proof Lessons, both Free. These cost you nothing and you'll enjoy them. Make the start today for a bright future in Electricity. Send in Coupon—Now!

**L. L. COOKE, Chief Engineer
Chicago Engineering
Works**

2150 Lawrence Ave.
Dept. 1-C Chicago

Get Started Now!
Mail Coupon



**GET
MY
FREE
BOOK!**

L. L. COOKE, Chief Engineer,
Dept. 1-C, 2150 Lawrence Ave., Chicago, Ill.

Send me at once without obligation your big illustrated book and complete details of your Home Study Course in Electricity, including your outfit and employment service offers.

Name.....

Address.....

Occupation.....



**\$20 a Day for
Schreck**

"The biggest thing I ever did was answer your advertisement. I am averaging \$600 a month from my own business now. I used to make \$18 a week."

A. SCHRECK, Phoenix, Ariz.



\$700 in 24 Days

"Thanks to your Course, I made \$700 in 24 days in Radio. I ran from \$10 to \$40 clear profit every day."

FRED G. McNABB
7 W. 16th St.,
Atlanta, Ga.

The "Cooke Trained Man is the "Big Pay" Man

Classified Advertisements

WORLD'S BEST WANT AD MEDIUM

Advertisements in this section, 25 cents per word, each insertion, minimum 10 words, payable in advance.
To be inserted under proper classification in September issue, copy should be in our office July 18th.

ADVERTISING AGENCIES

A TEN Dollar Ad may put your proposition over. \$10 pays for a 4 line 24 word classified ad one Sunday in 10 of the largest newspapers. Reach over 7 million readers. Minneapolis Tribune, Buffalo Courier, St. Louis Post-Dispatch, Pittsburgh Press, Indianapolis Star, Atlanta Journal, Detroit Free Press, Birmingham News, Cincinnati Enquirer, Little Rock Gazette. Free catalogue showing other lists of newspapers and magazines sent on request. Ankrum Advertising Agency, 22 W. Jackson Blvd., Chicago. Largest classified advertising agency in the world.

ADVERTISE in the classified section of newspapers and magazines, to secure help, money, or to sell. 24-word advertisement in nine big Metropolitan papers \$10.00. Nearly two million circulation. Many other bargain lists. Write for Free 58-page Directory No. 26. Brinckerhoff Advertising Agency, 37 W. VanBuren, Chicago.

ADVERTISE in 24 Big Sunday Newspapers, 24 words \$15.00. Excellent for securing Agents, Salesmen, and Business Opportunities. Catalog listing 1,000 leading Dailies, Weeklies, Mail Order Magazines, Everything. Free. Wade Advertising, Baltimore Bldg., Chicago.

"ADVERTISING Simplified," a handy book of rates and valuable information mailed free on request. Charles H. Touzalin Agency, 706 Union Trust Bldg., Chicago, Ill.

ADVERTISING—All newspapers and magazines; publishers' lowest rates. Largest classified agency on Pacific Coast. Rate sheet free. Baum, 815-333 West Second, Los Angeles.

INCH Display 100 Monthly Magazines, \$4.00 Ad-Meyer, 4112M Hartford, St. Louis, Mo.

COUNTRY papers. All publications. European, Foreign. Lowest rates. Catalog. Owl Agency, Times Building, New York.

FOR ADVERTISERS

100 MAGAZINES—Twice—6c Word; \$4 Inch; Copy 15c. Arthur Machemer, Sinking-Spring, Penna.

YOUR circulars, 6x9 or smaller, mailed to guaranteed mail buyers. 35c hundred; \$2.50 thousand. National Mail Order Service, Bristol, Tenn.

ADVERTISERS, 28-word adv. 300 Rural weeklies, covering Ill., Ind., Mich., \$12.50. Order today. Yorton Agency, B-373-PM, Syracuse, N. Y.

CIRCULARS mailed to proven buyers. Submit sample for rates and further particulars. Penn Advertising Service, Glen Rock, Penna.

GUARANTEED Lists, agents, buyers, opportunity seekers, \$4.00 thousand; 500, \$2.25. Co-operative mailing that gets results. Also producers sales-creating literature. Price list free. Demuth Co., Englewood, N. J.

ADVERTISE in 300 country newspapers, 28 words, \$10.00. Keator, Hartford Bldg., Chicago.

25 WORDS 88 magazines; \$1.00. Thrice \$2.00. Smith's Service, 1194, Wenatchee, Wash.

25 WORDS, \$1.00; 70 monthlies, circulation 7,000. F. F. Johnson, 1485 2 East, Salt Lake, Utah.

SALES PROMOTION

\$50 TO \$50,000 Daily Sales Developed During 28 years for clients by our direct mail plans, copy, campaigns. One product, 1923, an idea; this year \$100,000 orders booked. Fifty year old concern desired 50 national representatives in 1925; we produced 40 in three months, 700 dealers in 10 months at \$1 each, for another. Ten years Sales Promotion Manager Larkin Co. Submit sales problems for Free diagnosis. James C. Johnson, 118A Woodbridge Ave., Buffalo.

LETTERS, advertisements, circulars, booklets, written by nationally known mail advertising specialist. Outline your proposition for free suggestions and booklet "Direct-Mail Advertising." Ernest F. Gardner, 510-P Ridge Arcade, Kansas City, Mo.

AUTOMOBILE SUPPLIES

YOUR auto will look like brand new. Use Dri-Klean-It. Removes mud, dirt, dust. No soap or water used. Clean your car for 5c. Free sample. Agents wanted. American Accessories Co., Desk 431, Cincinnati, Ohio.

SELF steering Automobile Leaders. Write Britzius Mfg. Co., Dover, Minn.

BATTERY Tester and Inspector. Regular \$50.00 value; \$32.00. Battery Shop Equipment and Supplies at Wholesale, Adams-Barr, Columbus, Ohio.

VULCANIZER—service station sizes. Reasonable prices. Adams-Barr, Columbus, Ohio.

66 MILES on 1 Gallon—Amazing Gas Saver. All autos. 1 free. Critchlow, B-133, Wheaton, Ill.

GENERATORS, Starters, Electrical parts for all cars. Taken from wrecked cars. Lowest prices. Rhoads Electrical Parts & Ser. Co., 4138 Olive St., St. Louis, Mo.

AUTOMATIC Air Compressor, complete with motor, only \$16.50 monthly. Quickly builds your business. Send postal for particulars. Hoharth, Troy, Ohio.

AUTO Emblems. Any Lodge. Write, North Central Distributors, Dept. J, Ashland, Ohio.

VULCANIZING Auto Tires is a Paying Business on account of new tires advancing. We have Plants near you from \$100 up. We save you 50%. Catalog Free. Instruction Book \$1. Equipment Exchange, 108 East 11, Los Angeles, Calif.

BEAUTIFUL Ornaments—Motor Car Mascots. Write for Catalogue. United Auto Supply, 1922 Westlake, Seattle, Wash.

BARGAINS on Radiators. All standard makes radiators furnished at bargain prices. State Make and model. We guarantee satisfaction. Independent Radiator Co., 1119 Wabash Ave., Chicago.

USED Auto Parts for Any Car. Allen's Parts Co., 2001 So. 9th, St. Louis, Mo.

\$250.00 TO \$300.00 profit monthly easily earned with One Day Battery Service. It costs only \$20 monthly. Send postal to Wilhobart, Troy, Ohio.

VACUUM Base Trouble Light Sticks Anywhere. Literature Free. Vacuette Co., Santa Monica, Calif.

GOVERNORS for Auto Engines. Let us show you how to make a power plant for the shop or farm. A. C-S Governor Co., 215 W. Manchester Ave., Los Angeles.

EXPERT Automobile Painting. Easy money for Mechanics. Complete Course \$1.00. R. Petty, Master Painter, 1015 Lydia, Kansas City, Mo.

"WHEN fixing your car" use Atlas Babbit Hammer. Strong, Durable. Saves trouble. Weight 2 pounds. Pay Postman \$1.00. Atlas Manufacturing Co., Garwood, N. J.

MANUFACTURE Fibro-Seal. Guaranteed Puncture Plugger; Para-yulkine. No-cement Instant Weld Patch; Super-Radholyte. 20-Minute Battery-Charging Fluid. I'm headquarters for Guaranteed Formulas for High-class Automobile Specialties and all lines. Investment small—profits enormous. No Machinery necessary. Valuable literature Free! Start a worth-while business with unlimited possibilities! Miller, Chemist, 1706-A Jetton, Tampa, Fla.

\$500 REWARD for any foul plug we fail to fire with our newly patented ignition boosters. Fits any spark plug. Eliminates foul plugs and undue repair bills. More hills in high gear. 3 to 7 miles more per gallon of gasoline. Satisfaction guaranteed. Agents clearing big money. Inexpensive, \$2.00 set of four, \$3.00 set of six, etc. Answer this ad and we will explain how to get full set as free sample. Jackson Mfg. Co., 1818 Curtis, Denver, Colo.

SAVE \$5 to \$10. You can now remove carbon while you drive by new scientific method at a cost less than 10 cents per cylinder. Free interesting pamphlet explains everything. Write today. Boone Specialty Co., 110 West 112th Place, Chicago.

AUTOMOBILES

PATENTS. Time counts in applying for patents. Don't risk delay in protecting your ideas. Send sketch or model for instruction or write for Free book "How to Obtain a Patent" and "Record of Invention" form. No charge for information on how to proceed. Communications strictly confidential. Prompt, careful, efficient service. Clarence A. O'Brien, Registered Patent Attorney, Security Bank Building (directly across street from Patent Office), Washington, D. C. See pages 140 and 141.

AUTO Mechanics, Garages, Battery Stations. Automobile Students or anyone mechanically inclined; \$75.00 to \$150.00 week in spare time; may be operated by anyone, anywhere, without previous experience, special ability or large capital; may be operated in Garage, Service Station or in "Back Yard"—it gets the business! Address: Maulsby, Box 5108, Gateway Station, Kansas City, Mo.

FREE Instructions on expert motor valve reseating. Write Douick Mfg. Co., Battle Creek, Mich.

COMICS for Cars—1,500, 25c. Nichols, 1014 Thatcher, Boise, Idaho.

FORD Chassis made dependable tractor by using Shaw Equipment. Pulls 16" plow, etc. Particulars Free. Shaw Manufacturing Company, Dept. B-4, Galesburg, Kans.

\$300.00 TO \$500.00 profit monthly in One Day Battery Service. Easy monthly payments allowed. Postal brings particulars without obligation. Hobbarts, Troy, Ohio.

FOR FORD OWNERS

PUT a "Bingo Timer" on your Ford. Guaranteed best made. Thousands in use. Requires no oil. No more trouble. All Dealers or direct with full particulars—\$1.50. Agents make big money. United Machinery Company, Cincinnati, U. S. A.

UNDERSLING with "RKO" Swing Lo Irons. See "Red-I-Kut" ad page 134.

66 MILES on 1 Gallon—Amazing Gas Saver. All autos. 1 free. Critchlow, C-133, Wheaton, Ill.

DIRECT Engine Driven Tire Pumps for Ford Cars. Cigarette Mfg. Co., Upper Marlboro, Md.

ONE Day Battery Service pays big in smaller shops. Only \$16.50 monthly. Postal brings particulars. Hobbarts, Troy, Ohio.

MOTORCYCLES, BICYCLES AND SUPPLIES

1923 HARLEY-DAVIDSONS, \$168; 1922, \$118; 1921, \$111; 1920, \$85; 1919, \$65; 1917, \$50; 1916, \$45; 1915, \$40; 1914, \$35. Guaranteed. Money refunded if not satisfied. Circular free. Wisconsin Cycle Sales Co., 726 National Ave., Milwaukee, Wis.

DON'T buy a Bicycle Motor Attachment until you get our prices. Shaw Mfg. Co., Dept. 27, Galesburg, Kans.

SEND for Bargain Bulletin. All makes of rebuilt motorcycles at lowest prices. Used parts half-price. Ash Motor Corporation, Rochester, N. Y.

OVERSTOCKED Used Motorcycles, 1923 Indian Chief \$95.00, 1923 Harley Davidson \$95.00, 1923 Henderson DeLuxe \$120.00. Two hundred others; write for free list. Myerow Brothers Co., 15 Berkeley St., Boston, Mass.

ALL used Harley-Davidson parts at big discounts. Tremendous bargains in used motorcycles. Don't fail to get our prices before buying. Oliver Cycle & Motor Co., 1045 N. Grand, St. Louis, Mo.

1923 INDIAN and Sidecar \$110; 1921, \$55; 1925 Harley-Davidson \$165; 1923, \$90; 1920, \$55; 1917, \$35. Hoffman's, 6074 Butler St., Pittsburgh, Pa.

CLEVELAND Motorcycles, brand new, complete, many extras, \$65.00. Equipment Co., Carle Place, N. Y.

MOTORCYCLES \$5—\$90.00. Typewriters \$4.00—\$28.00. Rent \$1.00. Send cash. Knights, 1512 Locust, St. Louis, Mo.

AVIATION

LEARN to Fly; \$100.00 including Solo. We guarantee to solo you regardless of the number of flying hours required. Our instructors are ex-army aviators and air-mail pilots with wide experience. Our training equipment is the best obtainable. Our course requires about two weeks, depending on the individual. No bond required, no charge for breakage. Eight years without an accident. 76 students graduated in 1925. Commercial aviation is a rapid growing industry. Don't delay! Enroll now in one of the oldest and best known flying schools in America. Robertson Aircraft Corporation, operators of the United States Air Mail, St. Louis-Chicago, Lambert-St. Louis Airport, Anglum, Mo.

PATENTS. Time counts in applying for patents. Don't risk delay in protecting your ideas. Send sketch or model for instructions or write for Free book "How to Obtain a Patent" and "Record of Invention" form. No charge for information on how to proceed. Communications strictly confidential. Prompt, careful, efficient service. Clarence A. O'Brien, Registered Patent Attorney, Security Bank Building (directly across street from Patent Office), Washington, D. C. See pages 140 and 141.

EARN \$3,500 to \$10,000 a year. Prepare for flying. Complete ground course in mechanics of aviation. Write for free catalog. Western Airplane Corporation Desk K-8, Monadnock Block, Chicago.

AEROPLANE Engines, New 165 H. P. Gnome motors \$3,000.00 worth for \$35.00 F.O.B. Dayton. Write for booklet. Ice sleds, motor boats, aeroplanes. The biggest bargain of the war surplus sales. Resistal goggles \$2.50. Liberty, Curtiss, Le Rhone, Lawrence, Hispano, Renault and Mercedes engines also. Complete aeroplane wings \$7.50 each. Marvin A. Northrop, 730 Washington Ave., North, Minneapolis, Minn.

LEARN to Fly, \$100. Our instructors of long experience, our modern training airplanes, and the best equipped flying field in the middle west, make us the best equipped school in the country to teach you to fly. Write for booklet. Porterfield Flying School, 2514 East 59th Street, Kansas City, Mo.

MOTORS: Curtiss OXX-6 Class A (under Fifty Hours) for Plane, Sea-Sled, Motor boat, etc., \$275.00. All Motor and Plane Spares at Best Prices. Send for Catalogue. Monumental Aircraft Co., 339 N. St. Paul Place, Baltimore, Md.

LEARN to fly. Courses as low as \$100.00. New Standards \$800.00 up. Everything for Aircraft. Write for Catalogue, New Jumbo Type Resistal Goggles \$3.00. Nicholas Beazley Airplane Co., Marshall, Mo.

THE latest in scientific, experimental flying machine capable of adjustment and variation of 100 effects. Aluminum model. Send for circular. Kasnar Rollcopter Co., 1201 W. Chicago Ave., Chicago, Ill.

CURTISS Pulitzer Racer Construction Set including Full Sized Plans and Genuine Curtiss Reed Propeller \$4.00 Postpaid. Special Offer: Wonderful Scientific Airglider with Ground Launching Device 50c Postpaid. Plans: Curtiss 35c; S. E. V. 75c; Loening 75c; "Bat" Catboat 17" Long. Construction Set, \$1.50; Plan 25c. Big Catalog Listing Latest Types of Model Airplanes, Boats and Supplies 5c. W. Phipps Company, 367 Wilson Avenue, Brooklyn, N. Y.

FUTURE Aviators, Attention! Short cut information on Flying—Costs—What to Buy; Condensed Facts on Aviation. By Army and Commercial Flyers, 9 years experience. Send \$1.00 for course. Jekls & Hay, 2734 S. Normandie, Los Angeles, Calif.

AIRPLANE, Sled, Boat, Propellers \$5.75 upward. Leather Helmets, \$3. Aviation Goggles, \$3. "Aerodrive" Boat, Sled Blueprints, \$1. Supplies List, 5c. Ostergaard, Dunning Postoffice, Chicago.

KING Bird, three place luxury plane. Write Western Airplane Corporation, Suite 403, Monadnock Block, Chicago.

AIRPLANES. How to build them and be sure they will fly. Learn the two most powerful influences on the stability and operation of an airplane. Get our free information, blue prints and propeller literature. Crawford Airplane Mfr., 2225 American Ave., Long Beach, Calif.

TEN lessons in the air of twenty minutes each will make you a pilot by our advanced method of training. This, together with our five-weeks shop course at \$100.00, makes America's oldest aircraft factory the most popular flying school. Work after class hours guaranteed. Special evening course, including shop work, field, and flying, \$175.00. Employment furnished during the day paying \$20.00 to \$40.00 per week. Heath Airplane Company, Chicago, Ill.

IF in need of airplane supplies, tell us your needs. Our prices will interest you. Propeller circular 4c. Motorcycle biplane circular 4c. Heath Airplane Company, Chicago, Ill.

NEW and used JNs, Hispano and OX5 motors. Thomas Morse Scouts. Parts, supplies, wings. Everything for Aviation. Southern Airways, Inc., San Antonio, Tex.

A SIMPLE, Thorough Home Course in Flying. Prepared by Licensed Pilot. Costs Only \$1. Send for It Now. Airway School, San Mateo, Calif.

COMPLETE Scale Plans with Building-Flying Instructions for following 3-foot Model Aeroplanes, 25c each postpaid: JN4D-2; DeHavilland; NC-4; Bleriot, Nieuport or Taube Monoplanes; Cecil Peoli Racer. Complete 48 pp. catalog 5c; listing hundreds of parts and supplies for experimenters. Ideal Aeroplane Co., 165½ Spring Street, New York.

THE American School of Aviation announces a new correspondence course in Mechanics of Aviation. A thorough training in Practical Aeronautics. American School of Aviation, Dept. 1861, 3601 Michigan Ave., Chicago, Ill.

BOYS fly a three foot model aeroplane. 12 inch mounted propeller for 25c. Aero Shop, 3050 Huribut Ave., Detroit, Mich.

BOOKS AND PERIODICALS

MANUSCRIPTS Wanted—Meador Publishing Co., 27 Beach St., Boston, Mass.

SHOCARD Writers, Artists, Pressmen—Mixing proportions 500 beautiful colors. Book \$1.00 prepaid. Fine Arts, 2033-37 College, Indianapolis, Ind.

WHERE'D Cain Get Wife? 15 pages, 15c. Jabe Studio, Los Angeles.

TRUTH forced from words! Free sample, or The Learned Alphabet Puzzle Booklets, 50c. R. C. Hill, 602 W. Jefferson, Detroit, Mich.

SCIENTIFIC Books. Send for descriptive circular. Levi Bryant, 543 East 47th St., Chicago, Ill.

"THE Little Things You Ought to Know," the book every person needs. 25 cents each. Monitor Pub. Co., Box 2084, Middle City Sta., Philadelphia, Pa.

EVOLUTION or the Bible! Our latest book entitled "Evolution or Eden," a sort of debate between a fundamentalist and a modernist, sheds much light on this subject; easy to understand. \$1.00 per copy. Low-Publishers, 4441 Indiana Ave., Chicago.

CURIOUS Books, Unique Novelties, Stunning Pictures. Samples, 10 cents Prepaid. Linds, 214 W. 31th Street, New York.

GROOM The Spirit. The World's Greatest little book tells you how. Price One Dollar. J. J. Sanders, Florence, Ariz.

HYPNOTISM—25 easy lessons \$1.00. "Mindreading?" (Any distance) Wonderful 50c. Popular Institute, A430 Milwaukee Ave., Chicago.

FREE—Send for my Newthought, Self-culture, Occult, Mystic and Scientific book literature. Martens Publisher, Burlington, Iowa.

INDUSTRIAL Alcohol. Wright's book. Full directions for making, fully illustrated. \$2.50. Spoon & Chamberlain, 120 P. M. Liberty Street, New York, N. Y.

PICTURES AND POSTCARDS

ART Photos—4—\$1.00. Ben Meyer, 35 West 31st., New York.

ART Pictures, Books and Novelties. 200 Pictures and Catalog \$1.00. Howard Sales Co., Dept. 15, 1188 Folsom St., San Francisco, Calif.

JOIN live postcard club. Membership lists, including catalog, 10c. Harvey Teeple, Decatur, Ind.

EXCHANGE postcards. Membership \$1.00 year, half 50c, quarter 25c. Roy Morris, 402 East Grove St., Ontario, Calif.

75 BEAUTIFUL Art Pictures and Bathing Beauties 25c (coin). Photo Sales Co., 3242 Riehton, Suite 400, Detroit, Mich.

PAINTING reproductions—Something new—Looks hand painted. Three beautiful 12x15 Samples \$1.00. Retail \$4.50. Art Printers, West New York, N. J.

GAMES, ENTERTAINMENTS AND PLAYS

VENTRILQUISM taught almost anyone at home. Small cost. Send 2c stamp today for particulars and proof. George W. Smith, Room 8-93, 125 N. Jefferson Ave., Peoria, Ill.

YEAGER'S Flyer Catch Game. The latest game out. Fun for young and old; postpaid 25c. Carl P. Yeager, Birdsboro, Pa.

NOVELTIES, CURIOS, ETC.

SEA Shells (Florida). Twenty-five \$1 postpaid. Curio Collectors Co., Box 44, Dunedin, Fla.

MAGIC TRICKS, BOOKS AND JOKER NOVELTIES

CARD tricks, Coin tricks, Hypnotism, Ventriloquism. 64 page books. Complete guides, 10c each. Geo. Senner, Louisville, Ky.

ILLUSTRATED Magic Catalog 6c. Lynn's, 105 Beach, Jersey City, N. J.

FREE—Our Puzzle, Trick, Game, Joker, Novelty Catalog. Wright & Son Co., Indiana Ave., Peoria, Ill.

CHALK-TALK your way to popularity. Audiences at your feet if you learn how to entertain with a few simple pictures. Little artistic ability needed. "How to Chalk Talk" tells what to say and what to draw. Profusely illustrated. Make \$10 and more a night. Send No Money. Just order on a postal. Pay postman \$1.00 and postage. Popular Mechanics Press, Room 808, 200 East Ontario St., Chicago, Ill.

UNIQUE Novelties—Magical Mysteries—Perplexing Puzzles. Catalogue Free. Killian, 1390 Temple, Detroit.

FOR something different, send 10c for "Fun-Magic-Mystery." New 80-page Book of 500 Tricks. Also contains Catalog largest line Magic Tricks and Supplies in South, at lowest prices. Send 10c today! Lyle Douglas, Station A, Dallas, Texas.

LARGE book explaining 100 magic tricks, illusions, etc. \$1.00. "Clayton," 7605 Ljwood Ave., Cleveland, Ohio.

BOOKS, Magic, Mysteries, Magic Tricks, Novelties. Catalog Free. Singer, 555, Hancock, Wis.

FREE with \$25 order die box. Send 20c for our large catalogue of tricks, wigs, sensational escapes. Oaks Magical Co., Dept. 548 Oshkosh, Wis.

SEVEN Magical Delusions and Catalogs—25c. Gilmargio, Morgan Park, Ill.

MAGIC—Tricks, Books and Supplies. For Amateurs as well as the great professionals. Anyone can learn through our instructions. Feature Acts in Mind-Reading, Spiritualism, Rope Ties, etc. Large illustrated Professional Catalog, 20c. Chicago Magic Co., 140 S. Dearborn St., Dept. B, Chicago, Ill.

READ sealed messages in dark; messages retained by audience; burned message appears on blank slate; spirit message appears on slate in sitter's presence; spirit rappings; spirits appear in the dark; answer questions written on folded papers while blindfolded. All this you can do with directions in "Behind the Scenes with the Mediums." 69 best secrets of mediums fully exposed. The best because most baffling, yet all easy to do. Send No Money. Just write a postal. Pay postman \$1.50 and postal charges. Popular Mechanics Press, Room 808, 200 East Ontario St., Chicago, Ill.

STAMP COLLECTING

READY About September 25th, 1927 Edition Scott's Postage Stamp Catalogue. About 1,600 pages. No increase in price. Scott's Catalogue is the complete and authoritative handbook of Philately. It lists, describes, and illustrates every stamp ever issued by any government in the world up to the time of its going to press. Gives perforation, watermark, color, paper, and price at which each stamp may be purchased, used or unused, from this company. Indispensable to the collector. 83rd edition. Cloth bound \$2.00; with thumb index \$2.50; shipping weight 3 lbs.; postage extra. For sale at all dealers. Note: Due to the large number of philatelists visiting America to attend the International Stamp Exhibition the advance sales of the Catalogue are unusually heavy and you are advised to order now. Send for free price list of sets. Scott Seald packets, albums, catalogues and accessories. Scott Stamp and Coin Company, 1 West 47th St., New York, N. Y.

MYSTERY Packet—Stamps from Lands of Cannibals, heathens, sun-worshippers, wild savages, including Albania, Herzegovina, Antioquia, Chad, Congo, Cochín, Cape Good Hope, Dutch Indies, Dominican Republic, Guadeloupe, Gold Coast, Kouang-Teheou, Malay, Siam, Togo, Travancore, Ubangi, Volta; (many unused) and other mysterious, far-off places. 105 stamps, all different, only 5 cents to approval applicants! Big illustrated lists free with every order. Write Today! C. D. Reimers Co., 100 Flatiron Bldg., Ft. Worth, Tex.

MAGNICAROCIOUS 10c. Snap. Only one to each approval applicant. 109 dif. stamps, including one of the Biggest stamps issued. Scarce Liberia, hidden Hyderabad, Congo, beautiful Mozambique, Hong Kong, Gabon, remote Travancore, picturesque Nyassa, wild Somali Coast, Perforation Gauge, Millimetre Scale and Jumbo Price List. Stamps bought. Fine approvals to adults sending reference. Payn Stamp Co., 945 Grande Vista Drive, Los Angeles, Calif.

ARABS! Bandits! Head-Hunters! Egypt (sphinx); Malay (tiger); Benadir (elephant); Tunis (arab); Turkey (sacred mosque); Belgium (showing battle between angel and "old horns"); Congo (head hunter)—All of these mysterious and remarkable stamps are contained in our Famous Phantom Packet—55 fine varieties (to approval applicants only) for 8 cents. Nothing like it; order at once! Pacific Stamp Co., Box 138, Helena, Mont. Extra! Send us, with your order for the Phantom Packet at 8c, the names of three of your friends who collect stamps; and we will give you, free of charge, a scarce set of 11 dif. Albania—bandit land!—cataloguing over \$1.50. Supply limited; write immediately!

O-O-O-O-H, Boys! What a Thrill! The Fenway "Jungle" Packet!—Contains scarce stamps from jungle and cannibal-land! Included are: Abyssinia, Congo head hunters, Kenya and Uganda, Nyassa camels, Mozambique, Ivory Coast, Upper Volta, Togo, Ubangul, Tanganyika, Fiji Islands (cannibals) and other savage lands. This wonderful packet from far-away countries to new approval applicants for only ten cents! Fenway Stamp Co., 161 Massachusetts Ave., Boston, Mass.

ANCHERS \$\$\$ Outfit—only 12c! Fine triangle stamp; set German stamps with (pre-war) value forty million dollars (interesting!); perforation gauge, mme. scale; small album; airmail set; scarce stamp from smallest republic on earth; newspaper set; packet good stamps from Travancore, Johore, Dutch Indies, etc. Entire outfit for 12c to approval applicants! (Nice pocket stock book, value 25c, with every order!) Ancher Stamp Co., 148½ Clerk St., Jersey City, N. J.

FREE—A Monstrous Menagerie! The ferocious tiger; the kangaroo, leopard, oxen, camel, ant-eater, snake, caribou, swan, giraffe, flying horse, screaming eagle, wild elephant, etc. This wonderful packet of hard-to-get stamps—all containing pictures of curious birds, beasts and reptiles—free to approval applicants enclosing 5c postage! Big illustrated lists also free. Write today! Mystic Stamp Company (Dept. 8), Camden, N. Y.

SESQUICENTENNIAL Specialty! "Exhibition," "Charity," "Coat-of-Arms," "Pictorial," "Airmail," "War Sufferers," six wonderful sets; packet beautiful British, French, Portuguese Colonies; 100 different foreign. Big value, 15c, to approval applicants. Deering, 38 Fairmount, Marlborough, Mass.

500 DIFFERENT 35c. Ask for approvals. De Luxe Stamp Co., Parsons, Kans.

BEST one-cent approval in America. F. P. Hand, 1117 So. 60th St., Philadelphia, Pa.

287 SIAM, Persia, Mexico, Salvador, Greece, Venezuela, Jamaica, etc.—20c. Anderson Belling, 16 Latourette, Bayonne, N. J.

51 DIFFERENT mint Persia, Cataloguing \$14.64 for \$1.75, to Approval Applicants. G. Bucknam, 63 Court St., Boston, Mass.

FREE Premium to Approval Applicants Sending Reference. Send Your Want List. Bucknam, Box 2792, Boston, Mass.

BIG Packet Catalogue One Dollar with One Hundred Twenty Page Precancel Catalogue to Approval Applicants. Send Ten Cents for Mailing. Ye Olde Hobbie Shoppe, Port Huron, Mich.

APPROVAL Stamp Packet Sent Free. Cornish Co., Schenectady, N. Y.

SAMOA. 6 var.—trees, ships, huts—15c. Allion, Angola, Ind.

OVER 200 all diff. stamps from all over the world—and 1,000 stamp hinges only 25c. Mountain City Stamp Co., P. O. Box 335, Mannington, West Va.

FREE Premium to approval applicants furnishing satisfactory reference and stamp. Joseph A. Lux, 211 Memminger St., Greenville, S. C.

200—200—200—200 ALL different stamps; 200 hinges; approval sheet to hold 200 stamps; perforation gauge, millimeter scale and ruler; duplicate stamp container—all for only 15c to approval applicants. Edge-wood Stamp Company, Milford, Conn.

FREE—Set pictorials with 250 different foreign for 10c. Approvals—We buy stamps. Smith Stamp Co., Box 171, Hopkinton, Iowa.

FIFTY different South America 25c. Fred Onken, 630 79th Street, Brooklyn.

MAGNICAROCIOUS Packet Foreign Stamps. Beauties from Distant Lands. (Many Richly Colored, unusual designs) free for 2c. Gray Stamp Company, Toronto, Canada.

IDENTIFY water marks with Hussman Water Mark Detector. Lacquered tin box with directions and 1,000 stamp hinges, 15c. Bargain Packets, 100 British Colonies, 35c; 100 French Colonies, 30c; 100 Portuguese Colonies 40c; 100 New Europe 10c; 50 Asiatic, 15c; 50 African, 25c; 50 Australian, 25c; 50 So. & Cent. America, 25c; 500 all different 35c; 1,000 all different 95c. Hussman Stamp Co., Dept. PP, 620 Olive St., St. Louis, Mo.

ILLUSTRATED album, 50 different foreign stamps, packet hinges, perforation gauge, hints to collectors, and big illustrated price list—complete outfit, all for 10c to approval applicants. Special: 1,000 unused stamps only 50c. W. Betts, Clearfield, Pa.

200 STAMPS, Bargain List, Magazine, 15c. Harvey Teeple, Decatur, Ind.

START a Stamp Collection—70 different stamps from 70 different foreign countries, including Africa, Asia, Australia, Europe, West Indies, etc. Our pamphlet which tells "How to make a collection properly," and price list of albums, packets and sets all for only 15 cents. Queen City Stamp Co., Room 36, 604 Race St., Cincinnati, Ohio.

50 FRENCH Colonials, 30 British Colonials, 20 Portuguese Colonials, 30 South and Central America, all different; price lists, etc., all only 25c to introduce approvals. Fennell Stamp Company, Dept. P, St. Louis, Mo.

FREE, Hungary Charity No. 565 to 567 and a surprise packet given to those requesting for my 1, 2 and 3c approvals and also my 50% discount and better. Chas. W. Schmidt, P. O. Box 4832, Frankford Station, Philadelphia, Pa.

STAMPS sent on approval at 70% discount. Reference required. Emory Renold, Hanover, Pa.

STAMPS on approval ½c up. Free premium. Herbert Keigwin, Middletown, N. Y.

STAMPS, 100 all different. Postage 2c. Lists free. P. M. Quaker Stamp Co., Toledo, Ohio.

110 NEW Europe All Different, a wonderful collection cataloguing several dollars, free to collectors requesting our Net Approvals. Postage 2 cents. Badger Stamp Co., Milwaukee, Wis.

500 DIFFERENT only 25c (regular price 50c), many unused, from British, French, Italian and Portuguese Colonies, Chile, Fiume, Guatemala, Persia, Siam, etc., to all approval applicants. Big bargain lists free. Victoria Stamp Co., London, Can.

STAMPS, 100 varieties, Africa, Brazil, Peru, Cuba, Mexico, etc., 10c. 50 different U. S. 25c; 1,000 mixed, 40c; 1,000 hinges, 10c. List free. C. Stegman, 5941 Cote Brillante, St. Louis, Mo.

FREE! 25 different United States with 50% discount approvals to reliable parties. Seidenberg, Baroda, Mich.

UNITED STATES—Send on approval. Send me your want list. Ref. Please. M. Hanna, New Kensington, Pa.

SPECIAL. 50 Varieties French Colonies, very fine, to Approval Applicants only, 10c. Richard Lamprecht, Valparaiso, Ind.

110 DIFFERENT Stamps, many unused, high values, free to collectors requesting our Net Approvals. Postage 2 cents. Christensen, Milwaukee, Wis.

24 VARIETIES Cuban stamps, 10 cents. List of 6,000 low-priced stamps free. Address Chambers Stamp Co., 111P, Nassau St., New York City, N. Y.

FREE! Loose Leaf Postage Stamp Album at rate of 8 pages each month given with subscription to monthly Journal. Send 2c stamp for prospectus. United Stamp Co., Marquette Bldg., Chicago, Ill.

FREE! 12 scarce Azerbaijan to approval applicants. Mammoth Illustrated Price List, 2c. Penna. Stamp Co., Manor, Pa.

FOR Russian stamps, membership address: Collectors Cooperative Society, P. O. Box 388, San Francisco, Calif., or Philatelic International, 1 Trerskaja Yamskaja 3, Moscow, Union Socialist Soviet Republics.

NEWFOUNDLAND Stamps on approval. None better—none cheaper. Send want list and references. Rev. Butler, St. Georges, Newfoundland.

FRENCH Colonies Free—Jungles, Tigers, Native Chief, 2c postage. Empire Stamp Company, Toronto, Canada.

100 STAMPS from 30 Countries, 5c. Lufbery, Port Orange, Fla.

STAMP packets, 1,000 Varieties, \$1.10. Two Thousand Varieties, \$4.50. 100 Varieties and list, 10c. Norman Shultz, Colorado Springs, Colo.

200 DIFFERENT stamps, Triangle, Pictorial, etc., 10c. R. H. Carlton, 380 W. So. Temple, Salt Lake, Utah.

COVERTCO Packet, 250 varieties unused and used stamps 15 cents. Covert Stamp, 39 State, Rochester, N. Y.

ZANZIBAR, Abyssinia, Travancore, Herzegovina, Quellmane, Mozambique, Stamps, Menagerie Collection, Album, 10c. Liberty, 3974 Arsenal, St. Louis, Mo.

PACKET of 23 stamps, no two countries alike. Packet hinges. Set of \$1 and \$2 U. S. Rev., all for 5c. P. M. Miami Stamp Co., Toledo, Ohio.

20 UNUSED stamps free. All different. Postage, 2c. P. M. Fisk Stamp Co., Toledo, Ohio.

105 CHINA, etc. 2c. Album (500 illustrations) 3c. Bullard, Sta. A, Boston

50 VAR. Scandinavians 10c. Gronberz, Box 5441, Philadelphia, Pa.

1,000 MIXED U. S. and Foreign Stamps 25c. Phil. Lundsted, Cape Cottage, Me.

RARE COINS

12 DIFFERENT Coins 25c. Half-Dime 15c. Brooks, 2725½ Line Oak, Dallas, Tex.

STOCKS — Bonds, Domestic — Foreign, bought—sold. Dealers in all marketable securities. Frank O. Everett & Co., 29 Broad St., New York.

COIN over 100 Years old and Price List 10c. Fred Greenclay, 1626 Washington, Denver, Colo.

SPECIAL—1787 Massachusetts cent, 50c. Durso, 25 Mulberry, New York City.

LINCOLN Half Dollar \$1.39; California Half Dollar \$1.23; White Cent and bargain Price list 10c. Arey, Box 483, Muskogee, Okla.

44 DIFFERENT Coins \$1.00, 44 Different bills \$1.00, 100 assorted bills \$1.00. Otto Odehon, Independence, Mo.

40 OLD coins, all different, \$1.00. Monroe Half-Dollar, Uncirculated, \$1.00. Lexington Concord Half-Dollar, Uncir., \$1.00. List Free. Claud Denney, Box 315, Dallas, Texas.

RARE Coin, Bank Notes, Stocks and Bonds, 20,000,000 Mark and price list 10c. Geo. Best, Cedar Rapids, Iowa.

NICKEL 3c and 2c 15c; California Gold ¼, 25c; California Gold ½, 53c; 100,000 German Marks, 10c; \$5 and \$20 1861 Confederate Bills, 15c; 5 Different Copper Coins and Price Lists, 10c. Al E. Bonsall, Richmond, Ind.

\$2 TO \$500 Each Paid for hundreds of Old or Odd Coins. Keep All Old Money. It may be very valuable. Send 10 cents for Illustrated Coin Value Book, 4x6. Get Posted. Guaranteed Prices. We Buy and Sell. Clarke Coin Office, LeRoy, N. Y.

CALIFORNIA gold, ¾ size, 27c; ¾ size, 53c; three-cent-piece and catalogue, 10c. Norman Shultz, Colorado Springs, Colo.

UNITED STATES, Large Cent, two-cent bronze, three-cent nickel and Bargain List, 25c. Fifteen dates large cents, \$1.00. George Coffin, Greenwood Mountain, Me.

UNITED STATES and Foreign Money, Medals, Catalogue and Villa Bill 10 cents. Alexis Mengelle, Colorado Springs, Colo.

GET Profit and Pleasure in collecting Old Coins. Send 10c for Sample Old Coin, together with my Large Illustrated Coin Catalogue. You'll be delighted with it. Send for it right now. B. Max Mehl, Professional Numismatist, Mehl Bldg., Dept. P., Fort Worth, Texas. Largest Rare Coin Firm in U. S.

FOR BOYS

SPECIAL Imported Binoculars. Powerful, Brilliant, Adjustable. Leatherette case—\$1.00 postpaid. Inventors Bureau, 417-B West 21st, New York.

EVERYTHING a boy wants to learn. Woodworking, electricity, metal working, gymnasium, printing, collecting stamps, etc., making musical instruments, games, woodcraft, scouting, whittling, hunting, trapping, fishing, boats—almost everything. Complete instructions in 700-page illustrated book. Send no money. Just ask for "Every Boy's Book of Handicraft, Sports and Amusements." Pay postman postal charges and \$3.00. Popular Mechanics Press, Room 808, 200 East Ontario St., Chicago, Ill.

CAMERAS AND PHOTO SUPPLIES

EARN \$50 to \$250 each week! Learn Professional Photography. Wonderful openings now in all branches—Motion Picture, Portraiture, Commercial, News. Experts train you quickly at home or in big, modern New York or Chicago studios. Write for illustrated Free Book and Free Camera Offer—your choice of Professional View Camera or real Motion Picture Camera. Just send name and address to New York Institute of Photography, Dept. 49A, 12 West 33rd St., New York City.

GLOSSY Prints Any Size 2c. Developing 5c. Eastman Kodak Studio, Armstrong, Iowa.

PHOTOGRAPHIC equipment and accessories of every description are listed and illustrated in our 228-page catalogue. It will pay you to secure a copy which is issued free, as our prices are low. We also deal in used goods which are sold under the same guarantee as new goods. Ask for our Bargain Book. Central Camera Co., Dept. E-108, 112 S. Wabash Ave., Chicago, Ill.

BIG Money Saved on Photographic Lenses and Apparatus—goods exchanged; repairing done. Ralph J. Golsen, 1128 Argyle St., Chicago, Dept. P.

HAVE You a Camera? Write for Free sample of our big magazine, showing how to make better pictures and earn money. American Photography, 116 Camera House, Boston, 17, Mass.

BARGAINS in Kodaks. Ray, 296 5th Ave., New York.

LEARN "Transography," a new process. Saves time and money. Send \$1.00 for complete instructions and negative. Particulars with sample photos, 10c. Koch's Studio, Collbran, Colo.

HAND-COLORED Crisp, clean enlargements, from your negative. 7x10 wide border \$1.00. Aug. Pokorny, 1822 So. Throop St., Chicago, Ill.

KODAK Films—Special trial offer; your next kodak film developed, 5c—prints, 2c each. Moser & Son, 1917 St. James Ave., Cincinnati.

EXPERT Kodak finishing. Trial Order. Your next Roll film developed free. Beautiful Glossy-tone Prints, 4c each. Immediate Service. Herman Studio, 706 Calhoun, Ft. Wayne, Ind.

SEND 10c for the latest and greatest Bass Book of Cinema Apparatus; gives full description of all types of instruments as well as the price. Or, send \$3.00 for a 500-page Cinema Hand Book containing full instructions of the making and taking of films. Bass Camera Company, 105 N. Dearborn St., Chicago, Ill.

KODAK Film—Special Trial Offer—Your next roll developed 5c, prints 3c each. Beautiful 6x10 mounted Enlargement 40c. Sameday Service. Fleet Photo Service, 1210 G. N.W., Washington, D. C.

MODERN Photography in all its branches now taught by mail. New Successful Method. Students earning \$300.00 while learning. Big opportunity. Write for particulars and unusual offer open for short time. Dept. 3431, International Studios, Inc., 3601 Michigan Ave., Chicago.

FILMS Developed. Special Trial Offer. Any Size Kodak film developed 5c, prints 3c each. Trial 6x10 Enlargement in handsome folder 40c. Overnight Service. Roanoke Photo Finishing Co., 209 Bell Ave., Roanoke, Va.

UNEXCELLED Gloss Prints. Trial Offer. Your Kodak Film Developed and printed only 10c. F R B Photographers, Dept. "C," 1503 Lincoln Ave., Cincinnati, Ohio.

MOTION PICTURES

BARGAINS. Machines, Films, Stereopticons, Slides. National Equipment Company, Duluth, Minn.

MAKE Movies with the new Institute Standard Professional which does work equal to cameras costing into thousands of dollars, yet costs only \$100. For standard gauge film used in all theaters. Weighs only 16 lbs. You can make big money in spare or full time. Write for free booklet. New York Institute of Photography, Dept. 49A, 14 West 33rd Street, New York City.

BIG Money Nightly—Complete Outfits, installment plan. Good Movie Camera, \$37.00. Ralph J. Golsen, Dept. M, 1128 Argyle St., Chicago.

SACRIFICING New \$150 Sept spring motor Movie Camera and leather case, \$37.50. Eastman negative Film 2½ cents foot. Printer \$25. Movie Projector \$37.50. Motor driven suit case Projector \$85. Movie Films \$2 reel. Ray, 296 5th Ave., New York.

NEW and Rebuilt Machines for Big Theatres—Schools—Churches—Traveling Shows. Also Films—Supplies and Complete Theatre Equipments. Bargain List Free. Monarch Theatre Supply Co., Dept. P, Memphis, Tenn.

\$35.00 PROFIT nightly. Small capital starts you. No experience needed. Our machines are used and endorsed by government institutions. Catalog free. Atlas Moving Picture Company, 482 Morton Bldg., Chicago.

FILM—Million Feet for Sale. Cowboy—Drama—Comedy and Feature Specials. Mix—Hart—Chaplin and best Movie Stars. \$3.00 per reel up. Genuine List Free. We Supply the World. Dept. G, Monarch Films, Memphis, Tenn.

MAKE money writing photoplays; details free to beginners. No correspondence course. Producers League, 230 Wainwright, St. Louis.

\$\$\$ FOR Photoplay Ideas. Let us help you make your story. Write for particulars. Universal Scenario Company, 206 Security Bldg., Western and Santa Monica Blvd., Hollywood, Calif.

MOVIE films, 1,000 ft. reels. Complete stories. \$2.50 each; shipped anywhere on receipt of remittance with order. Independent Films, 177 Golden Gate Ave., San Francisco, Calif.

SCENERY TO RENT

SETTINGS for Opera, Plays, Minstrels, Plush drops. Address Amelia Grain, Philadelphia.

EDUCATIONAL AND INSTRUCTION

YOU can have a business profession of your own and earn big income in service fees. A new system of foot correction; readily learned by anyone at home in a few weeks. Easy terms for training; openings everywhere with all the trade you can attend to. No capital required or goods to buy, no agency or soliciting. Address Stephenson Laboratory, 1 Back Bay, Boston, Mass.

ARTIFICIAL Marble sanitary flooring instructions, ornamental casting, concrete, plaster, papier-mache decorations, garden furniture, statuary. Rubber-moulds. 15 years' instructing the public, particulars and 200 illustrations free. Chris Mahler, Huntington, N. Y.

\$100.00 AUTO Electrical Course for \$2.00. R. Maulsby, 3611 Main, Kansas City, Mo.

ENGINES for airplanes fully described in "Aeroplane Engines in Theory and Practice," by John B. Rathbun. A book used by the government. Includes all makes of engines. For mechanic, builder, and flyer. Send No Money. Just order on a postal. When postman hands you book, pay him \$2.50 and postal charges. Popular Mechanics Press, Room 808, 200 E. Ontario St., Chicago, Ill.

BE a Laboratory Expert. Earn from \$300 to \$500 Monthly. Study Microbiology Sanitation. Day, Evening classes. Diplomas, Degrees Granted. 71-piece outfit Free to students. Write for our Free Prospectus To-Day. International College of Microbiology, 7202 W. Grand Ave., Chicago, Ill.

ENGINEERING Courses Simplified. Lowest Prices. Descriptive Circular free. Lightning Method, Box 999, Long Beach, Calif.

AN Embalming or body-preserving Process. Obvious, permanent, and may be visible. F. L. Jones, 669 G. P. O., New York City.

MECHANICAL Engineering. Interesting, Highly Paid Work. Special Home Study Course. Write for Particulars and Free Copy of "Machine Designer's Manual." Harbor Technical College, 851 Pine Ave., Long Beach, Calif.

ALL men—women wanting Government Positions, \$140—\$225 monthly, should get our "Exam Coaching" immediately. Write, Ozment 101, St. Louis, Mo.

FINGER Print Experts—Excellent paying positions; particulars free. Finger Print Headquarters, 188 East 79th, New York.

\$115—\$400 MONTHLY paid—Ry. Station—office positions. Free passes, experience unnecessary. Write Baker, Supt., (ABT) Star Bldg., St. Louis, Mo.

STEAMSHIP Positions—Europe, Orient. Good pay. Experience unnecessary. No compulsory service. Send stamped addressed envelope for list. Box 30-X, Mount Vernon, N. Y., or Box 330-A, Santa Monica, Calif.

EARN \$25 weekly, spare time, writing for newspapers, magazines. Experience unnecessary. Details Free. Press Syndicate, 981, St. Louis, Mo.

TRACE missing people; earn big money; free particulars. National Headquarters, 188 East 79th, New York.

MAKE Drawings, Resemble Printing. Simple dipping process, 10c. Fine Arts, 2033-37 College, Indianapolis, Ind.

WHAT School? Free Catalogs and reliable information about all Schools and College sent on request. Vocational guidance. Partial scholarships and reduced rates for students. Complete directory of all educational institutions in U. S., 480 pages, \$2. Educational Aid Society, Dept. 604, 168 N. Michigan Ave., Chicago.

WORLD-ROMIC System, Masterkey 5,000 languages. Primers \$1.98. Chinese, French, Spanish—Languages, 8 West 40th, New York.

ARE You interested in Writing short stories, poems, songs, photoplays, For Profit? Then send for our new edition of actual letters from prominent editors, who want your manuscripts. It's Free if you send for it Now. Address M. Mendelsohn, Editor, Dept. 102, Writer's Digest, 22 E. 12th St., Cincinnati, Ohio.

STUTTERING, stammering, all speech defects corrected. Wilson Schools, Arnold Place, Dayton, Ohio.

SONG Poem Writers—Send for proposition. Ray Hibbeler, D15X, 2104 N. Keystone Ave., Chicago.

DOUBLE Entry Bookkeeping mastered in 60 hours with 8 keys; guaranteed; diplomas, International Bookkeeping Institute, Dept. 8, Springfield, Mo.

SIMPLIFIED Shorthand or Bookkeeping, 25c. Marr, Teacher, 605, Nashville, Tenn.

USED educational matter of all kinds. Sold on repurchase basis. Big saving. Money-back guarantee. List free. (Courses bought.) Lee Mountain, Pisgah, Ala.

STUDY Patent Solicitation. Full particulars, Patent Law, 301 Hennepin Ave., Minneapolis, Minn.

USED educational matter. Lowest prices; terms. Catalog free. Mention Subject. Fred Goetz, 440-A Sansome, San Francisco.

RADIO OUTFITS AND SUPPLIES

BUILD Super using Davisco Long wave air core transformers and standard parts. Selectivity unparalleled, freedom from interference, tone unsurpassed, volume equal to power amplifier. Long range loop reception. Entirely new principle in Super-Het. Ask for literature, blue prints 50 cents. We can furnish parts to commercial set builders at special discount. Davisco, 30 Euclid Arcade, Cleveland, Ohio.

RADIO Finger Ring. Wear it as a Ring—use it as a Radio. Brings in Local Stations. Price \$1.00. Barlow, Pleasant Hill, Mo.

DISTRIBUTORS of Kits and Parts on: Victoreen Super Heterodyne, Samson Transcript, Silver-Cockaday, Ultradyne. All Silver-Marshall Products, Roberts Knockout, Drilled and Engraved Panels for all circuits. Dealers Write for Discounts! Maurice Schwartz & Son, 710-712 Broadway, Schenectady, N. Y.

ELECTROLIC Charger. Instructions \$1.00. 180 Harman Street, Brooklyn, N. Y.

LONG Distance Crystal Set Plans. \$1.00. Loudspeaker volume. Patent pending. Write Burgess, 618 3d St., S. W. Washington, D. C.

SPECIAL Discounts Radio. Send 10c for list. Martien Radio Shop, Galion, Ohio.

RADIOS—One and five-tube sets \$5.50 to \$22.50 delivered. Literature free. Agents wanted. Seminole, 427 East 16th, New York.

BIG Profits recharging radio and auto batteries. Outfit, easy payments, Hobbarts, Troy, Ohio.

TRADE AND TECHNICAL SCHOOLS

TRAIN in Los Angeles for Automotive and Electrical Trades. Big pay jobs ready when you complete short practical training course in famous million dollar shops. Expert instructors. Free employment service. Board and room jobs. Reduced summer railroad and boat fares and tuition. Write for big free catalog quick. Say whether Auto or Electrical school. National Automotive & Electrical Schools, Dept. 93, 4004 So. Figueroa St., Los Angeles.

EARN \$10 to \$20 per day. Learn Sign Painting, Auto Painting, Paperhanging, Decorating, Show Card Writing at a real school; no mail courses. All practical training—short time. Low cost. Chicago Painting School, 148 West Austin Ave., Chicago, Ill.

GET a Foreman's Job in any trade. Train yourself to earn more money. Become an expert Blue Print Reader. You can do it in spare time. My training will give you advancement in a few weeks. Write now—tell me what trade you want—I will send my plan at once. Carroll Rumsey, 165 Drexel Bldg., Philadelphia, Pa.

TELEGRAPHY—Both Morse and Wireless—taught thoroughly and quickly. Tremendous demand. Big salaries. Wonderful opportunities. Expenses low; chance to earn part. School established fifty years. Catalog free. Dodge's Institute, Fern St., Valparaiso, Ind.

LEARN Bricklaying at home or in school run by contractors. Catalog free. Associated Building Employers, B490, A. B. E. Building, Grand Rapids, Mich.

BUSINESS OPPORTUNITIES

QUIT Slaving for the other fellow and Hire Yourself as Boss! Manufacture These Biggest-Selling Specialties. 300 to 900% profit. Investment Small. No Machinery Necessary. I'll tell you how to make: Fibro-Seal, Guaranteed Puncture Plugger; Para-Vulkine, No-Cement-Instant-Weld Patch, Super-Radiolyte, 20-Minute Battery Charging Fluid; Guaranteed Metal Polishing Cloth; Non-Thermic Ice Saver Cloth; Tuffnit—Prevents Runs in Silk Hosiery; Fly-Nox, Instant Fly-killing Spray. Valuable Literature describing these, also sixty others. Free! Write today! Miller, Chemist, 1706-C Jetton, Tampa, Fla.

PATENTS. Time counts in applying for patents. Don't risk delay in protecting your ideas. Send sketch or model for instruction or write for Free book "How to Obtain a Patent" and "Record of Invention" form. No charge for information on how to proceed. Communications strictly confidential. Prompt, careful, efficient service. Clarence A. O'Brien, Registered Patent Attorney, Security Bank Building (directly across street from Patent Office), Washington, D. C. See pages 149 and 141.

\$12,000 YEARLY Easy. Real Business. Particulars Free. Vaculite Co., Santa Monica, Calif.

SHERIDAN'S Directory. Latest, Largest and Best Buyers' Guide. Wholesale Supply Sources for Thousands of Articles, \$1.00. S. Van Auker, 34 Riehton, Detroit, Mich.

\$50.00 WEEKLY, spare time, mailing form letters. We furnish everything. Samples 10c. Whitney, Station C, Cincinnati, Ohio.

PUBLISH a Magazine of your own and start a mail order business on \$1.00 capital. Sample magazine and plan. 25c (coin). E. D. Tupper, P. O. Box 184, Los Gatos, Calif.

\$1,000 BUYS copyrighted book that should interest 20,000,000 Automobile Owners. Sells for \$1.00 per copy. Will set outright. C. J. Strickland, 1101 Elizabeth, Charlotte, N. C.

10c PUTS your name on mailing list year. Receive offers from wholesale supply houses everywhere. Kentucky Agency, Covington, Ky.

CHEMICAL Expert furnishes Manufacturing Formulas and Processes with complete working directions. Reliable individual service only. No lists. Charges reasonable. Correspondence invited. Dr. Arthur Van-Heeden, 508 South Oakley, Chicago.

MORE Money. Made without leaving home. Sure. Either sex. Investment negligible. Particulars Free. Pacific, Prineville, Ore.

ATTENTION! You can have a business of your own. Establish and operate New System Real Estate Business, brokerage and insurance agency in your community. Office at home. Earn \$5,000 year. Representatives wanted everywhere. Send stamp free booklet. Hayes Realty Association, Cincinnati, Ohio.

NEED energetic state agent. Article in general use. No technical training or investment required. Cynthio Co., 726 Seaboard, Seattle, Wash.

MECHANICS, carpenters, painters, start furniture refinishing and handyman shop on nearly nothing; winning plan brings customers quickly. John Braceland, 1439 So. Ninth, Philadelphia, Pa.

SUCCEED—Our twenty scientific processes put you wise. Excellent. 50c. No stamps. Holland, Box A-473, Astoria, Ore.

DODGE the Rat! Profitable, Whole or Sparetime Work. Information 2c Stamp. Interstate Specialty Co., 120 East Eighth St., Lawrence, Kans.

COMPLETE Collection 10 successful money-making business plans \$1.00; (sample 25c). Elite Co., 38 Elizabeth St., New York.

MIRRORS Resilvered at Home. Costs Less 5 cents per square foot; you charge 75 cents. Immense profits plating like new brass worn-off auto parts, reflectors, tableware, stoves, etc. Outfits furnished. Details Free. Sprinkle, Plater, 127, Marion, Ind.

START a Permanent Business of your own selling New Style Guaranteed Hosiery for men, women, children. We deliver and collect. No capital or experience needed. Sworn proof of Profits \$12 daily up, furnished. Become our District Manager. Get others working for you. Write to The Maccohee Textile Company, Card 2588, Cincinnati, Ohio.

OLD Autos Look Like New. Two fellows have invented new auto finish, applied without brush in 15 minutes, gets hard as glass in two hours. No rubbing, no painting, just beautiful finish. Send today and have your car like new. Live wire men with small capital can make big money handling this. Wonderful opportunity. Reserved territory. B. B. Specialties, 331 JJ Walnut, Philadelphia.

COMMON Law Companies Organized. Financing. Box 8-299, 311 Fifth Avenue, New York.

BIG Money easily, quickly, for shrewd men. Brains, not capital, required. Confidential particulars free. E. Weed, P. O. Box 1293, Denver, Colo.

YOUR favorite products; manufacture them yourself. Guaranteed manufacturers' formulas supplied. All lines. Latest specialties. Romig, Box 103D, Station W, New York.

IMPORT your own goods! List of 50 German manufacturers \$1.00. Particulars—stamp. G. A. R. Company, 2256 Maypole Ave., Chicago.

\$750,000,000 MAIL-ORDER business in 1925. Many grow rich in this great trade. Sell merchandise, information, patented articles, various preparations. Breniser's Famous Mail-Order Handbooks tell how. Eleven brochures \$3. One book with complete catalog, 25c; none free. Breniser, (Established 1900) 335 Walnut, Philadelphia.

MAIL order Booklet, where to buy Books, Novelties, Specialties, 10c. Harvey Teepie, Deatur, Ind.

ARE You Old at Forty? See our advertisement on page 65 of this issue. The Electro Thermal Company, 2160 Main Street, Steubenville, Ohio.

\$25.00 WEEKLY. Start a spare time Mail Order Business. Particulars for stamp. Mas.

66 MILES on 1 Gallon—Amazing Gas Saver. All autos. 1 free. Critchlow, D-123, Wheaton, Ill.

RAISE Money quickly to promote business, invention, or any proposition, by using our inexpensive proved unerring method. Get free circular. Interstate Commercial Service, Elizabeth, N. J.

DON'T gamble in mail order business. Be sure. Free circular puts you wise. MacRae, M49 Oregonian Building, Portland, Ore.

START your own moneymaking business recharging auto and radio batteries. No experience needed. Outfit, easy payments. Hobart, Troy, Ohio.

START your own business; no capital nor experience required. Gold Leaf Window Signs; 500% profit. Samples free. Consolidated, 69 T—West Van Buren, Chicago.

MONEY in Dry Cleaning; we furnish instructions and machinery; experience unnecessary. Potter Manufacturing & Supply Co., 3850-52 Easton Ave., St. Louis, Mo., U. S.

TOYS—make at home—permanent and profitable. Details for stamp. Leonard J. Cooper, Springville, Erie Co., N. Y.

INVENTORS—Write for our Guide Book, "How to Get Your Patent" and Evidence of Invention Blank. Send model or sketch of your invention for our free Examination and Instructions. Randolph & Co., Dept. 435, Washington, D. C.

MARBLE mixing instructions, covering wood or cement flooring 1/2 in. thick, fire-proof, waterproof, low cost, sanitary, all colors. Particulars, 200 illustrations free. Chris. Mahler, Box 122, Huntington, N. Y.

ENTER a new business. Earn \$3,000 to \$6,000 yearly in professional fees making and fitting a foot specialty, openings everywhere, with all the trade you can attend to; easily learned by anyone at home in a few weeks, at small expense; no further capital required, no goods to buy, job hunting, soliciting or agency. Address Stephenson Laboratories, (1) Back Bay, Boston, Mass.

COST \$5.00, your profit \$104.75. Transferring Decalcomania letters on autos, trunks, bags, etc. Send today for outfit or free samples. World Monogram, Dept. 73, Newark, N. J.

EARN \$10 daily silvering mirrors, plating and refinishing metalware, autos, chandeliers, bedsteads, headlights. Outfits furnished. E. Decle Laboratories, 1133 Broadway, New York.

SCHEMER Magazine, Alliance, Ohio, 28th year, prints big profit Schemes, Ideas, Formulas. Subscriber made \$25,000; another \$10,000. Try your luck. Year \$1.00; three months, 30c. None free.

TATTOOING Supplies. Complete Electric Outfits. Lowest Prices. Catalogue. "Waters," 965 Putnam, Detroit.

LEARN the collection business. Good income, quick results. Interesting booklet, "Skillful Collecting" free. National Collectors Assn., Long St., Newark, Ohio.

\$3,000 TO \$5,000 Yearly. Want it? Others are making it. Send check or money order today for our invaluable books "How to Sell Real Estate," \$3.00—and "How to Conduct Real Estate and Insurance Business," \$1.50. Absolute satisfaction guaranteed. Free circulars. Realty Book Co., Dept. 52, Cleveland, Ohio.

PATENTS Procured; Trade Marks Registered—A Comprehensive, experienced, prompt service for the protection and development of your ideas. Preliminary advice gladly furnished without charge. Booklet of information and form for disclosing idea free on request. Richard B. Owen, 30-Owen Bldg., Washington, D. C., or 41-R Park Row, New York.

MAKE toys and novelties at home. Big profits. Instructions and illustrations. 25c. Astroffite Company, Sharpsburg, Pa.

FREE Booklet describing 52 plans for making \$20.00 to \$100.00 weekly in home or office business of your own. Downs Co., 2323 Myrtle St., St. Paul, Minn.

CHEMICAL Expert will furnish Formulas and Trade Secrets. All lines. Lists Free. W. L. Cummings, Ph. D., 228 Gordon Ave., Syracuse, N. Y.

RESPONSIBLE manufacturer wants competent men to manage office and salesmen. \$300 to \$1,500 necessary; will allow expenses to Trenton if you qualify. Address Manager, 536 Forst Richey Bldg., Trenton, N. J.

SIGNS and Showcards Easily painted with Letter Patterns. Large variety of Styles and Sizes. Samples for stamp. John Rahn, 42126 Neva Ave., Chicago.

UNPATENTED Ideas Can Be Sold. I tell you how and help you make the sale. Free particulars (Copyrighted). Write W. T. Greene, 810 Jenifer Building, Washington, D. C.

WE Start You in Business, furnishing everything; men and women, \$30.00 to \$100.00 weekly operating our "New System Specialty Candy Factories" anywhere. Opportunity lifetime; booklet free. W. Hilmyer Raesdale, Drawer 4, East Orange, N. J.

TELEGRAPHY

TELEGRAPHY—Both Morse and Wireless—taught thoroughly and quickly. Tremendous demand. Big salaries. Wonderful opportunities. Expenses low; chance to earn part. School established fifty years. Catalog free. Dodge's Institute, H St., Valparaiso, Ind.

CHEMISTRY

EXPERIMENTERS! Students! Chemists! Read "Popular Chemistry"! Experiments, News, Information! Year, \$1.00! Sample, 10c! Eight different copies, including fireworks formulas, mineralogy lessons, 50c (no stamps)! Wright Press, West Caldwell, N. J.

YOUR chemical problem solved and working process furnished Five Dollars. Write me. W. Steadman Richards, Consulting Chemist, address, Box 2402, Boston, Mass.

FORMULAS AND TRADE SECRETS

500 VALUABLE Formulas, 25c. Circular Free. Harvey Teeple, Decatur, Ind.

CONCRETE Waterproofing Processes, making Hard, Light Colored Damp-proof concrete building blocks. Concrete Machine Co., 5 Main St., St. Louis, Mo.

FORMULAS: New, different. Make beverages, extracts, syrups, flavors, etc. Home and manufacturing specialties. Valuable information free. Western Formula Co., 1813 Queen Anne Ave., Seattle, Wash.

GUARANTEED formulas of the better grade supplied by chemist. Best sellers duplicated. Latest specialties. All lines. Romig, Box 103E, Station W, New York.

10,000 FORMULAS. A real Gold Mine of money-making ideas. Tells how to make almost everything under the sun. You can make and sell cosmetics, muclage, anti-freeze solutions, battery solutions, beverages, cheese, chewing gum, cleaning preparations, extracts, hair preparations, inks, bluing, leather polish, mirrors, perfumes, polishes, typewriter ribbons, carbon paper, washing powders, liquid soap, and hundreds of other profitable articles. Send No Money. Just write a postal for "Hendley's 20th Century Book of Formulas." Pay postman postage and \$1. Popular Mechanics Press, 200 E. Ontario St., Room 808, Chicago, Ill.

FORMULA by Richards means the best. Your chemical problem solved and working process furnished \$5.00. Write me. W. Steadman Richards, Industrial Chemist, Box 2402, Boston, Mass.

FORMULAS—Silvering Mirrors and hundreds others, with Business Library for \$1.00 Prepaid. Globe Novelty Co., South Bend, Ind.

FORMULAS, Guaranteed Best Chemical Science can devise. Stamp brings big bunch valuable literature describing Latest Reliable Processes for Manufacturing All Lines. Don't Buy till you've received these Profitable Propositions. No recipe-book trash. 20 years giving satisfaction. Miller Chemist, 1706-U Jetton Tampa, Fla.

FORMULAS—Processes—Any Formula Dollar Bill. Hance, Chemist, 57 Saratoga, Yonkers, N. Y.

MOTION Picture Formulas, Developing and Coloring. Will send practical formula. Can be used in any Film Laboratory or home use. Color your own film. Very interesting. \$1.00 per copy. Mahoney, 337 Stephen St., Belleville, N. J.

FOUND. Method of making non-alcoholic flavoring emulsions. Ten times strength of flavoring extracts. Household and manufacturing. Send \$1 for formulas and process. A. M. Schmidt, Formula Craftsman, 224 8th St. SW, Washington, D. C.

SAWDUST and chemicals makes sanitary flooring. Directions \$1.00. Universal Supply Co., Eastwood, N. Y.

EASY money maker, just like I use myself; why not you? Particulars for red stamp. W. P. Stump, Henet, Calif.

500 FORMULAS including Luminous Paint—Renewing Dry Batteries—Resilvering Mirrors—Gas Tonic Puncture Plugger, 25c. Catalog Free. Ideal Book Shop, Park Ridge, Ill.

\$5.00 WILL furnish you with guaranteed formula for manufacture of any article. Chemical analysis of any nature. Chemical Technical Laboratories, 173 State St., Boston, Mass.

SPECIAL Formulas for Manufacturing and Business purposes. Any one you want \$5. You must be satisfied or your money will be refunded promptly. National Information Bureau, 316E Shepard Building, Grand Rapids, Mich.

15,000 FORMULAS in "Scientific American Cyclopaedia of Formulas." Includes following and many others: accidents and emergencies, agriculture, alloys and amalgams, artists' materials, beverages, cements, glues, pastes, muclages, bleaches, renovating, coloring metals, dyeing, glass, heat treatment of metals, household formulas, ice cream, confectionery, chewing gum, lapidary work, exterminating vermin, lubricants, paints, varnishes, photography, condiments, canning formulas, rubber, soap, candles, soldering, toilet preparations, perfumes, waterproofing, fireproofing, writing materials. Send No Money. Just write a postal. When postman hands you book, pay \$5.50 and postal charges. Popular Mechanics Press, Room 808, 200 East Ontario St., Chicago, Ill.

AGENTS WANTED

NO Dull Times in the Food Business. Selling Federal Pure Food Products is the greatest, surest and safest business in the world today, and here is your opportunity to get into it. You can make \$3,000, \$5,000, \$10,000, or more per year—the only limit is your ability to take care of the business. You will need no experience or money to get into this business. Your \$20.00 starting order sent on trust. We teach you everything you need to know. We furnish you with license. No Dull Times, for the People Must Eat, and our food products are the fastest selling, surest and quickest repeat order goods in the world. Sell on sight in every home where food is used—repeat orders immediately and every week thereafter. A real big business all your own. Every new customer adds a great deal to your weekly income. Your business once established, has a market value just like a store and can be easily sold. The greatest money-making opportunity of your lifetime because you risk absolutely nothing, as we guarantee your sales, and we will not let you fail. Remember! Guaranteed! Best products, biggest sellers, surest repeat orders. No capital or experience is required. We furnish capital and everything necessary for you to become a Federal Distributor. Exclusive territory will be given honest men or women who write at once. Federal Pure Food Company, 2309 Archer Avenue, Dent, A, Chicago, Ill. Largest packers of Pure Food specialties in the world. Reference, any bank, Dun or Bradstreet rating agency. Express or Railway Company in America.

\$8.50 TO \$20.00 daily pay. Introducing New Insured Hosiery for men, women, children. 57 styles, 40 colors. Must wear or replaced free. Repeat orders sure. Nyland made \$95 in one month. Edwards \$460.60. Mrs. Bone, \$445.25. Why not you? Even spare time work should pay you \$3 per hour. Your Pay Daily in advance. We deliver and collect. You spend all your time writing orders. No experience or capital needed. We furnish samples. All grades, colors, including silks. No matter what you are doing now, write for our offer. Macochee Textile Company, Card 2568, Cincinnati, Ohio.

MANUFACTURE Very Latest, Biggest-selling Advertised Specialties yourself—No Machinery Investment small—All lines. Stamp brings Valuable Interesting Literature explaining how others sell your products and big bunch lists Guaranteed Formulas. 300 to 1,200% profit to you. Reliable Information Only. No "Master Formula" trash. Miller, Chemist, 1706-V Jetton, Tampa, Fla.

AGENTS instantly step into \$5,000 class helping us supply growing demand for Tarnoff—amazing preparation that magically makes autos look "brand new." Not a polish, not a varnish, not a paint! Sensational seller—big repeater. Exceptional opportunity for fat profits—All Cash—and "flying start" in big-paying business of your own. Speak Quick for local agency. Send 50c (coin) today for \$1 size sample, and full details of our highly co-operative sales plan. Tarnoff Chemical Co., 1406 W. 26th St., Cleveland, Ohio.

AGENTS, Salesmen, Crewmen, You'll Have the Devil's own time finding a better seller than "Zippo." Splendid profit on snappy 50c "Go-Getter" repeat article that sells on a ten-second demonstration. Works while you watch it! Demonstrates value while others waste time making claims. New development! Greatest scientific triumph of the age. It's the berries. Write immediately for complete proposition. Karam-Smith Company, 608 F St., Fort Wayne, Ind.

FREE—Get This Quick! Chicago's Wonder Shirt Line. Sell newest, stylish, snappy, Stylemor Shirts. Amazing values at low prices. Make \$100.00 weekly easy. Complete assortment of large swatches makes selling Stylemor Shirts a cinch. Experience or capital unnecessary. Be your own boss. We will show you how to build a big business of your own. We will deliver and collect. Exclusive territory open. Write today for big free outfit. Stylemor, 81 W. Van Buren, Chicago, Ill. Dept. 1007.

PATENTS. Time counts in applying for patents. Don't risk delay in protecting your ideas. Send sketch or model for instruction or write for Free book "How to Obtain a Patent" and "Record of Invention" form. No charge for information on how to proceed. Communications strictly confidential. Prompt, careful, efficient service. Clarence A. O'Brien, Registered Patent Attorney, Security Bank Building (directly across street from Patent Office), Washington, D. C. See pages 140 and 141.

IF I Send You a Suit made in the latest style from the finest goods, will you keep it, wear it, and show it to your friends as a sample of my sensational \$25.00 suits guaranteed regular \$50.00 values? Could you use \$3.00 an hour for a little spare time? If so, write me at once for my wonderful new proposition. Just write your name and address on a card and mail to Dept. 328, Salesmanager, 133 So. Peoria St., Chicago.

AGENTS—Best seller; Jem Rubber Repair for tires and tubes; supersedes vulcanization at a saving of over 800 per cent; put it on cold, it vulcanizes itself in two minutes, and is guaranteed to last the life of the tire or tube; sells to every auto owner and accessory dealer. For particulars how to make big money and free sample, address Amazon Rubber Co., Philadelphia, Pa., Dept. 505.

AGENTS: \$75.00—\$200.00 weekly. Gold Leaf Window Letters easily applied. Unlimited demand. Free Samples. Lewis Co., 368 A. Milwaukee St., Milwaukee, Wis.

AUTO Emblems—Wall Emblems—All lodges. \$10.00 daily easy. Everybody buys. New. No competition. Free sample offer. Write! Crafts, 3300P Lawrence Ave., Chicago.

TAKE it Easy! You don't have to work your head off this Summer if you take orders for Carlton's ready to wear dresses. \$35 to \$75 commission easy in 5 half days! Every woman, every home, means a sale. 90% repeat orders. No selling experience needed by our plan. Sample line actually Free to First applicant in each town. Write quick! Carlton, Inc., 337 S. Franklin St., Dept. 553A, Chicago.

AMAZING Large Cash Commissions Introducing Beautiful \$3.95 and \$4.95 Fit-to-Measure Guaranteed Shoes. Actual Samples Furnished. Write for Your Territory. Style Arch Shoe Co., Dept. 129-1, Cincinnati, Ohio.

AGENTS, \$240 month and new automobile. Introduce finest line latest style silk hosiery. Your pay daily in advance. Extra bonus besides. No experience needed. Samples furnished. Silk hose free. We give you extra fine silk hose for your own use. Write for special offer. Jennings Hosiery Co., Dept. 1431, Dayton, Ohio.

SELL Show Cards, protected territory. Write for particulars. Konkel Printing Co., Minneapolis, Minn.

EASY money applying gold initials, monograms on automobiles. Anyone can do it. Simply transfer from paper. Charge \$1.50, cost \$0.06. Samples and information free. World Monogram, Dept. 35, Newark, N. J.

66 MILES on 1 Gallon—Amazing Gas Saver. All autos. 1 free. Critchlow, E-133, Wheaton, Ill.

AGENTS—Men or women, write for our list of Juvenile Specialties selling direct to the home; sixteen different pieces from a 25c Cedar Chest to The Daisy Desk, an educational equipment with adjustable stand at \$12.50. Let us have your application now; we will furnish complete sample outfits to the first 500 sales people answering this call. Charles W. Hall & Co., Inc., Valparaiso, Ind.

IMPORTED Five-color pencil; write Red, Blue, Black, Green, Indelible. Everyone a prospect; no competition. Sample \$1.00. Square Deal Co., P. 236 West 55th St., New York.

WANT \$500? Free Sample Exclusive Territory? Just Out! Amazing New Patent! Wonderful necessity. Fast Seller. Experience unnecessary. Write American Manufacturing Co., 2206 E. Powell, Chicago.

\$11.80 DAILY in advance (Send for sworn proof) Introducing New Insured Hosiery. 57 styles, 40 colors, guaranteed seven months. No capital or experience required. You simply take orders. We deliver and collect (or you can deliver, suit yourself). Credit given. Pay you daily, monthly bonus besides. School line now ready. We furnish samples. Spare time will do. M. H. Mathews, Card 5868, Cincinnati, Ohio.

NECKWEAR — Wonderful proposition. Get details. Astor, 318-M Broadway, New York.

AGENTS—Big Seller—\$20 a Day Easy selling Taylor Caps—made-to-measure—every man buys—some want 2 or 3 caps. Samples Free and Cap Free to good agents. Write quick for fast money making proposition. Address Taylor Cap Manufacturers, Dept. K-145, Cincinnati, Ohio.

AGENT makes \$57 a day driving nails in tire! Amazing discovery heals all punctures—one tire was punctured 837 times without a leak. Send for free Sample Offer. O. S. Nelson, L-3025 Logan Bldg., Mitchell, S. Dak.

THANCO Vanilla—Bottle Yourself; Concentrated; add water; free labels. Crushes competition! 500% profit. Immense seller, homes, bakeries, stores. Write Thomas Manufacturing Co., Indianapolis, Ind.

NEW specialty; easy seller, \$1; \$5 per hour easily made. Write for proposition. W. A. Coderre, 200 S. Fourth, Marshall, Minn.

BIG season on. Rhinestone Initial Buckles sell on sight. \$15.00 daily in advance. No investment. Exclusive territory. Chaton Novelty Co., 606 Blue Island, Chicago.

SELLING Like Blazes! Eleven-piece toilet goods assortment at \$2.00 with two-piece carving set Free to your customers. 100% profit. Davis Products Co., Dept. 56, 1321 Carroll, Chicago.

VICTOR Glare Shield, handsome, permanent, protects driver against all glare. Exclusive territory, big commissions. Gateway Company, Wirthman Building, Kansas City, Mo.

SALESMEN: Write your name and address on a postal and mail to us. We'll show you sure earnings of \$20.00 a day. Will you risk one minute and a one-cent stamp against \$20.00? Mind you, we say we'll show you. Address Dept. 913, William C. Bartlett, Inc., 850 W. Adams St., Chicago.

AGENTS sell complete line Guaranteed Hosiery, Lingerie, Neckwear. Lowest prices. Big profits. Samples furnished. Full or part time. Monarch Company, 630 Market, Philadelphia, Pa.

17 HOSIERY Styles, 50 Shades, Largest Commission, Premium to customer and Agent. We deliver. Send three references for \$10.00 Sample Outfit. S. Q. S., Dept. 106, Lexington, Ky.

REAL Selling Sensation! Tremendous earnings whole or part time! Patented Hot Water Bottle. Invention needed everywhere. Big commissions. Extra bonus. We deliver. Write quick, C817, Lobl Corp., Middleboro, Mass.

AGENTS—New Plan. makes it easy to earn \$50.00 to \$100.00 weekly, selling shirts direct to wearer. No capital or experience needed. Represent a real manufacturer. Write now for Free Samples. Madison Company, 566 Broadway, New York.

AGENTS wanted to sell Men's Hats direct from Factory. Send for Catalogue. Model Hat Mfg. Co., Dept. 5, East Orange, N. J.

GOLD Initials, easily applied on Automobiles. Biggest moneymaker today. Cost 5c, you get \$1.50. No experience needed. Free samples. "Ralco," Monograms, 1043 Washington, Boston, Mass.

SALESMEN Selling to Men. We have logical side line for you that will sell along with any other line you may now be handling and probably make more money for you than your present line, provided you are now selling to men. Get full facts at once by addressing Salesmanager, 844 West Adams St., Dept. 512, Chicago.

AGENTS—Large profits in Pearls, every woman a customer, excellent quality guaranteed indestructible Pearl Necklaces; Retail \$1.00 up, handsome boxes Free; Sample \$1.75. Brunelle, 75 Park Ave., Albany, New York.

AGENTS—Sell the greatest novelty out. Sun Visor Caps with celluloid eye shade. Entire country is going wild over them, also Auto Radiator Flag holders with 5 flags, get our terms. Unger, 571 Harrison St., Chicago.

QUICKSPARK instant starting any Ford car, truck, Fordson. Saves 20% Gas. One free. Apple 288-R303 East Water St., Milwaukee.

SELL Glo-Zo polish—big demand—large profit. been a repeater for 15 years. Munson Co., Falconer, N. Y.

60 MILES on 1 Gallon—Amazing Gas Saver. All autos. 1 free. Critchlow, H-133, Wheaton, Ill.

IF I send you shoes in the style you select—the leather you like—high or low as you please, will you keep them, wear them, show them to your friends as sample of my \$15.00 Custom-Grade shoes to sell at \$7.35? Advise today. I will immediately mail complete outfit, absolutely Free. Dept. A178, Forrest Dustin, 932 Wrightwood, Chicago.

AGENTS or House to House Canvassers. Opportunity to earn \$50 to \$75 weekly, selling our patented pearl garters. Send for booklet. Namiot Inc., 132 Nassau St., New York City.

PERFUMED Beads from California. Fast Sellers. No Competition. License unnecessary. Big margin. Hire subs. Clean up. Mission, 519PM, 2328w. Pico, Los Angeles, Calif.

AGENTS. New Patent Flossfork cleans between teeth where brush can not reach. Quick sales to men, women, children. Side line or exclusive territory. Sample 25 Cents. Particulars free. P. O. Box 4330, Chestnut Hill, Pa.

AGENTS: New Invention. My Comb cleaner a winner. Good profits. Send for wholesale price list. P. Miller, Box 3, Tremont Station, New York City.

SAVE the manufacturer's profit. Manufacture your favorite products yourself. Guaranteed manufacturers formulas supplied. All lines. Latest specialties. Best sellers duplicated. Analytical work carefully performed. Romig, Box 103C, Station W, New York.

\$20 DAILY selling Tapestry Table Scarfs, Catalogue Free. Glenwood Mills, Kittanning, Pa.

PORTRAITS, photo pillow tops, frames, sheet pictures, medallions, merchants signs, food products, photo jewelry, guaranteed hose, toilet requisites, luminous crucifixes. Catalog 50 specialties free. 30 days' credit. Jas. C. Bailey Co., Dept. C-8, Chicago.

AGENTS—\$90 a Week—\$2 to \$5 an hour spare time. Make this with the celebrated line of Ho-Ro-Co Soaps, perfumes, toilet articles and specialties; over 200 items. Big profit makers. La-En-Strait Hair Dressing selling like hot cakes. Write for Free Sample Case offer. Ho-Ro-Co Mfg. Co., 788 Ho-Ro-Co Bldg., St. Louis, Mo.

AGENTS—Make a dollar an hour. Sell new kind of sharpeners. Sharpens all knives and tools quickly. Demonstrating sample free. Premier Mfg. Company, Dept. 58, Detroit, Mich.

AGENTS—Three Lines. Rubber Specialties, housedresses, undergarments, combined for big earnings. This proposition satisfies. B. & G. Manufacturing Company, Dept. 935, Pittsburgh, Pa.

AGENTS wanted to sell our high-grade sanitary household Brushes at lower retail prices. Big demand. 70% Commission. Write at once. Favorite Brush Co., P. O. Box 335, Springfield, Mass.

\$75.00 TO \$150.00 Weekly to Introduce "Chieftain." 3 for \$4.95. Guaranteed Tailored Shirts. Samples and full working outfit Free. Your Pay Daily. Cincinnati Shirt Company, Secy. 1588, Cincinnati, Ohio.

\$60-\$200 A WEEK. Genuine Gold Letters for store windows. Easily applied. Free samples. Liberal offer to general agents. Metallic Letter Co., 438-B North Clark, Chicago.

GREATER Profits, Tremendous repeat orders with Wear-Ever Rubber Repair. Sample Free. Wear-Ever Company, 68 Houghton, Worcester, Mass.

AGENTS wanted everywhere. Something new. Mexican Candied Fruits sell easily. Very good commission. Send dollar for samples and details. Garcia, BX 347, Nogales, Ariz.

TEN Dollars a Day, six days a week, selling McNeess Products. The repeat business does it. Qualify for Resident Manager and add as much or more to your own earnings. A Big Opportunity for a real worker. Write Furst-McNeess Co., 506, Sunlight Bldg., Freeport, Ill.

AGENTS: 100% profit selling our low-priced beautiful and attractive Felt Rugs. Easiest and surest way of doubling your money. Perfect color combinations win perfect admiration and insure quick sales. Excellent opportunity to build substantial business. Eastern Mills, Everett, Mass.

KLEENZIT Kleening Pencil—New, different, instant appeal to housewives and tailors. Sell like hot cakes. Removes spots from clothes without leaving marks or rings. 50c seller—big profit. Agent's sample 25c. Write quick. Exclusive territory. Argyle Specialty Co., Dept. P, Argyle, Wis.

AGENTS and salesmen, if you are looking for good money-making propositions, send for a free copy of our Weekly Mail Order Catalogue. Joseph P. Geiger, 207A Hearst Bldg., Chicago, Ill.

MAKE \$75 a Week and Liberal Bonus. Commissions paid in advance. Sell Pioneer tailored-to-measure, all-wool suits at \$23.50. Striking leather brief case and 100 large swatch samples furnished. We train the inexperienced. Write Pioneering Tailoring Co., 159 W. Harrison St., Dept. V1117, Chicago.

REPRESENT manufacturer. Guaranteed \$10.00 colored slickers \$2.95. Largest commissions advanced. Coat, outfit free. Jerome, 207 So. Green, Chicago.

I'll Pay You \$2 hour passing out samples Wonder Product, taking orders. Easy money; full or spare time. 242 Goodwin Bldg., Strawn, Ill.

LOOK—71% profit selling Wonder-Glo Hairdressing. Sample and particulars 10c. Abbott Specialty Co., 3 Smith St., Court, New Bedford, Mass.

YOU Can Make Good Durable Paint and Varnish 40c per gallon. Write Dept. 2 Emmellmann Bros. Mfg. Co., Indianapolis, Ind.

SOMETHING new—Presto Rubber Repair for tires, tubes; all rubber goods put on cold, no heat, acid or tools; vulcanizes itself in few minutes. Sells to auto owners and dealers, sample free. Pioneer Products Co., Dept. A, Roebling, N. J.

FRENCH Perfume, American bottled, ounce gift package, \$1.00. Pearl Necklace, Genuine Jap Imitation, graduated, 24-inch, indestructible. Sample, \$1.00. Usually sells \$3.50. Bluebell Products, 4339 Olive, St. Louis, Mo.

AMBITIOUS Men to Sell and Install Ideal Corner Dust Shields for stairways; a device that makes housework easier; liberal commission, easy to sell. Ideal Stairway Equipment Co., Canton, Ohio.

LITTLE Wonder Pencilknife, Clip, Eraser, Cigarette, Nailcleaner, Letteropener, made of finest Sheffield steel, fits on pencil. Sample and catalog of 20 best agents' specialties of 10c. Klees Co., 1710 Undercliff Ave., New York.

SELL Surety, the Original, Genuine Powdered Hand Soap, and make \$5,000 yearly. We furnish sales plans, advertising and Free Samples. Write quick. Surety Mfg. Co., 26A W. Washington St., Chicago.

\$35.00 PROFIT on \$1.50 Outfit; Gold Transfer Monograms for Automobiles. Free Samples. National, Station D, Brooklyn, N. Y.

WE Pay \$50 a Week and Expenses and give auto to men and women introducing our goods. Mariax Co., D-29, 4520 Magnolia, Chicago.

GENERAL Agents Wanted to Sell Post Cards through Our Original, Trust Scheme Method. No Talking required, Big Profits. Sample and Selling Plan 10c. Herman Studio, 706 Calhoun St., Ft. Wayne, Ind.

AGENTS—500% profit selling Genuine gold window letters. Scripts. Experience unnecessary. Free sample. Premier Sign Co., 121 N. Francisco, Chicago.

MIRRORS Resilvered at Home. Costs Less 5 cents per square foot; you charge 75 cents. Immense profits, plating like new; brassy, worn-off autoparts, reflectors, tableware, stoves, etc. Outfits furnished. Details Free. Sprinkle, Plater, 128, Marlon, Ind.

WE pay \$18 a week, furnish auto and expenses to introduce our Soap and Washing Powder. Huss-Beach Company, Dept. A-12, Chippewa Falls, Wis.

COST \$7.50. Your profit \$312.00., Transferring decalcomania letters on autos, trunks, bags, etc. Send today for outfit or free samples. Monogram Co., Newark, N. J.

SHOVEY'S Profits \$75 Three Days after receiving sample Morey Auto Rim Tool. Big profits for lire agents. M. Morey Rim Tool Co., Blissfield, Mich.

HERE Is Your Opportunity to establish a sound, dignified, permanent business of your own. You have the distribution of an article having practically limitless demand. No obligations. Write today. National Tire Service Association, Inc., Box 71, Clinton Hill Station, Newark, N. J.

NEW line—New field, biggest commission. \$90 weekly full time—\$30 spare time, taking orders Furniture, Rugs, Dishes, House Furnishings direct from catalog. Easy payments. No collections. Outfit Free. Fish Furniture, Dept. A98, 2225 Pershing, Chicago.

MIDDLE Aged Man: Invest Postage Stamp for Valuable information concerning Helpmate Soap. N. E. Badgley, 1063 W. Madison, Chicago, Ill.

GET posted—Good prices paid for butterflies, insects. See Sinclair display advertisement, page 28.

\$\$\$\$\$\$ IN the Circular-mailing business. Send ten cents for large assortment of the kind that pays. M. Northern Co., Northern Bldg., Harmon, La.

GOLD Sign Letters. \$9.75 for Thousand. Non-Tarnishable. Free Sample. Catalogue. Foil Sign Works, 438 Broadway, Denver, Colo.

AGENTS Wanted—for amazing new line of auto spot and trouble lights, featuring special patented clamp and adjustment. Every motorist a prospect—right prices—big commissions—Write at once to Glade Mfg. Co., 209 S. State St., Chicago.

15c ON every 25c sale means big daily profits. Box 500, Shreveport, La.

GENERAL Agents—County Managers wanted to appoint agents and sell dealers. "Green Diamond" Glare Shields provide positive protection. Twenty million motorists eager prospects. Exclusive territory. Particulars free. Franklin Company, 1145 Kasota Bldg., Minneapolis, Sample 25c.

\$60-\$200 A WEEK. Genuine Gold Letters for store windows. Easily applied. Free samples. Liberal offer to general agents. Metallic Letter Co., 438-A North Clark, Chicago.

AGENTS: Self-Threading needles; sell at sight. Package and Self-Selling Plan 10c. Newmyre, Eiters, Pa.

DISTRIBUTORS wanted for Mystifying Radio Gas Lighters and Masterlite Cigar Lighters. Everybody interested. Sell to consumers, dealers. Big profits. Steady business. Selling plans free. M. Masterlite Co., 110 East 23rd St., New York.

AGENTS: Gingham House Dresses \$8.75 dozen. Retail \$1.50 each. Sample sent C.O.D. for \$1. Write for free catalogue. Economy Sales Co., Dept. 696, Boston, Mass.

AMAZING profits, new fast selling specialty. I. Jankow, 41 Forsythe, New York.

CHANGE your luck selling cards, full pack of 52 cards 10c postpaid. Peery, 140 Ainsworth Ave., Portland, Oreg.

AGENTS—Write for Free Sample Dri-Klean-It. Makes your car look like new. Removes mud, dirt, dust. No soap or water used. American Accessories Co., Desk 831, Cincinnati, Ohio.

AGENTS, \$72 a week. Bonus besides. Introduce finest line guaranteed hosiery. Beats store prices. 126 styles, colors. Credit given. Samples furnished. Auto to travel in. Write quick. Wilknit Hosiery Co., Dept. 631, Greenfield, Ohio.

AGENTS: Be my partner. Make \$15.00 daily; ride in Chrysler closed car; show samples; distribute teas, coffee, spices, extracts, things people eat. This unusual offer to the first person answering in your locality. Write or wire Health-O Quality Products Co., Dept. 100 H, Cincinnati, Ohio.

\$2.00 AN hour for special advertising work among local families. Exceptional opportunity; pay starts immediately. American Products Company, 6096 American Bldg., Cincinnati, Ohio.

THREAD-CUTTING Thimble 25c. Seller Sample 15c. Irvel, 3973 Elston, Chicago.

OUR two in one knife and scissor sharpener sells all the year around. Sample 25c. Guaranteed Knife Sharpener Co., York, Pa.

66 MILES on 1 Gallon—Amazing Gas Saver. All autos. 1 free. Critchlow, G-133, Wheaton, Ill.

DISTRICT Agents—Sell \$23.50 suits and overcoats, all wool, one price. Wonderful value, liberal commissions in advance; money back guarantee; 9x13 swatch outfit free. Write R. P. Harvey, Mgr., Box 90, Chicago.

AUTO owner tire agent wanted each locality to use and take orders for hand-made Mellingier cord and balloon tires; guarantee bond 15,000 miles; shipped prepaid on approval; get your tires free; no capital or experience required; make \$100 to \$300 weekly. Write for wholesale prices and sample kit. Address Mellingier Tire Co., Dept. 400, Kansas City, Mo., or Dept. 400, Philadelphia, Pa., or Dept. 400, Oakland, Calif.

TAILORING Agents—Sell Simpson's new \$23.50 virgin wool union made to order suits and overcoats. Commission in advance. Exclusive territory. Big outfit 175 samples free. Write J. B. Simpson, 843 Adams St., Dept. 1225, Chicago.

BIG Money monogramming autos, trunks, bags, etc. Make \$20 to \$25 daily. No experience needed. Samples, information free. Monogram Co., Newark, N. J.

GOLD Leaf Window Letters and Script Signs. No experience; 500% profit. Samples free. Consolidated, 69U—West Van Buren, Chicago.

TOILET Preparations under your label. Samples. Tyrell Products, Martin's Ferry, Ohio.

AGENTS make 500% profit handling auto initials, sign letters, novelty signs, etc. Catalog free. Hinton Co., 4317 Homerlee Ave., East Chicago, Ind.

SOMETHING new. "Retco" Necktie Pressers remove wrinkles from worn neckties "while you sleep." Big money maker. Whirlwind Seller, Particulars free. "Retco," Box 103, Salem, Mass.

SELLING Like Blazes! Eleven-piece toilet goods assortment at \$2.00 with two-piece carving set Free to your customers. 100% profit. Davis Products Co., Dept. 56, 1321 Carroll, Chicago.

AGENTS, New Patent Just Out! Nothing like it ever sold—makes perfect Buttonhole in few seconds. Retail \$3. Sells on sight. Women can't resist. Agts. make \$25 up daily. Get our free sample offer. The Marvel Corporation, Box 150D, Mesilla Park, N. M.

MAKE \$15.00 daily selling "Fixit" Rubber Repair (Liquid Rubber). Doubles mileage of tires and tubes. Sensational seller and money maker of 1926. Sample free. Marquette Rubber Co., DD2327 Wolfram St., Chicago.

EASY to Earn \$10 Daily selling our Seven-in-One Vest Pocket Wonder Tool for Radio, Automobile, Electrical or Home use and other live, popular priced specialties. All 100% profit items—and Ready Sellers. Write Today for particulars. G. M. Z. Co., 309 Sixth Avenue, New York.

AGENTS—Here's a New One. "Best-ever Powdered Hand Soap." Sells like wildfire. Marvelous Discovery. Removes grease, paint, ink, oil, in fact anything from the hands. Cannot harm skin. 150% Profit. Great Repeater. Agents simply coin money. "Free Samples Get the Business." Write immediately. Besterer Products Co., 1937 E. Irving Park, Chicago.

\$31.00 PROFIT—with \$1.50 Outfit—Big Money—Easy Work. Selling Gold Monograms for Automobiles, Luggage, Windows, Wagons. No Experience. No License. "Samples Free." NuLife Monograms, Hartford, Conn.

\$18 DAILY selling "Lanowa" Polishing Cloths and Mitten Dusters. Great repeaters. Tremendous demand. Appoint agents. Free sample. Fraser Products, 305-J 43rd, Kansas City, Mo.

DO you want good live agents—fellows who can get the business? Ask me how others are doing it. I'll gladly render the necessary assistance without cost to you. Address: M. L. Rund, Mgr. Classified Advertising, Popular Mechanics Magazine, Chicago.

SALESMEN—Are You Making Enough Money? Let us show you how to make Big Profits with Jiffy Washing Tablets. No experience required. Write for Free Sample and Plans. Jiffy Soap Products Co., Dept. A, Dayton, Ohio.

YOU can be your own boss with our Key-Check outfit. Good for \$5 a day stamping names on pocket key checks, fobs, etc. Sample check with your name and address, 20 cents. Pease Die Works, Dept. M, Winchester, N. H.

DISTRIBUTORS To Sell Retail Stores and Hire Agents. Exclusive territory. Article retails for one dollar. Attractive display carton holds twelve. Strong appeal to motorists. Protecto Shield, Inc., 156 Edinboro St., Boston, Mass.

\$1 PER hour selling Dirt-Solve Washing Powder. Big repeater; exclusive territory. Premiums for customers. Sample free. Goodspeed Products Co., Rutland, Vt.

STOP Daily Grind. Make big money in a business of your own. Local or Mail Order. Experience unnecessary. Circular free. Write today. S. Viggiano, 321 Larimer Ave., Pittsburgh, Pa.

AGENTS, both sexes, we manufacture and control new household article. Fast seller. Big profits. Exclusive territory. Write now. Connolly, 123 Liberty St., New York.

OUR Luminous Crucifix Shines in the Dark. Every one amazed at the wonderful effect. Easily demonstrated. Easily sold. W. G. Hannan Co., Dept. B, 2539 So. State St., Chicago.

AGENTS, our super-embossed display signs for all stores are tremendous sellers. \$75 to \$100 per week easily made. Write now for details. Artistic Signs, 799-R Broadway, New York.

FORMULAS—All Kinds. Catalog Free. Clover Laboratories, Park Ridge, Ill.

AGENTS Get our proposition selling United No-Cement Tube Patch. United Patch Company, Covington, Ky.

MANUFACTURER lamb wool polishers, dusters. Newhall, 358 Broad St., Lynn, Mass.

MAKE Big Money selling our household necessities. Real money makers. Every housewife will buy. Particulars free. Snell Products Co., 1021 State Ave., Cincinnati, Ohio.

MILLIONS stolen. Remarkable new \$5.00 Check Protector stops forgery. Inks, protects two colors. Sensational sales, profits. Write. Safety Devices Corp., Grand Rapids, Mich.

WASH Clothes the new way. Use the Torrent Automatic Washer. You will be delighted. Special offer to one in each locality. Storm Royalty Co., 3601 Enrich Ave., St. Louis, Mo.

WANT distributing agent for Hanslick, powdered handsoap; removes anything from the hands without injury to skin; everybody a customer; great opportunity for hustler to get in business; sample free. Solar Products Co., A2144 So. Troy, Chicago.

EVERY Autoist will buy Auto Mitten Dusters. Send for Particulars and Free Sample. National Fibre Broom Co., St. Louis.

CALIFORNIA Rosebuds selling like hot cakes. Agents coin money; new stuff. Big profits. Catalog free. Mission Factory PM, 2328 West Pico, Los Angeles, Calif.

REMNANT Store, Bethel, Ohio. Greatest Dry Goods Bargains on Earth. Agents and Dealers.

A BUSINESS of Your Own—Making Sparkling Glass Name and Number Plates, Checkerboards, Signs. Big Book and Sample Free. E. Palmer, 512 Wooster, Ohio.

AGENTS wanted—To sell Ray-O-Lite cigar and gas lighters. Big earnings. Sample 50c. Rapid Mfg. Co., 799-E Broadway, New York.

"LIQUID-LEATHER" Fills Holes in Shoes, Rubbers, Tires. Dries Instantly. Pliable, Waterproof. Just Imported from France. Tube Retail 60c—Cost 25c. Sells Housewives, Sub-Agents. NuLife Leather, Hartford, Conn.

AUTOMOBILE Specialties. Guaranteed formulas for all latest money makers. Lowest prices. Write for free lists. Murphay, Chemist, Tujunga, Calif.

MAIL-ORDER Houses and Distributors; We pack French made beauty creams, face powders, perfumes, toilet preparations with your label. Chemist, A2700 Wabash Ave., Chicago.

STARTLING New Invention for the lawn, Medicine Bottle for the Lawn and Garden. Turns water to medicine for the Lawn, yet uses only water. Attach it to a hose, turn on the water, and watch the crowds gather to see what's going on; makes water roll up like a smoke bank. Gets 'em all. Takes the place of Sprinkler; everybody buys. Sells for only \$2.00. Agents make half and more. Selling by the thousands. Nothing like it. To save delay send one dollar for Agent's sample. Write for our proposition. Lawn Inventions Company, La Crosse, Wis.

BIG Money Selling New Household Clean-ing Set. Washes and dries windows. Sweeps, scrubs, mops. All complete only \$2.95. Over half profit. Write Harper Brush Works, 132 3rd St., Fairfield, Iowa.

SELL guaranteed shirts, overalls and work pants. Big variety of shirts, including silks, with a splendid line of union made work and flannel shirts, overalls, coveralls, work pants, play suits, all guaranteed. Sell direct to wearer full or spare time. No experience required. Write today for Free Selling Outfit. Nimrod Shirt Co., Dept. 8, 4922-24-26-28 Lincoln Ave., Chicago.

AGENTS—Wonderful seller, new discovery. Auto Rubber Repair for tires and tubes. Superior to vulcanizing. Put on cold at very little cost. Outlasts tire or tube. Sells to every auto owner and accessory dealer. Agents if you want big profits, made quick, write for particulars and free sample to Waltham Rubber Co., 13 South St., Waltham, Mass.

MAN in each town to plate auto parts, reflectors, bathroom fixtures, refinish beds, mirrors, chandeliers; by new method. No capital or experience required. Simple plan of manufacturing at home starts you in big money-making business. Outfit furnished. Free particulars and proofs. Gun Metal Co., Ave. H, Decatur, Ill.

WE Start You Without a Dollar. Soaps, Extracts, Perfumes, Toilet Goods. Experience unnecessary. Carnation Co., Dept. 2480, St. Louis.

GIVE Away finest laundry soap Free. You'll make \$10 daily easy by new selling plan. Big repeat business. Write quick. Wolverine Soap Co., 28 Wolverine Bldg., Grand Rapids, Mich.

AT Last! Diamond Rival Discovered! Amazing blue white Rajah Gem astounds jewelry world and deceives experts! Beautiful Sample case Free! \$100 weekly! Write Quick! Rajah Diamond Co., Dept. F-7, Salisbury, N. C.

SELL by mail! Big Profits! Books, Formulas, Novelties, Bargains. Particulars Free! Elco, 523 South Dearborn Street, Chicago.

AGENTS make \$100 week placing advertising Cigar Lighters with glass front. Every dealer wants one. Write for free plan. Drake Mfg. Co., Dept. M, Milwaukee, Wis.

AGENTS—Make a dollar an hour. Sell Mendets, a patent patch for instantly mending leaks in all utensils. Sample package free. Collette Mfg. Co., Dept. 404, Amsterdam, N. Y.

BUSINESS Guide with Free Legal Service Sells everywhere; Wells cleared \$1,185 in 35 days. Write for free outfit. Nichols Co., Naperville, Ill. Dept. 4B.

\$5,000 YEARLY easy, selling our money-making specialties; we undersell them all. Catalog free. Samples 25c. Mills Sales Co., 13 East 16th Street, New York.

BIG Money and Fast Sales. Every owner buys Gold Initials for his auto. You charge \$1.50; make \$1.35. Ten orders a day easy. Write for particulars and free samples. American Monogram Co., Dept. 40, East Orange, N. J.

AGENTS—Clever Invention! Inksnoon makes every pen a fountain pen. Fast office seller; big profit, demand increasing everywhere. Exclusive territory offered. Sample free. H. Marul Company, Tribune Bldg., New York, N. Y.

EASY pleasant work for Mechanics, Shop Men, Clerks, during spare hours; will add many dollars to their salaries. Also want persons who can give full time. Big wages assured. Novelty Cutlery Co., 67 Bar St., Canton, Ohio.

AGENTS—N-R-G Laundry Tablets, the old reliable moneymaker for live agents. Millions sold—200% profit—sales waiting for you. Clothes washed spotlessly clean in 10 minutes without rubbing. Free samples. N-R-G Company, 230 W. Superior, Chicago.

AGENTS: 500% profit. "Happy Home Make Shampoo" builds your own big business. Martin of Indiana made \$75.00 in one day. Missouri man made \$750.00 one month. Exclusive territory. Geo. A. Schmidt & Co., Dept. P, 236 W. North Ave., Chicago.

AGENTS \$1. Retail \$3. Your Profit \$2. Wonderful pocket Adding Machine with Magic Writing Pad. Particulars Free. Typewriter Supply, 905 Hersh Bldg., Pittsburgh, Pa.

WILLIAMS' No-Water Hand Soap. In tubes, has taken Auto owners by storm; washes dirtiest hands perfectly clean without water; easy demonstration makes quick sale. 150% profit. Williams Co., Dept. 265 Montclair, N. J.

GET Our Free Sample Case—Toilet articles, perfumes and specialties. Wonderfully profitable. La Derma Co., Dept. A, St. Louis, Mo.

A \$5,000 A YEAR Job. You can make it worth that and more. 400% to 600% profits selling Perry Photo Medallions. No portraits so desirable. Indestructible, hand-colored, fade-proof. Built from photo supplied by customer. Guaranteed. No money risk. No margin of profit so big in any other line. Write, Perry Photo Novelty Corp., 1793 Jerome Ave., Dept. PM, New York.

AGENTS make \$3.00 an hour taking orders for our 40 Fascinating Kitchen Specialties. No competition. Write quick. General Products Co., Dept. 7K, Newark, N. J.

FIBRE Brooms—detachable handles, fine finish. Good profits, repeat sales. The Fibre Broom People, 147 New Jersey Ave., Brooklyn, N. Y.

POLMET—The Wonderful Polishing Cloth that cleans all metals without liquid, paste or powder. Approved by "Good Housekeeping" and "Modern Priscilla"—sells fast at 25c. Sample free. Gale & Co., Inc., 15 Edinboro St., Boston.

FREE Booklet describes 52 plans for making \$20.00 to \$100.00 weekly in home or office business of your own. Downs Co., 2323A Myrtle, St. Paul, Minn.

BIG Money—fast sales; everyone buys gold initials for their autos; sell \$1.50, profit \$1.44. Ten orders daily easy. Samples, information free. World Monogram, Dept. 16, Newark, N. J.

EARN \$10 daily silvering mirrors, plating and refinishing metalware, autos, chandeliers, bedsteads, headlights. Outfits furnished. E. Decie Laboratories, 1133 Broadway, New York.

AGENTS: Big Money Monogramming by Transfer Method. Catalog Showing Over 50 Styles and Particulars Free. Motorists' Accessories Co., Mansfield, Ohio.

AGENTS: Our gold-eyed Needle Cases are wonderful sellers; immense profits; \$50 to \$300 weekly; proof and particulars free; sample outfit 15c; factory prices. Paty Needle Co., 231 Davis Square, Somerville, Mass.

AGENTS—Sell 5c fast selling candy specialties to stores. Big profits. Lorrac Products Co., Albany, N. Y.

INSTANT Weld. Repairs largest punctures without cement or heat. Lenn's profit one day, \$56. Write quick. Free sample; territory going fast. Tourists' Pride Mfg. Co., Desk T, Minneapolis, Minn.

OVER 100% Profit. Self Lighting Gas and Cigar Lighters; Everybody interested, repeat business. Sell individuals, dealers, subagents. Particulars Free. P. Bernhardt, 127 West 30th St., New York.

SOMETHING New—"Handy Packet." An attractively put up package of useful household necessities. Positively a sale in every home; fine side line; big profits. Send for sample. Prentice-Lee, 145 East 23rd St., New York.

NOW that you have read all these offers, read Maceochee Company (Cincinnati, Ohio) advertisement again.

HIGH-GRADE SALESMEN WANTED

BIG Money for Men. Let Fairbanks—with 40 years' success—put you into business introducing—taking orders—full or spare time—for America's greatest made to measure suit and overcoat values—all wool and all one price—\$23.75. Just show the big 9x13" samples—130 new stylish fabrics—in 30 fashion styles. Get orders on the spot. Pays you \$4 profit on every sale—cash in advance. We ship and collect—guarantee perfect fit, style, workmanship, and satisfaction. No investment—no deposit—no capital needed. Big complete outfit given free. Sales course, just what to do and say, accompanies outfit—all free. Write quick for exclusive territory and all particulars. Tell us if you have had previous selling experience. Fairbanks Tailoring Company, Dept. 666, Oakley Blvd., at Wabansia Ave., Chicago, Ill.

MANUFACTURER with a successful local record wants salesmen, full or part time, city or country. Manufacturer desires national distribution of article of proven merit; unconditional guarantee; big money; interesting work. Write Highland Machine Co., Sales Dept. 4, 462 Pa. Ave., N. W., Washington, D. C.

SALESMEN, Calendars and Advertising Novelties that attract and Prices that make them sell. Write Selmore Advertising Co., Potsdam, N. Y.

TAILORING Salesman—Many men in your town pay \$15 to \$20 more than our wholesale prices for the same woollens, workmanship and high-grade, perfect fitting, tailored-to-measure suits and topcoats—all these are live prospects. Complete selling outfit free. 200 choice cloth samples—all wool; six prices, \$18.50 to \$45.50. Positive 8-day tailoring service. Substantial commissions, "immediate" bonus and special prizes. Protected territory. Free advertising. Experience unnecessary. Our sales manual tells you "how." Write us about yourself, giving two business references for quick action. Wholesale Direct Tailors, Dept. 1206, 83-89 Ellicott St., Buffalo, N. Y.

SALESMEN: Galacite, the most successful patented puncture-proofing compound for auto tires, is making \$5,000 to \$10,000 a year for our hundreds of authorized representatives. Sells to car owners and dealers in big quantities. Seals any puncture instantly and makes tire puncture-proof for life. Positively guaranteed. Backed by a large, well financed corporation of long standing. Complete elaborate outfit and extensive advertising co-operation ready to back you in your community. The best money-making proposition ever offered you. Write at once to C. F. Johnson & Co., 19 West Jackson Blvd., Dept. 155, Chicago.

SALESMEN—Get this big sensational order-getting shirt outfit Free. Sell Stylemor Shirts all year round. It's Chicago's Wonder shirt line. Advanced Spring Showing of Smartest, snappy patterns. Large double swatches, low prices, quick service, makes shirt selling easy. Bellard of Texas made \$46.00 in two days. We deliver and collect. Write today for big free outfit. Stylemor, 81 W. Van Buren, Chicago, Ill. Dept. 1107.

EXCEPTIONAL Opportunity Offered; sell our Famous Radiumized Health Products, a scientific drugless treatment needed in every home. The \$2,500,000,000 spent yearly for health insures you a permanent and profitable business with no dull seasons. Experience unnecessary; pleasant, fascinating work; big commissions. Exclusive territory. Write for special offer. Radium Applicator Co., 359-P, Riley, Buffalo, N. Y.

DISTRICT Salesman: Must be reliable. Prefer married man, 30 years old or over, and permanent resident in his community. Exceptional opportunity for good man. Address Dept. 513, Goodwear Chicago, Inc., 814 W. Adams St., Chicago.

"LUMINITE"—Magic Color-Action Window Salesman. Proof our Improved Quick Change Letter System boosts users' sales 200%. Only dead dealers indifferent. If you can spot a winner, start making 20-minute demonstrations and pocket \$100 weekly. Protected territory. Display Products Co., A-210, West Eighth, Kansas City, Mo.

AMAZING new invention, duplicates anything typewritten, handwritten, drawn, ruled. Inexpensive, easily operated. Salesmen coin money. Write free sample offer Today! Stenograph, 1271 a California, San Francisco.

\$100—\$200 WEEKLY. Retailers' live-wire specialty. \$10 weekly guaranteed against cost. Reliable house. Guarantee dealers turnover or money back. Pay you to investigate. Appleton Specialty Co., Cedar Rapids, Iowa.

WANTED—Auto Mechanics to act as part or full time salesmen. Make big profits, build steady income selling our complete line guaranteed hand tools. Be our agent in your shop; buy your tools at wholesale. Write for free catalogue and money-making plan. J. G. Woods, Inc., 37 West 20th St., New York, N. Y.

WE have a line of goods for which every man in America is a prospect. It has everything any competing line has and something besides. It can be handled profitably by tailoring, shirt, hosiery, necktie, shoe, raincoat, and other salesmen now selling to men. For full facts, address Madison Bros., 135 So. Peoria, Dept. 11, Chicago.

ADVERTISING Salesmen wanted to take orders for Auto Key Purse; new invention; sells to advertisers by thousand; commission 20%; sample by mail 25c. Novelty Cutlery Company, 522 McGregor Ave., Canton, Ohio.

SALESMEN Wanted—Forty dollars and upwards for live salesmen. Salary and commission. Self addressed envelope for proposition. Complete line of samples. Tampa Token Cigar Co., Box 7166, West Tampa, Fla.

YOU Can Make \$50.00 to \$200.00 a week traveling and appointing agents for us. Write immediately for particulars. J. M. Pitkin & Co., 100 Pitkin Bldg., Newark, New York.

\$40.00 SUITS for \$23.50! All one price. Union made of finest quality Virgin Wool. You don't have to know anything about selling clothing. We'll train and equip you to make success. If you are honest and willing to work. Write at once. Dept. 912, William C. Bartlett, Inc., 850 West Adams, Chicago.

GOLFERS—Salesmen, Will's golf ball marker cuts and colors owners name on two opposite sides for permanent identification. Big profits. Best summer seller. O. W. LeSueur & Co., 246 W. 69th St., Chicago.

SALESMEN—Make \$25-\$100 Weekly selling our Advertising and Commercial Pencils. Distinctive designs, lowest prices, liberal commissions. U. S. Advertising Pencil Works, Quincy, Ill.

TAILORING Salesman—\$100-\$150 Week selling union hand-tailored made-to-measure suits, \$23.50-\$29.50. Liberal commissions advanced. Wood & Co., 651 S. Wells, Chicago.

SALESMEN—Sideline—Pick up big commissions selling plain advertising Toy Balloons for World's Largest Balloon Factory. Pioneer Rubber Company, Willard, Ohio.

EARN \$20 daily. Establish income for life selling for \$1 a year \$1,000 accident policy. Write W. C. Stone, 11 So. LaSalle St., Chicago.

HARDWARE Salesmen, for patented combination padlock; no keys; cannot be picked; retails \$1; simple, strong, practical lock. Excellent connection for right man with successful growing company. Write Defender Lock Co., Dept. B, 68 Cliff St., New York.

SALES Organizations—Salesmen: Quick selling line of Auto Necessities paying 20% commission means real money to you. Exclusive territory. Wilman Company, 1949 Canton, Toledo, Ohio.

SALESMEN to sell full line paints, varnishes, roof coatings, specialties and Murphy's Oil Soaps (Nationally Advertised) direct to factories, mills and farmers. Local territory. Large commissions. The Phoenix Oil Co., Paint Division, Cleveland, Ohio.

SALESMEN—Hurry, \$300 monthly. Fastest selling proposition ever put out. Giving leather traveling bag free with only 4 boxes cigars. Box 372, Watertown, Wis.

GENUINE Gold Leaf Letters anyone can put on Store windows. Guaranteed to never tarnish. Large Profits. Enormous Demand. Free Samples. Write today. Metallic Letter Co., 438-D North Clark, Chicago.

\$2,000 YEARLY Reasonable for Hour's Work Daily. \$1,000 Monthly Easy. Vacuum Base Auto Trouble Light Sticks Anywhere. Literature Free. Vacuette Co., Santa Monica, Calif.

DISTRIBUTOR wanted Radium active water Generators; handsome returns quickly and easily obtained for small financial requirements necessary secure exclusive selling rights. Radium Laboratories, Key Route Inn, Oakland, Calif.

SALESMEN—To sell a necessity for every store, jobber and factory. No commissions held back. Paid immediately! Opportunity to build permanent business. \$4,000.00 to \$6,000.00 annually. References required but no money. Write E. R. Engle, Manager, Dayton, Ohio.

SALESMEN—Salary and expenses guaranteed against commissions while you learn to sell our specialty. A business of your own. Box 221, Iowa City, Iowa.

SELL Printing. Low prices. High quality. \$1.00 per thousand commission. Send 10c for outfit. Ozark Press, Joplin, Mo.

FATTEN up the old B-R. Sell storekeepers' Window Display Cartoons. Popular as Hot Dogs at Carnivals. Get dope. Business Building Cartoons, 25 Beaver, New York.

ANY Salesmen Can Sell Them! Merchants everywhere use punchboards. Someone sells them. Why not you? Collect big commissions daily. Newest, largest, elaborate catalog sent upon request. Lincoln Sales Co., 9 So. Clinton, Chicago, Dept. D.

MAKE big money Selling Stone's Auto Enamels, Top Dressing, Auto Cleaner, Polish, Paint Remover. Our selling plan assures success. Exclusive territory. Write today for full information and territory wanted. Stone Chemical Products Co., Los Angeles, Calif.

GOLD Leaf Window Letters and Script Signs. No experience; 500% profit. Samples free. Consolidated, 69V—West Van Buren, Chicago.

MR. BRUSH Salesmen—Old Established New York Brush Manufacturers require the services of men in all territories to sell their extensive line of Sanitary Twisted in Wire Brushes. We pay larger commission than any other Brush House in the country. Write immediately for our proposition. Wire Grip Sanitary Brush Corporation, 15 Mercer Street, New York.

SELL Men's Shoes direct. \$50 to \$100 weekly. Every man a prospect. Easy sales. Low priced. Real comfort, long wear. You take orders, keep big deposit. We deliver and collect. Full or part time. We help you succeed. Easywear Shoe Company, Dept. 229, Indianapolis.

BECOME Your Home Town's Leading Business Man. Big money. Easy work. Selling groceries, coffee, canned goods, auto oils, men's shirts, ladies' hosiery direct to consumer. Undersell competition. Commission advanced. Liberal credit plan. No experience or capital necessary. Loverin & Brown Co., 1775 So. State, Chicago.

MINUTES Pay Dollars demonstrating wonderful three pound Calculator. Retails \$15.00. Work equals \$300 machines. Adds, subtracts, multiplies, divides automatically. Five year guarantee. Big demand; large profits, experience unnecessary. Write quick for liberal trial offer and protected territory. Lightning Calculator Co., Dept. F, Grand Rapids, Mich.

SALESMEN—Become Independent. Own Your business, experience unnecessary selling our \$7,500.00 Accidental Death; \$50 Accident; \$25 Sick Weekly Benefits—\$12.50 Yearly. Other Amounts proportionate. Guaranteed steady income from renewals. \$250,000 Deposited Insurance Department. Universal Policy, Dept. A, 30 Clinton St., Newark, N. J.

FOUR \$7.50 sales to merchants net you \$20.00 daily. Sayers Systems, 2803 Sheffield Ave., Chicago, Ill.

TRAVELING Salesmen calling on retail stores wanted by large manufacturer to sell unique line of business-boosting articles. Year round, fast selling, main or side line. If not earning \$150 weekly, address Union Specialty Works, Inc., 222 Charles St., Booneville, N. Y.

CALIFORNIA Rosebuds selling like hot cakes. Agents coinng money. Absolutely new. Big profits. Catalog free. Mission Factory SP, 2328 West Pico, Los Angeles, Calif.

WANTED—Tailoring Salesmen, make \$60 to \$125 per week. Biggest merchants in many towns have started with our line. We are the largest made-to-measure tailoring house in the country, furnishing elaborate sample equipments, including 500 all-wool fabrics. You make your own profits from \$8.00 to \$15.00 on each order. Guaranteed absolute satisfaction, perfect fit, best workmanship, or no sale. Write for our line and all accessories to be sent free. Tell us all about yourself. Address N. O. Perry, Sales Manager, Box 483, Chicago, Ill.

SALESMEN—Selling Supreme Shirts means big business, big repeats, big commissions. Write today for Free Kit. Supreme Shirt Co., 276-m Fifth Ave., New York.

SELLS for \$9.75. Prints ad on wrapping paper, envelopes, etc. \$4.00 commission. Send 10c for sample work. Automatic Ad-Stamp, Joplin, Mo.

SALESMEN Can make \$5.00 a day selling our Calendars, Pencils, Signs, Advertising Novelties, Yardsticks, Whistles, etc. Liberal terms. Sells entire year. Fine side line. Local and traveling agents. Model Calendar Co., Dept. 226, South Bend, Ind.

TAKE orders for coffee, sugar, flour, meats, canned goods, staple groceries also paints, radio sets, tires, auto and tractor oils. No capital or bond required. We deliver and collect. Permanent business. Big pay. Write at once. Hitchcock-Hill Co., Dept. 50, Chicago.

HELP WANTED

WORK for Uncle Sam. Get Government Jobs. Men—women. 18 up. Commence \$95 to \$158 month. Steady work. Short hours. Paid vacation. No layoffs. Pull unnecessary. Common education sufficient. Candidates coached without leaving home. Full particulars and 32-page book—Free. Write immediately. Today sure. Franklin Institute, Dept. W-3, Rochester, N. Y.

WE Start You in Business, furnishing everything. Men and women, opportunity to earn \$35 to \$100 weekly operating Ragsdale's original "New System Specialty Candy Factories" anywhere; wholesale or retail. Big commercial candy book free. W. Hillier Ragsdale, Drawer 350, East Orange, N. J.

\$16.50 DAILY Easy. Big New Seller. 6 pairs hosiery guaranteed 12 months. You simply take orders. We deliver and collect. Your Pay Daily. 49 styles, 40 colors. We furnish samples. Micochee Textile Company, Card 2608, Cincinnati, Ohio.

MEN 18-35. Become Railway Postal Clerks. Commence \$1,900 year. Common education sufficient. Candidates coached. Full particulars Free. Write immediately. Franklin Institute, Dept. W-16, Rochester, N. Y.

\$35.00 WEEK. Boys—men. Become Auto Repairmen. Sample lessons free. Franklin Institute, Dept. W-400, Rochester, N. Y.

MEN, 18 up. wanting to qualify for U. S. Mail Service positions, \$142 to \$225 monthly. Write immediately for free particulars. P. Bradford, 112 Bergen Ave., Jersey City, N. J.

GET posted—good prices paid for butterflies, insects. See Sinclair display advertisement, page 28.

MEN, 18 up. Become Railway Mail Clerks. Commence \$158 month. Sample coaching Free. Franklin Institute, Dept. W-16, Rochester, N. Y.

MANUSCRIPTS Wanted: Stories, Poems, Articles, Plays, etc. We help authors. Submit manuscripts to Writers' Society, 603, Hannibal, Mo.

MAKE money writing Photo-plays; details free to beginners. No correspondence course. Producer's League, 230 Wainwright, St. Louis.

DON'T prepare for any Civil Service Examination without seeing our catalogue. Free. Columbian Correspondence College, Washington, D. C.

EARN \$10 daily silvering mirrors, plating and refinishing metalware, auto, chandeliers, bedsteads, headlights. Outfits furnished. E. Decie Laboratories, 1133 Broadway, New York.

SILVERING Mirrors, French plate. Easily learned; immense profits. Plans free. Address, Wear Mirror Works, Dept. 34, Excelsior Springs, Mo.

INVENTORS desiring to secure patents should write for our book "How to Get Your Patent," tells our terms and methods. Send sketch for our examination and instructions without charge. Randolph & Co., Dept. 418, Washington, D. C.

U. S. GOVERNMENT wants men. \$1,700—\$1,900 and up at start. Railway Mail clerk examination coming. Let our expert (former Government examiner) prepare you for this and also Rural Carrier, Post Office, Customs, Internal Revenue, and other branches. Write today for free booklet. Dept. 8, Patterson Civil Service School, Rochester, N. Y.

MEN: Become Railway Postal Clerks. \$158 month. Sample coaching Free. Franklin Institute, Dept. W-16, Rochester, N. Y.

INFORMATION

FOREIGN Service—With mining, oil, electric, railway, fruit, sugar and other companies in Latin American; men interested write for further particulars. Foreign Service, box 69, Station D, New York City.

FOODS from Twenty Lands. Popular Mechanics new Cook Book made up of recipes sent by our readers from 20 countries. Many delightful foreign dishes, and many American ones, too. Only a few copies for sale. Send No Money. Just order on a postal. When postman hands you book, pay \$1.50 and postal charges. Popular Mechanics Press, Room 808, 200 East Ontario St., Chicago, Ill.

RELIABLE information on any one mechanical subject. \$2.00. Technical Research Bureau, Dept. A, 377 National Ave., Milwaukee, Wis.

ACCURATE specific information on any one subject \$5.00. National Information Bureau, 316A Shepard Building, Grand Rapids, Mich. Prompt service, satisfaction guaranteed.

CONCRETE Handbook, describing 173 ways of using concrete in the home, shop and on the farm, with full directions for doing these things yourself with ordinary tools. 138 illustrations. It is "written so you can understand it." With "Home Mechanics," 98 cents, postpaid. Popular Mechanics Press, 200 East Ontario, Room 808, Chicago, Ill.

BUSINESS SERVICE

MAKE 'Em Pay—My system will make them pay their bills. Write for the acid test. Literature free. Burleigh L. Horr, Horr Omelia Block, Rhinelander, Wis.

BUSINESS Problems Solved—all kinds—buying, selling, financial, increasing business, advertising, getting men, getting positions, special formulas, processes, etc. Long business experience, thorough research, complete files of information. Complete solution of problem \$5, particulars free. Satisfaction guaranteed. All confidential. National Information Bureau, 316P Sheppard Building, Grand Rapids, Mich.

DELAWARE Incorporator. Charters: Fees Small; forms. Chas. G. Guyer, 901 Orange St., Wilmington, Del.

TYPEWRITERS AND SUPPLIES

UNDERWOOD Typewriters—only \$3.00 down. Easy monthly payments. Low prices at less than manufacturers. 10 days' free trial. Rebuilt, all worn parts replaced. Just like a new machine. 5-year guarantee. Write for a big free catalogue B-151. Shipman-Ward Mfg. Co., C-151, Shipman Bldg., Chicago, Ill.

ALL makes, lowest prices, 5-year guarantee. Several specials. Free illustrated catalogue. Henry Typewriter Co., 217 West 125th St., New York, N. Y.

HIGH-GRADE typewriter ribbons 60c cash (not stamps). Babcock, 3821 E. Lake, Minneapolis, Minn.

TYPEWRITERS, all standard makes, thoroughly re-manufactured by the famous "Young Process" and shipped direct from factory to you on 10 days' trial. Guaranteed 5 years. Easy monthly payments. Write today for free catalog. Young Typewriter Company, Dept. 5758, 654 W. Randolph St., Chicago.

TYPEWRITERS, all standard makes. \$10 up. Fully guaranteed. Free trial. Write for complete illustrated lists. Northwestern Typewriter Exchange, 121 N. Francisco Ave., Chicago.

100 TYPEWRITERS Free. Overstocked. Rent rebuilt Underwood or Remington \$3.00 month. If you pay its value in rental, we give machine free. Particulars free. Pittsburgh Typewriter Exchange, 945 Hersch Bldg., Pittsburgh, Pa.

TYPING SERVICE

TYPEWRITING, considerate revision, make your poems publishable. Blakewhitling, Branford, Conn.

PRINTING, ENGRAVING AND MULTIGRAPHING

1,000 6x9 CIRCULARS, 250 words. \$2.00 prepaid. Success, 2722½ So. Marshall, Philadelphia.

PICTURES Make Printing Powerful. Cut catalog 10c. Superior, 2602 Brooklyn, Detroit.

DRAWINGS and Cuts made to order. Samples. Cressman, Washington, N. J.

\$3.00 DELIVERED, 500 Watermarked Bond Letterheads, 8½x11, and 250 envelopes, money with order. Job Printing Specialty. National Printing Company, Goshen, Ind.

CALENDAR Blotter Cards. Cost less than plain business cards. Samples. P. Wetzel, Valhalla, N. Y.

225 BOND letterheads, envelopes, billheads, cards, \$1.25 each. Combination, \$4.00. Economic Press, Leonia, N. J.

250 EACH Hammermill Bond Letterheads, Envelopes, \$3.00. Samples. Midland Press, 543 West Hickory, Kankakee, Ill.

DISTINCTIVE, Artistic Business Stationery that Creates Confidence. 1,000 Letterheads or Envelopes \$3.00. Samples. Moulton Printing Company, 1410-P. E. 8th, Kansas City, Mo.

250 BOND Letterheads or envelopes \$1.25; 500, \$2.25; 1,000, \$3.75 postpaid. Industrial Press, 510 Jefferson Street, Jefferson City, Mo.

NEARGRAVURE Process—(facsimile Copperplate—Lithography—type Emboss.) Samples Stamp. Sollday's, Knox, Ind.

AUTOMATIC sealing tape pressfeeder \$125.00; particulars 10c. Standard Tags, 76 Beekman, New York.

\$1.00—250 BUSINESS Cards, postpaid; 10c extra west Mississippi. Sample for Stamp. Business Card Specialty Shop, P-12, Jackson, Mich.

200 BUSINESS cards, \$1.00; 1,000, \$2.95. Delivered. Acorn Press, Box 273, Newport, Ky.

PRINTING: Lowest Prices in America. Fine work, quick service. Stationery, circulars, office forms, etc. Large price list and samples free. Pitts, Amana, Iowa.

COMMERCIAL Printing. Prices Right. Samples Free. The Fox Press, Frankfort, N. Y.

HIGH Grade Art and Plate Work furnished for any purpose at reasonable prices. Get our quotations first. Ed. Erb, Commercial Artists, 115 Elmer Street, Vineland, New Jersey.

QUALITY Printing! Reasonable Prices! Send for Free Standardized samples and prices. Folders, Circulars, Catalogs our specialty. Ernest Fantus, 525 South Dearborn, Chicago.

1,000 LETTERHEADS or Envelopes, \$3.00. Sent Prepaid. Samples Free. Monitor Press, Morrisville, Pa.

250 LETTERHEADS, 250 white envelopes printed and mailed \$3.00. Samples printing free. Sunco, Mohawk, N. Y.

250 Hammermill Bond Letter Heads or envelopes, \$1.50; 500, \$2.25. Pfleger Bros., Hackensack, N. J.

MULTIGRAPH typewriting business correspondence, two dollars thousand. Hammermill Bond Letterheads, four dollars. Mayeva Corporation, Monmouth, Ill.

PRINTING, Catalogues, Periodicals, Stationery, Etc. Prices Right. Quotations, Anville Printing Company, Anville, Pa.

GUARANTEED Printing should have your preference. Fifty expert printers. Secure our prices. We print anything but money and postage stamps. Waverly Publishing Co., Box 9, Waverly, Iowa.

1,000 BOND Letterheads; \$2.95 Delivered. Atoka Press, Atoka, Okla.

WE print Stationery, Booklets, Catalogs, Circulars, Samples. Commercial Press, Batavia, Ohio.

PRINTING OUTFITS AND SUPPLIES

PRE-USED Printing Presses, Type supplies. List for 2c stamp. Popular Barcains, Richland, Pa.

COMPLETE printing outfits, presses, type, ink, paper, supplies. Write for Catalog. Kelsey Company, G-11, Meriden, Conn.

PRINTING Outfits, Presses, Type, Supplies. Stamp for information. Nicholas, M-110 High St., Boston.

PRINTING Outfits—Presses, type supplies, type novelties. Send stamp for catalogue. Model Press, York, Penna.

DUPLICATORS AND DEVICES

YOU can make 50 to 100 copies of a letter, notice, etc., at a cost of three cents on a Hoyer Quality Duplicator. Write for free trial offer. The Hoyer Duplicator Co., 14 S. Wells St., Chicago, Ill.

ADDING MACHINES

FREE Trial. Marvelous new Adding Machine. Adds, Subtracts, Multiplies, Divides, automatically. Work equals \$350.00 machine. Price only \$15.00. Speedy, durable, handsome. Five-year guarantee. Used by largest corporations. Write today for catalog and free trial offer. Lightning Calculator Co., Dent, E. Grand Rapids, Mich.

NEW \$3.50 Automatic Adding Machine. Adds, Subtracts, Multiplies. Absolutely accurate. Capacity \$999,999.99. Fully guaranteed. 75,000 pleased users. Makes adding easy, positive, quick. Eliminates Mistakes. Saves Time. Postpaid \$3.50. Bassett Co., 1458 A Hollywood Ave., Chicago.

RUBBER STAMPS

RUBBER Stamps, Stencils, Adamee, 180 Harman St., Brooklyn, N. Y.

MAILING LISTS

A RESULT Producing Mailing List. Lady buyers of beauty clays and toilet preparations, absolutely guaranteed all fresh names \$4.00 per thousand. W. A. Heise, 1315 Steiner St., San Francisco, Calif.

FIRST time offered—names 500 Minnesota Pool and Billiard Halls for \$2.50. June list. 100% correct. Interstate Sales Co., Box 700, Minneapolis, Minn.

MAILING Lists \$4.00 Thousand. Nantell Distributing Co., 624 Barnard Ave., Cudahy, Wis.

2,500 NAMES 1926 Mail Order Buyers—hundred 50c; thousand \$4.00. Guaranteed correct. D. G. Perkins Co., Box 481, Lockport, Ill.

GUARANTEED fresh mail buyers' names, 35c hundred; \$2.50 thousand. National Mail Order Service, Bristol, Tenn.

NAMES—100 \$1.00. Ben Meyer, 35 West 31st, New York.

100 NAMES 25c. Just Received. Supply Co., 427 East 16th, New York.

FOR SMOKERS

HOMESPUN Tobacco Guaranteed—Chewing, five pounds, \$1.50; ten, \$2.50. Smoking, ten, \$1.50. Pine free; pay when received. United Farmers, Bardwell, Ky.

SEND 10c, Silver or Stamps, for sample package 20 fine cigarettes. Large pocket tin Special Blend smoking tobacco also sent for 10c. Direct-to-smoker. French Tobacco Company, Dept. 6, Statesville, N. C.

HOMESPUN Tobacco-Chewing, 5 lbs., \$1.25; 10 lbs., \$2.50; 20 lbs., \$4.50. Smoking, 5 lbs., \$1.00; 10 lbs., \$2.00; 20 lbs., \$3.50. Farmers Union, Mayfield, Ky.

BOATS AND LAUNCHES

BUILD your own boat: Newly designed, Speedy V-Bottom out-board motor, runabouts, Cabin Cruisers. Knock-down or patterns. 55 Models. Send 25c for catalog. Brooks Boat Co., Inc., Rust Ave., Saginaw, W. S. Michigan.

BOAT Building Plans for amateurs. Rowing, sailing, speed, cruising. Free catalog. The Rudder, 9 Murray Street, New York.

NEW Boat Book telling how to make 21 kinds of boats. Also many other helpful ideas on boating. Profusely illustrated. With this we include the big book, "Outdoor Sports the Year Round." Directions for making all sorts of devices for outdoor recreation. Send no money. Simply pay the postman \$1.98 plus postage when books are delivered. Popular Mechanics Press, Room 808, Popular Mechanics Building, Chicago, Ill.

OPTICAL GOODS

SPECIAL Imported Binoculars. Powerful, Brilliant, Adjustable. Leatherette case—\$1.00 postpaid. Inventors Bureau, 417 West 21st, New York.

BINOCULARS! Binoculars! Binoculars! Salesman's samples at cost prices. Send for complete list. Geneva Optical Company, 72 Linden St., Geneva, N. Y.

RAZORS AND BLADES

RENEW your old safety razor blades quickly and easily. Make new blades better. Apply Nura to your strop or strop-er, and see the difference. Nura makes blades last indefinitely. Straight razors seldom, if ever, need honing. Stop buying blades. Will not injure Strop. Guaranteed. Send 50 cents, no stamps. Nura Co., Box 342, Rochester, N. Y.

16 TO 26 Mitchell's razor blades \$1.00 postpaid. New blades. Factory direct. Mitchell Co., Inc., Aurora, Ill. Name your razor. Sample blade free.

GILLETTE style blades. Dozen 45 cents. Automatic stropper \$1.50. Wallace Kutz, 132 Chambers, Phillipsburg, N. J.

FOR THE HOME

WANTED—you to test the famous waterproof Valspar Varnish, Valspar Stains and Enamels. Try the famous boiling water test yourself! Best protection for automobiles, boats, machines of all kinds, radio cabinets, furniture, floors and all wood and metal surfaces, outdoors and indoors. Send 20c for 40c sample of Clear Valspar, transparent Valspar Stain, or opaque Valspar-Enamel (stating color desired). Valentine & Company, Dept. A, 456 Fourth Ave., New York, N. Y.

RECIPES for merchants, grocers, manufacturers, physicians, druggists, painters, shoemakers, harness makers, jewelers, blacksmiths, miners, furriers, barbers, bakers, dyers, renovators, tanners, gunsmiths, farmers and families generally. In 600-page book, "Dr. Chase's Recipes." Thousands sold. Send no money. Pay postman postage and bargain price of \$1.75. Popular Mechanics Press, Room 808, 200 East Ontario St., Chicago, Ill.

PURE New Honey in the Comb \$2 Gallon. Six Gallons for \$11. Eat a little of our pure honey each day and you will never take colds or flu. Try and see. Order from this advertisement. Fulghum Seed Co., Lorain, Ohio.

REFRIGERATING Machine, Homemade. Operates successfully. Gives better service than ice. This and 328 other practical articles in our book "Home Mechanics." Just ask for this and "Handbook for Women" containing 394 valuable household helps and pay postman 98 cents and postage for the two books. Popular Mechanics Press, Room 808, 200 East Ontario St., Chicago, Ill.

BEAUTIFUL Carved Vermillion Arch. Arch is one piece and is 12 ft. wide by 4½ ft. high and is supported by 2 eight inch round mahogany columns. Height over all is 11½ feet. Several extra solid vermilion boards, panels and trim included. Suitable for residence, music store or ice cream parlor. Cannot be duplicated for \$2,500. \$300. S. R. Dee, Harvey, Ill.

ANTIQUÉ furniture readily made from measured drawings and photographs contained in new book entitled, "Measured Drawings of Early American Furniture." Send no money. Just write a postal for the book. Pay postman postal charges and \$2.50. Popular Mechanics Press, Room 808, 290 E. Ontario St., Chicago, Ill.

DIAMONDS, WATCHES AND JEWELRY

SUMATRA Diamond Rings, Watches, Etc., \$1.00 week. Catalogue Free. Barnes, 24 Calender, Providence, R. I.

HIGH-GRADE Swiss watches cheap. 6 and 15 jewel. Trial. Ralph Pile, Somerset, Penna.

WATCHES. Chinese, musical watches, 24-hour watch, modern watches. Much more in "Time and Its Measurement." Pay postman postage and \$1.50. Popular Mechanics Press, Room 808, 290 E. Ontario St., Chicago, Ill.

ANTIQUES, WAR RELICS AND INDIAN GOODS

FLINT-LOCK pistols, rifles, powderhorns, Indian Curios, 1926 Catalogue 4c. Nagy, A-8 South 18th, Philadelphia.

FLINTLOCK pistols, rifles, powderhorns, swords, daggers, Indian curios. Catalogue free. Collectors Exchange, 1536B Willington St., Philadelphia.

FOR Dens. Relics from Europe's battlefields; also medals. Illustrated catalogue 25c, with Sample War Photos. Welsh, 1889 Albany Ave., Brooklyn, N. Y.

SEND 5c for fine, new list Indian relics, antique firearms. F. E. Ellis, Webster Groves, Mo.

PHONOGRAPHS AND SUPPLIES

BUILD your own phonographs. We can supply you with motors, tone arms and all accessories at wholesale prices. Write for catalogue AX. Pleasing Sound Phonograph Co., 204 East 113th St., New York, N. Y.

BUILD your own Phonograph. We furnish everything. Catalog sent free. American Phonograph Co., 3752 Belmont, Chicago.

COMPACT Phonograph. Portable. No larger than a camera. \$12.50 each. Send Postal money order. Schmidt, 61 Park Place, New York.

MUSIC AND MUSICAL INSTRUMENTS

PLAY piano by ear. New easy method; chart and instructions \$1. D. W. Shanahan, 682 South Park Ave., Buffalo, N. Y.

SONG Poem writers—send for proposition. Ray Hibbeler, D1, 2104 N. Keystone Ave., Chicago.

SONG Poems Wanted—Original melodies to your lyrics, on a new plan. For particulars, write, Raymond H. Clark, Composer-Publisher, Ashland, Me.

CORNETISTS—Trombonists—Saxophonists—Clarinetists. Get "Free Pointers." Name instrument. Virtuosi School, Buffalo, N. Y.

SAXOPHONES, all other Band and Orchestra Instruments, best makes, new and used, on easy terms. Also buy, exchange, repair. Write today for free catalogs, bargain bulletin and "Musical Booster" magazine, all free. Get acquainted with the big Professional Supply House. Crawford-Rutan, 1010 McGee, Kansas City, Mo.

SHARPS and Flats—Free. Very interesting. Send for it Today. Harry L. Alford, 192 No. State St., Chicago, Ill.

WRITE Songs. Big money and reputation. Write for information. J. Gordon Pub. Co., 201 N. Hoyne Ave., Chicago.

VIOLINS. Deep, Mellow, Soulful—on credit. Easy terms for wonderful instrument. Get details today. Gustav F. Henning, 2424 Gaylord St., Denver, Colo.

I WANT Song Poems. Casper Nathan, 3544 N. Racine, Chicago.

"MUSIC Composed" to words. Bauer Bros., (formerly of Sousa's Band), Oshkosh, Wis.

BIG Song Hit! "When Eve Was Absent Without Leave." Copy, 30c. L. A. Wachlin, Sayville, N. Y.

SONG Poem Writers—Stamp brings "Song Writers' Guide." Wm. Van Beaver, B1-1239 Elm St., Green Bay, Wis.

I BUY, sell, publish, songs. Chester Echer, 104 Baldwin Ave., Jersey City, N. J.

PATENT ATTORNEYS

PATENTS. Booklet free. Highest references. Best results. Promptness assured. Send model or drawing for preliminary examination. Watson E. Coleman, Patent Lawyer, 644 G. Street, Washington, D. C.

PATENTS. Time counts in applying for patents. Don't risk delay in protecting your ideas. Send sketch or model for instruction or write for Free book "How to Obtain a Patent" and "Record of Invention" form. No charge for information on how to proceed. Communications strictly confidential. Prompt, careful, efficient service. Clarence A. O'Brien, Registered Patent Attorney, Security Bank Building (directly across street from Patent Office), Washington, D. C. See pages 140 and 141.

PATENTS—Write for our Guide Books and "Record of Invention Blank" before disclosing inventions. Send model or sketch of your invention for Free Inspection and Instructions. Terms Reasonable. See advertisement on pages 142 and 143. Victor J. Evans & Co., 934 Ninth, Washington, D. C.

LACEY'S Patent Sense. Valuable book free. See ad page 144.

UNPATENTED Ideas Can Be Sold. I tell you how and help you make the sale. Free particulars (Copyrighted). Write W. T. Greene, 807 Jenifer Building, Washington, D. C.

PATENTS Procured. Prompt Service. Personal, careful and efficient service. Highest references. Moderate fees. Send sketch or model for actual search and advice. George P. Kimmel, Master of Patent Law, 55K, Legal Bldg., Washington, D. C.

U. S. AND foreign patents, trademarks; moderate rates. 22 years' experience. George C. Heinicke, 32 Union Square, New York; registered in U. S. and Canada.

PATENTS Procured: Trade Mark Registered—A comprehensive, experienced, prompt service for the protection and development of your ideas. Preliminary advice gladly furnished without charge. Booklet of information and form for disclosing idea free on request. Richard B. Owen, 30-Owen Bldg., Washington, D. C., or 41-R Park Row, New York.

"INVENTOR'S Advisor," the valuable Patent book with 139 mechanical movements and illustrations, sent free upon request. M. M. Labiner, Patent Attorney, 3 Parkrow, New York.

INVENTORS—Write for our Guide Book, "How to Get Your Patent" and Evidence of Invention Blank. Send model or sketch of your invention for our prompt examination and instructions free. Randolph & Co., Dept. 430, Washington, D. C.

INVENTORS: Send sketch or model for advice and exact cost of patent. Ask for our Free book: "How to Obtain a Patent." Tells what every inventor should know. Established twenty-eight years. Highest references. Prompt service. Reasonable charges. Chandlee & Chandlee, 474 Seventh, Washington, D. C.

PERCY S. WEBSTER, 203 Saving and Loan Building, Stockton, California. Long established organization. Patent booklet free.

"INVENTORS' Guide" sent free on request; this book contains illustrations of patented inventions and gives valuable information and advice for all who have original ideas or improvements. Frank Ledermann, Registered Attorney and Engineer, Woolworth Bldg., 1712, New York.

PATENTS. Trade marks, copyrights. Prompt, personal, reliable service. Over 36 years' active practice. Write for terms. Book free. Address E. G. Siggers, N. U. Bldg., 918 F Street, Washington, D. C.

FOR INVENTORS

PATENTS. If you have an invention which you wish to patent you can write fully and freely to Munn & Co., for advice in regard to the best way of obtaining protection. Please send sketches, or a model of your invention and a description of the device, explaining its operation. All communications are strictly confidential. Our Handbook on Patents is sent free on request. This explains our methods, terms, etc., in regard to Patents, Trade Marks, Foreign Patents, etc. "Scientific American" contains Patent Office Notes, Decisions of interest to inventors and particulars of recently patented inventions. Munn & Company, Solicitors of Patents, 1523 Scientific American Building, New York; 524 Scientific American Bldg., Washington, D. C.; 1313 Tower Bldg., Chicago, Ill.; 666 Hobart Bldg., 582 Market St., San Francisco, Calif.; 521 Van Nux Building, Los Angeles, Calif.

UNPATENTED Ideas Can Be Sold. I tell you how and help you make the sale. Free particulars (Copyrighted). Write W. T. Greene, 806 Jenifer Building, Washington, D. C.

PATENTS. Time counts in applying for patents. Don't risk delay in protecting your ideas. Send sketch or model for instruction or write for Free book "How to Obtain a Patent" and "Record of Invention" form. No charge for information on how to proceed. Communications strictly confidential. Prompt, careful, efficient service. Clarence A. O'Brien, Registered Patent Attorney, Security Bank Building (directly across street from Patent Office), Washington, D. C. See pages 140 and 141.

LACEY'S Patent Sense. Valuable book free. See ad page 144.

INVENTORS—Write for our Guide Books and "Record of Invention Blank" before disclosing inventions. Send model or sketch of your inventions for our free inspection and instructions. Terms reasonable. See advertisement on pages 142 and 143. Victor J. Evans & Co., 157 Ninth, Washington, D. C.

YOUR ideas developed. Confidential. Drawings made. Experimental tests conducted. Models built complete. Low cost. The Practical Mechanic, South Haven, Mich.

HOW to Sell Your Invention without Being Swindled. Free Instructions. Write Today. Scholtz & Co., Wyandotte, Mich.

PATENTS Wanted—We buy and sell practical patents. Big opportunity, undeveloped field. Describe briefly. M. Okamura, Box 1290, Honolulu, Hawaii.

PATENTS wanted, cash or royalty basis. Send description. Box 126, Dowagiac, Mich.

HAVE You an Invention? If so, write for our free book, "How to Get Your Patent," tells our terms and methods. Send model or sketch for our free examination and instructions. Randolph & Co., Dept. 144, Washington, D. C.

GET your own patents. Legal blanks, complete instructions \$1. Cutting Sons, Campbell, Calif.

I SELL Patents. Established in 1900. The only man in America who has spent the past 25 years exclusively at this work. An experience highly valuable to you, if you have a good patent to sell. Charles A. Scott, 773PM Garson Avenue, Rochester, N. Y.

PATENTS Procured: Trade Marks Registered—A comprehensive, experienced, prompt service for the protection and development of your ideas. Preliminary advice gladly furnished without charge. Booklet of information and form for disclosing idea free on request. Richard B. Owen, 30-Owen Bldg., Washington, D. C., or 41-R Park Row, New York.

INVENTORS! We will furnish names of firms where you can buy materials for your inventions. \$1.00. Technical Research Bureau, 377-National Ave., Milwaukee, Wisconsin.

MR. INVENTOR: If you have a patent for invention for sale. Write Hartley, 38 Court St., Bangor, Me.

PATENTS FOR SALE

Outright or Royalty. Match Dispenser. Takes place present match boxes and retails for half. A five and ten cent repeater. Patented May, 1926. U. A. Lewis, 1902 So. Mt. Clair St., Dallas, Texas.

OUTRIGHT or royalty, recently patented Cotter Pin, No. 1,548,688. Has many new advantages over old type. Write for sample. Ben Johnson, 465 Logan St., Bridgeport, Conn.

NUMBER. Re. 7,582,670. Sanitary Smoker for Pipes and Cigarette holders; self-filtering, cooling. Anti-Nicotine or full strength. Unlimited possibilities. Fred A. Eckelmann, Broadway Hotel, Portland, Ore.

MOTION-PICTURE Device. Absolutely essential in all theaters. Either outright sale or royalty. Investigate. H. H. Clonts, 115 So. Willomet, Dallas, Tex.

OUTRIGHT—Gauge made to fit on top end of drill press, arranging drill spindle to depth required. B. Bollie, Box 691, Plano, Ill.

CATCHY, useful, low-priced novelty. Patent and producing equipment sold very cheap. Sample Free. Troib, 68 Houghton, Worcester, Mass.

FOR Sale—Patent Waterer; Serial No. 758,418. Patent No. 1,566,176. Patented Dec. 15th, 1925. Joe Weber, Route 3, Gimmell, Iowa.

COMBINATION sink stop and drain. Jacob Binder, 159 Moore St., Ludlow, Ky.

FOR Sale outright, patented practical metallic Railway tie. N. P. Kosteck, Montezuma, Colo.

OUTRIGHT—Indexed Key Ring. Patent No. 1,466,572, a time and lock saver, an article of merit as proven by use at an Army Camp for some time; the variety of combinations makes it a ten cent or one dollar article; hangs up or folds like card case; keys hang as on ordinary ring. Model on request. L. A. Walters, Care Pennsylvania Sugar Company, Miami, Fla.

OUTRIGHT or royalty, Fire Fighting Apparatus. No fire station is complete without this remarkable extinguisher. Jas. C. Witt, Simmesport, La.

OUTRIGHT—safety device that automatically stops elevators when persons or objects are in path or near elevator shaft. F. E. Mayotte, 120 N. Summer St., Adams, Miss.

ROYALTY basis, newly patented smoking pipe that affords a cool and nicotine-free smoke. Raymond Austin, 403 Vermont St., Quincy, Ill.

OUTRIGHT or Royalty basis, recently patented pulling jack, adaptable for all classes of structural work principally in repairing steel cars. Operated by compressed air and easily adjusted to either long or short pulls. Easily handled, set up, or taken apart. Robert A. Maxey, 1511 Campbell St., Kansas City, Mo.

OUTRIGHT or Royalty: Light Trap, destroys bugs attracted to light. Used on electric lights, kerosene, gasoline lamps, etc. Simple, safe. Costs nothing to operate. Sauer Bros., Chico, Calif.

PATENT 1,369,641. Improved Drawplate Baking Oven. Sale outright. Farwell, Derby Street, Weymouth, England.

WILL sell on royalty basis patent No. 1,585,459, on knock-down table. C. O. Bauer, 725 N. Wilton Place, Hollywood, Calif.

OUTRIGHT or royalty basis. Radiator drain device controlled from dash board. Drains radiator while driving, in half the regular time. George Bearing & Mfg. Co., Amarillo, Tex.

OUTRIGHT—Internal Gauge Glass Cutter. Patent No. 1,579,980, satisfactorily demonstrated, equal pressure any length cut, severs with clean cut and forces apart without other aid. Renewable cutter. Long lived. Model sent to interested parties. L. A. Walters, Care Pennsylvania Sugar Company, Miami, Fla.

WHY let your patent lie idle? Tell our two million five hundred thousand readers about it! The majority of our readers are especially interested in new ideas and inventions. Ask me to tell you how other inventors successfully sold their patents. M. L. Rund, Mgr., Classified Advertising, Popular Mechanics Magazine, Chicago.

SURVEYING INSTRUMENTS

LARGEST stock of new and used surveying instruments in the country direct from factory. Satisfaction guaranteed or money refunded. Wissler, 619 N. Broadway, St. Louis.

MODELS AND MODEL SUPPLIES

PATENTS. Time counts in applying for patents. Don't risk delay in protecting your ideas. Send sketch or model for instruction or write for Free book "How to Obtain a Patent" and "Record of Invention" form. No charge for information on how to proceed. Communications strictly confidential. Prompt, careful, efficient, service. Clarence A. O'Brien, Registered Patent Attorney, Security Bank Building (directly across street from Patent Office), Washington, D. C. See pages 140 and 141.

LET our experience be your guide. Models that are models; Tools and equipment for economic mantg. Patterns of all types; manufacturing in all branches. Satisfaction guaranteed. United Machinery Company, Cincinnati, U. S. A.

MODELMAKER. Volume I, 1924, \$1.60; Volume II, 1925, \$2.10. Handsomely bound. Cloth gilt. Single numbers 10 cents. 122 Liberty St., New York.

WE Build Models, design, develop and manufacture articles in large or small quantities. Hohmerier Mfg. Co., 1385 E. 17th St., Cleveland, Ohio.

SHIP Model Book. All about models. Directions and patterns for building. Benjamin Packard, \$4.00. The Rudder, 9 Murray, New York.

THE Modelmaker, a magazine for all interested in making working models. Sample 10 cents. Modelmaker, 122 Liberty St., New York.

SPECIAL machine builders, tool and die makers, inventor's models, production work of all kinds. Dent, L. Quality Hardware & Machine Co., Ravenswood and Thorndale Avenues, Chicago, Ill.

WE make working models for inventors and do experimental work and carry a complete stock of brass gears and model supplies. Send for catalogue. The Pierce Model Works, Tinley Park, Ill.

MODEL steam engines and boilers. Boat and boiler fittings. Send 10c stamp for catalogue. Refunded with first order. Model Machine Shop, P. O. Box 5, Station Y, New York City.

MODELS. Tools and Dies, and General Manufacturing, new invention, our speciality. Logan Machine & Manufacturing Co., 126 S. Clinton St., Chicago, Ill.

MANUFACTURING

METAL-CRAFT—Eventually—Metal-Craft. Competent Engineers, Designers and Producing Organization await your commands on dies, stampings, die-casting, deep pressing, screw-machine and wire products. Plating, Enameling, Burnishing, Assembling, Wrapping and Packing to your specifications. Large completely equipped plant which guarantees prompt, efficient service. It is not the quality of raw materials alone, nor the precision in manufacture, and not just the service rendered that has given Metal-Craft the good reputation they bear—but all of these, as a constant certainty, in combination. Estimates promptly furnished. Metal-Craft Manufacturing Company, Chicago, Box 259-W.

RUBBER Articles developed and manufactured. Middle States Rubber Corp., Independence, Mo.

MANUFACTURING Models, Dies, Stampings, Brass Work, one or thousands. Baum's Metal Specialties, Kansas City, Mo.

MODELS. Tools, Manufacturing. Lowest Prices. Schmidt, 61 Park Place, New York.

METAL Stamping—Manufacturing—Models—Tools—Dies. Henry H. Knabe Tool Works, 2150 Rusk St., Madison, Wis.

WANT reliable firm to manufacture new bird-cage holder on royalty basis. For information, address Box 1027, Long Beach, Calif.

OUR factory will make your models, manufacture your articles as well as build your tools, dies and fixtures. Standard Die & Specialty Co., 1932 Austin Ave., Chicago, Ill.

WE design and build special machinery, tools, dies, jigs and fixtures. Experimental work. Light stamping, quantity production. Reliable Machine Co., 400 West 23rd St., New York City.

WIRE goods made to order. Cooley Mfg. Co., 530 N. Western Ave., Chicago.

METAL articles of merit to manufacture, wanted by large metal stamping company. Box K, Barnum Station, Bridgeport, Conn.

DESIGNING and Building of Special Machinery and Mechanical Devices. C. J. Sandberg, 1737 N. Whipple St., Chicago, Ill.

MACHINE work of any kind wanted by well equipped shop. The Greaves-Klusman Tool Co., Cincinnati, Ohio.

MACHINERY, TOOLS AND SUPPLIES

SCALE locomotive castings and track. Racing marine engines, boilers and speed-boat construction sets. Small hexagon bolts and nuts. Castings from your patterns. Seamless steel copper and brass tube, rods, bars, angles. Any length cut. Singer, 15 Moore St., New York.

BARGAIN. New 1 1/4" pitch 5/8" width of roller 5/8" diameter of roller cutter pin type roller chain, 75c ft. in 50 ft. lots. Tensile strength—10,000 lbs. Regular retail price \$1.50 ft. S. R. Deg. Harvey, Ill.

CARPENTERS—A booklet of rafter lengths for all buildings up to 44 feet in width and 1 to 14 inch rise; lengths are figured for building widths inches as well as even feet; common rafters, hips, and jacks, all included in the table. A wealth of complete figures ready for use; also instructions for use of Speed Square. 30 cents postpaid. Swanson Square Company, 7 No. 4th Ave., Maywood, Chicago.

CONCRETE Building Block Machines and Molds. Catalog free. Concrete Machine Co., 5 N. Main St., St. Louis, Mo.

16" SMITH and Mills Crank shaver, \$300.00; 20"x10" Bradford engine lathe, \$375.00; 10" Drill press with chuck, new, \$19.25; No. 60 Heald auto cylinder grinder, \$750.00; Geared chain hoists, one ton, \$27.50; 1/4 H.P. New motors \$15. Write for complete machinery and supply catalog. Cincinnati Machinery Supply Co., 218 E. Pearl St., Cincinnati, Ohio.

OTHERS have successfully sold their machinery through our columns—so can you. Ask me for proof. M. L. Rund, Manager, Classified Advertising, Popular Mechanics Magazine, Chicago.

START a business of your own. Nickel, silver, copper and gold plating. Large profits. Two dollars for full information or twenty cents for samples and particulars. Electro Platers Supply Co., 547 Considine Ave., Norwood, Ohio.

FOR MECHANICS

WE need mechanics of all trades, aged 25 to 40 years; for positions as claim adjusters, appraisers and inspectors; our work is interesting and remunerative. Write for application blank to Robert Thomas, P. O. Box 905, Pittsburg, Pa.

KINKS on Metal Work. 419 discoveries for anyone who works with metal. For mechanic, machinist, or the man who tinkers at home. 287 illustrations. Send No Money. Just write a postal asking for "Machinist's Kinks." When postman hands you book, pay postage and price of book, \$1.50. Popular Mechanics Press, Room 808, 200 E. Ontario St., Chicago, Ill.

"BLUEPRINT Reading" is a compact book telling how to read machine blueprints. Send No Money. Just pay postman postal charges and \$1. Popular Mechanics Press, Room 808, 200 E. Ontario St., Chicago, Ill.

MACHINIST. Complete instructions for all sorts of work on shop machines. A book used by technical schools for years, yet up-to-date, authoritative and complete. Send No Money. Just ask for "Complete Practical Machinist," by Rose. Pay postman postal charges and \$3.00. Popular Mechanics Press, Room 808, 200 East Ontario St., Chicago, Ill.

FOR MEN

CARPENTERS. Ideas for those who like to tinker with tools, and for professional carpenters. 40 articles on saws and sawing, 17 on benches and bench equipment, 22 on doors and door hanging, 18 on lumber, 13 on mitering, 74 on tools, 22 on shop equipment, and many others—366 in all, and 229 illustrations. Send No Money. Just write a postal. Pay postman postage and \$1.50. Popular Mechanics Press, Room 808, 200 E. Ontario St., Chicago, Ill.

SPEECHES. No matter where you must speak, here is help. 366 pages of instruction and anecdotes, toasts and complete speeches for the amateur or professional. Send No Money. Simply write a postal for "Speeches, Their Preparation and Delivery." Pay postman postal charges and \$1.25. Popular Mechanics Press, Room 808, 200 East Ontario St., Chicago, Ill.

CONCRETE Houses. Beautifully illustrated book showing many pleasing ideas for concrete homes. Practical instruction for owner and builder. Drawings of best construction methods. 215 pages. Send No Money. Simply write a postal for "Concrete House." Pay postman postal charges and \$3.00. Popular Mechanics Press, Room 808, 200 East Ontario St., Chicago, Ill.

ENGINES, MOTORS AND DYNAMOS

FOR Sale—Used Motor Generator Sets—Tungars. Satisfaction guaranteed. Sold subject trial. Also, One Day Battery Chargers. Terms if desired. Ira Helmick, Box PM, Troy, Ohio.

DIESEL Engines—Marine, Locomotive, Stationary. Growing importance of the Diesel Engine cannot be overestimated. This new book should be in the hands of every student of mechanical engineering. 500 pages. 286 illus. Pay postman \$5 and postage when he delivers book. Popular Mechanics Press, Room 808, 200 E. Ontario St., Chicago.

MOTORS: Alternating Current, 1/4 Horse, 110 V., 1.750, \$6.50. New Direct Current, 1/4 Horse, 110 V., 1.750, motors \$3.75. Used Direct Current, 1/4 Horse, 32 V., 1.750, Westinghouse, \$5.50. Also other bargains. Queen City Electric Co., 1736 Grand Ave., Chicago, Ill.

MOTORS—Good, Practical, Twentieth horsepower, 115-volt, alternating-direct current. Order now. Pay postman. Perry Trading Co., Dept. M7, 815 Lake Ave., Racine, Wis.

ALTERNATING current, single phase, rebuilt; guaranteed motor bargains. 1/2 HP. Ellington, \$7.50; 3/4 General Electric or Westinghouse, \$10.00; 1 Wagner, \$15.00; 3 Wagner, \$75.00; 5 HP. Century, \$85.00. Many other bargains. Tell us your needs. Send for motor price list. Hyre Electric Company, 615 G. R., So. Dearborn St., Chicago, Ill.

FOR Boat, sport car, stationary service. Six cylinder, side exhaust, air-cooled. 60 pounds, 30 H.P. price \$25.00 Cash. C.O.D. \$25.00 subject to inspection. Cost \$175.00. Pierce-Arrow. Garland Stephens, Wytheville, Va.

WASH machine motors rewound \$10. Electric fans rewound and repaired. A. L. Krauth, 213 Cherry St., Quincy, Ill.

GAS Engine 2 H.P. A1 Condition. Write for Particulars. F. Murphy, 245 First St., Jersey City, N. J.

MOTORS, 1/30 H.P., 110 V. A.C. 60 cycle or D.C. Slightly used; A High-Grade Motor, Not a Toy. \$3.00 postpaid, four zones. E. U. Engineering Co., Orange, N. J.

BENDING MACHINES

THE famous Hossfeld Wrenchless Universal Bender is the last word in bending machines; bends metal, cold or hot, into most any conceivable shape, including Eye-bolts and Automobile Spring Eyes. Bends up to 1" bars or 1 1/4" Pipe cold. Used by the largest corporations, yet so inexpensive that even a farm shop need not be without one. Send for Circular. Hossfeld Mfg. Co., Box 344, Winona, Minn.

BLACKSMITHS

BLACKSMITH Notice: Young smith or handy man make more money doing hard jobs easy. In job shop or factory be a Master Machine and Plow Blacksmith and Expert Tool Dresser. With Colored Tempering Charts. All for One Dollar. Samples Free. W. M. Toy, Sidney, Ohio.

FOR SALE—MISCELLANEOUS

ADDRESSOGRAPHS. Letter Folders, Multigraphs, Envelope Sealers, Duplicators, less than half price. Guaranteed. Pruitt Co., 117 No. Market, Chicago.

WANTED MISCELLANEOUS

MAIL us your discarded Jewelry, Gold, Crowns and Bridges, Watches, Diamonds, Silver, Platinum, and old False Teeth. Money promptly mailed. Goods returned if offer refused. United States Smelting Works, (The Old Reliable), Dept. 71, Chicago.

MAIL us your Platinum, Magneto Points, Discarded Jewelry, Diamonds, Old Gold, Silver, Gold Crowns, Bridgework. Cash promptly mailed. Your goods returned if offer refused. D. Davis, 1726 Roosevelt Rd., Chicago.

REAL ESTATE, FARM AND ORCHARD LAND

FOR Sale, 20 acre farm in Arkansas. This property is adjoining a railroad and is five minute ride from town. Selling on account of illness and will accept any reasonable offer. Vincent Nedza, 4801 So. Loomis St., Chicago, Ill.

ATTENTION—"Get acquainted." Cash for your property. Farm, Hotel or Retail Store, no matter where located; confidential service. Hayes' Business Agency, Cincinnati, Ohio.

FIVE Thousand acres fertile Georgia Land. Improved, well stocked, Game and Fish. Price \$10.00 acre. F. L. Gibson, Thomasville, Ga.

WANTED: Farm wanted at cash price. Will deal with owner only. J. Stiever, Dept. 29B, Wabasha, Minn.

\$10 MONTHLY buys 5 (five) acres Isle of Pines orange and poultry farm land. \$100. H. Harrison, Santa Fe, Isle of Pines, Cuba.

FOR Wisconsin Farm Bargains or Lake Front, write B. B. MacDonald, Ladysmith, Wis.

BARGAINS—Beautiful lake frontage, productive farm lands, grassy sheep ranches. Write owners, Emerson Bros., Tripoli, Wis.

OZARK land; ten acres near White River and proposed Dixie Dam, \$100; \$5 monthly. Alvin Zimmermann, 1800 N. Fifth, Kansas City, Kan.

HERE'S your land! \$10 down and \$10 a month buys 20 acres of my best land in Cent. Mich. for \$400, or 10 acres for \$250. Write at once for free 48-page picture book. G. W. Swigart, P1259 1st Natl. Bank Bldg., Chicago.

PECAN-Orange-Fig Groves "On the Gulf" Monthly payments. Guaranteed care. Big, quick returns. Suburban Orchards, Dent M. Biloxi, Miss.

SELL your property quickly for cash, no matter where located. Don't pay big commission. Particulars free. Real Estate Salesmen Co., Desk B, Lincoln, Nebr.

\$10.00 DOWN, \$3.00 monthly, buys 5 acre Cadillac, Michigan, Fruit or Poultry farm land, Camp Site or Summer Home. Near fine lakes and streams, \$200.00. Best hunting, fishing, bathing, swimming. Good auto roads. Get booklet and map. O. Hermann, 140 So. Dearborn St., Chicago.

ROOTS AND HERBS

HERB Doctor Book—10 cents. 250 receipts for making herb medicine. Hazzard Company, Box 1, Vanderveer Park, Brooklyn, N. Y.

DOGS AND PETS

WANTED: Mink and live Fur animals. Describe and price today. Garland Stephens, Wytheville, Va.

POLICE Dogs—Imported Studs at Service. Puppies for sale. Cherycroft Kennels, Omaha, Nebr.

BEAUTIFUL White Collie Puppies \$7.50 to \$50.00. Prepaid. Write, Morgan, Manor Kennels, Marco, Ind.

FOR Sale—Well-broken beagles, 2 to 5 years. A No. 1. Will ship on trial. James I. Shepperd, Seven Valleys, Pa.

PERSONAL

UNUSUAL Horoscope Consisting of Extensive four page Special Horoscope, and Astro Analysis. Send 50c and birthdate. Money returned if dissatisfied. Prof. Bolles, Box 125, Cranford, N. J.

LEARN the Secrets of health. A priceless Book sent for 25c. Interstate Specialty Co., 120 East Eighth St., Lawrence, Kans.

STOP stammering. Increase salary. Descriptive booklet Free. Samuel A. Robbins, 399 Boylston, Boston, Mass.

FOR Pearly Teeth use Sno-White, the magic whitener. 25c postpaid. Stanley Specialties, 1510 Cornell St., Chicago, Ill.

WEALTH and success come only to them who follow the psychological laws of success. You can't succeed if you don't know how. Get our free book "Why Most Men Fail." Mack Institute, Wabash Sta., PM, Pittsburgh, Pa.

HYPNOTISM and Auto Suggestion. Learn how to hypnotize other people, yourself and animals. Learn clairvoyance, mind reading and telepathy. Clearly explained in "Practical Lessons in Hypnotism and Auto Suggestion." Send no money. Pay postman postal charges and \$1.25. Popular Mechanics Press, Room 808, 200 East Ontario St., Chicago, Ill.

ARE you unlucky, in trouble, sick, a failure or surrounded by evil influence, worry and fear? (Advice free.) Send birthdate and quarter for horoscope reading; questions answered free. Hoffman's 6074 Butler St., Pittsburgh, Pa.

ASTROLOGER will read your life. Test predictions for one year 20c, dimes or stamps. Send year and birthdate. Money back, if dissatisfied. G. Niemeyer, 621 McConnell Terrace, Atlantic City, N. J.

FALLING Sickness. Read "Facts About Epilepsy" by world famous authority. Fads exposed Free. Held, 815 Reliance Bldg., Chicago.

BOOKLET on Hypnotism—Practical Psychology. Quickly learned by easy lessons. Clear, Practical, Habits and diseases cured. Our students get results for wealth and power; Don't Be a Doubter. No Fake. Send 4c in stamps for booklet and testimonial letters. Prof. Fernando, Dept. P, Springfield, Mass.

SEND 25c coin and your date of birth for forecast of your vibrations for 1926. Arvel Synclare, Numerologist, Box 25, Patton, Calif.

TOBACCO or Snuff Habit Cured or no pay. \$1.50 if cured. Remedy sent on trial. Superba Co., N3, Baltimore, Md.

ETIQUETTE. 378 pages of clear type covers all subjects. Send No Money. Just write a postal asking for "Etiquette, An Encyclopedia of Good Manners and Social Usage." Pay the postman \$1.25 and postal charges. Popular Mechanics Press, Room 808, 200 East Ontario St., Chicago, Ill.

MISCELLANEOUS

TATTOOING—learn tattooing, with my outfits. Send for circulars; they explain everything. Sergt. Bonzey, 367 South Main, Providence, R. I.

HARRIS Tweed, cream of Scotch Home-spuns direct from Makers. Suit-lengths by Post, \$2.00 per yd. Samples free on stating shades desired. Newall, 270, Stornoway, Scotland.

FUNNY White Mule magazine, including snappy pocket novelty, 10c. White Mule, Beaver Dam, Wis.

MIRRORS Resilvered at Home. Costs Less 5 cents per square foot; you charge 75 cents. Immense profits, plating autoparts, reflectors, tableware, stoves. Refinishing metalware, etc. Outfits furnished. Write for information. Sprinkie, Plater, 288, Marion, Ind.

TOYS made at home. Cutting patterns, animals, garden sticks, trees, glider, weather vane, kites, jumping jack, tumbling clown, doll's furniture and house, tops, boats, automatic pistol, noise maker, airplane model, tricks and wire puzzles, circus tent and animals, pine cone toys, bird houses, bow and arrow. All in one new book, "Hand Work for Boys." Send No Money. When postman delivers book, pay him \$1.50 and postal charges. Popular Mechanics Press, 200 E. Ontario St., Room 808, Chicago, Ill.

LET a dollar bring you this fountain pen leader. Color deep cherry red. A pen for service. Order from the Double W., 4935 Fountain, St. Louis, Mo.

GUARANTEED Anti-Backlash (Quadruple) Fishing Reel \$4.50. Satisfaction or price refunded. Circulars. Fishhook Co., Windfall, Ind.

WATCHMAKER'S Lathe, with complete screw cutting attachment, for sale at a Bargain. R. Jaegermann, 5815 Easton Ave., St. Louis, Mo.

ELECTRICAL Kinks on all phases of practical electricity. 47 ideas on wiring, 45 on making electrical devices, 19 on lighting, 5 on transformers, 5 on motors, 8 on generators, 11 on switches, 22 on testing, 12 on repairing, 11 on battery manufacture and repair, 5 on telephones, and 9 on electrician's tools, 214 articles, 162 pictures. Send no money. Just write postal for "Electrical Kinks." Pay postman postage, and \$1.50. Popular Mechanics Press, Room 808, 200 E. Ontario St., Chicago, Ill.

GET posted—good prices paid for butterflies, insects. See Sinclair display advertisement, page 28.

MEXICAN made pistol holsters, cart-ridge belts, lariats, sombreros, horse-hair goods; list free. Ingersoll Leather Co., 307 Fannin, Houston, Tex.

DRAFTING. Learn Mechanical Drawing. Big demand for men. Pocket-size. Start at beginning and learn by a series of simple lessons. Send No Money. Just write postal for "A Practical Course in Mechanical Drawing." Pay postman postage and \$1.00. Popular Mechanics Press, Room 880, 200 E. Ontario, Chicago, Ill.

UNUSUAL Gifts for all occasions, anniversaries, etc. Large illustrated catalog, just issued, free. Send for it. Higher value, lower prices, uncommon articles. Any item sent for examination. Write Now—C. Crane Co., 1651 Park Ave., Racine, Wis.

WEEDS—Cut them with cutter bar on Shaw Garden Tractor. Also plows, cultivators and runs belt machinery. Low prices. Immediate delivery. Shaw Manufacturing Company, Department C, Galesburg, Kans.

SHIP Models—Worth-while—Easy to make. Decorative ships. Picturesque Barbary Pirate Felucca and Beautiful Spanish Treasure Galleon (both 17th century). Instructions so simplified that any handy person can make these models with a few household tools almost without expense. No personal knowledge of ships or naval architecture required. New book only one of its kind. Pay postman \$2.50 plus postage when book is delivered. Popular Mechanics Press, Room 808, 200 E. Ontario St., Chicago.

CUTS anybody can make. Simple, cheap process. \$1. Specimens, particulars, 2c stamp. M. Day, Windfall, Ind.

AMATEUR Cartoonist's money making plan \$1.00. Particulars free. Smith's Service, Wenatchee, Wash.

FORTUNES in Common Minerals. Facts and figures 10c. Minerals Identified \$1.00. Mineral Specimens. Busket, Joplin, Mo.

ARTIFICIAL Eyes. Booklet free. Denver Optic, 559 Barclay, Denver, Colo.

LOCKSMITHING. 500 tricks of the trade; how to make keys; how to open locks and safes; safe drilling; how to set combinations; key-cutting tables; umbrella work; everything you should know to become a lock expert. Copiously illustrated. Only complete book on subject sold at reasonable price. Send No Money. Just write a postal for "Locksmithing." When postman hands you book, pay \$1.50 and postal charges. Popular Mechanics Press, 200 East Ontario St., Room 808, Chicago, Ill.

I CATCH from 45 to 50 foxes in from 4 to 5 weeks' time. Can teach any reader of this magazine how to get them. Write for particulars. W. A. Hadley, Stanstead, Quebec.

Don't Be A Slave

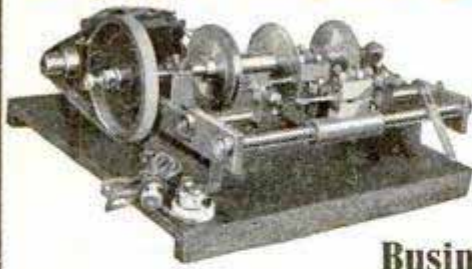

Be Independent,
Start Your Own
Business Now!

Make Big Profits with the BEISSER KEY MACHINE

No Experience Necessary—Others Make **\$20 to \$50 a Day**

You can do the same. Devote all or spare time. The only machine that will cut any type of Key—Bitted, Double Bitted, Yale and Flat Steel Keys—in one operation. The only machine that will make first Keys without taking lock apart. **MAKES A DOZEN DUPLICATE KEYS PER MINUTE.** Big demand for duplicate Keys for autos, apartments and residences. This is your money-making opportunity.

Write Today for Full Particulars.

BEISSER KEY MACHINE CO.
407 Fort Street E. DETROIT, MICH.

DOUBLES TIRE MILEAGE

and Makes Pumping Up Tires Unnecessary



Line up with big money. The Hughes "Airlox" Valve Cap is a proven success. Air-tight. Eliminates all troubles due to under-inflation; lasts life of tire. Positive necessity to auto owners. Doubles tire mileage. Tested and approved by leading auto manufacturers. \$1.00 a week for hustlers. Unlimited demand. No competition.

FREE SAMPLES TO AGENTS to use and introduce in exclusive territories. Immense uncrowded field. Don't hesitate. Write today for facts and **FREE SAMPLES.**

AIRLOX RUBBER CO.
424 N. Homan Ave. Dept. 805-G, Chicago, Ill.

EASY \$100 a Week FUGO FIRE EXTINGUISHER



Unusual opening for live agents in every locality. Make \$5000 or more a year—easily. FUGO—the instantaneous automatic fire extinguisher—is needed and wanted in every home, store, theatre, garage, shop, school, automobile, etc. Cheapest fire protection available today. Within reach of all.

1 Qt. Size \$5.00 2 Qt. Size \$7.50

Recharged in a jiffy. Amazing 30-second demonstration clinches sale—each one sold sells others. Territory going fast. Write at once for wonderful proposition that will **MAKE YOU BIG MONEY.**
THE NATIONAL FORMETAL CO.
240 St. Clair Ave., N. E. Cleveland, Ohio

FREE Big Auto or Electr. book that means hundreds of dollars to you. Check which you want in squares below. Clip and mail today.

GREER COLLEGE—Auto. & Electr. Trades

Dept. 801
2024 S. Wabash Name.....
Chicago, Ill.

Auto Electr. Address.....

Science Discovers the Secret of CARUSO'S Wonderful Voice

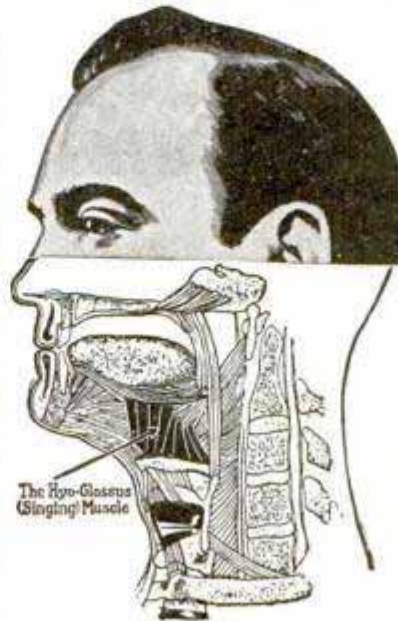

Why is it that the humble peasant boy of Italy became the greatest singer of all time? This diagram of his throat will show you. Caruso's marvelous voice was due to a superb development of his Hyo-Glossus muscle. Your Hyo-Glossus muscle can be developed, too! A good voice can be made better—a weak voice become strong—a lost voice restored—stammering and stuttering cured. Science will help you.

Your voice can be improved 100%

A few very fortunate persons—like the late Caruso—are born with the ability to sing well. But even Caruso had to develop his Hyo-Glossus muscle before his voice was perfect. You can develop a beautiful singing or speaking voice if your Hyo-Glossus muscle is strengthened by correct training. Professor Feuchtinger, A. M.—famous in the music centers of Europe for his success in training famous Opera Singers—discovered the secret of the Hyo-Glossus muscle. He devoted years of his life to scientific research and finally perfected a system of voice training that will develop your Hyo-Glossus muscle by simple, silent exercises right in your own home. The Perfect Voice Institute guarantees that Professor Feuchtinger's method will improve your voice 100%. You are to be your own judge—if your voice is not improved 100% in your own opinion, we will refund your money.

Grand Opera Stars His Students

Hundreds of famous singers have studied Physical Voice Culture. Over 10,000 happy pupils have received the benefits of his wonderful training. You do not know the possibilities of your voice. If you want to sing—but lack the proper training because you have not the time nor means to study—here is your chance. You can now train your voice at a very small cost in the privacy of your own home. If you want to improve your speaking voice—if you stammer or stutter—Prof. Feuchtinger will help you.

Inspiring New Book FREE!

You will do yourself a great and lasting good, by studying the new book, "Physical Voice Culture." It may be the first step in your career. Do not delay. Mail the coupon today.

Perfect Voice Institute

1922 Sunnyside Avenue Studio C-135 CHICAGO

Perfect Voice Institute

1922 Sunnyside Avenue Studio C-135 CHICAGO

Please send me **FREE** your new book, "Physical Voice Culture." I have put X opposite the subject that interests me most. I assume no obligations whatever.

.....Singing.....Speaking.....Stammering.....Weak Voice

Name

Address

.....Age.....

Now! Let BUICK HIMSELF train you quick for big pay AUTO JOBS



D.D. BUICK, Chief Engineer

AUTO MECHANICS! Let this famous expert, D. D. Buick, train you right. Mr. Buick, pioneer of the Valve-In-The-Head Motor, and one of the organizers of the Buick Motor Car Company, knows just what you need to be trained quickly for big pay jobs. Come to this great school, operated under supervision of the State Board of Vocational Education, State of Michigan. Thousands are needed in auto work. And this great expert is devoting his life to training men like you.

Famous Expert heads Great Detroit Trades College

Where else can you get training like you can in the Detroit School of Trades, right here in Detroit, center of the world's automobile industry? This great university of trades trains you right on the job—no books. Its great corps of expert instructors fit you quick for big pay. An unexcelled employment department. Day and night classes. Every single branch of automobile work you learn easily, quickly and at amazing low cost. Graduates of this big school are earning amazing wages. They are in constant demand. You can't afford to take chances. Investigate the exceptional training of this wonderful college of trades.



In this great college of trades each department is a big school in itself.

15 Big Money Trades Taught

Besides Automobile Courses, this great school trains hundreds of men in other trades—you do the actual work. (Bricklaying, Plastering, Plumbing, Carpentry, Contracting and Estimating, Electricity, Sign Painting, Paper Hanging, Metal Finishing, Interior Painting, Painting, Acetylene Welding.) This is the one where you can get thorough training in every branch of trades. Don't work longer at pitiful low pay. In only a short time you, too, can be out on the job earning the big wages a trade offers you. Fill out the coupon right now and send it to Mr. Buick. Learn what wonderful opportunities this great college of trades offers you. But don't delay. Send in the coupon this very minute.

DETROIT SCHOOL OF TRADES
Department 826-A Detroit, Michigan

D. D. Buick, Chief Engineer
Detroit School of Trades
Department 826-A
Detroit, Michigan

Send me at once your Free literature about the famous Detroit School of Trades. I want to earn big money.

I am interested in the trade of.....

Name.....

Address.....

City..... State.....

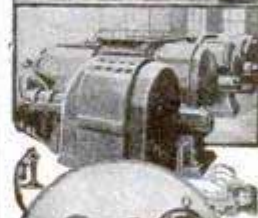

LEARN BY DOING

Every phase of all branches of

ELECTRICITY

taught by

Actual Practice

In America's foremost institution for trade training

No Books Used

Individual Instruction
Start Any Day

Write for FREE 64-page catalog

THE NEW YORK ELECTRICAL SCHOOL

44 West 17th St., New York City

Open All Summer

OPPORTUNITIES IN Traffic Management

Become a Traffic Expert

The opportunities in traffic management are limited only by the boundaries of the business world. The trained traffic man is in demand by transportation systems and by industrial organizations.

Three Detroit Firms Pay Their Traffic Managers Over \$20,000 a Year

Prepare for this growing, profitable profession at home in your spare time under supervision of traffic experts. Low cost; easy terms. Thru the LaSalle Problem Method you learn by doing.



This Book FREE!

Valuable 64-page booklet free. Send for it NOW.
LaSalle Extension University, Dept. 864-T Chicago

ADDING MACHINE

Fits Vest Pocket

SEND NO MONEY

A marvelous calculator. Does the work accurately and quickly as a \$300 machine. Invaluable to anyone who uses figures. Don't carry pad and pencil. This startling invention will solve all problems in a minute. Business men, students, professional people, all need this **HANDY HELPER.**

Don't send money. Just name and address. Pay postman only \$2.95 plus few cents postage. Try it for 10 days. Your money back if not satisfied.



Counts To 1 Billion

Results in plain sight all the time -- clears instantly. Made of steel and brass, in handsome case, fits vest pocket; weight only 3 oz. Send for yours now - you'll save time and money.

PRICE \$2.95

Reliable Adding Machine Corp., Dept. 4-B
184 W. Washington St., Chicago, Ill.

AGENTS Here's a dandy chance to make money. Everybody wants one. Fine profit. Write for new offer.

"I would not part with it for \$10,000"

So writes an enthusiastic, grateful customer. In like manner testify over 100,000 people who have worn it.

The Natural Body Brace

Comfortable and Easy to Wear

Overcomes Weakness and Organic Ailments of women and men. Develops erect, graceful figure, brings restful relief, comfort, health and strength.

Not Sold in Stores—

Made to Measure—Makes work easy and walking a pleasure; replaces and supports misplaced internal organs; reduces enlarged abdomen; straightens and strengthens the back; corrects stooping shoulders; develops lungs, chest and bust; relieves backache, curvatures, nervousness, ruptures, constipation.

Get Well—Stay Well Write today for illustrated booklet, measurement blank, etc., and read our very liberal proposition.

HOWARD C. RASH, Pres., Natural Body Brace Co. 223 Rash Building • • SALINA, KANSAS



30 Days Free Trial



FREE Book on Deafness

Write today for 168 page FREE book giving full particulars and testimonials from hundreds of grateful users whose hearing has been restored by use of our "little wireless phones for the ears."

Wilson Common-Sense Ear Drums require no medicine but effectively replace what is lacking or defective in the natural ear drums. They are simple devices, which the wearer easily fits into the ears where they are invisible. Soft, safe and comfortable.

WILSON EAR DRUM CO., Incorporated 922 Todd Building LOUISVILLE, KY.

THE WOTEN GASOLINE ENGINE

Air-cooled—Water-cooled. One-half H. P. in 15 pounds. Handiest little engine ever made. Ideal wherever power is needed. Also the Metalumen Model Airplane Engine, one-half H. P. in 3½ pounds. The market demands them in thousands. Generous agency propositions on request. Complete line of small gasoline and steam engines, battery chargers, etc. Catalogue Free.



DYNAMIC MANUFACTURING CO. First Nat'l Bank Bldg., Dept. 7, CHICAGO

HAIR GROWS!

when our Vacuum Cap is used a few minutes daily. Sent on 60 days' FREE trial at our expense. No drugs or electricity. Stops falling hair, cures dandruff. A postal brings illustrated booklet.

MODERN VACUUM CAP CO. 558 Barclay Denver, Colorado

How to Straighten Bow and Knock-kneed Legs!

Improve your personal appearance by using the new patent "Lim-Straitner," Model 18. Corrects bow and knock-kneed legs safely, quickly and permanently at home. No costly operation or discomfort. Is worn at night. Easy to adjust; its result will save you soon from further humiliation and will improve your personal appearance 100 per cent. Write today for copyrighted Physiological and Anatomical book and experience of others without obligation. Enclose a dime for postage.

M. TRILETY, Specialist Dept. 1421L BINGHAMTON, N. Y.

Fibre-Lite Limbs BRACES AND TRUSSES

DO NATURE'S WORK. GREAT INVENTION. EASY TERMS. AGENTS WANTED. WRITE FOR FREE FIBRE SAMPLE. WORMAN CO. 252-P HENNEPIN AVE. MINNEAPOLIS, MINN.

I Made



MY FIRST WEEK

"Since then I have been earning over \$100 every week selling the Stay-Prest Trousers Presser."—S. L. PATTERSON of Iowa.

You too can make these big profits selling this wonderful new invention. Every man who sees it wants 2 to 6 at once.

Sell Stay-Prest TROUSER PRESSERS

They went like wildfire from the start. It was the very thing men everywhere had been hoping someone would invent. It's a common thing to sell six to a customer. ANYONE CAN SELL THEM! The Stay-Prest puts in knife-edge crease, removes baggy knees and smooths out entire surface. Easy to use—takes only a few seconds. Saves nap of cloth. Looks rich. Folds to 15 inch package. Over 1,000,000 satisfied customers prove that the article is right. **Four Patents.**

LOOK AT THESE RECORDS

- \$33 G. M. Stewart, W. Va., tried selling this big repeater in spare time and made \$33 his first week so decided to devote full time to it.
 - \$17 S. D. Mathews, Minn., gave this a trial as a side line. He made \$17 in his first two hours and decided to devote his full time to the work.
 - \$500 J. W. Varner, Iowa, made over \$500 the first month he sold this big money-making specialty.
 - \$32 Mrs. Helen Rhodesby, Oklahoma, made \$32 the first day she tried selling this device.
- She is now one of the most successful "salesmen" of it.



YOUR PROFITS IN ADVANCE

Your profits in advance on this big new specialty and it sells quickly—average sale made in 8 minutes. 40% profit to you. Big repeater. You simply write orders. We ship and collect.

FREE TO ANY MAN OR WOMAN

Special offer enables you to obtain Selling Outfit absolutely free. The Stay-Prest folds into neat, light, compact case. Outfit has everything necessary to begin at once to make \$20 a day—\$35 to \$50 a week spare time—or \$100 to \$150 a week full time. Simply mail the coupon and make the quickest money of your life.

THE GETGEY-JUNG COMPANY K-121 G. & J. Bldg. CINCINNATI, O.

Canadian Distributors: SMITH & ROURKE 110 Dundas St., London, Ont., Canada.

THE GETGEY-JUNG COMPANY
K-121 G. & J. Bldg., Cincinnati, Ohio

Please send me full information about the "Stay-Prest" Trousers Presser and your New Selling Plan.

Name.....

Address.....

City..... State.....

BOYS

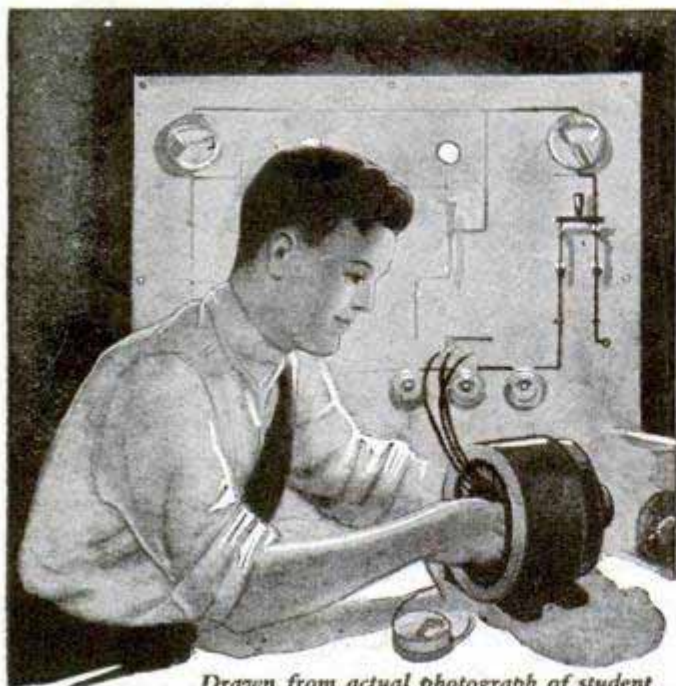

Drawn from actual photograph of student doing spare time electrical work

Learn Electricity Make Big Money

How would you like to earn two or three dollars every evening after school and prepare yourself for a fine big job at the same time? Here's the opportunity of a lifetime for you fellows who like Electricity. Begin right now to prepare yourself for a regular man's size job in this fascinating field. Your chances for a big success are simply wonderful—the pay is big (thousands of men earn \$70 to \$200 a week) and advancement comes swift and sure.

I Will Train You at Home

With my easily earned, spare time Electrical Course I will train you at home like I have trained hundreds of other boys who are now big successful men. It will not interfere with your school work and you can earn more than the small cost of the course doing odd electrical jobs in your spare time. The Course pays for itself. I will show you how to get this work and how to do it. Some of my boy students make \$10 to \$15 a week this way.

Tools, Apparatus and Radio Course —Given Without Extra Charge

Send me the coupon below and I will tell you all about the big outfit of tools, apparatus and instruments and a new Radio Course that I am giving to my students for a limited time. I will send you my big interesting Electrical Book and a sample lesson, too—all Free. You will be tickled with the things I will send you Free. Mail the coupon right now.

L. L. COOKE, Chief Engineer
Chicago Engineering Works
Dept. O1C CHICAGO

Look What This Boy Is Doing

"Although the School term is coming to a close, and I am pretty busy with my examinations, I manage to keep up with my electrical studies and work."

"I guess I forgot to tell you I am now in business for myself. Am doing fine, but owe it all to you. If it had not been for your Course, I, being under age, could not have secured my license in this town. But I got it, and now have all the work I can do, averaging \$20 to \$30 a week, thru spare time work."

"I went out on a job tonight after school, on which I made \$3 and brought home another on which I made \$2.50—\$5.50, for 4 hours' work and no material furnished by me."

ROGERS SMITH,
1215 Chestnut St.,
Greenville, N. C.

Use This "FREE BOOK" Coupon

L. L. COOKE, Chief Engineer,
Chicago Engineering Works,
Dept. O1C 2150 Lawrence Avenue, Chicago

Send me your Big Outfit Offer, your big Electrical Book, Sample Lesson and particulars of your Electrical Course and Extra Radio Course. This will not obligate me in any way.

Name.....

Address.....
This Coupon only for use of boys 15 years old or more.



1,000 Hotel Positions Open!

HOTELS, restaurants, clubs, apartments everywhere need trained men and women. Over 70,000 high-class positions paying up to \$10,000 a year are open each year in the hotels of the United States. In 1926 the Hotel Business is America's largest industry in new construction. Over a billion dollars' worth of New Hotels and Restaurants being built this year will need nearly 200,000 trained men and women.

Hotels start you at salaries up to \$3,500 a year, with your living usually included. At any time you have your choice of over 1,000 hotel positions open.

You can have one of these high-class big-pay positions, fascinating work and with luxurious apartment and meals usually furnished FREE! No previous experience necessary. The Lewis Schools guarantee to give you the valuable knowledge that it has taken some of the most successful hotel men years to obtain—men who are now making \$5,000 to \$50,000 a year. Age is no obstacle—young and old alike have equal chance for success. Past experience absolutely unnecessary. A common school education is all you need. We train you by mail in your spare time at home with the Lewis Simplified Study Plan, and put you in touch with big opportunities. All of your training under the personal direction of Clifford Lewis, former U. S. Government Hotel and Restaurant Expert, now Managing Consultant for over 225 Hotels of 50 to more than 600 rooms each, throughout the United States, totaling over 26,000 rooms. Our students employed, our methods endorsed by leading hotel men everywhere.

Send today for FREE BOOK, "Your Big Opportunity," showing how we can train you for one of these splendid positions, and explaining our Money-Back Guarantee.

LEWIS HOTEL TRAINING SCHOOLS

CLIFFORD LEWIS, Pres.
Room E-376 Washington, D. C.



SAXOPHONE MUSIC Catalog

Just out—complete catalog of latest jazz hits, also standard saxophone solos, duets, trios, quartettes—2,000 selections. Largest general dealers of saxophone music and supplies in the world. Expert repairing. Send for free catalog today.

FINDER & URBANEK Inc., Dept. 1757, 1322 West Congress St., Chicago

LAW High-Grade Instruction By Correspondence Prepares You for the Bar—Est. 1892

University Methods. Standard Text-Books. Approved by Bench and Bar. Graduates practicing in every state. Send today for Free Catalog and Rules for Admission to the Bar. CHICAGO SCHOOL OF LAW, 802 Reaper Block, Chicago, Ill.



BE A RAILWAY TRAFFIC INSPECTOR

EARN UP TO \$250 PER MONTH EXPENSES PAID

Unusual opportunities in this uncrowded profession. Travel; meet big railway officials. Preparation easy in 3 months' spare-time homestudy.

START AT \$120 PER MONTH Expenses paid

Upon graduation we secure position for you or refund your money. More men needed!

MAIL COUPON TODAY



Standard Business Training Inst. Buffalo, New York

Send me, entirely free, Booklet No. D-300 giving full particulars about course in Railway Traffic Inspection.

Name.....

Street.....

City.....

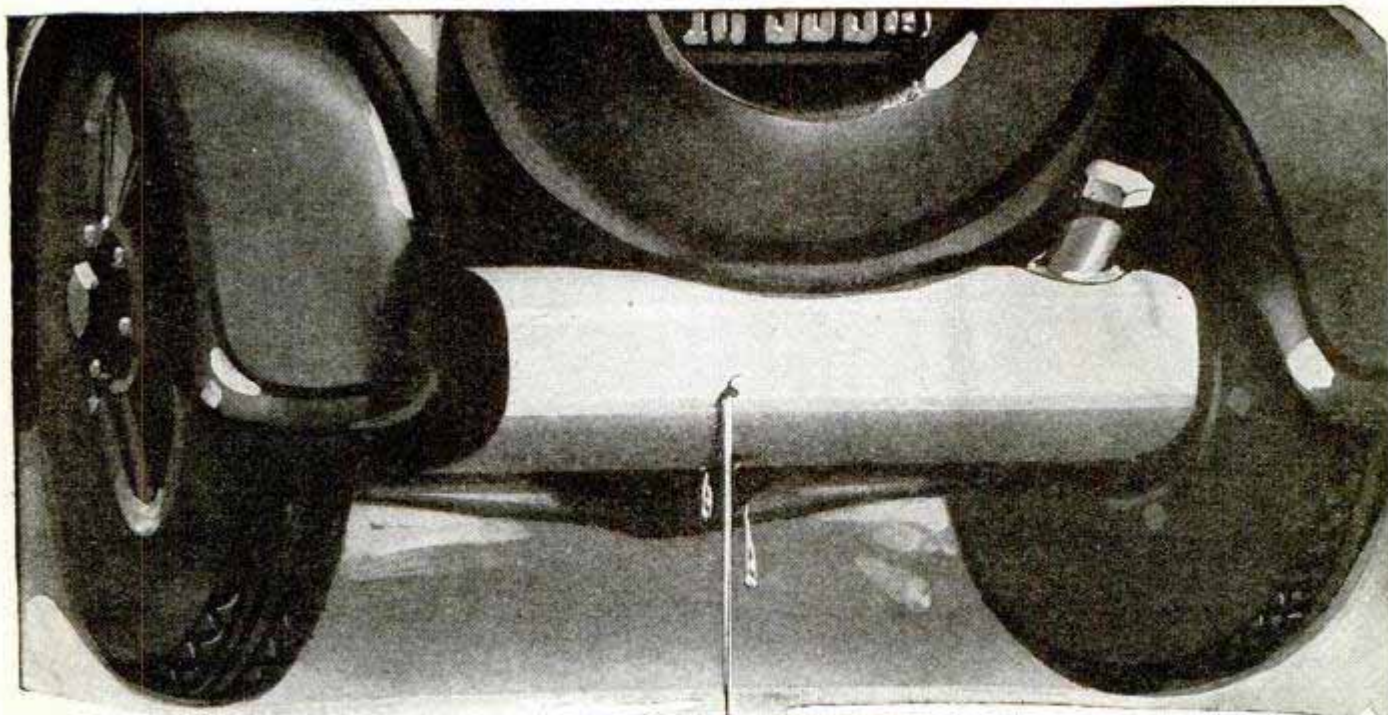

You're Losing Half Your Gasoline!

FOR every ten gallons you buy you are losing five! That's a startling statement, but true. You are getting just half the power, half the mileage you should out of your gasoline! For now an amazing new invention—a ridiculously simple little device—makes practically any car give twice its regular mileage!

57 Miles on a Gallon

With this wonderful new invention auto drivers in all parts of the country have chalked up records of from 37 to 57 miles on a gallon of gasoline. Every day we hear of some new record—some difficult feat such as pulling a car through deep sand, or up a mountain, on half the usual gas.

Here's how this amazing new invention works. Your carburetor is adjusted to make starting easy—it gives a rich mixture to start a cold engine. But once your engine gets heated up, the mixture is far too rich, resulting in faulty explosion. Half the gasoline is drawn into the cylinders in a raw state and, instead of exploding, it burns. This causes a heavy deposit of carbon.

But with this startling little device in your car all this is changed. As soon as the engine warms up, this device automatically begins to admit a much larger volume of air, thoroughly vaporizing all the gasoline, giving it fully 50% more power—breaking it up so that it explodes instead of burning!

A Carbon Remover

Not only does this invention save you half your gasoline, but it also removes carbon, saving you

the expense and time of having your carbon scraped out—a job costing from from \$5 to \$25.

The Stransky Vaporizer is absolutely automatic and self-regulating. It has no springs, shutters, diaphragms or delicate parts to get out of order. It requires no adjustment—you can attach it in three minutes. And it will lengthen the life of any car.

AGENTS Earn \$120 a Day!

This is one of the greatest propositions of the century for agents—over twenty million people want this amazing little device! J. M. James made \$120.00 in one day. J. A. Williams made \$48.00 in three hours. Vernon Gaines made \$94.00 in one day. One demonstration brings from five to twenty orders. Ideal for spare time workers. Splendid opportunity for distributors and managers. Write at once for sample offer.



J. A. STRANSKY, Inventor, at address below.

Introductory Sample Offer

To introduce this new invention in your community, Mr. J. A. Stransky, the inventor, will send a sample at his own risk. Write at once for his proposition. The price is so low that all your neighbors will want to order through you, giving you a generous profit.

Send the request blank for full details of our amazing offer.

J. A. Stransky Manufacturing Co.
K-10 Stransky Bldg.
Pukwana So. Dakota



J. A. Stransky Manufacturing Co.
K-10 Stransky Bldg., Pukwana, So. Dakota

Please send me full details of your special introductory offer.

Name.....

Address.....

City.....State.....



Three Years Ago \$40 a Month

—now he heads his own business!

In 1922 J. H. Bryson, now head of the Bryson Novelty Manufacturing Company, Fayetteville, Tenn., was clerking in a grocery store at \$40 a month. Thru a LaSalle advertisement he became interested in LaSalle home-study training, selected Higher Accountancy as his course, and immediately started a rapid succession of advancements—until in 1925 he became president and proprietor of the firm which bears his name, now doing a nation-wide business. Two recent orders—one for 750,000 oil gauges; the other for 600,000 yardsticks—give a slight idea of the magnitude of his operations.

"During the last six months," writes Mr. Bryson, "our products have been shipped into every state in the Union, as well as to a number of foreign countries. Our business is on a good paying basis and is rapidly increasing.

"Had it not been for LaSalle and the self-confidence and inspiration which came from the knowledge secured from you, I would still be working as a grocery clerk or somewhere in this same channel... Nothing I could say would express the gratitude I feel toward LaSalle for my training. If it can help to accomplish what I have already accomplished, I feel that there is no limit to what it can do."

Send for Free Outline of LaSalle Salary-Doubling Plan

Without cost, would you like to learn what your future can be with LaSalle's help?

The true facts about your opportunities, together with information and data of the utmost value, are contained in a 64-page book which LaSalle will send you if you are sufficiently interested in your future to ask for it.

With it you will receive a copy of "Ten Years' Promotion in One," the inspiring story of how one man, after many wanderings, found the shorter path to responsibility and power. Action today means a bigger job and better pay in the months to come.

Fill in, clip and mail the coupon NOW!

— — — Find Yourself Thru LaSalle! — — —

LA SALLE EXTENSION UNIVERSITY
The World's Largest Business Training Institution
Dept. 864-R Chicago

I should be glad to learn about your salary-doubling plan as applied to my advancement in the business field checked below. Send also copy of "Ten Years' Promotion in One," all without obligation.

- Business Management
- Higher Accountancy
- Modern Salesmanship
- Traffic Management
- Railway Station Management
- Law—Degree of LL.B.
- Commercial Law
- Industrial Management
- Modern Foremanship and Production Methods
- Personnel and Employment Management

- Banking and Finance
- Modern Business Correspondence and Practice
- Expert Bookkeeping
- C. P. A. Coaching
- Business English
- Commercial Spanish
- Effective Speaking



Name.....
Present Position.....
Address.....



Will You Wear This Suit?

Show it to your friends and neighbors as a sample of our fine quality, hand-tailored **All-Wool Suits**, guaranteed \$40 values at amazing low price of \$23.50, take their orders, keep handsome profit for yourself and send orders to us.

Agents Making BIG MONEY

\$3.00 to \$5.00 an hour in spare time, \$75 to \$150 a week for full time. We supply handsome Swatch Line Outfit, large size samples and all latest styles in elegant Leather Case.

Positively finest selling outfit ever furnished salesmen. Write for yours at once, pick out your suit and get started making the Big Money right away. Address Dept. 727.

JAMES OLIVER, Inc., 848 W. Adams St., Chicago
Write name and address below and mail at once.

Name.....727
St. and No..... R. F. D..... Box.....
Town..... State.....



"BECOME A LIGHTNING TRICK CARTOONIST"

Send \$1.00 for Laugh Producing Program of 23 Trick Drawings with Instructions. Catalog of Chalk Talk Supplies Free. **BALDA ART SERVICE, Dept. 1, Oshkosh, Wis.**



Every Boy His Own Toymaker

Greatest boys' book ever written. Tells how to make a Steam Engine, Telephone, Magic Lantern, Boats, Kites, Balloons, electrical and mechanical toys, traps, fishing tackle, sleds, stunts, diving boards, Bird Houses, etc. Fully illustrated 130 200 kinds. Iron, Wood and Wire Puzzles. Sample leader and Catalog 10c. **WESTERN PUZZLE WORKS, SAINT PAUL, MINNESOTA.**

Delivered to You Free

for 30 days trial on approval. You can have your choice of **44 Styles**, colors and sizes of the famous **RANGER Bicycles**. Express prepaid. **Factory-to-Rider** Prices save you \$10 to \$25 on your bicycle.

\$5 a Month if desired. Many boys and girls easily save the small monthly payments. Parents often advance first payment.

Tires best quality, at factory prices, express prepaid. Lamps, wheels and equipment, low prices. **Send No Money, do business direct with makers.**

Mead CYCLE COMPANY
DEPT. 109 CHICAGO

Write today for free Ranger Catalog, factory prices and marvelous easy payment terms



Skin Troubles

Cleared up—often in 24 hours. To prove you can be rid of Pimples, Blackheads, Acne Eruptions on the face or body, Barbers' Itch, Eczema, Enlarged Pores, Oily or Shiny Skin, simply send me your name and address today—no cost—no obligation. **CLEAR-TONE** tried and tested in over 100,000 cases—used like toilet water—is simply magical in prompt results. You can repay the favor by telling your friends; if not, the loss is mine. **WRITE TODAY.**
E. S. GIVENS, 428 Chemical Bldg., Kansas City, Mo.



Grow Taller

Science has found the way to add inches to your height. No need to envy and look up to the big fellows. No need to have the disadvantages of the little man. This course makes it possible for you to be on a level with your fellow men. Course is easy, inexpensive and results sure. Mail coupon for free information today!

L. GLOVER,
Room 24, 459 San Carlos Ave.,
Sausalito, Calif.

Without any obligation to me, send me full information on how to grow taller.

Name.....
Street..... City.....

LEARN *to* FLY

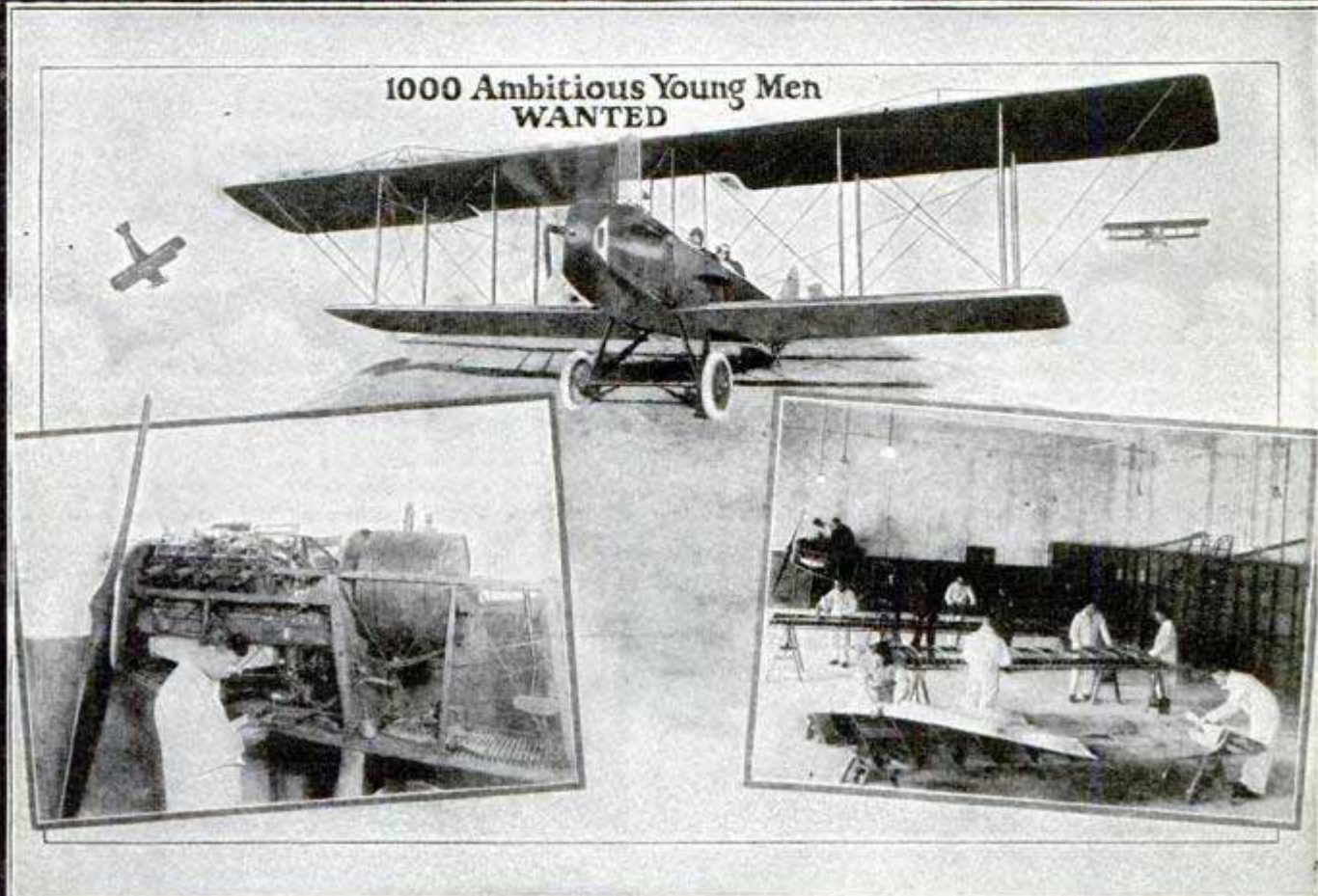

1000 Ambitious Young Men
WANTED

Sweeney System of Practical Airplane Mechanics

These photographs show how Sweeney students are trained by DOING. After thorough ground school work, under skilled instructors in the construction and repair of planes, recovering wings, tuning motor, etc., learning everything about the mechanical work by actual practice, the student then, if he wishes, goes into the air and qualifies as a pilot under safe and experienced pilots, with double controls for actual flying. Here's the great business of the future. The National Air Transport alone has invested \$700,000 on the Kansas City air route. They are spending \$1000 a day to operate an over-night service to New York City. Ambitious men are wanted as pilots and ground mechanics. At the great SWEENEY SCHOOL you learn not only by doing, but you get personal instruction.

THE SWEENEY SYSTEM

is divided into two parts. **FIRST:** You are thoroughly taught in the ground school. This fits you as an aviation mechanic. You can build your own plane and do anything required in aviation mechanics and construction and repairing when you have finished this work. You are thoroughly taught motors, etc., and work with thousands of dollars' worth of new material, including all types of engines—**SECONDLY:** After completing this work, if you want to be a

pilot, you take all the actual flying necessary to make you a competent pilot. Now when you understand that two to seven hours is all the average man needs to learn expert flying you will appreciate what this ample experience in the air under skilled men will do for you. Aviation is no longer a mystery—no longer a hazard; no, it is a business growing greater and more important. This has been wonderfully demonstrated in the successful flights over the North Pole and also in the big part Aviation is now playing in commercial activities. Progress is rapid. More men are needed every day. You can qualify as a mechanic, or an engineer, or repair man, or builder; five men on the ground are needed for one man in the air, but if you want to become a pilot you easily master the work and can go into postal, government, or commercial work. Flyers are in demand, earning big money at fairs, taking up passengers, etc., \$5 for a 10 minute flight is pretty fine pay!

Opportunities in FLYING

- Aviation Mechanics—\$50-\$125 Week
- Riggers—\$50-\$75 Week
- Flyers—\$125-\$225 Week
- Taxi Service—\$100-\$3001 Week
- Aerial Photo Pilot—\$200-\$250 Week
- Special Messenger Service—\$125-\$200 Week
- Aerial Advertising—\$225-\$500 Week
- Crop Dusting—\$125-\$200 Week
- Crop Survey—\$125-\$225 Week

SEND NAME TODAY for full details of this aviation mechanical course and photographs of planes and equipment actually used; also full information as to the commercial end of flying and opportunities for young men.

SWEENEY SCHOOL OF AVIATION

LEARN TO FLY BY FLYING
Sweeney
SCHOOL OF AVIATION
2806 SWEENEY BLDG, KANSAS CITY, MO.

--- SEND THIS NOW ---

EMORY J. SWEENEY, President
2806 Sweeney Bldg., KANSAS CITY, MO.
Please send me full information about your Aviation Course.

Name.....Age.....
Address.....
Town.....State.....



“There’s One Man We’re Going to Keep”

“Ed Wilson, there, is one of the most ambitious men in the plant. I notice that he never fools away his spare time. He studies his International Correspondence Schools Course every chance he gets.

“It’s been the making of him, too. He hasn’t been here nearly so long as Tom Downey, who was laid off yesterday, but he knows ten times as much about this business.

“I’m going to give him Tom’s job at a raise in salary. He’s the kind of man we want around here.”

HOW do you stand in your shop or office? Are you an Ed Wilson or a Tom Downey? Are you going up? Or down? No matter where you live, the International Correspondence Schools will come to you. No matter what your handicaps or how small your means, we have a plan to meet your circumstances. No matter how limited your previous education, the simply-written, wonderfully-illustrated I. C. S. textbooks make it easy to learn.

This is all we ask: Without cost, without obligating yourself in any way, put it up to us to prove how we can help you. Just mark and mail this coupon.

INTERNATIONAL CORRESPONDENCE SCHOOLS Box 5591-E, Scranton, Penna.

Without cost or obligation, please tell me how I can qualify for the position or in the subject before which I have marked an X:

BUSINESS TRAINING COURSES

- | | |
|---|---|
| <input type="checkbox"/> Business Management | <input type="checkbox"/> Salesmanship |
| <input type="checkbox"/> Industrial Management | <input type="checkbox"/> Advertising |
| <input type="checkbox"/> Personnel Organization | <input type="checkbox"/> Better Letters |
| <input type="checkbox"/> Traffic Management | <input type="checkbox"/> Show Card Lettering |
| <input type="checkbox"/> Business Law | <input type="checkbox"/> Stenography and Typing |
| <input type="checkbox"/> Banking and Banking Law | <input type="checkbox"/> Business English |
| <input type="checkbox"/> Accountancy (including C.P.A.) | <input type="checkbox"/> Civil Service |
| <input type="checkbox"/> Nicholson Cost Accounting | <input type="checkbox"/> Railway Mail Clerk |
| <input type="checkbox"/> Bookkeeping | <input type="checkbox"/> Common School Subjects |
| <input type="checkbox"/> Private Secretary | <input type="checkbox"/> High School Subjects |
| <input type="checkbox"/> Spanish | <input type="checkbox"/> Illustrating |
| <input type="checkbox"/> French | <input type="checkbox"/> Cartooning |

TECHNICAL AND INDUSTRIAL COURSES

- | | |
|---|--|
| <input type="checkbox"/> Electrical Engineering | <input type="checkbox"/> Architect |
| <input type="checkbox"/> Electric Lighting | <input type="checkbox"/> Architects' Blue Prints |
| <input type="checkbox"/> Mechanical Engineer | <input type="checkbox"/> Contractor and Builder |
| <input type="checkbox"/> Mechanical Draftsman | <input type="checkbox"/> Architectural Draftsman |
| <input type="checkbox"/> Machine Shop Practice | <input type="checkbox"/> Concrete Builder |
| <input type="checkbox"/> Railroad Positions | <input type="checkbox"/> Structural Engineer |
| <input type="checkbox"/> Gas Engine Operating | <input type="checkbox"/> Chemistry |
| <input type="checkbox"/> Civil Engineer | <input type="checkbox"/> Automobile Work |
| <input type="checkbox"/> Surveying and Mapping | <input type="checkbox"/> Airplane Engines |
| <input type="checkbox"/> Metallurgy | <input type="checkbox"/> Navigation |
| <input type="checkbox"/> Steam Engineering | <input type="checkbox"/> Agriculture and Poultry |
| <input type="checkbox"/> Radio | <input type="checkbox"/> Mathematics |

Name.....
Street.....
Address.....

City..... State.....

Occupation.....

Persons residing in Canada should send this coupon to the International Correspondence Schools Canadian, Limited, Montreal, Canada.

ART

We Teach COMMERCIAL ART

Meyer Both Company, maintaining the most widely known Commercial Art Studios in the World, offers you a practical training based upon 25 years' success in producing over a quarter million drawings for leading advertisers. This attractive profession equally open to men and women. Home study instruction.

Get Facts Before You Enroll in Any School
Send 4c in stamps for illustrated book telling of the success of our students.

MEYER BOTH COMPANY
Dept. 16
Michigan Ave at 20th St
CHICAGO, ILL.

LANGUAGE POWER

Mastery English wins friends, increases chances for success. Sherwin Cody's wonderful new invention gives you language power in only 15 minutes a day fascinating spare-time study at home. No rules to memorize. Learn correct English this new, easy way. Write for free book today.

SHERWIN CODY SCHOOL OF ENGLISH
58 Searle Bldg. Rochester, N. Y.

LEARN WATCH REPAIRING

Be a watchmaker—you can learn this profitable trade by correspondence in a few weeks in your own home by the DeSelms Chart System. After you complete the course you will know a watch from A to Z. You will know just what the matter is and how to repair one. When you graduate you will be a practical watchmaker and repairer and competent to fill any position. Positions for our graduates. Ask for our Free Book. It explains our system and terms.

THE DeSELMS WATCH SCHOOL
LOGANSPORT, INDIANA

LEARN to PITCH

56 Illustrations—How to pitch the “Fade-away,” “Knuckler,” “Smoke Ball,” and Speed. How to keep in condition. Lessons by Matty, Johnson, Wood, Walsh, White and Rucker sent postpaid for 25 cents.

J. C. DORN, 721 S. Dearborn St., Dept. 65, CHICAGO, ILL.

GOV'T. POSITIONS

<ul style="list-style-type: none"> <input type="checkbox"/> Railway Mail Clerk <input type="checkbox"/> P. O. Clerk <input type="checkbox"/> Forest Ranger <input type="checkbox"/> File Clerk <input type="checkbox"/> Matron <input type="checkbox"/> General Clerk <input type="checkbox"/> Chauffeur-Carrier <input type="checkbox"/> Skilled Laborer <input type="checkbox"/> Watchman <input type="checkbox"/> Postmaster <input type="checkbox"/> RFD Carrier 	<ul style="list-style-type: none"> <input type="checkbox"/> Meat Inspector <input type="checkbox"/> Special Agent (investigator) <input type="checkbox"/> Stenographer-Typist <input type="checkbox"/> Immigrant Inspector <input type="checkbox"/> City Mail Carrier <input type="checkbox"/> U. S. Border Patrol <input type="checkbox"/> Typist <input type="checkbox"/> Seamstress <input type="checkbox"/> Steno-Secretary <input type="checkbox"/> Auditor
---	--

Mr. Ozment, Dept. 111, St. Louis, Mo.
Send me particulars about positions marked “X” —salaries, locations, opportunities, etc.

NAME.....
ADDRESS.....

New Opportunities for Home Trained Men IN ELECTRICITY

FREE—64-PAGE BOOK—MAIL COUPON

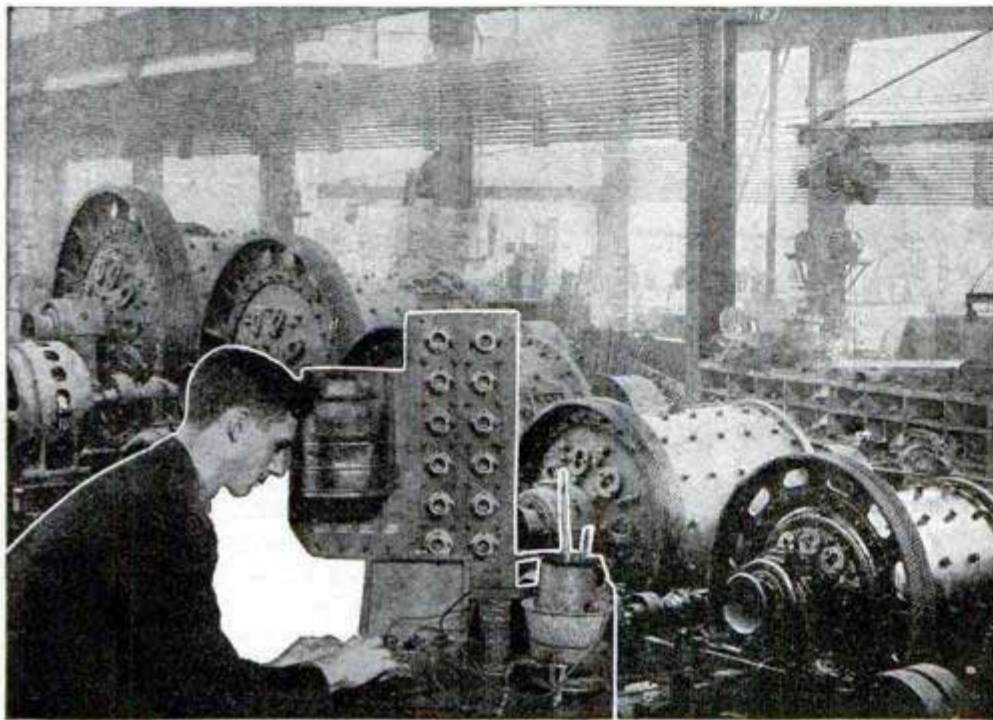

ELECTRICAL EXPERTS are needed now as never before. Even electrical trades are making record money. But men with expert electrical training such as we give you, are earning \$3250 a year and up by the thousands. And the big modern electrical "boom" has only started. Jobs by the hundreds are opening up. Electrical refrigeration, power plants, battery stations. A profitable business for yourself. The kind of job you've always wanted. Where you do the bossing and let the other fellow do the \$25 a week hard work.



Charles F. Stelmets, A. M. Ph. D. "Electric wizard" of General Electric was for the last six years of his life on the Advisory Board of School of Engineering. You get personal advice and training from men who know how to tell you to succeed.

FREE EMPLOYMENT SERVICE and it doesn't cost you a penny. Thousands

of firms look to us for men. Allis-Chalmers, Harnischfeger Corp'n., Commonwealth Edison are only a few places where S. of E. men get rapid advancement. Hundreds have been helped by us in selecting the right place to go into business for themselves. Coupon brings you big FREE book with all details.

WHATEVER YOUR AGE or EXPERIENCE

we can train you for success and big pay in electrical work. Hundreds of our most successful students are not even high school graduates. You don't need to know a single fact about electricity. In 22 years of teaching men to be a success we have found just what you should know and how to teach it to you to insure the quickest success when you go on the job. Earn \$65 a week and up. It's "in the cards" for you if you act and send the coupon.

SATISFACTION GUARANTEED OR MONEY BACK is the way we stand behind S. of E. training. We can afford to because S. of E. men make good. They have the prestige for some of the biggest electrical men in America are S. of E. men. A signed money-back guarantee bond is yours the minute you enroll. Your training must satisfy you or every penny is returned.

GET STARTED—MAIL THE COUPON NOW. A big 64 page book in colors and illustrated with

\$65 a WEEK AND UP! Get into a field that's not crowded. Draw real pay! If you can be reached by mail, we can train you for success in electricity.



After you get your Diploma for home-study we offer you entirely FREE 30 days residence training, if you want it. Above and below—S. of E. students at work and equipment.



S. of E. men go far because our training is best for success. Many S. of E. men are succeeding with Allis-Chalmers, mfgs. of the turbine shown below and other big electrical concerns.



pictures of successful S. of E. men and their jobs will be rushed post-paid. Full details on S. of E. home training and the big opportunities that await you. **Mail coupon right now.**

My Personal Challenge

"Whatever your age or experience, we can train you for success in electricity. Put yourself in my hands for a few hours a week and a big pay future is yours."



OSCAR WERWATH, President.

Your home equipment is real electrical experts' tools. Not toys! Actual value \$60. Same things you use on the real job.

\$50 Outfit FREE

An electrical expert's outfit complete, of finest materials, when you enroll.



SCHOOL OF ENGINEERING OF MILWAUKEE
Dept. 4-C, Box 572, Milwaukee, Wisconsin
Send me FREE and postpaid without obligation your big 64-page book telling about S. of E. training and opportunities for me in electrical work. Also details of your employment service and money back guaranty.

Name.....
Age..... Education.....
Address.....
City..... State.....

In Business for Yourself

One way to apply S. of E. training and make big pay is to go into business for yourself. Be your own boss. Tell others what to do. Hundreds of S. of E. men locate in business for themselves. With our help it's easy to get started. Just a few hours a week in work with a "kick" in it.
Make a start—SEND COUPON.



CHICAGO TECHNICAL COLLEGE

*Drafting
Engineering
Electricity
and Architecture*

[23rd Year]

A MAXIMUM of practical training in a minimum of time is offered you by one of "America's oldest and largest schools of specialized engineering" . . . technical training of college standard for men who have neither the time, money nor preliminary education to attend a university. Over 1000 men enroll each year in day and evening classes.

Short, Intensive Training

of a very practical sort puts you immediately into a high salaried position. Many of our students are assisted to responsible positions before graduation . . . they earn while they learn.

Chicago Technical
College Bldg.



If you can't
come to Chicago
**STUDY
AT HOME**

Ten months from today you can be a trained draftsman. . . Trained men are in demand. . . at high salaries. Enter a profession, without sacrificing time. Study

DRAFTING

In your spare time. . . We have been giving technical training for 23 years. . . Instructors are experts, the same instructors as in the resident school.

FREE TRIAL LESSON

To see how much you will like this high-grade profession, and

FREE OUTFIT

a regular \$25 draftsman's outfit is included in the price of the course.

Send for

40-Page Book

of facts about drafting. . . send for it, free. Write today for the Free trial lesson in drafting, sample drawings made by students and the book of information. Address Dept. 630.

Courses are arranged to suit your needs: 2-year diploma; 3-year B. S. degree; special short courses adapted to the individual. Instructors are experts, actively at work in the very professions they teach. Tuition is low, terms easy. Enter any time.

Write for Free 72-Page Blue Book

It tells about the courses (full descriptions); about the great demand for Chicago Technical College trained men; about college athletics and other interesting facts you'll want to know. Send for the Blue Book now, without obligation! Address

Chicago TECHNICAL College

Dept. 18, 118 East 26th St., Chicago



. . . and, perhaps you, too, due to the lack of money, time and education necessary to master a trade, wonder what to get into *quickly* and make the most out of. Haven't you *overlooked* the very thing you are looking for? 60,000 Moler graduates *know* Modern Barbering is easy to learn, *quick* to earn, *clean* and **FASCINATING!** **FIND OUT!** Write for catalog "B-8."

Address the Branch
of the **MOLER SYSTEM OF COLLEGES** nearest you.
(Street address not needed)

Chicago, Ill.	Denver, Colo.	Houston, Tex.
New York, N. Y.	New Orleans, La.	San Antonio, Tex.
St. Louis, Mo.	Omaha, Nebr.	Minneapolis, Minn.
Kansas City, Mo.	Milwaukee, Wis.	Seattle, Wash.
Cincinnati, Ohio	Atlanta, Ga.	Tacoma, Wash.
Cleveland, Ohio	Fargo, N. D.	Toronto, Ont., Can.
Detroit, Mich.	Memphis, Tenn.	Winnipeg, Man., Can.
	Dallas, Tex.	

**Learn Watchwork, Jewelrywork
and Engraving** A fine trade commanding a good salary, and your services always in demand. Address **Horological**, Dept. P, Bradley Institute, PEORIA, ILLINOIS, for our latest catalog.

STAMMERING
Fully explained. Quick, easy cure guaranteed. Information, diagnosis, phonograph record and catalog free. America's foremost school. Established 1894.
153 Stimson Ave. The LEWIS INSTITUTE, Detroit, Mich.

OPPORTUNITIES IN Salesmanship

Become a Salesman

Every phase of business revolves around selling. The trained salesman is in demand—he can fix his own hours, choose his own field, control his own pay. His income depends only upon his results—there is no limit to what he can earn. We train you to sell successfully thru the LaSalle problem method under supervision of expert salesmen. Train in your spare time. Low cost; easy terms. 64-page booklet, "The Modern Salesman, Ambassador of Progress," free. Send for it today. LaSalle Extension University, Dept. 864-S Chicago



FREE

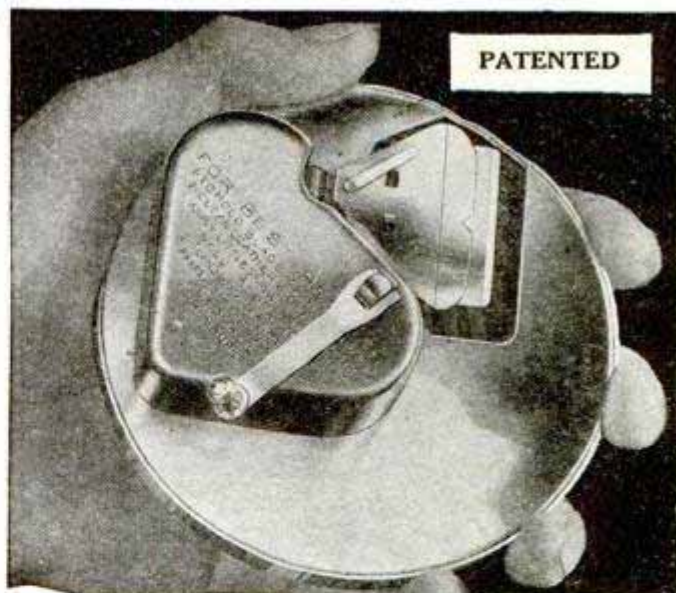
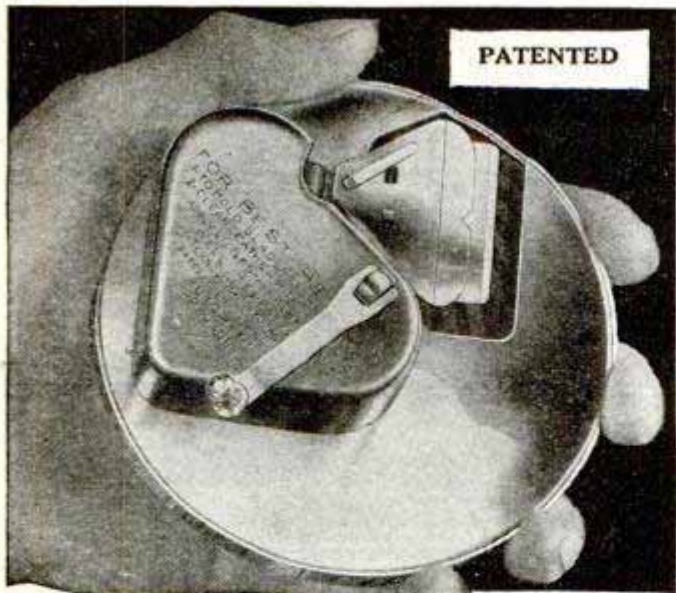

Use This Amazing Invention and All Guarantee To Keep You in Razor Blades for Life



Sensational New Invention Guarantees You 365 Slick Shaves A Year—No More Blades To Buy

KRISS-KROSS marks such a radical advance in shaving comfort and economy that it deserves to be called much more than a stropper. Rather it is a blade rejuvenator. Makes hundreds of keen, quick shaves blossom where only one grew before.

KRISS-KROSS strops your blade on the diagonal just like a master barber. Pressure decreases automatically. Nickel jig flies up to notify you when your blade is ready, with the keenest cutting edge that steel can take!

And now for my smashing offer! For 30 days only, to introduce KRISS-KROSS stropper, I will give you an amazing new kind of razor free. Really three razors in one. Can be made straight or T-shape in a jiffy. Comes with 5 special blades.

Use these blades and keep renewing them with KRISS-KROSS super stropper. If any one goes back on you I'll recondition or replace them free! This sweeping written guarantee solves your blade problem for all time. I mean every word when I say, "I'll keep you in Razor Blades for Life."

Write for Details at Once

This astonishing offer is limited. Send for information on amazing KRISS-KROSS inventions today. They are never sold in stores—and they're even more remarkable than I can tell you here. Clip the coupon at once. Mail it today!



Rhodes KRISS KROSS
RHODES MFG. CO. STROPPER
Dept. K-370, St. Louis, Mo.

Rhodes Mfg. Co., Dept. K-370, 1418 Pendleton Ave., St. Louis, Mo.

Please send me without obligation details of your offer to keep me in Razor Blades for Life. Also full description of free razor and stropper.

Name.....
Address.....
City..... State.....

Make \$30 to \$60 A DAY
—With This Astonishing Shaving Invention

Marvelous Device Offers Surprising Profits to Agents and Spare Time Workers. Even Office and Factory Men Make \$6-\$12 EXTRA an Hour Showing KRISS-KROSS to Friends and Fellow Employees. Investigate Without Delay.

HERE is the most sensational money-maker you ever heard of. So immensely popular that it brought H. King \$66 in one day! G. M. Hale cleared \$8 in fifteen minutes. And J. C. Kellogg made over \$200 in 7 days.

Sensational Money Maker

KRISS-KROSS, the startling invention that makes these big profit records possible, ushers in a new era in shaving comfort and economy. It is a blade rejuvenator—a super stropper—unlike anything ever seen before. Uses a diagonal stroke just like a master barber. Stropps heavy at the start—light at the finish. Prolongs the life of any-make blade for months and years—and gives keen, velvety shaves forever. No wonder men everywhere jump at the chance to buy the minute they see it.

"Made \$104 in 3 Days"

And no wonder men like N. C. Paige (Mo.) write: "I have made \$104 so far this week (3 days). I don't have to 'sell' at all. People just simply take it out of your hands." And R. S. Hopkins (Mich.) says: "I made \$20 my very first day."

When men like these are making such big profits—many of them in spare time without experience—you are bound to realize what KRISS-KROSS offers you, too. Don't miss this unusual opportunity to get your share and put away \$200-\$450 cash profit every 30 days.

Get Generous Offer Quick

Be the KRISS-KROSS representative in your territory. Full or spare time. Write us at once. Find out all about this new easy way to make big money quickly! No obligation. Clip the coupon immediately. Mail it tonight.

RHODES MFG. CO.

Dept. K-370
1418 Pendleton Ave., St. Louis, Mo.

Rhodes Mfg. Co., Dept. K-370
1418 Pendleton Ave., St. Louis, Mo.
Please send me full details of your amazing KRISS-KROSS Stropper with list of generous commissions, and tell me how I can make big profits with it in my full or spare time.
Name.....
Address.....
City..... State.....



Follow this Man

Secret Service Operator 38 is on the job

FOLLOW him through all the excitement of his chase of the counterfeit gang. See how a crafty operator works. Telltale finger prints on the lamp stand in the murdered girl's room! The detective's cigarette case is handled by the unsuspecting gangster, and a great mystery is solved. Better than fiction. It's true, every word of it. No obligation. Just send the coupon and get—

FREE!

The Confidential Reports No. 38 Made to His Chief

And the best part of it all is this. It may open your eyes to the great future for YOU as a highly paid Finger Print Expert. More men are needed right now. This school has taken men just like you and trained them for high official positions. This is the kind of work you would like. Days full of excitement. Big salaries. Rewards.

Can you meet this test?

Can you read and write? Are you ambitious? Would you give 30 minutes a day of your spare time preparing yourself for this profession? Would you like a life of excitement, thrilling adventures and high pay? Answer "yes" and I'll show you how to attain all this.

Send the coupon and I'll send the Free Reports—also a wonderful illustrated book telling of the future awaiting you as a Finger Print Expert.

T. G. COOKE, Pres.

UNIVERSITY OF APPLIED SCIENCE
1920 Sunnyside Ave., Dept. C-135 Chicago, Ill.

University of Applied Science
1920 Sunnyside Ave., Dept. C-135 Chicago, Ill.

Gentlemen:—Without any obligation whatever, send me the Reports of Operator No. 38, also your illustrated Free Book on Finger Prints and your offer of a FREE course in Secret Service Intelligence and the Free Professional Finger Print Outfit.

Name.....
Address.....
Age.....

Music Lessons

WITH AN ACCREDITED SCHOOL

At Home

A Complete Conservatory Course By Mail

Wonderful home study music lessons under great American and European teachers. Endorsed by Paderewski, Master teachers guide and coach you. Lessons a marvel of simplicity and completeness.

Any Instrument Write telling us course you are interested in—Piano, Harmony, Voice, Public School Music, Violin, Cornet, Mandolin, Guitar, Banjo or Reed Organ—and we will send our FREE CATALOG with details of course you want. Send NOW.

University Extension Conservatory, 306 Siegel-Myers Bldg., Chicago, Ill.

Home Made Candies for Profit



Turn your kitchen, basement or spare room into a small candy shop and start making a handsome income almost from the very first day. Home-made candies sell like hot cakes. Many who are now well-to-do or rich started just this way. Our now up-to-the-minute home-study course, prepared by a man who has himself made a big success in the candy business, gives you tested recipes, complete instructions and many other important "secrets" of the trade. Free book explains everything. Send for your copy today.

THE CAPITOL CANDY SCHOOL
Dept. B-8, 631 Penna Ave., Washington, D. C.

MAGIC

Taught at Home

New! Different! Teaches you Big Tricks, Illusions, Stage Stunts, "Patter" and the Principles of Magic. Learn at home. Earn \$250 to \$1,000 a month. Write today for special offer.

Tarbell System, Inc., 1926 Sunnyside Ave., Dept. C-935 Chicago, Ill.

LEARN WATCHMAKING AND ENGRAVING

BY OUR PROFIT-SHARING PLAN
OUR GRADUATES SUCCEED

One of our Iowa students started in a very small way—now doing over \$30,000 a year. Another in Wisconsin, over \$10,000 the first year. Day or night classes. Call or write for FREE BOOK

Chicago School of Watchmaking, Dept. 1901, 4844 Lincoln Avenue, CHICAGO

THIS WONDERFUL INVENTION



converts any ordinary cook stove into a gas stove. OXO-GAS is made from kerosene and air. Cheaper, cleaner and more efficient than coal. Responsible distributors wanted.

GLORIA LIGHT CO.
115 N. May St. Chicago, Ill.



BECOME A RAILWAY POSTAL CLERK

Pay has been raised from \$1900 to \$2700 a year. Steady job. Pleasant work. Common education sufficient. No "pull" necessary. Mail coupon for FREE Catalog.

Patterson Civil Service School
Dept. 88 ROCHESTER, N. Y.
Sirs: Send me without charge your Catalog, describing this and other U. S. Government positions.

Patterson Civil Service School
Dept. 88 Rochester, N. Y.

Name.....
Address.....

Learn Autos in Los Angeles

I NEED men *quick* to fill jobs paying \$60 to \$100 a week. I train you in my great school of shops to be a real Auto Mechanic—and the best repair shops in Los Angeles are willing to pay top salaries to my graduates because they know my *quality* training makes you a real Auto Mechanic.

BIG PAY JOBS OPEN NOW!

This is Truth! I know I can find you a good job because this 21-year old auto school has a world-wide reputation for giving the most *complete* training. 16,000 successful graduates are boosting National. California has most autos—ideal training center—you learn by actual work on a half-million dollars worth of equipment—with expert instructors. I don't rush you through half-trained. I train you *right*. That's why National-trained men get the best jobs and salaries. And I have a special offer to make to men who can start training now.



National Automotive

& ELECTRICAL SCHOOL
Dept. 450, Los Angeles, Calif.

If you live West of the Mississippi I'll give you my big

\$1.00
Auto
Book
FREE!

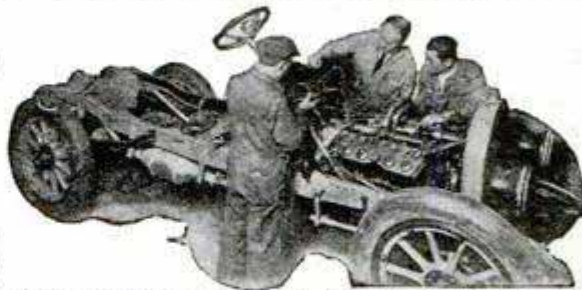

I NEED men now to fill jobs waiting. So I'll send you my 84-page illustrated catalog—*free*—if you live west of the Mississippi. It costs me \$1.00 a copy—and I must ask men in other states to send \$1.00 with the coupon below. I will credit the dollar to your account if you come to National. But I know you men in the West can come *now*. So I'll rush you a free catalog—give you a 30% discount on your tuition—get you a bargain railroad or boat fare to Los Angeles—get you part time jobs to pay your room and board while training—and help you get any big pay Auto job you want, after you finish training. But you must come NOW. Mail the coupon—*quick!* before this offer expires.



J. A. ROSENKRANZ, Pres., NAT'L AUTOMOTIVE,
Dept. 450, 4004 So. Figueroa, Los Angeles

Rush me your catalog and Special Training Offer. (If you live East of the Mississippi enclose \$1 which will be credited to your account at 5% interest).

Name.....
Address.....
City..... State.....



"Been on a
vacation
Bill?"

"No, Jim — I've stopped smoking. Gained six pounds in a week. You know how I used to smoke—a package of cigarettes and a cigar or two a day—it sure had some hold on me. But I'm cured—

took a scientific home tobacco treatment—fixed me up in two weeks.

"Wasn't hard on me at all—noticed improvement the first day—I feel like a new man. It didn't interfere with my work—didn't leave any druggish after-effects—the money I saved in the last two weeks has paid for the treatment alone.

"Why don't you take it? It has cured men like you and me for over forty years—it is a doctor's individual prescription that sure fixes you up. Just send the coupon for full information NOW. No obligation. All correspondence is strictly confidential."



A Doctor's
Prescription

The Keeley Institute, Dwight, Ill.

Please send me, without any obligation on my part, your free booklet which will tell me how to rid myself of the tobacco habit.

Name.....
Town.....
Street..... State..... PM-8

FREE 1000 Illustrations ELECTRIC CATALOG!



Write today for your copy. Save 50% direct from Manufacturer. No Middleman's Profit. OUR SPECIAL: 8 Room Electric Set, ready to hang, \$24.50—Other bargains.



UNITED LIGHTING FIXTURE CO.
83 Flatbush Ave. Dept. P, Brooklyn, N. Y.



FLY

Young man learn aviation. Build this classy plane and learn to construct and operate aircraft. Use your motorcycle engine or our "Meteor" 21 h. p. motor. We furnish parts very reasonable to build this wonderful little "Meteorplane," the World's first successful motorcycle engine aeroplane. Send \$3.50 for complete set of blue prints and parts price list of this latest Model M-T-2.

IRWIN AIRCRAFT CO.
126 O Street, Sacramento, Cal.

Mathematics Made Easy by ROPP'S CALCULATOR AND SHORT-CUT ARITHMETIC

Shows the Answer as Quickly as a Watch shows the Time to all Problems likely to occur in the Office, Store, Shop, Bank, Farm, or Factory. Over 2,000,000 Sold



Explains and simplifies every principle in Arithmetic, Mechanics, and Mensuration.

PRICES POSTPAID
Desk Size...\$1.50
Leatherette, Pocket Size...\$1.00
Pocket Size, Cloth...\$0.50
Pocket Size, Paper...\$0.35

Popular Mechanics Press, Room 208, 200 E. Ontario St., Chicago

\$1.00 DEPOSIT DELIVERS Complete Outfit

Violet Ray

**QUICK RESULTS
No Medicine**

Just \$1.00 brings you a complete outfit identical with the kind doctors have bought from us for years and used successfully in treating the ailments listed. Violet Rays give quick relief, permanent results. They scientifically and painlessly remove the cause of pain and sickness. Dr. L. H. Leight, Millerton, N. Y., writes: "I am having wonderful success in treating neuritis, and all stomach cases. I have given over 2,000 treatments with your outfit."

**10 Day FREE Trial
at your home**

Send for Violet Ray Outfit without fail. Treat yourself and family with it. You'll be amazed at how Violet Rays enable you to conquer pain, disease, nervous troubles—how they give vigor, beauty, health. Owning an outfit saves doctor bills, delays, medicines—relieves pain. You should have this health machine in your home.

Send for FREE Book

Explains how Violet Rays (discovery of the world renowned scientist, Nikola Tesla) work and heal, what doctors and plain folks accomplish with them. Shows charts of human body explaining where pains start and how to banish them. Send for FREE copy today. Free for limited time only. *Vi-Rex Company, 2304 Warren Ave., Chicago.*

For special free advice, state your ailment

for
**Health
Vigor
Beauty**

**Ailments
successfully
treated
with
Violet Rays**

- Rheumatism*
- Neuritis*
- Paralysis*
- Catarrh*
- Nervousness*
- Skin Diseases*
- Hay Fever*
- Headache*
- Colds*
- Constitution*
- Sprains*
- Asthma*
- Deafness*
- Eczema*
- Eye Diseases*
- Falling Hair*
- Goitre*
- Insomnia*

Mail Coupon—Send No Money

VI-REX COMPANY
2304 Warren Ave., Dept. 28, Chicago

Please send me without cost or obligation your free book describing your VI-REX Violet Ray outfits and details of your \$1.00 offer.

Name.....
Address.....
City..... State.....
Ailment.....

**Don't Envy The Plumber
BE ONE!**

\$11.00-\$16.00 PER DAY and work EVERY day, is the Plumber's wage.

Every skilled workman will tell you that Plumbers have the best of it. WINTER and SUMMER the Plumber is busy at top wages. No skilled Plumber is ever out of a job—compare his opportunities with any trade, plus the opportunities of having your own shop.

We teach you Plumbing with TOOLS (not books) under Licensed, Master PLUMBERS in one of the finest equipped schools in America. We make you a Plumber, every branch is taught thoroughly—Lead Work—Blue Print for plan reading—all other tricks.

LEARN IN 8 to 12 WEEKS without previous experience. If you are making less than \$60.00 a week you owe it to yourself to investigate. Get FREE catalog that tells in pictures and words how we teach this trade. Special rates now.

KANSAS CITY SCHOOL OF PLUMBING
2030 Troost Ave. KANSAS CITY, MO.

**Here's the Career
for YOU**



Get into Motion Picture Camera Work, Portrait and Commercial Photography. Learn at home. Big money while learning.

Earn up to \$250 a week

Hundreds of positions pay \$75 to \$250 a week. Or open your own studio. Easy, fascinating work.



CAMERA FREE

to students. Your choice of real Motion Picture Camera using professional film or 5 x 7 View Camera, anastigmat lens.

Write for big Free Book on Professional Photography. Explains amazing opportunities.

NEW YORK INSTITUTE OF PHOTOGRAPHY
12 W. 33d St., New York, N. Y., Dept. 49

Note: If you prefer to come to our studios for instruction, write for Catalog K-49 to nearest address: 10 W. 33d St., New York, or 630 So. Wabash Ave., Chicago.



**Learn to Drum!
Free Lessons!**



With every Ludwig Trap Drum outfit we furnish big, free instruction course. These easy lessons enable you to play in a short time.

Go to any music dealer or write us direct for full details.

Ludwig & Ludwig
1611 N. Lincoln St., Chicago, Ill.

COOK WITHOUT COAL

At last the ideal way to cook in the summer without coal or wood has been discovered. This is a new invention called a "Heat Fountain" which converts any stove or range into a gas stove. It combines ordinary kerosene (coal oil) with air to have a perfect cooking gas. No piping—no changes to your present stove or range necessary. Simply slip this little device into it and you have instant cooking heat at the turn of a valve. Easily regulated to simmer a tea kettle or bake an oven full of bread. Already over 275,000 women have found this wonderful device a veritable life saver. Find out how you can do away with the misery of a hot kitchen in summer—get rid of soot, ashes, dirt, smoke and drudgery of coal and wood. Yet use your own range. Use this new invention on 30 days trial. Simply write for free book, and full details of our offer. Send name and address to

OLIVER OIL BURNER CORP.

Dept. K-130 210 Chestnut Street St. Louis, Mo.

**FREE Electrical
Training Book**

Mail postcard for amazing FREE book on electricity. Shows you how to earn \$150 to \$600 a month in this immense field. Famous S & H shop-type training fits you quick at home for big jobs. Exclusive system. Lack of experience or education no bar. Write S & H Engineering Co., 1422 W. Monroe St., Dept. K-1, Chicago, Ill.

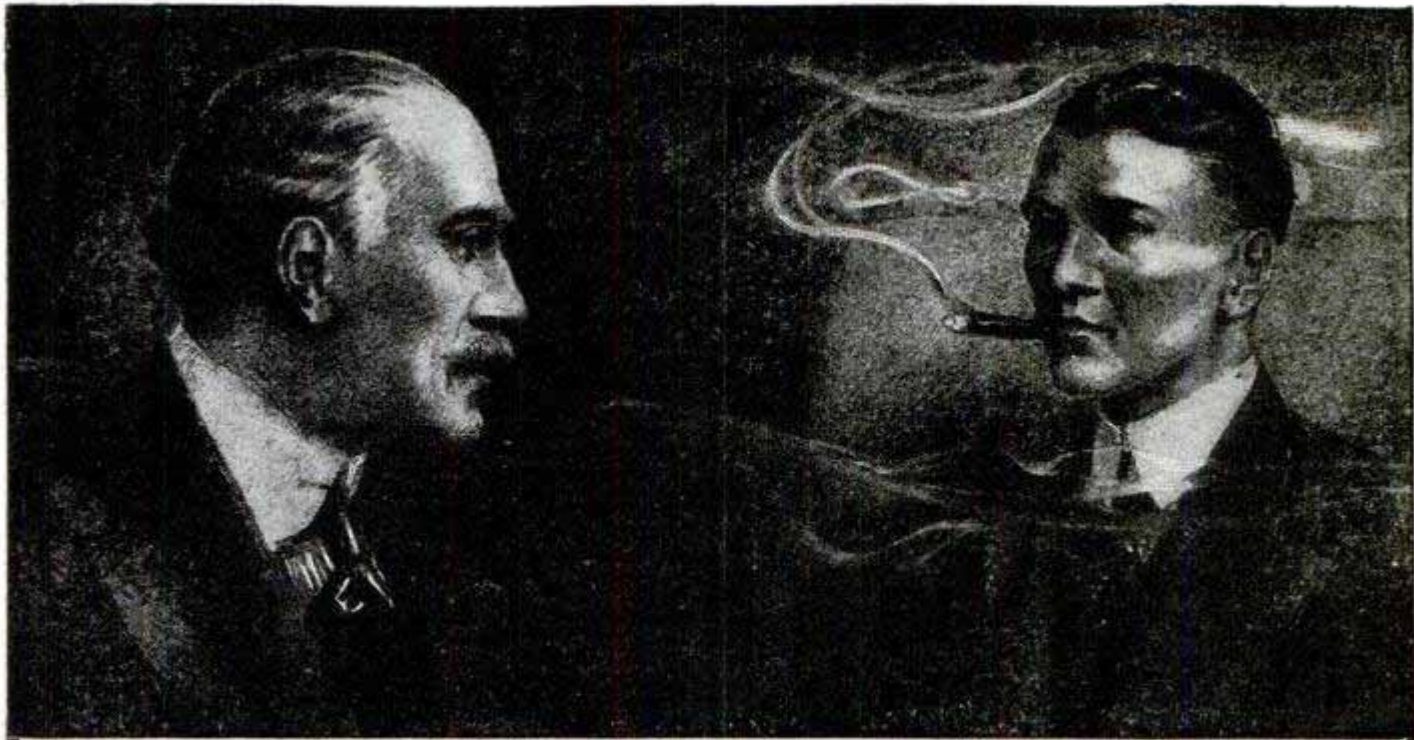

Tobacco Is Hurting You

Look at the facts square in the face, Mr. Tobacco User. You may think tobacco is not hurting you.

That is because you haven't as yet, perhaps, felt the effects of the nicotine poison in YOUR system. For you know that nicotine, as absorbed into the system through smoking and chewing tobacco, is a slow working poison. Slow, yes—but sure.

Tobacco is lowering your efficiency. It slows a man down. Makes it harder for you to concentrate your mind on your work. You haven't near the amount of "pep" and energy you would have if you stopped using it. There's many a man twice as old as you in years who's twice as young in energy, simply because he lets tobacco alone.

Some day you will realize to what an alarming extent tobacco has undermined your system.

When your hands begin to tremble—
and your appetite begins to fail—
and your heart seems to "skip a beat" now and then—
and slight exertion makes you short of breath—
then you have a right to suspect that
TOBACCO is getting the upper hand.

Any well-informed doctor will tell you that these are only a few of many symptoms of tobacco poisoning.

And YOU know that the use of tobacco in any form is an expensive, utterly useless habit. You know you ought to quit.

Tobacco Habit Banished Let Us Help You

It doesn't make a particle of difference whether you've been a user of tobacco for a single month or 50 years, or how much you use, or in what form you use it—whether you smoke cigars, cigarettes, pipe, chew plug or fine cut or use snuff—Tobacco Redeemer will positively remove all craving for tobacco in any form in a very few days. Not the slightest shock to the nervous system. Your tobacco craving will usually begin to decrease after the very first dose—there's no long waiting for results.

Tobacco Redeemer contains no habit-forming drugs of any kind and is marvelously quick, scientific and thoroughly reliable.

It is in no sense a substitute for tobacco. After finishing the treatment you have absolutely no desire to use tobacco again or to continue the use of the remedy. It helps to quiet the nerves and make you feel better in every way.

Results Guaranteed A single trial will convince you. Our legal-binding, money-back guarantee goes with each full treatment. We will refund every cent you pay for the treatment if after taking it according to the easy-to-follow directions, it should fail to banish the tobacco habit completely.

SEND Coupon for Free Proof Let us send you our free booklet on the deadly effects of tobacco, together with testimonial letters from men all over the country telling how they have been absolutely freed from the tobacco habit by this simple home treatment. You could not ask for stronger proof that Tobacco Redeemer will free you from the habit than the evidence we will gladly send on request. Just mail the coupon—or a postal will do.

NEWELL PHARMACAL CO.
Dept. 300 Clayton Station St. Louis, Mo.



Free Book Coupon

NEWELL PHARMACAL CO.

Dept. 300 Clayton Station St. Louis, Mo

Please send, without obligating me in any way, your free booklet regarding the tobacco habit and proof that Tobacco Redeemer will positively free me from the tobacco habit or my money will be refunded.

Name

Street and No.

Town..... State.....

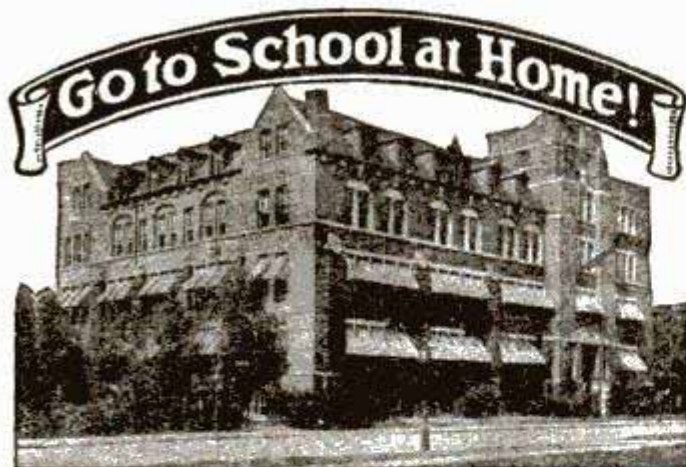

High School Course in Two Years!

You Want to Earn Big Money!

And you will not be satisfied unless you earn steady promotion. But are you prepared for the job ahead of you? Do you measure up to the standard that insures success? For a more responsible position a fairly good education is necessary. To write a sensible business letter, to prepare estimates, to figure cost and to compute interest, you must have a certain amount of preparation. All this you must be able to do before you will earn promotion. Many business houses hire no men whose general knowledge is not equal to a high school course. Why? Because big business refuses to burden itself with men who are barred from promotion by the lack of elementary education.

Can You Qualify for a Better Position

We have a plan whereby you can. We can give you a complete but simplified high school course in two years, giving you all the essentials that form the foundation of practical business. It will prepare you to hold your own where competition is keen and exacting. Do not doubt your ability, but make up your mind to it and you will soon have the requirements that will bring you success and big money. YOU CAN DO IT.

Let us show you how to get on the road to success. It will not cost you a single working hour. Write today. It costs you nothing but a stamp.

American School

Dept. HC-74, Drexel Ave. and 58th St., Chicago

American School

Dept. HC-74, Drexel Ave. and 58th St., Chicago

Send me full information on the subject checked and how you will help me win success.

- | | |
|------------------------------|----------------------------|
| Architect | Business Law |
| Building Contractor | Lawyer |
| Automobile Engineer | Machine Shop Practice |
| Automobile Repairman | Mechanical Engineer |
| Civil Engineer | Shop Superintendent |
| Structural Engineer | Employment Manager |
| Business Manager | Steam Engineer |
| Cert. Public Accountant | Foremanship |
| Accountant and Auditor | Sanitary Engineer |
| Bookkeeper | Surveyor (& Mapping) |
| Draftsman and Designer | Telephone Engineer |
| Electrical Engineer | Telegraph Engineer |
| Electric Light & Power | High School Graduate |
| General Education | Wireless Radio |
| Vocational Guidance | Undecided |

Name

Address

ELECTRICITY

Practical-Technical TRAINING



Great demand for practical-technical electricians and engineers. Fascinating work. Rapid advancement. Thousands of positions open. Finlay trained men earn \$10 to \$25 a day and more. Send today for latest catalog, beautifully illustrated, explaining One and Two year courses in Electrical Engineering. Also 12 weeks course in Practical Electricity. Degrees and certificates of efficiency awarded.

Courses to suit your needs

Finlay condensed method now in 24th successful year trains head and hand. Completely equipped shops and laboratories. Faculty of trained experts. Students assisted to positions.

EARN \$10 to \$25 A DAY

FINLAY ENGINEERING COLLEGE
110 Finlay Bldg., Kansas City, Mo.

"STAMMERING

Its Cause and Cure"

You can be quickly cured if you stammer. Send 10 cents, coin or stamps, for 288 page cloth bound book on Stammering and Stuttering. It tells how I cured myself after Stammering and Stuttering for 20 years. **BENJAMIN N. BOGUE**
6936 Bogue Building, 1147 N. Ill. St. Indianapolis

Learn Advertising at HOME

The highest paid men in the world are advertising men. You can learn easily and quickly at home during your spare time. Bigger opportunities now in advertising than ever before. Tremendous demand for our graduates at big pay.

Send for **FREE Book**. Giving interesting information and vital facts—just what you want to know about advertising. Write today!
PAGE-DAVIS SCHOOL OF ADVERTISING
Dept. 135C 3601 Michigan Ave., Chicago, U. S. A.

YOU CAN OIL PAINT

Amazing new method teaches men or women to earn after first lesson. **OIL PAINT** photos—portraits, landscapes or art subjects. Earn \$18 to \$50 and more a week. **OIL PAINT OUT-FIT GIVEN**. Send now for free illustrated book. **PICTORIAL ART STUDIOS, Inc.**, Dept. MP, 2721 No. Clark St., Chicago

LEARN WATCHMAKING

and become independent. We help you secure a position. Easy to learn. Send for **FREE CATALOG**.
ST. LOUIS WATCHMAKING SCHOOL, Dept. 5, ST. LOUIS, MO.



Learn How to WRESTLE

In Your Own Home By Mail

Yes, learn to become an expert wrestler right in your own home, by mail, from the greatest wrestler the world has ever known. Be an athlete, be strong, be healthy—**Learn how to throw and handle big men with ease. Learn to defend yourself.** All taught in our course of lessons, and illustrated with hundreds of charts and actual photographs by

Farmer Burns and Frank Gotch

Farmer Burns, "the grand old man of the mat," taught Frank Gotch, the World's Champion, all he knew about wrestling, so Gotch said. He will now teach you **Scientific Wrestling—Physical Culture**—**Jiu-Jitsu—Self Defense**. Every man and boy in America, no difference what age, needs this wonderful course of lessons. Write today—your name, age and address on a postcard or letter brings you our fine book absolutely free, no obligation of any kind. A splendid book on wrestling and physical culture. Write today stating your age.
Farmer Burns School of Wrestling C-177 Range Bldg., Omaha

This Week's Book FREE

Where you will learn
your trade this summer

Million Dollar Sweeney School

65,000 Successful
Graduate Mechanics



Jobs Pay \$50 to \$100 a Week

Put in the summer in the **Million Dollar Sweeney Workshops** and fit yourself for one of these jobs as a mechanic, chauffeur, tire man, painter, garage operator or demonstrator. YES—there are over 17 million cars and trucks in the United States needing service. Plenty of opportunities. You don't need any experience for **Sweeney Trains you with tools, not books** and the proof is that over 65,000 men in all parts of the U. S. and many foreign countries got their start here. Get ready this summer for a \$50 to \$100 a week job this fall. Remember our employment department helps you find a satisfactory high pay position in whatever part of the country you want to work. **The first step is to send for my FREE book.**

The Sweeney Auto School offers you the greatest opportunity you ever had. A big reduction in tuition—a Million Dollar Building—10 stories high—over 12 acres of floor space devoted to the "Sweeney System of Practical Instruction" under expert instructors. Just across the plaza from the Union Station, short distance from beautiful new Two Million Dollar Memorial Building. Recreation after work; swimming pool, entertainment, band and orchestra, Radio Broadcasting Station, WHB. Remember **there's only one Sweeney Auto School—only one "Sweeney System."**

LEARN A GOOD TRADE

One that will pay you \$200 to \$500 a month and more. Get in the biggest business in the world—the Automotive Business. Make more money in 1926 than you ever dreamed possible. I want to prove that you can do what thousands of men just in your position have done as a result of "Sweeney Training." I say, take up the **Auto Business Now**. Learn it at **Sweeney's, Kansas City, Mo.**

**COME
RIGHT
NOW!**

If you are mechanically inclined, if you like to work with tools, you will learn under the "Sweeney System," by actually doing the work on the most complete gas engine and electrical equipment. Over \$200,000 invested. \$50,000 Radio Station WHB. You'll get dirty and greasy, but you'll learn through the **Sweeney System of Practical Training** that fits you for the big pay jobs waiting for Sweeney Trained men.

FREE CATALOG AND SPECIAL OFFER



Get my big FREE 64-page catalog. It shows hundreds of actual photographs of men at work in my magnificent new school. Tells all about wages, profits, opportunities in auto business. Explains step by step how you learn. Interesting letters from graduates telling how they made good. Shows how men come from all over the world to this big school. Makes you want to join the crowd. Tells everything you want to know. I will gladly send you a copy beautifully illustrated. I'll tell you how to get into business for yourself. No colored students accepted.

Send for
**FREE
Book**

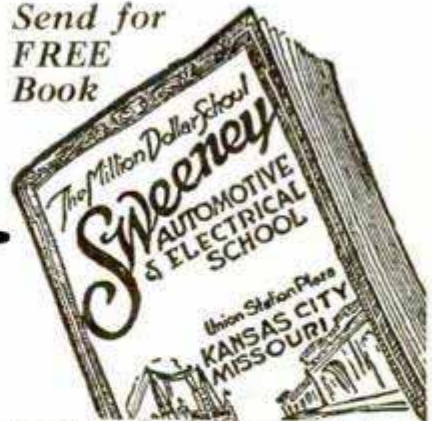

EMORY J. SWEENEY, President
2831 Sweeney Bldg., Kansas City, Mo.

Please send me your Free 64-page catalog and special offer.

Name..... Age.....

Address.....

Town..... State.....

LEARN A TRADE
Sweeney
AUTOMOTIVE & ELECTRICAL SCHOOL
2831 SWEENEY BLDG. KANSAS CITY, MO.

A Great Book Free with this pay-raising library

For a short time only every subscriber to the New Library of Machine Shop Practice will receive, absolutely free, a copy of Gardiner's Practical Foremanship—one of the greatest books on the principles and practice of modern foremanship ever written. This practical pay-raising book quickly prepares you for a foreman's job. It comes to you absolutely free with

Machine Shop Practice 9 volumes—3065 pages—3608 illustrations

(A combined home-study course and reference library)
The New Machine Shop Library is written for practical men. It gives you the best methods for every kind of machine shop work. It explains machine tools and their operation, drawing and design, tool work, gears and grinding, jigs and fixtures, automatic screw machines and their tools and all of the mathematics you will ever have to use. It is plainly written, completely illustrated—the very best kind of help to the machine shop man who wants to advance himself.

Sent
**F
R
E
E**



No money down—
only 7c
a day

FREE EXAMINATION COUPON

McGraw-Hill Book Co., Inc., 370 Seventh Ave., New York
Send me for 10 days' free examination the New Library of Machine Shop Practice. If satisfactory I will send you \$1.50 in 10 days and \$2.00 monthly until the special price of \$19.50 is paid. If not wanted, I will return the books at your expense.
On receipt of my first payment of \$1.50 it is understood that I am to receive, free of charge, a copy of Gardiner's Practical Foremanship.

Signed.....
Address.....
City and State.....
Position.....
Employer..... P. M. 8-1-26

STOP USING A TRUSS

Do Away With Steel And Rubber Bands

FREE TRIAL

TRADE MARK

STUART'S ADHESIF

PLAPAO-PAD

Inner surface is made adhesive to secure the PLAPAO-PAD firmly to the body, keeping the PLAPAO continually applied and the pad from slipping. No straps, buckles or springs attached. Soft as velvet—easy to apply.

PATD APRIL 6 1909

It's the Non-Slipping, yet Non-Rigid Pad and What is Within It That Counts

FREE to 5,000 Truss Sufferers

To the extent of 5,000 sufferers who may apply I will send, ABSOLUTELY FREE, a sufficient quantity of the Plapao to positively convince them that this is the only logical, common-sense way of treating rupture. Plapao is a highly astringent medication placed within the Plapao-Pad and being absorbed through the skin, creates a wonderful feeling of relief and at the same time tends to strengthen the weakened muscles and thus permanently close the rupture opening. The process of recovery is natural, so you'll have no use for a truss—you can throw it away forever! Old and young have testified under oath that the Plapao-Pads cured their rupture—many of them long-standing, aggravated cases—without delay from work. Patent allowed in U. S. and foreign countries. Awarded Gold Medal at Rome and Grand Prix at Paris.

Send No Money—for a sufficient quantity of the Plapao is sent without charge to enable you to give it a thorough test; you pay nothing for this trial now or ever. Write for it and full information today. Address Plapao Laboratories, Block 1427 St. Louis, Mo.

LEARN CARTOONING



The Landon PICTURE CHART method of teaching makes ORIGINAL drawing easy to learn. Hundreds of sketches like the above explain every step in creating ORIGINAL heads, figures, animals, etc.

Successful Cartoonists Earn Big Salaries

The cartoonists who draw "Freckles and His Friends," "Winnie Winkle," "Regular Fellers," "Cicero Sapp," "Guss and Gussie," "Mom 'n Pop" and hundreds of other artists, including Dorman Smith, Ethel Hays and Edwina, credit their start to the Landon Course of Cartooning. They learned to draw through the Picture Chart Method in their spare time, at home, and are now earning from \$75.00 to \$300.00 and more per week. Send 6c in stamps today for sample Picture Chart and full explanation of this wonderful course and information showing possibilities for you. Please state your age.

The Landon School

738 National Bldg., CLEVELAND, OHIO

AUTOMOTIVE AND POWER
INVENTORS
M. P. LAUGHLIN, Engineer Patent Attorney
47 West 42nd Street, New York City

Prompt, Conscientious service at fair rates, for your Patent Protection.

Learn RADIO
At Home-By Mail

\$3,000 to \$10,000 a Year. How to build, repair, install, sell radios now, quickly learned. Simple, easy home-study plan. 1000-mile set free with course. Low cost, easy terms. Send now for free big book on radio opportunities.

RADIO ASSOCIATION OF AMERICA
4513 Ravenswood Ave. Dept. A-8 Chicago, Ill.



WANT \$158-\$225 A MONTH? RAILWAY MAIL CLERKS

U. S. GOVERNMENT JOBS

Mail Coupon Before You Lose It

Steady Work—No Layoffs—Paid Vacations—Travel, See Your Country—Common Education Sufficient
Many other Gov't Jobs for Men-Boys, 18 Up

FRANKLIN INSTITUTE, Dept. W-179, Rochester, N. Y.
Sirs: Rush to me, without charge: (1) Specimen Railway Mail Clerk Examination questions; (2) tell me how to get a U. S. Government job; (3) send list of places at which examinations are held; (4) send copy of 32 page illustrated book, "How to Get U. S. Government Jobs."

Name.....
Address.....

Learn



Aviation

At Home in your spare time.
Be an expert Airplane Engineer.

Earn \$3,500 to \$10,000 a Year

Practical course—takes only a few months. Write for special offer on free airplane parts and free catalog.

WESTERN AIRPLANE CORPORATION
Dept. M-8 Monadnock Block CHICAGO



Test Your Art Ability, FREE

Do you like to draw? Our simple scientific Art Ability Questionnaire will tell if your talent is worth developing and how much training you will need. Your true score given. Commercial artists make big money. Learn at home, in spare time, with the Federal course. Write today for your Questionnaire, giving age and occupation.

FEDERAL SCHOOL OF COMMERCIAL DESIGNING
619 Federal Schools Bldg. Minneapolis, Minn.

Keynote To Popularity

Popularity is yours. Everyone will seek your company, if you play tenor banjo. Enroll for our course. We start you with an \$18 professional gift tenor banjo. Prof. Six was director of Glee and Instrumental Clubs at N. Y. University. His picture, diagram and phonograph record method is so simple you play immediately.

Don't Send a Single Cent
Write for particulars about our course and we will reserve an \$18 gift tenor banjo for you. Write now for book and free first lesson. **New York Academy of Music, Studio 1-B, 100 Fifth Ave., N. Y. C.**



Health Food Directory

How to select the proper foods for gaining weight; reducing; building vitality; disease resistance; constipation; building muscle, etc. Rates and tabulates standard branded foods. No other book like it. 150 pages of valuable information. Special price 25c, postpaid. Limited edition.

Macfadden Publications, Inc., Dept. P. M. 8, 1926 B'way, N. Y. City

SCIENCE FINDS NEW DRUGLESS GLAND STIMULANT

Science has discovered a new method of applying a positive-nature force. The method is radically new, wholly different—a tremendous step forward in regaining and preserving prostate gland health. Amazing effects have been produced in thousands of men, many beyond sixty.

"A hundred years ahead of modern medicine," writes a New York physician. Doctors and Osteopaths are using and prescribing it. Brings treatment directly to the Prostate Gland without drugs, medicine, massage, violet rays or the application of electricity. Absolutely safe—absolutely natural, pleasant and easy to use.

Does what Gland Tablets can never do. Directly stimulates the prostate gland and often restores it to normal size and functioning in six days! Also frequently tones up entire system, usually routes constipation and piles. Bladder weakness and frequent painful urination relieved in most cases—often as though by magic. So astonishing is the effect of this wonderful nature-force that these results are unconditionally guaranteed or no charge is made.

Scientist's FREE Book, "Why Many Men Are Old at Forty," explains these amazing facts about old age. This book is now FREE. No obligation at all. But write at once, as the edition is limited, and every man past 40 should know these vital facts. Simply ask for FREE Book.

THE ELECTRO-THERMAL CO., 2160 Main St., Steubenville, Ohio
Western Address: Dept. 21-C, 711 Van Nuys Building, Los Angeles, Calif.



"I'm making real money now"

"SEE that coupon? Remember the day you urged me to send it to Scranton? It was the best thing I ever did.

"Mr. Carter called me in today. Said he'd been watching my work for some time—ever since he learned I was studying with the International Correspondence Schools.

"Then he asked me if I thought I could take over Bill Stevens' job. I told him I was sure I could—I'd had that goal in view ever since I started my I. C. S. course.

"I start tomorrow, Mary, at an increase of \$60 a month. It's wonderful how spare-time study helps a man to get ahead."

For thirty-four years, the I. C. S. has been helping men to win promotion, to earn more money, to get ahead in business and in life.

You, too, can have the position you want in the work you like best. Yes, you can.

All we ask is the chance to prove it. Without cost or obligation, just mark and mail this coupon.

Write for Free Booklet

INTERNATIONAL CORRESPONDENCE SCHOOLS
Box 5594-E, Scranton, Penna.

Without cost or obligation, please tell me how I can qualify for the position or in the subject before which I have marked an X:

BUSINESS TRAINING COURSES

- | | |
|--|---|
| <input type="checkbox"/> Business Management | <input type="checkbox"/> Salesmanship |
| <input type="checkbox"/> Industrial Management | <input type="checkbox"/> Advertising |
| <input type="checkbox"/> Personnel Organization | <input type="checkbox"/> Better Letters |
| <input type="checkbox"/> Traffic Management | <input type="checkbox"/> Show Card Lettering |
| <input type="checkbox"/> Business Law | <input type="checkbox"/> Stenography and Typing |
| <input type="checkbox"/> Banking and Banking Law | <input type="checkbox"/> Business English |
| <input type="checkbox"/> Accountancy (Including C.P.A.) | <input type="checkbox"/> Civil Service |
| <input type="checkbox"/> Nicholson Cost Accounting | <input type="checkbox"/> Railway Mail Clerk |
| <input type="checkbox"/> Bookkeeping | <input type="checkbox"/> Common School Subjects |
| <input type="checkbox"/> Private Secretary | <input type="checkbox"/> High School Subjects |
| <input type="checkbox"/> Spanish <input type="checkbox"/> French | <input type="checkbox"/> Illustrating <input type="checkbox"/> Cartooning |

TECHNICAL AND INDUSTRIAL COURSES

- | | |
|---|--|
| <input type="checkbox"/> Electrical Engineering | <input type="checkbox"/> Architect |
| <input type="checkbox"/> Electric Lighting | <input type="checkbox"/> Architects' Blue Prints |
| <input type="checkbox"/> Mechanical Engineer | <input type="checkbox"/> Contractor and Builder |
| <input type="checkbox"/> Mechanical Draftsman | <input type="checkbox"/> Architectural Draftsman |
| <input type="checkbox"/> Machine Shop Practice | <input type="checkbox"/> Concrete Builder |
| <input type="checkbox"/> Railroad Positions | <input type="checkbox"/> Structural Engineer |
| <input type="checkbox"/> Gas Engine Operating | <input type="checkbox"/> Chemistry <input type="checkbox"/> Pharmacy |
| <input type="checkbox"/> Civil Engineer | <input type="checkbox"/> Automobile Work |
| <input type="checkbox"/> Surveying and Mapping | <input type="checkbox"/> Airplane Engines |
| <input type="checkbox"/> Metallurgy | <input type="checkbox"/> Navigation |
| <input type="checkbox"/> Steam Engineering | <input type="checkbox"/> Agriculture and Poultry |
| <input type="checkbox"/> Radio | <input type="checkbox"/> Mathematics |

Name.....
Street.....
Address.....

City.....State.....

Occupation.....

Persons residing in Canada should send this coupon to the International Correspondence Schools Canadian, Limited, Montreal, Canada.



LUMINOUS PAINT

Make Your Watches, Clocks, Etc., Visible by Night

The very latest discovery in the scientific world. Hitherto, practically unobtainable except at an exorbitant price, we have at last succeeded in producing this remarkable LUMINOUS PAINT, which, applied to the surface of any article, emits rays of white light, rendering it perfectly visible in the dark. **THE DARKER THE NIGHT, THE MORE BRILLIANT IT SHINES.** Quite simple to use. Anyone—you can do it. A little applied to the dial of your watch or clock will enable you to tell the time by night. You can coat the push buttons or switch plate of your electric lights, match boxes, and innumerable other articles; make your own Luminous Crucifixes, Luminous Rosaries, etc. Small bottle, price 25c. Larger sizes, 50c and \$1 postpaid. **JOHNSON SMITH & CO., Dept. 568, RACINE, WIS.**

Serpent's Eggs

Box contains 12 eggs. When lit with a match, each one gradually hatches itself into a snake several feet long, which curls and twists about in a most life-like manner. Price per box, 10c postpaid, 3 for 25c.



CIGARETTE MAKER



Roll your own and save money. Makes them better and quicker besides saving more than half. Use your favorite brand of tobacco. Neat, useful and handy. Pocket size, weighs 4 oz. Made entirely of metal, nickel-plated. Price 25c postpaid.

MIDGET BIBLE

GREAT CURIOSITY Smallest Bible in the World. Size of a postage stamp. 200 Pages. Said to bring good luck to the owner. A genuine work of art. Must be seen to be appreciated. Make good money selling them to friends, church acquaintances, etc. PRICE 15c each, 3 for 40c, 12 for \$1.35, 100 for \$7.50. Also obtainable in Leather Binding, with gold edges. Price 50c each, 3 for \$1.25, \$4.50 per doz. Magnifying Glass for use with Midget Bible, 15c.



STAGE MONEY



With a bunch of these bills, it is easy for each person of limited means to appear prosperous by flashing a roll of these bills at the proper time and peeling off a genuine bill or two from the outside of the roll, the effect created will be found to be all that can be desired. Prices, postpaid: 40 Bills 20c, 120 for 50c, or \$3.50 thousand postpaid.

Wonderful X-Ray Tube

A wonderful little instrument producing optical illusions both surprising and startling. With it you can see what is apparently the bones of your fingers, the lead in a lead pencil, the interior opening in a pipe stem, and many other similar illusions. A mystery that no one has been able to satisfactorily explain. Price 10c, 3 for 25c, 1 dozen 75c. **Johnson Smith & Co.**



Good Luck Ring

Quaint and Novel Design

A VERY striking and uncommon ring. Silver finish, skull and crossbone design, with two brilliant, flashing gems sparkling out of the eyes. Said by many to bring Good Luck to the wearer, hence its name, Good Luck Ring. Very unique ring that you will take a pride in wearing. **ONLY 25 CENTS.**

Exploding Cigarettes



JUST LIKE ORDINARY CIGARETTES. BUT SUCH REAL STARTLERS! The box contains ten genuine cigarettes of excellent quality. They appear so real, but when each cigarette is about one-third smoked, the victim gets a very great surprise as it goes off with a loud BANG! A great mirth provoker yet entirely harmless. Price 25c per box.

Popular Watch Charms



Very pretty little curiosities and decidedly novel. Fitted with Magnifying Lenses that enlarge the pictures to a very surprising degree; in fact, it seems almost incredible that a clear picture could be possible in such a small compass, and how sharp and distinct they show up when you look through. Come in assorted views—Actresses, views of Panama Canal, Lord's Prayer in type, etc. **15c ONLY 3 for 40c; \$1.35 doz.**

Mystic Skeleton

A jointed figure of a skeleton 14 in. in height, will dance to music and perform various gyrations and movements while the operator may be some distance from it. **10c & pd.**

Novelty Badges



Kissing Permit 10c. Garter Inspector 10c. Two very novel metal badges, nickel plated, that you can wear, giving you fun out of all proportion to their trifling cost. 10c, each badge, 3 for 25c, or 75c per doz. p.pd.

MAGIC FLUTE

Wonderfully Sweet Toned and Musical



The Magic Flute, or Humanatone, is a unique and novel musical instrument that is played with nose and mouth combined. There is just a little knack in playing it which, when once acquired after a little practice will enable you to produce very sweet music that somewhat resembles a flute. There is no fingering, and once you have mastered it you can play all kinds of music with facility and ease. When played as an accompaniment to a piano or any other musical instrument, the effect is as charming as it is surprising.

BLANK CARTRIDGE PISTOL

Protection against Burglars, Tramps & Logs

Prices **50c \$1.00**



Well made and effective; models on latest type of Revolver; appearance alone is enough to scare a burglar. When loaded it may be as effective as a real revolver without danger to life. It takes standard 22 Cal. Blank Cartridges obtainable everywhere. Price 50c, superior quality, \$1.00 postpaid. Blank Cartridges, by express, 50c per 100 Holster (Cowboy type) for Blank Cartridge Pistol, 50c **Johnson Smith & Co., Dept. 568, Racine, Wis.**

BOYS! BOYS! BOYS!

THROW YOUR VOICE



Into a trunk, under the bed or anywhere. Lots of fun fooling the teacher, policeman or friends.



THE VENTRILO

a little instrument, fits in the mouth out of sight, used with above for Bird Calls, etc. Anyone can use it.

Never Fails. A 32 page book on ventriloquism, the Ventrilo, ALL FOR 10 CENTS



Everything about the Ku Klux Klan told in a clear, fearless manner. Book tells all—How it started and was oppressed in 1871—The New Ku Klux Klan—How Organized—How Members are Enrolled—Oath of the Klan—Questions for Candidates—Creed—Objects of the Order—Obedience—Fidelity—Pledge of Loyalty—Ku Klux Klan and the Masons—The Jews—The Masons—Real K. of C. Gath—The Negro Ku Klux Klan, etc., etc. Latest and most complete book on the Klan published. Price 35c, Postpaid. Stamps or Coin

PISTOL, OPERA & FIELD GLASS

PRICE POSTPAID, \$1.00



It is made in the shape of and looks like a regular Automatic Pistol. No one is likely to stop and ask you whether it is real or not. Thus it is likely to prove itself very handy in an emergency. On pressing the trigger it opens up, as shown in the illustration at the right, revealing nine most useful articles—Opera and Field Glass, Telescope, Mirror, Magnifying Glass and Burning Lens, Reading Glass, Sun Dial, Sun Compass, etc. In the handle of the revolver there is a place for various pocket necessities, such as First Aid Articles, Buttons, Pins, etc. The Pistol is of sheet metal, blued finish, that can be carried comfortably in pocket. **PRICE \$1.00, 1**

HOT DOG! SENSATIONAL NEW NOVELTY



It is made of rubber like a small balloon. Contains a curious chemical that acts in a most remarkable way. Squeeze the deflated balloon with the hand and it suddenly becomes quite warm and fills itself up with air. It is SELF-BLOWING. Play all sorts of jokes with it. Lay it on a chair; place it secretly underneath anyone; underneath anyone's pillow; drop it in someone's pocket, and after a short time, when friction causes the chemicals to act, a large and superbly colored balloon develops. Each Hot Dog in a small box. Quite harmless but loads of fun. **15c, each, 3 for 40c., \$1.35 doz. postpaid.**

Female Sex Indicator



Male Sex Indicator

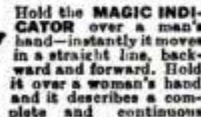

Hold the MAGIC INDICATOR over a man's hand—instantly it moves in a straight line, backward and forward. Hold it over a woman's hand and it describes a complete and continuous circle. The same action can be obtained over a letter written by a man or woman, etc. It is fascinating; baffling. We have never been able to figure out how it's done, but we've never seen it fail. Many novel and entertaining tests may be performed with the Sex Indicator. For example, similar results can be obtained with animals, cats, dogs, rabbits, over birds, chickens, canaries, etc. Also used to predetermine the sex of chickens and birds, etc., in fact it is sold as a patented sex tester in Europe. Price 25c, or 3 for 85c. p.pd. **JOHNSON SMITH & CO., Dept. 568, RACINE, WIS.**

JOHNSON SMITH & CO.

Dept. 568

RACINE, WIS.



A Deluxe Edition of our new 1926 CATALOG mailed on receipt of 25c. Handsome cloth binding. Only book of its kind. 420 pages of all the latest tricks in magic, the newest novelties, puzzles, games, sporting goods, interesting books, curiosities in seeds and plants, etc., unobtainable elsewhere. Remit by Money Order, Check, Coin, Stamps, etc. Stamps of foreign countries also accepted.



I Can Stop Foot Pains In 5 Minutes

Nothing to wear in the shoes, no arches, braces, bandages, pads, cushions, no special shoes, no soakings, ointments, powders or liniments, no tiresome exercises; yet happy and almost instant relief from aches, pains, burnings, itching, twitchings and throbbings in the feet and legs.

In my ten years of practice as a foot specialist I have found that practically all foot troubles come from weak, sagging or fallen arches and poor circulation. I have devised a simple home method that anyone can use that quickly adjusts misplaced bones, raises the arches, strengthens and invigorates the foot muscles, increases the blood circulation in the feet and legs, stops the aches and pains, and permanently corrects the cause of foot troubles, making the feet strong and self supporting.

I will gladly send any foot sufferer full particulars and a copy of my new book on how to end foot troubles, free and post-paid. Write today and learn how easy it is to have sound, strong feet, free from aches and pains.

Dr. F. H. GRIFFITH, Foot Specialist
Suite 3153, 3118 Troost Ave., Kansas City, Mo.



Can You Fix It?

Repair any auto fault, learn how NOW. You can do it easily in this new simple way.

These FIVE Big Books are up to the minute on automobile engineering subjects; chock full of little known facts about construction, operation and repairs. Electric wiring treated in complete detail—illustrations and diagrams make everything clear and easily understood by anybody. The most interesting and most practical set of books ever written on modern automobile engineering. Whether you want to fit yourself for garage owner, repair expert or merely wish to know more about your car, you will realize the values of these splendidly bound volumes. This is the new 1926 Edition with 70 new and up-to-date wiring diagrams.

"NO MONEY" OFFER

An amazing new plan of distribution brings these books to you for examination without one cent of payment to us. We don't ask a penny of you, but ship the books to you FREE. Look them over—read them as much as you want to; note the splendid photographs and drawings and then if you decide you want them, send us \$2.00, and then only \$3.00 a month until \$24.80 is paid. That is all; nothing more to pay us. If you send NOW we will include

Consulting Membership—FREE

Yes, we actually give you a certificate of membership in the AMERICAN TECHNICAL SOCIETY which entitles you to free consultation on any subject related to Automobile Engineering. Eighteen specialized experts are at your disposal—ready at any time to help you. With this library and this membership you ought to be able soon to know all there is to be known about autos. Note:—In addition to all this, those who send now will be entitled to the services of our EMPLOYMENT DEPARTMENT without charge. We are in daily contact with firms all over the country who need good men and are willing to pay big. This service costs you nothing. Don't miss this special offer. Send now.

American Technical Society,
Automobile Division, A-C19, Chicago, Illinois

You may send me your new complete Automobile Engineering library (1926 edition) 5 big volumes bound in flexo covers for ten days Free Examination. If satisfied, I will send you \$2.00 then and \$3.00 per month, until the special low price of only \$24.80 is paid, otherwise I will return them and owe you nothing.

Name.....
Address.....
City..... State.....
Reference.....



LEARN TENOR BANJO

Banjoists! Earn big money through Charles McNeil's famous Home Study Banjo Course. Simple as A B C—yet has all technical requirements. Includes phonograph records, demonstrating jazz strokes, "breaks" and chords, played by Charles McNeil, 6 years with Isham Jones-Brunswick Records. Easy payments. Send for Free Book.

Chicago Tenor Banjo Institute
Dept. C-135
621 N. Lincoln St. Chicago, Ill.

ASK FOR FREE BANJO OFFER-NOW!

Brain-Feast

Solvents, grapefruit, berries, tomatoes, UNDER PROPER CONDITIONS:—dissolve tumors, blood clots, lime in joints (enabling use of limbs), eliminate catarrhal matter from nose, ears, tonsils, bronchials, etc. PYORRHOEA. See reprint "Dental Digest". PREGNANCY. Delivery painless. Eat nerve or muscle food TO SUIT OCCUPATION prevent undue retention of WASTE in blood (basis of all disease).

Educational Booklet 1 Oc. **BRINKLER SCHOOL OF EATING**, Dept. 42-B, 131 West 72nd St., New York

MOTORCYCLES



Used and Rebuilt Indian, Harley-Davidson, Ace, Henderson and Cleveland motorcycles at a saving of 50%. Send for our latest list.

"Motorcycles shipped to all parts of the world."

WALKER-INDIAN CO., 188 Mass. Ave., BOSTON

NO JOKE TO BE DEAF

—EVERY DEAF PERSON KNOWS THAT



I make myself hear, after being deaf for 25 years, with these Artificial Ear Drums. I wear them day and night. They stop head noises and ringing ears. They are perfectly comfortable. No one sees them. Write me and I will tell you a true story how I got deaf and how I make you hear. Address



Medicated Ear Drum

GEO. P. WAY, Artificial Ear Drum Co. (Inc.)
80 Hoffman Bldg., 2539 Woodward, Detroit, Mich.



"Independent" GOLD POINT Lever, Self-Filler Stylopen \$2
"Makes Writing a Pleasure"
Jumbo, \$3.50; Red, \$3.00; Black

J. C. ULLRICH & CO., 161 Washington St., N. Y. Est 1884 Agents Wanted

150 TO 300 MONTHLY FROM ONE DAY BATTERY CHARGING



Charge batteries in 1/2 the time required by others and get the business. Latest method recommended by the leading battery companies and approved by the U. S. Bureau of Standards. BIG YEAR ROUND PROFITS. Best paying business in automotive field. Requires no special experience, uses small space. 30 DAYS' FREE TRIAL at our risk under absolute money back guarantee. Write today for bulletin X, giving full particulars.

Hobart Bros. Co. Box M8 Troy, Ohio.

ONLY \$16 MONTHLY—MORE THAN PAID BY INCREASED PROFITS

30 DAYS FREE TRIAL ON ABSOLUTE MONEY BACK GUARANTEE

Made in both power drive and hand drive models

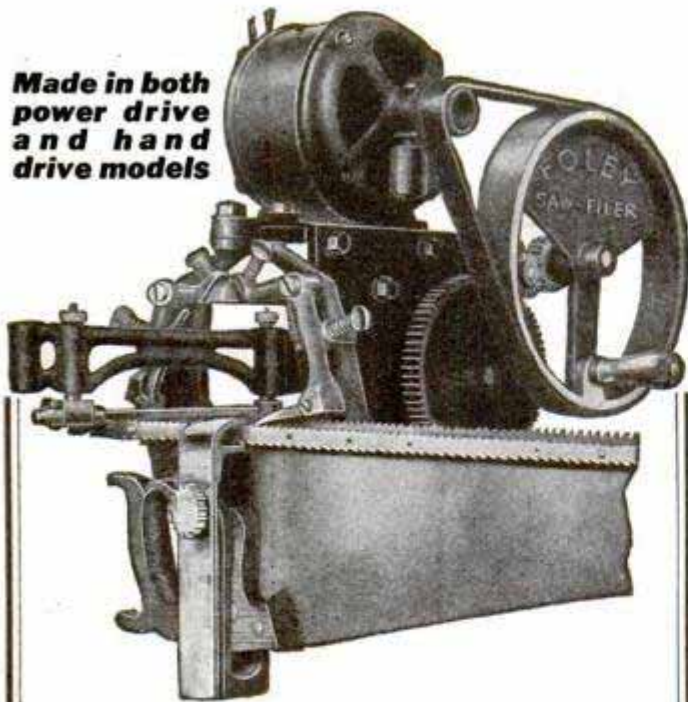

\$15 to \$20 a Day
IN YOUR
Profit OWN BUSINESS

HERE'S a business that's not overcrowded with competition, a cash business—no credit losses—a business for whose service there is a big, steady, year 'round demand everywhere, a business that requires very little capital to start—a clean, dignified business. Think of the many people in your community who have saws that need to be filed frequently—carpenters, contractors, butchers, factories, farmers and many homes. You can now file saws *automatically* with machine-precision—with the

FOLEY AUTO-MATIC SAW FILER

With it one man can do four to six times as much work as the most expert hand filer, and so accurately that saws will cut better than new. It files hand saws, band saws, back saws and circular saws. It is very easy to operate. You get 50c or more for filing each saw, and \$1.25 to \$1.50 for retooling saws. You can file 6 to 8 saws in one hour with one machine. With the Foley Rotary Saw Set you can set a saw perfectly in one minute.

The Foley quickly pays for itself and goes on earning profits year after year.

Send the coupon today for full information on Foley Saw Tools.

FOLEY SAW TOOL COMPANY
206 Foley Bldg., 914 E. Lake St., Minneapolis, Minn.
Send me full information on Foley saw filing equipment.

Name.....
Address.....
City.....State.....



If someone said to you—
“Let's Go Into Business”

I'll put up all the money, furnish the factory and equipment; buy a \$1,000,000 stock; advertise for you; take care of your orders and guarantee your profits; all you have to do is sell—

WHAT WOULD YOUR ANSWER BE?

This is exactly the opportunity we offer you. We put our immense shops, force of 800 workmen, and tremendous stock of merchandise at your disposal. We advertise for you, teach you, train you, cooperate with you. We give you an elaborate selling equipment that fairly talks. We authorize you to take orders and collect a deposit, which you put in your pocket as your profit. After that the responsibility is ours. We fill the orders, ship them direct to your customers, collect the money due us, and absolutely guarantee perfect satisfaction. There is no chance for you to lose a single penny. This is the kind of partnership we offer you, if you are honest, industrious, willing to work hard for success, and have a clean record. If you have selling experience, so much the better, but it isn't necessary. If you are interested and think you are the man we want, sign and send the coupon. Address Dept. 514.

GOODWEAR Chicago, Inc.

→ Send This Coupon for Facts! ←

GOODWEAR Chicago, Inc.,
West Adams St. at Peoria, Chicago, Dept. 514.

Gentlemen: Please send me the facts about your proposition. I am willing to work hard for success if the opportunity you offer is all you claim for it.

Name.....
Address.....
Town.....State.....

NEW COUNTERPHASE SET MODELS AND B-POWER UNITS

ANNOUNCED in the 10th edition of “BETTER TUNING”
Now ready.

Send for your copy to-day. Learn why we say that the COUNTERPHASE-EIGHT and NEW COUNTERPHASE-SIX are the best products we ever produced. Learn why the B-POWER UNIT is different and better than any on the market.

“BETTER TUNING”
10th edition sent on receipt of 10c. Circulars free.



BREMER-TULLY MFG. CO. 532 So. Canal Street CHICAGO, ILL.

Books on 76 Subjects

No doubt you have wondered where you could get books on subjects not to be found in book stores. Popular Mechanics Press has specialized in supplying books on any subject. Look over this list. You will find books here that you have long wondered where you could secure. Check the books you want, and mail this advertisement as your order blank.

- | | |
|--|--|
| ACCOUNTING
Accounting Practice... \$7.00 | DOG RAISER
Complete Book of the Dog... \$3.00 |
| ACFOR
Training for the Stage... \$1.75 | DRILL OPERATOR
Modern Drilling Practice... \$3.00 |
| ADVERTISING EXPERT
Principles of Advertising... \$5.00 | DRY CLEANER
Practical Dry Cleaner... \$3.25 |
| AIRPLANE
Practical Aviation... \$3.00 | ELECTRICITY
Practical Electricity... \$3.25 |
| ARCHITECT
Easy Steps in Architecture... \$1.50 | ELECTROPLATER
The Modern Electroplater... \$3.00 |
| ARTIST
Rosenberg's Practical Art... \$5.00 | ENGRAVING
The Art of Engraving... \$4.50 |
| ARTS CRAFTS
Arts Crafts Lamps... \$1.00 | ENGLISH
Self Improvement in English... \$2.50 |
| AUTHOR
The Way Into Print... \$1.00 | ESCAPE ACT
33 Rope Ties... \$1.00 |
| AUTOMOBILE
Dyke's Encyclopedia... \$6.00 | FARMER
Cyclopedia of Agriculture... \$4.50 |
| AUTO-SUGGESTION
Auto-Suggestion... \$3.50 | FINANCIER
Law of Financial Success... \$1.00 |
| BANKING
American Banking Practice... \$4.00 | FINGER PRINT EXPERT
Finger Print Instructor... \$3.15 |
| BARBER
The Barber's Manual... \$5.00 | FORMULAS
Henley's Formulas... \$4.00 |
| BASKETRY
Raffia Basketry as an Art... \$2.50 | FORTUNE TELLER
Language of the Hand... \$0.75 |
| BLACKSMITH
Modern Blacksmithing... \$1.25 | FOUNDRYMAN
Foundry Work... \$2.25 |
| BLUE PRINTER
Blue Printing... \$2.00 | FURNITURE MAKING
Mission Furniture (3 vols.)... \$3.00 |
| BLUE PRINT READING
Blue Print Reading... \$2.00 | GEAR CUTTER
Gear Cutting Processes... \$3.00 |
| BOAT BUILDER
Boat Book... \$0.50 | HOBBIES
Hobbies... \$1.50 |
| BOOKKEEPING
Single and Double Entry... \$6.00 | HOME MECHANICS
Tinkering with Tools... \$2.00 |
| BIRD HOUSES
Boys' Bird Houses... \$1.00 | HUNTER
The Still Hunter... \$2.00 |
| BRICKLAYER
Plain and Fancy Brickwork... \$1.50 | ICE BOATING
Ice Boating... \$1.00 |
| CABINET MAKER
Modern Cabinet Work... \$10.00 | INSPIRATIONAL BOOKS
You Can... \$1.00 |
| CARPENTER
Modern Carpentry... \$3.00 | JOURNALISM
Training for the Newspaper... \$1.75 |
| CHALK TALKER
Tarbell's Chalk Talk... \$1.50 | LATHE OPERATOR
Lathe Work for Beginners... \$2.50 |
| CHARACTER BUILDING
Character Building... \$1.25 | LOCKSMITHING
Locksmithing... \$1.50 |
| CHARACTER READING
Text Book of Humanology... \$2.00 | LOOM FIXER
Practical Loom Fixing... \$1.50 |
| CHEMISTRY
General Chemistry... \$3.75 | MAGIC
Modern Magic... \$2.00 |
| CHIROPRACTOR
Practice of Chiropractic... \$11.00 | MAIL ORDER BUSINESS
Selling by Mail... \$4.00 |
| CIRCUS
Amateur Circus... \$1.75 | MILLING MACHINE
Production Milling... \$3.00 |
| CIVIL ENGINEER
Civil Engineering... \$5.50 | MINING
Elements of Mining... \$6.00 |
| CIVIL SERVICE
Course in Civil Service... \$1.50 | MODEL MAKING
Model Sailing Boats... \$2.00 |
| CONCRETE
Concrete Products... \$3.00 | OCCULTISM
Occultism Simplified... \$1.00 |
| CONTRACTOR
Builders' Handbook... \$6.00 | PAINTER
Expert Wood Finisher... \$3.50 |
| DEBATER
Elements of Debating... \$1.50 | POLICEMAN
The Policeman's Art... \$1.50 |
| DENTIST
Operative Dentistry... \$6.50 | POULTRY RAISER
\$4,223 from a Town Lot... \$1.00 |
| DENTIST, MECHANICAL
Full Denture Prosthesis... \$8.00 | PSYCHO-ANALYSIS
Outwitting Our Nerves... \$2.50 |
| DETECTIVE
Instruction for Detectives... \$1.00 | PUBLIC SPEAKER
Art of Public Speaking... \$2.25 |
| DICTIONARIES
Universal Dictionary... \$1.25 | RABBIT RAISING
Practical Rabbit Keeping... \$1.50 |
| DIESEL ENGINES
Diesel and Oil Engineering... \$5.15 | RADIO
Lefax Radio Handbook... \$3.50 |

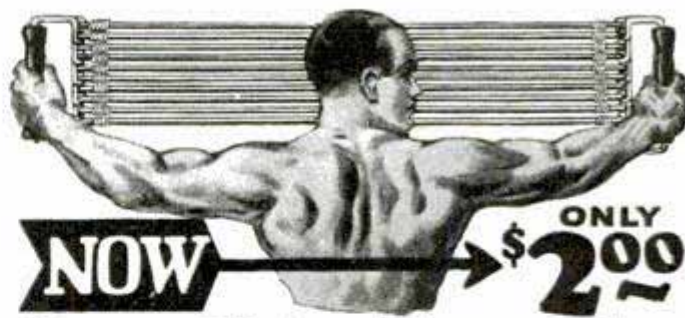

Now **\$2.00** ONLY

Giant Chest Expander

and Progressive Exerciser

Be a muscular Marvel. Have the muscles of a superman. Become strong for your health's sake or to astound your friends with extraordinary feats which only men of giant strength can do.

Use This Money Saving Coupon



Free instructions. The Giant Chest Expander and Progressive Exerciser is made with new, live springy rubber so as to give it long wear and great resisting qualities. Sold with a guarantee to give entire satisfaction or money back. Made two ways, either

5 Cables or double strength 10 Cables
for **\$2** The double strength exerciser has resistance of over 200 lbs. for **\$4**

Order Today Send at once and get your Giant Exerciser at the present low introductory price. This price is made so low because we want everyone to enjoy muscles and strength at the lowest possible cost. Don't pay more—order from us—get the most for your money. Use coupon now.

PROGRESSIVE EXERCISER CO.,
400B Langdon Bldg.,
Broadway and Duane Street, New York

Enclosed is \$4 for your 10 cable Progressive please find \$2 for your 5 cable Exerciser. (Check the Exerciser you want.) It is understood that if I am not satisfied with this Exerciser, I will return it within 5 days and get my money back.

Name.....
Address.....
City..... State.....



New Way to Earn

\$5 to \$10 per day at Home

COULD you use \$5 to \$10 per day extra money? You can earn it in spare time, in a pleasant, new way. No previous experience necessary. Complete outfit furnished free to members. Everything made so clear a child can follow instructions. Hundreds already earn steady incomes this way. Success positively guaranteed.

WRITE FOR FREE BOOK

Members are taught to decorate beautiful Art Novelties, lamps, shades, tables, chairs, bookracks, also etching on copper and brass, also pillow tops, batik, etc. Complete instructions for opening an Art Corner in your home, or Art Novelty Store, or selling to other stores. **FIND OUT** about this golden opportunity by writing today. Mail coupon or letter NOW enclosing 2c stamp.

FIRESIDE INDUSTRIES
Dept. 66-K,
Adrian,
Mich.

Gentlemen: Please send me, **Free**, the book of Fireside Industries, which tells how I may earn money at home by Decorating Art Novelties; also particulars of your Money-Making Guarantee. I enclose 2c stamp.

Name.....
Address.....
City..... State.....

(Write plainly in pencil)

Send No Money

Just check the books you want, write your name and address below, and mail the whole advertisement. It is your order blank. When postman hands you books, pay him the price and the postal charges. If you prefer to send cash, postage will be prepaid. We have many other books on these subjects and on 2,000 other subjects. Catalog free.

CHECK THE BOOKS YOU WANT AND MAIL TODAY

Name.....
City..... State.....
Address.....

Mail to **Popular Mechanics Press,**
Room 708, 200 East Ontario St., Chicago, Ill.

Learn ELECTRICITY in Los Angeles!



WE have more calls for trained Electrical Experts than we can supply. Hundreds of Big Pay Jobs are waiting for you here—NOW—in studios, power houses and vast California hydro-electric projects. Electrical firms know National's reputation for turning out only *thoroughly trained* students. They want men so badly now that I am making a special offer to get 100 new students this month. This Fall these students will take electrical jobs paying \$60 to \$200 a week. Do you want one of these jobs?

You train at National on a quarter million dollar's worth of new electrical equipment—in a Million Dollar School. Expert instructors. 16,000 graduates. One of the oldest schools in America—giving the most complete training. Special Radio Courses. Complete practical training in every branch of electricity. Free employment service. Earn while learning.

Special Offer! If you live West of the Mississippi, I'll send you my big \$1.00 Electrical Book FREE!

Usually I charge \$1.00 for my 84-page catalog of Electrical opportunities. But to Western men—who can come to California and start training at once—I'll send this book free. All others must send \$1.00—which will be deposited to their account at 5% int.

Reduced Tuition For the next 30 days—to get men quick to fill jobs waiting—I'll reduce the training price 30%.

Lowest R. R. and Boat Fares

I'll get you a low rate to Los Angeles if you'll write at once. I need men now. Just sign the coupon.



National Electrical School, Dept. 661, Figueroa and Santa Barbara Sts., Los Angeles, Calif.

Send me your Electrical Catalog and Special Tuition Offer. (If you live East of Mississippi River, enclose \$1 which will be deposited in your account at 5% interest.)

Name.....
 Address.....
 City..... State.....

National Electrical School
 Dept. 661, Figueroa & Santa Barbara Sts.
 Los Angeles, Calif.



Hotels Start You With Salaries up to \$3,500 a Year — with your living

HOTELS, restaurants, clubs, apartments, everywhere need trained men and women—salaries to start up to \$3500 a year with your living. Over 70,000 high-class positions paying up to \$10,000 a year are open every year in the hotels of the United States. Today this is the 4th INDUSTRY IN AMERICA—with over \$1,000,000,000 in new hotels and clubs being built in 1926. These new hotels, clubs, restaurants, etc., will need nearly 200,000 trained men and women. You can have one of these high-class big-pay positions, fascinating work and luxurious meals and apartment usually furnished FREE! No previous experience necessary. The Lewis Schools guarantee to give you the valuable knowledge that it has taken some of the most successful hotel men years to obtain—men who are now making \$5,000 to \$50,000 a year. We train you by mail in your spare time at home with the Lewis Simplified Study Plan, and we put you in touch with big opportunities. Our students employed, our methods endorsed by leading hotel men everywhere. Send today for Free Book, "YOUR BIG OPPORTUNITY," showing how we can train you for one of these splendid positions, and explaining our Money-Back Guarantee.

LEWIS HOTEL TRAINING SCHOOLS
 Room E-388 Washington, D. C.

FREE BOOK COUPON
 LEWIS HOTEL TRAINING SCHOOLS, Room E-388, WASHINGTON, D. C.
 Send me without obligation the Free Book, "YOUR BIG OPPORTUNITY."

Name.....
 Address.....
 City..... State.....

FROST-RADIO

Type 700 Metal Frame Rheostats

To meet the requirements of new tubes an entirely different type of metal frame rheostat has been designed by **FROST-RADIO** engineers to give perfect output (volume) as well as filament control. Supplied in resistances from 2.5 to 75 ohms. Bakelite pointer knob; smooth acting lever; carries 25 to 50% overload without overheating. Ask your dealer to show you these new models. List: 50c.



HERBERT H. FROST, Inc.
 160 North LaSalle Street Chicago, Illinois
 New York City Los Angeles

150 TO 300 MONTHLY FROM ONE DAY BATTERY CHARGING

\$ Charge batteries in 1/3 the time required by others and get the business. Latest method recommended by the leading battery companies and approved by the U.S. Bureau of Standards. **Big year round profits.** Best paying business in automotive field. Requires no special experience, uses small space. **30 days' free trial** at our risk under absolute money back guarantee. Write today for Bulletin X, giving full particulars.



HOBART BROS. CO.
 Box M8 TROY, OHIO

30 DAYS FREE TRIAL
 OR REFUND MONEY BACK GUARANTEE

ONLY \$16 MONTHLY—MORE THAN PAID BY INCREASED PROFITS

Charleston!



Everybody's doing it! Arthur Murray, world's foremost dancing teacher, has invented a remarkable new method which enables *anyone* to learn all the newest dances at home—in a few hours—at *very little cost!* No music or partner needed. *Success positively guaranteed!* "300,000 learned dancing by mail."

FREE! 32-Page Book and TEST LESSON

To prove you can learn easily and quickly, Arthur Murray will send you his 32-page book and Test Lesson FREE. To cover mailing, please enclose 25 cents. Act NOW and be a good dancer quickly.

Arthur Murray Studio 647
7 E. 43rd St. New York City

Be a REAL ESTATE Specialist

Learn my amazingly successful system—right at home—in your spare time. Let me train you for real success. Let me put you in touch with big business. Let me do for you what I have done for other wide-awake men and women. D. H. Garrett says: "Made \$630 in one week before I was half through your training." Mrs. A. Moore says: "Have a new car, a dandy office and money in the bank, all through my own efforts and without any capital to start with." M. I. Stokes says: "Made \$900 in three months in my spare time." Send your name and address at once for my new, free book, "How to Become a Real Estate Specialist," giving full facts about my remarkable Home-Study Course, my Free Business Service and positive proof of big success. Address DIRECTOR, Dept. 44-H, American Business Builders, Inc., 18 East 18 Street, New York, N. Y.

Start Piano Tuning Business YOURSELF No capital needed. \$200 to \$500 month, full time. \$2 to \$4 an hour, spare time. We train you at home at small cost. Write MACK INSTITUTE, Wabash St., 8-2, PITTSBURG, PA.

FOREST RANGERS

Men wanting forest ranger, mail clerk, or other government positions, write for particulars.
MOKANE, 236, DENVER, COLO.

WANT WORK AT HOME?

Earn \$18 to \$60 a week RETOUCHING photos. Men or women. No selling or canvassing. We teach you and furnish WORKING OUTFIT given with each enrollment. Limited offer. Write today. Artcraft Studios, Dept. 50, 3900 Sheridan Rd., Chicago

TELEGRAPH-RADIO

\$18 to \$35 a week while training for Radio and Telegraph Operator jobs at \$150 to \$300 per month. Write for particulars.

CHICAGO TELEGRAPH INSTITUTE
Dept. 1-8-6 1338 S. Michigan Avenue, CHICAGO

500 Miles, No Tubes or Batteries

This record reported in many instances. Marvelous crystal set invented by Chicago man. Big, beautiful radio operates without cost and built to sell at \$10. To introduce we will ship you this instrument for only \$3.95. Send today. This offer limited.

AERIAL ELECTRIC CO., 128 W. Kinzie St., CHICAGO, ILLINOIS

PATENTS

REGISTERED ATTYS. U. S. AND CANADA

LANCASTER & ALLWINE

Send for our Original Form

EVIDENCE OF CONCEPTION

418 Ouray Bldg. WASHINGTON, D. C.

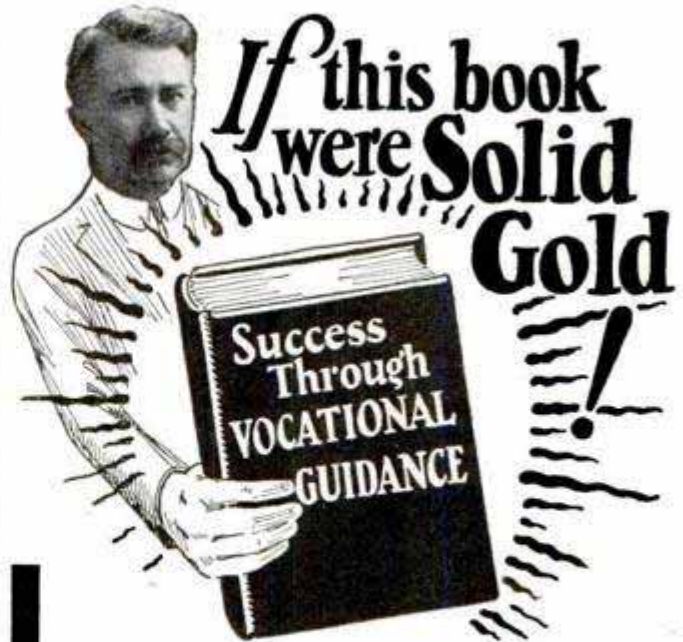

If this book were Solid Gold!

It Would be Worth Only \$1000

But—if this book will help you solve your biggest problem, FINDING THE LINE OF WORK IN WHICH YOU CAN MAKE THE BIGGEST SUCCESS and THE MOST

MONEY—it will be worth many thousands of dollars to you in increased income and happiness.

"Success through Vocational Guidance," by James McKinney and A. M. Simons, contains the most practical information on HOW TO CHOOSE YOUR LIFE WORK; based on U. S. Army methods, supplemented by Vocational Guidance research at the leading Universities. In simple language, it tells you how to find both the *line of work* and the *job* for which you are best adapted.

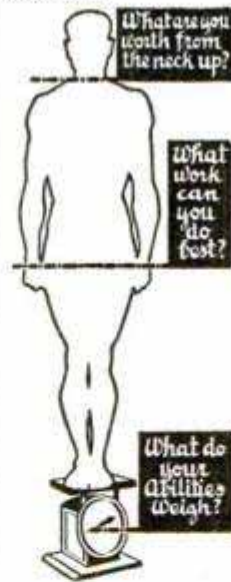

What are you worth from the neck up?

What work can you do best?

What do your abilities weigh?

Priceless Analysis and Advisory Service FREE!

The book will solve your biggest personal problem—HOW TO ANALYZE YOURSELF, how to chart your abilities and limitations, your good points and bad, your ambitions and talents. Few of us know ourselves *accurately*. This service, personally given by McKinney and Simons, makes an *individual* analysis of YOU. Included, without extra cost, with each volume.

Half-price Offer:

"WHAT CAN I DO BEST?" "IN WHICH FIELD CAN I MAKE THE QUICKEST SUCCESS?" These two questions, which you'd give a great deal to have answered RIGHT, McKinney and Simons answer through their book and analysis service. *Satisfaction guaranteed by a money-back guarantee* of the American School, a million-dollar institution. *Mail the coupon today!*

American School Drexel Ave. & 58th St., Chicago Dept. PAC-74

HALF-PRICE OFFER

AMERICAN SCHOOL
Drexel Ave. & 58th St., Chicago. Dept. PAC-74

Send me the McKinney and Simons book and the Questionnaire from which they will give me a Vocational Analysis. I enclose \$5, special half-price cost for the book and the complete service, which you agree to return on demand *if in my opinion* they are not worth many times the price.

Name

Address

MONEY BACK GUARANTEE

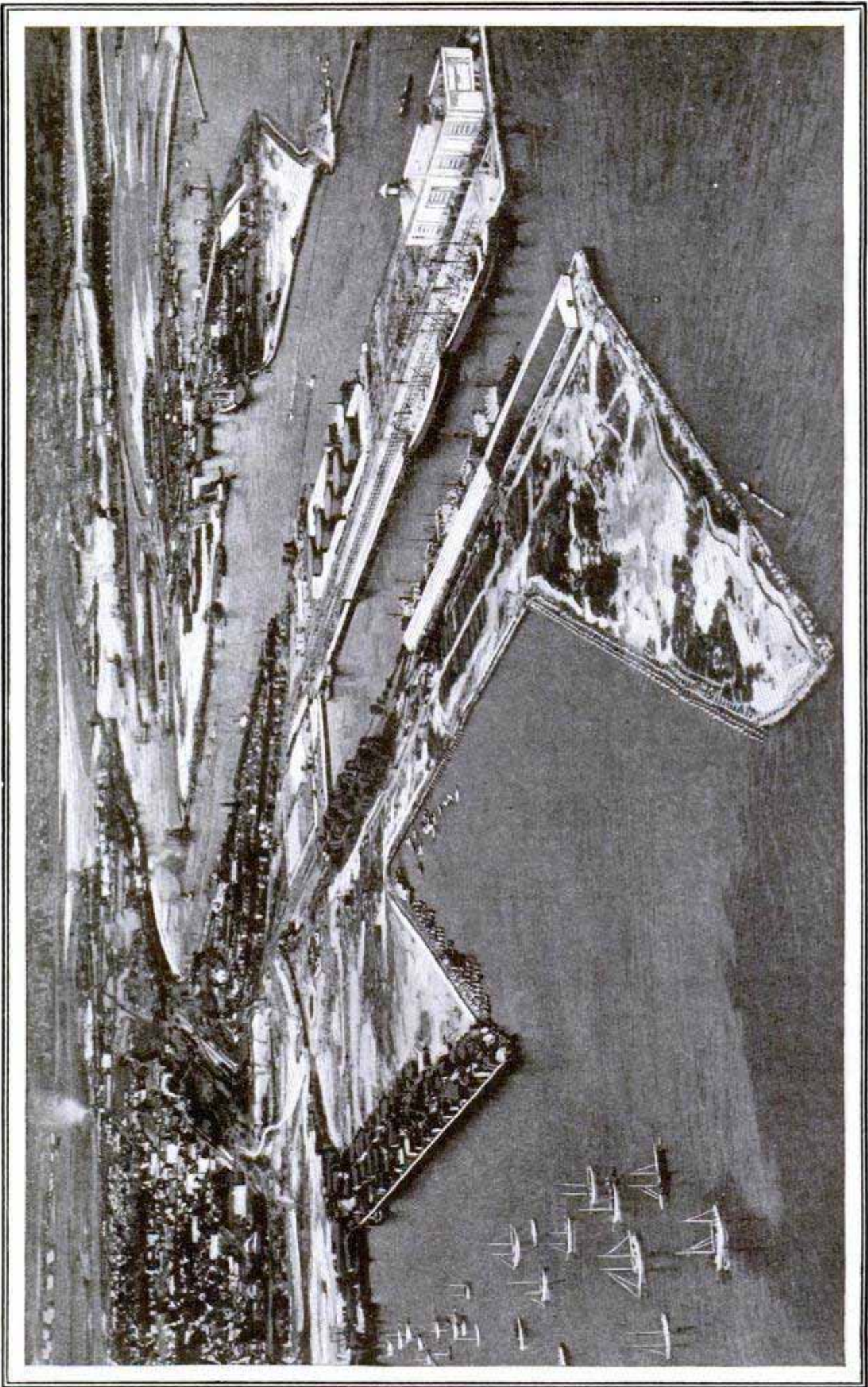

General View of Los Angeles Inner Harbor Today: Seventeen Years Ago, This Area Was a Swampy Flat; an Outer Harbor, Eighty Acres in Extent, and a \$10,000,000 Breakwater Nearly Two Miles Long, Are Important Features of the Harbor Plan Not Shown Here—See Page 192

Popular Mechanics Magazine

REGISTERED IN U. S. PATENT OFFICE

WRITTEN SO YOU CAN UNDERSTAND IT

Vol. 46

AUGUST, 1926

No. 2

2044

The Mighty Monoplane "Josephine Ford" in Flight; First Aircraft to the Top of the World, Its Place in History Is Secure

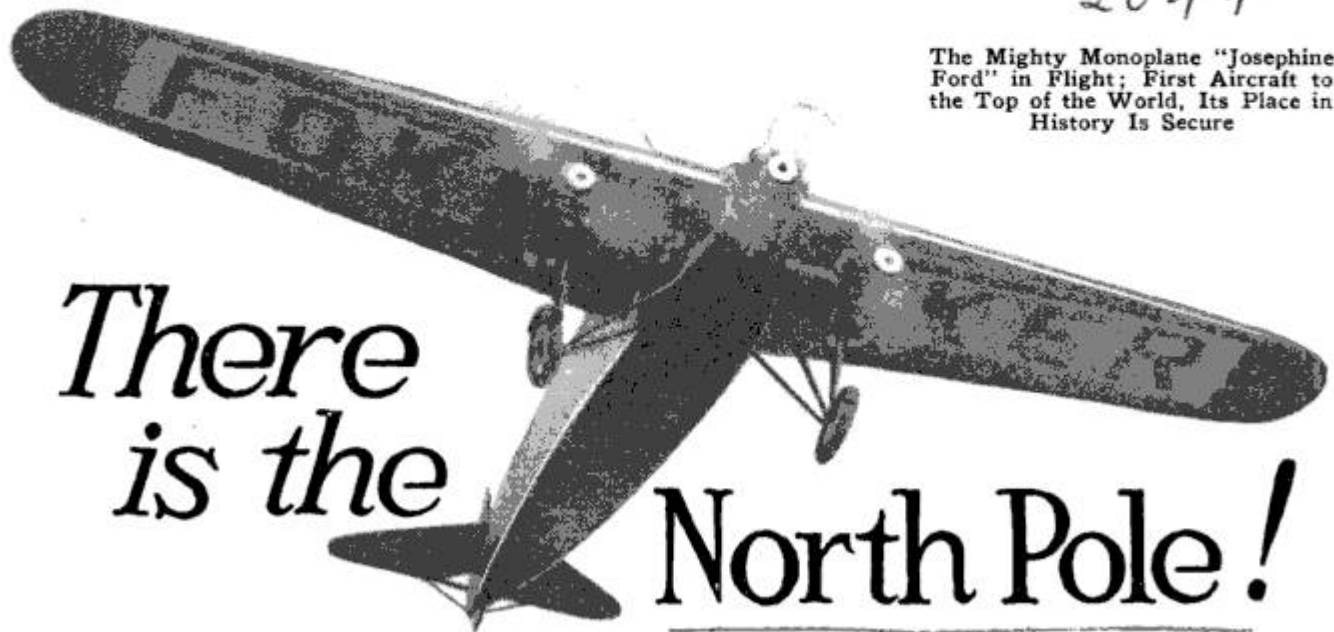

There is the North Pole!

How the Heavens Direct Man to the Roof of the World with the Aid of Sun Compass and Other Novel Instruments

Lieut. By CORLEY McDARMENT, *Leordon Hotel, Washington D.C.*

"RIGHT here is the north pole!" How can anyone say this as a positive fact, especially if he is whizzing through the air at a hundred miles an hour at the time? Within one week, an airplane and an airship have sailed over the desert of frozen ice men call the Arctic, and, without a lake, a river or a piece of land to guide them, they went directly to the pole.

To accomplish such a feat is a tribute to the ingenuity of man. One wonderful thing about it is that a way has been found to cheat the ice floes by sailing on the wind, and the other is to know when the exact top of the world has been reached. But man alone could never tell when he has flown to the north pole; he must depend upon the landmarks of the heavens which have been set by a mightier hand.

If the sky should be obscured, the north pole could never be found except with a tape line. No position on the earth can be fixed unless some celestial body, whose habits are known, can be seen. In re-

gions south of the Arctic, where the sun rises at points in the east which can be predetermined by tables, it is easy to locate a position at sunrise. But beyond the Arctic circle, where during the summer the sun never sets, but swings low and red around the horizon for the whole twenty-four hours, the problem has never been easy until recently.

Time does not exist at the north pole. That is, a person cannot put his finger on the right hour and make it mean anything. By merely taking a few steps a man may walk around twenty-four hours of time as it is counted far down the meridians, or he may step from one day on one side of the world to another. He can gain or lose whole days merely by walking a few steps. At the north pole, the pole star is very nearly directly overhead. Around this star revolve the Great Dipper and Cassiopeia. Also, the sun in summer swings around this star once in twenty-four hours. But the exact position of the north pole cannot be found by traveling up to a place where the pole star is di-

2044

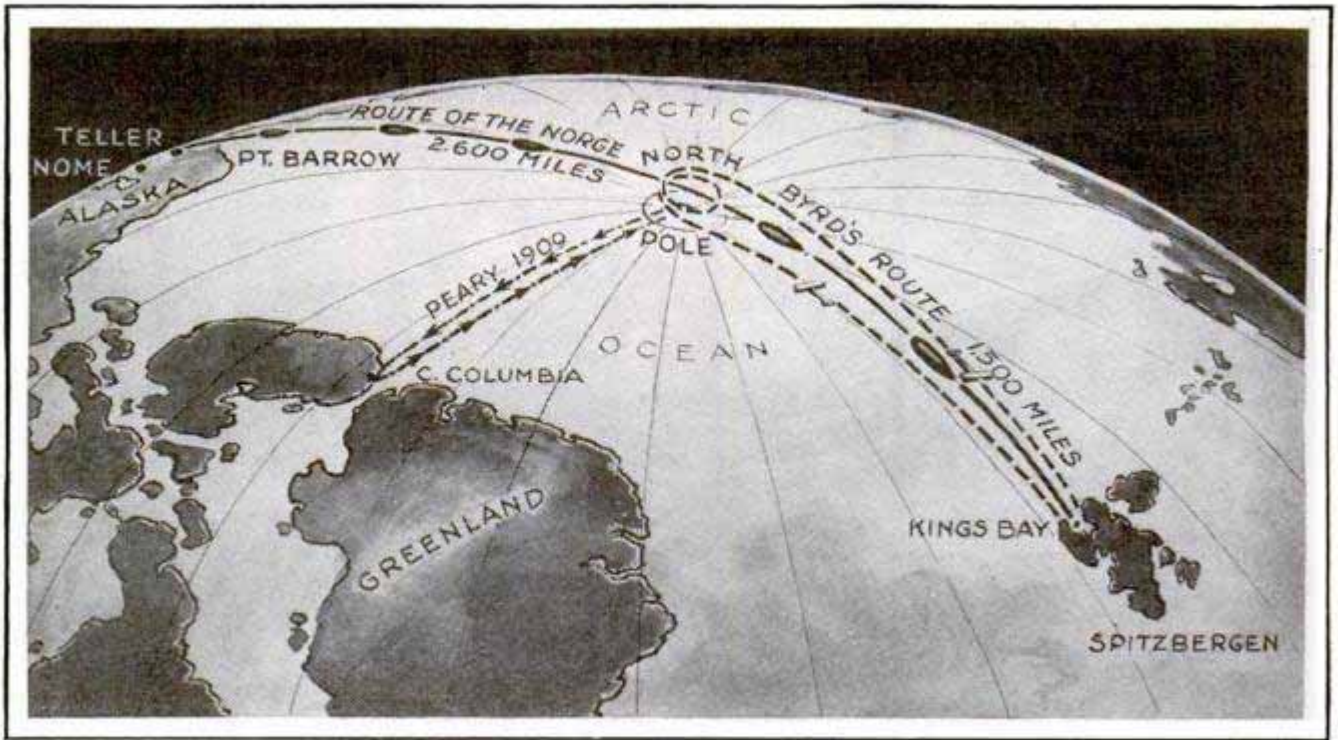

Amundsen and Byrd Traveled in a Few Hours by Air Distances That Took Peary Painful Months with Dogs and Sleds; the Three Pathways of the Polar Pioneers

rectly overhead. The means of determining this position must be by the sun.

The latest developments in aerial navigation which enabled Lieut. Comm. Byrd and Pilot Bennett, and, a week later, Amundsen, Lincoln Ellsworth and Col. Nobile, to determine quickly and accurately their position at all times during their flight to the pole were the Bumstead sun compass, the bubble sextant and Littlehale's method of finding geographic location.

With these instruments it was unnecessary to use the mariner's compass, which is of little value at these high altitudes on account of magnetic variation throwing it off as much as thirty degrees, or the old-style sextants depending on the finding of a horizon, which is frequently obscured from an aircraft. Also, optical illusions such as mirages distort the horizon and prevent accurate readings with the ordinary sextant.

To eliminate the necessity for a clear horizon, a new kind of sextant has a horizon all its own. This instrument combines the regular sextant with a simple bubble level. A tiny electric bulb is used to locate the bubble at night.

A watch must be used with the sextant, which, by sighting on the sea or an artificial horizon, will show the angle of the celestial body to the horizon; in other

words, show how high in the sky the sun has risen. By using a watch and a table showing the position of the earth, the exact location may be calculated quickly. In order to check on the position of the pole, the aerial navigator needs only to fly a little distance beyond the spot for his readings to be off, and they will be off at every place except at the pole itself. The navigator knows exactly what his readings should be when he reaches the pole and he can read a bearing to within ten miles.

The sun compass, which came into prominence with the flights, is really not much more than an ordinary sun dial. The face of the instrument is divided into twenty-four spaces corresponding to the hours of the day, and a single hand, acting as a pointer, moves by clockwork around the dial. Beneath this clock face is a compass card with the directions. The pointing hand of this sun compass is unique. It does not stop at the pivot, but extends a little beyond and there it is bent directly upward. It is like a clock with a hand extending from 12:00 to 6:00 o'clock bent straight up near the pivot. The compass card and clock dial are set in such a way that the navigator can interpret the shadow of this upright hand, or post, and the instrument is lined up with the true direction as predetermined

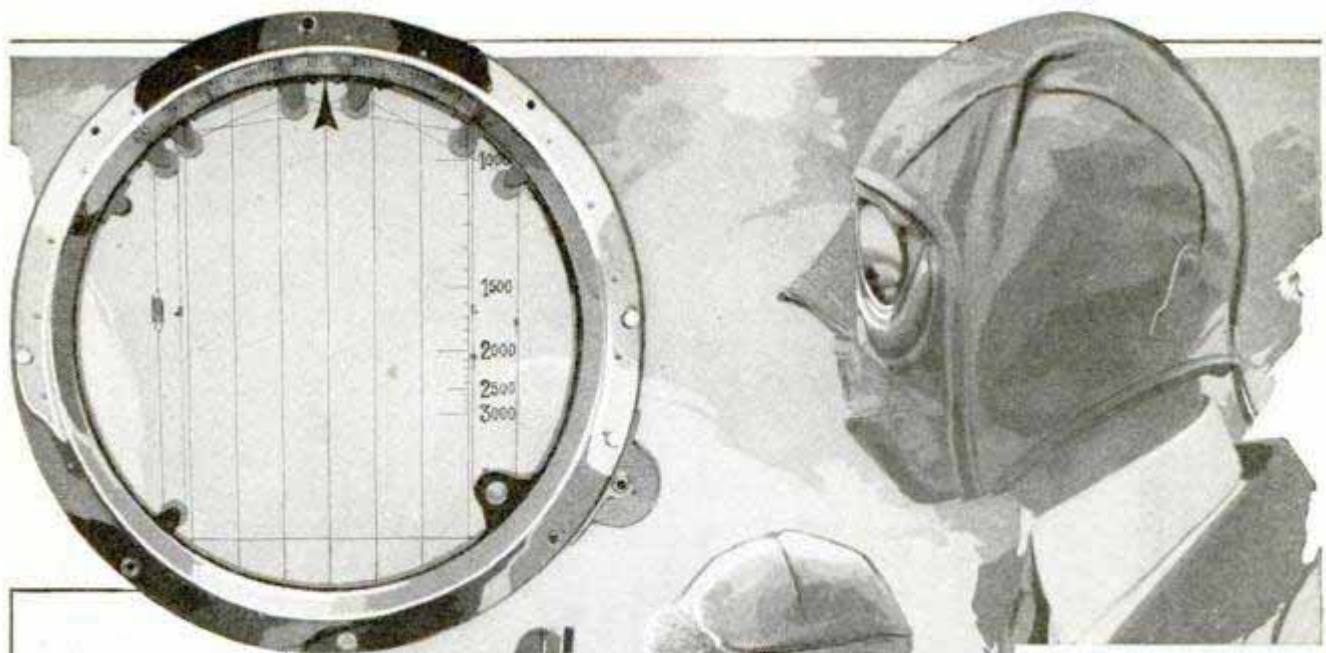

Bearing Plate That Shows Effect of Wind in Changing Plane's Course; Sights Are Taken on Stationary Objects

Lieut. Comm. Byrd Wearing Special Leather Helmet and Mask; at 2,000 Feet, It Was Eight Degrees above Zero near the Pole



Byrd Using the Special Sextant from the Plane's Observation Seat; This Instrument Had a Horizon All Its Own, Making the Navigator Independent of the Natural Line

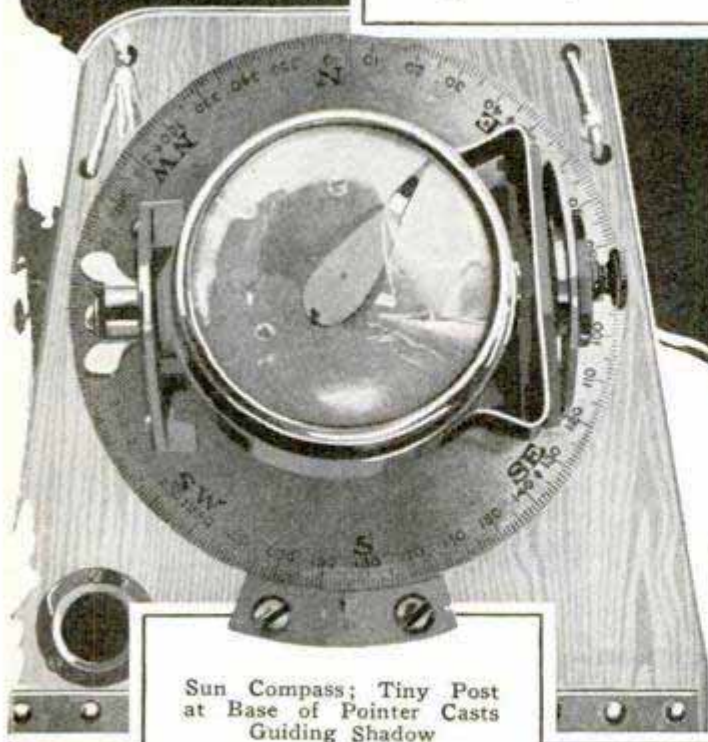

Sun Compass; Tiny Post at Base of Pointer Casts Guiding Shadow



Point Hour Hand at Sun; Halfway between That and Twelve O'clock Will Be Approximate North

by celestial observation. The shadow of the post can be made to fall directly upon the pointing hand when a true course is held. This is possible because the hand moves around the dial following the sun.

When Comm. Byrd desired to travel a due north course, he set the compass dial for north and then so maneuvered his plane that the shadow thrown by the post would be exactly superimposed upon the hand of the clock. The sun compass is small enough to be held in the hand and is very easy to use when the clock has been accurately set to sun time and the sun is unobscured enough to cast a shadow.

Another instrument which aviators use is the bearing plate, or drift indicator. With it Comm. Byrd was able to determine the influence upon his airplane of the wind which would drive it off its course unless allowance were made for such drift. It is a small glass plate, located in the bottom of the cockpit and covered with cross wires, through which a sight can be taken on some stationary object below. It also gives quite accurately the speed the plane makes over the ground, which, on account of the wind, may differ from the air speed.

One of the most interesting methods of

locating the position of the north pole is Littlehale's formula. This is a simplified system of using the nautical almanac, which contains the apparent position of the sun, moon and principal stars in the heavens for all hours of the day. The almanac is made up ahead of time, by a few years, because the future positions of the celestial bodies can be calculated easily.

On his trip Comm. Byrd had, in addition to his dashboard clock, two Greenwich-time chronometers, wrist watch and another small watch. As extreme cold sometimes causes variations in timepieces, it was necessary to provide means for checking the hours. Also there were two sun compasses.

In calculating the course, Comm. Byrd took drift observations every three or four minutes. He was sighting so constantly on the bright, sunlit snow beneath the plane that his right eye began to show symptoms of snow blindness and he had to shift to his left.

Flying at a height of about 2,000 feet, a temperature of eight degrees above zero was encountered. From the plane, the ice-covered surface of the Arctic ocean could be seen for fifty miles in every direction. The trip of Byrd and the "Norge" added about 100,000 square miles to the earth's explored area, but left between three and four million square miles as yet unseen by man.



The "Norge" in Flight; in Addition to Practically the Same Kind of Instruments as Employed by Byrd, Amundsen Made Use of a Radio Direction Finder Which Helped Him Reach a Landing in Spite of Fog

2144

WATCHES TO RUN BY RADIO, ENGINEER PREDICTS

Pocket watches which will be accurately synchronized, if not kept running, by impulses sent from a central radio station, are predicted by an eastern engineer. The timepieces will be like special receiving sets. They will have neither mainsprings nor batteries, and although static offers certain problems, it is believed that these difficulties can be overcome. The present use of radio in sending out time signals and the transmission of energy in small quantities by wireless are cited as indicating that the radio watch is not an impossibility.

SAILOR FASHIONS SHIP MODELS OF TURKEY BONE

1938

Bones of Christmas turkeys were employed in fashioning replicas of two sailing vessels by the boatswain of a Pacific liner while on a voyage from South America to California. The ships are three-masted affairs and handsomely colored. The breastbone was used for the hulls and smaller bones for the masts, spars and other parts.



Boatswain Jack Taylor with Model Ships He Fashioned from Turkey Bones during Spare Time

Steamer Hollywood
Buenos Aires to Los Angeles.

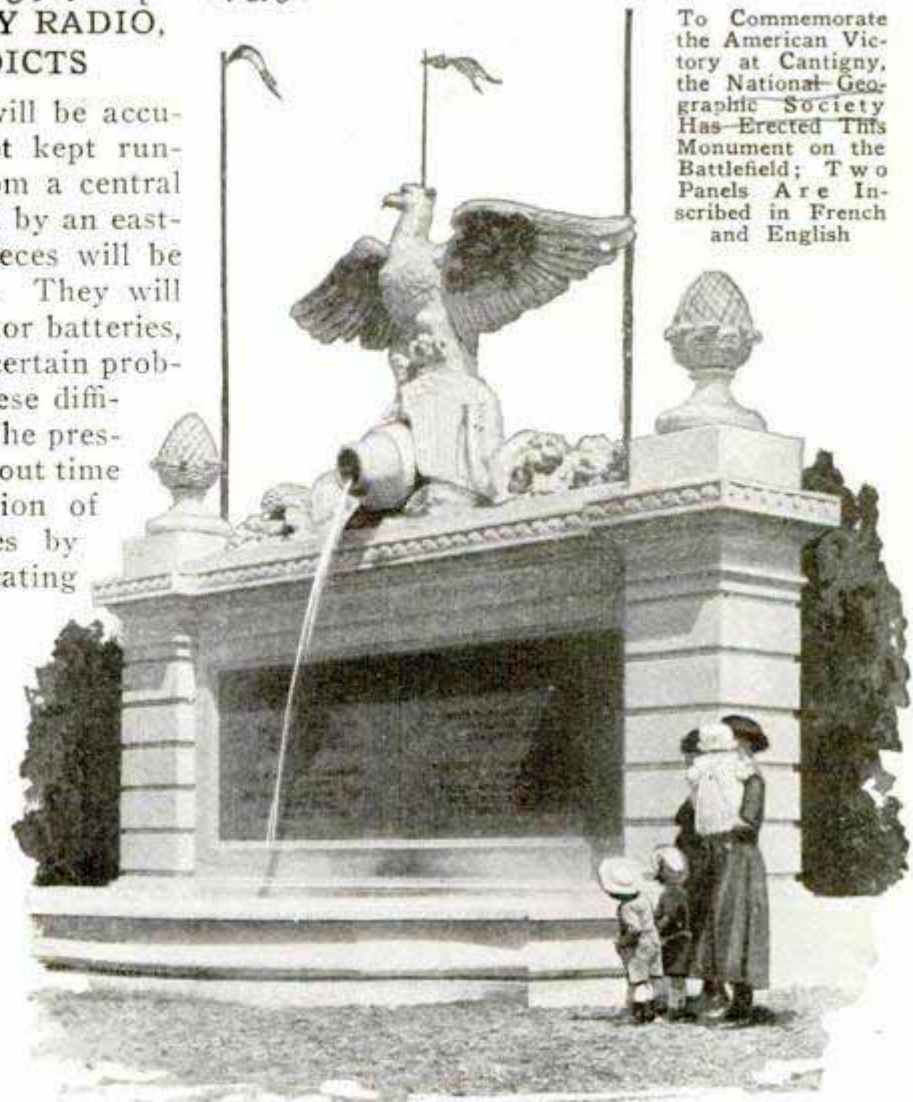

To Commemorate the American Victory at Cantigny, the National Geographic Society Has Erected This Monument on the Battlefield; Two Panels Are Inscribed in French and English

FIRST U. S. WORLD-WAR VICTORY MARKED BY MONUMENT

At Cantigny, scene of America's first important victory in the World war, a monument has been erected by the National Geographic Society. Two panels bear dedicatory sentiments.

ANTITOXIN TO CURB MEASLES AND AID IN CURE 2022.

Discovery of a measles antitoxin which can be used both for preventive and curative control of an epidemic, recently has been announced by the American Medical association. Doctors N. S. Ferry and L. W. Fisher of Detroit, Mich., found the organism that causes measles. From the soluble toxin it produces, the antitoxin is derived in large quantities through the use of horse serum. A blood serum from convalescent measles patients has already been employed with some degree of success as a means of prevention.

HOW LIMIT OF HUMAN SPEED IS BEING MEASURED

International

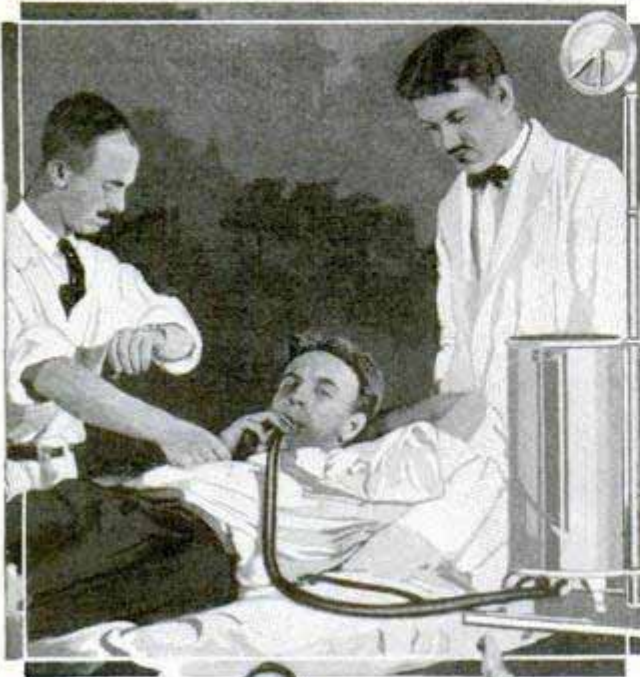

Whether or not a runner will break a record depends chiefly on two factors, Prof. Hill declares, the degree to which he can overdraw his oxygen "account" and his maximum capacity for taking in oxygen during the race. He has found that man comes nearest his speed limit in the 100 and 220-yard dashes, but that lower records in the longer runs of 500 yards, three quarters of a mile and three miles are yet possible. An average running speed of six yards a second, he says, may be maintained for distances between five and ten miles. A woman's athletic ability is about sixty-seven per cent of that of a man of equal weight, Prof. Hill has estimated. He recognizes



Breathing Tests with Measuring Gauge, and Runners at the End of a Race; Insert, Charles Paddock's Strained Expression Shows Fatigue's Mark at Finish of a Swift Sprint

What fixes the limit of a runner's speed? Can better training, more game-ness and keener competition produce constantly lower records or is there a point beyond which no athlete can go? According to Prof. A. V. Hill, an English authority, man's running ability is largely determined by his oxygen "borrowing power," that is, the ability of the muscles to draw on temporary substitutes within the body when the supply from the outside is insufficient during great effort.

three different kinds of fatigue; that which results from violent strain for a short period, exhaustion resulting from more moderate but prolonged effort, and that due to wear and tear on the body as a whole.

213 VALLEY OF AMAZON IN RUBBER COULD SUPPLY WORLD

Sufficient rubber to supply the entire world could be grown in the Amazon valley, according to James R. Weir of the department of agriculture, providing suit-

Washington
10 8.

able measures were taken to protect the crop against diseases. Trees there, it has been found, are subject to attacks from fungi which reduce their growth and starve them to death.

LATEST BALL FOR WATER SPORT HAS WINGED AIR SEAL 2064

A rubber ball which can be deflated and carried in the pocket is one of the latest devices for use in water and land games. Simple rules for both amateurs and professionals have been written by Tom Robinson, swimming coach at Northwestern university, where the ball was first introduced. The sphere is made of extra-strong rubber and has a patented cap. It is blown up by the lungs, a hard rubber plug is inserted in the filling tube which is then pushed into the ball with the finger, the tube turning wrong side out in the process and forming an air-tight seal. The disappearing filling tube is the unique feature. The ball comes in three sizes, a small one for water baseball, a play ball which can be blown up to twelve inches in diameter, and a still larger size, capable of inflation to more than fifteen inches across. Deflated, the ball rolls up and

occupies little more space than a folded handkerchief will do.

Cito Ball



Coach Tom Robinson, Famous Swimming Teacher, Throwing the New Collapsible Rubber Ball, and Inserts Showing Its Disappearing Plug

American distributors. Schroeder & Tremayne, Inc.
 500 N. Commercial St. St. Louis Mo.
 Chicago, Ill.

2083



Mrs. Lillian Cram of Portland, Oreg., at Her Easel on Which She Is Fashioning a Picture in Rags

PICTURES PORTRAYED IN RAGS BY WOMAN ARTIST

Brightly colored pictures are fashioned from hundreds of tiny pieces of cloth by a western woman. She works on an easel, the fragments being pasted in place and cut to fit with scissors. By careful choice of designs and shades, she achieves artistic and unusual results.

STORKS FORCE POWER COMPANY TO BUILD THEM PERCHES 2139

To save a 60,000-volt transmission line in Morocco from being wrecked by hordes of storks, the French company owning it has been forced to build special perches along the entire line from Casablanca to Rabat. The big birds discovered as soon as the line was built that the steel masts supporting the wires were ideally designed as supports for stork nests, giving much firmer foundations than a tree or a roof. The huge nests, however, interfered seriously with the insulation of the line. The special perches, and smooth shields over the masts on which the birds could not gain a footing, ended the trouble.

Compagnie Francaise Thomson-Houston Paris France

2049

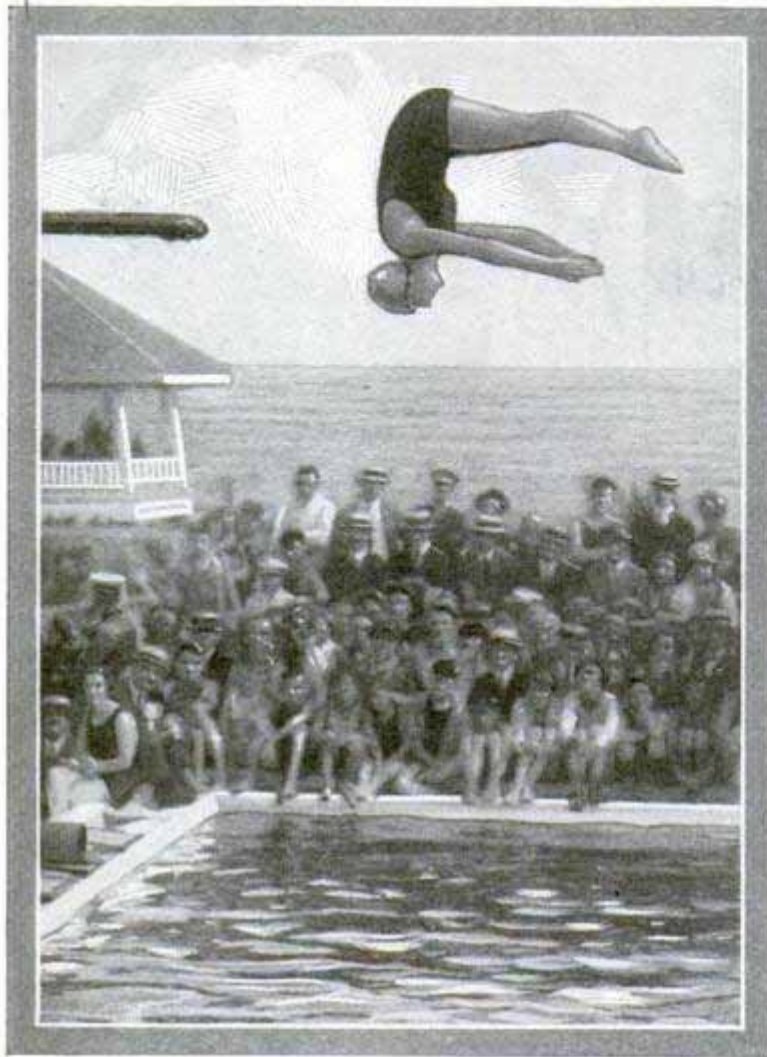

It's as Easy

drowned because he could not swim, which is all wrong. He drowned because he lost his head.

To a lot of people that sounds like heresy, yet practically all adults, most girls, and quite a few boys can float in water, with mouth and nose well above the surface, without moving hand or foot, while anybody, with an occasional kick and a bit of paddling, can float indefinitely. The ability to float without kicking or paddling depends upon the body being slightly lighter than the volume of water it displaces. Tom Robinson, swimming coach at Northwestern university and swimming instructor to the children of an entire town, says that practically every girl is able to float motionless in the water. Not so many of the boys who come to college are able to do it, because they are lean and compact, with heavier tissue, but in

SWIMMING is one of the easiest things a person can learn, once the fear of water has been mastered. It is as easy to swim as it is to walk; easier, in fact, because the water offers a soft couch and you can turn over, lie on your back and rest whenever you get tired.

It is almost impossible to drown, if you keep your head and don't become panic-stricken from fear of the water. Every now and then the papers record that somebody has waded out beyond his depth, and, because he couldn't swim, was drowned. The conclusion is drawn that he

later life, after they have put on a bit of fat, they can do it. The feet, it is true, will sink toward the bottom until the body is vertical in the water, but with the arms spread out on the surface, the head, and sometimes even the neck, will be above the water.

For those who haven't the necessary amount of fat, floating, with the aid of an occasional kick and paddle, comes easy.

If you are in that class, try lying on your back in the water, with hands either stretched out on either side, or down along your body. Kick slowly, just enough to keep your feet near

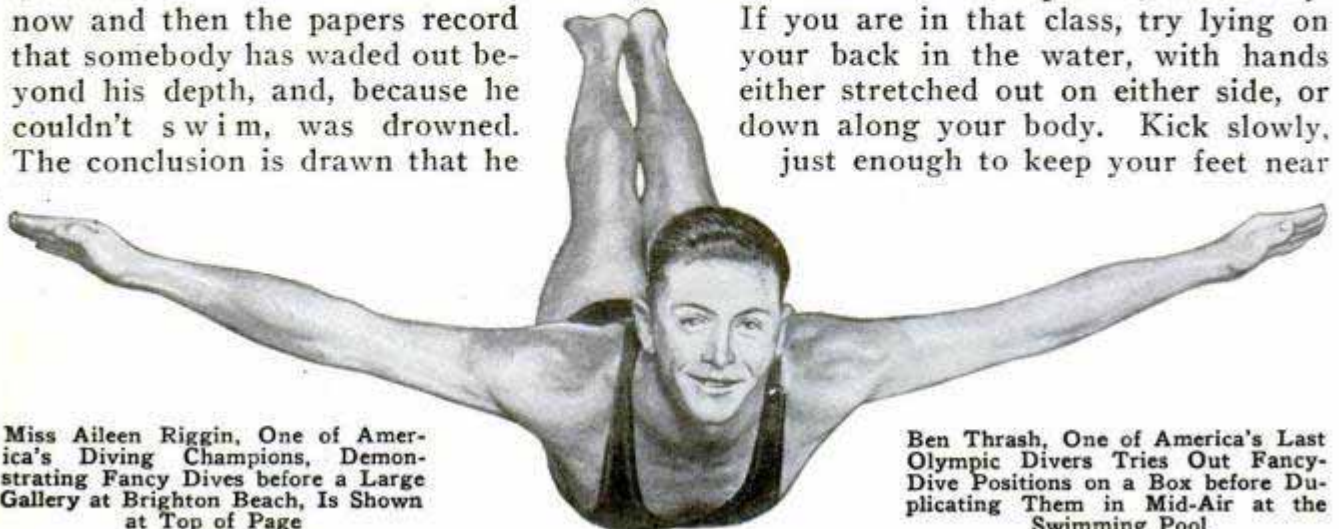

Miss Aileen Riggan, One of America's Diving Champions, Demonstrating Fancy Dives before a Large Gallery at Brighton Beach, Is Shown at Top of Page

Ben Thrash, One of America's Last Olympic Divers Tries Out Fancy-Dive Positions on a Box before Duplicating Them in Mid-Air at the Swimming Pool

to SWIM as to WALK

Helen Wainwright, American
Aquatic Queen for Four Years,
in a Graceful Swan Dive

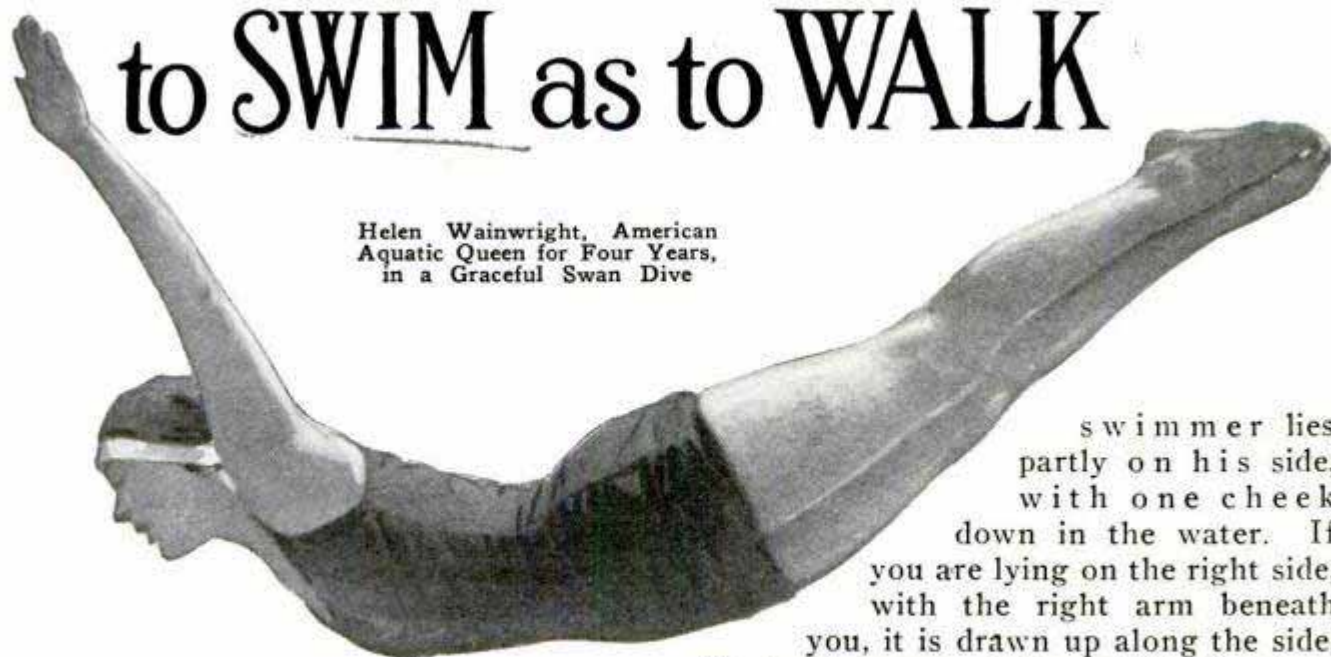

swimmer lies partly on his side, with one cheek down in the water. If you are lying on the right side, with the right arm beneath you, it is drawn up along the side,

the surface, and wiggle your hands up and down at the wrist, moving them just enough to keep your face clear. You will soon find you can slow down to an almost imperceptible motion and still keep afloat.

The main thing when learning to swim is to conquer the instinctive fear of the water. If you start by floating, and discover that you can lie on your back, for hours if necessary, most of the fear is gone. Nothing can happen to you in the water as long as you keep your wits about you. Even a cramp, feared by so many, is only painful, not dangerous. You don't need both legs or both arms to keep afloat, and if cramp temporarily puts you out of commission, the other three will see you through, if you don't lose your head.

Most swimming coaches start their pupils with some form of the simple dog paddle, the easiest stroke to master since it is the instinctive action of a new swimmer struggling to keep his head above water. It isn't a speed stroke, and it is accompanied by a lot of unnecessary splashing, but with a bit of practice it is easy to learn to co-ordinate the kick with the stroke and achieve a fair rate of progress through the water. The dog paddle, too, has the advantage of keeping the head well up, a benefit to the new swimmer who is still chary about sticking his nose beneath the surface, because he has not learned how to regulate his breathing.

From the dog paddle such coaches as Tom Robinson advance their beginners to a simple overhand stroke in which the

the hand passes out beyond the head, as far as it will reach, and is then swept down and back, with palm extended. While the underneath arm is sweeping back in the stroke, the other is drawn up past the chin, extended to its limit, and swept down, back and slightly sideways. The two strokes thus alternate, accompanied by vigorous, but well-timed kicks.

From the overhand stroke the swimmer can progress to the breast stroke, or sailor's stroke as it is sometimes called, and here, for the first time, he begins to get his nose wet. Stand in water about breast-deep, place your hands together just beneath your chin, with the palms and the fingers touching, and then bend over and launch yourself forward, shoving your feet to the surface with a strong push. At the same time, keeping your hands together, extend them full length, turn them to bring the palms out and the backs together, and then sweep them sideways and back, accompanying the stroke with a shoving kick, made by drawing up the knees and then extending them. Carry the stroke through until the hands almost reach the hips, then draw the arms up, bring the hands together again just below your chin, and repeat the stroke. You can practice it first at home or on the beach.

While the hands are being brought forward the face will be under water, so you start with a good breath and hold it. As the stroke starts sweeping backward, it pulls the body forward and up, lifting the face so you can get a fresh breath on each stroke. It takes practice to learn to swim

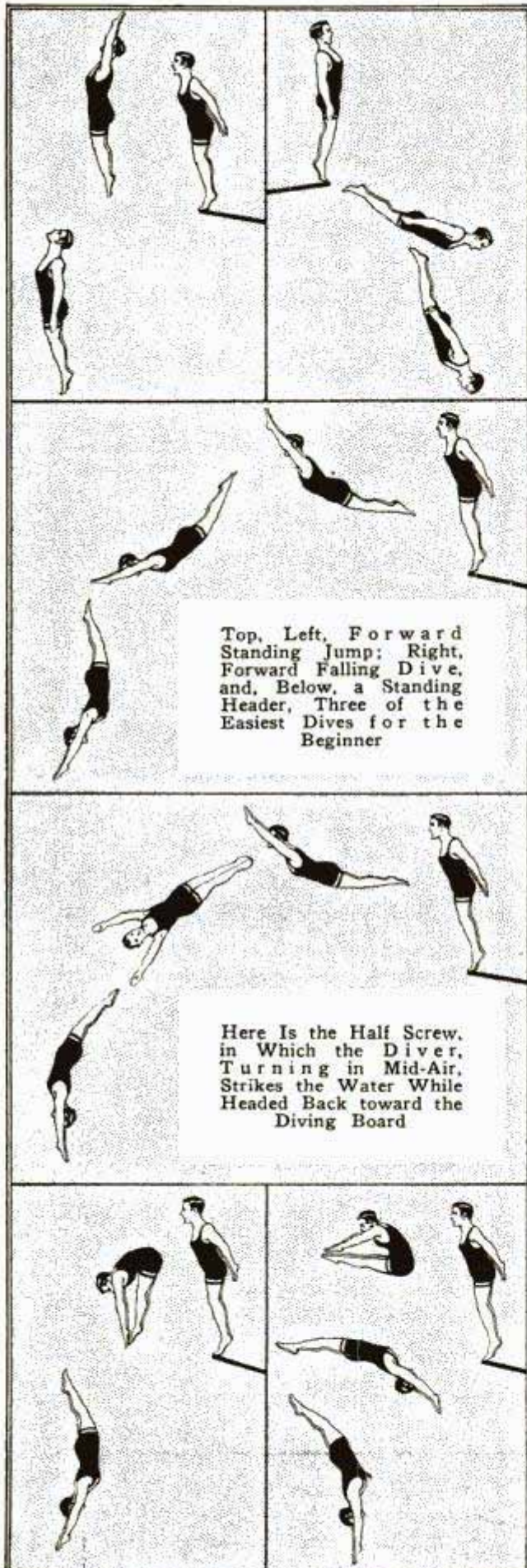

with your nose under water, holding your breath and timing your breathing with your swimming. The practice is necessary, though, before you can graduate into such speed strokes as the Australian crawl, the greatest of them all.

The crawl requires the same position as the breast stroke, but the arms, instead of working together, move separately, are lifted entirely out of the water while being brought forward, in order to reduce friction and drag, and breathing is accomplished by turning the head sideways during the stroke, until the nose clears the surface. The crawl stroke is very much like that of the under arm in the overhand stroke. As the body turns slightly to the side the under arm is brought back and down, while the other hand, which is at the hip after completing its stroke, is brought up by doubling the elbow above the water, raising the hand clear until it can swing forward to reach out for the next stroke. It starts that stroke just as the first hand completes one, and the body rolls to the other side, to enable the first elbow to clear the water while the hand is being brought forward to position.

There are numbers of good swimming strokes, but nothing faster than the crawl has been invented.

After a swimmer has mastered the breast stroke he can try swimming on his back for a change. The position is the same as for floating, but the arms, instead of paddling at the sides, are brought up past the head, extended full length, and then swept down and back, accompanying the stroke by a vigorous kick.

Plain diving is as easy to learn as swimming. The chief requirement is confidence and a cool head. Not everyone can learn to do the fancy dives, one, one and a half and double somersaults, jackknife or pike dives, or such things as head stands and borers, but anyone who has discovered how hard it is to drown himself can learn to do a graceful dive, even from a high board. The dives pictured here are from the official catalog of the 1920 Olympic games, at Antwerp, and show the form on which Olympic divers are judged. The upper three are simple dives, quickly mastered by anyone. The half screw, or borer, and the pikes require more practice and a higher diving board.

2011

Johnny Weismuller, American Swimming Champion, Demonstrating Various Strokes: Left, Is the Simple Paddle for Beginners, and at the Right, Two Views Showing How the Arm Is Lifted in the Australian Crawl



The Breast, or Sailor's Stroke, at Left, Is Accompanied by the Scissors Kick, Which Imparts a Powerful Forward Thrust When It Is Properly Timed with the Arm Movements



The Back Stroke Comes Easy, Once the Trick of Floating Is Mastered, as Illustrated at the Right



The Side Stroke Follows the Beginner's Paddle, with the Body Turned Sideways and the Chin under Water



Here Is Another View of the Side Stroke, Which Lies Midway between the Simple Paddle and the Australian Crawl, the Greatest Speed Stroke of All



2066

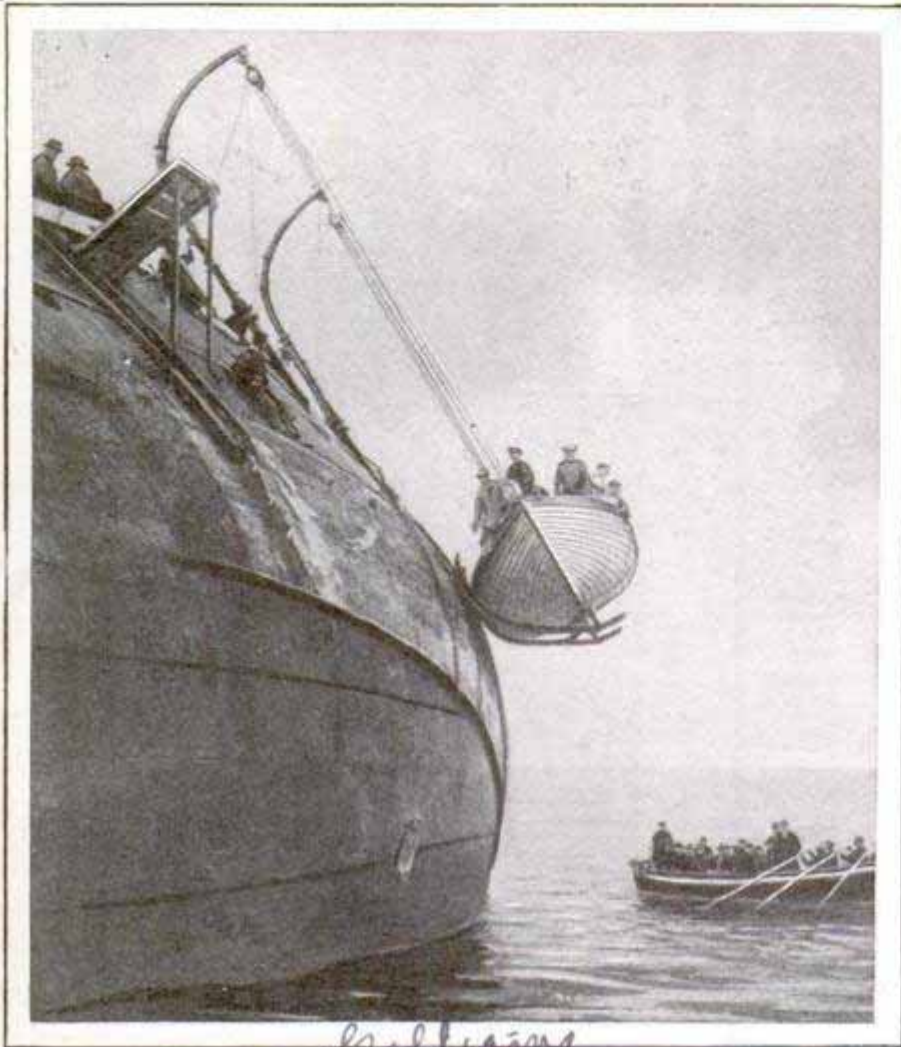

Sliding Down Leaning Steamer Hull on Its Pair of Skids, the Lifeboat Is Kept from Capsizing While Being Launched

PAIR OF SKIDS FOR LIFEBOAT PREVENTS UPSETTING

To keep lifeboats from tipping over while they are being lowered down the side of a vessel, a pair of skids, easily attached to the bottom, have been devised. The boat is little likely to catch and capsize while descending with this arrangement in place, as it keeps an upright position until it strikes the water.

DANGER POINTS OF YOUR BODY

The Adam's apple, and not the region of the heart or the solar plexus, as is commonly believed, is man's most vulnerable

part, according to an English authority. It has been found that a slight blow may result in serious impairment to the breathing or swallowing, and that a hard blow may cause death. Japanese experts in self-defense methods demonstrate that a blow with the edge of the hand above the temple or ear may cause concussion of the brain or fracture of the skull, and that blows on the nape of the neck are dangerous.

SHEET-IRON HORSES PULL COACH

Life-size model horses cut from sheets of galvanized iron have been prepared from small photographs of the live animals to give the proper setting for an old stage-coach owned by a western collector. Slides were made from the snapshots, projected to the required size on a screen and the outlines marked on the iron, which was cut out. The sheets were then mounted on boards, and a few touches of paint completed the illusion.

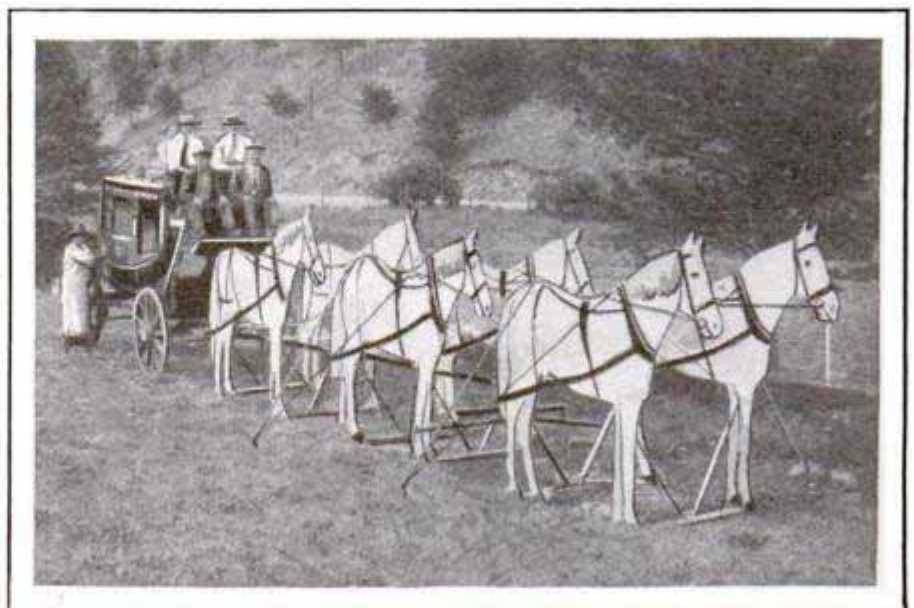

Realistic Sheet-Iron Horses Modeled from Actual Photographs

Made by Mr. George E. Turner, Tinsmith, near [unclear] Colo.

2142
J. K. B. 5/1/26

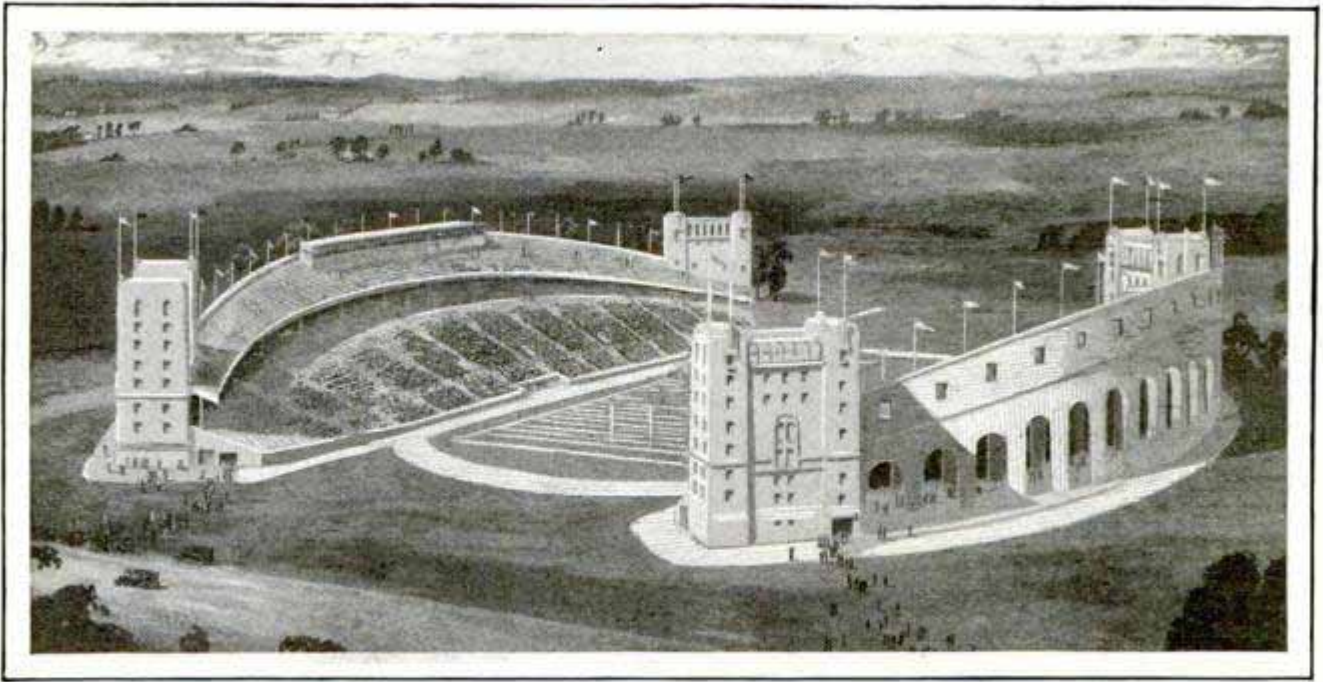

Architect's Drawing of Northwestern University's Stadium, Now under Construction at Evanston, Ill.; Eventually, the Structure Is to Have a Third Deck, Affording, in All, Seats for 75,000 Persons

UNIVERSITY STADIUM TO SEAT SEVENTY-FIVE THOUSAND

Two decks of Northwestern university's new stadium in Evanston, Ill., will be finished in time for the first football game this fall, it is planned. Later, a third deck is to be added, giving a total seating capacity of 75,000, while, according to the plans, about 45,000 persons will be accommodated in the first two sections.

found in the product and, for some time, the government has been attempting to establish a uniform system of grading throughout the country. Weight is already one factor in pricing and classifying eggs in larger lots. For instance, in Chicago the rule is that a case of thirty dozen No. 1 eggs must weigh not less than fifty-eight pounds. No. 2 eggs must weigh fifty-three pounds or better to the case.

PUTTING FRUIT TO SLEEP

As a substitute for cold storage, an English professor has been attempting the preservation of fruits simply by keeping the air of the room in which they are placed at exactly the same temperature and degree of humidity. The effect is said to be a state of torpidity, halting decay. Apples stored by this method were found to be in good condition after four months, according to reports.

SCALES FOR WEIGHING EGGS AID IN GRADING

Should eggs be sold by the pound instead of by the dozen? The question was further discussed recently before the bureau of standards and scales for weighing individual eggs to determine their grade were demonstrated. Wide differences are



Special Scales for Weighing Eggs Separately as Basis for Determining Grade to Which They Belong

The requirements vary in different sections of the country.

W. A. Halzid, Deputy state scaler of weight and measures of Oregon

J. M. Campbell, Professor of Botany, Northwestern University, England.

2145

2106

maker unknown

RAILWAY TRAINS TO RIVAL AIRPLANES IN SPEED

Cont. J. G. Harris, 7151 Bennet Ave. Chicago

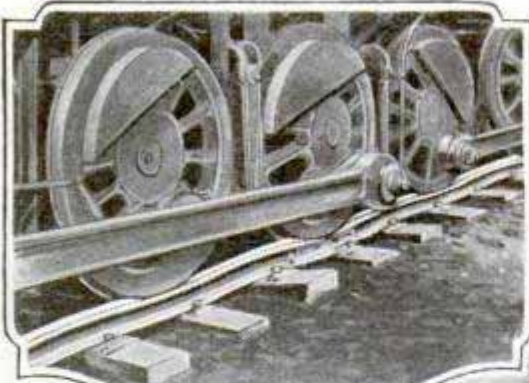

Ordinary Track, Above, and Proposed Cement Roadbed for High-Speed Trains

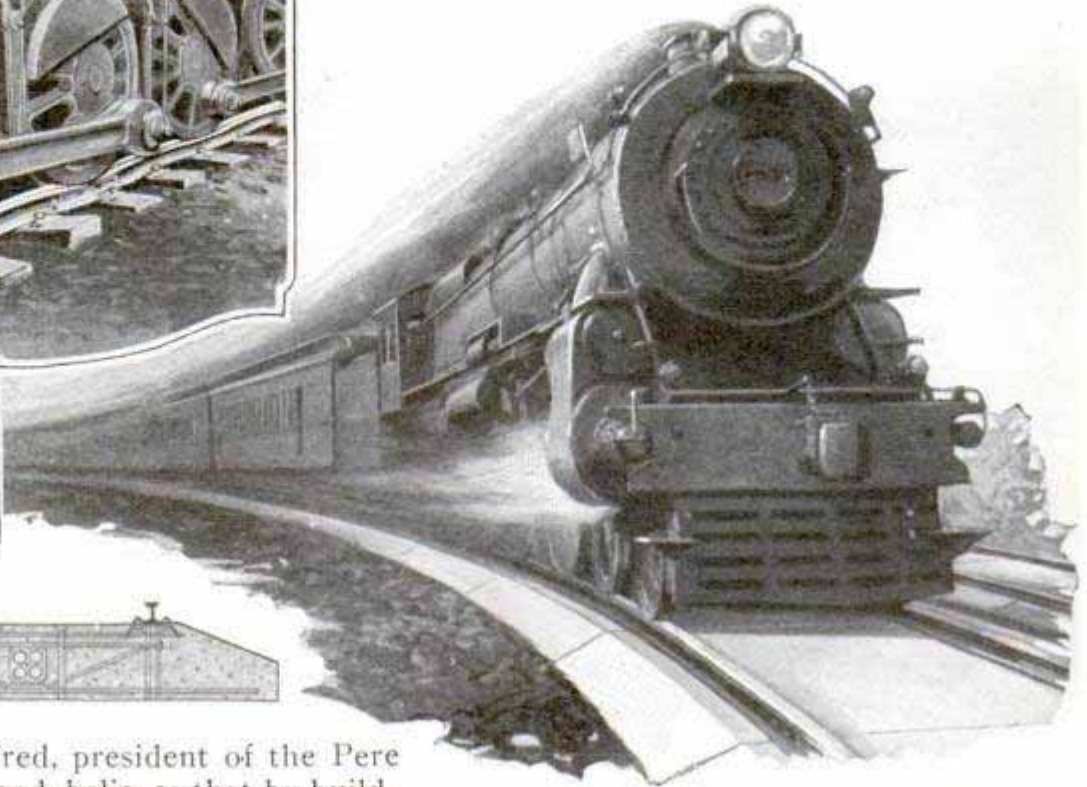

Frank H. Alfred, president of the Pere Marquette railroad, believes that by building a thick concrete roadbed and equipping locomotives and cars with roller bearings, a train may compete in speed

with airplanes. A section of this new track is to be built near Detroit. The new-style roadbed is to be a slab of concrete, eighteen inches thick by ten feet wide. The rails are to be carried on steel trusses which will be imbedded in the concrete and, in addition to forming a place to which the rails will be attached, the truss will distribute the weight of passing trains evenly throughout the heavy concrete roadbed.

Railway - construction engineers say that this proposed plan is



High-Speed, Three-Cylinder Freight Locomotive Developed by Union Pacific Railway to Haul Mile-Long Freight Trains at Fifty Miles an Hour; It Is More Than 102 Feet in Length

novel and, if it proves successful, it will be the first revolutionary design in railway-track improvement. Tracks have always been built flexible so that, when a train passes over a section, the part bearing the weight is depressed, just as a plank supported at both ends bends when a heavy man walks on it. A train depresses the track underneath it until it is literally standing in a "trough" and always is climbing uphill. This will not happen in the rigid type of track for here the ideal of a steel ball rolling on a smooth, rigid surface will be approached. Due to decreased resistance, it is estimated that this type of a roadbed will save \$420 a mile in fuel each year. But this amount is negligible as compared with the great economy of maintenance.



Log Raft Used on Glacier National Park Lake; Entire Craft, Including Oars and Locks, Was Fashioned by Hand

LOG RAFT ROWED LIKE BOAT OVER MOUNTAIN LAKE 2024

Campers near a western lake utilized natural materials to fashion an efficient raft. It was made of small logs securely fastened together and propelled by crude oars also cut from poles. The seats were so placed that occupants were able to keep their feet dry.

WEATHER REPORTS BY RADIO TO GUIDE FLYERS 2059

Bi-hourly weather bulletins broadcast from naval radio stations along the Atlantic coast have been started to safeguard aviators. Beginning at seven o'clock in the morning, the first outline of temperature and wind conditions is sent out on 550 kilocycles from each of the stations, with subsequent reports at intervals of every two hours. Fifteen minutes after each broadcast from the individual observatories, the messages are repeated from the radio station at Lakehurst on 3,475 kilocycles, so that each station will know the weather conditions near the others. The service will be extended as flights become more frequent in other areas.

WOMAN'S DESIGN FOR LIBRARY WINS IN NATIONAL CONTEST 1895

Women have scored again in competition with men. First medal for a scheme of mural decorations for a library has been awarded to Miss Margery Stocking of Brooklyn, N. Y., in a contest in which 125 entrants from art schools throughout the country participated. The prize was awarded by a New York society. The students were given blueprints of plans and devised their designs from them.



Miss Stocking with Prize-Winning Drawing

*new York Times
5/20/26*

219 Juency St.

1947

Powell Mobile Boat Works, 2347 Chicago Ave. 2351
Clyburn

LATEST BOAT ALSO RUNS ON LAND SERVING AS AUTO

Amphibious

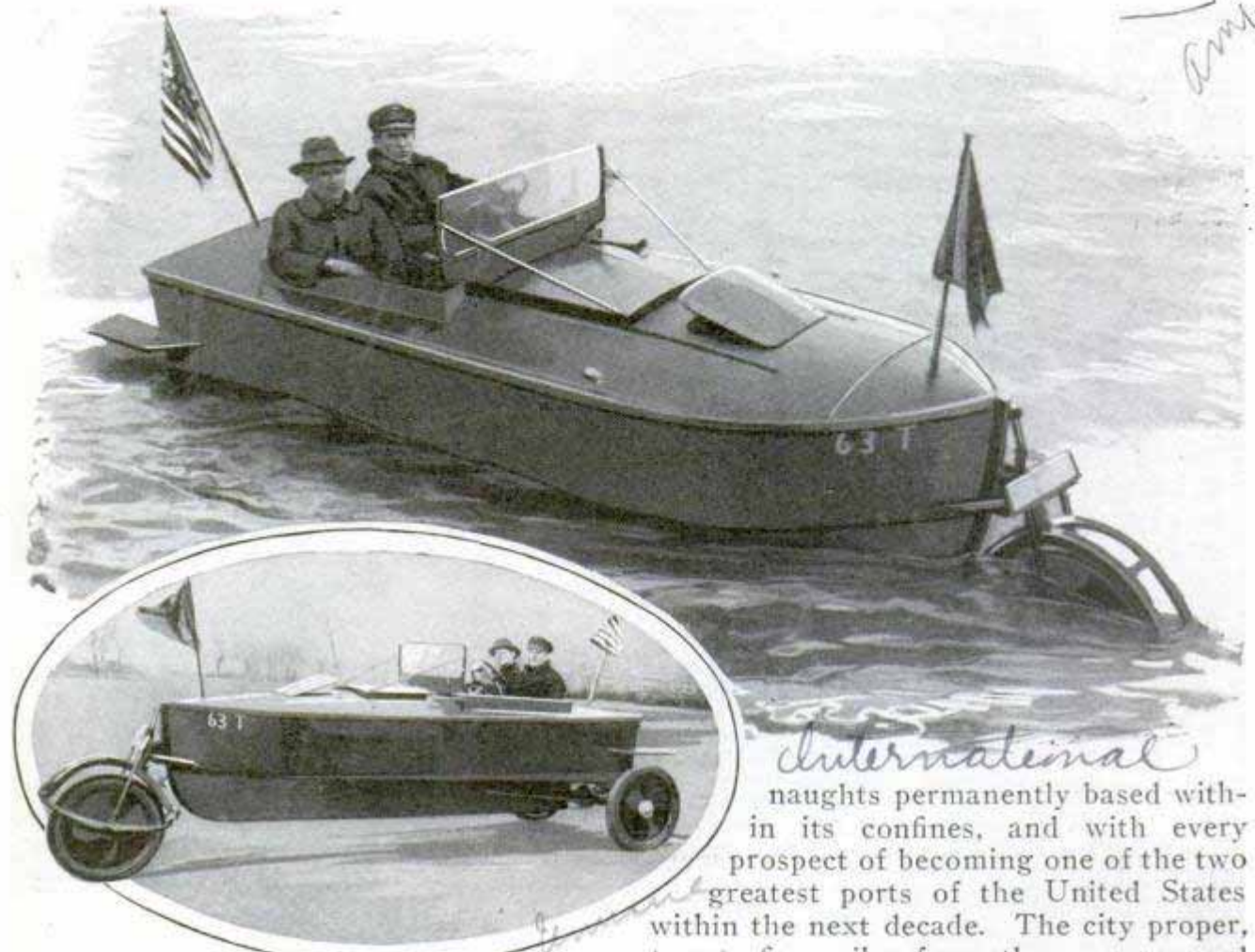

At Home on Land or Water; Two Views of Auto That Serves as Boat or Car

Run by a propeller attached to the axle when it is in the water, a three-wheeled amphibious vehicle has passed a successful test recently, being driven from the highway into Lake Michigan, where it continued the journey, and then out again without stopping the motor. A large fore wheel is used for steering. There is ample room for two passengers, and the hull is designed to navigate safely in rough water.

TURNING SWAMPS INTO HARBOR COSTS THIRTY MILLION

Just seventeen years ago, the present site of Los Angeles harbor was a swamp and a mud flat—a little bay into which emptied a half dozen boggy sloughs. Today the same spot is the location of one of the busiest ports in the world, with docking facilities for the largest ships afloat; with the nation's great dread-

International
 naughts permanently based within its confines, and with every prospect of becoming one of the two greatest ports of the United States within the next decade. The city proper, twenty-five miles from the sea, annexed the towns of Wilmington and San Pedro and, in return, promised to spend \$10,000,000 within ten years in developing the waterfront. The federal government built a \$10,000,000 breakwater nearly two miles long to shield the harbor. Business from the Panama canal justified enlarging on the first plans so that the total amount expended to date is nearly \$30,000,000, giving Los Angeles forty miles of city-owned waterfront. The city builds the wharves and rents them to the steamship companies. Features of the work, besides the breakwater, are the outer harbor, embracing some 800 acres used for anchorage for the battle fleet and merchant ships that do not visit the docks, a main channel leading inland from the outer harbor and a turning basin at the upper end of the inner harbor where ships may reverse their course as they are not allowed to turn around in the channel. Oil and lumber are the principal commodities handled. One part has been set aside for pleasure craft and another for fishing boats.

2042

Cont. Frank W. Howe, 3rd floor Times Bldg. Los Angeles, Calif.

English botany
copy
FLOWERS DRIED IN SAND KEEP SHAPE AND COLOR 2006

Lovers of flowers in their natural state are afforded a way of drying cut blossoms in sand instead of pressing them. The method requires dishes sufficiently deep so that the blossoms can be covered to a depth of at least an inch. White scouring sand will do. It should be laid half an inch deep in the dish, the flowers placed stem downward in the layer and then sprinkled over until all the petals and the entire blossom are fully covered. The flowers should be held firmly as this insures a complete dusting. When covered, they are placed in their dish in a warm, dry place. In about a week, some of the blooms will be thoroughly dried but others may require much longer. By this method, the blossoms are said to retain their natural shapes and colors even for years.

ROPE FIRE ESCAPE HAS CONTROL FOR SPEED 1840

Fitted with a clamp casting which has a screw wheel to regulate the speed of descent, a rope fire escape now on the market permits the user to lower himself quickly or slowly as he desires. The same casting also supports the shoulder rope fastened under the armpits. A person can descend from a height of four stories in from one-half to two minutes.



Lowering Himself with Rope Fire Escape; Regulator above Loop

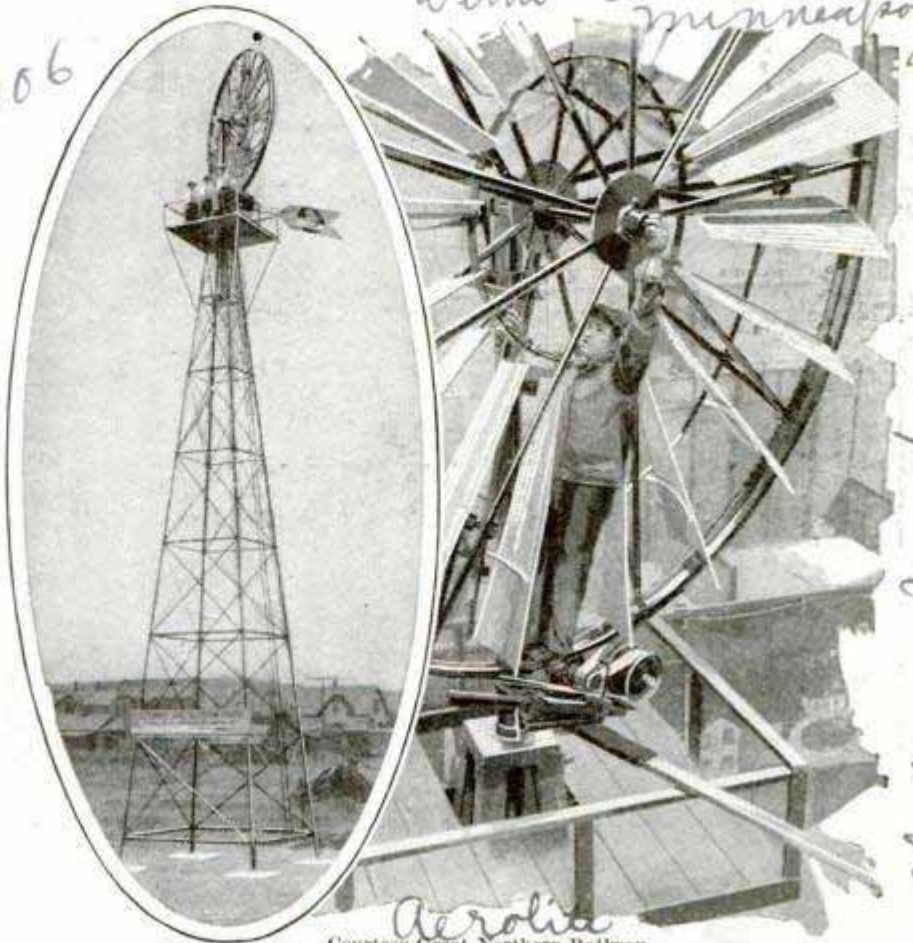

Tower and Close View of Wind Wheel Railroad Uses to Generate Current for Operating Light Signals

RAILROAD PUTS WIND TO WORK TO OPERATE SIGNALS

Batteries for low-voltage, light-type signals over several miles of the Great Northern railway are now being charged from an alternating-current generator operated by a windmill. The wheel is on a tower sixty feet high, is fourteen feet in diameter and differs from other mills of its kind in that it is mounted behind instead of in front of the pole and the tail is below instead of behind the wheel. The generator is of 1.2 kilowatts' capacity. The system is expected to save the railroad many thousands of dollars in signal operation.

at Culbertson, Mont.

Wm. E. E. Mullins
Ag. America Express Co.

1900. Mainwoshke, of
World Electric Co. Minneapolis, Minn.



Spinning a Perfect Circle with a Seventy-Five Foot Lariat While Standing on a Horse's Back Is No Mean Feat, Even for Carlos Correon, Mexican Rope Artist, Who Demonstrates His Skill as One of the Features of the Rodeos

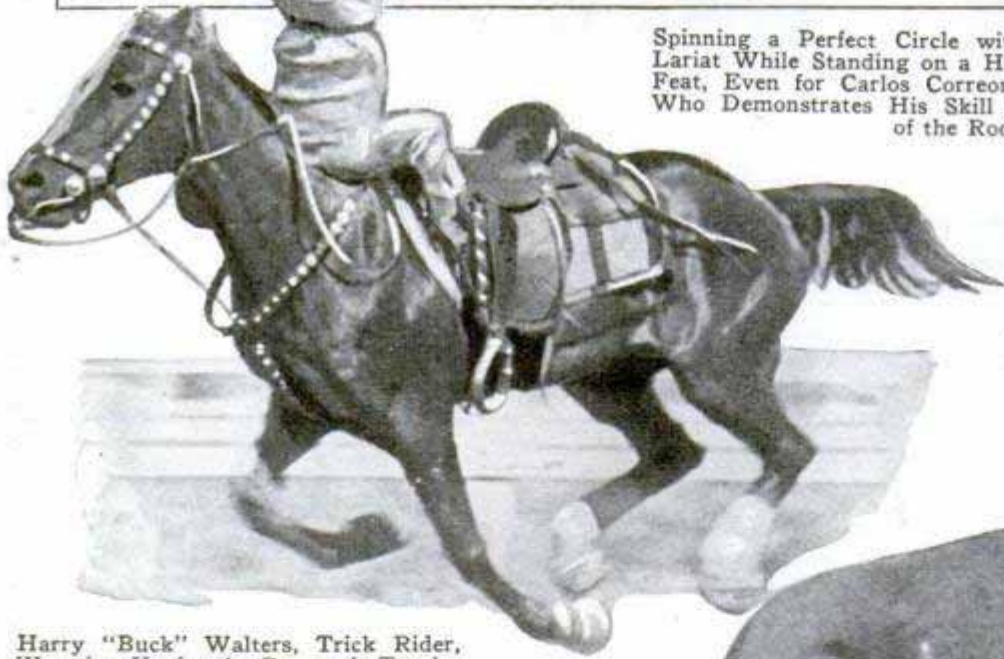

Harry "Buck" Walters, Trick Rider, Warming Up for the Roosevelt Trophy Contest at the Pendleton Roundup

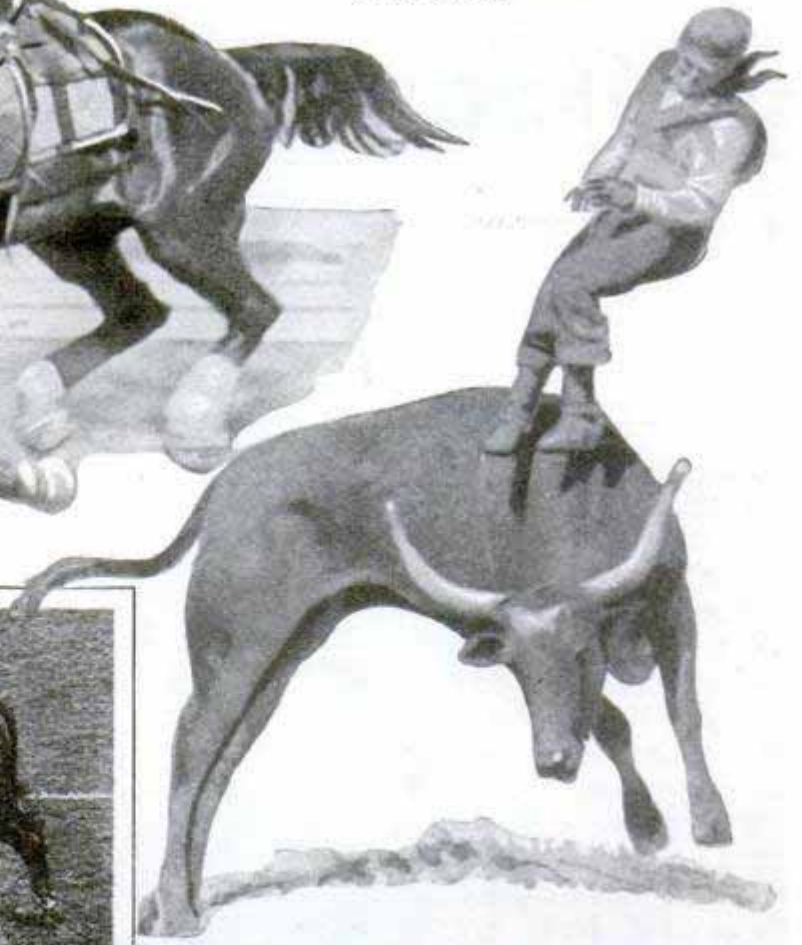

The End of a Perfect Ride on a Long-Horn Steer, Who Removes His Burden by Sending It Straight Up, and, at the Left, a Bull Dogger Starting to Throw His Animal by Twisting Its Head Sideways



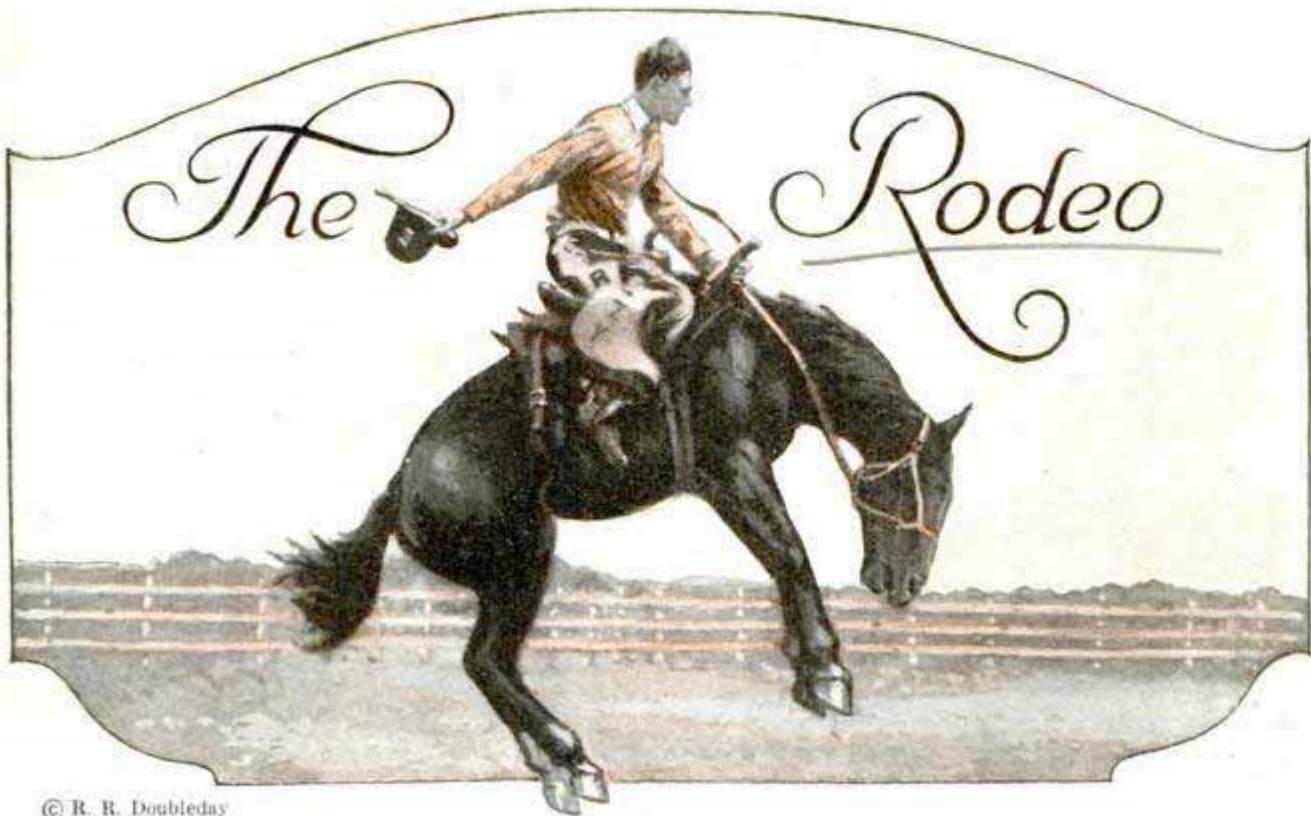

© R. R. Doubleday

Cowboys and Girls from Western Plains Who Risk Lives in Thrilling Feats Are Amateurs, Competing Only for Prizes

By BOB BECKER, *Chicago Tribune*

OUT of the west, the land of cattle, expert horsemen and bucking bronchos, there has come in recent years a new kind of sport to thrill red-blooded Americans who admire athletic skill, courage and daring. This is the rodeo, the great annual event of cowboy sports which is the Olympic of western life and tradition, and decides championship titles in bronk riding, steer wrestling, trick and fancy riding, calf and trick roping and bareback riding.

When the hard-riding cowboys who risk their necks atop wild horses first appeared in the middle west and east, the public had a faint idea that the rodeo was a kind of a wild-west show. But gradually the spectators have realized that the western classic is a series of contests, with no paid performers. The cowboys and cowgirls are "on their own." All that they receive for riding steers and bucking untamed bronks is what they can win of the big purses which are put up for each event.

But let Tex Austin tell about this "only pure American sport." Tex, as he is known from the cattle country of Texas

to the Montana prairies, has lifted the rodeo from the little towns of the west where rival ropers and riders from different ranches used to compete for supremacy, to an international sensation. He started to work as a cow hand when he was just fourteen. A couple of years ago, Tex took 167 cowboys and cowgirls, a herd of 236 horses and 160 steers to England to compete for international championships at Wembley. On the opening day more than 100,000 spectators saw the finest riders and ropers that the west ever produced do their "stuff." Overnight the cowboy contests became a sensation, and in nineteen days, more than a million excited enthusiastic Englishmen stormed the stadium gates to see the Americans compete against one another.

Tex has invaded New York on two different occasions. The second rodeo he staged there brought 275,000 New Yorkers to the stadium where the cowboys and cowgirls competed for championships and \$50,000 in prizes. Now Tex is introducing the cowboy sports to the middle west, as he staged a world-championship rodeo in

1951

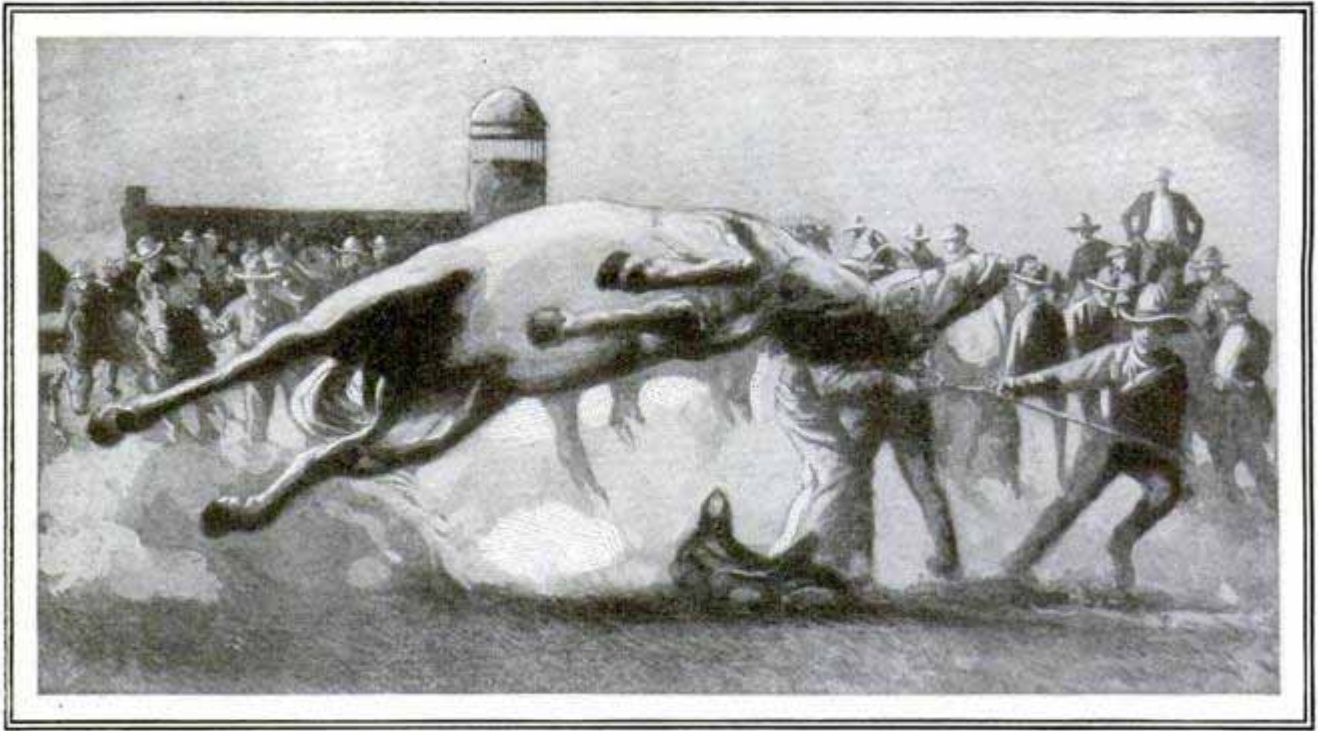

After the Wild Horse Is Roped, It Must Be Saddled; Above Is One of the Killers Objecting to the Saddling Process; Usually the Saddling Is Done in a Narrow Log Chute

Chicago last August, when \$30,000 was handed out to winning contestants, and at present he is working on plans for another this fall.

"There is no other sport in the world that calls for the same endurance, gameness and skill and the same rivalry in competition," Tex said a few days ago in Fort Worth, Tex. Pushing his big Stetson to the back of his head and swinging his six-

feet-four-inches of brawn and muscle from the saddle, he continued:

"Every contestant that competes in the world's-championship rodeo has to pay his or her expenses during the contests, and stiff entrance fees besides. And talk about it being on the level; say, do you think anyone could fix a bucking bronk or wild horse? They are out to do their wickedest, to throw the rider or wrestler, and the cowboys have to do their best because they get nothing if they don't win.

"No athlete ever goes into a contest in better condition than a cowboy or cowgirl who takes part in a big rodeo. The bronk rider has to keep himself in perfect condition. The man with blurred eyes or soft muscles that don't pull together would be safer in a ring with Jack Dempsey than aboard such outlaw horses as Deerfoot, Overall Bill, Rawlins Gray, Headlight, Abe Lee, Heel Do, Black Thunder, Cross-O-Baldy, Broken Box, or any of



Throwing a Thousand Pounds of Unwilling Steer Requires Strength and Skill in Equal Proportions



Steer Rider Clings to Horns and a Strap around Animal

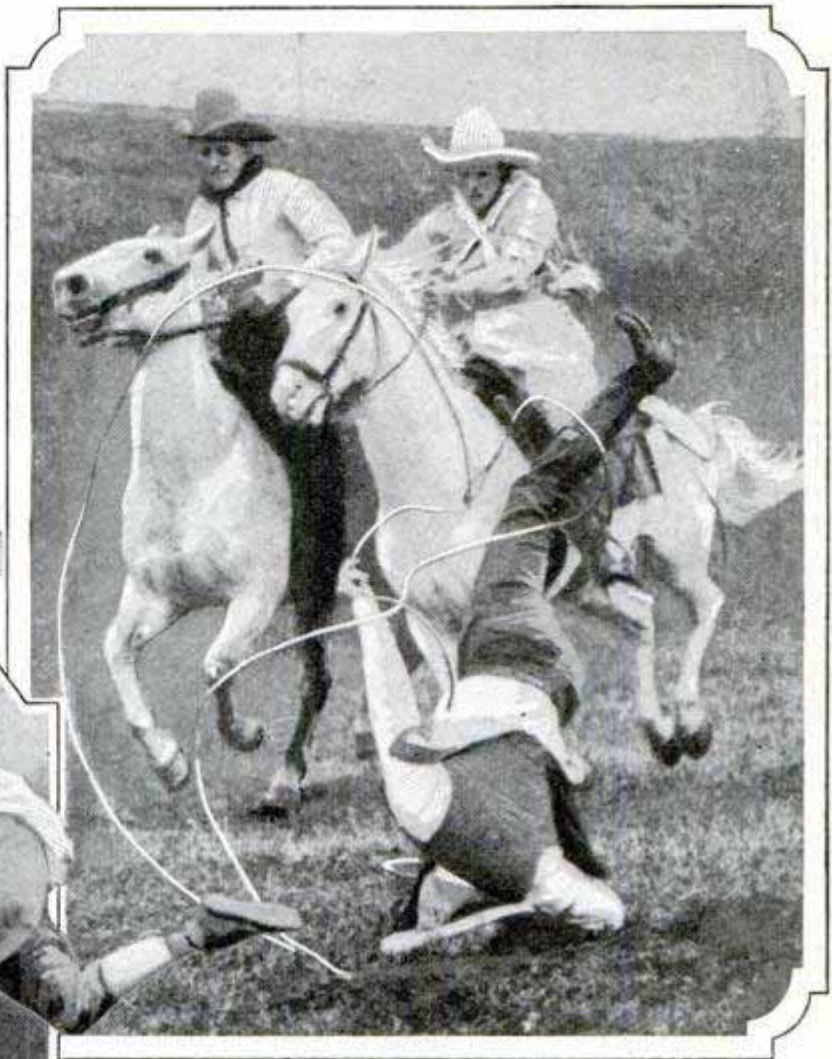

© U. & U.

Standing on His Head, the Trick Roper, Above, Throws His Lariat over Two Galloping Horses and Brings Them to a Stop; the Feats Performed with a Length of Rope Are a Constant Surprise to City-Bred Spectators at the Rodeo



Mabel Strickland, Champion Cowgirl Trick Rider, Above, Demonstrates Her Skill in and Out of the Saddle; Frequently the Stunt Riding Results in Serious Injuries

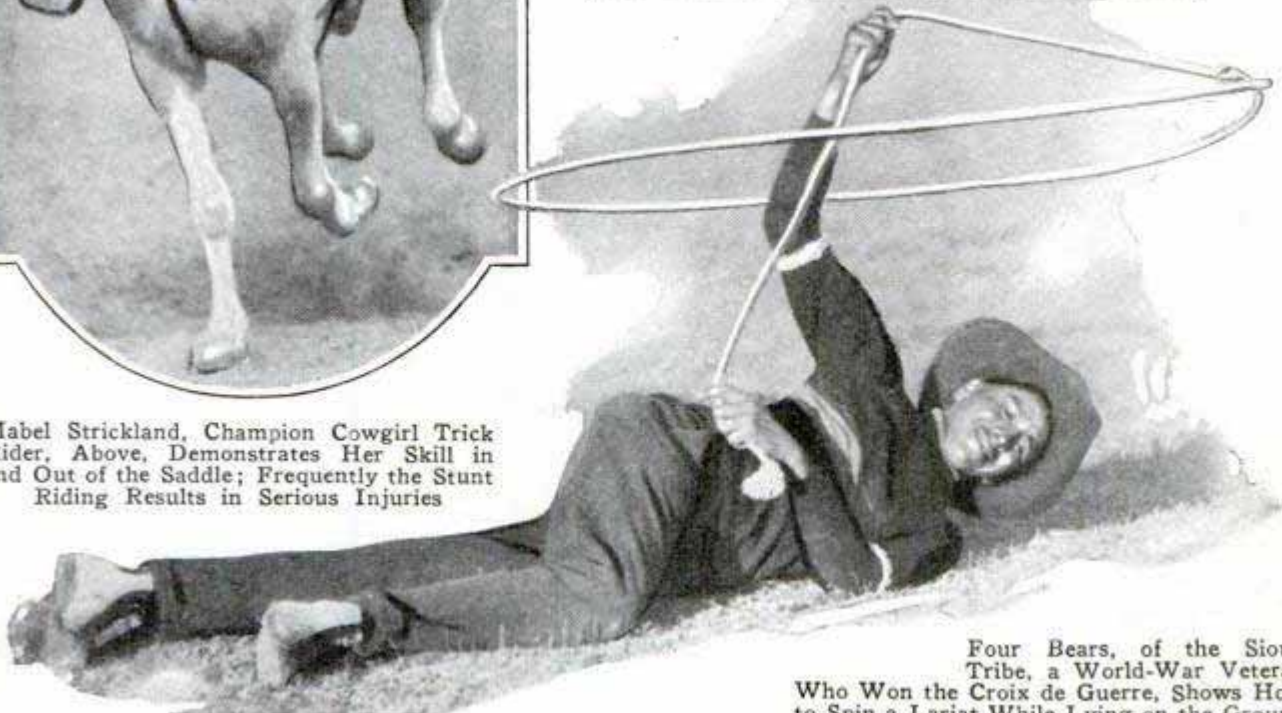

Four Bears, of the Sioux Tribe, a World-War Veteran Who Won the Croix de Guerre, Shows How to Spin a Lariat While Lying on the Ground

the other dozens of bad actors at the Chicago rodeo.

"As another illustration, look at the steer wrestlers. Wrestling long-horned steers is one of the most dangerous sports in which the cowboys excel. The wrestler must throw himself from his racing horse to the horns of the steer, get a hold around its head and throw it in a few seconds. (The world's record is seven seconds.) He trains for this event for months. It takes courage of the first water. Why, Red Grange making a flying tackle on a gridiron has a soft job compared to the cowboy who makes a dive from a galloping horse to the steer's horns and wrestles it out with his weighty, mean opponent. Last summer at the Chicago rodeo, Johnny Roberts was painfully injured the very first day in a steer-wrestling contest. Did he quit? He did not. He tackled 'em every day even when each twist and strain meant pain. I've had contestants with broken ribs that refused to give up. I call that real gameness."

"Punkin rollers" haven't a chance in these world's-championship cowboy contests, according to Tex. A "punkin roller" is a would-be rider, a rank amateur who does not know how to stick in the saddle when a bronk begins to "Charleston." Only "top hands," the cream of all the west's best riders, ropers and steer wrestlers can enter the championship contests, which means that spectators are seeing the best-trained western athletes in the cowboy world.

Tex says that the present-day rodeo or cowboys' contest is simply an outgrowth of the intense rivalry that has always existed in the west

between different cattle outfits. In the old days, whenever the cowmen from the various ranches got together, they would always brag about their wonderful riders and ropers, and—presto!—the war was on. After the cattle were shipped and the heavy work was over, the cowboys would meet to decide which outfit had the best bronk riders, trick ropers, steer wrestlers and bareback riders. Western towns used to foment these contests to decide championships. Finally towns pushed the contest idea until prizes totaling many thousands of dollars were put up for the winning cowboys. Out of these have grown the organized rodeos which have been held in Chicago, Fort Worth, Cheyenne, Pendleton, and other places in the west.

For the world's-championship rodeo "salty, hardboiled" mounts, outlaw animals which have the meanest reputation for vicious bucking, speed and other characteristics which go to make up a wild bronk, are secured. Riders who enter the saddle bronk-riding contests have no choice of mounts. The name of each horse is put on a piece of paper and the contestant pulls one blindly from a hat. He never rides the same horse twice during any one rodeo. After riding a different horse each day and trying to stay on its back, the contestant's score is tabulated. From this the judges decide who is the best rider. It's "hard stuff on the square," this rodeo game, besides which, as one observer commented, automobile racing is a pleasure. When the cowboys and cowgirls were in England



Tony, the Mount Used by Miss Ruth Roach in the Championship Rodeos, Is Equally at Home on Two Feet or Four; the Horses of the Trick Riders Are an Intelligent Lot

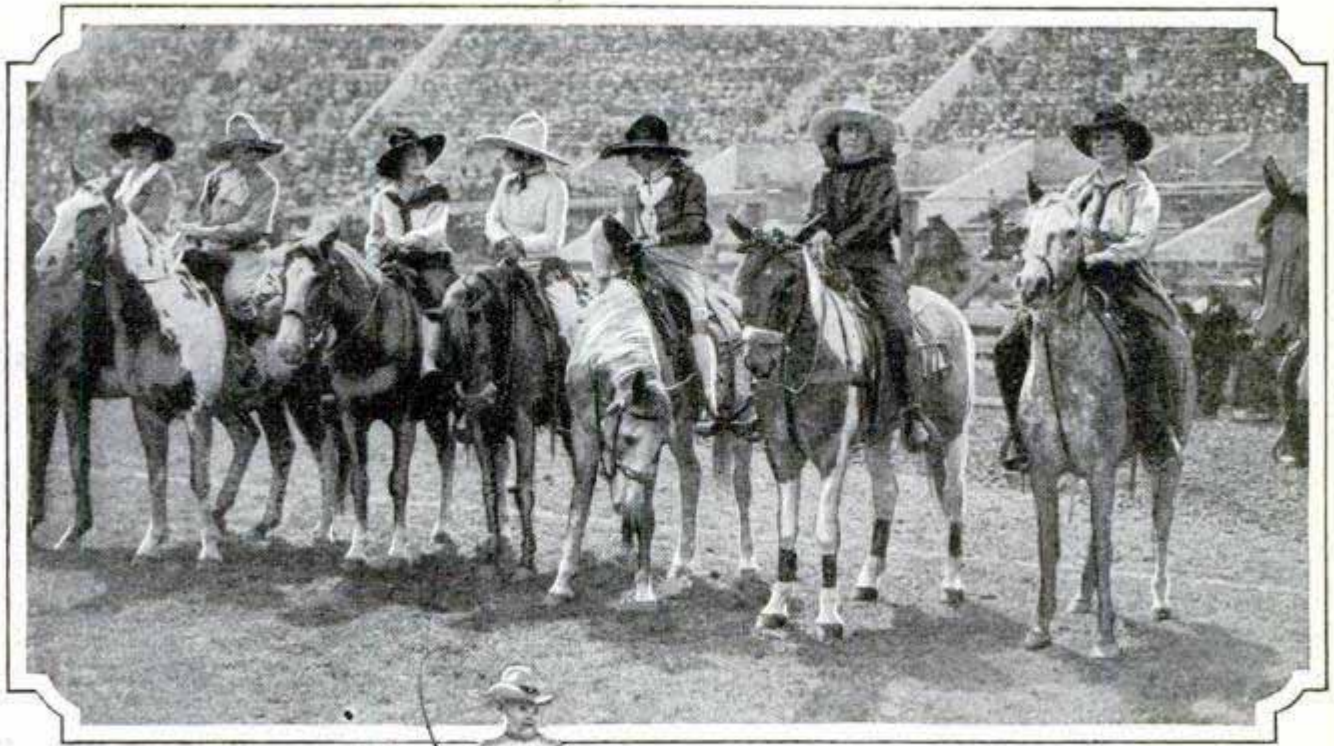

Band of Cowgirls
Lined Up for Parade
before the Rodeo;
Right, the Thrilling
Moment in the Bull
Dogging, When the
Cowboy Leaps from
His Horse to the
Steer's Neck, While
the Judge Alongside
Times Him



The Wild Horse Wins the Bucking Contest; the Worst Un-
broken Animals Are Gathered In to Supply Mounts

competing for international championship, the English thought there was some trick in it and pride in their horsemanship led a good many amateur riders into the ring to show up these picturesque cowboys from the States. The result was a good many laughs, not a few broken ribs and collar bones and a multitude of bruises and sore heads, as the outlaw horses tossed 'em far and wide.

Although the cowboys produce plenty of thrills for spectators at a rodeo, the performances of the girl bronk riders are more impressive if only for their novelty. Many of the girl contestants are married, and it is a case of husband and wife traveling long distances to compete for cups and cash prizes. Mabel Strickland, long hailed as the "Queen of the Cowgirls" and winner of many championships in trick and fancy riding, is the wife of an expert bronk rider. Ruth Roach and Nowata Slim also are married.

And does it pay? These western ropers and riders who put their skill and sometimes risk their lives against untamed horses and steers think so, as big rodeos put up big purses. The purse for the steer wrestlers' contests is \$4,300. Each day a rider has the chance to win a first prize of \$100, a second prize of \$60 and a third bringing \$40. All cash.

At the end of the nine days of contests, the wrestler making the best time on all steers wrestled wins \$1,000 and the world's-championship title and solid-gold belt, while second, third and fourth places

bring \$700, \$500 and \$300, respectively. Another pot of gold containing \$4,300 is put up for the bronk riders to shoot at. And a similar amount goes to the winners of the calf-roping contest, while trick and fancy riding, and other events, are also remunerative for the contestants who have class and can sweep the field.

But there is an old and ungrammatical saying in the west that "there never was a horse could not be rode, or a man who could not be thrown," and because this is true, there are thrills galore in the cowboy contests, where skill, gameness and pluck are needed to win over wild bronks and savage long-horned steers.

1898
SAWDUST SOAKED IN ARSENIC TO KILL MOSQUITOES

Sawdust immersed in a weak solution of water and arsenic and scattered on breeding places from airplanes, is being tried by the United States marine corps as a means of combating the mosquito. The method is said not to be injurious to fish, birds or persons, because the poison is diluted.

2048
ORIGIN OF FIRST AMERICAN SOUGHT IN ALASKA

Seeking evidence of early settlements in America, an expedition has gone to Alaska from the national museum. Eskimo legends, one of which relates to a great battle fought in ages past between the inhabitants of Seward peninsula and a tribe of invaders from Asia, will be in-

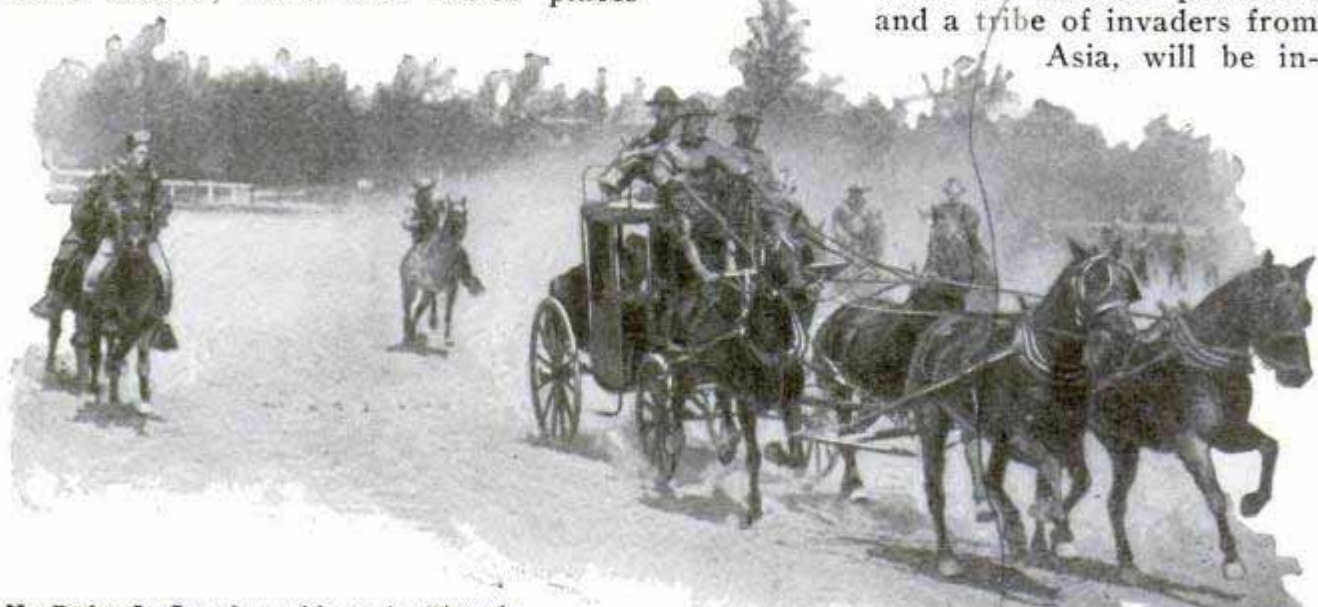

No Rodeo Is Complete without the "Attack on the Deadwood Stage," One of the Most Shot-Up Coaches in History

*Turne Dumbies navy classed
Washington se. C.*

*Dr. Alex Hrdlicka
Anthropologist*

700 North Esrow,
Oak Park, Ill 201

vestigated. It is supposed that the ancestors of the American Indians crossed over from Siberia and gradually worked their way down the Pacific coast and then east and south. Occasional finds of pottery and ivory objects support this theory, but also present a problem. The Eskimo makes no pottery, so the relics could not have been the work of his ancestors, and the ivory articles suggest a higher artistic development than is shown by the Eskimos of today. Identification of the tribes that left these objects is one of the purposes of the expedition. It is the opinion of scholars that no single invasion of America was made by primitive man, but that small groups drifted across the ice fields through periods of perhaps thousands of years. This would partly explain the differences that exist between the Indians in the three Americas.

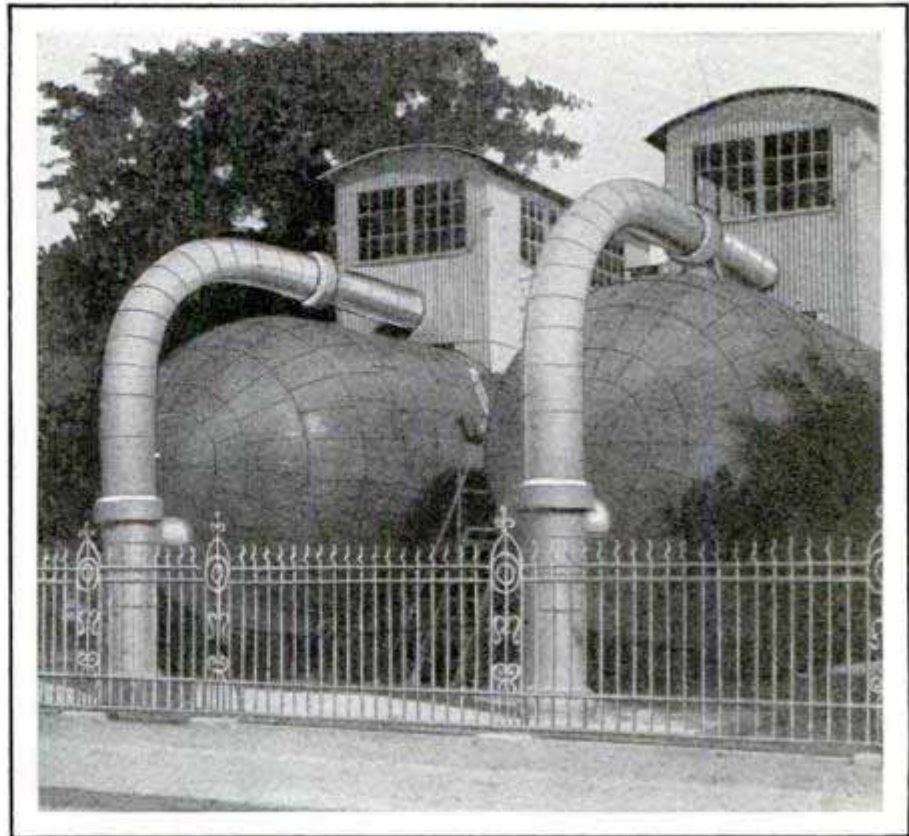

Where Reserve Steam Power Is Held for Swedish City When Hydroelectric Plant Fails; the Two Accumulators

**STORAGE TANKS FOR STEAM
SUPPLY RESERVE POWER**

2029

Malmo

When power from the hydroelectric plant of a Swedish city is interrupted, a steam supply, sufficient for operating the generators as long as an hour, is furnished immediately from two insulated accumulators. These are simply large iron tanks filled to within ninety per cent of their capacity with water raised to a temperature considerably above what its boiling point would be in the open air. When steam is drawn off, more is instantly available. A relatively small boiler is sufficient to keep the accumulators charged and ready for service. The insulation is such that heat losses are negligible even in low temperatures outdoors. Automatic valves keep the pressure in the tanks constant.

**LAND ROWBOATS FOR CHILDREN
HELP BUILD MUSCLE**

1967

Propelled with two hand levers which actuate chain and sprocket gears, a boat-shaped car for children has been devised by a western inventor as a healthful exerciser and amusement source. It has three gears, and the smaller cars, little more than sixty inches long, attain a speed of five miles an hour, while a larger one, for two operators, can be driven twenty miles an hour. Steering is accomplished by pulling harder on one side, a pivoted front wheel acting as a rudder. Automatic brakes are also provided for added safety.



Working the Handles Propels the Boat-Car Swiftly and Affords Healthful Exercise

Kanoe Kraft - Tallman 34 20 March

Western Union Co., 1775 Broadway New York
Warner Bros. 1600 Broadway
VOICE IS GIVEN TO DRAMA OF SILVER SCREEN
New York

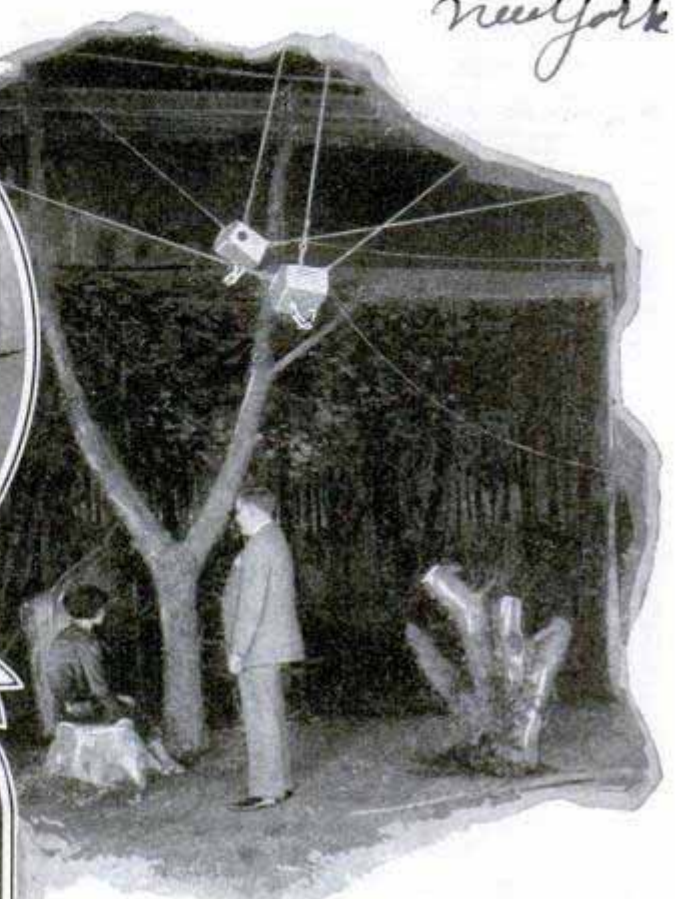
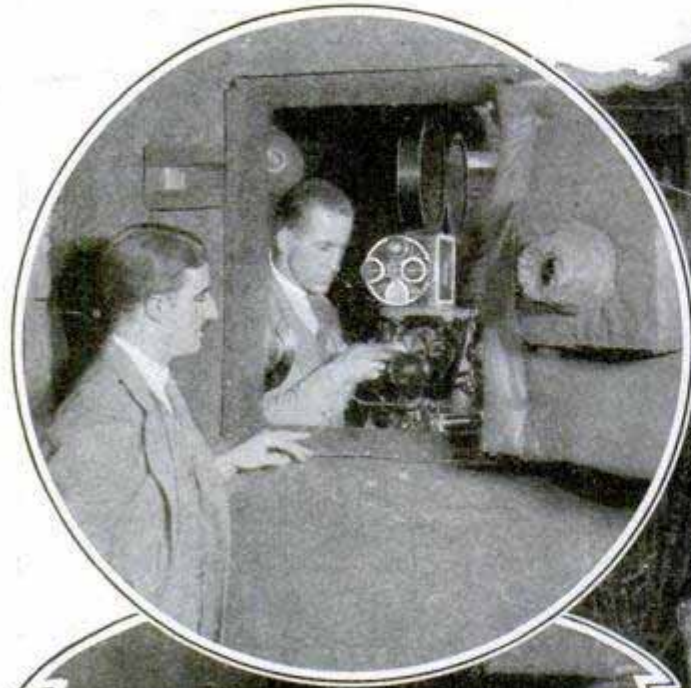

Soundproof Camera Booth, Special Microphones Above and Recording Apparatus Showing Wax Disks



Warner Bros. Pictures

An invention which will bring to motion-picture audiences in every corner of the world the music of the greatest symphony orchestras and the vocal entertainment of the most popular stars of the operatic, vaudeville and theatrical fields, has just been announced. It will make it possible for every performance in a movie theater to have full orchestration accompaniment of the picture regardless of the size of the house. The apparatus by which combined films and sound records will be reproduced is no more complicated

than an ordinary motion-picture projector nor is any special skill required of the operator. If the film breaks, there is no interference with the accuracy of synchronization. The sound record is not controlled by the film itself. For recording a microphone of an improved type, electrical amplifying apparatus and a record-cutting mechanism are employed. The recording can be carried on at a distance so that the actors may be grouped naturally in any scene and need not be crowded before a microphone. The second feature is an electrical reproducer which converts the movements of a needle in the grooves of a sound record into electrical vibrations. An important use of the new system will be in providing musical programs for pictures already taken.

☐The Popular Mechanics' Bureau of Information offers its free service to all readers of our magazine. Names and addresses of manufacturers and dealers in articles described will be promptly furnished by addressing the Bureau.

1790

in lecture at Island Art.

POPULAR MECHANICS

TRAIN MIND AS ALARM CLOCK TO WAKE AT CERTAIN HOUR

In India and other parts of the Orient, some natives have developed the ability to sleep a predetermined number of hours to a remarkable degree. An Indian scholar, for instance, slept three days and awoke within a half minute of the time set for arising, a traveler there reports. Others in that country are said to have such power of mental concentration that they can submit to minor surgical operations without apparent pain. Generations of study along the lines of applied psychology have produced these faculties, in the opinion of investigators.

OPTICAL ILLUSION TO AID AUTO SAFETY CAMPAIGN

Markers signifying which way automobiles should turn have been used successfully on English highways. They are in the form of arrows and other characters and are set flush with the surface of the pavement. While their adoption has been a help to the driver, it is suggested that improvements could be made so that the signs would not appear to be distorted, but remain clearly visible to an autoist twenty yards or so distant as well as when seen from above. The use of porcelain or studded glass insets is recommended so that

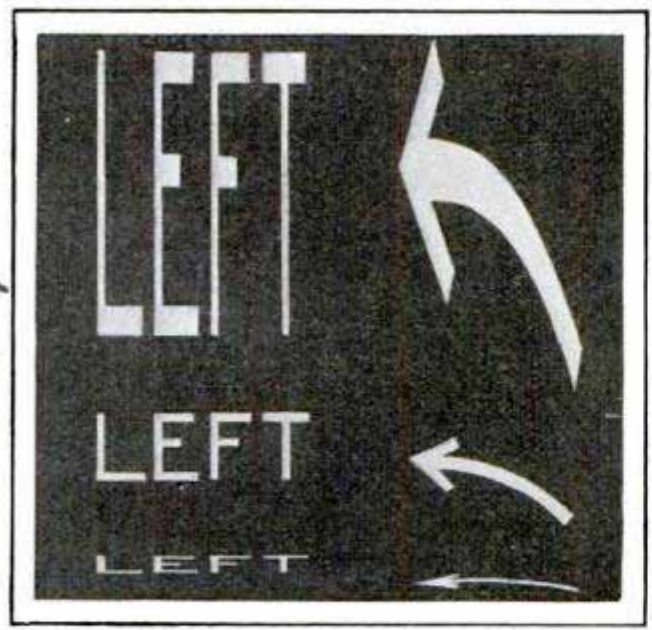

Different Styles of Pavement Traffic Signs Lettered to Overcome Distortion

the marks will not be so easily dimmed by dust and mud.

motor 3/9/26

Capt. Leonard F. Plugge, D. Sc.



Automatic Phone with Ear and Mouthpiece Combined in One Unit; Transmitter Is Kept Proper Distance from Lips for Clear Speech

LATEST PHONE IN ONE UNIT TO IMPROVE TONE

Receiver and transmitter are combined in a unit telephone instrument similar to those used abroad, but said to be an improvement in that various mechanical defects have been overcome. The mouthpiece is so adjusted that it is always at the proper distance from the lips for clear speech and the cap is designed to deflect the sound directly into the transmitter. The quality of the voice is unaffected by the position in which the instrument is held. Contact springs for switching the circuits with the dial are concealed in a phosphor-bronze rest and are actuated through a lever by a small push rod, held in position by the weight of the phone.

MYSTERY OF COLORS REFLECTS WONDERS OF LIGHT RAYS

When you mix blue and yellow paint, a shade of green is the result, but yellow and blue lights intermingled produce a pink glow. Light itself is colorless, but passed through a glass prism, a beam of it is split into the radiant red, orange, yellow, green, blue, indigo and violet of the rainbow. What is commonly called color, as in a flower, for instance, is the result of the blossom's power to select, absorb and reflect only certain rays of light that fall upon it. A white object is one that sends back all rays that strike it. Black, on the other hand, absorbs the rays.

Automatic Electric Co. 1083 W. Van Buren. Chicago

Harmon, Capt. G. Belmont abt. Chicago

4/11/26

1080

New York

HOW UNCLE SAM MAKES YOUR MONEY LAST LONGER

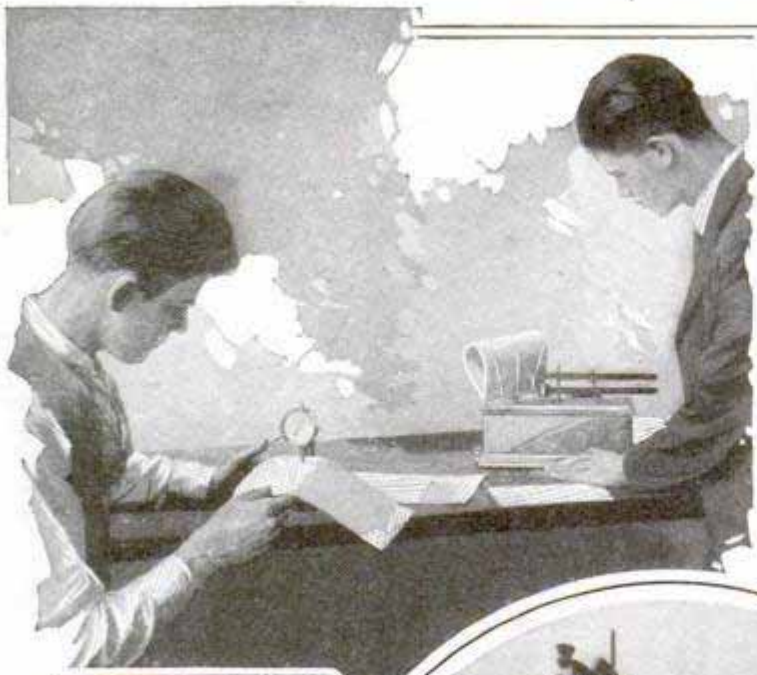

Measuring the Thickness and Weighing Samples of Currency Paper with Accurate Instruments to Insure Uniformity

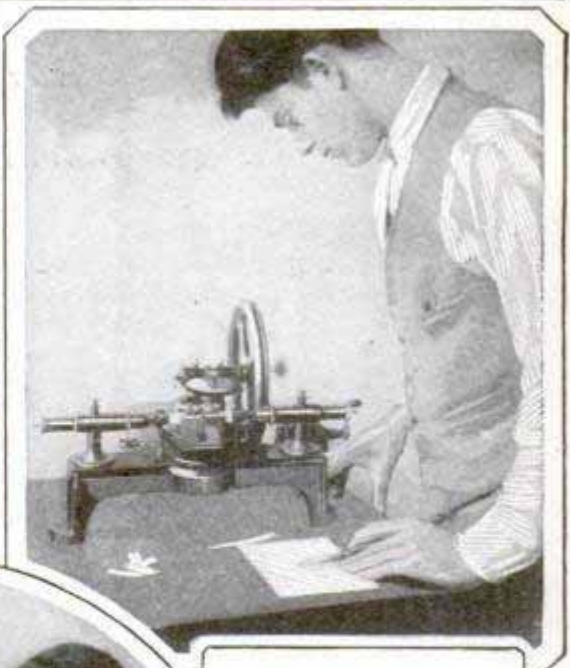

Giving a Sample Folding Test; Good Bill Paper Should Stand 2,000 Foldings without Breaking

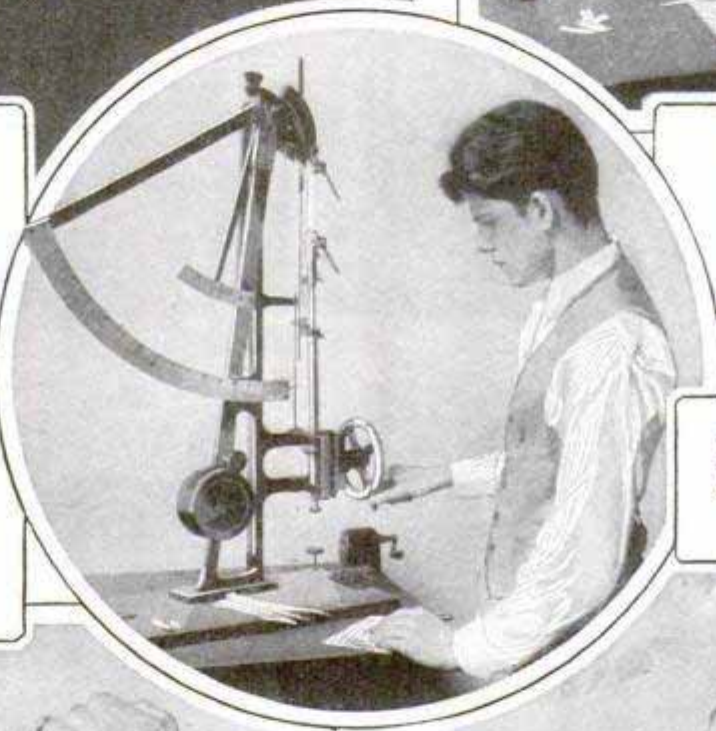

The Tensile-Strength Test; High Standards Are Required to Insure Long Wear and Guard against Counterfeits

Below, Searching for Spots, Stains and Other Defects in Bill Paper

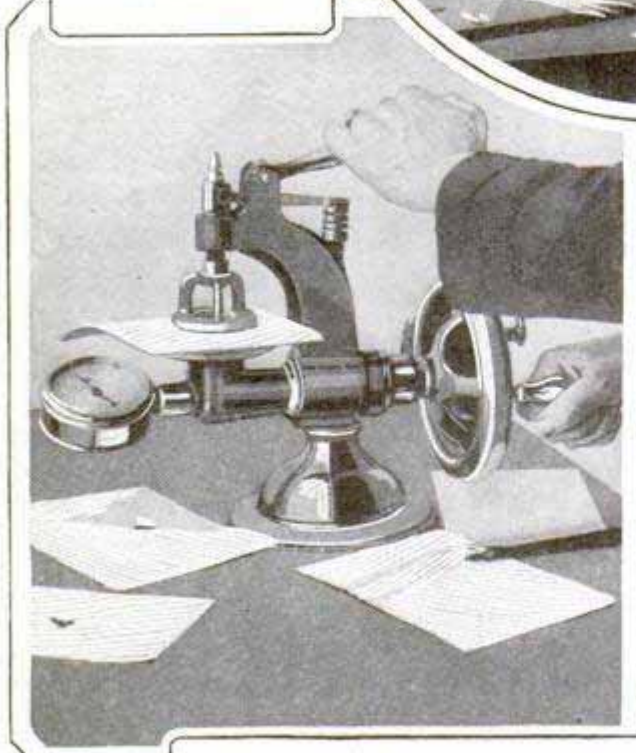

Applying the Bursting Test; Pressure of Glycerin Expands the Rubber Diaphragm Pressed against the Sample, Finally Causing the Paper to Break



WEAR ON YOUR PAPER MONEY INCREASED BY PROSPERITY

More than 1,200 tons of worn-out paper money is destroyed in the United States every year. Greenbacks, gold and silver certificates, which formerly lasted from eighteen to twenty-four months, now are put out of commission after eight to ten or twelve months of service. Dollar bills are even worn to shreds in the short period of five weeks. Our present use of currency is thrice that of 1916 and is six times greater than it was twenty-six years ago. Our use of currency has increased because our national prosperity has demanded a maximum of paper money in constant circulation. To make it last longer, the paper has been subjected to extraordinary tests which simulate the wear and tear to which the currency is subjected. An automatic eraser is used in a rubbing test, which duplicates the surface wear, a register keeping count of the total number of rubs. The test is completed when a hole is finally worn in the paper. As paper is susceptible to the weather, these tests are conducted in a constant-temperature chamber where the heat is seventy degrees and the humidity sixty-five. The folding test is carried on by special devices electrically operated. The paper specimens work over small rollers in such a manner that the material is folded again and again. An attachment keeps count of the number of folds, and when the sample finally breaks, the machinery stops and a bell rings. The currency paper will not break until exposed to about 2,000 foldings. Science also is armoring paper against dirt, dust and greasy stains. It is bathed in glue to cement together its fibers. Then, by spraying the paper with formaldehyde, a dirt-resisting coating has been developed. To prevent fraud, the dollar bills now bear the head of Washington. Lincoln adorns the fives. Jackson's face is on the tens, Cleveland's on the twenties, Grant's on the fifties and Franklin's on the hundred-dollar notes. A proposal to cut down the size of paper money to decrease the cost of replacement is being considered.

☐ Africa is the original home of coffee; tea was first produced in Asia and cocoa in America.

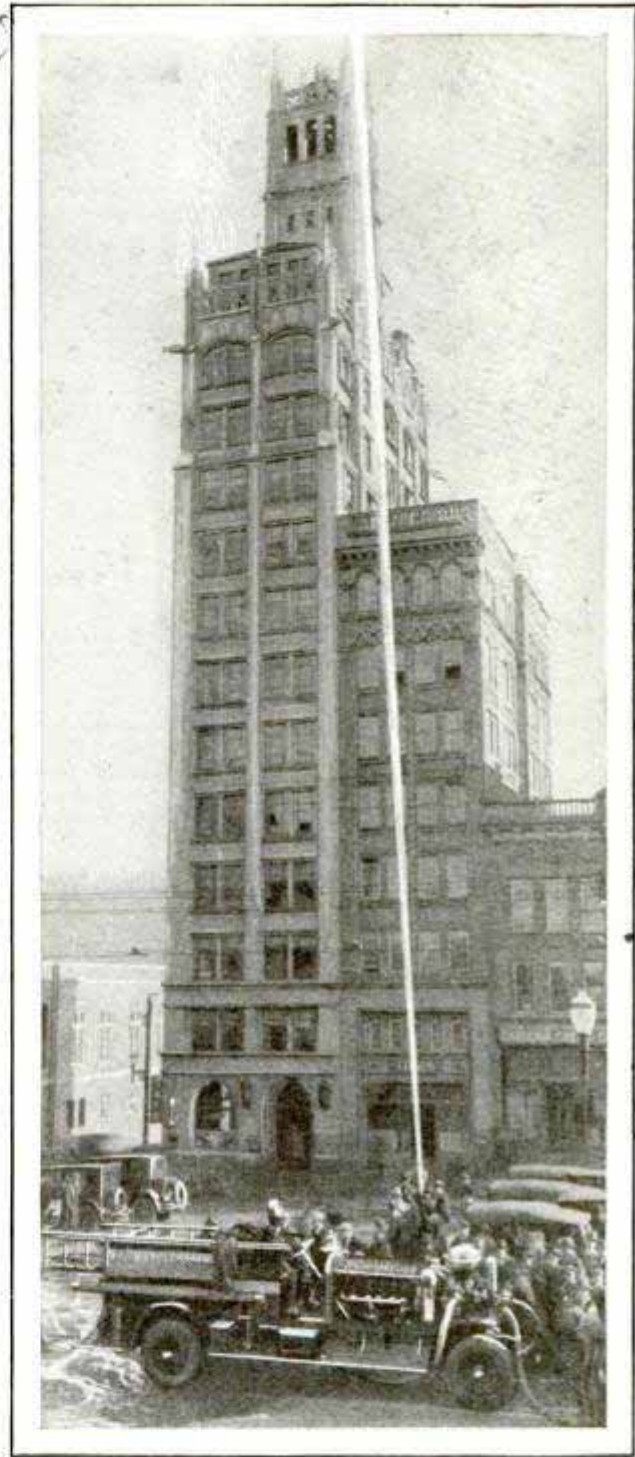

Testing the New Fire Engine; the White Column Represents the Stream Rising Well over Tall Building

FIRE ENGINE'S SOLID STREAM TWO HUNDRED FEET HIGH, 1921

Pumping a two-inch stream of water 200 feet high without breaking it into a wider and ragged spray, as usually happens, was the performance of an improved type of fire engine in a southern city, recently. The liquid shaft rose thirty feet above a tall building before it broke, demonstrating how effective the apparatus would be in directing a solid column of water into the upper stories.

Adorno & Fire Engine Co., Alfred & Celerini Sts
Cincinnati, Ohio

North Chicago, Ill.

Academy of Sciences

1988

also at 960-60th St Oakland Calif.



Canoe Folded into Pack and Collapsible Three-Passenger Boat in Use with Outboard Motor

MOTORBOATS FOLD INTO PACK FOR EASY CARRYING

Folding boats and canoes with outboard motors, which can be bundled so that a man can carry them on his back or they may be strapped to the auto running board, are now offered to the camper who wishes to spend part of his time on lake or river. The smallest size, eleven feet four inches long, weighs only ninety pounds complete and collapses into a package about four feet long and less than a foot thick. Larger sizes, up to those having a capacity of six or seven persons, are made on the same pattern. The ribs are seated in automatic self-locking metal pockets so that they cannot slip out when the boat is assembled. The craft are made of extra-heavy waterproofed duck, and can be set up ready for use in a few moments.

CANCER IS CAUSED BY MILDEW 1933 SCIENTIST HOLDS

Cancer and various other diseases are caused by abnormal forms of mildew in the opinion of Prof. J. Tissot, of the Paris natural history museum. He holds that food is the source of many of these ailments, but is dangerous in this respect only when mildewed or rotten. In support of his theory, Prof. Tissot reports that he has transformed several bacterial cultures into mildew, and has found that the mildew which caused typhoid fever was identical with that of the mildew of maize, diphtheria with that of barley, and cholera of poisonous mushrooms. He discovered that the virus of measles was identical with the organism of mildew from lettuce, scarlet fever and rabies with the mildew of carrots, and smallpox, identical with that of potatoes. Tuberculosis cultures were transformed into mildew identical with that of the human organism, he says, leading to the belief that the disease develops spontaneously in man.

MOVIES IN HOME ARE SHOWN WITHOUT SCREEN

For home, school or commercial use, a cabinet somewhat resembling that of a talking machine has a translucent screen in the front, on which motion pictures are shown from a mechanism within the box. A particular feature is that "stills" also can be shown, the apparatus being adapted to the display of film from an ordinary small pocket camera. Pictures up to sixty in number can be fitted on a strip a yard long. When a motion film is used, it is fed horizontally and rewinding and threading are easily done, a special motor being installed for reversing the film.

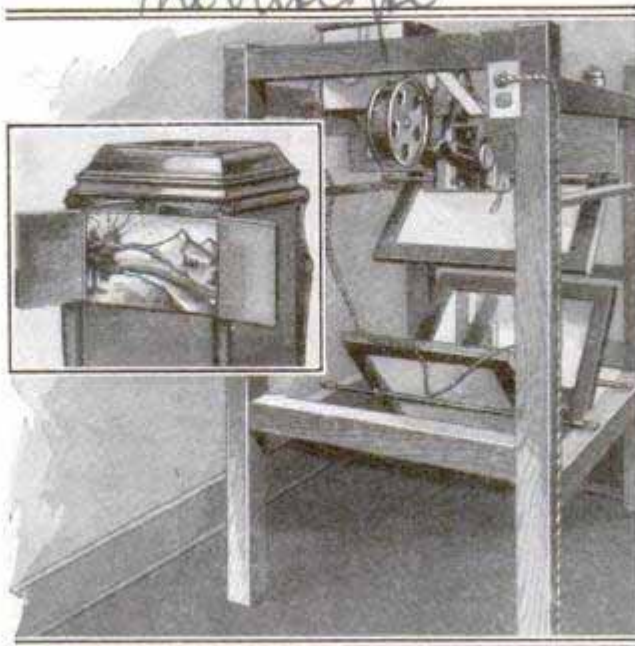

Interior of Motion-Picture Cabinet, with Inset Showing How Film Appears during Operation

Inv. A. S. Merriman 1487 Central Ave

5024 Cringer Place
Berkeley, Calif.
Patent No. 1,460,071 6/26/23
1,591,259 8/26/25

A PLANT THAT SHRIVELS AWAY AT A TOUCH

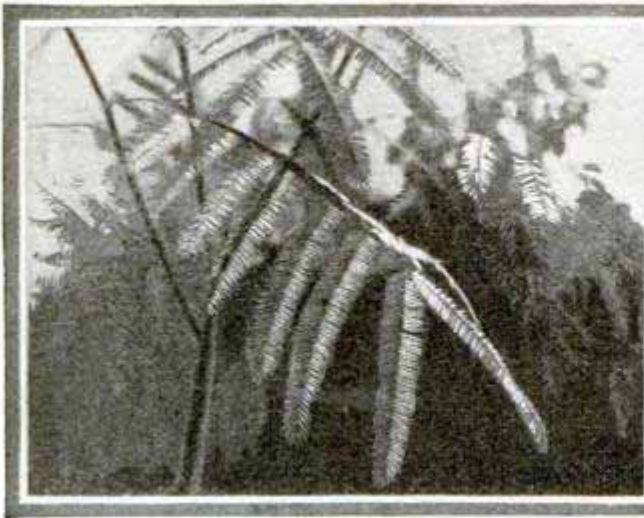

Leaves of "Sensitive Plant" Normally Extended, and, at Right, Shut after Being Stroked with the Finger; They Open Slowly but Close Quickly at Only a Slight Touch

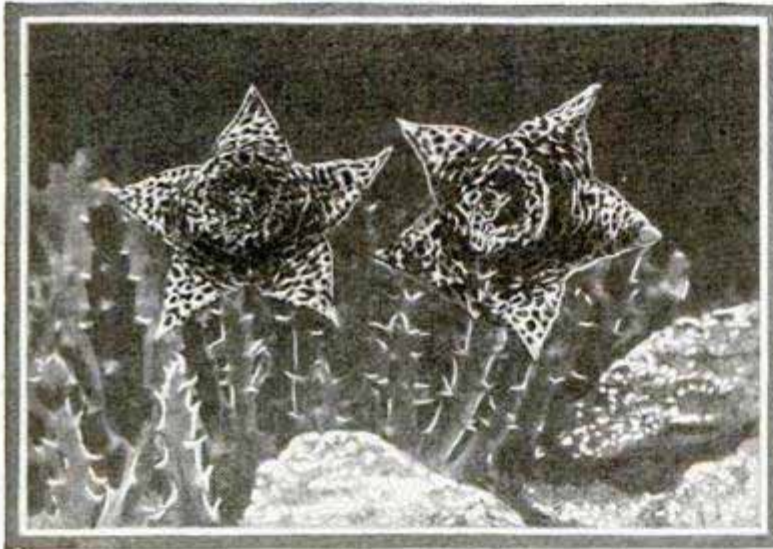

"Star of the Desert," a Rare and Beautifully Colored Cactus Blossom Has Stars within Stars to Its Center, But Is Characterized by a Disagreeable Odor



The Electric Plant; Rubbing the Hand against Its Leaves Produces Shocks



Courtesy The Sphere
 Three Phases in the Development of Castalia Daubiana, a Rare Water Lily; First, the Parent Leaf Floating and Attached Only by Stem; It Fades Away as New Leaves and Blossoms Form

10 S. Eighth St.
Richmond, Va.

5/2/26

208
196 3

ALL U. S. SUBJECT
TO QUAKES

1991
Interest in earthquakes in this country has been centered largely on the Pacific coast in recent years, but temblors are not confined to that area. Some scientists believe that an earthquake risk exists in all parts of the country and is a nation-wide problem. As evidence of this, an eastern section of the Seismological Society of America has been formed

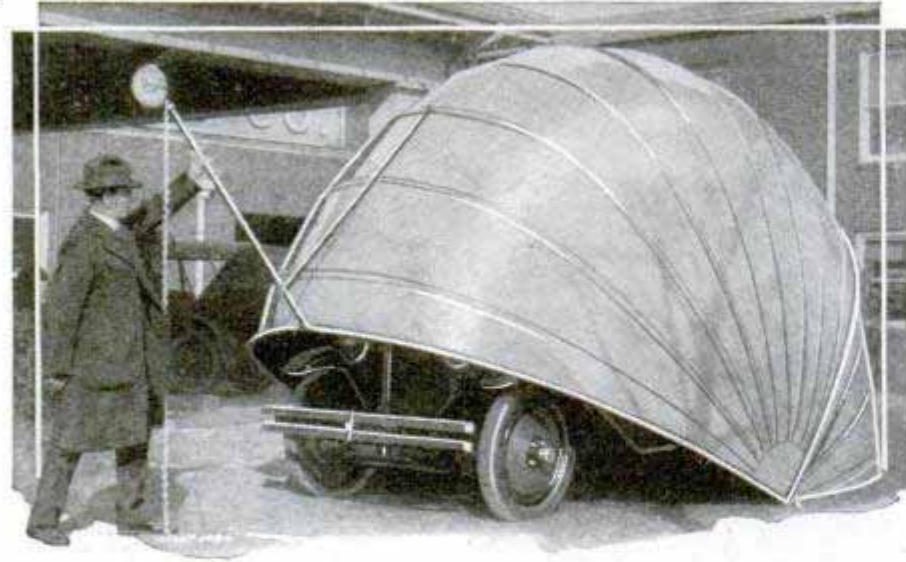

Pulling the Shell over the Auto; Weighted Pole Handle Simplifies This Operation and Also Helps Throwing Cover Back

PORTABLE GARAGE OF METAL
HAS FOLDING SECTIONS

Solution of the garage problem is offered by a southern inventor in a folding metal shell that is large enough to accommodate the average medium-sized car and takes up but little more room than the auto itself. It is constructed in telescoping sections and the front part swings on an axle for opening or closing by means of a weighted lever. The top, being curved, quickly sheds moisture and the entire garage can be easily moved.

to study quakes. Observatories now have such delicate seismographs that slight tremors as well as the severe shocks that do great damage are recorded, and by cooperation between the stations, they are able to find the location of a quake, sometimes before the shaking stops. Insurance companies are recognizing earthquake risks and, by collecting seismological data, are placing the writing of this kind of insurance on a scientific basis.

2008

TRAVELING RADIO MUSICIAN
RIVALS GERMAN BAND

German street bands have a rival in the traveling radio man and his portable receiver. He carries his set from a shoulder strap, an umbrella-shaped antenna brings in the music and the whole outfit is hauled on a tricycle.

Berlin

ELECTRIC FLATIRON
CAN'T BURN WORK

Electric current is turned on or off automatically by a switch in a flatiron just introduced, keeping it at the right working temperature and preventing scorching or more serious accidents. The operator need not worry about the current once the iron is connected and set to work. Leaving the cord in the socket with the electricity on does no harm, as the automatic switch will cut off the supply before the iron gets too hot and turn it on again, if too cold.



Radio Concert Man on Tour with His Umbrella-Shaped Aerial, Loud Speaker and Set in Case on Back

1985

Westinghouse Electric
East Pittsburgh, Pa.

Million Dollar automatic
iron. Price \$175

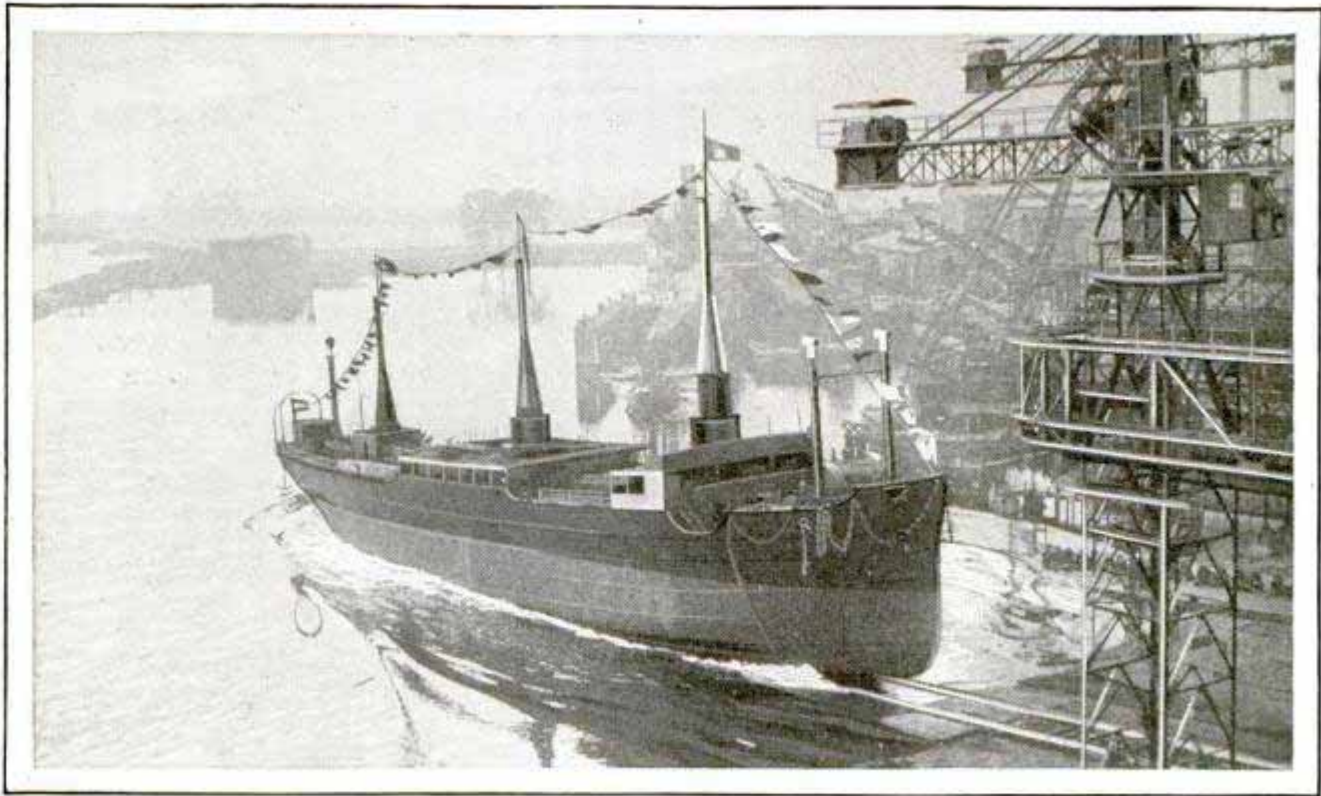

© Pacific & Atlantic

The Largest Rotor Ship Yet Built Takes the Water; Scene at the Launching of the 3,000-Ton "Barbara," Constructed by the Transport Department of the German Government

BIG LINER WITH THREE ROTORS LAUNCHED IN GERMANY

The rotor system of ship propulsion has been adapted to a 3,000-ton vessel, the "Barbara," recently launched by the transport department of the German government for the fruit trade with Italy and South America. The boat has three rotors, capable of developing some 1,200 horsepower, while it carries a 1,000-horsepower engine for use in times of calm. Anton Flettner's first rotorship, the "Buckau," now the "Baden-Baden," is of but 600 tons' displacement, but he believes that the principle will prove equally successful with the larger vessel.

Oct 20 21.

WHICH WHEEL FOR NEW TIRE?

To obtain the longest mileage, the two best tires on a car should be placed on the rear wheels. Some drivers assert that the best tires belong on the front to minimize the danger from blowouts and the risk of losing control of the car, but this hazard is considered negligible, and the real fault usually lies in the driver losing his head. The spare should replace the more worn of the rear tires at the end of several thousand miles of driving. On new cars, all

Kansas City Star 5/10/26

tires may remain as originally placed for several thousand miles, then the front ones should be put on the rear wheels.

JAWS OF FISH SPRING HOOKS ON WEEDLESS BAIT

2019.

Hooks are concealed within an automatic lure for fish so that they cannot become entangled in the weeds or catch on snags but are automatically released when the bait is struck.

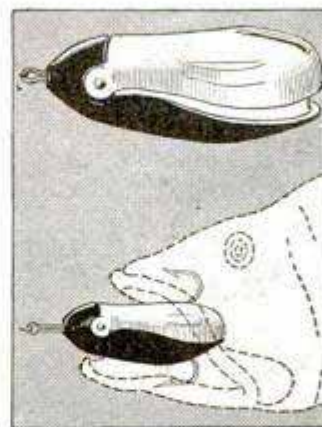

The exterior is made of pyralin and the mechanism inside of brass. In tests, this bait has been dragged through rushes and lily pads, over matted

weeds, and it also has been floated into snags and allowed to sink to the bottom. In cases where the hooks were sprung, it was fish that did it. Even when the bait came down on shore hard enough to release the hooks, they returned to the shell because the pressure was not maintained.

The Fenner Weedless Bait Co. 4 Street

Handicraft in

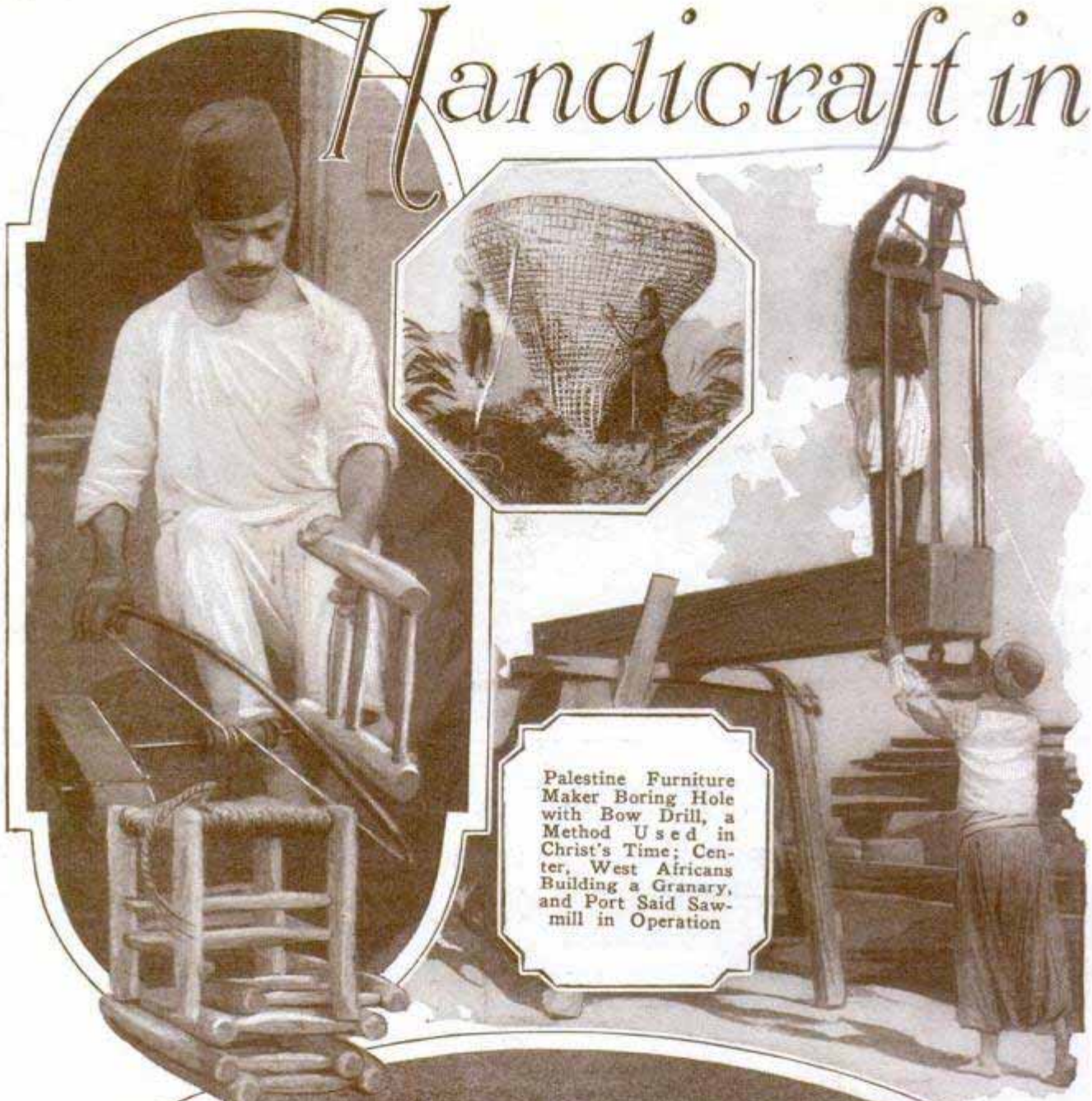

Palestine Furniture Maker Boring Hole with Bow Drill, a Method Used in Christ's Time; Center, West Africans Building a Granary, and Port Said Saw-mill in Operation



Egyptian Irrigation Plant; a "Tomba" or Archimedean Screw Is Used to Lift Water

Remote Places

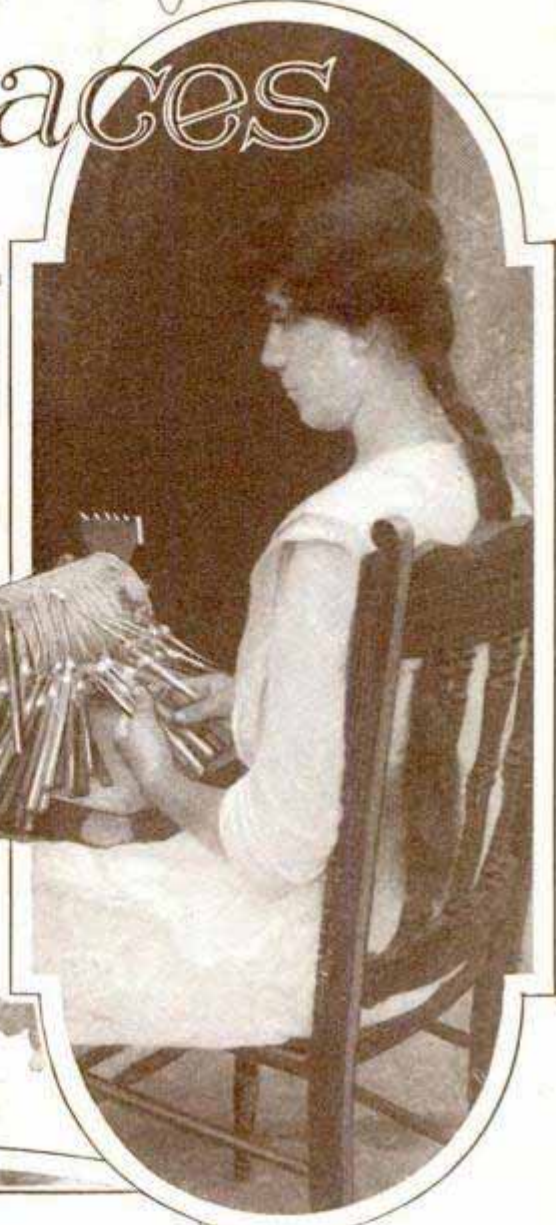

Weaving Cashmere Shawls in India, and a Porto Rican Lace Maker

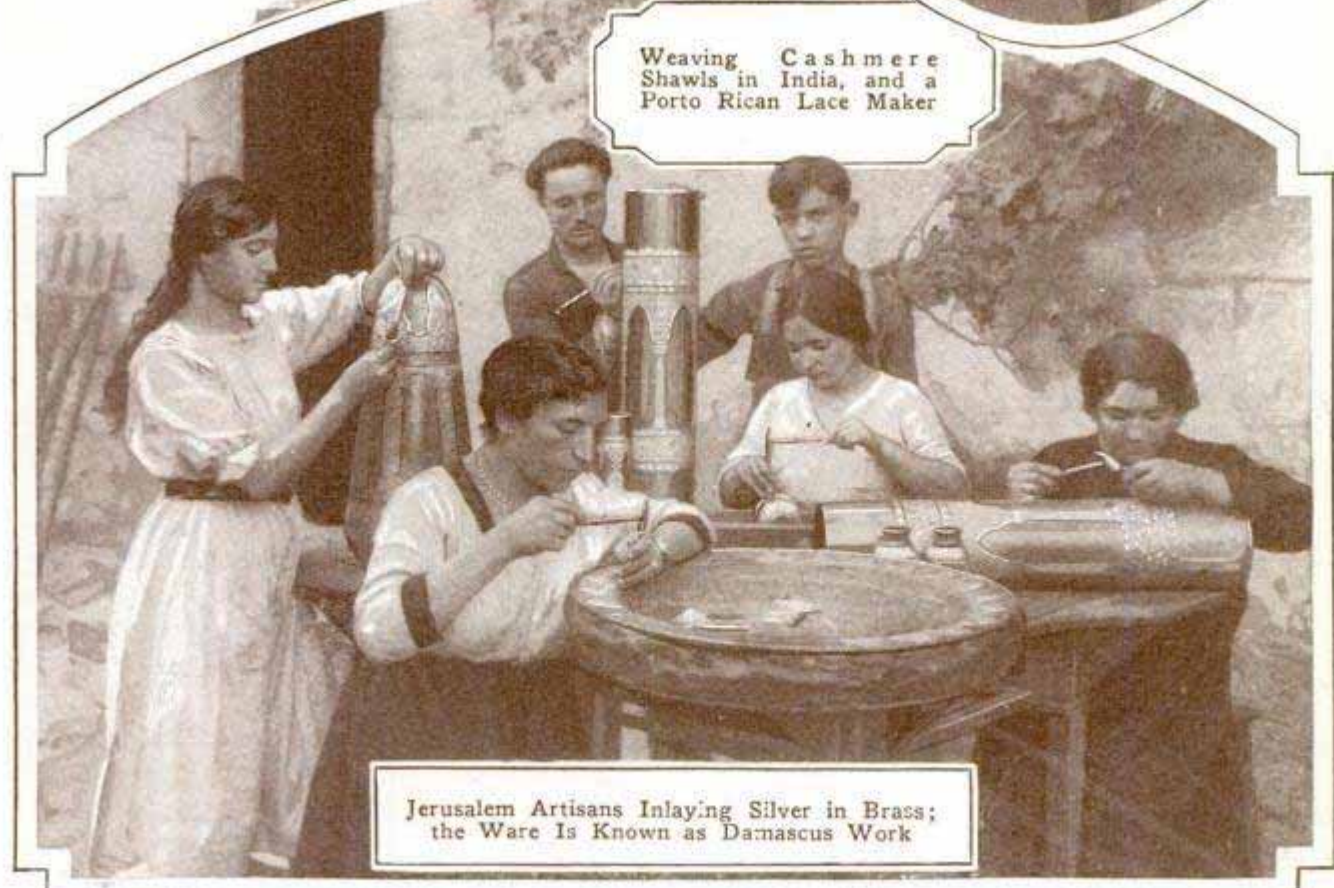

Jerusalem Artisans Inlaying Silver in Brass; the Ware Is Known as Damascus Work

Chairman of
Committee on trees
Junior association
of Commerce
some destination in this
country. Japan at present
is the largest importer
of white cedar from
the United States.



With Days of the Ox Team Almost Forgotten, Modern Loggers Adapt the Motor Truck to a Special Railroad for Hauling

POLE ROAD FOR MOTOR TRUCKS SIMPLIFIES HAULING LOGS

Rainy weather and mud, serious obstacles to the log haulers, have been overcome by white-cedar cutters in southwestern Oregon by building a road of poles nearly two miles long. It is like a railroad, motor trucks and trailers with specially flanged wheels attaining a speed of four to five miles an hour and climbing grades as steep as four and one-half per cent even when loaded. The road can be built for about ninety cents per lineal foot and from 12,000,000 to 16,000,000 feet of lumber can be hauled over it before extensive repairs and alterations are necessary, the builders estimate. Some of the logs are swung high on aerial cables across deep canyons before they start their journey on the motor way. Then they go successively by river, flat car and finally by steamer to the Orient or to

tion, trouble is likely to result. Some cities are recognizing the importance of planting trees within their borders not only for beauty's sake but for the welfare of the citizens. A decrease in insanity among inmates was noted at a state prison following the beautifying of the grounds.

ESKIMO EYESHADE FOR MOVIES GUARDS ACTORS' VISION

2053

As a protection against "Kleig eyes," a malady sometimes suffered by motion-picture actors from too much exposure to the brilliant studio lights, an eyeshade the Eskimos use to prevent snow blindness is said to have been found effective. It is fashioned of bone and rawhide, and lined with fur. Narrow slits provide a partial view while shutting out the glare of the lamps. The shade is worn while the performer is resting or awaiting appearance before the camera.



Motion-Picture Actress Wearing Eskimo Shade to Protect Her Eyes from Strong Studio Lights

Marceline Day Metro-
Edwards Mayer Co

HEATLESS LIGHT SECRET SOUGHT FROM NATURE

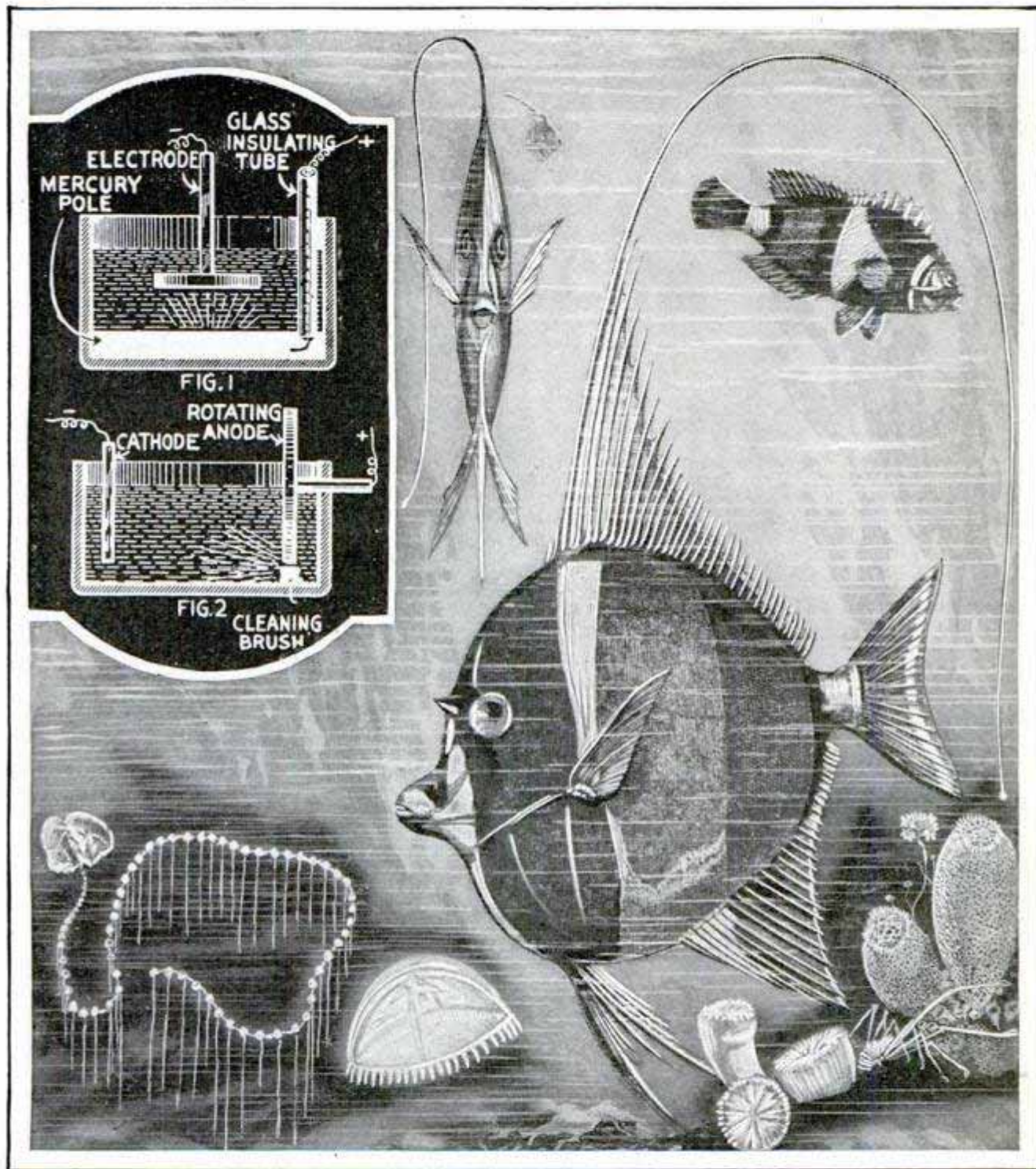

Photos Courtesy Dr. E. B. Harvey

Cold Light in Nature, and Two Ways of Producing the Same Phenomena by Simple Experiments; at the Left Is a Luminous Praya, Next Sea Jelly, Then a Pruning-Knife Fish, with Front View Above, and in the Lower Right Corner Are Luminous Corals, Crustaceans and Sponges

One of nature's greatest secrets is the production of heatless light and power. Hundreds of animals, fish, insects, germs fungi, vegetables and flowers, produce cold light. Many of the fish living in the deepest parts of the oceans have luminous organs. Some of these take the form of lanterns, or hanging lamps, that

stand out from the head or other parts of the body to light their way to catch food. Many of the jellyfish, seaslugs and crustaceans, sponges, coral worms, starfish, sea urchins, wheel animalculæ, seaweeds, crabs, lobsters, snails, squid, octopus, frogs, toads and minute bacteria are very luminous. With man-made light, however

only a fraction of one per cent of the energy in the coal that generates the present form of electric light in use is converted into light. The bulk of it is dissipated as heat. Experiments in the mechanical production of cold light have taken numerous forms. Zinc sulphide and similar phosphorescing substances, like luminous paints used on the faces of watches and clocks, have been tried. But these are not of great practical value. Chemical reactions are all capable of emitting light. We cannot see light emission in many, but that is simply because they are not carried out rapidly enough. Whenever we are able to carry out a chemical reaction quickly, and without a noticeable development of heat, we obtain what has been termed a cold light. Vacuum tubes, however, have given the best results in man's effort to rival nature. D. McFarlan Moore, in 1896, developed tubes to give what he termed "etheric" light. He placed various gases in his tubes and fitted each tube with a "make-and-

break" vibrator of the kind used with electric bells. The object of the vibrator was to interrupt the current so as to intensify the glow. The greater the number of vibrations the brighter is the light. Another type of vacuum light has been developed by C. F. Dussand, of Paris. He mounts a number of ordinary tungsten incandescent lamps on a revolving wheel and connects each lamp with an electrical circuit. Each rotation of the mounting wheel lights and cuts off the current and the speed of the wheel makes it possible to light each lamp for an exceedingly short period. This produces the effect of a continuous glow. The rotation speed is arranged so as to cause the time of lighting of each lamp to be half the duration of its darkness. Although none of these methods have proved entirely satisfactory, it has been demonstrated that the production of the so-called cold light is possible, opening an alluring field to inventors.

AUTO IS RUN BY AIR PROPELLER ON WATER, SNOW OR ICE

197
Driven by an airplane motor and propeller, a five-passenger auto constructed by a Maine inventor has a boat-shaped body so that it can run on the water.

Air-tight pontoons on both sides under the running boards add to its buoyancy and the car will travel also over

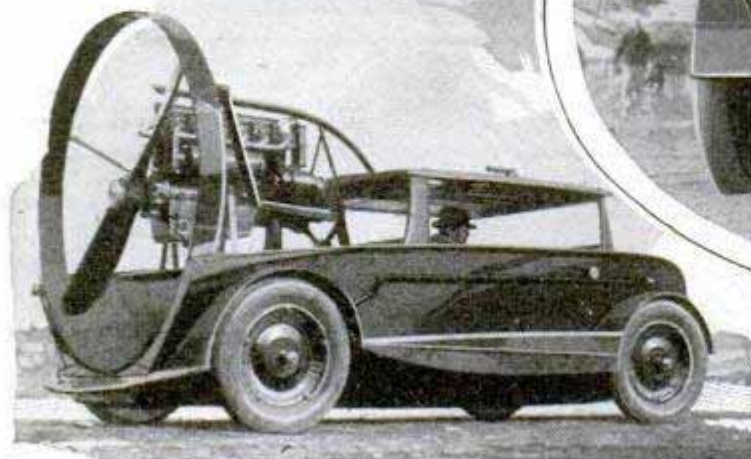
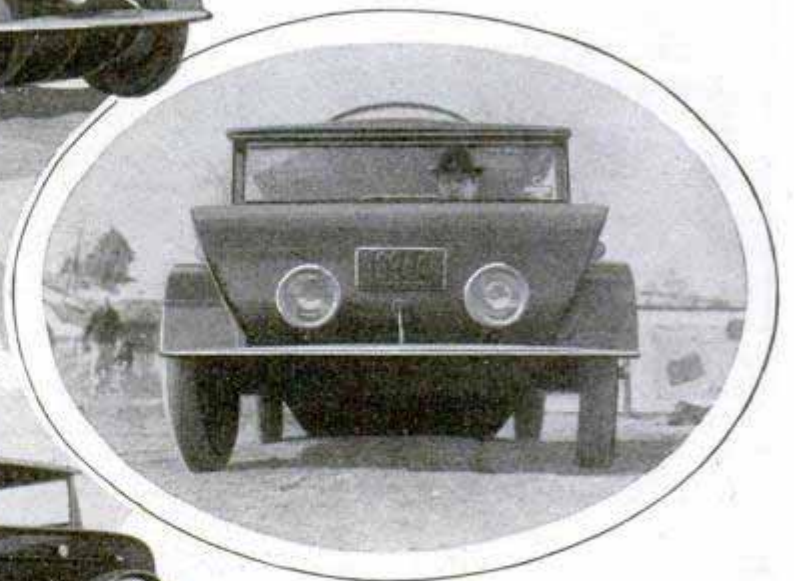

Views of Versatile Air-Driven Auto;
Band over Propeller Blades Insures
Greater Safety

*of Mr. George McLaughlin,
Bangor, Maine.*

ice or snow. The front wheels are used for steering, eliminating the need of a rudder. The motor develops seventy horsepower, affording a speed of sixty miles an hour. The interior is finished like a limousine.

1529

HUGE TELESCOPE TO SHOW MOON AT TEN MILES

With a huge telescope Prof. George Willis Ritchey is now constructing in Paris, it is hoped that the moon can be seen as though only ten miles distant and that stars now 15,000 times farther away than any at present visible through the largest instruments, will be seen. If successful, the telescope will increase the observable universe millions of times, it is estimated. The reflector will be nineteen feet eight inches in diameter, and it required two years to build the special furnace in which the glass is to be prepared.

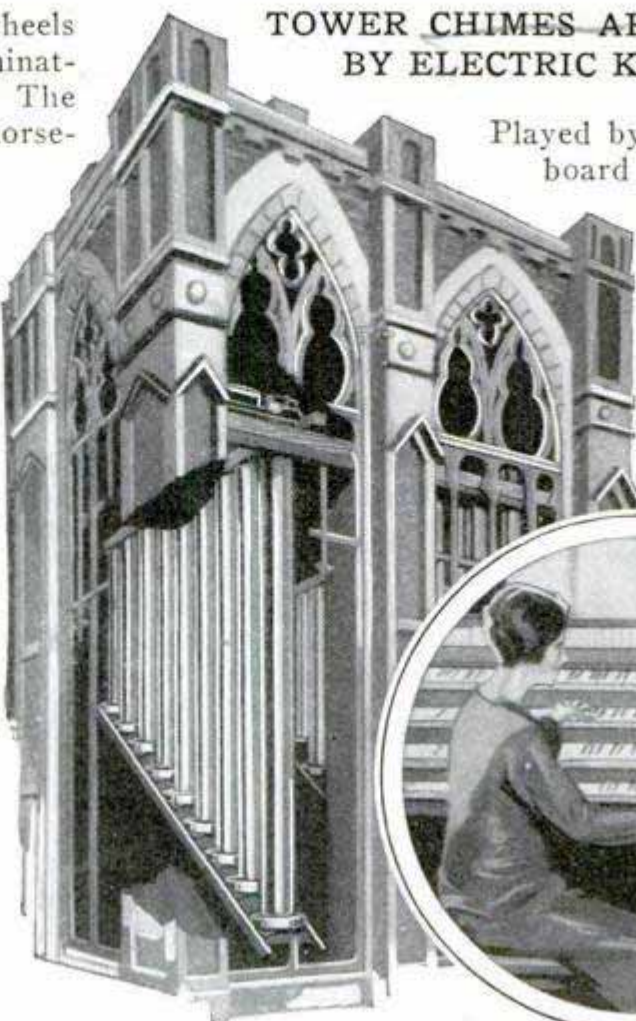

TOWER CHIMES ARE OPERATED BY ELECTRIC KEYBOARD

Played by an electric keyboard several hundred feet away, a set of tubular chimes in a tower on the mountain-side at Avalon Bay, Santa Catalina island,

1989



Chimes Similar to Those at Avalon Bay and Operating Keyboard at Player's Right; Silencers Prevent Slurring Tones

1682

ZINC GOLF TEE EASY TO FIND OR PUSH IN HARD GROUND

Shaped so that it can be easily pushed into hard ground as well as into turf, a zinc golf tee is plainly visible because of the brightness of the metal, lasts a long time and will not damage the blades of the lawnmower even if it is run over, for the zinc cuts easily. The stem of the tee is channeled for quick insertion and the metal is so stiff that it is not likely to bend under considerable pressure.



furnishes tourists pleasing music and is also used for radio programs. To aid the player, telephone apparatus transmits the tones to him as soon as the key is pressed, so that he does not have to wait for the vibrations to reach him through the air. Silencer or tone dampers are also installed on the chimes, shutting off the tone of one just as the other is played. This prevents muffled and overlapping sounds, often the cause of unsatisfactory results in ordinary sets of chimes. The keyboard is like that of an organ and actuates electrical apparatus which strikes the tubes.

W. C. Morgan
J. C. Ravenswood and
Bertram Area
Chicago

2005

LINOLEUM FROM WASTE PAPER

Serviceable floor linoleum from paper on a flax or jute canvas backing is being made in England. To cheapen the product, waste paper is used in the process. During the repulping, the paper undergoes a secret chemical treatment which is said to render it as tough as leather. The covering is said to dye well.

Jack Shipman
2048 Lawrence Ave

English inventor
Shipman

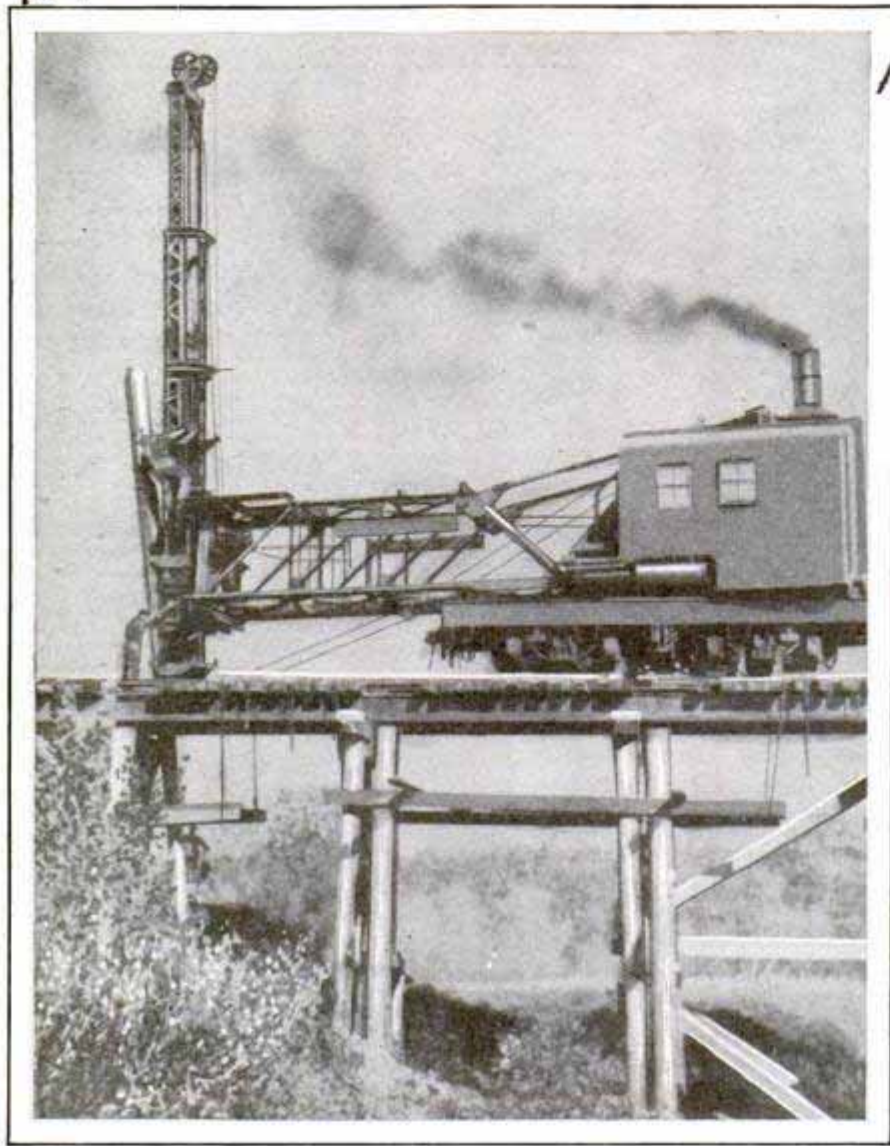

Combination Outfit in Use as a Pile Driver; It Can Easily Be Converted into a Crane for Heavy Lifting

CRANE AND PILE DRIVER IN ONE AID RAILROAD WORK

Combination pile drivers and cranes now in railroad service have proved practical as they save the loss incident to keeping one outfit idle when two separate units are kept, and certain features of the arrangement adapt it to hard service as well as exacting duty. For instance, it has a full-circle swing, so that piles can be driven at either end of the car and rigid construction permits crowding and driving piles that are not inclined to go straight. A long truss allows driving thirty feet from the center line of the track or twenty-one feet and a half ahead of the front axle. A regular crane boom can be substituted for the truss when it is desired to use the outfit for service as a locomotive-crane.

GRAPE SEED YIELD 1935 MOTOR OIL

Extracting lubricating oil from grape seeds is reported to be a budding industry in southern France. The product is said to be especially adapted to delicate motors such as those of airplanes, and is replacing castor oil which had to be imported. Chemists have discovered a way to eliminate the high acid content from the grape oil, a substance that formerly limited the use of the product and now several plants are preparing the oil in connection with distilling operations. Seven or eight gallons of oil can be made from the seeds of a ton of grapes.

PHONOGRAPH THAT FITS IN HANDBAG

2007

Music for picnics and camping trips is supplied by a midget phonograph that fits the pocket or a handbag and yet plays records up to ten inches in diameter. Features of the compact outfit are a speed and tone regulator and a special sound box. The phonograph folds into a round nickel case about the size of a tobacco pouch.

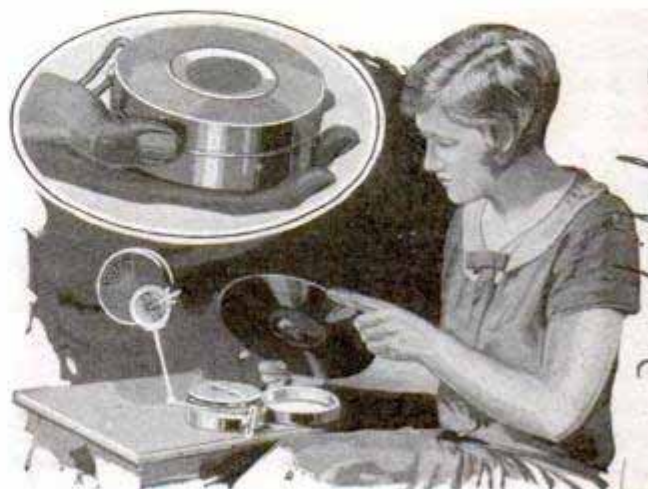

Phonograph Packed, and Below, Ready for Playing; It Takes Ten-Inch Records or Less

Science Service Bulletin
78
Price 55 - ch Illinois

Ltd, 159-162, New Bond

in care of *April, 1926* *Southampton St.*
Strand, W.C. 2
What Is Your Pet Brain-Twister? *London*
Eng

"Puzzle Genius" Tells How He Invents Problems and How They Furnish Entertainment and Profit

By FENN SHERIE

reporter for Strand.

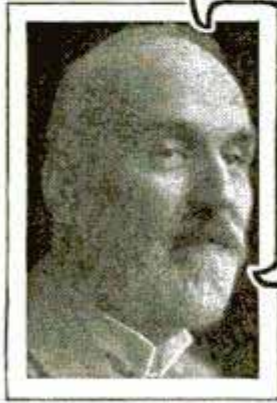

Henry E. Dudeney

THE solving of problems is part of our very existence," declares Henry E. Dudeney, who is known in England as the "Puzzle Genius." "Perplexities large and small confront us every hour of the day. Every task we

undertake, every game we play, has its own little set of puzzles—some of them easy, others apparently insoluble—and our brains are continually grappling with them. If there were no puzzles to solve there would be no questions to ask—and then what a dull world it would be!

"For puzzle solving is only another name for reasoning; the unfortunate people who cannot solve puzzles have to be sent to lunatic asylums—because, as we say, they have lost their reasoning powers. Some people imagine that a man who is constantly applying his brain to puzzles and problems must be a crank. On the contrary, puzzle makers—and puzzle solvers—must of necessity be clear-thinking, logical people."

Mr. Dudeney speaks with authority, for he has been inventing puzzles and problems for nearly sixty years.

"As I have already explained," he continued, "I have been of an inquiring turn of mind ever since I can remember. Like most children, I took an interest in all things problematical from a very early age, and 'Why?' and 'How?' were two of the first words in my vocabulary.

"As a youth I took a great interest in mechanical toys and the various puzzle games they sold in the shops. Conjuring tricks—which, after all, are only puzzles of which the performer tries to hide the solution—also fascinated me.

"I once saw an illusionist perform a

'Vanishing Lady' trick. The lady stood in the center of the stage. Four attendants came on and erected a kind of tent round her. The illusionist fired a pistol, the tent collapsed, and the lady had apparently vanished into the air.

"I was extremely mystified and tried to fathom the secret by a process of deduction. The lady could not have escaped through the wall at the back of the tent, I reasoned, for the trick was performed on a bare stage in a local church hall. There was no trapdoor in the floor. Yet she had left the stage somehow. Then my mathematical mind got to work. How many people were there on the stage at the commencement of the performance? Two—the illusionist and the lady. Four attendants had entered to erect the tent. Two plus four equals six. So far, so good.

"Then in a flash, a possible solution came to me. I went to see the show again and carefully counted the number of attendants who left the stage after the tent had been erected. There were five! The problem was solved.

"That incident may seem irrelevant, but I mention it to emphasize that the secret of solving problems is to develop the art of 'exact thinking.' Even mathematics—frequently regarded as the schoolboy's terror—can be made fascinating if only the teacher will endeavor to show that its whole foundation is the science of 'exact thinking,' and that dry-as-dust problems can be solved by methods similar to those of Sherlock Holmes, the schoolboy's hero."

"When did you begin to publish puzzles?" I asked.

"At the age of nine," Mr. Dudeney replied. "I made up one or two simple little teasers to amuse my brothers and sisters—there were nine of us in the family—and somebody suggested that I should send them to a boys' paper. To my great delight they were accepted, and I received five shillings each for them."

"Can you remember any of them now?" I asked.

"Yes; here is one.

"I will warn you that it is done by a trick—as you will see when I show you the solution later."

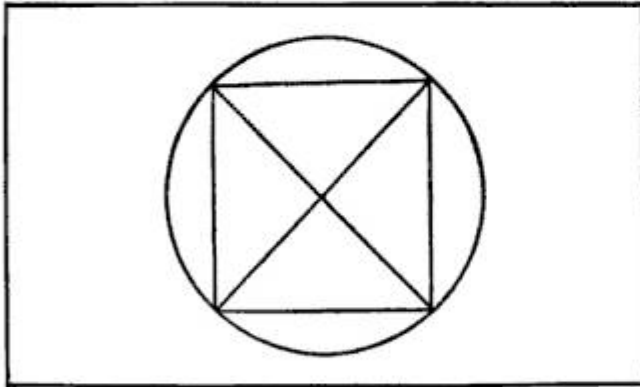

Can You Draw the Figure Shown with One Stroke of the Pencil, Never Lifting the Pencil from the Paper or Going Over a Line Twice?

Although the history of puzzles goes back to ancient times, there is no trace of any man prior to Mr. Dudeney having devoted his life to the study of them. Most of the mathematicians who earned fame as makers of problems have been one-puzzle men. For instance, one man's reputation as a puzzlist rests upon a single problem, called the "Fifteen Schoolgirls," which is as follows:

How could fifteen schoolgirls walk out on seven days in triplets without any girl ever walking twice in a triplet with another girl?

It is not the answer to a problem that interests the puzzle king, but the solution—which is quite a different thing; and for that reason his fame among the professors of higher mathematics is no less than it is among the solvers of puzzles.

I asked him to explain how his popular problems are devised.

"More often than not," he said, "I discover a mathematical principle which interests me, and then I wait until I can think out a means of disguising and dressing it up in such a manner that it will appeal to the general public.

"For instance, has it ever occurred to you that if it were possible to remove the hub of a wheel and continue the spokes to the center, a little problem would present itself?"

I said that it had not.

"What do you think would happen?" he asked.

"I suppose they would all meet," I replied.

"On the contrary," said Mr. Dudeney, "wherever any two spokes met they would form a barrier which would prevent any other spokes meeting on the same plane. Perhaps I can explain the principle more clearly by setting you a simple little problem."

This was the problem:

Take six cigarets and try to place them together so that each cigaret touches the other five.

I did my best to solve the little teaser, but had to admit defeat. Mr. Dudeney promised to show me the solution at the conclusion of our interview.

"Of course, it is not always an easy matter to word a problem clearly and concisely so that the conditions shall allow no opportunities for quibbling," he continued. "Some puzzles are propounded purposely to trap the unwary, and quite naturally people are apt to seek loopholes in every teaser they attempt to solve. I remember once that, after wording a puzzle with extreme care to make sure that there could be no possible quibble, I received a most amusing solution. It was the old 'egg' problem in which nine points had to be connected, using 'the fewest possible straight lines.' A reader claimed to have solved it by drawing a single straight line, pointing out that he had fulfilled the conditions by making all the rest crooked!"

"Here is the diagram in case you may like to try it."

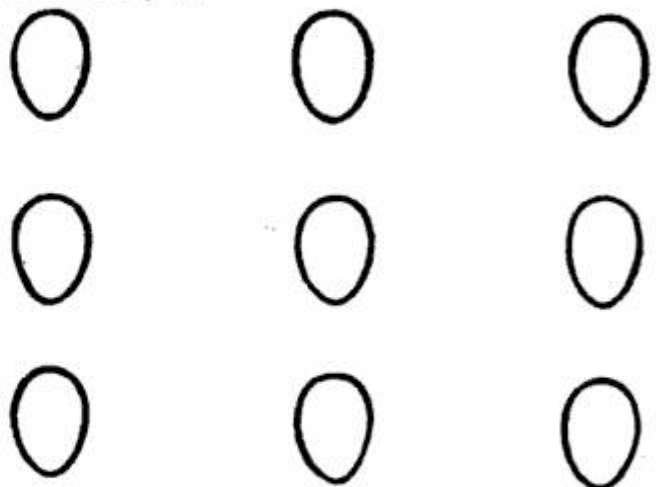

Can You Connect These Nine Eggs with Only Four Straight Lines?

"You referred just now to puzzles which had a 'catch' in them," I said. "Do you consider that such problems may be regarded as legitimate puzzles?"

"Certainly," said Mr. Dudeney. "They all constitute valuable tests in the art of exact thinking. Here is an example:"

A lady was seated in her private chamber when her son entered. Upon receiving the parental command, "Depart, my son, and do not disturb me," he replied: "I am of a truth thy son; but thou art not my mother, and until thou hast shown me how this may be I shall not go forth."

Mr. Dudeney smiled at my expression of perplexity.

"Don't bother about the solution now," he said; "I'll tell it to you presently."

"What do you consider your most popular problem?" I asked, renewing the assault.

"The one which I call 'The Spider and the Fly,' Mr. Dudeney replied. "Here it is."

Inside a rectangular room, measuring thirty feet in length and twelve feet in width and height, a spider is at a point in the middle of one of the end walls, one foot from the ceiling, as at A; and a fly is on the opposite wall, one foot from the floor in the center, as shown at B.

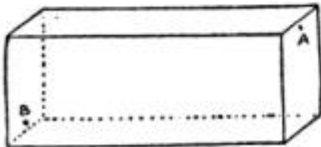

What is the shortest distance that the spider must crawl in order to reach the fly, which remains stationary? Of course, the spider never drops or uses its web, but crawls fairly.

"The idea for that problem came to me in an idle moment while I sat in my chair smoking and gazing at the ceiling," Mr. Dudeney explained. "And, strangely enough, the method of solving it occurred to me almost as soon as I had conceived the puzzle itself. I was rather surprised, therefore, to find that it gave rise to a great deal of discussion and controversy when it was first published. When I show you the solution presently you will see that it may be obtained by a comparatively simple process of deduction.

"Quite a large proportion of the letters I receive come from hospitals. On one occasion I received a letter from a medical officer explaining that one of his patients, a wounded man, was suffering from insomnia because he could not work out the solution to one of my problems, and he begged me to forward it to him secretly so that he could pretend to help the poor fellow to solve it. I did as requested, and had the satisfaction of hearing that the ruse worked successfully.

"Again, I receive a remarkable number of letters asking for a solution of the old problem, 'Water, Gas, and Electricity.' I receive, on an average, three or four

letters a week asking for the solution, so you may perhaps care to publish it again."

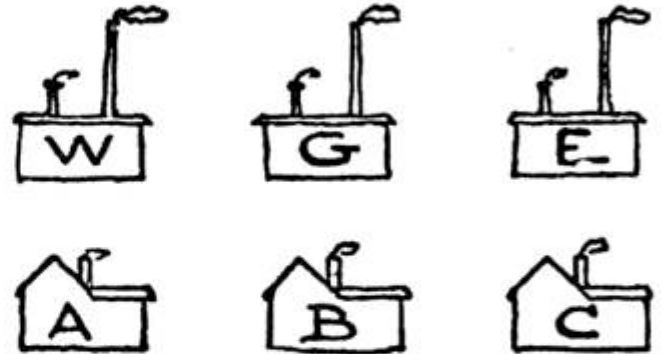

The Puzzle Is to Lay On Water, Gas and Electricity from W, G and E, to Each of the Three Houses A, B and C, without Any Pipe Crossing Another

"Regarding the process of 'exact thinking' to which you have referred," I asked, "can you explain by a simple example how this may be applied?"

"Certainly. For instance, I have heard people argue for hours upon end over the old conundrum, 'Brother and sister have I none, but that man's father is my father's son.' By 'exact thinking' it is easy enough to see that 'my father's son' is either myself or my brother. But as it is clearly stated that I have no brother, it must refer to myself. The problem, simplified, now becomes, 'That man's father is myself.' Obviously 'that man' is my son. It seems simple enough, but there are still thousands of people who are unable to solve it clearly because they will not grasp the fundamentals."

"And now will you give me the solutions to some of the brain-teasers you have shown me in the course of our chat?" I asked.

Mr. Dudeney took up a pencil and paper and bade me sit beside him at the table.

"Let me see," he commenced, "the first problem—the one I invented as a boy—was to draw this figure without lifting pencil from the paper.

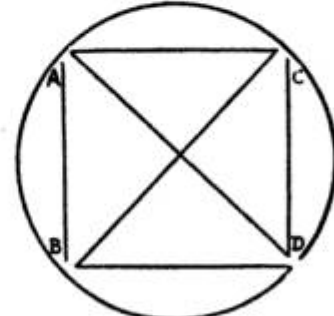

"I mentioned that it was done by a trick. The trick is to fold the paper. Then, by inserting the point of the pencil in the fold, two straight lines, A B and C D, can be drawn in one stroke. Now straighten out the paper without

moving the point of the pencil from D, and the figure may be completed in the single stroke.

"Now for the cigaret puzzle. You discovered at the first attempt how three cigarets could be placed together so that each touched the other two. What could be easier, therefore, than to arrange the other three cigarets in a similar fashion and place them transversely across the first three?" I kicked myself for not having seen the solution before, and then turned to the egg problem.

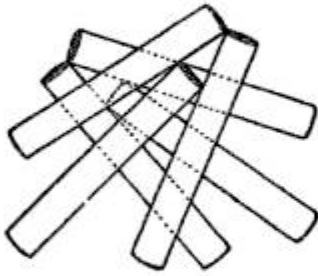

each touched the other two. What could be easier, therefore, than to arrange the other three cigarets in a similar fashion and place them transversely across the first three?"

I kicked myself for not having seen the solution before, and then turned to the egg problem.

"This is equally simple," said Mr. Dudeney. The nine eggs can be connected by four straight lines, thus:

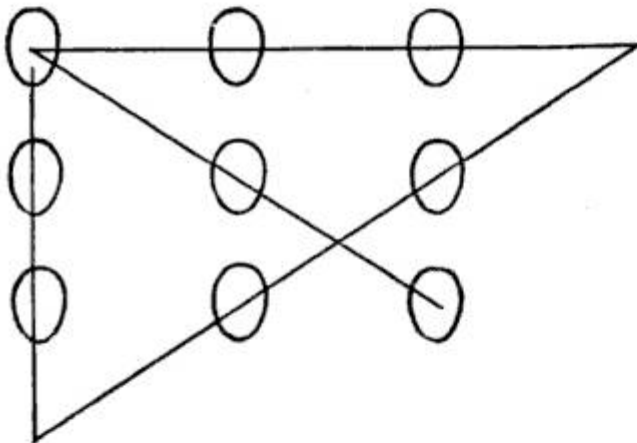

"The 'catch' in the puzzle concerning the youth who received the parental command, 'Depart, my son,' is simply that the command came from his father, who also happened to be present.

"The 'Fifteen Schoolgirls' puzzle is solved as follows. Give the girls the numbers 1 to 15 and they can be grouped in this manner for the seven days:

1st day	15	1	2	11	10	14	7	4	12	13	8	6	3	5	9
2nd day	15	3	4	13	12	2	9	6	14	1	10	8	5	7	11
3rd day	15	5	6	1	14	4	11	8	2	3	12	10	7	9	13
4th day	15	7	8	3	2	6	13	10	4	5	14	12	9	11	1
5th day	15	9	10	5	4	8	1	12	6	7	2	14	11	13	3
6th day	15	11	12	7	6	10	3	14	8	9	4	2	13	1	5
7th day	15	13	14	9	8	12	5	2	10	11	6	4	1	3	7

"To solve the puzzle of the spider and the fly, imagine the room to be a cardboard box. Then the box may be cut in various different ways so that the cardboard may be laid flat upon the table. If you cut it as shown in the diagram and

take the shortest route between the spider and the fly, as indicated by the dotted line, you will find that the distance is exactly forty feet. It will be seen that the spider actually passes over five of the six sides of the room.

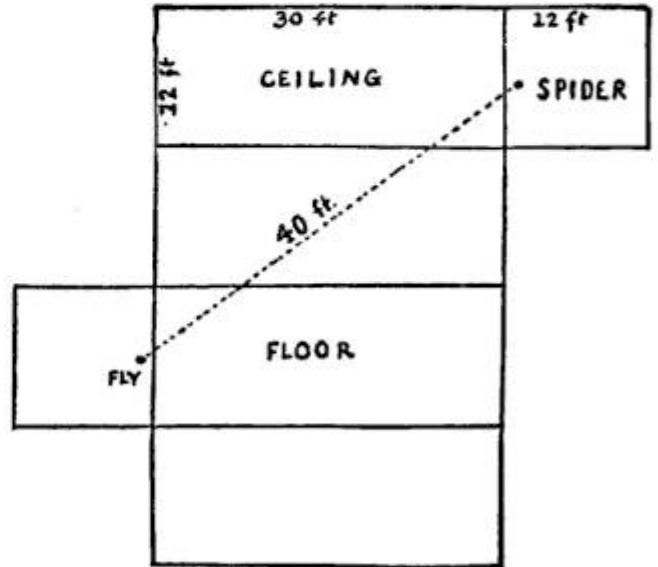

"Now for the 'Water, Gas and Electricity' teaser. According to the conditions, in the strict sense in which one at first understands them, there is no possible solution. In such a dilemma always look for some verbal quibble or trick. If the owner of the house A will allow the water company to run their pipe for house C through his property (and we are not bound to assume that he would object)

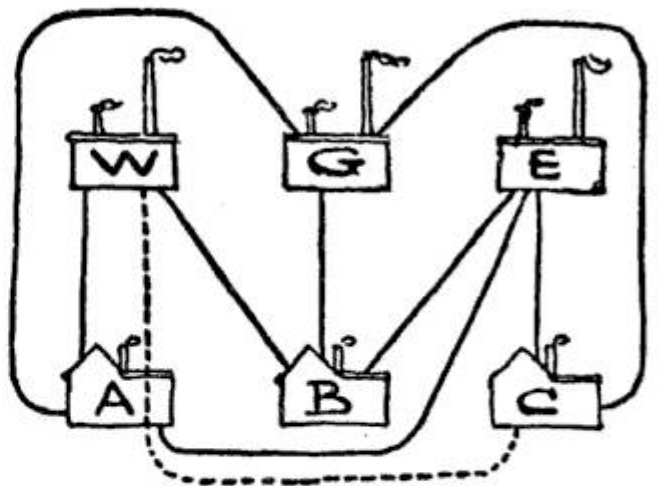

the problem may be solved as shown in the diagram."

Names and addresses of manufacturers and dealers in articles described in this magazine will be furnished by our Bureau of Information. Send no stamps; the service is free.

Iserman Engineering Company
 POPULAR MECHANICS 221
for the Williamsport yards of a Iserman Coal Co

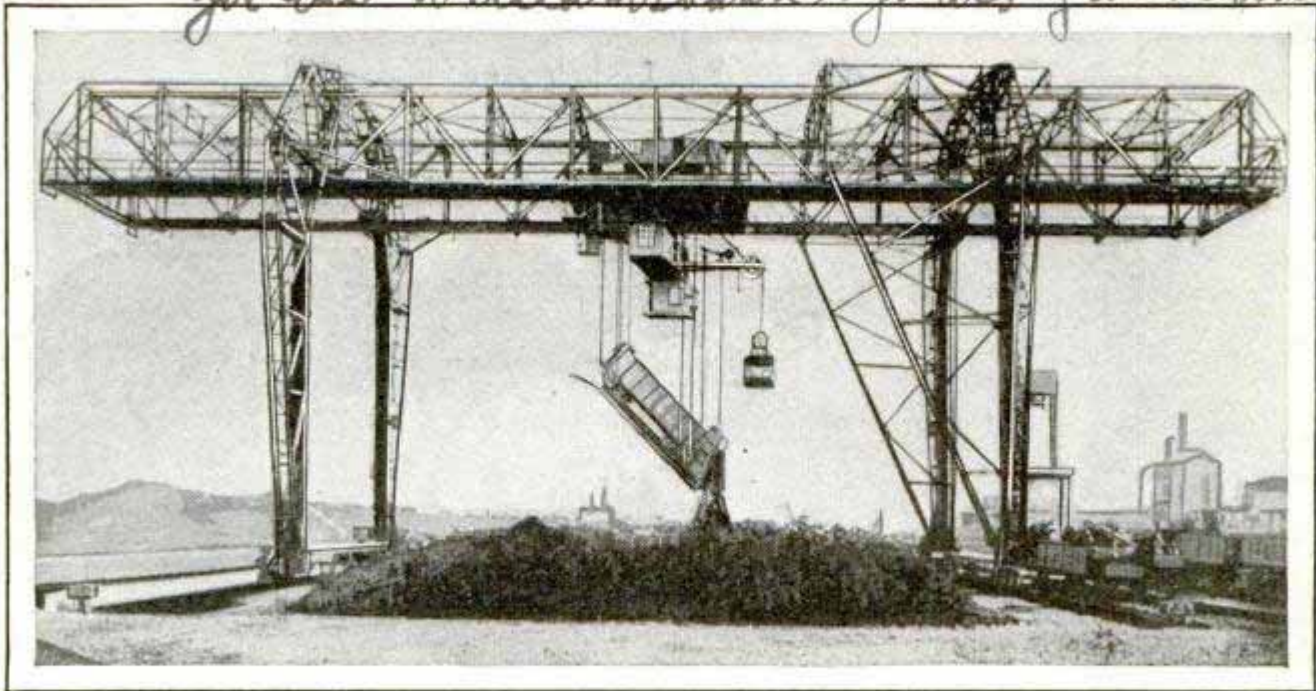

Powerful Coal Unloader in Operation; Cars Are Lifted from the Tracks, Moved to the Dumping Heap and Then Tipped, Permitting the End Gate to Open and the Contents to Run Out

CRANE PICKS UP FREIGHT CARS AND EMPTIES THEM 2067

Cars are swung from the railroad tracks, tipped on end and dumped at the rate of fifteen an hour with a huge crane constructed for a German coal company. The powerful hoist is suspended on a bridge that has a span of 125 feet.

cause the moon is relatively much smaller than the earth, objects would disappear more quickly because of a closer horizon. In one of the flat-bottomed "craters," all that could be seen would be a plain with only the tops of the highest summits ranging as a rampart about it, but in the black sky overhead the stars would sparkle despite the presence of the sun during the lunar day. The earth would appear as an enormous moon. Light reflected from it upon the satellite is visible to us here as a faint illumination of the dark part of the moon at dawn or evening, when it appears as a slender crescent.

SKY WOULD BE BLACK ON MOON AND SHADOWS VERY DARK 2080

Due to the absence of an atmosphere, scholars say that landscapes on the moon would appear vastly different from those on earth, could a person visit our earth's satellite. Instead of blue, the sky would be black and shadows would be extremely dark although reflected light from other surfaces than those exposed to the direct rays of the sun would modify them to some degree. Distant peaks would stand out in bold relief, and be-



PLANT GROWS IN SEALED BULB 1966

That a plant can grow inside of a hermetically sealed glass bulb was demonstrated before the National Academy of Sciences. Water drawn up through the roots and evaporated from the leaves was condensed on the sides of the glass and, running down, used again.

© Henry Miller
 Plant Growing inside Tightly Sealed Glass Bulb; Air and Water Were Used Repeatedly

*L'd Illustration
 Paris*

Washington D.C.

NOVEL ELECTRICAL EYE ENABLES BLIND TO READ

Disembodied Optophone

11/28/39

(C. 71)

*Main factory Glasgow Scotland
Caster St. Anniesland*

Mr. E. E. Fornering 'Albion' London, Eng.

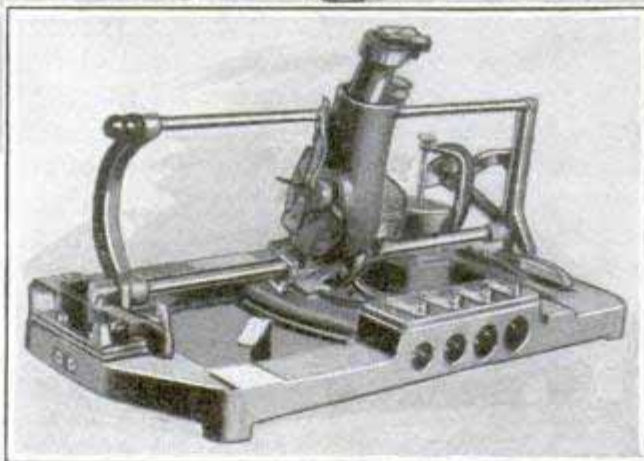
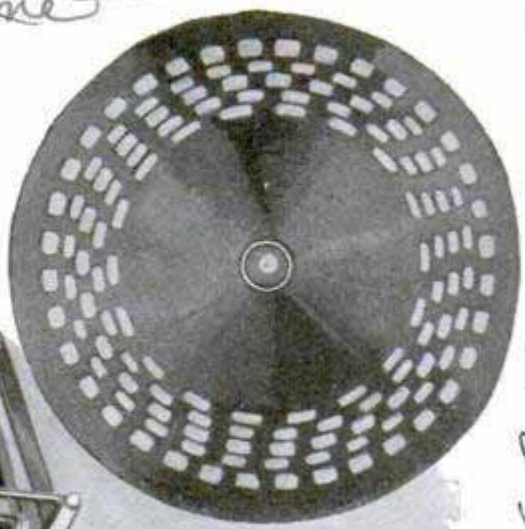
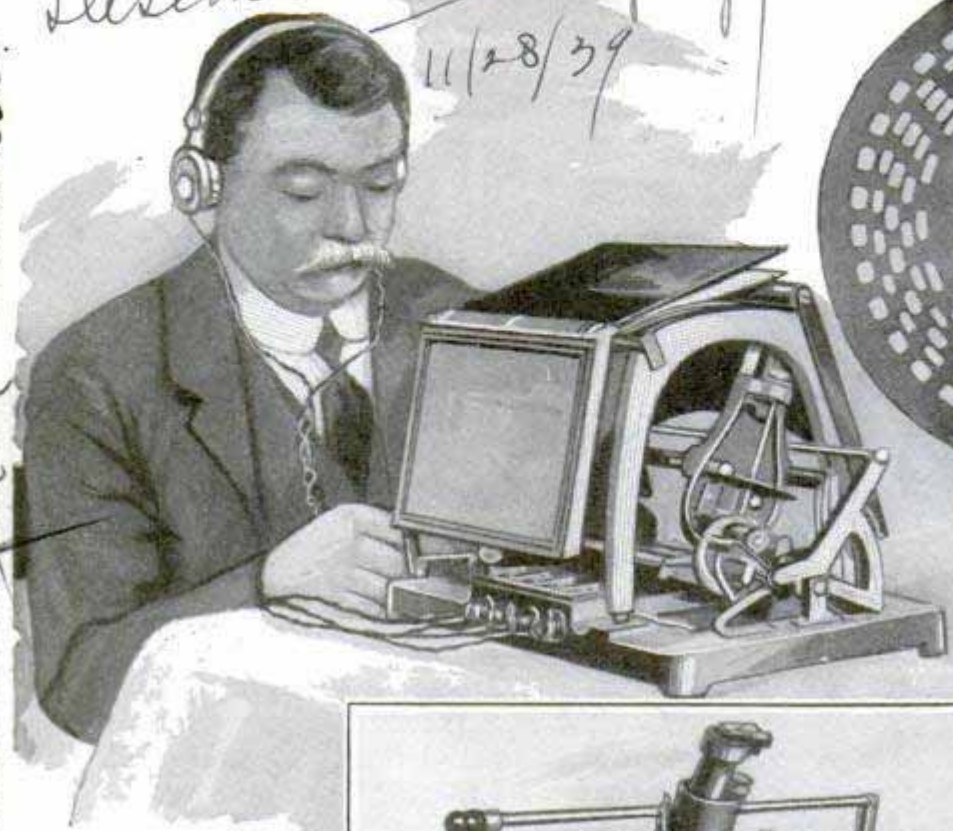

Blind Man Reading as Type Is Translated into Sound; the Perforated Disk and Instrument Uncovered

A remarkable electrical instrument enabling the blind to read ordinary printed matter laid on it, has been invented by an English professor. By its use, blind people can read their newspaper or favorite book almost as easily as normal folk. This device translates printed type into sounds which are heard in a telephone receiver strapped over the head and ears. The brain of the "optophone," as it is called, is selenium, a metal which has the strange property of varying its resistance to the passage of an electric current according to the intensity of the light falling upon it. A telephone receiver is connected with a battery and the sensitive selenium. When light is flashed from an electric bulb onto the selenium, a current passes to the telephone in which musical sounds are heard. The pitch, or musical note of the sounds depends on the frequency of the light pulsations. A blind person wishing to read a newspaper or

book printed in ordinary type, or a typewritten letter, simply places the printed page, face downward, on a glass plate supported by a book rest. The selenium tablet is just under the glass plate, and its upper surface is pierced so that a ray of electric light passes up through the glass to the book or paper. A motor rotates a disk pierced with five rings of concentric circles, and, as it revolves, the light from the electric bulb beneath is projected by lenses onto the type to be read. This light forms on the printed page five bright spots in line. Each letter on which the light falls produces a different sound in the earpiece. The blind have to learn an alphabet of sound, which can be done in twelve to twenty hours. The reading of words is practiced, at first, on a simple book, such as a child's primer, and in many cases a reading speed of over 60 words a minute has been attained in three to four months.

NON-SECTARIAN RADIO PARISH HAS NINE DENOMINATIONS

Representatives of nine religious denominations have organized a radio parish in Maine with their own pastor and a group of business men, and others interested, to assure financial support. The action was taken largely as a result of the many responses received from radio fans on hearing the minister's sermons when he was pastor of another church. He resigned so that he might give his entire time to the radio audiences.

Rev. Howard C. Hough

FRAME YOUR OWN PICTURES WITH METAL CORNERS

Pictures can be framed in a few moments even by inexperienced persons with the aid of metal corner pieces now on the market. They replace the ordinary miter joint which requires careful cutting and fitting. The pieces are shaped to hold molding strips that form the sides of the frame. These strips are cut to the required lengths and with square ends, and then simply inserted in the corner pieces. Small brads or nails, driven from the back side, are used to hold them in position.

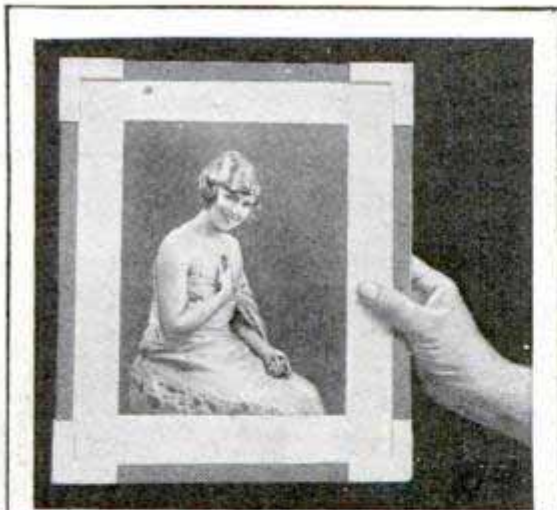

© C. A. Oldroyd

Picture in Finished Frame and Inserting a Side in the Slot of the Metal Corner

Art Angles, Ltd.



Trimmer in Use, and Inset Showing Its Narrow Saw Blade and Connection to Pole

POLE SAW FOR TRIMMING TREE SAVES CLIMBING

Weighing only eight pounds, a narrow-bladed saw and long pole for trimming trees permit cutting limbs as high as twenty feet above the ground and up to six inches in diameter. An additional advantage is that the operator can stand at one side, thereby protecting himself from falling branches.

FORM HOT-DOG VENDERS' UNION TO HELP TRADE IN BERLIN

A union of "night sausage dispensers" has been organized in Berlin to stimulate the trade in frankfurters and rolls. The vendors are said to hold a virtual monopoly of the sales and have combined to increase the outdoor business which is sometimes brisk after theaters. Members of the organization wear white uniforms and dispense their merchandise from nickel kettles.

N.Y. Times 4/11/20

Clay. Gas Co., Andubon, Iowa.

1947

461-8th Ave. New York

QUAINT DOLLS ARE FOUND IN ALL PARTS OF WORLD



For Centuries, Dolls Have Been the Favorite Playthings of Children in Almost Every Region of the Globe, from Alaska to the African Jungles; Here Are a Few Samples of a World-Wide Collection

Left to Right, Javanese Puppet in Native Dress, Gay French Doll from Nice, France, an Almond-Eyed Pet from Japan, an Italian Beauty and a Veiled Mussulman Lady Doll from Cairo, Egypt



Mrs. W. Kendall Evans and Part of Her Doll "Family" Which She Collected during a Round-the-World Cruise; Chinese Dolls, at Left and Right, Illustrate the Elaborate Care Oriental Craftsmen Lavish on the Tiny Costumes



Pleasantville, NY

2051

**HUES OF FLOWERS
DUE TO SAP**

2113

Flowers of the same kind are of different colors largely because the pigment carried in the sap is either dissolved or held in certain specialized cells. Chemical action of the various substances in solution may produce the blue, purple or violet shades, or another group of chemicals may result in orange, red or yellow flowers. It is possible to group all blossoms into two "families," the blue and the yellow, and with each of these are found red and white. In an average collection of 996 plants, 284 were found to have white flowers, 226 yellow, 220 red, 141 blue, 73 violet, 36 green, 12 orange and 4 brown. White flowers were the most fragrant, and the red had a more pleasing odor than the yellow.

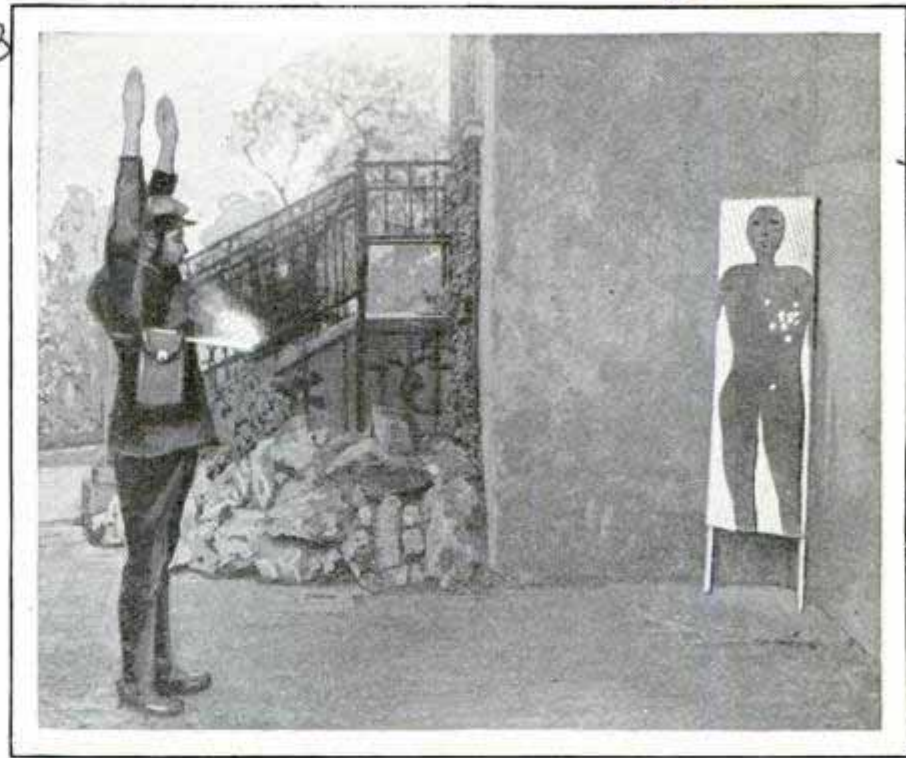

Demonstrating Effect of Bandit Gun on Target; Weapon Is Fired by Movement of Hands Upward, to Take Robber by Surprise

**RAISING HANDS FIRES PISTOL
WHEN BANDIT ATTACKS**

2051

"Hands up!" from a bandit brings an unexpected reply from the intended victim with the aid of a pistol rigging a German inventor has devised. Raising the arms fires the weapon which is fastened, within a small case like that of a camera, around the body. The connections which actuate the weapon are concealed. The inventor, practicing with a target, was able to demonstrate that the arrangement would inflict serious wounds on a bandit.

**RADIO SET ON WHEELBARROW
LIGHTENS FARM TASKS**

2107

Farmers and commuters in western Pennsylvania have been doing their chores and garden tasks to radio music this season. The set is placed on a wheelbarrow, a temporary aerial erected, if a loop is not used, and an iron pin driven into soft plowed soil for a ground. Daylight-saving schedules in the cities have given impetus to the outdoor radio craze as many farmers would miss the programs entirely unless they tuned in while at work. Dogcarts and small express wagons are also used to carry the sets.



**DOG'S CROSS EYES
CURED WITH
GLASSES**

1974

Glasses with special lenses, which were changed frequently, were fitted to a valuable Chow puppy to straighten its eyes. Several months' treatment were given and the owner is reported to have spent about \$300 for the cure.

Long
Foi

Special Lenses Were Found Useful in Straightening This Chow Puppy's Cross Eyes

N.Y. Times 5/27/26

Owner, C. E. Douglas,
91 Main City N.Y.

Chicago Evening Post 5/31/26

Inventor, Edmund Weber
German engineer

method was not used. By means of a specially mounted airplane propeller on the ground, electrically charged air was projected in such a fashion as to constitute a curtain of air which precipitated the fog and thus opened a clear path for landings. The successful completion of these important experiments will remove one of the worst hindrances to safe aerial navigation. The field for the use of fog-precipitation apparatus is wide and no doubt will ultimately be used in great cities to lessen traffic jams and other dangers of foggy days, and also in harbors and channels where shipping becomes congested and delayed by reason of fog.

2094.

**IDOL THIRTY-FIVE FEET TALL
UNEARTHED IN FLORIDA**

Believed to have belonged to a race that existed 2,000 years ago, a wooden idol, thirty-five feet tall, has been excavated from a burial mound in Florida. The features are apparently those of a female of the Mongolian type and were carved from shells. The body was made of the sea mangrove, or "wood eternal" as it is sometimes called. The mound was discovered about 500 yards from the ocean beach on an elevation not far distant from the location of an early white settlement.

Kansas City Times 3/26/26

**JOCKEYS TRAIN ON
ROLLER-MOUNTED
ROCKING-HORSE**

German jockeys ride a wooden rocking horse somewhat like the common toy to help in training for the early-season races. It has rollers on the bottom of the runners so that it makes considerable progress in a forward direction besides the customary rocking motion. It is so balanced that it is not likely to tip over.

Many animal trainers declare that tigers are more intelligent than lions.



Playing Two Banjos at Once; This Is Possible with the Double-Necked Instrument for Unusual Effects

**DOUBLE-NECK BANJO FOR JAZZ
PRODUCES NOVEL EFFECTS**

Two banjos are practically combined in one in an instrument an eastern orchestra leader has devised to furnish novel effects. The player may alternate from one set of strings to the other or employ a single set. They are strung differently without impairing the quality of the tones.

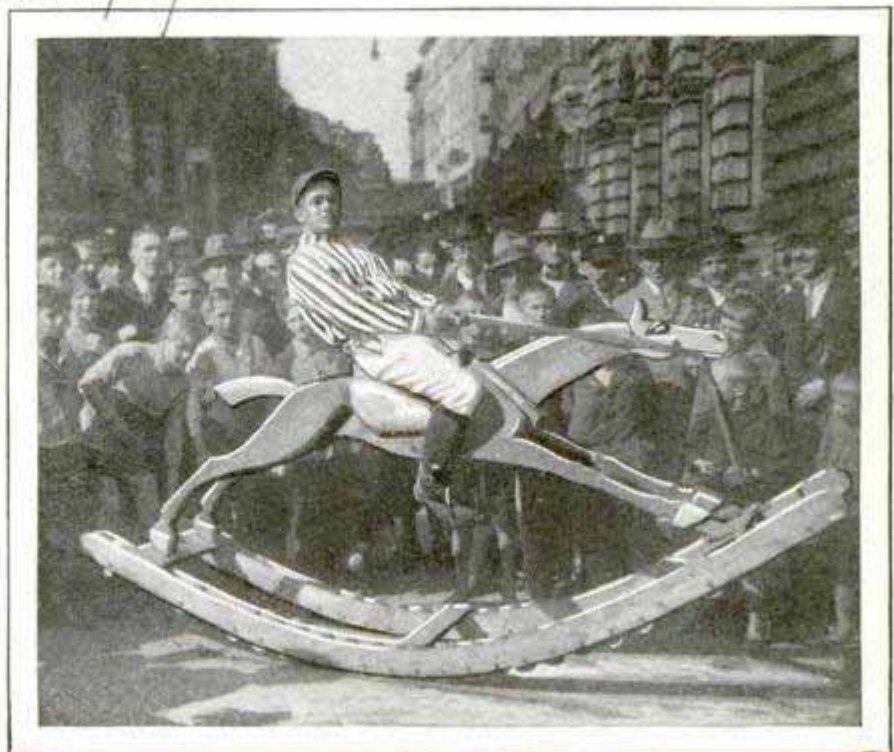

© Henry Miller

Jockey Riding Wooden Rocking-Horse to Train for Real Races

Before opening of International Horse races in Munich

Broward County

*2060
New York
A. S. ...*

*William L. Lange
225 E. 24th St. New York
Bill Bailey Barum & Bailey*

1850

Fifteen Years Under the Sea

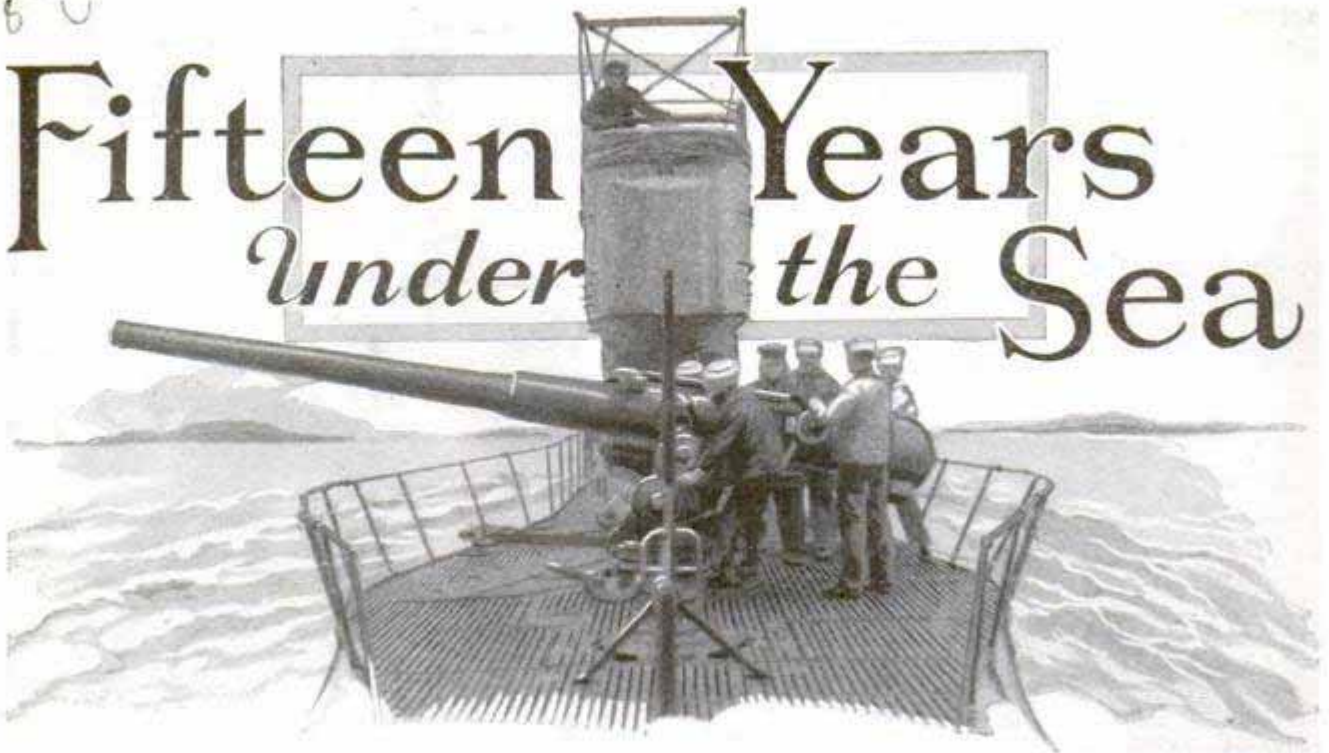

The Story of Capt. Frank T. Cable Who Helped Raise the Submarine from a Little Fish to a Whale

By SAMUEL TAYLOR MOORE,

22 E 38th St
New York

THE head of an electric company in Philadelphia grunted over the letter in his hand. It was a request for assistance from a customer. That crazy inventor at the New Jersey shipyards was in trouble again! His foolish contraption called a submarine boat had flooded and sunk and the electrical equipment had been ruined. He hadn't paid for it either. Nothing to do but send a man up there.

This happened in 1897. The young man selected for the job was named Frank T. Cable. Born on a rocky farm in New Milford, Conn., in the closing days of the Civil war, he had deserted the plow to enter the field of electrical engineering. At the age of thirty-three he was one of the experts in the company's employ.

On the ride to Elizabethport the young technician recalled what he had read and heard of the strange experiments of the middle-aged school-teacher-inventor, Holland. Vaguely he recollected a claim that Holland had once remained on the bottom of the Passaic river for twenty-four hours in an underwater canoe. Then he had built two larger boats. A reporter, who had been refused a trip, dubbed one of the craft the "Fenian Ram" because

money from the Fenian skirmishing fund had financed the inventor. Weird stories of the subsurface cruises of the boat had been printed in metropolitan newspapers. Both boats were stolen on a dark night by dissenters in the Fenian organization. With inventive persistence, Holland had constructed another undersea craft in conjunction with an American army officer, Lieut. Zalinski. It was wrecked beyond repair at its launching.

If young Cable wished to remind himself of the utter impracticality of Holland, evidence was available in his failure to complete a contract for the United States government, after the navy department had authorized the building of three submarines. The inventor finished one, the "Plunger," but far from ever navigating beneath the waves, the surface trials even had proved failures. What the muser did not know was that the failure of the "Plunger" was due primarily to official interference and red tape, precluding any possibility of success. He was to learn that lesson by bitter personal experience.

Arrived at the shipyards, Cable solved the immediate problem confronting the submarine builder. In four days the job

7050

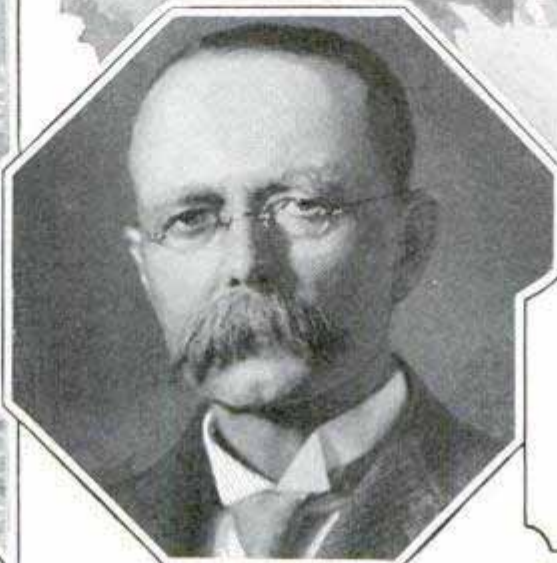
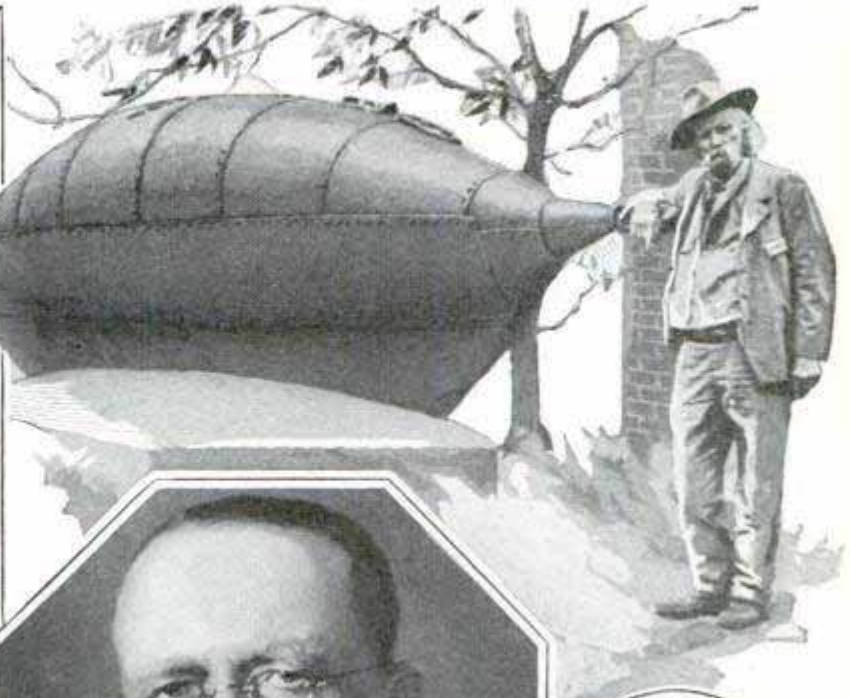

Submarine Built by the Confederate Navy during the Civil War, Now Preserved at a Veterans' Home; Left, John P. Holland, Father of the First Practical "Sub"

The British Submarine "M-1," Mounting a Twelve-Inch Gun, Which Was Lost Recently Supposedly after Having Collided with a Surface Ship

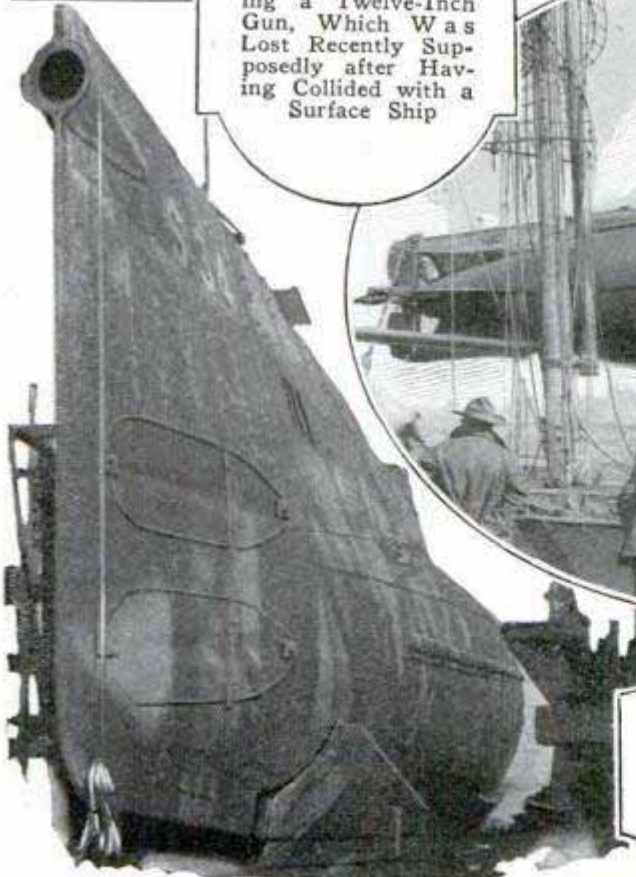
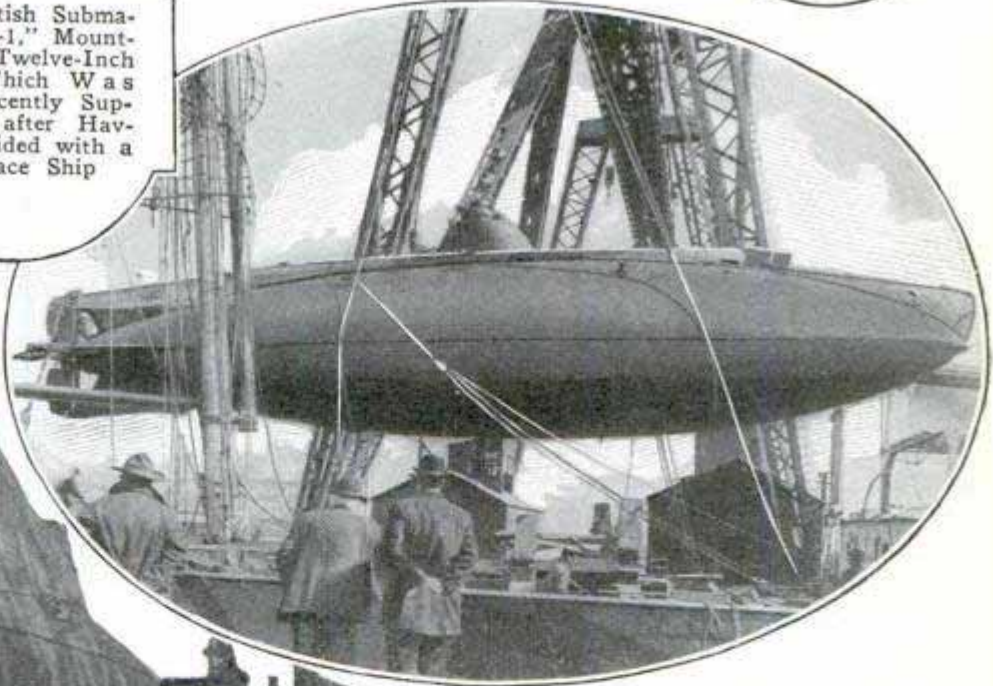

When Submarines Were Little Fish They Could Be Picked Up and Loaded on the Deck of a Warship, as Above; This Was Back in 1908. At the Left Is One of the Big Thousand-Ton Coast-Defense Boats Now in Use, Which Is Less Than Half the Size of a Fleet Submarine

1850.

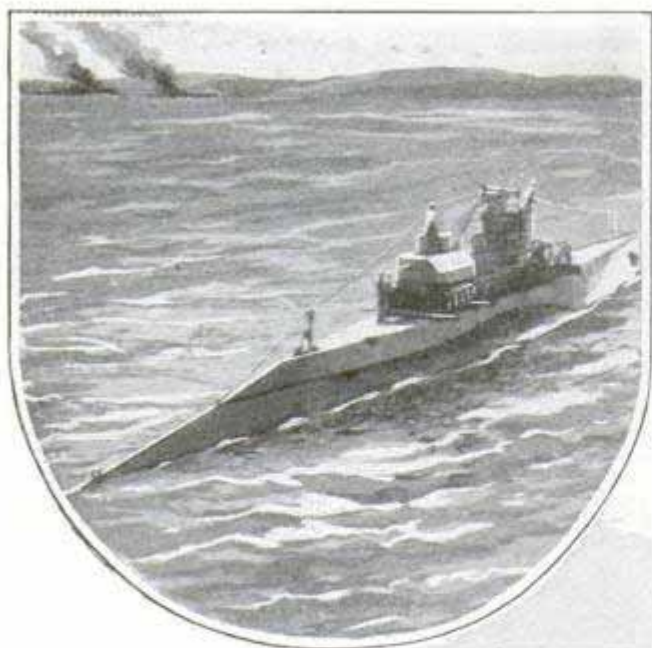

Submarine Dashing Shoreward with Amphibian Tank on Back; When the Sub Goes Down the Tank Proceeds on Its Own Power

Gradually, during the next two months, every dubious feature of the strange boat emerged in clarity. The doubter was converted. And his enthusiasm for the future of the submarine equaled that of the inventor. What matter if the well-known ghost failed to walk, or even crawl, on pay days! Landlords and grocers had waited before on inventors and promoters. Here was a thing worth experiencing poverty and hardship for.

At sixty years of age, Capt. Cable is today recognized as an international authority on undersea boats. He is one of the greatest submarine-boat builders in the world, with his own shipyard, huge foundries, machine shops and ways sprawling for half a mile along the eastern shore of the Thames river at Groton, Conn. His submarines are serving the navies of the United States, Great Britain,

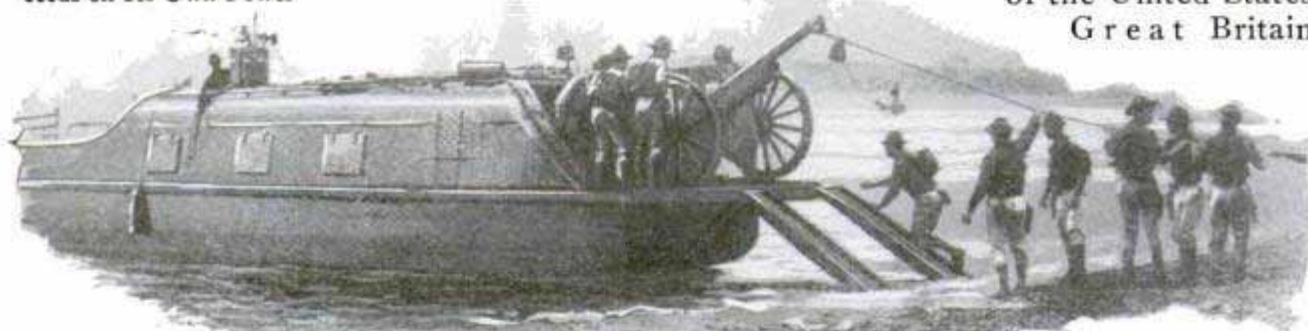

Marines Landing Artillery from Armored Boats; Below, the Amphibian Tank as It Appears When It Waddles Ashore

was completed. Grateful for the efficient aid, the inventor offered the young electrical expert to take a cruise in his weird craft. "Not on your life. You couldn't pay me to go down in that thing," was the answer. Yet six months later Cable was skipper of the "Holland," as the submarine was named.

It came about in this way. Holland, impressed with the capabilities of the younger man, invited him to join his small staff. The salary was more than Cable was receiving. But would it be paid regularly? He had formed a liking for the little Irish dreamer, so he went to his employers. They advised him to accept—for one reason because it would place him in a position to learn what chance the company had of collecting money due and overdue. His old job was always open, he was told.

Young Cable was frankly skeptical when he joined the Holland enterprise.



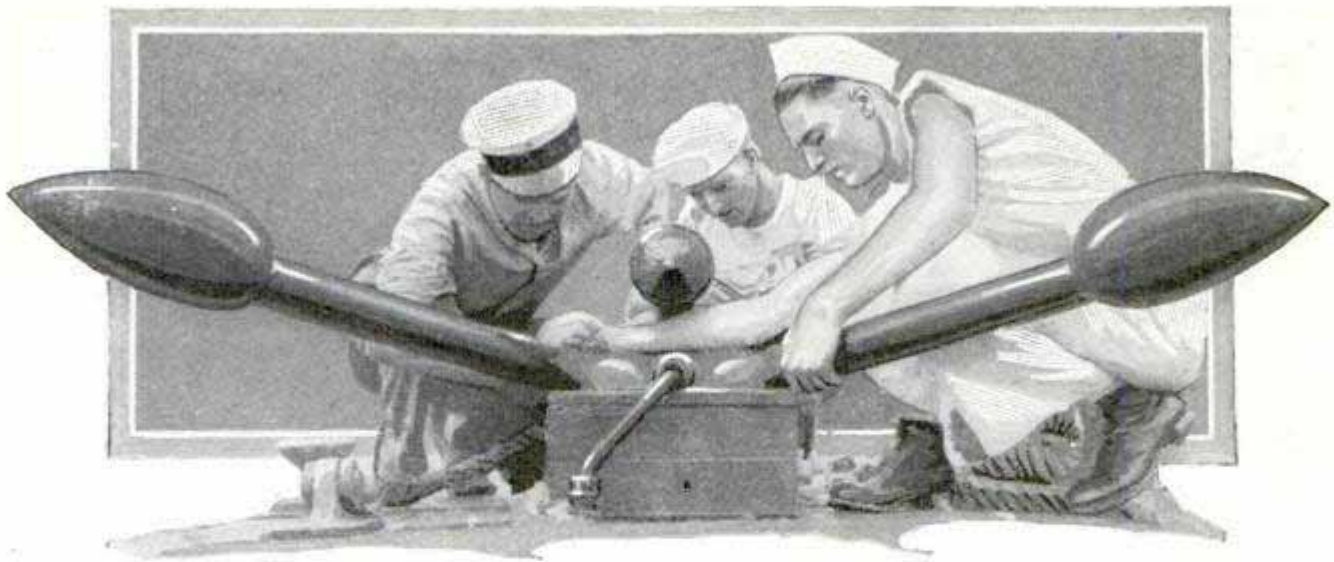

The Ears of a Submarine, an Electrical Listening Device That Tells the Crew Inside When Other Ships Approach, the Course They Are Sailing and Their Distance from the Hidden Sub

Japan, Chile and Peru. He trained the first subsurface crews of this country, England, Russia and Japan in person.

In the twenty-eight years since Capt. Cable supervised the completion of Holland's egg-shaped submersible, the submarine has made history. It was a Herculean task to overcome naval antagonism and gain a hearing for the merits of the underwater boat. The grim specter of death hovered within the hull more than once. It is a matter of pride with the captain that, in fifteen years of sailing under the sea, never has he been involved in a fatal accident.

Although submarine experiments are recorded as far back as the reign of King James, it was the gasoline motor that made subsurface navigation possible. Like the airplane, the submarine was obliged to wait for the perfection of a compact power plant. The early gasoline engines have been replaced in recent years by heavy-oil engines of the Diesel type, yet a reliable motive unit remains a persistent problem in development.

The original "Holland" survived only through the grace of Providence. Present-day submarines are equipped with three periscopes, commanding vision in all directions and overhead as well. But it was not until 1902 that the periscope was adapted from French submarines. A circle of small oblong ports in the conning tower provided the only means of visibility when the hatches were secured in preparation for a dive. In the busy traffic of New York harbor it was only

safe to accomplish brief porpoise plunges. The maiden dive of the "Holland" ended in a mudbank off Staten island, and the skipper and crew held their breaths until the boat was freed by emptying the ballast tanks with compressed air.

To add to complications, war with Spain was impending. The Spanish battleship "Vizcaya" had anchored off New York to retaliate for the presence of the ill-fated "Maine" off Havana. As the "Holland" lacked any official status, it was under close surveillance by naval authorities, who feared that misguided patriotism might lead to the employment of the subsurface craft in some rash act. Pursued by a navy boat on one cruise, the "Holland" eluded its pursuer by hiding behind a barge near Perth Amboy. News of the maneuvers of the weird craft finally reached the ears of the captain of the Spanish battleship and shortly thereafter he weighed anchor and departed.

From the date of Fulton's submarine experiments, which were advanced under the patronage of the great Napoleon more than 100 years before, the most energetic antagonists of the undersea boat were always naval officers. The traditional naval code of respect for an opponent's bravery unified opposition to underwater weapons.

The shadow of tragedy descended on the "Holland" on one of its early trips while naval observers were on board. After a satisfactory demonstration in the harbor, the boat was approaching its dock when the engineer collapsed at his post.

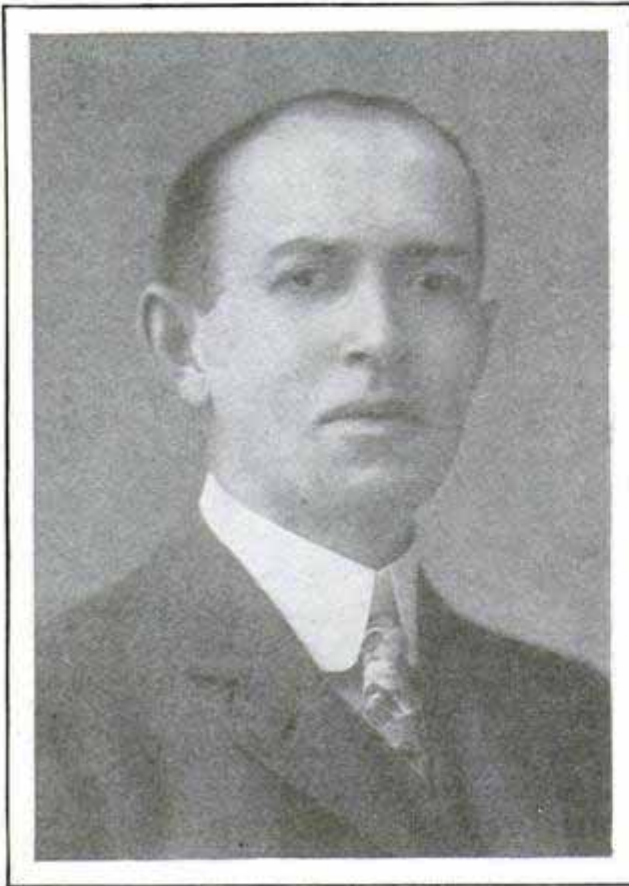

Frank T. Cable, Who Joined the Inventor Holland in the Early Days and Helped Develop the Submarine

Carbon monoxide from the gasoline-engine exhaust was responsible. Two of the crew who rushed to assist the unconscious engineer were likewise overcome. Capt. Cable descended into the hull from his post on the bridge only to be felled by the fumes as the others had been. Would-be rescuers who sought to bring out the limp bodies were in turn stricken down until a total of eight persons were unconscious within the hull. It was four hours later before the last victim was brought back to life after more cautious workers

had succeeded in removing the bodies. That incident settled the future of the submarine, observers firmly believed. No chance of tempting any of those men back into a hull that might be saturated with poison at any moment. Yet the following morning every man of the crew reported for duty at the usual hour. As a precaution, however, a cage of mice was carried along in the engine room thereafter, and in all early submarines.

In the first torpedo-firing experiments, thrills in large measure attended. The control of torpedoes, once they left the firing tubes, was an unsolved problem and they dove and ricocheted in all directions. On one occasion the torpedo acted as a boomerang, and after passing through the center of a target, it maneuvered in a wide circle and headed straight back for the craft that fired it. Only expert navigation prevented a collision.

In November, 1898, the "Holland" started on a successful cruise to Washington and later was taken over by the government which ordered six additional boats of the same type. While these were being built, Capt. Cable was supervising the construction of an advanced type of craft, christened the "Fulton," which later was sold to Russia for use against the Japanese navy. After a visit to St. Petersburg to train a Russian crew, he was rushed to Tokyo to help the Japanese launch a submarine campaign. The first Japanese submarine crew was composed entirely of officers. They proved ideal students, but before the new undersea boats were prepared to maneuver, peace was declared.

What of the future of the submarine?

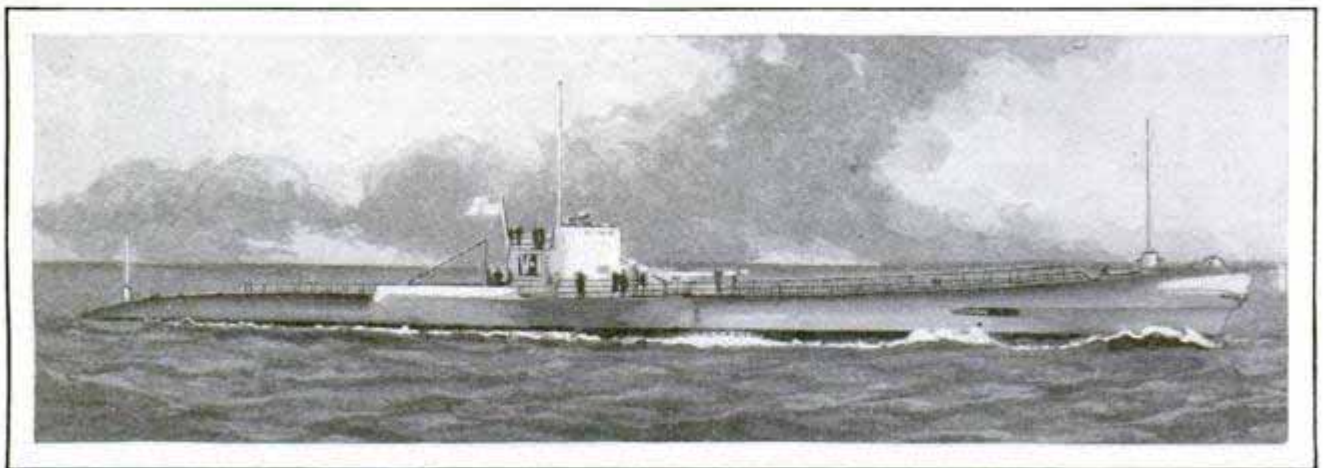

One of America's Biggest Fleet Submarines, the "V-1," Which Recently Established a World's Record by Submerging to a Depth of 220 Feet; on the Surface, It Is as Fast as a Battleship

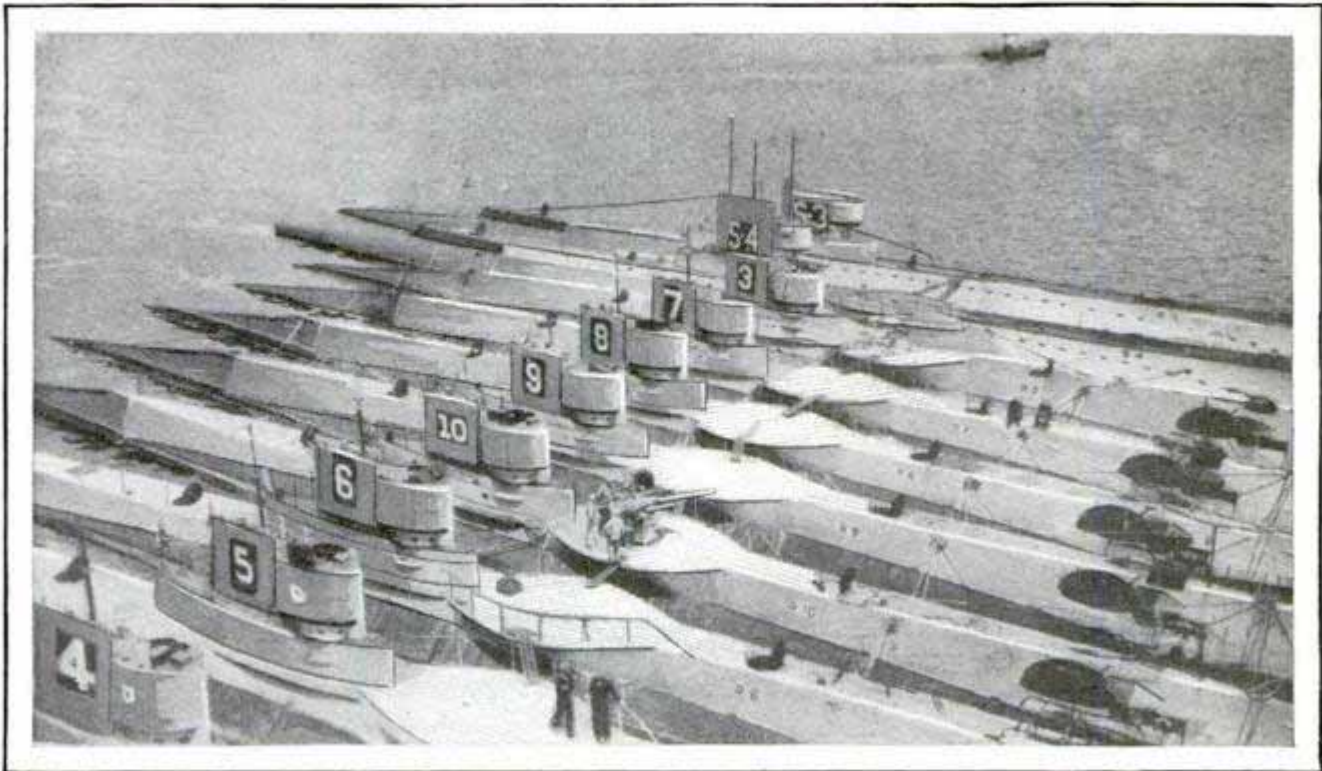

Flock of American Submarines Tied Up alongside Their Surface Tender, on Board Which the Crews Can Sleep in Comfort When in Port; the Tender Carries Supplies and Makes Emergency Repairs

Prophets have said that the next war may well see capital ships capable of submerging, that a decisive naval encounter may occur in mid-ocean with only a few bubbles rising to the surface to mark heroic events happening below.

Capt. Cable does not share such a vision. He believes that the future will see a reversion to the smaller types of submarines, watchdogs of our coasts. Cost will be one factor. The modern V-type submarine represents an investment of millions. Admitting that the habitability of undersea boats must be improved, he foresees increased speed and efficiency, rather than increased size, as the pre-eminent objectives.

The submarine will not replace the capital ship. Its effect on the surface fleet will be indirect. Huge battleships are comparatively slow, offering an easy target. Light cruisers, small and fleet, are the most difficult targets for a torpedo.

HOW SEEDS BREATHE

Like many human beings, seeds require oxygen in order to grow, and for this reason it is important that the soil in which they are planted be loose and porous. By means of sensitive measuring instruments, scientists have been able to determine the

amount of oxygen a seed takes in. The quantity is greatly increased when the seed is on the verge of sprouting. Rice and a kind of California weed will germinate in sealed jars from which the air has been exhausted, if moisture and a sufficiently high temperature are provided.

ICE CREAM MOLDED IN SLICES BY HANDY DISHER 1786

\$3.25

Bulk ice cream is formed into attractive flat cakes for serving on pie, in sandwiches, or other ways, by a disher that re-

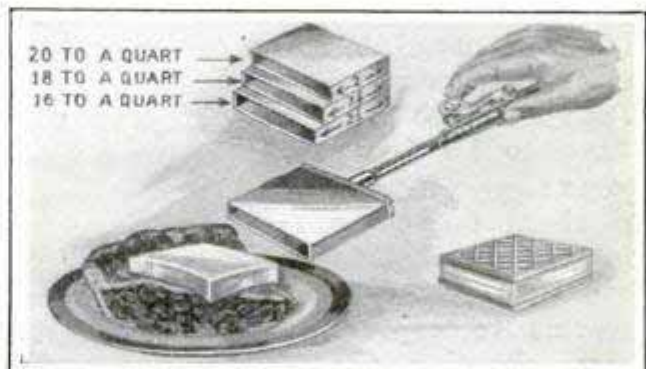

Disher in Use, and Diagram Showing Different-Sized Slices It Forms for Sandwiches or Pie

duces waste. It is adjustable to three sizes, to obtain sixteen, eighteen or twenty slices from a quart of cream. The implement is easily used and cleaned.

Let. Bats 5/15/26

*Mayer Mfg. Corp.,
1608 Wabash*

RACER SETS RECORD AS LIFE HANGS BY A THREAD

J. G. Parry Thomas, driving his 400-horsepower racer "Babs" over the sands at Pendine, Wales, broke his own speed record when he covered one kilometer at the rate of 171.69 miles an hour. An ad-

ditional thrill was received at the end of the test. Mechanics found that an off-side shock-absorber bolt had worked loose and was held in place by a single thread. This alone probably saved Thomas from death or serious injury.

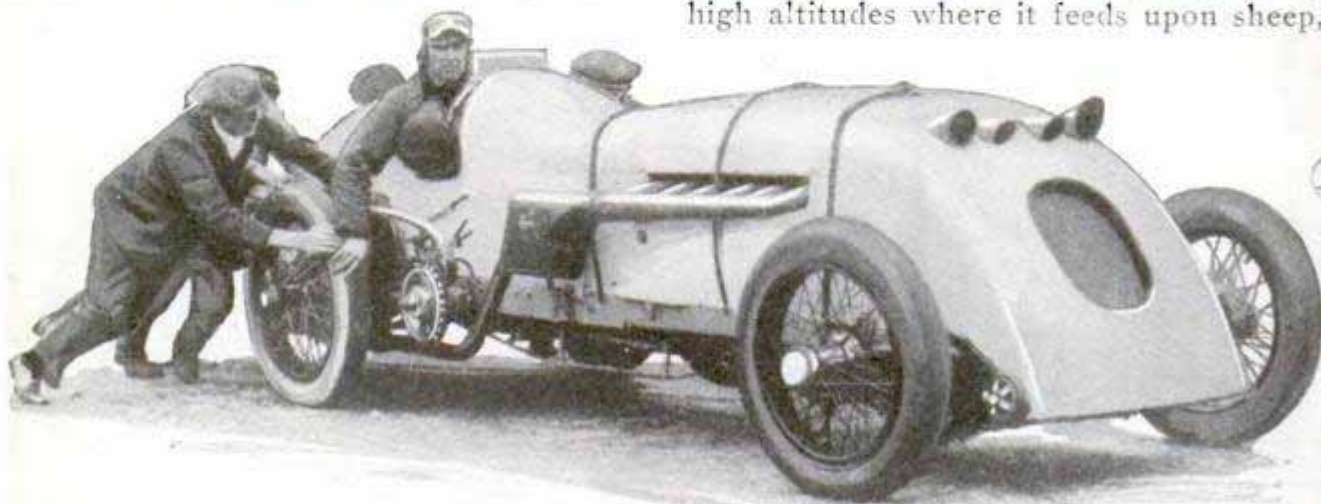

Wheeling Thomas from the Course after the Run; Shortly After the Photo Was Taken, He and His Mechanics Received a Shock; They Discovered a Shock-Absorber Bolt Loose and Hanging by One Thread

deer and moose. In captivity, some often remain inactive in their cages for weeks, while others beat against the walls of their confinement in suicidal desperation.

THIS INSECT FLIES THIRTEEN MILES A MINUTE

Swifter of flight, perhaps, than any other living creature, the lowly botfly can attain a speed of 815 miles an hour, according to measurements by Dr. Charles H. T. Townsend, formerly of the department of agriculture. It could travel from Washington to San Francisco in four hours. So rapidly do these insects move, that scientists sometimes resort to firearms to capture them, shooting the flies with .22-caliber cartridges loaded with dust shot or fine sand. Naturalists say that the high-speed motion-

HOME GREENHOUSE ADDITION EASY TO ERECT

Private conservatories are generally associated with costly and pretentious homes, but an eastern firm has placed a "knock-down" greenhouse on the market sufficiently simple and cheap to be used as an addition to modest dwellings. It is prepared ready for erection, all parts being cut to fit, so far as possible. The outfit includes plant benches with galvanized steel frames and replaceable bottoms, ventilating apparatus and heating coils with fifteen feet of piping to the boiler. Putty, paint, bolts, nails and screws are also furnished. The conservatory can be placed on concrete footings.



Conservatory Added to Dwelling; Parts Are Prepared Ready for Assembly

Hitchings & Co, Elizabeth, N.J.

1982

Emb. S. O. Winters
Electric National Bank Bldg
Washington D.C. 20713

101 Park Av. New York
6700 N. Broad St. Dallas
Dorset, Mass.
Boston
Philadelphia
Chicago
San Francisco
Barre, Pa.

2679

PLACES DESCRIBED BY VIRGIL
FOUND IN ITALY

Explorers in southern Italy are reclaiming scenes described by Virgil and other ancient writers from the borderland of myth. Scholars from the national museum and the university of Naples, in attempting to trace the wanderings of Aeneas, have found that one of the great buildings described in the "Aeneid" was the temple of Apollo, the ruins of which are now being excavated from the acropolis at Cumæ. Virgil tells of a hundred doors that led from the temple to the Sibyl's sanctuary beneath, from which voices issued at her call. Archeologists have dug out fourteen circular shafts, each two feet in diameter and leading from a cave to the temple. They originally were topped with the bronze heads of goddesses through which ran little tubes, terminating at the half-parted lips. This indicates clearly, scholars say, how the alleged voice of the oracle was produced.

NEW HEAT-RESISTING STEEL
STANDS TORCH TEST 1611

A steel composite introduced by a western man is said to be so thoroughly resistant to heat that an acetylene torch has little effect on it. A demonstration recently showed that a hole could not be cut in it with the torch, and it resisted also other heat tests.



Trying Vainly to Melt the Steel with Torch

4115 Newbury St. Dr. J. Joseph
Dr. J. Joseph
Los Angeles, Calif. c/o Mosler Safe Co.

1853

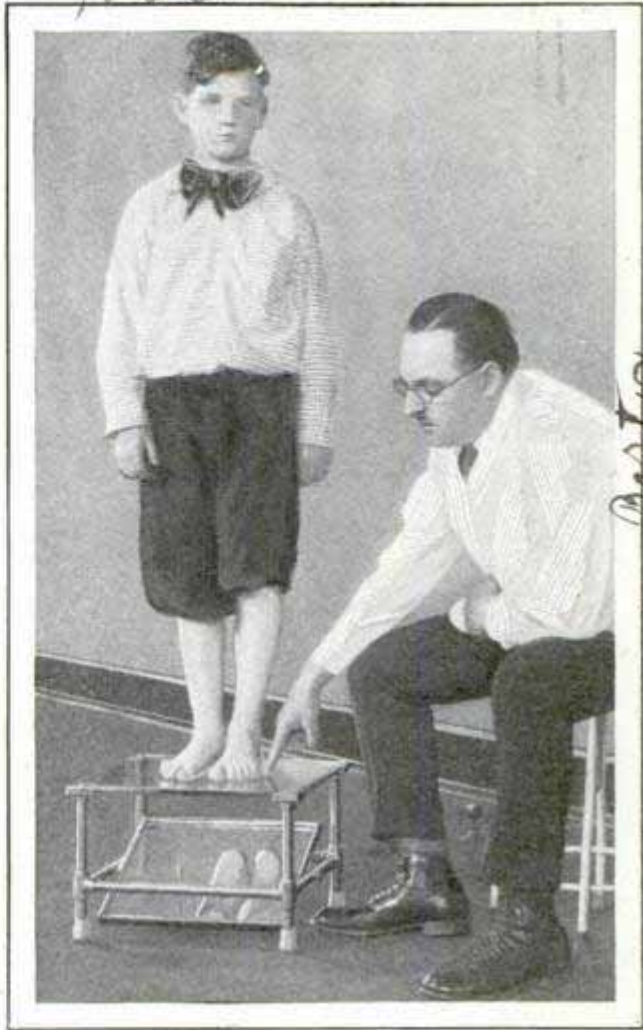

If the Child Has Flat Feet, the Ailment Is Plainly Revealed in Reflecting Mirror Below

MIRROR REFLECTOR FOR FEET
HELPS FIT SHOES

Both the top and the bottom of the foot can be seen at once with the aid of a reflecting apparatus an eastern physician has devised to aid him in studying pedal ailments of children and others. The subject stands upon a glass beneath which is the mirror, so adjusted that the sole of the foot is plainly visible. Fallen arches and other troubles are revealed by the use of this reflector, and an examination of the feet in this manner helps to determine what kind of shoes would be best for the person to wear.

Boston
Lelyveld, at Childers Food Clinic
Which Co. Boston, Mass.

Dr. J. Joseph
4115 Newbury St.

At no place in Cuba is the sea more than forty miles distant.

John in the Forum

2117

MYSTERIOUS GAS FOUND ON SUN SOUGHT HERE

Coronium, one of the gases found in the sun's corona, may have a terrestrial existence, in the opinion of some scientists, although, so far, it has not been discovered in any of the stars. For many years, it was believed to be a new element, but is now thought to be an old one under physical conditions that have not yet been simulated in the laboratories. In that respect, the gas is in somewhat the same status as was helium. This gas was found in the sun nearly sixty years ago, but it took more than a quarter of a century to discover it here. Helium, found in natural gas wells, is now made available for aircraft use by means of improved processes which have reduced its cost from \$1,000 to ten cents per cubic foot. It is expected that coronium may be located in the surface of the earth.

Practical

SMALL-CAR GARAGE HAS SPRING ROOF

For storing small automobiles, such as are used in England and on the continent, a garage with a top adjusted on a spring hinge, saves space and can be opened or closed by a child. The entire top rises or descends somewhat like the door of a mousetrap, and the garage is being made in such numbers that one can be purchased for only a few dollars.

1807

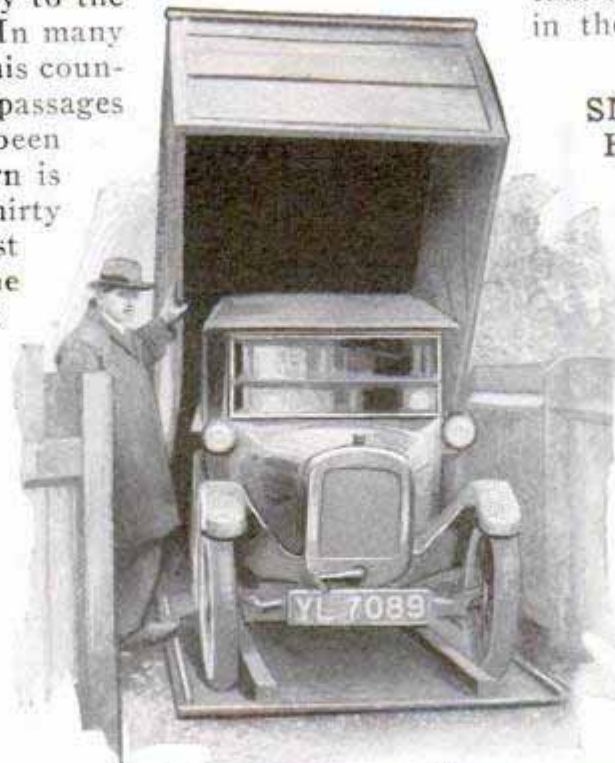

Lowering the Roof and Walls of the Snug Garage; Cleats on the Floor Aid in Backing the Car Straight

*Sordon England. Ltd.
Helsham Road. Pictrey*

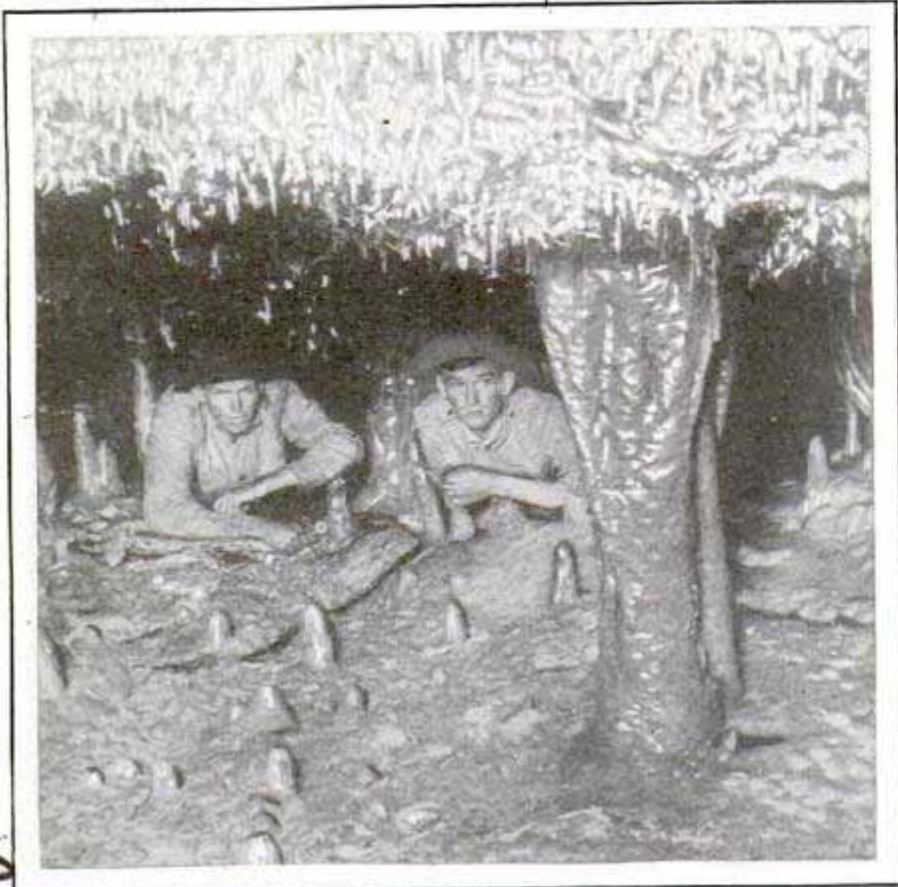

U+U.

Inside Diamond Cave; the Cavern's Beauty Has Delighted Travelers and Many of Its Passages Are Yet to Be Explored

© Olympic Jones

DEPTHS OF BIG DIAMOND CAVE LURE EXPLORERS

Persons with a longing for exploration do not have to journey to the poles for adventure. In many of the large caves of this country are deep, twisting passages that have never yet been visited. Such a cavern is the Diamond cave, thirty miles from the nearest railroad station in the heart of the Ozark mountains. More than twenty miles of its interior have already been explored, and it is said by many to be one of the most beautiful of the large caves of the world. Fantastic shapes, spires and minarets have been formed from the accumulated deposits of drippings.

near Jasper, Arkansas.

1868

175 1 1/2 miles 306 & Wabash. Chicago

TRIPLE ORGAN FOR SIX-THOUSAND-SEAT THEATER

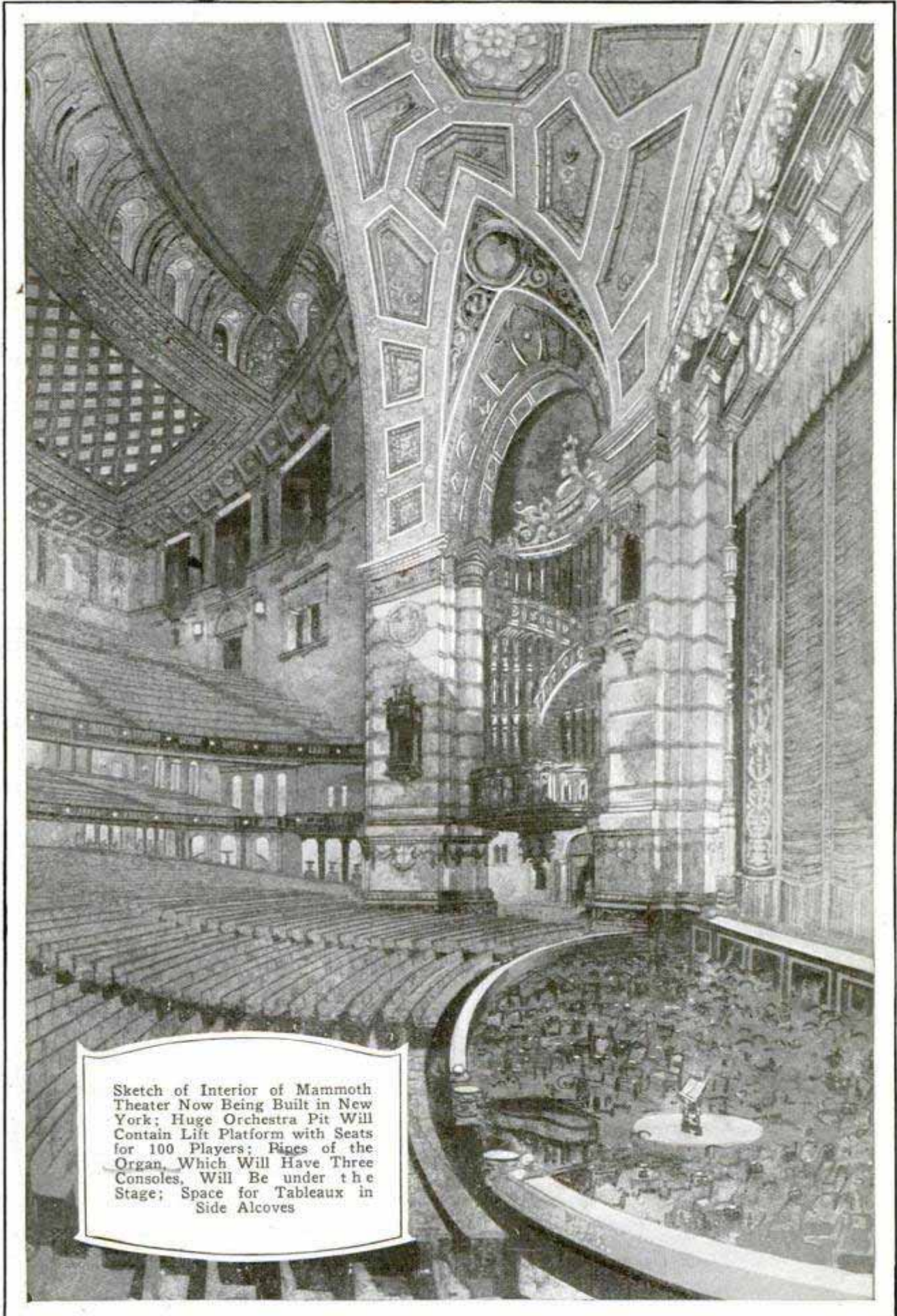

Sketch of Interior of Mammoth Theater Now Being Built in New York; Huge Orchestra Pit Will Contain Lift Platform with Seats for 100 Players; Pipes of the Organ, Which Will Have Three Consoles, Will Be under the Stage; Space for Tableaux in Side Alcoves

Theatre architect - Walter W. Ahlschlager²³⁷
65 & Huron. Chicago

1899



Outfit in Various Arrangements to Show Its Many Possibilities; Note the Fire Shield on Stove

**FOLDING STOVE FOR CAMPERS
 FITS UNDER AUTO SEAT**

1899 Including an oven, a grill and a frying pan with a folding handle, a collapsible steel cooking outfit for campers slides into a canvas bag when not in use and can be stowed under the rear seat of a small automobile. It is intended for open fires of wood or charcoal, and is so arranged that the cook can fry, percolate, boil, bake or toast foods all at the same time. Windshields on three sides keep the heat and flames directed on the cooking surface, and the oven has been constructed to afford even and effective distribution of heat.

**STATIC AIDS FOREST SERVICE
 IN FIGHT AGAINST FIRES**

2068 Static electricity, unpopular with the radio listener, may be "tamed" and set to work as the protector of property. Officials of the United States forest service have found that it has a distinct connection with the relative humidity in the atmosphere, the factor that does much to govern the occurrence and spread of fires. By measurements of the static's intensity and direction, observers are able to forecast periods of low humidity, when fire hazards are greater, and thus be prepared to combat emergencies. Static, the service also reports, gives a clue as to the probable occurrence of thunderstorms from one to twenty-four hours in advance. The importance and value of such warnings are fully realized when it is explained that nearly one-fourth of all forest fires happening in the western parts of the country are caused by lightning.

**ONE MAN PLAYS WHOLE BAND
 AND OPERATES "ACTORS"**

1760 To play four guitars, a music box, two sets of bells and two tambourines, besides operating fifteen "actors" who do stunts, a merry-go-round with animated figures and a Ferris wheel with occupants, is said to be easy for a western inventor. It is done by foot and knee power, actuating geared mechanisms which control the various units of the "theater." While operating the pedals, the player strums a fifth guitar.

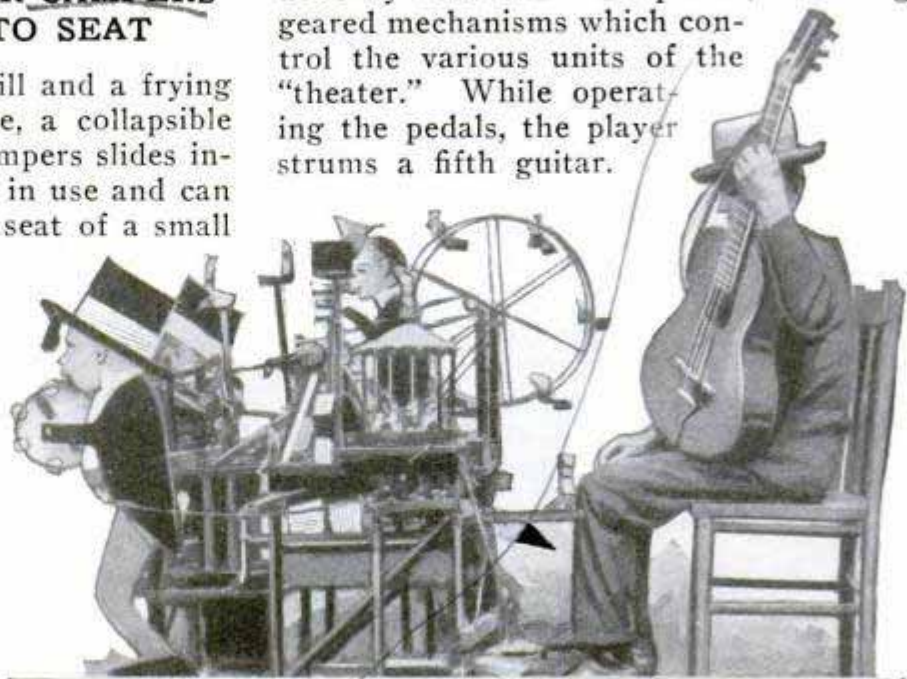

Playing the Guitar, the Operator Works Pedals and Levers with His Feet and Knees, Causing Model Actors to Perform

J. H. Burton, Neb.

CHURCH WHERE WASHINGTON SERVED IS RESTORED

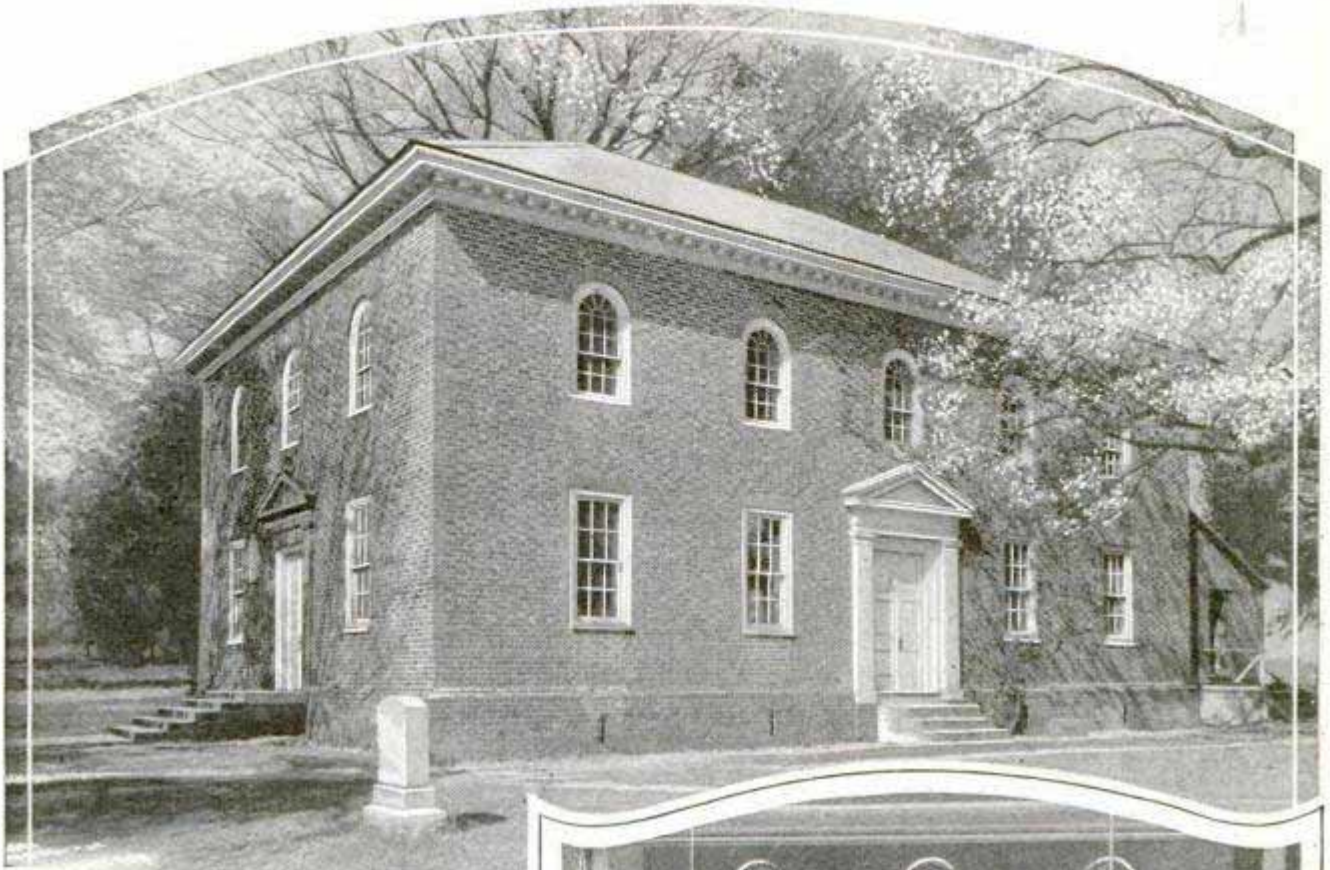

© Harris & Ewing
 Where the Father of His Country Served
 as Vestryman: the Old Falls Church as It
 Looks Rebuilt

Just as it stood when George Washington and its other vestrymen received it from the builder on Dec. 20, 1769, the Old Falls church, six miles out of Washington, D. C., on the Lee highway, has been restored recently for preservation as another shrine to the first president. The old church is as closely associated with Washington as the bigger edifice at Alexandria, Va., where he usually worshiped, and, in fact, both churches were served in that day by the same minister. The Falls church was first known as the "upper church" and that at Alexandria as the "lower church," probably by reason of their location in relation to the Potomac, river, which was the principal highway of the time.

Records of the parish show a frame church was built on the site in 1734, and on March 28, 1763, the vestry met to decide whether to repair this building or

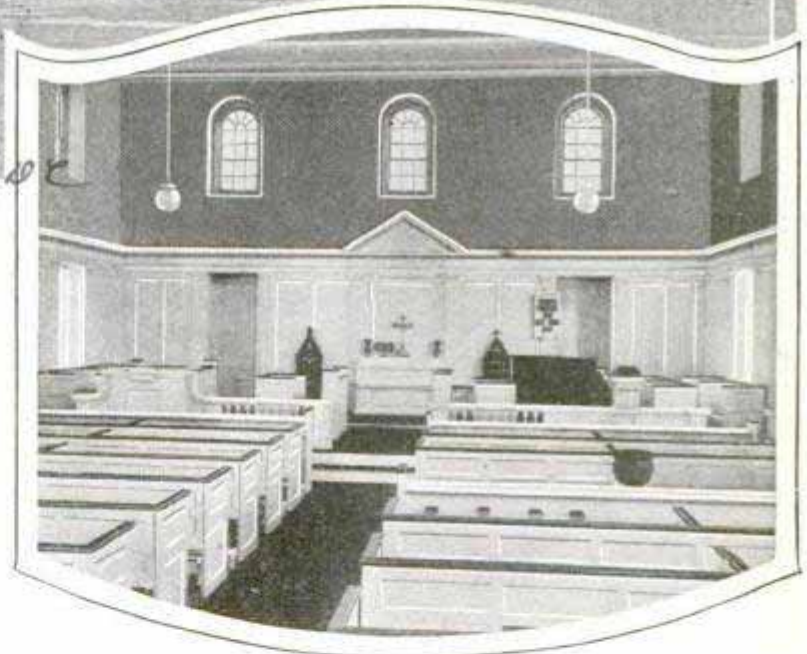

erect another. Present were eight vestrymen, including George Washington, and the two church wardens, and they decided to build a brick church on the same site. James Wren, a descendant of Sir Christopher Wren, the most famous church architect in history, was commissioned to prepare the plans, and the contract was awarded to him at a price equivalent to about \$3,000.

In the early part of the eighteenth century the church fell into neglect, as the result of the location of the capital, with its larger churches, near by, but in 1840 it

was restored, and continued active until the Civil war, when it was used first as a hospital and later as a stable for Union cavalry. The soldiers tore out two windows and knocked out the bricks beneath them to make doors for the animals. The recent restoration plainly shows the new bricks put in to fill the gaps.

The interior is plain but dignified, forty by sixty feet, with a height of thirty feet and a plain ceiling. The chancel platform runs the entire width of the building, with a massive white altar in Ionic style, white wainscoting, and, back of the altar, a wall paneled and handsomely carved. The side and front walls are tinted a light tan, and the ceiling is done in ivory white. The two rows of windows have small panes; in the lower row they are rectangular and in the upper finished in half circles. The building, standing in a two-acre plot, is surrounded by ancient trees, which can be seen through the plain windows, giving an effect, according to Archdeacon Neve, "more beautiful than stained glass."

PUNCHES FOR RAILWAY TICKETS REQUIRE MANY DESIGNS

2099 Designing more than 100 different cuts or patterns each year for conductors' ticket punches is the task of an eastern man. The cutting part is an eighth of an inch square and the design must be one that can be duplicated in metal to afford cutting edges. By means of the different-shaped holes in the tickets, auditors are able to identify quickly the various divisions. On one large railroad, each conductor is provided with three punches all with the same symbol, which is never allotted to another conductor on the same road except in case of the death or retirement of the original holder.

BILLION-CANDLEPOWER LIGHT FOR AIRMEN

1589 One of the most powerful beacons in the world has been erected on Mt. Afrique near Dijon, France, to guide aircraft. It is visible for 300 miles, being plainly seen from the British coast, from Brussels, Frankfort and Milan, and is placed at an altitude of about 500 feet.

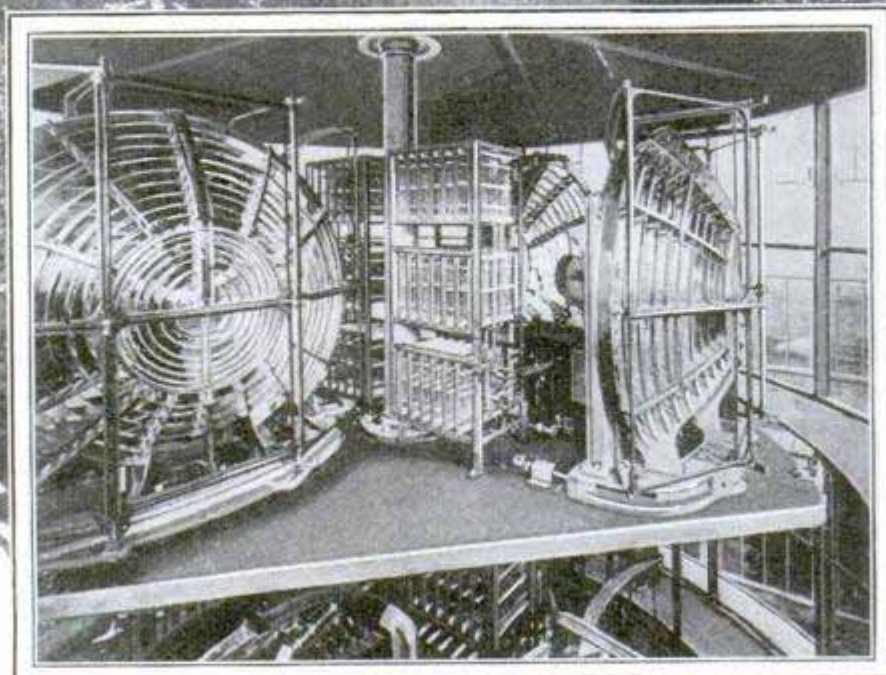

View of the Lighthouse on Mt. Afrique, Where It Is Visible to Aviators over a Wide Area, and Interior of the Lamp Room, Showing the Reflectors

RADIO SAFEGUARD FOR MINERS

Radio assumes the role of protector of miners in an instrument developed for the Pennsylvania fields. It operates in connection with the ventilating system and is intended to ring a bell if dust or gas collects in dangerous quantity. A simple radio circuit is employed, consisting of a variable condenser, a vacuum tube, a sensitive relay and alarm bells. While air passing between the plates of the condenser remains clear, the circuit stays open. But when it becomes filled with dust or gas, the circuit is closed and the alarm rings.

ODD DRIFTWOOD FIGURES MADE AS HOBBY

Images of weird beasts and birds are constructed of ocean driftwood as a diversion by a Pacific coast business man who spends many spare hours hunting odds and ends that will fit in with his fantastic designs. Ingenuity is employed in making these images. A beach moose, for instance, has horns made of fish bones, legs of Manzanita wood, while the round body is formed by a fishnet float. One of the driftwood freaks is obviously an ostrich and names for others may be conjured up, although some are difficult to classify. The hobby, however, provides entertainment for its originator and his friends.

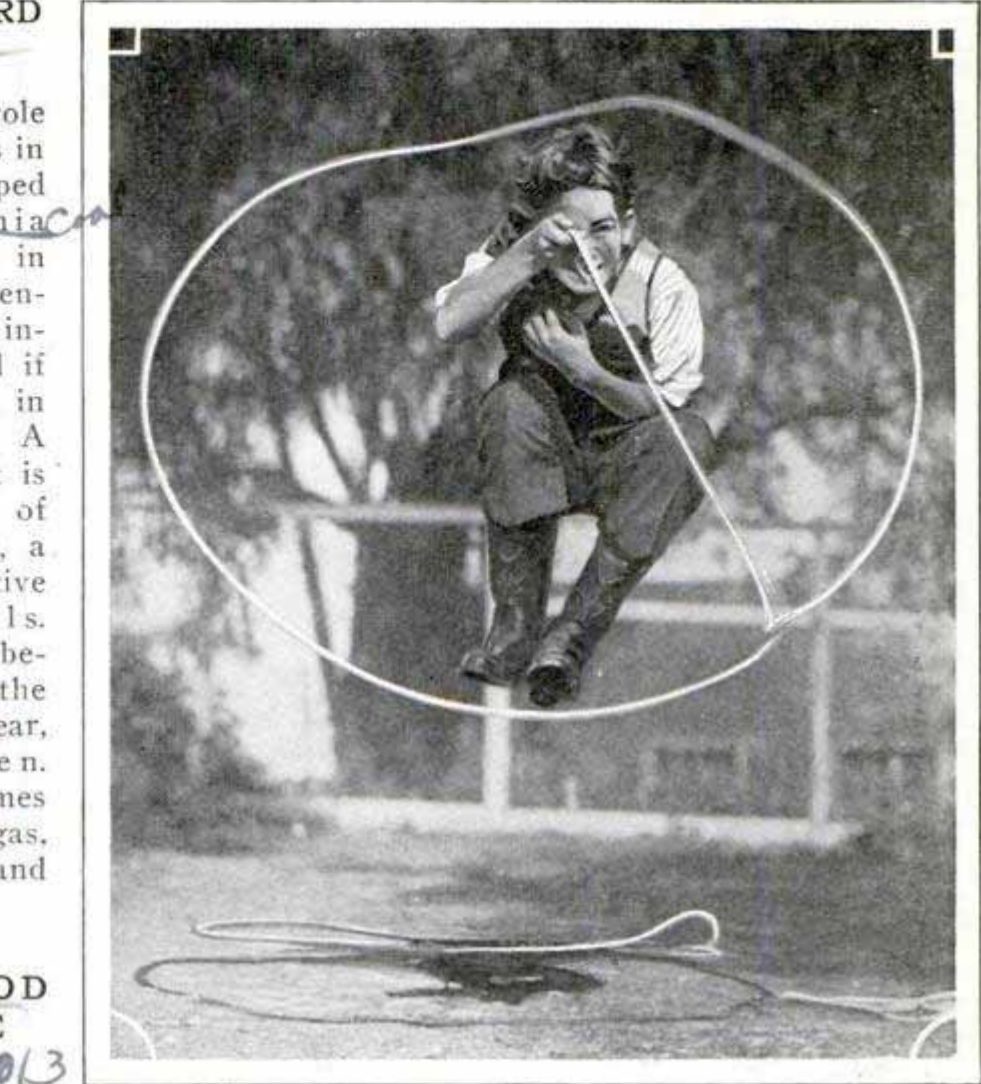

Young Cummings Jumping through a Rope Loop, One of the Favorite Stunts of Experts with the Lariat

SCHOOL-BOY CHAMPION ROPER AT AGE OF SIXTEEN

Donald Cummings, sixteen-year-old high-school boy of Los Angeles, has become the permanent owner of the William S. Hart roping cup, as he has won the contest three times in succession. He is champion youthful roper of the southwest and adept at stunts that tax the skill of much more expert lariat throwers.

☛ Blossoms for perfume are picked at the time of day when their scent is strongest.

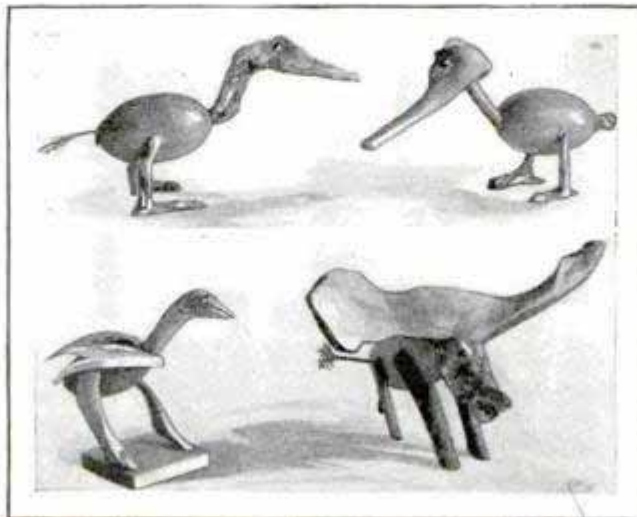

Odd Images Fashioned from Bits of Driftwood; Some of the Pieces Require Little Alteration

*Inquiries to - H. E. Thomas
911
Lunchley Ave / Portland, Ore.
made by Charles Schloth
Portland, Ore.*

1999

TWO INCHES OF SEA'S BOTTOM AS SEEN UNDER LENS



Tiny Submarine Polyps Suggesting a Fanciful Design for Women's Hats



Details of a Polyp Invisible to Unaided Eye, Revealed by Powerful Microscope Magnifying 15,000 Diameters

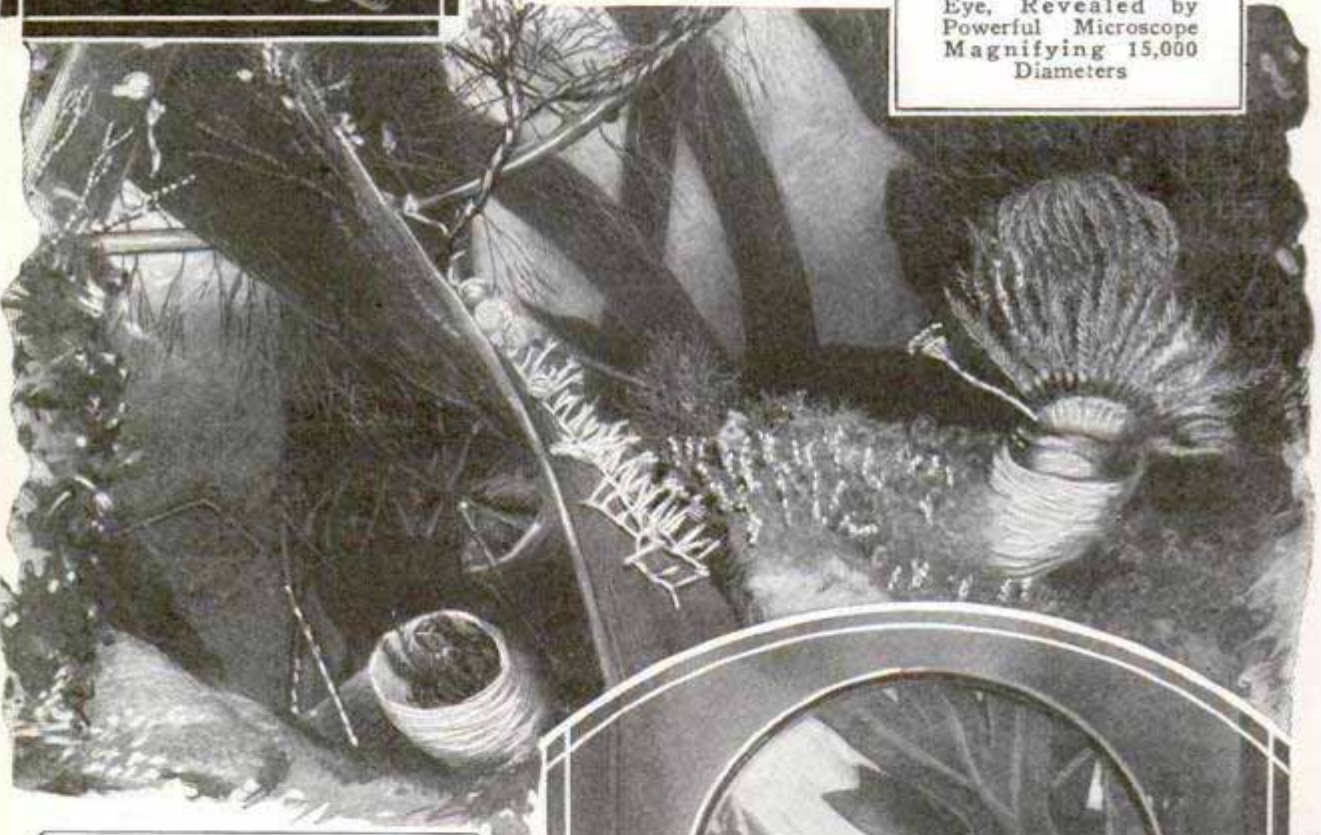

Above Is a Fraction of a Plot of Sea Bottom, Only Two Inches Square, with Its Weird Flora and Fauna as They Appear under the Large Microscope, and, at Right, the Whole Plot under a Reading Glass; This Intricate Wonderland Was Discovered in a Dead Scallop Shell and Contains, Among Other Things, Tube-Building Worms, Sea Mats and Polyps with Balloonlike Projections Budding from Their Sides; These Eventually Separate from the Parent Polyp and Swim Away; the Original Exhibit from Which These Photographs Were Made Is in the American Museum of Natural History in New York City

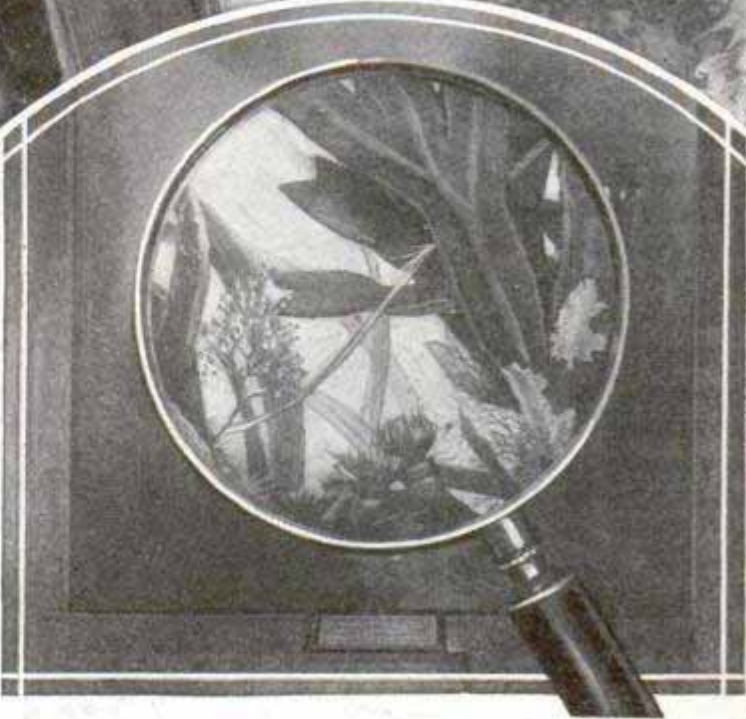

1998.

COPPER POISONING POSSIBLE FROM HOME BREW

The increase in bootleg and home-brewed liquors has called attention to the danger of poisoning from copper utensils, according to an eastern authority who points out that some samples contain as much as thirty-two milligrams of copper to the liter. The human system can absorb from five to ten milligrams a day, but beyond that point, there is danger, it is said. A kind of diabetes and other diseases are believed partly due to copper poisoning. In brewing, the organic acids in the mash attack the copper worm of the condenser, when that metal is used, producing a dangerous solution. Similar action may occur when copper utensils are used for ordinary cooking purposes.

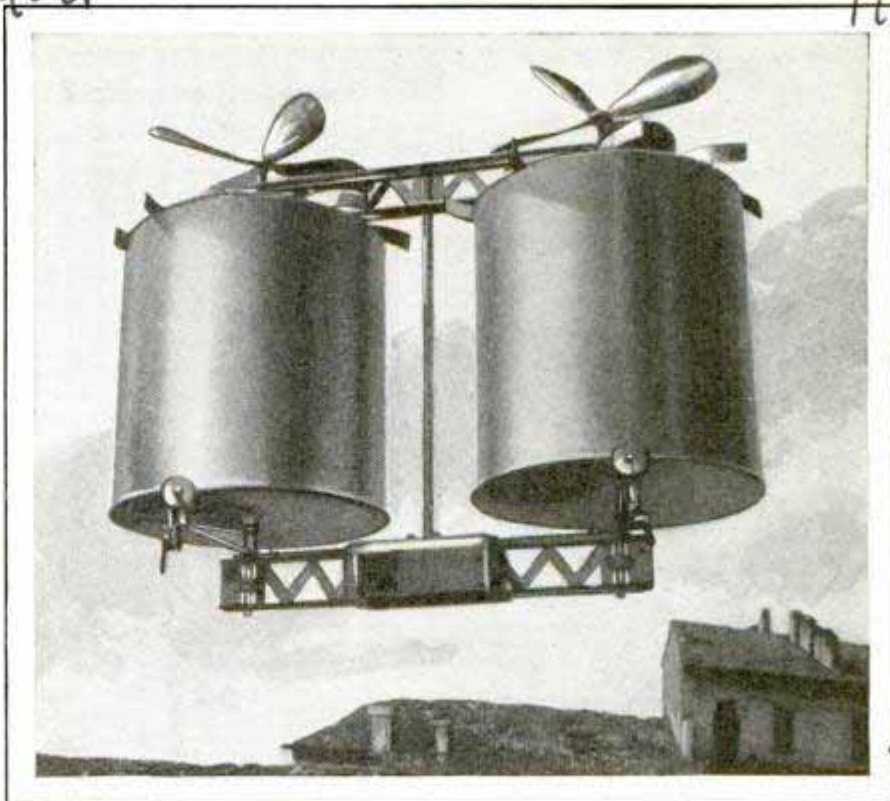

Flight of First Rotor Ship of the Air; Cylinders Are Filled with a Buoyant Gas and Revolve in Wind

FLIGHT OF AERIAL ROTOR SHIP LATEST IN AVIATION

Rotating cylinders, similar to those on the rotor ship, have been adapted to aerial use in a model patented by an Italian experimenter. The cylinders use the air currents for propulsion and are filled with gas to give buoyancy.

TINY PHONE FOR DEAF HIDDEN WITHIN THE EAR 2033

Almost entirely concealed, an electric aid for the deaf has no headband, the receiver being worn within the ear and the transmitter hidden under the clothing. About the only part of the apparatus visible when it is in use, is a portion of the small black cord leading to the receiver, most of which is also out of sight but securely held in place. Sound gathering and amplifying chambers in the transmitter, which is only one-fourth of an inch thick, are shaped to prevent distortion of tones.



Phone in Place; the Amplifying Apparatus Is Concealed within the Clothing

WHY WATERFOWL FLOAT 2087

Air retained in the feathers of water birds helps keep them afloat, naturalists have learned. Moisture does not work into the frills because they are so completely oiled that their surfaces do not get wet. Ducks swimming in icy water are kept warm because their body heat is preserved by an almost motionless blanket of air which is retained in the fine meshwork of feathers.

American Phonograph Corp. 19 W. 44th St. New York.

Elpidio Piccoli
Pavia, Italy
Prof. Joseph Paneroff, Kings College, Cambridge, England.

1230 Lynton Bldg. 1101 State St. Chicago

Best for
H. S. and

244
956

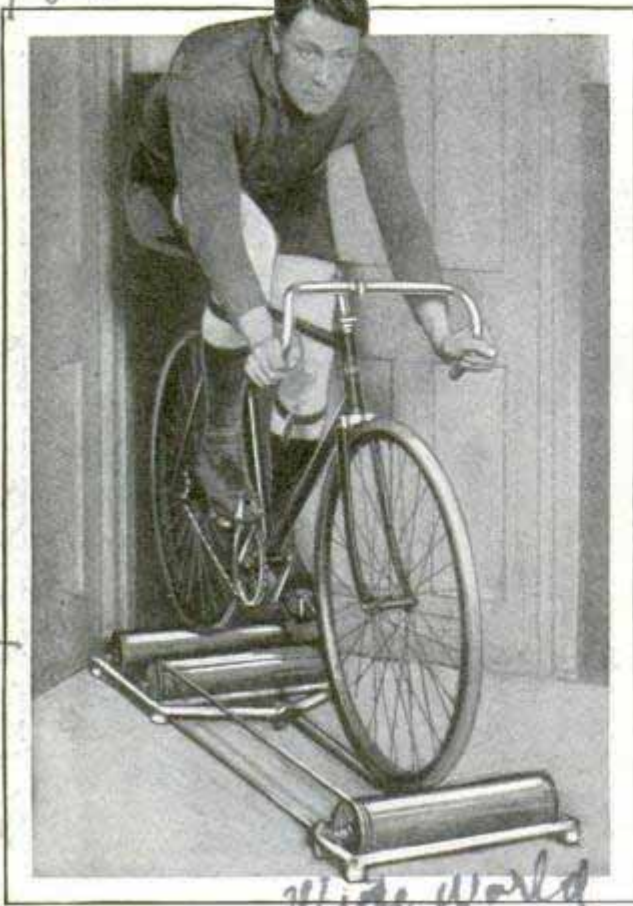

Pedaling Fast But Getting Nowhere; Cyclist Training on Wheel Held Stationary by Rollers

CYCLE RACER TRAINS AT HOME ON TREADMILL

Unfavorable weather does not prevent an English bicycle racer from keeping in training. He has arranged a roller-treadmill apparatus, places his wheel upon it and pedals at speeds of forty-five miles an hour in his home, the rollers keeping the bicycle stationary.

WHEN OCEAN CURRENTS STRAY 2131 FISH ARE DESTROYED

Death of half a million oysters has caused alarm among pearl culturists in Japan and may be due to an ocean current straying from its path, scientists believe. Such occurrences, upsetting the balanced plan of nature to which birds and fish adapt themselves, often prove disastrous to man as well as to wild life. In 1925, the warm El Nino current that flows along South America south of the equator wandered far from its usual path, probably due to the weakening of the cool Humboldt current from the Antarctic. Tropical fish invaded the harbors of Chile,

and millions of sea fowl that live along the rainless cliffs starved to death because they were deprived of their usual sources of food. Rains fell, sweeping 35,000 tons of valuable guano into the sea and damaging the deposits, while the warm wet spell gave mosquitoes an opportunity to breed in greater numbers and there was a consequent increase in malaria. In 1902, Norwegian fishermen experienced a disastrous season. The cod were small, arrived late and a cod-liver oil famine resulted. Greenland seals and white whales swam as far south as the Shetland islands. The cause was believed to be the failure of the warm current to reach the Arctic seas.

LAWN SPRINKLER ON ROLLER 2062 SAVES WETTING SHOES

Especially adapted to watering golf courses or large lawns, a sprinkler attached to a small roller can be pushed or pulled about by the hose so that the attendant does not need to walk in damp grass to change its position. Three nozzles are provided. They revolve in a clockwise direction, the outer ones cov-

Roller stand - \$15.00

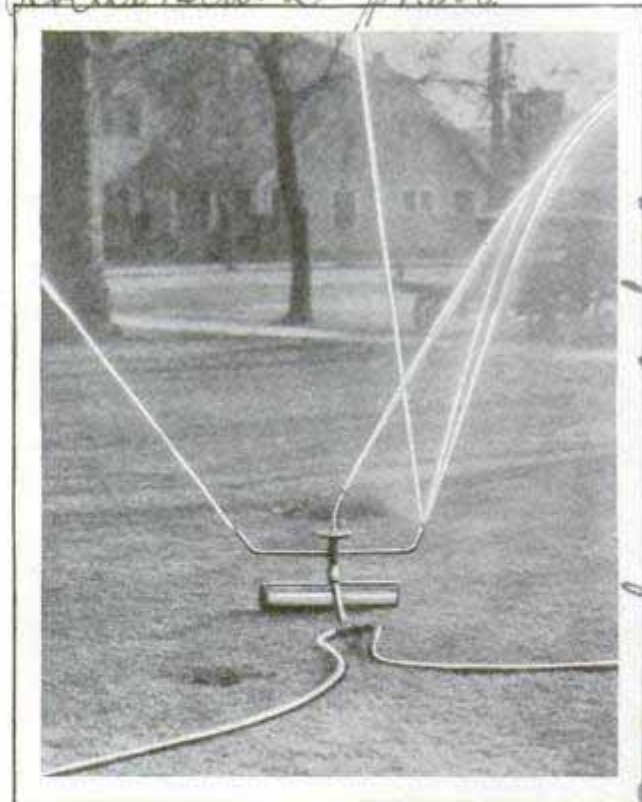

Sprinkler Nozzles on Cylinder Are Easily Moved by Pulling Hose without Danger of Upsetting Them

ering a wide area and a single inner one wetting the grass near the roller.

W. J. Bailey English Champion

Wide World

*Johnson
Huron
Blackstone Ave
Chicago - J. Clever
The Buckner Mfg. Co. 1615
Friends, Calif.*

*Continental Edition
London Daily Mail*

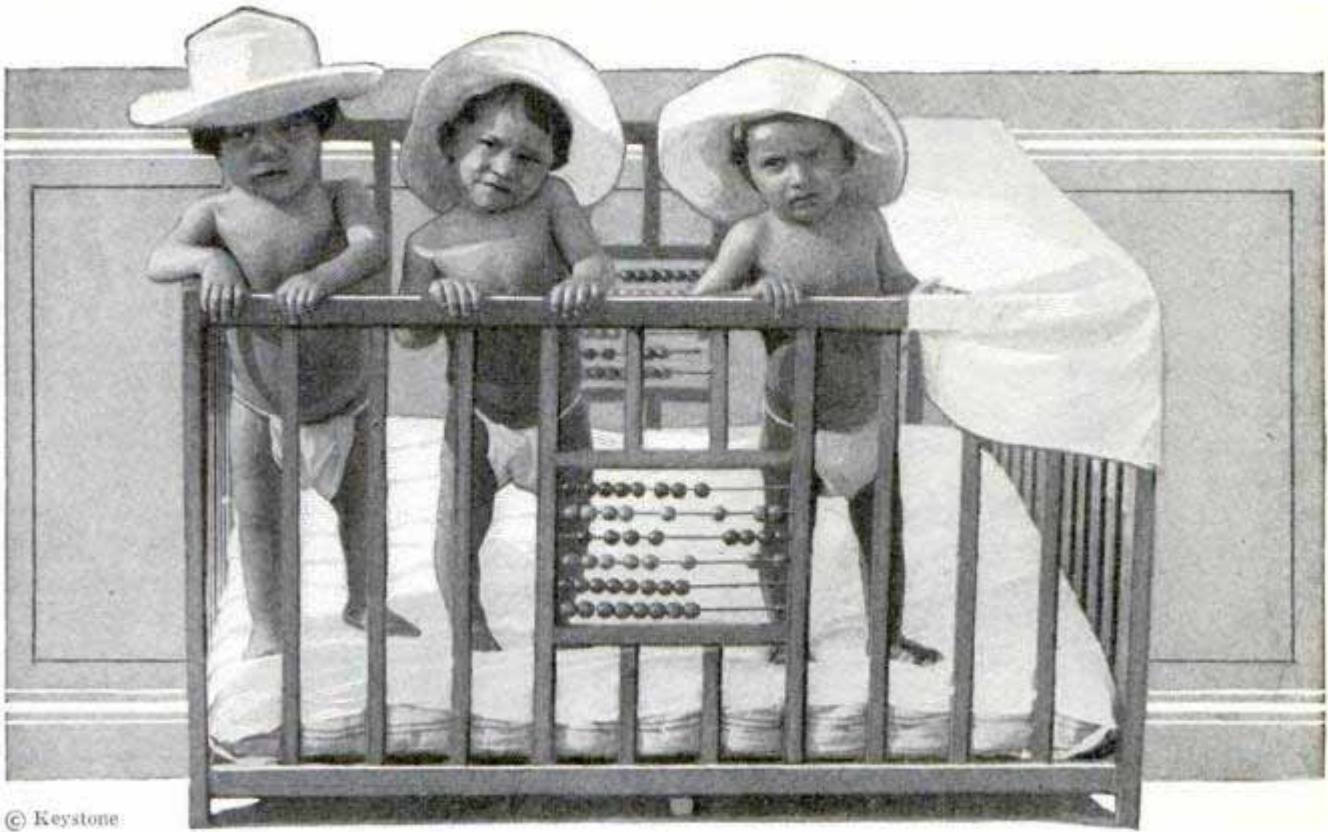

© Keystone

Three Young Passengers of the Hospital Ship, Which Cruises off Boston Loaded with Children Who Spend Their Days in the Cold, Open Air, Absorbing Health-Giving Ultraviolet Light

It's as Easy to Add Life to Your Years as Years to Your Life

By HERMAN N. BUNDESEN, M. D.

Commissioner of Health of the City of Chicago

SCIENCE has added another generation to the average man's life, and in the process we have become so accustomed to thinking of our health as something for somebody else to look after that we are beginning to forget our own personal concern in it.

We are told that our lives have been lengthened from fifteen to twenty years and let it go at that. What a lot of us overlook is that the increased length of life is due to the elimination of mass diseases, such as smallpox, yellow fever and diphtheria, that used to wipe out thousands and millions, but that we are still subject to common colds, pneumonia, rheumatism, kidney disease, cancer and other individual complaints. Of what use are the extra years if we are going through them crippled with rheumatism or some other infection?

It is just as easy to add life to your years as it is to add years to your life—and a much pleasanter job. One out of every ten people dies from pneumonia.

Few ever need die of that disease, if they eat the proper food, get the right amount of sleep and plenty of sunshine and build up a proper resistance.

We have found out a lot about food in the last few years, and the biggest discovery of all is that the best diet is useless unless accompanied by sunshine, either natural or artificial, or its substitute—cod-liver oil. That has been proved over and over again in the laboratories here and elsewhere. We have fed two cages of rats the same kind of food, kept them in a room where they got only the light diffused through ordinary glass windows, and exposed one cage for a short time each day to the ultraviolet rays from a mercury quartz lamp. The animals in the cage without direct sunlight, despite the best of food and care, languished and died, and those in the cage receiving the artificial sunlight thrived and grew fat. Change the process and give them plenty of artificial sunlight, but take out of their food any one of its essentials, and the rats

droop and die. Good food and plenty of sunlight go together.

Ultraviolet rays, whether from the quartz lamp or natural sunlight, must be taken in moderation, until the skin becomes sufficiently pigmented to resist burning. One minute's exposure under a quartz lamp the first day will cause a slight "sunburn," but the time can gradually be increased day by day as the tan pigment appears in the skin.

Sunburn from natural sunlight is not only exceedingly painful, but may be harmful. It can be avoided, however, by regulating the burning to produce a slow tan. From fifteen to thirty minutes' exposure is all anyone ought to have the first day. If the clouds are thick, or the air smoky, cutting down the passage of the actinic, or ultraviolet, rays, the time can be increased, of course. If you do get sunburned, the best treatment is cold cream and talcum powder. Use a mild cold cream of the type sold in tubes. Don't use a jar, as it has been exposed to the air and undoubtedly contains growing germs, while the tube type will be sterile. Rub the cream in very slowly, avoiding breaking the skin. Use only a clean towel to rub off the excess cream. Contact with anything unclean, if the skin is broken or peeling, offers an opportunity for infection to get in. Abscesses and virulent sores, and in some cases blood poisoning, are the penalties for failing to observe this caution.

Why do we have common colds and a sharp increase in pneumonia every win-

ter? It is because the sun is so far down to the south that we only get a portion of its ultraviolet rays, and because the pall of smoke over our cities keeps most of even that small part from reaching us. Then is when cod-liver oil comes to the rescue. It is the only known substitute for the ultraviolet ray.

Why do we eat a grapefruit or an orange for breakfast? They, like tomatoes, raspberries, lettuce, lemons and similar foods, are rich in the vitamin C, one of the essentials of a well-balanced diet. Try getting along without your quota of this vitamin and invariably you will develop scurvy. Vitamin A, which is found in milk, cream, ice cream, butter, spinach, eggs and also in cod-liver oil, prevents and cures rickets, malnutrition and bad teeth. We have found in our experiments with rats that if we take vitamin A away, one or more of these diseases appears without fail. Vitamin B, which also occurs in milk, as well as in whole grains, cereals, cabbage, tomatoes, spinach, beans and similar foods, is the one that gives you an appetite.

When a child loses his appetite, it isn't so much because he has been eating candy and sweets, but because he didn't eat his cereal and other foods containing vitamin B. One of the best ways to punish a naughty child, by the way, is to make him eat a plate of ice cream every day. Why? Because often naughtiness can be traced back to some deficiency in diet which has affected his health, and a child with a sick body can't think clearly. Give him ice cream, which contains milk, is rich in vitamins, fat, proteins, sugar and minerals, and you will build up his body and his resistance and give him a healthy mind.

If you give him the right food, plenty of sunshine and fresh air, and the proper amount of sleep, you will build up the bodily resistance which overcomes disease. If the neighbor's child has some contagious disease, the way to keep your child from getting it is not only to keep him away from the quarantined home but to build up his resistance also and thus enable him to defeat the attack of the germs.

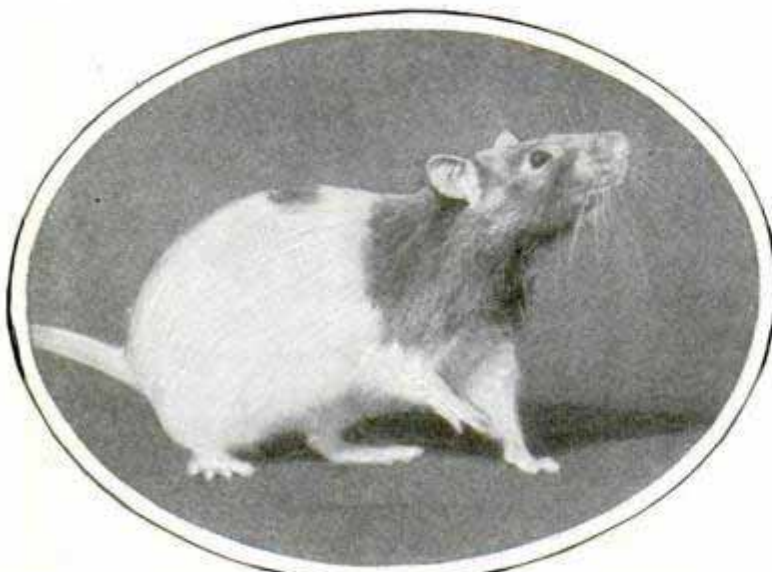

One of the Japanese Cape Rats, Which Reached America on a Freighter; They Grow to Ten Inches in Length

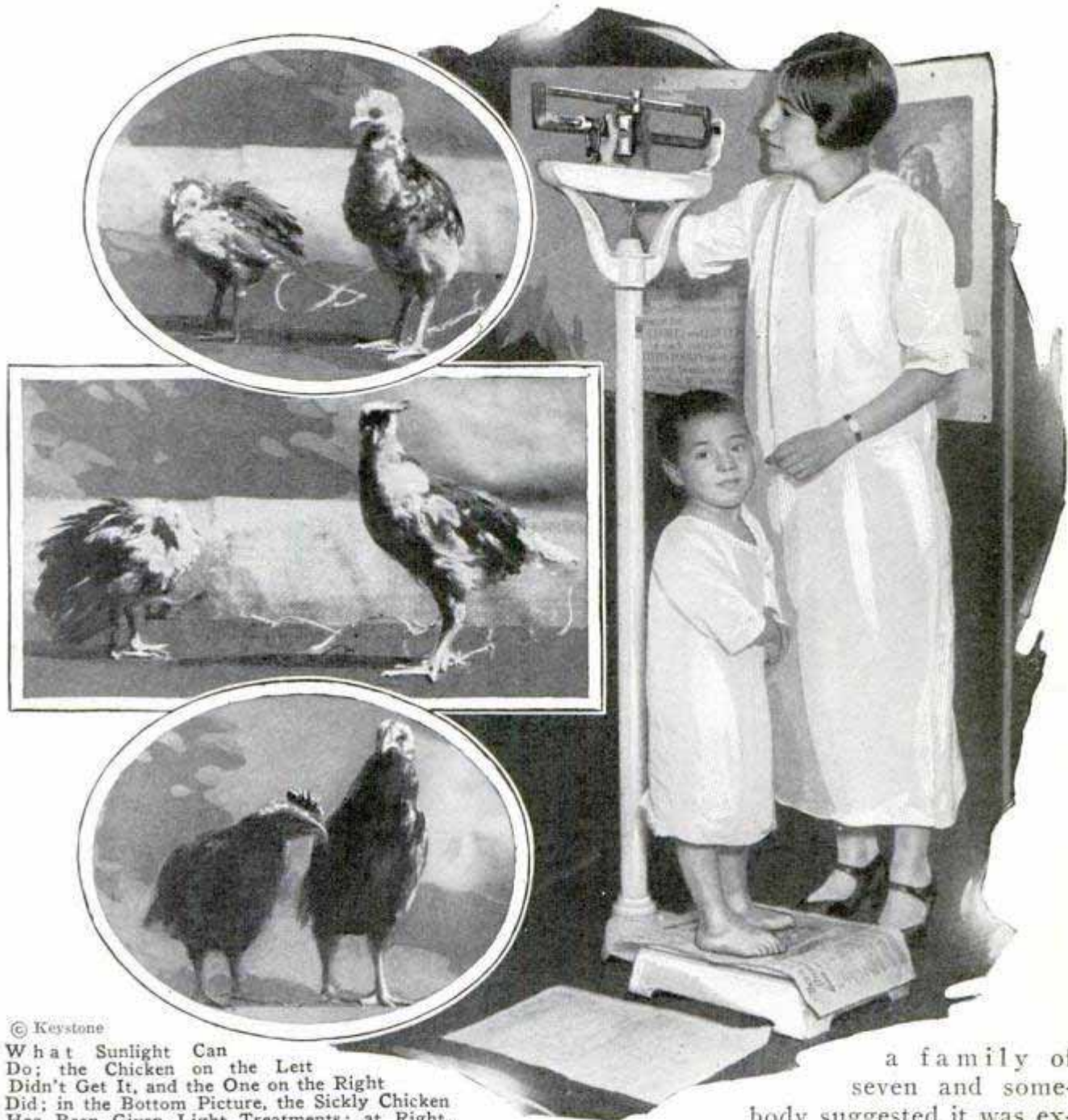

© Keystone

What Sunlight Can Do; the Chicken on the Left Didn't Get It, and the One on the Right Did; in the Bottom Picture, the Sickly Chicken Has Been Given Light Treatments; at Right, Weighing a Clinic Baby

A man told me the other day that he caught a cold because he forgot to wear his rubbers, and another said he got the "flu" from his boy who got it from another boy. They were both essentially wrong. The first one caught a cold because he didn't have the bodily resistance to defeat it, the second got the flu from his boy for the same reason. And don't be afraid of drafts. A draft has never killed anybody yet, but fear of them kills tens of thousands. A draft is nothing but good, fresh air, full of life-giving oxygen. The draft doesn't give you a cold, but the bad air before or after you shut the draft off may do so. If you have

a family of seven and somebody suggested it was extravagant to have seven individual toothbrushes when you might as well all use one, you would be revolted by the idea. Yet, you will sit around in a tightly closed living room, breathing the air that has been down in six other pairs of lungs and that contains more germs than could cling to any community toothbrush.

Every radiator in my home and office has a humidifier on it, evaporating gallons of water a day. Why? Did you ever stop to think why nature dictated that your thumb should grow just so long and no longer? We don't know, but we do know why she did a number of other things, such as providing that the mucous mem-

brane in your nostrils, and also your lips, should always be moist.

That moisture is there to catch and trap the germs which are floating around everywhere and to keep them out of your system. But in the winter time, if you live in a dry-heated house, the air will take up the moisture from your body and you will begin to crack just as the furniture cracks under the same conditions. The germs lighting on these dry, cracked surfaces find an easy way into your body and you get a cold, if nothing worse.

Out at the American Institute of baking they have been experimenting with the other big factor in health—that of balanced diet—by feeding different foods to groups of rats. Some of them were placed on a diet of potatoes, some on apples, some on spinach, others on cabbage, rice, baked beans, eggs, milk and bread. The rats that ate potatoes lost about a third of their weight and died in twenty-six days. Why? Because potatoes do not contain all of the vitamins. The rats that ate apples lived only fifteen days. A rat on a pure-butter diet, rich in necessary fats but lacking vitamins, lived thirty-seven days but lost about two-thirds of its weight in the process. The rat that ate rice, the principal food of millions in China, lived eighty-five days, while the one that was placed on a cabbage diet lasted but forty days. Eggs, milk and baked beans proved more nearly

complete foods and the rats that ate them grew faster and larger than those on an ordinary mixed diet.

In the bread experiments, a rat placed on a diet of white bread made with water died in eighty days, while those that lived on white bread made with milk grew at about the same rate as those on a mixed diet. That shows why milk plays such an important part in the human diet. When the miller turns out white flour he takes away its most important vitamin. Mix it with water for bread and it isn't a complete food, but mix it with milk and you not only get back all the food value the miller took away, but more for good measure.

One more thing about the common cold. Don't take cough medicine to cure a cough. First find out what caused the cough—bad air, poor food, lack of sunlight, the things that weakened your bodily resistance—correct that fault, and then, if you want to, take the cough medicine. You can't cure the cough with cough medicine as long as the original cause persists.

An extra fifteen or twenty years added to your life is pleasant, but put life in those years by keeping yourself so fit that disease can't get you.

☞ The temperature of the moon's surface, at its noontime, rises to 250 degrees Fahrenheit, scientists have calculated.



© Keystone
Scene in a New York Health Center Where Tenement Children Are Taught to Cook Well-Balanced Meals, Which They Then Eat, an Effective Method of Inculcating Diet Lessons

2000 *Transit Co., 1520 Spruce St. Phila.*
POPULAR MECHANICS 249
Batteries - Philadelphia Electric

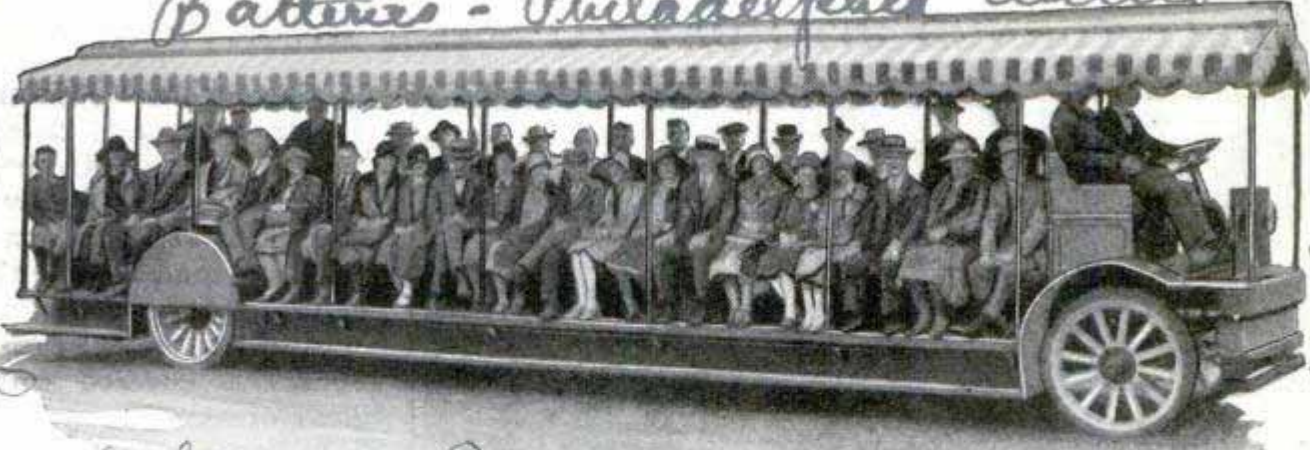

Storage Battery Co., Ontario and

Loaded for a Trip through the Exposition Grounds; Huge Side-Door Auto Truck for Carrying Passengers about the Sesquicentennial in Philadelphia; Conductor Walks through Center Aisle to Collect Fares

ELECTRIC BUS FOR EXPOSITION CARRIES FORTY PERSONS

Visitors at the sesquicentennial exposition in Philadelphia are carried about the grounds in an electric bus with two longitudinal seats, each holding twenty persons. The vehicle is operated by a crew of two men, has a speed of six to eight miles an hour, is over thirty-three and one-half feet long and weighs six tons empty. It is especially fitted to the service because of the ease of getting on and off. To collect the fares, the conductor passes down a center aisle between the seats. A fleet of twenty-five of the busses has been provided for the fair.

Berlin are all served by a central studio in which three programs can be broadcast simultaneously. One of the compartments is large enough to hold an orchestra of 150 members. Remote control is not favored in Germany, theater and operatic performances being given at the studios. Persons appearing before the microphone are paid for their time, even lecturers from the universities receiving compensation. In addition to this, some of the stations sell time to firms which wish to use radio for direct advertising.

FIFTY SHIRTS IRONED IN HOUR ON IMPROVED PRESSER

Shirt cuffs, neck bands and yokes are ironed at one operation in a time and labor-saving presser especially for laundry use. It is operated in somewhat the same manner as a steam clothes press, the various parts of the garment fitting into different spaces between the leaves. Fifty shirts can be ironed in an hour with this apparatus, the manufacturers assert.



Shirt Ironer in Operation; It Presses Cuffs, Collar Bands and Yokes at a Great Saving in Time

GERMAN RADIO FANS PAY FEE FOR LISTENING IN

For the privilege of listening to radio programs, Germans pay the letter carrier fifty cents a month and the money goes to the government for the encouragement of broadcasting. If there is a balance, it is applied to the taxes. Owners of receiving sets must have licenses. When a person acquires a set, it is customary to notify the proper official, who places his name on the radio list. More than 1,250,000 names are now on the records. The post-office department owns the majority of the shares of the broadcasting companies and issues the licenses to the private interests that operate them. A general co-operative movement has been accomplished throughout Europe as to assigning wavelengths to prevent interference. A number of large stations in

Commercial Truck Co., 100 Hunting Park Av. Phila.
Chassis - Atlantic City
Speaking from W.B. Es.

Roll Co., 65 na + Woodlawn Gr. Phila.
Body - J. Es.
Laundry
Massachusetts

David S. Loeve

Prosperity Co.

NIGHT TURNED INTO DAY TO MAKE PLANTS GROW

Boyer Thompson Institute for
2061
Plant Research, I. N. S.
Yonkers
N.Y.

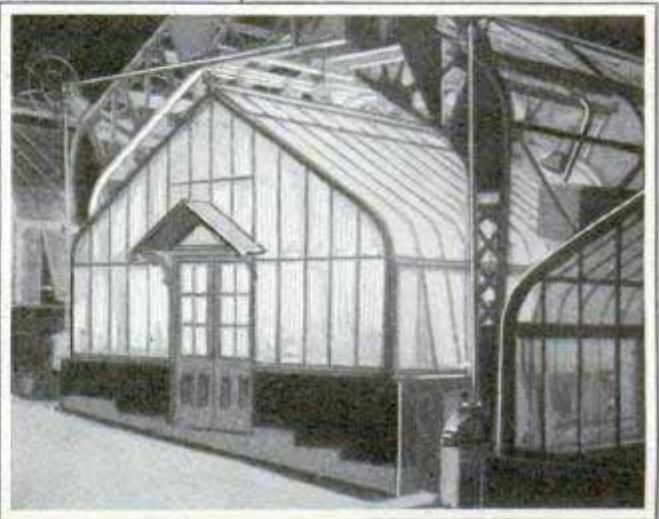
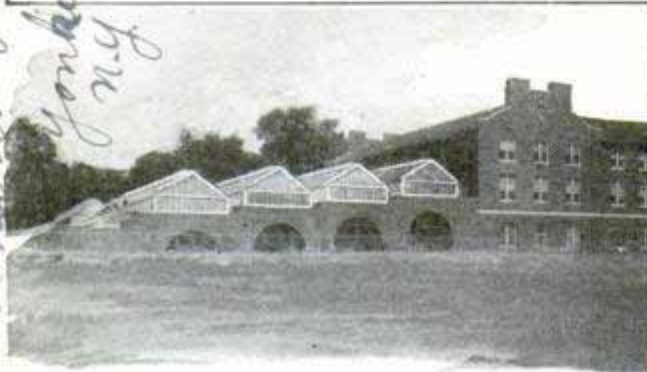

equipment into position and the observers check any differences noted between the plants' behavior under this illumination as compared with natural light. One inclosure at the greenhouses is covered with glass of varying ray-absorbing characteristics, so that certain rays of the

Interior View of Greenhouse, Showing Battery of Lights in Steel Frame; the Laboratories from the Outside, Illustrating Arrangement to Give Full Exposure to Sun, and a Lighted Section

Batteries of electric lights are used extensively in an eastern research laboratory in studying plant growth. The greenhouses are placed to receive the full benefit of the sun's rays during the day and, at night, cranes move the artificial lighting

sun which are injurious to plant growth may be investigated. Temperature and humidity are automatically controlled in the research rooms, and in a basement contrasts studies are made in two rooms, one absolutely dark and the other lighted.

AUTO MATS WITH PADDED SLITS KEEP OUT DUST AND DRAFTS

For the comfort of the small-car driver, slotted floor mats lined with padded material and fitted around the pedals and emergency-brake handle, keep out dust and air currents. They are shaped to fit without alterations, are quickly installed and are not likely to split or become ragged. Besides adding to the appearance of the



car and the comfort of the driver they save time and work as cleaning will not be needed as often as without them.

EARTH TREMORS ARE STUDIED TO PREVENT DISASTERS 2118

Study of earthquakes as with a microscope is now being conducted in California to help prevent such damage as occurred in San Francisco in 1906 and in Santa Barbara last year. The seismometer, an improved form of instrument for recording earth tremblings, is one of the aids in this work. It consists chiefly of a pendulum weighing hardly an ounce, attached to a tungsten-steel wire no thicker

Goodyear Tire & Rubber Co. Inc.
Akron, Ohio.

Pres. Geological Society

than a spider's web. The pendulum carries a small mirror which reflects a pencil of light that registers on a moving photographic film so that a picture of even slight tremors is obtained. By studying their frequency and intensity, a gauge of earthquake activity is afforded which may aid in giving forecasts, just as weather warnings are spread when storms approach. In the opinion of some scientists, earthquake centers are largely located in belts related to zones of growing mountains where there are wide differences in elevation. One belt surrounds the Pacific and another crosses the West Indies. The Carnegie institution is establishing four earthquake-observation stations in southern California.

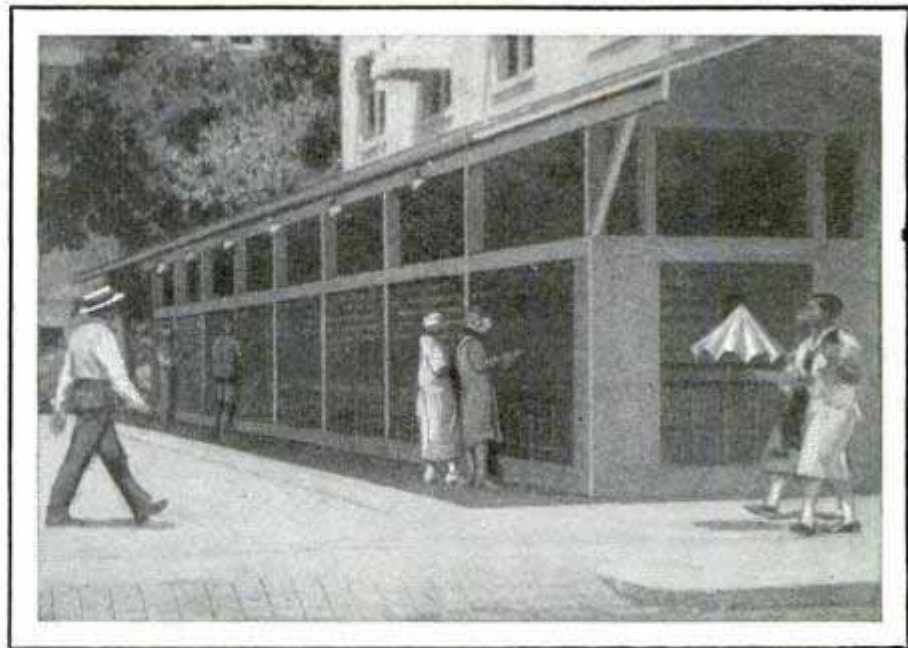

Post Office Lock Boxes in Alley at Miami, Fla., an Innovation Made Necessary by Lack of Space in Main Building

OUTDOOR POST OFFICE IN MIAMI HAS TWO THOUSAND BOXES

Lack of floor space in the Miami, Fla., post office led to the installation of more than 2,000 lock boxes placed outdoors in what formerly was an alley. A wooden shelter affords shade and electric lights set along the eaves illuminate the boxes in the evening.

2115 PERFUME FROM CRUDE OIL

Production of delicate perfumes from ill-smelling petroleum is one of the latest achievements of chemistry. Alcohols which recently have been widely employed as solvents for lacquers and similar substances are also prepared from crude mineral oils. Scientists predict that when petroleum becomes scarce and the remaining supply is wholly used in the manufacture of refined materials, fuel for internal engines may be made from coal and water. By passing steam over a bed of red-hot coal, "water gas" is formed. Conducted at high temperature and pressure over finely divided nickel, copper, iron or other metal, a combination of carbon and hydrogen is formed having high heating value.

1988 AUTO TESTED STANDING STILL UNDER ROAD CONDITIONS

To find out how the chassis of an English make of car will perform under actual road conditions, it is run in a special testing unit before leaving the factory. The rear wheels are raised from the ground and the apparatus so loaded that different gradients are reproduced in effect, while measurements are taken of the performance of the chassis as to speed, movements of gear changes, clutch and opera-

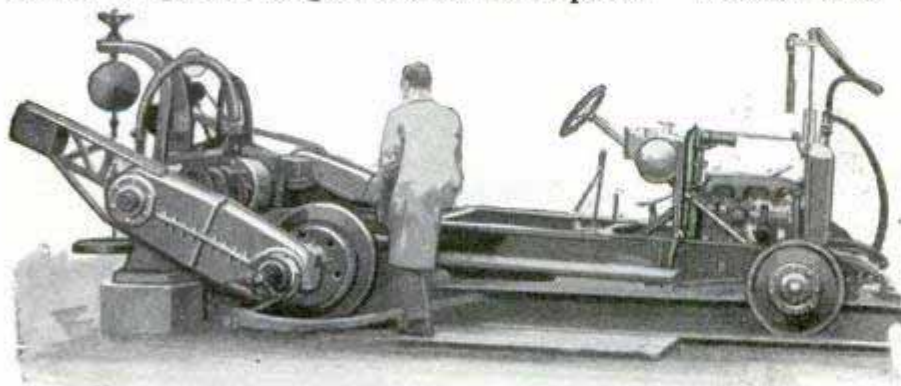

Giving Auto Chassis Road Test, While It Remains Stationary; Performance on Grades Is Easily Checked

tion of pedals and brakes. The test is done under the car's engine power and lasts two hours.

at Armstrong & Sibley Works.

*Mr. Paridley Adams
 Elm St. New York
 170
 Cambridge, Mass.
 Harold S. Curb.
 Arthur S. Liddle, chm.
 Charles River Road
 30*

1905

Novel and Useful



Worn Like a Wrist Watch, Recorder Registers Each Stroke by Touching Stem

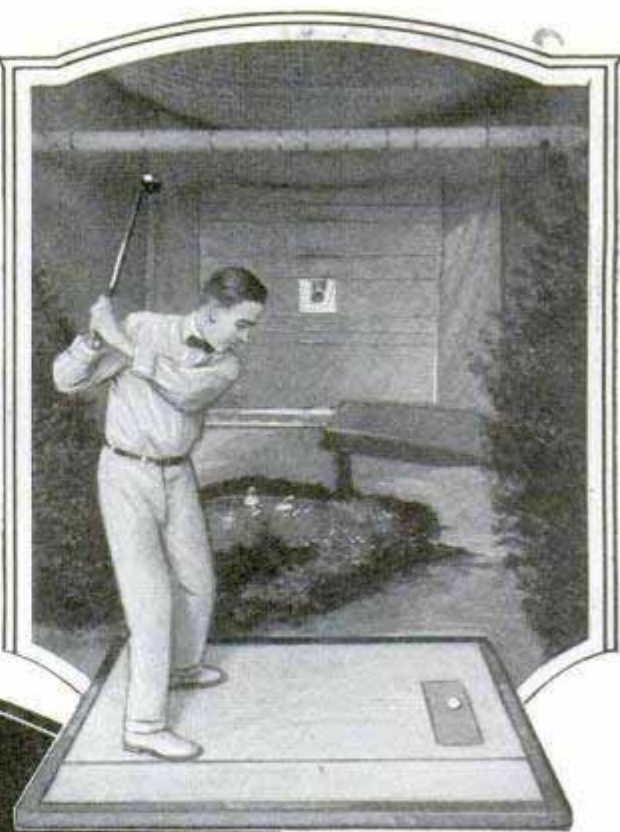

Hugh Meehan of Chicago Practicing on His Indoor Golf Course; Entire Equipment Is Quickly Stored Away

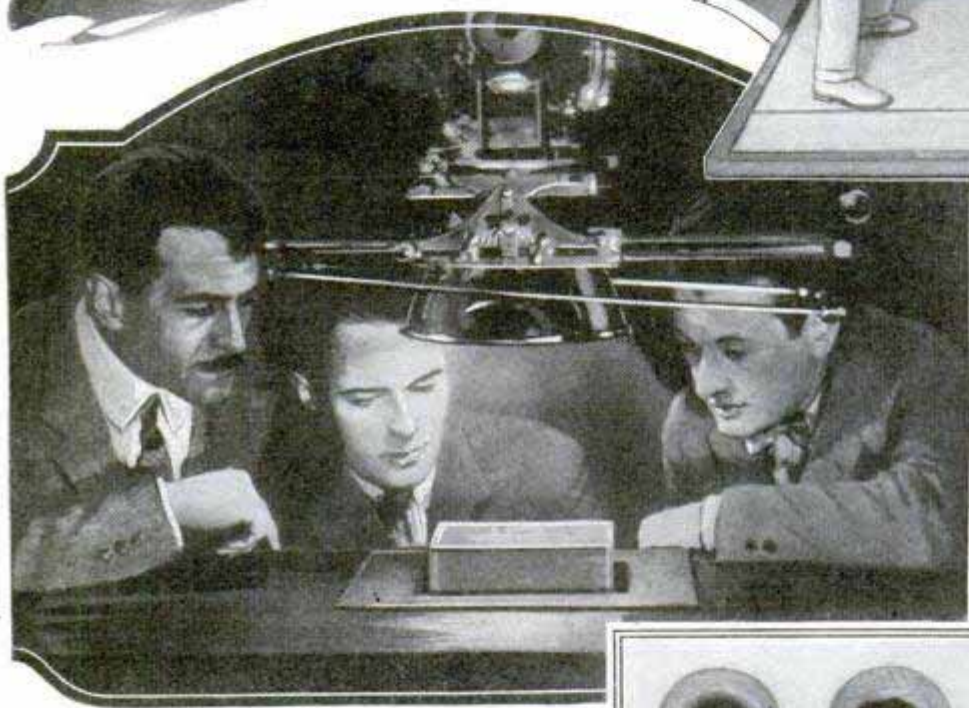

X-Rays Now Serve the Golfer in a Practical Outfit that Exposes the Interior of the Ball to Show If the Core Is Round; at Right Are Sample Photographs Showing Good and Imperfect Balls; Below, Apparatus for Putting Practice at Home; Putts from One to Eighty Feet Are Recorded; Ball Is Driven from Measured "Green" into Hole in End of Bottom Box, Affording a Fascinating Game and Aiding in Reducing the Number of Strokes on the Links

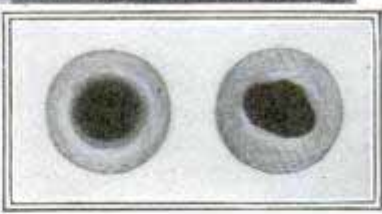

Side-Opening Golf Bag Has Shielded Top and Is Quickly Closed

Things for Golfers

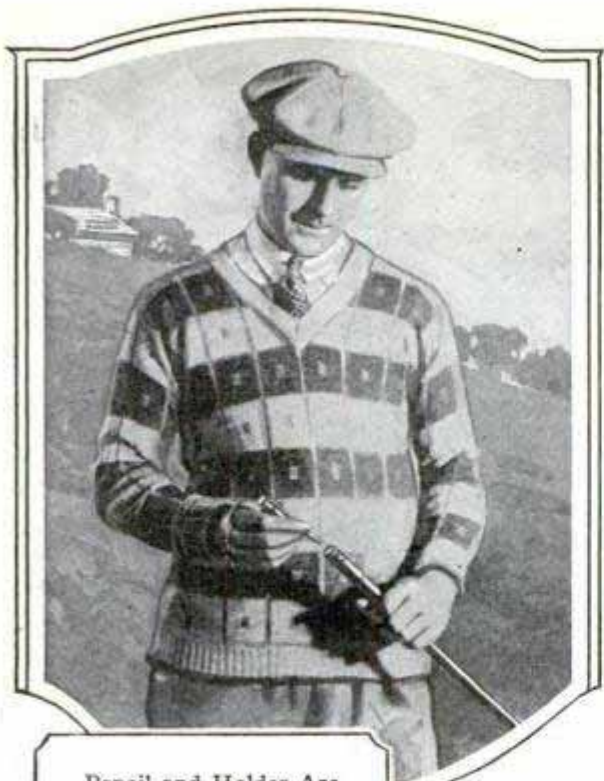

Pencil and Holder Are Easily Inserted in End of Putter for Use in Writing Score

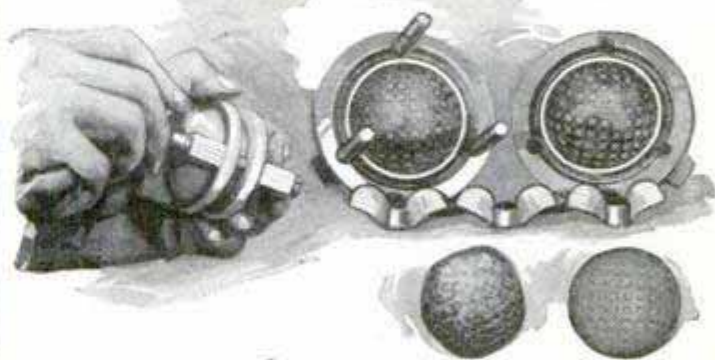

Mold for Repairing Battered Old Balls; with It, You Can Reshape and Mend Spheres at Home



Rack Snapped on Bag Keeps Different Clubs Apart for Quick Selection and, at Right, a Mirror Surrounded by Model Poses of Correct Strokes That Will Help You Improve Form

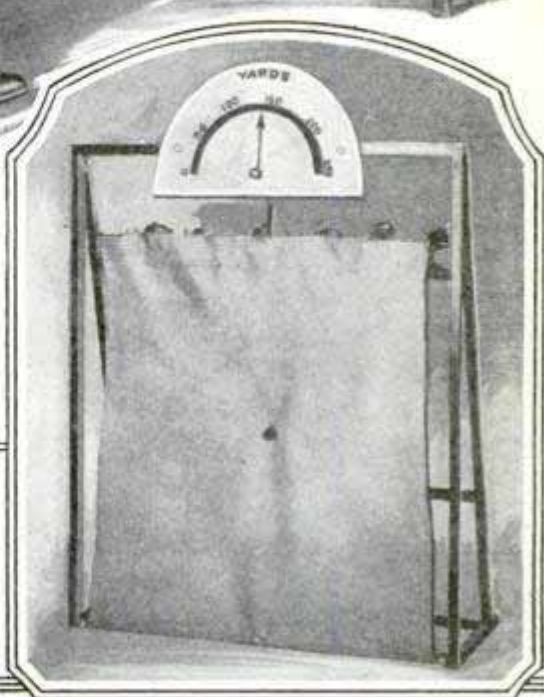
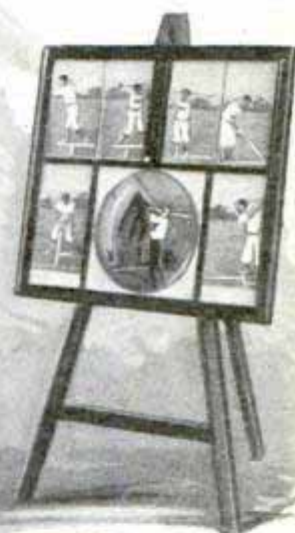

Arm Guide in Practice Helps Develop Muscles for Accurate Shots; at Right, Screen with Indicator Registers Yardage Equal to Trial Drives Indoors or Outdoors



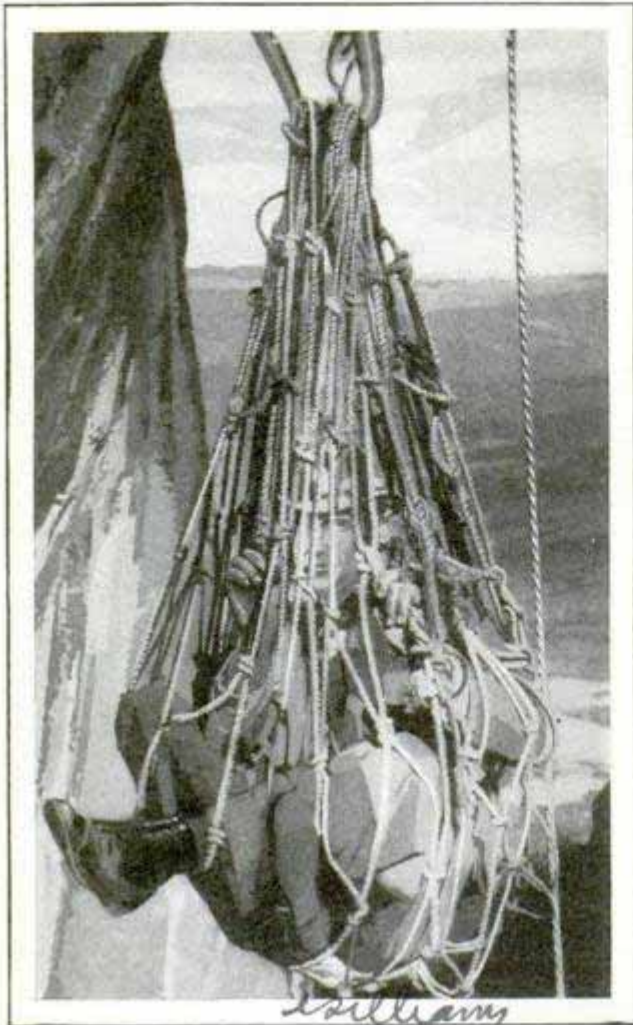

Nearing the Summit; Passenger in Rope Elevator Used to Lift Persons to Grecian Monastery on High Cliff

ROPE-BASKET ELEVATOR LIFTS VISITORS TO MONASTERY

Persons visiting the monastery of St. Barlaam, near Meteora, Greece, are lifted to the top of the 250-foot cliff on which the building stands by means of a rope-basket elevator. It is strongly constructed and woven like a coarse net for security.

SEARCH BATTLEFIELD OF AGES FOR LIGHT ON HISTORY 2091

To enrich man's knowledge of the past, scholars under the direction of Dr. James H. Breasted, of the university of Chicago, are digging into the ancient mound of Megiddo or Armageddon, in northern Palestine. More than 1,400 years before Christ, it was the scene of the first battle of which history has preserved a detailed account. Since then, down to the time of Lord Allenby's defeat of the Turks during the World war, the passing years have left their record. The mound is a veri-

table "layer cake" of history, awaiting the scientist's cutting. It was the strategic point of the martial crossroads between Asia and Egypt and, consequently, the battleground of the nations for centuries. Mud-brick walls and other debris from settlements and forts were washed down by rains to form new levels for later structures. This process, repeated again and again, has resulted in a piled storehouse of information, and by digging into the mound, scholars expect to find relics of battles mentioned in the Bible, historical records on stone and may be able to see the relation of one set of objects to the other, as well as the nature and order of events. The only previous work done on the site was by a German expedition nearly twenty years ago. When Dr. Breasted's excavators started, they found the top of the mound growing with wheat which native farmers had planted, but leased it from them, and already a large portion of the top has been removed.

THIRTY-INCH ELECTRIC METER, 1875 CAN BE READ A BLOCK

Thirty-two inches in diameter and weighing nearly 100 pounds, an electric meter built for a Chicago substation can be read from a distance of a block or more. It is designed to measure a current of 50,000 kilowatts, each division on the scale representing 1,000. Nearly three months were required to complete the instrument and it was necessary to calibrate the scale by hand. At night, it is illuminated by electric lamps with reflectors.



Huge Electric Meter to Save Steps in Substation, as It Can Be Read from Considerable Distances

*Jewell Meter Co.
1650 Walnut.*

at El Segundo, Calif

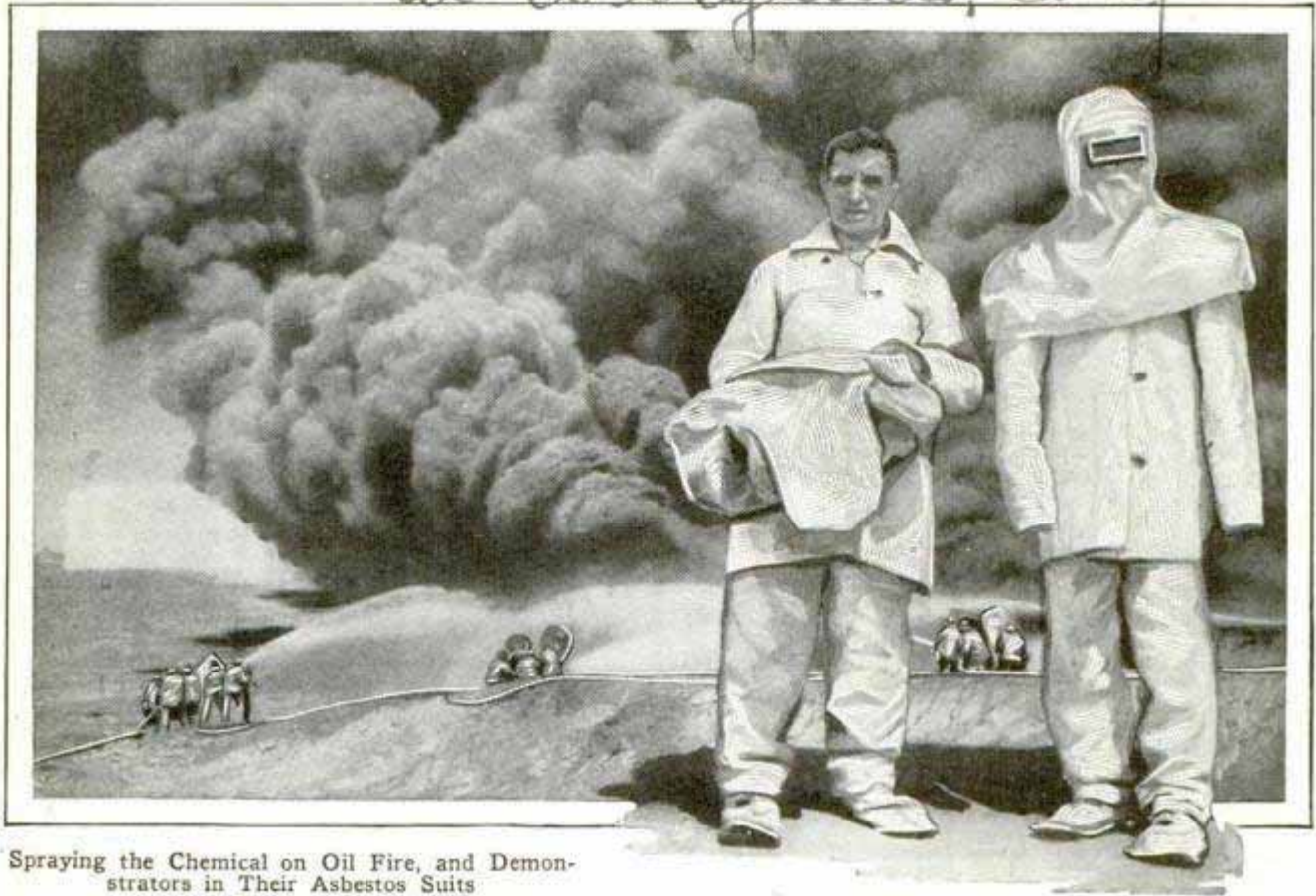

Spraying the Chemical on Oil Fire, and Demonstrators in Their Asbestos Suits

FIFTY-THOUSAND-DOLLAR FIRE TESTS NEW EXTINGUISHER

To demonstrate the effectiveness of a chemical process for extinguishing oil fires, a large tank of petroleum was ignited in California recently. Men, dressed in asbestos suits to shield them from the heat, applied the chemicals through hose. The test is reported to have cost \$50,000.

ARMORED CABLE TOOL REMOVES POSSIBILITY OF INJURY

To remove the steel covering on armored cable without injuring the conductors or the insulation, a pair of pliers has been patented. The tool will operate on three sizes without adjustment and it eliminates the use of a hacksaw and also the possibility of injuring the wireman or his clothing. It is especially adapted to tight corners. A pair of wide-mouth pliers also is provided in the tool, said to be

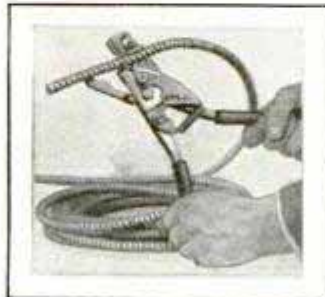

capable of all the functions of ordinary gas pliers. Heavy leverage is afforded and the cutting blades will sever wire, cable or non-metallic conduit up to half an inch outside diameter.

CLOUD OF WHITE BUTTERFLIES NEARLY HALTS TRAVELERS

Jungles are usually associated with forms of wild life far more dangerous than butterflies, but three travelers in a small automobile were nearly blocked recently, while passing through a densely wooded area in Ceylon, by a cloud of the white and yellow insects. The butterflies descended with smothering impact, producing the sensation of having been struck by a cotton hammer, according to one of the party who described the "attack." The wheels of the auto skidded and with difficulty made headway through the thousands of tiny bodies which covered the car and its occupants, forcing the men to shield their faces. The stifling encounter lasted seven minutes, when the butterfly legions were left behind. Millions of the insects gather in close formations such as this during migrations. Similar occurrences have been reported in this country.

Mr. J. M. Bidder
Loomis
2023

2116
Monsieur de Crissel.
Creme des fleurs
Paris

Triangle Conduit Co. Inc.
New Harbor Road and Cooper Ave.

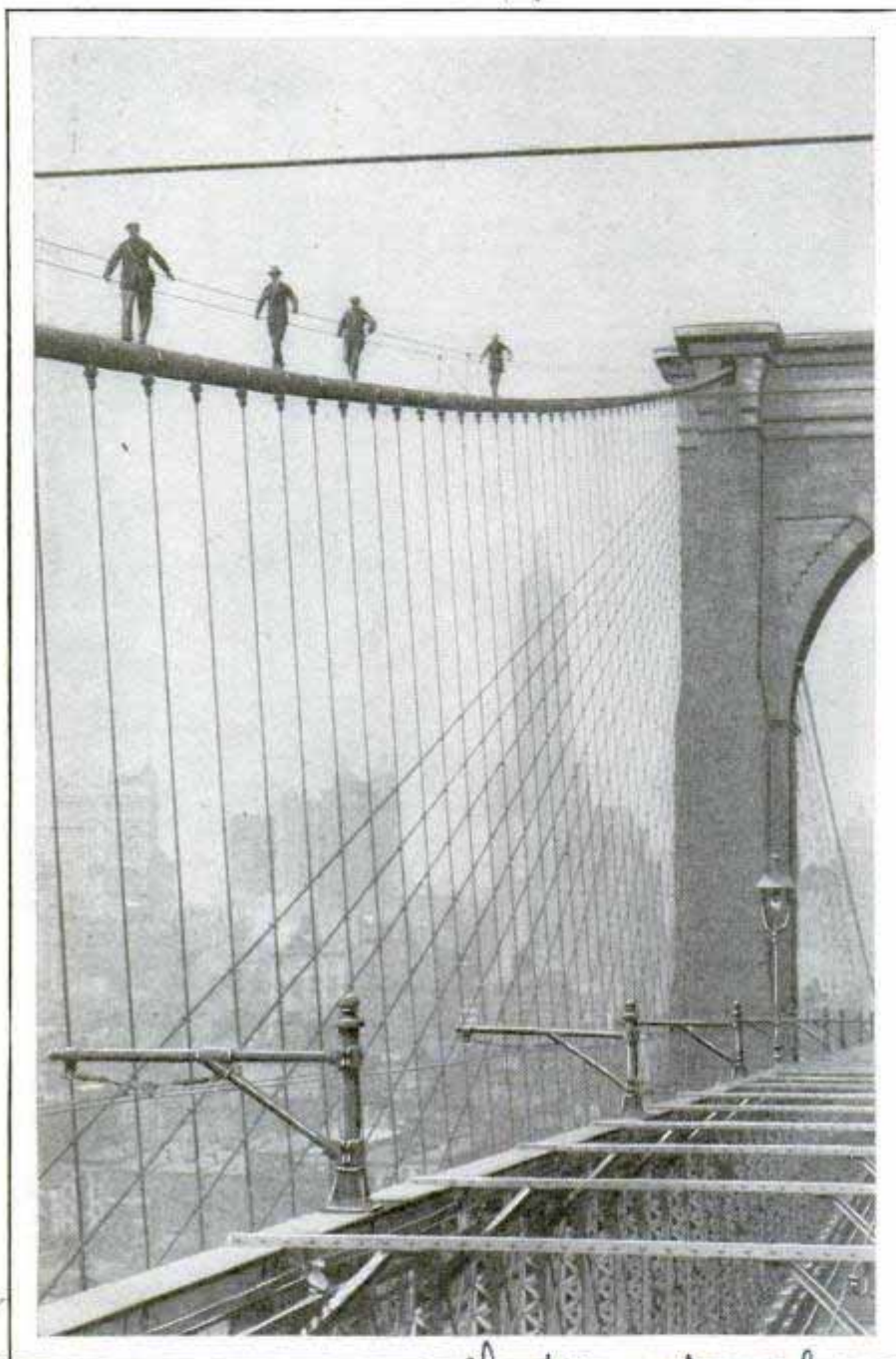

Proving That They Can Qualify as Brooklyn Bridge Cable Painters, Candidates Take the Walking Test Before Being Hired

PAINTERS TAKE CLIMBING TEST TO GET BRIDGE JOB

Applicants for jobs as painters on Brooklyn bridge had to satisfy the New York civil-service commission that they could climb about among the cables before they were accepted. The test, given to prevent needless loss of life through hiring inexperienced persons, eliminated several candidates at the start. Of the first sixteen men who had reported for work, only four made the demonstration climb to prove that they "knew the ropes" and were unsusceptible to dizziness.

COAL TAR YIELDS THOUSANDS OF COLORS

939
What is it about one color that makes it "fast" while another fades? To the average purchaser this is one of the unsolved mysteries. The answer lies in the retorts and stills where the tar by-product of the conversion of coal into coke is blended with such substances as salt or alcohol, acids or bleaching powder to produce not only the myriads of chemical dyes, but an even dozen deadly war gases and the elements of four high explosives, besides countless other things. Unlike paints, dyes are not the product of mixing. You can't take a blue dye and a yellow and blend them to get green. Each is the result of a separate process. When a color fails, it may be because the wrong dye was used, or because the wrong kind of material was used. Textiles produced specially for window drapes are dyed with color which will be fast to sunlight, but may not withstand washing.

Some of the brilliant chintz patterns adapted for drapes, however, may have been designed for another purpose and dyed fast to washing but not to sustained sunlight. The result is quick fading. The colors which are fast to nearly all the enemies of dye are, unfortunately, the less brilliant series, and mainly those which take well on cotton goods. Cotton is a vegetable fiber and a dye which takes well to it may be entirely unsatisfactory when applied to such an animal fiber as wool, or vice versa. Silk is an animal fiber which may not take the dye that goes on cotton, while artificial silk is a chemical

product which takes the same dyes as cotton or linen, both vegetable-fiber materials. Then there are combinations of cotton and silk, cotton and wool, and others, which must have their own special dyes. Some 10,000 have actually been produced on a laboratory scale, some 3,000 in larger quantities, and virtually 1,000 are available in the form of cheap commercial dye. Some of the tests made to determine the fastness of dyes are quite unusual. Sun exposure and washing can be easily duplicated in the laboratory, but chemists have never been able to reproduce the effect of perspiration, though its chemical composition is well known. One dye maker solved the problem by dyeing cloth and having it made up in shirts, which he presented to locomotive firemen, with the request that they wear them at their work, and then return them to the laboratory for examination.

SOLDIERS OF FOUR U. S. WARS HONORED IN MEMORIAL

Soldiers and sailors who fought for this country in the Revolutionary, Civil, Spanish-American and World wars are honored in a forty-ton monument designed by Gutzon Borglum and erected in Newark, N. J. It was cast in five parts in Florence, Italy, and welded into a unit by a special process. The entire group is eighteen feet wide, forty-five feet in length and cost, completed, about 125,000 dollars.

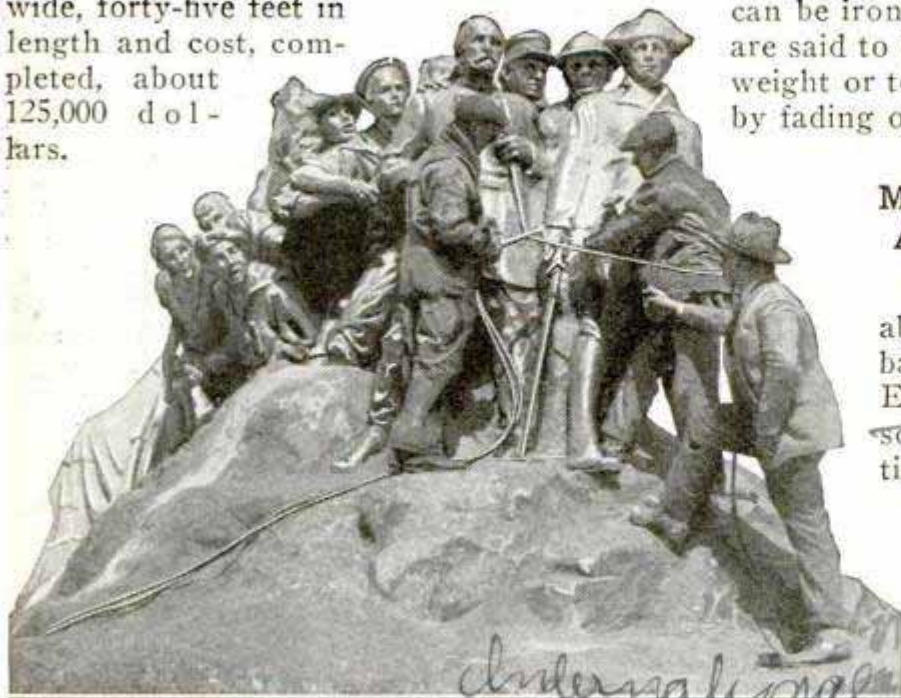

Welding the Forty-Ton, Four-Wars Memorial into One Piece; the Separate Units Were Cast in Florence, Italy



Ironing over the Flexible Beading without Fear of Crushing or Loosening It

FLEXIBLE BEADING FOR DRESSES IRONED WITHOUT BREAKING

Sparkling beads of many colors for decorating women's garments are being made of a flexible glasslike material so that they can be ironed without breaking. They are said to be adapted to fabrics of any weight or texture and are not damaged by fading or washing.

MOLDED-PAPER PIPE ABSORBS NICOTINE

Light in weight and durable, molded papier-mache tobacco pipes introduced by an Englishman are said to absorb practically all the nicotine as it is produced within the bowl. A specially designed mouthpiece prevents the rest from reaching the smoker's throat. The pipes cost less than the briar variety and bowls and stems can be replaced.

1910 Jewell
Cartier Road Printer, Ltd,
Newhampton, England,

Wide World
Ironing over the Flexible Beading without Fear of Crushing or Loosening It
MOLDED-PAPER PIPE ABSORBS NICOTINE
Light in weight and durable, molded papier-mache tobacco pipes introduced by an Englishman are said to absorb practically all the nicotine as it is produced within the bowl. A specially designed mouthpiece prevents the rest from reaching the smoker's throat. The pipes cost less than the briar variety and bowls and stems can be replaced.

Windy New York
Highly Valued by the
Cherished
d. w. A. W. McAllister
c/o George H. Holden, Esq.

*University of Nebraska
Lincoln, Neb*

*Miss A. Lawrence M. Jenkins
935 Columbus Ave
New York*

1848



Treating a Sick Parrot in Bird Hospital While Two Fellow "Patients" Look On

WOMAN DOCTOR TREATS BIRDS TO SAVE LIVES OF PETS

Ills to which birds are liable have been studied for the past twenty years by a New York woman who gives the pets medical attention or performs operations on them. Parrots and other kinds of birds often develop sicknesses due to the change in climate and food, and the average owner is little skilled in the proper ways of treating their maladies.

WHERE OCEANS COME FROM

Water imprisoned inside the earth blew off as steam, condensed and formed the seas, in the opinion of Dr. W. J. Humphreys, of the weather bureau. Other scientists are discarding the theory that the center of the earth is a molten mass, and believe that the core may be a solid ball of iron or iron-nickel alloy nearly 4,000 miles thick. The surface crust, one authority estimates, is not over thirty-six miles thick. It is lighter than the interior and may be separated

1976

from the core by a fluid or semifluid layer. One scientist holds that the earth was probably once a part of the sun's atmosphere. A passing star, attracting the sun, caused some of its atmosphere to break loose, and on cooling, it formed this planet.

FIFTY SLAVES WORK FOR YOU

Approximately 500,000,000 horsepower are now available from generating plants throughout the country, affording each man, woman and child the equivalent of fifty slaves capable of performing many tasks. The ancient Greek trireme with its ten marines, twenty sailors and 170 rowers was considered an efficient boat in its day, but a single modern vessel such as the airplane carrier "Saratoga" has propelling machinery with power equal to that of 2,000,000 galley slaves and carries 179 officers and 1,695 men. Less than two per cent of the total horsepower developed in 1919 was produced from water. Before 1869, only animal power was used in farming, but today some 20,000,000 mechanical horsepower are employed while animal power has more than doubled.

BAGGAGE HATCH ON COACH TOP SHIELDS GRIPS FROM DUST

Constructed on top of the motor coach, a baggage hatch like that on a steamer keeps the passengers' grips out of the way and protects them from dust. Being inclosed, the pieces cannot fall off, and storing the baggage here leaves more room for the occupants of the coach below.

1790

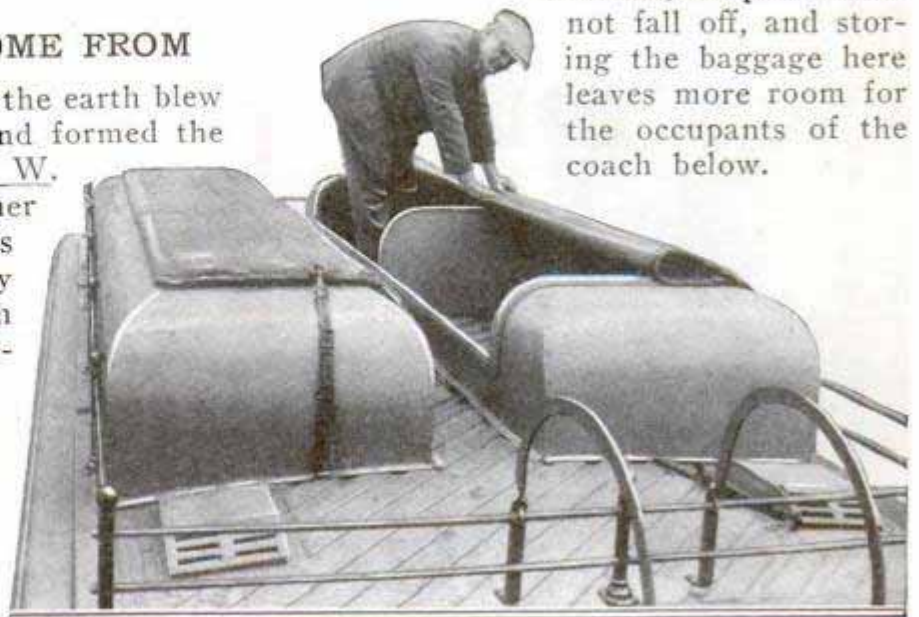

Baggage Compartments on Top of Motor Coach Have Tight-Fitting Covers to Keep Off Dust and Rain

Used in West



George Lenke and Hans Benkuhn Shooting Out Lights While Riding Bicycles on a Tight Wire; Lenke Was Killed in a Performance Shortly after This Photograph Was Taken

DO the many folks who daily provide thrills for fair, circus and theater crowds really take any undue risk?

Does the act that holds the gaze of breathless thousands require any great amount of skill, endurance or real daring, or is it merely a clever trick?

The truth is that most of the feats you see involve an element of very real danger and the penalty for a single mistake in judgment of time or distance, a moment's carelessness or some utterly unforeseen accident, is injury or death.

To be in condition for a performance lasting only a few minutes, many hours of vigorous work are required every day and behind that are years of training, natural talent and cultivated fearlessness. Skilled mechanics build the apparatus used and it is constantly tested and carefully inspected at every performance.

Despite all precautions fate, in the form of some seemingly trivial circumstance, sometimes steps in with tragic results. For instance, one performer, who tells stories while balancing at the top of an unsupported ladder, has had two nasty falls. The first occurred when the electric current failed and the theater was

plunged into momentary darkness, causing him to lose his balance and fall on his nose. The second was due to some draperies becoming entangled in his ladder. On this occasion he broke two ribs.

Another comedy acrobat has perfected the art of falling scientifically, which, he explains, consists in taking the shock first with the feet, then with the forearms and finally rolling up into a ball and turning over backward. He places a rickety ladder on an even more rickety table, climbs to the top, and, after swaying perilously for some time, eventually falls backward, a distance of twenty feet. Despite his skill, he was hurt once when his table was placed in the wrong position, causing him, as he rolled over, to strike his head against one of the wings.

According to experienced performers, persons in the audience are incapable of judging which are the most difficult and dangerous feats presented for their entertainment. One of the most wonderful tricks, from an acrobat's point of view, is that of performing a double somersault in the air, jumping from the stage and landing on the feet without the aid of a springboard. Few have succeeded in

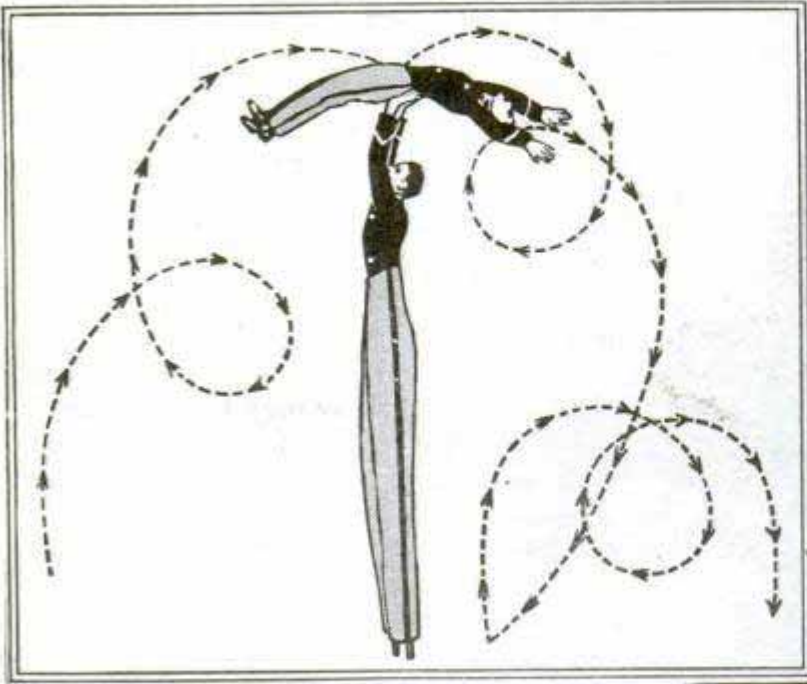

Acrobat Catch and Throw on Stilts; a Lighted Aerial Act and Daring Horsewoman Training

accomplishing this, and most of those who have done so have ceased to include it in their acts because it does not draw sufficient applause, the reason being that it is all over before the audience has time to realize what has actually happened.



Lower Photo Courtesy Sells-Floto

Among the daring wire walkers are Con Colleano and Jack Delino. Colleano's most thrilling feat consists in performing a forward somersault on a tight wire, and sometimes he exaggerates the danger of this trick by intentionally missing it at the first attempt. Although he gains more applause when he succeeds with the trick, the intentional miss is really the more difficult to perform.

While many performers purposely make intentional misses so that the climax will be better appreciated, there is no opportunity for such innovations on the flying trapezes. One of the reasons for this is that there is danger even in falling into the life net. A landing on the forehead is likely to result in a snapped neck. The net is tightly stretched, its meshes are stiff and if it is not always placed at exactly the same distance below the trapezes, a performer is likely to miscalculate his landing and suffer serious injury. While learning, young acrobats usually are protected with a life belt to which is



attached a rope fastened to a support overhead so that if they miss a trapeze, they will not fall to the net. After sufficient practice and training in falling, they work for another long period without the belt before they are considered ready for appearance in public.

In the last two years, Mayme Ward, blindfolded and with a sack tied over her head, has made more than 900 leaps from a high platform close to the peak of the "big top" into the hands of her husband, Eddie Ward, who swings from a trapeze forty feet distant. She has missed but about a dozen times although she turns a double somersault while shooting downward. Long practice has enabled her to gauge just how hard to jump.

Another hazard not evident to the man in the circus seat is the lighting. One afternoon may be bright with sunshine and the next cloudy. The jumpers and catchers must not be deceived by the changed appearance of the trapezes and the illusions caused by shifting shadows.

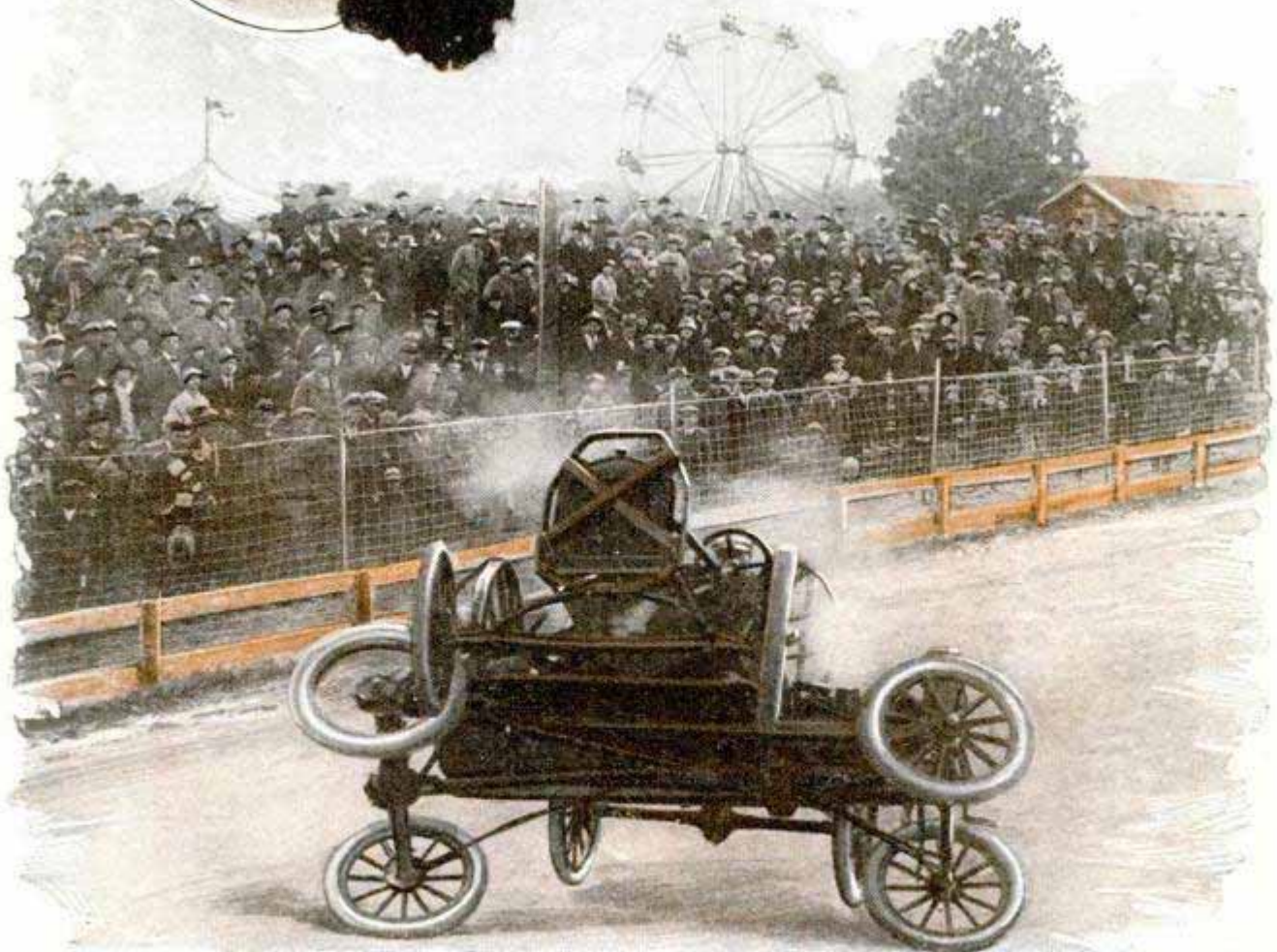

Lower Photo Courtesy World Amusement Service Association

Miss Irma Ward on the Rings and an Exciting Moment in Auto Polo Showing One Car Being Driven over the Other; Steel Hoops Protect Radiator and Motor

Partly because artificial electric lighting is more uniform and because the temperature generally is more comfortable, many acrobats prefer evening performances. Rain-soaked ropes present a menace and perspiring hands are likely to slip. The tape on trapeze bars is carefully wrapped and inspected regularly. Skilled riggers are required to set up the apparatus and it is exactly measured with steel tape and level, for trapezes will not swing so far or so straight if the supports are not accurately adjusted.

Materials of the finest quality are used in constructing apparatus for these split-second thrillers. For instance, Cliff Curran this season staked his life on the

strength of a steel pole weighing 1,800 pounds and composed of several sections fitted into each other. Climbing to the top of the slender shaft, ninety feet high, he did various acrobatic stunts while swaying back and forth like a gigantic inverted pendulum. The steel was made from a secret formula discovered by a German scientist who died without sharing his find with anyone. There are

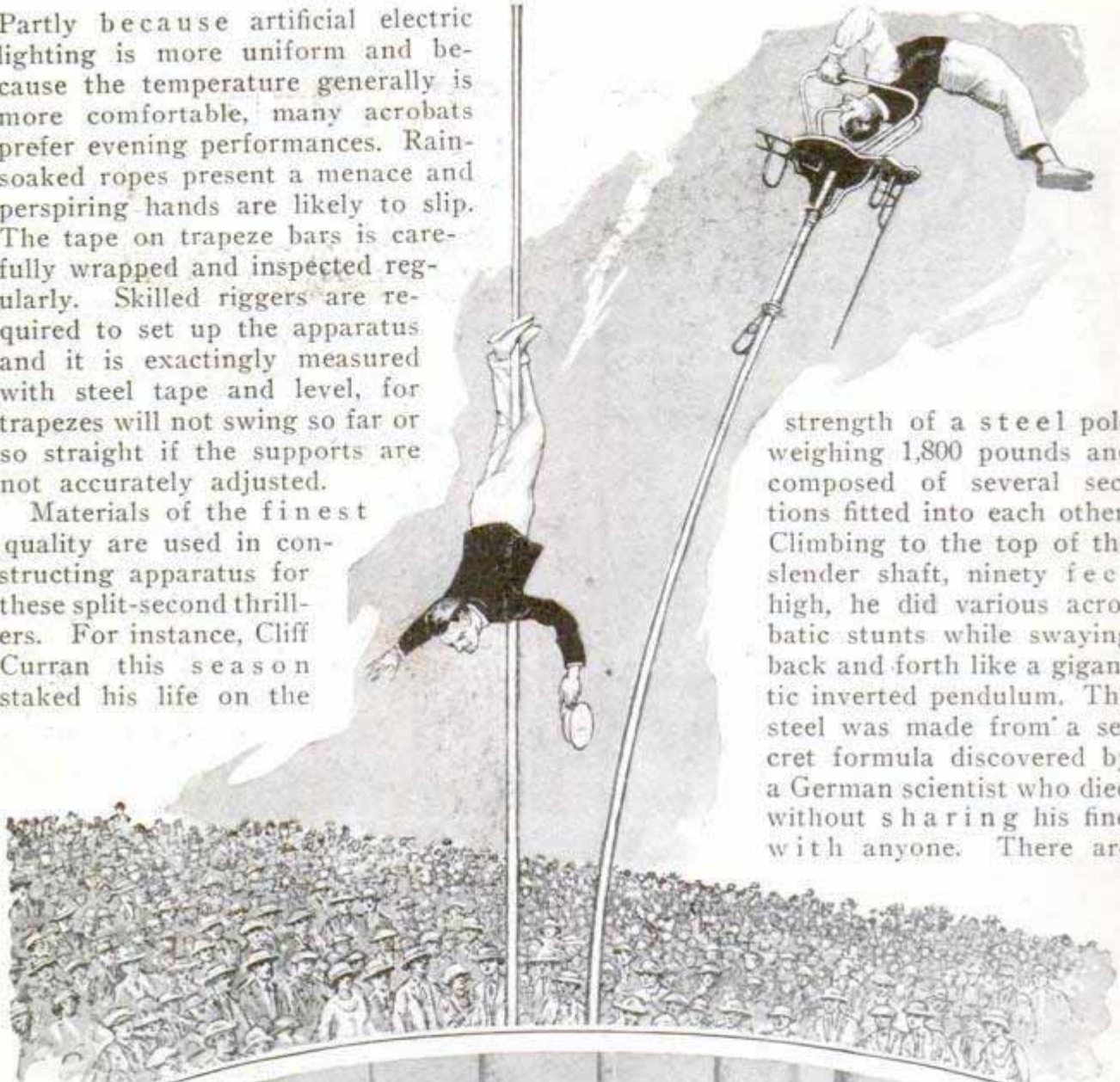

Sketch of Cliff Curran Doing Stunts on Swaying Steel Pole Ninety Feet High; and the Flying Wards, Mrs. Ward Fourth from Left in Front, Mr. Ward Second Standing

704

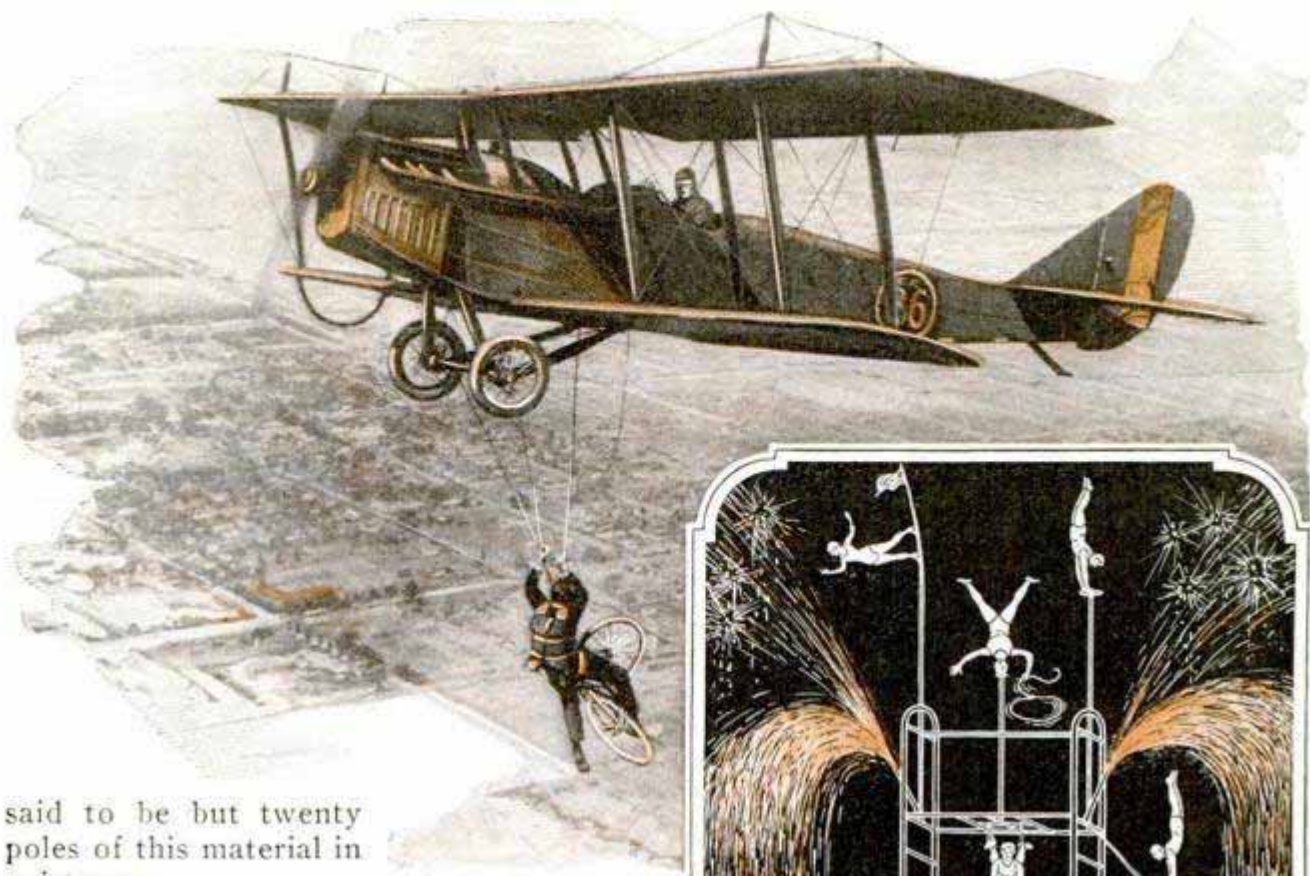

said to be but twenty poles of this material in existence.

While the sense of time, almost an instinct with the acrobatic teams who perform dangerous acts on high trapezes, is one of their assets, perfect balance, coolness and self-confidence are the principal aids of the "stunt" folk who do amazing feats on the edges of skyscrapers and at other lofty heights. "Sig" Smith, a steeplejack by profession, fills moments of his spare time with thrillers on the tops of high buildings with his partner, Lillian Hart. Walking a plank blindfolded while

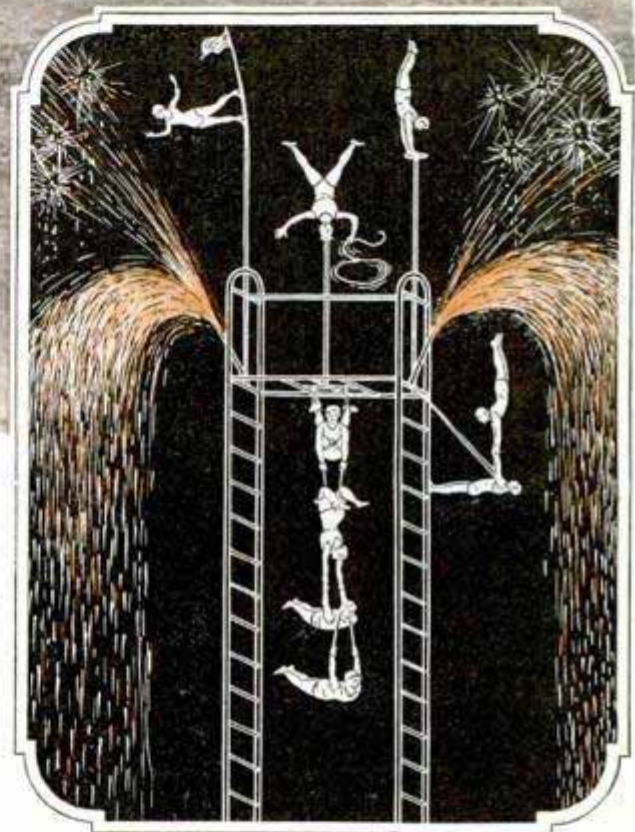

Al Johnson Ready for Bicycle Parachute Jump from Plane and Sketch of Four Lorenzos' Acts

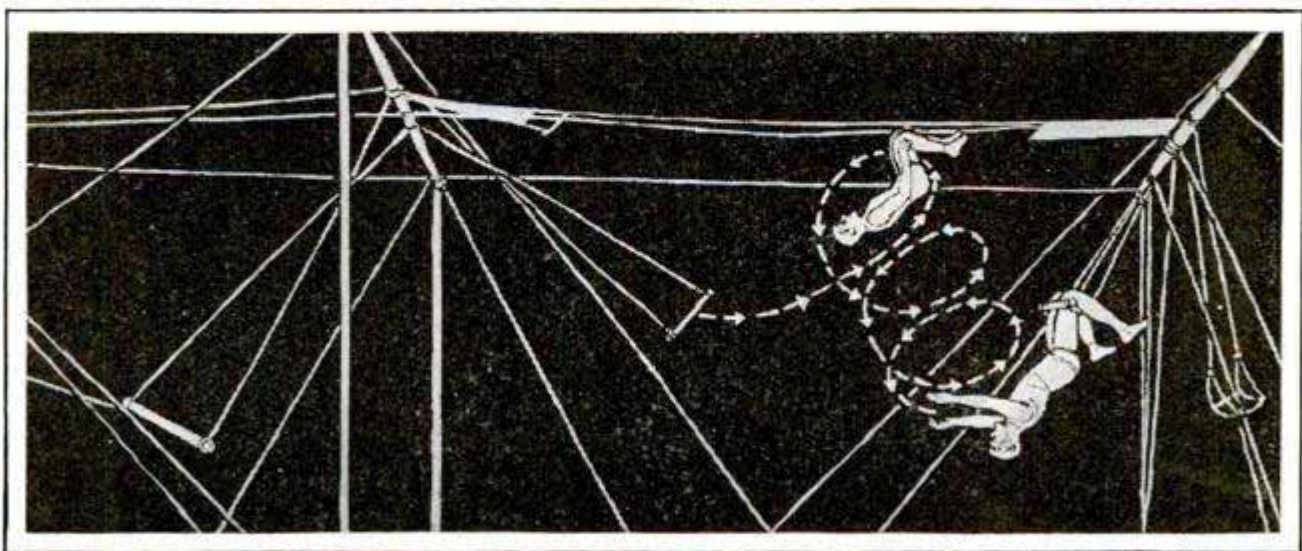

One of the Thrillers of the Flying Ward; the Jumper, after Leaving the Trapeze, Turns a Triple Somersault in the Air Before the Catcher Grabs Him

Thriller acts, according to officials of a leading booking agency, bring from \$500 to \$3,000 a week to the performers, depending upon the number of persons and the nature of their stunts. The "week" is usually but five days long in fair and outdoor carnival contracts, and producing companies often pay transportation costs of both actors and apparatus. Managers declare that the thrillers are becoming more popular with the crowds each year and, with the increased facilities for showing on en-

hundreds of feet above the street, skipping the rope on a narrow projecting board and hanging by his knees while holding Miss Hart by the hands in a giant swing, are some of his stunts.

Al Johnson, member of a California team of dare-devils, is given the distinction of being the first man to ride a bicycle while 300 feet above the earth. His cycle is attached to an airplane and as the craft speeds along, Smith cuts loose and drops, the parachute, strapped to his back, opening while he works the pedals.

A desire to "show off" or loss of temper often spells disaster to the performer who forgets that practically every move he makes has been timed to harmonize with the law of gravity. Not long ago, a young man, one of the most brilliant circus aerialists in the business, in an impetuous moment before his leap to a flying trapeze, jumped violently on the platform. He paid for his instant of anger with his life. A guy rope was loosened, he missed the catcher's hands by the fraction of an inch and broke his neck in the net.

A Ward Troupe in an Outdoor Exhibition of Skill and Carefully Timed Teamwork on Flying Trapezes

larged theater stages, they are also winning greater approval for indoor programs. There is a constant demand for novelty. Scouts are sent abroad to see

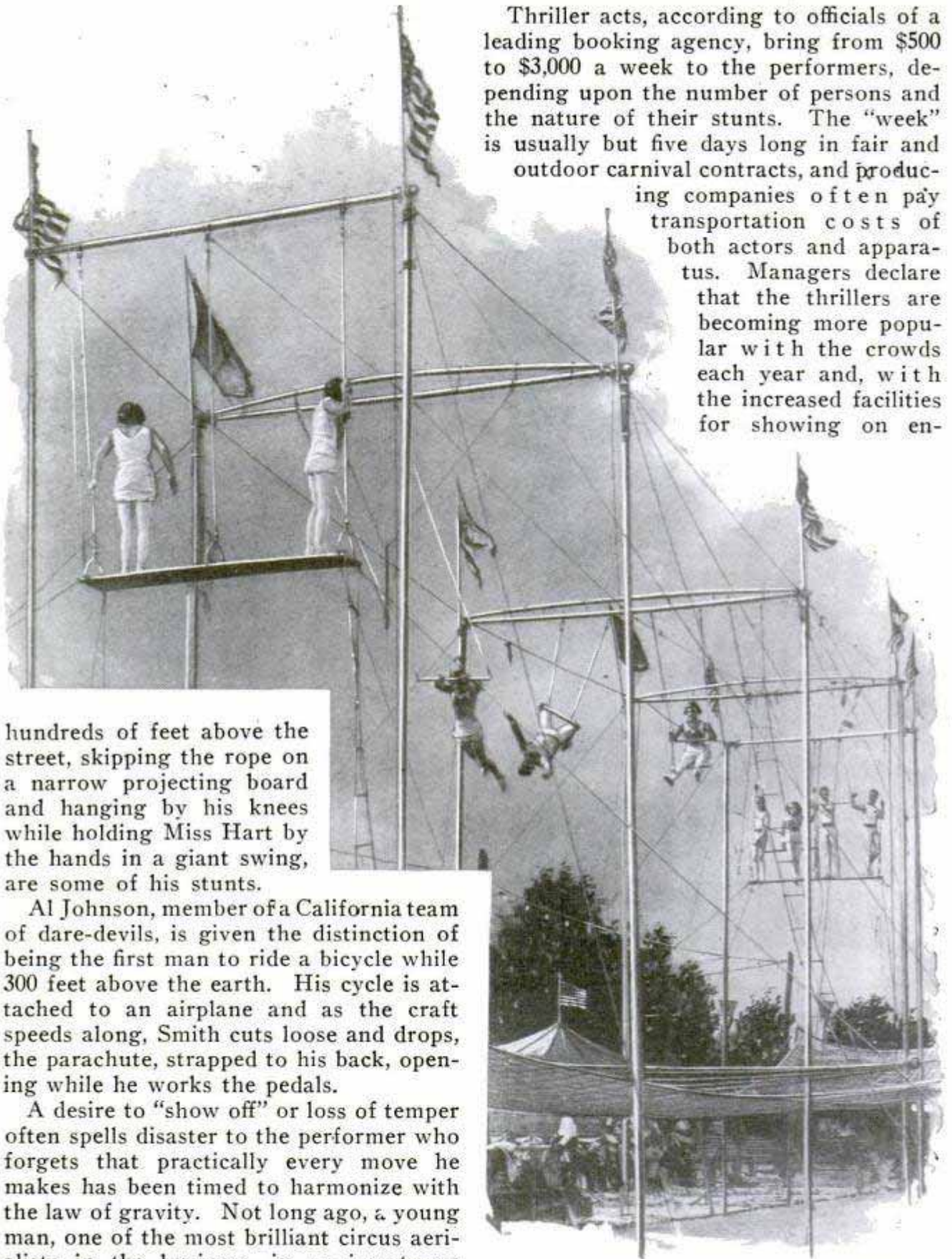

1919 Southern Pacific
Journal
Sacramento Calif

what the foreign producers are offering. One result of this policy this year was "Nathal," a French acrobat disguised as an ape. He climbed tent riggings, grandstand girders and other heights in lifelike imitation of a real monkey.

Just as many of the hazards of the acts are not apparent to the audience, so the spectators miss what the performers declare is one of the greatest delights in their work, the opportunity to study and criticize each other. Aerial acrobats, for instance, have little chance to look at the crowds below them, but when they are not flying through the air they are carefully scrutinizing their fellow actors. Most performers encourage this criticism from their associates.

2035

**TIME FROM LIGHTING SOCKET
LATEST HOME LUXURY**

Electric clocks for the home, run by power from the house-lighting circuit and regulated, as are electrically operated timepieces in public places, from a central station, have been introduced in an eastern city. They need no cleaning or oiling, no winding, are noiseless and never run down. Power is supplied from a motor that floats in oil and makes exactly 3,600 revolutions each minute. Through suitable gearing, this is reduced to one revolution per hour for the minute hand and the necessary movement for the hour hand. The clock requires but little current.

Telchron Clock

**AUTO-SPRING SHOCK ABSORBER
HAS BALL BEARINGS 1517**

Inserted between the leaves of the automobile springs, a series of rubber disks, containing six ball bearings, are said to permit the leaves to slip back and forth practically without friction, thus absorbing the road shocks. The disks are usually put between the front three leaves of the spring, about an inch from the end of each leaf, so that the ball bearings take the load. They are held in position by the rubber.



Setting the Train Indicator; a Turn of the Dials Exposes the Station Names

**TRAIN GUIDE SET BY LEVERS
SAVES TIME AND ERRORS**

Station names are exposed on a train board now in use on a western railroad simply by touching a series of levers, and track and train numbers as well as time of departure are indicated by turning dials within a control chamber at the side of the board. This arrangement saves time in making a set-up. When the train has gone, the entire board is cleared for another list by pressing a single key. The names are printed on individual turning strips and are visible at a fair distance.

**LIME FOR PURIFYING WATER
1986 TO SAVE FISH**

Lives of millions of fish now being killed annually by acid mine drainage and stream pollution in Pennsylvania, Maryland, West Virginia and Ohio, could be saved by neutralizing the water by a treatment with lime, the bureau of mines reports. Some attempts already have been made in this direction by installing equipment designed to neutralize the free acids in the waste by contact with lime, limestone or marl. Lime is considered the best for this purpose, as it contains less inert material than limestone.

Electric Time Co. of America, Inc.
30 Irving St. New York

Mr. Patrick J. Lanagan Chief Engineer
Southern Pacific
San Francisco

no message after

National Lime Assn.
918 Washington St. N.W.
Washington, D.C.

Theo. B. Plank
E. Vernon

ANCIENT ART HELPS TO IMPROVE YOUR RADIO SET

1657 Diamonds brought from France and a rare metal, tantalum, from Australia, play an important part in building your radio set. From the diamonds are formed

now used on sixty-five railroads in connection with the storage batteries for operating electric signals and is also employed in

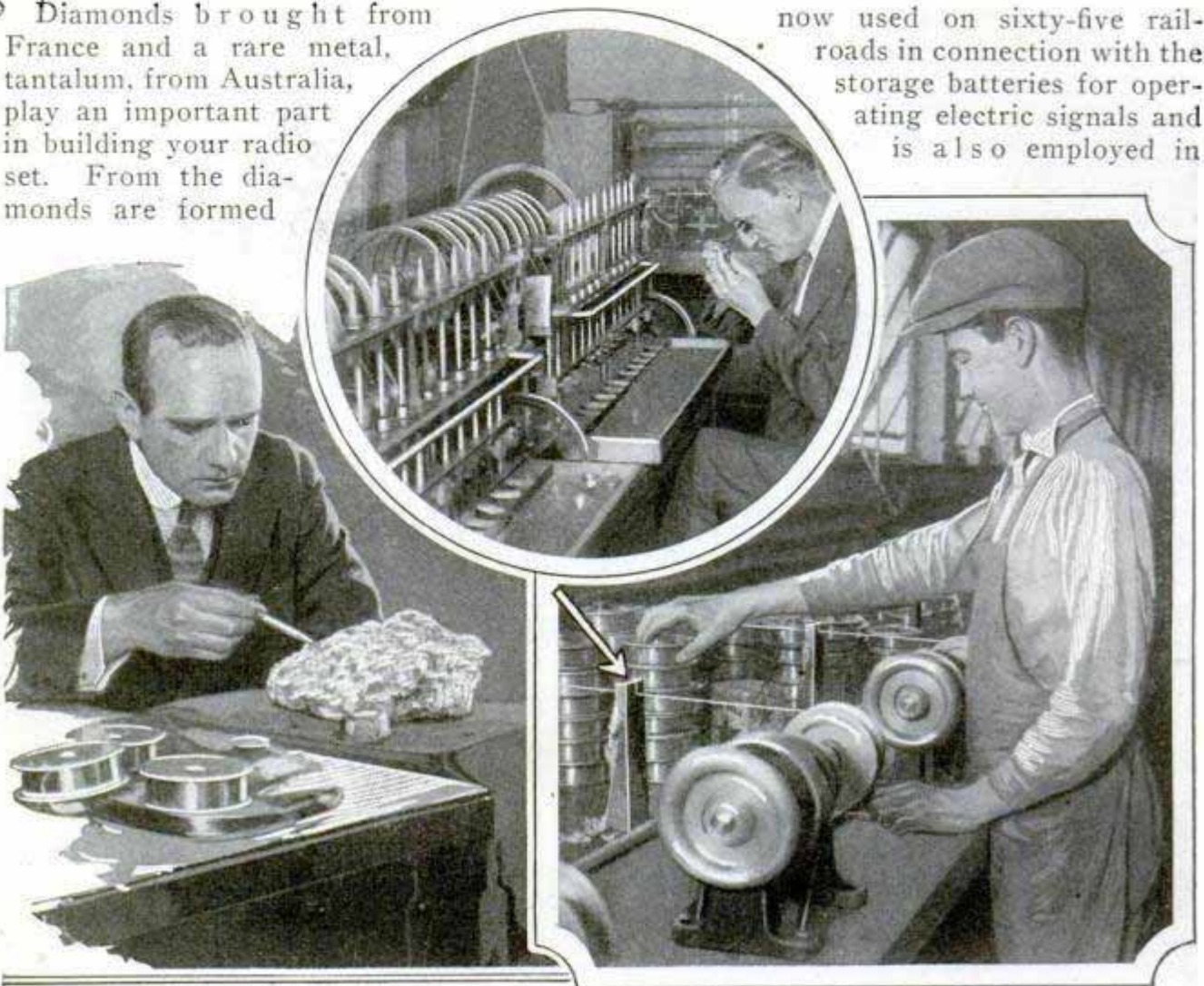

Courtesy Fansteel Products Co.
 Dr. E. W. Engle, Chief Engineer, Examining a Piece of Tantalum Ore; Right, Drawing Wire through a Diamond Die Indicated by Arrow, and Above, the Die Polisher at Work

the dies through which the fine filament wires are drawn. Tiny holes are punched in the stones by a secret process, developed in Europe some 500 years ago, so that wires as small as four ten-thousandths of an inch in diameter may be manufactured. In a 201A vacuum tube, for instance, the molybdenum filament is so tiny that it would take seventeen miles of it to weigh a pound. Tantalum has two properties that adapt it especially to electrical uses. One is that, when immersed in an acid solution, it will pass electric current in only one direction. The other is that it will absorb many times its volume in gases over a temperature range from red to white heat. This aids in maintaining a proper vacuum within the radio tube. The metal has been adapted to the construction of a type of rectifier

telephone and telegraph signals. This practical application of the metal was the result of the disappointing failure of an experiment. In making the wire, it is essential that the dies be kept polished so that the minute holes will not become ragged. To clean them, ordinary needles are inserted in wooden pegs and placed in the holes. The pegs are then rocked back and forth in a special device, while the dies, several of them being treated at once, turn at 1,400 revolutions per minute.

1954
 (Soft-coal smoke that pollutes the air of many cities, is an indirect cause of decay in children's teeth, according to an eastern dentist. He explains that the fumes interfere with the sun's ultraviolet rays, and that an insufficiency of these rays makes the teeth of city children decay.

Dr. Weston A. Price
Cleveland, Ohio

almost

**TROPIC HEAT FIFTY MILES UP
SCIENTIST BELIEVES**

1890

If aviators are ever able to make flights to altitudes of fifty miles, they will be more in need of electric fans than electrically heated suits, in the opinion of Prof. H. H. Turner of Oxford university. On the basis of observations made on meteors, when they first become visible after entering the atmosphere from outside space, he has drawn the conclusion that the temperature fifty miles or so from the earth's surface is warm or actually tropical. Unmanned pilot balloons have been sent up to heights of about twenty miles, but the knowledge of the upper air has been greatly extended by the study of "shooting stars."

1834

**SEARCHLIGHT AS BANDIT ALARM
AIDS POLICE AND CITIZENS**

Having been "retired" after many years of service in the U. S. navy, a 43,000,000-candlepower searchlight has been adapted to new duties as a robber alarm. It is mounted on top of a hotel in a Massachusetts city, and when word of bandits or burglars is received at night, its beams flash a signal visible for many miles, to put citizens on their guard and warn police to look out for suspicious persons.

Bancroft Worcester Mass



Powerful Searchlight Mounted on Building Top as Means of Spreading Bandit-Alarm Signal

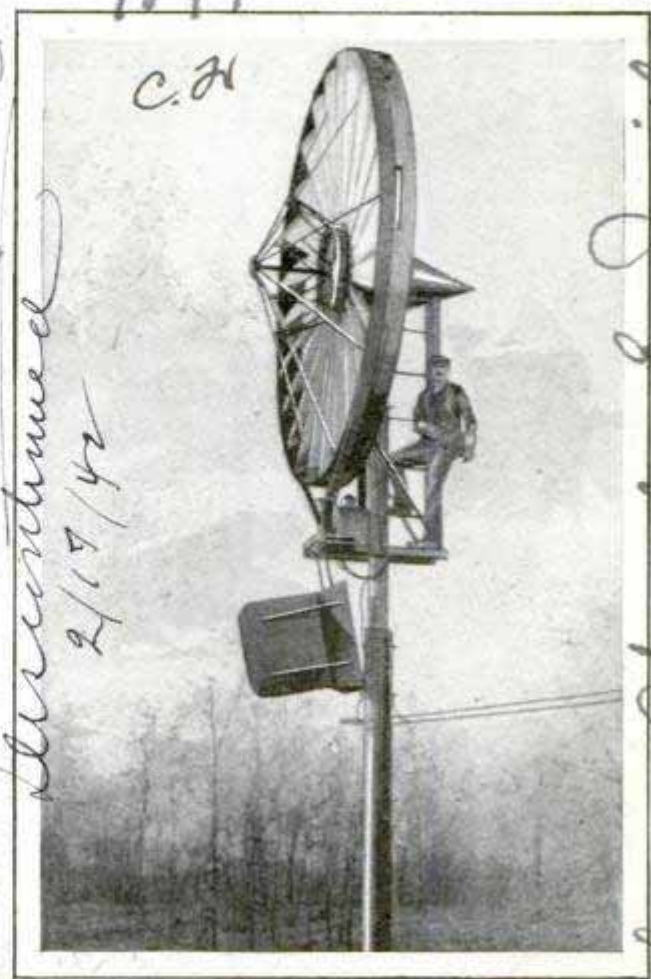

Indiana Farmer's Homemade Windmill Plant Which Generates Current for Lighting and Power

**WIND-DRIVEN ELECTRIC PLANT
CAN SUPPLY THREE HOMES**

Electricity for three farmhouses is supplied by a homemade, wind-driven generator an Indiana man has constructed. A drivewheel, twelve and one-half feet in diameter, is connected to a generator by a belt, both being supported by a single gas pipe, twenty-one feet above the ground and seven feet below, anchored in concrete. Features of the plant are its oiling system, which needs attention only about once a year, and a cone extending from the center of the wheel to keep the force of the wind within the circumference of the driver. Twenty-four propeller blades are pivoted on one side and held with coil springs, so that, if the wind becomes too strong, the blades will straighten out, allowing the blast to pass through and preventing damage. A regulator controls the amount of electricity produced according to the velocity of the wind. Current is stored in a large battery which meets the requirement of lighting and other purposes for two weeks.

*Small outfit \$150.00
Large outfit J. of Anderson*

*continued
2/17/42*

*1891
C. H.*

Anderson Rubber Works, Anderson, Ind

Small outfit \$150.00

1819

*Wanted
Detroit Free Press 4/18/26
Die Woche 3/24/26*

Lost World Is Found in Yucatan Jungles

Explorers Uncover Magnificent Ruins of Temples and Palaces Covered with Carved Writing Rivaling Ancient Culture



View of the Palace of Uxmal, Supposedly the Home of the Ancient Kings of Yucatan; Note the Pyramidal Opening in the Wall; the Ancient Americans Never Solved the Secret of an Arched Opening

TRACES of a lost and forgotten world in which there flourished, centuries before Columbus discovered America, a civilization that rivaled that of ancient Egypt have been uncovered in Yucatan, one of Mexico's tropical provinces, by the Mason-Spindler expedition from Harvard university.

Magnificent temples, ancient walled cities and vast palaces of the Maya kings were found in the heart of the jungles, adding another chapter to the story already partially learned in ruins earlier discovered in Yucatan, British Honduras and Guatemala, where the cities of Palenque, Tikal, Naranjo, Copan and Quiriqua have been explored.

The new ruins abound in geometrical designs and beautiful carvings, but like all other Maya buildings, possess no arches—an architectural trick which they never mastered. Instead, their huge doorways either were built up in the form of pyramids, or with straight sides capped by a gigantic stone piece. How they were

able to carve out and move the enormous stones remains as great a mystery as the building of the pyramids in Egypt. The blocks were perfectly matched and laid without the use of mortar.

The history of the Maya civilization remains one of the most fascinating enigmas known to man. Developing in South America, their empire attained a high degree of civilization; then, for some unknown reason, they left their cities and moved northward into Central America and lower Mexico. The time of the migration has been definitely placed at about 200 A.D., and during the next four hundred years they built their cities in Honduras and Guatemala. None of the inscriptions found on the monuments in this district bears a date later than 600 A.D., but the new finds in Yucatan are expected to bring the story down several hundred years, possibly to the time of the first Spanish conquistadores.

When Hernandez de Cordoba's three caravels came in sight of the flat sandy

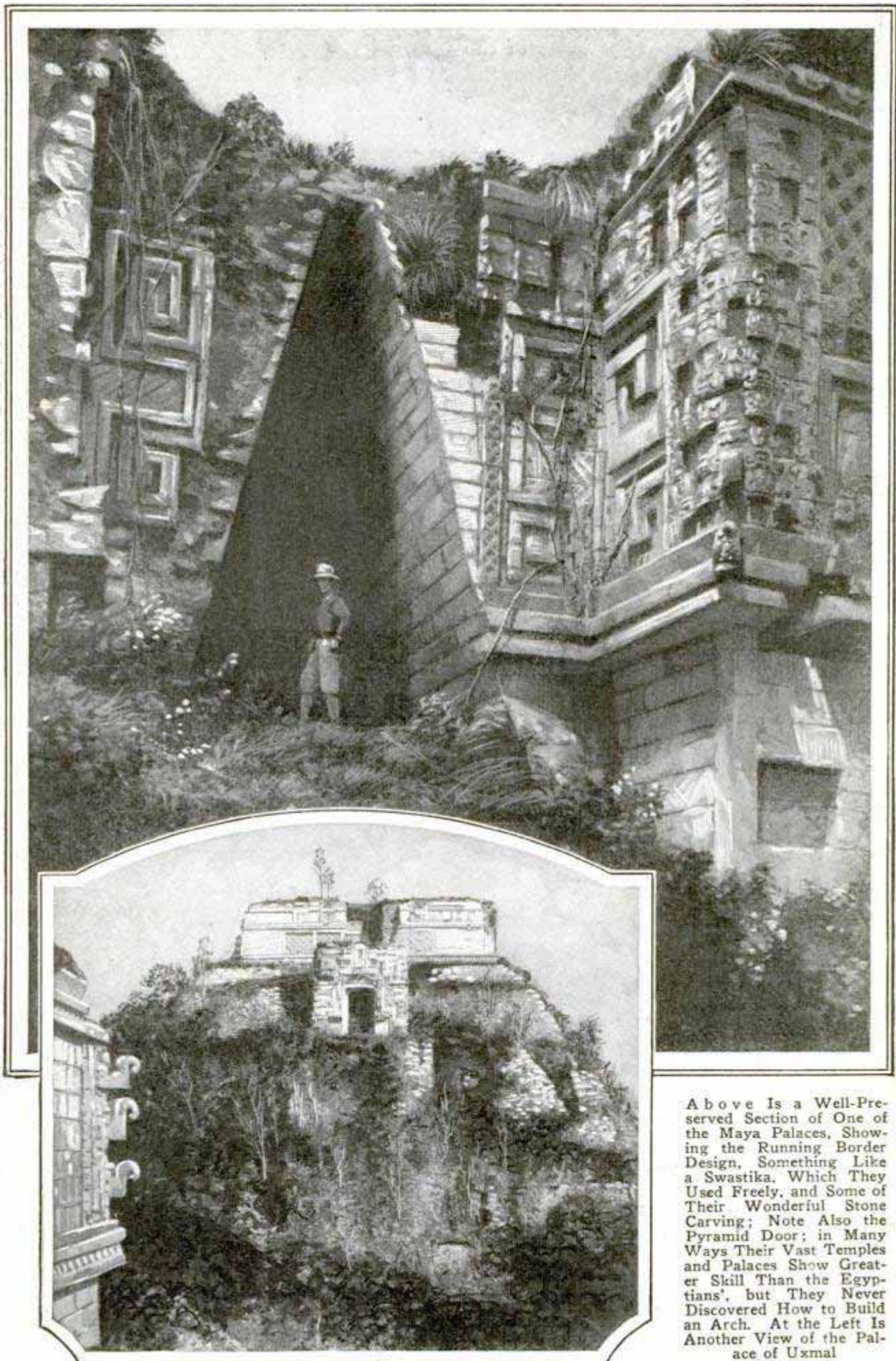

Above is a Well-Preserved Section of One of the Maya Palaces, Showing the Running Border Design, Something Like a Swastika, Which They Used Freely, and Some of Their Wonderful Stone Carving; Note Also the Pyramid Door; in Many Ways Their Vast Temples and Palaces Show Greater Skill Than the Egyptians', but They Never Discovered How to Build an Arch. At the Left is Another View of the Palace of Uxmal

1819

Markham Chicago

shore of the Yucatan peninsula and saw the brilliantly white stone temples of the first real city the Europeans had found in America, the Maya strength undoubtedly had already begun to decline. Their wealth of gold and precious stones excited the Spanish invaders, and in the resulting wars all of the leading caste of the Mayas were wiped out and only the dullards left, and it is from these that the present Maya tribes, who have reverted to the lowest form of life, have come.

For many years there have been rumors in Yucatan that somewhere in the interior of the jungle there still exists a city, called Iximaya, inhabited by the last remnants of the powerful Mayas, but no one has ever seen it, and come back to tell the tale. Two Americans who went in search of the city several years ago never returned. The native rumors, however, describe the city as being surrounded by a wall four miles in length, inclosing vast temples and altars to the sun.

The Maya ruins abound in hieroglyphs which bear a very close resemblance to the Assyrian, their divisions of time and numbers are virtually the same, and even the holidays they observed are quite similar, which gives basis for the belief that the original culture might have come over an ancient land bridge with Europe—the fabled lost continent of Atlantis.

Everdri
**CIGARET BOX FOR SWIMMERS,
 HOLDS MATCHES AND KEYS**

Strapped to the swimming-suit belt, a waterproof cigaret case also has space for matches, or with the rack removed, may be used for jewelry, keys or other articles. A rubber-lined spring top fits down tightly to keep out moisture.

Rome Mfg Co

**LOUD-SPEAKER PHONE SYSTEM
 SPEEDS CAR SWITCHING**

1866
 "Car 10176 coming on track fourteen. Let 'er go on track three instead." The



Using Loud Speaker to Direct Freight-Car Movements; "Hump" Foreman Seated before Microphone

order booms out of a loud speaker in the signal tower man's loft in the Illinois Central freight yards near Chicago. Without leaving his levers to answer the phone, the tower man can execute the command which was given by the switching "hump" foreman. His office is connected to eleven towers disposed throughout the yards and the orders are heard simultaneously in each. He speaks through a microphone such as is

used in radio and his voice is amplified through vacuum tubes.

**SEWING KIT THAT FITS POCKET
 HAS THIMBLE FOR TOP**

1885

Needles, two kinds of thread and a thimble are carried in a compact sewing kit for emergency use. It is so small that it may be slipped into the vest pocket of a man's suit or into a woman's handbag. Space has been saved by using the thimble as a cover for the tiny tube-shaped holder



Sewing Kit Opened to Show Needle, Spool of Thread and Thimble Which Serves as Cover

that contains the equipment. The thimble is threaded on the inside so that it can be screwed on.

Spangler Novelty Co

HOW FAST CAN MAN TRAVEL ON WHEELS AND LIVE?

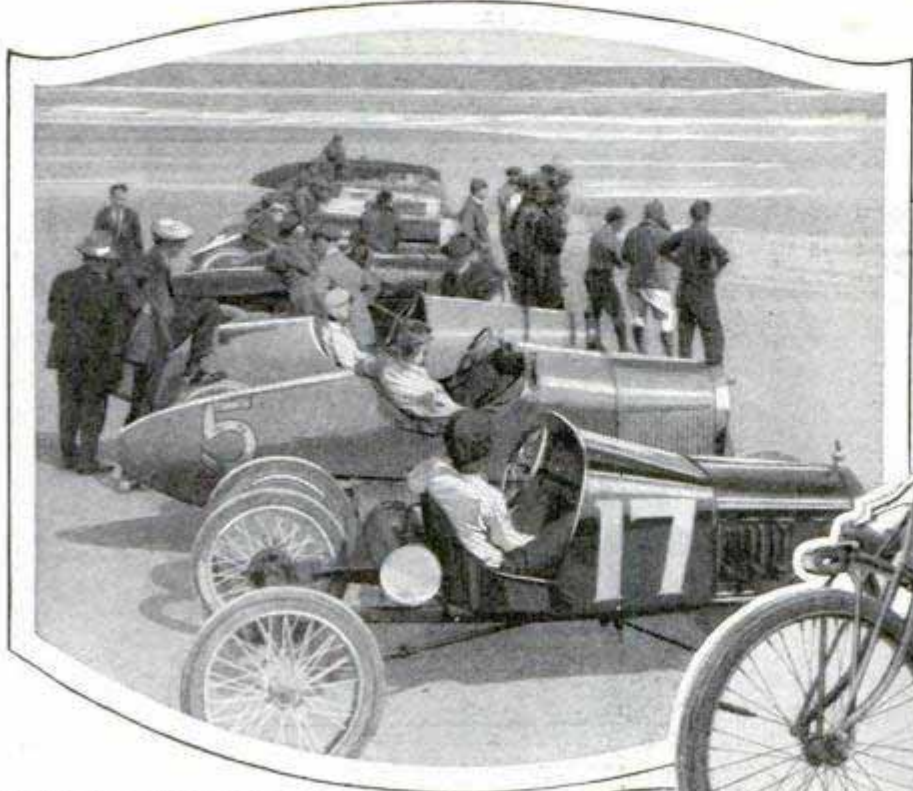

Seymour rode to his motorcycle record the machine was tuned to as nearly perfect mechan-



Ready for a Speed Duel at Daytona Beach, Fla.; Johnny Seymour on His Motorcycle and Sig Haugdahl in His Racer, Pared Thin to Cut the Wind

Johnny Seymour, riding a twin-cylinder motorcycle, recently attained a speed of 131 miles an hour, a world's record. Four years ago, Sig Haugdahl driving a race car of his own design made 180.27 miles an hour. Ralph DePalma, seven years ago, set a mark of one mile in 38.83 seconds from a standing start, while Tommy Milton holds the straightaway record of one mile in 23.07 seconds. All these records were made at Daytona Beach, Fla. Who will be the first human being to drive an automobile at a speed of 200 or perhaps 300 miles an hour? Are such speeds possible with gasoline vehicles? Can man-made machinery stand the strain? Is it possible to hold a car in its course when traveling faster than three miles a minute? What is the final goal of speed? When Johnny

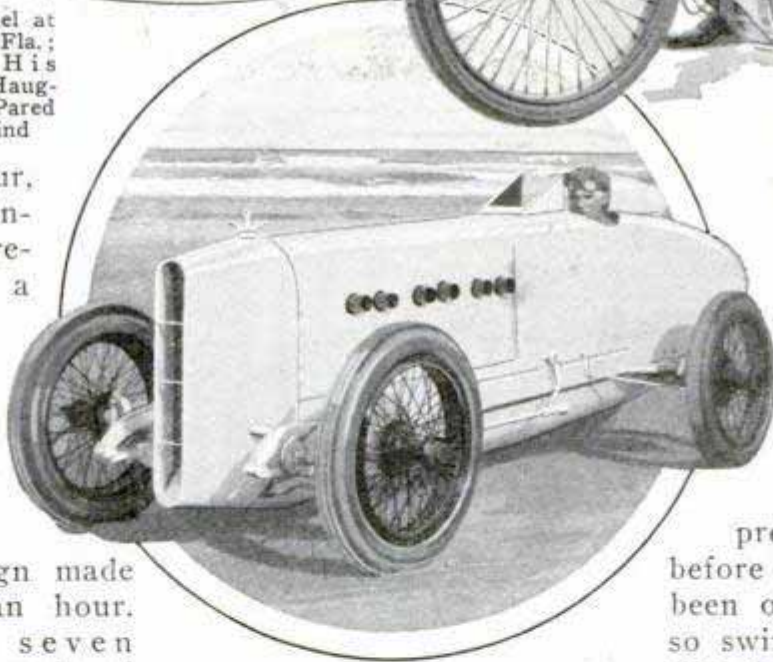

ical operation as possible. The slightest imperfection probably would have resulted in the rider's death. Sig Haugdahl's ride to fame followed months of painstaking

preparation. Never before had an automobile been operated at a gait so swift. The velocity was much more than

double the fastest speed ever made by an express train. The strains were the greatest to which a motor car had ever been subjected. The apparently insurmountable obstacle that had to be overcome was to secure perfect balance in the wheels. Engineering science has demonstrated that a very slight difference in "tire weight," when the wheels are revolving at 1,500 revolutions or more a minute, may result in a fatal smashup. An automobile whose wheel balance is perfect for a speed of seventy miles an hour is entirely out

of balance, according to racing requirements, when its velocity is doubled. Haugdahl rigged up his racing car under laboratory conditions to simulate the track try-out. He found that an automobile tire turning at 1,800 revolutions a minute was so affected by centrifugal force that its diameter was increased one inch. Allowance had to be made for this in balancing the wheels. Further research proved that a tire revolving at a high speed would develop a so-called "heavy spot" at various points. This would throw the wheel out of balance. Altogether, it took about a month of patient experimentation to secure complete wheel balance. When a motor car travels at a speed of three miles a minute or faster, the resistance of the wind is very important. The Haugdahl racer was equipped with a sharp nose like the keel of a ship which gradually tapered to maximum width in the driver's compartment. All projecting parts were cut away. The car was trimmed down so that it offered the slightest possible resistance to the wind. It is only on a straight-away course such as Daytona beach that a speed of 180 miles an hour could be attempted. Haugdahl tells that it was impossible for him to hold his car in a straight course. The path of the car wob-

bled over a stretch of roadway 100 feet wide. To attempt even a slight curve at that speed would have ended in a wreck. The nervous strain of that wild ride was terrible. He believes faster cars can be built and that the real problem is to find men with the endurance to drive them.

1371 SAND BOX FOR WASHING DISHES REDUCES BREAKAGE

To reduce loss from breakage and to save time in cleaning hotel crockery, an English proprietor uses wooden troughs filled with a mixture of damp sand and salt. Stains from grease, tea and other substances are quickly removed by rubbing the dishes in this preparation, it is said. The utensils are then given a final cleaning with water. About twenty-five per cent of the mixture is salt.

1908 BOARDWALK CHAIRS ON SHIP ADD SEA LUXURY

Steamer decks are now being furnished with comfortable roller chairs, such as are commonly seen on boardwalk promenades on shore. They hold three or more persons and can easily be shifted about to shield the occupants from the wind.

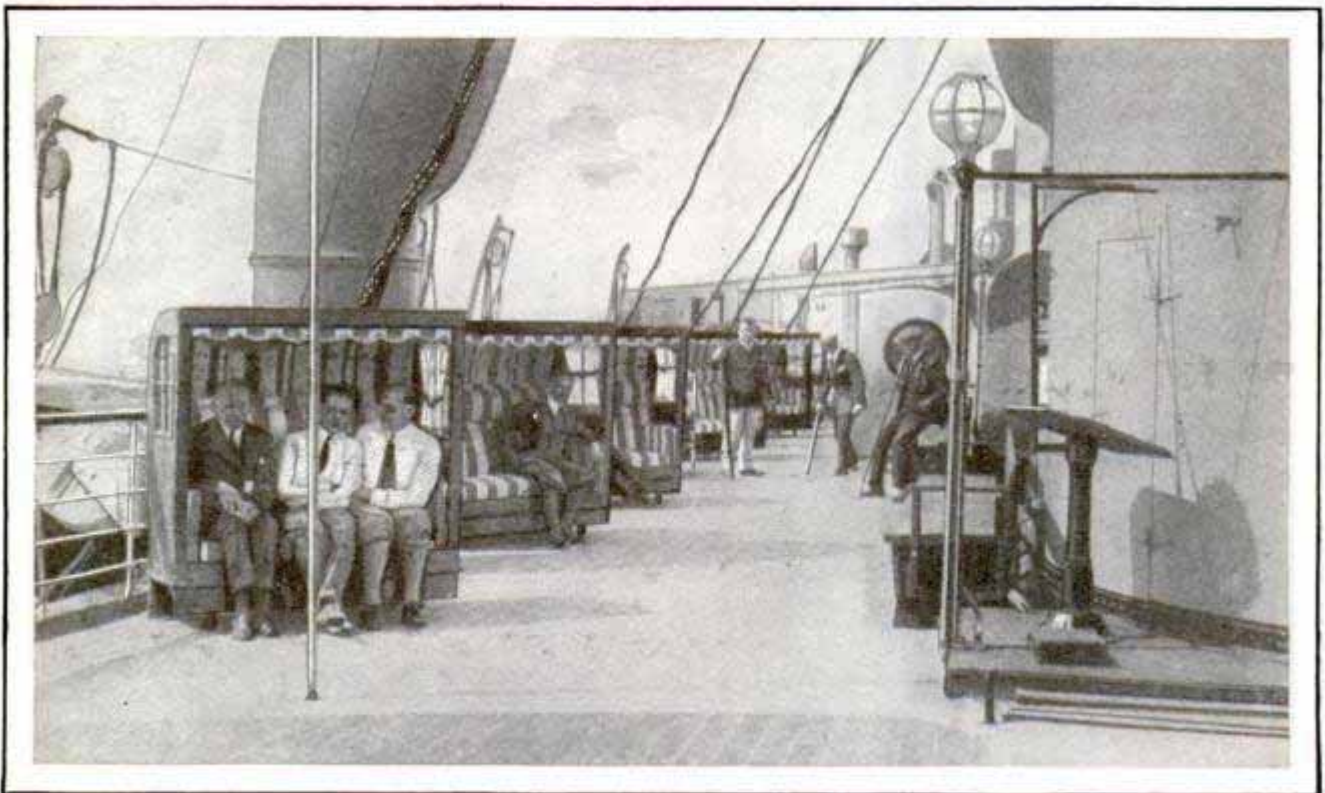

Like a Beach Promenade, the Modern Steamer Deck Is Furnished with Comfortable Sheltered Seats for Watching Games; They Are Easily Moved to Protect Occupants from Wind or Sun

S.S. Hamburg, Hamburg American Line

4/30/26

Built for Houston

Texas Ship Channel

RIFF COURIER RUNS SEVENTY MILES OVERNIGHT

1915

Running nearly seventy miles from sunset to sunrise, or in about ten hours and thirty minutes, is the feat credited to Hammouch Ben Hadge, a Rifian warrior, sixty-seven years old. He arrived panting at the gates of Oujda, French Morocco, with the message, "No peace without autonomy," for the Rifian representatives sent from the Atlas hills tribes where the courier had started at sunset. In 1882, J. Saunders of New York ran seventy miles in eleven hours, thirty-four minutes and five seconds.

2000

GUIDE ON CLUB TO IMPROVE GOLF GAME

To help golfers make more accurate strokes on the green, a putter has been designed. The head is made of aluminum and a pyralin cap cover forms the design of a T-square, one line of which is parallel to the face of the club and the other perpendicular to it, giving a true line to the cup. The cap has two compartments in

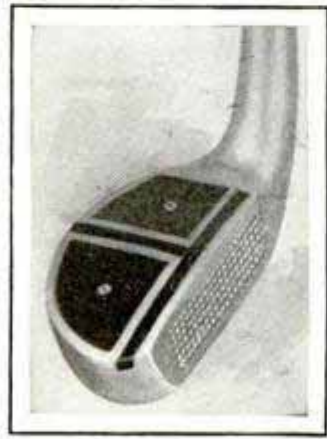

which small pieces of lead are inserted to give weight to the club. The player can regulate the weight at will. This is considered a great advantage to one who habitually cuts or slices his putts, because he can correct the tendency by redistributing the weights in the front and rear compartments.



Testing Fireboat Equipped with Diesel Engine; It Can Throw Thirty-Nine Streams at One Time and Has Considerable Speed

FIREBOAT WITH DIESEL ENGINE THROWS MANY STREAMS

Thirty-nine columns of water can be thrown simultaneously from a Diesel-engined electric fire boat added to the equipment of an eastern city. Besides its enlarged fire-fighting facilities, it is said to have greater speed than similar boats and to be efficient in all-around operation.

STAGE PLAYS FOR RADIO ONLY IN BRITISH THEATER

Plans for a theater in which plays will be acted only for the benefit of a radio audience are under way in London. The project is the result of a recent successful broadcast of an opera performance from the Covent Garden opera house. Persons wishing to watch the actors were admitted on payment of a small charge.

Head at Houston, Texas
First Diesel Electric fireboat

E. J. du Pont de Nemours & Co., Inc.
Wilmington, Del.

The Thistle, Outer, N.Y. Herald

461 Canal St.

11/16/16

Do You Remember When



The Original Village Blacksmith Shop Immortalized by Longfellow



Mr. Ford at the Fireside of the Wayside Inn, Sudbury, Mass.; Ancient Andirons, the Old Rifle and the Powder Horn on the Mantel Are Only a Few of the Relics Preserved



The Forge of the Village Shop Where the Smith Toiled with Brawny Arm; It Has Seen Service for 150 Years; at the Right, Mr. Ford Standing beside the Old Apple Grinder at the Wayside Inn



These Antiques
 collected
 by
 Henry Ford
 were in daily
 use?



The Old General Store at Diamond Hill, R. I., Has Been Purchased for a Model Colonial Village

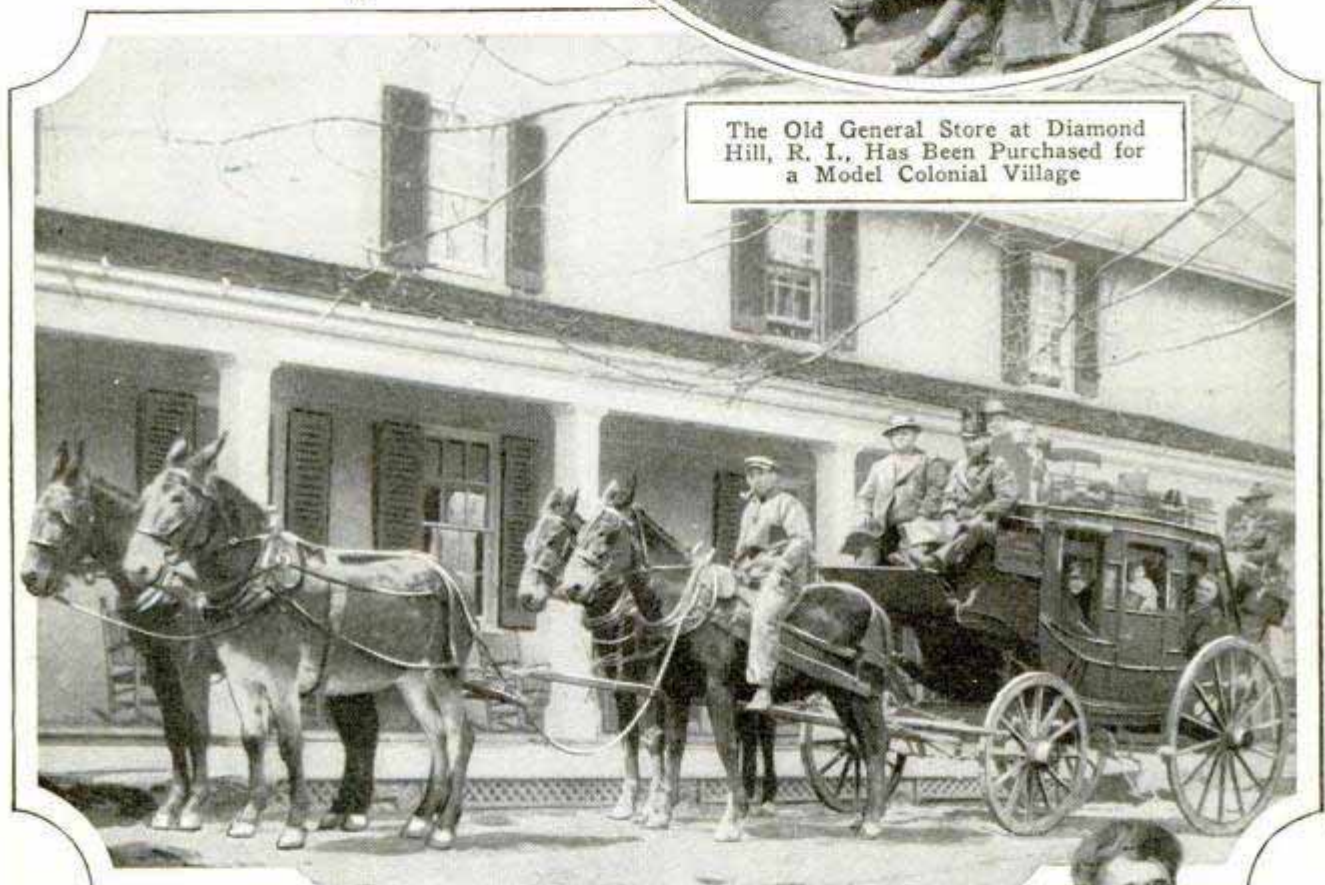

Stagecoach That Once Rattled over the Roads in the White Mountains More than Half a Century Ago; It Broke Down on a Trip to California

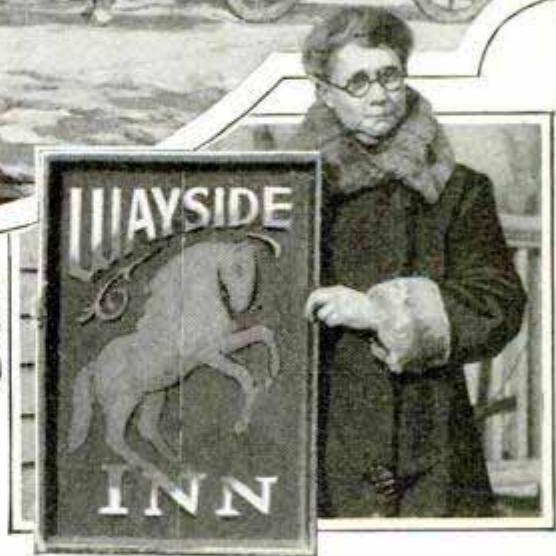

One-Horse Shay and Mrs. William Diehl Holding Original Red-Horse Sign That Adorned the Wayside Inn, Made Famous by Longfellow's Poem; It Was Lost for Twenty-Five Years but Found Again in Wellesley Hills by Mr. Diehl

2018

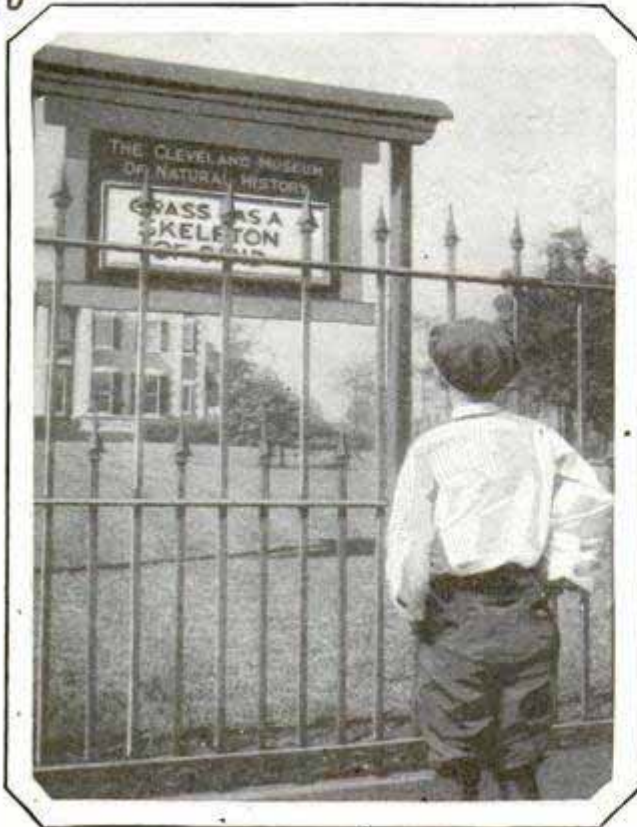

Natural-History Facts for Those Who Have Not Time to View the Exhibits; Sign at Cleveland Museum

WONDERS OF NATURAL HISTORY TOLD BY WAYSIDE SIGNS

Few of thousands of persons who pass the Museum of Natural History at Cleveland have the time to go inside, so a wayside signboard has been built on which interesting facts are given so that those who ride may read. "Grass has a skeleton of sand," one of the signs reads.

BIMETALLIC NUMBER PLATE TO FOIL CAR THIEVES

"More difficult to counterfeit than money," is the verdict of the underwriters laboratories on a special kind of automobile number plate now being manufactured. It is to be attached to the dashboard of the car and is made of copper and a white metal. The digits of the numbers are raised and



Auto Number Plate in Position on Dashboard, and Close View Showing How It Is Embossed

stand out clearly in polished relief against a background of oxidized copper. The numeral plate is fastened in such a way that it can be removed only by prying. This results in mutilation that cannot be repaired. Besides the numbers, the plate carries a design characteristic of the make of the automobile.

SOUND WAVES THAT KILL FISH MAY CURE DISEASE

1931 Sound waves which kill fish and cause a liquid to heap itself into a pronounced mound are being produced and studied by Dr. Robert W. Wood, of Johns Hopkins university, and Alfred L. Loomis, a New York banker. The waves have strange properties that may prove of importance in the treatment of disease. They are produced by an apparatus that has much in common with radio, employing a high-power alternating current which reverses itself 200,000 to 400,000 times a second. The reversals cause a quartz plate to expand and contract with great rapidity, as if it were breathing, and this constant vibration generates sound waves. With movements counted in hundreds of thousands to the second, the waves are several octaves above the highest notes audible to the ear. These sound waves travel through oil and into a beaker of water immersed in the oil. If a fish is swimming in the water, the waves have immediate effect on the creature. The first symptoms are such as to indicate that the swimmer has become numbed. Five minutes of exposure to the waves

will result in the death of the fish. One of the curious phenomena brought about by the passage of the waves, is that the water fills with air bubbles, as the air in the liquid is forced out by the vibrations. These bubbles, each the size of a pinhead, instead of rising, remain in fixed positions, vibrating

Practical Physics

*Hedco Number Plate Corp
115 03 roadway
New York
1930*

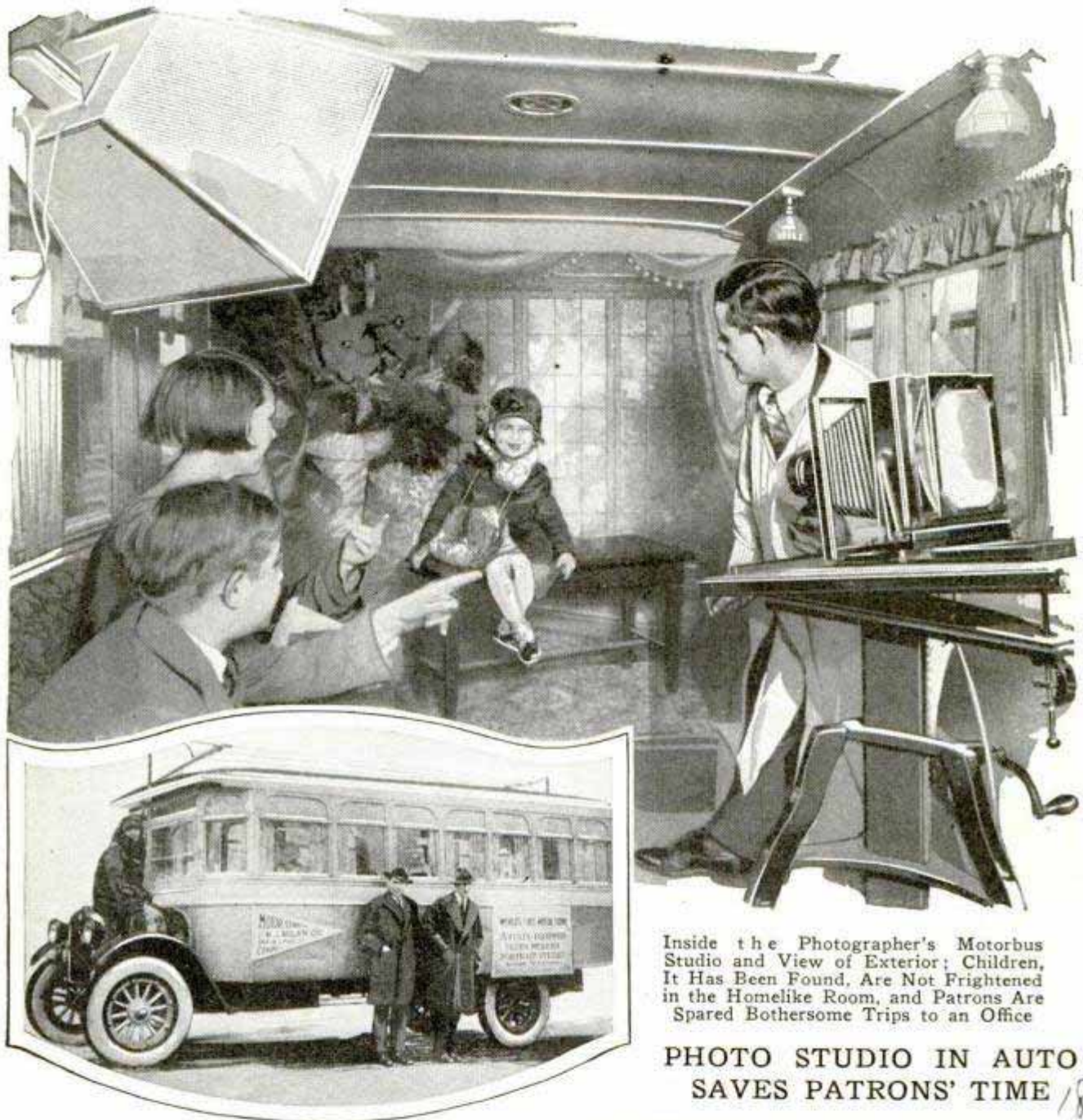

Inside the Photographer's Motorbus Studio and View of Exterior; Children, It Has Been Found, Are Not Frightened in the Homelike Room, and Patrons Are Spared Bothersome Trips to an Office

PHOTO STUDIO IN AUTO SAVES PATRONS' TIME 1856

actively like dancing gnats. Another curious thing is that, when the waves are started in the oil bath, there is immediate formation of a mound at the surface, in which the oil takes the shape of a well-defined hillock, with its peak in the center. When a finger is inserted in the water one feels a distinct tingling of the flesh, produced by stimulation of the circulation. When withdrawn, the finger smarts and tingles in a way suggesting the sensation produced by catching a swiftly driven baseball. The medical possibilities are indicated by the stimulus given the circulation in any portion of the body that may be immersed in the water carrying the vibrations.

Motorization of the photographer's studio has been accomplished in a completely equipped auto coach a Chicago man has designed. He drives to the homes of his patrons who have but to step into his car for their poses, saving trips downtown at busy hours. Developing and printing materials, with the necessary screens, shades and other apparatus, are carried in the coach and various lighting facilities are afforded. The traveling studio already has made a cross-country tour to the east and back, visiting among other places Washington, D. C., and on the return trip, Detroit.

Under heavy pressure, a slab of marble will bend like stiff tar or wax.

1619

Illustrated *Exhausted* 2/27/26

Dummy Funnels in Motorized Liners

WHAT IS INSIDE THE FUNNEL OF A MOTOR LINER.

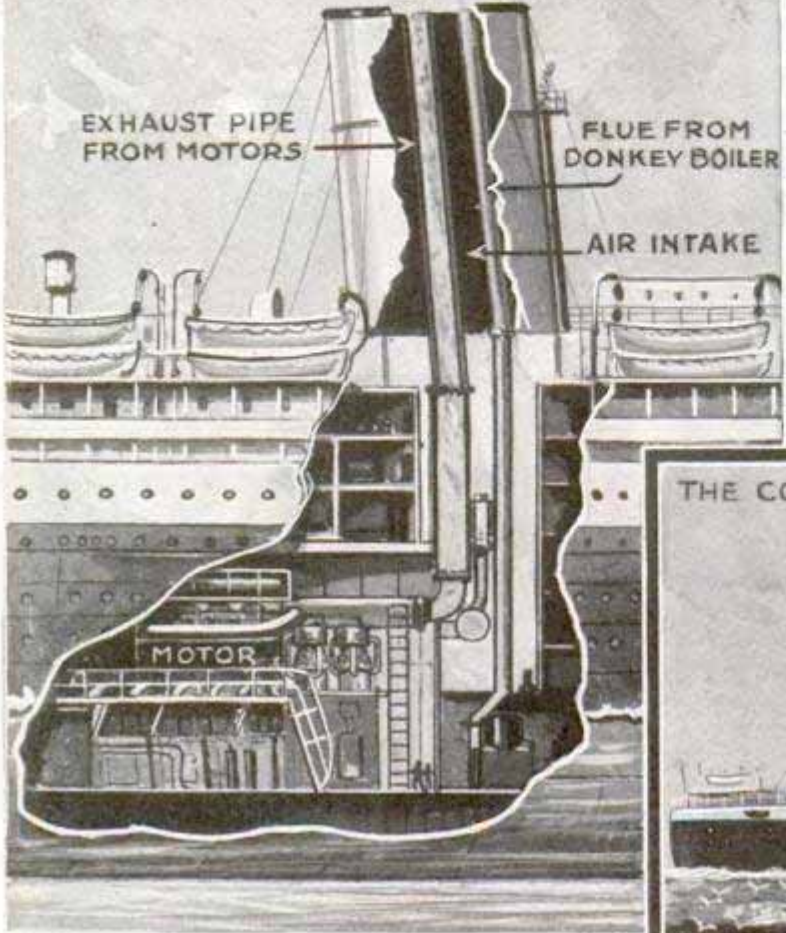

THE "CITY OF ROME" OF 1881 WITH POWERFUL AND RELIABLE STEAM ENGINES, YET ABLE TO CARRY A LARGE SPREAD OF CANVAS TO SATISFY THE OCEAN VOYAGERS OF THOSE DAYS



THE COMPROMISE—THE REDUCED HEIGHT OF

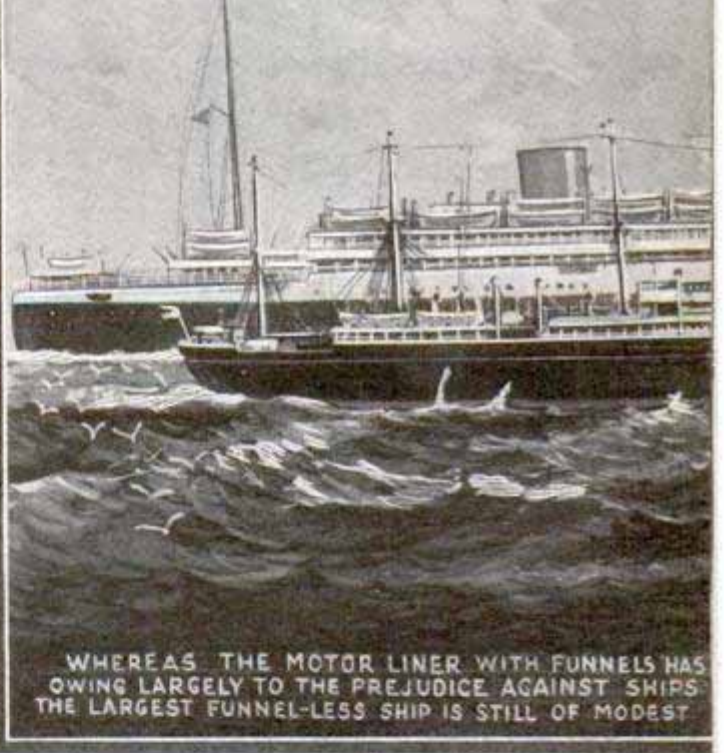

SPACE OCCUPIED BY MACHINERY IN A FUNNEL-LESS SHIP

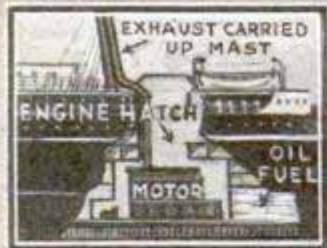

INCREASED HEAD RESISTANCE
OWNER'S FUNNEL MARKINGS RETAINED

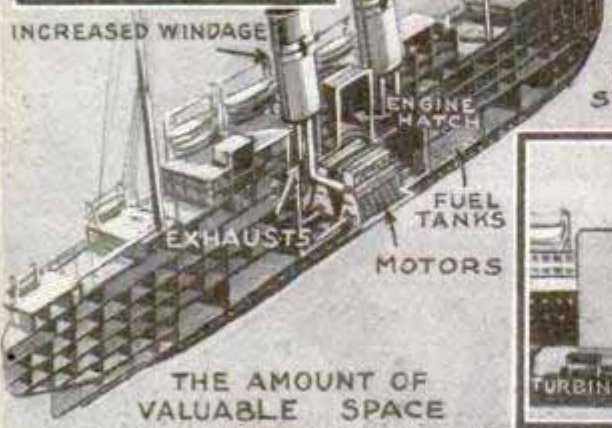

THE AMOUNT OF VALUABLE SPACE OCCUPIED BY THE MOTOR LINER'S UNNECESSARY FUNNELS

SPACE OCCUPIED BY MACHINERY IN THE STEAM-DRIVEN LINER

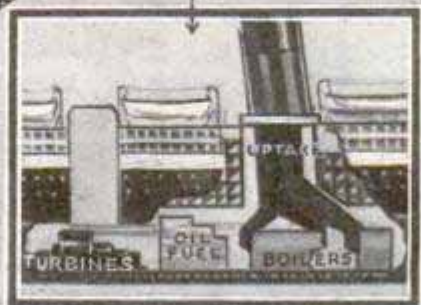

MOTOR SHIPS BUILDING AT THE END OF 1925—GROSS TONNAGE 994,186

© Illustrated

Constructors, Forced to Provide Smokestacks for Smokeless Ships, Convert Them into Air Ducts, Covering for Exhaust Pipes, and Use the Base Space as Storerooms for Supplies

to Satisfy the Ocean-Going Public

THE COMING OF POLE MASTS, HUGE FUNNELS AND TWIN SCREWS. THE "CAMPANIA" OF 1892



HOW THE DUMMY FUNNEL OF THE "OLYMPIC" IS USED.

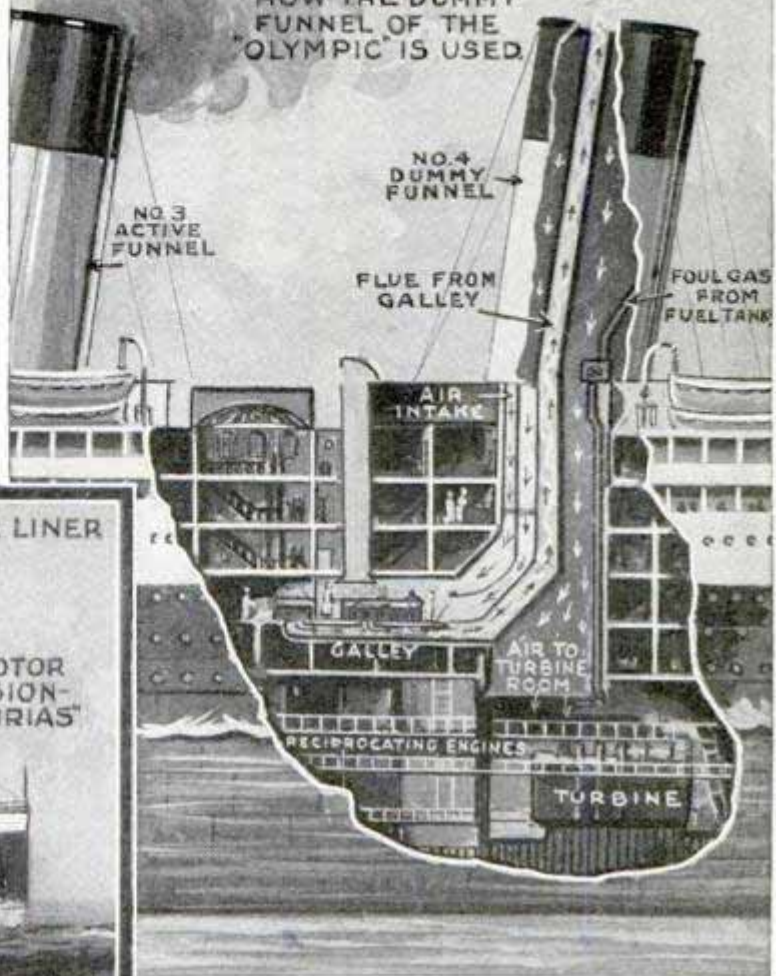

THE FUNNELS OF THE LATEST MOTOR LINER

DUMMY FUNNEL

THE LARGEST MOTOR SHIP IN COMMISSION—THE LINER "ASTURIAS"—22,137 TONS.

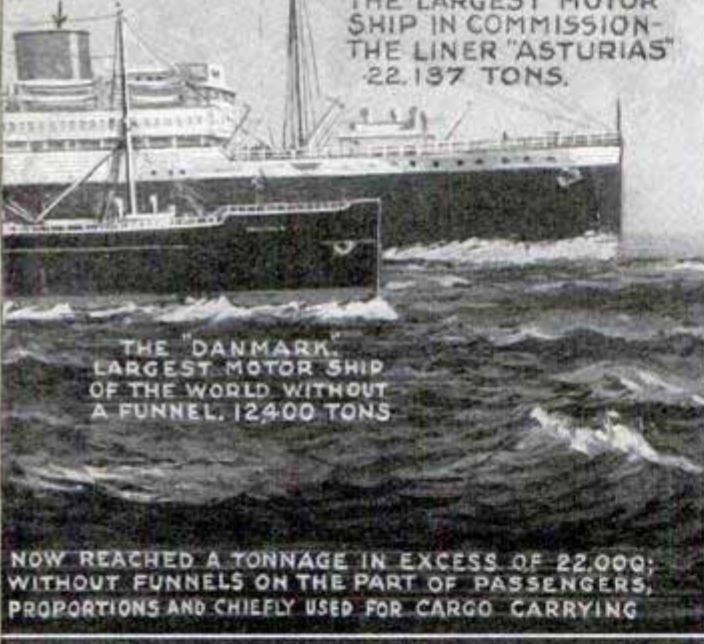

THE "DANMARK," LARGEST MOTOR SHIP OF THE WORLD WITHOUT A FUNNEL, 12,400 TONS

NOW REACHED A TONNAGE IN EXCESS OF 22,000; WITHOUT FUNNELS ON THE PART OF PASSENGERS, PROPORTIONS AND CHIEFLY USED FOR CARGO CARRYING

THE SHIP WITH THE NUMEROUS FUNNELS (A CRAZE THAT HAS PASSED)

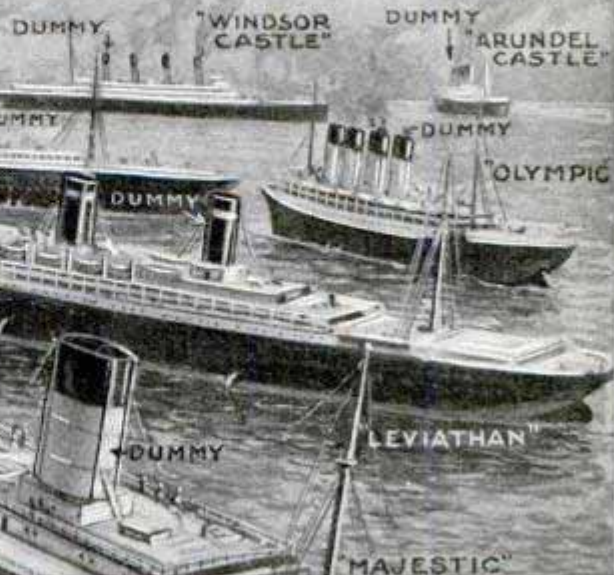

"BERENGARIA"

DUMMY

"WINDSOR CASTLE"

DUMMY

"ARUNDEL CASTLE"

DUMMY

"OLYMPIC"

DUMMY

"LEVIATHAN"

"MAJESTIC"



STEAMSHIPS BUILDING AT THE END OF 1925—GROSS TONNAGE 938,750

2026

L.H. G. Gage

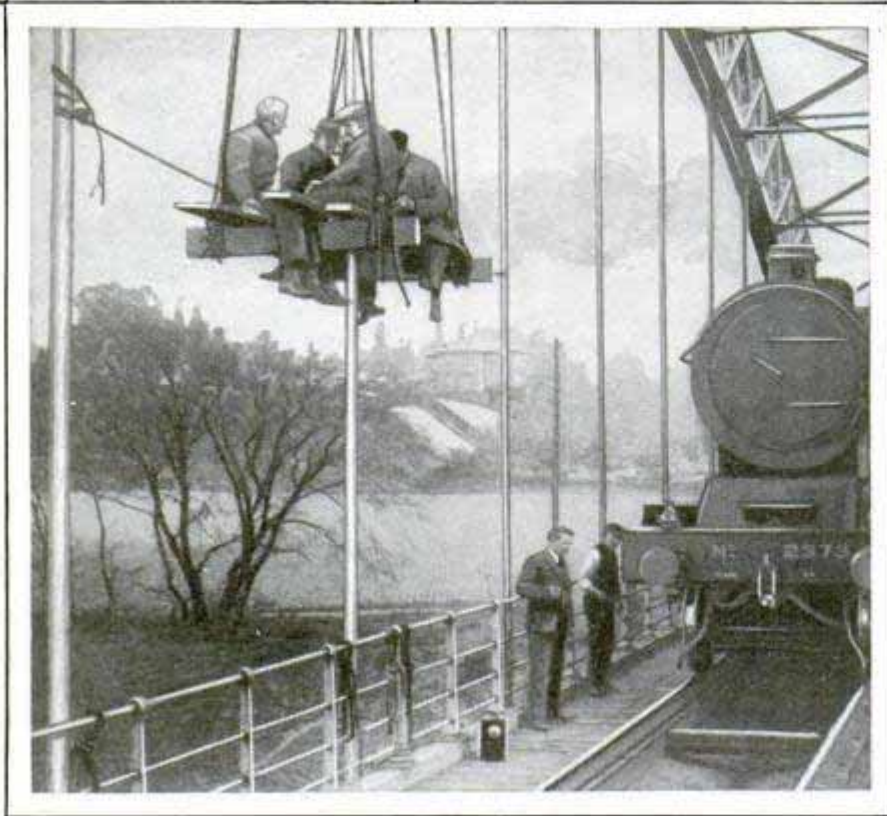

Testing Strain on Bridge While Engine Is Run over It; Observers on Platform Study Stresses with Aid of Special Instruments

STRAIN ON BRIDGES IS TESTED WHILE THEY ARE IN USE

at West Wylam

While heavy locomotives were run across the bridge over the river Tyne in England during a safety test recently, delicate instruments erected on a temporary platform around one of the main supports of the structure, recorded the strain. Similar tests were made at different parts of the bridge and with the engines running at various speeds to reveal any weakness.

VEST-POCKET CRIBBAGE BOARD CARRIES PEGS INSIDE

1880

Folding into a small packet, less than five inches long and half an inch thick, a cribbage board now on the market may be carried in the player's pocket, or occupies but little space in his luggage. The pegs are held securely on the inside of the board when not in use by means of a small pouch.

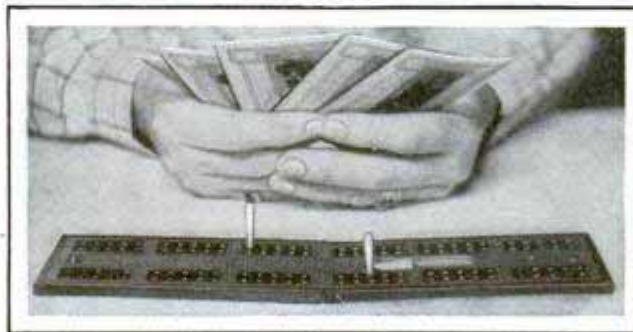

Pocket-Size Cribbage Board for Travelers; Pegs Are Fastened in a Small Pouch on the Inside

SEEK PREVENTION OF OIL-TANK FIRE BY LIGHTNING

2001

An oil fire in California attributed to lightning, which caused the death of two men and a loss of \$10,000,000, has resulted in a search for some way of eliminating this hazard. Oil-storage tanks are necessarily so large that reinforced concrete rather than metal tanks must be used. The tops are of wood, often covered with felt as a protection from the heat of the sun and evaporation. Frequently the space between the surface of the oil and the top of the tank becomes filled with an explosive mixture of air and oil

Schenectady N.Y.

vapors. In general, no lightning protection is used. In experiments at the General Electric laboratory with artificial lightning and miniature oil tanks, it was shown that where there are explosive mixtures, the protection problem is exceedingly difficult. Just as a considerable voltage may appear on transmission lines a mile or more from the lightning discharge, because of "wireless" or induction effect, so may sparks be caused by voltages induced in metal parts of the tank, even though the tank is not struck directly. A spark caused by a lightning stroke several miles away may ignite the mixture. If a tank were made completely of insulating material, there could be no spark, but there are always pipes, nails and conducting strips more or less isolated. Grounded wires strung over the tank, as in the case of a protected transmission line, would reduce the danger, but it would only mean that the storm would have to come closer to

Emil Kahn, 95 Nassau St.

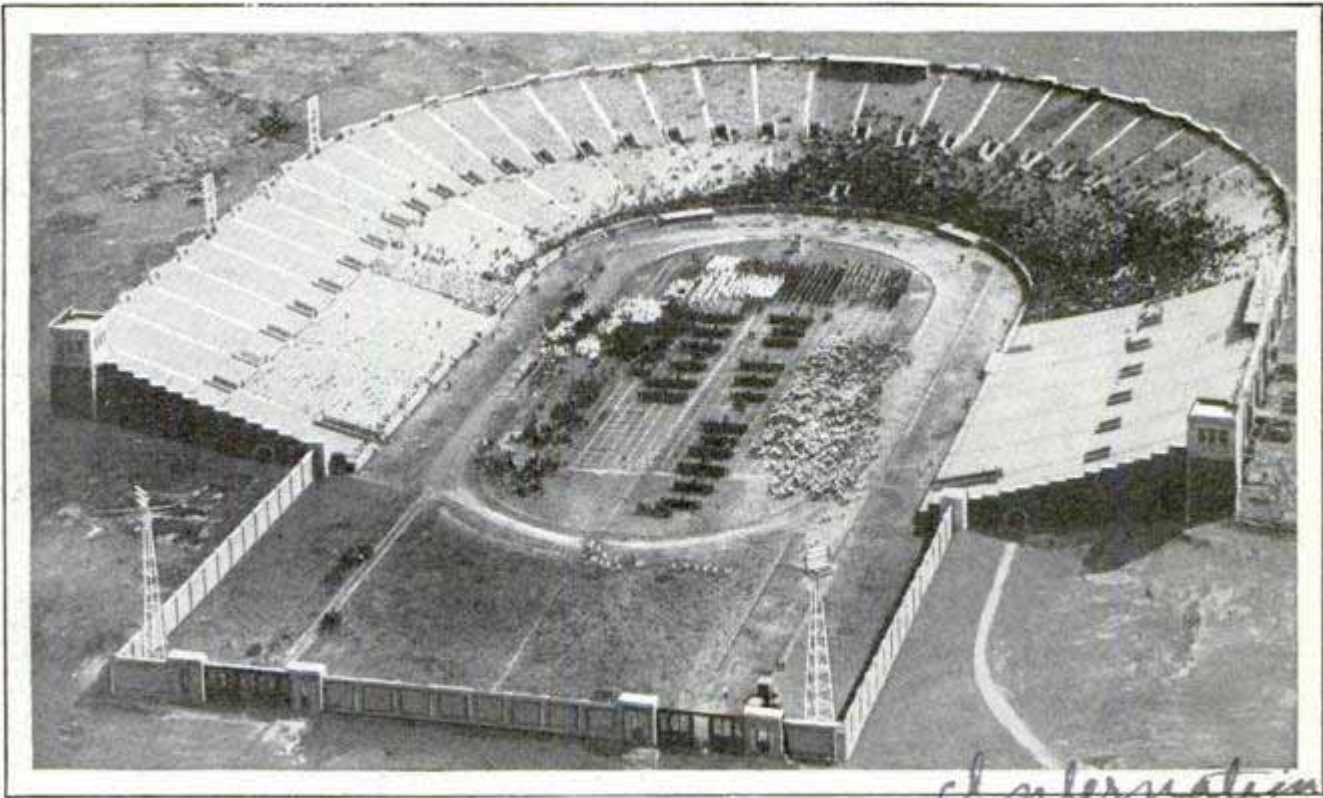

International

Where Parades and Pageants Are Being Staged for Visitors to the Sesquicentennial Exposition in Philadelphia; 100,000 Persons Are Easily Seated in the Stadium

cause the spark. The only safe method where there is explosive gas is a complete metal tank, inside of which no sparks can occur. Even then there is danger when projections extend from the surface. There are a number of principles that can be applied to prevent the tank from being struck. It has been found, for instance, that lightning never strikes the ground nearer a conducting rod than four times its height. A number of rods properly placed about the tank would either take the hits or cause the lightning to strike the ground some distance away. Grounded wires strung over the tank, a grounded metal net or metal roof also afford a protection. The researches showed that a standing man is fifteen times more likely to be struck than a man lying flat on the ground.

2056

**NEW STAR BRIGHTER THAN SUN
INVISIBLE TO UNAIDED EYE**

Discovery of a new star, which astronomers estimate is 4,000 times too faint to be seen by the unaided eye, has been announced. It is said to be 10,000,000 times brighter than our sun and is thought to have been formed during some celestial catastrophe that occurred millions of years ago.

*Prof Max Wolf
and Reissmuth*

**BIG STADIUM FOR EXPOSITION
SEATS HUNDRED THOUSAND**

One of the chief structures erected for the sesquicentennial exposition in Philadelphia is the monster stadium where parades and other outdoor events are held. It has a seating capacity of 100,000 persons.

**CUSHION PAD FOR EGG CRATES
REDUCES BREAKAGE**

Corrugated-cardboard pads with lengthwise grooves, placed between the layers in the egg crate, have been found effective in preventing the partition fillers from slipping and thus reducing breakage. They act as cushions and yet do not cut off ventilation. They are durable but so light that they add practically nothing to the



weight of the shipment and their use will mean a worth-while saving.

*1990
The Laregor. I own.
Cushion.*

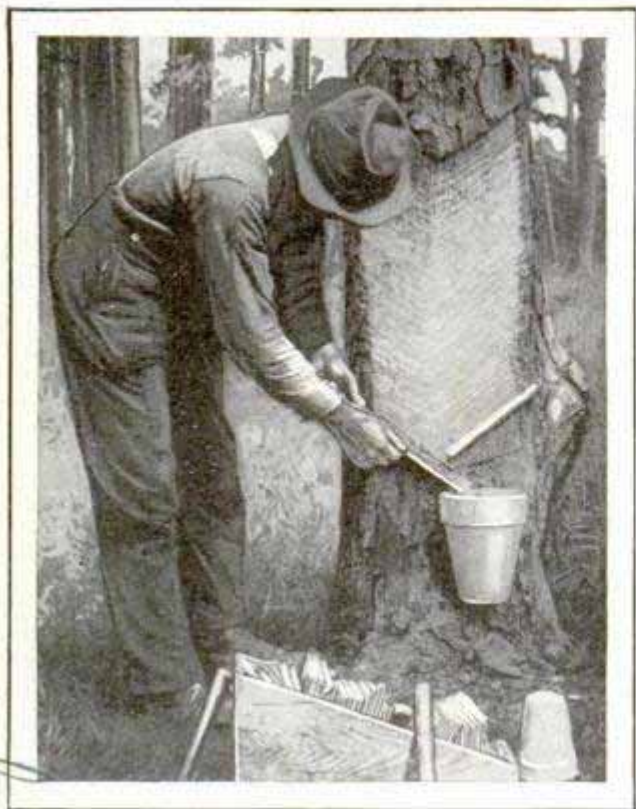

Improved Method of Gathering Sap for Turpentine; Only Bark Is Cut Away to Preserve the Tree

TREE TAPPED FOR TURPENTINE SAVED BY METAL GUTTERS

The turpentine industry in the south has been stimulated and further destruction of trees prevented through a cup of two thin metal gutters and an earthenware pot, the invention of a professor at the university of Georgia. The metal strips are fixed diagonally to the exposed base of the tree and direct the exuding sap into the receptacle which is suspended below the cut. Only the bark is stripped away, and this method prevents chopping and weakening the tree, a process that often caused extensive damage in the forests, as strong winds blew the trees down. Turpentine oil is now used extensively in paint and varnish manufacture, rubber making and in printing woolen and cotton goods to keep the colors from running together. The gutter inven-

tion, it is believed, will result in a revival of the turpentine-collecting industry in parts of the south where the supply had been diminished by the rapid destruction of trees.

Madison Wis

FIND ANCIENT CHINESE DRUG GOOD FOR COLDS

2057

Used by the Chinese for more than 5,000 years as a treatment for asthma, ephedrine has been found good for colds, as an anæsthetic and for raising the blood pressure or arresting bleeding in cases of hemorrhage. These uses are partial results of research conducted with the substance at the university of Wisconsin. Experiments are under way to determine if the drug is beneficial in treating hay fever. According to Dr. Ko-Kuei Chen, scientist at the university, ephedrine is considered superior to adrenalin in raising the blood pressure as its effects last over a longer period. The ancient Chinese doctors found that the substance caused muscles around the air passages in the lungs to relax, thus promoting easier breathing. The same experience has been met with in tests conducted with the drug at large clinics in Pennsylvania and Minnesota.

BOOK SHOWS MOVIES OF GOLF 1937 BY SPINNING PAGES

With the aid of a small book of illustrations showing successive stages in the different strokes of golf shots, players may study the correct form to improve their own game. Turning the pages rapidly produces the effect of a motion-picture film, or if more detailed study is desired, the pages may be turned slowly. A "still" is available at any time as a pattern for the player to follow, and the book is of sufficiently small size to allow it to be carried conveniently with the rest of the golf equipment.

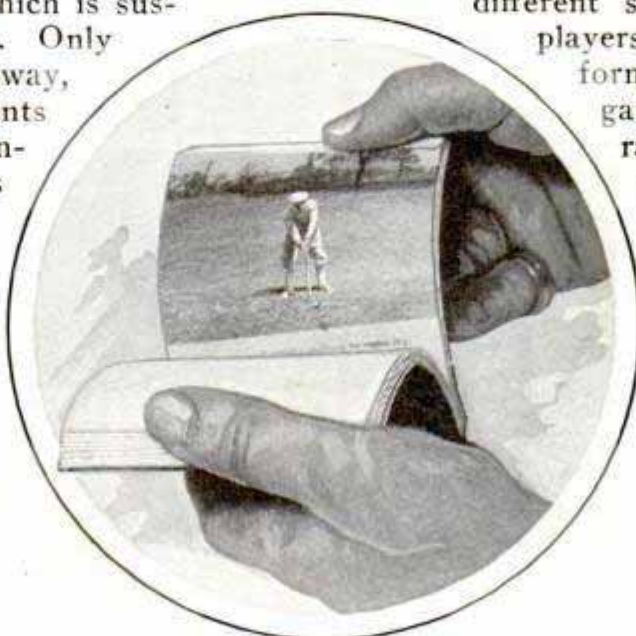

Turning the Pages Rapidly Produces "Motion" Pictures of Different Steps in Golf Strokes

Chester Harton Golf Institute

Prof. Charles A. Iderty Dept. Chemistry

and on 9 20. 9/9/37

ONE OF NATION'S GREATEST FEATS OF ENGINEERING

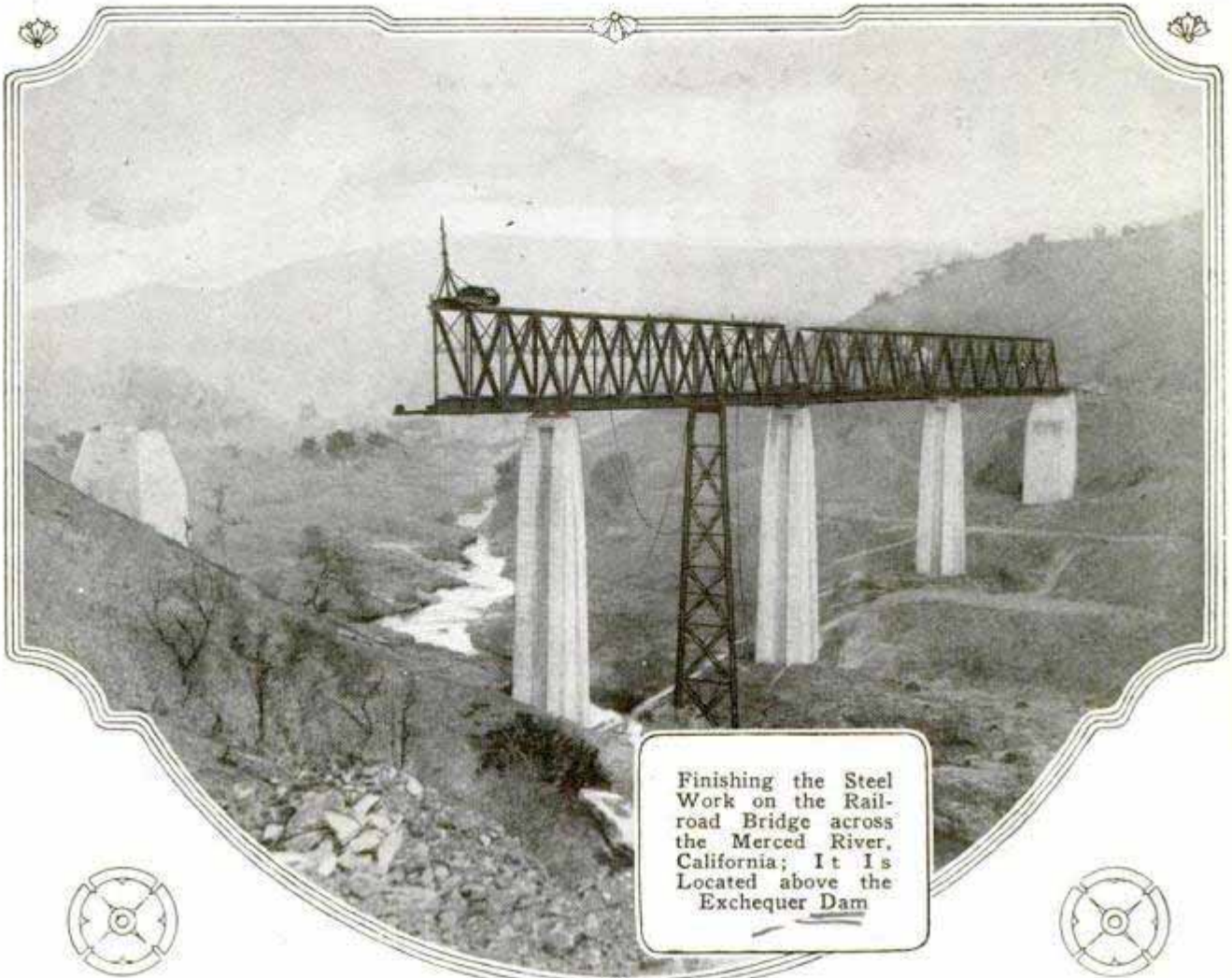

Finishing the Steel Work on the Railroad Bridge across the Merced River, California; It Is Located above the Exchequer Dam

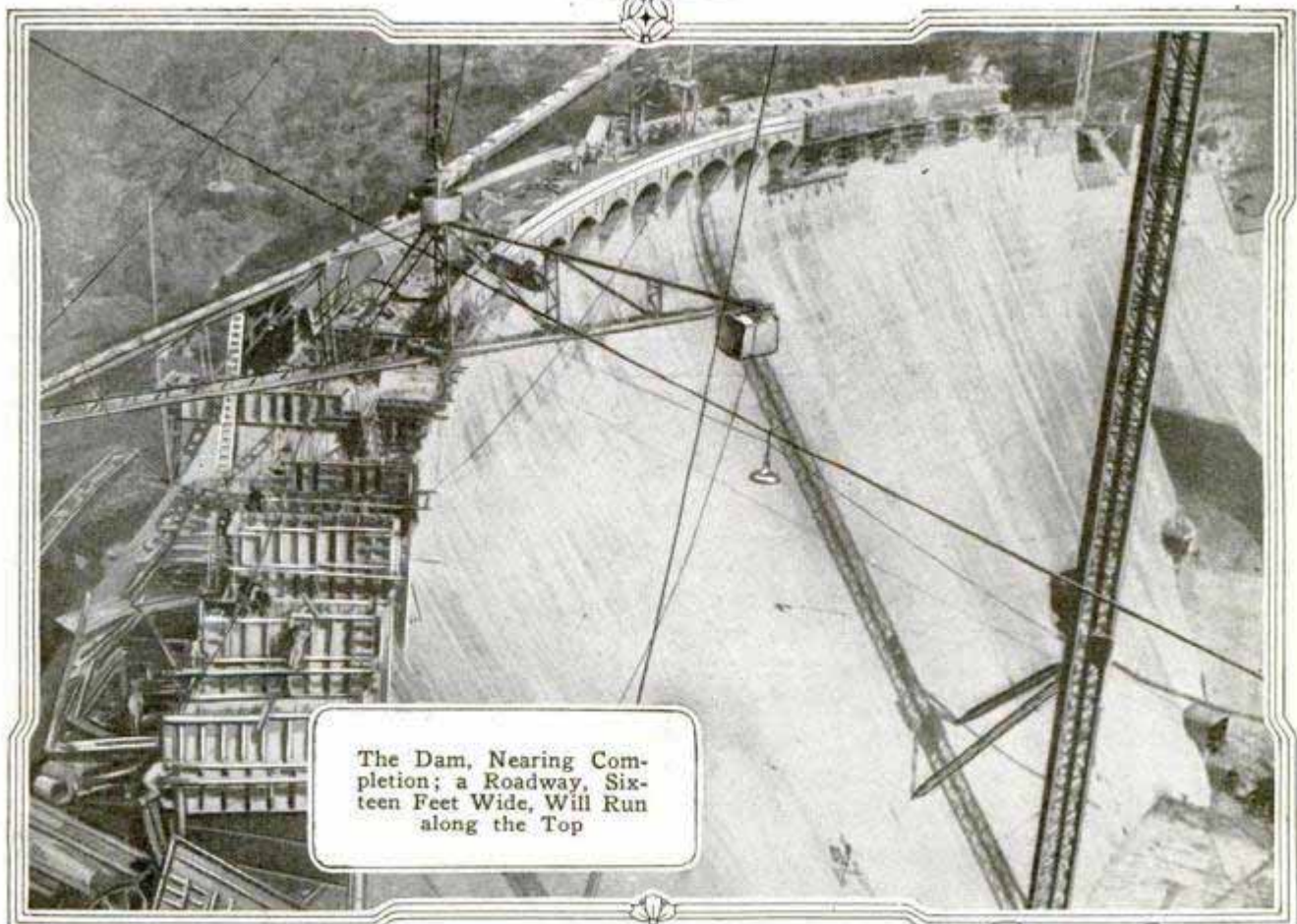

The Dam, Nearing Completion; a Roadway, Sixteen Feet Wide, Will Run along the Top

1845

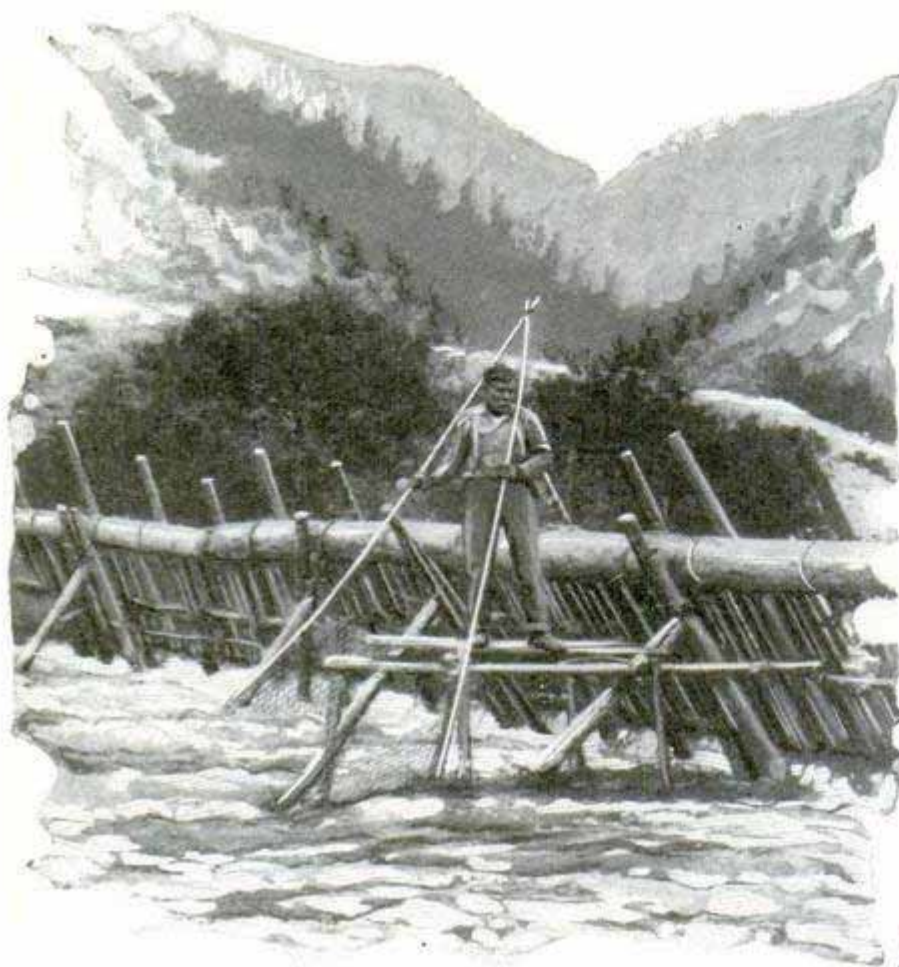

Indian Using the Dip Net to Lift Salmon from the Trap; behind Him Is the Crudely Fashioned Weir

INDIANS TRAPPING FOR SALMON SHOW SKILL AS BUILDERS

Certain rites are observed by fishermen in almost every land, but among the Hoopa Indians in northern California, the annual trapping for salmon, a principal food supply, is attended with special ceremonies and has caused a direct departure from tribal customs. The men do all the work of building the traps, for they believe that, if women assisted, no fish would come. Furthermore, no nails must be used, for these, too, are supposed to frighten the fish. The traps, white men declare, are inefficient, being crude affairs of stakes and boards with funnellike entrances and spreading "wings" to guide the fish into them. It is in constructing the weir across the stream that the Indians display their greatest cunning. Although it is swept away at each flood season, the workers cheerfully rebuild it every year and consider its destruction a good omen, a promise of a plentiful supply of fish the following year. It stretches straight across

the stream and is like a picket fence, and the upper ends of the sticks are lashed to heavy logs which are securely braced by supporting timbers. The pickets slope downstream, adding to the strength of the weir and making it possible to rake driftwood over its top. Lashings are made of hazel boughs, for the Indians consider this kind the only suitable offering to the spirits that control the fishing. The salmon are lifted out with dip nets of coarse mesh, attached to two long sticks.

ROLLER SKATE ON POLE ADDS TO BOYS' SPORT

1893

To increase the sport of roller skating, a pole with a third skate attached to one end, permits the boy to sit down while coasting and has a brake to check the momentum on curves or other places. It is carried like a hockey stick on a level course to help attain speed and is quickly placed into service as a seat. Fancy turns and movements can be executed with the pole, using it as a rudder.



Using the Roller Pole for Balance and Riding on It as a Coaster

Coaster Skate Co.

2.00

POWDER MIXED WITH WATER CONQUERS OIL FIRES



Conquering the Blazing Pool of Oil with Stream of Foam, and Close View of the "Gun"

Heavy fuel oil and gasoline, 250 pounds of the mixture in a big pool, blazed up with a fierce flame. A queer-looking car was wheeled up, a hose connected and out shot a foamy mixture of powder and water. By a stop watch, the blaze was entirely extinguished in just twenty-six seconds from the time the thick stream first struck the pool. This happened at a test of the fire-fighting equipment in Chicago recently, before representatives of insurance companies and firemen. As water was forced through the hose, the powder was poured into it from the mixer, the result being a smothering coating of thick foam that shut off the oxygen from the flames. The apparatus is expected to be of special benefit in combating oil fires as it does not spread the ignited liquid.

BULLET-PROOF ROTARY SHIELD TO PROTECT SOLDIERS

Tests with a whirling shield that is said to deflect machine-gun fire less than a foot from the soldier's face have been conducted by the army. It was devised especially to protect men on tanks from flying shell fragments as well as bullets and consists chiefly of a mushroom-shaped cap of half-inch steel, about three feet in diameter and two feet high. A series of narrow slits in the cap, although too small for clear vision

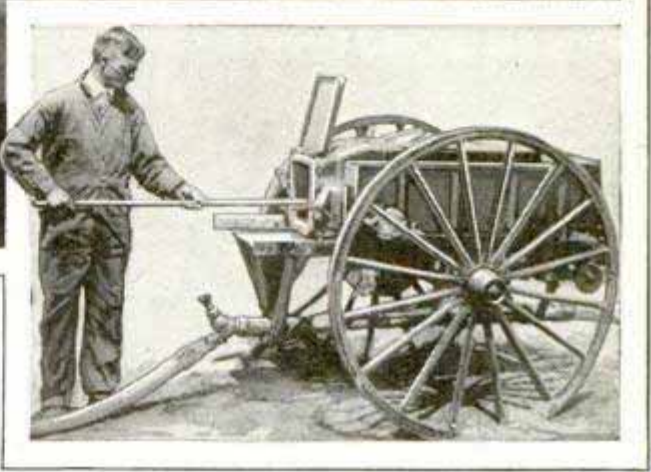

when the shield is stationary, permit a good view when the steel is rotating so that men behind it can see out and are safe from gun fire at the same time.

BALLOON-TIRE VULCANIZER HAS POWERFUL CLAMP

Both the inside and the outside of balloon tires are vulcanized in one operation with a special outfit now on the market.



It has a steam-heated curing arm of special design which is inserted inside the tire during the repair process. It also is provided with a powerful clamping arrangement that is said to exert tons of pressure on the vulcanized area, and sufficient to force little rivets of rubber through the fabric. Heat is supplied from a boiler fitted with a burner for use with either gas or gasoline.

*Anderson & Beam Vulcanizer Co.,
1119 N. Harrison St. Indianapolis, Ind.*

Inf. given up at lunch

To Save Work



Cooper with Self-Basting Tray, Saves Gas, as Only One Burner Is Needed for Preparing Meats, Vegetables and Desserts, and Foods' Nutritious Juices Are Retained; Section View at Right

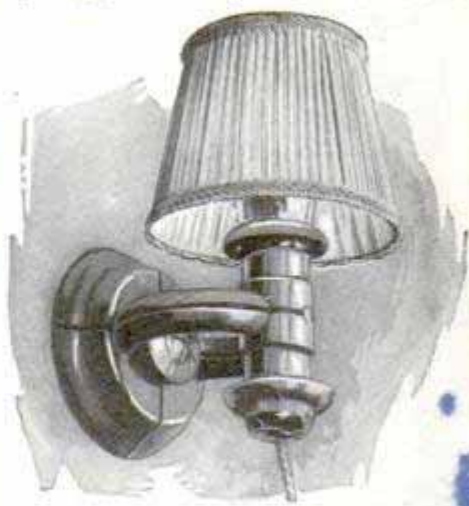

Various Lighting Effects Are Possible with This Perpendicular Lamp Bracket, and Socket at Bottom Affords Extra Connection for Cord or for Another Bulb



Ironing-Board Cover That Snaps On, Has Strong Elastic Band around Edge



Timing Switch Automatically Turns Electric Current to the Cooking Dish, Flatiron or Other Implement On and Off as Desired



Two-Handled Can Opener Prevents Cuts from Round or Square Lids

in Your Home



Bluing in Tape Form Cannot Be Spilled and Amount to Use per Gallon of Water Is Marked on Edge



Folding Hanger for Women's Garments and Soft-Haired Brush Both Slip into Leather Case to Fit Traveling Bag



Electric Dishwasher, Built as Part of Sink, Cleans, Rinses and Dries; a Revolving Dasher Hurls Water to Every Part of the Stack and a Turn of the Handle Drains the Washer

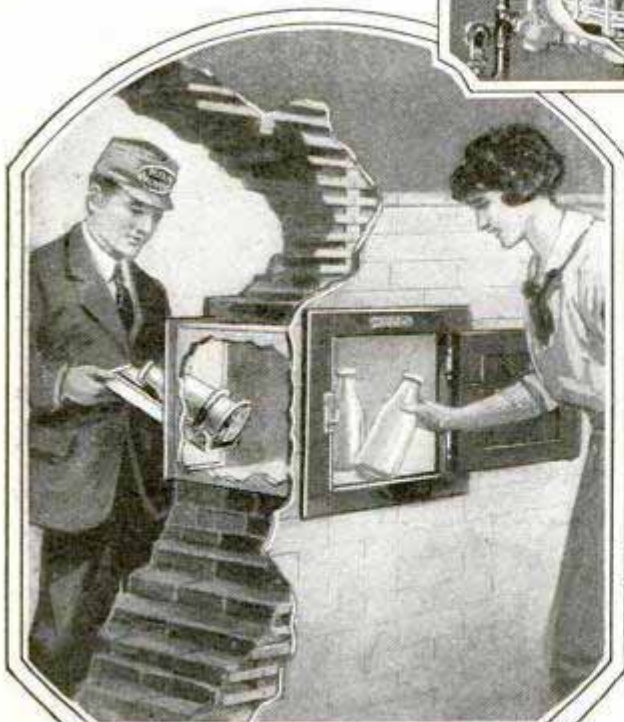
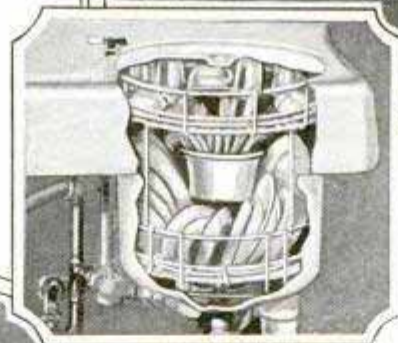

Milk-Bottle Trap Locks When Last Bottle Is In; Unlocks Only from Inside



For Better Pie Crusts, Biscuits and Other Pastry, This Meshed Mixer, Replacing Knife, Quickly Blends Shortening with Flour

1809 *Heather of Calif*
STEAM FROM WELLS IS SUCCESSFULLY HARNESSSED

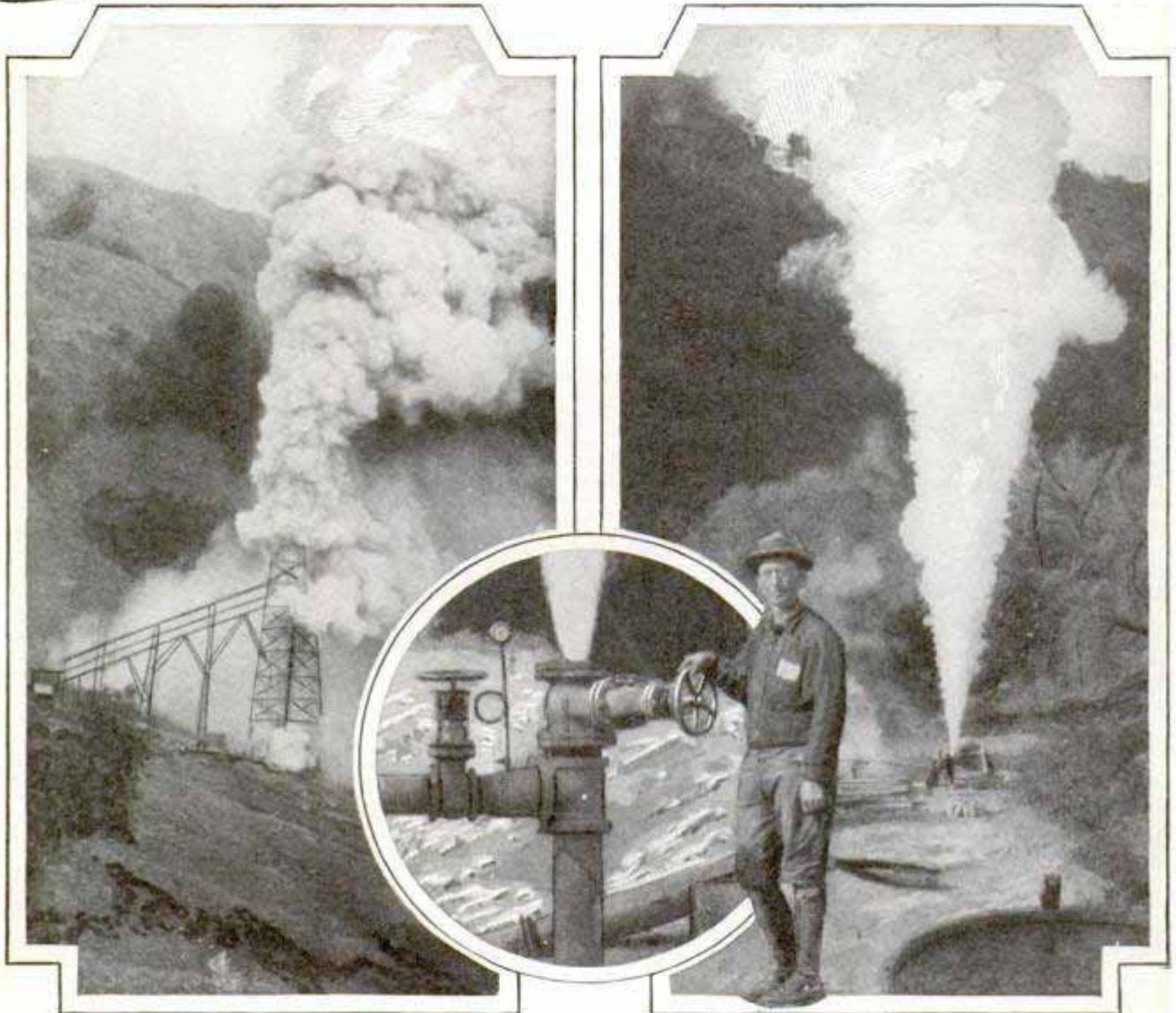

Scenes at California's Natural Power Plant Where Man Has Tapped and Harnessed a Subterranean Steam Supply; Pressure of 276 Pounds Was Developed at One of the Wells

Development of steam at high pressures from the ground by means of wells has proved a success in California. There seems to be no doubt but that the problem presented by non-condensable gases can be solved. A small turbine containing blades of different metals has been operated on natural steam from one of the wells and the drilling engines have used it for several months with no trace of corrosion. So far the tests indicate that a metal for turbine blades can be made which the gases will not attack. In drilling the wells, an open hole is first driven into rock as far as possible. Into this a ten-inch steel casing is set, and the space between the casing and the walls of the hole filled with cement. Then the hole is drilled deeper into the rock until the flow of steam is good. Considerable difference

in quantity and pressure of steam is found in different wells. The highest pressure reached is 276 pounds. Some wells, after having been opened for a while and then closed, show rapidly rising pressure, while in other cases, it takes several days to build up the highest pressure recorded. In cold weather the steam clouds rise to a height of 500 feet and more.

**BIG INCREASE IN MOTORSHIPS
 1592 AND POWER OF ENGINES**

Tonnage of motorships completed in 1925 was nearly three times that of 1923, according to reports from England, and motor vessels totaling about 1,500,000 tons are in course of construction. The figures do not include ships under 2,000 tons and are considered the more remarkable

motor ship.

because the period covered was not especially active in shipbuilding. Firms that once embark on motor-vessel programs do not go back to steamers, it has been found. Instead, more orders are placed for motorships. The principal advantages claimed for this form of propulsion are that additional cargo space is provided, there is a wider range of action, higher average speed, the task of refueling is simplified, and both fuel and lubricating-oil consumption are reduced. A comparison was made between two ships of about 9,200 tons each, one a steamer, the other burning oil. It was found that the oil burner cost about \$25,000 less per year to run, while its cargo capacity was thirteen per cent greater. The tonnage of motorships built in 1925 was 1,004,915 and the horsepower 420,820. Engines of far greater power are being built as part of the rapid conversion to motor vessels.

PORTABLE SPRAYER HAS MOTOR AND SERVES AS CLEANER 1922.

Operated by current from a light socket, a motor-driven sprayer now on the market is said to throw a fine mist of liquid insecticide twenty feet and with sufficient force to penetrate cracks and crevices. It is easily carried about, motor and all, and special attachments are provided whereby

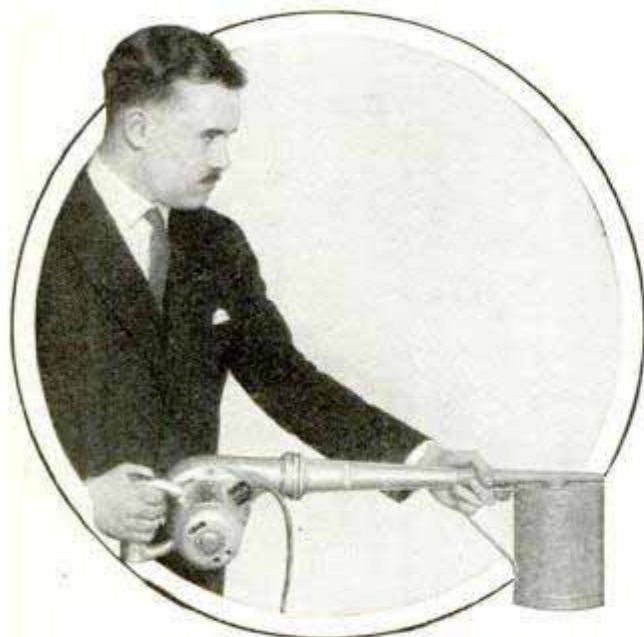

Motor Blower on Sprayer Affords a Stronger Blast than a Hand-Power Plunger, and Saves Work

it may be used as a vacuum cleaner or as a blower to remove dust.

*Clements Mfg. Co.
601 Franklin St.*

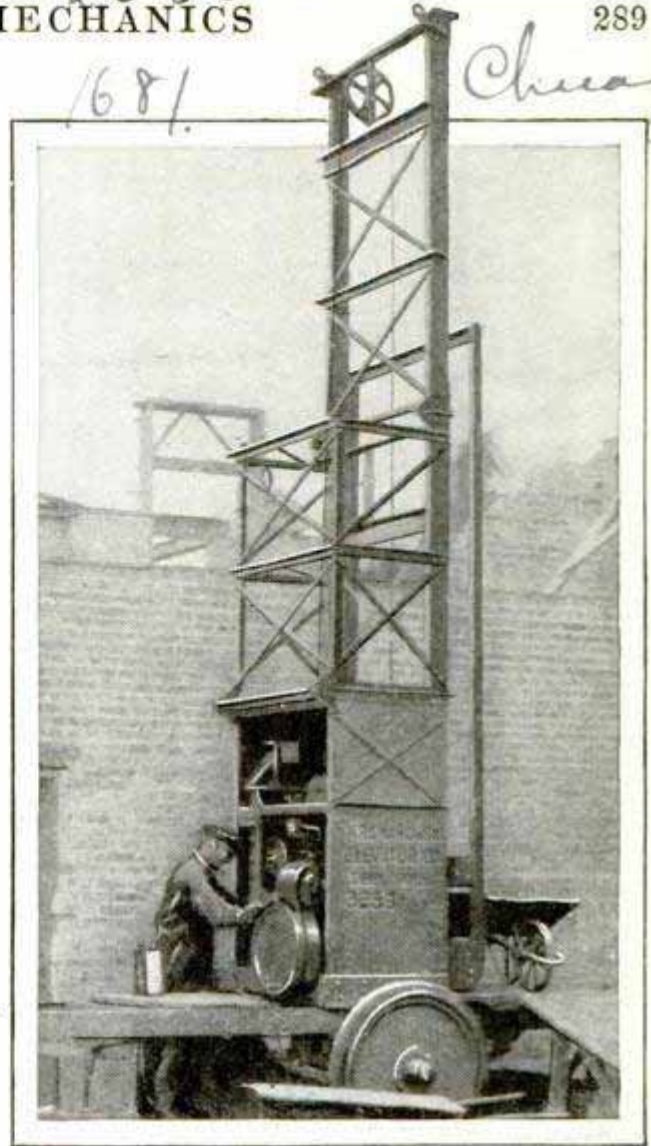

Contractor's Portable Hoist in Operation; It Can Be Moved Quickly to Any Part of the Job

ELEVATOR ON TRAILER TRUCK EXTENDS LIKE TELESCOPE

For hoisting building materials, a portable telescoping elevator mounted on a rubber-tired trailer truck, saves the contractor considerable time and labor. It can be extended to reach to the top of a three-story structure and can be moved at a moment's notice to any part of the job.

Patent pending 1831
RULING PEN WITHOUT SCREWS

Fitted with a sliding sleeve instead of the usual screw, a ruling pen now on the market is said to be more easily adjusted to drawing lines of different widths and can be cleaned thoroughly with little trouble. The spread of the blades is held by an arrangement of notches and a catch on the sleeve. To release them, the blades are simply pressed together, and to aid in resetting, the notches are numbered. The pen is said to be especially useful on large tracing work.

2.35
*A. Welcome, 930
Margaretta Bldg*

Cleveland Crane & Engineering Co.



Replicas of Museum Rings, Illustrating Symbol's Use in Wedding Rites of Different Countries

WEDDING RITES OF CENTURIES REVEALED IN RINGS

Replicas of various styles of wedding rings which have been collected in the museums of the world, were displayed by a Los Angeles jeweler not long ago, illustrating the widespread use of this symbol throughout the centuries. The wedding ring was probably developed from the engagement band which came into use in early Roman times. It was first made of iron and later of gold and signified a vow that the contract would be fulfilled. The ring custom was of secular origin and, a few centuries later, became connected with ecclesiastical rituals.

1726 MOTOR COACH AS DINING CAR TO SERVE AUTO TOURISTS

Persons stopping at automobile-tourist camps and visitors at country fairs, and the like, will have dining-car facilities similar to those provided on the railroads in a completely appointed motor coach designed for serving meals. It is equipped with four tables and eighteen chairs, has a kitchen with hot and cold water, a refrigeration system, soda fountain and other conveniences of a modern restaurant. An improved ventilating system, radio and attractive schemes of interior and exterior decoration are additional fea-

tures. The coach is said to have been conceived from a two-wheel pushcart used by a young man in supplying edibles to campers at a Maine resort a few years ago. His business was so successful that an inventor, who had become interested in it, planned the motor dining car which has been prepared for use this summer.

1860 WINDOW WASHERS' RAIL CAGE REDUCES ACCIDENTS

To safeguard the lives of window washers on tall buildings and to save time, a cage large enough to hold two men is suspended from a permanent rail hung from the eaves or bracketed to the wall. The car runs on a ball-bearing carrier and can easily be pushed along. It is raised or lowered by means of a chain hoist. Besides room for the workers, there is space for pails, brushes and wipers. Guards on each side of the cage prevent falling. The apparatus is useful when the sides of the building are to be cleaned and the rail can be installed in such a way

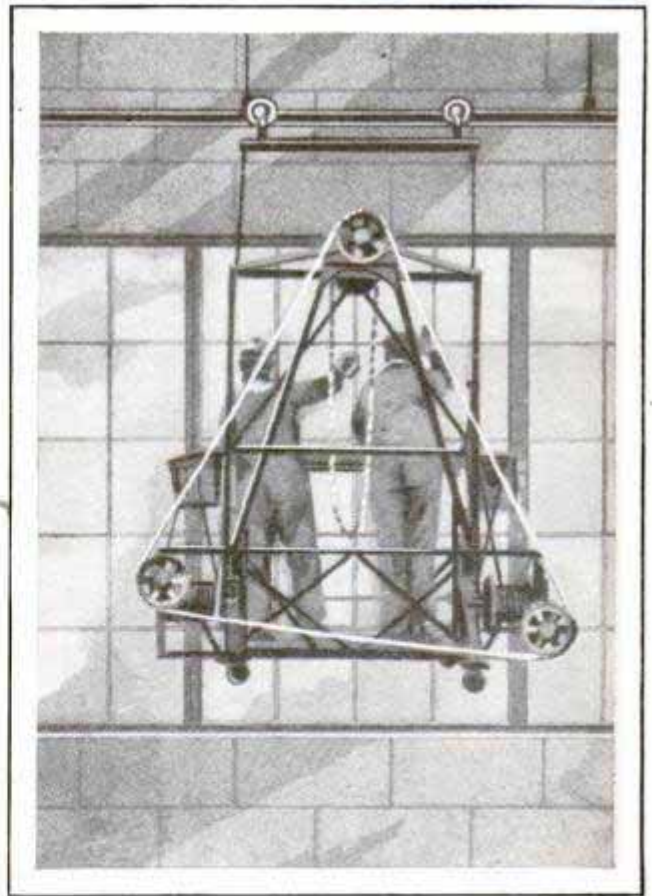

Window Washers' Cage on Track Is Pushed along Entire Side of Building

that it does not mar the appearance of the structure.

Serialized by Earnest S. Prindle in 1926

Brand Central Terminal New York

A great safety coach

Wickcliffe, Ohio

aero

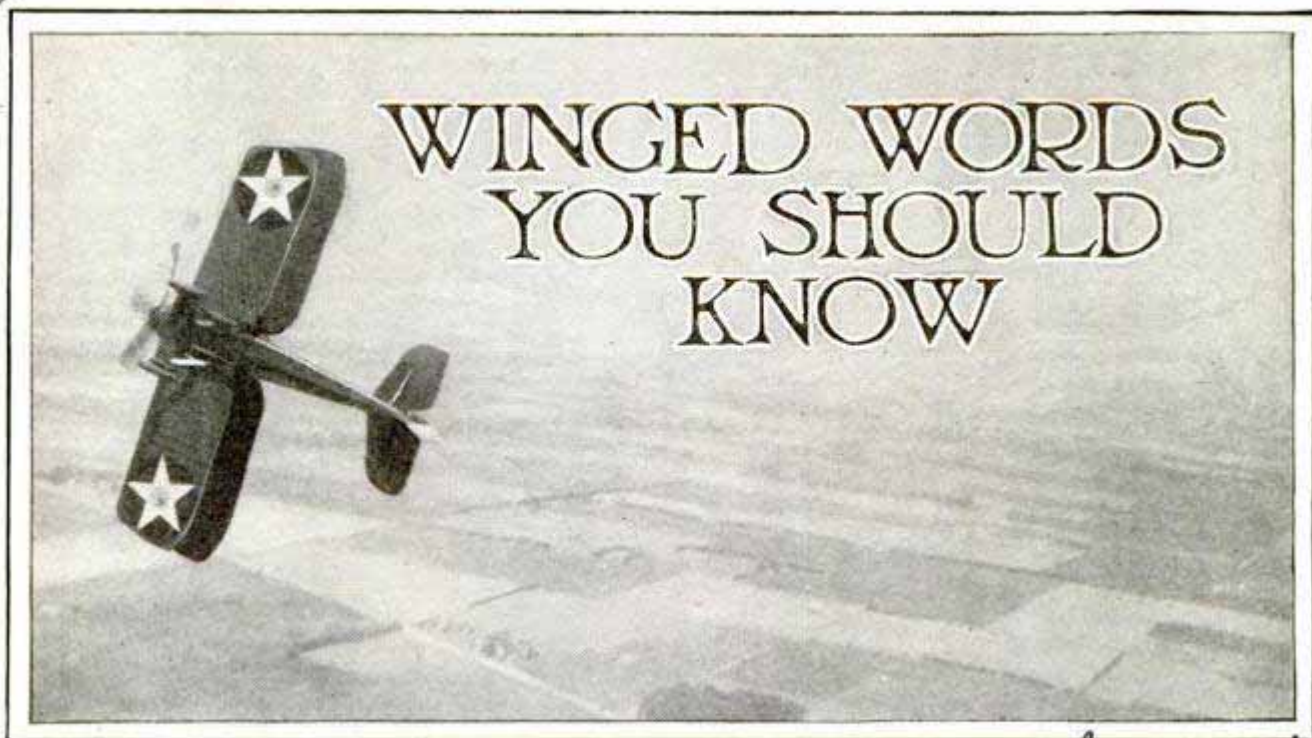

By CAPT. TOWNSEND SCOTT *Scott & Son 209 E. Fayette St. Baltimore Md.*

WITH the constantly increasing number of planes carrying passengers, mail and freight and daily playing a more important part in our lives, a language of the air has been born.

Australia there is a bird which has no wings. It runs along the ground crying, "kee-wee, kee-wee." In America there is also a member of the flying fraternity who cannot fly and he is named after his Australian cousin "Kee-Wee." He is the

ground officer in the air service.

ground officer in the air service.

Kay-Det: The would-be "peelo," while in training is known as a cadet, pronounced kay-det.

Crew: The enlisted men who tend a ship are its crew, and the leader of this band is the crew chief.

Job: All planes are jobs. Having a rotten job has nothing to do with the pilot's occupation. It describes the chariot in which he must ascend to heaven.

Jenny: A Curtiss J. N. training plane, slow and fairly sure, used to train kay-dets.

D. H.: During the war, the U. S. decided that it must have a better engine than anybody else, so the Liberty was designed. Then it was suddenly discovered that

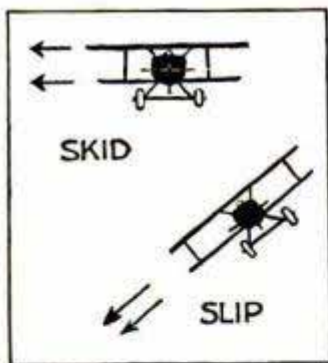

those of the frontier or of the Forty-niners, have been coined to meet a new human need resulting from the conquest of another element—the air.

The "gun" of the pioneer days

has come to mean the throttle of an airplane, to "zoom" is to make the plane alternately climb and dive, and drifting with the wind is described by the one word "crab." Some of the other expressions in daily use and their meanings follow:

Pilot: The aviator or flyer of an airplane, frequently pronounced "Peelo," the alleged French pronunciation.

Kee - Wee: In

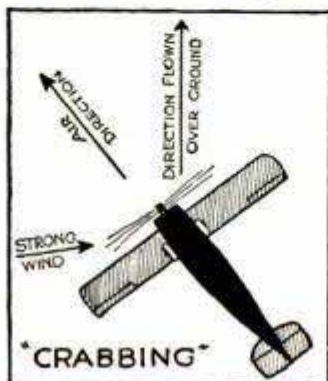

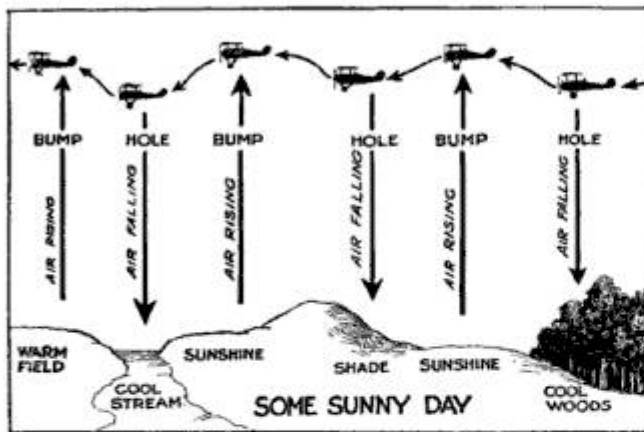

we had no plane to fit the motor. Finally it seemed that it would fit in a British plane called the DeHaviland or D.H.

Martin: A large, two-motored plane, built to carry bombs, generally known as "pills."

Crate: Planes of ancient vintage.

Attack: Larger planes capable of doing damage to ground area in wartime.

Hotter than Air: The branch of the air service which has to do with aircraft

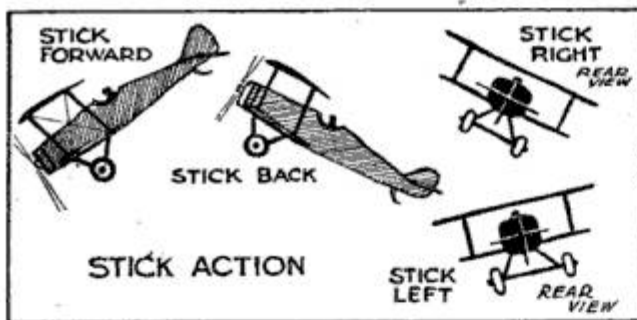

made lighter than atmosphere is called lighter-than-air, affectionately known as "Hotter than Air," and its members are the boys who ride the rubber cows.

Rubber Cow: All aircraft kept aloft by gas, such as a balloon or dirigible.

Prop: The propeller, which pushes or pulls the aircraft through the air.

Gun: The throttle or accelerator. "Give her the gun," means "step on it."

Tac: The tachometer, or "tac," is an instrument which tells how many revolutions or "revs" per minute the prop is making.

Altimeter: The instrument which shows through diminished air pressure, how high the plane is above "Grandma Earth."

Stick: An arrangement resembling a broom handle situated in front of the pilot's seat and attached to a universal joint on the floor. This is connected by

wires to the elevators and ailerons and controls them. The peelo grasps the stick gently but firmly in one hand and pushes it in the direction toward which he wishes the plane to tilt, the horizontal guiding of the plane depending on the rudder, controlled by a bar on which he places his feet.

Elevator: The elevators make the plane point up or down and consist of horizontal rudders, placed on each side of the regular rudder on the tail of the plane.

Ailerons: The flaps on the rear ends of the wings which cause the plane to tilt from one side to the other.

Contact: The signal yelled out as a warning to show that the switch is on and that any movement of the prop may start the motor.

Revving Up: After the motor has been started, the peelo warms it up to be sure it is in working order. He watches the tac to see how many revs the prop is making. This is revving up.

Conk: When the motor stops suddenly from any cause, it is said to have conked.

Taxi: Running the plane over the ground on the take-off.

Stall: When the ship is headed up at a greater angle than that at which its speed will allow it to climb, it will stall like a fivver on a hill, and topple over toward the earth.

Roll: To turn the plane over and over sideways.

Crab: When the wind is blowing hard enough, the plane must be headed at an angle into the wind to fly toward its destination. The result is that the plane moves over the ground in a sidewise position. This is called crabbing.

Flying Speed: Like the bicycle, the airplane must be kept moving in order to be controlled, otherwise it will topple over. The speed necessary to keep the plane going without losing altitude, and under

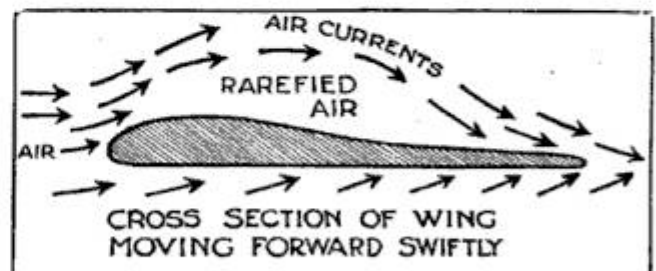

control, is called flying speed. If the motor conks, the plane must be headed down

1904 Society Electro
Chauffage industriel
13 bis rue
des
Mathurins
Paris
Mrs
Mathurins

to keep up flying speed so that it can be landed in the nearest field. Landings of this sort are called forced landings.

Low and Slow: Never has a kay-det been born who hasn't been warned by his family to fly low and slow. As pointed out before, the only way to keep control of a plane is to keep it always at good speed. Also, no matter what position the plane gets in, if it is high enough, it can be righted before it touches the earth. To fly low is dangerous.

Flop: Any unlevel or unusual flying.

Jazz Ride: Any pleasure ride generally implying a few flops.

Wash-Out: Anything or anybody who is useless, or anything of a boring, or sanctimonious nature is a wash-out.

Crack-Up: When anyone washes out a plane without doing any real damage to himself, he is said to have cracked-up.

Crash: A serious accident.

Bumps and Holes: Over cool spots on the ground, air falls; over warm spots, it rises. These currents cause uneven flying and are called bumps and holes.

Why She Flies: Air is theoretically a solid matter. The propeller is built on the principle of an auger or screw which, if



Using Flatiron with Electric Shoe Attached and as Heater

ELECTRIC SHOE FOR FLATIRONS ALSO HEATS DISHES

Ordinary domestic flatirons are quickly converted into electric ones by attaching a metal shoe or base a French inventor has introduced. It is supplied with current from a lighting socket and, when turned over, may be used as a plate to keep dishes warm.

WEIGH YEARLY FALL OF SOOT TO MEASURE SMOKE EVIL

Tangible evidence as to the magnitude of the smoke problem has been gathered by weighing the annual fall of soot in several large cities. In the dirtiest of ten centers observed in 1924, it was found that 794 tons of soot and dust fell per square mile for the year, while in the cleanest community the deposit was 101 tons per square mile. Soot from industrial chimneys contains a great quantity of ash grit and but little nitrogen, so that it is not valued highly as fertilizer, while deposits from domestic chimneys, although richer in nitrogen, contain a larger proportion of tarry matter, which clogs the pores of plants and ultimately stunts or kills them.

Lloyd W. Parsons in Industrial Soot

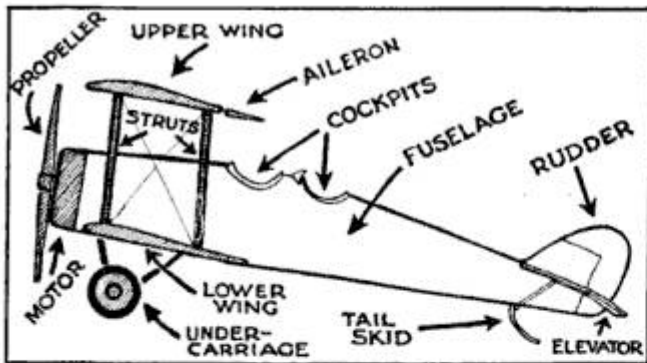

turned, must necessarily penetrate further into the material in which it is placed. It acts in the same manner as a propeller on a boat. As the propeller is turned rapidly by the motor, it pulls the plane over the ground attaining more and more speed. As the wings of the plane move through the air, the air hitting upon their entering edge is thrown upward as shown in the diagram. The faster the plane moves the higher above the wing the air is thrown, causing a rarefaction of air on the tops of the wings. This causes suction on the tops of the wings, same having a tendency to pull the wings up and so cause the plane to rise from the ground.

LATEST ACHIEVEMENTS IN WORLD OF INVENTION

1917

Engine

Mallery formerly

in charge of engine

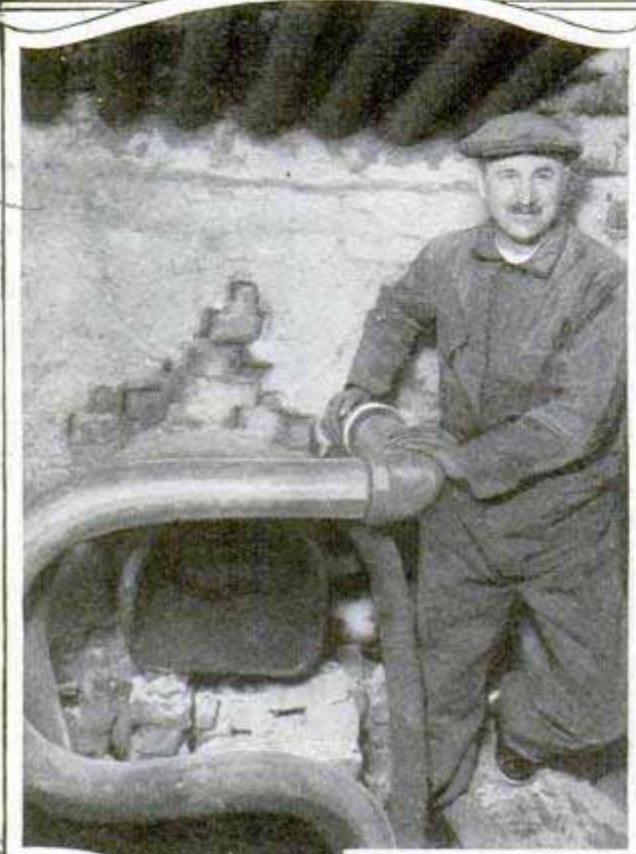

Furnace Appliance Which Converts Refuse Materials, Such as the Residue from Crude Oil, into a Burnable Gas for Generating Power, and, at Right, Light Airplane Engine in Test at McCook Field



Harold

W. A. Dis Apr 20
McCook Field

Wm. R. Russell, Navy Yard
Testing Section, Washington
D.C.



Sounder Measures Depth from Ship's Keel to the Bottom of the Ocean



Testing Improved Waterproof Paper Cups at Bureau of Standards

Inventor

**HOW TO BE SAFE IN TORNADO
IS TOLD BY EXPERT** 1977

Although almost any place in the path of a tornado is dangerous, a person is safer inside a house or other building than exposed to the whirling timbers and other debris outdoors, according to Prof. Frank H. Colyer of the southern Illinois state normal university. His observations are based on a study of the results of the disastrous storm that swept through Missouri, Illinois and Indiana last year. The basement is generally one of the safest places of the house, he declares, although a person should be careful to keep away from stoves and furnaces. Lying near a strong box, steel bed or exceptionally stout table sometimes protects from serious injury as the objects keep timbers and ceilings from falling. Hallways where the walls are close together are usually safer than large rooms, for if the ceiling should drop, there is nothing to break the crash in a large room.

**WOODEN HORSE THAT "WALKS"
EXERCISES CHILDREN** 1874

To replace the old-fashioned children's rocking-horse, a similar amusement device now on the market is operated in somewhat the same way but moves forward while the rider performs the same rocking motion. The child places its feet on a front cross member which is covered with rubber to prevent marring the floor. Leaning forward causes the rear of the horse to rise slightly and bring up the hind legs. When the child rocks back, the front legs move out in front as the weight is shifted to the rear. Thus the horse "walks" ahead, the exercise bringing the child's muscles into beneficial play besides affording amusement. It has been suggested that larger horses would afford grown-ups healthful sport.



Riding the Walking Horse for Healthful Exercise and Fun; It Makes Steady Progress as Child Rocks



Mrs. McCaig in the Center and Samples of Her Posterette Designs of California Scenes

**WOMAN PAINTER PAST SIXTY
DEVELOPS UNIQUE ART**

"Posterettes," tiny paintings of California scenes painted by Mrs. Flora McCaig of Pasadena, and reproduced on glued stamps slightly larger than the familiar Red Cross sticker, are being used by persons sending letters and even by commercial firms. They are printed in bright colors to represent the landscapes as the artist sees them and are carefully finished. Mrs. McCaig, now over sixty years old, has exhibited other paintings and developed the idea of the posters to express the delight she took in the scenic features of her California home.

Calif

Sovereign Toy Co.
1421 ~~Adams~~ St. Chicago

1997

6.6 Hursh Ches Hill
Erig

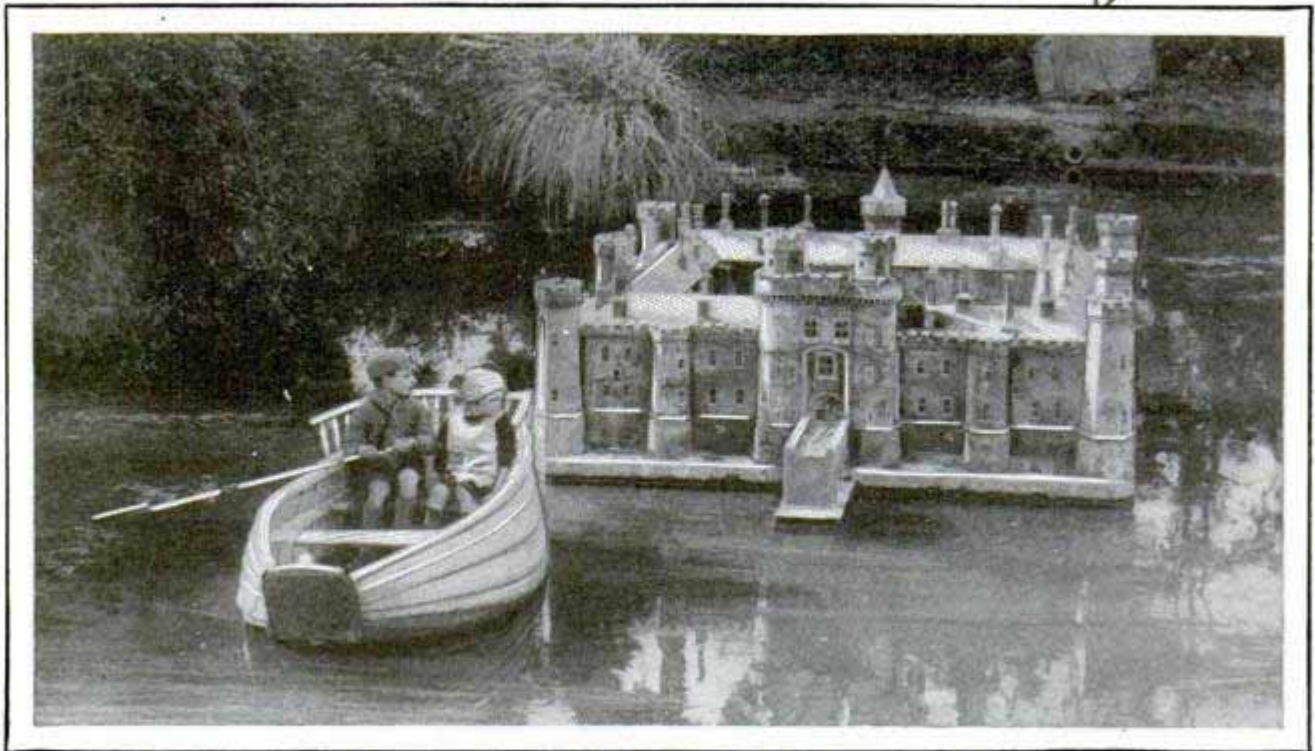

Clay Castle Model in Pond Setting; Its Size Is Apparent from Rowboat and Children beside It; the Materials Used Soon Showed Signs of Aging, Helping the Illusion

MODEL CASTLE BUILT OF CLAY FOR POND DECORATION

Set in the midst of a small lake, a model of an old English castle has been fashioned of clay by a British artisan. It is said to be an exact replica of the one occupied by the earl of Sussex in the time of Charles II and twelve years were required to complete it.

BUCKET LIFT ON REFUSE TRUCK SIMPLIFIES LOADING

1972 Unpleasant odors and dust are reduced in handling garbage or ashes in a motor truck that has a bucket that lowers to a point requiring only a thirty-inch lift for dumping the receptacle. When ready for



Filling the Lift Bucket on Refuse Truck Is Easy as It Is Lowered within Thirty Inches of the Ground

emptying into the main container on the truck, which has a capacity of five to six tons, the hopper is raised and lowered again for refilling by a chain mechanism operated from the driver's seat. To dump the truck, a huge door is automatically unlatched at the rear, and the body elevated to an angle of forty-five degrees. Faster loading with less labor and dirt on streets is obtained with this truck, it is claimed, and it also reduces exposure to disease. A metal curtain confines dust and odors after the bucket is dumped.

DEATH OF MANY TREES CAUSED BY LACK OF FOOD

1955 Proper nourishment is as essential to trees as it is to human beings, experts declare, and since the tree is dependent entirely on its environment for food, care must be taken to see that the soil has the necessary elements for growth. Trees send out distress signals in the form of brown leaves, thin foliage and dead branches when they are not obtaining sufficient nourishment. Growing plants are likely to exhaust the nitrogen, phosphorus and potassium in the soil so that these elements often must be supplied artificially to insure the tree's proper growth.

Chicago

Robert C. Scarborough

Trey 110 St.

C. L. May. Slavery

Atia Corp 150 Broadway

You Can Raise This Aerial Mast Alone

By HENRY S. LARABY

SIMPLE to build, strong and easily raised, this aerial mast is neat in appearance, and the materials required are not expensive.

The completed mast is 35 ft. high, which is sufficient for good results; it is also strong enough to withstand a heavy gale without guy wires, although these can be used if desired. The materials are easy to obtain, all lumber being of standard sizes with the one exception of the post C, which is 7 by 7 in. This size is used to increase the strength where it is most needed, at the base, and the piece, as specified in the material list, is long enough to supply also the three blocks

E, F and G, or they may be ordered cut at the mill if desired. These blocks are 8 in. long and need not be tapered.

The lumber should be free from knots and planed smooth so as to take a good coat of white paint. The holes are all drilled first and, when painting, allow the paint to run all the way through the bolt holes. After the paint is dry, mark each piece for identification; on the two side-pieces that have the bolt holes nearest the top, mark "side," and on the two side-pieces that have the bolt holes farthest from the top, mark "back" and "front," respectively. Having drilled and marked the base post C, place it in the ground just deep enough to allow the lower bolt hole to clear the ground. See that the post stands straight; pack the dirt down

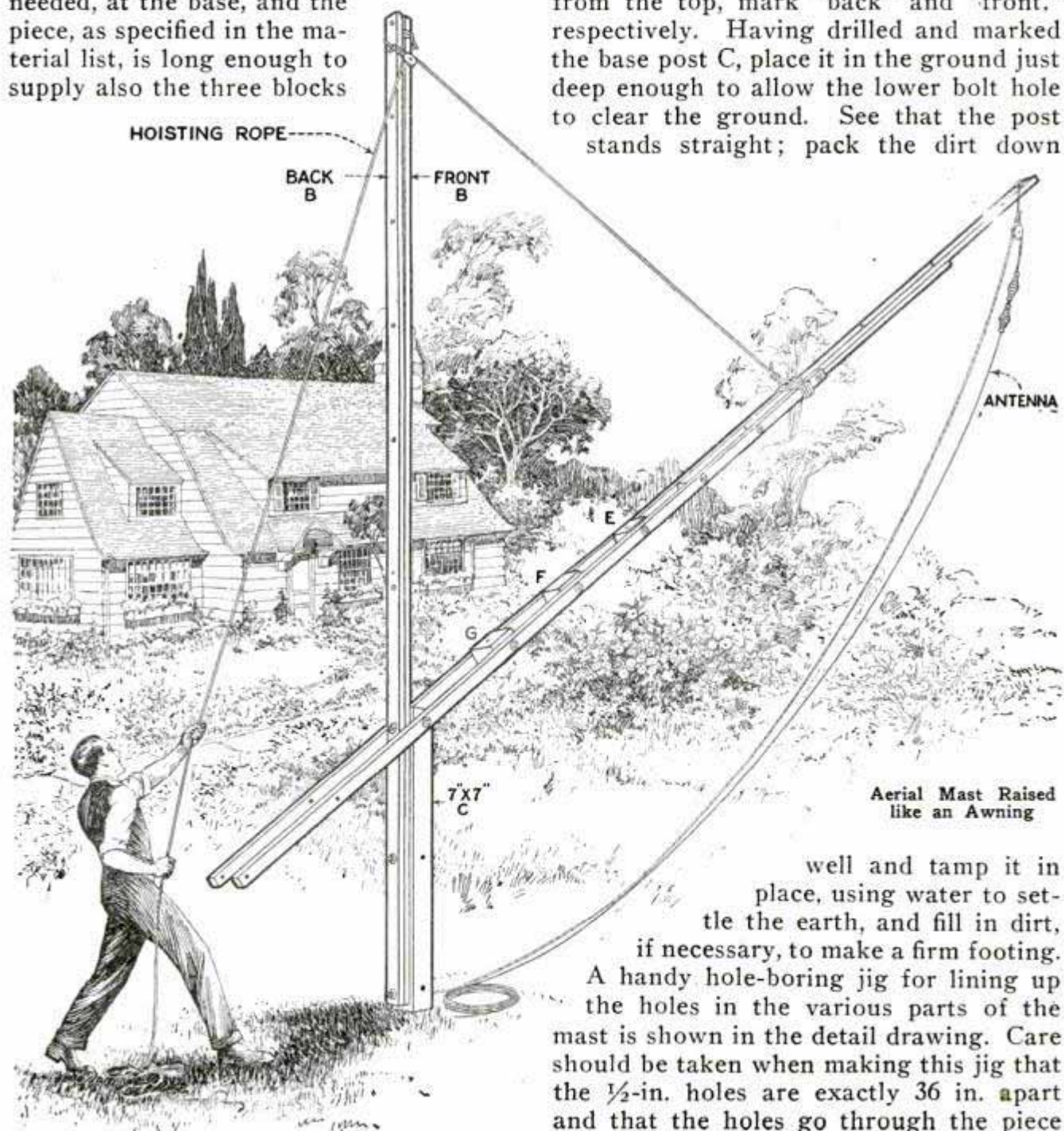

Aerial Mast Raised like an Awning

well and tamp it in place, using water to settle the earth, and fill in dirt, if necessary, to make a firm footing.

A handy hole-boring jig for lining up the holes in the various parts of the mast is shown in the detail drawing. Care should be taken when making this jig that the $\frac{1}{2}$ -in. holes are exactly 36 in. apart and that the holes go through the piece

perfectly straight. The jig should be of the same width as the pieces to be bored, so it will not move while the drilling is being done. Mark one end of the jig with an "X," so that this end can be placed in the same position when all the pieces are bored. Be sure the bit cuts a clean hole, and work away from the first hole bored. The holes in the 7 by 7-in. piece can be bored halfway from each side insuring a straight-line hole through the piece.

The piece that has been marked "front" must face in the direction of the aerial wire that is to run from the top of the mast. When the mast is finished, this piece must stand straight up and down against the base when they are bolted together; so, before going farther, make sure that it is straight, using a level if necessary. The two front and back pieces B are then temporarily bolted together, and a pulley is fastened to the top of these pieces with a piece of rope, as shown in the detail drawing. The end of a 60-ft. braided clothesline is threaded through this pulley. Now set the pieces upright against the back of the post C, as shown in the drawing on page 297, and bolt them to this post temporarily. The short rope holding the raising pulley is looped around the back piece at the top, so that the strain of raising is equally distributed on both pieces.

The next step is to assemble the side-pieces and top unit; the former are bolted to the blocks, as shown at E, F and G, while on the ground. The top unit is then assembled and bolted in place; a pulley for the aerial is permanently fastened to the top of this unit and the halyards threaded through it and coiled at the base of the mast, so as to be ready when required. The upper part of the mast is now ready for raising, and is mounted on the base post with one bolt and hoisted into position. Now run the other two side

bolts through the base post, and then remove the back piece B from its temporary position, freeing the raising pulley which falls to the ground. The back and front pieces B are then bolted in place in front

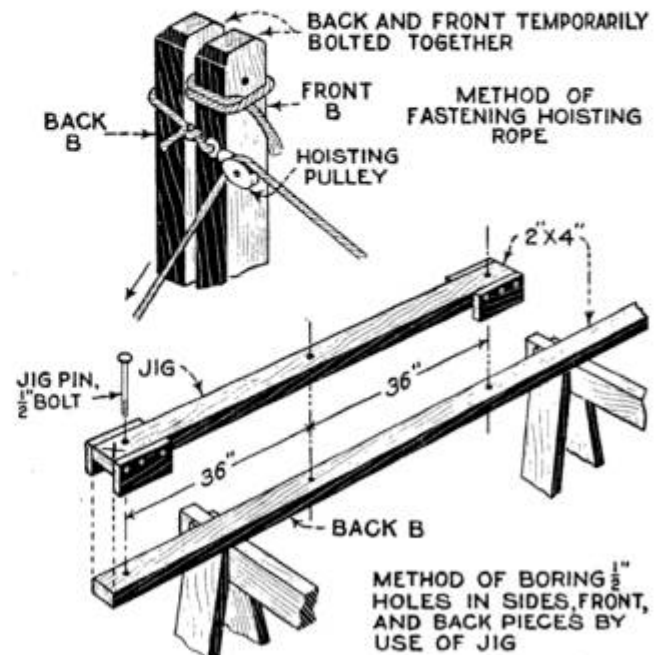

and back of the base post, giving added strength to the assembly. Paint the bolt heads and nuts to prevent rusting, and the mast is completed, and ready for the aerial.

If you do not wish to use more than one mast, the other end of the aerial can be fastened to some high part of the house or other high position near the point where the lead-in wire is to be taken to the set. A boat cleat is screwed to the base post at a convenient height for fastening the halyard after the aerial wire has been drawn taut. It is suggested that two sash weights, fastened to a small pulley, be used in the manner shown in the full-page illustration. This keeps the aerial tight at all times, yet allows sufficient slack to prevent the wire from breaking in high winds. This device also prevents swaying of the aerial, a common trouble.

MATERIAL LIST

4 pieces, 2 by 4 in. by 24½ ft., yellow pine.
 1 piece, 7 by 7 in. by 14½ ft., yellow pine.
 1 piece, 2 by 4 in. by 17 ft., yellow pine.
 1 piece, 2 by 4 in. by 12½ ft., yellow pine.
 1 piece, 5 by 5 by 8 in., yellow pine.
 1 piece, 6 by 6 by 8 in., yellow pine.
 1 piece, 7 by 7 by 8 in., yellow pine.
 8 ½ by 12-in. galvanized carriage bolts.
 10 ½ by 10-in. galvanized carriage bolts.

2 ¾ by 3-in. galvanized eyebolts.
 2 galvanized pulleys.
 1 piece galvanized wire, No. 12 gauge, 3 ft. long.
 75 ft. ¾-in. rope for halyards.
 60 ft. cheap clothesline.

Tools Required

Crosscut saw, square, rule, monkey wrench, level, brace, ½ and ¾-in. bits, hammer, spade and plane.

*925 W. Wrightwood Ave
Chicago
896-X*

*892. A.
Sterling Mfg. Co., 2831 Prospect Ave, Cleveland, O.*

"Canned" Units Feature Latest Set

"Canned" coils and balanced capacities are features of several new sets. The six-tube receiver shown in the illustration is a notable example of this method of construction and has many features of interest. The past year has shown great activity in the development of tuned radio-frequency circuits. In the early stages of this development, it was the general opinion that this type of circuit was limited by the capacity coupling between the elements of the tubes. Many methods of overcoming this trouble were tried out and one of the best solutions found was the application of the Wheatstone-bridge principle in balancing the capacities. A simple variation of the bridge is employed in the set here under consideration and the method is further improved by the use of high-efficiency coils completely inclosed in metal shields or "cans." The result is a receiver highly selective, having increased amplification without the howling and squealing that previously limited the amount of amplification obtainable; the shielded coils render the energy pick-up from powerful near-by stations almost negligible. Other interesting features are the semi-shielded condensers of special design. Each condenser is inclosed in a transparent dust-proof case, and the panel lights over each dial make tuning in dimly lighted rooms much easier. The receiver has been tested by Popular Mechanics Radio laboratory on a 30-ft. inside aerial, bringing in Texas, New York, Colorado and Louisiana stations, through locals, with clarity and good volume.

Combined Tube Rejuvenator and Tester Boosts Tubes and Checks Result



\$12.50

Tube Rejuvenator and Tester

A tube rejuvenator combined with a tester, which tells the operator when tubes need boosting, checks the emission improvement during treatment and determines the filament emission afterward, takes the guesswork out of this very helpful operation. It can be used with any of the UV, UX, C or CX-tubes and is made in two types, one for 50 to 60-cycle supply and the other for 25 to 40-cycle frequency. The instrument is 6 by 7½ by 5 in. high, weighs 4¾ lb. and is provided with a handle for carrying.

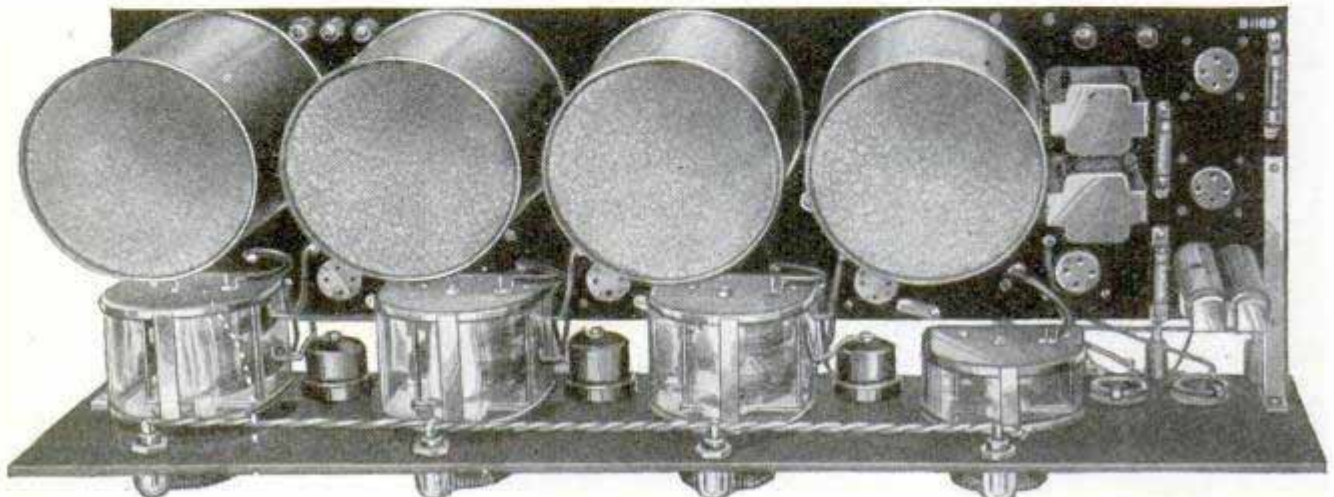

Interior View of the Set, Showing "Canned" Coils and General Layout of the Receiver; Notice the Panel Lights over Each Dial to Make Tuning Easier in Dim Light

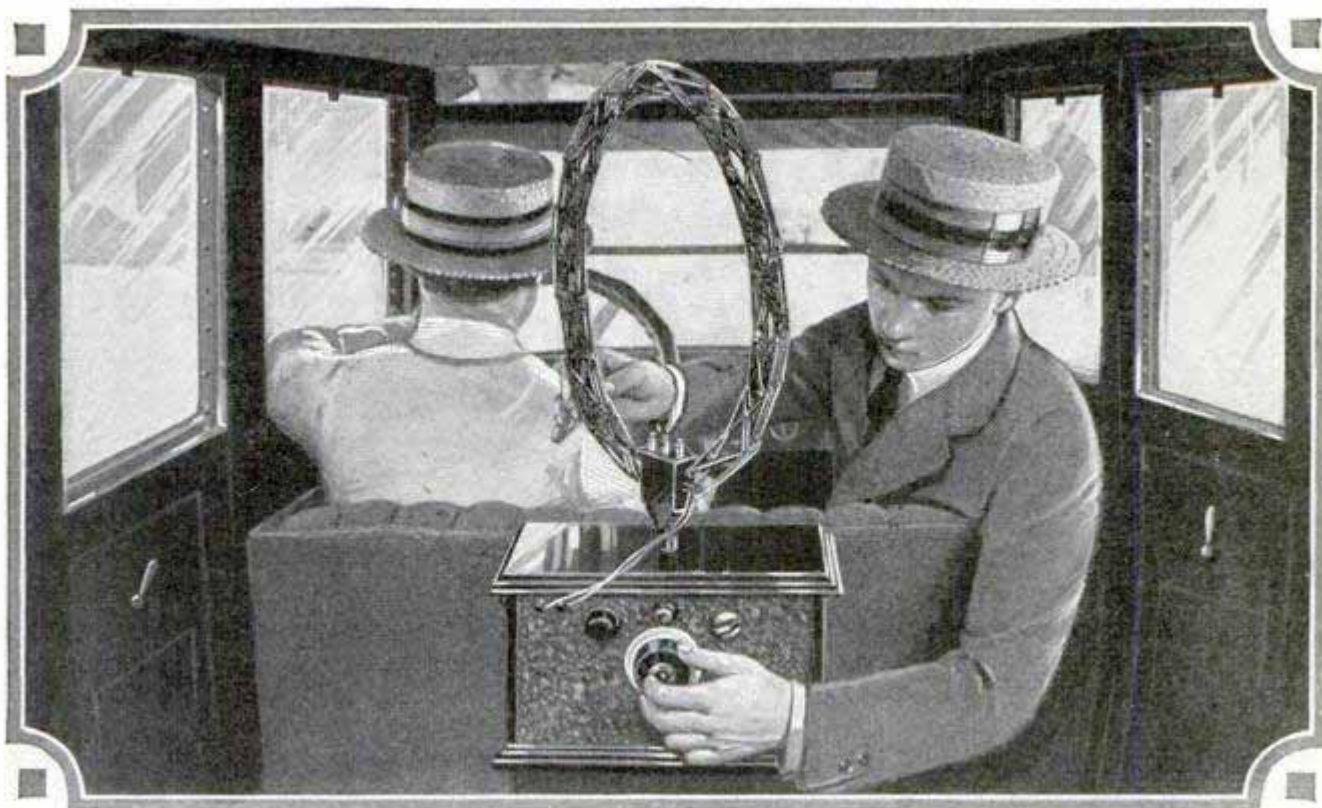

A Radio Set for Your Car

By J. B. SMITH

A REAL good radio set for the car must meet several conditions not found in all sets; it must occupy a limited space, work on a loop aerial, and deliver enough volume to operate a small loud speaker. The author looked for a set of this kind for some time and finally decided to try the four-tube loop set described in *Popular Mechanics Magazine* of August, 1925. The results were so good that I think it is worth while to pass the idea along to others who would like to try it out. Standard parts are used that can be obtained from any dealer in radio supplies and the set is simple to build. Four 201A tubes are used and the 6-volt battery in the car furnishes the A-battery for the filaments of these tubes. No radical changes were made in the original hook-up, and the layout of the parts is practically the same. The original diagrams are given with the few changes made, and those who have built the set can make the same changes and obtain still better results. The panel light is optional and the dotted lines indicate the proper connections if it is used; a small light of this type is useful at night when the set is operated in the car. The panel and subpanel

can be of any size to suit the builder, or the original layout, as shown in the illustration used. This will depend on the type of parts, but the original layout will answer in most cases.

The best results were obtained with the specified parts as they are especially adapted for a set of this particular type. The sockets are of the shock-absorber type, "sponge-rubber" cushion preferred, the variable condenser is the old straight-line wavelength kind and the potentiometer is the noiseless, graphite type. The a.f. transformers can be of any good make, $3\frac{1}{2}$ to 1 ratio; the r.f. transformer is of the type specified and must be used for best results in this particular circuit. Note that the grid condenser is mounted on the grid post of this r.f. transformer and is provided with spring clips for the gridleak. The loop binding posts are mounted on a strip of bakelite screwed to a small brass bracket. The loop leads can either be taken out through the back of the cabinet from these posts, or flexible leads from the stationary and rotor plates of the variable condenser taken to loop jacks mounted on the front panel at the points indicated, and the loop posts eliminated.

The wiring diagram is so plain that it needs little explanation; the construction of the filament-control jack is shown below and the blades numbered to correspond with the numbered connections in the wiring diagram. Plugging in the horn or phones automatically lights the tubes and places the set in operation. This jack is mounted directly below the variable condenser, but can be shifted to either side, and the condenser lowered if you wish to place the panel light directly above the condenser dial. The ordinary battery connections are shown below the wiring diagram; the two 45-volt B-batteries are placed under the back seat of the car as shown in the photo. Well-insulated leads from these batteries are twisted together and run under the car-



pet along the edge, to the socket half of the multiplug, shown in the lower photo, which is placed in the corner below the back of the front seat. The A-battery leads taken from the car battery terminals, should be of heavily insulated battery cable, and preferably run through loom. These leads are then taken up through a hole bored in the car floor and soldered to the multiplug socket. The multiplug cable is made up of various colored wires that are taken to the terminal posts in the set through a hole drilled in the cabinet. The plug and socket are marked so that the correct connections are made when the plug is shoved in the socket, connecting both A and B-batteries. This type of battery connection is also handy when the set is to be used in the house on another set of

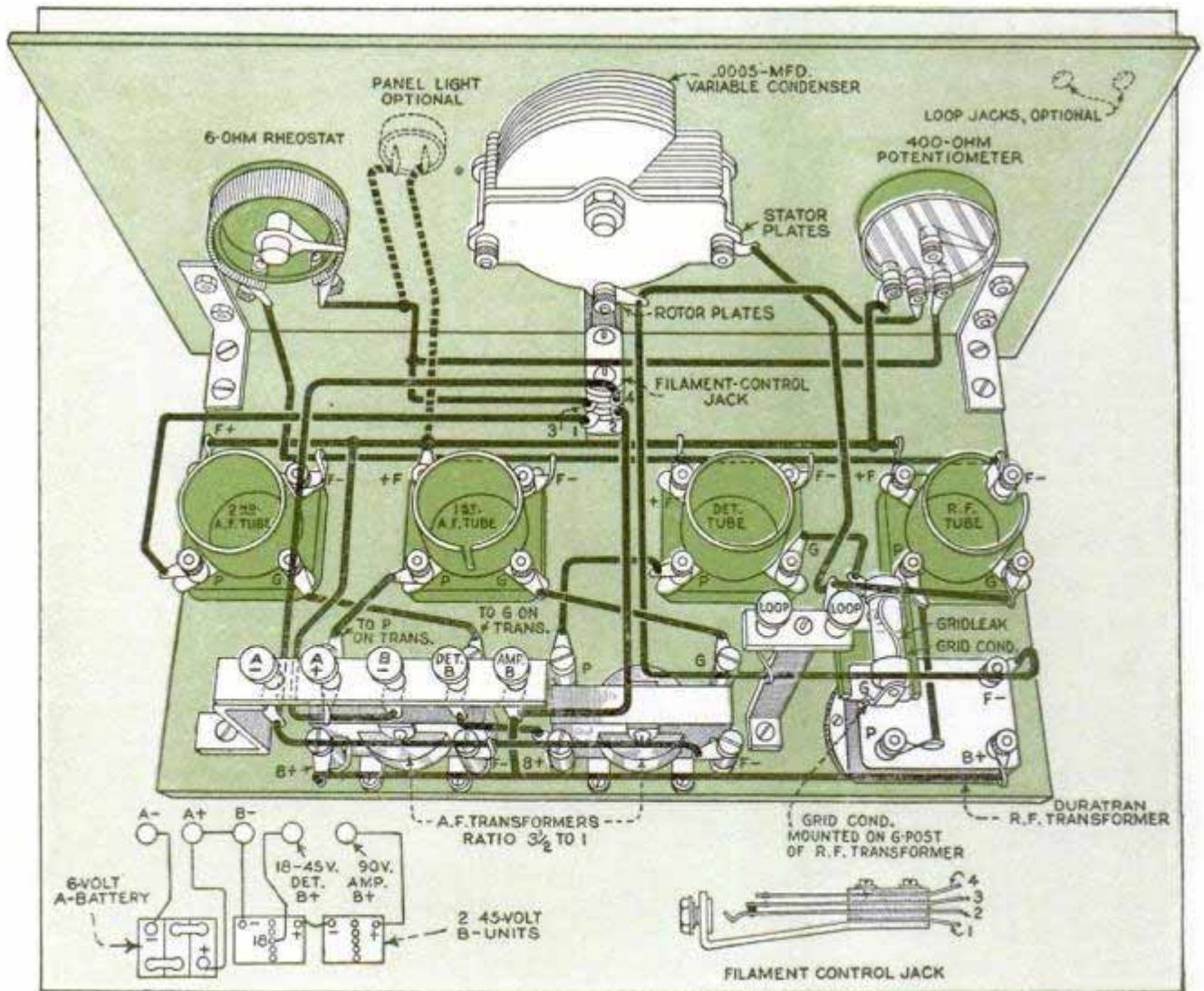

Wiring Diagram Showing Lugs under All Terminals to Be Soldered; Below, Battery Connections and Details of Filament-Control Jack

batteries. The loop can be any small tapped type, and is mounted in a convenient position on the top of the cabinet; flexible leads from the loops are connected to loop-plugs and plugged into the loop-jacks as shown in the illustration.

The cabinet for the set can be of the standard type, or homemade as was the case with the one shown in the illustration. It is mounted on the back of the front seat by means of two shelf brackets of the type ordinarily found in the five and ten-cent stores. The loud speaker can be one of any of the small types on the market and is mounted up in one corner of the car at the rear, and does not show in the photographs. The horn cord is tacked along the inside of the car so as to be out of the way and brought down to a point near the set. The horn plug is fastened to the cord and when the set is not in use this plug can be dropped into one of the side pockets of the car. The set tunes very sharp and the loop must be rotated in the direction of the sending station for best results.

To operate the set, plug in the horn and turn up the rheostat. Then slowly rotate the condenser dial until a station is picked up. Volume and clarity are obtained by adjusting the potentiometer, and with a little practice really remarkable results can be obtained. Keep the rheostat

turned down as low as possible for best results, and be sure to remove the horn plug when the set is not in operation. One reason, of course, for the sharp tuning of this set is the use of a tapped loop. When the whole inductance of the loop is used, or a loop of the untapped type, the full 180-degree range of the tun-

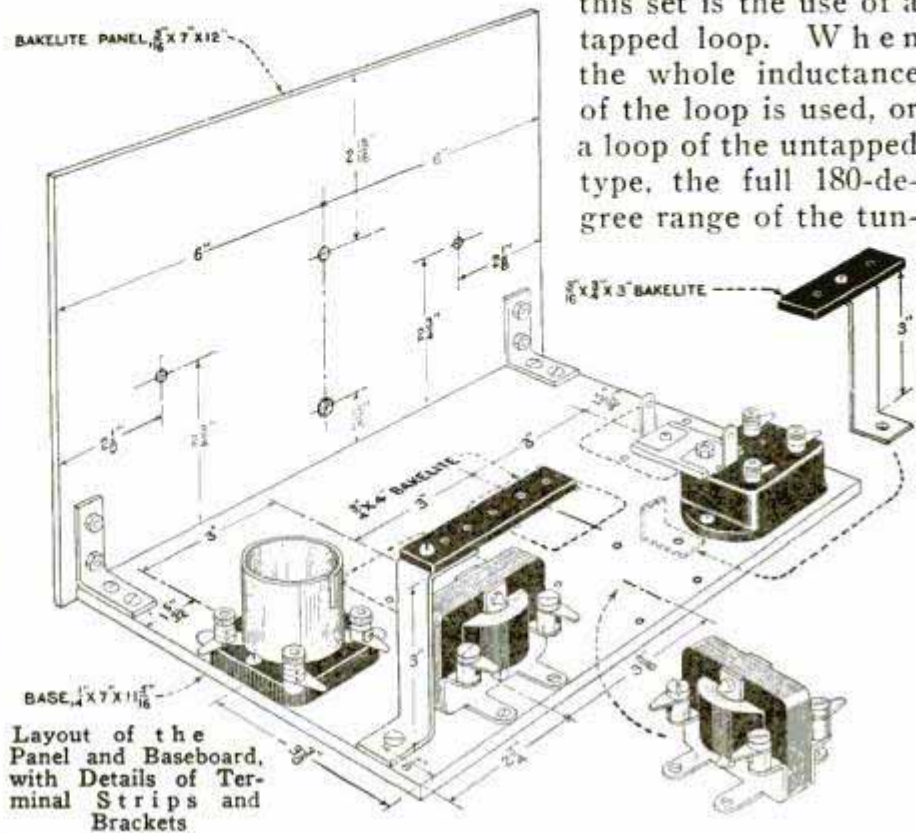

ing condenser varies between wavelengths of 370 to 550 meters; when the center tap is used on a tapped loop the condenser range varies between 150 and 400 meters. This method of tuning not only brings in the lower waves better, but completely cuts out the higher-wave stations; at the same time separating stations by several points more on the dials than in the usual way.

When located several miles from the broadcasting station, the dial has to be set right on the dot to bring the station in, and so, of course, a good vernier dial is essential to the successful operation of

MATERIAL LIST

- | | |
|--|--|
| 1 tapped loop. | 2 a.f. transformers, ratio $3\frac{1}{2}$ to 1, any good make. |
| 1 7 by 12-in. cabinet. | 4 201A or 301A tubes. |
| 1 7 by 12-in. panel. | 7 binding posts. |
| 1 7 by 11½-in. baseboard. | 2 small angle brackets for mounting front panel. |
| 1 low-loss variable condenser, .0005 mfd. | 2 large shelf brackets for mounting cabinet in car. |
| 1 vernier condenser dial. | 1 Jones multiplug, type BP. |
| 1 400-ohm potentiometer (Centralab or similar type). | 2 cord-tip jacks and plugs. |
| 1 6-ohm rheostat. | 2 45-volt B-batteries, large flat type. |
| 1 filament control jack. | 4 oval-head nickelplated screws. |
| 1 .00025-mfd. grid condenser (with gridleak clips). | 3 two-foot lengths round tinned-copper busbar wire. |
| 1 2-megohm gridleak. | 1 bakelite strip, 3-16 by ¾ by 4 in. (for battery terminals). |
| 4 standard sockets (shock-absorber type). | 2 4½-in. brass strips, 1-16-in. stock, ½ in. wide. |
| | 1 Duratran r.f. transformer. |

the set on distant stations.

Some practice in tuning is necessary before maximum results can be expected, but if the set has been carefully built, and the parts specified used, the results will be very satisfactory. It can be moved from the auto to the house in a very few minutes without the usual fussing with battery connections. The battery plug in the floor board can be left connected or not as desired, but for the sake of safety it can be disconnected when the car is not in use. If you wish a blueprint to work from, showing detailed wiring diagrams, you can obtain it for 15 cents, to cover the cost of mailing, from Popular Mechanics Radio department, 200 E. Ontario st., Chicago, Ill. Specify blueprint No. 113.

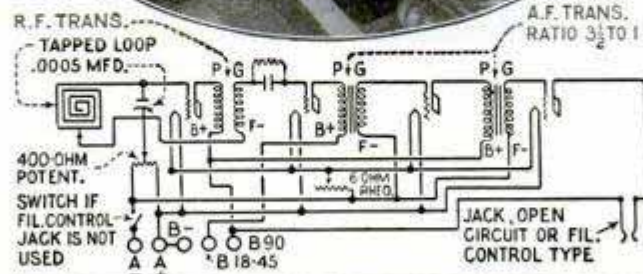
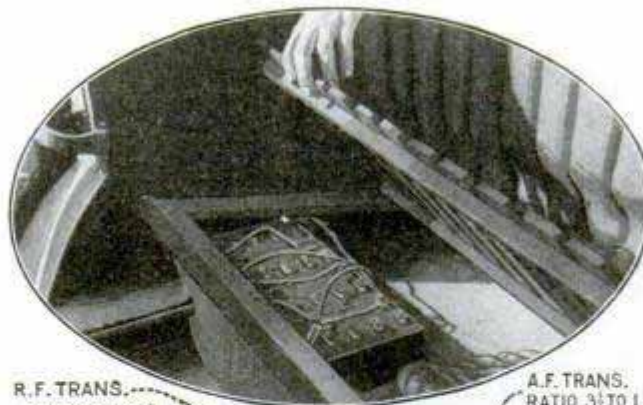

Above, Car Seat Lifted to Show Position of B-Batteries; Below Multiplug for All Connections

Forestalling Radio Troubles

Every radio-set owner can be his own service man and save bills. The necessary equipment is very simple, and, if best results are to be maintained, it is a good idea to thoroughly overhaul the set at least twice a year. The following simple tools are needed: A small double-scale voltmeter, a screwdriver and a pair of pliers, a 2-in. camel's-hair brush, some pipe cleaners, such as are used to clean the stems of ordinary smoking pipes, and some fine sandpaper. Remove all dust from between the plates of the condensers with the pipe cleaners, and from other parts of the set with the camel's-hair brush. All terminals should then be tightened; corroded or dirty terminals should be loosened, and the wire and terminal thoroughly cleaned and brightened with

the sandpaper. They should then be tightened until good contact is assured. The batteries should be tested by means of the voltmeter. The tubes should be turned on during this test. Dry-cell A-batteries should test 1.1 volts or more per cell, and the dry-cell B-batteries should test 17 volts or more per 22½-volt block, or 34 volts or more per 45-volt block. Storage A-batteries testing less than 1.8 volts per cell should be recharged. It is well to have several new tubes on hand for comparison with the old tubes. Old

tubes that have lost their ability to give good results should be rejuvenated, if possible, or replaced with new ones. The aerial should be gone over to see that all connections are tight and that there are no breaks in the wires. If slack, the wires should be tightened. Last but not least, see that the ground connection is tight.

751- Non-Metallic Subpanel Brackets

Non-metallic subpanel brackets are now offered to the radio builder. They are

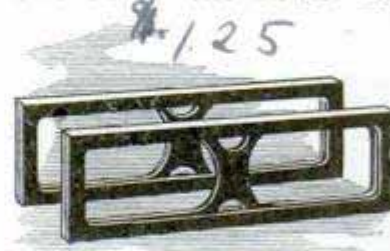

made of a strong insulating material, so that wires may touch them or be run through or near them without danger of short circuits and disturbing capacities. They are tested for structural strength, and the neat and efficient design with elimination of unnecessary metal in the fields of the various coils and condensers are of interest.

*Warfield Radio Mfg. Corp. New York
64 Jersey St.*

Here Are Radio's Latest Novelties *812-R*

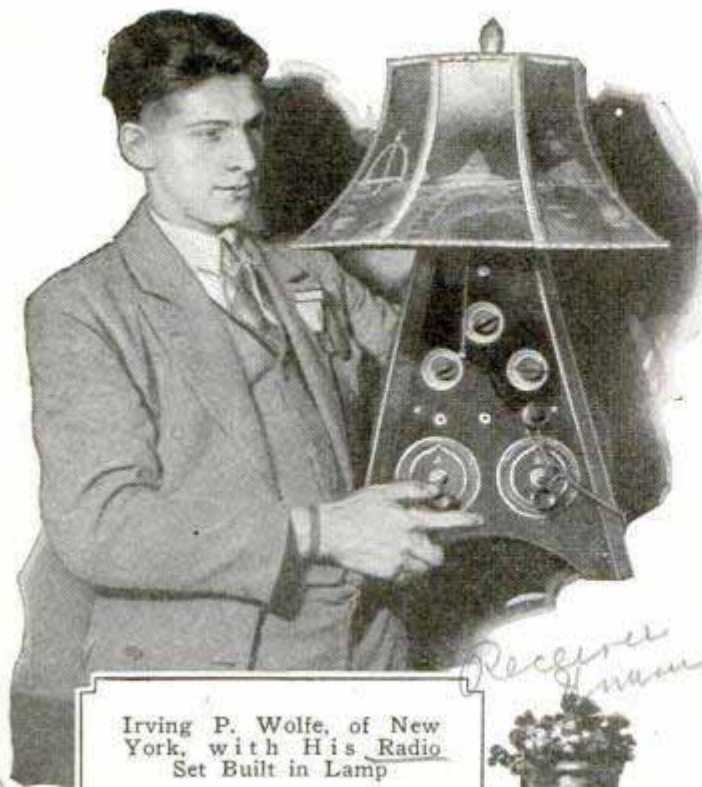

Receiver
 Irving P. Wolfe, of New York, with His Radio Set Built in Lamp



Above, Ushichiro Tokumi and His Radio Clock Switch That Can Be Set to Turn the Radio Set On or Off Automatically; Left, Complete Radio Set Built into a Table Which Harmonizes with the Other Furniture in the Room; the Loop Aerial Is Mounted on the Shelf under the Table, and a Cabinet Horn, Not Shown in the Photo, under the Instrument Panel or on the Table, as Desired

*Mr. Frank R. Porter
 1320 Vermont Ave
 Washington D.C.*



Furniture
 David R. Lowe, of Berlin, Demonstrating New Radio Tube Combining Detector and Two Stages of Amplification; Tuning Coils Complete the Set; Left, Tube Showing Six-Prong Base



896-R



What's Wrong with Your Set?

By FLOYD GRAHAM

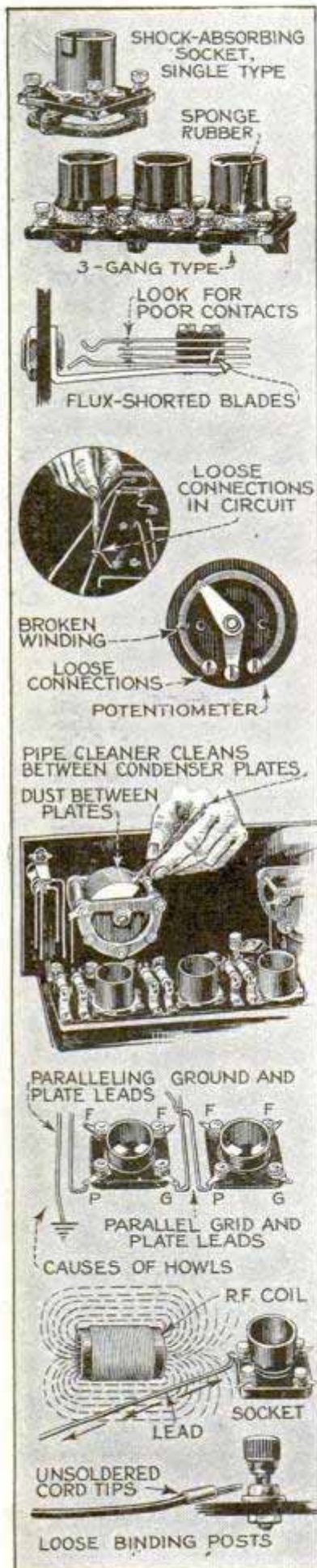

HAVING disposed of the general difficulties commonly met with in detector circuits and sets of the one-tube type in the July issue, we will now consider the amplifier and sets of the multitube type, and their troubles.

Carefully examine the jacks and see that the blades make proper contact, cleaning them so that no small particle of solder or flux remains to short the blades. Search all wiring for loose connections, as two wires merely touching each other do not make a good electrical contact. Wires should be joined to busbars by bending them around the latter for a good mechanical joint, then carefully soldered. A connection of this type offers a minimum of resistance to the current. To simply put two busbar wires together and solder them means not only mechanical weakness, but also high resistance, as solder alone is not a good conductor.

Ground and plate leads that run parallel cause howls, and so do parallel grid and plate leads. An example is shown in one of the marginal illustrations. Other sources of howls and noises are shown, and the reader should check carefully and note if any of the conditions indicated exist in his set. Radio-frequency coils of the solenoid type are surrounded by a field of energy that has a tendency to stray to any wires or instruments within reach. These coils should be kept at right angles to other coils or wires in the circuit, so that such fields will be kept within reasonable and safe bounds.

Dust between condenser plates is another common source of trouble, and an ordi-

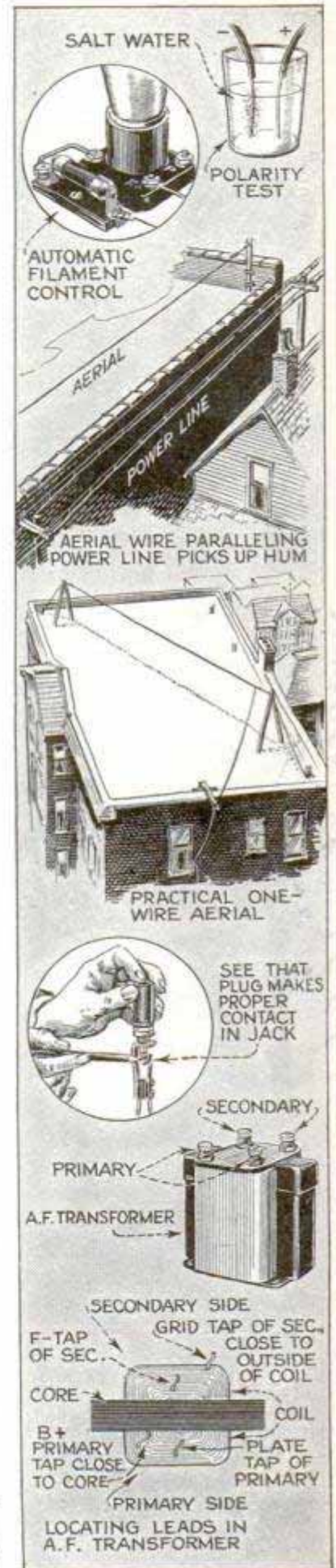

nary pipe cleaner can be used to keep the plates free from it. Potentiometers are wound with very fine wire and breaks sometimes occur; if this happens, put in a new one. Keep all terminals tight. Loose cord tips mean high resistance resulting in losses; hence they should be carefully soldered or plugs of the screw-type used to reduce the loss.

Humming or microphonic noises in the horn are sometimes noticeable when the set is jarred or when someone walks across the room, causing vibrations which are taken up by the tubes, or the vibrations may be transferred from the set to the horn, if the latter stands on the same table. Sockets of the spring-suspension or rubber-cushioned type will prevent tubes from vibrating, and a new tube, just marketed, is especially designed to prevent this trouble. Its base is made up of two parts, separated by a tough sponge-rubber section that efficiently takes up such vibrations.

If an outdoor aerial is used, see that it does not parallel any high-tension lines and keep it as nearly at right angles to any such line as circumstances will allow. A well insulated, one-wire aerial of the type shown is ideal for radio reception and will give even better results than an aerial made up of a number of wires with more joints and other possibilities of poor connections. It is a good idea to make no soldered connection to the lead-in wire, but have the aerial and lead-in in one

piece. It can be threaded through one end of the insulator from which the lead-in is to be taken and a turn or two made around the horizontal section of the wire to prevent slipping, the lead-in wire being continuous down to the set. Loop aerials that have high resistance give poor results. Even one of the best may be found defective in this respect. The only remedy is to exchange it for a good one or rewind it with a good grade of stranded loop wire, obtained at the radio store.

When connecting batteries watch the polarity carefully, for the battery current must go through the set in the proper direction or it will not work. Most modern battery terminals are plainly marked for polarity but if this marking is lacking or has become illegible, a simple test is the following: Add a pinch of salt to a glass of water, bare the leads from the battery and hold them in the solution without letting

them touch each other.

Bubbles will appear more abundantly at the end of the negative lead.

Automatic filament-controls for amplifying tubes are now in common use and eliminate many unnecessary rheostats. However, if defective, they will permit either too little or too much current to flow to the tube and cause trouble. Therefore, it is a good plan to have several of varying resistances on hand, that can be clipped in temporarily for test, until the one that works best is found.

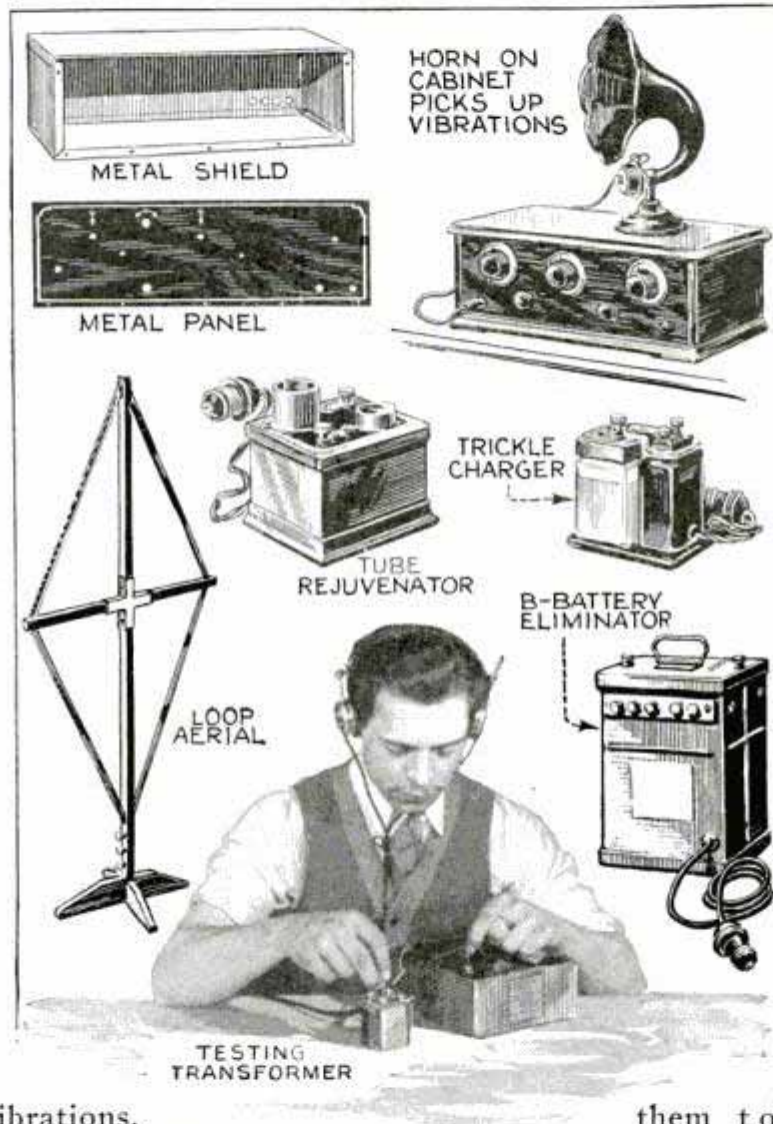

Horn and phone plugs may not make good contacts with the blades of the jack, and a small flashlight is handy for examining such connections. Some of the earlier and cheaper plugs and jacks caused a great deal of trouble in this respect, so be sure yours are efficient.

In rare cases, a. f. transformer terminals are not marked, and the radio builder is at a loss to know which is which. A standard type of transformer is illustrated in its original case, and with the case removed to show where the various leads will be found. This arrangement holds good for any transformer of this type, and the terminals can be marked for identification. Also, these transformers sometimes burn out, and the open winding will immediately cause a sharp drop in volume. The break can be located by slightly wetting the tips of two fingers and placing one on each transformer terminal, thereby establishing a grid return for the blocked tube and thereby partly restoring the volume. A better method is given in the illustration, which shows the operator testing for an open winding with headphones and 45-volt B-battery in series with the suspected winding. If no click is heard in the phones, the winding is open. Sometimes open windings are caused by corroded connections at the terminal posts, or the soldered connection to the coil end may have been broken by turning the posts. In such cases, the break can be easily remedied but if it is deep in the winding, it is better to replace the transformer than hunt for a break.

B-battery eliminators have now passed the experimental stage and are practical if used under the proper conditions. A-battery eliminators are still in the experimental form and with a very few exceptions are not in general use. The little trickle charger shown in the illustration is very popular with users of dry-cell-tube sets, as it will keep the 4-volt A-battery charged and requires little at-

tention, but is not adapted for charging larger storage batteries, although if a limited number of the large tubes are used, and the set is not operated over long periods, it can be used with good results.

No set will work well with old and defective tubes. If your tubes are of the type that can be rejuvenated, which your dealer will tell you, the little instrument for this purpose shown in the illustration should be part of your equipment. It is not expensive and if the tubes are not too far gone, they can be brought back to nearly their original efficiency. The instrument shown is one of the several similar types that may be used for either the dry-cell or storage-battery tubes, and works from the 110-volt 60-cycle circuit.

Last but not least, are you troubled with body capacity affecting the accurate tuning of the set? This form of trouble is not so common now as in the past, owing to improved parts, and the use of metal shielding. Metal panels are now available as well as knockdown metal linings designed to fit the standard cabinets. These are shown in the illustration. The panels may be had in drilled and decorated designs for some of the popular circuits, as well as plain; they are supplied with insulated bushings for mounting the instruments so that part of them comes in contact with the metal panel. Shielding of this type improves the performance of any set. These last suggestions are given as general advice, not as trouble data.

Uses for Old Battery Clips

Terminal clips from discarded B-batteries are useful in many ways in the construction of radio sets, and especially in experimental hookups. The clip can be drilled or filed as shown in Figs. 1 and 4 for use on vacuum-tube sockets as shown. Fig. 2 shows how two clips may be soldered to a narrow strip of brass cut from a third clip, a

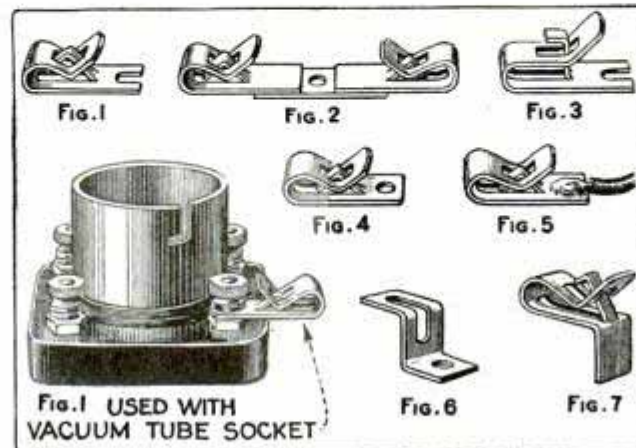

Clips from Discarded B-Batteries Make Handy Connectors for the Experimental Hookups

hole being drilled through the center for a mounting screw. This double clip makes an excellent multiple connector. The clip in Fig. 3 is formed to make a coil mounting, handy in holding coils in accurate positions, and in Fig. 5 the clip is shown as a quick connector for loop-aerial leads. The tongue is first removed from the clip shown in Fig. 6, and the clip then drilled and shaped to make a permanent coil mounting. The same idea can be employed in making a subpanel bracket. A permanent connector for coil terminals and similar leads is shown in Fig. 7. An assortment of these clips will come in handy, especially to the experimenter who wishes to try out various circuits.

Wire Bender Made from Pliers

A handy wire-bending tool can be made from a pair of common gas pliers by grinding one jaw down to the shape indicated by the dotted lines in the illustration. The legs are separated and one of the jaws ground down to half its original thickness and to the shape shown by the full lines.

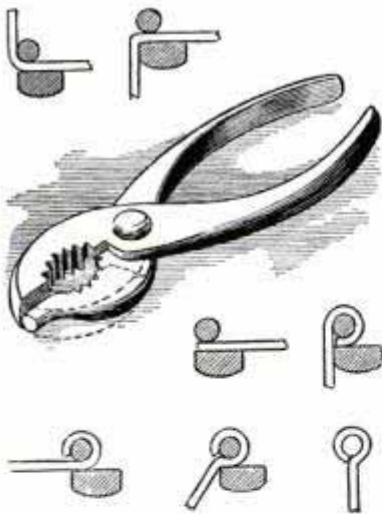

This should leave the tip $\frac{5}{32}$ in. in diameter for a distance of about $\frac{3}{16}$ in. The shaded portions in the detail drawings illustrate the tip of the tool after it has been assembled, and the position of the bus-bar wire during the bending operation.

The upper sketches show the way to obtain a rounded or sharp bend, and the lower how to form a loop to go over a terminal post.

Stenographers Use Radio for Practice Dictation

Stenographers who wish to increase their speed in taking dictation are listening in on radio speeches sent out by the various broadcasting stations. Often the speech will appear in the newspaper so they can check their transcription.

Rotor Mounting Easily Made from Condenser Plate

Many radio experimenters find it difficult to mount rotor shafts on cardboard

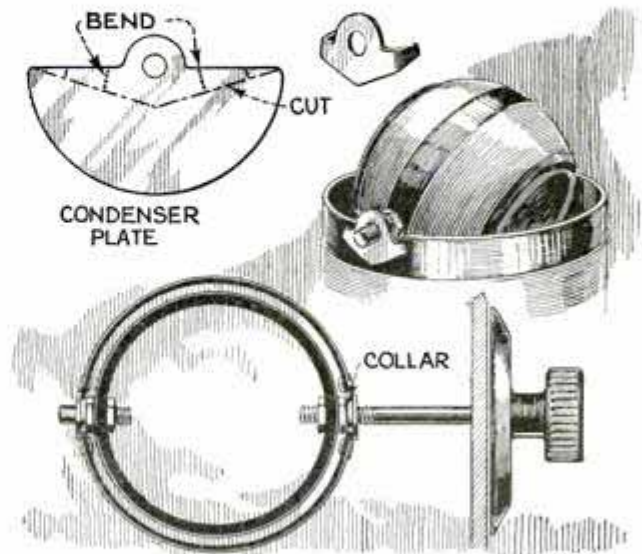

Mounting Collar for Rotor Unit Is Cut from Old Variable-Condenser Plate

tubing; this difficulty can be overcome by the method shown in the illustration. A rotor plate from an old variable condenser is cut along the line indicated in the upper illustration, and bent to the shape shown at the right. The prongs are thrust through the tube to hold the collar in place, and the shaft will then turn easily in the hole. The lower illustration shows the method of connecting the rotor shaft to the rotor unit. The dial is mounted on the end of this shaft in the usual manner. —Hubert A. Vachon, Haverhill, Mass.

p45. Q
One-Inch Jack Needs Small Space

Jacks of novel design have lately made their appearance on the market. They are well made and take up very little room as they are only 1 in. long, lending themselves nicely to under-panel construction.

The old type jack originated in telephone switchboard construction and has not before been refined for radio purposes. The new jacks are available in the regular standard types and take the ordinary horn or phone plug.

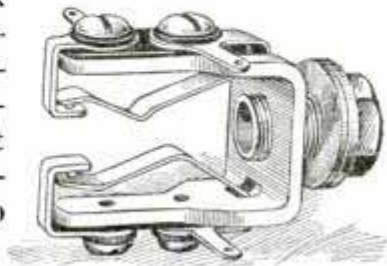

*Herbert H. Frost, Co.
314 W. Superior St.*

Metal Strip for Multiple Dry-Cell Connections

When several dry cells are to be connected in parallel, for multiple hookups of many cells, the battery connectors

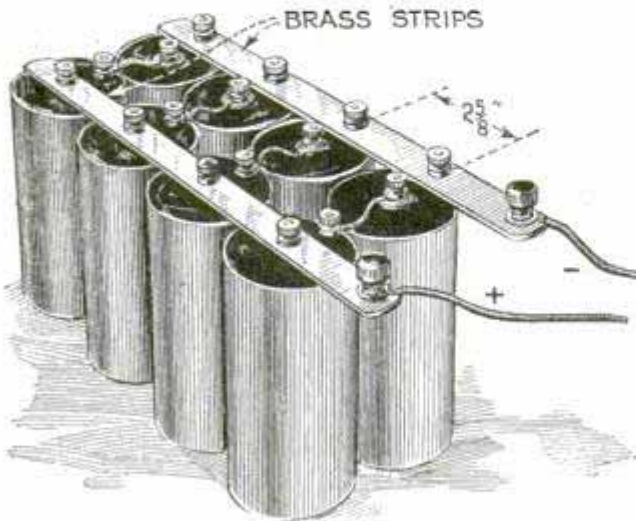

Dry Cells Connected in Parallel Series, Showing Brass Strips Used for the Parallel Connections

shown in the illustration will be found neat and handy. They are simply strips of brass slightly longer than the combined length of the cells set against each other in a straight line. As many $\frac{3}{16}$ -in. holes are drilled in the strip as there are parallel terminals to be connected; these holes are spaced $2\frac{5}{8}$ in. apart. An old battery binding post is then mounted on the end of the strip. The cells are arranged in the correct position, the strip is placed over the battery binding posts and the nuts screwed on. This serves to hold the cells rigidly together and makes a solid connection.

Making Low-Loss R.F. Transformers

The best kind of r.f. transformers are cylindrical in shape, says the U. S. bureau of standards, after it had conducted exhaustive tests on all the different kinds of coils. To make them extremely low-loss, wind them on a collapsible cylinder and give them a good coating of collodion, which makes them strong. Then remove the coil from the cylinder and mount it on the subpanel by means of a $\frac{1}{4}$ -in. strip of bakelite, a $\frac{1}{2}$ -in. screw at each end holding this strip to the subpanel. Now the primary, which is of smaller diameter than the secondary, should be fastened to the center of the strip in the same way as the latter is attached to the subpanel; only

$\frac{1}{4}$ -in. screws are used on these and they are tapped directly into the strips holding the secondary. The best location for the primary is in the center of the secondary, as the induction is then evenly distributed. The spacing between the primary and secondary and the number of turns of wire on the primary determine selectivity and volume of signals, and the ratio of the number of turns between the primary and secondary should be about 1 to 10. The larger the primary is, both in diameter and in number of turns, the broader the set will tune and the more volume it will have. This is advantageous for locations quite some distance from broadcasting stations, but in large cities, such as Chicago, it is necessary to have selectivity, which is gained by decreasing the diameter and the number of turns of the primary. If .00035-mfd. condensers are used to tune the secondaries, the latter should have about 54 ft. of wire, which means about 108 turns on a 2-in. diameter. Primary coils, $1\frac{1}{2}$ in. in diameter, having 11 turns, have been found very satisfactory with this size of secondary.

774-Q.—

Collapsible Loop

A new collapsible loop that folds and unfolds in small space is shown in the illustration. It is especially adapted for portable sets. The only adjustment necessary to prepare the loop for use is to unfold it by pulling at the top. It will hold any adjustment with all wires taut and pivots on a hardwood base. When not in use it can be placed in a drawer, or pushed into the lid of a portable set.

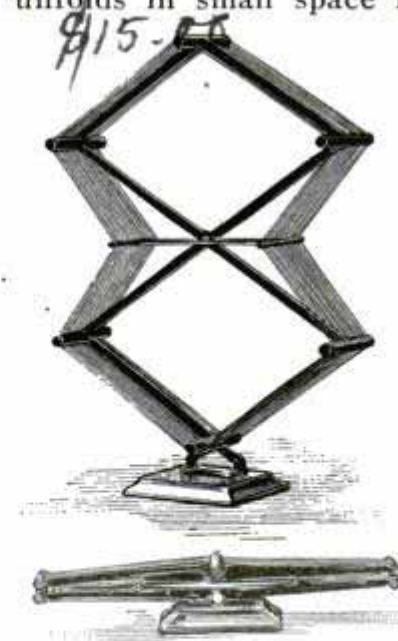

When not in use it can be placed in a drawer, or pushed into the lid of a portable set.

Howling is often caused by the plate and grid leads running parallel and too closely together.

Richard J. Davis 5252 Broadway Chicago

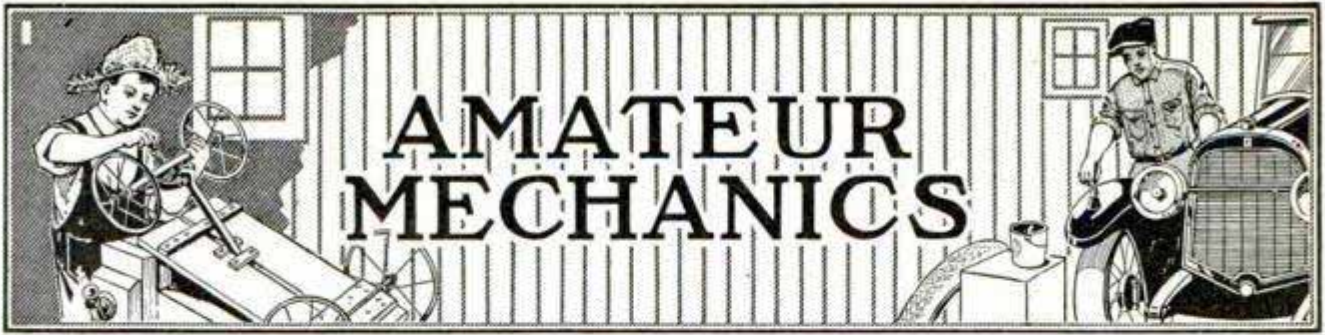

A Boat for Your Outboard Motor

By B. FRANCIS DASHIELL

*1620 Q St. N.W.
Washington, D.C.*

THE average rowboat is not entirely suitable for use with the outboard boat motor. The boat described in this article has been designed for the following: Perfect balance with the weight of the motor on the stern; a substantial stern

and parts to carry the weight and hold up against vibration and strain; an easily riding bow that does not ship much water when the going is rough; large substantial seats; a front deck giving a motorboat appearance; light weight; ease

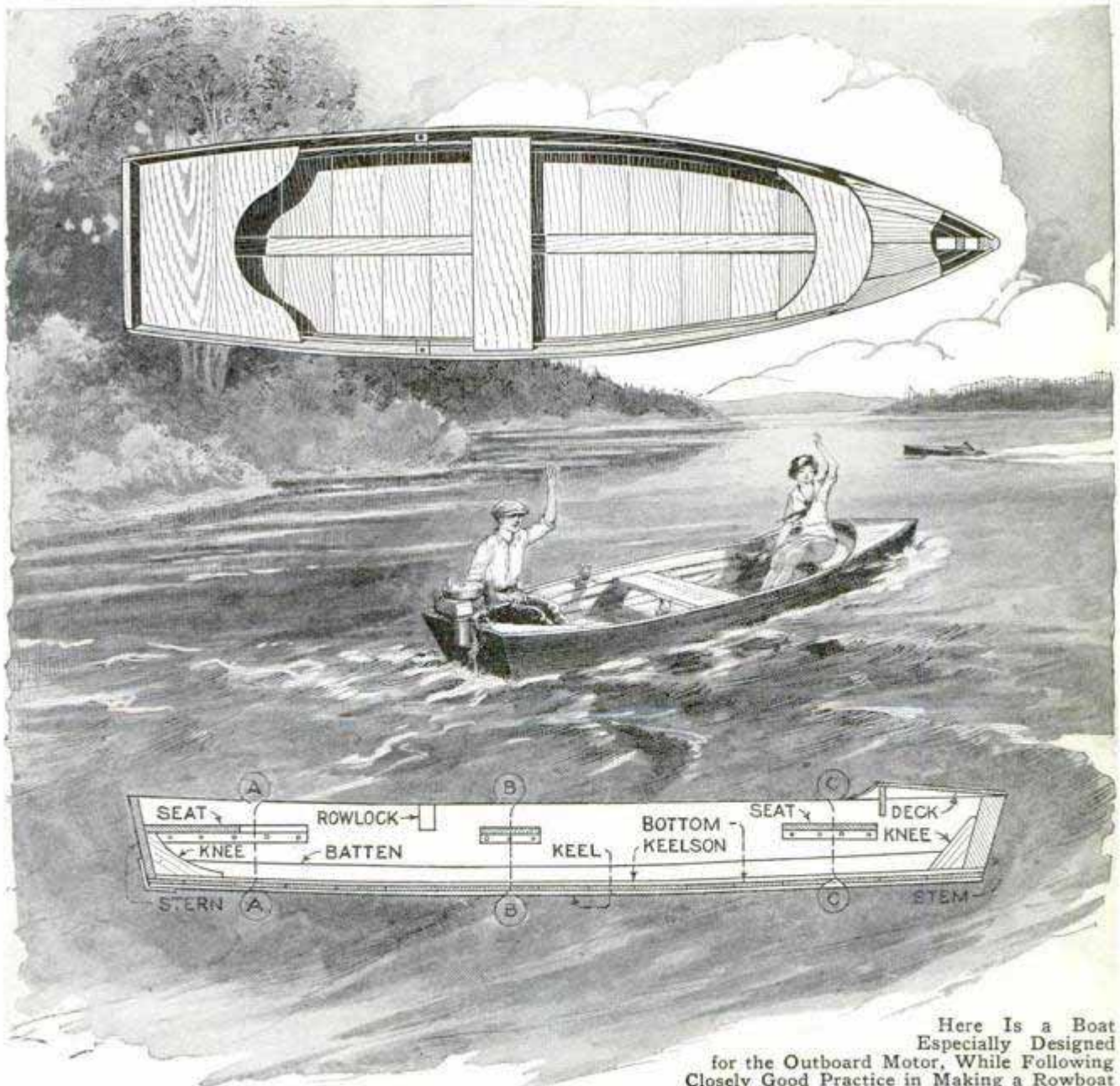

Here Is a Boat Especially Designed for the Outboard Motor, While Following Closely Good Practice in Making a Rowboat

of rowing, etc. The use of a motor on such a rowboat permits the builder to get into the motor-boat class to some extent, and a few of the refinements of the latter are embodied in the design. While this particular boat has been designed especially for use with an outboard motor, still the fundamentals of general rowboat practice have been closely followed.

The sides are two cypress boards, dressed on both sides, $\frac{7}{8}$ in. in thickness, 16 in. wide, and 15 ft. 7 in. long, one to each side. No great difficulty should be experienced in obtaining these boards but in some localities it may be necessary to make them up by using two boards; for instance, a 12 and a 4-in. width, doweled along the edges and clamped with a butt strap piece along the entire length. However, this type of construction is not recommended. The boards must be sawed to the shape indicated by the drawing so as to give the proper curvature to the bow and stern. If a band saw is available, the two boards can be shaped together readily; otherwise, a narrow saw and plane must be used, doing the work by hand. Boards of this length will construct a boat 15 ft. in length.

The stem piece is made of oak. The use of this wood lessens the danger of splitting and will furnish a substantial anchor for the screws used in attaching the sides. A piece of oak 3 in. thick, 6 in. wide and about 20 in. long is necessary. Two grooves are cut on the opposite sides, as shown in the drawing, to receive the ends of the side boards. The top and bottom are cut flush with the edges of the sides after they have been placed and this is best done just before the bottom boards are put on, so that a watertight joint may be assured.

The stern is of cypress, not less than $1\frac{1}{2}$ in. thick. It may be necessary, although somewhat poor practice, to build the stern up of two widths, splicing along the joined edges with dowels and a longitudinal butt strap, as well as cross battens. A single width is much to be preferred. The oak knees need be no particular shape, as they are simply braces. They should be about 2 in. in thickness, and used to strengthen the stem and stern. They are attached to the keelson and keel, preferably with bolts passing through these and the bottom.

The knees cannot be set in place until the bottom, keelson and keel have been put on. The general shape is indicated in the drawings, but may be altered to suit any special condition.

The battens consist of two cypress pieces, each 4 in. wide, dressed to $\frac{7}{8}$ -in. thickness, and running the full length of the side pieces, except for the thickness of the stern and the depth of the stem piece. One batten is attached along the inner lower side of each side board, and furnishes additional bearing and screwing surface for the bottom boards.

After the sides have been carefully shaped they are placed side by side on their edges, top down. Sixteen temporary cross pieces are cut from scrap material, about $1\frac{1}{2}$ in. wide and $\frac{7}{8}$ in. thick; eight for the top spacing and eight for the bottom. Nail the bottom cross pieces to the side boards at their respective positions as indicated in the drawing (spacing arrangement). Turn the whole over so that it rests on the temporary cross pieces and nail on the top spacing pieces. When this has been done the sides will then assume their proper curvature. If there is any apparent lack of symmetry in the lines of the boat it may be adjusted by releasing the proper cross pieces and re-nailing. The front ends of the sides should now be trimmed off and the stem piece inserted. If the fit is perfect, the sides should be permanently attached with screws. The stern is next fitted and the sides also attached with screws. The bottom is now put on, and the bottom temporary cross pieces should be removed, one at a time, as the screwing on of the bottom boards progresses.

The bottom is of cypress boards, dressed to $\frac{7}{8}$ -in. thickness and about 10 in. in width. These are attached to the boat, being placed across, and screwed firmly in place; screws being placed in the edges of the side and batten, alternately. The screws should be set in about 1 in. from the sides of the bottom boards and then spaced about 2 in. apart the rest of the distance across. The edges of the bottom boards and the side pieces should be fitted carefully so as to be parallel.

The keel and keelson are of the same size; 3 in. wide and $\frac{7}{8}$ in. thick. However, the keelson, which runs the full

length down the center of the inside bottom of the boat, is shorter than the keel. The keelson butts up against the inside of the stern and stem pieces and the knees rest upon it. The keel runs the full length of the outside from tip of stem to stern. The keelson and keel are held together through the bottom boards of the boat, with screws, copper rivets or bolts. Brass screws are

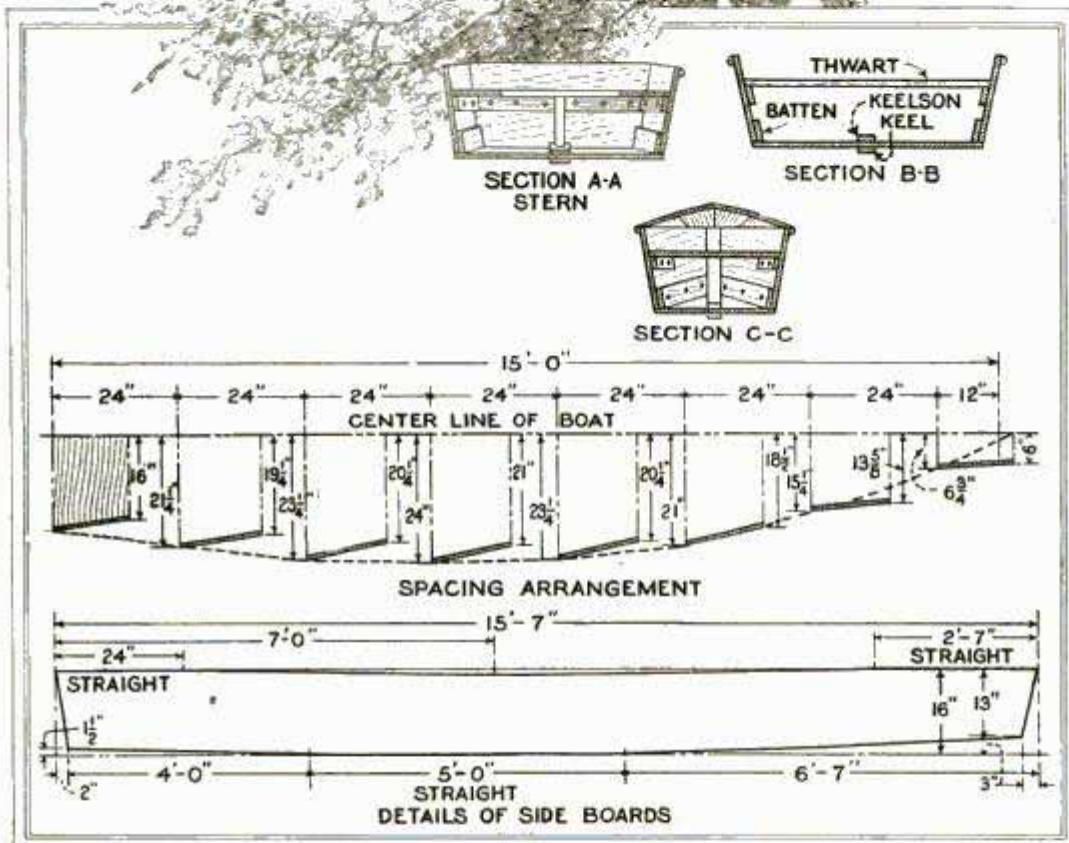

Details of Construction of the Outboard-Motor Boat. This Craft Is Simple Enough for Any Handy Man to Build, with Ordinary Tools

used satisfactorily, in addition to small wood bolts, about $3\frac{1}{2}$ in. in length, spaced about 12 in. apart along the entire length.

The midship thwart should be placed in position so as to give the boat more stability during the rest of the construction, after which the remaining temporary top cross spacers may be removed. The stern seat should be deep enough so that the operator can be seated while the motor is attached. The motor takes up a certain amount of inboard space and, in the average rowboat, the operator is compelled to sit to one side, resulting in an uneven balance. The rear seat should be low enough to allow plenty of clearance for the motor clamps. The bow seat should also be roomy, comfortable and low.

The deck may be arranged in any way

desired. It should be somewhat higher at its inner end, so as to shed water. A cross or bulkhead piece is set across between the sides, and used to support the deck. Two of these may be fitted if desired, one just aft of the stem piece.

All joints in the stern and stem assembly, along the bottom and between the bottom boards should be made watertight. The surfaces in contact should be carefully fitted, and a good make of marine glue may be used between the surfaces before the parts are drawn up by screws. Thick white lead may also be used. A piece of calking cotton, or any loosely woven material may be placed between the joints. This cotton may be dipped in white lead or placed between joints which have been spread with marine glue. The



calking cotton is best used in the stem and stern assembly and along the sides of the bottom, while the joints between the bottom boards may be filled simply with the marine glue. The screws draw the parts together and force out surplus glue or lead, which, when set, will provide a boat that will stay dry for many seasons. However, unless built of very well-seasoned lumber, no boat will stay tight if it is permitted to remain out of water and exposed to the rays of the hot summer sun.

The outside upper edge of the sides should be finished off with a large half-round strip of molding, or a more elaborate coaming effect can be had by finishing with a flat strip around the top, projecting over the edge and filled in with a strip of quarter-round molding. Rowlocks should be set in the proper places,

and brass rings attached to the stem and stern. If desired, a small steering wheel can be placed in the bow with line running around the sides to the motor or rudder. The hardware used in assembling the boat may be of galvanized iron and such galvanized screws, bolts, etc., will serve very well. No excessive sizes are necessary.

The boat should be thoroughly painted. No attempt will be made here to describe any particular finish as every individual has his own ideas as to colors. At least two coats of lead-oil primer should be given, followed by the top color coats which may be finished off with one or two coats of clear spar varnish. If a natural finish is desired, a coat of wood filler should be applied, followed by a shellac coat and two or three coats of good waterproof spar varnish.

Simple Tool Opens Seed Rows



The illustration shows a simple device for opening rows for seed.

It is made by hinging a long stick to a beveled block as indicated. The handle must be long enough to allow one to walk in the furrow and push the tool along. It

should be given a couple of coats of paint.—Miss Olive M. Rogers, Palatka, Fla.

New Use for Blowtorch

There are many uses for a gasoline blowtorch besides heating the soldering copper and burning away old paint. It will be found handy for spraying a mixture of oil and kerosene between the leaves of your automobile springs, and around the inaccessible spots in the wear-

ing parts of the brake rods and pins, which always seem to elude the jet from the oil-can. For applying liquid insect exterminators a blowtorch is far superior to the old-fashioned squirt gun. The liquid is under an even pressure and the easily regulated spray may be directed into all the tiny cracks where the pests lie hidden.

Drip Catcher for Paintpots

When painting floors, a Wisconsin painter eliminates the need of placing papers on the floor under his paintpot pail by gluing a paper plate to the bottom of the pail, as shown in the illustration. The pail may then be moved about from place to place without annoyance and the drippings caused by laying the brush across the top of the pail, or wiping the bristles on the edge, will be caught on the plate.



Saving Oil-Stove Wicks

Many oil stoves use a cotton wick held in a perforated cylindrical metal holder, the top of the wick extending above the holder. When the wick has burned down to the holder it is discarded and a

new one put in. As these wicks cost around 35 cents each, and, with this practice, are only worn down about $\frac{3}{4}$ in., the cost of wicks is quite an item. The expense can be materially reduced in the following way: Take old wicks and remove one wick from its holder without injuring it. Leave the other wick in its holder but cut it off all the way around and about an inch below the top of the holder. The cutting must be done carefully and accurately. Mark with a pencil and use a discarded safety-razor blade if available. Place the old wick removed from its holder on top of the wick just cut down. This gives a new wick of proper length and at no cost except a few minutes' work. The new wick will feed the oil perfectly, if the edges of its two parts are accurately fitted together. If there is any doubt as to this, make sure with a few thread stitches.

Campers' Water Canteen

While on a summer's camping trip and using a small tent having a sewed-in floor cloth, the writer experienced some trouble with the water canteen during sultry nights. Sometimes the stopper of the water bottle became dislodged through the unconscious movements of the sleeper, and it was often a problem how to stow this equipment so that there would be no danger of spilling water on the blanket yet have the water handy. The drawing shows how the problem was solved. The barrel was simply placed outside of the tent and a length of rubber tubing

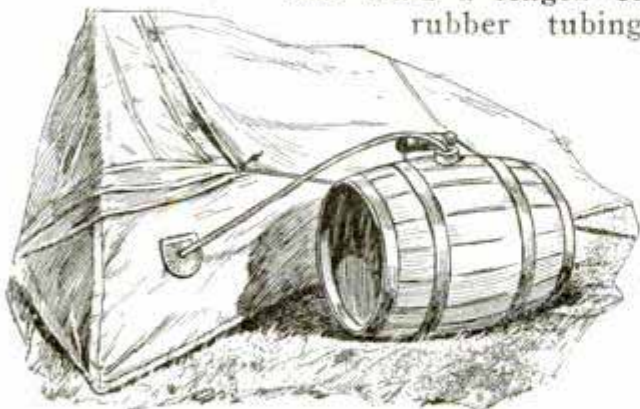

Rubber Tube Supplies Camper with Water Inside of Tent from Outside Canteen

used as a siphon. A leather washer sewed both inside and outside, around the hole in the tent, prevented wear on the canvas. —Frank M. Small, Tampa, Fla.

A Bathtub Washboard Hook

If a laundry sink is not available, it is sometimes better to wash large, heavy articles in the bathtub than in a small wash-



Handy Hook on Washboard Facilitates Washing Clothes in Bathtub

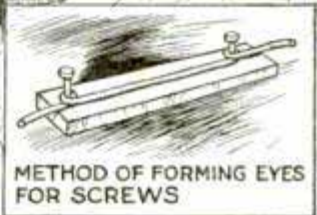

tub, which does not provide sufficient room for handling them conveniently. The hook shown in the drawing engages the edge of the tub and retains the washboard at the proper angle. Without it, the board would slip down too far into the tub. The hook is made of No. 10 galvanized-iron wire. Estimate the length of wire needed, allowing about 6 in., or more, at the ends to give leverage for forming the eyes, which are easily made by bending the wire around a nail, or nails, driven into a board. The excess wire at the ends is then cut off. The hook is formed with a wrench and a hammer.

Cleaning Electric Coffee Pot

An easy way to clean the tube of your electric percolator and to remove any deposit on the inside is to put four heaping tablespoonfuls of salt in the coffee compartment. Use as much water as in cooking coffee and allow it to percolate for the same length of time. Any grains of coffee lodged in crevices will have fallen to the bottom and the brown deposit on the surface of the utensil will be gone, by the time this is done.

Novel Doll House

Two little girls abandoned an elaborate doll house for the table arrangement shown in the photo. They objected to



New Departure in Children's Doll House Partitioned Off on Table Top with Railings

the ceilings of the other house, which hampered them in moving their dolls and furniture about. One of them conceived the idea of having the rooms partitioned off with railings on top of a table. Later a taller table for an upper floor was added. Between the rooms, openings are left in the partitions to serve as doorways. The two tables are made of light pine, so that they can be easily moved about, and being separate, can form either a two-story house as shown, or placed end to end to make one long building. The upstairs partitions are higher than those on the lower table, because there they do not interfere with the child's reaching into the different rooms. The furniture is painted in some contrasting color. Most of the toy furniture was made by boys in the manual-training department of a school. The front of the lower table is cut out so that a stool may be used while playing. This house has been the most absorbing and useful toy these children ever owned.

Saving the Rain-Water Barrel

When the hoops rust off and the old rain-water barrel seems ready to fall to pieces, go to the junk yard and get 10 or 12 ft. of old sprocket chain, make it into loops, the size of barrel hoops, slip over the barrel and tighten them securely. These serve as well, stay in place better and will never wear out.—Willis Mehanna, Bussey, Iowa.

Cork Forms Removable Mount for Camera Lens

My reflex camera does not have a removable lens; so, wishing to use a lens of shorter focal length for close work, I provided a cork stopper to mount it on. The stopper was tapered slightly and made a tight fit in the threads on the front board to prevent leakage of light around the edges. The center of the stopper was cut out and smoothed down with a small round file, so that the new lens was a tight fit in the hole. After fastening the lens with small screws, the stopper was given two coats of black ink, both to improve its appearance and prevent reflections to the interior of the camera. By using a lens of which the focal length was not more than one-half of the available bellows extension of the camera, life-size photos of small objects, bugs and flowers could be obtained.—H. W. Rogers, Ithaca, N. Y.

Bicycle Lawn Mower

Mowing the lawn weekly proved too arduous a task for two boys, or at least they thought so, and, therefore, they rigged up the unusual mowing device shown in the photo. It consists of an ordinary grass mower attached to the front fork of a bicycle. The handle of the mower is removed and a short piece of wood of the same width and thickness is substituted. This piece is bolted to the fork at two points.



Boys Attach the Lawn Mower to Bicycle and Make Task a Pleasure

Hints for the Fisherman

by Bob Becker

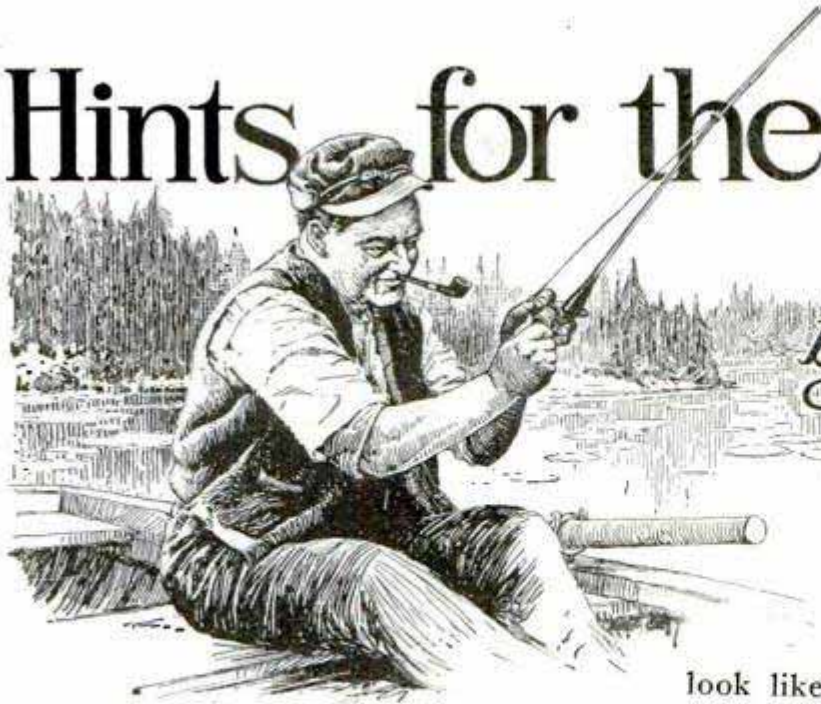

JUST as the hunter who sallies forth to the game fields must have his gun and outfit in order if he wishes to get the best results, and just as the automobilist must prepare for a tour and carry spare tires and a few tools for repairs, so the fisherman, with designs upon the big ones of his favorite lake or stream, should have his tackle in the best condition if he wants the most fun out of his sport. A loose ferrule that may bring trouble when a fish is played, a poorly wrapped rod tip or a reel that is dirty and not working properly, may spell the ruin of a day's sport with bass, pike, muskellunge or trout and the wise fisherman puts the taboo on these annoyances by a few hours of work before the "battle" with the big fish begins.

If you are planning on fixing up "Old Faithful," your pet fishing rod that

has served you on many a trip, here are a few tips on how to make your wooden weapon look like new irrespective of whether it cost three, five, or seventy-five dollars. First, remove the guides by cutting through the windings. An old razor blade or a keen knife will do this trick. Take off the tip and the ferrules. If they do not come off easily application of a little heat to the metal (by means of a match, if nothing else is handy) will easily solve the problem.

In fixing up a rod for a fishing season it is well to remove all the silk windings and all the varnish. By scraping the stick with a sharp steel edge (I use part of the blade of an old hunting knife taped in two places so that it may be gripped by the hands) the old varnish can be removed easily but one should be careful not to scrape too hard as you must preserve the enamel

on the bamboo, especially where the various parts of the rod are joined. If your rod is solid wood like hickory





coat of varnish instead of shellac, which results in a messy job because the color preservative that will be

used later on the silk wrappings turns varnish white, and presto!—the job is ruined! So the trick is, apply a light coat of good shellac first and you have a solid foundation to work on.

In cementing the tip and ferrules to the rod, fishermen can use a wide variety of materials. Marine glue, sealing wax or ferrule cement are a few of the ingredients available. We prefer the regular ferrule cement which can be purchased in any sporting goods store. It comes to you a hard, brittle (when cold) stick of wax-like substance wrapped something like a big stick of candy. When you're ready to use it on the rod scrape the wood free of any of the old cement, then heat both the wood and metal, melt a little of the cement, smear it on and then shove the parts on firmly. As soon as they have cooled sufficiently you're ready to proceed with your job.

Winding the rod and fitting the guides are the next items to be tackled. Guides should be placed in position and held there either by thread or small rubber bands. With your gay-colored silk thread wind tightly and evenly toward the agate

or bethabara this "manicuring" operation does not need to be done so carefully, as there is no danger of injury to any enamel.

The next operation is sandpapering. Buy the finest sandpaper that you can obtain, find a small flat block of wood, 4 or 5 in. long and about 2 in. wide, spread a piece of sandpaper over this block and then use plenty of elbow grease as you rub down the rod. But don't bear down too hard if you're working on a bamboo rod, as the slogan is, "remember the thin enamel coat on the bamboo must be preserved." After giving the rod a thorough rubbing down, wipe it clean so that it will be shipshape for the next operation. This next step is where many fishermen make a fatal error, as far as the appearance of their rods is concerned. They put on a

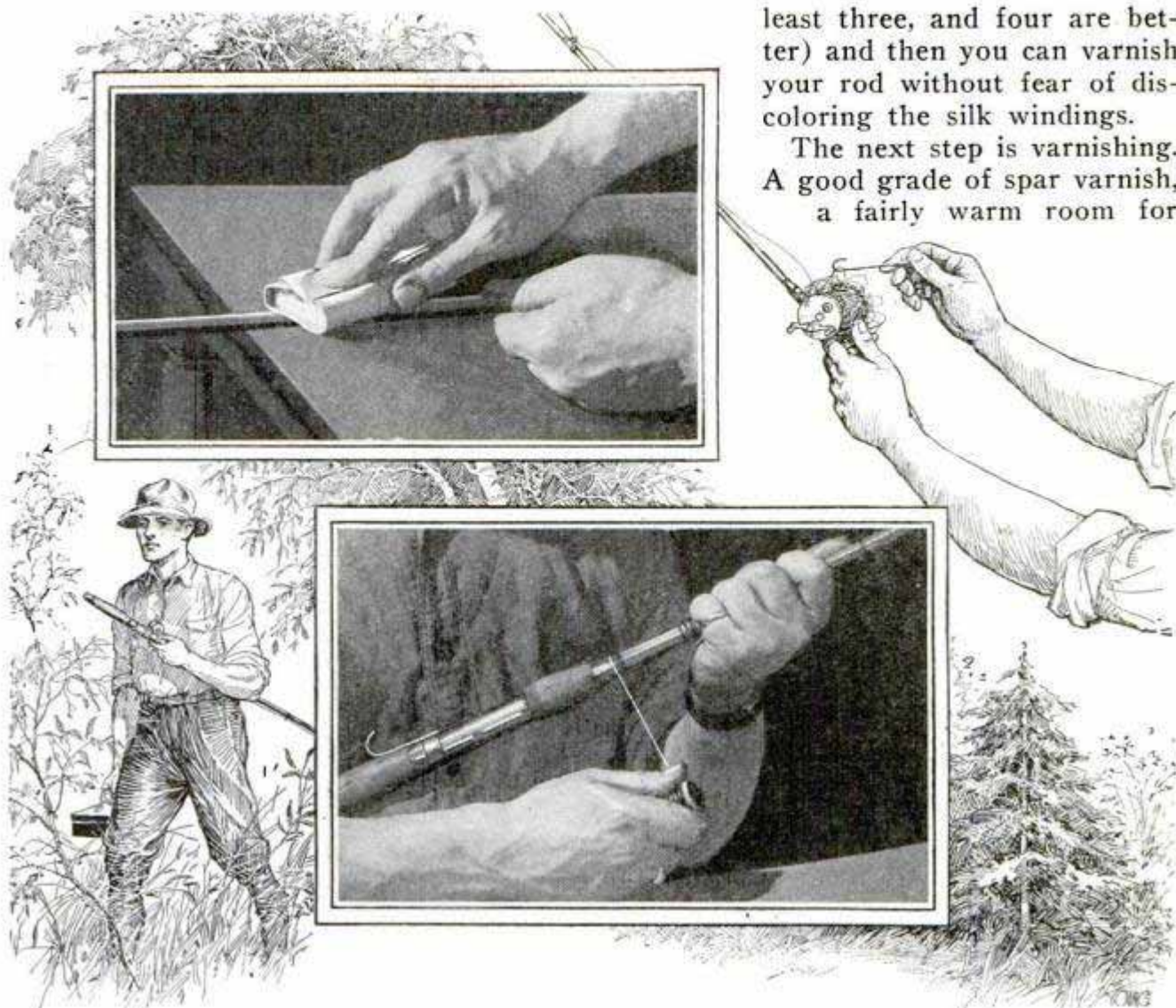

least three, and four are better) and then you can varnish your rod without fear of discoloring the silk windings.

The next step is varnishing. A good grade of spar varnish, a fairly warm room for

which will assure a neat even job. Practically every home rod worker uses the following method in winding a guide. In starting the thread he turns in one end of it so that three or four turns are passed over it (Fig. 1). When nearly finished with the winding the next trick is to throw a loop of thread on the side of the rod (Fig. 2) so that three or four turns can be made over this loop. Then at the finish put the end of the thread through this loop (Fig. 3), pull the end through and cut it.

Every fisherman who owns a fishing rod of wood which is gayly yet tastefully decorated with colored silk wants the windings to look well. To achieve this end note the following suggestions, designed to keep the colors of the silk bright and clear after the varnish is applied. Any drug store can furnish the combination; banana oil and collodion in equal parts. Use a good camel's-hair brush and put on several coats of this color preservative (at

the work, a good brush that doesn't shed hairs and plenty of patience are the big factors in the success of this operation. Put on three or four thin coats, always allowing the rod to dry for several days between each application. If you can keep the rod in a room free of dust it will come out looking like a million dollars and quite ready for some tussles with big fish.

Thousands of fishermen prefer steel rods for their "weapons" while on fishing trips, as these sturdy tools require little or no "petting," and can be abused more than a bamboo, hickory or bethabara rod. As a rule there are no colored silk windings to worry about and hence home work on these steel "whips" is a negligible item. If agate guides are used on your rod the main thing is to examine them closely after the winter storing period to see if they are intact. A cracked agate means a cut line and poor casting.

The reel is an important item in the fisherman's kit so don't slight it when polish-

ing things up for a trip. Take it apart carefully for cleaning. Put a drop or two of the finest lubricating oil on the vital parts and it is ready for use. Tissue paper is much better for cleaning the delicate parts of a reel than rags as the lint from the latter can be injurious to the finely attuned parts of any bait-casting reel, whether cheap or expensive.

After the outfit is cleaned, revamped, polished and all ready for strenuous combat with the finny tribes the fishing clan, which numbers many millions, finds it worth while to keep in mind a few don'ts if the outfit is to stand the gaff, and last for one or more vacations. We might call these "don'ts" the ten c o m m a n d m e n t s for successful Waltonians. They apply to the fisherman with a modest outfit as well as to the angler with hundreds of dollars invested in expensive tackle:

If you're fishing along a river, or on the bank of a lake don't lay your rod on the ground, unless you're sure you are the only fisherman in the territory. Stand the rod against a tree or in some brush so that no one can come along and step on it. Sand (or foreign particles of any kind) in a reel will ruin it. So don't carry your reel loose in your pocket, in the bait box or in a suit case where it may pick up some dirt. We use a small leather case for our pet reel. A small pouch with draw strings is also good and can be made at home at practically no cost. After fishing in the rain dry your rod, reel and line. The reel should be wiped with a dry cloth and a few drops of oil applied. See that all

moisture is removed from the rod. Unwind all the line on your reel and let it dry out thoroughly before you start out again. Don't use a knife blade in trying to unsnarl a "backlash" on your casting reel. Backlashes (better known as "bird's nests"!) should be treated with a button hook or better yet a hairpin, neither of which has cutting edges. Don't let anybody step on your line when you're in a

boat, on the shore or anywhere else. The plunk of a big outdoor boot on a fish-line is almost as bad as using a knife on it. A step doesn't break the line at the time but it is apt to part a little later when you have a whopping big fish on it. Don't leave your lines, rods or reels out overnight. The soaking they will get from the dew is almost as injurious as that received in a rain.

Another point is this, if the joints of your fishing rod fit rather tight don't twist the joints when you take them apart. Separate them by a straight pull and begin with the tip. Tight-fitting ferrules can be "eased up" by rubbing with a piece of emery paper. Don't take your rod apart and toss the pieces on the ground, as sand in the ferrules means trouble. When walking through the brush with your rod don't carry it tip first. Grasp it just above the butt so that the point trails behind you waist high. Many a steel rod has been ruined and many a wooden rod broken by ramming the tip into trees. Never stand a rod or any of your tackle (reel, hip boots, lures, lines, etc.) near a hot stove or a radiator. Keep these things away from heat, if you want them to last.



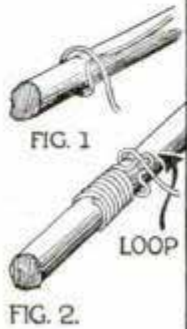

No matter how careful one is when on a fishing trip there may be an accident. Hence, the wise fisherman takes around a little emergency repair outfit so that he can make a quick repair in the field. One day last summer, just two hours before taking a train for home, we were on a small lake trying to get a mess of black bass to take back with us. A light rain had started to fall and the bass were hitting. With our time limited we were casting for all we were worth as fish were wanted badly and in a hurry. And then trouble stepped into the picture. We were using an inexpensive wooden rod. It cracked just above the ferrule, a decided fracture that would not permit us to even land a minnow unless repairs were made right away.

But our emergency kit was there for our rescue. Out came the tape, ordinary rubber tire tape. We wrapped the tip with this and in five minutes we were ready to take on any bass. With this repaired rod we hooked and landed eight good sized black bass and called it a day.

The fisherman can't foresee accidents but he can be ready for them with a pocket

repair kit.

On a long canoe and fishing trip which will take one far away from a base of supplies or tackle shop it is a wise idea to tuck in the duffel bag some or all of the following items: Lest the rubber boots fail take a small amount of rubber cement and rubber cloth; to repair a snag in your boot apply just a small amount of cement, put on the patch and then lay a stone, your tackle box or other heavy weight over it. This trick insures a repair job that will hold for a long time.

Practically every fisherman using wooden fishing rods carries along tire tape and ferrule cement. Both cost little, take up practically no space and are invaluable in repair jobs. We are still using an old bamboo rod that cost but six dollars four years ago although twice on trips to secluded lakes, reached by long hikes, we have broken the tip of this rod and had to make emergency repairs. Each time the break did not spoil our fishing, as the lateral splice which can be made with tire tape saved the day. The stunt is simple. When the tip breaks place the broken

ends side by side for $1\frac{1}{2}$ or 2 in., and then bind them with tire tape. Such a repair will hold although it is temporary and you will have to eventually replace the tip. With the tire tape take along the ferrule cement. If your rod should develop a loose ferrule, heat it with a match, remove it from the wood, clean both the wood and the metal and then apply the melted cement. Take time out while it cools and you're then ready for more fishing.

In our little pocket repair kit we have the following articles which are "standing by" for trouble: A small flat file, a pair of wire-cutting forceps, a pair of baby pliers, a roll of tire tape for hastily repairing a long break, some rubber cement and cloth for repairing rubber boots or rubber pacs, a couple of feet of light copper wire so that in case one of the guides on a steel or bamboo rod is broken we can make a new one out of wire, and ferrule cement.

After an experience with a leaky canoe last summer we are considering the addition of a piece of ordinary laundry soap to this kit, as in a pinch it will do for repairing leaks. After traveling fifteen miles to a muskellunge lake with an Indian

guide we secured a canoe and started out upon the lake for a wonderful day's sport. But the canoe leaked like a sieve. In the rickety old tumbledown boathouse where the canoe had been stored we found, after quite a search, a chunk of laundry soap. With it we filled the cracks in this manner: first moistening the places we rubbed the cake of soap over them until a thin layer was deposited. Through this the water could not flow and after ten or fifteen minutes of work with the laundry bar we went after the muskies. Moreover we kept our feet dry while doing it, as the holes in the canoe were plugged quite thoroughly by our repair work.

There are tricks in every trade and fishing is no exception. Checking up on your outfit before you start on a trip, packing along a simple little repair kit so as to be ready for accidents, and observance of a few common-sense rules in the care of tackle not only mean the saving of money for the angler but success when a big one grabs the lure and starts a fight, as faulty, neglected tackle can't cope with the big fighters of lake and stream that are now waiting for the disciples of Izaak Walton.

Coil Spring Protects Lawn Hose

When the sill cock for the attachment of the lawn hose is in such position that the hose, when in use, must lie across the

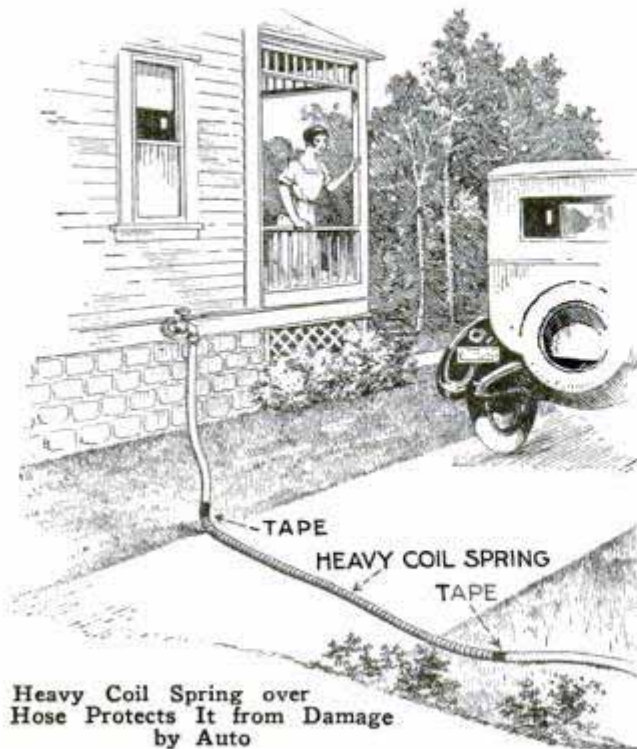

driveway, it occasions much annoyance. Either the hose must be moved each time a car passes in or out, or it must sooner or later become damaged by driving over it.

To eliminate this difficulty, a Wisconsin home owner employs a stout coil spring, 10 ft. long, which slips over the rubber hose at the portion crossing the driveway. Wrappings of rubber tape at each end of the spring hold it in place. With the hose thus protected, a heavily laden auto or truck may pass over it repeatedly without causing the slightest damage.

Curing Elusive Knock in a Ford

A knock in a Ford car was heard only when the car was going uphill. After considerable investigation the cause was found to be a weak crank spring. This permitted the crank to fall back against the crankshaft, and every time the motor made a revolution there was a knock, which seemed to be in the engine. A new crank spring remedied the trouble.—Chas. Latour, Jr., Plattsburg, N. Y.

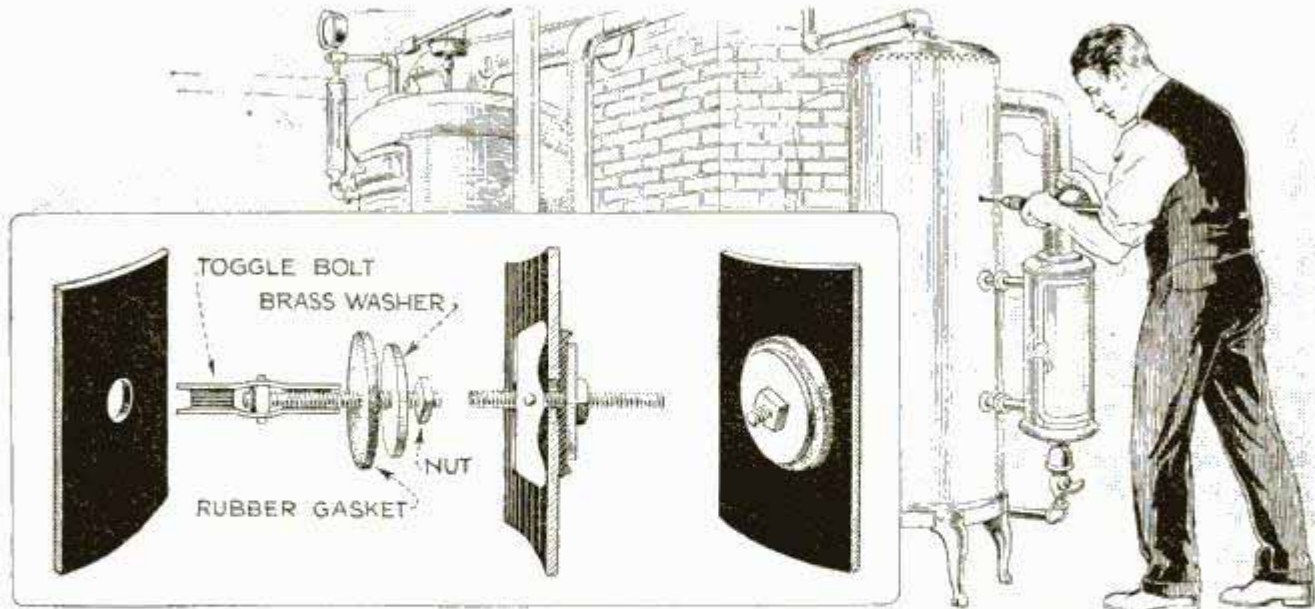

Simple Repair for the Leaky Range Boiler or Tank, Employing Only a 5-Cent Toggle Bolt, a Brass Washer and a Rubber Gasket

How to Fix That Leaky Tank

THERE are several ways of repairing a leak in a tank or range boiler. Sometimes a tapered steel punch is driven into the hole so as to turn the edges of the metal around the hole inward and thus form a surface that can be tapped for a common pipe plug. The plug should be coated with a mixture of litharge and glycerin before being screwed in. If the hole is in a tank of considerable thickness it can be quickly and easily repaired by using a special combination tap and plug that cuts and threads its way through the wall of the tank. A small leak in a seam may often be closed by merely rubbing a cold chisel along the edge of the seam or joint, but no attempt should be made to calk the seam unless the metal of the tank is of considerable thickness and the rivets are closely spaced and quite close to the seam edge, and even then extreme caution must be used.

One of the simplest repairs for a small hole in a range boiler, or any similar tank, for that matter, is shown in our illustration. Obtain, from the hardware store, or from the "five-and-ten," a $\frac{3}{16}$ by 3-in. toggle bolt. This costs about a nickel. Also get a brass washer about $1\frac{1}{2}$ to 2 in. in diameter, and with a hole a neat fit on the bolt. Cut a rubber washer or gasket a little larger in diameter than the brass washer from rubber about $\frac{1}{8}$ in. thick; two pieces cut from an old inner tube will serve if no thicker rubber is available.

Drill or file the small hole in the tank to a size that will pass the link of the bolt, pass the link through the hole, then put on the rubber and brass washers and tighten up the nut. It is advisable to curve the washer to the contour of the tank, and to file the metal beneath the gasket clean and smooth. A little candle wicking may be wrapped around the bolt shank to prevent leakage along the bolt.

Convenience in the Pantry

Our pantry is small and we have to make use of all the available shelving.

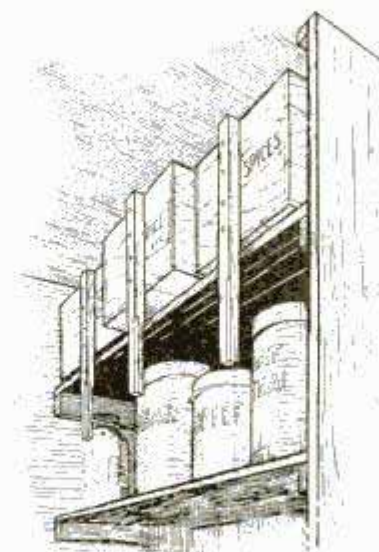

The boxes on the top shelf could not be taken down conveniently and a box or chair was necessary to stand on. By attaching handles to the boxes, as shown in the illustration, the difficulty was entirely over-

come. The handles should, of course, extend far enough down to be reached from the floor.—M. A. Veatch, Billings, Mont.

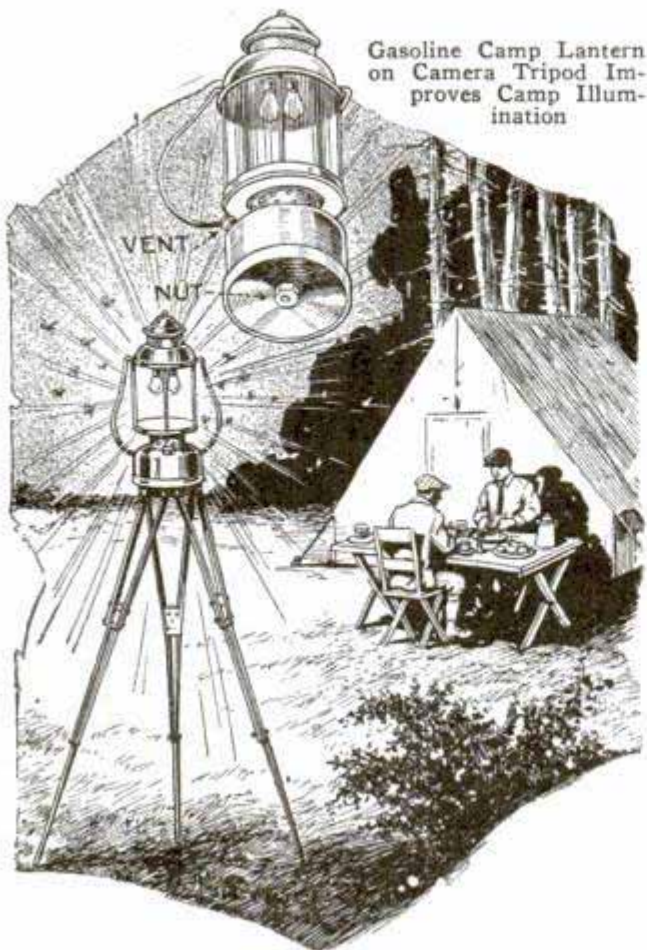

Gasoline Camp Lantern on Camera Tripod Improves Camp Illumination

Illuminating the Camp

Nearly every well-equipped camper carries a gasoline camp lantern, and there is usually a tripod from a camera available. These articles can be combined to give better camp illumination. It has been learned from experience that the efficiency of the camp lantern depends largely upon getting it so placed that the light is spread evenly over the camp site. Finding such a place isn't always easy, but by putting the lantern on the tripod, an ideal installation is obtained. Merely screw a brass nut that fits the screw in the head of the tripod to the bottom of the lantern. Light the lantern, screw it onto the tripod head and set the tripod wherever light is needed. The bottom of the camp lantern is slightly recessed so that the nut soldered to the bottom of it in no way interferes with setting the lantern down on a flat surface.

Getting Rid of Gophers and Moles

Gophers and moles damaging lawns and gardens can be driven away by dropping moth balls into their burrows and runways. I was troubled by gophers in my lawn, and all efforts to trap or poison them were unsuccessful. I experimented by dropping a dozen or more moth balls into the several openings. That was three months ago, and we have not had a gopher or mole on the place since. Obviously, the camphor balls have no worse effect upon these rodents than to drive them away. Nevertheless, it is an effective means of getting rid of such pests, especially where children may be endangered by the use of either traps or poison.—P. B. Robinson, Los Angeles, Calif.

Inner-Tube Repairs

In repairing auto inner tubes, a lot of time is lost in letting the air out of the tube after the leak has been found, and unless one is very careful, there is a chance of losing the location of the leak while the air is being let out. This trouble can be overcome by letting the air out of the tube through the puncture, which is easily done by enlarging the hole slightly with a sharp instrument, such as an ice pick, nail or the point of a knife blade. The enlarged hole is easy to see and can be patched as effectively as a smaller one.

Split-Handle Hoe Eases Hand and Arm



A gardener, whose labor was greatly increased by the hard clay and gravel soil of his garden, devised the split-handle hoe shown in the drawing, and thus relieved his hands and arms from the strain commonly experienced in gripping a smooth, round handle. The handle was sawed through the center to about three-quarters of its entire length and the halves spread to receive the short round pieces which served as hand grips. In use the handle does not put so great a strain on the small muscles of the hands and arms, but more on the shoulders and upper arms.—G. E. Hendrickson, Argyle, Wis.

A Chinese Teaser for Your Wits

THE puzzle shown in the accompanying illustration is an ancient Chinese trick, and, while a very simple one, once the secret is known, will keep the uninitiated working for hours, and get him tangled up in all kinds of knots and snarls before he discovers the method of solution, if he ever does.

The puzzle consists of a small wooden ladder of four steps. This may be made of any size and any wood. The only thing to be careful of is to get the steps far enough apart so that the fingers will go

between them comfortably; about $1\frac{1}{2}$ in. apart will do. Two $\frac{1}{16}$ -in. holes are drilled in each step and another in the top of one side piece, and through these holes is threaded a length of fine fishing line, about a yard long. Between each pair of steps and on top of the upper one the line is also threaded through little round "counters." These may be cut from a large dowel, made from old corks, or, in fact made in any way handy; the exact size and shape do not matter in the least. They are from $\frac{1}{16}$ to $\frac{1}{8}$ in. thick, and have a $\frac{1}{16}$ -in. hole drilled in the center for the cord also. Fig. 1 shows how the puzzle looks when finished and threaded. The end of the line is threaded through the hole in the top left-hand corner of the ladder and a bead is knotted on the end to keep it from pulling out again. On the free end of the line a fine-wire needle is knotted. The problem is to get the line out of the holes in the ladder, but to leave the counters threaded on the line, as in Fig. 4.

Step No. 1 in the solution is shown in Fig. 2. Take a couple of turns of the line around the top right-hand end of the ladder, not too tight, but enough to hold the

line. Then thread the line back again through all the counters and the holes in the ladder, down the right-hand side and up the left. As will be seen, this exactly reverses the original threading, and, if the turns were thrown off the upper end of the ladder the line could be drawn out of both ladder

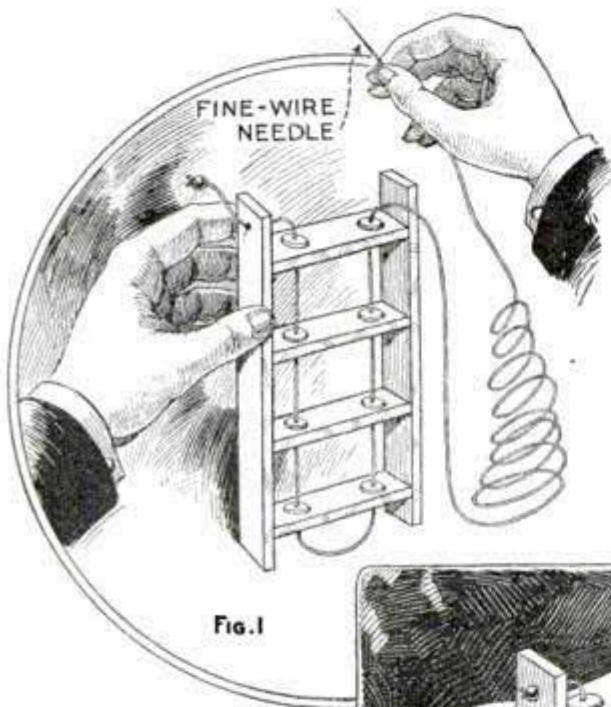

Fig. 1

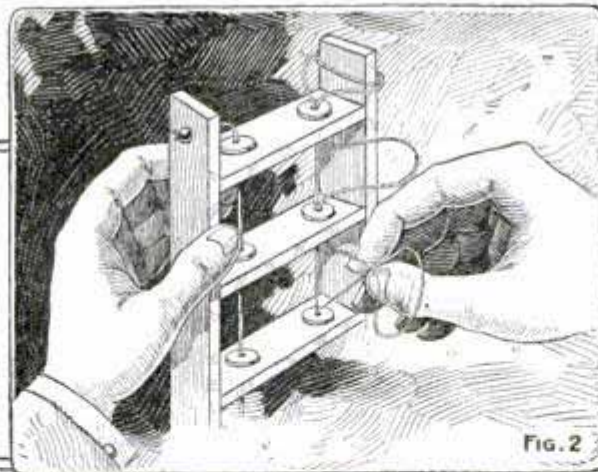

Fig. 2

A Puzzle from China, Which, Though Very Simple, Will Vastly Puzzle the Solver the First Time It Is Tried

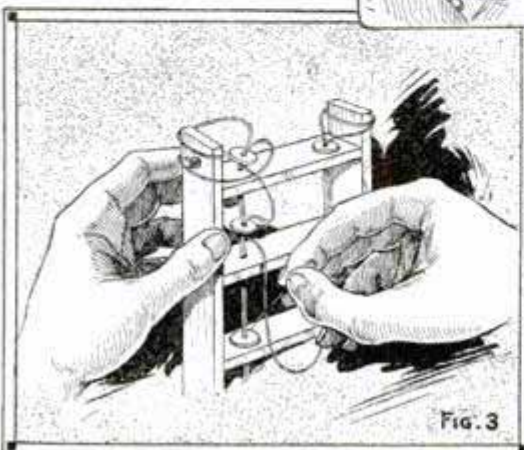

Fig. 3

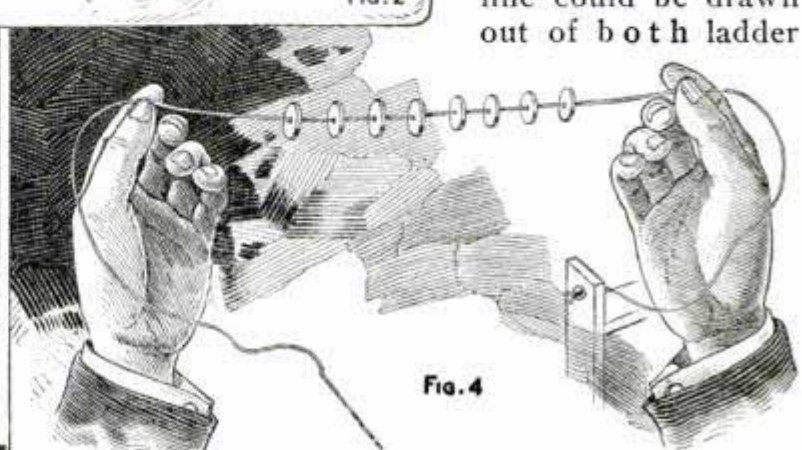

Fig. 4

and counters. This isn't what we want, however, so leave the turns on the upper right-hand side. After passing through the counter on the upper left-hand side of the ladder, take another two turns around the left side at the top, as shown in Fig. 3, and thread the line back again, this time, however, passing the line only through the counters, and not through the holes in the ladder. The turns on

each side at the top of the ladder can now be thrown off, and the line can then be drawn out of the holes in the ladder, leaving the counters on the line, as shown in Fig. 4. During the two threadings in the solution of the puzzle the line may become crossed and may not pull clear of the ladder easily. This can be overcome, however, as will be seen the first time the solution is attempted.

Indoor Game for Air Rifle

In cold or rainy weather, when out-door games cannot be indulged in, the boy

"Shooting" the Cork into the Tumbler Provides Indoor Sport for Air-Rifle Enthusiasts

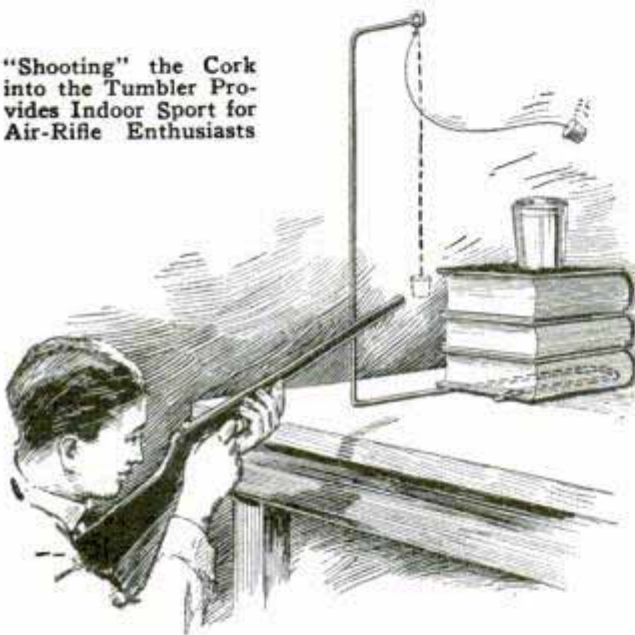

with an air rifle may while away the hours in an interesting game that will meet the approval of the most cautious parent.

After first taking care to observe that the chamber of the gun is empty, a small bracket should be made from heavy-gauge wire, as shown. This is placed upon the edge of a convenient table and books piled upon the base portion to prevent it from tipping or moving while the game is in progress. From the upper arm of the rack, a small cork is suspended by means of a stout cord and a heavy cup or tumbler is placed upon the pile of books.

The barrel of the blank-loaded air rifle is placed near the cork and the gun fired in an endeavor to toss the cork into the tumbler. This is much more difficult than would at first appear, as the strength of the explosion, the angle of firing and the possible deflecting of the cork against the

tumbler must all be considered. If several players take part in the game, each shooting in turn, it may be made highly interesting. The length of the string suspending the cork will depend upon the height of the rack and the height and position of the tumbler.

Gluing Linoleum to Iron Steps

To attach a strip of linoleum to an iron stair tread with glue seems nearly impossible. However, it can be done in the following way; Dissolve three parts of glue in eight parts of water and to it add one-half part of hydrochloric acid and three-quarters of a part of zinc vitriol. Let the whole boil for five or six hours. Apply this to both the stair tread and the back of the strip of linoleum with a brush. Place the linoleum in position and put a weight on it for at least twenty-four hours. The linoleum will stick to the iron and a cause of accidents on stairs will be avoided.

Garden Rocker Settee

With only a little work, one home owner turned out an attractive rocker settee for his garden.

The legs of an old settee were removed and those taken from an old rocking-chair substituted, as shown in the photo. Before using, each

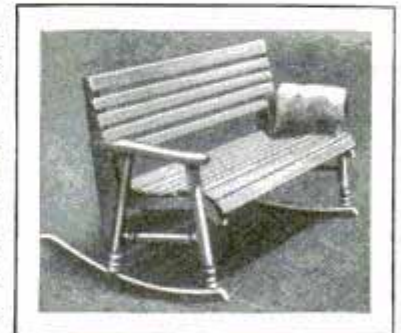

joint was glued to make it as strong as possible. This settee was found to be the most popular piece of his garden furniture.

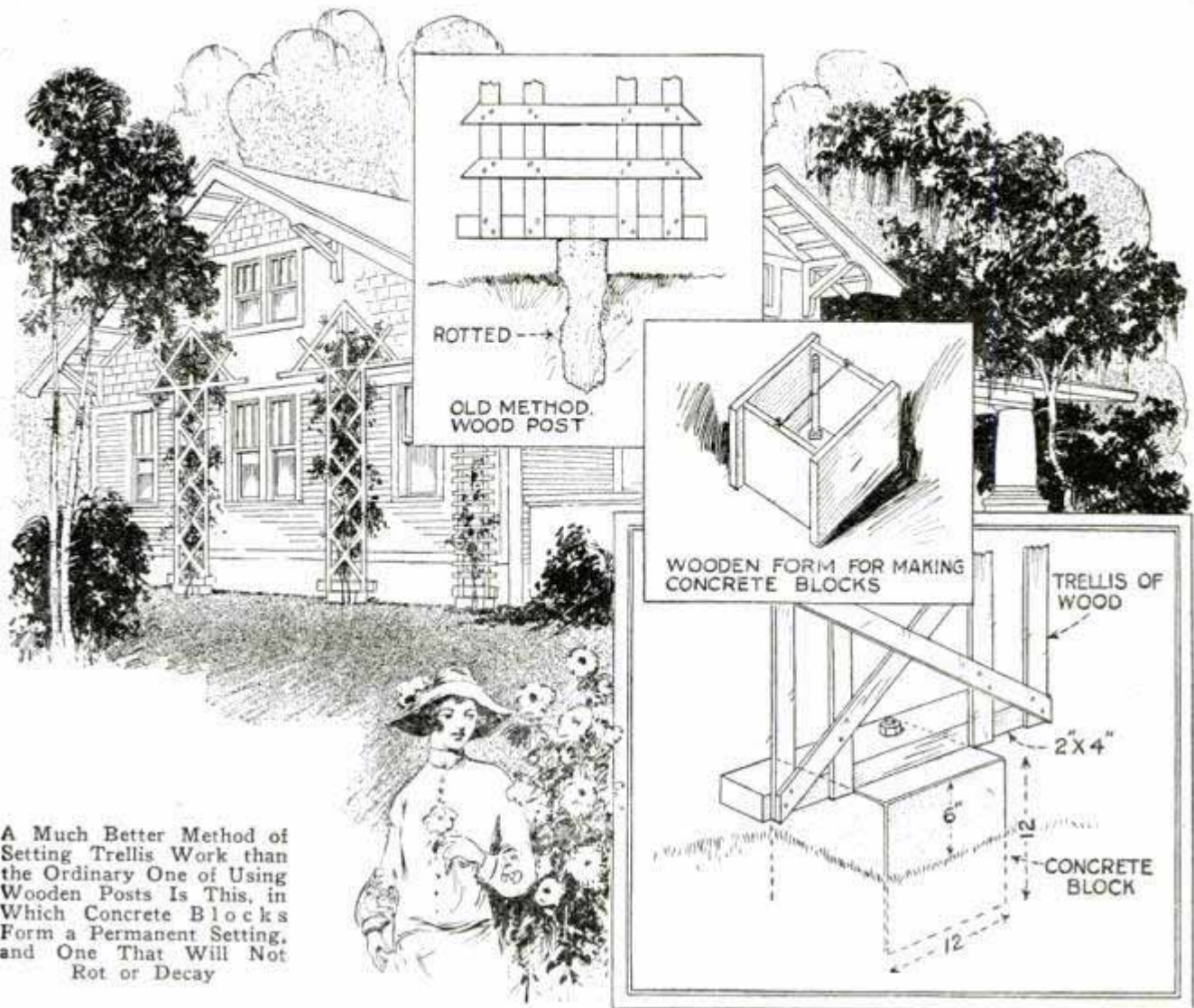

A Much Better Method of Setting Trellis Work than the Ordinary One of Using Wooden Posts Is This, in Which Concrete Blocks Form a Permanent Setting, and One That Will Not Rot or Decay

Setting Trellis Work

There is no question about the improvement that can be effected in the looks of the home by the employment of simple trellises, but the common method of setting these has one great defect. In this method the bottom of the trellis is nailed to a post sunk in the ground, and this rots in time. A much better way to set the trellises permanently is shown in the illustration. A simple wooden form is made that will hold 1 cu. ft. of concrete, as shown in the detail, and a bolt, about $\frac{1}{2}$ by 14 in., is suspended by means of a twisted wire so that the head of the bolt is about 2 in. from the bottom of the form. The wire can be fastened to two nails partly driven into the upper edges of the box at the center. The form is then filled with concrete. After the concrete has cured, the block is removed from the form, and a short length of 2 by 4-in. stock drilled and fastened to the block by means of the bolt. The trellis is then nailed or

screwed to the 2 by 4, using either galvanized roofing nails or brass screws.—Harry Lampert, Fillmore, Calif.

Adjustable Screen-Door Hook

When a screen door of the ordinary type is used, it may be necessary to change its position on account of swelling or sagging of the door. To overcome this, a hook made with an adjustable loop, as shown, may be used. The wire from which the hook

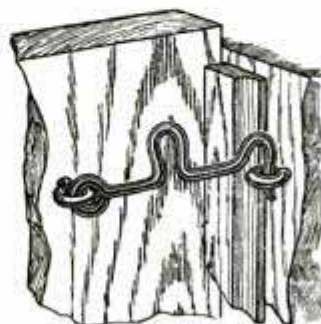

is made should be stiff enough to hold the door securely but such that the loop may be opened with a screwdriver or closed with a pair of pliers to lengthen or shorten the latch as may be necessary.—G. E. Hendrickson, Argyle, Wis.

Mirror Helps Sign Painter

Gold-leaf lettering has to be put on from the inside and it is almost impossible for the workman to see just how his job

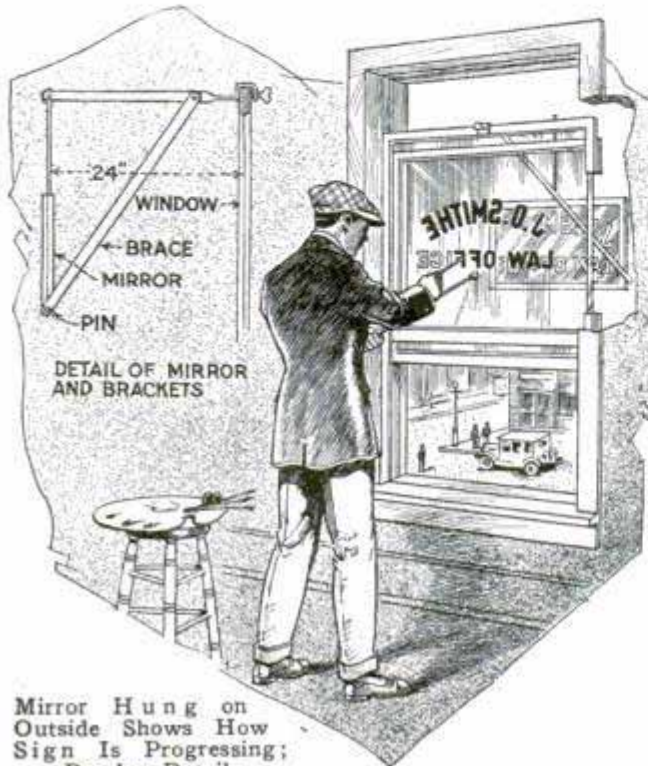

Mirror Hung on Outside Shows How Sign Is Progressing; Bracket Details

is progressing unless he endangers his life by leaning out of the window to take a look at it. After lettering a number of office windows in the usual way, the writer devised the method of watching this work as shown in the illustration. It was no trick at all to rig up a bracket for holding the mirror. The bracket is made rigid, to keep the mirror from swinging, and folds up conveniently when carrying it from job to job. The bracket is fastened to the sash and moved along as the job progresses.—P. B. Robinson, Los Angeles, Calif.

Painting Brick Foundations

If paint is put over bricks in a home it may mean damp cellars as the temperature of a cellar is seldom the same as outdoors. In the summer it is cooler and in the winter, warmer. This difference in temperature, added to the fact that the larger part of the cellar wall is beneath the ground, makes for dampness within the basement. Except after a beating rainstorm the outside of the bricks will not be damp, because the constant circu-

lation of air dries them. Inside the air is more stagnant. The dampness gathers on the bricks, and, as bricks are porous, soaks into them. If the bricks are unpainted, this dampness is drawn out of the bricks on the outside and evaporates, with a resulting dry cellar. If you paint the bricks, the lead in the paint fills these pores and prevents the dampness from getting out.—J. S. Hagans, Chicago, Ill.

Corn Cobs and Insulation

In erecting a new poultry house last fall, we were anxious to make it as warm as possible and decided to pack the walls with some insulating material. We had no sawdust, so someone suggested grinding up corn cobs in our feed grinder and using the cob meal for the purpose, and we turned out 40 bu. in about two hours. It was tamped between the walls and when doing so, we sprayed old crankcase oil on the meal to discourage insect life. The meal packs like sawdust and, as long as it is kept dry, is just as lasting.—G. G. McVicker, North Bend, Nebr.

Non-Slip Clothesline Pole

Clothesline poles often slide along the line during a high wind and fall on the ground, causing more or less damage to the suspended garments. To prevent this trouble, a deep slot should be sawed lengthwise into the butt of the pole and the two halves spread apart by a wooden wedge which is nailed in the crotch. This provides two legs for the pole and, although a clothesline supported with such a pole can swing back and forth, there is no lateral sliding, and it cannot be dislodged easily.—G. E. Hendrickson, Argyle, Wis.

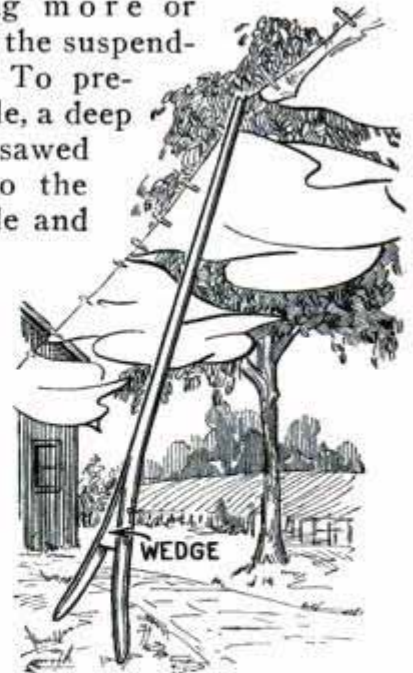

This "Wiggle Turk" Amuses Everyone

By LEONARD J. LEBOLT

Toy Turtle, "Worked" by a Slotted Thread Spool, Moves Its Feet, Head and Tail, Which Makes It Appear Alive

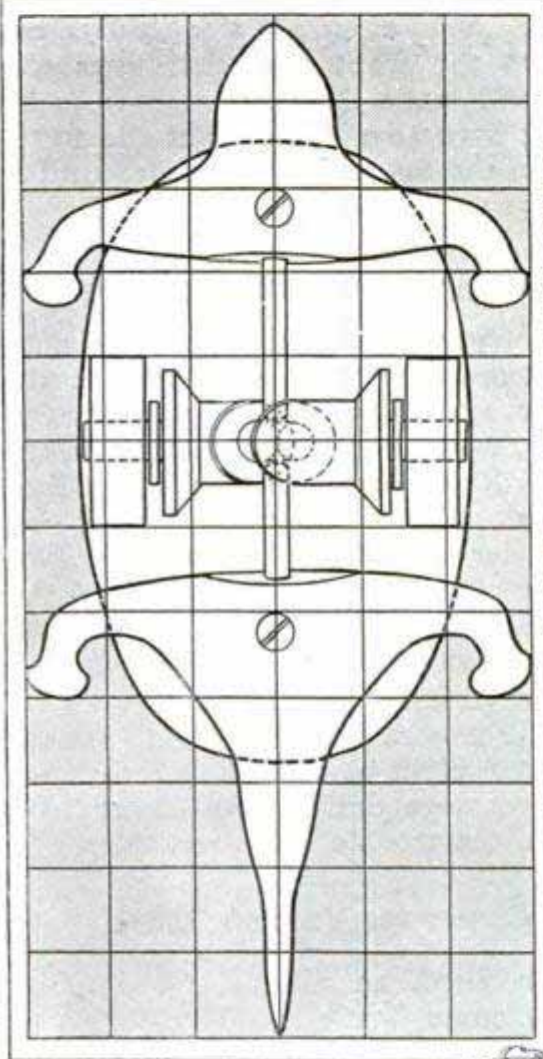
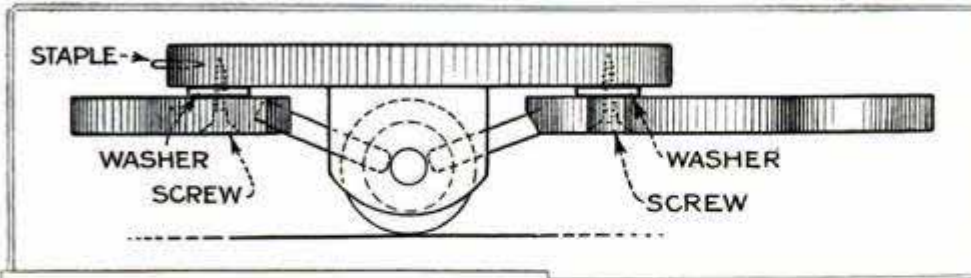

Above, Diagram for Laying Out All Parts of the "Wiggle Turk"

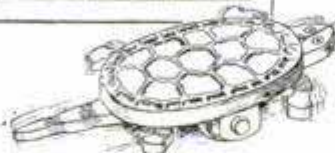

LIKE a real turtle, as it moves all feet, tail and head while it is pulled over the floor, the toy wood "turk" shown in the illustration will be particularly appealing to children. It is made of $\frac{1}{2}$ -in. wood, which is obtainable almost anywhere, an empty thread spool of medium size and a few short lengths of $\frac{1}{8}$ or $\frac{3}{16}$ -in. dowel rod. The head and front legs are one piece as well as the tail and hind legs. The activating mechanism is a thread spool, sawed in two pieces with a diagonal

cut. Both pieces are driven on a short length of dowel rod, or any small wooden rod that happens to be handy, so that there will be a space of about $\frac{1}{4}$ in. between the parts of the spool. Washers are slipped on the shaft and it is then put in the bearings, which are made of $\frac{1}{2}$ -in. wood cut to the shape shown in the detail drawing. The bearings are nailed to the back with a few small finishing nails. Holes are drilled and countersunk through the center of the front and hind members as indicated and a hole is drilled diagonally in each member for a short piece

of dowel rod, which is cut long enough to project into the slot in the spool without binding. Then the front and hind members are screwed loosely to the underside

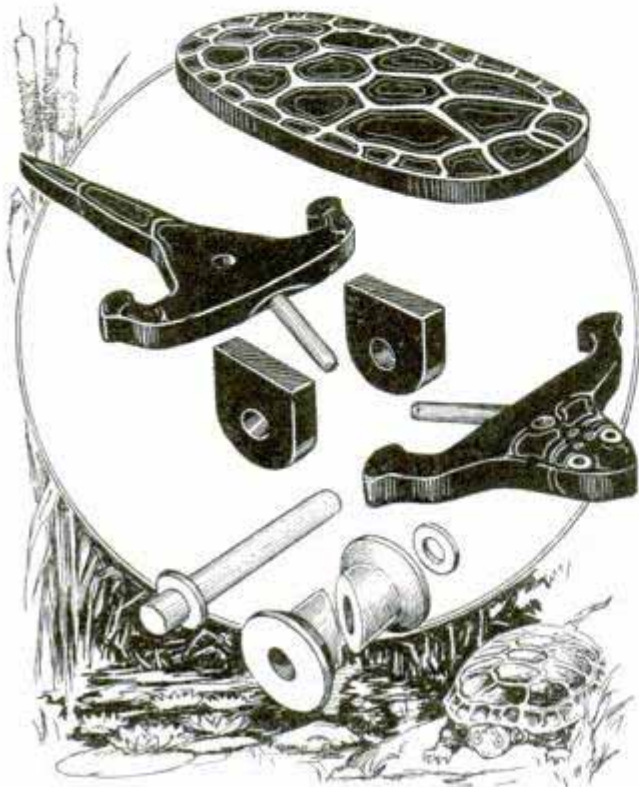

Details of the Turtle Showing Its Durable Construction and Simple Mechanism

of the body with flat-head screws, washers being provided between these members and body to reduce friction.

To get the same shape and design as that shown in the drawing cut a piece of paper 6 by 12 in. in dimensions and lay off lines to make 1-in. squares. Then proceed to reproduce the outline, drawing the curves through the same sections of the squares. It is, of course, necessary to do the cutting with a fret saw or jig saw. A fret saw can be purchased cheaply at almost any hardware store and will be found useful for many other purposes besides cutting out toys. After the parts are cut out, care being taken to have the grain of the wood run lengthwise through the narrow sections such as the tail, take a smooth half-round file and dress down the rough edges. Sandpaper is used to give the parts a smooth surface, and if desired to give the toy an exceptionally good finish, apply a coat of shellac.

The painting of the turtle is a factor which adds considerably to its appearance. Quick-drying lacquers, which can be obtained in most paint or hardware stores,

are very adaptable to paint toys of this kind. Keep in mind that bright contrasting colors are most appealing to the children, and proceed to paint the likeness of a real turtle. After the painting has been completed and is dry, drive a small staple or tack into the edge of the body just over the head and attach a string by which the toy can be pulled over the floor. When this is done the spool is revolved and a side-to-side movement given to the front and hind members, which will make the turtle appear to be walking naturally. The faster the turtle is pulled the faster it will wiggle, until it seems to make a super-turtle speed.

Remedy for Overheating Auto

The owner of a popular make of auto was troubled with water boiling in the radiator after driving only a short distance. Several mechanics worked on the car in order to locate the trouble, but they all failed. The radiator was flushed out, the muffler was cleaned, work was done on the motor, the valves were ground, the carbon cleaned out and a new fan belt installed, but nothing seemed to help. In fact everything was tried except an ice pack. It was at last suggested that the fan blades might be bent out a little more to create more draft. The owner tried this and the trouble was over.

Carrier for Vacuum Bottle

When filled, an all-metal vacuum bottle is quite heavy and by providing a holder of the kind illustrated, the bottle can be handled much easier. The holder is made of strap leather, about $\frac{3}{4}$ in. wide and $\frac{3}{8}$ in. thick, and is put together by riveting or sewing. Rivets are used to attach the bail so that it can pivot readily at this point.—R. D. Curtis, Dayton, Ohio.



Special Truck Body Aids Florist

A Long Island florist has solved the problem of carrying plants of all sizes, shrubs and small trees by having a special body built on his truck as shown in the drawing. The general design and appearance of the body are similar to the usual truck. The difference, how-

A false bottom is fitted with rollers so that it can be slid partly out, providing easy access to the more or less fragile plants. Part way up on each side of the body are two hinged shelves, which are suspended on chains. The cus-

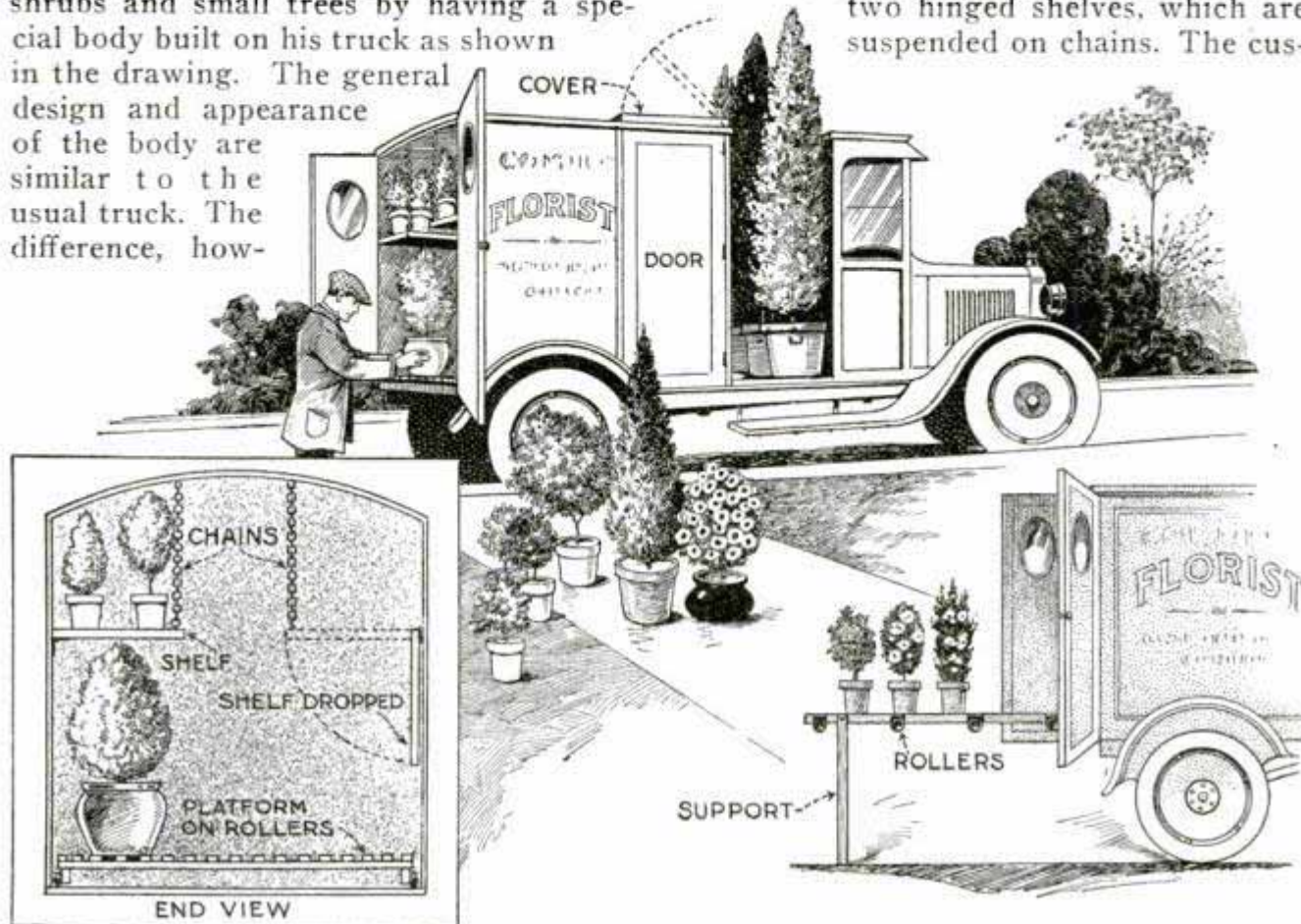

Specially Built Body on Florist's Truck Accommodates All Kinds and Sizes of Plants and Shrubbery Conveniently and a Rolling False Bottom Facilitates Loading

ever, is easily noted on closer examination. The forward part of the body, close behind the driver's seat, is cut out at the sides and the top to permit carrying tall shrubs and trees. Swinging doors are provided on the sides, hinged to open toward the back. These can be kept closed or open as the occasion requires. As the top of the opening is not braced or supported, the natural springiness of the frame causes the open space to vary at the top, and to prevent the doors from binding when this happens, they are simply allowed to rest against the side of the body and are fastened with a hook and eye instead of being set in frames. The hole on top is edged with a ridge front and back. This ridge helps to keep a hinged cover in place as shown. When no tall plants are to be carried, the doors and cover can be closed and the space used for other purposes. The remaining part of the body is also ingeniously arranged.

tomary pair of doors are provided at the back.—Frank W. Hart, Bayside, N. Y.

Floor Protectors

In trimming windows, waxing floors, etc., where the shoes are hard on the floor, protectors which slip over the shoes come in very handy. These can be made in a few minutes from an old inner tube. A Ford high-pressure tube is about the right width. Cut off a section as long as your foot and cut an oblong piece from the top side of this section to fit over the instep as shown in the drawing.



☞ You will have no trouble in keeping lice from your fowls during warm weather if you use plenty of disinfectant, spraying it on with a spray pump.

Amusing Puzzle in Physics

The device shown in the drawing is interesting for grownups as well as children. It consists of two equal weights of 1 oz.

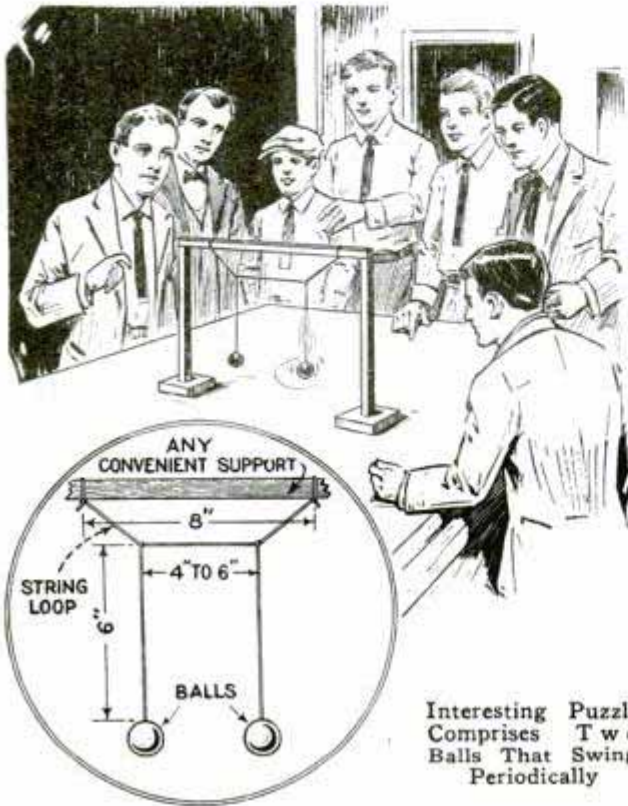

Interesting Puzzle
Comprises Two
Balls That Swing
Periodically

or slightly less, two standards on bases and a horizontal bar of wood, preferably 1-in. material, and some string. Lead or iron balls are good to use for weights but heavy fish-line sinkers or hexagon nuts will do just as well. The apparatus is set up as shown, the two weights being attached to lengths of cord 6 or 7 in. long. The length of both must be exactly equal. A slack string is tied to the crosspiece at points about 8 in. apart, and the strings holding the balls are tied to this string at points 4 to 6 in. apart. The strings should be tied so that they can be slipped along to vary the distance between them. In operation, one ball is held stationary and the second ball is allowed to swing. The first ball is then released. The swinging ball will gradually impart its energy to the other ball and will then lose its own energy so that the other ball starts swinging vigorously. Then as soon as the ball is hanging at rest it absorbs energy from the other ball and starts swinging again, while the other one comes to a stop. This periodical action will be repeated several times.—Robert F. Payne, New York City.

Doubling Life of Typewriter Ribbons

When a typewriter ribbon becomes worn to such an extent that a new one must be provided, do not throw away the old one if it is not worn through, but sew it to the new one in such a manner that the old one will be on the side hit by the type bar of the machine. If the old one is attached firmly and evenly and wound carefully on the spool the first time, it will go on nicely, and it can easily be seen that by the type bar hitting the old one and making the impression through the new one that the wear on the new one will be reduced to a minimum. Constant striking of the type bars on the ribbon sometimes wears them through before the ribbon is really worn out so far as ink is concerned, and by this method the life of the average ribbon can be doubled. In offices where large numbers of machines are used, and where heavy work is done, worth-while saving can be made in this way.—Henry A. Courtney, Atlanta, Ga.

Loose-Leaf Binders

I had made up about 1,000 booklets to be put in loose-leaf binders, using two brass binding posts with screws. The screws were machine-threaded and fitted in a loose manner. Putting these together by hand proved a tedious job, so I devised the method shown in the illustration. When all my binders were ready, I laid as many as I could on a flat table and set

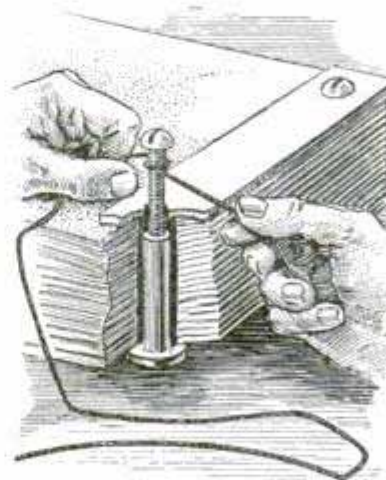

up the two posts in each. I then started the screws into each of them, but instead of putting them all the way in by hand, I took a short piece of ordinary cotton twine, wrapped it around the top of the screw once, and, using it as a snubber, pulled the short end of the string forward, holding the other end in my hand.—Kenneth E. Peterson, Oakland, Calif.



All Shop Notes published in 1925, in book form—Fifty Cents—from our Book Department

You Can Make This Floor Sander

By EDWARD SHAW

MOST modern homes have either hardwood floors or parquet floors in some part of the house. If it becomes necessary at any time to refinish these, a big problem presents itself. To sand the floors by hand would involve a great deal of work and to make use of any of the acid cleaners is not entirely satisfactory. A small rotary sander, capable of doing a good job, can be easily and cheaply constructed by the man handy with tools. The material required, exclusive of the motor, should not cost more than three dollars. A hardware store, or the neighborhood repair shop, would find a machine of this type a source of considerable profit, either if rented out to home owners, or

used by one of its own men to refinish floors in local residences.

The perspective drawing and photograph show the completed outfit. In the second drawing is given a general assembly of the outfit showing the driving

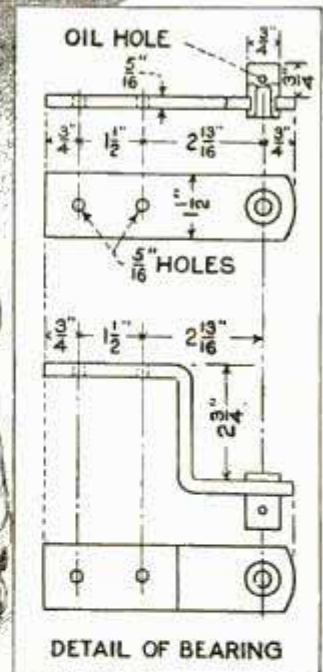
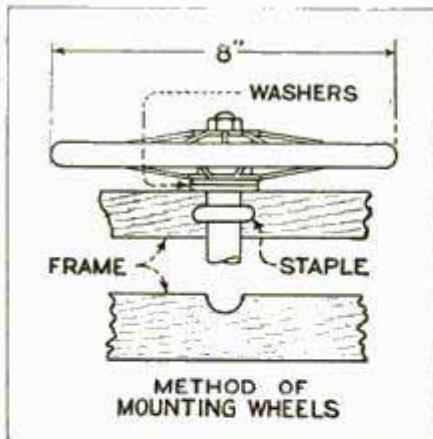
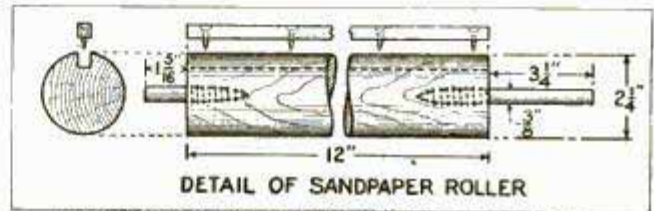

Various Details of Construction of the Floor Sander and Perspective Drawing of the Completed Machine in Use

motor mounted in place, power supply cord, etc. A 1/4-h.p., 1,750-r.p.m. motor is used and it is advisable to use one of the

George B. Carpenter & Co. 440 N. Wells Chicago

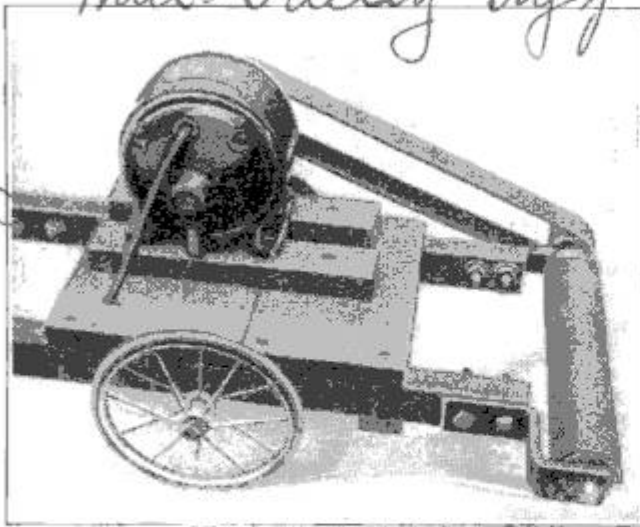

fit is pushed around. All wood used throughout is white pine and all the principal dimensions are given.

In using the outfit the power is turned on by means of the cord switch and the

Upper Left, Photo of the Original Machine; Below, Drawings for Assembling the Sander

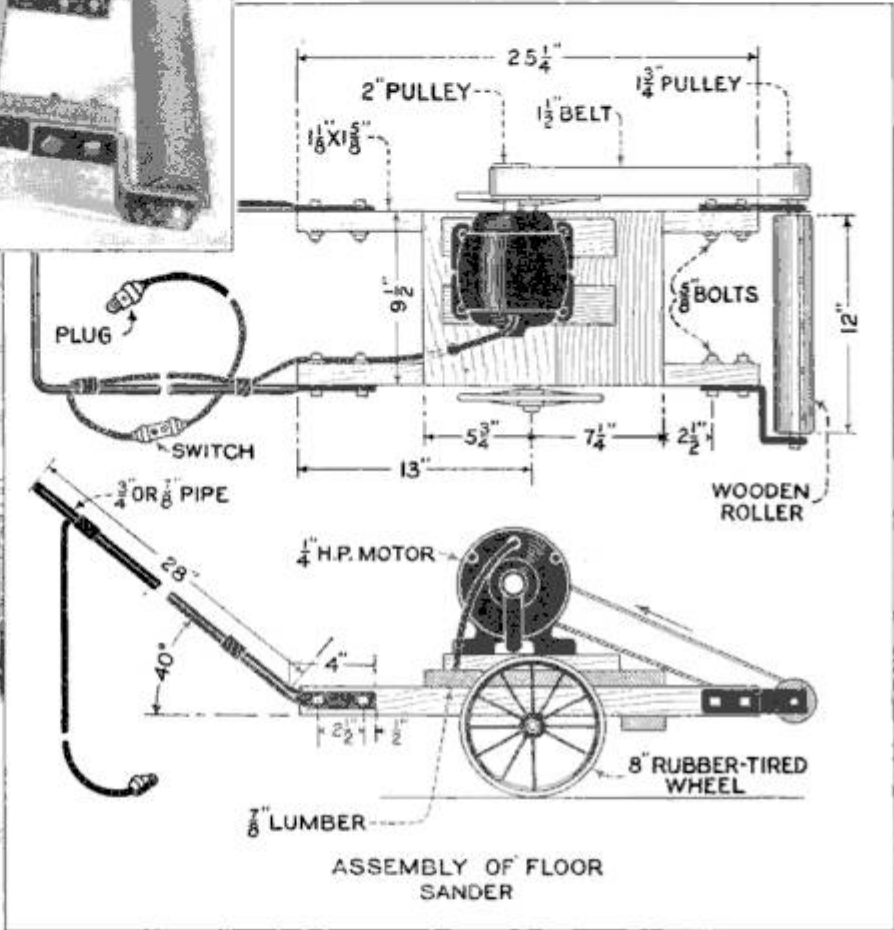

inclosed type, or else it will be necessary to cover it up while in use in order to keep out the dust. The abrasive used is coarse No. 00 Aloxite cloth, which, at the speed of the roller, cuts well and does not easily clog. For the roller, a rolling pin was used into each end of which had been fastened lag screws, as indicated in the detail. The brackets which support the wooden rollers are provided with bronze bearings, in which the roller is free to turn. One of the brackets is offset to enable the machine to come in close to the wall when in operation. It is very important to use but a very little oil in these bearings so as not to take a chance on having it get into the floor.

These details are all shown in the drawings, as well as the means used for mounting the shaft that carries the two 8-in. rubber-tired wheels upon which the out-

handle is lifted slightly until the roller begins to cut. In going across the floor it is well not to attempt to take too large a cut. Take a medium depth cut and travel slowly over the entire floor in some uniform fashion, going over it a second time if the floor is in bad shape. It is best to watch the Aloxite cloth and if it should become clogged with the old shellac or varnish taken off the floor, it should be replaced by a new piece.

After sanding the floor, several coats of varnish or shellac and wax can be applied.

Making Phone Receiver Comfortable

The soft sponge-rubber caps used on radio headphones can be applied to advantage also to the ordinary desk-phone receiver. The cap is slipped over the receiver end, which it will grip even more

tightly than it will the average radio head-phone. If provided with such a rubber ear cap, an ordinary phone is much more comfortable. In addition, disturbing noises and sounds are eliminated, because the cap fits the ear much better than the hard-rubber end. Phones used in the open air, for instance, on construction work, are very uncomfortable in cold weather, and the caps will help here, because the soft rubber does not feel so cold as the hard variety.

Door Construction

Mechanical tests of doors by the forest products laboratory have shown that, if put together by the through mortise-and-tenon method, the doors will have greater stiffness and resistance to sagging than either the dowel-joined doors or the type called "blind-mortised and tenoned." The last-mentioned, in which the tenons of the horizontal members, or rails, do not go clear through the vertical stiles, showed the lowest strength, but were somewhat superior to the doweled doors in stiffness. On being subjected to a damp atmosphere the blind-mortised and tenoned doors swelled the most, and in dry air showed the largest opening of joints. The doweled doors were the least affected by change of atmospheric conditions.

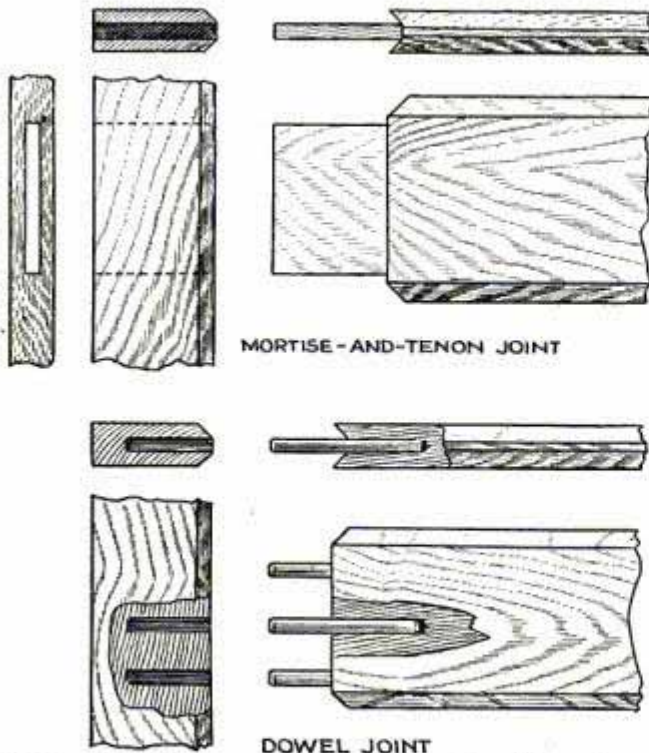

Doors with Mortise-and-Tenon Joints Are Stiffer But Swell More Than Those with Dowel Joints

Extension Oilcan Holder

To oil nearly inaccessible places in machinery the extension oilcan holder shown

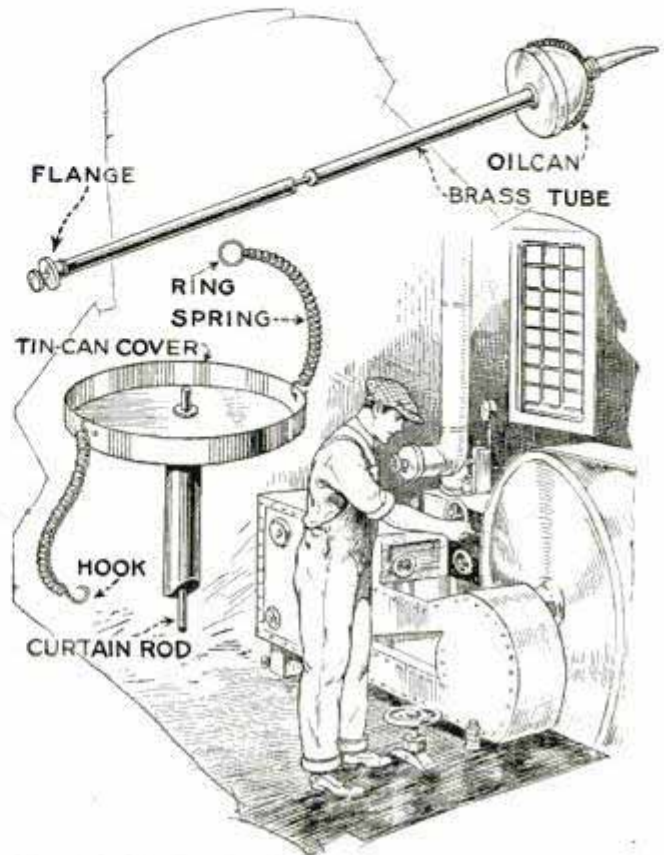

Extension Holder for Oilcan Permits Oiling Otherwise Inaccessible Places

in the illustration will be found useful. It consists of a heavy tin-can cover into which the base of the oilcan fits. A hole, slightly larger than the diameter of a metal curtain rod, is drilled in the exact center and two small holes in the rim of the cover as shown. A suitable length of $\frac{1}{2}$ -in. brass tubing is soldered over the center hole, at right angles to the face of the cover and a small flange to the opposite end of the tube. Two stiff coil springs, fastened to the cover and slipped over the spout, hold the oilcan in position securely. A curtain rod is slipped inside of the tube and a washer soldered to the end to act as a push button. In use the can is guided with one hand while the button is pushed with the other.

When winding springs on the lathe, it is a good kink to turn the spindle backward a few times in order to relieve the strain of the spring. This eliminates the danger of injuring the hands as the spring will not fly back when the wire is cut off.

Portable Desk for Lumber Yard

Wholesale or retail lumber dealers who are compelled to carry a tally book about the yards when selling lumber from the



Shelf Wedged between Boards of Lumber Pile Serves as Writing Desk

various piles, or when taking inventory of stock, are often inconvenienced by the inability to find a suitable book rest. A Wisconsin lumberman overcame this difficulty in the following way: A board upon which the tally book is fastened is provided with two flat-iron strips, which project about 6 or 8 in. beyond the end of the board. These are bent at a slight angle and, when inserted between the boards of a lumber pile, will hold the book at the height and slope desired for writing.

Welding Closed Containers

Metal tanks, barrels and drums are widely used to transport and store liquid products. When made by welding, such containers are permanently tight, but those made by other methods frequently develop leaks which the operator is called on to repair. Whatever work has to be done, the welder should never apply the

welding or cutting torch to such containers until he is positive that they are thoroughly clean and properly vented. Make it a rule to clean every container regardless of what you think was in it. Thorough steaming of the container will effectively remove traces of volatile liquids, such as gasoline, and scrubbing it with a strong lye solution will remove all oily materials. Possibly the easiest and safest way to protect the operator is to flush the container thoroughly with water. Then turn it so that the damaged section is uppermost and fill up with water to the defect to be repaired. Welding is then done with the least possible space inside. This precaution applies not only to oxyacetylene welding, but to repairs by any other process as well. Even a blow from a hammer or friction, generating static electricity, may cause a spark that may ignite the gas in the tank. In welding or cutting on any type of closed container, the handhole or other fittings should always be opened before applying the flame.

Canvas-Bottom Concrete Form

Undesirable eddies that wash the cement out of concrete poured under water, even though the mixture is carefully deposited through a tremie, can be prevented by using a form with a canvas bottom. The canvas, while allowing the concrete

to settle into all the irregularities of the foundation, prevents water disturbances on the outside of the box from coming under the edges and through the bottom. Such a form can be used to advantage in pouring foundations for bridges, buildings, retaining walls, head gates, and other structures, where available pumping facilities cannot completely remove the water.

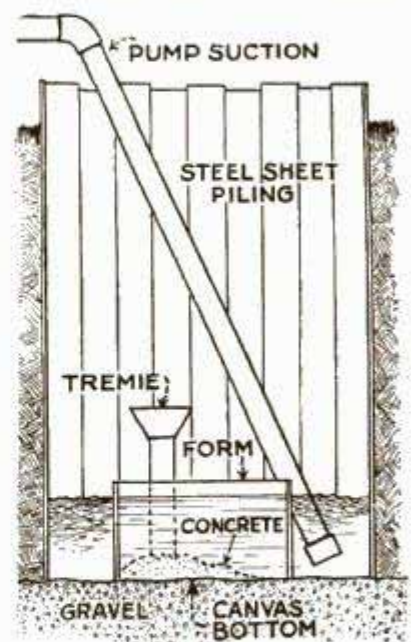

Farmer's Saw Driven by Auto

The farmer who has occasional need of a power-driven saw, grinder or similar apparatus, which requires from one to ten horsepower, can rig up his automobile to let the engine do the

ings at each end and at the center. Braces, G, which are $\frac{3}{16}$ by $1\frac{1}{4}$ by 10-in. flat iron, are riveted to the frame and the body part of the jack to hold the latter rigid to the frame. Two hook bolts, F, threaded to a distance of 4 in., connect the standards,

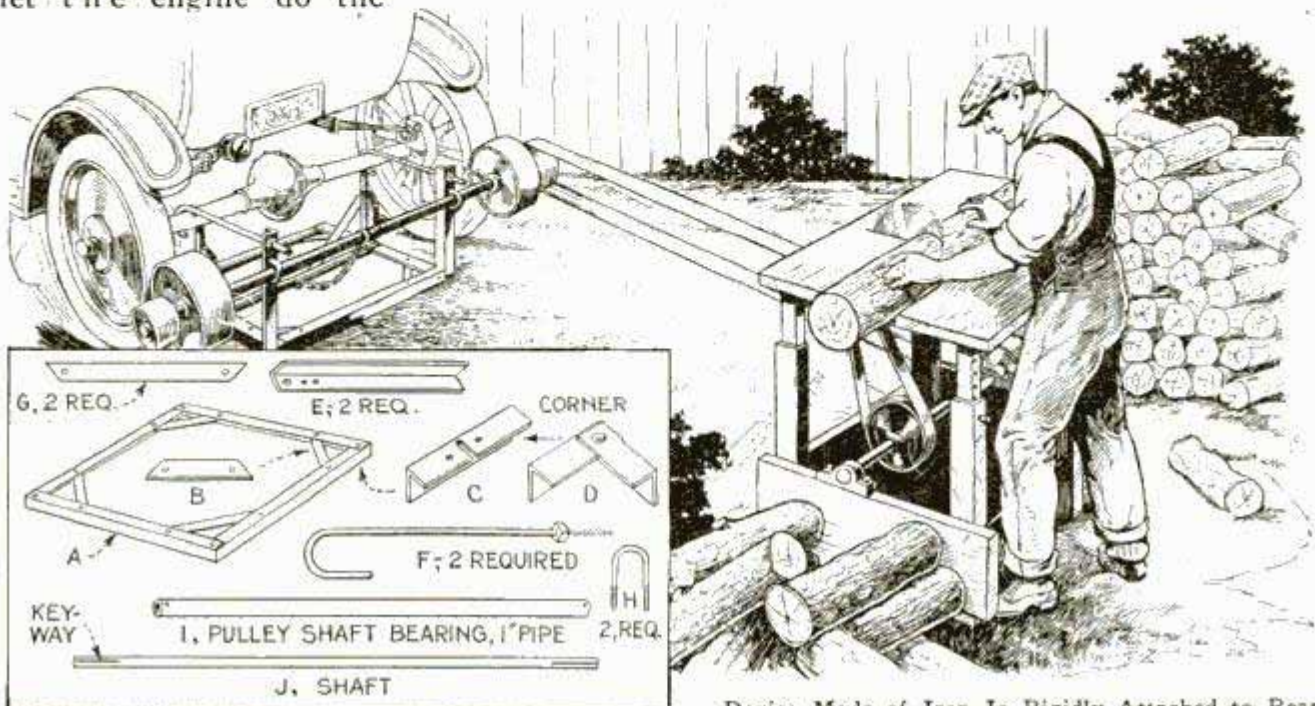

Device Made of Iron Is Rigidly Attached to Rear of Auto for Running Circular Saw

work. A simple device for transmitting the power to a saw is shown in the illustration. It consists of a shaft with two pulleys that come in frictional contact with the rear wheel, and another pulley to take the belt running the saw. The frame is about 3 ft. square and is made of $1\frac{1}{2}$ -in. angle iron. It is braced at each corner with a piece of strap iron, as shown at B. Four of these braces are necessary and they are $\frac{3}{16}$ by $1\frac{1}{4}$ by 10 in. in dimensions.

The main frame, A, is made by cutting a $\frac{1}{4}$ -in. slot in one side of the angle iron, as shown at C, every 3 ft. of a 12-ft. length. The length is then bent at the slots to form a square, and overlapping parts at the corners drilled with a $\frac{5}{16}$ -in. hole for rivets, as shown at D. The standards, E, for the shaft bearings are also made of $1\frac{1}{2}$ -in. angle iron; each piece is 14 in. long. A piece of $1\frac{1}{2}$ -in. pipe, I, 4 ft. 4 in. long, is attached near the top of the two standards by means of two U-bolts, H. A 1-in. shaft is put through the pipe, centered, and, after wrapping oakum or other material about the shaft to fill the pipe at a position about 4 in. from each end, babbit is poured into the pipe to form bear-

ings at each end and at the center. Braces, G, which are $\frac{3}{16}$ by $1\frac{1}{4}$ by 10-in. flat iron, are riveted to the frame and the body part of the jack to hold the latter rigid to the frame. Two hook bolts, F, threaded to a distance of 4 in., connect the standards, E, to the axle of the car and hold the pulley wheels against the tires of the auto when the device is in operation. To use it, the car is backed to position over the frame, the latter being staked to the ground or attached to the floor. The car axle is lifted by means of the jacks until the wheels clear the surface. The two hook bolts are then set over the axle and the nuts turned on until sufficient pressure is given the two pulley wheels against the tires. A smaller pulley may be added to the end of the shaft for slower-speed machinery, and thus two or more machines can be driven at the same time. A chain connects the pipe supporting the shaft with the frame of the device, preventing the former from falling back beyond a determined distance. To move the device from place to place it may be inverted so that the wheels will roll on the ground and the frame then hitched to the rear of the car.—W. Mitchell, Rogers, Nebr.

☐ A flat piece of aluminum, $\frac{1}{8}$ in. thick by 1 in. wide, makes an excellent tool for cleaning files. A piece 5 in. long will be found most suitable.



Self-Closing Cover for Milk Strainer; Detail of Opening Lever in Insert

Two Kinks for the Dairyman

Anyone who has visited a dairy farm during the time when flies are numerous will appreciate the usefulness of the device shown in the photo, which prevents flies from getting into the milk strainer and thus makes for better sanitation. It is simply a cloth cover for the strainer, stretched over a wire frame. It is attached to a wall at such a height that it fits flatly on the strainer when let down, and is operated by a pedal and lever, as indicated in the photo. When a bucket of milk is poured into the strainer, the cover is lifted out of the way by pressing on the pedal, which, when released, allows the cover to drop down by its own weight. To keep an accurate record of the milk given by each cow, it is a good idea to weigh the milk on a spring scale and enter the amount on a chart. The weight of the pail is, of course, deducted.

☐ A straight bar magnet greatly facilitates the job of removing valve-spring retaining pins, which are hard to grasp with pliers.

Adjustable Reamers as Mandrels

Sometimes the lathe man finds it necessary to turn the outside of a small piece true to a hole already sized and finished. This means that the piece must be held by some method that will keep the hole true. I have found nothing better for this kind of work than the adjustable reamers now so common. They are always accurately centered, and the shape of the movable cutters gives them just the grip to hold the work. With proper care, the reamer is not injured in the least, and the marks left on the inside of the work are hardly noticeable. The reamer should be expanded quite firmly against the walls of the hole in order that no slipping may occur, which would injure the hole by actually reaming it. A little judgment will tell how large a cut can be taken with safety.—S. J. Gee, Montpelier, Idaho.

Speeding Up Concreting

Faced with the problem of carrying on simultaneous concreting operations requiring two different mixes, one to be conveyed by motor dump trucks and the other to be spouted, I worked out an interesting hoisting-tower tripping device, which saves much time, labor and extra equipment.

To put into effect a two-mix plan it was thought advisable to use the same hoist tower and to make provision for discharging the bucket at a lower level than that at which it discharged for spouting operations. So, I figured out the arrangement shown in the accompanying illustration. It consists of two guide arms of channel iron, slightly flared at the lower end, which are pivoted to the corner posts of the tower and held, when in operating position, by supporting rods, as shown. The supporting rods

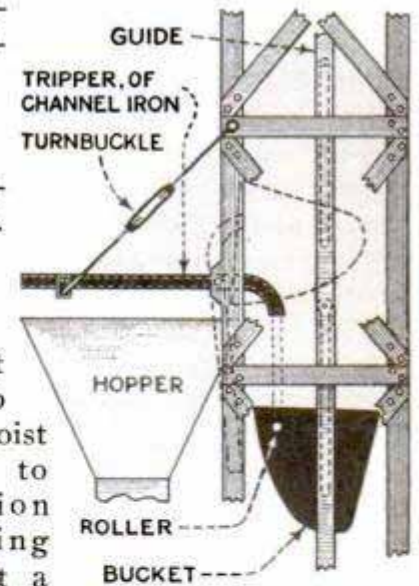

are provided with turnbuckles which permit quick adjustment to engage or to disengage the tripping device. When the bucket is to be discharged at the upper level these rods are disengaged and the tripper arms fall to a perpendicular position, allowing the bucket to pass by and up the tower. For discharging at the lower level the operator simply raises the tripping arms, pulls out the supporting rods, places the holding blocks at the lower ends of the rods in slots cut in the lower sides of the tripping arms to receive them, and twists the turnbuckles a few times to lock the arms. This operation is accomplished in a few seconds. On either side of the bucket is a small roller securely mounted on a pin.

As the bucket is raised these rollers enter the flared ends of the trippers and follow along the channels, holding the lip of the bucket down while the bottom is being carried upward to the discharging position.—August Jeffers, Bedford, Ind.

Making Washers

When making several hundred small brass washers from $\frac{1}{4}$ -in. round stock I found it rather troublesome to pick them out of the cuttings, which were collected in the small box I had placed to catch the washers as they were cut off. By fastening a piece of spring wire, about 10 in. long to the toolpost on the lathe, and inserting the other end in the hole drilled in the stock, the washers would slide down the wire as fast as they were cut off. This end of the wire was bent to form a hook to hold it in place, and the wire was placed in front of the tool post and slanted, to allow the washers to slide. The moving of the tool at each cut tends to stiffen the tension on the wire, holding it in place until the washers are all cut, when they are removed.—Chas. G. England, Washington, Pa.

Handy Workbenches for Garage

On each column in a San Francisco auto-service station, two handy benches for

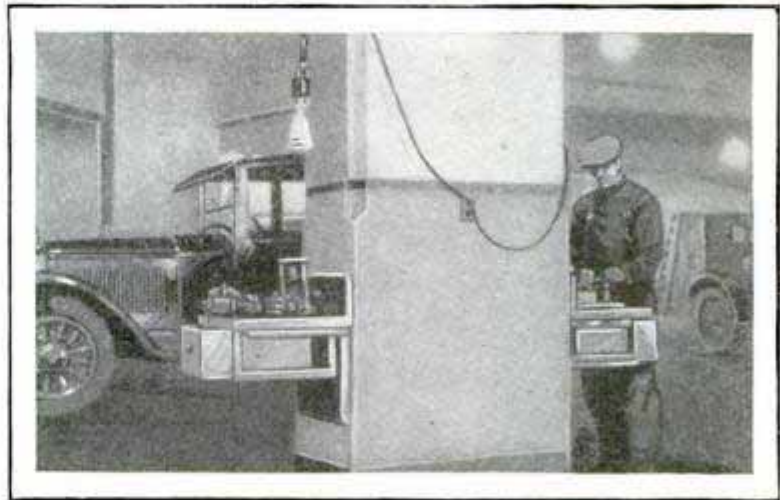

Small Workbenches Attached to Columns in Auto-Service Station Handy for Small Jobs

small jobs have been arranged as shown in the photo. The benches are provided with a vise and drawer for tools, and are narrower at the front than at the column side, so that there is no tendency for cars being driven down the aisles to catch the front edges.—Charles W. Geiger, San Francisco, Calif.

Binder Heads Make Pump Jack

The pump jack shown in the photo was made from two binder heads and a single cogwheel from the end of the trip arm, and gives a 6-in. stroke. It has been in use for a number of years and still gives excellent service. Two old bundle mechanisms from old binders were required to furnish the three wheels, two of which are alike, and the two shafts. The boxings were made of maple, soaked in oil, and oilcups are screwed down into the wood above the bearing to permit hard oil to be fed to the bearing. The pulley wheel was salvaged from a scrap heap. The pitman was a piece of hardwood, 1 in. thick, 2 in. wide, and long enough to reach the proper distance.

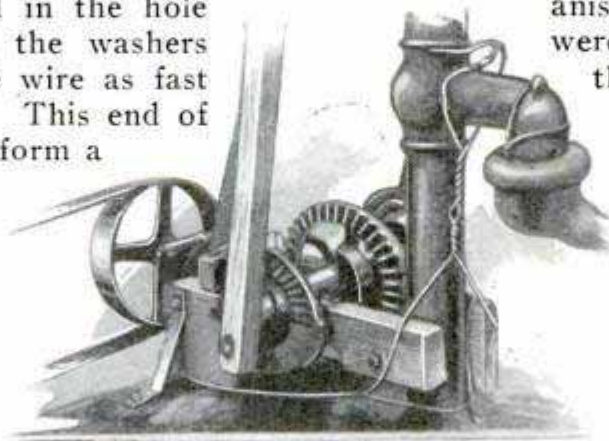

Efficient Pump Jack Made from Old Binder Parts Gives a 6-Inch Stroke



Easily Made Orchard Ladder Which Facilitates Picking and Can Be Moved About Readily

Convenient Orchard Ladder

Fruit pickers will find the ladder shown in the illustration of considerable utility and a great improvement over an ordinary ladder. It enables the picker to reach the top branches of the trees, can be moved about very easily and will not tip over. It is made from a ladder, two old mower wheels, or any other wheels of similar size, and some wooden braces and crosspieces. The upright braces are lengths of 1 by 4-in. stock, while the handlebars are made of 2 by 4-in. stock and fastened to the axle with iron yokes.

Asbestos for Annealing

Asbestos is used in practically every foundry for covering hot castings. This paper is torn after being used once or twice, and it is then usually thrown away, which is an expensive practice. The torn paper can be used in the annealing bin by tearing it into small shreds, which make excellent material to bury castings in. The paper will soon become pulverized and will last a long time.

Method of Locating Partitions

While doing a job of electrical wiring, difficulty was found in avoiding partitions and joists, which could be seen from an unfinished attic but were invisible in the furnished and plastered rooms below. A horseshoe magnet and a common compass overcame this difficulty. The magnet was placed close to the ceiling where it was desired to cut a hole, and the exact spot could be located on the other side by the dipping of the compass needle, which pointed to the pole of the magnet when the compass was moved in a circle around the approximate location of the magnet. This method is applicable to other difficulties of location where it is not feasible to measure, or drill test holes.—Floyd A. Meek, Rockbridge, Ill.

Turning Edges of Screen Wire

When cutting strips of screen for doors and windows the dealer is often requested to fold back the rough edges about $\frac{1}{2}$ in. so that they will not unravel when tacked on the frames. Although special tools of the tin shop may be used for this purpose, the dealer in most cases has none of these

and will find the illustrated method quite a timesaver. At the end of the screen counter, a straight stick, about $\frac{1}{2}$ in. square, and of a length equal to the width of the counter, is nailed to act as a gauge, and $\frac{1}{2}$ in. from this, toward the screen rack, a deep slot is sawed across the counter as indicated. To fold the end of a cut piece, it

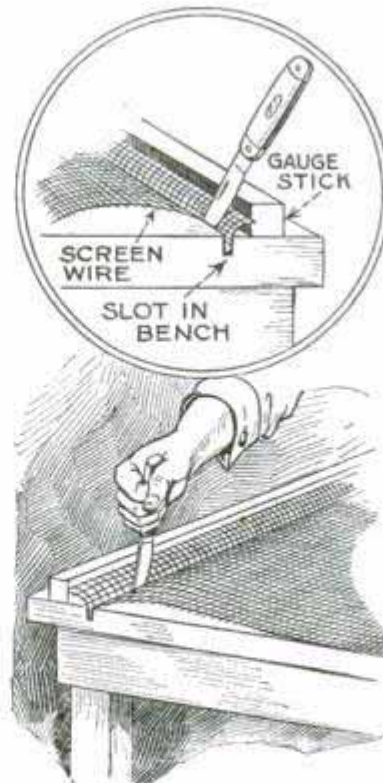

is placed against the stop gauge and a dull knife drawn across it over the slot in the counter.

Why Your Car Shimmies and How to Cure It

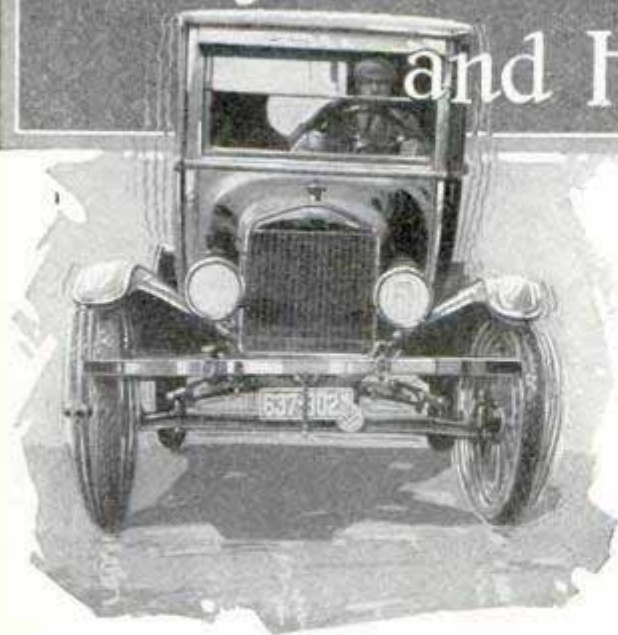

THERE is nothing more annoying than shimmy in a car, whether it be the slight, sudden shimmy felt when the car wheels hit a rut in the road or the violent, uncontrollable vibration sometimes encountered in a balloon-tired automobile at high speed. In by far the greater number of cases the shimmy is easily cured, and still more easily prevented. Often the owner of the car can, with an hour or two of work, cure the trouble permanently, and any owner can prevent low-speed shimmy with a little time spent on the care and proper lubrication of steering connections. For the cure of the violent shimmy at high speed, cooperation with the manufacturer's service station may be necessary, but, even here, the owner can help a great deal by not allowing conditions to arise that will aggravate the trouble.

The front wheels of a car, if adjusted properly, do not point straight ahead, neither are they straight up and down. Here is a sketch of the front axle and wheels, looking at them from the rear (Fig. 1). Notice that the wheels are closer at the bottom than at the top, due to the steering-knuckle spindle or king pin being set at an angle in the axle. This inclination of the wheels is usually about 2°. The idea is to

make the center line of the king pin or spindle correspond, as nearly as possible, with the center line of the wheel at the point where the tire touches the road. This permits the car to be steered more easily. Another reason for it is that the wheels have a tendency to spread at the bottom and come together at the top when speeding, and the "camber" helps to compensate for this tendency.

To offset the wearing action on the tires produced by the camber, and to make them wear more evenly, the wheels are "toed-in" at the front. Here is another sketch (Fig. 2). This is a top view of the front axle, and you will notice that the distance A is less than B. The difference between the two is the toe-in. In general it amounts to about $\frac{3}{8}$ in., although on the Ford it is about $\frac{1}{4}$ in. The toe-in offsets a tendency of the wheels to "open up" at the front at high-speed, besides helping to equalize the wear on the tires.

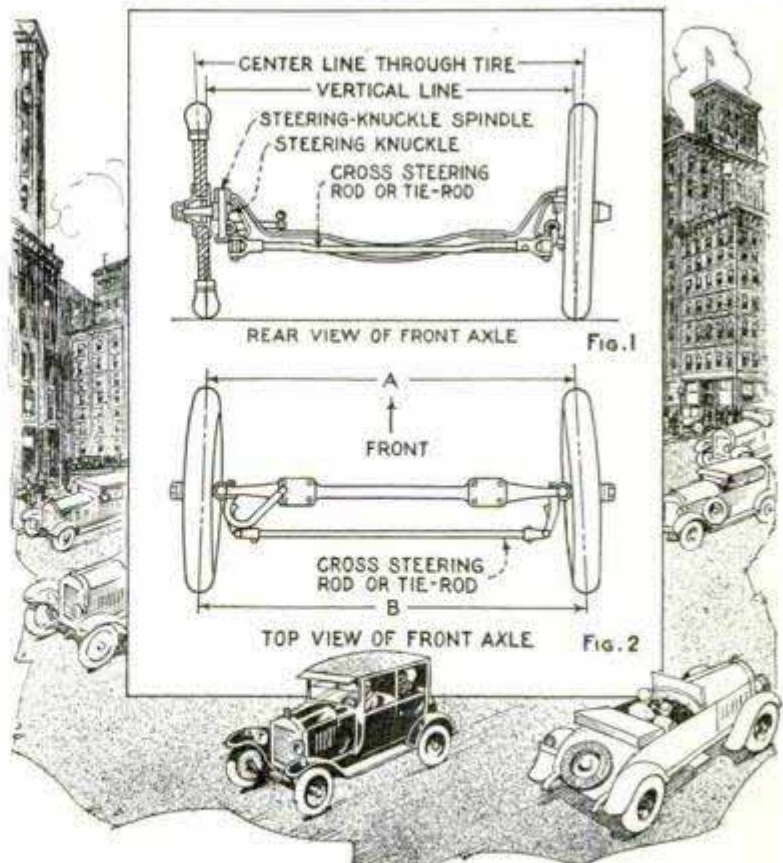

Rear View and Plan of Front Axle, Illustrating What Is Meant by "Camber" and "Toe-In" on the Front Wheels of the Car

Too much toe-in, however, is as bad as too little so far as tire wear is concerned, for too much will cause the tread rubber to be ground off. Toe-in is sometimes called "gather," but the first term is the one generally used.

There is quite a little more to the design of the front wheels of a car than merely sticking them on the axle ends. And this is not all; there is the "caster effect." You have noticed how easily your bed or bureau rolls on its casters, and how quickly and smoothly it is "steered" in one direction or another. Well, the reason for this is all in the design of the caster; you know how the little wheel touches the floor at a point to the rear of the caster's vertical axis, which is the center line of the pin that goes up into the foot of the bedpost. Because of this, the wheel trails, and does not tend to change the direction of motion of the bed when pushed straight, yet the bed can be steered in any direction with scarcely an effort. The same principle has been used for years in the steering wheel of bicycles; look here (Fig. 3).

A center line drawn through the steering column of the bicycle strikes the ground in front of a vertical line drawn through the axle of the wheel, so that the wheel, in effect, actually trails behind the steering axis, and, like the bed caster, the wheel tends to follow a straight line. This is why a cyclist can steer without using his hands. Exactly the same principle is used in the car. The front axle is "pitched" or tilted so as to throw the bottom of the steering-knuckle pin or king bolt forward, and thus cause its center line to strike the road ahead of the vertical axis of the wheel. Get your boy's bicycle and turn the front wheel to the right or left, then

back straight again, noticing how the front end of the machine acts. Turning the wheel actually raises the front of the machine slightly; it is the same in the car, and the weight of the body tends to bring the wheels back to the straight-ahead position. The amount of caster varies all the way from 2 to 14°, depending on the type of car.

All this is necessary in understanding the cause and cure of shimmy. There are, in general, two distinct types of shimmy; low and high speed. Low-speed shimmy generally occurs between 15 and 30 miles an hour, and is noticeable whenever the

car goes over rough pavements, uneven roads, or other surfaces that happen to have just the right characteristics to start the wheels shimmying. In these cases the motion is usually not very violent, and will, in nine cases out of ten, be found due to backlash or play somewhere in the steering-gear linkage. This, then, is the first place to look when your car starts shimmying at low speeds. Go over all the joints and knuckles in the linkage thoroughly, fitting new pins

wherever necessary. It is a good idea to check the adjustment of the front-wheel bearings also at the same time, and remedy any play that is found in them. Another simple cause of an annoying shimmy is too much lubrication of the springs. The springs need a certain amount of friction between the leaves, and if this is destroyed by too much oil or grease, the body may tend to "hop" or vibrate with the disturbance of the front wheels, and this aggravates the shimmy.

Shimmy at high speeds is a much more serious problem, partly because it is usually more violent and partly because a permanent cure is by no means so easy. The

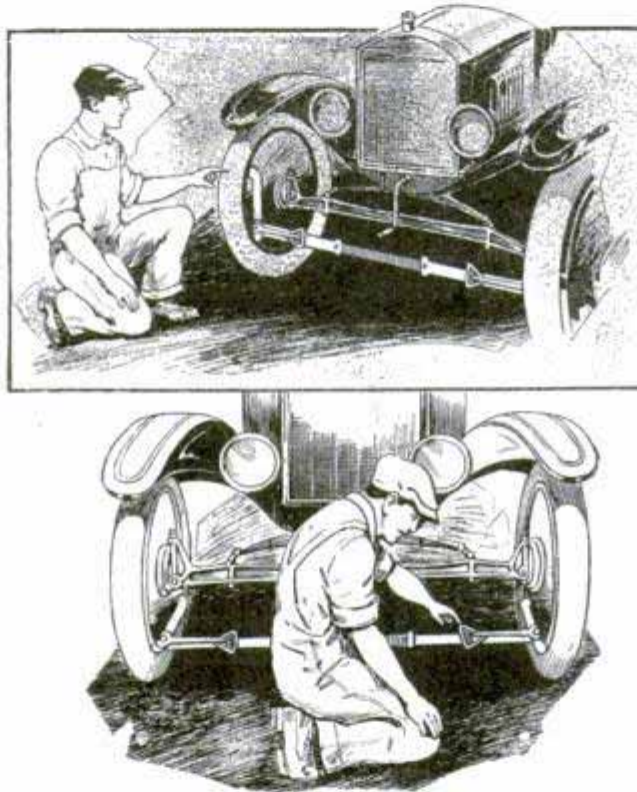

Above, Checking the Camber of the Wheels with Special Gauge; Below, Checking Toe-In

first remedy to apply is to watch the tire pressures closely. Balloon tires especially are sensitive to underinflation, but even high-pressure tires will cause a shimmy if they get very soft. So keep your tires at the pressure recommended by the maker of the car, even if it does involve checking two or three times a week, and see especially that the front-tire pressures are kept equal.

The next thing is to check the toe-in of the front wheels. Set the right front wheel straight ahead, then tie one end of a long, stout string to a spoke on the front of the wheel, pass it around the back of the forward part of the tire, then around the front and lead it back to the rear wheel, keeping it as near the center of the wheel as possible. Pass it across the back of the car, around the rear side of the left rear wheel, then forward to the left front wheel and make it fast temporarily. Go back to the right side and see that the right front wheel is pointed straight ahead. This will be seen if the string touches both sides of the tires on the right wheels equally. Now take the free end of the string, keeping it taut, and hold it so that it touches the rear side of the front tire, at the center. Measure the distance from the string to the front side of the tire, and this will give the toe-in. This may be adjusted by means of the cross steering rod or tie-rod, and the maker's specifications should be followed closely. There are special gauges made for checking the toe-in and camber, but the string method is a good one for you, provided care is taken.

If the axle is not properly pitched it can be remedied by using an iron wedge between the front spring and spring seat

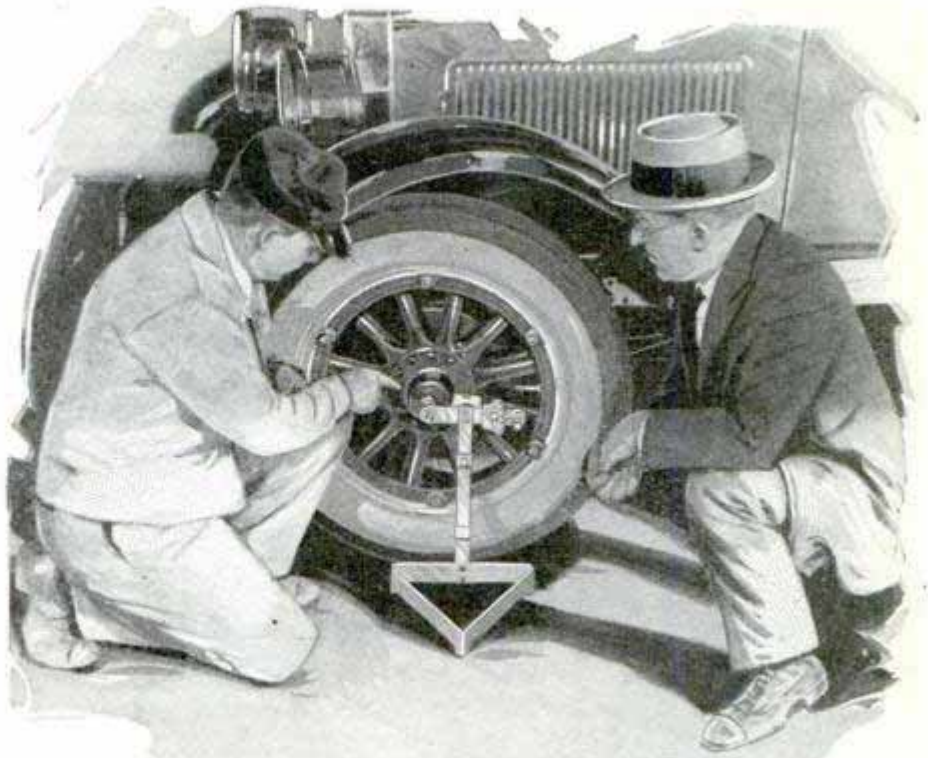

FIG. 3

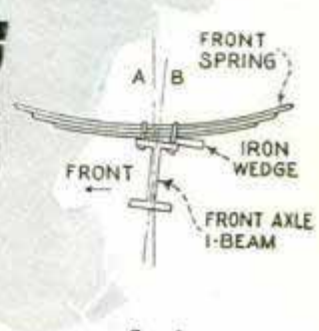

FIG. 4

Above, Gauge That Automatically Registers "Pitch" of Axle; Below, Diagrams Explaining Caster Effect

(Fig. 4). Since the amount of caster has been determined by experiment by the manufacturer and varies in almost every car, you will have to find out what yours should be before you can check it. A clever gauge is now being made that is attached to the front-wheel spindle and which, when the wheel is swung to the left and then to the right, automatically registers on a dial the amount of pitch on the front axle.

Balloon tires have caused much head-scratching on the shimmy problem. Many manufacturers have found it advisable to reduce the amount of toe-in to about $\frac{1}{8}$ in. and this puts the owner under the necessity of keeping very careful check, to see that play in the steering mechanism does not alter it. Another maker has found that reducing the amount of caster, and consequently causing the car to steer harder, tends to dampen out the wheel

wobble, and still another has found that, while wheels themselves are usually balanced, vulcanizing on tires or putting in heavy repair boots causes unbalance and induces shimmy.

The things to do, then, in a case of high-speed shimmy are: Keep the tires inflated to the proper pressure; keep the wheels in balance; keep the steering linkage free from play; check the toe-in of the front wheels and the pitch of the axle; keep the front-wheel bearings adjusted, and don't allow too much play in king bolts or bushings before replacing them.

Large Oil Tanks on Lanterns

One construction company, which has considerable road work to do, saved much

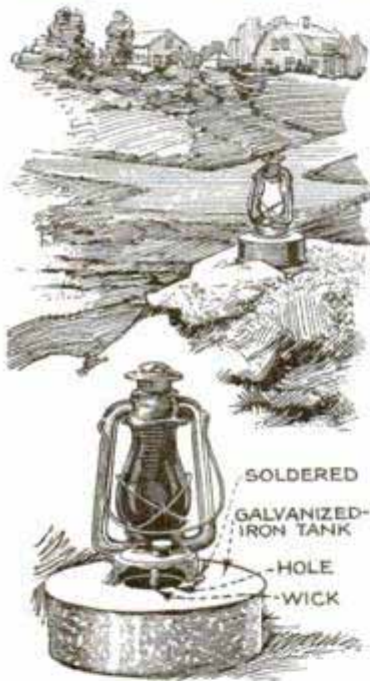

labor by providing the red lanterns with oil tanks of 1-gal. capacity so that they required attention only about once a week instead of daily. The tanks were made of galvanized iron, with a hole in the top slightly smaller than the bottom of the original reservoir, and the lanterns were soldered over

this hole after the bottom of the small tanks had been cut away. After putting in an extra-long wick, the lanterns were ready for use.

Enameling over Putty

Every one who has tried to put on white enamel over newly puttied holes has noticed how persistently the putty shows through the flat white coats. If, instead of regular putty, a thick paste made of white lead and ordinary flour is used, the filled holes will cover as readily as the wood. A child's box sled, finished in this way, has stood hard usage and all kinds of weather for over two years.

Cleans Typewriter Quickly

Typewriter operators find it a difficult matter to clean their machines, because the dust and dirt from erasures enter every crack and corner and often remain there until the machine is taken apart. However, there is a simple solution to this problem, if a bicycle pump is used in connection with the other cleaning tools. It is quite an easy matter to blow the dirt out with the pump. A stiff brush is commonly used to clean the type, but it will be found that, if the bristles are covered with a soft cloth, the work will be greatly simplified. The bristles merely stir up the oily dirt without removing it, but the cloth, backed by the stiff bristles, will make the type look like new. When the platen roll begins to look shabby and rough, it can be renewed by smoothing it with very fine sandpaper. Most typewriter rolls can be removed quickly and easily and it is then a simple matter to do this.

Rubber Stamp Attached to Thimble

In canning factories, cold-storage plants and other places, where numerical or other identification and grading stamps are used, the thimble stamp shown in the drawing will be found very useful. The small round rubber stamps are removed from the original wooden handles and are mounted on thimbles, the ends of which have been flattened for this purpose. The stamps are fastened with glue or rubber cement. The operator then

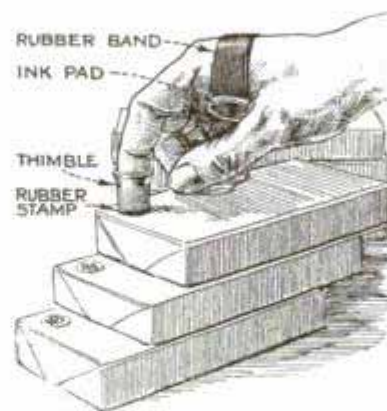

provides himself with a pad, strapped to the hand as shown, for inking the stamps. This is made from a cross section of an old

inner tube with the ink pad glued to it. With a little practice he can ink and stamp much more rapidly than in the usual manner, and both hands are practically free to move or turn boxes and crates.—G. E. Hendrickson, Argyle, Wis.

Remedy for Run-Down Pump

A pump that persists in "running down" can be remedied in a short time in the following way: Remove the leather check valve and cut a piece of rubber from an old inner tube, or piece of rubber-patching stock, the same size and shape as the worn-out flap; attach this on the underside of the flap with the screw already in the latter. Put the pump together again, and you will have no more trouble of this kind. The rubber is more flexible than the leather and will not allow sand to collect on it.—Clyde Brindel, Yorktown, Ind.

Markers for Centering Short Work

A method of marking off the centers of short round pieces which is quicker than any of the various tools generally used for this purpose, is shown in the drawing. The complete set-up comprises two lengths of straight, round rod, two thin tool-steel cutters or markers, and a couple of clamps of suitable design. Both markers are ground to a central sharp edge on one side, this edge being also slightly convex. In assembling, the markers are placed between the rods at each end and all are held together by the

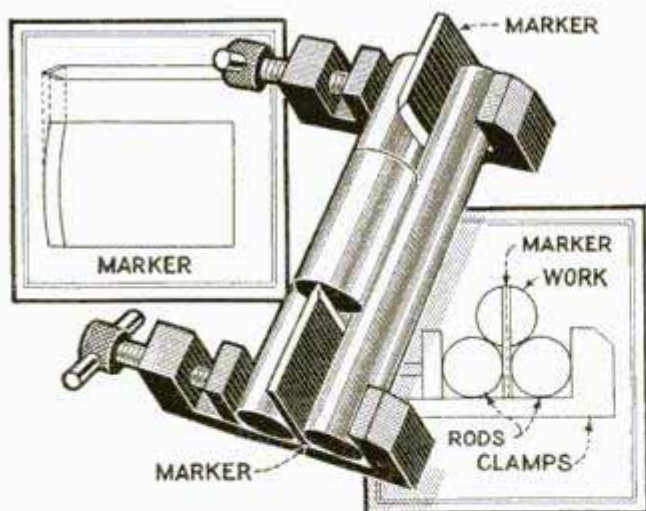

Handy Tool for Center Marking Short Round Stock Quickly and Conveniently

clamps. The piece of short stock is placed between the rods and driven sharply first against one and then against the other marker. After giving the piece a quarter turn the operation is repeated. Thus a cross mark is produced in each end and in practically the same time required to mark one end with the ordinary method.



Outside Hay Chute

For feeding cattle in the yard, the outside chute illustrated herewith, which was built by an Oklahoma farmer, will be found convenient. The barn had a haymow of average size. At one end, the yard came up to the barn and the owner wished to feed the outside stock direct from the haymow. To do this it was necessary to build a chute with a floor at a 30° angle. The chute is 10 ft. from the ground and consequently the hay falls well away from the barn.

To Strengthen a Magnet

A permanent U-magnet may be strengthened in the following way: Place a keeper of iron or steel on the side of the magnet, from pole to pole and as near its ends as possible. Lay the magnet, keeper side down, on the bench, with the ends projecting over the edge. Hold the magnet firmly in place and, with a hammer or like object, strike the keeper sharply to the floor. Turn the magnet over and repeat the process. Do this several times.—Dexter W. Allis, Everett, Mass.

Tattooing Hogs Is New Marking Method

AS the ballyhoo man at the circus might say, "Step right this way, ladies and gentlemen, and see the new curiosity, the tattooed hog—just discovered by

the device and the method of using it. The application of the marks causes no material pain or discomfort. "While the

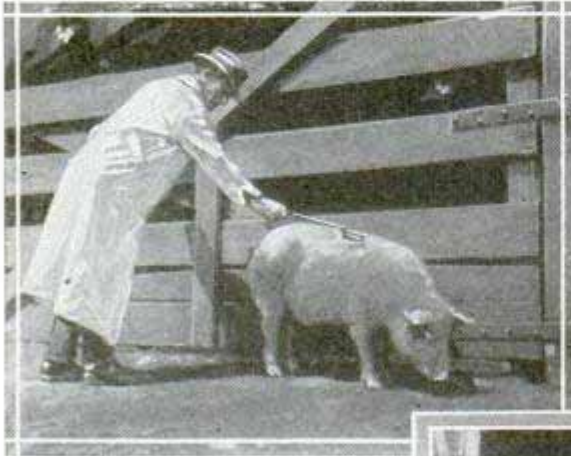

Upper Left, Tattooing the Hog; Necessary;

Below, How Blocks

science." And while the subject of tattooing hogs may be new now, it probably will be so familiar within a few years as to be accepted as a matter of common procedure. Tattooing hogs, as conducted experimentally by scientists of the federal bureau of animal industry during the last five years, is a promising means of tracing tuberculosis, hog cholera and other ailments of swine to lurking sources of infection. Instead of fighting these microscopic foes in the dark, as one might say, the tattoo method of marking hogs enables one to determine just where the diseases have their strongholds.

The new method, in keeping with modern times, speeds up the process. The work must be done quickly to be practical, so the method provides for applying a full set of tattoo marks at one stroke of the marker and takes only a second. The instrument used in tattooing is a metal holder slotted to receive babbitt-metal blocks in which, when molten, phonograph needles are imbedded. The needles may be arranged to form figures, letters or other symbols. The blocks can be used in any desired combination, so it is possible to obtain a great variety of characters. The illustrations show the appearance of

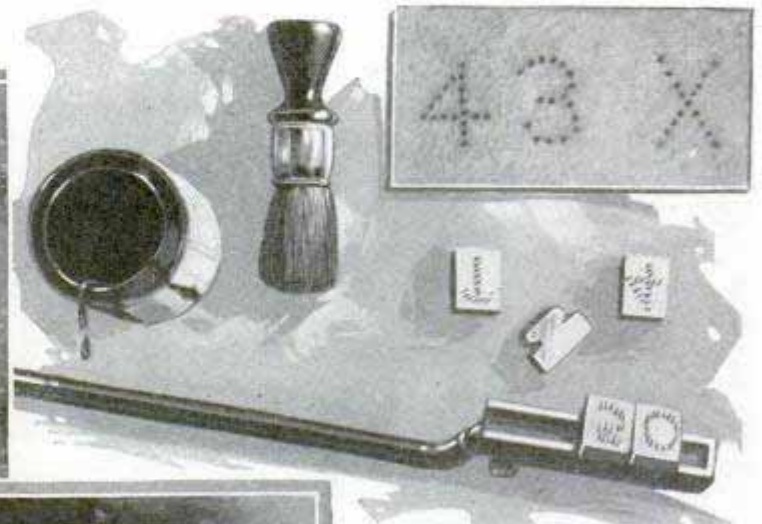

Upper Right, the Materials Necessary; Below, How Blocks

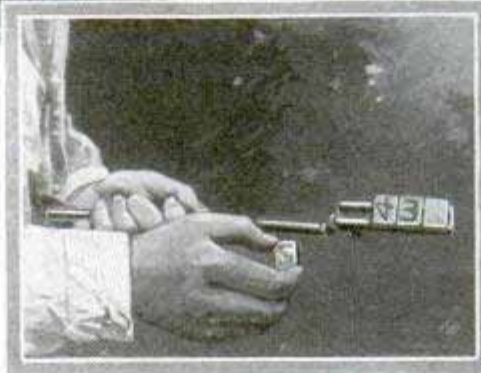

hogs sometimes grunt or hump their backs," Dr. Murray, the inventor, states, "very few squeal, and that is generally from excitement. An animal near a hog that

is tattooed is just as likely to squeal as the one marked." This comment is based on experimental work with about eight thousand head.

The pigment found to be best adapted for the work is ordinary black automobile enamel, preferably a thick, sticky grade. It is applied to the points of the tattoo instrument with a small brush, a stencil brush being especially good for the purpose. The mark should be applied on the shoulder or fore part of the back. In that part of the body there is nearly always a thick layer of fat free from nerve ends and as the points are only a quarter of an inch long, the hog scarcely notices the operation. When a hog is tattooed in the manner described, the numbers or symbols used are plainly visible on the dressed carcass, even months afterward. Extensive inquiry among various branches of the live stock trade has failed to show any objections to the tattoo marks on carcasses. It is advisable, however, not to tattoo hogs on the hams. In developing the method, the investigators found that hogs could be

successfully tattooed also without any pigment provided the animals were slaughtered within the next 36 hours.

This phase of the work has a very practical application when hogs are shipped for immediate slaughter. The marks in that case are pink, due to slight capillary hemorrhages, instead of black which is the obvious result when the black pigment is used in the manner formerly described. Of course, the ability to tattoo hogs without any pigment greatly hastens and simplifies the work. But, as already implied, the mark in that case lasts only a short time unless the hog is slaughtered. Persons familiar with packing-house procedure know that hog carcasses receive very rigorous treatment, including immersion in the scalding vat and later under the beaters and scrapers which remove the hair. That is why a good tattoo mark, being below the surface of the skin proves satisfactory, while tags, paint marks, chalk and similar marking devices are undependable under packing-house conditions.

The principal use for the device appears to be systematic disease-control work, as conducted by state organizations and the U. S. department of agriculture. In this connection the tattoo method is sponsored by the federal bureau of animal industry, which about 15 years ago gave the swine industry the preventive serum treatment for hog cholera and more lately has been responsible for administering the nationwide campaign to eradicate tuberculosis. The bureau also conducts federal meat inspection and has charge of suppressing such plagues as foot-and-mouth disease. With such an organization actively interested, stock owners are assured that the use of the tattoo device will mean prompt and systematic action in getting the greatest benefits from it. The device can be made and used by anyone.

☛ In a loose-pin hinge, the pin often will work up and out. Removing it and driving it in from the bottom, will save trouble.

Depth Gauge for Sawing

There are many instances when the woodworker has to have a depth gauge and a miter box is too small. An easily

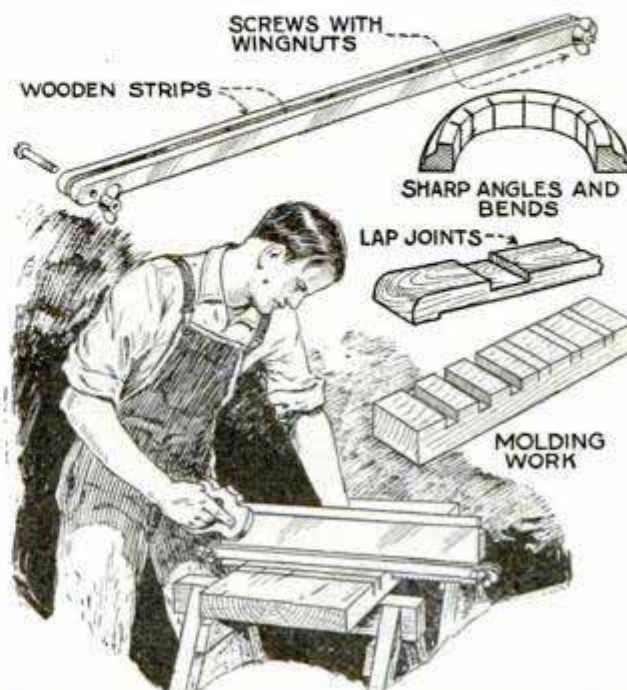

Useful and Easily Made Depth Gauge for Work Too Large for a Miter Box

made depth gauge is shown in the accompanying illustration. It consists of two wooden strips, about 2 in. longer than the saw and drilled at both ends for screws and thumbnuts. The strips are attached to the saw as shown, so that it will cut to the desired depth, then tightened again.

Converting Driveways into Walks

The accompanying photo shows how a western city changes its driveways into walks when the pedestrian traffic becomes more important than the vehicular. Iron posts, about 3 in. in diameter and painted white, were set across the roadway at intervals of 3 ft. The white paint makes them stand out against the dark road, at night as well as in the daytime, thus showing that the way is blocked, while the spacing permits the pedestrian to pass through easily.

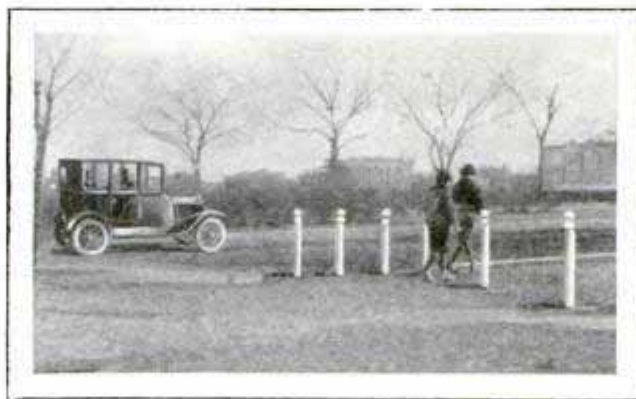

White-Painted Posts on Driveway in a Western City Insure Safety for Pedestrians

DOING YOUR OWN CONDUIT WORK

by
E.R.Haas

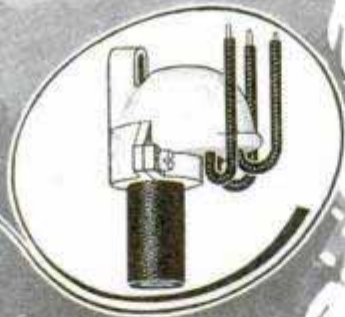
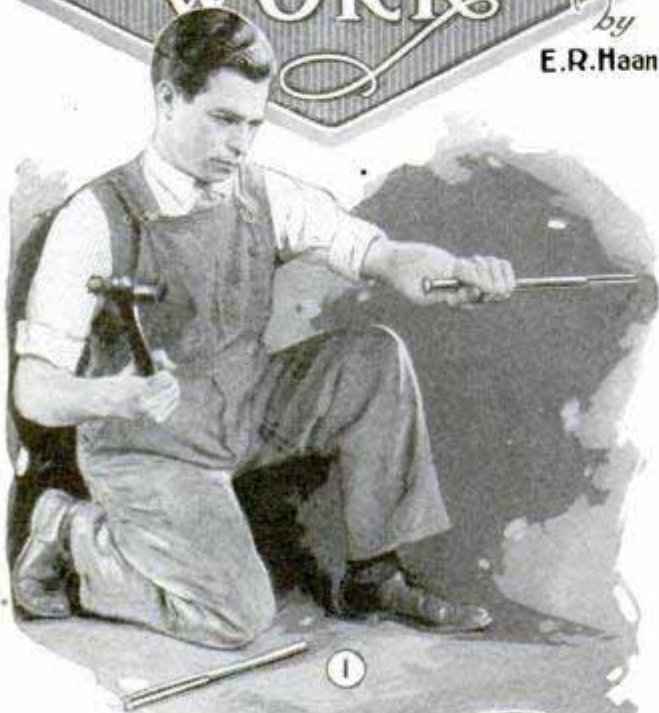

WHERE wiring has to be done in damp places such as basements or outdoors along the sides of buildings it is advisable to use rigid metal conduit, which protects the wires from mechanical injury and reduces the possibility of short circuits or grounds. This method of installation is especially recommended for service lines so that they can be run along the outside of the building as shown in Fig. 2. We have previously shown other methods of service-line installation where conduit is not available, but the conduit method is far superior and should be followed if possible. The fittings used are shown in the details. Ordinary pipe clamps are used to hold the conduit securely to the wall. In case of brick or concrete walls these clamps are screwed into wooden plugs driven into small holes made in the concrete. A pipe cap of the type shown, or any other kind which will not permit water to get into the pipe, is fitted at the top. At the bottom the conduit can be bent to a right angle or an L-fitting can be used as shown. Any electrical store and many hardware stores in the smaller towns handle conduit of the $\frac{1}{2}$ and $\frac{3}{4}$ -in. sizes which are most commonly used. Conduit is either lined or unlined. Lined conduit has a paper tube inside, treated with an asphaltic or similar compound and unlined conduit does not have this. Single-braided conductors can be installed in the former but double-braided conductors must be used for the latter. Where conduit is to be brought through a brick or concrete

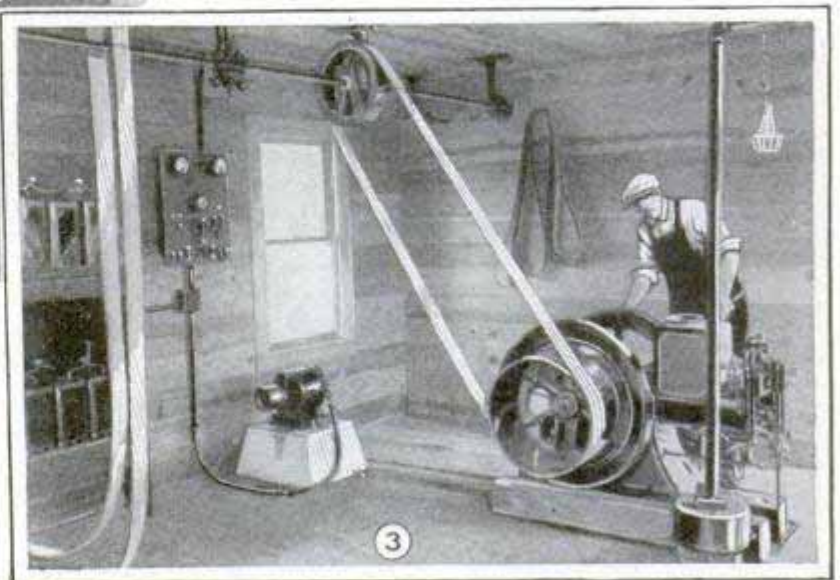

wall a star drill, obtainable at any tool store, should be used to make a hole as shown in Fig. 1. The length of conduit is measured, cut off, threaded and bent if necessary.

Bending is accomplished in different ways, Fig. 4 showing how a "hickey" is used for this purpose. This tool merely consists of a 4-ft. length of 1-in. pipe with a tee screwed on one end. It is advisable to make one before starting the work of installing the conduit as it will be necessary to use it constantly. This tool is used by placing the conduit on the floor and slipping the tee over the end. The worker then places one foot on the conduit close to the tee and pushes down on the handle. Care should be taken to move the tee to different points while bending to prevent the conduit from buckling. Other methods of bending conduit are shown in Figs. 6 and 7, the latter being especially adapted to bending heavy conduit, as a considerable leverage is obtained with this arrangement. When bending conduit one should always take care not to make the bends too sharp or the conduit may buckle, which will make it useless, as the wires cannot be run through it.

After the conduit has been completely installed, the wires are pulled through. This is done with the aid of a "fish" wire, a length of flexible wire, which can readily be pushed through the conduit. One

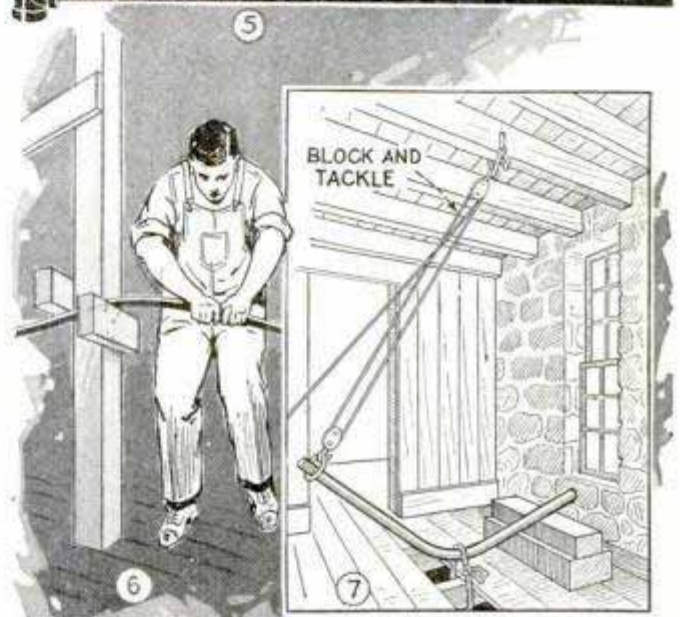

METHODS OF BENDING CONDUIT

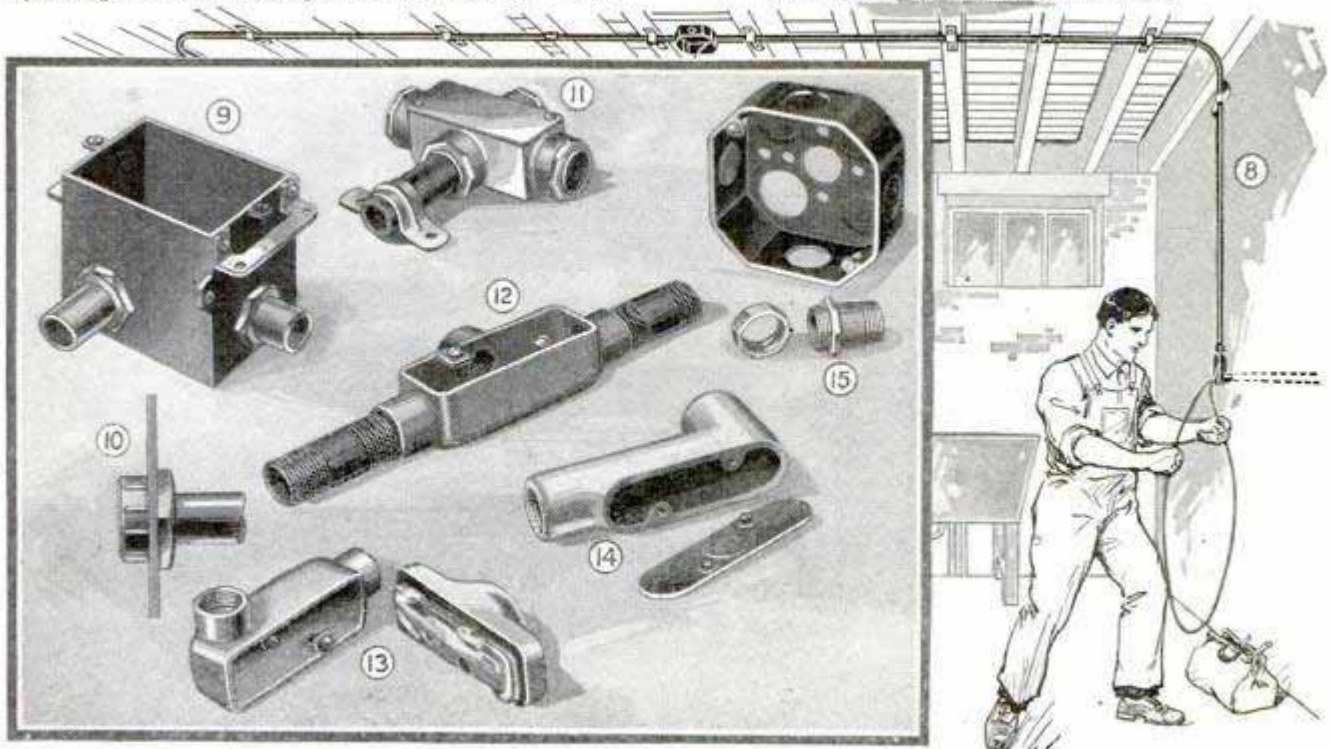

end has a hook formed so that the bared ends of the wires can be attached and pulled through. Do not attempt to pull the wires through the conduit separately but pull them through together. It will be found, especially during hot weather, that the wires are apt to stick in the conduit. To reduce this friction to a minimum, dust soapstone on the wires, or if this is not available use ordinary flour.

Conduit usually comes in 10-ft. lengths, threaded at both ends. Do not attempt to fit a coupling between two 10-ft. lengths because it will be too hard to pull the wires through a 20-ft. length of conduit. Always screw in a special fitting with a removable cover of the types shown in Figs. 11, 12, 13 and 14. This enables the worker to pull the wire through the 10-ft. lengths separately and he can also tap off for other outlets by using a 4-outlet fitting shown in Fig. 11 or a 3-outlet fitting as shown in Fig. 12. Fig. 13 shows a fitting having a porcelain cover for a drop light, in cases of open-conduit work, and Fig. 14 shows an L-fitting. In Fig. 8 the worker has pulled the wire from the ceiling outlet to the L-fitting, where the conduit projects through the concrete wall, and he is pushing the wire through the horizontal length of conduit.

Fig. 9 shows a switchbox to which the conduit is screwed by means of two nuts as shown in the detail Fig. 10. A ceiling outlet, having a number of perforations, which can be easily punched out to accommodate the conduit on any side, is shown in Fig. 15. A neat conduit job in a farm workshop, equipped with a lighting plant is shown in Fig. 3.

Bell Alarm on Scales

When using scales to sack vegetables or grains to a uniform weight one may

find he has not adequate light, as in a granary or cellar. It is a strain on the eyes to be watching the beam of the scales when nearing the predetermined weight. With a doorbell and a dry cell, wired as shown in the detail, an automatic alarm is made, which notifies the worker the moment the required weight is reached. Attach a length of bell wire to one post of the dry cell and to the iron crossbar above the weight end of the beam, another wire to the other terminal of the dry cell and to one post of the bell and a third wire

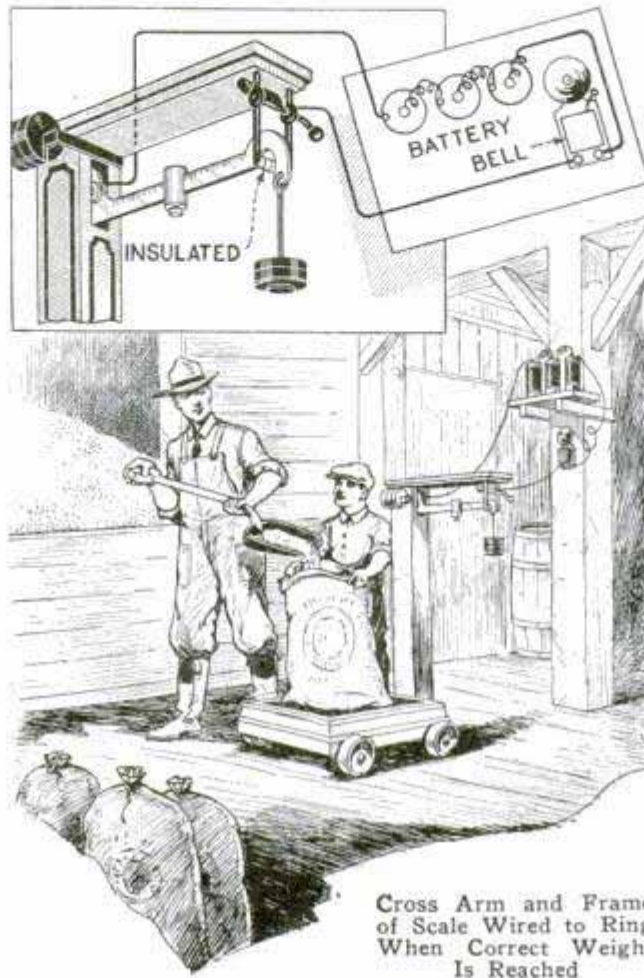

from the other post of the bell to one of the bearings that support the beam of the scale. The iron crossbar below the weight end of the beam, on which the beam normally rests, must be insulated from the beam. A wrapping of paper or tire tape will serve this purpose. The sliding weight is set at the number of pounds desired in the sacks or crates. When the weight that the scales are set for is reached the beam will rise and make contact with the crossbar above and ring the bell. When the full sack or crate is removed the beam drops to the insulated crossbar and breaks the circuit.

Test for Leaky Tire Valves

A common method of testing tire valves for leakage is to hold the stem in a can of water, with the wheel turned to bring the valve stem to the upper side. If the car is standing in a poorly lighted garage, or one

of the angle valves or disk wheels is being used, this is difficult to do. A better plan, in this case, is to turn the wheel until the valve is at the top, in the case of ordinary straight valves, put a few drops of water in the small valve cap and turn it back in place. Any air leakage past the small cap will be shown by a sputter that can be heard several feet away from the valve. Often the sound will be irregular. The air leaking past the valve inside builds up pressure until a defective valve cap will no longer hold it, when it escapes with a hiss. After the test has been made, remove the cap and shake out the water.

Record Form for Checking Pipe Fittings

Here is an ingenious and simple method of keeping a record of pipe fittings, which was developed in a large eastern engineering company's shop. Where reducing tees have three different sizes of openings, as often happens, the problem of recording these openings in an orderly manner was always more or less difficult. The accompanying reproduction of a blank used by this engineering concern shows how easily it can be done. Reducing el-

REDUCING TEES						
NO.						
T						
REDUCING ELBOWS						
NO.						
90°						
NO.						
	45°					

Blank Used by Engineering Company for Recording Pipe Fittings

bows and return bends can be checked or recorded on the same blank. The blank tells the whole story without the necessity of explanatory remarks such as are often found written on records pertaining to fittings of this character.

Countersinking Machine for Drilling Brake Lining

In a San Francisco auto-repair shop an old drill press has been used

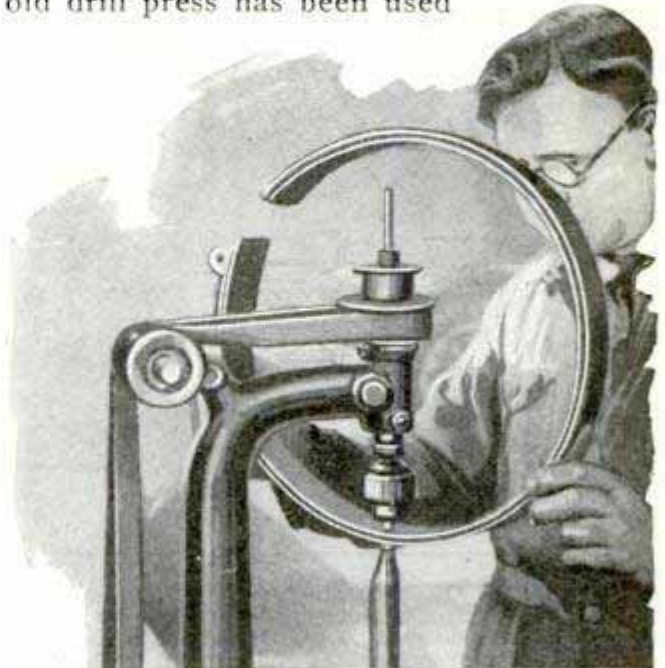

Homemade Machine for Drilling and Countersinking Rivet Holes in Auto Brake Bands

in building a brake-lining countersinking machine at a saving of \$85. The countersinking tool is put in the chuck and the guide arm is clamped in place on the drill table, the plate being operated by a foot lever, leaving both hands of the operator free to handle the work. In operation, the brake band is held over the guide and the lever pressed down, which lowers the drill. This drills and countersinks the lining in one operation. There is a shoulder on the tool, which prevents it from drilling too far. After drilling and countersinking, the rivets are placed in the holes and clinched by a foot-operated rivet machine.—C. W. Geiger, San Francisco, Calif.

Starting Gasoline Blowtorch

When starting a gasoline blowtorch, it is customary to place the hand over the nozzle to catch the fine stream of gasoline and direct it down to the generating pan. Of course, there will be gasoline left on the user's hands after doing this, and if a match is used to light the torch the gas on the hand may become ignited. The user must be careful to hold the match in the other hand while lighting the torch, or use a cork of the proper size in the nozzle of the torch to deflect the gasoline.

1943

Is This Your Home?

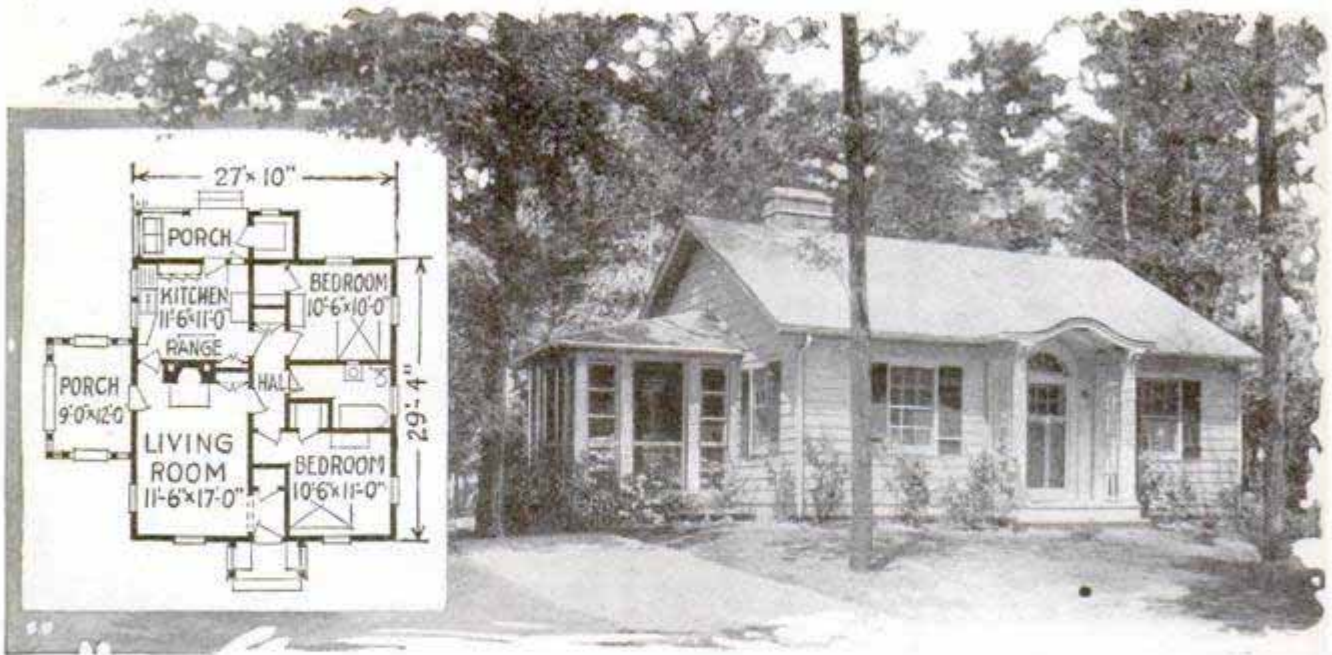

Copyright, Architects' Small House Service Bureau

Plan No. 4A9

QUESTIONS regarding home building addressed to this magazine will be answered by The Architects' Small House Service Bureau of the United States, Inc., controlled by the American Institute of Architects and endorsed by the United States Chamber of Commerce. Inclose 10c and self-addressed envelope. Blueprints, specifications and material list for the house shown here may be obtained at nominal cost. Inclose self-addressed stamped envelope for reply. If further information is desired, send 5c and stamped envelope for a 24-page booklet explaining how the Small House Service Bureau functions and showing 12 sample plans. A new booklet, entitled "Fifty Ways to Lower Home Building Costs," illustrated by ten bureau houses actually lived in, and showing how as much as \$1,000 can be saved on a home, may be obtained for 20 cents.

IN this delightful colonial bungalow, you have an excellent example of the theory that a small, inexpensive home can be as attractive and comfortable as a larger, more expensive dwelling. It has neither cellar nor second story. Louvers in the gables give the roof ventilation so that the rooms beneath can be kept cool in hot weather. The exterior is finished in wide siding on frame construction. All windows have double-hung sash and solid shutters. The entrance is through a graceful latticed porch on which side benches are attractive features.

Probably the most attractive feature of this plan is an open porch of generous dimensions placed at the side where it has privacy. This has particular advantage in that it offers an outdoor dining room since it is conveniently located with respect to the kitchen.

By a slight change in the plan, which would not increase the cost of the house,

the porch could be shifted far enough to the rear to give it two doors, one opening into the kitchen and the other into the living room. It could then be inclosed with casement windows and converted into an all-year-around dining room.

The living room is a generously proportioned, attractively arranged room. A fireplace gives an opportunity to warm the house on chilly days and forms at the same time the principal feature of the room. It has a mantel of a simple and pleasing colonial design. At the right of the fireplace is a built-in bookcase.

The kitchen arrangement is excellent. The space for the refrigerator is provided with a door so that it can be iced from the outside. There is also a broom closet, built in back of the bookcase in the living room. The back porch has laundry tubs at one end and a good-sized storage room at the other. The lot size required would be 45 to 50 feet.

IN accordance with the editorial policy of this magazine never to accept compensation in any form for what appears in our reading pages, and also to avoid the appearance of doing so, we are obliged to omit the name of the maker or the seller of any article described. This information, however, is kept on file and will be furnished free, by addressing Bureau of Information, Popular Mechanics Magazine, Chicago. [Editor.]

Whets Your Appetite for Boring Holes

The charm which this wonderful "Yankee" Ratchet Brace has for mechanics is easily understood. It has a silent smoothness of action to which they have not been accustomed.

For No. 2100 is made and finished like a precision tool. The famous "Yankee" Ratchet works like the stem-wind of a watch.

And the new "Yankee" Chuck is the most efficient ever made. Ball bearing, quick centering, and accurate. Slip into it any shape bit (round, square, any taper) and the bit is held in a vise-like grip. Yet chuck releases bit at a turn of wrist.

Handles are hard rubber and indestructible.

Finished beautifully in keeping with its perfect mechanism.

Some Other "Yankee" Tools

Ratchet Breast and Hand Drills
Ratchet Screw-drivers
Automatic Feed Bench Drills

Push Braces
Automatic Push Drills
Vises, Removable Base

Dealers Everywhere

Sell "Yankee" Tools

FREE Tool Book

Here's a mighty interesting little Book for you. It shows all "Yankee" Tools and their operation. Write for your copy today.

"Yankee" on the tool you buy means the utmost in quality, efficiency and durability



NORTH BROS. MFG. Co., Philadelphia, U. S. A.

"YANKEE" TOOLS

Make Better mechanics

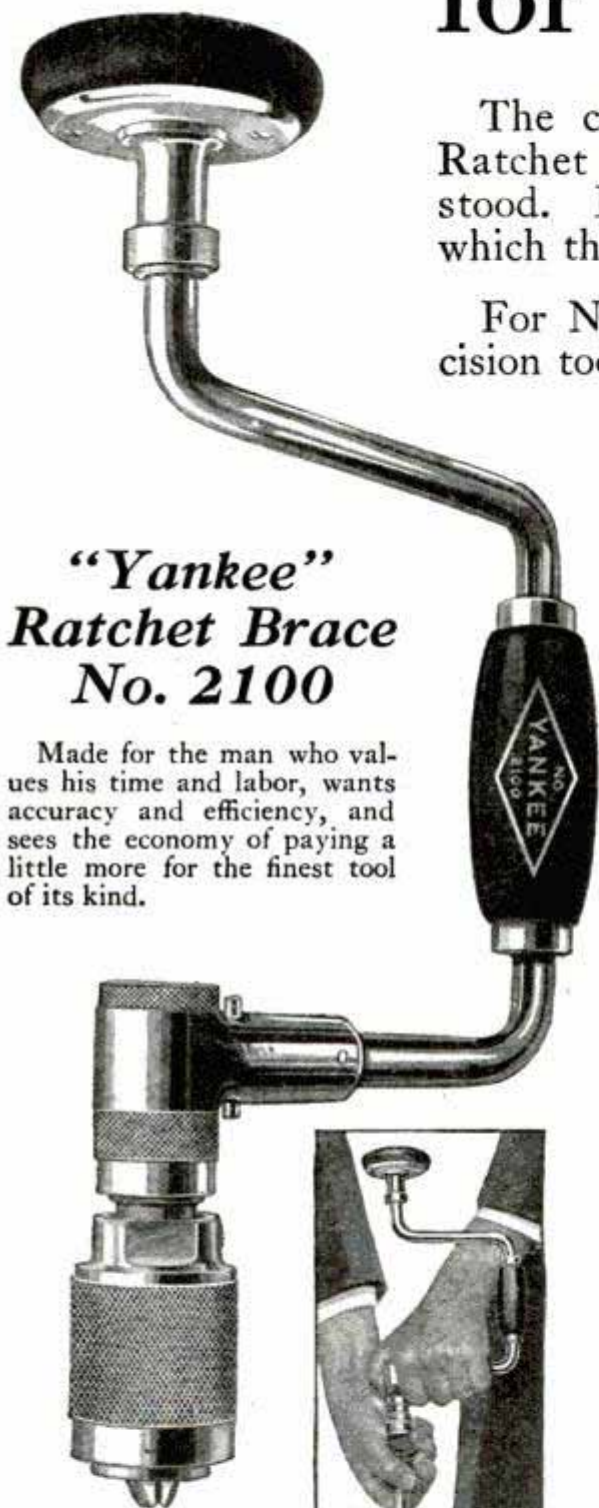

"Yankee" Ratchet Brace No. 2100

Made for the man who values his time and labor, wants accuracy and efficiency, and sees the economy of paying a little more for the finest tool of its kind.

Try
This Test
Yourself

Put Auger Bit into chuck of "Yankee" Brace. Bore deep into tough wood. Then pull upward with all your strength. Bit will not come out of chuck.

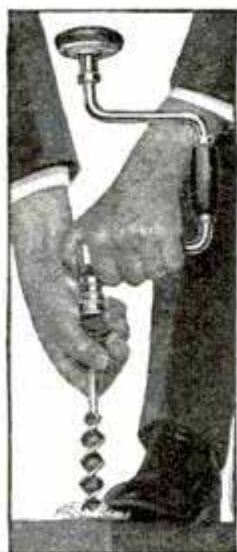

Joining the wires in a great trunk nerve between New York and Chicago

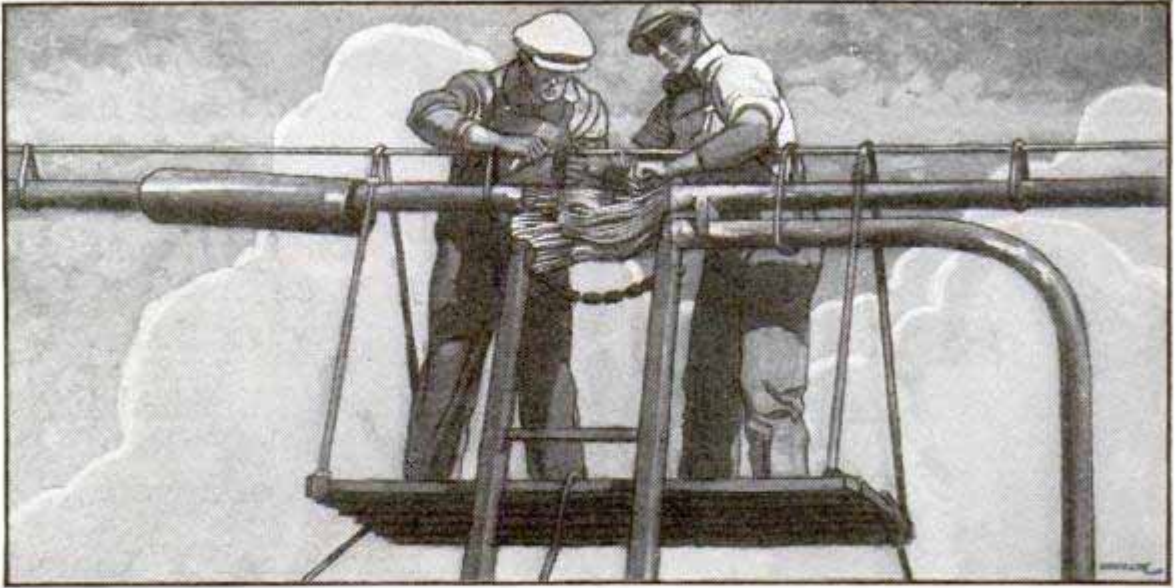

The Nerves of a Nation

THE magnitude of our present system of telephone communication was beyond the thoughts of men fifty years ago. While at that time Bell, the inventor, had a prophetic vision of places and houses and factories connected by telephone, even he could not have foreseen the American city of skyscrapers with more telephones in one building than are to be found in many a foreign country.

The massed multitudes of the modern city can no longer be served by wires strung in the air. We now have telephone cables

no bigger than a man's wrist, each containing 2400 thread-like wires, carrying beneath the city streets their millions of spoken messages. Long distance cables overhead and underground connect cities with one another by storm-proof conductors, now being extended into a country-wide network.

At the present time nine-tenths of the 45,000,000 miles of telephone wire in the Bell System are in cable. The service of each telephone user has become more and more reliable with the extension of this cable construction.

AMERICAN TELEPHONE AND TELEGRAPH COMPANY
AND ASSOCIATED COMPANIES

BELL



SYSTEM

IN ITS SEMI-CENTENNIAL YEAR THE BELL SYSTEM LOOKS FORWARD TO CONTINUED PROGRESS IN TELEPHONE COMMUNICATION

One Dollar

TAKE a look at Dollar Topkis — the biggest dollar's worth.

Here are fabrics like those in high-price makes; and in wide variety.

Here is Topkis individual tailoring, generous full size, comfort-fit.

Made by Topkis for active bustling men. Reinforced at every strain point. Dandy pearl buttons. Strong buttonholes, rugged seams.

The greatest value in men's apparel — the Topkis Union Suit, at your dealer's, One Dollar.

Men's Shirts and Drawers,
Boys' and Children's Union
Suits, 75c each. In Canada,
Men's Union Suits, \$1.50.

TOPKIS BROTHERS COMPANY
Wilmington, Delaware
General Sales Offices:
93 Worth St., at Broadway, New York

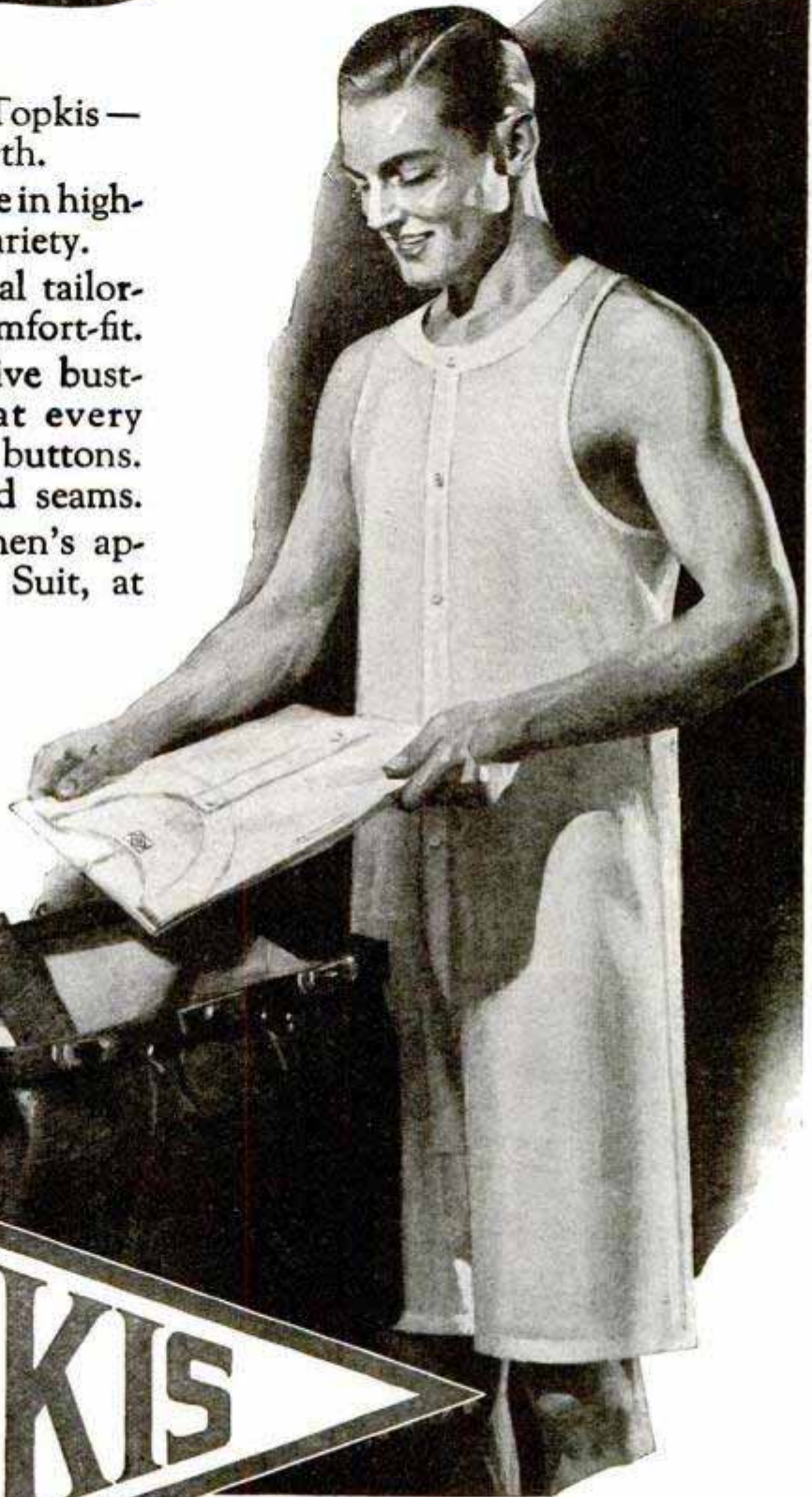

Flatlock Seam,
at waistline,
made by nine
needles, forms
strongest part
of the garment.

TOPKIS

Athletic

Underwear

AT THE TOP OF UNDERWEAR FAME STANDS THE TOPKIS NAME

Over 400 Tons of Metal Rising Like a Mammoth Toy!

*-To Good Tools it Owe its Ease of Operation
and Apparent Lightness*

Three short blasts from the ship's whistle—the rumble of gears in the bridge house—and, in less than one minute, the huge bridge smoothly lifts itself clear of the channel.

In bridge construction the smallest details must be planned and executed with extreme care. Upon the accuracy of its many members, depends the success of the completed bridge. On work of this kind where accuracy is important, you will always find Brown & Sharpe Tools at work proving their High Quality.

Ask your dealer for Small Tool Catalog No. 30 listing over 2300 Brown & Sharpe Tools. If he cannot supply you, write to us direct.

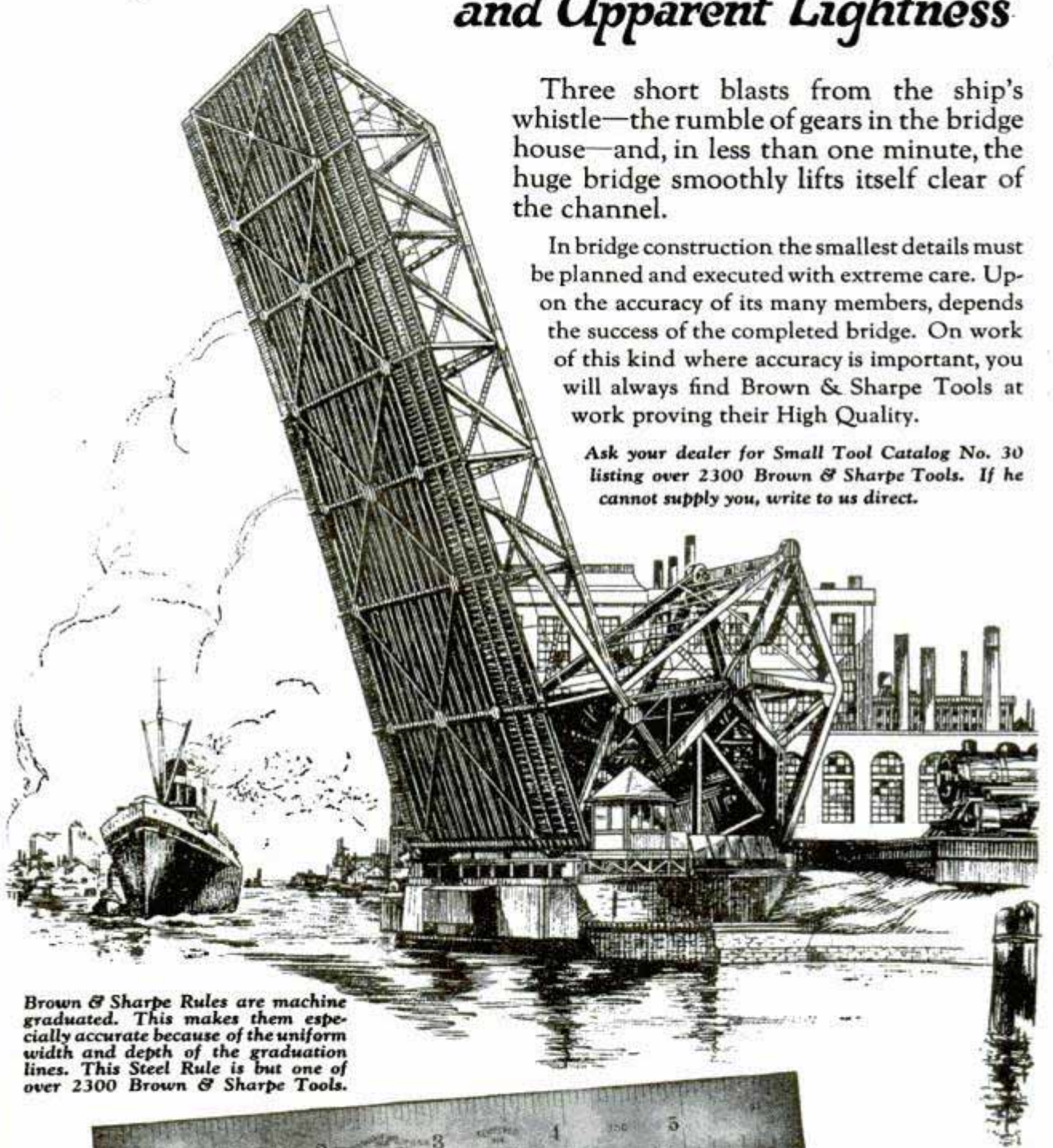

Brown & Sharpe Rules are machine graduated. This makes them especially accurate because of the uniform width and depth of the graduation lines. This Steel Rule is but one of over 2300 Brown & Sharpe Tools.



BROWN & SHARPE TOOLS

BROWN & SHARPE MFG. CO., Providence, R. I., U. S. A.

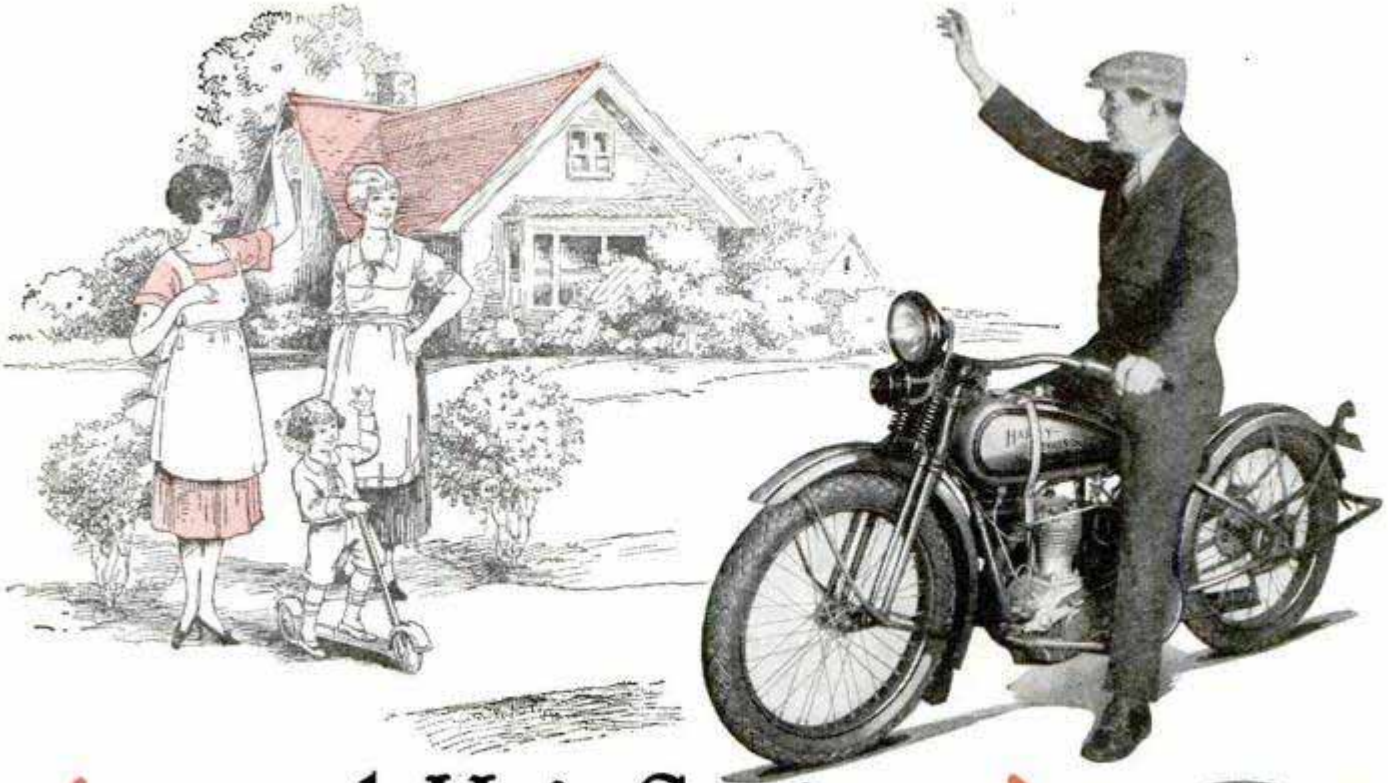

—and He's Saving 6 Cents Every Mile!

RIDING the new Harley-Davidson Single costs *seven times less* than driving a low-priced automobile. Only one cent per mile!

A gallon of gasoline carries you 80 miles—a gallon of oil 800 miles—a pair of low-cost tires 10,000-12,000 miles. Almost no garage expense—any 2 x 8 foot space will house or park your Single.

Easier to ride and control than a bicycle—safe. Almost self-balancing, with simple controls, and *instinctive steering*.

See your Dealer today—and mail Coupon for full details.

HARLEY-DAVIDSON MOTOR COMPANY
Dept. P. Milwaukee, Wis.

The HARLEY-DAVIDSON [New-Type Motorcycle] Single



mail **Now**



Easy to buy—your Dealer offers a convenient Pay-As-You-Ride Plan, and the price of the Single, complete with built-in electric equipment, f. o. b. Milwaukee, is only

\$235

HARLEY-DAVIDSON MOTOR CO.
Dept. P. Milwaukee, Wis.

Interested in your Single; send catalog and Dealer's Name.
 Interested in your Dealer proposition. Is my territory open?

Name _____
Address _____

You'll be proud to own both

SARGENT planes will contribute not only to the pride you take in owning and using good tools—but to the improvement of your work as well. These are good planes—two of the finest money will buy. And the two which will fill practically every need you will ever have for finishing tools. Yet they are not expensive by any means—costing less than you would expect to pay for such planes.

Get them without delay.

You'll be more than pleased with the way they cut, with their simplicity of adjustment, and with their edge-holding cutters of durable chromium steel. Sargent Auto-Set has an exclusive feature—time and trouble saving—which your hardware dealer will be glad to show you. The steel block plane is the handiest little plane you ever saw. Look for the Sargent trade-mark. It is a guarantee of excellence and long life in planes.

SARGENT & CO., *Manufacturers*, 49 Water St., New Haven, Conn.

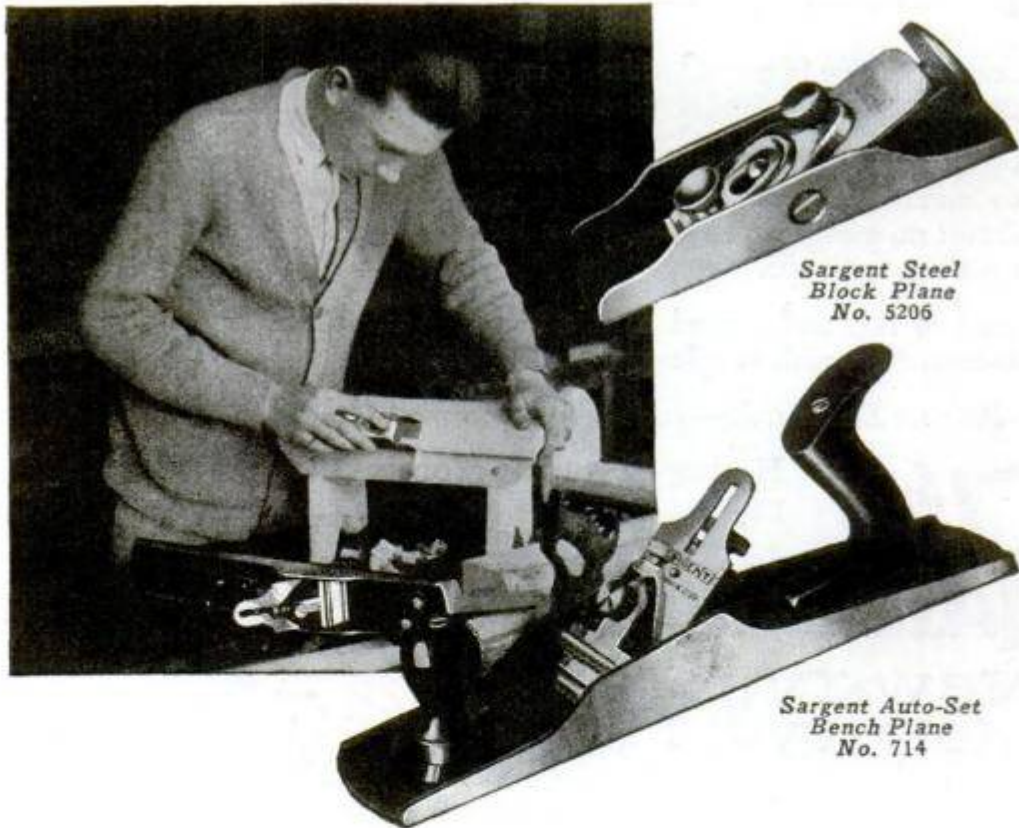

SARGENT

PLANES

In every
summer sport—
you'll be sure-footed
in KEDS

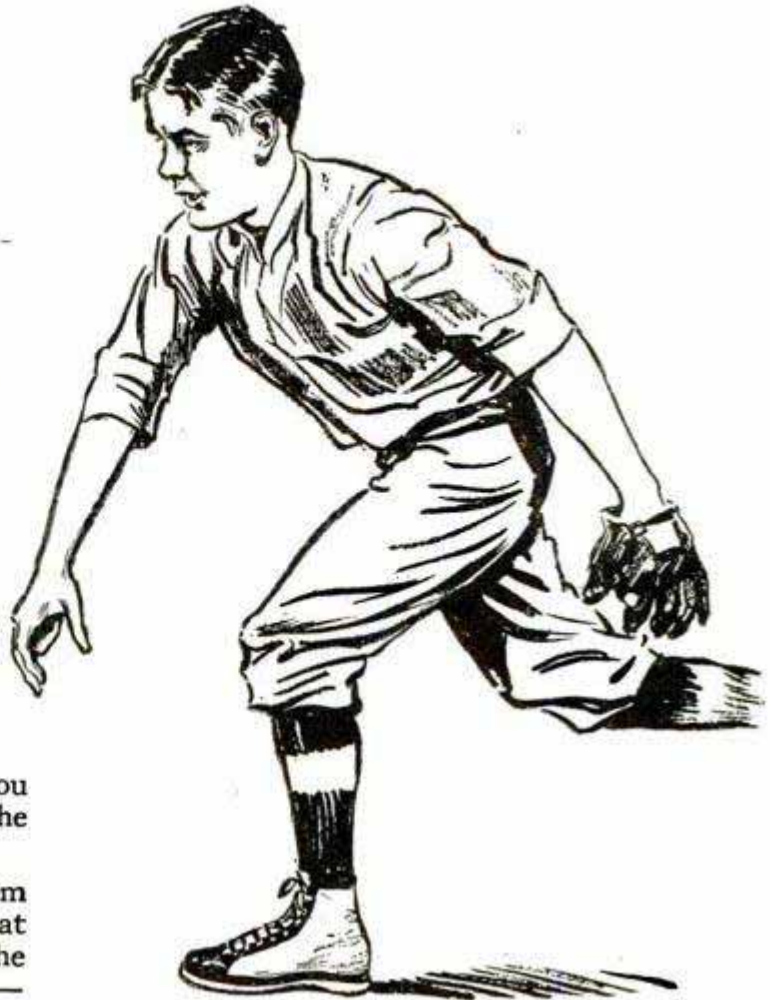

QUICK, sure footwork—that's what you need in baseball, handball, tennis—all the summer sports. And you'll get it in *Keds*.

It's because these wonderful shoes make them quick and sure of foot that nearly all the great athletes wear *Keds*. Last year alone (1925) the winners of 21 national tennis championships—and a long list of great champions in other sports—played in *Keds*.

And millions of boys everywhere find *Keds* the best of all canvas rubber-soled shoes for all sports use and for everyday wear.

Playing games—hiking on holiday trails—climbing—scrambling through underbrush or sailing—you get real foot-freedom in *Keds*.

You will like their live, springy, sure-gripping soles—their strong canvas uppers that support the ankles—their special Feltex innersoles that help to keep the feet cool even on hottest days—and their snug fit that gives foot comfort all day long.

Your dealer either has genuine *Keds* or can get

them for you. Look for the *name Keds* on the shoe.

Keds come in high and low models—plain and athletic-trimmed—with plain, corrugated and vulcanized crepe rubber soles. Prices from \$1.25 to \$4.50. *Keds* are made only by United States Rubber Company.

Our 1926 *Keds Hand-book of Sports* contains all kinds of information on games, sports, camping, vacation suggestions and dozens of other interesting subjects. Sent free if you address Dept. 1570, 1790 Broadway, New York City.

United States Rubber Company

Keds

Trademark Reg. U. S. Pat. Off.

THE "CONQUEST"

A *Keds* model made in white with black trim or brown with gray trim, both with vulcanized crepe rubber soles.



THE "SPORTSTER"

A sturdy athletic-trim *Keds* model—built for the hardest wear. Comes in white with black trim or brown with gray trim. Gray corrugated soles.



*They are not Keds unless
the name Keds is on the shoe*

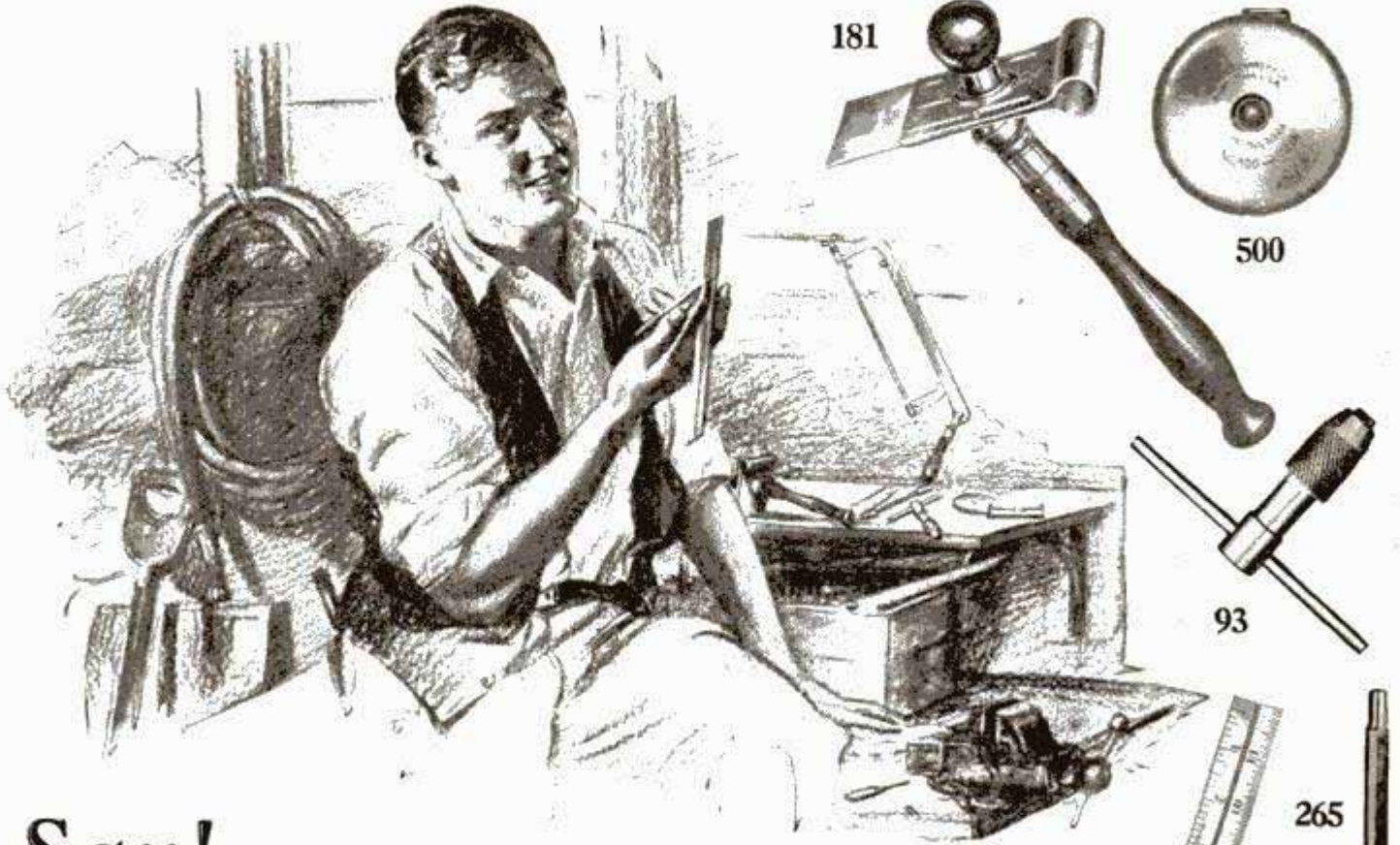

Say! Here's a handy handful

"If I didn't have 'em in my chest, there's a lot of little jobs around the place that never would be done.

"There's the No. 94 Combination Square. That's seven tools all by itself—a square, plumb and level, height, depth and marking gage, miter and rule.

"There's the No. 152 Hacksaw Frame. The adjustable handle—sets in 13 different positions—makes that a lot different from most Hacksaw frames.

"And, there's the No. 500 Steel Tape, the No. 108 Aluminum Line Level, the No. 560 Insu-

lated Handle Pocket Screw Driver—greatest thing on the light circuits you ever saw—the No. 181 Cabinet Scraper, the No. 93 T Handle Tap Wrench—best little tool in the world for hand taps, small drills, reamers, etc.—the No. 195 Double-lip Countersink, and the No. 265 Nail Sets—made square so they won't roll. That last is quite an item, too."

Send for free copy of Catalog No. 23 "AP."

THE L. S. STARRETT CO.
World's Greatest Toolmakers
 Manufacturers of Hacksaws Unexcelled
 Steel Tapes—Standard for Accuracy
 ATHOL, MASS.

9309

Use Starrett Tools





WM. C. KOBIN

who, by developing one of America's greatest mercantile successes, has made it possible for thousands of others to enjoy positive business independence without one cent of investment.

I have a plan which I would like to explain to 100 men who have hoped some day to have a business of their own. No investment required ~ ~ more than a permanent income assured. If you are interested, just fill in and mail the coupon below.

Wm. C. Kobin

WM. C. KOBIN,
600-724 N. Noble Street, Indianapolis, Ind.

PM 1

I feel sure that I could succeed in a business of my own. I understand you have a plan which requires no investment, and I would like to be one of the 100 men to be considered for it.

Name _____

Address _____

City and State _____

Who wouldn't?

FOR THAT perfect "balance" of fine Turkish and American tobaccos, that extra delicacy of taste and aroma which are Fatima's and Fatima's alone—who wouldn't pay a few cents more?

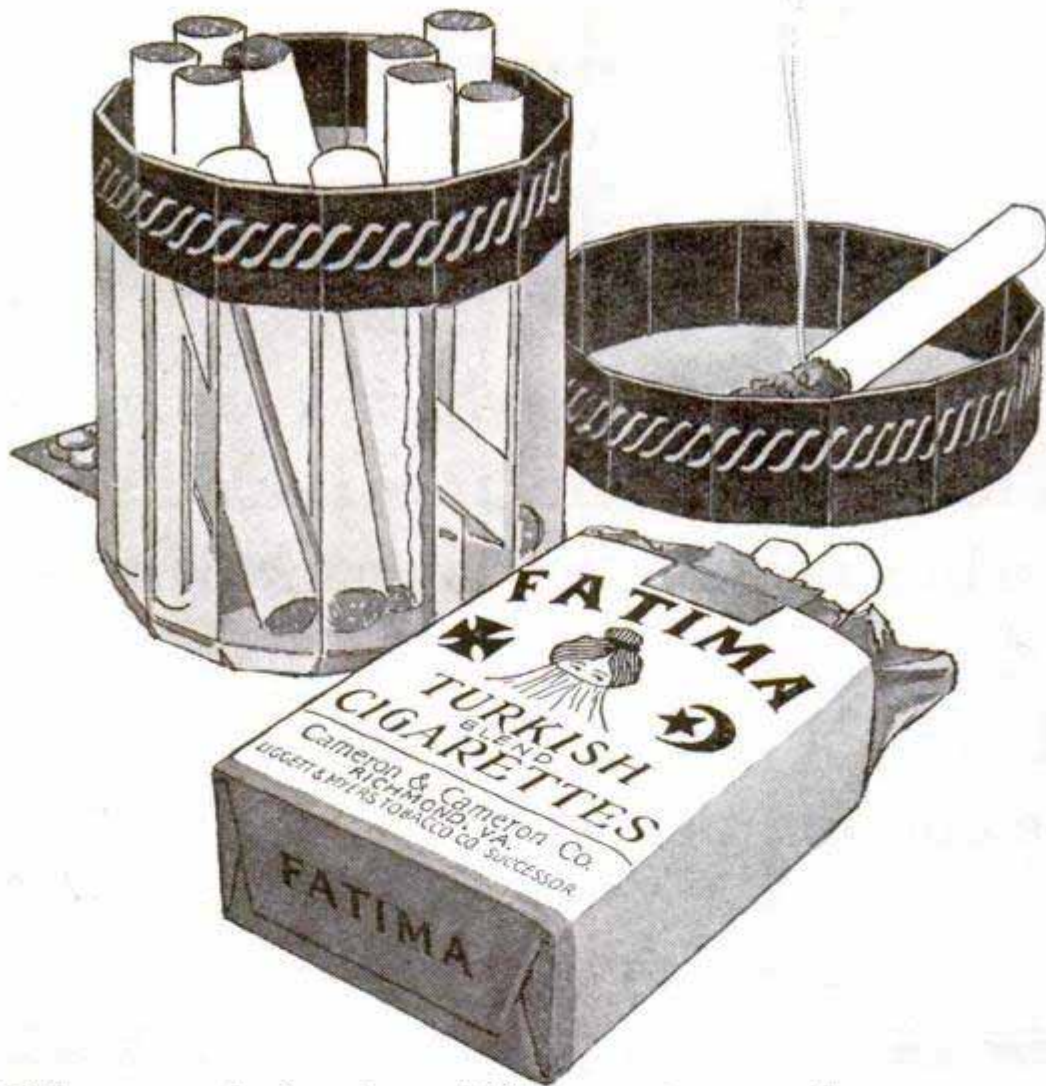

What a whale of a difference just a few cents make



*Buy separately
or in assortments*

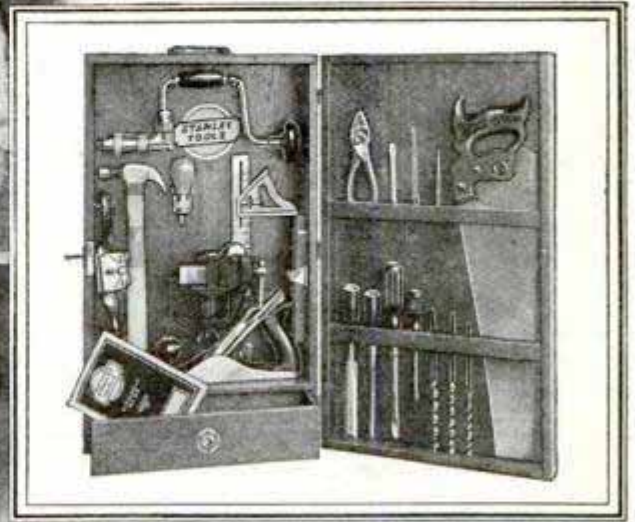

Is there a breakfast nook in your home?

NO wonder so many homes now have breakfast nooks. They save lots of work and add to the enjoyment of breakfast. It's not difficult to construct a little breakfast nook, yourself. You can also make your own work bench, porch swing, or bookcase. You can do scores of repair jobs around home. And among the pleasures of life there are not many which are greater than the satisfaction of making things with your own hands.

For satisfactory work you must have good tools. There are no better tools than Stanley Tools. Carpenters everywhere use Stanley Tools and Stanley Tools are used in manual training classes from coast to coast.

You can buy Stanley Tools separately and so collect your own set. For your convenience in buying, there are also sets of Stanley Tools at a wide variety of prices. In chests: from No. 904 containing 12 Stanley Tools at \$15, to No. 850 containing 49 Stanley Tools at \$95. Or there are assortments in strong cardboard boxes with simple directions in each for making your own chest. Prices \$5 to \$20.



Ask your hardware dealer to show you the line of Stanley Tools. Send for our Catalogue No. 34 which describes Stanley Tools both separately and in assortments. Address: The Stanley Works, New Britain, Conn.

The best tools are the cheapest to use
Ask your hardware dealer

STANLEY TOOLS

THE MOST COMPLETE LINE

Happy Faces

Men tell us this makes
shaving a morning joy



Please accept a full 10-day tube of this olive-oil-containing shaving cream that corrects 5 mistakes of old-type shaving soaps

GENTLEMEN:—Here's a shaving cream made by experts in skin care that softens the toughest beard in one minute, that leaves the skin as soft and fine as if a lotion had been used. It ends the use of lotions, as unnecessary.

May we send you a tube to try? We worked some 18 months perfecting it. Made up and discarded 130 different formulas before we found the right one. It excels in many ways any shaving soap you have ever tried.

Five mistakes corrected

1. *Lather too scanty.* Palmolive Shaving Cream multiplies itself in lather 250 times. A tiny bit, just one-half gram, suffices for a shave.
2. *Slow action.* Palmolive Shaving Cream acts in one minute. Within that time the beard absorbs 15% of water. And that makes a hard beard wax-like, soft.
3. *Dries on face.* The lather of Palmolive Shaving Cream maintains its creamy fullness for ten minutes on the face.
4. *Hairs lie down.* That is due to weak bubbles. Strong bubbles are essential to support the hairs for cutting. Palmolive bubbles are strong . . . they hold the hairs erect for the razor.
5. *Skin irritation.* The palm and olive oil content of Palmolive Shaving Cream leaves the face in fine condition. Men like the after-effects.

Let us prove this

We ask your permission to prove these things—to send you a tube to try.

Will you do us the kindness to mail this coupon?—for your sake and for ours.

THE PALMOLIVE CO. (Del. Corp.), CHICAGO, ILL. 3343

10 SHAVES FREE and a can of Palmolive After Shaving Talc

Simply insert your name and address and mail to Dept. B-1223, The Palmolive Company (Del. Corp.), 3702 Iron Street, Chicago, Ill.
Residents of Wisconsin should address The Palmolive Company (Wis. Corp.), Milwaukee, Wis.

Please print your name and address clearly

SPECIAL SUMMER RADIO BARGAIN BULLETIN FREE



Just off the press! Our Special 1926 Summer Bargain Bulletin. Lowest prices on parts, accessories, kits and sets—standard apparatus only. Just drop us a line—do it today!

DEPT. PM

CHICAGO SALVAGE STOCK STORES

509 S. State Street CHICAGO, U. S. A.

REFINISH YOUR CAR FOR \$2.00

A "New" Auto for 200 Cents
Latest invention—"Speed Auto Finish" puts actual glass-like lustre into old enamel. Your car looks like it just came from the factory. No polish, no paint. Applied with cloth in fifteen minutes; stone dry in two hours. Nothing like it, in stores.

ANYONE CAN DO IT

No brush, no rub, no muss. Brightness lasts many weeks, then becomes part of original finish. SEND \$2 for one-car quantity, under rigid guarantee of money back at once if not all we say.

B. B. SPECIALTIES, 331 E. Walnut, Philadelphia.
Wonderful opportunity for men with cars to represent us. Exclusive territory both consumers and dealers. Super-liberal commissions. Write.

30 Days' Free Trial

Select from 44 Styles, colors and sizes, famous Ranger bicycles. Delivered free on approval, express prepaid, at Factory Prices. You can easily save \$10 to \$25 on your bicycle. Prices \$21.50 and up. \$5 a Month on any Ranger if desired. Parents can easily earn small monthly payments. Pay as you ride. Best quality, at factory prices, express prepaid. Lamps, wheels and equipment, low prices. Send No Money, do business direct with makers.



Mead CYCLE COMPANY
DEPT. R- CHICAGO
109

Write today for free Ranger Catalog, factory prices and marvelous easy payment terms



Real MOVIES

—Make them yourself with
VICAM Standard
MOVIE CAMERA

Camera, Tripod, Projector and 2 Magazines Complete outfit for taking and showing standard size pictures. Equal to biggest cameras. Loads in daylight. Projects on wall or sheet.

\$37

Send 10c in Stamps for illustrated BOOKLET
VICAM PHOTO APPLIANCE CORPORATION
1224 Belmont Avenue, PHILADELPHIA

21 Jewel
Santa Fe Special
on credit

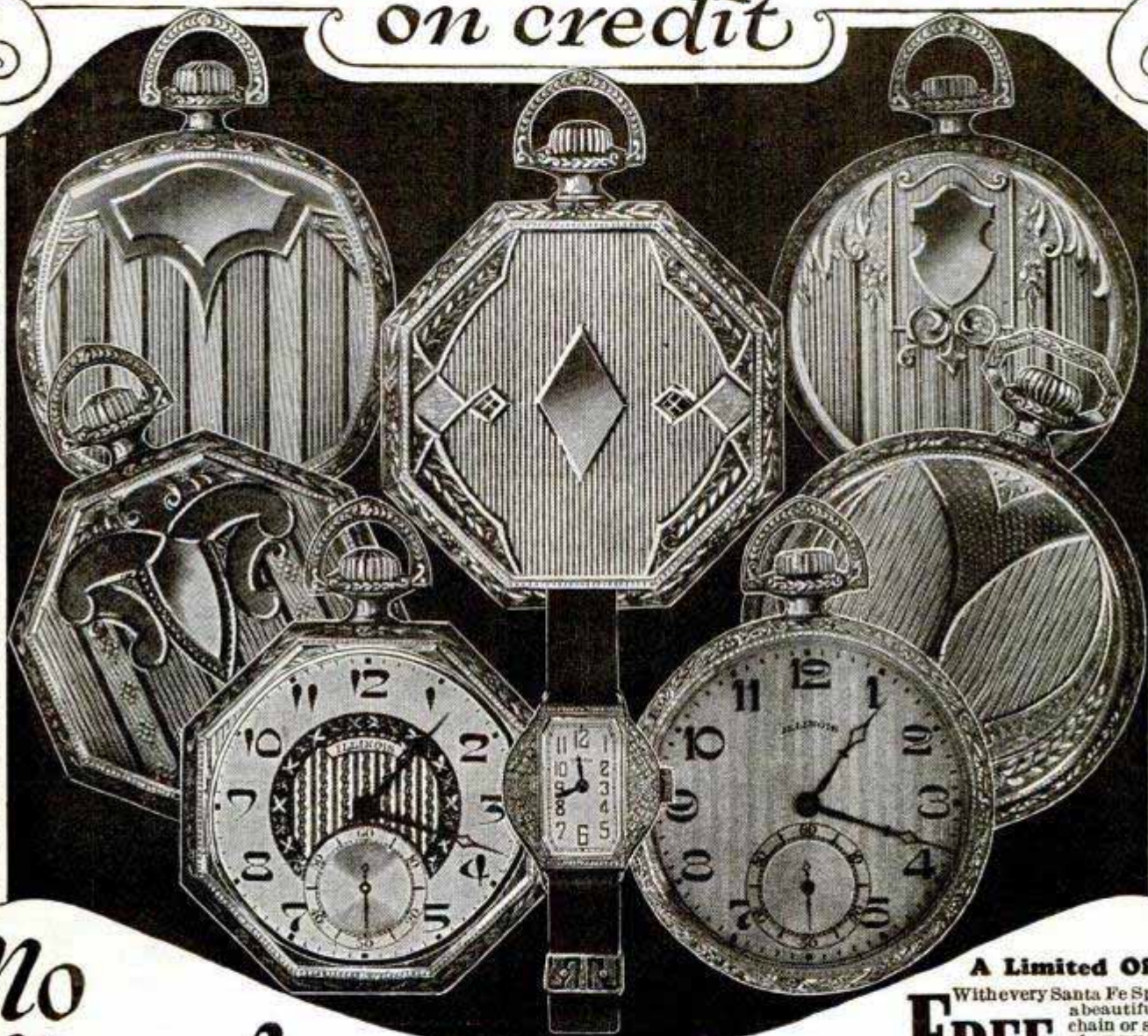

**No
 Money
 Down**

A Limited Offer!
 With every Santa Fe Special,
 a beautiful gold
FREE chain or strand
 of exquisite
 pearls. Write
 while offer lasts.

WE will send this famous watch direct to you, express prepaid, on **FREE** Approval. Examine watch and be convinced it's the best watch buy you ever saw. You save $\frac{1}{3}$ to $\frac{1}{2}$ your money by purchasing a Santa Fe Special Watch. We trust you—wear watch while paying for it.

Mail Coupon for FREE Watch Book →

Clip the coupon, fill out and receive the **FREE WATCH BOOK**. All the newest watch case designs in white or green gold, fancy shapes and thin models, are shown. Read our easy payment offer. Select the watch you would like to see; we will send it to you on approval, express prepaid. Wear the watch 30 days **FREE**. Return at our expense if not fully satisfied.

SANTA FE WATCH COMPANY

86 Thomas Building Topeka, Kansas
The Home of the Great Santa Fe Railway

SANTA FE WATCH CO.
 86 Thomas Building
 Topeka, Kansas

Please send prepaid and without obligation your Watch Book Free, explaining your "No Money Down" Offer on the Santa Fe Special Watch.

Name.....

Address.....

BURGESS FLASHLIGHTS & BATTERIES



SOMETHING to remember is that any good flashlight case practically never wears out. Filled with a Burgess Flashlight Battery, you have done about all that you can to insure yourself against the inconvenience and danger always present in darkness. Burgess Flashlight Uni-Cels will fit any case you may have. Try them—no better batteries are made.

A Laboratory Product

BURGESS BATTERY COMPANY
GENERAL SALES OFFICE: CHICAGO

*Canadian Factories and Offices:
Niagara Falls and Winnipeg*





**Anybody
Can Use
It**

KESTER READY TO USE METAL MENDER

The Household Solder

Here's why thousands use Kester Metal Mender. **Simple**—Requires Only Heat! Anyone can use it. **Safe**—No messy pots or dangerous acids. **Sure**—Genuine Solder makes firm metal joints. **Satisfactory**—Works equally well on light or heavy, old or new work. **Economical**—Saves many times its price.

Your Dealer Can Supply You

Soldering Booklet
"It's a Cinch to Solder"
Upon Request



CHICAGO SOLDER COMPANY
4201-383 Wrightwood Ave., Chicago, U.S.A.

SENT ANYWHERE ON 10 DAYS FREE TRIAL

5 TUBE GUARANTEED RADIO

**BIG POWERFUL
MIRACO ultra 5**

Users everywhere report it gets programs coast to coast, Canada to Gulf, loud and clear on speaker; outperforms \$100 to \$250 sets. Many hear Europe. Marvelous value. Let users' testimony convince you. Retail \$59.50

FACTORY PRICES—SAVE 1/3 TO 1/2. Smaller Sets \$13.75 up, retail. FREE! Literature on latest 1 to 5 tube models, new low prices and SPECIAL OFFER! Write! **(Agents & Dealers)**

MIRACO RADIO GETS 'EM COAST & COAST

MIDWEST RADIO CORPORATION
Pioneer Builders of Sets
407-B-E 8th St., Cincinnati, Ohio



ALL-AMERICAN
TRADE MARK

Pioneers in the Radio Industry

Balkite Radio Power Units
Manufactured by
FANSTEEL PRODUCTS CO., Inc.
North Chicago, Illinois

RADIO LATEST CATALOG OF NEWEST PARTS AND KITS **FREE**
Fresh from the press. Shows all the newest standard parts and kits at big savings. Most complete line in America.
Send name and address, also name of friend. Send at once.
BARAWIK COMPANY, CHICAGO, ILL.

AGENTS—\$100 to \$200⁰⁰

Selling Super Built \$13.50 Suits. Rendell made 31 sales in five days. Profit \$111.00. It's easy. We show you how.

YOU GET YOUR PAY EVERY DAY

If you have an ounce of ambition and want to make money write for free samples.

CHICAGO SUPER BUILT GARMENT CO., Inc.
Desk 1A, 416 So. Dearborn St. Chicago, Illinois



Own a Typewriter !

A Bargain You Can't Ignore!
Try It Free, and See!



GET YOUR typewriter now. A genuine Shipman-Ward rebuilt Underwood is the one you want—"the machine you will eventually buy!" Everyone needs it; now anyone can afford it. Don't send a cent—but do get our big special offer—our valuable book on typewriters and typewriting—free. You can learn to write on this standard-keyboard machine in one day. A

week after the expressman has brought it, you'd feel *lost* without it. A trial will *prove* it—and doesn't cost you a penny!

A New Plan

Our rebuilt plan gives you the *best* machine and saves you a *lot* of money.

The Underwood is so famous a make, and No. 5 so popular a model, you'll have to speak up if you want one of the lot we are just completing now!

We rebuild from top to bottom; *replace every single worn part*; each machine is in *sparkling* condition. New typewriters are commonly guaranteed for a year; we guarantee these completely rebuilt Underwoods *five years*: That's our *Better-Than-New Guarantee!* And we guarantee a big saving in money!

We don't ask for a cent now. Nor any money at all, unless you are completely won by the wonderful writing machine we ship you for an unrestricted 10-day free trial. When you do buy, take advantage of our very liberal scale of monthly payments. A host of our patrons have paid for their typewriters out of money made typing for others. (One woman made a *thousand dollars* at home last year with her Underwood.)

Free Trial Offer

If you know typewriters, you know the perfect work and the ease and speed of an Underwood. If you have never owned a typewriter, start with the finest! You can try this one at our risk. But, the time to act is NOW. Don't miss out on this present bargain offer. Don't



This is a
Genuine
UNDERWOOD

*
The ace of
All Writing
Machines!



* **Act NOW If • Ever !** *

FREE!

do longer without the convenience of a typewriter.

Our plan gives you the opportunity of a *thorough trial* before you buy. You run no risk whatever. You start to pay for your typewriter *after* you have found it the one and only machine for you! But get the facts before this lot of machines is all in use. Clip the information coupon before you turn the page. It will pay you! Note the very useful book you will receive free! Write for full particulars at once.

Get our catalog that tells how we rebuild these wonderful Underwood typewriters in the largest factory of its kind in the world, and lowest prices and terms in existence. We will also include free, the new Type Writing Manual—it gives many examples of uses for your typewriter: in business accounts, social correspondence, recipes, shopping lists, household accounts, etc.; school work, literary work, etc. Clip coupon now!



Mail to SHIPMAN-WARD MFG. CO.
C212 Shipman Building, Chicago

Please send me full offer, with Type Writing Manual FREE, prices, terms, etc., and full information about your FREE course in Touch Typewriting. All without obligation; this is NOT an order!

Name.....

Street.....

P. O.....

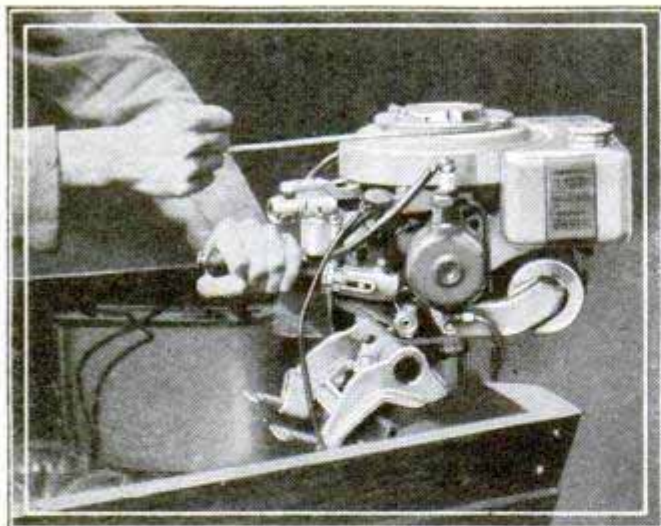

Quick Starting ~as sure as your car

NOW Evinrude has adopted the same type ignition that Ford uses on motor cars. High tension jump spark. Standard dry cell battery current is transformed into secondary current of 13,000 volts.

Start motor on battery current if you wish. Simple push plug—no terminals or clips. Switch from battery to magneto as easily as you plug in your radio loud speaker, without misfiring. Brilliant electric light furnished by magneto while running, by battery when motor is stopped. Entire equipment waterproof.

This is only one of the twelve new refinements which make the Evinrude the preferred outboard motor. There are included Self-Steering—Extra Power—Electric Light—30% Hotter Spark—Improved Tilt-Up—Tiller and Rope

Steering—Shear-off Pin Compartment—Improved cooling—Leather Tiller Handle—New Locking Device—New Carburetor.

Don't fail to see this motor at the Evinrude dealer's. It represents the maximum in outboard motor construction.

There is only one Evinrude Motor Co. Don't be confused by any other use of this name.

EVINRUDE MOTOR CO.

521 Evinrude Bldg.
Milwaukee, Wisconsin

DISTRIBUTORS:

115 East 23rd St., New York, N. Y.
259 Atlantic Ave., Boston, Mass.
117-119 Broadway, Oakland, Calif.
211 Morrison St., Portland, Oregon
79 Columbia St., Seattle, Wash.

The New 1926 Champion EVINRUDE Sport Twin

You can be a MAGICIAN

Give shows Earn big money

Stage regular performances that will entertain your friends and give you extra money. Large catalog sent containing all information about the latest Tricks, Wigs, Handcuffs, Mail Bag, Straitjacket, Milk Can, Mind Reading, Tricks with coins, cards, cigarettes, cigars, hats, match boxes, glasses, chemical tricks, parlor and stage tricks, spirit tricks, tricks suitable for both amateur and professional, and loads of other mystery.

Send 20c now for this beautiful catalog and you will receive your personal copy by return mail.

Sent FREE—Large die box with \$25 order

OAKS MAGICAL CO.
Dept. 400 Oshkosh, Wis.

WRITE
for big book
on wrestling.
Tells secrets
you've al-
ways wanted
to know.



Learn How to WRESTLE

In Your Own Home
By Mail

Yes, learn to become an expert wrestler right in your own home, by mail, from the greatest wrestlers the world has ever known. Be an athlete, be strong, be healthy. Learn how to throw and handle big men with ease. Learn to defend yourself. Learn from the World's Champions.

Farmer Burns and Frank Gotch Secrets

Farmer Burns, who taught Frank Gotch—trainer of SEVEN World's Champions, will teach you Scientific Wrestling—Physical Culture—Jiu-Jitsu and Self-Defense. Write today for big wrestling book, illustrated with many fine pictures—shows holds and secret tricks used by champions. Tells how easy it is to learn the marvelous breaks, falls and holds that make you an expert. Send today for this wonderful book. Enclose only 10c to help cover cost of wrapping and postage. Be sure to state age. No obligation.

Farmer Burns, C-977 Ry. Exch. Bldg., Omaha, Neb.

Send Now for
Farmer
Burns'
Book



\$100 to \$125 PROFITS WEEKLY

New line of quality toilet goods sells like wildfire. No experience required. All you do is take orders from this beautiful sample case. Finest perfumes, soaps, facial creams, bath salts, face powders—wonderful products at prices that appeal to all women. Just send name and address for FREE CATALOG.

NATIONAL SOAP & PERFUME CO.
512 W. Huron St. Dept. A-B CHICAGO



BUCHSTEIN'S FIBRE LIMB

is soothing to your stump—strong, cool, neat, light. Easy payments. Braces for all deformities.
D. BUCHSTEIN CO.
610 3rd Ave., So.
MINNEAPOLIS, MINN.

Send for Catalog Today

AGENTS \$65⁰⁰ and FREE SUIT a Week

Write Today Outfit FREE

No question about it, any man can easily earn \$65 a week just showing our wonderful outfit and taking orders for our high-grade tailoring—lower prices—better clothes—bigger cash profits.

SUIT FREE—SEND NO MONEY

To introduce unbeatable values, classy styles and perfect tailoring, we make this introductory free suit offer for taking a few orders—something different, better, bigger, more liberal than any offer ever made.

Handsome complete outfit of 200 large real cloth samples—everything furnished. Just drop us a line today for free suit and sample outfit offer.

SPENCER MEAD COMPANY
Wholesale Tailors Dept. V-816 CHICAGO



5-Room ALADDIN

\$478 NOT PORTABLE



WE PAY THE FREIGHT

You can buy all

the materials for a complete home direct from the manufacturer and save four profits, on lumber, millwork, hardware, labor. Price includes all lumber cut to fit; highest grade interior woodwork, siding, flooring, windows, doors, glass, paint, hardware, nails, lath, roofing, with complete instructions and drawings. Freight paid to your station. Permanent Homes—NOT PORTABLE. Many styles of year 'round dwellings, summer cottages and garages to choose from. Write nearest mill today for FREE Money-Saving Catalog No. 1549

THE ALADDIN CO., BAY CITY, MICHIGAN
 Wilmington, North Carolina; Portland, Oregon; Toronto, Ontario

WURLITZER

TRADE MARK THE WORLD'S LARGEST MUSIC HOUSE

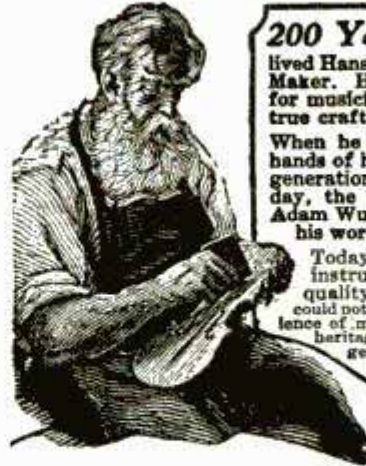

200 Years Ago in the little town of Shoeneck lived Hans Adam Wurlitzer, Master Violin Maker. His shop was a gathering place for musicians of the time, for he was a true craftsman.

When he died his shop passed into the hands of his eldest son, and for seven generations, down to the present day, the descendants of Hans Adam Wurlitzer have carried on his work.

Today in every Wurlitzer instrument you will find a quality, a character, that could not come from mere excellence of manufacture. It is the heritage of these seven generations of music craftsmanship.



Try any Wurlitzer Instrument in your Own Home

YOU may now have any Wurlitzer instrument for a generous free trial in your own home. Examine the instrument, show it to your friends, play it as much as you wish. No obligation to buy—no expense for the trial. We make this liberal offer because we want you to try for yourself these wonderful instruments, the result of 200 years' experience in musical instrument Building. Easy payments are arranged to suit your convenience. This is your opportunity to try a famous Wurlitzer instrument in your own home.

Send for New Catalog

The greatest musical catalog ever published! Over 3,000 articles—every known instrument described and illustrated; many of them shown in full colors. Gives you lowest prices and all details of Free Trial, Easy Payment plan. All sent FREE—no obligation.

Send this Coupon

THE RUDOLPH WURLITZER CO., Dept. C177
 120 W. 42nd St., New York 117 E. 4th St., Cincinnati
 329 S. Wabash Ave., Chicago 134 Golden Gate Ave., San Francisco

Send me, absolutely free, your new illustrated catalog, with prices and description of every known musical instrument. Also tell me how I may try any instrument in my own home and pay for it in small monthly sums. No obligation.

Name.....
 Address.....
 City..... State.....
 Instrument..... (State instrument in which you are interested)

Copyright, 1924, The Rudolph Wurlitzer Co.

Cal. 30-40

KRAG CARBINE STYLE
 The famous all-round rifle suitable for hunting or target practice. Serviceable condition. Shipping weight, 12 lbs. **\$15** PRICE F.O.B. Another Lot Just Received! **12-in. Blade**

KRAG BAYONET 40 Cents Postage Extra
 With Scabbard. For use in home, store or outdoors. 2 1/2 lbs. **C.O.D.**

CATALOG FREE ON REQUEST
 Army—Navy—and Sporting Goods
W. STOKES KIRK, 1627-PM, North 10th St., Philadelphia, Pa.

GET YOUR SLICE OF BIG PROFITS
 with this amazing new

DOUBLE EDGED RAZOR BLADE PARING KNIFE
 The fastest selling home necessity ever offered. Sells for 25c. Your price \$1.50 dozen, prepaid. Guaranteed.

MORGAN MANUFACTURING CO., 440 S. Dearborn St., Dept. G, Chicago

AGENTS 500% PROFIT
GENUINE GOLD LEAF LETTERS

S guaranteed to never tarnish. Anyone can put them on stores and office windows. Enormous demand, large profits. Paul Clark says: Smallest day \$28.70. R. L. Reel made \$920 in two months. Write today for free sample and liberal offer to general agents.

METALLIC LETTER CO., 433-B N. Clark St., CHICAGO

Do Your PRINTING

Cards, stationery, circulars, labels, paper. Complete Outfits \$8.85 up, Rotary Jobber, \$150, Card Cutters \$3 Save Money. Print for others, big profit. Easy with rules sent. Write for catalog presses, type, paper, cards ink, etc. **THE PRESS CO., L-37, MERIDEN, CONN.**

AGENTS! Make your dreams of \$90 every week come true!
SELL THE OVERSIZED JOHNSON RED PENS

Each pen is hand made and ink tested in our own factory. Five year guarantee with every pen—\$7.00 value for \$3.50. Send for Agent's Sample at \$1.75 C. O. D. plus postage and complete literature, or send for literature only.

JOHNSON PEN CO., Dept. PM-7, 117 S. First St., Rockford, Ill.

FINEST QUALITY GENUINE DIAMONDS

CASH OR CREDIT
SATISFACTION GUARANTEED OR MONEY REFUNDED

Our values are unexcelled—prove it for yourself by investigation and comparison. Blue-white Diamonds of dazzling brilliance and colorful fire, in latest style ring mountings. Priced especially low for quick selling—order now!
Every ring sent in handsome gift box.

No. 841 \$143.75 per wk. \$3.25 per wk.
No. 27 \$97.50 per wk. \$2.50 per wk.
No. 31 \$97.50 per wk. \$2.50 per wk.
No. 28 \$37.50 per week \$1.00 per week
No. 12 \$48.75 per week \$1.25 per week

Send for Free Catalog

Write now for our big Diamond Book—absolutely free! Fully illustrates Diamonds, Watches, Silverware, Toilet Sets and Gift Novelties.

All goods delivered on payment of one-tenth purchase price. Balance weekly, semi-monthly, or monthly as convenient.



WEDDING RINGS

No. 824—The "Elite" 18-K white gold, \$7.50. Set with 3 Diamonds, \$22.50; 5 Diamonds, \$32.50; 7 Diamonds, \$42.50; 9 Diamonds, \$52.50; 12 Diamonds, \$67.50. All Platinum, \$25 up. With 3 Diamonds, \$50; 5 Diamonds, \$70; 7 Diamonds, \$80; 9 Diamonds, \$100; surrounded by Diamonds, \$200.



WRIST WATCH No. 839
14-K white gold hand engraved case. Fancy wing ends. Silver dial. High grade 15-Jewel movement. \$25. \$2.50 down and \$1.00 a week.

Railroad Watches—Guaranteed to Pass Inspection

HAMILTON No. 992. 21 Jewels, Adjusted to 5 Positions. Gold filled 25-Year Case. \$55
ELGIN'S LATEST RAYMOND. 21 Jewels, 8 Adjustments. Runs 40 hours one winding. Gold filled 20-Year Case. \$55
ILLINOIS "BUNN SPECIAL." 21 Jewels, Adjusted to 6 Positions. Gold filled 25-Year Case. \$50
HOWARD RAILROAD WATCH. 21 Jewels, 8 Adjustments, 25-Year Gold filled Case. \$80



LOFTIS The National BROS. & CO. ESTD 1858 Jewelers
DEPT. C-894
108 N. State Street, Chicago, Ill.
Stores in Leading Cities

17-Jewel ELGIN No. 15
Green gold, Elgin Watch; 25-year quality case; 12 size; gift dial; \$30. \$3 down \$1 a week

Imperial Sanitary Floor

Put on like Plaster
Wears like Iron
-waterproof
fireproof
resilient
noiseless
dust-less

Base and Floor one solid piece

A composition material easily applied in plastic form over practically any kind of floor. Laid about 1/8 inch thick. Imperial floor does not crack, peel or come loose from foundation. A continuous, fine-grained, smooth, non-slipping surface. No crevices to gather grease, dirt, dust, disease germs or moisture.

Ideal Floor for Kitchen, Pantry, Bath Room, Laundry, Porch, Garage, Restaurant, Theatre, Hotel, Factory, Office Building, Railroad Station, Hospital—wherever a beautiful, substantial floor is desired. Several practical colors. Full information and sample FREE of your first and second choice of colors.

Imperial Floor Co., 60-64 Halstead St., Rochester, N. Y.

A Success for 15 Years

Earn \$100 a Week Profits in Advance

Sell Gibson extra fine men's made-to-order all-wool suits at \$31.50, direct to wearer. Regular \$55 values. **Biggest commissions paid in advance.** We deliver and collect. 6 x 9 cloth samples (over 100 styles—all one price) and complete outfit in handsome carrying case, furnished to ambitious men who are willing to hustle and earn \$100 weekly. Write today.



W.Z. GIBSON, Inc., 161 W. Harrison St., Dept. V-516, Chicago



THIS CLEAR, POWERFUL 6 POWER VEST POCKET TELESCOPE with glove leather case \$2

Only 3 1/4 in. long! Easily slips in vest pocket, powerful, precise, Postpaid adjustable to either eye, 6 full magnifications bring distant objects close in full detail. Thorough satisfaction or money back.

BOSTON SPORTING GOODS CO. Dept. P. 80 Boylston St. BOSTON, MASS.



I Made \$21.00 In Five Hours

—Writes Peter Werner, III, Sell Madison "Better-Made" Shirts for Large Manufacturer Direct to wearer. No capital or experience needed. Many earn \$100.00 weekly and bonus.

Write for Free Samples

MADISON SHIRT MILLS, 562 Broadway, New York

RAISE BELGIAN HARES

NEW ZEALAND REDS—Chinchillas—Flemish Giants
MAKE BIG MONEY—We supply stock and pay you following prices for all you raise: Belgian Hares \$2 each—New Zealand \$3 each—Chinchillas \$4 each—Flemish Giants \$5 each. 32-page illustrated book, catalog and contract, also copy of *Fur Farming* magazine, tells how to raise skunk, mink, fox, etc., for big profits, all for 10c. Address

OUTDOOR ENTERPRISE CO., Box 25, Holmes Park, Mo.

Sensational New Camera

Takes Regular Black and White Photos

Finished quickly inside the camera. The marvelous new "Keller-camera" is absolutely new. Inexpensive Keller-cards and papers are used as negatives. No expensive films or plates. No expense for developing or printing. We send you powders to be mixed with water only. Ten different models selling at from \$5.50 to \$52 each. Photos and post cards 3 1/4 x 5 1/2, 3 x 4 1/2 and 2 1/2 x 3 1/2 inches. These pictures are not brownish and scenes are not reversed. You can make money taking and selling photos, selling cameras or doing both.

Exclusive territory. Write today.
CROWN CAMERA CO., 439 Canal St., Dept. 301, New York, N. Y.

Great New Invention



For Seekers of Health—Power—Beauty

Generate High Frequency Violet Ray, Mechanical Vibration, Medical Electricity and Ozone—the four greatest curative agents. Combined or separate. They operate on the electric light in your home or on their own motive power at less than 50 cents per year.

WRITE Ask for the book on these inventions which has just been prepared. It will be sent to you without cost. Re-vitalize yourself. Bring back energy. Be wholly alive. WRITE TODAY!

Lindstrom & Co., 30 W. Lake St., Dept. C-135, Chicago

Direct at Factory Prices

Sample \$1.18 3 for \$3.00 Postpaid

Hand Forged Razor Steel Blades

Send for our 100-page FREE List and "HOW TO USE A RAZOR."

Maher & Grosh Co.

106 A St., Toledo, Ohio



A Genuine \$2 Knife for \$1.18 Postpaid

Handy shaped Blade makes this knife best for mechanics, sportsmen and farmers; light but strong; re-sharpened easily. Stag handle. German silver finish; blades file tested, hand forged from razor steel and warranted.

NO 57

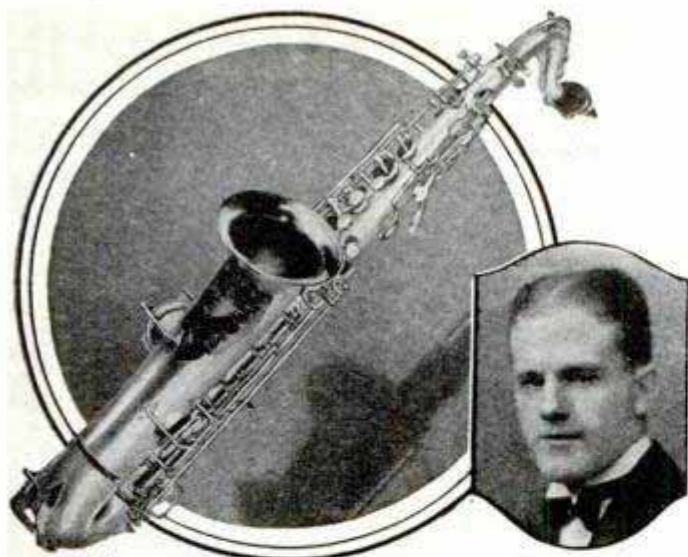

You can play

EDDIE SHARPE
Saxophonist
Paul W. Whitman's
Concert Orchestra

this easy fingering Buescher Saxophone, Most wonderful music. 3 lessons given on request with each new Buescher True-Tone. Teach yourself. Many play scales right off—easy tunes first week. You can.

Easy to Play, Easy to Pay 325D

Try any Buescher Instrument for 6 days. Satisfaction or no sale. Easy terms arranged. Send postal for catalog and details of trial and payment plans. Mention instrument preferred. No obligation. Send today.

BUESCHER BAND INSTRUMENT CO.
1728 Buescher Block Elkhart, Indiana



Lacassia
VEGETABLE
OIL Soap

Big Money
Made by agents selling our wonderful Facial Soap, Perfumes, Toilet Articles, Spices, Extracts, etc. Free cake of soap and agents' terms mailed to any address.

LACASSIAN CO. Dept. 455 ST. LOUIS, MO.

"Best Pen I Ever Had—and costs less!"
That's what users of the Postal say. New filling method—easiest ever devised. Holds 4 times usual amount of ink. Transparent (always know how much ink you've got!). Unbreakable. Only \$2.50! Sent C. O. D. Order now and try it! Money back if you don't like it. Postal Pen Co., Inc., Dept. P. M. 8, 25 W. 43rd St., New York City

REMINGTON
PORTABLE TYPEWRITER
Dealers and Branches Everywhere

**I Pay Men \$40
A DAY!**

S. W. Allen of California made \$40.80 in one day's "joyful work"! Hundreds of other men are reporting amazing incomes—many of them doubling and tripling their former salaries.



Just Wear This FREE Cap

Just wear this beautiful hand tailored FREE RAIN-PROOF Cap. When your friends see it, nine out of ten will want one like it. They can't resist the Rain Proof idea—it's so new and unique. You can make a splendid income in full or spare time. No experience is needed. "I haven't found a man who doesn't fall for the made-to-measure idea," writes Chas. Horstman. Send at once for FREE Selling Outfit. Taylor Cap Mfgs., Dept. K-108, Cincinnati, O.

PREST-O-LITE COMBINATION
5-IN-1 OUTFIT

Convenient Canvas Roll Case

\$7.50



Repairing
a radiator



Heating and
bending rod

The right heat for every job—instantly

SOLDERING, brazing, melting and fusing jobs are out of the way in quick time if you have one of these Prest-O-Lite 5-in-1 Outfits. They are saving time and money in thousands of garages.

The outfit is portable. Can be carried right to the job and your heat is ready the instant you turn on the gas. Rubber hose, wrench and four different-size torch heads come with the outfit—also a handy soldering iron that stays hot.

This equipment operates on Prest-O-Lite Gas in convenient tanks. Economical as well as easy to operate. You exchange your empty tank for a full one at any one of the thousands of Prest-O-Lite Service Stations located all over the country—paying a small amount for the gas only.

Ask about this profit-producing equipment at any Prest-O-Lite Service Station, or write us direct for detailed information. The price is only \$7.50 complete.

THE PREST-O-LITE CO., INC.
INDIANAPOLIS, IND. Dept. L-8
New York San Francisco
In Canada: Prest-O-Lite Company of Canada, Ltd., Toronto, Ontario

Prest-O-Lite Gas

Shoot the Best Gun

The NEW BENJAMIN is the finest air rifle ever made. Unlike all others. Has amazing accuracy—shoots hard and far. It's the original American genuine AIR operated rifle. One to six pump strokes compress air to any desired degree of power. Same force as in air drills and air hammers except you control the shooting force. Never loses force—no springs or levers to get out of order. Makes crack shots quickly, inexpensively. Gives years of delightful recreation with utmost safety. At your dealer's, or sent postpaid for \$5.00.

Shoot 5 Days FREE

We give you five days, ammunition supplied, to test the NEW BENJAMIN. If in this time you don't believe it to be the finest air rifle you've ever seen or used, and if you don't believe it is the one and only air rifle for you, return it, postpaid, and your money will be refunded at once.

The NEW BENJAMIN AIR RIFLE

America's Original Air Rifle

\$5 at your dealer's or sent postpaid direct from factory on FREE Trial as above if dealer does not handle it—write for our wonderful offer.

Get This Book and Details FREE



BENJAMIN AIR RIFLE & MFG. CO.
635 N. Broadway, St. Louis, Mo.

Please send your amazing offer and free copy of "The Shooter's Art," telling how to become a crack shot, how to hold, aim, and handle guns and guide others in use of guns.

Name.....

Address.....

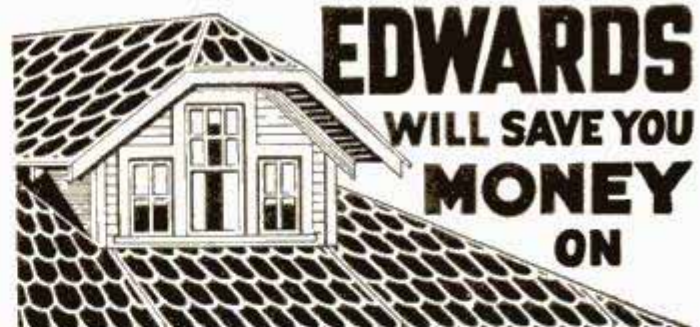
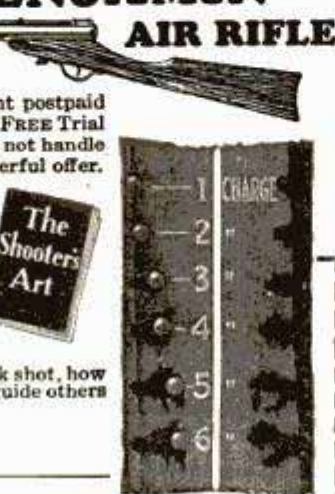

EDWARDS WILL SAVE YOU MONEY ON

METAL ROOFS

We own our own steel mills, roll our own sheets, make them into high-grade REO METAL SHINGLES, Sidings, Ceilings and Roofings of every type and style for every kind of building. We control every operation from the raw material to the finished roof and we sell direct from our factories to the user. Not a dollar to divide with anybody but the customer! You get better value for less money.

OUTLAST THREE ORDINARY ROOFS

EDWARDS METAL ROOFS are weather-proof, lightning-proof, fire-proof! The galvanizing bends with the metal. No tools required.



LOW-COST ALL-METAL GARAGES

Any size. Any style. Portable. Ready to erect. Complete with frames, doors, sash and hardware. Ornamental, durable, economical. Blue-prints and complete instructions FREE.

Write today. Get our low prices and Free Samples. Ask for Roofing Book No. 150 or for Garage Book No. 150

THE EDWARDS MFG. CO.
800-850 Butler St. Cincinnati, O.



PLUMBING and HEATING



ALL-CAST PIPELESS FURNACE

Buy At Wholesale—Save Half
Send coupon for FREE bargain catalog. Explains our new easy method and shows everything in highest grade Plumbing Outfits, Heating Plants, Water Supply Systems, Pipe, Fittings, etc. For 50 years we have been saving our customers hundreds of thousands of dollars and now we have made arrangements so that you can BUY ON EASY TERMS.

FREE PLANNING SERVICE

Send us a rough sketch of your rooms and we will figure the wholesale cost of Heating Plant or Plumbing Outfit designed especially to fit your

home. Kinks and Wrinkles and Savings that will surprise you. With our simplified plans and new easy method, you can do the installing. We loan tools FREE. Our Bonded Guarantee is backed by Million Dollar Plant and 50 Years in Business.

HARDIN-LAVIN CO.

Established 1876
107-17 West Pershing Rd., Chicago, Ill.

MAIL THE COUPON NOW!



HARDIN-LAVIN COMPANY,
107-17 West Pershing Rd., Chicago, Ill.

Gentlemen: Please send me your FREE BARGAIN CATALOG with special wholesale prices. I am interested in: PM-8-26

- Water Supply System
- H. W. Htg. Plant
- Strm. Htg. Plant
- Pipeless Furnace
- Warm Air Furnace
- Bathroom Outfit

NAME.....
ADDRESS.....
P. O..... STATE.....

Bodies of Rare Beauty for Fords

At Factory Prices!

Write for circular A-2 showing this De-Luxe Model and others.



\$22.75 AND UP

SPORT FACTORIES, Aurora, Ill.

AUTO OWNERS



WEBSTER'S Guaranteed Air-Tight Valve Cap enables you to pump up your tires once and never touch them again until punctured or worn out. Eliminates 90% of flat tires. The life of a tire is doubled. Insures even inflation, car runs better, saves money, time and worry. Set of 5 prepaid, 60c.; 12 sets \$3.60
F. Webster 720 Dover Pl., Dept. 9, St. Louis, Mo.

SHAW MOTOR ATTACHMENT MAKES YOUR BIKE A MOTORCYCLE!

A high grade 2 1/2 H. P. motor attachment quickly clamped on any bike frame. Speed 4 to 40 miles an hour. 90 to 125 miles per gallon of gas. **Special Low Price Now!** Write today for Complete Description and Special Low Prices on SHAW Motor Attachments and the SHAW Complete Motorcycle. **SHAW MANUFACTURING COMPANY**
Dept. 37 Galesburg, Kansas



MOTORCYCLES



RELIABLE STANDARD MAKES that you can **DEPEND** on. Enjoy the glorious experience of going wherever you like—when-
ever you like. The price is within your means—
25% to 50% less than others. These machines
are lightly used, thoroughly overhauled
or rebuilt. Send for catalogue.
MYEROW BROS.,
15 Berkeley St. Boston, Mass.



Buoyant, steady and graceful

THERE'S a joyousness—a sense of absolute freedom about canoeing that comes with no other sport. "What shall we do this summer?" is uppermost in the minds of thousands. Why not let an "Old Town Canoe" help answer the question for you?

You'll be mighty proud of your "Old Town." These canoes are patterned after actual Indian models. Graceful, sleek and fast, "Old Town Canoes" win the admiration of all who see them. Remarkably low in price too. \$64 up. From dealer or factory.

The 1926 catalog is beautifully illustrated with all models in full colors. Write for your free copy today. OLD TOWN CANOE Co., 1668 Middle St., Old Town, Maine.

"Old Town Canoes"

MOTORCYCLES

LESS THAN HALF COST

Ace, Indian, Cleveland, Harley-Davidson, Henderson Motorcycles and Sidecars, new, used and rebuilt. **Rider Agents Wanted.** Write for FREE trial offer, agent's free outfit and big bargain bulletin. **New American Bicycles** in different styles and colors. Write for illustrated catalog giving our money saving prices.

AMERICAN MOTOR CYCLE CO.

2047 W. Chicago Ave., Dept. 835, Chicago



STOP FORD END-PLAY!

C-A ADJUSTABLE BEARING corrects and prevents end-play without removing motor. Eliminates many troubles. Easy to install—simply drop pan. Only \$3.75. Ask your dealer or sent prepaid by ADJUSTABLE BEARING CO. Dept. P BRAZIL, IND.

This Year~ make it a Real Vacation!

Thrilling, foaming speed with the Super Elto outboard motor! Instantly attached to any rowboat. Easily portable. World famous for easy starting. Multiplies the pleasures of fishing, racing, vacationing. Write today for new catalog—beautifully illustrated—intensely interesting.

Elto Outboard Motor Co.
Ole Evinrude, Pres.
Dept. aa, Minns. Home Bldg.
Milwaukee, Wis.

The Super
Elto

"Starts With a Quarter Turn"



Magic

Learned Easily At Home

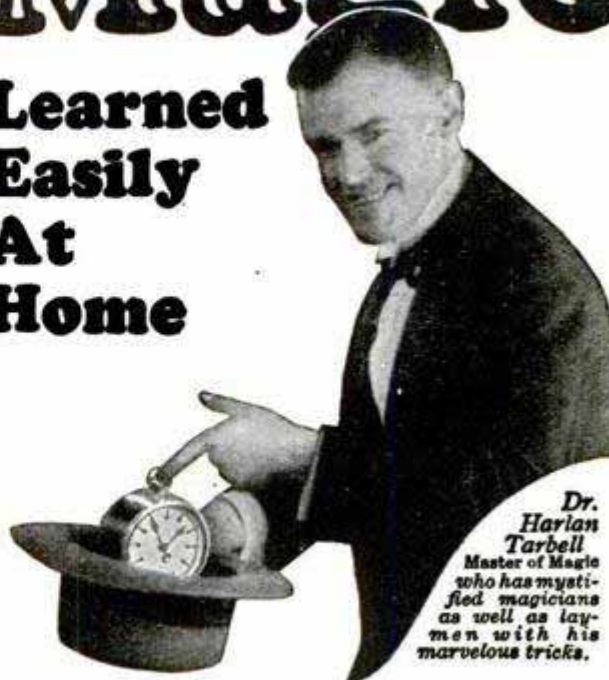

Dr.
Harlan
Tarbell
Master of Magic
who has mystified
magicians
as well as lay-
men with his
marvelous tricks.

Astonish Your Friends

Gain that magnetic popularity that makes you the center of any crowd. Business and social success is assured the man who can perform mystifying tricks. You can earn big money either on the side or as a professional, as well as being the most popular person in your crowd. Why envy others' skill? You can learn Magic yourself, quick and easy.

Earn \$250 to \$1000 a Month

Even sleight-of-hand, generally supposed to require long practice, is NOW made simple to learn. For Dr. Harlan Tarbell, one of the really Great Magicians, has finally opened up the secrets of his profession in a completely illustrated course offered at a merely nominal cost. Through the wonderful Tarbell System you will be able to mystify and entertain your friends with simple tricks taught in your very first lesson. After that Dr. Harlan Tarbell takes you through the entire maze of sleight-of-hand, card tricks and elaborate stage diversions. The apparently superhuman doings of the accomplished magician become as simple as ABC when you just know how.

Mail Coupon for Special Offer

There is a tremendous demand for magic entertainment. Clubs, Lodges, Charity and Social affairs—all will pay high fees to the man who knows Magic. Dr. Harlan Tarbell really gets as high as \$250 for an half hours work right now. Opportunity everywhere to make money aside from your regular occupation. Salesmen find it a tremendous asset. Find out all about this unprecedented opportunity to learn Magic. The coupon brings full details without any obligation. Mail it TODAY.

Tarbell System, Inc.

1926 Sunnyside Ave., Studio C-135 Chicago

Tarbell System, Inc.

1926 Sunnyside Ave., Studio C-135 Chicago

Tell me all about Dr. Tarbell's new and simple system by which I can learn the secrets of MAGIC. No obligation on my part.

Name.....

Address.....

\$351⁰⁰ CLEARED ~ IN ONE DAY

So writes W. H. Adams of Ohio in August 1925. V. A. Marini of California reports \$11275 sales in three months. Jacob Gordon of New Jersey \$4000 profits in two months." Alexander of Pennsylvania "\$3000 profits in four months." Ira Shook \$365 sales in one day. Bram bought one outfit April 5 and 7 more by August 28. Iwata, bought one outfit and 10 more within a year. Mrs. Lane of Pittsburg says "sold 8000 packages in one day. J. R. Bert says "only thing I ever bought that equaled advertisement." John Culp says:

"Everything going lovely.
Crispette wrappers scattered all over town. It's good old world after all." Kellogg, \$700 ahead end of second week.



WE START YOU IN BUSINESS

Furnish secret formulas, raw material, and equipment. Little capital required; no experience needed.

Build a Business of Your Own

No limit to the sale of Crispettes. Everybody likes them. It's a delicious food confection. Write for facts about a business that will make you independent. Start now, in your own town.

Profits \$1000 a Month Easily Possible

Send postal for illustrated book of facts. It contains enthusiastic letters from others—shows their places of business, tells how and when to start, and all information needed. Free. Write now!

LONG-EAKINS COMPANY

828 High Street

Springfield, Ohio

FISHERMEN



You don't need to worry about carrying a cumbersome minnow pail on your fishing trip; just pack the new patented WALLACE minnow bucket cover in your kit, borrow a pail, snap on the cover and you have a minnow pail that will keep minnows alive longer than any other bucket on the market. Will last a lifetime.

Sent postpaid for \$1 if your dealer cannot supply. Money cheerfully refunded if you are not satisfied. Send today to:

Wallace Specialty Mfr's. P. O. Box 367, ALGONAC, MICH.

You Can Save \$35⁰⁰



\$4.45 and up

Recover it yourself.

Custom tailor made to fit all makes and models. Roof

and quarters sewed together, with rear fasteners, welts and tacks, complete. Anybody can put it on. Give name, year, model number of your car. Catalog FREE. Agents wanted. LIBERTY TOP & TIRE CO. Dept. I, Cincinnati, O.

MAKE YOUR Ford INTO THIS Sport Car—Save \$50 to \$150 with Red-i-Kut Life-Size Patterns \$5⁰⁰

Famous sure-fit RED-I-KUT life-size patterns and picture instructions show how you can easily convert your Ford into this Fast, Saucy, Sport Car as thousands have done, with easily obtained material. No need to lay up the car. Rear seat folds, making 4-passenger car. Look at Wilfred Eno's.

Eno says: "It took me 3 Sundays to build it and I sure am proud to hear them say, 'He built that snappy sport car.' I never cut any steel or did any woodwork before, but one can't go wrong with Kuempel patterns." St. Louis Mo.



The Lark life-size patterns for each part of the body so you can't go wrong, picture instructions and CONICAL DISK WHEEL PATTERNS. Only \$3.00 delivered. \$4 extra brings patterns for Jifty Top and Gosum windshield. RKO Steel for Lark \$10 complete. Extreme West \$13. Order now while we can make good delivery, and really enjoy the wonderful spring days in your Lark. Keen, Classy, Up-to-the-minute. You can build it. Over 11,000 in use. Don't hesitate. "Swing Lo" Underling iron, no frame cutting kind. \$5.99. Only \$4.99 when ordered with Lark patterns. Send 10c coin for actual body photo and new manual of other distinctive sport body patterns from \$3.00 up—"RKO" Steel "Swing Lo" Irons, Tees and Windkicks. ORDER RIGHT NOW. KUEMPEL CO., 75 Kuempel Bldg., Guttenberg, Iowa

AGENTS
\$100⁰⁰
a Week

New Wonder ALL BRASS SPARK PLUG

**Saves Gas
Stops Carbon and**

increases power on any motor. Guaranteed to outlast and out-perform all others. Has 7 features of super merit. Easiest selling Plug on the market. West sold 5 gross one week. Rhodes sold 1,600 first month. Our men average \$100 a week. Exclusive territory to District Agents now. No capital or experience required.

WRITE FOR FREE PLUG OFFER

WESTINGALE ELECTRIC CO., 1751 Belmont Avenue, Dept. 190, Chicago, Ill.

House Plans Free

Plans and pictures of 25 one and two story dream homes. Porches, closets where you want them. Vestibules, breakfast alcoves. Everything planned for comfort and convenience. Expert advice on new way to build at big saving.

WRITE FOR BOOK

Learn how you can build your home at wholesale Buy direct. 30 per cent less on material—40 per cent less on labor cost. Complete material for this beautiful home cut to size—ready to erect for \$915—is good illustration of amazing savings actually available to you. Others at \$373 to \$1375 with freight prepaid to all points east of Mississippi and north of Mason and Dixon line. Write for free book today—see with your own eyes how to build the home of your dreams and save from \$200 to \$1500. No obligation.

LAFAYETTE
Six rooms,
two closets,
bath, hall—

\$915⁰⁰



LIBERTY HOMES CO.
Dept. 12-K Bay City, Michigan

Save money when you build

You and This New Machine Can Earn \$500 a Month



Operate a Tire Repair Shop

70,000,000 Tires in use. America's greatest opportunity for men with small capital. We furnish everything—\$100 and up. Easy payments. We train you FREE right at home. Start making money at once. Write today for Free Book of Opportunity.

Haywood Tire Equipment Co. 1344 S. Oakley, Chicago

SOFT SNAP FOR AGENTS

GLAROFF Kills Headlight Glare
Our representatives making from \$12 a day up to \$8000 yearly. Simple new device protects driver from glare of headlights and sun. Write for Special Free Offer. GLAROFF MFG. 805-L Read St., Sioux Falls, S. D.

INSTANT WELD Make \$200 to \$500⁰⁰ per WELDS RUBBER INSTANTLY

A New Scientific Principle without heat or cement. Instantly repairs punctures or blow-outs. Better—Quicker—Easier than vulcanizing. ONCE ON—ALWAYS ON. Every auto owner is a prospect. Repeat orders sure. Big profits. Appoint sub-agents.

Write for Free Sample Today.
TOURISTS PRIDE MANUFACTURING CO.
Desk 50-H MINNEAPOLIS, MINN.



Famous sure-fit RED-I-KUT life-size patterns and picture instructions show how you can easily convert your Ford into this Fast, Saucy, Sport Car as thousands have done, with easily obtained material. No need to lay up the car. Rear seat folds, making 4-passenger car. Look at Wilfred Eno's.

Eno says: "It took me 3 Sundays to build it and I sure am proud to hear them say, 'He built that snappy sport car.' I never cut any steel or did any woodwork before, but one can't go wrong with Kuempel patterns." St. Louis Mo.

The Lark life-size patterns for each part of the body so you can't go wrong, picture instructions and CONICAL DISK WHEEL PATTERNS. Only \$3.00 delivered. \$4 extra brings patterns for Jifty Top and Gosum windshield. RKO Steel for Lark \$10 complete. Extreme West \$13. Order now while we can make good delivery, and really enjoy the wonderful spring days in your Lark. Keen, Classy, Up-to-the-minute. You can build it. Over 11,000 in use. Don't hesitate. "Swing Lo" Underling iron, no frame cutting kind. \$5.99. Only \$4.99 when ordered with Lark patterns. Send 10c coin for actual body photo and new manual of other distinctive sport body patterns from \$3.00 up—"RKO" Steel "Swing Lo" Irons, Tees and Windkicks. ORDER RIGHT NOW. KUEMPEL CO., 75 Kuempel Bldg., Guttenberg, Iowa

The "Lark" Class—Snap

38-inch Easy Riding Seat



The owner of a
Tycos
Stormoguide
is his own Weather Forecaster.

If your Dealer cannot supply You, write
Taylor Instrument Companies
ROCHESTER, N.Y.
Canadian Plant, Tycos Bldg Toronto
There's a Tycos Stormoguide Thermometer for Every Purpose

Tire AGENTS WANTED

Use and introduce **MELLINGER CORD TIRES**
15,000 MILES GUARANTEED
Lowest Wholesale Prices in America. Shipped prepaid on approval. Make big money all or part time. No capital or experience. Sample sections furnished.

YOUR TIRES FREE! Simply send name today for valuable FREE BOOK: tells how thousands have gone into big business. **SPECIAL AGENTS' OFFER.** Wholesale Prices and FREE SAMPLE KIT. Write nearest address.

MELLINGER TIRE & RUBBER CO.
Dept. 415, Kansas City, Mo., Dept. 415, Philadelphia, Pa.
Dept. 415, Oakland, Calif. **WRITE NEAREST OFFICE**



Ranger \$5 a Month

Finest bicycles built—44 Styles, colors and sizes. Factory-to-Rider prices. **FREE** delivery, express prepaid on **30 Days Free Trial.** Cash or easy payments. Bicycles, \$21.50 and up.

Tires lamps, wheels and equipment at half usual prices. Send no money. Write today for big catalog, special factory prices, free trial plan and marvelous offers.

Mead CYCLE COMPANY
DEPT. R-109 CHICAGO

Write today for free Ranger Catalog, factory prices and marvelous easy payment terms



BUILD SHIP MODELS!

Easy to build and sell. Plans and instructions: Pirate Ship, 52c—Viking Galley, 42c—Magellan's "Victoria" 77c—Hudson's "Half Moon," 92c—Chinese Junk, 47c—or all for \$2.90.

SEA ARTS GUILD, 405A Eleventh Avenue, Milwaukee, Wis



Your shaving brush will
STAPUT

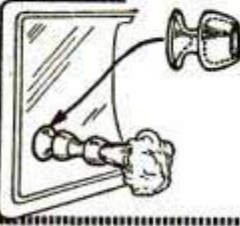

Use the vacuum-footed STAPUT Shaving Brush Holder—do away with the exasperation of dropping your shaving brush on the floor or into the water. At home, in a sleeper, on board ship—it's all the same to the STAPUT. Fits any size brush. Send the coupon with a quarter today. Agents wanted.

STAPUT MFG. CO., 9008 Dexter Blvd., DETROIT, MICH.

Gentlemen:—Enclosed find 25c for a Staput.

Name _____
Street _____ City _____ State _____

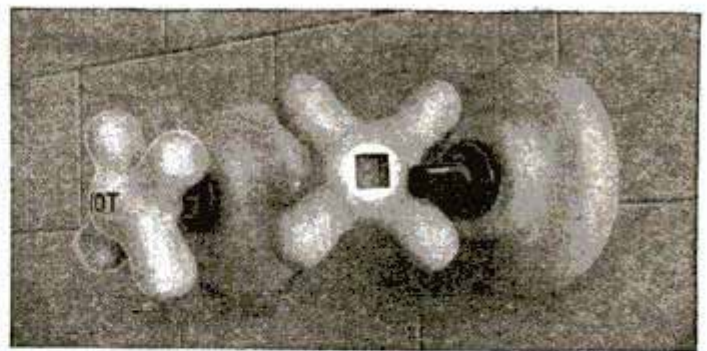

Porcelain handles will STAY tight if set with SMOOTH-ON No. 1

To make porcelain handles tight on bath tub and wash bowl faucets, and on sink and flush tank pulls, fill the hole in the handle with a soft putty of Smooth-On No. 1, and then force the handle onto its spindle. Once the Smooth-On hardens, it becomes solid metallic iron, which will keep the handle tight for all time. You yourself can make this repair equal to a professional job and at a cost of only a few cents.

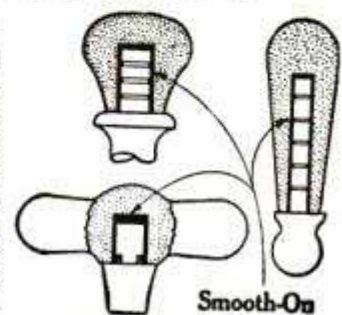

Keep Smooth-On handy and you can save much money on such repairs as: Stopping leaks in steam, water, gas, oil or stove pipes, mending cracks, breaks or leaks in furnaces and boilers, radiators, tanks, sinks, pots and pails, making loose handles tight on umbrellas, knives, hammers, brushes, drawers, etc., tightening loose screws, hooks, locks, door knobs, etc.

Use it also on your car for making bursted water jackets and pumps good as new, stopping leaks in radiator, hose connections, gas tank and gas, oil and exhaust lines, making a fume-proof joint between exhaust pipe and tonneau heater, tightening loose headlight posts, keeping grease cups, hub caps and nuts from loosening, etc.

How to make HOME and AUTOMOBILE REPAIRS



Do it with SMOOTH-ON

Write for **FREE BOOK**



Get Smooth-On No. 1 in 7-oz., 1-lb. or 5-lb. tins at any hardware store or if necessary direct from us. If you want us to send a sample 7-oz. can, enclose 35 cts. in stamps when you return the coupon.

SMOOTH-ON MFG. CO.
Dept. 37, 574 Communipaw Ave.
JERSEY CITY, N. J.

Do it with SMOOTH-ON

SMOOTH-ON MFG. CO., Dept. 37, 574 Communipaw Ave., Jersey City, N. J.
Please send the free Smooth-On Repair Book.

Name.....
Address.....
.....
.....

\$5 Down and You Can Buy Any WITTE Engine

From 1½ to 7 H-p.



To Prove that this "super-powered" one-profit, light weight WITTE will save you one-half the time, labor and cost of any job on the place, I guarantee it to do the work of 3 to 5 hired hands.

Nearly a Year to Pay
No Interest Charges—Scrap the Old One—
Pay a Little of It Down on the New WITTE

With my generous terms my engine pays for itself. Increases farm profits \$500 to \$1000 a year. Thousands say the WITTE is ten years ahead of any other make—simple and trouble-proof at rock-bottom, direct-to-you prices. Completely equipped with WICO Magneto, square, protected tank, die-cast removable bearings, speed and power regulator and throttling governor. All sizes 1½ to 30 H-P.

FREE—Write today for my big, new illustrated book and full details of my guaranteed offer. No obligation, absolutely Free. Or, if interested, ask about our Log and Tree Saws, 3-in-1 Saw Rigs or Pump Outfits.

ED. H. WITTE

Witte Engine Works

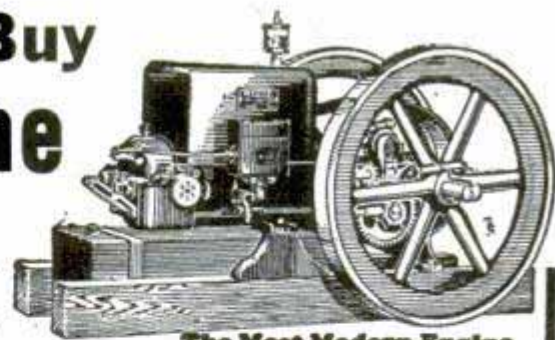

The Most Modern Engine

Burns Kerosene, Gasoline, Gas-Oil, Distillate or Gas—

YET DELIVERS 25% or MORE POWER

Cheapest to operate and guaranteed for a lifetime. No cranking required. Compact and easily moved. Balanced fly-wheels with throttling governor that saves money. Fifty New Features—**Write Me Today**—a post card will do.

1745 Witte Building, Kansas City, Mo.
 1745 Empire Building, Pittsburgh, Pa.
 1745 Witte Bldg., San Francisco, Calif.

Quick shipments also made from nearest of these warehouses: Minneapolis, Minn., Atlanta, Ga., Trenton, N. J., Richmond, Va., Tampa, Fla., New Orleans, La., Dallas, Tex., Laredo, Tex., Denver, Colo., Billings, Mont., New York, N. Y., Albany, N. Y., Bangor, Me., Portland, Ore., and Los Angeles, California.



The New Sypher No. 10

Biggest lathe value on the market. Length over all 30 in.; between centers 14 in. Swing over bed 7¾ in. Includes counter shaft, Bronze taper bearings. Weight 60 lbs. No. 11 Lathe, 40 in. over all; 24 in. centers, 7¾ in. swing. Price \$75.00. Time Payments if desired. Write today for circular.

\$60

The Sypher Mfg. Co. Dept. D Toledo, Ohio

Write for free catalog illustrating and describing our complete line of 1500 Good Tools.

GOODELL-PRATT COMPANY

Toolsmiths
 Greenfield, Mass., U. S. A.

Makes Old Ford a Tractor

We furnish everything for converting Ford Auto Chassis with Engine into a handy Farm Tractor. Just right for truck growers, small farms, nurseries, etc. Pulls 16" Plow, Discs, Seeds, Cultivates; Runs Belt Machinery. We also build Garden Tractors and Cutter Bar Mower Attachments.

Handles Easily
 Turns in 15' Circle



Write for Free Particulars.
SHAW MFG. CO., Dept. F, Galesburg, Kan.

BURN YOUR NAME ON TOOLS

WITH THE ARKOGRAF

PROTECT YOUR TOOLS FROM THEFT

Write with electricity any name or design on the hardest and finest tools and instruments, or any metal, like writing on paper with pen or pencil. Complete Outfit \$3.50—Prepaid Anywhere. Interesting illustrated circular free. Write today. Agents wanted.

ARKOGRAF PEN CO., 1171 E. Stark St., Portland, Oregon

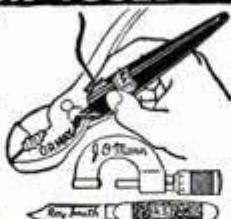

Efficient Speed Reduction
 for **Speed Reducers**

write for free book on your **10 Herhead**

FOOTE BROS. GEAR & MACHINE CO.
 216 N. Curtis Street CHICAGO, ILL.

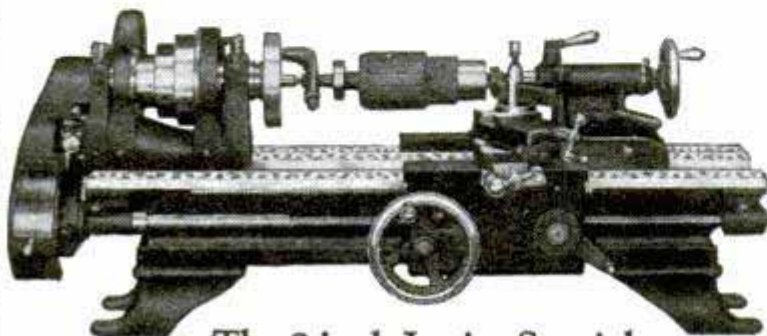

The 9 inch Junior Special

A Practical Back Geared Screw Cutting Bench Lathe

Shipping Weight 350 lbs., Distance between Centers 16½ inches, Width of Cone Belt 1 inch, Length of Bed 3 feet, Power Required ¼ H. P.

9 inch, Back Geared Screw Cutting Lathe \$150

Countershaft and Equipment

This is the first time that a small, substantial, Back Geared Screw Cutting Lathe, suitable for general all-around machine work, has been built to sell at such a low price. The Compound Rest, Back Gearing, Lead Screw, Head Stock and Tail Stock are the same in design, quality and workmanship as on our finest lathes.

Just the Lathe You Need for—

—turning Commutators, undercutting Mica, making Bronze Bushings, refacing Valves, finishing semi-machined or oversize Pistons, cutting threads, turning, boring, drilling, polishing, filing, besides hundreds of other jobs.

Write for Folder No. 22-B and Easy Payment Plan

South Bend Lathe Works

812 East Madison St.

South Bend, Indiana

SIMONDS

CRESCENT-GROUND
CROSS-CUT SAWS

TOUGH TEETH FOR TOUGH TIMBER

ALL through the timber country, Simonds Saws are standard with woodsmen—men who count upon cutting tools most. These shrewd appraisers of tool quality know that only specially treated steel is used for Simonds products. To them, Simonds near-century of experience in the manufacture of tempered steel cutting edges is assurance of highest quality. You, too, will find that it pays to specify "Simonds" in buying saws, knives and files.

SIMONDS SAW AND STEEL CO.
"The Saw Makers" Fitchburg, Mass. Established 1832

Branch Stores and Service Shops in Principal Cities

Send 35c for an All-Work File to
FAYETTE R. PLUMB, Inc.
4817 James St. PHILADELPHIA

WONDERFUL "AWL FOR ALL"



This little tool is a marvel. Will mend anything from thin fabrics up to heavy shoe and harness leathers. Worth its weight in gold. Easily carried in the pocket ready for any emergency. Only \$1 postpaid. Special terms to agents. Big money maker. Write today for territory.
C. A. MYERS COMPANY, 6339 Woodlawn Avenue, CHICAGO, ILL., U. S. A.

CALCULATIONS

in Office, School, Store and Shop can be instantly made with the Midget Slide Rule. It gives the answer to any problem involving fractions, mixed-numbers, decimals, whole-numbers, roots, powers, Logs, and Trig. Functions. Thousands of these rules are used by Accountants, Engineers, Clerks, Students, etc. It is the most versatile calculator ever invented. If you have any figuring to do, order a Midget Slide Rule on trial. Made of aluminum with figures on white celluloid. Size 4". Price with Instruction Book, \$1.50. Leather Case, 50c extra. Catalogue Free. Sent C. O. D. if desired. Your money back if you are not satisfied.
GILSON SLIDE RULE CO., Niles, Mich.

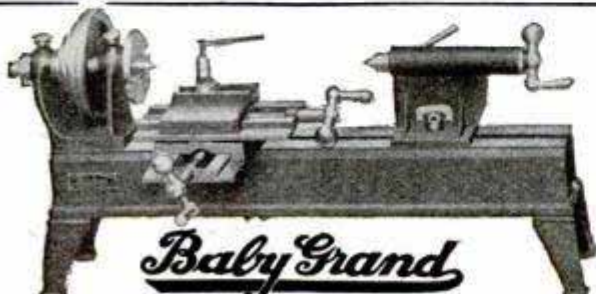

Baby Grand

A practical lathe for shop or home. Cone or Back Geared Head; 6" swing, 12" or 18" between centers; speed 180 to 1750 R. P. M. Will do wood or metal turning. Low price, high quality. Send for complete information on Baby Grand Lathe, Drill, Grinder, etc.
The Watson Mfg. Co., 108 Watson Bldg., Toledo, O., U.S.A.

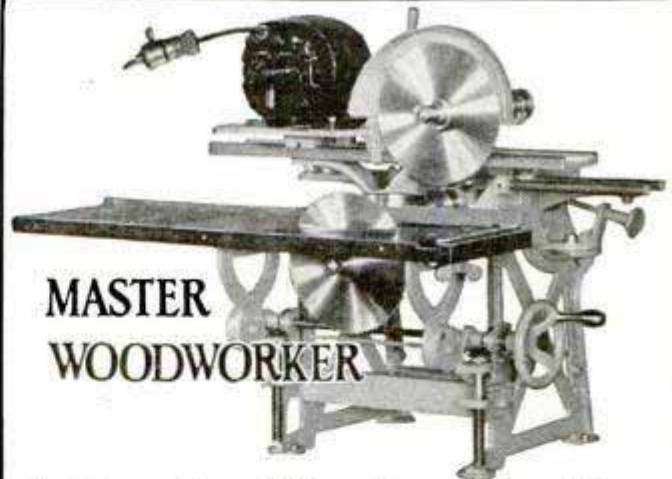

MASTER WOODWORKER

A Complete Woodworking Shop In One Machine

Hundreds of men who like to make things at home have bought Master Woodworkers and are getting lots more fun out of their hobby than ever before. The Master is a compact, durably constructed machine that is actually 12 machines in one, doing: routing, planing, rabbeting, boring, ripping, grinding, stair housing, jointing, moulding, crosscutting, tenoning, mitering, plowing and mortising. Runs from a lamp socket.

Thousands now in daily use by contractors and builders everywhere. Sold on easy monthly payments. Send coupon for full information.

MASTER WOODWORKER MFG. CO.
612 Brush Street, Dept. H., Detroit, Michigan
Send me complete information about the Master Woodworker.

MARVELOUS Hand Made Tools

Try This Test Yourself

Lock any other wrench with a Cornwell wrench of equal size and exert pressure until one of them breaks. **No wrench made will break a Cornwell.** These tools, including complete line of chisels, bolt and rivet busters, punches, wrenches, screw drivers, pliers, etc., are made of finest **Swedish Charcoal Process Molybdenum Steel**, from our famous **Cornwell secret formula**. They are forged, heat treated, and hardened and tempered in oil. **All tools made by hand, NOT drop forged and case hardened.**

LET US DEMONSTRATE CORNWELL TOOLS

Ask for salesman to call and show you many startling demonstrations that **no other tools in the world will stand.** Or send for free descriptive booklet, order tools and make these demonstrations at our risk.

Money Back If Not Satisfied If you ever saw tools as good as these, return your order and get your money back. Guaranteed finest tools made in the world. Any tools not standing amazing tests described instantly replaced or money refunded.

Amazing Booklet—FREE

CORNWELL QUALITY TOOLS CO.

Dept. D, Cuyahoga Falls, Ohio
Send me illustrated booklet with prices on Cornwell Secret Formula Hand Made Tools.

..... Occupation
Name:
Address:
City: State:



CRESCENT WOODWORKING MACHINERY

High in quality, moderate in price. Ask for circulars describing bench machines for the small shop. If you are interested in the larger machines we can supply you with Band Saws, Saw Tables, Self Feed Rip Saw, Shapers, Jointers, Variety Wood Workers, Planers, Planers and Matchers, Disk Grinders, Cut Off Table, Swing Cut Off Saws, Boring, Hollow Chisel Mortisers, Tenoner, Universal Wood Workers. Ask for circulars.

The Crescent Machine Co.,
93 Columbia St., Leontia, Ohio



Gerstner Tool Cases

are unusual values. Selected materials, skilled workmanship, finest finish and the latest designs give a value that cannot be beaten. Toolmakers and Machinists get our free catalog

H. Gerstner & Sons

432 Columbia St., DAYTON, OHIO.

\$25.00 a DAY CLEAR SURFACING FLOORS



Write Quick for Details

Scores of inexperienced men whom we started as American Universal Floor Surfacing Contractors are making up to \$10,000 a year in this wonderful, new, uncrowded field. Electrically driven American Universal Machines do 500% more work and 100% better work than most expert hand scraper, and earn six men's pay. Work is plentiful, fascinating, immensely profitable. Experience unnecessary. Small amount starts you. We furnish everything, teach you, help you succeed. Opportunity of lifetime to be your own boss and make big money.

AMERICAN FLOOR SURFACING MACHINE CO.
523 So. St. Clair St. TOLEDO, OHIO

A Perfect Heat Machine for Mechanic or Handyman

Every man who has ever used a Turner Blotorch Master No. 45 says that it contains everything they have ever wanted in a Blotorch. From soldering a leaky pan to fine radio or electrical work—the Master No. 45 is supremely efficient and economical. If you want a perfect heat machine



Ask for the MASTER No. 45 TURNER BLOTORCH

Gives 400° greater heat with present-day kerosene or gasoline. Perfect flame-regulation for all kinds of work. Absolute safety because only one opening in tank and that above fuel line. Large, comfortable, pistol grip handle.

\$8.25 Post Paid

Ask your hardware man for a Turner Master No. 45, or send direct. In U. S. and Canada

THE TURNER BRASSWORKS
Industry Ave., Sycamore, Ill.

Free! DISSTON SAW CHART

Gives facts about sawing and saws. Helps you do better, faster work. Write for it. Henry Disston & Sons, Philadelphia, U. S. A.



Now, Only \$39

Let Me Send You the Greatest LOG SAW Offer

—I ever made. One man saws 15 cords a day—easy. Falls trees, saws limbs. Make big money. Use 4 H.P. Engine for other work. Saws faster than 10 men. Shipped from Factory or nearest of 10 Branch Houses. Cash—Easy Terms. Write for 30-Day Trial Offer and big FREE book.

OTTAWA MANUFACTURING COMPANY
1741-W Wood Street, Ottawa, Kan.
Room 1741-W Magee Bldg., Pittsburgh, Pa.

SPEED WAY SHOP

Six Complete Motor Driven Tools

A compact metal and woodworking outfit for mechanics, householders and "handy" men. Attaches to lamp socket.

Only \$10 Down—Easy Payments

Every tool in the "Shop" is high grade, for regular work. A money maker for the small job man. Get full particulars. Write today.

Electro-Magnetic Tool Company
DEPARTMENT 28
1830 South 52nd Ave., Cicero, Illinois (Adjoining Chicago)

WHAT EVERY MASON WANTS



We have Masonic books and lodge supplies for Blue Lodge, Chapter, Commandery, Scottish Rite, and Shrine.

Our Rituals Are Used the World Over Send for free catalog of books and rituals for Masons, Odd Fellows, Knights of Pythias, Knights of Columbus, Elks, etc.

EZRA A. COOK, Publisher, Inc.
1350 N. Clark St., Dept. M, Chicago, Ill.

If You Know Good Tools You'll Appreciate the K-D CONVERTIBLE SAW FRAME



No other saw like it in principle or effect. Reaches over, under and around obstructions, to get at the most difficult sawing jobs. K-D's solid steel one-piece frame goes clear to tip of pressed steel pistol grip handle. Convertible to fit 3, 6, 8, 10 and 12 inch blades.

Price \$1.50

complete with 3 in. hack saw blade and 12 in. wood saw. At dealers or direct from maker—

K-D Mfg. Co.
Lancaster, Pa.
Export Department:
Woolworth Bldg., New York City

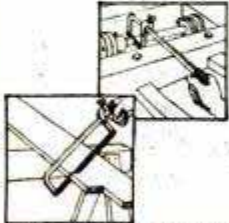

With the 3 in. hack saw blade it is easy to reach behind projections. If you break your last blade you can still use it with the K-D Frame.



\$100 a week Selling Shirts.

Fred Frankel, Ill., writes: "I earned \$110 first week selling Carlton Shirts direct to consumer." You can, too. No capital or experience required. We pay 25% cash commissions daily and big extra bonuses. Write for FREE SAMPLES.

CARLTON MILLS, INC. (Shirt Manufacturers)
114 Fifth Avenue, Dept. 106, New York City

SEND FOR THE INTERNATIONAL CATALOG

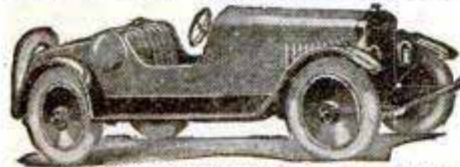

Our net price list. Full line of auto bodies and accessories for Fords at Wholesale Prices. Save big money on bodies by buying Direct from Factory.

FOR FORD—Prices from \$27.85 up. Factory to consumer direct—Pay Only One Profit.

International Body Works, 914 W. Ohio Street, Dept. 7, Chicago, Illinois

HOW A BOY BUILT UP A GREAT SQUAB FARM



Started small in backyard when at school with no money, now has \$30,000 plant, ships to New York 150 bbls. squabs yearly, receiving \$75 to \$100 a barrel. You can do the same. Send for this book. Price is fifty cents but we will mail it to you for the names and addresses of four of your friends and only ten cents, silver or U. S. stamps. Write today to

Squab Publishing Co., 634 A St., Melrose Highlands, Mass.

AGENTS \$75⁰⁰A Week SURE

Make \$75 a week and liberal bonus selling famous Pioneer tailored-to-measure, all-wool suits at \$23.50. Striking leather brief case containing nearly 100 large swatch samples furnished—other equally remarkable values at \$29.50 and \$34.50. We train the inexperienced. Men with determination and willingness to work for success, write for this big money-making opportunity.

PIONEER TAILORING CO.
159 W. Harrison St., Dept. V-1118 Chicago



WADE BENCH LATHE

AMATEUR MECHANICS, REPAIR SHOPS, INVENTORS, STUDENTS
A real machine tool for the home work bench—capacity 4" dia. x 12" length. For Metal—Wood—Composition Materials—Turning—Facing—Boring—Drilling—Winding—Thread Cutting. Accurate—Strong—Quiet—Compact. Slide-rest has travel entire length of bed. Leader-rod inside bed. No. 1 Lathes, plain headstock, \$28.00. No. 2 Lathes, back-gear headstock, \$56.00. Complete line of accessories at equally low prices. Write for free catalog.

THE GEROLD CO., Dept. P-25, 120 Liberty St., New York

"I Raze You!"

Welcome news! Here's Barbasol in my hand, and I hold a *straight* shave, *full* satisfaction, and *four* of a kind. No brush. No rub-in. No after-smart. No trouble. Try Barbasol—3 times—according to directions. 35c and 65c tubes.

Wonderful for Sunburn

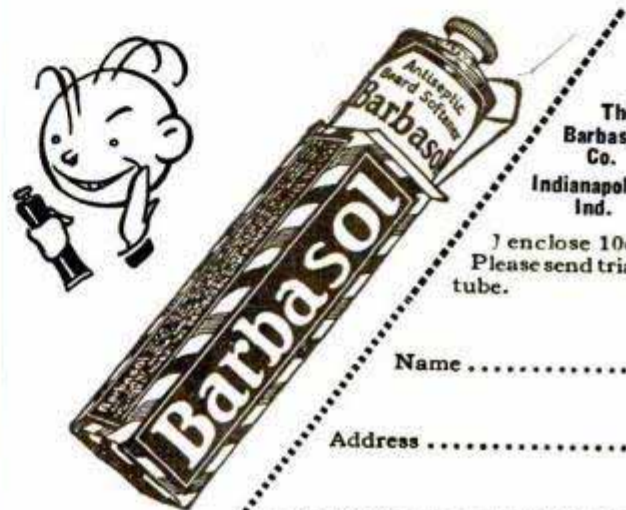

The Barbasol Co.
Indianapolis Ind.

I enclose 10c. Please send trial tube.

Name

Address

P-M-8-26

For Modern Shaving

KARAS HARMONIK TRANSFORMERS ORTHOMETRIC CONDENSERS

The highest quality parts possible to produce.

KARAS ELECTRIC CO., 1115 Association Bldg., CHICAGO

NEW VEST POCKET ADDING MACHINE

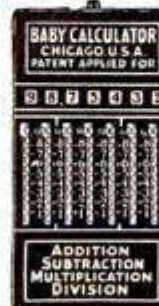

ADDS, SUBTRACTS, MULTIPLIES, DIVIDES
Does work of \$300 machine. Guaranteed 5 years. NOT A TOY.

Made of steel and indestructible. Million dollar capacity. Fits in pocket. Will not make mistakes. So simple child can operate it. Everybody should carry one for figuring.

FREE TRIAL \$2.50
Total Cost

SEND NO MONEY—Just name and address. We will ship Calculator immediately. On delivery pay postman \$2.50 (Plus few cents Postage) (If outside U. S. send cash). If not satisfied after 10 day trial you get your money back. THOUSANDS OF SATISFIED USERS. This is lowest priced practical calculator made. "Why pay more for inferior imitations?" Order from this ad.

AGENTS

BABY CALCULATOR SALES CO.
P. O. Box No. 1118 Chicago, Ill. Dept. 31
Write for big commission and territory proposition.



PA INVENTORS.

**JUST
ACROSS
STREET
FROM
U.S. PAT.
OFFICE.**

At the right is a view of my drafting and specification offices where a large staff of experienced experts are in my constant employ. All drawings and specifications are prepared under my personal supervision.



PROTECT YOUR IDEAS Take the First Step Today

If you have a useful, practical, novel idea for any new article or for an improvement on an old one, you should communicate with a competent Registered Patent Attorney AT ONCE. Every year thousands of applications for patents are filed in the U. S. Patent Office. Frequently two or more applications are made for the same or substantially the same idea (even though the inventors may live in different sections of the country and be entirely unknown to one another). In such a case, the burden of proof rests upon the last application filed. Delays of even a few days in filing the application sometimes mean the loss of a patent. So lose no time. Get in touch with me at once by mailing the coupon on the opposite page.

Prompt, Careful, Efficient Service

This large, experienced organization devotes its entire time and attention to patent and trademark cases. Our offices are directly across the street from the U. S. Patent Office. We understand the technicalities of patent law. We know the rules and requirements of the Patent Office. We can proceed in the quickest, safest and best ways in preparing an application for a patent covering your idea. Our success has been built on the strength of careful, efficient, satisfactory service to inventors and trademark owners located in every state in the Union.

Clip this Coupon and Mail

TENTS

Write for these FREE BOOKS

NO CHARGE for Information On How to Proceed!

The booklet shown here contains valuable information relating to patent procedure that every inventor should have. And with it I will also send you my "Record of Invention" form on which you can sketch your idea and establish its date before a witness. Such evidence may later prove valuable to you. Simply mail the coupon and I will send you the booklet, and the "Record of Invention" form, together with detailed information on how to proceed and the costs involved. Do this NOW. No need to lose a minute's time. The coupon will bring you complete information entirely without charge or obligation.

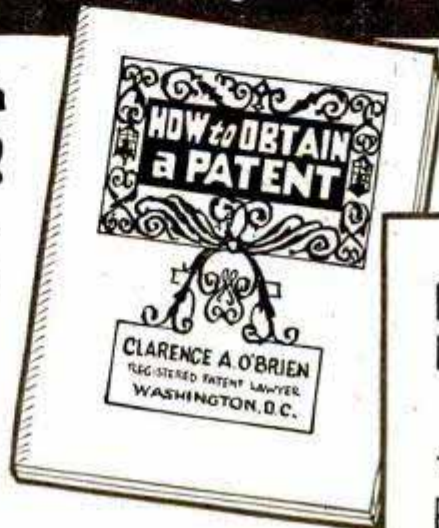

STRICT SECRECY PRESERVED

All communications, sketches, drawings, etc., are held in strictest confidence in strong, steel, fireproof files, which are accessible only to authorized members of my staff. Feel free to write me fully and frankly. Your case will have my personal attention. It is probable that I can help you. Highest references. But FIRST—clip the coupon and get my free book. Do THAT right now.

Clarence A. O'Brien

Registered Patent Attorney

Member of Bar of: Supreme Court of the United States; Court of Appeals, District of Columbia; Supreme Court, District of Columbia; United States Court of Claims

Practice confined exclusively to Patents,
Trademarks and Copyrights

FREE COUPON

CLARENCE
A. O'BRIEN

Registered
Patent Attorney

70-K Security Savings and
Commercial Bank Bldg.,
Washington, D. C.

Please send me your free book, "How to Obtain a Patent," and your "Record of Invention" form without any cost or obligation on my part.

Name.....

Address.....

It Now!

(Important: Write or Print name clearly)

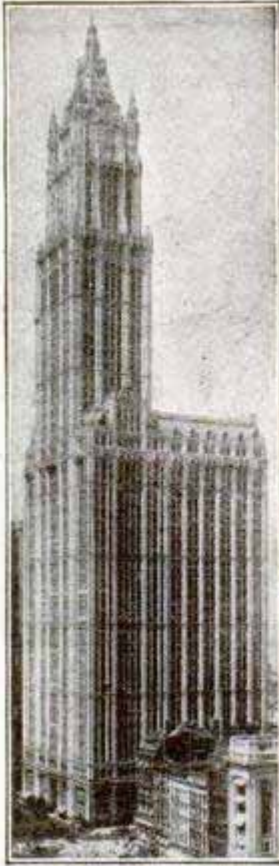

Our New York Office
Suite 1007 Woolworth Bldg.



Our Philadelphia Office
Suite 714-15 Liberty Bldg.



Our Washington Office
Victor Building

PATENTS TRADE-MARKS AND COPYRIGHTS

Have You An Idea?

Our Offer: FOR THE PROTECTION OF YOUR INVENTION YOUR FIRST STEP

Before disclosing an invention the inventor should write for our blank form

"RECORD OF INVENTION"

This should be signed and witnessed and returned to us together with model or sketch and description of the invention for

INSPECTION and INSTRUCTIONS

No Charge for the Above Information

**Our Four Books Mailed
Free to Inventors**

Our Illustrated Guide BOOK

HowtoObtain a Patent

Contains full instructions regarding U. S. Patents. Our Methods, Terms, and 100 Mechanical Movements illustrated and described.

Our Trade Mark Book

Shows value and necessity of Trade Mark Protection. Information regarding *Trade Marks and unfair competition in trade.*

Our Foreign Book

We have Direct Agencies in Foreign Countries, and secure Foreign Patents in shortest time and lowest cost.

Progress of Invention

Description of World's Most Pressing Problems by Leading Scientists and Inventors.

We Regard a Satisfied Client as our best advertisement, and furnish anyone, upon request, lists of clients in any state for whom we have secured patents.

*Highest References—Prompt Attention
—Reasonable Terms*

VICTOR J. EVANS & CO.

PATENT ATTORNEYS

Main Offices: 956 9th St., N. W., Washington, D. C.

Opposite U. S. Patent Office

PATENTS TRADE-MARKS AND COPYRIGHTS

IMPORTANT

TO HAVE YOUR CASE MADE SPECIAL AND AVOID DELAY YOU SHOULD HAVE YOUR CASE MADE SPECIAL IN OUR OFFICE to secure protection, save correspondence and secure early filing date in Patent Office. To secure special preparation of your case send \$25.00 on account with model or sketch and description of invention.



MAIN OFFICE, VICTOR J. EVANS & CO.—VICTOR BUILDING, WASHINGTON, D. C.

Our Lawyers Practice in all U. S. Courts and defend Clients in Suits involving Patents, Trademarks and Copyrights

All Communications and Data Strictly Confidential. Interference and Infringement Suits Prosecuted

OUR ORGANIZATION OFFERS PERSONAL SERVICE By Experienced Patent Lawyers, Solicitors and Draftsmen

**FREE
COUPON**

**VICTOR J. EVANS & CO.
PATENT ATTORNEYS**

NEW YORK OFFICES
1007 Woolworth Bldg.

CHICAGO OFFICES
1114 Tacoma Bldg.

PHILADELPHIA OFFICES
714-715 Liberty Bldg.

PITTSBURGH OFFICES
514 Empire Bldg.

SAN FRANCISCO OFFICES
Hobart Bldg.

MAIN OFFICES: 956 9th Street, N. W., WASHINGTON, D. C.

Gentlemen: Please send me *Free of Charge* your books as described on preceding page.

Name

Address



Our Chicago Office
Suite 1114 Tacoma Building



Our Pittsburgh Office
Suite 514 Empire Building

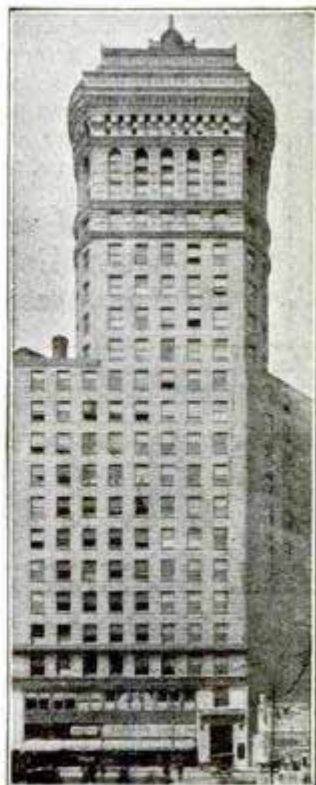

Our San Francisco Office
Suite 1010 Hobart Building

PATENTS

TRADE MARKS • DESIGNS • FOREIGN PATENTS

MUNN & CO. PATENT ATTORNEYS

Associated since 1846 with the Scientific American

1572 SCIENTIFIC AMERICAN BLDG.
New York City

523 SCIENTIFIC AMERICAN BLDG.
Washington, D. C.

1312 TOWER BUILDING
Chicago, Ill.

665 HOBART BUILDING
San Francisco, Cal.

520 VAN NUYS BUILDING
Los Angeles, Cal.



Books and Information on Patents and Trade Marks by Request. Associates in All Foreign Countries.

PATENTS

As one of the oldest patent firms in America we give inventors at lowest consistent charge, a service noted for results, evidenced by many well known patents of extraordinary value. *Book, Patent-Sense, free.*

LACEY & LACEY
Established 1869
704 F St., Washington, D. C.



PATENTS

Send us sketch or model for advice and exact cost of patent. Our book "How to Obtain a Patent" sent free. It tells how to apply for Patents, Trade Marks, Foreign Patents, Copyrights, etc.; gives information on Patent Procedure; tells what every inventor should know. Thousands of inventors, who are our clients, are our reference.

CHANDLEE & CHANDLEE, 25 Years' Experience
473 7th St. Washington, D. C.

Have You An Invention?

If so the WORLD PROGRESS will send you upon request sample copy Free containing SUGGESTIONS TO INVENTORS as to Inventions Needed. We invite manufacturers to address us regarding inventions they want.

Subscription for one year 60 cents

WORLD PROGRESS PUB. CO., Inc.
Room 203 Victor Bldg. WASHINGTON, D. C.

PATENTS

Booklet Free Highest References
Promptness Assured Best Results

Send drawing or model for preliminary examination of Patent Office records.

ALL BUSINESS GIVEN PROMPT AND PROPER ATTENTION

Listed Patent Lawyer in the latest editions of the Rand-McNally Directory of Bankers and Attorneys, of Chicago, Ill.; The Baggott & Ryall Directory of Attorneys, New York City; The Lawyers Guaranteed Directory, Detroit, Michigan; The Lawyers and Bankers Quarterly, published by the Legal Directory Publishing Company of St. Louis, Mo.; the American Lawyers Annual, Cleveland, Ohio.

WATSON E. COLEMAN,
REGISTERED PATENT LAWYER

644 G Street, N. W., Opp. U. S. Pat. Office
WASHINGTON, D. C.

INVENTORS PROTECT YOUR IDEAS

Before disclosing your invention send for our Evidence of Invention Blank. This should be signed and witnessed and returned to us with a model or sketch and a description of your invention for our Inspection and Instructions which are free.

Also send for

Our guide book "How to Get Your Patent" which is sent free upon request. This book includes full instructions regarding U.S. Patents, Trade Marks, our Terms, Methods, etc.

WRITE TODAY

RANDOLPH & COMPANY

300 Victor Bldg., Washington, D. C.

Please send me FREE OF CHARGE your Evidence of Invention blank and your guide, "How to Get Your Patent."

Name.....

Street.....

City..... State.....

EVIDENCE
OF
INVENTION
BLANK

To whom it may
concern.

HOW TO GET
YOUR PATENT

RANDOLPH & CO.
WASHINGTON
D. C.

Terms
Reasonable
Best
References

RANDOLPH & CO.

300 Victor Bldg. Washington, D. C.

PATENTS

To the Man with an Idea

I offer a comprehensive, experienced, efficient service for his prompt, legal protection and the development of his proposition.

Send sketch, or model and description, for advice as to cost, search through prior United States patents, etc. Preliminary advice gladly furnished without charge.

My experience and familiarity with various arts frequently enable me to accurately advise clients as to probable patentability before they go to any expense.

Booklet of valuable information and form for properly disclosing your idea free on request. Write today.

Richard B. Owen, Patent Lawyer
9-303 Owen Bldg., Washington, D.C.
41-E Park Row, New York City

TRADE-MARKS
REGISTERED

We Purchase Patents We Manufacture Metal Items



We have a complete Sales Organization for distributing to Domestic and Foreign trade, Hardware, Metal Notion and Novelty Items



The Boye Needle Company
Manufacturers and Distributors

4335 to 4343 Ravenswood Avenue
Chicago, Ill., U. S. A.

BRANCHES: NEW YORK • SAN FRANCISCO

Tires Hammered Full of NAILS LEAK NO AIR



MAKE YOUR TIRES PUNCTURE-PROOF In ONE Minute

Galacite The new scientific invention—has the marvelous property of sealing all punctures the moment they occur. ACTS INSTANTLY. You can pick up any number of nails WHILE RIDING without the loss of a pound of air. One application, made in a minute, without taking tire off wheel or rim, actually makes tire puncture-proof for life. Guaranteed not to injure tire, tube or valve. On the contrary Galacite preserves rubber, lengthening the life of both tube and tire,—

Often Increasing Tire Mileage from 10,000 to 12,000 Miles

MAKE THIS TEST Take a hammer and drive as many nails into a tire as you wish, 10, 50, 100, it makes no difference; all punctures are sealed instantly. Used in all kinds of tires including low pressure BALLOONS. Galacite is inexpensive and can be tried out at our risk. Warranted for one year but will last indefinitely.

GUARANTEED TO DO ALL WE CLAIM

Don't confuse Galacite with anything else ever intended for the same purpose; it is new and different—a revolutionary invention, the result of years of research and experiment. We are a long established highly rated concern. Galacite is backed by our Money Back Guarantee. It must make good—or we will. *You take no risk.*

AGENTS—Earn \$5,000 to \$10,000 a Year

TREMENDOUS PROFITS Galacite agents make almost unbelievable success. A NAIL DRIVING demonstration does the selling. No lengthy arguments. Demonstrate and sell to car owners, Garages, Filling Stations. Work all or spare time in your home town or travel. You can also manufacture and sell GALACITE PUNCTURE PROOF inner tubes. The market for Galacite is inexhaustible. EXCLUSIVE territory and splendid FREE ADVERTISING HELPS make your business permanent. RUSH your name to us for full particulars. TERRITORY IS GOING FAST. Delay may cost you the chance to make \$5,000 to \$10,000 a year. Send no money, just your name, but WRITE TODAY.

C. F. JOHNSON & CO. 19 W. Jackson Blvd., Dept. 306 CHICAGO

PATENTS

Trade Marks, Copyrights, Patent Litigation Handbook with illustrations, 100 mechanical movements. Sent free on request.

ALBERT E. DIETERICH
formerly member examining corps U. S. Patent Office
PATENT LAWYER and SOLICITOR

621-A, Ouray Bldg.
27 Years' Experience Washington, D. C.

C. L. PARKER

Ex-Examiner U. S. Patent Office

ATTORNEY-AT-LAW and SOLICITOR OF PATENTS

McGILL BLDG. WASHINGTON, D. C.
Patent, Trade Mark and Copyright Law.

BLUE BOOK ON PATENTS

AND PRIORITY RECORD BLANK GRATIS.

MONROE E. MILLER, PATENT LAWYER
111-2 Ouray Building, WASHINGTON, D. C.
ELECTRICAL AND MECHANICAL EXPERT

Catch! Fish

Mink, Muskrats with our new folding galvanized **STEEL WIRE TRAP**. Write for our **FREE TRAP OFFER** and Bargain Catalog of Supplies. \$1 Box of our famous Fish Bait for 50c. **WALTON SUPPLY CO., 3505 JUNIATA AVE., ST. LOUIS, MO.**

Buy Army Aero Motors

129 miles per hour, 5 passengers, Ortonville, Minn.



\$3000.00 Original cost to U. S. Army. New, majority original crates. Specifications: 165 H. P. 9 cylinder air cooled Gnome rotary motors weighing 292 pounds. Complete with two magnets, oil pump, switch, oil gauge, throttle, carburetor and mixing valve ready to install in your aeroplane motor boat, ice sled or scooter. Blue prints of sleds furnished \$1.00 each. Build your own speed boat. Army now using 400 H. P. American made motors—reason, low price. Complete stock parts. I can furnish propellers, pusher or tractor \$25.00 each. **AERO ENGINES.** Curtiss \$150.00-\$350.00. Le Rhone \$50.00-\$100.00. Hispano \$300.00 up. Liberty \$2250.00. Sport plane motor 50 H. P., 149 lbs., \$100.00. Set sport plane wings \$35.00. **AEROPLANES.** Thom's Morse, new, \$750.00. Avro \$950.00. Curtiss \$950.00. Standard Hispano \$1950.00 5 passenger, 3 passenger \$1650.00. Resistal goggles with extra pair clear glass, \$2.60 postpaid. Parts for all planes and flying instruction at my flying field.

SALE PRICE \$3500 EACH
F.O.B., Dayton, O.
Cash with order

WRITE for CIRCULAR, Gnome motors, 16 page booklet ready for press. Inclose postage.

MARVIN A. NORTHPROP

730 Washington Avenue, North, Minneapolis, Minnesota

On the JOB

at Home Workshop
or Factory Bench



The *do-all* gives you six man-size machines in one—

Jig Saw Drill Press
Turning Lathe Filing Machine
Circular Saw Buffer & Grinder

You can change from one to the other in actually one minute. Never before has so complete and so compact an Outfit been offered at so low a price. Precision built for hard work and steady wear. Mounted as a portable unit. Fully guaranteed. This is a machine that will *Make* or *Save* you money.

Free illustrated catalog showing all combinations, attachments, etc., sent on request. WRITE TODAY!

Do-All Appliance Co. 152-58 Whiting St., Chicago, Ill.



do-all

The "6 in 1" Machine

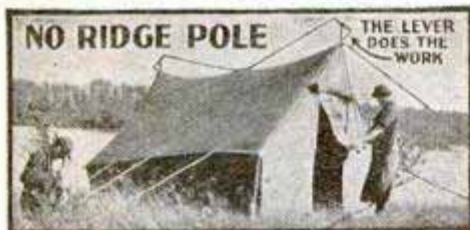

Can be carried on side of car.

Greatest Auto Touring Tent

Nothing else like it. All the comfort, headroom and cot space of a wall tent without the bother of carrying a long, cumbersome ridge pole.

THE WENZEL POLELESS TOURING TENT

Has no ridge pole. The two self-adjusting levers fitted with coil springs keep the ridge firm. Has guy ropes like a real Army tent. Stands firm when others blow down. Made of genuine mineral-dyed Army Khaki duck—pliable, waterproof, mildew-proof and odorless. Equipped with bobbinet and curtain door and rear window. Detachable floor fits over sod cloth—makes tent insect-proof. Uprights are jointed, seamless steel.

Costs Much Less

Wenzel Poleless Touring Tent costs 20% to 50% less than the unsteady, cumbersome square types which require heavy framework.

Folds Compactly

Entire tent folds into bundle smaller and lighter than any other tent of equal size. Simple to erect.

Easy to Carry



Mail Coupon for Literature

H. WENZEL TENT & DUCK CO.,
1062 PAUL ST., ST. LOUIS, MO.

Without obligation, send me illustrated literature and name of nearest dealer.

NAME _____
ADDRESS _____
CITY _____ STATE _____



Daven Bass Note Circuit Demonstration Set—seen from above.

Build NEXT Year's Set Sensation NOW!

UNQUESTIONABLY the sensation of the coming season will be the Daven Bass Note Circuit. Already it is a sensation with the limited number of fans who have had a chance to hear it.

Build it *now*—and yours will be the most talked of radio set in your locality. All your friends will be copying it.

The Daven Bass Note Circuit is just what its name implies. It transmits, completely and perfectly, *all the low notes in the music*, with the same clarity and beauty that characterize the higher vibrations. This is something no hook-up has yet been able to do.

The Daven Bass Note Circuit was developed at the request of the fan. We had innumerable demands for a RADIO Amplification end that would be as good as the AUDIO Amplification end represented by the popular Daven Super Amplifier; one that would perfect detection and eliminate noises and losses; one that would be easy to assemble.

The Daven Bass Note Circuit, built of the famous Daven parts, is easy to assemble and to operate, because built on a *straight line*.

Go to the Authorized Daven Service Dealer in your locality. He will be glad to demonstrate the new quality of reception which the Daven Bass Note Circuit brings, and supply you with the necessary Daven units for putting together this important new type of receiver.

The Daven Units That Make Up



Bass Note Circuit

- | | |
|--------------------------|-----------------------------|
| 1 Set D. R. F. Coils | 1 Daven Leakandenser No. 22 |
| 1 Daven Super-Amplifier | 1 Daven 1/4 Ampere Ballast |
| 3 Daven Mu-20 Tubes | 1 Daven 1/2 Ampere Ballast |
| 1 Daven Mu-6 Power Tubes | 1 Daven Type "A" Condenser |

"The Sine of Merit"

DAVEN RADIO CORPORATION

TRADE MARK "Resistor Specialists" REGISTERED

165 Summit Street NEWARK, N. J.



RESISTOR HANDBOOK

This complete authoritative handbook on Daven Amplification may be secured from your dealer for 25c or sent direct by mail for 30c. Complete Catalog Free.

Double Rigid Double Rapid



**Saves Time!
Saves Your Face!**

GET next to Gem Double Life Blades! Let your face revel in double-cool, double-clean, double-quick Gem shaves!

Gem Blades are double-thick and double-reinforced! They won't bend! They won't quiver! They're double-keen! They smooth away the whiskers at the dermal line!

Double-protected, double-sealed—they're backed by a double-satisfaction guarantee! Sold everywhere.

P.S.—Double your shaving joy with a Gem de Luxe Razor. It's scientifically right, perfectly balanced. If you have an old Gem Razor that isn't doing its bit, send it to our service department, our guarantee means something. Send it to the

GEM SAFETY RAZOR CORPORATION
Brooklyn, N. Y.

GEM Double Life BLADES

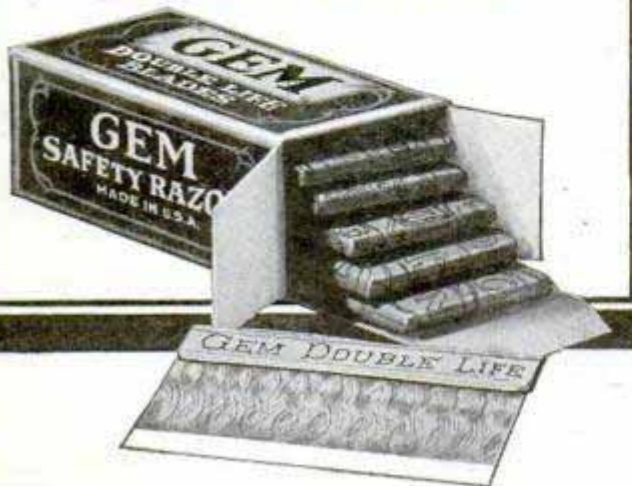

Be sure You get these CONN FEATURES



R. E. CLARK,
solo trombonist
U. S. Marine
Band, uses a
Conn.

EXCEPTIONALLY easy playing; beauty of tone; perfect scale; absolutely dependable mechanism, are features of every Conn instrument for band and orchestra. As world's largest builder of band instruments Conn has developed improvements and patented features which enable you to make faster progress, quick success in a big way. The world's foremost artists use Conns. And Conn features **COST NO MORE!**

Free Trial, Easy Payments on any Conn cornet, trombone, saxophone -- everything for band or orchestra. Write now for Free literature and details of trial offer; mention instrument.

C. G. CONN, LTD.
831 Conn Bldg., Elkhart, Ind.

CONN BAND INSTRUMENTS

WORLD'S LARGEST MANUFACTURERS

A new Parks!

Cabinet Shop
Special No.10

\$290

as illustrated
with motor



You ought to have this handy Parks in your shop!

A compact, complete machine designed just like a big production outfit at one-fifth the cost. Nothing extra to buy. Motor is included, operating from any light socket. Fits in a corner of your basement. Does any kind of cabinet and joinery work. Circular saw, jointer and bandsaw on permanent all-steel frame. Add lathe, shaper and other attachments at small cost. You can make money with this Parks! Write for circular.

The Parks Ball Bearing Machine Co.
1500-1540 Knowlton Street, Cincinnati, Ohio
Canadian Factory: 200 Notre Dame East, Montreal, Can.

PARKS WOODWORKING MACHINES

NEW DOUBLE-HEAD REVERSIBLE SPARK PLUG

ABSOLUTELY GUARANTEED FOR 2 YEARS

USERS "WILD OVER IT"

A New Spark Plug with increased value and efficiency—for all makes of cars, trucks and tractors. Double head means double service. Usable at both ends. Two plugs in one. Automatically cleans itself by running; without detaching wires. Color of spark, visible on top; shows how efficient they fire. Positively a sensation. Entirely new. Exclusive principle. In a class by itself. Everybody wild over it. All say it's a wonder.

MORE PROOF—G. Engesser of Iowa says:

"Your Double Head Reversible Spark Plug is the best I've ever used. I had to clean plugs daily before using yours."

EVERYBODY SATISFIED

There is nothing else like it—means unlimited spark plug service. Its life is perpetual. That's the reason we do not hesitate to guarantee it for two years.

NEW PRINCIPLE—SELLS ITSELF

Wherever demonstrated everyone is convinced of the increased value in this new principle and easily sells itself. Every user is a sales booster.

SPECIAL INTRODUCTORY OFFER

To the first person in each locality we are willing to send a set under a very special offer.

BE THE FIRST IN YOUR LOCALITY

CHICAGO TIRE LUG COMPANY, INC.,
SPARK PLUG SALES DIVISION
179-338 W. 47th St. CHICAGO, ILLS.



AGENTS "MAKE BIG MONEY"

This field is tremendous. The money-making possibilities are wonderful. Spare time or full time. They all make money. No experience necessary. Your profits are only limited by the number of automobiles in your locality. Every car owner that sees this new plug is interested and wants to buy.

VISIBLE CAP FITS EITHER END \$60 TO \$120 PER WEEK

Ordinary profits do not belong in this class, because the advertising value of each satisfied user creates a bigger demand and this demand must be supplied. That's why we want distributors everywhere. This means big money to each distributor. Irregardless of what you may have sold before, here is a real article, with a real proposition, in an unlimited field.

Agents Wanted Everywhere

The demand for territory will be big, so we advise you to act promptly. Remember, we want to be fair to everyone.

COSTS NO MORE Than Any Ordinary Spark Plug—Outlasts Them all

Agents Wanted Everywhere
The demand for territory will be big, so we advise you to act promptly. Remember, we want to be fair to everyone.

MAIL TODAY

CHICAGO TIRE LUG CO., Chicago, Ill.
179-338 W. 47th St.
Gentlemen:—Kindly mail me free particulars about your latest invention and direct factory selling plan.
Name.....
St. or R. F. D.....
City.....
State.....

Outboard Motor Owners—Here's Big News!

If you have an Elto, Johnson, Evinrude, Lockwood-Ash or Caille outboard motor, you'll surely want a McNAB MANEUVERING RUDDER. Just attach a McNab and you'll have supreme and sensitive control. Your motor runs ahead always—you don't touch the motor control at all.

Go forward or reverse at any speed—rotate your boat as if on a pivot—stop her in less than boat length—take on or let off passengers at shore or dock, without stopping motor. A wonderful invention—a sensation! Every owner enthusiastic.

Sold by Outboard Motor Dealers everywhere. If yours can't supply write for FREE BOOK and prices.



Fits All Motors

- Steers
- Brakes
- Maneuvers
- Reverses

McNab Corporation
Dept. 51, Yonkers, N. Y.

Send me your Free Book on the McNab Rudder:

Name

Address

Make of Outboard Motor

CARPENTERS

ABC Protractor Square saves time. Write for circular and price. Stamping Tool Company, La Crosse, Wis.

Walter Critchlow, B-116, Wheaton, Ill., has patented a new Vapor Humidifier and Gas Saver for all autos that beats anything ever gotten out. One Ford owner reported 66 miles on 1 gallon. He offers 1 free. Write him for one. He also wants county and state distributors who can make \$500 to \$2,500 per month.

AGENTS—\$50 to \$75 WEEKLY

Agents everywhere are rolling up remarkable earnings. Exclusive territory. Write to-day—right now. New invention makes discarded safety razor blades a practical and useful knife. Brand new. Experience unnecessary. Everybody buys. 200% profit. Whale for quick sale. Send for full information.

A. N. GITS CO. 5419 W. Chicago Av., CHICAGO

FORD OWNERS JUST RITE TIMER INSERT



is the greatest invention of today. Replaces roller in timer. We guarantee Just Rite will outlast your car. To introduce this wonderful timing device, for a limited period, we will, upon receipt of 25c, mail you a sample postpaid. Also our

JUST RITE Ford Foot Accelerator,

for 50c, cannot be beat. This device is easily installed by anyone. We are looking for good and reliable representatives everywhere to distribute our line of Ford accessories. Send for descriptive literature.

JUST RITE ACCESSORIES CO.

Dept. 8 1926 So. Wabash Ave. CHICAGO, ILLINOIS

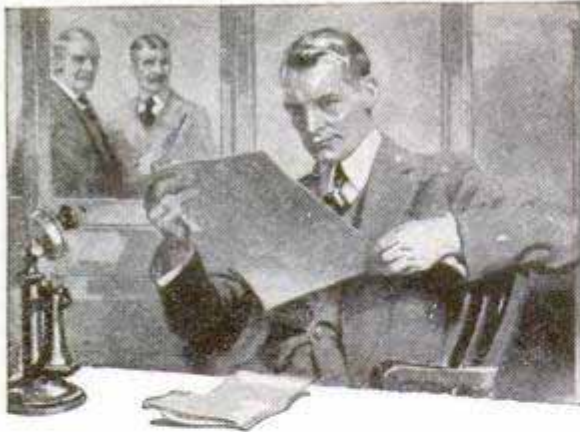

"I wish we had more men like him"

"I've given him two promotions in the last year and he's made good each time.

"I always feel safe in moving him up because I know that he's preparing himself to handle bigger work.

"The International Correspondence Schools keep me advised of the progress he is making and I've encouraged him to keep on. His spare-time studying certainly has made him a valuable man to this firm."

Why don't you study and get ready for promotion too? We'll be glad to help you if you will only make the start. And the way to do that is easy.

Choose the work you like best in the coupon below; then mark and mail it to the International Correspondence Schools today. This doesn't obligate you in the least, but it will bring you information that will help to start you on a successful career. This is your opportunity. Don't let it slip by.

Mail the Coupon for Free Booklet

INTERNATIONAL CORRESPONDENCE SCHOOLS
Box 5593-E, Scranton, Penna.

Without cost or obligation, please tell me how I can qualify for the position or in the subject before which I have marked an X:

BUSINESS TRAINING COURSES

- | | |
|--|---|
| <input type="checkbox"/> Business Management | <input type="checkbox"/> Salesmanship |
| <input type="checkbox"/> Industrial Management | <input type="checkbox"/> Advertising |
| <input type="checkbox"/> Personnel Organization | <input type="checkbox"/> Better Letters |
| <input type="checkbox"/> Traffic Management | <input type="checkbox"/> Show Card Lettering |
| <input type="checkbox"/> Business Law | <input type="checkbox"/> Stenography and Typing |
| <input type="checkbox"/> Banking and Banking Law | <input type="checkbox"/> Business English |
| <input type="checkbox"/> Accountancy (including C.P.A.) | <input type="checkbox"/> Civil Service |
| <input type="checkbox"/> Nicholson Cost Accounting | <input type="checkbox"/> Railway Mail Clerk |
| <input type="checkbox"/> Bookkeeping | <input type="checkbox"/> Common School Subjects |
| <input type="checkbox"/> Private Secretary | <input type="checkbox"/> High School Subjects |
| <input type="checkbox"/> Spanish <input type="checkbox"/> French | <input type="checkbox"/> Illustrating <input type="checkbox"/> Cartooning |

TECHNICAL AND INDUSTRIAL COURSES

- | | |
|---|--|
| <input type="checkbox"/> Electrical Engineering | <input type="checkbox"/> Architect |
| <input type="checkbox"/> Electric Lighting | <input type="checkbox"/> Architects' Blue Prints |
| <input type="checkbox"/> Mechanical Engineer | <input type="checkbox"/> Contractor and Builder |
| <input type="checkbox"/> Mechanical Draftsman | <input type="checkbox"/> Architectural Draftsman |
| <input type="checkbox"/> Machine Shop Practice | <input type="checkbox"/> Concrete Builder |
| <input type="checkbox"/> Railroad Positions | <input type="checkbox"/> Structural Engineer |
| <input type="checkbox"/> Gas Engine Operating | <input type="checkbox"/> Chemistry <input type="checkbox"/> Pharmacy |
| <input type="checkbox"/> Civil Engineer | <input type="checkbox"/> Automobile Work |
| <input type="checkbox"/> Surveying and Mapping | <input type="checkbox"/> Airplane Engines |
| <input type="checkbox"/> Metallurgy | <input type="checkbox"/> Navigation |
| <input type="checkbox"/> Steam Engineering | <input type="checkbox"/> Agriculture and Poultry |
| <input type="checkbox"/> Radio | <input type="checkbox"/> Mathematics |

Name.....
Street.....
Address.....
City..... State.....
Occupation.....

Persons residing in Canada should send this coupon to the International Correspondence Schools Canadian, Limited, Montreal, Canada.

What \$1 Will Do!

Yes, only \$1 will bring your choice of these Big Bargains for your approval and 15 DAY TRIAL. Simply pin \$1 bill to this ad, indicate your selection and mail it TODAY. If you can duplicate your selection for less money elsewhere, send it back and your \$1 will be refunded. If satisfied, pay balance in 10 equal monthly payments. NO RED TAPE--PROMPT DELIVERY DEALINGS CONFIDENTIAL



B80--Ladies 18K White Gold Ring; beautifully designed, AA-1 Blue-white Diamond. \$50. \$4.90 a Month.

B81--Ladies hand-engraved 18K White Gold Birthstone Ring set with 2 Blue-white Diamonds. Any birthstone furnished. \$25. \$2.40 a Month.

B82--Ladies hand-carved 18K White Gold ring, with 3 Blue-white Diamonds. \$45. \$4.40 a month.

B83--Gents 14K Solid Gold hand-engraved Ring with AA1 Blue-white Diamond set in White Gold square-top. \$42.50. \$4.15 a Month.

B84--14K White Gold Wristwatch; 4 Blue-white Diamonds; 4 Blue Sapphires. Guaranteed 16 Jewel movement. \$42.50. \$4.15 a Month.

B85--Famous Bulova Gents Strap Watch, 14K Gold-filled case; guaranteed 16 Jewel movement. \$28.50. \$2.75 a Month.

B86--12 size 21 Jewel Illinois Victor Watch; 14K Green Gold filled case. Price \$45. \$4.40 a Month.

Its a Bulova
B85--\$28.50

3,000 Big Bargains in Diamonds, Watches and Jewelry shown in this catalog. Send for it Today--it's FREE.

L.W. SWEET Inc.
DEPT. 66-N 1660 BROADWAY NEW YORK



\$17 A WEEK IN SPARE TIME

THAT'S what Dorothy Bagley of Ohio earned in spare time, the very first week she became an agent for our beautiful imported and domestic fabrics. You may do even better. No experience or capital needed. Write for big sample book. Address

THE NATIONAL IMPORTING CO., Dept. H-8, 573 Broadway, N. Y. C.

Here Men!

A CHANCE FOR QUICK SUCCESS

ALL WOOL MADE TO MEASURE SUITS

\$23.50

No fancy selling to make big money with the new Fall line of Wright tailored to measure clothes. Two prices--\$23.50 and \$31.50. Suits every taste. All wool fabrics. Guaranteed fit and tailoring. Orders come easy--you just take measures and pocket \$3.00 to \$7.00 profit on the spot. We attend to everything else. Complete outfit furnished you to do big business. **130 all wool 9x13 samples.** Advertising helps and complete instructions so clear you can't fail--**all FREE.** No deposit. Exclusive territory given. Rush application today. Tell us your past experience.

WRIGHT & COMPANY, Dept. 19, 2226 to 2302 Wabasha Ave., Chicago, Ill.

For men out of doors

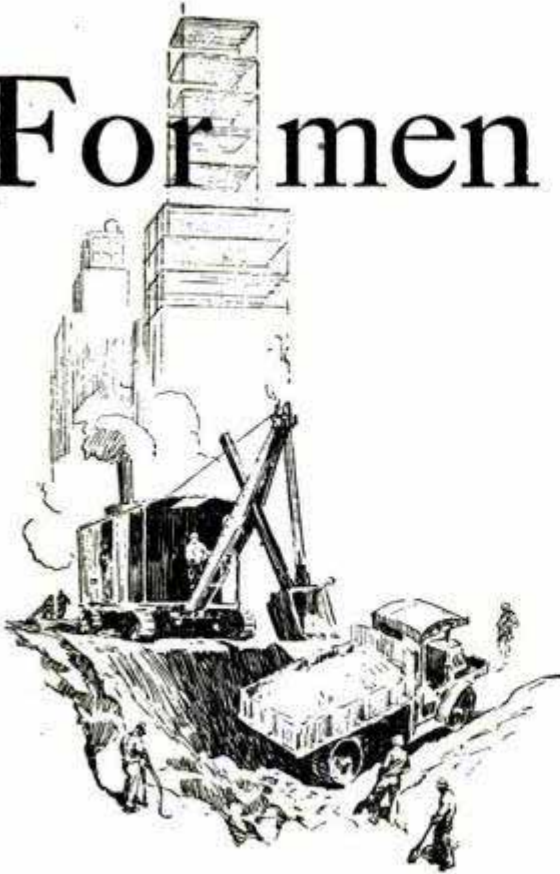

MEN whose work requires writing at the scene of action almost invariably use Corona.

It is the personal writing machine of the world—with standard keyboard, big-machine conveniences throughout, and a nineteen-year record of durability.

Look for "Corona" in your phone book.

L C Smith & Corona Typewriters Inc

Established 1903

709 E. Washington Street, Syracuse, N. Y.

Sales offices in principal cities of the world

Also manufacturers of the L C Smith Typewriter, the ball-bearing office machine



CORONA

THE PERSONAL WRITING MACHINE

Suppose You Were Offered Diamonds at 60% of Market Price

Suppose a reason you rarely think of makes possible here radically low prices, even for finest quality diamonds. Thousands of representative people, bankers, lawyers, merchants, others—continually reap this real advantage. Everything sent for Free Examination. This 3/4 century, oldest, largest diamond banking institution in the world, rated over \$1,000,000.00,—converts into cash the diamonds on which money was loaned and not repaid. Loan values, a fraction of market values, are the price basis. Diamonds too from big cash deals direct with European cutters. Must sell now

Why Pay Full Prices

When Much Less Buys the Same See this 3/4 less 1/16 ct., snappy solitaire for \$69.50. Try to match at \$115.00. Examine free any bargain at our risk. Startling, legitimate offers here of diamonds at 60% of market price. Send now for full details. Diamonds of unusual qualities (also watches) from unpaid loans, offered at radically low prices based on mere loan values. Then, too, we have hundreds of diamonds from big, cash, European deals with diamond cutters, who sacrificed these gems away under the market. Send now for our latest offers of this internationally known cash headquarters.



Unpaid Loan Listings Ready

As low as \$60 a Carat

Radically different from a catalog. List accurately describes every diamond in full detail with guaranteed exact weight, color, quality, etc. Explains Guaranteed Cash-like Insurance Policy Loan guarantee. Also Unlimited Exchange privilege at price paid us. Gives full details of free examination offers. Don't wait, the very diamond you want may be in this very list at a price that will amaze you. Costs nothing to see. Write today. A postal will do, or—Mail Coupon NOW!



Command Recognition
a DIAMOND Does It

JOS. DE ROY & SONS
Only Opposite Postoffice
1947 De Roy Bldg., Pittsburgh, Pa.
Without obligation to buy, send me free, in plain envelope, your Latest Bargain List of Diamonds, Watches, and other Jewels.

Name _____
Address _____
City _____ State _____
References by Permission:—Bank of Pittsburgh, N. A.; Marine National Bank; Union Trust Co., Pittsburgh, Pa. Your bank can look us up in the mercantile agencies.

Interlox MASTER SLIDE RULE

Takes accurate inside or outside measurements

MASTER RULE MFG. CO., 813 E. 136th St., New York

Works fast. Slides in and out quickly. Durable made of brass trimmed boxwood. Any length 2 to 8 feet, 20 cents per lineal foot. If not at dealer's, sent postpaid. Dealers and Agents: request attractive proposition

Get this book FREE Auto Bargains

Amazing price cuts. Surplus stock of factories pressed for money and large purchases make possible our low prices. Everything from Cotter pin to Power Plant.

Save \$200 on Rear Axles

Book full of new and used replacement parts and accessories. Nationally advertised products. Sensational Bargains. Write Today! Ask for Radio Catalog Free.

WARSHAWSKY & CO.
1915-35 So. State Street Dept. PM-8 CHICAGO, ILL.



HERE'S THE REAL THING

I'm a Mechanic—I know

The Blade with the Reputation

STAR HACK SAWS

CLEMSON BROS., Inc. - Middletown, N.Y.

The skilled mechanic, profiting by his long experience, uses great care in selecting his tools.

Mechanics use Star Blades because they know what these blades will do.

Let us send you free sample blades.

CLEMSON BROS., Inc., MIDDLETOWN, N. Y.

MINNEAPOLIS LEGS ARMS



Largest Artificial Limb Center in the World
More limbs and braces shipped daily than from any other city.
Write: MPLS. ARTIFICIAL LIMB CO., 242 S. 4th St., MINNEAPOLIS, MINN.

Big 3-ft. Telescope

Makes people and objects miles away seem close. Brings new pleasures to home, farm, camp, travel, sport. See moon and stars as never before. New Ferry "Wonder" telescope has 5 sections—over 3 ft. long open, 12 in. closed. Fully brass bound. Powerful lenses.

FREE! Yes, Absolutely FREE! Hand-some leatherette covered Carrying Case, light, strong, complete with strap. Handy for farmers, auto tourists and hikers.

Only
\$1.85



5 Sections 8-Power Lenses Thousands Delighted!

"I am delighted with the 'Wonder' telescope. Today I have been watching submarines 3 miles off the coast."—Philip Brush. "I can see across the Mississippi 3 miles and see people fishing."—M. L. Thorn. "I am nearly 80 years old and if I could not get another would not take \$10.00 for it."—A. R. Walker. "I can tell time on the church clock 5 miles away."—Edward Foeter. "Could tell color of aeroplane 4 miles away."—Mrs. L. M. Yarbrough. "I saw a Light House 18 miles away."—Clyde Scribner.

Send No Money

Send name and address and Ferry Wonder 3-ft. Telescope with free Carrying Case will come by return mail. Pay postman special bargain price of \$1.85 plus a few cents postage. Satisfaction guaranteed or your money back. Supply limited.
Order Today! **FERRY & CO., Dept. 177-c, CHICAGO**

500 Quarts of Fire Quenching Gas from 1 Quart of Liquid

At last the ideal way to put out fires quick has been discovered. This is a new fire gun that shoots a chemical more than 25 feet without pumping. And this chemical coming in contact with fire creates a gas of more than 500 times the original volume. This gas smothers out fires instantly by shutting off the air. It puts out celluloid, gasoline, kerosene fires that water only makes worse. Absolutely stainless to clothes, harmless to people. Inexpensive. Always ready. Absolutely necessary for cars and homes, farms, garages, factories, schools, etc. Write at once for low price introductory offer to the Weldon Manufacturing Company, Dept. 7-K, Grand Rapids, Michigan. Agents or spare-time workers interested in making up to \$25 a day should write immediately for sales plan.—Adv.

Make \$100 Weekly—sell RADIO

Demonstrate Once—Results Mean Sure Sale

Sell what everybody wants—radio at low prices—easy sales—big profits—music from Coast to Coast—4, 5, 7 tube radio.

12 Selling Free Lessons

Establish a business of your own. Start sparetime—evenings. Sales course of 12 lessons and 10 radio service lessons teach you everything you need. Exclusive territory to proven men!

FREE Book! Tells how 3100 men have made big increase in their income under this unusual plan. Ask for Ozarka Plan No. 100 and don't fail to mention the name of your county.

OZARKA, Inc. 120 Austin Avenue P, Chicago, Illinois



Sell Made-to-Measure Suits

TAILORING AGENTS **Given! SUIT FOR YOURSELF**
\$60 A WEEK

Spare time agent: \$40 to \$60, full time \$50 to \$90 a week, selling finest line of tailoring in country. Sold with guarantee of absolute satisfaction or money back!

BIGGEST PROFITS

We pay biggest cash profits and give you fine suit made to your special measure to keep and use as sample for only a little work on your part.

FREE OUTFIT We put you in business for yourself and train you to make \$3,000 to \$5,000 a year. Send for Free Outfit with snappy styles, big cloth samples, order book, etc.—everything to operate profitable business. **Write Quick!**

O. K. TAILORING CO., Dept. 370, Chicago



Lake cruise

between **CHICAGO** and **DETROIT**

BY **62⁰⁰**

Largest Fleet of Liners on the Great Lakes

A 4-day round trip cruise in either direction including berth and meals on the luxurious steamers *Eastern States* and *Western States*, the fastest ships out of Chicago. Music, deck games, dancing, with hostess in attendance. Equipped with wireless. Autos carried. Unlimited stop-over privileges at Mackinac Island and either Detroit or Chicago. Service three times weekly from Detroit, June 24th to Sept. 4th; from Chicago, June 26th to Sept. 6th. Tickets limited to sleeping accommodations.

[Illustrated Booklet of D&C TOURS mailed up—on receipt of 2 cent stamp. Address Dept. PM]

Overnight Service to

Mackinac Island

"The Summer Wonderland"

from Chicago or Detroit
Three times weekly June 24th to Sept. 6th. Week-end \$31 trips. Round trip including berth and meals. . . .

Grand Cruise between

Buffalo and Chicago

Special round trip rate including berth and meals on all steamers in effect every Monday, June 24th to September 6th. Eight-day limit. Stop-overs at Niagara Falls, Detroit, Mackinac Island, or Chicago. . . . \$80

Overnight Service between

Detroit and Cleveland

daily to December 1st. Fare \$3.60 one way; \$6.50 round trip. Also daylight trips during July and August. Autos carried. Wireless aboard.

Between Detroit and Buffalo and Niagara Falls

new

\$7000,000
'GREATER DETROIT'
and
'GREATER BUFFALO'

—the largest steamers of their type in the world—550 feet long—with 650 first class staterooms and crew of 300 men.

The *Greater Detroit*, "The Leviathan of the Great Lakes," and *Greater Buffalo*, "The Majestic of the Great Lakes," provide overnight service daily to November 1st, between Detroit and Buffalo and Niagara Falls. Fare \$6.00 one way; \$11.50 round trip.

FOR RESERVATIONS or further information address E. H. McCracken, Acting General Passenger Agent at Detroit, Michigan.

A. A. Schantz
President

J. T. McMillan
Vice-Pres. & Gen. Mgr.

DETROIT & CLEVELAND NAVIGATION COMPANY

A FULL YEAR TO PAY *Charge it!*

Wear While Paying



PA3—Lady's wrist watch latest style solid 14 Kt. gold, highest grade 17 ruby and sapphire jewel movement, lifetime guarantee. Featured at **\$22**



PA4—Fiery blue white diamond—best quality 18 Kt. white gold—artistically carved, hand pierced, lady's mounting. Featured at **\$49.50**

A full year to pay

All transactions strictly confidential
10 DAYS FREE TRIAL
 Pin only \$1 to your order, and your choice comes to you parcel-post prepaid on **10 Days Free Trial**. Then pay postman only \$1 more on delivery, and after free trial pay balance in 12 equal monthly payments. Satisfaction guaranteed or money back. **FREE**
 "Royal Book of Gems"
 Thousands of special values in genuine diamonds, watches and jewelry illustrated. Your copy sent immediately on request.
FREE
 No red tape, No delay



PA7—Three large perfectly matched genuine blue sapphires, 18Kt. white gold dinner ring, exquisite design. Price **\$42.50**



PA5—Three perfectly matched blue white diamonds set in a beautifully hand pierced mounting—18Kt. white gold—latest creation. Featured at **\$36.75**

ROYAL DIAMOND & WATCH CO.
 ESTABLISHED 1895
 ADDRESS DEPT. 1638 170 BROADWAY, N.Y.



"I like the Crescent 8 in. Wrench because~"

it fits about nine out of every ten bolts or nuts that I ever have occasion to touch on my Reo," says F. C. Greutker, of Buffalo.

Car owners, and other tool users as well, find Crescent Tools are reliable time savers for all classes of mechanical work.

CRESCENT TOOL COMPANY
 210 Harrison Street JAMESTOWN, N. Y.
 Originators of the Crescent Wrench



Sure, It's a King!

"IT'S the finest saxophone I've ever played"—this is the opinion of thousands of King owners when asked how they liked their instrument.

Whether you are just learning to play or are a finished musician you will find King

Band Instruments easiest to play.

Every King Instrument has the latest improvements—is built by experts and is laboratory-tested. Every King is fully guaranteed.

It is easy to own a King Instrument. They are sent on 10 days free trial and sold on convenient payment terms. King Band Instruments and Saxophones are fully described in beautifully illustrated catalogs. Send for free copy.

THE H. N. WHITE CO.
 5211-78 Superior Avenue Cleveland, Ohio

Makers of **KING** Band Instruments and Saxophones

The H. N. White Co., 5211-78 Superior Ave., Cleveland, O.
 Kindly send me your latest catalog.

..... (Instrument)
 Name,
 Address,
 City, State

FREE FOR TEN DAYS TRIAL

Special Reduced Prices

Real Bargains. All standard makes—Young Process re-manufactured, like new—good as new—without a flaw. Guaranteed 5 years—no money down—easy terms. Extra for beginners.

Complete Course in FREE touch typewriting
 Write for illustrated catalog, free trial offer, low reduced prices now.

Young Typewriter Co., 654 W. Randolph St., Dept. 1108, Chicago



Big Saving



Lighting Fixtures
READY TO HANG

(Direct from the Manufacturer)

Completely wired, including glassware. Send for New Catalogue No. 27. Just reduced prices.

Special proposition to DEALERS.

ERIE FIXTURE SUPPLY CO.
 STA. A ERIE, PA.

I Offer You \$8.00 a Day and a DODGE TOURING CAR

Write quick for new proposition. We offer \$8.00 a day and a new Dodge touring car, for demonstrating and taking orders for Comer All-Weather Topcoats and Raincoats. Spare time. No experience required. Sample outfit free. Write now.

Comer Mfg. Co., Dept. W-5117, Dayton, O.



AGENTS AND SIGN MEN

Now Making \$50.00 to \$100.00 and Up Per Week Selling Our

GOLD LEAF SIGN LETTERS



For store and office windows, board signs, trucks and glass signs. We also make to order script signs and business emblems singly or by the thousands. A permanent business. No capital or experience required. Big demand in every city. Samples and Literature Free.

CONSOLIDATED SIGN LETTER CO. 69X W. Van Buren CHICAGO, ILL.

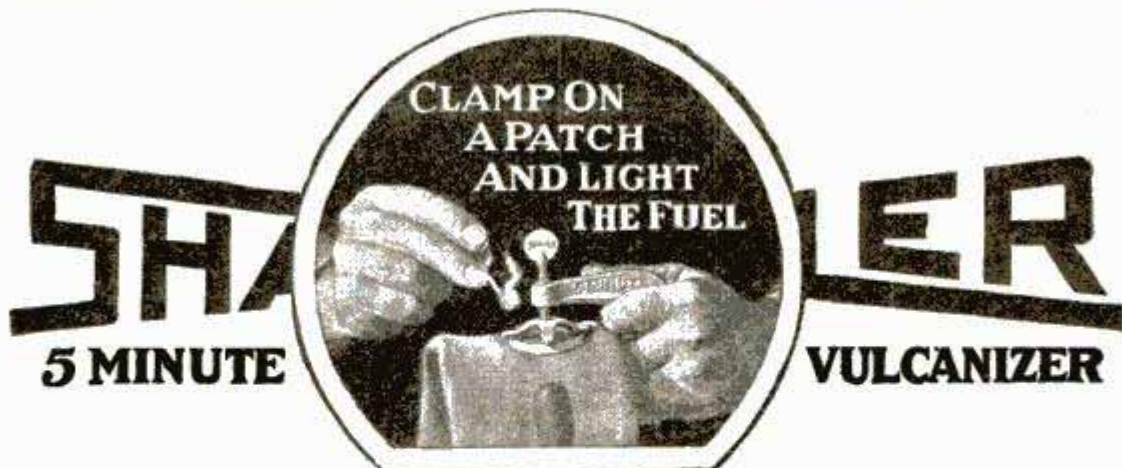

Why It Makes Puncture Repairs Permanent



left, that creates just enough heat to VULCANIZE the raw rubber patch on the bottom of the pan firmly to the tube. It comes to you all in one piece, like a cartridge for a gun. No patch to cut to fit. No cement, no muss, no fuss.

To make a repair, you clamp one of these little tin pans over the puncture

The Shaler Patch - & - Heat Unit is the secret. It's a little tin pan full of prepared solid fuel, illustrated at

with the Shaler Clamp furnished with each outfit, and light the fuel. In five minutes take off the pan and throw it away. That's all. The repair is part of the tube because it is heat-welded (*vulcanized*.)

Nearly five million motorists will tell you that they carry the Shaler outfit to use when the spare is flat and the last tube is punctured, not because they like to fix punctures, but because it is the easy, quick

way of making permanent repairs in an emergency.



Buy the Complete Outfit

in this little box for only \$1.50 wherever auto supplies are sold. Slightly higher in Canada and far West.

C. A. SHALER CO. • Main Office and Factory: WAUPUN, WIS., U. S. A.

MOVIES IN YOUR HOME



Practical Movie Machines in many wonderful models, some as low as \$3.75 and use same size film as big theatres. Fine films at lowest prices with a film exchange service. Many biblical films. Write for free illustrated catalog.

PARAMOUNT MFG. CO.
Dept. MB, 120 High Street, Boston, Mass.

AGENTS! EXPERIENCE UNNECESSARY



Science has finally produced it. An instantaneous metal cleaner—neither sloppy liquid nor messy paste. Dry magic floss. Touch it to silver, nickel, copper or brass. The metal shines bright and clean instantly! No hard rubbing! Approved by Good Housekeeping Institute. Agents making up to \$50 a day! Makes a Sensational Demonstration

AMAZING DISCOVERY ABOLISHES METAL POLISH

Imagine! Touch tarnished articles with Lightning Polishing Floss and you make them bright as new. Demonstrations positively astonishing! Every one a sale! Agents collect real money on every call.

HOUSEWIVES, AUTOISTS AND STORES

Everybody Buys These Products. Housewives buy the Lightning Polishing Cloth. Autoists buy Lightning Polishing Floss. Sell both to stores and offices in big quantities. Nothing else like them. Sure big, quick MONEY GETTERS. Sample Free! Exclusive territory. Real cooperation. Triple profit. Answer this ad at once. Make big money. Easy! Quick! Don't delay. Write NOW! FREE test sample and proposition by return mail.

A. A. LIGHTNING PRODUCTS CORP., 1773 Greenleaf Ave., Chicago



21 Jewels

Nothing less than 21 Ruby and Sapphire jewels is good enough for the Burlington masterpiece.

Quality and Style

Adjusted to the second—temperature—synchronism—positions. 25 year Gold Strata Case, in 100 exquisite designs. Only \$1 down. Balance in small monthly payments. Send for free book.

Burlington Watch Company
19th Street and Marshall Boulevard
Dept. C-135 Chicago, Illinois



\$35 Complete Outfit as illustrated

Delivery Paid East of the Mississippi

\$38 Delivery Paid West of Miss.

Saw Table Can be purchased with 6-inch saw for \$22.50. Delivery paid East of Mississippi. \$24.50 Delivery paid West of Mississippi.

Motor This heavy duty motor can be furnished separately for delivery paid East of Mississippi. \$13.90 Delivery paid West of Mississippi. Complete with Cord, Plug and flat or grooved Pulley. Guaranteed 50% Overload. Special Prices on Quantities of 10 or Over.

PAUL J. DEVITT, 1101-1107 So. 2nd St., Phila., Pa.

MECHANICS BENCH SAW

With this saw you can make your own repairs in shop, home, farm or garage. Makes a clean edge on the toughest wood—no planing necessary. Rips, cross-cuts, bevells, miters, mortises, tenons, or grooves. Attach to any lamp socket. Weight only 61 lbs. Will cut up to 1 3/4. All metal. Saw size 6 in. Table 10x13, base 7x11. height 7 in. Table tilts for beveling 5 degrees left 10 degrees right.

WRITE FOR OUR NET PRICE BUILDERS' HARDWARE CATALOG



Military Binocular

NEW WORLDS Will Open Up for You



These Binoculars will prove a never-ending lifetime joy! Indispensable for camping, hunting, hiking, yachting, races, motoring, skid-ins, observation, bird and nature studies, etc. New Worlds will open up for YOU! When off for a hike sling a pair over your shoulder (they add that smart military air) and enjoy glorious vistas as never before.

Free Trial

CONQUER Distance! Follow flight of fowl high in sky! Observe movements of deer, bear, birds, ships, people off in the distance. Autos roaring 'round the track! Horses tearing down the turf! Make your eyes 8 times stronger! Bring objects right to your feet! Keep a pair in your car! Motoring will become a joy!

8-Power

HUNDREDS SUPPLIED TO ARMY AND NAVY OFFICERS

These are the GENUINE French and German Army Officers' 8-POWER PRISM Binoculars; famous PREMIERE QUALITE; brand new, PERFECT. Brilliant illumination, exquisite definition; remarkable light-gathering power. Wide field of vision—many times area of field glasses. Central focusing with individual eye-strength and width adjustments. Handsomely finished rich grain leather. Heat and moisture proof. Complete with leather case, neck and shoulder straps. Usually sell for \$40.00 to \$50.00. Advantageous foreign exchange rates make possible the bargain price. **\$23.50**

Our Plan is Different!

Send NO Money now! Pay NOTHING on delivery. See, Try, Test, ENJOY Binoculars for 10 Days' Trial Absolutely FREE!

If pleased, you may pay on Budget Plan:

\$5.00 MONTHLY or if you wish to pay cash at end of 10 DAYS, deduct \$1.75 and send Check or Money Order for **\$21.75** in FULL SETTLEMENT. Other wise return them. Order NOW! Send NO Money! Pay NOTHING on Delivery.

"3 Generations of Honorable Dealings"

SEAEVER-WILLIAMS CO.

Importers, Exporters, National Mail-Order House

365 WASHINGTON STREET, BOSTON, MASS.

Largest Distributors of Binoculars in America

Clip and mail this Ad. NOW! Please tell us something about yourself. We will appreciate and respect the information. THANK YOU!

Pop. Mech. 8-26



To Europe in 10 Hours!

FAST aeroplanes will do it some day, who knows how soon! Wouldn't you like to know something about them; how they are built and how they fly? Building and Flying your own Model Aeroplane is the best way to find out. You can see how the body and wings are joined; how the tail and rudder work; what the controls do. And when your Model flies in the air—that's the real thrill!

Ideal Scale Drawings and Building-Flying Instructions show how to make perfect 3-ft. Models of Famous 'Planes. Complete Drawings and Instructions for any one of the following sent postpaid for 25 cents—Curtiss JN4D-2 Training Plane; DeHavilland "Round-the-World" Flyer; NC-4 Naval Seaplane; Bleriot, Nieuport or Taube Monoplane; or Cecil Peoff Racer. (Set of 7—\$1.25 postpaid.)

48 pp. catalog of Model Aeroplane Parts & Supplies—5c postpaid

IDEAL AEROPLANE & SUPPLY COMPANY
408 WEST BROADWAY NEW YORK

Beware

of imitation cone speakers. Be sure you get what they imitate, but cannot duplicate -- the CROSLEY MUSICONE. For a year production has not yet caught up with selling



CROSLEY MUSICONE

Write Dept. 15 for Booklet
THE CROSLEY RADIO CORP.
Cincinnati, Ohio
Prices slightly higher west of the Rockies.

Dealers sell Crosley Radios from \$9.75 to \$75. and the Musicone Loudspeaker at \$14.75

Pin a Dollar Bill to This

and get this fine 5 card case. Genuine leather. Masonic or Shrine emblem stamped on in gold free. (No other emblem supplied on this case.) Your name or other stamping 35c extra per line.

Cash must accompany order



We carry EVERYTHING MASONIC

Send for free catalogue No. 3 of Books, Monitors, Jewelry; No. 4 of Lodge Supplies.

We have been in business 67 years!

REDDING & COMPANY

200 Fifth Ave., or 9 West 23 St.

New York

SOLDERALL

METAL IN PASTE FORM



The only convenient metal solder

Every Electrical Connection needs Solderall for perfect reception **25c**

The SOLDERALL CO., NEWARK, N.J.

UNBREAKABLE TWO YEAR GUARANTEED TRIO PEN

SELLS FOR
\$1.25

SAMPLE 67c

Writes like a \$7 Pen

"IT'S THE POINT" →



Pens finished in beautiful green, red, black, or purple, ladies' or men's style. Money refunded if not pleased. Write for wholesale prices and selling plans. \$15 Daily easily made.

F. SPORS & CO., 355 Main St., LESUEUR CENTER, MINN.

OIL HEAT

**Astonishing Simplicity
Marks an Epoch in Oil Burner
Construction and Efficiency**

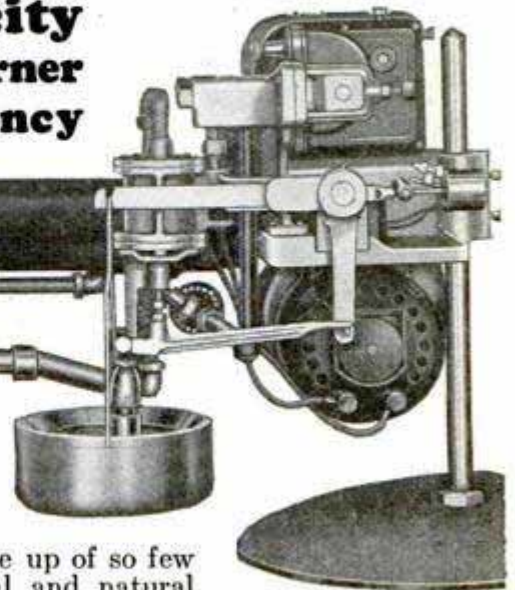

The HI-LO OIL VAPOR BURNER operates with absolute certainty, without intricate machinery and embodies simplicity of construction that makes it thoroughly understandable to any one in ten minutes' time.

The HI-LO Oil Vapor Burner is made up of so few parts that by very simple mechanical and natural laws, it will accomplish all that the complicated high priced oil burner does—and then some.

The HI-LO feature increases or diminishes the heat automatically as required without nerve racking ignition explosions or ignition failures. It always produces perfectly regulated heat in accordance with weather conditions.

*Desirable territory open to responsible dealers.
Send for catalog and dealers' plan.*

**GLORIA LIGHT COMPANY 111-8 N. MAY STREET
CHICAGO, ILLINOIS**

Mr. Arthur Crist, Ithaca, N. Y., a dealer for four years, has just placed an order for two car loads—over \$70,000. Other dealers' records accordingly.

\$4⁰⁰ "SUPER GAS SAVER" FOR FORDS COSTS YOU ONLY—1¢

**"MR. WEEKS," Famous Aviator and Inventor
Wants Users in All Parts of the Country to Introduce This
WONDERFUL INVENTION**

60 MILES ON A GALLON



The amazing fact that a Ford can run 60 miles on one gallon of gasoline was recently brought to light through tests conducted by America's foremost engineers, where it was shown that a gallon of gasoline contains sufficient heat units which if properly atomized and mixed with air would give this additional mileage.

It is common for Ford owners to make from 40 to 44 miles per gallon after this marvelous device is attached.

Finds Our Claims Correct I find that your claims for increased mileage are correct and that a big saving is made by your SUPERS. **M. J. VAN LEEUWEN, Mass.**

DO NOT SEND ANY MONEY

To introduce this marvelous device—for a limited time—we have arranged a plan whereby anyone can secure one of these SUPER CARBURETORS for only one cent. Just send your name and address and we will mail you full FREE PARTICULARS—and also explain how you can make \$60 to \$150 PER WEEK.

**AGENTS
WANTED**

Write Today for Free Particulars

**WEEKS SUPER CARBURETOR COMPANY
426-1642 Eleventh St. Milwaukee, Wis.**

MAIL TODAY
Gentlemen: Please mail me full free particulars about your wonderful invention.
Name _____
St. or R. F. D. _____
Town _____
County _____
State _____

Fits-Kit FOLDING HACKSAW

THE TOOL OF A THOUSAND USES

Bright Nickel finish
Weight one pound
Equipped with one blade

\$2.50 POST-PAID



IT FITS THE KIT—Made from the best grade of number one TEMPER steel.



When open and ready for use has a most desirable PISTOL GRIP. Channel Back provides magazine for holding and protecting extra blades. Blade can be used in vertical or horizontal position.



Angular position of blade as shown here is an EXCLUSIVE feature. Does special work which cannot be done with any other hacksaw frame. STRONG, RIGID, DURABLE, FULLY GUARANTEED. Order from your Jobber or Dealer or mail us \$2.50 and send your dealer's name.

ATLAS PRODUCTS CO.

134 W. 35th St., LOS ANGELES, CALIF.

World's Greatest Screwdriver

\$1.75



Has power of 20'

UNIQUE OFFSET RATCHET

straight handle screwdriver Works in close quarters where ordinary screwdrivers are useless. Two milled bits furnished. Satisfaction guaranteed or your money back. Ask for FREE catalogue of other Unique Tools.

Representatives Wanted Everywhere
LANE UNIQUE TOOL CO., Dept. P. M., 422 S. Dearborn St., CHICAGO, Ill.

PIMPLES

Cleared up—often in 24 hours. To prove you can be rid of Pimples, Blackheads, Acne Eruptions on the face or body, Barber's Itch, Eczema, Enlarged Pores, Oily or Shiny Skin, simply send me your name and address today—no cost—no obligation. CLEAR-TONE tried and tested in over 100,000 cases—used like toilet water—is simply magical in prompt results. You can repay the favor by telling your friends; if not, the loss is mine. WRITE TODAY. E. S. GIVENS, 429 Chemical Bldg., Kansas City, Mo.

Buy Now Pay Later



Handy Tools for Handy Men!

Better work with bigger volume can be easily had with amazing speed and accuracy on

BOICE-CRANE BENCH SAWS

Do ripping, mitering, grooving, rabbeting, sanding, grinding and other operations better, quicker and easier. Driven by any 1/4 to 1/2 h. p. motor; portable; attached to any light socket. Sold with or without motor. Greatest values at lowest prices.

Write today for descriptive catalog of Bench Saws, Lathes, Jointers, Band Saws and the Boice E-Z Pay Plan.

W. B. & J. E. Boice, Dept. P. M. 8-B, Toledo, Ohio

SENSATIONAL Typewriter Offer

3

AFTER 10 DAY FREE TRIAL

DON'T SEND US A CENT—we'll ship you a genuine L. C. Smith for a 10-Day Free Trial. Put it to any test in your home or office—no one will urge you to buy. Compare it with any machine made. Then, if you decide to keep it, we'll make you the LOWEST PRICE EVER OFFERED and give you EASY MONTHLY PAYMENTS so small you'll never miss them.

The ONLY Ball-Bearing Typewriter



Because of its ball-bearing construction, the L. C. Smith is the easiest running and longest wearing typewriter made. ALL THE 1926 ATTACHMENTS.

Guaranteed for 5 Years HIGHEST QUALITY re-newed. Don't buy any typewriter until you have tried an L. C. Smith. For the sake of your future satisfaction, accept our FREE TRIAL OFFER.

\$3 Worth Extras FREE

By acting now, you get Tools, Waterproof Cover, valuable Home Study Course in Touch Typewriter Free. Play safe. Use the ball-bearing L. C. Smith 10 days before deciding on any machine. Write TODAY for details of our Special Offer and manual of typewriter information.

Smith Typewriter Sales Corp.

118-360 East Grand Avenue, Chicago

AGENTS MAKING BIG MONEY



SELLING Jewell Can Openers

Every home needs one. Big profits on each sale. Locks on without handling can, turns like winding clock—and off she comes. Written up by Popular Mechanics Magazine on page 793, May issue. Send 50c today for sample and special offer.

CHARLES N. LOCKWOOD
Dept. PM, 612 No. Michigan Blvd., CHICAGO

Beautiful HOUSES \$900 and BUNGALOWS

CAN BE BUILT FOR AND UP

This and many others in my new book, Building Plans for Modern Homes, will save you hundreds of dollars. One of the most complete and comprehensive books of plans ever published by any architect. New edition just off the press. Nearly 600 floor plans and photographs of Colonial houses, bungalows, etc., costing from \$200 up; gives sizes and cost to build. Sent postpaid for \$3.00.



FREDERICK H. GOWING
ARCHITECT

101 Tremont St., BOSTON, MASS.

BOW LEGS?

OUR GARTER (Pat'd) Makes Trousers Hang Straight

If Legs Bend In or Out. Self Adjustable. Free Booklet—Plain Sealed Envelope

THE T. GARTER CO. Dept. 2, New London, New Hampshire



500 PUNCTURES Yet Leaks No Air



Over
1,000,000
Sold

We Want Agents

OVER 18,000,000 car owners are waiting for my amazing, long-life, no-trouble, air-filled, Milburn Puncture-Proof Inner Tube—the only tube to successfully withstand the 500-nail-hole-test without loss of air. Costs no more than the ordinary tube and is sold under a positive, money-back guarantee.

**Makes Motoring a Pleasure
Doubles Tire Mileage**

Users of Milburn Puncture-Proof Tubes everywhere are enjoying the easy riding performance of the air-filled tube without the annoyance of punctures and slow leaks. And a tire mileage increase from 12,000 to 15,000 miles. Many users report 30,000 miles (double mileage) without removing a tire from the wheel.

Test the Milburn at My Risk

You'll be delighted. And you'll realize how easily orders are secured. Sales experience is not necessary to coin money selling the Milburn. *Positively the biggest tube value obtainable.* Absolutely non-competitive. I control all basic patents. Car owners buy on demonstration. It makes no difference what tires they use or what car they drive.

\$5,000 to \$10,000

That's what the Milburn Agency will net you per year—and more. Stop working for others. Get into business for yourself selling Milburn Puncture-Proof Tubes. My *No-Capital-Direct-From-Factory-Sales-Plan* makes it easily possible. Line up your territory rights on this whirlwind seller—NOW—full or part time.

FREE TUBE OFFER

To every car owner answering this ad. Act quick. Clip and mail your FREE TUBE COUPON—NOW. References: Industrial State Bank, Chicago—Baker State Bank, Chicago.

**C. M. MILBURN, President
Milburn Puncture-Proof Tube
Company, Inc.
176-336 W. 47th St.
CHICAGO, ILLINOIS**

FREE TUBE COUPON—MAIL NOW

**C. M. MILBURN, President,
MILBURN PUNCTURE-PROOF TUBE CO., INC.,
176-336 W. 47th St., Chicago, Ill.**

If the money-making opportunity is as big as you claim, I am interested in receiving the facts so that I can enjoy a share of the profits selling MILBURN PUNCTURE-PROOF TUBES. Without obligation, send me information about commission and free tube offer to car owners.

Name.....
Address.....
City.....
State.....

**Money-Back
Guarantee**

We hereby agree to refund to any purchaser the full amount paid for any Milburn Puncture-Proof Tube that leaks air when punctured by anything not larger than a twenty-penny spike. We also guarantee that casings will last much longer and give much greater mileage where Milburn Puncture-Proof Tubes are used.

PROOF

J. D. Cooper—"I have made 30,000 miles with my Milburn Puncture-Proof Tubes and have not as yet removed a rim or casing and my casings are in excellent condition."

S. C. Winfrey—"I have driven 500 nails in one of my Milburn Puncture-Proof Tubes without loss of air."

J. S. MacElroy—"Received the shipment of 200 Milburn Puncture-Proof Tubes and find them as represented. Hope to send you another 200 tube order soon."

J. T. Berdahl—"Have been using Milburn Tubes since 1922, driving every day. Have pulled out any number of nails without loss of air."



**THIS
BIG FREE BOOK**
tells you exactly how—



Richly illustrated; full of explicit practical counsel from experts to amateurs. Well worth a quarter—but you get it for nothing! Use the coupon below.

Furniture Finishing as experts do it—

YOU can practically duplicate the fine work master-craftsmen do on expensive furniture and costly cabinetwork. Your home-built creation will do you proud, finished as our **FREE BOOK** tells you how. Make use of its easily-followed instructions given by professionals. Send for it right away!

Make Shabby Things Look New Again

You can refinish worn, shabby, scuffed, old furniture so it will look almost new, and save yourself many a dollar—through this book. It tells you in plain English just how to finish all kinds of wood—old or new, hard or soft; how to stain wood expertly; how to do everything in wood-finishing for yourself at home. You will find the book mighty useful!

JOHNSON'S WOOD DYE

(Penetrating Stain)

With Johnson's Wood Dye you can treat inexpensive soft woods so as to rival costly hardwood in beauty. It is extremely easy to apply, dries perfectly in four hours, and never will rub off nor smudge. So deeply does it penetrate that the original color of the wood is not betrayed even though the surface is marred. Comes in 17 handsome shades, including these very popular numbers:

No. 124—Golden Oak No. 140—Early English
No. 129—Dark Mahogany No. 123—Dark Oak
No. 127—Brown Mahogany No. 131—Walnut
And all other fashionable and standard wood colors.

S. C. JOHNSON & SON, Dept. P. A. 8, RACINE, WIS.
"The Wood Finishing Authorities"
(Canadian Factory—Brantford)

Please send me Free your 25c Instruction Book on Home Beautifying and Wood Finishing.

My Dealer is.....

My Name.....

Address.....

City and State.....

Leading Paint and Hardware Stores often have a supply of this 25c Book to present to customers. Ask at such a store first for your copy **FREE**. Or just mail coupon and let us send you one.



Tire Punctured 857 Times **LEAKS NO AIR!**

Most Startling Discovery Since Pneumatic Tires Were Invented! Magic Tire Fluid Heals Punctures Without Loss of Air. No More Slow Leaks, Valve Leaks or "Porous Tubes." It Even Prevents Rim Cuts and Broken Side Walls. Generous Free Trial Offer!

Sensational Invention Astonishes Experts!

AT last science has done it! For a quarter of a century autoists have awaited this astonishing invention that makes any air-filled tire absolutely puncture-proof—and ends tire troubles! No more "flats" or slow leaks! No more patching tubes or changing tires on the road. No more maddening delays when you're in a hurry! Is it any wonder that auto owners everywhere are simply delighted?

Guaranteed to Seal Punctures While You Drive

So remarkable is Aer-Pruf—the new discovery of a South Dakota inventor—that it has quickly become a coast-to-coast sensation. Tests have shown that it never fails. Steve H. Temple writes that he drove a tire over 3000 miles after it had been punctured 50 times. And one tire, treated with this magic fluid, was punctured with 857 nails—and never leaked a pound of air!

Aer-Pruf seals punctures the instant they happen. You keep spinning along without knowing you have a puncture. Does away with changing and patching tubes or tires on hot, dusty roads, in blazing sun, in drenching rains, on dark nights, in freezing snow storms! Seals punctures small as a tack or large as a ten-penny spike! Slow leaks, valve leaks and porous tubes, too. Will not freeze in zero weather and resists heat of hottest summer day! Actually *preserves* rubber. Will last a lifetime of tube or tire—and can be applied in a jiffy.

Free Sample Offer

Now, to introduce his new invention, Mr. O. S. Nelson, the inventor, will send you a sample at his own risk. You test it free! And if you are not amazed and delighted, he will pay you for your time testing it. This amazing offer is absolutely without parallel—and is strictly limited to 30 days only. Take advantage of it at once. Fill out the coupon now. Mail it today!

*Aer-Pruf Tires Are
Air-Filled Tires*

**\$14
an
hour**

AGENTS

So startling and marvelously successful is this new invention that salesmen are piling up big liberal commissions for just a few hours' work. J. O. Bright made \$29.00 in two hours. H. J. Dubois netted \$9.00 in five minutes. And Frank Ryman made \$57 in a single evening. Every auto owner wants to buy on sight. Most amazing demonstration you ever saw—just pound nails into an old casing and watch their eyes stick out when it leaks no air! Ideal for full or spare time—\$200 to \$400 a month! Check bottom of coupon for generous proposition. Mail it tonight!

**AER-PRUF MFG. CO.,
L-2212 Logan Bldg., Mitchell, So. Dakota**

Please send me full details of your special FREE sample offer and your offer to pay me for testing samples of AER-PRUF, if I am not amazed and delighted with them.

Name.....

Address.....

City..... State.....

Check this space if interested in becoming representative.

AER-PRUF MFG. CO.
L-2212 Logan Bldg. Mitchell, So. Dakota



**BULLDOG
PIPELESS FURNACE**

**2 1/2 Tons
Heats 5 Rooms**

"There is no heater to compare with the Bulldog. I burned 2 1/2 tons of coal last winter and heated five rooms and a bath."—Walter Geary, Gloucester, Mass. That's what the Bulldog

does with coal! Now read, in the letter of Mr. Redetzke, what it does with about the lowest grade fuel you can think of! Why not cut down *your* fuel bills?

Heats Home for 25c a Week
"I can run my bulldog furnace for fourteen days in normal weather conditions on the actual cost of fifty cents." So writes F. R. Redetzke, of Cleveland, North Dakota, and he adds: "Hard to believe, is it? That's what some of my neighbors thought until I showed them! We have an unlimited amount of grain screenings which I use for fuel."

Heats Seven Rooms Instead of One!
"Your letter received asking about the Bulldog furnace. We have had ours in about six weeks and so far it does all Babson Bros. claim for it. We have seven rooms, four on the first floor and three on the second, and it heats them fine. We find it takes a little more coal to heat the whole house than it did to heat one room with a stove using chestnut coal."—J. B. Smith, 19 Elm St., Somerville, N. J.

Cuts Coal Bills in Half
"I had a hot air furnace in our 7-room house before I got the Bulldog and our house was always cold. With the Bulldog it only takes half as much coal and we had weather below zero, and the house was nice and warm in the morning when we got up. We never have the draft on more than half an hour at a time, and it has the place red hot. It is easy to regulate and keeps the fire all day in mild weather."
Jess T. Conrad,
1211 W. Arch St., Shamokin, Pa.

No Money Down!

Comes Completely Erected. You Install It Yourself.

The Bulldog is sent to you for *free inspection*. Then, if satisfied, you make only small monthly payments at our remarkably low price. Write today! *Don't* miss this chance to cut down your fuel bills! *Install a Bulldog Furnace*. It comes to you completely erected—goes through any door—fits any height of basement—and you install it yourself in less than two hours! In fact, H. B. Keater, of Libertyville, N. Y., says he installed

his Bulldog in 28 minutes! *Don't* put up with the old fashioned stove heat or some outworn furnace—when you can so easily get the greatest advance in scientific heating at an astonishingly low price. The Bulldog burns almost any kind of fuel, from hard coal to cheap screenings. Keeps a wood fire over night. We have factory connections in both east and west and ship from the nearest point.

Send for Free Book

Learn how to have all the heat you want—where you want it—and save money! Remember the Bulldog is *different*—and *better*! Complete combustion of gases save 25% of your fuel bill. Exclusive Gable-Top Radiator receives *all* the direct rays of the fire. Exclusive oblong fire-pot is not only ideal for coal, but enables you to keep a wood fire over night. Remember—the Bulldog is sent for *free inspection*—then small monthly payments at an amazingly low price! Send for Free Book TODAY!

BABSON BROS., 19th St. and California Ave.
Dept. C-135 Chicago, Ill.

**Babson Bros., Dept. C-135
19th St. and California Ave., Chicago, Ill.**

Without obligating me in any way, please send me your free catalog and special offer on the Bulldog Pipeless Furnace.

(Print Name and Address plain.)

Name

Address