

MARCH

Improving Your Set — Page 483

N.S.E.  
25 CENTS

# POPULAR MECHANICS

## MAGAZINE

WRITTEN SO YOU CAN UNDERSTAND IT

REG. TRADE MARK GREAT BRITAIN No. 410425

REG. U.S. PAT. OFF.

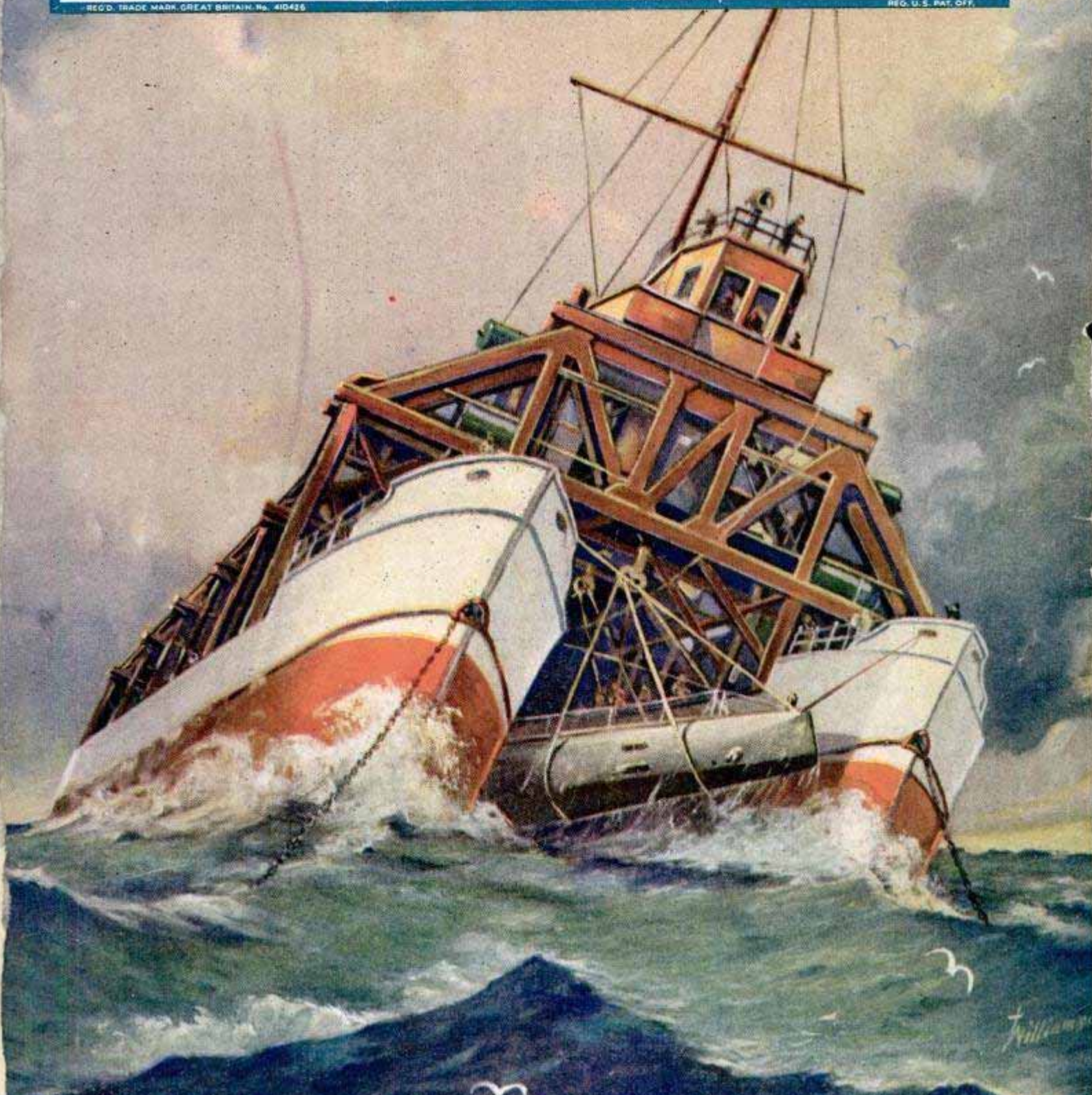

# It takes *only* 8 weeks to get a big job



George W. Smith runs a big Ford Agency and Repair Shop at West Alexandria, Ohio. He says, "I am clearing over \$800 per month."



My method is the shortest successful system ever known for training Big Salary men.  
J.H. MCSWEENEY,  
President.

*Read what these men are doing in the Auto, Tractor and Electrical Business. Here is your big chance to get "on easy street." Come to the great McSweeney Shops on the biggest Special Offer ever made.*

## Big Firms Need Trained Men

The Auto, Tractor and Electrical Business is on the boom. Thousands of trained men will be needed during the next few months. I get calls every day from Garages, Battery Stations, Auto Repair Shops and other **successful** concerns for McSweeney men. When the big fellows need high-grade men, they know where to come for them. **They want McSweeney-trained men.**

## My Training Unusual

Scientific tool training—that's the secret. You do things here according to the latest engineering standards. Thousands of dollars have been spent in modern tools and equipment. That's why my men are at home in the biggest shops in the country. If you want to succeed the way Smith and Collins and the rest have—qualify by the same method.

## I'll Pay Your Railroad Fare and Board You

In order to fill the openings that now exist, I am making an offer no one has ever made before—**Free railroad fare, Free board.** But even that is not all. I'll tell you about the rest in my letter.

## Send for **FREE** Book

My big illustrated training book tells how others are succeeding. It tells many things you ought to know about Autos and Tractors. Write for it and my **short time** offer NOW. It soon expires.



C. E. Gillispie has charge of a fleet of trucks and tractors with the State Highway Commission, due to McSweeney training.



W. W. Peace gets \$250 a month and expenses operating a tractor in the oil fields.



D. M. Collins, Williamsville, West Virginia, writes, "Shortly after finishing McSweeney training, I started in as manager of a garage at \$300 per month."

## McSweeney **AUTO TRACTOR AND ELECTRICAL** Shops

Dept. 148  
**CINCINNATI** 9th and Walnut  
**CHICAGO** 517 So. Laflin  
**CLEVELAND** 1815 E. 24th St.



McSweeney Auto, Tractor and Electrical Training Shops, Dept. 148 (Address shops nearest you) Cincinnati, O., or Chicago, Ill., or Cleveland, O.

Without any obligation send me your big free book on Autos. Also information regarding special temporary offer.

Name.....  
 Street.....  
 City..... State.....

**3 Big Training Shops**  
 Cincinnati Chicago Cleveland

# who tests your tubes?

WHO makes the vacuum tubes you use? is one important question. Who tests them? is another.

The same great research laboratories that developed the MAZDA lamp have developed the Radiotron. The five great factories that manufacture the MAZDA lamp, manufacture the Radiotron. And the same genius and the same scrupulous accuracy are behind the test methods developed for the RCA test laboratories.

You would not think of putting into your lighting socket today, anything but a MAZDA lamp. Why put into your radio socket, anything but an RCA Radiotron—backed by the same skill, the same engineering and manufacturing resources?

A Radiotron is far more difficult to make than an electric lamp. It demands accuracy to the hundredth of an inch. It demands ten million times rarer exhaustion of the air from the tube. And to guard against error in the turning out of hundreds of thousands of Radiotrons—to insure the high standards of uniform perfection that have made famous the names of RCA, General Electric and Westinghouse, the RCA laboratories have developed tests delicately exact. When you buy a vacuum tube—know who made and tested it. Look for the RCA mark and the name Radiotron on the base.

RADIO CORPORATION OF AMERICA  
CHICAGO NEW YORK SAN FRANCISCO



# RCA-Radiotron

MADE BY THE MAKERS OF RADIOLAS

# "Sorry— my dances are all taken"

**N**OT a dance with her? It spoiled his entire evening. Other men had dances with her, but he had none. It seemed odd that he was always "just too late." Or — was that her way of deliberately refusing to dance with him?



A great many young men are inclined to have a grimy-looking skin spotted with blackheads and dull in appearance. Few realize that this hinders their success in life. Pompeian Massage Cream helps you overcome this handicap by giving you a clear, ruddy complexion.

***Clears the Skin:*** Pompeian Massage Cream thoroughly cleanses the pores. It helps clear up blackheads and pimples by stimulating



healthy circulation, and by keeping the skin clean and the pores open.

***Easy to Use:*** After shaving or washing, rub it in gently. Continue rubbing and it rolls out, bringing with it all the dirt and skin impurities. Result—a clean, healthy skin with clear, glowing color.

*Use Pompeian Massage Cream regularly at home—then you'll get the full benefit. At all druggists.*

## Special Introductory Offer

**1/3 of 60c jar for 10c.**

For 10c we send a special Trial Jar containing one-third of regular 60c contents. Contains sufficient Pompeian Massage Cream to test thoroughly its wonderful benefits. Positively only one jar to a family on this exceptional offer.



The Pompeian Co., Cleveland, O., Dept. 76  
Gentlemen: I enclose a dime (10c) for 1/3 of a 60c jar of Pompeian Massage Cream.

Name \_\_\_\_\_

Street Address \_\_\_\_\_

City \_\_\_\_\_ State \_\_\_\_\_

# Popular Mechanics Magazine

200 E. Ontario Street, Chicago, U. S. A.

H. H. WINDSOR, Founder

H. H. WINDSOR, Jr., Editor and Publisher

London: Hachette & Cie.,  
16-17 King William Street, Charing Cross, W. C. 2

Paris: Hachette & Cie.,  
111 Rue Reaumur

Melbourne: Gordon & Gotch  
509-513 Little Collins St.

ISSUED MONTHLY

SUBSCRIPTION:

SINGLE COPY, 25 CENTS

In United States and its possessions, also Canada, Cuba, and Mexico, per year, postpaid - \$2.50  
To all other countries in the Postal Union - 3.00  
All subscriptions are discontinued at expiration. Please examine the date printed on your wrapper.

Entered as Second Class Matter Sept. 15, 1903, at the Post Office at Chicago, Illinois, under Act of March 3rd, 1879.  
Entered as Second Class Matter at the Post Office Department, Canada.

Published monthly by POPULAR MECHANICS CO.

Copyright, 1926, by Popular Mechanics Co.

Copyright in Australia. Copyright in France

<i>Concrete and colored glass</i>		<i>Model Home</i>		<i>411</i>
Vol. 45	<i>405</i>	Contents for	March, 1926	No. 3
Advertising—shop windows set at angles afford better display	394	Glare Shield—worn on hat to protect auto driver	466	
Agriculture—farm land of Texas	395	Golf		
Airplane—pilot of pygmy airplane rides lying down	383	meter in head of golf club records force of stroke	450	
Airship—largest semirigid dirigible christened in snow-storm	402	slow movies from scaffold show golfer's style	434	
Alcohol—made from coal	442	Health—chart helps doctors check spread of disease	383	
Archæology—is clue to lost nation found in Arizona relics?	448	Heat—cities to use sewage gas for light and heat	427	
Archery—sight set in middle of bow improves aim	441	Holder <i>for battery tester</i>	463	
Arctic Regions		for cigar box cover	458	
mapping the land of the midnight sun	428	Horses—non-skid pads for horses	360	
search for Inaccessible Pole to be made by airplane	380	House Planning—questions and answers	527	
Art—colored glass used to paint with concrete	405	House Plans—colonial house with shingle exterior	527	
Auger—for boring stumps helps clear land	427	Household Devices	460	
Automobile		Housing—four-fifths as many houses as families in U. S.	417	
taxi on runners driven by propeller	447	Hydroelectric Power		
that bucks like horse	385	for farms uses small streams	384	
Automobile Touring—meals served in bus on long distance run	393	horsepower at Wilson dam read on many gauges	450	
Automobiles—Equipment and Supplies		Iceboat—like airplane speeds at ninety miles an hour	357	
pedal for auto accelerator	368	Insects		
bars on windshield visor deflect rain and snow	357	timber losses caused by boring insects	407	
Badminton—played indoors	402	Inventions—of recent years show greatest progress	402	
Beads—U. S. imports millions of dollars worth	472	Kaleidoscope—adapted to produce designs	462	
Beaver—dam-building skill	463	Lifeboat—righted by rails attached to keels	370	
Birds—average speed of	356	Lighthouse—on wrecked ship	457	
Biology—life lengthened by science	353	Lighting—arc lamp with "liquid lens" to improve movies	448	
Bottle—stopper that locks has removable key	402	Lock—for autos requires no key	471	
Bridges		Magnet—small hand lifts fifty pounds	434	
bridging the rivers of the world	371	Manual Training—school trains naval electricians	384	
completes Victory road	434	Mental Tests—tests with model runway show cab drivers' skill	378	
Buddha—life of, told in silk on tapestry	427	Model—of railway system honors inventor	356	
Buffalo—number of, in Canadian herds	457	Monument—cross-tipped marble tapers honor war dead	416	
Building Construction—wooden cover for building permits winter work	459	Motorcycle—cyclist breaks speed record behind	448	
Business Places—unique, in west	403	Navigation—riding sea of derelicts	409	
Cartoons—how they are syndicated	451	Newspapers—walls in Russian factory display	416	
Chair—folding, for outdoors with loops for arms	447	New York City		
Circus—keeping it in motion	387	blowing up harbor to widen channel	417	
Clamp		cost of traffic delays in New York City	440	
fastener for tape measure	462	North American Indians—Miles' relics recall war days	393	
on ash tray prevents tipping over	407	Oceanography—hunting mountains under the sea	361	
Coaster—steered like sled	370	Packing—for auto valves	386	
Condenser—special, on engine reduces water waste	407	Paper Money—life of average dollar bill	393	
Coolidge, Calvin—frame for president's photo made by war veteran	385	Parachute—man blown over cliff to test	472	
Corn—with fourteen ears developed by Burbank	385	Pictures—artist paints on cobwebs instead of canvas	418	
Cotter Pin—steel, puller has jaws that lock	409	Pipe—big armored concrete pipe supplies water power	359	
Cotton—American used in last six months	402	Plow—and harrow combined	448	
Dances and Dancing—on galloping platform by Cos-sacks	368	Police—policing the Arctic wilds	443	
Deaf—teaching deaf children to talk	434	Printing—type-setting machine for office use	394	
Egyptology—find temple dating back to time of Abraham	397	Radiator—cap has hinged top	379	
Electric Lighter—match shaped	367	Radio—steam heat improves radio reception by keeping set dry	481	
Electric Lighting—for auto tourists	395	Radio Aerial		
Electricity—students' hair-raising stunt	367	mast clamps to ridgepole	482	
England—sea only eight miles distant	462	novel, easily installed	481	
Feet—how to keep happy	467	Radio Apparatus		
Fire Apparatus—extinguisher carried in sling on back	396	audio-frequency transformer simplifies wiring	479	
Fish		attachable peg for ground pipe	481	
farming the ocean bottom	466	combination tube tester and trouble shooter	485	
Fruit Culture—upper air to save orange crop	381	designs of switch plates harmonize with room	356	
Furniture—the model home	411	jack controls both amplifier stages	479	
Games—football with fingers played on table	442	portable lamp for radio receiver run by A-battery	486	
		push-pull adjustment features variable condenser	486	
		switch locks and prevents tampering	479	
		vernier dial has device for changing ratio	485	

[Continued on Page 4]

*Radio Tube Phone for 368 Pain, World Without*

Radio Application		
radio tube phone to aid deaf	368	
telephonic communication between liners at sea	479	
Radio Battery		
for wet B-batteries	475	
how to build your own B-eliminator	477	
Radio Broadcasting		
fifty-kilowatt radio station latest marvel of wireless	359	
latest German wireless station	408	
Radio Construction		
connectors make wiring easy	474	
drilling wood or bakelite without splitting	480	
good ground increases efficiency	486	
machine winds low-loss coils	482	
Radio Loop—built-in for portable	480	
Radio Loud Speakers		
device for shifting horn from radio to record	475	
variable resistance controls	475	
Radio Questions and Answers	528	
Radio Receivers		
built like lamp	481	
for fifty cents	473	
getting rid of the squeals	483	
Radio Repairing—testing audio-frequency transformers	486	
Radio Tubes		
sensitivity not determined by light	409	
testing of, necessary for DX reception	482	
Railroads		
forty-four railroads have automatic train control	394	
train speed to rival planes with roller bearings	384	
Rubber—salvage tons of old rubber	416	
Safety Devices and Measures		
guards keep cars on track at bridges and floats	442	
"spider net" of woven cord saves lives at fires	380	
wrecked auto as warning	417	
Salvage		
boats linked by bridge lift submarines	463	
fire boat nozzles used to salvage sunken ship	386	
Saws and Sawing Rigs		
hacksaw with steel frame cuts corrugated iron	456	
portable sawmill run by tractor	457	
saw for cutting grain shocks	459	
Screen—storm cover for screen door	433	
Ships		
becomes submarine during storm	433	
built with soft bows to increase safety at sea	407	
retired from sea find odd jobs	465	
Silk		
difference in silk and wool shown by tests	462	
patterns sent by cable	357	
Skates—motor-driven roller skates	459	
Slot Machine—holds thirty different things	393	
Smoke Nuisance—annual cost in U. S.	367	
Sound—pictured in sand to show vibrations	465	
Staircase—spiral, of concrete cast in single mold	378	
Steel		
and refining costs cut by silica process	370	
new, takes razor edge	355	
Straw—pressed in briquettes as substitute for coal	383	
Sun—seek way to use heat without producing steam	356	
Surf Riding—board has two rudders	465	
Swing—with handlebar seat	440	
Tank (Military)—"eye" for army tanks guards driver against gas	395	
Teleggraphy—key of solid gold opens gates afar	360	
Telephone		
calls read by camera from automatic counter	418	
how phone calls are made shown by exhibit	458	
photos replace numbers on switchboard	466	
Tier—foot power vegetable and flower tier	393	
Tractor—and scow combined to travel sea or desert	426	
Treasure-trove—hunting hidden treasure	419	
Tunnels—speed wear on rails by dampness and smoke	368	
Ventilation—fresh air fed to auto tunnel by eighty-four motors	441	
Walking Stick—holds folding table for playing cards	418	
Weather—instruments for recording in high altitudes	466	
Weeds—eradicated along right of way with steam	378	
Welding—portable outfit for linemen	386	
Windmill—riding on wings thrills dare-devils	379	
Windows—locked by wedge	465	
Wire—fence good substitute for ground	475	
Wood—balsa wood serves as ice and saves lives	450	
Carpentry—making mortise and tenon and dado joints	492	
Cleanliness—excelsior for cleaning greasy hands	489	
Clock—burl from tree makes case for	490	
Clothespin—new use for	504	
Coal—how to burn soft	505	
Crime—baffling chicken thieves	506	
Diving Platform—novel	489	
Drills—preventing small drills from breaking	499	
Exhaust Fan—made from a windmill	502	
Eyes—homemade paper eye shield	507	
Fence Posts—sharpening	508	
Fish—how to keep an aquarium successfully	498	
Flowers—aspirin revives	490	
Furnace—adjusting the draft	508	
Garage—door swings up to open	500	
Grindstone—saving the	497	
Hot-Water Bag—makes automobile equipment	504	
Jack—makes tire carrier, contractor and expander	496	
Knots—a quick bag tie	490	
Latch—novel garage door	504	
Meat—sealing canned meat	499	
Moth Balls—putting life into	499	
Paper—measuring and cutting paper from rolls	498	
Petroleum—sediment trap in oil burning supply pipe	506	
Phonograph—provides music for two rooms	491	
Pipe (Tobacco)—breaking in a new pipe	508	
Poultry		
hanging sash on poultry house	504	
watering trough	503	
Pumps—repairing	491	
Rust—removing stains made by	495	
Safety Devices and Measures—safeguarding children	489	
Salt—cover shaker when not in use	497	
Saws and Sawing Rigs—support for one-man saw	491	
Solder and Soldering—cleaning rolled seams on tubs before soldering	497	
Stamps—removing from envelopes	489	
Stilts—to take place of stepladder	498	
Stovepipes—holding furnace pipe sections	497	
Stucco—treating before painting	497	
Swine—adjustable concrete pig creep	500	
Tank—filling gasoline	490	
Tin Cans—"baling" empty	488	
Toys		
how to make a toy derrick	501	
swinging darkey toy	503	
Trough—repairing leaky caves	508	
Umbrella—taking care of	487	

## SHOP NOTES

Automobiles—Equipment and Supplies		
magnet holds trouble lamp	511	
small bottle useful to motorist	512	
Automobiles—Radiator—cleaning	526	
Barrels—simple safety attachment for hoisting	514	
Battery Charger—care of	524	
Bees—to save honey	512	
Building Construction		
proper use of pine siding	514	
siding saves time in stonework	525	
Built-In Furniture for the Home—Part XVI—a break-fast nook	517	
Cleaning—steam, a stone building	521	
Coal Yard—cement banking saves coal	521	
Concrete—time-saving forms for	512	
Conduits—wooden balls plug	516	
Desk—portable, for shipping clerks	525	
Door—winter door for receiving room	523	
Enamel—white, baked	520	
Erosion		
sagebrush mats protect canal banks	516	
small dams prevent creek-bank	514	
Glass—never slip gauge for glazier	515	
Grinder—making a convertible toolpost	509	
Holes—drilling, in edge of disk	521	
Incubator—reading the, thermometer	522	
Machinery—support helps turn thin walls	524	
Mechanical Drawings—shorthand	523	
Motor Truck—homemade dump truck distributes load evenly	511	
Nuts (Mechanical)—brass locknuts	523	
Oilstones—care of	522	
Poultry—durable nests made of concrete	515	
Pulley—making patterns for small sheaves	524	
Sand Bucket—improved, for wells	526	
Screwdriver—for arbor press	512	
Sheet Metal—marker for	522	
Skate—sharpening jig	513	
Snow—labor saving shovel	516	
Tile—hook for deep trenches	515	
Truck—collapsible sides for shop truck	513	
Window—suggestions on sash installation	516	
Workbench—tailboard serves as	526	

## AMATEUR MECHANICS

Automobiles—Repairing		
loosening the engine cylinder head	507	
preventing rattle of brake rods	507	
Automobiles—Safeguarding—preventing theft	502	
Automobiles—snubbers—for Ford car, homemade	499	
Brass—plated brass and iron distinguished by magnet	508	
Buttons—making metal	507	

Buildings Cleaning Stone

roadcasting - Station  
y Islands - Cuffs for

474  
434





Radio  
Sou  
Radio  
Fr  
Snai

# DRAKE'S PRACTICAL MECHANICAL BOOKS

## THEY WILL RAISE YOUR PAY— ORDER ON 5-DAY TRIAL

The books listed below will perfect you in your chosen trade—pave the way to the big positions. Written in non-technical language—easy to read and understand. *Every book covers its subject completely. An entire course of instruction condensed into one volume.* Your choice sent postpaid—you benefit 5 days—money refunded in full if not entirely satisfactory. Order direct from this page.

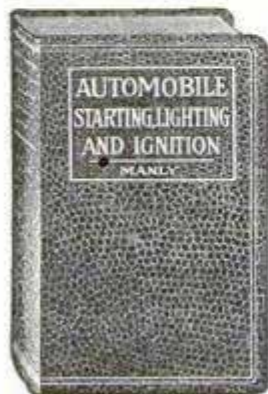

### Automobile Books

- Automobile Starting, Lighting and Ignition, by Manly... 700 pp. **\$3.00**
- Brookes' Automobile Handbook. **\$2.00**
- Ford Motor Car, Truck and Tractor, by Manly... Cloth **\$1.50**
- Automobile Battery, Care and Repair, by Manly... Leatherette **\$2.00**
- Motorcycle Handbook, by Manly **\$1.50**

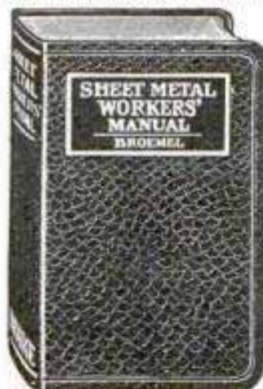

### Shop Practice Books

- Sheet Metal Workers' Manual... **\$2.00**
- Oxy-Acetylene Welding and Cutting... Cloth **\$1.25**
- Slide Rule and Logarithmic Tables. **\$2.00**
- Handbook for Millwrights... Cloth **\$2.00**
- Machine Shop Practice... Cloth **\$2.00**
- Mechanical Drawing and Machine Design... Cloth **\$2.00**

### ORDER DIRECT FROM THIS PAGE —ON OUR MONEY-BACK PLAN

The books listed above are only a few of the many in our catalogue, which you will receive promptly after filling out and mailing us the attached coupon. For quick action order direct from this page—cross name of each book wanted and send in with price quoted. We prepay postage and send the books on our money-back plan.

**FREDERICK J. DRAKE & CO.**  
PUBLISHERS

1008 Michigan Ave., Chicago  
Drake Books Are For Sale at All Book Stores

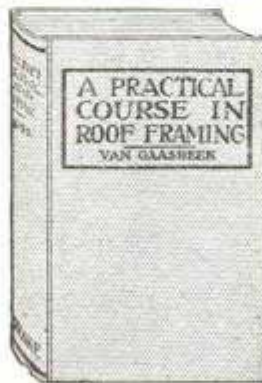

### Carpentry Books

- Cloth Binding
- Modern Carpentry, 2 vols. .... **\$3.00**
  - The Steel Square, 2 vols. .... **\$3.00**
  - Modern Estimator. .... **\$1.50**
  - Timber Framing. .... **\$2.00**
  - Builder's Architectural Drawing... **\$2.00**
  - Concretes. .... **\$1.50**
  - Practical Bungalows. .... **\$1.00**
  - Roof Framing, by Van Gasbeek... **\$1.50**

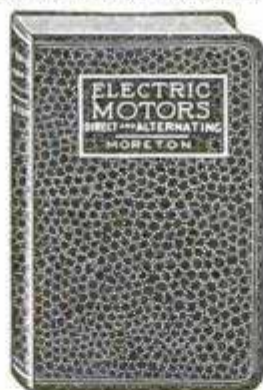

### Electrical Books

- Telephony, Including Automatic Switching, by Smith, 450 pp. Leatherette **\$2.50**
- Practical Applied Electricity. .... **\$2.00**
- Wiring Diagrams and Descriptions. **\$1.50**
- Armature and Magnet Winding... **\$1.50**
- Electric Motors, D. & A. .... **\$1.50**



### Painting and Decorating

- Ross Crane Book of Home Furnishing and Decoration... Cloth **\$3.00**
- House Painting Methods with the Brush and Spray Gun, by Vanderwalker. Cloth... **\$2.00**
- Interior Wall Decoration, by Vanderwalker... Leatherette **\$4.00**
- The Mixing of Colors and Paints, by Vanderwalker... Cloth **\$2.00**
- A Show at Sho' Cards... Cloth **\$4.00**
- Sign Painting, by Atkinson... Cloth **\$4.00**
- Strong's Book of Designs, Leatherette **\$4.00**
- Modern Painter's Cyclopedia. Cloth **\$2.00**
- Automobile Painting... Cloth **\$1.50**
- New Hardwood Finishing... Cloth **\$1.50**
- Wood Finishing, Plain and Decorative... Cloth **\$2.00**

### Steam Engineering

- Swingle's Handbook for Steam Engineers and Electricians, Leatherette... **\$4.00**
- Examination Questions and Answers for Marine and Stationary Engineers, Leatherette... **\$2.00**
- Steam Boilers... Leatherette **\$2.00**
- Swingle's Catechism of Steam, Gas and Electrical Engineering, Leatherette **\$1.50**

### Modern Languages

- By Prof. P. S. Allen, U. of Chicago
- French without a Teacher... Cloth **\$1.25**
  - Spanish without a Teacher... Cloth **\$1.25**
  - German without a Teacher... Cloth **\$1.25**
  - Everyday French... **\$1.25**
  - Everyday Spanish... **\$1.25**

**FREDERICK J. DRAKE & CO.**  
1008 Michigan Avenue  
Chicago, Ill.

GENTLEMEN:—Please send me free, postage paid, your illustrated catalogue which lists and describes 200 Practical Mechanical Books for Home Study.

My name is .....

and my address .....

Mail Coupon For Free Catalogue  
Your Guide to Home Study



# Boosts His Salary 125 Per Cent



By Substituting an  
Organized Plan for  
Haphazard Methods  
of Acquiring  
Business  
Experience

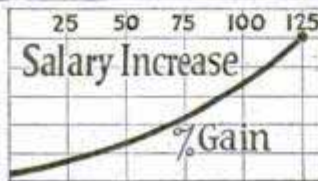

"I say without boasting and simply as a statement of fact, that I have earned more than fifty times the cost of my LaSalle training in special accounting work since taking it up; and in addition, my regular income, or salary, has increased approximately 125 per cent."  
E. G. WILHELM,  
Pennsylvania.

## How You Can Fit Yourself for Bigger Opportunities

The brief story of how E. G. Wilhelm more than doubled his income—as summarized in the above paragraph from his letter to LaSalle Extension University—is set forth in print not because it is unusual, but because it fairly represents what any man of average intelligence may expect, within a comparatively few months, if he will follow a well-organized plan of home-study training. Such a "well-organized plan," developed to a high degree of practical effectiveness, finds its best example in the LaSalle Problem Method.

### No Previous Experience

Under this plan a man quickly masters the principles of Higher Accountancy, let us say, during spare hours at home and *demonstrates* that mastery thru the solution of practical problems lifted bodily from business life. He does not need to know a thing about bookkeeping to start. He is given whatever groundwork or review he may need; then step by step he is given a thoro working knowledge of Auditing, Cost Accounting, Business Law, Organization, Management, Finance, and is thoroughly coached and prepared for his C. P. A. examinations.

### Valuable Information Free

Does Accountancy as a profession *pay*?

The answer to this question, together with a clear outline of the steps by which a man may quickly fit himself to take advantage of his opportunities, is clearly set forth in LaSalle's 64-page book, "Accountancy, the Profession that Pays." To the man eager to advance to a commanding executive position—even though he may not plan to make

Accountancy his life profession—this book will prove of the utmost value, presenting as it does a complete analysis of Accountancy in its relation to the entire structure of business. The coupon will bring you a copy, without the slightest obligation.

Is it worth 2 cents and two minutes of your time to obtain a clear picture of what might be ahead of you in this fascinating branch of business?

—Your start toward greater earnings, real success, is as near you as the point of your pencil. For the sake of a brighter future—ACT!

CLIP AND MAIL

### LASALLE EXTENSION UNIVERSITY

The World's Largest Business Training Institution

Dept. 364-R CHICAGO

Please tell me about your *salary-doubling plan* as applied to my advancement in the business field checked below. Send also copy of "Ten Years' Promotion in One," all without obligation.

#### Higher Accountancy

- |  |  |
|--|--|
| <input type="checkbox"/> Modern Salesmanship                         | <input type="checkbox"/> Modern Foremanship and Production Methods |
| <input type="checkbox"/> Business Management                         | <input type="checkbox"/> Personnel and Employment Management       |
| <input type="checkbox"/> Law: Degree of LL. B.                       | <input type="checkbox"/> Expert Bookkeeping                        |
| <input type="checkbox"/> Traffic Management                          | <input type="checkbox"/> Business English                          |
| <input type="checkbox"/> Railway Station Management                  | <input type="checkbox"/> Commercial Spanish                        |
| <input type="checkbox"/> Commercial Law                              | <input type="checkbox"/> Effective Speaking                        |
| <input type="checkbox"/> Industrial Management Efficiency            | <input type="checkbox"/> C. P. A. Coaching                         |
| <input type="checkbox"/> Banking and Finance                         |  |
| <input type="checkbox"/> Modern Business Correspondence and Practice |  |



Name.....

Present Position.....

Address.....

# BUILDERS TRADE GUIDES



## AUDELS CARPENTERS AND BUILDERS GUIDES—4 VOLS. \$6

Inside Information for Carpenters, Builders, Joiners, Building Mechanics—all Woodworkers. **1600 pages; 3700 diagrams; flexible; pocket size.** Short-cut instructions, new methods, ideas, solutions, plans, systems—money saving suggestions. An easy progressive course for the apprentice. A practical daily helper and Quick Reference for the master worker. A Helping Hand to Easier and Better Work and Better Pay. To get this aid for yourself, simply fill in and mail the **FREE COUPON** below.

**INSIDE TRADE INFORMATION ON:**  
 How to use steel square; How to file and set saws; How to build furniture; How to use mitre box; How to use chalk line; How to use rules; How to make joints; Carpenters' arithmetic; Mensuration problems; Estimating strength of timbers; How to set girders and sills; How to frame houses and roofs; How to estimate costs; How to build houses, barns, garages, bungalows, etc.; How to read and draw plans; Drawing up specifications; How to excavate; How to use settings 12, 13 and 17 on the steel square; How to build hoists and scaffolds—skylights; How to build stairs; How to put on interior trim; How to hang doors; How to lath—lay floors; How to paint.



## AUDELS PLUMBERS AND STEAMFITTERS GUIDES—4 VOLS. \$6

A new set—just out! A practical, illustrated, Reference Library and Study-Course for Master Plumbers, Journeymen and Apprentice Steamfitters, Gas Fitters and Helpers, Sheet Metal Workers, Draughtsmen, Master Builders, Engineers and all Building Trade Students. **1670 pages; 3642 diagrams; flexible; pocket size.** Guides explain all the principles, advances and short cuts of the Plumbing and Heating trade. Contains instructions on how to figure and estimate jobs. Use **FREE COUPON** below to examine, without obligation, this valuable work.

**INSIDE TRADE INFORMATION ON:**  
 Soldering, tinning. Joint wiping, bending, beating. Pipe—iron—steel, threading. Mathematics, tables, physics. Materials—iron, steel, copper, brass, lead, tin, antimony. Sheet metal—galvanized—plate. Sanitation, syphonage, tanks. Drainage, sewage, purification. Fixtures—bath—kitchen. Pipe fittings, soil pipe, tools. Laying out work. Roughing. Screwed fittings, flanges, joints. Pipe bending, examples. Elbows. Heating, ventilation, refrigeration. Water supply, mains, wells, tanks. Gas-fittings. Underwriters. Sheet metal work, problems, methods, brazing, heating, lead burning. Welding, various welds, methods. Blacksmithing, forges; tools.



## AUDELS MASONS AND BUILDERS GUIDES—4 VOLS. \$6

A new, complete, illustrated trade reference library, for Bricklayers, Cement Workers, Plasterers, Tile Setters and Stone Masons, including a practical outline of Steel Construction. **1100 pages; 2067 diagrams; flexible; pocket size.** A practical Trade Assistant explaining modern methods of masonry construction. Easy to understand and apply. A reliable and authentic reference work and study-course for Master Journeyman and Young Mechanic. Use **FREE COUPON** below and find out for yourself, without obligation, whether this set will benefit you.

**INSIDE TRADE INFORMATION ON:**  
 Bricklaying, tools, materials; Brick designs, patterns, bonds; Setting frames and foundations; Mortars, scaffolds, estimating; Mortars and mortar mixing; Tile setting, mosaic, hollow tile; Straight edge test, trowelling; How to figure brick work; Safe loads, piers, chimneys; Boiler settings, anchors, fire stops; Labor tables; Concrete, forms; How to figure concrete work; Stucco—on old and new buildings; Plastering—wood lath—metal; Plasterers agreement; Plastering on various surfaces; Stonemasonry; Cutting, finishing, estimating stone; Derricks, rigging; Steel construction; Fire proof; How to read blue prints.



## PRACTICAL ELECTRICITY — 1 VOL. \$4

Audels Handy Book of Practical Electricity is a simplified Ready Reference and Study Course in one pocket size, leather bound volume—for Engineers, Professional Electricians and Students. **1040 pages; 2600 diagrams; flexible red leather bound.** A reliable authority and handy helper for every electrical worker. Contains important and valuable wiring diagrams, calculations, machine sketches, helps on maintenance and repair. Use this **FREE COUPON** today and find out, without obligation, how this handy book will help you in your daily work.

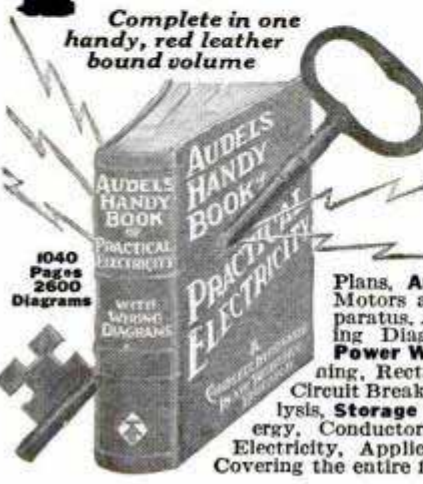

**INSIDE TRADE INFORMATION ON:**  
 Electro-Therapeutics, X-Rays, Shocks, Welding, Brazing, Radio Hook-ups, Motion Pictures, Telephone, Telegraph, Cranes, Bells, Elevators, Pumps, Tools, Ship Drive, Railways, Vehicles, Automobile Electric Systems, Ignition, Generation, Lighting, Plant Management, Power Plans, Armature Winding, Repairing, A. C. Motors and Apparatus, D. C. Motors and Apparatus, Alternator Construction, Dynamos, Wiring Diagrams, Sign Flashers, Cable Splicing, Power Wiring, Outside Wiring, Switches, Lighting, Rectifiers, Converters, Transformers, Fuses, Circuit Breakers, Rheostats, Electro Plating, Electrolysis, Storage Batteries, Magnetism, Electrical Energy, Conductors, Insulators, Static, Dynamo, Radio Electricity, Applications, Ready Reference and Index Covering the entire field of Modern Electricity.

## Learn More and You Will Earn More!

Know your job and you'll never be without one. The skilled man is always in demand. Knowledge is power. Learn your trade thoroughly by easy reading. This coupon is your opportunity for advancement and better pay. You risk nothing in sending for Audels Guides for free examination. Send it NOW!

**FREE EXAMINATION COUPON**

**THEO. AUDEL & CO.,**  
 65 W. 23 ST., NEW YORK CITY

Please mail me for free examination the books marked (x) below. If I find them satisfactory, I agree to mail \$1 in 7 days, on each set ordered, and to further mail \$1 monthly on each set until I have paid the purchase price.

4 CARPENTERS GUIDES \$6     4 PLUMBERS GUIDES \$6

4 MASONS GUIDES \$6     1 ELECTRICIANS HANDY BOOK \$4

NAME .....

ADDRESS .....

OCCUPATION .....

EMPLOYED BY.....

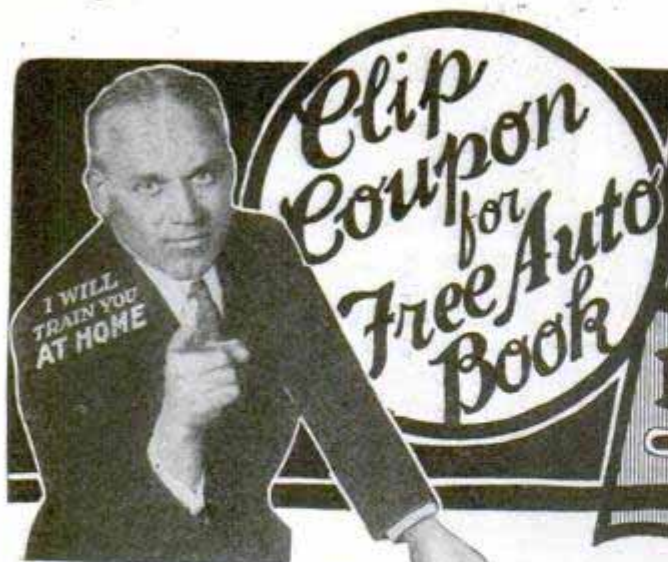

# BE AN AUTO EXPERT

- Earn up to \$10,000 a year -

Go to School AT HOME the Cooke "JOB-WAY"

FREE Auto Book

## PROOF! See What I Can Do For YOU!

Send coupon for this amazing **FREE BOOK** right now. See what it has done for others. See what it can do for you! Just think of this! —Walter Mayville, Harold Lester, M. J. Morrison, Herbert Trask, Allen Pomeroy and dozens of others without previous auto experience—**in only a few months** after enrolling—were in business for themselves, making **Big money**. My Free Book tells you all about their wonderful, **QUICK** successes. Send for it.

**Start to Make Money Quick!**  
You don't have to wait to finish to make real money with Cooke "Job-Way" training. Many of my students make money right in the very first few weeks.

**\$215 in a Single Week!**  
Only 15 weeks after enrolling, Ernest B. Tucker, Cotton, Minn., wrote me he was making as much as \$215 in a single week! That's the kind of **QUICK RESULTS** you want! Find out what you can do today!

**Raises His Salary Almost 300% in 7 Short Months**  
Cooke "Job-Way" boosted the salary of Gust Alevra, Box 172, Parkerton, Wyo., a foreigner with little education, from \$18 a week to \$50 a week in only 7 months and he gives my training full credit.

**GET THE FACTS!**  
Send for this remarkable **FREE Auto Book**. Get all the facts about this amazing "quick results" Training Method. See what others did. Find out what you can do.

**ACT NOW!**  
**MAIL THIS "JOB-WAY" COUPON**  
B. W. COOKE, Directing Engineer  
CHICAGO MOTOR TRAINING CORPORATION  
1916 Sunnyside Avenue, Dept. 316, CHICAGO, ILL.  
Send me **FREE** Auto Book and proof that you will show me the **QUICK WAY** toward a **BIG JOB** and a **RAISE IN PAY**. Also send your **4 Outfits** Offer. It is understood that this obligates me in no way and no salesman is to call on me.



**4 BIG OUTFITS INCLUDED Free of Extra Cost**

Tools, Test Bench, Radio Receiving Set. All equipment included **Free** of extra charge. Also 293 wiring diagram charts. Wonderful Offer Now. Act quick. Clip coupon for full details.

My training includes ALL Electrical work—Ignition, Starting, Lighting—All Mechanical end Welding, Brazing, Vulcanizing—also Business Course, Salesmanship, Advertising, Buying, How to Keep Simple Books—Also Auto Magazine, also 4 Outfits. Nowhere else I know of, can get you ALL this training.

B. W. Cooke is in no way connected with any other person or training of similar name. Nowhere else can you get the original, genuine copyrighted Cooke "JOB-WAY" training. I train you with Tools which I give you and illustrated **JOB—not books**. Find out how "Job-Way" fits you for Big Pay. Learn what it has done for others, see what it can do for you. Mail coupon to me right now!

**Common Schooling All You Need** Men between 15 and 60 and with little education quickly and easily finish my training. Many become Garage Owners, Managers, Superintendents, Foremen, Auto Experts, in the class with **BIG PAY** executives. I back you up with the entire resources of this great Institution. Employment service for your whole life. Also Lifetime Consultation service. Notice on this page what a few of my students have done—then send for my **Free Auto Book** right away! Address me personally.

**B. W. COOKE DIRECTING ENGINEER**  
CHICAGO MOTOR TRAINING CORPORATION  
1916 Sunnyside Avenue Dept. 316 CHICAGO

## The World's Biggest Business Needs You!

If you're earning a cent less than \$50 a week, **clip coupon now**. Get my Free Book. Let me show you how Five Thousand Million Dollars are spent every year for **Auto Upkeep alone**. Let me show you how salaries are raised—doubled—tripled in such **quick time** it's **positively amazing!** Look at this—from \$33 a week to **\$225 IN A SINGLE WEEK** is what Cooke "Job-Way" did for Bernard Rumpel, 365 Edison Place, Glendale, N. Y., only 10 months after enrolling! No other business offers you so many wonderful opportunities. No other Training can show such marvelous **QUICK RESULTS**. Get all the facts. Send for my Free Book Today!

**Earn Up to \$150 a Week!**

Don't sell your time for low pay. Raise your **PAY QUICK**. Be a Big Pay man. My book will show you the way.

## Learn Right at Home!

Keep your present job. Get started for Big Pay **QUICK** as an Auto Expert, through Cooke "Job-Way," quickly, easily, right in your own home. Send for my free book: it shows you how successful I've been and how successful I am. Being a practical Directing Engineer, Owner and Head of this Institution, I know what practical money making training you need to become a **BIG PAY MAN** and to get **QUICK RESULTS** and that training I give you.

## The Only "Job-Way" Training on Earth!

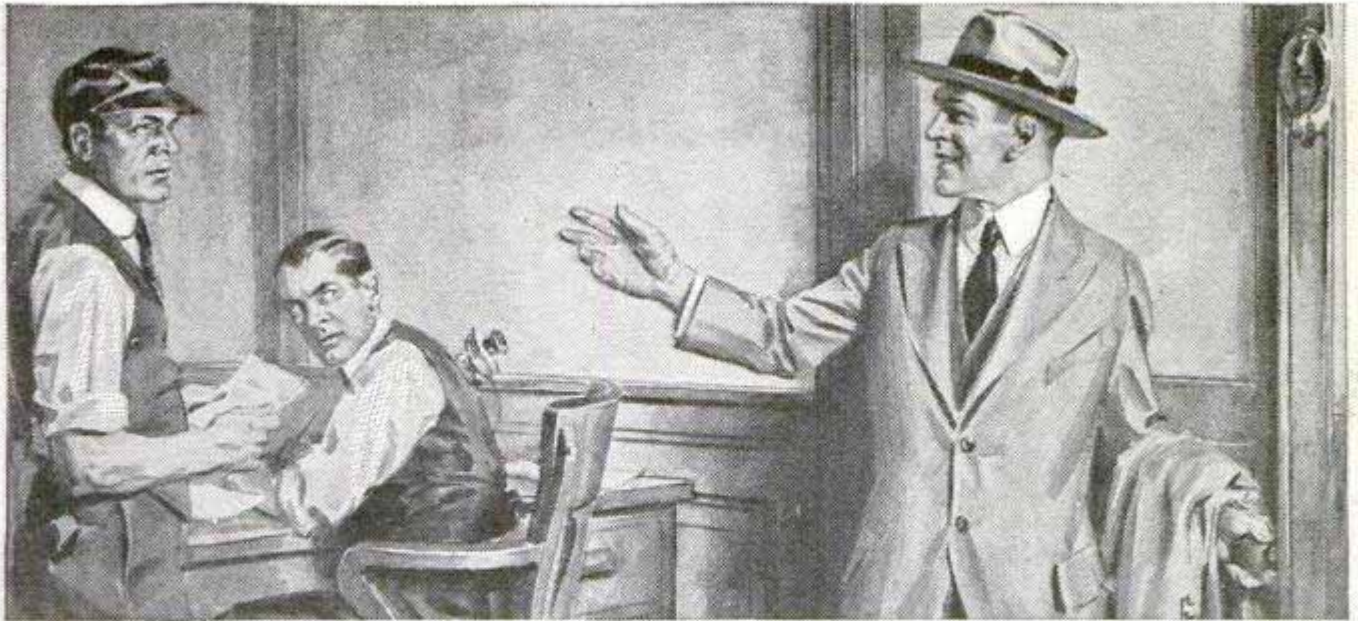

## “Good Bye, Boys!”

“TODAY I dropped in for a last word with the boys at the office. And as I saw Tom and Dave there at the same old desk it came to me suddenly that they had been there just so the day I came with the firm four years ago.

“When I started here I was put at a desk and given certain routine things to do. It was my first job and I took it as a matter of course. But after a few months I began to realize that I was nothing but a human machine—doing things that anyone could do and that I couldn't expect to advance that way.

“So I had a talk with the manager, and I'll never forget what he said: ‘If you want to get ahead, put in some of your spare time getting special training along the lines of your work. We want men who care enough about their future not only to do their work well, but to devote part of their spare time to preparation for advancement.’

“That very night I wrote to Scranton and a few days later had started studying evenings at home. Why, do you know, it gave me a whole new interest in our business. In a few months I was given more important work and more money. Since then I've had three increases. Six months ago I was put in charge of my department, and now my big chance has come—I'm to be manager of our western branch at \$5000 a year!

“Tom and Dave could never see any sense in my studying nights—they said eight hours was enough for any man to be bothered with business. They had the same chance I had—they could have been big men in the firm today. But they stood still while I went up to one of the best jobs in our business. It just shows what spare-time training will do.”

Every day, men who have let the International Correspondence Schools help them are moving up to more responsible positions and bigger salaries. Clerks have become advertising, sales and business managers; mechanics have become foremen, superintendents and engineers; carpenters have become architects and contractors; men and boys have risen from nothing to splendid positions of responsibility

because in spare hours at noon and at night they have learned to do some one thing well.

If you want to make more money, show your employer you're trying to be worth more money. If you want a bigger job, show him you're willing to prepare for it.

There's a simple, easy way to do it. For 34 years the International Correspondence Schools have been training men and women right in their own homes whenever they had a little time to spare. More than two million have stepped up in just this way. More than 180,000 are studying now. Ten thousand are starting every month.

Can you afford to let another priceless hour pass without finding out what the I. C. S. can do for you? Here is all we ask—without cost, without obligating yourself in any way, just mark and mail the coupon.

The  
I. C. S.  
is the oldest  
and largest  
correspondence  
school in the  
world

### INTERNATIONAL CORRESPONDENCE SCHOOLS

Box 5559-E, Scranton, Penna.

Without cost or obligation, please tell me how I can qualify for the position or in the subject before which I have marked an X:

#### BUSINESS TRAINING COURSES

- |   |   |
|---|---|
| <input type="checkbox"/> Business Management            | <input type="checkbox"/> Salesmanship           |
| <input type="checkbox"/> Industrial Management          | <input type="checkbox"/> Advertising            |
| <input type="checkbox"/> Personnel Organization         | <input type="checkbox"/> Better Letters         |
| <input type="checkbox"/> Traffic Management             | <input type="checkbox"/> Show Card Lettering    |
| <input type="checkbox"/> Business Law                   | <input type="checkbox"/> Stenography and Typing |
| <input type="checkbox"/> Banking and Banking Law        | <input type="checkbox"/> Business English       |
| <input type="checkbox"/> Accountancy (including C.P.A.) | <input type="checkbox"/> Civil Service          |
| <input type="checkbox"/> Nicholson Cost Accounting      | <input type="checkbox"/> Railway Mail Clerk     |
| <input type="checkbox"/> Bookkeeping                    | <input type="checkbox"/> Common School Subjects |
| <input type="checkbox"/> Private Secretary              | <input type="checkbox"/> High School Subjects   |
| <input type="checkbox"/> Spanish                        | <input type="checkbox"/> Illustrating           |
| <input type="checkbox"/> French                         | <input type="checkbox"/> Cartooning             |

#### TECHNICAL AND INDUSTRIAL COURSES

- |   |  |
|---|--|
| <input type="checkbox"/> Electrical Engineering | <input type="checkbox"/> Architect                                   |
| <input type="checkbox"/> Electric Lighting      | <input type="checkbox"/> Architects' Blueprints                      |
| <input type="checkbox"/> Mechanical Engineer    | <input type="checkbox"/> Contractor and Builder                      |
| <input type="checkbox"/> Mechanical Draftsman   | <input type="checkbox"/> Architectural Draftsman                     |
| <input type="checkbox"/> Machine Shop Practice  | <input type="checkbox"/> Concrete Builder                            |
| <input type="checkbox"/> Railroad Positions     | <input type="checkbox"/> Structural Engineer                         |
| <input type="checkbox"/> Gas Engine Operating   | <input type="checkbox"/> Chemistry <input type="checkbox"/> Pharmacy |
| <input type="checkbox"/> Civil Engineer         | <input type="checkbox"/> Automobile Work                             |
| <input type="checkbox"/> Surveying and Mapping  | <input type="checkbox"/> Airplane Engines                            |
| <input type="checkbox"/> Metallurgy             | <input type="checkbox"/> Navigation                                  |
| <input type="checkbox"/> Steam Engineering      | <input type="checkbox"/> Agriculture and Poultry                     |
| <input type="checkbox"/> Radio                  | <input type="checkbox"/> Mathematics                                 |

Name.....

Street.....

Address..... 3-6-24

City..... State.....

Occupation.....

Persons residing in Canada should send this coupon to the International Correspondence Schools Canadian, Limited, Montreal, Canada.



Wide World Photo

# Sudden New Demand for Daring Young Men!

AVIATION in America is on the threshold of an amazing new development. For in the past few months gigantic commercial air lines have been established. The biggest capital and business forces in the world are behind this enterprise. Even in the beginning, thousands of young men are needed. For those who can qualify there will be highly paid jobs which will lead quickly and surely to advancement and success.

## Big Opportunities Await the Trained Man

Look over the fields of work which are open to the young man today. You will find that Aviation is the ONE FIELD that is not overcrowded—the ONE FIELD in which there is plenty of room at the top. Think of it! Only 21 years ago Orville and Wilbur Wright made the world's first airplane flight. Now airplanes fly around the world. Yes, Aviation offers the same wonderful opportunities today that the automobile and motion picture industries did 15 and 20 years ago. Men who got in on the ground floor of those industries made fortunes before others woke up.

## Easy to Become an Aviation Expert—\$50 to \$100 a Week

You can qualify now quickly for one of these exciting highly paid jobs through a new, sure, easy method of training. The study of Aviation is almost as interesting as the work itself. Every lesson is fascinating and packed full of interest. That's why Aviation is so easy to learn—you don't have to force

yourself to study. Only one hour of spare time a day will give you the basic training in an amazingly short time.

One student, S. F. McNaughton, Chicago, says: "Your lessons are like a romance, and what is more, after one reading, the student gets a thorough understanding. One never tires of reading them." James Powers, Pa., another student, says: "I am indeed surprised that such a valuable course can be had from such practical men for so little cost."

Men who have had actual experience in Aviation give you personal attention and guide you carefully through your training. They select the lessons, lectures, blueprints and bulletins. They tell you the things that are essential to your success. Every lesson is easy to read and quickly understood.

### PREPARE FOR ONE OF THESE POSITIONS

Aeronautical Instructor  
\$60 to \$150 per week  
Aeronautical Engineer  
\$100 to \$300 per week  
Aeronautical Contractor  
Enormous Profits  
Aeroplane Repairman  
\$60 to \$75 per week  
Aeroplane Mechanician  
\$40 to \$60 per week  
Aeroplane Inspector  
\$50 to \$70 per week  
Aeroplane Salesman  
\$5,000 per week and up  
Aeroplane Assembler  
\$40 to \$65 per week  
Aeroplane Builder  
\$75 to \$200 per week



### Big Book on Aviation FREE

Send coupon below for New Free Book, just out, "Opportunities in the Airplane Industry." It is interesting and instructive and will show you many things about Aviation which you never knew before. Only a limited number offered—get yours before the edition is exhausted.

### AMERICAN SCHOOL OF AVIATION Dept. 1353, 3601 Michigan Ave., Chicago, Ill.

American School of Aviation,  
3601 Michigan Ave., Dept. 1353, Chicago, Ill.

Without any obligation, send me your Free Book, "Opportunities in the Airplane Industry," also information about your Course in Practical Aeronautics.

Name.....

Street.....

City..... State.....

RAILROAD FARE TO CHICAGO INCLUDED WITHOUT EXTRA COST IF YOU ACT NOW!

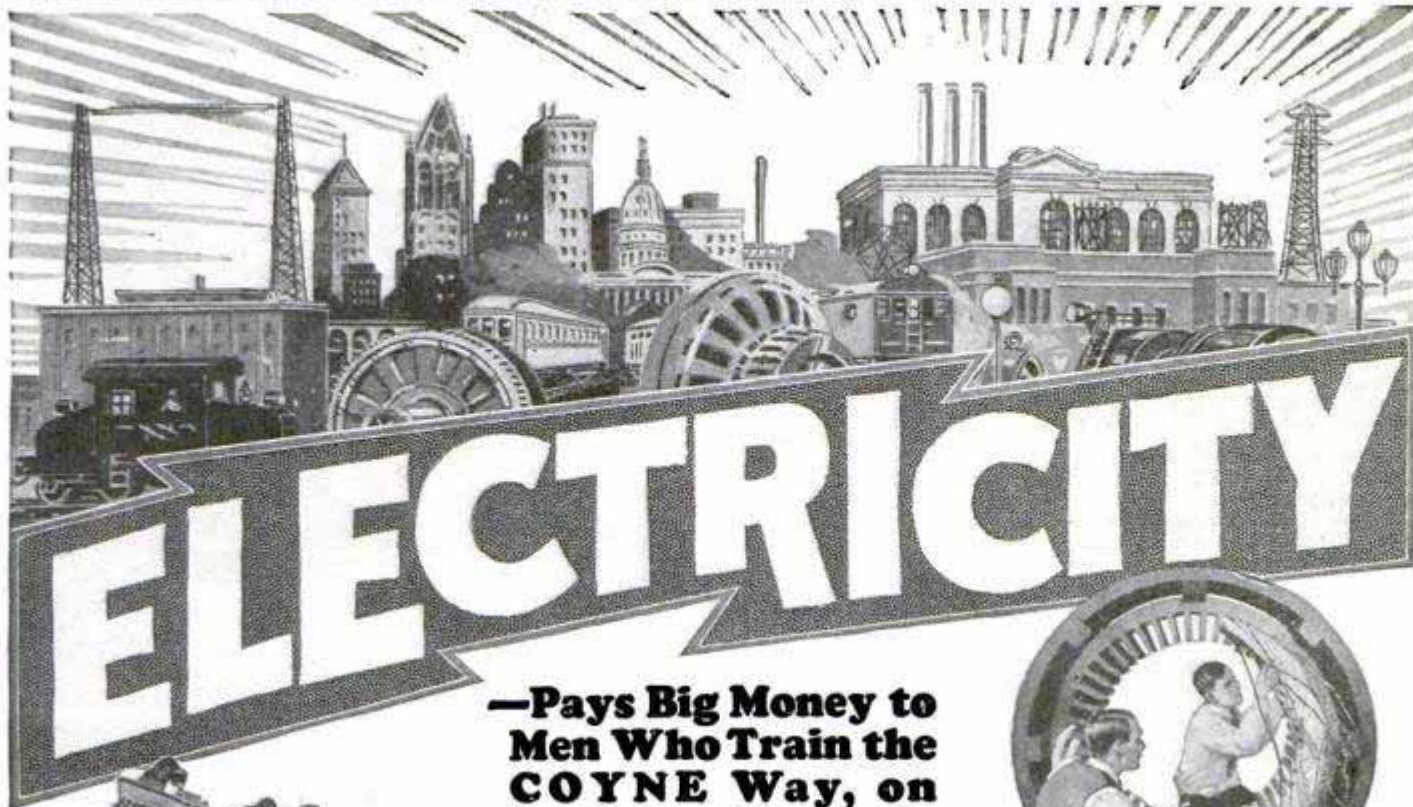

Students  
Constructing Outdoor  
Substation at COYNE

### You Don't Need Advanced Education or Experience

Don't worry if you lack advanced education, knowledge of higher mathematics, or experience. My course is a *practical, LEARN-BY-DOING* Course. Every COYNE student receives *INDIVIDUAL* and *PERSONAL* instruction, on *COMPLETE* electrical apparatus, under *EXPERT INSTRUCTORS*, in the COYNE Shops at Chicago.

### FREE RAILROAD FARE TO CHICAGO

As a special inducement for prompt action I'll include with your tuition your Railroad Fare to Chicago. Send the coupon for details right away, before this offer expires.

### —Pays Big Money to Men Who Train the COYNE Way, on Real Equipment, in Great Shops!

If you are going to train for one of the thousands of *BIG-PAY* opportunities in the fascinating Electrical Field, why not train on real, gigantic electrical equipment such as you will find in the great Shops of COYNE at Chicago, the electrical center of the world? COYNE training is thorough but easy to understand, because *EXPERT* instructors guide you at every turn, as you work with your own hands on big, modern apparatus.

**Hundreds of COYNE-Trained Men Earn \$60 to \$200 a Week**



Students producing "artificial lightning" on Tesla coil in great shops of Coyne

Students operating large switchboard at Coyne

**EARN WHILE YOU LEARN AT COYNE**

I want to send you a copy of my big, attractive Electrical Book. It is 12 x 15 in size and contains 151 photos of electrical scenes. Tells about dynamos, radios, autos, airplanes, farm lighting and power, etc. *Absolutely FREE, Remember.*

## COYNE ELECTRICAL SCHOOL

H. C. LEWIS, President Established 1899  
1300-10 W. Harrison St., Dept. 1353 Chicago

*Not a Correspondence Course  
All Practical, Personal Training*



Student Winding Stator at COYNE

### COMPLETE ELECTRICAL TRAINING

**In 12 Happy Weeks at Coyne**

My newly enlarged Electrical Course is the result of 27 years of experience, solving the needs of young men and of the Electrical Field. COYNE has been teaching Electricity in a *PRACTICAL* way since 1899.

My course is thorough, easy to master, and fits men for *BIG* Electrical jobs, the *HIGH-SALARIED* thrilling jobs.



H. C. LEWIS  
President, Coyne  
Electrical School

### We Teach Electricity and Nothing Else

COYNE teaches only *ONE* thing—*ELECTRICITY*. We are *SPECIALISTS*. Our interests are not divided, nor is Electricity a sideline or merely an "additional" subject with us.

**You Can Start Any Day of the Year at COYNE**  
—No Classes or Seasons

### SEND COUPON NOW

H. C. LEWIS, President  
COYNE ELECTRICAL SCHOOL  
1300-10 W. Harrison St.  
Dept. 1353, Chicago, Illinois

Dear H. C.—You can just bet I want one of those big, handsome *FREE* 12x15 books, with 151 actual photographs printed in two colors. Send it quick, before the supply is exhausted. Be sure to tell me all about Railroad Fare and Special Courses without extra cost.

Name .....

Address .....

Now you

can "KNOCK DOWN"  
\$60 to \$90 a week  
like the Rest of 'Em

Learn bricklaying. Get into the big money class—QUICK. I'll train you right at your home—in your spare time. In just a few short months, you can be ready to step into a real job in the best game in the world—the building game.

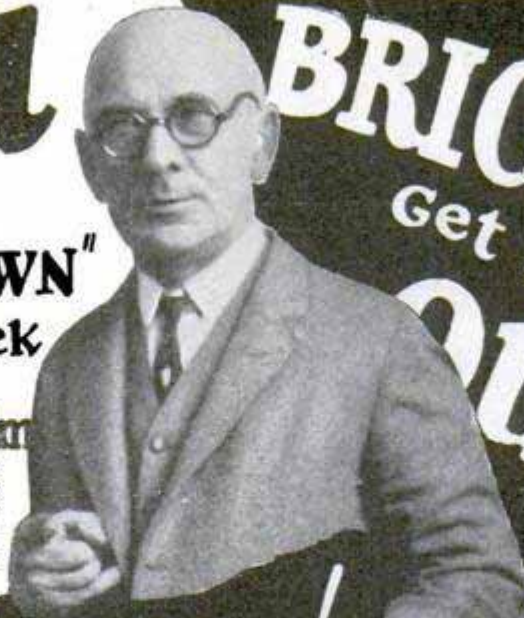

Be a  
**BRICKLAYER**  
Get Ready  
**QUICK**

Learn at Home!

Get  
**FREE** Book  
NOW

**Big Pay Jobs Going Begging**

Get into the best paid trade of all. You're needed. Don't waste your time at any ordinary job when you can be making \$10, \$12, \$14 and even \$16 a day. The way is open NOW—for the first time—for you to take a new, easy, short cut to quick success and big pay as a bricklayer. Plenty of jobs waiting. Easy work once you know the trade. Very healthful. And short hours—with time-and-a-half or DOUBLE time for every minute beyond the regular day. Considering everything, no other trade offers opportunities that begin to compare with those open to you as a bricklayer. Decide to be one now. Write me quick—I'll show you the way.

**I Train You at Home  
Amazing New Method**

You learn right at home, in your spare time. Then in a few short months, you'll be ready to quit your present job for another one a whole lot better. I train you by a remarkable new method, carefully developed by experts who know the trade from A to Z. You learn the trade step by step, using real brick, trowel and mortar. You train in your basement, attic, shed, barn, garage or other handy place. You get real experience as you go along—by actually building corners, angles, jambs, pilasters, panels, and doing every job that a regular bricklayer does on the wall.



**Learn  
To Read Plans  
and Blue Prints, Too**

No need to stop at even a bricklayer's big pay. While I'm teaching you the trade, I also teach you to read plans and blue prints. Also to estimate and lay out work. I give you the extra knowledge that a man needs to become foreman, superintendent, contractor or builder. There are opportunities, any number of them, for the ambitious man who has this EXTRA knowledge. You get it—**quick**—through the **Job Analysis Method.**

**Big Building  
Boom Ahead!**

The building business—the greatest industry in the world—is going ahead by leaps and bounds. Experts say 1926 will be a record year. That means plenty of work and big wages. The time is ripe, right now, for you to get started. No reason why YOU shouldn't make the same big money a lot of others are making. You can, easily—QUICKLY. Let me show you how.

**READ!**

**Others Learning Fast**

"Received my first set of lessons a few days ago. They are very interesting and simple. I now feel sure that I can become a bricklayer."

H. Eghiam,  
Van Nuys, Calif.

"I received your instructions on bricklaying and am more than satisfied. I have my brick, have been practicing the jobs and feel sure I am going to get along all right."

A. Campeau,  
Herkimer, N.Y.

"I have been laying brick for some time—foundations, chimneys and repair work. But since looking over your lessons, I know I am going to build on a larger scale next year."

J. Anderson,  
Monmouth, Ill.

**REAL MONEY!**

Bricklayers' wages from recent report compiled by National Association of Builders Exchange.

	Per Hour
Atlanta.....	\$1.25
Baltimore.....	1.50
Chicago.....	1.50
New York City..	1.50
Pittsburgh.....	1.62½
Kansas City....	1.37½
St. Louis.....	1.75

These figures are for regular time. For overtime there is always a bonus—either time-and-a-half or DOUBLE time.

**ACT QUICK!  
Free Book Explains**

New, FREE book, "The Quick Way To Big Pay Everyday" tells you everything. Tells you how I myself started years ago as a bricklayer and then became foreman, superintendent and builder—and how I can now train you to do everything that I have done, and MORE. No need to lose a minute. Clip the coupon. My message for you is important. Send for it today.

for you to mail

W. P. Cissel,  
Chief Instructor,  
National School of Brick-  
laying, Dept. P-10, Ninth and  
G Sts., N. W., Washington, D. C.  
Send FREE book, "The Quick Way  
To Big Pay Everyday," which tells  
how I can quickly become a brick-  
layer by practicing at home in spare  
time.

**THE NATIONAL SCHOOL OF BRICKLAYING**  
Ninth & G Sts., N. W., Dept. P-10, Washington, D. C.

.....Name

.....Address

**Remember**—you train with real brick, trowel and mortar at home—in spare time. Easiest, simplest, shortest and best method ever devised. Hundreds of diagrams, charts, photographs and blue prints make every step just as clear as if I stood right beside you. Learn more about this big opportunity. It's ready for you—write me—NOW.



# Can you fix it?

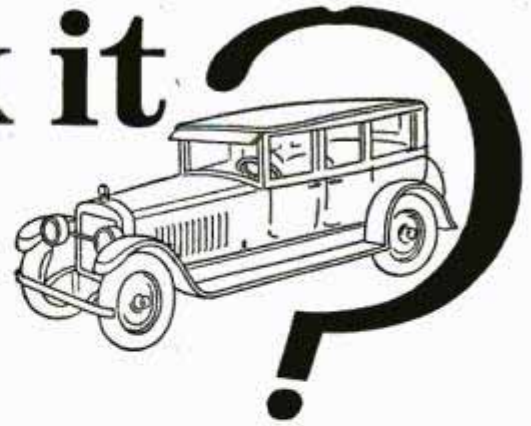

New books have "jiffy index," making all facts instantly available. You find anything you want to know in a moment, in this brand new 1926 edition.

## These books tell how

HERE are the most interesting, the most practical books we have ever published on automobile construction, operation and repairs. Brimful of facts, photographs and explanations so easy to understand that anyone can learn how in almost no time.

Over 2000 pages, with diagrams, blueprints and everything else needed to make anyone an authority on automobiles.

Whether you want to qualify as garage owner, auto repair expert or merely wish to know how to keep your own car 100% efficient, you will welcome these books, especially on our

### No Money Offer

This plan brings this valuable information within the reach of everyone. You don't send us a single penny. You don't have to pay us anything—just send your name and address and we'll send you the complete set of 5 volumes, specially bound in Flexo covers.

Read them carefully; keep them 10 days; find out anything you want to know, and then if you want to keep them, send only \$2.00 then and \$3.00 per month until the special low price of \$19.80 is paid. There is no further obligation.

### American Technical Society Membership Free

This is a great organization for the publishing and spreading of specialized knowledge—we have over a million dollars of resources, enabling us to get the cooperation of the largest automobile manufacturers and dealers, who have furnished us plans and photographs. If you send NOW for this new edition of Automobile Engineering, we will include a Consultation Membership in this great organization.

Eighteen automobile experts will be ready to help you at all times. You can write or wire any time for special information. Answers will be sent to you promptly—without cost.

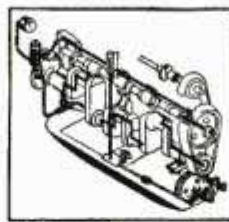

Modern Oiling System

### Don't Hesitate

There are no strings to this offer—it means just what it says. Send name and address on the coupon and ALL of the five books—the complete set—will be sent to you for examination.

Remember one fact only which you can find in these books may save you an expensive repair or help you to a better job.

### Learn All About Autos

Get these five big books on this liberal offer and learn all the things you want to know about autos. Carburetors, engines, springs and spring suspension, brakes, 4-wheel drives, lubrication systems—all are fully covered.

These complete and comprehensive auto books are yours if you want them on this easy plan. Send for a set NOW; there's nothing to pay.

Jiffy  Index  
Puts Facts  
At Your Fingertips

You don't have to read the books through; the index enables you to put your finger on the information wanted in a jiffy.

### For Free Offer, Use Coupon

American Technical Society,  
Spec. Dept. A-319, Chicago, Ill.

I would like to look at the 5 Auto Books described above. Send them on your FREE offer. I will examine them carefully and return them in 10 days unless I like them; in which case I will send you \$2.00 then and \$3.00 per month until the total price of only \$19.80 is paid. You are to also send me Free Consulting Membership Certificate in the American Technical Society.

Name.....

Street.....

City..... State.....

Reference.....

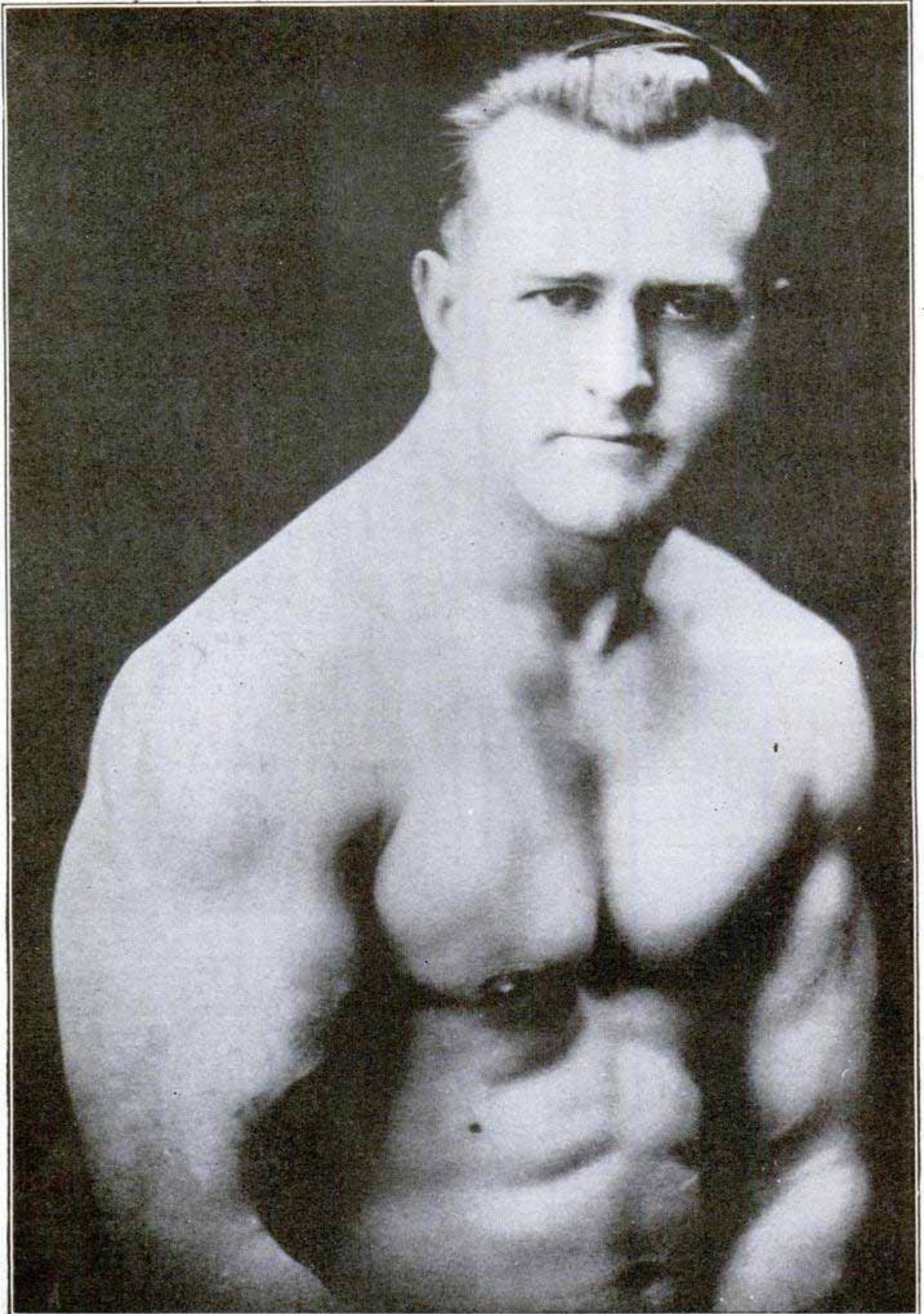

**EARLE E. LIEDERMAN, *The Muscle Builder***  
*Author of "Science of Wrestling," "Muscle Building," "Secrets of Strength," and "Here's Health," etc.*

# How Strong Are You?

## Can You Do These Things?

*Lift 200 lbs. or more overhead with one arm; bend and break a horseshoe; tear two decks of playing cards; bend spikes; chin yourself with one hand.*

**C**AN you do any of them? I can and many of my pupils can. It is remarkable the things a man really can do if he will make up his mind to be strong. It is natural for the human body to be strong. It is unnatural to be weak. I have taken men who were ridiculed because of their frail make-up and developed them into the strongest men of their locality.

### I WANT YOU FOR 90 DAYS

These are the days that call for speed. It once took four weeks to cross the ocean—now it takes less than one. In olden days it took years to develop a strong, healthy body. I can completely transform you in 90 days. Yes, make a complete change in your entire physical make-up. In 30 days I guarantee to increase your biceps one full inch. I also guarantee to increase your chest two inches. But I don't quit there. I don't stop till you're a finished athlete—a real strong man. I will broaden your shoulders, deepen your chest, strengthen your neck. I will give you the arms and legs of a Hercules. I will put an armor plate of muscle over your entire body. But with it come the strong, powerful lungs which enrich the blood, putting new life into your entire being. You will be bubbling over with strength, pep and vitality.

#### A Doctor Who Takes His Own Medicine

Many say that any form of exercise is good, but this is not true. I have seen men working in the factories and mills who literally killed themselves with exercise. They ruined their hearts or other vital organs, ruptured themselves or killed off what little vitality they possessed.

I was a frail weakling myself in search of health and strength. I spent years in study and research, analyzing my own defects to find what I needed. After many tests and experiments, I discovered a secret of progressive exercising. I increased my own arms over six and a half inches, my neck three inches and other parts of my body in proportion. I decided to become a public benefactor and impart this knowledge to others. Physicians and the highest authorities on physical culture have tested my system and pronounced it to be the surest means of acquiring perfect manhood. Do you crave a strong, well-proportioned body and the abundance of health that goes with it? Are you true to yourself? If so, spend a pleasant half hour in learning how to attain it. The knowledge is yours for the asking.

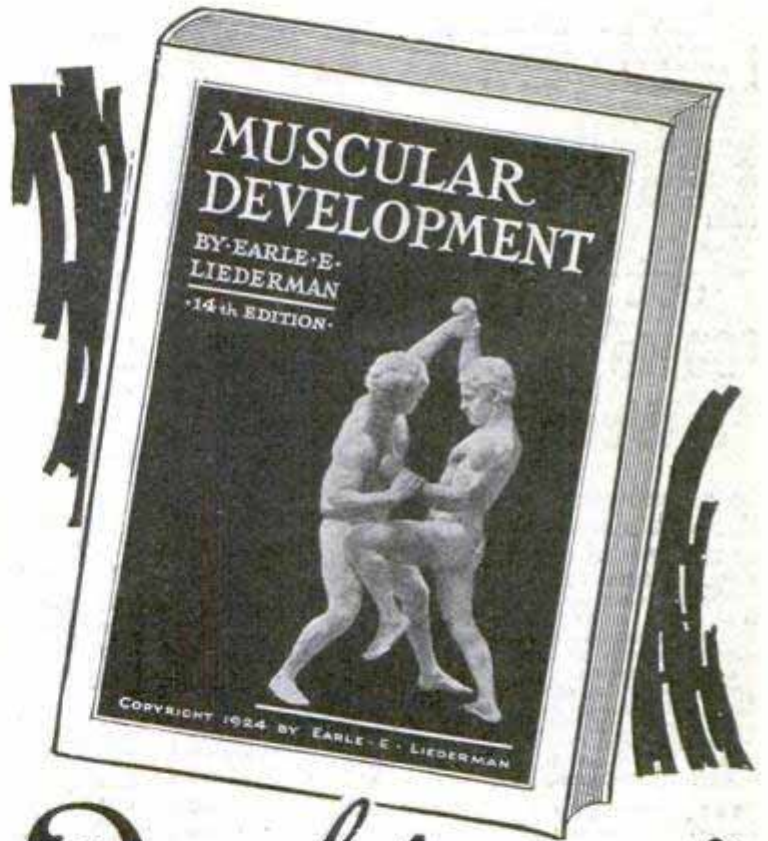

Send For My New  
64 Page Book

# "Muscular Development"

IT IS FREE

It contains forty-three full-page photographs of myself and some of the many prize-winning pupils I have trained. Some of these came to me as pitiful weaklings, imploring me to help them. Look them over now and you will marvel at their present physiques. This book will prove an impetus and a real inspiration to you. It will thrill you through and through. This will not obligate you at all, but, for the sake of your future health and happiness, do not put it off. Send today—right now, before you turn this page.

**EARLE E. LIEDERMAN**

Dept. 2003, 305 Broadway, New York City

**It  
Is  
F  
R  
E  
E**

**DON'T  
SEND ONE  
PENNY**

**YOUR  
NAME AND  
ADDRESS  
ON A  
POSTAL  
WILL DO**

**EARLE E. LIEDERMAN**  
Dept. 2003, 305 Broadway, New York City

Dear Sir: Please send me, without any obligation on my part whatever, a copy of your latest book, "Muscular Development." (Please write or print plainly.)

Name .....

Address .....

City..... State.....

If you want a job while training, I'll help get you one. Come to my big schools at Chicago, Cleveland, Detroit or Boston

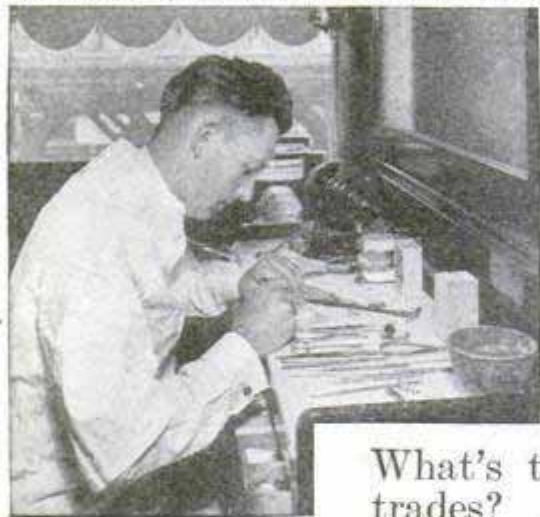

# This Dental Laboratory Expert earns \$20 a day!

What's the use of training for the old, overcrowded trades? If you're going to prepare for big-salaried jobs or a profitable business of your own GET INTO THE NEWEST PROFESSION — "Laboratory Dentistry." Biggest opportunity for success of the century, because there are ten times as many jobs as men to fill them, because there are a dozen cities crying for Laboratories for each EXPERT capable of operating one!

Easiest, pleasantest work you ever saw! Your own boss, money and success yours from the very beginning. You can start with a "shoe-string." We prepare you in a few months to run a business of your own, to do any job. Common schooling, ability to use your fingers ALL YOU NEED! Free R. R. Fare to Chicago, Cleveland, Detroit or Boston for a limited time!



### Jobs at \$60 to \$125 a Week!

In a business where there are many times as many jobs as Experts, salaries are high, hours are easy, opportunities are everywhere! McCarrie-trained Graduates always get the preference—Dentists everywhere recognize the high-standing of our graduates. No books here—learn with tools and instruments. Start quick—get ready in a few months for your big opportunity! *Mail Coupon today!*

**FREE!**  
R. R. Fare  
TO  
**Chicago  
Cleveland  
Detroit  
OR  
Boston**

### RUBBER PLATES

Learn to make partial upper or lower plates with soldered, cast or wire clasps, with palatal bars; with lingual bars. McCarrie-trained Students learn to make full rubber plates of every type, including Vulcanite base-plates, butted gums, carved gums, etc.

### CROWNS

Here's only a small part of your practical training in Crown-work: Two-piece, seamless, open-face, Richmond, cast-base porcelain, Carmichael, split-pin, carved (swaged) cusp, cast cusp, etc.

### BRIDGE WORK

Complete training in both fixed and removable bridge-work. Interchangeable teeth, gold dummy, Sanitary, porcelain dummy jobs—Roach, Gilmore, Bischoff and all forms of cast-clasp work is taught—not with books but in actual Laboratory.

### METAL BASE DENTURES

Cast bases of Aluminum, gold, Watt's metal, etc., are included in your training. Both centrifugal and air pressure casting machines are used. Free Catalog contains complete list of subjects in course.

### 70,000 DENTISTS NEED LABORATORY WORK!

Only a few hundred Laboratories in all the U. S.—most of them in Chicago and New York. Dentists can't afford to do their own mechanical jobs. They can buy the services of a Laboratory Expert at \$3.00 an hour and sell their own time at \$6 to \$15 an hour. Dentists will encourage you to learn mechanical work, start a "Lab" of your own, give them quicker service than sending to Chicago or New York. Dentists can't wait and keep their patients waiting.

### WE HELP YOU OPEN A LABORATORY OF YOUR OWN!

Many of my graduates open a Laboratory of their own. To encourage more men to go into this wonderful profession, we will help you find a good location for your Laboratory, and help you make a success of it. Write for complete information on how you can find yourself in a profitable business of your own after you become a Dental Laboratory Expert.

### INTERESTING CATALOG—FREE!

Right this minute there are openings for 150 Dental Laboratory Experts in locations where they can do a business of \$5,000 to \$20,000 a year. But you can't cash in, take advantage of these OPPORTUNITIES until you're trained. Catalog tells you how quickly and easily you can get ready, how hundreds of others have SUCCEEDED! Tells you how you learn in a few months BY DOING ACTUAL LABORATORY JOBS under one of the world's greatest Mechanical Dentists! Brings you FREE R. R. Fare offer and other big inducements. Write for free Catalog today!

### McCarrie School of Mechanical Dentistry

1338 S. Michigan Ave. Dept. 3201-C Chicago, Ill.

**EARN while you LEARN!**  
Day students make all or part cost of course by part-time night work. Night students can find plenty of good jobs to see them thru. We'll help you!

### McCarrie School of Mechanical Dentistry,

1338 S. Michigan Ave. Dept. 3201-C, Chicago, Ill.

Without obligation, please send me your Free R. R. fare offer and free catalog with complete information about how I may become a Dental Laboratory EXPERT. How you will help me open a Laboratory, how you will help me find a job while I take my training, etc.

Name.....  
St. No. or R. F. D.....  
City..... State.....

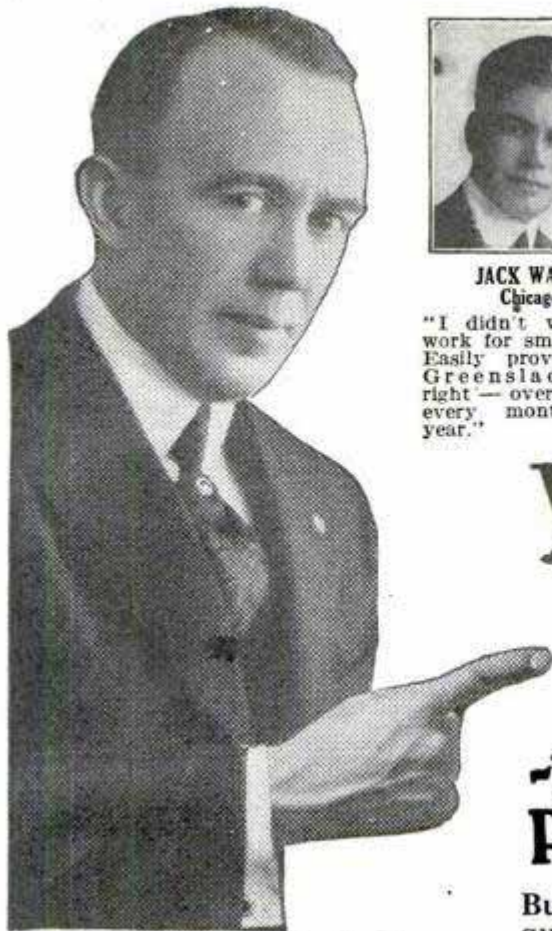

**J. E. GREENSLADE, President**  
National Salesmen's  
Training Association



**JACK WARD**  
Chicago

"I didn't want to work for small pay. Easily proved Mr. Greenslade was right—over \$1,000 every month last year."



**WARREN HARTLE**  
Chicago

"After 10 years in the railway mail service I decided to make a change. Earned more than \$1,000 the first 30 days."



**F. WYNN**  
Portland

"Last week my earnings amounted to \$554.37; this week will go over \$400. Thanks to the N. S. T. A."



**CHARLES V. CHAMPION**  
Illinois

"I'm now President, and my earnings for 1925 will easily exceed the five figure mark, thanks to your training."

# You're Fooling Yourself

## -if You Think These Big Pay Records Are Due to LUCK!

But don't take my word for it! When I tell you that you can quickly increase your earning power, I'LL PROVE IT! FREE! I'll show you hundreds of men like yourself who have done it. And I'll show you how you can do it, too.

I'LL come directly to the point. First you'll say, "I could never do it. These men were lucky." But remember the men whose pictures are shown above are only four out of thousands and if you think it's luck that has suddenly raised thousands of men into the big pay class you're fooling yourself!

### Easy to Increase Pay

But let's get down to your own case. You want more money. You want the good things in life, a comfortable home of your own where you can entertain, a snappy car, membership in a good club, good clothes, advantages for your loved ones, travel and a place of importance in your community. All this can be yours. And I'll prove it to you. Free.

First of all get this one thing right, such achievement is not luck—it's KNOWING HOW! And KNOWING HOW in a field in which your opportunities and rewards are ten times greater than in other work. In short, I'll prove that I can make you a Master Salesman—and you know the incomes good salesmen make.

Every one of the four men shown above was sure that he could never SELL! They thought Salesmen were "born" and not "made!"

When I said, "Enter the Selling Field where chances in your favor are ten to one," they said it couldn't be done. But I proved to them that this Association could take any man of average intelligence, regardless of his lack of selling experience, and in a short time make a MASTER SALESMAN of him—make him capable of earning anywhere from \$5,000 to \$10,000 a year. And that's what I'm willing to prove to you, FREE.

### Simple as A. B. C.

You may think my promise remarkable. Yet there is nothing remarkable about it. Salesmanship is governed by rules and laws. There are certain ways of saying and doing things, certain ways of approaching a prospect to get his undivided attention, certain ways to overcome objections, batter down prejudice and outwit competition.

Just as you learned the alphabet, so you can learn salesmanship. And through the NATIONAL DEMONSTRATION

METHOD—an exclusive feature of the N. S. T. A. System of Salesmanship Training—you gain the equivalent of actual experience while studying.

The N. S. T. A. System of Salesmanship Training and Employment Service will enable you to quickly step into the ranks of successful salesmen—will give you a big advantage over those who lack this training. It will enable you to jump from small pay to a real man's income.

### Remarkable Book, "Modern Salesmanship" Sent Free

With my compliments I want to send you a most remarkable book, "Modern Salesmanship."

It will show you how you can easily become a Master Salesman—a big money-maker—how the N. S. T. A. System of Salesmanship Training will give you the equivalent of years of selling experience in a few weeks; how our FREE Employment Service will help select and secure a good selling position when you are qualified and ready. And it will give you success stories of former routine workers who are now earning amazing salaries as salesmen. Mail the attached coupon at once and you will have made the first long stride toward success.



Dept. C-12

N. S. T. A. Building

Chicago, Ill.

National Salesmen's Training Association, N. S. T. A. Building, Dept. C-12

Chicago, Ill.

Send me free your book "Modern Salesmanship," and Proof that I can become a MASTER SALESMAN.

Name.....

Address.....

City..... State.....

Age..... Occupation.....

# Learn High School Subjects At Home

**Question and Answer Method Makes Each Subject Fascinating and Easy**



It is not too late for you to acquire the essentials of a High School education. A remarkable series of Pocket Size Question and Answer books bring the High School to your home; you learn in spare time—only a few minutes a day—in the most fascinating way imaginable. Each subject boiled down—all the non-essentials left out. No dry-as-dust lessons or essays. Just the most important FACTS presented in the most successful teaching method known.

## In Use in Thousands of High Schools

For years these books have been purchased by High School students, principals, and teachers. Letters by the score say: "Students think these are the best books they have." "Regard them as invaluable and indispensable." "Nothing like them—we experienced a new thrill in our work." Now for the first time offered to the public. Like having a teacher at your elbow, but without class work or correspondence. No lessons to prepare—nothing to do but read and absorb high school knowledge in the easiest, most interesting way.

## 6 Subjects—Only \$5 for All

These Question and Answer books, if placed in the form of a correspondence course, would cost at least \$5.00 each, or \$30 for the set of six. Since no further instruction is needed, they are sold as books, at \$5 for the entire set. The subjects treated are **Biology—English Grammar and Composition—Ancient and Medieval History—Physics—Elementary Algebra—Latin.**

Without question, this is the biggest bargain in education ever offered!

## Make Yourself 23 Times More Valuable

U. S. Government Census figures show that High School graduates earn 2300% more than grammar school graduates. Can you afford to go through life under the handicap of not having had this training? Will you let \$5 stand between you and MULTIPLIED earning capacity?

## Send No Money

Question and Answer books arrive pay the postman \$5 plus postage. Examine and read the books 10 days. If not delighted return them and your money will be refunded at once. This guarantee is made possible only because the books are so fascinating, so instructive, and so valuable. Write NOW. This announcement may not appear again.

Do not send money now. Just mail coupon or a letter. When the

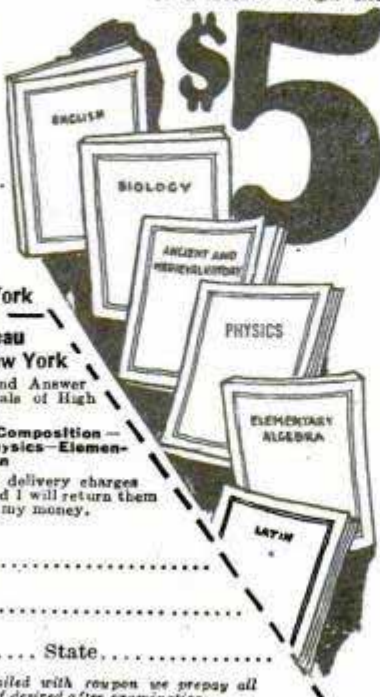

**High School Home-Study Bureau**

Dept. 13, 31 Union Square, New York

**High School Home-Study Bureau**

Dept. 13, 31 Union Square, New York

Please send me the six Question and Answer books which constitute the essentials of High School education.

**Biology—English Grammar and Composition—Ancient and Medieval History—Physics—Elementary Algebra—Latin**

I will give the mail man \$5.00 plus delivery charges when the books arrive. If not satisfied I will return them within 10 days and you are to refund my money.

Name .....

Address .....

City .....

State .....

Note: If check or money order is mailed with coupon we prepay all delivery charges. Money back if desired after examination.

## Be a Popular Favorite—Play the TENOR BANJO

**\$18 TENOR BANJO**  
with case  
**FREE**  
When You Enroll

45,000 successful students back up our claim that you can play a piece in 30 minutes by following our printed instructions. Study in leisure time at home. Begin at once.

### Picture Lessons Make It Easy

You can't fail to learn—pictures explain every move. You don't have to be able to read notes. We teach you, in our large New York conservatory, by mail.

### Play for Fun or Money

Get in on parties. Entertain your friends. Be popular. Play at dances. Earn money in spare time.

### Write for Special Offer

**\$18 TENOR BANJO**, in genuine Seal Grain Fabrikoid Case, **FREE** when you enroll. Write for special offer and guarantee.

**FIRST HAWAIIAN CONSERVATORY of MUSIC, Inc.**  
9th Floor, Woolworth Building, Dept. 160  
New York, N. Y.

Approved as a Correspondence School Under the Laws of the State of New York

Low Prices—  
Easy Terms!



## ELECTRICAL

Course for men of ambition and limited time. Over 4000 men trained.

Condensed course in Theoretical and Practical Electrical **ENGINEERING** including the closely related subjects of Mathematics and Mechanical Drawing taught by experts. Students construct motors, install wiring, test electrical machinery. Course complete

## IN ONE YEAR

Prepare for your profession in the most interesting city in the world. Established in 1893. Free catalog.

**BLISS ELECTRICAL SCHOOL**  
233 Takoma Ave. WASHINGTON, D. C.



## LEARN WATCH REPAIRING



You can learn by our modern and original system of instruction every part of the **Watch Repairing Trade** at home as good or better than at a shop. You can earn money while learning and secure a well paying position or start in business after completing our course of instruction. Good watch repairers are always in demand and earn from \$50 to \$75 per week. For particulars apply to the **Wisconsin School of Watch Repairing**  
166 Mason St., MILWAUKEE, WIS.

## "STAMMERING

Its Cause and Cure"

You can be quickly cured if you stammer. Send 10 cents, coin or stamps, for 288 page cloth bound book on Stammering and Stuttering. It tells how I cured myself after Stammering and Stuttering for 20 years. **BENJAMIN N. BOGUE**  
6931 Bogue Building, 1147 N. III. St. Indianapolis



## SHORTHAND IN ONE MONTH

Boyd—the Wonderful, New, Easy System. Writers hold World's record. 100 to 150 words a minute in 30 days guaranteed. New Principles—dictation first week. Best for Court Reporting and Secretaries. Also Typewriting, Bookkeeping and Commercial Law. Send today for Catalog and Money-Back Guarantee  
**CHICAGO HOME STUDY SCHOOLS, 802 Reaper Block, CHICAGO, ILLINOIS**

## Learn Photography at HOME

Earn \$3,000 to \$10,000 a year. Prepare quickly during spare time. Also earn while you learn. New easy method. Nothing else like it. Send at once for free book, "Opportunities in Modern Photography" and full particulars. Special offer open now  
**International Studios, Inc., Dept. 1353, 3801 Michigan Ave., Chicago, U. S. A.**

# Don't Pay Me a Cent If I Can't Give You a *Magnetic Personality* -5 Days FREE Proof!



**N**O matter how lacking you are in qualities of leadership, no matter how colorless, timid, unsuccessful and discouraged you may be, I GUARANTEE to so magnetize your personality that your whole life will be completely transformed!

I can give you poise that banishes self-consciousness, charm that makes you irresistibly popular, personal power that will indelibly influence the minds of others and amaze your friends.

I'll make you a fascinating force in social life, a powerful, dynamic, commanding figure in your profession. You'll become more popular, more prosperous, more gloriously successful than you ever dreamed possible!

Let me send you the proof—absolutely free! If within 5 days you do not experience a decided change in your personality, if you do not find yourself making new friends with ease, if you do not discover yourself already on the way to social popularity, business success and personal leadership—just say so. Tell me my principle of personal magnetism can't do every single thing that I said it would do. And you won't owe me one penny!

## What Is Personal Magnetism?



### What Is Sex Magnetism?

What is that magnetic, powerful influence that draws one man to one woman—forever, irresistibly? What is that strange, never-failing spark that awakens love? What is it, in man or woman, that seems to draw and fascinate—the hypnotic power that no one can resist?

You have it. Everyone has it. *But do you use it?*

What is this marvelous force that raises the sick to glowing, vibrant health, the timid to a new confident personality, the unsuccessful to positions of wealth and astonishing power?

You have it—everyone has it—but *not one person in a thousand knows how to use it!* It is not a fad nor a theory. It is simply you, yourself—your manner—your own marvelous personal force, released and magnified a hundred fold in an amazingly clear-as-crystal, scientific way! More necessary than good looks. More valuable than money. For without it a salesman is handcuffed! Without it a business man is powerless to command! No actor, no teacher, no orator, no statesman, can long hold his audience spellbound without this supremely influential magnetic force!

Personal magnetism! How easy to release it! How wonderful its results! No long study or inconvenience. Not the slightest self-denial. Just a simple, clear, age-old principle that taps the vast thought and power resources within you, releases the full sweep of your magnetic potentialities and makes you almost a new person from what you were before!

Personal Magnetism is not hypnotism. Hypnotism deadens. Magnetism awakens, inspires, uplifts. Personal Magnetism is not electricity. It is *like* electricity in one way—while you cannot see it, you can observe its startling effects. For the moment you release your Personal Magnetism you feel a new surge of power within you. You lose all fear. You gain complete self-confidence. You become almost over night the confident, dominant, successful personality you were intended to be—so fascinating that people are drawn to you as irresistibly as steel is drawn to a magnet!

## The Facts Are Free

The fundamental principles of Personal Magnetism have been put into an extra large volume under the title of "The Cultivation of Personal Magnetism." It is bound in beautiful dark burgundy, with the title gold embossed. Its scope is as broad as life itself. "Fires of Magnetism," "Sex Influences," "The Magnetic Voice," "Physical Magnetism," "The Magnetic Eye," "The Road to Power" and "The Winning Personality" are only a few of the subjects covered in this amazing book. A magnificent book that tells you just how to cultivate the magnetic influence of your nature.

You *can* sway and control others. You *can* command success. You *can* influence people to do the things you want them to do. Through this amazing book you gain the key to a magnetic personality in 5 days—or you don't pay one penny! That is my free offer to you.

## Send Coupon Today

You must see this wonderful volume—examine it—let it influence indelibly your own personality. You send no money with the coupon—you pay no C. O. D. You get the book first. If you aren't stirred and delighted in the 5 days' period, return it and it costs you nothing. Otherwise keep it as your own and remit \$3 in full payment. You are the sole judge. You do not pay unless you are absolutely delighted. And then only \$3.

You simply can't delay! Clip and mail the coupon NOW.

Ralston University Press, Dept. 13-F, Meriden, Conn.

RALSTON UNIVERSITY PRESS, DEPT. 13-F  
MERIDEN, CONN.

All right—I'll be the judge. You may send me the volume "Cultivation of Personal Magnetism" for 5 days FREE EXAMINATION in my home. Within the 5 days I will either remit the special low price of only \$3.00 or return the book without cost or obligation.

Name.....  
Address.....  
City.....State.....

# FASCINATING

. . . . and perhaps you, like other ambitious men, due to the lack of money, time and education necessary to master *difficult* mechanical trades, wonder what *you* can get into *quickly* and make the most out of, *now!* Haven't you *overlooked* the very thing you are looking for?

For *there is* a profession begging for clean-cut, *earnest* men, like yourself! *Look into it!* 60,000 Moler graduates *know* Modern Barbering is easy to learn, inexpensive, *quicker* to earn, *clean* and FASCINATING! It *pays better* than you think! **FIND OUT!** Write for catalog B.3.

**Address the branch of the MOLER SYSTEM OF COLLEGES nearest you**  
(Street address not needed)

Chicago, Ill.  
New York, N. Y.  
St. Louis, Mo.  
Kansas City, Mo.  
Cincinnati, Ohio  
Cleveland, Ohio

Detroit, Mich.  
Denver, Colo.  
New Orleans, La.  
Omaha, Nebr.  
Milwaukee, Wisc.  
Atlanta, Ga.

Memphis, Tenn.  
Dallas, Tex.  
Houston, Tex.  
San Antonio, Tex.  
Minneapolis, Minn.  
Seattle, Wash.  
Portland, Ore-on

Los Angeles, Calif.  
Salt Lake City, Utah  
San Francisco, Calif.  
Tacoma, Wash.  
Fargo, No. Dak.  
Winnipeg, Man., Can.  
Toronto, Ont., Can.



# ELECTRICITY

## Complete Study Course and Pocket Library \$10



### SHIPPED FREE

A set of HAWKINS GUIDES is a good friend to the electrical worker. It tells you how to do any job the right way—without guessing or taking chances.

Hawkins Guides put the facts about modern electrical engineering at your finger tips, making your chances for advancement in the electrical field unlimited.

### HAWKINS GUIDES INCREASE YOUR PAY

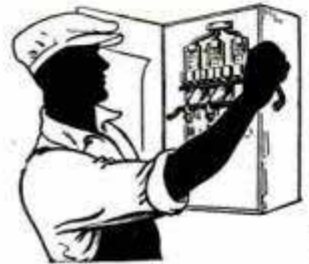

Electricity is king! It is the great ruling force—transportation, communication, light, heat, power—almost every modern activity is dependent on electricity. Industry is demanding electrical men that know their jobs!

Hawkins Guides teach you all you need to know about electricity in easy, step-by-step lessons. Daily spare time reading of the Guides will greatly increase your value to yourself and your employer in a few weeks. Hundreds of our friends have written us and told us this!

ing of the Guides will greatly increase your value to yourself and your employer in a few weeks. Hundreds of our friends have written us and told us this!

### READERS OF HAWKINS GUIDES KNOW HOW



"You can't stump him on an electrical job." "He certainly knows his business." "Certainly have to hand it to him for knowing how." —These are the things employers say about our friends who are readers of Hawkins Guides. No matter what question or problem comes up the Ready Reference Index enables you to give an expert answer at once.

### HAWKINS STARTS YOU WHERE OTHERS LEAVE OFF

Don't work any longer at low wages when easy reading of HAWKINS GUIDES will give you the money-making knowledge of the expert! Easy daily reading of the Guides will teach you in a few months what it has taken the expert a lifetime to learn!

With HAWKINS GUIDES in hand you have a running start to success in the electrical field. You will actually begin where others left off!

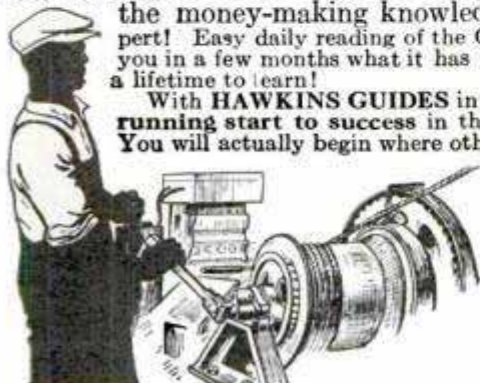

## NOW!

This coupon is your golden opportunity. Tear it out—send it now!

### FOR EXAMINATION!

#### REAL ELECTRICAL EDUCATORS

"Hawkins Guides at \$10 are the best investment I have ever made. Am able to take up almost any electrical job and have never gone to an electrical school."—B. Roessler, Oenaville, Texas.

#### AS EASY AS A. B. C.

"Everything in Hawkins Guides is very plain and anybody can read and understand them as easy as A. B. C."—J. Knight, Tobyhanna, Pa.

#### OTHER READERS SAY

"Worth ten times their price." "Helped me to two raises in four months." "Better than a school of instruction." "Studied them when I was laid up and got further ahead than if I had been on the job."

### Hawkins Guides Explain These Points So You Can Easily Understand:—

Magnetism—Induction—Experiments—Dynamo—Electric Machinery—Motors—Armatures—Armature Windings—Installing of Dynamos—Electrical Instrument Testing—Practical Management of Dynamos and Motors—Distribution Systems—Wiring—Wiring Diagrams—Sign Flashers—Storage Batteries—Principles of Alternating Currents and Alternators—Alternating Current Motors—Transformers—Converters—Rectifiers—Alternating Current Systems—Circuit Breakers—Measuring Instruments—Switch Boards—Wiring—Power Stations—Installing—Telephone—Telegraph—Wireless—Bells—Lighting—Railways. Also many Modern Practical Applications of Electricity and Ready Reference Index.

### Hawkins Guides—10 POCKET SIZE NUMBERS

Each number easy to carry around and read in spare time. Big type and clear diagrams. Easy to study and learn. Durable, flexible binding—gold edges. 3,500 pages—4,700 illustrations. Shipped free for examination. Pay only \$1 a month if satisfied. Price of set, complete, \$10.



### EXAMINE GUIDES FREE! \$

Let the Guides themselves demonstrate their practical value to you—as a study course, reference work and complete electrical library. You are the judge. Simply send this coupon. No obligation unless you are entirely satisfied. Tear out on dotted line—fill in—mail it NOW!

\$1 PER MO.

### FREE EXAMINATION COUPON

Theo. Audel & Co., 65 W. 23rd St., New York City

Please send me (postpaid) for my approval Hawkins Electrical Guides, 10 numbers (price \$1 each). If satisfactory I will mail you \$1 in 7 days and further mail \$1 monthly until purchase price of \$10 is paid.

Name.....

Address.....

Occupation.....

Employed by..... 3-T-30

# Draw a MAN'S Pay



# JOBS WAITING!

<p><b>WANTED—MALE HELP.</b> <b>Professions and Trades.</b> <b>DRAFTSMAN—AT ONCE—WHO CAN DO</b> good lettering. You may also preferred. Experience not necessary. Excellent opportunity in pleasant office. Apply Saturday or Monday morning. Room 546 1st National Bank Bldg.</p> <p><b>DRAFTSMAN \$400 Month</b> Excellent opportunity for young man to become shop executive in short time if he proves his worth. Light, clean office in new building; short hours.</p> <p><b>KINDRED PRODUCTS CO MR. ORRINGTON</b></p> <p><b>DRAFTSMAN—TO DESIGN TOOLS.</b> Jigs, fixtures, punches and dies; good pay; steady position to right man. Call for personal interview. Hill Pump Valve Co., 5202 Broadway.</p> <p><b>DRAFTSMAN—DETAILER ON HIGH CLASS</b> cabinet work. Excellent production. Good pay. See Mr. Ziegler, 1000 Broadway.</p>	<p><b>WANTED—MALE HELP.</b> <b>Professions and Trades</b> <b>DRAFTSMAN—MACHINE DETAILER AND</b> tracer, \$400 wk. Fisher Bldg.</p> <p><b>DRAFTSMAN—FOR ORNAMENTAL AND</b> decorative iron work. Must be good detailer. Good job for night party. Call Monday on J. GOLDBERG, Atlantic Hotel.</p> <p><b>DRAFTSMAN DETROIT EDISON</b></p> <p><b>ELECTRICAL MEN WITH POWER HOUSE AND SUBSTATION LAYOUT EXPERIENCE.</b> GOOD OPPORTUNITY AND STEADY EMPLOYMENT. STATE AGENCIES AND SALARY DESIRED.</p> <p><b>THE DETROIT EDISON COMPANY DETROIT, MICHIGAN</b></p> <p><b>DRAFTSMEN BEGINNERS \$250 Month and Bonus</b></p> <p>We want four clean cut young men who have just finished a good drafting course to fill vacancies created by promotions in our drafting department. men preferred. Ex...</p>
---	--



**Fred M. Dobe, M.E.**  
Chief Draftsman  
He has been drafting and teaching twenty-five years, and has trained a hundred men who are now Chiefs

## This Offer Means Business!

What line do you like? Mechanical? Electrical? Or, it may be Building or Engineering. Automobiles. Radio. *They all need draftsmen.* Read the Want Ads in any newspaper!

I can fit you to fill any drafting position. To prove it, I'll send one lesson free. Furthermore, I'll furnish every tool. That's how much I need more men; 100 concerns depend on my classes for new blood in their drafting rooms.

**It's Easy** You don't learn from books. I teach drafting on the board. We do the same work you'll later do for pay! That's why Dobe men make good on any job they take; why they're spoken for weeks ahead of graduation. You can assure your future in any field, in one evening with this free lesson!

My classes will always be open, but the free lesson offer will not! So, whatever you do, don't postpone using this coupon.

### This Coupon Good for One Lesson:

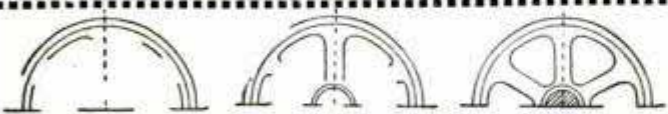

A free lesson, to see how easy and interesting drafting really is!

**CHIEF DRAFTSMAN DOBE**  
Div. 83-53, 1951 Lawrence Ave., Chicago:

I want the free drafting lesson to see how I like it. Send it in time to get all my tools without charge if I decide to learn.

Name.....Age.....

Address.....

# Real Music TAUGHT FREE

**IN YOUR OWN HOME**  
**Piano, Organ, Violin, Guitar, Mandolin, Banjo, Cornet, etc.**

By one of the oldest and most Reliable Schools of Music in America—Established 1895



You can read Music like this quickly

IN order to introduce our Home Study Music Course in your locality, we offer you, absolutely free, a course of lessons. After you have learned to play we are positive that you will recommend the lessons of the **American School of Music** for either beginners or advanced pupils. Our lessons are suited to your needs. It matters not if you do not know one note from another, our lessons are so simple and easy that any person who can read English can learn to play. We send out lessons to you weekly, and with our free tuition offer, your only expense is for postage and music you use, which averages about 2 cents a day. Thousands of pupils all over the world write—"Wish I had known of your wonderful school before." Write to-day for our convincing free booklet which explains everything in full. Write now to the

**AMERICAN SCHOOL OF MUSIC**  
52 Lakeside Bldg. Chicago, Illinois

## LEARN WATCH REPAIRING

Be a watchmaker—you can learn this profitable trade by correspondence in a few weeks in your own home by the DeSelms Chart System. After you complete the course you will know a watch from A to Z. You will know just what the matter is and how to repair one. When you graduate you will be a practical watchmaker and repairer and competent to fill any position. Positions for our graduates. Ask for our Free Book. It explains our system and terms.



**THE DeSELMS WATCH SCHOOL**  
LOGANSPORT, INDIANA

## Learn Advertising at HOME

The highest paid men in the world are advertising men. You can learn easily and quickly at home during your spare time. Bigger opportunities now in advertising than ever before. Tremendous demand for our graduates at big pay.

Send for **FREE Book**. Giving interesting information and vital facts—just what you want to know about advertising. Write today!  
**PAGE-DAVIS SCHOOL OF ADVERTISING**  
Dept. 1353 3601 Michigan Ave., Chicago, U. S. A.

## LEARN MECHANICAL DENTISTRY

Earn \$35 to \$125 a week. Taught by actual practices—day or night. Three months' course. Modern laboratories. No previous training required. Established 30 years. For 36-page catalog, write Dept. 2.

**BODEE DENTAL INSTITUTE**  
NEW YORK 136 W. 52d St. PHILADELPHIA 1305 N. Broad St. BUFFALO 501 Washington St. BROOKLYN 85 Court St.

**MINSTRELS** Musical Comedies and Revues, with full instructions for staging. You can stage your own show with our books. Full line of plays, stage songs, crosshairs, monologues, afterpieces, vaudeville acts and make-up. **CATALOGUE FREE.**  
**T. S. Denison & Co., 623 S. Wabash Ave., Dept. 19 Chicago**



Wonderful, new device, guides your hand; corrects your writing in few days. Big improvement in three hours. No failures. **Complete outline FREE.** Write C. J. Ozment, D-34, St. Louis, Mo

**HARRY M. LAMON—**

President of the National Poultry Institute. Formerly Senior Poultryman in charge of Poultry and Egg investigations for the entire United States, in the U. S. Department of Agriculture. Knows the poultry business from A to Z. Has helped poultry raisers by the thousand, even those in foreign countries, to increase, double and **TRIPLE** their profits.

# I Have the ANSWER to your financial problem

## Let the Other Fellow Pay YOU the Fancy Prices

When you pay 60 cents to a dollar for eggs, or 50 cents a pound for poultry meat, does it ever occur to you that you're looking right square at a golden opportunity to make some real money—probably the very answer to your own financial problems? When it comes to food, people want the best. That's the reason nearly everybody eats eggs and poultry. But in spite of the enormous demand less than 15% of our total population are producing them. And that makes prices high. Hard on the consumer, but fine for the producer. So the idea is to be a producer. You can. It's easy. I'll show you the way, just as I've shown thousands of others.

## Big Money and Fun Be Your Own Boss

Another thing! You can get to be your own boss—*get there quick*—and have a good time doing it. No business is more interesting—or more healthful—than raising poultry. There's a fascination about fowls, once you get to know them. And when they begin to make money for you, become boosters for your bank account, help you buy new cars, new clothes, new things for the house—when they put you on "easy street"—they're well WORTH knowing.

## Earn \$1,000 a Year in Spare Time

Start small, if you want to. You'll be astounded at the money you can make from a back yard or vacant-lot flock. Up to \$1,000 a year, just in your spare time. Think of it! Then if you want to grow larger, you can by simply reinvesting the profits. Very little capital required. All you need is a knowledge of the poultry business. And I can give you that—*quickly*. If you have the desire and ambition to "get somewhere," I can show you the "tricks of the trade" in no time. My booklet tells you all about the plan. Write for it today—*sure*.

## Sure Methods that bring Success Quick

You want success in a hurry. All of us do. And you can have it, if you'll follow my simple methods. I show you how to get eggs in winter, when they're sky-high in price. How to tell a good layer, a *profit maker*, from a loafer. How to keep your flock healthy, happy and "right on the job." How to avoid mistakes and get every cent's worth of profit that's coming to you, regardless of the size of your flock. If you are willing to profit by what I and others who have "been at the game" for years and years have learned, I'll *even guarantee* your success **IN ADVANCE.**

## GET the Facts, the Proof in MY FREE BOOK

Get my new, FREE book—*quick*. In it, I tell you all about the National Poultry Institute; about our remarkable, new, home-study course that brings success in just a few short weeks; about our unique plan of working right along with you as often and as long as you want us to; and scores of other interesting facts that will *positively mean money to you*. Get this book before you do anything else. Then you can decide—**QUICKLY**—whether or not this opportunity is as big as I say it is. I'm waiting to hear from you—**NOW.**

National Poultry Institute  
Dept. 400-G, Washington, D.C.

This **FREE BOOK** will open your eyes

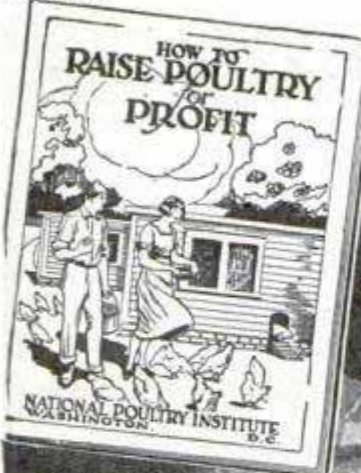

Make **BIG MONEY** up to \$10,000 a year **RAISING POULTRY**

## You Have the Same BIG Opportunity That They Did

### In Business Now

"Your course has been my stepping stone to success. I started in 1922 with just a small flock, while working as a clerk. In 1924 I was able to open my own commercial hatchery, together with a feed store. You have enabled me to earn a good income and brought me untold satisfaction and pleasure."  
—J. J. Harris, Pelham, Ga.

### Success in France

"While serving as Captain during the war, I saw the possibilities of poultry raising in France. Before I enrolled in your school, I knew no more about poultry raising than a babe. Now I am making a *real success* of a commercial poultry farm."

### 100% Better

"I have a back-yard flock that has improved 100% since I have been following the methods given in your course."  
—D. Tognarelli, Chicago, Ill.

**MAIL THIS NOW**

National Poultry Institute  
Dept. 400-G, Washington, D. C.  
I want to know more about the **BIG OPPORTUNITY** waiting for me in the Poultry Business. Send **FREE** book at once.

Name.....  
Address .....



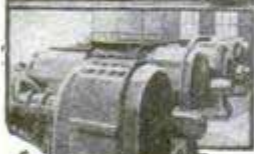

# Learn By Doing!

Every phase of all branches of

## ELECTRICITY

Taught By Actual Practice

In America's foremost institution for trade training.

Established 1902

### No Books Used

Individual Instruction. Start Any Day.

A SPECIAL and SEPARATE Course in Ignition, Auto Lighting and STARTER Systems.

Write for FREE 64-Page Catalog

**THE NEW YORK ELECTRICAL SCHOOL**  
44 West 17th Street NEW YORK CITY



## DO YOU LIKE TO DRAW?

It's Easy To Learn When Shown In The Right Way

Some of the cleverest cartoonists and comic artists in America today learned how to draw quickly—by following **CARTOONIST EVANS' SIMPLE AND EASY METHOD**. This school is recommended by foremost cartoonists because they know the students are handled right. If you like to draw, send 6c in stamps for **portfolio of cartoons and full details**. The course is **NOT EXPENSIVE**.

**The W. L. Evans School of Cartooning** 821 Leader Building CLEVELAND, OHIO

"THERE'S MONEY IN IT"

## AT HOME LEARN TELEGRAPHY AT HOME MORSE AND WIRELESS

TEACH YOURSELF

in half usual time, at trifling cost, with the wonderful Automatic Transmitter, **THE OMNIGRAPH**. Sends unlimited Morse or Continental messages, at any speed, just as an expert operator would. Adopted by U. S. Government, and leading Universities, Colleges and Telegraph Schools. 3 Styles. Catalog free. **OMNIGRAPH MFG. CO., 13-19 Hudson St., NEW YORK**  
If you own a Radio Phone Set—and don't know the code—you are missing most of the fun.

## LEARN PHOTOGRAPHY!

Earn \$200 to \$500 monthly. Or start your own business. Photography and Photo-Engraving taught by largest college of its kind in world. Established 1893. Big demand for graduates. Write for free book. **Illinois College of Photography, Box 436, Effingham, Ill.**

Comedies, Dramas, Musical Comedies and Revues, Minstrel Choruses, Songs, Blackface Plays, Everything for Burnt Cork Shows and All Amateur Entertainments. Monologs, Dialogs, Speakers. **CATALOGUE FREE.**

## PLAYS

Vaudeville Acts How to Stage a Play Make-up Goods

**T. S. DENISON & CO., 623 So. Wabash, Dept. 9, CHICAGO**



## Work for "Uncle Sam"

MEN 18 TO 45

City and Rural Mail Carriers

\$141.67 to \$275.00 Month

Many Other U. S. Gov't Jobs Now Obtainable

STEADY WORK. PAID VACATION. COMMON EDUCATION SUFFICIENT. PULL UNNECESSARY.

MAIL COUPON—TODAY SURE

Coupon  
Franklin  
Institute  
Dept. N316  
Rochester, N. Y.

Rush to me, WITHOUT CHARGE, (1) Your Illustrated Civil Service Book. (2) Send pointers on how to get a position as City or Rural Mail Carrier at \$141.67 to \$275.00 a month.

Name .....

Address .....

# FREE!



**“MEN! Here's  
the 'dope' you've  
been looking for-**

**How TO GET INTO THE  
RADIO BUSINESS”**

*J.E.S.*

**\$50 to \$250 a Week  
in Work That is  
Almost Romance**

If you're earning a penny less than \$50 a week, clip coupon now for FREE BOOK! New book, profusely illustrated, tells all about the Radio Profession, thousands of openings—in work that is almost romance! YOU can learn quickly and easily at home, through our tested, improved methods, to take advantage of these great opportunities! Why go along at \$25 or \$35 or \$45 a week, when you can pleasantly and in a short time learn to be a Radio Expert, capable of holding the big jobs—paying \$50 to \$250 a week?

**Clip Coupon for Free Book**

Don't envy the other fellow who's pulling down the big cash! Our proven home-study training methods make it possible for you, too, to get ready for a better job, to earn enough money so you can enjoy all the good things of life. Most amazing book ever written on Radio tells how—thousands of interesting facts about this great field, and how we can prepare you, quickly and easily in your spare time at home, to step into a big-pay Radio job. You can do what thousands of others have done through our training. GET THIS NEW FREE BOOK. SEND COUPON TODAY.

**J. E. SMITH, President  
National Radio Institute  
WASHINGTON, D. C.**

Dept. CT-7

**NOW!  
Special  
Short Time  
Offer:  
6  
BIG  
OUTFITS**

**Radio  
Needs  
Trained  
Men**

**National  
Radio  
Institute,  
Dept. CT-7,  
Washington,  
D. C.**

Dear Mr. Smith:  
Without obligating me  
in any way, send me your  
big FREE BOOK, "Rich Re-  
wards in Radio," and all infor-  
mation about your practical,  
home-study, Radio Course.

**These Instruments  
FREE of Extra Cost**

All instruments shown here and others—SIX BIG OUTFITS—sent to all our students free of extra cost under short time special offer. **Clip coupon now**—find out all about this big unequalled offer while you still have time to take advantage of it. Our training is intensely practical—these instruments help you learn to do the practical work. Receiving sets, from simplest kind to thousand-mile receiver. Many other big features.

**My Radio Training Is the Famous  
“Course That Pays for Itself”**

Spare time earnings are easy in Radio when you know it the way we teach you. Increase your income almost from the start of your course thru practical knowledge we give you. We show you how to hold the job, then our



**J. E. Smith  
President**

big Free Employment Department helps you get one. Free Book "Rich Rewards in Radio" tells how.

Howard B. Luce of Friedens, Pa., made \$320 in 7 weeks during his spare time. D. H. Sutt of Newport, Ark., writes, "While taking the course I earned in spare time work approximately \$900." Earl Wright of Omaha, reports making \$400 in a short time while taking his course—working at Radio in his spare time only! Sylvester Senso, 207 Elm Street, Kaukauna, Wis., made \$500.

And when your training is completed you're ready to step into a real big Radio job like C. C. Gielow, Chief Operator of the Great Lakes Radio Telegraph Company; E. W. Novy, Chief Operator of station WRNY; Edward Stanko, Chief Operator of Station WGR; and hundreds of other N. R. I. trained men. The National Radio Institute, originators of Radio Home-Study Training, established 1914, today offers you the same opportunity these men had, under a bond that guarantees you full satisfaction or money refunded. It's your big chance to get into Radio—mail coupon for FREE Book and proof!

**SEND THIS COUPON TODAY**

Name.....  
Address.....  
Town..... State.....  
Age.....

# BUILDING TRADES NEED TRAINED MEN

Thousands of good positions at good salaries

THE building trades are still booming. Trained men are in demand at good salaries. Government experts estimate that billions of dollars will be spent for construction this year.



To-day the most vital need of this great building program is men—trained men—men who can step right in and do the skilled work that building construction requires.

There is a simple, easy, practical way by which you can prepare for a better position, at a bigger salary. You can do it right at home, in spare time, no matter where you live, through the International Correspondence Schools.

A recent investigation of 13,298 students enrolled in I. C. S. Building Trades Courses showed that 1921 had become Architects; 246 had become Designers; 494 had become Chief Draftsmen; 2827 had become Draftsmen; 1845 had become Contractors; 211 had become Assistant Foremen; 4030 had become Foremen; 2354 had become Superintendents.



You, too, can have the position you want in the work you like best; an income that will give you and your family the home, the comforts, the luxuries you would like them to have. No matter what your age, present occupation, or your means, you can do it!

All we ask is the chance to prove it. That's fair, isn't it? Then, mark and mail this coupon.

TEAR OUT HERE  
**INTERNATIONAL CORRESPONDENCE SCHOOLS**  
BOX 5564-E SCRANTON, PA.

Explain, without obligating me, how I can qualify for the position, or in the subject, before which I mark X.

- |   |  |
|---|--|
| <ul style="list-style-type: none"> <li><input type="checkbox"/> ARCHITECT</li> <li><input type="checkbox"/> Architectural Draftsman</li> <li><input type="checkbox"/> Contractor and Builder</li> <li><input type="checkbox"/> Building Foreman</li> <li><input type="checkbox"/> Concrete Builder</li> <li><input type="checkbox"/> Structural Engineer</li> <li><input type="checkbox"/> Structural Draftsman</li> <li><input type="checkbox"/> Plumber and Steam Fitter</li> <li><input type="checkbox"/> Heating and Ventilation</li> <li><input type="checkbox"/> Plumbing Inspector</li> <li><input type="checkbox"/> Foreman Plumber</li> <li><input type="checkbox"/> Sheet Metal Worker</li> <li><input type="checkbox"/> CIVIL ENGINEER</li> <li><input type="checkbox"/> Surveying and Mapping</li> <li><input type="checkbox"/> Reading Architects' Blue Prints</li> <li><input type="checkbox"/> ELECTRICAL ENGINEER</li> <li><input type="checkbox"/> Electric Lighting and Rys.</li> <li><input type="checkbox"/> Electric Wiring</li> <li><input type="checkbox"/> Telegraph Engineer</li> <li><input type="checkbox"/> Telephone Work</li> <li><input type="checkbox"/> MECHANICAL ENGINEER</li> <li><input type="checkbox"/> Mechanical Draftsman</li> <li><input type="checkbox"/> Toolmaker</li> <li><input type="checkbox"/> Machine Shop Practice</li> <li><input type="checkbox"/> CHEMIST</li> <li><input type="checkbox"/> Pharmacy</li> </ul> | <ul style="list-style-type: none"> <li><input type="checkbox"/> Navigation</li> <li><input type="checkbox"/> SALESMANSHIP</li> <li><input type="checkbox"/> ADVERTISING</li> <li><input type="checkbox"/> Window Trimmer</li> <li><input type="checkbox"/> Show Card and Sign Painting</li> <li><input type="checkbox"/> BUSINESS MANAGEMENT</li> <li><input type="checkbox"/> Private Secretary</li> <li><input type="checkbox"/> Business Correspondent</li> <li><input type="checkbox"/> BOOKKEEPER</li> <li><input type="checkbox"/> Stenographer and Typist</li> <li><input type="checkbox"/> Higher Accounting</li> <li><input type="checkbox"/> COMMERCIAL LAW</li> <li><input type="checkbox"/> Common School Subjects</li> <li><input type="checkbox"/> Mathematics</li> <li><input type="checkbox"/> GOOD ENGLISH</li> <li><input type="checkbox"/> ILLUSTRATING</li> <li><input type="checkbox"/> Railway Mail Clerk</li> <li><input type="checkbox"/> CIVIL SERVICE</li> <li><input type="checkbox"/> Mining Engineer</li> <li><input type="checkbox"/> Gas Engine Operating</li> <li><input type="checkbox"/> STATIONARY ENGINEER</li> <li><input type="checkbox"/> Textile Overseer or Supt.</li> <li><input type="checkbox"/> TRAFFIC MANAGER</li> <li><input type="checkbox"/> AUTOMOBILES</li> <li><input type="checkbox"/> AGRICULTURE</li> <li><input type="checkbox"/> Poultry Raising</li> <li><input type="checkbox"/> French</li> <li><input type="checkbox"/> Spanish</li> <li><input type="checkbox"/> Banking</li> </ul> |
|---|--|

Name \_\_\_\_\_

Present Occupation \_\_\_\_\_ Business Address \_\_\_\_\_ 3-6-24

Street \_\_\_\_\_

and No. \_\_\_\_\_

City \_\_\_\_\_ State \_\_\_\_\_

Persons residing in Canada should send this coupon to the International Correspondence Schools Canadian, Limited, Montreal, Canada.

## YOU CAN OIL PAINT

**TALENT NOT REQUIRED—ANYONE CAN LEARN!**

It's amazing how quickly our new method enables men and women to actually oil paint with ease and professional skill—even after the first lesson. Nothing difficult or tiresome to master. You begin to oil paint photos, portraits, landscapes or any art subject at once and earn real money. One student writes she earned the entire cost of the course in less than a week after completing the second lesson. You can do it, too. Our business methods show you how.

**EARN \$18.00 TO \$50.00 OR MORE A WEEK AT HOME**

Demand for color art work is growing daily. Graduates everywhere tell us they are unable to keep up with orders. Learn more about this fascinating profession. Ask for our free illustrated booklet. It tells all about the course and free working outfit. Remember, no talent is required. You, too, can learn. So write today.

Pictorial Art Studios, 2731 N. Clark St., Dept. M. P., Chicago

## ANY BOOK IN PRINT

Delivered at your door. We pay the postage. Standard authors, fine editions, new books, all at biggest savings. Be sure to send postal for Clarkson's catalog. **FREE** Write for our great book catalog. This catalog is a short course in literature and is so used by some of America's leading universities; 300,000 book lovers buy from it. Free if you write now.

**DAVID B. CLARKSON THE BOOK BROKER**  
321 CLARKSON BUILDING, CHICAGO, ILLINOIS

A FILE
NOT A FILE

### Stop Forgetting

Make Your Mind an index from which you select facts, figures, names, faces. Develop concentration, self-control; overcome bashfulness, forgetfulness. Write today for FREE memory and concentration test and illustrated booklet, "How to Remember."

**PROF. HENRY DICKSON**  
Dept. 7053 Evanston, Ill.

## LEARN PIANO TUNING AT HOME

Send for FREE copy of the 28th ANNIVERSARY EDITION of our book "Winning Independence." Read how students master TUNING with our Tune-A-Phone, and WHY our graduates head the profession in all parts of the world. With Bryant's patented devices, tools, charts, and lessons, one learns quickly and easily. Low tuition, easy terms. Diploma granted. **MONEY-BACK GUARANTY**, \$10 to \$25 a day, exceptional opportunities, and an ideal profession await you.

**BRYANT SCHOOL OF TUNING, (71) Bryant Bldg., Augusta, Michigan**

## No Joke to STAMMER

Be successful. Master perfect speech. Win happiness. Send for full information and special phonograph record. Dime covers postage.

153 Stimson, The Lewis Institute, Detroit

### Go into Business for Yourself

Make storekeeper's profits without storekeeper's troubles. We'll show you how. In fact, we'll put you into business, furnish everything you need, train you, carry stock for you—without your investing a penny. We'll work with you until we've made you a success. We have done it for others. We'll do it for you—provided you are honest, ambitious and willing to work hard. If you are, write us. You'll hear from us at once with FACTS. Address Dept. 215.

**GOODWEAR Chicago, Inc.**  
844 West Adams Street CHICAGO, ILL.

# Laugh If You Like—!



## — But I Did Learn Music Without a Teacher

**I**T was at a little social gathering. Everyone had been called on to entertain and all had responded with a song or with a selection on some musical instrument. And now it was my turn.

I had always been known as a "sit in the corner." I had never been able to either sing or play. So they all murmured as I smiled confidently and took my place at the piano. Then I played—played as no one else had played that evening. First ballads, then classical numbers and popular tunes.

For the first time in my life I was the very center of attraction.

They had listened—dumfounded. For a moment, now that I had finished, they remained silent. Then thunderous applause! Then questions.

"How did you do it?" they chorused. "And you're the one who didn't know a note!" "Why didn't you tell us you were taking lessons privately?" "Who was your teacher?"

For a moment the questions overwhelmed me.

"Teacher? I never had one," I replied. "I learned by myself, at home."

They laughed in disbelief.

"Laugh if you want," I countered. "I did learn music without a teacher."

"A few months ago I didn't know one note from another. I loved music. But I couldn't afford a private teacher. And I couldn't bear the thought of monotonous exercises. Anyway, I thought a person had to have talent to become a musician."

"You all know how I've just sat around while the rest of you entertained. Time after time I longed to be able to play."

"Then one night I sat at home alone, reading a magazine. Suddenly my eye caught a startling announcement. It told of a new, easy method of quickly learning music—right in your own home—and without a teacher. It sounded impossible—but it made me wonder. After all, I decided, it 'doesn't cost a cent to find out.' So I signed the coupon, and—well, you know the rest."

The course, I explained to them, was more helpful than I ever dreamed possible. It was amazingly simple—even a child could learn to play this quick, easy way. I chose the piano.

And from the very beginning I was playing *real notes, catchy tunes*—just like a regular musician! It was just like a fascinating game!

Now I can play anything—jazz or classical. I am never at a loss to entertain. No more dreary hours of solitude for me. And I even play in an orchestra and make money having a wonderful time!

You, too, can learn to play your favorite instrument by this easy "at home" method that has helped almost half a million people to increased pleasure and financial gain. You don't have to know a thing about music—progress is rapid because every step is easy to understand. Pick out the instrument you want to play. The U. S. School of Music does the rest. And it costs just a few cents a day!

### Free Book and Demonstration Lesson

Our wonderful illustrated free book and our free demonstration lesson prove how anyone can learn to play his favorite instrument quickly and for just a fraction of what old slow methods cost.

If you really want to learn to play—if new friends, good times, social popularity and increased income appeal to you—act now! Sign the coupon and send it before it's too late. Instruments supplied when needed, cash or credit. **U. S. School of Music, 73 Brunswick Bldg., New York City.**



**U. S. SCHOOL OF MUSIC,  
73 Brunswick Bldg., New York City.**

Please send me your free book, "Music Lessons in Your Own Home" with introduction by Dr. Frank Crane, Demonstration Lesson and particulars of your Special Offer. I am interested in the following course:

Have you above instrument? .....

Name .....

Address .....

City.....State.....

### Pick Your Instrument

Piano	Cello
Organ	Violin
Harmony and Composition	
Drums and Traps	
Sight Singing	
Ukulele	Guitar
Plectrum Banjo	
5-String Banjo	
Tenor Hawaiian	
Banjo Steel Guitar	
Mandolin	Harp
Clarinet	Cornet
Flute	Saxophone
Piccolo	Trombone
Voice and Speech Culture	
Automatic Finger Control	
Piano Accordion	



# High School Course in Two Years!

## You Want to Earn Big Money!

And you will not be satisfied unless you earn steady promotion. But are you prepared for the job ahead of you? Do you measure up to the standard that insures success? For a more responsible position a fairly good education is necessary. To write a sensible business letter, to prepare estimates, to figure cost and to compute interest, you must have a certain amount of preparation. All this you must be able to do before you will earn promotion. Many business houses hire no men whose general knowledge is not equal to a high school course. Why? Because big business refuses to burden itself with men who are barred from promotion by the lack of elementary education.

### Can You Qualify for a Better Position

We have a plan whereby you can. We can give you a complete but simplified high school course in two years, giving you all the essentials that form the foundation of practical business. It will prepare you to hold your own where competition is keen and exacting. Do not doubt your ability, but make up your mind to it and you will soon have the requirements that will bring you success and big money. **YOU CAN DO IT.**

Let us show you how to get on the road to success. It will not cost you a single working hour. Write today. It costs you nothing but a stamp.

### American School

Dept. H-374, Drexel Ave. and 58th St., Chicago

### American School

Dept. H-374, Drexel Ave. and 58th St., Chicago

Send me full information on the subject checked and how you will help me win success.

- |                             |                           |
|-----------------------------|---------------------------|
| ....Architect               | ....Business Law          |
| ....Building Contractor     | ....Lawyer                |
| ....Automobile Engineer     | ....Machine Shop Practice |
| ....Automobile Repairman    | ....Mechanical Engineer   |
| ....Civil Engineer          | ....Shop Superintendent   |
| ....Structural Engineer     | ....Employment Manager    |
| ....Business Manager        | ....Steam Engineer        |
| ....Cert. Public Accountant | ....Foremanship           |
| ....Accountant and Auditor  | ....Sanitary Engineer     |
| ....Bookkeeper              | ....Surveyor (& Mapping)  |
| ....Draftsman and Designer  | ....Telephone Engineer    |
| ....Electrical Engineer     | ....Telegraph Engineer    |
| ....Electric Light & Power  | ....High School Graduate  |
| ....General Education       | ....Wireless Radio        |
| ....Vocational Guidance     | ....Undecided             |

Name.....

Address.....

# Be A Success!

**\$5,000 to \$10,000 a Year**

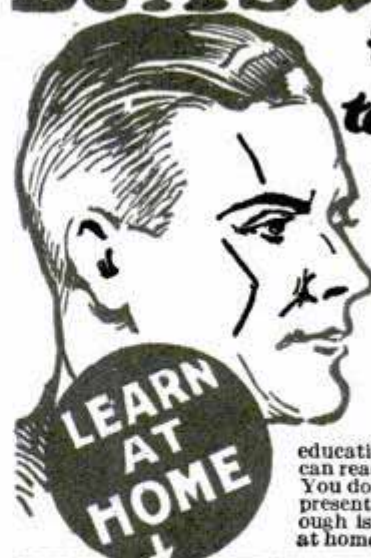

Don't remain in a low pay rut, figuring success is a streak of luck coming only to a few. You have it within your reach NOW! This opportunity being offered you has placed many a man, young and old, on the road to success. Make your decision right now. With Ambu training, you'll find yourself in the expert class. No experience or high school education necessary. Just so you can read and write. We do the rest. You don't even have to give up your present work—so simple and thorough is our training you can learn at home in spare time.

## AUTOMOTIVE ELECTRICITY & RADIO ENGINEERING

We specialize in these two fields because they offer the greatest opportunities in shortest time. Experts in big demand. Ambu trained men are making good, earning \$5000 to \$10,000 a year and more. We help you get started in business for yourself. Don't be a slave to underpay.

**WRITE TODAY** Send a card or letter asking for Free copy of Book which brought success to others, and state whether interested in Automotive Electricity or Radio Engineering, or both. **WRITE TODAY!**

**AMBU ENGINEERING INSTITUTE**  
2632 Prairie Ave. Dept. 20-C Chicago, Ill.

## PIANO JAZZ

By Note or Ear. With or without music. Short Course. Adult beginners taught by mail. No teacher required. Self-Instruction Course for Advanced Pianists. Learn 259 styles of Bass, 684 Syncopated Effects, Blue Harmony, Oriental, Chime, Movie and Café Jazz, Trick Endings, Clever Breaks, Space Fillers, Sax Slurs, Triple Bass, Wicked Harmony, Blue Obligato, and 247 other Subjects, including Ear Playing. 133 pages of REAL Jazz, 25,000 words. A Postal brings our FREE Special Offer.

Waterman Piano School, 1826 W. Adams St. Los Angeles, Cal.

## TELEGRAPHY

(Morse and Wireless) and RAILWAY ACCOUNTING taught thoroughly. Big salaries; great opportunities. Oldest, largest school. Endorsed by Telegraph, Railway, Radio, and Government officials. Expenses low—opportunities to earn large portion. Catalog free. **DODGE'S INSTITUTE**, Jones St., Valparaiso, Ind.

## LEARN WATCHMAKING

and become independent. We help you secure a position. Easy to learn. Send for FREE CATALOG.

ST. LOUIS WATCHMAKING SCHOOL, Dept. 5, ST. LOUIS, MO.

**Clear-Tone**  
TO  
**Clear Your Skin**

Your skin can be quickly cleared of Pimples, Blackheads, Acne or any Eruptions on the face or body, Barbers Itch and Eczema, Enlarged Pores, Oily or Shiny Skin. CLEAR-TONE has been Tried, Tested and Proven its merits in over 100,000 test cases.

**FREE** WRITE TODAY for my FREE Booklet — "A CLEAR-TONE SKIN" telling how I cured myself after being afflicted for fifteen years.

**E. S. GIVENS** 128 Chemical Bldg. Kansas City, Mo.



# PLAY A SAW!

I'll Teach You in 24 Hours

**Be Popular!**  
**Amaze Everybody—**  
**Play for Fun or Money**

Wonderful music from a saw—sweet and mellow like a rare old violin. Tone effects that are positively startling—all so unexpected that nothing compares with it in winning instant popularity in your social group or as a salaried entertainer. *And it's so easy!*

Just to prove how quickly you can learn, I'll send you a genuine "Musical Saw" (special temper, process patented) for FIVE DAYS' TRIAL. I guarantee that in 24 hours you can play tunes like "Old Black Joe" and "Home, Sweet Home." Then the latest jazz and song hits, operatic and classical music. Amazingly simple—no notes to read, no dreary practice.

## Thousands Successful by My Method

Just three short, simple lessons reveal every secret of my 12 years' success as a professional saw musician—secrets with which I have taught thousands. Many of my pupils are on the vaudeville stage, playing in dance orchestras, making big money as entertainers. Let me prove that you, too, can quickly play like a professional—amaze your friends and always be in demand at parties and entertainments.

## PHONOGRAPH RECORD FREE! of Saw Solo and Duet

Two beautiful selections. You'll wonder that a saw can produce such marvelous music. But the FREE phonograph record proves it. Send for it today. Mail coupon for free record and big free trial offer. Let me show you letters from pupils who are now stage celebrities.



Robert S. Alter, broadcasting celebrity, has delighted audiences of six leading stations, including an appearance from WSN "Steamship LEVIATHAN."



"Bud" Gamble is paying his way around the world with the Musical Saw. Is now in Europe.



Charles Guglielmi booked to play saw solos in Broadway (New York) motion picture theatre.

*Mail Coupon*



**C. J. MUSSEHL**  
 Pioneer Artist on the Musical Saw, has taught thousands to become Experts, Vaudeville Stars and High-Priced Entertainers.

I'll Loan You The Saw 5 Days Free!



C. J. Mussehl, Pres.  
 Mussehl & Westphal  
 255 W. Water Street

FORT ATKINSON, WIS.

Without obligation to me, send me, postpaid, the Free Phonograph Record of Saw Solo and Duet; also full particulars about your big, Free Trial Offer.

Name.....

Address.....

Town and State.....

**Mussehl & Westphal**  
 Fort Atkinson, Wis.

# BOYS

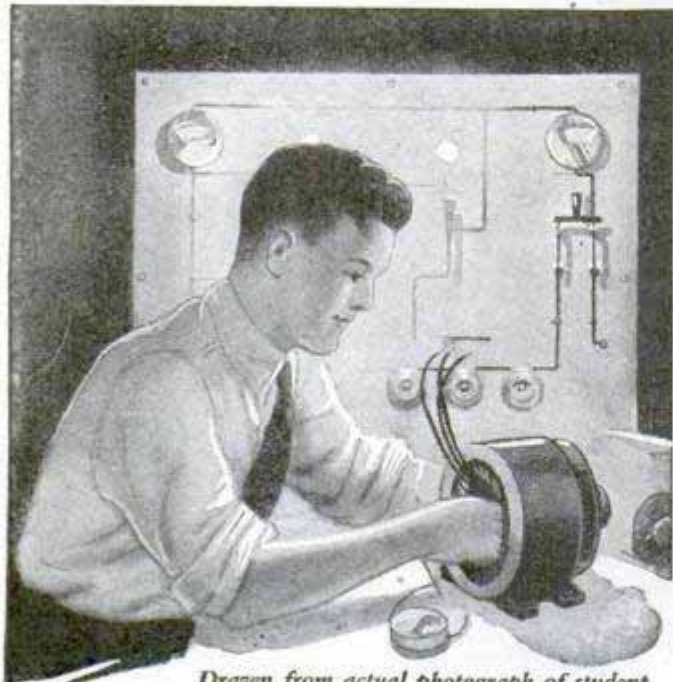

Drawn from actual photograph of student doing spare time electrical work

## Learn Electricity Make Big Money

How would you like to earn two or three dollars every evening after school and prepare yourself for a fine big job at the same time? Here's the opportunity of a lifetime for you fellows who like Electricity. Begin right now to prepare yourself for a regular man's size job in this fascinating field. Your chances for a big success are simply wonderful—the pay is big (thousands of men earn \$70 to \$200 a week) and advancement comes swift and sure.

### I Will Train You at Home

With my easily earned, spare time Electrical Course I will train you at home like I have trained hundreds of other boys who are now big successful men. It will not interfere with your school work and you can earn more than the small cost of the course doing odd electrical jobs in your spare time. The Course pays for itself. I will show you how to get this work and how to do it. Some of my boy students make \$10 to \$15 a week this way.

### Tools, Apparatus and Radio Course —Given Without Extra Charge

Send me the coupon below and I will tell you all about the big outfit of tools, apparatus and instruments and a new Radio Course that I am giving to my students for a limited time. I will send you my big interesting Electrical Book and a sample lesson, too—all Free. You will be tickled with the things I will send you Free. Mail the coupon right now.

L. L. COOKE, Chief Engineer.  
Chicago Engineering Works  
Dept. O-13 CHICAGO

### Look What This Boy Is Doing

"Although the School term is coming to a close, and I am pretty busy with my examinations, I manage to keep up with my electrical studies and work.

"I guess I forgot to tell you I am now in business for myself. Am doing fine, but owe it all to you. If it had not been for your Course, I, being under age, could not have secured my license in this town. But I got it, and now have all the work I can do, averaging \$20 to \$30 a week, thru spare time work.

"I went out on a job tonight after school, on which I made \$3 and brought home another on which I made \$2.50—\$5.50 for 4 hours' work and no material furnished by me."  
ROGERS SMITH,  
1215 Chestnut St.  
Greenville, N. C.

### Use This "FREE BOOK" Coupon

L. L. COOKE, Chief Engineer,  
Chicago Engineering Works,  
Dept. O-13 2150 Lawrence Avenue, Chicago

Send me your Big Outfit Offer, your big Electrical Book, Sample Lesson and particulars of your Electrical Course and Extra Radio Course. This will not obligate me in any way.

Name.....

Address.....

This Coupon only for use of boys 15 years old or more.



## Send 10c for a Master Key

which tells how environment is created. How circumstances are controlled. Why some persons attract success, power and wealth. Why others fail. How anyone may determine whether he is destined to be a success in life or not. Over a million copies printed during the last ten years. A record seldom equalled.

Sent postpaid for only 10c  
THE MASTER KEY SYSTEM  
714 N. Ninth St., St. Louis, Mo.

### BIG DEMAND—BIG PAY

## Be a Plumber!

We Train You Quick —Learn To Do Any Job —Step right into a Big Pay Job or Start a Shop of Your Own. Work the year

around—Earn more in one day than some folks do in a week. Why serve 4 years Apprenticeship? LEARN in 8 to 12 WEEKS—REAL PLUMBERS TEACH YOU. Learn All Branches including lead wiping, plan work, etc. Strictly tool using system. No books used. The Plumber Modernizes the Home and Turns Drudgery into Pleasure. Field growing daily. Don't envy a Plumber—Be One. Write for information—Special Tuition Fee and Amazing opportunities. Don't delay—Do it Today.

KANSAS CITY SCHOOL OF PLUMBING  
2030 Troost Ave. KANSAS CITY, MO.



## BE AN ARTIST

WE CAN TEACH YOU DRAWING in your own home during your spare time. Twenty-five years of successful teaching proves our ability. Artists receive large salaries.

Write Today for Art Year Book

SCHOOL OF APPLIED ART  
ROOM NO. 2 BATTLE CREEK MICH.



\$40.00 Suit for Only \$23.50

Think of being able to offer a \$40.00 suit made of the finest quality of pure Virgin Wool; fit, fabric and fashion guaranteed, at the powerfully attractive price of \$23.50! Can you sell such values? You can, if the experience of 2,500 other salesmen means anything. And you don't have to know anything about selling clothing. We'll take you, train and equip you to go out and make a success of this work if you are honest, ambitious and willing to work. If you are, write us. You'll hear from us promptly with the full facts. Address Dept. 813.

William C. Bartlett, Inc., 850 Adams St., Chicago



# Play Your Way to Greater Popularity with the fascinating HAWAIIAN GUITAR

**Play all the  
LATEST HITS  
just as the  
Hawaiians do**

**\$15**  
**HAWAIIAN GUITAR**  
with Genuine Seal Grain  
**Fabrikoid Cover**

**FREE**  
when you  
enroll



Be the most popular member of your set. Get in on all the good times. Play all the new song and dance hits. Entertain your friends—or play professionally. Be in demand everywhere. We will help you.

## Learn Quickly and Easily in Spare Time at Home

Even if you don't know one note from another, our method is so simple, plain and easy that you begin a piece your first lesson. In half an hour you can play it! You study in spare time—when you like—as long as you like. And your lessons are always before you to refer to at any time.

## Complete Conservatory Course

You get 52 complete printed lessons. Nothing is omitted. Pictures explain every move. And no matter how little you know about music, no matter if you have never touched a musical instrument, our easy picture method will make you an accomplished player.

## Only 4 Motions to Learn

Then you can play any music—popular songs, classical, old-time melodies, native Hawaiian airs—or real jazz—separately or with accompaniment. You'll never be lonesome when you can play the Hawaiian Guitar. By our simple method you learn—and learn quickly. No waiting for class to form—you can begin now.

**No  
Extras  
—We  
Furnish  
Everything**

Including the Free Hawaiian Guitar, in genuine Seal Grain Fabrikoid Case—picks, steel playing bar and 52 pieces of music.

## Other Courses

Famous teachers conduct our courses in Tenor Banjo, Violin, Mandolin, Banjo, Ukulele, Ukulele.

## Our Native Hawaiian Instructors Will Show You How

You receive expert instruction from such world-famous players as Kolomoku, Kalaluki, Ferera and Seville. They quickly teach you the secrets of this fascinating instrument. And remember—the services of these gifted native masters of the Hawaiian Guitar are obtainable only through this old-established New York Conservatory.

## New Invention Makes It Easy

Our course includes a marvelous invention which helps you to make rapid progress. You will be astonished how quickly you learn to play this popular musical instrument, the Hawaiian Guitar, just as the Hawaiians do!

## Our Written Guarantee

Anyone can play the Hawaiian Guitar. We guarantee in writing to teach you. The success of 45,000 students backs up our claim. Like them, you can soon be a full-fledged player, your popularity established and constantly increasing, a professional career ahead of you if you desire. And we coach and advise you after graduation—with no extra expense.

## Pay as You Play

We make it easy for you to obtain the many advantages of this big Conservatory. You start with a small first payment—then pay while learning. It comes to only a few cents per lesson. And bear in mind—your only investment is the moderate cost of your lessons—we furnish everything else.

## This Sweet Toned Hawaiian Guitar FREE

This sweet-toned Hawaiian Guitar would cost you at least \$15 in any music store without the genuine Seal Grain Fabrikoid Case. We give you the entire outfit free when you enroll, including everything necessary to carry on your studies and play the instrument. We can do this because we make them in huge quantities in our own factory.

**First Hawaiian  
Conservatory of Music, Inc.  
6th Fl., Woolworth Bldg.,  
Dept. 148 New York**

Approved as  
a Correspondence School  
Under the Laws of the  
State of New York

**This is the Popularity Coupon—MAIL IT NOW**  
First Hawaiian Conservatory of Music, Inc.  
Dept. 148, 9th Floor, Woolworth Bldg., New York, N. Y.  
Please mail full information about your 52-lesson  
Hawaiian Guitar Course. I am not obliged to  
enroll unless I want to.

Name.....  
Address.....  
City..... State.....

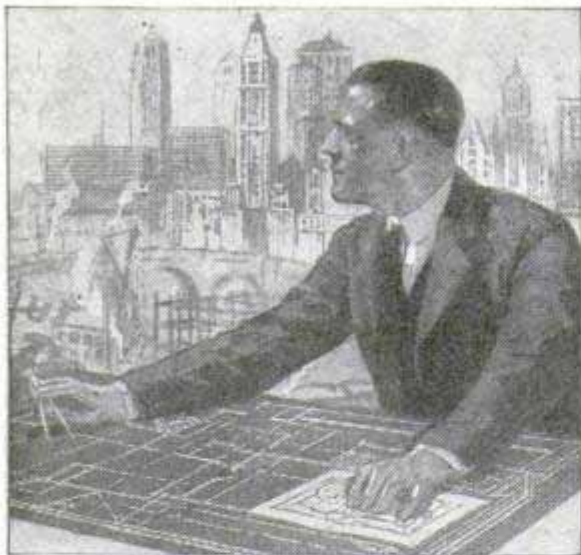

## Former Bricklayer Now Earning \$12,000 a Year

"When I enrolled with the International Correspondence Schools, I was a bricklayer and I didn't know a thing about blueprints. Today I have my own contracting business and I am able to figure the most difficult jobs and execute them to the satisfaction of everyone concerned. My income is between \$12,000 and \$15,000 a year. It certainly was a lucky day for me when I sent in that I. C. S. coupon."

That's a true story of what just one student of the International Correspondence Schools has done. There are thousands of others. Every mail brings letters from men and women telling of increases in income and salary due directly to spare-time study.

One hour a day spent with the I. C. S., in the quiet of your own home, will prepare you for success in the work you like best.

Mail the coupon for Free Booklet

### INTERNATIONAL CORRESPONDENCE SCHOOLS BOX 5562-E SCRANTON, PA.

Explain, without obligating me, how I can qualify for the position, or in the subject, before which I mark X.

- |   |  |
|---|--|
| <ul style="list-style-type: none"> <li><input type="checkbox"/> ARCHITECT</li> <li><input type="checkbox"/> Architectural Draftsman</li> <li><input type="checkbox"/> Contractor and Builder</li> <li><input type="checkbox"/> Building Foreman</li> <li><input type="checkbox"/> Concrete Builder</li> <li><input type="checkbox"/> Structural Engineer</li> <li><input type="checkbox"/> Structural Draftsman</li> <li><input type="checkbox"/> Plumber and Steam Fitter</li> <li><input type="checkbox"/> Heating and Ventilation</li> <li><input type="checkbox"/> Plumbing Inspector</li> <li><input type="checkbox"/> Foreman Plumber</li> <li><input type="checkbox"/> Sheet Metal Worker</li> <li><input type="checkbox"/> CIVIL ENGINEER</li> <li><input type="checkbox"/> Surveying and Mapping</li> <li><input type="checkbox"/> Reading Architects' Blu. Prints</li> <li><input type="checkbox"/> ELECTRICAL ENGINEER</li> <li><input type="checkbox"/> Electric Lighting and Rys.</li> <li><input type="checkbox"/> Electric Wiring</li> <li><input type="checkbox"/> Telegraph Engineer</li> <li><input type="checkbox"/> Telephone Work</li> <li><input type="checkbox"/> MECHANICAL ENGINEER</li> <li><input type="checkbox"/> Mechanical Draftsman</li> <li><input type="checkbox"/> Toolmaker</li> <li><input type="checkbox"/> Machine Shop Practice</li> <li><input type="checkbox"/> CHEMIST</li> <li><input type="checkbox"/> Pharmacy</li> </ul> | <ul style="list-style-type: none"> <li><input type="checkbox"/> Navigation</li> <li><input type="checkbox"/> SALESMANSHIP</li> <li><input type="checkbox"/> ADVERTISING</li> <li><input type="checkbox"/> Window Trimmer</li> <li><input type="checkbox"/> Show Card and Sign Painting</li> <li><input type="checkbox"/> BUSINESS MANAGEMENT</li> <li><input type="checkbox"/> Private Secretary</li> <li><input type="checkbox"/> Business Correspondent</li> <li><input type="checkbox"/> BOOKKEEPER</li> <li><input type="checkbox"/> Stenographer and Typist</li> <li><input type="checkbox"/> Higher Accounting</li> <li><input type="checkbox"/> COMMERCIAL LAW</li> <li><input type="checkbox"/> Common School Subjects</li> <li><input type="checkbox"/> Mathematics</li> <li><input type="checkbox"/> GOOD ENGLISH</li> <li><input type="checkbox"/> ILLUSTRATING</li> <li><input type="checkbox"/> Railway Mail Clerk</li> <li><input type="checkbox"/> CIVIL SERVICE</li> <li><input type="checkbox"/> Mining Engineer</li> <li><input type="checkbox"/> Gas Engine Operating</li> <li><input type="checkbox"/> STATIONARY ENGINEER</li> <li><input type="checkbox"/> Textile Overseer or Supt.</li> <li><input type="checkbox"/> TRAFFIC MANAGER</li> <li><input type="checkbox"/> AUTOMOBILES</li> <li><input type="checkbox"/> AGRICULTURE</li> <li><input type="checkbox"/> Poultry Raising</li> <li><input type="checkbox"/> French</li> <li><input type="checkbox"/> Spanish</li> <li><input type="checkbox"/> Banking</li> </ul> |
|---|--|

Name \_\_\_\_\_ Business Address \_\_\_\_\_ 3-6-24  
 Present Occupation \_\_\_\_\_  
 Street \_\_\_\_\_  
 and No. \_\_\_\_\_

City \_\_\_\_\_ State \_\_\_\_\_  
 Persons residing in Canada should send this coupon to the International Correspondence Schools Canadian, Limited, Montreal, Canada.

# ART

## We Teach COMMERCIAL ART

Meyer Both Company, maintaining the most widely known Commercial Art Studios in the World, offers you a practical training based upon 25 years' success in producing over a quarter million drawings for leading advertisers. This attractive profession equally open to men and women. Home study instruction.

Get Facts Before You Enroll in Any School

Send 4c in stamps for illustrated book telling of the success of our students.

**MEYER BOTH COMPANY**

Dept. 16

Michigan Ave at 20th St  
CHICAGO, ILL.

WRITE for big book on wrestling. Tells secrets you've always wanted to know.



## Learn How to WRESTLE

In Your Own Home  
By Mail

Yes, learn to become an expert wrestler right in your own home, by mail, from the greatest wrestlers the world has ever known. Be an athlete, be strong, be healthy. Learn how to throw and handle big men with ease. Learn to defend yourself. Learn from the World's Champions.

### Farmer Burns and Frank Gotch Secrets

Farmer Burns, who taught Frank Gotch—trainer of SEVEN World's Champions, will teach you Scientific Wrestling—Physical Culture—Jiu-Jitsu and Self-Defense. Write today for big wrestling book, illustrated with many fine pictures—shows holds and secret tricks used by champions. Tells how easy it is to learn the marvelous breaks, falls and holds that make you an expert. Send today for this wonderful book. Enclose only 10c to help cover cost of wrapping and postage. Be sure to state age. No obligation.

Farmer Burns, 1773 Ry. Exch. Bldg., Omaha, Neb.

Send Now for Farmer Burns' Book

## WANT GOV'T JOB?

All men-women, 18-65, wanting to qualify for Government Positions, \$140-\$300 monthly, local or traveling—Write Mr. Ozment, 111, St. Louis, Mo.



## Your Choice

\$20<sup>00</sup>

Musical  
Instruments

FREE TO OUR  
STUDENTS

Your choice of a Violin, Tenor Banjo, Hawaiian Guitar, Banjo, Cornet, Ukulele, Banjo Ukulele, Guitar, Mandolin or Banjo Mandolin. You will be proud to own any one of these instruments and you can have one absolutely free. A few cents a day for lessons is your only expense. Our system of teaching is so easy that you can play several pieces by note with the first four lessons. We guarantee success or no charge instrument and lessons sent on one week's free trial. Write for booklet today no obligation.

CHICAGO CORRESPONDENCE SCHOOL OF MUSIC  
Orchard and Willow Streets Dept. 69 Chicago, Illinois



# Put YOURSELF in this picture

Here's the career that offers you everything!

## Money—Fascination—Romance—Fame

HOW would you like to be a Cameraman with one of the big Motion Picture Companies, making pictures of the famous stars, enjoying all the fun and thrilling variety of studio life, AND EARNING up to \$250 a week or even more? Or how would you like to travel all over the world, filming big news events and scenic wonders? Or be a Portrait Photographer with a big-paying position or operating your own studio? Artistic portraits bring as high as \$200 a dozen or more, and it's practically all clear profit! Or how would you like to go in for advertising photography? Here's one of the fastest-growing and best paying fields in the world. Or perhaps you'd like to be a news photographer, on the staff of a newspaper, right in the thick of things with your camera?



## \$75 to \$250 a week for Work that seems like Play!

Man, here's a career for you with a kick in it! The kind of work you really enjoy! Take your choice of the many fascinating branches. Wonderful oppor-

tunities for women, too. Why slave away for small pay in a dull, uninteresting job when Professional Photography is calling you to wealth, romance, fame!

**No Experience Needed** Even if you've never used a camera in your life you can quickly qualify for a career in Professional Photography. Yes, you can do it in your spare time at home, without losing a day or a dollar from your present job. The famous experts of the New York Institute of Photography, the largest school of Photography in the world, will train you by mail. They'll teach you the whole fascinating profession from beginning to end. They'll make you a real Master Photographer, ready for the BIG MONEY. They'll show you how to make money on the side, right from the start—they'll help you to a position—or show you how to start your own

business. But that isn't all. Here is a wonderful offer if you act quickly:

### CAMERA FREE

Your choice of a real Motion Picture Camera or a 5x7 View Camera, latest model, genuine anastigmat lens. Just decide which branch of Photography you want to take up and you get your camera absolutely FREE.

New York Institute of Photography Dept. 49 12 West 33rd St., New York City

Gentlemen: Please send me FREE your illustrated booklet on Professional Photography explaining how I can learn at home. Also tell me about FREE CAMERA.

## Send for big FREE BOOK Now

Just mail the coupon or write and we will send you free our fascinating illustrated booklet that tells all about the golden opportunities in Professional Photography and how you can make money quickly. Send for it right now—it means real money to you.

**NEW YORK INSTITUTE OF PHOTOGRAPHY**  
Dept. 49 12 West 33rd Street NEW YORK CITY

Name.....

Address.....

Note: We also teach in our New York and Chicago studios. If interested in coming for personal instruction write for Catalog R-49 to nearest address: 10 West 33rd Street, New York City or 620 South Wabash Avenue, Chicago, Ill.

City.....State.....



# They Called Me a "Human Clam" But I Changed Almost Overnight

AS I passed the President's office I could not help hearing my name. Instinctively I paused to listen. "That human clam," he was saying, "can't represent us. He's a hard worker, but he seems to have no ability to express himself. I've given up hopes of making anything out of him."

So that was it! That was the reason why I had been passed over time and again when promotions were being made! That was why I was just a plodder—a truck horse. I was a failure unless I could do what seemed impossible—learn to use words forcefully, effectively and convincingly.

## In 15 Minutes a Day

And then suddenly I discovered a new easy method which made me a powerful speaker almost overnight. I learned how to bend others to my will, how to dominate one man or an audience of thousands. Soon I had won salary increases, promotion, popularity, power. Today I always have a ready flow of speech at my command. And I accomplished all this by simply spending 15 minutes a day in the privacy of my own home on this most fascinating subject.

\* \* \*

There is no magic, no trick, no mystery about becoming a powerful and convincing talker. You, too, can conquer timidity, stage fright, self-consciousness and bash-

fulness, winning advancement in salary, popularity, social standing, and success. It is the power of forceful, convincing speech that causes one man to jump from obscurity to the presidency of a great corporation; a timid, retiring, self-conscious man to change almost overnight into a popular and much applauded after-dinner speaker. Thousands have accomplished just such amazing things through this simple, easy, yet effective training.

## Send For This Amazing Book

This new method of training is fully described in a very interesting and informative booklet which is now being sent to everyone mailing the coupon below. This book is called, *How to Work Wonders With Words*. In it you are shown how to conquer stage fright, self-consciousness, timidity, bashfulness and fear. Not only men who have made millions but thousands have sent for this book—and are unstinting in their praise of it. You are told how to bring out and develop your priceless "hidden knack"—the natural gift within you—which will win for you advancement in position and salary, popularity, social standing, power and real success. You can obtain your copy absolutely free by sending the coupon.

## NORTH AMERICAN INSTITUTE

3601 Michigan Avenue  
Dept. 1353  
Chicago, Illinois



### What 15 Minutes a Day Will Show You

- How to address business meetings.
- How to propose and respond to toasts.
- How to make a political speech.
- How to tell entertaining stories.
- How to write better letters.
- How to enlarge your vocabulary.
- How to develop self-confidence.
- How to acquire a winning personality.
- How to strengthen your will-power.
- How to be the master of any situation.

North American Institute,  
3601 Michigan Avenue., Dept. 1353  
Chicago, Illinois.

Please send me FREE and without obligation my copy of your famous book, *How to Work Wonders With Words*.

Name.....  
Address.....  
City..... State.....

# 3 Drafting Lessons *actually* FREE

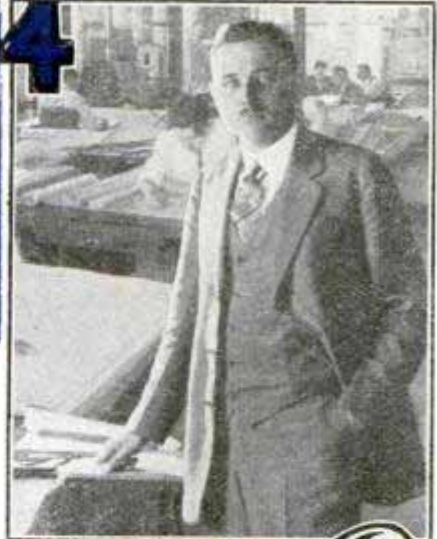

The Expert Draftsman designs the plans of buildings, machinery, and nearly everything that is made. He does important work and earns big money.

**—to prove you can learn at Home in Spare Time!**

We have invented a new, simplified way to teach Drafting—the first real improvement in Drafting home-instruction in history. We want you to see it, try it—without one penny of cost or obligation. We want to show you how we get away from the copying methods used in the past. See how we make you think, solve problems, do actual drafting room jobs from the first lesson!

## Draftsmen Wanted! \$60 to \$125 a Week!

70,000 fine jobs advertised last year. Get ready to fill one. Get out of the rut. Make something of yourself. Plan your future in Drafting. Even if you have only common schooling, even if you know nothing of drafting, we guarantee to make you a real Draftsman or to refund your money! Special surprise offer right now to the first 500 men who answer this ad—reduced price, easy terms. Coupon brings complete information.

### A new, rapid, simplified Home-Training

Copying drafting lessons prepares you to be only a "tracer." This new "Job-Method" gives you actual drafting room jobs in a new one-step-at-a-time way. With pictures which you can understand almost without reading the "lessons." And that is why American School-trained Draftsmen can qualify for a good job at big pay when they graduate.

### Get my JOB-AND-RAISE Offer, quick!

Coupon brings three lessons absolutely free. Get them. It will not cost you a penny to test YOUR ability to get ready for a fine Drafting job and certain increase in pay. Coupon also brings my sensational Job-and-Raise offer, combining training and jobs in a new way.

### Start with the coupon—mail it today!



**Chief Drafting Engineer**  
**AMERICAN SCHOOL,**  
 Dept. D-374-A, Drexel Ave. & 58th St., Chicago  
 Rush 3 Free Drafting Lessons, Job and Raise offer, complete information, money-back guarantee, etc., to prove I can become a real draftsman at home in spare time.

Name .....

St. No. ....

State..... City



## I WILL MAKE THIS CONTRACT WITH YOU

- Your name here.....
- When you enroll for our home-training in Drafting, we agree to give you:
1. Complete Drafting training, by the new Practice-Method.
  2. Professional Drafting Outfit, as illustrated.
  3. We will help you get a good Drafting position at a substantial increase in pay.
  4. All these things we guarantee, or we'll refund every cent of your money.

*O. C. Miller*  
 Director Extension Work

### Start with the Coupon! Climb to the top in 4 jumps

Thousands of men now earning \$5,000 to \$10,000 a year as Expert Draftsmen started with a coupon. They investigated, they trained, they were placed in a good job, and they made good! You, too, can travel this quick road to success:

1. Mail me the coupon. Get my free lessons, the facts about the opportunities waiting for you in Drafting.
2. I will train you at home in your spare time by a new simplified job method—supply without extra cost a valuable Drafting outfit.
3. I will enter into an agreement with you to prepare you for a well paid position and then to give you, without extra cost, an efficient Employment Service which will help you find the high-salaried Drafting position you seek. Your money refunded, if we fail to make good.
4. After you are established in a good Drafting job, we offer you a valuable Promotion Service—without extra charge. Coupon brings full details of this amazing offer.

**THIS OUTFIT**  
 Given to every Student absolutely without extra charge

O. C. MILLER, Director Extension Work

**American School** Drexel Ave. & 58th St., Dept. D-374-A, CHICAGO

# YOU CAN BE A MAN OF MUSCLE



**STRONGFORT**  
BUILDER OF MEN

You don't have to be a weakling. You don't have to be one of the crowd of ordinary fellows. You can be an outstanding figure in any gathering and in any contest—you can be a leader.

It's up to you if you've felt the shame of weakness and incapacity and timidity. You needn't be the goat another day.

Believe me, you can be husky and strong. You can have rolling, beautiful muscles to compare with the best of them—a peppy fellow with a powerful body, bulging arms, a punch and a grip that commands respect and admiration wherever you mix with men and women.

## STRONGFORTISM

Through this system I have built up some of the strongest men of the period, and today they are attracting great crowds wherever they exhibit their tremendous muscular ability. Take, for instance, Hajnos, known the world over as "The Navy Hercules." This man is one of my great triumphs in muscular development. You ought to see what a wonderful specimen he is—what a wonderful body!—what arms!—what legs! He is a marvel. I am almost jealous of him—yet I'm mighty proud to be his teacher—as he says, "My only teacher."

You, young man, who wants to be strong; you, middle-aged man, who wants to be stronger; you, athlete, who needs further development; you, business man, who needs exercise and who seeks health through muscular development—to all of you I say:

## Send for My Book

It will tell you more about muscle building and health than any other book available. It will pay you to read it through, as it will help you to understand just what a wonderful thing STRONGFORTISM is and what it can do for you. Send for your copy today. Use coupon below.

### LIONEL STRONGFORT

Physical and Health Specialist for Over 25 Years

Dept. 129

Newark, N. J.

### FREE CONSULTATION

Clip and Send This Coupon (Absolutely Confidential)

Mr. Lionel Strongfort, Strongfort Institute, Dept. 129, Newark, N. J.—Please send me absolutely free my copy of your book, "Promotion and Conservation of Health, Strength and Mental Energy." I enclose a ten-cent piece (a dime) to help cover mailing expense, and have marked (x) before the subjects in which I am most interested.

- |               |                   |                         |
|---------------|-------------------|-------------------------|
| .. Colds      | .. Weak Eyes      | .. Lung Troubles        |
| .. Catarrh    | .. Flat Chest     | .. Poor Circulation     |
| .. Asthma     | .. Despondency    | .. Round Shoulders      |
| .. Headache   | .. Emaciation     | .. Skin Troubles        |
| .. Rupture    | .. Rheumatism     | .. Stomach Disorders    |
| .. Thinness   | .. Nervousness    | .. Increased Height     |
| .. Pimples    | .. Constipation   | .. Muscular Development |
| .. Insomnia   | .. Short Breath   |                         |
| .. Overweight | .. Weak Heart     |                         |
| .. Weak Back  | .. Great Strength |                         |

Name.....

Age..... Occupation.....

Street.....

City..... State.....

## \$60. to \$100. Weekly Selling 40 to 550 Meter Set

### Spare Time Profits—No Capital

Public wants this Amazing New Set. Coast-to-coast reception. Receives all waves, 40 to 550 meters. Shot sub-panel makes assembly quick and easy. We need distributors everywhere. Demonstration sells. We carry stock. Set sells at half store prices. \$60 to \$100 weekly easily made.

### FIVE TUBE DEMONSTRATOR WITH RADIO TRAINING



Our Special Plan trains you in Radio—gives you a Free Demonstrator Set and appoints you as distributor.

The entire cost is less than regular dealer's price for Set alone. Hundreds are making big money in spare time. Get started now while territory is still open. Write Today! Don't miss this opportunity to make a fortune in Radio. Get complete sales plan Free!

### AMBU ENGINEERING INSTITUTE

2632 Prairie Avenue, Div. 6-C, Chicago, Illinois

# Music Lessons

WITH AN ACCREDITED SCHOOL

## At Home

### A Complete Conservatory Course By Mail

Wonderful home study music lessons under great American and European teachers. Endorsed by Paderewski. Master teachers guide and coach you. Lessons a marvel of simplicity and completeness.

**Any Instrument** Write telling us course you are interested in—Piano, Harmony, Voice, Public School Music, Violin, Cornet, Mandolin, Guitar, Banjo or Reed Organ—and we will send our FREE CATALOG with details of course you want. Send NOW.

University Extension Conservatory, 263 Siegel-Myers Bldg., Chicago, Ill.

## Learn to Mount Birds



Learn at home by mail, to mount birds, animals, game heads; tax furs, make rugs and robes. Complete lessons. Easily and quickly learned by men, boys and women.

**FREE** Write today for Free Taxidermy Book. Tells all about it. Every Sportsman, Hunter, Trapper and Nature lover should know this wonderful fascinating art. Save your trophies. Big profits. Success guaranteed. Our school is 20 years old—75,000 graduates. Investigate today. Write for Free Book.

Northwestern School of Taxidermy

9773 Elwood Bldg., Omaha, Neb.

## Anyone CAN LEARN



No talent or experience necessary. Fascinating work. Pays big money. Complete instruction book tells about: Alphabets, Colors, How to Mix Paints, Show Cards, Window Board and Wall Signs, Ready made letters, Gilding, Tricks of the Trade, also gives 100 Alphabets and Designs. Book bound in flexible imt. leather-gold edges, and four half bearing Show Card Pens. Sent postpaid \$3.00. (C.O.D.) 10c ex. Ogilvie Pub. Co., 57 Rose St. Dept. 50, N.Y. City



**EARN MONEY IMMEDIATELY—WE FURNISH EQUIPMENT TO START!!**

# WANTED TO TRAVEL

## \$1500 to \$3000 a YEAR

Men, 17 up. Several hundred wanted immediately. Travel—See your country at BIG PAY. Common education sufficient. Experience unnecessary.

### FULL PARTICULARS—FREE

Write immediately for full particulars, free sample training in Selling and Free Book, "How To Be a Big Paid Salesman."

FRANKLIN INSTITUTE, Dept. N-702, ROCHESTER, N. Y.



# LEARN *to* FLY

## 1000 Ambitious Young Men WANTED



**You Fly  
by Flying**

## Sweeney System

of Practical Airplane Mechanics opens up a world of opportunities for young men. *You Learn by Doing!*

### Opportunities in Flying

Aviation Mechanics—  
\$50-\$125 Week  
Riggers—\$50-\$75 Week  
Flyers—\$125-\$225 Week  
Taxi Service—\$100-\$300 Week  
Aerial Photo Pilot—\$200-\$250  
Week  
Special Messenger Service—  
\$125-\$200 Week  
Aerial Advertising—\$225-\$500  
Week  
Crop Dusting—\$125-\$200  
Week  
Crop Survey—\$125-\$225 Week

### Skilled Airplane Mechanics Wanted

Now after years of preparation, aided by the best flyers in the world, I have perfected the system of teaching whereby in a short time you become a skilled mechanic, and also if you wish, a skilled pilot. The mechanical and repair work end of aviation, as well as airplane construction, is thoroughly taught you!

All the resources, skill, experience and reputation of the great Million Dollar Sweeney School insure that the Sweeney aviation course is the simplest, most efficient, most practical system in the world.

**LEARN TO FLY!** Aviation is no longer a mystery—no longer a hazard; no, it is a business growing greater and more important; you can qualify as a mechanic, or an engineer, or repair man, or builder; five men on the ground are needed for one man in the air, but if you want to become a pilot you easily master the work and can go into postal, government, or commercial work. Flyers are in demand, earning big money at fairs taking up passengers, etc. \$5 for a 10 minute flight is pretty fine pay! The building of the new million dollar Fokker plant here means liberal high paid employment for hundreds of aviation mechanics.

**SEND NAME TODAY** for full details of this aviation mechanical course and photographs of planes and equipment actually used; also full information as to the commercial end of flying and opportunities for young men.

### SWEENEY SCHOOL OF AVIATION

LEARN TO FLY BY FLYING  
**Sweeney**  
SCHOOL of AVIATION  
2306 SWEENEY BLDG, KANSAS CITY, MO.

**T**HIS photograph shows Instructors Wimer and Spencer working with students. The Sweeney System first prepares a student by intensive practical work on motors, building, recovering wings, rigging and all details of construction, repairing and handling. This is called ground school work. Instructor Spencer, an overseas flyer, tells you that it took about 4000 mechanics and assistants to keep several hundred flyers in the air at his field in France. To show you the quality of the men who teach you look at Spencer and Wimer for instance. Spencer was an army pilot and has been teaching and doing commercial flying since 1917. Wimer is a college man, went overseas, was with the 1st Air Park, was an observer, spent over 200 hours in the air and since the war has been with two big aircraft corporations.

### THE SWEENEY SYSTEM

is divided into two parts. **FIRST:** You are thoroughly taught in the ground school. This fits you as an aviation mechanic. You can build your own plane and do anything required in aviation mechanics and construction and repairing when you have finished this work. You are thoroughly taught motors, etc., and work with thousands of dollars worth of new material, including all types of engines. Liberty 12s, Sturdevants, Gnomes, Hall Scott fours and sixes, etc.

**SECONDLY:** after completing this work if you want to be a pilot you take ten hours of flying. Now when you understand that two to seven hours is all the average man needs to learn expert flying you will appreciate what ten hours in the air under skilled men will do for you.

### SEND THIS NOW

EMORY J. SWEENEY, President  
2306 Sweeney Bldg., KANSAS CITY, MO.

Please send me full information about your Aviation Course.

Name..... Age .....

St. No. or R.F.D.....

Town..... State.....



# SHOW CARD LETTERING

## Learn at Home

HERE is the very course you need if you want to get a good paying position as a Show Card Letterer or Sign Letterer, or have a business of your own. This course is complete and practical and especially arranged to meet the needs of the student who studies at home. It was written by E. L. Koller, Principal of the School of Art of the International Correspondence Schools, member of the American Federation of Arts, and The National Society of Craftsmen.

Mr. Koller has had twenty years' teaching experience, and his success in helping other men and women is an indication of what he can do for you.

H. L. Wood, a clerk, made more than \$700 "on the side" before he had completed his course and also won \$125 in prizes. Harry William Lord writes that he has more than doubled his salary as a result of studying this I. C. S. course in spare time. William Whitman, a former wagon builder, now has a sign painting business of his own and is earning nearly three times as much as he did before enrolling with the International Correspondence Schools.

There is no doubt that Show Card Lettering and Sign Lettering offer a real opportunity to ambitious men and women. Just mark and mail the coupon and we'll gladly send you a booklet telling all about the I. C. S. course in Show Card Lettering, or any other subject in which you are interested.

INTERNATIONAL CORRESPONDENCE SCHOOLS  
Box 5561-E, Scranton, Penna.

The oldest and largest correspondence schools in the world

Without cost or obligation on my part, please tell me how I can qualify for the position or in the subject before which I have marked an X:

SHOW CARD LETTERING

- |   |   |
|---|---|
| <input type="checkbox"/> Business Management            | <input type="checkbox"/> Salesmanship           |
| <input type="checkbox"/> Industrial Management          | <input type="checkbox"/> Advertising            |
| <input type="checkbox"/> Personnel Organization         | <input type="checkbox"/> Better Letters         |
| <input type="checkbox"/> Traffic Management             | <input type="checkbox"/> French                 |
| <input type="checkbox"/> Business Law                   | <input type="checkbox"/> Stenography and Typing |
| <input type="checkbox"/> Banking and Banking Law        | <input type="checkbox"/> Business English       |
| <input type="checkbox"/> Accountancy (including C.P.A.) | <input type="checkbox"/> Civil Service          |
| <input type="checkbox"/> Nicholson Cost Accounting      | <input type="checkbox"/> Railway Mail Clerk     |
| <input type="checkbox"/> Bookkeeping                    | <input type="checkbox"/> Common School Subjects |
| <input type="checkbox"/> Private Secretary              | <input type="checkbox"/> High School Subjects   |
| <input type="checkbox"/> Spanish                        | <input type="checkbox"/> Illustrating           |

TECHNICAL AND INDUSTRIAL COURSES

- |   |  |
|---|--|
| <input type="checkbox"/> Electrical Engineering                           | <input type="checkbox"/> Architect                                   |
| <input type="checkbox"/> Electric Lighting                                | <input type="checkbox"/> Architects' Blueprints                      |
| <input type="checkbox"/> Mechanical Engineer                              | <input type="checkbox"/> Contractor and Builder                      |
| <input type="checkbox"/> Mechanical Draftsman                             | <input type="checkbox"/> Architectural Draftsman                     |
| <input type="checkbox"/> Machine Shop Practice                            | <input type="checkbox"/> Concrete Builder                            |
| <input type="checkbox"/> Railroad Positions                               | <input type="checkbox"/> Structural Engineer                         |
| <input type="checkbox"/> Gas Engine Operating                             | <input type="checkbox"/> Chemistry <input type="checkbox"/> Pharmacy |
| <input type="checkbox"/> Civil Engineer                                   | <input type="checkbox"/> Automobile Work                             |
| <input type="checkbox"/> Surveying and Mapping                            | <input type="checkbox"/> Airplane Engines                            |
| <input type="checkbox"/> Metallurgy <input type="checkbox"/> Mining       | <input type="checkbox"/> Agriculture and Poultry                     |
| <input type="checkbox"/> Steam Engineering <input type="checkbox"/> Radio | <input type="checkbox"/> Mathematics                                 |

Name.....

Street Address.....

City..... State.....

# ELECTRICITY

FREE BOOK

Send for it

## LEARN in 12 WEEKS

Prepare for a good paying position in 12 weeks. Salaries from \$10 to \$25 a day not uncommon for Finlay trained men. Finlay Condensed Method, now in 23rd successful year, trains head and hand, combining practical shop work and intensive study. In 12 weeks we teach you HOW and WHY. Thousands of successful men have taken this short road to long pay. You have the same opportunity.

## EARN \$10 to \$25 a DAY

Send for Finlay Catalog and full details on 12 weeks' course in Practical Electricity. Thousands of positions open. Enroll any time. Completely equipped shops and laboratories. Faculty of highly trained experts. Certificates awarded. Students assisted to positions. Success is calling you NOW. Write today and get the facts.



**FINLAY**  
**ENGINEERING COLLEGE**  
105 FINLAY BLDG., KANSAS CITY, MO.



Grandpa Walked, Fa'her Motored,  
**NOW YOU CAN FLY**  
in a **LINCOLN SPORTPLANE**

100 miles per hr. with 30 HP engine. Blue Prints and Material Now Ready for Builders! Build your own plane and fly it yourself. Send 10c for illustrated catalog.

Lincoln Standard Aircraft Corp., Lincoln, Nebr.

## Make BIG Money

# TULLOSS NEW WAY

### LEARN AT HOME QUICKLY IN SPARE TIME.

Graduates earn \$35 to \$45 a week. SO CAN YOU. Speed of 80 to 100 words a minute. guaranteed. Supersedes old methods—easy for anyone. WRITE TODAY FOR AMAZING OFFER

Entire course ON TRIAL. Complete business training included. Send for New, Descriptive Book and limited Special Offer. ACT QUICKLY.

**THE TULLOSS SCHOOL, 339 College Hill, Springfield, Ohio**

## Stop Making Mistakes in English

Wonderful new way to improve your English. No rules to learn. No hard study. Grammar, spelling, punctuation, and expression, taught in 15 minutes a day—at home. Self-Correcting feature makes it fascinating as a game. Write today for Free Book "How to Speak and Write Masterly English" and 15 minute test which you can take in your own home. The answers are given so that you can tell at once just where you stand. Address



**SHERWIN CODY SCHOOL OF ENGLISH**  
53 Searle Building ROCHESTER, N. Y.

## Learn Watchwork, Jewelrywork and Engraving

A fine trade commanding a good salary, and your services always in demand. Address **Horological**, Dept. P, Bradley Institute, PEORIA, ILLINOIS, for our latest catalog.

## Music Instructor

These books are illustrated and gotten up to make the method of self-teaching so simple that any one without any knowledge of music could learn to play any of the following:



SAXOPHONE	30c	MANDOLIN	30c
ACCORDION	30c	PIANO	30c
BANJO	30c	UKULELE	30c
GUITAR	30c	VIOLIN	30c

The above prices are postpaid. Any above 4 titles, \$1.00 postpaid.  
J. C. DORN, 725 S. Dearborn St., Dept. 17, CHICAGO



Samuel Glassberg



## Tremendous Future for Every Man Who Enters Building Business Now. Leading Minneapolis Builder Tells How . . .

"Years ago, when one entered the building business, it was necessary to start at the bottom and work up step by step. My start was to carry the water bucket and be a general helper, at \$3.00 per week. I learned by experience, and it took me many years. Often I have wished I could have had the easy, quick, thorough training offered to boys and men today. The Chicago Tech. School for Builders can teach the fundamentals of building, give every man in 10 months' training what took me about 10 years to learn in the slow, hard school of experience. Today this modern method enables every boy and man to obtain his training during spare time. Opportunities now in the building business are the best ever, growing greater every year. There is an endless opportunity for trained men." So writes Samuel Glassberg, greatest home builder of the northwest, Pres. Glassberg Construction Co., Minneapolis. A self-made man who plans, finances, and builds an average of 75 homes annually, and knows every branch of the building business. He started as a boy. Today he has his own lumber mills, finance company, and employs more than 180 men.

### Learn at Home in Spare Time to Earn \$3,000 to \$10,000 a Year

Get into the building business . . . no matter what your job is now. No overcrowding in this tremendous field—room for thousands of new men every day. For building is America's second largest industry. Why huck the competition of crowded industries where only a few men advance to big-pay jobs? Why stay at low wages? In spare time—at home—any man can get his start to become a building expert—and can earn \$65 to \$150 per week.

Clerk or carpenter—office man or bricklayer—salesman or superintendent—it makes no difference. Thousands of specialists—men who can read blue print plans and boss the others—are demanded for the \$6,000,000,000 of buildings that will be erected this year.

Men who are in the building game now know the high wages—\$10 to \$20 a day—paid to foremen, superintendents, and experts in various branches of building.

### Building—Plan Reading—Estimating

Even men with ordinary training make real big money in the building field. But trained men win the top—salaries of \$3,000, \$5,000 and \$10,000. Fit yourself for this work. We'll show you the way. You can get into the building business quickly . . . easily. Or if you are in it now . . . and want to advance . . . you can get the training now that you must have for success.

### FREE TRIAL LESSON—No Education Necessary

To show you how simple this Builder's Course is we send you a free trial lesson and actual blue print plans. Our book "How to Read Blue Prints" . . . written by a practical building expert, covers the first lesson. You will find this whole course as easy to read and understand as your daily newspaper with everything written in everyday language. You learn from actual blue print plans—from practical building experts. That's why Chicago Tech. School for Builders graduates get ahead so fast—why they are picked for the big jobs. And you don't need any other education.

### Earning Less Than \$75 a Week? Then Act Now—Send the Coupon

Send the coupon. It places you under no obligation. Get the facts—today. Find out about this building course—what it has done for others—what it offers you. Builders in your own town or city are making big money. Here's your chance to get into the same big-pay field—or to have a building business of your own. Send the coupon. "How to Read Blue Prints," the Blue Print Plans and a book describing our whole course will be sent to you at once. See for yourself what building means in dollars and cents to you!

### From Foreman to Contractor and \$450 a Month

"When I entered as a student I was in charge of a job as a foreman at \$8.00 a day. For the past four months I have been contracting and have averaged \$450.00 a month."

Writes R. H. Edney, Asheville, N. C.

### Salary Increased From \$1.50 a Day to \$210 a Month

"In 1920, I was a ditchman working for \$1.50 a day. And now my salary is \$210.00 a month. Chicago Tech. Training has taken me out of the ditch and landed me on the top of the building."

So writes P. J. Marchand, New Orleans.

### FREE Trial Lesson and Blue Print Plans

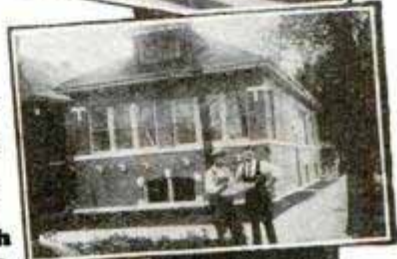

### Qualify for a Good Paying and Permanent Position

- Plan Reading
- Estimating
- Foremanship
- Superintendence
- Building Construction
- Building Management
- Contracting
- Building Homes
- Real Estate and Insurance
- Public Estimating
- Building Inspecting
- Buying and Selling
- Building Material
- Quantity Surveying
- Promoting



## Mail This Now!

Chicago Technical School for Builders, Dept. 377, 118 East 26th St., Chicago, Ill.

Yes, I want to earn more. Send me, without obligation, details of the opportunities in the business of Building, details on how I can increase my earnings, and a copy of your book, "How to Read Blue Prints." It is understood that no salesman will call on me.

(Write or print name plainly, please)

**Chicago Technical School for BUILDERS**

Dept. 377, Chicago Tech. Bldg., 118 E. 26th St., Chicago

Name .....

Address .....

City ..... State .....

Occupation .....

# Get Into This



Are you ambitious? Are you seeking a better job or a business of your own? If so, here's your chance—a chance to really cash in. There are more amazing money-making opportunities in the automobile business now than ever before. Follow the lead of the thousands of "Michigan State" graduates. They have already proved what real training will do for an ambitious man. They are making big money. You can too! This school has 20,000 graduates. 700 students here now. Come to Detroit, a fine city.

Big business and pleasant climate all year round. Come now and fit yourself for a better job or to run a garage business of your own. Thousands of battery shops, auto electrical shops, tire and welding shops are needed now. Only trained men can run them. Good work is what car owners want, and it takes a trained man to do it. Jerry De Nooyer, Battle Creek, Mich., writes: "Am Service Manager of Cadillac and Olds service station at \$80 a week."

Ray Walker, Bethlehem, Pa., says: "Had my pay raised three times this summer. When I went to M. S. A. S. I knew nothing about a car."

## START NOW!

A thorough training in Detroit, at the "Michigan State," fattens the pay envelope or starts you in business for yourself. You can take a full Automotive Course in 12 weeks. Or our great Master Course in 30 weeks. Or specialize in any of its money-making branches; be an Auto Electrician, Battery Service Man, Engine Man, Tire Expert, or Machinist. All courses include training in Business, Shop Management, Service, Selling, etc., by one of the big men from Detroit's auto plants. Classes always open. You can start at once. Jump right on the train for Detroit. I. Diner, proprietor of General Garage, New Hamburg, Ontario, says: "I started in business 6 months ago and your course has paid me double already."



## Learn at Detroit The Auto Center

Without any previous experience—just a liking for mechanics—you can learn the auto business from A to Z in a few weeks at the Michigan State Automobile School in Detroit, the heart of the industry. Then step out, equipped with knowledge and training, to a future of certain, big money making. You have great advantages, learning the business here. It's the fountain head of the automotive industry. You are taught under factory endorsed methods. You learn both theory and practice on latest equipment. Go through the great Ford plants. Visit the other auto factories. Learn their methods first hand—and it all means greater opportunities and more certain success. The Michigan State Automobile School, in Detroit, the automobile center, is the logical place to learn the auto business.

### NOW 20 MILLION CARS

Figures just released show 20,200,000 automobiles now registered in the U. S. A. Every year the figure grows. That means more skilled auto men needed—more money spent for repairs—more money that you can be earning when you become a M. S. A. S. graduate. Victor and Elmer Hanson (Buick and Chevrolet dealers), Wakefield, Mich., write: "The net worth of our business is now \$35,000."

### JUMP A HEAD OF THE CROWD

Some men think they can learn the business by starting in green as a helper in a garage. They are wrong. Years of dirty work will be wasted learning wrong methods from poor mechanics. Save all this by coming to the auto center for a few weeks. Learn right, under expert instructors. Learn the short cuts and best ways of doing electrical repairs, engine work, all about autos, trucks and engines. O. E. Parker, Buick dealer, Howell, Mich., writes:

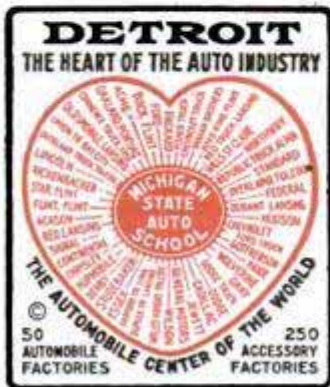

"After finishing at the school I could locate any trouble and fix it, and in many cases quicker and better than men who had years of experience."

## 1926 Buick Master Six

Completely equipped chassis of the 1926 "Master Six" Buick, just furnished to us. The co-operation of the automobile manufacturers is one of the big advantages which you have in coming to the "Michigan State" in Detroit, the Auto Center. Many of the big companies assist us for your benefit. Here you work on up-to-date equipment, under the guidance of expert instructors. M. S. A. S. courses are long and thorough. Your M. S. A. S. diploma means much to you. It gives you the double prestige of being a "Michigan State" graduate, and of being a Detroit-trained man.

**MICHIGAN STATE**  
303 Auto Building Detroit, Michigan

Learn Autos Where Autos Are Made

# BIG MONEY Business

## Here is a Chart of Facts—

authentic figures which point out the opportunities. Autos are increasing faster than repair shops or mechanics can keep up with them. 20 million cars are in use now. The auto industry leads all others in value of production. There are more autos than telephones. 269 cars to every service station. This shows as plain as A-B-C **where the big chance is today.** Walter Burk, Danville, Ill., writes: "I take care of 60 big trucks for the State of Illinois Highway Department, and have been with them since I graduated." What thousands of others have done, you can do, too. You have even a **better chance** than they had, because there is a **bigger demand** for trained men than ever was before. Service managers tell us that 100,000 new trained auto mechanics are needed **every year.** Not nearly enough are starting, and a **trained man** can get a good job any place and any time.

**20,200,000**  
Automobiles in U.S.

One Car to Every  
6 People

269 Cars to Every  
Repair Shop

Thousands more Trained  
Men are Needed

## Good Positions Open

The demand for trained men is greater than the supply. We cannot fill all the calls we get. Look into any garage that is run by trained men—everybody busy, earning big money. These opportunities can be yours too with "Michigan State" training. **Earn while you learn if necessary.** Some students work evenings to pay their way. Others work days and take our evening classes.

## FREE BUSINESS COURSE

Business Management Course by Packard Service Manager is Free to all students. Tells how to locate and start a garage, how to meet customers, how to sell cars, gives you invaluable business advice. No extra charge.

## Home Study Course

This is free to students who intend to come to School later but can't come now. You can start to learn at home. Helps you get a garage job right away. Write for full information and explain your circumstances.

## AUTOMOBILE SCHOOL

3729 Woodward Avenue, Detroit, Michigan

**The Automobile Center**

## YOU CAN MAKE GOOD TOO

Here is Harold Grenert, Holyoke, Mass., one of the thousands of "Michigan State" graduates who have achieved quick success. He is just an ordinary fellow, much like the rest of the men who come to this School to get their start on the **Road to Success.** Read his letter:

### From \$20 a Week to \$70

"I now have complete charge of all electrical equipment on the busses operated by the Hartford, Conn., and Springfield, Mass., Bus Co. I have three electricians under me. I receive \$70.00 a week as a salary. Two years ago I left a \$20.00 a week job. Thanks to the M. S. A. S. training, I now receive \$70.00, more than three times as much."



## Write Us Today

Get all the interesting facts. They will open the way to a brighter future for you. Write a letter or a postcard or use this coupon. **Do it now.** (Colored students not enrolled, except for our home study course.)

## QUALITY TRAINING ONLY

The best training is the only kind you can afford to get. "Michigan State" graduates earn more money. Their Detroit training makes them wanted—Your "Michigan State" diploma will be a valuable money-making asset. The Michigan State Automobile School is known the world over. Wherever autos are used, Detroit-trained men get the best jobs, highest pay. Leading factories, dealers, service stations, garages, shops and farms want men who have trained their heads as well as their hands—the M. S. A. S. Detroit-kind.

**Mail  
Today!**

Michigan State Automobile School  
303 Auto Building, Detroit, Michigan

Send me free and without obligation complete information about Detroit training to make the most money, also *photographic book on Detroit*, "Auto School News," Chart of your Courses, and hundreds of your Graduates' letters.

Name .....

Street or R. F. D. ....

City..... State.....

I am interested in { 12 weeks' Auto Course  
30 weeks' Master Course  
Home Study Course

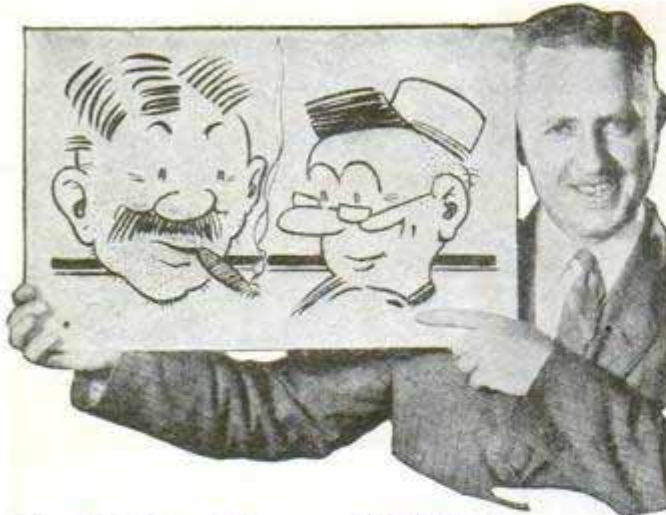

# \$100 a Week in This Fascinating Work

**\$50 to \$250 a Week Paid to Good Cartoonists! You Can Easily Learn This Fascinating Profession Right at Home in Spare Time. Send for Free Booklet Explaining Method.**

THERE isn't a more attractive or highly paid profession today than cartooning. Millions of dollars are spent every year for good cartoons by the 20,000 or more newspapers and magazines in the United States alone. Capable artists earn \$50 to \$250 a week. Fontaine Fox, Briggs, Bud Fisher, Sid Smith and others *make more money* than the presidents of most corporations. Think of it!

## Quick Easy Way to Learn Cartooning

Yet of all the professions cartooning is now positively one of the easiest to learn. You don't need to know a thing about drawing. Through our amazingly simple method many who never dreamed they could draw have easily learned cartooning. You too—without any apparent talent at all—can easily learn to dash off side-splitting cartoons that may mean ease and independence for you within a surprisingly short time. You learn right at home, yet your work receives the personal correction of one of America's foremost artists. Many students actually sell enough work during their training to pay for it.

### Mail Coupon for Free Book

Learn more about the wonderful money-making opportunities in cartooning, and how this method makes it easy for you to learn. Read about our students—their success—what they say—how easy it was—actual reproductions of their work—how they made big money while studying. Booklet entirely free. Send for it NOW. **Washington School of Cartooning, Room 303-D, 1113-15th St., N. W., Washington, D. C.**

**WASHINGTON SCHOOL OF CARTOONING,  
Room 303-D, 1113-15th St., N. W.,  
Washington, D. C.**

Please send me without obligation, your illustrated FREE BOOKLET on Cartooning.

Name .....  
(Write Name Plainly)

Address .....

City.....State.....

If under 18 years, please state age .....

## Your Choice

# \$20<sup>00</sup>

## Musical Instruments

# FREE TO OUR STUDENTS

Your choice of a Violin, Tenor Banjo, Hawaiian Guitar, Banjo, Cornet, Ukulele, Banjo Ukulele, Guitar, Mandolin or Banjo Mandolin. You will be proud to own any one of these instruments and you can have one absolutely free. A few cents a day for lessons is your only expense. Our system of teaching is so easy that you can play several pieces by note with the first four lessons. We guarantee success or no charge. Instrument and lessons sent on **one week's free trial**. Write for booklet today, no obligation.

**CHICAGO CORRESPONDENCE SCHOOL OF MUSIC**  
Orchard and Willow Streets • Dept. 70, • Chicago, Illinois

# FREE Electrical Training Book

Mail postcard for amazing FREE book on electricity. Shows you how to earn \$150 to \$600 a month in this immense field. Famous S & H shop-type training fits you quick at home for big jobs. Exclusive system. Lack of experience or education no bar. Write **S & H Engineering Co., 1422 W. Monroe St., Dept. C-1, Chicago, Ill.**

## FREE

**Wonderful Book that tells how / your brain can earn more!**

Pelmanism increases the earning power of the mind as physical training develops muscles. Doubled salary in six months not at all unusual. Strengthens your weak links; awakens sleeping powers.

**Find Out What Holds You Back**  
If you are not earning \$1,000 more every year, send now for wonderful free book showing how Pelmanism has helped 550,000 people. Write today.

**The Pelman Institute of America**  
Suite 63, 19 West 44th Street NEW YORK

Send for this FREE Book

## BE AN OFFICER

### in the U. S. Coast Guard

# \$1700 Up to \$7,500 Yearly

\$780 yearly at the U. S. Academy while training. You rank Ensign to Captain in service. Age requirements 18 to 24. Write Dept. M, for information.

**COAST GUARD PREPARATORY SCHOOL**  
4000 Ga. Ave N. W. Washington, D. C.

**WHY NOT** spend Spring, Summer and Fall, gathering butterflies, insects? I buy hundreds of kinds for collections. Some worth \$1 to \$7 each. Simple outdoor work with my instructions, pictures, price-list. Send 10 cents (not stamps) for my illustrated Prospectus before sending butterflies.

**MR. SINCLAIR, DEALER IN INSECTS,**  
Dept. 6, Box 1424, San Diego, Calif.

#2 FEMALE  
#1 MALE

# RADIO EXPERTS

## EARN BIG MONEY

## YOU CAN LEARN AT HOME

# FREE!

## 3 Tube Set

No other profession in the world offers the same big possibilities. Immense salaries await trained men in this fascinating, growing field. Fit yourself to be the radio expert of your own community. Thousands of men also needed in the great radio factories. I will quickly train you at home to be a radio expert. Write for all the facts today; learn how to get a wonderful 3-tube, receiving set free. Remember, we guarantee satisfaction or refund tuition.

**WRITE TODAY**  
A. G. MOHAUPT, Radio Engineer  
**Radio Association of America**  
Dept. 1353, 4513 Ravenswood Ave., Chicago

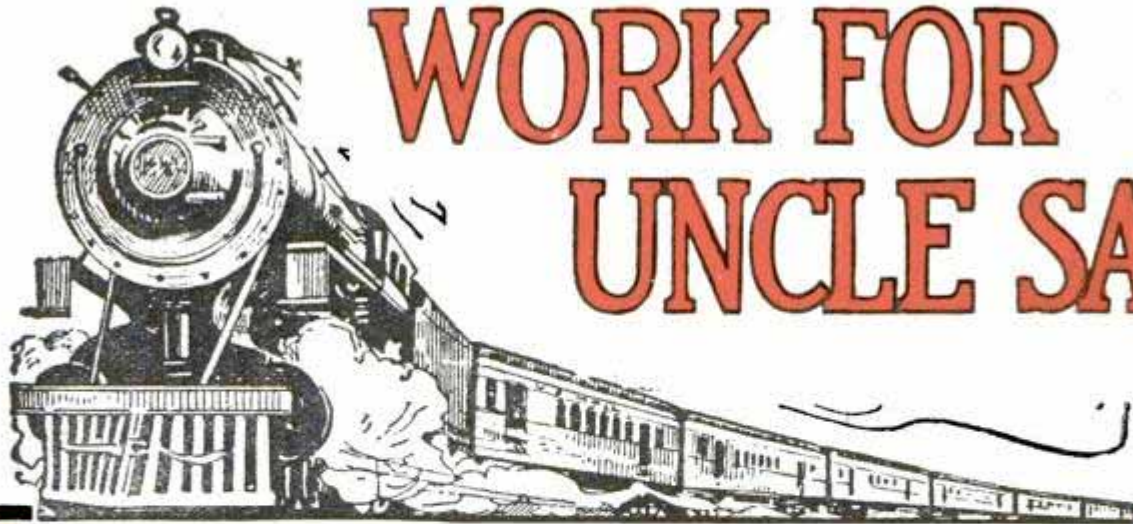

# WORK FOR UNCLE SAM

## TRAVEL ON GOVERNMENT PAY

**Commence \$158 Month**

**Raise to \$225 Month**

**Many other U. S. Government Jobs Open to Men and Boys 18 up**

**Postoffice Clerks  
Income Tax Auditors**

**City Mail Carriers  
Clerks at Washington, D. C.**

Steady positions. Strikes, poor business conditions, lockouts or politics do not affect them. U. S. Government employees get their pay for full twelve months every year. There is no such thing as "HARD TIMES" in the U. S. Government Service.

### RAILWAY POSTAL CLERKS

Railway Postal Clerks now get \$1900 the first year, being paid on the first and fifteenth of each month. \$79.16 each pay day. Their pay is increased to a maximum of \$2700 a year. \$112.50 each pay day. They get extra allowance for hotel expenses when away from home.

### PAID VACATIONS

Railway Postal Clerks, like all Government employees, are given a yearly vacation of 15 working days (about 18 days). When on runs they usually work 3 days and have 3 days off duty or in the same proportion. During this off duty and vacation, their pay continues just as though they were working. When they grow old, they are retired with a pension. As Railway Postal Clerks are continually traveling, they have an excellent chance to see the country. They are furnished with a railroad pass.

### City Mail Carriers—Post Office Clerks

Clerks and Carriers commence at \$1700 a year and automatically increase \$100 a year to \$2100 with further increase to \$2300. They also have 15 days vacation. Examinations are frequently held in the larger cities. City residence is unnecessary.

### What Will You Earn 5 Years From Now?

Compare these conditions with your present or your prospective condition, perhaps changing positions frequently, kicking around from post to pillar, no chance in sight for PERMANENT employment; frequently out of a position and the year's average salary very low. **DO YOU EARN \$1900 EVERY YEAR? HAVE YOU ANY ASSURANCE THAT A FEW YEARS FROM NOW YOU WILL GET \$2700 OR MORE A YEAR, EVERY YEAR?**

### Get Free List of Positions

Fill out the coupon. Tear it off and mail it today—now, at once. **DO IT NOW**—This investment of two cents for a postage stamp may result in you getting a U. S. Government Job.

**FRANKLIN  
INSTITUTE  
Dept. N-176  
ROCHESTER,  
N. Y.**

Kindly rush to me entirely free of charge (1) a full description of the position checked below; (2) Specimen examination questions; (3) Free copy of illustrated book, "U. S. Government Positions and How to get them"; (4) A list of the U. S. Government Jobs now obtainable.

**Railway Postal Clerk** .... (\$1900-\$2700)  
**Post Office Clerk** ..... (\$1700-\$2300)  
**City Mail Carrier** ..... (\$1700-\$2100)  
**Rural Mail Carrier** ..... (\$2100-\$3300)  
**Clerk at Washington, D. C.** ..... (\$1140-\$1860)  
**Income Tax Auditor** ..... (\$2040-\$3000)

Name .....

Address .....

Use This Coupon Before You Mislay It—Write or Print Plainly

# Science Discovers the Secret of CARUSO'S Wonderful Voice

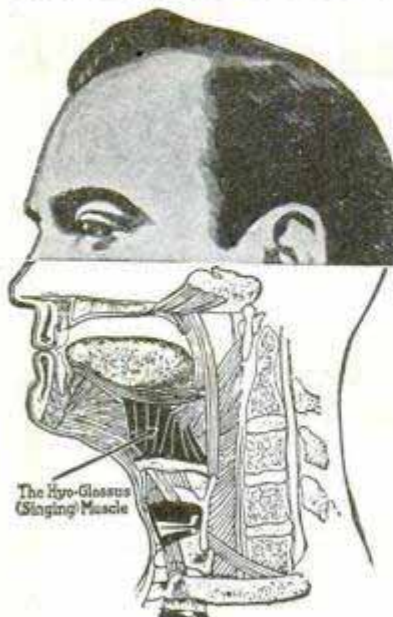

Why is it that the humble peasant boy of Italy became the greatest singer of all time? This diagram of his throat will show you. Caruso's marvelous voice was due to a superb development of his Hyo-Glossus muscle. Your Hyo-Glossus muscle can be developed, too! A good voice can be made better—a weak voice become strong—a lost voice restored—stammering and stuttering cured. Science will help you.

## Your voice can be improved 100%

A few very fortunate persons—like the late Caruso—are born with the ability to sing well. But even Caruso had to develop his Hyo-Glossus muscle before his voice was perfect. You can develop a beautiful singing or speaking voice if your Hyo-Glossus muscle is strengthened by correct training. Professor Feuchtinger, A. M.—famous in the music centers of Europe for his success in training famous Opera Singers—discovered the secret of the Hyo-Glossus muscle. He devoted years of his life to scientific research and finally perfected a system of voice training that will develop your Hyo-Glossus muscle by simple, silent exercises right in your own home. The Perfect Voice Institute guarantees that Professor Feuchtinger's method will improve your voice 100%. You are to be your own judge—if your voice is not improved 100% in your own opinion, we will refund your money.

## Grand Opera Stars His Students

Hundreds of famous singers have studied Physical Voice Culture. Over 10,000 happy pupils have received the benefits of his wonderful training. You do not know the possibilities of your voice. If you want to sing—but lack the proper training because you have not the time nor means to study—here is your chance. You can now train your voice at a very small cost in the privacy of your own home.

If you want to improve your speaking voice—if you stammer or stutter—Professor Feuchtinger will help you.

### Inspiring New Book FREE!

You will do yourself a great and lasting good, by studying the new book "Physical Voice Culture." It may be the first step in your career. Do not delay. Mail the coupon today.

#### Perfect Voice Institute

1922 Sunnyside Ave. Studio 13-53 CHICAGO

#### Perfect Voice Institute

1922 Sunnyside Ave. Studio 13-53 CHICAGO

Please send me FREE your new book "Physical Voice Culture." I have put X opposite the subject that interests me most. I assume no obligations whatever.

.....Singing.....Speaking.....Stammering....Weak Voice

Name.....

Address.....

Age.....

# Learn to Make SHOW CARDS

— Quick Easy Way!

Every Store Needs Clever Show Cards

Earn \$50 to \$100 a week. Business of your own. Marvelous new method makes it amazingly easy to learn at home. Write now for special Free Offer and illustrated book to Washington Show Card School, Dept. 303-D, 1115-15th St., N. W., Washington, D. C.

Earn BIG Money In Spare Time

# LAW STUDY AT HOME

Become a lawyer. Legally trained men win high positions and big success in business and public life. Be independent. Greater opportunities now than ever before. Big corporations are headed by men with legal training. Earn \$5,000 to \$10,000 Annually. We guide you step by step. You can train at home during spare time. Degree of LL.B. conferred. LaSalle students found among practicing attorneys of every state. We furnish all text material, including fourteen-volume Law Library. Low cost, easy terms. Get our valuable 108-page "Law Guide" and "Evidence" books FREE. Send for them NOW. LaSalle Extension University, Dept. 364-L Chicago. The World's Largest Business Training Institution

## NEW WRITING DEVICE

Patented. Teaches children and adult quickly how to write correctly. No failures. Satisfaction assured. Write today. VIC. HANSEN WALLACE, IDAHO

## SUCCEED With Your Own Products

Make them yourself. Formulas, Processes. Trade-Secrets. Modern master methods.

CATALOG FREE W. THAXLY CO. Washington, D. C.

## Last Call For FREE Book

Your last chance on this offer

For a short time only we will give every subscriber to the New Library of Machine Shop Practice a copy of French's Engineering Drawing—the greatest book on mechanical drawing ever written. This book makes drawing as plain as day—tells you all about instruments, plans and methods—and prepares you to handle any drawing job you will ever have to do. It comes to you absolutely free with

## Machine Shop Practice

9 volumes — 3065 pages — 3608 illustrations (A combined home study course and reference library)

The New Machine Shop Library is written for practical men. It gives you the best methods for every kind of machine shop work. It explains machine tools and their operation, drawing and design, tool work, gears and grinding, jigs and fixtures, automatic screw machines and their tools and all of the mathematics you will ever have to use. It is plainly written, completely illustrated—the very best kind of help to the machine shop man who wants to advance himself.

Sent FREE No money down—only 7c a day



### FREE EXAMINATION COUPON

McGRAW-HILL BOOK CO., Inc., 370 Seventh Ave., New York Send me for 10 days' free examination the New Library of Machine Shop Practice. If satisfactory I will send you \$1.50 in 10 days and \$2.00 monthly until the special price of \$19.50 is paid. If not wanted, I will return the books at your expense.

On receipt of my first payment of \$1.50 it is understood that I am to receive, free of charge, a copy of the second edition of French's Engineering Drawing.

Signed.....  
 Address.....  
 City and State.....  
 Position.....  
 Employer..... P.M. 3-1-26



# 3 Electrical Lessons actually FREE!



*to prove you can learn at home in spare time*

## Get Ready Quick! for a Big-Pay Job IN ELECTRICITY

I can help place hundreds of men in fine Electrical jobs at salaries from \$60 to \$125 a week. They need not be high school graduates (the grades will do) but they must be willing to devote part of their spare time to learning Electrical principles and practice by a new Job-method built by 23 leading Electrical Engineers, and simplified for home-study. 3 Lessons sent you absolutely Free to prove how interesting and easy and valuable this instruction has been made.

### I will make this Contract with YOU:

A million dollar institution stands back of this agreement to PREPARE you to fill a well-paid Electrical job and then to help you FIND THE JOB—or to refund the small amount charged for your training! Here is your opportunity to get out of the class of under-paid, money-worried men, always out of a job or afraid to lose one. To step into the rank of men who are paid BIG SALARIES for what they KNOW, instead of starvation wages for what they DO!

#### Training built by 23 Noted Engineers

This is no one-man, one idea school. America's leading Electrical Engineers have helped me build this wonderful home-training—men from

Westinghouse  
Western Electric  
American Tel. & Tel.  
General Electric  
Mass. Inst. Tech.  
Columbia University  
and other leading corporations and universities.

#### PROOF! that we place men in JOBS!

"I received your letter today and hurried immediately to the Bodine Electric Company, with the result that I got the position."  
JOHN ALMQUIST, III.

LOUISIANA PUBLIC SERVICE COMPANY  
New Iberia, La.

"Under your caption G-045 you have a construction superintendent whom we might be interested in employing. Will you please put him in touch with us, or give us all necessary information regarding his character and qualifications."  
J. G. DIX, President

"I have just received a notification from the Commonwealth Edison Co. employment department to start to work in their generating station. I am very grateful to you for this help you gave me."  
JEROME OVERHOET



AMERICAN SCHOOL—the Million Dollar Educational Institution



Your name here . . . . .  
When you enroll for my home-training in Electricity, I agree to give you:

1. COMPLETE training in Electricity, including the Electrical Engineering subjects you will need to fill positions at \$60 to \$125 a week.
2. I will help you get a GOOD JOB at a big raise in pay.
3. I guarantee to refund your money if you are not satisfied.

AMERICAN SCHOOL  
By Chief Engineer Dunlap

### Get My Job and Raise Offer Quick!

If you have reached the point where you realize YOU MUST train and specialize to get anywhere, write me immediately! I will show you the wonderful opportunities, the enormous salaries, the many openings waiting in this billion dollar industry. I will tell you about the most sensational combination TRAINING-AND-JOB offer ever made, which is practically a guarantee of your success. Mail coupon and get 3 Free Electrical Lessons and complete information.

### 4 Costly Electrical Outfits Given!

I send you absolutely without extra cost, as a part of this training, 4 costly outfits of standard size tools and materials, so you learn Electricity BY DOING actual Electrical jobs. One of these outfits is a \$10 Electric Motor—a real motor and generator, the same type as the big fellows in a power plant. I send it to you "knock-down" and have you wind the field and armature and assemble it. That's the way I teach every branch of Electricity! House-wiring, Electric Light, Radio, and Motor outfits included.

### 3 Electrical Lessons Free!

Chief Engineer Dunlap, Electrical Division  
AMERICAN SCHOOL Drexel Ave. & 58th Street Dept. E-374, CHICAGO  
Send me your combination TRAINING-AND-JOB offer, 3 Free Electrical lessons, facts about the opportunities in Electricity, etc.

Name . . . . .  
St. No. . . . .  
City . . . . . State . . . . .

CHIEF ENGINEER DUNLAP, Electrical Division

**American School** Drexel Avenue & 58th Street Dept. E-374 CHICAGO

# \$5 DOWN Buys Any Latest Model WITTE Engine

Now, more than ever, the need for economical, dependable power is felt by the producer who is faced with ever-increasing labor costs. **WITTE Throttling Governor ENGINES** answer this important question perfectly—now an economical, dependable power plant is within the reach of everyone.

Today the **WITTE ENGINE** sells at the lowest price in history. Into this **WITTE** has gone the ripe experience of more than 42 years of engine building—over 100,000 users all over the world have placed upon it their stamp of approval. You, too, can put a **WITTE** on your place, secure in the knowledge that represents the



**Standard  
of Power**

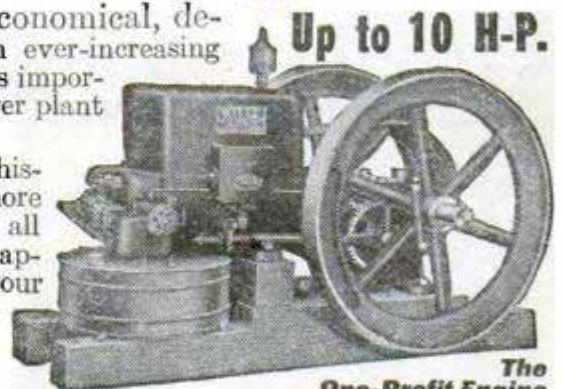

**Up to 10 H-P.**

*The  
One-Profit Engine*

**The WITTE Throttling Governor**

the original and leader of the throttling-governor type. An even steady speed with a big surplus of power for the heavy loads. The minimum in fuel consumption—the **WITTE ENGINE** burns kerosene, gasoline, gas-oil, distillate or gas at a fuel cost of less than 2c an hour per H-P. Simple, trouble-proof and guaranteed for a lifetime of hard work. Completely equipped with **WICO Magneto**, speed and power regulator and throttling governor.



## The WICO Magneto

—the most perfect system of high tension ignition known. Makes starting easy, even at 40 below zero—sure performance in any climate or temperature. Not affected by rain, hail, snow or sleet. The perfect replacement for old-style battery-equipped engine.

**Makes all Jobs Easy and Cheap**—No need to do the hard, back-breaking work—no need to pay high prices for poor labor—you can show \$1,000.00 more profit every year you have a **WITTE** working on your place. Investigate now!

*All Sizes, 2 to 25 H-P. Easy Terms. Scrap the Old One—Pay a Little Down on the New Witte!*

**Ask for Our Big FREE ENGINE BOOK** or if interested, ask for our Log and Tree Saw, 3-in-1 Saw Rig or Pump catalog.—ED. H. WITTE.



**WITTE ENGINE WORKS**

1744 WITTE BLDG., KANSAS CITY, MO.  
1744 EMPIRE BLDG., PITTSBURGH, PA.  
1744 WITTE BLDG., SAN FRANCISCO, CALIF.

# PATENTS

**Booklet Free Highest References  
Promptness Assured Best Results**

Send drawing or model for preliminary examination of Patent Office records.

**ALL BUSINESS GIVEN PROMPT AND PROPER ATTENTION**

Listed Patent Lawyer in the latest editions of the Rand-McNally Directory of Bankers and Attorneys, of Chicago, Ill.; The Baggott & Ryall Directory of Attorneys, New York City; The Lawyers Guaranteed Directory, Detroit, Michigan; The Lawyers and Bankers Quarterly, published by the Legal Directory Publishing Company of St. Louis, Mo.; the American Lawyers Annual, Cleveland, Ohio.

**WATSON E. COLEMAN,**  
REGISTERED PATENT LAWYER

644 G Street, N. W., Opp. U. S. Pat. Office  
**WASHINGTON, D. C.**

*Whatever Your Question;*—be it the pronunciation of Fascista, the spelling of a puzzling word, the location of Esthonia the meaning of soviet, realtor, vitamin, etc., this Supreme Authority—

**WEBSTER'S NEW INTERNATIONAL DICTIONARY**

contains an accurate, final answer. 407,000 Words 2700 Pages, 6000 Illustrations.  
Regular and India-Paper Editions  
G. & C. MERRIAM CO., Springfield, Mass.  
Write for specimen pages, prices, etc.; and FREE Pocket Maps, per Popular Mechanics.



# AUDELS ENGINEERS & MECHANICS GUIDES

## Salary Increased 100 Percent

"Audel's Guides gave me information I was unable to get from much higher priced works. By their use I have increased my salary 100 per cent."

C. Pelsor, Lic. Engineer, Springfield, Mass.

## Aid To Getting a License

"My set of Audel's Guides are just the books I need as an aid to getting my engineering license. I would not take \$25 for them now or any other time."

R. Anderson, Detroit, Mich.

## Guides Great Educators

"I think Audel's Guides do more to educate men that want to climb the ladder of success than any other organization or school in the country."

C. P. Luntington, Rawlins, Wyoming.



Here are the correct answers to Engineering and Mechanical Questions—in a handy form. When you are stuck on a job, consult Audel's Guides. It will save time, labor and money for you. These authentic guides teach the best engineering practice. Don't guess or take chances. Study your job. Study Audel's Guides on subjects you are interested in. They prepare you for the job higher up. The engineer and mechanic who reads and thinks as he works puts character into his profession. He is the master of his job. He is the outstanding man who is in demand in these days when power plant and boiler room economy is so important.

## Complete Engineering Taught in Practice and Theory in These Practical Pocket-Educators

Audel's Guides are 8 handy pocket books—price \$12, payable \$1 a month. These up-to-date educators explain in plain language the theory, practice and rules that have to be known by engineers, mechanics, machinists, firemen, oilers, draughtsmen and engineering students.

Audel's Guides are Good Helpful Counselors, worth hundreds of dollars to any mechanic. By learning more you earn more. Read list of subjects covered—all easy to understand and apply. Engineering calculations figured out in simple arithmetic with sketches and examples.

Judge the value for yourself. Examine Guides Free! Send coupon NOW. Make up your mind about keeping these educators after a week's trial.



## INFORMATION Answers On:

Engine Principles  
Valve Setting  
Pumps,  
Engines—  
Corliss Engines  
Uniflow Engines  
Pumping Engines  
Contractors Engines  
Locomotives Engines  
Marine Engines  
Turbine Engines  
Gas and Oil Engines

Indicators  
Producers  
Aviation  
Steam  
Fuel Economy  
Boiler Construction  
Firing  
Oil Burners  
Stokers  
Boiler Repairs  
Pipe Fitting  
Heating  
Refrigeration  
Elevators  
Dynamometers  
Motors  
Lighting  
Wiring  
Electrical Diagrams  
Radio  
Electrical  
Reference and Calculations

\$1

\$1 PER MONTH  
SET—8 GUIDES \$12

## ANSWERS—In A Handy Form

covers, gold edges. Easy to carry in pocket for daily reading. Handy to keep on table or shelf for quick reference. 4750 pages, 8754 illustrations. Highly endorsed by engineers everywhere as an Educator and a Helper to Better Pay. Examine the set free! Send no money. Pay nothing to postman. Merely tear out and mail this coupon today!

These 8 beautiful books are printed in big type, on strong paper. Flexible in big type, on strong paper. Flexible in big type, on strong paper. Flexible in big type, on strong paper.

## Our Guarantee

Examine Audel's Engineers & Mechanics Guides without charge. If you like this Master Set, keep it. If not, send it back. Pay us only if you are satisfied. No charge if you are not. This is the fair play plan on which we have distributed educational books for nearly 50 years.

**NOW!**

The foreman, superintendent, chief of today is the man that yesterday STOPPED EVERYTHING until he got this coupon into the mail! Send this coupon now. Learn more so you can earn more!

## FREE THEO. AUDEL & CO.

EXAMINATION 65 West 23rd St. NEW YORK CITY

COUPON Please send me postpaid, for free examination

AUDELS ENGINEERS & MECHANICS GUIDES —8 numbers, \$12. If satisfied, I agree to send \$1 in 7 days and \$1 monthly until paid.

Name.....

Address.....

Occupation.....

Employed by..... 3-T-30

# Electrical Experts are in Big Demand!



It's a shame for you to earn \$15 or \$20 or \$30 a week, when in the same six days as an Electrical Expert you could make \$70 to \$200—and do it easier—not work half so hard. Why then remain in the small-pay game, in a line of work that offers no chance, no big promotion, no big income? Fit yourself for a real job in the great electrical industry. I'll show you how.

## Be an Electrical Expert Earn \$3,500 to \$10,000 a Year

Today even the ordinary Electrician—the “screw driver” kind—is making money—big money. But it's the trained man—the man who knows the whys and wherefores of Electricity—the Electrical Expert—who is picked out to “boss” the ordinary Electricians—to boss the big jobs—the jobs that pay \$3,500 to \$10,000 a year. Get in line for one of these “Big Jobs.” Start by enrolling now for my easily learned, quickly grasped, right-up-to-the-minute, Spare-Time Home-Study Course in Practical Electricity.

**I Will  
Train You at  
Home for a  
Big Pay Job**  
*L.L.C.*

**5 Big Fine  
Outfits  
to work with  
No Extra Charge**

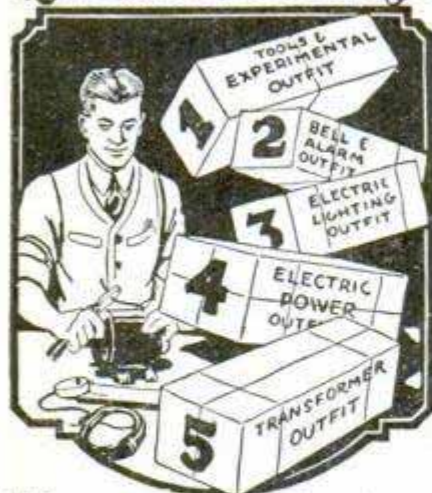

With me, you do practical work—at home. You start right in after your first few lessons to work at your profession in the regular way and make extra money in your spare time. For this you need tools, and I give them to you—5 big complete working outfits, with tools, measuring instruments, and a real electric motor—5 outfits in all.

### Age or Lack of Experience No Drawback

You don't have to be a College Man; you don't have to be a High School Graduate. As Chief Engineer of the Chicago Engineering Works, I know exactly the kind of training you need, and I will give you that training. My Course in Electricity is simple, thorough and complete and offers every man, regardless of age, education, or previous experience, the chance to become, in a short time, an “Electrical Expert,” able to make from \$70 to \$200 a week.

### Your Satisfaction Guaranteed

So sure am I that you can learn Electricity—so sure am I that after studying with me, you, too, can get into the “big money” class in electrical work, that I will guarantee under bond to return every single penny paid me in tuition, if, when you have finished my Course you are not satisfied it is the best investment you ever made. And back of me in my guarantee stands the Chicago Engineering Works, Inc., a two million dollar institution, thus assuring to every student enrolled, not only a wonderful training in Electricity, but an unsurpassed Student Service as well.

### FREE Book on Electricity

I want to send you my Electrical Book and Proof Lessons, both Free. These cost you nothing and you'll enjoy them. Make the start today for a bright future in Electricity. Send in Coupon—Now!

**L. L. COOKE, Chief Engineer  
Chicago Engineering  
Works**

**2150 Lawrence Ave.  
Dept. 13 Chicago**

**Get Started Now!  
Mail Coupon**



**GET  
MY  
FREE  
BOOK!**

**L. L. COOKE, Chief Engineer,  
Dept. 13, 2150 Lawrence Ave., Chicago, Ill.**

Send me at once without obligation your big illustrated book and complete details of your Home Study Course in Electricity, including your outfit and employment service offers.

Name.....  
Address.....  
Occupation.....



**\$20 a Day for Schreck**

“The biggest thing I ever did was answer your advertisement. I am averaging \$500 a month from my own business now. I used to make \$18 a week.”  
**A. SCHRECK, Phoenix, Ariz.**



**\$700 in 24 Days**

“Thanks to your Course, I made \$700 in 24 days in Radio. I run clear profit every day.”  
**FRED G. McNABB  
7 W. 16th St.,  
Atlanta, Ga.**

**The “Cooke Trained Man is the “Big Pay” Man**

# Classified Advertisements

WORLD'S BEST WANT AD MEDIUM

Advertisements in this section, 25 cents per word, each insertion, minimum 10 words, payable in advance.

To be inserted under proper classification in April issue, copy should be in our office February 18th.

## ADVERTISING AGENCIES

TO secure agents or salesmen or for selling farms and reaching investors, use classified (want) ads in largest newspapers and magazines. Price list No. 30 sent free. Ankrum Advertising Agency, 20 W. Jackson Blvd., Chicago, Ill. The largest classified advertising agency in the U. S.

ADVERTISE in 24 Big Sunday Newspapers, 24 words \$15.00. Catalog listing 1,000 leading Dailies, Weeklies, Magazines, 4c stamps. Union Advertising, Baltimore Bldg., Chicago.

ADVERTISE in 24 big Sunday Newspapers, 24 words \$15.00. 300 Rural Newspapers 28 words \$10.00. 100 Big weekly newspapers 24 words \$5.00. Service 100%. Consultation Free. National Advertising Service, Richmond Hill, New York.

LEGITIMATE Advertising. All Publications, Latin America, United States, Country papers. Catalog free. Owl Agency, Times Building, New York.

25 WORDS—355 Rural Weeklies, \$14.20. Ad-Meyer Agency, 4112-M Hartford, St. Louis.

ADVERTISING in all magazines and newspapers at publisher's lowest rates. Rate book free. Taylor's Advertising Service, Dept. F, Freeport, Ill.

ADVERTISE, 25 words in 210 Rural Newspapers \$7.50. List free. Shaw, 221A Northeast, Washington, D. C.

ADVERTISING 222 Magazines .08c word, \$6.00 inch, \$45.00 page. Sample 10c. Diamond Advertiser, Norton, Mass.

ADVERTISE—28 words 72 country newspapers \$3.20. Miller, 1009 S. Salina, Syracuse, N. Y.

FREE. Advertising rates. Agents names \$5.00. 1,000. Pennell, Covington, Ky.

INCH Display 100 monthlies \$4. Cove, 233P, Champaign, Ill.

ADVERTISE in 350 weeklies, \$3.33 line. Keator, Hartford Bldg., Chicago.

## FOR ADVERTISERS

YOUR Advertisement—3 weeks free. 22 leading newspapers. Pay one week regular rate 4c word. Affiliated Newspapers, Bedford Building, Chicago.

ADVERTISE in Modern Advertiser, 3c word; twice 5c; inch display, \$2. Lorenz, Box 156, Madison, Ind.

MY letters bring orders. \$3.00. F. Elliott, 1742 Kenilworth, Chicago.

I WRITE letters, folders, booklets, complete followup for manufacturers, mail order dealers. Long experience. Write for details. L. Taylor, Box M44, Freeport, Ill.

ADVERTISE 28 words in 300 country newspapers including one inch display and classified ad in magazine of national circulation, \$10.00. Keator, Hartford Bldg., Chicago.

25 WORDS, 88 magazines, \$1.00; Thrice \$2.00. Inch display \$2.00; Thrice \$3.40. Smith's Service, 1194, Wenatchee, Wash.

GUARANTEED mailing lists. Write for rates. French, 1903 E. Chase, Baltimore, Md.

1,000 3x6 CIRCULARS Printed and Mailed, \$4.00. Universal Mailers, 650 Center, Waukegan, Ill.

## SALES PROMOTION

\$50 TO \$50,000 Daily Sales developed during 36 years for clients by my direct-mail plans, copy, campaigns. A \$25,000 annual volume increased ten-fold in twelve months. Another, from an initial expenditure of \$720 developed in four years sales by mail of half million yearly. Ten years Sales Promotion Manager Larkin Co. Submit sales problems for Free diagnosis. James C. Johnson, 118A Woodbridge Ave., Buffalo.

CENTRAL and South America Offer You a Tremendous Virgin Field. We Translate Your Letters into Spanish. Advertise Your Products. Appoint Local Agents and Ship Your Goods. Investigate! All America Sales Promotion Company, 921 Tribune Building, New York.

## AUTOMOBILE SUPPLIES

PARTS—New and Used. For Cars—Trucks. Save 50—80%. Bankrupt Supplies. Complete new Tops with Curtains \$20.00. Starters and Generators \$10.00—\$20.00. Brightman Auto Exchange, 321 Windsor Ave., Hartford, Conn.

VULCANIZING Auto Tires is a Paying Business on account of new tires advancing. We have Plants near you from \$100 up. We save you 50%. Catalog Free. Instruction Book \$1. Equipment Exchange, 108 East 11, Los Angeles, Calif.

BARGAINS on Radiators. All standard makes radiators furnished at bargain prices. State Make and model. We guarantee satisfaction. Independent Radiator Co., 1119 Wabash Ave., Chicago.

AUTOMOBILE Parts—New and Used Parts for all cars. You can save 25 to 75% buying from us. Satisfaction guaranteed. Free Catalogue to repairmen. Century Parts Company, 1724 S 18th St., St. Louis, Mo.

YOU need our combination Auto License Keytainer: Latest Nufold road map. Name section, all three \$1.00. Edw. J. Lynassen, N339, Syracuse, N. Y.

66 MILES on 1 Gallon—Scientific Gas Saver. All autos. Demonstrating Model Free. Critchlow, A-132, Wheaton, Ill.

USED Auto Parts for Any Car. Allen's Parts Co., 2901 So. 9th, St. Louis, Mo.

BEAUTIFUL Ornaments, Motor Car Mascots. Write for Catalogue. United Auto Supply, 1922 Westlake, Seattle, Wash.

## AUTOMOBILES

AUTO Mechanics, Garages, Battery Service Stations and Automobile Students; \$75.00 to \$150.00 a week in your spare time; not a selling proposition but a bona fide Business which can be operated by anyone, anywhere, without previous experience, special ability or large capital; may be operated in the Garage, Service Station or in the "Back Yard"—it gets the business! Address: Maulsby, Box 5108, Gateway Station, Kansas City, Mo.

PATENTS. Time counts in applying for patents. Don't risk delay in protecting your ideas. Send sketch or model for instructions or write for Free Book "How to Obtain a Patent" and "Record of Invention" form. No charge for information on how to proceed. Communications strictly confidential. Prompt, careful, efficient service. Clarence A. O'Brien, Registered Patent Attorney, 58-E Security Bank Building (directly across street from Patent Office), Washington, D. C. See pages 140 and 141.

DYKE'S Automobile and Gasoline Engine Encyclopedia. The latest edition contains information on repairing and adjusting every part of every motor car now in use. Tells how to find out what is wrong and how to fix it. Mechanics everywhere depend upon this compendium to keep them up-to-date. Send No Money. Just ask for Dyke's Auto Encyclopedia on a post card. When the postman hands you the book, pay the few cents postage and \$6. Money back if not delighted. Popular Mechanics Press, Room 803, 200 E. Ontario St., Chicago, Ill.

FORD Chassis made dependable tractor by using Shaw Equipment. Pulls 16" plow, etc. Particulars Free. Shaw Manufacturing Company, Dept. R-4, Galesburg, Kans.

MOTORCAMPERS! We supply camp car plans for the amateur builder. Pacific Vehicle Works, Box 574, Los Angeles.

PATENTS: My fee in installments. Free personal advice. Frank T. Fuller, Washington, D. C.

TOURING Atlas. Road maps of every state. Shows kind of road and distances between towns. Key to each map. Latest edition. With Popular Mechanics Auto Tourist's Handbook, 98 cents. Send no money. Just ask for Touring Atlas and Tourist's Handbook. Pay postman 98 cents and postal charges. Popular Mechanics Press, Room 803, 200 East Ontario St., Chicago, Ill.

## AUTOMOBILE SUPPLIES, ACCESSORIES AND HOUSEHOLD GOODS WANTED

SELL Quality Merchandise at the right price with 100% profit. \$7.50 starts you in business. Two sales a day nets \$80.00 a week. To assure territory write now for particulars. Stoner-Harris & Co., Dept. Pl, 186 No. LaSalle St., Chicago.

100,000 REPRESENTATIVES Wanted! Sell by mail. Through Agents, or Direct! Detailed Information—25c! None free. Surety Service, Desk A, 551 Harvard St., Rochester, N. Y.

## FOR FORD OWNERS

INSTANT Starting in zero weather guaranteed to users of the instant manifold heater for Fords, Chevrolet, Star and Overland Four. Saves your batteries and cuts out 3/4 of usual "choking." This saves gas and prevents dilution of oil. Pays for itself in 10 days, besides convenience of instant starting. Easily installed in 15 minutes. Guaranteed for life of your car. Send \$2.50 for outfit complete prepaid. 4-A Products Company, Mfgs., 3704 Downing, Denver, Colo.

"FORGET IT"—Automatically Oil Your Ford Universal with a Hardy Oiler. No wearing parts. Postpaid \$2.25, or at your Dealers. Mention Year. See our Ad. Page 157, this magazine. Hardy Mfg. Co., Medford, Ore.

A FORD shock absorber that actually does more than any other at less than makers' price while they last. Kerslake's Machine Shops, Paris, Kentucky.

66 MILES on 1 Gallon—Scientific Gas Saver. All autos. Demonstrating Model free. Critchlow, B-132, Wheaton, Ill.

UNDERSLING with "RKO" Swing Lo Irons. See "Red-i-Kut" ad page 154.

CARBURETOR For Fords—Simmons Superpower Easy Starting, high mileage. \$3 Postpaid. Carburetor Sales Co., Box 2263, Brooklyn Station, Cleveland, Ohio.

FORD Thermatic Carburetor Regulators. Free Demonstrator. "Watch it work." Owens, 1919-C Broadway, New York.

DIRECT Engine Driven Tire Pumps for Ford Cars. Clagett Mfg. Co., Upper Marlboro, Md.

ELECTRIC-Exhaust Intake manifolds, for Ford Cars. F. M. Starbuck, Summersville, W. Va.

## MOTORCYCLES, BICYCLES AND SUPPLIES

1923 HARLEY-DAVIDSONS, \$168; 1922, \$118; 1921, \$111; 1920, \$85; 1919, \$65; 1917, \$50; 1916, \$45; 1915, \$40; 1914, \$35. Guaranteed. Money refunded if not satisfied. Circular free. Wisconsin Cycle Sales Co., 726 National Ave., Milwaukee, Wis.

OVERSTOCKED Used Motorcycles, 1923 Indian Chief \$95.00, 1923 Harley Davidson \$95.00, 1923 Henderson DeLuxe \$120.00. Two hundred others; write for free list. Myerow Brothers Co., 15 Berkeley St., Boston, Mass.

REAL Bargains in Used Motorcycles. All Makes and Models to pick from, \$50.00 and up. Free circulars. Write Today. Motorcycle Parts, Repairs and Accessories. Knuths' Harley-Davidson Agency, 2525 Fond du Lac Ave., Milwaukee, Wis.

SEND for Bargain Bulletin. All makes of rebuilt motorcycles at lowest prices. Used parts half-price. Ash Motor Corporation, Rochester, N. Y.

USED Harley-Davidson Parts 40% to 80% Discount. Tower Cycle Co., 4305 North Florissant, St. Louis, Mo.

DON'T buy a Bicycle Motor Attachment until you get our prices. Shaw Mfg. Co., Dept. 27, Galesburg, Kans.

## AVIATION

CURTISS Pultzer Racer, construction set, including full size plans and genuine Curtiss-Reed Duralium Propeller \$4.00 postpaid. Special Offer. Wonderful Scientific Airglider with ground launching device. Flies 350 feet. 50c Postpaid. Big Model Airplane, Boat and Supply Catalog, 5c. W. Phipps Co., 367 Wilson Ave., Brooklyn, N. Y.

**AEROPLANE Motors.** New complete Army \$3,000.00, 165 horsepower 9 cylinder Gnome air-cooled engines \$25.00 P.O.B. Dayton, Ohio. Need storage space. Hundreds sold. Ideal for iceboats, snowsleds, motor boats and wind wagons. Aeroplanes and parts. Ford propellers, \$5.00 up. Aeroplane propeller hubs with attachments fitting any automobile motor, \$5.00. Famous Resistal Goggles with extra pair clear glass, \$2.60 postpaid. Blue-prints successful snowsled and iced sled \$1.00. Write for booklet. Marvin A. Northrop, 200 Builders Exchange, Minneapolis, Minn.

**AIRPLANES,** motors and supplies; 80 H.P. LeRhone rotary motor \$125; 100 H.P. Gnome rotary motor \$135; 130 H.P. Clerget rotary motor \$200; Lawrence 28 H.P. motor \$125; Curtiss 200 H.P. \$300; tan leather helmets \$3.75 and \$5; non-shatterable goggles—oval \$2.50, wide-vision \$4; motometers with 12-ft. tubing \$7.50; leather breeches \$12; airplane cloth 65c yd.; done \$2.50 gal.; compass \$10; aerial camera \$100. Floyd Logan, 716 W. Superior, Cleveland, Ohio.

**HEATH** propellers represent the most efficient method of aerial drive. Each propeller individually designed for the particular work to be done, as laid out by America's oldest aeronautical engineers. If in need of airplane supplies tell us your needs. Our prices will interest you. Propeller catalog 4c; Motorcycle Biplane circular 4c; Ford or Motorcycle sled blueprints \$2.00 each. Resistal goggles \$2.90. Wool Jersey Helmets 9c. Heath Airplane Company, Chicago, Ill.

**PATENTS.** Time counts in applying for patents. Don't risk delay in protecting your ideas. Send sketch or model for instruction or write for Free book "How to Obtain a Patent" and "Record of Invention" form. No charge for information on how to proceed. Communications strictly confidential. Prompt, careful, efficient service. Clarence A. O'Brien, Registered Patent Attorney, 58-E Security Bank Building (directly across street from Patent Office), Washington, D. C. See pages 140 and 141.

**TEN** lessons in the air of twenty minutes each will make you a pilot by our advanced method of training. This together with our five weeks' shop course at \$100.00 makes America's oldest aircraft factory the most popular aircraft factory, the most popular flying school. Work after class hours guaranteed. Heath Airplane Company, Chicago, Ill.

**NEW 28** horsepower, two cylinder Lawrence Motor with propeller \$75.00. Extra for coil \$8.50. New 80 horsepower, LeRhone \$80.00. These motors can be used on Snow Sled, Sea Sled, Wind Machines. All kinds Airplanes, Motors and Parts. Send 10c for our catalogue. Crawford Airplane Company, Venice, California.

**COMPLETE** Scale Plans, with Building-Flying Instructions for following 3-ft. Model Aeroplanes, 25c each postpaid: JN4D-2; DeHavilland; NC-4; Bleriot; Nieuport or Taube Monoplanes; Cecil Peoli Racer. Complete 48pp. catalog 5c; listing hundreds of parts and supplies for experimenters. Ideal Aeroplane Co., 165½ Spring St., New York.

**FOR** snow sleds and airplanes. 28 H.P. motor weighing 155 pounds. New, \$125. Others to 200 H.P. Propellers \$3 to \$25. Used aviators leather coats, mighty warm \$10. Smith Machinery Co., P. O. Box 153, Houston, Texas.

**REMANUFACTURED** Curtiss OX H.P. airplane motors. Better than new and fully guaranteed and tested. \$225.00 while they last including propeller. Send 2c for our circular. Heath Airplane Company, Chicago, Ill.

**EARN** \$3,500 to \$10,000 a year. Learn Airplane Engineering Now at Home. The World Flyers were Airplane Engineers. Write for free catalog. Western Airplane Corporation, Desk K-3, Monadnock Block, Chicago.

**"AERODRIVE** Propellerized": Boat's Speed doubled. Detailed Blueprints, \$1. Blueprints two types Speedy Sleds, \$1. Aeronautical Supplies. Ostergaard Aircraft, Dunning, Chicago.

**BOYS,** get a three-foot model aeroplane free. Nothing to sell. Write to Aero Shop, 3050 Huribut Ave., Detroit, Mich.

**ENGINES** for airplanes fully described in "Aeroplane Engines in Theory and Practice" by John B. Rathbun. A book used by the government. Includes all makes of engines. For mechanic, builder, and flyer. Send No Money. Just order on a postal. When postman hands you book, pay him \$2.50 and postal charges. Popular Mechanics Press, Room 803, 200 E. Ontario St., Chicago, Ill.

**THE American School of Aviation** announces a new correspondence course in Mechanics of Aviation. A thorough training in Practical Aeronautics. American School of Aviation, Dept. 1861, 3601 Michigan Ave., Chicago, Ill.

**AVIATION Fans:** Send one dollar for beautiful pair sterling silver wings, mounted on bar pins with safety catch, and identification card issued by National Flyers' Association. Thousands being worn by pilots' aviation mechanics, and aero enthusiasts. Wallace Aero Company, Bettendorf, Iowa.

**MOTORS:** Curtiss OXX-6 Class A (under Fifty Hours) for Plane, Sea-Sled, Motor boat, etc., \$200.00. All Motor and Plane Spares at Best Prices. Send for Catalogue. Monumental Aircraft Co., 339 N. St. Paul Place, Baltimore, Md.

**PATENTS:** My fee in installments. Free personal advice. Frank T. Fuller, Washington, D. C.

**NEW** nine-cylinder Gnome aeroplane engine \$45. Albert Latshaw, Clarion, Mich.

**LEARN to Fly!** Write for booklet. Robertson Aircraft Corp., Anglum, Mo.

#### WELDING AND SOLDERING

**ALUMINUM Solder**—Applied with soldering iron same as soldering brass. Sample 35c. Large bar \$1.00. Modern Machine & Pattern Co., Terre Haute, Ind.

**ACETYLENE** Brazing and Soldering Torches, \$2.00. Light welding and lead burning torches, \$7.00. Postage prepaid upon receipt of price. Marshall Mfg. Co., Kansas City, Mo.

#### BOOKS AND PERIODICALS

**HYPNOTISM** Amuses, Astounds, Insures health, wealth, happiness. 25 Easy Lessons \$1.00. "Mindreading" (any distance), wonderful, 50c. Success guaranteed. Popular Institute, M-430 Milwaukee Ave., Chicago.

**"MASTER Key"** (Success Wonderful), 410 Pages, Cloth, \$2.65. Bargain Lists New—Used; All subjects, 10c. Phibop's Library, 1014 Belmont, Chicago.

**ASTROLOGY;** Palmistry; Clairvoyance; Telepathy; Ventriloquism. Copy 25c. Smith's Novelty, M9145-47 Bishop St., Chicago.

**CONCRETE** Handbook, describing 173 ways of using concrete in the home, shop and on the farm, with full directions for doing these things yourself with ordinary tools. 138 illustrations. It is "written so you can understand it." With "Home Mechanics." 98 cents, postpaid. Popular Mechanics Press, 200 East Ontario, Room 803, Chicago, Ill.

**FREE**—Send for my Newthought, Scripture, Occult, Mystic and Scientific book literature. Martens Publisher, Burlington, Iowa.

**FREE** Book, "Elijah Coming Before Christ." Megiddo Department, Rochester, New York.

**ARTS-CRAFTS** Library—How to make lamps, decorative lamp shades, metal etched articles, and many other useful art objects. Three cloth-bound pocket-size books. Send no money. Just write a postal. When the books arrive, examine them, and if you are more than pleased, pay the postman \$2.98 and the few cents postage. Popular Mechanics Press, Room 803, Popular Mechanics Building, Chicago, Ill.

**ART.** Tattooing in Ancient and Modern Times. 25c. Catalog Free. Powkes, 8430 John R., Detroit, Mich.

**INDUSTRIAL** Alcohol. Wright's book. Full directions for making, fully illustrated. \$2.50. Spon & Chamberlain, 120 P. M. Liberty Street, New York, N. Y.

**CURIOUS** Books, Unique Novelties, Stunning Pictures. Samples, 10 cents Prepaid. Linds, 214 W. 34th Street, New York.

**MIRACLES** of the ages in a nutshell. How to read character on sight; the nine great religions; Illusion in the drama; Astronomy without a telescope; Evolution of the earth; the story of period furniture; Everyday miracles of modern chemistry; Find your right job; Catholic, Jew, and Ku Klux Klan; Evolution of architecture; Origin of musical instruments; and How to write stories that sell. These twelve books give all important facts on these fascinating subjects. Called "The Nutshell Library." In paper, the 12 books for \$2.98. In board covers and boxed for your library shelf, \$4.98. Send No Money. Nutshell Library sent C.O.D. Popular Mechanics Press, Room 803, 200 E. Ontario St., Chicago, Ill.

**THE Real Estate Educator;** complete Real Estate course, artistic cloth, \$2 postpaid. Marvel Co., Finley, N. Dak.

**ENCYCLOPAEDIAS** most all makes; Harvard Classics, half price. Dalton Rice, Crilly Bldg., Chicago.

**CLASS.** Trade Magazines. List free! Teopb Magazine Agency, Middletown, N. Y.

**SHOP NOTES** for 1926 now ready. Get your copy from this announcement. Only a limited edition. Contains all the articles published in the Shop Notes department of Popular Mechanics Magazine during 1925. Send No Money. Just write a postal and we'll send 1925 Shop Notes and Auto Tourist's Handbook. Pay the postman 98 cents when he hands you the two books. Popular Mechanics Press, 200 E. Ontario St., Room 803, Chicago, Ill.

#### PICTURES AND POSTCARDS

**TRUE-BLUE** friends everywhere. Exchange cards, letters, stamps. Movie fans. Leading club—17 years. Hundreds listings, dime. Year, \$1; half, 50c; quarter, 25c. Ed Ericson, 326, Elroy, Wis.

**EXCHANGE** Postcards! Very interesting, educational, fascinating, instructive pastime. Membership and List 10c. Popular Exchange, Windsor, N. C.

**75 BEAUTIFUL** Art Pictures and Bathing Beauties 25c (coin). Photo Sales Co., 3212 Riehon, Suite 400, Detroit, Mich.

**PICTURES,** Books and Novelties. Particulars Free. Howard Sales Co., Dept. 15, 1188 Folsom St., San Francisco, Calif.

**JOIN** Live Postcard Club; Membership lists including Catalog, 10c. Harvey Teeple, Decatur, Ind.

**EXCHANGE** cards; plan given 10c stamps; membership \$1.00. F. F. Johnson, 1485 So. 2 East, Salt Lake, Utah.

**100 MYSTIC** Photos. Vivacious beauties. 25c. Smith's Novelty, M9145-47 Bishop St., Chicago.

**SIX** copies of picture you specially prize exactly like original for one dollar. William Sarrasin, 2110 Sout Ridgeland, Berwyn, Ill.

#### GAMES, ENTERTAINMENTS AND PLAYS

**PLAYS,** musical comedies and revues, minstrel music, blackface skits, vaudeville acts, monologs, dialogs, recitations, entertainments, musical readings, stage handbooks, make-up goods. Big catalog free. T. S. Denison & Co., 623 So. Wabash, Dept. 11, Chicago.

**P-L-A-Y-S,** Speakers, Dialogues, Drills, Joke Books, Wigs and Beards. Catalogue free. Ames Publishing Co., Dept. 40, Clyde, Ohio.

**PLAY** Cootie, The Bug Game, at your next party. Score cards, special dice, and instructions, complete, \$1.25 postpaid. Grico Mfg. Co., Not. Inc., Downers Grove, Ill.

**VENTRILQUISM** taught almost anyone at home. Small cost. Send 2c stamp today for particulars and proof. George W. Smith, Room S-53, 125 N. Jefferson Ave., Peoria, Ill.

**PLAYS,** Minstrel Shows, Musical Comedies. Send for catalogue. Old Tower Press, 59 E. Adams St., Chicago.

**"THREE** Popular Games" 10c. Roman Arndt, 3689 Townsend, Detroit, Mich.

**100 LIGHTNING** Chalk Talk Stunts \$2.00. Cartoonist, 2925 Euclid, Kansas City, Mo.

#### NOVELTIES, CURIOS, ETC.

**FASCINATING** Novelties, Books! Big Catalog—Free! Supreme, 3246 Normal, Chicago.

#### MAGIC TRICKS, BOOKS AND JOKER NOVELTIES

**MAGIC** tricks, Card tricks, Coin tricks, Popular books by celebrated magicians, 10c each. Books on Ventriloquism, Hypnotism, complete guides, 10c each. Princess Yogi, wonderful card trick, creates sensation, 10c. Disappearing spots; best, most entertaining card trick on the market, 10c. Geo. Fenner, Louisville, Ky.

**MAGIC**—Tricks, Books and Supplies. For Amateurs as well as the great professionals. Anyone can learn through our instructions. Feature Acts in Mind Reading, Spiritualism, Rope Ties, etc. Large illustrated Professional Catalog, 20c. Chicago Magic Co., 140 S. Dearborn St., Dent. B. Chicago, Ill.

**FREE** Magic Book, 500 Tricks, Puzzles, Jokes and European Novelties. Explains 33 Tricks you can do. Amaze and mystify your friends. Easy to learn. Prices very low. Write today, enclosing 4c postage. Lyle Douglas, Station A, Dallas, Texas.

**READ** sealed messages in the dark. Read messages retained by audience. Make burned messages appear on blank slate. Make spirit messages appear on slate in sifter's presence. Produce spirit rappings. Make spirits appear in the dark. Answer questions written on folded papers while blindfolded. All this you can do if you have the directions contained in our book, "Behind The Scenes With The Mediums," 69 of the best secrets of mediums fully exposed. These are the best because most baffling, and yet all are very easy to do. Send No Money. Just write a postal for this marvelous book. When postman hands you book, pay him \$1.50 and postal charges. Popular Mechanics Press, Room 803, 200 E. Ontario St., Chicago, Ill.

**FREE** with \$25 order die box. Send 20c for our large catalogue of tricks, wigs, sensational escapes. Oaks Magical Co., Dept. 518 Oshkosh, Wis.

**200 KINDS** of Iron, Wood and Wire Mechanical Puzzles. Leader with Illustrated Folders 10c. Western Puzzle Works, St. Paul, Minn.

**MAGIC** Goods, Tricks, Books, Novelties, Amuse and entertain. Lists for stamp. Van Aiken, 34 Biehton, Detroit, Mich.

**OH BOY!** Dandy Bead puzzle, 10 cents. Carl W. Leach, 113 N. O'Keefe St., Cassopolis, Mich.

**BOOKS.** Magic, Mysteries, Magic Tricks, Novelties, Catalogue Free. Sinker, 535 Hancock, Wis.

**250 MAGIC** tricks; 360 Clever toasts, 20c. Smith's Novelty, M9145-47 Bishop St., Chicago.

**BOOK** of Magic, Set Trick Cards, and Illustrated Catalog, 10c. Piedmont Novelty Shop, Box 631, Danville, Va.

**250 MAGIC** tricks, 1,000 funny conundrums, 25c. Rodgers Company, 843 Locust, Cincinnati.

**SEVEN** Magical Delusions and Catalogs—25c. Gilmaglio, Morgan Park, Ill.

**ESCAPE** from any rope tie and mystify your friends. You can easily make \$10 a night giving escape entertainments in Churches, Clubs and country schools. The book, "33 Rope Ties and Chain Releases" tells how to conduct an entire entertainment. It tells how to escape when someone plays a trick on you and ties you more securely than you expected. Tells how to escape from the famous mummy tie in which you are bound from head to foot with 75 feet of strong rope. No knife or other instrument is needed. Send No Money. Just write a postal and ask for "Rope Ties." When the postman hands you this wonder book, pay 98 cents and the postage. Popular Mechanics Press, 200 E. Ontario St., Room 803, Chicago, Ill.

**STAMP COLLECTING**

**63 LEFT.** We advertised packet No. 329 last month and only 63 are left. First come, first served—100 diff. stamps from 100 different countries only 75c. Also (new this month) Scott Seald Packet No. 334, 12 diff. Lebanon, 25c (get this country in your album); No. 335, 12 diff. Syria, 25c; F255, Dime Set, French Equatorial Africa, on Chad, 1924, 5 stamps, .10; No. C106, Dime Set, 6 Cameroon, 1925, (pictorial), .10; No. 1702, Ecuador, 1872, -97, 40 stamps, \$1.25. (Set); Scott Seald Packets—No. 8, 1,000 all diff., \$1.25; No. 3, 2,000 all diff., \$5.00; No. 22, Asia only, 100 diff., .60; No. 21, South America only, 100 diff., .60; No. 331, Paraguay, 25 diff., .50; No. 332, Azores, 10 diff., .50; No. 147, Austria, 300 diff., .50. Our free 80 page price list will be sent you on request. Prices hundreds of sets, dime sets, Scott Seald Packets, also our full line of albums, catalogues, toms, hinges, watermark detectors, etc. Please note our new address in writing. Scott Stamp and Coin Co., 1 West 47th Street, New York, N. Y.

**ARABS!** Bandits! Head-Hunters! Egypt (sphinx); Malay (tiger); Benadir (elephant); Tunis (arab); Turkey (sacred mosque); Belgium (showing battle between angel and "old horns"); Congo (head hunter)—All of these mysterious and remarkable stamps are contained in our Famous Phantom Packet—55 fine varieties (to approval applicants only) for eight cents. Nothing like it; order at once! Pacific Stamp Co., Box 138, Helena, Mont. Extra! Send us, with your order for the Phantom Packet at 8c, the names of three of your friends who collect stamps; and we will give you, free of charge, a scarce set of 11 diff. Albania—bandit land!—cataloguing over \$1.50. Supply limited; write immediately!

**1,000 MIXED** stamps, .21; 1,000 hinges, .09; five Iceland Free Approval Purchasers. Postage Extra. Sunshine Stamp Co., Box 823, Salt Lake, Utah.

**BIG** Commission to Agents for the Best approval sheets of stamps ever offered. Write for sample outfit. Pioneer Stamp Album with 500 stamp illustrations, 500 mixed stamps over 40 countries, 500 hinges, All for 25c. Bargain Packets, 100 British Colonies 35c.—100 French Colonies 20c.—100 Portuguese Colonies 40c.—100 New Europe 10c.—50 Asiatic 15c.—50 African 25c.—50 Australian 25c.—500 all different 35c.—1,000 all different 95c. Hussman Stamp Co., Dept. P., 620 Olive St., St. Louis, Mo.

**O-O-O-O-H, Boys!** What a Thrill! The Fenway "Jungle" Packet!—Contains scarce stamps from jungle and cannibal-land! Included are: Abyssinia, Congo head hunters, Kenya and Uganda, Nyassa camels, Mozambique, Ivory Coast, Upper Volta, Tozo, Ulangui, Tanganyika, Fiji Islands (cannibals!) and other savage lands. This wonderful packet from far-away countries to new approval applicants for only ten cents! Fenway Stamp Co., 161 Massachusetts Ave., Boston, Mass.

**MYSTIC'S** "Mysterious" Packet! Contains stamps from the lands of cannibals, heathens, sun worshipers, and wild savages. Included are Kenya and Uganda, Persia, Africa, Dutch Indies, Gold Coast, Federated Malay States, Eritrea, Nyassa, Travancore, Siam, Congo, etc. This wonderful packet containing 105 all different (mostly unused) for only 8 cents to approval applicants. Mystic Stamp Co., Dept. 8, Camden, New York.

**STAMP** Collectors Outfit only 25c. includes 32-page book "How to Collect Stamps" Album (illustrated), 100 Hinges, 110 different stamps from Comoro, Guinea, Hejaz, Iraq, Sudan, Zanzibar, etc.; also "free stamps" coupon. For new customers only. Harry Inor, 801 State Life Bldg., Indianapolis, Ind.

**ANCHERS \$\$\$** Outfit—only 12c! Fine triangle stamp; set German stamps with (pre-war) value forty million dollars (interesting!); perforation gauge, mm. scale; small album; 2 approval sheets; airmail set; scarce stamp from smallest republic on earth; newspaper set; packet good stamps from Travancore, Johore, Dutch Indies, etc. Entire outfit for 12c to approval applicants! (Nice pocket stock book, value 25c, with every order!) Ancher Stamp Co., 148 1/2 Clerk St., Jersey City, N. J.

**OLD** Colony Approvals at 50% discount contain many unusual stamps. Our price list of sets sent to all asking for approvals. Packets: 2,000 all different \$2.00; 1,000 varieties \$1.85; 500 varieties \$2.00; 100 varieties \$0.65. Imperial albums \$6.00; Modern albums \$2.00; International Junior albums \$3.50; all albums sent postpaid on receipt of price. Want lists filled from a stock of 40,000 varieties to those sending satisfactory references. Approval Department, Old Colony Stamp Co., 333 Washington St., Boston, Mass.

**BIRDS** and Beasts, 25 All Different curious birds and beasts, stamps, including reptiles, man-eating tigers, the sacred serpent of Armenia, strange cattle in Iraq, the hardworking oxen, screaming eagle of Albania, giraffe, lion, parrot, swan, elephant, flying horses, etc., etc., all for 10 Cents to applicants for Park Perfect Approvals. Order Today. Park Stamp Co., 589 Beacon St., Boston, Mass.

**BIGGEST** Stamp Value of Today: Fine packet, over 230 diff. Gold Coast, Cameroon, Triangles, Aeroplane, Tehad, Irish set, Eurus, Togo, Hyderabad, Trinidad, Siam, Uruguay, 50c and \$1 U. S., largest stamp, set 8 Latvia, etc. This surprise for 10c to approval applicants. Thousand bargain lists free, 100 diff. U. S. 25c; 1,000 hinges 9c. Hawkeye Stamp Co., Cedar Rapids, 39, Iowa.

**FREE** "Magnificerocious." Snap, 100 Different stamps, including many unused; also largest stamp in the world, to approval applicants sending 2c postage. Imperial Album 90c postpaid, 1,000 Quality Hinges 12c, 1,000 Different Stamps \$1.25, 1,000 Mixed 40c. Payn Stamp Co., 945 Vista Drive, Los Angeles, Calif.

**10 MOZAMBIQUE** Pictorials; 6 Azerbaijan; 3 Lichtenstein and 10 Rhein-Ruhr for 10c to Approval Applicants. Theo. Nelson, 1142 Oakdale Ave., Chicago, Ill.

**WHOLESALE;** \$10.00 catalog \$1.00 Only. Liberia, Nyassa, Armenia, Grossman's, Box 120, Madison Square Station, New York.

**ILLUSTRATED** Album, Packet Stamps, Hinges, etc. 10c, to Approval Applicants. George Linn Company, Columbus, Ohio.

**HONORBLT** Packets. List free. C. W. Ritchie, Watertown, S. Dak.

**"EXHIBITION,"** "War Prisoners," "Airmail," "Pictures," "Eagles," "Red Cross"; six sets unused, different countries, five French, five British, five Portuguese Colonies. Packet Bulgaria, 100 different foreign, 15c to approval applicants. Deering, 38 Fairmount, Marlborough, Mass.

**BARGAIN**—Send me \$1.00 and receive by return mail 100 different Stamps. Catalogue value not less than \$7.50. Joseph Jaeger, Hotel Lucerne, New York City.

**ALBUMS**—with 250 foreign Postage Stamps \$2.50, 500 \$5.00, 1,000 \$10.00. Approvals proportionately. W-O-S, Agenev, Box 64, Muskogee, Okla.

**SNAPS**—200 different stamps, 10c; 60 different United States Stamps, 12c. With each order we give free our price list of sets, packets, albums, etc., and our pamphlet which tells "how to make a collection properly." Queen City Stamp Company, Room 36, 604 Race, Cincinnati, Ohio.

**FRENCH** Colonies Free—Jungles, Tigers, Native Chiefs, 2c postage. Empire Stamp Company, Toronto, Canada.

**FOREIGN** Stamp Collection Sent Free. Cornish Co., Schenectady, N. Y.

**50 DIFFERENT** French Colonies 15c; 100 50c; 200 \$1. Fred Onken, 630 79th Street, Brooklyn.

**200—200—200—200** ALL different stamps; 200 hinges; approval sheet to hold 200 stamps; perforation gauge, millimeter scale and ruler; duplicate stamp container—all for only 15c to approval applicants. Edgewood Stamp Company, Milford, Conn.

**FREE!** 25 different United States with 60% discount approvals to reliable parties. Seidenberg, Baroda, Mich.

**STAMP** Album Free; spaces for 1,200 stamps, with purchase of 50 stamps from 50 different countries for 25 cents. B. Nagle, 1101 Marion, Reading, Pa.

**BEST** one-cent approvals in America. F. P. Hand, 1117 So. 60th St., Philadelphia, Pa.

**FREE**—25 Portuguese Colonials to approval applicants, 2c stamp postage. Lightbown's, Osborne Rd., Southsea, England.

**WRITE** now! Foreign stamps on approval. Good premiums! Edward Muller, 77 Johnson Street, Brooklyn, N. Y.

**DANZIG** Stamps Free. Wonderful assortment from Danzig with Big Catalogues free for 2c. Midland Stamp Co., Toronto, Canada.

**FREE**—3,000 variety collection. Request approvals and particulars. Herbert Kelzwin, Middletown, N. Y.

**6 HAITI** 7c; 7 Lithuania Airpost 32c; 16 Armenia 16c; 6 Mozambique Free. Fred Jackson, Montana, Calif.

**FREE!** Free! Free! Mozambique Co. 15 unused, 10 postage, 5 dues, beautiful bicolors, very pretty, to approval applicants, stating varieties in collection. Hungary Prisoners 3 varieties unused, cat. 12c, for names three boy friend collectors. W. A. Lieson Co., Springfield, Mass.

**50 FRENCH** Colonials, 30 British Colonials, 20 Portuguese Colonials, 30 South and Central America, all different; price lists, etc., all only 25c, to introduce approvals. Fennell Stamp Company, Dept. P, St. Louis, Mo.

**COLLECT** Precancel Stamps! 50 different Precancels and a sample copy of the Windy City Precancel News 10c. Adolf Gunesch, 3520 Lowe Ave., Chicago, Ill.

**NEW ZEALAND**—25 fine varieties 20c postpaid. Allison, Angola, Ind.

**FREE, Hungary** Charity No. 565 to 567 and a surprise packet given to those requesting for my 1, 2 and 3c approvals and also my 50% discount and better. Chas. W. Schmidt, 3227 Benner St., Wissinoming, Philadelphia, Pa.

**20 DIFFERENT**, Turkey 8c, Approvals. Fryrear, 1411 4th Ave., Cedar Rapids, Iowa.

**THOUSANDS** of good stamps to send on approval; 50% discount; gift with each invoice. Vinet & St-Denis, 226b Carriere Street, Montreal, Canada.

**UNITED STATES** Stamps. Complete stock priced reasonable. Selections sent. Price Lists Free. 200 Different Stamps 7c, with approvals, 10 Liberia, 50 Greece, 100 British Colonies, 10 Congo, 10 Ruanda, 25c each. Midwest Stamp Co., Kemper Bldg., Kansas City, Mo.

**PICTORIALS!** pretty Mozambique and Armenian pictorials; European banknotes; rare Morocco Airmail; and Big Foreign packet; 9c to approval applicants. Flower City Stamp Co., St. Thomas, Ontario.

**500 MIXED** 15c. 75 Var. U. S. 15c 100 Var. Precancels 15c. Charles Peugh, Elma, Wash.

50 FREE to approval applicants. Postage 2 cts. Thomas A. Gorton, 533 Cleveland Ave., Oneida, N. Y.

JAPAN—40 different 15c. Browne, 90 Kemper St., Wollaston, Mass.

55 DIFFERENT British Colonies 15c. 50 different Portuguese Colonies 20c. 50 different French Colonies 18c. 100 foreign 3c to approval applicants. Glen R. Knight, Box 3, Sausalito, Calif.

NET Approvals. Premium to new applicants sending reference. Tower Stamp Co., 42 Westville St., Dorchester, Mass.

FREE—3 Abyssinia to Approval Applicants sending 2c postage and reference. F. H. Marsh, 524 Hamilton Ave., Indianapolis, Ind.

500 DIFFERENT only 25c (regular price 50c), many unused, from British, French, Italian and Portuguese Colonies, Chile, Flume, Guatemala, Persia, Siam, etc., to all approval applicants. Big bargain lists free. Victoria Stamp Co., London, Can.

TRIANGLE Stamps! We offer to approval applicants: 100 all different fine stamps from far-off countries: Travancore, Upper Volta, Tchad, Madagascar, Malay, etc. Also three triangle stamps, including scarce Liberia—all for 7c. Order Now! C. D. Reimers Co., Flatiron Bldg., Fort Worth, Tex.

109 DIFFERENT Including set "War Prisoners," Bulgaria and Turkey Picture Stamps, 10 cents. Sonnee Stamp Company, 675 Ivy, St. Paul, Minn.

COVERTCO Packet, 250 varieties unused and used stamps 15 cents. Covert Stamp, 39 State, Rochester, N. Y.

FREE Premium with Approvals. Net prices. Reference. 150 different U. S. 6c. Clarkson, Ridgewood, N. J.

ELEPHANT Tusk Hunters, Cannibals, sugar gatherers, famous bicolored Mozambique picture set (10 beautiful stamps), only 3c to approval applicants. 1,000 Hinges 10c; 1,000 different foreign \$1. Big Album 75c. Sunflower Stamp Co., Hutchinson, Kans.

100 BRITISH Colonies 30c. 100 Portuguese Colonies 35c. 100 Central Americans 40c. 100 all different 15c. 25 Bosnia 25c. Advance Stamp Co., 26 E. 23rd St., New York, N. Y.

110 NEW Europe All Different, a wonderful collection cataloguing several dollars, free to collectors requesting our Net Approvals. Postage 2 cents. Badger Stamp Co., Milwaukee, Wis.

STAMPS, 100 varieties, Africa, Brazil, Peru, Cuba, Mexico, etc., 10c. 50 different U. S. 25c; 1,000 mixed, 40c; 1,000 hinges, 10c. List free. C. Stegman, 5948 Cote Brillante, St. Louis, Mo.

FREE! 12 scarce Azerbaijan to approval applicants. Pennsylvania Stamp Co., Manor, Pa.

50 DIFF. stamps for Approval Applicants sending 2c postage. Rubin Hoffman, 405 Pennsylvania Ave., Brooklyn, N. Y.

500 MIXED U. S. and Foreign stamps 12c. R. H. Carlton, 380 W. So. Temple, Salt Lake, Utah.

CURIOSITY Packet, 104 unused in blocks 12c. Big 20-page List, set Air Mails Free. Rueger, 31 Cambridge, Dayton, Ohio.

1,000 MIXED U. S. and Foreign Stamps 25c. Phil. Lundstedt, Cape Cottage, Maine.

ZAMBESIA, Zanzibar, Abyssinia, Herzegovina, Travancore stamps, menagerie collection, album, 10c. Liberty, 3974 Arsenal, St. Louis, Mo.

24 VARIETIES Cuban stamps, 10 cents. List of 6,000 low-priced stamps free. Address Chambers Stamp Co., 111P, Nassau St., New York City, N. Y.

STAMPS, 100 all different. Postage 2c. Lists free. P. M. Quaker Stamp Co., Toledo, Ohio.

110 DIFFERENT Stamps, many unused, high values, free to collectors requesting our Net Approvals. Postage 2 cents. Christensen, Milwaukee, Wis.

PACKET of 23 stamps, no two countries alike. Packet hinges. Set of \$1 and \$2 U. S. Rev., all for 5c. P. M. Miami Stamp Co., Toledo, Ohio.

FREE, "Liberty" packet to approval applicants sending 2 cent stamp. P. Earl Stamp Co., 1811 26th Av. North, Minneapolis, Minn.

STAMPS sent on approval at 70% discount. Reference required. Emory Renoll, Hanover, Pa.

FREE! Loose Leaf Postage Stamp Album at rate of 8 pages each month given with subscription to monthly Journal. Send 2c stamp for prospectus. United Stamp Co., Marquette Bldg., Chicago, Ill.

20 UNUSED stamps free. All different. Postage, 2c. P. M. Fisk Stamp Co., Toledo, Ohio.

ONE dollar stamp, catalog value, 2 foreign bills, triangle stamp, airplane set, and 100 stamps, all for 25 cents, only to new customers requesting approval sheets. Tell your friends. Pettet, 690 S. Boul., Atlanta, Ga.

#### BARE COINS

GET Profit and Pleasure in collecting Old Coins. Send 10c for Sample Old Coin, together with my Large Illustrated Coin Catalogue. You'll be delighted with it. Send for it right now. B. Max Mehl, Professional Numismatist, Mehl Bldg., Dept. P, Fort Worth, Texas. Largest Rare Coin Firm in U. S.

CALIFORNIA gold,  $\frac{3}{4}$  size, 27c;  $\frac{3}{8}$  size, 53c; three-cent-piece and catalogue, 10c. Norman Shultz, Colorado Springs, Colo.

OLD Money Wanted. Will pay \$100.00 for 1894 Dime, S. Mint., \$50.00 for 1913 Liberty Head Nickel (not Buffalo). Big premiums paid for all rare coins. Send 4c for Large Coin Folder. May mean much profit to you. Numismatic Co., Dept. H, Ft. Worth, Tex.

40 OLD coins, all different, \$1.00. 100 old coins, all different, \$3.00. Monroe Half-Dollar, Uncirculated, \$1.00. Alabama Half-Dollar, Uncirculated, \$1.00. Claud Denney, Box 315, Dallas, Tex.

FIVE coins including large American cent 25c. Durso, 25 Mulberry, New York City.

CALIFORNIA gold quarter 27c; Half 52c; 1776  $\frac{5}{8}$  50c; 1853 dime 25c; silver 3c 20c. A. Wylie, Wheaton, Ill.

FIVE Civil War Tokens 50c. 1,000 mixed foreign stamps 35c. California Half Dollars \$1.10. 3c piece and bargain price list 10c. Arey, Box 483, Muskogee, Okla.

11 DIFFERENT Coins 25c; 44 Different \$1.00. Otto Oddehon, Independence, Mo.

SELL by mail European Bonds, Money, Foreign Coins. Profitable Business. Literature free. 100 Assorted Pieces \$1.00. Hirsch, 70 Wall St., New York.

OLD Coins, Large Spring Selling catalogue of coins for sale free. Catalogue quoting prices paid for coins, ten cents. William Hestlein, 101A Tremont Street, Boston, Mass.

UNITED STATES, Large Cent, two-cent bronze, three-cent nickel and Bargain List, 25c. Fifteen dates large cents, \$1.00. George Coffin, Greenwood Mountain, Me.

FIVE Different Foreign Nickels, only 10c. Leo Phaneuf, 813 Ridge St., Marquette, Mich.

50,000 GERMAN mark 5c. List free. American Exchange, 102 Popejoy, Iowa.

#### FOR BOYS

ANY School Boy Can Turn \$1.75 into \$125.00. Postalize Camerow, 1125 Royal, New Orleans.

25 EASY Money-Making Plans, Quarter, Press Studios, Walton, Nebr.

NEW Boat Book telling how to make 21 kinds of boats. Also many other helpful ideas on boating. Profusely illustrated. With this we include the big book, "Outdoor Sports the Year Round." Directions for making all sorts of devices for outdoor recreation. Send no money. Simply pay the postman \$1.98 plus the few cents postage when the books are delivered. Popular Mechanics Press, Room 803, Popular Mechanics Building, Chicago, Ill.

#### CAMERAS AND PHOTO SUPPLIES

PHOTOGRAPHIC equipment and accessories of every description are listed and illustrated in our 228-page catalogue. It will pay you to secure a copy which is issued free, as our prices are low. We also deal in used goods which are sold under the same guarantee as new goods. Ask for our Bargain Book, Central Camera Co., Dept. E-103, 112 S. Wabash Ave., Chicago, Ill.

FOR Sale, Enlarging, Reducing and Copying Camera, 8x10, Cooper Hewitt light; complete outfit. Chester Kingman, 444 Grand Ave., Brooklyn, N. Y.

SEND us your Films. We develop, print, enlarge. Careful attention to details that make superior quality pictures. Rolls developed 9c, prints 3c each; trial 6x10 enlargement in folder 40c. Wellington Photo Services, Riverdale, Md.

MODERN Photography in all its branches now taught by mail. New Successful Method. Students earning \$300.00 while learning. Big opportunity. Write for particulars and unusual offer open for short time. Dept. 3431, International Studios, Inc., 3401 Michigan Ave., Chicago.

HAVE You a Camera? Write for Free sample of our big magazine, showing how to make better pictures and earn money. American Photography, 116 Camera House, Boston, 17, Mass.

FILMS Developed. Special Trial Offer. Any Size Kodak film developed 5c, prints 3c each. Trial 6x10 Enlargement in handsome folder 40c. Overnight Service. Roanoke Photo Finishing Co., 209 Bell Ave., Roanoke, Va.

UNEXCELLED Gloss Prints. Trial Offer. Your Kodak Film Developed and printed only 10c. F R B Photographers, Dept. "C," 1503 Lincoln Ave., Cincinnati, Ohio.

KODAK Films—Special trial offer; your next kodak film developed, 5c—prints, 2c each. Moser & Son, 1917 St. James Ave., Cincinnati.

#### MOTION PICTURES

SEND 10c for the latest and greatest Bass Book of Cinema Apparatus; gives full description of all types of instruments as well as the list price. Or, send \$3.00 for a 500-page Cinema Hand Book containing full instructions of the making and taking of films. Bass Camera Company, 105 N. Dearborn St., Chicago, Ill.

FILM—Million Feet for Sale. Cowboy—Drama—Comedy and Feature Specials. Mix—Hart—Chaplin and best Movie Stars. \$3.00 per reel up. Genuine List Free. We Supply the World. Dept. G, Monarch Films, Memphis, Tenn.

\$35.00 PROFIT nightly. Small capital starts you. No experience needed. Our machines are used and endorsed by government institutions. Catalog free. Atlas Moving Picture Company, 482 Morton Bldg., Chicago.

NEW \$150 Spring-Operated Movie Camera, standard size, finest lens; leather case, \$35. New Home Projector, 1,000 foot reels—\$35. New \$225 motor driven Projector \$85. Films, 5 reel Dramas \$10. Comedy \$5. Ray, 296 5th Avenue, New York.

FILMS for toy machines. Selected standard gauge, 100 ft. \$1.25; 200 ft. \$2.00 postpaid on receipt of remittance. These are not complete subjects. Order direct from this ad. No lists. Independent Films, 177 Golden Gate Ave., San Francisco, Calif.

FILMS of every kind and character. Comedies—Westerns—Andy Gump Cartoons—Educational and Special Feature Subjects. Rock Bottom Prices. Wonderful Guaranteed List Free. Dixie Film Co., P. O. Box 407, Memphis, Tenn.

NEW and Rebuilt Machines for Big Theatres—Schools—Churches—Traveling Shows. Also Films—Supplies and Complete Theatre Equipments. Bargain List Free. Monarch Theatre Supply Co., Dept. P, Memphis, Tenn.

MAKE money writing photoplays; details free to beginners. No correspondence course. Producers League, 230 Wainwright, St. Louis.

MOVIE Machines and Films for the home write for Catalogue. Elder, 589 Broadway, Chelsea, Mass.

BARGAINS: Machines, Films, Stereopticons, Supplies. National Equipment Company, Duluth, Minn.

\$\$\$ FOR Photoplay Ideas. Let us help you market your story. Write for particulars. Universal Scenario Corporation, 206 Security Bldg., Western and Santa Monica Blvd., Hollywood, Calif.

#### SCENERY TO RENT

SETTINGS for Opera, Plays, Minstrels. Plush drops. Address Amelia Grain, Philadelphia.

#### EDUCATIONAL AND INSTRUCTION

GOLD!—500,000 men or women, any age. No selling. Particulars for 25c coin. Doak, Box 494, Mount Vernon, Iowa.

USED educational matter. Lowest prices; terms. Catalog free. Mention Subject. Fred Goetz, 440-A Sansome, San Francisco.

LEARN Paying Mechanical Business from handyman instruction sheets. Each sheet a winning trade sample sheet, 10c. Edw. Emmet, 1409 No. Sedgwick St., Chicago.



**YOU** can have a business profession of your own and earn big income in service fees. A new system of foot correction; readily learned by anyone at home in a few weeks. Easy terms for training; openings everywhere with all the trade you can attend to. No capital required or goods to buy, no agency or soliciting. Address Stephenson Laboratory, 1 Back Bay, Boston, Mass.

**ARTIFICIAL** Marble sanitary flooring instructions, ornamental casting, concrete, plaster, papier-mache decorations, garden furniture, statuary, Rubber-moulds, 16 years' instructing the public, particulars and 200 illustrations free. Chris Mahler, Huntington, N. Y.

**BE** Successful. Course in Scientific Thinking and Psychology \$2. R. E. Lee, Box 191, Highland Park Station, Los Angeles, Calif.

**LEARN** bricklaying in School run by 600 building contractors. No apprenticeship or age limit. Good demand for our graduates. Qualifies you to work anywhere. Associated Building Employers, 400 A. B. E. Building, Grand Rapids, Mich.

**SHORTHAND** in 30 days; written with ABC's; sample lesson free. Dickinson, 321-A Broadway, New York City.

**CAN** You Add? Substantial award for correctly adding dividends of 310 companies. List free. Kerr & Co., Monadnock Building, San Francisco, Calif.

**BECOME** Patent Lawyer. Full particulars. Patent Law, 301 Hennepin Ave., Minneapolis, Minn.

**BARBERING!** Course in Modern Scientific Barbering. Learn at Home. Practice on the Family. Become Expert Barber. Complete Instruction Course. Practical Scientifically Prepared. Worth \$10. Mailed for only \$2 (Bill) or Money Order. Particulars Free. Foster, Expert Barber, Dent A, 613 E. 60th St., Chicago, Ill.

**SPEED:** Key to phrasing shorthand, one dollar. Address E. Kinsey, 8940, 3rd Ave., N. W., Seattle, Wash.

**WORLD-ROMIC** System, Masterkey 5,000 languages. Primers \$1.98. Chinese, French, Spanish—Languages, 8 West 40th, New York.

**USED** educational matter of all kinds. Sold on repurchase basis. Big saving. Money-back guarantee. List free. (Courses bought.) Lee Mountain, Pisgah, Ala.

**USED** educational matter bought, sold, exchanged. Hanfling, 799 Broadway, New York.

**DOUBLE** Entry Bookkeeping mastered in 60 hours with 8 keys; guaranteed; diplomas, International Bookkeeping Institute, Dent, 8, Springfield, Mo.

**SHORTHAND** in four evenings. Arthol course seven dollars. Sent approval. Particulars. Hollefreund's College, Stratford, Ontario, Canada.

**AUTO** Tourist's Handbook—An indispensable help for those who wish to make a motor trip. Tells how to prepare your car for the long grind to avoid trouble, how to make and use camp equipment, how to cook on the road and how to make comfortable sleeping quarters. Will reduce your touring bill many dollars if you follow the ideas presented. With this we give "Auto Owner's Handbook" filled with helpful ideas for drivers. Send no money. Pay the postman 98 cents plus postage when he delivers the two books. Popular Mechanics Press, Room 803, Popular Mechanics Building, Chicago, Ill.

#### RADIO OUTFITS AND SUPPLIES

**TWIN** Cones Speaker: Convert your phones into the latest speaker. Parts to build \$1.00. Ray F. Kuns, Station O, Cincinnati, Ohio.

**BIG** money made repairing burnt-out Radio Tubes. Instructions \$1.00. Duck Mfg. Co., Freeport, Ill.

**DON'T** buy tubes! You can build a crystal set for less than \$1 that will receive distant stations. Complete plans, with lifese drawings, \$1. Particulars and picture of my set free. Amon Carr, 1507 West 58th Street, Chicago.

**ATWATER** Kent, Crosley Receivers—Speakers. Bargains. Write Simms, Lake, New York.

**2,650** MILES Distance with one tube. Any novice understands our simplified instructions, 25c. Big Booklet Free. Vesco Radio Co., Oakland, Calif.

**CRYSTAL** Radio Receiving Sets. Only 50c Prepaid. Guaranteed. Agents wanted. Tru-Blu Supply Co., 106 Lake Ave., Rochester, N. Y.

**TUBES**—201A or 199. New, no seconds. Tested and guaranteed. Money back if they won't do everything the high priced tubes do. \$1.40 each. Evans-Lawrie Company, 782 Commonwealth Avenue, Boston, Mass.

**ALL** latest model Crosley Sets at greatly reduced prices. J. Noid, 27 Chestnut St., Schenectady, N. Y.

**RADIO** Fans—End all crystal troubles for a year. The James 2 Side Crystal, lasts longer, outperforms, outdistances. Has five times the contact surface of other crystals. Price 50c prepaid, C.O.D. 60c. Order today. The Star King Co., 204 Davis St., San Francisco, Cal.

**RADIO** Bargains—Crosleys, Atwater-Kents, Radiolas, Mu-Rads, Radiotron tubes, etc. Save 25 to 50 per cent. Harr, Nora Springs, Iowa.

**SELL** the Radio Fone Lamp Loud Speaker. Latest radio reception reproducer. Write for sample outfit. Radio Film Supply, 1030 Forbes Street, Pittsburgh, Pa.

**NOW** 100% radio reception. Startling results. Send stamp for free copy. Illinois Diagram Co., 5331 Van Buren, Chicago.

#### TRADE AND TECHNICAL SCHOOLS

**LEARN** Photo-Retouching. One of the most profitable fields of commercial art. Positions always open. Earnings \$50 to \$100 a week. We offer a thoroughly practical and easily mastered course of twenty-five lessons. No special ability required. Write at once for full particulars. School of Commercial Illustrating, 582 Century Bldg., Indianapolis, Ind.

**LEARN** bricklaying in School run by 600 building contractors. No apprenticeship or age limit. Good demand for our graduates. Qualifies you to work anywhere. Associated Building Employers, 400 A. B. E. Building, Grand Rapids, Mich.

**DO** you want \$12 to \$20 per day? Learn now Sign Painting—Decorating Paper Hanging—Auto Painting, Show Card Writing. Catalog Free. Chicago Painting School, 118 W. Austin Ave., Chicago.

**DOUBLE** your earning power. You can quickly become a foreman under my training. I teach you to read blue prints and take charge of work. Trained men are in demand. Write today—tell me your trade—I will show you how to succeed. Carroll Rumsey, 167 Drexel Building, Philadelphia.

**TELEGRAPHY**—Both Morse and Wireless—taught thoroughly and quickly. Tremendous demand. Big salaries. Wonderful opportunities. Expenses low; chance to earn part. School established fifty years. Catalog free. Dodge's Institute, Fern St., Valparaiso, Ind.

**LEARN** Piano Tuning and Repairing. Trial lesson free. Chicago School Piano Tuning, River Forest, Ill.

#### BUSINESS OPPORTUNITIES

**\$11.80** DAILY in advance (Send for sworn proof) Introducing New Insured Hosiery, 57 styles, 40 colors, guaranteed seven months. No capital or experience required. You simply take orders. We deliver and collect (or you can deliver, suit yourself). Credit given. Pay you daily; monthly bonus besides. New line now ready. We furnish samples. Spare time will do. Maccoche Textile Company, Card 2583, Cincinnati, Ohio.

**PATENTS.** Time counts in applying for patents. Don't risk delay in protecting your ideas. Send sketch or model for instructions or write for Free book, "How to Obtain a Patent" and "Record of Invention" form. No charge for information on how to proceed. Communications strictly confidential. Prompt, careful, efficient service. Clarence A. O'Brien, Registered Patent Attorney, 58-E Security Bank Building (directly across street from Patent Office), Washington, D. C. See pages 140 and 141.

**GET** into newest, most profitable, most fascinating profession in the world. Be a movie reporter. Travel, earn big money, enjoy life. You can do it easily with our wonderful new motion-picture camera and simplified instructions. We start you out. Send for Free Booklet 9. Liberal allowance for your old camera, movie or still. New York Institute of Photography, 14 West 33rd St., New York City.

**LEARN** to manufacture something; we will show you how. It is easy, leads to plenty money, independence. Send four cents stamps for seventy page Catalog. Langco National, Syracuse, N. Y.

**PERMANENT** employment. Lawn Mower sharpening, Manufacturing toys. Instructions 25c. 415 South Lawndale, Kansas City, Mo.

**MAIL** Order News contains latest money-making schemes, opportunities and suggestions showing big profits. Complete instructions how to start profitable Mail Order Business of your own. Everything explained. Sample copy of this big magazine 25c. None Free. Established 23 years. Mail Order News, 360 Bristol Bldg., New York.

**MONEY-MAKING** Business Chances. Information 10c. Lewis Eisenman, R514 Alouez Blvd., Green Bay, Wis.

**GO** into Business of own at home or office earning good growing income, without investment or canvassing. Get free interesting details. Interstate Commercial Service, Box 263, Elizabeth, N. J.

**MIRRORS** Re-Silvered at Home. Costs Less 5 cent per square foot; you charge 75 cents. Immense profits, plating autoparts, reflectors, tableware, stoves. Refinishing metalware, etc. Outfits furnished. Write for information. Sprinkle, Plater, 127 Marion, Ind.

**MAKE** \$15 a day with Amazing New Men's Reducing Belt. Sells on Sight. Exclusive Territory. Big Repeats. No Experience. No capital needed. Free Samples. Work spare time. If you make good, chance to become District Manager of several counties, with salary, traveling expense with bonus. Territory going fast. Write or Wire Vito Co., Dept. C-63, New Haven, Conn.

**DOLLARS** Yearly in your Backyard. No mushroom dope. Particulars free. Metz, 313 East 89th, New York.

**STATE** Representatives for Dud's Gas. Cleans stone, brick, tile buildings, wire, frosted, leaded glass; fortunes being made. S. Hampton, 2395 Grand Avenue, New York.

**MANUFACTURE** doll beds at home. Instructions, Sample \$1.00. D. H. & M. Supply Co., Box 75, Dunrieth, Ind.

**MONEY** in Dry Cleaning; we furnish instructions and machinery; experience unnecessary. Potter Manufacturing & Supply Co., 3850-52 Easton Ave., St. Louis, Mo., U. S.

**SUCCEED** With Your Own Products—Make them yourself. Formulas, Processes, Trade-Secrets. Modern master methods. Catalog free. B. Thaxly Co., Washington, D. C.

**A WORTHWHILE** Mail-Order Business by new methods, quick, sure, positive and big, is yours if you want it. Free circular gives latest information. MacRae, Publisher, M805 Oregonian Building, Portland, Oreg.

**\$100.00** BUYS profitable mail order business. Inventories \$300.00. Investigate. Frateher, 912 Michigan Avenue, Detroit.

**MAKE** \$20 per 100, Stamping names on Keychecks. Send 25c for sample and instructions. J. Keytag Co., Cohoes, N. Y.

**MAKE** Money at Home—making toys. We show you how. Send \$1 for complete working drawings and instructions. DeKalb Designing Co., Decatur, Ga.

**EARN** \$12.00 Daily—Start your own Business; Repair, Redecorate Homes, Automobiles; Retrim, Clean Cars. Easily Learned at Home. Modern trade Instructions sent upon approval. Pay when satisfied. DeWilde, Sheboygan, Wis.

**\$10** DAILY I made Spare Time Home. Booklet for Stamp. Sample and Plan 15c. Albert Scott, Cohoes, N. Y.

**BUILD** splendid business making chipped glass number and name plates, signs, check-boards. Write for particulars. Simdex Utility Co., 1133 Broadway, New York.

**BATTERY** Shop Equipment and Supplies at Wholesale. Adams-Barr, Columbus, Ohio.

**OPEN** Toilet Goods Shop Anywhere. We Furnish Everything. Liebig's, Beaver Dam, Wis.

**CHEMICAL** Expert furnishes Manufacturing Formulas and Processes with complete working directions. Reliable individual service only. No lists. Charges reasonable. Correspondence invited. Dr. Arthur Van-Heeden, 508 South Oakley, Chicago.

**SUCCEED**—Our twenty scientific processes put you wise. Excellent. We make money, so can you. Only 50c. Holland Laboratory, Box 473, Astoria, Oreg.

**MEN** or boys, handy with tools, make new combination articles. Needed in every home. Stool, Step, Bench, Stand, Writing table, Service tray, Drafting table, etc. All in one. Drawings and Patterns \$1.00. Home Equipment Co., Drawer 923, Butler, Penna.

**NEW** Punchboard assortments. Unusual profits. Catalog Free. None to kids. Gramams, 51 West Cedar, Denver, Colo.

**QUICK Profit, Honest, Guaranteed workable Mail Order Plans** and complete instructions, including detailed working specifications of plans that have made fortunes. Written by a fully competent and reliable authority under bond. Mail Order Service, Box 93, Omaha, Nebr.

**PRODUCTS** under your own label, or bulk. Tyrrell Products Company, Martins Ferry, Ohio.

**66 MILES** on 1 gallon—Scientific Gas Saver. All autos. Demonstrating model free. Critchlow, C-132, Wheaton, Ill.

**MANUFACTURE** in Home or Shop. Newest, fast-selling novelties, toys, preparations, mail-order, agents' goods. Free list. Reliable plans, patterns, processes, commercial information. Manufacturers' Bureau, 2937A Tracy, Kansas City, Mo.

**START** manufacturing Insect Powder, Ant Powder, Roach Powder, Fly Killer, Rat Paste, Disinfectants, etc., at home. Big profits. We supply guaranteed formulas. Buy your materials anywhere. Information free. Furman Company, San Antonio, Tex.

**START** manufacturing. Machinery unnecessary. Progressive manufacturers now using my guaranteed formulas. Catalog free. Thomas Lav, Chemist, Box 4012, Portland, Oreg.

**\$5,000—\$10,000 YEARLY** income in your own town. Anywhere. Write, McEwan, 720 N. Michigan, Chicago.

**GET** into Business for yourself. Sell by mail. Send for Free literature on spare time money making enterprises. Demuth Company, Englewood, N. J.

**SAWDUST** and chemicals make sanitary flooring. Directions \$1.00. Universal Supply Co., Auburn, N. Y.

**FREE** Booklet describes 52 plans for making \$20.00 to \$100.00 weekly in home or office business of your own. Downs Co., 2323 Myrtle St., St. Paul, Minn.

**GOOD** Steady profits derived from retinning business. Our process gives best results. Rusted, ice cream and milk cans must be retinned. Callender, 2531 W. 48th, Chicago.

**LET** silver foxes be your biggest money-makers. Also German Police Dogs and beagle hounds. E. Winter, Lebanon, Wis.

**MAKE** Money on the Side. A brand new proposition. No capital required. Splendid mail-order feature evenings. Dept. P. Klein-A-Pine Company, Fargo, N. Dak.

**TATTOOING** Supplies. Complete Electric Outfits. Lowest Prices. Catalogue, "Waters," 965 Putnam, Detroit.

**MAKE-MONEY** Magazine. Greatest Magazine of opportunities. 25c year, three months 10c; Advertising 1c word. Publishers, 1043 Washington, Boston, Mass.

**PUBLISH** a magazine for \$2.50. Sample particulars 15c. Cope, 233P, Champaign, Ill.

**MONEY** Making Business Chances, particulars for dime. Bernard Novitsky, 14 Stark, Pittston, Pa.

**MAKE** \$35.00 a week with potato chips; \$10.00 starts you; sample and particulars 2 dimes. General Sales Co., Muncie, Ind.

**MAKE** and sell Never Freeze Radiator Solution. Cost 4 cents gallon. Formula \$1.00. Homer Dunn, 2125 Summer Ave., Waco, Tex.

**ARE** you old at forty? See our advertisement on page 153 of this issue. The Electro Thermal Company, 2137 Main St., Steubenville, Ohio.

**RCN** a Profitable Mail Order Business in Your Spare Time. Sample and Particulars 25c. Satisfaction Guaranteed. United Specialty Co., Smithboro, N. Y.

**WANT** More Money? Start Little Mail Order Business. Samples and Plan Free. Mailing Charges 10c. Snydam 10748 112th St., Richmond Hill, N. Y.

**MAKE** Money, silvering mirrors, refinishing auto headlights, tableware; metal plating, bedsteads, chandeliers. Outfits furnished. International Laboratories, Dept. 71, 309 Fifth Ave., New York.

**\$50 WEEKLY** up made by men, women, giving lessons in popular subject; home, office, all (spare) time. Short, easy preparation. Instructions free. Dickinson, 321-M Broadway, New York.

**BE** the Boss Yourself. Have others working for you. Unlimited possibilities. Valuable information. Write quick. Rezal Service, 305-J 43rd, Kansas City, Mo.

**20,000 MARK** German Government Bonds only one dollar; remit money order. Julius Lowitz, 312 S. Clark, Chicago, Ill. Established thirty-one years.

**GOOD** Money easily earned at home spare time Silvering Mirrors, Glass Embossing, Chipping, Frosting, Gold Leafing, etc. Paterson & Co., Brooksville, Ky.

**SCHEMER** Magazine, Alliance, Ohio, 28th year, prints big profit Schemes, Ideas, Formulas. Subscriber made \$25,000; another \$10,000. Try your luck. Year \$1.00; three months, 30c. None free.

**EARN** Big Money with Merryground, Ferris Wheels, Novelty Riding Devices, Everywhere. "MooreMade," LaPeer, Mich.

**SIGNS** and Showcards Easily painted with Letter Patterns. Large variety of Styles and Sizes. Sample for stamp. John Rahn, a2120 Neva Ave., Chicago.

**\$50 A WEEK.** Mail Order business. Booklet tells how. Sample and plan 25c. Complete outfit free. Omaska Sales Service, Box A623, Omaha, Nebr.

**MAKE** These Big-selling Specialties Yourself! Free Interesting Literature explains how others will sell your goods. Chemist's Lists Guaranteed Reliable Money-making Formulas. All lines. No "Master Formula" Junk. Miller, Chemist, 1706-H Jetton, Tampa, Fla.

**PATENTS** Procured; Trade Marks Registered—A comprehensive, experienced, prompt service for the protection and development of your ideas. Preliminary advice gladly furnished without charge. Booklet of information and form for disclosing idea free on request. Richard B. Owen, 30-Owen Bldg., Washington, D. C., or 41-R Park Row, New York.

**MAKE** big money. Safe and Lock Expert. Wayne Strong, 3706½ Lan Franco St., Los Angeles, Calif.

**ENTER** a new business. Earn \$3,000 to \$6,000 yearly in professional fees making and fitting a foot specialty, openings everywhere, with all the trade you can attend to; easily learned by anyone at home in a few weeks, at small expense; no further capital required, no goods to buy, job hunting, soliciting or agency. Address Stephenson Laboratory, (1) Back Bay, Boston, Mass.

**MAIL** Order Business is your opportunity. Breniser's Famous Handbooks teach how to start small, grow big. Sell merchandise, service, ideas; enormous profits. Spare time to begin. Get complete set, 11 books, \$3.00, and be posted. Breniser, 325 Walnut, Philadelphia. Descriptive Catalog and big batch interesting mail order information, 25c. None free.

**\$3,000 TO \$6,000** Yearly. Want it? Others are making it. Send check or money order today for our invaluable books "How to Sell Real Estate," \$3.00—and "How to Conduct Real Estate and Insurance Business," \$1.50. Absolute satisfaction guaranteed. Free circulars. Realty Book Co., Dept. 52, Cleveland, Ohio.

**UNPATENTED** Ideas Can Be Sold. I tell you how and help you make the sale. Free particulars (Copyrighted). Write W. T. Greene, 810 Jenifer Building, Washington, D. C.

**INVENTORS**—Write for our Guide Book, "How to Get Your Patent" and Evidence of Invention Blank. Send model or sketch of your invention for our free Examination and Instructions. Randolph & Co., Dept. 435, Washington, D. C.

**EARN** \$10 daily silvering mirrors, plating and refinishing metalware, autos, chandeliers, bedsteads, headlights. Outfits furnished. E. Decie Laboratories, 1133 Broadway, New York.

**WE** Start You in Business, furnishing everything; men and women, \$30.00 to \$100.00 weekly operating our "New System Specialty Candy Factories" anywhere. Opportunity lifetime; booklet free. W. Hillier Ragsdale, Drawer 4, East Orange, N. J.

**ATTENTION!** You can have a business of your own. Establish and operate New System Real Estate Business, brokerage and insurance agency in your community. Office at home. Earn \$5,000 year. Representatives wanted everywhere. Send stamp free booklet. Hayes Realty Association, Cincinnati, Ohio.

**RESPONSIBLE** manufacturer wants competent men to manage office and salesmen. \$300 to \$1,500 necessary; will allow expenses to Trenton if you qualify. Address Manager, 536 Forst Richey Bldg., Trenton, N. J.

**MARBLE** mixing instructions, covering wood or cement flooring ½ in. thick, fireproof, waterproof, low cost, sanitary, all colors. Particulars, 200 illustrations free. Chris. Mahler, Box 123, Huntington, N. Y.

**I** MADE \$30 a Week Home. French Breadmaking. 15 years' experience; Free Booklet tells. Ashbrook 67, Marengo, Ohio.

**COST \$5.00, your profit \$104.75.** Transferring Decalcomania letters on autos, trunks, bags, etc. Send today for outfit or free samples. World Monogram, Dept. 73, Newark, N. J.

**LEARN** the collection business. Good income, quick results. Interesting booklet, "Skillful Collecting" free. National Collectors Assn., Long St., Newark, Ohio.

**MAKE** toys and novelties at home. Big profits. Instructions and illustrations, 25c. Astroline Company, Sharpsburg, Pa.

**CHEMICAL** Expert will furnish Formulas and Trade Secrets. All lines. Lists Free. W. L. Cummings, Ph. D., 228 Gordon Ave., Syracuse, N. Y.

**PATENTBOOK,** 139 mechanical movements and illustrations, sent free. Labinere, 3 Parkrow, New York.

**MAIL** Order Booklet, where to buy Books, Novelties, Specialties, 10c. Harvey Teeple, Decatur, Ind.

**MAKE** \$20 weekly writing spare time. Box 161, Oak Park, Ill.

**SELL** Copyrighted Business Plans by Mail. Enormous Profits. Particulars Free. Jerold Hinds, Monticello, Ill.

**STEPPING** stones to wealth circulars free. Guarantee Specialty Co., 4823 Liberty Ave., Pittsburgh, Pa.

## TELEGRAPHY

**TELEGRAPHY**—Both Morse and Wireless—taught thoroughly and quickly. Tremendous demand. Big salaries. Wonderful opportunities. Expenses low; chance to earn part. School established fifty years. Catalog free. Dodge's Institute, H St., Valparaiso, Ind.

## WANTED—BUSINESSES FOR SALE

**IF** You Want to Sell Your Business for Cash quickly and privately, we take the prospective buyer directly to you at our expense, no matter where located. We specialize in selling out-of-town businesses. If your business is worth \$5,000 or more, write us. The Mutual Security System, 68 W. Washington St., Chicago.

## CHEMISTRY

**YOUR** chemical problem solved and working process furnished Five Dollars. Write me. W. Stedman Richards, Consulting Chemist, address, Box 2402, Boston, Mass.

**TECHNICAL** information, analysis, formulas, trade secrets. Jacob Sluyter, Chemist, 313 East Second St., Davenport, Iowa.

**EXPERIMENTERS** Laboratory apparatus. Chemicals. Radio. Catalog 5c. Chemical Apparatus Co., 4402 West End, Chicago.

## FORMULAS AND TRADE SECRETS

**TOMBSTONE** Renewing: We will send amazing money getting process to 2 Men, Women or Boys to go partners working cemeteries; spare time or steady; lonesome work but dollars jingle. Sterling Specialty Co., 231 Federal Boulevard, Denver, Colo.

**SPECIAL** Formulas for Manufacturing and Business purposes. Any one you want \$5. You must be satisfied or your money will be refunded promptly. National Information Bureau, 316E Shepard Building, Grand Rapids, Mich.

**LOOSE** Joints or broken furniture permanently repaired with a cement that is stronger than the wood itself; made from discarded material in your home. Send 25c and the formula is yours. K. D. Strawn, 1491 E. 114th St., Cleveland, Ohio.

**CONCRETE** Waterproofing Processes, making Hard, Light Colored, Dampproof concrete building blocks. Concrete Machine Co., 5 Main St., St. Louis, Mo.

**SUCCEED** With Your Own Products—Make them yourself. Formulas, Processes, Trade-Secrets. Modern master methods. Catalog free. B. Thaxly Co., Washington, D. C.

**750** GOOD formulas 35c; 200 10c. Rodgers Company, 843 Locust, Cincinnati.

**CAST** Steel. The real fundamentals of working and tempering. Consult Fred Bryan, Mansfield, Pa., who knows by instructions, and thirty years practical experience.

**500** FORMULAS including Luminous Paint—Renewing Dry Batteries—Resilvering Mirrors—Gas Tonic—25c. Catalog Free. Ideal Book Shop, Dept. DF, Park Ridge, Ill.

**GUARANTEED** Money and Time Saver, for automobile painters. Removes paint in an hour at cost of 15c per car. Formula and instructions \$5.00. Auto Laundry, Mankato, Minn.

**CAST** Steel. Real fundamentals of working and tempering. Consult Fred Bryan, Mansfield, Pa.

**FORMULAS—All Kinds.** Catalog Free. Clover Laboratories, (Dept. CF), Park Ridge, Ill.

1,000,000 FORMULAS, 1,016 pages, \$1.98. 500 Formulas Free if you order quick. Ideal Book Shop, Dept. DM, Park Ridge, Ill.

**CONFIDENTIAL** concrete formula adopted by New York builders. \$1. Paul Manning, Jamaica Park, N. Y.

**FORMULAS; Beverages, Syrups, extracts, flavors and other manufacturing specialties.** Free information. The Formula Co., 1613 Queen Anne Ave., Seattle, Wash.

3,000 VALUABLE Formulas and Recipes, for \$1.00. E. Kephart, Box 34, Station Y, New York City.

500 VALUABLE Formulas, 25c. Circular Free. Harvey Teeple, Decatur, Ind.

**FORMULAS, Best Chemical Science can devise.** Stamp brings big bunch valuable literature describing Guaranteed Reliable Processes for manufacturing all lines. Don't buy till you've seen these valuable lists. 28 years supplying the Best. Miller, Chemist, 1706-F Jetton, Tampa, Fla.

10,000 FORMULAS. A real Gold Mine of money-making ideas. Tells how to make almost everything under the sun. You can make and sell cosmetics, mullage, anti-freeze solutions, battery solutions, beverages, cheese, chewing gum, cleaning preparations, extracts, hair preparations, inks, bluing, leather polish, mirrors, perfumes, polishes, typewriter ribbons, carbon paper, washing powders, liquid soap, and hundreds of other profitable articles. Send No Money, just write a postal for "Henley's 20th Century Book of Formulas." Pay postman postage and \$4. Popular Mechanics Press, 200 E. Ontario St., Room 803, Chicago, Ill.

### AGENTS WANTED

**NO Dull Times in the Food Business.** Selling Federal Pure Food Products is the greatest, surest and safest business in the world today, and here is your opportunity to get into it. You can make \$3,000, \$5,000, \$10,000, or more per year—the only limit is your ability to take care of the business. You will need no experience or money to get into this business. Your \$20.00 starting order sent on trust. We teach you everything you need to know. We furnish you with license. No Dull Times, for the People Must Eat, and our food products are the fastest selling, surest and quickest repeat order goods in the world. Sell on sight in every home where food is used—repeat orders immediately and every week thereafter. A real big business all your own. Every new customer adds a great deal to your weekly income. Your business once established, has a market value just like a store and can be easily sold. The greatest money-making opportunity of your lifetime because you risk absolutely nothing, as we guarantee your sales, and we will not let you fail. Remember! Guaranteed! Best products, biggest sellers, surest repeat orders. No capital or experience is required. We furnish capital and everything necessary for you to become a Federal Distributor. Exclusive territory will be given honest men or women who write at once, Federal Pure Food Company, 2309 Archer Avenue, Dept. A, Chicago, Ill. Largest packers of Pure Food specialties in the world. Reference, any bank, Dun or Bradstreet rating agency, Express or Railway Company in America.

**DISTRICT Agents—For Union Made pure wool suits and topcoats** retailing at \$23.50, none higher. A remarkable line of 45 beautiful fabrics tailored by a large and well known old established firm, sold only thru our own stores and district agents. A real opportunity for any good man. Big money to start and chance for advancement. We furnish large sales outfit, 9x13 cloth samples. Men over 30 years of age with tailoring or clothing experience preferred. Can use ambitious spare time men in smaller towns. Interested only in serious men who seek a future. Write for free sample and full information. Address M. T. Harvey, Mgr., Box 90, Chicago.

66 MILES on 1 gallon—Scientific Gas Saver. All autos. Demonstrating model free. Critchlow, D-132, Wheaton, Ill.

**AWAY Ahead of Every Thing Else!** That's "Zippo" as a seller. Show your sample, talk a minute and pocket your profit. A real Sure-Fire, He-Man Money-Getter that repeats—and say, Boy, it actually sells on a ten second Show-Down. If we didn't know we had a proposition that any man could sell eight out of every ten calls, you can bet your sweet life we wouldn't spend money telling you about it. Karam-Smith, 603 F Street, Ft. Wayne, Ind.

**GET into Business for Yourself.** Make storekeeper's profits without storekeeper's troubles. We'll show you how. In fact, we'll put you into business, furnish everything you need, train you, carry stock for you without your investing a penny. We'll work with you until we've made you a success. We have done it for others. We'll do it for you—provided you are honest, ambitious and willing to work hard. If you are, write us. You'll hear from us at once with facts. Address Dept. 214, Goodweir Chicago, Inc., 844 West Adams, Chicago.

**AGENTS—Send for free sample "Fretnot"**—washday wonder. You can clear at least \$20 to \$100 weekly, according to spare or whole time. You don't have to talk; if she doesn't buy at sight, leave sample; she will be looking for you long before you are able to make the rounds again. Samples furnished free. Premiums for your customers. Exclusive territory. Credit given. Empire Specialties Co., 1549 N. Wells, Dept. 101, Chicago.

**AGENTS—Sell Genuine Gold Leaf Window Letters and Script signs; no experience; 500% profit.** Consolidated, 636 S. Dearborn, Chicago.

**AGENTS: Write today for complete line New Guaranteed Hosiery.** Biggest, best, most beautiful ever offered. All Styles for every member of the family. Highest quality, low priced. Easy to get orders. Our new line of Silk Hosiery can't be beat. Every home a customer. Sell eight or ten pairs a day. Often sell that many in one family. Any man or woman can make \$45 week with this line of insured hosiery. Even spare-time workers make \$12 to \$18. Write today for samples. Jennings Co., Dept. 431, Dayton, Ohio.

**IF I Send You a Suit made in the latest style from the finest goods, will you keep it, wear it, and show it to your friends as a sample of my sensational \$25.00 suits, guaranteed regular \$50.00 values? Could you use \$1.00 an hour for a little spare time? If so, write me at once for my wonderful new proposition.** Just write your name and address on a card and mail to Dept. 181, Knickerbocker Tailoring Co., 133 So. Peoria St., Chicago.

**FREE—Get This Quick!** Chicago's Wonder Shirt line. Sell newest, stylish, snappy, Stylemor Shirts. Amazing values at low prices. Make \$100.00 weekly easy. Complete assortment of large swatches makes selling Stylemor Shirts a cinch. Experience or capital unnecessary. Be your own boss. We will show you how to build a big business of your own. We will deliver and collect. Exclusive territory open. Write today, for big free outfit. Stylemor, 81 W. Van Buren, Chicago, Ill. Dept. 1002.

**AGENTS—\$90 a Week—\$2 to \$5 an hour spare time.** Make this with the celebrated line of Ho-Ro-Co Soaps, perfumes, toilet articles and specialties; over 200 items. Big profit makes. La-Em-Strait Hair Dressing selling like hot cakes. Write for Free Sample Case offer. Ho-Ro-Co Mfg. Co., 783 Ho-Ro-Co Bldg., St. Louis, Mo.

**AGENTS: New Selling Plan!** \$1.25 premium free to every customer on a \$2.00 sale, consisting of 8-oz. Vanilla, 6-oz. Shampoo, 4-oz. Lemon Lotion. A big hit everywhere. Complete details free. Territory going fast. Write today. The C. I. Togstad Company, Dept. 18-C, 29 South Clinton St., Chicago, Ill.

\$50,000. **PICTURE Man Friedman** made canvassing. Beginners can make \$100.00 weekly with my sales talk. Experienced men make more. Free book "Profits in Portraits" explains. Samples Free. Picture Man Friedman, Dept. 8-E, 541 W. Lake, Chicago.

**AGENTS—Make a dollar an hour.** Sell new kind of sharpeners. Sharpen all knives and tools quickly. Demonstrating sample free. Premier Mfg. Company, Dept. 53, Detroit, Mich.

**SELL Fine Made-to-Order All Wool Suits** at \$31.50. Regular \$55 Values. Over 100 6x9 Cloth Samples. All One Price. Furnished. Hustlers Earn \$100 Weekly. Write W. Z. Gibson, Inc., 161 W. Harrison St., Dept. Q-517, Chicago, Ill.

**\$100 A WEEK: Agents, Crew Managers, sell Extracts, Toilet Articles, other necessities.** Guaranteed line, Particulars free. Midwest Drug Co., 191 E. Naghten St., Columbus, Ohio.

**LIBERAL Commissions Selling New Games and Toys.** Samples. Wholesale. Cardinell, Montclair, N. J.

1,000 MEN needed at once for the Biggest proposition in the Country. Don't miss it. Send \$1.00 at once for Sample. Golden Rule House, Palmyra, N. J.

**AGENTS: \$11.80 daily in advance** (Send for sworn proof) Introducing New Insured Hosiery. 57 styles, 40 colors, guaranteed seven months. No capital or experience required. You simply take orders. We deliver and collect (or you can deliver, suit yourself). Credit given. Pay You Daily, monthly bonus besides. New line now ready. We furnish samples. Spare time will do. M. H. Mathews, Card 5863, Cincinnati, Ohio.

**BEST Money Maker on Market.** Everybody can draw first time they try from postal cards, photographs or any other model, as good as original. Sample \$2.00, in quantity \$1.00. Ask particulars. Resilla Manufacturing Co., Box 1371, Los Angeles, Calif.

**MANUFACTURER'S Agents and Salesmen to sell Spray Finishing Equipments to Factories—Public Institutions—Garages—Paint Contractors.** Factory established 20 years. Four Factory Branches—National Distribution. Big Financial Rating. Ask any Banker. Pasche Air Brush Co., 1900 Diversey Blvd., Chicago, Ill.

**AGENTS—Good salary and commission selling "Ratskyll,"** new rat and mouse exterminator; ready for use; no bait required; non-poisonous; rodents die outside premises; no odor. Empire Specialties Co., 1549 N. Wells, Dept. 301, Chicago, Ill.

**AGENTS: \$8.00 to \$16.00 Daily Easy.** Introducing "Chieftain" Fine Quality, Guaranteed Tailored Shirts. Just show samples, write orders. We deliver and collect. Your Pay Every Day. No capital or experience necessary. Spare time pays you big. Send today for free samples. Cincinnati Shirt Company, Secy. 1583, Cincinnati, Ohio.

**AGENTS: 100% profit; wonderful little article.** Something new; sells like wildfire. Carry in pocket. Write at once for free sample offer. Albert Mills, Manager, 5783 American Bldg., Cincinnati, Ohio.

**EVERY Autoist will buy Auto Mitten Dusters.** 200% Profit. Free Sample Offer. National Fibre Broom Co., St. Louis, Mo.

**HERE'S The Line That Satisfies.** You'll sell yourself on first sight. New Rubber Specialties for every purpose. Over fifty fast sellers needed in every home; honest goods that we guarantee and the profits are large enough to give you a steady income and make you stick the year round. Write B. & G. Rubber Co., Dept. 872, Pittsburgh, Pa.

**AGENTS—\$11.25 starts 15 stores working for you, bringing \$47.25 week steady; no selling; Samples displayed in stores work for you.** Write "Master," 816½ Chestnut, St. Louis.

**AGENTS make \$3.00 an hour taking orders for our 40 Fascinating Kitchen Specialties.** No competition. Write quick. General Products Co., Dept 7K, Newark, N. J.

**AGENTS—Best seller; Jem Rubber Repair for tires and tubes; supersedes vulcanization at a saving of over 800 per cent; put it on cold, it vulcanizes itself in two minutes, and is guaranteed to last the life of the tire or tube; sells to every auto owner and accessory dealer.** For particulars how to make big money and free sample, address Amazon Rubber Co., Philadelphia, Pa., Dept. 505.

**AUTO owner tire agent wanted** each locality to use and take orders for handmade Mellinger fabric and cord tires; guarantee bond 8,000 and 12,000 miles (no seconds); shipped prepaid on approval; get your tires free; no capital or experience required; make \$100 to \$300 weekly. Write for wholesale prices and sample kit. Address, Mellinger Tire Co., Dept. 300, Kansas City, Mo. or Dept. 400, Philadelphia, Pa.

**SELL Radium Health Products—A scientific, drugless treatment needed in every home.** The \$2,500,000,000 spent yearly for health gives you a tremendous market, with no dull seasons. 100% profit. Exclusive territory. Write Radium Applicator Co., 359-S Riley, Buffalo, N. Y.

**"MAKE and Sell Your Own Goods."** Tremendous profits. No Machinery. No experience. We show you how. Write quick for free book. Clover Laboratories, (Dept. PC.), Park Ridge, Ill.

**ALTA Shock Absorber.** Agents can make big money; cost six dollars cash here, selling at twelve dollars. Rare opportunity. Alta Company, 900 O'Farrell, San Francisco, Calif.

**MAIL Order and Agency propositions, including large imprint catalog free.** Pruitt Publishing Co., Station E-16, Kansas City, Mo.

**20th CENTURY Specialties.** Agents (or Mail Order Men). Information 20c. F. G. Briggen, 67 Roslyn St., Rochester, N. Y.

**"LIQUID-LEATHER"** Fills Holes in Shoes, Rubbers, Tires. Dries Instantly. Reliable. Waterproof. Just Imported from France. Tube Retail 60c—Cost 25c. (Dozen in Display Carton.) Sells Housewives, Sub-Agents. Free Sample. Nulife Leather, Hartford, Conn.

**WORLD'S Largest Neckwear Manufacturer wants Agents.** Remarkable opportunity. Immediate commissions 32½%. Advance Styles, complete line. Greatest values. Beacon, 3510 Beaconwear Bldg., Boston, Mass.

**AGENTS—\$40 week.** Introduce finest line insured Hosiery. All styles, colors. 90c hour for spare time. No experience needed. Samples furnished. Wilknit Hosiery Co., Dept. 2278, Greenfield, Ohio.

**TO show Selin Products for Kitchen, Toilet, Table and Laundry is to sell them.** To sell is to make friends. To make friends means \$35 to \$95 weekly. Free Circular. Selin, Dept. A, Selinsgrove, Pa.

**AGENTS!** Just out. New Spark Plug invention, the Beacon-Lite; visible flash from each explosion in cylinders. Big gas savers. Sell on sight. Make \$90 a week easy. Write quick for Free Demonstrator Offer and special Free Deal to start. Central Petroleum Company, 2043 Century Bldg., Cleveland, Ohio.

**AGENTS—No canvassing. No Delivering. No Money Invested. Pleasant Work. Big Money Appointing Local Agents to Introduce Welcome Foods. Welcome Products, 326 Harvey, Ill.**

**We pay \$48 a week, furnish auto and expenses to introduce our Soap and Washing Powder.** Buss-Beach Company, Dept. A12, Chippewa Falls, Wis.

**IMMENSE Profits Silvering Mirrors at Home.** Plating like new, brassy worn-out autoparts, reflectors, tableware, stoves, re-finish metalware, etc. We train you. Plans Free. Sprinkle, Plater, 128, Marion, Ind.

**BIG money daily selling guaranteed Union Made to measure men's suits \$12.50.** Lined suits, flap pockets, \$13.50. Latest patterns—also raincoats, topcoats, caps, riding breeches, boys' suits. Attractive outfit free. Double Service, 1327CB, Washington, Chicago.

**AGENTS, Something new; an Auto Accessory—A Household Necessity.** Every owner a prospect. Sample 50c. Stannard Supply Co., Lake Geneva, Wis.

**AGENTS—"We furnish samples"** if your character and ability warrant, of our complete line hosiery and neckwear. We are "Pioneers" in selling to the consumer. Our Agents make over \$60 weekly. Give references, experience. Pennsylvania Company, Dept. 8, 127 North 8th, Philadelphia, Pa.

**PATENTED Household Necessity.** Hailed with delight wherever shown. Eliminates pesky nuisance. Anyone between eight and eighty can sell it. Samples 25c; five for dollar. Moneyback Guarantee. Seidel Co., Dept. P, Northampton, Mass.

**BIG Money Selling New Household Cleaning Set.** Washes and dries windows. Sweeps, scrubs, mops. All complete only \$2.95. Over half profit. Write Harber Brush Works, 132 3rd St., Fairfield, Iowa.

**LARGE Manufacturer wants agents.** Make \$100 weekly. Outfit free. Sell made-to-measure genuine Cravenette Gabardines, \$14.50. Whitecoats, \$12.50. Reversible Raincoats, \$9.75. Standard Raincoat Co., 16 West 17th Street, New York.

**FOR Steady, pleasant income sell old reliable herb medicine.** Full time or side line. Makes friends and boosters everywhere. Extra fine commissions. Free box and agency terms. Write Bassett's Native Herbs Company, Established 1879, Dept. E, Columbus, Ohio.

**SELL by Mail! Big Profits! Books, Formulas, Novelties, Bargains. Particulars Free!** Elco, 523 South Dearborn Street, Chicago.

**SALES Agents—Take orders High Grade Tailored Neckwear.** Guaranteed for 6 months. Insured never to roll, twist, stretch or bunch. Not sold in stores. Write for beautiful line samples. Better-Made Cravat Co., Wholesale Dept. 6, Columbus, Ohio.

**GET our line first. Big pay daily.** Best made shirts, shoes, suits, pants, raincoats, etc. Sample kit free. Jim Montgomery, 320 So. Franklin, Chicago.

**FREE Sample. "Rain Shield Wiper."** Retail \$1.00—Costs (25 cents). Sold Clear and Rainy Days. No Cloth—No Paste—No Attachment. (1) Rub keeps Windshield clear (48) hours. Experience Unnecessary. Nulife Corporation, Hartford, Conn.

**SALESMEN:** Write your name and address on a card and mail to us. We'll show you sure earnings of \$20.00 a day. Will you risk one minute and a one cent stamp against \$20.00? Mind you, we say we'll show you. Address Dept. 812, William C. Bartlett, Inc., Chicago.

**FIBRE Brooms—detachable handles, fine finish.** Good profits, repeat sales. The Fibre Broom People, 147 New Jersey Ave., Brooklyn, N. Y.

**AGENTS—Mesco Corn and Callous Remover** will build you a steady repeat business. Send today for pocket-size trial outfit. The Moss Co., 275 Searle Bldg., Rochester, N. Y.

**AGENTS:** Sell unique neck-tie pressers. The most wonderful article ever shown. New. No competition—sells on sight. Send 50c for Sample. J. J. Heinrich, 2135 Michigan Ave., Chicago.

**BE your own boss. Build permanent business.** Take orders men's—boys' tailored suits—\$13.95—\$22.50—\$4 commission. Free outfit. Fashion Clothing, 2654N Lake, Chicago.

**CREATE Mail order or Local Business.** New Simple plan gets money, easily, quickly. Steadily. Particulars Free. Edw. Burke, 733 Nineteen, Oakland, Calif.

**AGENTS make \$40 to \$80 weekly selling typewriters re-manufactured like new by the "Young Process."** Lowest prices and easiest terms ever offered. Big Commission—no investment—real opportunity to start in business for yourself. Write Today. Young Typewriter Co., Dept. 7103, 654 W. Randolph St., Chicago, Ill.

**GET Free Sample Outfit! Earn \$3,000 to \$5,000 a year selling most complete line guaranteed Hosiery and Underwear in America.** No experience needed. You can become District Manager and have others working for you—if you act quick! Write today. Malloch Knitting Mills, 563 Grant St., Grand Rapids, Mich.

**66 MILES on 1 gallon—Scientific Gas Saver.** All autos. Demonstrating model free. Critchlow, G-132, Wheaton, Ill.

**IMPORTED—Patented, 5-color pencil; writes Red, Blue, Black, Green, Indelible; sells on sight, everyone a prospect; no competition. Sample \$1.00.** Square-Deal Co., P-236 West 55th St., New York.

**CLEAN up 50c to \$1.00 each sale.** Paid immediately. No delivery, license, nor stock necessary. Free particulars. Mission Factory, 519PM, 519 N. Halsted St., Chicago.

**GETS-U-OUT Tire Lug—New patented auto accessory.** Just out. One minute demonstration. Sure sale. Absolutely prevents auto getting stuck in mud, sand or snow. Big profit. Money back guarantee. Write for exclusive sales territory. Arthur J. Benson, 338 W. 47th St., Dept. 3, Chicago.

**MEN wanted to sell my new puncture-proof inner tube; demonstrate by driving nails into tire.** In tests have given good service after having 500 nail holes in them. Doubles tire mileage. Sold under money-back guarantee. Big money and exclusive territory. Free tube offer. Write D. M. Milburn, 334 W. 47th St., Chicago.

**INCH Display Advertisement 166 Magazines Year \$50.** Weed's Popular Services, Atlantic City, N. J.

**QUICK-SELLING Novelty.** Complete radio set embodied in beautiful ring. Retailing at only 50c. One agent averages \$125 weekly. Agent's Sample 25c. Particulars free. Ross Merchand, Station Eye, New York.

**WILDFIRE sellers! America's cheapest 25c Chemical Windshield Raincloths.** Sample. Box 265, Station C, Los Angeles, Calif.

**QUIT ringing doorbells. I made \$800 monthly, no soliciting, no goods to buy, why not you? Details free.** R. McNow, 303 Wilkinson, Omaha, Nebr.

**AGENTS, Distributors, clean up quickly.** No competition. Sell "Presto." Necessity and Novelty. New Moth-killer, deodorant, flies, germ and insect chaser. Guaranteed, sells at sight, 1 to 6 every home. Not a liquid or powder. Retail 25c each, costs \$1.25 dozen. Free sample. Franco Mfr., 530 N. Waller, Chicago.

**\$5.00 REWARD for any foul spark plug we fail to fire with our Ignition Booster.** Agents clearing \$100 and over weekly selling our Newly Patented Auto Specialties. Others doing it, so can you. Jackson Mfg. Co., 1818 Curtis St., Denver, Colo.

**MANUFACTURE your own products.** Free list reliable plans, patterns, processes for making newest, fast-selling mail order, agents' goods, toys, novelties. Mfg. Bureau, 397A Tracy, Kansas City, Mo

**SELLING Like Blazes! Eleven piece toilet goods assortment at \$2.00 with two piece carving set Free to your customers.** 100% profit. Davis Products Co., Dept. 56, 1311 Carroll, Chicago.

**SELL charming Fashion Frock dresses.** \$50.00 weekly easy. Below retail prices. Guaranteed. Free outfit and sample dresses. Fashion Frocks, Inc., Dept. 3-AR, Cincinnati, Ohio.

**WANT \$50.00 weekly for spare time? And fine automobile free? Write for amazing money-making plan.** No experience necessary. Easy work. Address Desk BC3, Healtho Products Co., Cincinnati, Ohio.

**MARVELOUS Invention! Does away with phonograph needles.** Preserves records. Saves \$25 in needles. Pays \$90 weekly. Sample on approval if requested. Evernlay, Desk B-3, McClurg Bldg., Chicago.

**NEWEST Invention! Sells everywhere.** Automatically prevents telephone and iron cords from tangling and kinking. \$90 weekly. Samples for test if desired. Never-knot, Dept. 3-1, McClurg Bldg., Chicago.

**SIGN agents.** Wonderful sign letters; never tarnish. Samples free. Monroe Sign Corporation, New Haven, Conn.

**AGENTS, Salesmen, get our sure fire proposition.** Details 10c. The Exchange, 214 So. 13th St., Allentown, Pa.

**AGENTS make big money selling our household goods.** Webster Co., 522 Wrightwood, Chicago, Ill.

**SELL \$50 mail shorthand course for \$10.** Macewan, 720 N. Michigan, Chicago.

**GREATEST Sensation of the specialty world.** Over 1,000 genuine embossed Display Signs for retail merchants. Write for information. Artistic Signs, 799-R, Broadway, New York.

**AGENTS, earn big money soliciting yearly subscriptions for magazines; Ladies' Home Journal, etc.** Acheson, 2226 West Carv., Richmond, Va.

**BIG Money. Your Own Business.** Operate Cleaning and Pressing Shop. Complete instructions. Acheson, 2218 West Carv., Richmond, Va.

**SALESMEN—Our men earn \$5 to \$7.50 per hour selling Supreme Shirts.** Write for Free kit. Supreme Shirt Co., 276-M Fifth Avenue, New York.

**SPRING clean-up time in women's shoe game.** Main or side line. No investment. Big money. Style-Arch Shoes, Dept. C-4, Cincinnati, Ohio.

**AGENTS—Distributors: Big money selling Ford Thermatic Carburetor Regulators.** Free demonstrator. "Watch it work." Need managers in few districts. Owens Company, 1919-B Broadway, New York.

**MARVELOUS New Invention 400% Profit.** Liquid Quick Mend for hosiery and fabrics. Tremendous demand. Over hundred other fast sellers. Local and General Agents, J. E. Johnson Co., Dept. 439, 69 E. South Water St., Chicago.

**FREE Booklet describes 52 plans for making \$20.00 to \$100.00 weekly in home or office business of your own.** Downs Co., 2323A Myrtle, St. Paul, Minn.

**AGENTS Wanted to mail circulars.** Fast selling goods. New methods. Big profits. Particulars free. Peerless Service, Waterville, Me.

**CADDIE—For wife and sweetheart, guaranteed seller.** 75 cents parcel post. Auto-bronze Company, 1527 Fawn Street, Philadelphia.

**BIG Money to Live Agents.** Selling Burgid to hotels, bakeries, hospitals, restaurants. Everyone a prospect and buyer. No poison. Every package guaranteed. Territory rights given and protected. Write for details at once. Wex Sales Co., 657 34th St., Milwaukee, Wis.

**YOU Can Make Good Durable Paint and Varnish 40c per gallon.** Write Dept. 2, Emmelmann Bros. Mfg. Co., Indianapolis, Ind.

**AGENTS—Large Profits selling United No-Cement Tube Patch.** United Patch Company, Covington, Ky.

**GET posted—Good prices paid for butterflies, insects.** See Sinclair display advertisement, page 42.

**CAN you beat this money making line? Big variety of shirts, including silks, with a splendid line of union made work and flannel shirts, overalls, coveralls, work pants, play suits, all guaranteed.** Sell direct to wearer full or spare time. No experience required. Write today for Free Selling Outfit. Nimrod Shirt Co., Dept. 8, 4922-24-26-28 Lincoln Ave., Chicago.

**EARN \$15.00 Daily.** Sell Uptheygo Cuff Buttons Direct to Wearers. Stretch Like Rubber. Permits Sleeves to Be Raised over Elbows Instantly, without Unbuttoning Same. Lowered they close automatically. A New High Grade Durable Convenience that Appeals to All. Write Today. Flexo Mfg. Co., Sheboygan, Wis.

**MAGIC Polishing Cloth—Great seller.** Big Profit. Free sample to workers. Get this proposition. Newton Co., 102 Main St., Newark, New York.

**SUCCEED With Your Own Products—**Make them yourself. Formulas, Processes, Trade-Secrets. Modern master methods. Catalog free. B. Thaxly Co., Washington, D. C.

**AGENTS.** Our Silent Selling Method should make big money for you. No experience required. Colman Mercantile Co., 4421 Manchester Avenue, St. Louis, Mo.

**BUILD splendid business** making chipped glass number and name plates, signs, checkboards. Write for particulars. Simplex Utility Co., 1133 Broadway, New York.

**AGENTS.** No-Water hand soap in tubes taking autoists by storm; washes dirtiest hands perfectly clean without water; quick sale, big profits. National Service Co., Dept. "A," Pierre, S. Dak.

**TWELVE Big Money-Making Opportunities.** Including America's Greatest Magazine and Big Wholesale Catalog. All for 25c. Free—14 Articles worth \$2.00. Limited Offer. Write Quick. Lawrence Products Company, Beaver Dam, Wis.

**AGENTS—Sell 5c fast selling candy specialties to stores.** Big profits. Lorrac Products Co., Albany, N. Y.

**AGENTS \$500 monthly easy selling Magic Gas.** New discovery. \$1 box equals 33 gallons gasoline. Proven merits. Your name on cans, 300% profit. Write quick. P. A. LeFebvre & Co., Dept. P, Alexandria, Ont., Canada.

**SOMETHING new—Presto Rubber Repair** for tires, tubes; all rubber goods put on cold, no heat, acid or tools; vulcanizes itself in few minutes. Sells to auto owners and dealers, sample free. Pioneer Products Co., Dept. A, Roebbing, N. J.

**MANUFACTURE Chipped Glass Numbers;** particulars free. Beveridge, 160-22 Locust Avenue, Jamaica, N. Y.

**AGENTS sell 60 5 cent packages** chewing gum or candy mints. You keep \$1.00. Send us \$2.00. We trust you. Acheson, 2247 West Cary, Richmond, Va.

**YOU can be your own boss** with our Key-Check outfit. Good for \$5 a day stamping names on pocket key checks, fobs, etc. Sample check with your name and address, 20 cents. Pease Die Works, Dept. M, Winchester, N. H.

**MANUFACTURE lamb wool polishers,** dusters. Newhall, 65 Court, Brooklyn, N. Y.

**HY-GRADE agents** can average \$50.00 per week besides bonus, selling Household Products. Premiums. Co-operative Sales Plan makes sales easy. County Sales Agents Wanted. Write now for territory. Hy-Grade Chemical Co., Winthrop, Me.

**"IMMEDIATE" Stone Houses,** \$100. Agents' fortune-maker. Bandley, Box 171, New Orleans, La.

**AGENTS—30% commission.** Full line glove silk lingerie and guaranteed hosiery, mill to wearer; lowest prices. Get particulars. Wright Hosiery Mills, Philadelphia, Pa.

**AGENTS—Flashing device** easily sold to garages, barber shops, shoe shining parlors, etc., using globe signs and advertising. Inexpensive. Real proposition for live wires. 100% profit. Exclusive territory. Phelos Electric Co., 29 So. Clinton St., Chicago.

**GENERAL Distributors, Agents, Salesmen—**Send for our live wire proposition and sample. Exclusive territory to workers. See our display ad on page 157. Wallace Rim Tool Mfg. Co.

**ARE You Old at Forty?** See our advertisement on page 153 of this issue. The Electro Thermal Company, 2137 Main Street, Steubenville, Ohio.

**GIVE Polishing Cloth Free** with every package Rust and Stain Remover. Make 233%. Get Particulars. Quality Products, 2712-A Elliott, Minneapolis, Minn.

**MAKE 1926 pay you \$65.00 week.** Our men make this and more selling shoes direct to wearer. Superior Shoe Co., Bangor, Me.

**ANY man handy** with paint brush can start furniture refinishing, job painting, handyman shop on nearly nothing; mostly all profit; experience not needed; winning plan brings customers quickly. John Brace-land, 1457 So. Ninth, Philadelphia, Pa.

**\$8.50 TO \$20.00 Daily pay.** Introducing New Insured Hosiery for men, women, children. 57 styles, 40 colors. Must wear or replaced free. Repeat orders sure. Nyland made \$595 in one month. Edwards \$400.60. Mrs. Bone, \$445.25. Why not you? Even spare time work should pay you \$3 per hour. Your Pay Daily in advance. We deliver and collect. You spend all your time writing orders. No experience or capital needed. We furnish samples. All grades, colors including silks. No matter what you are doing now, write for our offer. Macochee Textile Company, Card 2563, Cincinnati, Ohio.

**AGENTS.** Salesmen—Sell New Thermo-static Automatic Carburetor Control Attachment for Fords. Big profit, full or part time. Burns 95% air. Doubles Mileage. Attached in 2 minutes. No drilling. Does automatically exactly what Ford manual says do by hand. Cadillac now using Thermo-static Carburetor Control under Blanche license. Write today. A. C. Blanche & Co., Dept. 805CX, 602 Lake St., Chicago.

**"C-WELL" Electric Lamp** for Sewing Machines. Fits all makes. Every woman with a sewing machine will buy. Liberal profits. Ask our selling plan. Lucark Trading Co., 799 Broadway, New York.

**AGENTS—Comb cleaners,** self-threading needles and other good sellers to housewives get the money. Particulars. L. Miller, Box 3, Tremont Station, New York.

**PATENTS.** Time counts in applying for patents. Don't risk delay in protecting your ideas. Send sketch or model for instructions or write for Free book "How to Obtain a Patent" and Record of Invention" form. No charge for information on how to proceed. Communications strictly confidential. Prompt, careful, efficient service. Clarence A. O'Brien, Registered Patent Attorney, 58-E Security Bank Building (directly across street from Patent Office), Washington, D. C. See pages 140 and 141.

**AGENTS—Mail dealers,** Concealograph, Secret Correspondence System. Sample 10c. Particulars free. Liggett, 875 Drexel Bldg., Philadelphia.

**A \$5,000 A YEAR Job.** You can make it worth that and more. 400% to 600% profits selling Perry Photo Medallions. No portraits so desirable. Indestructible, hand-colored, fade-proof. Built from photo supplied by customer. Guaranteed. No money risk. No margin of profit so big in any other line. Write. Perry Photo Novelty Corp., 1793 Jerome Ave., Dept. PM, New York.

**REMPE E-Z Typewriter Cleaner.** Makes type cleaning a pleasure. Repeater. Exclusive territory. Rempe Mfg. Co., 2827 Myrtle, Oakland, Calif.

**66 MILES on 1 gallon—Scientific Gas Saver.** All autos. Demonstrating model free. Critchlow, E-132, Wheaton, Ill.

**AGENT'S Protector—Book** every agent should have. Particulars Stamp. "Moore-Made," LaPeer, Mich.

**AGENTS Wanted—Something new—Fyr-Fyter** sells easily. Makes a spectacular demonstration; car owners, homes, factories, stores, practically buy on sight. Our men make \$10 to \$50 a day. Exclusive territory to producers. If you wish to establish a business of your own with unlimited possibilities for making big money, write us today. Fyr-Fyter Co., 998 Fyr-Fyter Bldg., Dayton, Ohio.

**AGENTS.** Big profits. Best and cheapest window letters made. Easily applied. Dime brings five samples. Particulars free. Staibrite Co., 1115 Second Ave., New York.

**WE pay \$200 Monthly Salary,** furnish car and expenses to introduce our guaranteed poultry and stock powders, cleaner, etc. Bigier Company, X 368, Springfield, Ill.

**\$20 DAILY Selling Ver-I-Ezy Men's Shoes** direct. Sell relatives, friends, neighbors first. Low priced. Give real comfort, long service. You take orders, keep big commission. We ship and collect. Full or part time. Write Now. Easy-wear Shoe Company, Dept. 229, Indianapolis, Ind.

**\$100 WEEKLY—Pleasant Work;** Appointing local agents to introduce Mother Hubbard Foods; no canvassing; no delivering; no money invested. Mother Hubbard, 556 Congress, Chicago.

**AGENTS—Three big lines** hosiery, silk underwear, men's shirts. Liberal commissions. Send for free illustrated catalogs. Helix Co., 213ta Fourth Ave., New York.

**MAKE big money** selling Eureka Patching Paste. Patches fabric and rubber. Eureka Cement Co., 208 E 53rd St., Chicago, Ill.

**DIRECT factory representative** to sell changeable letter signs to merchants. Excellent opportunity. Good income assured right men. Address, Maze Manufacturing Co., Norwood Station, Chicago.

**NEW camera** takes and finishes photos in one minute. Make money selling cameras or taking photos. Exclusive territory. Crown Co., Dept. 951, Norwalk, Conn.

**IF We Give You shoes** made-to-your measure in any one 60 leathers, 50 different styles, will you keep them, wear them, show them to your friends as sample of our \$10 Made-To-Order shoes to sell at \$6.85? Advise us today. Your complete outfit will go forward absolutely free at once. Dept. 2000, Tailor-Made Shoe System, 932 Wrightwood, Chicago.

**TAILORING Salesmen:** Our guaranteed \$23.50 and \$31.50 tailored to order suits are \$10 to \$20 dollars cheaper than store prices; commission in advance; monthly bonus; protected territory; beautiful assortment 6x9 swatches free. Our national advertising campaign makes selling easy—big repeat business. DeLonge's record \$343 in one week. In one state alone 47 men average \$57.18 weekly. J. B. Simpson, Dept. 1182, 843 Adams, Chicago.

**BRING Home the Bacon—selling Stuart's** famous Food Flavors. Quick sellers. Big profits. Write for free sample and terms. C. H. Stuart & Co., 6367 Main, Newark, New York.

**EVERYBODY uses Extracts.** Sell Duo Double Strength Extracts. Complete line of household necessities. Big repeaters. Write today. Duo Co., Dept. E-1, Attica, N. Y.

**GIVE Away finest laundry soap Free.** You'll make \$10 daily easy by new selling plan. Big repeat business. Write quick. Wolverine Soap Co., 28 Wolverine Bldg., Grand Rapids, Mich.

**AGENTS: \$65 to \$100 a week.** High grade all wool suits made to measure, \$25 and \$30. Biggest commission in advance. Money-back guarantee. Free sample outfit. Write C. G. Ferrin, Mgr., Box 1997, Chicago.

**WONDERFUL! Startling! Amazing!** Our Ex-Cel Luminous Crucifix and Magical (Luminous) Necklace shine brilliantly in the dark. Sell on first demonstration. Big profits to you. Write for further particulars, or better still, send for sample and territory protection immediately. Crucifix \$1.50, Necklace \$1.00, postpaid. W. G. Hannan Co., Dept. B, 2539 So. State St., Chicago.

**\$100 TO \$150 Weekly.** Wonder-Automatic Washer. Patented. Does large family washing spotlessly clean in 30 minutes. Creates its own power. Will last a lifetime. Sells for \$7.50. Unusually large commissions. Eureka Supply Co., Dept. 6, Sedalia, Mo.

**SHOW Us the Housekeeper Who Likes** to clean stair corners. Ideal Dust Shields keep corners clean. Agents wanted. Ideal Stairway Equipment Co., Canton, Ohio.

**START Business of Your Own.** Increase your income. Catalogue dependable formulas free. S. and L. Laboratory, 321 Larimer, Pittsburgh, Pa.

**AGENTS: 500% profit.** "Happy Home Maker Shampoo" builds your own big business. Martin of Indiana made \$75.00 in one day. Missouri man made \$750.00 one month. Exclusive territory. Geo. A. Schmidt & Co., Dept. P, 236 W. North Ave., Chicago.

**GOLD-LEAF Sign Letters;** make and sell; 1,000% profits. Particulars, Johnston Co., Quincy, Ill.

**PORTRAITS,** photo pillow tops, frames, sheet pictures, medallions, merchant's signs, food products, photo jewelry, guaranteed hose, toilet requisites, luminous crucifixes. Catalog 50 specialties free. 30 days' credit. Jas. C. Bailey Co., Sta. C, Chicago.

**MAKE Money,** silvering mirrors, refinishing auto headlights, tableware; metal plating, bed stands, chandeliers. Outfits furnished. International Laboratories, Dept. 71, 309 Fifth Ave., New York.

**AGENTS,** both sexes, we manufacture and control new household article. Fast seller. Big profits. Exclusive territory. Write now. Connolly, 123 Liberty St., New York.

**300% PROFIT—Quick Seller—Fast Repeater.** Sample Free. Bestever Products Co., 1941-PM Irving Park, Chicago.

**AUTOMOBILE Specialties.** Guaranteed formulas for all latest money makers. Lowest prices. Write for free lists. Murohy, Chemist, Tujunga, Calif.

**REPLATE** brassy worn-off Automobile parts, Reflectors, Bath Room Fixtures, Worn Spoons, Forks, etc., with pure silver. Looks like new. Use U-Kan-Plate Polish. Positively no mercury. \$1.00 half pints postpaid. Satisfaction Guaranteed. Agents wanted. Dept. A, U-Kan-Plate Co., Philadelphia.

**RARE Opportunity.** Men and Women make enormous profits. Articles cost 5c sell quickly for \$1.00. Make \$15 to \$30 daily. Particulars Free. Bags, 3239 Archer, Chicago, Ill.

**AGENTS—Big profits selling Veripure Vegetable Soap for Toilet, Bath, Etc.** Write for Territory. Veripure Laboratories, Box 999, Chicago.

**BIG Money monogramming autos, trunks, bags, etc.** Make \$20 to \$25 daily. No experience needed. Samples, information free. Acme Products, 905 Broad, Newark, N. J.

**MAN** in each town to plate auto parts, reflectors, bathroom fixtures, refinish beds, mirrors, chandeliers; by new method. No capital or experience required. Simple plan of manufacturing at home starts you in big money-making business. Outfit furnished. Free particulars and proofs. Gun Metal Co., Ave. H, Decatur, Ill.

**AGENTS—Shine-Brite Polishing Cloth** polishes all metals. Sample free. Knoll Products, Box 532, Kankakee, Ill.

**AGENTS** make 500% profit handling auto monograms, sign letters, Novelty signs, etc. Catalog free. Hinton Co., 122 E. 58th St., Chicago, Ill.

**MAKE \$75—\$100 Weekly.** Famous Sun-lite household products; Big Quantity Seller; You risk nothing. Your money back for every unsold item. Amazing offer free. Summit Specialty, Union City, N. J.

**\$400 TO \$500** a month easily earned selling New Guaranteed Auto Discovery. Nothing else like it. Big demand; sure repeater. Free folder explains; get it today. Boone Specialty Co., Dept. 327a, Boone, Iowa.

**AGENTS** wanted to sell to Retail Stores our fancy signs; three colors, shaded with airbrush, great variety. C. Pohlmann, 929 Second Avenue, New York.

**WHY Buy Other's Goods?** Start your own profitable business, making them. Free valuable literature tells how, including Chemist's Interesting Lists Guaranteed Reliable Formulas for Latest Specialties. Miller, Chemist, 1706-K Jetton, Tampa, Fla.

**DON'T Buy** so-called "Master Formulas" (old recipe-book-stock-formulas). Get this Free, Interesting, Valuable literature describing Latest, Guaranteed, Special Manufacturer's Formulas for all lines latest specialties. Miller, Chemist, 1706 Jetton-G, Tampa, Fla.

**IF** you want good live agents—fellows who can get the business—ask me how others are doing it. I'll gladly render the necessary assistance. M. L. Rund, Mgr. Classified Advertising, Popular Mechanics Magazine, Chicago.

**ATTABOY—Pung Chow and Joker.** Greatest Amusement games ever played on Billiard or Pool Table. Brooks Mfg. Co., 1183 44th Street, Brooklyn, N. Y.

**OVER 100% Profit, Self-Lighting Gas and Cigar Lighters.** Everybody interested; repeat business. Sell individuals, dealers, subagents. Particulars Free. P. Bernhardt, 148 Chambers St., New York.

**AGENTS:** Full or spare time—to sell hand painted scarfs, doilies, pillows. Extremely low priced. A wonderful new process. Our agents are cleaning up. Paintographs practically sell themselves. Write for full particulars of liberal agency offer and circulars describing Paintographs today. Bradford's Paintographs, Inc., St. Joseph, Mich.

**TURN** your spare time into dollars selling Polmet Polishing Cloth that cleans all metals without liquid, paste or powder. Retail 25c. Our agents say it sells like "hot-cakes." Prove it yourself with free sample sent on request. F. C. Gale Co., 122 Edinboro St., Boston.

**ONLY** one sale a day means \$200 per month! Marvelous new adding machine. Retail \$15.00. Work equals \$350 machine. Ads, subtracts, multiplies, divides, automatically. Computes feet and inches. Speedy, accurate, durable, handsome. Five-year guarantee. Offices, Stores, factories, garages, lumbermen buy one to dozen. A fortune for live agents. Write quick for protected territory and free trial. Lightning Calculator Co., Dept. F, Grand Rapids, Mich.

**BIG Money Selling "Jiffy Tire & Tube Repair Kit."** Contains 3 Self-vulcanizing Tire Shoes; Large Outfit Tube Patch; 3 Puncture sealers, everything complete. Sells to every auto owner and Accessory Dealer. Agents average \$30 to \$100 weekly. We also manufacture Nationally known "Jiffy Tire-Doh." Exclusive territory and free samples. Chicago Tire Patch Co., 347-65 E. 55th St., Chicago, Ill.

**SELF-THREADING Needles.** Needle Books, Machine needles, find sales in every home. Fine side lines, easily carried, big profits, sample and catalogue free. Prentice Lee, 145 East 23rd St., New York.

**AT Last! Diamond Rival Discovered!** Amazing blue white Rajah Gem astounds jewelry world and deceives experts! Beautiful Sample case Free! \$100 weekly! Write Quick! Rajah Diamond Co., Dept. F-7, Salisbury, N. C.

**WILLIAMS' No-Water Hand Soap.** in tubes, has taken Auto owners by storm; washes dirtiest hands perfectly clean without water; easy demonstration makes quick sale. 150% profit. Williams Co., Dept. 265, Montclair, N. J.

**BIG Money and Fast Sales.** Every owner buys Gold Initials for his auto. You charge \$1.50; make \$1.35. Ten orders a day easy. Write for particulars and free samples. American Monogram Co., Dept. 40, East Orange, N. J.

**INSTANT Weld.** Repairs largest punctures without cement or heat. Lenn's profit one day. \$56. Write quick. Free sample; territory going fast. Tourists' Pride Mfg. Co., Desk T, Minneapolis, Minn.

**WE Pay \$50 a Week** and expenses and give a Ford Auto to men to introduce poultry and stock compounds. Imperial Co., D. 23, Parsons, Kans.

**AGENTS—Make a dollar an hour.** Sell Mendets, a patent patch for instantly mending leaks in all utensils. Sample package free. Collette Mfg. Co., Dept. 404, Amsterdam, N. Y.

**\$60-\$200 A WEEK.** Genuine Gold Letters for store windows. Easily applied. Free samples. Liberal offer to general agents. Metallic Letter Co., 438-D North Clark, Chicago.

**AGENTS—Clever Invention!** Inkspoon makes every pen a fountain pen. Fast office seller; big profit, demand increasing everywhere. Exclusive territory offered. Sample free. H. Marui Company, Tribune Bldg., New York, N. Y.

**POLMET—The Wonderful Polishing Cloth** that cleans all metals without liquid, paste or powder. Approved by "Good Housekeeping" and "Modern Priscilla"—sells fast at 25c. Sample free. Gale & Co., Inc., 15 Edinboro St., Boston.

**WASH** Clothes the new way. Use the Torrent Automatic Washer. You will be delighted. Special offer to one in each locality. Storm Royalty Co., 3610 Enright Ave., St. Louis, Mo.

**WE Start You Without a Dollar.** Soaps, Extracts, Perfumes, Toilet Goods. Experience unnecessary. Carnation Co., Dept. 201, St. Louis.

**GET** Our Free Sample Case—Toilet articles, perfumes and specialties. Wonderfully profitable. La Derma Co., Dept. A, St. Louis, Mo.

**BUILD** your own Business! Free Valuable literature explains how you can easily make your own Goods—have others selling them. Miller, Chemist, 1706-A Jetton, Tampa, Fla.

**AGENTS—\$240 a month.** Take orders for well known line of household specialties, food flavors, toilet preparations, etc. Full or spare time. Build a big permanent business. Must satisfy or money back. Write for free sample Outfit and offer. C. H. Stuart & Co., 5567 Main, Newark, N. Y.

**MAIL-ORDER** Houses and Distributors; We pack French made beauty creams, face powders, perfumes, toilet preparations with your label. Chemist, A2700 Wabash Ave., Chicago.

**AGENTS—Here's a New One.** "Best-ever Powdered Hand Soap." Sells like wildfire. Marvelous Discovery. Removes grease, paint, ink, oil, in fact anything from the hands. Cannot harm skin. 150% Profit. Great Repeater. Agents simply coin money. "Free Samples Get the Business." Write immediately. Bestever Products Co., 1945 E. Irving Park, Chicago.

**WINDOW Sign Letters.** One Thousand for \$9.75 Beautiful design. Perfect cut. Free samples, catalogue. Foil Sign Works, 832 W. 11th Street, Oakland, Calif.

**AGENTS—Write for Free Samples.** Sell Madison "Better-Made" Shirts for large Manufacturer direct to wearer. No capital or experience required. Many earn \$100 weekly and bonus. Madison Co., 566 Broadway, New York.

**AGENTS—Stamping names on Pocket Key Protectors; sample Check with your name and address. 25c. Stamping Outfits, Emblem Checks, Check Fobs, Name Plates.** Hart Mfg. Co., Desk 2, 303 Degraw St., Brooklyn, N. Y.

**ORIENTAL Perfumes** bring 100% net profit. Good sellers and better repeaters. Romola Parfumerie, Inc., Woodlawn 10, Chicago.

**NEW Marvelous Self-Lighting Pocket Cigar and Gas Lighters.** No Friction. Sells on Demonstration. Sample 25 cents. Rapid Mfg. Co., 799 Broadway, New York.

**EVERYBODY Buys Davis' Nifty Toilet Goods Assortments.** Useful, handsome gifts free to our customers. Over 250 high quality products. All repeaters. 100% profit. 25 years of success. Write! Davis Products Co., Dept. 56, Chicago.

**AGENTS—\$60 to \$200 weekly** putting up our Burnished Genuine Gold window letters; scripts. Experience unnecessary. Free samples. Premier Letter Co., 121 N. Francisco, Chicago.

**EASY, pleasant work for Mechanics, Shop Men, Clerks,** during spare hours; will add many dollars to their salaries. Also want persons who can give full time. Big wages assured. Novelty Cutlery Co., 67 Bar St., Canton, Ohio.

**AGENTS \$1. Retail \$3. Your Profit \$2.** Wonderful, pocket Adding Machine with Magic Writing Pad. Particulars Free. Typewriter Supply, 905 Hersch Bldg., Pittsburgh, Pa.

**\$31.00 PROFIT—with \$1.50 Outfit—Big Money—Easy Work.** Selling Gold Monograms for Automobiles, Luggage, Windows, Wagons. No Experience. No License. "Samples Free." NuLife Monograms, Hartford, Conn.

**BUSINESS Guide with Free Legal Service** Sells everywhere; Wells cleared \$1,185 in 35 days. Write for free outfit. Nichols Co., Naperville, Ill. Dept. 4B.

**AGENTS** make \$100 week placing advertising Cigar Lighters with glass front. Every dealer wants one. Write for free plan. Drake Mfg. Co., Dept. M, Milwaukee, Wis.

**CALIFORNIA** Rosebuds selling like hot cakes. Agents coining money; new stuff. Big profits. Catalog free. Mission Factory PM 519 No. Halsted, Chicago, Ill.

**DUSTLESS** Sponge Cloth. New Invention. (1) Rub—Dusts. Cleans and Polishes Automobiles, Furniture, Pianos. Retail (50c)—Costs (16c). "Sample Free." NuLife Sponge, Hartford, Conn.

**BIG Profits with Exclusive Territory—\$50 to \$100 weekly easy.** More has often been made in one day's work. A hot or cold running water bath equipment for any home at only \$7.50. No plumbing or water works required. Investigate. Send no money. Write today. Sanitary Supply Co., 753 Allen Building, Toledo, Ohio.

**\$20 PROFIT** daily selling self-threading needles, needlebooks; cost 3-5c each; sell 25c; three samples 25c. Catalog free. Needlebook Specialty Co., 661 Broadway, New York.

**AGENTS: \$300—\$500 monthly** easy taking orders for Morey Rim Tool. Autoists and trade buy on sight. M. Morey Rim Tool Company, Blissfield, Mich.

**BIG Money—fast sales; everyone** buys gold initials for their auto; sell \$1.50, profit \$1.44. Ten orders daily easy. Samples, information free. World Monogram, Dept. 16, Newark, N. J.

**AGENTS—N-R-G Laundry Tablets.** The old reliable moneymaker for live agents. Millions sold—200% profit—sales waiting for you. Clothes washed spotlessly clean in 10 minutes without rubbing. Free samples. N-R-G Company, 230 W. Superior, Chicago.

**GENUINE Gold Leaf Letters** anyone can put on Store windows. Guaranteed to never tarnish. Large Profits. Enormous Demand. Free Samples. Write today. Metallic Letter Co., 438-A North Clark, Chicago.

**AGENTS:** Our gold-eyed Needle Cases are wonderful sellers; immense profits; \$50 to \$300 weekly; proof and particulars free; sample outfit 15c; factory prices. Paty Needle Co., 231 Davis Square, Somerville, Mass.

**A BUSINESS** of your own. Make and sell chipped glass name and house number plates, checkerboards, signs. Booklet Free. E. Palmer, Dept. 512, Wooster, Ohio.

**EARN \$10 daily** silvering mirrors, plating and refinishing metalware, autos, chandeliers, bedsteads, headlights. Outfits furnished. E. Decle Laboratories, 1133 Broadway, New York.

**AGENTS—Steady income.** Large manufacturer of handkerchiefs and dress goods, etc., wishes representative in each locality. Factory to consumer. Big profits, honest goods. Credit given. Send for particulars. Freeport Mfg. Co., 59 Main St., Brooklyn, N. Y.

Now that you have read all these offers, read Macochee Company's (Cincinnati, Ohio) advertisement again.

### HIGH GRADE SALESMEN WANTED

**WANTED—Tailoring Salesmen,** make \$60 to \$125 per week. Biggest merchants in many towns have started with our line. We are the largest made-to-measure tailoring house in the country, furnishing elaborate sample equipments, including 500 all-wool fabrics. You make your own profits from \$8.00 to \$15.00 on each order. Guaranteed absolute satisfaction, perfect fit, best workmanship, or no sale. Write for our line and all accessories to be sent free. Tell us all about yourself. Address N. O. Perry, Sales Manager, Box 483, Chicago, Ill.

**\$91.50 WEEKLY** and up—Your Pay Daily. Introducing New 12 months Insured Hose for men, women, children. You write orders. We deliver and collect (or goods on credit and you can deliver, suit yourself). No experience or capital needed. Samples furnished. All colors, grades, including silks, lises, chiffons, heathers. Write quick. Macochee Textile Company, Card 3043, Cincinnati, Ohio.

**WANTED: Salesmen** to sell Toy Balloons and Squawkers to retail stores. \$200.00 per month easy. National Novelty Co., Gallon, Ohio.

**SALESMEN,** sell men's all wool suits tailored to order for \$29.50. Values to \$45.00. Fit and satisfaction guaranteed. Experience unnecessary. Our instructions enable you to take measurements accurately. Earning possibilities \$75.00 up, weekly. Commissions advanced daily. Spring line now ready. Lee, Whitecup & Gollender, Inc., Dept. 3, 71 Fifth Avenue, New York.

**DISTRICT Manager** for Dr. Gelber's Pyorrhea Home Treatment, 160 Newark Ave., Jersey City, N. J.

**WANTED: Salesmen** to sell our Men's Wide Belts on 20% commission basis, \$200.00 per month easy. National Mailing Service, Gallon, Ohio.

**HERE'S big money maker.** Masterlite Pocket Cigar Lighter; something new in specialty field; sells instantly upon demonstration to consumers and dealers. 50c (stamps) brings sample and selling plans. M. Masterlite Mfg. Co., 110 East 23rd St., New York. (Manufacturers well known Raido Gas Lighter.)

**WANTED: Salesmen** to sell Premiums to Bakeries and other merchants. \$200.00 per month easy. National Premium Co., Gallon, Ohio.

**12 PAIR Men's Pure Silk Hose** cost you only \$1.00 on our co-operative plan. Approved by U. S. Supreme Court. Money back if dissatisfied. Send \$1.00, stating size and color wanted. Conley Sales Co., Dep. F, 186 N. LaSalle St., Chicago, Ill.

**SELL finest quality line Waterproof,** high top boots and work shoes made in the country. We are the largest concern in this field. Write for new free sales Manual at once. Carson Shoe Co., Essex Station, Boston, Mass.

**TIME-SAVER Rubber Half Soles** becoming popular as rubber heels. Something new. Big seller. Quick money. Sell on sight all retail trade and direct. Outwear leather. Cost half. User attaches. No nails. Best season now starting. Write today for the Timesaver facts or send forty cents and pencil outline of shoe sole for your pair if you want to get started at once. Timesaver Co., 771 Arcade, Cleveland, Ohio.

**SALESMEN—We will pay you well.** Hardenburg's famous line of Leather Goods, Diaries, Calendars and other Advertising Specialties. Product of forty-eight years' experience. Easy sales, satisfied customers, big commissions. A serious offer for hustling salesmen. No canvassers. H. B. Hardenburg & Co., Inc., 413 Elizabeth Ave., Linden, N. J.

**THE Improved Luminite Window Bulletin.** Motion—Color—Light. Dignified, yet attention compelling. "Any sign any time" quick, easy, with our exclusive patented changeable letter system. Proof increasing merchants sales 100 to 200%. Liberal commissions. Protected territory. 20 minute demonstration often sells. Workers making \$100 to \$125 per week. World-wide distribution. Ask for evidence and sales plan. Display Products Company, 818 Wyandotte, Kansas City, Mo.

**EXPERIENCED Vacuum Cleaner Salesmen** for a cleaner that can be sold to every home. Responsible representatives are making \$500 to \$1,000 monthly. Past seller—sure repeater. Exclusive territory. The Marvel Co., Dept. 76, Hammond, Ind.

**TIRE Salesmen—Sell tires and tube** direct from factory. Complete line, high quality, low prices, liberal commission. Cable Rubber Co., Sandusky, Ohio.

**SALESMEN—Get this big sensational,** order-getting shirt outfit Free. Sell Stylemor Shirts all year round. It's Chicago's Wonder shirt line. Advanced Spring showing of smartest, snappy patterns. Large double swatches, low prices, quick service, makes shirt selling easy. Bellard of Texas made \$16.00 in two days. We deliver and collect. Write today for big free outfit. Stylemor, 81 W. Van Buren, Chicago, Ill. Dept. 1102.

**A PAYING Position** Open to representative of character. Take orders shoes-hosiery direct to wearer. Good income. Permanent. Write now. Tanners Shoe Mfg. Co., 1-410 C St., Boston, Mass.

**BECOME Your Home Town's Leading Business Man.** Big money. Easy work. Selling groceries, coffee, canned goods, auto oils, men's shirts, ladies' hosiery direct to consumer. Undercut competition. Commission advanced. Liberal credit plan. No experience or capital necessary. Lovrin & Browne Co., 1775 So. State, Chicago.

**SALES Manager** for largest Eastern Tailoring House. To secure direct sales force. Superior line \$29.50 up. Extra trousers free. Large commissions. N. E. Wholesale Tailors, Harrison Ave., Boston, Mass.

**DISTRICT Manager—Largest New England House.** Suits, overcoats, \$23.50 factory to wearer. Largest commissions. Possibilities \$5,000 up. Boston Wholesale Clothing, 47 Beach, Boston.

**SALESMEN: Write your name and address** on a card and mail to us. We'll show you sure earnings of \$20.00 a day. Will you risk one minute and a one cent stamp against \$20.00? Mind you, we say we'll show you. Address Dept. 811, William C. Bartlett, Inc., Chicago.

**DISTRICT Salesman: Must be reliable.** Prefer married man, 30 years old or over and permanent resident. Exceptional opportunity for good man. Address Sales Manager, 844 West Adams, Dept. 213, Chicago.

**MR. BRUSH Salesman:—Old Established** New York Brush Manufacturer requires the services of men in all territories to sell their extensive line of Sanitary Twisted in Wire Brushes. We pay larger commissions than any other Brush House in the country. Write immediately for our proposition. Wire Grip Sanitary Brush Corp., 15 Mercer St., New York.

**SALESMEN: write for particulars** of an interesting and profitable business, selling and operating aluminum refillable salesboard, Square Hole Board Co., 120 Scheerer Ave., Newark, N. J.

**BEST Seller.** Jean Rubber Repair for tires and tubes; supersedes vulcanization at saving of over 800%; put it on cold vulcanizes itself in two minutes; guaranteed to last life of tire or tube; sells to every auto owner and accessory dealer. Get particulars how to make big money and free sample. Amazon Rubber Co., Philadelphia, Pa. Dept. 510.

**\$50.00 DAILY Selling Salesboards—Make** up to \$33 on single sale selling largest, lowest priced line; no sample to carry; write for 3-color catalogue and full particulars. Lincoln Sales Co., Dept. E, 9 So. Clinton, Chicago.

**TAILORING Salesmen: Our guaranteed** \$23.50 and \$31.50 tailored to order suits are \$10 to \$20 cheaper than store prices; commission in advance; monthly bonus; protected territory; beautiful assortment 6x9 swatches free. Our national advertising campaign makes selling easy—big repeat business. DeLonge's record \$343 in one week. In one state alone 47 men average \$57.18 weekly. J. B. Simpson, Dept. 1174, 843 Adams, Chicago.

**DISTRICT Agents—For Union Made** pure wool suits and topcoats retailing at \$23.50, none higher. A remarkable line of 45 beautiful fabrics tailored by a large and well known old established firm, sold only thru our own stores and district agents. A real opportunity for any good man. Big money to start and chance for advancement. We furnish large sale outfit, 9x13 cloth samples. Men over 30 years of age with tailoring or clothing experience preferred. Can use ambitious spare time men in smaller towns. Interested only in serious men who seek a future. Write for free samples and full information. Address M. V. Harvey, Mgr., Box 00, Chicago.

**TAKE orders** for coffee, sugar, flour, meats, canned goods, staple groceries; also paints, radio sets, tires, auto and tractor oils. No capital or bond required. We deliver and collect. Permanent business. Big pay. Write at once. Hitchcock-Hill Co., Dept. 50, Chicago.

**SIDELINE—Good Commission.** Printed Advertising Tying Tape; well introduced; sold to any line business; pocket samples. Neuer, 75 Grand Street, New York.

**SALESMEN Wanted.** Necessary product, no competition. Rapid Sales Co., 687A Main St., Worcester, Mass.

**SIDELINE Salesmen—35c article** eliminates automobile accidents; fast seller; over 400% profits. Sample free. Klear-Vu, 625 Buder Bldg., St. Louis, Mo.

**SELL Men's High Top Boots and Waterproof Quality Work Shoes** factory to Wearer. Our new sales manual will put you in the big earning class in twenty-four hours. Write for free copy today. Carson Shoe Co., Essex Station, Boston, Mass.

**EASY Selling Specialty.** Beautiful, Attractive, Appealing, Luminite Window Bulletin. Increase merchants' business 50% to 100%. Protected territory. \$8 commission on each \$20 sale. Thousands being sold; sells itself on demonstration. Display Products Co., Ltd., 106 Gibraltar Bldg., Kansas City, Mo.

**TRAVELING Salesmen** calling on retail stores wanted by large manufacturer to sell unique line of business-boosting articles. Year round, fast selling, main or side line. If not earning \$150 weekly, address Union Specialty Works, Inc., 222 Charles St., Booneville, N. Y.

**SALESMEN** wanted in exclusive territories by an old established concern, to call on factories, hospitals, schools, department stores, institutions, cemeteries and public buildings. Wonderful advertising co-operation. Proposition will pay from four to ten thousand a year to right man. C. B. Dolge Company, Westport, Conn., Sales Department.

**YOUR trade** uses salesboards. Make up to \$35 on single sale. Largest, lowest priced line. No samples to carry. Elaborate 3-color catalog free. Lincoln Sales Co., Dept. D, 9 So. Clinton, Chicago.

**IF You Think** in Terms of \$6,000 the First Year write Us Now. Strong line for retail stores. Nationally advertised. Established concern. Best season now starting. Liberal weekly advance to producer. The Continental Co., 1922 Euclid, Cleveland, Ohio, Dept. 200.

**SELLS for \$9.75.** Prints ad on wrapping paper, envelopes, etc. \$1.00 commission. Send 10c for sample work. Automatic Ad-Stamp, Joplin, Mo.

**MEN Wanted—to sell dependable** fruit trees, shrubbery, etc. Steady demand. Complete cooperation. Pay check weekly. Write Perry Nurseries, Dept. B, Rochester, N. Y.

**CALIFORNIA Rosebuds** selling like hot cakes. Agents coining money. Absolutely new. Big profits. Catalog free. Mission Factory SP, 519 No. Halsted, Chicago, Ill.

**\$60-\$200 A WEEK.** Genuine Gold Letters for store windows. Easily applied. Free samples. Liberal offer to general agents. Metallic Letter Co., 438-B North Clark, Chicago.

**SALESMEN** Can make \$5.00 a day selling our Calendars, Pencils, Signs, Advertising Novelties, Yardsticks, Whistles, etc. Liberal terms. Sells entire year. Fine side line. Local and traveling agents. Model Calendar Co., Dept. 226, South Bend, Ind.

**FOUR \$7.50 sales** to merchants net you \$20.00 daily. Sayers Systems, 2803 Sheffield Ave., Chicago, Ill.

**SALESMEN—Become Independent.** Own Your business, experience unnecessary selling our \$7,500 Accidental Death; \$50 Accident; \$25 Sick Weekly Benefits—\$12.50 Yearly. Other Amounts proportionate. Guaranteed steady income from renewals. \$250,000 Deposited Insurance Department. Universal Policy, Dept. A, Newark, N. J.

## HELP WANTED

WHY not sell us your spare time, \$2 an hour, \$19.70 daily easy for full time. Introducing New Style Guaranteed Hosiery for men, women, children, 57 styles, 40 colors, including silks, lises, chiffons. No capital or experience required. Just write orders. We deliver and collect. Your Pay Daily; also monthly bonus. Free auto offer besides. We supply samples. Maceochee Textile Company, Card 2603, Cincinnati, Ohio.

RAILWAY Postal Clerk, City Post Office Clerk, City Letter Carrier, Rural Letter Carrier positions highly desirable; obtainable only through competitive Civil Service Examinations. Highly helpful correspondence instruction for reasonable charge. Inquiries solicited. Federal Correspondence School, Inc., Kellogg Building, Washington, D. C.

BUILD splendid business making chipped glass number and name plates, signs checkboards. Write for particulars. Simplex Utility Co., 1133 Broadway, New York.

MEN, women wanting government position \$1,700 to \$2,700 yearly, write Central Institute, Centralia, Ill.

10,000 APPLICANTS to operate Art, Gift Shops, Tea Rooms. Write for particulars. Unit Art Works, Dept. A2, 422 Lenox Ave., New York City.

HOTELS Need Trained Men. Nationwide demand for high-salaried men; past experience unnecessary. We train you by mail and put you in touch with big opportunities. Big pay, fine living, interesting work, quick advancement; permanent. Write for Free Book "Your Big Opportunity." Lewis Hotel Training Schools, Suite J-351, Washington, D. C.

IMMENSE Profits Silvering Mirrors at Home. Plating like new, brassy worn-off autoparts, reflectors, tableware, stoves, refinishing metalware, etc. We train you. Plans Free. Sprinkle, Plater, 77, Marion, Ind.

"UNCLE SAM" Wants You. Steady jobs. \$95-\$225 month. Sample examination coaching free. Write immediately. Franklin Institute, Dept. N-16, Rochester, N. Y.

QUALIFY for \$150-\$300 railroad jobs. Fireman, Brakeman, Baggageman, Sleeping Car or Train Porter. 810 Railway Bureau, East St. Louis, Ill.

LOCOMOTIVE Firemen for railroads nearest their homes—everywhere; beginners \$150-\$250 monthly; promoted, locomotive engineer, \$3,000-\$4,000 yearly. Best paying positions on railroads. Railway Association, Desk M1, Brooklyn, N. Y.

MEN, 18 up, wanting U. S. Mail Service positions, \$142 to \$225 monthly; steady; experience or correspondence course unnecessary; particulars free. Write P. Bradford, 112 N. 50th St., Philadelphia, Pa.

\$35.00 WEEK. Boys—men. Learn Auto repairing. Sample lessons free. Franklin Institute, Dept. N-400, Rochester, N. Y.

ARE you old at forty? See our advertisement on page 153 of this issue. The Electro Thermal Company, 2137 Main St., Steubenville, Ohio.

GET posted—good prices paid for butterflies, insects. See Sinclair display advertisement, page 42.

\$158 MONTH. Railway Postal Clerks. Men 18 up. 25 coached free. Write immediately. Franklin Institute, Dept. N-16, Rochester, N. Y.

66 MILES on 1 gallon—Scientific Gas Saver. All autos. Demonstrating model free. Critchlow, H-132, Wheaton, Ill.

U. S. GOVERNMENT wants men. \$1,700-\$1,900 and up at start. Railway Mail clerk examination coming. Let our expert (former Government examiner) prepare you for this and also Rural Carrier, Post Office, Customs, Internal Revenue, and other branches. Write today for free booklet. Dept. 3, Patterson Civil Service School, Rochester, N. Y.

DON'T prepare for any Civil Service Examination without seeing our catalogue. Free. Columbian Correspondence College, Washington, D. C.

MAKE Money, silvering mirrors, refinishing auto headlights, tableware; metal plating, bedsteads, chandeliers. Outfits furnished. International Laboratories, Dent. 71, 309 Fifth Ave., New York.

COMMENCE \$142-\$158 Month. Mail Carriers, Railway Mail Clerks. Men 18 up. Travel—see country. Sample coaching—free. Write immediately. Franklin Institute, Dept. N-16, Rochester, N. Y.

WANT a U. S. Government Job? \$1,140 to \$3,000 year. Become Railway Mail Clerks, (Travel—See your country) Rural and City Mail Carriers, Post-Office Clerks, Clerks in Government offices. Steady work. Paid vacations. Experience unnecessary. Full particulars and sample coaching—free. Write immediately. Franklin Institute, Dept. N-3, Rochester, N. Y.

WE need more men for Railway telegrapher service in and out of Chicago. No experience required. Day work. Salary \$20 to \$30 while in training. Call or write W. H. Dye, Supt. Room 1114, 159 No. State St., Chicago.

\$158 MONTH. Railway Postal Clerks. 25 coached free. Write immediately. Franklin Institute, Dept. N-16, Rochester, N. Y.

MEN Wanted—prepare as firemen, brakemen, colored train or sleeping car porters, wire for application blank; experience unnecessary; first class roads, no strike. Name position wanted. Railway Institute, Dept. 35, Indianapolis, Ind.

MEN wanting forest ranger, railway mail clerk and other govt. positions. Write for particulars. Mokane, B-23, Denver, Colo.

BECOME a Landscape Architect. Uncrowded profession of wonderful opportunity for money-making. Easily mastered by mail. Earn while you learn. Write for book. American Landscape School, 56-E, Newark, N. Y.

STEAMSHIP Positions—Europe, Orient. Good pay. Experience unnecessary. No compulsory service. Send stamped addressed envelope for list. Box 30-X, Mount Vernon, N. Y. or Box 336-A, Santa Monica, Calif.

\$115-\$400 MONTHLY paid—By. Station—office positions. Free passes, experience unnecessary. Write Baker, Supt., (ABT) Star Bldg., St. Louis, Mo.

SILVERING Mirrors, French plate. Easily learned; immense profits. Plans free. Address, Wear Mirror Works, Dept. 34, Excelsior Springs, Mo.

ALL men-women, 18-60, wanting to qualify for Government Positions, \$140-\$225 monthly, local or traveling, write Mr. Ozment, 101, St. Louis, Mo., immediately.

STORIES, poems, plays, etc., are wanted for publication. Good ideas bring big money. Submit manuscripts or write Literary Bureau, 522, Hannibal, Mo.

EARN \$10 daily silvering mirrors, plating and refinishing metalware, auto, chandeliers, bedsteads, headlights. Outfits furnished. E. Decle Laboratories, 1133 Broadway, New York.

FINGER Print Experts—Excellent paying positions; particulars free. Finger Print Headquarters, 188 East 79th, New York.

INVENTORS desiring to secure patents should write for our book "How to Get Your Patent," tells our terms and methods. Send sketch for our examination and instructions without charge. Randolph & Co., Dept. 418, Washington, D. C.

MAKE money writing Photo-plays; details free to beginners. No correspondence course. Producer's League, 230 Wainwright, St. Louis.

MEN wanting forest ranger positions, \$1,500-\$2,400 year. Write for free particulars of exams. Mokane, B-21, Denver, Colo.

## INFORMATION

ACCURATE, specific information on any one subject \$2. National Information Bureau, 316A Shepard Building, Grand Rapids, Mich. Prompt service, satisfaction guaranteed.

ADVICE on any subject \$1.00. Universal Bureau, 3610 Enright, St. Louis, Mo.

AUTOMOBILES: 753 ideas on repairing and improving, in Popular Mechanics three new books: Auto Repairman's Handbook, Auto Owner's Handbook, Auto Tourist's Handbook. Send No Money. Just write a postal. Pay postman the postage and \$1.50. Popular Mechanics Press, Room 803, 209 E. Ontario St., Chicago, Ill.

## BUSINESS SERVICE

BUSINESS Problems Solved—all kinds—buying, selling, financial, increasing business, advertising, getting men, getting positions, special formulas, processes, etc. Long business experience, thorough research, complete files of information. Complete solution of problem \$3, particulars free. Satisfaction guaranteed. All confidential. National Information Bureau, 316F Shepard Building, Grand Rapids, Michigan.

MAKE 'Em Pay—My system will make them pay their bills. Write for the acid test. Literature free. Burtleigh L. Horr, Horr Omelia Block, Rhinelander, Wis.

CHARTERS—Delaware; best, cheapest; free forms. Colonial Charter Co., Wilmington, Del. (99)

DELAWARE Incorporator. Charters; Fees Small; forms. Chas. G. Guyer, 901 Orange St., Wilmington, Del.

HAVE a Broadway-New York City office address. \$3.00 month. Mail forwarded daily. Ford's Service, 929 Broadway.

REPRESENTATION in Washington, D. C. Mail address. Information, Anything, Anytime. Service, 517 Kresge Bldg.

## TYPEWRITERS AND SUPPLIES

UNDERWOOD Typewriters—only \$3.00 down. Easy monthly payments. Low prices at less than manufacturers. 10 days' free trial. Rebuilt, all worn parts replaced. Just like a new machine. 5-year guarantee. Write for a big free catalogue C-151. Shipman-Ward Mfg. Co., 1513 Shipman Bldg., Chicago, Ill.

TYPEWRITERS All Makes. Save One-half. Thoroughly rebuilt in our factory to the famous "Young Process." Fully guaranteed. Free trial. We handle all standard makes. Cash or sold on easy terms. Write for catalog. Young Typewriter Co., Dent. 5753, Chicago, Ill.

100 TYPEWRITERS Free. Overstocked. Rent rebuilt Underwood or Remington \$3.00 month. If you pay its value in rental, we give machine free. Particulars free. Pittsburgh Typewriter Exchange, 945 Hersch Bldg., Pittsburgh, Pa.

TYPEWRITERS. All Models, used and rebuilt, at lowest prices. Send for price list before buying elsewhere. We save you money. Big Money-Making Plans free with order. Keith's Supply House, Dept. A, Long Branch, N. J.

TYPEWRITERS, all standard makes. \$10 up. Fully guaranteed. Free trial. Write for complete illustrated lists. Northwestern Typewriter Exchange, 121 N. Francisco Ave., Chicago.

TYPEWRITERS, Checkwriters, Adding Machines. Real bargains. Write for list. Earl Warring, Parkersburg, Iowa.

USED L. C. Smith \$5, 2 color ribbon—back spacer \$18.50. Used Oliver \$18. Ray, 296 5th Ave., New York.

TYPEWRITERS—portable, standard, visible, \$2-\$35. Rent. Motorcycles \$10-\$75. Knight, 1512 Locust, St. Louis, Mo.

TYPEWRITER Ribbons of Quality Priced Right. Write. Midwest, Box 47, Springfield, Ill.

TYPEWRITERS—All Makes; Wonderful Values. Typewriter Bargain House, Ada, Okla.

## PRINTING, ENGRAVING AND MULTIGRAPHING

TYPE, Rule, Border, Ornaments, Novelty, Leads, Slugs, Multigraph Type. Highest quality, lowest prices, immediate shipment. Send for catalogue. Trade Monotypers, 702 Pennsylvania Ave., Baltimore, Md.

\$3.00 DELIVERED. 500 Watermarked Bond Letterheads, 8½x11, and 250 envelopes, money with order. Job Printing Specialty, National Printing Company, Goshen, Ind.

250 EACH Hammermill Bond Letterheads, Envelopes, \$3.00. Samples. Midland Press, 543 West Hickory, Kankakee, Ill.

GUMMED Labels, 500 name and address, 2 lines 35c, 3 lines 55c. Catalogue. Eastern Label Co., B. Clintonville, Conn.

5,000 LOTS 5½x8½ Circulars, \$9.50; Ad. Slips, \$4.75; 3½x5 Four-page Folders, \$13.75. All Printing Lowest Prices. Elegant Samples Free. Good's Printery, Harrisonburg, Va.

1,000 LETTERHEADS \$3.00; 1,000 Envelopes \$2.75. Samples. Riley-Zaur Company, 1517 S. 48th Court, Cicero, Ill.

225 BOND letterheads, envelopes, billheads, cards, \$1.25 each. Combination, \$4.00. Economic Press, Leonia, N. J.

GET Our Prices and House Magazine. Jacobus Service, Irvington, N. J.

PICTURES make printing Powerful. Cut Catalog 10c. Superior, 3127 Grand River, Detroit.

BUSINESS and Professional Stationery at prices that are right. The Arrow Press, Kankakee, Ill.



**GUMMED Labels**, with name, business and address, 500-25c; 3,000-\$1.00. Label Printers, Valhalla, New York.

200 **PRINTED Bond Envelopes** \$1.00. Hobert Humphrey, 2521 Louise Ave., Knoxville, Tenn.

**CIRCULARS, Folders, Catalogs, Advertising Literature** our Specialty. Reasonable prices; prompt service. Prices, samples free. Established 1891. McCafferty Printing Co., Washington, Ind.

500 **THREE line stickers** 25c. 500-6 1/2 white envelopes, \$2.00, prepaid. Cope, 233P, Champaign, Ill.

**LETTERHEADS** Blue or Grey, envelopes to match. Samples. "Q" Shop, Roaring Spring, Penna.

**EMBOSS your Stationery** with Hand Embosser. Circular Free. Midwest, Box 47, Springfield, Ill.

1,000 **HAMMERMILL Bond letterheads**, \$3.00; envelopes, \$3.50; plus postage; satisfaction guaranteed. Amherst News Co., Amherst, Ohio.

200 **GOOD Quality white envelopes** printed, \$1.00. Satisfaction guaranteed. Whitlock Press, Box 232, Washington, D. C.

1,000 **LETTERHEADS** or Envelopes, \$3.00. Sent Prepaid. Samples Free. Monitor Press, Morrisville, Pa.

**"NEARGRAVURE-EMBOSO"** (type embossed)—500 fine, Plain, Ripple Bond Letterheads, Special \$5.75 postpaid. Solidays, Knox, Ind.

**MULTIGRAPHED letters** \$3 thousand. Manuscripts typed 75c thousand words. Excel Service, 135 Liberty St., New York.

5,000 **BOND Letterheads** \$11.75. Ewan, 49 Pearsall Ave., Jersey City, N. J.

1,000 **NOTEHEADS** \$2.60; Business Cards \$2.60. 1,000 Letterheads \$3.00; 5,000 \$9.40. 1,000 Envelopes \$3.00; 5,000 \$11.20. Samples. Moulton Printing Company, 1410 E. 8th, Kansas City, Mo.

**WE print Stationery, Booklets, Catalogs, Circulars. Samples. Commercial Press, Batavia, Ohio.**

250 **LETTERHEADS**, 250 white envelopes printed and mailed \$3.00. Samples printing free. Sunco, Mohawk, N. Y.

**QUALITY Printing! Reasonable Prices!** Send for Free Standardized samples and prices. Folders, Circulars, Catalogs our specialty. Ernest Fantus, 525 South Dearborn, Chicago.

500 **BOND letterheads**, printed, prepaid, \$1.60; 500 envelopes, \$1.60. Roe, Art Printer, Carleton, Mich.

1,000 **LETTERHEADS, Envelopes, Cards**, \$3.00 postpaid; 500, \$2.25. Samples Free. Art Servis Press, 68 Houghton, Worcester, Mass.

#### PRINTING OUTFITS AND SUPPLIES

**PRINT your own cards, stationery, circulars, paper, etc.** Complete outfits \$8.85; Job Presses \$12, \$35; Rotary \$150. Print for others; big profit. All easy, rules sent. Write for catalog presses, type, paper, etc. Press Company, A-11, Meriden, Conn.

**PRE-USED Printing Presses.** Type supplies. List for 2c stamp. Popular Bargains, Richland, Pa.

**PRINTING Outfits—Presses, type supplies, type novelties.** Send stamp for catalogue. Model Press, York, Penna.

#### DUPLICATORS AND DEVICES

**YOU can make 50 to 100 copies** of a letter, notice, etc., at a cost of three cents on a Heyer Quality Duplicator. Write for free trial offer. The Heyer Duplicator Co., 14 S. Wells St., Chicago, Ill.

#### ADDING MACHINES

**NEW \$3.50 Automatic Adding Machine.** Adds, Subtracts, Multiplies. Absolutely accurate. Capacity 999,999.99. Fully guaranteed. 75,000 pleased users. Makes adding easy, positive, quick. Eliminates Mistakes. Saves Time. Postpaid \$3.50. Bassett Co., 1458 R. Hollywood Ave., Chicago.

**FREE Trial.** Marvelous new Adding Machine. Adds, Subtracts, Multiplies, Divides, automatically. Work equals \$350.00 machine. Price only \$15.00. Speedy, durable, handsome. Five-year guarantee. Used by largest corporations. Write today for catalog and free trial offer. Lightning Calculator Co., Dept. E, Grand Rapids, Mich.

#### MAILING LISTS

**MAILING Lists** for every need. 1,500 Classified names just off the press \$1.00. J. C. Fuchs, Sterling Place, Longmeadow, Mass.

2,000 **SPORTSMEN'S addresses** \$5.00. Earl Warring, Parkersburg, Iowa.

**NAMES**—new 1926 lists New York State Auto owners. Every one a prospect. \$5.00 a thousand. Earle Supply Co., Star Lake, N. Y.

#### FOR SMOKERS

**TOBACCO**—Kentucky Sweet Leaf. Smoking, 15 lbs., \$2.00; Chewing, 15 lbs., \$2.50. C.O.D. Ernest Choate, C35, Wingo, Ky.

#### BOATS AND LAUNCHES

**BUILD your own boat:** Newly designed, Speedy V-Bottom out-board motor, runabouts, Cabin Cruisers, Knock-down or patterns. 55 Models. Send 25c for catalogue. Brooks Boat Co., Inc., Rust Ave., Saginaw, W. S., Michigan.

**HOW to Make Your Boat Leakproof.** Send for Booklets. L. W. Ferdinand & Co., 152 Kneeland St., Boston, Mass.

**SPEEDY boat,** Ford propelled, easily built; Blueprint and directions, sixty cents. Marine Cooler booklet free to Ford boat-owners. C. C. Hubbell, 4B East Ave., Norwalk, Conn.

**MAKE 16' Rowboat;** blueprint 30c. Weesho-Uco, 31st Office, Detroit.

**BUILD your own boat.** Do your own concrete work. Two new books tell how to make 21 kinds of boats and 173 articles from concrete. Each book filled with pictures. Send No Money. Just write a postal and say, "Send Popular Mechanics Boat Book and Concrete Handbook." Pay postman postage and \$1. Popular Mechanics Press, Room 803, 200 E. Ontario St., Chicago, Ill.

#### OPTICAL GOODS

**WONDERFUL Microscopes** magnifying 500 times, equipped with additional high powerful lens useful for many purposes. \$1 C.O.D. Richard Valles, 142 Pearl St., Brooklyn, N. Y.

#### FOR MEN

**CARPENTERS: Popular Mechanics Carpenters' Handbook** is filled with ideas for those who like to tinker with tools, and for professional carpenters. 40 articles on saws and sawing, 17 on benches and bench equipment, 22 on doors and door hanging, 18 on lumber, 13 on mitering, 74 on tools and their care, 22 on shop equipment, and many others—306 in all, and 229 illustrations. Send No Money. Just write a postal. Pay postman postage and \$1.50. Popular Mechanics Press, Room 803, 200 E. Ontario St., Chicago, Ill.

#### RAZORS AND BLADES

**RAZOR Blades** Sharpened. Our New Process insures Keen blades—Smooth shaves. Double Edge Blades 35c dozen; Single 25c. Trial Offer until April—Four dozen double or Five single edge sharpened, \$1.00 postpaid. Fisher & Smith, Piqua, Ohio.

**DULL Safety razor blades** Hollow-Ground better than new. (Patented Process.) Gillette, Durhams, 45c—all others 35c Dozen. Mail two blades for Free Trial. John Henry Company, 323 Gloyd, Kansas City, Mo.

#### FOR THE HOME

**MEN! Women! Make \$1 an Hour** at Home. Weaving Colonial Rugs, genuine fluff rugs, fancy fabrics, from new and other materials. Home weavers always busy. You learn in 30 minutes. We guarantee it. Looms now as low as \$9.90. Liberal Pay-As-You-Weave terms. Solve your money problem by writing for Free Loom Book today. Union Loom Works, 480 Factory St., Roanville, N. Y.

**FURNITURE: Make Furniture** at Home. Popular Mechanics books tell how to make all pieces. "Mission Furniture and How to Make It, Book 1, Book 2, Book 3." Send No Money. Just write postal. Pay postman postage and \$3. Popular Mechanics Press, Room 803, 200 E. Ontario St., Chicago, Ill.

**MODELS of ancient ships—How to build them.** Plans and instructions of Clipper Ship, 82c; Santa Maria, \$1.02; Pirate Ship, 52c; or all for \$2.35. Richter & Stroesser, 405W Eleventh Ave., Milwaukee, Wis.

**GRANDFATHER'S Clock Works.** \$5.00. Build your own case; Instructions free; make good profits selling your friends. Clock works with chimes for old or new cases. Write for full particulars. Clock Co., Ruffner St., Philadelphia.

**POCKET Postal Scales,** capacity 16 ounces, 69c. "Erie," Waukegan, Ill.

**FOODS from Twenty Lands.** Popular Mechanics new Cook Book made up of recipes sent by our readers from 20 countries. Many delightful foreign dishes, and many American ones, too. Only a few copies for sale. Send No Money. Just order on a postal. When postman hands you book, pay \$1.50 and postal charges. Popular Mechanics Press, Room 803, 200 East Ontario St., Chicago, Ill.

#### DIAMONDS, WATCHES AND JEWELRY

**HIGH-GRADE Watches, Rings, Pearls,** Extra Cheap. Ralph B. Pile, Somerset, Pa.

#### WATCH REPAIRING

**ALL makes of watches** repaired by experts. Estimates given first; watches returned prepaid if price is unsatisfactory. Write. International Watch Service, 5P, Fordham Station, New York City.

#### ANTIQUES, WAR RELICS AND INDIAN GOODS

**RELICS** from Europe's battlefields. Weapons, medals, etc. Illustrated catalogue 25c (with sample War Photographs). Lieut. Welsh, 1889 Albany Ave., Brooklyn, N. Y.

**SEND 5c for fine, new list** Indian relics, antique firearms. F. E. Ellis, Webster Groves, Mo.

#### PHONOGRAPHS AND SUPPLIES

**NEW invention** produces rich, mellow, pleasing tone from phonograph (except Edison). Volume. Tone variety. Eliminates scratching. Surprising. 50c. Particulars. F. Gerwin (University), Shawnee, Okla.

**BUILD your own Phonograph.** We furnish everything. Phonograph Parts and Radio catalog sent free. American Phonograph Co., 3752 Belmont, Chicago.

**BUILD Your Phonograph.** Spring Motors, Electric Motors, Tonearms, Amplifiers, Accessories. Latest Equipment also in Radio Mechanism and Cabinets. Catalog mailed for ten cents. Hoosier Mfg. & Supply Co., 313 Baldwin Block, Indianapolis, Ind.

#### MUSIC AND MUSICAL INSTRUMENTS

**BAND and Orchestra Instruments—All** makes of new and used instruments sold, exchanged and repaired. Standard and popular music sold. Write today for catalogue and Free subscription to "Musical Booster" magazine. "Deal with the Professional House." Crawford-Rutan Co., 1051 Grand Ave., Kansas City, Mo.

**"MUSIC Composed"** to words. Bauer Bros., (formerly of Sousa's Band), Oshkosh, Wis.

**VIOLINS, Deep, Mellow, Soulful—on credit.** Easy terms for wonderful instrument. Get details today. Gustav F. Henning, 2424 Gaviard St., Denver, Colo.

**PIANO Jazz: Teaches Ear Playing.** Negro Harmony, Player Piano Effects, Chimes, Blues, Chords, Sweet Harmony. Particulars Write "Piano Bill," Toronto 3, Canada.

**BIG Song Hit!** "When Eve Was Absent Without Leave." Copy, 30c. L. A. Wachlin, Sayville, N. Y.

**DRUM outfit.** De Luxe finish, 10 articles, new \$48.50, cost \$125.00. Bedford Instrument Co., Maple Heights, Bedford, Ohio.

**SECRETS of Trumpet** playing \$1.50. Fred Elias, Trumpet Instructor, 3343 So. 17th St., Omaha, Nebr.

**I WANT Song Poems.** Casper Nathan, 2544 N. Racine, Chicago.

**WRITE Songs.** Big money and reputation. Write for information. J. Gordon Pub. Co., 201 N. Hoyne Ave., Chicago.

**SONG Hit** Writer Wants Song Poems. Box 801, Cincinnati, Ohio.

**COMBINATION Vanity Bag** Ukulele. Easily made. Blueprint 25c. William Quemore, Camden, N. J.

**PLAY Piano** by Earl! A Sound system. Write for free booklet. You'll be glad you did! Boucher's Harmony Studio, 127 Metcalf St., Ottawa, Canada.

**SONG Poem Writers—write Ray** Hibbeier, Dl, 2104 N. Keystone Ave., Chicago.

#### PATENT ATTORNEYS

**PATENTS.** Time counts in applying for patents. Don't risk delay in protecting your ideas. Send sketch or model for instructions or write for Free Book "How to Obtain a Patent" and "Record of Invention" form. No charge for information on how to proceed. Communications strictly confidential. Prompt, careful, efficient service. Clarence A. O'Brien, Registered Patent Attorney, 58-E Security Bank Building (directly across street from Patent Office), Washington, D. C. See pages 140 and 141.

**PATENTS—Write for our Guide** Books and "Record of Invention Blank" before disclosing inventions. Send model or sketch of your invention for Free Inspection and Instructions. Terms Reasonable. See advertisement on pages 141 and 143. Victor J. Evans & Co., 934 Ninth, Washington, D. C.

**PATENT** Procured. Prompt Service. Personal, careful and efficient service. Highest references. Moderate fees. Send sketch or model for actual search and advice. George P. Kimmel, Master of Patent Law, 55E Legal Bldg., Washington, D. C.

**SAMUEL GOLDSTEIN**, Registered Patent and Trade-Mark Attorney, formerly member Examining Corps, United States Patent Office. Reasonable charges. Prompt service. Write for particulars. No. 1440 Broadway, New York, N. Y.

**STRONGER** Patents at reasonable prices—drawing, specification, claims, \$20. Send description of invention with half fee. Prompt, efficient action. American Patents Corporation, Barrister Building, Washington, D. C.

**COMMERCIALIZE** your inventions according to My Cooperation Plan before patenting. Write for booklet. Ralph Burch, Patent Lawyer, Jenifer Building, Washington, D. C.

**PATENTS**, Trade marks, copyrights, prompt, personal, reliable service. Over 36 years' active practice. Write for terms. Book free. Address E. G. Siggers, N. U. Bldg., 918 F Street, Washington, D. C.

**MONROE E. MILLER**, Ouray Bldg., Washington, D. C., Patent Lawyer; Mechanical, Electrical Expert. Booklet and Priority Record blank gratis.

**PATENTS**: My fee in installments. Free personal advice. Frank T. Fuller, Washington, D. C.

**ESTABLISHED 1864**. Milo D. Stevens Company. Free Booklet. Patents, Trade-Marks, Copyrights. Offices, Monadnock Block, Chicago; Barrister Building, Washington, D. C.

**INVENTIONS** Patented; Trade-marks Registered; Reasonable charges; prompt service; plain advice; request particulars. Jaynes & Jaynes, 700 Kellogg, Washington, D. C.

**PATENTS**—Prompt Personal Service. Send for Record of Invention Form. Send sketch or model. References furnished. Write today. Jacobi & Jacobi, Patent Lawyers, 600 Ouray Building, Washington, D. C.

**RICHARD E. BABCOCK**, Patent Lawyer, Washington Loan & Trust Bldg., Washington, D. C. Established 1877. Booklet.

**MILLIONS** spent annually for ideas! Hundreds now wanted! Patent yours and profit! Write today for free book—tells how to protect yourself, how to invent, ideas wanted, how we help you sell, etc. American Industries, Inc., 500 Kresge Bldg., Washington, D. C.

**PATENTS**—Send for form "Evidence of Conception" to be signed and witnessed. Form, fee schedule, information free. Lancaster and Allwine, Registered Patent Attorneys in United States and Canada, 221-Ouray Bldg., Washington, D. C.

**PATENTS**, Trade-Marks, Designs. This Firm has 27 years' experience and gives expert personal service at reasonable rates. We properly protect your invention. Write for free information and exact cost of procuring patent before proceeding. John B. Thomas & Co., 902 F St., N. W., Washington, D. C.

**PATENTS**—Our book "How to Obtain a Patent" sent free upon request. Contains full information about patents, trade-marks and designs. If you will send us a sketch of your invention we will promptly make search of the Patent Office records and advise you as to patentability, our charge for the service being \$5.00. Prompt, efficient service with moderate charge. Over twenty years' experience. Bank and commercial references. Talbert & Talbert, Registered Patent Lawyers, 597 McGill Bldg., Washington, D. C.

**U. S. AND** foreign patents, trademarks; moderate rates, 22 years' experience. George C. Heinicke, 32 Union Square, New York; registered in U. S. and Canada.

**PERCY S. WEBSTER**, 203 Saving and Loan Building, Stockton, California. Long established organization. Send for free book on Patents.

**FRED H. HAYN, M. E.**, formerly First Assistant, Examiner U. S. Patent Office, 24 years' exp. 1. W. Hellman Building, Los Angeles, Calif.

**PATENTS** Procured; Trade Marks Registered—A comprehensive, experienced, prompt service for the protection and development of your ideas. Preliminary advice gladly furnished without charge. Booklet of information and form for disclosing idea free on request. Richard B. Owen, 30-Owen Bldg., Washington, D. C., or 41-R Park Row, New York.

**UNPATENTED** Ideas Can Be Sold. I tell you how and help you make the sale. Free particulars (Copyrighted). Write W. T. Greene, 806 Jenifer Building, Washington, D. C.

**PATENTS**. Booklet free. Highest references. Best results. Promptness assured. Send model or drawing for preliminary examination. Watson E. Coleman, Patent Lawyer, 644 G Street, Washington, D. C.

**INVENTORS**—Write for our Guide Book, "How to Get Your Patent" and Evidence of Invention Blank. Send model or sketch of your invention for our prompt examination and instructions free. Randolph & Co., Dept. 430, Washington, D. C.

**INVENTORS**: Send sketch or model for advice and exact cost of patent. Ask for our Free book: "How to Obtain a Patent." Tells what every inventor should know. Established twenty-eight years. Highest references. Prompt service. Reasonable charges. Chandless & Chandless, 474 Seventh, Washington, D. C.

**MEXICAN** Patent Attorney. Patents and Trade-Marks procured for Mexico. References. R. Alcolea, Donceles 80, Mexico, D. F.

**PATENTS**, Trade-Marks, Copyrights. Very reasonable. Sanders, 7 Rand McNally Building, Chicago, Ill.

**PATENT** Book Free. Charles W. Lovett, Patent Attorney, Lynn, Mass.

"**INVENTOR'S** Advisor," the valuable Patent book with 139 mechanical movements and illustrations, sent free upon request. M. M. Labiner, Patent Attorney, 3 Parkrow, New York.

"**INVENTORS'** Guide" sent free on request: this book contains illustrations of patented inventions and gives valuable information and advice for all who have original ideas or improvements. Frank Ledermann, Registered Attorney and Engineer, Woolworth Bldg., 1712, New York.

**LACEY'S** Patent Sense. Valuable book free. See ad page 144.

#### FOR INVENTORS

**PATENTS**. If you have an invention which you wish to patent you can write fully and freely to Munn & Co., for advice in regard to the best way of obtaining protection. Please send sketches, or a model of your invention and a description of the device, explaining its operation. All communications are strictly confidential. Our Handbook on Patents is sent free on request. This explains our methods, terms, etc., in regard to Patents, Trade Marks, Foreign Patents, etc. "Scientific American" contains Patent Office Notes, Decisions of interest to inventors and particulars of recently patented inventions. Munn & Company, Solicitors of Patents, 623 Woolworth Building, New York; 524 Scientific American Bldg., Washington, D. C.; 1313 Tower Bldg., Chicago, Ill.; 666 Hobart Bldg., 582 Market St., San Francisco, Calif.; 521 Van Nuys Building, Los Angeles, Calif.

**INVENTORS**—Preliminary investigations only to determine if your inventions are patentable. Neither preparing nor prosecuting applications for patents, I am in a position to give you honest opinions. Communications secret. R. Emmitt Patterson, Barrister Bldg., Washington, D. C.

**PATENTS**—Send for booklet. Contains valuable information for inventors. Bank and commercial references. Prompt service, twenty years' experience. Talbert & Talbert, Registered Patent Lawyers, 538 McGill Building, Washington, D. C.

**PATENTS**. Time counts in applying for patents. Don't risk delay in protecting your ideas. Send sketch or model for instructions or write for Free Book "How to Obtain a Patent" and "Record of Invention" form. No charge for information on how to proceed. Communications strictly confidential. Prompt, careful, efficient service. Clarence A. O'Brien, Registered Patent Attorney, 58-E Security Bank Building (directly across street from Patent Office), Washington, D. C. See pages 140 and 141.

**COMPLETE** Inventors' Service. Engineering, drafting, models, experimental and machine work, patterns, castings, inventions perfected. Prices quoted upon receipt of sketch. Buying information on any article \$1.00. Information on any mechanical subject, \$2.00. Technical Research Bureau, Dept. A, 377 National Ave., Milwaukee, Wis.

**WANT** Patent that protects or worthless ornament? My first patents were worthless, now they sell. Write for my 25 years' experience. Henry Fletcher, 53 Cannon St., Bridgeport, Conn.

**INVENTORS**—Write for our Guide Books and "Record of Invention Blank" before disclosing inventions. Send model or sketch of your invention for our free inspection and instructions. Terms reasonable. See advertisement on pages 142 and 143. Victor J. Evans & Co., 157 Ninth, Washington, D. C.

**MR. INVENTOR**. If you have a patent or invention for sale. Write Hartley, 44 Central St., Bangor, Me.

**LACEY'S** Patent Sense. Valuable book free. See ad page 144.

**HAVE** You an Invention? If so, write for our free book, "How to Get Your Patent," tells our terms and methods. Send model or sketch for our free examination and instructions. Randolph & Co., Dept. 144, Washington, D. C.

**GET** your own patents. Legal blanks, complete instructions \$1. Cutting Sons, Campbell, Calif.

**I SELL** Patents. Established in 1900. The only man in America who has spent the past 25 years exclusively at this work. An experience highly valuable to you, if you have a good patent to sell. Charles A. Scott, 773PM Garson Avenue, Rochester, N. Y.

**PATENTS** Procured; Trade Marks Registered—A comprehensive, experienced, prompt service for the protection and development of your ideas. Preliminary advice gladly furnished without charge. Booklet of information and form for disclosing idea free on request. Richard B. Owen, 30-Owen Bldg., Washington, D. C., or 41-R Park Row, New York.

**UNPATENTED** Ideas Can Be Sold. I tell you how and help you make the sale. Free particulars (Copyrighted). Write W. T. Greene, 807 Jenifer Building, Washington, D. C.

**WANTED** Mechanics Earn \$10.00 to \$20.00 a day. Out of the grease. No clock to punch. Opportunity limited. Write today for particulars. Stoner-Harris & Co., Dept. P2, 186 N. LaSalle St., Chicago.

**PATENTS** wanted by manufacturers. Send description. Box 126, Dowagiac, Mich.

**CASHING** in—If you have a practical, useful invention to sell, write promptly. American Patents Corporation, Barrister Building, Washington, D. C.

**PATENTS**: My fee in installments. Free personal advice. Frank T. Fuller, Washington, D. C.

**LEARN** to obtain patents at total cost of \$10 to \$40. Full particulars free. National School of Patent Law, Washington, D. C.

**INVENTORS'** Universal Educator—contains 9000 mechanical movements; 50 perpetual motions. Tells how to obtain and sell patents. Suggests new ideas. Explains how to select your attorney and avoid patent sharks. Price (revised edition) \$2.00 postpaid. Albert E. Dieterich, 621 Ouray Bldg., Washington, D. C.

#### PATENTS FOR SALE

**FOR** Sale: New Invention—Automobile Bumper. Patent 1,564,488—or royalty. Emil Nastri, 396 Marcy Avenue, Brooklyn, N. Y.

**COMBINED** Sash-lift and Window Lock. Light steel stamping (very simple, convenient, effective; universal demand, no competition. Applied by anyone without mortising or removing sash. Low cost and basic patents defy competition. Any reasonable terms if you mean business. Box 185, Fremont, Mich.

**PATENT** just out and is for sale at a reasonable price. Issued Dec. 15, 1925, No. 1,566,261. (Emergency Wheel-Supporting Device). The only invention of its kind out. Here is something for Henry Ford to look at in improving a Ford Car. Communicate with Mr. Ladelfa, Esq., soon, for patent may be sold any day. Philip Ladelfa, Esq., Cuylerville, N. Y.

**OUTRIGHT** or Royalty: Spring lubricating device for Ford Cars. This patented reservoir holds the oil directly against the spring leaves, thereby eliminating all noises and keeps springs rust proof. Easily installed and manufactured for about 10c. L. H. Williams, Box 1177, St. Joseph, Mo.

**PATENT** for Sale: Steam Throttle Reverse. Joseph King, Casselton, N. Dak.

**FOR** Sale—Patent 1,544,168, Gearing Drill Brace. W. E. Nolan, 90 St. Mary's Ave., San Francisco, Calif.

**FOR** Sale—Patent on Draw Bar For Automobiles and Trucks. Self-Steering device. Can be used in garages and on farms. Will sell for cash or part cash and royalty. For full particulars, address W. D. Giddings, Box 35, Fort Pierre, S. Dak.

FOUR patents pending for absolute prevention of daylight bank robberies—Interest for sale. J. B. McCutchen, Bakersfield, Calif.

PATENT Endless Auto Chains. Royalty or partnership. Can be put on in Mudhole. Want Manufactured cheaply. Elton Beck, Herrick, Ill.

WILL place on royalty with reliable manufacturer, patented folding shaving brush with soap holder for bar or tube. Neat, sanitary, convenient. A real article with universal demand. John S. Newlon, Butler, Mo.

FOR Sale or Trade, Patent 1,371,213 on a Coin or no Coin Check operated Hanger for all Approvals, 4 articles secured by Check. Placed anywhere. Address D. A. Heidt, No. 708 Bristol Dr., Utica, N. Y.

OUTRIGHT or Royalty basis newly patented three sided checker board. A novelty game for everybody. Marion P. Hodges, P. O. Box 332, Pacific Grove, Calif.

PANTOGRAPH—patent for. Will sell outright or royalty basis. This is different from others. Geo. Mattila, Box 1371, Los Angeles, Calif.

OUTRIGHT or royalty; simple adjustable newspaper holder; assures perfect comfort while reading. John D. Payne, 252 W. 113rd St., New York.

OUTRIGHT or Royalty; British rights, U. S. pending, adjustable golf club. Shackle in construction and manufactured at a very low cost. W. Elliott, 12424 St. Clair Ave., Cleveland, Ohio.

PATENTS No. 1,562,077, also No. 1,493,800 and No. 1,527,776 for sale. Best offer takes them or each. W. J. Bliffert, 1359 7th St., Milwaukee, Wis.

PATENT on Improved Pie Rack. E. Suter, Box 172, Elizabeth, Pa.

INVENTIONS For Sale—Unusual opportunities. Manufacturers and investors write W. T. Greene, 819 Jenifer Bldg., Washington, D. C.

YOU have a worth-while patent, haven't you? Why don't you tell our two million five hundred thousand readers about it? Most of them are specially interested in patents and new inventions. Ask me to tell you how other inventors successfully sold their patents. M. L. Rund, Manager Classified Advertising, Popular Mechanics Magazine, Chicago, Ill.

#### SURVEYING INSTRUMENTS

LARGEST stock of new and used surveying instruments in the country direct from factory. Satisfaction guaranteed or money refunded. Wissler, 619 N. Broadway, St. Louis.

#### DRAWING INSTRUMENTS AND DRAFTING SUPPLIES

DRAWING Instruments, mail order, all grades, cheaper than store prices. Circulars. Preiluthner, 36 West 88th Street, New York.

DRAFTING. Learn Mechanical Drawing. Big demand for men to make accurate drawings to scale. This pocket-size, cloth-covered book starts you at the beginning and leads you by a series of simple lessons to the more difficult assignments that you would get in an architect's or engineer's office. Send No Money. Just write a postal for "A Practical Course in Mechanical Drawing." Pay postman postage and \$1. Popular Mechanics Press, Room 803, 200 E. Ontario St., Chicago, Ill.

DRAFTSMEN send \$1.00 for magazine, "Drafting." W. D. Browning, Memphis, Tenn.

#### MODELS AND MODEL SUPPLIES

PATENTS. Time counts in applying for patents. Don't risk delay in protecting your ideas. Send sketch or model for instructions or write for Free book "How to Obtain a Patent" and "Record of Invention" form. No charge for information on how to proceed. Communications strictly confidential. Prompt, careful, efficient service. Clarence A. O'Brien, Registered Patent Attorney, 58-E Security Bank Building (directly across street from Patent Office), Washington, D. C. See pages 140 and 141.

MODEL Steam plant for miniature power boats. Fired by Sterno heat. Absolutely safe and easy to handle. Steel boiler with 12 water tubes will keep 50 lbs. pressure with engine wide open. Send 4c stamp for circular S. Model Machine Shop, 417 East 71 St., New York City.

MODEL Steam Engines, Boilers and Model Pipe line fittings. Model Making Supplies. Send 20c for this year's illustrated catalogue and hand book. Bathe Mfg. Co., Dept. D., 5214 Woodland Ave., Philadelphia.

SPECIAL machine builders, tool and die makers, inventor's models, production work of all kinds. Dept. L. Quality Hardware & Machine Co., Ravenswood and Thorndale Avenues, Chicago, Ill.

WE make working models for inventors and do experimental work and carry a complete stock of brass gears and model supplies. Send for catalogue. The Pierce Model Works, Tinley Park, Ill.

THE Modelmaker, a magazine for all interested in making working models. Sample 10 cents. Modelmaker, 122 Liberty St., New York.

#### MANUFACTURING

METAL-CRAFT — Eventually — Metal-Craft. Competent Engineers, Designers and Producing Organization await your commands on dies, stampings, die-casting, deep pressing, screw-machine and wire products. Plating, Enameling, Burnishing, Assembling, Wrapping and Packing to your specifications. Large completely equipped plant which guarantees prompt, efficient service. It is not the quality of raw materials alone, nor the precision in manufacture, and not just the service rendered that has given Metal-Craft the good reputation they bear—but all of these, as a constant certainty, in Combination. Estimates promptly furnished. Metal-Craft Manufacturing Company, Chicago, Box 259-W.

WE design and build special machinery, make models, dies, stamping tools, do general machine work and light manufacturing. Marshall Mfg. Co., Kansas City, Mo.

WIRE goods made to order. Cooley Mfg. Co., 530 N. Western Ave., Chicago.

METAL Stampings, Dies and Special Machinery. Mail us your drawing or sample for estimate. Send for our free catalogue of Model Supplies. The Pierce Model Works, Tinley Park, Ill.

WE design and build special machinery, tools, dies, jigs, and fixtures. Experimental work. Light stamping, quantity production. Reliable Machine Co., 406 West 23rd St., New York City.

WE design and build special machinery. All kinds of machine and engineering work. Supplies etc. TAO Engineering Co., 1025 North Sixth St., St. Louis, Mo.

PATTERNS, wood and metal. Models, tools and dies. Brass, bronze, aluminum and iron castings. Screw machine work, production work of all kinds. Write Modern Machine & Pattern Co., Terre Haute, Ind.

LIGHT stamping and manufacturing. Acme Tool Co., Mason City, Iowa.

OUR factory will make your models, manufacture your articles as well as build your tools, dies and fixtures. Standard Die & Specialty Co., 1932 Austin Ave., Chicago, Ill.

#### MACHINERY, TOOLS AND SUPPLIES

20" WALCOTT Metal shaper \$185.00; 12" Hently metal shaper \$125.00; No. 60 Heald Auto cylinder grinder \$750.00; 14"x5' Prentive engine lathe \$120.00; 17"x8' Champion engine lathe, quick change and taper attachment, \$350.00; 10" Drill press with chuck \$14.25; 24" Barnes drill press with all power feeds \$190.00; five H.P. Electric motor \$60.00; 2 1/2 H.P. Electric motor \$175.00. Terms to suit on single machines or complete shop. Complete line of machinery and supplies. Write for lists. Cincinnati Machinery Supply Co., 218 E. Pearl Street, Cincinnati, Ohio.

"ARTISAN" Lathe! Greatest machine built for Experimenting, Mechanic, Repairman. 11" Swing; 18" Gap; 24" Centers; Graduated Compound; Quick-change Gears. Accurate, compact, powerful. Largest capacity; lowest price. Free Catalog. Write Today. Artisan Manufacturing Company, 831 West Sixth St., Cincinnati, Ohio.

12 H. P. AUTO Steam Engine, Tube Boiler, Gas Tank, Burner, Pumps, Gauges, Complete, best Mechanical Condition. Worth \$500.00. Must go for \$175.00. John A. Statler, R. 6, Martinsburg, W. Va.

SHOP or laboratory is not complete without a Buss-Bunsen for those jobs which require heat. Price 50 cents prepaid. H. Kahrs, Valley Stream, N. Y.

BARGAIN! Brand new machinists' Vises; Swivel Base; 3 1/2" Tool-steel Jaws; fully guaranteed; Retail \$15.00; Our Price—\$9.85 cash with order. Immediate delivery. Service Shop Equipment, No. 214 Elm, Wyoming, Ohio.

CONCRETE Building Block Machines and Molds. Catalogue free. Concrete Machine Co., 5 N. Main St., St. Louis, Mo.

THE Parrish Spring Eye Bender makes a perfect eye up to two inches in diameter on steel up to four inches in width. J. O. Parrish, Pomona, Cal.

#### ELECTRICAL

ELECTRICAL Kinks on all phases of practical electricity are to be found in Popular Mechanics new book, "Electrical Kinks." There are 47 ideas on wiring, 45 on making electrical devices, 19 on lighting, 5 on transformers, 5 on motors, 8 on generators, 11 on switches, 22 on testing, 12 on repairing, 11 on battery manufacture and repair, 5 on telephones, and 9 on electrician's tools. 214 articles, 162 pictures. Send no money. Just write a postal asking for "Electrical Kinks." When the postman hands you the book, pay the few cents postage, and \$1.50 for the book. Popular Mechanics Press, Room 803, 200 E. Ontario St., Chicago, Ill.

DYKE'S Automobile and Gasoline Engine Encyclopedia. Latest edition contains information on repairing and adjusting every part of all motor cars now in use. Tells how to find out what is wrong and how to fix it. Mechanics everywhere depend upon this compendium to keep them up-to-date. Send No Money. Just write a post card. Pay postman the postage and \$6. Popular Mechanics Press, Room 803, 200 E. Ontario St., Chicago, Ill.

#### FOR MECHANICS

KINKS on metal Work. Popular Mechanics New Book, "Machinist's Kinks" contains 419 discoveries of extreme value to anyone who likes to work with metal. For the mechanic, machinist, or for the man who likes to tinker at home. 287 illustrations. Cloth bound. Send No Money. Just write a postal asking for "Machinist's Kinks." When the postman hands you the book, pay the few cents postage and the price of the book, \$1.50. Popular Mechanics Press, Room 803, 200 E. Ontario St., Chicago, Ill.

#### ENGINES, MOTORS AND DYNAMOS

MOTORS \$3.50 Postpaid. Good, Practical, twentieth horsepower, 115 volt alternating-current. Order Now. Send Money-Order. Immediate shipment. Perry Trading Company, Dept. M3, 815 Lake, Racine, Wis.

GUARANTEED 1/2 hp, 110 volt, 60 cycle, single phase, used motors with pulley at \$7.50, cash with order. We repair, rewind, electric motors and generators, etc. Bargains on electric fans. General Distributing Co., Security Storage Bldg., Duluth, Minn.

BARGAINS. A. C. Motors, New 1/2 H.P. General Electric with Pulley \$29.85. All kinds, all sizes, both new and rebuilt. Send for price list. Tell us your needs. Hyre Electric Co., 615 MX So. Dearborn St., Chicago.

BRAND new 1/2 H.P. 110 V. Direct Current motors \$3.75. Also bargains in larger motors. Queen City Electric Co., 1736 Grand Ave., Chicago, Ill.

MOTORS! Brand new, fully guaranteed 1/2 hp.; 110/220 Volts; 60 cycle; single phase. Retail \$42.00; Our price—\$29.25; cash with order. Immediate delivery. Service Shop Equipment, No. 214 Elm, Wyoming, Ohio.

BRAND new 1 KW Westinghouse, 32 volt, 1,150 speed, light and power Generators at \$48.00 each. 25% cash, balance C.O.D. General Distributing Co., Security Storage Bldg., Duluth, Minn.

#### BENDING MACHINES

THE famous Hossfeld Wrenchless Universal Bender is the last word in bending machines; bends metal, cold or hot, into most any conceivable shape, including Eye-bolts and Automobile Spring Eyes. Bends up to 1" bars or 1 1/4" Pipe cold. Used by the largest corporations, yet so inexpensive that even a farm shop need not be without one. Send for circular. Hossfeld Mfg. Co., Box 344, Winona, Minn.

#### BLACKSMITHS

BLACKSMITH Notice: Young smith or handy man make more money doing hard jobs easy. In job shop or factory be a Master Machine and Blow Blacksmith and Expert Tool Dresser. With Colored Tempering Charts. All for One Dollar. Samples Free. W. M. Toy, Sidney, Ohio.

#### FOR SALE—MISCELLANEOUS

PECAN Nuts, genuine mammoth nader-shells, sweet as honey, pound \$1.25; five pounds \$5.00; wholesale price quoted. W. Karstaedt, Grower, Dayton, Ohio.

FOR Sale: Watchmaker's Lathe at a bargain. R. Jaegermann, 5815 Easton Ave., St. Louis, Mo.

MULTIGRAPH Type made from hardest metal. \$1.50 per 1,000 characters. Satisfaction guaranteed. Send for catalogue. Trade Monotypers, 702 Pennsylvania Ave., Baltimore, Md.

FOUR section, neat closing, brass bound telescope sent prepaid, 98c. Carl Peterson, 6619 Glenwood, Chicago.

SHORT Stories, Articles, Poems, What and Where to Sell. Send 50c (no stamps). C. A. Finlayson, Box 127, Laurium, Mich.

ADDRESSGRAPHS. Letter Folders, Multigraphs, Envelope Sealers, Duplicators, less than half price. Guaranteed. Pruitt Co., 117 No. Market, Chicago.

WE take orders for doll beds. Waterloo Doll Bed Mfg., Waterloo, Wis.

PURE Honey. Guaranteed, Five Pounds \$1.25. F.O.B. Here. Sootin, Liberty, N. Y.

MONEL Metal rings, cuff links, watch chains, etc. Send ten cents for complete information. Farman Company, San Antonio, Tex.

FOR Sale to Settle Estate: Stock of 1,000 "Nuway" soap-saver cups, perforated aluminum, to swing under hot water tan. (Advertisement May, 1925, "Modern Priscilla.") Sample to parties interested free, retail 50c. Offers considered on stock, dies, mailing cases. Chas. E. Audinwood, Executor, Derby Line, Vt.

BUY—Exchange—Sell! Many of our readers have for sale or exchange the article you are looking for—and lots of them are looking for the very items you want to turn into cash. Get together! Let our two million five hundred thousand readers know your wishes—they'll help you! Send your ad today to M. L. Rund, Manager Classified Advertising, Popular Mechanics Magazine, Chicago.

ANSWERS to all mathematical problems likely to occur in the office, store, shop, bank, farm, or factory. Explains and simplifies every principle of arithmetic, mechanics and mensuration. Over 2,000,000 sold. Send No Money. Just write a postal and ask for Ropp's Calculator. When the postman hands you the book, pay \$1.00 and the postage. Popular Mechanics Press, 200 E. Ontario St., Room 803, Chicago, Ill.

#### WANTED—MISCELLANEOUS

MAIL us your Platinum, Magneto Points, Discarded Jewelry, Diamonds, Old Gold, Silver, Gold Crowns, Bridgework. Cash promptly mailed. Your goods returned if offer refused. D. Davis, 1726 Roosevelt Rd., Chicago.

CASH for old gold, silver, diamonds, by return mail, sent us in any form. We pay highest prices. If our prices are unsatisfactory, return cash and get your goods right back. Persons in need of ready cash need not hesitate at all; dealings are confidential. Gardner, "The Old Reliable," Dept. B-41, E. 29th St., New York.

WANTED—Small machine tools, lathes, saws, printing presses, type, rubber stamp equipment. My home-office-mail business pays. Stamp, Cothran, 387N Jackson, Atlanta, Ga.

MAIL us your discarded Jewelry. Gold, Crowns and Bridges, Watches, Diamonds, Silver, Platinum, and old False Teeth. Money promptly mailed. Goods returned if offer refused. United States Smelting Works, (The Old Reliable), Dept. 71, Chicago.

CASH Money for diamonds, old gold, platinum, silver, old watches, gold crowns, bridgework. Cash by return mail, Petersen, 2010 S. Division, Grand Rapids, Mich.

#### REAL ESTATE, FARM AND ORCHARD LANDS

WANT to dispose of 24 acre farm in Arkansas. Four room house and barns for cattle. This property is adjoining a railroad and is five minutes' ride from town. Will accept any reasonable offer. Vincent Nedza, 4801 So. Loomis Ave., Chicago, Ill.

STROUT'S Catalog Just Out! Farms, Businesses! Copy Free! Valuable illustrated buyers' guide. Hundreds equipped money-making farms, multitude of village homes, stores, gas stations, auto inns, etc. The pick of 27 states. Free copy saves you time and money. Write today, Strout Farm Agency, 255-P, 4th Ave., New York City.

ATTENTION—Get acquainted. Cash for your property. Farm, Hotel or Retail Store, no matter where located; confidential service. Hayes' Business Agency, Cincinnati, Ohio.

SEIZED and Sold for Taxes. 4 1/2 acres on Georgian Bay, \$40.50. 12 1/2 acres for farm, \$43.20. 25 acres hunting campsite, \$60.30. 50 acres Muskoka Lake District, \$63.00. 100 acres hunting and trapping, \$91.80. 160 acres farm Canadian West, \$315.00. Mining claim near mines that have paid millions, \$378.00. These prices are not first payments, or price per acre, but the total amount asked. Also beautifully situated hunting and fishing camps for moose, deer, caribou, ducks, partridge, trout, whitefish, bass, etc.; best in North America. Summer cottage sites, farms, heavily wooded tracts, acreages large and small, for pleasure and investment, all offered at ten cents on the dollar of their value, and on easy monthly payments of \$5 and upwards. Send for illustrated list describing the above and hundreds of other properties seized and sold for taxes. Every property is fully described and offered at a stated price. Send no money. Send for list today so you will have first choice. Tax Sale Service, Room 617, 72 Queen Street West, Toronto 2, Ontario, Canada.

HERE'S your land! \$10 down and \$10 a month buys 20 acres of my best land in Cent. Mich. for \$400, or 10 acres for \$250. Write at once for free 48-page picture book. G. W. Swigart, P1259 1st Natl. Bank Bldg., Chicago.

\$10.00 DOWN, \$3.00 monthly, buys 5 acre Cadillac, Michigan, Fruit or Poultry farm land, Camp Site or Summer Home. Near fine lakes and streams. \$200.00. Best hunting, fishing, bathing, swimming. Good auto roads. Get booklet and map. O. Hermann, 140 So. Dearborn St., Chicago.

PECAN-Orange-Fig Groves "On the Gulf" Monthly payments. Guaranteed care. Big, quick returns. Suburban Orchards, Dept. M, Biloxi, Miss.

\$5.00 DOWN, \$5.00 monthly; 10 acres improved poultry, fruit, stock, woodland; \$100; Ozarks. Fishing, hunting, trapping. Alvin Zimmermann, 1800 N. Fifth, Kansas City, Kans.

SELL your property quickly for cash, no matter where located. Don't pay big commission. Particulars free. Real Estate Salesmen Co., Desk B, Lincoln, Nebr.

120 WELL improved, with team and cows, \$1,200.00. Terms. Bill Arthur, Mountain View, Mo.

#### ROOTS AND HERBS

FREE! Indian Medicine Man Book. Contains 250 valuable herb medicine formulas for home use. Write today. Shawnee, P145 West 112th St., Chicago.

#### DOGS AND PETS

RAT Terriers, Newfoundlands, St. Bernards, Police Dogs. We send on approval. Descriptive circular 10c. Fairview Farm, Elmore, Minn.

BEAUTIFUL registered bull pups \$15. Bulldogs, 501 Rockwood, Dallas, Texas.

RAISE guinea pigs. Pay better than poultry or rabbits; easy to raise; little space required. We guarantee market. Particulars and booklet how to raise free. Cavies Distributing Co., 3102 Grand Ave., Kansas City, Mo.

#### POULTRY

BABY Chicks—11c up. Rocks, Leghorns, Reds. Catalogue Free. Goshen Poultry Farms, Goshen, Ind.

#### PERSONAL

YOUR Name artistically written in finest Liquid Gold Ink. Full set cards \$1.00. T. Kromer, P.M. 553 Almyra Ave., Youngstown, Ohio.

"SMILE O' Pearls." Antiseptic Tooth Whitener instantly whitens the teeth. Removes all stains and discolorations. Keep your teeth pearly white; Sample Jar \$1.00 postpaid. LaFond Laboratories, 457 Selden Ave., Detroit, Mich.

UNUSUAL Horoscope Consisting of Extensive four page Special Horoscope, and Astro Analysis. Send 50c and birthdate. Money returned if dissatisfied. Prof. Bolles, Box 125, Cranford, N. J.

TOBACCO or Snuff Habit Cured or no pay. \$1.50 if cured. Remedy sent on trial. Superba Co., N3, Baltimore, Md.

SEND 25c and your date of birth for forecast of your vibrations for 1926. Arvel Synclaire, Numerologist, Box 25, Patton, Calif.

HIGH Blood Pressure inexpensively overcome, without drugs. Send address. Dr. Franklin Stokes, Mohawk, Fla.

YOUR Name on 20 Fine Cards 10c and stamp. Kleist, 814 Lloyd St., Milwaukee, Wis.

FEET! Feet! Sore or Callous, prompt relief, safe. Information 25c. Chapco, 36 Sales St., Worcester, Mass.

#### MISCELLANEOUS

8x8—65! I'll prove it. Very simple. We challenge you to find the flaw. Send 25c to P. O. Box 127, West Salem, Wis.

FORTUNES in Common Minerals. Facts and figures 10c. Minerals Identified \$1.00. Mineral Specimens, Buskett, Joplin, Mo.

GET posted—good prices paid for butterflies, insects. See Sinclair display advertisement, page 42.

VACUUM Cleaners—50-70% discount on slightly used and samples; Eureka, Premier, Ohio, Apex, etc. Guaranteed 3 years. \$15-18. Catalog free. Kahn, 1413 Fulton Ave., New York.

MEXICAN made pistol holsters, cartridge belts; horse hair goods, lariats, sombreros. List free. Ingersoll Leather Co., 307 Fannin, Houston, Texas.

VELVETY Fudge Smooth as Silk. Easily made for pleasure or profit. Learn the secret, 50c. Address Jones, The Old Candy Maker, 1309-A West Forest Ave., Detroit, Mich.

MIRRORS Re-Silvered at Home. Costs Less 5 cents per square foot; you charge 75 cents. Immense profits, plating autoparts, reflectors, tableware, stoves. Refinishing metalware, etc. Outfits furnished. Write for information. Sprinkle, Plater, 288, Marion, Ind.

CUTS anybody can make. Simple, cheap process. \$1. Specimens, particulars, 2c stamp. M. Day, Windfall, Ind.

ARTIFICIAL Eyes. Booklet free. Denver Optic, 559 Barclay, Denver, Colo.

HOMEOPATHIC and Biochemic preparations sent postpaid to all parts of the world. Manual and booklets free. Halsey Bros. Co., 111 N. Wabash Ave., Chicago, Ill. Established 1855.

CAN You Draw? Make money at home. Something new. No canvassing. Sample and particulars 10c. "Straley," 1017 W. Mulberry, Springfield, Ohio.

FORMS to Cast Lead Soldiers, Indians, Marines, Trappers, Animals, 151 Kinds. Send 10c for Illustrated Catalogue. Henry Schierke, 1034 72nd St., Brooklyn, N. Y.

FOR Your Den. If you have a small drawing you'd like enlarged, send it with \$1.00. L. A. Washlin, Sayville, N. Y.

\$3.50 POCKET automatic adding machines. Absolutely accurate. Fully guaranteed. Bassett, 1458-S, Hollywood Ave., Chicago.

BE First to Gold Monogram Stationery. Monogram Die, Materials \$1.00—Additional Dies .50c. Write for Specials. Prince-Prints, 723 Lawton Place, Fort Wayne, Ind.

LOCKSMITHING. All the tricks of the trade, including instructions for making keys of all sorts, and all the tricks of opening locks and safes, safe drilling, directions for setting combinations, key-cutting tables, umbrella work; in fact, everything you should know to become a lock expert. Copiously illustrated. The only complete book on this subject that is sold at a reasonable price. Send no money. Just write a postal for "Locksmithing." When postman hands you book, pay him \$1.50 and postal charges. Popular Mechanics Press, 200 East Ontario St., Room 803, Chicago, Ill.

CARD tricks that will mystify any audience. Wrap pack in newspaper. Let someone insert knife dividing pack, you tell audience card above knife and card below, before pack is examined. Let spectator tear a secretly chosen card. Pieces of torn card placed in box which he keeps. Unprepared egg is broken open and card is found restored inside egg except for one corner which is in box. These and 50 other marvelous card effects fully explained in "Modern Card Effects." Send No Money. Just write a postal. Pay postman \$1.50 and postage when he delivers book. Popular Mechanics Press, Room 803, 200 East Ontario St., Chicago, Ill.

COMMERCIAL work. Directions for decorating with pressed leaves, antique painting, preserving plants, bouquets of colored grass, tree cone decoration, fungi decoration, decalcomania, diaphanie, gas-light pictures, crystallized grasses, Grecian painting, copper impressions of leaves, skeleton leaves, leather work, modeling in clay, moss work, monochromatic drawing, paper flowers, pearl work, ornamenting with shells, etching shells, transparencies. All this and much more in "Youman's Household Guide." Send No Money. Just order on postal. When postman hands you book, pay \$2 and the postal charges. Popular Mechanics Press, Room 803, 200 East Ontario St., Chicago, Ill.

# FREE This New Book

Tells how, with \$5 to start, I made more than \$100,000 as a Real Estate Specialist. Tells how I help other ambitious men and women make big money my way. Tells how you, yourself, can learn the secrets of my success—use my money-making system—build up a big-profit business of your own—right at home—in your spare time. Send at once for this intensely interesting book of fascinating facts and positive proof of amazing success.

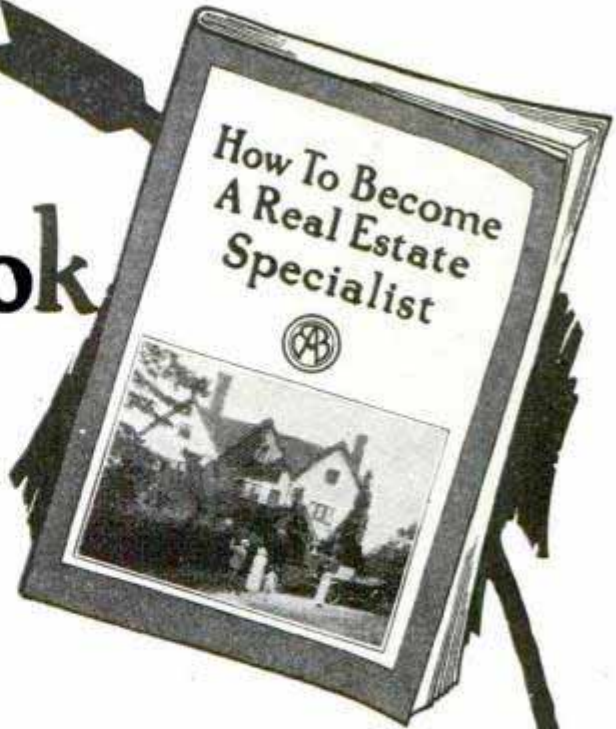

WHEN I say that this new book tells you about a way to make **big** money—that's just what I meant—**BIG MONEY!** D. H. Garrett made \$630 his first week. F. W. Hovey made \$1,500 in one deal. N. B. Moltere did a business of \$56,000 in one month. L. C. Clarke cleaned up \$4,500 in one transaction. And other wide-awake men and women are making more money in the Real Estate business than they ever dreamed possible.

But don't take my word for it—don't take **anybody's** word. Get the free book of **facts** and **proof**. It doesn't cost a penny. Yet it can be worth more to you than any other book you ever possessed.

You will find this book one of the most amazing books of business opportunity you ever read. It tells just how you can get into Real Estate—the business of a million opportunities—where trained men often make as much in *one deal* as the average man makes in *a whole year of hard work*.

Why be satisfied with small pay? Why be content with \$20, \$30, \$40 a week?

Why struggle along, year after year, on an income too small to meet your needs? Why keep plodding along in a business that is limited in its opportunities—a business that offers you no attractive future—no chance to make really big money?

There is no room on this page to tell you of the many money-making opportunities that Real Estate holds for you. So, get my free book—**and get it now**. It contains facts you can't afford to miss—positive proof of what I have done—what others are doing—and what you, yourself, can do.

Write your name and address at the foot of this page. Tear it out and mail it. Then you will receive—without charge—your copy of this book of business opportunity, which points a straight, sure path to a better business life and a bigger bank account.

Don't wait. Don't delay. Don't cheat yourself out of this big chance to make big money. Get the facts—the brass-tack facts—before it is too late. American Business Builders, Dept. 44-C, 18 East 18th Street, New York.

---

## American Business Builders

Dept. 44-C, 18 East 18th Street, New York

Send me your free book "How to Become a Real Estate Specialist," containing facts and proof of how I can make big money in Real Estate.

Name .....

Address .....

.....



## "Four Raises in Two Years"

"AND it hasn't been hard to get them, either. Why, it seems only yesterday that I was wondering if I would ever make as much as \$45 a week. And now I'm making \$75.

"Tom Dawson was speaking about it today. 'Gee,' he said, 'I wish I had started studying with the I. C. S. when you did. Here I am plugging away at the same old job and the same old salary while you've gone 'way up. I bet you're making twice as much as I am. And to think that two years ago we were working side by side.'

"I told him it wasn't too late if he would only make the start and he said he was going to send in one of those I. C. S. coupons right away.

"I hope he does, because an I. C. S. course is the very thing he needs to get out of the rut. I wouldn't be making anywhere near \$75 a week if I hadn't started to study just when I did."

How much longer are you going to wait before you take the step that will bring you advancement and more money? To earn more you've got to learn more. And to learn more you've got to study in that hour after supper that most men throw away.

One hour a day, spent with the International Correspondence Schools in the quiet of your own home, will prepare you for the position you want in the work you like best. Put it up to us to prove it.

### Mail the Coupon for Free Booklet

INTERNATIONAL CORRESPONDENCE SCHOOLS  
Box 5565-E, Scranton, Penna.

Without cost or obligation, please tell me how I can qualify for the position or in the subject before which I have marked an X:

#### BUSINESS TRAINING COURSES

- Business Management
- Industrial Management
- Personnel Organization
- Traffic Management
- Business Law
- Banking and Banking Law
- Accountancy (including C.P.A.)
- Nicholson Cost Accounting
- Bookkeeping
- Private Secretary
- Spanish  French

- Salesmanship
- Advertising
- Better Letters
- Show Card Lettering
- Stenography and Typing
- Business English
- Civil Service
- Railway Mail Clerk
- Common School Subjects
- High School Subjects
- Illustrating  Cartooning

#### TECHNICAL AND INDUSTRIAL COURSES

- Electrical Engineering
- Electric Lighting
- Mechanical Engineer
- Mechanical Draftsman
- Machine Shop Practice
- Railroad Positions
- Gas Engine Operating
- Civil Engineer
- Surveying and Mapping
- Metallurgy
- Steam Engineering
- Radio
- Architect
- Architects' Blue Prints
- Contractor and Builder
- Architectural Draftsman
- Concrete Builder
- Structural Engineer
- Chemistry  Pharmacy
- Automobile Work
- Airplane Engines
- Navigation
- Agriculture and Poultry
- Mathematics

Name.....

Street..... 3-6-24

Address.....

City..... State.....

Occupation.....

Persons residing in Canada should send this coupon to the International Correspondence Schools Canadian, Limited, Montreal, Canada.

# Make Furniture At Home



—either for your own pleasure or to sell. It is easy when you have the instructions supplied in Popular Mechanics Home Furniture Making Library. This library consists of the

following cloth-bound, profusely illustrated books of which many thousand have been sold to satisfied customers everywhere:

1. Mission Furniture—Part 1

2. Mission Furniture—Part 2

These two practical, money-saving books contain full directions and drawings for the making of all sorts of furniture, including tables, chairs, stools, davenports, electric table lamps and many

other useful and beautiful articles of furniture. Crystal clear instructions in 2 handy books; 240 pages—123 illustrations. Just follow directions and you'll be amazed at your good results. Use the furniture in your own home or sell it. One man writes he

Crystal clear instructions in 2 handy books; 240 pages—123 illustrations. Just follow directions and you'll be amazed at your good results. Use the furniture in your own home or sell it. One man writes he

Crystal clear instructions in 2 handy books; 240 pages—123 illustrations. Just follow directions and you'll be amazed at your good results. Use the furniture in your own home or sell it. One man writes he

Crystal clear instructions in 2 handy books; 240 pages—123 illustrations. Just follow directions and you'll be amazed at your good results. Use the furniture in your own home or sell it. One man writes he

Crystal clear instructions in 2 handy books; 240 pages—123 illustrations. Just follow directions and you'll be amazed at your good results. Use the furniture in your own home or sell it. One man writes he

Crystal clear instructions in 2 handy books; 240 pages—123 illustrations. Just follow directions and you'll be amazed at your good results. Use the furniture in your own home or sell it. One man writes he

Crystal clear instructions in 2 handy books; 240 pages—123 illustrations. Just follow directions and you'll be amazed at your good results. Use the furniture in your own home or sell it. One man writes he

Crystal clear instructions in 2 handy books; 240 pages—123 illustrations. Just follow directions and you'll be amazed at your good results. Use the furniture in your own home or sell it. One man writes he

## BECOME A LANDSCAPE ARCHITECT

Established 1916.



Dignified, exclusive profession. Little competition. \$5,000 to \$10,000 incomes for experts. Easy to master under our correspondence methods. Assistance extended to students and graduates. Write AMERICAN LANDSCAPE SCHOOL, 107-NA NEWARK, NEW YORK

### HOW TO MAKE DEVICES FOR OUTDOOR WINTER SPORTS

Motor-Driven Sleds and Ice Boats—Coasting Bobsleds and Toboggans—Skis—Glders—Ice Yachts with Boat Book, 98c. Send No Money. Just write a postal.

Popular Mechanics Press, Room 703, 200 E. Ontario St., Chicago

## Make Arts-Crafts Lamps

Some make them for pleasure, and some make them for sale.

For either purpose, these cloth-covered, illustrated books will be a wonderful aid. They tell just how to make 33 kinds of lamps for table and wall. The directions are so clear that even boys can make the lamps with these books.

**Arts-Crafts Lamps, How to make them Lamps and Shades in Metal and Art Glass The two Arts-Crafts Lamp Books . . \$2**

Either book alone, \$1

Send No Money—just write a postal

**Popular Mechanics Press**

Popular Mechanics Building

Room 703, Chicago, Ill.



# WARNING! You can't become an ELECTRICAL EXPERT in one month!

I have trained 16,000 men in my big schools. And I know how long it will take you to become an *electrical expert*. I know that you need THOROUGH training to get a *good* job. And I have proved that my way of teaching electricity is the right way to train you to get one of those big-pay jobs *quicker*! I don't promise you a big-pay electrical job 30 days after you enroll for my course. But—

**I will absolutely guarantee that when you complete my electrical course you can become a REAL Electrical Expert, thoroughly trained and capable of holding down a high-salaried job. And I'll help you land that job!**

I wouldn't dare print such a guarantee unless I could back it up. But everybody knows that National's Electrical Course is thorough and complete. Nationally famous instructors train you. You use as few books as possible. You work right with the instructors on a half-million dollars' worth of new electrical equipment. *You learn by doing.*

## I Help You All Through Your Life!

It may take you six months or a year to learn Electricity. But when you enroll for my course you are entitled to stay in this big school all your life! You can take part of my course and come back years later to take the rest, at no extra cost. You can stay in any department until you have mastered it thoroughly. I don't rush you through half-trained. I'll always help you to learn more and earn more. National stands behind you all through your life!

When you graduate from National you know your stuff! I'll help you get a job and your superior training will quickly get you bigger pay than other men who have merely learned a smattering of electricity. California is undergoing a tremendous hydro-electrical development. Los Angeles is the center of the West's Big Pay electrical jobs.

## With National Training You Know MORE than Other Men

How can you hope to be a foreman or superintendent—or hold any other big-salaried electrical job—unless you know *more* than the other men? Isn't it ridiculous to expect to learn electricity in three or four months when leaders in the electrical industry say it takes years!

## My Free Book Tells the Truth

Don't be misled by promises. Get my free book of facts. It tells the *Truth* about the electrical industry. Learn about my sensational Lifetime Scholarship—the greatest proposition ever offered any man who seriously wants to learn electricity *right* and earn real money. My course may cost you a few dollars more but you'll agree that it's worth thousands of dollars more.

Every statement I make here is backed by 21 years' experience teaching men like you. I *guarantee* my training. And if you want to be a real Electrical Expert instead of a "half-baked dud," you'll mail this coupon for my free book and learn the facts before you decide.



Mail Coupon Now for

**FREE**  
 Electrical Catalog  
 It tells how you  
 too can win a  
 big pay job  
 Quickly

National  
 Electrical School  
 Dept. 552  
 Santa Barbara & Figueroa Street  
 LOS ANGELES, CALIFORNIA

I am interested in the Big-Pay Opportunities of the Electrical Industry. Send me your FREE 64-page illustrated catalog.

# NATIONAL ELECTRICAL SCHOOL

Dept. 552

4004 South Figueroa Street

Los Angeles, California

MAIL THIS "SUCCESS COUPON" NOW

Name.....  
 Address.....  
 City..... State.....

# Quickly Learn to Play Hawaiian Guitar

## Play Like This Native

Bring the romantic, enchanting, entrancing and melodious strains of the great instrument of the Hawaiian Islands into your soul. Become popular and successful. This **short cut method** of home instruction enables you to quickly master Hawaiian Guitar so you will play as well as Native Hawaiians.

Our staff of Hawaiian instructors have perfected a method of teaching, so simple, that without musical knowledge, you quickly learn to play real music from notes. **Simple as learning your A, B, C's** and it will not be long before you will play interesting Broadway hits.

**Only four simple motions to learn.** You will then play any music, whether it be popular, dance or classical. Almost from first lesson, you play love songs like Aloha Oe.

To help you get started, we furnish **free** when you enroll as a student, a beautiful, full tone, genuine, \$18.00 Hawaiian Guitar. Only 1,000 free instruments given away; if you want to act in on **free offer**, write for particulars at once—you must **act quickly**.



### New Invention—

**Kno-All-Chart QUICKLY TEACHES YOU HOW TO PLAY**

The newest invention of our Hawaiian instructor, which is exclusively used by us and which we call the "Kno-All-Chart," quickly



teaches you how to play and read notes. So simple is this device that any one can understand it and begin to play immediately.

### Picture Method Easy

**Free \$18 Hawaiian Guitar when you enroll**

We do not depend upon our printed instructions alone for your success as a student, but we also supply you with many pictures of our professors' playing. This enables you to imitate the pictures. **Isn't this easy?**

### Phonograph Records FREE

As an additional guide, we also furnish you with **phonograph records** of our Hawaiian instructor's own playing of the pieces you are learning. This practically brings our professors from our studio to your own home and enables you to listen to their playing just as if they were actually in front of you.

### Genuine \$18.00 Hawaiian Guitar Free

Enroll as a student, and secure **free**, a beautiful, full tone, genuine \$18.00 Hawaiian Guitar.

We also furnish every bit of equipment so it is never necessary for you to spend an extra penny. When you graduate, you get a **beautifully engraved diploma**, and after graduation, we also give you **six months' free service** and consultation. Send for free particulars now.

**JAZZ**

Your Way to Popularity and Success

No forming class to wait for. Start at once and join hand wagon of success and popularity. Do it through Hawaiian Guitar.

Send for free First Lesson and Book. So positive are we you will become one of our students, that if you write at once, we will send you **free**, our first lesson which will enable you to see just what you can expect when you enroll. You will also receive our **big book** of full particulars. Write for your copy and **free lesson** today.

Write at **Hawaiian Studio No. 523** once of New York Academy of Music 100 Fifth Ave., New York, N. Y.

**HAWAIIAN STUDIO No. 523 of New York Academy of Music 100 Fifth Avenue, New York, N. Y.**

Please rush your book, "How to Learn Hawaiian Guitar" and my first free lesson. Also reserve a gift Hawaiian Guitar for me. This obligates me in no way whatever.

Name .....

Address .....

City ..... State .....

# STOP USING A TRUSS

Do Away With Steel And Rubber Bands

## FREE TRIAL



Inner surface is made adhesive to secure the PLAPAO-PAD firmly to the body, keeping the PLAPAO continually applied and the pad from slipping. No straps, buckles or springs attached. Soft as velvet—easy to apply.

It's the Non-Slip-ping, yet Non-Rigid Pad and What is Within It That Counts

PAT'D APRIL 6 1909

### FREE to 5,000 Truss Sufferers

To the extent of 5,000 sufferers who may apply I will send, **ABSOLUTELY FREE**, a sufficient quantity of the Plapao to positively convince them that this is the only logical, common-sense way of treating rupture. Plapao is a highly astringent medication placed within the Plapao-Pad and being absorbed through the skin, creates a wonderful feeling of relief and at the same time tends to strengthen the weakened muscles and thus permanently close the rupture opening. The process of recovery is natural, so you'll have no use for a truss—you can throw it away forever! Old and young have testified under oath that the Plapao-Pads cured their rupture—many of them long-standing, aggravated cases—without delay from work. Patent allowed in U. S. and foreign countries. Awarded Gold Medal at Rome and Grand Prix at Paris.

**Send No Money**—for a sufficient quantity of the Plapao is sent without charge to enable you to give it a thorough test; you pay nothing for this trial now or ever. Write for it and full information today. Address Plapao Laboratories, Block 1427 St. Louis, Mo.

# NO JOKE TO BE DEAF

—EVERY DEAF PERSON KNOWS THAT



I make myself hear, after being deaf for 25 years, with these Artificial Ear Drums. I wear them day and night. They stop head noises and ringing ears. They are perfectly comfortable. No one sees them. Write me and I will tell you a true story how I got deaf and how I make you hear. Address



**GEO. P. WAY, Artificial Ear Drum Co. (Inc.)** 80 Hoffman Bldg., 2539 Woodward, Detroit, Mich.

## LEARN WATCHMAKING AND ENGRAVING



**BY OUR PROFIT-SHARING PLAN OUR GRADUATES SUCCEED**

One of our Iowa students started in a very small way—now doing over \$30,000 a year. Another in Wisconsin, over \$10,000 the first year. Day or night classes. Call or write for **FREE BOOK**

Chicago School of Watchmaking, Dept. 1401, 4844 Lincoln Avenue, CHICAGO

## How to Straighten Bow and Knock-kneed Legs!

Improve your personal appearance by using the new patent "Lim-Straitner," Model 18. Corrects now Bow and Knock-kneed legs safely, quickly and permanently at home. No costly operation or discomfort. Is worn at night. Easy to adjust; its result will save you soon from further humiliation and will improve your personal appearance 100 per cent. Write today for copyrighted Physiological and Anatomical book and experience of others without obligation. Enclose a dime for postage.

**M. TRILETY, Specialist** Dept. 1308 BINGHAMTON, N. Y.

## Buchstein's Fibre Limb

is soothing to your stump—strong, cool, neat, light. Easy payments. Braces for all deformities. **D. BUCHSTEIN CO.** 610 3rd Ave., So., MINNEAPOLIS, MINN.

**LEARN RADIO FREE** STUDY IN SPARE TIME AT HOME Earn a Diploma in Radio Engineering. Free Twin Superdon Set offer if you act now. Write **AMERICAN RADIO ENGINEERS** Dept. 425, Hearst Sq., Chicago, U. S. A.

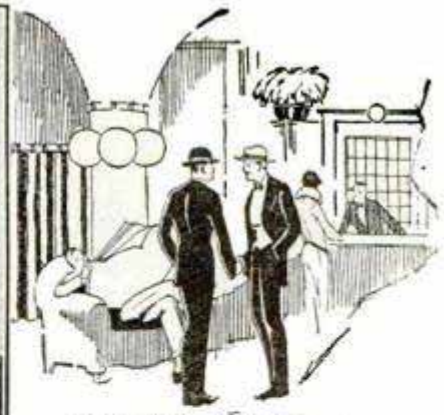
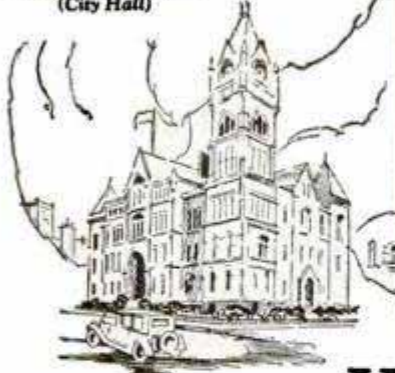

GRAND RAPIDS  
(City Hall)At the Left—Hotel Rowe,  
Grand Rapids, Michigan.  
Inset—Ernest W. Neir,  
Manager.Home-Study Business  
Training Pays!

"We have been interested in learning of the specialized business training taken with your institution by Mr. Ernest W. Neir, whom we selected last year as Manager of the Hotel Rowe. Our experience with Mr. Neir confirms our experience with others—the man who adds specialized training to his personal abilities is the man who makes good in difficult business situations."

(Signed) FRED M. ROWE,  
President Holden Hotel Co.

"It Doubled My Income!"

"I am often asked how I happened to take up accounting when my particular field was hotelwork. Frankly, that training added greatly to my hotel knowledge, and it also gave me my first real insight into business. Again and again I have referred back to it for answer to business problems that came up. Of course I appreciate strongly the fact that my income has more than doubled. But I appreciate even more the fact that I have been enabled to make good in a difficult field."

(Signed) ERNEST W. NEIR.

## Hotel Manager Doubles Income . . . Thru Home-Study Business Training

It took years for Ernest W. Neir to come up thru the ranks in hotel work by the "experience route." Then he took up home-study training with LaSalle. At about this time he was made manager of the Hotel Rowe, Grand Rapids—one of the city's finest hotels.

His task was to put the hotel on a paying basis. And it was at this point that LaSalle became of very practical assistance. The training Mr. Neir had chosen was Higher Accountancy. *With its aid he not only changed losses into profits, but he also increased his salary more than 100 per cent.*

Commenting on Mr. Neir's successful administration, Fred M. Rowe, president of the controlling Company, says: "He has given the hotel an individual atmosphere that pleases guests, *and yet he maintains the highest efficiency.*"

Mr. Neir, in turn, is frank to give credit to LaSalle for this latter achievement. ". . . That training," he writes, "added greatly to my hotel knowledge,

*and it also gave me my first real insight into business."*

His experience made him a good hotel man. LaSalle helped him to become a good *business* man.

### Send for Free Outline of LaSalle Salary-Doubling Plan

How much is it worth to you to gain, in a comparatively few months, substantial promotion—a new confidence and self respect?

The way to all these things is outlined in a fascinating book, "Ten Years' Promotion in One"—a book which has set thousands and thousands of men on the path to real achievement. The coupon will bring it to you FREE.

In addition, we will send you a 64-page book describing the unusual opportunities in any of the business fields listed below. If you want to look back a year from today and see a record of real progress, then—TODAY is the day to start, and the moment NOW.

# LASALLE EXTENSION UNIVERSITY

THE WORLD'S LARGEST BUSINESS TRAINING INSTITUTION

FIND YOURSELF THRU LASALLE!

LASALLE EXTENSION UNIVERSITY Dept. 364-R CHICAGO

I would welcome an outline of your *salary-doubling plan*, together with a copy of "Ten Years' Promotion in One," all without obligation.

- |  |   |   |
|--|---|---|
| <input type="checkbox"/> <b>Business Management:</b> Training for Official, Managerial, Sales and Departmental Executive positions.  | <input type="checkbox"/> <b>Modern Business Correspondence and Practice:</b> Training for position as Sales or Collection Correspondent, Sales Promotion Manager, Mail Sales Manager, Secretary, etc. | <input type="checkbox"/> <b>Modern Foremanship and Production Methods.</b>  |
| <input type="checkbox"/> <b>Modern Salesmanship:</b> Leading to position as Sales Executive, Salesman, Sales Coach or Trainer, Sales Promotion Manager, Manufacturer's Agent, Solicitor, and all positions in retail, wholesale, or specialty selling. | <input type="checkbox"/> <b>Higher Accountancy:</b> Training for position as Auditor, Comptroller, Certified Public Accountant, Cost Accountant, etc.   | <input type="checkbox"/> <b>Personnel and Employment Management.</b>        |
| <input type="checkbox"/> <b>Law:</b> Training for Bar; LL.B. degree.   | <input type="checkbox"/> <b>Traffic Management—Foreign and Domestic:</b> Training for position as Railroad or Industrial Traffic Manager, Rate Expert, Freight Solicitor, etc.                        | <input type="checkbox"/> <b>Railway Station Management.</b>                 |
| <input type="checkbox"/> <b>Banking and Finance.</b>   |   | <input type="checkbox"/> <b>Industrial Management.</b>                      |
|  |   | <input type="checkbox"/> <b>Commercial Law.</b>                             |
|  |   | <input type="checkbox"/> <b>Expert Bookkeeping.</b>                         |
|  |   | <input type="checkbox"/> <b>Business English.</b>                           |
|  |   | <input type="checkbox"/> <b>Commercial Spanish.</b>                         |
|  |   | <input type="checkbox"/> <b>Effective Speaking.</b>                         |
|  |   | <input type="checkbox"/> <b>C. P. A. Coaching for Advanced Accountants.</b> |



**free!**  
mail  
coupon  
now

Name..... Present Position..... Address.....

# Big Pay Jobs



**T**HE auto tractor and electrical business offers untold opportunities to the trained mechanic. The automotive industry **NEEDS TRAINED MEN** and there are thousands of chances to start a business of your own.

My system of practical training has started thousands of men on the road to success during the past twenty years. I can do the same for you. Many of our graduates are now earning from **\$200 TO \$500 A MONTH** and many have a flourishing business of their own. You can do the same. Get busy and let me train you for a **BIG PAY JOB**.

## PHILADELPHIA'S SESQUI-CENTENNIAL

will open up thousands of jobs right here in Philadelphia and vicinity. Quick action on your part and you will be trained and ready to grasp the opportunities that will be open for **PETZ Graduates**. The first step is to send at once for our **FREE CATALOG**.

**DON'T DELAY**  
Send today to



**Petz Automotive School**  
6 to 14 N. 20<sup>th</sup> St., Phila., Pa.

## Big Money for You as an Automobile Mechanic

These four practical books, written by five well known teachers of automobile practice will teach you right in your own home during your leisure time just what you need to know about automobile troubles and repair. They will teach you automobile construction, maintenance and repair as experts know them and will help you to earn an expert's pay.

**Practical Automobile Library: Four Books—\$1.50 in 10 days and \$2 monthly for 6 months—only \$13.50 in all!**

Hundreds of question-answering diagrams—hundreds of clearly-marked illustrations—make the books plain and readily understandable. All the explanations and descriptions are clear, simple, direct. Every chapter is packed with definite, step-by-step, how-to-do-it information. Here is your opportunity to enter a big-pay field.

**Sent FREE**

**Send No Money**  
Mail the Coupon

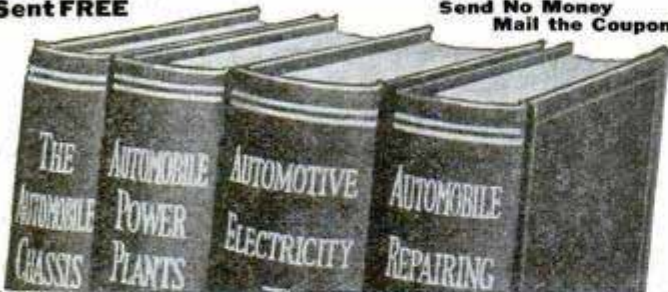

### FREE EXAMINATION COUPON

McGraw-Hill Book Co., Inc., 370 Seventh Ave., New York

Send me for 10 days' free examination the New Practical Automobile Library. If satisfactory I will send you \$1.50 in 10 days and \$2.00 monthly until the special price of \$13.50 is paid. If not wanted, I will return the Books at your expense.

Signed .....

Address .....

City and State .....

Position .....

Employer .....

P. M. 3-1-2



**HERE'S YOUR CHANCE**

# BOYS!

to get **FREE** just what you've wanted for a long time  
The latest model of \$1.00

## EVERSHARP PENCIL

With polished red barrel, nickel trimmed, with pocket clip, large exposed eraser, new perfected tip, and twelve extra leads in magazine and a

## \$2 EAGLE SELF-FILLING FOUNTAIN PEN

(14 Kt. Solid Gold, Iridium Pointed) Russet finish barrel with purple ends, long size, gold-filled lever and ball end pocket clip **BOTH** for only **THREE** yearly subscriptions to **POPULAR MECHANICS MAGAZINE**

Think of it! Fifteen minutes of your spare time and these

## TWO WONDERFUL PRESENTS

are yours, without a penny's cost! The subscription rate of **POPULAR MECHANICS** in the U. S. and countries in the Postal Union, is \$2.50 a year, postpaid. All other countries, \$3, postpaid.

**READ CAREFULLY.** Send us **THREE** yearly subscriptions to **POPULAR MECHANICS**, with \$7.50 money order to cover, and we will mail you this Beautiful Pencil and Pen by return post.

**START TODAY—RIGHT NOW.** To get your three yearly subscriptions and mail them to

## POPULAR MECHANICS MAGAZINE

Room 408, 200 East Ontario Street Chicago, Illinois



# LEARN TENOR BANJO

## I Can Teach You to Play!

For the first time in the history of my long playing career—5 years with Isham Jones' Recording Orchestra, coupled with many years of vaudeville and teaching experience—I am now in a position to offer you my famous Home Study Tenor Banjo Course. I call it "The Key to Successful Banjo Playing." It is my course—compiled after years of study and experience with the tenor banjo—the instrument I helped to develop. I am now using this course successfully in my school—The Chicago Tenor Banjo Institute, and am training beginners, advanced students, and professional artists to bigger pay jobs with this marvelous course.

## Easy to Play the McNeil Way

This course can now be yours. Just as if I were sitting at your elbow teaching you the correct finger positions—melody, chords, harmony, etc., etc. My course is a personalized, "A-to-Z" Course. It includes everything you will ever want to know about tenor banjo playing. An added feature to help you is the phonograph record—free when you enroll—played by myself, illustrating breaks, jazz strokes, etc., etc.

## EASY TO PAY—WHILE LEARNING TO PLAY!

It's yours—all yours, for a small initial down payment and the balance in easy terms. Write today for free booklet and details.

**CHARLES McNEIL, Studio Director**  
**CHICAGO TENOR BANJO INSTITUTE**  
Dept. 1353 1621 N. Lincoln St. CHICAGO, ILL.

**Mr. Charles McNeil, Studio Director,**  
**CHICAGO TENOR BANJO INSTITUTE,**  
Dept. 1353, 1621 N. Lincoln St., Chicago, Ill.

Dear Sir: I would like to find out more about your new Home Study Tenor Banjo Course. Without obligation, please send me literature and full information.

Name .....

Address .....

City .....

State .....

# Right now—for You— Greatest Opportunity in History of Auto Business!



View in Dept. of Automotive Electricity  
in the Greer Shops

You know this is the kind of work you want to do. Then why wait? Right now your opportunity is ripe. The Greer way will make it very easy for you. Get full information and our special offer immediately. Use coupon below.

## Prepare Now—Start Good Auto Job Before Summer

Trained Auto men are needed everywhere. Here's the chance of your lifetime to get into the **big pay** end of this business. Be the man who **knows**—who can do a job right and supervise other men.

The actual **auto experience** you get here will place you in a good job at the end of your course. You will be prepared to look the world in the face, and to rise to the top of any branch of this business. All over the country there are Greer trained men—top notchers in the shops where they work, or owning shops of their own. Why not you?

### Our Shop System

There is just one way to learn how to do anything—to practice doing it, with someone showing you how. That is exactly how you learn at the Greer Shops. When you have become skilled enough with the shop apparatus, you will do work on actual cars: overhauling, trouble-shooting, battery work, ignition—according to what each car needs. There are between 75 and 100 customers' cars in our shops at all times. Advanced students put them in shape, with the advice and help of instructors. This way you learn more in a few weeks than by years of dirty apprenticeship.

### What Line Interests You Most?

Your training here will start you into any branch of the Auto, Truck or Tractor business. There will be no more mysteries for you in any of these lines—nor in Motorboat or Airplane engines.

How would you like to keep the motorboats in shape around some beautiful resort this summer? How would you like to specialize in the electrical end of the auto business? Trouble

Besides the millions of cars already in use the factories are turning out new ones *faster than ever before.*

## Who Is Going to Keep Them All In Shape?

Trained men are scarce and they are needed more and more every day. Now is your time to start a big future in an interesting **big pay** job—by 8 to 12 weeks' training in the big Greer Shops (a resident shop course—not a correspondence school).

shooting, lighting, ignition and battery service are especially in need of men with Greer training.

Vulcanizing experts are also more and more in demand, because rubber prices are making new tires so expensive. The training you get in the Greer shops starts you **right** in any of those branches of the business. You can't afford to pass up this wonderful chance.

## We Pay R. R. Fare to Chicago —Tools Free

We pay Railroad fare to Chicago on all cash enrollments. This makes it as easy for those who come from a distance as for those who live near by. The tool set is given—absolutely free—a fine outfit that you will be proud of while training and out on the job afterward.

### Free Employment Service

Our employment department is in touch with many places where good auto men are needed. Our students are given preference by leading concerns that need dependable men. We will help you find the job where you fit best, and will stand back of you for life with help and advice.

If you need extra money while learning, we have plenty of part time jobs.

### Send For Free Book Now

This interesting 64 page auto book will tell you all about the Greer shops and how we fit you for a **man's job at man's pay** in shortest possible time. Send for this book today—right now—so you can decide this matter for yourself. Remember all we can do is **offer** you this chance. It is **your** future at stake. **You** are the one whose whole life will depend on how you decide this question. Are you going to take the lazy way and do nothing about it? Or are you going to send this coupon—the first step toward a **real future?**

Send it **now**. Address me personally, please. Erwin Greer, President.



Home of the Greer Shops

**ERWIN GREER, President**  
Greer College—Automotive & Electrical Trades  
2024 South Wabash Ave., Dept. 301, Chicago

Please send me your free book and offer. It is understood I am not obligated in any way.

Name .....

Address .....



Learning to  
Make Storage  
Batteries  
in the  
Greer Shops

## Need More Money?



## Become a SALESMAN

A SUCCESSFUL business executive has said: "If the average young man will prepare himself to be a salesman, and stick to his work like many of them cling to a small-salaried job, I believe he can make a bigger income and make it quicker than in any other occupation I know of. He doesn't have to be a 'born' salesman; all he needs is a little ambition and the nerve to make a start."

### NEVER BEFORE

### Such a Training for Salesmen

Make up your mind that in a year you are going to be a salesman. You can do it—hundreds of others are. The common sense way to prepare yourself is in spare time at home. The Federal Course in Creative Salesmanship brings you a *practical* training entirely new and different. It not only instructs you in every type and method of selling—it also gives you a wonderful training in memory, concentration, will power, shows you how to analyze and think clearly, and build up your health and energy.

### GET THIS BOOK

### "The Vital Spark in Business"

Learn of the master salesmen who have contributed their experience to this modern scientific course. Realize how simple, interesting, and result-getting is the proven Federal method of *personal* instruction, criticism and coaching. Start now for a bigger income in this field where the good man is sought after. Send the coupon, giving age and occupation.

## Federal School of SALESMANSHIP

301 Federal Schools Building, Minneapolis, Minn.  
Please send me your book, "The Vital Spark in Business."

Age.....Occupation.....

Name.....

Write your address plainly in margin

## Tires With 500 Nail Holes Leak No AIR

A new puncture-proof inner tube has been invented by a Mr. D. L. Milburn of Chicago. In actual test it was punctured 500 times without the loss of air. This wonderful new tube increases mileage from 10,000 to 12,000 miles and eliminates changing tires. It costs no more than the ordinary tube. Mr. Milburn wants them introduced everywhere and is making a special offer to agents.

Write Mr. D. L. MILBURN  
4650 Shields Ave., Chicago

MILBURN PUNCTURE PROOF TUBE

## EXPOSED!

### 69 Tricks of Mediums Fully Explained

Every detail given for performing the seemingly impossible feats of famous mediums. Startling revelations that show how easy it is to fool the credulous. Many of these tricks have made the greatest magicians wonder.

### You Can Do These Tricks

What makes a trick good is its simplicity. No complicated or expensive apparatus needed for these, the best of spiritualistic tricks. You can do such wonders as:

1. Produce spirit message on blank paper.
2. Read messages while blindfolded.
3. Produce spirit rappings.
4. Produce spirit voices.
5. Produce writing on blank slates.
6. Read sealed letters in total darkness.
7. Reproduce a burned message.
8. Read messages retained by the writers—and 61 other marvels used in spiritualistic seances.

### Make Money Giving Entertainments

Clubs, Lodges, Sunday Schools, Churches, and organizations of all sorts are eager for entertainers who can mystify audiences with such inexplicable manifestations as these. You can make from \$10 a night up to \$50 or more, depending upon the size of the community in which you work. Anyone can do this. You need no special gifts.

**Send No Money** Just write a postal for our marvelous book, "Behind the Scenes with the Mediums." When postman hands you book, pay him \$1.50 and postal charges.

POPULAR MECHANICS PRESS  
Room 703, 200 East Ontario Street CHICAGO, ILL.

The man who studies gets ahead. Popular Mechanics Press will advise you what books to read to advance in your trade. 200 East Ontario Street, Chicago, Illinois.

## 366 SHORT CUTS FOR CARPENTRY WORK

**Popular Mechanics New Carpenter's Handbook** is filled with illustrated short cuts and improved methods for doing all sorts of carpentry work and odd jobs. Each idea was discovered by a practical man in the course of his work. Each idea is practical, a time-saver, a money-saver. The 229 Pictures are so clear that in many cases, the picture itself explains the short cut. This new book is a book for professional carpenters, for amateurs, and for boys. It is destined to be just as popular as the many other handbooks published in recent months. This new book is beautifully bound in golden brown cloth, is a handy size, and sells for the remarkably low price of \$1.50.

**Send No Money** Simply write a postal saying that you want Popular Mechanics New Carpenter's Handbook. It will be sent C. O. D. and you may pay the postman the price of the book and the few cents postage when he delivers the book to you. If you live outside the U. S. or if you are not at home when the postman delivers your mail, send \$1.50 with your order.

POPULAR MECHANICS PRESS  
Room 703, Popular Mechanics Bldg., 200 E. Ontario Street, Chicago, Ill.

# 60 MILES ON A GALLON OF GASOLINE

## TESTS SHOW FORD CAN RUN 60 MILES ON A GALLON

The amazing fact that a Ford can run 60 miles on 1 gallon of gasoline was recently brought to light through tests conducted by America's foremost engineers, where it was shown that a gallon of gasoline contains sufficient heat units which if properly atomized and mixed with air would give this additional mileage. Great strides have already been made in this direction by the recent invention of a simple attachment which can be installed in a few minutes without any alterations to the motor. It is common for Ford Owners to make from 40 to 44 miles per gallon after this marvelous device is attached.

## MOST WONDERFUL INVENTION TODAY BRINGS JOY TO FORD OWNERS

### Starts Ford Instantly

Starting a Ford Car in cold or zero weather is something every Ford Owner dreads—everybody realizes that difficult starting is an abuse on the starter and battery. Thousands of Ford Cars are "laid up" during the Winter just for these reasons. This great difficulty has been overcome. "The SUPER positively starts a Ford Car instantly in the coldest weather."

### Marvelous Device

The SUPER is no trick affair—requires no mechanical adjustments and contains all the scientific principles of carburetors costing \$20 to \$35 and in its natural action uses up every particle of unused gasoline and breaks it up into a perfect vapor. The hitherto impossible is now realized by the SUPER.

### Everybody Satisfied

#### Saves 3 to 7 Dollars Per Month

The best investment I ever made. The SUPER is saving me from three to seven dollars each month, besides putting new life into my motor.  
A. H. WORRA, Iowa.

#### Makes 44 Miles Per Gallon

I have tried the SUPER and the results of the experiment are satisfactory. One quart of gasoline run my Ford 11 miles over improved roads which is just about again as far as I could run with the plain Ford Carburetor.  
G. E. YODER, Penn.

#### Finds That Our Claims Are Correct

I find that your claims for increased mileage are correct and that a big saving is made by your SUPER, in fact, the best device I have met with in that line.  
M. J. VAN LEEUWEN, Mass.



*The  
Heart  
of the  
Motor*

### Eliminates Oil Pumping in Front Cylinder

What a wonderful relief to Mr. Ford Owner when he realizes that he can run his car without the motor pumping oil in the front cylinder. Sounds like an awful lot to expect of any device, but that is what the SUPER does and this is only one of its many advantages because it puts real efficiency into any Ford Car.

### Complete Combustion

The SUPER is so designed that it takes advantage of the present Ford Carburetor and properly atomizes the light as well as the heavy elements of the fuel, converting every atom of gasoline and kerosene into power preventing liquid fuel from passing into the cylinders, thus avoiding carbon formation and oil dilution.

### Easy to Sell

#### Sells Like Hot Cakes

This is a recent letter from one of our distributors: "Enclosed find draft for 200 more SUPERS, rush as I need them badly. I sold and banked \$104.00 in one day. Hope to sell 1000 SUPERS next month."  
A. W. LEONARD, Penn.

#### Making Big Profits Every Noon

I have been working the SUPER at noon only. Yesterday noon I made more money with the SUPER than I did at my 11 hours' hard work in the factory all day.  
J. L. LEHNER, Wis.

#### Had No Previous Selling Experience

This letter shows what ambition does: "I sold six SUPERS in less than 2 hours tonight. I think it's a pretty good start—for it's the first thing I ever sold."  
E. MANGOLD, Ind.

E. MANGOLD, Ind.

## \$60.00 TO \$150.00 PER WEEK EASY

You just can't help making Big Money selling the SUPER because a trial sells itself and soon everyone in the neighborhood get talking about this marvelous device. Men like Leonard, Shaw, Manner, Kinsley, Peters, Sands, Beck and Hall are not exceptional salesmen, but just the type of men that saw an opportunity and were quick to grasp it when within reach. No previous selling experience is necessary, just a little ambition on your part to make money is all we ask and we will extend the same opportunity to you. Spare time will pay you well. If you can devote your entire time so much the better, because the SUPER is a whirl-wind seller and takes hold in a locality like wildfire.

### Men Wanted Everywhere To Introduce

We want distributors in all parts of the country to take orders and deliver the SUPER and to look after the repeat business that is bound to follow and to such distributors we are willing to assign territory. You do not have to own a Ford to take up this proposition but if you have a Ford it is easier to explain its many advantages. However a Trial of the SUPER convinces the most doubtful person and tells a wonderful story.

### A REAL FUTURE HERE

**WEEKS SUPER CARBURETOR CO.**

426-1618 Eleventh St., Milwaukee, Wis.

**MAIL TODAY**  
WEEKS SUPER CARBURETOR CO.  
426-1618 Eleventh Street, Milwaukee, Wis.  
GENTLEMEN: Please mail me full free particulars about your wonderful invention.  
Name .....  
St. or R. F. D. ....  
Town .....  
County .....  
State .....

# There Ain't No Santa Claus



**I**F YOU were offered a job at a salary of one cool million a year, would you take it? You'd grab it. Well, fellows, don't be misled by any such big-salaried jobs, 'cause "there ain't no Santa Claus"; but—I can put you in line for one of the nicest little jobs you ever dared dream about. Big money? I'll say it is. And when it comes to steady work, there's no such thing as a day off. Business is always prosperous.



## The Man You Work For

Did you ever listen in while some of these big bankers talked about investments? When they want to make a sure clincher, they say, "It's as sure and safe as a U. S. Government Bond;" and that's some sure—there isn't anything better. Well, how about getting on the inside with the crowd that make these bonds so sure that every other country in the world would like to get a hat full?

Did you ever check up on what these government employees get? I want to tell you it's worth looking into. It's big money, sure money, and in just about as pleasant surroundings as any fellow ever wished for.

When you work for Uncle Sam, your friends know you are a somebody. They respect you. And why shouldn't they? In almost every case you're holding down the job they would like to have, but don't know how to get it.

## I Will Show You How

A lot of fellows think every good job in the government is secured by some kind of pull. And they're right. But it isn't the kind of pull they talk about. It's by doing just a little work and pulling yourself out of that rut you've been traveling in all these years.

Honest, fellows, you'd laugh if you knew how easy it is when the thing is explained to you by someone that knows. I tell you what you do. You just write a letter to Arthur R. Patterson, giving your name and address, and I'll tell you all about it. After completing your course with me and receiving your rating, if you are not offered a job within one year I will refund the small fee I charge for teaching you. You couldn't get a better break than that.

But let's not argue over this thing. Fill in the coupon below or drop me a line. This won't cost you a cent. I'm not going to bother you. I just want to tell you about it. If you don't like what I tell you, why, forget it. But if you do, you're going to write me another letter some day and thank me.

Let me hear from you—right away. Take my little tip. There's some good thing breaking. Mark your envelope **PERSONAL** and send it to

**ARTHUR R. PATTERSON, Principal**  
**PATTERSON CIVIL SERVICE SCHOOL**

*Approved as a correspondence school under the laws of the State of New York.*

**83 Wisner Bldg. Rochester, N. Y.**

**PATTERSON CIVIL SERVICE SCHOOL**

83 Wisner Building, Rochester, New York

Send me your big **FREE BOOK** and tell me how I can secure a position with the U. S. Government paying from \$1140 to \$2700 a year to start, with excellent chances for advancement. This doesn't cost me a penny.

Name.....

Address.....

City..... State.....

## Practical Electrical Education

Learn by the thorough approved scientific methods which our twenty years of specializing enable us to give you.



Become a **Commercial Electrical Engineer in one year, or learn an Electrical Trade in from three to six months. Light, Heat, Power, A. C. and D. C. Armature Winding, Automotive Electricity, Radio included.** Course unexcelled. Illustrated catalog **FREE**. Be sure to mention age and education.

**SCHOOL OF ENGINEERING OF MILWAUKEE**  
Dept. PM.-326A 415 Marshall St., Milwaukee, Wis.



## MONEY IN SQUABS

My big **FREE Pigeon and Poultry Book. ILLUSTRATED IN NATURAL COLORS** is a complete guide to the pigeon raiser. Gives description and prices on all best varieties. Write Today.

**FRANK FOY & SONS, Box 28, Clinton, Iowa**

## Learn Watchwork, Jewelrywork and Engraving

A fine trade commanding a good salary, and your services always in demand. Address **Horological**, Dept. P. Bradley Institute, PEORIA, ILLINOIS, for our latest catalog.

## Free With Wrestling Course

My book on **Muscle and Strength Developing** will be mailed you free of all charges with the purchase of my complete, illustrated **Wrestling Course** at the price of \$1.00. Send your dollar **NOW** for this exceptional offer. **Charles MacMahon, P. 3-26, 180 W. Somerset St., Phila., Pa.**

## TELEGRAPH-RADIO

\$18 to \$35 a week while training for Radio and Telegraph Operator jobs at \$150 to \$300 per month. Write for particulars.

**CHICAGO TELEGRAPH INSTITUTE**  
Dept. 1701 1338 S. Michigan Avenue, CHICAGO



## Play Piano <sup>BY</sup> EAR

*-in 90 days!*

**YOU** can play real tunes from the start. No notes to puzzle you — no tiresome scales to practice.

You need not know a thing about music. Even if you have never touched a piano, if you can hum or whistle a tune, we can teach you to play all popular song hits *by ear* at a very small cost. No need now to spend years practicing under old-time method. My new and original system teaches you easily and quickly. Write at once for

## Free Booklet

to show you how easily it can be done.

This wonderful home course is offered at a ridiculously low cost. A little practice gives amazing results. You can sit down and play any popular jazz piece that you hum.

**FILL IN THE COUPON TODAY**

*Coupon*

Illinois School of Music of Chicago  
Dept. E  
608 Hearst Square, Chicago

Please send at once, without obligation, your Free Book explaining how you can teach me to play piano by ear in 90 days.

Name.....

Address.....

**Send NOW for FREE Book**

# No Wonder \$60<sup>a</sup> day is Easy



27,000,000 Readers of National Magazines are waiting to buy this astonishing invention from YOU. It is never sold through stores. Start cashing in now—while the name "KRISS-KROSS" is on every tongue!

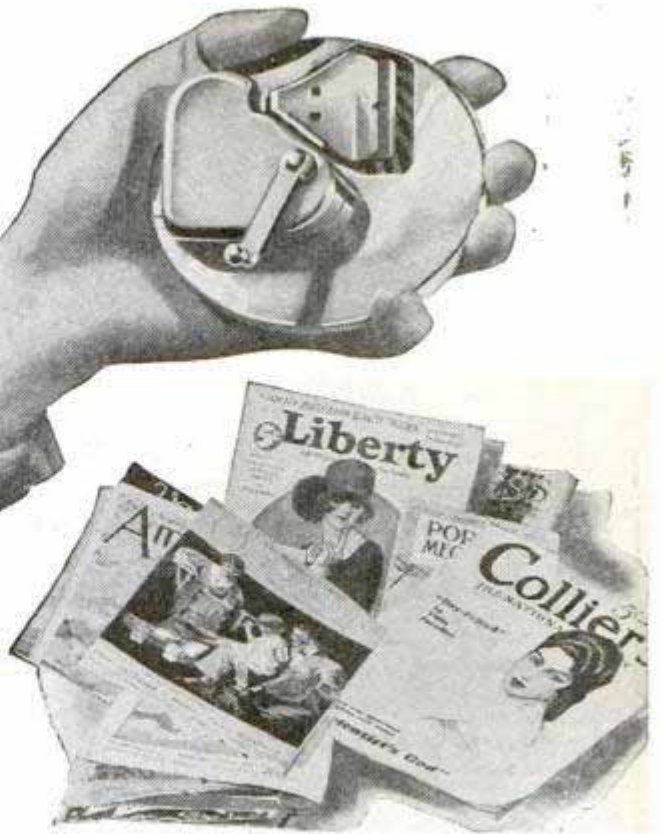

## When You Show Men This Amazing New Way to Shave!

Marvelous new invention offers unbelievable opportunity to make big money: Kriss-Kross Salesmen everywhere are cleaning up \$30 to \$60 a day with clock-like regularity. Read every line of this announcement.

I DON'T care who you are—you never had a chance to make money like this before. The KRISS-KROSS idea has swept the country like wildfire. Unless you are making over \$300 a month, you're simply cheating yourself if you pass up this opportunity to put away \$350 to \$800 cash profit every 30 days!

### What Is It?

KRISS-KROSS—the magic self-seller—is a super-stropper or blade-rejuvenator. It is showing millions of men an amazing new way to shave without buying new blades. Unlike anything ever placed on the market before. This astonishing invention prolongs the life of any make blade for weeks, months, and even years! Its mechanical ingenuity is little short of marvelous. It strops with a diagonal stroke, just like a master barber. Eight "lucky leather grooves" do the trick in eleven seconds and leave your blade with the keenest edge that steel can take!

### Give Men a Mystery Gift Razor Free!

Our unique selling plan makes everything easy as ABC for you. One of the greatest helps we give you is a brand new kind of razor that you offer FREE to every man you meet. Just think what a wonderful opening that gives you!

This unusual razor is really three razors in one! It is instantly adjustable—straight, T-shape, or diagonal. Exclusive feature cuts beard resistance 45% and gives the smoothest shaves you can imagine. As an attention-getter and salesman, this FREE razor has never had an equal in the history of selling!

### FREE \$5,000 Sales Manual Shows Exactly How to Sell

And now, in addition to advertising in all the big magazines, we are going still farther to help you make big money with KRISS-KROSS. At an expense of \$5,000 we have prepared a

brand-new sales manual—the equal of a \$150 course in salesmanship. This surprising little book tells you exactly how to sell KRISS-KROSS—what to do and save. This remarkable book with all its selling secrets could easily sell for \$2. We give it to you FREE!

### Get Started at Once

Right now is the time to begin reaping big profits with KRISS-KROSS. Thousands of dollars are being spent to pave the way for you through advertising. Territories are going fast. Find out all about this sensational, money-making business without delay. See how simple it is to make \$100—\$225 a week with KRISS-KROSS—the most unique self-seller of all time. This proposition calls for quick action! Clip the coupon immediately. No obligation. Mail it tonight!

## RHODES MFG. CO.

Dept. C-370

1418 Pendleton Ave., St. Louis, Mo.

Rhodes Mfg. Co., Dept. C-370  
1418 Pendleton Ave., St. Louis, Mo.

Please send me full details of your nationally advertised KRISS-KROSS stropper—and explain your unusual sales plan. Also tell me how I can make big money, giving away KRISS-KROSS razors FREE.

Name.....  
Address.....  
City..... State.....

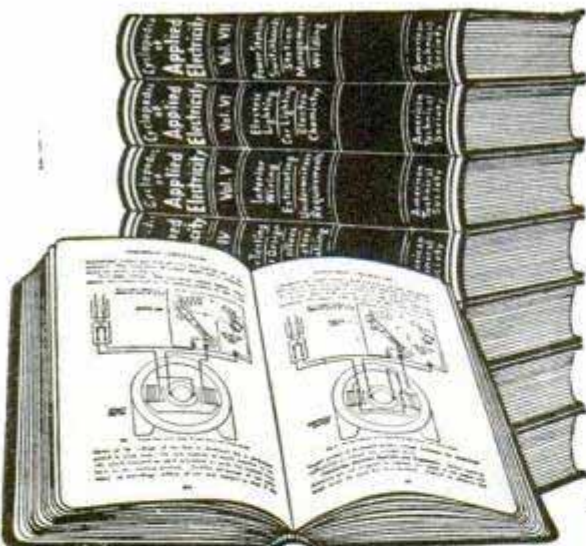

## 8 BIG BOOKS ON ELECTRICITY

Here is an amazing offer on 8 big electrical books, brimful of interesting and valuable facts and illustrations on electricity; facts that will increase your pay if you learn how to use them. Read all about our

**No Money Offer** To make it possible for every man with a spark of ambition in his make-up to benefit by this easy way of learning, we have set aside a limited number of complete sets to be sent FREE, without a penny down. Look the books over; read them and see how complete and thoroughly all subjects are treated and yet how plain and easy to understand. Take ten days to do this and then, if you don't realize how helpful and profitable they can be to you, send them back. If, however, your own good judgment proves their value and you see how profitable having them will be, just send us \$2.00 and only \$3.00 per month until the special price of only \$29.80 is paid.

### FACTS THAT INCREASE YOUR PAY

Knowing means earning. The man that has specialized knowledge or knows where to get it ALWAYS makes the most money. Here is your opportunity, your chance to get into the Bigger Pay Class. You don't have to read the book through; the jiffy index is complete and simple. You can put your finger on the facts you want to know in a few seconds. Get these books now; don't hesitate—no offer could be more liberal!

**MEMBERSHIP FREE** In addition to this unusually complete set of 8 full volumes, bound in new flexo covers, we will for a limited time include a certificate of consulting membership in the American Technical Society, which will entitle you to FREE consultation service. Twenty highly paid experts will be ready to help you, entirely without cost to you.

Don't let this opportunity slip by; send for your books NOW. Use the coupon below.

### AMERICAN TECHNICAL SOCIETY Special Dept. E-319, Chicago, Ill.

You may send me the 8 Big Books—APPLIED ELECTRICITY. If I like them I will send you \$2.00 in 10 days after I receive them and \$3.00 per month until only \$29.80 has been paid. Otherwise I will return the books and will not owe you anything.

Name.....

Address.....

City..... State.....

Reference.....

# Brain-Feast

Solvent fruit, such as grapefruit, berries, tomatoes. UNDER PROPER CONDITIONS:

(1) Dissolve or disintegrate tumors, goitres, gallstones, deposits of lime in joints.

(2) Dissolve phlegm or mucus, remove the source of colds, catarrh and consumption.

(3) Correct liver and kidney troubles; headaches.

(4) Dissolve blood clots as in paralysis.

(5) Dissolve the impurities which cause blemishes to the skin as acne, eczema.



### Intensive Feeding. Juices, No Water

New rich blood builds healthy tissue, displacing diseased tissue. No diagnosis required, only activities. Write us for particulars of Government Bulletins, describing experiments on convicts, hens, cows, etc. Deficient feeding produced disease, whereas full nutrition cured e.g. paralysis, blindness in hens, rats, etc., pellagra, beriberi, skin affections, etc., in men.

The following extracts are from sworn statements of pupils:  
**PARALYSIS.** Age 61. Right hand and leg helpless three years; restored in three weeks.

Another, age 65, bedridden, hemiplegia. Sensation restored in three days. Could walk two miles daily after six weeks.

**ARTHRITIS.** All joints swollen with lime deposits. Knees and wrists locked immovable for eight months. Blind for two years. Can now see, walk and do home work.

**CATARRH, HAY FEVER, RESULTING DEAFNESS** decreased from the first meal.

**GALL STONES.** Age 80 bedridden, cholice every week for years, but not one attack since instruction over a year ago, now can do housework.

**TUMORS.** Case age 40. Tumors weighing several pounds dissolved within a year.

**GOITRE.** Collar reduced 17 to 15, normal size.

**UTERINE HEMORRHAGE.** Age 50. Three years in rolling chair; weak from constant discharges. Now does housework including washing.

**ECZEMA.** Age 69. Eyebrows lost. Skin cracked and scaling. Normal in three months.

**PYORRHOEA.** Age 65. Pus ceased on 7th day.

**PREGNANCY.** Age 39. With last two children suffered no nausea, no swollen feet nor constipation as previously. Delivery painless.

**CONSTIPATION.** Three healthy eliminations daily.  
**BRAINY MEALS** make mental work easy. Muscle nourishing meals build firm flesh. Sworn statements. Over 6,000 pupils. Educational book, 10 cents.

**BRINKLER SCHOOL OF EATING**  
DEPT. 42, 131 WEST 72nd STREET, NEW YORK

## DRAW CARTONS

### Turn Your Talent Into Money

Cartoonists earn from \$50 to \$300 per week—some even more. Remarkable new Circle System of Drawing teaches you in half the usual time. Send for booklet and sample lesson plate explaining full details of the Course.



**THE NATIONAL SCHOOL OF CARTOONING**  
423 Park Building Cleveland, Ohio

## WANT WORK AT HOME?

Earn \$18 to \$60 a week RETOUCHING photos. Men or women. No selling or canvassing. We teach you and furnish WORKING OUTFIT given with each enrollment. Limited offer. Write today. Artcraft Studios, Dept. 50, 3900 Sheridan Rd., Chicago

## WANTED—RAILWAY MAIL CLERKS

**\$158.00 to \$225.00 a Month for Life**

Every second week off with full pay—no "lay-offs" because of strikes, poor business, etc.—sure pay—rapid advancement to higher positions. City and country residents stand same chance. Common sense education sufficient—no political influence.

### TRAVEL—SEE YOUR COUNTRY

Mail Coupon today—sure. Every day's delay means so much less chance of appointment from the next examinations—so do it at once.

Take this First Step for  
a U. S. Government Job  
Use Coupon Before You Lose It

### COUPON

FRANKLIN INSTITUTE, Dept. N-174, Rochester, N. Y. Kindly rush to me, entirely free of charge, (1) A full description of the position checked below; (2) Sample examination questions; (3) A list of U. S. Government Jobs now obtainable; (4) Tell me how I can get the position here checked.

...Railway Mail Clerk (\$1900 to \$2700) ... Customs Positions (\$1140 to \$1860)  
... Postoffice Clerk (\$1700 to \$2300) ... Internal Revenue (\$1140 to \$1860)  
... City Mail Carrier (\$1700 to \$2100) ... Rural Mail Carrier (\$2100 to \$3300)  
... Income Tax Auditors ..... (\$2040 to \$3000)

Name .....

Address.....





## Popular Mechanics New Handbooks

If you could thumb through these new books, you would want them all. They are literally jammed with practical ideas. Each one is written so clearly that a boy can understand the directions. Each is the experience of a practical man or woman. Most articles are illustrated with photographs or drawings. The practical nature of the subjects has made a wide sale for them already although they have been, on the market only a few weeks. Here are the titles of those now available:

Popular Mechanics Lathe Handbook No. 1	<b>Any 2 for \$1</b>	Popular Mechanics Boat Book
Home Mechanics Handbook No. 1		Automobile Owner's Handbook
Handbook for Women		Auto Tourist's Handbook
Popular Mechanics Concrete Hand- book No. 1		Auto Repairman's Handbook No. 1
		Drilling and Thread Cutting

### Order Several at One Time

So low is the price that it is certainly wise to order as many of these at one time as you can use. You may have any two for \$1. These books make good presents. They are splendid for boys taking manual training courses.

*Free Magazine*, Personal Advancement with each order.

### POPULAR MECHANICS PRESS

Popular Mechanics Bldg., Room 703, Chicago, Ill.

## Learn Pattern Making

How to make joints, wood turning, sawing, machine tools, simple patterns, crooked patterns, large pattern work, pipe work, stove patterns, molding-machine work, core-making, loam patterns and molds. Send no money. Just write a postal for this complete book. Ask for "Pattern Making". Pay postman postage and 98c.

Popular Mechanics Press, Room 703, 200 E. Ontario St., Chicago, Ill.

## EVERYBODY'S HANDBOOK of Electrical Kinks

This is a brand new book similar to Popular Mechanics other "kink" books. It is made up of 214 ideas and short cuts for doing electrical work of all kinds. It is a book for amateurs as well as professional electricians. If you are interested in wiring, electric lighting, the making of electrical devices, experimenting, repair work, battery manufacture and repair, or telephones, you will find many helpful articles in this book. If you are interested in radio, you should have this book to learn some of the short cuts used by electricians in wiring and making apparatus.

#### THE BOOK CONTAINS

- |  |  |
|--|--|
| 47 ideas on wiring                     | 11 ideas on switches                       |
| 45 ideas for making electrical devices | 6 ideas on installation                    |
| 19 ideas on electric light'g           | 22 ideas on testing                        |
| 5 ideas on transformers                | 12 ideas on repairing                      |
| 5 ideas on motors                      | 11 ideas on battery manufacture and repair |
| 8 ideas on generators                  | 5 ideas on telephones                      |

There are 162 Pictures to make the ideas clear. Boys can follow the directions as well as men. If you understand the simple fundamental principles of electricity, this book will be a wonderful help to you.

**Send No Money** Just write your name and address on a postal card and say that you want the New book of Electrical Kinks. When the postman hands you the book, hand him \$1.50 and the few cents postage. If you live outside the U. S. or do not expect to be at home when the postman calls, send the \$1.50 with your order. Address

Room 703 Popular Mechanics Bldg.  
**POPULAR MECHANICS PRESS** 200 E. Ontario St., Chicago

# I Received \$9200 for One Drawing -While Learning

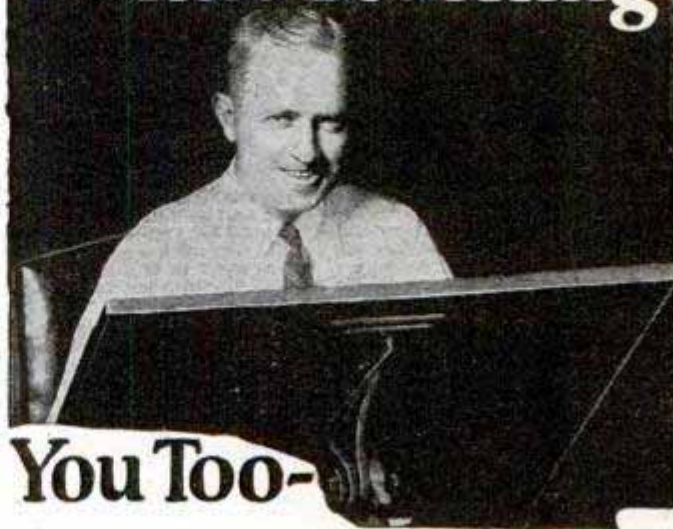

## You Too- Can Learn to Draw This Easy, Quick Way

HERE'S positive proof that learning to draw at home the Washington School way can easily and quickly qualify you for big money positions now open in this attractive profession.

Mr. G. O., one of our students in Terre Haute, Indiana, wrote: "I will send you a lesson next week for your approval. I appreciate your course of instructions. I have made considerable money while learning. I received \$92.00 for one drawing."

YOU too—without any previous training—and no matter how little apparent talent you have—can now easily learn illustrating, designing and cartooning through this amazingly easy method—this method that has been tested and proved by hundreds of successful Washington School graduates.

Right now there is a tremendous demand for original drawings. Trained commercial artists earn up to \$200 and more a week! And now with just a few hours' pleasant home study YOU can easily and quickly get one of these high-paying artists' jobs.

### Mail Coupon for Free Book

A new handsomely illustrated book has just been printed, which gives all the most up-to-date information on the thousands of wonderful opportunities in Commercial Art and shows how this startling method easily enables you to enter this field. It tells about our students—their success—what they say—actual reproductions of their work—how they made big money while studying. This attractive book will be sent without cost or obligation. Send for it. Mail coupon now! Washington School of Art, Room 303-D, 1115-15th St., N. W., Washington, D. C.

WASHINGTON SCHOOL OF ART,  
Room 303-D, 1115-15th St., N. W.,  
Washington, D. C.

Please send me without cost or obligation your new book on Art, "Quick Easy Way to Become an Artist," and details of your special offer.

Name.....  
Please write plainly Mr., Mrs. or Miss

Address.....

City..... State.....

# Don't Gamble with Your Future

## Is the U.S. Gov't's Choice Good Enough for You?

### A Practical Electrical SHOP Course—Not a Correspondence School

This is the U. S. Government's own Veterans' Bureau Course, which we took over when Congress decided it had served its purpose for the Veterans. Now this opportunity is open for you—to make your start quickly in this most fascinating, **big pay work**—practical Electricity. The World's greatest progress is right in this field. Right now the opportunities are unlimited and the quicker you get this training, the bigger success you will make.

**SPECIAL OFFER NOW** for men who enroll immediately. In 12 weeks you can get the training that will put you in a **real electrical job**. Think of it! Before spring is over you will be started in this most interesting work—with **big pay** and a **bigger future**. Send right now for our Free Electrical Book and this special offer. Use coupon below.

### The Money-making End of Electricity

Here you learn by actually **doing** electrical problems—under supervision of electrical experts. That is the way to learn the practical uses of electricity that mean **money** to you.

ERWIN GREER, President Greer College—Electrical Division—Dept. 301 E—2024 S. Wabash Ave., CHICAGO  
Please send me your free book and offer for Electrical course. It is understood I am not obligated in any way.

Name .....

Address .....

The same chief instructor is in charge who developed this school for the Government. The same training system is being followed—the plan that has proved to be successful and practical for initiating men into the **money-making** end of electricity.

In addition to the equipment bought from the Government school, we have added many new features. We have recently taken over completely one of the largest strictly radio schools in the country.

**Made Simple and Easy** Our remarkable training plan makes the course doubly interesting and very easy. Simple experiments begin the very first day—with a friendly, helpful instructor always at hand.

One great advantage of our system is that you get individual attention. You go ahead as fast as you are able. No one is held back because someone else is slow.

### We Pay R. R. Fare to Chicago—TOOLS FREE

We pay Railroad fare to Chicago on all cash enrollments. The tool set is given—absolutely free—regardless of what payment plan you use. A truly handsome outfit that you will be proud of while training, and later—on the job.

**Free Employment Service** Our employment department has more jobs than it can fill at the present time. We help you get the right sort of job, and we stand back of you for life with help and advice.

You may return at any time—without charge—to "brush up" on any subject, or to learn about latest developments and inventions.

Part time jobs for men who wish to earn extra money while training.

**Send This Coupon—NOW** Do not delay and let this chance slip by. This is the ideal time to get into the electrical business, while the demand is growing so fast for men who know. Write or print your name and address very carefully, please,—clip the coupon and send it in at once

## FREE INFORMATION

Just What You're Waiting For

### CHORDS, CHORDS, CHORDS, on the TENOR BANJO

Learn advanced chords, and jazz strokes as used in general playing of banjo parts of orchestration. This course is written by **JOHN MARTELL**, Author, composer, soloist, and teacher of many artists. This course is so easy to understand and written so plain and simple that you need not know any music at all to start. This course is for beginners and advanced players. Furthermore, this is Mr. Martell's master course on chords, jazz, and latest in modern music. Write for our chord information free.

LEARN AND BE POPULAR. John Martell, Director

NEW YORK INSTITUTE OF MUSIC  
143 East 34th St., N. Y. CITY

## Heat Without Coal

At last the ideal way to heat your home, without coal or wood, has been discovered. This is a new invention called the "Heat Fountain" which converts any stove, heater, range or furnace into a gas heater. It combines ordinary kerosene (coal oil) with air to have a perfect heating gas. No piping—no changes to your present heating plant necessary. Simply slip this little device into any stove or furnace and you have instant heat, any degree desired, at a turn of a valve. Already 200,000 homes, many of them in Canada and Alaska, have found this wonderful device the most dependable for heating even in sub-zero weather. Find out now how you can be done forever with soot, ashes, dirt, smoke and drudgery of coal and wood—the worry of coal shortages, strikes and exorbitant prices. Find out how you can use this new invention in your home on 30 days' trial. Simply write for free book "The New Way to Heat Homes" and full details of our offer. Send name and address to

OLIVER OIL BURNER CORPORATION  
Dept. C-130 210 Chestnut St., ST. LOUIS, MO.

# LEARN CARTOONING

Successful cartoonists earn big salaries. Many of the most popular cartoonists of today learned to draw in their spare time, at home, through the Landon Course of Cartooning and now earn \$75 to \$200 or more per week.



The Landon Picture Chart Method of teaching ORIGINAL drawing makes cartooning easy to learn. Hundreds of sketches like the above explain every step in creating ORIGINAL heads, figures, animals, etc.

Send 6c in stamps today for sample Landon Picture Chart and full explanation of this wonderful course, also long list of successful Landon students and information showing possibilities for you. Please state your age.

The Landon School, 738 National Building, Cleveland, Ohio

### Former Students Who Are Now Successful Comic Strip Artists

**BLOSSER**—Now drawing "Freckles and His Friends."

**BYRNES**—Now drawing "Reg'lar Fellers."

**BRANNER**—Now drawing "Winnie Winkle."

**LOCHER**—Now drawing "Cicero Sapp."

**TAYLOR**—Now drawing "Mom 'n Pop."

**EDWINA**—Now drawing "'Cap' Stubbs."

**CRANE**—Now drawing "Washington Tubbs II."

**ETHEL HAYS**—Now drawing "Flapper Fanny."

**PAUL FUNG**—Now drawing "Gus & Gussie."

**KNICKERBOCKER**—Now drawing "This and That."

# It's Fun to Make Things

Let the other boys wonder how you can make so many interesting things. Make your own motor sled. Make your own radio. Make your own skis and snowshoes. You can learn how to make almost anything that any boy could want by following the pictures and the simple directions in

## The Boy Mechanic Library

And just think of it, there are nearly 4,000 separate articles in the four beautiful volumes! Some of the most fascinating subjects are listed below.

### How to Make Things

- |                   |                       |
|-------------------|-----------------------|
| Bats              | China painting        |
| Winter sports     | Decorative metal work |
| Camping           | Furniture making      |
| Ice boats         | Farming               |
| Water sports      | Poultry               |
| Toboggans         | Models                |
| Tents             | Laboratory helps      |
| Skis              | Household helps       |
| Indian snowshoes  | Wood working          |
| Skating           | Electrical devices    |
| Gymnasium         | Photography           |
| Wind wagons       | Music                 |
| Motor sleds       | Outdoor games         |
| Radio             | Stoves                |
| Magic             | Furnaces              |
| Trapping          | Wireless              |
| Pets              | Tricks                |
| Leather work      | Puzzles               |
| Carpentry         | Bicycle               |
| Painting          | Flowers               |
| Toys              | Hunting               |
| Fishing           | Rites                 |
| Fruit growing     | Metal working tools   |
| Entertainments    | Secret locks          |
| Automobile        | Swings                |
| House decorations | Sleds                 |
| Drafting          | Power devices         |

Learn how to make things to sell. Learn how to make things to enjoy yourself. Buy the complete library, including Book 1, Book 2, Book 3 and Book 4.

### Send No Money

Simply sign your name and address to the attached coupon and mail it at once. When the postman delivers the books to your door, pay him the price of the books and the few cents postage. That is all.

**POPULAR MECHANICS PRESS**  
Popular Mechanics Building  
Room 1778 CHICAGO, ILL.

**Mail the Coupon Today!**  
**POPULAR MECHANICS PRESS**  
Popular Mechanics Building  
Room 1778, Chicago, Ill.

Please send me at once C. O. D. The Boy Mechanic Library comprising Book 1, Book 2, Book 3, and Book 4. I will pay postman \$7 and the few cents postage.

Name .....

City .....

State .....

St. No. or R. F. D. ....

If you want individual books at \$2 each, check the numbers of the books you want: 1  2  3  4



## “Which Man Shall I Promote?”

WILL your employer think of you when the next good position is open? Will he say, “There’s a man who is training himself to handle bigger work,” or will he pass you by as just an ordinary routine worker?

Do not try to fool yourself. Your employer is watching you more closely than you may think. He’s constantly checking up on your work, your abilities, your ideals, your aspirations. Stored away in the back of his mind or filed away in black and white, are his impressions of the kind of man you are and the kind of man you want to be.

He’s willing and anxious to pay you more money the minute you prove that you are worth more money. But he can’t take chances. When he promotes a man, he wants to be sure he will make good.

Decide now—today—that you are going to be ready when your chance comes. Choose the position you want in the work you like best—then train for it. You can do it in spare time in your own home through the International Correspondence Schools.



### Mail the Coupon for Free Booklet

#### INTERNATIONAL CORRESPONDENCE SCHOOLS

Box 5563-E, Scranton, Penna.

Without cost or obligation, please tell me how I can qualify for the position or in the subject before which I have marked an X:

#### BUSINESS TRAINING COURSES

- |   |   |
|---|---|
| <input type="checkbox"/> Business Management            | <input type="checkbox"/> Salesmanship           |
| <input type="checkbox"/> Industrial Management          | <input type="checkbox"/> Advertising            |
| <input type="checkbox"/> Personnel Organization         | <input type="checkbox"/> Better Letters         |
| <input type="checkbox"/> Traffic Management             | <input type="checkbox"/> Show Card Lettering    |
| <input type="checkbox"/> Business Law                   | <input type="checkbox"/> Stenography and Typing |
| <input type="checkbox"/> Banking and Banking Law        | <input type="checkbox"/> Business English       |
| <input type="checkbox"/> Accountancy (including C.P.A.) | <input type="checkbox"/> Civil Service          |
| <input type="checkbox"/> Nicholson Cost Accounting      | <input type="checkbox"/> Railway Mail Clerk     |
| <input type="checkbox"/> Bookkeeping                    | <input type="checkbox"/> Common School Subjects |
| <input type="checkbox"/> Private Secretary              | <input type="checkbox"/> High School Subjects   |
| <input type="checkbox"/> Spanish                        | <input type="checkbox"/> Illustrating           |
| <input type="checkbox"/> French                         | <input type="checkbox"/> Cartooning             |

#### TECHNICAL AND INDUSTRIAL COURSES

- |   |  |
|---|--|
| <input type="checkbox"/> Electrical Engineering | <input type="checkbox"/> Architect                                   |
| <input type="checkbox"/> Electric Lighting      | <input type="checkbox"/> Architects' Blueprints                      |
| <input type="checkbox"/> Mechanical Engineer    | <input type="checkbox"/> Contractor and Builder                      |
| <input type="checkbox"/> Mechanical Draftsman   | <input type="checkbox"/> Architectural Draftsman                     |
| <input type="checkbox"/> Machine Shop Practice  | <input type="checkbox"/> Concrete Builder                            |
| <input type="checkbox"/> Railroad Positions     | <input type="checkbox"/> Structural Engineer                         |
| <input type="checkbox"/> Gas Engine Operating   | <input type="checkbox"/> Chemistry <input type="checkbox"/> Pharmacy |
| <input type="checkbox"/> Civil Engineer         | <input type="checkbox"/> Automobile Work                             |
| <input type="checkbox"/> Surveying and Mapping  | <input type="checkbox"/> Airplane Engines                            |
| <input type="checkbox"/> Metallurgy             | <input type="checkbox"/> Navigation                                  |
| <input type="checkbox"/> Steam Engineering      | <input type="checkbox"/> Agriculture and Poultry                     |
| <input type="checkbox"/> Radio                  | <input type="checkbox"/> Mathematics                                 |

Name .....

Street .....

Address .....

City .....

State .....

Occupation .....

Persons residing in Canada should send this coupon to the International Correspondence Schools Canadian, Limited, Montreal, Canada.

# Young outdoor men wanted



To a few sturdy young men—lovers of fresh air and sunshine—who want to get away from the grind of indoor work—John Davey's national organization, The Davey Tree Expert Company, offers an exceptional opportunity. Constantly increasing demand will create a limited number of openings. These young men selected will be thoroughly trained by the Company and given a permanent position if they make good. If you are single, between 20 and 30 years of age, free to travel, healthy, industrious, having a good practical education, and able to furnish satisfactory references, you have good chance to qualify. Pay is good at start, advancement assured on merit. We want only men who desire permanent employment in a growing organization and will accept only clean, sturdy young men, thorough Americans, not afraid of vigorous outdoor work. Fill out the coupon and mail it promptly—before the few available openings are all spoken for by other men.

**THE DAVEY TREE EXPERT CO., Inc.,**  
575 Federal Bldg., Kent, Ohio

I believe I am qualified for employment as a member of the Davey Organization in the profession of Tree Surgery. Please send me, without any obligation, a qualification blank to serve in place of a personal interview.

Name.....  
Address.....

The man who studies gets ahead. Popular Mechanics Press will advise you what books to read to advance in your trade. 200 East Ontario Street, Chicago, Illinois.

POPULAR MECHANICS  
**LATHE**  
- HANDBOOK N°1 -



POPULAR MECHANICS PRESS  
CHICAGO

## 259 Discoveries For Lathe Operators

This book contains the experiences of 106 successful operators in the U. S. and in the principal foreign manufacturing countries. 83 articles tell how to make special lathe tools and attachments. 33 on gauges and indicators. 23 on special devices for holding work. 9 special lathe centers. 29 on how to do unusual jobs. 28 on boring and drilling. 11 on thread cutting.

**212 Illustrations** The pictures make it easy for a beginner. Every article is written so anyone can understand it, and every kink has been thoroughly tested.

Just write a postal. Popular Mechanics Lathe Handbook and Drilling and Thread Cutting Handbook will be sent C. O. D. Pay postage and 98c for the 2 books.

**POPULAR MECHANICS PRESS**  
Room 19, Popular Mechanics Building, Chicago, Ill.

**Send No Money**

### Poultry Miller's Guide

- Tells all about chickens—care, feeding and raising for profit. Also describes IDEAL INCUBATORS, Hot Water and Electric—IDEAL BROODERS—Coal and Oil Burning—Baby chicks, Eggs for Hatching. Special LOW PRICES.

**J. W. MILLER CO., Box 12, Rockford, Ill.**



### Poultry and Squabs for Profit

Foy's big book. CONTAINS MANY COLORED PLATES, encyclopedia of poultry information. Low prices on **BABY CHICKS**, fowls, eggs and incubators. Written by a man who knows. Mailed FREE.

**FRANK FOY & SONS Box 18 CLINTON, IOWA**



### 64 BREEDS

Chickens, ducks, geese and turkeys. Pure-bred, high quality, hardy and most profitable. Fowls, eggs, incubators, brooders; lowest prices. *America's great plant.* At it 33 yrs. Fine new 100 page book and catalog free.

**R.F. Neubert Co., Box 908, Mankato, Minn.**



### WEBER'S BEST

laying, BEST paying fine pure-bred Northern raised chickens, ducks, geese, turkeys, chicks, eggs at lowest prices. *America's great industry, my 44th year.* 100 page Catalog and Poultry Book Free.

**W. A. Weber, Box 82 Mankato, Minn.**



### PLANS for Poultry Houses

All styles, 150 illustrations; secret of getting winter eggs, and copy of "The Full Egg Basket." Send 25 cents.

**INLAND POULTRY JOURNAL, Dept. 74 Indianapolis, Ind.**

### SQUAB BOOK FREE!

Pigeons Printed in Natural Colors

Make money breeding squabs. Sold by millions. Start small, grow big. Start now. Read how our customers sell squabs for \$12 a dozen. We have been established for 25 years. Better look into this. Let us send you, at no cost to you, our big, illustrated free book telling how to make money breeding squabs. We sell Racing Homers also. Write

**Plymouth Rock Squab Co. 634 H. St., Melrose Highlands, Mass.**



# STAMMERER S

Learn to speak correctly, increase earning power! Our methods invariably successful. Booklets Free

**SAMUEL A. ROBBINS, 419 Boylston St., Boston, Mass.**

### Shop Notes—50c

Nearly 250 pages of valuable ideas for everyone who likes to make things. Profusely illustrated. New volume issued each year. 14 back numbers available. 50 cents each.

**POPULAR MECHANICS PRESS, Popular Mechanics Bldg., Rm. 703, Chicago, Ill.**

### "BECOME A LIGHTNING TRICK CARTOONIST"

Send \$1.00 for Laugh Producing Program of 23 Trick Drawings with Instructions. Catalog of Chalk Talk Supplies Free.

**BALDA ART SERVICE, Dept. 1, Oshkosh, Wis.**



## No Joke to be Bald!



**Grow New Hair Quick**

### Let Me PROVE It To You FREE

The photos show what HAIRERBS did for me—I believe I can do the same for YOU. Let me prove it to you, FREE. For dandruff, or hair that is thinning, provided you are under 45 years of age and your scalp is not burned or scarred, HAIRERBS WILL HELP YOU. No apparatus, no useless massage—a simple, quick, NATURAL treatment which MUST succeed or your money back. Send in the coupon below or drop us a postal.

**You CAN'T Lose!**

**THE VREELANDS, CLEVELAND, OHIO**

**THE VREELANDS, 15 Euclid-Windsor Bldg., Cleveland, Ohio**

Name.....  
Address.....  
City..... State.....

**HAIRERBS DOES GROW HAIR!**

# Swear Off Tobacco



Tobacco Tells on Nervous System



Tobacco Ruins Digestion



Tobacco Stunts Boy's Growth



Tobacco Robs Man of Vitality



Tobacco Steals from You the Pleasures, Comforts, Luxuries of Life

## Tobacco Habit Banished Let Us Help You

### Quick Results

Trying to quit the tobacco habit unaided is often a losing fight against heavy odds, and may mean a serious shock to your nervous system. So don't try it! Make the tobacco habit quit you. It will quit you if you will just take **Tobacco Redeemer** according to directions.

It doesn't make a particle of difference whether you've been a user of tobacco for a single month or 50 years, or how much you use, or in what form you use it. Whether you smoke cigars, cigarettes, pipe, chew plug or fine cut or use snuff—**Tobacco Redeemer** will positively remove all craving for tobacco in any form in a few days. Your tobacco craving will usually begin to decrease after the very first dose—there's no long waiting for results.

**Tobacco Redeemer** contains no habit-forming drugs of any kind and is marvelously quick, scientific and thoroughly reliable.

### Not a Substitute

**Tobacco Redeemer** is in no sense a substitute for tobacco, but is a radical, efficient treatment. After finishing the treatment you have absolutely no desire to use tobacco again or to continue the use of the remedy. It helps to quiet the nerves, and will make you feel better in every way. If you really want to quit the tobacco habit—get rid of it so completely that when you see others using it, it will not awaken the slightest desire in you—you should at once begin a course of **Tobacco Redeemer** treatment for the habit.

### Results Absolutely Guaranteed

A single trial will convince the most skeptical. Our legal, binding, money-back guarantee goes with each full treatment. If **Tobacco Redeemer** fails to banish the tobacco habit when taken according to the plain and easy directions, your money will be cheerfully refunded upon demand.

### Let Us Send You Convincing Proof

If you are a slave of the tobacco habit and want to find a sure, quick way of quitting "for keeps" you owe it to yourself and to your family to mail the coupon below or send your name and address on a postal and receive our free booklet on the deadly effect of tobacco on the human system, and positive proof that **Tobacco Redeemer** will quickly free you from the habit.

**Newell Pharmacal Company**  
Dept. 300, Clayton Station, St. Louis, Mo.



### Free Book Coupon

**NEWELL PHARMACAL CO.,**  
Dept. 300, Clayton Station, St. Louis, Mo.

Please send, without obligating me in any way, your free booklet regarding the tobacco habit and proof that **Tobacco Redeemer** will positively free me from the tobacco habit or my money will be refunded.

Name.....

Street and No.....

Town..... State.....



# Men Wanted

## In Building Trades and Auto Industry

**COME TO DETROIT,** the Wonder City, and learn one of the high paying trades taught at the Big School, known as the Detroit School of Trades. Endorsed by Contractors, Builders and Manufacturers, operated under the Supervision of the State Board for Vocational Education.

### Mr. Buick says

D. D. Buick says: The Detroit School of Trades gives you a practical training on the actual work with tools, not books; under skilled instructors who are Master Mechanics. Each student receives individual training, not class instruction.

### D. D. BUICK

Mr. D. D. Buick, Director and Chief Engineer of this school and one of the founders of The Buick Motor Co., says: "Come to our School. Become a trained man and you will not have to work for low wages or be out of employment. A training in this School will mean your future Success in life."

## Greatest Year in History of the World

1926, it is said by those in position to know conditions, will be greatest year in world's history for prosperity, progress, success and opportunity. This begins period of years of building, development, expansion of magnitude never before witnessed. Wonders accomplished—riches—wealth—to fill coming years. Be prepared.

## We Teach Big Pay Trades

Learn a good trade. Put yourself in a position to keep pace with prosperity. Trained men in greater demand than ever. Opportunities will go to the man in a position—QUALIFIED—to grasp them. Learn your trade here in Detroit where the whole world looks for best examples in modern methods. The city "Dynamic" where things are done in a big way.

### DO IT TODAY

Don't wait until tomorrow. Be a *now* man—give yourself a chance. Make today a big day for yourself by sending in this coupon.

## LEARN ONE OF THESE TRADES

Below is a list of most successful trades today and successfully taught in this Big School:

Bricklaying—Plastering—Plumbing—Carpentry—Estimating and Contracting—Electricity—Paper Hanging—Painting and Decorating—Sign Painting—Show Card Writing—Auto Striping—Auto Mechanics—Auto Trimming—Metal Finishing—Auto Painting—Acetylene Welding—Custom Shop Course

## Act Now—TODAY

Don't delay in this important matter. Time is worth more today than it ever was. To put off action until tomorrow is a day's pay lost. The quicker you get here and have learned your trade, the sooner you will be on the road to success.

Select the trade you are interested in, write this in the coupon at the corner, fill in name and address, tear off and MAIL today.

Detroit School of Trades, Dept. 326-A, 217-221 Woodward Avenue, Detroit, Michigan  
I am interested in this

trade.....

Send me full particulars about same.

Name.....

Address.....

## DETROIT SCHOOL OF TRADES

Department 326-A

217-221 Woodward Avenue,

DETROIT, MICHIGAN



## These Facts Have Built This Big School

"Learned my trade at your school of plastering last spring. Have been making top wages ever since. Recently went into the contracting business and now have number of men working for me. When I enrolled in your school, was working for Ford Motor Co., making \$6.00 per day. Since learning plasterer's trade have never made less than \$12.00 per day. Since going into contracting business have made as much as \$200.00 in one week. Thank you for all you have done for me."

ARTHUR AUGUSTINE,  
Plastering Contractor.

"Took course in your plumbing department. After few months in your school, went up for examination and take great pleasure in informing you I was successful and now have my license. You take a lot of trouble and pains in teaching your students—you do all in your power to make tradesmen of them."

GEO. B. WELLS.

"Having taken your course in Auto Painting (Pyroxylin-Lacquer) am now working in a Duco Refinishing Shop, here in Columbus, Ohio. My employer says often that 'I am doing very good work.' Going into business for myself in few days, having rented a refinishing shop."

G. C. SAYLES.

"After taking your custom shop course, am back in Hibbing, Minn., and opening up a shop of my own. Already secured more auto painting than can handle."

VICTOR MISKA.

"After taking your complete course in bricklaying, am working for large building contractor. Get union scale of \$1.50 per hour. Joined bricklayers union."

GERALD WAJET.

More letters from students—records of the success of our students—proof of what this school has done, is doing and will do for its students, are available to you at any time.

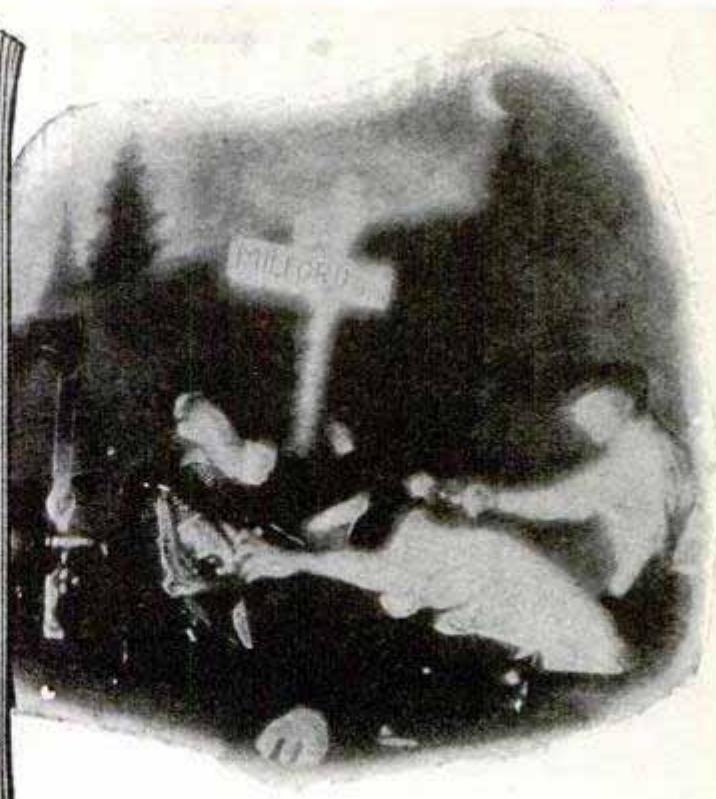

## Send for this Free Book!

**A FASCINATING BOOK** of Detective stories that shows how ordinary boys and men have won nationwide fame, thousands of dollars in rewards, and important official positions by solving finger print mysteries!

"... Shortly before midnight a young couple slipped away from the dance. They sought out a long, low, rakish roadster. With powerful headlights picking out the path, it moved cautiously through the parking space and out onto the high road.

"Early next morning—a farm boy found the girl's dead body crumpled in the wayside ditch. Concealed in the bushes at the side of the road lay the boy's lifeless body, also shot from behind."

Who had committed the murder?

Read the rest of the story on page 15 of our new Finger Print book. Find out how the murderers were traced, tried and convicted, and how a certain finger print expert solved five murder mysteries and secured 97 convictions in less than a year.

Find out how you can become a Finger Print Expert.

### Thirteen Thrilling Stories of Mystery and Achievement

Thirteen stories of crime, daring robberies, mysterious murders, thrilling escapes. You'll enjoy "Snowflakes," a great dope story—"The Invisible Finger Print," a blackmail mystery.

In "Foiled," a true account of a great political coup, you'll read of the astounding rise of a young country photographer who saved the Mayor of his city and was later appointed to the most important identification position in the state.

You'll read of men who achieved fame, big rewards and important positions in a short time through the study of finger prints.

Any man who can read and write can become a finger print expert.



#### PARTIAL LIST Graduates U. of A. S. Recently appointed Finger Print Experts of these States, Cities and Institutions.

State of Iowa  
State of Idaho  
State of Colorado  
St. Paul, Minn.  
Columbus, Ohio  
Detroit, Mich.  
Pittsburgh, Pa.  
Great Falls, Mont.  
Idaho Falls, Idaho  
East Lansing, Mich.  
Schenectady, N. Y.  
Lorain County, Ohio  
El Paso, Texas  
Galveston, Texas  
Houston, Texas  
Lincoln, Nebr.  
Everett, Wash.  
Ogden, Utah  
Butte, Mont.  
Pueblo, Colo.  
Albany County Penitentiary  
Albany, N. Y. (tiary)  
Wilkes Barre, Pa.  
Livingston, Mont.  
Alhambra, Calif.  
Tulsa, Okla.  
Havana, Cuba

### Finger Print Experts Needed!

More and more the detection of crime resolves itself into a problem of identification. Trained men are needed every month to fill the new positions that are created. Records show that University of Applied Science graduates get first choice at the big positions. Listed below are some of the city and state bureaus to which U. of A. S. men have been appointed.

You can learn finger print identification in a few months in your spare time—at home.

### Send the Coupon!

This book cannot be bought at any newsstand or bookstore—but it will be sent to you FREE if you write to us at once. Thirty-two pages, illustrated in color with weird crime pictures. This book explains your opportunities in the finger print world—shows how you can get your training in a few months—tells how you can get a professional finger print outfit free. Write for this book today.

University of Applied Science

1920 Sunnyside Ave., Dept. 13-53 Chicago, Ill.

University of Applied Science, Dept. 13-53  
1920 Sunnyside Avenue, Chicago, Ill.

Please send me free your 32-page illustrated book "Finger Prints." I understand that there is absolutely no obligation. Also tell me how I can become a finger print expert by studying a few months in spare time—and how I can get a professional finger print outfit free.

Name.....

Address.....

City.....State.....

**\$100 DEPOSIT DELIVERS Complete Outfit**



**Violet Ray**

**QUICK RESULTS  
No Medicine**

Just \$1.00 brings you a complete outfit identical with the kind doctors have bought from us for years and used successfully in treating the ailments listed. Violet Rays give quick relief, permanent results. They scientifically and painlessly remove the cause of pain and sickness. Dr. L. H. Leight, Millerton, N. Y., writes: "I am having wonderful success in treating neuritis, and all stomach cases. I have given over 2,000 treatments with your outfit."

**10 Day FREE Trial  
at your home**

Send for Violet Ray Outfit without fail. Treat yourself and family with it. You'll be amazed at how Violet Rays enable you to conquer pain, disease, nervous troubles—how they give vigor, beauty, health. Owning an outfit saves doctor bills, delays, medicines—relieves pain. You should have this health machine in your home.

**Send for FREE Book**

Explains how Violet Rays (discovery of the world renowned scientist, Nikola Tesla) work and heal, what doctors and plain folks accomplish with them. Shows charts of human body explaining where pains start and how to banish them. Send for FREE copy today. Free for limited time only. *Vi-Rex Company, 211 S. Peoria St., Chicago.*

For special free advice,  
state your ailment

**Mail Coupon—Send No Money**

**VI-REX COMPANY**  
211 S. Peoria St., Dept. 23, Chicago

Please send me without cost or obligation your free book describing your VI-REX Violet Ray outfits and details of your \$1.00 offer.

Name.....

Address.....

City..... State.....

Ailment.....

*for  
Health  
Vigor  
Beauty*

**Ailments  
successfully  
treated  
with  
Violet Rays**

**Rheumatism  
Neuritis  
Paralysis  
Catarrh  
Nervousness  
Skin Diseases  
Hay Fever  
Headache  
Colds  
Constipation  
Sprains  
Asthma  
Deafness  
Eczema  
Eye Diseases  
Falling Hair  
Goitre  
Insomnia**

**New Magnetic Discovery  
BUILDS HEALTH!**



Be in top-notch physical condition—and stay there! The **Vit-O-Net Electro-Magnetic Blanket** the greatest health discovery in recent years. Gives new life—new power. Soothing magnetic warmth relaxes nerves and muscles. Eliminates disease-breeding poisons through pores and other waste channels. Increases circulation. Dissolves congestions responsible for scores of ailments.

**Used by Greatest Hospitals and Physicians**  
Scores of the country's best hospitals and physicians use the **Vit-O-Net Magnetic Blanket** for Rheumatism, Neuritis, Nervousness, Colds, Catarrh, Kidney troubles, etc. Frequently successful after all other methods fail. Helps to restore health. Pays for itself over and over again.

**Get Free Health Document**

Tells why 90% of diseases are caused by improper elimination. Reveals valuable health secrets you ought to know.

Write for your copy today!

**VIT-O-NET MFG. CO.,**  
Representatives Wanted  
Desk 536, 4100 Ravenswood  
CHICAGO, ILLINOIS

**NO MORE BALD HEADS**



WHEN our VACUUM CAP is used a few minutes daily. We accept no pay until you have tried the Cap 60 days and are satisfied. The Vacuum Cap is an appliance that draws the blood to the Hair Roots and starts a new healthy crop of hair. It stops Dandruff, stops the hair from falling out.

Bought by Doctors and men who know that it is the only reasonable HAIR GROWER known to science. No Drugs Used. Write for application blank, testimonials and booklet on "HAIR," sent sealed in plain envelope, FREE.

**THE MODERN VACUUM CAP CO.**

R-559 BARCLAY, DENVER, COLO.

**DON'T WEAR  
A TRUSS**

**BE COMFORTABLE—**

Wear the Brooks Appliance, the modern scientific invention which gives rupture sufferers immediate relief. It has no obnoxious springs or pads, Automatic Air Cushions bind and draw together the broken parts. No salves or plasters. Durable, Cheap. Sent on trial to prove its worth. Beware of imitations. Look for trade-mark bearing portrait and signature of C. E. Brooks which appears on every Appliance. None other genuine. Full information and booklet sent free in plain, sealed envelope.

**BROOKS APPLIANCE CO., 215-B State St., Marshall, Mich.**



**A PERFECT LOOKING NOSE  
Can Easily Be Yours**

**Trados Model No. 25** corrects now ill-shaped noses quickly, painlessly, permanently and comfortably at home (excepting cases caused by improper bone structure). It is the only adjustable, safe and guaranteed patent device that will actually give you a perfect looking nose. Over 90,000 satisfied users. For years recommended by physicians. 16 years of experience in manufacturing Nose Shapers is at your service. **Model 25 Junior** for children. Write for testimonials and free booklet, which tells you how to obtain a perfect looking nose.

M. TRILETY, Pioneer Noseshaping Specialist  
Dent. 2476 Binghamton, N. Y.

Information on any book free. Write Popular Mechanics Press, Chicago, Ill.



**Bow Legs and Knock  
Knees Unsightly!**

Send for booklet showing photos of men with and without THE PERFECT LEG FORMS.

**PERFECT SALES CO., 140 N. Mayfield Ave.  
Dept. S, Chicago, Ill.**



# Building Draftsmen WANTED



## \$9,000 in Four Months

"I have made \$9000 in four months on nine buildings" writes Wm. J. Petrusek, Chicago, Ill.

## \$210 Per Month

"I am making \$210 per month as Architectural Draftsman. Thanks to Chicago Tech." Geo. E. Shafner, Haley, Tenn.

## \$6,000,000,000 in Building Train at Home for Big Money in This Fertile Field

Six Billion Dollars in one year! Think of it! Today Building is probably America's greatest and most profitable industry. Here is a field whose future is insured by the normal growth in population and the industrial expansion of our country. There is a big building shortage now and many competent observers predict that our largest cities will be practically rebuilt in the next ten years due to ever higher standards of living. Six Billion Dollars spent each year in building means fortunes for thousands who have the vision to grasp the opportunity open now to get in on the ground floor.

## In Chicago Earn While You Learn



### Chicago Tech. Building

Short Day or Evening Courses offered in Building Construction and Drafting in our Chicago School. Part time positions defray living expenses. 72-page "Blue Book" tells all. Ask for it if interested in coming to Chicago to attend the College.

## Get Into Big Pay This Easy Way

Architectural or Building Draftsmen are needed everywhere. Get out of the low or moderate pay job. Step into a *real* job. You can do it with training in Architectural Drafting. Salaries are big because of the tremendous demand and the shortage of trained Building Draftsmen. Work is steady and you have a splendid chance to go into business for yourself. This is the opportunity offered to you by this old established school of Architecture and Building Construction. Step out of the \$40 a week class. Learn how to earn \$50 to \$100 a week—and later \$5,000 to \$10,000 a year as chief or superintendent.

## Train at Home—Earn as You Learn

No need to quit your present job. Keep your present income and prepare for a bigger one. Our simple "Practice Plan Method" will qualify you quickly in your spare time. Into it has gone over 25 years of experience and the best knowledge of our large staff of architects and builders. It is simple, complete, successful. Practical, successful builders guide you. Lessons in plain English. A common schooling is all you need. Get the facts now—today.

## FREE TRIAL LESSON AND BLUE PRINTS

Just to show you how easy it is to learn Architectural Drafting by our method, we will send you a Trial Lesson and Blue Prints Free. Test yourself and see how you like the work. Send no money—just the coupon. Get this Free Lesson now with our Big Book of Opportunity also free. Make your first step today—it costs you nothing.

**This \$25.00 Drawing Outfit Sent** without extra cost. Good for a lifetime. Mail the coupon and learn how to secure this valuable outfit.

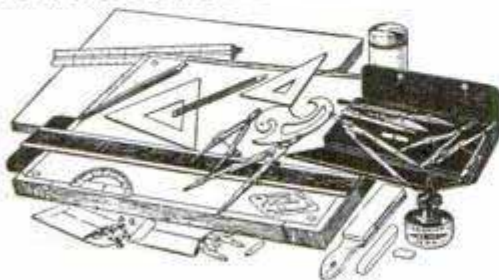

**CHICAGO TECHNICAL COLLEGE**  
Dept. 330, Chicago Technical Building  
118 East 26th Street CHICAGO, ILLINOIS



## MAIL COUPON TODAY

Chicago Tech. College, Dept. 330, Chicago Tech. Bldg., 118 East 26th St., Chicago, Ill.

Send me, without obligation, your Free Trial Lesson, Blue Prints and Book of Opportunity. I want to know how to become a Building Draftsman. It is understood that no salesman will call on me.

NAME.....

ADDRESS.....

CITY OR TOWN.....STATE.....

Architectural Drafting  
 Machine Drafting

Electrical Drafting  
 Structural Drafting

# This Tenor Banjo FREE

WORTH \$18



## When You Enroll

This handsome full-size, professional tenor banjo is yours when you enroll. We want to make one thousand new friends this month. We want to present one of these wonderful, delightful instruments as a gift to each of one thousand readers of this magazine—and here's why.

Before becoming a professor, and a lover of music, particularly the tenor banjo, Prof. Six yearned and yearned for the possession of a genuine, professional instrument, the same kind used by the big, successful professionals of the world. Now we want you to succeed. We want to help every music-lover that we can, attain success, and this gift offer is made to pave the way for you, and no previous musical knowledge is necessary.

We have another surprise for you! Not only do we start you on the way to popularity, success and fame by supplying you with an instrument that you can compare to any used or displayed in your town, but under personal supervision you will be given, by mail, the benefit of Professor Harry S. Six's twenty-two years' experience as director of Glee and Instrumental clubs of New York University. We don't just send you a lot of printed words and instructions and trust to luck that you will catch on. Our method is different and has proven to be the simplest devised by man—that is why we claim you'll be able to play in thirty minutes. Put us to the test.

## Learn in 30 Minutes With My Picture Method

Arthur Brisbane, the highest paid journalist in the world, once said that "a single picture is worth a thousand words." He was right, for it stands to reason, when you take your instrument in hand along with the actual photographs of our professor in action as your guide, it is easy to imitate and do the right thing. But that is not all.



**Phonographic Records Free** We also furnish as an additional guide, phonographic records of our professor playing the piece you are learning, along with our thorough, printed and illustrated, easy-to-read course.

Doesn't that sound easy? It is easy. If you could sit at our desk and see the letters and telegrams from our pupils you would be convinced that we have perfected the simplest, yet most highly efficient course to insure your mastery of the tenor banjo.

## Don't Send a Single Cent

Investigate offer today. Don't put off until tomorrow, because you might forge and miss this wonderful opportunity. It might be the turning point in your career. Don't send a single cent. Just drop a line—use coupon or postal card will do—telling you are interested in receiving full particulars about course and to reserve one regular eighteen dollar, full size professional tenor banjo for you, which is offered as a gift.

Act quickly, because there may not be enough gift banjos to go around for the million or more readers of Popular Mechanics. This does not obligate you in any way. Therefore, do not hesitate—put in your reservation now, this very minute. You will soon join our happy army of enthusiastic finished tenor banjo musicians.

**EARN BIG MONEY—**

**FREE BANJO COUPON**

New York Academy of Music  
Studio 12a-100 Fifth Ave., New York

Please rush all free information relative to your Tenor Banjo Course and reserve a gift banjo for me. This obligates me in no way whatever.

Name.....

Address.....

City..... State.....

## Charleston!



Everybody's doing it! Learn the easy Murray way—and be an expert Charleston dancer!

Arthur Murray, world's greatest dancing teacher, has invented a remarkable new method which enables anyone to learn all the newest dances at home—in a few hours—at very little cost! No music or partner needed. Success positively guaranteed! "300,000 learned dancing by mail."

**FREE! 32-Page Book and 3 Dancing Lessons!**

To prove you can learn easily and quickly, Arthur Murray will send you his 32-page book and three FREE lessons, including Fox Trot, Secret of Leading, and How to Gain Confidence. To pay cost of mailing, printing, etc., enclose 10 cents. Act NOW and be a good dancer soon.

**Arthur Murray Studio 610**  
7 E. 43rd St. New York City

# STAMMER

If you stammer attend no Institute till you get my large FREE book entitled "STAMMERING, Its Origin and The Advanced Natural Method of Treatment." Ask for special tuition rate and a FREE copy of "The Natural Speech Magazine," published monthly in the interest of those afflicted with stammering, stuttering and other speech impediments. Largest, best equipped and most successful school in the world for the cure of stammering. Est. 1898. 20 years. No sing-song or time-beat. Write today. MILLARD INSTITUTE OF NORMAL SPEECH, 2317 Millard Bldg., MILWAUKEE, WIS. Branch Summer School, Seattle, Wash.

## STUDENTS ART Now Art and Life



**ART MAGAZINE** Publishes cash art assignments, lessons and articles on Cartooning, Designing, Poster work, Lettering, Chalk-talking, etc. Beautiful roto-prints birds, animals, scenery, etc. CLEAN, Interesting, helpful. For Art and Nature students. Satisfaction or money refunded.

**Cut This Out** Send with \$1 now for 4 Months' Trial Subscription or 6 Big Back Issues.

**ART and LIFE Dept. 2653 KALAMAZOO, MICH.**



## Hotels Start You With Salaries up to \$3,500 a Year — with your living

**HOTELS, restaurants, clubs, apartments, everywhere need trained men and women—salaries to start up to \$3500 a year with your living. Over 70,000 high-class positions paying up to \$10,000 a year are open every year in the hotels of the United States. Today this is the 1st INDUSTRY IN AMERICA—with over \$1,000,000,000 in new hotels and clubs being built in 1926. These new hotels, clubs, restaurants, etc., will need nearly 200,000 trained men and women.**

You can have one of these high-class big-pay positions, with luxurious meals and apartment and fascinating work. No previous experience necessary. The Lewis Schools guarantee to give you the valuable knowledge that it has taken some of the most successful hotel men years to obtain—men who are now making \$5,000 to \$50,000 a year. We train you by mail in your spare time at home with the Lewis Simplified Study Plan, and we put you in touch with big opportunities. Our students employed, our methods endorsed by leading hotel men everywhere.

Send today for Free Book, "YOUR BIG OPPORTUNITY," showing how we can train you for one of these splendid positions, and explaining our Money-Back Guarantee.

**LEWIS HOTEL TRAINING SCHOOLS**  
Room J-388 Washington, D. C.

**FREE BOOK COUPON**

LEWIS HOTEL TRAINING SCHOOLS, Room J-388, WASHINGTON, D. C.  
Send me without obligation the Free Book, "YOUR BIG OPPORTUNITY."

Name.....

Address.....

City..... State.....

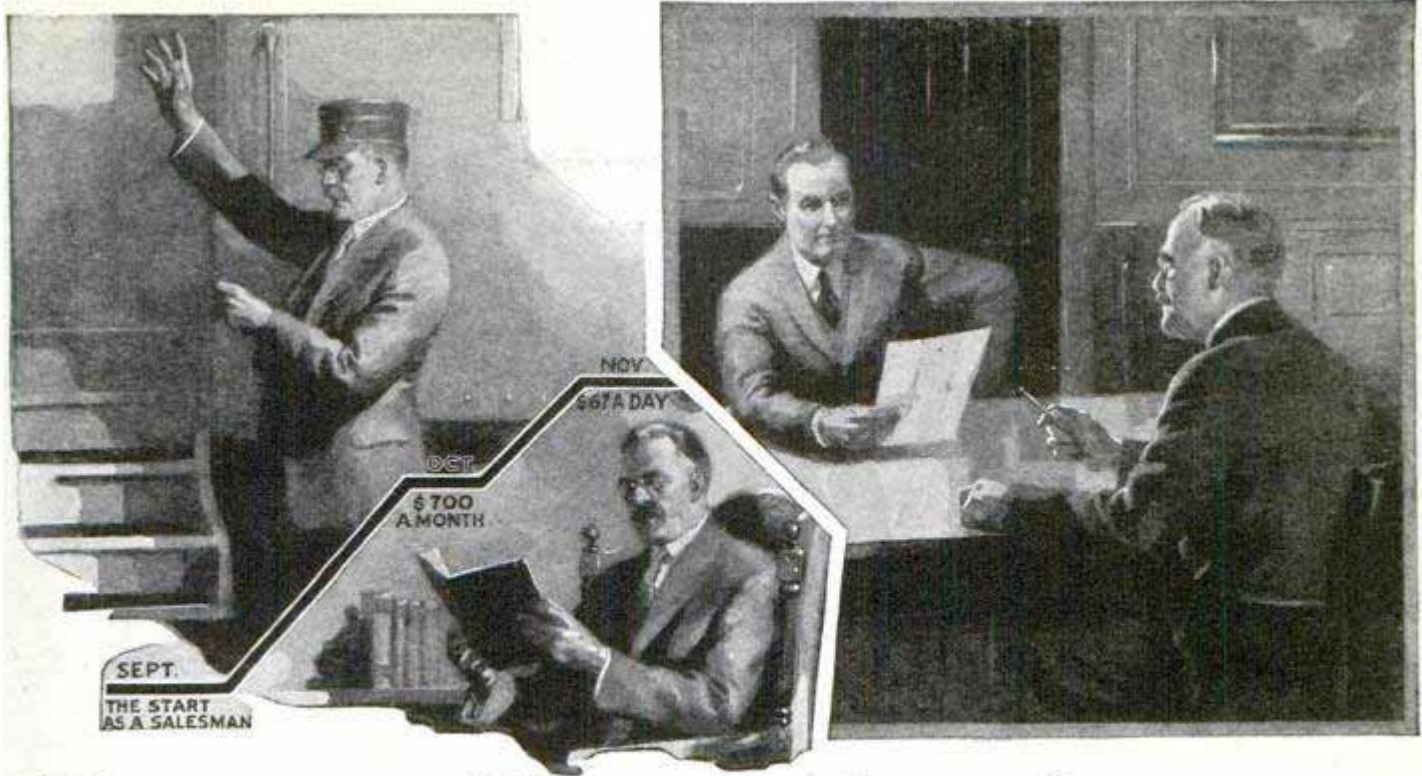

# Fourteen Years a Conductor— Then Salesmanship and \$700 a Month

Do you know the quickest way to make dreams come true?—It's the salesmanship way.

For out in the *selling* field, if a man makes good, "raises" come to him automatically—and many times a year. There was C. A. Thomas, for example.

Thomas, a California man, had been a conductor on a railroad for fourteen years. "One day," said Mr. Thomas, telling of his experience, "I came in on my passenger run and never went out again. Instead, I undertook to sell real estate. The first month I did not make a sale. I saw that I needed something to help me, and I believed I would find it in LaSalle's training in Modern Salesmanship. You can judge for yourself the aid it gave me when I tell you that the next month I cleared \$700, and last month I averaged better than \$67 a day throughout the month. . . ."

J. J. Graney writes of similar success. He was a mail carrier when he enrolled with LaSalle.

"I have not worked nearly so hard since I have been selling," writes Graney, "but have increased my earning power about 400 per cent. During September I earned \$225, October \$500, November close to \$700, and I expect to make \$1,000 this month."

Were these men—and hundreds of others—merely "lucky"?

Men privileged to master Salesmanship thru the LaSalle Problem Method will tell you that their success was far from luck; it was the logical result of knowing the hows and whys of their profession.

Whether or not you have had experience in selling—that is not important. The point is that any man of average intelligence who will follow the LaSalle *salary-doubling plan* can quickly multiply his earnings. And this fact applies with doubled force to the man now in the field who is sincerely

striving to increase his volume, to really *sell* in dozens of places which he is now forced to leave without an order.

The complete story of the LaSalle *salary-doubling plan*, which thousands of men have followed with such gratifying results, is outlined in a fascinating book entitled "Modern Salesmanship." This book tells clearly the opportunities in the selling field—points the way to a quick mastery of the very methods whereby the big producers top the list year after year, earn big five-figure salaries. The information contained in this book is of priceless value to the man seriously ambitious to make a real success in the selling field. And—the coupon brings it to you, *free*. If your future is worth a two-cent stamp and two minutes of your time—place the coupon in the mail TODAY.

CLIP AND MAIL

## LASALLE EXTENSION UNIVERSITY

The World's Largest Business Training Institution

Dept. 364-SR

Chicago

I should be glad to receive an outline of your *salary-doubling plan*, together with a copy of "Salesmanship in a Nutshell," also copy of "Ten Years' Promotion in One," all without obligation.

Modern Salesmanship—  
Salesmanship in a Nutshell

Other LaSalle Opportunities

The LaSalle plan opens the way to success in every important field of business. Check below the opportunity that appeals to you.

- |  |  |
|--|--|
| <input type="checkbox"/> Business Management                         | <input type="checkbox"/> Banking and Finance                       |
| <input type="checkbox"/> Traffic Management                          | <input type="checkbox"/> Modern Foremanship and Production Methods |
| <input type="checkbox"/> Higher Accountancy                          | <input type="checkbox"/> Personnel and Employment Management       |
| <input type="checkbox"/> Railway Station Management                  | <input type="checkbox"/> Expert Bookkeeping                        |
| <input type="checkbox"/> Law — Degree of LL.B.                       | <input type="checkbox"/> Business English                          |
| <input type="checkbox"/> Commercial Law                              | <input type="checkbox"/> Commercial Spanish                        |
| <input type="checkbox"/> Industrial Management Efficiency            | <input type="checkbox"/> Effective Speaking                        |
| <input type="checkbox"/> Modern Business Correspondence and Practice | <input type="checkbox"/> C. P. A. Coaching                         |

Name.....

Present Position.....

Address.....





# Choose as Your Profession Electrical Engineering

Electricity offers a brilliant future to the young man who is about to choose his career. Never before has there been such wonderful opportunity in this great field. Big paying positions in electrical work the world over are open to trained men—men who possess specialized, practical knowledge. Come to the School of Engineering of Milwaukee—one of the largest and best equipped electrical schools in America. Here you are trained in both theory and practice by a faculty of experts. You learn in large, finely equipped laboratories. If you have 14 high school credits or equivalent, you can become an Electrical Engineer with a Bachelor of Science degree in three years. If you lack these credits they can be made up at School of Engineering in a short, intensive Junior E. E. course.

## A Complete, Practical, Electrical Education

Learn by the thorough approved scientific methods which our twenty years of specializing enable us to give you. In addition to Electrical Engineering, the following complete courses are given: A. C. and D. C. Armature Winding—Electric Light, Heat, Power Wiring and Testing—Practical Electricity—Drafting—Electrotechnics—Commercial Electrical Engineering—Junior Electrical Engineering and Automotive Electricity.

## Earn While You Learn

By our special system you may earn part of your way while learning. Our Employment Department will help secure you a position to which you may devote a part of each day, spending the remainder at the school. This plan both solves the students' financial problems and provides splendid experience at the same time. Low tuition fee. Board and room reasonable. Daily Broadcasting. WSOE. School Orchestra. Fraternities.

**Spring Term  
Opens Mar. 29.**

## Write for FREE Catalog

Write today for our free, illustrated catalog. Read about this wonderful institution and the great opportunities that lie before you. Find out about our specialized method of training and the details of our "Earn While You Learn" plan.



**SCHOOL OF ENGINEERING OF MILWAUKEE**  
Dept. P. M. 326. 415-17 Marshall Street, Milwaukee, Wis.

Without obligating me in any way, please mail free 72-page illustrated book, "Electricity and the One Best Way to Learn It," and particulars regarding the course I have marked with an X.

- .... **Electrical Engineering.**
- .... **Electrotechnics.**
- .... **Commercial Electrical Engineering.**
- .... **Junior Electrical Engineering.**
- .... **Automotive Electricity.**
- .... **Radio Sales, Service and Broadcasting.**
- .... **Armature Winding.**
- .... **Light, Heat, Power Wiring and Testing.**
- .... **Practical Electricity.**
- .... **Home Laboratory Service.**
- .... **I am interested in your "Earn While You Learn" Plan.**

Name..... Age.....  
 Address.....  
 City..... State.....  
 Education.....

## Learn



## Aviation

At Home in your spare time.  
Be an expert Airplane Engineer.

**Earn \$3,500 to \$10,000 a year**

Practical course—takes only a few months.  
Write for special offer on free airplane parts and free catalog.

**WESTERN AIRPLANE CORPORATION**  
Dept. M-3 Monadnock Block CHICAGO



If you write poor and with difficulty, I can show you how to steady your nerve and write with ease as plain-as-print. Send for samples and **FREE BOOK**, "How To Become An Expert Penman." Act Quick! Send Today! Your name written on a card if you enclose stamp.

**T. M. TEVIS, Box 25X, CHILLICOTHE, MO., U. S. A.**



## FLY

Young man learn aviation. Build this classy plane and learn to construct and operate aircraft. Use your motorcycle engine or our "Meteor" 20 h. p. motor. We furnish parts very reasonable to build this wonderful little "Meteorplane," the World's first successful motorcycle engine airplane. Send \$3.50 for complete set of blue prints and parts price list of this latest Model M-T-2.

**IRWIN AIRCRAFT CO.**  
126 O Street, Sacramento, Cal.



# New Way to Make Money at Home

Could you use \$5 to \$10 per day extra money? You can earn it in spare time, in a pleasant, fascinating, new way. No previous experience necessary. Complete outfit furnished free to members. Everything made so plain and clear a child can follow instructions. It sounds too good to be true but hundreds already know it is like a dream come true. Success guaranteed.

## FREE Beautiful New Book on Home and Gift Decoration

Members are taught to decorate beautiful Art Novelties, lamps, shades, tables, chairs, bookracks, also etching on copper and brass, also pillow tops, batik, etc. Complete instructions for opening an Art Corner in your home, or Art Novelty Store, or selling to other stores. **FIND OUT** about this golden opportunity by writing **TODAY**. You'll say "It's just what I've wanted." Mail coupon or letter **NOW** enclosing 2c stamp.

## FIRESIDE INDUSTRIES

Dept. 66-C  
Adrian,  
Michigan

Gentlemen: Without obligation on my part, please send me, **FREE**, the book of Fireside Industries, also particulars of your Guarantee and the special co-operative privileges and services. I enclose two-cent stamp.



Name.....  
 Address.....  
 City..... State.....

# WIN \$1000

## Do You Like to Draw?

Copy this sketch and send us your Drawing. The Competition is being held to advertise

### The North American School of Drawing

and is Open to Everybody who likes to Try.

The only persons not allowed to compete are those who have had Drawings purchased by a newspaper or advertiser. This Competition is confined strictly to Amateurs.

### PRIZES

1st Prize - \$100	4th Prize - \$15
2nd Prize - 50	5th Prize - 10
3rd Prize - 25	6th Prize - 5
7th to 20th Prizes \$2.50 each	

### BEGIN NOW!

Copy this Drawing in pencil or pen and ink. See how well you can do it. Sit down and try. First of all read the Rules of the Competition. You can draw on any paper. Prizes will be awarded to the best drawings.

All drawings will be returned to the competitors at the close of the competition.

**DON'T MISS THIS! SOMEONE WILL WIN THE \$100. WHY NOT YOU?** Send in your sketch today.

### Rules of the Competition

- 1.—Anyone is eligible to compete except employees of the North American School of Drawing and Professional Artists.
- 2.—All sketches must be mailed on or before March 1st, 1926.
- 3.—Only one sketch may be submitted by each competitor.
- 4.—The bottom left-hand corner of the envelope should be marked plainly —"Competition."
- 5.—Competitor's full name and address must be written on the back of the drawing, with State or Province.
- 6.—Sketches must not be drawn on paper larger than 8 in. high by 6 in. wide.
- 7.—All sketches will be returned to competitors at the close of the competition, together with a list of the prize-winners. The North American School of Drawing cannot be held responsible for any sketch which may be lost in the mails or elsewhere.
- 8.—Sketches must be accompanied by a Post Office or Express Money Order for 50c (fifty cents) in return for which each competitor will receive an illustrated specimen lesson from the course of instruction issued by the North American School of Drawing, which will be sent with the results of the competition. Please do not send stamps or coins.
- 9.—Sketch and money order **MUST BE SENT IN THE SAME ENVELOPE**. Competitors are particularly requested **NOT** to send their sketch in one envelope and money order in a separate envelope.
- 10.—Sketches received insufficiently stamped will not be accepted. All packages should be sealed and bear letter rate of postage (2 cents for one ounce).
- 11.—Competitors agree to accept the decision of the Artists of the North American School of Drawing as final and conclusive.
- 12.—In the event of a tie for any prize offered, the full amount of that prize will be awarded to each tying contestant.
- 13.—The North American School of Drawing reserves the right to purchase any sketch submitted. Any sketches purchased will be paid for at the rate of \$10 (ten dollars) for each sketch.

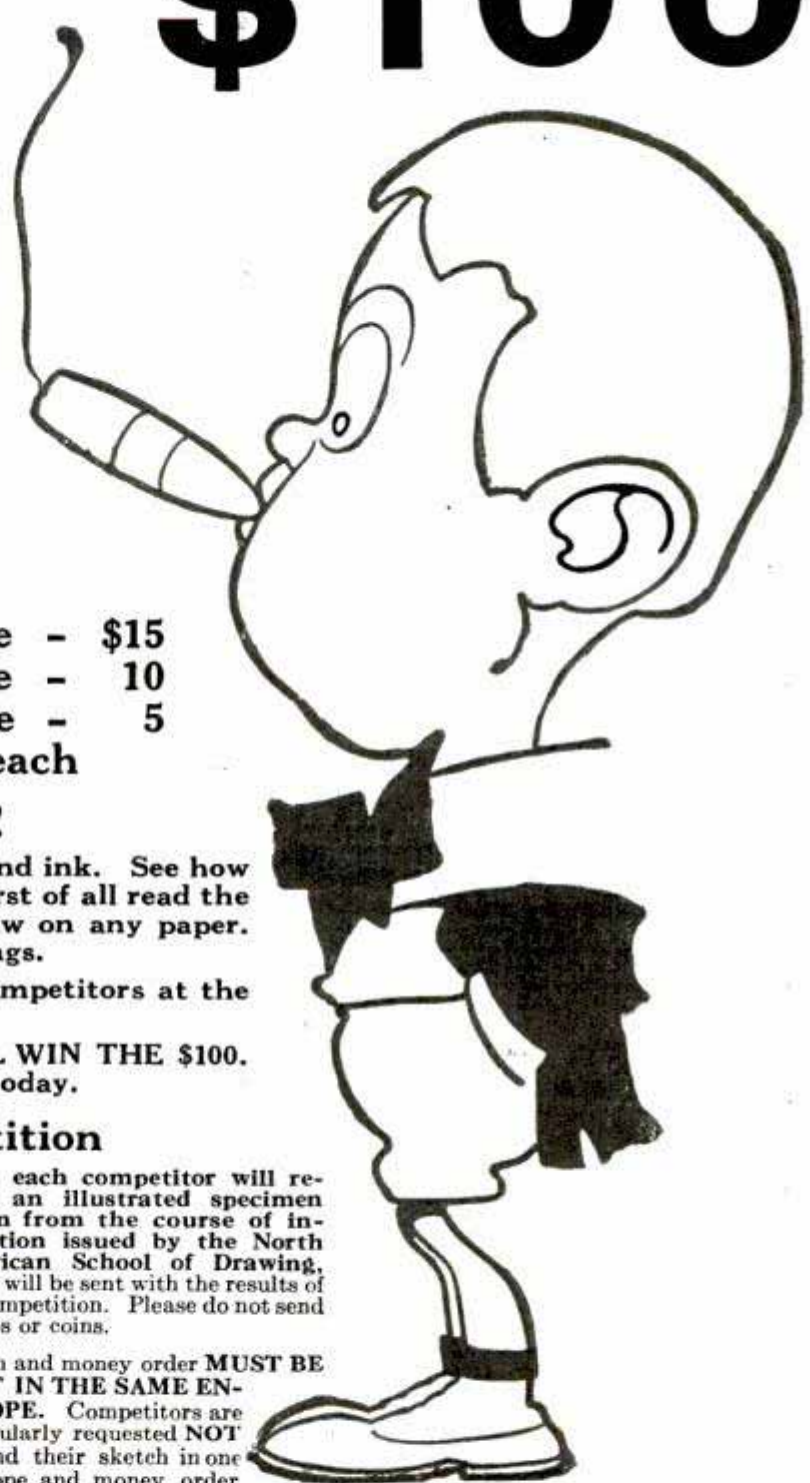

### The North American School of Drawing

155 Ontario Press Bldg.

37-41 McCaul St.

Toronto, Ont., Canada

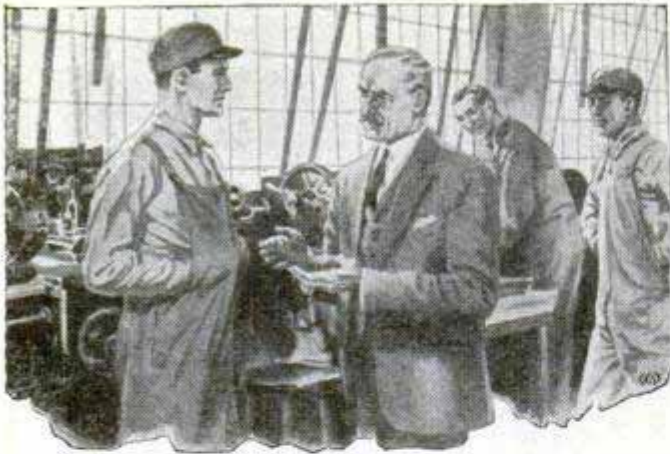

## The Boss Was Afraid to Make Me Foreman

"HE SAID he had always liked me and he thought I could handle men, but he was afraid to make me foreman until he was sure I knew more about the work.

"Tell you what I'll do," he said. "You take up a course with the I. C. S.—let me see that you really want to prepare yourself for advancement—and I'll promise to keep you in mind the next time there's a good job open."

"That sounded like a good proposition, so I began studying with the International Correspondence Schools. It changed my whole life.

"In three months the Boss called me in and said he was ready to make me Foreman. Just fourteen months after that he went before the Board of Directors to urge my appointment as Superintendent because he said I knew more about the business than anybody else in the plant.

"I'm making five times as much as I did before the Boss woke me up and literally forced me to take up an I. C. S. course and prepare to earn more money."

### Isn't that good advice for you too?

Why don't you take up a home-study course with the International Correspondence Schools and get ready for a real job at a salary that will enable you to give your wife and children the comforts you would like them to have?

Right at home, in the odds and ends of spare time that now go to waste, you can prepare for the position you want in the work you like best. At least find out how.

### Mail the Coupon for Free Booklet

INTERNATIONAL CORRESPONDENCE SCHOOLS  
Box 5560-E, Scranton, Penna.

Without cost or obligation, please tell me how I can qualify for the position or in the subject before which I have marked an X:

#### BUSINESS TRAINING COURSES

- |  |   |
|--|---|
| <input type="checkbox"/> Business Management                     | <input type="checkbox"/> Salesmanship                                     |
| <input type="checkbox"/> Industrial Management                   | <input type="checkbox"/> Advertising                                      |
| <input type="checkbox"/> Personnel Organization                  | <input type="checkbox"/> Better Letters                                   |
| <input type="checkbox"/> Traffic Management                      | <input type="checkbox"/> Show Card Lettering                              |
| <input type="checkbox"/> Business Law                            | <input type="checkbox"/> Stenography and Typing                           |
| <input type="checkbox"/> Banking and Banking Law                 | <input type="checkbox"/> Business English                                 |
| <input type="checkbox"/> Accountancy (including C.P.A.)          | <input type="checkbox"/> Civil Service                                    |
| <input type="checkbox"/> Nicholson Cost Accounting               | <input type="checkbox"/> Railway Mail Clerk                               |
| <input type="checkbox"/> Bookkeeping                             | <input type="checkbox"/> Common School Subjects                           |
| <input type="checkbox"/> Private Secretary                       | <input type="checkbox"/> High School Subjects                             |
| <input type="checkbox"/> Spanish <input type="checkbox"/> French | <input type="checkbox"/> Illustrating <input type="checkbox"/> Cartooning |

#### TECHNICAL AND INDUSTRIAL COURSES

- |   |  |
|---|--|
| <input type="checkbox"/> Electrical Engineering | <input type="checkbox"/> Architect                                   |
| <input type="checkbox"/> Electric Lighting      | <input type="checkbox"/> Architects' Blue Prints                     |
| <input type="checkbox"/> Mechanical Engineer    | <input type="checkbox"/> Contractor and Builder                      |
| <input type="checkbox"/> Mechanical Draftsman   | <input type="checkbox"/> Architectural Draftsman                     |
| <input type="checkbox"/> Machine Shop Practice  | <input type="checkbox"/> Concrete Builder                            |
| <input type="checkbox"/> Railroad Positions     | <input type="checkbox"/> Structural Engineer                         |
| <input type="checkbox"/> Gas Engine Operating   | <input type="checkbox"/> Chemistry <input type="checkbox"/> Pharmacy |
| <input type="checkbox"/> Civil Engineer         | <input type="checkbox"/> Automobile Work                             |
| <input type="checkbox"/> Surveying and Mapping  | <input type="checkbox"/> Airplane Engines                            |
| <input type="checkbox"/> Metallurgy             | <input type="checkbox"/> Navigation                                  |
| <input type="checkbox"/> Steam Engineering      | <input type="checkbox"/> Agriculture and Poultry                     |
| <input type="checkbox"/> Radio                  | <input type="checkbox"/> Mathematics                                 |

Name.....  
Street.....  
Address..... 3-6-24

City..... State.....

Occupation.....  
Persons residing in Canada should send this coupon to the International Correspondence Schools Canadian, Limited, Montreal, Canada.

# YOU Can Be a Dental Laboratory Expert

## Make Up to \$150 A Week This Expert Is Stivison Trained



He Can Earn More in one day than the average Mechanic does in a week. He got it the same way you will get it if you select the

### Stivison Way

Personal Instruction to Each Student In One Big School for Mechanical Dentists. Students are taught on Patients' work that is actually used. Only Modern Methods Taught. Thousands of dentists need Laboratory Experts.

### Stivison Trained Graduates Always in Demand

Jobs Hunt You. Every Dentist does Laboratory Work that he would gladly have done by an expert and pay Big Prices.

Real Dentist's Tools are furnished and Instructions given by Real Dentists on work that Dentists need. Our attractive Illustrated Catalog tells of many others who are earning big money and how easy you may be able to get into the Big Pay Class. If you live in Maine or California, it costs no more for you than it does for one living in Mo. or Kas., because WE PAY YOUR R. R. FARE TO KANSAS CITY. WE FURTHER ASSIST YOU in paying your TUITION by allowing You to Earn While You Learn. Bear in mind, the Catalog is Free and no man ever got in the Big Pay Class by wondering what he should do. Decide now and write for this "Short Cut to Success" today.

### STIVISON DENTAL INSTITUTE

503 McMillen Bldg.

Kansas City, Mo.



# Earn up to \$250 per Mo.

Expenses Paid  
Many Chances for  
Advancement

# BE A RAILWAY TRAFFIC INSPECTOR

## Trained Men Wanted

Prepare for this fascinating work with assurance that you will not have to hunt for a position upon graduation. For over seven years our graduates have been provided with positions or their money refunded. Start at \$110 a month or more, expenses paid. You take no risk and can prepare in your spare time.

### From a Graduate

Dan'l. M. Mack says: "I received my diploma on April 15, was on my way to take a position on the evening of April 16, and started to work on April 17. If this is not quick work, I don't know what it is. I found the school very thorough."

### Advancement Rapid

with experience. Meet high railway officials. Travel or remain near home. Highly confidential and important work.

## More Men Needed

We must train more men for positions soon to be open. Send coupon for full details, including low cost.

Standard Business Training Inst., Buffalo, N. Y.

Send me, entirely free, Booklet No. D-63, giving full particulars about course in Railway Traffic Inspection.

Name.....

Street.....

City.....

# FREE 64 Page Auto Book



**If you are mechanically inclined,** write today for your free copy of this dollar book. You want to make a success of life, to cash in on the amazing opportunities of the automotive business. The first step is to send for my big free book that gives all the facts and will open your eyes to how other fellows are making real money and are happy in the automobile business. Over 70,000 men date their prosperity from the day they got this wonderful book. It costs me over a dollar apiece to send this book but I will gladly send it to you free.

**Yes—You can do as well as these—**

Joe Warner, Moulton, Texas.

"Made \$3,300 clear last year. Own up to date garage."

John Anderson, Simpsonville, Ky.

"Making twice as much money as I ever made in my life. Head mechanic in a modern garage."

Lynton Harmon, Harrison, Me. "Would not take \$5,000 for what I learned at your school."

H. O. Wending, Altamont, Ill. "In business with another old student, hired two more Sweeney men, have a complete modern garage, sailing fine."

Ray Parker, Jackson, Tenn. "Making \$100 a week clear."

Kenneth White, Princeton, Ind. "Used to think \$3.00 a day was fine before coming to your school. Now making \$1.50 to \$3.00 an hour."

Ernest Moore, Milton, West Va. "From head mechanic to sales manager with Overland Agency. Can always recommend your school."

Frank Roe, Keller, Texas. "Every ambitious fellow has an equal chance."

—and thousands of others.

**JOBS PAY \$50 A WEEK AND UP COME RIGHT NOW.** If you are mechanically inclined, if you like to work with tools, you will learn under the "Sweeney System," by actually doing the work, everything about all kinds of automobiles, oxy-acetylene welding, vulcanizing, battery work, electrical work, aviation, building and repairing Radio sets. No experience or education needed. No books are used. You work on most complete gas engine and electrical equipment obtainable. Over \$300,000 invested. \$50,000 Radio Station WHB. You'll get dirty and greasy, but you'll learn by the "Sweeney System" that fits you for big pay jobs at \$50 a week and up, waiting for Sweeney trained men.

## SWEENEY SYSTEM OF PRACTICAL INSTRUCTION

This trains men by actual experience, working with their hands instead of learning from books. This book is a photographic trip thru world's famous and popular trade school. Get the facts about how easy it is now to make big money doing work you like. Be independent. Travel. See the world. Own your own garage, tire shop, battery station. Most fellows start in with jobs \$50 a week up. Take the first step now by sending for this big free book.

**E. J. SWEENEY, President**

**LEARN A TRADE—**  
**Sweeney**  
**AUTOMOTIVE & ELECTRICAL SCHOOL**  
 2331 SWEENEY BLDG. KANSAS CITY, MO.

## MEN WANTED FOR GOOD JOBS

let's go. If you want money, independence, a sure good pay job or business for yourself—travel—see the world—if you want to be somebody and have something—do the work you like, then clip this coupon or send post-card for this book today.

**My FREE BOOK Tells You—**

How to run a garage anywhere.  
 How to learn several good trades.  
 How to travel and see the world.  
 How to fit yourself for prosperity.  
 How to get a good mechanical job.  
 How to learn to be a chauffeur or truck driver.

How to learn to repair any make of car. How to weld.  
 How to learn batteries and auto tires.  
 Shows you hundreds of actual photographs of men at work in my big shops. Shows how 70,000 men got their start.  
 Shows how easy it is to learn; how much fun you have during recreation hours. Swimming pool, entertainment, band and orchestra, radio broadcasting.  
 Answers every question.

## AMAZING NEW OFFER!

The first step is to get my free 64-page book. I will gladly send it to you. And I will make you an amazing offer. I will make it easy for any man to learn the auto business. I will send you this valuable book

free—no cost—no obligation. No colored students accepted. EMORY J. SWEENEY, Pres.

**Send this NOW**

**EMORY J. SWEENEY, President**  
 2331 Sweeney Bldg., Kansas City, Mo.

Please send me your Free 64-page catalog and special offer.

Name..... Age.....

St. No. or R. F. D.....

Town..... State.....



J. A. Stransky



# Inventor Cuts Gasoline to 9¢ a GALLON!

**N**OW you can cut your gasoline cost as low as 9c a gallon. An amazing new invention makes practically any car give twice its regular mileage to the gallon. Many run from 37 to 57 miles and up to 61 miles on a gallon! This wonderful invention is the work of Mr. J. A. Stransky of Pukwana, S. Dakota. Already it is being used by over a million satisfied car owners—on all makes and models of cars. And now the inventor will send you a sample at his own risk! Read his offer below.

The Stransky Vaporizer is one of the biggest inventions of the century—an invention almost as revolutionary as the invention of the auto itself—and it is making fortunes for agents and distributors. Now you, too, can make big money just telling your friends about it. J. M. James made \$120 in one day. Vernon Gaines netted \$94 in eight hours. You can easily earn astonishing big profits in full or spare time.

## 61 Miles on a Gallon

Here's how this amazing new invention works. Your carburetor is adjusted to make starting easy—it gives a rich mixture to start a cold engine. But once your engine gets heated up, the mixture is far too rich, resulting in faulty explosion. Half the gasoline is drawn into the cylinders in a raw state and, instead of exploding, it burns. This causes a heavy deposit of carbon.

But with this startling little device in your car all this is changed. As soon as the engine warms up, this device automatically begins to admit a much larger volume of air, thoroughly vaporizing all the gasoline, giving it fully 50% more power—breaking it up so that it explodes instead of burning!

**\$120 in One Day!**

### Agent Earns Big Money

I took forty orders in one day and wasn't out long. My Ford runs better than it ever did.—**J. M. JAMES.**

### \$51 in One Hour

The results of one hour's work—17 men gave me orders for the Vaporizers.—**J. W. CRONK.**

### \$48 in 3 Hours

I went out Saturday about three hours and secured 16 orders.—**J. A. WILLIAMS.**

Not only does this invention save you half your gasoline, but it also removes carbon, saving you the expense and time of having carbon scraped out—a job costing from \$5 to \$25.

## One Million Satisfied Users

The Stransky Vaporizer and Decarbonizer is absolutely automatic and self-regulating. It has no springs, shutters, diaphragms or delicate parts to get out of order. It requires no adjustment—you can attach it in three minutes. It will lengthen the life of any car—and it's guaranteed to last the life of your car.

## Introductory Sample Offer

To introduce this new invention in your community, Mr. J. A. Stransky, the inventor, will send a sample at his own risk. Write at once for his proposition. The price is so low that all your neighbors will want to order through you, giving you a generous profit. Send the request blank for full details of our amazing offer.

**J. A. STRANSKY MANUFACTURING CO.**  
C-10 Stransky Bldg., Pukwana, So. Dakota

J. A. Stransky Mfg. Co.  
C-10 Stransky Bldg., Pukwana, So. Dakota  
Please send me full details of your special introductory offer.

Name.....

Address.....

City..... State.....



# DRAFTING PAYS from \$3,500 to \$10,000 a Year

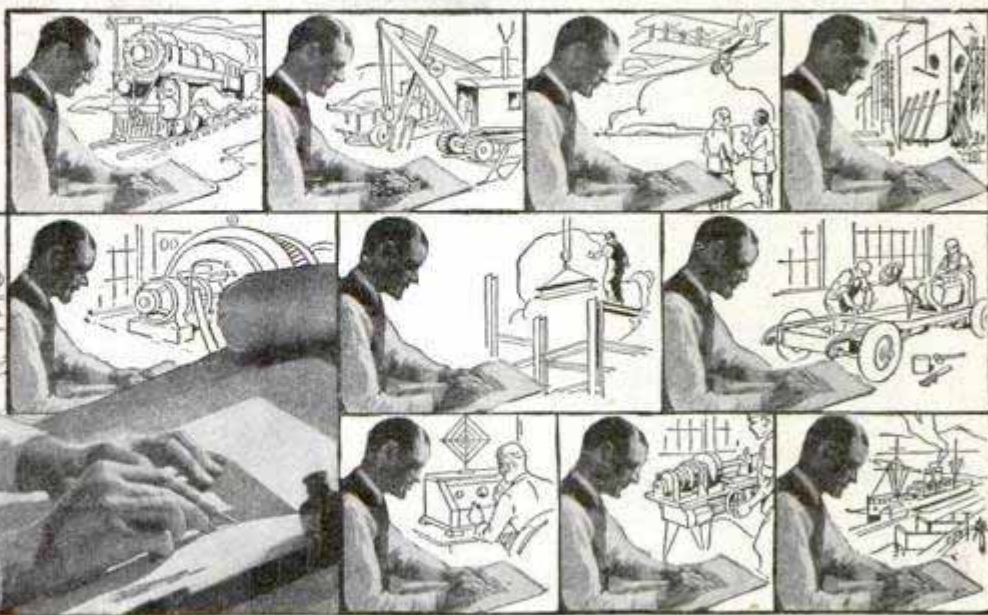

## Well Paid Positions ~ \$75 a Week up

Machine Shop or Mill—Railroading or Radio—Electric Companies or Public Service Stations—Building, Engineering, or Mining—All of the World's Work Calls for Draftsmen—All Interesting and Easy for the Draftsman—The Field that Leads Them All Will Always Be Drafting

**\$20 A DAY** If a hundred dollars a week sounds big—yes, or \$150—you aren't in the right line of business! Get into a broader field—the broadest of all. That's drafting!



"Have completed \$100,000 worth of work this year, thanks to Dobe instruction."—D. E. H. SANDERS (S. Car.)

Drafting is the BIG field, men. Every industry you can name BEGINS with the draftsman. Without mechanical drawings—by the thousands—every shop in the land would be STOPPED.

In fact, it is the SERIOUS SHORTAGE of draftsmen that brings this offer: I will furnish all instruments, supplies, even to the table, to those who start now!

**PAY AS YOU GO** Don't give me the excuse that you have no ready money for this golden opportunity. I am not so interested in cash; I want your application. I want at least 200 men to start right now. I want them ready to recommend by Spring! We will get a flood of letters saying "send us draftsmen," from every sort of industrial and engineering concern, and we must make good.

The first week's pay envelope of many a Dobe-trained draftsman has held enough to cover the entire cost of the course! Most students learn evenings, keeping on with their old work until ready to step into somebody's drafting room. The first month equips you to take on simple drafting jobs on the side. It helps you learn; I gladly permit this.

### Well-Paid Positions Every Way You Turn

A draftsman soon forgets the days when he used to wonder where to get a job. Instead, he asks "What line of work interests me most?" And "What part of the country suits me best?" Twenty of my graduates went to Florida this year; three are in Japan; last month one wrote me from Ceylon. And I wish we had the count of how many Dobe draftsmen have become chiefs!



"My new chief says, Dobe must teach right; I can handle everything so far. They pay me \$65 a week."—LEO NIECKEBERGER (Pa.)



"Just been made chief and got a good boost in pay. Your course has the goods."—Wm. G. HAZLETT (Col.)

Positions loom up almost as soon as you are enrolled in a Dobe class! We receive requests daily for men—for men only partly through our course. "We'll take a beginner," some concerns write us, "so long as he is a Dobe trained man and has begun right!"

**IT'S EASY** and interesting to learn drafting. For drafting isn't "drawing!" You don't need any "talent." A draftsman uses tools for every line and every curve. That's why drafting is so easily learned—and so interesting. For you do everything by rule. So, I guarantee if you can read and write, you can learn this line.

**WARNING!** The special offer of tools is for immediate action. Don't expect me to hold it open indefinitely. Clip the coupon now for free book:



Not a dollar's extra expense for tools, if you are prompt

## GOOD FOR TOOLS

Mail this IN TIME for my FREE TOOL offer and ENTIRE WORKING OUTFIT costs NOTHING extra, if you decide to ENROLL!

**CHIEF DRAFTSMAN DOBE**

1951 Lawrence Ave., Chicago, Dept. 13-53

Please send FREE and POSTPAID, without obligation, your new, fully illustrated book Successful Draftsmanship, complete information, terms, etc.



Name..... Age.....

P. O. ....

# TO Learn to Write

**GOOD** hand-writing has been truly called the "Bread and butter of a business education." It should be the determination of every body to learn to write at least a good business hand. **Good writing is the very foundation of business success.**

**Easy to Learn** By my system you can become a good penman at home, in your own room during spare time. Don't be content with the notion that good penmen "are born" such. Because one's ancestors may have been noted for poor penmanship, is no excuse for him to remain an illegible scribbler. My system is original, unique, and highly successful—the result of 25 years' experience.

**Your Spare Time** Just your spare moments—that's all I ask. If you follow my instructions you will soon be able to write a beautiful hand that will be a source of pride to yourself and envy to your friends. Notice the improvement shown in Mr. Campbell's writing below.

*Leland M. Campbell*

"I am astonished at the improvement I've made by means of The Tamblin System in so short time."

LELAND M. CAMPBELL,  
Campbelltown, Ohio.

*Leland M. Campbell*

Mr. Campbell wrote his upper signature July 20, and the lower one November 10—a little less than 4 months apart. Hundreds and hundreds of others in all parts of the world are doing as well with my system.

I have had unbounded success in making poor writers good ones and good writers better penmen than they thought possible.

*How to Become a Good Penman*

**FREE BOOK WRITE FOR IT TODAY**

**32 PAGES HIGHLY ILLUSTRATED.**

Penmanship is particularly adapted to correspondence instruction, and I absolutely guarantee satisfactory improvement. Distance no barrier. Ladies taught just as successfully as men.



Don't wait, don't delay, begin now to prepare for that position where good penmanship will be required. Send today for my **Free Book, "How to Become a Good Penman,"** which contains copies and beautiful specimens and tells how others have become good penmen by means of the **Tamblin System.** Your name will be beautifully written on a card with white ink if you enclose stamp

**F. W. TAMBLIN,**  
418 Ridge Building  
Kansas City, Mo., U.S.A.

## FREE BOOK COUPON

**F. W. TAMBLIN, 418 Ridge Bldg., Kansas City, Mo., U. S. A.**  
I am interested in improving my penmanship. Please send me free your Book "How to Become a Good Penman."

Name .....

Address .....

Sign and mail this today, before you forget it.

# Become an ARTIST!

**Big Prices Paid for Drawings**

Well-trained commercial artists earn \$50, \$75, \$100, \$150 a week, and sometimes even more. If you like to draw, develop your talent—learn the secrets that make your drawings worth *real money.* Well-trained artists are *always* at a premium.

## LEARN AT HOME QUICKLY



The Federal "Master" Course contains *exclusive lessons* by leading illustrators and designers. Every step is clear and simple, no previous training needed. You will receive *individual personal criticism* on your work. Write for "YOUR FUTURE," a 56-page book telling every detail, and how to turn your spare hours into money. If you are in earnest about your future, send 6c in stamps for this book. Kindly state your age and occupation.

Federal School of Commercial Designing  
614 Federal Schools Bldg.  
Minneapolis, Minn.

# LAW Free Book

Write today for **FREE** 128-page book, "THE LAW TRAINED MAN," which shows how to learn law in your spare time and earn more money. Qualify for a high salaried executive position or prepare to enter the practice of law. Study at home through the Blackstone Course prepared by 80 prominent legal authorities including **CHIEF JUSTICE WILLIAM HOWARD TAFT.** Blackstone graduates practicing law everywhere. LL. B. degree conferred. Magnificent 25 volume law library furnished immediately upon enrollment. Moderate tuition fee. Low monthly terms. Money Back Guarantee. Write for book today.

**Blackstone Institute, Inc.,** 4753 Grand Blvd. Chicago, Dept. 53  
America's Foremost Non-Resident Law School



# Free Trial

**In Your Own Home**



**FREE Instruction with Every Instrument**

## Deagan Xylorimba

Become a crack Xylorimba player right in your own home. Easiest instrument to play. Learn in a few hours with our 14 free complete lessons. Earn \$80.00 to \$200.00 a week. Deagan instruments are world-renowned—used extensively in leading dance, theatre and concert orchestras.

**FREE LESSONS—A YEAR TO PAY!**  
Our free trial, easy payment plan makes it easy to learn at home. Send coupon below for illustrated literature and details of our special free trial offer.

## Send Coupon Today!

**J. C. DEAGAN, Inc., Dept. 1353, 1770 Berteau Ave., Chicago, Ill.**

Dear Sirs: Without obligation, please send me literature and information regarding your free trial Deagan Xylorimba.

Name .....

Address .....

City..... State.....

Perhaps you, too, can cut your  
"B" battery costs in half

Just follow the chart. It gives you  
the secret of "B" battery economy

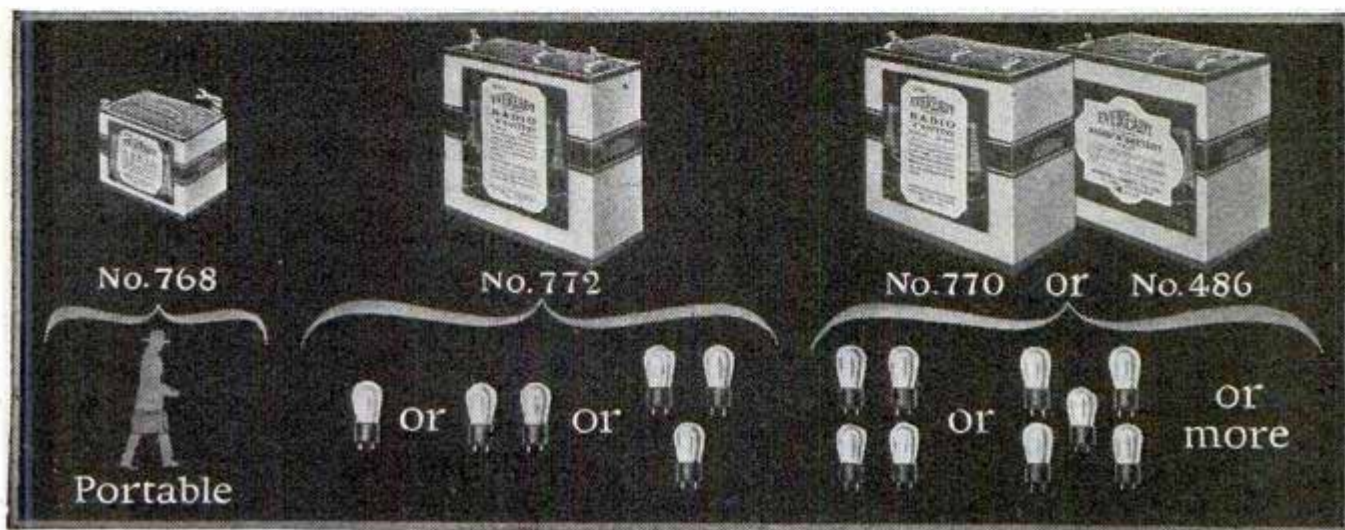

THOUSANDS of people have made the discovery that Eveready "B" Batteries, when used in the proper size and with a "C" battery\*, are the most economical, reliable and satisfactory source of radio current.

On sets of one to three tubes, Eveready "B" Battery No. 772, used with a "C" battery, will last a year or longer, usually longer. On sets of four and five tubes, either of the larger Heavy Duty Eveready Batteries No. 770 or No. 486, used with a "C" battery\*, will last eight months or more.

These figures are based on the average use of receivers, which a country-wide survey has shown to be two hours daily throughout the year. If you listen longer, of course, your batteries will have a somewhat shorter life, and if you listen less, they will last longer.

Here is the secret of "B" battery satisfaction and economy:

With sets of from 1 to 3 tubes, use Eveready No. 772.

With sets of 4 or more tubes, use either of the Heavy Duty Batteries, No. 770, or the even longer-lived Eveready Layerbilt No. 486.

Use a "C" battery on all but single tube sets.

Evereadys give you their remarkable service to the full when they are correctly matched in capacity to the demands made upon them by your receiver. It is wasteful to buy batteries that are too small. Follow the chart.

In addition to the batteries illustrated, which fit practically all of the receivers in use, we also make a number of other types for special purposes. There is an Eveready Radio Battery for every radio use. To learn more about the entire Eveready line, write for the booklet, "Choosing and Using the Right Radio Batteries," which we will be glad to send you on request. This booklet also tells about the proper batteries for the new power tubes. There is an Eveready dealer nearby.

\*NOTE: In addition to the increased life which an Eveready "C" Battery gives to your "B" batteries, it will add a quality of reception unobtainable without it.

Manufactured and guaranteed by

NATIONAL CARBON COMPANY, INC.  
New York San Francisco  
Canadian National Carbon Co., Limited, Toronto, Ontario

**EVEREADY**  
**Radio Batteries**  
-they last longer

Tuesday night means Eveready Hour—9 P. M., Eastern Standard Time, through the following stations:

WEAF—New York	WSAI—Cincinnati
WJAR—Providence	WEAR—Cleveland
WEEI—Boston	WWJ—Detroit
WTAG—Worcester	WGN—Chicago
WFI—Philadelphia	WOC—Davenport
WGR—Buffalo	WCCO { Minneapolis
WCAE—Pittsburgh	WCCO { St. Paul
	KSD—St. Louis
	EGO—San Francisco, 8 P. M.
	Pacific Coast Time

959

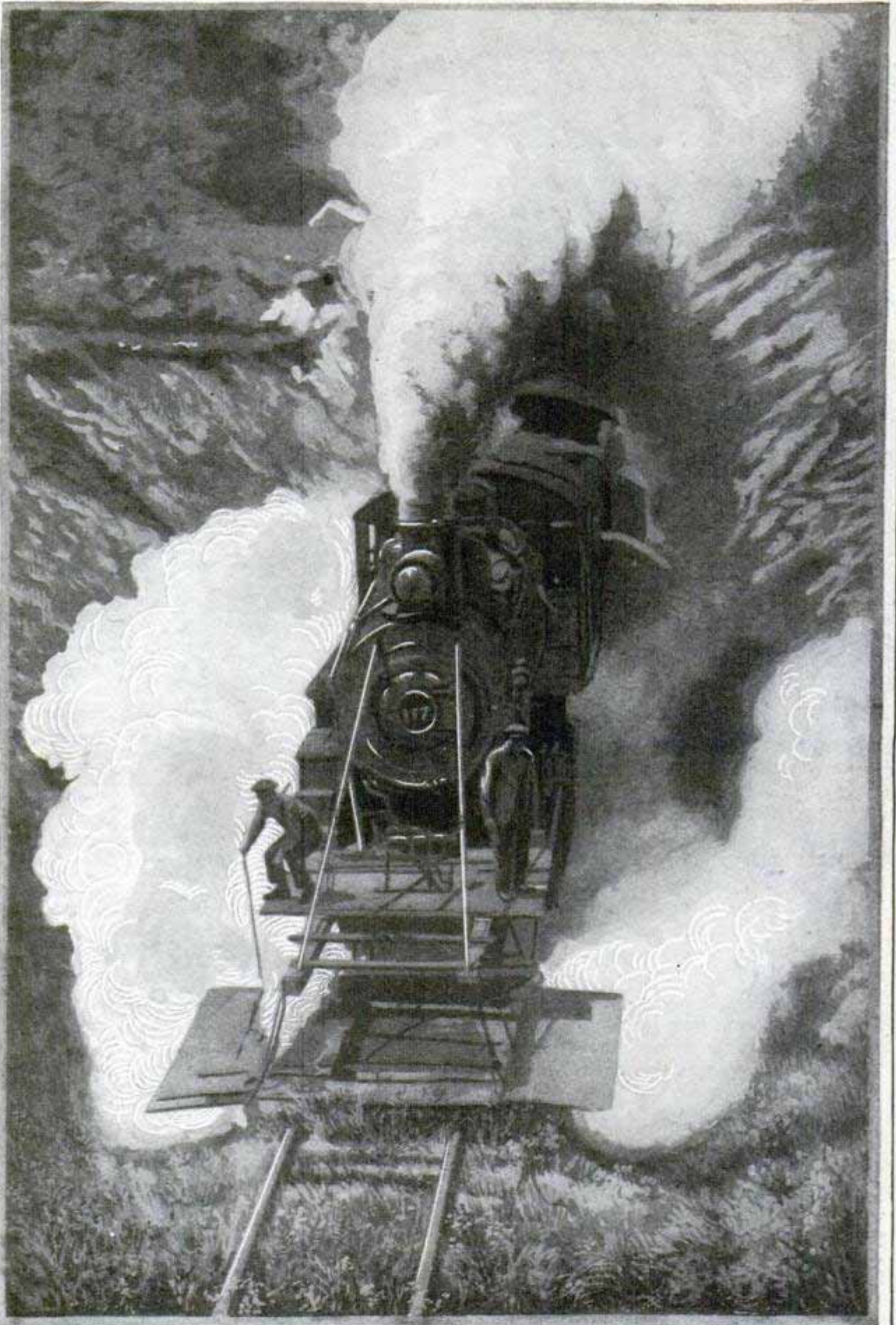

Killing Weeds by "Cooking" Them with Steam; Locomotive Clearing the Right of Way of Troublesome Growths; the "Sprinkler" Is Set in Front under Apron to Direct Vapor Downward—See Page 378

# Popular Mechanics Magazine

REGISTERED IN U. S. PATENT OFFICE

WRITTEN SO YOU CAN UNDERSTAND IT

Vol. 45

129

MARCH, 1926

No. 3

## A World without Pain?

*Journal of Pharmacology and Experimental Therapeutics*

### Goals of Longer Life, Freedom from Disease and Painless Treatments Extended as Science Gropes for Nature's Secrets

A NEW anaesthetic, twice as powerful as ethylene, sure in its action, and swift in permitting recovery, since full consciousness returns within a minute after the flow of gas is stopped, is science's latest discovery in the fight to banish pain.

The new anaesthetic, called propylene, is produced from ordinary artificial gas, and besides its other features rarely produces any after sickness or nausea. In fifteen major operations only one patient was rendered sick by the gas.

With the normal span of life steadily growing longer as one after another of the mass diseases have been conquered, scientists are confident that in the next half century they will add another twenty years to the average life, bringing it well up to four score years. What this means may be realized when statistics of the past are studied. In the sixteenth century the average life span was but twenty years—the ripe old age of those who grew up being more than offset by the appalling infant mortality due to lack of knowledge of children's diseases. At the close of the eighteenth century the average was still less than twenty-five years. A hundred years ago, in America, it had reached thirty-five years; by 1870 it was forty-one

years, and in the fifty-six years since it has almost reached sixty years.

With the exception of occasional sporadic pests, such as the influenza epidemic which swept away 22,000,000 lives during the war, man has virtually ceased to die from mass complaints, and now dies an individual death, due to breakdown of his own body machinery. Vaccines, toxins and anti-toxins, as well as better medical training, have conquered smallpox, diphtheria, measles, and the myriad diseases that in the Middle Ages claimed a vast proportion of the population in the years of infancy and childhood.

With the individual death from personal troubles replacing the mass diseases, the perfection of medicines and anaesthetics—the latter less than 100 years old—takes on renewed importance, since they deal with the treatment of the individual. The ancients knew how to use drugs made

from the poppy, belladonna, mandrake, solanum, mandragora and nepenthe to produce unconsciousness, and back as early as the third century Chinese record the use of hemp by physicians for this purpose, but they never became general and major operations continued to be performed more often than not without anything to relieve the pain. The sleep-producing qualities

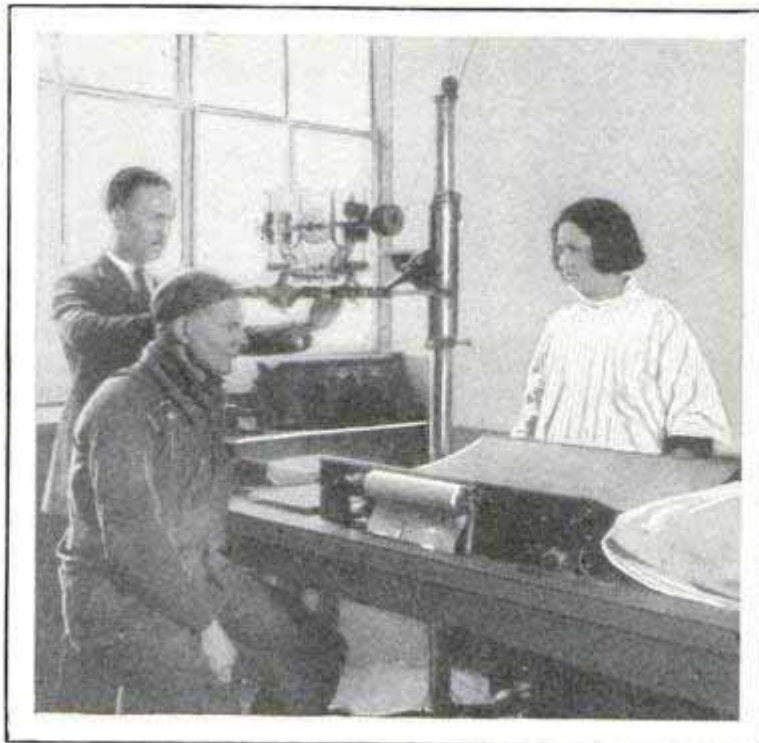

Treating a Workman in the X-Ray Laboratory of an Industrial Plant; Such Hospitals Are Helping Keep Employees Healthy

Cont. *Norman C. McLeod, 1917 St. Paul St. Baltimore Md*

*June 1924 p. 485 - January 1926 499) Published at Mount Royal and published at Baltimore Md.*

929



Top, Taking Blood Specimens for a Test; Center, Treating Yellow-Fever Bearing Mosquito Breeding Swamp, and Below, Microscopic Diagnosis to Isolate Disease Germs



of ether were discovered in the year 1800, but were not put to any practical use for half a century, while it was not until 1847 that chloroform was first used by a physician. The modern science of the cure and prevention of disease did not come into being until still later. Medicine and surgery have been revolutionized in the last thirty years, all with the idea of preventing pain and of prolonging life. Anthrax, cholera, dysentery, hookworm, yellow fever, malaria, leprosy, meningitis, bubonic plague, pneumonia, lockjaw, tuberculosis and typhoid, to mention only a few, have yielded to treatment, to preventive measures, such as the elimination of the mosquito-borne yellow-fever germs, and, through isolation of all their germs, have been, or are being conquered.

Now that science has virtually completed that phase of its work and is turning to the personal diseases, to heart trouble, diabetes, rheumatism, hardening of the arteries, and the host of bodily and mental complaints, an entirely new theory of life

is being developed. Physical examination at stated intervals, preventive medicine, supervised recreation, and other developments are paving the way for the anticipated further extension of life. The chief troubles of the human race are due to the complicated, multi-cell structure of the body. If the human body had but one cell it could be immortal, as one-celled forms of life are. A paramecium, which is composed of only one cell, has been cultivated in the laboratory by Dr. Woodruff for a period corresponding to 8,500 of its generations, and the 8,500 generations of this one-celled life form correspond to approximately a quarter of a million years in the life of a man. Dr. Alexis Carrel, back in January, 1912, took part of a chicken's heart and began growing it in his laboratory. It is still alive after a

little more than fourteen years and growing so fast that it must be divided daily.

Natural death—the personal and individual death which overtakes man in old age—came into being as a result of the evolutionary processes which intervened between the original one-cell life and the multi-cell organism which is the human body today. Death, scientists hold, is not a



*Am. M. Co. ...  
Carnes, Canton, Ohio*

necessary attribute or consequence of life, and life can and does go on without death. When the multicellular human being does succumb he is merely paying the price for the privilege of enjoying a more complex and interesting life. With so many cells

**NEW STEEL, HARD YET PLIANT,  
1013 TAKES RAZOR EDGE**

Many of the qualities of the celebrated Damascus steel are said to be found in a modern product which an Ohio man has

*carb. Van*

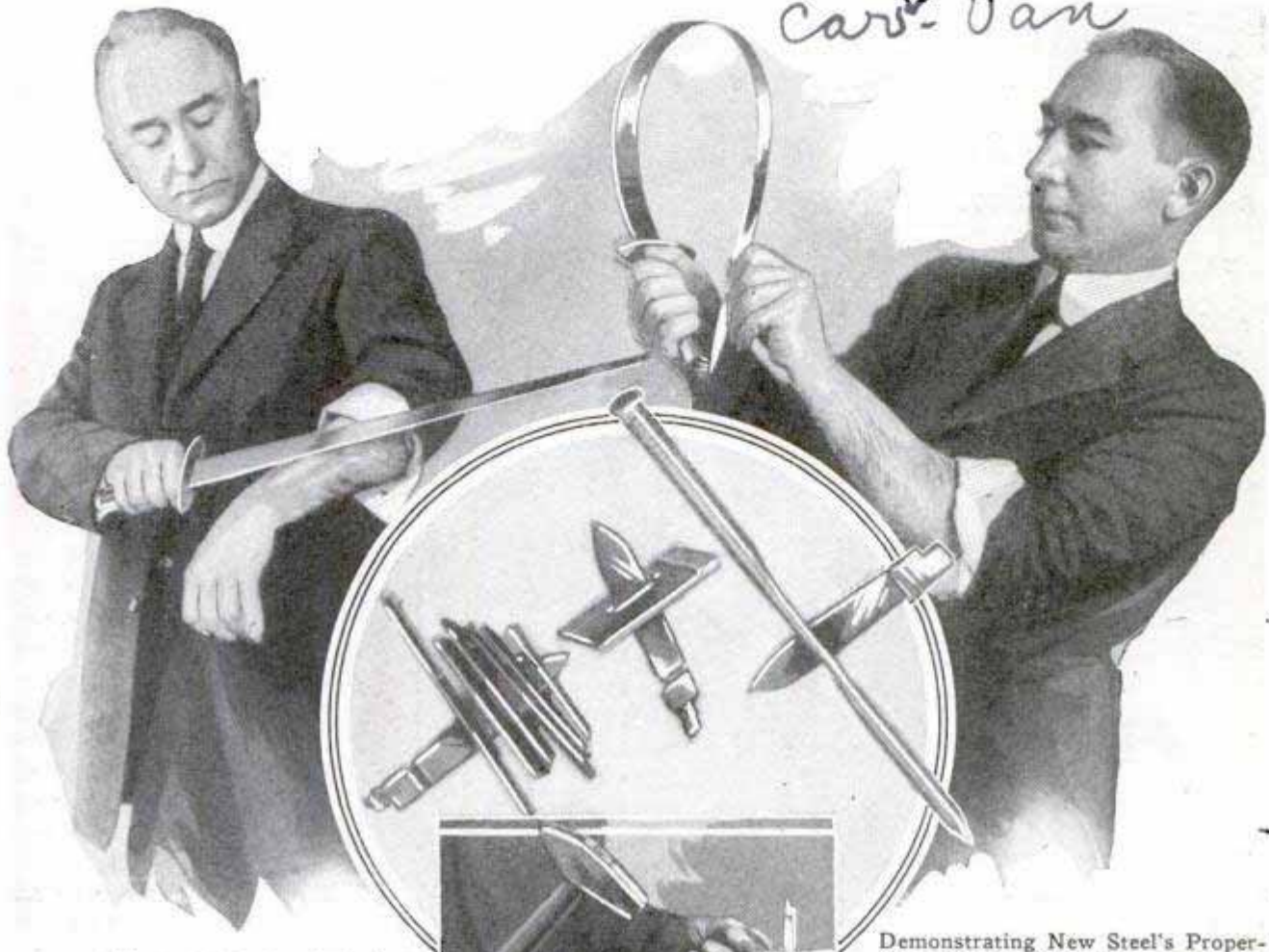

attuned in one body it follows, according to this theory of life, that some must wear out before others, just as one part of a motor car will give out first, and upset the working of the whole machine. When that happens to the body, if the part involved is the carburetor, or heart, the machine will stop as quickly as a motor car with a similar complaint, or if it is one of the other vital parts, an equally serious breakdown occurs, while some minor failure is accompanied by a correspondingly minor, or serious, form of disease.

It is here that modern science has begun to play the part of garage mechanic to repair and replace the worn-out parts. As the mechanics become more successful, the life span grows. The time is not so far off, according to the doctors, when the man who dies before seventy will be either the victim of an accident, or personally to blame.

Demonstrating New Steel's Properties; Sword of It Shaves Hair or Can Be Bent Double; Knife Blades Penetrate Other Steels without Being Damaged and Take Different Degrees of Temper

developed by a secret process. He combines iron and carbon in such a way that the resulting steel will bend, keep an edge of razor sharpness, is tough and can be driven through other steels without breaking. A bar of the material, fifteen inches long, was tempered to five different degrees, one end of it being hard enough to cut glass, a section was sharpened like a razor and would cut dry hair without honing or stropping, while other parts in the same bar would cut off a spike under blows of a hammer, would spring or could be bent backward and forward with the thumb and forefinger without breaking. Vanadium is an important element used in the preparation of the steel.

Ⓐ A day in China is divided into twelve parts of two hours each.

*Mfr - Canton Cutlery Co. 1212 7th St. Canton, O.*

102  
Dr Edward Nicholl lately Dr. R. for Hammoth, Litchtoni Park near Hefrepton

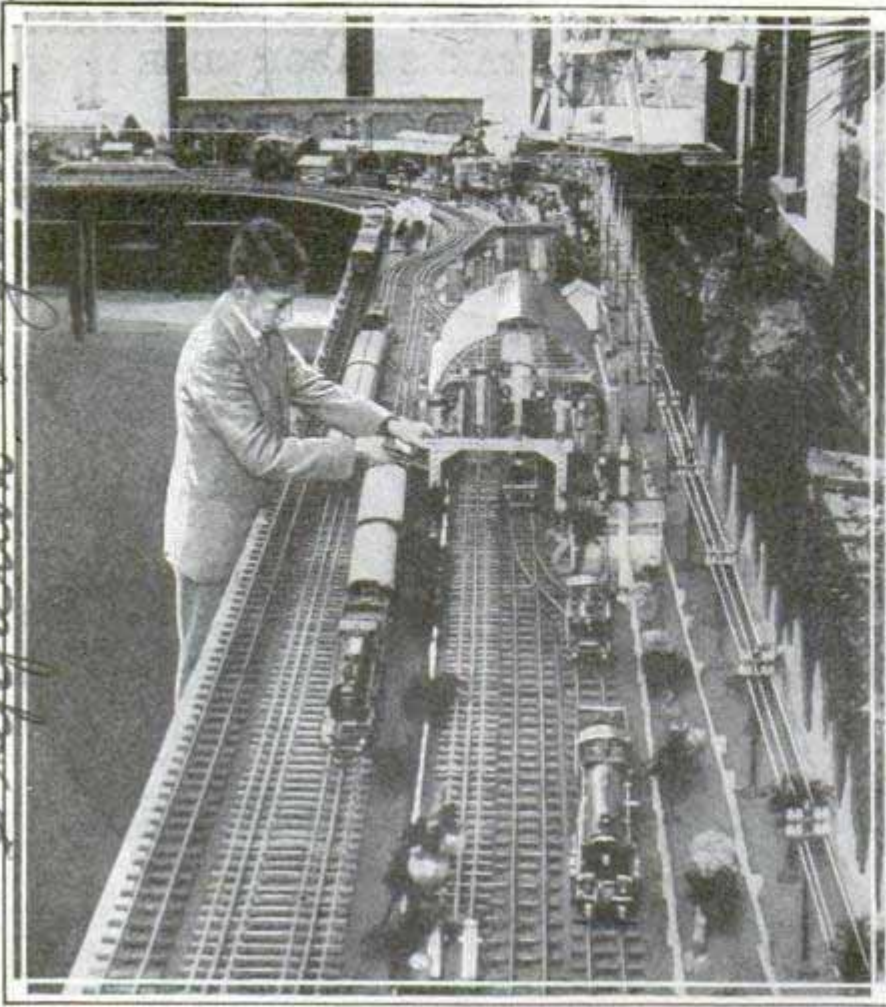

Model Railway System Has Four Main Tracks Besides a Subsidiary, and Its Locomotives Are Run by Steam, Electricity or Clockwork

**MODEL OF RAILWAY SYSTEM HONORS INVENTOR**

For the entertainment of his grandsons and to honor the memory of Richard Trevithick, who preceded Stephenson by several years with the invention of England's first passenger locomotive, a British statesman has erected a complete model railway system. It includes 550 feet of rails, four main tracks and one subsidiary, seven model locomotives, and numerous stations, bridges and other equipment. Two of the lines are for electric, one for steam and another for clockwork-driven trains. On Christmas eve, 1801, Trevithick's locomotive hauled the first load of passengers ever conveyed by steam.

**SEEK WAY TO USE SUN'S HEAT WITHOUT PRODUCING STEAM**

Success in harnessing the sun for industrial purposes will probably come, not by turning its heat into steam but by finding some way whereby to convert the heat energy directly into power or to make substances which will produce power, according to W. B. Parsons, an engineering-

authority. He points out that one of the most successful steam plants operated by the sun was capable of running only a small engine with an over-all efficiency of less than five per cent. It was constructed in Egypt in 1913 and had a heat reflecting surface of 13,269 square feet. Only low-pressure steam could be developed. Considering the sun as a source of power, it is estimated that each square foot of its surface exposed to the earth, some 585,750 millions of square miles if projected flat, radiates sufficient heat to generate 12,500 horsepower. Only a small portion of this total energy reaches the earth as most of it is scattered into space, but, theoretically, an acre of sunlight during the noon hour on a clear day at sea level would furnish over 5,100 horsepower-hours. Assuming that there are nine hours of maximum-

intensity sunshine each day and that one-half of the energy is recoverable, a strip of land ten miles wide and 100 miles long would daily develop 14,700,000,000 horsepower-hours. On a fifty-per-cent basis of efficiency, enough sunlight falls on the Great Salt Lake to produce energy equal to that furnished by the whole annual world consumption of fuel.

656 5 for \$1.00 Reg.  
**DESIGNS ON SWITCH PLATES HARMONIZE WITH ROOM**



Decorated electric-switch plates to replace plain ones, are intended to blend with the wall paper or color scheme of rooms. The finish is baked on so that it cannot readily tarnish, wear off or fade. The plates can be installed in a few moments.

☐ Nearly half a million persons make their homes on the desert sands of the Sahara.

Cyclopaedia of Engineering Co. 5010 Spring Lane Ana

Journal of Franklin Institute 15 S. Seventh St



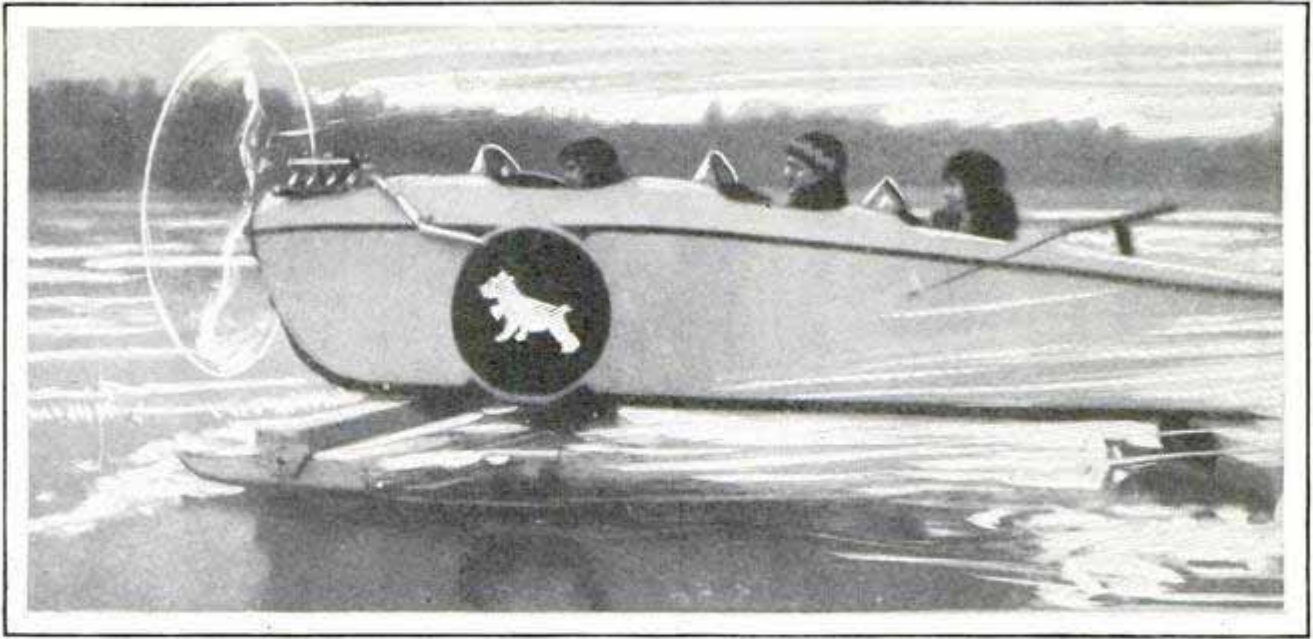

Scooting over the Ice on a Trial Spin, the "Airplane" Boat Developed a Speed of Seventy-Five Miles an Hour and Was Turned in a 100-Foot Circle at Forty Miles

**ICEBOAT LIKE AIRPLANE SPEEDS NINETY MILES AN HOUR**

Ice is seen as an ally of the air for army service as a result of the invention, by a civilian employe at McCook field, of an iceboat with a body like the fuselage of an airplane. It is capable of making a speed of ninety miles an hour, its propeller is driven by a motorcycle engine and the framework, cockpits and control system are patterned closely after those of a plane. The rudder is a rear runner which may be operated by a steering wheel near the back, but is also connected to the control apparatus in the forward cockpits. The bottom of the boat is waterproof and will remain afloat with three passengers should the ice break. Runners are of carbonized steel and are attached in such a way that they act as shock absorbers. Because of the limited space available during tests, the craft has not been driven at more than seventy-five miles an hour. It can turn in a 100-foot circle without danger while going forty miles an hour.

**SILK PATTERNS SENT BY CABLE KEEP WOMEN IN STYLE**

Women in Los Angeles need not be more than twenty-four hours behind their sisters in Paris in the matter of the latest patterns in silk. The designs are now cabled across the ocean from France to manufacturers in California who are waiting with the raw silk on the looms. Just a day after a new pattern appears abroad, it can be purchased across the counters of a department store here. Since 1915, when

silk culture was first started in California, more than 220,000 mulberry trees have been set out and millions of silkworms put to work. It is said that a larger amount of silk is obtained from cocoons in California than in the Orient, as the growing period for mulberry leaves is about two months longer. Between 400 and 600 yards of silk are recoverable from a cocoon in China and Japan, while, in California, the amount is from 1,000 to 1,900 yards.

**BARS ON WINDSHIELD VISOR DEFLECT RAIN AND SNOW**

Two or four bars, set horizontally below the automobile windshield visor, are set to keep rain and sleet from striking the glass and are far enough apart so that the driver can see between them. They may

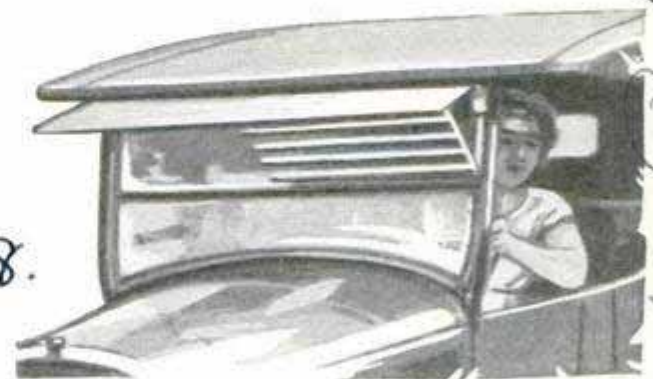

Ribs below Windshield Visor Keep Off Driving Rain or Snow, Eliminating Need of a Wiper

be raised out of the way when not in use or, if desired, help keep the glare of the sun from the eyes. With this arrangement, a windshield wiper is not needed.

*Chicago Daily News*

*1036*  
*1038*  
*inventor, R. B. Martin, Wash. Seattle, Wash.*

975

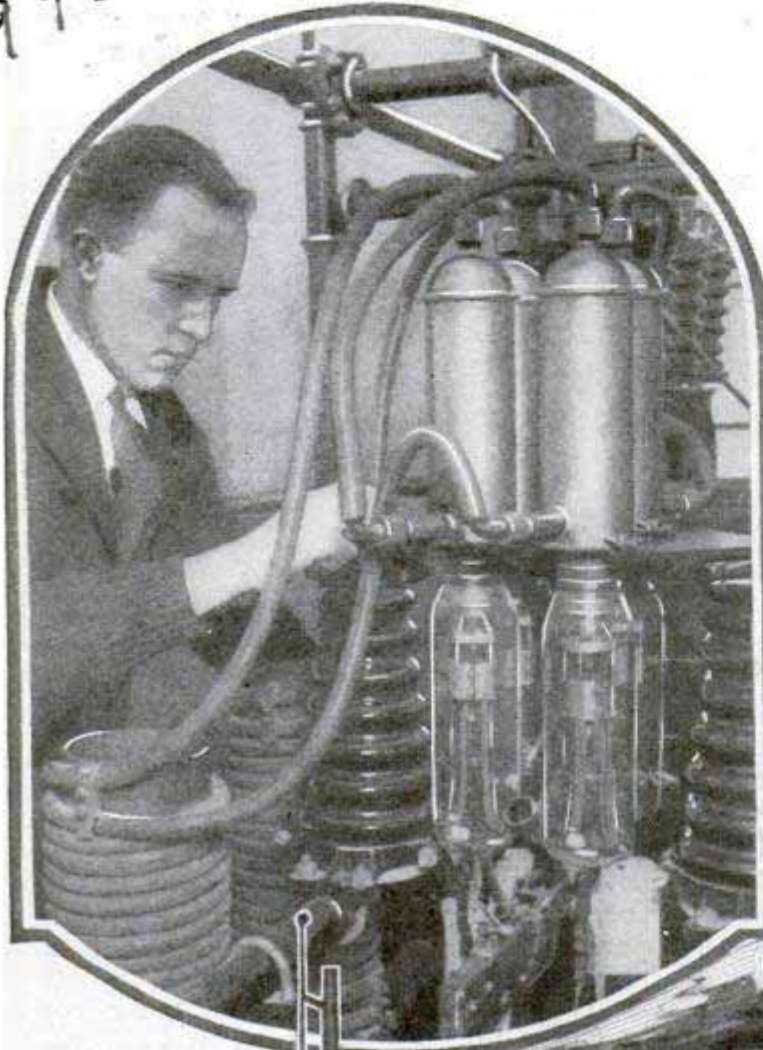

Equipment at Radio Station WJZ: Some of the Ten-Kilowatt, Water-Cooled Tubes, and Below, One of the Short-Wave Antenna Masts with Coil in Center

Huge Water Cooler to Supply the Tubes

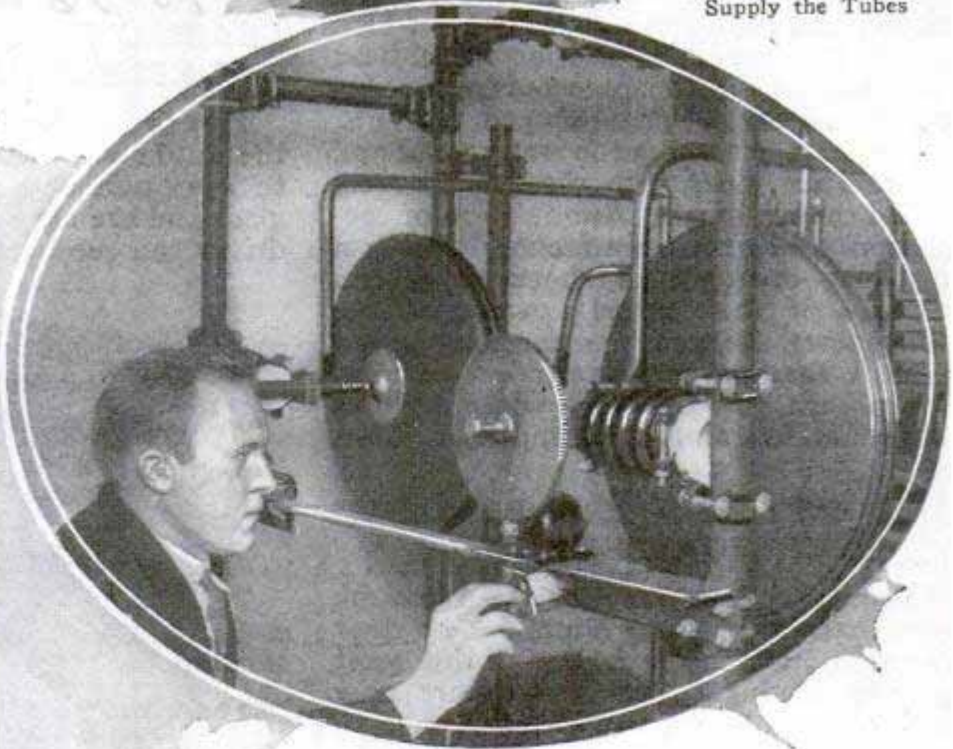

Big Vernier Condensers of the Transmitter Set Have Small Electric Motors to Turn Them; One Is Seen above Operator's Hand; Because the Station Can Be Sharply Tuned, Interference Is Reduced, Experiments Have Shown

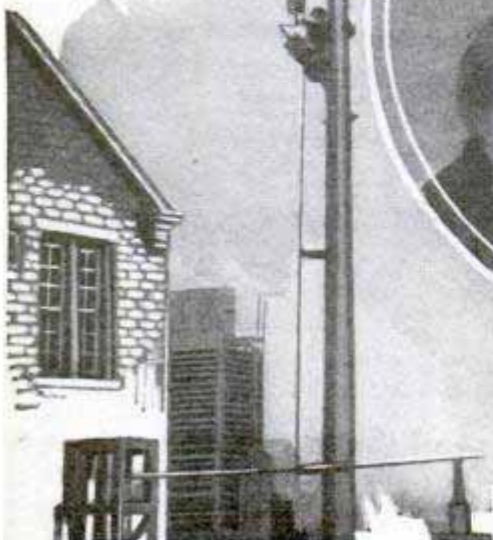

**FIFTY-KILOWATT RADIO UNIT  
LATEST WIRELESS MARVEL**

Radio's astounding development in the last few years is reflected in the equipment of broadcasting station WJZ at Bound Brook, N. J. a fifty-kilo-watt unit that is expected to span great distances and also overcome much of the static and other stray noises that bother the radio fan. The station's apparatus includes sixty-four ten-kilowatt tubes, all of them water-cooled. A tank that has a capacity of cooling 100 gallons of water a minute has been constructed for this purpose. The condensers are operated automatically by small electric motors. Coils of the short-wave antenna, which will broadcast on seventy meters, are exceptionally rigid and are made of copper tubing of the same size as the aerial itself.

1053

**DUST EXPLOSIONS  
KILL MANY**

Dust explosions and fires resulting from them, killed forty-five persons, injured twenty-eight and did approximately \$3,000,000 property damage in the United States during the past year, according to an associate of the government chemistry bureau. There are 22,000 establishments in this country that handle dusty products, or that manufacture articles likely to give off dangerous dust. Investigation by the bureau of chemistry has shown that practically all combustible dusts, and some not considered combustible, will explode when mixed with the proper proportion of air and ignited by a flame or spark. One common source of such accidents lies in hot bearings, while it has been shown that static sparks can ignite dust. According to an authority of the bureau, no record of a spontaneous dust explosion has ever been obtained. Prevention of the formation of dust clouds in factories and the elimination of all sources of ignition, are urged as ways of avoiding explosions.

<sup>1039.</sup>  
**BIG ARMORED CONCRETE PIPE  
SUPPLIES WATER POWER**

What engineers consider a remarkable example of reinforced-concrete construction is represented in a huge conduit, near

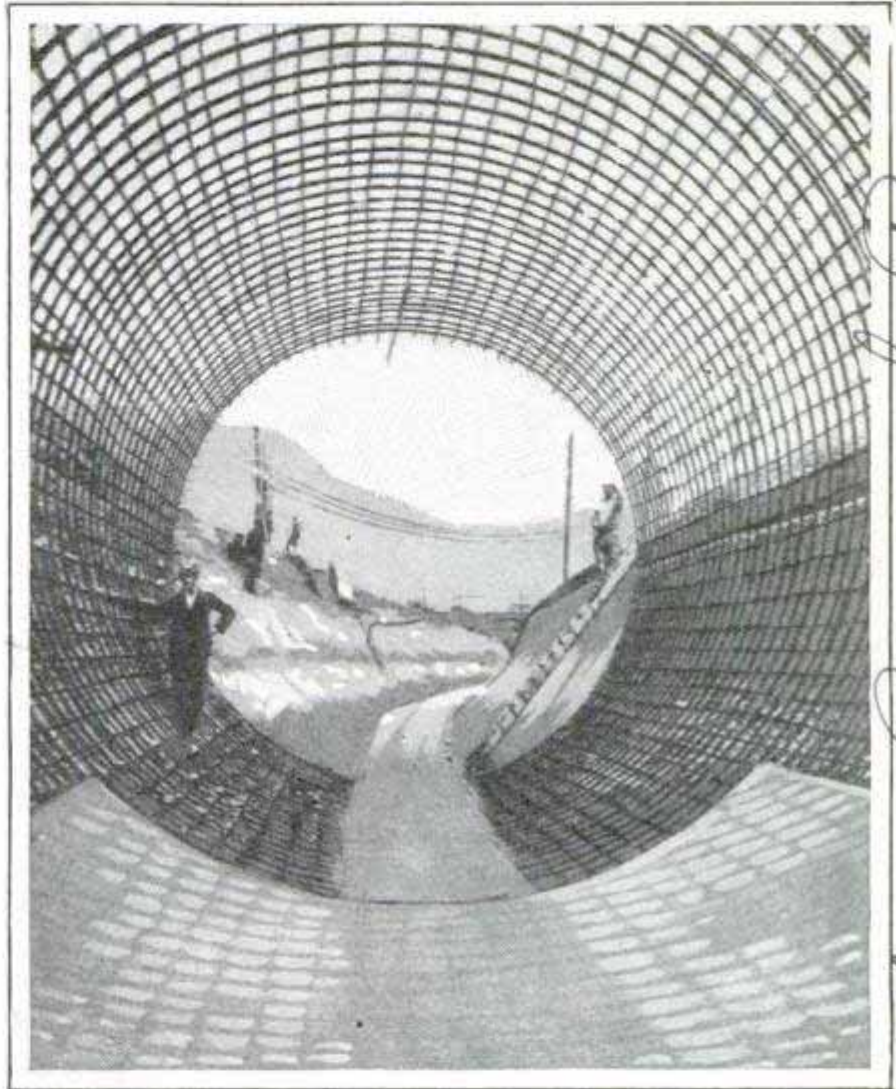

Concrete Pressure Pipe for French Water-Power Station under Construction; besides the Reinforcing Ribs, an Earth Filling Adds Strength

Grenoble, in the French Alps, constructed for a power station. The pipe has an internal diameter of nearly nineteen feet and will handle pressure of a column of water under a head of from twenty-three to forty-six feet. It will utilize the flow from two rivers which have a combined volume, in the spring months when the snow is melting, of more than 7,000 cubic feet per second. A gravel chamber has been constructed to free the water of pebbles before it enters the intake canal leading to the power house. Besides being ribbed with a network of supports, the concrete pipe is further strengthened with a thick earth filling over the top.

☐ The United States now has approximately 52,000 towns and post offices.

Highton G. Brown

Brac-Romanche Power Station

Literary Digest  
11/25/25

**TELEGRAPH KEY OF SOLID GOLD OPENS GATES AFAR**

"The president will flash the signal for the opening of the ceremonies by press-

Chief White House Telegrapher Edward Smithers, with Nugget-Bordered Gold Key Which Presidents Use at Important Ceremonies

© P. & A.



ing a gold telegraph key in the White House." News dispatches have often included such a phrase and the gold key has come to be one of the most important implements in national affairs. With it, the Alaska-Yukon Pacific exposition was opened in Seattle, Wash.; President Wilson touched it to blow up the Gamboa dike of the Panama canal, and it has figured in many other events that happened thousands of miles from Washington. The key is mounted on a slab of Alaska marble and is studded with a score of gold nuggets. It was given to Edward Smithers, chief telegrapher at the White House, by President Taft, in 1909.

**HUGE LOST STATUE OF LINCOLN PLACED IN CHICAGO PARK**

After years of obscurity in a warehouse, a heroic-sized bronze statue of Lincoln, by St. Gaudens, has been placed on a granite base in Grant Park, Chicago. The piece, which shows the figure of the great president seated, was finished in 1906. Nine years later, it was shipped across the country for exhibit at the San Francisco fair, and the following year was returned

to Chicago. While plans were being made for its permanent display, it became temporarily "lost," to the public at least, until interest was re-aroused in it by newspaper and other publicity. The statue was considered by St. Gaudens the best he ever made of Lincoln.

**SALMON ARE ABLE TO TRAVEL HUNDREDS OF MILES A WEEK**

That salmon travel amazing distances in short periods is indicated by the journey of one fish which was liberated at the southern end of Nova Scotia last June and was caught less than a month later in the Moisie river, Quebec. Identification was made by means of the silver tag which had been placed in one of the salmon's fins when it was first captured. Its journey was between 800 and 1,200 miles long. Fish movements are important where the fishing industry is highly developed, and by means of the tags, valuable knowledge is being gained as to the habits of salmon and other fish.

**NON-SKID PADS FOR HORSES HELP PREVENT ACCIDENTS**

Pads of woven material, which may be quickly inserted within horses' shoes, have been devised by a former British army captain to keep the animals from slipping. Several of the protectors may be carried in the



Preparing Material for the Non-Skid Pads, and Inserting One

pocket and no tools are necessary when fitting them. They are said to afford such a secure footing that horses can be ridden over ice with little danger of falling.

*1035*  
39 Charlotte  
mamtoba, Can.  
Chrystie  
W. J. Jamieson  
Capt. C. C. Jamieson

*1021*

*over*

*1028*

*Chicago Evening Post*  
*1/19/10*

*no further information*

# Hunting Mountains under the Sea

Washington, D. C.

Ocean

Ranges and Valleys Never Seen by Man Are Named and as Well Known as the Peaks and Plains of the Continents

OFF the western coast of Africa lies the Congo Canyon, bigger and deeper than the Grand Canyon of Arizona, and more strangely beautiful, but no man has ever seen its depths, and it is improbable that any man ever will. For the Congo Canyon is at the bottom of the Atlantic, one of the vast valleys between the giant mountain peaks whose tops fail to break the surface of the sea, and so remain unknown to all but the hydrographers who plot the mystery land under the waves.

Out in mid-Atlantic is a tall and stately peak named, for some forgotten reason, Mount Laura Ethel. Put it down in the midst of the rockies and it would tower up with the best of them, but because its highest point falls just a few score fathoms short of reaching sunlight, thousands of transatlantic passengers each year sail over the hidden mountain top without ever knowing it is there. To the hydrographer who constructs the marine charts of the world virtually every part of the ocean floor has its name. To him it is a land of hills and valleys, plateaus and yawning canyons. There is the Telegraph Plateau, half as big as Europe, yet appearing on the maps of no school geography. It lies beneath the North Atlantic, between Ireland and Newfoundland, and because its vast plains are so level and so close to the surface, it made the laying of the first

Atlantic cable possible. Then there is the Crozet Rise, the Japan Trench, the Cape Trough, the Marianne Ridge, the Brazil Basin, the Tuscarora Deep, and a vast mountain chain, known as the Edward VI range, to name but a few of the famous lands beneath the sea. The latter mountains, lying in the North Atlantic, have only recently been added to the underwater geographies, for vast stretches of sea remain to be charted. In 1901, the British cable ship "Britannia" discovered an entire new mountain chain in the South Pacific.

When one of the undersea mountains bursts through the surface and becomes an island it gets on the everyday land maps. The Bermudas are merely the tops of a mountain chain whose peaks rise almost straight from immense depths. St. Helena, where Napoleon spent his last years in exile, is another mountain top, as is lonely Ascension island. Off the

Kuril islands, the bottom drops sheer to a depth of five miles. Similar yawning depths adjoin Guam, the mid-Pacific naval station of the United States, and the Philippines. Only a mile or two off the coast of Porto Rico, the mountain of which the island is the top drops almost straight down for 27,366 feet. Charts of the ocean depths have been prepared for many years. The first of the Atlantic was made in 1854 by Matthew Fontaine Maury, the famous American

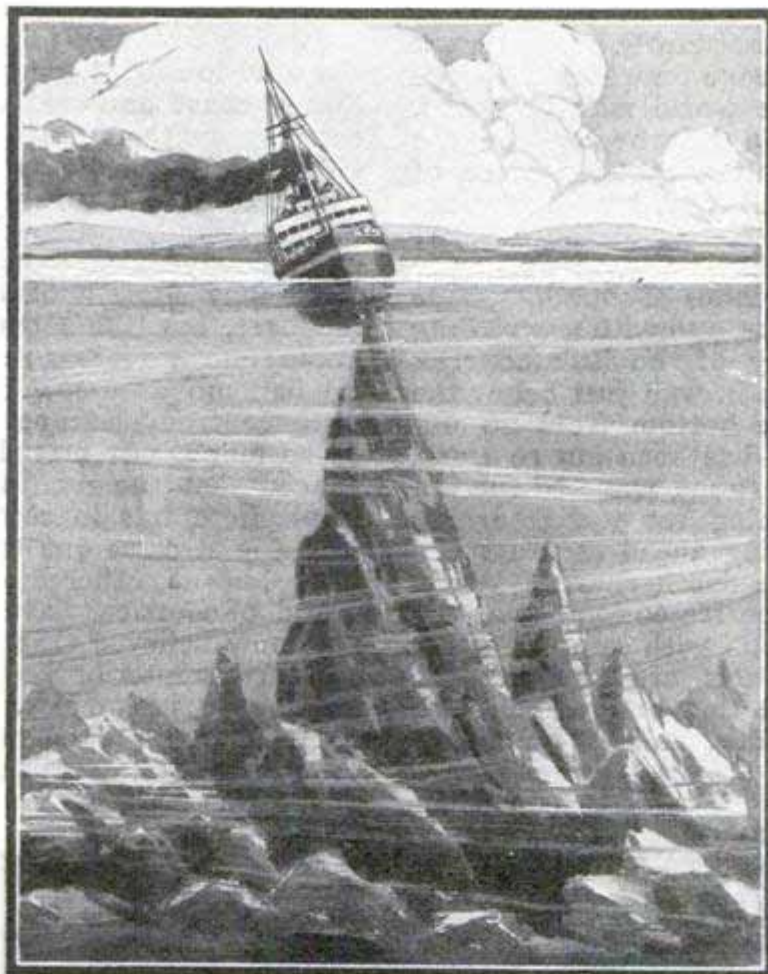

An Undersea Mountain, Projecting to Within a Few Feet of the Surface, Is a Trap for Every Ship Until Charted and Marked

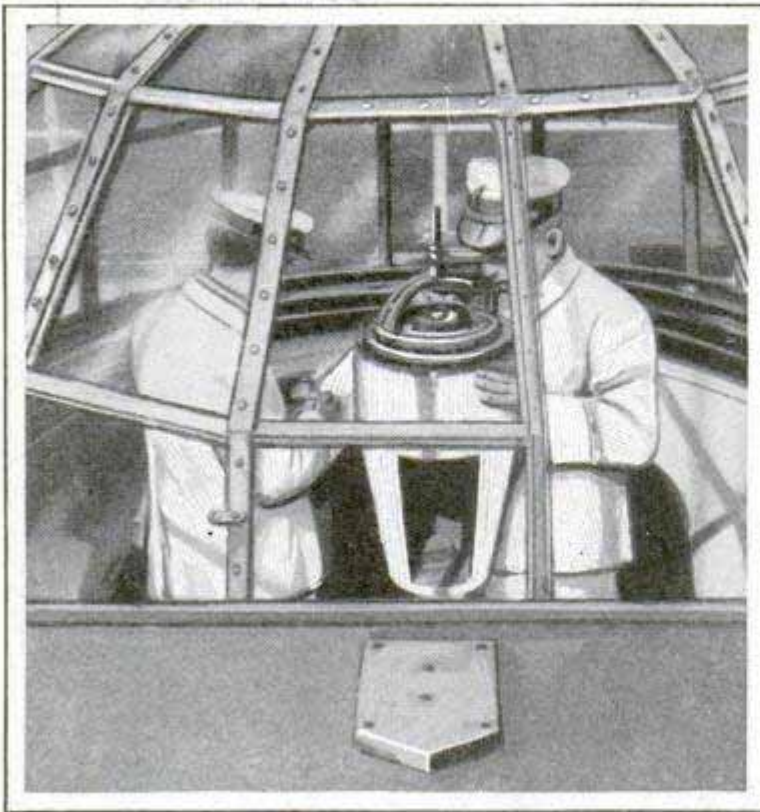

Officers Making Magnetic Declination Observations Aboard the Non-Magnetic Schooner "Carnegie"

oceanographer. It was he who named the Telegraph Plateau. In recent years survey ships have constantly been at work adding new knowledge on which the shipping charts of the world may be based. The compass ship "Carnegie," of the United States, built without a piece of magnetic metal on board, has revolutionized the magnetic charts of the oceans; United States coast and geodetic-survey ships, with new methods of sounding, have mapped the bottoms, and with a wire drag have located many of the isolated rock pinnacles which lie in wait just below the surface to rip the bottom from an unwary ship. Radio has been put to work, and by flashing a sound wave to the sea bottom and listening for the returning echo, a ship plowing ahead at full speed can make accurate depth charts. Water bottles have been perfected to open at any desired depth and fill with samples of the water, and new nets are trapping the strange marine life that browses through the hidden mountain valleys far below the surface of the oceans.

The results of the constant study of the earth under the sea as well as the interior under the land above sea level are expected to have an important bearing on the further knowledge of earthquakes and their causes, the distribution of metals, oil and other valuable minerals, and solve the mysterious movement of the earth's crust. More than 5,000 earthquakes are recorded each year by the many seismographs in use throughout the world. Only comparatively few are strong enough to be felt by man, yet every day there are many minor quakes recorded only by the delicate needle in some laboratory. Scientists hope that, with the completion of accurate surveys of the entire undersea world and a computation of the distribution of its mass, they can, by studying the quake reports, solve the relation of small temblors to large ones, and perhaps learn to predict the imminent arrival of

destructive quivers. There are no "everlasting hills," despite the poet's phrase, according to Dr. William Bowie, chief of the division of geodesy of the United States coast and geodetic survey. The earth, notwithstanding its mass and rigidity, is as plastic as soft putty under the stresses and strains of gravitational force. Islands and continents drift across it, so slowly that measurements a century apart may show a dislocation of only a few feet, but the movement does exist. Some time ago it was reported that America had moved a few feet westward, the distance from Europe being lengthened by so much. At first the theory was advanced that the drifting of the western hemisphere was in some way connected with the stresses due to the earth's rotation, but as other bodies, notably the island of Corsica, have moved eastward, it is now believed that a readjustment of the earth's interior has caused a general shifting of the surface.

The surface movement is determined by thousands of observations of the stars made



Mountain Ranges of the Pacific Ocean Whose Tops Project Above the Sea and Are Known as Islands; East of the Philippines and Guam Are Two of the Deepest Canyons in the World

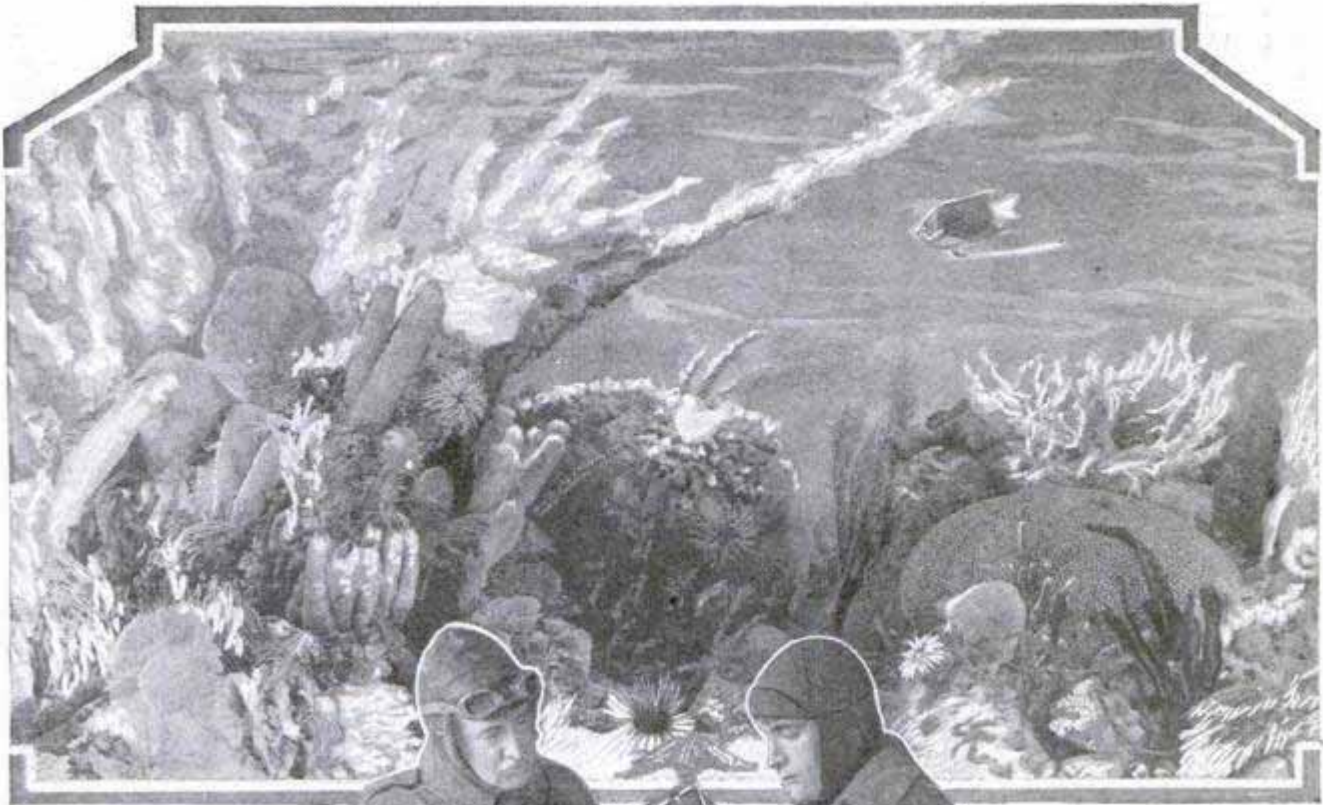

The Plains and Valleys under the Sea Have Their Teeming Life, Their Jungles, Forests and Meadows and, in Tropical Seas, a Brilliant Array of Colors; the Coral Jungles Yield Constantly New and Surprising Information Which Has a Bearing on the Study of the Sub-Ocean World



The Aerial Camera Is the Latest Aid in Charting the Lands under the Ocean, Since Its All-Seeing Eye, from Far Above, Readily Detects Things the Surface Observer Cannot See; at Left Is Dr. W. T. Lee and an Army Flyer Inspecting Their Camera before an Observation Flight, and Below Is an Aerial Picture Showing a Dredged Channel, in the Lower Left Corner, a Deeper Cove above It, and, to the Left of the Channel, the Dark Blotches That Mark Shoals Not Far beneath the Surface

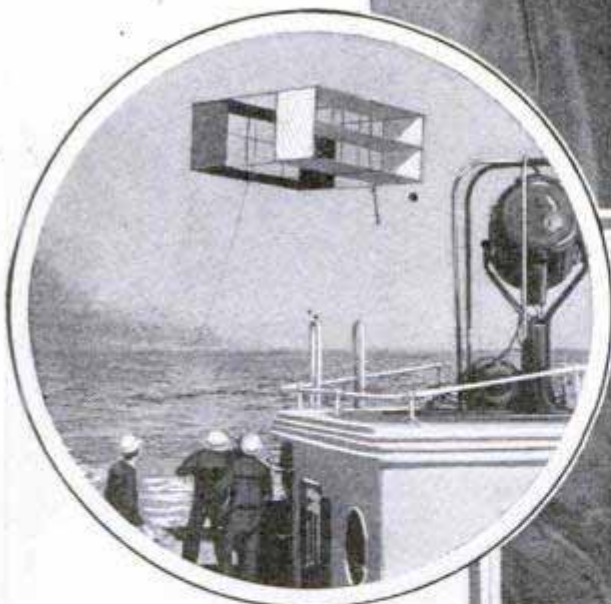

Weather-Bureau Observations of Wind Currents Are Regularly Made at Sea by the Coast and Geodetic-Survey Vessels; Above, Sailors Are Launching a Big Box Kite to Carry Aloft Recording Instruments That Write in Ink a Record of the Skies; Half of the Kite Is White and Half Black to Permit It to Be Seen against Clouds or Bright Sky



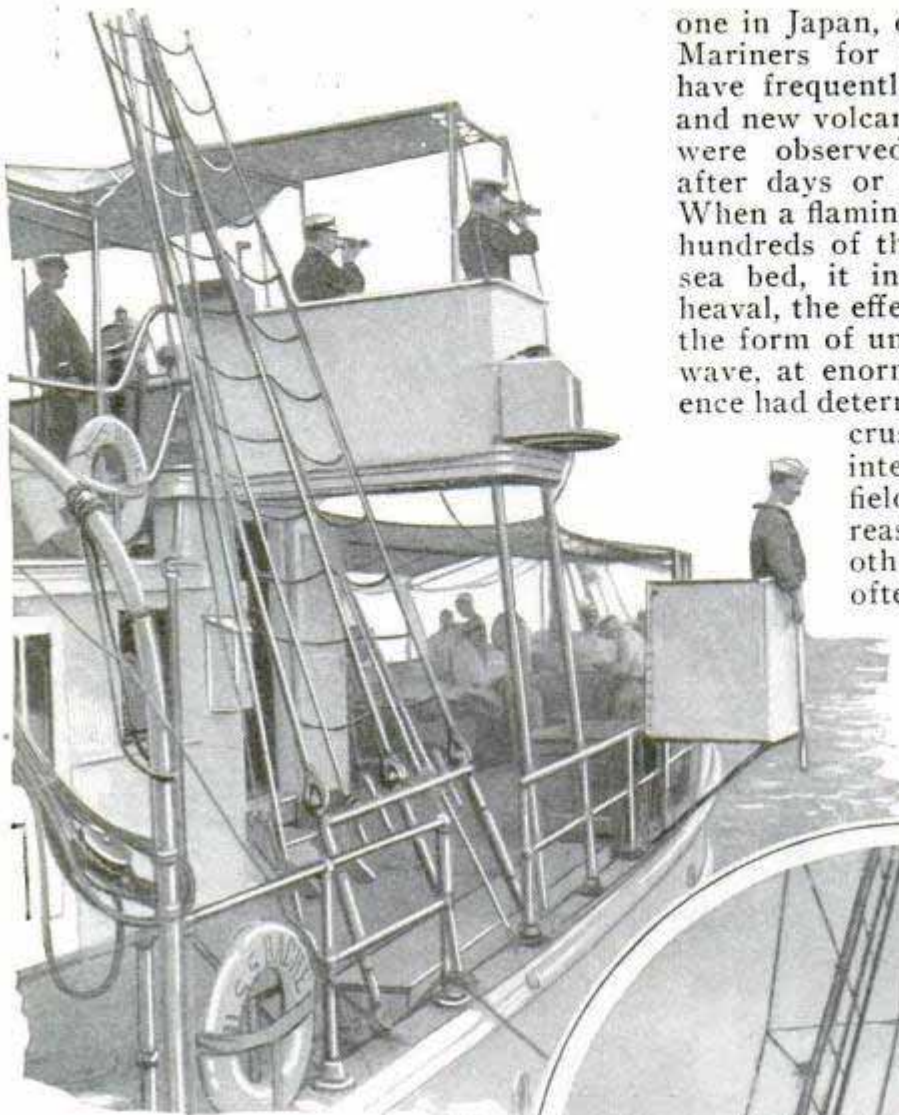

A Sailor Stationed in a "Pulpit" on the Ship's Side Makes Soundings with a Hand Line and Weight in Shallow Water; at Right, String of Shock-Absorbing Cushions Which Acts as Spring on Tow Line in Deep-Sea Dredging

at different points on the land surface, and checked repeatedly every few years. Once the exact latitude and longitude of a given spot are determined by observations of the stars, even a shift of a few feet can be discovered. Scientists have been somewhat limited in their study by reason of the fact that no accurate data on the land under the seas existed. Their calculations, even as to the size of the earth, were based on observations made from dry land, and of the earth's surface of 200,000,000 square miles only slightly more than one-fourth — 57,000,000 square miles in round numbers — is dry land.

Yet the cause of many earthquakes, such as the destructive

one in Japan, originated beneath the sea. Mariners for more than two centuries have frequently reported strange islands and new volcanoes that rose from the sea, were observed, and disappeared again after days or years. Some few remain. When a flaming volcano can emerge from hundreds of thousands of feet below the sea bed, it indicates a tremendous upheaval, the effects of which may be felt in the form of unusual tides, or even a tidal wave, at enormous distances. Since science had determined that the entire earth's crust is floating on a plastic interior, much as the arctic ice fields float on the ocean, the reason why earthquake and other disturbances occur more often under the sea than under the land is apparent. If something must give way to release the tremendous internal pressure as the earth readjusts its crust, it is easier for the

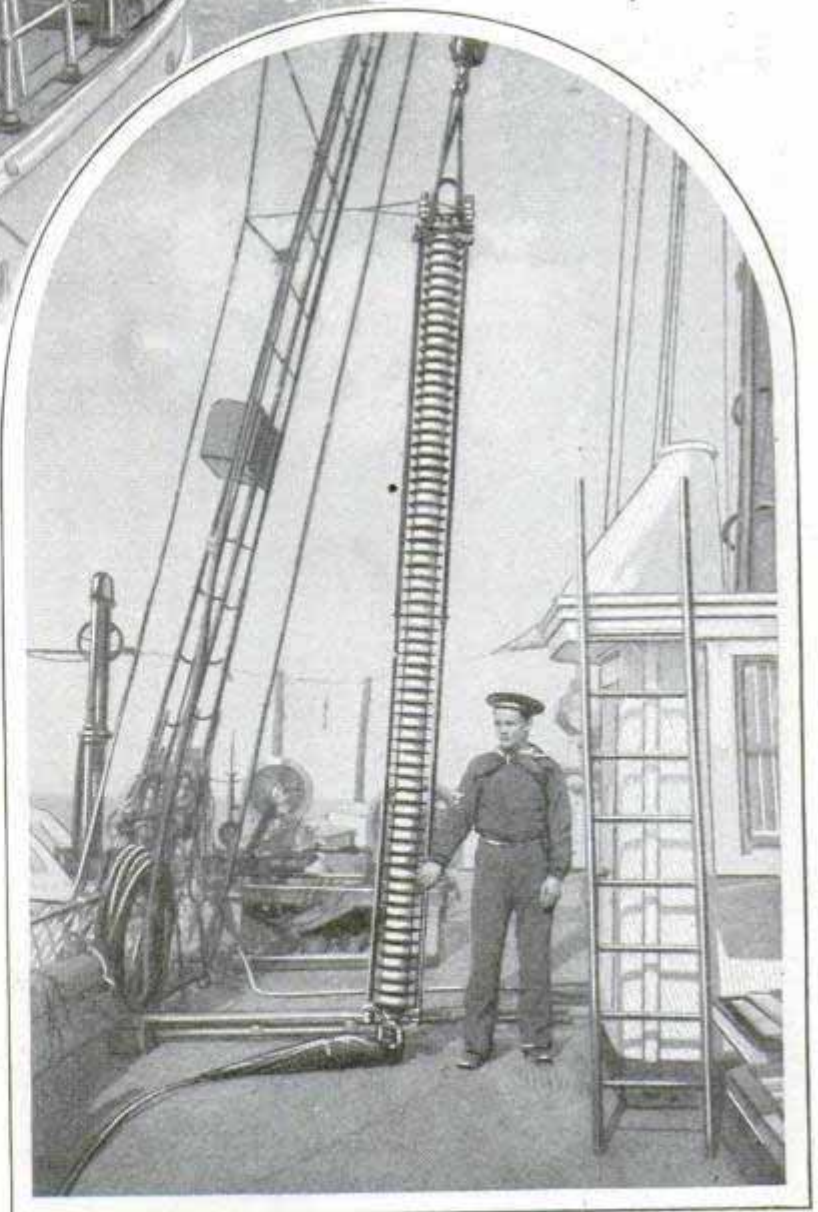



610

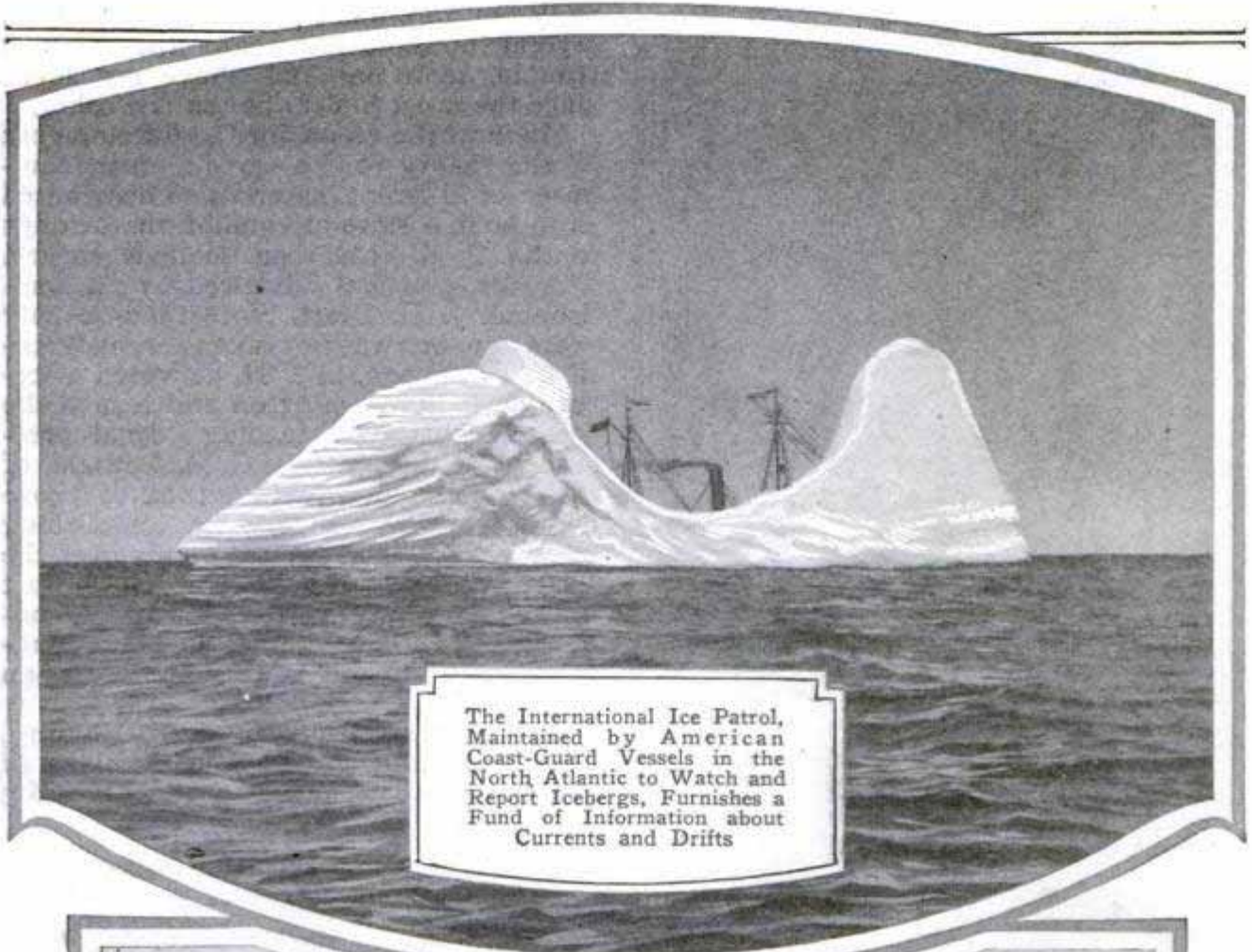

The International Ice Patrol, Maintained by American Coast-Guard Vessels in the North Atlantic to Watch and Report Icebergs, Furnishes a Fund of Information about Currents and Drifts



Party from a Geodetic-Survey Vessel Sounding for Shoals in a Busy Harbor; Constant Watch Is Kept over the Shifting Menace of Sand Banks

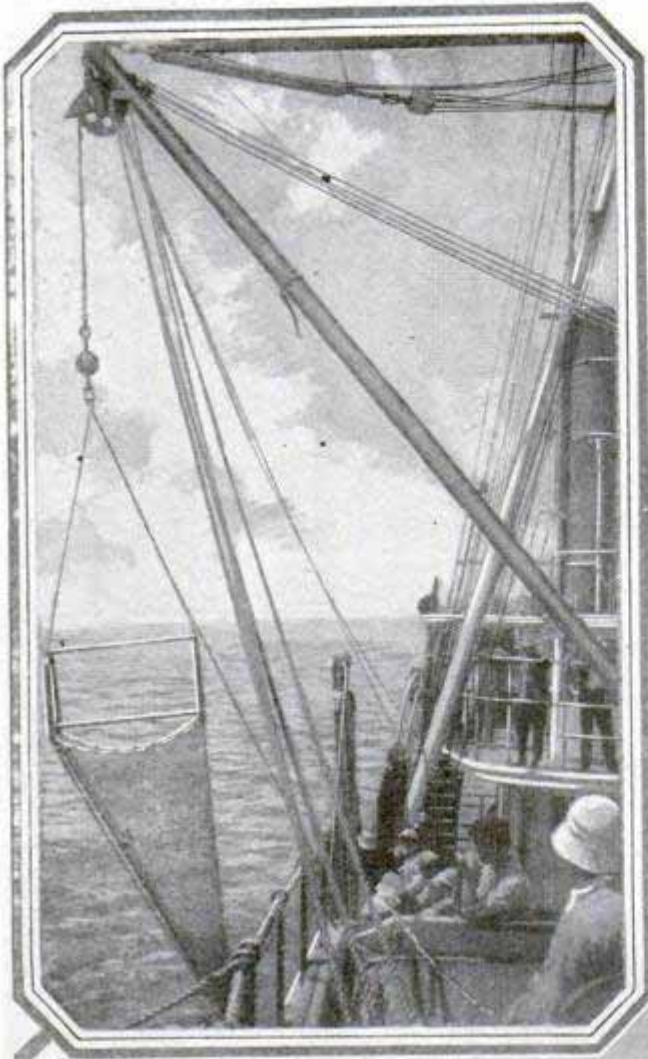

explosion to burst out on the sea bottom, several thousand feet nearer the scene of trouble, than on land above sea level, since the crust under the sea is weaker.

Much of the credit for the development of the theory of the earth's crust, composed of different materials so distributed as to be in a state of equilibrium, belongs to the U. S. coast and geodetic survey. The idea was first advanced by an Englishman, J. H. Pratt, more than seventy years ago, but was not taken seriously until C. E. Dutton, in 1889, delivered a lecture on it in Washington and named the theory "isostasy," meaning "equal pressure." In the nineties, G. R. Putnam, of the geodetic survey, undertook to prove or disprove the theory by establishing gravity stations at several points over the United States, and decided that the crust under this country was in substantial equilibrium, with the reservation that mountain ranges possibly were supported as an extra load.

Later investigations by J. F. Hayford, Dr. Bowie and three mathematicians of the survey determined that the entire

Lowering a Beam Trawl. Above, to Gather the Living Wonders of the Deep as Part of the Work in Surveying the Hidden World; at Right Is a Party of Coast Surveyors Setting Up a Hydrographic Signal on the Rocky Coast of Alaska

earth's crust, extending for some sixty miles below sea level, was in almost perfect equilibrium, and that even the added weight of mountain ranges was compensated for by lighter material under them, a fact that may in part explain why volcanic eruptions on land occur usually in mountain peaks rather than in the denser mass of the low lands.

If the earth's surface were cut up in hundred-mile-square blocks, to the depth of sixty miles—the thickness of the crust—the separate blocks would weigh so nearly the same, the scientists have decided, that they would float side by side without change of level. The theory can be demonstrated by cutting blocks of metals of different specific gravity to the same cross-sectional area, but allowing sufficient height so that all will weigh the same, and then floating them in a basin of mercury. Despite the difference in size, they all would float to the same depth, so their bottom surfaces would be in line, while the tops would stand out at irregular heights. Lead and silver, two of the heavier metals which will float in mercury, would be represented by shorter blocks as compared with nickel, copper, cast iron, zinc and antimony.

505

**ELECTRIC MATCH LIGHTS PIPE'S, CIGARS OR CIGARETS**

Pipe smokers as well as devotees of cigars or cigarettes are served by an electric lighter with the heating element passed over a knob that fits inside the pipe bowl. Either direct or alternating current can be used from a lighting circuit and is turned on by pressing a button on one side of the holder. The stand is eight inches high and has a broad and heavy base to prevent tipping.

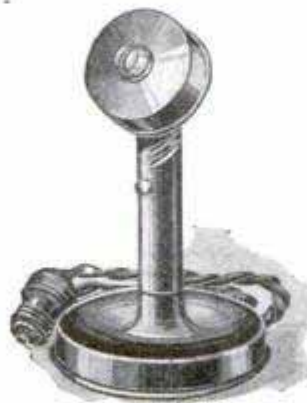

*Russell Electric Co. 340 W. Huron*

**STUDENT HAIR-RAISING STUNT SHOWS STATIC'S POWER**

Static electricity is capable of other queer antics than causing howls in your

1022

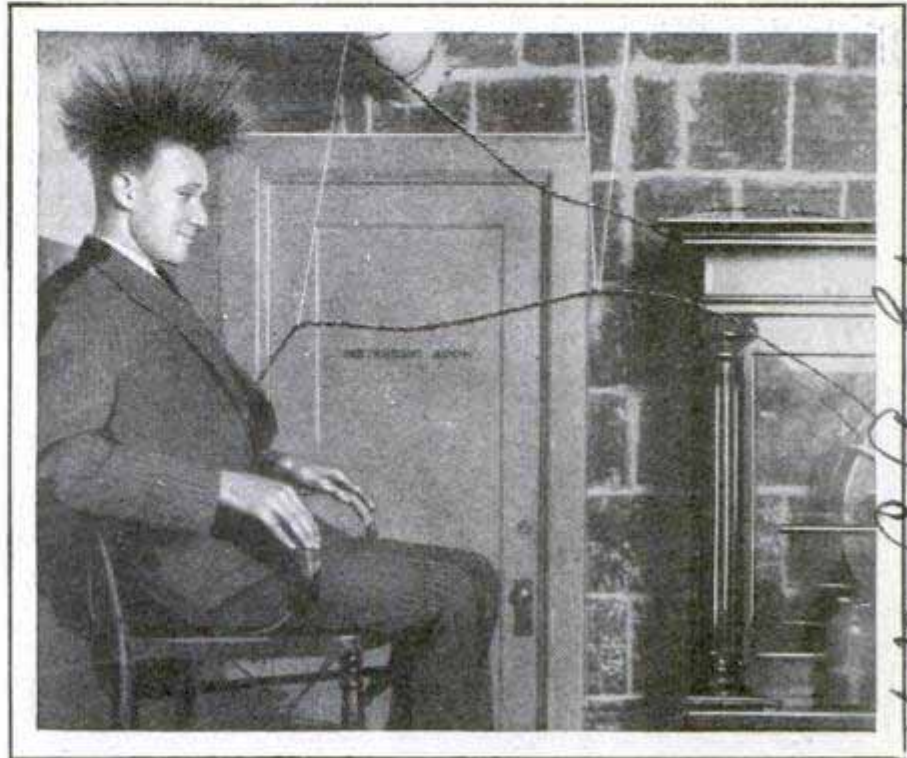

He May Have Been Frightened, but Fear Did Not Lift His Hair; It Was Static Electricity from Generator at Right

radio set. At a public exhibition in Portland, Oreg., current from a static generator lifted the hair of men students who sat in chairs near by, giving a realistic imitation of what sometimes happens in registering sudden and intense fear. When the test was tried with young women who had bobbed hair, the results were not so pronounced. Their hair straightened out but did not stand up, possibly because it had been kinked by waving or similar treatment.

103

**ANNUAL COST OF SMOKE IN U. S. SEVEN DOLLARS PER CAPITA**

Damage to property by smoke and soot in America's greatest cities costs the public about seven dollars per capita each year, according to estimates prepared by the United States bureau of mines. Besides this loss, there is the economic waste of burning coal by inefficient methods, and health authorities point out the menace of a smoke-laden atmosphere. In England, plans have been made for the building of 100 demonstration homes which will be heated and lighted by gas and electricity. Records will be kept of the maintenance costs of these houses, for comparison with dwellings that use coal

*Export. 30 Church St. New York City*

*U. M. C. A. Educational Dept. Portland Ore. N.Y. Bulletin 11/26 Central Terminal*

*506.92 no 21 new York*

*Acton London England*

**DANCE ON GALLOPING FLOOR TESTS COSSACKS' SKILL**

930. One of the features of a recent Cossack show in London was a dance performed

Russian Dancers Performed on Platform While Cossacks Rode Horses at a Gallop

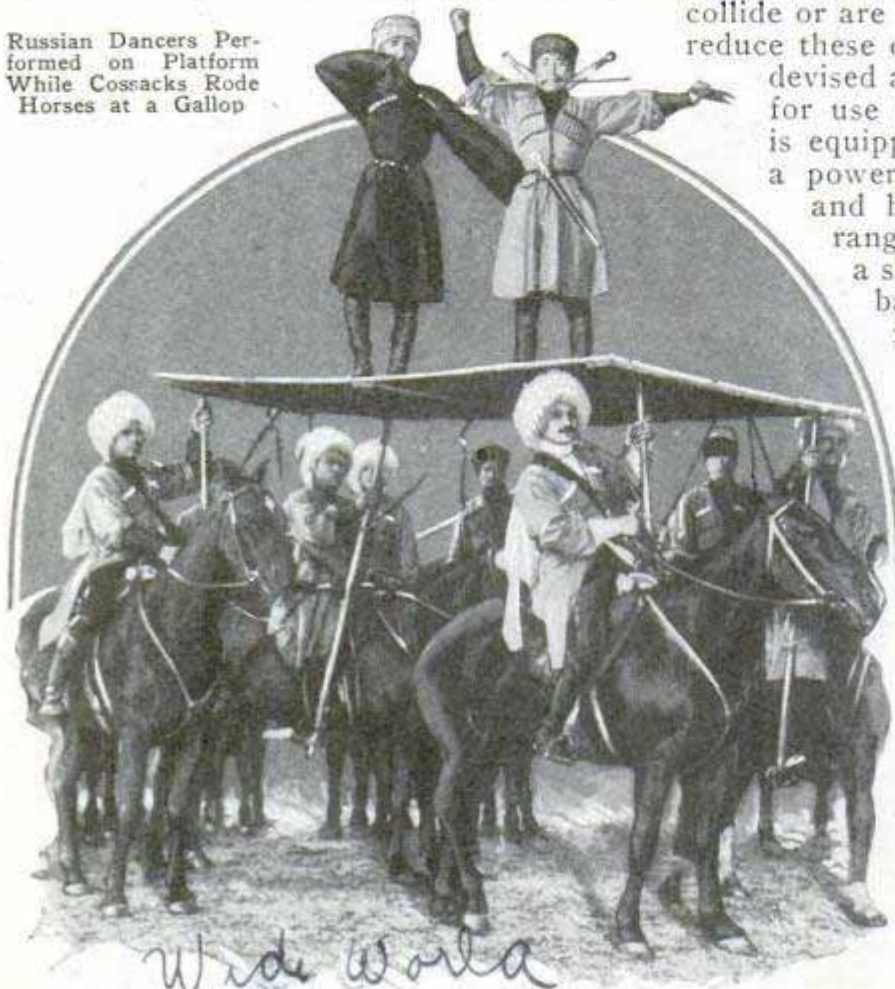

*Wide World*

by two men who were supported upon a platform on poles carried by horsemen. The uprights were fastened to the stirrups and were steadied by the riders as the horses galloped along.

**PEDAL FOR AUTO ACCELERATOR ADDS TO DRIVING COMFORT**

Leg strain, foot burns and damage to the floor of the car are prevented in a pedal for the auto accelerator to rest the driver's foot. It can be adjusted to fit persons of different height, is easily installed and consists of few parts. A steady pressure can be exerted with it and chance of accidental contact with the accelerator is less likely. The pedal has rubber inserts to protect the shoes.

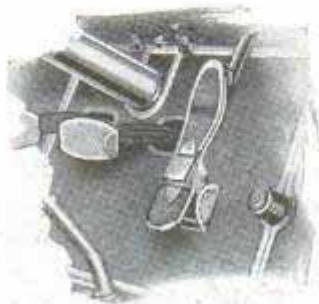

3326

**SEARCHLIGHTS FOR LIFEBOATS AID IN RESCUE**

932. In the excitement of shipwrecks at night, lifeboats not infrequently capsize, collide or are run down by steamers. To reduce these dangers, a London firm has devised a special electric searchlight for use on motor-driven boats. It is equipped with silvered reflectors, a powerful gas-filled type of bulb and has a carriage to alter the range of the light swiftly. By a single turn of a switch at the back of the lamp, the long-range concentrated beam may be changed into a close-range diffused illumination but the central core of light shines undimmed while the change is being made. Besides the searchlight, the boat is also provided with a radio outfit. Controls for the different units are closely grouped for easy handling.

**RADIO-TUBE PHONE AID DEAF**

978. Instruments which make use of the principles of radio amplification of sounds for the help of the deaf have been available for some time and now the vacuum tube has been adapted as a sort of "booster" for the telephone, so that persons hard of hearing may carry on conversation with but little difficulty. The apparatus is contained in a separate box which may be placed against the wall or in the desk. It can be adjusted to meet the needs of the person for whom it is intended, but its use by those not hard of hearing is discouraged as it naturally amplifies all sounds equally. Some hearing aids using radio are said to enable a person suffering from as much as a sixty-per-cent loss in hearing to understand normal speaking three feet away.

967

**TUNNELS SPEED WEAR ON RAILS BY DAMPNESS AND SMOKE**

Long tunnels are proving "rough on rails," since dampness and sulphur from the locomotive smoke speed corrosion. Wheels of passing trains chip flakes of rusted metal from the rails, leaving exposed portions open to further action from water and smoke.

*Wholesale - Marshall Field Chicago Auto Supply Co.*

*Bell Telephone Co.*

*Adamo Mfg Co 591 N. Chambers St.*

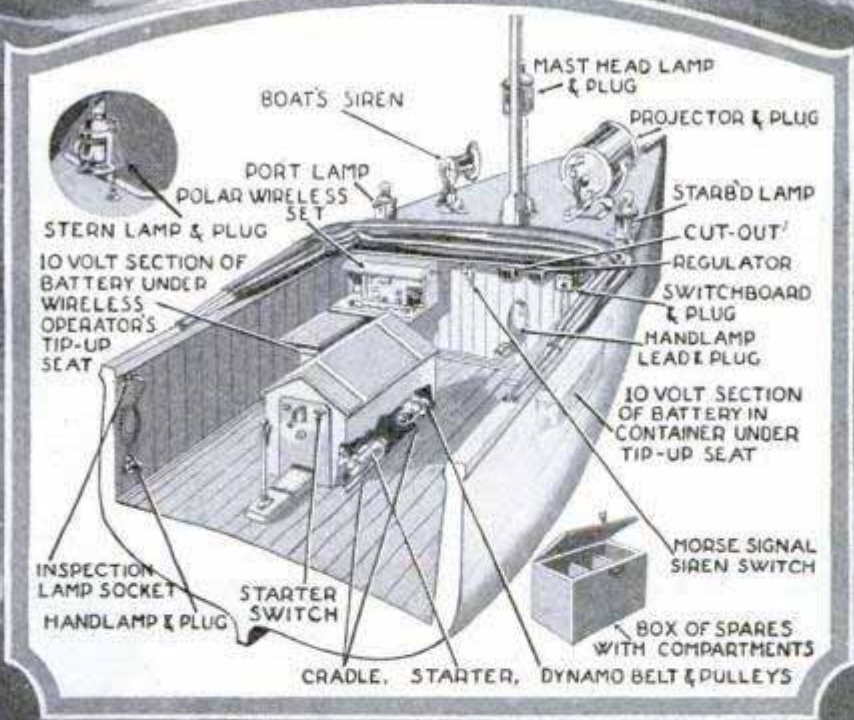
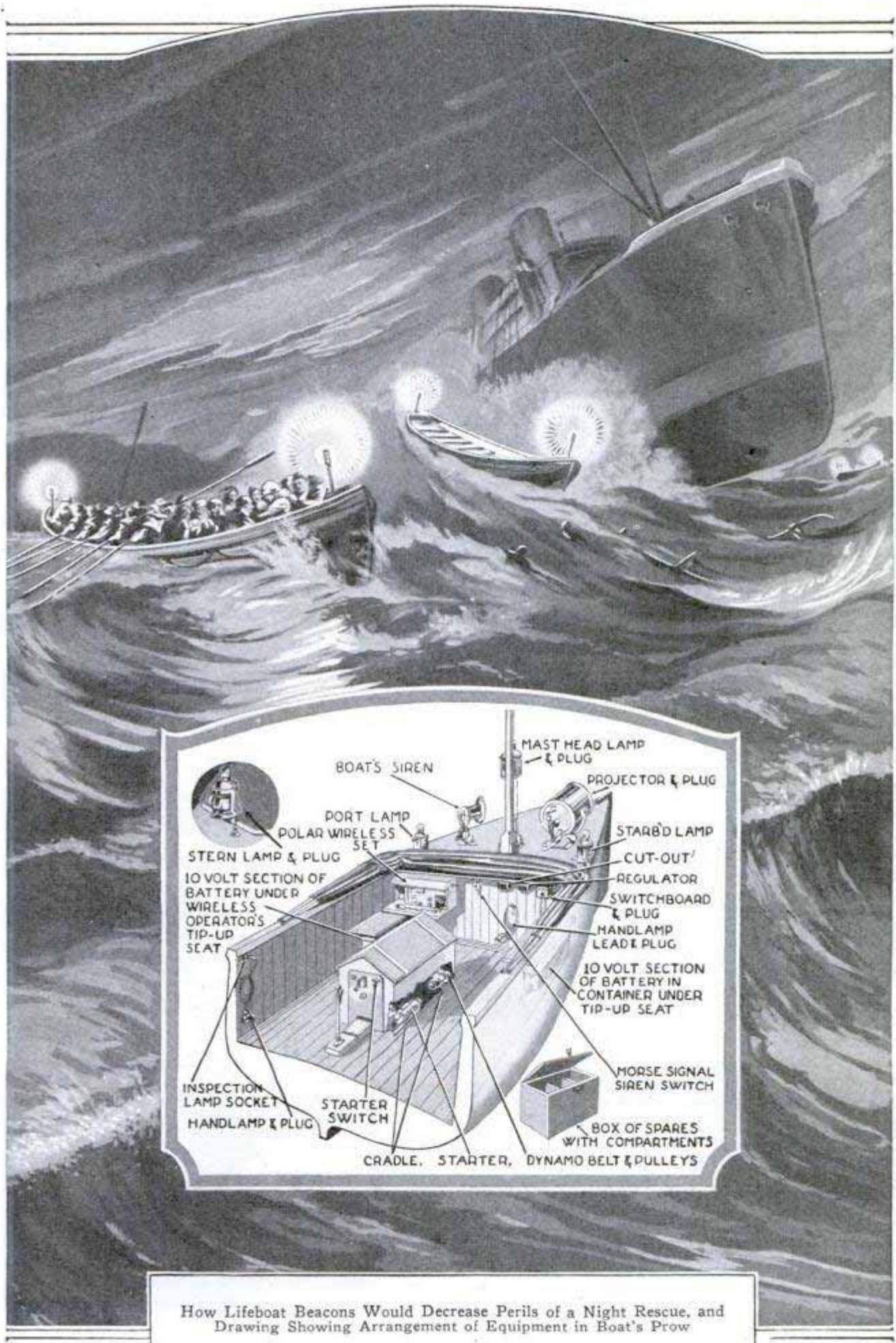

How Lifeboat Beacons Would Decrease Perils of a Night Rescue, and Drawing Showing Arrangement of Equipment in Boat's Prow

**LIFEBOAT RIGHTED BY RAILS ATTACHED TO KEEL**

Two long folding rails attached to the keel of the lifeboat have been devised by a British sea man to afford survivors a secure grip and help them right the boat



Inventor and Lifeboat with Grip Rails on Keel

in case it capsizes. The rails are within easy reach and when not in use, lie flat against the keel so that they do not interfere with the position of the boat in the deck racks or davits.

**STEEL AND REFINING COSTS CUT BY SILICA PROCESS**

Marked reduction in the costs of producing steel, refining petroleum and of refrigeration is forecast by Dr. W. A. Patrick of Johns Hopkins university, through the application of an absorbent substance known as silica gel which he invented during the war. It is made with water glass and acids and resembles coarse sand but contains innumerable pores so fine that they cannot be seen even under powerful microscopes. Prof. Patrick estimates that the total surface of the pores, in one gram of silica gel would cover half an acre. The material's use in the manufacture of steel lies in its ability to absorb the moisture from the air that enters the blast furnaces. Water vapor often causes considerable difficulty, but the silica substance, it is said, practically dehydrates the air. Its use is reported to have increased the output of steel in one factory ten per cent and to have decreased the cost of coke fifteen

per cent. In refining crude oil, the gel helps remove sulphur-bearing elements and gum-forming compounds, and the method is said to be cheaper than any yet found. In refrigeration processes, the gel acts as a vacuum pump in absorbing the water vapor and causing freezing as a result. This method of turning water into ice, that is, by pumping off the vapor, has been used for many years. The silica gel makes the use of a pump unnecessary. It absorbs the vapor and condenses it into water. By placing a small flame under the gel, this condensed vapor is driven off, leaving the material free to absorb more vapor. The process is continued until the water is frozen, and thus ice is actually formed by the application of heat. Theoretically, eighty pounds of ice can be obtained from 100 pounds of water by evaporating twenty pounds of the latter.

**COASTER IS STEERED LIKE SLED BY LEANING RIGHT OR LEFT**

Suited to children from four to fourteen years old, a coaster now on the market has no tongue or handlebars but is steered simply by leaning to either side. This shifting of the weight causes all four wheels to turn in the desired direction. One knee rests on top of the coaster and propulsion is obtained by pushing with the other leg. Rubber tires and steel disk wheels add to the pleasure of riding.

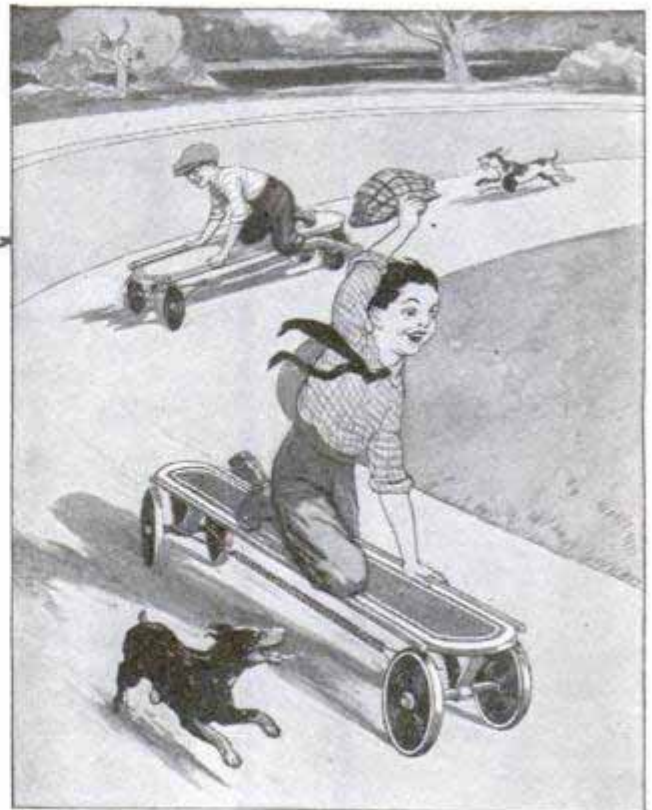

Without Handlebars or Tongue, This Coaster Is Steered Simply by Leaning

*Knee Roaster Co.  
2915 S. Wabash*

*Capt. A. J. Saunders*

*Baltimore, Md.*

973

965

984

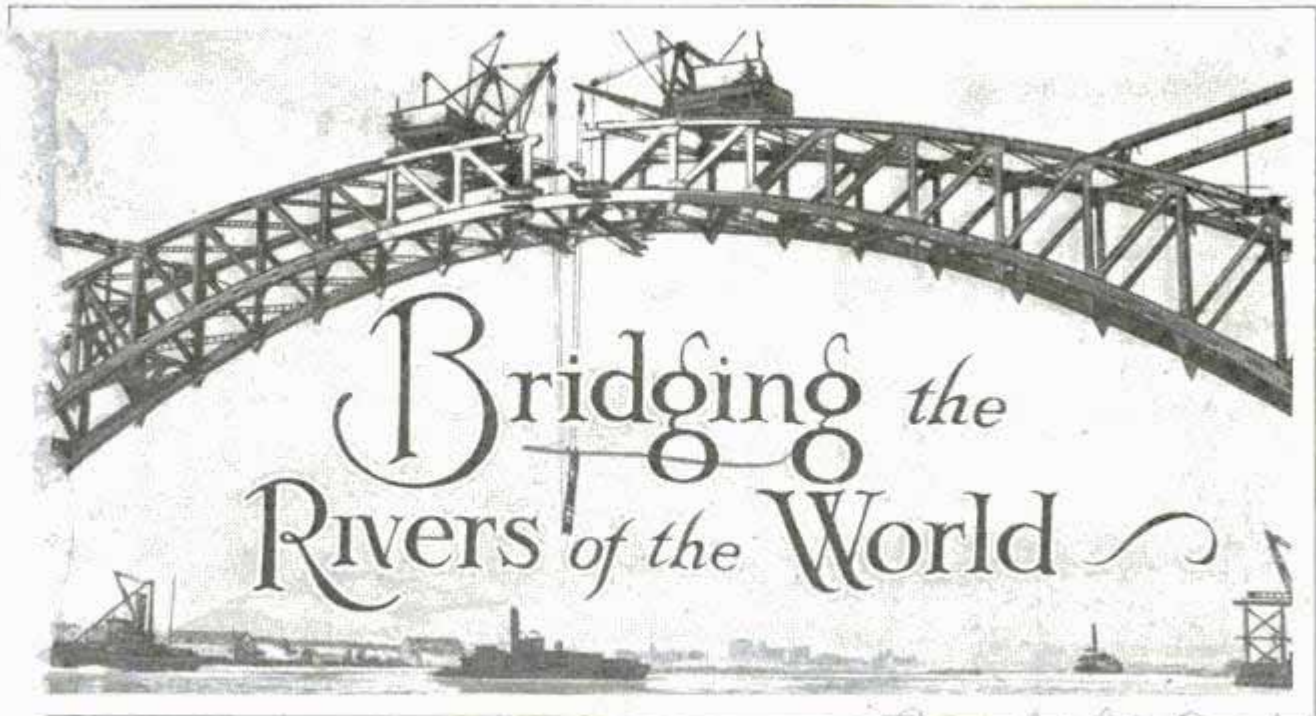

By BOYDEN SPARKES

*Bridge Building*

was in the Philippines, on the island of Luzon. American engineers in olive-drab khaki and leathern boots that laced to their knees were cutting a swath through a jungle inhabited by half or wholly savage people. Stung by insects and harassed by homesickness, these men were building a railroad, using breech-shouldered natives to perform the labor.

Now the construction had reached a rocky gorge down which tumbled the white water of an unnamed river. There a bridge was necessary. For the engineers and their white foremen that bridge was nearly a finished mental job. A sheaf of blue papers, marked with ruled lines of white and with mystical figures and curves and other symbols of engineers, was, for them, the bridge. Timbers and steel with which to build it had followed them on rails that had pushed the frontier of white man's rule to the brink of that chasm.

The white foreman, Patrick Boyle, who served as the blasting expert of the bridge-building force that now moved in ahead of the mere railroad workers, had gotten, somewhere, a brown flat-faced assistant, Jose de Pina y la Cruz.

The day the crew moved forward to blast away the surface clay, the foreman seemed in a bit of a hurry. A round, vertical hole had been drilled down into the clay. Dynamite sticks, with percussion caps affixed to flexible, insulated wires, were placed by him in this drill hole.

"Pronto, muchacho!" he ordered and then, with a mixture of Irish brogue and

bad Spanish, instructed his assistant to carry the magneto box with its plunger over the hill, uncoiling the wires as he went. He finished with a warning to the Filipino to wait beside the magneto box until he, the boss, arrived.

Some of the men whose work waited on this blasting job retired over the hill with the native assistant of the blasting boss. They saw him select a spot sheltered as much as possible from any flying rocks. They saw him fasten the copper wire ends to the binding posts of the magneto box. Then, before any of them could frame suitable words of remonstrance, they saw the little brown man lift the plunger and drive it down.

There was a ground-shaking explosion. With a reverberating "boom," something like a volcano seemed to have been opened on the other side of the hill. Clods sailed high into the air and in the center of the inverted cone of debris, as if to answer an unspoken question in the minds of the watchers, was a bright red fragment of what had been a flannel shirt.

They reassembled Patrick Boyle in a basket, but Jose de Pina y la Cruz, who had started to run away when he recognized the import of that bit of flying red cloth, did not even return for the funeral services.

I thought of that incident the other day when Ralph Modjeski, one of the most famous bridge builders of the world, told me that as a rule the loss of life on bridge-building jobs is due to inexperienced workmen.

"There are unavoidable hazards connected with the work," he said, "but as a rule it is the green man who takes hold of the wrong rope, or steps on the unsecured bit of staging, or does something else against which the experienced workman would have been warned by a knowledge as sure as instinct. Sometimes, though, accidents happen to the most cautious, the most experienced workmen. I have had a few narrow escapes myself." Then he told about a critical day in the construction of a bridge he built across the Mississippi at Thebes, Ill. It was the great moment in the building of a bridge, the making of the central connection, the placing of that final link which makes the structure an actual bridge.

There was a gap of about twenty-five feet separating the steel arms that had been built out over the river from opposite shores of the wide Mississippi. Two groups of workmen for months and months had been working toward each other. If the reckonings of the engineers or the performance of the contractors were inaccurate in the slightest degree, that perfect junction which was necessary would fail. No matter how confident an engineer may be, it is a problem for which mere paper answers are unsatisfactory. Relief does not come until that rendezvous of steel high above mid-river has been kept.

Mr. Modjeski, treading as sure-footedly as any of the contractor's cat-footed steel workers, made his way out to the end of one of the outthrust arms. One hundred feet below him the yellow waters of the greatest of rivers moved toward the distant Gulf. A flat car, bearing a pin that was about to be set in position by a giant traveling crane, was at the end of that part of the unfinished span where Mr. Modjeski stood. It was not an ordinary pin. It weighed something over a ton.

At a signal, the man in the control cabin of the traveler swung the long arm of the

boom into position, but a trailing cable knocked against the pin. It started to roll. Mr. Modjeski was standing on a plank, holding by one hand to a cast-iron loop on the side of the flat car. He saw at a glance that the pin was not going to catch him in its fall, but he saw, too, that the dragging cable was going to sweep down on his outstretched arm. He re-

leased his hold on the car, and as he did so, the huge pin crashed down on and broke the plank on which he stood. In a flash he had grabbed the iron loop again and hung with nothing but air between him and the Mississippi far below. Some of the other workmen quickly leaped to the relief of the chief engineer,

hauling him safely to the floor of the car a few seconds after the geyser splashed up by the fall of that great pin had dropped back to the river.

The building of bridges is in the field of engineering what grand opera is to musicians, or Chinese porcelains to connoisseurs of art. It is a work that calls for skill and daring. But above all else, the successful completion of the work calls for a fanatical accuracy even to the least of the details. A single error of mathematics, or the tolerance of any of that sort of scamping that is more or less common in the erection of big buildings, and there is an accident like that which occurred in 1907 to the first bridge which the people of Canada tried to thrust across the St. Lawrence river at Quebec.

It was within fifteen minutes of quitting time for the eighty-five men who were working on the mighty web of steel which these human spiders were spinning across the St. Lawrence. Suddenly they felt the vast structure sinking beneath their feet, at first a slight sag, and then, with a grinding, crashing noise, a drop of thousands of tons of metal into the water. Seventy-four of the workmen died in that horrible fall; eleven others were picked up from the river and taken to hospitals.

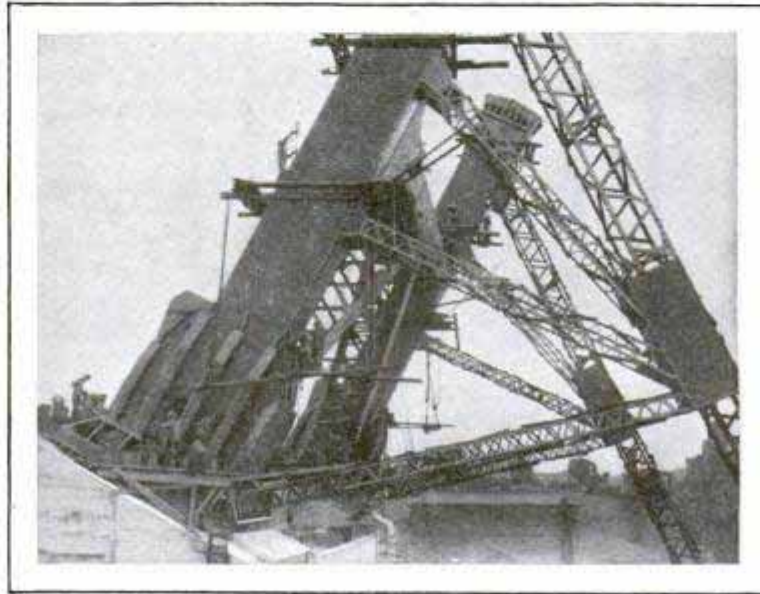

Erecting the Giant Towers from Which the Cables of the Delaware Suspension Bridge Are Hung; the Towers Are 380 Feet High



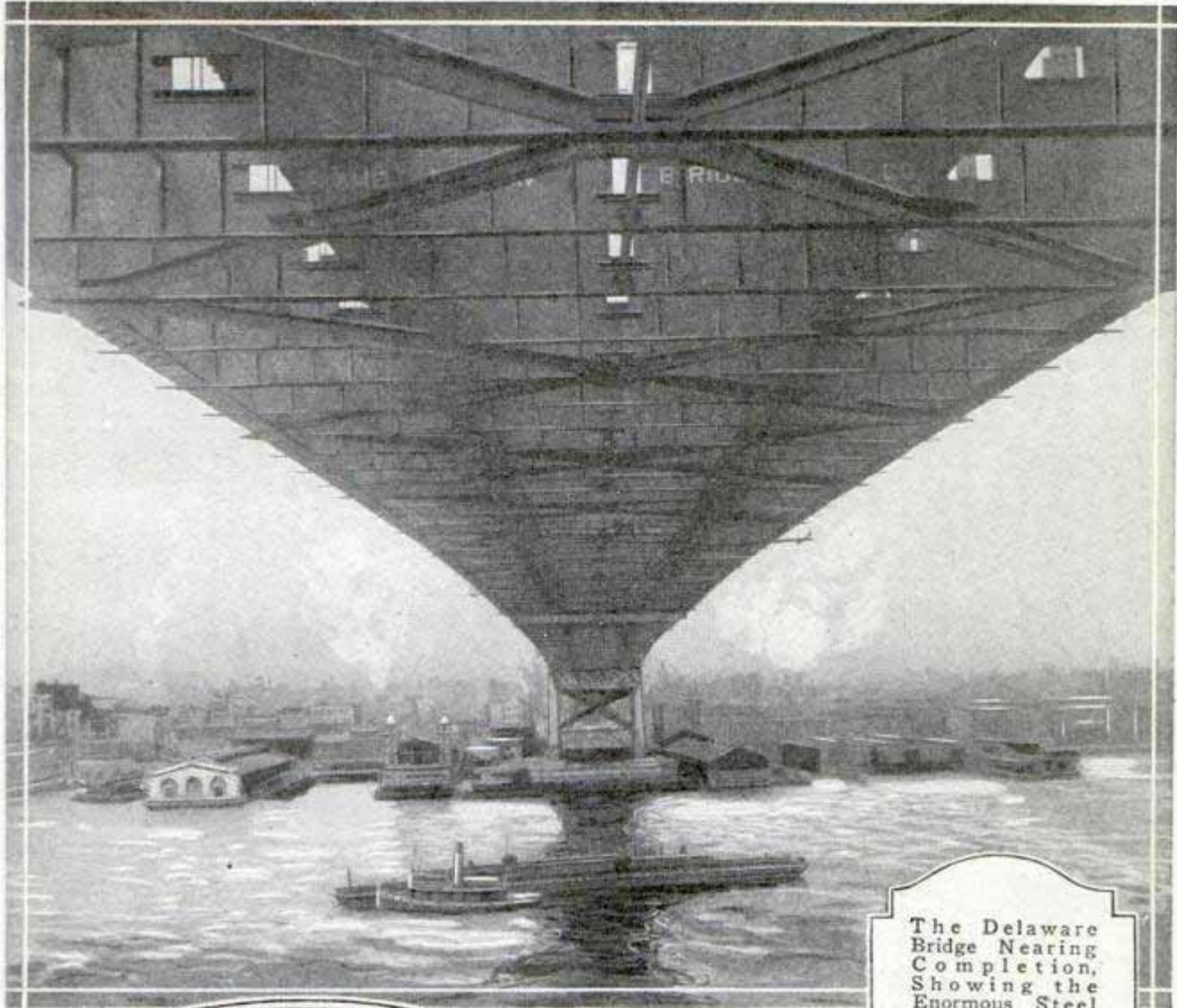

The Delaware Bridge Nearing Completion, Showing the Enormous Steel Girders Supporting the Road

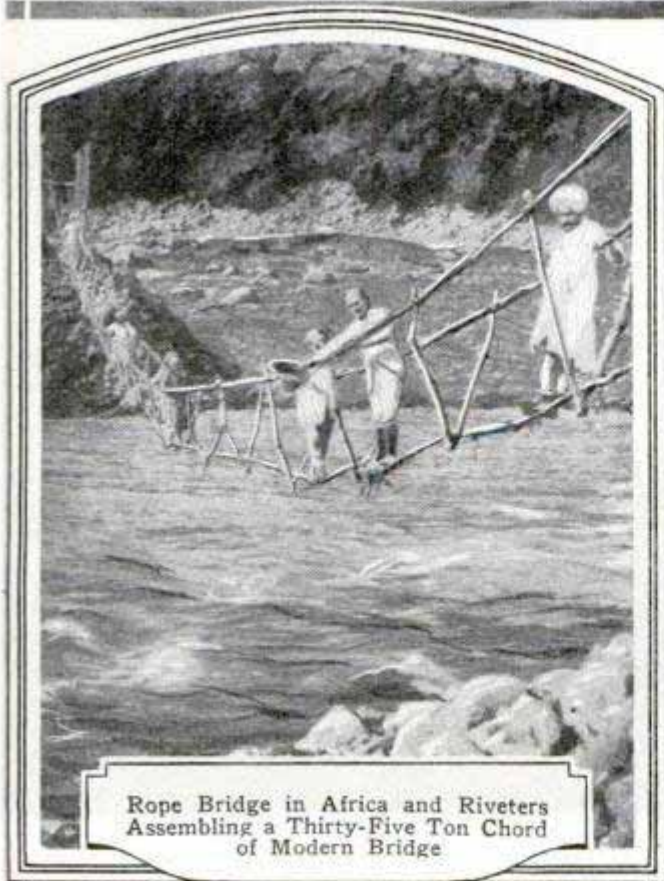

Rope Bridge in Africa and Riveters Assembling a Thirty-Five Ton Chord of Modern Bridge

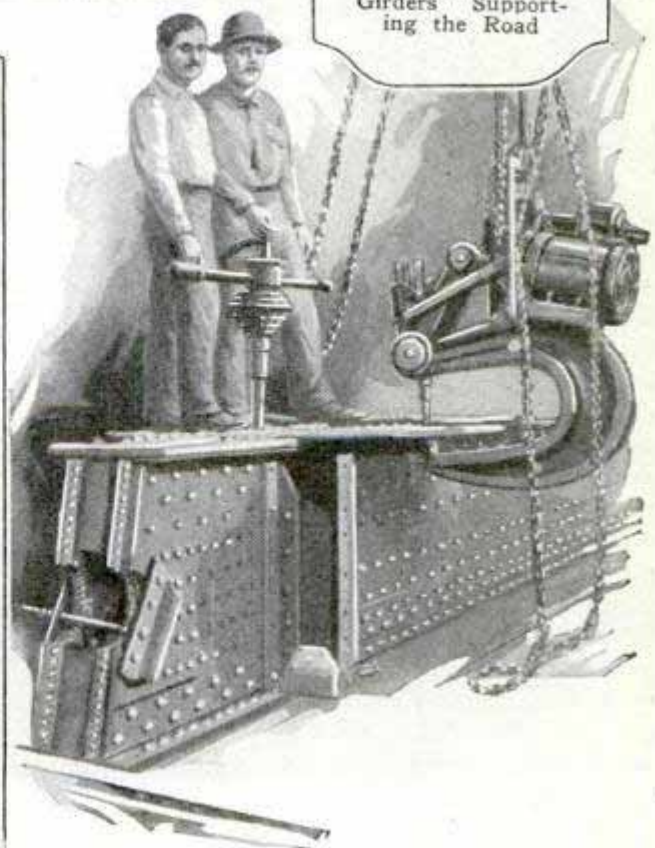

It required a lot of inquiry to fix the blame for that collapse. Engineers say it was the result of an inadequate inspection service, and, also, of anxiety to build a bridge too light in design. Somewhere in the planning there had been a human failure. It was not the steel that failed; the metal had simply been assigned a task too great for it.

Even the least of bridge-building jobs is a tremendous struggle and the umpire is the law of gravity, with which there can be no argument. When the United States was spreading itself across this

out of insurance benefits are the caisson workers who report at the call of any contractor who undertakes a big bridge job. They are the men who work under heavy air pressure below the level of water, when the foundations are being laid on the bed of the stream that is being bridged. When Mr. Modjeski was building the Memphis bridge across the Mississippi in 1914, about the time Europe flamed with war, something happened which helps to justify the attitude of actuaries toward caisson workers. It was at the Arkansas end of the J. T. Harahan bridge. Eight

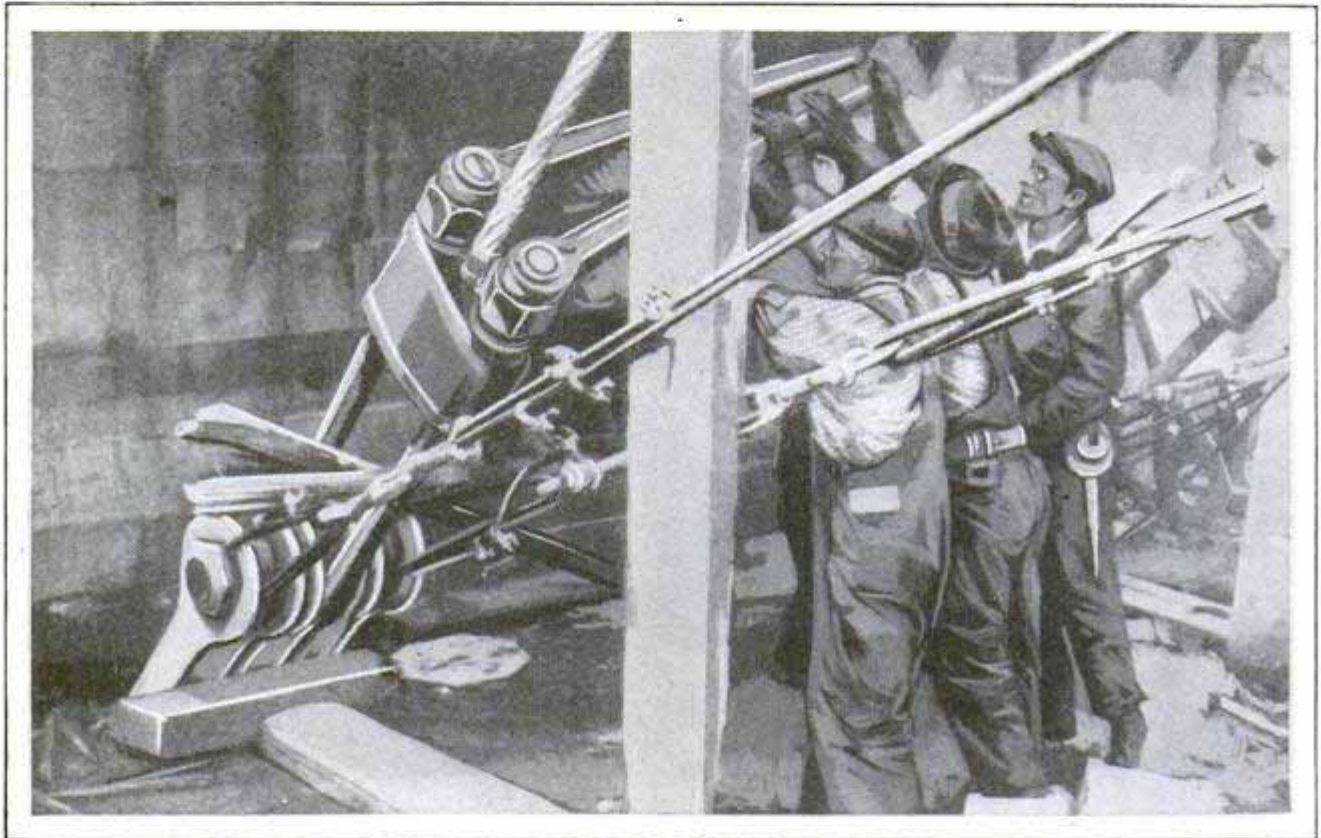

Four-Foot Wrenches Give the Leverage for Tightening the Clamps Which Hold the Steel Cables of the Delaware River Bridge; the Cables Are Spun in the Air from Individual Wire Strands

continent as ink from an upset bottle widens in a huge blot, there was always an ample supply of men to occupy whatever posts of danger there were to be filled. Grizzly bears, hostile Indians, rattlesnakes, bad men of every race were not sufficiently menacing to hold back that spreading flood. Human nature has not changed; the frontiers of today are the places in the community where those men work whose occupations are rated in the tables of insurance actuaries as "risks not acceptable." This phrase means that the hazard of their jobs is at least 200 per cent greater than the normal hazards which confront those who serve as lawyers, oculists, florists, auditors and in other mild occupations. At the forefront of those aristocrats of hazard who are counted

men, one of six gangs of caisson workers, started down a ladder into a vertical shaft to the air lock above the working chamber where the gang they were to relieve was expecting them. About fifteen minutes later, an impatient signal inquired of those in charge at the surface why the relief had not been sent. Immediately the outside lock tender and the superintendent began to descend the ladder to investigate. Thirty feet from the bottom of the shaft the lock tender called out that he could see the men piled up at the bottom. He did not finish his observation. An unseen enemy had filled his lungs, poisoned his blood. Without a cry, his hands relaxed and he too plunged downward onto that cushion of dead men. The shaft was filled with a gas that had been generated

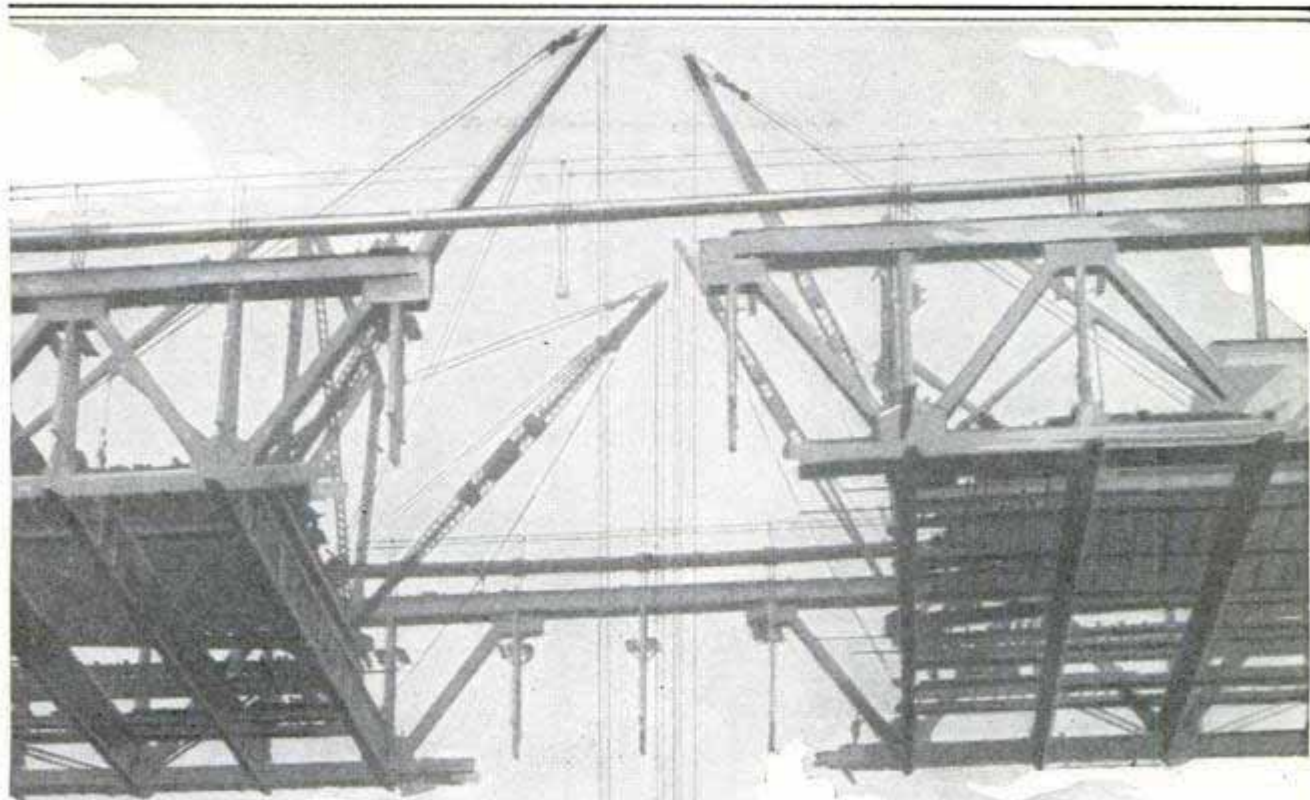

mysteriously. The men in the working chamber beneath that death trap were brought out one by one in a hoist bucket through a material lock. The dead were brought up by men in diving suits and helmets. It was one of those unavoidable accidents that beset the men who make our wonderful transportation systems possible.

"They follow the job," Mr. Modjeski told me. "Fear seemingly has been left out of them. On the

Philadelphia-Camden bridge over the Delaware river where I am now engaged, it was suggested that the iron workers wear life preservers so that any who happened to drop into the river might have a better chance of surviving, but they scoffed at the idea.

"We have kept speed boats in the river ready to dash to the rescue of any who dropped into the water. We have used circus life nets. We have kept these nets strung be-

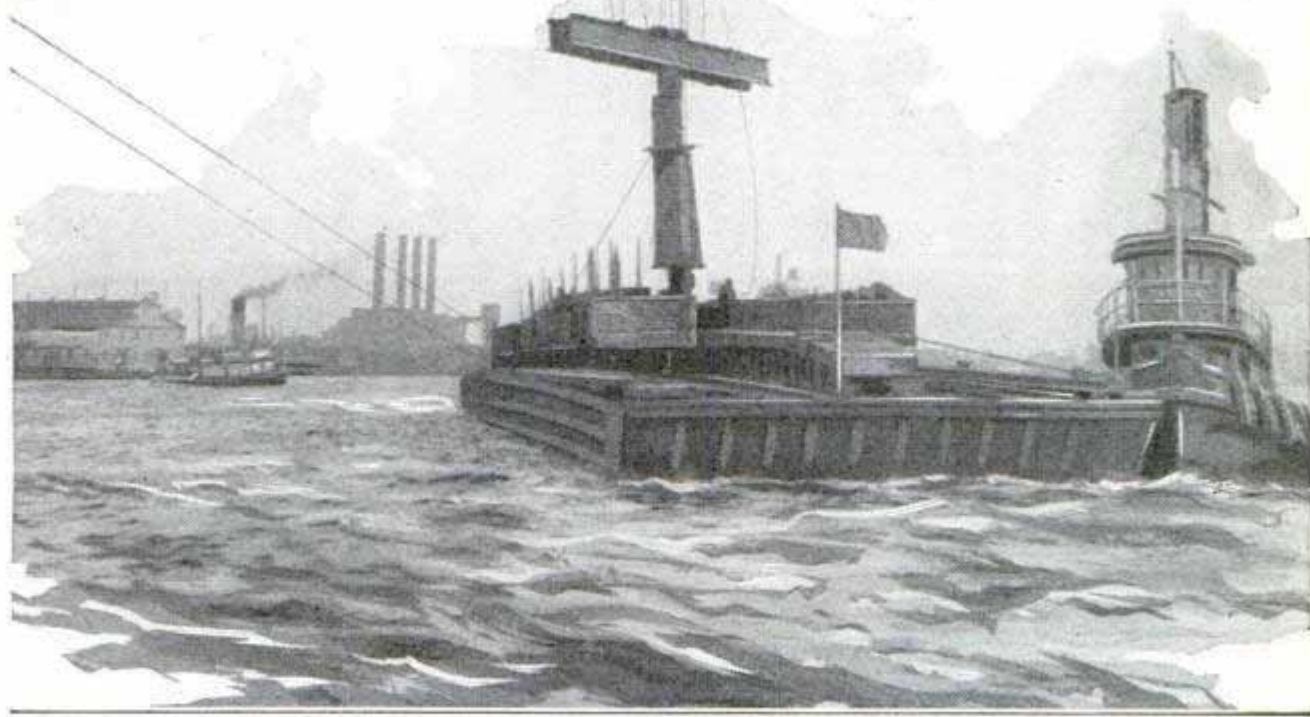

Hoisting the Connecting Girder in Place to Link the Ends of the World's Longest Suspension Bridge

neath the ends of the bridge as the steel was pushed out from the shores of Pennsylvania and New Jersey. We took exceptional precautions with the staging, but in spite of all this the number of men who have lost their lives that this bridge might be built is just about the same in proportion to the weight and cost of the structure as on any of the large bridge-building operations."

Work had just started for the day one morning last August, when Theodore Jorines and Albert Miedema rode out into space on a huge steel beam that was about

fished out so little disturbed by the accident that he only stopped to change into dry clothing before returning to work.

"Since it is to the first interest of contractors to reduce the loss of life on these undertakings, the problem is being studied constantly with the idea of making the work less dangerous."

"If bridges are better today than forty or fifty years ago," Mr. Modjeski said, "it is because steel is better. The most important stride forward since I started was the invention of pneumatic tools. When every rivet had to be driven by hand, en-

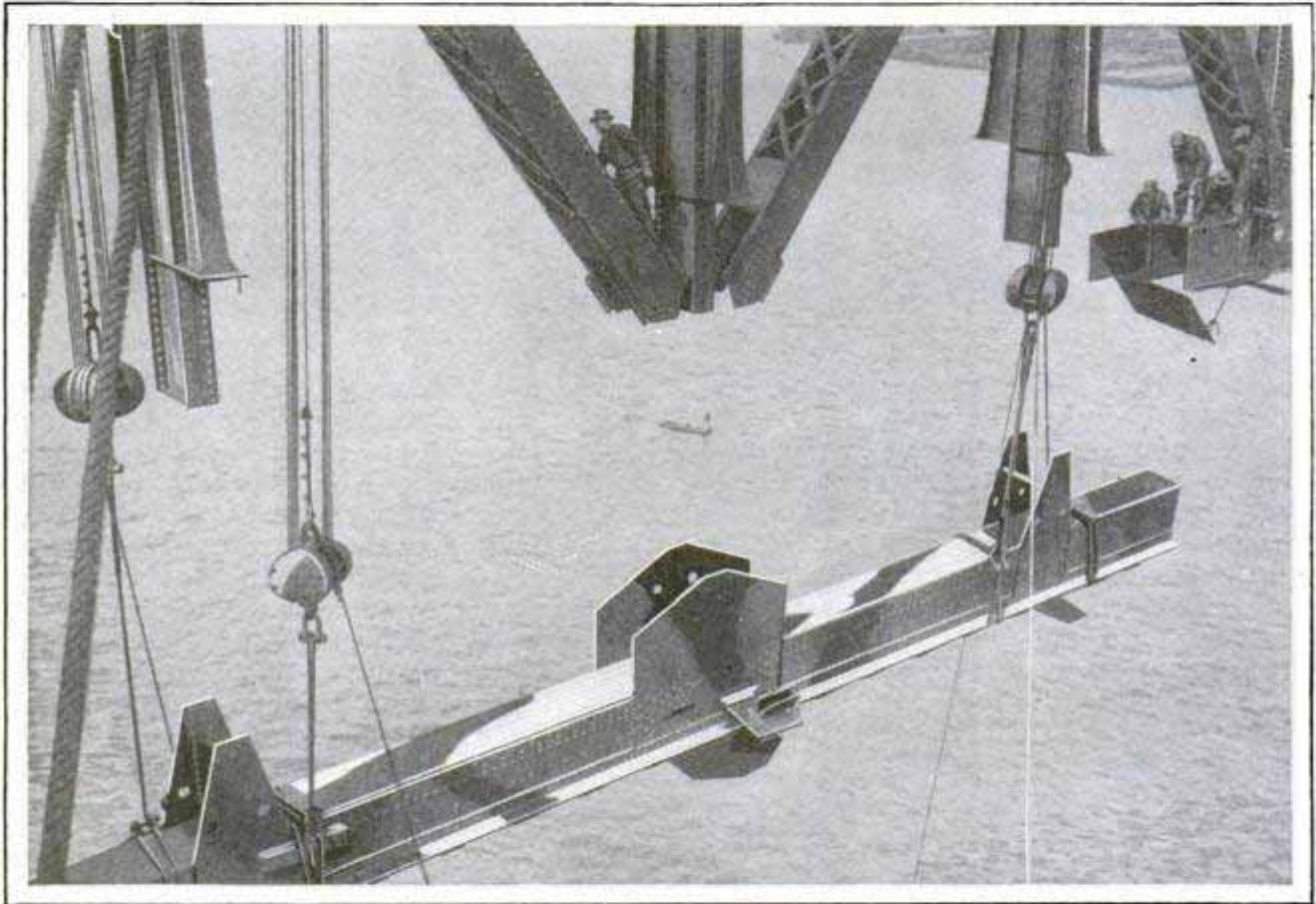

Sure-Footed Iron Workers, Perched Far above the Swirling River, Wait to Bolt and Rivet the Last Connecting Girders in Place, Completing Their Work on the Delaware River Suspension Bridge

to be swung into place by the great traveling crane. The men were standing up, arms outspread, to signal, when the beam slipped in the slings. They were thrown, of course, and turned several times in the air before they struck the river bank sixty feet below. They were the sixth and seventh men to die, and since that time, four or five of their fellows have fallen to death or otherwise been fatally injured.

"They get reckless," explained Mr. Modjeski. "But even so, I have seen them fall and live. On the bridge at Thebes one iron worker missed his footing and fell 110 feet into the Mississippi. That is a long way to drop. However, he was

gineers saved as much as they could on rivets. Now we can afford to be prodigal with rivets, which is important because of the steady growth of the loads that bridges must carry today."

There are still some thrilling challenges that have not been met by the bridge builders of the world, according to Mr. Modjeski. One of these is the straits of Dover; another is San Francisco bay, where a 3,000 or 4,000-foot tunnel combined with a bridge would be necessary; another is the Hudson river as it flows past Manhattan island, where a span of 3,400 feet would be necessary in order to satisfy the exacting requirements of the war department.

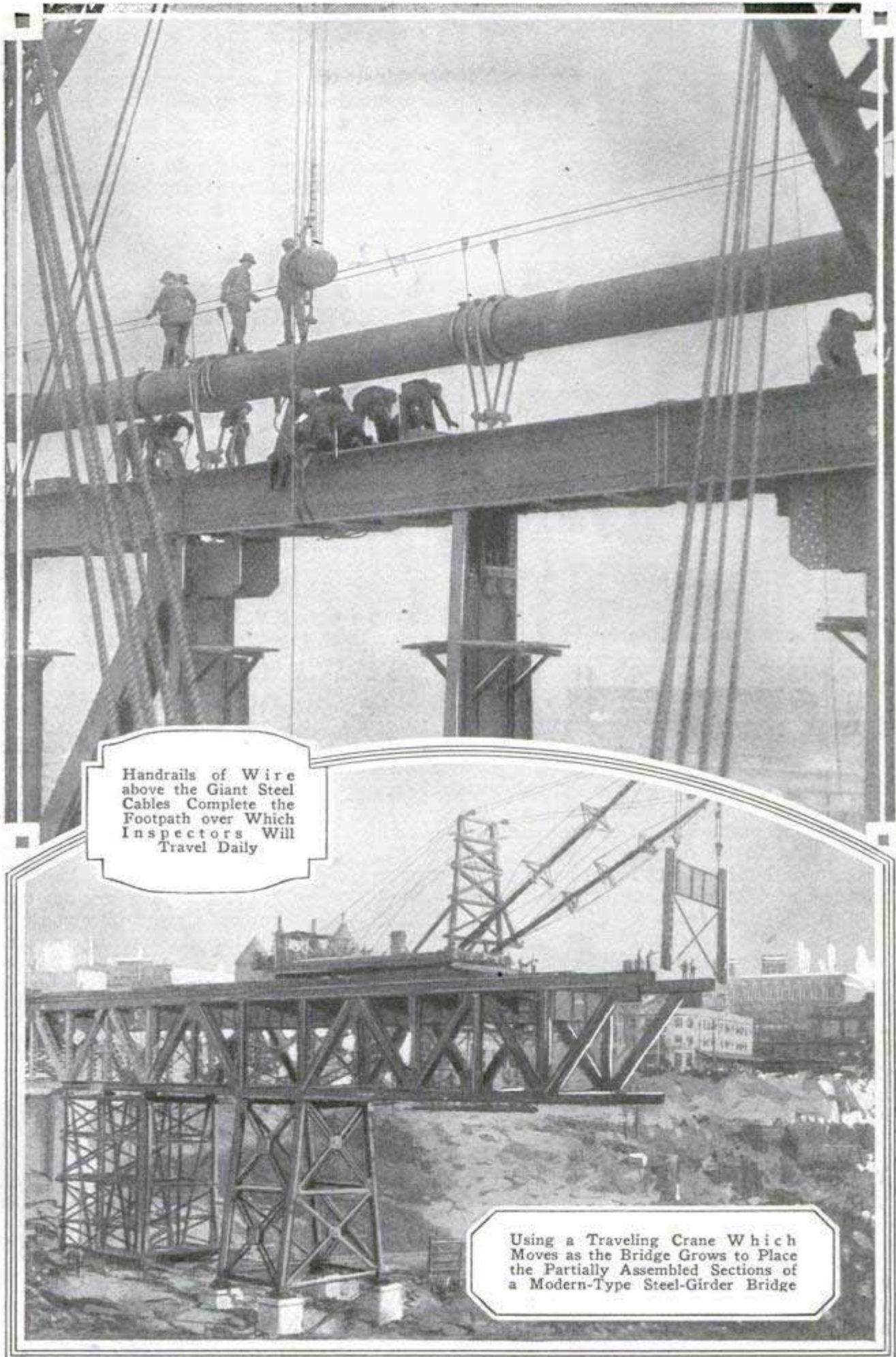

Atlanta-Birmingham  
 P. O. Birmingham Ala  
 Birmingham Ala  
 1926

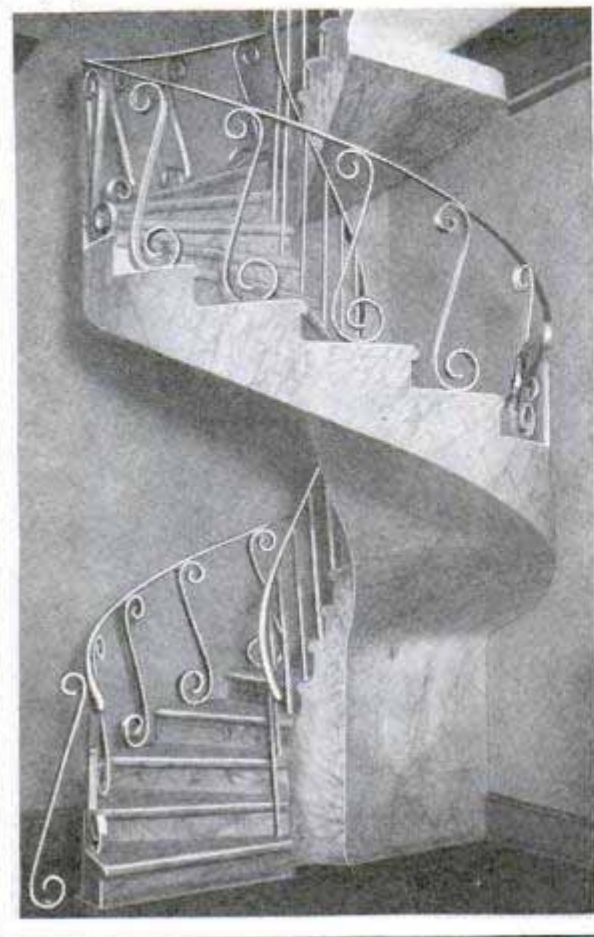

Ornamental Concrete Work of Unusual Design, a Staircase Cast as Unit in Molds

**SPIRAL STAIRCASE OF CONCRETE  
 —CAST IN SINGLE MOLD**

Planned and built by a practical construction man, a spiral staircase in a Florida printing plant, has no central support, but is said to be capable of standing a strain of 170 tons and has a carrying capacity of 4,800 pounds. It was built in a single unit from a mold carefully measured to specifications and the concrete poured around reinforcing. Its surface was grained to resemble that of marble. Besides giving an artistic touch to the interior, the stairway saves space.

steam. A "sprinkler" arrangement was attached to the front of the locomotive with shields to direct the vapor down against the track. Moving slowly, the engine thoroughly treated the weedy section, the steam proving especially effective close to the ties and between the rails where the growths would have been hard to reach by other means. Another use for the steam system is in clearing snow and ice from switches.

942 Jan  
**TESTS WITH MODEL RUNWAY  
 SHOW CAB DRIVERS' SKILL**

Are you mentally qualified to drive a cab? On the basis of actual results from more than eighteen months of experiments, Dr. A. J. Snow, consulting psychologist for a large Chicago cab company, feels that science has a means of determining the answer with a considerable degree of accuracy by a series of interesting psychological tests, some of which were described in Popular Mechanics in November, 1924. At that time, the examinations had been given too short a time to derive definite conclusions. But since then, after testing more than 12,000 drivers and prospective drivers, analysis of the findings has been made.

Briefly, the tests aim to determine the subject's intelligence; his ability to react to lights, sounds and the sense of touch; and whether or not he is likely to be reckless, easily scared or quickly fatigued. The trials are now given by cab companies in more than a score of cities. Some concerns offer them to the public at large. They take only half an hour and the results are known almost immediately. The psychology department of the University of Pennsylv-



As Signals Flash in Box, Candidate Endeavors to Guide Toy Cars Accordingly with Controls

959  
**WEEDING RAILWAY  
 RIGHT OF WAY  
 WITH STEAM**

When growth of weeds became troublesome along the right of way of a southern railroad, one of the engineers devised a way to kill them with

The Sphere  
 12/5/25

Dr. Morris S. Viteles  
 U. of Pennsylvania  
 Dept. of Psych.

vania makes use of a toy electric railroad to determine if a prospective cab driver is mentally fit to receive a license. The subject is asked to control the tiny cars with hand and foot levers according to the directions of lights flashed on a board in front of him. False signals are also given to determine if the candidate is easily distracted. The examiner has a set of controls to govern the lights and move the cars. Dr. Snow's analysis of results shows that the eight tests he has used provide a means for weeding out the unfit candidate for cab driving. Out of the 12,000 men tested, some fifteen per cent were rejected because of unsatisfactory showing in the mental examinations and tests. But the conclusions were not drawn from the mere paper records made by the candidates. For ten weeks, when the examinations were first started, careful files were kept of the performance both of men who passed the tests and of those who did not,

for at the beginning even men who failed to pass were retained in order that they might be compared to those who received passing marks. In the ten weeks' trial period, twenty-one men who had made unsatisfactory grades in the tests had twenty-six accidents, while 198 who passed creditably had but fifty accidents.

From January 1 to April 30, 1925, after the tests had been used as a basis of hiring drivers, while the company's business showed an increase of thirty-eight per cent over the same time for the previous year, accidents decreased three per cent, although, in 1924, they were twenty-nine per cent more numerous than during a corresponding period in 1923. From March 1 to May 1, 1925, the drivers were divided into two classifications. In one group were newly recruited chauffeurs who had passed the tests satisfactorily. They comprised nine and one-half per cent of all the company's drivers. In the second group were placed the rest of the men, scores of whom had had considerable experience and were known to be competent drivers although they had not been given the tests. In the period observed, the men of the first group had but .5 of an accident per man while those of the second had .8 of an accident each.

*no information available*  
**RIDING WINDMILL WINGS THRILLS DAREDEVILS** *956*

Lashed to the wings of a Dutch windmill, more than 200 feet high, near San Francisco, Calif., daring "human flies" enjoyed the thrills of an unusual ride

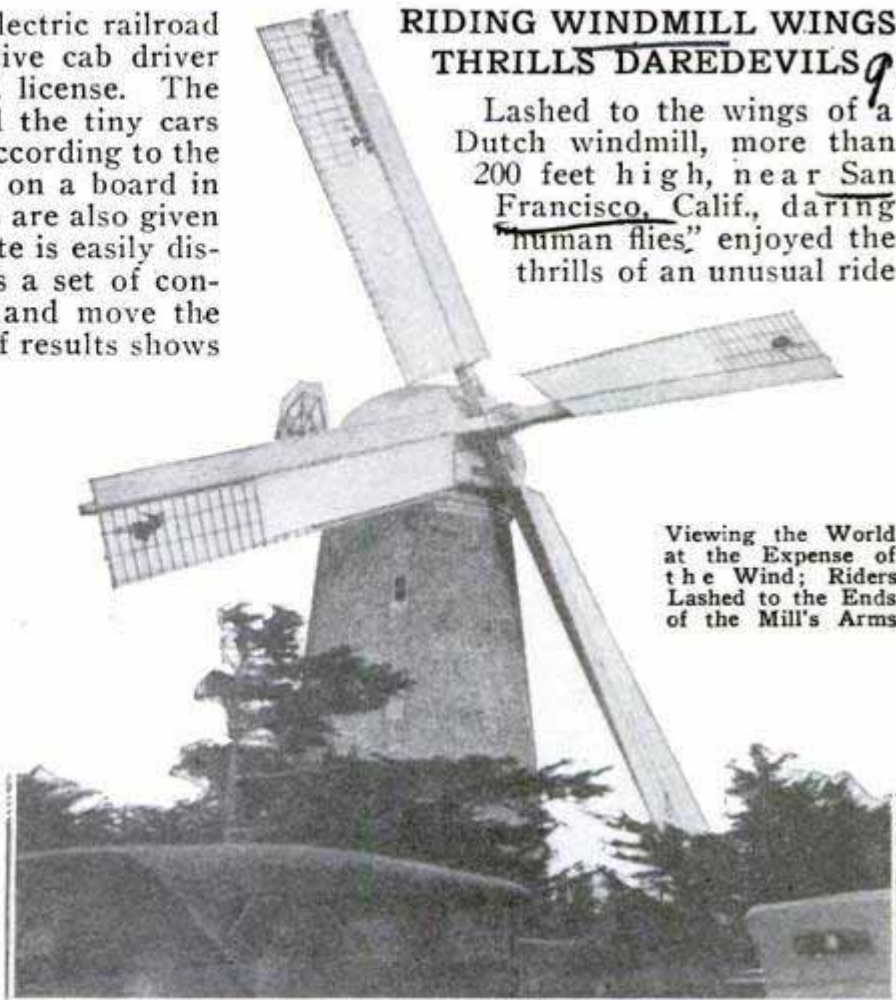

Viewing the World at the Expense of the Wind; Riders Lashed to the Ends of the Mill's Arms

around the huge circle described by the mill's arms. The open latticework on the blades afforded greater security than would have been possible on smooth wings, but the stunt demanded careful balancing. Photographers equipped with motion-picture cameras rode the mill and took views on their topsy-turvy journey.

*Auto*  
**EASILY OPENED RADIATOR CAP HAS HINGED TOP** *898*

Radiator cap and thermometer are combined in a compact unit so adjusted that a quarter turn of a handle loosens the cap

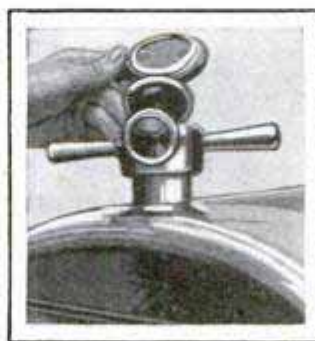

so that it can be thrown back for water. Another quarter turn in the opposite direction secures it again. Since the cap is not removed entirely, there is no danger of its dropping or being lost, the handle keeps the

fingers away from steam and hot water, and the thermometer is locked to the cap in such a way that it cannot be taken off without special tools.

*Semaphoric Indicator  
 Sales Co. 1175 Irving Ave.*

## "SPIDER NET" OF WOVEN CORD SAVES LIVES AT FIRES

957 Patterned after a spider's web, a circular net of stout rope, is one of the

Pole. It is believed to lie in the center of a huge ice field and to be more difficult to reach than the North Pole. A primary objective of the undertaking is to open up a trans-Arctic air route for commercial purposes between the continents.

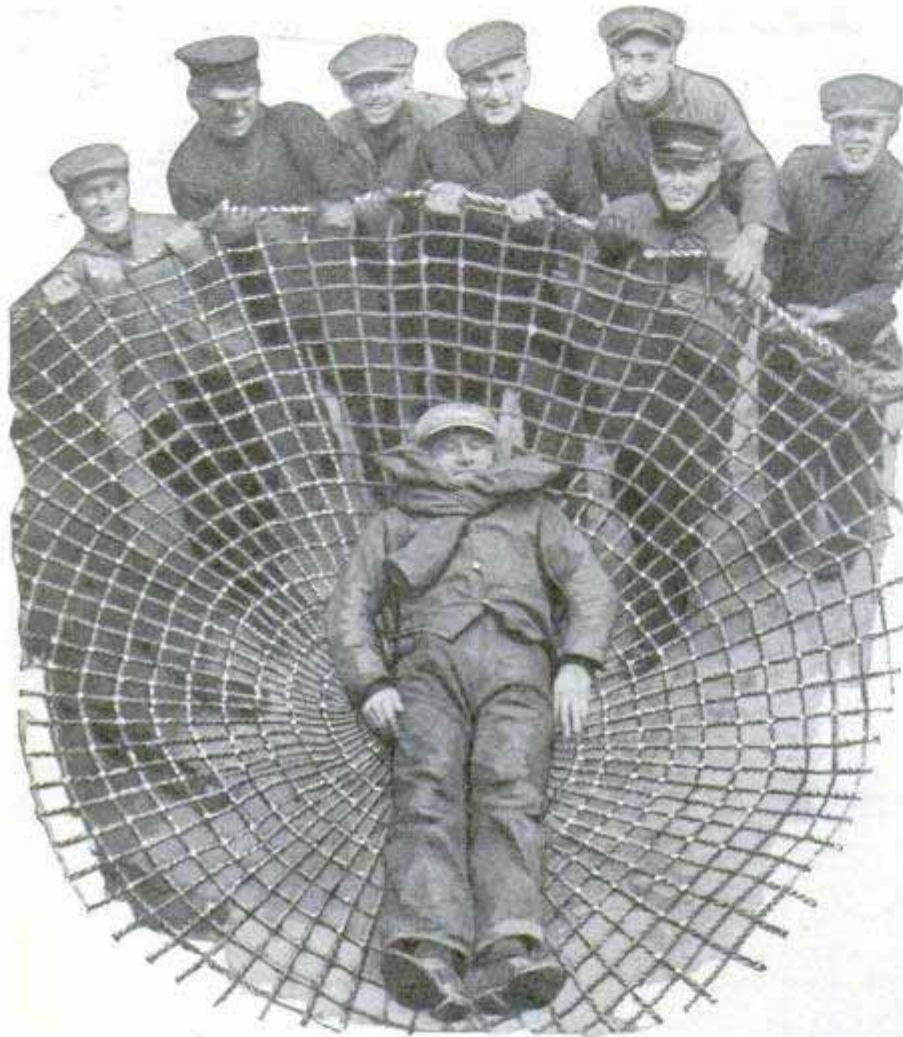

Firemen in Drill with Life Net, a Circular Mesh of Stout Cord with Large Cable on Edge for Tight Grip

pieces of equipment with which Philadelphia firemen drill at their fire school to become efficient in saving lives. The shape of the mesh enables several men to keep a firm grasp on it, and the strands are so arranged that they will yield sufficiently to prevent injury to a falling body.

## SEARCH FOR INACCESSIBLE POLE TO BE MADE BY AIRPLANE

970 Where do the birds go when they keep on flying north? What sort of country lies some 400 miles from the North Pole at 84 degrees north latitude and 160 degrees west longitude? To answer these and other perplexing riddles of the land of ice, an airplane expedition, headed by Capt. George H. Wilkins, is planning to make a 1,900-mile non-stop flight from Point Barrow, Alaska, to Spitzbergen next May, in search of the so-called Inaccessible

party will greatly aid its success. Capt. Wilkins accompanied Stefansson on his last Arctic trip. Others who have been selected for the expedition are Lieut. Benjamin Nelson, an experienced aviator, and Earl Rossman, an Arctic motion-picture photographer. Lieut. James H. Doolittle, winner of the Schneider cup, and Lieut. John A. Macready, army transcontinental flyer, have been asked to join the party.

## A CORRECTION

921 In the January issue, page forty-three, the statement was made that a moving model of a brontosaurus, as illustrated, had been made for the American Museum of Natural History in New York City. The model was not made for the museum, but is a reproduction of a fossil specimen on display there. It was made by Messmode and Damon, of New York.

Detroit Aviation Society  
American Geographical



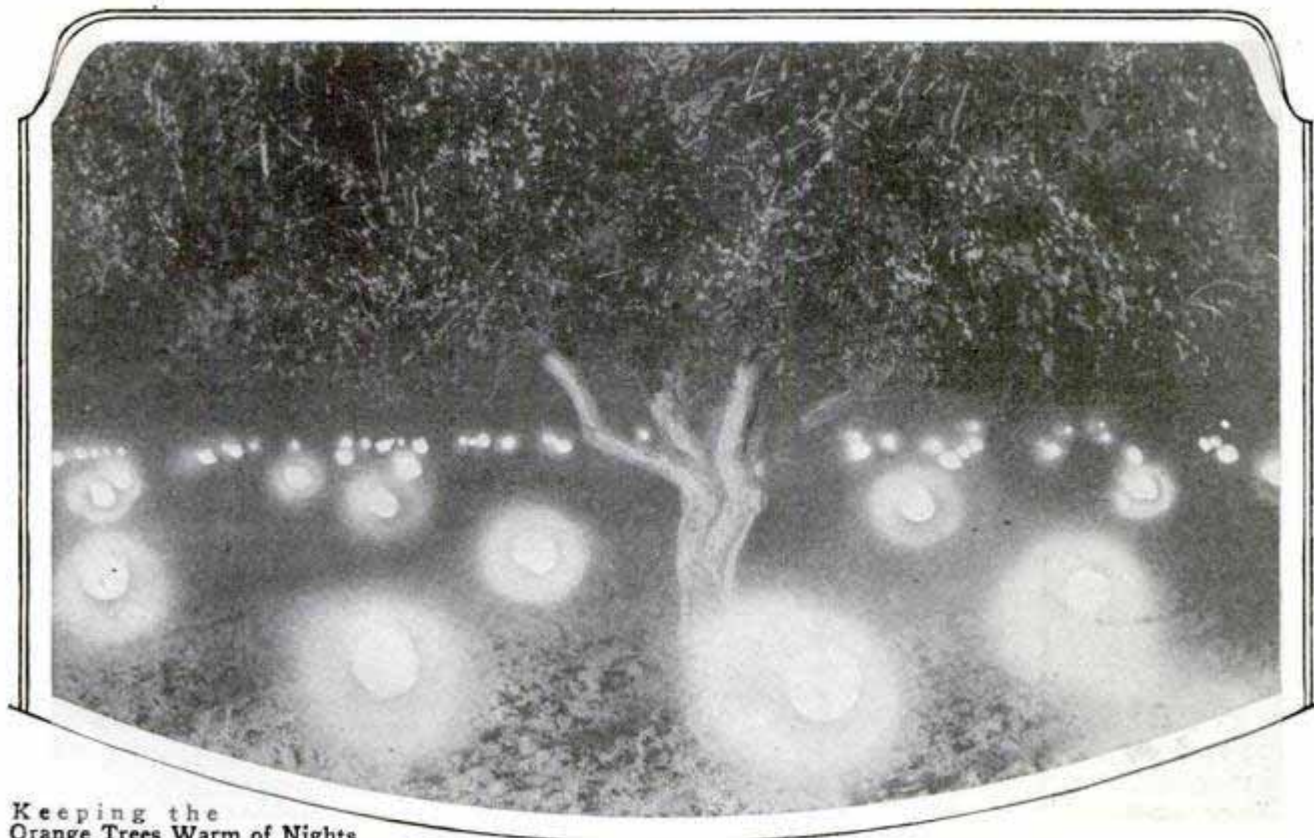

Keeping the  
Orange Trees Warm of Nights

## Upper Air to Save the Orange Crop

Unique "Windjammers" Bring Down Warm Currents to Mix with the Cold Air Which Collects on Ground beneath Groves

By N. C. McLOUD, *1717 St. Paul St.  
Baltimore, Md.*

CALIFORNIA fruit growers have learned that it is possible to reach up above the trees and protect their fruit from frost by bringing down the warmer air from above the orchards. To do this they have been working with ingenious machines known as "windjammers," intended to mix the warm air above with the cold layer near the ground. The process has brought interesting results.

This method of orchard protection had its origin in work of the United States weather bureau in demonstrating that there is strong temperature inversion on the average frosty night in southern California, and that the air at the ground is several degrees colder than that above the tree tops. The findings caused inventors to attack the problem of keeping the air well

mixed and preventing its formation in strata.

More than one device along this line failed to meet the tests of actual use. The latest type is said to furnish adequate protection for ten acres. In this outfit there is a pipe of large diameter stretching up into the air for a distance of thirty-five feet. The apparatus uses artificial heat in addition to its function of mixing the layers of air. The pipe starts vertically at a point twenty-five feet from the ground, and is built in the form of an elbow, caus-

ing the upper end to be horizontal. The base is supported by an open framework. Below the lower end of the pipe there is a large oil-burning furnace. An airplane propeller, between furnace and pipe, forces heated air upward and causes it to be dis-

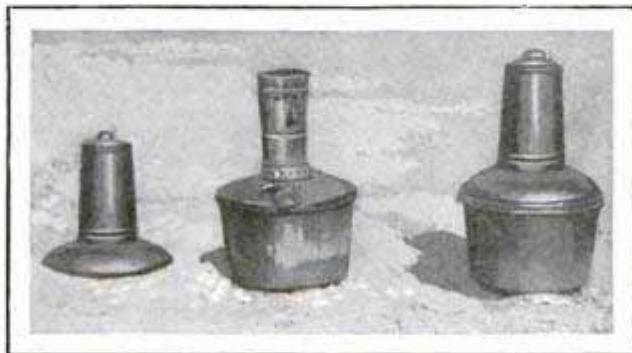

Three Types of Heaters Used in the California Orange Groves to Drive Frost Away

charged toward the tree tops. The warm current thus is sent forth to mix with the air lying above the orchard, to spread a protective wave over the trees.

Another machine is of rather unusual design, which gives it similarity to a Chinese temple. This outfit is built entirely of steel, on a concrete foundation, and equipped with a gasoline motor of 120 horsepower, geared to a vertical shaft. At the summit of the structure, forty feet above ground, is an airplane propeller, connected with the shaft, and revolving at 700 turns to the minute. Operation of the propeller is intended to bring down warm air from above the trees, sending it through the tanklike "barrel" beneath the roof. In this barrel an oil-burning furnace gives added heat to the descending current, and the blast is then directed among the trees. At a point fifty feet from the outlet, the temperature is raised five degrees Fahrenheit without the furnace and eight degrees when the furnace is in operation.

Another form of machine, of simple construction, uses a fifteen-inch galvanized sheet-iron pipe, extending upward for thirty-five feet. Near the base is a forty-

the other forcing it horizontally over the tops of the trees. Small oil burners supply additional heat for the currents. Without the furnaces in operation, the discharged air averages six to seven degrees higher than the outer air at the same elevation. The furnaces increase this difference to thirty-five degrees.

Orchard heating has passed through long evolution. In the first attempts, coal baskets made of large-mesh wire screen were set in the orchards at the rate of forty baskets to the acre. This gave good results, and brought the development of heaters burning oil. The first heaters had low stacks, and these were followed by high-stack outfits which gave better combustion and less smoke. The use of heaters on a large scale, however, creates a serious smoke nuisance, and properly developed windjammers are looked upon as the solution of this problem as well as that of actual protection.

Oil heaters are used also in the cranberry bogs on the Columbia river, where it is not possible to provide frost protection by flooding the bogs as practiced in Wisconsin and New Jersey. With the use of these outfits there is nearly seven



Left, Type of "Windjammer," Which Brings Down Warm Air from Above and Spreads It over the Ground; Right, Another Type That Sends Warm Air above Tree Tops; Both Use Airplane Propellers

inch centrifugal blower operated by a gasoline motor, to create suction for drawing the warm air from above the tree tops. The descending air is divided between two outlets, one throwing a current downward against the ground, and

degrees increase in the temperature at the surface of the vines.

One of the reasons the flesh of the salmon is red is that it contains a pigment of that color found in sea plants.

from Munich Germany.  
POPULAR MECHANICS

Acetylen - Chromidgas Motor  
Ingenieur Hans  
Bauerstr. 43.

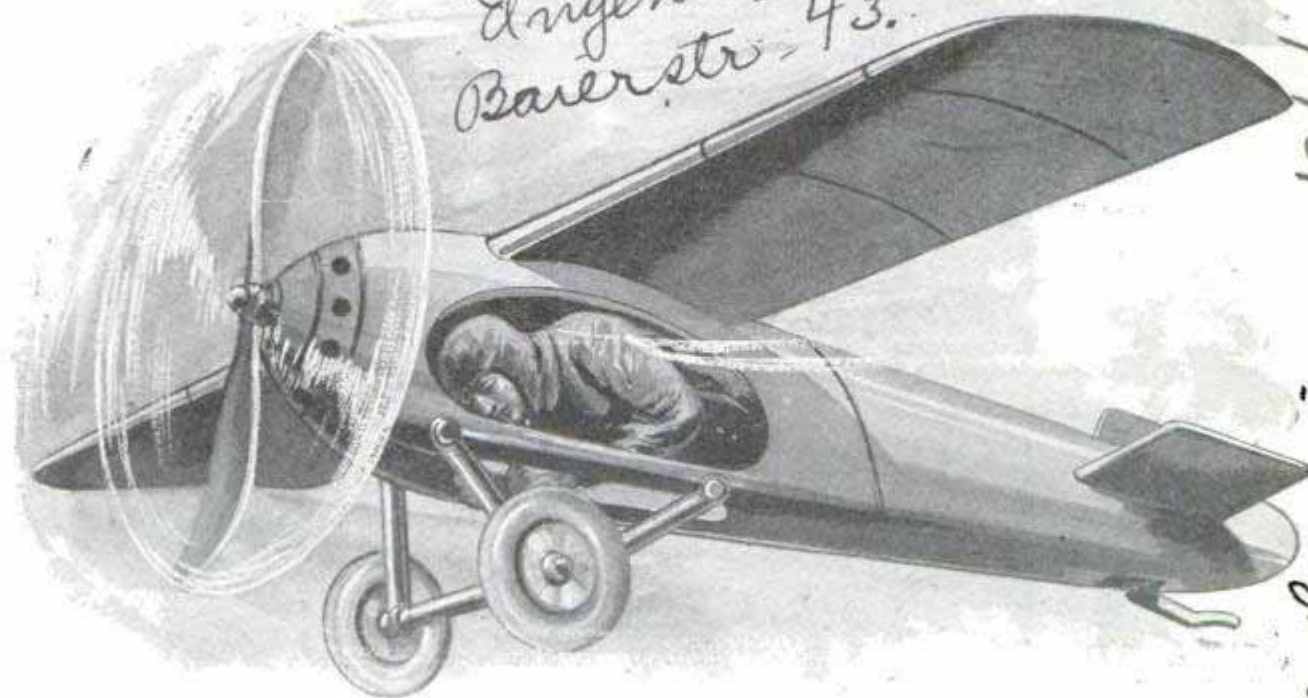

© Henry Miller

Drawing of Midget Plane in Flight, Showing How Pilot Lies in Fuselage and Operates Controls; the Entire Ship with Motor Weighs Only 125 Pounds

### PILOT OF PYGMY AIRPLANE RIDES LYING DOWN 974

To save space, most of the fuselage of a tiny airplane introduced in Germany is devoted to a compartment for the pilot, who lies prone while managing the controls. The motor of the plane develops only four-tenths of one horsepower, and the entire ship, including equipment, weighs but 125 pounds.

### HEALTH CHART HELPS DOCTORS CHECK SPREAD OF DISEASE 972

By means of a carefully tabulated chart showing the number of cases in certain disease epidemics and the rapidity of their increase or decrease, doctors of the Chicago health department are able to forecast, with a fair degree of accuracy, how fast an epidemic will spread and to make preparations for combating it. The chart is compiled from statistics gathered from the reports of a number of years and is arranged in graphic form according to the various health divisions of the city. When an increase of sickness



Health Commissioner Bundesen of Chicago at the Disease-Campaign Map

Dr. Herman Bundesen  
Chicago, Ill.

above normal is discovered, if the ailment is of a contagious nature, extra precautions can be taken at once, more physicians assigned to the afflicted district and other steps taken to stop the epidemic.

### STRAW PRESSED IN BRIQUETTES AS SUBSTITUTE FOR COAL 983

Burning the straw piles on the grain fields just to get rid of the waste will soon be a thing of the past, a Kansas professor predicts, for the material may be pressed into briquettes and used to partly supplant coal. It is first formed into heavy bales by a modified baler and then broken into smaller pieces.

Prof. W. H. Anderson  
Agricultural Engineering Dept.  
Iowa State Agricultural College  
Manhattan, Kans.

**SCHOOL IN BATTLESHIP ON LAND TRAINS NAVY ELECTRICIANS**

Because electrical installations in war vessels are so different from others, the navy has found it practical to erect a model wooden battleship on land at Hampton Roads, Va., as a training school for electricians. It is constructed to scale and is equipped with practically all the electrical apparatus found on a real ship, so that students may learn how to lay circuits for light-

has been devised to meet the needs of the farm or country home. It utilizes power from small streams, is designed to give continuous service and requires practically no attention save to refill the grease cups. No batteries, fuel or other expensive items are needed. Power is developed in either thirty-two-volt, 125-volt or 250-volt direct current, depending upon the size desired, one, three or five-kilowatt

*951 James Duffell & Sons Springfield, Ohio*  
*The Hoopes Water Wheel Co. Springfield, Ohio*

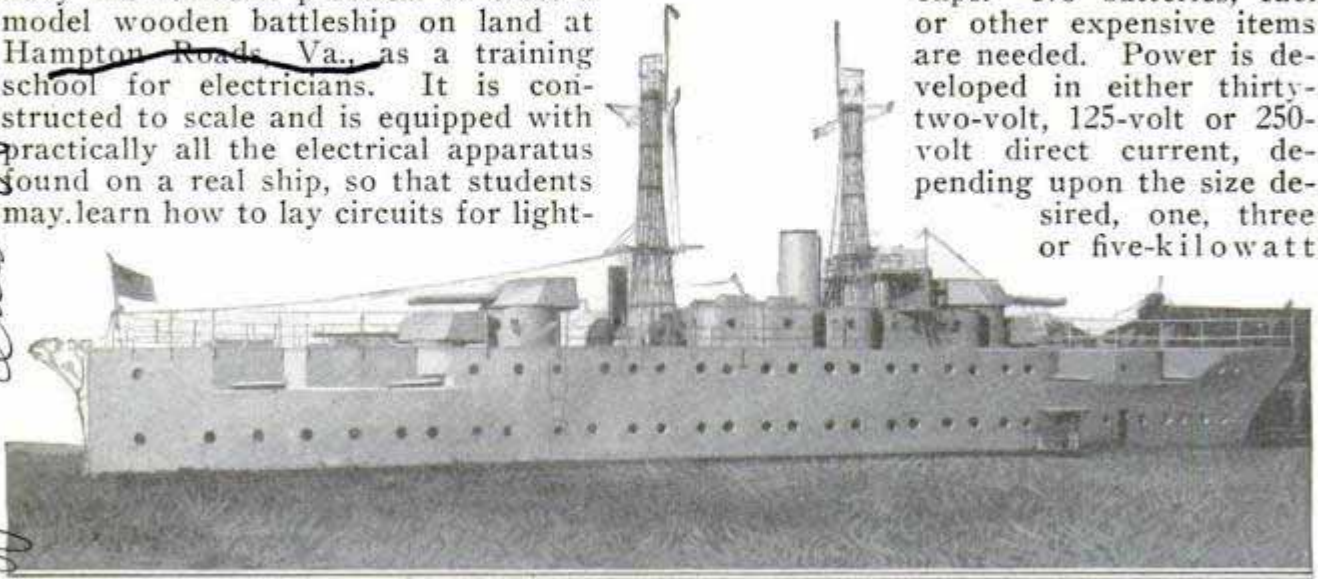

Where Naval Cadets Are Trained to Be Electricians; Model Battleship on Land Contains Classrooms and Affords Actual Practice in Wiring and Installing Intricate Systems Used on Real Ships

ing and ventilating systems, for the turret-training and gun-elevating gear, gun-fire controls and even the searchlights.

**ELECTRIC PLANT FOR FARMS USES SMALL STREAMS**

Completely incased so that a separate power house is not needed, a compact hydroelectric outfit now on the market

capacity. The smallest will light approximately twenty-five forty-watt bulbs or run a one-horsepower electric motor. The next provides sufficient current for seventy-five forty-watt bulbs or a three-horsepower motor, and the largest will light 125 forty-watt bulbs or run a five-horsepower motor. Lamps such as are used in city homes and electric stoves, heaters, irons, toasters, and similar equipment, may be enjoyed on the farm with this power plant, which will also operate small machinery. The generator; instrument board, containing a volt meter, switch and cut-out; turbine rotor and shaft connecting it to the generator, are all protected from the weather in a plate-steel housing. The unit is easily installed and the smallest will operate on as little as a seven-foot head and a flow of 250 cubic feet of water per minute.

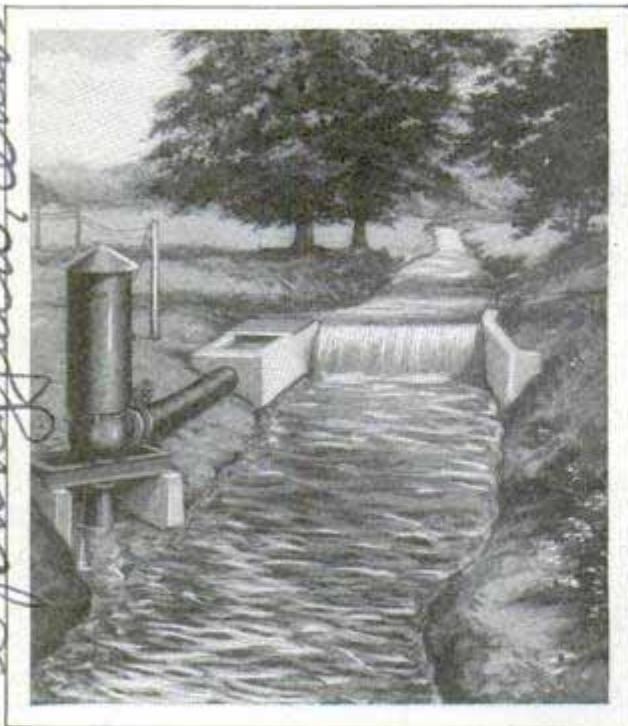

Small Hydroelectric Plant for Farm or Country Home Installed at Stream

**TRAIN SPEED TO RIVAL PLANE'S WITH ROLLER BEARINGS**

If the public wants speed, the railroads can give it by constructing steel-trussed concrete roadbeds and using roller bearings, according to Frank H. Alfred, president of the Pere Marquette railway. Schedules comparable to those maintained by airplanes can be followed, he predicts, while the superior safety of the railroads will be continued. With the aid of engineers, he has worked out the type of roadbed and bearings, and by their general

*al meeting A. O. A.*

*naval hospital*  
**FRAME FOR PRESIDENT'S PHOTO  
 MADE OF BEADS AND SILK** *94 3*

Containing 2,000 yards of silk thread and more than 114,000 beads,

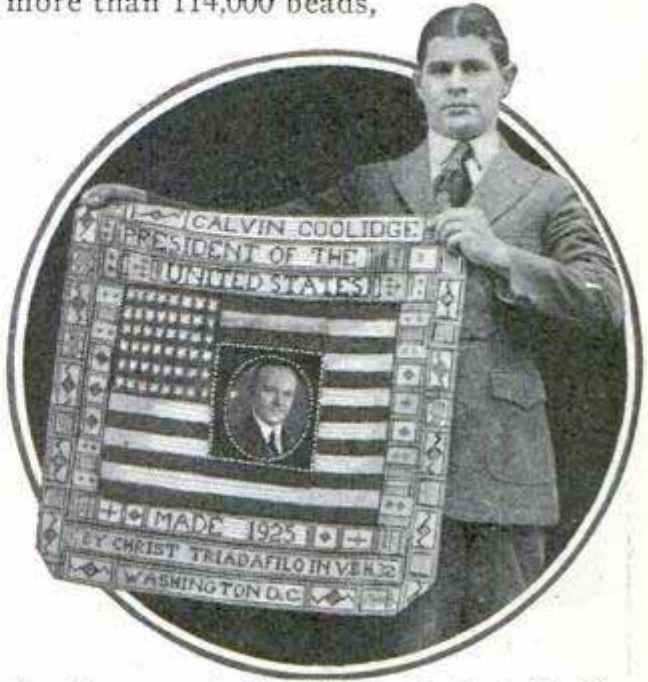

War Veteran and His Gift to President Coolidge, Elaborate Frame of Beads and Silk

a decorative frame for President Coolidge's photograph has been constructed by a World War veteran and presented to the chief executive. Several hours a day for six months were devoted to weaving the design which includes a replica of the flag, lettering and border figures resembling those of Indian origin.

**CORN WITH FOURTEEN EARS IS  
 DEVELOPED BY BURBANK** *1002*

During 1925, Luther Burbank produced a variety of maize from his rainbow corn, which grows to a height of eight feet and has from eight to fourteen ears to a stalk. This is but one of the plant wizard's developments for the year. He announced that he had perfected several major creations and improvements. A new camassia, a striking blue flower; a new species of torch lily that will bloom profusely in cold climates; an improved strain of the popular Shasta daisy; new fluffy giant asters and the development of eighty newly named gladioli are included in the year's accomplishments. He considers 1925 one of his most successful years.

*Luther Burbank Santa Rosa Calif.*

adoption, expects the lines to remain the standard of long-distance transportation. A recent report to the American Railway association showed that several railroad-operating records were established in 1925. The greatest volume of freight traffic was handled; more surplus cars and locomotives were kept in serviceable condition, eliminating delays; the greatest single-month volume of traffic was reached in October with a total of 44,061,988,000 ton-miles; for the week ending August 29, car-loading records were broken with a total of 1,124,436; the average daily movement of all freight cars reached a peak in October with 32.2 miles; less than carload-lot and miscellaneous shipments exceeded, by more than 2,000,000 cars, the record for the previous year; on September 30, 1,090,693 freight cars were moved, the greatest number in history, and the average load of freight per train was 796 tons in August, another high mark.

*Illustration 903*  
**AUTO THAT BUCKS LIKE HORSE  
 LATEST MOTOR THRILLER**

Plunges and turns like those performed by a bucking broncho are duplicated by a specially devised automobile for amusement-park patrons. The front part rises like a rearing horse, while the rear wheels carry the vehicle forward and around in circles. Several persons can ride in it at the same time, and spectators are given thrills as well as the occupants.

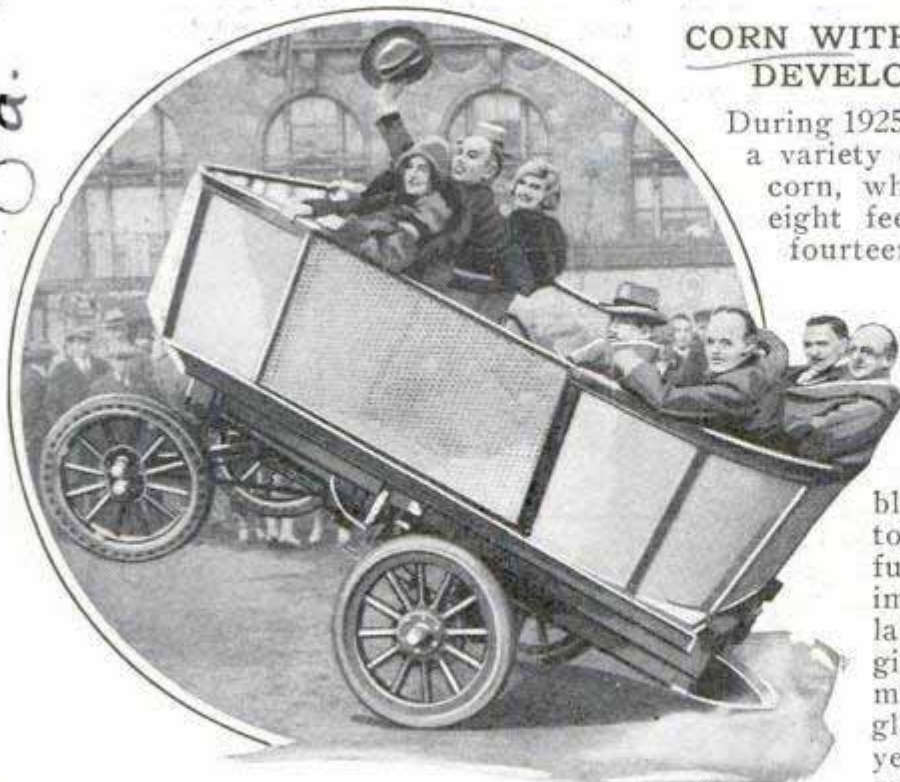

Geared to Buck and Plunge like a Broncho, This Rooney Motor Car Affords Pleasure-Park Patrons Novel Thrills

*At annual convention of national association of Chicago*

*Mr. Traver Engineering Co., Beaver Falls, Pa.*

**PORTABLE TANK FOR SOLDERING SAVES LINEMEN LABOR**

Intended especially for linemen in making repairs, a portable acetylene torch,

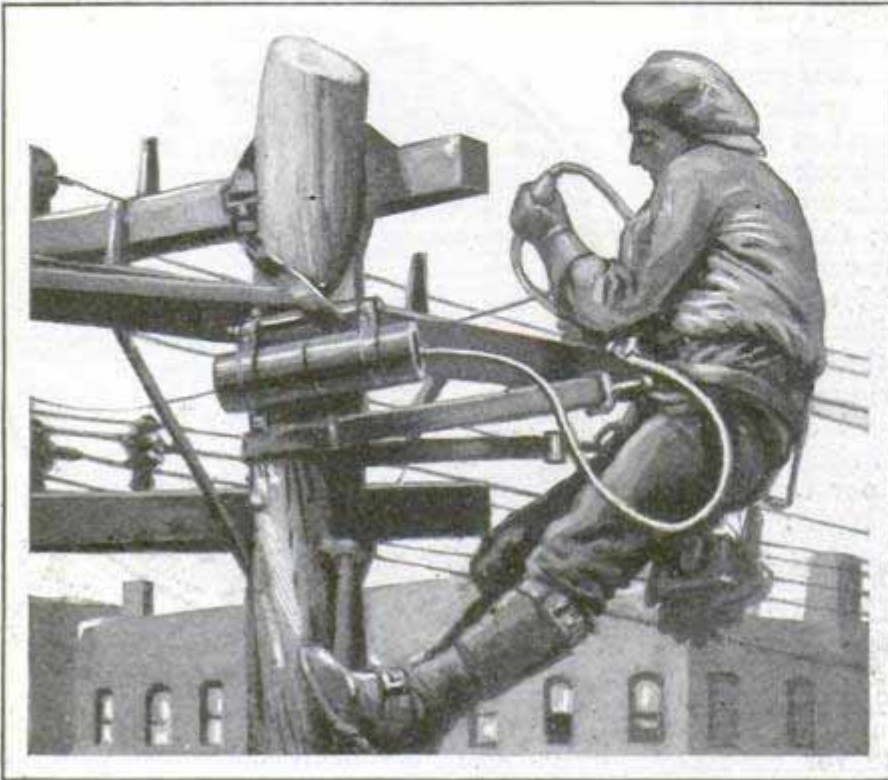

Repairing a Break in Line with Portable Welding Outfit; Acetylene Tank Slung on Pole and Special Torch

which can be slung over a crossarm or the top of the pole, quickly heats the soldering iron where the break is to be mended, saving preheating; extra trips and wasted time. An additional advantage is that the flame is not likely to be blown out even on extremely windy days. The torch is shaped to fit the particular needs of the line repairman and is light and easily handled. The special iron that goes with the outfit is attached directly to the gas tank, which is fitted with straps that may be adjusted over the lineman's back.

**FIRE-BOAT NOZZLES ARE USED TO SALVAGE SUNKEN SHIP**

How the monitor nozzles of two fire tugs enabled the British admiralty to raise a sunken ship, after six weeks' effort by other means had failed, has been revealed by Sir Frederic W. Young, famous English salvage officer. The ship had been sunk by a German torpedo in a soft mud bottom. To lift her with her valuable cargo, it was necessary to place thirty-two nine-inch steel cables under the hull, attaching them to winches on pontoons floating on the surface. After six weeks' work, only one wire had been placed un-

der the hull, ten feet back from the bow, the mud defying all efforts to remove it by various means. Finally two fire tugs were requisitioned, their nozzles removed and attached to long six-inch bronze tubes, connected to the fire-boat boilers and lowered to the bottom. The divers guided the nozzles as the high-pressure steam was turned on and literally blew tunnels under the wreck. The entire thirty-two wires were placed in three weeks, and the vessel, weighing 5,200 tons, was successfully lifted by pontoon barges. Sir Frederic also has revealed that the equipment with which the admiralty broke all previous lifting records at sea, consisted of six old 165-foot barges, hastily converted with any sort of parts and equipment which could be picked up without interfering with urgent war work in the shipyards, a circumstance to which he attributes

their success. "If time had permitted," he said, "the vessels would no doubt have been elaborately altered to preconceived conditions, and much of their efficiency would have been destroyed."

**VALVE PACKING IN AUTO MOTOR REDUCES POWER LOSS**

Attached to the valve stems of the automobile engine, a special packing has been devised to seal the intake chamber, thus preventing air leaks and dilution of the mixture from the carburetor. It is intended to afford maximum power from each cylinder, decreasing cold weather troubles, and is said to last for 10,000 miles. The packing is held in place by a spring adjusted between the underside of the valve head and a cup which fits over the sealing material.

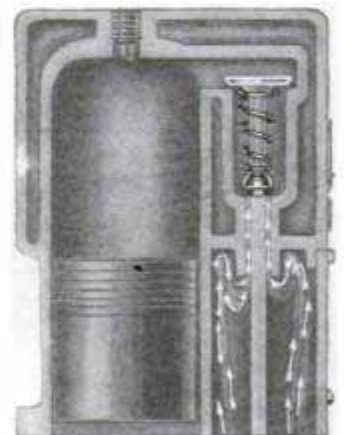

Lindblom Auto Part Co.  
2047 N. 6th St.

Chicago - 122 S. Michigan Ave  
927  
Before & restore of marine engineers at Olympia, England  
35

# Keeping the Circus in Motion



By EARL CHAPIN MAY, *Sharon, Conn*

YOU are awakened at peep of day by that unmistakable rumble of steel-hubbed circus wagons. You tumble out of bed and into your clothes. If you are lucky, you reach the railway yards in time to see the last of the hooded cages roll down the inclined "runs" from the gaudily painted circus "flats."

You trail this last cage, drawn by a team of dappled grays, to the circus grounds. There you may help erect the white tents, place the circus seats, water the elephants and in other ways prepare for the show which has been heralded by the billboards. You emerge about ten o'clock at night from the brilliantly lighted big top and stumble through deep darkness to home and bed, dog-tired. And on the following morning there is nothing left of one glorious day but fragrant memories and a few bits of rubbish where once the magic city stood. Circus day has come and gone!

"I wonder where they went from here," you remark. This is merely the echo of a question levied all the preceding day by hundreds of other "towners." No matter where a circus man goes he meets that constant query, "Where do you go from here?" It is an old question to the circus

man before his tenting season opens. For winter and summer he is asking himself, "Where do we go from here?" This question is prompted by the circus man's necessity for moving his amusement factory into a new cash market 150 times or more each season.

Motion is the essential characteristic of a circus. With the exception of a few big cities, such as New York, Chicago, San Francisco and Los Angeles, the "one-day stand" is the rule of the road with the fifteen bona-fide circuses attended by 12,000,000 Americans each year. To the townier who watches, with amazement, the smooth functioning of a traveling circus, the daily routine of setting up and tearing down is a thing to wonder at. But the circus man knows that his biggest problem is the problem of finding a market—of "routing the show into the money." "Any boob can run a circus; the trick is to know where to put it," old circus men say.

The circus that visits your town this season may have a cash replacement value of anywhere from \$200,000 to \$2,000,000. A twenty-car, three-ringed affair, is worth \$300,000 "on the rails." It costs \$3,800 a day to keep it in motion. The annual cost

of repairs, replacements and winter up-keep is about half of the cash replacement value. So, such a circus must not only maintain an average daily income of \$3,800 per day from April 1 to December 1—the length of its tenting season—it must also show a profit of at least \$150,000 during the season in order to break even. To accomplish this feat in tented-world finance, it must and does travel about 12,000 miles each season.

This yearly accomplishment is comparable to that which the owners of a candy factory employing 400 people would perform, if they erected their factory in a new town each morning, made and sold, for cash and locally, from \$3,800 to \$7,000 worth of candy before ten o'clock that night, then tore the factory down, loaded it on railroad cars, moved it from twenty-five to 250 miles that night and repeated that process for five months without pausing more than twelve hours in a town or

"stand," Sundays excepted. When a circus comes into winter quarters about December 1, the owner knows pretty well where it will go during the next year. And he builds his next circus in accordance with that information. The size and character of any circus are determined by the territory through which it is to travel. And the territory is determined largely by trade conditions. The circus man gets this vital information from banks, railroads, commercial agencies and crop reports, but in the last analysis he depends upon the "dope" sent him by local bill-posters or other tipsters.

The memory of a successful circus man on trade conditions is prodigious. He knows the population and character of every town of more than 2,000 in the United States and Canada. Moreover, he knows the population of each county in which those towns are located, the amount of circus license required, the character

Work That Sometimes Admits the Small Boy to the Circus Now Highly Organized; the Bucket Brigade in Action Carrying Water to the Animals from Portable Tank

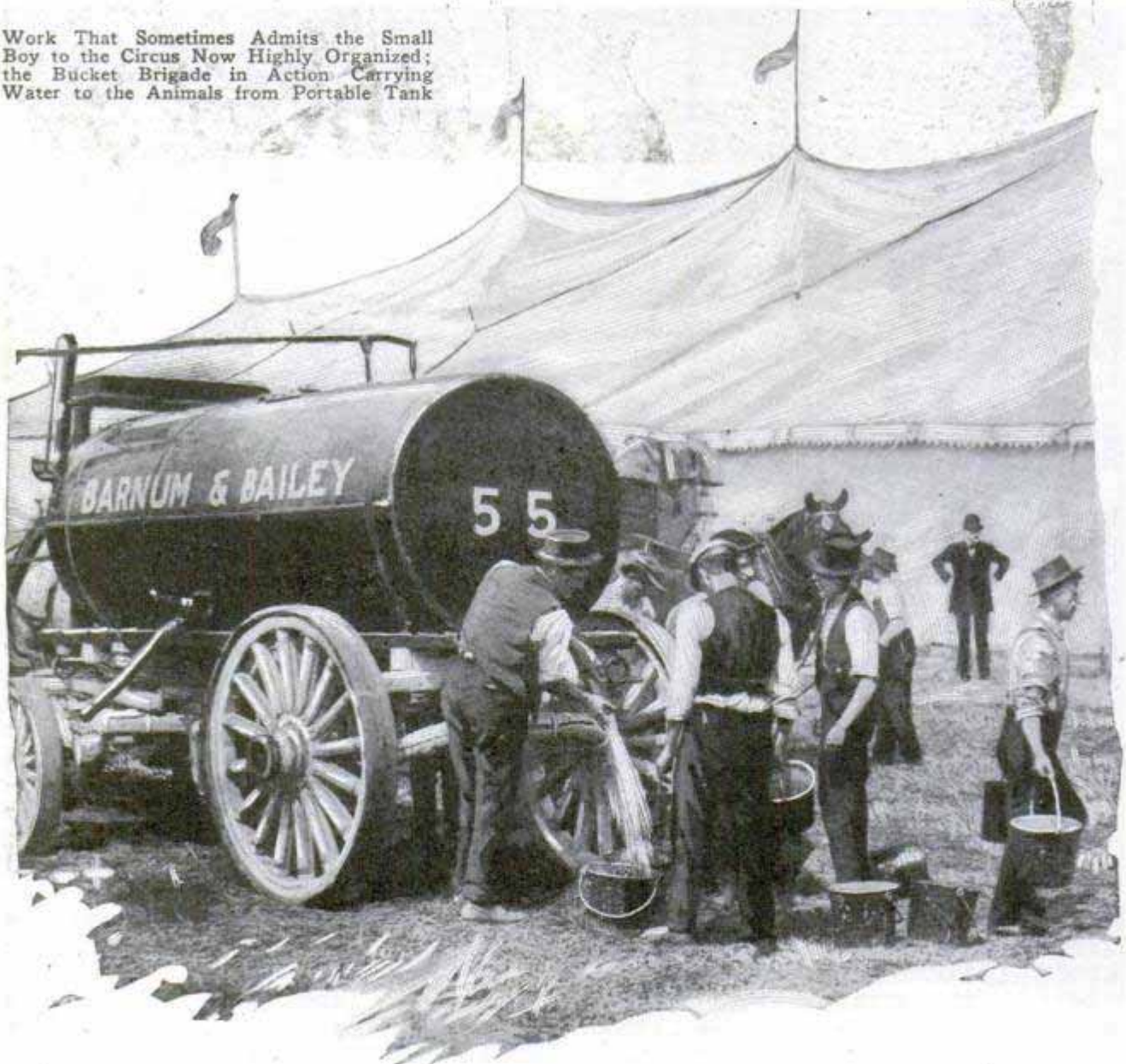



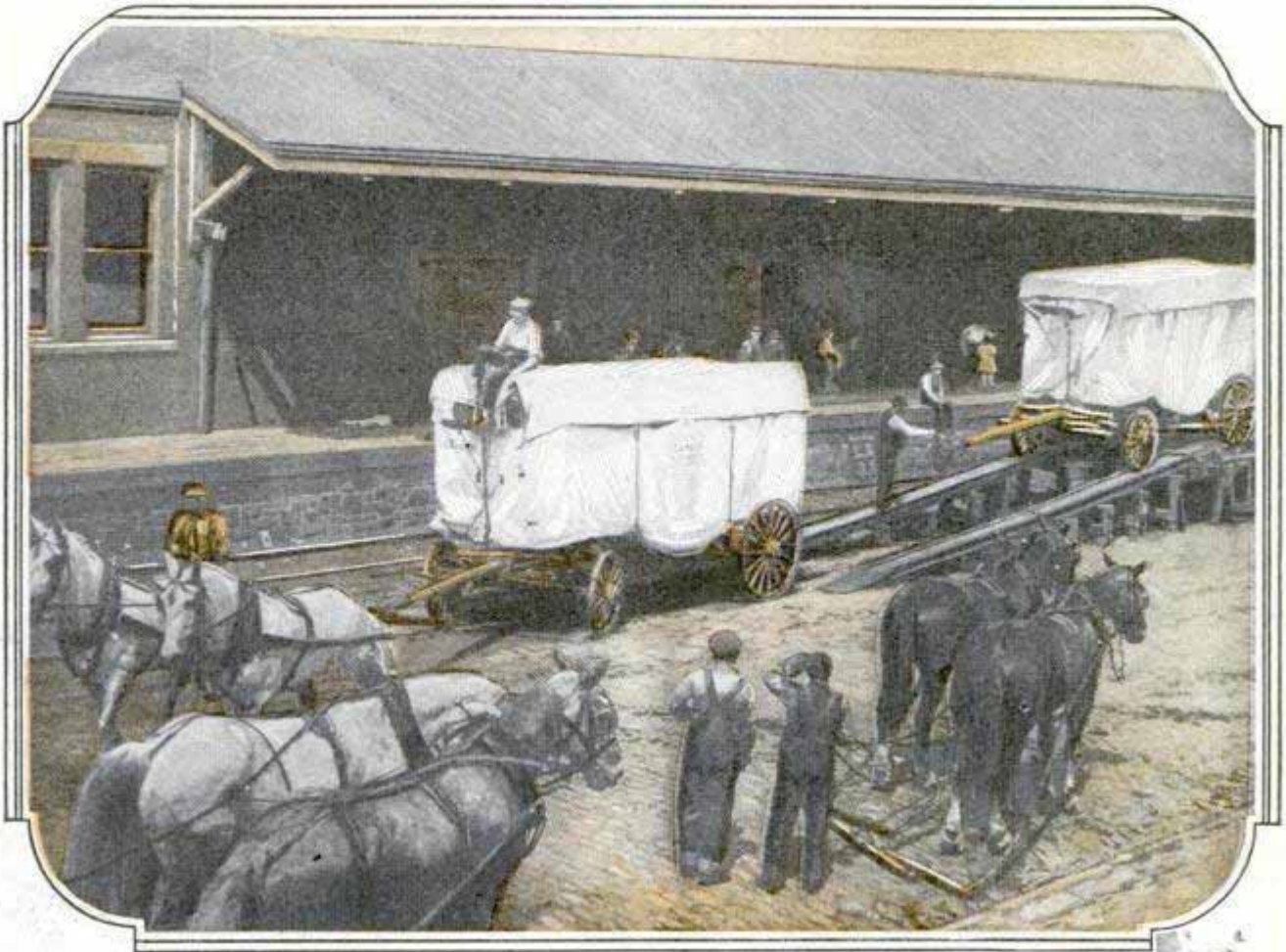

and cost of the circus grounds, their distance from the unloading or "spotting" point in the railroad yards, what time in the year is the best to visit that particular town and, what is vastly more important, what kind of a "show town" it is.

Plainview, Tex., for example, has a population of about 4,000. It is away out in the Panhandle country. Yet the Sells-Floto circus traveled 281 miles to get to that town last fall, because its owners knew that there would be 10,000 persons in town, if weather and crop conditions were fair, to see their circus. But a New England town of 4,000 can rarely be counted on for more than 2,000 circus patrons. The Sparks circus played Yazoo City, Cleveland,

Okolona and other Mississippi towns of from 2,000 to 3,000 population last October, but "cleaned up" in each town, because there was a bumper cotton crop. I have known the Ringling Brothers and Barnum & Bailey combined shows to play to 25,000 people in such towns as Fairmont, Minn., Concordia, Kans., and Norfolk, Nebr., because they knew that

Hauling the Animal Cages from the Flat Cars; Below, Crew of Dapple Grays, Willing and Alert Circus Movers

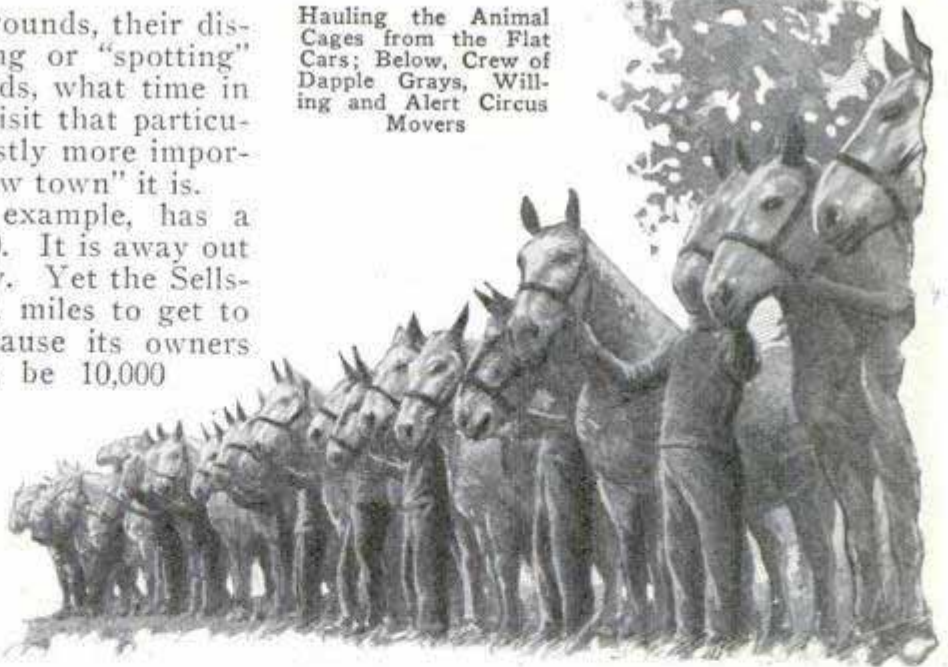

crops were good, the towns show-hungry and that, if they came into these towns just after the wheat harvest, there would be four times as many circus fans in the big top as there were citizens in each town.

There is a tradition in the circus business that either John or Charles Ringling can, while traveling through the country at night, stick a hand out of a Pullman

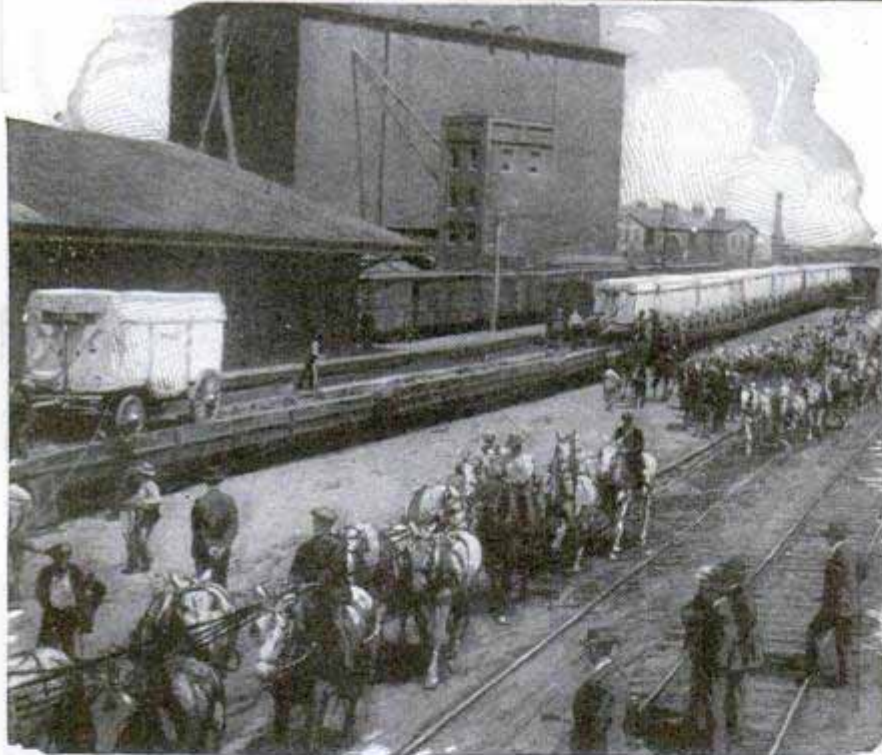

Assembling the Cages at the Show Grounds, and Work Horses Leaving the Railroad Freight Yards; Train of Cages at Left

window and tell what town they are approaching "just by the feel of the air." They know every blessed angle and corner of this fair land, do these circus people. But what is more, they know the history of each of the myriad towns which they may want to visit or avoid. This marvelous acquaintance with trade history and possibilities was illustrated to me one day last spring by Charlie Sparks.

We were standing at his canvas front door on the circus lot at Jackson Heights, Long Island. It was in early May. My

own town, Rochelle, Ill., was circus-hungry. It had not been visited by a circus for many years. It was and is a very prosperous town of 4,000 population, with a number of good factories and in a rich corn and oats section. The chamber of commerce had asked me if I could not get a good circus to visit Rochelle. So I put it up to my friend Charlie.

"Why don't you make Rochelle in July?" I asked him. I mentioned July because Illinois and other corn-belt towns are at their circus-best just after the corn has been "laid by" and the farmers have time to come to town. Without hesitating a moment, Sparks

replied, "No chance. The Gollmar show played Rochelle to only \$2,800 eight years ago. My nut is \$3,800."

I asked him about twenty other towns in various parts of the country. He reeled off facts and figures about them with equal ease and rapidity. If the average sales manager for any big manufacturing concern knew as much about territory as does the average circus owner—who is both production and sales manager—there would be fewer failures in American business.

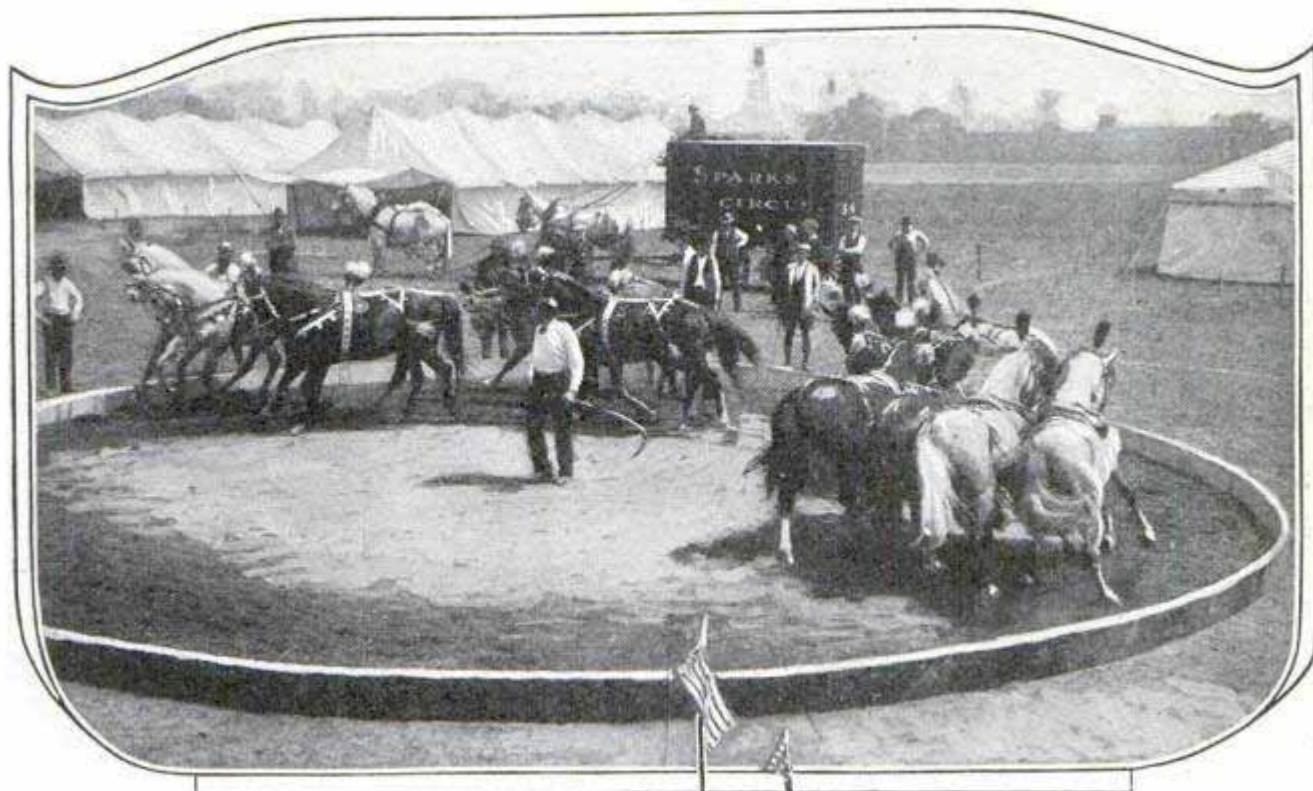

But the circus man has to know a lot more than merely trade facts, figures and history. He has to know whether the railroads will carry his circus into desirable territory at the proper times. The Florida east coast is a rich territory late in the fall. But nearly every fall the East Coast railway places an embargo on circuses. It has too much passenger and fruit business to handle.

Having decided in January upon the coming season's territory, a tentative route is laid out. After that, the program covering transportation is about as follows: Railroad contracts for the various movements from town to town are signed about three months in advance of the desired movements. About three weeks before the circus is to exhibit in Jonesville, Va., the "bill car," loaded with thirty billposters, banner tackers, programmers, lithographers and press agents, arrives in Jonesville and bedecks town and countryside for twenty miles around. The bill car is followed by a "box brigade" of five or six men, who travel by rail or motor car, usually by rail, to patch up after the bill car, especially if any opposition circus has been "covering paper." Anywhere



Above, Springtime Rehearsal of an Act to Entertain the Thousands Who Will Crowd the Big Top Later in Summer

from ten days to two months ahead of this box brigade, the contracting agent has arranged for circus license, circus grounds, meat, bread, hay and a dozen other essentials. One day ahead of the circus the "twenty-four-hour man" checks up on all these contracts, to be sure there will be no hitch in the proceedings.

If all's well with the world and the show has not been stuck in the mud of a pre-

vious day, or has not been wrecked on the road between towns, it rolls into Jonesville about four in the morning. Ten minutes later, it is "spotted" at a convenient crossing arranged for by the twenty-four-hour man. That worthy leads the "stake-and-chain" gang to the circus grounds. This gang lays out the plot by some mysterious method of surveying, marking each stake and center-pole location with an iron pin to which is attached a bit of red flannel, known as "the flag."

Twenty minutes after the stake-and-chain gang has left the circus train, the railroad runs are down, and the first wagon—the cookhouse or commissary wagon—is rolling toward the circus grounds. In an hour, all the wagons are off the flats, all the human beings and live stock unloaded and the big tops and smaller tops are rising. By ten o'clock the parade is on its way downtown. By one-thirty the last of the blue seats are in place. By two-fifteen the afternoon performance is on. By four-thirty the afternoon concert or "after show" is over. By five-thirty dinner is concluded, and the last husky hustles out just as the "flag comes down," indicating that meals are over for that day. By six-thirty the cookhouse and stables are on the way to the railroad yards. By nine p.m. the menagerie and

sideshow tents are "torn down" and loaded. By ten-fifteen the night show is over. By midnight every bit of the circus property has left the circus lot. By one a.m. the circus train is loaded and on its way.

And so it goes day by day. It is motion, motion, motion—provided the elements do not interfere. Weather is the one thing no circus man can figure on with certainty. He can, if he must, switch his circus route, on one week's notice, although such a switch is vastly expensive. But he cannot guess effectively on the weather. That is his one big bet. Last season the Sparks circus played to weeks of unbroken heat in Oklahoma and Kansas, heat so prolonged and intense that it was finally found necessary to do an almost unprecedented thing—wet down the canvas to keep it from dryrotting. Then the show ran into weeks of cloudbursts, so tremendous that many a night show was lost in the southern Mississippi valley. For twelve days all hands stayed on the lot and helped pry the show out of the mud.

The thing that keeps a showman in the show business is the thing that put the covered wagon across the western prairies. It is the fascination in wondering what lies beyond the horizon—the constant search for the pot of gold at the rainbow's end.

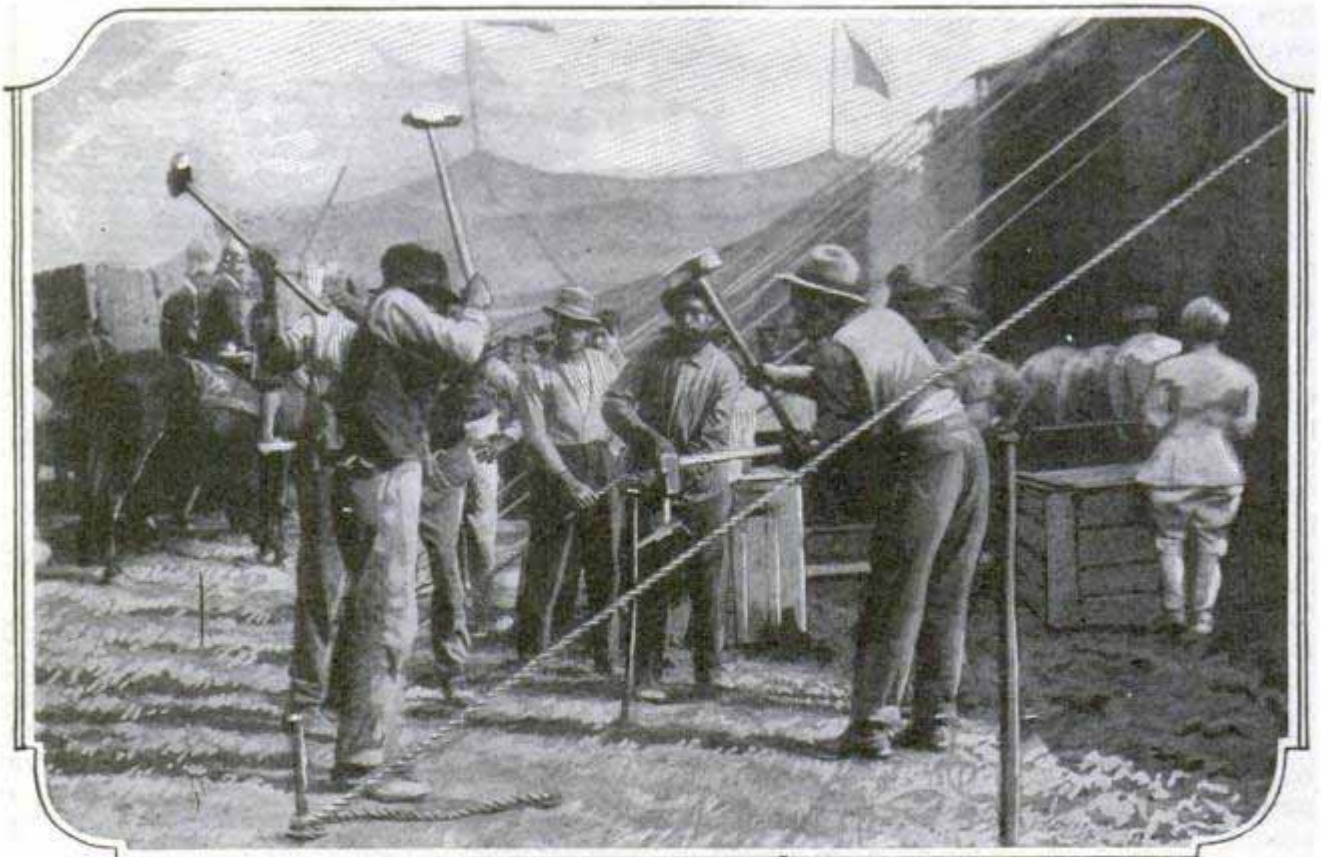

Motor-Driven Hammers Pound the Pegs for Some Shows, but the Skilled Sledge Gang Is Still to Be Seen, an Important Unit When the Circus Moves

*Handwritten:* 12/16/25. Brooklyn Daily Eagle

*Handwritten:* Plaster Co. H. Clark

### POPULAR MECHANICS THRILLS OF INDIAN WAR DAYS RECALLED BY MILES' RELICS

### FOOT-POWER VEGETABLE TIER SAVES TIME AND LABOR

Rifles used by Indian chiefs, war bonnets, and clubs as well as peace pipes are included in a valuable collection of relics gathered by the late Lieut. Gen. Nelson A. Miles, which have now been housed in the Museum of the American Indian, Heye Foundation, in New York. The articles recall many stirring and important events in American history and are considered especially valuable to writers, research-workers and scholars as sources of reference. Among the five rifles is the one carried by Joseph, chief of the Nez Perce tribe, who surrendered to Miles in 1877 after a masterly retreat. When the chief handed the weapon to his victor, he said, "From where the sun now stands, I fight no more against the white man." Another rifle was taken from Geronimo, an Apache leader who waged war for several years against settlers in Arizona and northern Mexico. The rifles carried by Chief Rain in the Face, Chief Lane Deer, a Sioux who attempted to kill Gen. Miles but missed and slew a soldier standing near by, and one that belonged to Sitting Bull, who was routed by Gen. Miles in the battle of the Little Big Horn, complete the collection. Other relics include an Arapahoe shield painted with characteristic figures, a drum, bows and arrows and a flute employed by the youth of the Sioux tribe in their woping.

Bunches of vegetables or flowers are quickly and securely tied in a simple outfit operated by a foot lever while the user remains seated. It automatically adjusts itself to bundles from one-fourth to five inches in diameter, and saves



Harvesting Vegetables in Adjustable Press Which Binds Them Securely and Ties Knots

### COIN-IN-SLOT MACHINE HOLDS THIRTY DIFFERENT THINGS

Thirty different articles are dispensed from a slot machine now on the market which is easily operated and automatically rejects imitation coins, slugs or other foreign pieces. It has a large glass-covered face, resembling that of a clock. By moving an arrow indicator opposite the space which holds the object the purchaser desires, dropping the coin in a slot and pressing a lever, the merchandise falls into a cup at the bottom. A list of the contents of the venter is attached to the face. The machine is loaded from the rear, articles being placed in small packages for easy dispensing.

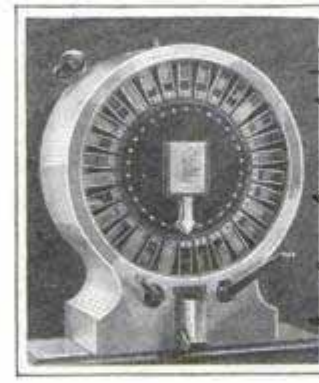

cutting string or tying knots by hand. The operation of the lever makes the cord fast to the bunch, which is inserted against a support on a tablelike rack at the top of the apparatus. The levers move in bronze bearings, adding to the ease of operation and life of the outfit.

### MEALS SERVED IN MOTOR BUS ON LONG-DISTANCE RUN

Passengers of a motor-bus line from Los Angeles to San Francisco are served with luncheon from a compact kitchen built as part of the vehicle. A button on the side of each chair summons the steward who takes orders for either hot or cold dishes. The bus also has a special compartment for women, another for smoking and a third for the driver. The entire rear panel of the smokers' room is a plate-glass window which permits an unobstructed view of the scenery. Washroom space is also provided.

Six months is said to be the average life of a dollar bill.

*Vertical handwritten:* Also see Paper, 1925-570

*Vertical handwritten:* 887... 961... 947

*Vertical handwritten:* Machine... 1194-14th St. P... Arrow Chassis

*Handwritten:* Jeffries Automatic Service Co. 727

Cologne, Germany

### SHOP WINDOWS SET AT ANGLES AFFORD BETTER DISPLAY

So that prospective buyers may view the goods from the side as well as from the front and to increase display space,



How a German Shop Keeper Has Obtained Extra Show Space; Windows Are Set at Angles, Giving Better View of Goods

a German merchant has constructed his show windows in triangular units. The plan gives a store in the middle of a block something of the advantage of a corner location—show room on two sides.

### TYPE-SETTING MACHINE SAVES TIME IN COPYING LETTERS

For duplicating letters, an office outfit that automatically sets type from a standard keyboard, is said to reduce the time required for preparing the copy from about two hours to five minutes. To accompany this machine, a distributor has been devised which sorts the type back into the proper compartments of the holder. The setter is about four feet high, two and one-half feet wide and sixteen inches deep. Set-ups are made directly into the drum of a standard duplicating device or into flat chases suitable for use on presses.

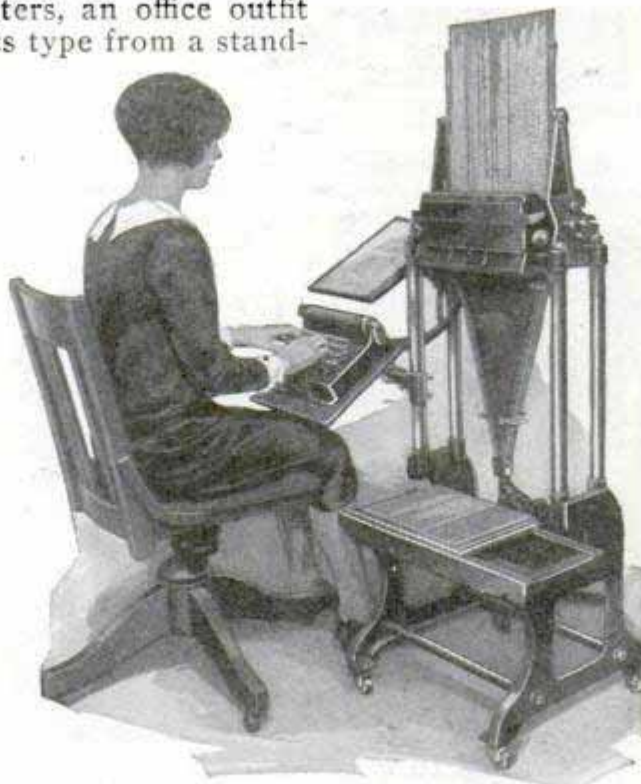

As Keyboard Is Operated, Type Falls into Forms at Bottom, Nearly Ready for the Presses

Letters or other documents are copied from the original just as they would be duplicated on a typewriter, and when the distributor is operated after the impressions have been made, defective or worn type is separated and discarded automatically, so that at no time in the process of preparing the forms or resorting is it necessary to handle the individual characters.

### FORTY-FOUR ROADS HAVE AUTOMATIC TRAIN CONTROL

With his arms folded, a locomotive engineer recently allowed his train to go past a danger signal at full speed. But no crash followed, for a safety control automatically applied the brakes, bringing the express to a halt. The demonstration was but one of many similar tests that have proved the effectiveness of various safety systems, which are now installed over more than 7,000 miles of track on forty-four of the leading railroads of the country. Such equipment eventually will be universal. An order of the Interstate Commerce commission directing that the work

be completed by Jan. 1, 1925, was extended because of the great cost involved. The total expense, it is estimated, will reach hundreds of millions. There are some thirteen distinct systems of train control, but all are aimed at the removal of the human element of error, reducing the danger of collisions and permitting trains to run with less headway, which will allow increased tonnage over given mileages without increased risks. Most of the installations are simpler than might be sup-

923

946. *Real Estate*  
*makers of control*  
*roads or*  
*no information on roads*

*Laboratory*  
*429 E Third*  
*Development Co.*  
*St. Louis, Mo.*  
*Rayton Engineering*  
*Manufacturing*

*N.Y. Times*  
*12/2/25*

posed. They make use of the tracks, signal systems and pneumatic devices already in operation. Briefly, the service of the automatic train control is to pick up the danger signal from the tracks and then operate the brakes independently of the engineer. The train may be stopped gradually or suddenly depending upon the nature of the trouble. In addition, the equipment gives the engineer a warning inside the cab in the form of three separate signals, either by lights or whistles. The first indicates that there is trouble, perhaps a mile ahead. The second tells that danger lies in the second block beyond and that the speed of the train should be reduced. The third means that the danger is immediate, probably within 2,000 feet or less, and that the train should be halted at once. If the engineer fails to regard the second signal, the automatic apparatus reduces the train's speed or halts it when the third signal is reached. If a train stops ahead, the fact is instantly relayed back to a locomotive cab as far as a mile behind. When a bridge washes out or tracks are destroyed, breaking of the circuit gives the warning.

**TENT LAMP FOR AUTO TOURISTS,  
ALSO LIGHTS GARAGE 934.**

As a substitute for candles or lanterns, an extension electric light for the automobile tourist is easily attached to the car, affords sufficient illumination for reading or writing in the tent and can also be used as an emergency garage or trouble lamp. The equipment includes ten feet of wire cable, a six-volt, four-candlepower bulb and a double or single-contact plug for socket insertion. A switch is provided at the base of the lamp, which is finished in black enamel or nickel.

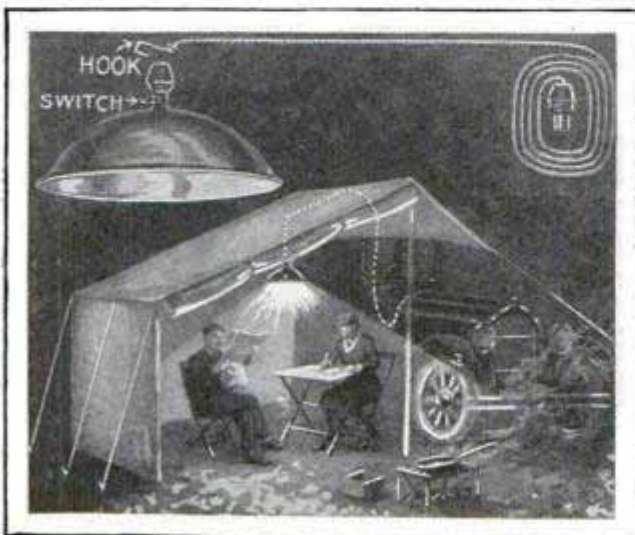

Extension Electric Light from Auto in Tent, and Detail of Shade, Switch and Cord

**FIRE EXTINGUISHER IN SLING  
— IS CARRIED ON BACK 924**

Equipped with a cradlelike holder, a portable fire extinguisher introduced in Germany can be strapped to the back or



With Fire Extinguisher Slung on Back, Hands Are Free for Carrying Other Tools

released in a few seconds. When it is taken out of its harness, it is in a position for immediate use.

**"EYE" FOR ARMY TANKS GUARDS  
DRIVER AGAINST GAS 918**

Greater safety for the operators and increased effectiveness of the army tank are seen as a result of an attachment tested at the Aberdeen proving ground. It consists principally of a stylus connected to the mechanism in such a way that every turn of the tank is indicated on a scale map of the territory being traversed. Thus, the drivers would not have to expose themselves to get their bearings by day or night and would not be so likely to suffer from gas attacks as they would be tightly inclosed in the tank. The stylus is controlled by a gyroscopic compass, mounted on the rear, and is geared to the tank so that its rate of travel across the scale map coincides with the actual rate of the machine.

Less than twenty-five per cent of the farm land of Texas is under cultivation.

*J. A. Smith Mfg. Co.*

*New York World 12/10/25*

*W. B. Rochester N.Y.*

747  
396

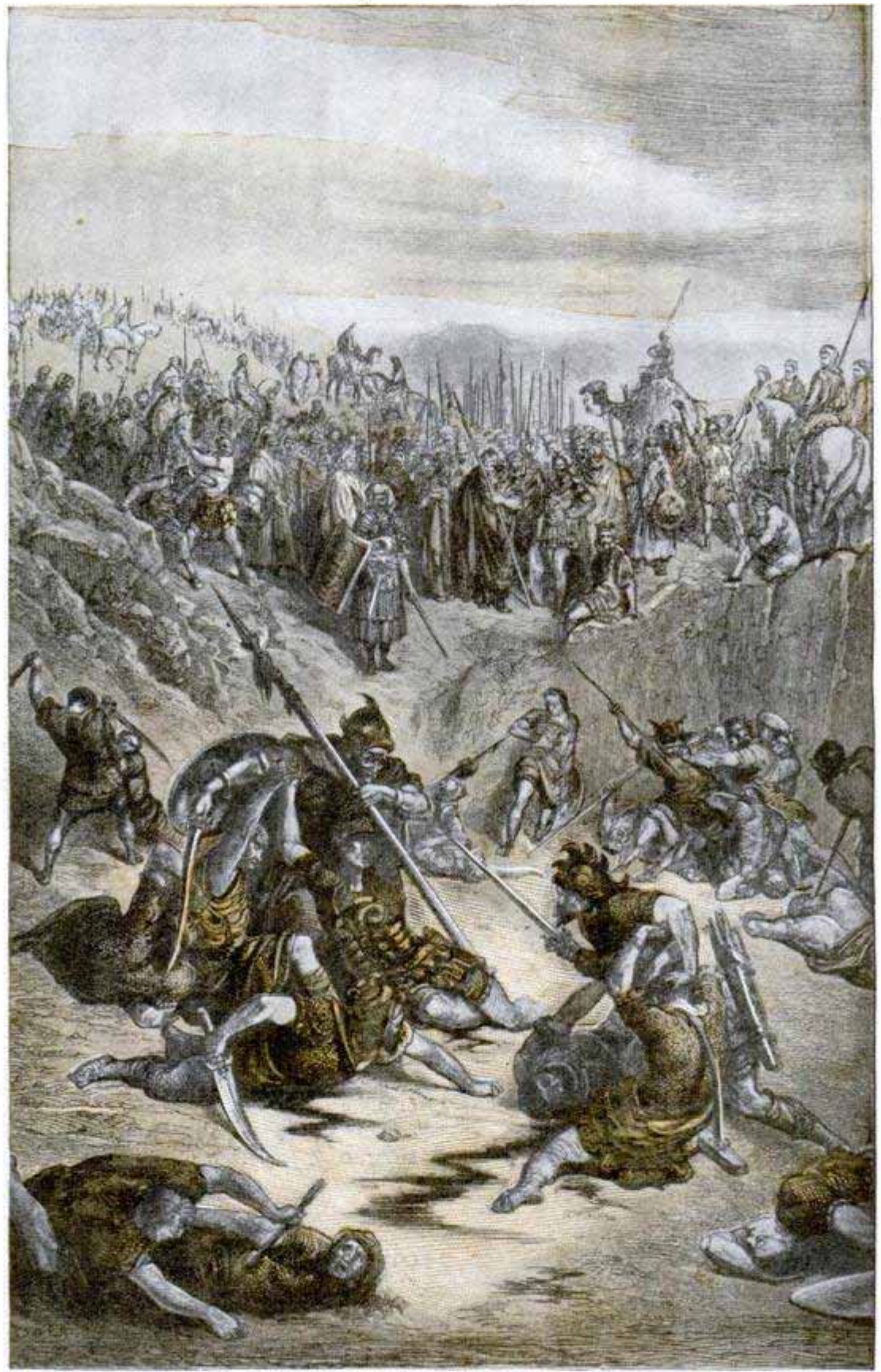

The Battle between the Champions of David and Saul's Son Isboseth, One of the Events Growing Out of the Suicide of Saul after His Defeat by the Philistines, as Pictured by Dore



# Find Temple Dating Back to Days of Abraham

**A** DISCOVERY which promises to be as important to Bible scholars as King Tut's tomb was to Egyptologists, has been uncovered in Palestine by an expedition from the University of Pennsylvania. The house of Ashtaroth, where King Saul's battle arr... was hung by the Philistines after his defeat, and the wall on which they exhibited his body, as described in I Samuel and Chronicles, has been found at Beisan in Palestine, the site of Beth-Shan or "House of Security" of the Bible.

The ruins of the temple, fifty by seventy-five feet in size, are important, but of still more interest is the discovery of two ancient cornerstone deposits, pottery jars containing a wealth of ingots, rings and jewelry made of pure gold, or gold and silver mixed. Aside from their archaeological worth, the finds in the two cornerstones of the temple were so numerous as to have considerable intrinsic value.

The ruins of the ancient wall of Beth-Shan, uncovered with the temple, still bear traces of fire, presumably the conflagration with which the Israelites wiped out the city when they came to avenge Saul's death and recapture his body. The first book of Samuel, after telling how Saul's army had been defeated by the Philistines and how he finally fell upon his sword and killed himself to escape capture, relates that the victors, on the following day, visited the battlefield to strip the slain, and found the bodies of Saul, his three sons and the king's armor bearer where they fell.

"And they cut off his head, and stripped off his armour," the account continues, adding, "And they put his armour in the house of Ashtaroth and they fastened his body to the wall of Beth-Shan."

To find the ancient ruins, the explorers dug down through layer after layer of earlier civilizations, and having reached the time of the Bible, discovered that still older layers lie beneath, for Beth-Shan is one of the earliest settlements in the world. The top layer was the debris of the Arab civilization which has occupied the spot for the last few hundred years. Under that were broken utensils, weapons



Stele of Pharaoh Seti I, Uncovered by the Pennsylvania University Museum Expedition in Palestine

and other remains of the Crusaders, who held the fortress hill as a strong point

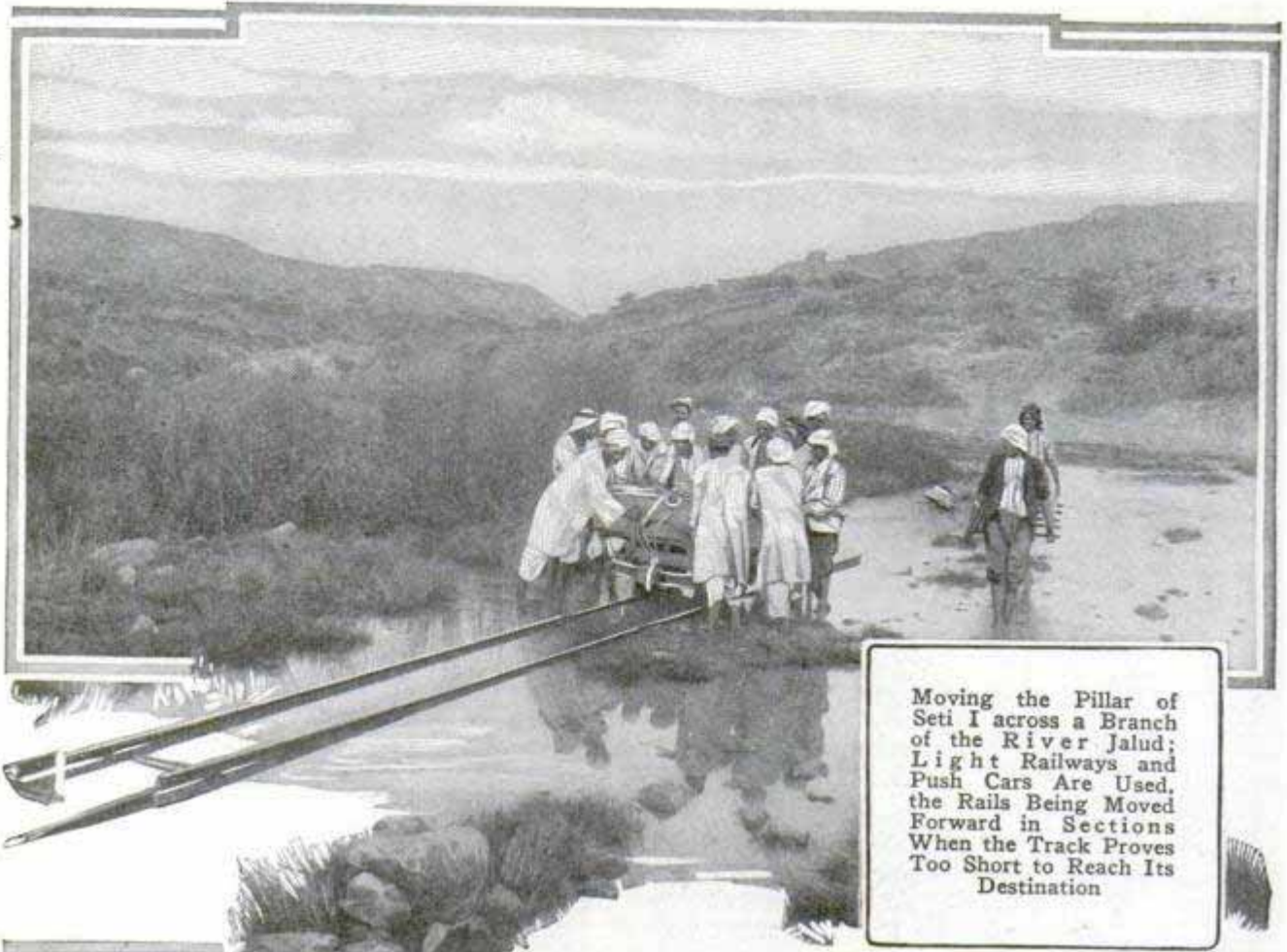

Moving the Pillar of Seti I across a Branch of the River Jalud; Light Railways and Push Cars Are Used, the Rails Being Moved Forward in Sections When the Track Proves Too Short to Reach Its Destination

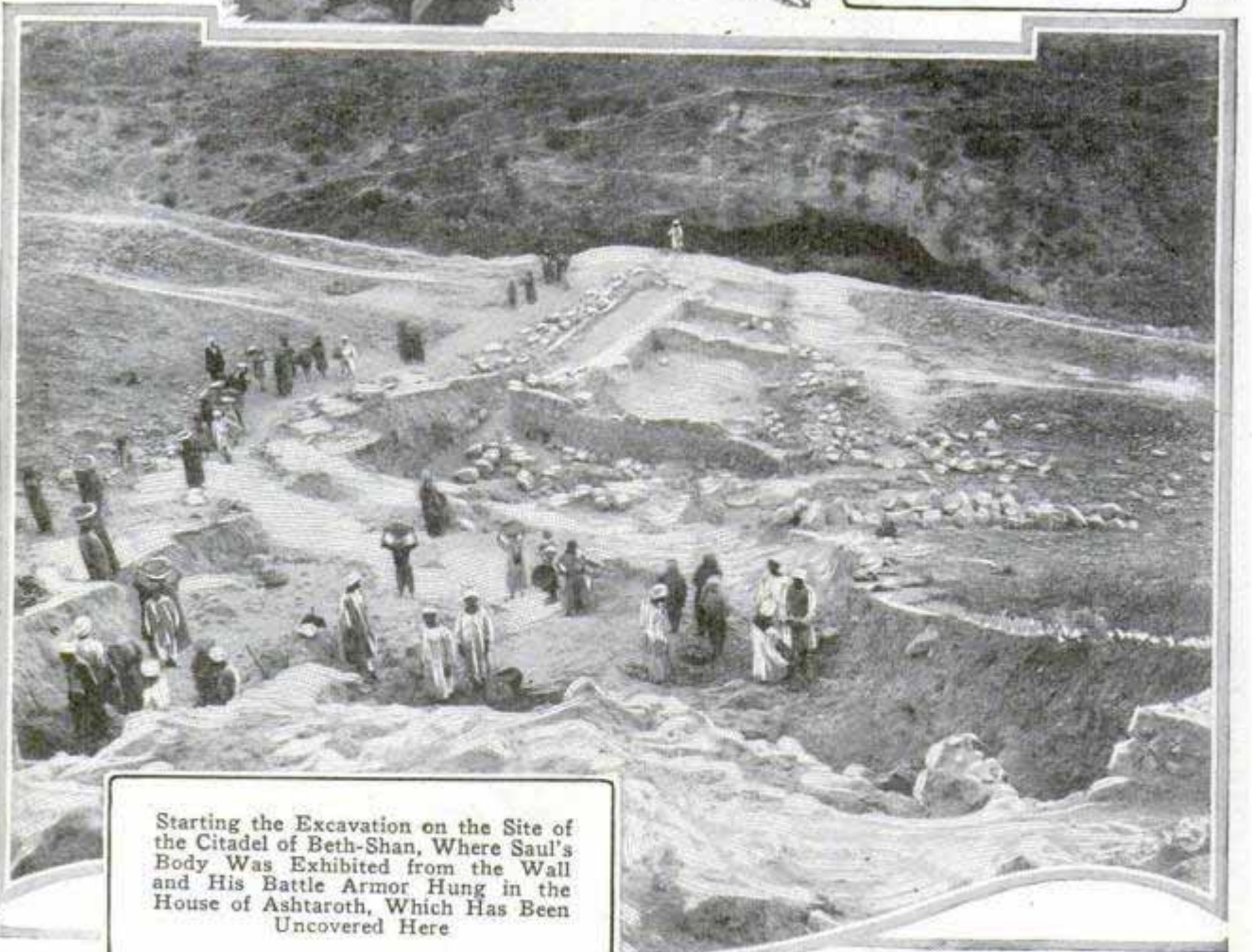

Starting the Excavation on the Site of the Citadel of Beth-Shan, Where Saul's Body Was Exhibited from the Wall and His Battle Armor Hung in the House of Ashtaroth, Which Has Been Uncovered Here

covering the valley of the Jordan while they fought for Jerusalem.

Beneath the debris of the Christian occupation were the evidences of the Arabs they displaced, Arabs who had taken the hill during the great period of Arab conquest. Beneath that came ruins of Christian, Roman and Greek civilizations. Next were the evidences of the Hebrew conquest of 2,900 years ago, and, underneath, the Egyptian civilization which goes back there to 3,200 years ago, and still earlier civilizations remain to be explored. As a strong point of the highway between Asia and Africa the hill was a strategic position before the dawn of recorded history and was capital of the Jezreel and Jordan valleys, as well as chief city of the once famous Decapolis, or league of ten cities.

The temple of Ashtaroth, which might have gone unnoticed in history save that the Bible linked it with the death of Saul, was erected by the Egyptians to their goddess Ashtaroth (Hathor or Astarte), about 1250 B. C., and was, so far as is known, the only pagan temple remaining intact at Beth-Shan when



Top and Bottom, Two of the Eight Memorials Erected by Moses to the Pharaoh's Daughter Who Found Him in the Bull-rushes, and in Center, a Bedouin Camp

it was conquered by the Philistines.

On one of the door jambs the explorers found the name of an Egyptian commandant of the city during the reign of Rameses II, the garrison commander boasting the hyphenated name of Rameses-Wesr - Khepesh. The stele of an Egyptian of the nineteenth dynasty, depicting him in prayer to his gods,

was another object uncovered near by. Adjoining it, the excavators finished removing a stele uncovered last year, on which appears mention of Kharu, the old name for the inhabitants of Canaan. The same word appears on a famous Israelite stele of King Merenptah, which is now in the Cairo museum.

Next a monument of the goddess Ashtaroth was found, showing her as wearing a long dress and the conical crown characteristic of all Syrian goddesses, with two feathers attached. Above her was written "Lady of Heaven, Mistress of all the Gods."

The room of the first of the three temples in which the stele of Ashtaroth was discovered had four stone drums concealed under its floor of hard clay, which



were thought to have once been the foundation for wooden pillars. The room was littered with cult objects, many of types never before discovered.

Beneath the nineteenth-dynasty temple was found still a third temple of Egyptian origin, thought to date from the fifteenth dynasty, or about 1500 B.C. An altar and a scarab from King Thotmes III's times were found here, and the floor of the temple still retains its bright blue color despite the passing of more than thirty-four centuries.

Still farther down another temple of Ashtaroth has been uncovered, and in it was found a golden image of the god-

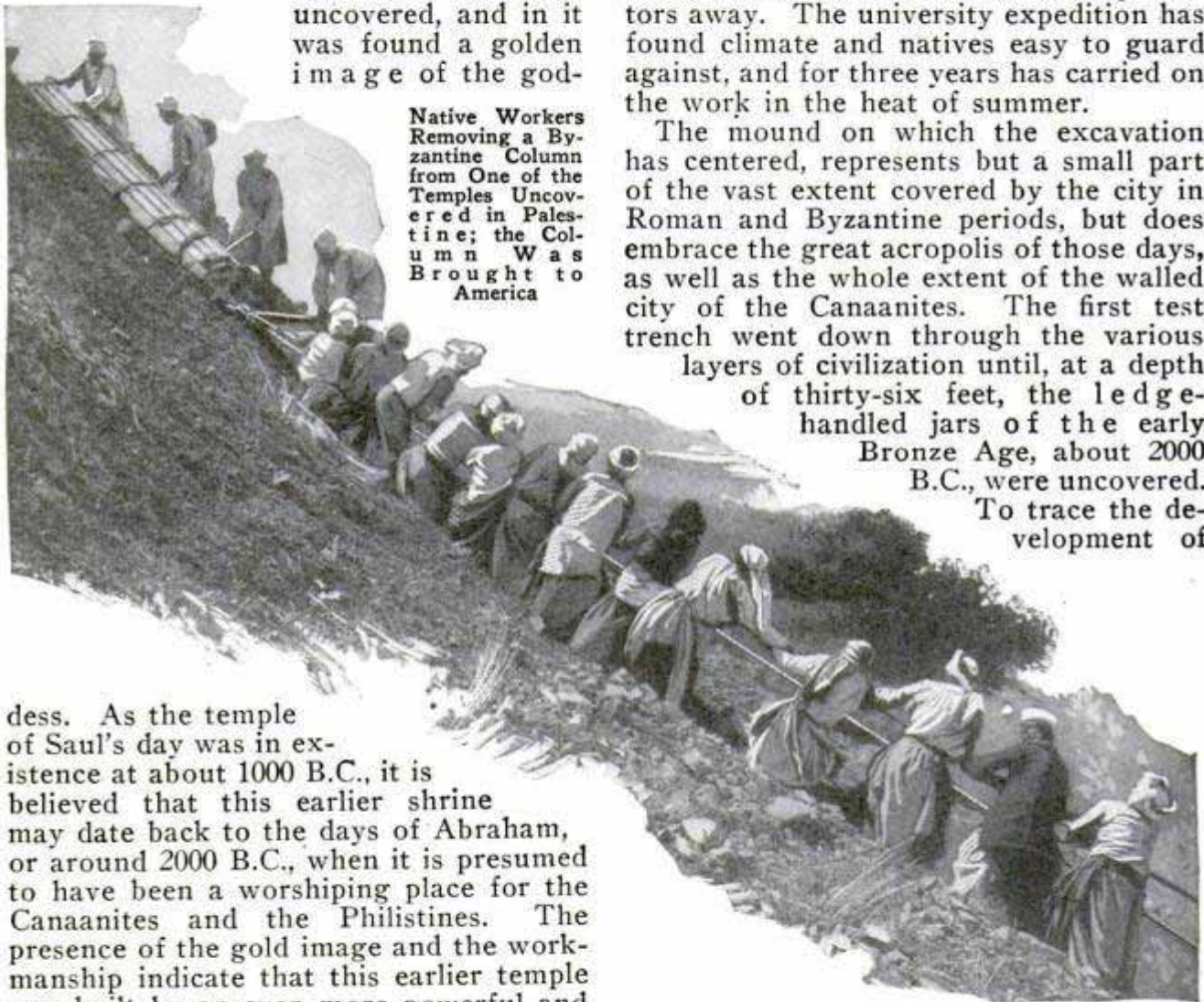

Native Workers Removing a Byzantine Column from One of the Temples Uncovered in Palestine; the Column Was Brought to America

dess. As the temple of Saul's day was in existence at about 1000 B.C., it is believed that this earlier shrine may date back to the days of Abraham, or around 2000 B.C., when it is presumed to have been a worshiping place for the Canaanites and the Philistines. The presence of the gold image and the workmanship indicate that this earlier temple was built by an even more powerful and skilled civilization than that of the days of Saul and David.

The region in which the university is working is one of the most fertile fields for exploration remaining. For centuries it was closed to outsiders by the Arab and Turkish rulers, and not until England took over the administration of Palestine under a League of Nations mandate could a permit be obtained to open the famous hill. As a result the ruins remain untouched. The region is famous in bible history for many reasons. It was

near this site that David slew Goliath, and around about the adjoining valleys of the Jordan and Jezreel, some of the most stirring exploits of Old Testament history occurred.

One result of the Turkish rule was the protection of the site of ancient Beth-Shan from molestation, since, some fifty years ago, it became the private property of the Sultan Abdul Hamid, preventing any haphazard digging by natives in search of valuables. The reputation of the place for excessive heat, a deadly climate, and a population said to be knaves and thieves, likewise served to keep visitors away. The university expedition has found climate and natives easy to guard against, and for three years has carried on the work in the heat of summer.

The mound on which the excavation has centered, represents but a small part of the vast extent covered by the city in Roman and Byzantine periods, but does embrace the great acropolis of those days, as well as the whole extent of the walled city of the Canaanites. The first test trench went down through the various layers of civilization until, at a depth of thirty-six feet, the ledge-handled jars of the early Bronze Age, about 2000 B.C., were uncovered. To trace the development of

such a superimposed series of civilizations, it is necessary to remove each complete stratum from the entire site in its turn. It took three years in this way to go down between twenty and thirty feet, through eight successive building periods, and reach the brick fortress of the time of Seti I, who ruled Egypt from 1313 to 1292 B.C.

The Egyptian fortress of the Pharaoh Seti had a fairly regular plan, with groups of small chambers and long corridors sur-

rounding open courts. The walls, which in some places still stood to a height of nearly ten feet, were built of large bricks of sun-dried clay, measuring twenty-one by fourteen inches and six inches thick. They were laid in mud mortar, and the faces of the wall were finished off with a fine mixture of clay and lime. The floors had a thick coating of cement laid over a bed of rubble. From one corner, adjoining what appeared to be the main court, a brick staircase led either to the roof or to an upper story. The main entrance, which had been partly destroyed in placing the foundation of later buildings, still showed the great sill and side jambs, all of carefully dressed and fitted blocks of basalt which dovetailed into the brick masonry of the main walls on either side, showing a high degree of workmanship.

Two commemorative steles, or wall plaques, of Seti I and Rameses II, together with a seated statue of Rameses III, all of basalt, featured the main court of the fort. The stele of Seti shows him as a young man wearing only the short skirt and headdress making an offering to Horus. After a long preamble, the text cut below the figure gives a brief account of the campaign of the first year of the pharaoh's reign, in 1313 B.C. One day a messenger came to Seti, according to the text, from the city of Beth-Shan requesting aid against the "vile one" of Hamath, who had formed a league with the men of Pella, a city just across the Jordan from Beth-Shan. Already they had shut up the chief of Rehab in his city, which lay a few miles to the south and was one of the "sister" cities of Beth-Shan.

Seti, at the time, was at Megiddo marching in a campaign against Palestine and Syria. He was resting his army there at the western end of the valley of Jezreel before attacking the Hittites, and seized the opportunity to clean up this local disturbance at Beth-Shan on his way. The stele explains that he sent the division of Ra to occupy Beth-Shan and the division of Amen to attack Hamath, while the division of Sutekh was sent toward the southern foothills of Lebanon as a demonstration to keep the Hittites off the flank of the main army. Seti's fourth division, that of Ptah, is not mentioned, but the explorers presume it was left at Megiddo to guard the road back to Egypt. The inscription concludes with the statement that the conflict was "finished in one day" with a complete victory for Seti.

The change in ownership of the Holy Land after the war has opened up the entire field for intensive study by archaeologists, but finds made before the war are still being examined and identified in museums throughout the world, for the work of translating ancient picture writing proceeds slowly. Announcement was recently made in Germany that eight stone tablets, found in 1905 by Flinders Petri in the ruins of an ancient temple on Mount Sinai, were stone records written by Moses. One of the tablets bears a letter of thanks sent by Moses to Hatshepsut, queen of Egypt, for saving him from the river Nile. At the time the tablets are supposed to have been carved by Moses' order as mementos to the queen, he had been promoted to the highest position in the Egyptian temple.

Native Workmen Listening to Arab Music Played on the Portable Phonograph After the Day's Work Excavating Ancient Biblical Treasures Is Over; Large Numbers Are Required to Remove the Debris



TENNIS IS PLAYED WITH CORKS ON INDOOR COURT

INVENTIONS OF RECENT YEARS SHOW GREATEST PROGRESS

1012 The venerable game of "badminton" has been developed into a strenuous sport

In the last twenty-five years, man has outstripped all other periods in the number and kind of his inventions and their practical application. A quarter of a century ago, no one had heard of the radio, submarines, war tanks, machine guns, airplanes and wireless telephones as articles of almost daily service. The world then was doubting Marconi and the little group of men who believed in radio, while experimenters with airplanes were tolerated as amusing "cranks." Today, the roar of the mail planes daily is heard over the route of the old Pony Express, armies of the

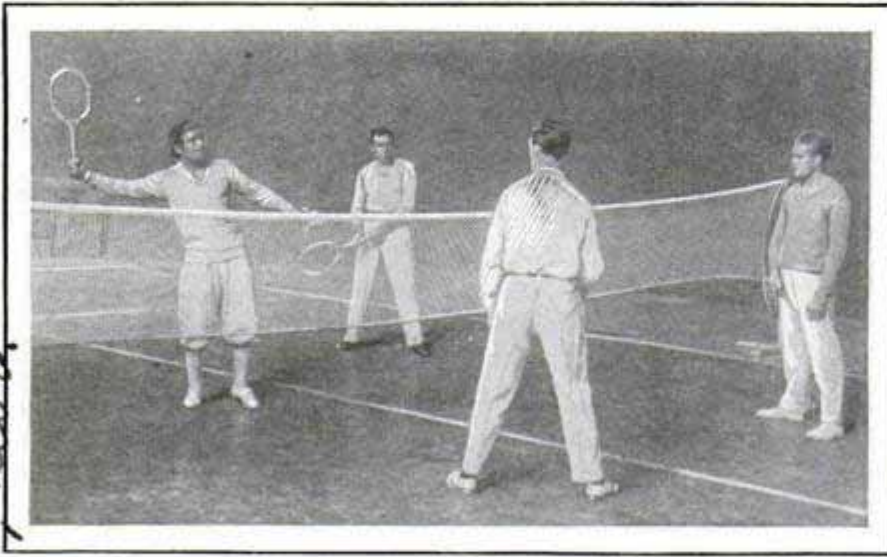

Douglas Fairbanks and Associates Playing the Cork Tennis Game in a Motion-Picture Studio Building; the Net Is Four and One-Half Feet High

that Douglas Fairbanks and others have found nearly as valuable as tennis for keeping in condition. It is played indoors on a court twenty-four feet wide, fifty-four feet long and without the side alleys. The net serves the same purpose as in tennis but is of a finer mesh and is four feet and a half high. Instead of balls, large corks wrapped with friction tape and with five feathers firmly inserted in them are used. Score is kept as in regulation tennis. Winged corks are being devised so that the game can be played out of doors. The feathered missiles, it was found, were too light to carry true in a wind.

LARGEST SEMIRIGID DIRIGIBLE CHRISTENED IN SNOWSTORM

1029 Circling over Scott Field, near Belleville, Ill., for nearly an hour in a light snowstorm and an eleven-mile wind, the "RS-1," the world's largest semirigid dirigible, recently completed a successful trial flight. The big bag, the first of its type to be built in this country, is 282 feet long, has a capacity of 755,500 cubic feet and is propelled by four 300-horsepower Liberty motors. It is the second largest dirigible in the United States, the Los Angeles being the biggest. An average speed of forty miles an hour was maintained during the test, which was conducted by Lieut. Orval Anderson and a crew of eight men. According to Lieut. Col. Paegelow, commanding officer, plans are under way for the erection of a mooring mast.

world fight in the air, and it is becoming the great highway for peace-time travel and shipping. Important applications and changes have been made in old inventions. The reaper, for instance, was known nearly a century ago, but only in the last twenty-five years has it been combined with the thresher. Motion pictures, relaying photographs by radio, the use of radium and the X-ray are achievements of the present century.

735 BOTTLE STOPPER THAT LOCKS HAS REMOVABLE KEY

Bottles are secured against tampering with a stopper that has a separate key to



expand two pieces of metal against a rubber section, wedging it to the neck. A reverse turn of the key releases the pressure so that the cork can easily be removed. The stopper is readily identified by touch, enabling a person to select the proper bottle even in the dark, and preventing accidents.

During the last six months of 1924, the world used 6,232,000 bales of American cotton.

1012 Van Horn, Nelson, Cant. Hall Co. Walton, N.Y. Herald Tribune 1/9/26

735 New York, D.C. new, martins + w. s. 7

*Los Angeles* 1939 *Los Angeles Museum*  
**Unique Places of Business in West**

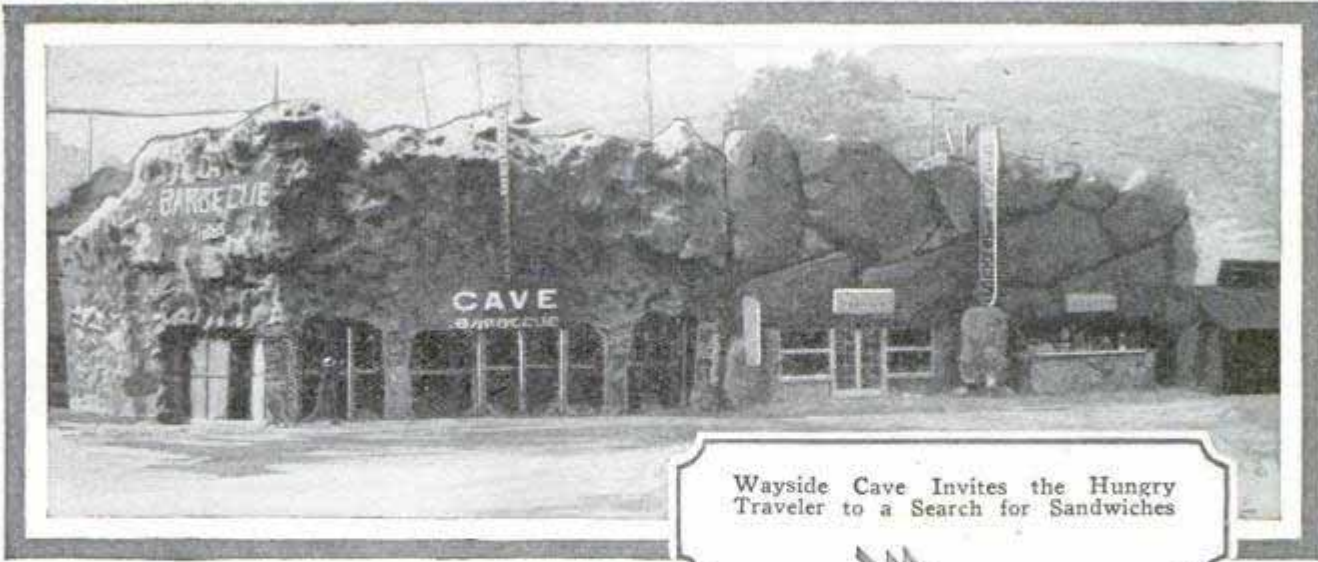

Wayside Cave Invites the Hungry Traveler to a Search for Sandwiches



A Firm of Los Angeles Realtors Adopts the Sphinx as a Silent Salesman



Waving a Welcome to Customers, Dutch-Windmill Pie and Cake Shop

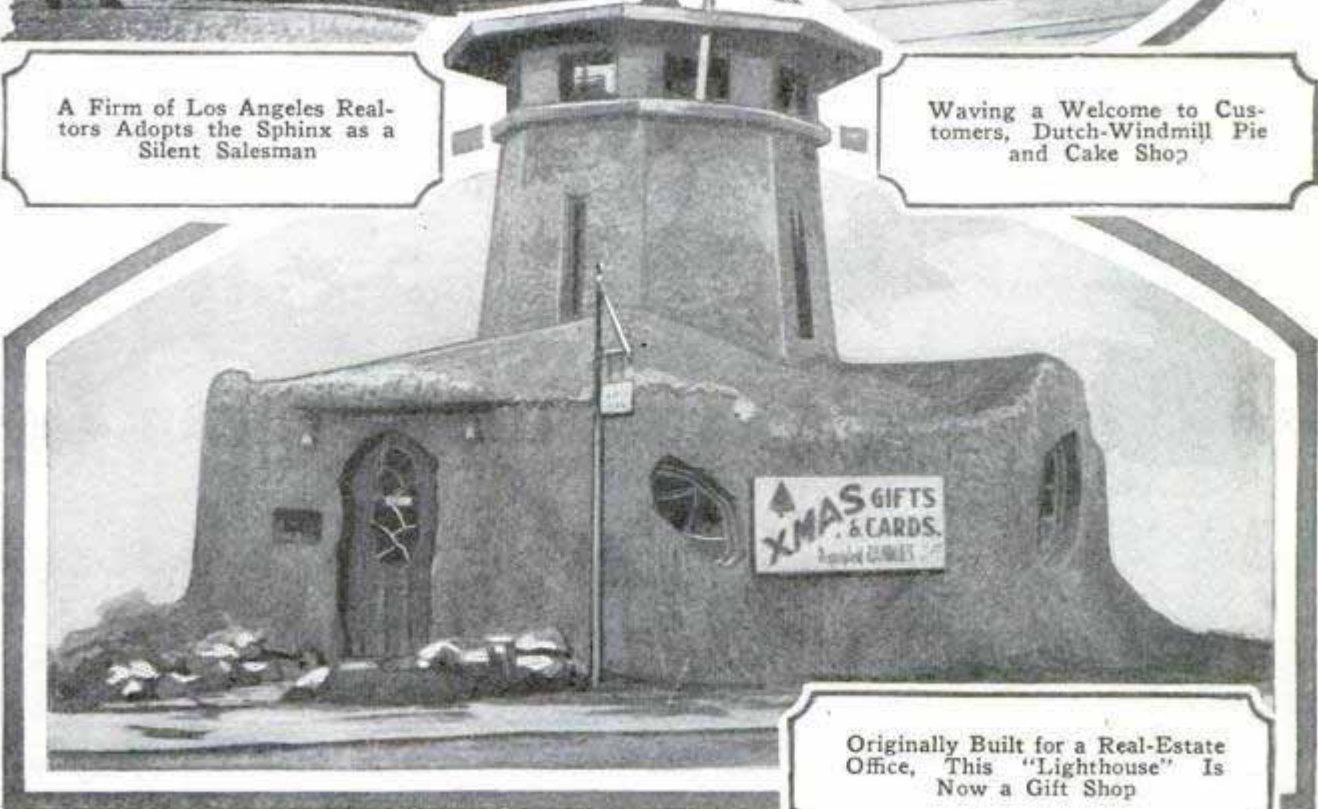

Originally Built for a Real-Estate Office, This "Lighthouse" Is Now a Gift Shop

Paul Honore, 253 E. Howard Ave.  
Detroit, Mich.

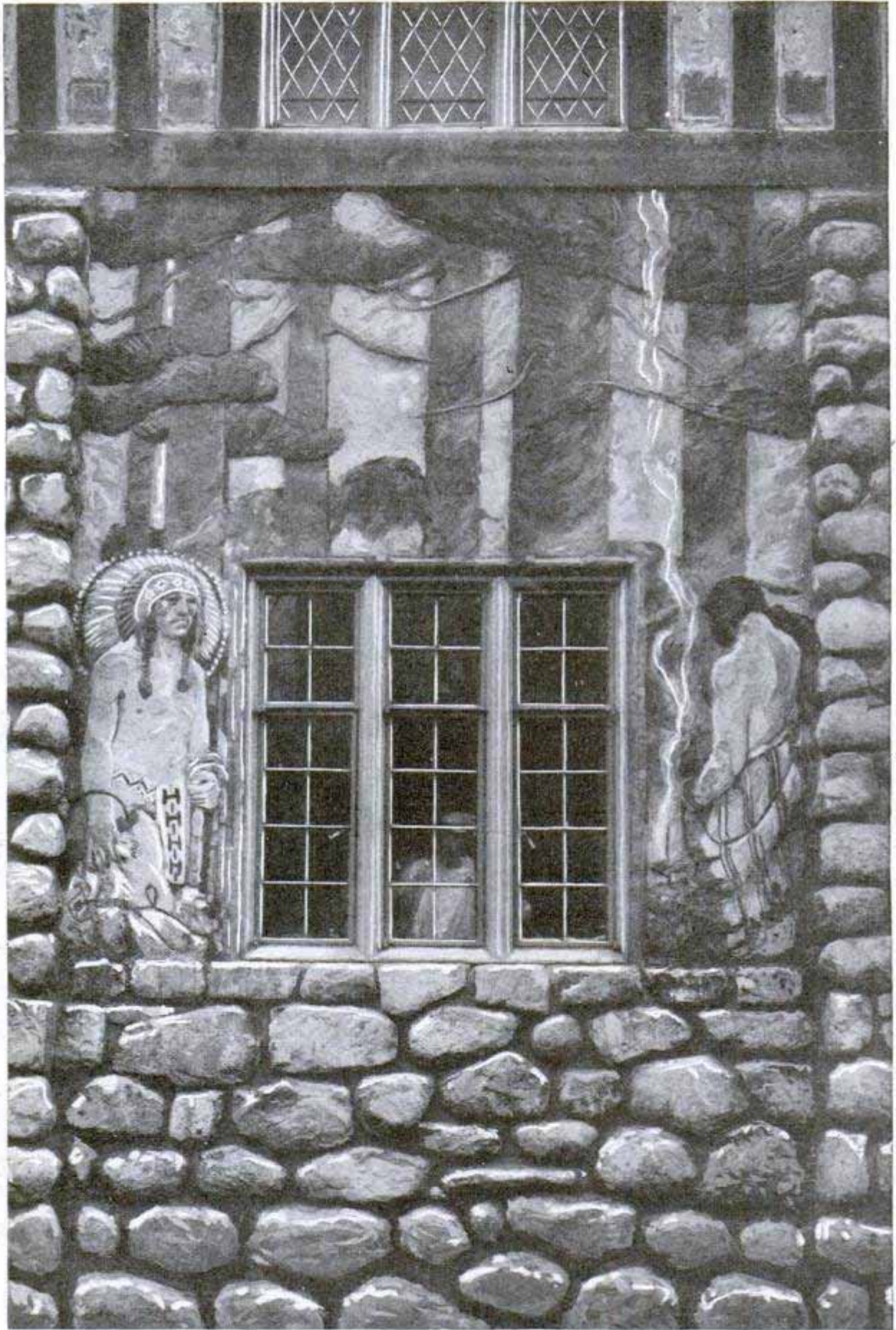

An Indian Scene in Many Colors, One of the Unusual Cement Paintings Decorating the Unique Courthouse at Midland, Michigan, Where an Artist Has Used Colored Ground Glass as Pigment



# Colored Glass Used to Paint with Concrete

USING colored ground glass as his medium, Paul Honore, a Detroit artist, has recently "painted" some vivid murals on the outside walls of a new courthouse at Midland, Mich., that promise much for American exterior decoration. Visitors have come from as far away as Florida and California to study the new material, and if their spoken intentions are any indication, similar colorful structures will soon be scattered over the country.

The big point about colored-glass cement is that it is lasting. Never will the richness fade from Honore's pictures of the pioneers of Midland county. Centuries from now, if the building is standing, visitors will still have their retinas tickled by the ruddy splendor of sunsets blazing on the walls, the gaudiness of woodmen's mackinaws and bandannas and the crazy-quilt riots of colors shown in Indian head-dress and blankets.

Heretofore the only kind of outside pictures that have been possible in this rigorous climate was the sort seen on the front of houses in Bavaria and Tyrol—like our more permanent billboards, done in oil paint. Periodic retouching is necessary to keep these designs fresh. Colored stuccos and plasters have been tried, but they will not weather nor dry uniformly. Our houses never could burst out in pictorial color because a soft, imperishable medium was lacking.

The uninformed person might ask, "Why not pour some good fast pigment into cement and make colored designs with that?" There are several objections, an important one being that the ultraviolet rays of the sun would gradually bleach out the color. At least one artist, who made some cement pictures of this kind, found his masterpieces cracking after several months indoors. The chemists who made Honore's cement for him couldn't wait a lifetime to see how fadeless their product was, so they did the next best thing to make sure. They exposed samples of the glass color material to special quartz lamps that in several weeks' time gave the equivalent of 250 years of sunlight. The cement didn't fade a particle.

Here's the recipe for the cement: Finely ground glass is mixed up in magnesian cement and then transformed into a paste

colored glass cement. Slow Chemical Co. Midland, Mich.

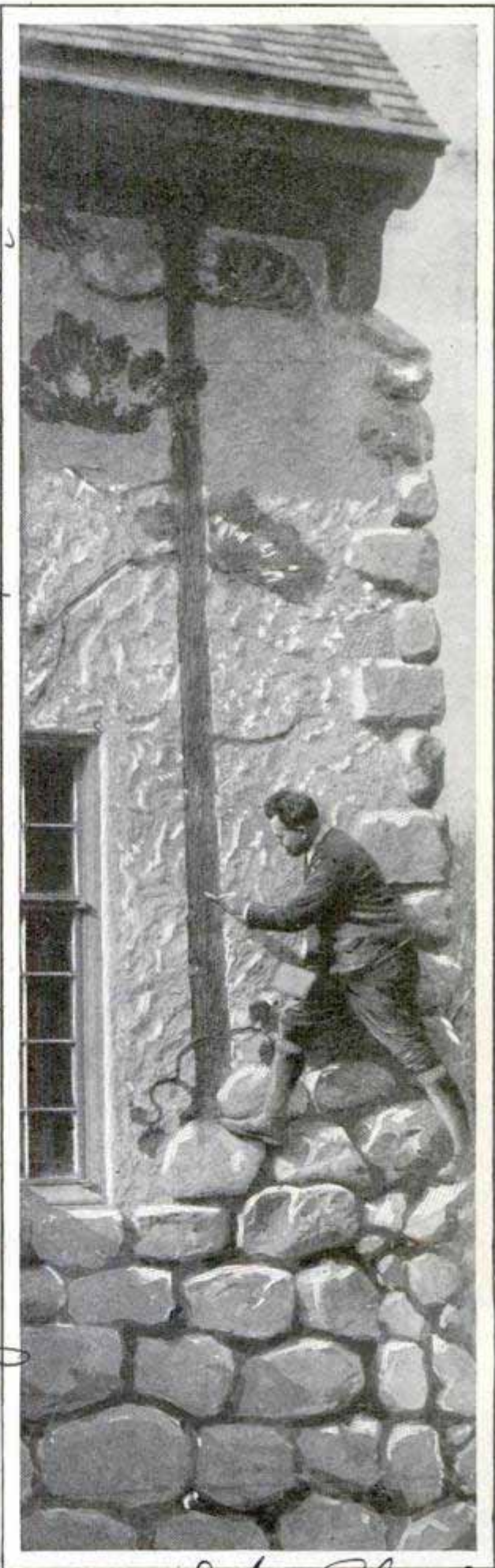

S. Abermayer Co., 2563 W. 18th, Chicago  
American Magnestone Corp., Springfield, Ill.

893

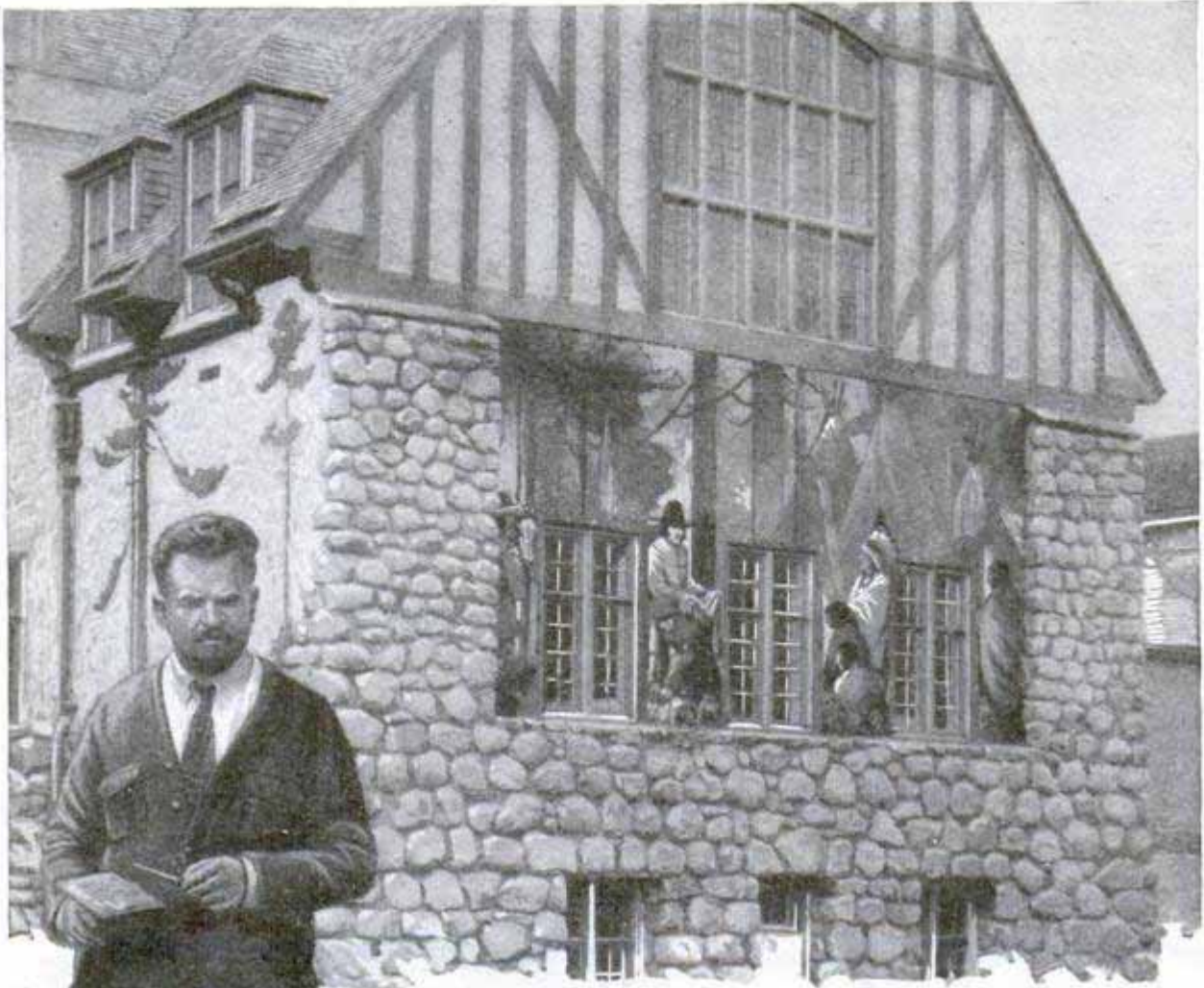

Paul Honore and One of His Ground-Glass Paintings on the Walls of a Novel Stone, Stucco and Timber Courthouse in Michigan

by the addition of liquid magnesium chloride. The artist applied the material with a small trowel, like a putty knife, a n-

where from one-eighth to one-quarter inch thick. The mixture sets in about four hours. When dry, both its feel and its appearance at close range remind one of the surface of a grindstone. Visualize a slab of colored sandstone, and you have a good idea how the material looks.

Mr. Honore explained why the color was so permanent. "Old paintings and tapestries have retained their color for centuries," he said, "because they were kept in houses with glass windows. That is to say, solar light, before it reached them, was robbed of its destructive rays by the glass. Glass screens off the ultra-violet rays.

"The color in my murals is imprisoned, so to speak, in sun-proof grains of glass.

The bleaching rays can never reach the pigment. Glass cement is also immune to gases and acid fumes that float through the air in a chemical-manufacturing town like Midland. In addition to these lasting qualities, the new cement also has non-cracking features to commend it."

There is something else quite noteworthy about that Midland building. So far as is known, it is the first courthouse ever built entirely out of materials gathered in the county erecting it. Hardware is, of course, excepted.

When Herbert H. Dow, of Midland, offered his idea of what the new courthouse should be like, he proposed an American design—not a Grecian temple with a blind-folded statue of Justice in front or on a dome. Furthermore, it was to be constructed of the field stone of the district, of plaster made there and timbers hewn there. Once the building started, almost every farmer contributed at least one load of stone so that the courthouse even has sentiment mixed in its mortar, so to speak.

With this aim of a home-products and home-folks building in mind, the other

problem was to get a design that would be appropriate. Bloodgood Tuttle of Cleveland, the architect, was told to design a building that would fit in and yet stand out. He chose a modified Tudor style. Honore was commissioned to cli-

**SPECIAL CONDENSER ON ENGINE REDUCES WATER WASTE**

Designed by a Swedish engineer for the Argentine railways, a locomotive of the turbine type is equipped with a special

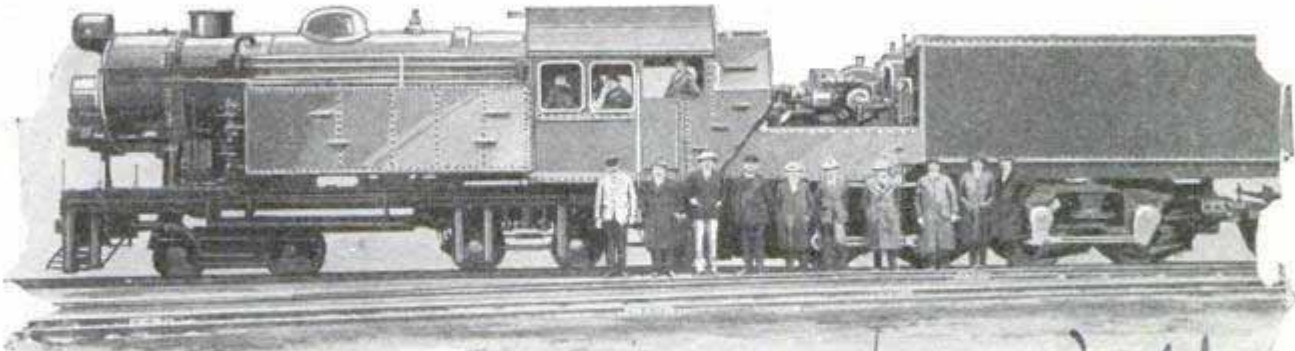

*Wide World.*

A "Camel" among Locomotives; Condenser Engine Designed by a Swedish Expert for the Railroads in Argentina Where Long Runs Must Be Made without Watering Places

max the whole project by depicting on the walls the life and surroundings of the original home folks of the county, the first settlers and their red-skinned neighbors. The plan of making the building entirely a home affair was carried to the extreme of turning the first sod with a spade of magnesia metal, a substance derived from the brine that oozes through the Midland county sands.

Chemists did the research work that led to the new medium. They began with stuccos and cements. When they hit on the ground-glass idea, they still had a lot of work ahead of them in determining what "mesh" of ground glass was best, and other technical details. But now that the process is perfected, a new plastic medium is at public disposal for a variety of uses. Lamp stands, window boxes and molded decorative articles of all kinds may possibly be fashioned from it.

*1008*

**SPRING CLAMP ON ASH TRAY PREVENTS TIPPING OVER**

To hold the ash tray in a convenient position and to keep it from upsetting, a rubber-covered spring clamp is adjustable to tables, desk, chairs and other objects. It is securely fastened to the holder with a wingnut, and has a specially constructed arm to keep the tray upright. The clamp is useful also on trains.



*Albert J. Inc Elfresh  
2126 Pearl St.*

condenser unit between the tender and the engine proper, so that it can cross long desert stretches with a minimum of water consumption. The tank is of unusually large capacity, and the drain on it is partly replaced by the condensed steam flowing back from the locomotive through the reclaiming apparatus.

**SHIPS BUILT WITH SOFT BOWS TO INCREASE SAFETY AT SEA**

*1024.*

With vertical instead of horizontal plates at the prow, vessels could be constructed so that they would not be likely to sink other ships in case of a collision and would be proof against serious damage themselves, according to E. F. Spanner, a British marine architect. He has produced figures to show that a boat of this soft-ended type, should be able to run head-on at ten knots an hour into a solid wall without rupturing the first forward hold. He believes that the vertical plates would yield sufficiently under the impact to take up the force of the collision, thus preventing the shock from reaching other parts of the ship. The soft prow would be built forward of the collision bulkhead. Other ships, from the largest liners down to those of only 150 or 200 feet in length, would also be protected from serious damage, Mr. Spanner states, assuming they were of ordinary seagoing steel construction, as the plates would be dented only instead of being cut through, and repairs would be less costly.

*Lindor Eng.*

*Christian Science 1/6/26*

Timber losses caused by boring insects amount to approximately \$40,000,000 every year.

# The Latest German Wireless Station



Interior of Konigswusterhausen Radio Station, Germany, One of the Largest in the World

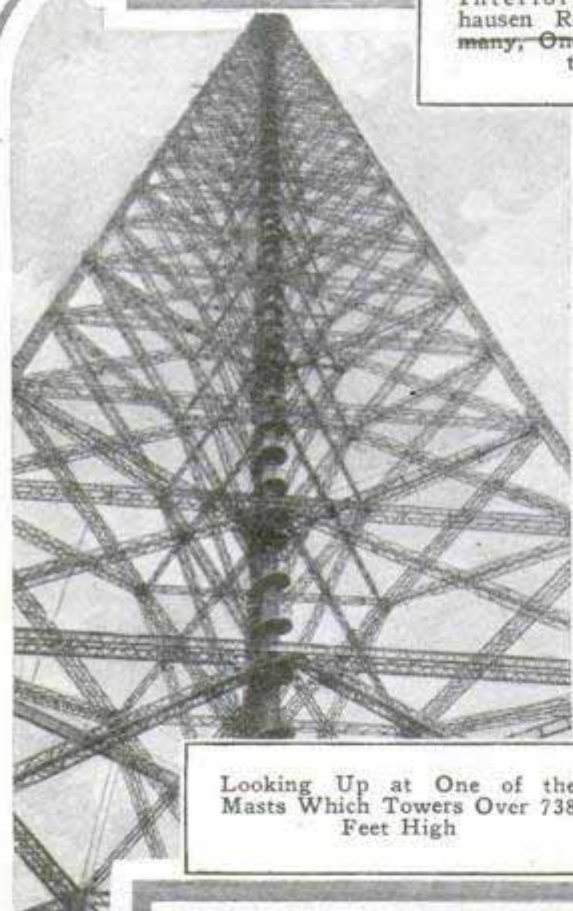

Looking Up at One of the Masts Which Towers Over 738 Feet High

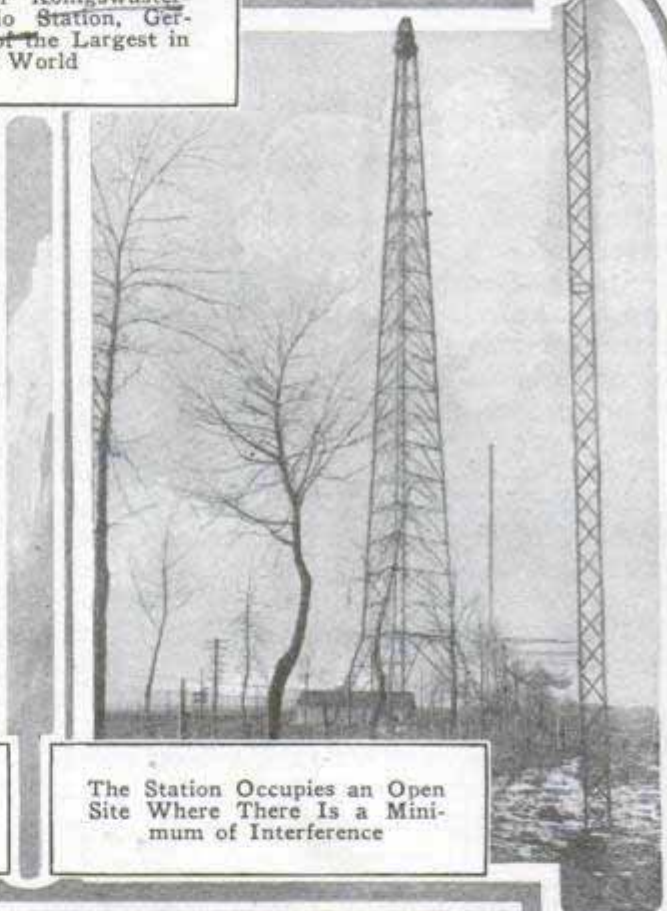

The Station Occupies an Open Site Where There is a Minimum of Interference



Another View of the Interior, Showing Panels of the Transmitter during Construction

Research Engineers  
POPULAR MECHANICS  
Sluper Radio Corp  
City

### SENSITIVITY OF RADIO TUBES NOT DETERMINED BY LIGHT

Contrary to popular impression, the amount of light given off by a radio tube is not an indication of its sensitiveness or general condition, according to research engineers. The fact that the tube emits light at all is only incidental to its operation, and in some, a manganese coating on the glass permits only a slight amount of light or none at all to penetrate, so that the illumination test is practically worthless so far as indicating how well the tube is functioning. What is desired in the tube is a flow of little particles of electricity, the electrons or negative charges. The easiest way to obtain this action is to heat certain kinds of wires in the glass bulbs from which the air has been exhausted. To make the flow abundant, the temperature must be quite high, and this is done in actual operation in the radio set by current from the A-batteries. The wire becomes incandescent under the heat and naturally emits light as a result, but the light itself has no connection whatever with the actual working of the tube.

### STEEL COTTER-PIN PULLER HAS JAWS THAT LOCK 950.

Removal of cotter pins is simplified by the use of a steel puller operated like a pair of pliers. When the handles are spread, the jaws are forced out of a steel housing, and a lug on the upper jaw throws them open to engage the pin. Closing the handles pulls the jaws back into the case and, at the same time, locks them on the pin, reducing the likelihood of slipping and also preventing the pin from dropping out and being lost.



### RIDDING THE SEA OF DERELICTS AT PERIL OF SAILORS' LIVES

Removing the hulks of wrecked ships from the sea lanes, so that they will not be

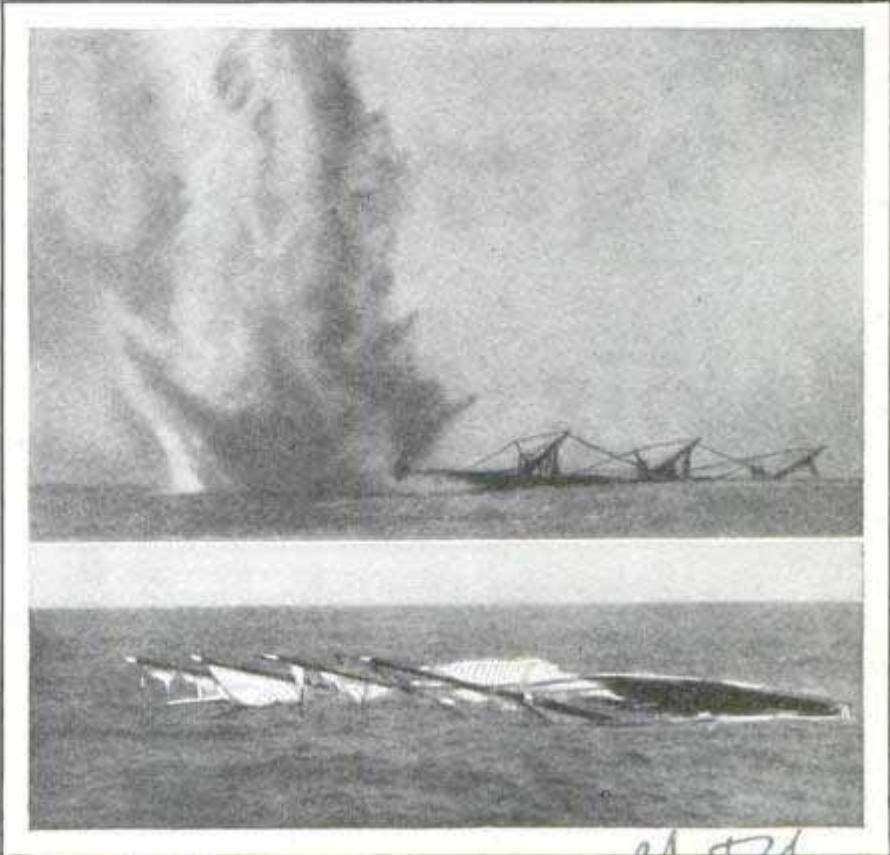

Clearing the Sea of a Derelict; a Mine Exploded under a Floating Wreck of the Schooner "James W. Howard"

a menace to navigation, is one of the perilous duties that falls to the coast-guard service. The task cannot be attempted in stormy weather as high waves make boarding the wreck extremely difficult and placing the charges of explosives with which to shatter the derelict, dangerous. Mines are usually attached to the wrecks and exploded by electric contact from a safe distance. In blowing up the schooner "James W. Howard," of Boston, as shown in the upper photograph, the coast-guard cutter "Modoc" had to wait several days after the wreck until the sea became sufficiently calm to permit small boats to be sent over for placing the mines. The job was only half finished when a heavy southwest storm approached, driving the wreck out of the path of coastwise shipping and compelling the "Modoc" to leave.

☐The Popular Mechanics' Bureau of Information offers its free service to all readers of our magazine. Names and addresses of manufacturers and dealers in articles described will be promptly furnished by addressing the Bureau.

Burke + Isants  
Madison Terminal Bldg

Percolator set  
Londers, Frary & Clark  
200 Lytle Ave. New York

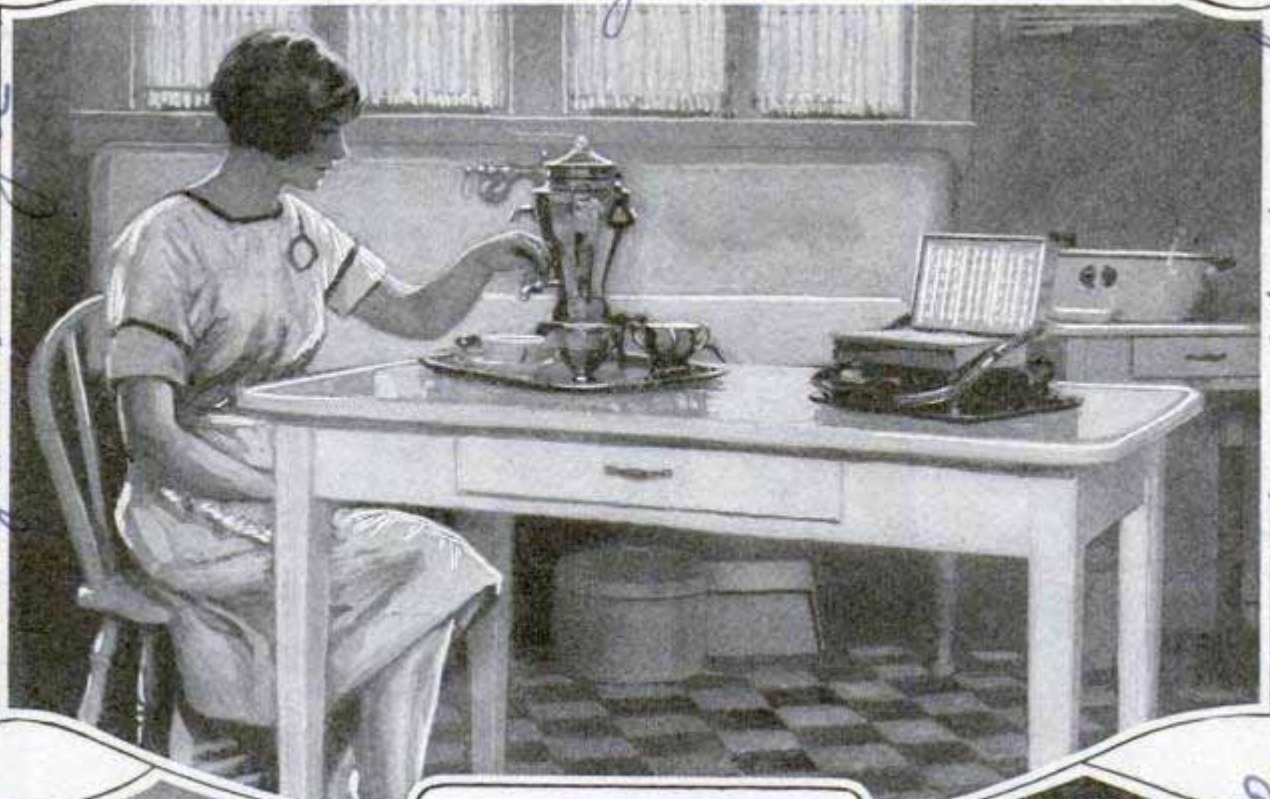

Toaster - Westinghouse  
Electric + myg Co 18. Pittsbu  
+ Randers, and myg Clark Pa

The Abundance of Convenient  
Electrical Appliances, Such as  
the Coffee Service Above, Is  
Expected to Be a Revelation in  
France, Where Electricity Is  
Used Mainly for Lighting

Cleveland Heater Co. 1905 W. 42th St  
Cleveland, Ohio



Latest Model Hot-Water Heater Sup-  
plies Service in Quantity, While  
Even the Floor-Polishing Brush Is  
Operated by an Electric Motor

Brushwasher - Washers Wash Washer Co  
129 W. 21st St. New York

The Kent Co  
Rome, N.Y.

Brooklyn, N.Y.

651 411

# The Model Home

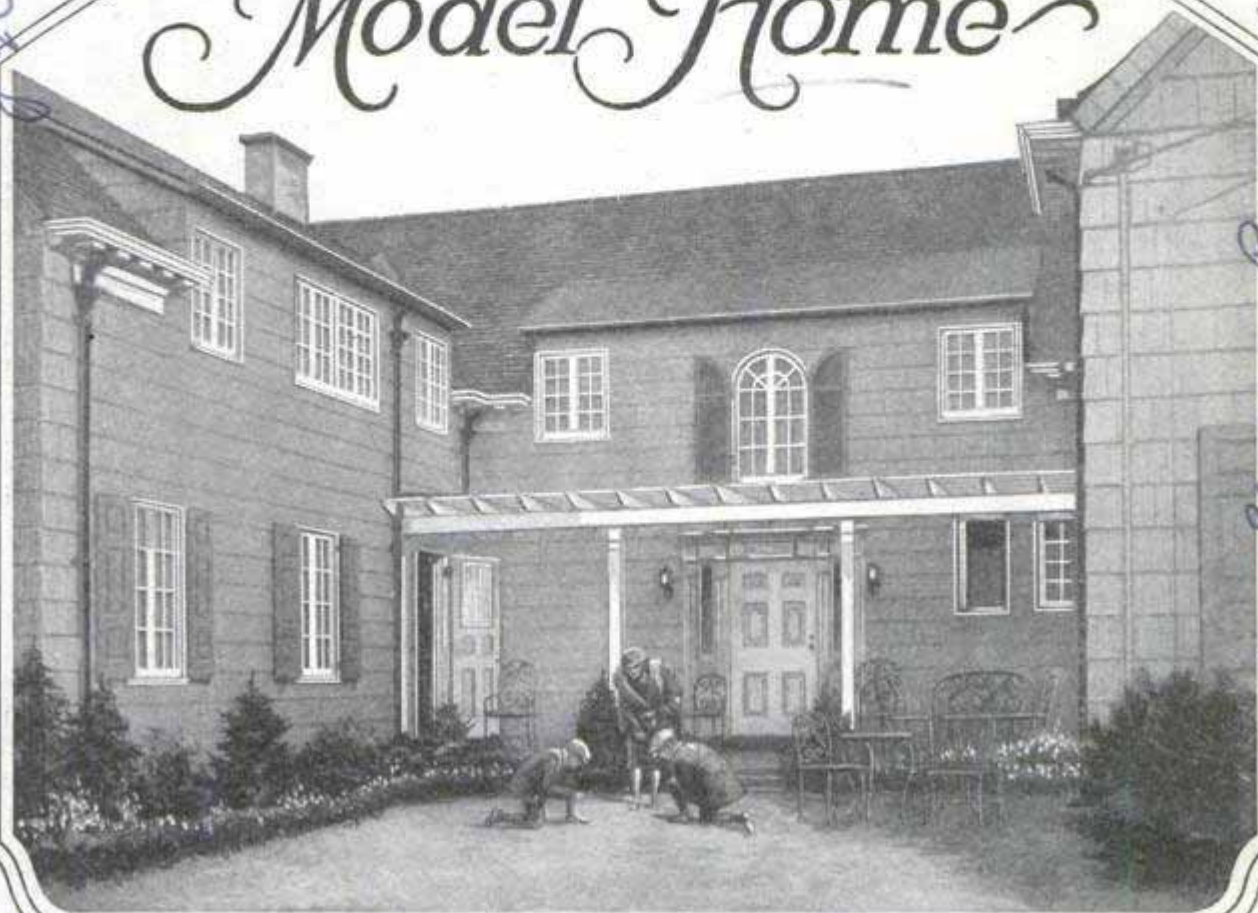

## American House, with Latest Labor-Saving Appliances Sent Abroad to Show How Work Is Lightened

IN the Grand Palais in Paris workmen are reconstructing from numbered pieces a "perfect home," erected, torn down and transported across the ocean from the United States. It will be the chief American exhibit at the International Exhibit of Household Appliances and Labor-Saving Devices.

The house represents the combined opinion of leading architects, interior decorators, electrical experts, and others, as to what the perfect home should be. It is of early colonial design, two stories high, of U-shape, with two wings forming a courtyard between them.

It is the interior equipment, however, that is expected to astonish the French housewives, to whom many of the everyday electrical and mechanical household appliances used in this country are unknown. The kitchen and laundry in particular are expected to make them rub their eyes. The vacuum cleaner, wash-

ing and ironing machines, fireless cookers, electrical refrigerator with its arrangement for delivering cubes of ice for table use, and numerous other electrical devices are still curiosities in most sections abroad. The laundry equipment includes white-enameled tubs and washing machine, electric ironer and a hand iron for more delicate work. The polisher for the floors has an electrically driven revolving brush. The hot-water heater works automatically, and for the table there are a number of electrical devices, including a silvered coffee machine, toaster and waffle maker. The rooms are lighted by softly shaded table and floor lamps, as well as wall sconces and overhead chandeliers. All the furnishings and decorations are accurate reproductions of early American designs, some of which were copied from original pieces in the American Museum. Upstairs the same electrical motif is carried out. There is a

Westinghouse Electric & Mfg Co  
East Pittsburgh, Pa.

Warming  
Pa.

Commission Dealer,  
Curling & Co. - Dan. Warming

Domestic Electric Co. 43 Warren, N.Y.  
Electric Corp. 120 Broadway, N.Y.

Apex Rotaries Corp.  
24 W 33rd St.

Westinghouse  
Electric & Mfg Co.

Lead Change W of the  
Electrost Start W of the  
Dance

*Buffalo Co-operative Store Co*  
**POPULAR MECHANICS**  
*Buffalo, N. Y.*

*Remily Electric Co 4841  
Edward St. Detroit Mich*

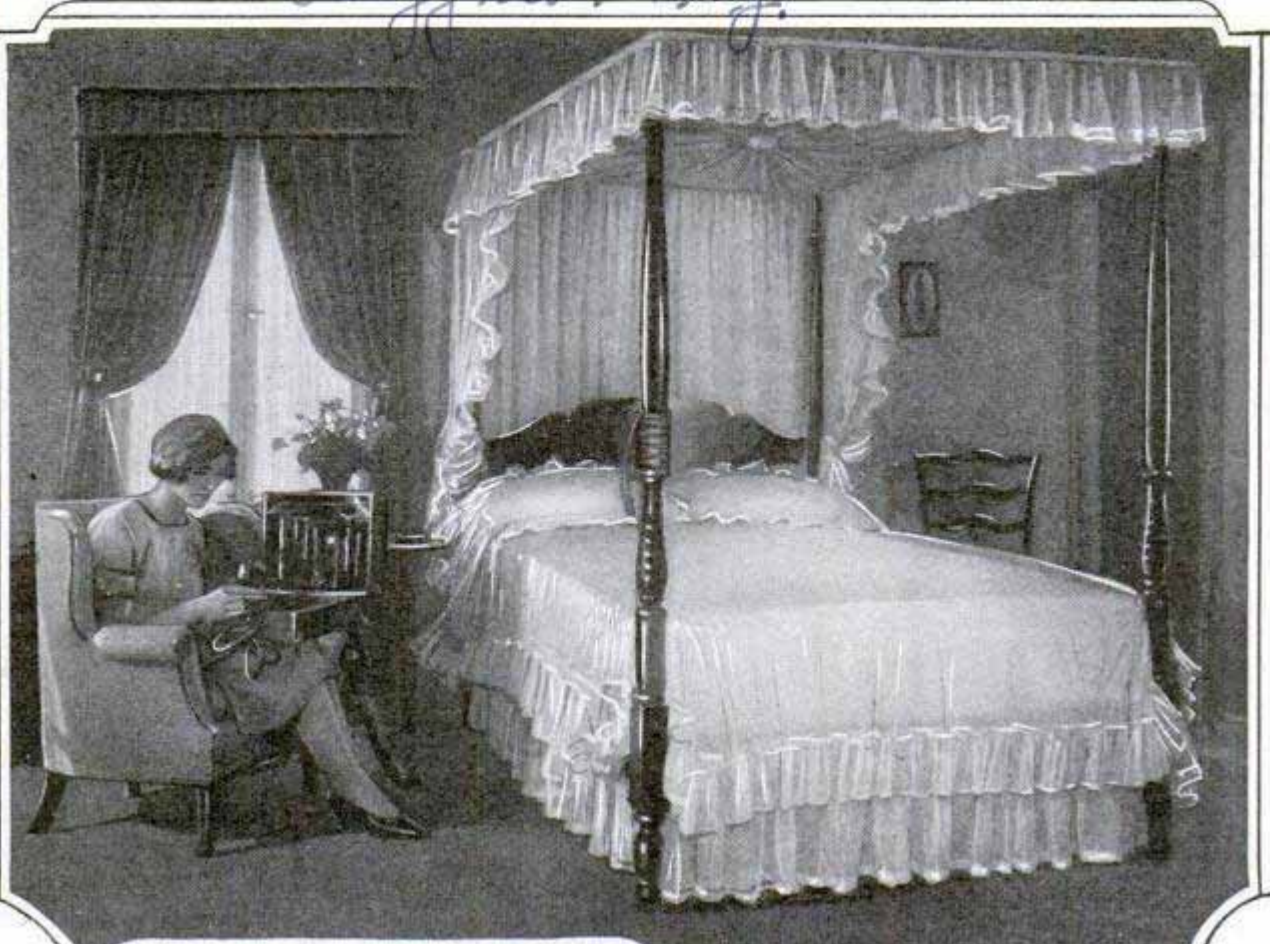

Latest Model Violet-Ray Outfit and Other Electrical Devices Are Shown amid a Setting of Fine Colonial Furniture, Modeled from Museum Pieces of Early American Handicraft; Above Is One of the Bedrooms; the House Contains Ten Rooms and Four Baths

*American Radio Corp  
40 W. 40th St  
New York*

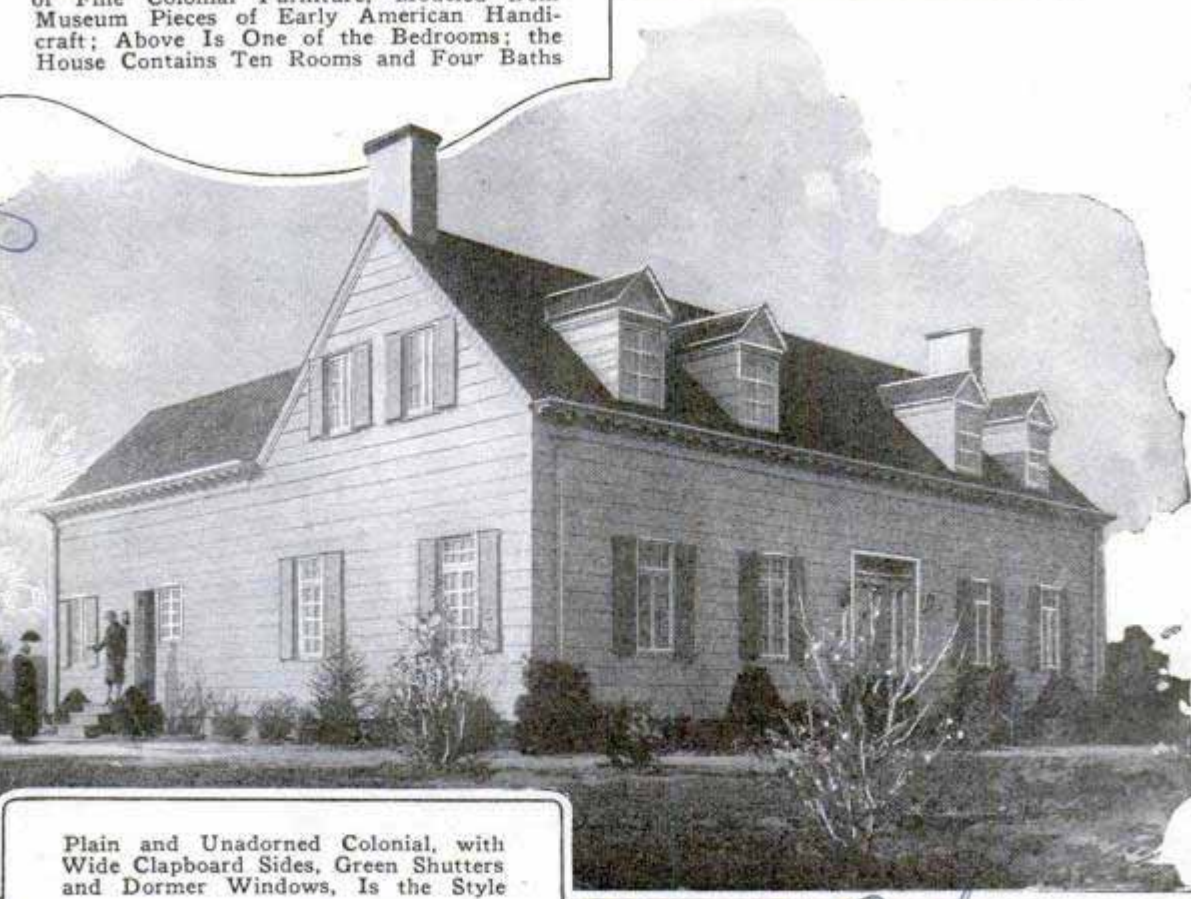

Plain and Unadorned Colonial, with Wide Clapboard Sides, Green Shutters and Dormer Windows, Is the Style

*Radio - Colonial Radio Corp  
Long Island City, N.Y.*





The Dining Room Shows the Simplicity and Charm of Early Colonial Style at Its Best, with Fireplace and Furniture in Keeping with the Period; Plenty of Wall Plugs Are Provided for the Many Electrical Appliances for Buffet and Table



Another of the Bedrooms, Showing the Special Wallpaper in Early Design, and the Electrical Heating Pad, an American Convenience Almost Unknown in France

*and Curling Iron  
 Russell Electric Co  
 740 W. Huron, Chicago*

and Hair Dryer

00 Torrington Conn

65



heating pad and an electric violet-ray machine, as well as a massage device. Even the fireplaces have electric fires, supplemented by portable heaters.

Throughout the ten rooms and four baths the same completeness of equipment has been carried out. After the exhibition closes the house will be presented to some Frenchman, selected by the French government for the most notable contribution to humanity in recent years. It will be taken apart for the second time, and finally erected permanently on the site chosen by the recipient.

The house attracted thousands while it was on display in Brooklyn.

*Phoenix Cabinet Co. Syracuse, N.Y.  
419 Harris Bldg.  
General Sales Dept. Co.  
44 W. Broadway  
New York*



Above is a View of the Hall, Showing the Wall and Table Lights, and beneath it, a Telephone Recess with Bell Box Hidden in Wall

*Westinghouse Electric & Mfg. Co.  
East Pittsburgh, Pa.  
Landers, H. Vanp + Clark, 200 Fifth Ave  
New York*

*Shapiro + Aronson, Inc  
20 Warren St. New York*

651

*Charles Leizer - Puritan Clothing Dryer Co., Cincinnati, O.*



French Women Who Still Do Their Housework by Old - Fashioned Methods Are Expected to Open Their Eyes When They See the Electric Ironing Device Which May Be Operated Sitting



For Smaller Work There Is the Electric Hand Iron. Above, and in the Background May Be Seen the Gas-Heated Clothes Drier Which Does Away with Clothes Lines and Makes Laundry Day Independent of the Weather; at the Left Is the Electrically Driven Washing Machine and Wringer and the Built-In Tubs



*Westinghouse Electric & Mfg Co., East Pittsburgh, Pa.*

*The Rainaday Co. Pittsburgh Pa.*

*Wide World*

976 **CROSS-TIPPED MARBLE TAPERS HONOR WAR DEAD**

In memory of Italian heroes who fell in the World War, a monument in

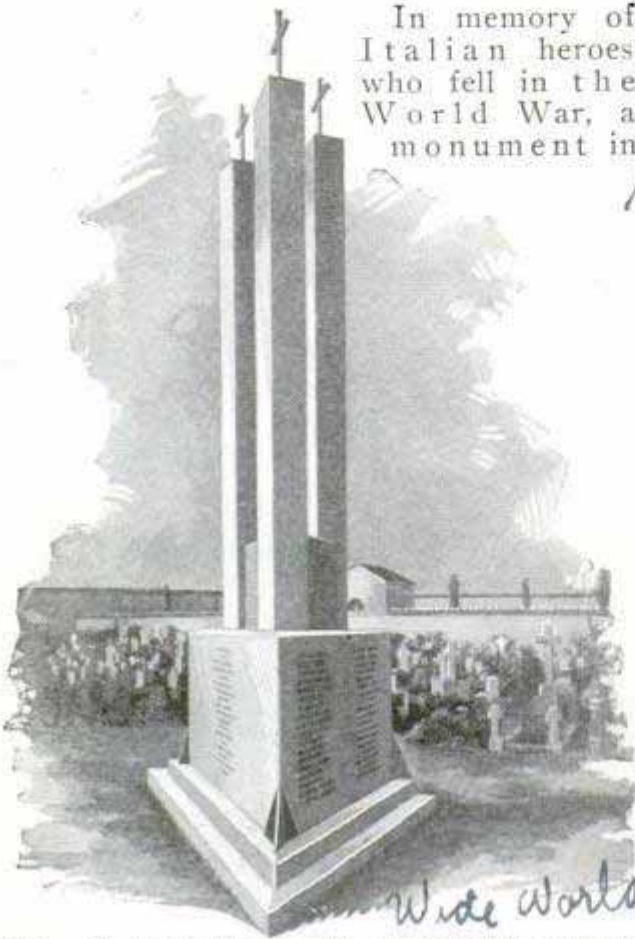

"Tapers" of Marble Erected in Memory of Italian Heroes of the World War

the cemetery at Parma suggests three tall candles set in a triangular base and each capped by a cross. Names of the soldier dead are seen on the foundation.

1016 **PENSIONS PAID BY U. S. YEARLY TWO HUNDRED MILLIONS**

More than \$200,000,000 is paid yearly by the United States to the survivors and to widows, helpless children and other dependents of soldiers of the wars. Since 1790, when the pension system was started, this country has paid out over \$7,000,000,000 to such persons. According to official figures, the World War cost the United States \$24,610,000,000, and since the signing of the armistice, \$1,371,645,477 has been expended for pensions. There are now 512,537 pensioners on the government rolls, as compared with 525,539 during the fiscal year of 1924. It costs about \$1,500,000 a

year to maintain the system, although the total amount expended yearly is growing smaller. Nearly \$6,500,000,000 has been paid in pensions as a result of the Civil War, which cost \$4,500,000,000.

1017 **SALVAGE TONS OF OLD RUBBER TO COMBAT HIGH PRICES**

The capacity of American plants for reclaiming rubber has been greatly increased since the imposition of high prices, due largely to the British monopoly, and it is estimated that no less than 400,000,000 pounds of rubber will be salvaged during the present year, to be used in place of the plantation product. In 1924, when the cost of raw rubber was thirty to thirty-five cents a pound, this country produced nearly 170,000,000 pounds of reclaimed material. The government estimates that American industries will need 900,000,000 pounds of rubber this year. Cultivation of a plant that yields rubber is being developed in Texas and other southern states as another means of meeting the situation. *scrch 12/27/26*

1000 **WALLS IN RUSSIAN FACTORIES DISPLAY NEWSPAPERS**

Workers in some of the factories in Moscow, Russia, have but to look at the walls of the buildings to find out the latest happenings, for newspapers, lettered in legible bulletin style, are posted in conspicuous places. The sheets are prepared in inks of various colors and much of the printing is done by hand.

Russians Lettering Newspaper Bulletin and a Sample Display on Factory Wall



*scrch 12/20/26*

*Wide World*

958

*newspaper  
461-8th Ave  
New York*

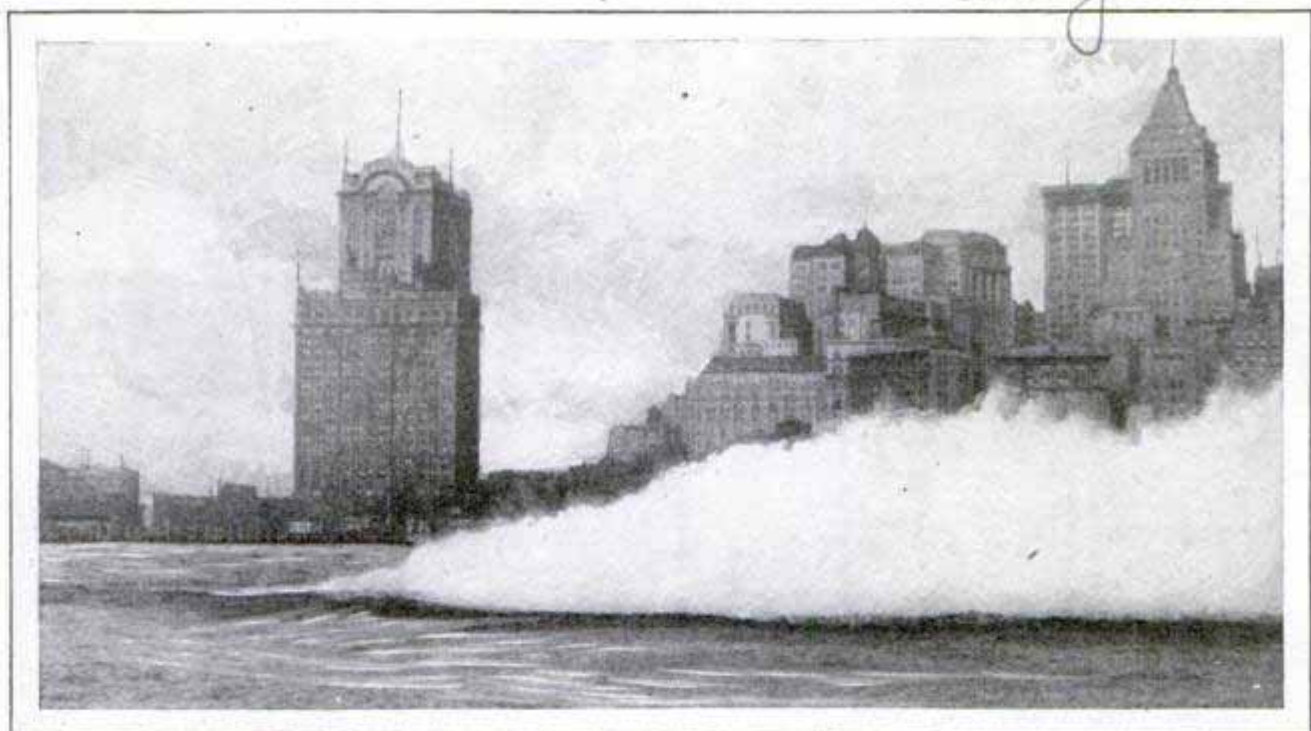

Taken an Instant After Submarine Charge of Dynamite Was Exploded; Column of Mud and Water Rising from New York Harbor during Blasting to Widen the Channel

### BLOWING UP NEW YORK HARBOR TO WIDEN CHANNEL *958*

Tons of dirt and water leaping in a sudden gush from the placid surface of New York harbor gave spectators a thrill recently as engineers started blasting the bottom to widen the channel near Governor's island. Each charge contained 500 pounds of dynamite and twenty-four hours were required to set it off.

### FOUR-FIFTHS AS MANY HOUSES AS FAMILIES IN U. S. *969*

In spite of the rapid increase in the number of flats and apartments, there are more than 20,000,000 dwellings to house about 25,000,000 families in the United States, a recent survey shows. By family is meant a group of people, not necessarily related, who live as one household and eat at the same table. However, there are several states that have a separate dwelling for every family, and even in more congested sections, the ratio is not so unbalanced as might be supposed. In Illinois, for instance, there are only about forty per cent more families than dwellings, and in New York state only twice as many families as dwellings. Philadelphia upholds its reputation as a city of homes, the number of which is only ten per cent less than the number of families. In crowded New York City, there are about four times as many families as dwellings. The size of the average American family is found to have increased slightly in the

last few years, but there is an average of only six persons to every dwelling the country over, including the large apartment buildings in the cities.

### "LOSE A MINUTE, SAVE A LIFE" WRECKED AUTO WARNS *925*

Its days of running service over, a wrecked auto in Lincoln, Nebr., has been placed at the curb of a downtown street as a warning against careless driving. The message is summarized in a safety slogan, "Lose a Minute, Save a Life."

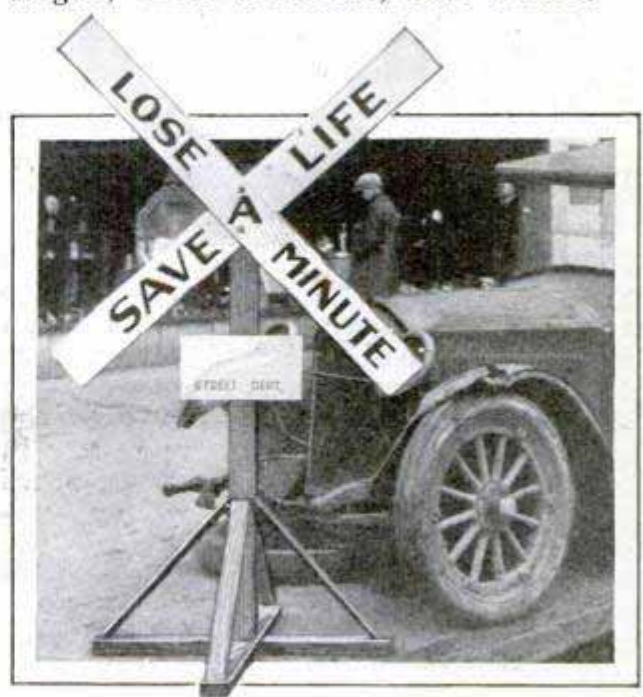

Wrecked Auto and Cross Sign, Silent Advocates of Safety, Displayed on Sidewalk at Lincoln, Nebraska

*New York Times  
12/20/25*



Nothing in the Picture Indicates It, but This Scene Is Painted on Cobwebs

### ARTIST PAINTS ON COBWEBS INSTEAD OF CANVAS

920 Filmy cobwebs, so delicate that a puff of wind may destroy them, are used by a peasant artist in the Tyrol as a substitute for canvas. He paints a variety of scenes in colors on the material, which is so thin that the picture is practically as distinct on one side as on the other. In spite of precautions taken to protect these pieces, they are likely to be torn and collectors guard them with great care.

### PHONE CALLS READ BY CAMERA FROM AUTOMATIC COUNTER

Development of the automatic-telephone system has necessitated two ingenious aids, an automatic counter which keeps a record of calls made and a camera to read the totals every month. Each subscriber's line is connected to one of the registers, which are set row upon row in panels behind tightly locked, dust-proof glass doors. In a machine-switching station, when a receiver is lifted from the hook, a mechanical "finger" goes "feeling" up and down an intricate device until an empty wire is located for the subscriber, the familiar "dial" tone is sounded, and the connection can be completed by turning to the proper numbers, if the

line is not busy. When the conversation is finished and the talkers hang up, the automatic register clicks a record of the call. With the special camera, these registers can be read once a month in a fraction of the time required by the old method, which generally took two persons working all night, one to read the numbers and the other to record them in a book. The camera contains sufficient film for seventy exposures and fits tightly around a section of six registers. Inside the instrument's hood are small but powerful electric lamps to illuminate the numbers recorded on the register. The exposed films are forwarded to a central mechanical department where they are developed and printed, and the long, narrow strips are distributed to the proper accounting offices. The developed film gives an absolutely accurate reproduction of the totals, which are entered upon special cards so arranged that they form a continuous record for a whole year and from which the number for the month can be computed almost instantaneously.

### CANE HOLDS FOLDING TABLE FOR PLAYING CARDS

872 Constructed like an umbrella, a small folding table, top, legs and all, can be placed inside a walking stick, which also collapses for carrying in the pocket when not in use as a cane. The table is well braced and is of the right height to permit players to use it comfortably when seated.

Card Table Ready for Use; When Folded, It Fits inside Cane Which Also Collapses When Empty



Mr. Mac Joseph  
Streatham, Eng.

New York Times  
12/20/25

*knowledg. Colombarie, Barnhurst Road, Besleyheath, nr London Eng.*

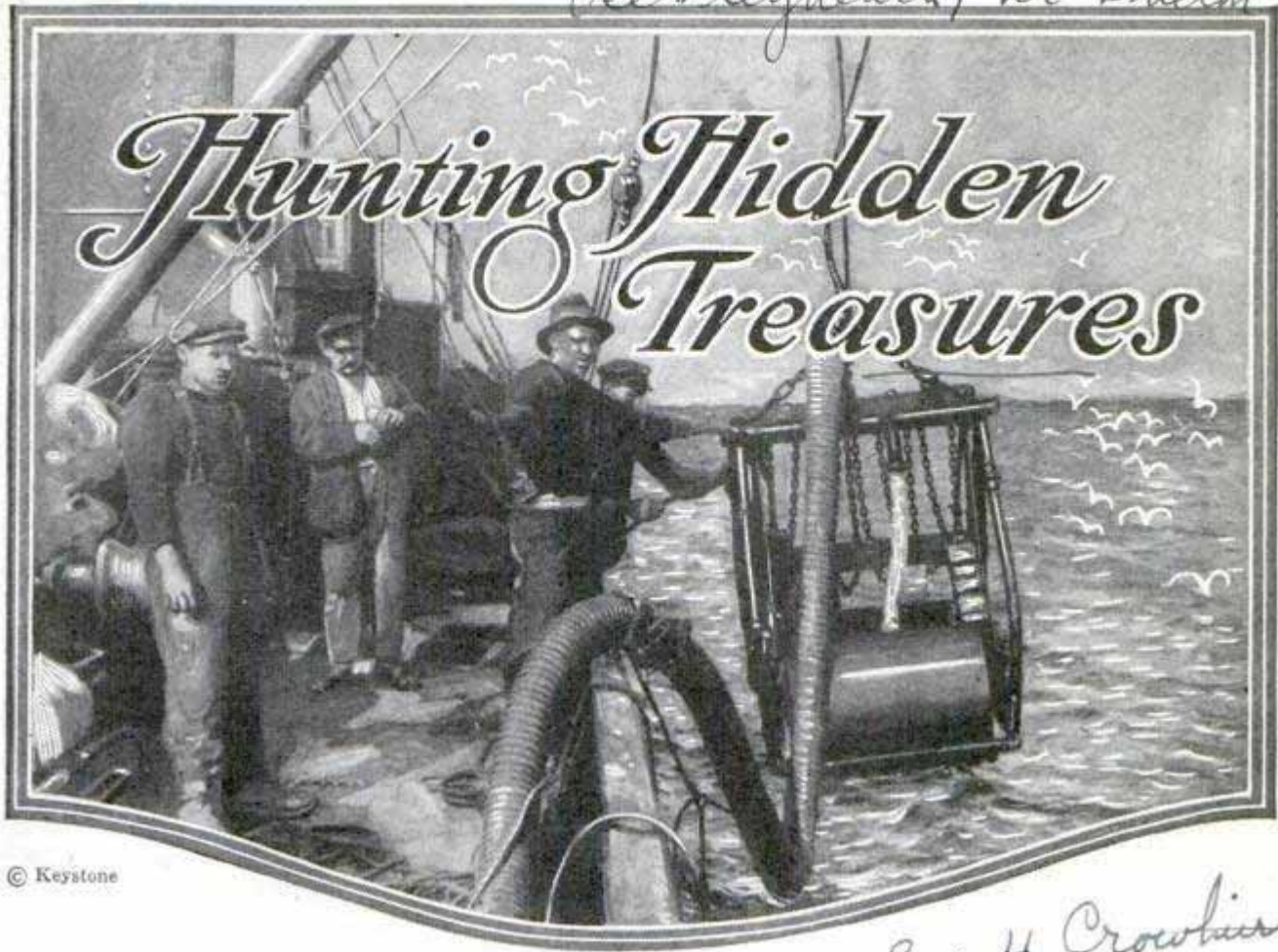

© Keystone

By HAROLD T. WILKINS

*Exp. 4, Crowhurst Road, Briston, S.W. 9, Eng.*

A SPANISH seaman, whose face bears a sinister scar, is dying of yellow jack in a plague hospital somewhere in the West Indies. Touched by the kindness of another patient, he beckons and whispers in his ear the secret of a chart, marked with mysterious crosses, anchors and other symbols.

"If you take your bearings from this chart, your fortune is made." He dies; the other seeks out a man of means and adventurous spirit. A syndicate is formed, a ship chartered, and it is sailing to the Spanish Main with picks and shovels to dig up the shining sands of a pirate cove. The treasure is, or more likely is not, found. That was the old-time treasure quest—true to fiction and even to real life.

Today, the quest is organized on scientific lines. An exploration ship, sent out by a learned society, calls, in passing, at some lonely outpost in the South Seas, whose cliffs and caves are known to have been the "bank" of a buccaneer or lesser piratical marauder. Syndicates, with plenty of capital, press into the quest the latest devices of modern engineering. They drain away lakes, blast mountains to pieces and pile up earth in thousands of tons by the aid of steam shovels, to search

for buried treasure of bygone centuries. Sometimes it is found, but oftener fate and chance take a hand in the game.

An American girl diver, Miss Jean Tolley, was recently acting a part in an underwater film, in Nassau harbor, the Bahamas. She dived deep and saw on the sea bed the handle of an iron chest sticking out of the sand. It was hauled up to the yacht from which she had dived, and the astonished performers pried open its sides, when a heap of Spanish doubloons, bearing the date 1790, rolled onto the deck. There were many thousand dollars' worth of them. The British government put in a claim to the treasure trove, and it was deposited in the vaults of the Royal Bank of Canada, pending a law suit.

In August, 1925, an American was searching the ancient ruins of an underground chapel at Torres Junction, Sonora, Mexico, armed with a chart given him by a Mexican woman, in whose family the document had been handed down for generations. He unearthed among the ruins three bags of seventeenth-century Spanish gold coins and ten bars of silver, valued at \$750,000.

Far away in the Philippines, at Calumpit, near Manila, American soldiers are

searching for the great hoard of Spanish gold buried 160 years ago by a Chinese mandarin when the British captured Manila. The finest string of pearls in the world is said to be hidden somewhere in these swamps.

The buried treasure of Sir Henry Morgan, the famous buccaneer of the Spanish Main, whose "bank" was in the lonely isles of the Caribbean sea, is being sought for by Bernard Keegan, the famous American deep-sea diver and second mate of the wrecking tug "Favourite," of the Panama canal. Tradition says the treasure is hidden in a sunken cave. The mouth of the cave, above water in Morgan's day, is now seventy-five feet below the surface of the sea. An

authentic treasure still waits to be found in the Panama Canal Zone. Somewhere in the woods which adjoin the old Camino Real, or royal treasure road to Nombre de Dios, are buried great loads of silver captured by the English buccaneer, Sir Francis Drake, and his sea rovers from the Spanish treasure bands, bound to Panama City. They hastily buried 57,000 pounds of silver in expectation of a return which was never made.

A remarkable story of scientific discovery is that connected with the drilling for the head of the vast meteorite imbedded in the soil in Arizona. Many experts and engineers recently attacked this body, which hit the earth many years ago. The ancestors of the Navaho Indians appear to have seen this comet strike the earth. This meteorite is 300 feet in diameter, lies 1,400 feet below the present surface, and is so hard that it blunts the edges of the finest-tempered steel drill. It is thought to be worth \$50 a ton as it contains microscopic diamonds, platinum,

iridium, nickel and pure iron. Hundreds of thousands of dollars and the wits of the cleverest American engineers and college professors have been vainly spent in trying to solve the mystery of the Money Pits of Oak island and its sheltered haven, Mahone bay, Nova Scotia. Three young

men once landed there with canoes and explored a grove of oaks. They found a clearing in the center of which was a large oak, scarred and blazed with an ax. A rough derrick appeared to have been attached to a lower, sawn-off limb, and block and tackle used. Beneath, some twelve feet in diameter, was a circular depression in the earth. The tide in the cove was low, and, prospecting around, they soon found a ring-

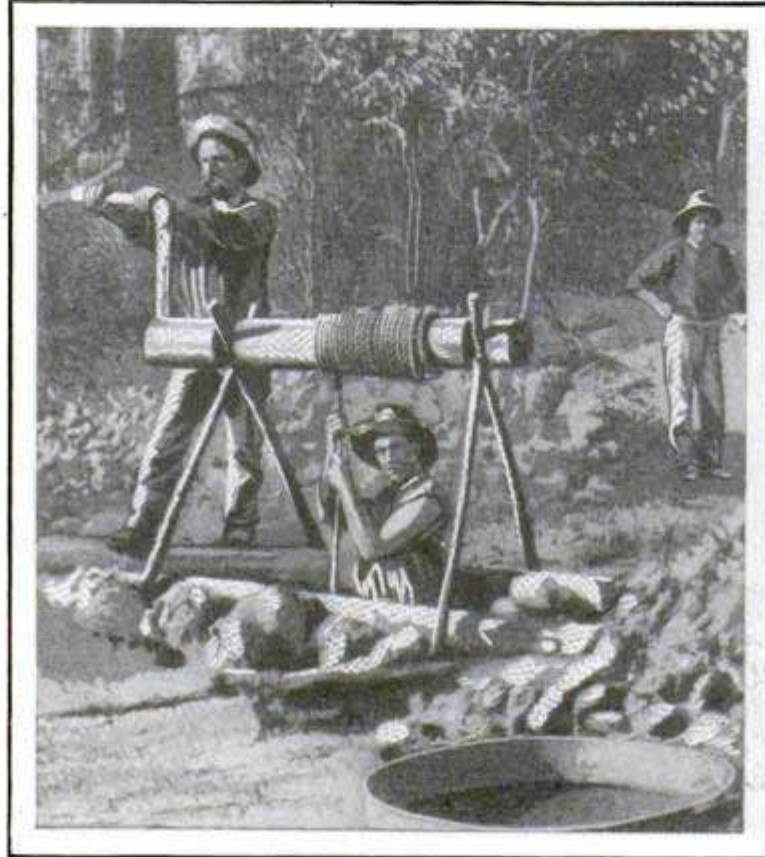

Working a Sapphire Mine in Australia; Simple Methods Still Prevail, Windlass, Pick and Shovel Being Widely Used

bolt, apparently a mooring place of bygone days. A copper coin, dated 1713, and an ancient boatswain's whistle were found.

Then the men dug down into the clearing beneath the oak, and found a shaft in which they could discern the work of other picks and shovels. Twenty feet below the surface, they uncovered thick planking, and ten feet deeper, a timber bulkhead. None of the natives would help as they said ghostly flares had been seen at night in the cove. Numerous attempts were made without success, to solve the secret of the pits, the most scientific being in the twentieth century when a syndicate sank 20 shafts in a ring around the pits, and bored a network of tunnels. About 126 feet below the surface, the drill encountered a piece of iron past which the incasing pipe could not be driven. A smaller auger was used, and thirty-three feet lower, it struck a layer of cement, seven inches thick, covering oak. Beneath was some soft metal and the drill brought to the surface a small fragment of sheep-





Once Owned by King David, This Plate, Approximately 4,000 Years Old, Is Now in the National Museum; Below, Pearl Necklace Worn by Madame Thiers and Valued at \$1,500,000 Contains 153 Beautifully Matched Pearls with a Diamond and Ruby Clasp



Diamond of 127 Carats Priced at \$300,000



Topaz Weighing 180,000 Carats or About Eighty Pounds in the Field Museum of Natural History Collection, Discovered by Dr. O. C. Farrington, Curator of Geology



Emblematic of the Grandeur That Belonged to Imperial Russia, the Elaborately Jeweled Crown; It and Other Regal Gems That Were the Property of the Czar's Family, Are Now for Sale by the Soviets

skin parchment upon which had been written in ink the syllable "wi." Wood and iron were also raised, but the soft metal, presumed to be gold, did not cling to the auger.

It was supposed that the layers of planking were treasure chests. During the borings, seven chests or casks were met with, but it seems most remarkable that any pirates or buccaneers acquainted with the

parchment, yellow with age and bearing an inscription in French. It directed him to go to a certain spot where he would find "buried in plaster, burnt wood, plate and ingots of silver, and a sheep's skull. Beneath is the secret of great treasure." He and his son dug deep at the spot indicated, and found the odd collection of articles together with a rusty iron-bound box. Inside was a chart in old French.



Where Precious Metal Is Handled like Common Freight; Piles of Silver-Lead Ingots on the Wharf at Port Pirie, South Australia

American coast should have gone to the astounding length of digging a hole over 160 feet deep, connecting it with the sea by an underground passage, and guarding it with layers of cement and timber. The syndicate sank a cofferdam near the ring-bolt and found drains, but a high tide rose and overwhelmed the dam. Hosts of engineers, equipped with the latest appliances known to mechanical science, have attacked these baffling pits, but in vain.

A vast treasure of gold doubloons, louis d'or, and grand seigneurs' family jewels from old chateaux in Quebec and France, awaits some lucky searcher on the land of a Catholic church in a little bay on the river St. Charles, near Quebec. It is known that Montcalm, in 1758, ordered all this treasure to be sewn up in hides and pigskins, deposited in brass-bound coffers, and taken in boats up the St. Charles river. All trace of this treasure vanished until the twentieth century, when a French habitant of an old chateau near Quebec found a small silver box in a cavity at the back of his fireplace. It contained a small

and the following: "Across the river St. Charles to the wood near the small bay and peninsula. Twenty feet NNW by N, toward a clump of firs. Fifty feet as the sun sets. Five feet deep and set in plaster, our great treasure out of the citadel."

The land on which the treasure now lies being church property, the two men dug secretly at night. They found nothing because the clump-of-firs clue was rendered useless by the growth of a large wood. The search was abandoned.

Some 600 miles southwest of Panama, in the Pacific, is far-famed Cocos island. Every year sees some ship sailing through the Golden Gate of San Francisco or past Long Island bound to this siren rock. Every year closes its eyes upon some baffled expedition creeping back to the home port. In September, 1925, the English yacht "St. George," sent out by the Scientific Research association, returned to England, after touching, among other places, at Cocos island. They searched for, but found no treasure on it, though there is said to be buried some twelve mil-

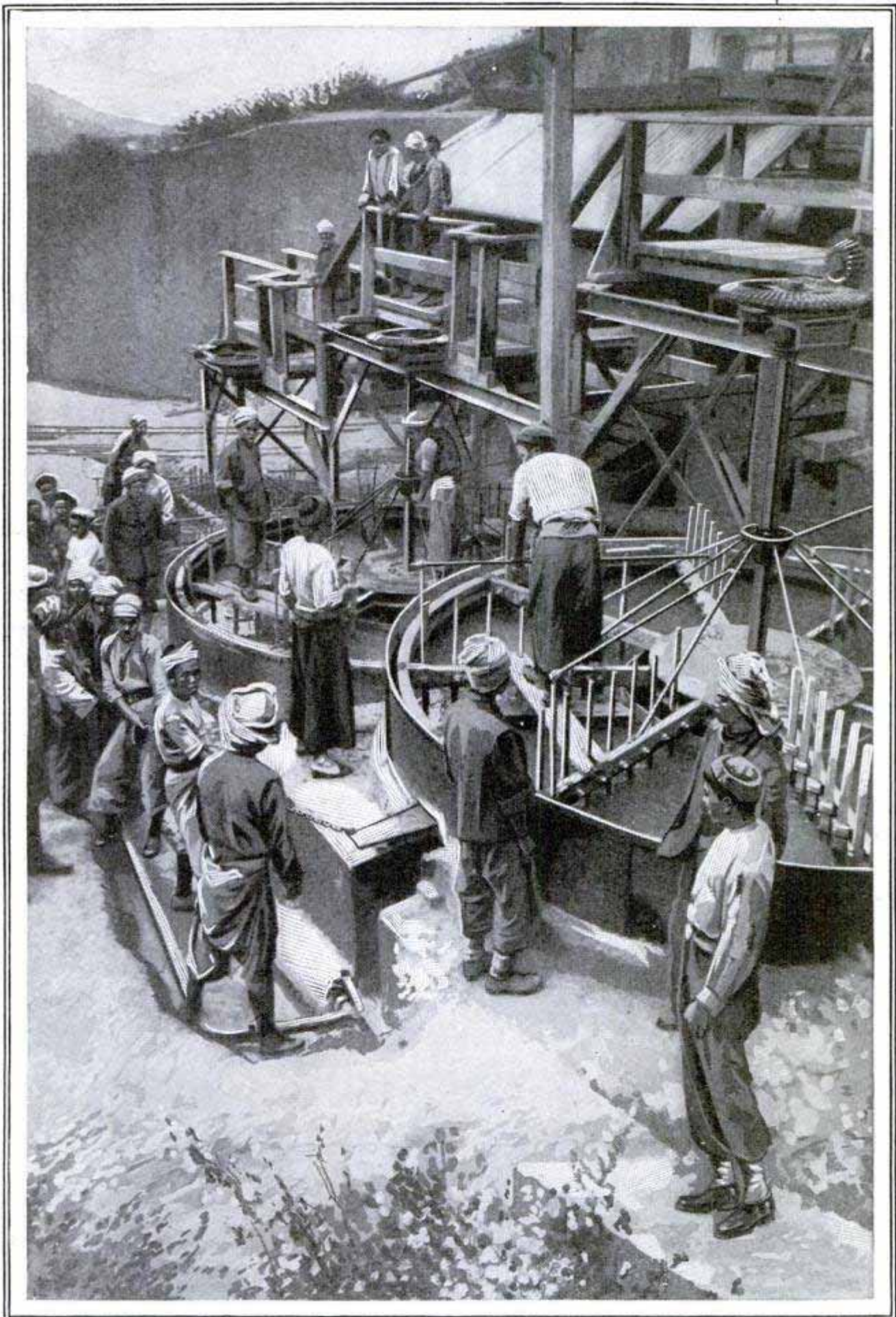

© U. & U.

Elaborate Apparatus Used in Burma to Wash Gravel in Search of the Most Precious of All Gems, the Ruby;  
Fine Specimens Are Valued Much More Highly Than Diamonds



© Keystone

lions' worth of plate and jewels stolen, in the revolutionary year 1820, from the Spanish residents of Lima, by a Capt. Thompson of the brig "Mary Dear." Two sea captains, named Keating and Bogue, of Newfoundland, about forty years ago, with the aid of a chart left by Capt. Thompson, are said to have found the treasure in a cave on the island; but the crew mutinied, Bogue was drowned in the surf, his pockets loaded with the loot, and Keating was carried out to sea.

A more costly treasure search, or one in which modern engineering science on a larger scale has been employed, would be hard to find than that of the sacred lake of Guatavita, Colombia. Thirteen years of hard work and \$75,000 were recently spent on draining this lake, in the bed of which is believed to lie \$5,600,000,000 worth of jewels and ornaments. The famous legend of El Dorado, or the "Gilded Man," had its origin in the fact that each new chieftain or Indian cacique cov-

ered himself with gold dust, and plunged into the waters of this lake, where it was washed off, while throngs of watchers threw in jewels and gold to propitiate the goddess of the lake. The lake is about forty-six feet deep and 13,000 feet wide, set in a cup surrounded by conical peaks. A tunnel was driven through the mountains and carried seventy feet below the level of its surface. The water was drained off through carefully prepared sluices, and twenty-five feet of bottom mud was exposed after three years of boring and sluicing. Ornaments and jewels were

found, but the mud set hard, and an attempt to drive the tunnel from the edge of the lake to the center was given up for lack of funds. Shafts were bored in the petrified mud, and channels driven through it. More gems were found, worth about



© U. &amp; U.



Seascope; Washing for Rubies, and Using Divining Rod

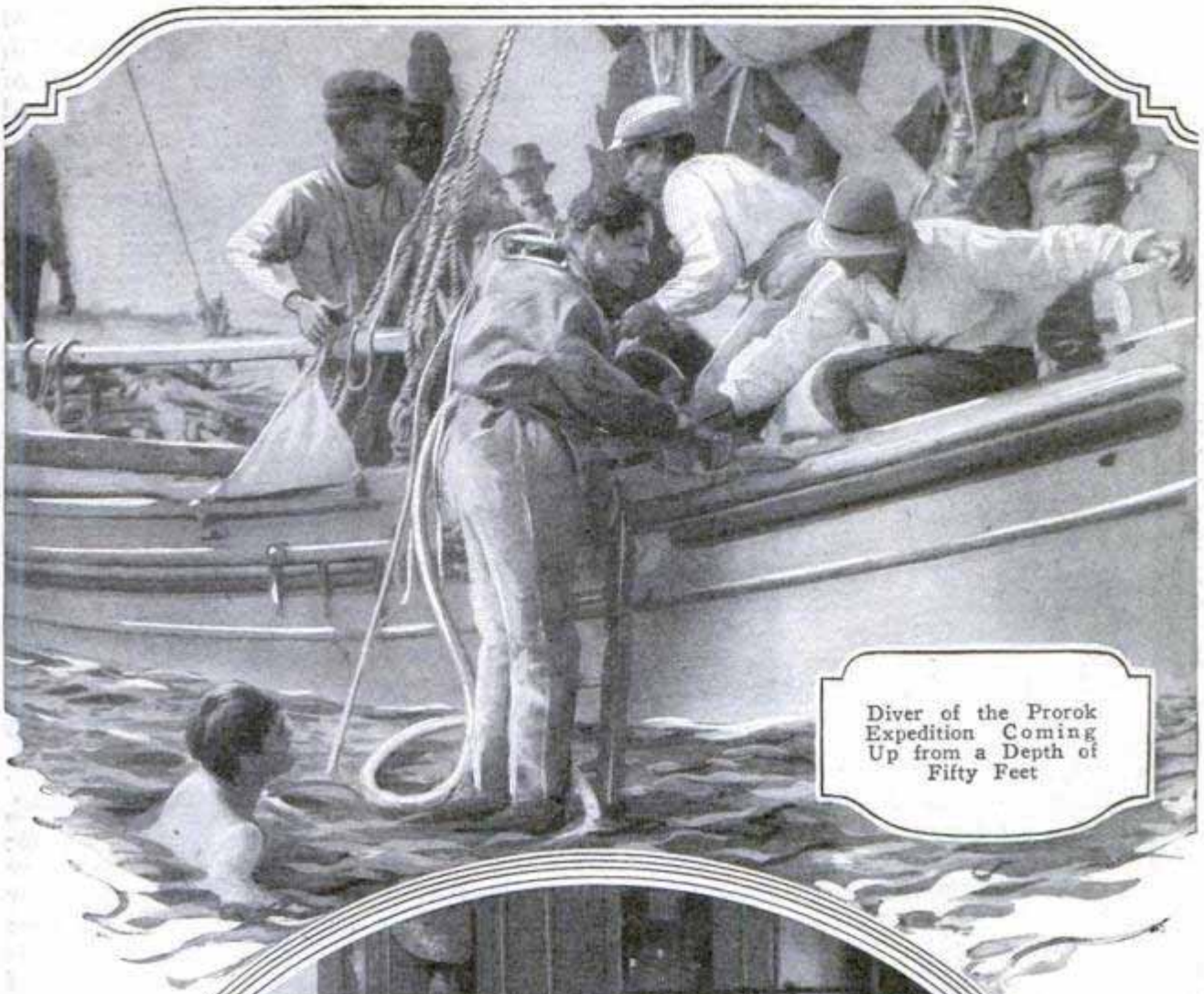

Diver of the Prorok Expedition Coming Up from a Depth of Fifty Feet



Curator of Russian Jewels Examining Some of the Imperial Utensils

\$10,000. The treasure had sunk very deep down in four or five hundred years. Finally, the concern went into liquidation.

Bolivia, too, has its hoard of Jesuit gold, \$44,000,000 worth of it, hidden at Sacambaya. Much good money has been spent in looking for it. It is not generally known that a native of Bolivia did, in 1912, without any flourish of trumpets, actually unearth a hoard of Jesuit gold, valued at \$4,500,000 and derived from gold mines in the district.

One thousand four hundred miles out from Bahia, in mid-Atlantic, is the strange and lonely island of Trinidad, a mass of volcanic rock, surrounded by boiling surf which makes it difficult for boats trying to land. Expeditions are constantly being fitted out to sail to this island on which pirates have buried an immense treasure of gold and silver, plundered from Peruvian churches, in the days of Bolivar, the liberator.

An old sea captain, on a voyage in the East Indies, was handed a chart of the island by a Finnish sailor, who pointed out a spot, called the sugar-loaf mountain, at the base of which the loot was buried. The Finn said he was the sole survivor of a band of pirates, the other members having been hanged by the Spanish in Cuba. Some time after, an English barrister, E. F. Knight, organized an expedition and set sail for Trinidad, calling on the way out at another lonely island in the

Salvages group (Great Pitou), south of Madeira. On this latter island, the British admiralty records vouch for the burial of \$2,000,000 by a mutinous crew who had murdered the captain of a ship, bound from Brazil to Cadiz, in 1804.

The English barrister and his comrades worked four days on the shining sands of the beach of Great Pitou, but the old chart had been made unreliable by the action of wind and waves on the landmarks. The shores of Great Pitou sank down on the horizon, and the ship sailed on over the Atlantic to Trinidad. Once on its terrible coast they landed mechanical appliances and stores with the utmost exertion. Near a ravine they found a cairn which the pirate's chart depicted as a landmark. They blew up thousands of tons of rock with dynamite and excavated mountains of earth to a depth of twenty feet in the ravine. Battling against tremendous odds they had at last to give up.

922  
**SCOW AND TRACTOR COMBINED TO TRAVEL SEA OR DESERT**

Capable of traveling over rough ground, sand and marshes as well as water, a combination boat and tractor built to carry supplies and men to a mine in the interior of Mexico, has broad steel paddles on its wheels. These propel the scow, which is seventy feet long and has a capacity of twenty men besides several tons of freight,

and also afford traction in case the outfit, being driven on land, should sink into soft sand or mud. The motor and chassis, removed from the boat body, are capable of doing dredging, excavating or hauling. A speed of five or six miles an hour on land or water is developed, and included in the equipment is a powerful winch for use when the outfit is working as an excavator.

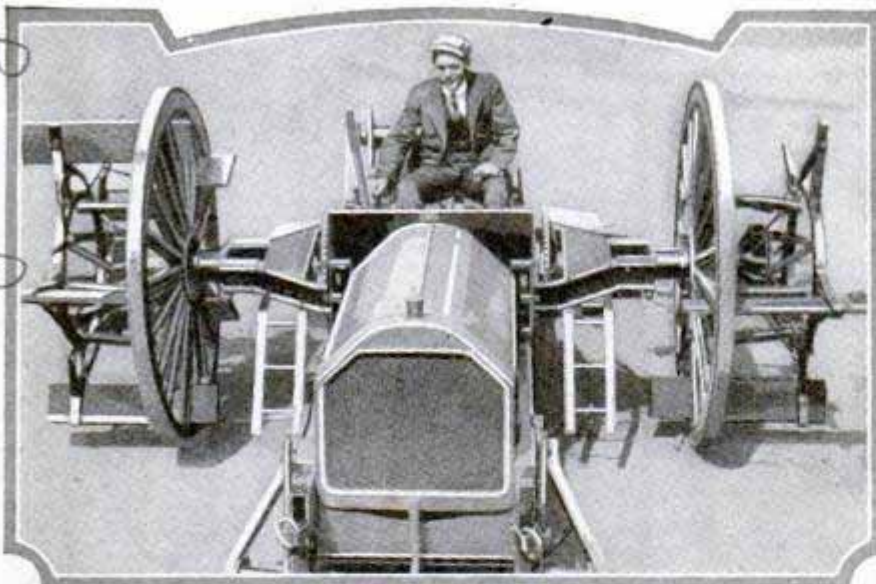

Upper View Shows the Chassis, Motor and the Huge Wheels with Paddles Attached to Spokes for Water Travel; Below Is the Long Metal Body

Emb. C. S. Percival 152 W. 65th St. New York City

*Suadish Monastery  
near Kumbuw,  
Tibet*

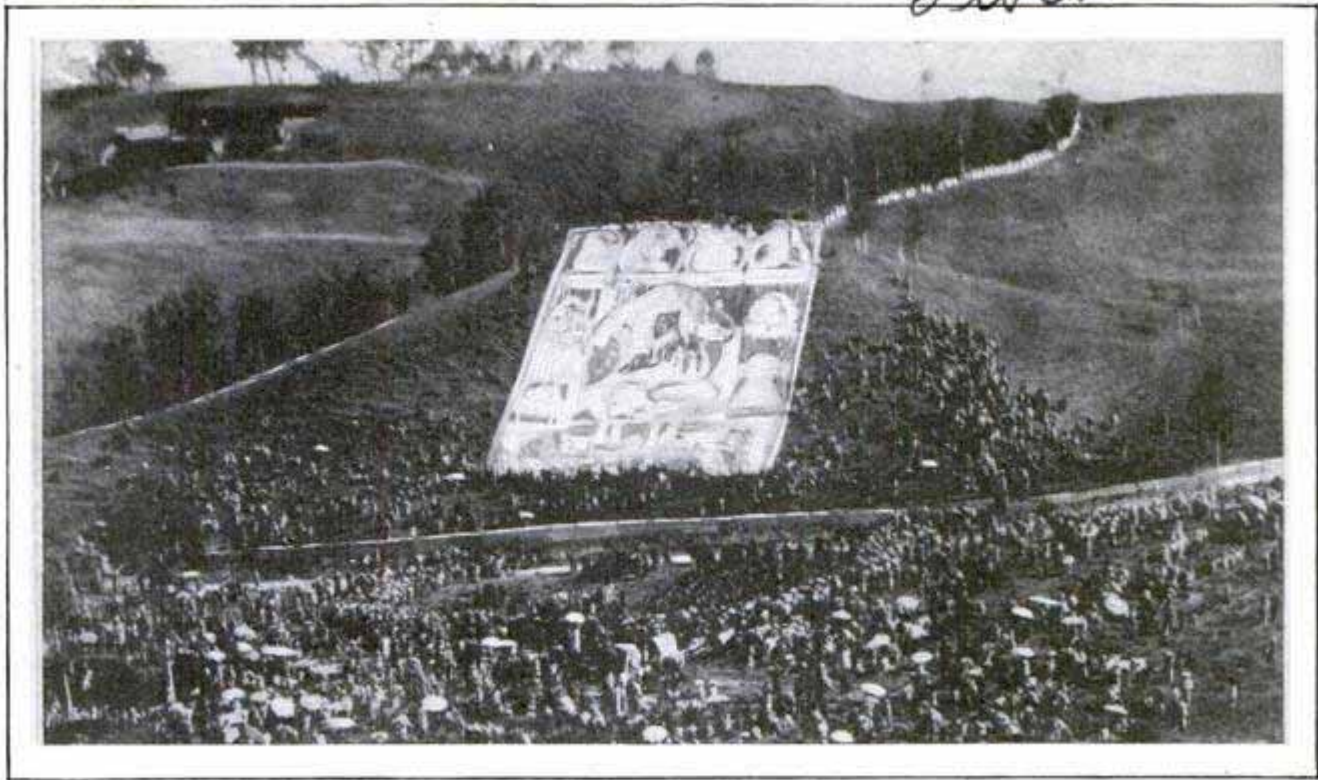

Natives Thronging to View the Great Tapestry of Buddha, Spread Out on the Hillside Once a Year by Tibetan Monks as a Religious Ceremony

**LIFE OF BUDDHA TOLD IN SILK ON HUGE TAPESTRY** 885

Besides a huge portrait, a piece of silk tapestry measuring 30,000 square feet, kept at a Tibetan monastery, depicts incidents in the life of Buddha on its intricately embroidered edges. Once a year, on a bright day, the monks spread the cloth on a hillside in the belief that the display will please Buddha and give him an opportunity to see his devout followers who come from hundreds of miles around to view the tapestry.

**CITIES TO USE SEWAGE GAS FOR LIGHT AND HEAT** 962

From a by-product in the treatment of city sewage, gas from which heat and light may be derived, can be salvaged instead of wasted as is now the practice, according to a report by the Illinois state water survey. Experiments already conducted indicate that, in a city of 50,000 persons, approximately 90,000 cubic feet of this gas are given off daily from treatment tanks. It is said to contain about seventy per cent methane, which is one of the chief combustible ingredients of natural gas and has a heating value greater than that of common fuel gas, while giving off no more odor than the ordinary commercial product. The gas is formed during the process of converting the sewage into liquids in special tanks. Carbon

dioxide and nitrogen are other gases formed. Experiments are now under way looking toward the collection and utilization of the gas and to developing a new type of tank which will yield a maximum salvage of this by-product.

**AUGER FOR BORING STUMPS HELPS CLEAR LAND** 916

Cut-over land is often cleared by dynamiting the stumps, and to simplify this work, a long hand auger to bore holes for placing the charges has been devised. It is said to operate successfully in all kinds of wood, bores an opening one and one-half inches in diameter, and is six feet long. The auger has also been used to bore holes for blasting quantities of hardened acid phosphate in warehouses.

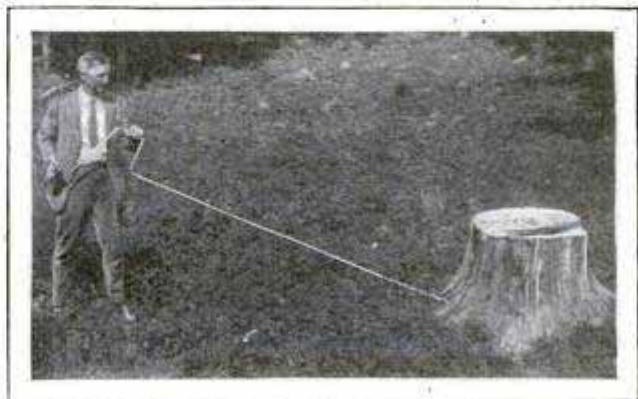

Boring Hole in Stump with Auger for Charge of Dynamite to Clear Land

*Cowan Alford Boring  
Machine Co. 1621 Brown.*

*Ala.  
Birmingham  
near Bleda, Birmingham*

national Bank Bldg  
Washington, D.C.

# Mapping the Land of the Midnight Sun

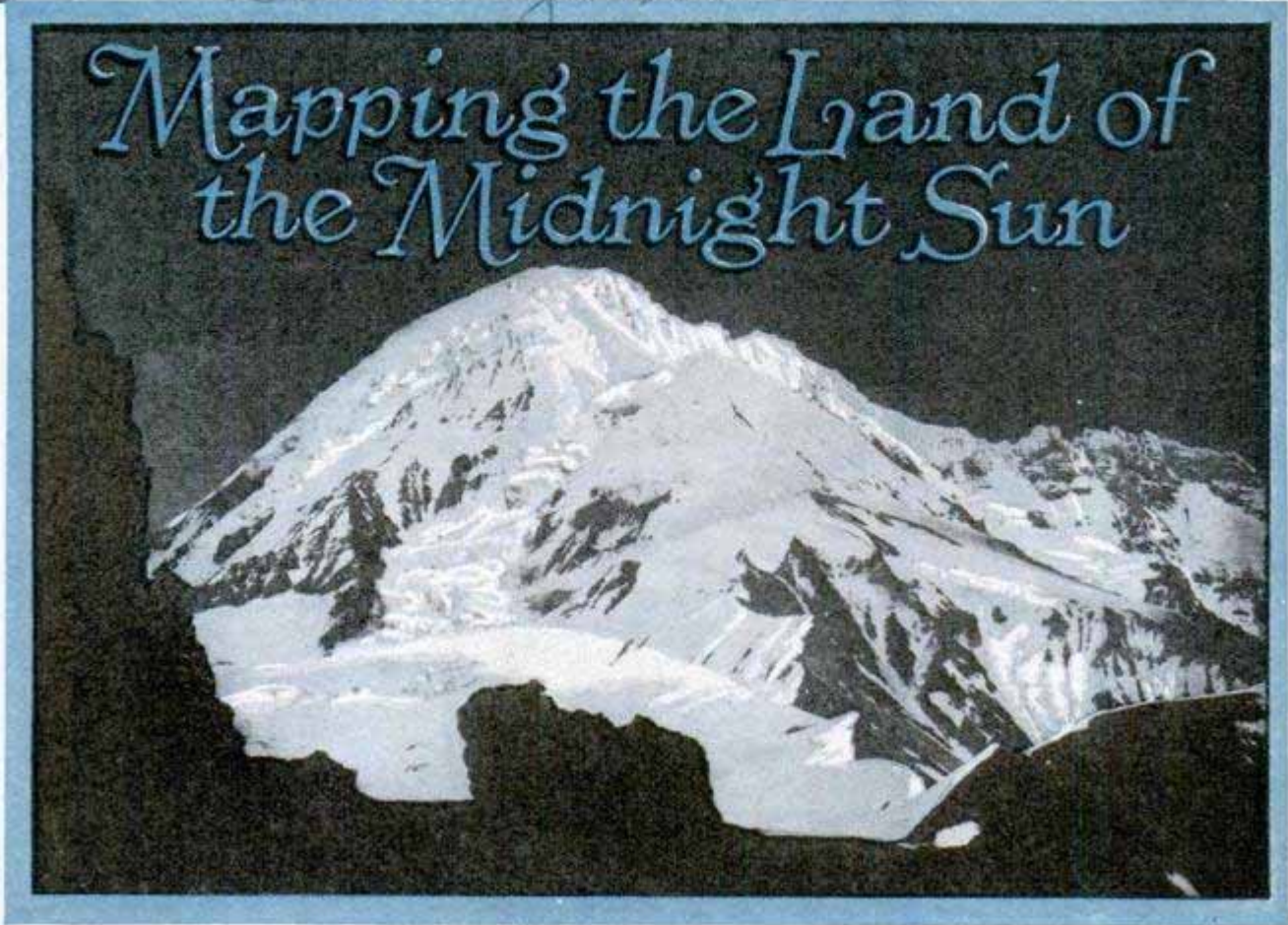

**T**HE exploration and mapping of some 7,000 square miles of territory in extreme northern Alaska, the greater part of which had never been seen by a white man, resulted from the expedition sent out last year by the geological survey. Gerald FitzGerald and Walter R. Smith, the topographer and geologist of the party, have returned after more than seven months of work, during five of which they did not see any human beings except the other two members of their party, and were entirely out of communication with the rest of the world. The other members were Faye Delezene and Walter R. Blankenship.

The story of their trip, as reported to the secretary of the interior, is a simple narration of the doing of the job, which was part of their routine duty, but through this simple account runs an enthralling undercurrent of the adventure and romance that are inseparable from exploration in unknown regions, where success depends upon the physical fitness and capable performance of each member in meeting pioneer conditions.

FitzGerald, Smith and Delezene sailed from Seattle and arrived at Nenana, the terminus of the Alaska railroad, last spring. The fourth member of the party, Blankenship, had arrived in Nenana from

Tanana with two dog teams of eleven dogs in each, the day before. Sixty miles out on the trail, Blankenship had lost a finger while unfastening the dogs from a snubbing post, but he came on to Nenana and had the wound dressed by a physician. This was the only accident of the entire trip. After two days' delay, the party set out with the two dog sleds, each loaded with about 400 pounds of camp equipment and instruments, for the head of Colville river, more than 1,000 miles away.

The route followed led down Tanana and Yukon rivers to Kaltag, overland to Unalakleet, an Eskimo village on Bering sea, northward along the coast, across Norton sound and the base of Seward peninsula, and beyond the Arctic circle to Kotzebue. The distance of about 700 miles from Nenana was accomplished in twenty-six days of actual traveling, so that the average was twenty-seven miles a day. The greatest distance made in one day was forty-two miles. Over nearly the entire distance from Nenana to Kotzebue, at least one man ran behind each sled to guide it by means of handlebars. Often it was necessary to go on snowshoes ahead of the dogs where the trail was obscured by drifts and newly fallen snow. The snow was four or five feet deep, and when the sleds missed the beaten trail a few



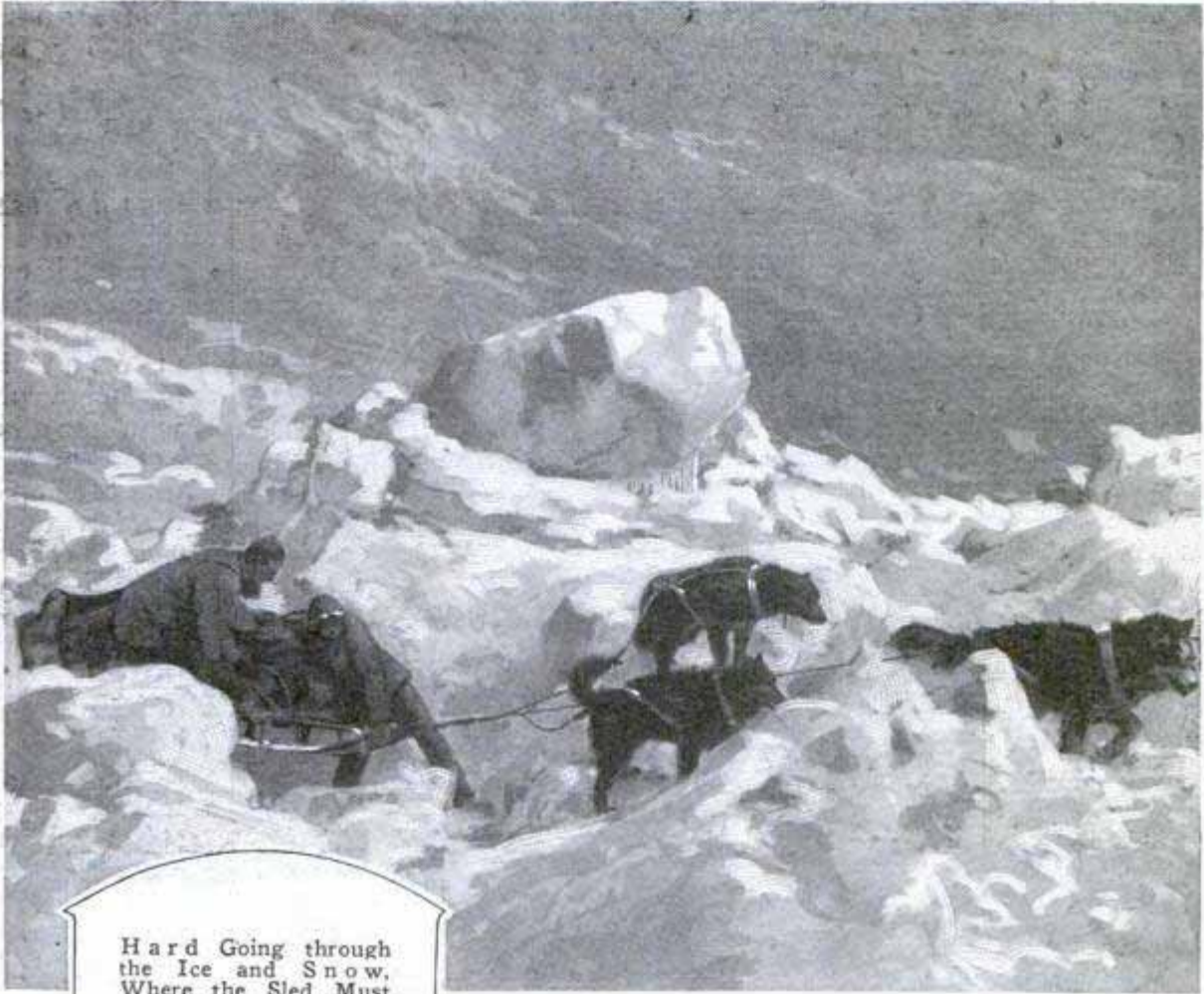

Hard Going through the Ice and Snow, Where the Sled Must Be Lifted over Hummocks to Help the Straining Dog Team; the Eskimo Teams Are Not of Much Assistance at Such Times

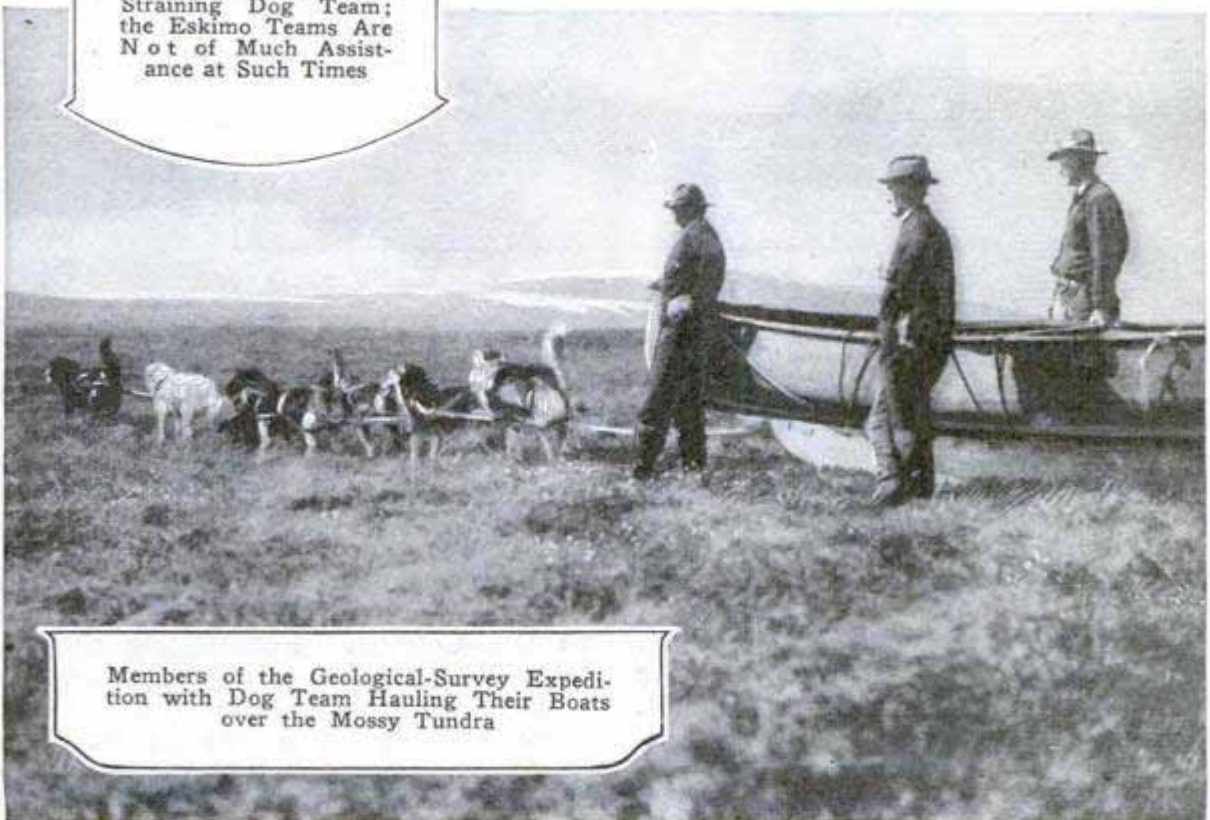

Members of the Geological-Survey Expedition with Dog Team Hauling Their Boats over the Mossy Tundra

inches, they would upset in the soft drifts. Little accidents of this kind would sometimes result in a fight among the dogs. The arrival at Kotzebue ended the first stage of the journey, the greater part of it on the trail over which the diphtheria antitoxin had been raced to Nome a few months earlier, and over which the mail

for Nome and places farther north is hauled at regular intervals throughout the winter, regardless of storms and temperature as low as sixty-five degrees below zero. When the survey party left Nenana, the weather was warm and it had been raining, a condition which suggested an early spring and which was rather discouraging for the long trip ahead over the snow. However, the temperature dropped in a few days, and before the party left the Yukon it was thirty degrees below. One member suffered a few frostbites. A heavy snowstorm was encountered while the party was crossing Norton sound on April 1. The snow became incrustated over the eyes of the dogs, and it was necessary for a man to go on ahead of the team. At times it was impossible to see the lead dog. Had it not been for a well-staked trail, the party probably would not have reached the roadhouse at Koyuk that night. When they arrived, however, at eight o'clock, the Eskimo keeper asked in astonishment, "Where you come from?" When informed that they had come from Bonanza, thirty miles across the sound, he replied, "I didn't think anyone would travel through that storm today."

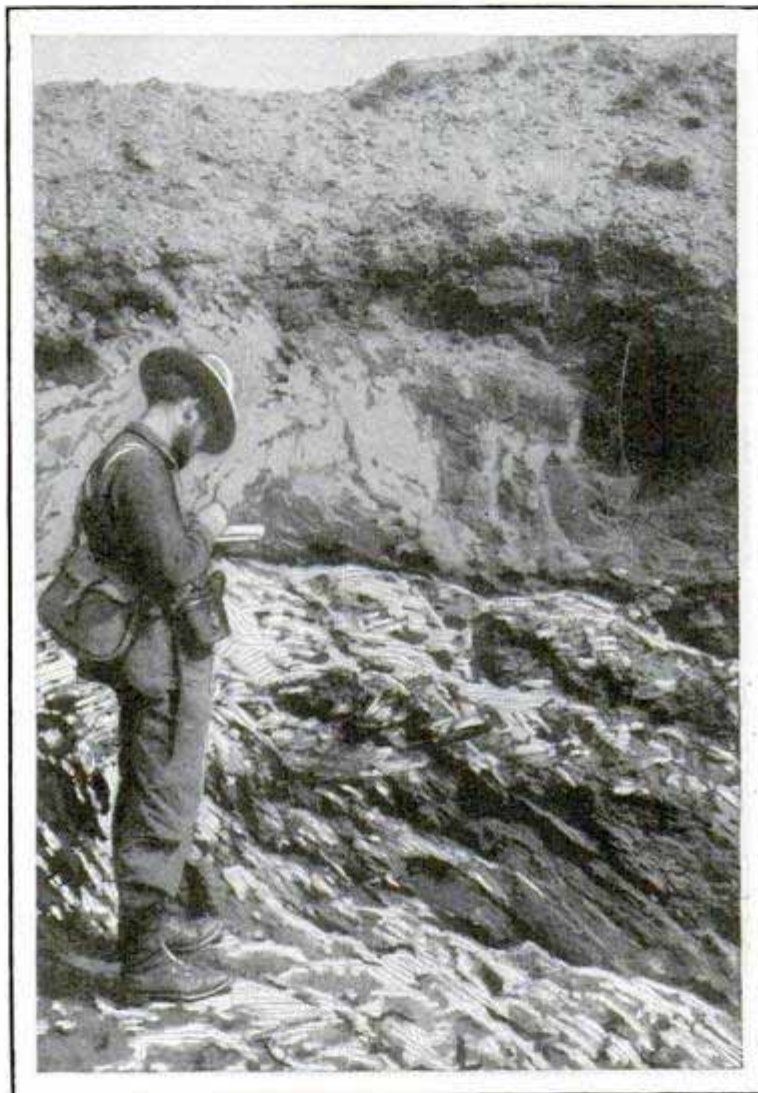

Geologist Examining a Specimen of a Mineral Deposit Found in Northern Alaska

At Kotzebue the party procured supplies for the summer and hired more teams to freight the provisions and canoes up Noatak river and across the De Long mountains of the Brooks range to the Arctic slope. Kotzebue marked the last roadhouse on the trip, and thereafter the party camped in tents, except one night

at the native village of Noatak. This village is probably unique in that it contains neither a white man nor a half-breed and not one of the population of 250 uses tobacco. The Eskimo drivers would not go farther than the head of Utukok river, on the Arctic slope, for fear that the snow would thaw before they could return. As the drivers turned back, the little party of four white men was left alone in the snow-clad Arctic wastes, to be for months out of communication, even by radio, with the rest of the world. Topo-

graphic and geologic mapping was begun from earlier surveys on the south side of the range and carried across to the headwaters of Utukok river. As fast as the weather permitted, the supplies were relayed on toward the head of Colville river, and a canoe, which had been cached by the party of the year before on the Utukok, was picked up and brought overland to the Colville. Fortunately the snow lasted longer than was at first expected, and before the ice left the Colville, the men were camped on its banks waiting to launch their boats. Several times the river opened and froze again during heavy storms, but on May 30 the boats were shoved out in the swift current, and the

586

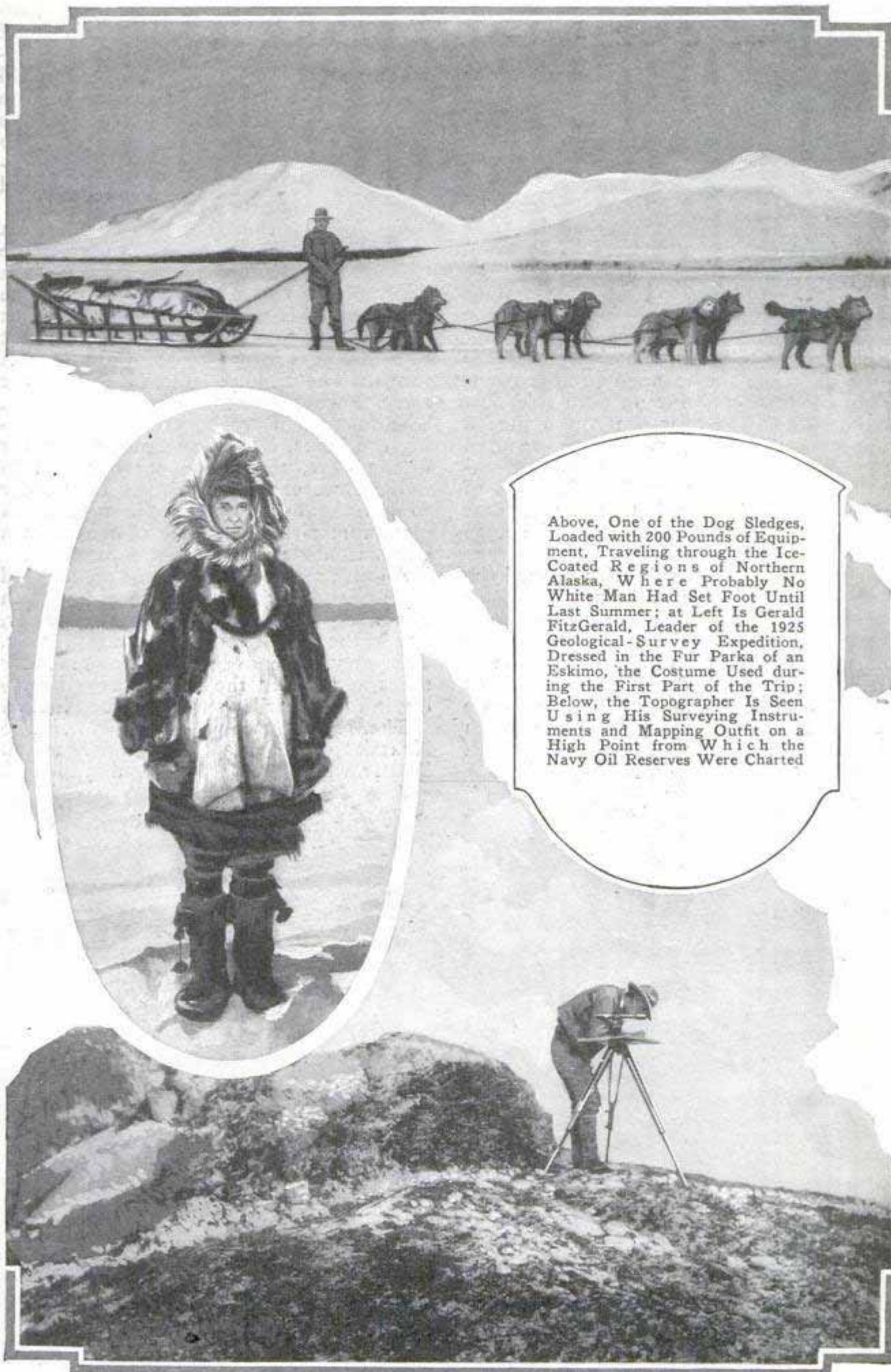

Above, One of the Dog Sledges, Loaded with 200 Pounds of Equipment, Traveling through the Ice-Coated Regions of Northern Alaska, Where Probably No White Man Had Set Foot Until Last Summer; at Left Is Gerald FitzGerald, Leader of the 1925 Geological-Survey Expedition, Dressed in the Fur Parka of an Eskimo, the Costume Used during the First Part of the Trip; Below, the Topographer Is Seen Using His Surveying Instruments and Mapping Outfit on a High Point from Which the Navy Oil Reserves Were Charted

actual exploration of the upper Colville was begun.

Over white rapids and angry whirlpools and beneath undercut snowbanks, the little group floated on, never knowing what would happen around the next bend, but realizing that, if a boat should upset, it and its burden could not be regained or replaced, and that if anyone was injured, there would be no hospital or physician. Sometimes the boats would strike a rocky bar and would have to be lifted across. The dogs followed along the bank, but in trying to keep within sight of the boats, they would swim across the river many times each day.

The party followed the river for more than 100 miles and mapped an area twenty to thirty miles wide on each side. In making the trips over the rough tundra away from the river, the dogs were used as pack animals, carrying packs of twenty-five or thirty pounds for distances of eighteen to twenty-eight miles a day. Over a short portage some of the dogs carried forty pounds.

During one of the side trips toward the north from the Colville, the headwaters of Meade river were discovered. Snowstorms were frequent, but the snow did not remain on the tundra, and by the middle of June, the hills were dotted with flowers of many species and colors. Caribou were seen in small bands every day, and enough were killed to supply the camp with fresh meat in abundance.

The country along the upper Colville is not thickly populated with small animals and birds. Formerly the Eskimos lived along its banks, and their old igloos, pieces of clay pottery and broken bone implements were found. The people probably migrated to the coast many years ago to be nearer to the traders and missionaries. Parts of the interior northland are now unknown to the Eskimos.

On July 13, the work was tied in to a previous survey of the central part of the Colville valley, and the party turned south up Etivluk river, a large tributary of the Colville. This river was ascended about eighty miles to its source, at the summit of a low pass in the heart of the Brooks range. The Etivluk is a swift, turbulent river, flowing over many rapids and bars. The dogs again proved very useful in lining the boats, but many times a day, for fifteen days, the entire party waded in swift ice water above their waists in order to get the boats across the rapids. A maximum airline distance of ten miles a day was made in this upstream travel.

A low, broad pass was found at the head of the Etivluk, and a portage of less than one mile put the explorers on Aniuk river, one of the main tributaries of the Noatak. The party descended the Aniuk about fifty miles and closed the new surveys by tying in to the earlier survey of the Noatak.

The return trip was made down the Noatak to Kotzebue, thence to Nome and Seattle, where the party arrived in the fall.

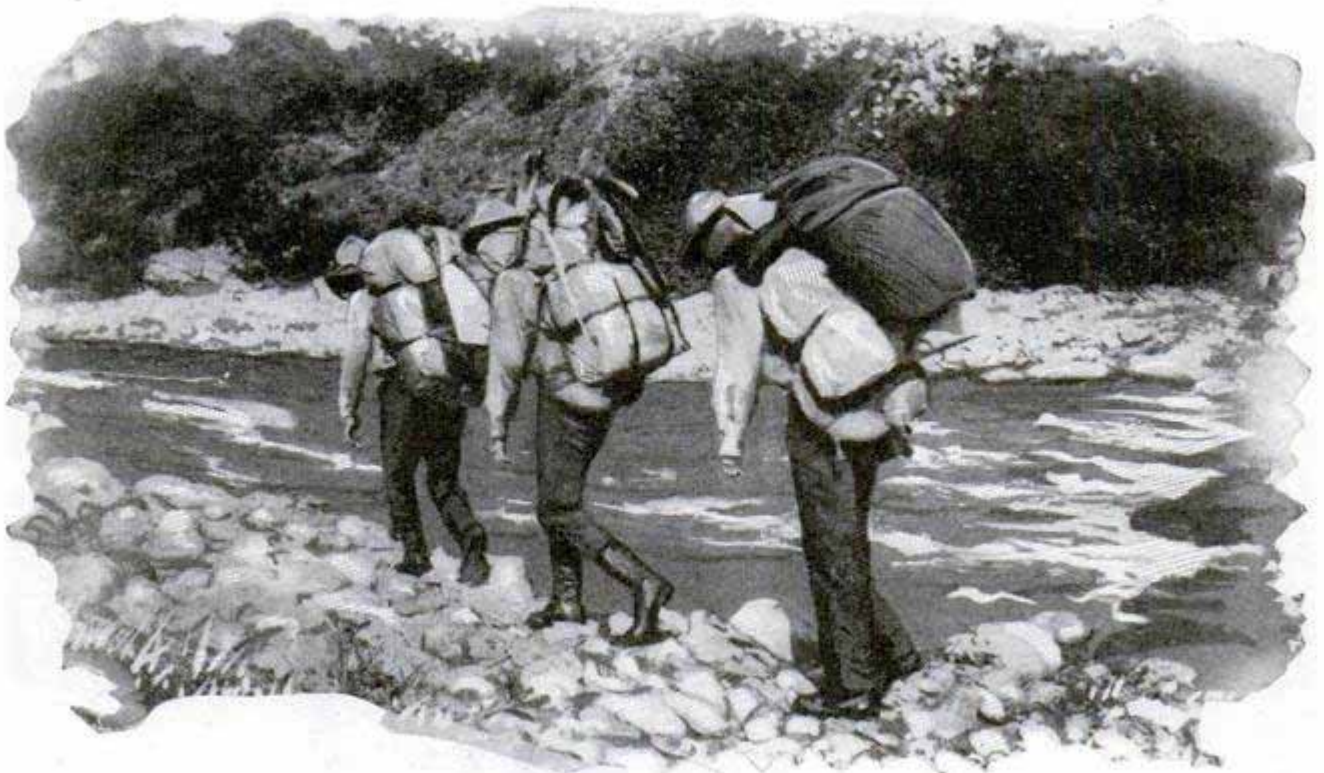

A Bit of Hard Going along an Unnamed River, Carrying Heavy Packs on Tumplines; during the Brief Summer Sleds Are Useless, and Away from the Streams, Supplies Must Be Carried in This Way

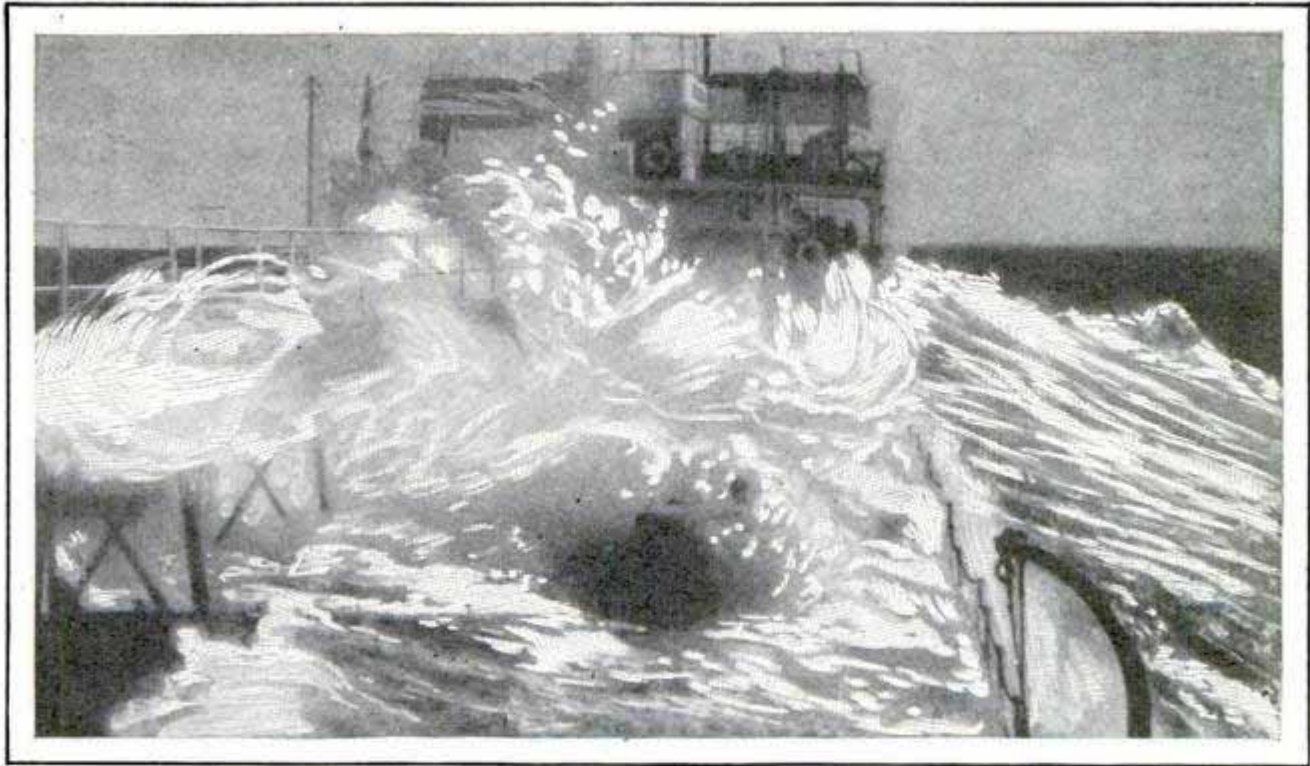

Almost Submerged by a Gigantic Wave; Photograph of Deck of Steamer "Trimountain" Snapped by a Sailor Whose Camera Caught the Angry Billow at the Height of Its Attack

**BIG SHIP BECOMES "SUBMARINE" DURING HEAVY STORM**

During a severe storm on the Atlantic, an alert seaman obtained the photograph shown here, a view of the S.S. "Trimountain," from New York, almost completely submerged by a heavy wave. It struck the steamer full on the side and, for a few seconds, nearly the entire deck was flooded. Although the big ocean greyhounds of today can plow through stormy weather with comparatively little difficulty, an occasional sea will give them considerable trouble.

1015

**INSECTS USE GAS AND ACIDS IN WAR AGAINST ENEMIES**

Use of poisonous gases and acids in the World War was an innovation in military science, but such tactics long have been used by various insect tribes. The "bombardier beetle," for instance, when pursued by an enemy or otherwise disturbed, discharges a sort of bomb in the form of an ill-smelling reddish acid fluid which changes into a bluish smoke or vapor when it comes in contact with the air. When a log under which these active creatures have made their home is lifted, they often may be seen scurrying away and covering their retreat with a barrage of tiny gas bombs. Their red heads and bodies and blue wing covers, like uniforms, harmonize with their military ac-

*with 12/20/25*

tions. Several species of beetles have similar weapons for defense. The acid secretion from some leaves a persistent red stain and has a bitter taste.

**STORM COVER FOR SCREEN DOOR PREVENTS DRAFT AND RUST**

994

Attached to the screen door with snap fasteners, a storm cover with a window at the top, protects the mesh from rust besides keeping rain and wind from entering the house. It can be adjusted or taken off in a few moments, is easily stored away and is said to last for years.



Cover in Place, Showing the Window; and Attaching It to Door with Snap Fasteners

*D. J. Russell  
Box 187  
Pine Bluff*

*California - on a road*

*Auto*  
**BRIDGE NEARLY MILE LONG  
COMPLETES VICTORY ROAD**

One of the last gaps in the transcontinental Victory highway from New York to San Francisco has been closed with the completion of a new bridge, nearly a mile long, across the San Joaquin river valley. The structure, seventy feet above the river, provides navigation beneath it for most ships, while one 270-foot span is of the lift-type and can be raised 135 feet above the water. The San Joaquin has acted as a barrier between Contra Costa and San Joaquin counties, but the new bridge will not link them but open up the fertile delta land country to automobile traffic from San Francisco or the east. The bridge, which cost over \$2,000,000, carries a concrete-paved road, twenty-one feet wide, with a one-way capacity of 1,200 automobiles an hour. The Victory highway, used by many transcontinental tourists, enters San Francisco via Oakland and the ferries across the bay.

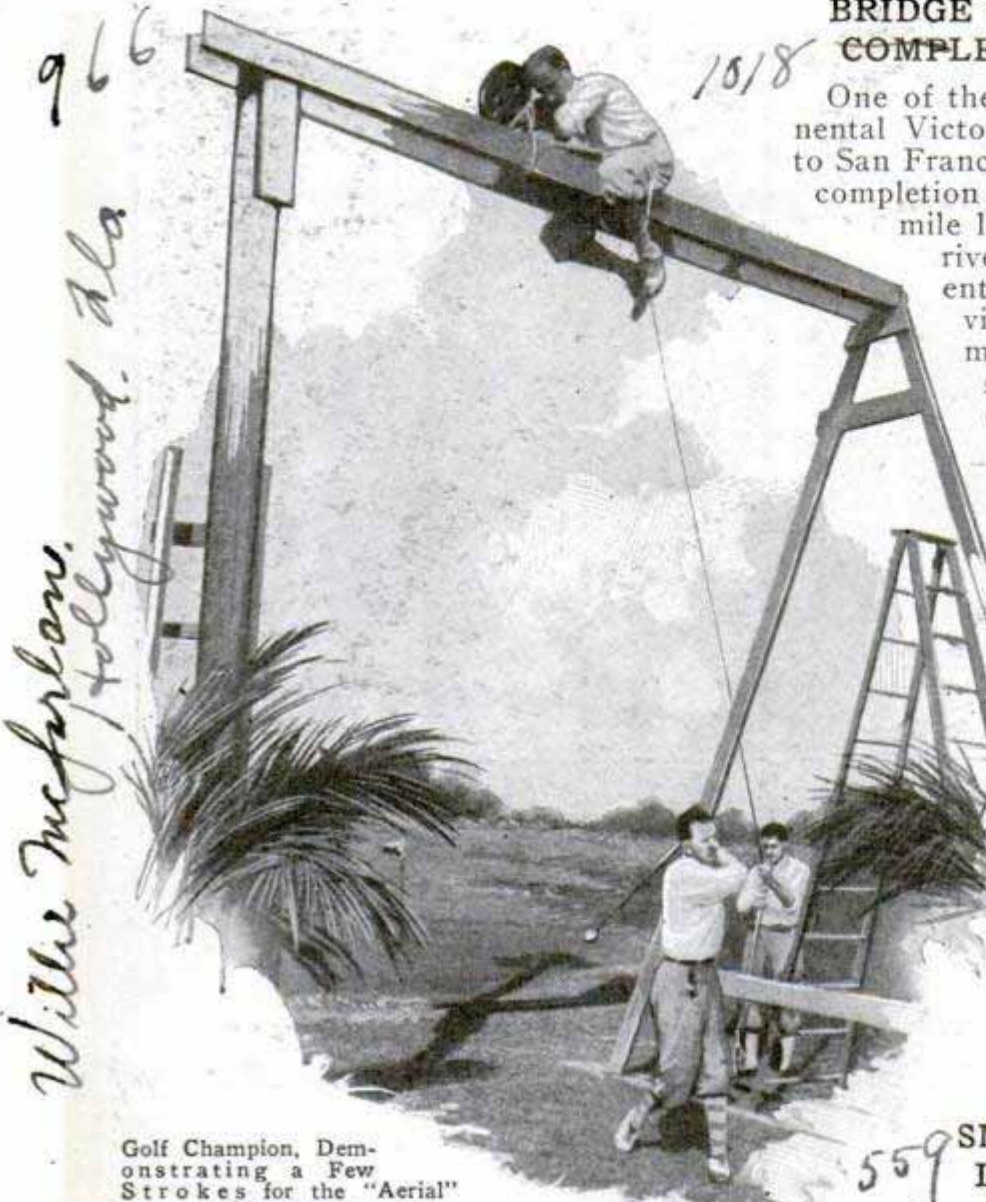

*Willie McFaylon,  
Hollywood, Fla.*

Golf Champion, Demonstrating a Few Strokes for the "Aerial" Cameraman

**SLOW MOVIES FROM SCAFFOLD  
SHOW GOLFER'S STYLE**

Golfers have been photographed from nearly every position in playing pose, from under glass, from close and distant range, but recently aerial movies have been taken, showing how a champion player makes a stroke as seen from a vantage point several feet above his head. The camera was an "ultra-rapid" instrument, producing the so-called slow-motion film for closer study of the subject, and was mounted on a scaffold. The operator straddled the crossbar and was further steadied by a rope about the waist and attached to the beam. The lens was directed at such an angle that the pictures would show clearly how far the player stood from the ball, how high the club was raised and the arc it described during the stroke.

☐ The snail's speed limit is about a half mile a week.

**SMALL HAND MAGNET  
LIFTS FIFTY POUNDS**

Supplied with current from the house-lighting socket, a magnet that will lift thirty to fifty pounds, is intended to save time and labor in handling metals. It is energized by closing the circuit with thumb pressure on a push button on the grip. Releasing the pressure, causes the magnet to drop its load. When only alternating current is available, a motor generator set is provided with the magnet to supply direct current, or battery equipment is furnished in case electric power cannot be obtained. The magnet is designed especially for use in foundries, in hardware plants and stores, and in machine shops for cleaning turnings or chips from places not easily accessible, although it is equally serviceable wherever it is necessary to separate magnetic from non-magnetic material.



*K + B Co.  
495 n Third St*



Training the Sense of Touch to Serve in Place of Ears; Deaf Children Interpreting Piano-String Vibrations as to Pitch, Rhythm and Volume through the Finger Tips

## Teaching Deaf Children to Talk

How Radio and Scientists Are Helping the Handicapped to Hear and Speak by Modern Methods

By PAUL PADDOCK

THE piano was going at a sprightly tempo.

"Jingle bells, jingle bells, jingle all the way."

Six young voices, rhythmically reciting the words instead of singing them, gave listeners a thrill, for the pupils were deaf and they were receiving the swing of the jolly sleighing song through vibrations that passed from the piano strings into their sensitive finger tips, placed lightly on top of the instrument.

The scene is the recreation room of the Central Institute for the Deaf at St. Louis, Mo., where medical science and the teacher of the deaf have joined hands in making useful happy citizens out of children who cannot hear. The school is a philanthropic enterprise, founded and directed by Dr. Max A. Goldstein, an internationally known ear specialist, who has devoted more than thirty years to study and practice with a view to helping those handicapped by deafness to break down the barriers of their shut-in world and to take their places in the ranks of normal

speaking and hearing persons. Because of its policy of uniting and correlating the efforts of specially trained teachers and doctors, the school has come to be recognized as one of the leading institutions of its kind. By modern methods, young children are taught to interpret sounds through their finger tips, and they learn to speak so clearly that anyone can understand them, further proving that deafness and dumbness no longer are inseparable. Since speech is only a reproduction of sounds heard, deaf persons were inevitably mute until modern science found a way to establish contact for them by means of vibrations.

The visitor sees about a hundred boys and girls, gathered from twenty different states. They range from three or four up to seventeen years in age and are living and studying happily under the direction of a specially trained corps of teachers in a well-equipped building that contains dormitory quarters as well as classrooms and laboratories. Besides the school for the young, there is a depart-

818 S Kingshighway



This Pupil Failed to Pass a Simple Hearing Test; the Doctor Found That Discharging Ears Were to Blame

ment of lip reading for older deaf persons, a division for the correction of speech defects and a normal training school, which has qualified more than 400 teachers for the deaf in its regular and post-graduate courses since it was started, in 1914.

Recently, the institute has become an important laboratory for the practical testing of what promises to develop into a most helpful aid to the deaf, the radio. With this marvel of the age at its service, the institute already has made two definite advances in this work. First, application of radio principles and those of the telephone has enabled teachers and investigators to determine accurately degrees of deafness and to prepare graphic charts of a child's hearing for the guidance of instructors. Second, by a radio amplifier, remnants of hearing are stimulated so that the capacity for receiving sounds is widened in pupils not entirely deaf. Its service here promises immeasurable benefit, for only a small percentage of congenitally deaf children can be proved profoundly and totally deaf, and of all the children at present in schools for the deaf, it has been found that more than thirty per cent have some degree of hearing.

The apparatus used for this stimulation is a large cabinet containing radio-ampli-

fying equipment. Headphones are attached so that a number of children can be tested and given treatment at once. The source of the sound delivered through the phones, is either a record played on a phonograph built as part of the cabinet, or the human voice spoken through a mouthpiece which may be plugged into the amplifier. Phone sets can be regulated separately as to volume of sound output, so that they can be made to fit the degree of hearing defect in each pupil. Some children who, at first, fail to distinguish the difference between simple vowel sounds, after periods of training, lasting from three months to a year, and practicing with the amplifier only a few minutes daily, demonstrate their ability to hear whole phrases of spoken language. Constant repetition of the same sounds is required to achieve these results, just as repetition is necessary in teaching a normal child to walk.

The use of the radio is in its infancy, and its application to the problems of the deaf is just begun, so that scientists cannot yet tell what results may be expected, but indications are that it holds most promising possibilities. To those who believe that there is something magical about the radio, as an aid to the hearing, the institute's research workers are prompt to answer that its effects are entirely due to enormous amplification of sound, and if a person is totally deaf, radio will be useless so far as receiving sounds directly is concerned.

Leaving this question of radio for the moment, the layman witnesses what is almost as wonderful: totally deaf children translating sound vibrations through their sense of touch. Here is a little girl who can repeat a variety of vowel and other sounds, changes of pitch, words and whole sentences, simply by interpreting the vibrations of a voice as they strike upon a piece of paper tightly stretched as a vibrating diaphragm across the larger end of an ordinary megaphone. She closes her eyes so that the instructor's lips will not give her a clue to the sounds, and places only the tips of the fingers of one hand on the diaphragm.

Going back to the music lesson you first saw, you learn that the pupil's performance is the result of patient training and proof of what can be accomplished by the acoustic method as developed at the Cen-



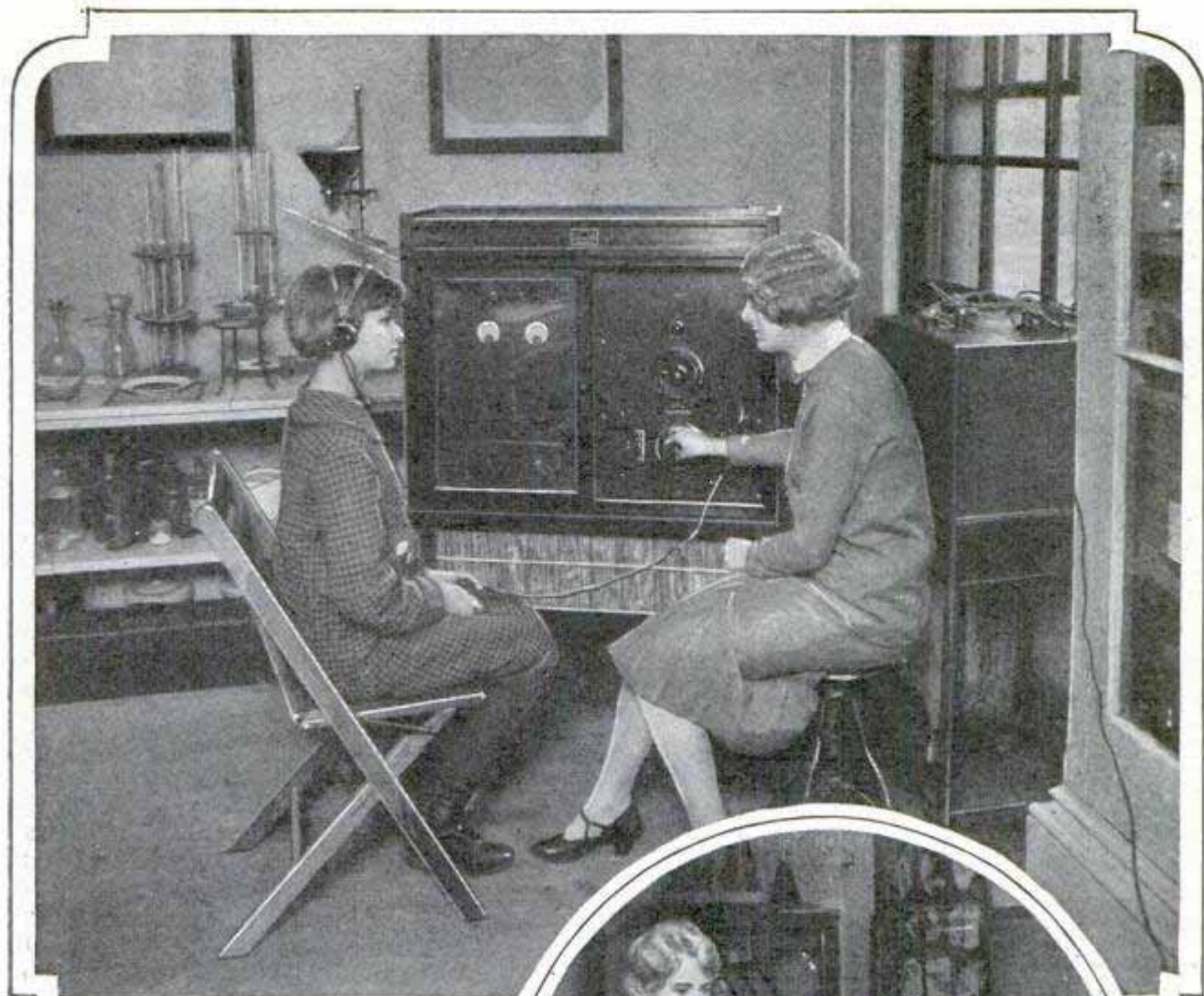

Testing a Central-Institute Pupil's Hearing with an Audiometer; This Instrument Makes Use of Certain Radio Principles in Producing Sounds of a Definitely Measured Intensity and Also Changes the Pitch of the Tones; the Child Strives to Hear the Vibrations through the Ear Phones; with the Audiometer, Remnants of Hearing That Might Easily Escape Other Tests, Are Discovered, Enabling the Teachers to Gain Access to the Child's Imprisoned Mind. At the Right, Another Pupil Is Demonstrating Her Ability to Interpret, through Her Finger Tips, Vibrations Produced by the Voice on a Piece of Paper Stretched over the Larger End of a Megaphone; the Little Girl's Eyes Are Closed So That She Cannot Read the Teacher's Lips. Before Visitors, She Repeated Words and Phrases in This Way, and after a Few Trials, Learned a Word That She Had Not Previously "Heard"



tral institute. Briefly, this method is to make use of sounds as produced by the voice, various musical instruments and radio apparatus to achieve perception and interpretation of the vibrations in the mind of the deaf child in teaching him speech. As the teacher plays, the pupil's voice responds to changes in pitch and volume as well as tempo. He keeps perfect time even when the rhythm is purposely made irregular. Only one step more, it seems, and he would be singing, were it not that difficulty in performing rapid changes of pitch offered an obstacle.

"These musical and other tests afford practical evidence in support of the theory of the eminent English physicist, John Tyndall, that the sense of hearing, is, after all, merely a modification of the sense of touch," Dr. Goldstein explains. "All other special organs of sense are modifications of the touch sense. They involve the reception and perception of special waves of motion. In case the natural organ of hearing ceases to function, a logical course is to endeavor to use some other channel for conveying the sound waves to the brain. With proper training, deaf pupils manage to do this effectively with their fingers and even with their feet. They learn to keep time while dancing to music from an orchestra by

interpreting the rhythm which is communicated from the instruments, through the floor into their feet, up the bones and into the special centers of the brain."

The pupils you have just heard and seen belong to the senior classes. Two of them are ready for graduation into a regular high school, where they will be able to compete creditably with hearing children as other graduates of the school are doing. To prove it, they recite an algebra lesson. Descend to the floor below, and you will see the real beginners of the institute, the three and four-year-olds, and how the first bridge is thrown across the gap that separates the deaf child from the rest of the world. The problem is to get the pupil, who is hardly more than a baby, to produce sounds with his vocal cords. To the layman, the task is like requiring him to draw or build something that he does not know exists and with nothing from which to copy and do it, so well that it can be identified. But the deaf child is given a guide, the teacher's voice, and again the sense of touch helps where the ears are useless.

Beginning with the pupil at this early age is important, for it is at a time when he naturally is trying to speak just as normal children do. Then, if he is allowed to go without this teaching, in a



Teachers Wondered Why These Pupils Had Trouble with Their Lessons. The Reason Was That They Had Poor Hearing; They Failed to Hear Whispers at Twenty-Five Feet

8.72

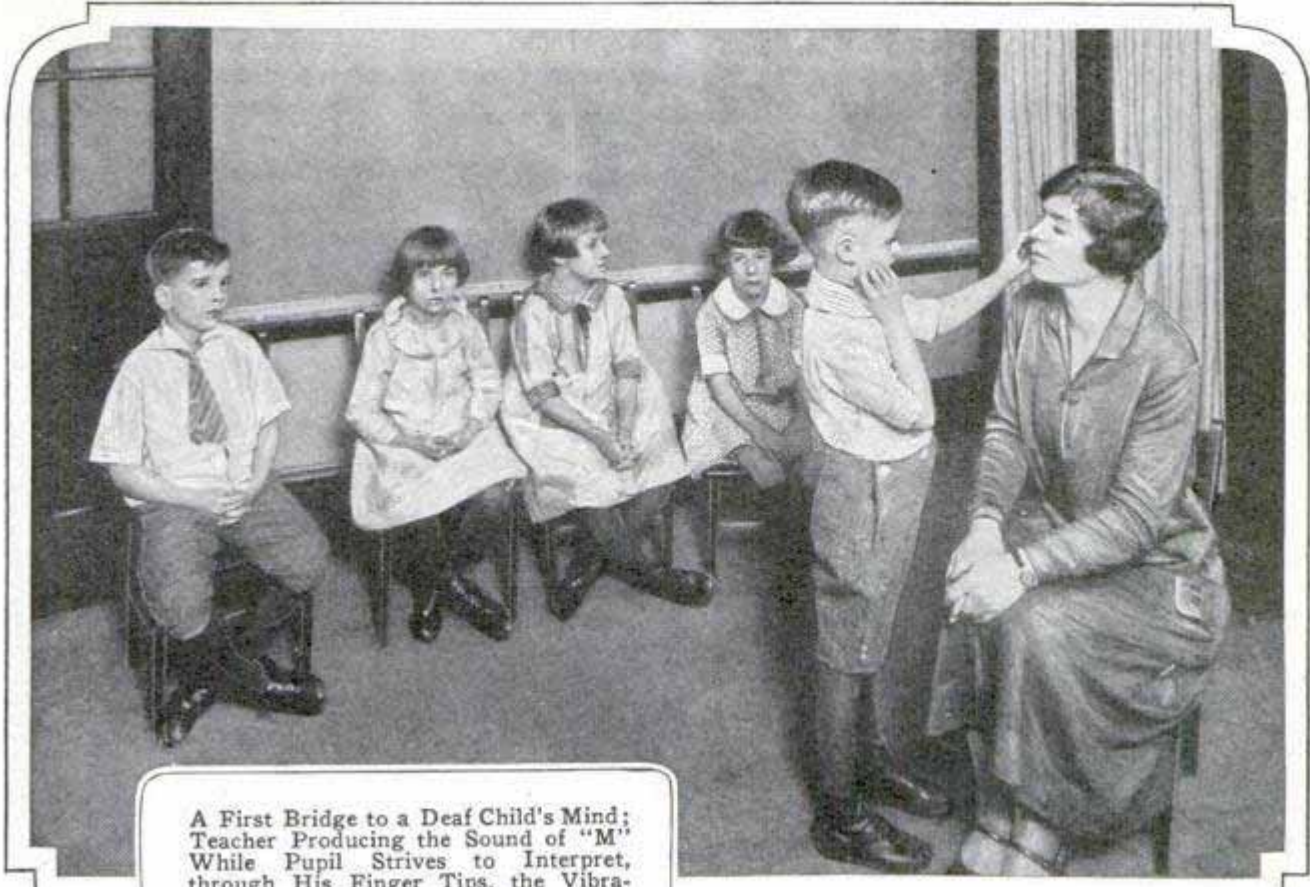

A First Bridge to a Deaf Child's Mind; Teacher Producing the Sound of "M" While Pupil Strives to Interpret, through His Finger Tips, the Vibrations from Her Cheek Bones



Another Radio Instrument to Aid the Deaf; It Stimulates the Remaining Sense of Hearing by Sounds Which Can Be Regulated to Fit Each Pupil

few years the vocal cords become shriveled up, just as muscles that are not used for long periods.

The pupil places his hands on the teacher's cheek bones. The instructor then makes the sound of "m," drawing it out slowly and distinctly. The child's hands, which have felt the vibrations of the tone, are placed on its own face so that he can feel the vibrations produced by his voice in trying to imitate the sound the teacher made. The time required for successfully taking this first step varies widely in different pupils, as mental efficiency is an important factor in their progress, just as it is with normal children. It may be days before the pupil even realizes what he is supposed to do. A great deal depends upon the skill of the teacher. Her special training is aimed to help her understand the deaf child's psychology; she is required to know much about physiology and the anatomy of the ear. Her task is not only to teach the child lip reading and speech, but she is his guide through the whole school course; he is dependent upon her for all that he acquires from his whole range of studies.

Once the contact is made, it is only a question of time and constant teaching until the child acquires a vocabulary, learns to read lips without depending upon his sense of touch and advances into simple problems in arithmetic and other studies.

In all the courses, the aim is to make the acquiring of hearing a cheerful and spontaneous task. The pupils develop eagerness and brightness, losing the dull, detached expression that usually identifies the sign-taught. Due to their training in lip reading and the application of the touch sense, they sometimes become even keener and more alert than a normal child, and their ability to concentrate easily—for there are no extraneous sounds to disturb them—aid them in their progress.

Recognizing that the deaf, if given proper instruction early enough, can be-

come useful members of society, other organizations throughout the country are putting forth renewed efforts in reclaiming deaf children by modern methods of teaching. There are now more than 200 schools for the deaf in the United States alone, and many public schools and colleges have special departments for teaching deaf children. As a result of the introduction of the principles of radio amplification, instruments are now being constructed by which large groups of children in the normal schoolroom may have their hearing capacity measured and classified with comparatively little expenditure of time and energy. This plan is now being seriously considered and introduced in public-school systems of many of our metropolitan cities. Chicago, Detroit, New York and Kansas City already have begun this work of classification, and the determination of even slight degrees of defective hearing in the mass of public school children. It is estimated that there are between 50,000 and 75,000 deaf children of school age in the United States. While their condition is deplorable, in the eyes of modern science, it is far from hopeless, for, assuming normal brain capacity, every one of them can be taught speech and lip reading so that they can take their places in the world.



Enjoying a Ride in the Push-Seat Swing

<sup>1007</sup>  
**SWING WITH HANDLEBAR SEAT  
DEVELOPS CHILD'S MUSCLES**

Besides affording healthful sport, a child's lawn swing, now on the market, is intended to develop leg and arm muscles, as it is propelled by pushing against supports for the feet and a pair of handlebars. The seat is suspended from three cords, which are adjustable for height to fit children of different ages, and is so arranged that the occupant can swing himself with little effort and yet gain sufficient exercise to benefit

him. The apparatus is easily set up, and occupies but little storage space.

☐Traffic delays in New York City, it is estimated, cost \$500,000 daily.

*Stevens Co.  
American Toy Ground  
Anderson, Ind.*

993

**FRESH AIR FED TO AUTO TUNNEL  
BY EIGHTY-FOUR MOTORS**

What engineers declare is one of the greatest triumphs in ventilation equipment and planning is represented in the automobile tunnel under the Hudson river in New York. The subway consists of two tubes. The main problem was how to insure sufficient circulation to get rid of noxious gases from the autos, and to supply fresh air for motorists and engines too. Some authorities believed that the task could not be accomplished. There were few data applicable to just such a situation, so tests were devised specially to meet the particular problems involved. The plan, as finally adopted, included the installation of eighty-four electric motors with a combined horsepower of 6,260 to turn fans for ventilating the tunnel, which was constructed so that the air would rise from vents near the roadway and pass through flues located in the ceiling. An exhaust-air duct runs the full length of each tube and occupies the upper portion of the passage. Ventilation is introduced at two points, instead of blowing the air into one and drawing it out at the other. Two-thirds of the motors will be kept running constantly, the remainder being reserved for emergency use.



Sight in Middle of Bow Helps Archers in Aiming at Target on Long Shots

**SIGHT SET ON MIDDLE OF BOW  
IMPROVES ARCHER'S AIM**

Fitted to the middle of the bow, a short sight, somewhat similar to that used on rifles, is said to enable the archer to direct the arrows more accurately. It does not interfere with the use of the bow and is said to be especially helpful on long-distance "shots," as it aids in gauging the correct elevation to counteract the downward course of the arrow.

**MOVIE COBWEBS  
MADE OF GLUE  
AND GLYCERIN**

From a mixture of glue, glycerin and powdered chalk, realistic imitations of cobwebs are prepared for motion-picture sets. The substance is placed between two boards which are suddenly drawn apart. Long strands of the composition are formed, which, when draped across old furniture or on walls or ceilings, satisfactorily pass for the real article. Buckets of paraffin wax, which has been melted, will quickly form into "icicles" when allowed to drip from the sets.

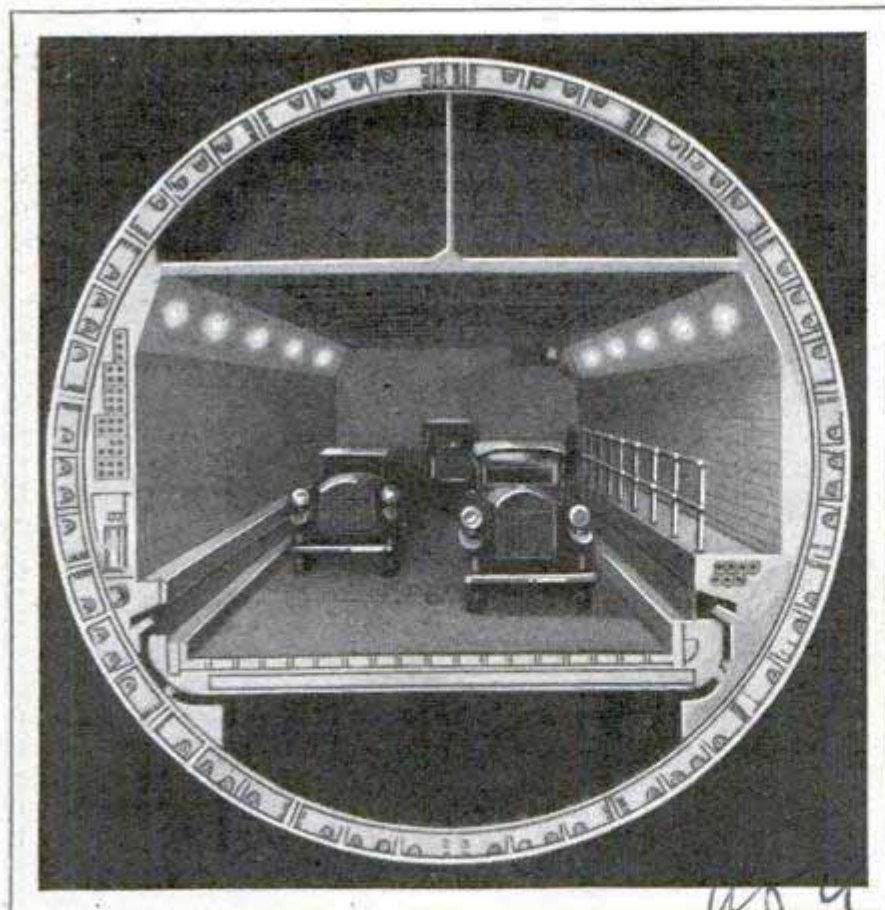

Cross-Section Sketch of Hudson River Tunnel for Vehicles, Showing Fresh-Air Vents at Sides and Upper Duct for Poison Fumes

*Southland Archery Club, Los Angeles, Cal.*

*Kans. City Times 1/2/26*

941

*Brooklyn  
Rail*

Inventor Pointing to Guards Tested in Railroad Yards



ALCOHOL IS MADE FROM COAL WITH AID OF STEAM

1004

While the process has not yet been developed to the point of commercial practicability, a system has been devised for producing alcohol from coal and steam. A model of the type of plant required for this was exhibited at a meeting of the American Association for the advancement of science. The process is said to be somewhat similar to that employed in using the nitrogen of the air for the production of ammonia and fertilizer which can now be done without the need of large amounts of water power to supply electricity.

GUARDS KEEP CARS ON TRACK AT BRIDGES AND FLOATS

To prevent derailments at bridges, turntables, car floats, transfer pits and other places in the track where the rails may not be in exact alinement, an eastern inventor has devised a set of wooden guards which are locked to the rails and act as supports to keep the car wheels from slipping off. They are specially adapted to car ferries, it is claimed, in transferring cars to and from the solid tracks, as changes in level and the unsteadiness of the float add to the danger of derailing. The new guards have undergone exhaustive tests for several months in Brooklyn, N. Y., yards, and, according to reports have been found to work satisfactorily.

One of the secrets of the method is the catalyst or substance used to cause the combination of the constituent elements of the product it is desired to make. Heat and pressures ranging from 1,500 to 15,000 pounds to the square inch are employed in the process.

FOOTBALL GAME WITH FINGERS PLAYED ON TABLE

992

One of the latest amusements in London is a mimic football game played on a table with the first and second fingers, which are inserted in miniature boots. Two, four or six persons can play at one time, goals are represented at the sides, and the rules are based on those which govern the soccer game.

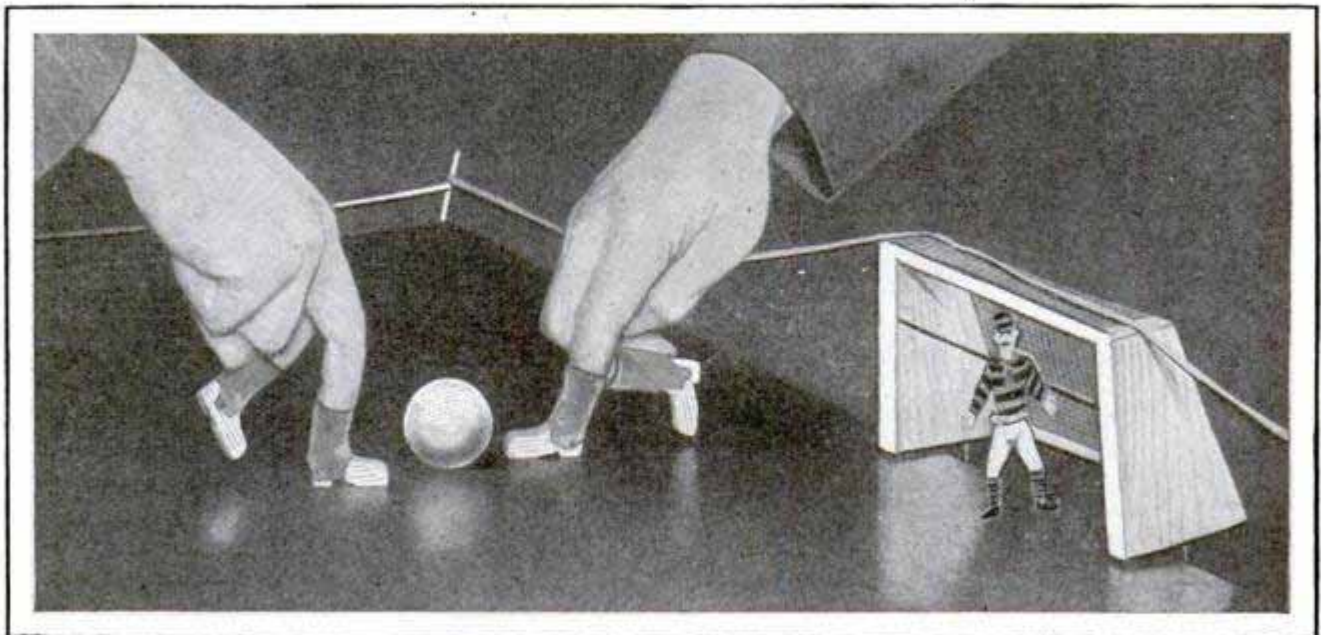
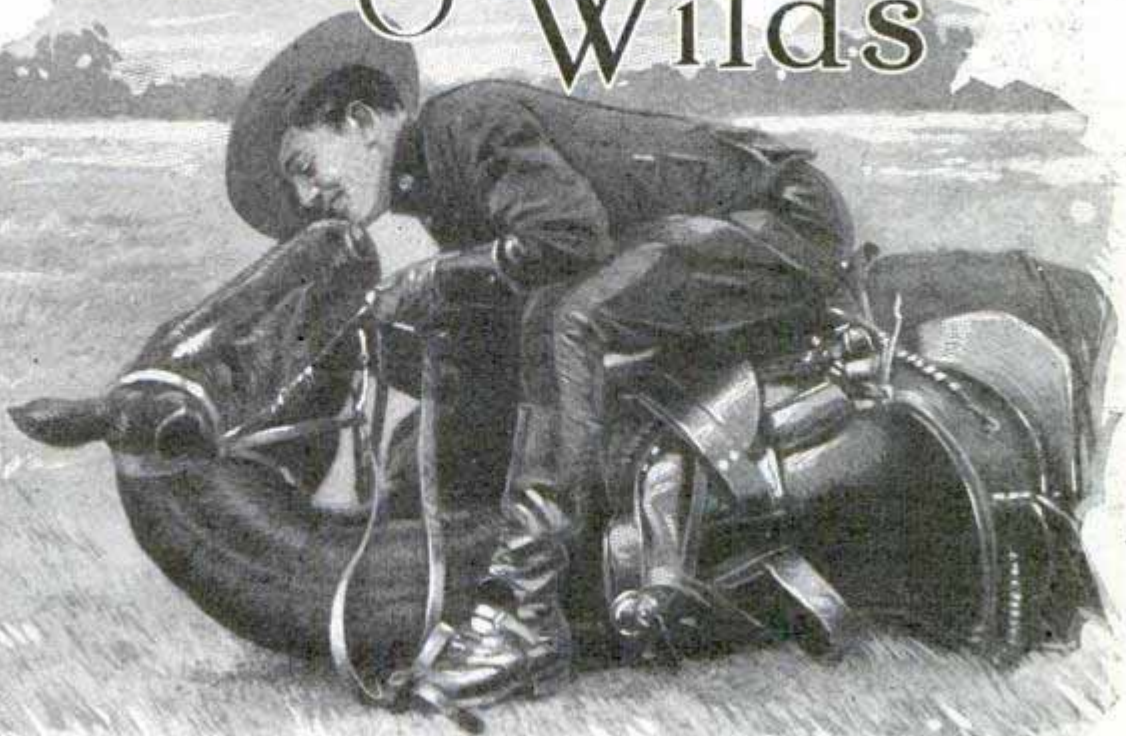

Table Football Players in Action; Little Boots Are Slipped on Fingers for Punting, and the Object, as in the Real Game, Is to Drive the Sphere within the Goals

*English*

# Policing the Arctic Wilds



Horses Are Regarded as Being as Important as the Men in the Northwest Mounted Police and Are Put through a Training School That Turns Them Out Schooled Well Enough for the Stage

By FRANCIS DICKIE,

*Heriot Bay,  
B. C., Canada*

RADIO audiences throughout the eastern section of the United States last winter heard several broadcasting stations halt their programs for three or four nights in a row to send out a message addressed to two men spending the winter far up above the Arctic circle. The message notified them that food was needed at another camp more than 100 miles away, because a supply boat had failed to reach it before the waters north of Hudson bay froze over.

The men at both camps were members of the world's most famous police force, the Royal Canadian mounted police, formerly the Royal Northwest mounted police. With barely a hundred officers and men in the Far North, they police a section embracing nearly one-third of all Canada, and do it so effectively that the fictionist who coined the slogan that "the 'Mounties' always get their man" did not exaggerate so far as might be expected.

They don't always get the man, but when failure comes, it is never through failure to try. Some of the celebrated cases in the annals of the fifty-two-year-old organization were not closed until one

constable after another had tracked a suspect for several years, if necessary.

The use of radio to deliver instructions to one post about sending food to another marks the advent of a new weapon in the policing of the wild. A number of the more distant posts were equipped with receiving apparatus last year, and sending sets will follow later. The wireless waves are expected to bridge the vast distances from Hudson bay to the heights of the Yukon and from Slave Lake to the Arctic sea at Coronation gulf, and simplify the work of guarding the Indians, Eskimos, hunters, traders, trappers, missionaries, and the wild life, moose, caribou and valuable fur bearers of the region. At present, months often elapse before the grapevine telegraph of the north, carrying messages on snowshoes or dog sled, gets word to the nearest post that a mounted man is needed at some distant camp.

Frequently a year or two pass before the principals and witnesses in a case can be rounded up and brought out to civilization, or a judge and court transported in to them. Last summer a judge of the Alberta courts, with prosecutor, defense

counsel, court stenographer and all the appendages of a white man's law court, went north by rail to Waterways, the end of steel, and then took steamer down the Mackenzie to Aklavik, in the river delta country, where an Eskimo was waiting trial for a murder committed at Coronation gulf. With a jury of trappers and steamboat men, they held court on the open deck of the ship and pronounced sentence.

On the same steamer, between twenty and thirty new recruits went north to spend two years in the mounted service at the far-flung posts above the Arctic circle. It takes so long to reach the ground and learn the territory that volunteers are accepted for not less than two years' service.

The red tunic and yellow-striped trousers of the mounted mark its men wherever they go, but there is little glory in wearing the uniform of the service. They work so far from civilization that the world seldom hears of their exploits, and the only record left is a constantly growing pile of reports, each stamped in turn "case concluded."

Inspector T. V. Sandys Wunsche recently handed in completed reports which set forth that he had traveled 2,540 miles to make the arrests in the case, 1,470 miles by steamer, 320 by launch, 250 on foot and 500 by canoe. He came back with a tribal

medicine man who had instigated a murder, the girl who had committed it and three of her brothers. The medicine man was sent to the penitentiary for manslaughter and the girl given a suspended sentence. The white man's law is enforced throughout the north, but tempered with leniency because, to the Indians and Eskimos, practices frowned on by civilization are considered proper. In this case no Indian in the Liard river country believed a crime had been committed when the tribal medicine man decided an eighteen-year-old-boy had bewitched an aged man who was dying, and advised the dying man's daughter to tie the boy out in the snow to drive out the witches. The boy died, and so did the sick man.

The witchcraft episode occurred at Thirty Mile Bar on the Liard river in northern British Columbia. An Indian of another tribe, following a trap line across the mountains, heard the gossip and passed it on to Frank Bass, who runs a little trading station at Liard post. Bass told a party of prospectors, and the story passed on down the river with them. Then the Indian agent in the Etikine country heard the yarn and sent it along to the chief Indian agent at Victoria, who in turn called on the mounted police to investigate.



Photos Copyright, Underwood & Underwood

Horsemanship Has Been the Major Boast, Next to Straight Shooting, of the Mounted Police Since Its Earliest Days; the Forage Caps Have Been Replaced by Stetsons, But the Tunics Are Still Red





Riding Instructor of the "Mounties" and a Bunch of Recruits with "Blackie," One of the Many High School Horses, Trained to Help Its Rider in Many Ways in Time of Need

In the meantime, half a year had elapsed, the nomad Indian tribe had moved on and the trail was almost blotted out, but the inspector started out and, after several weeks of travel, reached the vicinity. There his troubles began. None of the Indian tribes cared to talk about the affair, but advised the mountie to drop the case and go home.

The day after he arrived in the neighborhood, accompanied by two constables from another post, a native visited their cabin and proceeded to "witch" their weapons to keep them from using them. Watching until he believed no one was looking, the Indian slowly revolved on one foot before the gunrack and then touched each rifle in turn, confident that the process would keep them from shooting straight. He was doomed to disappointment, for the inspector, who had watched the performance out of the corner of his eye, arranged a shooting contest and, with the constables, easily out-shot the antiquated trade guns of the natives.

Information was scarce, but the party worked down the Liard, questioning everyone they met about the natives who had camped at Thirty Mile Bar the winter before. Eventually they learned the Loot family of a Dene tribe was responsible for the killing and began to trace them. Some days later, they found a spot beside the river where wolves had been digging and unearthed the body of an Indian boy, with hands and legs still frozen together as he had died while bound in the snow.

While they were thus employed, an Indian stopped his canoe to ask who told them that Atol, the Moccasin, was buried there. He was questioned and turned out to be one of the Loot brothers. Next, his sister, who had done the actual killing, his two brothers and big Alec, the giant medicine man of the tribe, were arrested. The inspector held an impromptu grand-jury investigation on the spot, and after hearing the evidence he had already gathered, committed the five for trial. The investigation disclosed that tying up a person was the accepted method of ridding him of witches, but that frequently if the affair occurred in the winter, the victim froze to death. The boy Atol lived six days bound out in the open.

In the winter months practically all travel by the mounties in the Far North is done by dog sled. Trips of 1,000 miles or more are quite common as they make their rounds. Those who returned last summer from their two years in the Hudson Bay country told of one occasion, while hunting for two Eskimos for the murder of two white men, when a team of thirteen dogs moved a boatload of provisions for four miles overland, the boat and load making a burden of 423 pounds per dog, several times the weight of the animals.

On another occasion, a mounted officer, traveling with one Indian from Split Lake post to Fort Churchill, went snow-blind and at the same time the Indian was stricken with pneumonia. The two made camp on Governor's island, in the Church-

ill river, and after fixing the Indian comfortably, the blind man boarded the sled and gave the dogs their heads. The team took him sixty miles down the river and into Fort Churchill, where he told his story. A relief sled was started out with one man, leaving at five in the morning, and was back at nine at night, having covered 120 miles in sixteen hours. The seven dogs of this team carried the 140-pound constable on the way out and the Indian and a quantity of mail on the return trip.

The records of the force are filled with deeds of heroism and self-sacrifice, or rather, they are filled with skeleton reports which oftentimes hide such deeds. For instance, those of Pleasant Camp, B. C., under date of May 19, 1898, state:

"Constable Frederick Hillier met death by drowning at the ford of the Kicking Horse river at five o'clock p.m. yesterday while returning from border-patrol duty. Report reached here too late to go in record of 18th. Immediate application made to Sergeant-Major Barlow, Atlan division, for constable to fill place on account of miners rioting on Porcupine creek."

Behind that brief entry lies a story of unequalled heroism. Two constables were riding the Dalton trail when they started to ford the river, made dangerous by spring floods. One horse, feeling the quicksand sucking at his feet, threw his rider and escaped. The other horse drifted down to a sandbar and reached land. The lucky rider looked back and saw his companion, waist-deep in the water, being drawn down by the sand scarcely thirty feet from the bank. The only rope they possessed had been tied at the saddle of the runaway horse.

The rider on the bank tried to spur his horse back into the stream, but the animal refused. The rider sprang off and plunged into the river toward his companion, who was silently awaiting his fate. Hillier, held by the sand, shouted to his companion to go back. "You can't help me a bit and you'll only get stuck yourself," he called. His friend refused to heed the warning and pressed on. Suddenly the doomed man jerked a revolver from his belt, shook the water from it and leveled it at his companion.

"Jack, I've got less than five minutes to live," he said. "Don't send me out with the stain of murder on my soul. You come another step and that's what you'll do."

The would-be rescuer hesitated for an instant, and in that moment the current snatched Hillier away. Three or four lines in the post log and a hurry-up call for another man because the miners were rioting was his obituary.

The history of the mounties goes back to 1873, when Sir John A. Macdonald decided to organize a body of men "without gold lace." Three hundred men were recruited in Toronto and sent to Fargo, N. D., then the railhead of all the northwest. From there, pulling one small cannon, they walked 800 miles overland to the foothills of the Canadian Rockies and began establishing their posts. Outnumbered by turbulent Indians more than a hundred to one, they succeeded in bringing about order. During the Boer war a detachment of mounties won fame in South Africa as dead shots, and again in the World War the force sent 738 former members to France and 174 to the Siberian front.



Horses of the Mounted Are Taught to Lie Down and Seek Cover as Well as Their Riders, a Valuable Trait When Pursuing Desperate Men into the Wilds of the Far North

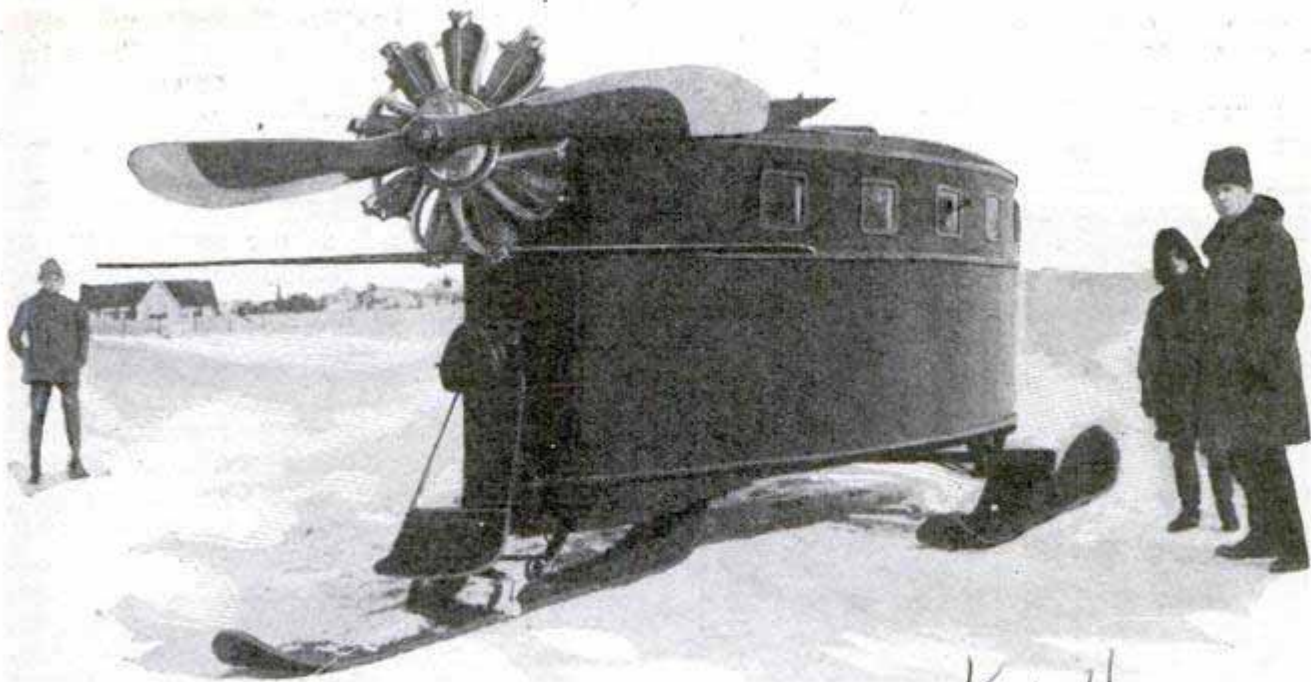

K & H

While Winter Snows May Block Roads to Other Vehicles, This Propeller-Driven Bus on Skis Makes Swift Trips over Ice and Crust between Helsingfors and Sveaborg in Finland

**TAXI ON RUNNERS FOR WINTER  
—DRIVEN BY PROPELLER**

Airplane and sled are combined in a useful vehicle for travel during the winter months between Helsingfors and Sveaborg in Finland. Three broad skis, two behind and one in front, have been adapted for runners and the bus, which will hold several persons, is driven by a powerful airplane propeller. Steering is done with the single ski.

possibilities and added efficiency gained by putting the eye in the needle.

**FOLDING CHAIR FOR OUTDOORS  
HAS LOOPS FOR ARMS 981**

For cyclists, campers or hikers, a folding easy-chair that fits in small space when rolled up and is quickly adapted for use, has two loops or slings to hold the arms, so that the occupant can be comfortable while reading. The seat may be placed against a tree or other support, protects the user from dampness and may be adjusted to various angles for reclining.

**998  
MAKING SINGLE NEEDLE TAKES  
WORK OF SEVENTY MEN**

Needles are insignificant things, but to finish a single one from a plain piece of steel to the article ready for use, the work of as many as seventy men is required, and the implement must pass through twenty-two processes before it is ready for the market. Most of the labor is in finishing and polishing them. In primitive times, thorns, pointed sticks and sharp bones were used for needles. One of the important steps in the development of the human race was the discovery of the timesaving



Cyclist Enjoying a Roadside Rest in Folding Chair; the Loop Straps Comfortably Support the Arms While Holding Paper

*Order to Frederic M  
Lelans, 16 Avenue  
F. T. Chera, France*

### ARC LAMP WITH "LIQUID LENS" TO IMPROVE MOVIES

Increasing the intensity of the light for motion-picture projectors and stereopti-

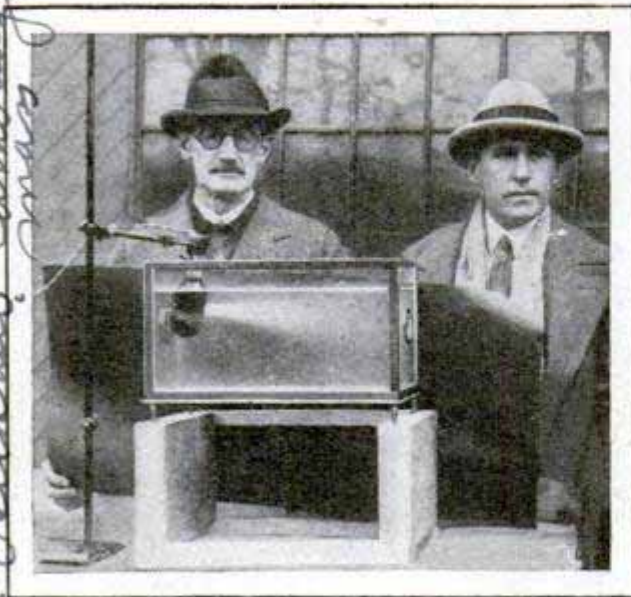

Lamp Surrounded by Its Liquid Lens, a Solution of Substances Which Increase Light's Intensity

cons, a liquid between the lamp itself and the lens, also absorbs the heat. It is a mixture of water and various other substances, and promises to be of great aid in medical application, as beneficial rays can be projected through it for hours over the body with less hazard, and the eye can also be brought close to the light source without danger.

### PLOW AND HARROW COMBINED IN ROTARY SOIL TILLER

Work that ordinarily can be done only by using several implements is said to be performed by a motor-driven harrow and plow for light soil tilling. It is steered and controlled with an extension bar and has a set of twenty revolving steel tines that dig into the ground, loosen and pulverize it while helping the outfit along. One man can easily manage the implement, and it is specially suited to work in orchards, as it can be guided between

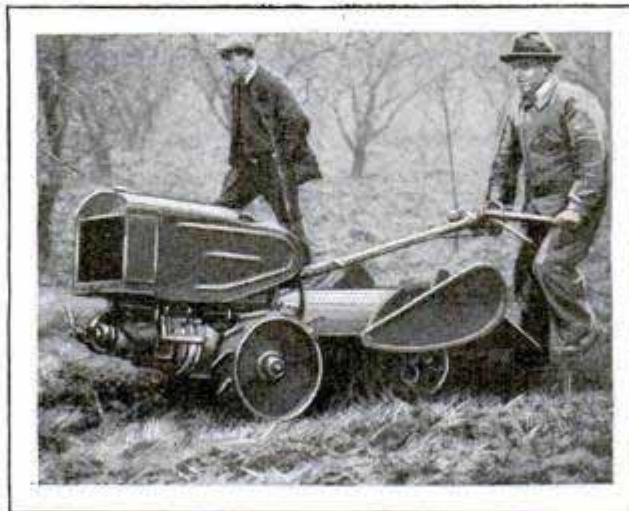

Tiller in Operation; Revolving Blades Help Propel the Apparatus and Loosen the Soil

trees, close to the trunks and without damage to branches, such as is likely to occur when larger equipment is used.

### CYCLIST BREAKS SPEED RECORD BEHIND MOTORCYCLE

Pedaling behind a motorcycle as a windbreak and directed through a special speaking tube attached to the driver's back, a bicycle rider in France recently shattered records by attaining a speed of seventy-four miles an hour. The motorcycle was constructed to meet the demands of the test, having a broad shield at the back to keep the wind from the racer and a streamline front of special design. So that the driver's words would be carried more distinctly through the speaking apparatus, a mask screen of transparent material was fitted over his face and around the mouthpiece. Both the driver and bicycle rider wore helmets. The demonstration was staged on the Mont Chery race track, near Paris.

### CLUE TO LOST NATION FOUND IN ARIZONA RELICS?

Did the Jews establish a kingdom in Arizona long before Columbus discovered America? Evidence which seems to support the theory that they did, has been found in a number of relics dug out of limestone, five feet below the surface, near Tucson. While some scientists are in doubt as to the genuineness of the objects, others declare that, whatever their origin, they must have lain under the earth for centuries. The relics show both Jewish and Christian influences and some bear dates of 760 to 900 A.D. The inscriptions have been interpreted as describing

the conflicts of the prehistoric Roman-Jewish kingdom in the southwest with the Toltec Indians, forerunners of the Aztecs. If the objects prove to be genuine, scholars believe that they will help clear up what has been a puzzle to many research students, the evidence of European or other outside influences in the rites and ceremonies of some of the Indian tribes.

Copyright, Special Press

Chicago Tribune 12/13/25

*W. W. Boerter Waterloo, Mass. 905  
H. S. McAlister and  
Signed Richell, Cambridge, Mass.  
Lundm.  
Rototillers  
58 Compton St. Lowell, Mass.*

*near Mont Chery track near Paris*

*1729*

*917*

*864*

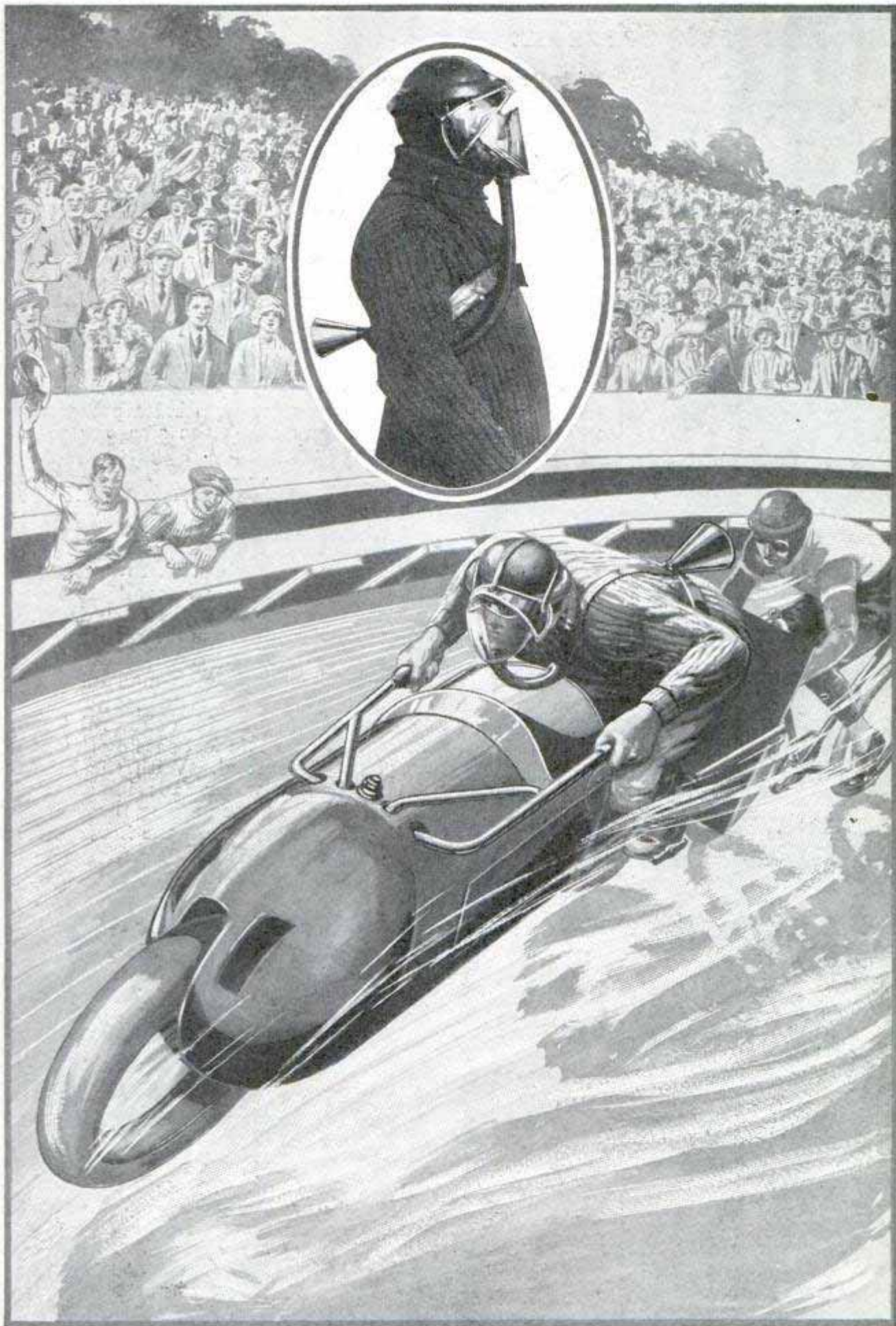

Bicycle Rider Sprinting behind Motorcycle at Seventy-Four Miles an Hour and Being Directed through Speaking Tube; Inset, Driver Wearing Mask with Horn Strapped on Back

**METER IN HEAD OF GOLF CLUB RECORDS FORCE OF STROKE**

How far can you drive a golf ball? A meter-equipped club now on the market

*Miss Naomi Arme*



Meter in Head of Golf Club Registers in Yards the Force of a Stroke against the Ball

is intended to eliminate much of the guesswork in such estimates, as it automatically translates into terms of yards the force of the blow when the club strikes the ball. The indicator is set in the head and has a button on the other side by which the mechanism is released for another registering after the reading has been taken.

**JUNGLE WOOD SERVES AS ICE AND SAVES LIVES**

But half as heavy as cork, balsa wood which grows in the tropics, particularly in Costa Rica and Ecuador, has been found excellent for insulation both from heat and cold. A small box of it, packed with fish at one degree above freezing, is said to have kept the contents at almost the same temperature without the use of ice on a journey halfway across the continent. The material is being used for shipping ice cream and chocolates and a New York architect is experimenting with it as lining for a house to keep out cold air and retain heat.

*J. H. Montgath Co. 204 Lewis, New York.*

The wood is also being used for the manufacture of toys, airplane propellers, stage scenery and for museum mountings and specimens. In a New York theatrical production, an imitation stone wall erected for a long run, weighed over two tons. The same set was reproduced in balsa wood for the road and weighed less than ten pounds. It has proved of special use in life preservers and rafts. The natives in the countries in which it grows discovered its value for boats and floats many years ago, the name "balsa" being the Spanish for raft. It is said to have about half the strength of spruce. An advantage claimed for the material in airplane propellers is that it permits the use of motors of slower speed. The government is now experimenting with balsa propellers, which are four times the size of one of ordinary wood, yet much lighter.

**HORSEPOWER AT WILSON DAM READ ON MANY GAUGES**

Whenever engineers wish to determine how much horsepower is available from the water flowing over Wilson dam in Alabama, a dozen or more men are required to read the gauges which are placed across the channel. Each man takes his place at a given spot on a floating weir and reads the gauge which shows the volume of water in cubic feet passing through that place per second. With the height from which the water falls known and with the total volume passing through all the open gates computed, the horsepower is readily determined.

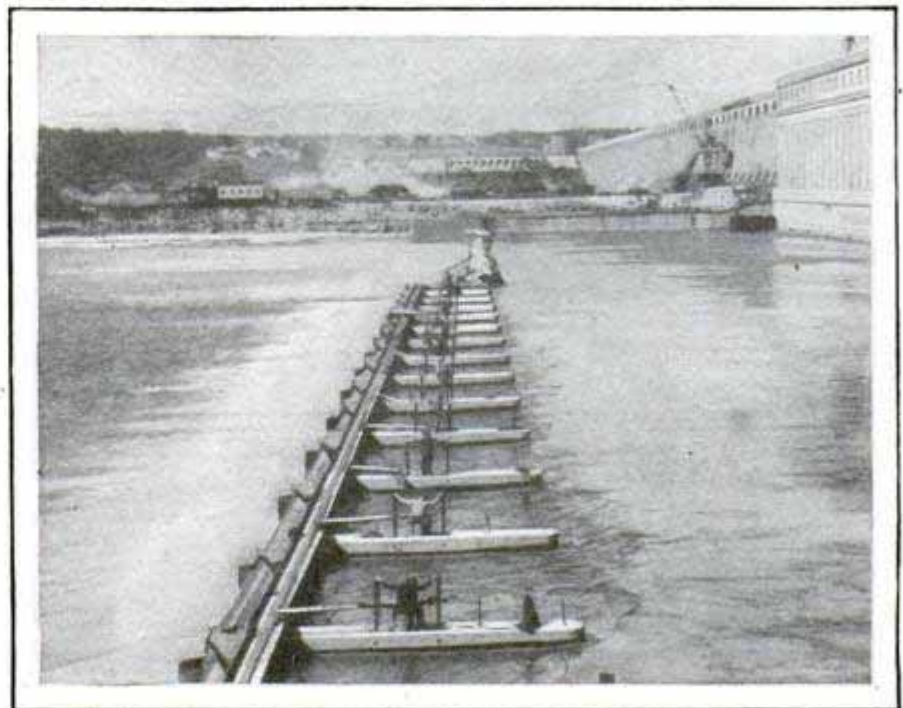

Reading the Gauges at Wilson Dam to Measure Horsepower

*Keystone*

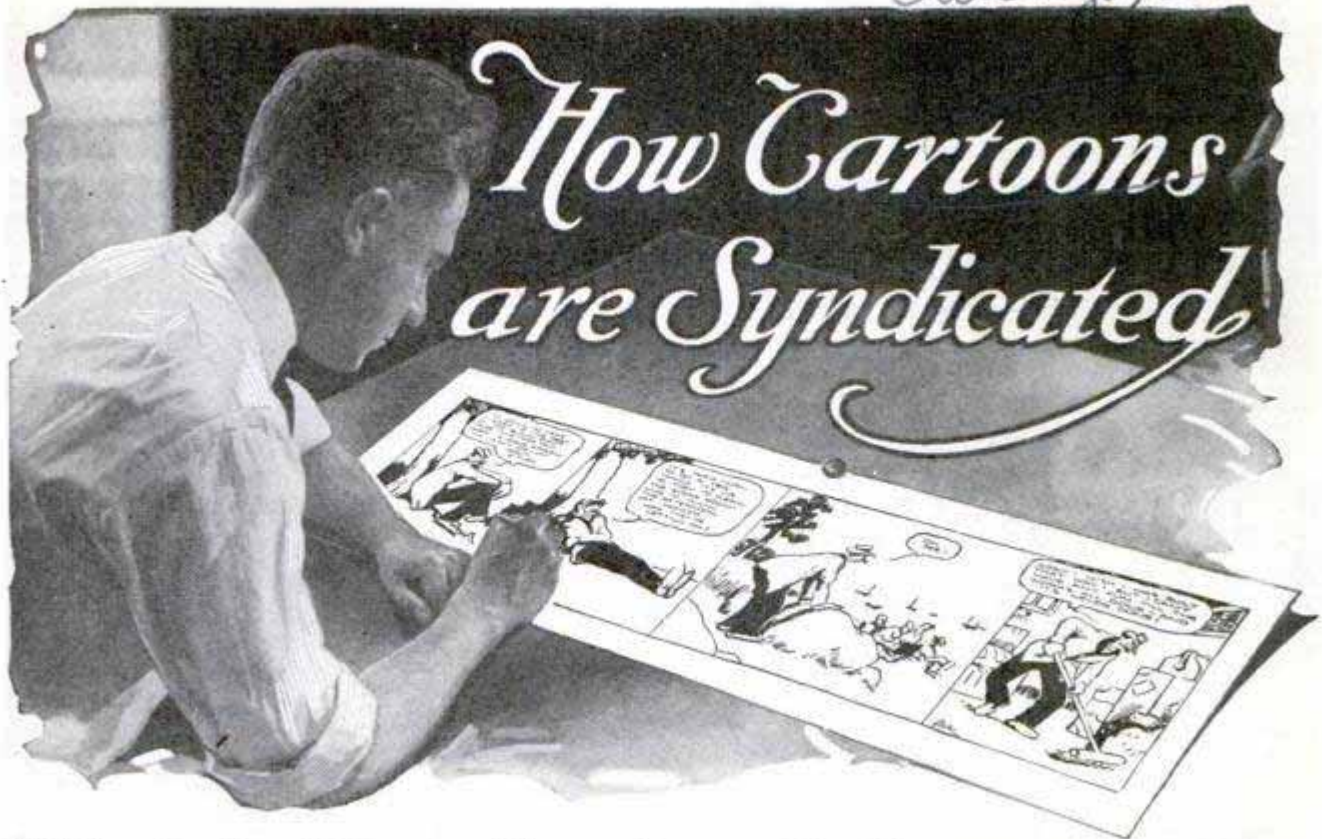

## Million Dollars' Worth of Space Devoted by Newspapers Each Year to Comic Strip Showing Gasoline-Alley Adventures

**I**N a hundred Sunday-morning newspapers from coast to coast each week appears a full page, in four colors, showing the adventures of a group of just average everyday people whose garages abut on one common alley. In as many, or more, papers the same characters appear each weekday in a "strip" seven or eight columns wide. In a year's time the papers devote more than a million dollars' worth of space (at their current advertising rates) to this one cartoon alone.

The reason lies in the new idea in newspaper comics—human-interest stories with a continuity, as the film people say, instead of the antics of impossible boys sawing holes in the floor for their elders to drop through, or performing similar stunts.

Frank King, creator of "Gasoline Alley," which appears in American newspapers reaching more than 5,000,000 people each day, was one of the leaders in creating the new style in cartoons. From a \$22.50-a-week artist on the Chicago Tribune staff, drawing fancy borders to fit around the pictures of beautiful divorcees and other news celebrities, he has become one of the highest-paid newspaper cartoonists, helping to keep a vast organization busy distributing his work and the work of his fellow comic-strip artists.

The story of the distribution, or syndicating, of the features which appear simultaneously in papers throughout the country is a story of big business organization. No one paper, even the largest of metropolitan dailies, could afford to employ an entire staff of feature writers and artists at the salaries they command, but by syndicating their output among scores or hundreds of papers, the smallest city can see each day the same features that appear in New York or Chicago, and pay only its proportionate share of the large expense.

Newspaper syndicates are owned by a number of the large-city papers, and others work independently, employing their own artists and writers. The cartoonists are usually ex-newspaper artists who got their start, as Frank King did, retouching photographs and drawing borders in some newspaper art room. Then comes a chance to do a cartoon on some timely subject, or the artist in his spare moments gets an idea for a whimsical drawing. From that, if his ideas hold out, he develops a strip; his paper tries it out for a while, and if it takes hold with the public, it goes into the syndicate, and a fat contract follows. Sidney Smith, creator of the Gump-family cartoon a few years ago signed a million-dollar contract, and his newspaper celebrated the event by

presenting him with the most expensive imported limousine on the market.

Both the Gumps and Gasoline Alley appeared in the Chicago Tribune for some time before they were sold to other papers. Both have the same basic idea, the daily adventures of ordinary Americans, each strip featuring various grown-ups and at least one youngster. The artist who creates a newspaper comic must not only be an expert cartoonist but a man with plenty of ideas. He plans his work weeks in advance, creates new situations, and then follows them along for days, and sometimes even for

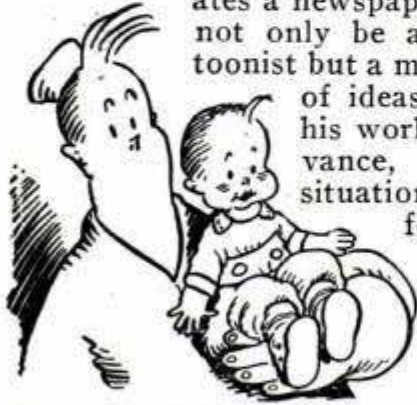

months. In a presidential-election year Andy Gump ran for chief executive on an independent ticket and burlesqued the issues of the day. The comics follow the seasons and their holidays, and, despite the fact that they must be planned days in advance, often mirror the news of the world.

It is customary to have two separate stories running through the cartoons, one in the daily strips and another for the full pages on Sunday, which appear in colors in the comic sections. The reason is that the papers which use the daily strip do not all have Sunday editions using comics, and some of those using the full page on Sunday do not use the daily strip. In addition, the artist, from time to time, must prepare extra strips and pages introducing the characters and giving a synopsis of their lives, to be used by new mem-

bers of the syndicate as they are added.

When the artist sits down at his desk each morning, he may have an idea in his mind, or may turn to the daily papers for one from the latest news, or, if everything else fails, he looks out of the window until an idea comes. The idea is then roughly sketched with pencil on a strip of white cardboard, and put in final form with pen

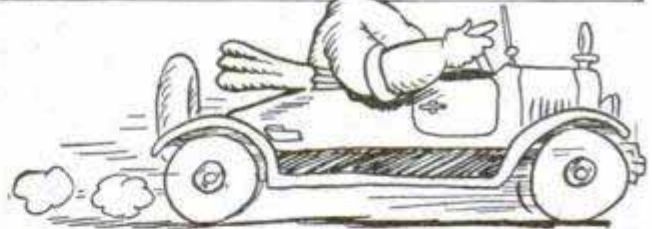

-King- CHICAGO TRIBUNE.



Frank King and His Fellow Artists Inspecting the Day's Work, and, Above, Some of His Drawings of Walt, Skeezix and Rachel, the Maid



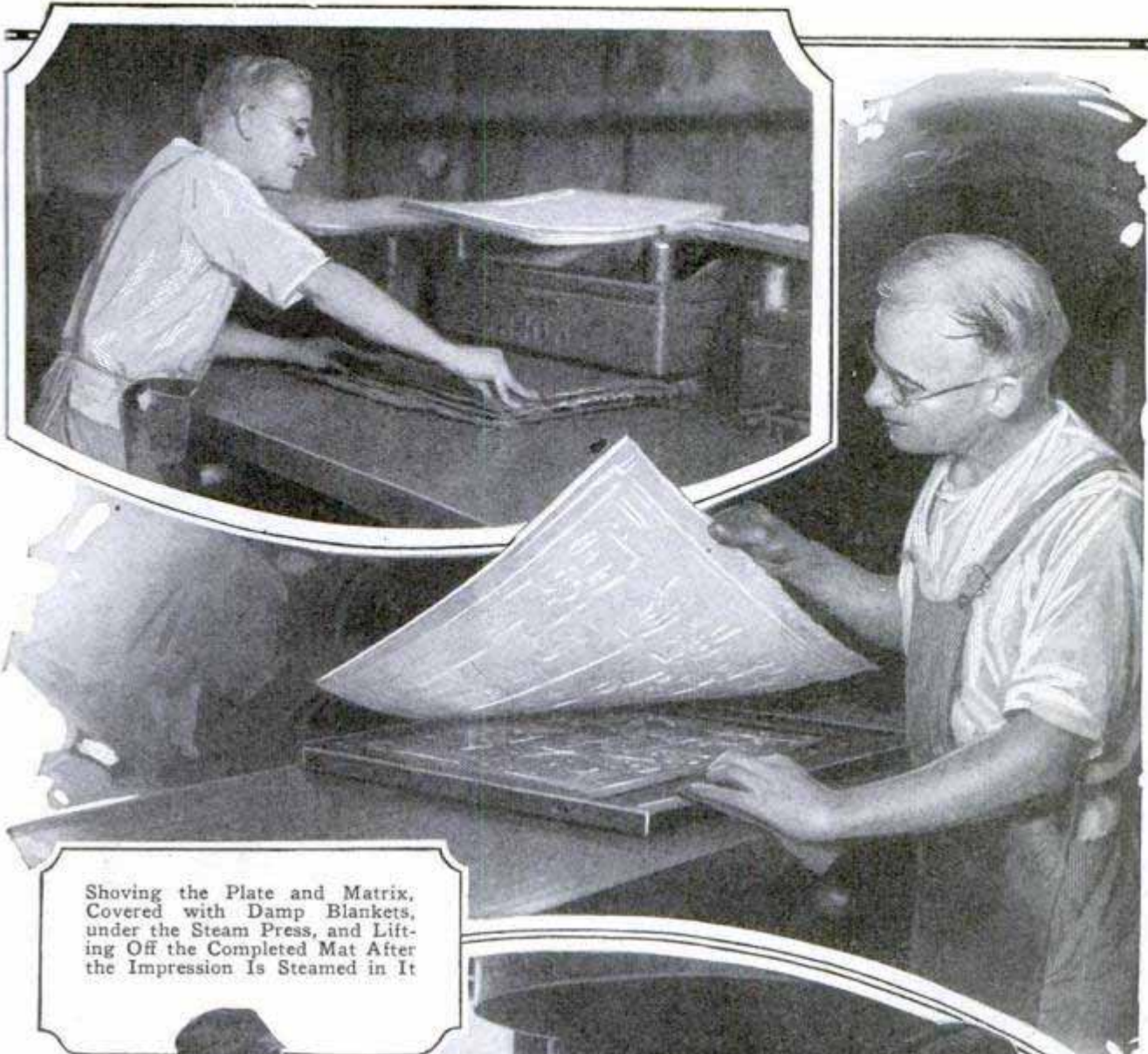

Shoving the Plate and Matrix, Covered with Damp Blankets, under the Steam Press, and Lifting Off the Completed Mat After the Impression Is Steamed in It

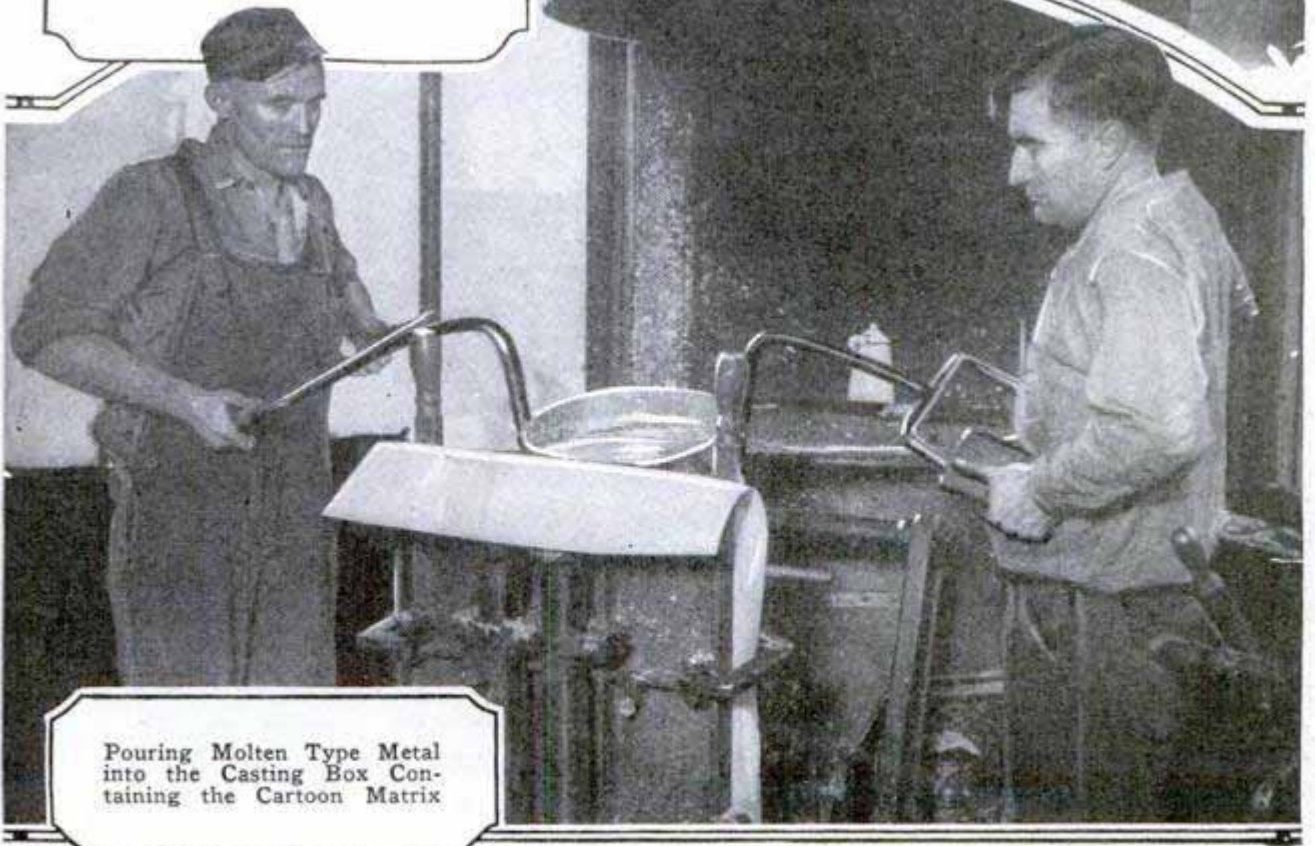

Pouring Molten Type Metal into the Casting Box Containing the Cartoon Matrix

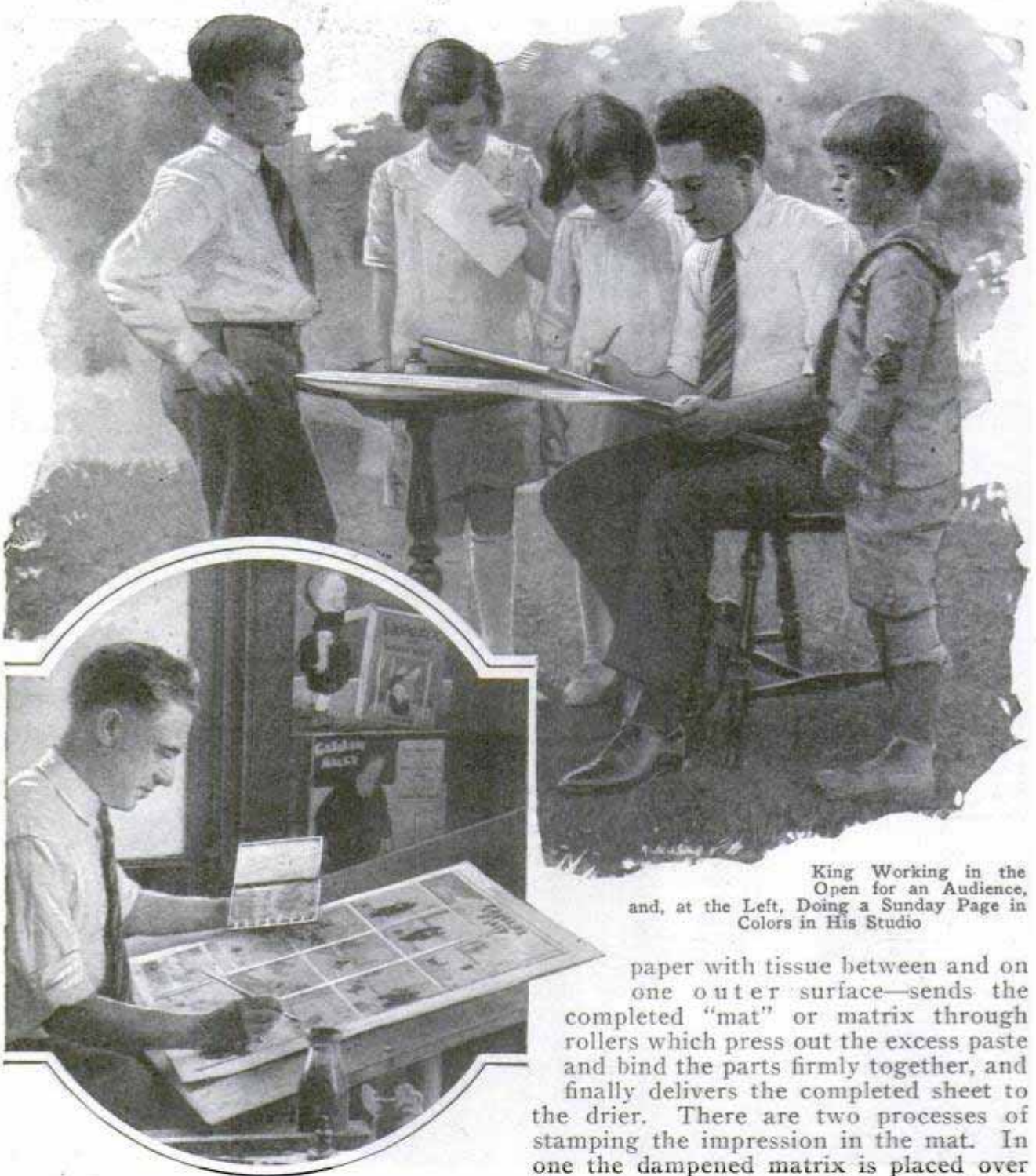

King Working in the  
Open for an Audience,  
and, at the Left, Doing a Sunday Page in  
Colors in His Studio

and ink, the larger black parts being filled in with a brush. The title may come first, or follow completion of the strip.

From the artist the strip or page goes to the engraving department, is photographed on a copper plate, engraved and prepared for the mechanical department.

The next step is to transfer the engraving to a paper mold in which type metal is poured to produce the printing plate. A machine carrying rolls of blotting paper and other rolls of a special tissue paper automatically cuts off sheets somewhat larger than a newspaper page, pastes them together—four sheets of the blotting

paper with tissue between and on one outer surface—sends the completed “mat” or matrix through rollers which press out the excess paste and bind the parts firmly together, and finally delivers the completed sheet to the drier. There are two processes of stamping the impression in the mat. In one the dampened matrix is placed over the engraved plate, rolled in until it fills every indentation, then covered with moistened blankets and placed in a steam-heated press to dry the impression in place. A faster process uses a drier mat and heavier rolling pressure, shortening the steaming process from several minutes to a matter almost of seconds.

The cartoonist delivers a full week's supply of strips at one time, and all are reproduced on one matrix, which is then clipped apart for convenience in mailing.

At the newspaper plant the process is reversed. The mat is placed in a casting box, surrounded by containing walls just type-high, and molten type metal poured

in. The casting boxes are water-cooled, and the hot metal chills so quickly that the tissue surface of the mat is hardly browned.

The casting, after being sawed to the proper size, is placed in the page form and made up along with the newspaper type. The page form then goes to the stereotyping machine, and a mat is made of it in the same way the original comic-strip matrix was produced. The page mat is bent into a half circle and placed in a large casting box, and the entire page cast in this form, ready for the circular roll of the high-speed presses which print the daily papers.

Being a friend or neighbor of one of the newspaper cartoonists is a precarious occupation unless one likes to see himself in print, for frequently they use their friends, not only for characters, but sometimes even by name. Walt, the leading man of Frank King's Gasoline-Alley bunch, is pictured as a large and carefree bachelor, who lately has been on the verge of marrying the widow Blos-

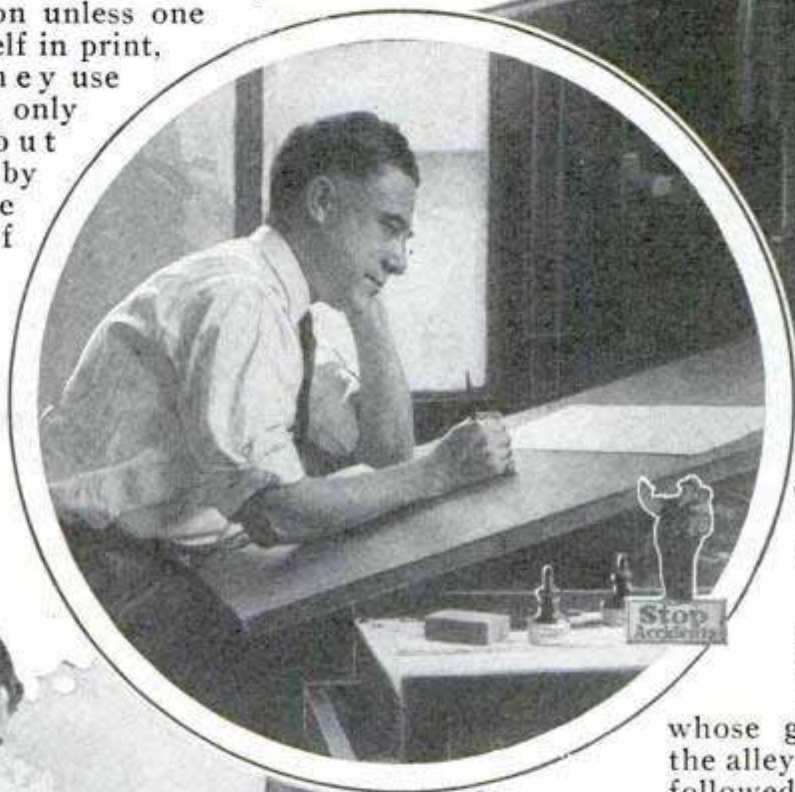

Cartoonists Keep Regular Office Hours, Cudgel Their Brains for Ideas, and Admire the Finished Job

som, a comely addition to the ranks of those whose garages abut on the alley. Few who have followed his adventures, however, know that Walt in private life is Walter Drew, a long suffering brother-in-law of the artist. It was on a Sunday visit to Drew several years ago that King got the idea for the cartoon strip, which, incidentally, started out not as a strip, but as a rectangle, a three-column-deep cartoon for the sporting pages. Drew had an alley garage back of his home, and King accompanied him there to watch him tinker with his car. Several neighbors were do-



ing likewise, and out of their alley friendship grew the idea. Bill, another of the Gasoline Alley characters is taken from real life, being a locomotive engineer.



Stacks of Mats Are Delivered to the Shipping Room and Those for Full Pages Wrapped in Large Packages and Backed with Cardboard for Mailing. While Daily Strips Are Cut Apart First

The doctor, known as "Doc," is a composite, according to King, of several characters.

The artists are flooded with ideas and suggestions from readers, most of them impractical for one reason or another, but Mrs. Blossom, the widow, grew out of one such letter. The writer explained that she was a widow and had few friends until she bought a small coupe and rented an alley garage. Then the neighboring garage occupants offered their advice and assistance and frequently took her riding in their larger cars. King introduced a widow to the alley, with the same results. Skeeze, a foundling left on the doorstep of the bachelor Walt, on St. Valentine's day, 1921, and since adopted and raised by him, is modeled after the artist's own son, who happens to be five years older than the cartoon youngster. King, however, explains that he went back in his memory and has reproduced many of the experiences and sayings of his own boy, attributing them to the comic-strip child.

Public taste and desires frequently shape the future for the comic-strip characters. Recently one paper, which features a cartoon built around a little orphan girl, thought she might be losing her popularity because her creator had had her adopted in a rich household. So, for an experiment, the strip was omitted one morning. The result was a flood of telephone calls, personal visits and letters, all demanding to know what had happened to Orphan Annie. The newspaper restored the cartoon next day, explained the omission, and invited suggestions

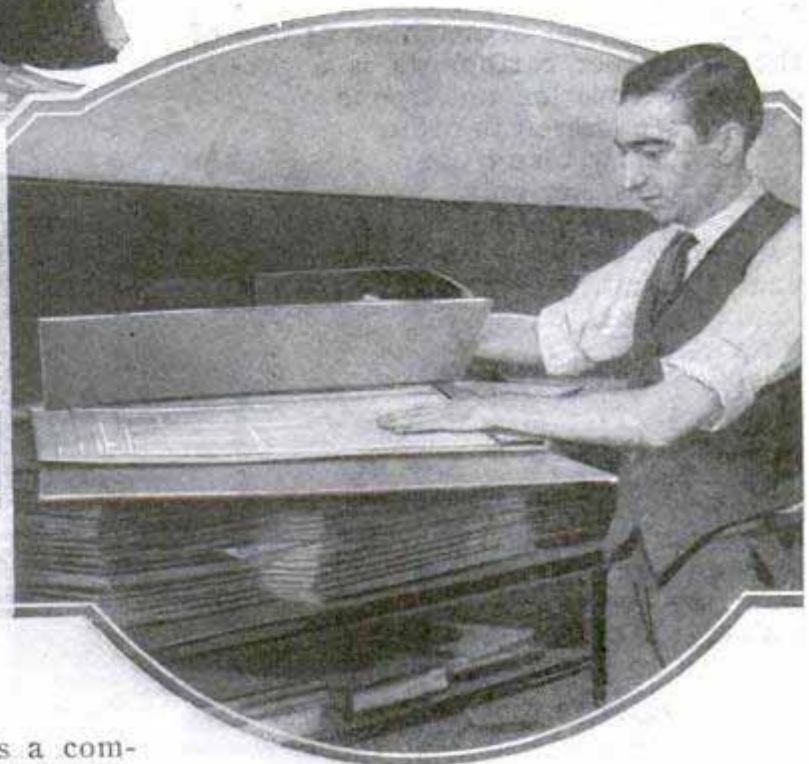

from readers as to Annie's future adventures. Hundreds of letters resulted, opinion being well divided as to whether she should remain the ward of a rich family, return to a previous home with a poor farmer or some other station in life.

### HACKSAW WITH STEEL FRAME CUTS CORRUGATED IRON



Ordinary hacksaw blades can be used for cutting corrugated iron and other metals with a patented frame introduced in England. It is constructed of steel and is triangular in shape, affording an easy stroke, and is fitted with a special cast-steel blade particularly adapted to cutting asbestos and similar material in either flat or corrugated form.

Arthur Collier, 453  
Briston Road, a Inc

### BUFFALO IN CANADIAN HERDS TOTAL TWELVE THOUSAND <sup>989</sup>

Canada's efforts to preserve the buffalo from extinction have been so successful that the herds have become a problem. Space in the national park at Wainwright, Alta., is exhausted. About 8,000 animals are kept there, and it is estimated that there will be nearly 2,000 more by the end of this spring. Many will have to be slaughtered or part of the herd taken to the Wood buffalo park near Fort Smith, in the northwest territories. In recent years, about 2,000 buffalo have been killed and commercial disposition made of the meat, and of the skins for robes, which were sold for \$50 to \$75 apiece. The present herds are the result of the government's care of an original herd of 700 once owned by a Montana man. The first steps in the preservation program were taken in 1907. The experiment has proved so successful that there are now about 12,000 buffalo in Canada.

### LIGHTHOUSE ON WRECKED SHIP PROTECTS NAVIGATION <sup>955</sup>

When salvaging operations were temporarily suspended on the monitor "Glatton," purposely scuttled in Dover harbor, Eng., during the war, the ship was fitted with a small lighthouse so that the wreck would not be a menace to navigation. The beacon was firmly attached to the highest part of the hull and, though small, provided sufficient illumination to warn boats of the danger. The monitor was sunk when it caught fire with 600 tons of ammunition on board.

### PORTABLE SAWMILL FOR FARM IS RUN BY TRACTOR <sup>960</sup>

Capable of handling logs as large as thirty-four inches in diameter, a portable



Running a Sawmill with Power from a Tractor; the Outfit Can Be Hauled Directly to the Timber

sawmill, run by power from the farm tractor, can easily be taken to the timber and quickly rigged up or taken down. The carriage is built in standard lengths of fourteen and twenty feet. With the former size, a forty-five-foot trackway and a forty-six-inch saw are suitable. A balance wheel, weighing 300 pounds, is also part of the regular equipment. The outfit is designed to reduce the cost of converting timber into lumber where only small quantities are needed and where the woods are inaccessible to larger units. To save fuel, the tractor may be rigged so that the sawyer will be able to control its speed, allowing it to idle when the saw is not cutting, and thus keeping the engine comparatively cool.

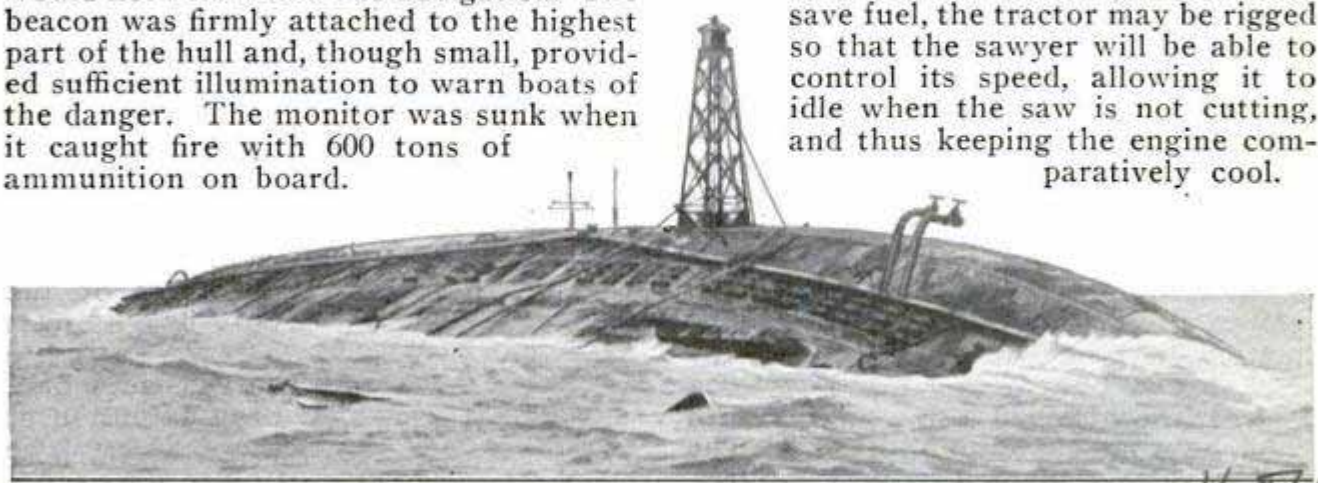

Wrecked Ship Becomes Foundation for a Lighthouse; Beacon on the Monitor "Glatton," Scuttled during the War, Warns Other Vessels While Salvaging Was Temporarily Halted

*J. A. Vance Co., Winston-Salem, N. C.*

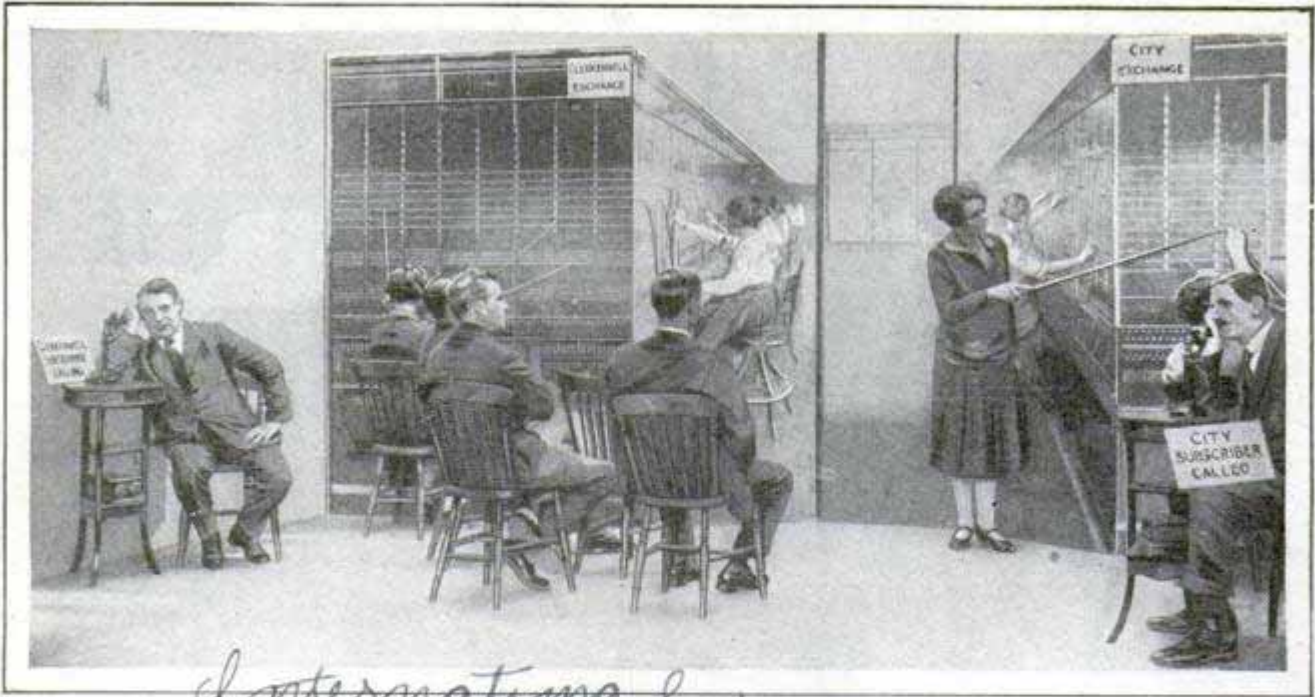

English Subscribers Listening to an Illustrated Talk on Telephoning; Screens in the Background Depict the Interior of the Exchange Stations; Successive Steps Are Pointed Out by Lecturer

**HOW PHONE CALLS ARE MADE SHOWN BY EXHIBIT**

Just what happens in a telephone exchange when a subscriber asks for a number has been graphically illustrated by a working model prepared in England. The apparatus consists of replicas of switchboards with operators on duty, and screens depicting the interior of the exchanges. Two persons seated at tables, one on each side of the display and using telephone instruments, represent actual parties to a telephone call. A lecturer explains the various steps involved from beginning to end of the call.

**SKILL OF DIAMOND CUTTERS INCREASES GEMS' VALUE**

If a young Hollander, Ludwig Van Berquen, had not discovered, some 450 years ago, that diamonds can be cut and polished with dust formed by rubbing them together, it is possible that the gems today would be no more highly regarded than they were centuries before Christ, just as bright glasslike crystals, extremely hard, but with no special play of color or brilliance. When Van Berquen went to Paris, the jewelry trade was highly developed and after several years of experimenting, he found that by imbedding the diamonds in cement and grinding them together, he obtained a fine powder with which he could cut and polish them. The art was rapidly adopted by gem workers, and the diamond's value mounted tremendously. Cuttings are now made in

much the same way as they have been for hundreds of years. The stones are first carefully examined to determine their structure and the most suitable way of cutting them to avoid waste. A groove is marked, the cutter places a steel instrument in the depression and strikes a sharp blow with a hammer. Great skill is required, for a single misdirected stroke may ruin a valuable stone. One of the most exciting incidents in the history of gems occurred when the great Cullinan diamond, which weighed a pound and three-quarters in the rough, was cut. The wedge was broken at the first blow, but at the second the great crystal, which looked like a lump of rough glass before it was polished, fell into two parts and from these were prepared the two huge diamonds now among the British crown jewels, and several smaller gems.

**HOLDER FOR CIGAR-BOX COVER IS EASILY ATTACHED**

Covers of cigar boxes are held open at the desired angle for displaying the goods



by an easily attached patented clamp that fits on the edge of the box. The lid rests between the curved sides of a prop extension at the back. The holder does not

hinder the removal of the boxes, cannot break the cigars and fits securely

988

Chicago, Ill. Post  
12/28/25

3184  
Ans. J. A. Suggs  
1020 Bush St.  
Berkeley, Cal.

**WOODEN COVER FOR BUILDING PERMITS WINTER WORK 986**

Temperatures of fifty degrees below zero failed to halt work on a hotel at Lake Louise, B. C., which was rebuilt after being partly destroyed by fire. An immense wooden sheet was constructed, five feet from the steel frame. It was lined with tar paper, and steam pipes connected with temporary boilers furnished heat for the workmen. The "overcoat" was 300 feet long, fifty-two feet wide and ten stories high, and cost a large sum, but the expense was considered justified since it enabled the workers to finish the hotel for the summer season. Concrete, brick and plaster work were all done behind the shelter, as temperatures almost as high as those of the mid-year months were maintained without difficulty.

**SAW FOR CUTTING GRAIN SHOCKS SAVES FARMERS LOSS 980**

Intended primarily for use in rice harvesting, but equally applicable to gathering wheat, oats and other grains in shocks, a patented cutter devised by a Texas farmer promises to save much of the loss that often results from rain on crops in the field. It consists chiefly of an ordinary tractor which pulls a band saw, one and one-half inches wide, operated by a separate motor. This saw cuts the top off the shock, freeing the grain-bearing part from the water-soaked base, thus permitting quick drying and hauling direct to the thresher. Only two men are required to operate the outfit, one to handle the tractor and the other to manipulate the cutter. The sawing can be done with little or no disturbance of the butts of the bundles, and the cutter can be regulated in height.

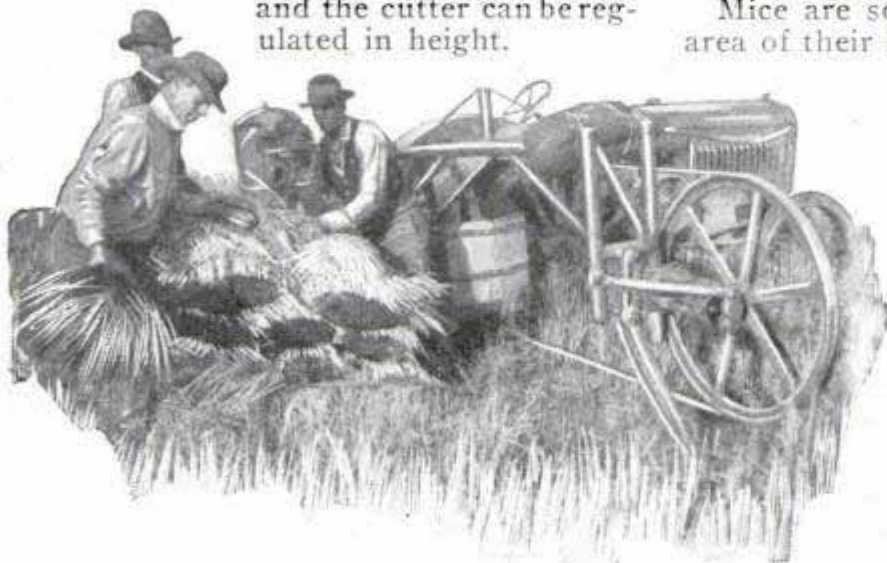

Rice Shock Tipped Back to Show Clean Cut Made by Motor-Driven Saw; Tops So Severed Dry Quickly

*W. Homer J. Walker  
Beaumont, Texas.*

**MOTOR-DRIVEN ROLLER SKATES RUN ON ROUGH GROUND 90**

Propelled by small acetylene or gasoline-burning motors, roller skates devised



On Motor Roller Skates over Rough Ground

by a German engineer are said to develop considerable power and will run not only on pavements but on rough surfaces as well. Controls are operated through connections reached with the hands. The engine is built on principles discovered in making small motors for airplanes.

**LIGHT WEIGHT OF HOUSE MICE PROTECTS THEM IN FALLS 968**

Mice are so light in proportion to the area of their bodies, that if they fell from a height of 1,500 feet, they would suffer only a slight bump, scientists declare. A falling mouse would be borne up after the manner of a parachute, air resistance and the comparatively large surface exposed checking the rate of descent. Rats and larger rodents are not so protected, while a horse or man falling from such an elevation, of course, descends at such speed, despite the greater air resistance, that the fall of necessity must end fatally.

*Ingenieur Hans Seibhardt  
München, Bayern, Germany.*

*Seibhardt of Munich*

*Auckland News  
11/12/25*

# Time and Money-Saving Tools

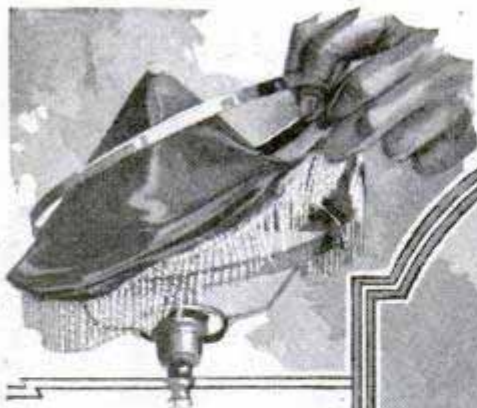

Held on Frame by Metal Band, Lamp-Shade Covering Is Easily Removed



Use for Safety-Razor Blades; They Fit Snugly in This Vegetable Peeler



Turn of the Knob Keeps the Toast from Burning

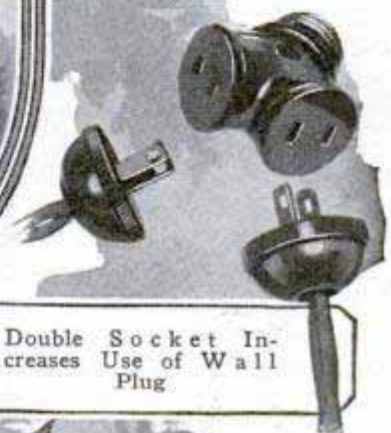

Double Socket Increases Use of Wall Plug

Rapid-Fire, Sliding-Blade Cookie Cutter Shapes Eighty-Six a Minute



Private Bath for Baby Eliminates Stoopng, and a Canvas Cover on Tub, with Pocket for Garments, Serves as Dressing Table



Embossed Name Strips for Stamping Laundry in Indelible Ink with Hot Iron



# for Woman's Workshop in Home

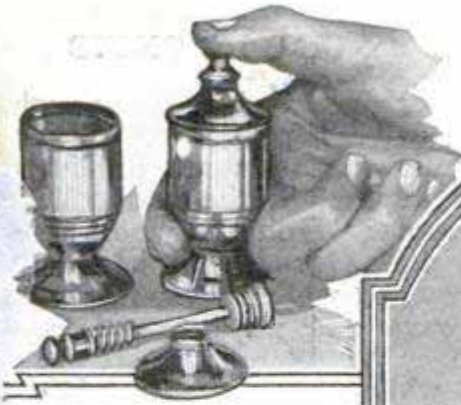

Salt and Pepper Cellars with Button Eliminate Shaking and Regulate the Flow

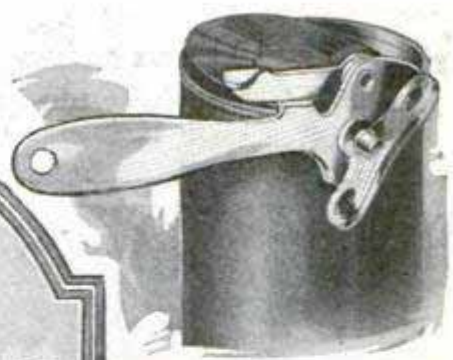

Can Opener without a Blade Leaves Smooth Edge to Prevent Cutting Fingers



Holder for Cooking Cauliflower without Breaking



Plug with Pointer Tells When Current Is On

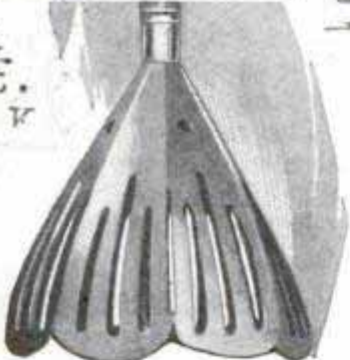

Cake Cover with Glass Knob Is Gaily Decorated, Saves Bother of a Box and Is Easily Cleaned

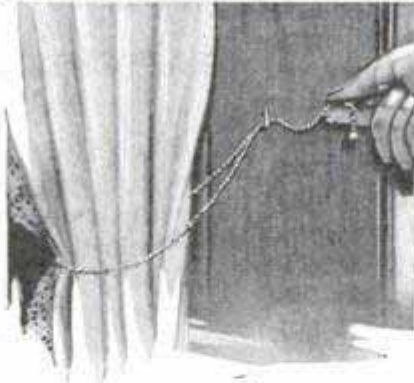

Metal Stems Hold Flowers and Permit Graceful Arrangement

Above Is a Chain to Keep the Curtains Back without Soiling or Mussing, and at the Right, a Combination Furniture and Auto Duster Made like a Glove; the Top Is of Canvas and the Lower Part of Mop Warp: It Is Quickly Cleaned, Saves the Hands and Produces a Polish



obtain it by addressing Bureau of Information, Popular Mechanics Magazine, Chicago.

897

*Always*  
**PLAYTHING OF PAST ADAPTED TO PRODUCE DESIGNS**

An adaptation of the old-fashioned kaleidoscope, which formed ever-changing

*Analyzer*

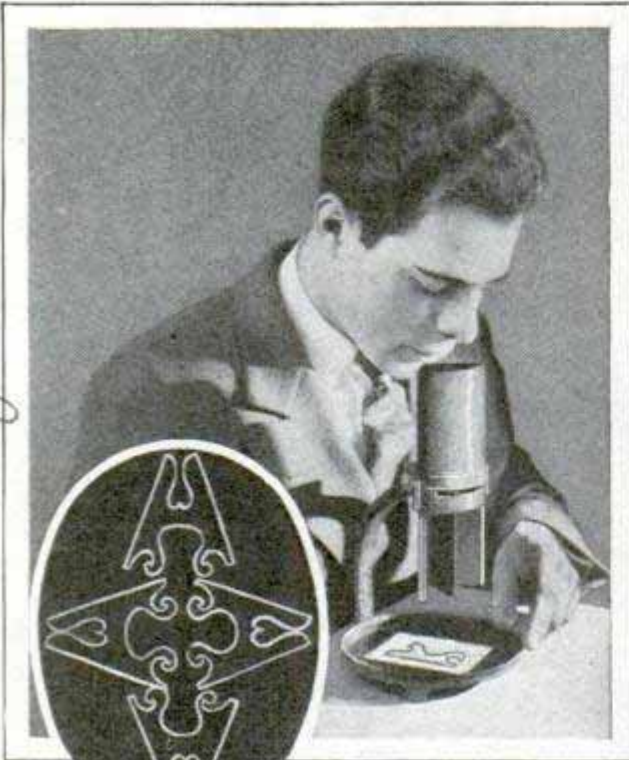

Simple Figure Reproduced Eight Times in Geometrical

Design by New Device; Inset Is What the Eye Sees

geometrical designs of colored glass when revolved in the hands, has been invented by a Chicago art instructor to assist artists and designers in producing new forms of patterns. Two black-coated glass reflectors are mounted above a revolving tray in such way that the angle between them may be varied from ninety degrees down to a narrow slit. At the top of the mounting is a peephole for the eye. Looking through it at an object placed on the tray, the eye sees a series of reflections which produce geometrically perfect duplications of the object or design. Varying the reflector angle changes the number of images seen from two, four, five, six, eight, to as high as ten and twelve. An infinite variety of designs may be seen by revolving the tray or changing the angle of the reflectors. A scrap of paper with a few curved lines appears as a complicated design. Even the scrap itself may be used. Jewelers' designs for complicated pieces are created by wadding a piece of paper and placing it between the reflectors, while a tiny fragment of silvered paper becomes a shimmering setting.

At no place in the British Isles, is the sea more than eighty miles distant.

936  
**DIFFERENCE IN SILK AND WOOL SHOWN BY SIMPLE TESTS**

As a guide for women who wish to avoid adulterations in buying wool and silk articles, the following tests are published in a bulletin prepared by the state college of North Dakota: "Hold the wool material to the light. It should be firmly woven, otherwise it will not keep its shape. Ravel out warp and woof threads and break them. Wool pulls apart with kinky ends, while cotton breaks. Wool burns slowly, giving off an odor of burning feathers, and leaves a large amount of ashes. Cotton makes a flame while burning, has the odor of burning leaves and gives a fine gray ash. If cotton is present in the wool, it will burn with a flame. This is one of the most simple and satisfactory tests for detecting cotton in wool material. The ends of cotton threads spread out when burning. Brush the surface of napped cloth briskly. If the nap loosens and drops off, the cloth will soon wear threadbare and look shabby. Pure silk is light in weight and has long endurance. When silk dresses and blouses crack or give at the seams, soon after they are made up, the silk is weighted. Before purchasing silk, burn a sample of it. True silk burns slowly, giving off an odor of burning feathers. The ash coils up into a tiny ball on the edge of the burning material. Weighted silk burns slowly, holding its shape after being burned."

**FASTENER FOR TAPE MEASURE SAVES EXTRA MAN**

748  
With the aid of a fastener attached to the end ring of the tape measure, one person can use the rule with little difficulty even on long meas-

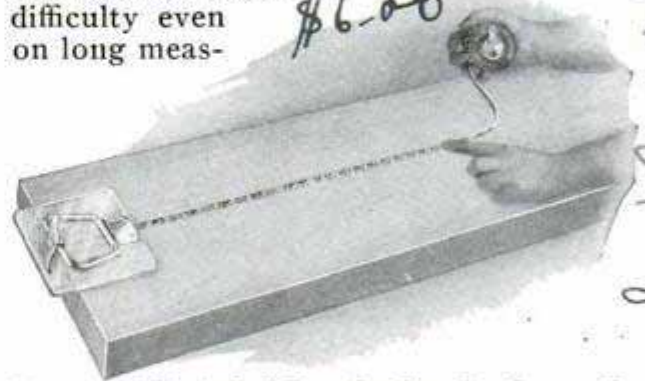

Fastener Holds End of Tape So That One Person Can Use Measure Easily

urements. The holder is a sharp prong that can be inserted in wood or other material or fits over the edge of the surface. When not in use, it is turned down to lie flat against the ring.

*Keuffel & Esser  
Adams and Third St  
Chicago*

*Dearborn Chicago*

520

12/4/25

*Specialty Co.,  
20 Church  
New York.*

### BEAVER'S DAM-BUILDING SKILL RIVALED BY ITS STUPIDITY 907

While beavers exhibit remarkable cunning in building their dams, they show surprising stupidity at times in other activities, and some of the powers popularly ascribed to them are mere myths, according to R. S. Hunt, a naturalist who has devoted much time to a study of the animals. For instance, they do not form lines and pass sticks to one another; they cannot tell which way a tree is going to fall before they gnaw it down; they cannot drive stakes or suck the air out of logs; do not use their tails as shovels or trowels, and they do not cut up large logs. An evidence of their apparent stupidity is in gnawing, perhaps the better part of a whole night, on a thick limb, then, on returning the next, cutting a new notch so far to the side, that the first is practically useless. They swim with their webbed hind feet only, using the tail as a rudder. The front feet are used in applying mud to their lodges—mounds of sticks, moss and soil inside of which they live. A shelf a few inches above the water is constructed on which to sleep. Entrance to the lodge is deep enough below the surface so that it will not be frozen solid in the winter. The beaver's principal problem is to store sufficient wood to afford bark and juicy food during the months when it is imprisoned. In doing this, an elaborate system of dams and canals as well as roads leading to the depths of the forests, is constructed. Where the current of the stream is slight, the dam will be almost straight, but where the flow is rapid, it will be curved to conform to the current, and successive series of dams will be built to raise the water.

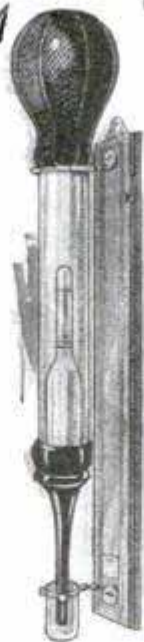

*Alford*

Battery Tester in Rack, Where Drippings Are Caught in Cup; Holder May Be Placed Directly on Battery or on Wall

### HOLDER FOR BATTERY TESTER PREVENTS ACID DAMAGE 844

What to do with the storage-battery hydrometer after using it, has been solved by a small holder that can be attached to the battery itself, keeping the instrument in safety and preventing dripping of acid on carpets or floor. The end of the glass tube rests in a small container and the handle is secured by a catch.

### BOATS LINKED BY BRIDGE LIFT SUBMARINES 950

For raising sunken submarines, German engineers have devised powerful tackle suspended from a strong steel superstructure which links two hulls. Pull is exerted at the center so that neither of the boats tips. The twin vessels straddle the submerged sub which is raised between them and thus taken to dock.

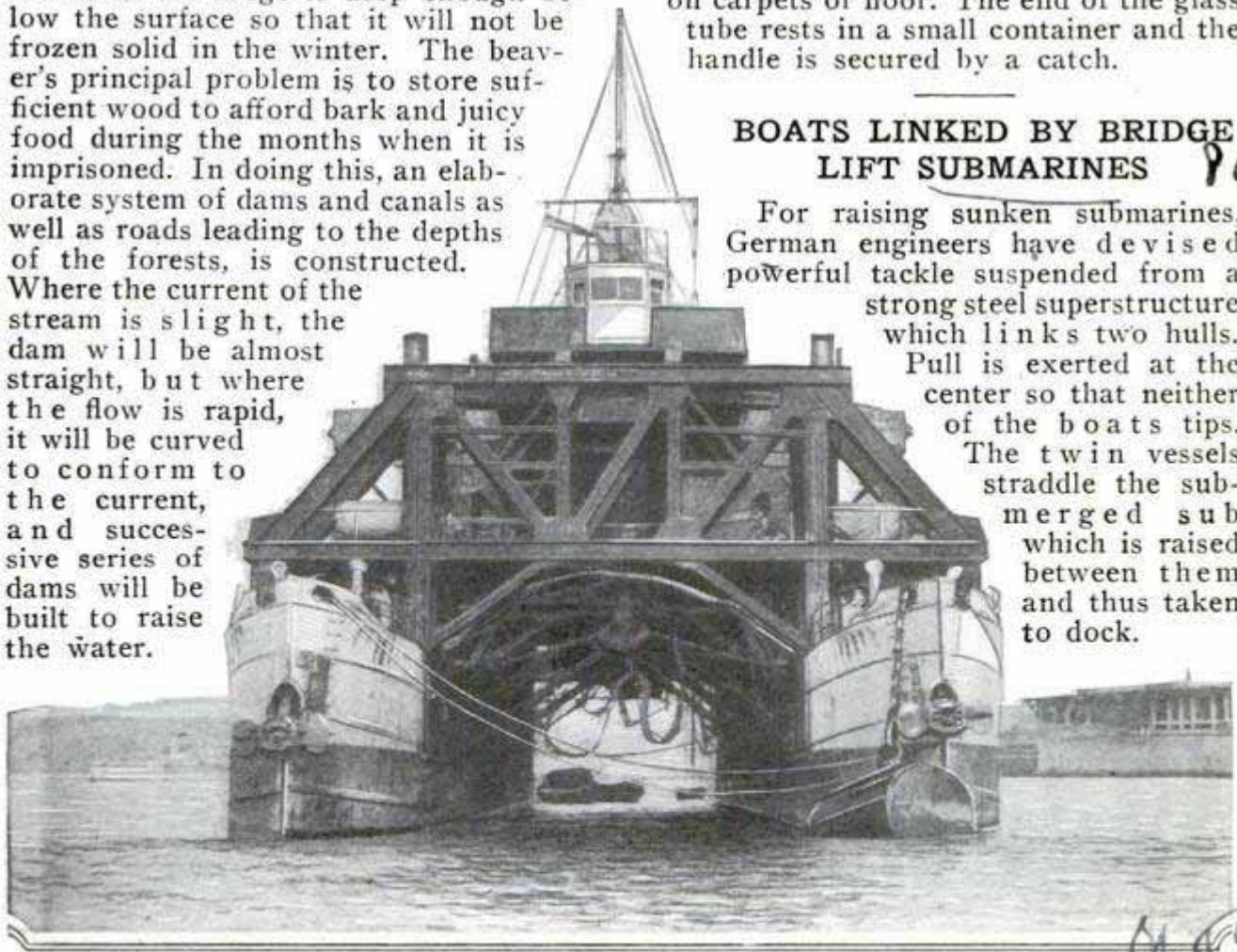

*Alford*

German Submarine Raiser; Powerful Lifting Apparatus Is Supported in Upper Framework and Stress Comes at the Middle, Preventing the Hulls from Tipping Sideways; Pilothouse in Upper Center

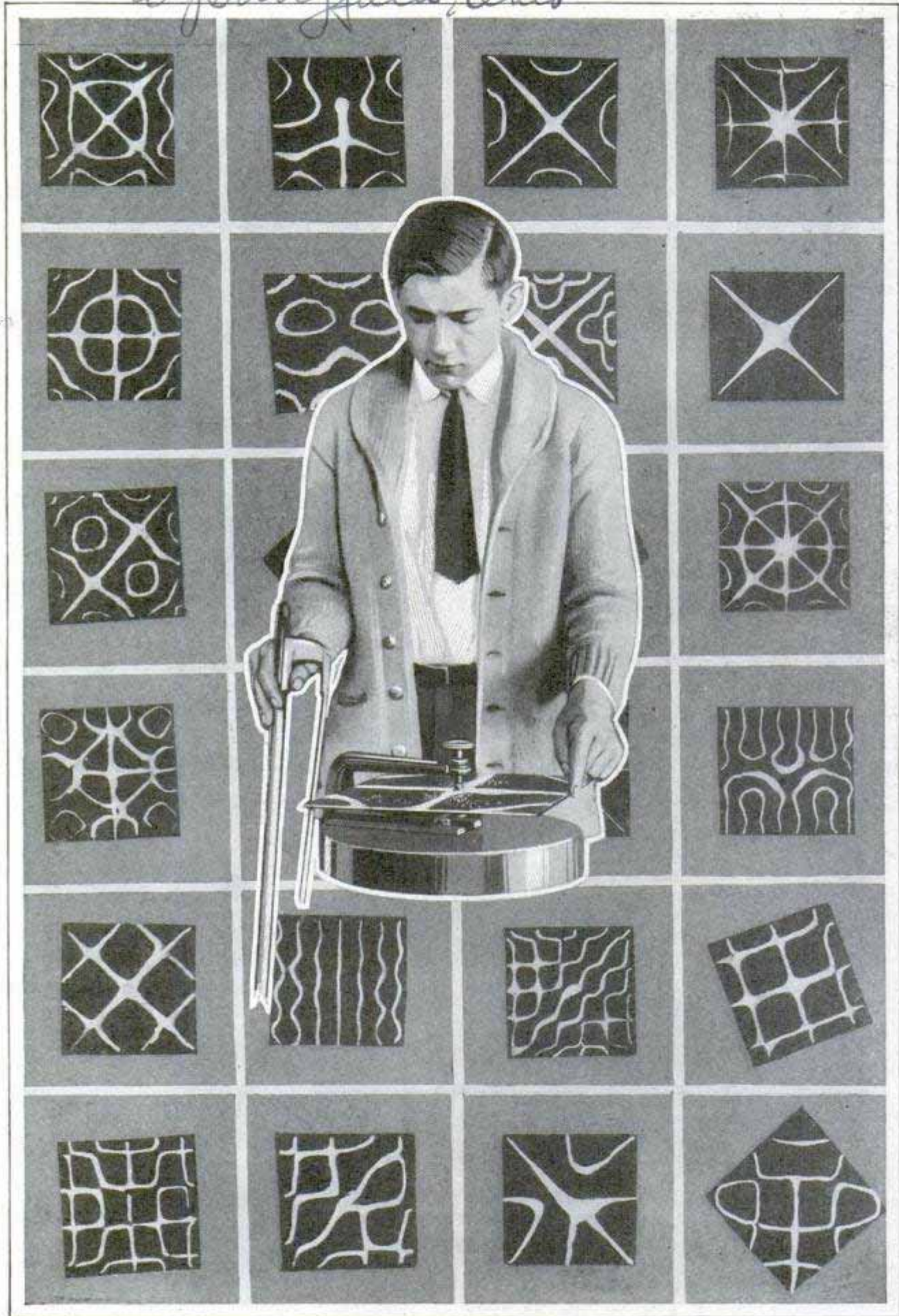

Sand Patterns, Produced by Vibrations, and, in the Center, How They Are Made; Metal Plate, Sprinkled with Sand, Is Held in Clamp, and Violin Bow Drawn against One Edge, While Finger Touches the Other

**SOUNDS ARE PICTURED IN SAND TO SHOW VIBRATIONS** 862

With a violin bow, a clamp, a square brass plate and a small quantity of fine sand, interesting "sound pictures" can be produced to show the effect of different vibrations. The sand is sprinkled on the plate, which is held in a horizontal position by the clamp. While holding the finger on an edge of the metal, the bow is drawn across another edge. The sand immediately leaves the parts of the plate that are in vibration and collects in geometrical patterns which can be changed simply by readjusting the clamp, moving the finger and the bow to a different place. The action of the sand illustrates what takes place when a stringed instrument is played, that is, the string is made to vibrate in equal parts instead of as a whole when the finger is placed at any point on it. Because the plate vibrates in different areas at the same time, the sand is shaken into the peculiar forms that appear. Plates of other material than brass may produce different sand patterns. The shape and size also affect the form of the figures.

**WINDOWS LOCKED BY WEDGE TO FOIL BURGLARS** 3419

Inserted between the sash and frame, a sharp-pointed wedge locks the window when it is closed and also serves to keep it open at any height for ventilation. Travelers who wish to obtain added safety at hotels or other places may slip this in their bag. The wedge is thin enough to suit most windows.

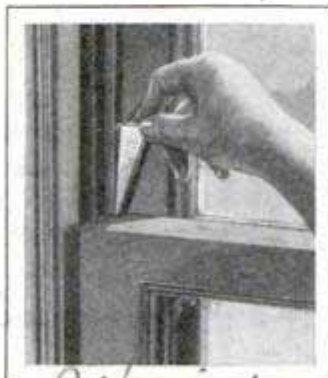

*Perfection Window Lock Co  
73 E. 20th St. N.Y.C.*

**SURFBOARD HAS TWO RUDDERS TO PREVENT SKIDDING** 909

To eliminate lateral skidding, one of the chief dangers in the sport of surfboard

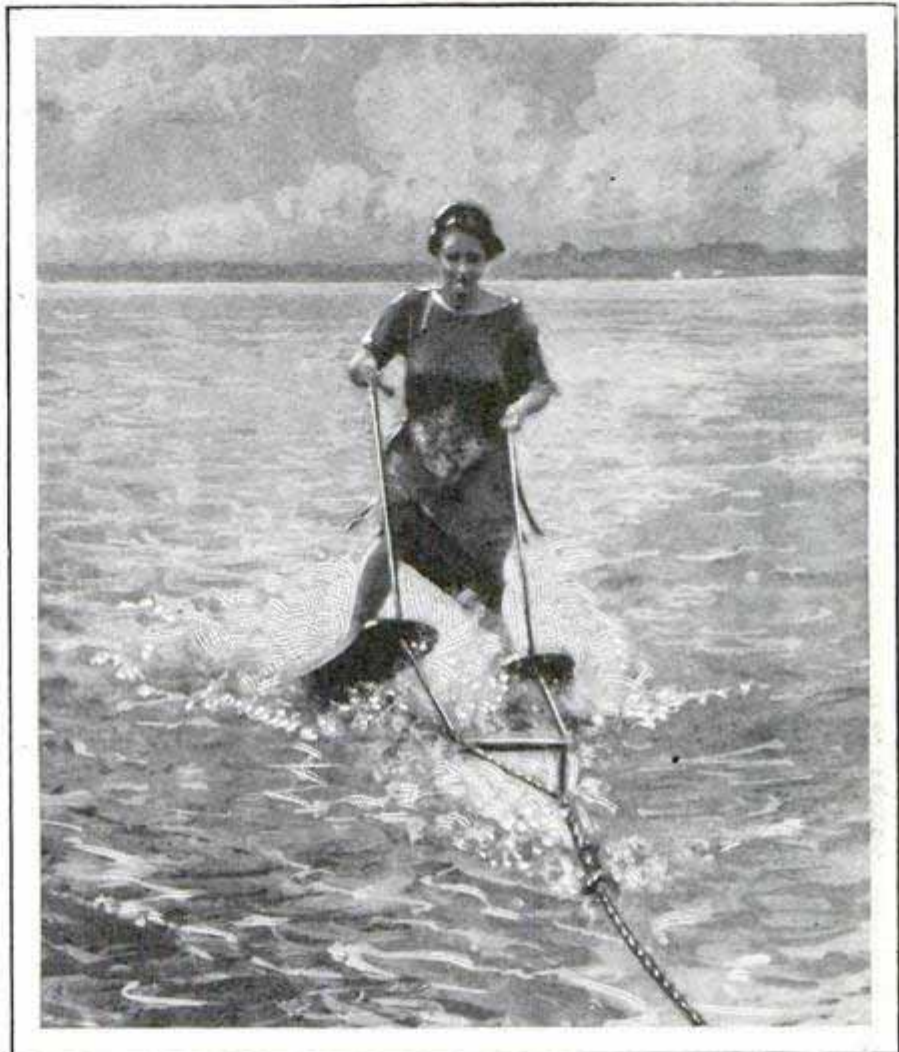

Roman Riding on the Waves; Double Surfboard Has Rudders and Is Intended to Prevent Lateral Skidding

riding, an eastern inventor has devised an aquaplane in the form of rudderlike strips, one for each leg. Their relative position may be shifted as needed by the rider, whose feet rest on pads that are connected by a rod with the end of the rudders.

**SHIPS RETIRED FROM SEAS FIND ODD JOBS** 916

Their days of usefulness for regular sea duty over, many old windjammers enter new careers, escaping the hands of the ship breakers. In Biscayne Bay, Fla., an old vessel has been fitted up as a restaurant; another in Valparaiso, Chile, is being used as a laundry and another as a storehouse for a steamship company. A number of the smaller hulls are converted into lighters for coast service. Some ships are fitted up as training vessels.

*N.Y. Times  
12/13/25*

904

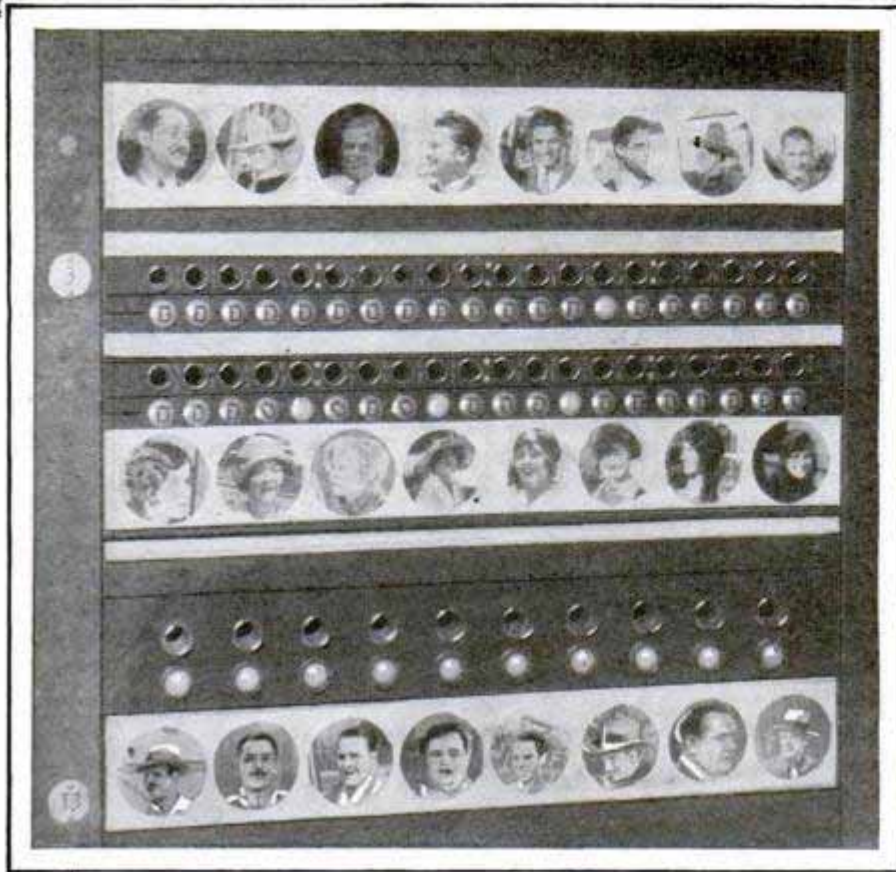

Photographs of Movie Stars Pasted on Switchboard Opposite Connections to Their Private Phones for Operator's Reference

### PHOTOS REPLACE NUMBERS ON PHONE SWITCHBOARD

Photographs of motion-picture stars opposite the connection of their private telephones on a switchboard in a California studio, save the operator the trouble of remembering numbers. They are uniform in size and in case of changes in dressing rooms, the pictures can be shifted accordingly, saving the trouble of copying names or other means of identification.

### FARMING THE OCEAN BOTTOM TO INCREASE FOOD SUPPLY

With population rapidly growing and land reserves diminishing, scientists are turning their attention to the possibilities of submarine farming as a means of replenishing the food supply. That the oceans hold fortunes in sunken treasure and in fish, everyone knows, but deep-sea pastures are not commonly regarded as gardens in spite of the fact that many plants already are being used for food. In the Northern Pacific, there are nearly 2,000,000 square miles of sea bottom which have never been explored. What grows several miles beneath the surface is little known, but waters to a depth of several hundred feet are crowded with many varieties of plants, ranging from those scarcely

visible to the unaided eye to the kelps, some of which have stems 100 feet long and tufts thirty feet across. So plentiful are these growths that the sea is sometimes compared to a thin vegetable soup. In Japan, 100,000,000 pounds of kelp are consumed annually. The product is dried and shredded, and appears on the market in about fifty varieties, including sheets, sticks, sugared sweets, powder as "curry" for rice, and even as a kind of tea. Forty-five factories in Osaka are devoted to converting the kelp into edible substances which have been used in Japan since 1730. From agar agar, a kind of seaweed, gelatin is obtained, and in Japan, it is used for window panes as well as a thickening for soups.

Appetizing dishes are prepared by the Scottish highlanders and Irish peasants from dulse, a seaweed, and a variety of ocean moss, collected in large quantities at low tide, is made into an easily digested kind of flour.

### GLARE SHIELD WORN ON HAT PROTECTS AUTO DRIVER

For protecting the eyes when driving by day or night, a shield adjusted to the hat brim is made in two sections, either or both of which may be tilted back to give a full view ahead if desired. After dark, for instance, the right side of the shield may be tipped back while the other blocks glare from approaching headlights and, at the same time, permits a clear view of the right-hand side of the road. With both flaps lowered by day, the driver can face the sun without squinting or injury to his eyes.



Instruments for recording weather conditions have been sent to a height of four and one-half miles by kites.

*all Lake City Utah*  
*Shompson*  
*Dr. Christian*

*July*

*and uses*

*910.*

*926*

*Get Bits 12/5/25*



# How to Keep Your Feet Happy

By S. C. WOLDENBERG, M. D.

*104 S. Michigan Ave.*

TO tell a person to look in his shoes for health, happiness and success may sound like a riddle, but it isn't. It is a simple truth, the importance of which is growing as we discover that many human ills may be traced directly to foot troubles and that foot trouble generally is due to ill-fitting shoes. Your efficiency at your work, the way you feel when the day's toil is done, your disposition may very likely depend upon how you are treating two of the most faithful, but often the most cruelly abused servants of your body.

The vice president of a large railroad company, liked for his cheery nature, recently became so cranky during working hours that even his best friends dreaded to enter his office. He was aware of his temper, thought that ill health was partly to blame, but did not know what was the matter with him until a friend convinced him that his real trouble lay in a minor foot ailment. A dull ache, all day long, kept him in ill humor. You know how you feel when your tooth aches. Throbbing, painful feet have much the same effect on the disposition.

When you buy your next pair of shoes, give a thought to your foot. Remember that it is a marvelous propelling machine as well as a support for the body. Nature intended that it should be unfettered, but civilization has produced customs and cement sidewalks; hence, we must incase our feet in shoes. They may be a source of comfort or a menace to your health. Much

depends upon your selection. If you would have a shoe that will not injure your feet, let it be one with a straight last, like that of the army shoe. It should be straight from the tip to the ball of the great toe and the distance from the ball of the great toe to the heel, should correspond, in the shoe, to that in the foot. The toe of the shoe should be rounded, not pointed, and the shank—the portion under the arch of the foot—should be stiff and firm, preferably. Avoid high heels if possible. However, for some persons, high heels may be indicated. In most cases, the body is held erect most easily when a person stands correctly so that a line drawn from the base of the skull to the heel will be perpendicular to the earth's surface. This is what is known as the average normal line of weight bearing.

The weight is distributed to the heel and ball of the foot in a tripod arrangement to help maintain the balance as well as support the body weight. Now, if the heels are too high, they tip the body forward. This must be offset by an effort on the part of the person. Strain on muscles that were not meant to be strained results. Just what this may amount to was computed by army tests.

It was shown that a soldier, five feet seven inches tall and weighing 154 pounds, when wearing a heel three-fourths of an inch thicker than the sole, had to exert strength enough to be constantly lifting fifty-six pounds from the ground to keep his

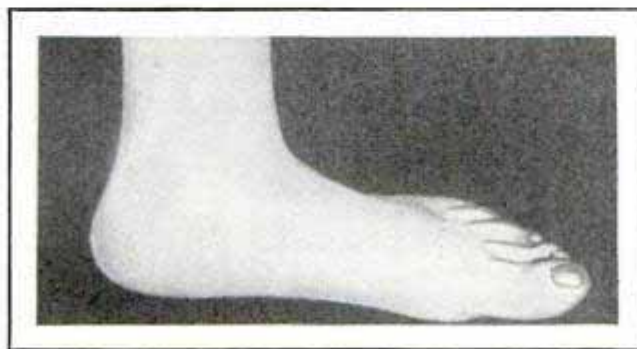

Typical Flat-Foot Condition, the Result of a Broken Arch Generally Due to Ill-Fitting Shoes

balance. In case he was loaded with sixty pounds of pack and equipment, the balancing strength required was 116 pounds.

The common effect of too high heels or too short shoes is to crowd the toes downward and inward and to contract the powerful heel cord that helps lift the weight of the body. This disturbance of the normal position of the body may produce such serious results as spinal curvature, backache, pains and deformities of the feet. Shoes for an adult person should be at least one-half inch longer than the distance from the heel to the tip of the great toe. Do not wear thin soles. Thick, firm leather—not the stiff, unyielding kind, like that of the heavy, hobnailed shoes—is better, for it helps in the support of the foot and decreases jarring. If they are of the proper shape, it makes little difference, other than seasonal, whether the shoes are low or high, although, with the low shoe, there is less interference with the tendons.

Of course, you want attractive shoes, but if you are tempted to select too small a size, just for the sake of fashion, and the clerk assures you that they will be all right after you have worn them awhile, remember that the popular idea that every pair of new shoes must be "broken in" is wrong. Your shoes should be just as comfortable the first day you wear them as they are after a month or more. What really happens in the majority of cases of so-called breaking-in, is that the foot is being broken down. Either consciously or unconsciously, you favor that part of the foot which is being chafed or pinched by ill-fitting shoes. In time, this may cause wrong posture of the body or deform the foot, resulting in a flat-foot con-

dition. A survey of about 1,300 school children in Chicago recently, showed that approximately twenty-six per cent of them were suffering from curvatures, and many cases were undoubtedly due to foot defects. The importance of selecting proper shoes for young, growing persons cannot be too strongly emphasized, for it is often at that time of life that foot defects are formed, resulting in serious troubles later. The soles of a young person's shoes should never be too heavy. A firm heel is preferred.

Care of the feet is as essential as the choice of proper shoes. One of the war's great benefits was repeated emphasis of this and other proofs of the relationship between foot troubles and shoes. Army examinations showed that in the south, where going barefoot is common, less than 100 men out of every 1,000 were suffering from pronated (out-turning) or flat feet. The number in other sections of the country reached as high as 252 out of every 1,000, particularly in the mountain regions of the west, where many wear heavy walking shoes, chosen with little thought of fit or comfort, but mainly for durability. Col. Munson, of the army medical corps, declares, "the effect of badly fitting shoes upon the psychology of war is very great. Even when the soldier is able to continue the march, the discomfort produced at every step soon reduces buoyancy of spirits, causing mental irritation, and materially diminishes the fighting capacity."

The same is even more true of the army of workers in peace times. You see them every day, trudging half-heartedly to and from their tasks, toeing in or toeing out, their heels run down at various angles, ankles bulging and many obviously suffering from corns, bunions, poor circulation, indigestion, nervousness and even more serious ailments. Remember that you cannot easily conceal your foot troubles. Almost any skilled orthopedic surgeon, by a glance at your shoes, can detect your pedal ailments. Improper weight bearing, and not necessarily poor workmanship, often causes your shoes to wear out in the peculiar manner they sometimes do, breaking open at the sides or toes or wearing

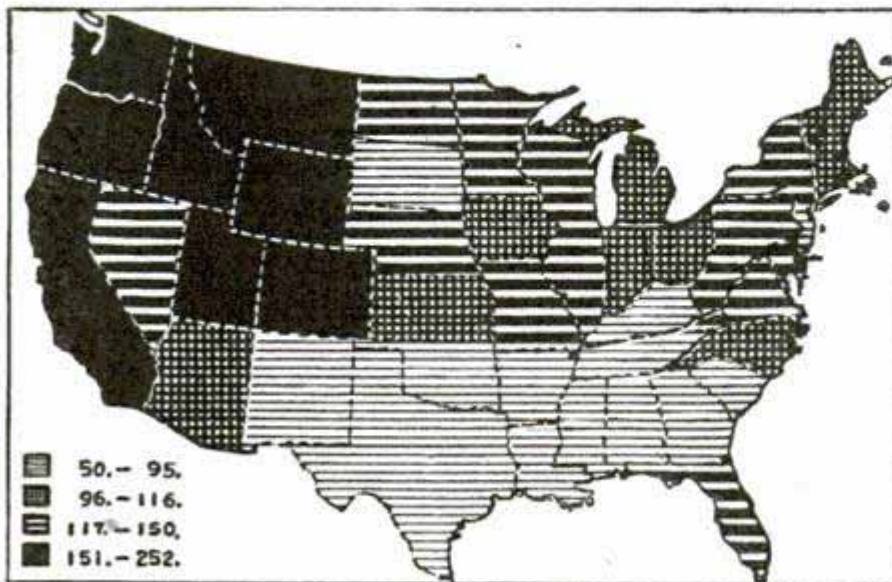

Cases of Flat and Pronated (Out-Turning) Feet per 1,000 Men, as Discovered during Draft Examinations; Notice the South's Favorable Record



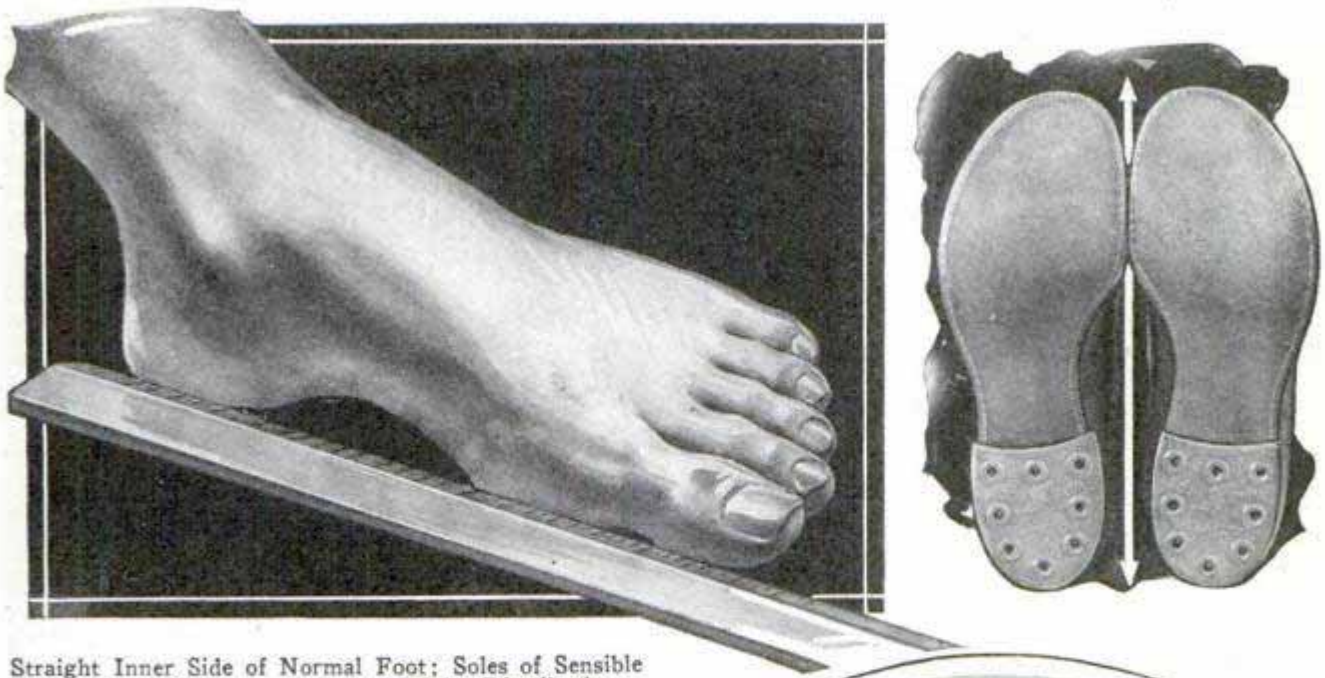

Straight Inner Side of Normal Foot; Soles of Sensible Shoes and Diagram of Body-Weight Distribution

off at various angles at the heel. Toeing out seems to be more common among women than among men. Ill-fitting shoes are almost always to blame. Women, as well as men, were intended to walk in a straight line, the feet pointing directly in front with each step.

An excellent treatment for the feet, whether you are suffering from corns, bunions, excessive perspiration and coldness or not, is what is known as the "contrast bath." This is nothing but alternate immersions in hot and cold water. A recommended method is to use a watch while taking the bath, keeping each foot first in water as hot as you can stand for a minute and then in cold for the same length of time, alternating the process. This should be done at least once, but preferably twice, a day. To make the water soft, a little washing soda should be used. Baths of this kind help stimulate the circulation which often is impeded by pressure of the shoes, prevent excessive perspiration, calluses and various forms of skin disease likely to afflict the feet. Remember that your feet were never intended to be cooped up in such tight quarters as a shoe. If you wear a close-fitting glove, you feel the stiffness and the swelling that it causes in a short time. With improper shoes, your feet suffer this mistreatment to a much greater degree, for the weight of your body aggravates the tightness of the shoe each time you step. If you are putting on weight each year and crowding your feet into narrower shoes, you are doing what an electrician does when he attempts to put a ten-horsepower load on a two-horsepower motor.

There are countless remedies for corns,

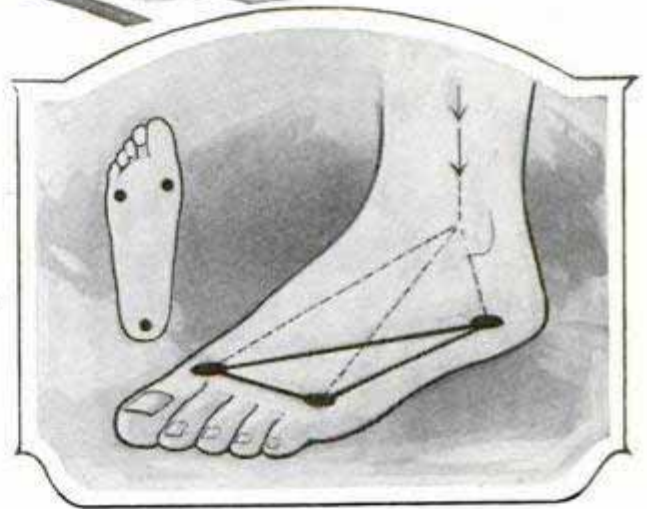

but the best of all is a correct shoe. A corn is nothing but a hardening of the skin, a callus which nature provides to resist unnatural pressure on that part of the foot. The right kind of shoe will eliminate the cause of the undesirable chafing and the corn will disappear. Thousands of soldiers were rid of their corns during the war, just by wearing army shoes. The calluses and corns returned in many instances when they went back to the footwear of civil life. One of the best ways to treat a corn or a callus is to rub it gently with pumicestone after washing the feet. This scrapes off the excess tissue, achieving the same effect as cutting, without the danger of inflicting a serious wound. Repeated rubbing will keep the corn down, and it will naturally vanish when proper shoes are worn.

A bunion is an overgrowth of the bones of the big toe due to unnatural pressure and constant irritation of the shoes. An operation is usually necessary for its entire removal, but properly fitting shoes will relieve the suffering in many cases. If conditions are not bettered by a proper

fit in shoes, you should visit a reliable specialist and let him prescribe a remedy which will fit your conditions.

In the majority of cases, artificial arches are not needed. The selection of shoes made along anatomical lines, that is, in accordance with the structure of your feet, will relieve arch troubles and prevent their development. If not, the only safe course is to seek the advice of a trustworthy specialist.

The bones in your feet have no keystone to support the arch as is the case in a building. They would fall of their own weight unless held in place by muscles and ligaments. Remember that there is no relation between the height of the arch and the strength of the foot. Many persons boast of high arches, believing that they indicate a superior foot. It may be that such a condition is a malformation and needs correction. An artificial arch that has been constructed along a common pattern may not be adapted to your special needs. Your foot may be compared to a carefully constructed bridge, made to conform to certain uses, grade conditions and angles. If a prop is needed, it must be adapted to that particular bridge. Putting in a bolster of any kind may throw the whole structure out of alinement and cause a disaster. Such a result is likely to follow a hap-

azard selection of artificial arches and improper shoes.

Even if you do considerable walking, your foot muscles may not get the proper exercise, for the reason that they are constricted within the shoe. The common practice is to do less and less walking with the increase of the automobile and other means of easy transportation. The malady called "automobile foot" is common among chauffeurs, draymen and others. It is simply a form of arch weakness. Such persons, and many others, would benefit by resorting to special exercises.

Here are three simple stunts that require but little time and produce helpful returns. Cross the legs and, while holding one knee stiff over the other, extend the supported leg. Now bring the foot upward and inward, repeating the movement until you have counted to 100 slowly. This exercises the large muscles in the front, rear and at the sides of the foot. Assume a squatting position, turn the feet on the outer side and curl the toes inward. Repeat while counting to 120. Picking up marbles with the toes is another excellent exercise. You may fail to clutch them at first, but practice will enable you to grip as many as five or six at one time. All these exercises should be done while barefooted and may be performed both at night and morning. The primary object

of these simple muscle developers and the wearing of correct shoes, is to prevent foot troubles. To cure a specific ailment may likely require the aid of a specialist, as has been noted, but with a little intelligence and care, you can save yourself suffering and the expense and trouble of treatments. Avoid pain and serious sickness by giving your feet a chance to perform their services as nature intended they should. Other things being equal, the battle in the industrial and business world today goes to the person who has good feet. You cannot be fully efficient at your work if your feet are being shackled, injured and cramped in ill-fitting shoes. If you have persistent aches and cramping of the toes and feet,

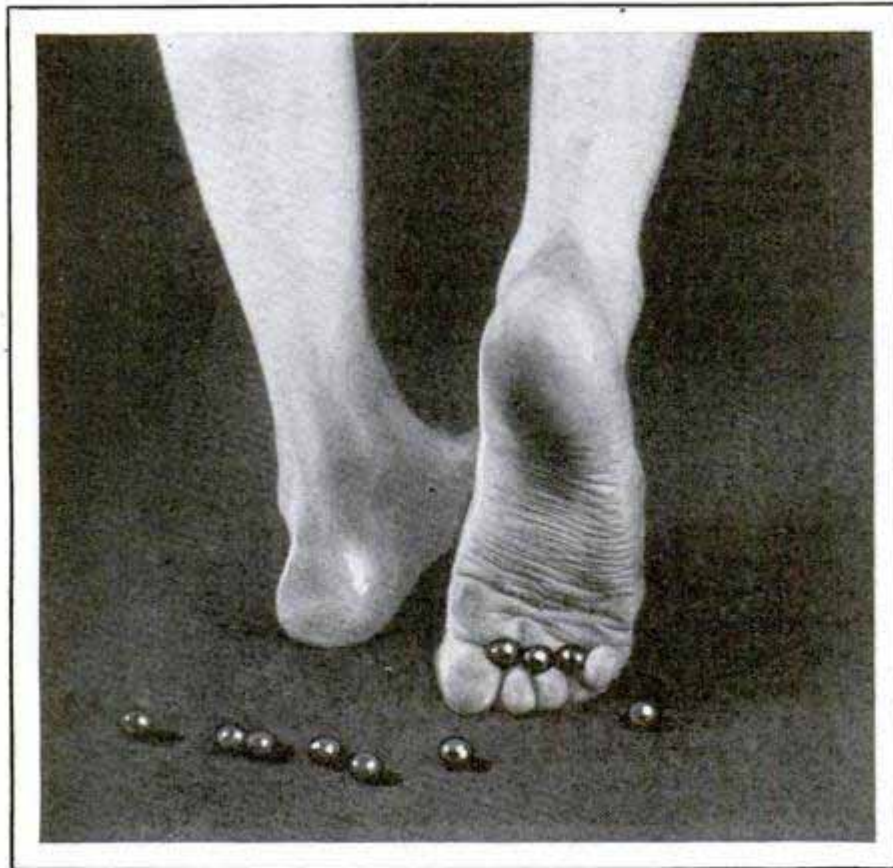

How Many Marbles Can You Pick Up with Your Toes? Practice Gives Foot and Toe Muscles Helpful Exercise

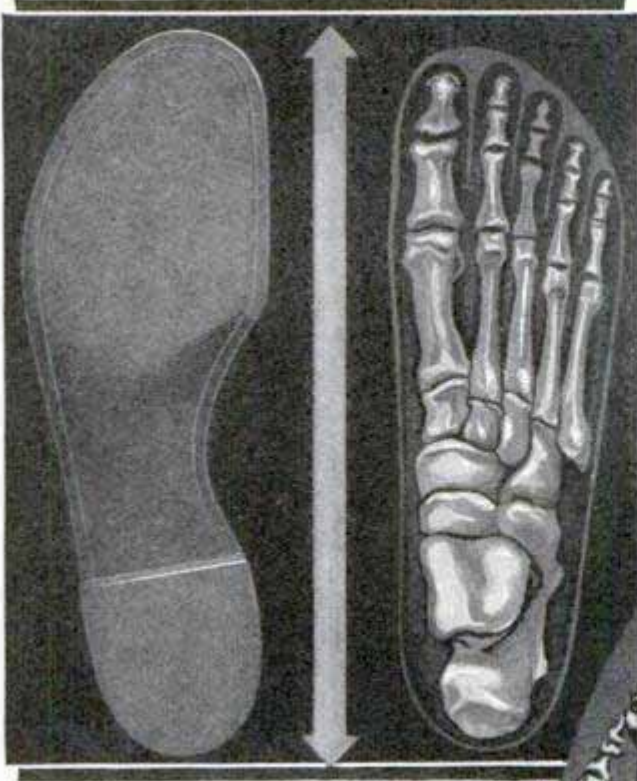

Straight Shoe Last Permits Bones of Feet to Lie Naturally Instead of Cramping Them as Shown at Right

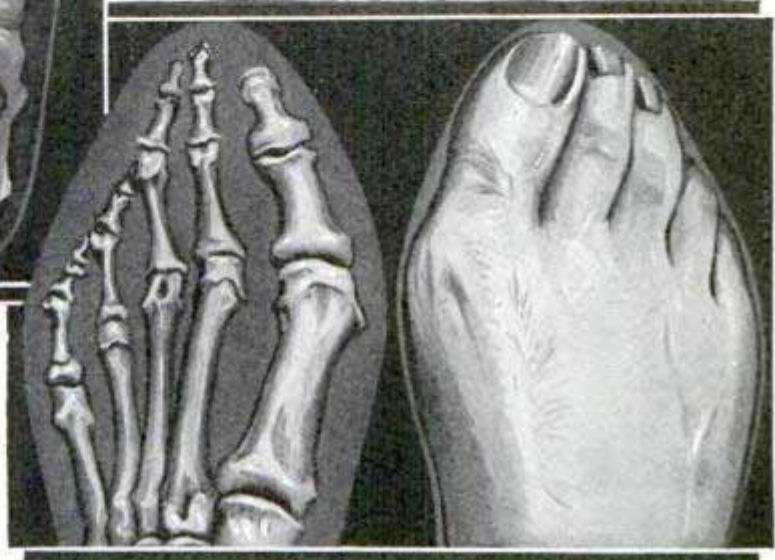

aches in the knees or in lower part of the back, at times mistaken for kidney trouble, look after your feet and, if necessary, consult a reliable physician. If you feel abnormally tired at night and lack the pep to take your daily exercises, you may find that the source of the trouble lies in your feet, and that a good pair of shoes may work the remedy.

It is a well-known fact, recognized by the most prominent doctors and surgeons of the country, that frequent backache is, many times, the result of flat or weak feet and incorrect posture. It is impossible for one in such a short article to show the different, definite reasons for this trouble as one would have to go into the details of the mechanism of the body. But, in brief, it can be stated that it may be the result of poor body mechanics. That is, when the feet are thrown out of their normal alinement, a stooping posture may result.

Assume that a man has defective feet or a sore spot on one or both of them. In order to avoid pain, he does not hold himself naturally. And he is put to an effort to maintain his weight in this abnormal posture. New pressure and strain are put upon the muscles of the foot and leg. This, in turn, upsets nature's plan for carrying the weight of the body upon the feet. The weight is distributed unnaturally upon them.

The shoe must give way to respond to the pressure. Conversely, continued wrong posture, if sufficiently pronounced, is likely to distort the foot and also the shoe. Not only will you be guarding your health, but you will be saving money when you choose properly fitting shoes.

Many persons apparently do not recognize the relation between a normal condition in the muscles of the leg and the condition of the foot. But we find defects in the shoe whose origin may not improperly be traced to the fact that the wearer has not kept his leg muscles in

good condition. Perhaps he has not exercised them properly, or has strained or weakened the muscles of the leg through constant standing in one position in his daily work. You can usually see many cases of distorted shoes in factories where large numbers of workers are on their feet all day.

### COMBINATION LOCK FOR AUTOS REQUIRES NO KEY 977

Affording more than 13,800 combinations, a three-dial auto lock now on the market is so adjusted that the driver must lock the car in order to stop the engine, thus insuring security automatically. It has no key, springs, cogwheels or tumblers, the action being obtained



through a coil which is connected up with the starting mechanism and is inclosed in a strong metal box to prevent tampering. The lock is designed to be placed near the dashlight so that the combinations can be set at night.

*Price - \$20.00.*  
*Stop Theft Lock Co., Albany, Ore.*

912  
472

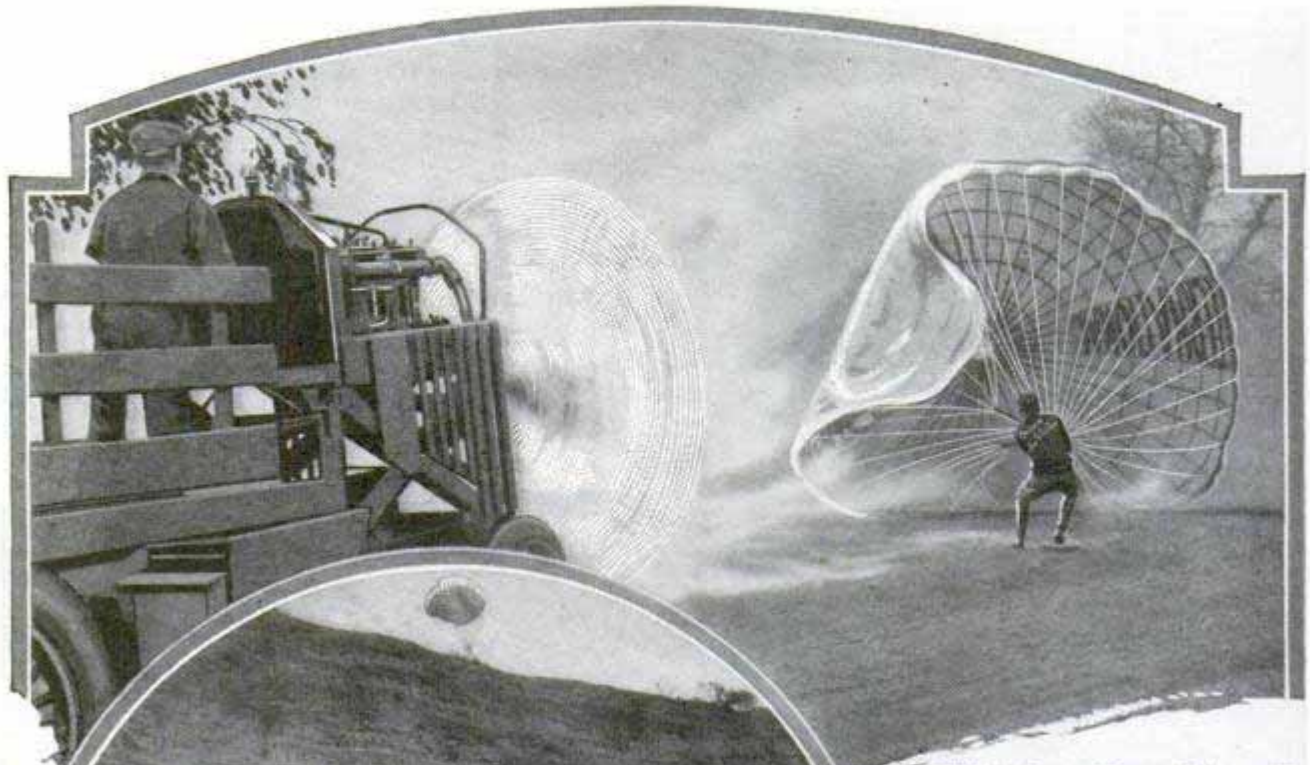

Wind from Motor-Driven Fan Opening Folds of Parachute Which Is Dragging Tester over Cliff; the Lower Is a Composite Photograph, Showing Parachute on Brink of Precipice and Jumper Just Landed

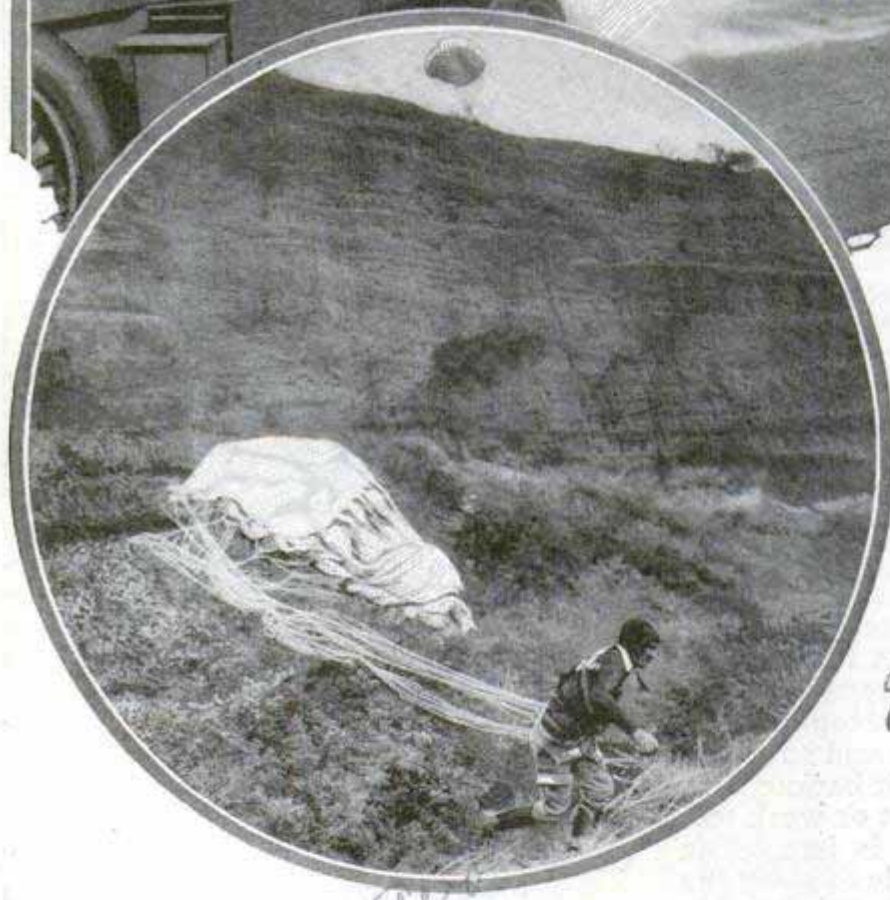

**MAN IS BLOWN OVER CLIFF TO TEST PARACHUTES**

Just to see if parachutes will open as they should, a California man permits himself to be blown over a cliff several times a day, trusting that the support will save him from death or serious injury when he lands at the bottom, 200 feet below. With the harness strapped securely to him, the daring jumper steps into the path of a powerful wind current caused by a motor-driven fan at the top of the cliff and near its edge. If the parachute is properly constructed, the blast of air will open the folds and the tester will be dragged along, suddenly swinging into space for a safe descent. At least three

trials with each parachute are required before the equipment is considered thoroughly tested.

**U.S. IMPORTS BEADS WORTH MILLIONS EVERY YEAR**

933 In 1626, Peter Minuit purchased Manhattan island from the Indians for about \$24 and a few strings of beads. These trinkets, among the first articles ever to be im-

ported into America, therefore figured importantly in the early history of the country, and their commercial significance is still great, for about \$10,000,000 worth are sent to the United States yearly from foreign markets, in spite of the large local manufacture. In the last five years, bead shipments valued at more than \$50,000,000 have been imported from a score of countries, including France, Germany, Spain, Italy, Czechoslovakia, Japan and China. The most expensive varieties come from France. They command more than \$3 a pound wholesale, while the cheapest kinds bring only a few cents per pound. The per-capita consumption of beads in America today is said to be larger than in any other country of the world.

*ny. James 12/13/25*

# A Radio Set for Fifty Cents

Method of Tuning Is Unusual, but Simple, and Principal Parts Are Made from Scrap

By WILL H. BATES

**T**HE crystal set, to be described, which can be built at a cost of about 50 cents, will give good volume on local stations, and will be found an interesting experiment because of the method of tuning.

The only parts you need to buy are the crystal and holder, 4 binding posts, a small spool of No. 22 d.c.c. wire and about 8 in. of a flexible wire. They can all be found at the 5 and 10-cent store.

A 6 by 6-in. block of wood forms the base, which can be beveled on the edges, sandpapered and stained. See that it is thoroughly dried in a slow oven. On the underside countersink four holes with a 1/2-in. bit, about halfway through the wood. Then drill holes through to the top to take the binding posts. In the center of the board, drill two holes, about 1 in. apart, to carry wires up to the crystal. Now cut grooves in the underside of the board, deep enough to receive the wires (covered with spaghetti) as shown in the detail drawing, and run a wire from the ground post to one side of the crystal; from one phone post to the other side of the crystal; and from the aerial post to the other phone post. When this wiring has

been done, turn the board over and mount the crystal holder near the center, then connect the wires coming up through the board to the binding posts of the holder.

Two small blocks, cut out in the shape shown, are mounted on top of the base just back of the crystal. The movable arm between them is held in place with a machine screw, and is tightened with a nut on the back to give the proper tension. This arm is made out of a thin piece of wood, about 3/16 in. thick, flat on the end drilled for the screw, and rounded out with a knife in a tapered effect, so that it may be pushed through the openings in the low-loss spiderweb coil.

The two metal disks can be cut out of a sheet of tin or brass, or even from the lids of tin cans, as was done in the set illustrated. One should have a strip 1/4 by 3/4 in. projecting at the side, as shown, which is used to bend around the edge of the other and hold the two together. They should be just a trifle larger than the coil, or about 3 1/2 in. in diameter. Mount them on the two little blocks, flush with the inside edges, so that they fit close to the coil when it is moved up between them.

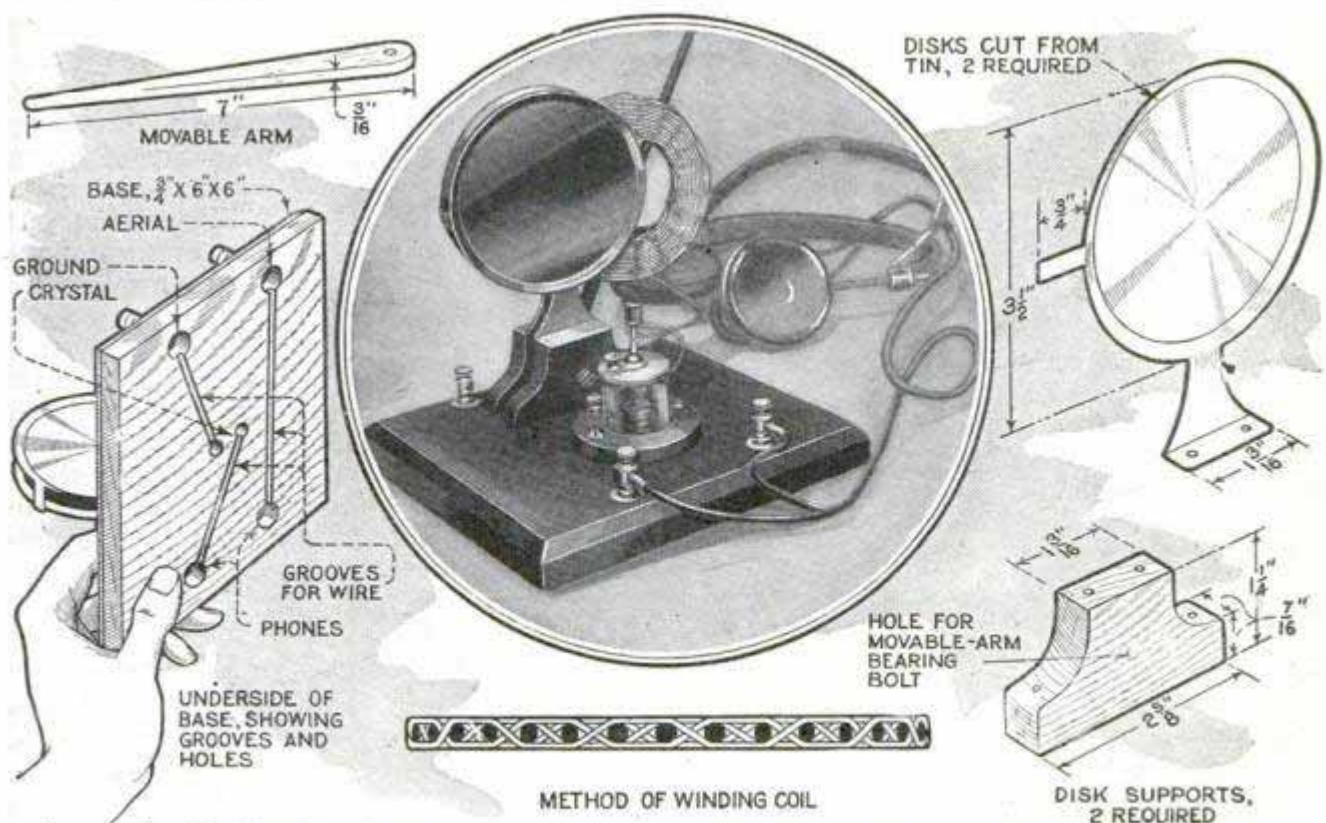

Construction Details of the Crystal Receiver; the Edge of the Coil Is Shown to Illustrate How the Winding Appears on the Finished Coil; Insert, the Finished Set, with Headphones Connected

The coil is wound on a spiderweb form with 17 or 19 spokes, which can be re-

station if it is within a few blocks of you, but even so, it will be found a very inter-

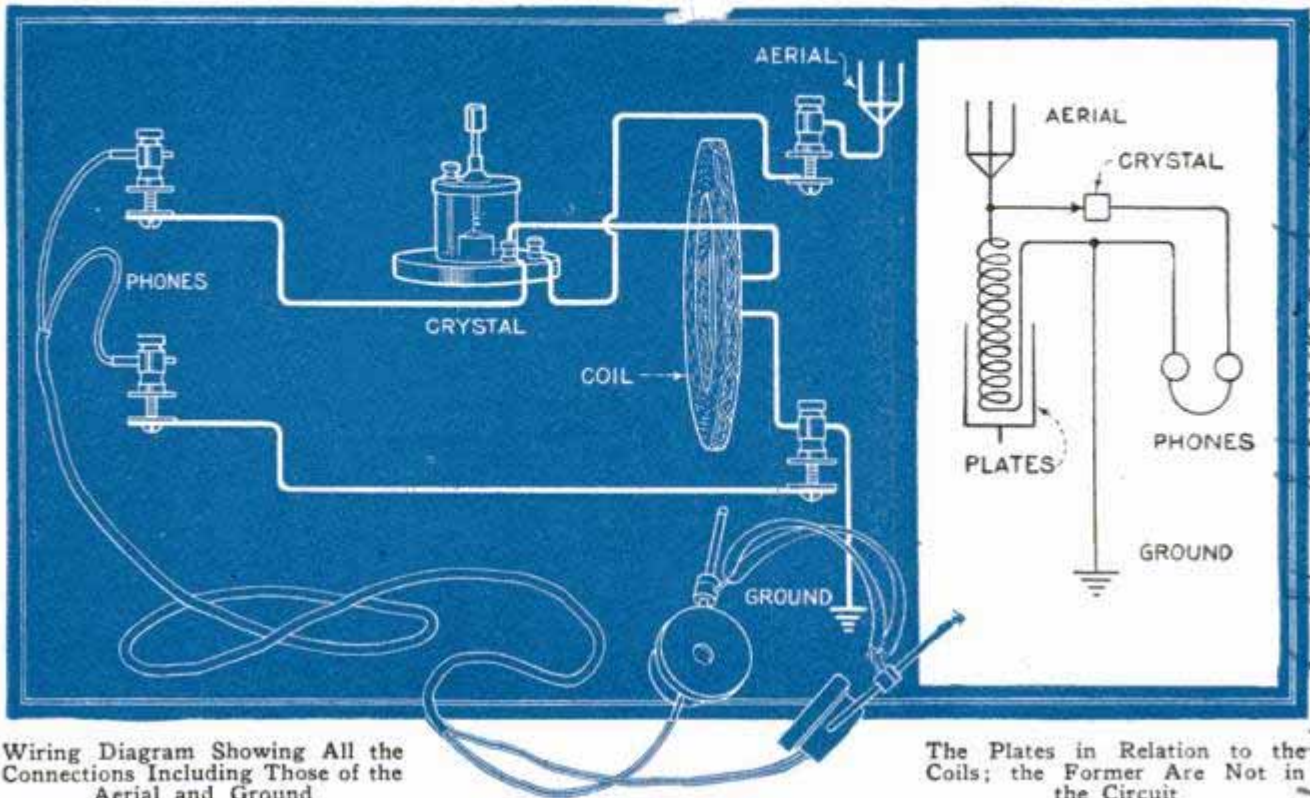

Wiring Diagram Showing All the Connections Including Those of the Aerial and Ground

The Plates in Relation to the Coils; the Former Are Not in the Circuit

moved afterward. Use the "over two and under two" method in winding. About 44 turns will be needed. A few more turns might be put on so that one can experiment by connecting the coil in the circuit, and take off one or two turns at a time until the local station with the highest wavelength comes in good and strong with the coil extended entirely out of the metal disks. The 44 turns were found to be about right for station KYW with a wavelength of 535. If you have no station with a wavelength as high as that, cut down the number of turns, as there is no advantage in having more turns than actually needed, unless you want to "fish" for distance, which is usually very uncertain with a crystal set. When the right number of turns has been found, remove the spokes and tie in the usual way. Solder the flexible wires (4-in. lengths) to the ends of the coil, and connect one end with the crystal and the other with the aerial binding post.

The coil is tuned by moving it up between the two metal plates. These plates pick up the stray eddy currents or the magnetic field thrown out around the coil. By absorbing these currents, it acts much the same as though the coil was being cut down by means of taps.

The set will be fairly selective on stations that are several miles away. You will not be able to tune out a powerful

esting experiment in one phase of the mysteries of radio.

626 *De*

**Handy Connectors Make Wiring Easy**

Handy connectors that simplify the wiring of the set are now available. They

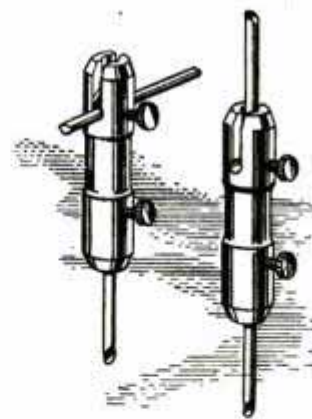

are quickly and easily attached, and need no soldering. Two ways of using them are shown in the illustration. At right angles, one end connection may be made through the slotted end without cutting the wire already in place. The setscrews make

good electrical connections, and the absence of soldering flux adds to the efficiency of the set.

**Cuffs for Frayed Terminals**

When using covered flexible wire in the set or on loop terminals, the fabric covering often frays, making a ragged-looking connection. This can be prevented by placing a short cuff of spaghetti over the end of the wire before soldering the joint.

*Illinois Radio Co., 800 S. 4th St., Springfield, Ill.*

**Wire Fence Is Good Substitute for Ground**

Wire fences are very good substitutes for grounds, especially in dry, sandy countries, where damp ground connections are not available. This is a handy thing for the tourist and camper to know, as it is a very simple matter to fasten the ground wire to a near-by wire fence and obtain good results, without the necessity of driving a rod into the ground, which would often be ineffective. The wire fence also acts as a counterpoise, forming a condenser of which the ground is one plate and the fence the other. Wire fences, in fact, often make better grounds than water pipes. Farmers who have difficulty in locating good grounds will also find springs and streams useful. A bare wire strung along the bed of the stream, will often be very effective.

**Resistance Unit Adapts Charger for Wet B-Batteries**

A tapped resistance unit, designed for use with the recent models of a.c. battery chargers of the tungar type, so that storage B-batteries can be charged at their proper rate, has lately appeared on the market. In addition to the rectifying tube in these chargers, a standard lamp socket is provided, into which the resistance can be screwed to reduce the charging rate to suit the size of the battery being charged.

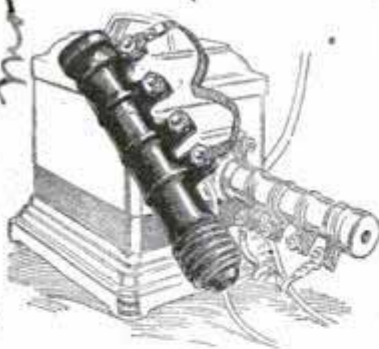

When radio B-batteries are to be charged, the rate must be reduced for the small battery plates. To this end, a resistor is needed, and a separate terminal is provided on the charger for the higher voltage required.

**Variable Resistance Controls Horn Volume**

A variable resistance of the carbon-pile type can be used to control the horn volume without disturbing the balance of the circuit. This unit may be connected across the output terminals; is mounted on the panel at a convenient point or placed on a long flexible lead, so that the volume of the set can be controlled at a distance, if desired.

**Device for Shifting Horn from Radio to Record**

A new device for shifting the horn from the radio set to the record, in combining the phonograph with a radio receiver, without disturbing the tone arm, has appeared on the market.

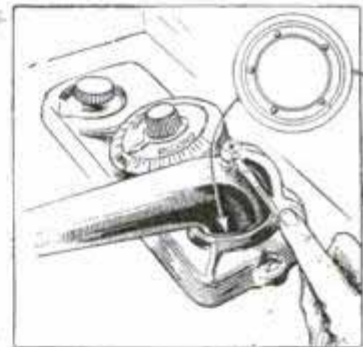
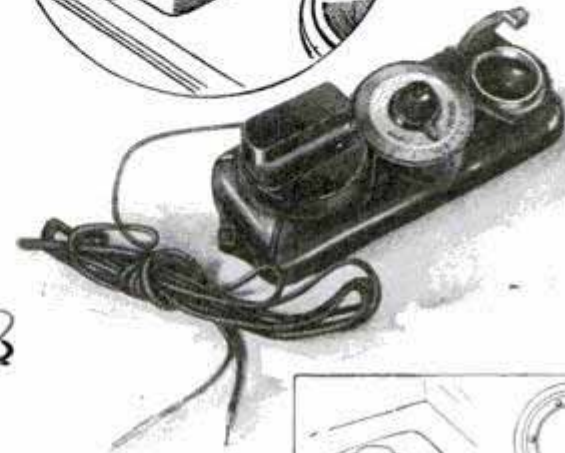
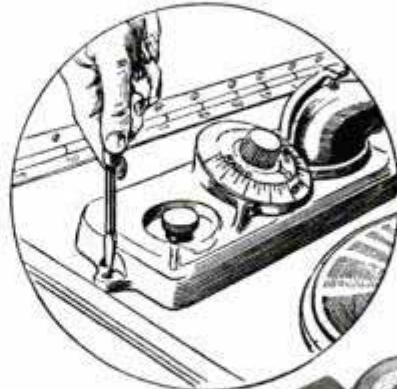

Handy Attachment Shifts Phonograph Horn from Radio to Record; Above, Fastening Unit in Place; Below, Adjusting Setscrew Holding Tone Arm in Place

This handy instrument can be fastened to any phonograph with the aid of a screwdriver in a very few minutes. It consists of a microphone and cord for connecting to the radio set, a dial, marked radio on one side and record on the other, and a mounting base for the tone arm. The tone arm is removed from the phonograph by taking out the three screws that hold it; it is then separated from its base by loosening the little screw at the top of the bracket, and the device is then mounted on the phonograph over the opening where the tone-arm base was before, in the manner shown in the upper illustration. The mounting receptacle is a reproduction of the tone-arm base. The ring containing the five bearings is placed under the tone arm which is then placed in position and the pin and setscrew adjusted as shown in the lower illustration. Shifting the dial now changes the phonograph horn over from the record to the radio set and the usual bothersome disconnecting of the microphone unit is no longer required.

Ward. Leonard Electric Co. New York

*Radio Strom*

665 7 1/2 14th Ave New York City

680-02

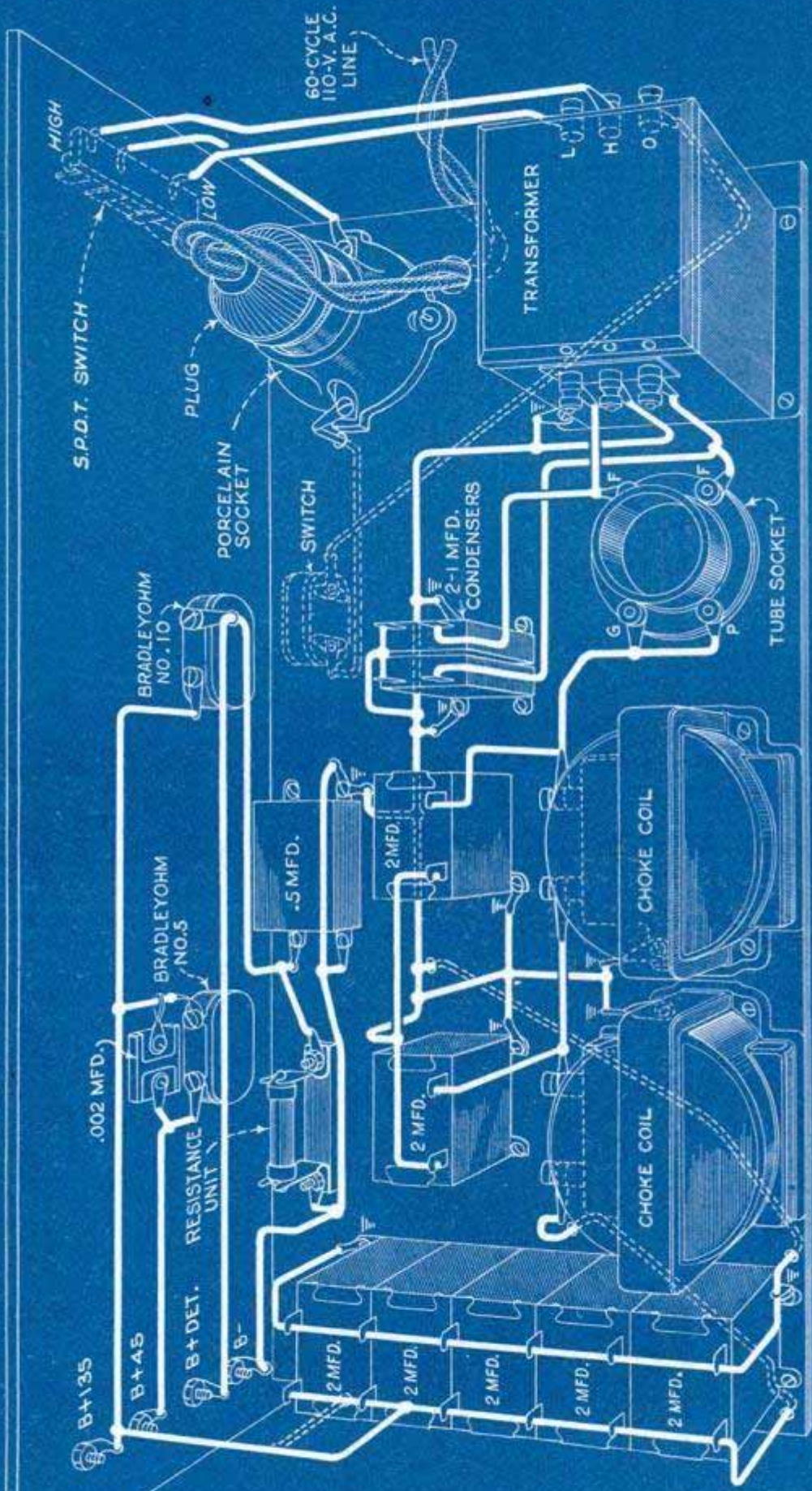

**B-BATTERY ELIMINATOR**  
 POPULAR MECHANICS MAGAZINE  
 MARCH 1926



# How to Build Your Own B-Eliminator

By F. L. BRITTIN

**C**ONTRARY to general opinion a B-eliminator cannot be built up from the usual three-element tube, a spark coil and a few common condensers. Every part must be specially built, the condensers must be able to carry the load, and at the same time small enough to permit compact assembly. Such parts being available now, the radio fan can build his own B-eliminator so as to deliver up to 180 volts if desired. The instrument to be described works smoothly without the slightest hum when properly constructed, and B-battery troubles are permanently eliminated. Full-strength B-voltage is always on hand, resulting in maximum efficiency of the set at all times. The source of supply is the 110-volt, sixty-cycle a.c. house-lighting current, and the eliminator can be plugged into any convenient wall socket.

We have shown two types of the eliminator to permit our readers to choose the one best suited for their needs. The circuit of both is practically the same. The arrangement shown in the large blueprint was built up in our laboratory for sets of the superheterodyne type requiring a variety of voltages. A standard-size bakelite panel is used, so that the device can be placed in a cabinet if desired. This panel is  $\frac{3}{16}$  by 7 by 18 in. The subpanel is  $\frac{3}{16}$  by 9 by 17 in., and is mounted on brackets, 2 in. above the base of the cabinet, in the manner shown in the illustration. Note that the push-pull switch is the only instrument mounted below the subpanel. The photo of the front panel and the completely assembled instrument will give the reader a good idea of the neat and compact arrangement. The various voltages indicated on the front panel are especially suitable for

the 1926 model of Popular Mechanics superheterodyne. Control No. 1 is for the first detector and oscillator plate voltages; No. 2 controls the intermediate voltages, and the maximum voltage is taken from the upper binding post. This voltage can be either high or low, depending on the way the small single-pole, double-throw switch, shown on the left side of the panel, is thrown. The position of the instruments on the front panel can be changed to suit the builder, but it is necessary that the instruments on the subpanel are arranged in the manner shown for best results, as it is essential to keep the input and output separated as far as possible.

The fixed condensers may be of any good type, but it is very important that they be of the highest grade, and should be tested to 800 volts at least. The five 2-mfd. fixed condensers placed across the output make for good quality, permitting the low notes to come through the set. The porcelain socket is of the common variety. Twisted lampcord of the length required is connected with a plug at each end and run through a hole in the sub-

panel directly back of the socket, then taken out at the rear of the instrument. In connecting the B-eliminator to the set, either use a cable or bind all the wires closely together in cable form.

By following these instructions the eliminator can be placed as near or as far from the set as desired. When throwing the S.P.D.T. switch from low to high voltage, it will be necessary to adjust

the No. 1 detector voltage. A C-battery is always advised with any radio set using audio amplification. The table at the end of this article gives the values to use with this eliminator and different types and

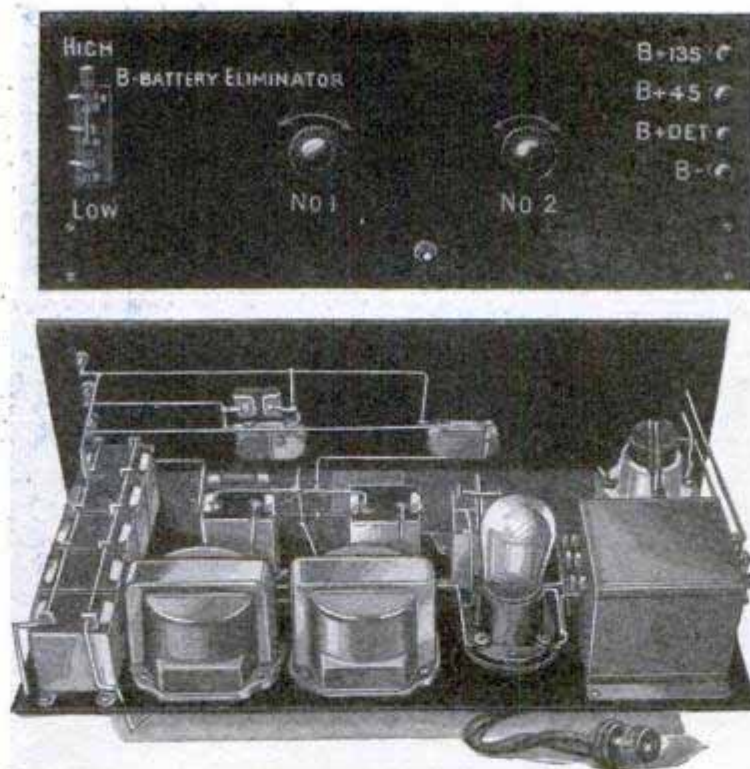

Rear View of Finished Instrument, Showing Compact Assembly; Above, Details of Front Panel with Controls Plainly Marked

combinations of vacuum tubes. The material list specifies the types of materials used in the models tested out in our laboratory.

The breadboard arrangement of the eliminator is for those who wish a simpler and cheaper type, suitable for sets requiring but three B-battery terminals, namely B—, Det. B and Amp. B. The board is 1/2 by 7 by 23 in. in dimensions and the same instruments are used with the exception of the No. 5 Bradleyohm and the .002-mfd. fixed condenser. The S.P.D.T. switch may be of the cheap porcelain type. The binding posts are mounted on strips of bakelite raised 1/2 in. at each end of the board. The wiring diagram is given above the photo of the completed instrument. This breadboard assembly can, of course, be arranged for the additional 45-volt terminal if desired, but the panel and subpanel design takes up

less room and improves the appearance. In both wiring diagrams the points to be grounded are marked with the usual ground symbol. These are not external grounds, however, but circuit grounds to the metal shells of the instruments, and are necessary to obtain good results.

In operating a device of this kind, it is always well to remember that it is connected to the power line, and like any other device operated by the house-lighting current, it should be turned off before handling any part except the insulated controls on the front panel. The push-pull switch on the front panel is used for this purpose. Do not forget to

turn this switch off when the set is not in use; this is just as important as turning off the A-battery. On the breadboard type of eliminator, pull the blade of the S.P.D.T. switch up-right to shut off the current. The eliminators use very little house current, and when correctly built, with the mate-

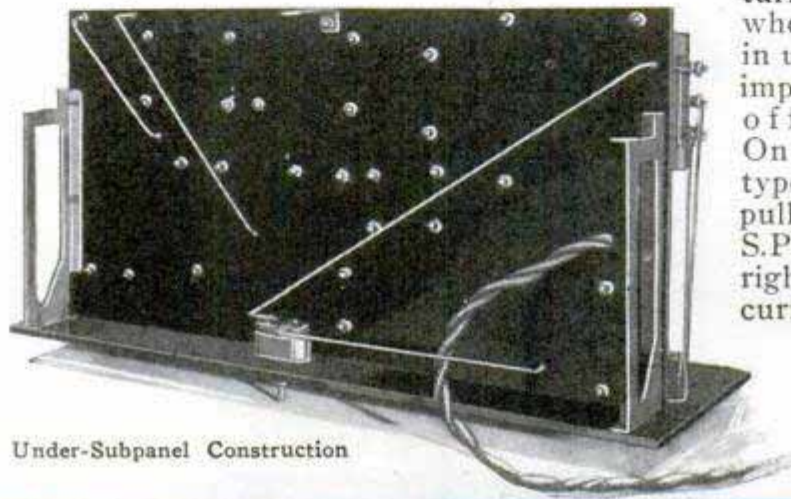

Under-Subpanel Construction

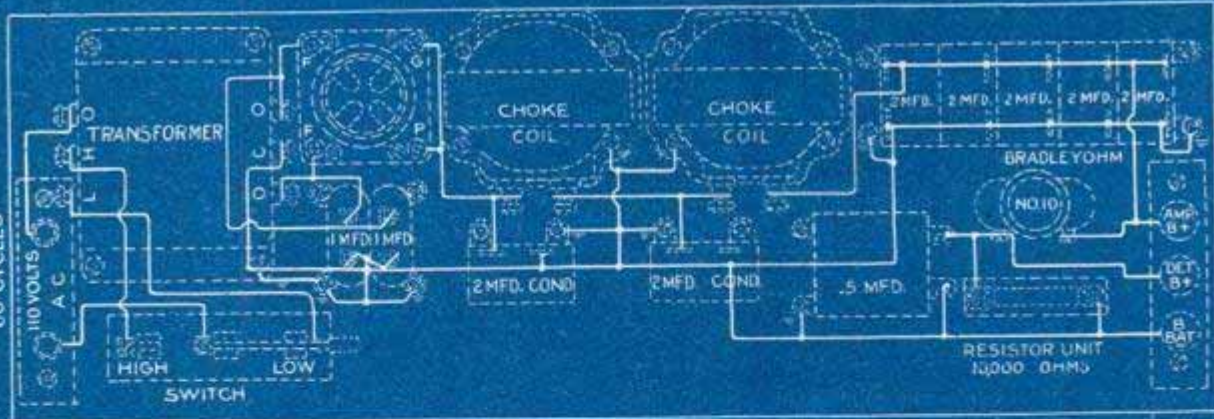

LAYOUT & WIRING DIAGRAM

- CONNECT TO CASE
- + WIRES SOLDERED TOGETHER
- WIRE PASSES OVER WITHOUT CONTACT

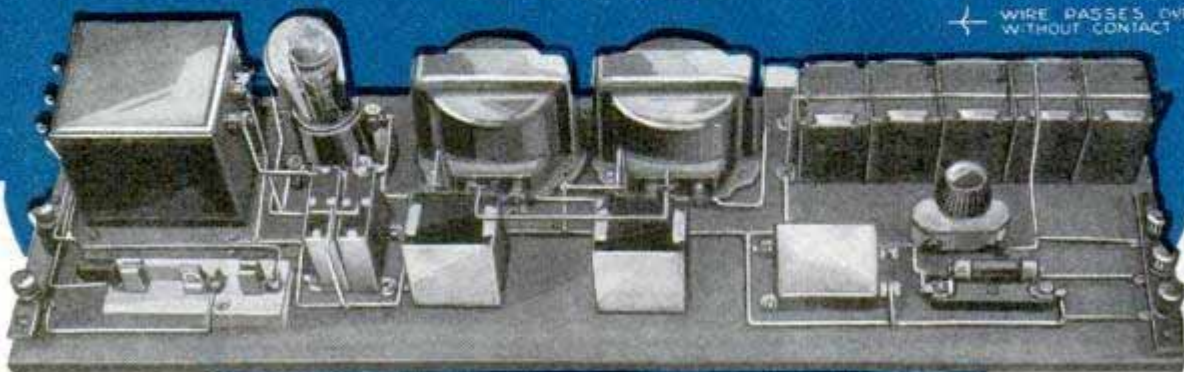

Breadboard - Type of Assembly

Simplified Wiring Diagram Above

rials specified, give excellent results. There is no upkeep expense, as the tube and other parts are practically indestructible.

A large blueprint of both circuits can be obtained from the Radio department of Popular Mechanics Magazine, 200 E. Ontario St., Chicago, for 15 cents. Specify blueprint No. 106.

C-BATTERY VOLTAGE TABLE

TYPE OF TUBE	NUMBER OF TUBES IN SET															
	WITH LOW-VOLTAGE TAP								WITH HIGH-VOLTAGE TAP							
	1	2	3	4	5	6	7	8	1	2	3	4	5	6	7	8
UV-201A; C-301A	10.5	9	7.5	6	4.5	3	1.5	1.5			19	16.5	15	12	10.5	9
UV-199 OR C-299	16	15	13.5	12	10.5	7.5	6	4.5								21
201A PLUS ONE UX OR 301A * CX-112			7.5	6	4.5	3	1.5	1.5	19	16.5	15	13.5	12	10.5	9	
UV-199 PLUS ONE UX OR C-299 CX-220			13.5	12	10.5	7.5	6	4.5							21	18
CX-112 OR UX-112	9	7.5	6	4.5	3	1.5			19	16.5	13.5	12	12	9	7.5	6
CX-120 OR UX-120	15	12	7.5	6	3	1.5					21	15	12	10.5	7.5	

MATERIAL LIST

- 1 bakelite panel, 3-16 by 7 by 18 in.
- 1 bakelite subpanel, 3-16 by 9 by 17 in.
- 2 Benjamin subpanel brackets.
- 1 socket, common porcelain type.
- 2 fixture plugs of the pull-apart type.
- 6 ft. lampcord.
- 1 Cutler-Hammer push-pull switch.
- 1 Acme B-4 transformer.
- 2 Acme B-2 choke coils.
- 1 Raytheon tube.
- 1 standard tube socket.
- 7 Tobe-Deutschmann fixed condensers, 2 mfd.
- 2 Tobe-Deutschmann fixed condensers, 1 mfd.

- 1 Tobe-Deutschmann fixed condenser, .5 mfd.
- 1 Bradleyohm variable resistor No. 10.
- 1 Bradleyohm variable resistor No. 5.
- 1 Bradley fixed resistor unit, 8,000-10,000 ohm.
- 1 fixed condenser, .002 mfd., any good make.
- 1 Marco S.P.D.T. switch.
- 4 binding posts with engraved tops.
- 39 round-head, brass machine screws, 6-32, 1/2 in. long.
- 2 round-head, brass machine screws, 6-32, 1 in.
- 4 doz. soldering lugs.
- 2 two-foot lengths No. 14 round, tinned-copper bus-bar wire.

Leich Electric Co, Seneca, Ill

694-OR

New Jack Controls both Amplifier Stages

A two-stage jack which has been marketed recently, is novel in that it may be used in a receiving set for controlling either one or two stages. By inserting a plug into the jack until the first notch is encountered, one stage of amplification may be cut into the circuit, and by pushing the plug all the way in, both stages are automatically connected in it. This eliminates an extra jack and the volume is controlled by a single operation.

Switch Locks Set and Prevents Unauthorized Tampering

The radio-battery switch shown in the drawing assures the operator that no one will tamper with the set during his absence. This will prove a boon where children are apt to turn on the radio set and leave the tubes burning after they have finished listening in. The nickel shaft of the switch shuts off the battery current when it is pushed all the way in. When the shaft is pulled halfway out, the

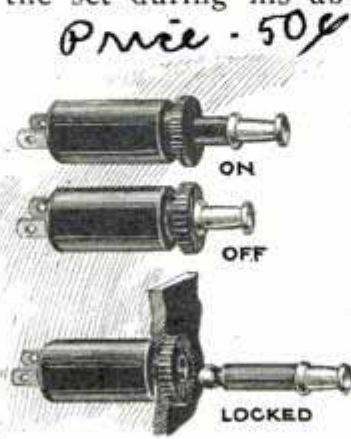

Price - 50¢

current is turned on. The shaft can be pulled all the way out of the switch and carried in the pocket of the owner, in the same manner as he would use his auto key. The A-battery is then shut off and the set cannot be operated until the "key" or shaft is replaced.

Audio-Frequency Transformer Simplifies Wiring

An audio-frequency transformer furnished with leads coming out of the base is intended to simplify the wiring of sets mounted on subpanels.

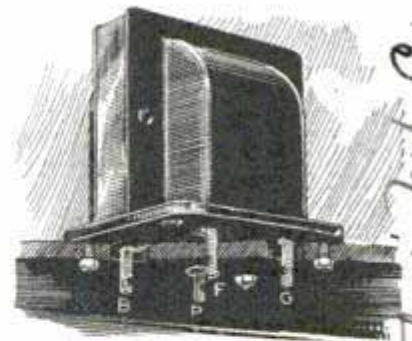

Obviously, this method of bringing out the leads provides neater assembly, shorter leads, and makes the set look like a factory-made job. Instead of the usual binding posts, soldering lugs are provided.

German telegraph authorities are making preparations to establish radio-telephonic communication between liners at sea and telephone systems in Berlin, Bremen, Hamburg and other German towns, via the radio stations at Norddeich, Cuxhaven and Swinemunde.

428-OR

637-OR

Leich Electric, 571, Chicago

Walbert Mfg. Co.  
925 W. Westwood Ave

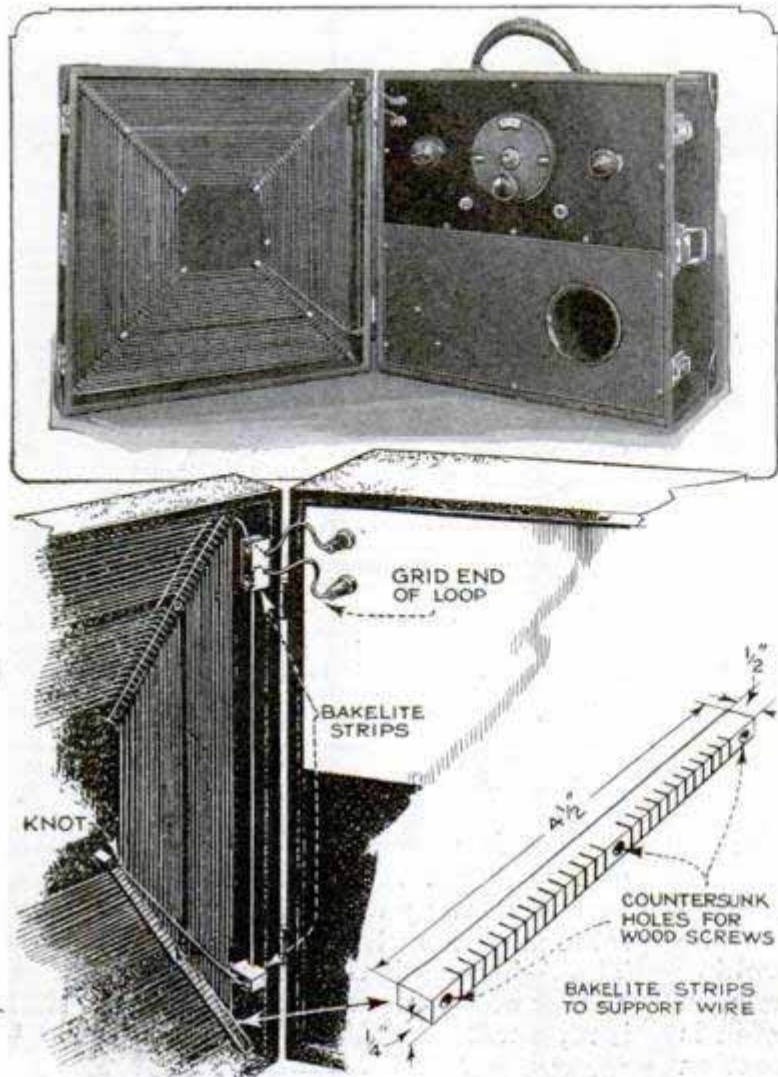

Loop Built in Lid of Portable Cabinet Is Adjustable for Directional Effect

**Built-In Loop for Portable Set**

A good loop of the pancake type can be built in the lid of a portable receiver cabinet as shown in the illustration. The lid can then be adjusted in any position for directional effects. A loop of this kind takes up very little space, and is much handier than the folding type. Four strips of bakelite,  $4\frac{1}{2}$  by  $\frac{1}{2}$  by  $\frac{1}{4}$  in., are slotted to take the loop wire easily. These slots can be cut with a circular metal-cutting saw and should be deep enough to take the wire. The turns should be spaced about  $\frac{1}{2}$  in. apart, and from 80 to 85 ft. of stranded silk-covered loop wire is used. The bakelite strips are countersunk for wood

screws and mounted in the lid as shown. The wire is then wound on and the ends brought out through insulating blocks of bakelite to the cord-tip plugs. Note that the grid end of the loop is taken from the inner turn. Sufficient wire should be left at the loop ends so that the lid can be turned out as required.

**Drilling Wood or Bakelite without Splitting**

Holes can be drilled in wood or bakelite panels without risk of splitting out ragged holes on the underside, if a little care is taken. Always drill the hole from the front side of the panel and clamp the piece to be drilled tightly against a piece of wood of similar size and about 1 in. thick. This prevents the chips on the underside of the panel around the hole from breaking away. Use sharp drills, and a tapered reamer in cases where it becomes necessary to enlarge the hole beyond the size of bits on hand.

**Colored Caps Indicate Leads to Set**

Attachment caps made in seven distinctive colors, to indicate the different connections to the receiver and battery leads, are now available. They will fit any standard binding posts by removing the post screws, and replacing them with the screws of the attachment cap, or they can be used as a binding post by putting the screw through the panel and fitting a hexagon nut underneath. The threaded ends of the colored caps match the colors of the battery cables now in use, making it practically impossible to connect the set wrong. The caps are covered with insulating material, so that it is not necessary to keep them separated.

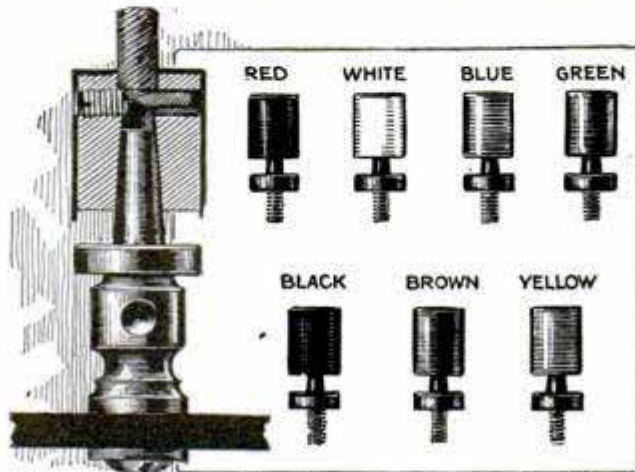

Safety Attachment Caps, in Seven Colors, Identify the Leads to the Set; Left, Binding Post with Cap

Radio station LRT, being installed on the South Orkney islands, is said to be the southernmost broadcasting outpost.

*Council Bluffs Iowa.*  
*Morris Regester Co.*

**Steam Heat Improves Radio Reception by Keeping Set Dry**

Moderate dry heat in the house improves the performance of the set, as it reduces the humidity. The effect on the radio set is to drive the dampness out of the coils, and other parts, with the result that the set becomes more sensitive. The receiver of the future may be so designed as to exclude dampness and this would be a great improvement. Artificial heat could even be applied to the set at intervals to obtain the same result. Some of the early instruments were built in separate, sealed boxes with the tubes in a sealed compartment. This idea may be revived. A common light bulb could be mounted in the set, which would radiate enough heat to keep away moisture. In warm, damp climates this trouble is a real problem and these suggestions should be beneficial. When coils, transformers, rheostats and other parts collect moisture, the set is often permanently injured.

**Novel Aerial Is Easily Installed**

An aerial so shaped that it is easily installed in limited spaces is now available. It is claimed to be more selective than the usual type, limiting interference without reducing volume. It is mounted on the ridgepole with lagscrews in the manner

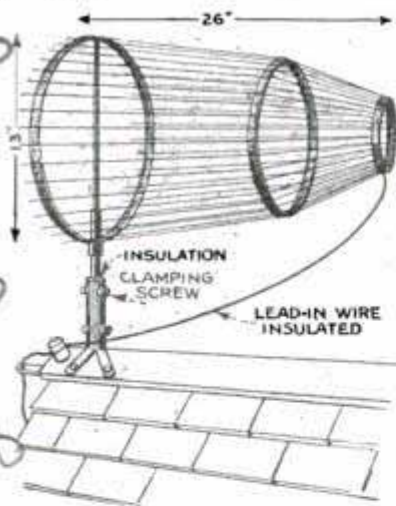

shown in the illustration, and can be turned in the desired direction and locked in place. This feature is of value as the aerial can be placed at right angles to any power line. The lead is taken to an insulator and

**CLOUD SPEAKER AND AMPLIFIER FOR THE CRYSTAL SET.** A novel and effective instrument described in the April, 1925, issue. This number may be obtained from the Circulation Department, price 25 cents.

**Radio Set Built like Lamp**

**Has Horn in Base**

A radio set built in the form of a table lamp with the horn concealed in the base is a recent novelty. The instrument com-



Upper Part of Lamp Shade Raised, Showing Instrument Panel, and Left, Closed for Use as Lamp

bines in one compact unit a three-tube receiver, a loud speaker and a table lamp. The lamp is built of copper, finished in either gold, silver or bronze to harmonize with various interiors. When the instrument is closed, no one would suspect that a complete three-tube reflex receiver was concealed within.

**Attachable Peg for Ground Pipe**

A peg for the end of the ground pipe to make it easier to drive the pipe into hard soil, has been marketed recently. This simple attachment is screwed to the end of a 6-ft. length of 1-in. pipe which is placed as close to the house as possible. A ground clamp, consisting of a strip of copper, with holes in one end and a heavy bolt in the other, is also available. This is fastened to the top of the pipe along with the ground lead from the set and lightning arrester. The installation is clearly shown in the drawing.

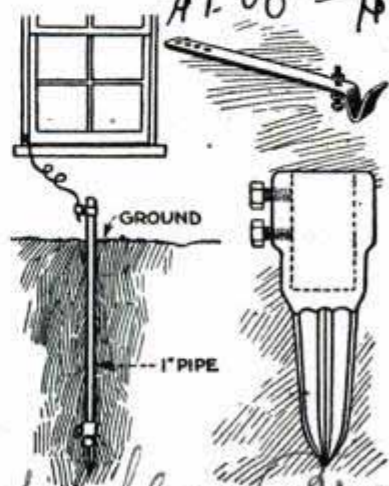

*Brown, Stickler & Brown, Inc.*  
128 N. Jefferson St.

Stanley Engineering Co. 70 Monroe St. Lynn, Mass

651-02

664-02

*Council Bluffs*  
**Handy Machine Winds  
 Low-Loss Coils** *cl wa.*

*675-06*

A handy machine for winding low-loss coils is one of recent novelties on the

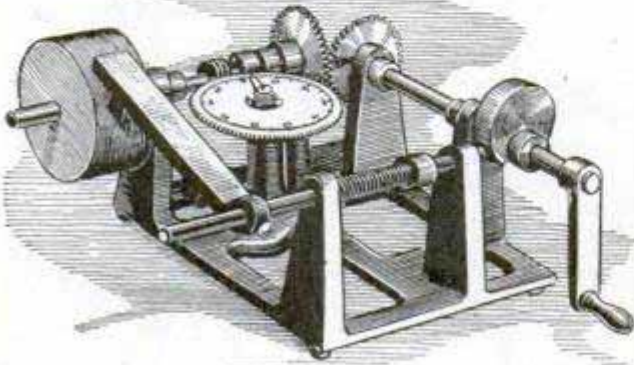

Honeycomb-Coil Winder Showing Simple Construction; Sample of Coil Made on the Machine

market. It will wind the popular honeycomb-type coil any width from  $\frac{1}{2}$  to 1 in., and the diameter may be arranged to suit by putting various sizes of wooden spools on the winding spindle. The recording dial is provided with a movable pointer for counting the number of turns. The instrument is finished in black enamel and is neat in appearance.

**Testing of Tubes Is Necessary  
 for DX Reception**

The ideal radio weather at hand, the set should be in the best possible condition to take advantage of distance-getting possibilities; the tubes should be tested, and if found to be of low efficiency, they should be placed in a tube booster and rejuvenated if they are of the type that can be so treated; if not, new tubes should be provided. Radio tubes lose their efficiency under constant use and the loss progresses to a point where the set operates very poorly and sometimes not at all, although the batteries are in first-class condition and the tube filaments apparently light as usual.

If the tubes are of the thoriated-tungsten type, rejuvenation is very satisfactory and makes a remarkable difference in the performance of the set. Most of the standard tubes now in general use, with the exception of the WD-11 and WD-12 types can be rejuvenated. This reactivating process consists in boiling thorium

atoms out of the interior of the tungsten filament so that they form a new layer on the surface, making possible greater activity within the tube. This is done by operating the filament for a very short time at a specified high voltage, followed by a lower voltage. There are a number of inexpensive tube boosters available for doing this at home, the 110-volt 60-cycle house-lighting current being suitable for the work.

Approximately the same results can be obtained by operating the tube filaments in the set with the A-battery in the usual manner, the B-battery being disconnected from the set. This operation should continue for several hours, the length of time depending on the condition of the tubes.

*632-06*

**Aerial Mast Clamps to Ridgepole**

Metal aerial-mast fixtures for fastening the mast to the ridgepole of the house are now available. The fittings are adjustable to fit various types of roofs and roof pitches, and consist of a cap with a sheave pulley and lugs for guy wires, a collar with lugs and a universal masthead with loop for attaching the aerial cable.

The pipe does not require threads at either end and can be purchased from the local plumber in the length required. One-inch pipe is used for the mast. By adding lengths of pipe the aerial may be made of any height, but in that case, one guy-wire collar should be used on each extra length of pipe to brace it sufficiently.

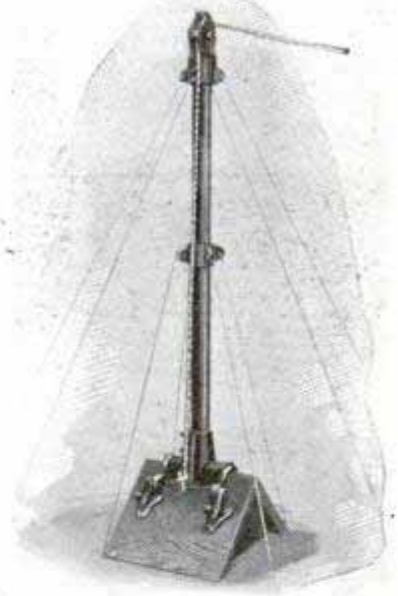

*Wreidag Mfg. Co., Wreidag, Ill.*  
**Colored Wires Identify Leads** *cl.*

If battery leads are not marked for identification, there is a chance of placing heavy voltage on the filament terminals. This can be avoided by using insulated wire with various-colored braided covering. Stranded wire of this type can be obtained in red, black, white, yellow, green and brown, and with different-colored tracer threads.

# Getting Rid of the Squeals

Howls, Hums and Reradiation Are Usually Easy to Prevent with a Little Time and Effort

**G**ETTING rid of squeals, howls and hums, and preventing reradiation, are topics of everyday conversation among radio fans. All are interested because these annoying ailments are so common, caused by induction from power lines, interference from regenerative receiving sets or improper tuning.

Power-line hum can usually be minimized or eliminated by running the aerial at right angles to the lines causing it, as shown in Fig. 1. Drumming noises from power lines often can be located in a leaky transformer in the neighborhood. In such cases the power company will usually co-operate to eliminate this trouble by repairing the transformer.

Squeals inherent in the set due to its design can be reduced and often elimi-

nated by properly tuning it. One-tube regenerative circuits of the kind shown in Fig. 3 are of this type. The reradiation is due to its conductive feedback into the aerial. However, this is not the only type of reradiating set that causes howls that interfere with the pleasure of other listeners within a range of several miles; all types of regenerative receivers are troublesome in this respect. Even the superheterodyne receiver, although it does not come under the regenerative heading, is a bad offender when used on an outside aerial.

In order to find out whether your set is causing such trouble, make arrangements with your neighbor to listen in to the same station at the same time. When tuning in your set to that wavelength turn

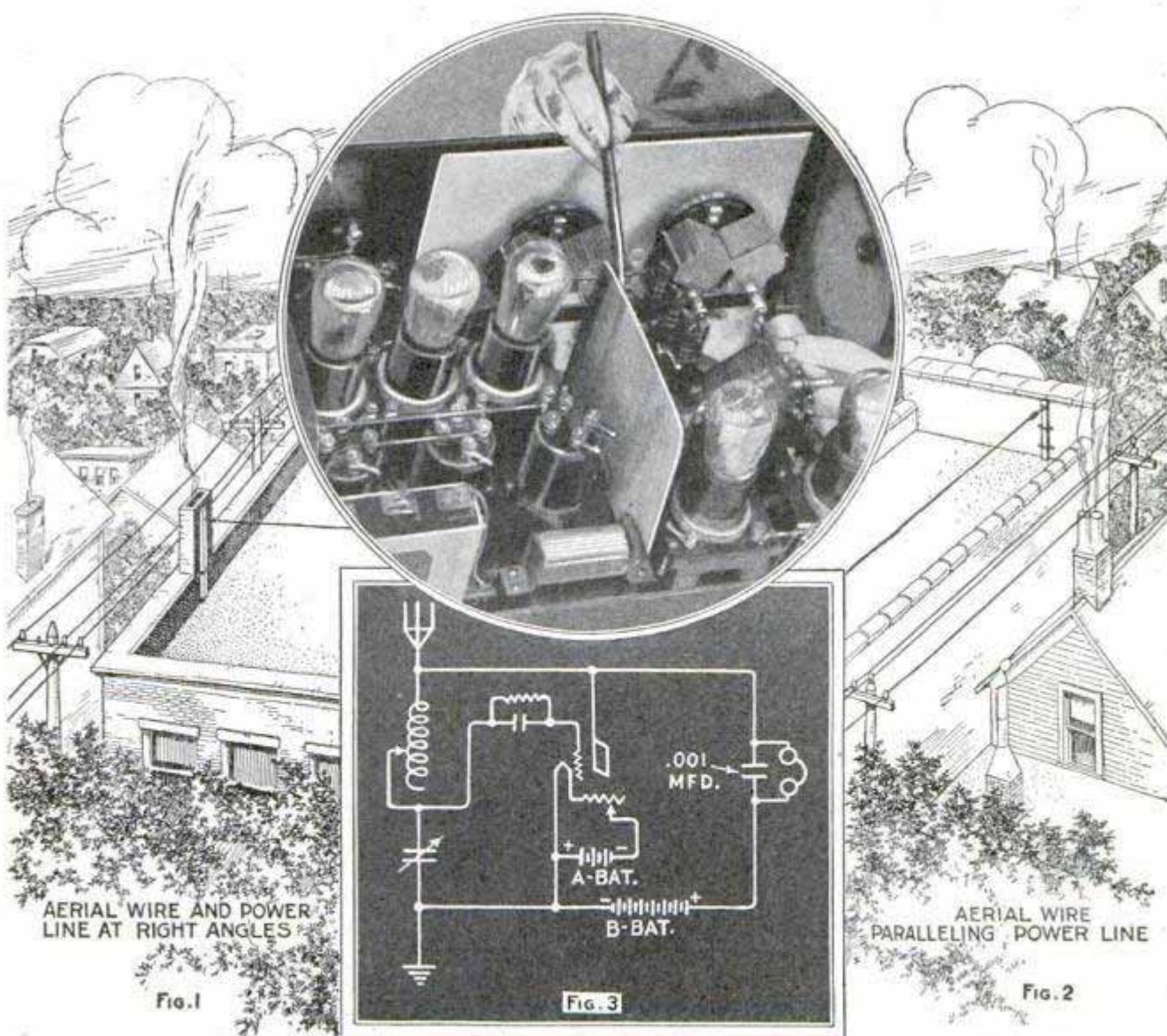

Above, Shielding Prevents Intercoupling between Transformers and Tubes; Below, Single-Circuit Regenerative Receiver, Which Acts as a Miniature Transmitting Station

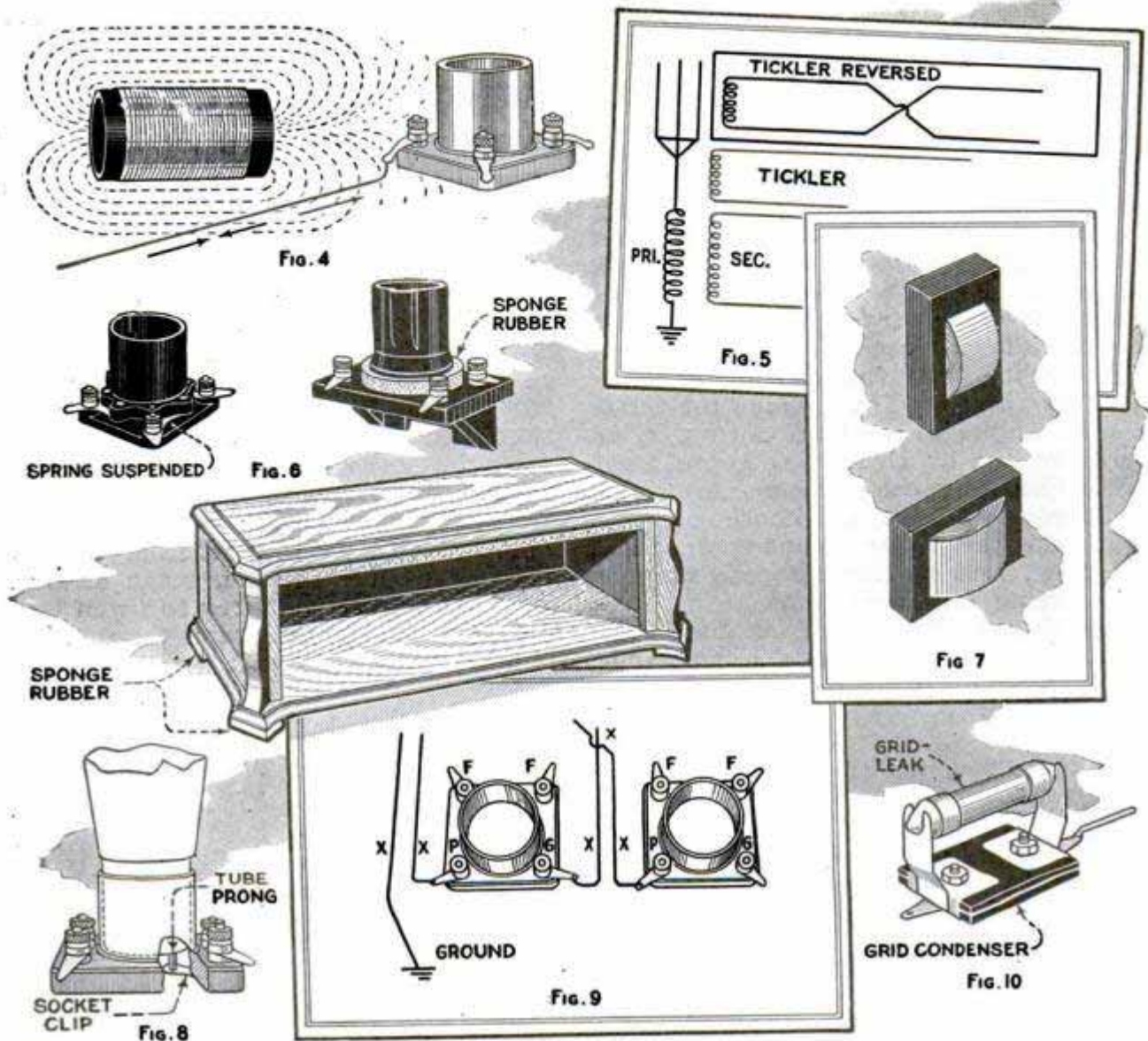

Squeals and Howls in Radio Reception Are Often Caused by Faulty Design and Arrangement of the Instruments, Microphonic Tubes, Poor Contacts, Wrong Gridleaks and Other Errors Which Anyone Can Correct

up the rheostats to make the signal as loud as possible up to distortion. This will usually drive the tubes into oscillation. If the set is of the popular tuned r.f. type, detune the first dial, which is closest to the aerial lead-in. Then switch off the set and get in touch with the neighbor to check up the results. If he has heard a squeal while you were carrying on these experiments, and no others in the neighborhood were tuning in to the same station in this way, your set is at fault.

Advancing the rheostats too far gains nothing and shortens the life of the tubes, besides spoiling your neighbor's reception. There are several rules for proper tuning that are well worth knowing. Practice tuning in powerful stations first, and do not try to pick up weak distant stations until you become an expert and know how to control your set. Use both hands, one hand for the regeneration control, such as a potentiometer or tickler if the set has one, and the other hand for the

tuning control. Keep the regeneration control always just below the point of oscillation; the set is then in the most sensitive condition. Turn back the regenerative control as soon as the set accidentally breaks into oscillation. Tune the set so that signals will come in without a whistle. The regeneration control can then be turned up a little to increase volume. Do not try to force regeneration in an attempt to obtain loud-speaker volume from a set not designed for this purpose. Do not force regeneration in an attempt to hear stations beyond the range of the set; be content with those that can be really heard.

Squeals originating in the design of a receiving set can often be traced to coupling tubes or transformers. This can be prevented by shielding these instruments, as shown in the photo insert. If the a.f. transformers are of the type shown in the upper part of Fig. 7, they should be turned at right angles to each other, to prevent



intercoupling of their fields. The lower transformer is of the vertical-core type, and turning it at right angles to another of the same type, has practically no effect, as this does not put their fields in a right-angle relation. Transformers of this type must be spaced a reasonable distance apart, but do not have to be turned. Transformers of the r.f. type shown in Fig. 4 should be placed in the set with care around coils carrying high-frequency currents, destroying the tone. These transformers should be mounted in such a position that the lines of force will cut each other as little as possible. Even with this precaution, the field from the coil sprays near-by wires and pieces of apparatus, inducing current in them that often causes broad tuning and distortion with its usual chorus of howls and squeals. A new doughnut-shaped coil, called a toroid coil, which is so designed that the field is confined to the coil regardless of the position in which it is placed in relation to other instruments and wiring, will remedy much of this trouble.

Receiving sets of the three-circuit type often give poor results if the tickler coil is reversed as shown in Fig. 5, as this "bucks" the current in the secondary coil, thus neutralizing the grid circuit. Horn noises are often caused by vibration, small tubes of the dry-cell type being especially apt to cause this trouble. To prevent it, use sponge-rubber pads under the corners of the cabinet, or use shock-absorber sockets of the type shown in Fig. 6.

A common source of trouble is poor contact of the tube prongs with the socket clips. Pull up the prongs of the socket with a stout string, replace the tube and reinsert the socket. A sectional view of the socket is shown in Fig. 8. Plate and ground leads running parallel as shown in Fig. 9, and plate leads touching grid leads, or running close to them, will cause howls. Keep such leads separated as far as possible, and when necessary to cross them, run the wires at right angles. Fig. 10 shows the common type of grid condenser and leak; trouble can often be traced to a defective condenser. It may have been ruined by excessive heat when soldering, and as a precaution against this,

soldering lugs should always be fastened to such condensers by means of two short brass machine screws, and the wire should be soldered to the end of the lug before the lug is screwed to the condenser. The gridleak may have too much or too little resistance; try different resistances until one is found that gives the best results.

666 - Vernier Dial Has Device for Changing Ratio

A new dial is provided with a device for changing the ratio. It is designed for mounting on the shaft of any standard condenser without the use of tools other than a screwdriver, and can replace the dial on any receiver where sharper tuning is desired. The ratio-changing device provides for any ratio between 6 to 1 and 20 to 1.



*National Co., A. M. S. 110 Brookline St. Cambridge Mass.*

668 - Combination Tube Tester and Trouble Shooter

An instrument which not only tests tubes under operating conditions but can be used to locate trouble in the set has lately made its appearance on the market. The illustration shows the method of reading the plate current of the tubes in milliamperes. The instrument is also provided with a combination plate and filament voltmeter for testing the A and B-battery voltage. In addition, it can be used to locate defective tube sockets, open circuits in transformers, poorly soldered joints in the circuit and defective contacts in the jacks. A tube tester of this type is really necessary to get the best results from any multi-tube set; one poor tube may spoil the reception in an otherwise perfect instrument and a check on the A and B-batteries is desirable at all times.

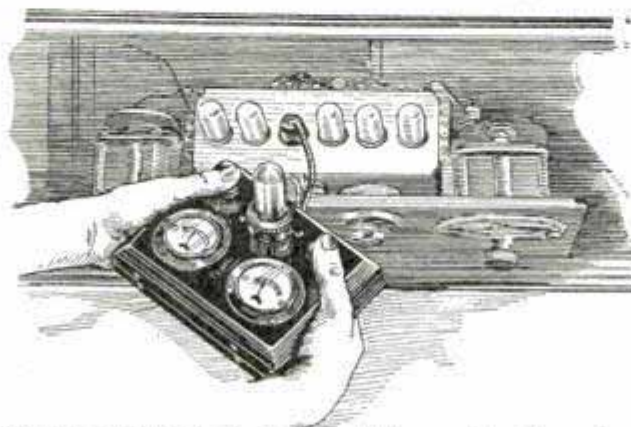

Showing Method of Testing Tubes under Operating Conditions with Combination Tester and Trouble Finder

*Sterling Mfg. Co. 283 Prospect Ave*

Push-Pull Adjustment Features

656-Q Variable Condenser

In a new variable condenser the movable plates are pushed or pulled by means of an insulated stem instead of rotated in the usual manner, for coarse adjustment. In

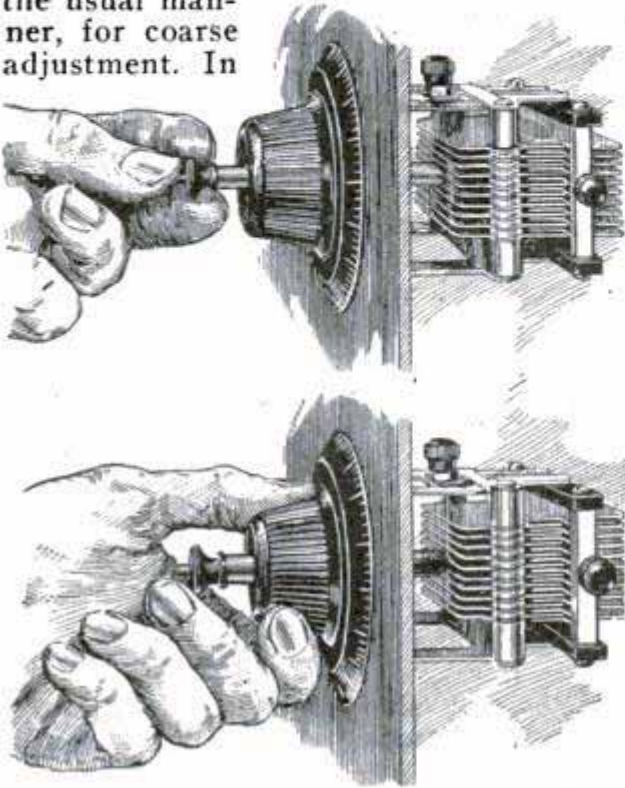

Above, Moving the Plates with the Stem for Coarse Tuning; Below, Fine Tuning with Dial

addition to this, very fine adjustment can be obtained in the usual way, by means of a dial. A micrometer screw coupled with the mechanism permits a movement of only .0001 in. Graduations on the stem are numbered 1 to 10 and on the dial from 0 to 100. The claim is made that body capacity and losses are reduced to a minimum. The movable plates are connected electrically to the frame and are grounded, and the fixed plates are 2 in. from the inside face of the panel.

Testing Audio-Frequency Transformers

A simple way to test a.f. transformers that are suspected of being grounded to the shell or frame, is of interest to all who have encountered such trouble. Connect one tip of a pair of headphones to the 16½-volt terminal of a 22½-volt B-battery unit, and the 22½-volt terminal to a short length of insulated wire. Without touching the bare wire with the hand, hold it against the case or shell of the transformer, being sure to make contact with the bare metal. Touch the free terminal of the headphones to each trans-

former terminal on the side of the transformer to which the wire is connected. Repeat this test on the other side of the transformer. A distinct click indicates that the terminal to which the connection is made is grounded to the frame. A similar test with the battery and phones can be used to locate an open circuit in the transformer; if there is no click in the phones when the connection is made across the coil, the circuit is open.

Good Ground Increases Efficiency

The radio set's efficiency can be increased from 25 to 100 per cent by the proper installation of a suitable ground. Many enthusiasts take great pains to erect a good aerial, then make the mistake of twisting the ground wire around a steam-radiator valve or gas pipe, and wonder why the results are not what they should be. A cold-water pipe makes a good ground under most conditions, but not always. The actual ground connection begins where the lead wire enters it. This means that if the water pipe is on the third story, the lead to the ground would be too long to be efficient. In a case of this kind it would be better to place a counterpoise under the aerial. When connecting the ground lead to a water pipe, always use a ground clamp.

Portable Lamp for Radio Receiver

657-Q Is Run by A-Battery

A small portable radio lamp, which is connected directly to the radio A-battery, is now available. It is designed along the

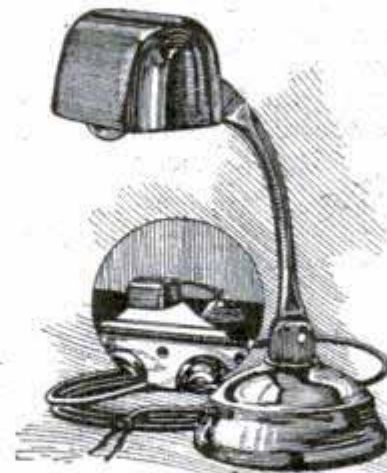

lines of a standard desk lamp, and supplies just the right amount of illumination for easy dial adjustment when placed on the cabinet, as shown in the insert. The eyes are shielded from the direct

rays, and the lamp adds to the appearance of the set. As it is provided with a long cord, it also makes a good trouble finder. A switch is placed in the base. The lamp is a 6-volt automobile bulb and thus draws very little current from the A-battery.



## Taking Care of the Umbrella

By FRANK V. FAULHABER

**B**ECAUSE an umbrella does not close as it should, a rib perhaps tearing into the covering, the user in his hurry and impatience often discards it without attempting to repair it. Usually the trouble is merely due to a broken rib or a rusty, broken wire, which might have been avoided with proper care. The life of an umbrella can ordinarily be lengthened and

the user can get much more service out of it by keeping all the joints oiled to prevent them from rusting. Use a small oilcan and put a drop or two on each joint, holding a small piece of cloth or paper under it to prevent getting oil on the covering, as shown in photo No. 3. Care must also be taken not to get too much oil on the joint, or it will run off on

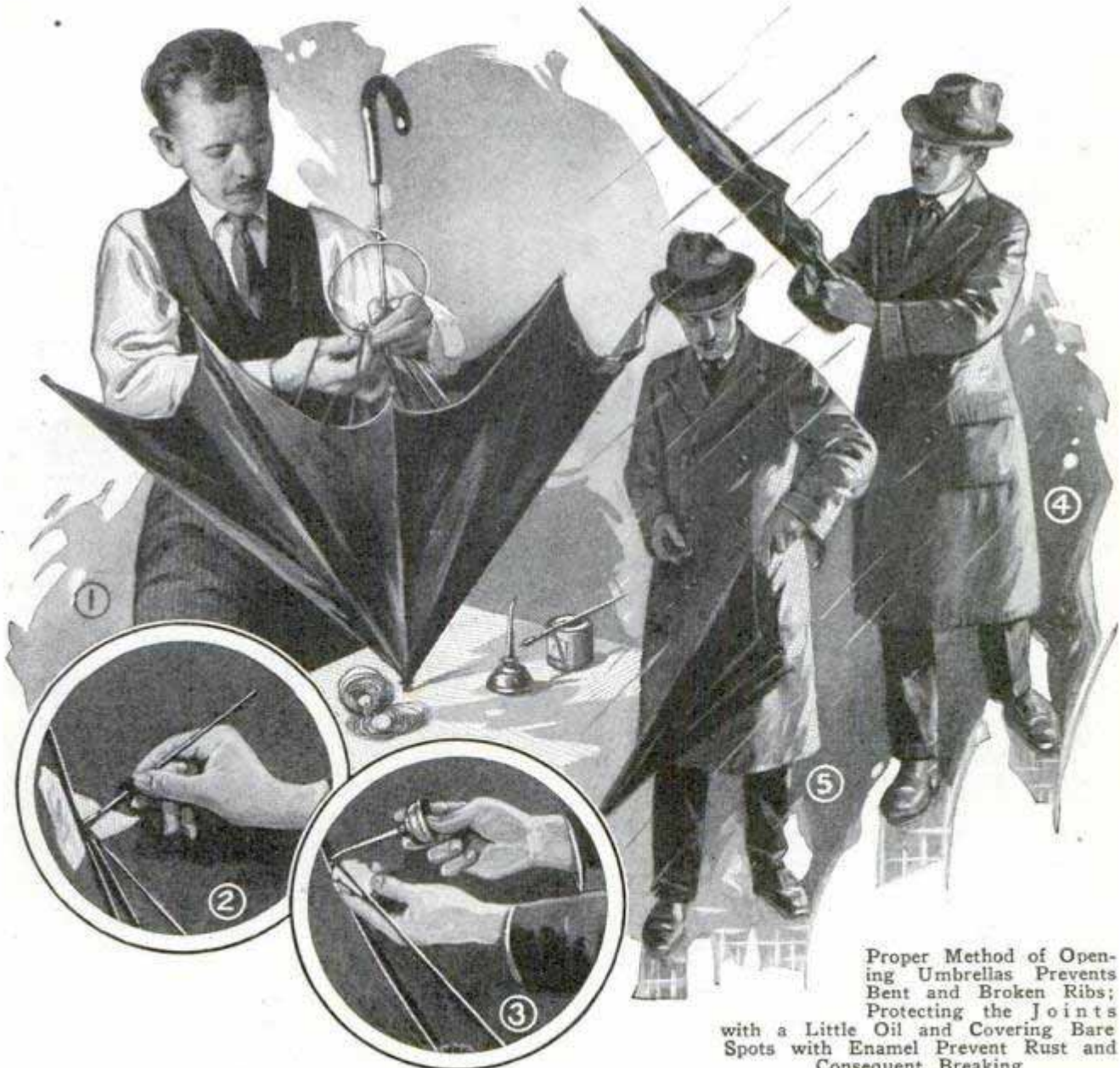

Proper Method of Opening Umbrellas Prevents Bent and Broken Ribs; Protecting the Joints with a Little Oil and Covering Bare Spots with Enamel Prevent Rust and Consequent Breaking

the covering after the umbrella has been put away.

In some instances, where the enamel has peeled off the ribs, it is good practice to touch up these spots with a little quick-

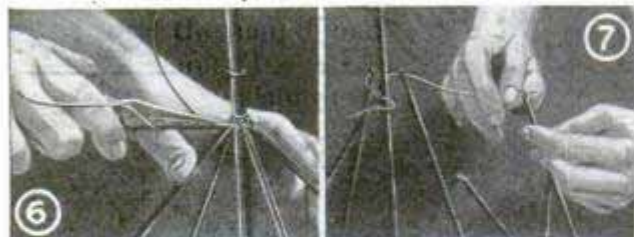

Rethreading the Ribs on a Thin Flexible Wire at the Sliding Sleeve Joint

drying black enamel or paint, applying it with a small camel's-hair brush, as shown in photo No. 2. Rusty joints become broken joints sooner or later, so preventing rust is, in most cases, preventing breaks, and your umbrella will last much longer. Oil should also be applied at the joint where all the ribs are attached to the sleeve at the handle. A thin, flexible wire holds the assembly together at this point.

When it is necessary to replace a broken rib, cut the threads that hold it to the covering. Do not pull the rib out, as the covering can easily be torn, especially if it is old. It is necessary to remove the

wire where the rib is fastened to the sliding sleeve. Take the other ribs off until the broken one is free, and after substituting a new one, rethread the ends of the ribs on the wire in their proper order. Should a new length of wire be necessary, use a flexible one, the same size as the old one and about 4 in. long. Threading the wire through the eyes of the ribs can be done best with the fingers, as shown in photo No. 7. Twist the wire tight with long-nose pliers, cut off the end and bend it down. This operation is shown in photo No. 6. When doing this, it will be found convenient to have a hole in the bench top, into which the ferrule of the umbrella is set to hold it vertically, as in photo No. 1.

Umbrellas are often opened in a hurry; the sliding sleeve is forced up before the covering has a chance to loosen, as shown in photo No. 4. This practice is the cause of most bent ribs. As soon as a rib is bent the umbrella does not open properly and by forcing it still more, other ribs may bend and break, or the covering may be torn by the strain. The proper method of opening an umbrella is shown in photo No. 5. Hold the umbrella down, twist it around a few times to loosen the covering and it will almost open of itself.

### "Baling" Empty Tin Cans

One junk dealer who bought up all the large square tin cans he could obtain used the ingenious method of baling them illustrated in the photo. The baler consists of a heavy "piston" with a connecting rod

which is fastened close to the rim of a large cog wheel to give a long stroke. This is so proportioned that the cans are compressed enough to admit another one

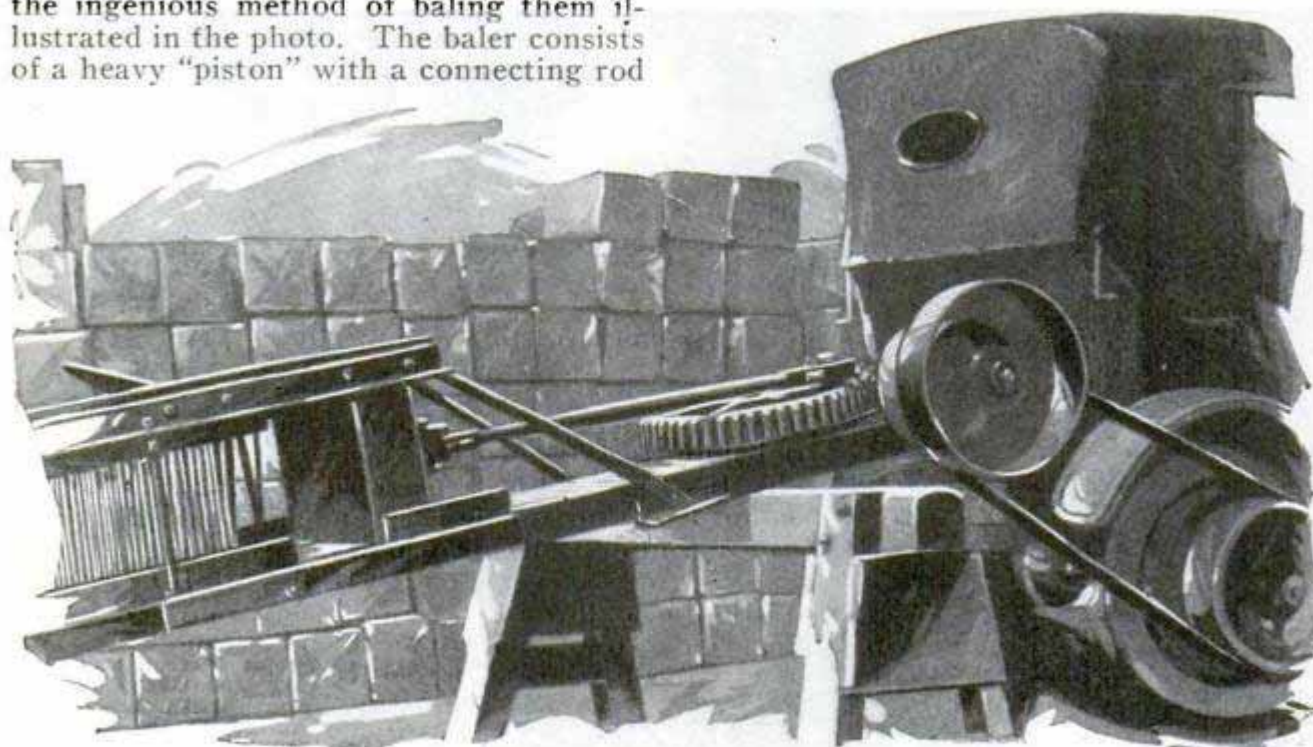

Old Tin Cans in Junk Yard Are Flattened for Baling by Means of Unusual Device Belted to the Rear Wheel of Automobile

at every stroke, and is run by a worm gear connected to a pulley on the rear wheel of the auto as shown. The piston slides in a steel frame of the proper size to fit the cans. When these are inserted in the frame and the baler is started running, the piston flattens them against the solid back of the frame. On each backstroke of the piston a can is inserted at the front end. The capacity of the baler is 40 cans, which are then tied up, forming a conveniently handled bale. The machine is mounted on a heavy piece of timber, and when in use, one end is placed on an ordinary sawhorse as shown.

### Removing Stamps from Envelopes

When you wish to save a stamp affixed to an envelope, do not attempt to remove the stamp from the envelope but remove the envelope from the stamp. Turn the envelope with the stamp down on the desk or table, then, keeping a fairly heavy pressure on the stamp, roll the envelope up and away from it. This is much more easily done than described, but a few minutes' trial will show how it is accomplished. It is not necessary to touch the stamp. If it happens, as is very likely, that a portion of the envelope remains on the stamp after it has been removed, roll the envelope portion off the stamp in the same manner. —F. C. Avery, Chicago, Ill.

### Safeguarding Children

Small children often fall against the stove and are then severely burned. Such accidents can be prevented by simply providing a fence around the stove as shown in the drawing. This can be made out of strips, 1 in. square. A baby's play yard will be just as useful for this purpose as a handmade fence. It should be fastened to the floor with screw-hooks and eyes so that the children cannot move it.—W. C. Ratcliffe, Tannersville, Va.



Small Baby Yard, Set around Stove, Prevents Accidents



Semicircular Diving Platform Made of Concrete Blocks Adds Attraction to Swimming Pool

### Novel Diving Platform

At Sulphur, Okla., there is a huge swimming pool fed continually by a spring of warm sulphur water. The water is crystal-clear, and people from far away come to use the pool for bathing. A diving platform is built in the pool of concrete blocks, forming a half-circle with convenient steps from the water's edge to a height of 8 ft. above the surface. This type of platform induces patronage and tends to increase one's skill in diving as the bather is tempted to try one step higher. Painted white and having an electric light on a pole at the top, the platform presents a neat appearance. —Dale R. Van Horn, Walton, Nebraska.

☛ A quantity of coarse excelsior, kept in a convenient box in the garage or workshop, will prove very efficient in cleansing hands of grease and oil. Dip a handful of the excelsior in water, rub soap into it and use as a brush.

### Filling the Gasoline Tank

Every tourist and auto driver who has had occasion to pour gasoline into the tank on the road appreciates the difficulty of doing this without the use of a funnel. Still, it is hardly advisable to take a funnel along just for this purpose, as it takes much room and may be bent and broken. However, the motorist usually carries a gallon oilcan and a piece of old inner tube can readily be obtained. Cut a slit in it to fit over the opening in the can, and it will be an easy matter to pour the gas into the tank, as shown in the illustration.

Piece of Old Inner Tube Makes Funnel



easy matter to pour the gas into the tank, as shown in the illustration.

### Burl from Tree Makes Case for Clock

As the accompanying photo shows, a pleasing case for a wall clock can be made from a burl cut from a tree. A burl is a kind of outgrowth caused by a number of branches trying to grow out of the same place at once. Burls of fair size are rather plentiful, and no two are ever quite alike. The burl is sawed from the tree in the same manner as a branch, the cut side providing a flat surface to hang against the wall. The bark is then removed to expose the twisted grain underneath. An inexpensive alarm clock can be used if



desired, and no change need be made in it other than removing the feet and the handle on top. A hole to fit the size of clock used is then cut through the burl, and the clock set in place. It should be so fitted that it will slip in and out of place easily, so that it can be wound and set. A small piece of tin, bent in a curve and with one end fastened in place of the handle, will serve as a spring and help keep the timepiece in place. The burl may be stained and varnished if desired, and this will bring out the peculiarities of the grain.—C. L. Meller, Fargo, N. Dak.

### A Quick Bag Tie

The knotted end of the cord is the key to the "quick-off" feature of the tie illustrated. Farmers can use the twine from bundles of grain, cut near the knot; others can quickly make a knot at the end of any cord. The tie holds as securely as any when tightly drawn, and can hardly be equaled when it comes to untying quickly; it can, in fact, be untied and removed with one hand and at a single pull. The tie is begun by laying the knotless end of the string about the gathered mouth of the bag, leaving quite two-thirds of the knotted end to work with. After the first loop has been thrown around the mouth of the bag and drawn tight, the tie is finished by passing the knotted end once more around the bag, looping it back, passing the looped end about the other end of the twine twice, and then pulling the knot tight by tugging hard at the loop and knotless end. On the other hand, it is evident that untying of the knot requires only a slight pull on the knotted end.—Louis Schneider, Clinton, Mo.

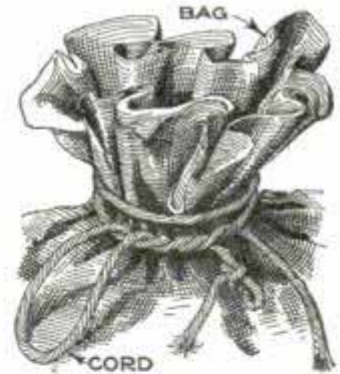

### Aspirin Revives Flowers

Aspirin, a coal-tar product, is used at the Emergency hospital of Dallas, Tex., to freshen and to revive cut flowers sent there to cheer the patients. The experiment has proved entirely successful with cut roses. The flowers are placed in a pot containing water and are not treated with aspirin until they show signs of wilting. A five-grain tablet of aspirin dropped in

Phonograph Provides Music for Two Rooms

The diagram shows a simple method of relaying phonograph music from one room to another. This hookup is useful at parties where two rooms are used for

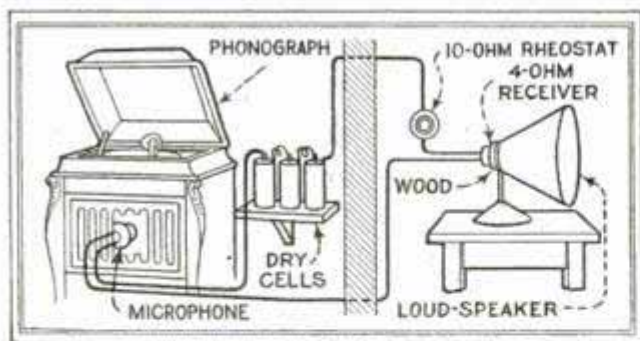

Relaying Phonograph to Another Room for Dancing by Means of an Improved Arrangement, Consisting of a Telephone Microphone, Dry Cells, Rheostat and Receiver, Fitted to a Tin Horn.

the water refreshes them. Another tablet is later placed in the water and the flowers are again refreshed. The operation may be repeated several times.—William Allen Ward, Dallas, Tex.

Repairing Pumps

When repairing pumps, I have found that, where there is a cement platform and bolts set in the cement, these bolts are in the way of the pump dog when the pipe is taken from the well, and may be bent or broken. To avoid this, I set 1/2-in. bolts in the cement when construction is done. These bolts are set back from the pump base, and steel straps are used to hold the pump in place. This gives plenty of room for the dog and the 1/2-in. bolts are not so likely to be broken or twisted off. It is well to coat the bolts with a thick paint when the nuts are replaced so as to prevent rusting.—W. O. Hendrickson, Argyle, Wis.



Handy Support Facilitates Sawing Trees Single-Handed

dancing or in case those who do not dance wish to listen to the music in another room. A microphone is placed at the mouth of the sound chamber of the phonograph, as shown. Four to eight dry cells are used and a 10-ohm rheostat is connected in to regulate the current. A loud speaker can easily be made from a tin horn and a telephone receiver wound to a resistance of about 4 ohms.

Support for One-Man Saw

Little difficulty is usually experienced in sawing horizontal timber, but to support the saw in a working position when cutting down trees is difficult. A simple support for this purpose can be made from a length of 3/16-in. round steel rod, commonly called pump rod. It is sharpened at the ends and bent to the shape shown. This device is driven into the tree and supports the saw properly without interfering with the "set" of the teeth.

*material from Telephone Maintenance Co. 20 W. My Chicago*

# Making Mortise and

by

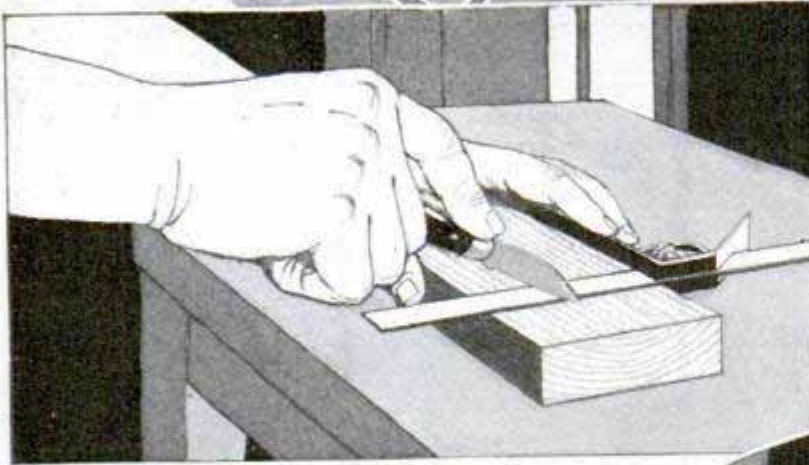

Squaring around the Rail for the Shoulders of the Tenon

THE old adage, "well begun is half done," applies particularly to the making of woodworking joints, and since no work can be perfect, errors and irregularities must constantly be reckoned with. It is, therefore, very important that laying out be carefully done, and that the processes follow one another in the correct order.

A simple form of the mortise-and-tenon joint is one in which the sides of the two members come flush, as in the meeting of the stile and rail in a door, and the method of setting out and making this joint is as follows: Surface the best side of the rail stock and mark it lightly with an "X" for an easy identification as the face side. Joint a good edge with the plane, testing for squareness with the try-square, holding the handle of the square against the face side. Mark this edge also with an "X." Next square the other edge and lastly the other side. The natural impulse is to take the four sides in rotation, but this is almost sure to bring poor results. Very accurate indeed is the surfacing of a piece of stock to within  $\frac{1}{4}$  in. of squareness or parallelism, so that, in squaring in rotation, the errors are continued in the same direction, instead of

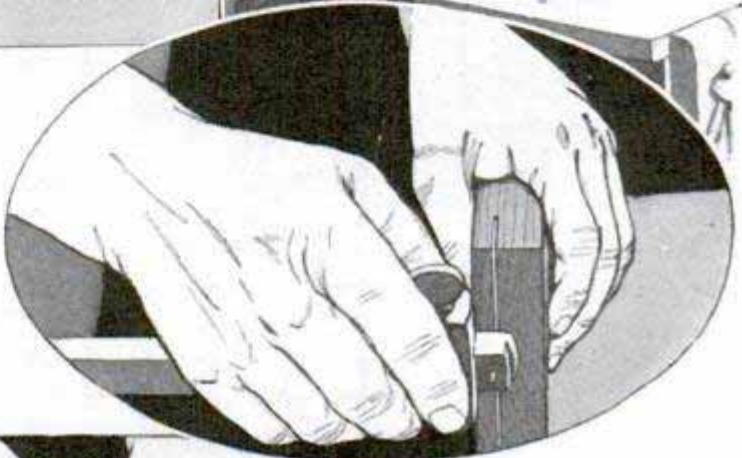

Above, Gauging the Thickness, and at Left, the Width of the Tenon

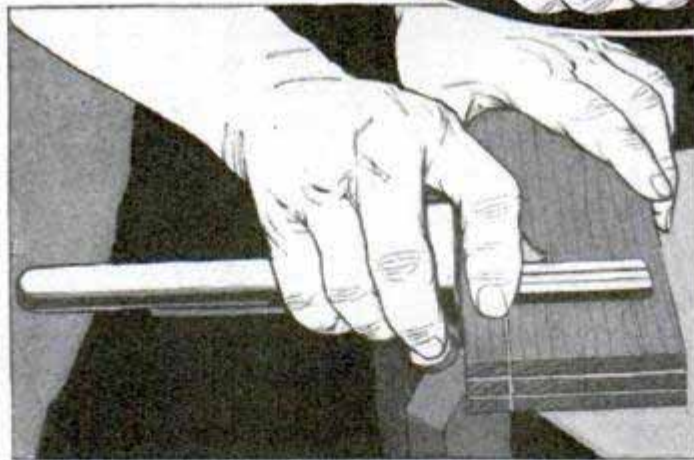

tending to neutralize one another. Square up the stile stock in the same manner, locate the position of the mortise and mark its length.

Measure the length of the rail to its shoulder, and with the point of a knife score a light line around the stock, squaring from face side and face edge. Here again, if the sides are taken in rotation, error is certain to result, and the lines will not meet at the last corner, especially if the square happens to be a little out of true.

Set a marking gauge for one-third the thickness of the stock, and guiding on the face side, gauge a line on both edges and end to the shoulder marks. With the same setting, mark one side of the mortise. Then set the gauge for two-thirds the thickness of the material, and repeat. The thickness of the tenon and width



# Tenon, and Dado Joints

Edwin  
M.  
Love

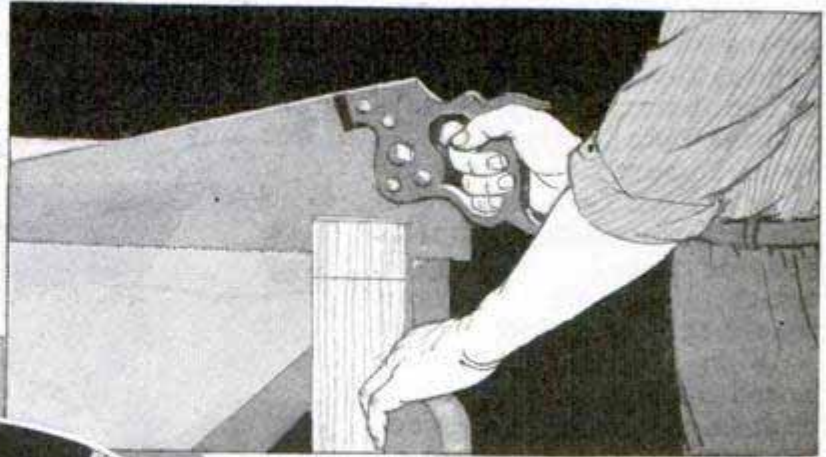

Cutting the Thickness of the Tenon with the Ripsaw

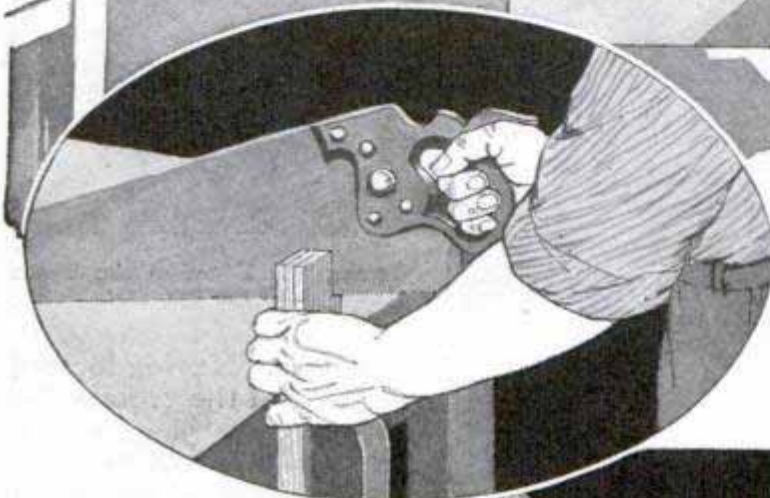

Above, Ripping the Tenon to Width, and at the Right, Sawing Off the Cheeks

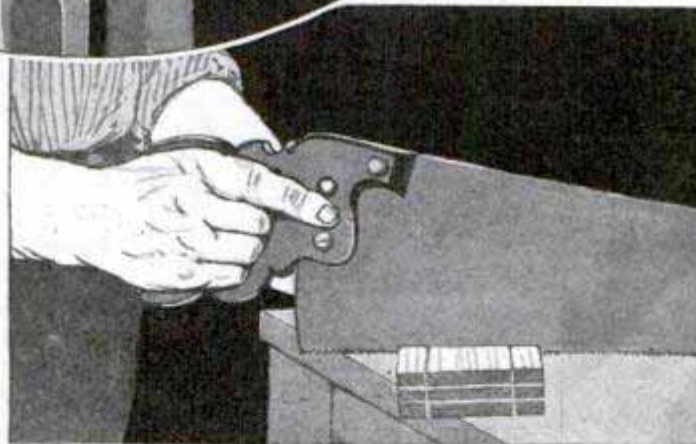

of the mortise are now determined.

The wisdom of gauging both pieces from the face sides is apparent, since, if one is thicker than the other, the good sides will come flush in the joining, and excess stock can be removed from the back. Moreover, the width of the tenon and the mortise would be dependent on the thickness of the material if gauged from both sides. Knowing the width of the tenon and its position on the rail, gauge both edges from the face edge. This completes the laying out.

Clamp the rail vertically in a vise and, with a backsaw or ripsaw, cut the cheeks or sides of the tenon, "splitting the line," that is, leaving half the line on the tenon, the kerf being in the waste wood. If there is any tendency for the saw to "run," or cut to one side, due to having longer or sharper teeth on one side than on the

other, cut alternately from one edge and then the other. If the mechanic is right-handed, the tenon is preferably to the left of the saw, so that the line is kept freely in sight; though, of course, when sawing alternately from one edge to the other, the

tenon must sometimes be at the right. Rip the edges before cutting the shoulders, thereby retaining the guide lines. Crosscut the side shoulders and then the edges. The broad side faces are much more conspicuous than the edges, so that, if any undercutting

occurs, it should be on the edge rather than the face, where it might be were the edges cut first. It is easy to cut the thin edge stock away without marring the faces.

Narrow mortises are best hollowed out with a chisel. Use a full-width chisel, and start cutting a short distance inside of the end mark, since the wood crushes back behind the flat side of the chisel, and if the edge is placed on the line, the mortise will be too long. This is an important point where the end of one board is being housed into another, as there is then no projecting shoulder to hide the mortise edge. Make cuts across the grain every  $\frac{1}{4}$  in., striking the chisel handle with a

mallet, or if this is lacking, with the side of the hammer head, the carpenter's usual method. Having chipped to the end of the mortise, rake out the chips and repeat until the proper depth is reached. Avoid prying against the mortise end, as this bruises the corner.

The tenon should always be a little shorter than the mortise depth, not only to make sure that it will not interfere with the closing of the joint in assembly, but to provide room for excess glue, which, if unable to escape, would split the piece.

Wide mortises may be bored out with brace and bit and smoothed with a chisel, the work being supported on the bench or in the vise.

Before assembling the joint, coat both the cheeks of the tenon and the sides of the mortise with glue, for in no other way is it possible to be certain that the full gluing surface is utilized. The ends of the mortise and the tenon absorb glue so rapidly that, unless they are previously sized, they cannot be relied upon to contribute to the strength of the joint.

The common gained

or dado joint is especially useful in drawer construction, or for supporting shelves in cabinets. This is really a form of the housed joint, with the mortise lying across the grain, receiving the full thickness of the other piece.

In the common form, the groove is cut the full width of the material. Surface the stock and mark the face edge and side

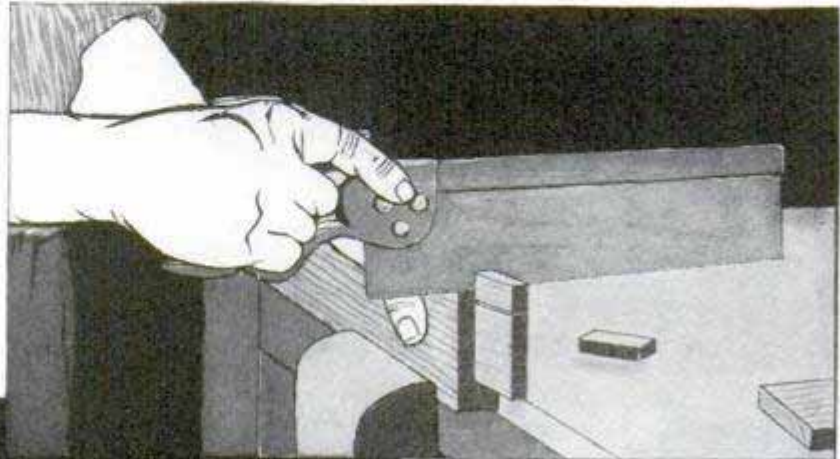

Cutting the Edges of the Tenon with the Backsaw

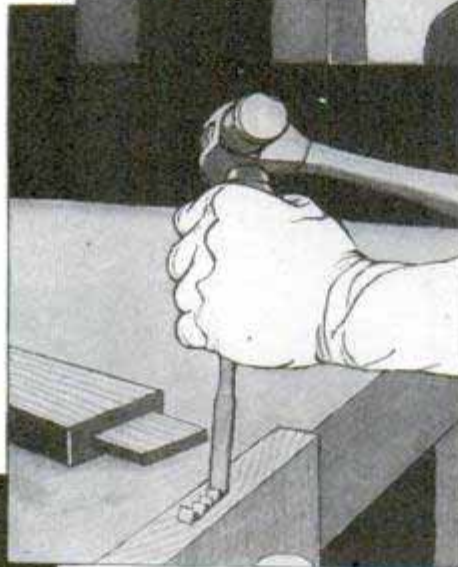

Above, Chiseling Out the Mortise; Left, Making the Mortise by Boring



as before. Having located one side of the groove, use the end of the mating piece as a pattern for marking the width, or, if this is not practical, simply measure it. Gauge the depth, which should not exceed one-half the thickness of the stock, and cut both sides with a backsaw or fine-toothed finishing saw, keeping the kerf in the waste wood. If one is skillful with the saw, no guide other than the

thumb of the left hand is necessary; but the average amateur will find it convenient to tack a straight strip of wood along the line against which to hold the saw.

If the dado is wide, chisel a slope on each side in the waste wood before chipping out; otherwise, holding the chisel flat, cut out nearly to finished depth, and smooth the bottom to the line. Use the hand to force the chisel, or, if the wood is tough, use a mallet or the side of the hammer head.

In assembling, if careful work has been done, the mating board should slide snugly in without looseness or crushing. The use of a "dutchman," or wedge, is to be frowned at, and is permissible only for painted work. Since all parts of the joint present end grain on one side, this wood must be sized if the joint is to be glued.

Sometimes the piece dadoed in does not come flush with the other. In this case make a blind dado, which is the type shown in the illustrations, chiseling

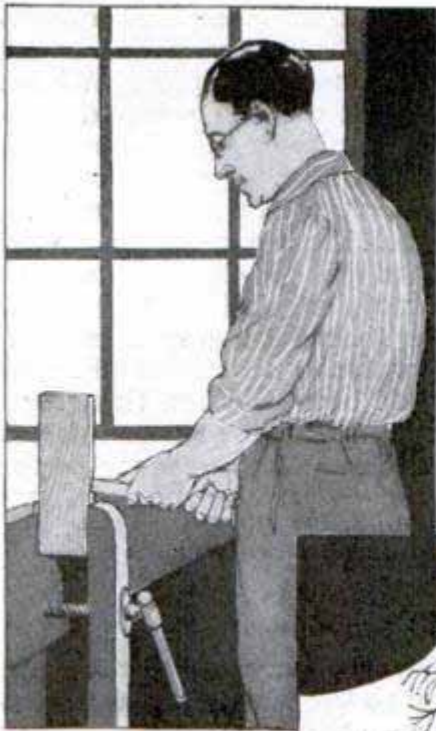

Above, Trimming the Mortise after Boring; Right, Marking the Width of a Dado

out a mortise at the blind end, so that a stroke can be made with a saw in cutting the sides. The blind dado can also be used with good effect with a flush shelf by notching the front edge of the latter to fill the space beyond the blind end.

The commonest fault of the amateur is that of trying to trim a tenon with a chisel. This is very bad practice. The tenon should always be cut to exact size with the saw, by "splitting the line," and experience seems to prove that if a man is so inexpert that he cannot do this he will only make matters worse by resorting to the chisel, which, in this case, is a more difficult tool to handle. Moreover, the guide lines are gone when the cheeks are cut away. It is true that some books recommend cutting a little distance from the line and planing and chiseling to size, but most authorities frown on the practice, and a mechanic would never think of doing such a thing. Occasionally, of course, any man will run

off a trifle, and might touch up the tenon with the rabbet plane, but the tenon should never be started with the intention of finishing it in this way. Sometimes one finds an amateur who trims a rabbet shoulder across the grain with the chisel, and this is worse still. If the saw kerf is made inside the line, the tenon will be made too thin, and will be a loose fit. If it is made on the line, the tenon will again be a trifle on the thin side, but if made as directed before, by splitting the line and keeping the kerf in the waste wood, the tenon thickness will be correct.

In sawing across the grain, it is more than ever necessary that the saw cuts be made in the waste, as the recess formed between the saw cuts in making a halved joint will receive a piece of wood that is already the full width of the stuff being used. In other words, the piece of wood that will go into the recess cannot be made wider to make up for any inaccuracy caused by careless sawing, whereas, should the tenon be cut a trifle narrower than intended, the mortise can be cut accordingly.

### Removing Rust Stains

Rust stains on the family wash are a frequent source of irritation to the busy housewife, while in many textile plants they also cause a loss by producing "seconds," etc. The stains may be the result of a number of sometimes entirely unsuspected causes. Some water contains enough iron in solution to produce a rust mark on white materials when it is used with a soap

Left, Guiding Saw with Strip in Cutting a Dado; Below, Chiseling the Waste Wood from Dado

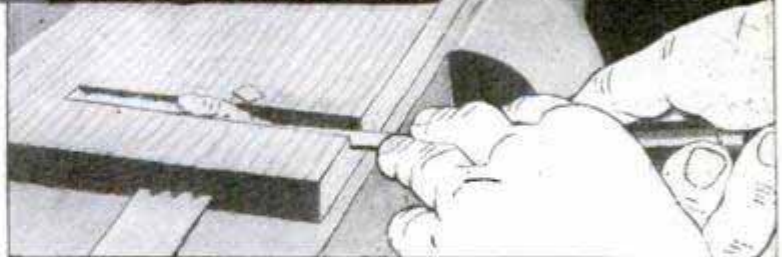
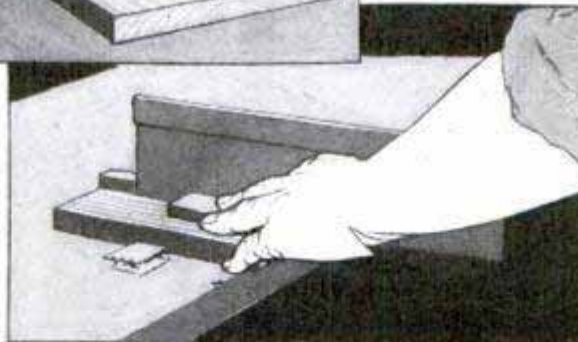
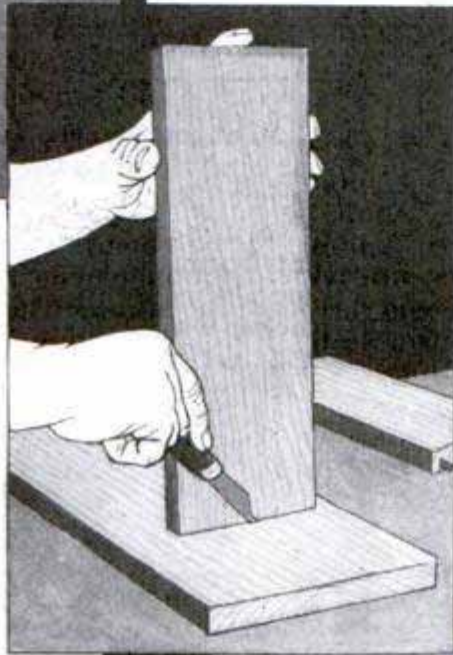

having an excessive amount of alkali. Other water is normally free of iron, but fungus growths containing iron may develop in the water mains, become dislodged with any increased flow of water, and thus carried into the consumer's premises. Again, the bluing used after washing may contain iron. This type of

bluing is entirely satisfactory provided the clothes are thoroughly rinsed, but if just a little too much soap or washing compound remains on them, the blue will develop a red iron mark. Frequently one may neglect wiping off a wire clothes line before hanging out the wash. There are many other causes of rust marks in the home, as, for instance, the various iron parts of washers, wringers, etc., but those given are probably the most common. In the ordinary household there is not usually enough difficulty of this kind to lead to much experiment on methods of removal, but in some factories it becomes an item of more interest.

Recently the British cotton-industry research association conducted extensive

investigations along this line and found a method which they considered good enough to recommend. They suggest sponging the mark with a cloth pad saturated with a cold solution containing 1 oz. of oxalic acid and 1 oz. of acid potassium fluoride in 1 qt. of water, until the mark disappears. The excess of solution should then be washed out of the fabric with plenty of clean water, and finally the entire wet space should be dipped into dilute ammonia water to neutralize all traces of the chemicals used. When this treatment is used with care, the rust mark can be removed successfully and, according to the association's report, the most delicate white fabrics will not be injured.—Chas. E. Mullin, Camden, N. J.

### Jack Makes Tire Carrier, Contractor and Expander

The accompanying photos show how an ordinary screw jack may be adapted to form a carrier for an extra tire on the car, making it possible to carry two tires instead of one. In addition, the jack may

round at one end and threaded to take nuts that bind them to the frame of the regular carrier. At the other end they are bent to form seats for the rim and the ends bent back to make pointed hooks. The supports are bolted to another flat-iron bracket which is riveted to the base of the jack, and strengthened by means of a pipe

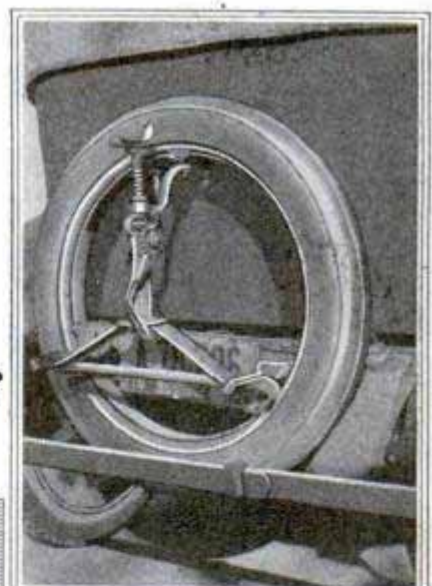

Above, Extra Tire in Position; Center, Details of Construction

be used for contracting and expanding the rims, and as it is rigidly attached to the car, the work is greatly facilitated.

The jack is attached to the rear of the car, behind the regular spare-tire carrier, by means of flat-iron supports, made as shown in the center detail. The lower ones are forged

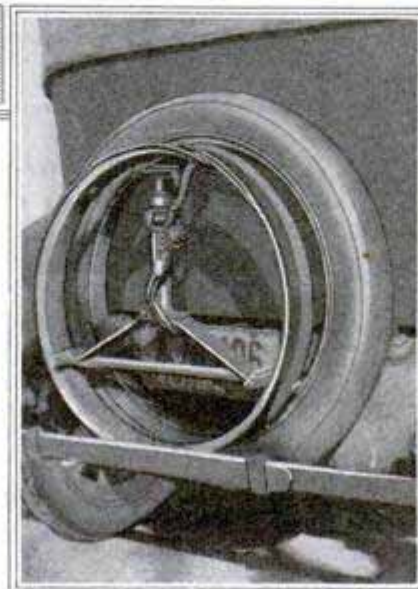

Above, Tire Removed: Left, Contracted Rim Ready for Casing

brace. The upper support is made of lighter iron bent around the neck of the jack and shaped so that it can be bolted to the upper bracket on the carrier. The handle of the jack is bent so that it lies against the bracket that is bolted to the jack base. To the swivel head of the jack another flat rim support, with

a hook similar to the lower ones, is riveted. When it is necessary to remove a casing from the rim, the hooks are engaged with the edge of the latter, and the screw of the jack is run down, causing the rim to contract. When a casing is to be put on a contracted rim, the latter is placed on the jack, the casing put in position, and the screw run up, thus expanding the rim and pressing it out against the casing. A few more turns of the screw then locks the rim firmly in place on the carrier. The ratchet wheel of the jack may easily be locked to prevent the theft of either tire. —Mrs. Hassie Terrell Hixon, Auburn, Alabama.

### Treating Stucco before Painting

Paint usually peels off stucco very soon, especially if the latter is new. To prevent this, the stucco should be coated with a solution consisting of 20 parts of sulphate of zinc and 80 parts of water. This will cut the caustic effect of the lime in the stucco. After this coat has dried, the paint is applied and it will then stick permanently. —L. H. Georger, Buffalo, N. Y.

### Holding Furnace-Pipe Sections

Those who are unfortunate enough to have a long run of smoke pipe from the furnace to the chimney, probably have experienced trouble by sections pulling apart when assembling the pipe. The writer solved this difficulty with a few cotter pins. Two sections were put together at a time. Two small holes were drilled opposite each other at the joint through both pipes. A cotter pin was spread wide apart and the ends then squeezed together with the fingers and inserted into the hole. Sections thus assembled will not part except by lifting out the cotters. By numbering each section and drawing a line across each joint with stovepipe enamel the sections can always be reassembled in exactly the same relation. —L. B. Robbins, Harwich, Mass.

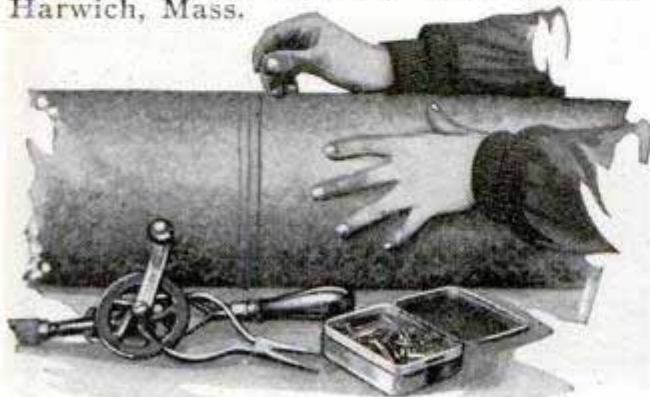

Stovepipe Sections Held Together Securely by Means of Small Cotter Pins

### Saving the Grindstone

Grindstones become soft if left standing in water. To prevent this trouble, a small felt-covered wheel can be arranged to be partly submerged in the water, and

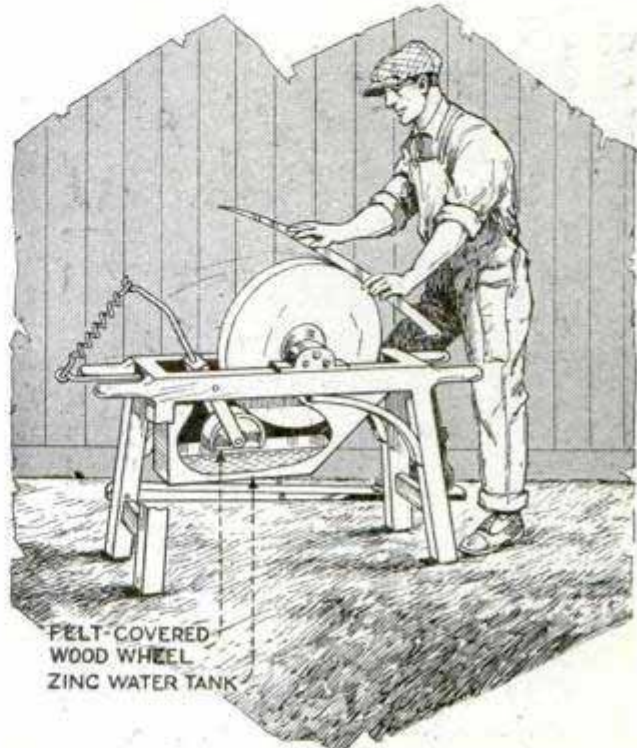

Small Felt-Covered Wooden Wheel Partly Immersed in Water Keeps the Grindstone Moist

at the same time the portion above the surface of the water should be kept in tight contact with the edge of the grindstone by means of a coil spring as shown.

### Cleaning Rolled Seams on Tubs before Soldering

When galvanized-iron tubs and pails with a rolled seam at the bottom develop a leak at this point and the joint is heated for soldering, any moisture, soap or grease in the joint will run out and prevent the solder from sticking. To overcome this apply the flame from the outside and below, and heat the seam until it appears dry and stops smoking; then clean the surfaces about the seam on the inside. When the soldering now is done in the usual way, there will be no trouble. If the soldering torch is held on the outside of a thin sheet of galvanized iron, the inside surface will be burned black, but by applying the flame to the thick seam, this is less likely to occur.

☞ To prevent the absorption of moisture by the salt in salt-shakers during damp weather, place a glass over each shaker, when not in use.



Paris Carpenter Finds Use of Stilts More Practical Than Stepladder

### Stilts to Take Place of Stepladder

For various kinds of work where stepladders are customarily used, a Paris carpenter finds stilts more practical, as they save the time lost in descending and ascending the stepladder every time its position is changed. The stilts are made so that the steps can be adjusted for height.

### Measuring and Cutting Paper from Rolls

A handy cradle which facilitates measuring and cutting off paper from rolls is shown in the photo. It is attached to the end of the counter or bench on the top of which a scale is marked off. The roll of paper is placed in the cradle and the end is pulled along the top of the counter until the proper length is unwound. Then the paper is cut off by simply pulling a pair of shears along the edge of a



Cradle on End of Store Counter Facilitates Cutting Off Measured Lengths from Paper Rolls

sharp piece of metal extending across the end of the counter.—Charles W. Geiger, San Francisco, Calif.

### How to Keep an Aquarium Successfully

"I never had much luck with my aquarium," is a statement you have often heard, but did you stop to consider that, may be, it wasn't so much poor luck as it was lack of knowledge? Fish, to thrive, need good treatment and good food as much as dogs, cats or birds. They breathe oxygen, which is found in the air, and exhale carbon dioxide. Plants, however, need carbon dioxide and give off oxygen. So, you see, that if there are enough fish and enough plants in an aquarium everything works well. This is called a "balanced aquarium." However, if there are too many fish or too many plants, there is too much of one kind of gas and not enough of the other, and one or the other of the living things in your aquarium begins to die. This is one of the biggest troubles of the aquarium keeper, but when you know the reason for it you have it cornered, as it is easily possible to increase or reduce the number of plants until you have a balanced aquarium and so keep all your fish alive.

Feeding fish is fortunately not difficult, but there are some important things to remember about it. Experiment to find out how much your fish readily eat, then give them just that much and at a certain time each day. Be regular about feeding them. Variety of food is one thing that makes healthy fish. Give them a change. Here are some kinds to try: cut-up grubs, scraped or shredded beef, and the manufactured forms, such as ant eggs, wafer food and ordinary crumb food. How often the water should be changed depends on the size of the aquarium.

A small bowl ought to be changed every week, a medium-size, every ten days or two weeks, and a large tank, well stocked with growing plants, only when the water is dirty or you wish to rearrange it. Make the aquarium comfortable for the fish; have a castle or some rock work

and some sand or pebbles on the bottom. Seashells are not advisable for the fresh-water aquarium, as they contain lime, which is injurious to the fish. Place the plants so that there is a stretch of clear water for swimming. Don't let the sun or very bright lights shine on the bowl, for this will heat the water, and warm water is uncomfortable for fish. Snails are scavengers, which help keep the fish bowl clean, and it is therefore a good thing to have a few in the aquarium.

Fish diseases are better left alone by amateurs, as their correct treatment is difficult. If you have healthy fish to begin with and treat them properly, you need have little fear of disease. However, for general poor condition, put the afflicted fish in a small basin of cold, salt water for a few minutes. It is advisable to do this during exceedingly hot weather also. If you have become very interested in your aquarium, you may wish to have some other aquatic pets besides goldfish. A paradise fish or two make a suitable addition, as they are beautiful and graceful, or some of the wild game fish will also thrive. The latter, of course, cannot be placed with the goldfish on account of their warlike tendencies. You may expect your fish to live to a ripe old age if you treat them right, for fish do not die young naturally. In fact, there is in Japan a goldfish which is 19 years old.—Donald Culver, Montclair, N. J.

### Sealing Canned Meat

To prevent canned meat from rising above the fat or paraffin sealing. I cut a number of strips of cedar  $\frac{1}{2}$  or  $\frac{3}{4}$  in. wide, a little longer than the diameter of the neck of the jar. These were pushed under the shoulder of the bottle as shown in the drawing. The paraffin was then poured in. This arrangement keeps the meat down effectively. When opening the can the stick is split and can then be removed easily.—Mrs. M. G. Alexander, Farran's Point, Can.



### Snubbers for Ford Car Made at Home

After he had broken three front springs in one summer, an autoist looked around for a cheap means of preventing further breakage. The remedy he finally devised consisted in riveting snubbers, made from an old belt, around the front axle and the

Old Belting Makes Good Snubbers for Light Cars and Prevents Breaking Springs



frame of the car. The belting was of four-ply canvas, 5 in. wide, and was cut in two, overlapping the splices 4 in. The photo shows the installation clearly.—Dale R. Van Horn, Walton, Nebr.

### Putting Life into Moth Balls

Putting life into moth balls is an interesting experiment for anyone to carry out as it causes curiosity to all those who see it, and is also a good advertising stunt to draw attention to window displays. A druggist found that it brought over 30 persons into his store every day to make inquiries and 25 of these made a purchase. Take a fruit jar that can be made air-tight and has good clear walls. Fill this two-thirds full of water and add equal quantities of potassium bicarbonate and citric acid until the solution is about 1 in. from the top. Then put four or five or more moth balls into the container and screw on the lid. The chemicals will begin to react and the balls will move upward and downward, sometimes two at a time and sometimes all of them, without apparent reason, and the glass wall magnifies the balls and makes them look like balls of cotton.—David J. Morris, Austin, Tex.

Small drills are easily broken, but if a short piece of pencil, with the lead removed, is slipped over them, with only the proper length exposed, pressure can be applied without danger of breakage, as the pencil will prevent the drill from bending and consequently breaking.

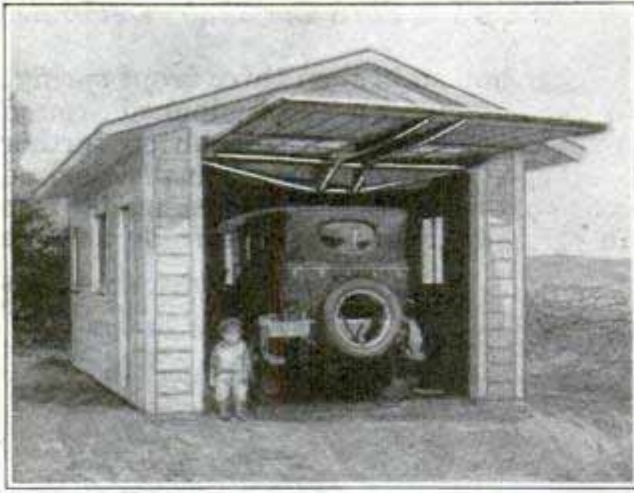

rod, and from this a  $\frac{3}{8}$ -in. rod runs down to a lever pivoted on the inside of the door jamb, so that, when the lower lever is down all the way, the door is locked open. Raising the lever lowers the door. The door is locked, when closed, by another lever, pivoted to the lower part of the door. It operates two rods that are

Garage Door That Is Easily Operated and That Does Not Blow Shut: It Swings on a Pipe Shaft

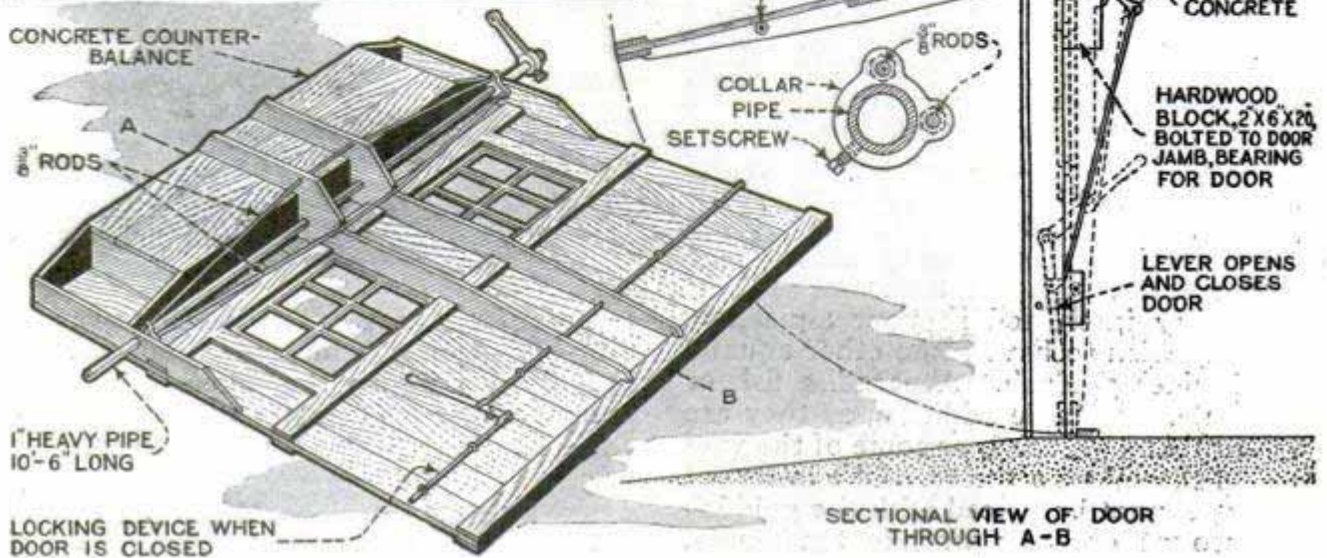

### Garage Door Swings Up to Open

The unusual type of garage door shown herewith is made of  $1\frac{3}{16}$ -in. pine shiplap, except the 2 by 4-in. bracing. At the inside top is a counterweight, made by filling a box form, 8 by 22 by 66 in., with concrete, reinforced with wire. Just below the counterweight is a shaft, on which the door swings. This is 1-in. extra-heavy pipe, 10 ft. 6 in. long, and 2 by 6 by 20-in. hardwood blocks are bolted onto the door jambs for bearings. A collar, with bosses drilled to take  $\frac{3}{8}$ -in. iron rods, is fastened to each end of the shaft;  $\frac{3}{8}$ -in. rods are threaded, passed through the holes in the collars and over and under the door braces and drawn up tight with nuts. On one end of the shaft is fastened an old auto connecting

attached to the door with staples and slide into holes drilled in blocks bolted to the jambs as indicated.

### Concrete Pig Creep Adjustable

To allow the smaller pigs to pass through but not the larger ones, an Indiana farmer made the concrete creep shown in the photo. Removable 1-in. boards, 8 to 10 in. wide, were used to reduce the size of the opening, which was otherwise large enough for the biggest hog to pass through. Incidentally, the gate serves as the corner post for three fences. Large screweyes were inserted in the concrete while pouring it. Lengths of pipe, to which the fence is attached, are slipped through the screweyes.—J. C. Allen, West Lafayette, Indiana.

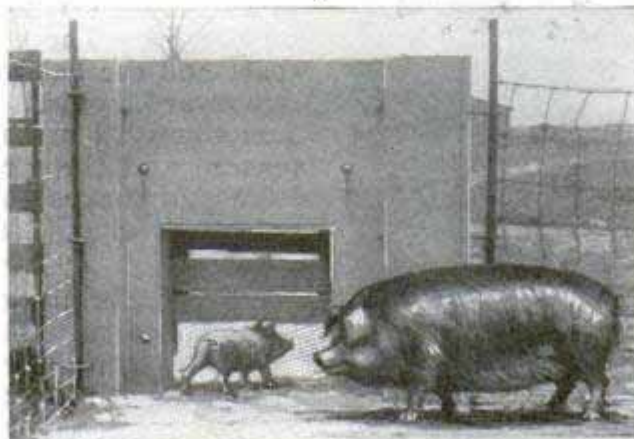

Concrete Pig Creep Is Adjustable to Allow Only the Small Ones to Pass through It



# How to Make a Toy Derrick

By RICHARD C. TARR

A TOY derrick to amuse the growing boy may be constructed without much trouble and at little cost to the home workman, or by the boy himself, and will stand up under considerable rough usage.

A base, 12 in. square, is first constructed of  $\frac{7}{8}$ -in. pine, battened at the ends to prevent warping, and provided with four wheels, cut from the same material with a coping saw or jigsaw, bored, and attached with screws to the four corners of the base. The socket for the mast is of brass tubing slightly larger than the mast, and having one end slit eight times, lengthwise, about 4 in. in from one end. The slitting is done with a hacksaw. These sections of the tubing are then spread out, drilled and screwed to the top of the base, keeping the tubing rigidly in an upright position. The socket of the derrick pictured was made from a discarded tire

pump. The mast is constructed of a 1 by 36-in. dowel stick, the boom is  $\frac{7}{8}$  by 22 in. and the mast handle is 1 by 4 in., all being dowel stock, which can be obtained from any large hardware store, or a dealer in manual training supplies. A footplate should be screwed to the bottom if a hole is bored through the base to secure additional depth for the mast socket; however, this is not necessary if the mast is permitted to rest directly on the base.

The pulleys at the top of the mast and ends of the boom are of cast lead, grooved with a hacksaw around the edge, and smoothed with sandpaper. Oblong openings are cut, slightly larger than the pulleys, in both ends of the boom and in the top end of the mast, about  $\frac{1}{2}$  in. from the end of the mast and the outer end of the boom, and  $1\frac{1}{2}$  in. from the inner end of the boom. The pulleys are then wedged in place temporarily with cardboard in their respective openings. Holes,  $\frac{3}{16}$  in. in diameter, are bored through wood and pulley, the latter removed, and the hole in it reamed slightly larger. The pulley is then replaced, and a short piece of stiff wire, or wire nail, forced into the hole, for the pulley to turn on. Care should be taken to bore the hole squarely to avoid binding the pulley.

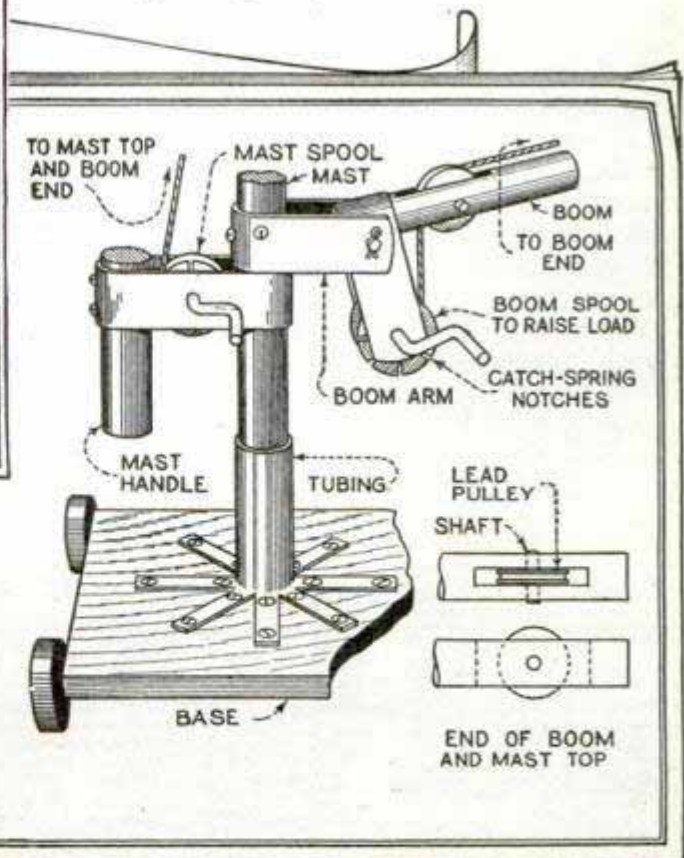
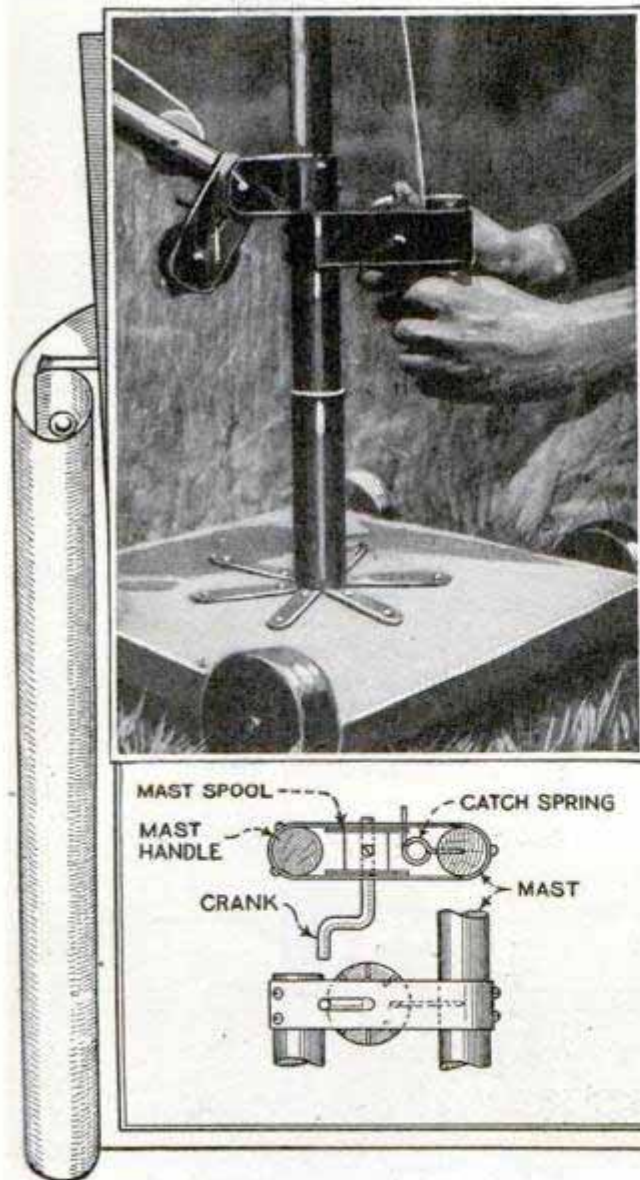

Close-Up View of the Derrick Base and Pulley Fittings, and Details of Construction of the Various Parts of the Toy

The arm securing the handle to the mast is  $\frac{1}{16}$  by 1 by 12 in., the boom arm,  $\frac{1}{16}$  by 1 by 6 in., and the spool bracket,

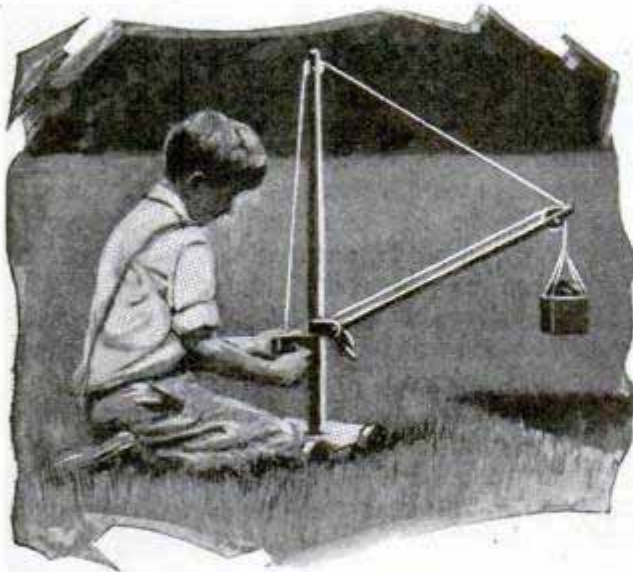

Photo of the Completed Toy Derrick in Use, with a Miniature Bucket at the End of the "Cable"

$\frac{1}{16}$  by 1 by 7 in., all sheet brass. The sketch shows their construction. The notches for the catch springs are made by drilling a series of  $\frac{1}{16}$ -in. holes in the sides of the spools in the places indicated, cutting smooth slits with a small chisel or broach and polishing with fine emery cloth. The catch springs, which hold the spools from turning when in use, and which are held back with one hand while operating the crank with the other, are rather tricky to place in the small holes bored into the mast and boom for them, but once placed will hold their position and work perfectly. The boom swings, within the boom arm, on a pivot made of a length of wire nail, drilled at the ends and held in place with small cotter pins or wire.

The construction of the spools can be readily understood from the sketches. Sheet brass,  $\frac{1}{16}$  in. thick, is used for the

sides, and a  $\frac{3}{4}$ -in. length of dowel for the centers. Two  $3\frac{1}{2}$ -in. lengths of wire serve as cranks, held in place by small brass screws driven into the spool centers, after the cranks are in place.

Lead weights placed on the outer edge of the base will prevent any tendency toward tipping when in use. The woodwork should be given one or two coats of white shellac, and may be stained, if desired, to any finish.

### Windmill Exhaust Fan

Satisfactory results have been obtained with an exhaust fan made from an old windmill. The arrangement is clearly shown in the accompanying photo. A circular hole, about 4 in. larger than the diameter of the windmill wheel, was cut in the wall, and the wheel was then carefully mounted

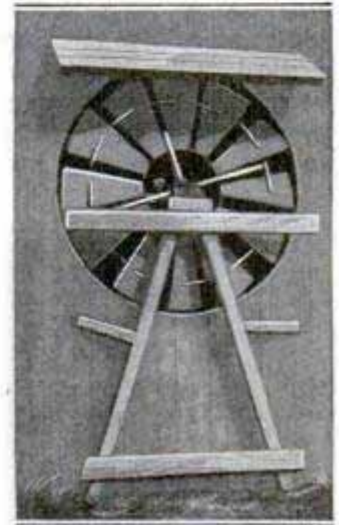

with bearings on the inside and outside, and a 10-in. pulley was keyed to the inside end of the shaft. This was belted to a small electric motor, so that the wheel made approximately 200 revolutions per minute. Obviously a large volume of air is displaced with this wheel in a short time.—Dale R. Van Horn, Walton, Nebr.

### Preventing Auto Theft

Theft of his automobile, with snap-on wires and a burned-out ignition coil in-

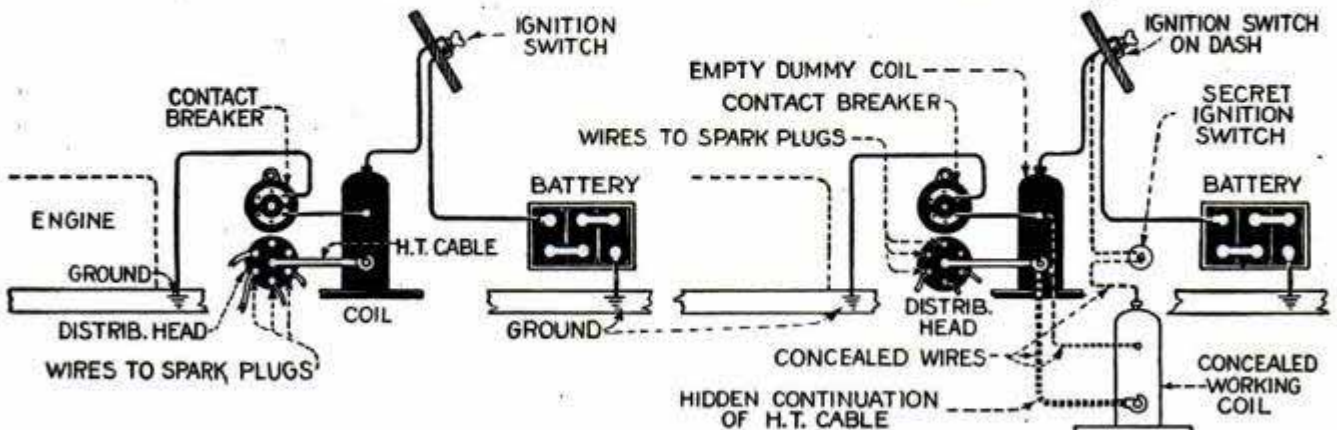

FACTORY WIRING

MODIFIED WIRING SCHEME USING DECOY COIL

Altering the Wiring System of an Auto and Substituting a Decoy Coil for the Regular Coil, Which Is Hidden, Make Car Theft-Proof

dicating the means by which the machine was taken, recently led a motorist to devise a plan to prevent this from happening again. The scheme involved the use of two coils; a dead one, occupying its usual place on the dash and acting as a decoy, and a carefully concealed working coil, to furnish the actual ignition current.

The problem had its obvious difficulties. If the wires leading from the decoy coil to the circuit breaker, ground and dash switch were to remain intact so as to give the appearance of undisturbed regularity, then it seemed necessary to run wires between these places and the working coil. Naturally this would not do, as the sight of two sets of wires would give the scheme away to the practiced eye of the expert crook. The illustration shows, at the left, the standard, factory-wired ignition system of the car, the ammeter and other minor details having been omitted for the sake of simplicity. The theft-proof wiring is shown at the right, the additional wires being marked as dotted lines. All visible coil connections appear as made at the factory. The wire that runs from the top of the decoy coil to the dash switch is a blind wire; it has copper connectors at both ends, but they are so attached that no electrical contact is made. The wire connecting the circuit breaker to the dead coil is continued through the hollow dummy coil and passed through a hole in the dash to the corresponding terminal on the concealed working coil. The high-tension cable connecting the dummy with the distributor head, is similarly fastened to the high-tension terminal of the working coil. Lastly, a wire is run from the top of the operating coil to the dashboard switch and a second, secret switch serves as additional protection. While ignition coils differ in shape and in electrical hookup, the principle of this wiring scheme may be applied to practically any car. No detour winding or bridging of the switch, not even the possession of the proper switch key, will be of the slightest help to the thief or unauthorized user as long as he remains unaware of the second coil.

## Poultry Watering Trough

Old auto casings may be used to advantage in the poultry yard by cutting holes

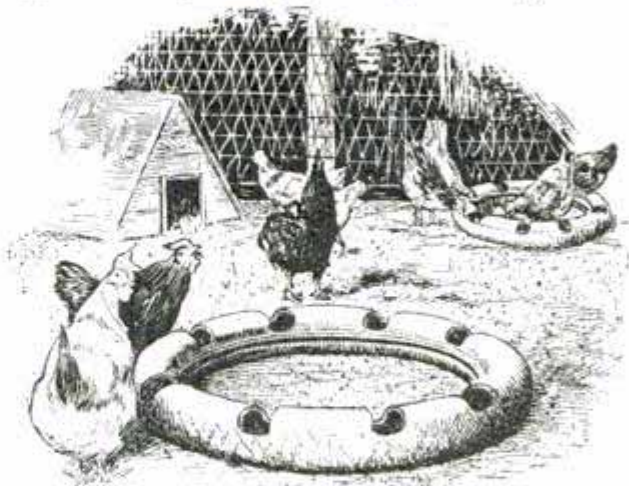

Using Old Auto Casings as Watering Troughs for Poultry

through one side of them, placing them flat on the ground and filling them with water. The holes are readily cut with a saw. Do not cut through the beads of the casing and cut only halfway down the tread, as shown in the drawing. The two beads of the casing lie close together, which keeps out most of the dirt.

## "Swinging Darkey" Toy Amuses Children

Although the principle of the toy shown in the illustration is not new, this adaptation is quite novel and will prove popular with the youngsters. It consists of a comic head cut from a magazine and glued to a piece of stiff cardboard. This is mounted on a small block of wood, a length of wire and a weight are attached to the block as indicated, and wire pins are provided under it to serve as pivots. The wire holding the counterweight must be bent so that the head will stand upright when the device is set on the table. A fishline sinker may be used for a counterweight. A swinging movement is imparted to the counterweight and will cause a similar rocking of the head.



This Swinging Head Proves Popular with the Youngsters



Sash Hung with  
Screen Hinges Removed and  
Replaced Easily

### Hanging Sash on Poultry House

Sash on poultry houses should be hung so that they can be easily and quickly removed or replaced. A good method of doing this is to use screen or storm-sash hinges, as shown in the accompanying illustration. With these hinges the removal of sash is but a few moments' work. They may be taken down in the morning and replaced at night, or in case a storm comes up, with little trouble.—Rufus E. Deering, Clements, Kans.

### New Use for Clothespin

Tubes of tooth paste or shaving cream usually find temporary resting places on the window sills or on shelves in the medicine cabinet and in either place they are often mashed. To put the tubes where



they can readily be seen, and on the theory of a "place for everything and everything in its place," it was found that clothespins make satisfactory tube holders. The old-fashioned type of wooden pins should be used for

this purpose, care being taken to select straight-grained ones. The head is cut off and a hole drilled through the shank for a woodscrew. A coat of white paint, and a minute's work fastening the holders to the cabinet, or wall, complete the job.—Chester Lyndelle, Trenton, N. J.

### Hot-Water Bag Makes Portable Gas Can

An old hot-water bag will be found very useful to the motorist. It takes up little space under the seat or in a door pocket, and, in an emergency, can be used to carry sufficient gasoline to enable the driver to reach the nearest service station. It can also be used to carry water for the radiator, or for any other purpose for which a pail is usually carried.—Maynard Bodley, St. Paul, Minn.

### Novel Door Latch

Resting on two flat-iron brackets, the door bolt shown in the drawing is actuated by means of a key that engages in notches cut in the top. A small round hole, about  $\frac{1}{4}$  in. in diameter, is the only outside clue

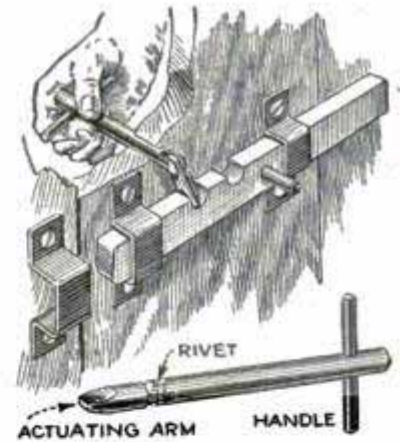

to the presence of the bar. The brackets are bent to the shape shown and screwed to the door, and a similar bracket is screwed to the door post to catch the bar when the door is locked. The key is made in two parts, cut from  $1\frac{1}{4}$ -in. stock. These are joined together with a rivet, one part being slotted to a depth of  $\frac{5}{16}$  in. and wide enough to fit freely over the shank formed by the other, the rivet being placed where it will permit freedom of movement. The key is pushed through the hole in the door; the end drops down engaging one of the notches in the bolt and, as the key is turned, will drive it one way or the other to open or lock the door. The shank of the pivoted end should be rounded on top to permit withdrawal of the key. A stop pin is screwed into the bar to prevent it from coming out of the brackets.—John McNeish, Boston, Mass.

# How to Burn Soft Coal

**T**HE first rule in feeding the furnace with soft coal is never to cover the fire completely with fresh fuel. The fresh coal may be placed at the front or the rear of the firepot, at one side or the other, but should never cover more than two-thirds of the fire. A great deal of the heat contained in soft coal is in the form of combustible gases, and if these are allowed to pass off unconsumed much of the heat value of the coal is lost. It is just like turning on the gas in the stove and failing to apply a match, then expecting the gas to heat a pot on the stove. By placing the



fresh coal in front, so that the gases must pass over the bed of live coals on their way to the chimney, but, as stated before, the fresh coal can be fed at the rear, or at either side of the furnace, depending on the design, and on the route the gases have to take to reach the smoke pipe. Another lesson may be learned from the

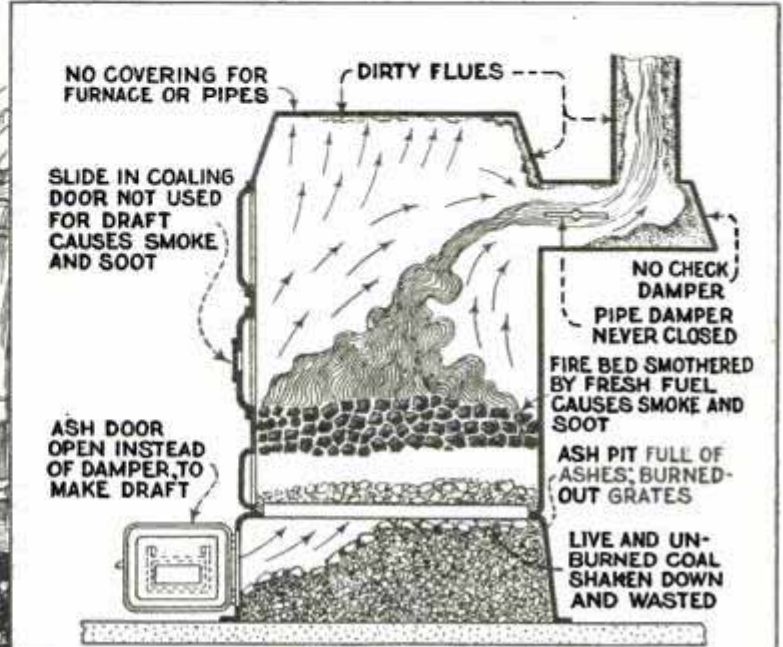

WASTEFUL FIRING, 25% OF HEAT DELIVERED TO ROOMS

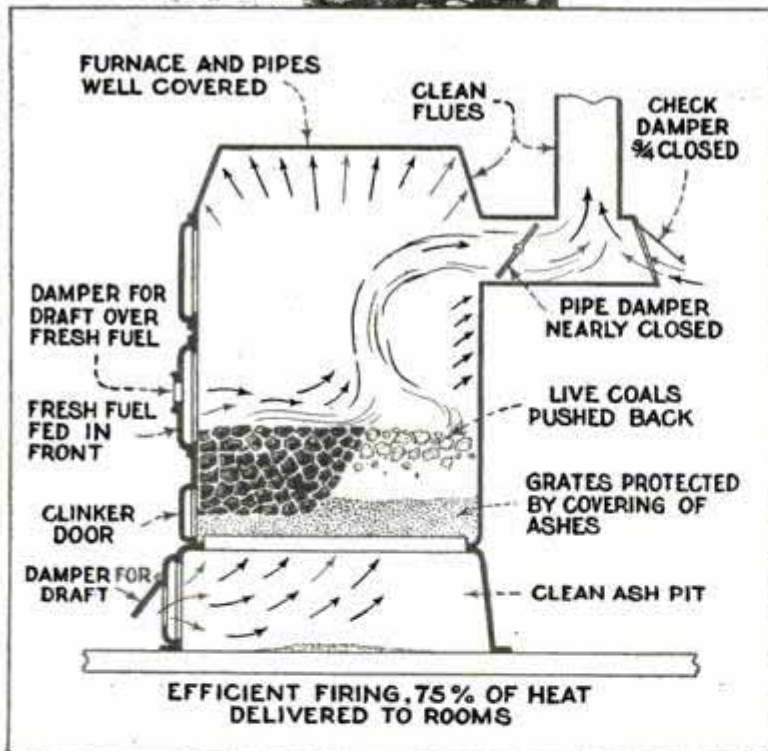

gas stove. We know that a gas flame will not burn properly without the correct amount of air, and that a flame that has insufficient air is not only a slow heater, but is also a smoky one. It is exactly the same with soft coal. The gases coming off the coal need to be mixed with air in order to burn and give up their heat, and the way to supply this air is to open the slide damper in the feed door so as to admit air above the fire. The degree to which this slide is opened depends on the coal and the condition of the fire, and must be found by experiment, but, in general, it will be found

fresh coal over a part of the fire only, the live coals that are exposed in the other part of the fire act as a match to light the combustible gases, and the heat goes to warm the house instead of going up the chimney. The most convenient method of firing is usually to push the live coal to the back of the fire and feed the

advisable to open it wide immediately after feeding the fire, and to shut it down partly or completely after the coal has become well ignited. Most soft coals need the air supply through the feed-door slide as long as they are black. When they are all red, of course, they no longer need the additional air.

By paying attention to both of the foregoing rules, smoke and soot can be prevented to a large extent; soot cannot be entirely prevented, of course, and the flues and other heating surfaces should therefore be given regular attention, to keep them as clean as possible. Soot insulates the heating surfaces just like asbestos, and this wastes coal, so it pays to give these surfaces regular cleanings, just as often as it can be done.

Soft coal is more easily ignited than hard, so less draft is usually required. Too much draft will make gas faster than the capacity of the combustion chamber to ignite it, and so waste fuel; so it pays to experiment with the draft, reducing it as much as possible without interfering with the proper burning of the fuel. At the same time, a strong draft is very necessary at times, when the fire has accidentally been allowed to become low, for example, and the house is cold, and the furnace should be capable of producing a strong draft when needed. All leaks around the furnace and smoke pipes, therefore, should be stopped.

In order to obtain better control of the rate of burning of the coal, some ashes

should be left on the grates. Try to operate the furnace with the ashpit damper closed and the feed-door damper open; if this will not work, open the ashpit damper just as little as will give the desired results. Don't shake the fire until it is absolutely necessary to brighten it, and stop shaking as soon as the first live coal drops through the grate. When cleaning the ashes from the sides of the firepot use the poker, or slice through the clinker door under the fire, not through the fire door.

Keep the firepot full of slowly burning fuel. This will produce more heat than a thin fire burning fast, and will require less attention. Arrange for some sort of water evaporation in the house, because moist air at 65° feels as warm as dry air at 75, and is more healthy. When using Pocahontas coal, moisten it slightly before firing, as this helps to coke the coal and produces better results. Don't bank a fire with ashes or stir up the fire bed so that ashes are turned over the unburned coal, as this will cause the ashes to melt and form clinkers.

Study the illustrations, and follow the hints contained in them.

### Baffling Chicken Thieves

A Nebraska poultryman, who had one disastrous experience with chicken thieves, decided to prevent a recurrence of the loss. Feeling that an ounce of prevention was worth a



Old Pipe, Held in 2 by 4-in. Brackets, Protects This Poultry House against Thieves

pound of cure, in this case at least, he barred all the windows.

A quantity of ½-in. pipe was purchased very cheaply at a fire sale. This was cut and jointed to form a number of sections of the proper length, and spaced, 6 in. apart, over every window on the place. The photo shows a typical installation. Pieces of 2 by 4-in. stuff, bored for the pipe, are bolted between the sash and at the ends, the bolts running through the sides of the building.

The pipes can, of course, be cut with a hacksaw, but before thieves could cut through any considerable number of the bars, their presence would undoubtedly be known.—D. R. Van Horn, Walton, Nebraska.

### Sediment Trap in Oil-Burning Supply Pipe

General adoption of oil burners for cook and heating stoves and furnaces brings up the problem of using cheap-grade oils without necessitating frequent cleaning of the burners. This may be accomplished by the installation of a sediment chamber at some point along the pipe line between the supply tank and the burner. The chamber shown in the illustration consists of a length of 1-in. gas pipe with caps at both ends; the upper cap being drilled to receive the two ends of the cut supply pipe, which are inserted and soldered in place as shown. In operation,

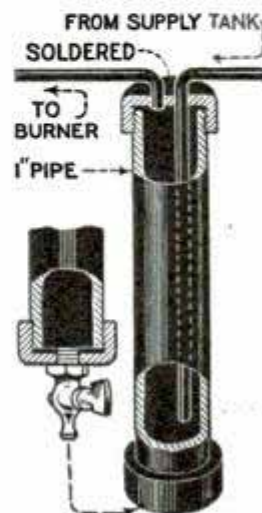

oil flowing from the supply tank enters the chamber near the bottom and in rising to escape through the outlet it leaves water or solid sediment possibly present in the oil at the bottom. By shutting the supply valve at the tank and removing the cap at the bottom of the sediment chamber occasionally the accumulated water or dirt may be removed, or the draining may be done by fitting the bottom cap of the chamber with a petcock. This eliminates the need of a wrench to remove the cap and also the necessity of closing the supply valve each time.

### Preventing Rattle of Brake Rods

Hand-brake rods on Ford cars sometimes strike against the running-board supports and rattle every time the springs are compressed. This can be stopped by slipping a piece of loom, such as used as insulation by electricians, over the brake rod. The best plan is to use a length almost reaching from the rod support to the clevis at the rear end. The loom can then be turned around when worn in one spot.—E. T. Gunderson, Jr., Humboldt, Iowa.

### Homemade Paper Eye Shield

About a year ago I was troubled with a bad eye which could not bear daylight and was so tender that a bandage was uncomfortable. Since I wear glasses all the time, I could not work without them. I tried colored glasses but too much light was reflected from the back side of the lens. Necessity caused me to construct the eye shield shown in the illustration.



The material used is black paper, which can be obtained at any photo-supply shop. A small wire eye is glued between two thicknesses of the paper and is slipped over the ear piece or side bar of the glasses and a slot is cut diametrically opposite the eye to fit the nose bar or bridge. A segment-shaped piece of the paper, pasted upright to the outer, or wire-eye, edge of the shield, prevents light from entering from that side.—Noble D. Gilkeson, Kansas City, Mo.

### Loosening the Engine-Cylinder Head

A cylinder head, put on after shellac has been applied to both sides of the gasket,

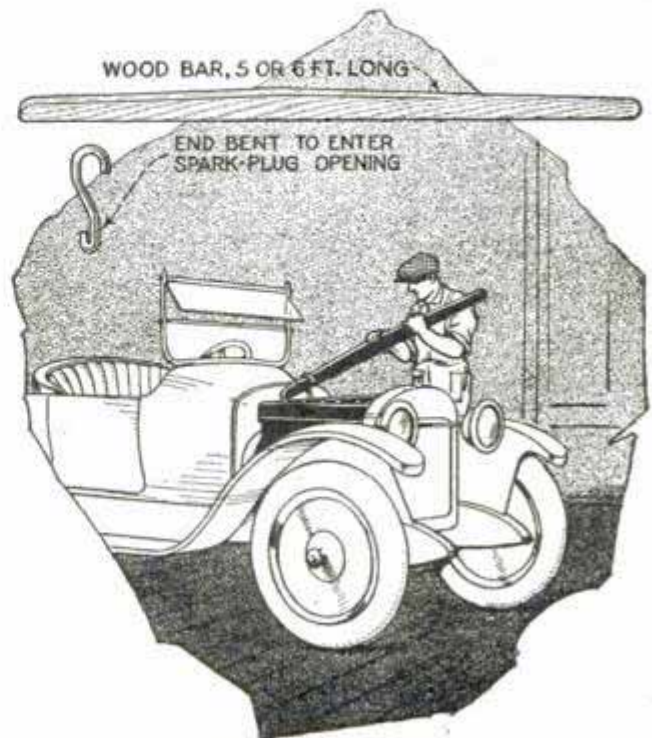

Removing Cylinder Head of Automobile Engine with Prybar Usually Saves Gasket

may be very difficult to remove, especially if the gasket must be used again. Driving a wedge under one edge is a practice which invariably destroys the gasket. Slacking off on the bolts and starting the engine is also most certain to blow the gasket, and the mechanic is often puzzled for a good method of removing the head with the least damage. In the illustration a prybar method of removal is shown. Simply provide an S-shaped hanger, one end of which can be passed through the spark-plug holes, while a bar engages the upper hook. The tightest cylinder head will come off readily, and the gasket can, in most cases, be used again.

### Making Metal Buttons

Serviceable metal buttons can readily be made from upholsterer's nails by bending the shanks to form eyes. This can be done by means of a pair of round-nose pliers. Buttons of this kind are handy for various uses and will last indefinitely.—C. M. Wilcox, Torrington, Conn.



### Sharpening Fence Posts

Sharpening fence posts usually requires one man to hold and turn the post while another wields the ax. This task may be

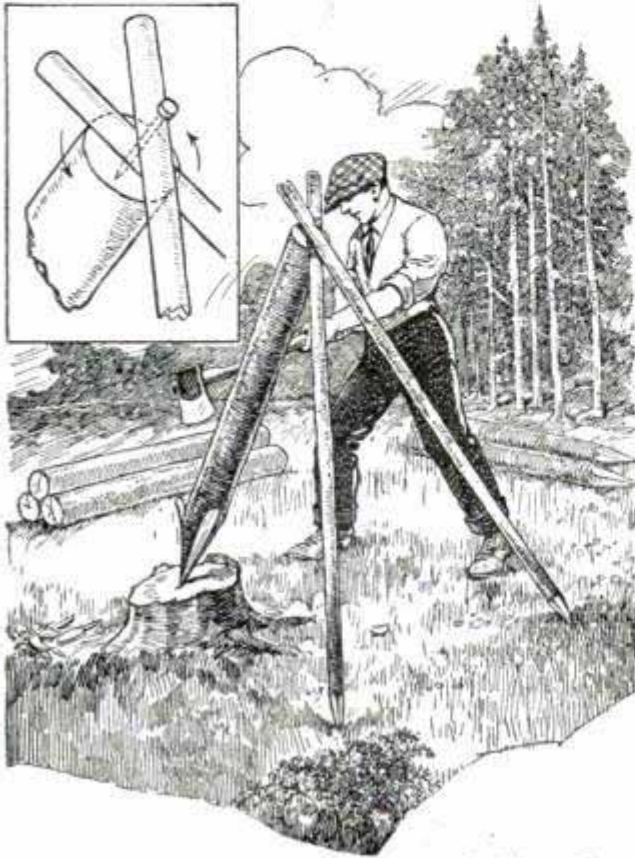

Novel Holder Facilitates Sharpening of Fence Posts

done by one man just as easily, if the simple holder shown in the illustration is used. It consists of two stout stakes hinged on a bolt, which projects 3 in. on one side and is sharpened to a needle point at that end. In use, the legs of the holder are opened and driven into the ground to support the device at a slight angle. The post to be sharpened is raised against the holder so that the bolt can be driven into the center. As one side of the post is cut down to the desired mark, it is turned on the bolt until the sharpening is completed.

### Breaking In a New Pipe

No matter if it be a half-dollar or a ten-dollar one, new pipes have to be broken in and you know how bitter, woody and unpleasant the taste of a new pipe is until you have smoked it long enough to get it "crusted." Here is a simple way to break it in and also add to its sweetness right from the start. When the bowl is new, moisten the inside of it with a little water, and then fill the bowl with ordinary granulated sugar and immediately dump it out again. A thin film of sugar will ad-

here to the inside of the moistened bowl; now, without knocking this film out, fill the pipe with tobacco and light up. That bitter, woody taste will be gone and the crust, which adds to the mellowness of the pipe, will form quickly. This process may have to be repeated several times.—Harry A. White, Davenport, Iowa.

### Repairing Leaky Eaves Trough

It sometimes happens that a section of eaves trough rusts through in one place, while the rest of it is still in good condition. This can easily be repaired as follows: Cut a piece of canvas large enough to cover the hole, coat it with tar and press it down over the hole. Then coat the patch with tar on the inner side and let it dry. The trough should, of course, be well cleaned and dried before applying the patch.—W. O. Hendrickson, Argyle, Wisconsin.

### Adjusting the Furnace Draft

Where remote control is used for regulation of furnace drafts, it is usual that some form of notched segment, series of pins for a ring or other means for holding the weight at any desired place is used. An arrangement which allows closer adjustment of the draft is shown in the illustration. It consists of a metal bracket made to support a small globe-valve wheel. The wheel moves on a threaded

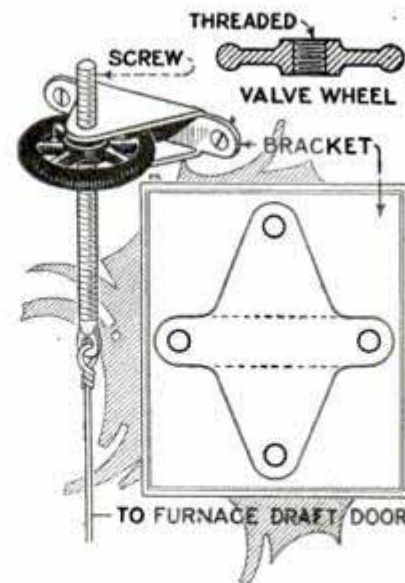

rod, which is in turn attached to the draft-door cable. The cable is led up from the furnace room to a convenient location, using pulleys to guide it if required. By turning the wheel the draft door can be raised or lowered by such small amounts that a uniform temperature can be maintained more easily.—G. A. Luers, Washington, District of Columbia.

Plated brass and plated iron can be distinguished from each other by means of a magnet; the magnet will cling to iron.



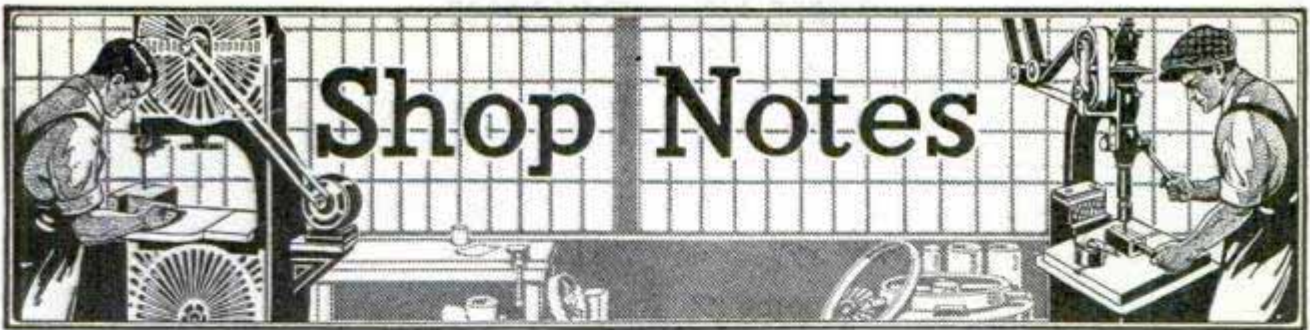

All Shop Notes published in 1925, in book form—Fifty Cents—from our Book Department

# Making a Convertible Toolpost Grinder

By RAY F. KUNS

**T**HE machine shown in the illustrations was designed to serve in a machine shop where a great variety of automobile and general machine-shop repair and construction work is conducted. Two years of daily service, in which time a number of grinder wheels have been worn out, would seem to prove that the design is good. The only expense or repairs needed in this time, outside of the wheels, has been the replacing of the belt.

In automobile work as well as in many other instances in our modern shops, heat-treated steel is used

to such an extent that grinding is becoming almost indispensable, if the materials are to be machined. It is necessary to grind after heat-treating, if the work is to be true and free from the inequalities occasioned by the hardening and tempering process.

Accurate grinding work requires an accurate grinding head and a machine free from disturbing vibration. Of necessity the wheel must turn at high speed, and bearings must be accurate and entirely free from play. For this reason ball bearings were given preference over plain bearings. Service has

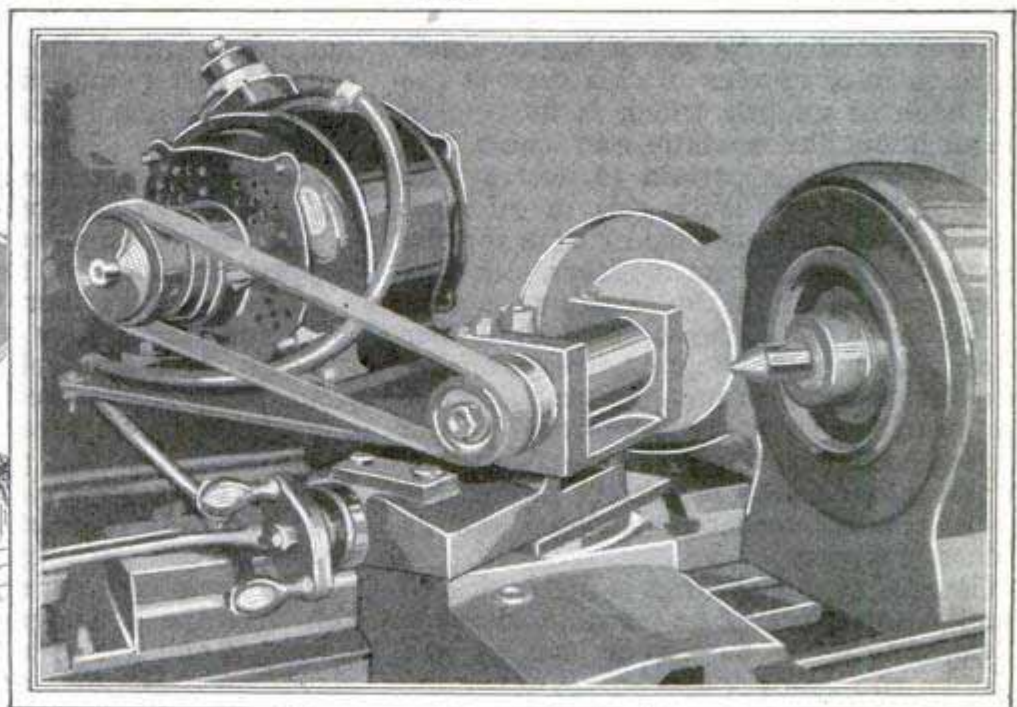
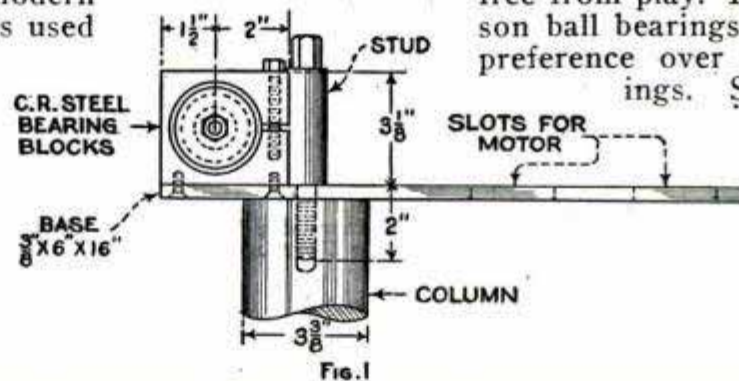

Upper Left, the Grinder Mounted on the Column for General Grinding; Right, Used to Grind Lathe Centers

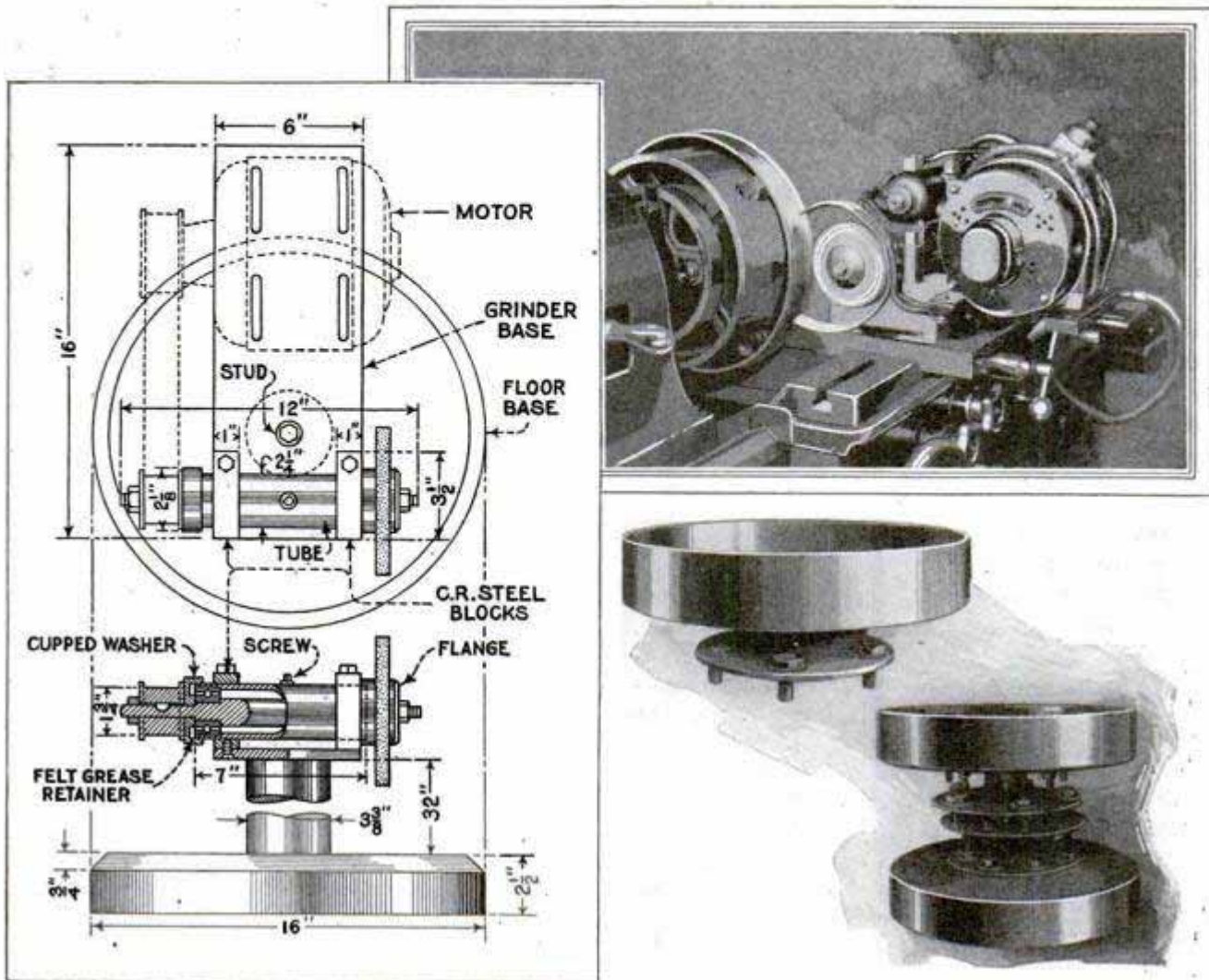

Left, General Details of Grinder and Column Assembly; Upper Right, Grinding Brake Drums; Lower Right, Some Reground Drums

proved the wisdom of the choice, since the bearings needed attention only once in a twelve-month period, and are still free of all play.

An essential to the use of ball or roller bearings in a grinder of this type is the exclusion of all grit which is floating in the air about the machine, and which, if it gains entrance, is certain to destroy the bearing quickly. With this in mind, it was decided to use a pipe or tube for the support of the ball-bearing races, and thus insure alinement of the bearings as well as exclusion of all dust from the inner sides. To prevent the dust from working into the bearings from the outer sides of the bearings they are protected by the cupped washers which come over the ends of the tube. Space is left, as shown, for a felt grease retainer which also acts as a dust excluder.

The size of the bearings is not indicated exactly, since it may be possible to adapt salvaged bearings to this service, as was done in the original machine. With the bearings at hand, the tube is selected to conform to them and machined to size on

the outer surface, the ends being bored out to receive the bearing races, which must be just a neat sliding fit. The shaft also must be designed to fit the bearings and the journal for the bearing cone must be just a snug sliding fit. A piece of a vanadium-steel axle was used for the original shaft. This is more difficult to machine, but is a most dependable material and one usually available without cost.

The bearing cones take the thrust of the cupped washers as they are forced on ahead of the grinder wheel on the one side and the pulley on the other. A flange of conventional pattern is made to hold the grinder wheel. The threads on the wheel end of the shaft are right-hand, while those on the pulley end are left-hand. It is a good plan to place a key in the pulley and shaft as an additional safeguard against turning.

As suggested by the title of this article, this machine is designed to serve double duty. When not in use on the lathe carriage, it is mounted on a column at one end of the lathe, where it is readily available as a tool-bit grinder and for other

light work. To facilitate this change a stud is made of such length that the upper end extends above the body of the grinder head. This stud is used to clamp the base of the grinder to the top of the column or to the lathe carriage. The base is made from  $\frac{3}{8}$  by 6-in. machine steel. The grinder head is supported in blocks of steel on the front end, and the other end is slotted to receive the motor.

The cold-rolled steel blocks that carry the tube are bored out to the size of the tube and slotted at the rear side. A screw is used to lock the tube into the blocks, after they have been assembled onto the base by means of two taper-head machine screws.

The motor is  $\frac{1}{2}$  hp., and is fitted with a pulley to drive the head at 3,000 r.p.m. The slots in the base of the grinder are made to conform to the base of the motor. This arrangement allows ready adjustment of the belt used to drive the machine. A Ford fan belt was selected for this task, since it is readily obtained. The rubber-composition type is preferred to the leather belt because it is lighter and more flexible, and consequently less likely to set up vibration.

The column was made from a  $3\frac{1}{2}$ -in. round machine-steel bar. The column base was machined from an old engine flywheel. The weight of these items helps to give rigidity when the grinder is used on the column. The base might have been made from 3-in. gas pipe mounted on a large brake drum and the entire column then turned over and filled with concrete to give it weight. When mounting the head on the lathe carriage, a nut to receive the stud is used.

The accompanying illustrations show some of the uses to which this little grinder has been put. Center grinding is always needed. Some brake drums may be turned in the lathe and again they must be ground as indicated in this case. By mounting the rotating knives or cutter heads of lawn mowers in the lathe and supplying a rest for the blade, extremely accurate grinding may be done on them with this machine. It is likely, too, that the cutting bar can be ground with it.

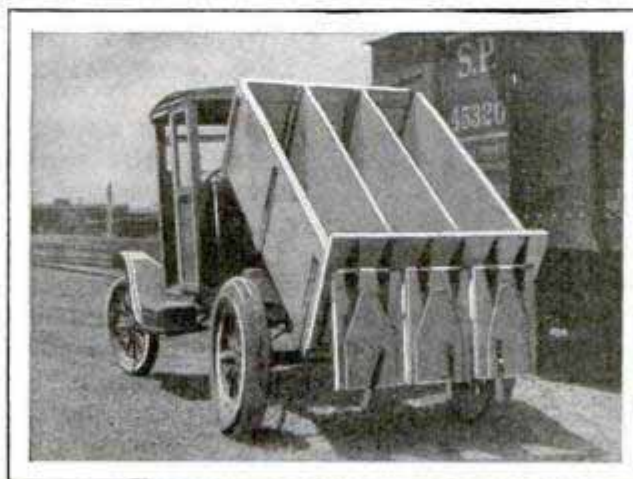

Truck Body Divided into Three Parts Permits Even Distribution of Loads

### Magnet Holds Trouble Lamp

When making repairs or adjustments on an auto engine at night, it is rather difficult to hold the lamp over the work properly. A handy lamp holder can be made

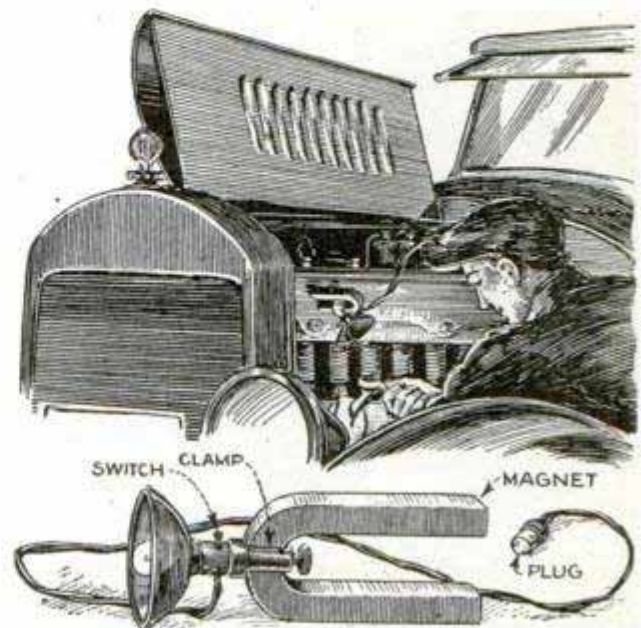

Trouble Lamp Held to Auto Engine by Magnet and Detail Showing Construction

from an old magneto magnet, which can be picked up at almost any junk shop. The magnet will adhere to any iron or steel surface, and by having the lamp adjustable, it can be swung around to any desired position.—Edwin E. Burgess, Jr., Baltimore, Md.

### Homemade Dump Truck Distributes Load Evenly

Where long stretches of highway are to be graveled at one time, a truck with a dump body having three divisions, each holding one third of a yard as shown, has been found a time and money saver. Common one-ton truck chassis are used. The body is bound with flat iron and has three compartments, each of which has a hinged door at the rear. The doors are of simple construction, each being provided with a knife lock, which permits dumping a load in three different places. This insures even distribution of gravel.

Blake C. Van Horn  
Waltm. Huber

### Time-Saving Forms for Concrete Steps

When making forms for concrete steps, it takes much time to notch the stringers and nail on the tread strips. This work

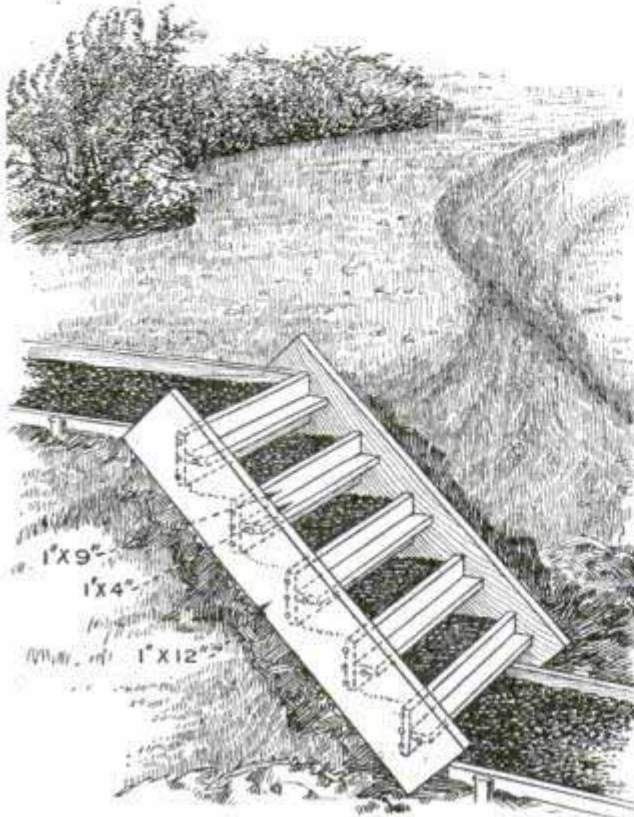

Convenient and Timesaving Forms for Concrete Steps Are Easily Made

can be eliminated by using the type of form shown in the illustration. As is evident, no diagonal cutting of lumber is necessary. The sides consist of 1 by 12-in. stringers, and 1 by 9-in. material is used for the risers. These pieces are cut to equal lengths so that they require only spacing and nailing. Lengths of 1 by 4-in. stock are used to brace the risers. After the concrete has been poured and troweled, a piece of roofing or sheathing paper is tacked over the whole incline. This will carry off rain and prevent the steps from being used until the concrete is sufficiently hard.—G. A. Luers, Washington, D. C.

### To Save Honey Bees

According to the claims of experienced bee keepers, grass or weeds, growing in front of hive entrances, causes a heavy loss of bees during the honey season. The bees returning to the hive overloaded with honey or pollen frequently fall before the entrance and, alighting in the thick grass, become chilled before they can crawl or fly into the hive. To prevent this one bee keeper has placed pieces of tar paper

or discarded linoleum upon the ground in front of the hives. These keep down and prevent the growth of grass or weeds and the bees settling upon them are exposed to the warmth of the sun where no obstruction is offered to hinder their flight into the hive after they have rested.—G. E. Hendrickson, Argyle, Wis.

### Small Bottle Useful to Motorist

A bottle small enough to be let down into the gasoline tank with a piece of string tied around the neck is very handy to carry in the auto tool chest when out driving. Should a tube have to be patched, gasoline is recommended as a cleaner for the part of the tube to be repaired. Also, if a spark plug needs cleaning, gasoline is used to do a good job. Greasy hands can also be cleaned very easily with gasoline, and the small bottle provides an easy method of getting it out of the tank.—S. N. Swenson, Harris, Minn.

### Screwdriver for the Arbor Press

In removing large screws, especially those of the flat-head type, the main difficulty is keeping the bit of the screwdriver in the slot, and the workman resorts to the use of a hammer and punch. This, of course, produces a very unworkmanlike job. However, the illustration shows a screwdriver that will take any size of screw on account of the detachable bit, and the fact that it is secured to the ram by a bail arrangement allows very fast use, the screwdriver following the up and down movement of the ram.

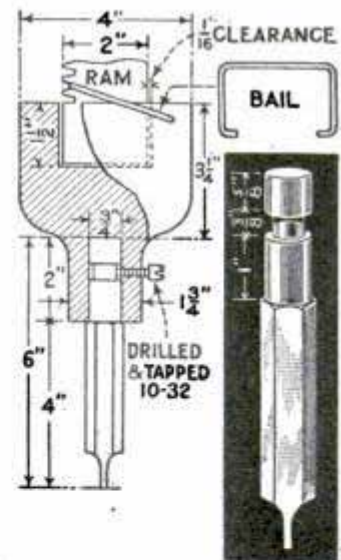

A wrench is put on the hexagonal section of the driver which turns in the fitting, the 10-32 screw simply holding the bit from dropping out. For use in removing the pole-shoe screws on motors and generator frames, a short piece of pipe can be put through the frame to keep it from turning, and the frame itself can be placed on a V-block made by sawing two triangular pieces out of a 12-in. section of channel iron. The body should be turned out of steel, allowing a clearance of  $\frac{1}{16}$  in. be-

tween it and the ram. The bits, which were of different sizes to fit various screw slots, were made from old chisels that had their temper drawn, and were chucked in a lathe and a 2-in. section turned down and also slotted. The end of the bit was ground to fit the screw slot, leaving a part of the hexagonal for putting on a wrench. When removing or replacing screws the press-operating arm is used to keep the bit in a screw slot. The bail, made of No. 18 gauge steel wire, fits through the rack of the ram and into two holes in the side of the body of the fitting.

### Collapsible Sides for Shop Truck

Fitted to a shop truck the folding sides shown in the illustration serve a double purpose: First, they prevent the load from scattering and second, they provide a gauge to limit the width of the load. When extended, the width should be such that the loaded truck will pass through any doorway in the building. Obviously, if the loading is restricted to this width there will be no danger of the load jamming or need of removing and rearranging it before it will go through. On the other hand, a truck nearly as wide as the doorways is not always convenient for other purposes, so the auxiliary sides are attached to the truck with hinges so that they can be folded down. In the center a strip of metal is pivoted, one on each side. These strips are bent at right angles at one end. When the sides are in use the strip is turned so that the bent portion rests against the truck; when letting them down it is reversed.

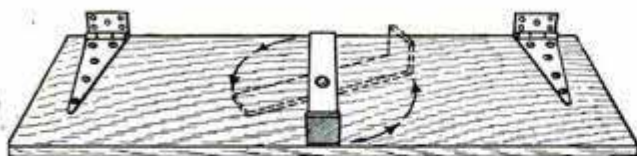

BOTTOM VIEW OF WING SHOWING ITS CONSTRUCTION

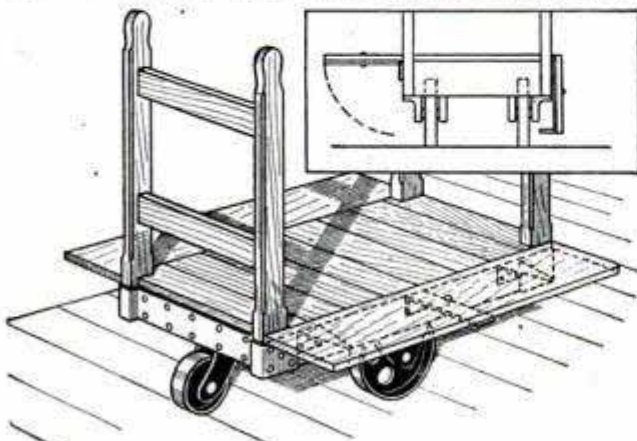

Collapsible Sides on Shop Truck Serve as Gauge to Measure Width of Doors

### Skate-Sharpening Jig

While large machine shops usually have a regular supply of jigs for holding all the various models of ice skates for sharpen-

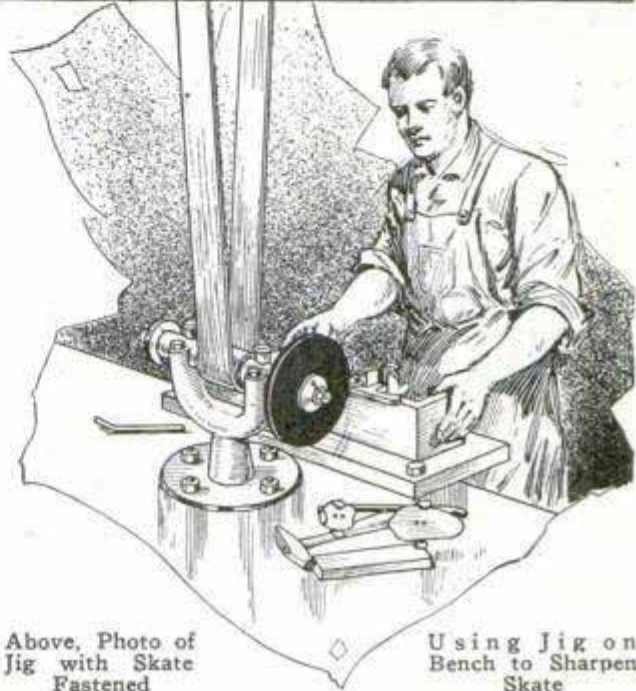
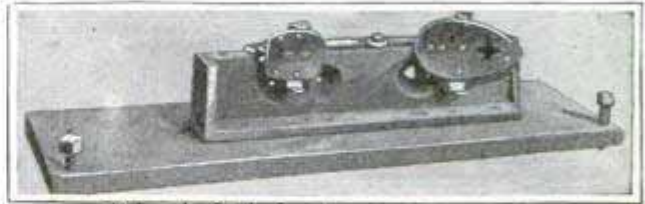

Above, Photo of Jig with Skate Fastened

Using Jig on Bench to Sharpen Skate

ing, the small shop has to work along with a makeshift or a quickly assembled jig. The jig shown herewith was designed by the owner of a small shop and will take skates of all sizes and types, enabling him to do a first-class sharpening job. The base consists of a heavy steel plate, 30 in. long, with a bolt at each end to act either as supports or to permit fastening permanently to the bench. The jig itself is a piece of angle steel somewhat longer than the largest-size skate. The vertical side rises 4 in. above the base and is drilled and tapped with holes, all along the edge, at about 1-in. intervals. One vertical end is drilled and tapped in the same way and a few holes are tapped in the vertical side. A skate is arranged as shown and clamped in position, with bolts and washers over the blade at the most convenient points. The jig is placed on the base, which has previously been adjusted in front of an emery wheel. By pushing the blade against the wheel and moving the jig to right and left the entire blade is ground evenly. The size of the wheel determines whether the blade will be flat or hollow-ground.—L. B. Robbins, Harwich, Mass.

*Used in large works,*  
*Le Poul de nemours Co.*  
 Simple Safety Attachment  
 for Hoisting Barrels

*Wilmington Del.*  
 Barrels are hoisted without risk of dropping them with the simple attachment

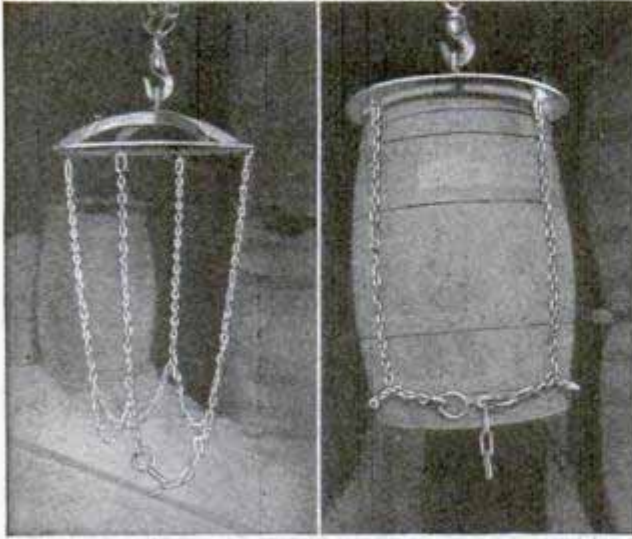

Simple Safety Sling for Hoisting Barrels Prevents Accidental Dropping of Burden

shown in the photos. It consists of a flat-iron ring large enough to fit over the head of the barrel, and heavy chains, which are slipped over the side and hooked securely around it near the lower head, so that the barrel cannot get loose.—R. G. Thackwell, Chicago, Ill.

### Small Dams Prevent Creek-Bank Erosion

The erosion of creek banks and the resulting lowering of the water level which occur during flood periods, are especially undesirable in municipalities because the sewer outlets are uncovered with undesirable results. It can be prevented by building small concrete dams along the streams

as shown in the photo. The dams are placed from  $\frac{1}{8}$  to  $\frac{1}{4}$  mile apart, depending on the slope of the stream, and are built just high enough to keep the bottom of the channel covered with water from bank to bank, during periods of extremely low flow. Concrete aprons, several feet wide, are built on the downstream sides to prevent damage from undermining.—Ivan E. Houk, Denver, Colo.

### Proper Use of Pine Siding

Be sure all siding is thoroughly dry before installation. Do not put siding on walls immediately after a rainstorm, but let the sheathing and framework dry thoroughly first. To fail in this may mean loose nails, open joints or buckling of portions of the siding. The proper lap for bevel siding is as follows:  $\frac{3}{4}$  in. on 4 in.; 1 in. on 5 and 6 in.;  $1\frac{1}{2}$  in. on wider stuff.

Siding should be cut with a miter saw at all corners. Wherever two pieces of siding join, it is best to use a splice joint. This is accomplished with a miter saw. Joints should be broken with as wide a space as convenient between the joints of overlapping tiers. Where siding butts up against window casings, a square, tight joint should be made. A metal flashing underneath the siding will prevent any possibility of water seeping in. For the finest finish and best work, nails in bevel siding should be countersunk and the depression filled with putty.

Before painting drop or bevel siding containing knots, a coat of thin white shellac should be applied. Siding should be given a priming coat as soon as it is laid, and for widths of bevel siding over

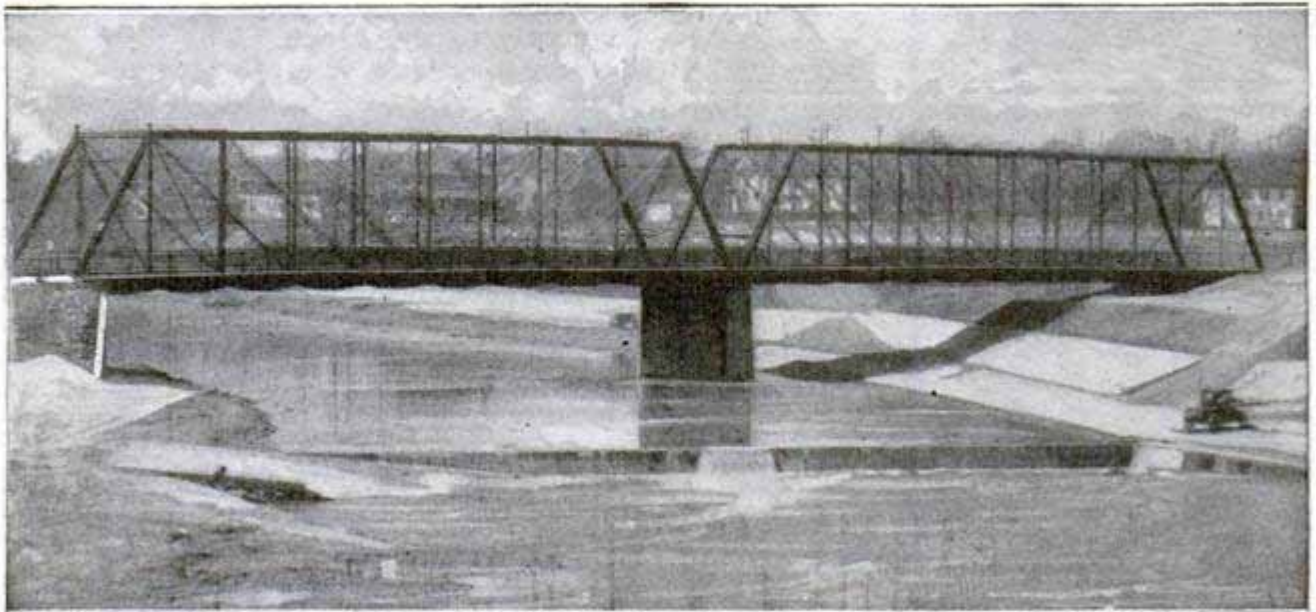

Small Concrete Dams High Enough to Keep Creek Bed Covered with Water Are Placed at Intervals of One Eighth to One-Fourth of a Mile to Prevent Erosion of Banks

8 in., it is advisable to paint the back side before it is put on. After the priming coat, it is well to let the building stand a few days, or as long as convenient, before putting on the finishing coats. This will insure that shrinking will have taken place, and that all surfaces will be properly covered.

There are always areas on the wall of a house where lengths of siding down to 18 in. must be used. Do not demand all long siding from your dealer. Considerable amounts of short siding develop in the process of manufacture and must be disposed of. If the mill man could not get rid of these short pieces, it would be necessary to charge more for the longer ones. Short lengths can also be used to advantage on the porch, on the garage and various outbuildings. At times, an excess of these shorts will accumulate and is sold at reduced prices. If you are in a position to use all short pieces, your dealer may be able to quote a very attractive price on such material.

#### Durable Nests for Poultry Made of Concrete

A simple and inexpensive method of forming the inside of a concrete hens' nest is shown in the illustration. The form is made of burlap, which is sewed in such a manner that it will have the juglike shape indicated. After the burlap form has been sewed, stuff it with rags, excelsior or similar material. Ordinary wooden boxes are used for the outside form. After the bottom of the box has been covered with concrete about 3 in. in thickness, the burlap mold is put in place and concrete is poured all around it. As soon as the concrete has set sufficiently to hold its own weight, remove the packing little by little. It is almost impossible to use wooden molds for this purpose as they cannot be readily removed and will swell after the concrete is poured.—H. H. Siegele, Emporia, Kans.

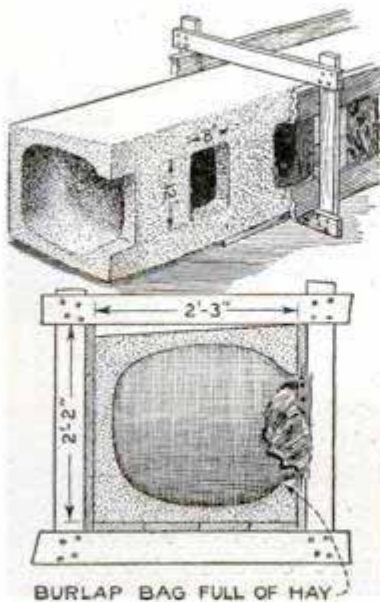

BURLAP BAG FULL OF HAY



Easily Made Tile Hook Facilitates Laying Drain Tile in Deep Ditches

#### Tile Hook for Deep Trenches

A tool known as a tile hook is valuable for laying tile in deep ditches. The hook consists of a strip of iron, 1 in. wide and 12 in. long, bent so that a 4-in. portion may be attached at right angles to a handle. With this tool the operator stands above the trench and puts the tiles in the correct position.—C. M. Baker, Wooster, Ohio.

#### Never-Slip Gauge Aids Glazier in Cutting Glass

In cutting glass for doors and windows, many glaziers employ a yardstick, or ruler, as a gauge along which to move the cutter. Unless firmly held, such a gauge is likely to move, causing more or less damage and expense. To prevent this, one need only obtain a discarded inner tube and from it cut a strip of rubber of the same length and width as the ruler. With this strip cemented firmly onto one side of the gauge, it will not slip and the worker consequently will be relieved of much strain on the hands or fingers.

### Labor-Saving Snow Shovel

To clear the sidewalk after a sudden heavy snowfall, a janitor lashed a double thickness of corrugated paper board to the



Baggage Truck and Piece of Corrugated Cardboard Make Handy Snow Shovel

front of a small, two-wheeled baggage truck. The sharp steel nose of the truck slid under the snow as easily as under a trunk or box and scraped the sidewalk clean, while the corrugated board widened the sweep and carried big heaps of snow to the curb. In a very short time the broad sidewalk was ready for traffic, and the inventor found time to chuckle at his neighbors, who were still sweating over their shovels.—E. L. Bowman, Evansville, Ind.

### Suggestions on Sash Installation

Sash should be well painted before, or immediately after installation. Dipping in linseed oil before the glass is applied gives a coating that will protect all points against the absorption of moisture. A good priming coat of thin paint should be applied as soon as the sash is in place. The tops and bottoms of the sash should be most carefully painted.

Good service demands that sash be back-puttied, that is, a small amount of putty be placed in the sash before the glass is laid in it, thereby forming an airtight and water-tight cushion for the glass. On the outside of the sash, a mixture of pure linseed oil, white lead and

whiting will give best puttting results. Proper balance and fitting are essential. Weights that are too light or too heavy are often the cause of broken glass. Windows that are fitted too tightly or too loosely are sure to develop annoyances that cause repair expense or replacement.

In cold climates storm sash are generally approved and their use in winter assures comfort and coal saving. Window sash last longer by thus protecting them against melting snow and driving rains.

### Sagebrush Mats Protect Canal Banks

In the arid western states erosion of irrigation-canal banks, due to high velocities of flow, can be prevented by lining the banks with sagebrush mats. Bundles of the brush are laid along the banks, covered with woven wire mesh and fastened securely at short intervals, either by piling large rocks on top of the wire, or by fastening the wire to posts set in the canal bed. The repairs are made during the winter and spring months when no water is carried in the canals.

### Wooden Balls Plug Conduits

Wooden balls can be used to stop the flow in sewers, blow-off pipes through dams, or other conduits where valves have not been installed. The balls are made slightly larger than the conduits and are lowered in front of the openings where the suction of the moving water catches them and pulls them into place, after which they are held securely by the water pressure, which tends to push them into the holes. The ball is dropped through the manhole and will take the position indicated in the drawing. In plugging a pipe through a dam, where the water is often several feet above the opening, the ball is built around a concrete core so that it will sink. Canvas wrapped around the ball helps to seal the small irregularities in the edges of the opening. Such a method was recently used at an irrigation dam where the water was approximately 200 feet above the pipe.

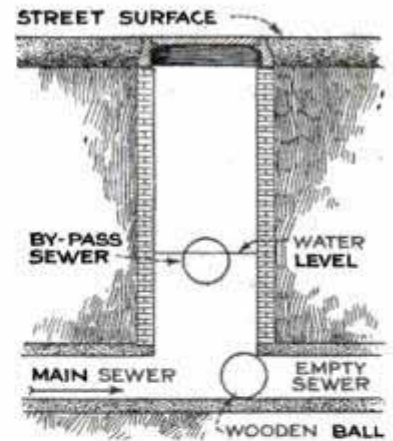



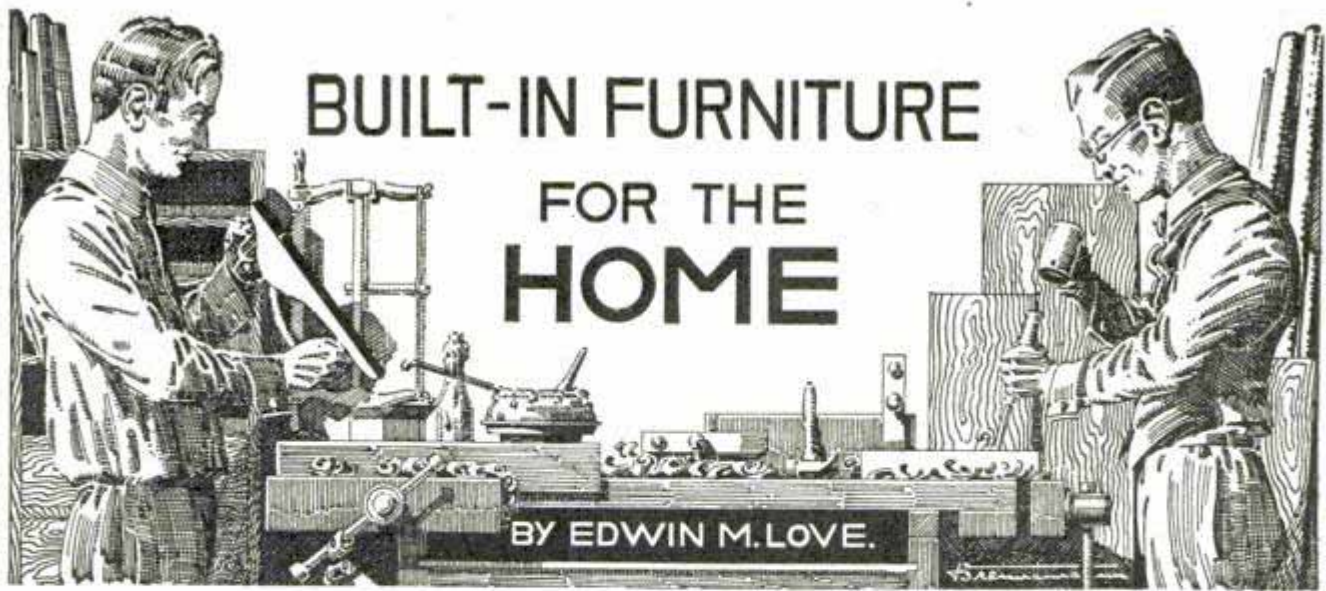

### Part XVI—A Breakfast Nook

**F**ROM many view points a breakfast nook is desirable. Being located in the kitchen, it reduces to a minimum the number of steps required in the preparation of a meal, saving both time and energy for all concerned. It enables the housewife to postpone clearing up the breakfast table, if need be, without exposing it to the scrutiny of early callers, and in addition, if it is well designed, adds to the beauty of the kitchen.

The nook illustrated calls for a recess 3 ft. 6 in. deep and 5 ft. 4½ in., from plaster to plaster, in width, though the design can be adapted to slightly smaller spaces. Glue up the table top from white-pine stock, 1¼ by 6 in., cut a little more than 4 ft. in length to allow for trimming, doweling every 10 in. and laying the heart side alternately up and down, so that warping will be reduced to a minimum. Also glue up stock for the two seat ends, uniting a piece of 1¼ by 10 in. by 3 ft. with one 1 ft. 9 in. long for each, as shown in the layout. The table legs are of 1¼ by 10-in. and 1¼ by 8-in. material, cut long enough for a finished length of 2 ft. 5 in. Surface all this stock before laying out, but keep as thick as the material will allow. Smooth the top by planing

diagonally with a jointer and finishing with the grain. Test for wind (twist) by laying narrow straightedges on each end and sighting over them.

Divide the face side of one seat-end blank into 2-in. squares and lay out the outline of the ends as shown in the perspective. If a bandsaw is available, it can be quickly cut out; but sawing by hand is not especially difficult. Use handsaws and compass saw or a turning saw, and smooth up with spokeshave, wood rasp and sandpaper. One completed end can be used as a template for outlining the other.

Glue up the seat fronts, using 1 by 12-in. stock, cut 4 ft. long. Measure out from the plaster of a side wall 16 in. and up from the floor 1 ft. 6 in., locating the point on the plaster of the end wall. Level to the corner and locate a point ½ in. below it. This gives the backward slope of the

top or seat frame. The slope of the front board is obtained by measuring out from the plaster on the floor 1 ft. 1 in. and connecting with a point on the seat line 1 ft. 3 in. from the side wall. If a stud is found that gives secure nailing, nail up a cleat of 1 by 2-in. stock to carry the seat end, allowing

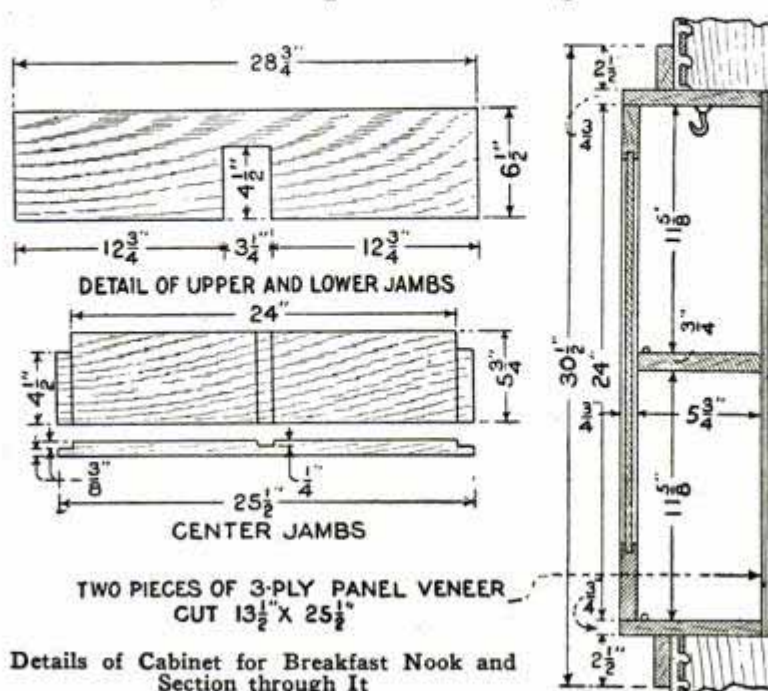

Details of Cabinet for Breakfast Nook and Section through It



$\frac{3}{4}$  in. for the thickness of the seat, and also a cleat for backing the end of the front. Otherwise cut a solid backing to the correct shape, using glued-up 1-in. stock, and nail in place.

Scribe the back edge of the seat end to the plaster, tack in place, and lay off for cleats on the inside face to correspond to cleats on the end wall, by leveling across and measuring from the back wall. Nail, but do not glue, the cleats, as gluing will cause the end to check when shrinkage occurs. Nail a back-wall cleat of 1 by 2-in. stock to support the back edge of the seat frame. Build the frame of 1 by 3-in. stock, sized to a width of  $2\frac{1}{2}$  in. as shown in the drawing. Lay it on its cleats and scribe the end and back to the walls, giving it a length of 3 ft. 4 in.

Nail a floor cleat with the front edge flush with the front-end cleats. Scribe the front board to the end wall and cut it to

the same length as the top frame. If it is a little narrow, glue and nail a strip to the upper edge. Nail to the wall and floor cleats, lay the seat frame in place and set up the seat end, toenailing it to the floor and nailing the front and frame to its cleats.

Shape a stop cleat of 2 by 3-in. stock, to fit under the front stile of the seat frame, as shown in the section, and make a lid of 1 by 12-in. stock. A cleat of 1 by 2-in. pine, 2 in. from each end on the underside, prevents warping. Hinge the lid with two nickelplated butterfly hinges, and near the front edge mortise in a flush ring lift. If there is any doubt as to the ability of the lid to carry the weight of persons sitting on it, glue and nail a projecting strip of 1 by 2-in. stock under each frame rail to act as stops. Build the other seat in the same way. Finish the table top to a width of 2 ft. 2 in. and a length of 4

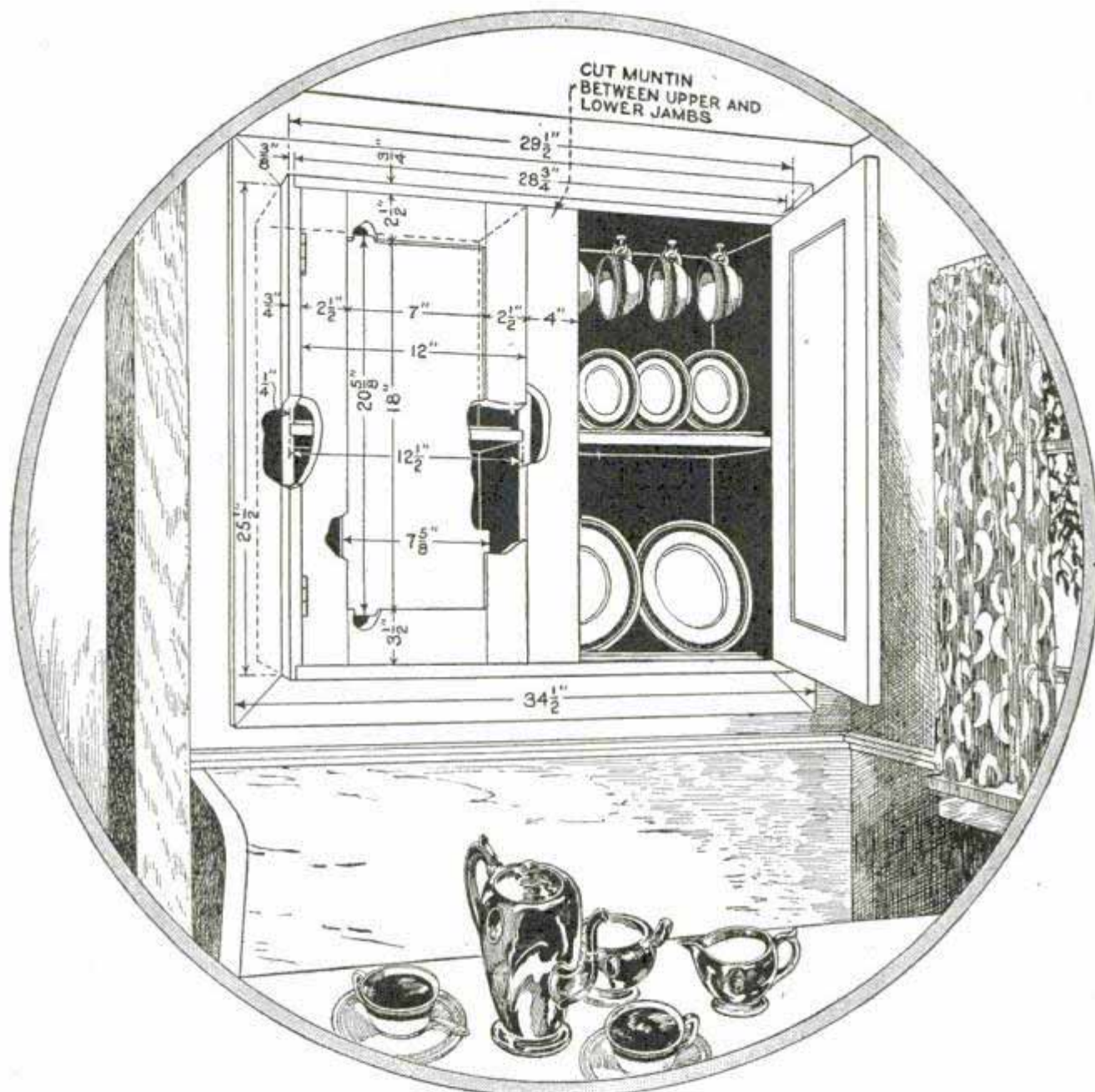

ft., rounding the corners to a radius of 1 in. and sandpapering off the corners of the edges. On the underside, nail two cleats of 1 by 2-in. stock, 12 in. long, set back from the ends 8 in. and centered on the width, for backing for the tops of the legs.

Lay out the legs from a center line as follows: Five inches to right and left for a distance of  $2\frac{1}{2}$  in. from the top end, which has been previously squared with the center line, curve inward to a radius of  $2\frac{1}{2}$  in. for a distance down of  $2\frac{1}{2}$  in.; taper outward for a distance of 1 ft.  $6\frac{1}{2}$  in. from this point to a width of  $5\frac{1}{4}$  in. from the center; curving outward to a  $2\frac{1}{2}$  in. radius for  $2\frac{1}{2}$  in., and finishing 8 in. from the center at a point 2 in. from the bottom end. The finished length of a leg is 2 ft. 5 in.

Lay out the stretcher according to the drawing, using two lengths of 1 by 5-in.

stock, and curving them to radii of 2 ft. 6 in. and 2 ft.  $3\frac{1}{2}$  in. Make each segment 1 ft. 9 in. long, and cut a  $\frac{3}{8}$ -in. tongue, 2 in. long, on one piece to fit into a corresponding slot centered in the thickness of the other segment. Fit carefully, and glue together. When dry, cut tenons,  $\frac{1}{2}$  in. thick and  $2\frac{1}{4}$  in. wide, to fit into mortises cut in the legs, as shown in the elevations. Be sure to keep these in a line with each other, rather than following the curve.

To attach the legs, lay the top upside down on a pad on the floor, and after applying glue to the mortises and tenons, assemble them and toenail the leg tops into the cleats and table top with six-penny finish nails. Square with the top, cut two braces of 1 by 3-in. stock, 7 in. long, miter on both ends, and nail to the legs and top. Sandpaper thoroughly, rounding the corners slightly. A handy accessory for the breakfast nook is the

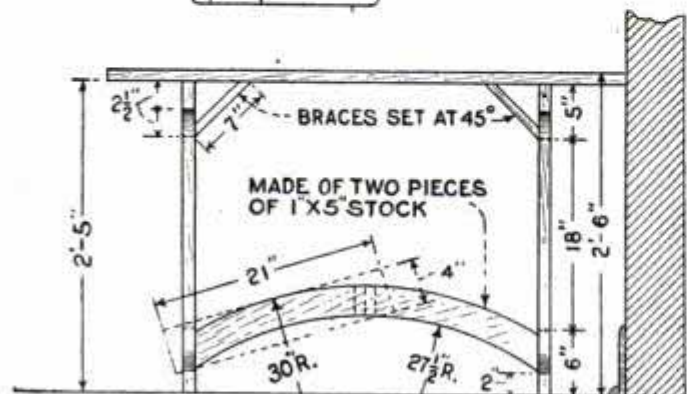
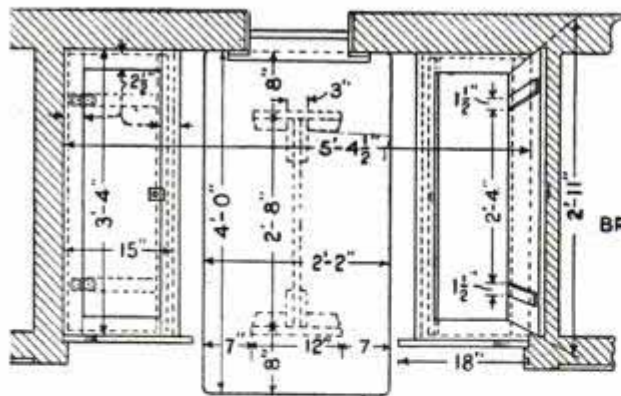

wall cabinet built to fit between three studs. It provides space for several cups, glasses, saucers and plates. Each of the two compartments has a space, 1 ft. wide, 2 ft. high and 5¼ in. in depth, behind the door.

Make the upper and lower side jambs of 1 by 7-in. stock. Cut the upper and lower jambs to a length of 2 ft. 4¾ in. and notch the back edges to a depth of 4½ in. for fitting around the center stud. The side jambs are 2 ft. 1½ in. long, with the ends rabbeted ⅜ in. deep to receive the ends of the top and bottom jambs. In the center of each is cut a dado, ¾ in. wide and ¼ in. deep, extending 5¾ in. from the back edge. The center jambs are ¾

in. narrower and notched out at the rabbets to fit over the upper and lower jambs in front of the notches. Assemble the jambs, brace the frame square by means of a diagonal strip of wood tacked across the face, and cover the back with two rectangles of three-ply ⅜-in. panel veneer, cut 13½ in. by 2 ft. 1½ in. Remove the brace and fit the muntin casing between the upper and lower jambs, nailing it to the center jambs with six-penny finish nails.

Make the stiles and upper rails of the doors of 1 by 3-in. stock, sized to a width of 2½ in., with lower rails 3½ in. wide. Be careful to select straight, well-seasoned wood for such light doors. Hang with 2½ by 2½-in. loose-pin butts, allowing them to project about ½ in.

To cut the opening for the cabinet, measure up on the wall 6 ft. 10 in., level a short line and locate a stud. Locate the two studs between which the cabinet is to be placed, and remove plaster and lath for a distance of 2 ft. 2½ in. from the upper line. Slip the cabinet over the center stud, level it with the inside of the upper jamb, 6 ft. 8½ in. above the floor, and wedge solidly, nailing through the end jambs into the side studs with eight-penny finish nails. Miter the 1 by 3-in. casing around the outside, fitting each piece to its side before cutting the miters. Near the front edge of the upper and lower shelves tack light strips of wood as stops for the dishes that are stood against the back of the cabinet.

☐ White enamel may be baked on galvanized iron at a heat of about 180° F.

#### MATERIAL LIST

##### Seats and Table

- 1 piece, 1¼ by 10 in. by 16 ft., white pine, S4S, sanded.
- 1 piece, 1¼ by 8 in. by 4 ft., white pine, S4S, sanded.
- 1 piece, 1¼ by 6 in. by 12 ft., white pine, S4S, sanded.
- 1 piece, 1¼ by 6 in. by 8 ft., white pine, S4S, sanded.
- 1 piece, 1 by 2 in. by 16 ft., pine or fir, S4S, sanded.
- 1 piece, 1 by 2 in. by 8 ft., pine or fir, S4S, sanded.
- 1 piece, 1 by 3 in. by 16 ft., pine or fir, S4S, sanded.
- 1 piece, 1 by 5 in. by 4 ft., pine or fir, S4S, sanded.
- 2 pieces, 1 by 6 in. by 10 ft., pine or fir, S4S, sanded.
- 1 piece, 1 by 7 in. by 14 ft., pine or fir, S4S, sanded.
- 1 piece, 1 by 12 in. by 16 ft., pine or fir, S4S, sanded.
- 1 piece, 2 by 3 in. by 8 ft., pine or fir, S4S, sanded.
- 1 piece, ¾ by ¾ in. by 12 ft., baseshoe.

- 1 piece, ⅝ by 6 in. by 8 ft., pine or fir, S4S, sanded, baseboard.
- 2 pair nickelplated butterfly hinges.
- 2 nickel flush ring lifts.
- Cost of materials, about \$12.
- Time to build, about 25 hours.

##### Cabinet

- 1 piece, 1 by 3 in. by 12 ft., pine or fir, S4S, sanded.
- 1 piece, 1 by 3 in. by 10 ft., pine or fir, S4S, sanded.
- 1 piece, 1 by 6 in. by 10 ft., pine or fir, S4S, sanded.
- 1 piece, 1 by 7 in. by 10 ft., pine or fir, S4S, sanded.
- 1 piece, ⅝ in. by 1 ft. 4 in. by 5 ft., three-ply pine or fir panel veneer.
- 2 pair 2½ by 2½-in. loose-pin butts.
- 2 forg catches.
- 2 1½-in. glass drawer pulls.
- Cost of materials about \$3.
- Time to build, 8 hours.

Tech News. Bulletin Nov. 1914

Steam Cleaning a Stone Building

Cement Banking Saves Coal

To meet the changing demand of present-day commercial conditions many old buildings are being altered or remodeled. In order to eliminate the undesirable contrast always present in such cases between the old dirty surfaces and the new stone put in the walls, some kind of cleaning of the old portions is generally carried out. Because of the detrimental effects of acid cleaning or sandblasting, scrubbing with soap powders and hand brushes is customarily employed. This method is effective, but slow and laborious, and in an effort to devise a faster and more efficient means of cleaning limestone, experiments with the use of live steam have been conducted at the bureau of standards.

An interesting demonstration of this experimental work was the steam cleaning of the remodeled building of the Baltimore Commercial Bank, Baltimore, Md., where the scheme was given a practical trial under commercial conditions. The use of live steam at 80-lb. pressure, blown directly against the stone through simple nozzles made of galvanized pipe fitted to the end of 1/2-in. steam-hose lines, was found to be very effective in removing the 20-year accumulation of dirt on this Indiana-limestone building. The cost of the job was somewhat higher than a bid received for acid cleaning. This increased cost is to be explained in part by the experimental character of the work, this being the first complete building ever cleaned with steam. The final color of the stone was not so bright as that of new stone work, but was considered entirely satisfactory, since it combined cleanliness with the appearance of age, which is usually thought desirable in stone buildings. The success of this practical test leads to the conclusion that steam cleaning would, in most cases, be an economical and effective method.

An eastern coal dealer, having a location below the sidetrack, laid a cement floor over the ground and a section of the

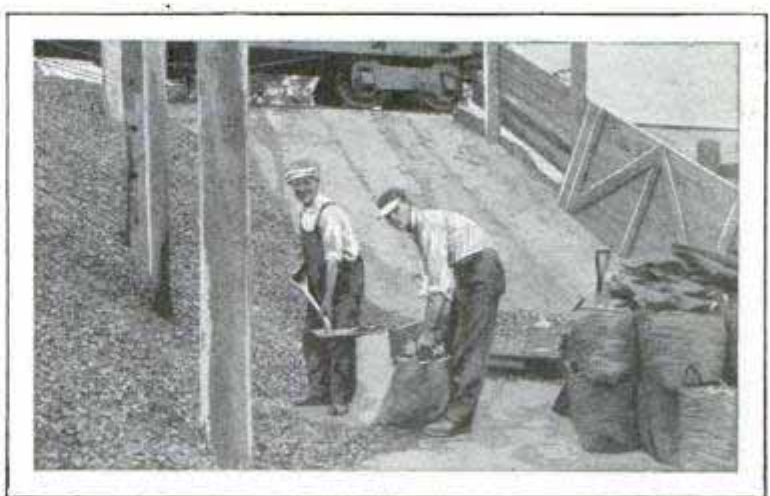

Inclined Bank Faced with Concrete Brings Coal from Cars into the Yard by Gravity

banking up to the track, on which the coal is thrown from the cars. The smooth surface of the concrete brings the coal down to ground level without rehandling, which greatly assists shoveling and prevents considerable waste.

Drilling Holes in Edge of Disk

In a small shop having no milling machine and index head, the writer had a precision job of drilling three holes in the periphery of a brass disk, which was done with accuracy by the method shown in the drawing. Three toolmakers' buttons were placed around the shoulder of the disk as indicated and after being set the proper distance apart the mandrel was gripped in a machine vise, blocks with V-grooves being used to hold the mandrel securely. To get the distance between the buttons on a circle 5 in. in diameter, is a simple calculation, and the buttons are set in the usual way. One button was brought into contact with an accurate block and the hole was then drilled.

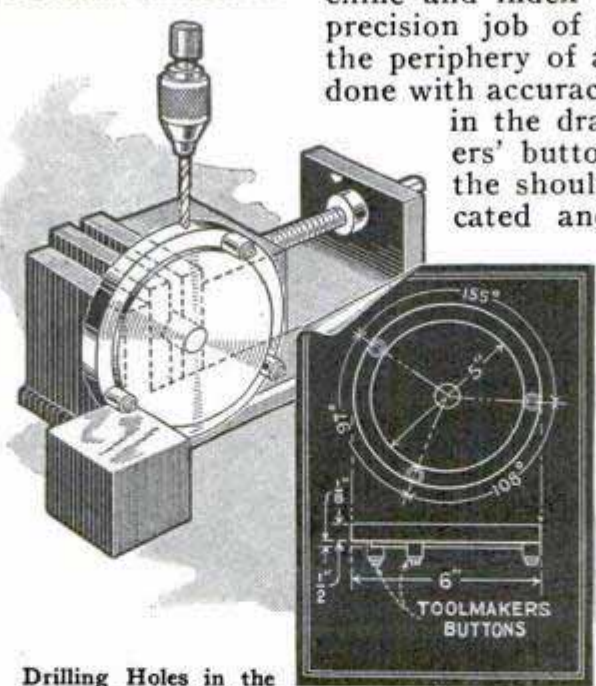

Drilling Holes in the Periphery of a Brass Disk

The other holes were drilled in the same way. The job was entirely satisfactory.—Hugo Ljungquist, Philadelphia, Pa.

### Reading the Incubator Thermometer

As incubators are usually installed in the cellar or basement of the home artificial light is necessary when reading the

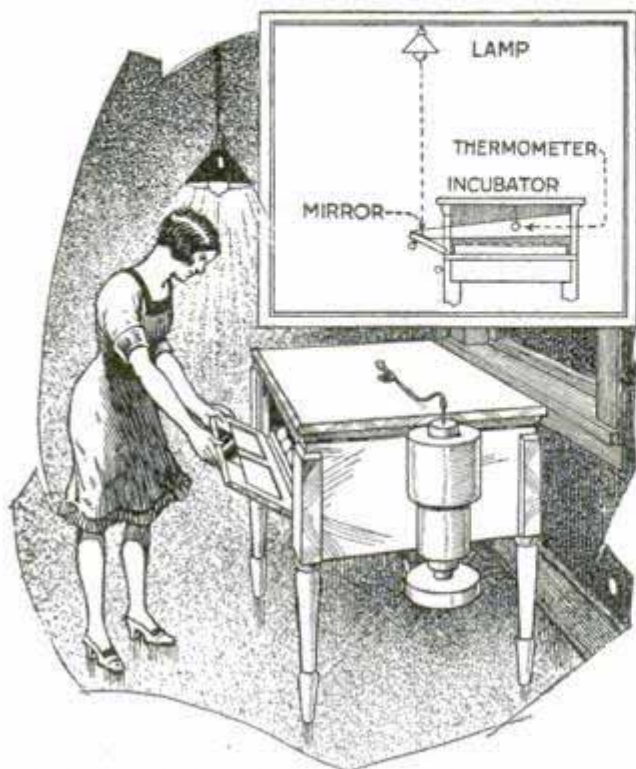

Lamp Directly Above and Mirror Inside of Incubator Door Facilitate Reading of Thermometer

thermometer. An overhead light is practical for this purpose in most cases, and if a mirror is placed on the inside of the outer door of the incubator the reading can be done instantly. By opening the door of the machine, as shown in the illustration, the light from above is reflected on the instrument and the temperature noted without difficulty.—G. E. Hendrickson, Argyle, Wis.

### Care of Oilstones

Oilstones should be properly cared for in order to retain the life and sharpness of the grit, to keep the surface flat and even, and to prevent glazing. With few exceptions, like the India and Crystalon, new stones should be soaked in oil for several days before using. An oilstone should be kept clean and moist. Allowing it to remain dry a long time or exposing it to the air tends to harden it. If the stone is kept in a dry place, it should be put in a box having a closed cover, and a few drops of fresh, clean oil poured on it. To restore an even flat surface on an oilstone, grind it on the side of a grindstone, or rub it down with sandstone or an emery brick. An oilstone can be prevented from glazing by the proper use of

oil or water; either will prevent the particles of metal that are cut away from the tool being sharpened from filling the surface of the stone. Plenty of water should be used on all coarse-grained natural stones. On medium or fine-grained natural stones, such as Arkansas or Washita, as well as on all artificial stones, oil should be used invariably, as water is not thick enough to keep the steel particles out of the pores. To further prevent glazing, dirty oil should be wiped off the stone as soon as possible after using. This is very important, for if the oil is left on the stone, it dries in, carrying steel dust with it. Cotton waste is one of the best things for cleaning a stone. If a stone does become glazed or gummed up, cleaning with gasoline or ammonia will usually restore the cutting qualities; but if this treatment is not effective, scour the stone with loose emery or a piece of sandpaper fastened to a flat board.—J. S. Hagens, Chicago, Ill.

### Marker for Sheet Metal

Workers in sheet metal, whether tin, brass or copper, will appreciate the usefulness of the line-marking tool shown in the illustration. Owing to the flexible nature of this kind of material it is difficult to hold a marking tool in contact with the work, and this is especially the case on brass sheets thin enough to be shipped in rolls. With the tool shown, however, it is impossible to slip off the work, as the metal is guided between two parts as it is slid along. The  $\frac{1}{2}$ -in. washers, held together and riveted by a short piece of steel, make a good body for this tool. The bottom washer is used as it is; the middle one is cut away on one side to within about  $\frac{1}{16}$  in. of the hole, and the top one is bent up at the opposite side

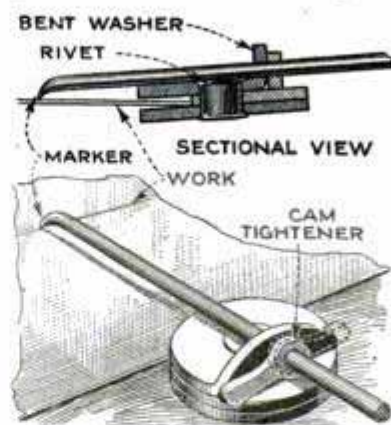

and drilled for the marking tool or scriber. This is held in place by a cam tightener made from a piece of metal, as shown, or from a length of wire, one turn of which is taken round the scriber, a short piece being left for a handle. By filing the outside of the loop it is made to tighten when brought over to one side and loosen when

turned to the opposite. To mark off a strip of metal before cutting, the scriber is set the required distance with a scale from the middle washer and is tightened in place with the cam. Then, with the thumb pressing on the scriber near the point and the four fingers keeping the tool in contact with the edge of the sheet, it is slid along to mark any width of strip desired within the limit of the tool. It is, of course, not practicable to make the scriber too long, as the sheet of metal would then be likely to buckle.—Harry Moore, Montreal, Can.

### Shorthand Mechanical Drawings

Complicated mechanical drawings may be simplified considerably by the use of symbols as shown in the illustration. The same steam piping is drawn in three different ways; the first showing the fittings drawn up in the usual way, the second showing the same somewhat simplified, and the lower one showing the drawing reduced entirely to symbols. Much work and time are, of course, saved by this method and the drawing is easier to read. A key of symbols is given in one corner of each drawing or separate key sheets, covering all the symbols used in each drafting department, may be issued.—Dr. Ing. Carl Commentz, Hamburg, Germany.

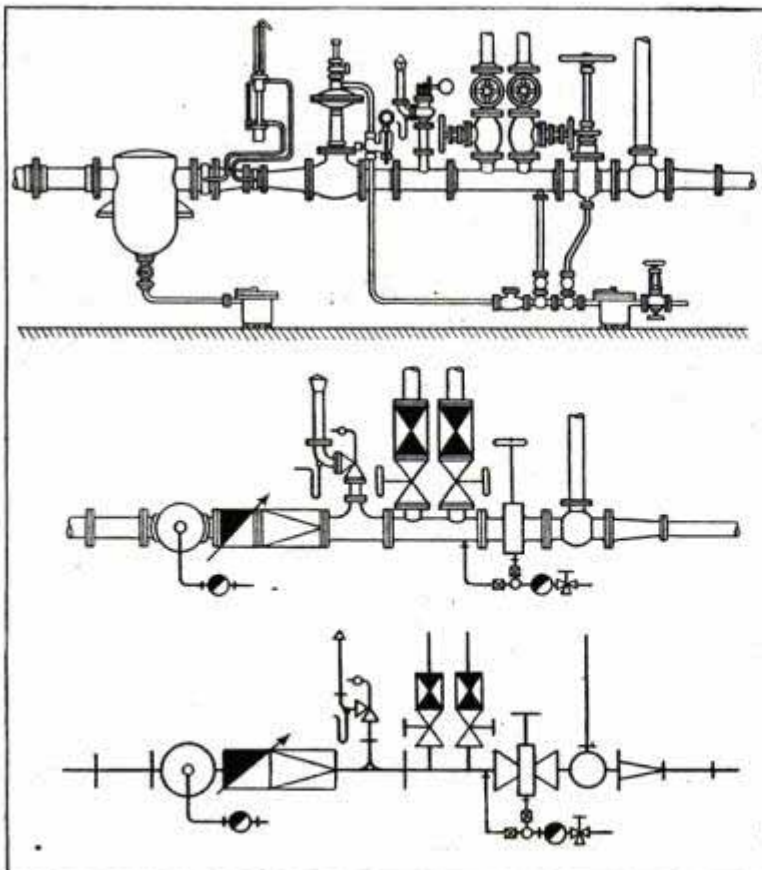

Mechanical Drawings Can Be Simplified Considerably by Using Symbols to Designate Parts

Method of Preventing Excessive Loss of Heat in Shipping or Receiving Rooms

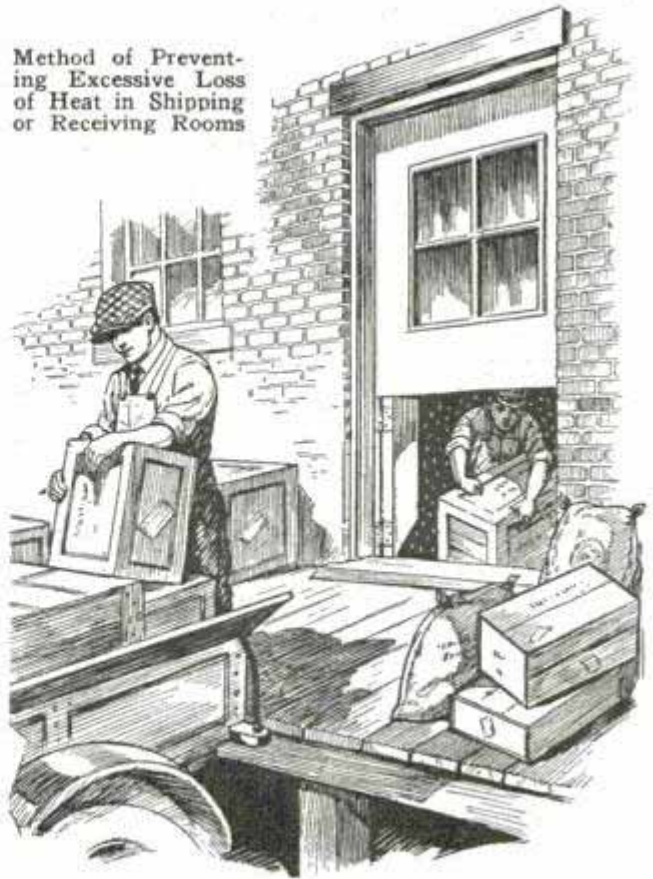

### Winter Door for Receiving Room

Factory or store receiving rooms often cannot be kept warm and comfortable in cold weather because of the necessity of frequently opening a large outside door to receive small boxes and parcels from delivery trucks, and where lumber or metal bars are being unloaded from cars on tracks outside the building, the door may have to be kept open for hours at a time. The discomfort from cold and loss of money in wasted heat may be partly prevented, if the bottom part of the door is cut and hinged so that it can be opened independently. A glass panel should be put into the upper section so that the clerk can see what is being unloaded.

### Brass Locknuts

In practically every power plant, and in every plumbing and steam-fitting shop, numerous old brass globe and other valves collect, which are usually sold as scrap brass. Before doing this, cut off the hexagonal ends from the old valves with a hacksaw. They can be cut off in a few moments and make locknuts, which are thicker and therefore better than the ordinary ones.

### Support Helps Turn Thin Walls

In turning up large cylindrical pieces, such as belt pulleys, etc., having thin walls, it is very difficult to prevent chat-



tering. However, this can easily be overcome by using a device of the kind shown in the drawing. A 3-ft. arm is made of heavy strap iron, about  $\frac{3}{8}$  by  $1\frac{1}{2}$  in., and bent to the shape shown. A roller, about  $1\frac{1}{2}$  in. in diameter and 1 in. long, is held in a U-piece made from strap iron which is fastened to the arm so that when the end of the arm is hooked inside the carriage the center of the roller will come even with the cutting tool. A piece of wire and a spring hold the bar, and this, in turn, gives the right pressure on the material at the cutting point. Being hooked inside of the carriage, the bar is kept just opposite the tool at all times as the tool moves. For turning the outside, the roller can be fixed to press on the inside, and the same result will be obtained. This device will instantly stop the chattering and will help do a much better job of cutting.—Ed Sundholm, Albert City, Iowa.

### Don't Overlook Your Battery Charger

The life of a battery-charger bulb can be greatly prolonged if it is properly handled. It may become inactive because of a sagging filament, for instance. But if the bulb is inverted as soon as any sagging is noticed, it will last much longer.

At a battery-charging station this has been the practice for some time, and the owner has reclaimed a number of rectifying bulbs by simply mounting the socket, in or outside of the charger, so that it will hang in an inverted position. Sometimes the bulb will light, but will not charge, and this trouble can usually be traced to a loose socket connection. A badly sulphated, or dead, battery may also cause this trouble. Chargers, of the vibrating type occasionally cease to function before the battery has taken a full charge. If this happens, it is a safe bet that the adjusting screw has worked loose and the vibrating points are too widely separated. If the ammeter shows a discharge, the points are sticking together and should be separated at once.—Glen F. Stillwell, Collinsville, Ill.

### Making Patterns for Small Sheaves

To the patternmaker with only limited molding practice, the making of a pattern for a small sheave pulley, such as shown in Fig. 1, for example, may be puzzling. He is not quite sure how the molder would prefer having it made, split on the line AB to be molded in green sand in a two or three-part flash or with a ring of green sand to make the groove, or perhaps a solid pattern with a core print turned on it as at B, Fig. 1, and a box to make the two half cores, these to be pasted together to form the groove. If the sides of the pattern are flat as in Fig. 2, he might be tempted to split the pattern through the middle on the line DE, doweling the two halves together in the usual way. When but one or two, or a half dozen castings are wanted, it makes little difference how the pattern is made, split or solid.

The molder can produce the castings from a pattern made either way. However, I prefer a solid pattern with the groove made in dry-sand core; the pattern is stronger and will retain its shape much longer. If the bottom of the groove is sharp or has a small radius that does not call for machine finishing, the dry-sand core method is the better way,

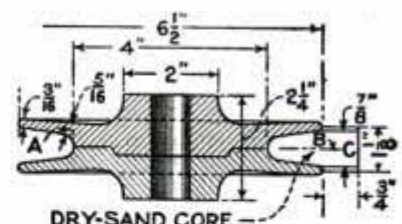

Fig. 1

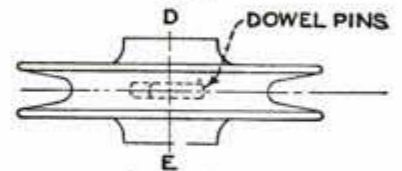

Fig. 2



as the sharp green sand would wash away with the pouring of the metal. The method indicated in Fig. 2 is not desirable.

If these sheave castings are to be made in large quantities, it is well to take the

### Siding Saves Time in Stonework

Use of framework and siding in the process of building stonework walls, has enabled an eastern contractor to save

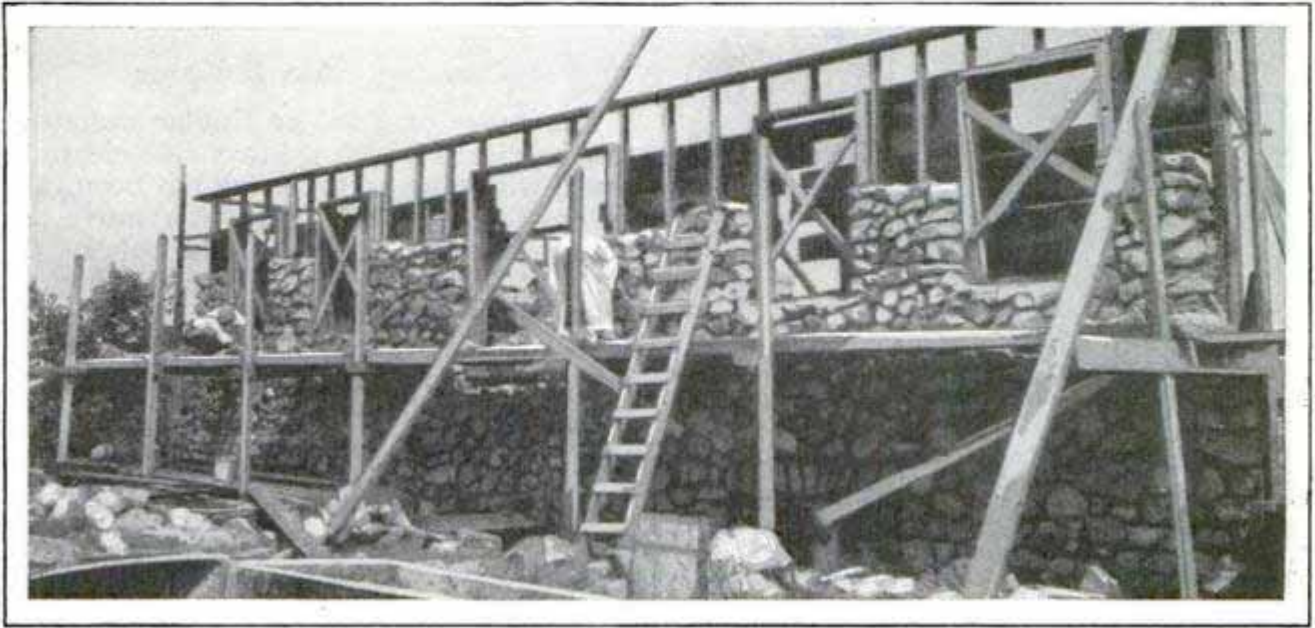

Wooden Frame Aids in Laying Stone Walls and Eliminates Need of Plastering

matter up with the foundry. When making a sheave pattern split through the middle, the apprentice patternmaker insists on making the joint faces of each half pattern recessed, as shown in Fig. 1. When but a few castings are wanted, this recessing is unnecessary; it calls for reverse chucking of the two halves of the pattern. By chucking with the joint face against the chuck, the half pattern can be turned and finished on both sides in one chucking and then doweled together with a single pin in the center. I have made them with only a piece of wire brad for a dowel. As an apprentice, the boy is taught to make his patterns up to a certain standard. A few visits to the foundry and a study of the jobs as they are made by the "old rounders" will convince him that it is not always necessary to line up to the so-called standard in the production of many patterns he is called upon to make.—M. E. Duggan, Kenosha, Wis.

much time in keeping the walls plumb, and the siding serves as a form to hold the inner facing of cement in place, eliminating the necessity of plastering after the wall is completed. The increased cost in erection appears to be more than offset by the saving in time.

### Portable Desk for Shipping Clerks

Shipping clerks, inventory men, appraisers and others engaged in clerical work which necessitates moving about the

store or warehouse with facilities for writing, figuring and checking, will find much convenience in the adoption of a portable desk of the type now in use in a Wisconsin factory. The desk was originally a small writing desk. The back legs were shortened about 6 in., and a pair of wheels and an axle from a discarded baby carriage were attached to them. Two handles were fastened at top.



Portable Desk Fitted with Wheels Is Convenient for Shipping Clerks and Appraisers



Vise Attached to Truck Tailboard Found Handy for Traveling Repairman

**Tailboard Serves as Workbench**

Obliged by the nature of his duties as truck inspector and traveling repairman to cut the working parts of his equipment to a minimum a mechanic, employed by a

large oil company, utilizes the tailboard of his truck as a workbench, after having bolted his vise on it, as shown. The handy location and utility of the arrangement save much extra work and delay on rush jobs.—Richard C. Tarr, Gloucester, Mass.

**Cleaning Auto Radiator**

The tubes of Ford or similar radiators can be cleaned with a brass rifle-cleaning brush when the bottom tank has been taken out for repairs. This will remove the lime, oil and dirt inside of the tubes. Of course the brush must be used with care, or holes might be made in the tubes. The proper size of brush for the Ford radiator is a rod for a .22 rifle.—E. T. Gundersen, Humboldt, Iowa.

**Improved Sand Bucket for Wells**

The ordinary sand bucket for use in removing sand deposits from large wells, is not entirely satisfactory. The city plant engineer of the pumping station at Lincoln, Nebr., has designed an improved bucket which works on the principle of dam dredges. It is built for an 8-in. pipe which is lowered with the jaws opened and locked. When the jaws strike the bottom, the impact releases the lock and the two halves automatically close and take a big bite. The action is rapid and positive, so that from a well 100 ft. deep it is possible to remove as high as five or six loads a minute. With the ordinary sand bucket, it sometimes takes fifteen or twenty minutes for the bucket to fill once. The accompanying photos show the two positions of the device.—D. R. Van Horn, Walton, Nebr.

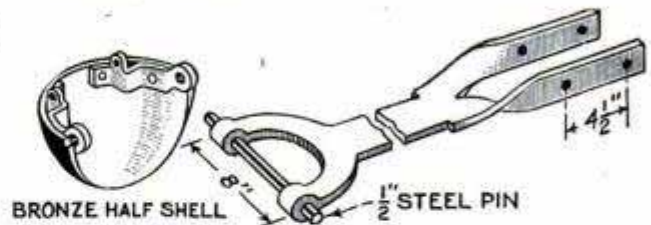
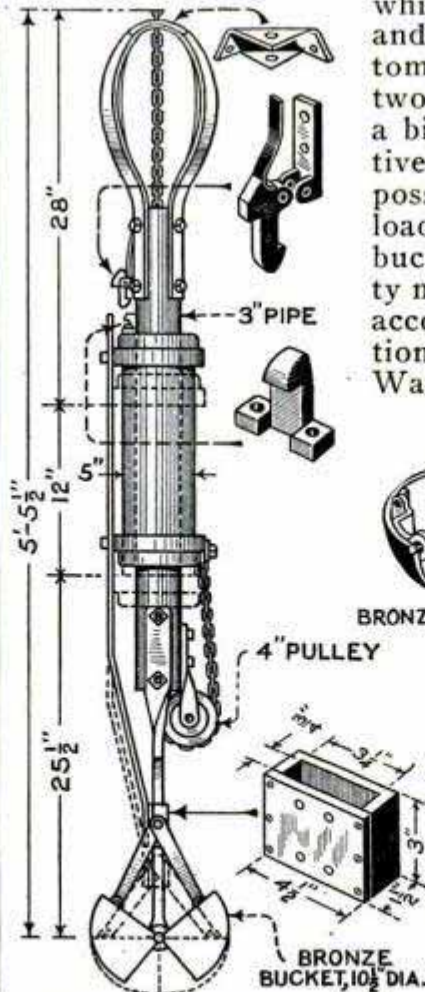
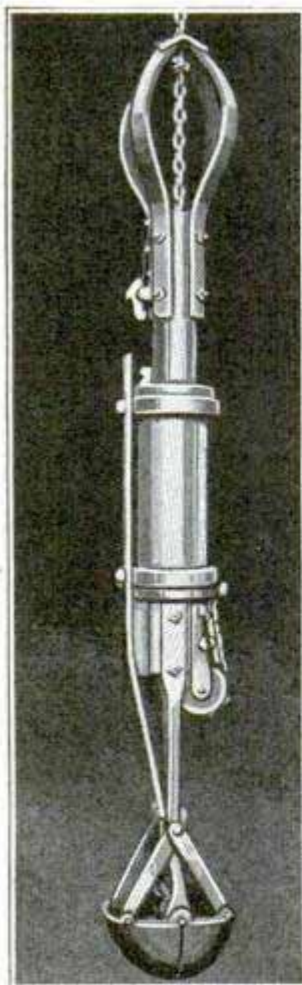

Improved Sand Bucket Works Like Clamshell, and with Its Use, Five or Six Loads Can Be Removed from a 100-Foot Well per Minute

# Colonial House with Shingle Exterior

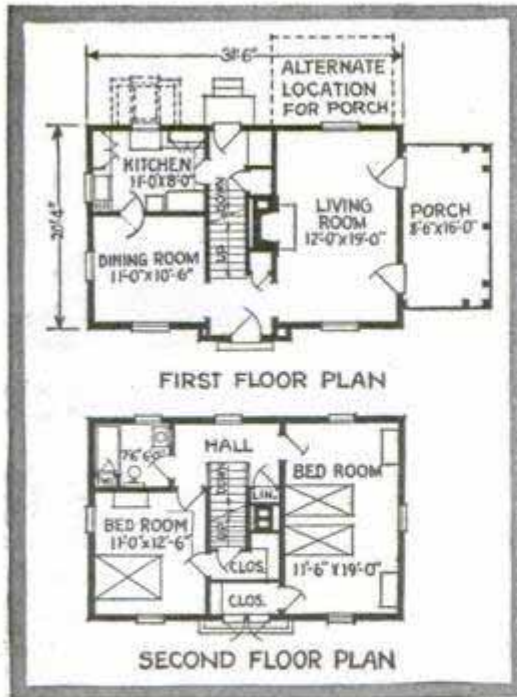

Plan No. 5A52

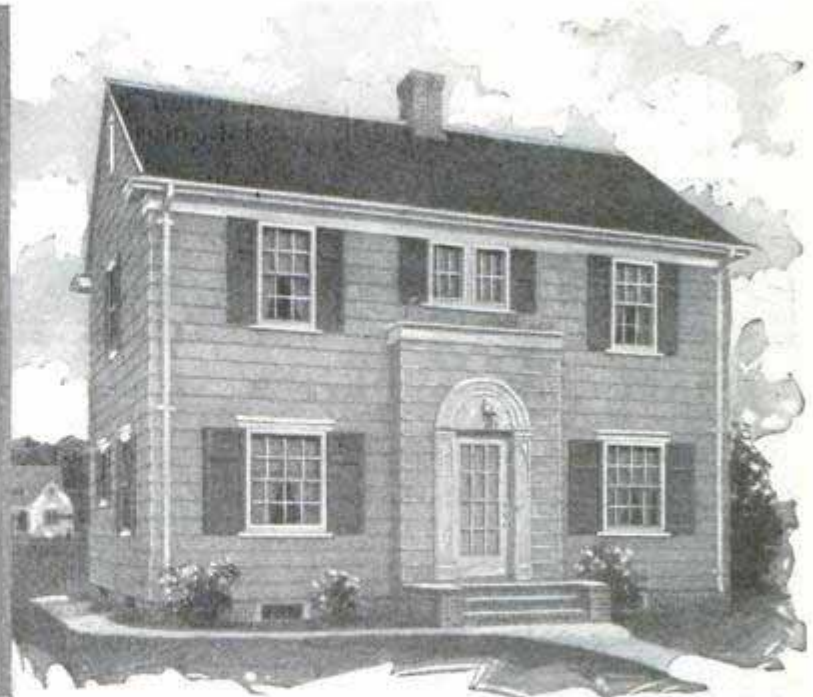

Copyright, Architects' Small House Service Bureau

**QUESTIONS** regarding home building addressed to this magazine will be answered by the Architects' Small House Service Bureau of the United States, Inc., controlled by the American Institute of Architects and indorsed by the department of commerce, United States government. Blueprints, specifications and material lists for the house shown above may be obtained at a nominal cost. Inclose self-addressed stamped envelope for reply. If further information is desired send five cents and stamped envelope for a 24-page booklet explaining how the small home bureau functions and showing twelve sample plans.

**T**HE charm of this design—its delightful homelike quality—does not depend upon expensive material or elaborate details, but upon good proportions, nice spacing of doors and windows, and the happy use of a delightful arched Colonial entrance.

In this home you will find a combination of good architecture and true building economy.

As planned, the house is of frame construction, exterior finished with shingles twenty-four inches long, laid eight inches to the weather.

The base is of cement, but might just as easily be of brick, if the owner desires. Stucco or siding can be used for the exterior, if preferred. The house will look equally well in either of these materials.

A fifty-foot lot is required if the porch is built at the side of the house. If placed at the rear, the house can be erected on a forty-foot lot. If the house is swung around and faced to the side, it can be accommodated on a thirty-five-foot lot.

There are five good-sized rooms and bath, within a very small space. There is no waste in hallways, because this is the ever popular center-hallway type with a living room running full depth of the house. Two good bedrooms and a bath complete the second-floor arrangement.

The house was designed to face west or

north, but can be reversed if it is desired to face it in any other direction.

## Home Builders' Questions

**Q.** How can the exact amount of discount or bonus on second mortgages be obtained? **A.** The amount of discount on a second mortgage is flexible. It depends on what proportion of the whole cost of the house is covered by the second mortgage, for how long a time it is to run, and who the lender is. It is a common practice to discount this paper at so much per \$1,000. If the contract is for \$5,000, the discount may be four per cent per thousand. The borrower would then take \$4,000 cash and give a second mortgage for \$5,000.

**Q.** We are thinking of buying a lot that has been filled with ashes and perhaps with other refuse. Can we build on this lot after it has settled? How long does it take to settle? **A.** It is not safe to build on a fill. It is very difficult to tell when settlement has been completed. The strength of this material is so unreliable that a building placed upon it probably will settle unevenly. If this takes place you will have cracked walls, cracked plaster, and more or less general deterioration. If you purchase this lot you should add the cost of excavation so you can build up from the original soil.

**Q.** How much slope must a roof have for shingles? **A.** Shingles should not be used when the slope is less than thirty degrees. If the slope is less, the shingles will not turn water properly and will deteriorate very rapidly. We recommend sheet roofing for low-pitched roofs.

**Q.** The paint on one side of my home comes off in strips. What causes this? **A.** When paint is put on wood that is even slightly damp, it will not adhere, but will blister, and come off in the long strips of which you speak. If there is some leakage from the roof or gutters so as to keep the wood continually damp underneath the paint, the paint will not adhere. To correct the fault have all the paint scraped off. Before any repainting is done see that the boards are thoroughly dried and that they will be kept so.

# WHAT YOU WANT TO KNOW

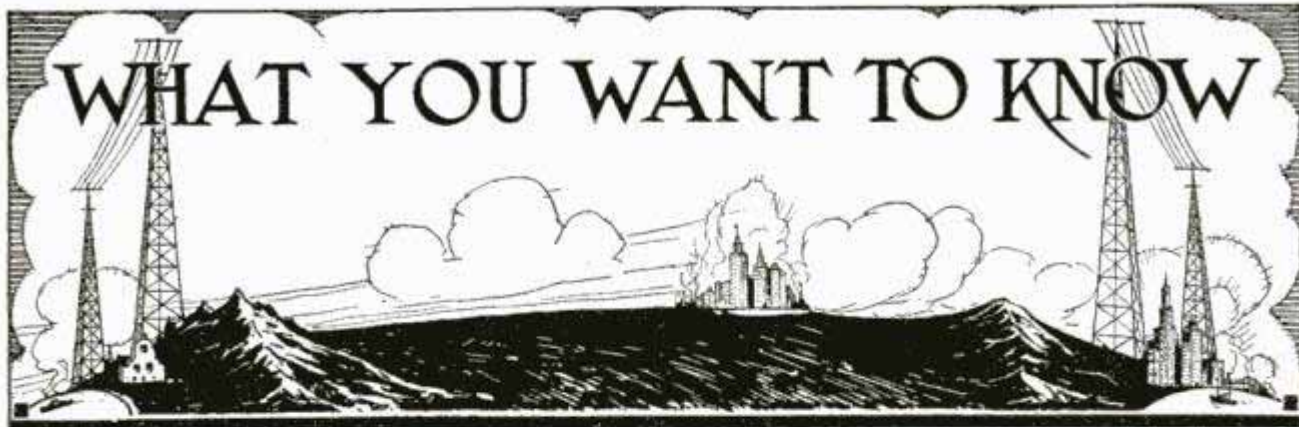

**Q.** What is the red terminal on the horn cord for, and how should it be connected to the plug? **A.** The red cord should be connected to the side of the plug that makes contact with the high-voltage B-positive side of the jack, as shown in Fig. 1. If your jack is not connected as shown, the right side can be determined by

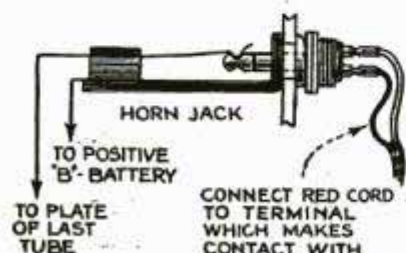

Fig. 1

trial, as the best results will be obtained when the polarity is correct for the microphone.

**Q.** Is a C-battery necessary with a resistance-coupled amplifier? If so what voltages are necessary with 90 and 135 of B-battery? **A.** C-battery is necessary to conserve the B-battery with any type of amplifier.

If you use 90 volts of B-battery, use 4.5 volts negative bias. If 135 volts are used, the negative bias should be 7.5 volts.

**Q.** How can I increase the selectivity of my five-tube neutrodyne receiver? **A.** Shorten your aerial, or reduce the number of turns on the primary of your first neutroformer. Reducing the distance between the primary and secondary coils also will result in greater selectivity.

**Q.** I have three .00035 variable condensers and wish to make a tuned r.f. receiver; how shall I wind the coils so that they will be the right size for these condensers? I have some bakelite tubing, 3 in. in diameter, that I wish to use. Also please tell me what size of wire to use. **A.** For the two r.f. stages the primary should consist of 9 turns, wound over a secondary consisting of 50 turns. The aerial coil can be wound on the same size tube, and 80 turns should be placed on it. Cut each tube about 3 in. long, and use either No. 22 or 26 d.c.c. wire for all coils.

**Q.** Would you advise the use of an a.f. transformer and two stages of resistance-coupled amplification? **A.** One a.f. transformer and two stages of resistance-coupled amplification will give excellent results. Both amplifier units should be of high quality; do not use a transformer of higher ratio than 3½ to 1.

**Q.** What results have been obtained with the new underground antenna? Is it practical, and does it eliminate static? **A.** We have experimented with this type of aerial, and the results were very satisfactory. It reduces static effects and gives good clear signals over a wide range. There are several good types on the market in 75 and 100-ft. lengths.

**Q.** Does a gas pipe make a good ground? I am using this type of ground and the results do not seem to be as good as I am told they should be. **A.** Gas pipes sometimes have rubber and other insulating materials at the joints and therefore make poor grounds. The use of gas pipes for grounds is also prohibited by the insurance companies. Steam pipes also sometimes have

rubber gaskets at the joints and the connecting bolts cannot be depended upon for good connections. A cold-water pipe offers the best type of ground.

**Q.** Can two stages of r.f. be added to a regenerative set? Will it increase the volume and range? **A.** The volume and range would be increased to a very small extent; the addition is not practical, considering the cost.

**Q.** I am having a great deal of trouble with body capacity in my set. When the headphones are touched, the stations are often lost; how can I prevent this? **A.** Ground one side of your filament battery if it is not already grounded. Also try connecting a .002-mfd. fixed condenser across the primary of the a.f. transformer. You may find it necessary to shield the instrument panel, but try the other suggestions first.

**Q.** Would straight-line frequency condensers improve my tuned r.f. receiver? Would I get better selectivity? **A.** These condensers will spread the stations out over the dial, giving a greater apparent selectivity, and make tuning easier on the crowded lower end of the dial. However, the selectivity of the set may depend on other factors that cannot be remedied by changing the condensers. Try a shorter aerial or reduce the number of turns in the aerial coil.

**Q.** Is it possible to make a good variable gridleak of the pencil-mark type? I have tried several leaks of this type, but do not seem to get good results with the hard tubes. **A.** It is very difficult to make a good gridleak of this type. We would advise you to purchase a variable gridleak. They are inexpensive and give satisfactory results.

**Q.** Can UV-199 or C-299 tubes be used in the perfect-tone six receiver described in the November, 1925, issue? **A.** We do not advise the use of the small tubes in this set. Best results are obtained with standard A-tubes.

**Q.** I have two 4½-volt C-batteries of the tapped type; how can I connect them so as to obtain a 4½ and a 9-volt negative grid bias? Also please show me how I can get 6 volts negative for the UX-112 tube at 90 volts. **A.** The diagram is given in Fig. 2. The upper batteries are connected so as to obtain 4½ volts negative bias for the UV-201A tube at 90 volts and 9 volts bias for the UX-112 tube at 135 volts. The lower diagram shows how to obtain 6 volts bias when using the UX-112 tube at 90 volts.

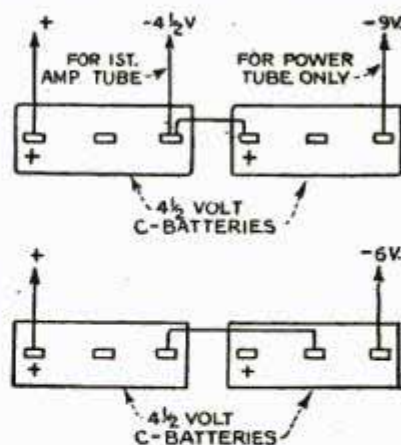

Fig. 2

**I**N accordance with the editorial policy of this magazine never to accept compensation in any form for what appears in our reading pages and also to avoid the appearance of doing so, we are obliged to omit the name of the maker or the seller of any article described. This information, however, is kept on file and will be furnished free, by addressing Bureau of Information, Popular Mechanics Magazine, Chicago. [Editor.]

# Whatever you are sawing —you need the saw that *cuts*



**I**T pays a man to buy a good saw the first time, for there is no telling what he will want to do with it.

He may saw a lot, — or only a little. He may work with clear, seasoned lumber. He may run into plenty of rough, heavy cutting. Probably he'll have both.

Anyhow, if he needs a saw at all he needs a saw that *cuts*.

Recognition of this fact made fame for Henry Disston. For he scrapped



Disston D-20, narrow blade, light weight, superior quality; a leader among Disston Saws

ancient saw-design to develop the fast, true, easy-cutting saw that bears his name.

The Disston Saw cuts faster, holds its edge longer, because of the steel Disston developed. It cuts more easily — truer and smoother and straighter—

because of the improved methods of Disston-trained craftsmen.

It had to surpass in cutting to become "The Saw Most Carpenters Use."

Say "Disston" to any hardware dealer.

### *Ask Disston*

Tell us what work you are doing, in wood, metal, stone, ivory, rubber, leather, cloth, fibre or other materials. We will tell you how to saw it better and easier. Disston issues many free books to aid saw users.

HENRY DISSTON & SONS, INC., PHILADELPHIA, U. S. A.

# DISSTON

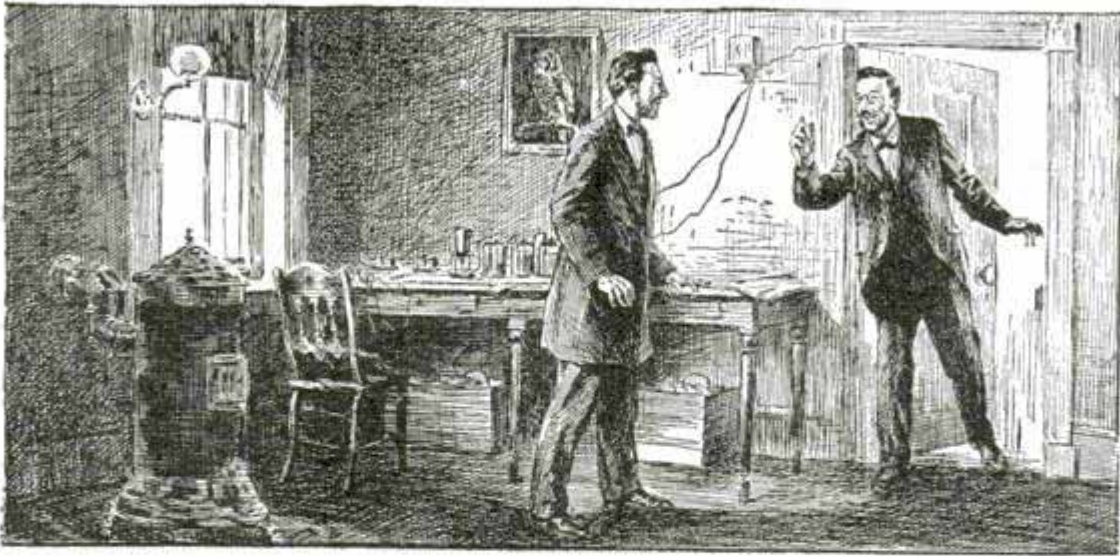

## *From One Sentence To Millions*

ON MARCH 10, 1876, a single sentence was heard over the telephone. Now, after half a century, 50,000,000 conversations are heard each day.

"Mr. Watson, come here; I want you," spoken by Alexander Graham Bell, the inventor, was the first sentence.

His first crude instruments had been tested by sounds and single words; the patent had been granted; the principle was established from which a world of telephones has since resulted. But at that time the telephone had not proved its practical usefulness—its power to command.

Bell's words, electrically transmitted over a wire, brought his assistant from another part of the building. And with his coming, the telephone became a dynamic factor in human affairs.

Since that first call untold millions of sentences have been heard over the telephone. Men have traveled vast distances in answer to its calls. The wheels of great industrial enterprises have turned at its commands. Everything that man can say to man has been carried to a distance over its wires, and the thoughts and actions of nations have been influenced through its use.

AMERICAN TELEPHONE AND TELEGRAPH COMPANY  
AND ASSOCIATED COMPANIES

*BELL*  *SYSTEM*

IN ITS SEMI-CENTENNIAL YEAR THE BELL SYSTEM LOOKS FORWARD  
TO CONTINUED PROGRESS IN TELEPHONE COMMUNICATION



"YANKEE" No. 15 With thumb-turn on blade.

"YANKEE" No. 10 Ratchet Driver.

"YANKEE" No. 41 Bore holes simply by pushing on handle.

"YANKEE" No. 30-A Regular No. 130-A Quick-Return with spring in handle.

Customer at the dealer's counter, trying tools on "Yankee" Demonstrator.

## Like play!—when you work with "YANKEE" TOOLS

Look for this "Yankee" Demonstrator on dealer's counter

No need to ask questions. Learn for yourself how easy, quick and sure "Yankee" Tools will work in your own hands.

With No. 15 you start wobbly screws by revolving thumb-turn on blade with thumb and fore-finger.

With "Yankee" No. 10, turn handle to and fro: and find out what it means to have a "Yankee" Ratchet Screw-driver in your kit.

Push down on the handle of "Yankee" Drill No. 41. See

how handy it is to bore holes in wood.

And on this Demonstrator you can operate the "Yankee" Spiral Screw-driver—the world-standard, high-speed screw-driving tool!

Your hardware dealer wants you to feel free to try "Yankee" Tools. That is why he displays on his counter this new mechanical Demonstrator.

Write us for "Yankee" Tool Book.

NORTH BROS. MFG. CO.  
Philadelphia, U. S. A.

### Chuck and Drill Points

enable you to drill holes with spiral screw-drivers.

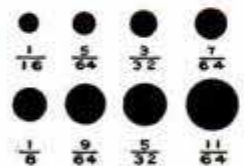

Drill Points same as for Push Drills.

"Yankee" on the tool you buy means the utmost in quality, efficiency and durability

# "YANKEE" TOOLS *Make Better Mechanics*

# "A cut above the ordinary"

IF, LIKE MOST MEN, your taste runs to Turkish Blend cigarettes and you are seeking one a cut above the ordinary because of the finer grades of tobacco it contains, then learn from Fatima *what a whale of a difference just a few cents make*





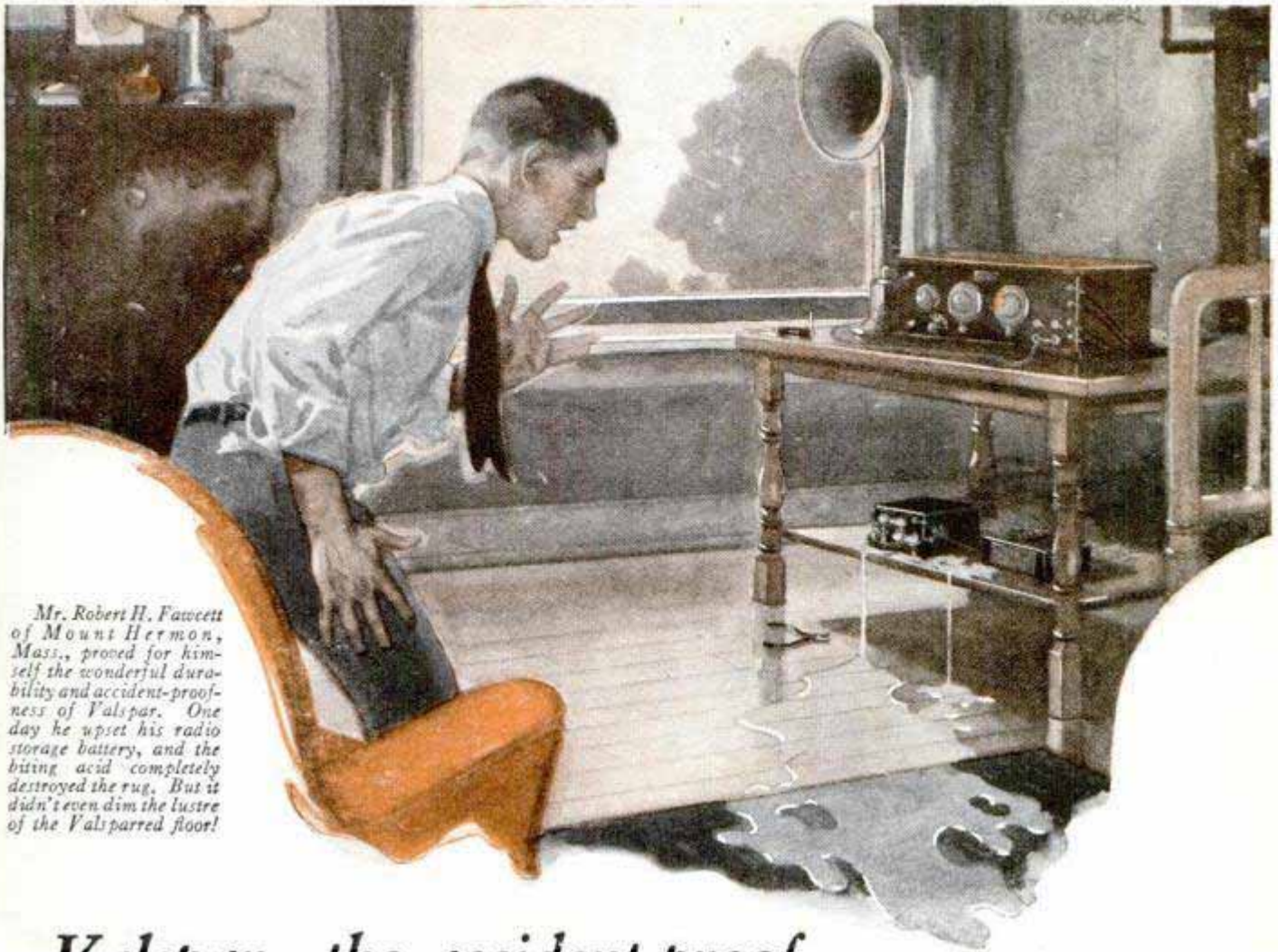

Mr. Robert H. Fawcett of Mount Hermon, Mass., proved for himself the wonderful durability and accident-proofness of Valspar. One day he upset his radio storage battery, and the biting acid completely destroyed the rug. But it didn't even dim the lustre of the Valsparred floor!

## Valspar—the accident-proof varnish of a hundred uses!

You'll find that Valspar comes in handy in a hundred ways. It's the most satisfactory finish for radios, cabinets, carpentry and metalwork, book-shelves, model boats and airplanes—it's a lasting protection for wiring, tools, musical instruments, autos and motorcycles.

Valspar is *the* accident-proof varnish. Spilled acids, ammonia, hot grease—even boiling water and disinfectants—will not dim its fine lustre. It provides a permanent and beautiful finish.

Valspar offers three types of finish. Clear Valspar (a transparent protection for fine wood and bright metalwork); Valspar Varnish-Stain (clear Valspar plus transparent wood stains, which bring out the richness of the natural grain); and Valspar-Enamel (which provides a complete range of solid-covering colors with all of Valspar's beauty and lustre).

All three finishes are easy to apply, dry hard overnight and can be rubbed to a dull finish if desired.

**This Coupon is worth 20 to 60 cents**

**VALENTINE'S**  
**VALSPAR**  
 The Varnish That Won't Turn White

**VALENTINE & COMPANY,**

**460 Fourth Avenue, New York**

I enclose dealer's name and stamps—20c apiece for each 40c sample can checked at right. (Only one sample each of Clear Valspar, Stain and Enamel supplied per person at this special price.)

*Valspar Instruction Book with Color Charts, 15c extra. Print full mail address plainly.*

Clear Valspar   
 Valspar-Enamel   
 Choose 1 Color . . . . .  
 Valspar-Stain   
 Choose 1 Color . . . . .  
 Valspar Book

P. M. 3-26

Dealer's Name.....  
 Address.....  
 Your Name.....  
 Address..... City.....



**“Hey!  
Heavy Handed  
Feller—Use the  
Ratchet Stop!”**

**“You’ll do better, more accurate work and y’won’t be springing that mike I just lent you!”**

A Ratchet Stop does help the man whose “feel” is not super-sensitive and it helps *any* man to do quicker accurate work because it relieves him of the necessity of always guarding against springing his mike by jamming the spindle against the work.

That’s one reason why a lot of men like the Starret No. 230—

it has a Ratchet Stop. Another, bigger, reason is the cut-away frame. You can get it into lots of places where an ordinary frame can’t be inserted.

Ask your dealer to show you this tool. Write us for descriptive matter and Catalog No. 23 “AP”.



**THE L. S. STARRETT CO.**

*World's Greatest Toolmakers  
Manufacturers of Hacksaws Unexcelled  
Steel Tapes—Standard for Accuracy  
ATHOL, MASS.*



8805

**Use Starrett Tools**

# The Newest

# Achievements of

# POWEL CROSLLEY JR.

INDUSTRIALIST, PIONEER RADIO BUILDER, MASTER OF MASS PRODUCTION

*Four entirely new radio sets employing four and five tubes*

- entirely new in principle, design, circuit and appearance.
- entirely unique in the results they give on distant and local stations.
- entirely original in their standards of beauty.
- entirely unprecedented in the value they introduce.
- two of them incorporating the Crescendon, a new and exclusive volume control.

*Now being demonstrated by Crosley dealers everywhere.*

**THE CROSLLEY RADIO CORPORATION, CINCINNATI, OHIO**

Owning and Operating WLW first remote control super-power broadcasting station in America



**The Crosley 4-tube—4-29**  
in which the Crescendon is equivalent to one or more additional tubes of tuned radio frequency amplification..... **\$29**



**The Crosley 5-tube—5-38**  
All the volume, selectivity, sensitivity and purity of tone available in the best 5-tube set—plus the Crescendon..... **\$38**



**The Crosley 5-tube—RFL-60**  
A set so marvelous in performance that its appearance on the market is bound to create a new standard of comparison..... **\$60**



**The Crosley 5-tube—RFL-75**  
For simplicity and speed in tuning, fidelity of tone, and decorative beauty—it stands unchallenged at twice the price..... **\$75**

*West of the Rocky Mountains all prices as published are 10% higher*

# CROSLLEY · RADIO

B E T T E R · C O S T S L E S S



## Home in a Hurry — the New, Safe Way

### Easy to Park

Ride to wherever you want to go — and park there. The New Single fits into any 2x8 space along the curb, in a hallway, shed, garage corner — any place.

### Easy to Buy

Your dealer has a "Pay-As-You-Ride" purchase plan that makes it easy for anyone to buy this new type motorcycle. Ask him about it.

**Mail  
this  
Coupon**

Harley-Davidson  
Motor Company,  
Dept. P  
Milwaukee, Wis.

- Send me free literature about the New Single.  
 Tell me about your dealer proposition.

Name .....

Address .....

City..... State.....

*We want a live dealer in every locality. A money-making opportunity for real workers. If interested, mail the coupon.*

**R**IDE a Harley-Davidson New Single—and be independent of street cars, buses and trains. Come and go without waiting or crowding — at a driving cost that's less than carfare or busfare! 80 safe, comfortable, quick miles to a gallon of gasoline—one-fourth the cost of running the most economical car! A brand new type of motorcycle — ideal for either city or country riding — for work or for pleasure. Plenty of power and speed for all road and traffic conditions. Almost self-balancing — easy to ride and control. Safe! And it's comfortable to ride! You float along smoothly on full balloon tires and a saddle that rests on 19 inches of shock-absorbing springs. The New Single scores on every point. It is the everyday mount for busy, thrifty people.

*Your Harley-Davidson dealer will gladly give you a ride. See him — and mail the coupon for illustrated literature.*

HARLEY-DAVIDSON MOTOR COMPANY  
Dept. P Milwaukee, Wis.

*The*  
**HARLEY-DAVIDSON**  
[ **New-Type**  
**Motorcycle** ] **Single**

## No. 231

Pocket Screw-Driver with different size blades and reamer which complete the set.

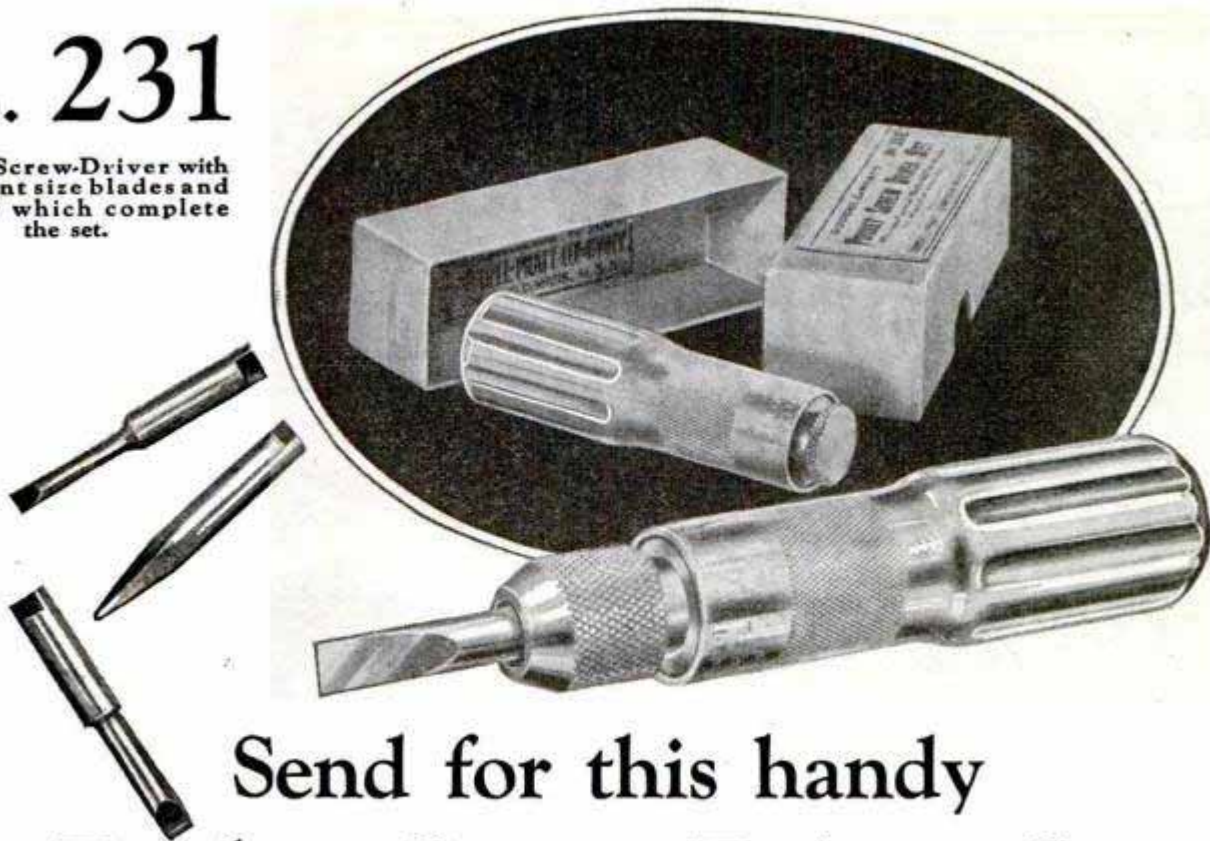

## Send for this handy Pocket Screw-Driver Set

and a 450-page book of Goodell-Pratt Tools  
\$1 brings both to you *Postpaid to any part of the U. S.*

**I**F you use tools at all, you will need this No. 231 Pocket Screw-Driver Set. And you are almost sure to find in the pocket size Goodell-Pratt Catalog one or more tools you will want to own. Take advantage of the special offer of the Screw-Driver Set and the book of tools. Mail the coupon.

The No. 231 Pocket Screw-Driver Set is a beautiful thing, nickel plated, buffed and handsomely polished. It contains a chuck, 3 screw-driver blades ( $\frac{1}{8}$ ,  $\frac{3}{16}$  and  $\frac{1}{4}$  inch wide)

and a reamer. The smallest blade gets even the smallest screws, such as those in a watch. All three tools are machined, made of best tool steel, hardened and tempered.

The reamer will ream out the holes in soft metals and wood. With the tools enclosed in the hollow handle, the set is only  $3\frac{1}{4}$  inches long.

GOODELL-PRATT COMPANY  
GREENFIELD, MASS., U. S. A.

*Toolsmiths*

*Tear out this coupon  
and mail with \$1  
today*



GOODELL-PRATT COMPANY  
Greenfield, Mass.

I enclose  check  
 money order  cash for \$1.00 for 450-page  
pocket catalog of Goodell-Pratt Good Tools and No.  
231 Pocket Screw-Driver Set.

Name.....

Address.....

City..... State.....

# The Latest Tool Information

## —The New BROWN & SHARPE Small Tool Catalog

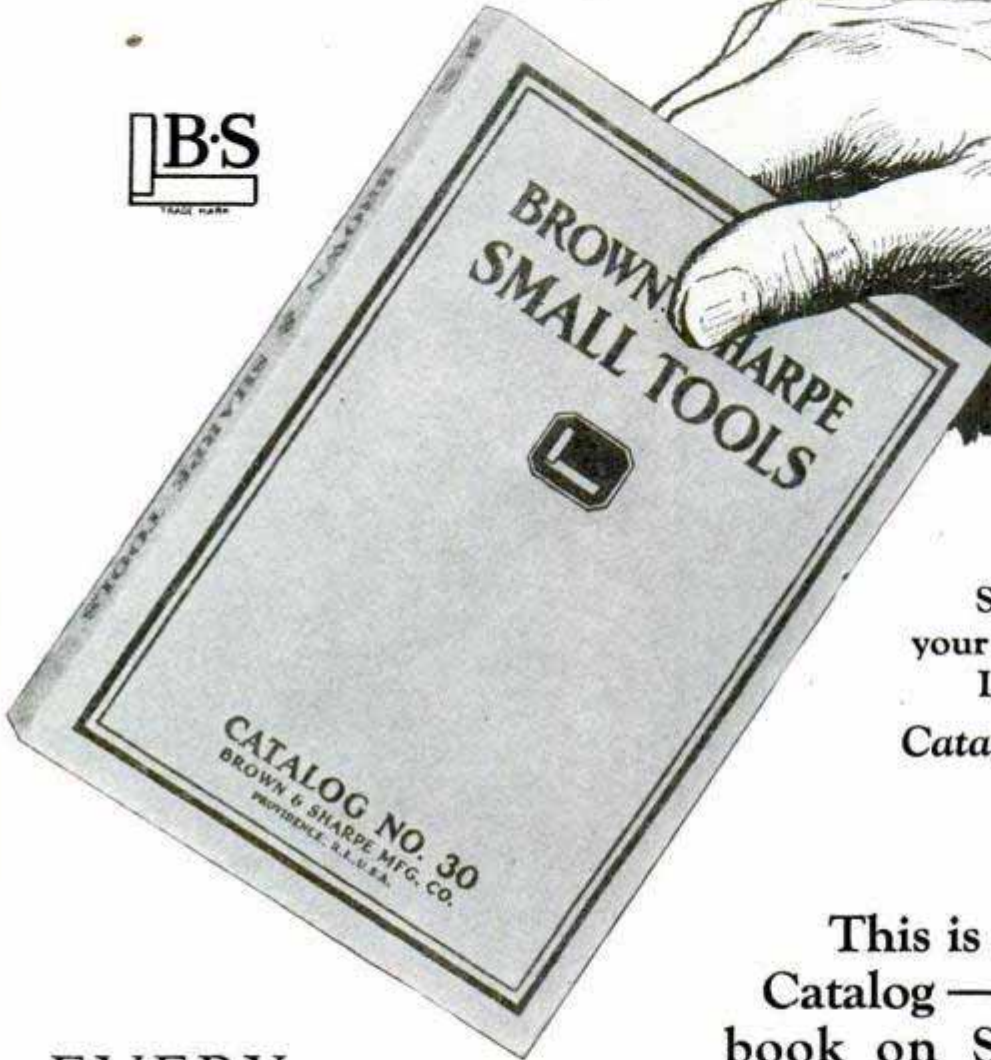

Send for  
your copy today.  
It's Free.  
Catalog No. 30

This is more than a  
Catalog — It's a hand-  
book on Small Tools

EVERY—

SHOP MECHANIC  
TOOL MAKER  
APPRENTICE

STUDENT MECHANIC  
MOTOR SERVICE MAN  
and REPAIR MAN

Should have a copy of this 448 page illustrated catalog of our 2000 tools and 1500 cutters. Listed among these tools and cutters is valuable information—helpful hints—and numerous reference tables. If you use tools you cannot afford to be without a copy.

# BROWN & SHARPE TOOLS

BROWN & SHARPE MFG. CO., Providence, R. I., U. S. A.

# 9 MILLION Families Have Made Us The WORLD'S LARGEST STORE

Q World leadership can never be the result of an accident. It must be merited. And a continuance of this leadership for years proves that the merit has been well won.

Q One family out of every three in America buys from the World's Largest Store because we sell them better goods for less money. "The Thrift Book of a Nation" is the guide to economy in these homes.

Q Our new Spring Catalog is ready now! Every page proves anew that the World's Largest Store gives the World's Biggest Bargains. But not in low price alone does Sears, Roebuck and Co. excel. We guarantee our goods—because we carry the kind of merchandise that can be honestly guaranteed.

Q Remember we value your good will above everything else. Remember we sell only merchandise that will give you honest service; Remember we ship 99 out of every 100 orders in less than 24 hours. Remember we guarantee a saving.

Q If you are going to buy anything this spring, whether it be for family, home, farm or shop, you must have our catalog—"The Thrift Book of a Nation." It is an index to the best values.

Q We have a copy for you. Just fill in and mail the coupon! But do it today.

Women like to buy from the World's Largest Store because they know the quality of our apparel is dependable. They know, too, our prices are unbeatable and our styles most appealing. You should have our new catalog.



We are value leaders. Our men's clothing and furnishing departments prove it to the satisfaction of 9,000,000 families. You make the greatest savings if your selections are from the Thrift Book. We give real 24-hour service.



A rod and a reel, a baseball and a mitt, a tent and a cooking outfit, a set of new tires and tubes—these are the things you buy in the spring. No high prices in these lines—but lots of quality. Our new catalog shows 35,000 bargains.

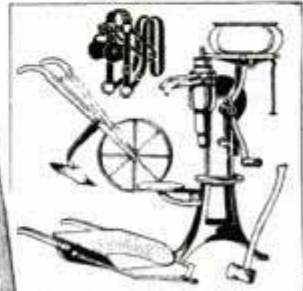

Most all American farmers can tell you of the excellence of our farm implements. They can tell you, also, of the big savings they made by buying from the World's Largest Store. No matter what you want for the farm, we have it.

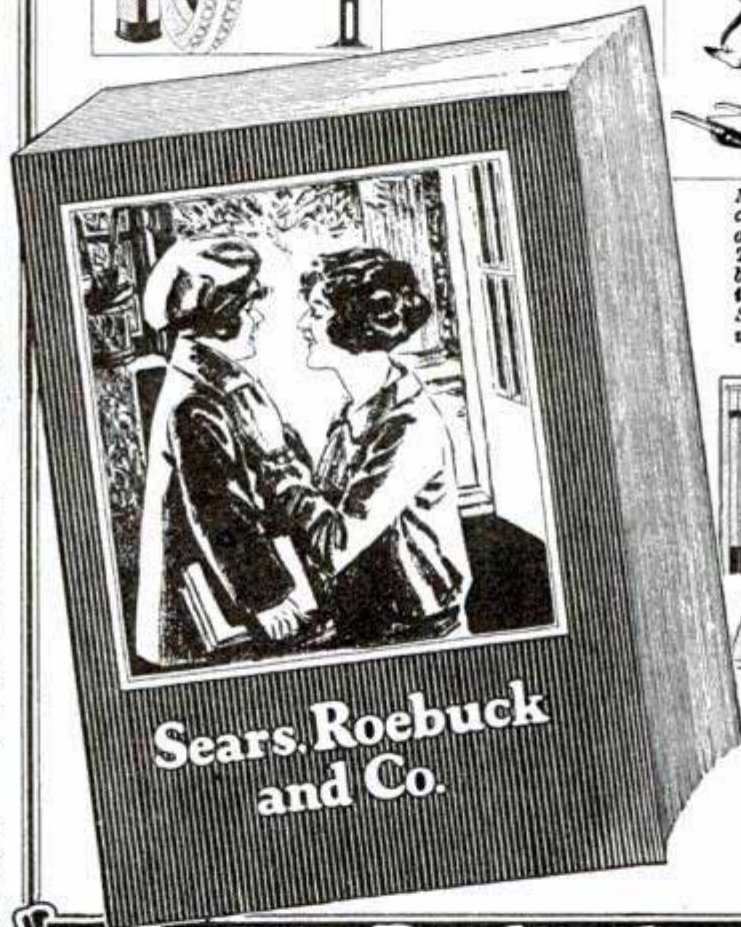

To help make your home more livable is one of our most pleasant tasks. We have paint to brighten it up; furniture to add to its attractiveness; utilities to make home-keeping easier. And we have lower prices on everything!

## Sears, Roebuck and Co.

Chicago • Philadelphia • Kansas City • Dallas • Seattle

SEND FOR YOUR FREE COPY OF OUR THRIFT BOOK

Mail the coupon TODAY to the store nearest you  
SEARS, ROEBUCK AND CO. 80P53  
Chicago • Philadelphia • Kansas City • Dallas • Seattle  
Send me your big Spring and Summer Catalog

Mail the Coupon

WORLD'S LARGEST STORE

We Own and Operate Super-Power Radio Broadcasting Station W-L-S—Tune in on 345 Meters

Name.....  
Postoffice.....  
Rural Route.....Box No.....  
State.....  
Street and No.....  
Shall we send FREE our Wall Paper Sample Book?.....

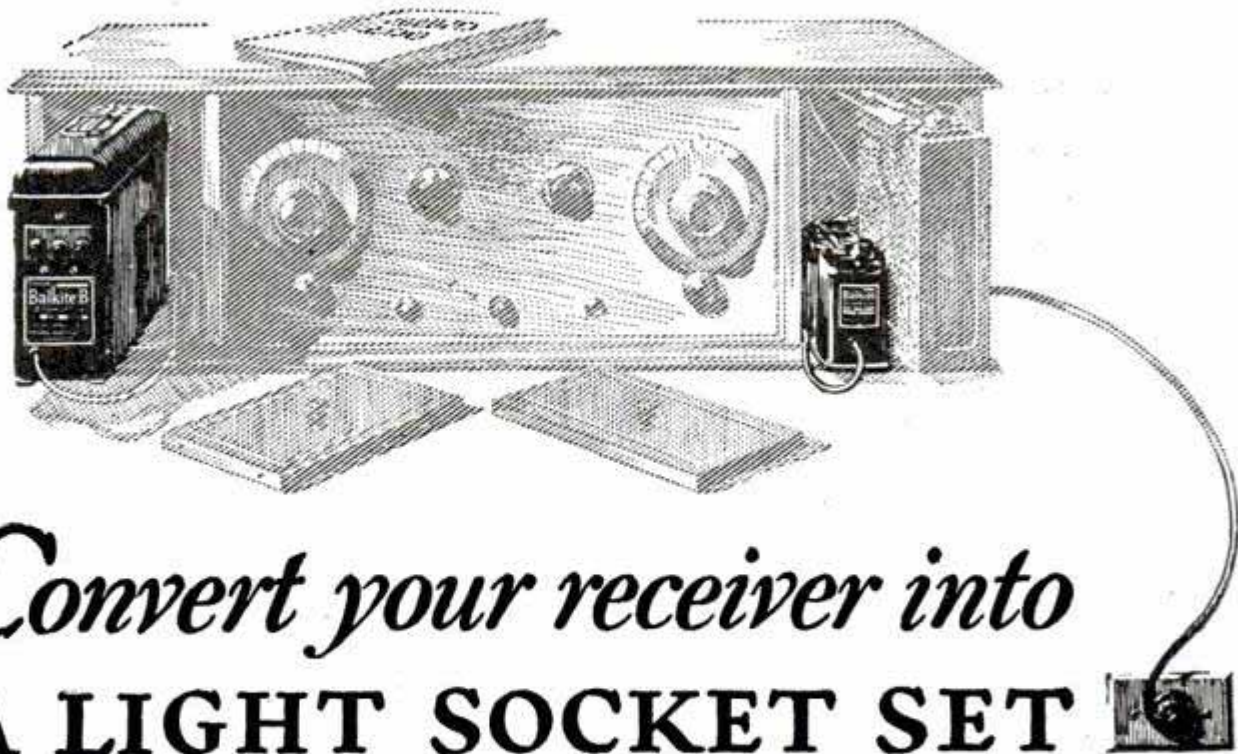

# *Convert your receiver into* **A LIGHT SOCKET SET** *with* **Balkite Radio Power Units**

Now you need wait no longer for a light socket set. Balkite Radio Power Units—the Balkite Trickle Charger and Balkite “B”—enable you to make a light socket set of your present receiver.

The Balkite Trickle Charger converts your “A” Battery into an automatic “A” power Unit that furnishes full “A” current from the light socket at all times. Balkite “B” replaces “B” batteries entirely and furnishes “B” current from the light socket.

This popular light socket installation is extremely simple to install, economical both in initial cost and in operation, and will fit in practically all present battery compartments. It is composed entirely of units that have demonstrated their success over a long period of time.

## *Noiseless—No bulbs—Permanent*

All Balkite Radio Power Units are permanent, entirely noiseless, have no bulbs, no moving parts, nothing to break or get out of order. Their current consumption is very low. All operate from 110-120 volt AC current, with models for 50, 60 and other cycles. All are tested and listed as standard by the Underwriters' Laboratories.

**【 The Balkite Railway Signal Rectifier is now standard equipment on over 50 leading American and Canadian Railroads 】**

FANSTEEL  
**Balkite**  
*Radio Power Units*

MANUFACTURED BY FANSTEEL PRODUCTS COMPANY, INC., NORTH CHICAGO, ILLINOIS

Sole Licensees in the United Kingdom; Messrs. Radio

Accessories Ltd., 9-13 Hythe Rd., Wellesden, N. W. 10



**The World's Only  
Ball Bearing Typewriter**



**Yours  
for  
10 Days  
FREE**

If you decide to keep it  
only **\$3.00**  
DOWN  
BALANCE  
EASY  
TERMS

**NEVER** has there been such a TYPEWRITER

BARGAIN on as EASY TERMS! A genuine SILENT Ball Bearing L. C. Smith—GUARANTEED 5 YEARS—at a 40% SAVING!

**Money Cannot Buy** a better typewriter. Because of its ball bearings and other exclusive features, the L. C. Smith has been recognized for over 20 years as the world's finest, easiest running, longest wearing typewriter. U. S. Government has bought 50,000. The choice of railroads, big corporations like the Standard Oil Co., etc.

**SEND NO MONEY** Just mail the coupon. No red tape; no obligation. We will promptly ship you the typewriter to use for 10 days in your home or office. See how wonderfully speedy and easy it operates, the perfect work it turns out. We depend entirely on the typewriter selling itself; no one will urge you to buy. If you don't think it the finest, easiest running machine ever used, we want you to return it at our expense. You'll want to keep it and you can, by paying \$3.00 down—and \$5 monthly until our Special Price of \$66.20 has been paid.

Now is the time to buy. Take advantage of this LOW PRICE, EASY TERMS OFFER. We may never be able to offer it again.

Send the coupon now—before this offer is withdrawn

**\$40 SAVED by Using this Coupon**

SMITH TYPEWRITER SALES CORP.  
113-360 E. Grand Avenue, CHICAGO, ILL.

Ship me the L. C. Smith Typewriter F. O. B. Chicago. I will deposit \$3 with the express agent on arrival subject to 10 days' trial. If I keep it I will send you \$1 a week until the \$63.20 balance of the special \$66.20 price is paid. The title to remain in you until then. It is understood that I have 10 days in which to examine and try the typewriter. If I choose not to keep it, I will repack and return it to the express agent, who is instructed to return my \$3. You are to give your standard 5-year guarantee.

NAME.....  
ADDRESS.....  
OCCUPATION.....  
EMPLOYED BY.....

**Only  
the L. C. Smith  
Has All These  
Features:**

- Ball Bearings at all points of wear and friction (636 of them)
- All of the writing always in sight
- Non-Shift Carriage
- Silent in Operation
- Two Color Ribbon
- Back Spacer
- Tabulator
- All the latest operating conveniences
- Beautiful—re-n<sup>e</sup>wed

**GUARANTEED  
FIVE  
YEARS**

**Send  
No MONEY  
Just this  
Coupon**

**FREE  
TO YOU NOW**

Complete Course of Lessons in Touch Typewriting; Tools; and Waterproof Cover; Complete Operating Instructions given with this machine. This is the easiest typewriter to operate and learn. You can learn to use it in a day with our instructions.

**Double Thick**  
**Double Keen**



**Break away  
from Bad Blades!**

**T**HE Gem Double Life Blade has the edge on all other makes. It's the keenest edge ever ground on steel—and the steel we use is double-heavy.

The Gem shaves you double-swift and double-smooth—for *double the shaves*.

Why be double-crossed by single-life blades when the Gem Double Life Blade will give you *more and better shaves at less cost?*

—Each Gem Blade double-protected and double-sealed. Sold Everywhere.

*P. S.—Your money does double duty when it buys a Gem de Luxe Razor.*

GEM SAFETY RAZOR CORPORATION  
Brooklyn, N. Y.

**GEM**  
*Double Life*  
**BLADES**

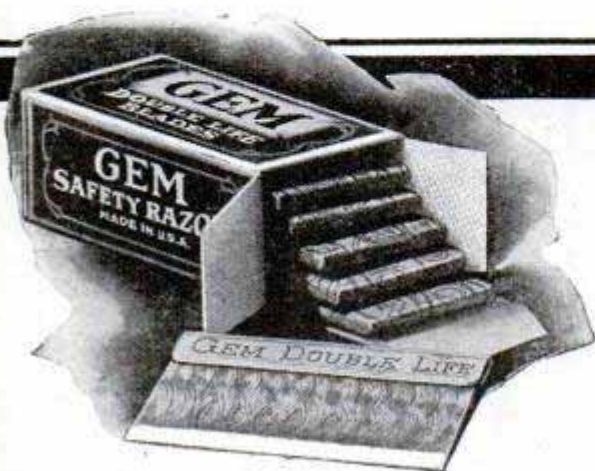

**Anybody Can Use It**

**KESTER**  
*READY TO USE*  
**METAL MENDER**  
*The Household Solder*

Here's why thousands use Kester Metal Mender.  
**Simple**—Requires Only Heat! Anyone can use it.  
**Safe**—No messy pots or dangerous acids.  
**Sure**—Genuine Solder makes firm metal joints.  
**Satisfactory**—Works equally well on light or heavy, old or new work.  
**Economical**—Saves many times its price.  
**Your Dealer Can Supply You**

Soldering Booklet  
"It's a Cinch to Solder"  
Upon Request

**CHICAGO SOLDER COMPANY**  
4201-328 Wrightwood Ave., Chicago, U.S.A.

**LATEST "COAST TO COAST" FULLY GUARANTEED**  
**RADIO'S-10 DAYS FREE TRIAL**  
**SAVE 1/3 TO 1/2**

Users everywhere report Miraco Radios get programs coast to coast on loud speaker; outperform sets three times as costly. Many hear foreign countries. Radio's most amazing values in unconditionally guaranteed, factory-built long distance sets—let testimony of users convince you.

**MIRACO RADIO GETS 'EM COAST TO COAST**

Powerful New Multi-tube Miraco gets long distance on loud speaker. Set. ONLY \$27.35 retail

FREE! Literature on latest improved 1 to 5 tube models, new low prices, testimony of users and SPECIAL OFFER. Write: **MIDWEST RADIO CORP'N**  
*Pioneer Builders of Sets*  
407-W E. 8th St. Cincinnati, O.

AGENT USERS WANTED  
Write for discounts.

**Make \$100 Weekly—sell RADIO**  
**Demonstrate Once—Results Mean Sure Sale**

Sell what everybody wants—radio at low prices—easy sales—big profits—music from Coast to Coast—4, 5, 7 tube radio.

**12 Selling Free Lessons**

Establish a business of your own. Start in spare time—evenings. Sales course of 12 lessons and 10 radio service lessons teach you everything you need. Exclusive territory to proven men!

**FREE Book!** Tells how 3100 men have made big increase in their income under this unusual plan. Ask for Ozarka Plan No. 100 and don't fail to mention the name of your county.

**OZARKA, Inc.** 120 Austin Avenue P, Chicago, Illinois

**KARAS HARMONIK TRANSFORMERS**  
**ORTHOMETRIC CONDENSERS**

The highest quality parts possible to produce.

**KARAS ELECTRIC CO., 1113 N. Rockwell Street, CHICAGO**

**Let the American Scroll Saw**  
**SOLVE YOUR SAW PROBLEMS**

You will like its sturdy mechanical construction. It will saw wood, fibre, bakelite 1 in. and metal 1/4 in. thick. Sold also without motor. We carry a complete line of bench woodworking machinery.

For details write to  
**DELTA SPECIALTY CO.**  
Dept. No. A-111  
858 Third St., Milwaukee, Wis.

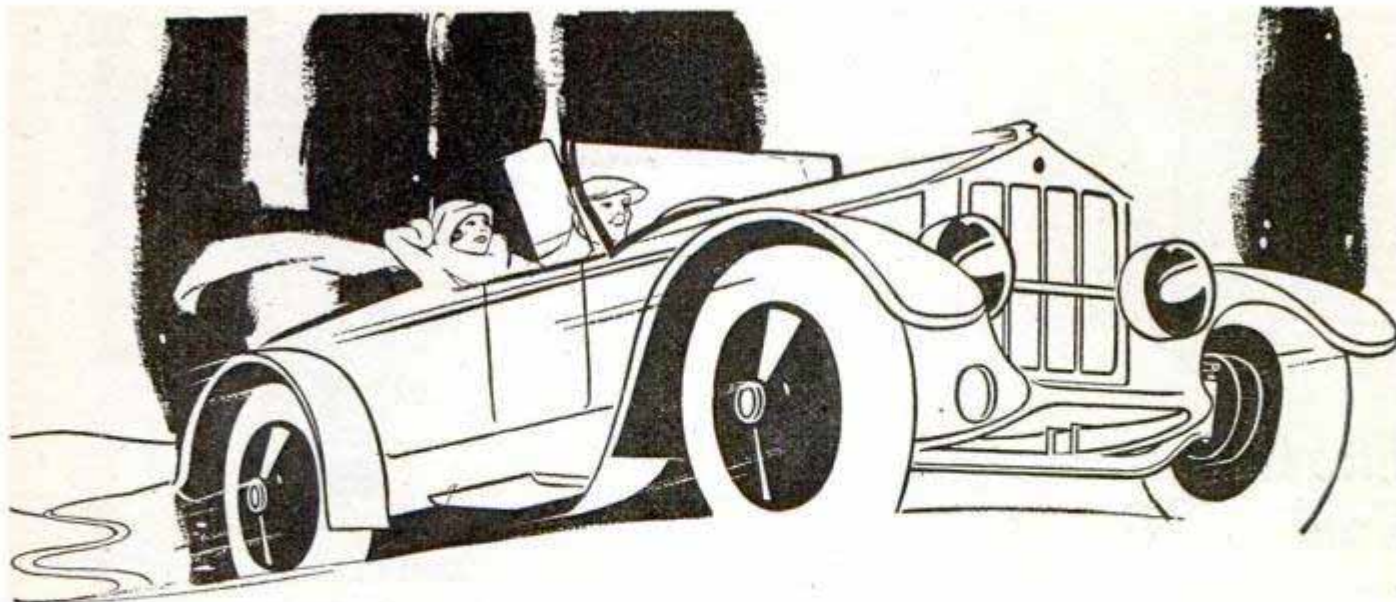

# 61 Miles on a Gallon

**Amazing Invention Makes Practically Any Car Give Double Its Regular Mileage to the Gallon! Fits Any Make or Model Car!**

Now you can cut your gasoline cost as low as 9c a gallon. An amazing new invention makes practically any car give twice its regular mileage to the gallon—many

run from 37 to 57 miles, and even up to 61 miles on a gallon of gasoline! This wonderful invention is the work of Mr. J. A. Stransky of Pukwana, South Dakota. Already it is being used by over a million satisfied car owners—on all makes and models of cars. And now the inventor will send you a sample at his own risk! Read his offer below.

## Earn \$250 to \$500 a Month

And now this amazing new invention is making fortunes for agents and distributors. Now you, too, can make big money—just telling your friends about it. You can easily earn astonishingly big profits in full or spare time—many are earning \$34 to \$69 every day. There is no reason in the world why you cannot start out with this astounding invention and clean up \$250 to \$500 every month.

Here's how this wonderful little device works. Every carburetor is adjusted to make starting easy—it gives a rich mixture to start a cold engine. But once the engine gets heated up the mixture is far too rich, resulting in faulty explosion. Half the gasoline is drawn into the cylinders in a raw state, and, instead of exploding, it burns. This causes a heavy deposit of carbon.

But with this startling little device in a car all this is changed. As soon as the engine warms up, this device automatically begins to admit a much larger volume of air, thoroughly vaporizing all the gasoline, giving it fully 50% more power

—breaking it up so that it explodes instead of burning.

To introduce this new invention, Mr. Stransky, the inventor, will send a sample at his own risk. Not only that, but he will actually pay you for testing his Vaporizer if you are not delighted with it.

The demand for the Stransky Vaporizer is enormous. Agents handling this device are simply coining money. Every auto owner in the country—and there are twenty million of them—wants this splendid new invention the minute he sees it. Just send the coupon at once for full details of our introductory sample offer. Be the man to cash in big in your community.

**J. A. Stransky Manufacturing Company**  
C-960 Stransky Bldg. Pukwana, So. Dakota

**Mail This Coupon Today**

J. A. Stransky Mfg. Co.,  
C-960 Stransky Bldg.,  
Pukwana, South Dakota.

Tell me how I can get samples of the Stransky Vaporizer at your risk.

Name.....

Street or R. F. D.....

City.....State.....

**\$51 an Hour**

The Stransky Vaporizer is one of the biggest sales propositions of the century—you can make big money quick. But don't take our word for it. Read what these men say.

J. W. Cronk made \$51 in one hour. He says: "The results of one hour's work—17 men gave me orders for the vaporizers."

**\$120 in One Day**

I have found out that the Stransky will do what you said it would. I took forty orders in one day, and wasn't out long. My Ford runs better than it ever did. I can save half the gas and it pulls better.—J. M. James.

**\$147.50 in One Day**

My profits for one day were \$147.50. In one week I made \$280. Yes, I am always on the job.—S. E. Herrick, Ore.

**\$48 in 3 Hours**

My gas bill has been cut nearly in half. I have removed every particle of carbon from my engine. Since I installed it, my engine runs as good as new, starts easier and quicker. I went out Saturday about three hours and secured 16 orders.—J. A. Williams.



## The Opportunity You've Waited For!

If you have wanted to get into business for yourself, in a live, hustling field, here's the opportunity you have waited for!

We want a live, hard-working sales representative in every locality to build up a big business on the Harley-Davidson Single, the new-type motorcycle. Easier to sell than cheap cars on a basis of travel economy and flexibility. 80 miles to a gallon of gasoline! No parking or garaging problem. Nearly every man between the ages of 15 and 50 is a prospect.

With our advertising, sales-help and organization backing you, a most profitable business can be yours—if you are a worker.

Write for full particulars. Do it today!

HARLEY-DAVIDSON MOTOR CO.  
DEPT. P MILWAUKEE, WIS.

# The HARLEY-DAVIDSON [New-Type Motorcycle] Single

See our other advertisement on Page 120

**SOFT SNAP FOR AGENTS**  
GLAROFF Kills Headlight Glare  
Our representatives making from \$12 a day up to \$3000 yearly. Simple new device protects driver from glare of headlights and sun. Write for Special Free Offer.  
GLAROFF MFG. CO. 808C Road St., Sioux Falls, S. D.

Information on any book free. Write Popular Mechanics Press, Chicago, Ill.



**Saw Table** Can be purchased with 6-inch saw for \$22.50  
Delivery paid East of Mississippi. \$24.50 Delivery paid West of Mississippi.

**Motor** This heavy duty motor can be furnished separately for delivery paid East of Mississippi. \$13.90 Delivery paid West of Mississippi. Complete with Cord, Plug and flat or grooved Pulley. Guaranteed 50% Overload. Special Prices on Quantities of 10 or Over.

PAUL J. DEVITT, 1101-1107 So. 2nd St., Phila., Pa.

## 100 Famous U. S. Army Aeroplane Radio Sets

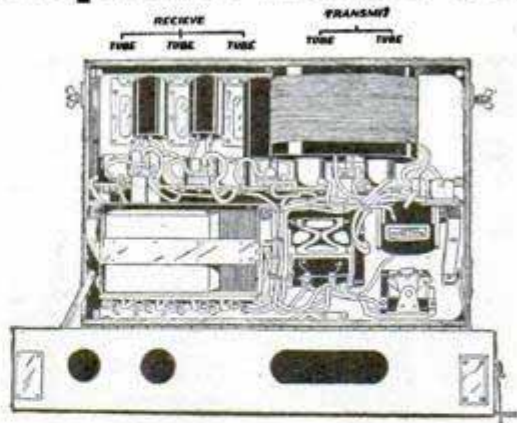

### MADE BY WESTERN ELECTRIC COMPANY 5 Tubes for Transmitting and Receiving

Here is your opportunity to get most wonderful Radio Set on the market. Receives and transmits by turn of switch. Receiving range 190 to 600 meters. A slight change necessary to transmit on assigned amateur wave lengths. Lives depended on reliability of this set during war. Rubber cushioned and insulated thruout. No vibration—static or distortion. Ideal for Home—Auto—Boat—Clubhouse or Portable Use.

### SPECIAL PRICE OFFER \$39.65 WHILE THEY LAST—Reg. \$138 Set—Only

We understand these Sets cost the government \$138. Only by special arrangements were we able to get 100 Sets and offer them to the public at this sensational price. Regular standard equipment is used for receiving. Any transmitter tube having same base as W. E. Co. power and oscillating tube may be used with this outfit. The greatest buy in Radio Today.

**DON'T DELAY!** Write today for complete details. Orders will be filled in rotation. At \$39.65 price 100 U. S. Army Broadcasting and Receiving Sets won't last long. Reserve yours today!

**WARSHAWSKY & CO.** 1915 South State Street Div. PM-03 CHICAGO

## Makes Old Ford a Tractor

We furnish everything for converting Ford Auto Chassis with Engine into a handy Farm Tractor. Just right for truck growers, small farms, nurseries, etc. Pulls 16" Plow, Discs, Seeds, Cultivates; Runs Belt Machinery. We also build Garden Tractors and Cutter Bar Mower Attachments.

Handles Easily Turns in 15' Circle



Write for Free Particulars.

SHAW MFG. CO., Dept. F, Galesburg, Kan.

## SHAW MOTOR ATTACHMENT MAKES YOUR BIKE A MOTORCYCLE!

A high grade 2 1/2 H. P. motor attachment quickly clamped on any bike frame. Speed 4 to 40 miles an hour. 90 to 125 miles per gallon of gas.

**Special Low Price Now!** Write today for Complete Description and Special Low Prices on SHAW Motor Attachments and the SHAW Complete Motorbicycle.  
SHAW MANUFACTURING COMPANY Dept. 37 Galesburg, Kansas



## MECHANICS BENCH SAW

With this saw you can make your own repairs in shop, home, farm or garage. Makes a clean edge on the toughest wood—no planing necessary. Rips, cross-cuts, bevels, miters, mortises, tenons, or grooves. Attach to any lamp socket. Weight only 61 lbs. Will cut up to 1 1/4" All metal. Saw size 6 in. Table 10x13, base 7x11, height 7 in. Table tilts for beveling 5 degrees left, 10 degrees right.

**WRITE FOR OUR NET PRICE BUILDERS' HARDWARE CATALOG**

# WINDOW SIGNS



## AGENTS

### 500% Profit

### Selling Genuine Gold Leaf Letters Guaranteed to Never Tarnish

For Store Fronts, Office Windows, Bank Windows, Office Doors, Panels, Board Signs, Trucks, Automobiles and Glass Signs of all kinds. No experience necessary. Anyone can put them on and make money right from the start without previous experience. All you have to do is to show your samples, the letters are very attractive and easy to sell. Letters costing 4c sell for 25c. One agent says: "Your letters are the best thing I have seen in years. I have made \$125.00 the first week and still going strong." Paul Clark says: "Smallest day \$28.70." H. Gilder made \$835.00 in six weeks.

### \$60 to \$200 a Week—Now Is the Time

**General Agents** It is easy to appoint sub agents for this line. We pay you 20% cash commission on all orders we receive from local agents appointed by you anywhere. We allow you 50% discount on your own orders. You can sell to nearby trade or travel all over the country as you please. Large demand for window lettering everywhere. WRITE TODAY for free sample, full particulars and liberal offer to general agents.

### Our Agents Are Coining Money

### Be a Traveling Sign Man

READ WHAT THEY SAY

**Makes \$38.75 in Two Days**

Gentlemen: Enclosed please find order and M. O. of \$4.00. Send balance C. O. D. I expect the next order will be a larger one, as I have plenty of sign work on hand. I will send you a picture of the job I have done here. I made \$38.75 in two days, and have about \$150.00 worth of orders already taken, besides many promises.  
Yours truly, A. E. WEINTRAUB, Helena, Ark.

**\$25.00 in Three Hours**

Gentlemen: Please find enclosed \$7.75 for order enclosed. Times are not good here, and this is a small town. However, I sold over \$25.00 worth in three hours. When I leave here and strike a live town, look out for my smoke. I am more than pleased with results. Believe I can make \$25.00 per day in a good town. Will send for a supply when these are up. Please send these by mail. I enclose extra stamps.  
Yours for business,  
J. B. TOWER, Portales, N. M.

**Takes in \$62.80 in Two Days**

Gentlemen: I received the order here today all O. K. and am wiring you tonight an order to be sent to East Radford, Va. I put up \$27.70 worth of jobs here today. I got \$35.10 out of Marion, Va. You may send me 500 more letters C. O. D. to Bristol, Tenn., on receipt of this letter.  
Yours truly,  
F. E. DURAWAY, Bristol, Tenn.

**MAIL COUPON AT ONCE**

**METALLIC LETTER CO., 430 N. Clark St., CHICAGO, ILL.**

For a quick, easy money-making proposition for agents, salesmen and sign painters, there is nothing to equal the selling and putting on of our gold and silver metallic letters for office windows, store fronts, bank windows, and glass signs. No experience is necessary. Anyone can put them on and succeed right from the start. You can sell to local and near-by trade, or travel all over the country as you please.

**Metallc Letter Co., 430 N. Clark St., Chicago**

Please send free sample, full particulars and liberal offer to general agents.

Name.....

Address.....

City.....State.....

# "Saws 25 Cords In 5 Hours"

Any hustler can make big money with the one-profit WITTE Saw RIG—Ed. Davis sawed 25 cords in 5 hours—another user sawed 40 loads of pole wood in 3 hours. Hundreds of owners make \$3,000 to \$5,000 a year. Sold on Easy Payments.

**5 H-P.  
3-in-1  
Saw  
Rig**

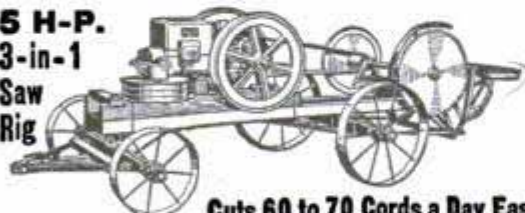

**Cuts 60 to 70 Cords a Day Easy**

A real all purpose outfit for farmers and men who make wood sawing a regular business. When not sawing you can fill silos, grind feed, shell corn, thrash and do other work. Easy to start at 40 below zero. Completely equipped with WICO Magneto, speed and power regulator, throttling governor and 2 fly wheels.

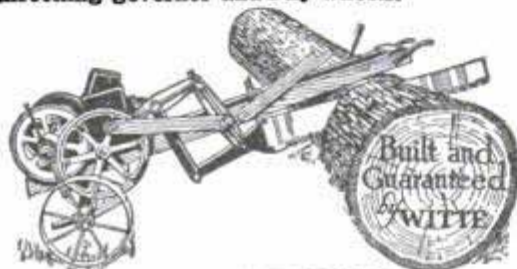

## WITTE LOG & TREE Saw

Cuts down trees and saws them up FAST—one man cuts 10 to 15 cords a day—makes ties. The WITTE is easy to run and trouble-proof. Thousands in use. Powerful engine runs other farm machinery. Uses all low priced fuels.

**EASY** Pay only a few dollars down and take a year for the balance of low price.

**PAYMENTS—MAKE YOUR OWN TERMS.**

**FREE** Write today for full description and low price—no obligation. Or if interested, ask for our Engine or Pump catalogs.

## WITTE ENGINE WORKS

**Kansas City, Mo. Pittsburgh, Pa.  
6746 Witte Bldg. 6746 Empire Bldg.  
6746 Witte Bldg., San Francisco, Calif.**

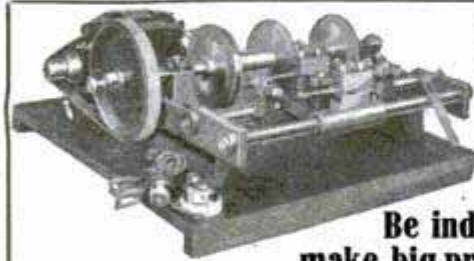

**Don't Be  
a  
Slave**

**Be independent and  
make big profits with the**

## BEISSER KEY MACHINE

You can start a business of your own, no experience necessary. Only machine that will make first keys without taking lock apart. Makes a dozen duplicate keys per minute.

Write Today for Full Particulars

BEISSER KEY MACHINE CO.

407 Fort Street, East Detroit, Michigan

*A new Parks!*

**Cabinet Shop  
Special No. 7**

**\$250**

as illustrated  
with motor

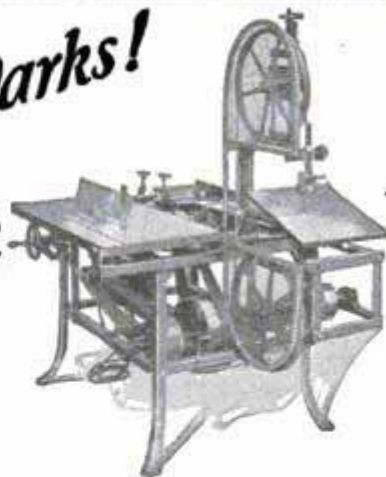

**You ought to have this handy Parks in your shop!**

A compact, complete machine designed just like a big production outfit at one-fifth the cost. Nothing extra to buy. Motor is included, operating from any light socket. Fits in a corner of your basement. Does any kind of cabinet and joinery work. Circular saw, jointer and bandsaw on permanent all-steel frame. Add lathe, shaper and other attachments at small cost. You can make money with this Parks! Write for circular.

**The Parks Ball Bearing Machine Co.  
1500-1540 Knowlton Street, Cincinnati, Ohio  
Canadian Factory: 200 Notre Dame East, Montreal, Can.**

# PARKS

WOODWORKING MACHINES

Send 35c for an All-Work File to  
**FAYETTE R. PLUMB, Inc.**  
4817 James St. PHILADELPHIA

## "Single 6" Wrench Set



Six strong, finely finished wrenches fitting nuts from 6/15 to 5/8 inches. Mounted on a sturdy key ring so that they can not be lost. Ideal for automobiles, sewing machines, radios and dozens of other needs everyone has.

Sent Parcel Post Prepaid if not at your Dealer.

**Niagara Metal Stamping Corp.**  
Dept. 201 Niagara Falls, N. Y.

## CALCULATIONS

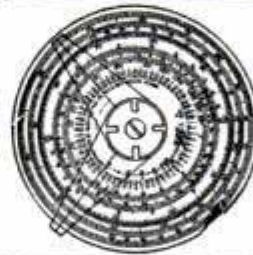

in Office, School, Store and Shop can be instantly made with the Midget Slide Rule. It gives the answer to any problem involving fractions, mixed-numbers, decimals, whole-numbers, roots, powers, Logs, and Trig. Functions. Thousands of these rules are used by Accountants, Engineers, Clerks, Students, etc. It is the most versatile calculator ever invented. If you have any figuring to do, order a Midget Slide Rule on trial. Made of aluminum with figures on white celluloid. Size 4". Price with Instruction Book, \$1.50. Leather Case, 50c extra. Catalogue Free. Sent C. O. D. if desired. Your money back if you are not satisfied.

**GILSON SLIDE RULE CO., Niles, Mich.**

## BURN YOUR NAME ON TOOLS WITH THE ARKOGRAF

**PROTECT YOUR TOOLS FROM THEFT**  
Write with electricity any name or design on the hardest and finest tools and instruments, or any metal, like writing on paper with pen or pencil. **Complete Outfit \$3.50**—Prepaid Anywhere today. Agents wanted. **ARKOGRAF PEN CO., 1171 E. Stark St., Portland, Oregon**



TAPER  
GROUND



Compare the cross-section of a Simonds Saw with any ordinary saw. The distinctive taper grinding of the Simonds Blue Ribbon Hand Saw insures ease of cutting—better results with less effort.

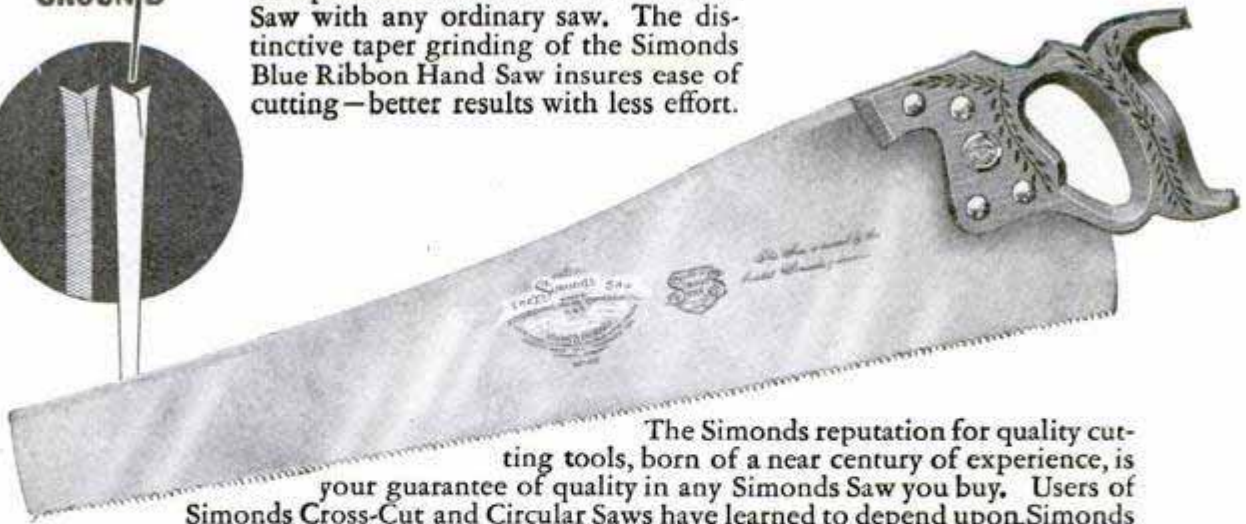

The Simonds reputation for quality cutting tools, born of a near century of experience, is your guarantee of quality in any Simonds Saw you buy. Users of Simonds Cross-Cut and Circular Saws have learned to depend upon Simonds quality. Every Simonds Saw MUST be perfect. Ask your dealer to show you a Simonds.

SIMONDS SAW AND STEEL CO., FITCHBURG, MASS.

"The Saw Makers"

Branch Stores and Service Shops in Principal Cities

Established 1838

# SIMONDS

Pronounced SI-MONDS

SAWS FILES KNIVES STEEL

**A NEW TOOL**

A SAW IN CUTTING      A FILE IN EFFECT

DOUBLE EDGED TOOL FOR KEEN ACCURATE CUTTING

FOR LOCKSMITHS, TOOLMAKERS, MACHINISTS, ELECTRICIANS, DIE-SINKERS, MECHANICS. ADAPTED TO RECEIVE SLOTTING OR BACK SAWS OF DIFFERENT THICKNESSES AND HOLD THEM RIGIDLY FROM SIDE DEFLECTION

POST PAID U. S. \$2.00      HENRY NOYES, 504 18th Street, Oakland, California

## TURN WASTED TIME INTO PROFITS!

Every Purchaser Finds Numerous Uses for the **TORIT Acetylene Torch No. 23**

An Improvement Over the Torit No. 13

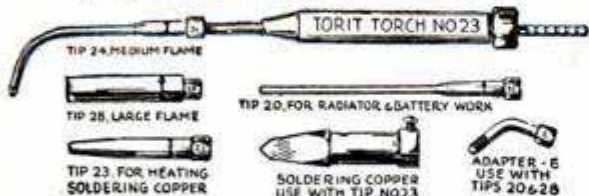

Uses Acetylene Only. No oxygen or air pressure required. Tips suck in air. Simply connect to Presto auto tank, light gas, and the outfit is put to work. Gives Heat Instantly! Beats anything you ever tried for soldering, radiator repairing, melting, lead burning, tempering, heating, light brazing, etc. Consists of torch, 4 tips for different kinds of work, soldering copper, 5 feet rubber tubing, tank connection, and full instructions. All ready to use. Quickly Pays for Itself. PRICE (Complete, as shown) **\$7.50**

**ST. PAUL WELDING & MFG. CO.**  
177 West Third Street      Saint Paul, Minnesota

**THIS BOOK tells you**

**free!**

—Just what you want to know about reducing speeds with the compact, efficient IXL Speed Reduction unit. IXL Speed Reducers may be built into machines, or installed in plants in place of belts, chains and open gearing. They are compact, efficient and safe, transmit power with least possible loss. Made in many types and sizes—up to fifty-thousand-to-one reduction. Send for free booklet.



IXL Spur Gear Speed Reducer

**FOOTE BROS. GEAR & MACHINE CO.**

230-240 N. Curtis St., Chicago, Ill.

Sales offices in all principal cities in U. S. and Canada

We make cut gears of all kinds, Micarta Pinions, Micarta Timing Gears, Flexible Couplings, Speed Reducers, Special Machinery.

**FOOTE BROS. GEAR & MACHINE CO.**

230-240 N. Curtis St. CHICAGO, ILL.

Please send without obligation a copy of the Foote IXL Speed Reducer Book.

Signed .....

Address .....



# ATKINS Hack Saws Cut Easier, Quicker

WHY should YOU look for the name "ATKINS" on the blade of the hack saw you buy?

Because it means *extra* value—ATKINS blades are "file tested," insuring longer life and quicker, easier metal cutting. It pays to use better blades.

"ATKINS" means as much on hack saw blades, frames and machines as it does on the famous ATKINS Saws for cutting wood, bone and stone. Look for the name on the blade.

Ask for our booklet "Saws in the Shop" and the ATKINS Hack Saw chart. Sent free.

E. C. ATKINS & CO. Est. 1857  
Dept. P. INDIANAPOLIS, U. S. A.  
*Leading Manufacturers of Saws for Every Use,  
Saw Tools, Saw Specialties and Machine Knives*

# ATKINS SILVER STEEL SAWS



## Red Devil Tools Better Made

### It's New—It's Different— "RED DEVIL" Giant Grip No. 444

Combines a plier and wrench; it's the greatest improvement since pliers were invented. The "444" has solved most of the plier and wrench troubles. So many things can be done with it that it's the most universal tool made. No springs, no adjusting nuts, no mechanism.

Instantly appeals to the mechanic or motorist for odd jobs around the house, garage, car or truck. It will move the most stubborn nuts or bolts, even when they are rusted fast.

Ask your dealer for "Red Devil" No. 444, 7½ inch. Price \$1 each.

Smith & Hemenway Co., Inc.  
Mfrs. of "Red Devil" Tools  
Irvington, N. J.

Branches: New York,  
Chicago, San Francisco,  
London, Eng.

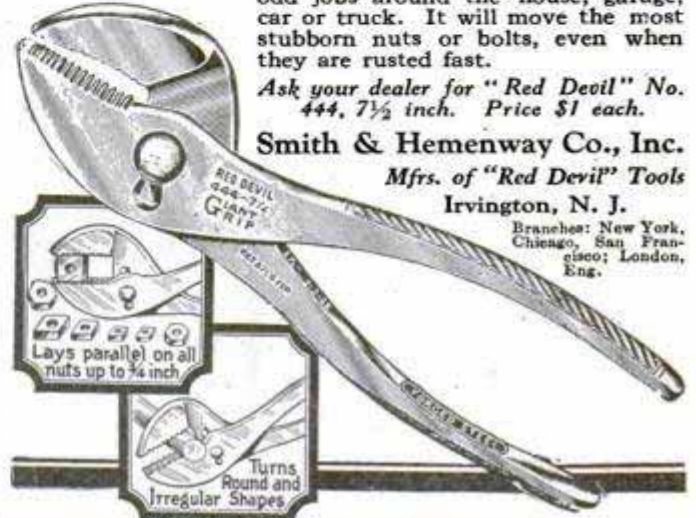



### TOOL CHESTS of QUALITY

for Machinists and Tool makers  
are shown in our free catalog.  
*Write for it to-day.*

*H. Gerstner & Sons*  
427 Columbia St., Dayton, Ohio

# MAKE \$15 A DAY

Exclusive Territory



**Sell the Handyman Tool**

**THIS** handy combination tool is a quick, easy seller. Some make \$20 a day. Used daily on farm, garages. Does work of one man. Low price, big profit.

**Only Tool of Its Kind**

Pulls posts, pipes, roots, small stumps; jacks up trucks, tractors, wagons; lifts buildings; stretches fence; splices wire; makes cider press, etc. Money back guarantee. Simple to operate. Lifts, pulls, or pushes with 3 TON CAPACITY.

**Make \$15 a day**—Exclusive Agency to man in each county. Write for sales plan and free demonstrating outfit proposition.

**Harrah Mfg. Company**  
Dept. B 2 Bloomfield, Ind.



# Different from all others—the NEW BENJAMIN

## AIR RIFLE

Made on a different principle from all other Air-Rifles. The Benjamin is really a strong air-pump used to compress the air in the air chamber to any degree of power desired. From one to six strokes of the pump give all the force necessary. Each additional stroke gives increased power. The Benjamin works on the same principle as all air-drills and air-hammers—with this difference:

You control the shooting force as you desire. Look at this block of hardwood. It shows how Benjamin power is regulated as you wish.

You can't have accidents with a Benjamin. It's safe, always, because you control the power. The Benjamin never loses shooting force, and has no springs to get out of order or shake your aim. Write us for an interesting folder about this wonderful air-gun.

If your dealer does not handle arms, and direct to factory—

**(PRICE \$5)  
POSTPAID**

**BENJAMIN AIR-RIFLE & MFG.  
CO., 615 N. Broadway, St. Louis, Mo.**

Ask your dealer for demonstration.

Pacific-Coast  
Representatives  
**THAYER & BOWER**  
Los Angeles  
Calif., and  
San Francisco  
Calif.



# SARGENT PLANES

See them at your hardware store.

Write for booklet.

**SARGENT & CO., 49 Water Street, New Haven, Conn.**

NOW, ONLY  
**\$4.00**  
DOWN

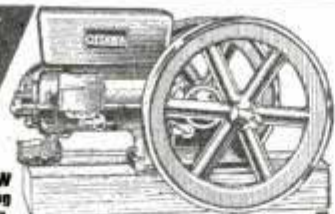

Put This MARVELOUS NEW ENGINE with Easy Starting Device To Work For You.

**Increase Your Profits \$1000.00**

Get my new FREE Book and ridiculously low prices—any size, 1½ H.P. up—Stationary, Saw Rig. Guaranteed to satisfy or your money returned. Built to stand hardest use. 30 days FREE trial. Send postcard for my new Free Book before you choose any engine. Write today. **Harry Overman, Pres.**

**OTTAWA MFG. CO.,** Desk 531-E King St., Ottawa, Kansas.  
531-E Mason Bldg., Pittsburgh, Pa.

## WHAT EVERY MASON WANTS

We have Masonic books and lodge supplies for Blue Lodge, Chapter, Commandery, Scottish Rite, and Shrine.

Our Rituals Are Used the World Over. Send for free catalog of books and rituals for Masons, Odd Fellows, Knights of Pythias, Knights of Columbus, Elks, etc.

**EZRA A. COOK, Publisher, Inc.**  
1350 N. Clark St., Dept. M, Chicago, Ill.



Keep it  
in your  
car!

# ZEV WATER-LESS SOAP

Removes dirt and grease perfectly without water. Leaves hands delightfully clean, soft and dry. Absolutely pure and neutral—as harmless as cold cream.

**The Convenience Is Worth Many Times the Cost**

Send 25c in stamps for half pound sample in convenient tin. Liberal terms to agents and dealers.

**PARKE CORPORATION, KALAMAZOO, MICH.**

# Going to Build Remodel or Repair?

DON'T think of building a new home or repairing an old one without a copy of our free woodwork catalog.

To those who contemplate building or remodeling, this book is a valuable work of reference. In it are found the latest ideas and most advanced styles for everything in millwork. It illustrates and describes windows and sash of all kinds, including porch and storm sash, doors, frames, mouldings, screens, porchwork, stairwork, hardwood flooring, interior finish, cabinet work—in fact, practically everything in manufactured millwork. Every article in the book shows a low money-saving price direct to you.

## FREE ESTIMATES

Send us your lumber and millwork bills for a free estimate. Let us quote prices on your material and tell you the exact amount of freight. Then compare our prices with others. This service costs you nothing and places you under no obligation whatever.



**CHICAGO MILLWORK SUPPLY CO., 1444 W. 37th St., Chicago, Ill.**  
PLEASE SEND ME YOUR FREE BOOK

Name \_\_\_\_\_ St. No. \_\_\_\_\_  
Town \_\_\_\_\_  
State \_\_\_\_\_  
Occupation \_\_\_\_\_

**Book is Free**

# Test these Tools at Our Risk!

Drive ¼-in. chisel through 1½-in. machinery steel. Lock our wrench with any other wrench and bring pressure until one breaks. Drive rivet punch through auto frame. Cut shavings off axle shaft with bearing scraper. If tools show slightest harm, return them.

## CORNWELL Hand-Made Tools

Made of finest Swedish Charcoal Process Molybdenum Steel, from our famous Cornwell secret formula. Forged, heat treated and hardened and tempered in oil. Made by hand, NOT drop forged and case hardened.

### Tools Like These Never Made Before

Mechanics amazed that such tools could be made. Place trial order at our risk. No other tools can stand these startling tests. Hundred thousand users.

### Money-Back Guarantee

We replace any tool not standing astounding tests described in booklet. If you ever saw tools like these, return your order and get your money back.

### Mail Coupon for Prices and Booklet

**CORNWELL QUALITY TOOLS CO.,**  
Dept. B, Cuyahoga Falls, Ohio

Send me illustrated booklet with prices on full line of Cornwell Secret Formula Hand-Made Tools.

..... Occupation  
Name .....  
Address .....  
City ..... State.....



# LOFTIS

BROS. & CO. F858

## DIAMONDS WATCHES

### CASH or CREDIT



No. 27  
Blue White, perfect-cut Diamond. Solid 18-k White Gold. Price \$100. Terms: \$10 down, then  
**\$2.50**  
A Week



No. 28  
Blue White perfect-cut Diamond. The ring is Solid 18-k White Gold, \$17.50. P & F \$3.75 down, then  
**\$1.00**  
A Week

**Genuine Diamonds GUARANTEED**  
We import Diamonds direct from Europe and sell direct by mail.

**Send For Free Catalog**  
Over 2,000 illustrations of Diamond-set jewelry, Watches, Wrist Watches, Pearls, Mesh Bags, Silverware, etc. Sent prepaid for your **FREE EXAMINATION**

**TERMS:** Goods delivered on first payment of one-tenth of purchase price; balance in equal amounts, payable weekly, semi-monthly, or monthly, as convenient.

**Money back if not satisfied**



18K

**WEDDING RINGS**  
All Platinum, \$25 up. With Diamonds: Three Diamonds, \$65; five Diamonds, \$80; seven Diamonds, \$95; nine Diamonds, \$110; surrounded by Diamonds, \$225. Solid White or Green Gold, \$5.00 up.



No. 16—Wrist Watch, Solid 18-k White Gold. 17 Jewels, \$27.50. 14-k, 16 Jewels, \$22.50.

**Railroad Watches—Guaranteed to Pass Inspection**  
HAMILTON No. 992, 21 Jewels, Adjusted to 5 positions. Gold \$55  
Filed 25-Year Case

ELGIN'S LATEST RAYMOND, 21 Jewels; 8 Adjustments. Runs \$55  
40 hours one winding. Gold filed 20-Year Case

**LOFTIS** THE OLD RELIABLE ORIGINAL  
BROS. & CO. F858 CREDIT JEWELERS  
Dept. L894 108 N. State Street, Chicago, Illinois  
Stores in Leading Cities

Listen in on WHT every Tuesday night from 7 to 7:30; every Friday night from 10 to 10:30, central standard time. Loftis Bros. & Co.'s hour of music.

## WHITE FLAME

**BURNERS** make your old kerosene lamps and lanterns give a brilliant white light better than electricity or gas. Doubles your light. Saves oil. NO MANTLE TO BREAK. Guaranteed Safe and Reliable. Delights every user. Send now for complete sample postpaid 50 cents, stamps or coin. 3 for \$1.25. Money Back if Not Satisfactory. Live Representatives Wanted. Exclusive Territory.

WHITE FLAME LIGHT CO., 68 Clark Bldg., Grand Rapids, Mich.



## SAVE YOUR BODY

Conserve Your Health and Efficiency First

"I would not part with it for \$10,000"

Sowrites an enthusiastic, grateful customer. "Worth more than a farm," says another. In like manner testify over 100,000 people who have worn it.

## The Natural Body Brace

Overcomes WEAKNESS and ORGANIC AILMENTS of WOMEN and MEN. Develops erect, graceful figure. Brings restful relief, comfort, ability to do things, health, strength.



For Boys and Girls Also

## Wear it 30 Days Free at Our Expense

Does away with the strain and pain of standing and walking; replaces and supports misplaced internal organs; reduces enlarged abdomen; straightens and strengthens the back; corrects stooping shoulders; develops lungs, chest and bust; relieves backache; curvatures, nervousness, ruptures, constipation, after effects of Flu. Comfortable, easy to wear.

**Keep Yourself Fit** Write today for illustrated booklet, measurement blank, etc., and read our very liberal proposition.

**HOWARD C. RASH, Pres., Natural Body Brace Co., 223 Rash Building - SALINA, KANSAS**

## Help Wanted

We require the services of an ambitious person to do some special advertising work right in your own locality. The work is pleasant and dignified. The pay is exceptionally large. No previous experience is required, as all that is necessary is a willingness on your part to carry out our instructions. If you are at present employed, we can use your spare time in a way that will not interfere with your present employment—yet pay you well for your time.

If you are making less than \$150 a month, the offer I am going to make will appeal to you. Your spare time will pay you well—your full time will bring you in a handsome income.

It costs nothing to investigate. Write me today and I will send you full particulars by return mail and place before you the facts so that you can decide for yourself.

**ALBERT MILLS**  
Gen. Mgr. Employment Dept.  
5155 American Bldg., Cincinnati, Ohio



LACASSIAN CO. Dept. 455 ST. LOUIS, MO.

## Big Money

Made by agents selling our wonderful Facial Soap, Perfumes, Toilet Articles, Spices, Extracts, etc. Free cake of soap and agents' terms mailed to any address.

## SALESMEN!

Unlimited earning possibilities. X-Cel-All Master-Lite scientific lighting a necessity wherever artificial light is used. Churches, schools, factories, etc., etc. Completely assembled HOME OUTFIT ready to attach to light socket, sells \$3.95. You collect and keep \$1.00. We ship to customer C. O. D. for balance. Try this and be convinced, then become permanent member of fast growing organization. Write or wire at once.

**X-Cel-All Company, Ltd., Dept. 211** Factory and General Offices, Monaca, Penna.



## Agents!

### \$20 a day

Meat Tenderer  
Mince Knife  
Cleaver  
Ice Tool  
Food Chopper  
Fish Scaler  
Nut Crumbler

**HANDIEST TOOL IN THE KITCHEN.** Housewives all say "Just what I want." The *Ideal Fiber Cutter* is a real household aid. Tested and Approved by Good Housekeeping. Two minute demonstration sells it—**100 PER CENT PROFIT.** Boorem, Pennsylvania says, "Have bought my home and car with Cutter profits." Bassett, Washington, new agent, writes, "Made \$7.50 in 2 hours today." You can do as well. No experience needed. (Work spare or full time. Write for details, **THE TYLER MFG. CO. Dept. M-5 Muncie, Indiana**



# Crippled Children and Young Adults

For 30 years McLain Orthopedic Sanitarium has been devoted to the treatment of crippled children and young adults. No plaster paris is used. No surgical operations performed requiring chloroform or any general anaesthetic. Facilities for immediate reception of patients. Parents may retain full charge of children and give them personal care during treatment, if desired.

**Write for FREE Books**  
 "Deformities and Paralysis" and "Book of References" show and tell of McLain Sanitarium's facilities for treating Club Feet, Infantile Paralysis, Spinal Diseases and Deformities, Hip and Knee Disease, Wry Neck, etc.

**McLAIN ORTHOPEDIC SANITARIUM**  
 902 Aubert Avenue,  
 St. Louis, Mo., U.S.A.

**AFTER TREATMENT**  
 Edward King  
 Has Straight,  
 Useful Feet

CLUB FEET  
 Edward King,  
 948 Humphrey,  
 Oak Park,  
 Illinois

JR773



## Sell Stylemor and make more



Pick a live wire. Don't waste any more time. Sell Stylemor shirts and make your hours count! 150 snappy, popular styles. Low prices. Smart selling outfit FREE. You only take orders. We deliver and collect. Highest commissions in advance and your own shirts free for a little work on your part. Unusual proposition. Write us today.

Stylemor, Inc., 81 W. Van Buren St., Dept. 805C, Chicago

## SHOW IT—and IT'S SOLD



The Handy Knife Sharpener is the fastest selling home necessity ever offered. Everyone a prospect. Sells for \$1.00, your profit 65c. Free deliveries. Guaranteed.

Morgan Mfg. Co., Dept. G, 443 S. Dearborn, Chicago

## Returns its Cost OVER AND OVER

### The "Trousers Friend"



**BEFORE USING TROUSERS FRIEND**  
 This scientific device made of everlasting steel, nickel plated, positively removes baggy knees and automatically preserves the creases without pressing, without dampening and so easily that anyone can adjust it in a moment. Hang your trousers in a "Trousers Friend" in the evening and put them on spick and span in the morning. Takes very little room in grip. Works equally well at home, in Hotel or Pullman.

**AFTER USING TROUSERS FRIEND**

**Order One Today; Send No Money**  
 Pay the Postman \$1.75 and postage. Use it thirty days; if not satisfied your money returned. If you remit with order we pay postage.

**NELSON MANUFACTURING COMPANY**  
 53 New Montgomery St., San Francisco

**Secure an agency** The "Trousers Friend" is filling a World need. We want you to present it to millions waiting for it. Write today.

# 5-Room ALADDIN

## \$478

NOT PORTABLE



**WE PAY THE FREIGHT**  
**You can buy all**

**the materials for a complete home direct from the manufacturer and save four profits, on lumber, millwork, hardware, labor.**

# 6-Room ALADDIN \$618



Living room, dining room, 2 bedrooms, kitchen, bath. 3 other plans in catalog. Very high grade lumber throughout.

# 7-Room ALADDIN \$765



Living room, dining room, kitchen, 3 bedrooms, and bathroom. All materials readicut, saving 18% on cost.

# Story and Half ALADDIN \$789



Story and a half semi-bungalow, with second floor available for 2 bedrooms. 2 floor plan arrangements. Any handy man can erect these houses.

# 7-Room ALADDIN \$954



Large living room with circle-tread open stairway, dining room, kitchen. 3 bedrooms, each with closet. Bath on second floor.

**Price includes** all lumber cut to fit; highest grade interior woodwork, siding, flooring, windows, doors, glass, paint, hardware, nails, lath, roofing, with complete instructions and drawings. **Freight paid** to your station. Permanent Homes—NOT PORTABLE. Many styles of year-round dwellings, summer cottages and garages to choose from. **Write nearest mill today for FREE Money-Saving Catalog No. 1544.**

**THE ALADDIN CO., BAY CITY, MICHIGAN**  
 Wilmington, North Carolina; Portland, Oregon; Toronto, Ontario

# EDWARDS WILL SAVE YOU MONEY ON METAL ROOFS

We own our own steel mills, roll our own sheets, make them into high-grade REO METAL SHINGLES, Sidings, Ceilings and Roofings of every type and style for every kind of building. We control every operation from the raw material to the finished roof and we sell direct from our factories to the user. Not a dollar to divide with anybody but the customer! You get better value for less money.

## OUTLAST THREE ORDINARY ROOFS

EDWARDS METAL ROOFS are weather-proof, lightning-proof, fire-proof! The galvanizing bends with the metal. No tools required.



## LOW-COST ALL-METAL GARAGES

Any size. Any style. Portable. Ready to erect. Complete with frames, doors, sash and hardware. Ornamental, durable, economical. Blue-prints and complete instructions FREE.

Write today. Get our low prices and Free Samples. Ask for Roofing Book No. 150 or for Garage Book No. 150

THE EDWARDS MFG. CO.  
300-350 Butler St. Cincinnati, O.

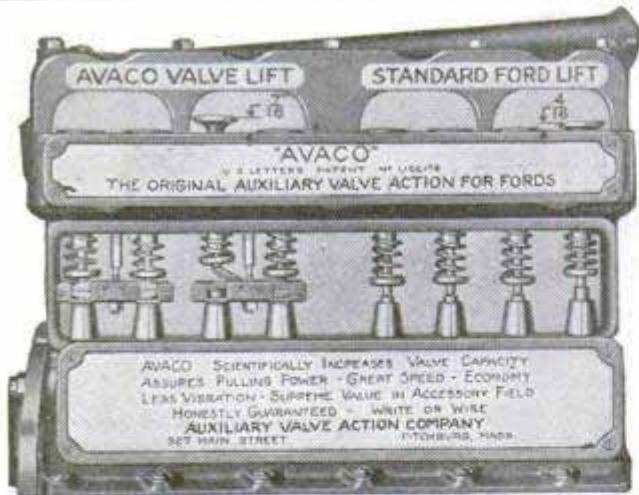

## AGENTS WANTED! Salesmen—Distributors

to use and introduce attachment that makes Fords run on 94% air. THERMOSTAT on exhaust automatically turns down needle valve as engine warms, exactly as Ford Manual says do by hand.

## BLANCHE AUTO THERMO An Automatic Carburetor Control

Makes Fords start easier winter or summer—saves half gas and oil—cuts repair bills one-half—reduces carbon formation one-half. Sells on sight to every Ford owner as easily as giving him a \$100.00 bill, because it saves \$100.00 every 10,000 miles.

## CADILLAC NOW USES AS STANDARD EQUIPMENT THERMOSTATIC CARBURETOR CONTROL UNDER BLANCHE LICENSE.

You can make Big Money selling this wonderful proven device. Experience not necessary. Blanche plan will start you without capital in a business of your own that makes you from \$250 to \$2000 a month profit. Write for free circulars now!

A. C. BLANCHE & CO. Dept. 805C, 602 W. Lake Street CHICAGO, ILLINOIS



A Silver Lining in Every Cloud

# SEE-KLEER

Makes Hundreds for You Each Time It Rains!

New scientific discovery prevents mist, rain, frost, snow, steam, sleet from collecting on any glass surface.

Agents: Sensational demonstration; quick sales; long profits. One application of SEE-KLEER with cloth or fingers guarantees clear vision for 24 hours. Used on windshields, eye-glasses, show-cases, display windows, etc. Your chance to clean up in a big, uncrowded field. Send name, address and 10c for large sample—then "See for Yourself!"

SEE-KLEER LABORATORIES  
1018 So. Wabash Ave., Dept. 805-C, Chicago, Ill.

## Tire AGENTS WANTED

Use and Introduce MELLINGER CORD TIRES  
15,000 MILES GUARANTEED  
Lowest Wholesale Prices in America. Shipped prepaid on approval. Make big money all or part time. No capital or experience. Sample sections furnished.

### YOUR TIRES FREE!

Simply send name today for valuable FREE BOOK; tells how thousands have gone into big business. SPECIAL AGENTS' OFFER. Wholesale Prices and FREE SAMPLE KIT. Write nearest address.

MELLINGER TIRE & RUBBER CO.  
PHILADELPHIA, PA. Dept. 415      KANSAS CITY, MO.

## Bodies of Rare Beauty for Fords

At Factory Prices!  
\$22.75 and Up

Write for Circular A-2 showing this Model and others.

SPORT BODY WORKS  
AURORA, ILL.

This model in grey prime, \$39.50

## MOTORCYCLES

RELIABLE STANDARD MAKES that you can DEPEND on. Enjoy the glorious experience of going wherever you like—when ever you like. The price is within your means—35% to 50% less than others. These machines are slightly used, thoroughly overhauled or rebuilt. Send for catalogues.

MYEROW BROS.,  
15 Berkeley St. Boston, Mass.

SEND 10c IN STAMPS FOR CATALOGUES  
BIG MONEY SAVING FOR YOU

Used and rebuilt motorcycles \$25 to \$100. used bicycles \$9.50, tandems \$20. All machines fully guaranteed. New bicycles and motorcycles at factory prices, save dealers' profits. Motorcycle and automobile tires \$3. Complete line frames, engines, supplies.

DENINGER PRICE CUTTER, ROCHESTER, N. Y.

## PAY AS YOU RIDE

## You-and This New Machine Can Earn \$500 a Month

Operate a Tire Repair Shop  
70,000,000 Tires in use. America's greatest opportunity for men with small capital. We furnish everything—\$100 and up. Easy payments. We train you FREE right at home. Start making money at once. Write today for Free Book of Opportunity.

Haywood Tire Equipment Co. 1344 S. Oakley, Chicago

Does Your Watch  
Tell Time in the Dark?



**Ingersoll**  
**RADIOLITES**  
Tell Time in the Dark

With a Radiolite under your pillow at night, you can find out the time almost without waking up.  
Models \$2.75 to \$6.50.

**TOSTWICH**  
THE GREATEST  
PROFIT-MAKER

The Tostwich brings amazingly big profits and sales wherever installed—a patented process—makes sandwiches taste 100% better than ever before. Full information without obligation to you—write today.  
**THE TOSTWICH CORPORATION**  
Dept. 1773, 646 No. Michigan Ave., Chicago



**CLASS RINGS & PINS**  
Largest Catalog Issued—FREE

Samples loaned class officers. Prices \$.20 to \$8.00 each. No order for class, society, club emblems too large or too small. Special designs made on request.



METAL ARTS CO., Inc. 7705 South Ave., Rochester, N. Y.

**Save 1/3 to 1/2**  
AT FACTORY PRICES

**Furnaces \$59.95** New **FREE** book up  
Quotes you lowest factory prices on Quality



beating stoves, furnaces, porcelain enamel combination ranges, coal and wood ranges and gas stoves. 200 styles and sizes. Cash or easy terms—as low as \$3.00 monthly. 30 days **FREE** trial; 360 days approval test. 24 hour shipments. 660,000 pleased Kalamazoo customers. Make a \$25 to \$75 saving by sending postal for **FREE** book today.  
**Kalamazoo Stove Co., Mrs.**  
391 W Rochester Ave.  
Kalamazoo, Mich.

**"A Kalamazoo**  
Trade Mark Registered **Direct to You"**

**Earn \$100 a Week**  
Profits in Advance

I pay men \$100.00 a week and up by my plan which I want to send you at once. Be your own boss, work where and when you like. You can do fine even without previous experience. **Biggest values—positively sell on sight.**



**Profits in Advance**



My plan pays biggest profits and commission in this line, all paid in advance, we attend to

**Sell fine** delivering orders and collections.

**TAILORING**

Astonishing values get orders easy when you show samples of our tailored to order, all wool, suits and overcoats—one price \$31.50. Our advertising helps you take orders quick.



**FREE!**

This big, fine sample outfit furnished *free*, contains 100 big all wool samples, all one price, \$31.50, fine colored fashions, stationery, supplies, tape, etc. All in classy, fine carrying case. Also complete sales manual, we place you in **Big Money Class.**

**W. Z. Gibson, Inc., Chicago**

Dept. Q-516, 161 West Harrison Street

Without obligating me in any way, please send me complete information regarding your new plan to earn \$100 weekly.

Name.....

Address.....

City..... State.....

**Do You Really**  
**Want Money?**



Do you really want to make from \$75 to \$100 a week? Would you like to do as well as S. W. Allen of California who made \$40.80 in one day's joyful work? Then you will never find a better opportunity than this wonderful Hand Tailored **RAIN-PROOF** Cap!

**Wear this Fine Cap**

Show it to your friends. Every man you know will want one like it. It's guaranteed **RAINPROOF**—moisture can't soak in! Choice of finest wools and latest styles. Far superior to store caps. \$10 a day extra in spare time is easy. No experience is needed. Write at once for our **FREE** Selling Outfit.

**TAYLOR CAP MANUFACTURERS, Dept. 55-C, Cincinnati, Ohio**



**ALL FREE**

10 year guar. Watch with chain and ring, large Eastman Roll Film Camera or 22 cal. Hamilton Rifle, yours for introducing finest assorted liquid perfume at 15c a bottle. Send for 20 bottles and choose gifts as per offer in our catalog. We trust you—just write to **BELL PERFUME CO., Dep. E 933, Chicago, Ill.**

**22 CAL. RIFLE**

# Your Choice \$100 DOWN

## SELECT NOW!

**Prompt Delivery—No Red Tape!**

Send No Money—just send your name and address. We'll open a charge account, and your choice of these special bargains will come prepaid for your approval and 15 Day Trial. You pay the Postman \$1. upon arrival. If satisfied, pay the balance in 10 equal monthly payments. Otherwise return and your deposit will be refunded.

### We Trust You

Your credit is good with us. Our Charge Account System is simple, easy and convenient. **TRANSACTIONS CONFIDENTIAL. ORDER NOW.**

Free—Complete booklet with 3,000 bargains in Diamonds, Watches and Jewelry. 10 months to pay on everything.



**A75—**Ladies 18K White Gold Ring; 3 AA1 Quality blue-white Diamonds. Regular \$50. value. Price \$42.50



**A76—**Ladies 18K White Gold. AA1 blue-white diamond and regular-cut diamond on each side of shank \$52.



**A78**  
14K White Gold Wrist Watch; 4 Regular cut Blue-white Diamonds; 4 Blue Sapphires. 15 Jewel Guaranteed movement. \$42.50.



**A77**  
Gents heavy 18K White Gold ring. 2 blue-white Diamonds; 1 Blue Sapphire. \$57.50

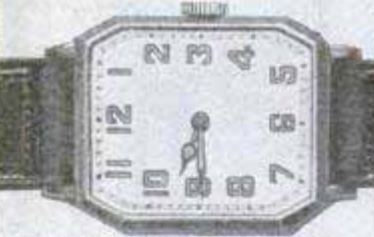

**A80—**Remarkable value in Gents' Strap Watch, high grade Gold Filled Case. Guaranteed to wear for 10 Years; dependable 15 Jewel Movement, Radium Hands and Dial, Genuine Leather Strap—price \$22.50



**A81**  
The best watch value ever offered. 12 size, 21 Jewel, Illinois Watch. Adjusted; 14K Gold Filled Case; will wear for 20 Years. Price \$45. Knife and Chain Free

AUTHORIZED CAPITAL \$1,000,000.

# L.W. SWEET INC.

66H-1650 - 1660 BROADWAY, NEW YORK



# New! LA TWIN MOTOR FOR ROWBOATS

The sensation of the year. Offering new advanced features in Power, Speed, Control, Weight and Performance. For example—

**NEW—**Super-Power Twin Motor—At normal speed develops 3.85 H. P. [Brake Test]. In racing trim develops 4.65 H. P.

- NEW—**Under-water Stream-Line Design
- Cuts the water like a knife
- NEW—**Giant Drive Propeller
- Gives flashing speed
- NEW—**"Safety Propeller"
- Protects Boat, Boaters and Motor
- NEW—**Super-charged Water Pump
- Insures a cool motor always at all speeds and reverse
- NEW—**Combination Propeller and Rudder
- Steers WITHOUT A RUDDER!
- NEW—**Unit Control Carburetor
- One easy adjustment for all speeds and weathers
- NEW—**"Top-Spin" Easy Starter with big Eiseman Magneto
- Gets you away in a flash
- NEW—**Combination Racing and Trolling Control
- One throttle lever for all speeds
- NEW—**Lifetime Guarantee
- Against all defects in material and workmanship
- NEW—**Five Days' Trial Offer
- Gives you a chance to match with any other Motor

[WRITE FOR FREE CATALOG FOLDER TODAY] (1)

# LOCKWOOD-ASH MOTOR COMPANY

616 Jackson St. Jackson, Mich.

## GET NEW 1926 KENNEBEC CATALOG

20 pages in colors. Describes 17 models Kennebec Rowboats and Canoes, including new Joy-Boy sponson type for outboard motor use. Light, strong, perfectly balanced, easy to paddle. **Write!**

**KENNEBEC BOAT & CANOE CO.**  
Dept. PM-1  
Waterville, Maine

### KENNEBEC CANOES

## Beautiful HOUSES \$900 and BUNGALOWS

**CAN BE BUILT FOR AND UP**  
This and many others in my new book, Building Plans for Modern Homes, will save you hundreds of dollars. One of the most complete and comprehensive books of plans ever published by any architect. New edition just off the press. Nearly 600 floor plans and photographs of Colonial houses, bungalows, etc., costing from \$200 up; gives sizes and cost to build. Sent postpaid for \$3.00.



**FREDERICK H. COWING**  
ARCHITECT  
101 Tremont St., BOSTON, MASS.



## Now—the Super Elto!

**Extraordinary Power!** Makes any row boat into a reliable launch—drives it at *thrilling, foaming speed!* The only quarter-turn starter! More powerful than ever, but same compactness, same light weight, same price! Same beautiful lines. Famous propello-pump. Designed and built by Ole Evinrude. **Intensely Interesting Catalog!** Most informative book on outboard motorboating ever published. Write for it today.

**4hp.**  
S.A.E. Rating

**ELTO OUTBOARD MOTOR COMPANY**  
Dept. AA, Manufacturers Home Bldg., Milwaukee, Wis.

# FOUND MONEY! \$12 a Day Easy

Let us prove how easy it is to make big money selling our beautiful dress goods, silks and wash fabrics. Low prices. Big commissions. No capital or experience needed.

**We Show You How**  
Just write and say you want to be our agent. Big sample book furnished with complete selling instructions. Wonderful opportunity. Write at once.



**THE NATIONAL IMPORTING COMPANY**  
Dept. C-6, 573 Broadway New York City

**make your time pay you**  
**\$50-\$75-\$100**  
**per week!**

**SALESMEN** wanted to sell Harrison clothes direct to men in your neighborhood! We pay highest cash commissions (\$4 or more on every suit) and sell finest clothes for the money! Splendid fit and tailoring, best values, easiest selling line. You collect commission in CASH when you make sale. We ship direct, collect direct. Prompt deliveries, satisfaction guaranteed, big repeat business. Handsome selling kit FREE. Write today, be on job in less than week. S. Harrison Bros., Dept. 306, 133 W. 21st St., New York City



# Great New Invention

for seekers of

# Health Power Beauty



Elco Health Generators at last are ready for you! If you want more health—greater power to enjoy the pleasures and delights about you, or if more beauty is your desire—write! Ask for the book on these inventions which has just been prepared. It will be sent to you without cost. It tells you how Elco Health Generators aid you in leaving the lethargy and hopelessness of bad health and weakness behind forever. Re-vitalize yourself. Bring back energy. Be wholly alive. Write today!

**10 Days Free Trial—Write for FREE BOOK**

**DIVINE RED DEVIL Water Motors**

Simple—strong—durable. Wonderful little workers for all sorts of household and shop uses. Thousands in use. For all light power purposes. Attaches to faucet.

Two sizes: 4" —\$4.25  
 6" —\$6.75

The higher the water pressure the more work they do.  
 Send today for catalogue.  
 Divine Water Motor Company  
 Utica, N. Y.

Self-Filler DE LUXE Stylo Pen

**"INDEPENDENT"**

All the best features of a Fountain. Lasts longer. Writes smoother. Improves handwriting. Eliminates fatigue. GUARANTEED

**\$2.00**  
 By Mail

14 Kt. White Gold Point. Chased Rubber Holder. Lever Filler. Pocket Clip.

Your Name in Gold Inlay, 25c.

Write for Pen Catalog. Agents Wanted.  
 J. C. Ulrich & Co., 161 Washington St., New York  
 Known the World Over for 40 Years.

**MOVIES IN YOUR HOME**

Practical Movie Machines in many wonderful models, some as low as \$3.75 and use same size film as big theatres. Fine films at lowest prices with a film exchange service. Many biblical films. Write for free illustrated catalog.

**PARAMOUNT MFG. CO.**  
 Dept. MB, 120 High Street, Boston, Mass.

**NEW MARVELOUS ONE - MINUTE CAMERA**

Taken and finishes pictures inside the camera in one minute. Agents wanted. Exclusive Territory. Make money selling these wonderful cameras or taking photos or both. Six different models. Photos 4x6, 3 1/2x5 1/2, 3x4 1/2, 2 1/2x3 1/2, 2x3 and 1 1/2x2 1/4 inches. No experience necessary. Any one can operate these cameras. Write today for special offer.

**CROWN MINUTE CAMERA COMPANY, Dept. 940, NORWALK, CONN.**

**ATKINSON AUTOMATIC TIMER**

**\$75 to \$100 Weekly**

**Every Ford Needs One**

**New Invention** that will make starting easy. Smoother running at all speeds. Short Proof—Kick Proof. Agents or Salesmen can earn big money. Sells for \$3.00. Write for free folder and confidential prices. Start quick before your territory is taken.

**ATKINSON AUTOMATIC TIMER CO., CYNTHIANA, KY.**

**Elco Electric Health Generators**

These great new inventions generate *High Frequency Violet Ray, Mechanical Vibration, Medical Electricity and Ozone.* Combined or separate.

They operate on the electric light in your home or on their own motive power at less than 50 cents per year. Elco Health Generators are positively the only instruments which can give you in one outfit Electricity, Violet Ray—Vibration and Ozone—the four greatest curative agents. Send coupon below. Get the Free Book NOW!



**For All These:**

- Rheumatism
- Gout
- Lumbago
- Neuralgia
- Sciatica
- Headache
- Neuritis
- Nervousness
- Circulation
- Weakness
- Paralysis
- Eye Trouble
- Asthma
- Hay Fever
- Sore Throat
- Catarrh
- Deafness
- Insomnia
- Pain
- Development
- Skin Disease
- Pimples
- Scalp Disorders
- Obesity

**MAIL the COUPON for FREE Book!**

Do not put this paper down without sending the coupon. Don't go on as you are with pains and with almost no life and energy. You owe it to yourself to be a better man or woman. You were put here to enjoy life—not just to drag through it. So do not rest another day until you have put your name on the coupon here. That will bring the whole story of these great new inventions. Do it today—now.



**Lindstrom & Company**

30 West Lake Street. Dept. 13-53, Chicago, Ill.  
 Please send me your free book, "Health—Power—Beauty" and full information on your 10-day Free Trial Offer.

Name .....

Address .....



# PA INVENTORS.

**JUST  
ACROSS  
STREET  
FROM  
U.S. PAT.  
OFFICE.**

At the right is a view of my drafting and specification offices where a large staff of experienced experts are in my constant employ. All drawings and specifications are prepared under my personal supervision.



## **PROTECT YOUR IDEAS**

### **Take the First Step Today**

If you have a useful, practical, novel idea for any new article or for an improvement on an old one, you should communicate with a competent Registered Patent Attorney **AT ONCE**. Every year thousands of applications for patents are filed in the U. S. Patent Office. Frequently two or more applications are made for the same or substantially the same idea (even though the inventors may live in different sections of the country and be entirely unknown to one another). In such a case, the burden of proof rests upon the last application filed. Delays of even a few days in filing the application sometimes mean the loss of a patent. So lose no time. Get in touch with me at once by mailing the coupon on the opposite page.

### **Prompt, Careful, Efficient Service**

This large, experienced organization devotes its entire time and attention to patent and trademark cases. Our offices are directly across the street from the U. S. Patent Office. We understand the technicalities of patent law. We know the rules and requirements of the Patent Office. We can proceed in the quickest, safest and best ways in preparing an application for a patent covering your idea. Our success has been built on the strength of careful, efficient, satisfactory service to inventors and trademark owners located in every state in the Union.

**Clip this Coupon *and* Mail**



# TENTS

## Write for these FREE BOOKS

### NO CHARGE for Information On How to Proceed!

The booklet shown here contains valuable information relating to patent procedure that every inventor should have. And with it I will also send you my "Record of Invention" form on which you can sketch your idea and establish its date before a witness. Such evidence may later prove valuable to you. Simply mail the coupon and I will send you the booklet, and the "Record of Invention" form, together with detailed information on how to proceed and the costs involved. Do this NOW. No need to lose a minute's time. The coupon will bring you complete information entirely without charge or obligation.



### STRICT SECRECY PRESERVED

All communications, sketches, drawings, etc., are held in strictest confidence in strong, steel, fireproof files, which are accessible only to authorized members of my staff. Feel free to write me fully and frankly. Your case will have my personal attention. It is probable that I can help you. Highest references. But FIRST—clip the coupon and get my free book. Do THAT right now.

### Clarence A. O'Brien

Registered Patent Attorney

Member of Bar of: Supreme Court of the United States; Court of Appeals, District of Columbia; Supreme Court, District of Columbia; United States Court of Claims

Practice confined exclusively to Patents, Trademarks and Copyrights

### FREE COUPON

CLARENCE A. O'BRIEN

Registered Patent Attorney

70-E Security Savings and Commercial Bank Bldg., Washington, D. C.

Please send me your free book, "How to Obtain a Patent," and your "Record of Invention" form without any cost or obligation on my part.

Name .....

Address .....

(Important: Write or Print name clearly)

**It Now!**

# PATENTS TRADE-MARKS AND COPYRIGHTS

## Have You An Idea?

### Our Offer: FOR THE PROTECTION OF YOUR INVENTION YOUR FIRST STEP

Before disclosing an invention the inventor should write for our blank form

#### "RECORD OF INVENTION"

This should be signed and witnessed and returned to us together with model or sketch and description of the invention for

#### INSPECTION and INSTRUCTIONS

*No Charge for the Above Information*

### Our Four Books Mailed Free to Inventors

*Our Illustrated Guide BOOK*

#### How to Obtain a Patent

Contains full instructions regarding U. S. Patents. Our Methods, Terms, and 100 Mechanical Movements illustrated and described.

#### Our Trade Mark Book

Shows value and necessity of Trade Mark Protection. Information regarding *Trade Marks and unfair competition in trade.*

#### Our Foreign Book

We have Direct Agencies in Foreign Countries, and secure Foreign Patents in shortest time and lowest cost.

#### Progress of Invention

Description of World's Most Pressing Problems by Leading Scientists and Inventors.

*We Regard a Satisfied Client* as our best advertisement, and furnish anyone, upon request, lists of clients in any state for whom we have secured patents.

*Highest References—Prompt Attention  
—Reasonable Terms*

## VICTOR J. EVANS & CO.

### PATENT ATTORNEYS

Main Offices: 956 9th St., N. W., Washington, D. C.

*Opposite U. S. Patent Office*

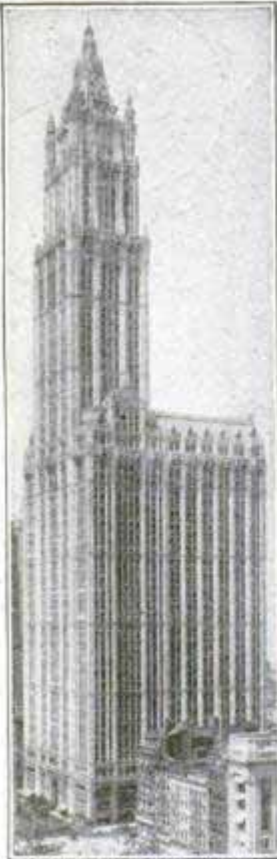

Our New York Office  
Suite 1007 Woolworth Bldg.

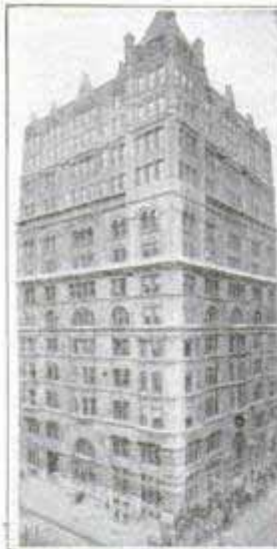

Our Philadelphia Office  
Suite 714-15 Liberty Bldg.



Our Washington Office  
Victor Building



# PATENTS TRADE-MARKS AND COPYRIGHTS

## IMPORTANT

TO HAVE YOUR CASE MADE SPECIAL AND AVOID DELAY YOU SHOULD HAVE YOUR CASE MADE SPECIAL IN OUR OFFICE to secure protection, save correspondence and secure early filing date in Patent Office. To secure special preparation of your case send \$25.00 on account with model or sketch and description of invention.



MAIN OFFICE, VICTOR J. EVANS & CO.—VICTOR BUILDING, WASHINGTON, D. C.

*Our Lawyers Practice in all U. S. Courts and defend Clients in Suits involving Patents, Trademarks and Copyrights*

All Communications and Data Strictly Confidential. Interference and Infringement Suits Prosecuted

OUR ORGANIZATION OFFERS PERSONAL SERVICE By Experienced Patent Lawyers, Solicitors and Draftsmen

**FREE  
COUPON**

**VICTOR J. EVANS & CO.  
PATENT ATTORNEYS**

NEW YORK OFFICES  
1007 Woolworth Bldg.

CHICAGO OFFICES  
1114 Tacoma Bldg.

PHILADELPHIA OFFICES  
714-715 Liberty Bldg.

PITTSBURGH OFFICES  
514 Empire Bldg.

SAN FRANCISCO OFFICES  
Hobart Bldg.

MAIN OFFICES: 956 9th Street, N. W., WASHINGTON, D. C.

Gentlemen: Please send me *Free of Charge* your books as described on preceding page.

Name .....

Address .....



Our Chicago Office  
Suite 1114 Tacoma Building



Our Pittsburgh Office  
Suite 514 Empire Building



Our San Francisco Office  
Suite 1010 Hobart Building

# PATENTS

TRADE MARKS • DESIGNS • FOREIGN PATENTS

## MUNN & CO. PATENT ATTORNEYS

*Associated since 1846 with the Scientific American*

672 WOOLWORTH BUILDING  
New York City

523 SCIENTIFIC AMERICAN BLDG.  
Washington, D. C.

1312 TOWER BUILDING  
Chicago, Ill.

665 HOBART BUILDING  
San Francisco, Cal.

520 VAN NUYS BUILDING  
Los Angeles, Cal.



*Books and Information on Patents and Trade Marks by Request. Associates in All Foreign Countries.*



## PATENTS

Send us sketch or model for advice and exact cost of patent. Our book "How to Obtain a Patent" sent free. It tells how to apply for Patents, Trade Marks, Foreign Patents, Copyrights, etc.; gives information on Patent Procedure; tells what every inventor should know. Thousands of Inventors, who are our clients, are our reference.

**CHANDLEE & CHANDLEE, 25 Years' Experience**  
473 7th St. Washington, D. C.

## PATENTS

**C. L. PARKER**  
Formerly Member Examining  
Corps, U. S. Patent Office  
**PATENT LAWYER**  
MCGILL BLDG.  
WASHINGTON, D. C.

Patents, Trade Marks, Copyrights, Patent Litigation  
*Pamphlet of instructions sent upon request*

SERVICE

## ★ PATENTS ★

YOU WITH AN IDEA!

We Give Genuine Personal Service. Write **FREELY**, sending DATA of your invention, for full advice. Our "Proof of Invention" folder mailed **FREE**.

**E. E. VROOMAN & CO., 525 9th St., N. W., Washington, D. C.**

27 YEARS' EXPERIENCE

SERVICE

## INVENTORS

who derive largest profits know and heed certain simple but vital facts before applying for Patents. Our book *Patent-Sense* gives those facts; sent free. Write **LACEY & LACEY, 646 F St., Washington, D. C. Established 1869.**



## BOW LEGS?

OUR GARTER (Pat'd)  
**Makes Trousers Hang Straight**

If Legs Bend In or Out. Self Adjustable.  
Free Booklet — Plain Sealed Envelope

**THE T. GARTER CO.** Dept. 2, New London, New Hampshire

# INVENTORS PROTECT YOUR IDEAS

Send for our Guide Book, **HOW TO GET A PATENT**, and Evidence of Invention Blank, sent Free on request. Tells our terms, methods, etc. **Send model or sketch and description of your invention for INSPECTION and INSTRUCTIONS FREE. TERMS REASONABLE. BEST REFERENCES.**

**RANDOLPH & CO.**  
300 Victor Bldg., WASHINGTON, D. C.

NAME \_\_\_\_\_

STREET \_\_\_\_\_

CITY \_\_\_\_\_ STATE \_\_\_\_\_

# PATENTS

## To the Man with an Idea

I offer a comprehensive, experienced, efficient service for his prompt, legal protection and the development of his proposition.

Send sketch, or model and description, for advice as to cost, search through prior United States patents, etc. Preliminary advice gladly furnished without charge.

My experience and familiarity with various arts frequently enable me to accurately advise clients as to probable patentability before they go to any expense.

*Booklet of valuable information and form for properly disclosing your idea free on request. Write today.*

**Richard B. Owen, Patent Lawyer**  
9-303 Owen Bldg., Washington, D. C.  
41-E Park Row, New York City

## TRADE-MARKS REGISTERED

## PATENTS

Trade Marks, Copyrights, Patent Litigation Handbook with illustrations, 100 mechanical movements. Sent free on request.

**ALBERT E. DIETERICH**  
formerly member examining corps U. S. Patent Office  
**PATENT LAWYER and SOLICITOR**

621-A, Ouray Bldg.  
27 Years' Experience Washington, D. C.

ESTABLISHED 1877

LAW OFFICES OF

**RICHARD E. BABCOCK**

PATENTS AND TRADE-MARKS

WASHINGTON LOAN & TRUST BUILDING

WASHINGTON, D. C.

BOOKLET ON REQUEST

## BLUE BOOK ON PATENTS

AND PRIORITY RECORD BLANK GRATIS.

**MONROE E. MILLER, PATENT LAWYER**  
411-2 Ouray Building, WASHINGTON, D. C.  
ELECTRICAL AND MECHANICAL EXPERT

## PATENTS Personal Prompt Service

Send for Record of  
Invention Form.

**JACOBI & JACOBI, Patent Lawyers,** 601 Ouray Building  
WASHINGTON, D. C.

## Have You An Invention?

If so the WORLD PROGRESS will send you upon request sample copy Free containing SUGGESTIONS TO INVENTORS as to Inventions Needed. We invite manufacturers to address us regarding inventions they want.

Subscription for one year 60 cents

**WORLD PROGRESS PUB. CO., Inc.**  
Room 203 Victor Bldg. WASHINGTON, D. C.

# Learn to Make BIG MONEY As an Inventor



*Raymond F. Yates, who with fourteen other famous inventors, now makes it easy for you to learn how to invent in your spare time at home.*

Amazing new home-study course now teaches you inventive science in your spare time; shows how to develop, patent, sell your ideas; how to make big money from inventions.

## Famous Inventors Now Teach You!

Invention is not a matter of luck. Edison says, "Invention is a science, and should be taught as a profession." Suppose you went home tonight and found a window rattling. Almost instinctively you would stop the rattle with a wedge. That instinct is the germ of your inventive ability, and you can develop it so strongly that in a remarkably short time you will think and act inventively. Every invention is based on exactly the same

principles that you use to "fix" the rattling window—first to see a problem, and then to find some fact which solves that problem. And now, for the first time, 15 famous inventors teach you how to acquire these simple, easily learned principles of invention.

## A Fortune for One Little Idea

Even so small an idea as a new kitchen knife can bring you thousands of dollars. Waterman, the inventor of the fountain pen, became a millionaire. The inventors of the metal-tip shoelace, the "humped" hairpin, the metal tape measure, the paper-match holder, have all received thousands of dollars for just one idea. It doesn't matter who you are, where you live, what you do—every day you meet problems which suggest ideas for money-making inventions.

## Learn How to Invent at Home

If you have ever had an idea for an invention, or if you would like to become a spare-time or professional inventor, see what this fascinating new course can do for you. Fifteen famous inventors now teach you at home the secrets of invention; show you how to get the information you want, how to perfect your ideas quickly, what to invent, and (just as important) what not to invent. You also learn how to avoid the mistakes which cost many inventors thousands and thousands of dollars. This complete course teaches you everything you want to know—how to get a patent, how to protect your patent rights, how to dispose of your invention to get the greatest possible profits, and hundreds of other facts about invention worth a fortune to you.

## FREE BOOK On Inventive Science

A wonderful book explaining this fascinating course will be sent to you free. It explains the course in detail, and proves that you can easily train your mind to think inventively so you may become a successful inventor. It shows how this course gives you, in a short time, a wealth of information which other inventors learned only after years of hard work and bitter experience. Get the advice of these fifteen famous inventors. Send for this book today. There is no cost or obligation. This bureau is not connected with patent attorneys or manufacturers. Our only work is to teach you how to develop your ideas so they will bring you big money.

## BUREAU OF INVENTIVE SCIENCE

Dept. 33, Wisner Bldg. ROCHESTER, N. Y.

BUREAU OF INVENTIVE SCIENCE,  
Dept. 33, Wisner Building, Rochester, N. Y.

Please send me without cost or obligation your free book "The Science of Invention."

Name.....Age.....

Address.....

City.....State.....

# PATENTS

**Booklet Free Highest References  
Promptness Assured Best Results**

Send drawing or model for preliminary examination of Patent Office records.

## ALL BUSINESS GIVEN PROMPT AND PROPER ATTENTION

Listed Patent Lawyer in the latest editions of the Rand-McNally Directory of Bankers and Attorneys, of Chicago, Ill.; The Baggott & Ryall Directory of Attorneys, New York City; The Lawyers Guaranteed Directory, Detroit, Michigan; The Lawyers and Bankers Quarterly, published by the Legal Directory Publishing Company of St. Louis, Mo.; the American Lawyers Annual, Cleveland, Ohio.

**WATSON E. COLEMAN,**  
REGISTERED PATENT LAWYER

644 G Street, N. W., Opp. U. S. Pat. Office  
**WASHINGTON, D. C.**

## U.S. PATENTS



**SEND FOR THIS FORM**

### DON'T LOSE YOUR RIGHTS TO PATENT PROTECTION

Before disclosing your invention to anyone send for blank form "EVIDENCE OF CONCEPTION" to be signed and witnessed. A sample form together with printed instructions will show you just how to work up your evidence and establish the same before filing application for patent. As registered patent attorneys we represent hundreds of inventors all over the United States and Canada in the advancement of inventions. Our schedule of fees will be found reasonable. The form "Evidence of Conception," sample, instructions relating to obtaining of patents and schedule of fees sent upon request. Ask for them—a post card will do.

PATENTS AND TRADE MARKS

**LANCASTER & ALLWINE**  
D.C.

Registered Patent Attorneys In U. S. and Canada.  
480 Ouray Bldg., WASHINGTON, D. C.  
Originators of forms "Evidence of Conception."

## Make \$75 to \$150 a Week No Experience Necessary FREE BOOK

**Shows and Teaches You How to SELL OUR MONEY-MAKING LINE**

Methods explained in this book now making thousands of dollars for our representatives. You can turn these ideas quickly into big profits for yourself. Easy to read. Plain, simple explanations. You learn quickly.

**UNIQUE SELLING PLAN—MILLIONS of PROSPECTS**

No collecting—no delivery—no capital needed. You deal with a large, financially responsible manufacturer

Write for FREE Booklet and full details.  
**M. F. BRONNER, Pres. Dept. B**  
Box 123, Essex Postal Station, BOSTON, MASS.



## LUCK

All around you there is abundant Success, Wealth and Happiness. Get Your Share. The "LUCKY SEVEN" Secret Rules are free to all who wear this Rare and beautiful Talisman Ring. On each side of this Odd and Charming Ring is moulded the figure of Fortuna—The "Goddess of Luck". Ancient belief, that her emblem brings luck and success to wearer in Love, Games, Business, Health and everything. Genuine 14-K Antique Gold S. Ring, mounted with one carat Blazing Blue White Mexican Im. Diamond. Guaranteed 20 years. Send strip paper to show finger size and we will send you this wonderful ring. When it arrives pay the postman only \$3.95. Nothing more to pay. Yours to keep, wear and enjoy forever. Wear 7 days—follow the 7 rules that we send you. If not satisfied your money quickly returned. Address  
**Radio-FlashDiamond Importing Co., St. Paul Minn. Dept 4L**

## FREE 1000 Illustrations ELECTRIC FIXTURE CATALOG!

Write today for your copy. Save 50% direct from Manufacturer. No Middleman's Profit. OUR SPECIAL: 8 Room Electric Set, ready to hang, \$24.50—Other bargains.  
**UNITED LIGHTING FIXTURE CO.**  
83 Flatbush Ave. Dept. P, Brooklyn, N. Y.

## THIS WONDERFUL INVENTION

converts any ordinary cook stove into a gas stove. OXO-GAS is made from kerosene and air. Cheaper, cleaner and more efficient than coal. Responsible distributors wanted.  
**GLORIA LIGHT CO.**  
111-3 N. May St. Chicago, Ill.

## GO INTO BUSINESS for Yourself

Establish and operate a "New System Specialty Candy Factory" in your community. We furnish everything. Money-making opportunity unlimited. Either men or women. Big Candy Booklet Free. Write for it today. Don't put it off!  
**W. HILLYER RAGSDALE, DRAWER 321, EAST ORANGE, N. J.**



## AGENTS!!! 300 to 500% PROFIT

Goods have Fine Appearance, Good Quality. Sells easy, and agents make big money. Write today for FREE CATALOGUE AND SAMPLES.

**National Soap Company**  
512 W. Huron St., Dept. D-7, Chicago

**60 Days Trial, Money back if not pleased**  
**New Unbreakable Fountain Pen**

**Agents Sample Only 67c**

Regular Retail Price \$1.25

**Writes Like a \$7 Pen**

**FREE**

Beautiful  
 Red, Green  
 Black or  
 Purple

Guaranteed for 2 Years

Ladies or Gents Style

New and unusual Mail Order Distributing Plans and Large Wholesale Specialty Catalog showing best sellers from all parts of the world. **Money refunded if not pleased.**

Latest Improved Point

Mark Check and Fill Out at Once

**F. SPORS & CO., 356 Main St., Le Sueur Center, Minn.**

- Send Sample C. O. D. 67c, plus few cents.
- Send 12 Pens Assorted Colors C. O. D. \$6.42, plus postage.
- Send Catalogue, no obligation on my part.

Name.....

Address.....

**ADDING MACHINE**

**Fits Vest Pocket**

A marvelous calculator. Does the work accurately and quickly as a \$300 machine. Invaluable to anyone who uses figures. Don't carry pad and pencil. This startling invention will solve all problems in a minute. Business men, students, professional people, all need this **HANDY HELPER**.



Counts To 1 Billion

Results in plain sight all the time -- clears instantly. Made of steel and brass, in handsome case, fits vest pocket; weight only 3 oz. Send for yours now -- you'll save time and money.

**SEND NO MONEY**

Don't send money, just name and address. We'll ship machine postpaid. Pay postman only \$2.95. Try it for 10 days. Your money back if not satisfied

**\$2.95**

Reliable Adding Machine Corp., Dept. 43  
 184 W. Washington St., Chicago, Ill.,

**AGENTS**

Here's a dandy chance to make money. Everybody wants one. Fine profit. Write for new offer.

**Agents \$12.00 a day**

**NEW Self-Heating IRON**

New invention now makes ironing easy in every home. Ends hot stove drudgery. Cuts ironing time in half. Saves steps. Costs one cent for 3 hours use. No attachments. No cords. No tubes. Gives quick regulated heat. Guaranteed. Sells fast. Mrs. Wagner, Ohio, sold 24 in few hours spare time.



Moyer, Pennsylvania, made \$164 in one week. You can do as well. Work all or spare time. No experience needed. No capital. New plan. Simply take orders. We deliver and collect. Commissions paid same day you take orders. Send for exclusive territory and **FREE OUTFIT OFFER**. Write today.  
**THE AKRON LAMP CO., 33 Iron St., AKRON, OHIO**

**Do Your PRINTING**

Cards, stationery, circulars, labels, paper. Complete Outfits \$8.95 up, Rotary Jobber, \$150, Card Cutters \$3 Save Money. Print for others, big profit. Easy with rules sent. Write for catalog presses, type, paper, cards ink, etc. **THE PRESS CO., L-37, MERIDEN, CONN.**

**WADE BENCH LATHE**



**AMATEUR MECHANICS, REPAIR SHOPS, INVENTORS, STUDENTS**

A real machine tool for the home work bench—capacity 4" dia. x 12" length. For Metal—Wood—Composition Materials—Turning—Facing—Boring—Drilling—Winding—Thread Cutting. Accurate—Strong—Quiet—Compact. Slide-rest has travel entire length of bed. Leadscrew inside bed. No. 1 Lathe, plain headstock, \$28.00. No. 2 Lathe, back-geared headstock, \$58.00. Complete line of accessories at equally low prices. Write for free catalog—just out  
**THE GEROLD CO., Dept. P-20, 120 Liberty St., New York**

**PRICES REDUCED**

Only \$3 Down



A Year to Pay

Yes, lowest prices on **UNDERWOOD, ROYAL**, and all standard makes on easiest terms ever offered. Re-manufactured like new by the famous "Young Process" to give a lifetime of service.

**10 Days Trial** Our liberal "direct from factory plan" saves half. You actually use the typewriter 10 days without obligation to buy. Let us prove we have the greatest typewriter bargains ever offered. You actually save from \$40 to \$50.

**Big Illustrated Catalog FREE** This interesting valuable book explains fully how "Young Process of Re-Manufacturing" guarantees you highest quality, perfect service and satisfaction. **Rush coupon today to YOUNG TYPEWRITER CO., (Est. 1911)**

**SEND COUPON NOW**

Young Typewriter Co., Dept. 1103, 654 W. Randolph St., Chicago

Send me Free book and Special Reduced Prices. This does not obligate me in any way.

Name.....  
 Address.....  
 City..... State.....

## Now Anyone Can Play a HOHNER HARMONICA



### This FREE Book Will Prove It!

Thousands of people of all ages, in all walks of life, are now playing Hohner Harmonicas for entertainment, education and inspiration. Thanks to the new instruction book they are enjoying the popularity that comes to those who can play this fascinating musical instrument.

If there is any greater satisfaction than *listening* to good music, it is surely that of being able to *play* it. This Free Instruction Book, containing charts, pictures and popular musical selections, will enable *you* to play the Hohner Harmonica with an ease that is most surprising. Ask your dealer for a copy today; if he cannot supply you, write direct to M. Hohner, Inc., Dept. 181, 114 East 16th Street, New York City.

Leading Dealers Everywhere  
Sell Hohner Harmonicas  
50¢ up.



## REMINGTON PORTABLE TYPEWRITER Dealers and Branches Everywhere

## Amaze Your Friends With Chemical Tricks

The Boy's Hand Book of Chemistry

Price 15 Cents

Write secret letters with invisible ink; pour blue, brown and black liquid from a glass of water; make a magic pitcher of bluing; make your own magic writing paper, your own ink and dyes. It's all easy if you have Chemcraft Junior—the pocket Chemical outfit. Get yours now. Order right away and get a FREE Copy of The Boy's Handbook of Chemistry; 100 pages of experiments, formulae, interesting chemical information, money-making suggestions and catalog of supplies.



Porter Chemical Co.  
113 Washington St.  
Hagerstown, Md.

BOTH  
**25¢**  
POSTPAID

# SEND NO MONEY

Genuine Full Cut Diamonds

Terms If Desired—6 Months to Pay. Outside U. S. Cash with Order.  
**\$25**



New No. 6132

This Reg. Trade Mark guarantees you genuine diamonds.

No. 6598—Any Initial (raised gold) or Eastern Star, Rebecca, Mason, Shrine, K. of C. emblem instead of initial if desired. Send number of ring, size of finger, initial or emblem desired and ring will be sent for inspection.

Ask for Free Catalog

**BUFFALO JEWELRY MFG. CO.**  
"The Mail-Order House"  
Dept. P  
501 Washington St., Buffalo, N. Y.

No Chips

No. 6132—Solid Gold Men's Initial or Emblem Ring. 2 Genuine Diamonds 4-100 each..... **\$25**

14-Kt. White Gold Top. Gold Emblem (any Lodge) or any initial (Old English) yellow or white Gold, in-laid in Genuine

**HOPE RUBY**  
Also, in Black Onyx



No. 6598

No. 6598—Ladies' Ring..... **\$15**  
Genuine Black Onyx with Genuine Full Cut Diamond. 14-Kt. White Gold.

# EARN MONEY in spare Time!

MY marvelous new low-priced invention combines a hot water bag, an ice bag and a syringe—all in one. Vital necessity in every home! My agents make big money in spare time or full time. Michael Short made \$43 the very first day. "30 orders a day is a cinch," writes T. B. Gilmore. "Make fine living with it," writes Mrs. Kennedy. Big commissions to wide-awake agents. Write today for money-making plan.

**LOBL MANUFACTURING CO.**  
Dept. 143, MIDDLEBORO, MASS.



Only 3 1/4 in. long

**THIS CLEAR, POWERFUL 6 POWER VEST POCKET TELESCOPE**  
with glove leather case **\$2**

Easily slips in vest pocket, powerful, precise, adjustable to either eye, 6 full magnifications bring distant objects close in full detail. Thorough satisfaction or money back.

**BOSTON SPORTING GOODS CO.** Dept. P, 80 Boylston St. BOSTON, MASS.

# \$10 A DAY AGENTS

Your chance to make big money, showing our full size samples complete and filled. Our machines approved by (Fire) Underwriters' Laboratories and big Insurance Companies. Be first in your vicinity. No experience necessary. We deliver and collect. Sell to Farmers, Stores, Garages, Elevators, Mills, Warehouses, Factories, Shops, Homes, Schools, Auto Owners, etc. We are largest manufacturers of portable extinguishers in the world. Our big national advertising and Sales Manual helps you. Pay starts at once. Territory going fast. Write quick for free outfit offer.

**THE FYR-FYTER CO.** 1008 Fyr-Fyter Bldg., Dayton, Ohio (633)







## Beautifully balanced

"OLD TOWN CANOES" are the exact reproductions of models built by the Penobscot Indians. These Indians were masters in the art of canoe building. Their canoes were speedy, they carried large loads easily and—they were beautifully balanced.

"Old Town Canoes" are not only steady, fast and beautiful—they are also light in weight and remarkably durable. Sturdy and rigid, "Old Town Canoes" stand up under the severest strains—they last for years without repairs.

"Old Town Canoes" are low in price too. \$64 up. From dealer or factory.

The 1926 catalog is beautifully illustrated with all models in full colors. It gives prices and complete information. Write for your free copy today. OLD TOWN CANOE COMPANY, 1663 Middle Street, Old Town, Maine.

## "Old Town Canoes"



### STOP FORD CRANKSHAFT END-PLAY!

**C-A ADJUSTABLE BEARING** corrects and prevents end-play without removing motor. Eliminates many troubles. Easy to install—simply drop pan. Only \$3.75. Ask your dealer or sent prepaid by ADJUSTABLE BEARING CO. Dept. P. BRAZIL, IND.

## MOTORCYCLES

### LESS THAN HALF COST

Ace, Indian, Cleveland, Harley-Davidson, Henderson Motorcycles and Sidecars, new, used and rebuilt. **Rider Agents Wanted.** Write for FREE trial offer, agent's free outfit and big bargain bulletin. **New American Bicycles** in different styles and colors. Write for illustrated catalog giving our money saving prices.

**AMERICAN MOTOR CYCLE CO.**

2047 W. Chicago Ave., Dept. 335, Chicago



### BETTER BOATS at Lower Prices



**Thompson BEATS the World on BOATS**

**The BEST that Skill and Experience can Produce**  
**TWO BIG FACTORIES**

Our complete line of 22 models offers you a variety to choose from. Prompt shipment from factory to you.

**Catalog Free — Save Money — Order by Mail**  
Please state kind of boat in which you are interested.

**THOMPSON BROS. BOAT MFG. CO.**  
423 Ellis Ave. PESHTIGO, WIS. Write to (Either Place) 1223 Elm Street CORTLAND, N.Y.

### PREST-O-LITE COMBINATION 5-IN-1 OUTFIT

The Prest-O-Lite 5-in-1 Outfit comes in a convenient canvas case. Four different torch heads, soldering-iron, rubber hose and wrench. \$7.50 complete

# \$7.50



## A time and money saver for garage or service station

ANYTHING that saves time and money for a garage man means more profit. That is the big reason why so many garages are equipped with Prest-O-Lite 5-in-1 Outfit.

This outfit gives you instant, intense heat wherever you want it. Carry it easily, right to the job and it's ready for work. And you'll find thousands of uses for it.

Four different-size torch heads come with this outfit, giving you just the right flame for every job of brazing, fusing, melting or soldering. There is also a handy soldering-iron that heats instantly and stays hot.

The Prest-O-Lite 5-in-1 Outfit operates on acetylene from the handy Prest-O-Lite Tanks—the same gas that is used everywhere for lighting on heavy-duty trucks. There is nothing complicated about its operation, nothing to get out of order.

When tank is empty, exchange it for a full one at any one of the thousands of Prest-O-Lite Service Stations, paying a small amount for the gas only.

Ask the nearest Prest-O-Lite Station jobber or supply depot about this profit-making, trouble-saving outfit. Or write us direct. It costs but \$7.50 complete.

**THE PREST-O-LITE CO., INC.**  
INDIANAPOLIS, IND. Dept. L-3  
New York San Francisco

In Canada: Prest-O-Lite Company of Canada, Ltd., Toronto, Ontario



Repairing radiator using 5-in-1 Outfit



Does brazing and welding quickly



Soldering a vacuum tank



Brazing a housing



# Prest-O-Lite

# Puncture Proof <sup>any</sup> TIRE

## with new wonder GALACITE

**THE COST per tire is Very Low**

**in 1 minute**



The greatest and most outstanding automotive invention of the past few years—banishes tire trouble forever. This wonderful new scientific discovery repairs a puncture instantly without taking the tire off wheel or rim. Actually makes any tire puncture-proof for life. Guaranteed not to injure tube, valve or tire. On the contrary, it preserves and lengthens the life of both tube and tire, often—

**Increasing Tire Mileage from 10,000 to 12,000 Miles.**

**MAKE THIS TEST** Take a hammer and drive as many nails into a tire as you wish, 10-20-100, it makes no difference. GALACITE seals the punctures instantly as soon as they are made. Stops all slow leaks and porous places. Used in all kinds of tires including low pressure Balloon. GALACITE is warranted for one year, but will last indefinitely.

**GUARANTEED TO DO ALL WE CLAIM**

Don't confuse Galacite with anything else ever intended for the same purpose; it is new and different—a revolutionary invention, the result of years of research and experiment. GALACITE is backed by a Money Back Guarantee. It must make good—or we will. You take no risk.

**AGENTS—\$5,000 to \$10,000 a Year**

**TREMENDOUS PROFITS.** Agents and Distributors everywhere to demonstrate and sell to car owners, garages, filling stations. Work all or spare time in your own home town or traveling. GALACITE sells itself. Every customer becomes so enthusiastic that he helps you sell his friends. A revolutionary invention that will make you independent. You can also manufacture and sell Galacite puncture proof inner tubes.

**ACT QUICK SEND NO MONEY.** Just your name and address will bring complete particulars by return mail. Get this information right now. Test it out. Get started while the territory you want is still open.

**C.F. JOHNSON & CO. 19 W. Jackson Blvd., Dept. 978, CHICAGO**

**CLASS 25¢ PINS**

BUY DIRECT FROM THE MAKER  
**CATALOG FREE**

Either pin shown made with any 3 letters and 2 figures 1 or 2 colors enamel. Silver plate 25¢ ea. \$2.50 doz. Sterling silver, 40¢ ea. \$4.00 doz.

**BASTIAN BROS. CO.**  
3490 630 Bastian Bldg., Rochester, N. Y. 2534



**4 TIES ON APPROVAL**  
**Send no Money**

Here's your chance to get 4 beautiful Rayon Silk Fibre Knitted Ties at factory prices—direct from the mill that weaves them. You save the jobber's and retailer's profit. We send you the ties on 3 days' approval. If you like them, you send your check or money order for \$1.50 within 3 days. Or you return the ties in the accompanying stamped container.

**NO C. O. D. TO PAY POSTMAN**

—nothing to pay if ties don't suit you. Just write on a post card, "Send the 4 ties," and you'll get them post-paid by return mail.

**GOVERNMENT SQUARE KNITTING MILLS**  
119 Government Square CINCINNATI, OHIO

**CORONA**

**Has Standard Keyboard**

and more big machine features than any other portable. Write for information to

Corona Typewriter Co., Inc.  
108 Main Street, Groton, N. Y.



**DARCHE "CALL-ME" ELECTRIC ALARM AND LIGHT CLOCK**

Will ring until you get up and STOP it. No home complete without one. Can be used as an "alarm clock" or "mantel clock." With a little effort on your part you can get one

**FREE OUR OFFER TELLS YOU HOW**

Agents, here is a big money-maker, no competition, sells on sight. A good punch board proposition. Write today for our descriptive literature. An ideal GIFT for any occasion. Mahogany finish. Size 10 1/2 x 8 1/2 x 4. This applies to U. S. only.

Darche Mfg. Co., 645 Washington Blvd., Chicago



**KEDS**—the athletic shoes worn by champions in every sport. Made only by the United States Rubber Company.



**Mount Birds**

We teach you by mail to stuff and mount all kinds of **Birds, Animals, Game Heads.** Also to tan skins and make rugs. Be your own taxidermist. Decorate your home with your beautiful trophies or increase your income selling specimens and mounting for others. Easily, quickly learned in spare time by men and women. Highest endorsements by thousands of students. Write today for our great free book "How to Mount Birds and Animals" Free—write today, N. W. School of Taxidermy, 1773 Elwood Bldg., Omaha, Neb.

Send for Book of **200 Home Plans** **FREE!**

**Swing a Hammer and Save \$500!**

Hundreds of buyers find our plans so easy to follow and the material so accurately cut and marked that they put up their homes themselves. Studs, joists, rafters and sheathing cut at mill by power-driven saws. Saves 30% labor and 18% lumber waste. Permanent construction.

**Highest Quality**  
All material guaranteed top quality. Everything furnished as specified. No extras. One guaranteed price covers all.



Gordon-Van Tine Home No. 624. Five Rooms and bath. Materials—**\$1011**

**Buy Your Home Direct From Mill!**

Over 200,000 customers help you save. Their volume enables us to operate on one small profit, and give you *wholesale prices*. Your savings run from \$200 to \$2,000. Homes planned for utmost in comfort and beauty. Many built-in features to lighten housework. Distinctive designs by skilled architects.

**Gordon-Van Tine Co.**

ESTABLISHED 1865

**Satisfaction Guaranteed or Money Back**  
690 Case Street DAVENPORT, IOWA

**Garages and Summer Cottages Build Yourself Save Money**  
**FOUR BIG MILLS**  
We ship from one nearest you.

**Send For Book**  
200 plans, photos, color illustrations. Homes as low as \$708; Bungalows, Colonial, etc. Also ask for building Material Catalog.

Gordon-Van Tine Co. 690 Case St., Davenport, Iowa

I expect to

- Build a.....
- Repair a.....  
Send me proper catalog

Name.....

Address.....

**MOTORS** large quantity brand new universal 110 volts standard very well constructed.  
General Electric about 1/70 H. P. 1080 R. P. M. orig. cost \$16.00 **\$6**  
Robbins & Myers " 1/30 H. P. 3000 R. P. M. " " \$14.00  
Edison used, about 1/40 H. P. 600 to 1800, controlled by governor.  
**SATISFACTION GUARANTEED OR MONEY REFUNDED**  
**WEXLER ELECTRIC MOTOR CO. 196 Centre Street, New York**

**Lighting Fixtures**  
**READY TO HANG**  
(Direct from the Manufacturer)  
Completely wired, including glassware. Send for New Catalogue No. 27. Just reduced prices.  
*Special proposition to DEALERS.*  
**ERIE FIXTURE SUPPLY CO.**  
STA. A ERIE, PA.

**Build and Fly Your Own 3 ft. Model Aeroplane!**

**Every Boy's Airplane**  
The simplest-to-make Model Aeroplane; all parts ready to put together without nails, wire or glue. Anyone can do it in 2 hours. Beautiful Monoplane Model; 3 1/4 ft. wing spread; guaranteed to fly. Complete Outfit, postpaid, **\$6.**  
**Send 5c now for complete 48 page catalog**

**IDEAL** Scale Drawings and Building—Flying Instructions show you how to build and fly accurate duplicates of any of the following famous 'planes. Complete plans for any one sent postpaid for 25 cents!  
Curtiss JN4 D-2 Training Plane; De Havilland "Round-the-World Flyer"; N-C-4 Naval Seaplane; Bleriot; Nieuport or Taube Monoplane; or Cecil Peoli Racer.  
(Set of 7 Plans, \$1.25 postpaid)  
**Ideal Aeroplane & Supply Co.**  
408 West Broadway, New York  
**Ask your Dealer for Ideal Model Aeroplanes**



**CRESCENT TOOLS**  
"—necessary for fast, efficient repairs"

This opinion of a veteran service station manager in an eastern city is echoed by the host of car owners who find there is nothing like the Crescent Wrench for the monthly "check-up" to keep body bolts and other fastenings tight and squeakless.

**Crescent Tool Company**  
210 Harrison Street  
Jamestown, N. Y.

*originators of the*  
**CRESCENT WRENCH**

**Crescent Tool Co.**  
210 Harrison St.,  
Jamestown, N. Y.  
Please send copy of your book for car owners.

Name.....  
Address..... Car.....

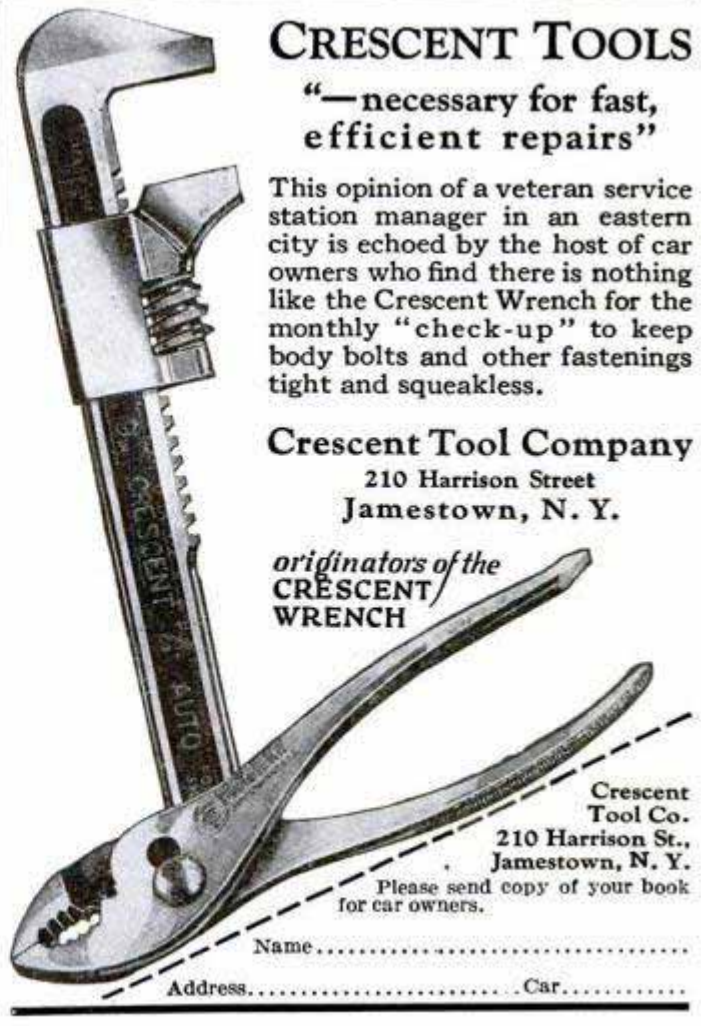

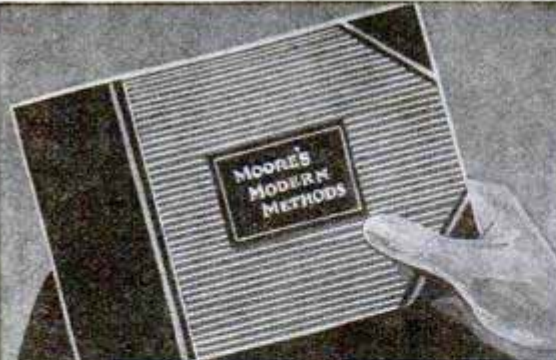

**FREE**

140-page Book full of life-size ruled forms, each one completely filled in. The answer to problems of accounting and record keeping for any business or profession.

Send for this FREE Book today

John C. Moore Corporation  
(Established 1839)  
3066 Stone St., Rochester, N. Y.

**MOORE'S LOOSE LEAF SYSTEMS**  
In Use In More Than 300,000 Offices

# INGERSOLL DOLLAR STROPPER

ROBERT H. INGERSOLL, originator of the famous Ingersoll Watch, offers you his remarkable new invention that brings back original keenness to used blades, makes them last longer and gives cleaner, smoother, more comfortable shaves. Already satisfying thousands of users.

## Hundreds of Shaves From Every Blade

The Ingersoll Dollar Stropper keeps razor blades practically as good as new — hundreds of shaves from every blade! That means no more discarding blades after merely a few shaves. Resharpen them and save \$5 to \$10 a year!



### Ten Days' Trial

Prove that the Ingersoll Dollar Stropper is all we claim. If you have not had the Stropper demonstrated by our representative and cannot get it at your dealers, send us \$1.00 for outfit—complete with 12-inch Strop and patent nickel-plated Holder. Automatically puts scientifically keen edge on blade! Money back guaranteed if ten-day trial doesn't convince that Mr. Ingersoll's new invention solves your razor-blade troubles. When writing, mention make of razor used.

AGENTS and DEALERS: Write for proposition.  
Robt. H. Ingersoll, Pres. New Era Mfg. Co.  
Dept. 583 476 Broadway, New York City

# FISHermen: This rod has a perfect casting action



Richardson Steel Rods have the balance—the "feel"—the Perfect Casting Action. Made to give fishermen a service that no other rod of three times the price can equal. Every Richardson Rod goes through 26 separate inspections before its final test. Then a "make-or-break" test to insure its absolute perfection. That's why Richardson pays 22% premium for a special spring steel of extraordinary tensile strength and flexibility. A Richardson Steel Rod for every purpose—priced to meet every purse. Detailed descriptions in 24-page illustrated catalog. Send for a free copy NOW.

**Richardson Rod & Reel Co.**  
528 Lake Shore Drive CHICAGO

## Attention Ford Owners!

Wonderful New Invention for Fords  
**Automatic Spotlight Bracket**



Moves the Spotlight Automatically with the steering wheel. Any spotlight may be attached. Makes night driving a pleasure. Light rays always in front of the car in turning corners, and passing other cars. Mailed anywhere for a \$2.00 bill. State year of Ford.

Agents Wanted. Liberal Discounts.  
IDEAL BRACKET CO., 1401 Weller Ave., LaPorte, Ind.

## MYERS ELECTRIC IRON CORD HOLDER

A wonderful invention. Keeps cord out of way while ironing. Grips the ironing board. Tested and approved by Good Housekeeping Institute.



AGENTS WANTED  
Sample 50 cents postpaid.  
C. A. MYERS CO.  
6339 Woodlawn Ave., Chicago, Ill., U. S. A.

# NEW VEST POCKET ADDING MACHINE

ADDS, SUBTRACTS, MULTIPLIES, DIVIDES  
Does work of \$300 machine. Guaranteed 5 years. NOT A TOY.  
Made of steel and indestructible. Million dollar capacity. Fits in pocket. Will not make mistakes. So simple child can operate it. Everybody should carry one for figuring.

**FREE TRIAL \$2.50 Total Cost**

SEND NO MONEY—Just name and address. We will ship Calculator immediately. On delivery pay postman \$2.50 (Plus few cents Postage) (\$3.50 cash outside U.S.). If not satisfied after 10 day trial you get your money back. THOUSANDS OF SATISFIED USERS.

This is lowest priced practical calculator made. "Why pay more for inferior imitations?" Order from this ad.

**BABY CALCULATOR SALES CO.**  
P. O. Box No. 1118 Chicago, Ill. Dept. 31  
Write for big commission and territory proposition.

**AGENTS**

# Get Tailored Pants

## FREE \$90 A WEEK



Your own fine trousers Free for taking a few orders and big, steady income assured. You don't need experience to earn \$90 a week showing men famous Hutchins Pants.

**Amazing Values** Tailored-to-measure at sensational low prices. Nearly every man buys. Absolutely guaranteed pants, finest materials and workmanship, for only \$5.95 a pair; 2 pairs, \$11. You merely take order and collect your own big profit in advance—a wonderful spare-time or full-time opportunity!

**SEND NO MONEY—FREE SAMPLES!** Send only name and address—no money! We send beautiful samples and sales outfit FREE. No deposit. But act quick. Make \$10 the first day. I show you how. Write this very minute.

**THE HUTCHINS PANTS CO., Dept. C-19, 316 East Fifth St., CINCINNATI, OHIO**

## Save Money on New or Used Auto Parts!

15 years of progress has made our stock of new and used accessories and replacement parts the largest in the world. We can furnish you with anything from a Cotter-Pin to a complete Power Plant.

**FREE! CATALOG**  
of Parts Both

**NEW AND USED**

The most complete catalog ever issued. Chockfull of bargains. Save 30% to 80% on your purchases. Buy from Warshawsky. Every item guaranteed to be just as represented.

**WRITE TODAY**  
**SURE!**

Big Illustrated  
Radio Catalog  
**FREE**

**A FEW SPECIAL BARGAINS  
IN NEW REPLACEMENT PARTS**  
Prices quoted are F. O. B. Chicago

Ford Cylinder Heads, New..... **\$3.75**  
Ford Cylinder Blocks, New. Complete with rings, wrist pins, pistons, bushings..... **\$20.00**  
Ford Counter Balance Crank Shafts. A \$19.00 value. New..... **\$12.50**  
Ford Triple Seal Pistons. New. Up to .005 oversize. Complete with wrist pins and bushings. Per set..... **\$5.00**  
Ford Gas Savers. New. 2-in. manifold, \$3.50 value..... **\$1.00**  
Ford Water Pump. New..... **\$2.50**  
Genuine Chevrolet Pistons. New. Up to .005 oversize..... **\$1.00**  
Nu-Life Ring Expanders. New..... **5c**  
Miles Piston Rings. New..... **40c**  
All sizes. A \$1.25 value.....

**WARSHAWSKY & CO.**

"World's Largest Car Wreckers and Replacement Parts House."

No Branches 1915 So. State St., Dept. P. M. 3 Chicago, Ill. No Branches

# Popular!



# Oh, man

There he is, popularity itself, and six weeks ago he was a social nobody. Now look at him! Invited everywhere! Center of attraction! Charming all the good times with his

## BUESCHER

### True Tone Saxophone

Where are you? Are you in the picture? Or out of it? Do you long for attention? the admiration of friends? gay parties? good times with those you like best? All these things, and more, are yours if you will earn your welcome--learn to play this most wonderful of all musical instruments.

**You Can Do It, Easy**

Within a week you can be playing tunes. 3 lessons, given on request with each new instrument, explain easy fingering and give you quick start. You might even be a wizard like Tom Brown, whose Buescher Saxophone has made him famous and rich.

**Six Days' Trial--Easy Terms**

Try a Buescher, any Instrument you choose, in your own home for six days. This is a most liberal offer. If you like the instrument, pay a little each month. Play as you pay. Without obligation, mail coupon below for beautiful literature and details of trial plan. Get Started! Now!

**BUESCHER BAND INSTRUMENT CO.**  
Everything in Band and Orchestra Instruments  
1356 Buescher Block Elkhart, Indiana

**Clip the Coupon NOW!**

BUESCHER BAND INSTRUMENT CO. 318  
1356 Buescher Block, Elkhart, Indiana

Gentlemen: Without obligating me in any way please send me your free literature. I am interested in the instrument checked below.

Saxophone  Cornet  Trumpet  Trombone  Tuba

Mention any other.....

Name.....

Address.....

Free *trial to Motorists*



# Free

Amazing New  
Auto Invention  
-the Marvelous  
Wesco-a Boom  
to Motorists!

**Makes Autos Run 60 Miles to a Gallon of Gasoline!**

I don't care what mileage you are making--how many so-called gas savers you have used, I positively guarantee that unless Wesco cuts your gas bills--half or less, removes all carbon, increases power and pep and eliminates spark plug trouble it will not only cost you nothing but I'll gladly pay you for your trouble. Just send name, make and model of car and say "I want to try Wesco at your risk."

**WESCO, 508 May Bldg., Sioux Falls, S. D.**

# FREE to Men Past 40



What is prostatic gland disorder? Why does it come to 65% of all men past a certain middle age? Are you a victim? Why does it cause sciatica, aching feet, back and legs, frequent nightly risings? Amazing book written by a well known American Scientist answers all these questions and tells of a wonderful new method that has already given relief to more than 20,000 men--restored the prostate gland to its proper functioning without the use of drugs, electricity or lessons. For a limited time you can get a copy of this book, free, by simply writing a request to the **Electro Thermal Co., 2155 Main Street, Steubenville, Ohio**, the concern that is distributing this book for the author. **No obligation, but write quick, for the edition is limited.** (Western office, Dept. 21-X, 711 Van Nuys Bldg., Los Angeles, Calif.)

# Let Boice Help You Build It!

He can help you build practically any job of woodwork quicker, easier and better with

## Boice-Crane Bench Machines



**14" Band Saw** uses blades 3/16" to 1/4" wide. Saws 7" stock. Table 12"x14" tilts 45 degrees. Bronze bearings.

**Handisaw Model 2** does ripping, mitering, grooving, sanding, grinding and drilling with accurate ease. Table 10"x13". Saw 7" dia. Cuts 2 1/2" stock. Dadoses 3/8" x 3/8". Cuts moulding.

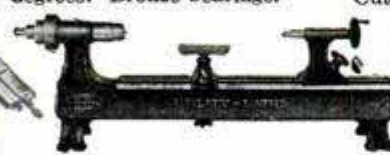

**8" Bench Lathe** does turning, drilling, sanding, sawing, grinding and jig sawing in wood or soft metal. Swings 8". Capacity C. to C. 19". Metal working model has compound slide rest. All Boice machines sold with or without 1/4 to 1/2 h. p. motor, which attaches to light socket.

Send 10c stamps or coin for Boice's new 64-page booklet containing helpful information and 60 illustrations and describing the complete line of Boice-Crane circular saws, 1/2 saws, band saws, mortisers, jointers, lathes and drills. Send money!

**W. B. & J. E. Boice, Dept. P.M. 3-B, Toledo, Ohio**

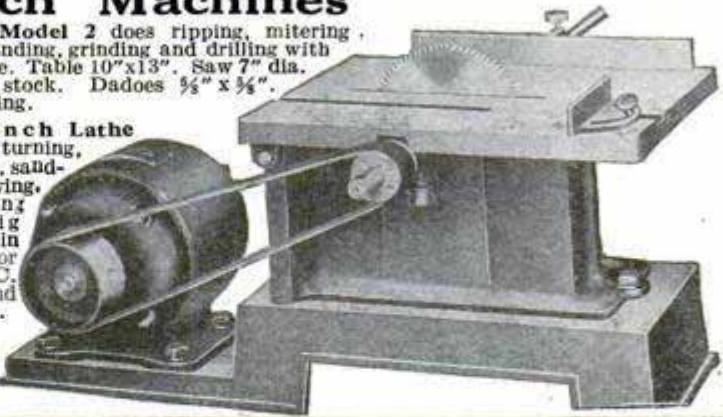

# Relieve rheumatic pain!



Absorbine, Jr. attacks the area of congestion. It awakens the sluggish circulation. It brings prompt relaxation and relief from acute pain.

Absorbine, Jr. is agreeable to use. It may be applied freely—it cannot burn. It is ordinarily stainless. Its pungent, agreeable odor quickly disappears.

Have the magic bottle ever ready for many regular toilet uses and as first aid in emergencies.

At all druggists', \$1.25, or postpaid. Send for free trial bottle.

W. F. YOUNG, Inc. Springfield, Mass.

**Absorbine Jr.**  
THE ANTISEPTIC LINIMENT

## RAISE BELGIAN HARES

NEW ZEALAND REDS—Chinchillas—Flemish Giants MAKE BIG MONEY—We supply stock and pay you following prices for all you raise: Belgian Hares \$2 each—New Zealand \$3 each—Chinchillas \$4 each—Flemish Giants \$5 each. 32-page illustrated book, catalog and contract, also copy of *Fur Farming* magazine, tells how to raise skunk, mink, fox, etc., for big profits, all for 10c. Address

**OUTDOOR ENTERPRISE CO., Box 25, Holmes Park, Mo.**

## MAKE YOUR Ford INTO THIS Sport Car—Save \$50 to \$150 with Red-i-Kut Life-Size Patterns \$5.00

Famous sure-fit RED-I-KUT life-size patterns and picture instructions show how you can easily convert your Ford into this **Fast, Saucy, Sport Car** as thousands have done, with easily obtained materials. No need to lay up the car. Rear seat folds making 4-passenger car. Look at **Wilfred Eno's**. Eno says: "It took me 3 Sundays to build it and I sure am proud to hear them say, 'He built that snappy sport car.' I never cut any steel or did any woodwork before but one can't go wrong with Kuempel patterns. St. Louis, Mo."



The Lark life-size patterns for each part of the body so you can't go wrong, picture instructions and CONICAL DISK WHEEL PATTERNS. Only \$5.00 delivered. \$4 extra brings patterns for *Jifty Top* and *Cozum* windshield. 22 csg RKO Steel for Lark \$10 complete. Extreme West \$13. Order now while we can make good delivery, and really enjoy these wonderful days in your Lark. Keen, Classy, Up-to-the-minute. You can build it. Over 11,000 in use. Don't hesitate. "Swing Lo" Undersling Irons, no frame cutting kind, \$6.99. Only \$4.99 when ordered with Lark patterns. Send 5c coin for new manual of other distinctive sport body patterns from \$5.80 up—"RKO" Steel "Swing-Lo" Irons, Tons and Windshields. ORDER RIGHT NOW. KUEMPEL CO., 70 Kuempel Bldg., Guttenberg, Iowa

## Save Time and Money Get a SHAW GARDEN TRACTOR

Now you can get a better power Garden Tractor at less cost. Amazingly Low Price on the SHAW. Just the thing for Truck Gardeners, Small Farms, Estates, etc.; Low Cost; Simple to operate.

**SPECIAL OFFER**  
Write at once for Special Offer. Address Dept. P. 2.

**SHAW MFG. CO.**  
GALESBURG, KANSAS



## DOUBLES TIRE MILEAGE and Makes Pumping Up Tires Unnecessary



I line up with big money. The Hughes "Airlox" Valve Cap is a proven success. Air-tight. Eliminates all troubles due to under-inflation; lasts life of tire. Positive necessity to auto owners. Doubles tire mileage. Tested and approved by leading auto manufacturers. \$100 a week for hustlers. Unlimited demand. No competition.

**FREE SAMPLES TO AGENTS**  
to use and introduce in exclusive territories. Immense uncrowded field. Don't hesitate. Write today for facts and FREE SAMPLES.

**AIRLOX RUBBER CO.**  
2512-14 W. Monroe St., Dept. 805-B, Chicago, Ill.

## Winterhoff Portable Tools

are regular He Man Tools, just the tool for light manufacturing and home work. You can not go wrong on these tools as they are guaranteed to be equal to the best.



10 1/2 in. Drills, Saws, Grinders, Disc Grinders—All Motor Driven

Winterhoff Tool & Machine Company  
106 South Elkhart Ave., Elkhart, Ind.

## BIG MONEY Made Selling MONO Oriental Dash Lights

Reflects beautiful colors on the automobile dash. Nickel plated. Thousands now selling. Sample postpaid 30c.

T. A. Waterman Metal Specialties Mfg. Co., 1354 Flower St., Los Angeles, California

## The "Lark" Class — Snap



# LUMINOUS PAINT

**Make Your Watches, Clocks, Etc., Visible by Night**

The very latest discovery in the scientific world. Hitherto, practically unobtainable except at an exorbitant price, we have at last succeeded in producing this remarkable LUMINOUS PAINT, which, applied to the surface of any article, emits rays of white light, rendering it perfectly visible in the dark. **THE DARKER THE NIGHT, THE MORE BRILLIANT IT SHINES.** Quite simple to use. Anyone—you can do it. A little applied to the dial of your watch or clock will enable you to tell the time by night. You can coat the push buttons or switch plates of your electric lights, match boxes, and innumerable other articles; make your own Luminous Crucifixes, Luminous Rosaries, etc. Small bottle, price 25c. Larger size, 50c and \$1 postpaid.

JOHNSON SMITH & CO., Dept. 497, RACINE, WIS.

## Serpent's Eggs Exploding Cigarettes

Box contains 12 eggs. When lit with a match, each one gradually hatches itself into a snake several feet long, which curls and twists about in a most life-like manner. Price per box, 10c postpaid, 3 for 25c.



## CIGARETTE MAKER



Roll your own and save money. Makes them better and quicker besides saving more than half. Use your favorite brand of tobacco. Neat, useful and handy. Pocket size, weighs 1/4 oz. Made entirely of metal, nickel-plated. Price 25c postpaid.

## MIDGET BIBLE

**GREAT CURIOSITY** Smallest Bible in the World. Size of a postage stamp. 200 Pages. Said to bring good luck to the owner. A genuine work of art. Must be seen to be appreciated. These good money selling items to friends, church acquaintances, etc. PRICE 15c each, 3 for 40c, 12 for \$1.35, 100 for \$7.50. Also obtainable in Leather Binding, with roll edges. Price 50c each, 3 for \$1.25, \$4.50 per doz. Magnifying Glass for use with Midget Bible, 15c.



## STAGE MONEY

With a bunch of these bills, it is easy for each person of limited means to appear prosperous by flashing a roll of these bills at the proper time and peeling off a genuine bill or two from the outside of the roll, the effect created will be found to be all that can be desired. Prices, postpaid: 49 Bills 20c, 125 for 50c, or \$3.50 thousand postpaid.

## Wonderful X-Ray Tube

A wonderful little instrument producing optical illusions both surprising and startling. With it you can see what is apparently the bones of your fingers, the leg of a lead pencil, the interior opening in a pipe stem, and many other similar illusions. After that, no one has been able to satisfactorily explain. Price 10c, 3 for 25c, 1 dozen 75c. Johnson Smith & Co.



**Good Luck Ring**  
Quaint and Novel Design

A VERY striking and uncommon ring. Silver finish, skull and crossbone design, with two brilliant, flashing gems sparkling out of the eyes. Said by many to bring Good Luck to the wearer, hence its name, Good Luck Ring. Very unique ring and will take a pride in wearing. ONLY 25 CENTS.



**JUST LIKE ORDINARY CIGARETTES, BUT SUCH REAL STARTLERS!** The box contains ten genuine cigarettes of excellent quality. They appear so real, but when each cigarette is about one-third smoked, the victim gets a very great surprise as it goes off with a loud BANG! A great mirth provoker yet entirely harmless. Price 25c per box.

## Popular Watch Charms

**15c**  
ONLY 3 for 40c; \$1.35 doz.

Very pretty little curiosities and decidedly novel. Fitted with Magnifying Lenses that enlarge the pictures to a very surprising degree; in fact, it seems almost incredible that a clear picture could be possible in such a small compass, and how sharp and distinct they show up when you look through. Come in assorted views—Actresses, Views of Panama Canal, Lord's Prayer in type, etc.

## Mystic Skeleton

A jointed figure of a skeleton 14 in. in height, will dance to music and perform various gyrations and movements while the operator may be some distance from it. **10c p.d.**



## Novelty Badges



**Kissing Permit 10c** Garter Inspector 10c  
Two very novel metal badges, nickel plated, that you can wear, giving you fun out of all proportion to their trifling cost. 10c, each badge, 3 for 25c, or 75c per doz. p.p.d.

## MAGIC FLUTE

Wonderfully Sweet Toned and Musical



Post Paid 25c

The Magic Flute, or Human-stone, is a unique and novel musical instrument that is played with nose and mouth combined. There is just a little knack in playing it which, when once acquired after a little practice will enable you to produce very sweet music that somewhat resembles a flute. There is no fingering, and once you have mastered it you can play all kinds of music with facility and ease. When played as an accompaniment to a piano or any other musical instrument, the effect is as charming as it is surprising.

## BLANK CARTRIDGE PISTOL

Protection against Burglars, Tramps & Dogs

Prices 50c \$1.00



Well made and effective; models on latest type of Revolver; appearance alone is enough to scare a burglar. When loaded it may be as effective as a real revolver without danger to life. It takes standard .22 Cal. Blank Cartridges obtainable everywhere. Price 50c, superior quality, \$1.00 postpaid. Blank Cartridges, by express, 50c per 100 Holster (Cowboy type) for Blank Cartridge Pistol, 50c Johnson Smith & Co., Dept. 497, Racine, Wis.

JOHNSON SMITH & CO., Dept. 497, Racine, Wis.

## BOYS! BOYS! BOYS! THROW YOUR VOICE



Never Fails. A 32 page book on ventriloquism, the Ventrillo, ALL FOR 10 CENTS



Everything about the Ku Klux Klan told in a clear, fearless manner. Book tells all—How it started and was oppressed in 1871—The New Ku Klux Klan—How Organized—How Members are Enrolled—Oath of the Klan—Questions for Candidates—Creed—Objects of the Order—Obedience—Fidelity—Pledge of Loyalty—Ku Klux Klan and the Masons—The Jews—The Masons—Real K. of C. Oath—The Negro Ku Klux Klan, etc., etc. Latest and most complete book on the Klan published. Price 35c, Postpaid. Stamps or Coin

## LOOK 35c Look

Wonderful instrument. Greatest thing yet. Nine separate articles in one. Everybody delighted with it. Odd, curious and interesting. Lots of pleasure as well as very useful. It is a double Microscope for examining the wonders of nature. It is also an Opera Glass, a Stereoscope, a Burning Lens, a Reading Glass, a Telescope, a Compass, a Pocket Mirror, and a Laryngoscope—for examining eye, ear, nose and throat. It is worth all the cost to locate even one painful cinder in the eye. Folds flat and fits the pocket. Something great—you need one. Don't miss it. Sent by mail, postpaid. **Only 35c or 3 for \$1.00**



## BABY TANK

Goes backward or forward by its own power. Nothing to wind. What makes it go is a mystery. It crawls along, overcoming obstacles just like the larger Tanks Perform dozens of most amazing "stunts." Runs ten times longer than most mechanical toys. Handsomely finished and camouflaged in natural colors. 25c postpaid.

Female SEX Indicator 25c Male SEX Indicator 25c  
Hold the MAGIC INDICATOR over a man's hand—instantly it moves in a straight line, backward and forward. Hold it over a woman's hand and it describes a complete and continuous circle. The same action can be obtained over a letter written by a man or woman, etc. It is fascinating; ha! ha! We have never been able to figure out how it's done, but we've never seen it fail. Many novel and entertaining facts may be performed with the Sex Indicator. For example, similar results can be obtained with animals, cats, dogs, rabbits, over birds, chickens, canaries, etc. Also used to predetermine the sex of chickens and birds, etc., in fact it is sold as a patented egg tester in Europe. Price 25c, or 3 for 85c, p.p.d. JOHNSON SMITH & CO., Dept. 497, RACINE, WIS.

# JOHNSON SMITH & CO.

Dept. 497

RACINE, WIS.

A Deluxe Edition of our new 1925 CATALOG mailed on receipt of 25c. Handsome cloth binding. Only book of its kind. 420 pages of all the latest tricks in magic, the newest novelties, puzzles, games, sporting goods, interesting books, curiosities in seeds and plants, etc.—unobtainable elsewhere. Remit by Money Order, Check, Coin, Stamps, etc. Stamps of foreign countries also accepted.

# WURLITZER

REG. U.S. PAT. OFF.

**"Bill Carola"  
Landaus  
Seranaders**

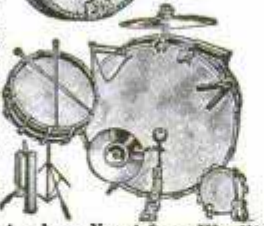

**Couldn't Play a  
Note—Now Makes  
\$100  
a week**

"When I sent for your catalog, I didn't know a note of music. A few months after I bought my Wurlitzer instrument, I had taken my place in a professional orchestra. Now I am making \$100 a week, three times what I made as clerk. I wish everybody knew how easy it is—anyone who can whistle a tune can learn to play a musical instrument."

—Bill Carola

**Free Trial  
Easy Payments**

You may now have any Wurlitzer instrument for a week's free trial in your own home. Examine the instrument, note the fine workmanship, the full, rich tone value and especially how easy it is to play. No obligation to buy—no expense for the trial. We make this liberal offer because we want you to try for yourself a genuine Wurlitzer instrument, the result of 200 year's experience in musical instrument building.

Easy payments are arranged to suit your convenience. This is your opportunity to try a famous Wurlitzer instrument in your own home. **Send for**

**Free Book**

Illustrates and describes every known musical instrument—more than 3000 articles, many of them shown in full colors. All genuine Wurlitzer instruments—buy direct from Wurlitzer and save money. Special offers on complete outfits.

We also give you our Free Trial, Easy Payment Plan. No obligation.

**Send Coupon Today!**

**The Rudolph Wurlitzer Co., Dept. 1773**

117 E. 4th St., Cincinnati 329 S. Wabash Ave., Chicago  
120 W. 42nd St., New York 134 Golden Gate Ave., San Francisco

Send me your Free Book on musical instruments. Also your Free Trial, Easy Payment Plan. No obligation.

Name .....

Address .....

City ..... State .....

Instrument .....

Copyright 1925, The Rudolph Wurlitzer Co.

# Florida is Calling You

Do you want to get away  
From the grind of every day—  
From the drudgery of things you have to do?  
Do you want to settle down  
Near a lively, busy town,  
Where the joy of living will appeal to you?

Do you want to scent the breeze  
Coming through the orange trees?  
Do you want to hear the birds call—loud and clear?  
Are you seeking perfect health  
That's combined with certain wealth  
And an income from an orange grove each year?

Do you want a piece of land  
That will grow to beat the band  
All the different garden crops that you enjoy?  
Do you want to make a "Nest,"  
And a permanent bequest  
For the future welfare of each girl and boy?

Do you want a sunny climate  
Where there's fishing all the time?  
Where there's ducks and deer and quail and other  
game?

Where the summer climate's cool,  
And within each lake and pool,  
You can swim in January—just the same?

Do you want to buy this land  
On an easy-payment plan,  
With about your monthly outlay for cigars?  
Do you want to read a book  
That will make you want to look  
On the finest land that lays beneath the stars?

Send a letter right away;  
Put it in the mail today,  
We will send this Booklet absolutely FREE.  
After you have read it through,  
If a thought occurs to you—  
Just address another letter here to me.

We will answer, straight and true,  
Questions that occur to you.  
We have nothing to evade or to conceal.  
On an Orange County Farm  
Life will take on added charm,  
And you'll never lack a dollar—nor a meal.

Send for our Big FREE Illustrated Book—  
"TWENTY ACRES AND PLENTY." It tells of  
almost unbelievable profits made from trucking and  
fruit-growing in our part of FLORIDA. Also about  
sick-and-out-of-work Clauses, and other protective  
features of our contract. **Address Sylvester E.  
Wilson, Dept. U-2, Orlando, Florida.**



**REDDING & COMPANY**

(Est. 1859) 9 West 23 St., N. Y. C.

**Masonic Books, Monitors, Bibles,  
Jewelry, and Lodge Supplies**

Send for catalogue 3 of Books and Jewelry;  
catalogue 4 of Lodge Supplies. No obliga-  
tions. Mail orders promptly filled.



# \$542<sup>00</sup> Earned IN ONE MONTH

## A BIG MONEY - MAKING BUSINESS

A BUSINESS TO ENTHUSE OVER — THE "IDEAL" LAWN MOWER SHARPENER

A wonderful invention that sharpens lawn mowers scientifically—quickly—perfectly; does the work as nothing else can.

**Fred C. Milkert, of Roselle, Ill., writes:** "The Ideal Lawnmower Sharpener put me in business, starting in the basement of my home and forcing me now for the third time to move into bigger quarters. Today the dream of my life—a shop of my own—is realized. With a machine like yours and a little hustle any man can have a business of his own and be independent."

**W. F. Kendt, Buffalo, writes:** "I sharpened 994 lawnmowers last season, and the receipts were nearly \$2,100.00 which is not bad for a side line."

**You Start Now** No town too small. **D. S. Newcomer, Vinton, Iowa, writes:** "People come for miles around and from other towns to get their mowers ground." Lawn mowers are dull—owners don't know where to get them sharpened. Mowing the lawn dreaded because of dull or improperly sharpened mower. Lawn mowing healthful, invigorating and pleasant when mower is "Ideally" sharpened. You do the work scientifically—you are in big demand.

### Lawn Mowers Sharpened to Razor Edge—

People glad—owners delight in mowing lawn with mower sharpened on an "Ideal." Mower runs light—click-click and the grass is cut. Build permanent business for yourself. Start now!

### Write Today—FREE

Detailed illustrated catalog and booklet "Let George Say It."

Write Today!

**Zeno Brandon, Middletown, O. writes:** "I made \$820.70 in 55 days with my "Ideal." Have made as high as \$38.70 in one day."

**Fred C. Milkert, Roselle, Ill. writes:** "Last June I sharpened 256 lawnmowers for which I received \$542.00."

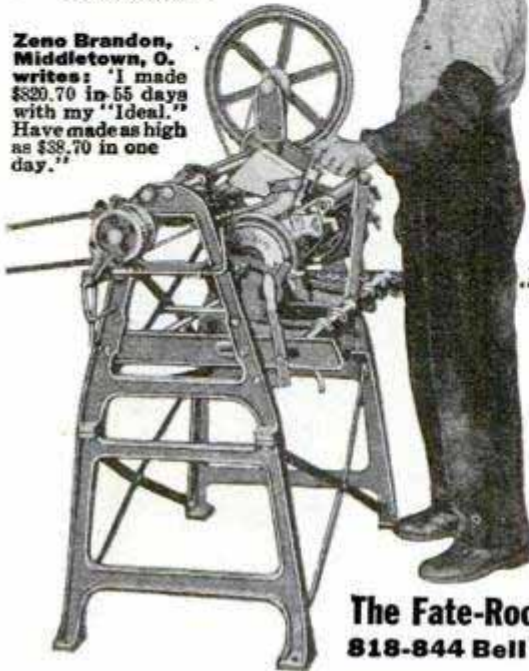

**The Fate-Root-Heath Company**  
818-844 Bell St., Plymouth, Ohio

**USE THIS—Mail it Today**

**The Fate-Root-Heath Company**  
818-844 Bell Street, Plymouth, Ohio

Please mail at once free Illustrated Catalog and booklet "Let George Say It."

Name \_\_\_\_\_

Address \_\_\_\_\_

### \$4.50 LIST PRICE WALLACE COMBINATION JACK and RIM TOOL



Just the tool for all motorists, garage owners. All-in-one. Ball Bearing. Fits all split rims. Will fit any style and size. If your dealer cannot supply you send your order direct to us. Representatives wanted everywhere. WALLACE RIM TOOL & MFG. CO. Dept. P. M., 24 S. Clinton St., Chicago



### Automatically Oil Your Ford Universal

No Valves — Runs in Oil Bath  
7,000 to 10,000 MILES PER GALLON  
Guaranteed. Price, \$2.25  
Mention Year. Postpaid  
Dealers' and Jobbers' Discounts  
HARDY MFG. CO., Medford, Ore.

### THE WOTEN GASOLINE ENGINE

Air-cooled — Water-cooled. One-half H. P. in 15 pounds. Handiest little engine ever made. Ideal wherever power is needed. Also the Metalum Model Airplane Engine, one-half H. P. in 3 1/2 pounds. The market demands them in thousands. Generous agency propositions on request. Complete line of small gasoline and steam engines, battery chargers, etc. Catalogue Free.

**DYNAMIC MANUFACTURING CO.**  
First Nat'l Bank Bldg., Dept. 7, CHICAGO



## FACTORY TO YOU AT WHOLESALE PRICES

FOR 8 ROOM HOUSE COMPLETE \$12.75



**FREE FIXTURE CATALOG**  
SEND FOR IT TODAY AND SAVE MONEY  
OUR CATALOG OF REMARKABLE VALUES WILL SAVE YOU REAL MONEY  
24 HOUR SERVICE  
SATISFACTION GUARANTEED OR MONEY REFUNDED

### PARAMOUNT ELECTRIC Co.

Dept. S—251 MARKET ST., PHILA. PA.  
Please send me FREE your Big Bargain Catalog—

Name \_\_\_\_\_  
Address \_\_\_\_\_  
P. O. \_\_\_\_\_ State \_\_\_\_\_  
Occupation \_\_\_\_\_

**Foot Pains** go in 5 minutes if you wear FAIRYFOOT CUSHIONS. Must help or no pay. Write to FOOT REMEDY CO., 22nd St. & Millard Ave., Dept. 28, Chicago, Ill.



**A Genuine \$2 Knife for \$1.18 Postpaid**  
Handy shaped Blade makes this knife best for mechanics, sportsmen and farmers; light but strong; re-sharpened easily. Stag handle. German silver finish; blades file tested, hand forged from razor steel and warranted.

### Direct at Factory Prices

Sample \$1.18 3 for \$3.00 Postpaid

Hand Forged Razor Steel Blades  
Send for our 100-page FREE List and "HOW TO USE A RAZOR."

**Maher & Grosh Co.**  
106 A St., Toledo, Ohio

# For Expert or Handy Man The Turner No. 45 Is Best

**\$8<sup>25</sup>**  
Postpaid

It permits you to do your best work because all the hazards and troubles common to ordinary blotorches have been eliminated by Turner patented features. Over 50 years' experience have enabled us to perfect a blotorch that is safe, fast, convenient and durable.

## TURNER BLOTORCH "Safe as a Candle"

There are eleven patented improvements. The Super-heating Burner Baffle and heater plug that perfectly gasifies present day kerosene or gasoline; the separate Adjusting and Cleaning Needle that gives freedom from orifice trouble; the Automatic

Safety Valve that prevents explosions; the seamless, solderless, leakproof, polished brass tank with but one opening and that above fuel line; the Pistol Grip that fits any hand perfectly, and other features. **FEARLESSLY GUARANTEED.**

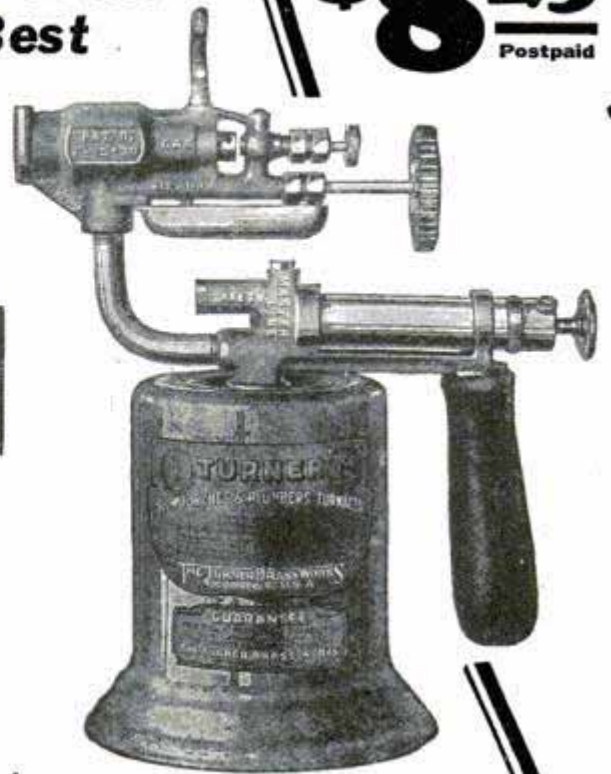

If your dealer can't supply you, write us direct.

**THE TURNER BRASS WORKS**  
Industry Ave., Sycamore, Ill.

The World's Largest Exclusive Manufacturers of Blotorches, Firepots & Brazers.



"Been on a vacation Bill?"

"No, Jim - I've stopped smoking. Gained six pounds in a week. You know how I used to smoke—a package of cigarettes and a cigar or two a day—it sure had some hold on me. But I'm cured—took a scientific home tobacco treatment—fixed me up in two weeks.

"Wasn't hard on me at all—noticed improvement the first day—I feel like a new man. It didn't interfere with my work—didn't leave any druggish after-effects—the money I saved in the last two weeks has paid for the treatment alone.

"Why don't you take it! It has cured men like you and me for over forty years—it is a doctor's individual prescription that sure fixes you up. Just send the coupon for full information NOW. No obligation. All correspondence is strictly confidential."



A Doctor's Prescription

The Keeley Institute, Dwight, Ill.

Please send me, without any obligation on my part, your free booklet which will tell me how to rid myself of the tobacco habit.

Name.....

Town.....

Street..... State..... PM-3



## FREE Book on Deafness

Write today for 168 page FREE book giving full particulars and testimonials from hundreds of grateful users whose hearing has been restored by use of our "little wireless phones for the ears."

**Wilson Common-Sense Ear Drums** require no medicine but effectively replace what is lacking or defective in the natural ear drums. They are simple devices, which the wearer easily fits into the ears where they are invisible. Soft, safe and comfortable.

**WILSON EAR DRUM CO., Incorporated**  
488 Todd Building LOUISVILLE, KY.

## Genuine DIAMOND



## WRIST WATCH

Simply send \$2.00 and this 14 Karat Solid White Gold Rectangular Wrist Watch set with four perfect cut, Genuine Diamonds comes to you all charges paid. Highest grade 15 ruby and Sapphire Jeweled Movement. Life time guarantee. Price only \$42.50.

Sent for \$2

10 DAYS' FREE TRIAL

If not satisfactory or if you can duplicate this watch for \$10.00, your deposit will be refunded.

\$4.05 PER MONTH

After trial pay balance \$4.05 a month for ten months.

FREE ROYAL CATALOG

Illustrates and describes thousands of special values in diamonds, watches and jewelry—send for your copy at once. Address Dept. 1544.

**ROYAL DIAMOND & WATCH CO.**  
Dept. 1544 170 BROADWAY, NEW YORK

**“My customers won't take any other”—**

says a leading Jobber of B-T Condensers

The reason is because year after year B-T products have proved best.

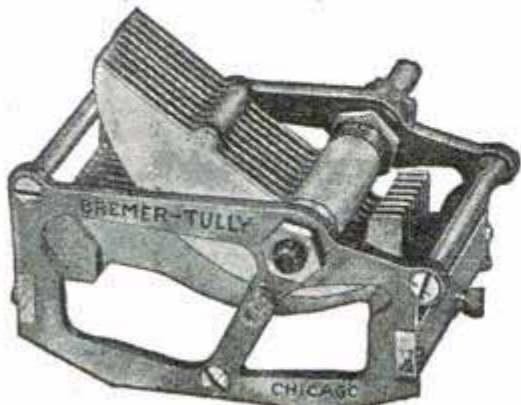

The B-T Straight Line Frequency Condenser has no equal in the number of superior features. Quality is the B-T watchword—and thru 20 years of RADIO experience, B-T know what is best for RADIO users.

The B-T line has no trick parts or trick claims. Before you buy, examine the B-T product—your judgment will do the rest.

All quality dealers carry the B-T line.

Send for complete parts circular.

**Bremer-Tully** 532 So. Canal St. CHICAGO, ILL.

**SOLDERALL**

METAL IN PASTE FORM

The only convenient metal solder

Every Electrical Connection needs Solderall for perfect reception

**25¢**

The SOLDERALL CO., NEWARK, N.J.

**MOTORCYCLES**



Price \$10 and up purchased through our Co-Operative Plan for as low as \$1.00 down and \$1.00 per week

Indians Harley-Davidsons Ace Henderson and Clevelands

Motorcycles shipped to all parts of the world

**WALKER-INDIAN CO., 188 Mass. Ave., BOSTON**

**Save 20 to 50% FREE RADIO CATALOG**



Get the lowest rock-bottom prices on radio parts, sets, kits. New free Radio Catalog and Guide brimful of standard, reliable, guaranteed goods. Over 100 latest hook-ups and illustrations. Be sure to get this thrifty book before you buy. It puts money in your pocket. Saves you as much as half on a set. Also please include name of radio fan. Send letter or postal NOW.

**THE BARAWIK COMPANY**

103-168 S. Canal St., Chicago, U. S. A.



**It Can't Corrode!**  
it's a **Beldenamel Aerial**

**N**O RADIO fan wants to put up an outdoor aerial more than once, if he can help it. That is why the experienced set owner installs a Beldenamel Aerial.

Every strand of a Beldenamel Aerial is carefully coated with baked Beldenamel to resist the corrosive action of atmospheric fumes and smoke. A bare copper aerial soon corrodes and becomes inefficient. A Beldenamel Aerial lasts for years without deterioration.

Specify **Beldenamel Aerial Wire**

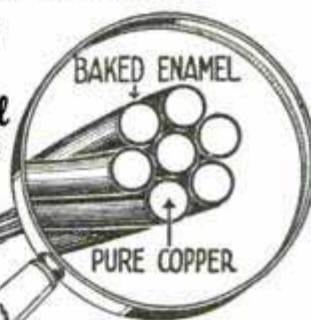

Install a permanent Beldenamel Aerial, sold in a distinctive striped carton, clearly labeled for your protection against substitutes. By using a 150-foot length, the aerial wire can be used as a lead-in without joints.

**Belden**

Send for Free Illustrated Booklet

Belden Manufacturing Company, 2306-K So. Western Ave., Chicago.

Please send me your latest illustrated booklet, free, describing Belden Radio Products and their use in Radio work.

Name .....

Address .....

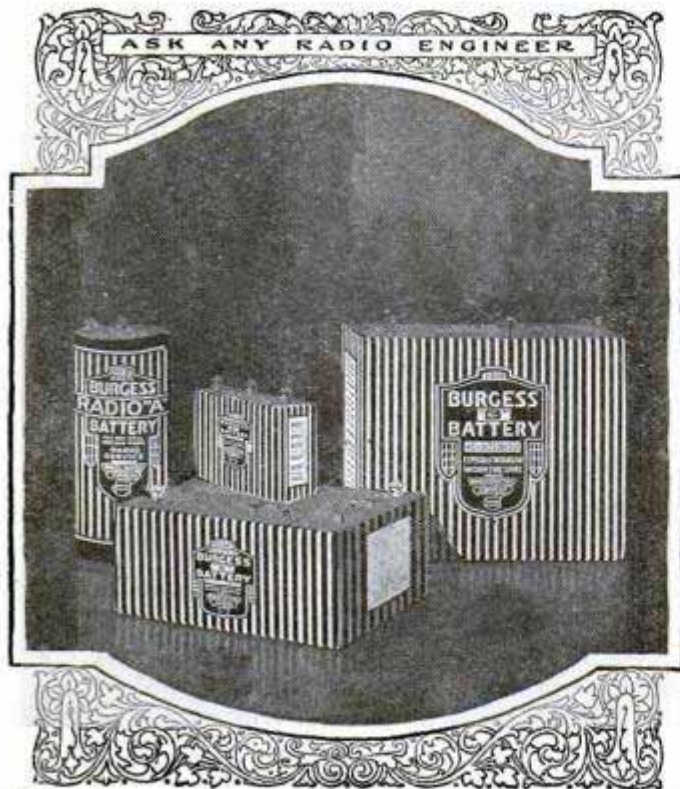

## Contributors to your radio entertainment

**V**ERY probably hidden away in the cabinet of your receiving set, the batteries you use are nevertheless surrendering their power unseen and unheard.

And to be able to contribute their energy and to add to the complete efficiency of your receiving equipment, those batteries must combine every desirable factor and formula known in the electro-chemical field.

Such Batteries are Burgess—products of the Burgess Laboratories—products which have been used by practically every famous explorer, the majority of amateurs and the leading radio engineers.

That's why when you use Burgess Radio 'A', 'B' and 'C' Batteries you are using batteries which assure the utmost dependability, longer life and complete satisfaction.

**BURGESS BATTERY COMPANY**  
GENERAL SALES OFFICE: CHICAGO

Canadian Factories and Offices:  
Niagara Falls and Winnipeg

**BURGESS RADIO BATTERIES**

View of inside construction of the "Model R" (Rauland-Lyric-equipped) showing steel chassis and arrangement of parts.

See it and hear it—  
then you'll know  
why we say—  
*Radio Built for  
the Years to Come*

**LATEST WHOLESALE RADIO CATALOG** Simply Send Name  
**FREE** TODAY for big 64-page book explaining liberal proposition paying agents \$60 to \$100 a week and how to get latest radio goods at Wholesale. *Live dealers and agents wanted.*  
**STANDARD RADIO CO., 1402 Walnut St., Kansas City, Mo.**

## Radio Blueprints at Cost!

Blueprints for the most popular sets described in Popular Mechanics Magazine can be obtained for a charge just sufficient to cover the cost of production and mailing. The sets for which blueprints are available are:

One Tube Ultra-Audion .....	April 1924 — 10c
One Tube Triple-Coil Receiver .....	May 1924 — 10c
One Tube Pocket Receiver .....	April 1925 — 10c
Two Tube Loud Speaker Set .....	May 1925 — 10c
Three Tube Portable Reflex Receiver .....	June 1925 — 10c
Three Tube Cockaday Receiver .....	April 1925 — 10c
Three Tube Ultra-Audion Receiver .....	Sept. 1925 — 10c
Three Tube Low-Loss Short Wave Receiver .....	Oct. 1925 — 10c
Four Tube Loop Set .....	Aug. 1925 — 10c
Five Tube Neutrodyne Receiver .....	Feb. Mar. 1924 — 10c
Five Tube No-Battery Set .....	July 1925 — 10c
Six Tube Perfect-tone Receiver .....	Nov. 1925 — 10c
Six Tube Self-contained Receiver .....	July 1925 — 10c
Eight Tube Superheterodyne Receiver (Four prints in set) .....	Feb. Mar. 1925 — \$1.00
Nine Tube Portable Superheterodyne Receiver (Three prints in set) .....	Sept. 1925 — 75c
New 1926 Model Popular Mechanics Superheterodyne .....	Jan. 1926 .....
Set of blueprints including full size drilling templates .....	75c

Address the **RADIO DEPT.**

**Popular Mechanics Magazine**  
200 E. Ontario St., CHICAGO

Back numbers of the magazines describing the construction of the sets can be obtained from our Circulation Department, price 25 cents each.

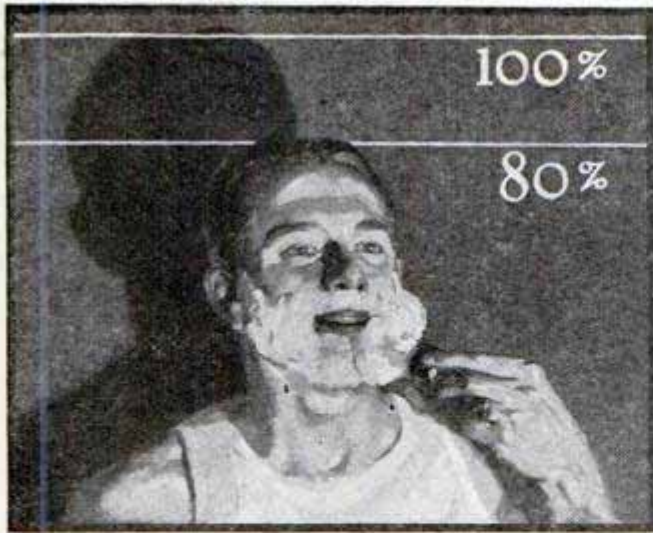

We win 80 out of every 100 men to this unique creation

# Say the word

And we'll send you a 10-day tube of this unique shaving cream to try

(NOTE COUPON BELOW)

GENTLEMEN:—

The way we win new customers to Palmolive Shaving Cream is by giving men a 10-day tube to try.

In less than five years we've gained top place in that way. 95% of the men answering our ads are wedded to other kinds of shaving soap. Yet we win 80 out of every 100 to this unique creation.

It's different from any other shaving cream known. 60 years of soap study stand behind it. We tried out 130 different formulas in perfecting it.

It embodies the four great essentials 1000 men told us they wanted in a shaving cream, plus a fifth that we ourselves found and added.

### 5 Important features

You'll find it superior in at least five major ways:

- 1—Multiplies itself in lather 250 times.
- 2—Softens the beard in one minute.
- 3—Maintains its creamy fullness for 10 minutes on the face.
- 4—Strong bubbles hold the hairs erect for cutting.
- 5—Fine after effects due to palm and olive oil content.

### Find Out

What we tell you is based on what we as expert soap makers know. One of our toilet soaps, Palmolive, is the leading toilet soap of the world.

Now in courtesy to us, will you accept a test of our shaving cream; give us the opportunity to prove the claims millions make for it?

THE PALMOLIVE COMPANY (Del. Corp.), Chicago, Ill.

To add the final touch to shaving luxury, we have created Palmolive After Shavin Tale—especially for men. Doesn't show. Leaves the skin smooth and fresh, and gives that well-groomed look. Try the sample we are sending free with the tube of shaving cream. There are new delights here for every man who shaves. Please let us prove them to you. Clip coupon now.

3141

## 10 SHAVES FREE

and a can of Palmolive After Shaving Tale

Simply insert your name and address and mail to Dept. B-1135, The Palmolive Company (Del. Corp.), 3702 Iron Street, Chicago, Ill.

Residents of Wisconsin should address The Palmolive Company (Wis. Corp.), Milwaukee, Wis.

.....  
 .....



# Make Your Home New

**free Book** HOW a handsome rug, a prettily shaded lamp, a big comfy chair makes home new. As you survey the rooms of your own home, picture what a delightful transformation a new piece of furniture here or a suite there will bring.

## The New Larkin Book Offers the Ideal Way

There's a cheerful, helpful plan whereby you may place these desired furnishings in your home NOW and pay for them on the most convenient liberal terms—The Larkin Better Homes Plan. The new Larkin Catalog pictures suites, tables, lamps, rockers, rugs, curtains, silverware, china, etc., and tells of this plan which delights thousands of home makers. There's a copy of this book for you. **Mail Coupon To-day**

Larkin Co Inc. 12  
 Buffalo, N. Y. Chicago, Ill. Peoria, Ill.

Send me my copy of the new Larkin Catalog No. 219 picturing fine furniture for every room of the home, and telling of the popular Larkin Better Homes Plan.

Name .....

Street and No.....

City.....State.....

# SUCCESSFUL AMERICAN FARMERS

*in Canada invite you to come*

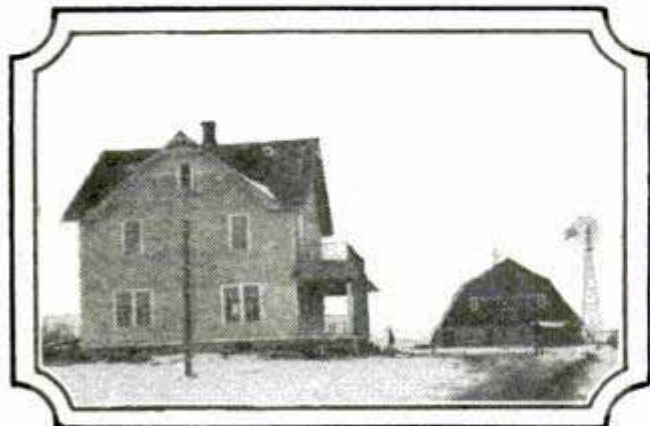

*Commodious house and barn on Mr. Sather's Farm*

## This Farmer's Experience Can Be Yours

"I came from Norway to Viroqua, Wis., in 1898, and raised tobacco there, but decided to come to Canada, so in 1905 I landed in Wetaskiwin and drove 85 miles east where I homesteaded 160 acres. In 1909 I sold my homestead and went back to Norway. In 1910 I returned to Alberta and bought my homestead back and three-quarter section of school land.

"I have now a large 2-story 8-room house, full basement. A large barn 50x70 and other necessary buildings. My crops have been above the average. I raised 7000 bushels of wheat on 170 acres.

"I raise horses, cattle, hogs and have milked a good many cows, but now only milk three as I do not care to be tied down as much as before.

"Our markets are good, low freight rates, good government. Schools are of the best and churches of all denominations. We have good neighbors and many are from the States in this part of Alberta. I feel like I have done better here than I could either in Norway or the U. S.

"I think this is the place for a man to get a start. The climate is good, although cold in Winter the air is dry. It will pay anyone from the States looking for a home to come look over Western Canada."

(Signed) LARS P. SATHER

Alberta, Can., Nov. 19, 1925

### THESE FACTS BRING SUCCESS:

Low Taxes; Low Priced Lands; Good Soil;  
Good Schools; Low Freight Rates; Big  
Yields per Acre; Good Laws; Good Markets;  
Favorable Climate.



J. N. K. MACALISTER, Supt. of Colonization

Dept. 503, Canadian Pacific Railway Depot  
Winnipeg, Manitoba, Canada

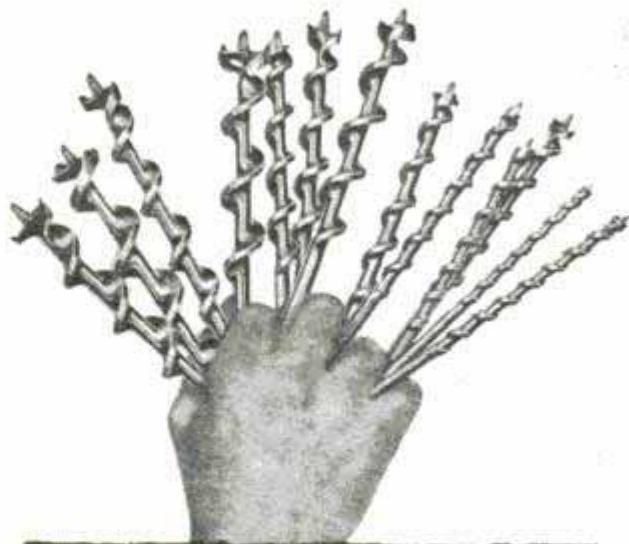

## YOU NEED ALL OF THESE BITS!

They will serve better and last longer if you buy them in a set and are careful to select Irwins.

There is an Irwin set that will give you a complete assortment of the needed sizes of auger bits—the best of woodboring equipment.

With such a set you save time by always having the size needed.

The case protects the bits against damage and loss, holds them quickly available for every job. A good set of bits is an economy.

Ask your hardware dealer to show you Irwin Bits in sets.

**THE IRWIN AUGER BIT CO.  
WILMINGTON, OHIO**



One of these three sets probably will just meet your requirements. Carpenter Set—13 bits and case. Home Set—6 bits and case. Handy Set—10 bits and case.

# IRWIN Auger Bit Sets

# \$983<sup>00</sup> PROFIT in Spare Time MADE \$23<sup>00</sup> INVESTMENT FROM

## BATON ROUGE MAN'S RECORD

shows, in addition to above profit on our CAIRO mold, he made \$15.00 profit on each of 300 lawn benches; \$2.50 profit on each of 250 ARDMORE vases; \$10.00 on each of 80 bird-baths, etc., etc.

## YOU CAN BEAT HIS SUCCESS!

This is just an average case. Full time operators build big enterprises of their own. Several have developed into big-scale successes from a "one-small-mold" beginning. The proof is yours for the asking. The investment is small. Our catalog shows hundreds of ways for you to prosper in this giant concrete industry. Get these FACTS now—FREE!

Write for New  
**ORNAMENTAL MOLD CATALOG**  
Concrete Equipment Co.  
570 Ottawa St., Holland, Mich.



Write for  
Machinery  
Catalog  
on Complete  
Block, Brick  
and  
Tile Plants.



\$

1

DOWN

## 21 Jewels

Nothing less than 21 Ruby and Sapphire Jewels is good enough for the Burlington masterpiece.

### Quality and Style

Adjusted to the second—temperature—synchronism—positions. 26 year Gold Strata Case, in 100 exquisite designs. Only \$1 down. Balance in small monthly payments. Send for free book.

**Burlington Watch Company**  
19th Street and Marshall Boulevard  
Dept. 13-53 Chicago, Illinois

# Big 3-ft. Telescope

Makes people and objects miles away seem close. Brings new pleasures to home, farm, camp, travel, sport. See moon and stars as never before. New Ferry "Wonder" telescope has 5 sections—over 3 ft. long open, 12 in. closed. Fully brass bound. Powerful lenses.

**FREE! Yes, Absolutely FREE!** Hand-some leatherette covered Carrying Case, light, strong, complete with strap. Handy for farmers, auto tourists and hikers.

**Only \$1<sup>85</sup>**

**5 Sections  
8-Power Lenses  
Thousands Delighted!**

"I am delighted with the 'Wonder' telescope. Today I have been watching submarines 3 miles off the coast."—Philip Brush. "I can see across the Mississippi 3 miles and see people fishing."—M. L. Thorn. "I am nearly 80 years old and if I could not get another would not take \$10.00 for it."—A. R. Walker. "I can tell time on the church clock 5 miles away."—Edward Foster. "Could tell color of aeroplane 4 miles away."—Mrs. L. M. Yarbrough. "I saw a Light House 18 miles away."—Clyde Scribner.

## Send No Money

Send name and address and Ferry Wonder 3-ft. Telescope with free Carrying Case will come by return mail. Pay postman special bargain price of \$1.85 plus a few cents postage. Satisfaction guaranteed or your money back. Supply limited.

Order Today! **FERRY & CO., Dept. 1773, CHICAGO**

# I Made



## MY FIRST WEEK

"Since then I have been earning over \$100 every week selling the Stay-Prest Trouser Presser."—S. L. PATTERSON of Iowa.

You too can make these big profits selling this wonderful new invention. Every man who sees it wants 2 to 6 at once.

# Sell Stay-Prest TROUSER PRESSERS

They went like wildfire from the start. It was the very thing men everywhere had been hoping someone would invent. It's a common thing to sell six to a customer. ANYONE CAN SELL THEM! The Stay-Prest puts in knife-edge crease, removes baggy knees and smoothes out entire surface. Easy to use—takes only a few seconds. Saves nap of cloth. Looks rich. Folds to 15 inch package. Over 1,000,000 satisfied customers prove that the article is right. **4 Patents.**

## LOOK AT THESE RECORDS

- \$33** G. M. Stewart, W. Va., tried selling this big repeater in spare time and made \$33 his first week so decided to devote full time to it.
- \$17** S. D. Mathews, Minn., gave this a trial as a side line. He made \$17 in his first two hours and decided to devote his full time to the work.
- \$500** J. W. Varner, Iowa, made over \$500 the first month he sold this big money-making specialty.
- \$32** Mrs. Helen Rhodesby, Oklahoma, made \$32 the first day she tried selling this device. She is now one of the most successful "salesmen" of it.



## YOUR PROFITS IN ADVANCE

Your profits in advance on this big new specialty and it sells quickly—average sale made in 8 minutes. 40% profit to you. Big repeater. You simply write orders. We ship and collect.

**FREE TO ANY MAN OR WOMEN**

Folds to Small Pack 15 in. Long

Special offer enables you to obtain Selling Outfit absolutely free. The Stay-Prest folds into neat, light, compact case. Outfit has everything necessary to begin at once to make \$20 a day—\$35 to \$50 a week spare time—or \$100 to \$150 a week full time. Simply mail the coupon and make the quickest money of your life.

**THE GETGEY-JUNG COMPANY** C-122 G. & J. Bldg., CINCINNATI, OHIO

**THE GETGEY-JUNG COMPANY**  
C-122 G. & J. Bldg., Cincinnati, Ohio

Please send me full information about the "Stay-Prest" Trouser Presser and your New Selling Plan.

Name .....

Address .....

City ..... State .....

# New Speed Way Shop

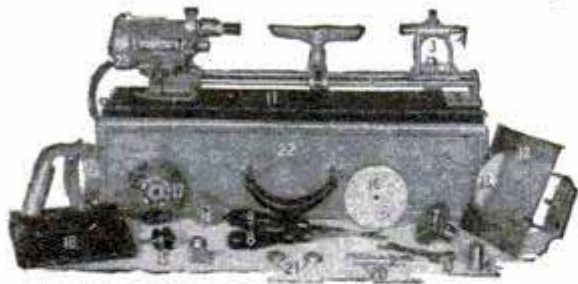

## 10 Days' FREE Trial in Your Own Home

The SpeedWay Shop consists of a compact metal and woodworking outfit for mechanics, householders and "handy" men. Driven by famous SpeedWay motor which is easily detached, giving you a Portable Electric Drill. Tools quickly interchangeable. We ship it to you for 10 days' free trial. Use these six motor driven tools and satisfy yourself that they are all we claim and more.

### Free Trial of Motor Driven Saw, Lathe, Grinder, Buffer, Cleaner, Drill

Attaches to any lamp socket. All packed under pressed steel case (No. 23 above) with lathe bolted to platform 25 in. x 6 in.

**Check the Numbers on the Photograph**

- |                 |                         |                                   |
|-----------------|-------------------------|-----------------------------------|
| 1. Lathe Bed    | 9. Gouge Chisel         | 17. 4-in. Wire Brush              |
| 2. Tool Rest    | 10. Universal Wrench    | 18. Tool Case                     |
| 3. Tail Stock   | 11. Base 25 in. x 6 in. | 19. Drill Handle                  |
| 4. Centers      | 12. Saw Table           | 20. Drill Bits                    |
| 5. Chuck        | 13. 5-in. Circular Saw  | 21. Nut and Washer                |
| 6. Spur Center  | 14. 2-in. Wheel         | 22. Steel Cover                   |
| 7. Face Plate   | 15. Arbor and Flanges   | 23. The Well Known SpeedWay Motor |
| 8. Parting Tool | 16. Cloth Buffer        |                                   |

## Only \$10.00 Down

Five minutes after receipt you can have the chips flying. Pay as you enjoy it. Use the SpeedWay Shop for pleasure or profit. Nothing will bring greater joy to the mechanic or tool lover, to all "boys under 90" who like to make things, than this SpeedWay Shop.

## Free Job Sheets

We furnish free, Job Sheets explaining just how to make Furniture, Birdhouse, Toys, Trellis, etc. You can do Radio jobs; polish auto and golf clubs; and endless other things.

**Write Today for Full Information**

Every tool in the "Shop" is high grade, for regular work. A money maker for the small job man. Send coupon for full particulars.

**ELECTRO-MAGNETIC TOOL COMPANY**  
DEPARTMENT 23  
1830 South 52nd Ave., Cicero, Illinois (Adjoining Chicago)

**SEND COUPON TODAY**

**ELECTRO-MAGNETIC TOOL CO.**  
Dept. 23, 1830 South 52nd Ave., CICERO, ILL.  
Dear Sirs: Please send me full particulars about 10-day free trial on SpeedWay Shop Model 260.

Name.....  
Address.....  
City..... State.....

## A Baby Grand Lathe in YOUR Home or Shop

An accurate, high grade tool for doing the most fascinating, educational and profitable class of work.

**Make the Things You Want** of metal, wood or other material, on this thoroughly practical machine built for honest service by experienced lathe builders and sold at a popular price direct from factory to user.

**POSITIVE MONEY-BACK GUARANTEE**

We also make Drills, Grinders, Accessories, Tools and Supplies.

The Watson Mfg. Co., Toledo, Ohio

103  
Watson  
Bldg.

Write today for illustrated folder giving complete description and prices.



## AGENTS WANTED \$3.95 Womens Spring Shoes at Factory Prices

GOOD PAY NO INVESTMENT

### Pile Up Amazing Profits Today!

Build up enormous "repeat" business for tomorrow. Women are spenders. Buy as high as 12 times as many pairs shoes as men. Spring BIG MONEY time in women's shoes. Necessity says: Buy new shoes! Fashion says: Buy new shoes! In every house in your town women eager for opportunity of securing choice 35 smartest spring styles at bargain (factory) prices. You write up orders. Interesting work. Pay daily. We deliver, we fit, we collect. Work fast. Send in application today. Big selling season just ahead. Highly-rated pioneer firm.

**STYLE-ARCH SHOE CO.**  
DEPT. D-3 CINCINNATI, OHIO

## Handbook for Farmers

861 discoveries by practical farmers, telling how to make, repair or improve the various devices and machines used about a farm or garden. 683 illustrations. "The Most Remarkable Book Ever Published for Farmers," says one authority. **Send No Money.** When the postman delivers the book to you, hand him \$1 plus the few cents postage.

**POPULAR MECHANICS PRESS**  
Popular Mechanics Building, Room 703, Chicago, Ill.

**Auto Tourist's Handbook** tells how to make equipment for inexpensive touring with Auto Owner's Handbook, 98c. **Send No Money.** Just write a postal. Pay postman postage and price. Popular Mechanics Press, Room 703, Chicago, Ill.

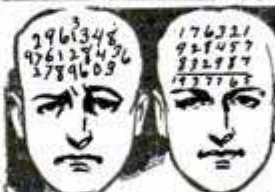

## ADD Quick! NEW EASY WAY

NEW patented pocket calculator adds, subtracts, multiplies, divides. Works like \$300 machine. A child can operate it. 9 columns—adds up to a million. Corrects errors without clearing total. Total always visible. Clears automatically. No mechanism—nothing to get out of order. **VEST POCKET SIZE—All-metal machine. Handsome etched brass. Wt., 4 oz. Fits in beautiful blue leatherette case—looks like pocket notebook. Rounded corners—can't tear pocket.**

**AGENTS! \$23 a Day**

Sells on sight to offices, stores, small business men. Endorsed by noted C. P. A's. Others earning \$15 to \$34 a day. Get special offer.

**FREE TRIAL—Don't send money. We trust you. Simply order on 10-day trial. Pay postman \$2.95 on delivery. Return it if not satisfied and get your money back. Avoid costly arithmetic errors. Save money on expensive machine—V-P-A serves same purpose. Compare at our risk before you decide. Write Reliable Adding Machine Corp., Dept. C-1, 184 West Washington Street, Chicago.**





This 80 page Book illustrates and describes the complete line of South Bend Lathes. Fill out and mail coupon for Free copy.

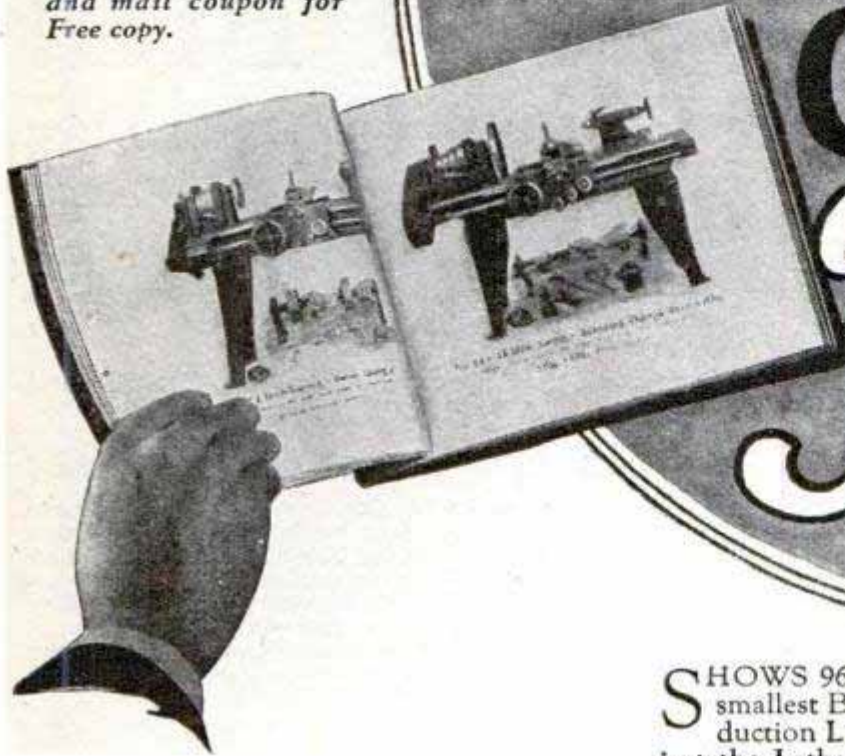

# New Lathe Catalog

# Free!

SHOWS 96 styles and sizes of Lathes from the smallest Bench Lathe to the largest Factory Production Lathe. In this Free Book you will find just the Lathe you want—Countershaft driven or Silent Chain Motor driven, Standard Change Gear or Quick Change Gear—all offered at surprisingly low net factory prices.

## The New South Bend Lathe

—is NEW in every one of its 352 parts. NEW in design and NEW in pattern development. It is heavier, stronger, has greater belt power, is more efficient and complete. It is a precision Lathe of the finest type. Although we have been building fine Lathes for 20 years and have 33,000 of them in use in the U. S. and 64 Foreign Countries, we devoted 2 years of special development work and an investment of \$250,000 to bring to you this New Masterpiece—the New South Bend Lathe.

Write or send coupon below for a Free copy of this New Lathe Catalog.

If desired, easy payment terms can be arranged for you in the purchase of any South Bend Lathe.

### SOUTH BEND LATHE WORKS

805 E. Madison St. : South Bend, Indiana

#### SOUTH BEND LATHE WORKS

805 E. Madison St., South Bend, Ind.

Gentlemen: I would like your net factory price on a Screw Cutting Lathe, size----- For (check kind of work)  Manufacturing  Garage Work  Machine Shop  Vocational Work  
Please send Free Catalog.

Name-----

Address-----

City-----State-----

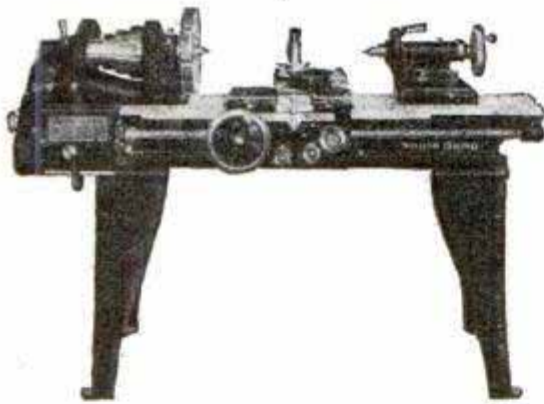

13 inch Swing over Bed, 5 ft. Bed, Quick Change Gear. Net Factory Price **\$387**  
Easy Payments if Desired.

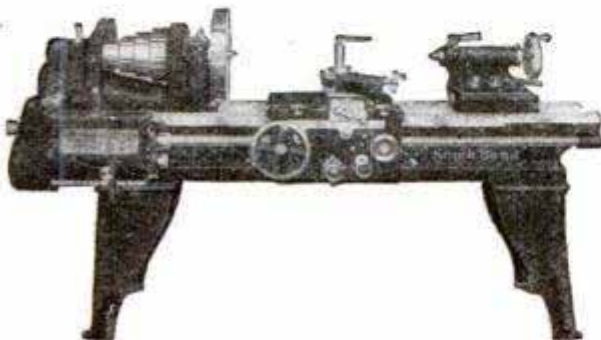

18 inch Swing over Bed, 8 ft. Bed, Quick Change Gear. Net Factory Price **\$693**  
Easy Payments if Desired.

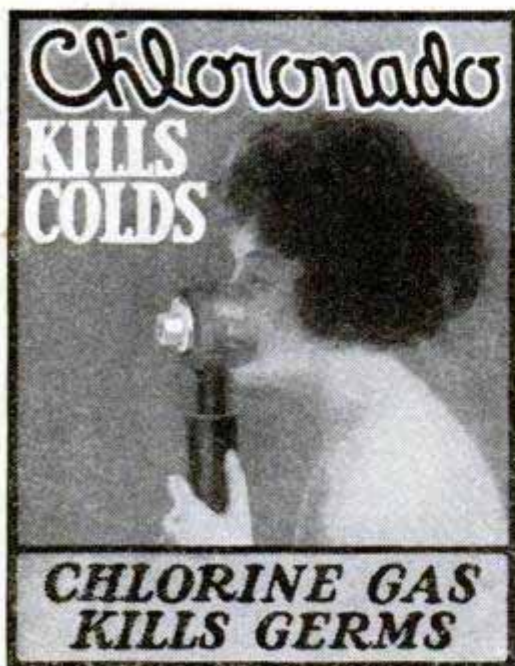

**Chloronado**  
**KILLS**  
**COLDS**

**CHLORINE GAS**  
**KILLS GERMS**

### Chloronado Needed Everywhere

Chloronado is the first scientific Chlorine Gas Generator for the home. Thousands now in use. Millions need this aid to the prevention of colds and other chronic respiratory ailments.

# Chloronado GOING BIG!

## Earn as Much as \$40 a Day

Here's the opportunity of a lifetime to build a highly profitable business.

Chlorine Gas—the treatment developed by U. S. Army Physicians—for colds, catarrh, hay fever, bronchitis, influenza and many other respiratory diseases can now be had by everyone in their own homes.

The same gas treatment used by President Coolidge and thousands of prominent people with remarkable results.

### A Money-Making Offer to Men and Women

Chloronado salesmen can easily earn \$5,000 or better—distributors \$10,000 to \$15,000. Everyone is interested in preventing disease—everyone is a prospect for Chloronado.

There is still some choice territory open to wide-awake salesmen and distributors. Enter your application in NOW—

Get the cream of the business in your locality by being the first to offer this amazing device. Live leads furnished to salesmen—National advertising and circularizing campaigns—every possible help and co-operation to aid you in building a permanent, profitable business. Write or wire for full details.

### A Very Interesting Proposition to State Distributors

**CHLORONADO LABORATORIES CO.** 439 E. Fort St. Detroit, Mich.

**"Interlox"**  
**MASTER SLIDE RULE**  
Takes accurate inside or outside measurements  
**MASTER RULE MFG. CO., 841-43 E. 136th St., New York**  
Dealers and Agents: request attractive proposition

Works fast. Slides in and out quickly. Durably made of brass trimmed boxwood. Any length 2 to 8 feet, 20 cents per lineal foot. If not at dealer's, sent postpaid.

**APEX VERNIER DIALS**  
ARE BEST ON ANY SET—ASK YOUR DEALER OR WRITE US  
**APEX ELEC. MFG. COMPANY, CHICAGO**

**Ideas for Housekeepers** Over 500 ideas in our Handbook for Women and Home Mechanics. Two books of discoveries for 98c. Send No Money. Just write a postal. Pay postman postage and price. Popular Mechanics Press, Room 703, Chicago, Ill.



**ONE DAY BATTERY CHARGING PAYS BIG YOU CAN CLEAR \$150 to \$300 MONTHLY PROFITS**

Thousands of HB users are making big profits every month. Every car owner and radio owner wants quick, reliable One Day Charging. Get their business with an HB One Day Battery Charger. Small cash payment brings you complete outfit on 30 days' trial with moneyback guarantee. Only \$16.50 monthly pays for your HB, easily made many times over by your increased battery charging business. Get an HB now. Start making \$150 to \$300 clear monthly profits. Write for free bulletin 326.

**HOBART BROS. CO. Box M3 TROY, OHIO**  
**MAKE YOURS THE BUSY SHOP WITH HB ONE DAY BATTERY CHARGING**

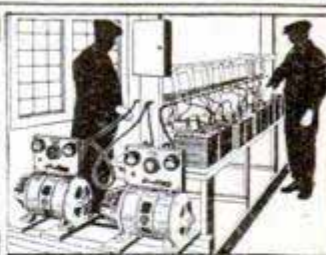

## Easy Money Repairing Balloon Tires

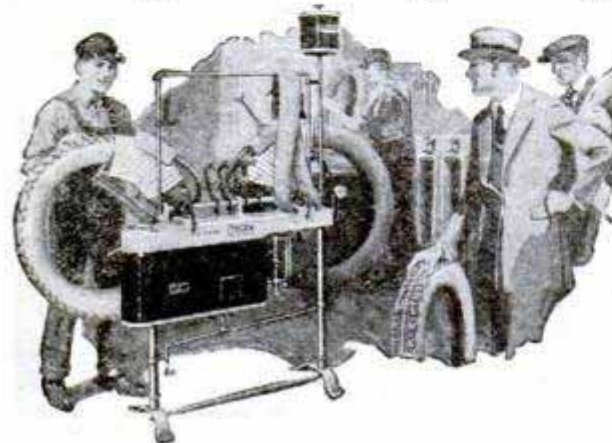

Go into the tire repair business NOW and make \$75 or more a week. One man made \$45 the first day he received his outfit. Millions of new autos every year and high price of tires creating enormous demand for tire repair work. No big investment necessary. We teach you. Easy to learn. *Big profits and independence if you act now.*

### **SHALER** New Tire Repair Outfit Makes it Easy for You

to become expert in a few hours and make big money right away. This wonderful outfit costs but little, yet does everything expensive complicated outfits do. A boy can operate it and make perfect repairs.

**WRITE QUICK** for new Shaler book on Balloon Tire Repairing, and full information..... **FREE**

**C. A. SHALER CO.**

2703 Fourth St.,

Waupun, Wis., U. S. A.

World's Headquarters for Tire Repair Equipment



*"Get Dad in—  
he'll love it"*

**The  
BRUNSWICK  
"Home Club"  
Billiard Table**

a beautiful dining or living  
room table in rich American  
Walnut, instantly con-  
vertible by removing  
the top into a com-  
plete billiard table

## Sport • Fun • Thrills Galore!

—all in your own home at small cost!

COME on, you sport lovers— you young fellows from 7 to 70! Here's some real fun for you! The sportiest, most fascinating game in the world— Billiards— now made available for every home through the Brunswick convertible "Home Club" Table—and you don't have to be well-to-do to own one either. That part's easy now!

There's nothing in all the world that will give you—and will continue to give you indefinitely—more genuine enjoyment, more entertainment per dollar invested than a Brunswick "Home Club" Billiard Table.

Here's a game that everyone

can enjoy. Get Dad into it— Mother too! Let's see who is champion in your house. Strength, size or age doesn't count in this wonderful sport. Sister has just as fair a chance to win as her big husky brother.

Skill is the thing that counts in billiards. Skill that comes with practice—that develops coolness, clear thinking, coordination of mind and muscle and SPORTSMANSHIP.

Get Dad to buy you one of these remarkable Brunswick "Home Club" Billiard Tables. They're convertible. With the

top on you have a beautifully finished American Walnut dining or library table. Take it off and you have a fully equipped, good sized billiard table for either carom or pocket billiards.

Everybody, of course, knows the quality of Brunswick-Balke-Collender Tables. They are the standard, used in all the fine clubs. If you will send in the coupon printed below, a full description of them, together with reasonable prices and easy terms, will be sent immediately.

Let's start today to enjoy life. Get your coupon off tonight.

Play **BILLIARDS** — the  
greatest home game ever devised

The Brunswick-Balke-Collender Company  
Established 1845 Branches in All Principal Cities of the U. S. and Canada

### Do People Like to Come To Your House?

They will, if you have something to entertain them with. Nothing offers as much interest, fun and enjoyment as a Brunswick "Home Club" Billiard Table. The party never lags or grows tiresome. Billiards or pocket billiards offers thrills, excitement, entertainment galore. Try it and see.

The Brunswick-Balke-Collender Company

Dept. H-343, 623 S. Wabash Ave., Chicago, Ill.

Gentlemen: Please send me complete description of your home billiard tables, together with prices and terms, and oblige.

Name \_\_\_\_\_

Address \_\_\_\_\_

# Don't Get Stuck In Mud, Sand or Snow



## USE Gets-U-Out Pressed Steel Tire Lugs

WHENEVER you attempt to drive your car or truck through deep mud, sand or snow—the chances are ten to one you're going to get stuck. And you'll probably end up by paying \$5 to \$10 towing charges.

But with a Set of 4 of my (patented) Gets-U-Out Pressed Steel Tire Lugs in the tool box, you're worry free. In a jiffy you slip 2 on each rear wheel—and out you go—even if you're buried up to the axles. In an instant you slip them off and replace them in the tool box. No fuss—no muss—no trouble—simple—a woman can use them. Constructed of steel, rust proof and with nothing to get out of order, my Lugs will last for years.

Your car deserves a Set.



AMAZING NEW INVENTION

### Grab This New Year Around Seller Earn \$75 to \$150 Weekly

OVER 20,000,000 car owners are waiting for my marvelous device. *Positively nothing like it.* One minute demonstration gets the order. Sells at a low price—with 100% profit. You'll positively coin money—full or spare time—with this much needed accessory. And it isn't necessary for you to invest your bank roll either.

ART. J. BENSON, Gen'l Mgr.

**CHICAGO TIRE LUG COMPANY**  
338 W. 47th Street, Dept. 4, CHICAGO, ILL.

### FREE OFFER To Agents

Act quick. Write me NOW—today—for my FREE OFFER—a postal will do. Territory going fast.

### PROOF

"Your Lugs have never failed to pull my heavy 2 ton truck out of deep mud, sand or snow." J. J. Andrest, Minn.

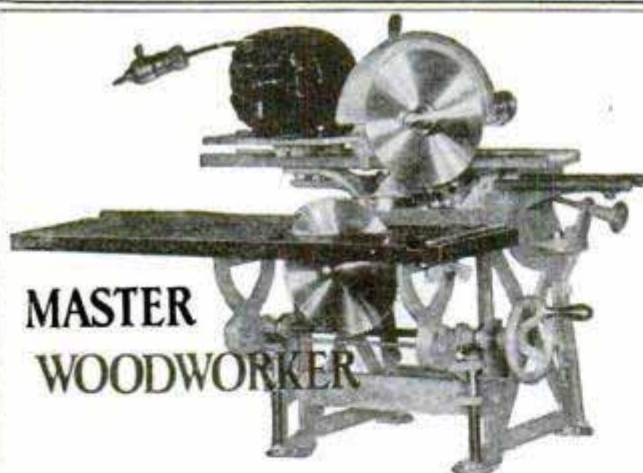

## MASTER WOODWORKER

Own Your Own Woodworking Shop—Low Price  
Easy Payments

Whether you make things from wood, for fun or for profit, you ought to own this wonderful low-priced, long-lived machine—a complete woodworking shop for home, factory or construction use.

The "Master" is 12 machines in one. It does cross cutting, ripping, jointing, boring, sanding, dadoing, planing, plowing, mitering, rabbeting, molding, band sawing, mortising, tenoning, grinding, matching and stair routing.

Wonderfully speedy and accurate—sturdy and reliable. Lasts a life time—runs from a lamp socket.

Model No. 10, illustrated, rips 1" stock, cross cuts 2" stock. Three larger models for heavier work.

Costs little—sold on easy payments.

MASTER WOODWORKER MFG. CO.  
612 BRUSH ST., DETROIT, MICH.

Send for big description book

P. M. S.



## "The finest Trumpet I've ever played"—

THIS opinion, expressed by thousands of owners of King Saxophones, Trumpets, Trombones and other band instruments, is a tribute to the exacting standards to which "Kings" are built. Every instrument is true in pitch and scale,—is easy to play and has a beautiful tone quality.

### Free Trial—Easy Payments

"Kings" are shipped on 10 days' trial, where there is no dealer. The payment plan makes possible the buying of some instruments for as little as \$5.00 per month.

### Send for a Catalog

If you play any instrument or are thinking of getting one, send for the "King" catalog before purchasing. This catalog will tell you how "Kings" are built, explain the various exclusive features which make "Kings" the finest instruments you can obtain.

THE H. N. WHITE CO.  
Manufacturers of KING Band Instruments  
5211-73 Superior Ave. Cleveland, Ohio

The H. N. White Co., 5211-73 Superior Ave., Cleveland, O.  
Kindly send me free without obligation your latest catalog on KING \_\_\_\_\_ (Instrument)

Name \_\_\_\_\_

Address \_\_\_\_\_

City \_\_\_\_\_ State \_\_\_\_\_

# FROST-FONES

**Highly sensitive to weak signals**

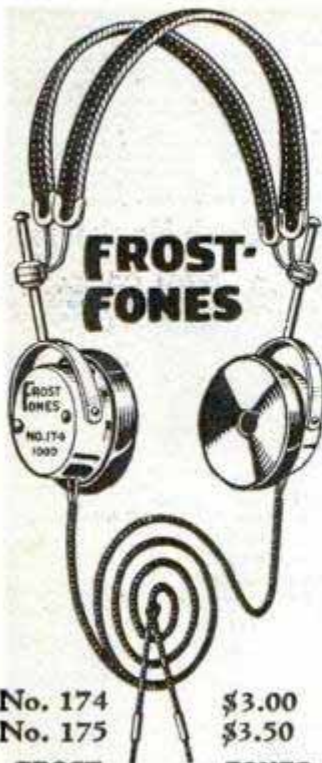

To get any real enjoyment out of DX work you must use a good pair of head fones, which are designed specifically to pick up weak signals. Due to our extreme care in winding coils, lapping shells, grinding magnets and testing and measuring **FROST-FONES** they are about twice as sensitive to weak signals as most other head fones. We could not be more particular about **FROST-FONE** quality if we built them to sell for ten dollars. Our huge production insures low prices and our rigid inspection guarantees high quality. Your dealer in your neighborhood stocks **FROST-FONES**. Order from him today.

No. 174 \$3.00  
No. 175 \$3.50

**FROST-FONES**  
**HERBERT H. FROST, Inc.**  
314 West Superior Street Chicago, Illinois  
New York Kansas City Los Angeles  
Export Office: 314 West Superior St., Chicago, Illinois

## BIG MONEY—Sell RADIO



### IMPERIAL 5-Tube Set

Demonstrate this wonder receiver. Every demonstration a sale. Price lower than others and performance not equalled by many sets costing several times our price. Hundreds of successful agents. Thousands of sets already sold. \$100 a week—every week—easy. Write at once for agent's proposition—before your territory is taken.  
SIMPLEX CO., 2035 S. Michigan, Dept. 24, Chicago



### 12-Cell—24-Volt Storage 'B' Battery

Positively given free with each purchase of a WORLD "A" Storage Battery. You must send this ad with your order.

Send Your Order in Today

# FREE!



WORLD Batteries are famous for their guaranteed quality and service. Backed by years of successful manufacture and thousands of satisfied users. Equipped with Solid Rubber Case an insurance against acid and leakage. You save 50 per cent and get a 2-Year Guarantee Bond in Writing. WORLD Battery owners "tell their friends." That's our best proof of performance. Send your order in today.

**Solid Rubber Case Radio Batteries**  
6-Volt, 100-Ampers.....\$8.25  
6-Volt, 120-Ampers.....13.25  
6-Volt, 140-Ampers.....14.00

**Solid Rubber Case Auto Batteries**  
6-Volt, 11-Plate.....\$11.25  
6-Volt, 13-Plate.....13.25  
12-Volt, 7-Plate.....16.00

Send No Money wanted and we will ship day order is received, by Express C. O. D., subject to your examination on arrival. **FREE "B" Battery** included. **Extra Offer:** 5 per cent discount for cash in full with order. Buy now and get a guaranteed battery at 50 per cent saving to you.

**WORLD BATTERY COMPANY**  
1219 S. Wabash Ave., Dept. 6, Chicago, Ill.

# World For AUTO and STORAGE BATTERIES RADIO

Approved and Listed as Standard by Leading Authorities including Radio News Laboratories, Popular Science Institute of Standards, Popular Radio Laboratories, Radio Broadcast Laboratories, Radio in the home, and Lofa., Inc.

# Let the Pure Tones Through

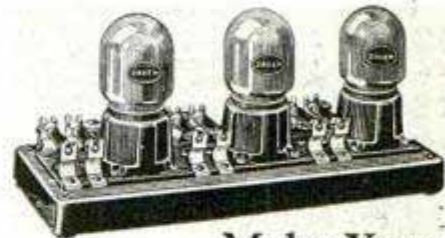

The Daven Super-Amplifier used with any set or circuit carries through the full, clear tones of the broadcasting station programs. If you prefer to assemble the Amplifier, obtain the Daven 3-stage Kit, which includes all parts except sockets

**Make Your Old Set a 1926 Model**

**PURE** tones, beautifully clear and full, go out from the broadcasting station. They reach your detector still pure and clear. But what then?

From the detector your amplifying apparatus operates. Distortion arises unless you take advantage of a method of amplifying that far-sighted manufacturers and thousands of set builders are now adopting—Resistance Coupled Amplification. Resistance Coupling is not new, *but Resistance Coupling with real volume amplification is new.* It is the most approved method of letting pure tones through.

The Daven Super-Amplifier costs little. It is easily and conveniently installed in any set made. Buy it complete to save hook-up labor. For those preferring to assemble, the Daven 3-stage Kit gives all the necessary parts except sockets. You will join hundreds who have written to thank us for the Daven improvements.

Write us today for *The Resistor Manual*, an authoritative book on Resistance Coupled Amplification, 25c at good dealers, 30c by mail.



The new Daven Special Coupling Condenser Type "A", for Resistance Coupled Amplification, sold separately and also included in all Daven Amplifiers, Kits, and Resisto-Couplers. For greater volume and better quality.



The new Daven High MU Tube Type MU-20, used with the Daven Super-Amplifier, gives 50% more volume—6 volt, 1/4 ampere. A Daven Power Tube Type MU-6 in the last or output stage helps any set regardless of the method of amplification—6 volt, 1/2 ampere.

DAVEN PRODUCTS SOLD ONLY BY GOOD DEALERS

## Resistor Specialists DAVEN RADIO CORPORATION

*"The Sine of Mccit"*  
Reg. U. S. Pat. Off. Newark New Jersey

CLIP THIS COUPON

DAVEN RADIO CORPORATION  
165 Summit St., Newark, New Jersey

Please send me the following on Resistance Coupled Amplification: *Check One*

Resistor Manual, 30c is enclosed.  
 Complete Catalog (free)

Name.....  
Address.....

*For Dealers: Send your letterhead and we will have our nearest distributor communicate with you*

THE BIG LITTLE THINGS OF RADIO



# JAPANESE ROSE BUSHES

## The Wonder of the World

Japanese Rose Bushes bloom all the year round. Just think of it. Six weeks after planting the seed, the plants will be in full bloom. It may not seem possible, but we positively guarantee it to be so. They will bloom every ten weeks, Summer or Winter, and when three years old the bush will be a mass of roses, bearing from five hundred to a thousand roses on each bush. The flowers are in three shades—white, pink, and crimson. The plants will do well both in and out doors. We guarantee at least three bushes to grow from each packet of seed. Price, 10c packet, 3 pkts. for 25c postpaid.

### Chinese Fragrant Tree Fern

Just introduced: noted for its rapid growth. An exceptionally pretty ornamental plant. Foliage is rich dark green. Forms grand pyramidal bushes about 6 feet high. Branches very desirable for decorative purposes, wreaths, etc. Seeds 15c pkt., 3 for 40c.

### Weather Plant

NATURE'S WEATHER PROPHECY By mysterious changes that take place this remarkable plant accurately forecasts the weather many hours in advance. Will grow anywhere all the year around. An interesting house plant. Bears large, fragrant, pink, butterfly shape flowers. Seeds, 15c packet, 3 for 40c, postpaid

## GROUND ALMONDS

Amazingly Prolific—Easily Grown From Seed The Ground Almond has a flavor that is MOST EXCELLENT, resembling the coconut. The meat is snow white, covered with a shell or skin of brown color. It grows close to the surface and anything from 200 to 300 Almonds may be expected from a single nut. There is no trouble whatever in growing anywhere and in any kind of soil. May be planted any time, and in eight or ten weeks from time of planting you will have an ENORMOUS CROP of the MOST DELICIOUS ALMONDS YOU EVER TASTED. Seeds 15c Pkt.

### Perfume Plant

Blooms only at night, giving forth the most delightful scented fragrance for quite a distance. Causes much comment. For house or garden. Also valuable because of rare perfume made from it. SEEDS, 10c pkt., 3 for 25c.

### SENSITIVE PLANT

Marvel of the Philippines. Leaves curl, fronds droop when touched. Apparently resents interference. A handsome shrub for house or garden; very curious and interesting. Seeds, 15c pkt., 3 for 40c, Japanese Nest Egg Gourd

### Calabash or Pipe Gourds

A luxuriant and rapid growing climber; thrives anywhere. Produces the ornamental gourds from which the famous African calabash pipes are made. Grow this interesting vine and make your own. Seeds, with instructions, 15c pkt., 3 for 40c.



Seeds 15c pkt., 3 pkts. for 40c. J.S. & CO.

## Mammoth Peanuts

Peanuts can be easily cultivated. Their culture is very simple and exceedingly interesting. Mammoth Peanuts grow to an astonishing size. It is a good producer, very prolific, and the giant nuts have a thick, heavily ribbed protecting shell. The plant is very attractive, the leaves being of odd shape and a handsome green shade, tinted through the center with white. You will derive much pleasure cultivating this interesting species. Seeds 15c pkt., 3 pkts. for 40c.

### Shoo Fly Plant

A very remarkable botanical curiosity you should have. Though quite odorless, it is said flies will not remain in a room where it is grown. Bears very pretty blossoms; blooms summer and winter. Grows rapidly from seed. SEEDS 15c packet, 3 for 40c, postpaid

### Japanese Climbing Cucumber

Unusually strong and vigorous growing vine. Attains twice the size of ordinary varieties. Grows readily on fences, poles, trellises, etc. One hill will keep an entire family supplied all summer.

## Gigantic Butter Beans

The New Edible Vegetable Wonder Grows to an astonishing size, the Beans measuring from 3 to 6 feet long, and weighing anything from 10 to 16 lbs. and even more. One Bean is sufficient for a family for several meals. Very palatable and rich in nutritious materials. The delicate Buttery Flavor is much appreciated. The Vines are easily grown, very prolific, and a most welcome and valuable adjunct to your garden. Try them; you will find them the most delicious vegetable you have ever tasted. Imported direct. Unobtainable elsewhere. Sample package of Seeds with full directions for cultivating and cooking. 25c, postpaid.

### A Few Other Seed Novelties You Should Cultivate—10c Pkt.

- Japanese Kudzu Vine (Jack and Beanstalk)
- Chinese Balloon Flower
- Purple Feather Grass (Ornamental)
- Curious Ferns Grown from seed
- Bird of Paradise Flower
- Japanese Hop Vine
- Caster Oil Plant
- Ornamental Cotton
- Job's Tears (Great curiosity)
- Cathedral Bells
- "Tiger" Flower
- Snake Cucumber
- Emerald Isle Kale
- Famous Passion Flower Vine
- Purchase
- Ornamental Gourds
- Boquet, or Red Cluster
- Pepper
- Salsify, or Oyster Plant
- White Velvet Okra

Nitto's Plant & Flower Food changes ill-nourished plants into Luxuriant Beauties, producing masses of blooms that will equal any. Causes plants to bloom early and ahead of others. Friends marvel at success. Brings out New Foliage and Flowers, and causes a Marvellous Transformation. Pkg. 15c, 3 for 40c.

# JOHNSON SMITH & CO.,

## THE REMARKABLE FIREFLY PLANT A Vine that Blooms at Night



Fills the Atmosphere with Fragrant Aroma One of the most rapid growing vines known. Under favorable conditions this vine has been known to grow OVER 25 FEET IN A SINGLE WEEK. In a very short space of time indeed the Vine has climbed to a great height, and is covered with IMMENSE FLOWERS, from 5 to 7 inches in diameter. It is, indeed, a great novelty, for, unlike other plants, the flowers OPEN IN THE EVENING, and remain open until about noon the following day. In dull weather they will remain open all day. It is a most INTERESTING SIGHT to watch the opening and closing of the flowers as the clouds appear and disappear. As the flowers open they give forth the most DELIGHTFUL, AROMA and the whole atmosphere around is full of scented fragrance. It is always the object of favorable comment, and much curiosity is aroused by people passing at night time as to the cause of the charming aroma, frequently stopping in an endeavor to satisfy their curiosity. PRICE, 19 CENTS packet, two packets for 35 CENTS, POSTPAID. JOHNSON SMITH & CO.

### The Great Wonderberry

A luscious berry that may be grown and ripened from seed in any soil or climate in 3 months. The flavor is fine and unsurpassed for eating raw, cooked, canned or preserved in any form. The fruit is blue-black in color, and tastes like a luscious, rich blueberry. One bush will produce an enormous amount of fruit, yielding great masses of rich fruit all Summer and Fall. Packet, 10c, 3 pkts. for 25c, postpaid.

### Bush Musk Melon

A vineless Musk Melon, grows in bushes, and thus can be cultivated in the smallest garden. The fruit is of the popular "Jenny Lind" type, but larger, averaging 5 inches in diameter. The flesh is very deep, edible almost to the rind and is colored light green, flushed with salmon toward the center. The quality is superb, lusciously sweet and juicy. Packet of seeds, with full directions for culture, 15 cents, 3 packets for 40 cents, p.pd.

### The Great Umbrella Palm

The Japanese Umbrella Palm is a semi-aquatic plant. It is easily grown from seed either in a bowl of water or in very damp soil. Probably the most usual, as well as the most interesting method, is to cultivate the plant in a bowl or jardiniere filled with water, with two or three inches of good garden soil at the bottom. The seeds soon commence to germinate, and the plant shoots up stems two to three feet high and rapidly assumes a most pretty palm-like appearance, as shown in the engraving. The tops of the stems are surmounted by a whorl of umbrella-shaped leaves, of a waxy appearance. We will send a package of this seed, with full instructions for culture, for only 15c or three packets for 40c postpaid.

### A Gracious House or Conservatory Plant



### Butterfly's Own Bush

This plant is a veritable refuge or haven for butterflies, and it attracts all the most beautiful types of butterflies to the neighborhood. Bees, too, are very fond of it. It is a pretty plant bearing perfectly double flowers, ranging from white to rich crimson, deep red and pink, lilac and other delicate shades. Packet 10 cents, 3 for 25 cents postpaid.

### FAMOUS MEXICAN FIREFLY PLANT

Beautiful hedge plant, grows 2 to 2 1/2 feet high and resembling a closely clipped evergreen. The globe-shaped or pyramidal bushes are close and compact, and of a pleasing light green color. May be grown singly or in the form of a hedge or background. In early autumn the whole bush becomes carmine or blood red, hence the name of Mexican Fire Plant, or "Burning Bush," as it is sometimes called. Selected Seeds, 10c

### CROWN OF THORNS

A very curious and remarkable window plant, can be trained over any desired form. Bright scarlet flowers. An object of rare and striking beauty, easily grown. It grows wild in Judea, and it is said that it was the crown of thorns was made which was worn by our Saviour. Packet 10 cents, 3 packets for 25 cents

### Asparagus Sprengeri

The best plant for hanging baskets. Masses of rich, gleaming foliage droop in a very graceful manner. The foliage when cut for decorative purposes will last weeks in water. The seed pods are very pretty red berries adding to its beauty. Packet, 10c, 3 pkts. for 25c, postpaid

### "Wong-Bok" Chinese Cabbage

Novelty from China and should be grown in every garden. Seems to be a cross between Celery and Cos Lettuce. Flavor is more mild than any other cabbage. Can be served on the table and eaten raw or cooked like cabbage, spinach or lettuce or made into salad. Grows very rapidly, easy to cultivate. You can create quite a sensation by cultivating this remarkable novelty. Seeds, 15c packet, 3 pkts. for 40c.

### TREE OF HEAVEN

This splendid ornamental tree is a native of China, and is called the Tree of Heaven, on account of its great beauty. Very hardy, thrives in any soil, no matter how poor, and grows from 6 to 10 feet high from seed the first summer. The leaves are from 5 to 6 feet in any length, giving it a grand appearance. Nothing outside the tropics can rival it for lawn decoration. Large panicles of bloom, followed in season by great clusters of colored seed pods, make the tree a continual thing of beauty. Packet, 15c; 3 packets 40c

### SURPRISE FLOWER GARDEN Over Hundred Varieties of Mixed Flower Seeds

MANY RARE AND CURIOUS NOVELTIES An Abundance of Flowers Assured Throughout the Season A mixture of easily grown annuals that bloom very soon after sowing the seed; others vary in their time of blooming. Those who cannot give the constant care necessary for finely arranged flower beds will be delighted with the Surprise Wild Flower Garden. Will prove a continual surprise and pleasure, as new varieties and the old garden favorites flower successively throughout the season. There are over a hundred varieties of seeds. Many of the plants may be taken inside as house plants and will bloom during the winter. Fine for children, also teachers for school gardens. Packet, 15 cents, three packets for 40 cents, postpaid. J. S. & CO

# Dept. 498, RACINE, WIS.

# Save On This Home

# \$803

**\$1606 FREIGHT PAID**

**INTERNATIONAL MILL & TIMBER CO.**  
C-2 South Wenona Ave. BAY CITY, MICHIGAN

Just think! Through our amazing new plan you can get this \$2400 bungalow for only \$1606—a clear cut saving to you of \$803 or actually a third! We furnish you with the finest materials cut to fit direct from our mill—saving you big money on your lumber, mill work and labor. Satisfaction guaranteed or your money back.

### Buy Direct from Mill—Save 4 Profits

You positively save four big profits by buying direct from our mill. We give you everything complete—all lumber cut-to-fit, windows, doors, flooring, shingles, lath, glass, paints, varnish, putty, hardware, nails, molding, cupboards—all plainly marked and easily assembled according to drawings and directions we furnish. We pay the freight. Write now for our beautiful book of homes which shows you a large number of lovely homes, priced from \$478 up. Send for it at once—no obligation.

**INTERNATIONAL MILL & TIMBER CO.**  
C-2 South Wenona Ave. BAY CITY, MICHIGAN

## PLUMBING-HEATING

### YOU SAVE HALF

Send for **FREE BOOK** of Guaranteed Plumbing and Heating. Everything cut-to-fit. 50 yrs. in business. Thousands of customers. "You saved me \$400.00," says Mr. Edw. Borkosky of N. J. Write today.  
**HARDIN-LAVIN CO., Dept. R.,—W. Pershing Rd., CHICAGO**

## RADIO TEXT BOOK & CATALOG

# FREE

Contains—  
75 Radio "Hook-Ups"  
300 Illustrations  
650 Articles  
64 Pages

"Build Your Own with RASCO Parts"

**RADIO SPECIALTY CO.**  
98-E, Park Place, NEW YORK, N. Y.

## AGENTS

### Big Money Quick!

**COMBINATION KING RADIO WONDER**  
First combination tube and crystal set ever made. Turn of a switch and either tube or crystal works as desired, or both together. 1000 Miles or more on headphones—Loud speaker on Locals. Two complete sets in one for only \$10.96 retail. Get my wonderful money making plan and special price to you.

**AERIAL ELECTRIC CO.**  
128-36 W. Kinzie Street, CHICAGO

# Startling Offers

## Unusual Cash Diamond Buys

Examine Free!

60% OF MARKET PRICE

As Low as \$60 PER CARAT

List of Rare Diamond Buys—Unbeatable Values

Sheet No. 1.

Exact Wt.	Description
\$82 1/2-3/32 ct.	Flawless Gem Fine Steel white color. Try to match at \$135.00.
\$116 3/4 less 3/16ct.	Wassalton Showy Brilliancy. Spread Try to match at \$235.00.
\$237 7/8-1/32 ct.	Flawless Gem Perfection and Proportion. Try to match at \$385.00.
\$345 1-3/32 ct.	Jaegerfont Rare color grade and Try to match at \$550.00.

Write for our latest lists and see the hundreds of startling offers in unset diamonds, beautiful mountings and others already mounted. You can now get the mounting you like best and the diamond of your choice—both at a price so low, you'll be amazed. Shows how and why: this 75-year-old, \$1,000,000.00, largest and oldest diamond banking institution in the world having just completed big cash deals direct with European diamond cutters, and having other diamonds on which money was loaned, but not repaid, can make these startling legitimate offers passing on the advantages to friends and customers alike. You make further savings here through our cash policy of no charge accounts—no installments, but extra value for cash.

### Why Pay Full Prices

### Costs Nothing to See

At our risk we send you any bargain you wish for absolutely free examination. No red tape. Try to match at full 60% more if you can or don't keep it. Diamonds of desirable quality at \$125 per carat. Yes, some even lower priced—also finest gems obtainable at higher per carat—but proportionately low bargain prices. Our bargains have guaranteed loan values, also unlimited exchange privilege at full price paid.

### Latest List Diamond Bargains

Send at once for latest list. Every gem described in full detail with exact weight, color, quality, etc. Get details of Free Examination Offer. No obligation to buy. List is free.

**JOS. DE ROY & SONS, 1942 DeRoy Bldg., Pittsburgh, Pa. Only opposite Post Office**  
Without obligation to buy, send me free, your Latest Bargain List of Diamonds, Watches and other Jewelry.

Mail Coupon NOW!

Name.....  
Address.....  
City..... State.....

## Band Directors!

# FREE 72 Page Victor!

### Series of Band Music

Here it is at last! The newest, biggest and best catalog of band music. Nothing ever printed like it before. It's unique! 72 pages of Marches, Waltzes, Overtures, Novelties, Drum and Trombone Solos, Characteristics and Concert numbers, from the world famous Victor series.

### F & U BAND MUSIC GUIDE

Interesting and instructive articles by Vandercook, Landers, Albert Cook, and Schonemann. Also 86 full size solo cornet parts. Everything you will ever need to know about bands, band music, band laws, and accessories.

A gold mine for the busy band director! In a handy size, 7x10 1/2. 2-color title page, durably bound to withstand rough usage. Don't hesitate a minute. We have one of these big band catalogs here waiting to hurry through the mail to you. Add your name to our free mailing list.

**SEND COUPON TODAY!**  
Tear off the coupon and mail it today. Don't hesitate! Act!

**Finder & Urbanek Dept. 1353, 1322 W. Congress Street, CHICAGO, ILLINOIS**

**free!**

**Use the Coupon!**

Finder & Urbanek, Dept. 1353, 1322 W. Congress St., Chicago, Ill.  
Dear Sir: I am interested in your new 72-page band catalog. Please send me one at once. I am enclosing 10c to cover packing and mailing.

Name.....  
Address.....  
City..... State.....

# "I MAKE \$25.00 A DAY SURFACING FLOORS"



Parr was making \$7 a day. Now he's making \$25 to \$40 a day.

**WITH THIS MACHINE**



Start in a small way and make big money. That's what Parr did and thousands of others have done. Like you they read an advertisement just like this and accepted the wonderful opportunity to get behind an electrically driven American Universal Floor Surfacing Machine and build up a big profitable business of their own.

They are men from factories, stores, and offices, young and old alike, who were looking for a future and an opportunity to make real money. They are now making from \$25 to \$40 a day with one American Universal Floor Surfacing Machine which does the work of six men and earns six men's pay. All started with just one machine, but many are now operating six or more machines and have become floor surfacing contractors on a large scale.

## EVERY NEW FLOOR MUST BE SURFACED EVERY OLD FLOOR NEEDS RE-SURFACING

There is surfacing work to be done in every new and old business or residence in your vicinity. If you are willing to don a pair of overalls, you can make from \$25 to \$40 a day every working day in the year—Winter and Summer, month in and month out.

## NO EXPERIENCE NECESSARY

Any intelligent man can learn to operate the electrically driven American Universal Floor Surfacing Machine in a very short time. It actually does in a day the work of six men scraping by hand and does much better work than can be done by hand.

Write now for particulars. Let us tell you how you can become an American Floor Surfacing Machine contractor. You can secure this information absolutely free without any obligation on your part.

**THE AMERICAN FLOOR SURFACING MACHINE COMPANY**  
Originators of Floor Sanding Machines  
523 South St. Clair Street TOLEDO, OHIO

## ILLINOIS MAN INVENTS NEW FORD GAS SAVER

Walter Critchlow, 326-B street, Wheaton, Ill., has patented a new gas saver that beats anything ever gotten out. On tests Fords showed as high as 61 miles on a gallon. This new invention saves gas and oil, makes a Ford start instantly in coldest weather and completely decarbonizes the engine. Mr. Critchlow offers 1 free to quickly advertise. Write him for one. He also wants County and State Distributors who can make \$500 to \$2500 per month.



**I Made \$21.00 In Five Hours**

—Writes Peter Werner, III, Sell Madison "Better-Made" Shirts for Large Manufacturer Direct to wearer. No capital or experience needed. Many earn \$100.00 weekly and bonus.

**Write for Free Samples**

MADISON SHIRT MILLS, 562 Broadway, New York



## The New Sypher

More for the money than ever built before. Length over all, 30 in. Between centers, 14 in. Swing over bed, 7 3/4 in. Includes counter shaft. Bronze taper bearings. Weight 60 pounds. Absolutely accurate. Time payments if desired. Write today for circular.

**\$60**

The Sypher Mfg. Co. Dept. D Toledo, Ohio



## Real MOVIES

—Make them yourself with **VICAM Standard MOVIE CAMERA**

Camera, Tripod, Projector and 2 Magazines Complete outfit for taking and showing standard size pictures. Equal to biggest cameras. Loads in daylight. Projects on wall or sheet.

**\$37**

Send 10c in Stamps for illustrated **BOOKLET**  
**VICAM PHOTO APPLIANCE CORPORATION**

1224 Belmont Avenue, PHILADELPHIA

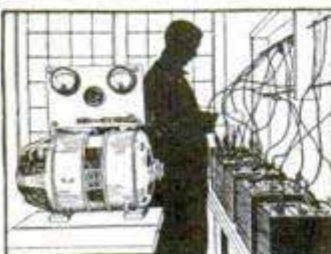

## \$150 to \$300 MONTHLY PROFITS EASILY MADE WITH ONE DAY BATTERY CHARGING

One Day Battery Charging will quickly build a great big moneymaking business for you. One Day Charge demanded by car owners and radio owners everywhere. \$150 to \$300 clear monthly profit easily made. No experience needed to operate an HB One Day Charging outfit. Only \$16.50 monthly pays for your HB. Small cash payment puts complete outfit in your shop on 30 days' trial with moneyback guarantee. Write today for free Bulletin 3.

**HOBART BROS. CO. Box M 33 TROY, OHIO**

**MORE HB ONE DAY BATTERY CHARGERS ARE IN USE THAN ANY OTHER MAKE**

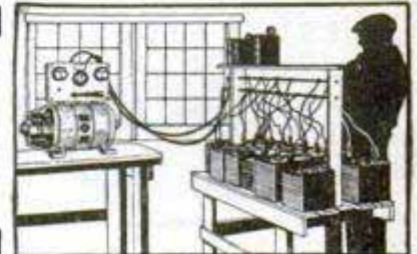



# FREE RADIO CATALOG

WRITE for a copy of our NEW 100-Page Radio Catalog—Parts, Accessories—Kits—Sets—Everything for the Fan.

DEPT. PM

## CHICAGO SALVAGE STOCK STORES

509 S. State Street CHICAGO, U. S. A.

### BIG RADIO OFFER—Send No Money

The most amazing Radio offer made! Everything you need to complete a set. 1 Pair long distance, super-sensitive ear phones head set (Guaranteed 2,000 ohms); 100 Feet heavy ribbon antenna complete to install with 2 loss-proof insulators; 1 sure-contact ground clamp; 25 Ft. high grade lead-in wire. Big \$5.00 value! Send no money. Just pay postman only \$2.65, plus a few cents postage upon arrival. Mail us your name and address at once!

APEX STAMPING COMPANY, Dept. M, RIVERDALE, ILL.



### AERODYN \$38.75 FIVE TUBE

Biggest little set in the world. Range, Tone, Selectivity, Volume. Latest type high grade parts. Thousands sold. Fully guaranteed. Satisfaction or your money back. Greatest value you ever saw. Agents write for Big money making offer.

Evans-Lawrie Company  
7 years of square dealing  
782 Commonwealth Ave., Boston, Mass.



15" Lathe  
as low as  
**\$250.00**  
Write for Catalog  
**SEBASTIAN  
LATHE CO.**  
107 Culvert Street  
CINCINNATI, O., U. S. A.

40 Years  
OF  
BIG VALUE  
Lathes



# At Last! Soldering Iron and Blow Torch In One!

*Saves Time, Trouble and Money!*

For every handy man! Pays for itself in one job! Enables you to do easily a lot of work that would otherwise require a plumber or tinsmith. Needs no pump or pressure system. Needs no stove or charcoal pot, or separate blow torch. No fussing! No trouble!



No need to waste time constantly re-heating your iron. Ready for use in a jiffy—stays ready for an hour—and you can regulate it for exactly the right amount of heat!

Burns for an hour at less than ¼ cent for gasoline and can be used where nothing else would be available! Just remove copper point and you have an ideal BLOW TORCH for burning off old paint, tempering tools, thawing frozen pipes, etc., etc. Send the coupon below! Why pay out good money to tinsmiths and plumbers for jobs you can easily do yourself with the Justrite! Send for one on Free Trial TODAY!

### For Every

Householder,  
Farmer,  
Auto Owner,  
Mechanic,  
Tinsmith,  
Radio Fan,  
Plumber,  
Electrician,  
Dentist,  
Jeweler,  
Painter,  
Printer,  
Garage,  
Repair Shop.

## Agents!

Get our extremely liberal offer to agents. Sales come fast, you'll be amazed. Just show people how this wonderful tool works. As soon as they see how much time and trouble it saves, they want it! Nine times out of ten a demonstration means a sale. Send post card for special Agents' Offer.

5 Days' Trial  
**Send No Money**  
No C. O. D.

The Justrite will be sent you prepaid for 5 days' trial—without your sending us one penny and without any C. O. D. See for yourself what a wonderful time saver and labor saver it is. If, at the end of 5 days you decide to keep it, send us only \$3.00. If not satisfied, after 5 days' trial, just return it. That's all! But send coupon today!

Mail for 5 Days' Trial. Send No Money. No C. O. D.

**JUSTRITE MFG. CO., Dept. 13-53**  
2071 Southport Ave., Chicago

Please send me by parcel post, prepaid, one Justrite Soldering Iron and Blow Torch, packed complete with sal ammonia and solder, ready for use. After 5 days' trial I will either send you \$3.00 or promptly return the tool.

Name.....

Address.....

# Play a Tune



On Your Favorite Stringed Instrument



## in 10 Minutes!

No Knowledge of Music Necessary  
No Tiresome Practice

Now you can pick up your favorite stringed instrument and play a tune almost instantly, even if you don't know one note of music. These wonderful "Instant Playing" Instruments take all the work out of learning to play. No expensive lessons. No complicated musical signs and symbols. Play by numbers instead of notes (or by notes if you wish). Just press the numbered keys and you are playing tunes. Hundreds are playing "Instant Playing" Instruments who could never learn the old way.

### Amazing New Invention

This is not merely a system of instruction—it is a new device invented by a musician, Prof. James F. Reed, that revolutionizes stringed instrument playing. "Instant Playing" Instruments give clearer, truer tones, are easier to finger and anybody can play. Famous Vaudeville Star, Trizzie Friganza, writes: "I learned to play a tune in 3 minutes and had never touched a stringed instrument before." John Matise wrote: "Played tunes on the Guitar the same day and am delighted. Anyone can play." Leonard Cleary: "In only a few days I have had my money's worth in fun. It certainly is one fine instrument." Constance Sedler: "I was playing in four minutes."

### SEND FOR FREE BOOK

Tells all about new "Instant Playing" Instruments and how you can play in 10 minutes. Also Free Catalog of special bargains in musical instruments. No obligation. Send for this Free Book now! Your friends will be astonished at your learning to play so quickly. You will be popular and always sure of a good time. Send coupon today.



Choose Your Instrument

What is your favorite stringed instrument? Send for this Free Book, and choose the one you would like to play. You can play it in 10 minutes! Send coupon now!

Ferry & Co., Dept. 9773, Chicago

FERRY & CO. Dept. 9773 Chicago, Ill.

Send me Free Book on "Instant Playing" Instruments and tell me how I can play tunes in 10 minutes. No obligation.

Name.....

Address.....

City..... State.....

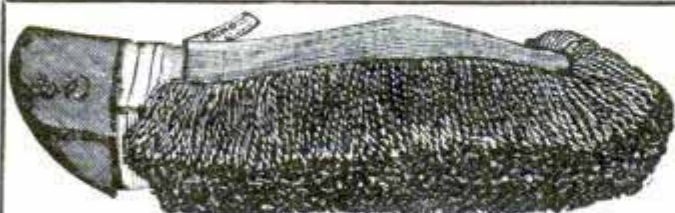

Fits the hand like a Glove

### The Season's Greatest SELLING HIT

Every Car Owner and Garage Will Buy

## AUTO MITTEN DUSTERS

Costs \$3.60 Doz. Sells for 75c or more

Sample with complete selling instructions by Parcel Post prepaid 50c, and sample cost may be deducted from first order.  
NATIONAL FIBRE BROOM CO., ST LOUIS, MO.

# AGENTS Some Set At \$2.00

Looks Like \$5.00 Worth Gives You \$1.00 Profit!

With Our Great Introductory Offer

Giving These \$1.25 Dress-Making Shears FREE



With each sale of our wonderful 11 piece Toilet Article Assortment for only \$2.00. Total Store Value \$4.60

\$20.00 a Day PROFIT on only TWENTY Sales



## MY! HOW THEY SELL!

You get the attention with the free Shears. Walter Harris sold 800 boxes in six weeks. Profit over \$100 a week. You can do this too.

**Act Now!** Sell like hot cakes year round. A baby could sell Lucky 11. Don't wait a minute. Save time. Send \$1.75 for complete outfit including display case. At least write for circulars explaining our unique plans, including 30 other packages. **ACT NOW!**

E. M. DAVIS CO., Dept. 5639, CHICAGO, ILL.

## AGENTS NEW SPARK PLUG Visible Flash



**Just Out—Amazing Invention—Beacon Lite Spark Plugs.** You see the flash of each explosion in the cylinders. Tells which are firing right. Greatest improvement in spark plugs since gas engines were invented. Wonderful gas savers. Agents coining money.

**\$90 A WEEK**

Easy to make with new sure-fire plans. Sells on sight to every auto owner. Phillips, Ont., writes "Sold 2 dozen today, 3 dozen yesterday. Rush 10 dozen." Write for special Free Demonstrator Offer and FREE deal to introduce these wonder spark plugs in your territory. Write quick—today.

CENTRAL PETROLEUM COMPANY  
1023 Century Building Cleveland, Ohio

## THE WONDER MACHINE SHOP, Only \$3.50

Famous Little Hustler Motor FREE

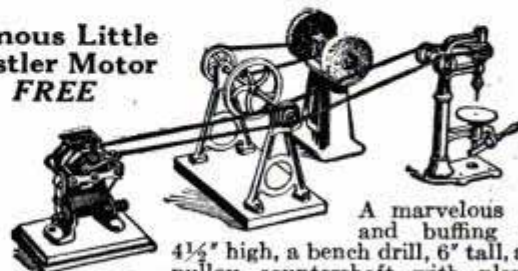

A marvelous emery and buffing wheel, 4 1/4" high, a bench drill, 6" tall, a three pulley countershaft with plenty of spiral spring belting and connectors. All for \$3.50, and Free, the famous Little Hustler Motor (runs on single dry cell) complete with switch, worth \$1.75, Free.

KNAPP ELECTRIC CORPORATION  
TOY DIVISION, Dept. 109 Port Chester, N. Y.

Use **LEPAGE'S** for permanent mending



WHEN you mend an article of useful household value, if you want to be sure of making a permanent repair, use LePage's Glue. The quantity of glue you use is so little, and the cost so small, why risk using anything but the best? As in everything else, the best is cheapest in the end. LePage's insures permanent repairs. Insist on LePage's.

**LEPAGE'S**  
GLUE

Now, Only **\$39**

Let Me **Send You the Greatest LOG SAW Offer** Puts the **OTTAWA** Working For You

—I ever made. One man saws 15 cords a day—easy. Falls trees, saws limbs. Make big money. Use 4 H-P. Engine for other work. Saws faster than 10 men. Shipped from Factory or nearest of 10 Branch Houses. Cash—Easy Terms. Write for 30-Day Trial Offer and big FREE book.

**OTTAWA MANUFACTURING COMPANY**  
1741-W Wood Street, Ottawa, Kan.  
Room 1741-W Magee Bldg., Pittsburgh, Pa.

**MEN \$75 Every Week**



**I Show You How SEND FOR SAMPLES**

Yes, hundreds make more. But no wonder Fashion Wear Shirts take prospects "off their feet" when you tell them the amazing low prices for these fashionable, smart shirts. You can earn \$10 to \$15 every day just calling at factories, offices, garages, etc.

**EVERY MAN WANTS THESE SHIRTS AT 3 for \$4.95**

Big profits for you. Satisfaction guaranteed or money back quick. You don't need experience. Samples sent absolutely free. Just send name on postcard. Make \$10 to \$15 the day samples arrive. But you must act quick on this unusual offer. Address **Charles Hope**,

**FASHION WEAR SHIRT COMPANY**  
1200-20 Jackson St. Dept. C-351 Cincinnati, Ohio

# How to Start the Day Right

A quick, cool, modern shave with Barbasol. No brush. No rub-in. A little easy razor play. And you're all set for the day. Try it—three times—according to directions. 35c and 65c tubes.



The Barbasol Co.  
Indianapolis Ind.

I enclose 10c; please send trial tube.

Name.....

Address.....

P.M.-3-26

**For Modern Shaving**

## ALUMINUM SOLDER

SOLDERS ALUMINUM of any description. NO ACIDS OR FLUX NECESSARY. For home, shop and garage use. Your tool kit is not complete without HAMILTON LEAD CO. ALUMINUM SOLDER. (Name on every bar.) Send 25c for 2 six inch bars, or \$1.00 for 9 bars; postpaid.

**HAMILTON LEAD CO., HAMILTON, OHIO**



**Clear-Tone**  
FOR

**PIMPLES**

Your skin can be quickly cleared of Pimples, Blackheads, Acne or any Eruptions on the face or body, Barbers Itch and Eczema, Enlarged Pores, Oily or Shiny Skin. CLEAR-TONE has been Tried, Tested and Proven its merits in over 100,000 test cases.

**FREE**  
E. S. GIVENS

WRITE TODAY for my FREE Booklet—"A CLEAR-TONE SKIN" telling how I cured myself after being afflicted for fifteen years.

129 Chemical Bldg. Kansas City, Mo.

# \$15 to \$20 a Day Filing Saws

is easily possible with the

## FOLEY AUTOMATIC SAW FILER

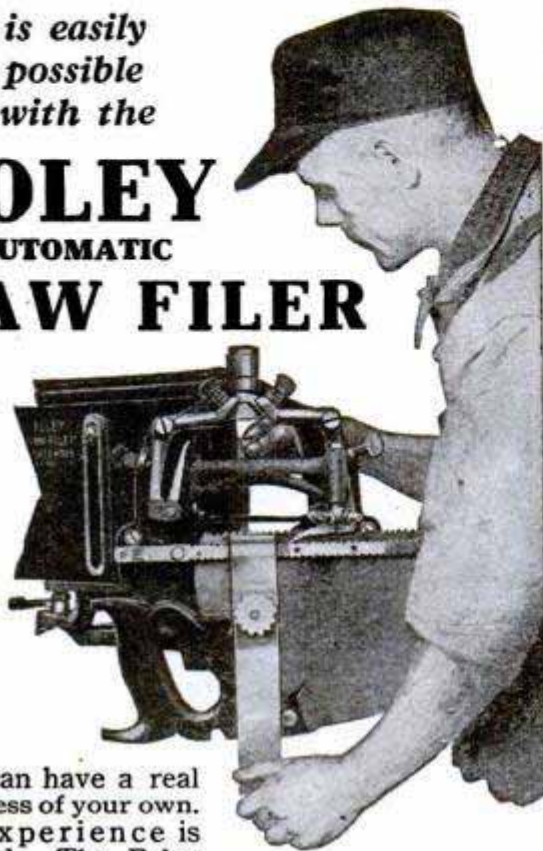

You can have a real business of your own. No experience is needed. The Foley Saw Filer and Saw Set are a sensation in the saw industry. Automatic in operation—files a saw perfectly in 5 minutes—sets it in 1 minute. Handles hand, back, band, meat, circular and other saws. Every contractor, carpenter, hardware store, manual training department, butcher, woodworker and home that owns a saw has business for you. Many factories and plants need Foley Saw Filers.

"It is just a year since I purchased your Saw Filer and Set, and am getting big business from carpenters. They all approve of my work done on your machine."

—JOHN T. BETZ, 12 Hill St., Bogota, N. Y.

"Am turning out fine work, better than any expert hand filing that I can do or have ever seen done in this city. Am completing a new workshop for my filing business with Foley Saw Tools."—C. R. KNIGHT, 804 2nd St., Klamath Falls, Ore.

### Special Offer to Agents

For demonstration purposes we will allow a liberal discount on your order. A few good territories are still open. Your town may be one of them. Be independent—mail coupon now for full details.

### FOLEY SAW TOOL CO.

Room 201 Foley Building  
914 E. Lake St., Minneapolis, Minn.

Send me more proof of what I can make with Foley Saw Tools and also your special offer to agents.

Name.....

Address.....

**\$351.00**

**Cleared in one day (Aug. 1925) by W.H. Adams Dayton, Ohio**



one day. J. R. Bert, Ala. "only thing I ever bought that equaled advertisement."

V. A. Marini, Santa Cruz, Cal. (Nov. 1924) reports \$11,275 sales in 3 months. J. Gordon of New Jersey says \$4000 profit in two months. Alexander of Penn. \$3000 profit in four months. Ira Shook, Flint \$365 in one day. Bram, bought one outfit then 10 more within a year. Patillo, Ocala, writes: "Crispettes all you claim and then some." John W. Culp, South Carolina, writes, "Everything going lovely. Wrappers lying all over. It's a good old world after all." Perrin, \$380 in 1 day. Mrs. Lane, Pittsburgh, 8000 packages in

### WE'LL START YOU IN BUSINESS

Furnish secret formulas, raw material, and equipment. Very little capital required; no experience needed.

### Build Paying Business of Your Own

No limit to the sale of Crispettes. Everybody likes them. It's a delicious food confection made with or without sugar. Write me for facts about a business that will make you independent. Start now, in your own town.

### Profits \$1,000 a Month Easily Possible

Send postal for illustrated book of facts. In contains enthusiastic letters from others—shows their places of business, tells how and when to start, and all information needed. Free. Write now!

#### LONG-EAKINS COMPANY

228 High Street

Springfield, Ohio



### Take Your Profit From Now On

300% advance on Crude Rubber drives Mr. Car owner to have his Tires repaired, instead of buying new ones.

### EASY TO LEARN

We give you instructions Plants \$100 and up Our free Catalog tells you how to save 50% on a plant we have near you. Instruction Book for a \$1.00 bill.

Equipment Exchange, 118 E. 11th St., Los Angeles, Calif.

## PLUMBING-HEATING

**YOU SAVE HALF**

Send for **BIG FREE BOOK** of Guaranteed Plumbing and Heating. Everything cut-to-fit. 50 yrs. in business. Thousands of customers. "You saved me \$400.00," says Mr. Edw. Horkosky of N. J. Write today.

HARDIN-LAVIN CO., Dept. R., W. Pershing Rd., CHICAGO

### Looks Like a Real

Protect yourself from toughs and hold-up men. Most amazing automatic, 4 1/2 in. long; gun-metal finish. Can't tell from real automatic until you pull the trigger, and presto! you have Opera Glass, Pocket Mirror, Magnifying Glass, Telescope, Reading Glass, Mirror, Sun Dial, Compass, etc. Loads of fun; useful, instructive; a real protector.

**AUTOMATIC \$1.48**



### Send No Money!

Just send name. On arrival of "Automatic" deposit with Postman \$1.48 plus a few pennies postage. Satisfaction guaranteed or deposit refunded. Supply limited. Order now. Big Bargain Catalog sent FREE. ORDER TODAY!

FERRY & CO., 3224 N. Halsted St., Dept. 8773, Chicago, Ill.

# 21 Jewel Santa Fe Special

*on credit*

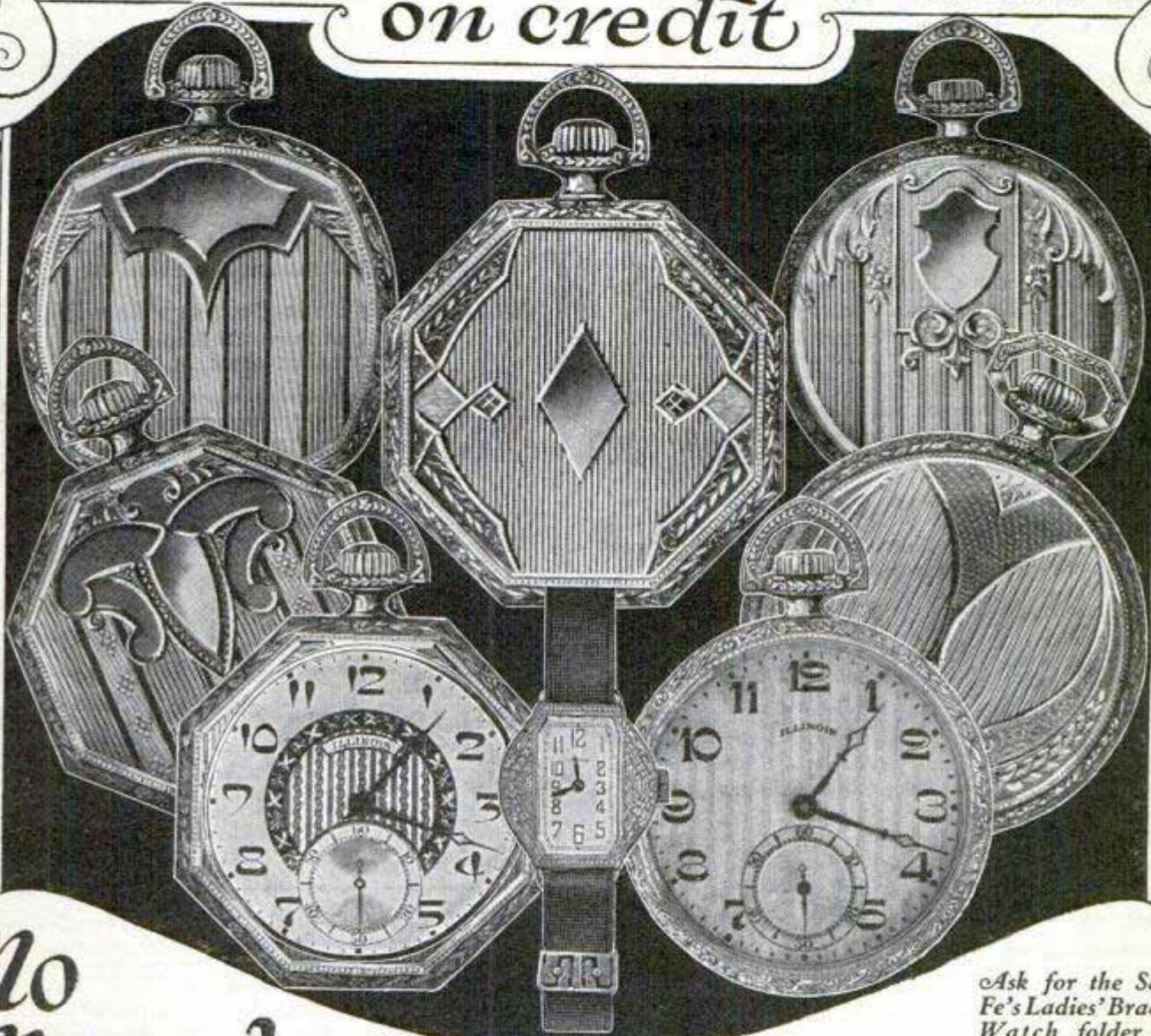

**No  
Money  
Down**

WE will send this famous watch direct to you, express prepaid, on FREE Approval. Examine watch and be convinced it's the best watch buy you ever saw. You save  $\frac{1}{3}$  to  $\frac{1}{2}$  your money by purchasing a Santa Fe Special Watch. We trust you—wear watch while paying for it.

*Ask for the Santa Fe's Ladies' Bracelet Watch folder and Diamond folder.*

## Mail Coupon for FREE Watch Book →

Clip the coupon, fill out and receive the FREE WATCH BOOK. All the newest watch case designs in white or green gold, fancy shapes and thin models, are shown. Read our easy payment offer. Select the watch you would like to see; we will send it to you on approval, express prepaid. Wear the watch 30 days FREE. Return at our expense if not fully satisfied.

## SANTA FE WATCH COMPANY

Dept. 36, Thomas Building Topeka, Kansas  
*The Home of the Great Santa Fe Railway*

### SANTA FE WATCH CO.

Dept. 36, Thomas Building  
Topeka, Kansas

Please send prepaid and without obligation your Watch Book Free, explaining your "No Money Down" Offer on the Santa Fe Special Watch.

Name.....

Address.....

# STOP THAT LEAK WITH SMOOTH-ON No. 1

**Y**OU can apply Smooth-On with radiator full or empty, hot or cold, without removal from the car and without putting inside anything that clogs the circulation.

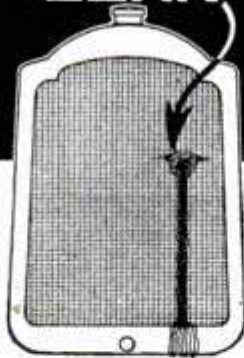

Merely roll the Smooth-On into a stiff putty, press it against and into the leak with your thumb or pack it into the defect with a knife blade or screw-driver, and scrape off the excess. The leak will stop instantly, and the repair is permanent. For a few cents and in a few minutes you will have avoided all the delays and expense of a professional repair job that couldn't be any better.

**Bursting Water Jackets.** Water jackets of automobile, stationary or marine gas engines which have developed long or short cracks or have even had pieces broken entirely out from freezing can be made thoroughly and lastingly serviceable by similar repair, or by applying Smooth-On under straps or a plate.

Smooth-On No. 1 can be used in a hundred ways in the household, and it often saves from \$50.00 to \$100.00 on the first job.

Keep a can of Smooth-On No. 1 with your tool kit and some day when caught with a repair job you will thank yourself for your forethought.

Get Smooth-On No. 1 in 7-oz., 1-lb. or 5-lb. tins at any hardware store or if necessary direct from us.



Write for  
**FREE BOOK**



Do it with **SMOOTH-ON**

SMOOTH-ON MFG. CO., Dept. 37,  
574 Communipaw Ave., Jersey City, N. J.  
Please send the free Smooth-On Repair Book.

Name .....

Address .....

P. M. ....

## FREE

This booklet tells how to stop not only water leaks in radiators, bursted water jackets, and at loose hose connections, but also how to stop gas leaks from the tank, gasoline lines and exhaust system, and oil leaks at gaskets and at cracks in crank or gear case. It also tells how to make headlight posts, nuts, hub caps and bolts and grease cups stay tight, and shows dozens of simple money saving Smooth-On repair jobs.

Sent free if you return the coupon.

SMOOTH-ON MFG. CO.  
Dept. 37, 574 Communipaw Ave.  
JERSEY CITY, N. J.

## LONDON—NEW YORK SAN FRANCISCO

Via the new 1926

# SUPER-HETRO RADIO

Any radio engineer will tell you that a Super-Hetro Receiver is the most powerful, most selective and greatest distance-getter of all. We offer a 5-tube Super-Hetro giving the results and volume of 8 tubes, in a beautiful cabinet, size 10 by 31 by 11, for the remarkable and most reasonable price of \$45.00 net. Unequaled in construction and appearance; sold on a free 10-day trial, with a coast to coast reception guarantee. Large circular on request.

**Mercury Electric Corporation Bldg.**  
48 West Burnside Avenue  
NEW YORK CITY, N. Y.

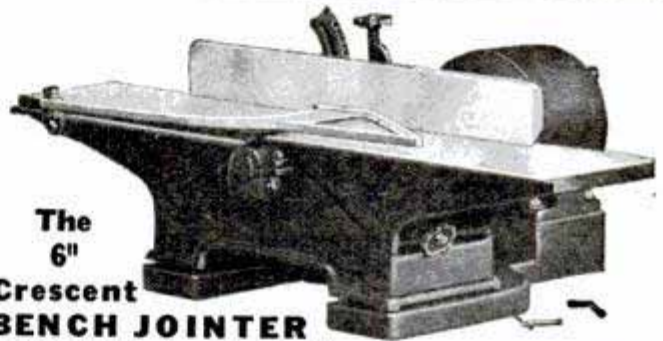

The  
6"  
Crescent  
**BENCH JOINTER**

Is the latest addition to our line of machines for the small shop. Ask today for special illustrated price list of 6" jointer, No. 12 saw table, with tilting top, 4" bench jointer, 20" band saw, each with individual motors.

**PRICES VERY LOW—QUALITY VERY HIGH**

Send today for circulars of band saws, saw tables, self-feed rip saw, shapers, jointers, variety wood workers, planers, planers and matchers, disk grinders, cut-off table, swing saws, borers, hollow chisel mortisers, tenoners, universal wood workers, are free for the asking.

**THE CRESCENT MACHINE CO., 93 Columbia St., Leontia, Ohio**

### "Best Pen I Ever Had—and costs less!"

That's what users of the Postal say. New filling method—easiest ever devised. Holds 4 times usual amount of ink. Transparent (always know how much ink you've got!). Unbreakable. Only \$2.50! Sent C. O. D. Order now and try it! Money back if you don't like it.

**POSTAL PEN CO., Inc., 25 W. 43rd Street, NEW YORK CITY**

2-cent stamp brings by return mail our

## Crackerjack SPORTING GOODS CATALOG

**IVER JOHNSON SPORTING GOODS CO.**  
10 Cornhill, Boston, Mass.

# STOP TOBACCO

Stop tobacco for a month and see how much better you feel. You can easily stop without suffering any inconvenience or feeling the usual craving. Simply get a box of Nicotol, use as directed and the habit quits you. Your health will be better, your resistance to disease will be greater and you will cease to be a slave to nicotine. Nicotol is sold under an ironclad money-back guarantee by druggists, or direct to you for \$1.00 by H. J. Brown Medicine Co., 20 Perry-Payne Bldg., Cleveland, Ohio.

Guaranteed for FIVE Years! A guarantee you'll never use; the average Underwood lasts for LIFE! © 1925, S-W Co.

Thousands use a typewriter at home—to their pleasure and profit. The typewritten letter wins. Stories that are typed sell. There's always a wealth of work for a typist. Learn and earn on an Underwood—fast, spirited touch, and beautiful writer. See our offer!



## Write Us a Check for THREE DOLLARS

### and Own an Underwood

Don't go another week without a typewriter. And don't pay another month's rental on some relic. A genuine Underwood is a joy to use—and easy to own. Act in time to receive one from this new lot!

If you've been "saving" for a typewriter, the time has come to *spend*. The cash involved? *Three dollars*. That's all that stands between you and actual use of your Underwood complete!

The Shipman-Ward price on a factory rebuilt Underwood makes it folly to buy a second-rate machine. And our plan of payment makes it equally foolish to wait.

Don't send *any* money now. But do let us have your name and address at once—for the big typewriter book that's *free*.

The biggest concern in the country buy Underwoods from us. You can make the same big saving, on one machine. So why pay the top price? This is a regular Underwood, the most popular model, with standard 4-bank keyboard, and every improvement; full size and complete equipment; tools and cover.

No other company makes such a wide-open offer; nor could we, on any other make of writing machine. See below.

## Why Be Old Fashioned?

**Modern Letters — Business or Social — Are TYPED!** Four hundred Underwood typewriters, fresh from our finishing room, ready for shipment. They will soon find homes! For the home use of typewriters is increasing by leaps and bounds. A man needs one constantly. A boy in school shouldn't be denied one. Girls who work get ahead much faster at the office if they have their own typewriters at home.

You'll be amazed at the uses everyone in your household will find for an Underwood typewriter. Don't try to do with a less perfect machine, though; it doesn't pay. It isn't necessary. Since Shipman-Ward started rebuilding Underwoods, a fine typewriter is not a luxury in any sense. Few things around your

house cost so little as will now buy your Underwood. Nothing you ever bought was purchased on such liberal terms. These machines are in sparkling condition, rebuilt from the platen down. Not a single worn part; not a fault nor a flaw; nothing but what is just as perfect as its gleaming nickel or enamel finish.

**Send No Money!** All we want is your name and address, and a chance to present the facts about the wonderful Shipman-Ward plan; a plan that has built one of the world's largest typewriter businesses; the plan that was made for the benefit of all consumers. You run no risk buying this way! We let the machine do all the selling. Our big book of typewriters in actual colors is the thing to think of now! Coupon brings it *free*.

### Free Book Coupon

SHIPMAN-WARD MFG. CO.  
2123 Shipman Bldg., Chicago

Please send **FREE**, full offer, catalog, typing manual, and outline your free course in Touch Typewriting without obligation!

Name.....

St. or R. F. D.....

P. O..... State.....

# Cultivate Your Musical Bump

Roger Kahn of Kahn  
Symphonic Dance  
Orchestra, N. Y.

Charles Straight of  
Straight's Orchestra  
Chicago

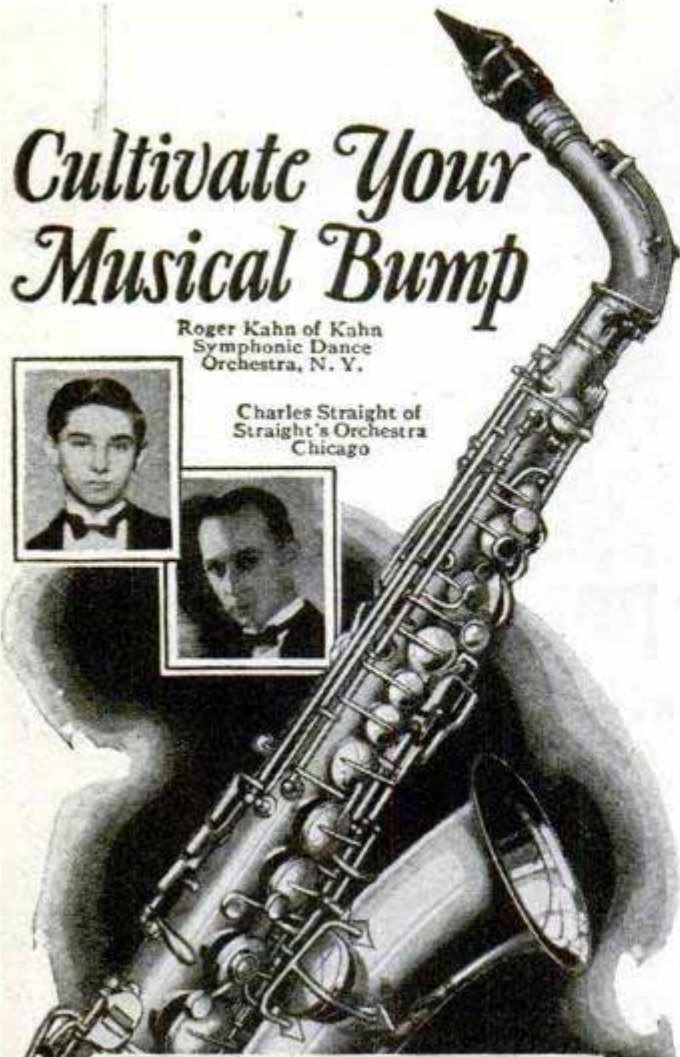

## Free Trial; Easy Payments on Any Conn Instrument

**E**NTERTAIN yourself and your friends; make big money playing whole or part time, if you choose, with a Conn saxophone. Easiest to play, beautiful in tone, perfect in scale, reliable action—chosen by foremost artists for its exclusive features, yet costs no more than others. You'll learn to play it quickly.

Send coupon for free book, "Success in Music and How to Win It," by Sousa and others, and details of trial offer on any instrument. Remember Conn is the only maker of every instrument used in the band.

**CONN**  
BAND  
INSTRUMENTS  
WORLD'S LARGEST MANUFACTURERS



C. G. Conn, Ltd., 331 Conn Bldg.  
Elkhart, Indiana

Please send "Success in Music" and details of trial offer on

.....Instrument

Name.....

St. or R. F. D.....

City, State..... County.....



## Sport-Thrills-Action on an Indian

**Y**OU'VE got to ride a motorcycle to know what a big kick it is. Throw your leg over. Grab those handlebars. Turn on the throttle. And something happens. You Go!

Go in, out and through crowded city traffic. Go around and ahead of dragging auto parades you meet on country roads. Go over side roads and paths where cars can't go. Go up those hills with a z—z—z—zip. Go! Go! Go! —and get more thrills, more sport, more joy out of life, the more you ride. It's a Go sport, motorcycling. You can't know what you're missing now until you come over and get out and Go.

Send now for the new Go folder. It describes in detail the new 1926 Indians and shows you vividly the joys and thrills which they hold in store for you.

Address Dept. P-3.

## Indian Motorcycle Co.

Springfield, Mass.



**One Year To Pay**



**No. CS2 - Price \$62.00  
\$2 Down and \$5 a Month**

This big cluster of seven best grade sparkling blue white diamonds is set in **SOLID PLATINUM** in this solid white gold ring. Guaranteed to stand any test.

**10 Days Trial**

**No Red Tape**

**SEND NO MONEY** You pay \$2.00 to postman after you get this ring. If you keep it, pay **only \$5.00 a month for 12 months**. If you are not satisfied after seeing the ring, return it in 10 days and we will return your money—every cent. You take no risk in ordering this beautiful, flashing diamond cluster ring. Pay for it in monthly installments, like putting money in a bank.

**Cluster Looks Like \$600 Solitaire**

You now can buy this gorgeous ring at the wholesale price. Compare it with similar rings at \$100.00. We guarantee it to stand any test or comparison. It is the greatest bargain ever offered by any Diamond Importer. We will give you 8% more than you paid for it when you exchange it for a larger diamond ring.

**WRITE FOR JEWELRY CATALOGUE**

This beautiful diamond cluster ring is a sample of the unexcelled values we offer our customers. A thousand and one other selections are shown in our catalogue. Brings our store into your home.

**STERLING DIAMOND & WATCH COMPANY**  
(Diamond Importers—\$1,000,000 Stock—Est. 1879)

**1540 Broadway Dept. 2127 New York, N. Y.**

## UTAH LOUDSPEAKER

Ours is the strongest guarantee! Use it 10 days. If not the finest you ever heard, return it and get your money. Dealers Everywhere.

**Utah Radio Products Co. Dept. 50, 1427 S. Michigan Ave. CHICAGO, ILLINOIS**

## SEND FOR THE INTERNATIONAL CATALOG



FOR FORD—Prices from \$27.85 up. Factory to consumer direct—Pay Only One Profit.

**International Body Works, 914 W. Ohio Street, Dept. 7, Chicago, Illinois**

Our net price list. Full line of auto bodies and accessories for Fords at Wholesale Prices. Save big money on bodies by buying Direct from Factory.

## Nestler Rubber Fusing Stations

An opportunity is offered one man in each community to secure the sole and exclusive right to operate the famous Nestler Rubber Fusing Process of servicing pneumatic tires. Unlike any other method on earth. The Nestler method is the perfected and only known way of successfully retreading pneumatic auto or truck tires, including all sizes of balloon tires. Every car owner needs Nestler Service. Nestlerized repairs outlast the tire. No previous experience necessary. We teach you the business in two weeks or less. Moderate capital required. Big profit on each tire you do. Here is your opportunity to have a permanent and highly profitable business in your own name. Remember only one man can secure this profitable franchise in each community. Act now if you want to be that man. Write today for two interesting books describing the Nestler Rubber Fusing Process and the methods that are being employed by Nestler licensees everywhere to build up prosperous businesses.

**NESTLER RUBBER FUSING CO., Inc.**  
Dept. X, 245 West 55th Street, New York City

## CANADA NEEDS TRAINED MEN

Never were opportunities so great. Thousands of good paying positions are waiting in every field of endeavor for men trained to fill them.

Whatever be the task confronting the nation, in war or peace, Canada is always in peril of failure so long as the young people of the country are economically unfitted for their tasks. Canadian industry and agriculture demand that you prepare to take your place in promoting the development of the country. There is a big job waiting for you in your present work, or any line you choose.

No matter where you live, the International Correspondence Schools will come to you. No matter what your handicaps, or how small your means, we have a plan to meet your circumstances. No matter how limited your previous education, the simply written, wonderfully illustrated I. C. S. text-books make it easy for you to learn. No matter what career you may choose, some one of the 280 Courses of the I. C. S. will surely meet your needs.

### Make Your Start NOW

When everything has been made so easy for you, when one hour a day spent with the I. C. S. in the quiet of your own home will give you the training for a good position, will bring you a bigger income, more comfort, more pleasure, and all that success means, can you afford to let another single priceless hour of spare time go to waste? Make your start right now!

### Fill in and Mail This Coupon TODAY

----- TEAR OUT HERE -----

**INTERNATIONAL CORRESPONDENCE SCHOOLS  
CANADIAN, LIMITED**  
Dept. 1893, 389 Mountain St., Montreal, Canada

Explain, without obligating me, how I can qualify for the position, or in the subject *before* which I have marked an X:

- |   |  |
|---|--|
| <input type="checkbox"/> ELECTRICAL ENGINEER            | <input type="checkbox"/> SALESMANSHIP            |
| <input type="checkbox"/> Electric Lighting and Railways | <input type="checkbox"/> ADVERTISING             |
| <input type="checkbox"/> Electric Wiring                | <input type="checkbox"/> Window Trimmer          |
| <input type="checkbox"/> Telegraph Engineer             | <input type="checkbox"/> Show Card and Sign Ptg. |
| <input type="checkbox"/> Telephone Work                 | <input type="checkbox"/> Railroad Positions      |
| <input type="checkbox"/> MECHANICAL ENGINEER            | <input type="checkbox"/> ILLUSTRATING            |
| <input type="checkbox"/> Mechanical Draftsman           | <input type="checkbox"/> Cartooning              |
| <input type="checkbox"/> Machine Shop Practice          | <input type="checkbox"/> BUSINESS MANAGEMENT     |
| <input type="checkbox"/> Toolmaker                      | <input type="checkbox"/> Private Secretary       |
| <input type="checkbox"/> Gas Engine Operating           | <input type="checkbox"/> Business Correspondent  |
| <input type="checkbox"/> CIVIL ENGINEER                 | <input type="checkbox"/> BOOKKEEPER              |
| <input type="checkbox"/> Surveying and Mapping          | <input type="checkbox"/> Stenographer and Typist |
| <input type="checkbox"/> Mine Foreman or Engineer       | <input type="checkbox"/> Cert. Public Accountant |
| <input type="checkbox"/> STATIONARY ENGINEER            | <input type="checkbox"/> TRAFFIC MANAGER         |
| <input type="checkbox"/> Marine Engineer                | <input type="checkbox"/> Railway Accountant      |
| <input type="checkbox"/> Ship Draftsman                 | <input type="checkbox"/> Commercial Law          |
| <input type="checkbox"/> ARCHITECT                      | <input type="checkbox"/> GOOD ENGLISH            |
| <input type="checkbox"/> Contractor and Builder         | <input type="checkbox"/> Common School Subjects  |
| <input type="checkbox"/> Architectural Draftsman        | <input type="checkbox"/> CIVIL SERVICE           |
| <input type="checkbox"/> Concrete Builder               | <input type="checkbox"/> Railway Mail Clerk      |
| <input type="checkbox"/> Structural Engineer            | <input type="checkbox"/> AUTOMOBILES             |
| <input type="checkbox"/> PLUMBING AND HEATING           | <input type="checkbox"/> Mathematics             |
| <input type="checkbox"/> Sheet Metal Worker             | <input type="checkbox"/> Navigation              |
| <input type="checkbox"/> Textile Overseer or Supt.      | <input type="checkbox"/> AGRICULTURE             |
| <input type="checkbox"/> CHEMIST                        | <input type="checkbox"/> Poultry Raising         |
|   | <input type="checkbox"/> Pharmacy                |
|   | <input type="checkbox"/> Spanish                 |
|   | <input type="checkbox"/> Teacher                 |
|   | <input type="checkbox"/> Banking                 |

Name.....

Present Occupation.....

Street and No.....

City.....Prov.....

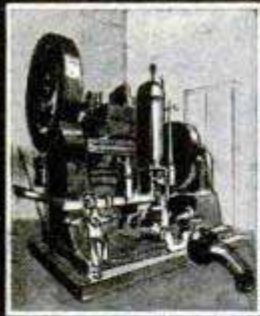

Be a Machine Draftsman—earn \$80 to \$150 a week



Be a Structural Draftsman—earn \$80 to \$200 a week



Be an Architectural Draftsman—earn \$60 to \$150 a week

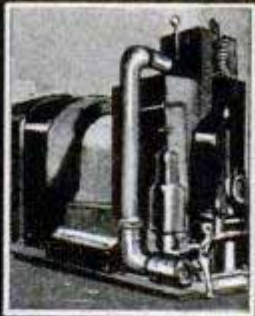

Be an Electrical Draftsman—earn \$60 to \$125 a week



Be an Auto Draftsman—earn \$80 to \$125 a week

# 3 Drafting Lessons Actually FREE!

to prove you can LEARN AT HOME, IN YOUR SPARE TIME!

We have invented a new, simplified way to teach Drafting—the first real improvement in Drafting home-instruction in history. We want you to see it, try it—without one penny of cost or obligation. We want to show you how we get away from the copying methods used in the past. See how we make you think, solve problems, do actual drafting room jobs from the first lesson!

## Draftsmen Wanted \$60 to \$200 a week!

70,000 fine jobs advertised this year. Get ready to fill one. Get out of the rut. Make something of yourself. Plan your future in Drafting. Even if you have only common schooling, even if you know nothing of Drafting, we guarantee to make you a real Draftsman or to refund your money! Special surprise offer right now to the first 500 men who answer this ad—reduced price, easy terms. Coupon brings complete information.

### A New, Rapid, Easier Training

Copying drafting lessons prepares you to be only a "tracer." This new "Job-Method" gives you actual drafting-room jobs in a new one-step-at-a-time way. With pictures which you can understand almost without reading the "lessons." And that is why American School-trained Draftsmen can qualify for a good job at big pay when they graduate.

### Win Success Through Drafting

Drafting is easy, fascinating work. Short hours. Big pay. And the Draftsman is always in line for promotion for executive positions. This training is Complete. It includes high-school subjects (if you need them) and all the Engineering and Mathematics required of Drafting Experts.

### Coupon Brings Three Lessons Free!

Get them. Test your own ability to learn Drafting and get ready for a fine job and big pay. Coupon also brings surprise offer, and complete information about your opportunities for success in Drafting.

Mail It Today!

### FREE Job Service

Our employment department will help place you in a good job. Demand exceeds the supply. No charge for nation-wide employment service. Read want-ads for Draftsmen every day in Chicago Tribune or any big city paper—see the opportunities for yourself—and get ready for them.

MAIL COUPON TODAY!



### Complete Costly Drafting Outfit GIVEN!

You need a fine outfit like this to do precise, neat Drafting. Not one penny of extra charge for this complete, valuable, high grade outfit. Imported instruments. Table, board, mahogany-edge T square, triangles, ink, thumb-tacks, etc., everything you will need. Retail value \$20. Coupon brings this Free Offer.

### CHIEF DRAFTING ENGINEER AMERICAN SCHOOL

Dept. D-374 Drexel Ave. & 58th St., CHICAGO

CHIEF DRAFTING ENGINEER, AMERICAN SCHOOL, Dept. D-374 Drexel Ave. & 58th St., Chicago

Rush 3 Free Drafting Lessons, Surprise offer, complete information, money-back guarantee, etc., to prove I can become a real draftsman at home in spare time.

Name..... Street No..... City..... State.....

# NEW FORD TIMER

## GUARANTEED for 3 YEARS

### Entirely New Principle

Study the illustration and you will note the rotating member is the brush principle traveling on the outside surface of the commutator—this assures you of a steady, even and powerful spark at exactly the proper time—The natural centrifugal action of the rotor keeps the commutator clean as it should be—provision is made for the elimination of any oil, grit or grime, therefore it cannot accumulate in the WEEKS SUPER TIMER. This principle is entirely new and unique.

### Sensational Invention

Millions of Ford Owners have been waiting for this SUPER TIMER—does away with common TIMER troubles. Entirely new principle. DYNAMO TYPE, no heavy pressure contact, no rollers to wear flat and cause endless trouble; smooth, easy, positive contact. The faster you run the hotter the spark, positive contact at all times, short circuits impossible, no oiling necessary, perfect firing, gives more power, saves wear and tear, adding many extra miles to the gallon, instant starting in the coldest weather, the motor promptly responds to the hot spark, the pick-up is marvelous. No parts to wear out, and the fact that the SUPER TIMER OUTLASTS 6 ORDINARY TIMERS enables us to guarantee this TIMER for 3 years.

### Ford Owners Wild Over It

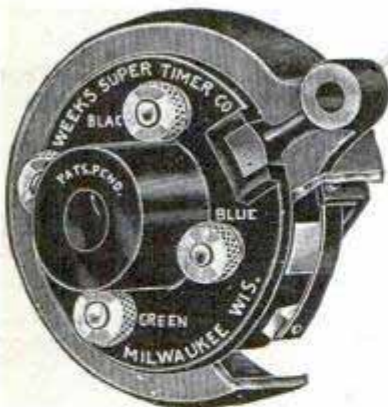

Beyond a question of a doubt the most needed article on a Ford today is a GOOD TIMER, one that would accomplish a real purpose and serve the owner—without continual care and attention, annoyance and trouble. The "SUPER" TIMER is the latest achievement of Mr. Weeks whose zealous interest is to make each and every Ford Owner the proud possessor of a better running Ford. Already the "SUPER" TIMER has met with instant approval. Ford Owners everywhere generously acknowledge it to be the BEST TIMER on the market. It is indeed a real TIMER for Fords.

### Fortunes Now Being Made

Every Ford Owner knows the value of a good reliable TIMER on a Ford. He has been accustomed to continual trouble—THE ORDINARY TYPE OF TIMER means nothing but trouble—THE PRINCIPLE OF CONSTRUCTION HAS BEEN WRONG—The SUPER is built on the DYNAMO TYPE—which in itself means uniformity, regularity and long life—When you consider the Big Fortunes now being made in the Ford Field you will realize the big opportunity this proposition offers you—an all-year-round seller—with tremendous profits.

### Be The First in Your Locality—

Its low cost makes it easy to sell and as our advertising campaign will bring in many requests for territory it is greatly to your advantage to act now—will send sample for trial.

### Weeks Super Timer Co.

426-703 Eleventh St.

MILWAUKEE, WISCONSIN

**MAIL TODAY**

WEEKS SUPER TIMER COMPANY  
426-703 Eleventh St., MILWAUKEE, WISC.

Gentlemen: Kindly mail me full free information about your wonderful invention.

Name .....

St. or R. F. D. ....

Town .....

County .....

State .....

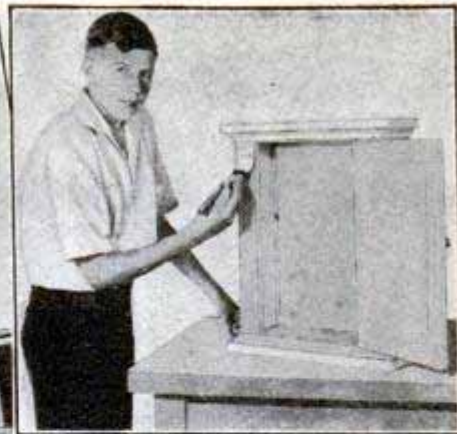
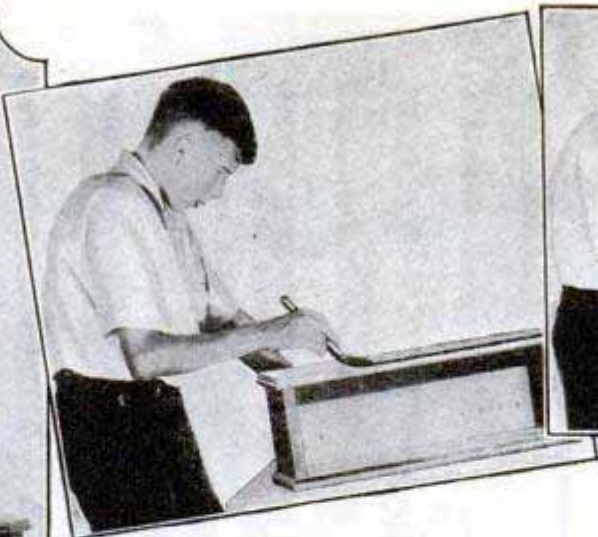

# The FINISH will Make or Mar Your Handicraft . . . .

*The Johnson Finishes  
are RIGHT and EASY*

**I**T'S the finish that counts, after all. No matter how skillfully you make home-made furniture, it takes the right kind of finishing to give that professional touch that makes you proud of your craftsmanship.

You will want the new Johnson Book on Wood Finishing. Gives complete instructions for finishing all kinds of woods—hard or soft—old or new. Tells how to stain wood artistically—everything you want to know about wood finishing. It's Free—just use the coupon below.



Stores displaying this sign carry a full line of Johnson's Artistic Wood Finishes. They will gladly give you a Free copy of the Johnson 25c Book on Wood Finishing.

## JOHNSON'S WOOD DYE

With Johnson's Wood Dye inexpensive soft woods such as pine, cypress, fir, birch, etc., can be finished so they are as beautiful and artistic as expensive hard woods. Comes in oil and spirit in 17 beautiful shades, among the most popular of which are:

- |                        |                       |
|------------------------|-----------------------|
| No. 131—Walnut         | No. 126—Light Oak     |
| No. 123—Dark Oak       | No. 124—Golden Oak    |
| No. 127—Brown Mahogany | No. 129—Dark Mahogany |

Johnson's Wood Dye is easy to apply. It goes on smoothly and will not rub off or smudge. Penetrates deeply, bringing out the beauty of the grain. Dries ready for the finish coat in four hours.

### FREE — this valuable book



Get this beautiful 25c Book on Wood Finishing absolutely FREE. Contains color charts, covering capacities, and hundreds of practical suggestions for the man who wants to make his home more artistic, cheery and inviting.

S. C. JOHNSON & SON, Dept. P. A. 3, Racine, Wis.  
"The Wood Finishing Authorities"  
(Canadian Factory—Brantford)

Please send me Free your 25c Instruction Book on Home Beautifying and Wood Finishing.

My Dealer Is.....

My Name.....

Address.....

City and State.....

# SAVE MONEY BUY PLUMBING & HEATING FROM Manufacturer Direct

You make two big savings when you buy from us. 1st: You save one-third to one-half because of our wholesale factory-to-user price. 2nd: You save the cost of unnecessary waste and high labor because of our cut-to-fit plan and easy installing features which enables you to put in your own plumbing or heating systems.

## "CHICAGO" Bathroom Outfit \$59.95

Special Price — Highest Grade

Fixtures furnished with our Chicago bathroom outfit are built along practical and attractive lines, are perfect and of the highest-grade that it is possible to MAKE. Shows that FIRST quality Hardin-Lavin products can be had at low costs.



HARDIN-LAVIN

### New Swinging Sink Faucet



\$4.65

New solid brass, heavily nickel-plated combination quick compression double sink faucet. White vitreous handles marked, "Hot" and "Cold." Snow white solid china elevated quick removable soap dish with drain. Easy to clean. This fixture is adjustable to fit any sink back. Also furnished without soap dish. D32½ — Price less soap dish. Shipping weight 7 pounds. . . . . \$4.65 D32¾ — Price complete as shown. Shipping weight 8 pounds. . . . . \$5.75

### Deep Apron Lavatory

Late design, white porcelain enameled, cast-iron drop apron lavatory, supported on concealed wall hangers; new low design, china indexed compression faucets, heavy brass nickel plated adjustable supply pipes and trap to floor or wall, size 17 x 19½ inches, weight 120 pounds.

Chicago D-11—Lavatory, Complete as shown with Iron-Pipe Connection. Special. . . . . \$12.75

### White Closet Outfit

Improved, snow-white, composition Chino closet tank, (beautiful and indestructible); fitted with solid brass elevated noiseless valves and improved china flushing handle. Highest-grade white vitreous china syphon washdown bowl. Highly polished, reinforced birch mahogany seat, with heavy brass, nickel-plated bar hinges, flushing ell, supply pipe, closet bolts, etc., weight 125 pounds.

Chicago D-12—White Closet Outfit, complete as shown, with iron pipe connections. Special. . . . . \$18.95

Chicago D-13—Bathroom Outfit, complete as shown and described. Special. . . . . \$59.95

All shipped out of our Chicago plant same day order is received. Order today and save. You cannot lose.

### White Enameled Bathtub

cast-iron, heavy white porcelain, enameled inside and over the 3¼ inch turned-over rolled rim; outside of tub is painted. This is our newest design, having a pleasing appearance and is the highest-grade leg tub manufactured. Fitted complete with heavy brass, nickel-plated compression bath faucet, with china indexed handles, nickel-plated heavy brass adjustable waste and overflow and supply pipes to floor; width 30½ inches, length 4½ or 5 feet, weight 300 pounds.

Chicago D-10—Bathtub complete as shown with iron-pipe connections. Special. . . . . \$31.10

## Everything in Plumbing and Heating at Wholesale Price

Send the coupon for our FREE bargain catalog which explains our new easy method of installing factory-fitted heating plants and plumbing systems. For fifty years we have been saving economy buyers hundreds of thousands of dollars in the cost of Bathroom Outfits, Hot Water, Steam and Warm Air Heating Plants, Pipeless Furnaces, Water Supply Systems, Water Heaters and Supplies. Everything you get from us is guaranteed to be highest quality, grade A merchandise with new exclusive features. We supply FREE INSTALLING PLANS and show you how with simple diagrams and clear instructions. All necessary tools loaned FREE.

### HOT WATER HEATING PLANT CUT-TO-FIT GUARANTEED

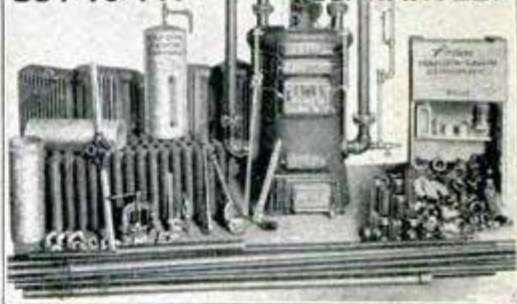

Complete Hot Water Plant ready for shipment with set of tools. Outfits complete as low as \$200

### 50 Years and Million Dollar Plants Behind Guarantee

Every Hardin-Lavin system is figured to eliminate long runs of piping, to save valuable time and unnecessary materials and expensive labor. Our many years experience with all kinds of conditions and types of construction means practical, money-saving service to builders, realtors, contractors, mechanics, institutions, home owners, etc. Write us about any plan or problem you have. We will help you without obligation—estimates free.

### Ask for Free Plan and Estimate

Send us a rough sketch or blue print of the arrangement of your rooms and we will figure the wholesale cost of your plumbing system or heating plant. We will show you many kinks and wrinkles and make savings that will surprise you. We furnish a Cut-to-Fit plumbing outfit or heating plant for the exact job with FREE Installing Plans so that any handy man can do the installing.

### Our BONDED GUARANTY and LABEL PROTECTS YOU

We guarantee that every water supply system, plumbing outfit, heating plant or any article that you buy from us, from the smallest fitting to a complete installation, is perfect and exactly as shown and of the HIGHEST GRADE possible. We further guarantee that if for any reason you are dissatisfied you can return any goods bought from us and we will immediately refund your money plus freight charges you have paid. Could Anything Be Fairer?

(Signed) HARDIN-LAVIN CO.

Send us Coupon today for your copy



FREE Bargain Catalog

Gives illustrations, complete descriptions, several wholesale prices on heating outfits of all kinds, water supply systems, complete bathroom outfits and plumber supplies, fittings, pipe, etc. All at wholesale.

Send for Your Copy TODAY

HARDIN-LAVIN CO., 107-17 W. Pershing Rd., Chicago, Ill.

Gentlemen: Please send me your FREE BARGAIN CATALOG with special wholesale prices. I am interested in:

Water Sply. System  Stm. Htg. Plant  Plumbing Fixtures  
 H. W. Htg. Plant  Pipeless Furnace  Bathroom Outfit

NAME .....

ADDRESS .....

P. O. .... STATE .....

When in Chicago you are invited to visit our New Plant



Est. 1876  
**Hardin-Lavin Co.**  
107-17 West Pershing Rd., Chicago, Illinois

# RIDE A RANGER

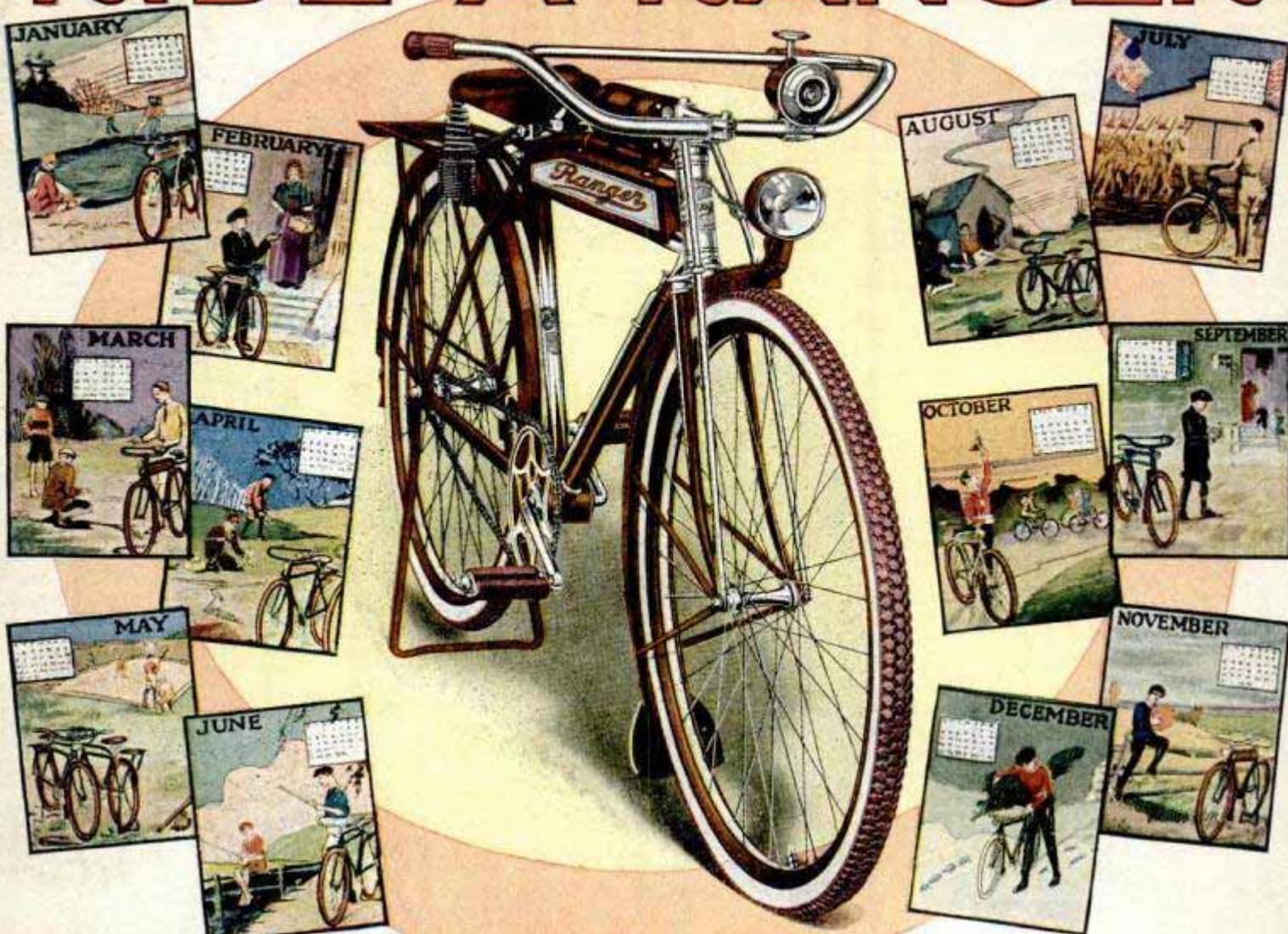

## ALL THE YEAR 'ROUND

### 30 Days' Free Trial

ment and exclusive features. If at the end of thirty days

### Factory-to-Rider

When you buy a Ranger you are dealing direct with the makers at Factory Prices. Your "Ranger" is waiting for you. The parks, country lanes and swimming holes are calling you out of doors to health and freedom. When we get your order your bicycle will leave on a fast express train (all charges prepaid) packed in a waterproof paper bag and enclosed in a strong wooden crate. Safe delivery in perfect condition guaranteed.

### Only \$5 a Month

If not convenient to pay cash for your "Ranger" bicycle, we will ship it to you at once and arrange with you to accept monthly payments which enables you to take advantage of our rock-bottom factory-to-rider cash price with only a slight amount added to cover the cost of extra bookkeeping on credit accounts. Parents frequently advance the initial small payment and energetic boys and girls save and earn the later monthly payments.

See for yourself the values found in Ranger bicycles with their complete equipment of accessories and extras. Send to-day for catalog and select the model you prefer. Ride it thirty days, test its speed, sturdy qualities, de luxe equipment you want to return it for any reason, send it back and you will not be out one cent.

There are 44 styles, colors and sizes in the famous line of **RANGER Bicycles** a model to suit every taste and any pocket book.

### 5-Year Guaranty

Every Mead "Ranger" is warranted for five years. This means we make good trouble arising from any defect in workmanship or material at no cost to you. Our guaranty is a written contract—we are directly responsible for the satisfaction and general performance of your bicycle because we made it.

Every Mead "Ranger" is war-

### Tires and Equipment

Our big free catalog illustrates and describes parts, equipment and sundries that our more than a million riders may need. All are carefully selected from the leading parts makers of the world, to Save You Money at our Factory Prices.



### Get this FREE Catalog

We have a copy all ready for you and it will be sent as soon as we receive the coupon in the lower corner of this page. If you prefer send a post-card—only write your name and address plainly. Turning the pages of the "Ranger" catalog is like walking down the aisles of the largest and greatest of bicycle stores seeing bargains, new ideas and conveniences that you never saw or heard of before.

RANGER Velocipedes and Two Wheel Sidewalk Bicycles are also in big demand. Ask for Factory Prices on the Ranger "Playcycle" line if interested. **Send No Money** Ask for the big catalog and full particulars of our Factory Prices, marvelous offers and Easy Payment terms.

# MEAD CYCLE COMPANY

DEPT. D-109 CHICAGO, U.S.A.

#### MEAD CYCLE COMPANY Dept. D-109, Chicago, U. S. A.

Send me the new Ranger Catalogue, factory-to-rider wholesale prices, 30-day Free Trial Offer and Easy Payment Terms.

Name.....  
R. F. D. or.....  
Street No.....  
Town..... State.....

#### FACTORY DISTRIBUTORS IN 407 CITIES

The nearest city (with a population of 25,000 or more) which I can conveniently visit to select a Mead Ranger is.....  
If you have a Special Factory Distributor there, send me letter of introduction to him so I can inspect the Rangers and take delivery from there at Factory prices or on Easy Payment Plan if I prefer.