

DECEMBER

THE ULLOA CIRCLE Page 899

N.S.  
25 CENTS

# POPULAR MECHANICS

## MAGAZINE

WRITTEN SO YOU CAN UNDERSTAND IT

REG. TRADE MARK, GREAT BRITAIN, No. 40428

REG. U.S. PAT. OFF.

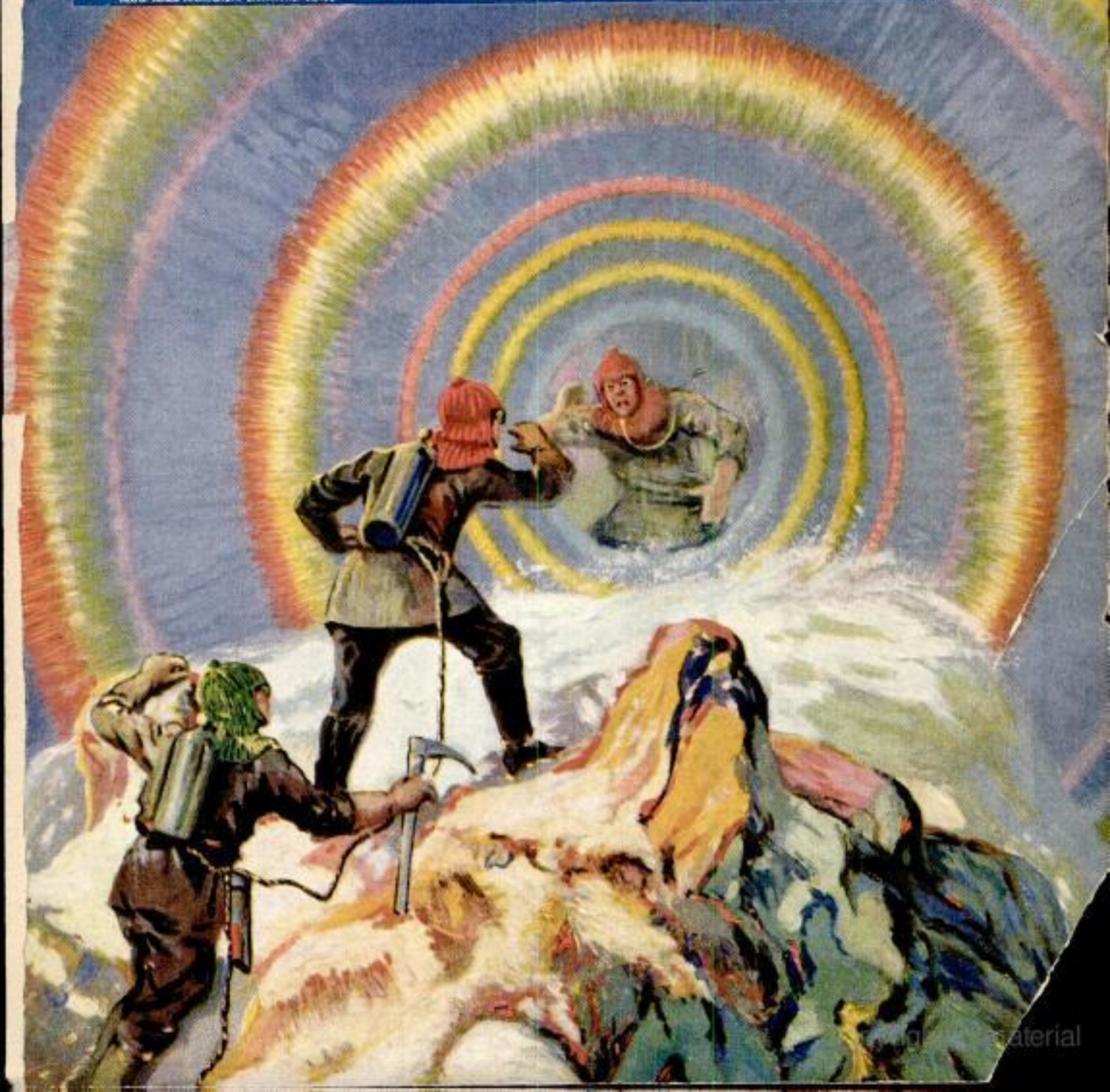

# It takes *only* 8 weeks to get a big job



George W. Smith runs a big Ford Agency and Repair Shop at West Alexandria, Ohio. He says, "I am clearing over \$800 per month."



C. E. Gillisple has charge of a fleet of trucks and tractors with the State Highway Commission, due to McSweeney training.



W. W. Peace gets \$250 a month and expenses operating a tractor in the oil fields.



D. M. Collins, Williamsville, West Virginia, writes, "Shortly after finishing McSweeney training, I started in as manager of a garage at \$300 per month."

*Read what these men are doing in the Auto, Tractor and Electrical Business. Here is your big chance to get "on easy street." Come to the great McSweeney Shops on the biggest Special Offer ever made.*

## Big Firms Need Trained Men

The Auto, Tractor and Electrical Business is on the boom. Thousands of trained men will be needed during the next few months. I get calls every day from Garages, Battery Stations, Auto Repair Shops and other successful concerns for McSweeney men. When the big fellows need high-grade men, they know where to come for them. They want McSweeney-trained men.

### My Training Unusual

Scientific tool training—that's the secret. You do things here according to the latest engineering standards. Thousands of dollars have been spent in modern tools and equipment. That's why my men are at home in the biggest shops in the country. If you want to succeed the way Smith and Collins and the rest have—qualify by the same method.

### I'll Pay Your Railroad Fare and Board You

In order to fill the openings that now exist, I am making an offer no one has ever made before—Free railroad fare, Free board. But even that is not all. I'll tell you about the rest in my letter.

### Send for **FREE** Book

My big illustrated training book tells how others are succeeding. It tells many things you ought to know about Autos and Tractors. Write for it and my short time offer NOW. It soon expires.

## McSweeney AUTO TRACTOR AND ELECTRICAL Shops

Dept. 145

**CINCINNATI**  
9th and Walnut

**CHICAGO**  
517 So. Laflin

**CLEVELAND**  
1815 E. 24 St.



McSweeney Auto, Tractor and Electrical Training Shops, Dept. 145 (Address shops nearest you) Cincinnati, O., or Chicago, Ill., or Cleveland, O.

Without any obligation send me your big free book on Autos. Also information regarding special temporary offer.

Name \_\_\_\_\_  
Street \_\_\_\_\_  
City \_\_\_\_\_ State \_\_\_\_\_

**3 Big Training Shops**  
Cincinnati Chicago Cleveland

## who tests your tubes?

WHO makes the vacuum tubes you use? is one important question. Who tests them? is another.

The same great research laboratories that developed the MAZDA lamp have developed the Radiotron. The five great factories that manufacture the MAZDA lamp, manufacture the Radiotron. And the same genius and the same scrupulous accuracy are behind the test methods developed for the RCA test laboratories.

You would not think of putting into your lighting socket today, anything but a MAZDA lamp. Why put into your radio socket, anything but an RCA Radiotron—backed by the same skill, the same engineering and manufacturing resources?

A Radiotron is far more difficult to make than an electric lamp. It demands accuracy to the hundredth of an inch. It demands ten million times rarer exhaustion of the air from the tube. And to guard against error in the turning out of hundreds of thousands of Radiotrons—to insure the high standards of uniform perfection that have made famous the names of RCA, General Electric and Westinghouse, the RCA laboratories have developed tests delicately exact. When you buy a vacuum tube—know who made and tested it. Look for the RCA mark and the name Radiotron on the base.

RADIO CORPORATION OF AMERICA  
CHICAGO NEW YORK SAN FRANCISCO



# RCA-Radiotron

MADE BY THE MAKERS OF RADIALAS

# Simplify and improve radio reception with Balkite Radio Power Units



U. S. Patent  
May 27,  
1924

## Balkite Battery Charger

This popular battery charger is entirely noiseless and can be used while the radio set is in operation. Charging rate 2.5 amperes. Operates from 110-120 AC 60 cycle current. Special model for 50 cycles. Also for 25-40 cycles with 1.5 ampere charging rate.

Price \$19.50  
West of Rockies, \$20  
In Canada, \$27.50



U. S. Patent  
May 27,  
1924

## Balkite Trickle Charger

Charges both 4 and 6 volt radio "A" batteries. Will furnish more current than is used for 6 dry cell or 2 storage battery tubes, if used only while the set is in operation. If allowed to "trickle" charge continuously will also furnish enough current for as many as 8 dry cell or storage battery tubes. Size 5 1/2 in. long, 2 1/2 in. wide, 5 in. high. Operates from 110-120 AC 60 cycle current. Special model for 50 cycles. Price \$10

West of Rockies, \$10.50  
In Canada, \$15

Balkite Radio Power Units simplify and improve radio reception. They reduce the amount of attention you must give your set. With their use your current supply is always exactly what is required for each circuit.

For the "A" circuit there are the Balkite Chargers. The popular Balkite Battery Charger can be used while the set is in operation. For sets of smaller "A" current requirements—there is the Balkite Trickle Charger. With a low capacity storage battery it enables owners of sets now using dry cells to make a most economical installation. For the "B" circuit there is Balkite "B." It eliminates "B" batteries entirely and supplies plate current from the light socket. Specially designed to serve sets of 6 tubes or less. For sets of 6 tubes or more there is Balkite "B" II.

## Noiseless—No bulbs—Permanent

All Balkite Radio Power Units are entirely noiseless in operation. They have no moving parts, no bulbs, and nothing to adjust, break or get out of order. Each is a permanent piece of equipment with nothing to wear out or replace. They require no other attention than the infrequent addition of water. They require no changes or additions to your set.

Manufactured by

FANSTEEL PRODUCTS COMPANY, Inc.  
North Chicago, Illinois

FANSTEEL  
**Balkite**  
Radio Power Units



U. S. Patent  
May 27,  
1924

## Balkite "B"

Eliminates "B" batteries. Supplies plate current from the light socket. Operates with either storage battery or dry cell tubes. Keeps "B" circuit always operating at maximum efficiency. Requires no attention other than adding water twice a year.

Will serve any set requiring not more than 20 milliamperes at 90 volts—practically all sets of 5 tubes or less, and most 6 tube sets. Occupies about same space as 45 volt dry "B" battery. Operates from 110-120 AC 60 cycle current. Special model for 50 cycles.

Price \$35  
In Canada, \$49.50



U. S. Patent  
May 27,  
1924

## Balkite "B" II

Same as the new Balkite "B" but will fit any set including those of 8 tubes or more. Operates from 110-120 AC 60 cycle current. Special model for 50 cycles.

Price \$55  
In Canada, \$75

The Gould Unipower is equipped with a special Balkite Radio Power Unit

BALKITE BATTERY CHARGER • BALKITE TRICKLE CHARGER • BALKITE "B" • BALKITE "B" II

ALL BALKITE RADIO POWER UNITS ARE TESTED AND LISTED AS STANDARD BY THE UNDERWRITERS LABORATORIES

# Popular Mechanics Magazine

200 E. Ontario Street, Chicago, U. S. A.

H. H. WINDSOR, Founder

H. H. WINDSOR, Jr., Editor and Publisher

London: Hachette & Co.,  
16-17 King William Street, Charing Cross, W. C. 2

Paris: Hachette & Co.,  
111 Rue Reaumur

Melbourne: Gordon & Gotch  
509-513 Little Collins St.

ISSUED MONTHLY

SUBSCRIPTION:

SINGLE COPY, 25 CENTS

In United States and its possessions, also Canada, Cuba, and Mexico, per year, postpaid . . . \$2.50

To all other countries in the Postal Union . . . . . 3.00

All subscriptions are discontinued at expiration. Please examine the date printed on your wrapper.

Entered as Second Class Matter Sept. 15, 1908, at the Post Office at Chicago, Illinois, under Act of March 3rd, 1879.

Entered as Second Class Matter at the Post Office Department, Canada.

Published monthly by POPULAR MECHANICS CO.

Copyright, 1925, by Popular Mechanics Co.

Copyright in Australia. Copyright in France

Vol. 44

Contents for December, 1925

No. 6

Advertising—real waterfall in painting . . . . .	928	Electric Bulbs—two-filament . . . . .	977
Airplanes		Electric Heater—fits kettle for frying doughnuts . . . . .	967
engine value drops \$10 an hour . . . . .	921	Ethnology—mound builders' mystery partially solved . . . . .	987
wings strong enough to walk on . . . . .	959	Excavators—ditch scraping plow cleans gutters . . . . .	886
Airlships—dirigible to blaze route over top of world . . . . .	927	Fires	
Armor—armored gunners to fight future sky battles . . . . .	960	fire-alarm training school . . . . .	906
Automobile Design—limousine taxicab protects driver from cold . . . . .	894	toll of, in U. S. . . . .	940
Automobile Parking—parking space in basement of bank . . . . .	889	First Aid—how to treat cut finger . . . . .	894
Automobile Touring—single-seater pygmy auto crosses continent . . . . .	944	Fish	
Automobiles—Equipment and Supplies		in tanks become seasick on long ocean trips . . . . .	978
auto towline with spring . . . . .	959	10,000 kinds in ocean . . . . .	928
balloon tire car steers with two wheels . . . . .	898	trained to eat out of hand . . . . .	922
Automobiles—Lighting		Fishing—reel for catching tuna fish . . . . .	960
rubber tail lamp for autos . . . . .	978	Flags—crocheted U. S. flag . . . . .	940
spotlight for auto . . . . .	940	Flowers—793 species of roses . . . . .	952
Automobiles—Repairing—auto elevator like seesaw . . . . .	970	Food—learning to feed the army and navy . . . . .	971
Automobiles—Wheels		Fountain—radio-controlled fountain . . . . .	985
collapsible rims for auto . . . . .	892	Fruits—gassing fruits and flowers to keep them fresh . . . . .	953
rubber disks on auto wheels . . . . .	914	Furnace—smoke detector for boilers operated by electricity . . . . .	952
Aviation		Garages—enter and exit signs phrased in motor terms . . . . .	945
air liner of the future . . . . .	890	Gases—liquid gas in steel bottles for filling auto tires, etc. . . . .	1000
battle cruiser converted into airplane carrier . . . . .	967	Gauges—focus auto lights without dark room . . . . .	961
photos of air eddies studied to improve airplane . . . . .	990	Geology—"world apart" yields giant bones . . . . .	941
plane modeled after sea to cross ocean . . . . .	976	Glass—bottles hold elephant in glass test . . . . .	886
rivers sought by airplane to fill dried-up lakes . . . . .	954	Grindstones—number of sizes and types of, reduced . . . . .	892
safety vane on plane wing . . . . .	912	Groover—electric, for weatherstrip jobs . . . . .	970
Awnings—crisscross canvas admit more light . . . . .	978	Guns (Ordnance)	
Bay of Fundy—tides to generate super-power . . . . .	959	army anti-aircraft gun . . . . .	986
Bells—church bell cast from coins . . . . .	939	big gun carved in stone honors war dead . . . . .	889
Boots and Shoes—high heels for men's shoes . . . . .	939	giant coast defense gun runs on railroad . . . . .	898
Borax—rare in early times . . . . .	893	Hangars—doors cost \$100 to open . . . . .	961
Bridges		Hay—time to cut to cure more easily . . . . .	969
motor bridge on round piers has little vibration . . . . .	884	Heaters—gas range and air furnace combined . . . . .	987
span rolled in place in four minutes . . . . .	968	Holland—Dutch draining Zuyder Zee . . . . .	944
Bullet-Proof—metal to foil bandits . . . . .	932	Home Builder—Questions and Answers . . . . .	1053
Butterflies—identified by odor . . . . .	985	Horses—round snowshoes for horses . . . . .	990
California—necklace of lights for lake . . . . .	912	House Moving—nothing built too big to move . . . . .	979
Candles and Candlesticks—birthday of candle observed in Paris . . . . .	883	Household Devices	
Caps—fiber helmet under cap for jockeys . . . . .	898	Houses—inglenook and gray shingles . . . . .	1055
Carpets—woven of paper yarn . . . . .	925	Hunting—lightweight duck decoys . . . . .	889
Casks—cottages made from . . . . .	939	Insects—dealers in . . . . .	970
Cathedrals—underground pumps to save cathedral . . . . .	897	Jews—gentile fire tenders hired for Jewish holidays . . . . .	990
Cement—gun fired into cement kiln to prevent clogging . . . . .	977	Kerosene—better light and no soot from kerosene lamp . . . . .	999
Cheese—Wisconsin's first cheese factory . . . . .	921	Language—names of garments traced to many languages . . . . .	992
Chromium—coating resists tarnish . . . . .	986	Life-Saving Apparatus—inhaler against smoke suffocation . . . . .	914
Cigarets—whole pack of cigarettes held in case . . . . .	893	Locks and Keys—guard fits inside keyhole to prevent picking locks . . . . .	906
Clock—clock turns receiver on and off for regular broadcasts . . . . .	1014	Locomotives	
Dead Sea, Palestine—British plan to recover chemicals of . . . . .	898	electricity beats steam in race . . . . .	913
Diatoms—turning fossil graveyard into wealth . . . . .	991	power to stop a train twice as much as to start . . . . .	914
Divers—how divers gambled lives to save "sub" crew . . . . .	881	single engine hauls train three thousand miles . . . . .	887
Dogs—training sleuth hounds and war dogs . . . . .	915	London—British parliament houses turn into epsom salts . . . . .	906
Drawing—reflector makes drawing easy . . . . .	896	Lubrication—high pressure auto greaser operates with one hand . . . . .	985
Ear—exploring mysteries of ear . . . . .	955	Masks—for dusty jobs . . . . .	925
Earth—weigh floating earth crust from a submarine . . . . .	945	McCarthy, Daniel—statue of . . . . .	896
Eclipse—expedition to watch one goes to Sumatra . . . . .	892	Meat—thaw frozen meat by electricity . . . . .	886
Eggs—exported from United States . . . . .	999	Mice—tinier than bees . . . . .	985
Electric Bulbs		Miter—for cutting rafters . . . . .	946
light bulb used to cook and bake food . . . . .	954		
manufacturers seek standard sizes in electric bulbs . . . . .	945		

Cable Transatlantic 947 [Continued on Page 4]

This One



PB9T-5TL-QUHL

*Painting with real waterfalls*

*Sketch-erapaper 952  
Clearer subject - 886*

*Smoke Detector 952*

Models	
motor fits on ring	883
tiny model of motorcycle with moving parts	889
toys as models aid industry	993
Monuments	
battleship bow forms memorial of battle of Zeebrugge	925
Tokyo to build memorial to earthquake dead	928
Motor Trucks—six-wheel all-metal truck	897
Mount Logan—conquering it	899
Moving Picture Stage Mechanism—corn flakes serve as snow in movies	914
Mowers—electric-motor lawn mower	990
Nail—for brick has spiral rib	921
Navigation—air-operated ship sounder	892
Niagara Falls—tunnel at, to supplant stairway	913
Ocean—exploring the bottom of the sea	962
Ornament and Decoration—flower baskets on lamp-posts	912
Paper Money—better than worn gold	1000
Pencil—carries five leads of different colors	905
Permalloy—four millions on permalloy—to win	947
Pests—poison gas routs black ants from nests	968
Phonograph—radio tubes in phonograph produce better tones	894
Photography—camera traps auto speeders	954
Pigeons—ten thousand race over hundred miles	905
Polish—prohibition changes method of polishing jewelry	999
Postal Service—post offices in city hats	960
Potatoes	
potato digger	1000
power from	884
Poultry	
apartment house	969
hens scared by airplanes refuse to lay	946
Pumps—proof against freezing	968
Radio Aerial—simple method of building large aerial	1004
Radio Apparatus	
battery cable eliminates binding posts	1013
improvements in fixed condensers	1008
logging plate behind dial makes tuning easy	1004
radio engraving machine works from light socket	1009
socket equipped with ball grip for tube prongs	1014
Radio Application—radio lighthouse with revolving aerial warns ships	884
Radio Battery	
ammonia water first-aid application for spilled battery acid	1009
its care and selection	1013
keep out of sunlight and in cool place	1014
Radio Construction	
by-pass condenser for noisy B-batteries	1009
good rheostats necessary for best reception	1014
increasing volume on high wavelengths	1009
markers prevent mixing radio wires	1008
rubber band makes good phone connector	1008
well-designed radio cabinet	1001
Radio Questions and Answers	1056
Radio Receivers—alternating current tube receiver	1005
Railroads—water-driven railway car	949
Riding—rope support for horseman	925
Roads—building a "ladder to the sky"	923
Safety Devices and Measures—goggles for onion peeling	944
Salt—brine from ice cream tanks damages street paving	922
San Francisco, Calif.—sewered arch at San Francisco	921
Sewing Machines—rank first as farm convenience	912
Ships	
carries half of self through canal	914
"phantom ship" memorial to whaling industry	887
Snails—live, stored for winter use	896
Soap—ingredients of early soap	920
Sound—recorded for future on disks of brass	926
Spark Plugs—flash reflecting shows missing cylinders	976
Steel—persons employed in and production of industry	969
Street Lighting—Chinatown lamps pagoda shaped	976
Street Traffic Regulations	
guide lines direct traffic	893
street names fastened to curb	883
Strops—safety razor blade stropper rolls in hand	961
Submarines—"XI" of British navy	945
Tables—extension table for kitchen has no leaves	960
Toboggans—foot toboggans for winter sport	946
Turtle—derby at wild west show	966
Vanity Cases—for men	952
Vegetables—garden truck grown faster under artificial light	893
Warfare—night air raid	907
Washer—has gearlike teeth	913
Waterproof—Texas "rubber" waterproofs clothing	883
Waterways—canal dug under mountain	928
Wells—four-bladed oil well bit	929
Winter Sports—bring thrills	929

Wood—old logs show endurance of	940
Wood Carving—totem pole carver	959
Wrenches—loose wrench tightens with close setting	986
Zoological Gardens—manger for monkeys preserves food	884

## AMATEUR MECHANICS

Automobiles—Fuel—mixture for starting auto in summer	1019
Automobiles—Repairing	
gasket for old-style muffler head	1028
re-covering auto floorboards	1018
winter car ailments avoided	1030
Beds—comfortable outdoor sleeping tent	1015
Bridges—concrete makes artistic bridge	1034
Brushes—homemade wire brush cleans stovepipe	1019
Diseases—place adhesive plaster over cracked finger tip	1034
Electric Battery—two cell lamp substituted for three cell if too weak	1029
Fence Posts—use for broken steel	1035
Flagpole—replacing rope on	1018
Galoshes—repairing	1018
Garbage—baby proof trash holder	1036
Grindstone—auto driven	1036
Ice	
farm ice house	1020
moving an auto on ice	1028
removing icicles from flat roof	1029
Kitchen Utensils—from ice box shelves	1035
Kites—flying a drinking cup kite	1035
Meerschaaum—cement	1015
Neckties—rack easily made for	1028
Nuts—hulling black walnuts	1017
Paints	
determining whiteness of lead paint	1034
newly mixed allowed to stand before using	1020
Pipes—bending pipe with fire	1020
Pants—first aid to frozen	1029
Plaster—repairing cracks in plaster walls	1027
Pumps	
force pump raises city water	1034
making old pump sanitary	1029
Saws and Sawing Rigs—sawing trees single handed	1019
Statuettes—snapshot statuettes for Christmas gifts	1021
Tires—inner tube runs toy engine	1028
Traps and Trapping—burrow trap for farm	1036
Typewriters—correcting typed papers	1029
Watering Trough—cheap	1017
Wax—sealing wax from dry cells used to repair doll	1019

## SHOP NOTES

Automobile	
flat sheets of iron inside of hood keep engine warm	1042
using old touring car for delivery	1039
Automobiles—Repairing	
freeing frozen bearings	1042
installing oval gasoline tank on old model Ford	1034
piston knock detector	1040
Bearings—money saved by ball bearings	1049
Built-In Furniture for the Home—Part XIII—Indirect lighting fixtures	1050
Butchers' Supplies—motor drives butchers' slicing machine	1049
Cement—to remove enameled letters on glass	1041
Conveyors—belt for, from motion picture film	1039
Electric Current—alternating and direct current tester	1048
Electric Switch—high switch reached by swing step	1041
Elevators—increasing safety of freight elevators	1054
Files—how to use them	1043
Holes—boring straight holes with lathe	1040
Locomotives—filling locomotive tanks	1041
Mortar—keeping it warm	1040
Pumps—high head pumps drain cofferdams	1049
Rubber—taking care of belts	1054
Saws and Sawing Rigs	
swinging saw cuts ice	1039
using log saw properly	1047
Sewage Plant—measuring sewage flow	1041
Solder and Soldering—soldering large sheet metal tanks	1042
Stains—a cheap mahogany stain	1048
Stile—auto stile over farmer's fence	1054
Swine—ringing large hogs	1042
Template—hinge on rubber cutting template	1053
Welding—compound for blacksmiths	1040
Windmill—novel tower	1048
Wire—one man barbed wire winder	1037
Workbench—temporary woodworking bench in machine shop	1048

# DRAKE'S PRACTICAL MECHANICAL BOOKS

## THEY WILL RAISE YOUR PAY—

### ORDER ON 5-DAY TRIAL

The books listed below will perfect you in your chosen trade—pave the way to the big positions. Written in non-technical language—easy to read and understand. *Every book covers its subject completely. An entire course of instruction condensed into one volume.* Your choice sent postpaid—you benefit 5 days—money refunded in full if not entirely satisfactory. Order direct from this page.

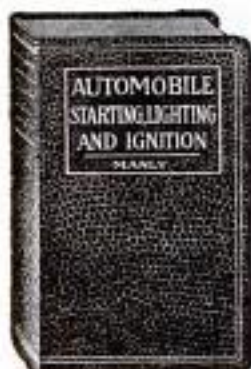

#### Automobile Books

Automobile Starting, Lighting and Ignition, by Manly... 700 pp. \$3.00  
Brookes' Automobile Handbook. \$2.00  
Ford Motor Car, Truck and Tractor, by Manly... Cloth \$1.50  
Automobile Battery, Care and Repair, by Manly... Leatherette \$2.00  
Motorcycle Handbook, by Manly \$1.50

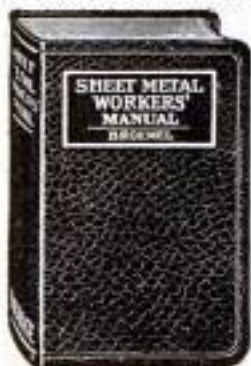

#### Shop Practice Books

Sheet Metal Workers' Manual... \$2.00  
Oxy-Acetylene Welding and Cutting... Cloth \$1.25  
Slide Rule and Logarithmic Tables. \$2.00  
Handbook for Millwrights... Cloth \$2.00  
Machine Shop Practice... Cloth \$2.00  
Mechanical Drawing and Machine Design... Cloth \$2.00

#### ORDER DIRECT FROM THIS PAGE—ON OUR MONEY-BACK PLAN

The books listed above are only a few of the many in our catalogue, which you will receive promptly after filling out and mailing us the attached coupon. For quick action order direct from this page—cross name of each book wanted and send in with price quoted. We prepay postage and send books on our money-back plan.

#### FREDERICK J. DRAKE & CO. PUBLISHERS

1008 Michigan Ave., Chicago  
Drake Books Are For Sale at All Book Stores

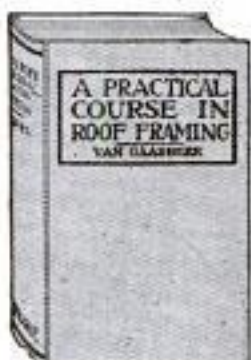

#### Carpentry Books

Cloth Binding  
Modern Carpentry, 2 vols. \$3.00  
The Steel Square, 2 vols. \$3.00  
Modern Estimator... \$1.50  
Timber Framing... \$2.00  
Builder's Architectural Drawing... \$2.00  
Concretes... \$1.50  
Practical Bungalows... \$1.00  
Roof Framing, by Van Gasbeek... \$1.50

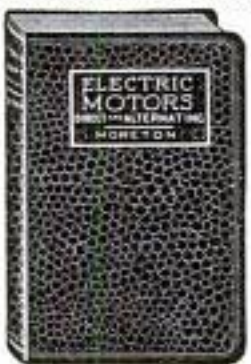

#### Electrical Books

Telephony, Including Automatic Switching, by Smith, 450 pp. Leatherette \$2.50  
Practical Applied Electricity... \$2.00  
Wiring Diagrams and Descriptions. \$1.50  
Armature and Magnet Winding... \$1.50  
Electric Motors, D. & A. \$1.50



#### Painting and Decorating

Ross Crane Book of Home Furnishing and Decoration... Cloth \$3.00  
House Painting Methods with the Brush and Spray Gun, by Vanderwalker. Cloth... \$2.00  
Interior Wall Decoration, by Vanderwalker... Leatherette \$4.00  
The Mixing of Colors and Paints, by Vanderwalker... Cloth \$2.00  
A Show at Sho' Cards... Cloth \$4.00  
Sign Painting, by Atkinson... Cloth \$4.00  
Strong's Book of Designs, Leatherette \$4.00  
Modern Painter's Cyclopedia. Cloth \$2.00  
Automobile Painting... Cloth \$1.50  
New Hardwood Finishing... Cloth \$1.50

#### Steam Engineering

Swingle's Handbook for Steam Engineers and Electricians. Leatherette... \$4.00  
Examination Questions and Answers for Marine and Stationary Engineers. Leatherette... \$2.00  
Steam Boilers... Leatherette \$2.00  
Swingle's Catechism of Steam, Gas and Electrical Engineering. Leatherette \$1.50

#### Modern Languages

By Prof. P. S. Allen, U. of Chicago  
French without a Teacher... Cloth \$1.25  
Spanish without a Teacher... Cloth \$1.25  
German without a Teacher... Cloth \$1.25  
Everyday French... \$1.25  
Everyday Spanish... \$1.25

FREDERICK J. DRAKE & CO.  
1008 Michigan Avenue  
Chicago, Ill.

GENTLEMEN:—Please send me free, postage paid, your illustrated catalogue which lists and describes 200 Practical Mechanical Books for Home Study.

My name is .....

and my address .....

Mail Coupon For Free Catalogue  
Your Guide to Home Study

# Multiplies His Earnings by the Salary-Doubling Plan!

A. W. Weber was working in a grocery store when he took up home-study business training. Eighteen months later, he had earned for himself the position of Assistant Auditor of the Ohio Savings Bank and Trust Company, Toledo, at a salary-increase of 150 per cent.

More recently, he has been made Assistant Secretary and Assistant Trust Officer of the bank in which he started as a clerk. His salary-increases now exceed 200%.



## LaSalle Made Possible the Opportunity

"My attention has been directed to our Mr. Weber, who is now in his second course of study with your institution. This is most interesting to us, as Mr. Weber's progress has been quite exceptional, he having advanced from a clerkship to Assistant Secretary and Assistant Trust Officer in our bank in the short period of five years.

"This attainment is most gratifying to us, and we are frank in giving expression to our belief that much credit is due to your splendid institution, through which medium opportunity was afforded in making it possible for him to accomplish the purpose.

"It has ever been our policy to be helpful and to encourage those of our employees in acquiring information and knowledge looking to their own betterment, and we are most anxious and willing to recognize and cooperate with those employees whose desires and ambitions are directed to greater achievements and further advancements." (Signed)

EDWARD KIRSCHNER,  
Vice-Pres. Ohio Savings Bank  
and Trust Company.

## LaSalle Training Changes Opportunities Into Dividends

"Without the knowledge obtained from your course, I would not be able to fill the position I hold today. Monthly dividends are being paid me on my investment in LaSalle training, in the form of increased salary, at a rate in excess of 125 per cent." (Signed)

ARTHUR W. WEBER,  
Asst. Sec'y Ohio Savings Bank  
and Trust Company.



Ohio Savings Bank and Trust Co., Toledo  
—one of the largest and best banks in Ohio

## —How Home-Study Training Nets A. W. Weber 125% a Month!

The prospect of working in a grocery store all his life did not satisfy A. W. Weber, a Toledo man. He resolved to make a *new start*—and to speed his progress he undertook LaSalle training in Higher Accountancy. He secured a job first as time-keeper in an automobile plant—then as clerk in the Ohio Savings Bank and Trust Co. Within 18 months his training had helped him to the position of Assistant Auditor.

Since that time, repeated promotions have advanced him to the position of Assistant Secretary and Assistant Trust Officer, and he writes that his *monthly dividends on his investment are at a rate in excess of 125%*. Read his letter, and the letter of his employer, in the column at the left.

Mr. Weber is now adding to his momentum by means of a second LaSalle course—home-study training in Law.

### Will You be Selected for Promotion?

You have often wondered whether or not it would pay you to take up specialized business training with LaSalle.

But—can there be any question about its paying when so many thousands of LaSalle members are advancing—thru its aid—to positions of responsibility and influence?

In the very bank of which Mr. Weber is an officer, thirty-eight other men and women have enrolled with LaSalle; in the Guaranty Trust Company, New York, LaSalle members number ninety-eight; in the Royal Bank of Canada, two hundred and seventy-nine.

During only six months' time, as many as 1,248 LaSalle members reported definite salary-increases totalling \$1,399,507, an average increase per man of 89 per cent.

### Send for Free Outline of LaSalle Salary-Doubling Plan

What would it be worth to you to increase your earnings 89 per cent—within a comparatively few months?

The LaSalle *salary-doubling plan* will show you how to do so. Simply fill out and mail the coupon—and a 64-page book describing this salary-doubling plan will be sent you FREE. Whether you adopt the plan or not, the basic information it will place in your hands is of very real and definite value.

Balance the two minutes that it takes to fill out the coupon against the rewards of a successful career—then clip and mail the coupon—*now*.

# LASALLE EXTENSION UNIVERSITY

The World's Largest Business Training Institution

CLIP AND MAIL

LASALLE EXTENSION UNIVERSITY

Dept. 1264-R

Chicago

I shall be glad to have details of your salary-doubling plan, together with complete information regarding the opportunities in the business field I have checked below. Also a copy of "Ten Years' Promotion in One," all without obligation.

- |   |   |  |  |
|---|---|--|--|
| <input type="checkbox"/> Business Management: Training for Official, Managerial, Sales and Departmental Executive positions.  | <input type="checkbox"/> Law: Training for Bar; LL.B. Degree.   | <input type="checkbox"/> Industrial Management; Factory Management; Training for positions in Works Management, Production Control, Industrial Engineering, etc.   | <input type="checkbox"/> Modern Business Correspondence and Practice: Training for position as Sales or Collection Correspondent, Sales Promotion Manager, Mail Sales Manager, Secretary, etc. |
| <input type="checkbox"/> Modern Salesmanship: Training for position as Sales Executive, Salesman, Sales Coach or Trainer, Sales Promotion Manager, Manufacturer's Agent, Solicitor, and all positions in retail, wholesale, or specialty selling. | <input type="checkbox"/> Commercial Law: Reading, Reference and Consultation Service for Business Men.  | <input type="checkbox"/> Modern Foremanship and Production Methods: Training for positions in Shop Management, such as that of Superintendent, General Foreman, Foreman, Sub-Foreman, etc.                 | <input type="checkbox"/> Business English: Training for Business Correspondents and Copy Writers.  |
| <input type="checkbox"/> Higher Accountancy: Training for position as Auditor, Comptroller, Certified Public Accountant, Cost Accountant, etc.  | <input type="checkbox"/> Traffic Management—Foreign and Domestic: Training for position as Railroad or Industrial Traffic Manager, Rate Expert, Freight Solicitor, etc. | <input type="checkbox"/> Personnel and Employment Management: Training in the position of Personnel Manager, Industrial Relations Manager, Employment Manager, and positions relating to Employee Service. | <input type="checkbox"/> Commercial Spanish: Training for position as Foreign Correspondent with Spanish-speaking countries.   |
| <input type="checkbox"/> Expert Bookkeeping: Training for position as Head Bookkeeper.  | <input type="checkbox"/> Railway Station Management: Training for position of Station Accountant, Cashier and Agent, Division Agent, etc.                               |  | <input type="checkbox"/> Effective Speaking: Training in the art of forceful, effective speech, for Ministers, Salesmen, Fraternal Leaders, Politicians, Clubmen, etc.                         |
| <input type="checkbox"/> C.P.A. Coaching for Advanced Accountants.  | <input type="checkbox"/> Banking and Finance: Training for executive positions in Banks and Financial Institutions.   |  |  |



NAME..... PRESENT POSITION..... ADDRESS.....



# BUILDERS

## TRADE GUIDES



4  
Vols.  
\$6

### AUDELS CARPENTERS AND BUILDERS GUIDES—4 VOLS. \$6

Inside Information for Carpenters, Builders, Joiners, Building Mechanics—all Woodworkers. **1600 pages; 3700 diagrams; flexible; pocket size.** Short-cut instructions, new methods, ideas, solutions, plans, systems—money saving suggestions. An easy progressive course for the apprentice. A practical daily helper and Quick Reference for the master worker. A Helping Hand to Easier and Better Work and Better Pay. To get this aid for yourself, simply fill in and mail the FREE COUPON below.

#### INSIDE TRADE INFORMATION ON:

How to use steel square; How to file and set saws; How to build furniture; How to use mitre box; How to use chalk line; How to use rules; How to make joints; Carpenters' arithmetic; Mensuration problems; Estimat-

ing strength of timbers; How to set girders and sills; How to frame houses and roofs; How to estimate costs; How to build houses, barns, garages, bungalows, etc.; How to read and draw plans; Drawing up specifications; How

to excavate; How to use settings 12, 13 and 17 on the steel square; How to build hoists and scaffolds—skylights; How to build stairs; How to put on interior trim; How to hang doors; How to lath—lay floors; How to paint.

"Audels Guides worth four times their price—handy too as I carry them in pocket for reference." W. J. Bates, Knoxville, Pa.



4  
Vols.  
\$6

### AUDELS PLUMBERS AND STEAMFITTERS GUIDES—4 VOLS. \$6

A new set—just out! A practical, illustrated, Reference Library and Study-Course for Master Plumbers, Journeymen and Apprentice Steamfitters, Gas Fitters and Helpers, Sheet Metal Workers, Draughtsmen, Master Builders, Engineers and all Building Trade Students. **1670 pages; 3642 diagrams; flexible; pocket size.** Guides explain all the principles, advances and short cuts of the Plumbing and Heating trade. Contains instructions on how to figure and estimate jobs. Use FREE COUPON below to examine, without obligation, this valuable work.

#### INSIDE TRADE INFORMATION ON:

Soldering, tinning, joint wiping, bending, beating. Pipe—iron—steel, threading. Mathematics, tables, physics. Materials—iron, steel, copper, brass, lead, tin, antimony. Sheet metal—galvanized—plate. Sanita-

tion, syphonage, tanks. Drainage, sewage, purification. Fixtures—bath—kitchen. Pipe fittings, soil pipe, tools. Laying out work. Roughing. Screwed fittings, hanges, joints. Pipe bending, examples. Elbows. Heating, ven-

tilation, refrigeration. Water supply, mains, wells, tanks. Gas-fittings. Underwriters. Sheet metal work, problems, methods, brazing, heating, lead burning. Welding, various welds, methods. Blacksmithing, forges, tools.

"Audels Guides are practical, easy to understand, reliable. Cover the field in plain language." W. F. Armiger, Annapolis, Md.



4  
Vols.  
\$6

### AUDELS MASONS AND BUILDERS GUIDES—4 VOLS. \$6

A new, complete, illustrated trade reference library, for Bricklayers, Cement Workers, Plasterers, Tile Setters and Stone Masons, including a practical outline of Steel Construction. **1100 pages; 2967 diagrams; flexible; pocket size.** A practical Trade Assistant explaining modern methods of masonry construction. Easy to understand and apply. A reliable and authentic reference work and study-course for Master Journeyman and Young Mechanic. Use FREE COUPON below and find out for yourself, without obligation, whether this set will benefit you.

#### INSIDE TRADE INFORMATION ON:

Bricklaying, tools, materials; Brick designs, patterns, bonds; Setting frames and foundations; Mortars, scaffolds, estimating; Mortars and mortar mixing; Tile setting, mosaic, hollow tile; Straight edge test, trow-

eling; How to figure brick work; Safe loads, piers, chimneys; Bolter settings, anchors, fire stops; Labor tables; Concrete, forms; How to figure concrete work; Stucco—on old and new buildings; Plastering—wood lath—metal;

Plasterers agreement; Plastering on various surfaces; Stonemasonry; Cutting, finishing, estimating stone; Derricks, rigging; Steel construction; Fire proof; How to read blue prints.

"Audels Masons Guides are the best books on the subject. Have laid brick 12 years and am able to judge." H. A. Bennett, Corlies, Pa.



### PRACTICAL ELECTRICITY — 1 VOL. \$4

Audels Handy Book of Practical Electricity is a simplified Ready Reference and Study Course in one pocket size, leather bound volume—for Engineers, Professional Electricians and Students. **1040 pages; 2600 diagrams; flexible red leather bound.** A reliable authority and handy helper for every electrical worker. Contains important and valuable wiring diagrams, calculations, machine sketches, helps on maintenance and repair. Use this FREE COUPON today and find out, without obligation, how this handy book will help you in your daily work.

Complete in one handy, red leather bound volume



1040  
Pages  
2600  
Diagrams

#### INSIDE TRADE INFORMATION ON:

Electro-Therapeutics, X-Rays, Socks, Welding, Brazing, Radio Hook-ups, Motion Pictures, Telephone, Telegraph, Cranes, Bells, Elevators, Pumps, Tools, Ship Drive, Railways, Vehicles, Automobile Electric Systems, Ignition, Generation, Lighting, Plant Management, Power

Plans, Armature Winding, Repairing, A. C. Motors and Apparatus, D. C. Motors and Apparatus, Alternator Construction, Dynamos, Wiring Diagrams, Sign Flashers, Cable Splicing, Power Wiring, Outside Wiring, Switches, Lighting, Rectifiers, Converters, Transformers, Fuses, Circuit Breakers, Rheostats, Electro Plating, Electrolysis, Storage Batteries, Magnetism, Electrical Energy, Conductors, Insulators, Static, Dynamic, Radio Electricity, Applications, Ready Reference and Index Covering the entire field of Modern Electricity.

### Learn More and You Will Earn More!

Know your job and you'll never be without one. The skilled man is always in demand. Knowledge is power. Learn your trade thoroughly by easy reading. This coupon is your opportunity for advancement and better pay. You risk nothing in sending for Audels Guides for free examination. Send it NOW!

FREE  
EXAMINATION  
COUPON

THEO. AUDEL & CO.,

65 W. 23 ST., NEW YORK CITY

Please mail me for free examination the books marked (x) below. If I find them satisfactory, I agree to mail \$1 in 7 days, on each set ordered, and to further mail \$1 monthly on each set until I have paid the purchase price.

4 CARPENTERS GUIDES \$6  4 PLUMBERS GUIDES \$6

4 MASONS GUIDES \$6  1 ELECTRICIANS HANDY BOOK \$4

NAME .....

ADDRESS .....

OCCUPATION .....

EMPLOYED BY..... 12 T 30

**D**ON'T be a low-pay man. Don't be a Job-Hunter. Change quick from Empty Pockets to STUFFED POCKETS. YOU TOO, have a right to enjoy BIG MONEY—and you don't have to wait. I'll show you a QUICK way—so quick that it is positively amazing—just a few happy, easy weeks. My Auto Book tells this romantic story of QUICK RESULTS. It's FREE to you. Send for it NOW—That Coupon brings it.

**B. W. COOKE**

Directing Engineer  
CHICAGO



I WILL  
TRAIN YOU  
AT HOME

Get  
RESULTS  
Quick  
The B.W.  
"COOKE-  
WAY!"

Be an **AUTO  
EXPERT**

Earn up to \$150 a week

You want RAISES IN PAY—Well then, take the QUICKEST way to them. QUICK RAISES are what you want. Clip Coupon—Get my free Book. Student after student reports \$100 a month extra, some even over \$200 a month EXTRA, spare time money, long before graduation—right in the early weeks of this famous "JOB-WAY" Auto Training. Did you ever hear of training that can show such quick and big results? Right at your home, I train you for a fine Big-Pay Auto Business of Your Own or the splendid Auto Experts' positions paying up to \$150 a week.

Get into the **AUTO BUSINESS**

The World's Biggest Business

Think of it—18,000,000 cars on the roads today—5 Thousand Million Dollars spent every year for upkeep alone! Wonderful opportunities to make Big Money and Quick Money in this gigantic Auto Industry. Get B. W. Cooke "Job-Way" Training. Be your own boss—go into business where up to \$10,000 or \$15,000 a year can easily be made! Remember with Cooke "Job-Way" training you don't have to wait. Hundreds of my students start right in collecting and spending Big Extra Money in the very first few weeks of their training! Read what John F. Plow did.

**\$30 a Week More Pay**

—Right in the First Few Weeks of My Training! 22 year old John F. Plow, Box 370, Ironwood, Mich.,—still in the earliest part of his training—writes that he has averaged \$30 a week EXTRA MONEY over his regular pay. But Mr. Plow is only one of hundreds. Think of it—how would you like a fine quick \$30 a week raise! That's the kind of opportunity Cooke "Job-Way" offers you! Mr. Plow says: "I can't get away without thanking you for it. Your course is O.K. in a million and I'll back up my statement with anybody."

See the  
Amazing  
**PROOF**  
on Page  
45

**\$300 in a Week! Big Pay Jobs Open**

Speaking of Pay Raises—look at this! Joseph Woronecki, 186 Adlek St., Hartford, Conn., was making only \$21 a week when he wrote me. Less than half-way through my training he wrote that he made \$300 in a single week in his own garage! That's an example of how quick my training gets amazing results. Find out what it can do for you. Get my Free Book today!

More trained Auto Men needed today than ever before! See how I back you up with the entire Resources of this Institution—how I give you Consultation Service—Employment Service for your whole life! Not a penny extra charge. See how the demand for B. W. Cooke "Job-Way" Auto men grows Bigger and Bigger every year. Send for my Free Auto Book quick!

**Get the PROOF!**

If you want a quick boost in Pay—if you want to make up to \$150 a week—send for my Free Auto Book right now! You don't need previous Auto Experience to MASTER Automotive Work the B. W. Cooke "JOB-WAY" Course! Common schooling all you need. I'll show you how so many men between the ages of 16 and 60—from all walks in life—become Garage Owners, Managers, Auto Technicians, Foremen, Auto Experts—in the class with BIG PAY EXECUTIVES. Get ALL the Facts! Clip Coupon Now!

LEARN **AT HOME** THE COOKE "JOB-WAY"

Keep your JOB! STAY HOME! Earn all your present job pays you, PLUS the big extra money which comes to so many of my students so quickly. Get started this quick way to Big Pay as an Auto Expert through Cooke "JOB-WAY"—RIGHT IN YOUR OWN HOME. Being a practical Directing Engineer, Owner, and Head of this Institution I know what practical, money-making training you need to be a Big Pay Man—I know what training you need to bring you QUICK BIG MONEY—and that training I give you!

**The Only "JOB-WAY" Training on Earth**

My training includes all Electrical Work—Ignition, Starting, Lighting—All Mechanical End-Welding, Brazing, Valves—also Business Course, Salesmanship, Advertising, Buying, How to Keep Simple Books—also Automobile Magazine, also 4 Outfits. Nowhere else I know of can you get ALL this training. Find out how B. W. Cooke "Job-Way" fits you for Big Pay and Quick Raises. Learn what it has done for others. See what it can do for you. MAIL COUPON RIGHT NOW!

**4 BIG OUTFITS  
INCLUDED  
FREE  
of extra cost**

Tools, Tool Bag, Test Bench, Radio Receiving Set—all equipment included. Also 233 Wiring Diagrams Charts. Write quick.

**B-W-COOKE** Directing Engineer  
CHICAGO MOTOR TRAINING CORPORATION  
1916-1926 Sunnyside Ave. Dept. 916 Chicago, Ill.

**AUTO  
FACTS**

MAIL **FREE  
AUTO  
BOOK**

**THIS QUICK!**  
CHICAGO MOTOR  
TRAINING  
CORPORATION  
1916-1926 Sunnyside Ave.  
Dept. 916 Chicago, Ill.

**B. W.  
COOKE,**  
Directing Engineer

Send me your Free Book "AUTO FACTS" and PROOF that you'll show me the way to a QUICK RAISE and BIG PAY as an Auto Expert, who need your 4 Outfits offer. It is understood that this obligation is no way, and that no salesman will call on me.

Name

Address

# THESE BOOKS WILL HELP YOU GET A BETTER JOB



Every one of the books listed below was written by an expert. They bring you the results of years of *practical* experience. They are, in every respect, the best and most helpful books of their kind ever written and are used by leading colleges, including Harvard, Yale, Cornell, Dartmouth, Purdue, Georgia School of Technology, Leland Stanford, etc. They contain much material that is not available in any other form—*anywhere!* New, complete, authoritative, and profusely illustrated, yet low in price.

**Order them for yourself—Buy them for Christmas gifts**

### Shop Practice Books

- 1—Lathe Work. 312 pages—334 illustrations - - - \$3.00
- 2—Drilling, Boring, Bench Work, Erecting. 383 pages—343 illustrations - - - \$3.00
- 3—Gauges, Jigs, Dies, Tempering, Heat Treatment. 347 pages—273 illustrations - \$3.00
- 4—Patternmaking. 420 pages—424 illustrations - - - \$3.00
- 5—Foundry Work. 568 pages—222 illustrations - - - \$4.00

### Automobile Books

- 6—Electric Starting and Lighting. 447 pages—265 illustrations - - - \$4.00
- 7—Electric Ignition. 245 pages—169 illustrations - - - \$2.50
- 8—Automobile Transmission, Mechanism, Lubrication, Tires. 351 pages - - - \$3.00

### Drafting Books

- 9—Sheet Metal Pattern Drafting. 294 pages—209 illustrations - - - \$4.00
- 10—Mechanical Drafting. 504 pages—442 illustrations - \$4.50
- 11—Structural Drafting. 319 pages—232 illustrations - \$3.25

### Building Trades Books

- 12—Heating and Ventilation. 313 pages—108 illustrations \$3.00
- 13—Brickwork, Terra-cotta, Hollow Tile, Building Stone, Plastering. 437 pages—346 illustrations - \$4.50
- 14—Estimating Building Costs, Specification and Contract Writing. 333 pages—36 illustrations - \$3.00
- 15—Geometrical Drawing, Ornamental Drawing, Architectural, Freehand and Perspective Drawing. 512 pages—245 illustrations \$5.00
- 16—Reading Architects' Blueprints. (Ten blueprints free.) 394 pages—103 illustrations - - - \$6.00
- 17—Steel Square—How to Use It - - - \$1.50
- 18—Plastering and Stucco Work - - - \$1.50
- 19—Plain and Fancy Brickwork - - - \$1.50
- 20—Hollow Tile Construction and Stucco Finish - - \$1.50
- 21—Plain and Reinforced Concrete Construction - - \$1.50



**A REAL BARGAIN**  
15 Good Books Only \$1 Each

- 39—Radio Handbook, 455 pages
- 40—Business Man's Handbook
- 41—Automobile Handbook, 347 pages
- 42—Bookkeeper's Handbook, 302 pages
- 43—Building Trades Handbook, 409 pages
- 44—Chemistry Handbook, 348 pages
- 45—Civil Engineer's Handbook, 411 pages
- 46—Concrete Engineer's Handbook, 368 pages
- 47—Machine Shop Handbook, 346 pages
- 48—Mechanic's Handbook, 330 pages
- 49—Pharmacist's Handbook, 346 pages
- 50—Poultryman's Handbook
- 51—Plumber's Handbook, 375 pages
- 52—Salesman's Handbook, 352 pages
- 53—Electrical Handbook, 414 pages

### Business Books

- 22—Salesmanship. 460 pages \$3.50
- 23—Advertising. 601 pages \$6.00
- 24—Good English. 442 pages \$3.00

- 25—Money and Banking - \$3.00
- 26—Business Law. 300 pages \$2.50
- 27—Traffic Management. 310 pages—166 illustrations - \$4.00
- 28—How to Sell Your Services. Foreword by B. C. Forbes. \$1.00

### Electrical Books

- 29—Electricity and Magnetism. 387 pages—309 illustrations - - - \$3.50
- 30—Electric Railways. 442 pages—291 illustrations - \$4.50
- 31—Alternating Currents. 335 pages—253 illustrations - \$3.50

### How to Prepare for Civil Service Examinations

- 32—Civil Service Spelling, Penmanship, Reading Addresses, Letter Writing, etc. 349 pages - - - \$3.00
- 33—Civil Service Shorthand and Typewriting—Speed Shorthand. 344 pages - \$3.50
- 34—Civil Service Geography, Bookkeeping, Copying, Manuscript. 332 pages - \$3.00

### Pharmacy

- 35—Pharmacy and Materia Medica. State Board Questions. 326 pages - - - \$3.00
- 36—Inorganic Chemistry for Pharmacy Students. 381 pages—69 illustrations - \$3.00

### Lettering Books

- 37—How to Design and Make Artistic Show Cards. 309 pages—254 illustrations - \$3.50
- 38—Artistic Alphabets for Show Cards and Signs. 338 pages—272 illustrations \$3.50

**PLEASE ORDER BY NUMBER**

Mail check, money order or stamps with coupon

INTERNATIONAL TEXTBOOK COMPANY, Box 5539-E, Scranton, Penna.

I am enclosing  check  money order  stamps, for which please send me the following books.....

(Write the numbers above)

It is understood that if I am not satisfied with these books, I may return them in five days and you will refund my money.

Name.....

Address.....



# They Called Me a "Human Clam" But I Changed Almost Overnight

**A**S I passed the President's office I could not help hearing my name. Instinctively I paused to listen. "That human clam," he was saying, "can't represent us. He's a hard worker, but he seems to have no ability to express himself. I've given up hopes of making anything out of him."

So that was it! That was the reason why I had been passed over time and again when promotions were being made! That was why I was just a plodder—a truck horse. I was a failure unless I could do what seemed impossible—learn to use words forcefully, effectively and convincingly.

## In 15 Minutes a Day

And then suddenly I discovered a new easy method which made me a powerful speaker almost overnight. I learned how to

bend others to my will, how to dominate one man or an audience of thousands. Soon I had won salary increases, promotion, popularity, power. Today I always have a ready flow of speech at my command. And I accomplished all this by simply spending 15 minutes a day in the privacy of my own home on this most fascinating subject.

There is no magic, no trick, no mystery about becoming a powerful and convincing talker. You, too, can conquer timidity, stage fright, self-consciousness and bash-

fulness, winning advancement in salary, popularity, social standing, and success. It is the power of forceful, convincing speech that causes one man to jump from obscurity to the presidency of a great corporation; a timid, retiring, self-conscious man to change almost overnight into a popular and much applauded after-dinner speaker. Thousands have accomplished just such amazing things through this simple, easy, yet effective training.

## Send For This Amazing Book

This new method of training is fully described in a very interesting and informative booklet which is now being sent to everyone mailing the coupon below. This book is called, *How to Work Wonders With Words*. In it you are shown how to conquer stage fright, self-consciousness, timidity, bashfulness and fear. Not only men who have made millions but thousands have sent for this book—and are unstinting in their praise of it. You are told how to bring out and develop your priceless "hidden knack"—the natural gift within you—which will win for you advancement in position and salary, popularity, social standing, power and real success. You can obtain your copy absolutely free by sending the coupon.

### What 15 Minutes a Day Will Show You

- How to address business meetings.
- How to propose and respond to toasts.
- How to make a political speech.
- How to tell entertaining stories.
- How to write better letters.
- How to enlarge your vocabulary.
- How to develop self-confidence.
- How to acquire a winning personality.
- How to strengthen your will-power.
- How to be the master of any situation.

## NORTH AMERICAN INSTITUTE

3601 Michigan Avenue  
Dept. 1359  
Chicago, Illinois



North American Institute,  
3601 Michigan Avenue., Dept. 1359  
Chicago, Illinois.

Please send me FREE and without obligation my copy of your famous book, *How to Work Wonders With Words*.

Name.....  
Address.....  
City..... State.....

*It stands to reason: There is no substitute for personal, practical training in great shops!*

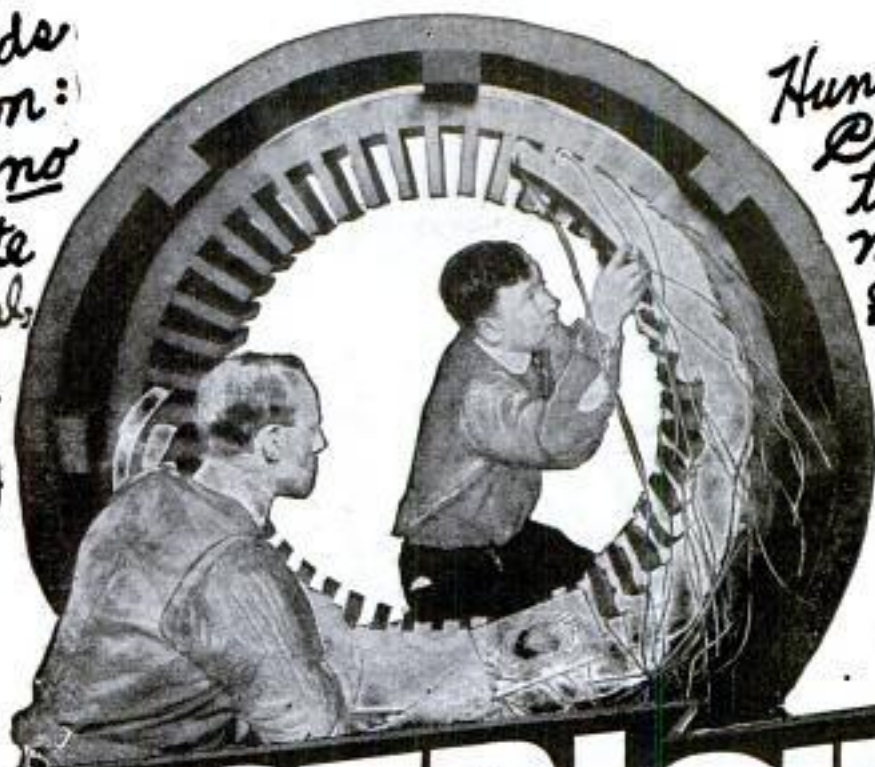

*Hundreds of Coyne-trained men earn \$60 to \$200 a week!*

**BIG SPECIAL OFFER IF YOU ACT AT ONCE**

*If you write without delay, I'll include with my course, without extra charge, my big Extra Courses in Radio Electricity and Auto, Truck and Tractor Electricity.*

# ELECTRICITY

**—Provides BIG REWARDS Day After Day, Week After Week, Year After Year!**

**Earn While You Learn at COYNE!**

My big EMPLOYMENT DEPARTMENT helps you to get a job to earn part or all of your expenses while training and assists you to a good job on graduation. It stands by you THROUGH LIFE without a penny extra cost to you.



Electricity is the Field of Wonderful Opportunities today. It offers BIG PAY, clean, fascinating work and steady employment — anywhere, any time! COYNE-TRAINED MEN are in demand because the Electrical Industry appreciates the care and thoroughness which I and my great staff of EXPERT INSTRUCTORS devote to students. Spend a few happy weeks at COYNE, working in big shops on great electrical apparatus, and inspecting great power houses and industrial organizations.

**You Don't Need Advanced Education or Experience**

Don't worry if you lack advanced education, knowledge of higher mathematics, or experience. My course is a practical, LEARN-BY-DOING Course. Every COYNE student receives INDIVIDUAL and PERSONAL instruction, on COMPLETE electrical apparatus, under EXPERT INSTRUCTORS, in the COYNE Shops at Chicago.

**COMPLETE ELECTRICAL TRAINING**

**In 12 Happy Weeks at COYNE**

My newly-enlarged and unusual course of instruction in Electricity is the result of 37 years experience, solving the needs of young men and of the Electrical Field. Remember, COYNE has been teaching Electricity in a PRACTICAL way since 1899. My course is absolutely thorough, easy to master, covers every single phase and factor of the subject and fits men for BIG Electrical jobs, the HIGH-SALARIED, thrilling jobs.



H. C. LEWIS, President Coyne Electrical School

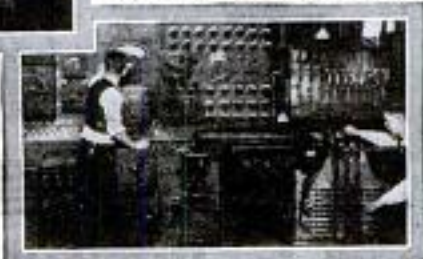

**WE ARE SPECIALISTS**

COYNE teaches only one thing—ELECTRICITY. Our interests are not divided, nor in Electricity a sideline with us. We have SPECIALIZED in the teaching of ELECTRICITY for more than a quarter of a century.

**COYNE**

**ELECTRICAL SCHOOL**  
H. C. LEWIS, President Established 1899  
1300-10 W. Harrison St., Dept. 13-59, Chicago

**Send Now for My Great Big FREE Electrical Book and Great Special Offer**

Be sure to send at once for my big FREE BOOK containing 151 actual photos of electrical operations and methods; also my special offer of 2 Big Courses without extra cost. Write today, sure, before this offer is withdrawn.

**SEND COUPON NOW**

H. C. LEWIS, President  
COYNE ELECTRICAL SCHOOL  
1300-10 W. Harrison St.  
Dept. 13-59, Chicago, Illinois

Dear H. C.—You can just bet I want one of those big, handsome FREE 12x15 books, with 151 actual photographs printed in two colors. Send it quick, before the supply is exhausted. Be sure to tell me all about 2 Big Special Courses without extra cost.

Name .....

Address .....



Wide World Photo

# Aviation Brings Quick Success!

## Sudden New Demand for Daring Young Men!

AVIATION in America is on the threshold of an amazing new development. For in the past few months gigantic commercial air lines have been established. The biggest capital and business forces in the world are behind this enterprise. Even in the beginning, thousands of young men are needed. For those who can qualify there will be highly paid jobs which will lead quickly and surely to advancement and success.

### Big Opportunities Await the Trained Man

Look over the fields of work which are open to the young man today. You will find that Aviation is the ONE FIELD that is not overcrowded—the ONE FIELD in which there is plenty of room at the top. Think of it! Only 21 years ago Orville and Wilbur Wright made the world's first airplane flight. Now airplanes fly around the world. Yes, Aviation offers the same wonderful opportunities today that the automobile and motion picture industries did 15 and 20 years ago. Men who got in on the ground floor of those industries made fortunes before others woke up.

### Easy to Become an Aviation Expert—\$50 to \$100 a Week

You can qualify now quickly for one of these exciting highly paid jobs through a new, sure, easy method of training. The study of Aviation is almost as interesting as the work itself. Every lesson is fascinating and packed full of interest. That's why Aviation is so easy to learn—you don't have to force

yourself to study. Only one hour of spare time a day will give you the basic training in an amazingly short time.

One student, S. F. McNaughton, Chicago, says: "Your lessons are like a romance, and what is more, after one reading, the student gets a thorough understanding. One never tires of reading them." James Powers, Pa., another student, says: "I am indeed surprised that such a valuable course can be had from such practical men for so little cost."

Men who have had actual experience in Aviation give you personal attention and guide you carefully through your training. They select the lessons, lectures, blueprints and bulletins. They tell you the things that are essential to your success. Every lesson is easy to read and quickly understood.

#### PREPARE FOR ONE OF THESE POSITIONS

Aeronautical Instructor  
\$60 to \$150 per week  
Aeronautical Engineer  
\$100 to \$300 per week  
Aeronautical Contractor  
Enormous Profits  
Aeroplane Repairman  
\$60 to \$75 per week  
Aeroplane Mechanician  
\$40 to \$60 per week  
Aeroplane Inspector  
\$50 to \$70 per week  
Aeroplane Salesman  
\$5,000 per week and up  
Aeroplane Assembler  
\$40 to \$65 per week  
Aeroplane Builder  
\$75 to \$200 per week



### Big Book on Aviation FREE

Send coupon below for New Free Book. Just out, "Opportunities in the Airplane Industry." It is interesting and instructive and will show you many things about Aviation which you never knew before. Only a limited number offered—get yours before the edition is exhausted.

### AMERICAN SCHOOL OF AVIATION Dept. 1359, 3601 Michigan Ave., Chicago, Ill.

American School of Aviation,  
3601 Michigan Ave., Dept. 1359, Chicago, Ill.

Without any obligation, send me your Free Book, "Opportunities in the Airplane Industry," also information about your Course in Practical Aeronautics.

Name.....

Street.....

City..... State.....



Be a Machine Draftsman—earn \$60 to \$150 a week



Be a Structural Draftsman—earn \$60 to \$200 a week



Be an Architectural Draftsman—earn \$60 to \$150 a week



Be an Electrical Draftsman—earn \$60 to \$125 a week



Be an Auto Draftsman—earn \$60 to \$125 a week

# 3 Drafting Lessons Actually FREE!

**to prove you can LEARN AT HOME, IN YOUR SPARE TIME!**

We have invented a new, simplified way to teach Drafting—the first real improvement in Drafting home-instruction in history. We want you to see it, try it—without one penny of cost or obligation. We want to show you how we get away from the copying methods used in the past. See how we make you think, solve problems, do actual drafting room jobs from the first lesson!

## Draftsmen Wanted \$60 to \$200 a week!

### FREE Job Service

Our employment department will help place you in a good job. Demand exceeds the supply. No charge for nation-wide employment service. Read want-ads for Draftsmen every day in Chicago Tribune or any big city paper—see the opportunities for yourself—and get ready for them.

MAIL COUPON TODAY!

70,000 fine jobs advertised this year. Get ready to fill one. Get out of the rut. Make something of yourself. Plan your future in Drafting. Even if you have only common schooling, even if you know nothing of Drafting, we guarantee to make you a real Draftsman or to refund your money! Special surprise offer right now to the first 500 men who answer this ad—reduced price, easy terms. Coupon brings complete information.

### A New, Rapid, Easier Training

Copying drafting lessons prepares you to be only a "tracer." This new "Job-Method" gives you actual drafting-room jobs in a new one-step-at-a-time way. With pictures which you can understand almost without reading the "lessons." And that is why American School-trained Draftsmen can qualify for a good job at big pay when they graduate.

### Win Success Through Drafting

Drafting is easy, fascinating work. Short hours. Big pay. And the Draftsman is always in line for promotion for executive positions. This training is Complete. It includes high-school subjects (if you need them) and all the Engineering and Mathematics required of Drafting Experts.

### Coupon Brings Three Lessons Free!

Get them. Test your own ability to learn Drafting and get ready for a fine job and big pay. Coupon also brings surprise offer, and complete information about your opportunities for success in Drafting.

**Mail It Today!**

### Complete Costly Drafting Outfit GIVEN!

You need a fine outfit like this to do precise, neat Drafting. Not one penny of extra charge for this complete, valuable, high grade outfit. Imported instruments. Table, board, mahogany-edge T square, triangles, ink, thumb-tacks, etc., everything you will need. Retail value \$30. Coupon brings this Free Offer.



**CHIEF DRAFTING ENGINEER  
AMERICAN SCHOOL**  
Dept. D-974  
Drexel Ave. & 58th St., CHICAGO

**CHIEF DRAFTING ENGINEER,  
AMERICAN SCHOOL,  
Dept. D-974, Drexel Ave. & 58th St., Chicago**

Rush 3 Free Drafting Lessons, Surprise offer, complete information, money-back guarantee, etc., to prove I can become a real draftsman at home in spare time.

Name .....

Street No. ....

City ..... State .....

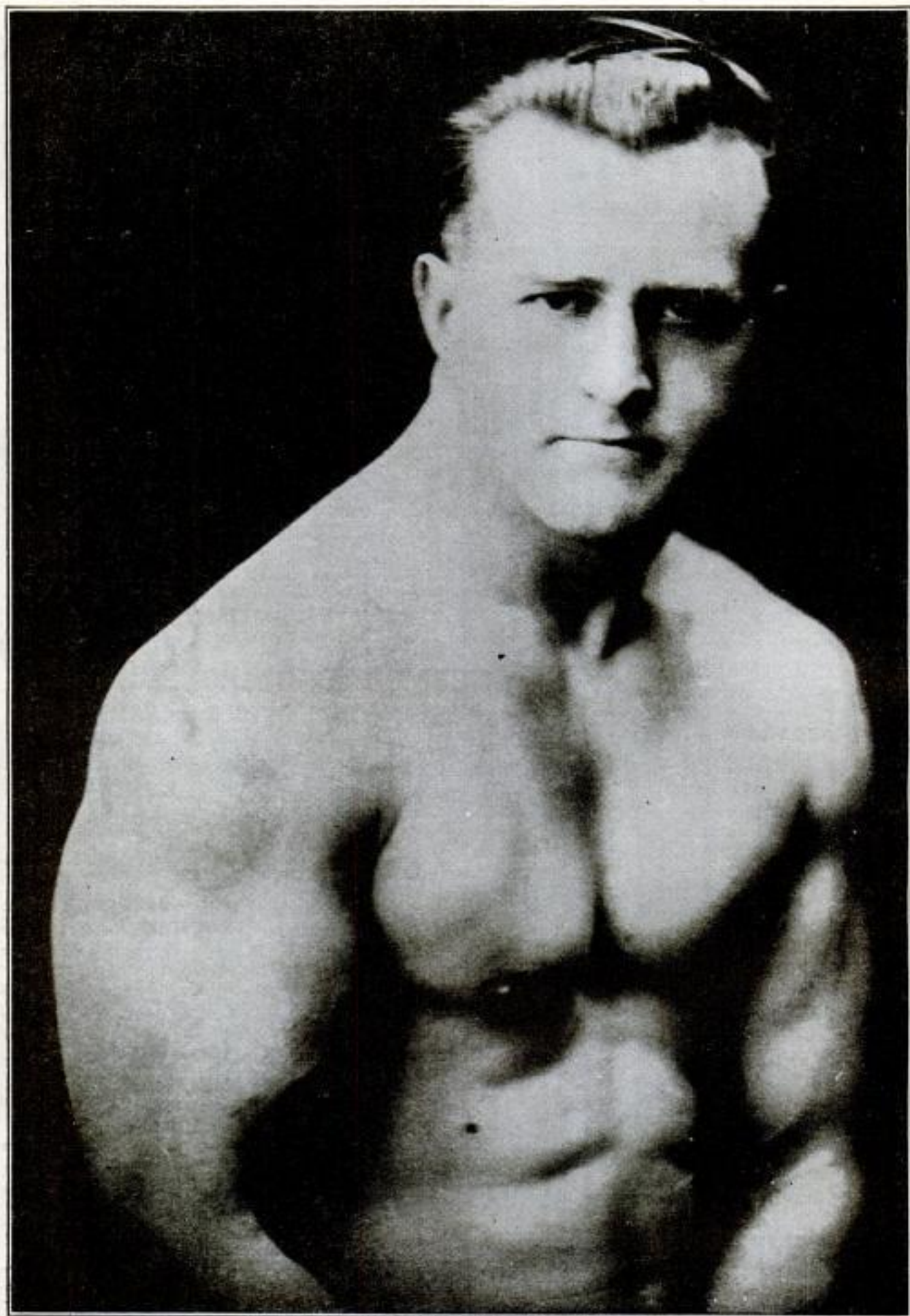

**EARLE E. LIEDERMAN, *The Muscle Builder***  
*Author of "Science of Wrestling," "Muscle Building," "Secrets of Strength," and "Here's Health," etc.*



# MUSCLES 5 cents a piece

Wouldn't it be great if we could buy muscles by the bag—take them home and paste them on our shoulders? Then our rich friends with money to buy them, sure would be socking us all over the lots.

But they don't come that easy, fellows. If you want muscle you have to work for it. That's the reason why the lazy fellow never can hope to be strong. So if you're lazy and don't want to work—you had better quit right here. This talk was never meant for you.

## I Want Live Ones

I've been making big men out of little ones for over fifteen years. I've made pretty near as many strong men as Heinz has made pickles. My system never fails. That's why I guarantee my works to do the trick. That's why they gave me the name of "The Muscle Builder."

I have the surest bet that you ever heard of. Eugene Sandow himself says that my system is the shortest and surest that America ever had to offer.

Follow me closely now and I'll tell you a few things I'm going to do for you.

In just 30 days I'm going to increase your arm one full inch. Yes, and add two inches to your chest in the same length of time. But that's nothing. I've only started: get this—I'm going to put knobs of muscles on your shoulders like baseballs. I'm going to deepen your chest so that you will double your lung capacity. Each breath you take will flood every crevice of your pulmonary cavity with oxygen. This will load your blood with red corpuscles, shooting life and vitality throughout your entire system. I'm going to give you arms and legs like pillars. I'm going to work on every inner muscle as well, toning up your liver, your heart, etc. You'll have a snap to your step and a flash to your eye. You'll feel the real pep shooting up and down your old backbone.

You'll stretch out your big brawny arms and crave for a chance to crush everything before you. You'll just bubble over with vim and animation.

Sounds pretty good, what? You can bet your old ukulele it's good. It's wonderful. And don't forget, fellow—I'm not just promising all this—I guarantee it. Well, let's get busy, I want some action—So do you.

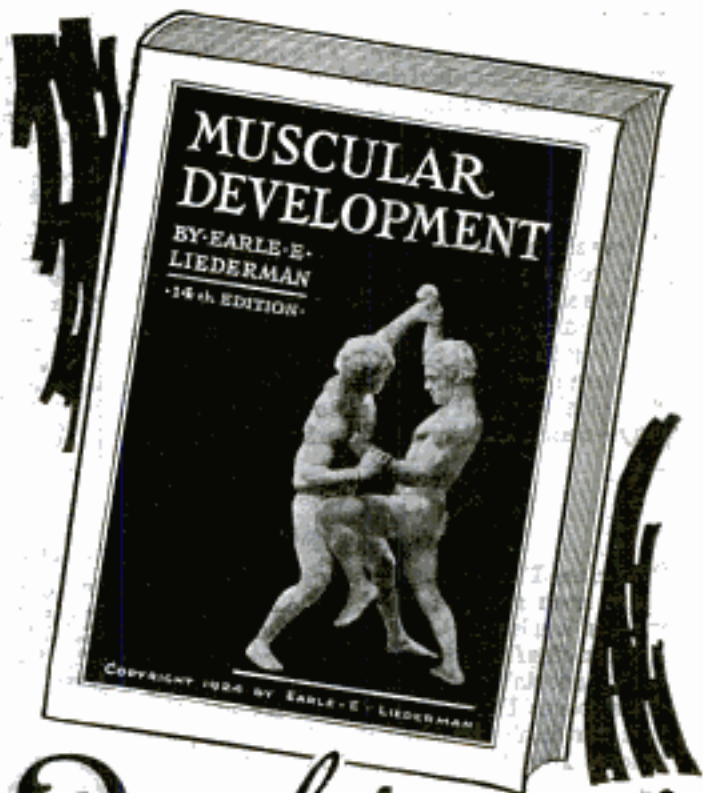

Send For My New  
64 Page Book

*"Muscular Development"*

IT'S FREE

Do you get that? It's free. I don't ask a cent. It's yours with my compliments. Take it and read it. It's the peppiest piece of literature you ever flashed your glimmers on. And 48 full-page photos of myself and some of my numerous prize-winning pupils. This is the finest collection of strong men ever assembled into one book—look them over—doctors, lawyers, merchants, mechanics and every line of trade you can think of. I swear you'll never let this book get out of your mitts again. And just think—you're getting it for nothing. Don't hesitate—there's no strings attached to it. Grab it.

Take your pen or pencil and fill out the coupon, or even your name and address on a postal will do—do it now before you turn this page.

**EARLE E. LIEDERMAN**

Dept. 2012 305 Broadway New York City

**EARLE E. LIEDERMAN**

Dept. 2012, 305 Broadway, New York City

Dear Sir:—Please send me absolutely free and without any obligation on my part whatever, a copy of your latest book, "Muscular Development." (Please write or print plainly.)

Name.....

Address.....

City..... State.....

# To Draw a Man's Pay, Learn to Be a DRAFTSMAN!

**I** TEACH a trade on which all other trades depend. It makes any man worth \$10 a day—or more—the world over. No building is built, no machine is made without *mechanical drawings*. Work can't start without the draftsman!



No "talent" needed! You can draft if you can hold a pen or pencil. The most "complicated" mechanical drawing, or architect's plan, is made a line at a time.



A few simple rules you carry in your head; and tools you can put in your pocket. That's all you need. Dobe trained men can handle any job—as any engineering or contracting firm will tell you! For I give you the same work you will later do for money. And I show you how to do it—the right way—the quick way—the workmanlike way.



The class I'm forming now can take a few more men ready for action. My course means business. Begin now, and start right in *drafting* from the hour you get the first material; with the sixth lesson you'll draw parts like this. Within six months you can make finished drawings like that below. And that's worth money!

My free book explains how anyone can master drafting. If interested in better work at better pay, do something about it now!

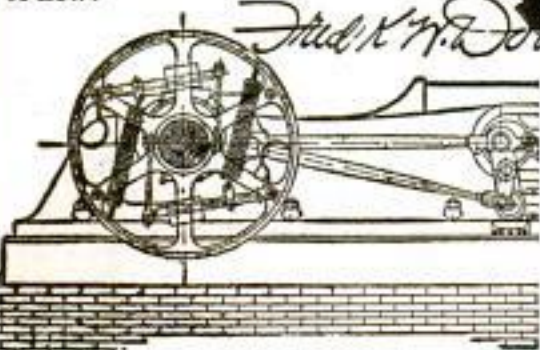

**DOES THIS LOOK HARD TO DRAW?**

A 24-year old student, Geo. Winterling, did it; in his third month of the Dobe course. He is a full-fledged draftsman today, and paid \$90 a week.

**\$100 A WEEK** may sound big to some. It is *not* big pay for draftsmen. Nor does drafting stop there; every Chief Draftsman once worked at the board; it is from the boys in the drafting room that Construction Bosses and Plant Superintendents are chosen. Every architect, and most engineers started at the drafting table.

**TO PROVE** there is a real demand for draftsmen, turn to the Help Wanted section of any big city newspaper. *Twenty calls for draftsmen to every job offered electrical or automotive workers.* A man can call himself an "electrician" and hang doorbells. Or, wash cars and call himself an "automotive expert." Do you want a *title*, or a *trade*?

**BLUEPRINTS** are needed before a brick is laid, or a wheel can turn. The draftsman comes first. And what an enjoyable job he has! Drafting room hours are short, and time flies when you're drafting. Or, perhaps the whole day is spent in discussion of some work. Whatever it be, your pay goes merrily on.

**NOW** about learning. You can become a draftsman, and a good one. I *guar-*

#### IF YOU ANSWER THIS IN TIME

To the next fifty men enrolling, no extra charge for complete working outfit! Full set of imported nickel silver drawing instruments, a Chief's Own drawing table, rules, squares, supplies—all included! So write at once.



#### CHIEF DRAFTSMAN DOBE

Over 25 years' experience in practical draftsmanship, he has taught it to thousands of men, young and old. Work is play when it's big work at big pay! Get Dobe's book free; see offer.

*antee* to train you. If you act in time, I'll furnish all the tools. (You don't need any books; this is a course where you *see* and *do* the actual work.) Look into this line that makes work worth while, and

lifeworthliving! Coupon below brings **SUCCESSFUL DRAFTSMANSHIP** book free.



#### CHIEF DRAFTSMAN DOBE

1951 Lawrence Ave., Div. 13-59 Chicago, Illinois

I want your book **SUCCESSFUL DRAFTSMANSHIP** free and post paid, full particulars about your personal instruction course, the price, terms, etc. *No obligation.*

Name ..... Age .....

Address .....

P. O. .... State .....

Clip  
Coupon  
Now!

# Let Me Show You the \$10,000 Future in Your Present Job

I don't care whether you are working for \$25 or \$100 a week. I don't care what you are doing now. A college education is not essential. I am *not* going to advise you to leave your present job. I just want a few minutes of your time to show you the unlimited opportunities for earnings right in your present connection and how you can start cashing in almost over night.

By J. E. GREENSLADE

The smartest men are often the poorest paid—everybody knows that. It is equally well known that most highest salaried men are just fellows of ordinary intelligence, ability and average education. But probably nine-tenths of all men are blind to the absurdly simple reason.

## The Secret of Big Earnings

Hard work is often three-fourths wasted unless you know how to do one thing—sell—sell goods, sell your work, sell yourself. As one business expert said: "There are two kinds of men—those who work for low pay and those who can sell." And no matter what your profession is, when you learn to sell you will find your earnings increasing at an amazing rate. You will find yourself stepping from a clerkship into an executive job, from a poorly paid employe to the man who signs the pay checks. You won't be afraid to ask for a raise.

## Salesmen Are Not "Born"

I upset one old superstition when I said that ability to sell will bring you more than hard work. I am going to upset another superstition when I say "Salesmen are not born." For during the past eighteen years I have changed men in every walk of life—mechanics, routine workers, trainmen, office men, etc.—into star salesmen. I have seen fellows too timid to ask a simple question become super-salesmen. Fellows like Ward came to me when they were earning \$25 a week. Ward now earns \$10,000 a year.

## You've Got to Sell or Fail

Unconsciously, every one of us makes use of the principles of salesmanship many times a day. Some of our attempts may be rather crude because we lack scientific knowledge, but they are part and parcel of every man's business success. Those who



know the secrets of scientific selling have a tremendous advantage. They are the men who bend others to their own wills, who overcome obstacles and who make their ideas stick! They are the men who make \$10,000 or more a year!

## Exceptional Demand for Trained Salesmen

City and traveling sales positions are open in every line all over the North American continent. For years thousands of leading wholesalers, jobbers and manufacturers have called on the Association to supply them with salesmen. Employment service is free to both employers and members, and thousands have secured positions through this Service. Surely this is a glowing tribute to the thoroughness and practicability of our System of Salesmanship Training and Employment Service.

## Send for Our Amazing New Book Free

Send for our amazing new Free Book, "Modern Salesmanship." It will open your eyes to facts you never dreamed of. See how easy you can master this subtle force in a few short weeks, spare time—and start using it to bring advancement immediately. Don't put off. Mail the coupon now.

**NATIONAL SALESMEN'S  
TRAINING ASSOCIATION**  
Dept. W-12, N. S. T. A. Bldg., Chicago, Ill.

National Salesmen's Training Association,  
Dept. W-12, N. S. T. A. Bldg., Chicago, Ill.

Please mail me FREE your illustrated book "Modern Salesmanship" and particulars of membership in your Association and Free Employment Service.

Name.....

Address.....

City.....State.....

Age.....Occupation.....

# LEARN CARTOONING

Successful cartoonists earn big salaries. Many of the most popular cartoonists of today learned to draw in their spare time, at home, through the Landon Course of Cartooning and now earn \$75 to \$200 or more per week.



The Landon Picture Chart Method of teaching ORIGINAL drawing makes cartooning easy to learn. Hundreds of sketches like the above explain every step in creating ORIGINAL heads, figures, animals, etc. Send 6c in stamps today for sample Landon Picture Chart and full explanation of this wonderful course, also long list of successful Landon students and information showing possibilities for you. Please state your age.

**The Landon School, 738 National Building, Cleveland, Ohio**

## Former Students Who Are Now Successful Comic Strip Artists

- BLOSSER**—Now drawing "Freckles and His Friends."  
**BYRNES**—Now drawing "Regular Fellers."  
**BRANNER**—Now drawing "Winnale Winkle."  
**LOCHER**—Now drawing "Cicero Sapp."  
**TAYLOR**—Now drawing "Mom 'n Pop."  
**EDWINA**—Now drawing "'Cap' Stubbs."  
**CRANE**—Now drawing "Washington Tubbs II."  
**ETHEL HAYS**—Now drawing "Flapper Fanny."  
**PAUL FUNG**—Now drawing "Gus & Gussie."  
**KNICKERBOCKER**—Now drawing "This and That."



## Hotels Start You With Salaries up to \$3,500 a Year — with your living

**HOTELS**, restaurants, clubs, apartments, everywhere need trained men and women—salaries to start up to \$3,500 a year with your living. Over 70,000 high-class positions paying up to \$10,000 a year are open every year in the hotels of the United States. Today this is the 1st INDUSTRY IN AMERICA—with over 3992,394,968 in new hotels being built in 1925—exceeding by \$200,000,000 the next largest industry. These new hotels, restaurants, etc., will need over 60,000 trained men and women.

You can have one of these high-class big-pay positions, with luxurious meals and apartment and fascinating work. No previous experience necessary. The Lewis Schools guarantee to give you the valuable knowledge that it has taken some of the most successful hotel men years to obtain—men who are now making \$5,000 to \$10,000 a year. We train you by mail in your spare time at home with the Lewis Simplified Study Plan, and we put you in touch with big opportunities. Our students employed, our methods endorsed by leading hotel men everywhere. Send today for Free Book, "YOUR BIG OPPORTUNITY," showing how we can train you for one of these splendid positions in 20 weeks or less, and explaining our Money-Back Guarantee.

**LEWIS HOTEL TRAINING SCHOOLS**  
 Room Z-388 Washington, D. C.

\*\*\*\*\* FREE BOOK COUPON \*\*\*\*\*  
 LEWIS HOTEL TRAINING SCHOOLS, Room Z-388, WASHINGTON, D. C.  
 Send me without obligation the Free Book, "YOUR BIG OPPORTUNITY."

Name.....  
 Address.....  
 City..... State.....

## How to Speak and Write Masterly English

Every time you speak or write you show just what you are. Mistakes in English reveal you as a person who lacks education and refinement. Lack of language power prevents you from presenting your thoughts in the strongest possible way. No matter what you do, real command of English will help you to your goal. Stop making mistakes in spelling, punctuation, pronunciation. Increase your vocabulary.

### WONDERFUL INVENTION

Only 15 minutes a day with Sherwin Cody's new invention—and you can actually SEE your English improve. It teaches by HABIT—makes it easier to do the RIGHT way. Wonderful self-correcting lessons include Spelling, Punctuation, Grammar and Expression.

**FREE BOOK ON ENGLISH AND 15 MINUTE TEST** Lack of language power may easily be costing you thousands of dollars every year. See what Mr. Cody can do for you; it costs nothing to find out. Mail a postal card or letter this very minute for free book, "How to Speak and Write Masterly English," and 15 Minute Test, which you can take in your own home. It will prove a revelation to you. **WRITE NOW.** Address

Sherwin Cody School of English, 512 Searle Building, Rochester, N. Y.



## YOU CAN OIL PAINT

Amazing new method teaches men or women to earn after first lesson. OIL PAINT photos—portraits, landscapes or art subjects. Earn \$10 to \$100 and more a week. OIL PAINT OUT-FIT GIVEN. Send now for free illustrated book. PICTORIAL ART STUDIOS, Inc., Dept. MP, 2781 No. Clark St., Chicago

## Learn Mechanical Dentistry

Most profitable profession today. Intensive 3 months' course. We guarantee to teach you. Practical instruction; individual attention; unequalled curriculum. Lowest co-operative tuition fee. Tools and materials free when you enroll. Write for Free Catalog NOW! N. Y. School of Mechanical Dentistry, Dept. F-68, Penn Arcade, 147-153 W. 33rd St., N. Y.

## 100 PARODIES ON Latest Songs 25c



Gallagher & Shean, "All for Love of Mike, 3 O'clock in the Morning, Peggy O'Neil, Carolina in the Morning, Smiles, Indiana, Michigan, and many others. Comic Dialects.

Complete 25c, 3 for 50c p. p.

J. C. DORN 723 So. Dearborn Street Dept. 3 CHICAGO



## Do You Want This Job?

**MEN 18 TO 45**  
**Become City and Rural Mail Carriers**

**\$1700 TO \$3300 YEAR**

**Many Other U. S. Gov't Jobs Now Obtainable**

**STEADY WORK. PAID VACATION. COMMON EDUCATION SUFFICIENT. PULL UNNECESSARY.**

**MAIL COUPON—TODAY SURE**

Coupon  
 Franklin  
 Institute  
 Dept. K318  
 Rochester, N. Y.

Send me, WITH-  
 OUT CHARGE, (1)  
 Your Copyrighted  
 Civil Service Book. (2)  
 Tell me how to get a position  
 as City or Rural Mail  
 Carrier at \$1700 to \$3300 a  
 year. (3) Send free sample exam-  
 ination coaching.

Name.....

Address.....

22 YEARS OF SUCCESS

CHICAGO TECHNICAL COLLEGE



FROM THIS RECOGNIZED COLLEGE OF ENGINEERING

a *Home-Study Course* in

# DRAFTING

Everything today is built from drawings made by Draftsmen. Industry calls for 50,000 new men yearly. Draftsmen work hand in hand with the architect, the engineer, the designer, the builder. And thus many men rise from such positions to be heads of great contractors' organizations, directors of railroads, chief engineers—responsible positions commanding very attractive salaries.



Mr. Raymond S. Zeitler

## DRAFTING HALL OF FAME

Mr. Raymond S. Zeitler says: "I have heard many excellent comments on your courses in engineering as being the best available and I believe the same."

Mr. Zeitler is the organizer of the Zeitler Gas Car & Locomotive Company, Chicago, Illinois. This company provides an equipment designed and patented by Mr. Zeitler, whereby any street, interurban or railroad car may be converted into a gasoline motor car for branch line service. Mr. Zeitler is also the author of the only book on this modern subject.

NOTICE—A well established Placement Bureau assists both graduates and undergraduates to find positions.

## FREE TRIAL LESSON

Prove your fitness and liking for one of industry's highest paid professions. We want you to know what Drafting is like... how readily you can progress... how we train and teach you by mail. So, before you enroll... FREE... without cost or obligation... we send you a trial lesson to study in your own home.

### Within Ten Months Increase Your Income

No special training or talent is required. In 10 months' time or less... we can train you... at home, in your spare hours... to be a good Draftsman.

And remember this: In Drafting a big income is open to every properly trained man. Thousands today are earning \$35 to \$100 per week. The reason is simple: Good Draftsmen are in constant demand.

### Book of Facts FREE

We will send you a 40-page Book. It tells you all about Drafting... and our courses. What prominent men say... where Draftsmen are employed... their salaries... their opportunities... what our students have done and are doing... how many have increased their salaries even before finishing their courses... how many hold high-sal-

aried executive positions today. Tells how 34 instructors give you from this recognized 22-year-old college a practical, short, home-study course.

### The Coupon Below Means Money to You

Find out what Drafting may mean to you... mail that coupon. Here is a field in which you can work and win. We make the test easy, for, with no obligation, we send you a trial lesson FREE. Note the fairness of this offer, the absence of exaggerated promises.

### \$25 Outfit Included

When you enroll, you will need drafting instruments; so, included in the cost of the course, is a \$25 "lifetime" set. If you have instruments, credit will be allowed. Note that we do not claim to give you these instruments "free". Tuition is low, payments easy.

### —In Chicago—Earn While You Learn—

Those who can come to Chicago will find opportunity to earn living expenses in part-time positions, outside of school hours, while attending day or evening classes at the College.

Chicago Technical College, founded 1904, is known as one of America's oldest and largest schools of specialized engineering. Over 1000 men enroll in resident day and evening courses yearly.

Diplomas in Civil, Mechanical and Electrical Engineering and Architecture granted after two years. Degree of B. S. conferred after three years in the day course. Short courses offered in Drafting, Plan Reading, Estimating, etc. Evening classes for day workers.

If interested in attending Day or Evening Classes at the College in Chicago write for 72-page "Blue Book"—mailed free.

Send Today for FREE Trial Lesson  
Fill Out the Attached Coupon NOW

# Chicago TECHNICAL College

Drafting—Engineering—Electricity—Architecture... all branches

Chicago Technical College,  
Dept. 1239, 118 E. 26th St., Chicago, Ill.

Send me, without cost or obligation, your  
FREE Trial Lesson and your 40-page Book  
of Facts about Drafting.

Name.....

Address.....

City and State.....



**Want  
To Learn  
To  
Play?**

**Here's How**

Take a tip from me! Six months ago, I didn't know one note from another. Today I am a well-paid saxophonist! And I didn't have to part with a fortune to attain my present success, either.

When I started to take the course that the U. S. School of Music offers, I was pretty well discouraged. I had always wanted to know how to play, but I felt that I couldn't afford to take lessons. For I knew, or thought I knew, that it would probably be years before I could play well enough to join an orchestra. And the cost of the lessons was no joke to a young fellow like me. When you are working for a salary, and have little time to practice, every penny and every hour counts.

Then I read an advertisement of the U. S. School of Music. And, say, it made me sit up and take notice. It offered just what I needed. Their amazingly easy Method simplifies the study of music, so that I could become an expert player in a few months time, and at a trifling cost. Well, boys, I thought I could do worse things than try it. And try it, I did.

### Easy Home-Study Method

That Method made good with me, all right! In a short time I was playing **real tunes and melodies**, not just scales. What's more, I played them **well!** So well, that even while taking my course, I was able to earn some extra money playing for entertainments.

Of course, my friends boosted me for these "jobs." Oh, yes, I made plenty of friends with my ability to "jazz" up parties. I actually became popular—I, who a few short months before, had wished I could play, if only to while away the time. Time! Every minute of my time is now in demand. And I am well paid for my pleasant work.

#### LEARN TO PLAY ANY INSTRUMENT

Piano	Mandolin
Organ	Drums and Traps
Violin	Harmony and Composition
Banjo	Ukulele
Clarinet	Piccolo
Flute	Trombone
Harp	Saxophone
Cornet	Piano Accordeon
Cello	Voice and Speech Culture
Guitar	Automatic Finger Control

#### Send for Free Book and Demonstration Lesson

Say! If I could do it, you can do it! Send for the Free Book and Demonstration Lesson of the U. S. School of Music. They will show you the real road to popularity and success.

If you are really interested in learning how to play, if you want to make good, **SEND FOR THEM AT ONCE!** Write NOW to the U. S. SCHOOL OF MUSIC, 712-A Brunswick Bldg., New York City.

Instruments supplied when needed, cash or credit.

## Be a Plumber!

### Earn Big Money Good Plumbers Are In Demand

Work the year around—GET BIG PAY—Apprenticeship requires 4 years. This is not necessary. The Kansas City School of Plumbing offers the PRACTICAL METHOD to learn all branches of the trade quickly. LEARN in 8 to 12 WEEKS—REAL PLUMBERS TEACH YOU. LEARN to do any job—step right into a big pay job or start a Shop of your own. The Plumber modernizes the Home. Plumbers can earn more in one day than some folks make in a week. Be a Plumber. Write for information. LOW TUITION Fee and opportunities offered. Do it today.

KANSAS CITY SCHOOL OF PLUMBING  
2030 Troost Avenue KANSAS CITY, MO.



## Learn to Mount Birds



Learn at home by mail, to mount birds, animals, game heads; tax furs, make rugs and robes. Complete lessons. Easily and quickly learned by men, boys and women.

**FREE**

Write today for Free Taxidermy Book. Tells all about it. Every Sportsman, Hunter, Trapper and Nature lover should know this wonderful fascinating art. Save your trophies. Big profits. Success guaranteed. Our school is 20 years old - 15,000 graduates. Investigate today. Write for Free Book.

Northwestern School of Taxidermy

9779 Elwood Bldg., Omaha, Neb.

## STOP GROPING IN THE DARK

Be Yourself—Get Into Your Stride—MAKE GOOD!



All men—women, 18 to 65 wanting to qualify for Government Positions, \$140-\$300, traveling or stationary—Write Mr. Ozment, 111 St. Louis, Mo., immediately.

### LEARN TO DRAW!



Remarkable book just off the press—"COMMERCIAL ART AND CARTOONING." Explains how to make illustrations for Books, Advertisements, etc. Also tells how to become a successful Cartoonist. NO CORRESPONDENCE COURSE—Everything complete in this book—14 chapters, over 125 illustrations. Tells about Elementary Drawing; Still Life; Pen, Ink, Charcoal and Crayon Work; Wash and Figure Drawing; Cartooning; Round Flexible; Imitation Leather—Gold top. Worth \$2.00. Sent postpaid for \$2.00 (C. O. D. 11c extra).

OGLIVIE PUB. CO., 57 Rose St., New York, Dept. 123



COMMERCIAL ART AND CARTOONING  
BOOK \$2.00  
PAID

## LAW High-Grade Instruction By Correspondence Prepares You for the Bar—Est. 1892

University Methods. Standard Text-Books. Approved by Bench and Bar. Graduates practicing in every state. Send today for Free Catalog and Rules for Admission to the Bar. CHICAGO SCHOOL OF LAW, 302 Reager Block, Chicago, Ill.



## STAMMER

If you stammer attend no Institute until you get my large FREE book "STAMMERING, Its Origin and The Advanced Natural Method of Treatment." Ask for special tuition rate. Established 22 years. Write today.

MILLARD INSTITUTE OF NORMAL SPEECH  
2317 Millard Building MILWAUKEE, WISCONSIN

## LEARN PIANO TUNING AT HOME

With our TUNE-A-PHONE, Action Model, tools, charts and lessons you learn easily and quickly. Earn big money. Estb. 1898. Money-back Guarantee. Diploma given. Low tuition; easy terms. Write today for our FREE book, "Winning Independence." Miles Bryant School of Piano Tuning, 40 Bryant Bldg., Augusta, Mich.

# ELECTRICITY

## Complete Study Course and Pocket Library \$10



### SHIPPED FREE

A set of HAWKINS GUIDES is a good friend to the electrical worker. It tells you how to do any job the right way—without guessing or taking chances.

Hawkins Guides put the facts about modern electrical engineering at your finger tips, making your chances for advancement in the electrical field unlimited.

### HAWKINS GUIDES INCREASE YOUR PAY



Electricity is king!

It is the great ruling force—transportation, communication, light, heat, power—almost every modern activity is dependent on electricity. Industry is demanding electrical men that know their jobs!

Hawkins Guides teach you all you need to know about electricity in easy, step-by-step lessons. Daily spare time reading of the Guides will greatly increase your value to yourself and your employer in a few weeks. Hundreds of our friends have written us and told us this!

ing of the Guides will greatly increase your value to yourself and your employer in a few weeks. Hundreds of our friends have written us and told us this!

### READERS OF HAWKINS GUIDES KNOW HOW



"You can't stump him on an electrical job."

"He certainly knows his business." "Certainly have to hand it to him for knowing how."

—These are the things employers say about our friends who are readers of Hawkins Guides. No matter what question or problem comes up the Ready Reference Index enables you to give an expert answer at once.

### HAWKINS STARTS YOU WHERE OTHERS LEAVE OFF

Don't work any longer at low wages when easy reading of HAWKINS GUIDES will give you

the money-making knowledge of the expert! Easy daily reading of the Guides will teach you in a few months what it has taken the expert a lifetime to learn!

With HAWKINS GUIDES in hand you have a running start to success in the electrical field. You will actually begin where others left off!



## NOW!

This coupon is your golden opportunity. Tear it out—send it now!

### FOR EXAMINATION!

#### REAL ELECTRICAL EDUCATORS

"Hawkins Guides at \$10 are the best investment I have ever made. Am able to take up almost any electrical job and have never gone to an electrical school."—B. Roessler, Oenaville, Texas.

#### AS EASY AS A. B. C.

"Everything in Hawkins Guides is very plain and anybody can read and understand them as easy as A. B. C."—J. Knight, Tobyhanna, Pa.

#### OTHER READERS SAY

"Worth ten times their price." "Helped me to two raises in four months." "Better than a school of instruction." "Studied them when I was laid up and got further ahead than if I had been on the job."

### Hawkins Guides Explain These Points So You Can Easily Understand:—

Magnetism—Induction—Experiments—Dynamometers—Electric Machinery—Motors—Armatures—Armature Windings—Installing of Dynamometers—Electrical Instrument Testing—Practical Management of Dynamometers and Motors—Distribution Systems—Wiring—Wiring Diagrams—Sign Flashers—Storage Batteries—Principles of Alternating Currents and Alternators—Alternating Current Motors—Transformers—Converters—Rectifiers—Alternating Current Systems—Circuit Breakers—Measuring Instruments—Switch Boards—Wiring—Power Stations—Installing—Telephone—Telegraph—Wireless—Bells—Lighting—Railways. Also many Modern Practical Applications of Electricity and Ready Reference Index.

### Hawkins Guides—10 POCKET SIZE NUMBERS

Each number easy to carry around and read in spare time. Big type and clear diagrams. Easy to study and learn. Durable, flexible binding—gold edges. 3,500 pages—4,700 illustrations. Shipped free for examination. Pay only \$1 a month if satisfied. Price of set, complete, \$10.



### EXAMINE GUIDES FREE!

Let the Guides themselves demonstrate their practical value to you—as a study course, reference work and complete electrical library. You are the judge. Simply send this coupon. No obligation unless you are entirely satisfied. Tear out on dotted line—fill in—mail it NOW!

\$1 PER MO.

FREE EXAMINATION COUPON

Theo. Audel & Co., 65 W. 23rd St., New York City

Please send me (postpaid) for my approval Hawkins Electrical Guides, 10 numbers (price \$1 each). If satisfactory I will mail you \$1 in 7 days and further mail \$1 monthly until purchase price of \$10 is paid.

Name.....

Address.....

Occupation.....

Employed by..... 12 T 30



## "Don't tell me you never had a chance!"

"Four years ago you and I worked at the same bench. I realized that to get ahead I needed special training, and decided to let the International Correspondence Schools help me. I wanted you to do the same, but you said, 'Aw, forget it!' You had the same chance I had, but you turned it down. No, Jim, you can't expect more money until you've trained yourself to handle bigger work."

There are lots of "Jims" in the world—in stores, factories, offices, everywhere. Are you one of them? Wake up! Every time you see an I. C. S. coupon your chance is staring you in the face. Don't turn it down.

Right now more than 180,000 men and women are preparing themselves for bigger jobs and better pay through I. C. S. courses.

You can join them and get in line for promotion. Mark and mail this coupon, and find out how.

### INTERNATIONAL CORRESPONDENCE SCHOOLS Box 5543-E, Scranton, Penna.

Without cost or obligation, please tell me how I can qualify for the position or in the subject before which I have marked an X:

#### BUSINESS TRAINING COURSES

- |  |   |
|--|---|
| <input type="checkbox"/> Business Management                     | <input type="checkbox"/> Salesmanship                                     |
| <input type="checkbox"/> Industrial Management                   | <input type="checkbox"/> Advertising                                      |
| <input type="checkbox"/> Personnel Organization                  | <input type="checkbox"/> Better Letters                                   |
| <input type="checkbox"/> Traffic Management                      | <input type="checkbox"/> Show Card Lettering                              |
| <input type="checkbox"/> Business Law                            | <input type="checkbox"/> Stenography and Typing                           |
| <input type="checkbox"/> Banking and Banking Law                 | <input type="checkbox"/> Business English                                 |
| <input type="checkbox"/> Accountancy (including C.P.A.)          | <input type="checkbox"/> Civil Service                                    |
| <input type="checkbox"/> Nicholson Cost Accounting               | <input type="checkbox"/> Railway Mail Clerk                               |
| <input type="checkbox"/> Bookkeeping                             | <input type="checkbox"/> Common School Subjects                           |
| <input type="checkbox"/> Private Secretary                       | <input type="checkbox"/> High School Subjects                             |
| <input type="checkbox"/> Spanish <input type="checkbox"/> French | <input type="checkbox"/> Illustrating <input type="checkbox"/> Cartooning |

#### TECHNICAL AND INDUSTRIAL COURSES

- |   |  |
|---|--|
| <input type="checkbox"/> Electrical Engineering | <input type="checkbox"/> Architect                                   |
| <input type="checkbox"/> Electric Lighting      | <input type="checkbox"/> Architects' Blue Prints                     |
| <input type="checkbox"/> Mechanical Engineer    | <input type="checkbox"/> Contractor and Builder                      |
| <input type="checkbox"/> Mechanical Draftsman   | <input type="checkbox"/> Architectural Draftsman                     |
| <input type="checkbox"/> Machine Shop Practice  | <input type="checkbox"/> Concrete Builder                            |
| <input type="checkbox"/> Railroad Positions     | <input type="checkbox"/> Structural Engineer                         |
| <input type="checkbox"/> Gas Engine Operating   | <input type="checkbox"/> Chemistry <input type="checkbox"/> Pharmacy |
| <input type="checkbox"/> Civil Engineer         | <input type="checkbox"/> Automobile Work                             |
| <input type="checkbox"/> Surveying and Mapping  | <input type="checkbox"/> Airplane Engines                            |
| <input type="checkbox"/> Metallurgy             | <input type="checkbox"/> Navigation                                  |
| <input type="checkbox"/> Steam Engineering      | <input type="checkbox"/> Agriculture and Poultry                     |
| <input type="checkbox"/> Radio                  | <input type="checkbox"/> Mathematics                                 |

Name.....  
Street.....  
Address..... 3-6-24

City..... State.....

Occupation.....

Persons residing in Canada should send this coupon to the International Correspondence Schools Canadian, Limited, Montreal, Canada

Play the  
**HAWAIIAN  
GUITAR**  
Just as the  
Natives Do

**FREE** when you enroll  
**\$15 HAWAIIAN GUITAR and Case**

Only 4 Motions used in playing this fascinating instrument. Our native Hawaiian instructors teach you to master them quickly. Pictures show how. Everything explained clearly.

**Play in Half Hour**  
After you get the four easy motions you play harmonious chords with very little practice. No previous musical knowledge necessary.

**Free Guitar and Outfit in Genuine Seal Grain Fabricoid Case** as soon as you enroll. Nothing to buy—everything furnished. No delay.

**Easy Lessons**  
[Even if you don't know one note from another, the 62 printed lessons and the clear pictures make it easy to learn quickly. Pay as you play.]

**Write at Once**  
You'll never be interested with this beautiful Hawaiian Guitar. Write for Special Offer and easy terms. A postcard will do. A771

**FIRST HAWAIIAN CONSERVATORY OF MUSIC, Inc.**  
9th Floor, Woolworth Bldg., Dept. 148 New York, N. Y.  
*Approved as a Correspondence School Under the Laws of the State of New York*

LAW

**STUDY AT HOME**  
Because a lawyer, Legally trained men win high positions and big success in business and public life. He Independent. Greater opportunities now than ever before. Big corporations are headed by men with legal training. Earn \$5,000 to \$10,000 Annually

We guide you step by step. You can train at home during spare time. Degree in LL.B. conferred.

LaSalle students found among practicing attorneys of every state. We furnish all text material, including fourteen-volume Law Library. Low cost, easy terms. Get our valuable 108-page "Law Guide" and "Evidence" books FREE. Send for them NOW.

**LaSalle Extension University, Dept. 1264-I, Chicago**  
The World's Largest Business Training Institution

## SPANISH

Learn at home on your phonograph. New Conversational Method. Endorsed by Spanish Embassy. You learn to speak, read and write Spanish as if you were living in Spain.

Write to-day for Free Descriptive Booklet  
International Correspondence Schools, Box 5544-E, Scranton, Pa.

WANT WORK AT HOME?

Earn \$18 to \$60 a week RETOUCHING photos. Men or women. No selling or canvassing. We teach you and furnish WORKING OUTFIT given with each enrollment. Limited offer. Write today.  
Aircraft Studios, Dept. 56, 5900 Sheridan Rd., Chicago

## LEARN MECHANICAL DENTISTRY

Earn \$35 to \$125 a week. Taught by actual practice—day or night. Three months' course. Modern laboratories. No previous training required. Established 20 years. For 36-page catalog, write Dept. 2.

**BODEE DENTAL INSTITUTE**  
NEW YORK 136 W. 104 St. PHILADELPHIA 1806 N. Broad St. BUFFALO 501 Washington St. BROOKLYN 85 Court St.

## BE AN ARTIST

WE CAN TEACH YOU DRAWING in your own home during your spare time. Twenty-five years of successful teaching proves our ability. Artists receive large salaries. Write Today for Art Year Book

**SCHOOL OF APPLIED ART**  
ROOM NO. 2 - BATTLE CREEK MICH.



## LEARN PHOTOGRAPHY!

Earn \$200 to \$500 monthly. Or start your own business. Photography and Photo-Engraving taught by largest college of its kind in world. Established 1893. Big demand for graduates. Write for free book. Illinois College of Photography, Box 4125, Effingham, Ill.

**MINSTRELS** Musical Comedies and Revues, with full instructions for staging. You can stage your own show with our books. Full line of plays, stage songs, crossfire, monologues, afterpieces, vaudeville acts and make-up. CATALOGUE FREE.  
**T. S. Denison & Co., 623 S. Wabash Ave., Dept. 19, Chicago**



# Can you fix it?



New books have "jiffy index," making all facts instantly available. You find anything you want to know in a moment.

## These books tell how

**H**ERE are the most interesting, the most practical books we have ever published on automobile construction, operation and repairs. Brimful of facts, photographs and explanations so easy to understand that anyone can learn how in almost no time.

Over 2000 pages, with diagrams, blueprints and everything else needed to make anyone an authority on automobiles.

Whether you want to qualify as garage owner, auto repair expert or merely wish to know how to keep your own car 100% efficient, you will welcome these books, especially on our

### No Money Offer

This plan brings this valuable information within the reach of everyone. You don't send us a single penny. You don't have to pay us anything—just send your name and address and we'll send you the complete set of 5 volumes, specially bound in Flexo covers.

Read them carefully; keep them 10 days; find out anything you want to know, and then if you want to keep them, send only \$2.00 then and \$3.00 per month until the special low price of \$19.80 is paid. There is no further obligation.

### American Technical Society Membership Free

This is a great organization for the publishing and spreading of specialized knowledge—we have over a million dollars of resources, enabling us to get the cooperation of the largest automobile manufacturers and dealers, who have furnished us plans and photographs. If you send NOW for this new edition of Automobile Engineering, we will include a Consulting Membership in this great organization.

Eighteen automobile experts will be ready to help you at all times. You can write or wire any time for special information. Answers will be sent to you promptly—without cost.

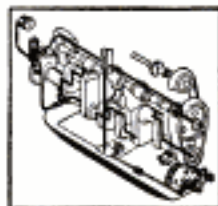

Modern Oiling System

### Don't Hesitate

There are no strings to this offer—it means just what it says. Send name and address on the coupon and ALL of the five books—the complete set—will be sent to you for examination.

Remember one fact only which you can find in these books may save you an expensive repair or help you to a better job.

### Learn All About Autos

Get these five big books on this liberal offer and learn all the things you want to know about autos.

Carburetors, engines, springs and spring suspension, brakes, 4-wheel drives, lubrication systems—all are fully covered.

These complete and comprehensive auto books are yours if you want them on this easy plan. Send for a set NOW; there's nothing to pay.

Jiffy



Index

You don't have to read the books through; the index enables you to put your finger on the information wanted in a jiffy.

### For Free Offer, Use Coupon

American Technical Society,  
Spec. Dept. A-919, Chicago, Ill.

I would like to look at the 5 Auto Books described above. Send them on your FREE offer. I will examine them carefully and return them in 10 days unless I like them; in which case I will send you \$2.00 then and \$3.00 per month until the total price of only \$19.80 is paid. You are to also send me Free Consulting Membership Certificate in the American Technical Society.

Name.....

Street.....

City..... State.....

Employed by.....

# BOYS



Drawn from actual photograph of student doing spare time electrical work

## Learn Electricity Make Big Money

How would you like to earn two or three dollars every evening after school and prepare yourself for

a fine job at the same time? Here's the opportunity of a lifetime for you fellows who like Electricity. Begin right now to prepare yourself for a regular man's size job in this fascinating field. Your chances for a big success are simply wonderful—the pay is big (thousands of men earn \$70 to \$200 a week) and advancement comes swift and sure.

### I Will Train You at Home

With my easily learned, spare time Electrical Course I will train you at home like I have trained hundreds of other boys who are now big successful men. It will not interfere with your school work and you can earn more than the small cost of the course doing odd electrical jobs in your spare time. The Course pays for itself. I will show you how to get this work and how to do it. Some of my boy students make \$10 to \$15 a week this way.

### Tools, Apparatus and Radio Course —Given Without Extra Charge

Send me the coupon below and I will tell you all about the big outfit of tools, apparatus and instruments and a new Radio Course that I am giving to my students for a limited time. I will send you my big interesting Electrical Book and a sample lesson, too—all Free. You will be tickled with the things I will send you Free. Mail the coupon right now.

**L. L. COOKE, Chief Engineer**  
Chicago Engineering Works  
Dept. O-19 CHICAGO

### Look What This Boy Is Doing

"Although the School term is coming to a close, and I am pretty busy with my examinations, I manage to keep up with my electrical studies and work.

"I guess I forgot to tell you I am now in business for myself. Am doing fine, but owe it all to you. If it had not been for your Course, I, being under age, could not have secured my license in this town. But I got it, and now have all the work I can do, averaging \$20 to \$30 a week, thru spare time work.

"I went out on a job taught after school, on which I made \$3 and brought home another on which I made \$2.50—\$5.50, for 4 hours' work and no material furnished by me."

**ROGERS SMITH,**  
2215 Chestnut St.,  
Greenville, N.C.

### Use This "FREE BOOK" Coupon

**L. L. COOKE, Chief Engineer,**  
Chicago Engineering Works,  
Dept. O-19 2150 Lawrence Avenue, Chicago

Send me your Big Outfit Offer, your big Electrical Book, Sample Lesson and particulars of your Electrical Course and Extra Radio Course. This will not obligate me in any way.

Name.....

Address.....

This Coupon only for use of boys 15 years old or more.

# ART

## We Teach COMMERCIAL ART

Meyer Both Company, maintaining the most widely known Commercial Art Studios in the World, offers you a practical training based upon 25 years' success in producing over a quarter million commercial drawings for leading advertisers.

Many of the full page illustrations appearing in leading national magazines are drawn by Meyer Both Trained Artists.

Our graduates are filling attractive positions in every section of the country. Home study instruction.

### GET FACTS BEFORE YOU ENROLL IN ANY SCHOOL

Ask the advertising manager of the leading newspaper in your locality about us. Send 4c in stamps for illustrated book telling of the success of our students, and the unusual opportunity for both men and women in this attractive profession.

### MEYER BOTH COMPANY

Dept. 16  
Michigan Ave. at 20th St.  
CHICAGO, ILL.

NOTE—To Art and Engraving Firms; Secure practical artists among our graduates. Write us.

## FREE 48 CHRISTMAS SEALS

in colors. Given FREE with 4 months' subscription to our magazine, full of good stories. Household Departments, etc. Big Bargain. All for 20 cents. ILLUSTRATED COMPANION, Dept. X-24, New York City

Comedies, Dramas, Musical Comedies and Revues, Minstrel Shows, Songs, Blackface Plays, Everything for Burnt Cork Shows and All Amateur Entertainments. Monologs, Dialogs, Speakers. CATALOGUE FREE. **T. S. DENISON & CO., 623 So. Wabash, Dept. 9, CHICAGO**

## PLAYS

Vaudeville Acts, How to Stage Play, Make-up Goods, etc.

## ZIP-ZIP



THOUSANDS of boys are made happy with this wonderful Zip-Zip shooter, something every boy wants and never gets tired of. Zip-Zip shooter is scientifically and practically

made; boys, if you like hustling and outdoor sports, get a Zip-Zip shooter with plenty of pep and force and learn that quick and sure aim. If your dealer happens not to have them, order from us. Zip-Zip shooter complete 35c or three for \$1.00; send stamps, coin or money order.



AUTOMATIC RUBBER CO., Dept. 44, Columbia, S. C.

# Make Yourself a Popular Favorite with the TENOR BANJO

## Play for Fun or Money

Don't be a wallflower. Get in on parties. Entertain your friends. Be popular. Play at dances, etc. Form an orchestra. Earn Money in spare time or become a professional. Our 52-lesson course will make you an accomplished player.



**\$18 TENOR BANJO**  
**FREE** when you enroll

In Genuine Seal Grain Fabrikoid Case

This beautifully made, sweet-toned, mellow Tenor Banjo is given to you. Free, in a Genuine Seal Grain Fabrikoid Case, as soon as you enroll. In a music store it would cost you \$18 to \$20. We can only afford to give you this splendid instrument because it is made in our own big factory. We also give you 52 pieces of music and everything necessary to play your Tenor Banjo. There are positively no extras.

### Complete 52-Lesson Course

Our method is so interesting, simple and practical you will not only be pleased but astonished at the rapid progress you make. Even if you are an absolute beginner in music, even if you can't tell one note from another, by means of our complete 52-lesson Conservatory Course, directed by expert instructors, you can soon realize your ambition to become a skilled Tenor Banjo player.

### You Can Play in 30 Minutes

45,000 successful students back up our claim that you can play a piece in 30 minutes by following our printed, illustrated instructions. Right from your very first lesson you are playing real pieces. No tedious practicing—no irksome scales—music from the very start!

### Pay as You Play

Low Price! Easy Terms! A small first payment starts you. And the entire 52-lesson course comes to just a few cents a lesson!

### Learn in Spare Time at Home

Study at your leisure. Select your own lesson time—practice whenever you find it most convenient. No waiting for a teacher—no appointments to keep—and your lessons are always at hand, to refer to whenever necessary. You are never hurried, never forced—but you can go ahead as fast as you like. And—no waiting for a class to form—you can begin now.

### Picture Lessons Make it Easy

You can't fail to learn because clear, distinct pictures explain every move. Everything is concise and easy to grasp. And with each succeeding lesson you will become more and more interested, more and more fascinated, by the wonderful music you find yourself able to produce!

Send this Popularity Coupon ~ NOW!

Interested in Other Courses?

Famous teachers conduct our courses in Hawaiian Guitar, Violin, Mandolin, Banjo, Ukulele and Ukulele. Write for literature.

**FIRST HAWAIIAN CONSERVATORY OF MUSIC, INC.**  
 9th Floor, Woolworth Building Department 160, New York

Approved as a Correspondence School under the Laws of the State of New York

### Our Written Guarantee

We guarantee in writing to teach you to play the Tenor Banjo. This guarantee protects you from every standpoint. In addition, after you graduate, we coach and advise you—at no extra expense. Bear in mind the success of 45,000 students—most of them without musical training when they enrolled. You can do as well as they have done. Get your enrollment in at once and get started on the great popularity-building career—music!

FIRST HAWAIIAN CONSERVATORY OF MUSIC, Inc.  
 9th Fl., Woolworth Bldg., New York, N. Y., Dept. 160  
 Please mail full information about your complete 52-lesson Conservatory Course on the Tenor Banjo, and free offer. I understand this does not bind me to enroll.  
 Name \_\_\_\_\_  
 Address \_\_\_\_\_  
 City \_\_\_\_\_ State \_\_\_\_\_



**My Earnings  
Increased 500%**  
*Thanks to Higher Accountancy*

100% 200% 300% 400% 500%

"Today my earnings are 500 per cent larger than when I started with LaSalle," writes W. A. Melcher, a New Orleans man. "When I received my first LaSalle assignment in Higher Accountancy," he continues, "I was employed by a large produce house of this city. I left that position to audit with a local firm of accountants, and finally accepted a lucrative offer from the business house with which I am now connected. The personal touch which you give to your clear instructions makes the student realize that you have a very vital interest in his success."

Not an unusual report to receive from a LaSalle-trained man. During only six months' time as many as 1,248 LaSalle members reported definite salary-increases totalling \$1,399,507. The average increase per man was 89 per cent. With men who are trained the LaSalle way, promotion is the rule, not the exception.

### Send for Salary-Doubling Plan

Are you—like Melcher—following a well-organized plan to double—triple—quadruple your salary? Or are you relying for advancement upon day-to-day experience? LaSalle offers a sound and practical salary-doubling plan which has added millions and millions of dollars to the earning power of its members. If a successful career is worth a 2c stamp and two minutes of your time, check the field of advancement that appeals to you, fill in your name and address, and place the coupon in the mail TODAY.

### LaSALLE EXTENSION UNIVERSITY

The World's Largest Business Training Institution

Dept. 1264-HR Chicago

I would welcome details of your salary-doubling plan, together with copy of "Accountancy, the Profession that Pays," also a copy of "Ten Years' Promotion in One," all without obligation.

#### Higher Accountancy

Training for positions as Auditor, Comptroller, Certified Public Accountant, Cost Accountant, etc.

#### Other LaSalle Opportunities

LaSalle opens the way to success in every important field of business. If more interested in one of the fields indicated below, check here:

- |   |  |
|---|--|
| <input type="checkbox"/> Business Management              | <input type="checkbox"/> Modern Business Correspondence and Practice |
| <input type="checkbox"/> Modern Salesmanship              | <input type="checkbox"/> Modern Foremanship and Production Methods   |
| <input type="checkbox"/> Traffic Management               | <input type="checkbox"/> Personnel and Employment Management         |
| <input type="checkbox"/> Railway Station Management       | <input type="checkbox"/> Expert Bookkeeping                          |
| <input type="checkbox"/> Law—Degree of LL.B.              | <input type="checkbox"/> Business English                            |
| <input type="checkbox"/> Commercial Law                   | <input type="checkbox"/> Commercial Spanish                          |
| <input type="checkbox"/> Industrial Management Efficiency | <input type="checkbox"/> Effective Speaking                          |
| <input type="checkbox"/> Banking and Finance              | <input type="checkbox"/> C. P. A. Coaching                           |

Name .....

Present Position .....

Address .....

## Learn Motion Picture Photography at Home



New plan qualifies you quickly in spare time at home for this great, fascinating profession. Camera rent, earn \$100 to \$200 a week and more. No previous experience required. Our experts train you by mail.

### MOTION PICTURE CAMERA FREE

Readsome Motion Picture Careers given free if you act quickly. Takes real motion pictures on standard professional film used in all theatres. Earn money on side.

#### Send for Illustrated Book—FREE

Write today for handsome, illustrated book explaining great opportunities in Motion Picture Photography, also Commercial, Studio Portraiture, News Photography, with details of FREE Motion Picture or View Camera. Address: Dept. 49 143 W. 36th St. New York Institute of Photography NEW YORK CITY

## ELECTRICAL

Course for men of ambition and limited time. Over 4000 men trained.

### CONDENSED COURSE IN THEORETICAL AND PRACTICAL ELECTRICAL ENGINEERING

including the closely related subjects of Mathematics and Mechanical Drawing taught by experts. Students construct motors, install wiring, test electrical machinery. Course complete



## IN ONE YEAR

Prepare for your profession in the most interesting city in the world. Established in 1893. Free catalog.

BLISS ELECTRICAL SCHOOL  
222 Takoma Ave. WASHINGTON, D. C.

## Music Lessons

WITH ACCREDITED SCHOOL

### At Home

Any Instrument Write training courses you are interested in: Violin, Cornet, Mandolin, Guitar, Banjo or Reed Organ—and we will send FREE CATALOG. SEND for it NOW!

University Extension Conservatory, 220 Siegel-Myers Bldg., Chicago

### Complete Conservatory Course by Mail

Wonderful home study music lessons under great American and European teachers. Endorsed by Paderewski, Master teachers guide and coach you. Lessons a marvel of simplicity and completeness.

## LEARN WATCH REPAIRING

Be a watchmaker—you can learn this profitable trade by correspondence in a few weeks in your own home by the DeSelms Chart System. After you complete the course you will know a watch from A to Z. You will know just what the matter is and how to repair one. When you graduate you will be a practical watchmaker and repairer and competent to fill any position. Positions for our graduates. Ask for our Free Book. It explains our system and terms.

THE DeSELMS WATCH SCHOOL  
LOGANSPORT, INDIANA



## TELEGRAPHY

Morse and Wireless and RAILWAY ACCOUNTING taught thoroughly. Big salaries! great opportunity. Oldest, largest school. Endorsed by Telegraph, Railway, Radio, and Government officials. Expenses low—opportunity to earn large portion. Catalog free. DODGE'S INSTITUTE, Jones St., Valparaiso, Ind.

### BOYS & GIRLS \$2.00 Given NO WORK JUST FUN

Simply sell 50 Sets of Our Famous Christmas Seals for 10c a set. When sold send us \$3.00 and keep \$2.00. Trust you till Xmas. American Christmas Seal Co. Dept. 69 Brooklyn, N. Y.

### Learn Watchwork, Jewelrywork and Engraving.

A fine trade commanding a good salary, and your services are always in demand. Address Horological, Dent. P. Bradley Institute, PEORIA, ILL. for our latest catalog.



Wonderful, new device, guides your hand; corrects your writing in few days. Big improvement in three hours. No failures. Complete outline FREE. Write C. J. Orment, D-34, St. Louis, Mo.



## See How Easy It Is To Learn Drawing This Quick Way

Through a remarkable short cut method anyone can now quickly learn to draw—right at home in spare time. No special talent needed! Become an Artist this quick easy way.

**Y**OU have always longed for it—this fascinating ability to draw. Now it can easily be yours. Illustrating, Rapid Sketching, Decorative Designing, Advertising Art, Cartooning—you can easily learn all of this right in your own home. Hundreds of our students never had a drawing pencil in their hands before starting, yet are high-salaried artists today.

### Big Money in Commercial Art

Trained artists earn \$50, \$75, \$100 and even over \$200 a week! Single drawings often bring over \$100. And now, with just a few hours' pleasant study each week, you can quickly learn to make drawings that have a real commercial value.

Hundreds of trained artists are needed today all over the country. Magazines, Department Stores, Advertising Agencies, Publishers, Manufacturers—these are just a few of the fields which are in urgent need of artists. Get into this attractive, big money field now.

### It's Fun Learning Art This Simple Way

It's all just like a pleasant game when you learn to draw with this simple method. You study right at home, yet every bit of your work receives the individual attention and criticism of a *real artist*. It's almost as though you had a famous artist standing at your elbow while you work. With this training you progress with amazing rapidity. Starting with straight lines and curves, you quickly learn action, perspective and all the more advanced secrets of

drawing. Almost before you realize it you are making drawings that *sell*.

### Send for FREE BOOK

You may be considering the study of art merely for the joy you can get from it; or you may want to turn your ability into the big money which is to be found in Commercial Art. In any case—if you feel that you want to learn to draw, send for our new Free Book on Art, which tells all about the wonderful opportunities for happiness and profits in art and describes this startling simple method which makes it so easy for you to learn to draw. Mail coupon for this Free Book and for our Special Free Offer.

**Washington  
School of Art**  
Room 3012-C  
1115-15th St., N. W.  
Washington, D. C.



WASHINGTON SCHOOL OF ART  
Room 3012-C, 1115-15th St., N. W., Washington, D. C.

Please send me your Free Book on Art which tells about your simple method. Also details of your special Free Offer.

Please Write Plainly

Name.....  
Mrs., Miss or Mr.

Address.....

City.....State.....

Age if under 16 years.....

## There is an Unusual Value in The COUPON Below

IT BRINGS YOU A

# FREE

6 MONTHS' SUBSCRIPTION TO

## "STRENGTH MAGAZINE"

And Also

A Free Copy of the  
Milo Bar-Bell Co.'s  
Booklet on Bar-Bells  
and Strong Men

## "STRENGTH"

is chock full of pictures of the human form (both male and female) in its height of perfection. It is full of pictures of perfectly muscled Strong Men and their doings the world over. "STRENGTH" is full of interesting, Healthful talks. "STRENGTH" is valuable to you in many personal ways.

You'll like it from cover to cover. You'll profit by its contents in many ways, besides hours of enjoyable reading. "STRENGTH" will show you how to get the most out of your life—how to thoroughly enjoy every moment of it. "STRENGTH" will bring you health and happiness and bring them to stay.

Fill in the coupon below with your name and address and in a few days you will receive your first copy of your six months' subscription along with the Booklet on Bar-Bells and Milo Strong Men. The remaining 5 issues of "STRENGTH" will be mailed to you as they are published. You get no back issues in this free subscription.

Send for this Catalogue on the Supreme Body, Strength and Health Developers—Milo Bar-Bells.

Get them both NOW

MILO BAR-BELL CO. P.M.-12-25  
2745 N. Paltherp St., Philadelphia, Pa.

Gentlemen: Please send me immediately and without obligation on my part a FREE 6 months' subscription to "STRENGTH MAGAZINE" and also your FREE Booklet on Bar-Bells and Strong Men.

Name .....

Address .....

City..... State.....



One of the  
Many Illustrations

## STOP USING A TRUSS

Do Away With Steel And Rubber Bands

# FREE TRIAL



Inner surface is made adhesive to secure the PLAPAO-PAD firmly to the body, keeping the PLAPAO continually applied and the pad from slipping. No straps, buckles or springs attached. Soft as velvet—easy to apply.

It's the Non-Slip- ping, yet Non-Rigid Pad and What is Within It That Counts

### FREE to 5,000 Truss Sufferers

To the extent of 5,000 sufferers who may apply I will send, ABSOLUTELY FREE, a sufficient quantity of the Plapao to positively convince them that this is the only logical, common-sense way of treating rupture. Plapao is a highly astringent medication placed within the Plapao-Pad and being absorbed through the skin, creates a wonderful feeling of relief and at the same time tends to strengthen the weakened muscles and thus permanently close the rupture opening. The process of recovery is natural, so you'll have no use for a truss—you can throw it away forever! Old and young have testified under oath that the Plapao-Pads cured their rupture—many of them long-standing, aggravated cases—without delay from work. Patent allowed in U. S. and foreign countries. Awarded Gold Medal at Rome and Grand Prix at Paris.

Send No Money — for a sufficient quantity of the Plapao is sent without charge to enable you to give it a thorough test; you pay nothing for this trial now or ever. Write for it and full information today. Address: Plapao Laboratories, Block 1427 St. Louis, Mo.



## Earn up to \$250 per Mo.

Expenses Paid  
Many Chances for  
Advancement

## BE A RAILWAY TRAFFIC INSPECTOR

### Trained Men Wanted

Prepare for this fascinating work with assurance that you will not have to hunt for a position upon graduation. For over seven years our graduates have been provided with positions or their money refunded. Start at \$110 a month or more, expenses paid. You take no risk and can prepare in your spare time.

#### From a Graduate

Ralph E. Becker: "Ten days after receiving my diploma I was given a position with a large railway company in the east. Traffic inspection offers steady employment and the opportunity to travel all over the country."

#### Advancement Rapid

with experience. Meet high railway officials. Travel or remain near home. Highly confidential and important work.

#### More Men Needed

We must train more men for positions soon to be open. Send coupon for full details, including low cost.

Standard Business Training Inst., Buffalo, N. Y.

Send me, entirely free, Booklet No. D-63, giving full particulars about course in Railway Traffic Inspection.

Name.....

Street.....

City.....

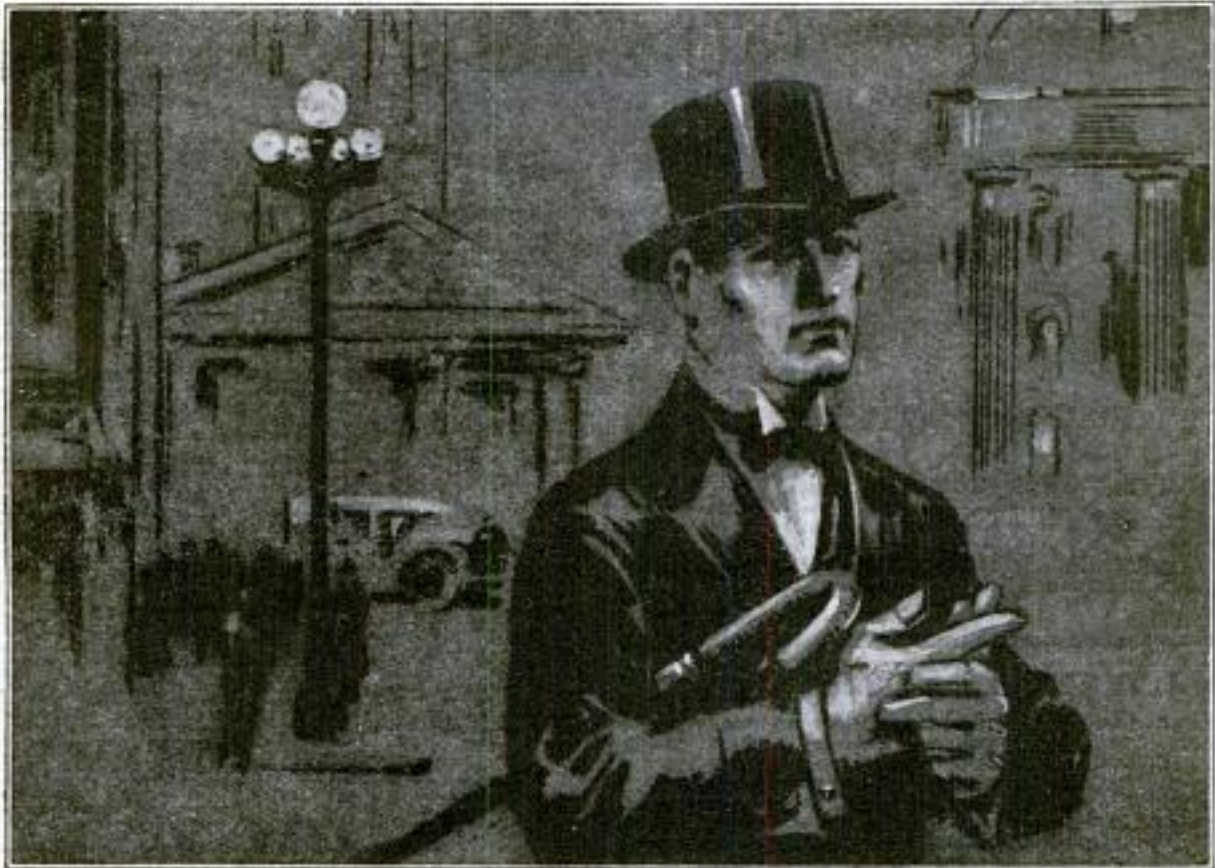

# Follow this Man!

*Secret Service Operator 38 Is on the Job*

Follow him through all the excitement of his chase of the counterfeit gang. See how a crafty operator works. Telltale finger prints on the lamp stand in the murdered girl's room! The detective's cigarette case is handled by the unsuspecting gangster, and a great mystery is solved. Better than fiction. It's true, every word of it. No obligation. Just send the coupon.

## **FREE** The Confidential Reports No. 38 Made to His Chief

And the best part of it all is this. It may open your eyes to the great future for YOU as a highly paid Finger Print Expert. More men are needed right now. This school has taken men just like you and trained them for high official positions. This is the kind of work you would like. Days full of excitement. Big salaries. Rewards.

**Earn \$2500 to \$10000 a Year**  
*You study at home in spare time*

No advance education is needed. Any man who can read and write, and think can make good. A wonderful book tells all about what others have done. Shows pictures of real crimes and the men who solved them. We'll send you a FREE copy with the free reports. Get the special offer now being made. Mail the coupon.

**UNIVERSITY OF APPLIED SCIENCE**  
1920 Sunnyside Ave., Dept. 13-59 Chicago, Illinois

**UNIVERSITY OF APPLIED SCIENCE**  
1920 Sunnyside Ave., Dept. 13-59 Chicago, Illinois

Gentlemen:—Without any obligation whatever, send me your new, fully illustrated Free book on Finger Prints and your offer of a FREE course in Secret Service Intelligence and the Free Professional Finger Print Outfit.

Name.....

Address .....

..... Age.....



## High School Course in Two Years!

### You Want to Earn Big Money!

And you will not be satisfied unless you earn steady promotion. But are you prepared for the job ahead of you? Do you measure up to the standard that insures success? For a more responsible position a fairly good education is necessary. To write a sensible business letter, to prepare estimates, to figure cost and to compute interest, you must have a certain amount of preparation. All this you must be able to do before you will earn promotion. Many business houses hire no men whose general knowledge is not equal to a high school course. Why? Because big business refuses to burden itself with men who are barred from promotion by the lack of elementary education.

### Can You Qualify for a Better Position

We have a plan whereby you can. We can give you a complete but simplified high school course in two years, giving you all the essentials that form the foundation of practical business. It will prepare you to hold your own where competition is keen and exacting. Do not doubt your ability, but make up your mind to it and you will soon have the requirements that will bring you success and big money. YOU CAN DO IT.

Let us show you how to get on the road to success. It will not cost you a single working hour. Write today. It costs you nothing but a stamp.

### American School

Dept. H-974, Drexel Ave. and 58th St., Chicago

### American School

Dept. H-974, Drexel Ave. and 58th St., Chicago

Send me full information on the subject checked and how you will help me win success.

- |                              |                            |
|------------------------------|----------------------------|
| .... Architect               | .... Business Law          |
| .... Building Contractor     | .... Lawyer                |
| .... Automobile Engineer     | .... Machine Shop Practice |
| .... Automobile Repairman    | .... Mechanical Engineer   |
| .... Civil Engineer          | .... Shop Superintendent   |
| .... Structural Engineer     | .... Employment Manager    |
| .... Business Manager        | .... Steam Engineer        |
| .... Cert. Public Accountant | .... Foremanship           |
| .... Accountant and Auditor  | .... Sanitary Engineer     |
| .... Bookkeeper              | .... Surveyor (& Mapping)  |
| .... Draftsman and Designer  | .... Telephone Engineer    |
| .... Electrical Engineer     | .... Telegraph Engineer    |
| .... Electric Light & Power  | .... High School Graduate  |
| .... General Education       | .... Wireless Radio        |
| .... Vocational Guidance     | .... Undecided             |

Name.....

Address.....

WRITE for big book on wrestling. Tells secrets you've always wanted to know.



## Learn How to WRESTLE

In Your Own Home  
By Mail

Yes, learn to become an expert wrestler right in your own home, by mail, from the greatest wrestlers the world has ever known. Be an athlete, be strong, be healthy. Learn how to throw and handle big men with ease. Learn to defend yourself. Learn from the World's Champions.

### Farmer Burns and Frank Gotch Secrets

Farmer Burns, who taught Frank Gotch—trainer of SEVEN World's Champions, will teach you Scientific Wrestling—Physical Culture—Jiu-Jitsu and Self-Defense. Write today for big wrestling book, illustrated with many fine pictures—shows holds and secret tricks used by champions. Tells how easy it is to learn the mysterious breaks, falls and holds that make you an expert. Send today for this wonderful book. Enclose only 10c to help cover cost of wrapping and postage. Be sure to state age. No obligation.

Farmer Burns, 1779 Ry. Exch. Bldg., Omaha, Neb.

Send Now for Farmer Burns' Book

STATEMENT OF THE OWNERSHIP, MANAGEMENT, CIRCULATION, ETC., REQUIRED BY THE ACT OF CONGRESS OF AUGUST 24, 1912, of Popular Mechanics Magazine, published monthly at Chicago, Ill., for October 1st, 1923.

State of Illinois, County of Cook, ss.  
Before me, a notary public in and for the state and county aforesaid, personally appeared H. H. Windsor, Jr., who, having been duly sworn according to law, depose and say that he is the editor and business manager of the Popular Mechanics Magazine and that the following is, to the best of his knowledge and belief, a true statement of the ownership, management, etc., of the aforesaid publication for the date shown in the above caption, required by the Act of August 24, 1912, embodied in section 442, Postal Laws and Regulations, printed on the reverse of this form, to-wit: First, That the names and addresses of the publisher, editor, managing editor, and business manager are: Publisher, Popular Mechanics Co., 300 East Ontario St., Chicago, Ill., Editor, H. H. Windsor, Jr., 300 East Ontario St., Chicago, Ill., Managing Editor, J. K. Weber, 300 East Ontario St., Chicago, Ill., Business Manager, H. H. Windsor, Jr., 300 East Ontario St., Chicago, Ill. Second, That the owners are: (If the publication is owned by an individual his name and address, or if owned by more than one individual the name and address of each, should be given below; if the publication is owned by a corporation the name of the corporation and the names and addresses of the stockholders owning or holding one per cent or more of the total amount of stock should be given.) L. S. Windsor, 300 East Ontario St., Chicago, Ill.; H. H. Windsor, Jr., 300 East Ontario St., Chicago, Ill.; Lina B. Windsor and Henry H. Windsor, Jr., Executors of the Estate of Henry H. Windsor, deceased, Chicago, Ill. Third, That the known bondholders, mortgagees, and other security holders owning or holding 1 per cent or more of total amount of bonds, mortgages, or other securities are: (If there are none, so state.) None. Fourth, That the two paragraphs next above, giving the names of the owners, stockholders, and security holders, if any, contain not only the list of stockholders and security holders as they appear upon the books of the company but also, in cases where the stockholder or security holder appears upon the books of the company as trustee or in any other fiduciary relation, the name of the person or corporation for whom such trustee is acting, in relation; also that the said two paragraphs contain statements embracing affiant's full knowledge and belief as to the circumstances and conditions under which stockholders and security holders who do not appear upon the books of the company as trustees, hold stock and securities in a capacity other than that of a bona fide owner; and this affiant has no reason to believe that any other person, association, or corporation has any interest direct or indirect in the said stock, bonds, or other securities than as so stated by Lina B. WINDSOR, Jr., Editor and Business Manager. Sworn to and subscribed before me this 28th day of September, 1923. J. GRAHAM, Notary Public. (My commission expires June 17, 1925.)

## Learn Photography at HOME

Earn \$3,000 to \$10,000 a year. Prepare quickly during spare time. Also earn while you learn. New easy method. Nothing else like it. Send at once for free book, "Opportunities in Modern Photography" and full particulars. Special offer open now. International Studios, Inc., Dept. 1253, 3601 Michigan Ave., Chicago, U. S. A.

## MUSIC LESSONS FREE

IN YOUR OWN HOME  
You can read Music like this quickly

Piano, Organ, Violin, Mandolin, Guitar, Banjo, etc. Beginners or advanced players. One lesson weekly. Illustrations make everything simple. Only expense about 25 per cent to cover cost of postage and music used. Write for FREE booklet which explains everything in full.

AMERICAN SCHOOL OF MUSIC, 51 Lakeside Building, CHICAGO

## LEARN WATCHMAKING

and become independent. We help you secure a position. Easy to learn. Send for FREE CATALOG.

ST. LOUIS WATCHMAKING SCHOOL, Dept. 5, ST. LOUIS, MO.



MAIL CLERKS WANTED!  
\$1900 TO \$2700 A YEAR  
TRAVEL—See Your Country MEN—BOYS 18 UP  
MAIL COUPON IMMEDIATELY

Franklin Institute  
Dept. K170, Rochester, N. Y.  
Sire: Send me, without charge, (1) Specimen Railway Mail Clerk Examination questions; (2) schedule showing places of U. S. Government examinations; (3) Send list of Government jobs now obtainable.

Name.....  
Address.....



# AUDELS ENGINEERS & MECHANICS GUIDES

## Salary Increased 100 Percent

"Audels Guides gave me information I was unable to get from much higher priced works. By their use I have increased my salary 100 per cent."

C. Pelsor,  
Lic. Engineer,  
Springfield,  
Mass.

## Aid To Getting a License

"My set of Audels Guides are just the books I need as an aid to getting my engineering license. I would not take \$25 for them now or any other time."

R. Anderson,  
Detroit, Mich.

## Guides Great Educators

"I think Audels Guides do more to educate men that want to climb the ladder of success than any other organization or school in the country."

C. P. Luntz,  
Rawlins,  
Wyoming.

Here are the correct answers to Engineering and Mechanical Questions—in a handy form. When you are stuck on a job, consult Audels Guides. It will save time, labor and money for you. These authentic guides teach the best engineering practice. Don't guess or take chances.

**Study your job.** Study Audels Guides on subjects you are interested in. They prepare you for the job higher up. The engineer and mechanic who reads and thinks as he works puts character into his profession. He is the master of his job. He is the outstanding man who is in demand in these days when power plant and boiler room economy is so important.

## Complete Engineering Taught in Practice and Theory in These Practical Pocket-Educators

**Audels Guides** are 8 handy pocket books—price \$12, payable \$1 a month. These up-to-date educators explain in plain language the theory, practices and rules that have to be known by engineers, mechanics, machinists, firemen, oilers, draughtsmen and engineering students.

**Audels Guides** are Good Helpful Counselors, worth hundreds of dollars to any mechanic. By learning more you earn more. Read list of subjects covered—all easy to understand and apply. Engineering calculations figured out in simple arithmetic with sketches and examples.

Judge the value for yourself. Examine Guides *Free!* Send coupon *NOW!* Make up your mind about keeping these educators after a week's trial.

## INFORMATION Answers On:

Engine Principles  
Valve Setting  
Pumps,  
Engines—  
Corliss Engines  
Uniflow Engines  
Pumping Engines  
Contractors Engines  
Locomotives Engines  
Marine Engines  
Turbine Engines  
Gas and Oil Engines

Indicators  
Producers  
Aviation  
Steam  
Fuel Economy  
Boiler Construction  
Firing  
Oil Burners  
Stokers  
Boiler Repairs  
Pipe Fitting  
Heating  
Refrigeration  
Elevators  
Dynamos  
Motors  
Lighting  
Wiring  
Electrical Diagrams  
Radio  
Electrical  
Reference and  
Calculations



\$1 PER MONTH  
SET—8 GUIDES \$12

## ANSWERS—In A Handy Form

These 8 beautiful books are printed in big type, on strong paper. Flexible covers, gold edges. Easy to carry in pocket for daily reading. Handy to keep on table or shelf for quick reference. 4750 pages, 8754 illustrations. Highly endorsed by engineers everywhere as an Educator and a Helper to Better Pay. Examine the set free! Send no money. Pay nothing to postman. Merely tear out and mail this coupon today!

## Our Guarantee

Examine Audels Engineers & Mechanics Guides without charge. If you like this Master Set, keep it. If not, send it back. Pay us only if you are satisfied. No charge if you are not. This is the fair play plan on which we have distributed educational books for nearly 50 years.

# NOW!

The foreman, superintendent, chief of today is the man that yesterday STOPPED EVERYTHING until he got this coupon into the mail! Send this coupon now. Learn more so you can earn more!

**FREE THEO. AUDEL & CO.**  
EXAMINATION COUPON 65 West 23rd St. NEW YORK CITY

Please send me postpaid, for free examination AUDELS ENGINEERS & MECHANICS GUIDES—8 numbers, \$12. If satisfied, I agree to send \$1 in 7 days and \$1 monthly until paid.

Name.....

Address.....

Occupation.....

Employed by..... 12 T 30



## Big Salaries Paid Automobile Experts

*Fastest growing industry in U. S. A.  
offers unusual opportunities to  
trained men*

THE automobile industry is one of the biggest and fastest growing industries in the United States. There are more than 18,000,000 cars registered in this country and the number is increasing every day.

The best way to prepare for success in the automobile field is to study, and there is no better way to do this than through a home-study course with the International Correspondence Schools.

We say this because many of the leading figures in the automobile world today are former I. C. S. students. The list includes Jesse G. Vincent, Vice-President of the Packard Motor Car Co.; Walter P. Chrysler, President of the Chrysler Motor Corporation; E. V. ("Eddie") Rickenbacker; Hiram Walker, Chief Engineer of the Chandler Motor Car Co.; J. V. Whitbeck, President of the Cleveland Automobile Co., and other men equally as famous.

Just mark and mail the coupon and we'll send you information about the I. C. S. Automobile Courses or any other course in which you are interested.

### INTERNATIONAL CORRESPONDENCE SCHOOLS

Box 5341-E, Scranton, Penna.

*Oldest and largest correspondence schools in the world*

Without cost or obligation on my part, tell me how I can qualify for the position or in the subject before which I have marked an X:

- |   |  |
|---|--|
| <input type="checkbox"/> Complete Automobile Course                       | <input type="checkbox"/> Gas Engine Operating                        |
| <input type="checkbox"/> Automobile Electric Equipment                    | <input type="checkbox"/> Complete Gas Engine Course                  |
| <input type="checkbox"/> Electrical Engineering                           | <input type="checkbox"/> Architect                                   |
| <input type="checkbox"/> Electric Lighting                                | <input type="checkbox"/> Architects' Blueprints                      |
| <input type="checkbox"/> Mechanical Engineer                              | <input type="checkbox"/> Contractor and Builder                      |
| <input type="checkbox"/> Mechanical Draftsman                             | <input type="checkbox"/> Architectural Draftsman                     |
| <input type="checkbox"/> Machine Shop Practice                            | <input type="checkbox"/> Concrete Builder                            |
| <input type="checkbox"/> Railroad Positions                               | <input type="checkbox"/> Structural Engineer                         |
| <input type="checkbox"/> Civil Engineer                                   | <input type="checkbox"/> Chemistry <input type="checkbox"/> Pharmacy |
| <input type="checkbox"/> Surveying and Mapping                            | <input type="checkbox"/> Airplane Engines                            |
| <input type="checkbox"/> Metallurgy <input type="checkbox"/> Mining       | <input type="checkbox"/> Agriculture and Poultry                     |
| <input type="checkbox"/> Steam Engineering <input type="checkbox"/> Radio | <input type="checkbox"/> Mathematics                                 |

### BUSINESS TRAINING COURSES

- |  |   |
|--|---|
| <input type="checkbox"/> Business Management                     | <input type="checkbox"/> Salesmanship           |
| <input type="checkbox"/> Industrial Management                   | <input type="checkbox"/> Advertising            |
| <input type="checkbox"/> Personnel Organization                  | <input type="checkbox"/> Better Letters         |
| <input type="checkbox"/> Traffic Management                      | <input type="checkbox"/> Show Card Lettering    |
| <input type="checkbox"/> Business Law                            | <input type="checkbox"/> Stenography and Typing |
| <input type="checkbox"/> Banking and Banking Law                 | <input type="checkbox"/> Business English       |
| <input type="checkbox"/> Accountancy (including C.P.A.)          | <input type="checkbox"/> Civil Service          |
| <input type="checkbox"/> Nicholson Cost Accounting               | <input type="checkbox"/> Railway Mail Clerk     |
| <input type="checkbox"/> Bookkeeping                             | <input type="checkbox"/> Common School Subjects |
| <input type="checkbox"/> Private Secretary                       | <input type="checkbox"/> High School Subjects   |
| <input type="checkbox"/> Spanish <input type="checkbox"/> French | <input type="checkbox"/> Illustrating           |

Name.....  
Street.....  
Address.....

City..... State.....

Occupation.....

*If you reside in Canada, send this coupon to the International Correspondence Schools Canadian, Limited, Montreal*

A FILE
NOT A FILE

## Stop Forgetting

**Make Your Mind** an index from which you select facts, figures, names, faces. Develop concentration, self-control; overcome bashfulness, forgetfulness.

Write today for **FREE** memory and concentration test and illustrated booklet, "How to Remember."

**PROF. HENRY DICKSON**  
Dept. 70512 Evanston, Ill.

## Anyone CAN LEARN

No talent or experience necessary. Fascinating work. Pays big money. Complete instruction book tells about: Alphabets, Colors, How to Mix Paints, Show Cards, Window Board and Wall Signs, Ready made letters, Gilding, Tricks of the Trade, also gives 100 Alphabets and Designs. Book bound in desirable int. leather-gold edges, and four half-bearing Show Card Penn. Sent postpaid \$3.00, (C.O.D.) 10c ex. Galle Pub. Co., 57 West St. Dept. 58, N.Y. City

How to Paint  
**SIGNS**  
and  
**Show Cards**

\$3

**EARN MONEY IMMEDIATELY—  
WE FURNISH EQUIPMENT TO START!!**

## STUDY AT HOME

Directed by

### The University of Chicago

Courses in English, History, Chemistry, Business, Education, Mathematics, Psychology, and 35 other subjects command credit toward a Bachelor degree. Begin any time. Address 15 Ellis Hall, University of Chicago, Chicago, Ill.

## LEARN WATCH REPAIRING

You can learn by our modern and original system of instruction every part of the **Watch Repairing Trade** at home as good or better than at a shop. You can earn money while learning and secure a well paying position or start in business after completing our course of instruction. Good watch repairers are always in demand and earn from \$50 to \$75 per week. For particulars apply to the **Wisconsin School of Watch Repairing** 105 Mason St., MILWAUKEE, WIS.

## PIANO JAZZ

By Note or Ear. With or without music. Short Course. Adult beginners taught by mail. No teacher required. Self-Instruction Course for Advanced Pianists. Learn 259 styles of Bass, 684 Syncopated Effects, Blue Harmony, Oriental, Chime, Movie and Cafe Jazz, Trick Endings, Clever Breaks, Space Fillers, Sax Slurs, Triple Bass, Wicked Harmony, Blue Obligato, and 247 other Subjects, including Ear Playing. 133 pages of REAL Jazz, 25,000 words. A Postal brings our FREE Special Offer.

**Waterman Piano School, 1826W. Adams St. Los Angeles, Cal.**

## No Joke to STAMMER

Successful. Master perfect speech. Win happiness. Send for full information and special photograph record. Dime covers postage.

153 Stimson, The Lewis Institute, Detroit

## No Better Christmas Present for \$2.50

than a year's subscription to

### Popular Mechanics Magazine

Containing 4500 Pictures and 3600 Articles

Much of it Interests Everybody  
Most of it Interests Anybody  
All of it Interests Somebody

Order through your Newsdealer or address the Publisher

### POPULAR MECHANICS COMPANY

200 East Ontario Street, CHICAGO, ILL.

# How a *Faux Pas* Made Me Popular

I never knew it was so easy to be popular until a humiliating experience showed me the secret

**T**HE day I met Grace we went swimming. There was another chap along—Harry something—a dapper, grinning fellow with his hair slicked back. He was awkward in the water and his bathing suit hung about him like a wet sack. I didn't see how Grace could stand him.

## My Fatal Mistake

That night at the hotel dance I learned a lesson. The first couple that caught my eye was Grace and Harry—but what a different Harry! His slick hair and dapper manner seemed to fit the picture perfectly. And how easily—how faultlessly he danced!

"Aren't you going to ask me to dance?" Grace called gaily to me.

I flushed, realizing I couldn't dance a step. "Why, I—I'd love to, but—"

"All right," Grace broke in, "the next dance is yours."

Before I could speak, the orchestra started to play—a dreamy, oriental tune. Grace stood waiting. I could feel Harry's smirking eyes on me. I made a wild stab. "I'm sorry—but I can't Tango."

"That's a waltz!" Grace laughed.

"I don't waltz either," I faltered, realizing I had made a faux pas—a blunder.

"I don't think you want to dance with me at all," she flashed. Before I could explain further, she and Harry had glided away. I stumbled out of the ball room. Grace's last words—"I'll never speak to you again!" were ringing in my ears.

## Why I Never Made Friends

That night I was mighty blue. Why couldn't I make a hit with the girls like the other fellows did? Girls liked me at first but later they went off with fellows who took them dancing. That was my weak point—I could never be popular unless I learned to dance. I had heard of a new way to learn—at home, without music or teacher. Arthur Murray, America's foremost dancing instructor, had perfected this method. I sent for his free booklet and test lesson.

The booklet came promptly and I read it through without stopping. Here was just what I needed. I tried the test lesson and was amazed at the ease with which I was able to master the steps. The lessons were so clear, so simple. I grew confident—eager to dance to music with a real partner.

## An Exciting Night

I continued learning so I could attend the coming mask ball at the hotel.

What an exciting night that was! I danced with many partners, keeping perfect time, gliding around the floor like a professional! Midnight found me dancing with a charming creature in a soft, clinging costume.

"Where did you learn to dance so divinely?" she murmured. She was masked but her voice thrilled me strangely. Later I told her the whole story—How I met a beautiful girl and lost



her in a day—how wretched I felt—how I learned to dance in my own room.

She caught my hand. "Oh, I'm so sorry—" Her voice broke—the voice that thrilled me so strangely. I brushed aside her mask. Imagine my wonder—surprise—joy! It was Grace who was smiling up at me!

What wonderful times we had together after that. We went everywhere—parties, balls and dances. No longer was I a gloomy wallflower, envying others. I was throbbing with new life, new popularity, acclaimed as a faultless dancer wherever I went. The day I wrote to Arthur Murray was certainly the luckiest in my life.

This story is typical. Thousands have learned to dance quickly and easily through Arthur Murray's course. And so can you.

## Free! 32 Page Booklet and Test Lesson

Read Mr. Murray's 32 page illustrated booklet and try the Free Test Lesson which proves how easy it is to learn. The book tells how Mr. Murray became private instructor to the "400," how he taught over 250,000 people to dance by mail, and how he can teach you to become a graceful, popular dancer in a few enjoyable evenings. And you'll enjoy the Test Lesson because it shows how quickly you can become a good dancer. Mail the coupon at once. Enclose only 10c to cover postage and mailing. Arthur Murray, Studio 549, 3 E. 43rd St., New York City.

Arthur Murray, Studio 549,  
3 E. 43rd St., New York City.

Without obligating me in any way, please send me your Free Test Lesson and your beautifully illustrated 32-page book which tells all about Arthur Murray's course in dancing and explains how it can make me a graceful dancer, right in my own home, without music, partner or private teacher. I enclose 10c to cover postage and mailing.

Name.....

Address.....

City..... State.....



I will train you at home in your spare time to fill \$70 to \$200 a week jobs ~~~ **be a BIG-PAY**

# ELECTRICAL

Don't you keep on working for \$25 or \$35 a week. Get into Electricity. Thousands of Cooke Trained Men who knew nothing about it a short time ago are now earning \$70 to \$200 a week in Electricity—and they don't work half as hard as you do. Why stick to your small pay job? Why stick to a line of work that offers no chance—no promotion—no big pay? Get into the world's greatest business. Electricity needs you. I'll show you how to do it. Get ready for the big-pay job now.

## Electrical Experts are in Big Demand

Even ordinary electricians—the "screw driver" kind—are making big money, but trained men—Electrical Experts who get the top salaries—are needed more now than ever before. Thousands of Cooke Trained Men easily earn \$3,500 to \$10,000 a year. That's the kind of a job you want—where you can plan and boss and supervise the work of others or go into business for yourself. Get started towards one of these big-pay jobs now. Learn to earn \$70 to \$200 a week—you can do it with Cooke training—recommended by more than ten thousand successful graduates. Just mail the coupon on the opposite page.

## Employment Service—No Extra Charge

I will train you for a big-pay job and then help you get it without extra charge. Hundreds of employers look to me for the

electrical men they hire. Last year I placed over one thousand men at big raises in pay. Hundreds of others were promoted by their employers through the help of my Vocational Service and other hundreds went into business for themselves with the help of my special Business Training. Mail coupon for big free book which explains this service and fourteen other features, many of which can't be had anywhere else.

## Age or Lack of Experience Bars No One

You don't need experience. You don't have to be a College man. You don't have to be even a high-school graduate. As Chief Engineer of this big two million dollar institution operating one of the world's greatest Training Schools, I know just what training you need to make a big success in electricity. Let me give you that training with my simplified, complete home course—the world famous "Cooke" Training—built on

**L. L. COOKE,**  
Chief Engineer  
Chicago Engineering  
Works, who has trained  
thousands of men for Big-  
Pay Jobs in Electricity.

## FREE to Students

Five big outfits of tools and materials are given free to my students. With these outfits you can perform experiments and do actual money-making electrical jobs. **Send Coupon today** for my big Free Book which tells all about my offer.

# 5

"NOT  
TOYS"

"REAL"  
TOOLS"

WONDERFUL  
WORKING OUTFITS



**\$9,000**  
a  
Year  
Auto Electricity pays W. E. Pence, Albany, Ore., over \$9,000 a year. 28 men enrolled for this training on his recommendation.



**\$125**  
a  
Week  
"Depend on me as a booster," says A. Schreck, Phoenix, Ariz. "I make over \$500 a month. Your advertising next started me to success."

REMEMBER—The COOKE Trained Man ~

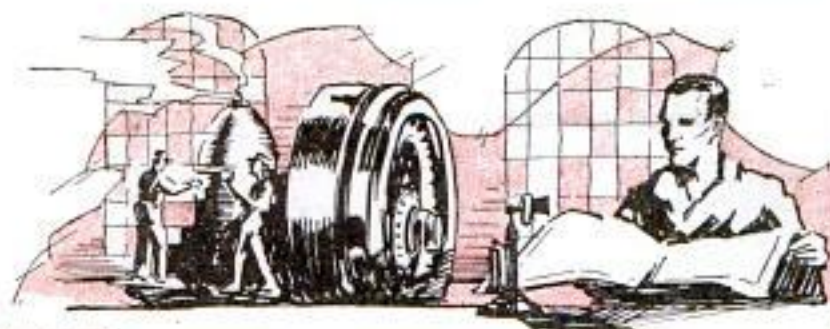

# EXPERT!

my own 20 years of engineering experience with the help of nearly 50 other engineers. Learn to earn \$70 to \$200 a week—only spare time needed.

## My Training Pays for Itself

You can start earning extra money a few weeks after you start my training.

I give you special instruction for doing simple electrical jobs in your spare time—show you how to get these jobs and tell you what to charge. Many of my students make as high as \$25 a week extra this way while studying. My course more than pays its own way.

### Engineers' Association Endorses Cooke Training

The American Association of Engineers, with 15,000 College and Practical Engineer Members, has approved Cooke training and the C.E.W. 100%. Their printed and publicly distributed report of their investigation is the only endorsement of a school they have ever issued. Full details of this endorsement sent with my free book.

## Your Satisfaction Guaranteed

I am so sure I can make you a big success in Electricity, just like I have done for the men whose pictures you see here and thousands of others who now boast my training, that I will guarantee your satisfaction with a signed, money-back guarantee bond. If my training doesn't satisfy you after you have finished, you get back every penny you pay me. A two million dollar institution stands back of this guarantee.

## Get Started Now—Mail Coupon

Get my free book—"The Vital Facts About Electricity." Read about the success of hundreds of other men—men who recommend this training and whose names and addresses are given in my book. Get the real dope about your opportunities in Electricity. See how easy it is to get started on the road to jobs that pay \$70 to \$200 a week. Don't deny yourself this chance to make big money. Get the facts NOW—MAIL COUPON AT ONCE for the facts and my guarantee.

## L. L. COOKE, Chief Engineer CHICAGO ENGINEERING WORKS, Inc.

Dept. 19, 2150 Lawrence Ave., Chicago, Ill.



**\$700 in 24 Days** "Thanks to you I made \$700 in 24 days in Radio," says F. G. McNabb, 848 Spring St., Atlanta, Ga. "I recommend your training everywhere."



**\$400 a Month** "I used to make \$50 a month. Last month with your training I made \$400," writes 71-year-old Carroll Miescher, Chicago, Ill."



is the **BIG-PAY Man** ~ ALWAYS

Thousands  
of  
**COOKE**  
Trained Men  
earn  
**\$3500 to \$10,000**  
a year!

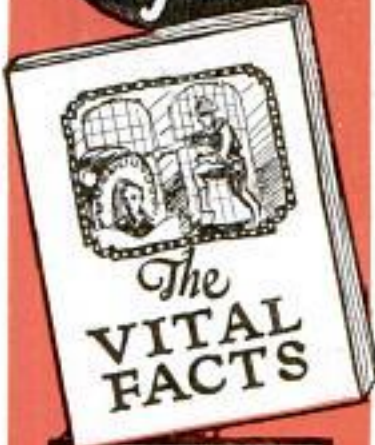

# FREE

My big book — "The Vital Facts"—gives you the "inside dope" on Electricity. Over 100 pictures, hundreds of facts, dozens of letters of PROOF from Cooke Trained Men. Send Coupon NOW!

## Free book coupon

L. L. COOKE, Chief Engineer,  
Chicago Engineering Works, Inc.  
Dept. 19 2150 Lawrence Ave., Chicago, Ill.

Send me at once, without obligation, your big illustrated book and complete details of your Home Study Course in Electricity, including your outfit and employment service offers.

Name .....

Address .....

Occupation .....

**\$1.00 DELIVERS**  
Complete Outfit



**Violet Ray**

**QUICK RESULTS**  
No Medicine

Just \$1.00 brings you a complete outfit identical with the kind doctors have bought from us for years and used successfully in treating the ailments listed. Violet Rays give quick relief, permanent results. They scientifically and painlessly remove the cause of pain and sickness. Dr. L. H. Leight, Millerton, N. Y., writes: "I am having wonderful success in treating neuritis, and all stomach cases. I have given over 2,000 treatments with your outfit."

**10 Day FREE Trial**  
at your home

Send for Violet Ray Outfit without fail. Treat yourself and family with it. You'll be amazed at how Violet Rays enable you to conquer pain, disease, nervous troubles—how they give vigor, beauty, health. Owning an outfit saves doctor bills, delays, medicines—relieves pain. You should have this health machine in your home.

**Send for FREE Book**

Explains how Violet Rays (discovery of the world renowned scientist, Nikola Tesla) work and heal, what doctors and plain folks accomplish with them. Shows charts of human body explaining where pains start and how to banish them. Send for FREE copy today. Free for limited time only. Vi-Rex Company, 211 S. Peoria St., Chicago.

For special free advice,  
state your ailment

— Mail Coupon—Send No Money —

**VI-REX COMPANY**  
211 S. Peoria St., Dept. 212, Chicago

Please send me without cost or obligation your free book describing your VI-REX Violet Ray outfits and details of your \$1.00 offer.

Name.....

Address.....

City..... State.....

Ailment.....

for  
**Health  
Vigor  
Beauty**

Ailments  
successfully  
treated  
with  
**Violet Rays**

**Rheumatism**  
**Neuritis**  
**Paralysis**  
**Catarrh**  
**Nervousness**  
**Skin Diseases**  
**Hay Fever**  
**Headache**  
**Colds**  
**Constipation**  
**Sprains**  
**Asthma**  
**Deafness**  
**Eczema**  
**Eye Diseases**  
**Falling Hair**  
**Goitre**  
**Insomnia**

**New Magnetic Discovery**  
**Builds Health**



Add 10 to 20 years to  
your life with the aid of

**Vit-O-Net Magnetic Health Blanket**

Be in top-notch physical condition—and stay there! The Vit-O-Net Electro-Magnetic Blanket the greatest health discovery in recent years. You can now have a tremendous reserve of real vitality. No longer will you feel nervous, fagged out or dull. Vit-O-Net gives you a new life—new power. Eliminates wastes and dissolves congestions responsible for scores of ailments. It adds years to your life.

**Vit-O-Net Magnetic Health Blanket**

Used by Greatest Hospitals and Physicians

For treatment of Rheumatism, Neuritis, Nervousness, Catarrh, Eczema, Blood Pressure, Kidney trouble, etc. Frequently successful after all other methods fail. Helps to restore health. Pays for itself over and over again.

Read these — "I can attribute my good health to the help of Vit-O-Net." "Received greater benefit from Vit-O-Net than from treatments costing \$1,600.00." "No words can express my love for my blanket." "Would not take \$500.00 for it or do without it for nerves." "I am an entirely new man."

Get Free

Health Document!

Tells why 90% of diseases are caused by improper elimination. Reveals valuable health secrets you ought to know. Write for your copy today!

Representatives Wanted

**Vit-O-Net Mfg. Co.** 4105 Ravenswood Avenue  
Desk 5125, Chicago, Ill.

**Magic Dot**  
**Seals Rupture**

Now you can throw away forever steel bands, chafing leg straps and other heavy makeshift devices. For a well known American scientist has found a new easy way to support rupture assisted by means of a wonderful little invention weighing less than 1-25 of an ounce. Not only do you do away with the objectionable pressure and intense strapping, but you eliminate the "caving down" of rupture—when running, straining, exercising, sneezing, etc.—which too frequently leads to strangulation. So great has been the success of this wonderful device that it is being offered to ruptured people for free inspection. Simply drop a postcard or letter requesting free literature to

**NEW SCIENCE INSTITUTE, 2119 Clay St., Steubenville, Ohio**

**Weight and Health**

**Can Be Restored** in as short a time as 10 days. To prove that you

can be rid of thinness, that tired feeling, sleepless nights, nervousness, and regain normal weight, health and vitality I send you Hilton's Vitamines absolutely free and postpaid to anyone who will write me. No cost. No obligation. If it cures you, makes you strong and gain weight, I will appreciate your telling others. That's all I ask. Simply send me your name and prove that you can feel and look 10 years younger. W. W. HILTON, 748 Gateway Station, Kansas City, Mo.

**NO MORE BALD HEADS**



WHEN our VACUUM CAP is used a few minutes daily. We accept no pay until you have tried the Cap 60 days and are satisfied. The Vacuum Cap is an appliance that draws the blood to the Hair Roots and starts a new healthy crop of hair. It stops Dandruff, stops the hair from falling out.

Bought by Doctors and men who know that it is the only reasonable HAIR GROWER known to science. No Drugs Used. Write for application blank, testimonials and booklet on "HAIR," sent sealed in plain envelope, FREE.

**THE MODERN VACUUM CAP CO.**

O-559 BARCLAY, DENVER, COLO.

# Be a RADIO EXPERT

They Earn \$50. to \$250. a week in Radio—most fascinating work on earth



Learn Quickly And Easily At Home This Practical Way ~ ~ ~ ~



## Government Spending Millions on Radio

U. S. Government now spends millions developing, using Radio. Postmaster General Hays said: "Probably the biggest part in the future of the postal service will be played by Radio." Photo above—sending out time signals at Arlington, great Government Radio station at Washington—Radio is fitting new uses, filling new needs never dreamed of before. Radio Experts see in greater demand than ever.

## Send Coupon Now

Get out of the low-pay rut, get into the most fascinating, easiest big-pay profession on earth. Free Book tells you how. ACT AT ONCE—SEND FOR BOOK TODAY.

## Train At Home For A Big-Pay RADIO JOB

Radio today is urgently in need of trained men—Radio Experts. Astonishing opportunities—thousands of them—have been opened up by enormous strides of the Radio Industry. That's why it's easy to make big money in Radio—\$50 to \$250 a week. Here's a field that is teeming with opportunities and room for expansion—a brand-new, wide-awake, and uncrowded industry. If you're earning a penny less than \$50 a week, clip coupon now for Free Book and proof.

### Your Satisfaction Guaranteed

Master Radio Engineers will show you how to qualify, quickly and easily at home, for Radio's fine jobs. We guarantee to train you successfully. You don't risk a penny, for we will gladly return every cent paid in tuition if upon completion of course you aren't absolutely satisfied. Back of this guarantee stands all the resources of National Radio Institute, U. S. Government-recognized and the Originators of Radio Home-Study Training. Established 1914.

### Age or Lack of Experience No Drawback

You don't need experience before taking this course, and common schooling is enough. Our tested, practical methods make learning clear and easy—the most natural thing on earth.

NATIONAL RADIO INSTITUTE  
Dept. 15-OB Washington, D. C.

### Famous Course That "Pays For Itself"

Spare time earnings are easiest in Radio—receiving sets everywhere nowadays. In every neighborhood there are scores of jobs you can turn your hand to in an hour or so after supper. Right at the start of your course we give you practical money-making lessons which teach you how to do this work, then how to get it—so by our practical plan you can make your course PAY ITS OWN WAY while you're studying.

### Get All The Facts At Once

Astonishing facts on the marvelous new industry of golden rewards—Radio—the fast-growing, live-wire line. Free Book puts all the facts before you. No obligation. Send coupon for it now.

### Instruments Given With Course

Receiving sets, from simplest kind to thousand mile receiver, included without extra charge in your course. Other apparatus given to help you learn. An UNEQUALLED OFFER. Many other big features for limited time only.

### Get This Book

"Rich Rewards in Radio"—most amazing book concerning Radio ever written, will be sent to you promptly when you send the coupon. ACT NOW



### You Can Do What Others Have Done

Why go along at \$15 or \$25 or \$35 a week, when thoroughly-trained Radio Experts earn a hundred or more in the same six days? What this training has done for hundreds of others, it can do for you. Send coupon at once.

Radio Needs Trained Men

## N.R.I. TRAINED MEN ARE SUCCEEDING BIG



### Operates WMAQ

"Accepted a position with Chicago Daily News—Station WMAQ. My income practically doubled, thanks to your fine course." Keith Kimball, Chicago, Ill.



### Gets Big Job

"Just been made Sales Manager of this Radio concern—a big raise in pay. Regret I did not take course sooner." R. E. Jones, Bay City, Mich.

"Your course is completely correct. Radio is worth \$40 week more to anyone in the electrical line. Since graduation have averaged \$50 to \$80 a week more." Preston Fowler, Gordon, Neb.

"The N. R. I. Course has been worth \$2500 a year to me, \$2500 in another year." Thanks a million, Ernest Andrew Shure, Latrobe, Pa.

"My charges for consultation now \$2.50 per hour. The course is worth to me at least \$50,000." R. W. Blackhill, Brooklyn, N. Y.



ORIGINATORS OF RADIO HOME-STUDY TRAINING  
(Established 1914)

## MAIL THIS COUPON

NATIONAL RADIO INSTITUTE,  
Dept. 15-OB, Washington, D. C.

Without obligating me in any way, send your Free Book "Rich Rewards in Radio"—also full information on your practical, home-study Radio course.

Name .....

Address .....

Town ..... State .....

**FREE  
JOB  
SERVICE** for  
Students  
and  
Graduates



**I will train you AT HOME for a better job and a big Raise in pay!** —Chief Engineer Dunlap

If you are now earning less than \$40 a week, better go into Electricity where Experts earn from \$60 to \$125 a week! Men with only common schooling can quickly master my new, simplified Job-Method of instruction. And you can, too!

### Training Built by 23 Noted Engineers

This is not a one-man, one-idea school. 22 famous Engineers and Executives of the following corporations and universities helped me make Dunlap-training complete and up-to-date.

- |                             |                            |
|-----------------------------|----------------------------|
| 1. General Electric Co.     | 8. Underwriters Lab., Inc. |
| 2. Commonwealth Edison      | 9. Columbia University     |
| 3. Crocker-Wheeler Co.      | 10. Dartmouth College      |
| 4. Cutler-Hammer            | 11. Massachusetts Inst.    |
| 5. American Tel. & Tel. Co. | 12. Lehigh University      |
| 6. Westingh. El. & Mfg. Co. | 13. University of Vermont  |
| 7. Western Electric Co.     | AND MANY OTHERS            |

### Many Extras, But No Extra Cost!

The first half of my training is Applied Electricity, a complete course in itself. In the second half I give you Electrical Engineering subjects, Electrical Drafting, Automotive Electricity, Radio, Business Management—all at one small price, and on easy terms!

### 4 Costly Outfits Given

Electricity is easy to learn by the Dunlap Job-Method, because I send you standard tools and materials and put you to work on actual Electrical jobs from the very beginning. First you learn bell-wiring, electric light house-wiring—the real thing, and when you're expert I issue you a WIREMAN'S CARD so you can go out and make money soon after enrolling. Four big outfits in all. One is a fine Radio Set. Another is this \$10 Motor. The same type as the big fellows in a power plant. It's sent knock-down. You wind the field and armature, assemble it, change it over to a generator. That's the way you learn every branch of Electricity here! That's why Burgkart has no trouble in placing my students and graduates in fine positions at good pay.

Mail Coupon quick for free book, guarantee and special offers

**CHIEF ENGINEER DUNLAP**

**The American School**  
Dept. E-974, Drexel Avenue & 58th Street, Chicago

**"I have placed hundreds of Electrical Experts in fine jobs"**

by **A. H. Burgkart**  
Employment Manager

Get ready for these fine

# JOBBS

### ELECTRICAL EXPERTS WANTED

**POWER-PLANT SUPERINTENDENT** wanted, for Middle West light and power property. Fairly good technical education required. Also ability to handle twenty to thirty men necessary. (Name on request.)

**DISTRIBUTION Superintendent** Wanted in town of 10,000 people. Must have experience in operating and maintenance. Location in New England. (Name on request.)

## ELECTRICAL EXPERT

Experienced in mechanical and electrical installations, repairs, tests, plant construction and operation wanted for Florida. (Name on request.)

### MAINTENANCE MAN WANTED

To handle all maintenance work for a group of sub-stations; must be able to make routine tests, inspections and repairs to all sub-station equipment, such as relays, grounds, arresters, transformers, oil switches, etc.; only men accustomed to such responsibility as this will be considered; location Southeastern states; reply giving complete outline of education and experience with references. (Name on request.)

### CHIEF ELECTRICIAN WANTED

For big hotel now under construction. Must understand maintenance, installation and repairs of large privately owned plant. Executive ability essential. (Name on request.)

## Illumination Design Man

Experienced in industrial, commercial and special lighting work in large central station property operating in Eastern Ohio and Western Pennsylvania. Give age, experience, salary expected and when available. (Name on request.)

### \$10 Motor Given



Motor Unassembled



**A. H. Burgkart,**  
the man who helps  
you get your job!

I have placed hundreds of students and graduates of the American School in fine Electrical positions in the past year. I had no difficulty in finding these men good jobs at a big increase

in pay, because Chief Engineer Dunlap has given them real training, the kind of training that employers demand.

### A Twin-Service—Training and Jobs

Opportunities, fine jobs, big pay are waiting for you in Electricity—wiring houses, superintending power plants, building Electrical machinery, in charge of construction, as Chief Electrician, as contractor or foreman. Prepare for these jobs RIGHT NOW! This job-service free to all students and graduates.

**MAIL COUPON TODAY!**

**Chief Engineer Dunlap**  
**AMERICAN SCHOOL, Dept. E-974**  
**Drexel Ave. & 58th St., CHICAGO**

I want to be an Electrical Expert. Please rush guarantee, job-service facts, complete information, money-saving offers.

Name.....

St. No.....

City..... State.....



# Don't Pay Me a Cent If I Can't Give You a *Magnetic Personality* -5 Days FREE Proof!



**N**O matter how lacking you are in qualities of leadership, no matter how colorless, timid, unsuccessful and discouraged you may be, I GUARANTEE to so magnetize your personality that your whole life will be completely transformed!

I can give you poise that banishes self-consciousness, charm that makes you irresistibly popular, personal power that will indelibly influence the minds of others and amaze your friends.

I'll make you a fascinating force in social life, a powerful, dynamic, commanding figure in your profession. You'll become more popular, more prosperous, more gloriously successful than you ever dreamed possible!

Let me send you the proof—absolutely free! If within 5 days you do not experience a decided change in your personality, if you do not find yourself making new friends with ease, if you do not discover yourself already on the way to social popularity, business success and personal leadership—just say so. Tell me my principle of personal magnetism can't do every single thing that I said it would do. And you won't owe me one penny!

## What Is Personal Magnetism?



### What Is Sex Magnetism?

What is that magnetic powerful influence that draws one man to one woman—forever, irresistibly? What is that strange, never-failing spark that awakens love? What is it, in man or woman, that seems to draw and fascinate—the hypnotic power that no one can resist?

You have it. Everyone has it. *But do you use it?*

What is this marvelous force that raises the sick to glowing, vibrant health, the timid to a new confident personality, the unsuccessful to positions of wealth and astonishing power?

You have it—everyone has it—but *not one person in a thousand knows how to use it!* It is not a fad nor a theory. It is simply you, yourself—your manner—your own marvelous personal force, released and magnified a hundred fold in an amazingly clear-as-crystal, scientific way! More necessary than good looks. More valuable than money. For without it a salesman is handcuffed! Without it a business man is powerless to command! No actor, no teacher, no orator, no statesman, can long hold his audience spellbound without this supremely influential magnetic force!

Personal magnetism! How easy to release it! How wonderful its results! No long study or inconvenience. Not the slightest self-denial. Just a simple, clear, age-old principle that taps the vast thought and power resources within you, releases the full sweep of your magnetic potentialities and makes you almost a new person from what you were before!

Personal Magnetism is not hypnotism. Hypnotism deadens. Magnetism awakens, inspires, uplifts. Personal Magnetism is not electricity. It is *like* electricity in one way—while you cannot see it, you can observe its startling effects. For the moment you release your Personal Magnetism you feel a new surge of power within you. You lose all fear. You gain complete self-confidence. You become almost overnight the confident, dominant, successful personality you were intended to be—so fascinating that people are drawn to you as irresistibly as steel is drawn to a magnet!

## The Facts Are Free

The fundamental principles of Personal Magnetism have been put into an extra large volume under the title of "The Cultivation of Personal Magnetism." It is bound in beautiful dark burgundy, with the title gold embossed. Its scope is as broad as life itself. "Fires of Magnetism," "Sex Influences," "The Magnetic Voice," "Physical Magnetism," "The Magnetic Eye," "The Road to Power" and "The Winning Personality" are only a few of the subjects covered in this amazing book. A magnificent book that tells you just how to cultivate the magnetic influence of your nature.

You *can* sway and control others. You *can* command success. You *can* influence people to do the things you want them to do. Through this amazing book you gain the key to a magnetic personality in 5 days—or you don't pay one penny! That is my free offer to you.

## Send Coupon Today

You must see this wonderful volume—examine it—let it influence indelibly your own personality. You send no money with the coupon—you pay no C. O. D. You get the book first. If you aren't stirred and delighted in the 5 days' period, return it and it costs you nothing. Otherwise keep it as your own and remit \$3 in full payment. You are the sole judge. You do not pay unless you are absolutely delighted. And then only \$3.

You simply can't delay! Clip and mail the coupon NOW.

Ralston University Press, Dept. 13-W, Meriden, Conn.

### RALSTON UNIVERSITY PRESS, DEPT. 13-W MERIDEN, CONN.

All right—I'll be the judge. You may send me the volume "Cultivation of Personal Magnetism" for 5 days FREE EXAMINATION in my home. Within the 5 days I will either remit the special low price of only \$3.00 or return the book without cost or obligation.

Name .....

Address .....

City ..... State .....

# Learn Autos In Detroit

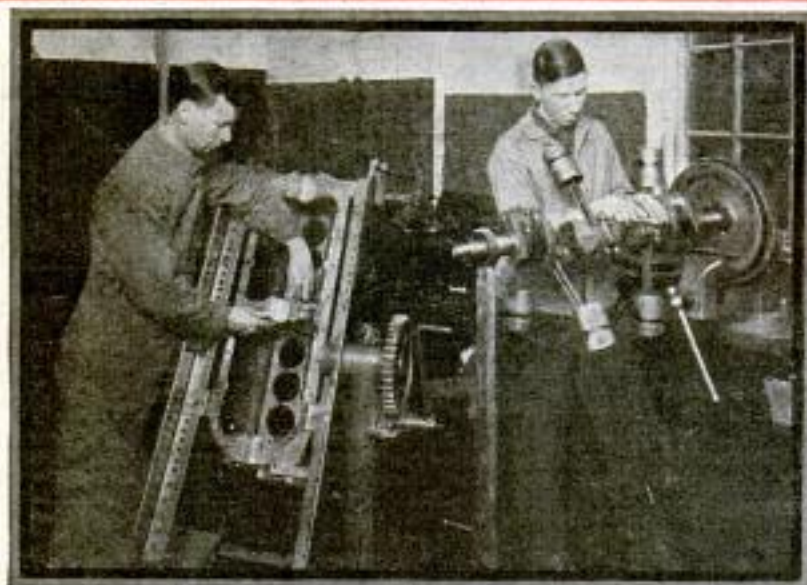

An example of the kind of practical shop training you get at the "Michigan State," in Detroit, the Auto Center. The knowledge we put in your head guides the skill we put in your hands. Sterling Stump (Pa.) says, "There are five garages in our town but half of the car owners ask for me. I am the only M. S. A. S. graduate here."

## No Experience Required

Whether you have auto experience or not, makes no difference. Green men get this training and start at once in better jobs, soon advance to have their own business, make big money. Men who have experience also say this training puts them way ahead of other men, into the big pay class at once, saves them years of dirty work. In just a few weeks, if you start now, you can be earning this bigger pay!

## No Education Needed Either

It just takes common sense, to learn by the practical methods we teach you. Ben Tamura (Hawaii) writes, "Have just started a little shop of my own and am averaging \$300 a month."

## 100,000 Trained Auto Men Needed Yearly

Where can you find such an opportunity as this? The Auto Business has grown in a short period to be the biggest business in the world. Its volume is above that of the steel or railroad industries. And it has more individual opportunities than any other business. A hundred thousand more trained men are needed every year, but they are not produced. So the field is getting bigger all the time. Green men can't draw the good pay. But trained men can. E. J. Aubrey (W. Va.) says, "I am clearing \$50 a week just at home. Haven't even got a shop yet."

## No Exaggeration

Note that we don't promise to put you on top of the world in a few weeks. We know the great need for skilled men, and the wonderful future ahead of you if you get started now. But we know it takes work. It takes real knowledge. And that we can give you. Then start in a good job and advance to big money. Auto knowledge means steady work, wherever you want to go, at good pay, and a certain future.



A class of 600 students in front of the M. S. A. S. Main Building

## By Practical Factory Approved Shop Methods

You can start right now to get ahead in the world! The great success-training of this world-famous "Michigan State Automobile School" can be brought to you at home if you are not ready to come to Detroit now. Read all about it in this announcement. And send the coupon on the opposite page for full detailed outlines of the Courses.

Herbert Wolf (Iowa) wrote us soon after graduating; "I started working for \$30 a week and soon got \$45. Now I have started my own garage and already make \$12 a day or more."

## Factories Endorse These Courses

Auto factories endorse "Michigan State" training methods. Because they are thorough, practical. Because they put knowledge in your head and skill in your hands. Because they really fit you to make good. Harold Grenert (Mass.) says, "Two years ago I left a \$20 a week job. Now I earn \$70 as auto electrician, thanks to M. S. A. S."

## Help to Get Jobs

"Michigan State" trained men are wanted, in Detroit, in your home town, in garages throughout the country. We place many of our graduates directly. This Employment Service is absolutely free. L. T. Middlebrooks (Cal.) writes, "Getting the best pay I ever received and all credit to the M. S. A. S."

## Come to Detroit the Auto Center

Of course Detroit is the place to learn autos. Over three-fourths of all cars come from here. Detroit training is practical training. Stick this in your memory,—the Detroit Trained

man has an immense advantage over all others. So come here as soon as you can. Come now if possible. If you can't come now, start to learn under our Home Study Plan. (This does not cost anything extra.) Then plan to come here to School later to finish in thorough "Detroit training." W. J. Anderson (Minn.) writes, "I used to be a blacksmith's helper at \$15 a month with board. Now I take in \$300 a month in my one-man garage. Soon I'll have a bigger shop and earn more."



**MICHIGAN STATE**  
312 Auto Bldg. Detroit, Mich.

**100,000 Trained Auto Men Wanted This Year**

# Or At Home!

You can earn more money. Skilled auto men are wanted everywhere at good pay. Service managers tell us that 100,000 more trained auto men are needed every year. They don't get a tenth of that number now. Here is your supreme chance to get out of the rut of poor pay. 18 million cars now, and three million or more new every year. Think of it!

L. H. Rafns (Cal.) says: "Have the Ford Agency here. Have disposed of one carload of Fords and have ten on the way now. Parts and accessory sales are about \$500 a week gross."

## Work With Real Tools and Learn to Use Them Right

You must have expert training to get these good pay jobs. We train you with tools. You learn how to use them right. You learn from real practice, how cars are made and how to repair them. You have head training too as well as hand training. The man whose hands only are trained, fails when he

hits the hard jobs. There are no hard jobs for Michigan State trained men, for they have the knowledge in their heads to guide the skill in their hands.

John Grabek (Minn.) writes, "I average \$325 a month on labor plus \$100 profit on parts and accessories."



### FREE Management Course

Through our close cooperation with the auto factories in Detroit, we secure one of the leading service managers to train our students in the business end of running a garage. This training is worth \$100 alone. But it costs you nothing extra. It is just another one of the big advantages of Michigan State training. All students get this free Business Course. A. H. Borland (British S. Africa) says: "I consider the Business Course one of the most valuable parts. You choose most efficient instructors."

### A Business for Go-Getters

The auto business is intensely interesting. There is something new in it all the time. New cars, new types of electrical systems, engines, etc. The skilled man understands these new things at once. He helps car owners when in trouble and quickly gets their confidence. He earns big money by doing this. Put yourself in such a place. As a green man you can never do it. But training will put you there quickly. J. T. Ghiardi (Mich.) says: "I went to two schools before going to yours, but they do not compare with old M. S. A. S." G. W. Raymond (Conn.): "Immediately after graduating I took a position at a Ford Service station, having as a helper a man who had been in the auto game for 20 years."

**AUTOMOBILE SCHOOL**  
3729 Woodward Ave. Detroit, Mich.

**Get Started Now!**

### Send for Photogravure Book

If you want to earn more, mail this coupon today. We'll tell you how to start. Also send you a handsome new illustrated book about Detroit. You ought to know about this great city, which has jumped to fourth in size in a few years. Read about how our graduates earn up to \$200 a week. They tell you in their own words. Get these facts now, for they may mean a wonderful difference in your own life. Don't wait. Fill it in and mail it now.

### I want to Earn More Now!

MICHIGAN STATE AUTOMOBILE SCHOOL,  
312 Auto Building,  
Detroit, Michigan.

Send me FREE and without obligation complete information about Detroit-training to make the most money, also photogravure book on Detroit, "Auto School News," Chart of your Courses, and hundreds of your Graduates' letters.

Name .....

Street or R. F. D. ....

City ..... State .....

I am interested in { 12 Weeks' Auto Course,  
30 Weeks' Master Course,  
Home Study Course



## The Making of an Unusual Salesman

**Here are Some of the Records**

**Big JOBS Now Open**

After spending fourteen years as conductor on a railroad, I came in on my passenger run and never went out again. I saw there were wonderful chances in the selling field; so I started in selling real estate. The first month I did not make a sale. I saw I needed something to help me, so I took up LaSalle training Salesmanship. The next month I made \$700 and last month I averaged better than \$47 a day throughout the month.

C. A. THOMAS, California.

My salary was practically doubled a short time ago, but my greatest satisfaction comes from knowing that the amount of business I have written this year is easily five times greater than before.

S. N. WILLIAMS, Kentucky.

With or without previous experience, you may become an unusually successful salesman. Men who sent for this book from one to six months ago have doubled their earnings.

If you are seeking advancement or greater opportunity, get full particulars of the LaSalle salary-doubling plan. The coupon will bring it to you, together with two valuable books—"The Making of an Unusual Salesman" and "Ten Years' Promotion in One," all without obligation.

If a successful career is worth two cents and two minutes of your time, clip and mail the coupon NOW.

### LASALLE EXTENSION UNIVERSITY

The World's Largest Business Training Institution

Dept. 1264-SR

Chicago

I should be glad to receive an outline of your salary-doubling plan, together with a copy of "The Making of an Unusual Salesman," also copy of "Ten Years' Promotion in One," all without obligation.

Modern Salesmanship—

"The Making of an Unusual Salesman"  
Other LaSalle Opportunities

The LaSalle plan opens the way to success in every important field of business. Check below the opportunity that appeals to you:

- |  |  |
|--|--|
| <input type="checkbox"/> Business Management                       | <input type="checkbox"/> Personnel and Employment Management         |
| <input type="checkbox"/> Higher Accountancy                        | <input type="checkbox"/> Banking and Finance                         |
| <input type="checkbox"/> Traffic Management                        | <input type="checkbox"/> Modern Business Correspondence and Practice |
| <input type="checkbox"/> Railway Station Management                | <input type="checkbox"/> Expert Bookkeeping                          |
| <input type="checkbox"/> Law—Degree of LL.B.                       | <input type="checkbox"/> C. P. A. Coaching                           |
| <input type="checkbox"/> Commercial Law                            | <input type="checkbox"/> Business English                            |
| <input type="checkbox"/> Industrial Management                     | <input type="checkbox"/> Commercial Spanish                          |
| <input type="checkbox"/> Modern Foremanship and Production Methods | <input type="checkbox"/> Effective Speaking                          |

Name.....

Present Position.....

Address.....

## Build Your Own Airplane!



Lincoln Sport Plane with 30-H.P. Anzani engine

**America's Smallest Practical Biplane** now completed, tested and in production.

Price complete, ready to fly, \$1495.00

WE WILL FURNISH YOU PLANS AND MATERIAL TO BUILD THIS SHIP, less motor for **\$147<sup>50</sup>**

**Special Offer:** For the next 30 days we will give you FREE with every order for a set of this material a **Home Study Course in Aeronautics**. This course covers airplane construction and many other subjects which will assist you really in the construction of this ship. Price of Course alone **\$5.00**

You can buy detailed blue prints of above ship without the material for \$15.00.

Write us at once.

Send 4c in stamps for complete catalogs.

**LINCOLN STANDARD AIRCRAFT CORP.**  
LINCOLN, NEBR.

## RAISE BELGIAN HARES

**NEW ZEALAND REDS—Chinchillas—Flemish Giants**  
**MAKE BIG MONEY—We supply stock and pay you**  
following prices for all you raise: Belgian Hares \$2 each—New Zealand \$3 each—Chinchillas \$4 each—Flemish Giants \$5 each. \$2-page illustrated book, catalog and contract, also copy of *Fur Farming* magazine, tells how to raise skunk, mink, fox, etc., for big profits, all for 10c. Address

**OUTDOOR ENTERPRISE CO., Box 25, Holmes Park, Mo.**

## A PERFECT LOOKING NOSE

Can Easily Be Yours

**Trados Model No. 25** corrects now ill-shaped noses quickly, painlessly, permanently and comfortably at home (excepting cases caused by improper bone structure). It is the only adjustable, safe and guaranteed patent device that will actually give you a perfect looking nose. Over 90,000 satisfied users. For years recommended by physicians. 16 years of experience in manufacturing Nose Shapers is at your service. **Model 25 Junior** for children. Write for testimonials and free booklet, which tells you how to obtain a perfect looking nose.

M. TRILETY, Pioneer Nose-shaping Specialist  
Dept. 2478 Binghamton, N. Y.



## BOW LEGS?

OUR GARTER (PAT'D)

**Makes Trousers Hang Straight**

If Legs Bend In or Out. Self Adjustable.  
Free Booklet—Plain Sealed Envelope

**THE T. GARTER CO.** Dept. 2, New London, New Hampshire



## FREE Book on Deafness

Write today for 168 page FREE book giving full particulars and testimonials from hundreds of grateful users whose hearing has been restored by use of our "little wireless phones for the ears."

**Wilson Common-Sense Ear Drums** require no medicine but effectively replace what is lacking or defective in the natural ear drums. They are simple devices, which the wearer easily fits into the ears where they are invisible. Soft, safe and comfortable.

**WILSON EAR DRUM CO., Incorporated**  
199 Todd Building LOUISVILLE, KY.

# Obscurity to Limelight and now Fame & Fortune!

Another JIMMY DeFOREST  
Trained Boy Hailed By News-  
papers as a "SENSATION"

You can do what Joe Canamare has done, for he has not always been a boxer. Until a very short time ago, he delivered laundry! His future was uncertain and his struggle for existence in the crowded East Side of New York was anything but easy. Today he is in the limelight! He has money to spend. He is a hero and idol whenever he appears in the ring. He is called by the newspapers the "Welterweight Sensation." Fame and fortune are now within his grasp!

## The Same Instruction That Made This Lad a Sensation Is Available To You

Without leaving your home or interfering with your present occupation you can learn all there is to know about boxing. All that I taught Jack Dempsey, Firpo, Pal Moore, Joe Gans and a host of other champions and great contenders about Attack, Defense, Ring Strategy and Generalship and the Tricks of the Game has been set down in my complete Course by Mail. Thousands are now learning to box under my direction by this method, where formerly I could train only two or three at a time in person. My methods, instructions and newly devised illustrations are so easy to understand that anyone can become a scientific boxer in an amazingly short time.

### 20 Weeks All You Need

Many of my boys were the rawest novices 20 weeks ago. Today they are clever boxers and are already tasting some of the glory and fat purses that will be theirs in a very short time. In 20 weeks I will teach you all there is to know about boxing so that you can enter a profession where fortunes are being made—or if you prefer, use your knowledge and new-born strength for self defense or keeping yourself fit.

**JIMMY DeFOREST**  
347 Madison Ave., Box 726, New York



## CANAMARE STOPS CUCCIA IN FIRST

Commonwealth Bout Has All  
the Skills of Dempsey-  
Firpo Battle

Joe Canamare, new welterweight sensation, scored another quick and impressive one-round knockout at the Commonwealth S. C., last night, when he put Tommy Cuccia out in 3 minutes and twelve seconds of the first session of their six-round contest. The bout was reminiscent of the now historic Dempsey-Firpo encounter.

When the pair came together in a hot mixup at the opening gong, Cuccia swapped punches with the hard-hitting Canamare, who has earned the reputation of a deadly hitter. One of Cuccia's wallops connected with Canamare's jaw and toppled him through the ropes. Joe, though dazed, hustled back to the centre of the ring, and in the ensuing mixup landed one of his "pile-drivers." Cuccia, though a sturdy battler who can take it, dropped as if he had been pole-axed, and the referee counted him out.

Canamare got a great ovation from the fans. Practically all of the other boxers on the card huddled around the ring or back among the spectators to see Canamare in action. After the bout Jess Mahon, matchmaking director of the club, said:

"I'll have Canamare back here next Saturday night if I can find an opponent who will meet him. But it's a tough job. Six leading welterweights turned down offers to meet him tonight, and it was only at the last minute, practically, that Cuccia consented to go on with him."

Canamare learned his boxing and how to hit from that past master of the art of fist-cuffs, Jimmy de Forest. Jimmy sat near his corner last night.

From the  
NEW YORK WORLD  
SEPT. 6th 1925

## I Am Looking for Boys to Train at My Camp— Without Cost

Every six months I select champions in each weight division from my pupils. I also select a second and a third choice in each division so that in the event any of the champions cannot come to my camp the second or possibly the third man will be called. If you are one of those selected you will receive a railroad ticket to my camp and all your expenses will be paid while you are under my personal training. The whole trip will not cost you a cent.

## My Champs Will be Fea- tured in New York City Bouts

After I finish polishing off my champions at my camp, I will match them for bouts at one of the big New York City Clubs.

If you are one of these lucky lads your future as a boxer will be assured. You will be off to a flying start and nothing will stand between you and a successful ring career with all of its glory, fat purses, and a life of ease and travel.

## Send for my New Book, "The Golden Age of Boxing"

It is brimful of action.

Contains many photos of great ring battles and champions. It explains how I teach boxing so successfully by mail and shows some of the special picture charts I use in my instructions. It contains a complete outline of my course, week by week. Send 10c to cover cost of mailing and postage and I'll send you a copy at once. Opportunity is knocking at your door. NOW is the time to ACT. Mail the coupon TODAY!

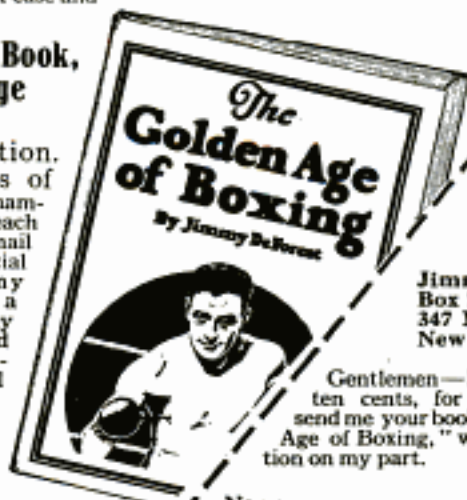

Jimmy DeForest  
Box 726  
347 Madison Ave.  
New York City.

Gentlemen—Enclosed find ten cents, for which please send me your book "The Golden Age of Boxing," without obligation on my part.

Name.....

Street No.....

City..... State.....



# Men Wanted TO COME TO DETROIT AND Learn a Trade AT THE DETROIT SCHOOL OF TRADES

**Endorsed by Contractors, Builders  
and Manufacturers**

Come to Detroit. Enroll in our School. Learn one of these high paying trades and your success in life is assured. We teach you on the actual work. You use the tools; not books.

- |             |                   |                   |
|-------------|-------------------|-------------------|
| Bricklaying | Electrical        | Auto Mechanics    |
| Plastering  | Paper Hanging     | Auto Trimming     |
| Plumbing    | Painting and      | Metal Finishing   |
| Carpentry   | Decorating        | Auto Painting     |
| Estimating  | Sign Painting     | (Duco-Zapon)      |
| and         | Show Card Writing | Acetylene Welding |
| Contracting | Auto Striping     | - and -           |

### SPECIAL CUSTOM SHOP COURSE

Why work for low wages when you can make from \$8.00 to \$14.00 per day at any of these trades after a short practical training at our School?  
Reasonable tuition rates.

#### RETURN COUPON

**DETROIT SCHOOL OF TRADES,**  
217-221 Woodward Ave., Dept. 125-A, Detroit, Mich.  
Please send me without obligation on my part full information regarding your School of Trades.

Name.....  
Address.....  
City and State.....  
Trade interested in.....  
We have no facilities for negroes

Learn...

# Electricity

**Men Wanted**  
For World's Highest Paid Profession

Big-pay jobs now open for electricians everywhere. We train you for expert's pay with most complete course, in heart of electrical projects. National training has made thousands of men successful

**YOU**  
Earn \$60  
to \$100 a  
Week Up—  
by this Guar-  
anteed Actual  
Training Method!

Learn a trade, the easy way—in laboratories and working on \$250,000.00 worth of new equipment. Special Commercial Radio Courses. Big electrical firms always want National-trained men. Write now for information about opportunities awaiting you here and



**FREE HANDBOOK**  
Tells you how to be a high-paid electrical expert quickly.

**NATIONAL ELECTRICAL SCHOOL**  
Dept. 71 Figures & Santa Barbara St.,  
Los Angeles, California



# BECOME A LANDSCAPE ARCHITECT

Established 1916.

Dignified, exclusive profession. Little competition. \$5,000 to \$10,000 incomes for experts. Easy to master under our correspondence methods. Assistance extended to students and graduates. Write

**AMERICAN LANDSCAPE SCHOOL, 107-NA NEWARK, NEW YORK**

## Delivered to You Free

for 30 days trial on approval. You can have your choice of 44 Styles, colors and sizes of the famous **RANGER Bicycles**. Express prepaid. **Factory-to-Rider** Prices save you \$20 to \$25 on your bicycle. **\$5 a Month** if desired. Many boys and girls easily. Parents often advance first payment.



**Tires**—best quality, at factory prices, express prepaid. **Mead CYCLE COMPANY**  
Lenses, wheels and equipment, low prices. Send **DEPT. A- CHICAGO**  
No Money, do business direct with makers.

Write today for free Ranger Catalog, Factory prices and marvelous easy payment terms

# U. S. Government Jobs



## \$1140 to \$3000 Year

**Many Positions: Railway Postal Clerks, City Mail Carriers, Income Tax Auditors, City Postal Clerks, Clerk at Washington, D. C.**

**MEN—WOMEN 18 OR OVER**

**Short Hours Pleasant Work**

**Rapid Advancement  
Permanent Employment  
Long Vacation with Pay**

Mail Coupon Now. Act at Once.

**DO IT TODAY**  
You may forget tomorrow

**FRANKLIN INSTITUTE**  
Dept. K178, Rochester, N. Y.

Kindly send me without any obligation whatever on my part, and entirely free of charge: (1) A full description of the position checked below; (2) Free Specimen examination coaching; (3) Free copy of illustrated book, "Government Positions and How to Get Them"; (4) A list of U. S. Government Jobs now obtainable.

- ... Railway Postal Clerks ..... (\$1900-\$2700)
- ... Post Office Clerk..... (\$1700-\$2100)
- ... City Mail Carrier..... (\$1700-\$2100)
- ... Clerk at Washington, D. C. .... (\$1140-\$1860)
- ... Income Tax Auditors..... (\$1860-\$3000)

Name.....  
Address.....

Use This Coupon Before You Mislay It—WRITE OR PRINT PLAINLY.

**B. W. COOKE**

Directing Engineer

# Be an AUTO EXPERT

Earn up to **\$150** a Week



Put an end to Low Pay right now! Don't keep on working for ordinary pay. Be an Auto Expert. Get into the class of men who earn up to \$10,000 a year. Clip that coupon this very minute—I'll send you my big book "Auto Facts" absolutely free! I'll show you how you can make the BIG MONEY. I'll give you proof that you can raise your pay quick—write now!

**B. W. Cooke.**

## "I Owe It All to B.W.Cooke"

My Free Auto Book will show you the secret that caused one man to rise from ordinary store clerk to the head of a fine money-making Auto Business—another to double his salary in a few short months—how hundreds of men got QUICK RAISES IN PAY—and BIG MONEY through Cooke "Job-Way." It will show you why men like M. J. Morrison, Parkersburg, W. Va., who tripled his salary quick and today is proprietor of his own Garage, say "I owe it all to B. W. Cooke." Proof that you can be a success is what you want. Proof is what I'll give you!

**NOW FREE!**

The Book that Shows the Way to a **BIG PAY JOB AND A RAISE**

I'll send you Absolutely Free the same amazing book that has shown hundreds of men like you the quick way to the BIG PAY class as Auto Experts. It is the book that has doubled and tripled men's salaries quick—the book that has brought big extra spare time money to men all over the world—and put others in their own money-making Auto Businesses in record breaking time. It points the way to a BIG JOB and a QUICK RAISE IN PAY FOR YOU!

Send Coupon Now

Be sure to send coupon at once for this remarkable book. Right now I am in a position to make you an outstanding offer of 4 Big Outfits which I'll include without a penny's extra cost. Get all the particulars at once!

Clip Coupon Now!

The **5** Thousand Million Dollar Industry

Every year car owners spend 5 Thousand Million Dollars for Auto Up-keep alone. That's why there are so many wonderful opportunities everywhere—in city or town, village or country—to start your own business—to be your own boss quick and make up to \$10,000 or \$15,000 a year with Cooke "Job-Way" training behind you. This Auto Business is the **ONE BUSINESS** for the man who wants BIG SUCCESS and MORE PAY—and wants it quick! It's the **BIG PAY BUSINESS FOR YOU!** Get all the facts. **Clip Coupon Now!**

**LEARN AT HOME!** The Cooke "JOB-WAY" Now!

Don't lose a day or a dollar to become a trained Auto Man. Keep your job and pay! My Free Book shows how I train you for Big Pay right in your own home. You don't need a lot of ready cash either. My big offer brings you the training you need to MASTER Auto Work—to boss the job—for just a few cents a week. If you are between the ages of 16 and 60, and can read and write plain, easy English—then write today. I'll show you the way to reach the Big Pay class quick! Find out why Cooke "JOB-WAY" is known as "the Training that pays its Own Way." Remember nowhere else on earth can you get the original, genuine, copyrighted Cooke "JOB-WAY" Home training. Mail that coupon to me now. It will bring you the full particulars!

**See How I Back You Up**

A big pay JOB and a QUICK RAISE is what you want. See how the demand for B. W. Cooke "JOB-WAY" trained men grows greater and greater every year. See how my Employment Department stands behind you your whole life long. How my Consultation Department helps you with your troubles all your life. Get all the facts. Clip the coupon now and read without delay!

**B. W. COOKE DIRECTING ENGINEER**  
CHICAGO MOTOR TRAINING CORPORATION  
1916-1926 Sunnyside Ave., Dept. 916-A, Chicago

## \$300 in a Week!

\$21 a week is all 18 year old Joseph Woronecki, 186 Affick St., Hartford, Conn., was making when he sent for my Book. Now he writes "By following your way I am making good money. Last week I drew in clear money THREE HUNDRED DOLLARS." Think of it. \$300 in a week! That's the kind of BIG PAY opportunities that are waiting for you!

## Make Money Quick!

My training brings results so quick, it's positively amazing! Take J. F. Plov, Box 379, Ironwood, Michigan. Right in the beginning of his training, he writes me that he has already boosted his pay \$30 a week since the day he enrolled. And he adds: "I can't get away without thanking you for it—Your course is one in a Million." Find out about this remarkable "quick-results" training today.

Get into the **AUTO BUSINESS**  
The biggest business in the world!

My big Free Auto Book shows you how. Think of it—18,000,000 cars on the roads today! Millions of new cars added every year! With all this tremendous growth there are less than half as many Repair and Service organizations per 1000 cars as there were 10 years ago! Thousands of money-making opportunities for you in this gigantic industry, the business that has become the **BIGGEST IN THE WORLD** even larger than the Steel Industry in value of production. Thousands of trained men are needed for the BIG JOBS—to boss the big business.

**MORE BIG PAY JOBS** are open for the trained man than ever before!

Big Outfits included FREE of Extra Cost

Act quick! Right Now I am Including Absolutely Free of extra cost, a fine set of

Mechanics Tools—Portable Electrical Test Bench and Radio Receiving Set—all equipment, also 292 Wiring Diagram Charts worth more than many which sell for as much as \$10.00.

Clip Coupon for full details.

**MAIL THIS "JOB-WAY" COUPON**

B. W. COOKE, Directing Engineer,  
Chicago Motor Training Corporation,  
1916-1926 Sunnyside Ave., Dept. 916-A,  
Chicago, Ill.

Send me your Free Book "AUTO FACTS" and PROOF that you'll show me the way to a QUICK RAISE and BIG PAY as an AUTO EXPERT. Also send your new 4 Outfits Offer. It is understood that this obligates me in no way, and that no salesman will call on me.

Name..... Address.....

## Learn Plumbing and Heating at Home



### Former Apprentice Now Earning \$360 to \$400 a Month

"When I enrolled with the I. C. S.," writes H. D. Dunn, "I was an apprentice. At the time I took the course the boss laughed at me, but in less than two months I could tell him things once in a while. And a few months later he decided to take up an I. C. S. course himself!"

"I now have my own plumbing and heating business and my income is between \$360 and \$400 a month."

Mr. Dunn is just one of thousands of men who have found that the best way to earn promotion and a larger salary is through the home-study courses of the International Correspondence Schools.

The Plumbing, Heating and Ventilation Courses are particularly attractive right now because of the unprecedented boom in building. These courses cover the entire needs of the trade and they are written by men who have spent years in doing the very work you want to do and who know the quickest, easiest, best way to show you how to solve every problem.

Just mark and mail the coupon and we will gladly send you free booklets describing the I. C. S. Plumbing, Heating and Ventilation courses or any other course in which you are interested.

The  
I. C. S.  
is the oldest  
and largest  
correspondence  
school in the  
world

#### INTERNATIONAL CORRESPONDENCE SCHOOLS Box 3542-E, Scranton, Penna.

The oldest and largest correspondence schools in the world

Without cost or obligation on my part, please tell me how I can qualify for the position or in the subject before which I have marked an X:

- |   |  |
|---|--|
| <input type="checkbox"/> Complete Plumbing and Heating Course             | <input type="checkbox"/> Plumbers' and Steam Fitters' Course |
| <input type="checkbox"/> Complete Plumbing Course                         | <input type="checkbox"/> Short Plumbing Course               |
| <input type="checkbox"/> Complete Heating Course                          | <input type="checkbox"/> Steam Fitters' Course               |
| <input type="checkbox"/> Complete Inspectors' Course                      | <input type="checkbox"/> Ventilation                         |
| <input type="checkbox"/> Electrical Engineering                           | <input type="checkbox"/> Business Management                 |
| <input type="checkbox"/> Electric Lighting                                | <input type="checkbox"/> Industrial Management               |
| <input type="checkbox"/> Mechanical Engineer                              | <input type="checkbox"/> Personnel Organization              |
| <input type="checkbox"/> Mechanical Draftsman                             | <input type="checkbox"/> Traffic Management                  |
| <input type="checkbox"/> Machine Shop Practice                            | <input type="checkbox"/> Business Law                        |
| <input type="checkbox"/> Railroad Positions                               | <input type="checkbox"/> Banking and Banking Law             |
| <input type="checkbox"/> Gas Engine Operating                             | <input type="checkbox"/> Accountancy (including C. P. A.)    |
| <input type="checkbox"/> Civil Engineer                                   | <input type="checkbox"/> Nicholson Cost Accounting           |
| <input type="checkbox"/> Surveying and Mapping                            | <input type="checkbox"/> Bookkeeping                         |
| <input type="checkbox"/> Metallurgy <input type="checkbox"/> Mining       | <input type="checkbox"/> Spanish                             |
| <input type="checkbox"/> Steam Engineering <input type="checkbox"/> Radio | <input type="checkbox"/> French                              |
| <input type="checkbox"/> Architect  | <input type="checkbox"/> Salesmanship                        |
| <input type="checkbox"/> Architects' Blueprints                           | <input type="checkbox"/> Private Secretary                   |
| <input type="checkbox"/> Contractor and Builder                           | <input type="checkbox"/> Better Letters                      |
| <input type="checkbox"/> Architectural Draftsman                          | <input type="checkbox"/> Show Card Lettering                 |
| <input type="checkbox"/> Concrete Builder                                 | <input type="checkbox"/> Stenography and Typing              |
| <input type="checkbox"/> Structural Engineer                              | <input type="checkbox"/> Business English                    |
| <input type="checkbox"/> Chemistry <input type="checkbox"/> Pharmacy      | <input type="checkbox"/> Civil Service                       |
| <input type="checkbox"/> Automobile Work                                  | <input type="checkbox"/> Railway Mail Clerk                  |
| <input type="checkbox"/> Airplane Engines                                 | <input type="checkbox"/> Common School Subjects              |
| <input type="checkbox"/> Agriculture and Poultry                          | <input type="checkbox"/> High School Subjects                |
| <input type="checkbox"/> Mathematics                                      | <input type="checkbox"/> Illustrating                        |

Name.....

Street.....

Address.....

City..... State.....

## Young outdoor men wanted



To a few sturdy young men—lovers of fresh air and sunshine—who want to get away from the grind of indoor work—John Davey's national organization, The Davey Tree Expert Company, offers an exceptional opportunity. Constantly increasing demand will create a limited number of openings. Those young men selected will be thoroughly trained by the Company and given a permanent position if they make good. If you are single, between 20 and 30 years of age, free to travel, healthy, industrious, having a good practical education, and able to furnish satisfactory references, you have a good chance to qualify. Pay is good at start, advancement assured on merit. We want only men who desire permanent employment in a growing organization and will accept only clean, sturdy young men, thorough Americans, not afraid of vigorous outdoor work. Write for additional information and qualification blank to serve in place of personal interview. The Davey Tree Expert Co., Inc., 301 Federal Bldg., Kent, Ohio.

## Welding

Expert welders are in demand in all parts of the world! Put yourself in the expert class with KERR'S MAIL TRAINING COURSE! Learn PRACTICAL welding at home and on the job. All metals covered, also cutting and brazing. Satisfy yourself before enrolling. Write for terms and a 5-day FREE EXAMINATION OF LESSONS. Give name, address, and where employed as reference. State if you have use of welding outfit, and that you will return lessons in good order, postpaid, within 5 days in case you don't enroll.

KERR'S WELDING SCHOOL, Box 1313, Dept. 2, Los Angeles, Cal.

## Learn Advertising at HOME

The highest paid men in the world are advertising men. You can learn easily and quickly at home during your spare time. Easier opportunities now in advertising than ever before. Tremendous demand for our graduates at big pay.

Send for FREE Book. Giving interesting information and vital facts—just what you want to know about advertising. Write today! PAGE-DAVIS SCHOOL OF ADVERTISING Dept. 1359 3601 Michigan Ave., Chicago, U. S. A.

## BOYS & GIRLS EARN XMAS MONEY

We trust you. Write for 20 sets Christmas Seals. Sell at 20 cents a set. Return us \$2.00. Keep \$2.00 yourself. Easy to earn \$10 before Christmas. F. B. WARNER COMPANY, 90 Chambers Street, Department T29, New York City

### \$100<sup>00</sup> EARNED BY YOUNG ARTIST IN 2 DAYS



Well-trained artists earn splendid incomes. The Federal home-study Course is a proven result-getter. If you like to draw, send 6c in stamps for 56-page book "Your Future."

State your age and present occupation.

**FEDERAL SCHOOL OF COM'L DESIGNING**  
611 Federal Schools Building  
Minneapolis, Minn.



# Play Tenor Banjo Like a Professional



Learn at Home—In Your Spare Time

Your Way to Success and Popularity

Prof. Harry S. Siz was for 22 years head of Glee and Instrumental Clubs of N. Y. University. His method enables you to play real music the first day.

**FREE**  
\$18.00 Tenor Banjo  
when you  
enroll



Shortly after you enroll, you will play tenor banjo like a professional. Our method of teaching you to read notes is as easy as A B C's. You quickly win your way to success and popularity. When you stop to think that artists as Paul Whiteman, Vincent Lopez and an endless chain of others have become independently wealthy through music, doesn't it make you stop and think—doesn't it make you wish that you, too, could have all these pleasures?

Musicians become internationally famous and travel all over the world. They receive invitations from heads of nations. You can enjoy the same success, perhaps in a smaller way in your own home town, because tenor banjoists are in demand, both as professionals and for home entertainment. Be popular in your set and receive invitations. Answer this advertisement at once and secure a genuine, full tone, professional size tenor banjo free with our course when you enroll as a student in our academy. Our method of home instruction is so easy, you will play real music the first day.

**Tenor Banjo**  
Given With  
Course for  
Limited  
Time  
Only

## Learn Quickly With Our Picture Method

Arthur Brisbane, the highest paid journalist in the world, once said that "a single picture is worth a thousand words." He was right, for it stands to reason when you take your instrument in hand along with actual photographs of our professors in action as your guide. It is easy to imitate and do the right thing. All you have to do is put the pictures before you and copy them—just the same as you would if you were sitting in our studio and getting personal instruction.



## Our Professors' Phonograph Records FREE

We also furnish as an additional guide, phonograph records of our professors playing the pieces you are learning along with our thorough printed and illustrated, easy-to-read course. This plan in reality and almost in actuality brings our professors to you in your own home. You have the opportunity to hear them play the piece you are learning, and you can accompany them with the aid of your own phonograph.

## Learn to Play for a Few Cents a Day

Regardless of the size of your purse, you cannot afford to miss this opportunity. There is no reason why you need hesitate to send for particulars because the payments are so small that they really amount to a few cents per day. Every student who enrolls at once will also secure a handsome, full tone, professional size tenor banjo free with the course when they enroll. You will be surprised how much we give you for a very little money.

## No Forming Class to Wait For

**Rush Coupon  
for FREE  
Information  
Booklet**

Send in coupon at once and receive full particulars. You can enroll immediately and get full benefit of the complete New York Academy of Music course without waiting for a forming class. There are no delays whatsoever. You start your lessons at once.

**NEW YORK ACADEMY OF MUSIC**

Studio 19, 100 Fifth Ave.

NEW YORK, N. Y.

## We Furnish Everything Including Tenor Banjo

When you enroll for our tenor banjo course, we start you off by presenting you with an \$18.00, full professional size, tenor banjo. We furnish every bit of equipment including a picture of the finger-board with all the notes placed in their proper positions. You get six months' free service after you graduate and have received your diploma. Send for free particulars today.

## Don't Send a Single Cent

Investigate today. Don't put off until tomorrow because you might forget and miss this wonderful opportunity. It might be the turning point in your career. Don't send a single cent. Use coupon or postal card will do—telling you are interested in receiving full particulars and to reserve a regular eighteen dollar, full size, professional tenor banjo for you. Act quickly.

**New York Academy of Music,  
Studio 19, 100 Fifth Avenue, New York, N. Y.**

Please rush all information relative to your tenor banjo course and receive a gift \$18 full tone professional size tenor banjo for me. This obligates me in no way whatever.

Name .....

Address .....

City..... State.....



Martin Ferri, Tiltonville, O., jumped from \$100.00 to \$300.00 a month after taking my Course. He specializes in Auto Electricity

The  
"Cooke"  
Trained  
Man  
Is the  
Big Pay  
Man!

**Free!**

the coupon  
brings  
you this  
Big  
Book  
Free!



# Electricity Needs You!

## Get Into This Interesting Big Pay Work—

### LEARN TO EARN \$70 TO \$200 A WEEK

Yes, you can make \$70 to \$200 a week in Electricity and not work half so hard as you do now. You can earn \$3,500 to \$10,000 a year as an Electrical Expert and I will show you how to do it. And with the 5 Big Outfits given to students, you can make extra money in your spare time, right at the start, while you are getting ready for the big job which I will help you get. The whole world is rapidly being electrified. Over a million homes a year are being wired for electric light. Hundreds of huge power houses are constructed every year. Entire railroad systems are replacing steam with electricity. Radio—Automobiles—Mining—Manufacturing—all depend on it. Electricity is the biggest thing in the world today.

### TRAINED MEN NEEDED EVERYWHERE

Right now there are more big jobs open to trained men than there are men to fill them. Even ordinary screwdriver electricians make \$8.00 to \$10.00 a day, but here's your chance to get a real job—a bossing job—the kind that pays \$12.00 to \$30.00 a day—or go into business for yourself—and you can get ready for it in a few short months' time right in your own home.

### EXPERIENCE UNNECESSARY

Don't hold back—Don't rob yourself of the things you want just because you may not know anything about electricity now. Nine out of ten of the thousands of successful, big-money men I have trained didn't know the first thing about it when they started with me. Don't let lack of education stop you either. If you can read and write I can make you the success you want to be and I will guarantee your satisfaction with a signed, MONEY BACK guarantee bond.

### WHY I CAN TRAIN YOU QUICKLY

As Chief Engineer of a two-million dollar corporation, and with 25 years of engineering experience, I know exactly what you must know to earn \$12 to \$30 a day as an Electrical Expert. That's exactly what I give you. My students get the big jobs because through my connections with the great Electrical Industry I know where the big jobs are and I train my "boys" to fill them and then I help them get them. The Cooke Trained man is the big pay man—ALWAYS.

### SEND FOR MY BIG FREE BOOK

The whole big story of electricity—everything laid open before your eyes—hundreds of pictures—hundreds of letters from other men who earn up to \$10,000 a year—it's all in my book—"The Vital Facts About Electricity." And you can have a copy free. Send me your name on the coupon below, today—NOW—while the feeling to be somebody—to be a big-money-maker—is upon you. Read about it in my book first.

L. L. COOKE, Chief Engineer

**Chicago Engineering Works**

Dept. 519, 2150 Lawrence Avenue, Chicago, Ill.

L. L. COOKE, Chief Engineer, CHICAGO ENGINEERING WORKS  
Dept. 519, 2150 Lawrence Avenue, Chicago, Ill.

Send me your book "The Vital Facts About Electricity" and full particulars of your Home Study Course, Five Electrical Outfits Offer, and your Employment Service. This does not obligate me to enroll with you.

Name.....

Address.....

City.....State.....

# Classified Advertisements

## WORLD'S BEST WANT AD MEDIUM

Advertisements in this section, 25 cents per word, each insertion, minimum 10 words, payable in advance.  
To be inserted under proper classification in January issue, copy should be in our office November 18th.

### ADVERTISING AGENCIES

TO secure agents or salesmen or for selling farms and reaching investors, use classified (want) ads in largest newspapers and magazines. Price list No. 20 sent free. Ankrum Advertising Agency, 20 W. Jackson Blvd., Chicago, Ill. The largest classified advertising agency in the U. S.

ADVERTISE in 21 Big Sunday Newspapers, 24 words \$15.00. Catalog listing 1,000 leading Dailies, Weeklies, Magazines, 4c stamps. Union Advertising, Baltimore Bldg., Chicago.

ADVERTISING in all magazines and newspapers at publisher's lowest rates. Rate Book free. Taylor's Advertising Service, Dept. F, Freeport, Ill.

25 WORDS in 75 Rural Newspapers \$1.40. Mailing lists of Agents, Shaw, 221A Northeast, Washington, D. C.

ONE Inch Display Ad, 355 rural weeklies, \$45.00. Admerer, 4112D Hartford, St. Louis.

### FOR ADVERTISERS

CATALOGUES, Booklets, Folders, Sales Literature, Planned, Written, and Printed. High quality work. Reasonable prices. Write George H. Foster, Mgr., Dept. M, 4342 North Robey, Chicago.

ADVERTISING 222 Magazines .08c word, \$6.00 inch, \$45.00 page. Sample 10c. 131 Magazines, 5,000 Newspapers, 24 words \$180.00. Inch, 98 words, \$520.00. 28 words 100 magazines, 100 newspapers, \$5.00. Inch \$12.00. Diamond Advertiser, Norton, Mass.

HOUSE Distributing. Sign Tackling. Mailing lists. Agents, Housewives, Farmers, Buyers, John Smeiter, 2342 West 12th, Chicago.

I WRITE letters, folders, booklets, complete followup for manufacturers, mail-order dealers. Long experience. Write for details. L. Taylor, Box M14, Freeport, Ill.

ADVERTISE in 300 country newspapers, 28 words \$10. Keator, Hartford Bldg., Chicago.

25 WORDS, 88 magazines, \$1.00; Three \$2.00. Inch display \$2.00; Three \$5.40. Smith's Service, 1194, Wenatchee, Wash.

YOUR Advertisement—3 weeks Free, 22 leading newspapers. Pay one week regular rate 4c word, Affiliated Newspapers, Bedford Building, Chicago.

INCH Display 100 Monthlies \$4; three \$8. Cone Agency, 233P, Champaign, Ill.

ADS in 3 sets of Co-operative magazines—inch \$7.40. Samples 25c. A. A. Barnes, Helena, Ark.

CIRCULARIZE guaranteed list. Agents' names \$5.00, 1,000. Pennell, Covington, Ky.

COMBINATION Winner 125 Monthlies, Three, 10c word; \$8.00 inch. Interstate, Munising, Mich.

### SALES PROMOTION

\$50 TO \$50,000 Daily Sales developed during 36 years for clients by my direct-mail plans, copy, campaigns. A \$25,000 annual volume increased ten-fold in twelve months. Another, from an initial expenditure of \$720 developed in four years sales by mail of half million yearly. Ten years Sales Promotion Manager Larkin Co. Submit sales problems for Free diagnosis. James C. Johnson, 118A Woodbridge Ave., Buffalo.

RAISE Money for Business. Picked list investors with Money. Accurate. Free suggestion preparing sales literature. Advertising Service, Suite 426, 28 Quincy, Chicago.

### AUTOMOBILE SUPPLIES

SCIENTIFIC Gas Saver. All autos. One free to introduce. Critchlow, H-124, Wheaton, Ill.

JOBBERS and representatives—send for bargain list of Auto supplies, including AC and Champion Plugs. Surplus Motor Supply, 335 Harrison, Oak Park, Ill.

MILLERITE-ETHYL-Super-Fuel Ingredient for Gasoline. Increases Power and Mileage—Saves Gas. Make it yourself by my simple Formula and clean up five to fifty thousand a year. This and eighteen other High Class Automobile Specialties described in the valuable literature I'll send you upon request—Hurry! Exclusive Territory! Miller, Chemist, 1109-1111 Grand Central, Tampa, Fla.

FOR Sale—One Day Battery Chargers, Motor Generator Sets—Tunings—Air Compressors. Sold subject trial. Terms if desired. Ira Heinick, Box M-1, Troy, Ohio.

DISTRIBUTORS and Representatives Wanted everywhere. Exclusive necessity. Kelly Automatic Roadline. Ford, Chevrolet, Overland and all others. John B. Kelly, 5218 Washington Blvd., Chicago, Ill.

AUTOMOBILE Parts—New and Used Parts for all cars. You can save 25 to 75% buying from us. Satisfaction guaranteed. Free Catalogue to request. Century Parts Company, 4105 Olive St., St. Louis, Mo.

VULCANIZING Auto Tires is a Paying Business on account of new tires advancing. We have Plants near you from \$100 up. We save you 50%. Catalog Free. Instruction Book \$1. Equipment Exchange, 108 East 11, Los Angeles, Calif.

HIGHEST prices paid for broken bendix drives and Ford generator armatures. Ship to Eclipse Tool Co., Indianapolis, Ind.

### AUTOMOBILES

PATENTS. Time counts in applying for patents. Don't risk delay in protecting your ideas. Send sketch or model for instructions or write for Free book, "How to Obtain a Patent" and "Record of Invention" form. No charge for information on how to proceed. Communications strictly confidential. Prompt, careful, efficient service. Clarence A. O'Brien, Registered Patent Attorney, 5898 Security Bank Building directly across street from Patent Office, Washington, D. C. See pages 172 and 173.

ELECTRICAL equipment of the Ford car fully explained in a leather-bound profusely illustrated book. Learn how to fix your lights, ignition, or starter while on the road without calling a mechanic. Save repair bills. Send No Money. Just write a postal for, "The Ford Standard Electrical Equipment." When the postman hands you the book, pay \$1.98 and the postage. Money back if not fully satisfied. Popular Mechanics Press, 200 E. Ontario St., Room 812, Chicago, Ill.

AUTOMOBILES: 755 ideas on repairing and improving. In Popular Mechanics three new books: Auto Repairman's Handbook, Auto Owner's Handbook, Auto Tourist's Handbook. Send No Money. Just write a postal. Pay postman the postage and \$1.50. Popular Mechanics Press, Room 812, 200 E. Ontario St., Chicago, Ill.

FORD Chassis cheaply converted into dependable tractor by using Shaw Equipment. Pulls 16" Plow; Harrows, Seeds, Cultivates, Etc. Full Particulars Free. Shaw Manufacturing Company, Department R4, Galesburg, Kan.

PATENTS: My fee in installments. Free personal advice. Frank T. Fuller, Washington, D. C.

### AUTOMOBILE SUPPLIES, ACCESSORIES AND HOUSEHOLD GOODS WANTED

100,000 REPRESENTATIVES Wanted! Sell by mail, through Agents, or Direct! Detailed Information—25¢! None free. Surety Service, World Distributors, 551 Harvard St., Rochester, N. Y.

### FOR FORD OWNERS

FORD Owners—Masterch. A Set of wrenches in one. Fits all Ford nuts. Self-adjusting ratchet. Made of heat-treated drop-forged steel. Non-slip, rise-like grip prevents skinned knuckles. Money-back guarantee. Pay postman \$1.50 plus postage on delivery. H. E. Laura, 576 West Broadway, New York City.

DELIVERY Bodies for Ford Model T. Chassis with Inclosed Cab. Suitable for Contractors, Grocersmen and Farmers. Three styles. Price \$37.50. Write Daniel Zimmerman, Craigville, Ind.

DIRECT Engine Driven Tire Pumps for Ford Cars. Cigaret Mfg. Co., Upper Marlboro, Md.

MAKE More "Jack," \$1-\$5 sparetime hour selling NABCO Auto & Radio Specialties. Attractive Holiday Line. Color Circulars Free. "Nasco," D-37, 1661 Evans, Detroit, Mich.

66 MILES on 1 Gallon. Wonderful Vapor Humidifier. One free to introduce. Critchlow, J-124, Wheaton, Ill.

UNDERSLING with "RKO" Swing Lo Irons. See "Red-1-Kut" ad page 152.

ELECTRICAL equipment of the Ford Car fully explained. Learn how to fix your lights, your ignition, or starter without calling an electrician. This book may save you many mechanic's bills any one of which might be more than the cost of the book. Send No Money. Just write a postal and ask for, "The Ford Standard Electrical Equipment." When the postman hands you this profusely illustrated leather-bound book, pay \$1.98 plus the postage. Popular Mechanics Press, 200 E. Ontario St., Room 812, Chicago, Ill.

### MOTORCYCLES, BICYCLES AND SUPPLIES

REAL Bargains in Used Motorcycles. All Makes and Models to pick from. \$50.00 and up. Money back if not satisfied. Free circulars. Write Today. Knuth's Harley-Davidson Agency, 2525 Fond du Lac Ave., Milwaukee, Wis.

1923 HARLEY-DAVIDSONS, \$168; 1922, \$118; 1921, \$111; 1920, \$85; 1919, \$65; 1917, \$50; 1916, \$45; 1915, \$40; 1914, \$35. Guaranteed. Money refunded if not satisfied. Circular free. Wisconsin Cycle Sales Co., 724 National Ave., Milwaukee, Wis.

PARTS For all makes; prompt Service. Expert advice, 75 Used Machines; description on request. Gillesman's, 3199 Blvd., Jersey City, N. J.

DON'T buy a Bicycle Motor Attachment until you get our prices. Shaw Mfg. Co., Dept. 27, Galesburg, Kans.

### AVIATION

PATENTS. Time counts in applying for patents. Don't risk delay in protecting your ideas. Send sketch or model for instructions or write for Free Book "How to Obtain a Patent" and "Record of Invention" form. No charge for information on how to proceed. Communications strictly confidential. Prompt, careful, efficient service. Clarence A. O'Brien, Registered Patent Attorney, 5898 Security Bank Building (directly across street from Patent Office), Washington, D. C. See pages 172 and 173.

CAPTAIN J. A. YONGE offers an up-to-date home-study course on Theory of Flight, Flying, Construction, modern airplanes and airships, etc. Only \$12.50 for ten instructive lessons. Write for information. Gary Flying School, Gary, Ind.

"LIGHT Planes." Complete or Parts. Blueprints for Builders, \$2.50. "Highlift" Replacement Wings for Jenny and Canuck. Propellers, \$10. Flying Instruction, \$100. Aviation Engineering Co., Lawrence, Kans.

HEATH propellers represent the most efficient method of aerial drive. Each propeller individually designed for the particular work to be done, as laid out by America's oldest aeronautical engineers. Propeller catalog 4c; Motorcycle Biplane circular 6c; Ford or Motorcycle sled blueprints \$2.00 each. Retail goggles \$2.99. Wool Jersey helmets 95c. Heath Airplane Company, Chicago, Ill.

PATENTS: My fee in installments. Free personal advice. Frank T. Fuller, Washington, D. C.

MOTOR: Curtiss OXX-6 Class A (under Fifty Hours) for Plane, Sea-Sled, Motor boat, etc., \$175.00. All Motor and Plane Snaps at Best Prices. Send for Catalogue. Monumental Aircraft Co., 339 N. St. Paul Place, Baltimore, Md.

**AEROPLANE** motors, all types, imported by Army Air Service. I purchased over 1,100; most sell; need storage space. A \$3,000.00 complete 165-horsepower Gnome motor, weighs 292 pounds, for \$25.00; never down. Useful for aeroplanes, motor boats, ice boats, etc. Instructions furnished. Others from 28 to 400 horsepower. Cash or time payment; Complete planes \$500.00 up. Learn to fly here. Residual goggles \$2.50. Propellers for all motors. Sample metal propeller, used Curtiss Planes, \$1.00. Write for Booklet, Marvin A. Northrop, 200 Builders Exchange, Minneapolis, Minn.

**BLUEPRINTS** showing detailed specifications concerning Ford motor for use with propeller; building high speed Ice Coach; fast Aerodrive boat attachment; speedy Ice Scooter; All only \$2.50 postfree. Propellers, \$5.50 upward. Aircraft Supplies Price list 5c. Ostergaard Aircraft, 4271 North Narragansett, Chicago.

**EARN \$3,500 to \$10,000 a year.** Learn Airplane Engineering Now at Home. The World Flyers were Airplane Engineers. Write for free catalog. Western Airplane Corporation, Dept. K-12, Monadnock Block, Chicago. See our Display ad on page 86, this issue.

**COMPLETE** Scale Plans with Building-Flying Instructions for following 3-ft. Model Aeroplanes, 25c each postpaid: JN4D-2; DeHavilland; NC-4; Curtiss Tractor; Bleriot; Nieuport or Taube Monoplanes; Cecil Peeli Racer. Complete 48-page catalog 5c, listing hundreds of parts and supplies for experimenters. Ideal Aeroplane Co., 165 1/2 Spring Street, New York.

**SEND One Dollar:** For Perfected Liberty Timer for your Ford. Installed in two minutes, drive five days at our risk. If after trial you do not consider idling, accelerating and general performance superior to any high-priced special ignition system being sold, your money cheerfully refunded. Best price on new and used airplanes, motors and parts. Wallace, Inc., Box 511, Bettendorf, Iowa.

**BOYS,** get a three-foot model aeroplane free. Nothing to sell. Write to Aero Shop, 2050 Huribut Ave., Detroit, Mich.

**TEN** lessons in the air of twenty minutes each will make you a pilot by our advanced method of training. This, together with our five weeks shop course at \$100.00, makes America's oldest aircraft factory the most popular flying school. Work after class hours guaranteed. Heath Airplane Company, Chicago, Ill.

**SPECIAL Offer.** "Airlighter." 300 ft. flights guaranteed; 40c postpaid. Big model catalog, airplanes, boats and supplies, 5c postpaid. W. Phipps Company, 367 Wilson Avenue, Brooklyn, N. Y.

**JOIN** the Gary Flying School and take your International Certificate! Captain J. A. Yonge, war and commercial pilot of ten years' experience, offers a complete flying course on entirely new lines. Considerable "solo" flying time and advanced air instruction are two special features. Write now for information. Gary Flying School, Gary, Ind.

**LEARN Aviation:** Send 25c for large illustrated booklet which tells how. Varney Aircraft Co., Peoria, Ill.

**ONLY \$495.00** for Curtiss Aeroplane less motor and flying course. Largest stocks of Planes, motors, parts and supplies. San Antonio Aviation & Motor School, San Antonio, Tex.

**AVIATION Fans:** Send one dollar for beautiful pair sterling silver wings, mounted on bar pins with safety catch, and identification card issued by National Flyers' Association. Thousands being worn by pilots' aviation mechanics, and aero enthusiasts. Wallace Aero Company, Bettendorf, Iowa.

**28 HORSEPOWER** airplane motors, new and slightly used; \$100 and \$125. Propellers \$2.00 to \$25.00. Leather coats \$70.00 and \$12.50. Smith Machinery Co., Box 153, Houston, Tex.

**THE American School of Aviation** announces a new correspondence course in Mechanics of Aviation. A thorough training in Practical Aeronautics. American School of Aviation, Dept. 1861, 3691 Michigan Ave., Chicago, Ill.

**LEARN to Fly!** Write for booklet. Robertson Aircraft Corp., Anglum, Mo.

**AIRPLANES, Motors, Parts, Supplies.** Prompt shipment, honest dealings. Learn to fly with us. Enroll any time. Write for Fall catalogue. Nicholas-Beasley Airplane Co., Marshall, Mo.

**FLYING!** Send fifty cents for cheapest method for Learning to Fly. Aviator James, 1793 Sedgwick Ave., New York.

#### WELDING AND SOLDERING

**ALUMINUM Solder.** Guaranteed to Solder Aluminum Sheet or cast. No flux. Will solder any metal to Aluminum. Send 50c for sample. Gardner Co., Box 247, Lamanda Park, Pasadena, Calif.

#### BOOKS AND PERIODICALS

**PHILOSOPHY and Phenomena of Spiritualism.** The author relates his thirty years' personal experience with spirits while in and out of his body. Led by them through the Spirit world, he visited Heaven and Hell and found many convincing proofs of Life after Death, and Spirit return. 500 pages. \$3.25. Franklin A. Thomas, Author, Malden, Mass.

**SHOP NOTES for 1926** now ready. Get your copy from this announcement. Only a limited edition. Contains all the articles published in the Shop Notes department of Popular Mechanics Magazine during 1925. Send No Money. Just write a postal and we'll send 1925 Shop Notes and Auto Tourist's Handbook. Pay the postman 98 cents when he hands you the two books. Popular Mechanics Press, 200 E. Ontario St., Room 812, Chicago, Ill.

**"COLORS and Rhythms."** About 100 pages. Chromotherapeutics. Marvellous Scientific Knowledge. Illustrations. Deluxe \$2.00; Plain \$1.00. Dept. M. Stevens, 242 Powell, San Francisco, Calif.

**FREE—Send for my Newthought, Self-culture, Occult, Mystic and Scientific book literature.** Martens Publisher, Burlington, Iowa.

**MENTAL and Spiritual Healing:** All Schools and Methods. Why pay \$100 to learn to heal? Technique complete \$3.50. International Book Concern, Los Angeles.

**"AMATEUR Electrician"** 64 pages (illustrated). "Toymaker Book" (illustrated). "Ford Joke Book"—all for 25c. G. Eisea, Bowling Green, Ohio.

**ANSWERS** to all mathematical problems likely to occur in the office, store, shop, bank, farm, or factory. Explains and simplifies every principle of arithmetic, mechanics and mensuration. Over 2,000,000 sold. Send No Money. Just write a postal and ask for Ropp's Calculator. When the postman hands you the book, pay \$1.00 and the postage. Popular Mechanics Press, 200 E. Ontario St., Room 812, Chicago, Ill.

**EDUCATIONAL** books and correspondence courses, bargain prices. Catalogue 1,000 courses free. Courses bought. Students Exchange, 47A West 42d St., New York.

**COURSE in Structural Drafting \$1.00.** W. D. Browning, Memphis, Tenn.

**ELECTRICAL** Ideas on all phases of practical electricity are to be found in Popular Mechanics new book, "Electrical Kinks." 47 ideas on wiring, 45 on making electrical devices, 19 on lighting, 5 on transformers, 5 on motors, 8 on generators, 11 on switches, 22 on testing, 12 on repairing, 11 on battery manufacture and repair, 5 on telephones, and 9 on electricians tools. 214 articles, 162 pictures. Send No Money. Just write a postal. Pay postman postage and \$1.50. Popular Mechanics Press, Room 812, 200 E. Ontario St., Chicago, Ill.

**DICTIONARY.** Latest edition of the Universal Graphic Dictionary at unusually low price. 1,192 pages. Illustrated with color plates. Large clear type. Convenient size for school or home. Substantial cloth binding. Good paper stock. Should be in every school desk, on every office desk, and in every home. Order more than one copy if you can use them. This price may not prevail long. Send No Money. Just write a postal. When postman hands you the dictionary, pay the postage and \$1.25. Popular Mechanics Press, 200 E. Ontario St., Room 812, Chicago, Ill.

**10,000 FORMULAS.** A real Gold Mine of money-making ideas. Tells how to make almost everything under the sun. You can make and sell cosmetics, mucilage, anti-freeze solutions, battery solutions, beverages, cheese, chewing gum, cleaning preparations, extracts, hair preparations, inks, bluing, leather polish, mirrors, perfumes, polishes, typewriter ribbons, carbon paper, washing powders, liquid soap, and hundreds of other profitable articles. Send No Money. Just write a postal for "Hensley's 20th Century Book of Formulas." Pay postman postage and \$1. Popular Mechanics Press, 200 E. Ontario St., Room 812, Chicago, Ill.

**INDUSTRIAL Alcohol.** Wright's book. Full directions for making, fully illustrated. \$2.50. Roon & Chamberlain, 120 P. M. Liberty Street, New York, N. Y.

**MASTER KEY** Wonderful for Success. 410 Pages \$2.65. Bargains New—used (all subjects). Lists 10c. Phipps Library, 1014 Belmont, Chicago.

#### PICTURES AND POSTCARDS

**JOIN** Popular Friendship Club. World's best. Exchange view postcards, letters, stamps. Enthusiastic members everywhere. Fascinating pastime. Membership two months, 10c; six months, 25c; one year, 50c. Oliver Gandy, Crisfield, Md.

**75 BEAUTIFUL** Art Pictures and Bathing Beauties 25c (coin). Photo Sales Co., 3242 Riehton, Suite 490, Detroit, Mich.

**PICTURES, Books and Novelties.** Particulars Free. Howard Sales Co., Dept. 15, 1188 Folsom St., San Francisco, Calif.

**TRUE-BLUE.** Old reliable. 17 years. Exchange cards, letters, stamps. Year \$1; half, 50c; quarter, 25c; booklet, 10c. Ed Erlson, Elroy, Wis.

**EXCHANGE** Postcards! Interesting and educational. Membership and list 10c. Popular Exchange, Windsor, N. C.

**ARTISTIC** Hand Made; Roll and 8x translucent pictures, 25c; Reprints 3c. Art Studio, Dallas, Tex.

**JOIN** Live Postcard Club; Membership lists including Catalog, 10c. Harvey Teente, Decatur, Ind.

#### GAMES, ENTERTAINMENTS AND PLAYS

**PLAYS,** musical comedies and revues, minstrel music, blackface skits, vaudeville acts, monologs, dialogs, recitations, entertainments, musical readings, stage handbooks, make-up goods. Big catalog free. T. S. Denton & Co., 623 So. Wabash, Dent. Ill. Chicago.

**VENTRILQUIST** taught almost anyone at home. Small cost. Send 2c stamp today for particulars and proof. George W. Smith, Room 8-37, 125 N. Jefferson Ave., Peoria, Ill.

**LATEST** work on Magic Cards and Dice. Catalog free. The F. & B. Co., Hoboken, N. J., Dept. F.

**PLAYS, Minstrels, Musical Comedies, Vaudeville Acts, Monologues, Make-Up, Wigs, Catalogue "D" Free.** Banner, 1061 Market St., San Francisco, Calif.

**100 LIGHTNING** Chalk Talk Stunts \$2.00. Cartoonist, 2925 Euclid, Kansas City, Mo.

#### NOVELTIES, CURIOS, ETC.

**LOOK!** New catalog and French novelty 25c. Ruth, Box 202, Morris, Ill.

#### MAGIC TRICKS, BOOKS AND JOKER NOVELTIES

**MAGIC—Tricks, Books and Supplies.** For Amateurs as well as the great professionals. Anyone can learn through our instructions. Feature Acts in Mind Reading, Spiritualism, Rope Ties, etc. Large Illustrated Professional Catalog, 20c. Chicago Magic Co., 140 S. Dearborn St., Dent. B. Chicago, Ill.

**A KNOCKOUT!** Surprise your friends with a Bootleg Cigar. Useful and Amusing. Sample only 35c; yet you wouldn't take a dollar for it. Why? Get one and see. Leland Company, Fruitvale, Calif.

**ESCAPE** from any rope tie and mystify your friends. You can easily make \$10 a night giving escape entertainments in Churches, Clubs and country schools. The book, "33 Rope Ties and Chain Releases" tells how to conduct an entire entertainment. It tells how to escape when someone plays a trick on you and ties you more securely than you expected. Tells how to escape from the famous mummy tie in which you are bound from head to foot with 75 feet of strong rope. No knife or other instrument is needed. Send No Money. Just write a postal and ask for "Rope Ties." When the postman hands you this wonder book, pay 98 cents and the postage. Popular Mechanics Press, 200 E. Ontario St., Room 812, Chicago, Ill.

**FREE** with \$25 order die box. Send 20c for our large catalogue of tricks, wigs, sensational escapes. Oaks Magical Co., Dept. 548 Oshkosh, Wis.

**MAGIC** goods, cards, books, novelties, tricks. Catalog free. C. Penner, 2401 Jefferson, Louisville, Ky.

**MAGIC** Catalogue free. Waldmann, 1456 First Ave., New York.

**BOOKS, Great Secrets, Mysteries, Magical Novelties.** Catalogue Free. Simco, 255 Hancock, Wis.

**SEVEN** Magical Delusions and Catalogs—25c. Gilmagico, Morgan Park, Ill.

## STAMP COLLECTING

ALTHOUGH thousands more were printed than in any previous year, unprecedented sales of Scott's Postage Stamp Catalogue, 1928 Edition, (out Oct. 10) will soon make copies very hard to get. This edition contains more than 1,500 pages—it lists, describes, illustrates type, gives color, watermark and perforation of every stamp ever issued by any government in the world to date of going to press. Also prices at which they may be bought, used, or unused from the Scott Stamp & Coin Co. Order from your Dealer—\$2.00 cloth, \$2.50 with thumb index, or we will supply you at this price plus forwarding (wt. 2 lbs.) if dealer is out of stock. New 50% Approvals. We now offer a greatly enlarged line of 50% approvals. Our World-wide connections enable us to offer approvals which are in a class by themselves for quality, value and desirability. State countries you prefer; references required. Scott Stamp & Coin Co., 33 West 44th Street, New York, N. Y. Philatelic Headquarters since 1860.

ARABS! Bandits! Head-Hunters! Egypt (sphinx); Malay (tiger); Benadir (elephant); Tunis (arab); Turkey (sacred mosque); Belgium (showing battle between angel and "old horns"); Congo (head hunter)—All of these mysterious and remarkable stamps are contained in our Famous Phantom Packet—35 fine varieties (40 approval applicants only) for eight cents. Nothing like it; order at once! Pacific Stamp Co., Box 138, Helena, Mont. Extra! Send us, with your order for the Phantom Packet at 8c, the names of three of your friends who collect stamps; and we will give you, free of charge, a scarce set of 11 diff. Albania—bandit land!—cataloguing over \$1.50. Supply limited; write immediately!

ANCHERS \$\$\$ Outfit—only 12c! Fine triangle stamp; set German stamps with (pre-war) value forty million dollars (interesting!); perforation gauge, mm. scale; small album; 2 approval sheets; airmail set; scarce stamp from smallest republic on earth; newspaper set; packet good stamps from Travancore, Johore, Dutch Indies, etc. Entire outfit for 12c to approval applicants! (Nice pocket stock book, value 25c, with every order!) Ancher Stamp Co., 148½ Clerk St., Jersey City, N. J.

FAMOUS Fenway Outfit. All for 12c; triangle stamp; small album; 250 hinges; 5 large French Colonials; 2 special deliveries; Airmail set; Red Cross set; Fantastic Fenway Packet containing 55 different, including Abyssinia, Azores, Cape of Good Hope, Bosnia, Crete, Congo, etc. This wonderful outfit and 16-page price list only 12c; to new approval applicants. Fenway Stamp Co., 161 Massachusetts Ave., Boston, Mass.

MYSTIC'S "Mysterious" Packet! Contains stamps from the lands of cannibals, heathens, sun worshippers, and wild savages. Included are Kenya and Uganda, Persia, Africa, Dutch Indies, Gold Coast, Federated Malay States, Eritrea, Nyassa, Travancore, Siam, Congo, etc. This wonderful packet containing 105 all different (mostly unused) for only 8 cents to approval applicants. Mystic Stamp Co., Dept. 8, Camden, New York.

STAMP Collectors Outfit only 25c. Includes 32-page book "How to Collect Stamps" Album (illustrated), 100 Hinges, 110 different stamps from Comoro, Guinea, Hejaz, Iraq, Sudan, Zanzibar, etc.; also "free stamps" coupon. For new customers only. Harry Icar, 891 State Life Bldg., Indianapolis, Ind.

500 FOR 25c mixed stamps from 40 different Countries, Australia, North, Central, and South America, Africa, China, Japan, British, French Colonies, War issues, Russia, etc.; also 500 stamp hinges, pocket approval book, perforation gauge, and 5 United States stamps issued from 1861 to 88. Biggest bargain ever offered to approval applicants. Satisfaction guaranteed or money back. Haseman Stamp Co., Dept. PM, St. Louis, Mo.

RARE Stamps from lands cloaked in mystery, hidden at earth's farthest corners. Bargain Offer Includes 50 beauties from Tanganyika, Uganda, Nyassa, Gold Coast, Kenya, etc. Also 25 Fantastic Wonders from Persia. All different. Many scarce, high values. Also unused Aeroplane Set. All for 16c to approval applicants only, giving references (scout number OK). Scarce Hayti stamp, catalogued \$1. Free with orders sent now. Belmers, 499 Flatiron Bldg., Fort Worth, Tex.

CIGAR Bands: Fine collection, 115 different American-German Bands, 50c. Premium with each order. Lloyd's, PM, Box 538, Houston, Tex.

THE "Magnificent" 10c Packet contains over 100 Stamps from Iceland, African Congo, Cape of Good Hope, Hindustan, New South Wales, Cochinchina, with bumper sheet watermark) Mozambique Pictorial, and many other stamps from the hidden parts of the world. Also Perforation Gauge and Scale, Also Snappy Lists to approval applicants. Imperial Album 90c postpaid. Collections Bought, Payn Stamp Co., 945 Vista Drive, Los Angeles, Calif.

START a Stamp Collection—70 different stamps from 70 different foreign countries, including Africa, Asia, Australia, Europe, West Indies, etc. Our pamphlet which tells "How to make a collection properly," and price list of albums, packets and sets all for only 16 cents. Queen City Stamp Co., Room 35, 694 Race St., Cincinnati, Ohio.

1,000 MIXED, over 20 countries, only 33c. Pkt. U. S. Revs. and Parcel Post, 8c; 50 diff. Fr. Coins, 14c; 1,000 prelabel hinges, 10c; 50 diff. British Coins, 19c. Ask for 50% Bymor Approvals, Bymor Stamp Co., Dept. P, St. Louis, Mo.

ZAMBESIA, Zanzibar, Abyssinia, Herzegovina, Travancore stamps, managerie collection, album, 10c. Liberty, 3974 Arsenal, St. Louis, Mo.

WONDERFUL Value in Stamp Packets: 3,000 All Different, Mounted, \$7.50; 1,000 All Different, \$0.75; 500 All Different British Colonials, Mounted, \$3.25; 500 All Different, \$0.30; 300 All Different, \$0.15; 200 All Different, \$0.10. Postage extra under 50c. Alois Von Isakovitz, Dept. A, Monticello, N. Y.

BEAUTIFUL picture stamps. ¼c up. Joseph Babcock, St. Joseph, Mich.

STAMP catalogued 75c free with 30c purchase from approvals. Tell your friends. Pettet Bros., 690 S. Boulevard, Atlanta, Ga.

500 DIFFERENT, many unused, from British, French, Italian and Portuguese Colonies, Chile, Flume, Guatemala, Persia, Siam, etc., for only 25c (regular price 50c), to all approval applicants. Big bargain lists free. With small album, package hinges and above packet only 30c. Victoria Stamp Co., London, Canada.

DANZIG Free—for 2c postage. Splendid assortment Danzig Stamps. Midland Stamp Company, Toronto, Canada.

"EXHIBITION" "War Prisoners," "Airmail," "Pictures," "Eagles," "Doves"; six sets unused, different countries, five French, five British, five Portuguese Colonies. Packet Dutch Indies, 100 different foreign, 15c to approval applicants. Deering, 38 Fairmount, Marlborough, Mass.

50 FRENCH Colonials, 30 British Colonials, 20 Portuguese Colonials, 30 South and Central America, all different; price lists, etc., all only 25c, to introduce approvals. Fennell Stamp Company, Dept. P, St. Louis, Mo.

JAHORE, 3 var. 3c. China, 12 var. 2c. With approvals, Henry Hunt, 1021 Bellerophon, Compton, Calif.

105 CHINA, etc., 2c. Album (500 illustrations) 3c. Bulard, Sta. A, Boston.

WHY not try Sheppard, 237 Balmbridge Street, Brooklyn, N. Y.

\$10.00 FOR 25c. A choice assortment of 500 all different stamps, guaranteed to catalogue over \$10.00, offered to approval applicants for only 25c. Edgewood Stamp Co., Milford, Conn.

500 STAMPS 17c, including Finland, Flume, Transilvania, Ceylon, Guatemala, Australia, (Swan), Dominican Republic, New Zealand, etc.; to approval applicants. Plenty U. S. Elmer, 15 School St., Boston.

100 STAMPS free to applicants sending postage. Tell your friends. Pettet, 690 S. Boulevard, Atlanta, Ga.

FREE—16 "Buck" Bill (Polish) to approval applicants sending postage. Tell your friends. Pettet Co., 690 South Boulevard, Atlanta, Ga.

105 VARIETIES, including British, French and Portuguese Colonies, a triangle stamp perforation gauge and small stamp book (Cat. Val. over \$2.00), all for six cents to approval applicants. Westland Stamp Co., 70 Westland Ave., Boston, Mass.

25 PRECANCELS—and copy "Badger's Precancel Partner." 4c to approval applicants. Badger's Partner, Brookville, Wis.

FREE! Fine set Bosnia to approval applicants. Penna Stamp Co., Manor, Pa.

FREE stamps to approval applicants. Valley Stamp Co., 3123 Texas Avenue, St. Louis, Mo.

FRENCH Colonies Free—Jungles, Tigers, Native Chief, 2c postage. Empire Stamp Company, Toronto, Canada.

1,000 STAMPS, all different, \$1.00. 100 different British Colonies 25c. 200 different Precancel 25c. Claud Denney, Box 315, Dallas, Texas.

STAMPS on approval—¼c up. Free Premium. Herbert Kelgwin, Middletown, N. Y.

WRITE for approvals and get a nice packet of stamps free. Cedric W. Lemont, Delaware, Ohio.

FREE—Set R. H. Stamps to approval applicants. Houghton, Box 505, Dayton, Ohio.

200 DIFFERENT stamps from many countries, catalog value about \$4.00; only eight cents to approval applicants. H. W. Myers & Co., 2931 Acton St., Berkeley, Calif.

CLASSY Stamps Free to approval applicants. 2c postage. Bond Stamp Co., Lima, Ohio.

FREE—Confederate States \$10 bill with 20 different unused stamps for a dime. B. Nagle, 1101 Marion, Reading, Pa.

FREE! 25 different United States with 60% discount approvals to reliable parties. Seidenberg, Baroda, Mich.

MOZAMBIQUE set 6c to applicants for 50% approvals. Kinman, 634 Union, St. Louis, Mo.

ALL different—500, \$0.50; 1,000, \$1.00; 2,000, \$4.00. Fred Onken, 639 79th Street, Brooklyn, N. Y.

THOUSANDS of stamps given away. Got yours? W. B. Campbell, Staunton, Va.

NET Approvals. Premium to new applicants sending reference. Tower Stamp Co., 42 Westville St., Dorchester, Mass.

FREE 25 different Portuguese Colonials to approval applicants, 2c postage. Lightbown, Osborne Road, Southsea, England.

FREE Fifty Diff. to Approval applicants. Dynamic Stamp Co., 265 Dickerson, Detroit, Mich.

5 AIRMAIL—20 unused 4c, 1,000 different 98c, 500 different 38c. Both \$1.25. Bucker, 528 Alameda, Dayton, Ohio.

25c BUYS \$1.00 worth different foreign stamps from our mail. Free Premium. Calculator Corp., Grand Rapids, Mich.

FREE "Liberty" packet to approval applicants sending 2 cent stamp. P. Earl Stamp Co., 1811 20th Av. North, Minneapolis, Minn.

BEST one-cent approvals in America. F. P. Hand, 1117 So. 66th St., Philadelphia, Pa.

110 DIFFERENT Stamps, many unused, high values, free to collectors requesting our Net Approvals. Postage 2 cents. Christensen, Milwaukee, Wis.

ROYAL Surprise Packet, 10 French Col., 10 British Col., 10 Port. Col., Small Album, 250 Hinges, Perforation Gauge and Millimetre Scale and a packet of 100 Diff. Stamps all for 10c to new approval applicants. Royal Stamp Company, 6029 Broadway, Dept. P, San Antonio, Texas.

24 VARIETIES Cuban stamps, 10 cents. List of 6,000 low-priced stamps free. Address Chambers Stamp Co., 111P, Nassau St., New York City, N. Y.

STAMPS, 100 all different. Postage 2c. Lists free. P. M. Quaker Stamp Co., Toledo, Ohio.

FREE! Loose Leaf Postage Stamp Album at rate of 8 pages each month given with subscription to monthly Journal. Send 2c stamp for prospectus. United Stamp Co., Marquette Bldg., Chicago, Ill.

STAMPS, 50 varieties, Africa, Brazil, Peru, Cuba, Mexico, etc., 10c. 50 different U. S. 25c; 1,000 mixed, 40c; 1,000 hinges, 10c. List free. C. Stegman, 5948 Coto Brillante, St. Louis, Mo.

PACKET of 23 stamps, no two countries alike. Packet hinges. Set of \$1 and \$2 U. S. Rev., all for 5c. P. M. Miami Stamp Co., Toledo, Ohio.

200 DIFFERENT stamps, set triangles, set animal stamps, other sets, U. S. Packet, blank approval book, 40 pages stamp bargain, \$5.00 value for only 25c to applicants. 1,000 Hinges, 9c; 100 U. S., 25c; 500 diff., 45c. Hawkeye Stamp Co., Cedar Rapids, Ia.

\$1.00 WORTH of Stamps for 3c. Hull, 14 West 101st, New York.

110 NEW Europe All Different, a wonderful collection cataloguing several dollars, free to collectors requesting our Net Approvals. Postage 2 cents. Badger Stamp Co., Milwaukee, Wis.

**CURIOSITY** Packet, 104 unused in blocks 12c. Big 20-page list, set Air Mails Free. Rugger, 31 Cambridge, Dayton, Ohio.

1,000 MIXED U. S. and Foreign Stamps 25c. Phil. Lundstedt, Cape Cottage, Maine.

**STAMP'S** Free—Ask for money-saving approvals. John P. Borresen, Cedar Falls, Ia.

100 DIFFERENT stamps, postage 3c. Glenwood Stamp Co., 30 Athol St., Springfield, Mass.

APPLY for our Superior Approvals and receive absolutely free 100 different foreign postage stamps. W. Kreithberger, 506 Dubois St., Union City, N. J.

**UNITED STATES** Stamps. Complete stock Postage, Dept's., and Revenues. Price list free. Voorhees, 7 So. Dearborn St., Chicago.

**FOREIGN** Stamp Collection Sent Free. Cornish Co., Schenectady, N. Y.

**FIVE**, Hungary Charity No. 565 to 567 and a surprise packet given to those requesting for my 1, 2 and 3c approvals and also my 50% discount and better. Chas. W. Schmidt, 3227 Benzer St., Waukegan, Philadelphia, Pa.

**STAMPS** sent on approval at 70% discount. Reference required. Emory Renold, Hanover, Pa.

**FIVE**—50 varieties to approval applicants sending 2c. Richard P. Lamprecht, Valparaiso, Ind.

20 DIFFERENT, Turkey 3c. Approvals. Fryer, 1411 4th Ave., Cedar Rapids, Iowa.

**PENNY** Approvals that Satisfy. Neil Gronberg, Box 3441, Philadelphia, Pa.

20 UNUSED stamps free. All different. Postage, 2c. P. M. Fisk Stamp Co., Toledo, Ohio.

**THREE** Irish stamps free to Approval buyers. 300 different stamps 25c. C. H. Hollister, Mukwonago, Wis.

#### RARE COINS

**GET** Profit and Pleasure in collecting Old Coins. Send 10c for Sample Old Coin, together with my Large Illustrated Coin Catalogue. You'll be delighted with it. Send for it right now. B. Max Mehl, Professional Numismatist, Mehl Bldg., Dept. P, Fort Worth, Texas. Largest Rare Coin Firm in U. S.

**OLD** Coins, Large Spring Selling catalogue of coins for sale free. Catalogue quoting prices paid for coins, ten cents. William Hesslein, 101A Tremont Street, Boston, Mass.

\$2 TO \$500 Each Paid for hundreds of Old or Odd Coins. Keep All Old Money. It may be very valuable. Send 10 cents for Illustrated Coin Value Book, 4x5. Get Posted—Guaranteed Prices. We Buy and Sell. Clarke Coin Office, LeRoy, N. Y.

100 WAR coins 75c; 40 different coins 50c; 25 different 30c; 10 Large foreign bills 20c; 10 Confederate bills 35c; 5 Roman coins 40c; 10 Austrian bills, Revolutionary War bills 1776 30c; 5 Mexican bills 25c; Historical newspapers 1819 25c; Civil War news 30c; 20c piece 55c. Retail catalogue free. Nagy 8P, South 18th, Philadelphia.

**OLD** Money Wanted. Will pay Fifty Dollars for nickel of 1913 with Liberty Head (not Buffalo). We pay cash premiums for all rare coins. Send 4c for large Coin Circular. May mean much profit to you. Numismatic Bank, Dept. H, Fort Worth, Tex.

**SELL** foreign coins, European bonds, money, etc., by mail from home. Profitable business. Literature free. Giant beginner's outfit \$1.00. "Oldest In The Line." Hirsch, 70 Wall St., New York.

U. S. INDIAN White Cent with price list 10c. Fred Greenday, 1626 Washington, Denver, Colo.

30,000 GERMAN mark 5c. List free. American Exchange, 102 Popelar, Iowa.

**CURIOS** Morocco and Egypt coins 25c. Durso, 25 Mulberry, New York City.

**UNITED STATES** 2c Bronze and Bargain Price List 10c. Arcy, Box 483, Muskogee, Okla.

CALIFORNIA gold, 3/4 size, 27c; 3/4 size, 53c; three-cent-piece and catalogue, 10c. Norman Shultz, Colorado Springs, Colo.

22 DIFFERENT foreign coins 50c. 20 different foreign notes 50c. Otto Oddehon, Independence, Mo.

40 OLD coins, all different, \$1.00. Monroe Half-Dollar, Uncirculated, \$1.00. Alabama Half-Dollar, Uncirculated, \$1.00. List free. Claud Denney, Box 315, Dallas, Texas.

CALIFORNIA gold Quarter 27c; Half 52c; 1843 cent 15c; Confederate (\$5, \$10, \$20) 25c. A. Wylie, Wheaton, Ill.

**WILDCAT** Bill and Lists, 6c; 10 Foreign Coppers and German Scrip, 25c; Gold 1/4, 27c; 1/2, 53c; Nickel, 3c and 2c, 15c; 100,000 German Marks, 10c; 5 Different Coins and Lists, 10c. Al V. Bonsall, Richmond, Ind.

#### FOR BOYS

**MAY** We suggest a Christmas Present for Your Boy!—19-inch Metal Sailboat. Knockabout rig. Lead ballast. One that will sail. Price \$6.00 prepaid. Circulars of Boats and Steam Engines on request. Rice Manufacturing Company, East Boothbay, Me.

**BOYS** and Girls Earn Xmas Money. Write for 50 Sets St. Nicholas Christmas Seals. Sell for 10c a set. When sold send us \$3.00 and keep \$2.00. No Work—Just Fun. St. Nicholas Seal Co., Dept. 43, Brooklyn, N. Y.

**EARN** \$2.00. Be First in your Town. Write now for 50 sets Christmas Seals. Sell for 10c a set. When sold send us \$3.00 and keep \$2.00. Trust you till Xmas. Neubecker Bros., 901 E. 23d St., Dept. 88, Brooklyn, N. Y.

**BOOKS**—"Amateur Electrician" (illustrated); "ToyMaker"; "Ford Jokes," all for 25c. G. Eisea Co., Bowling Green, Ohio.

**FUN** making things with the Boy Mechanic Library. Four large profusely illustrated books telling how to make almost everything from a sail boat to a toy automobile propelled by a motorcycle engine. Boys of any age can make these things with the crystal-clear illustrations and simple instructions in the Boy Mechanic books. Now \$2 per book or \$7 for the four if ordered at once. Send No Money. Just write a postal saying, "Send the Boy Mechanic Library." When the postman hands you the books, pay \$7 and postage. If you want single books, specify either Book 1, Book 2, Book 3, or Book 4. Popular Mechanics Press, 200 E. Ontario St., Room 812, Chicago, Ill.

#### CAMERAS AND PHOTO SUPPLIES

**PHOTOGRAPHIC** equipment and accessories of every description are listed and illustrated in our 228-page catalogue. It will pay you to secure a copy which is issued free, as our prices are low. We also deal in used goods which are sold under the same guarantee as new goods. Ask for our Bargain Book, Central Camera Co., Dept. E-100, 112 S. Wabash Ave., Chicago, Ill.

**MODERN** Photography in all its branches now taught by mail. New Successful Method. Students earning \$300.00 while learning. Big opportunity. Write for particulars and unusual offer open for short time. Dept. 1331, International Studios, Inc., 3621 Michigan Ave., Chicago.

**FILMS** Developed. Special Trial Offer. Any Size Kodak film developed 5c, prints 3c each. Trial 6x9 Enlargement in handsome folder 40c. Overnight Service. Roanoke Photo Finishing Co., 209 Bell Ave., Roanoke, Va.

**SUPERIOR** quality finishing. Trial offer: Any size 6 exposure roll developed and printed, 25 cents. One only 8x10 enlargement unmounted from negative, 35 cents. Carhuff Photo Finishing Co., 2129 W. Van Buren St., Chicago.

**HAVE** You a Camera? Write for Free sample of our big magazine, showing how to make better pictures and earn money. American Photography, 116 Camera House, Boston, 17, Mass.

**KODAK** Films—Special trial offer; your next kodak film developed, 5c—prints, 2c each. Moser & Son, 1917 St. James Ave., Cincinnati.

**ENORMOUS** Profits From Camera! An Income From a Camera, kind of pictures 100 firms want. 12 issues P-8 Bulletin, all \$2. Particulars, stamp. Press Studios, Walton, Neb.

**BETTER** Photo Finishing. Send one roll film and 15c for trial offer. Moore's Photo Studio, Alstead, N. H.

**DEVELOPING** 4c. Printing 3c each. Satisfaction guaranteed. Quick service. Cash with order. Universal Supply Co., Auburn, N. Y.

**KODAKS**, 3/4-5/4 \$9; with astigmat lens \$15. Kodaks exchanged. Ray, 296 5th Ave., New York.

#### MOTION PICTURES

**\$\$\$ FOR** Ideas. Photoplay plots accepted any form; revised, criticized, copyrighted, marketed. Advice free. Universal Scenario Corporation, 206 Security Bldg., Santa Monica and Western, Hollywood, Calif.

**SEND** 10c for the latest and greatest Bass Book of Cinema Apparatus; gives full description of all types of instruments as well as the list price. Or, send \$3.00 for a 500-page Cinema Hand Book containing full instructions of the making and taking of films. Bass Camera Company, 105 N. Dearborn St., Chicago, Ill.

**SEPT** spring motor Morie Camera, new, worth \$150, with leather case only \$40—Home Projector, 1,000-foot reels, \$30. Motor-driven sult case Projector \$110, 4,000 reels of Movie Films, 7,500 lantern slides. Ray, 296 5th Ave., New York.

**FILM**—Million Feet for Sale. Cowboy—Drama—Comedy and Feature Specials. Mix—Hart—Chaplin and best Movie Stars. \$3.00 per reel up. Genuine List Free. We Supply the World. Dept. G, Monarch Films, Memphis, Tenn.

**\$35.00** PROFIT nightly. Small capital starts you. No experience needed. Our machines are used and endorsed by government institutions. Catalog free. Atlas Moving Picture Company, 482 Morton Bldg., Chicago.

**MOVIE** films, 1,000 ft. reels. Complete stories, \$2.50 each; shipped anywhere on receipt of remittance with order. Independent Films, 177 Golden Gate Ave., San Francisco, Calif.

**FILMS** of every kind and character. Comedies—Westerns—Andy Gump Cartoons—Educational and Special Feature Subjects. Rock Bottom Prices. Wonderful Guaranteed List Free. Dixie Film Co., P. O. Box 407, Memphis, Tenn.

**NEW** and Rebuilt Machines for Big Theatres—Schools—Churches—Traveling Shows. Also Films—Supplies and Complete Theatre Equipments. Bargain List Free. Monarch Theatre Supply Co., Dept. P, Memphis, Tenn.

**MAKE** money writing photoplays; details free to beginners. No correspondence course. Producers League, 230 Wainwright, St. Louis.

**MOVIE** Films Price List free. Donald Elder, 589 Broadway, Chelsea, Mass.

#### SCENERY TO RENT

**SETTINGS** for Opera, Plays, Minstrels. Flush drops. Address Amelia Grain, Philadelphia.

#### EDUCATIONAL AND INSTRUCTION

**MAKE** \$66 a Week and Up. Learn Bricklaying at home in spare time by the Job Analysis Method. We can train you in few months. Under our plan you actually work with bricks in back yard, garage, basement, attic, or barn. Course covers all units of construction, corners, angles, jumbs, pilasters, etc. Also how to read blue prints and plan complete buildings. Free book, "The Quick Way to Big Pay Everyday," tells everything. Write for copy today. See page 88. The National School of Bricklaying, Dept. L-11 Ninth and G Streets, Washington, D. C.

**YOU** can have a business profession of your own and earn big income in service fees. A new system of foot correction; readily learned by anyone at home in a few weeks. Easy terms for training; openings everywhere with all the trade you can attend to. No capital required or goods to buy, no agency or soliciting. Address Stephenson Laboratory, 1 Back Bay, Boston, Mass.

**ARTIFICIAL** Marble sanitary flooring instructions, ornamental casting, concrete, plaster, papier-mache decorations, garden furniture, statuary. Rubber-moulds, 15 years' instructing the public, particulars and 200 illustrations free. Chris Mahler, Huntington, N. Y.

"**WHAT** to Invent for Profit" free. Patent News-N, Washington, D. C.

**SIMPLIFIED** Photo-engraving. Line and half-tone cuts. Particulars 2 cts. Horton & Fisher, Princeton, Ill.

**LEARN** Modern Barbering at Home. Hair-cutting, Shingling, Bobbing, Shaving, Honing, Strapping razors. Easily learned by any one. Practice on the family. Friends. My practical scientific instructions on modern barbering, complete for \$1 (bill), teaches you expert barbering at home. Foster, Expert Barber, 613 E. 68th St., Chicago, Ill.

**LEARN** Auctioneering. Successful Auctioneers make Big Money. Write today for free Catalog. Jones Nat'l School of Auctioneering, 8 N. Sacramento Blvd., Chicago, Carey M. Jones, Pres.

**SHORTHAND** in four evenings. Arthol course seven dollars. Sent approval. Particulars, Hollefreund's College, Stratford, Ontario, Canada.

**HOW I draw the "Americann Girl."** Showing actual work from start to finish. Free samples. Write Freeborn, Artist, Hicksville, Ohio.

**USED Books and Educational matter.** Bargain prices. Bulletin free. Write, Instruction Correspondence Exchange, 1968 Broadway, New York.

**HIGH School—College courses, Correspondence.** Diplomas. Dr. Humphrey, N. Baldwin, Sierra Madre, Calif.

**AMATEUR cartoonists.** Make money at home by mail. Complete working plan \$1.00; particulars stamp. Smiths Service, Wenatchee, Wash.

**USED educational matter of all kinds.** Sold on repurchase basis. Big saving. Money-back guarantee. List free. (Courses bought.) Lee Mountain, Pigeon, Ala.

**SELF-TAUGHT: Stenography or Book-keeping.** 25c. Write, Marr, Teacher, B665, Nashville, Tenn.

**THEATRICAL Scene-painting** taught by Mail. Practical Courses. For Literature send stamps. Enkeboll Art Studios, Omaha, Neb.

**USED educational matter bought, sold, exchanged.** Handling, 799 Broadway, New York.

**USED educational matter.** Lowest prices; terms. Catalog free. Mention Subject. Economy Educator, 440-A Sansome, San Francisco.

**LINOTYPE instruction;** largest, oldest school in existence; established 19 years; 1,000 have attended; course \$200; including printing, \$350. Empire School, 206 E. 12th St., New York.

**DOUBLE Entry Bookkeeping** mastered in 60 hours with 8 keys; guaranteed; diploma. International Bookkeeping Institute, Dent, 5 Springfield, Mo.

**FREE Book.** Start little Mail Order business. Pier, 219 Cortland Street, New York.

#### RADIO OUTFITS AND SUPPLIES

**LONG distance radio \$2.95.** Lambert's newest crystal success. No tubes. No batteries. No grief. Always ready. Works 600 miles. Fully guaranteed. We pay postage. Order direct from this add. Leon Lambert, Wichita, Kans.

**RADIO Experimenters.** Send for free Bargain list. Robert Bedford, Johnstown, N. Y.

**THOUSANDS of Satisfied Customers** bear 300 to 800 miles on Sharps' Crystal Sets. Copyrighted plans \$1.00. Complete kit and plans \$5.00. E. A. Sharp, Jr., 7052 N. Clark St., Chicago.

**TUBES 201A \$1.40, WD19 199 \$1.35.** Guaranteed. Send for money saver. Agents wanted. Kings Radio Sales, 1166 N. Kingshighway, St. Louis, Mo.

#### TRADE AND TECHNICAL

**MAKE \$46 A Week and Up.** Learn bricklaying at home in spare time by the Job Analysis Method. We can train you in few months. Under our plan you actually work with brick in back yard, garage, basement, attic, or barn. Course covers all units of construction, corners, angles, jambs, pilasters, etc. Also how to read blue prints and plan complete buildings. Free book, tells everything. Write for copy today. "The Quick Way to Big Pay Everyday." See page 88. The National School of Bricklaying, Dent, L-11, Ninth and G Streets, Washington, D. C.

**GET a Foreman's Job** in any trade. Train yourself to earn more money. Become an expert Blue Print Reader. You can do it in spare time. My training will give you advancement in a few weeks. Write now—tell me what trade you want—I will send my plan at once. Carroll Rumsey, 185 Drexel Bldg., Philadelphia, Pa.

**TELEGRAPHY—Both Morse and Wireless—**taught thoroughly and quickly. Tremendous demand. Big salaries. Wonderful opportunities. Expenses low; chance to earn part. School established fifty years. Catalog free. Dodge's Institute, Fern St., Valparaiso, Ind.

**DO you want \$12 to \$20 per day?** Learn now. Sign Painting, Decorating. Paper hanging. Auto Painting. Show card writing. Catalog Free. Chicago Painting School, 148 W. Austin Ave., Chicago.

#### BUSINESS OPPORTUNITIES

**COMPANIES organized.** Financing. Write, Box 8-209, 311 Fifth Avenue, New York.

**GREAT Discovery:** Coeur D'Alene Composition Gold-like Nuggets fool them all. They have the weight, color and look like the genuine article. Are you looking for something different? Think this over. These Nuggets attract attention—quick sales—big profits—expensively compounded and will wear forever. Formula and complete copyrighted manufacturing directions, also four other valuable formulas mailed for \$1.00. (No stamps.) Western Specialties Laboratory, 902 Hastings Ave., Coeur D'Alene, Idaho.

**PATENTS.** Time counts in applying for patents. Don't risk delay in protecting your ideas. Send sketch or model for instructions or write for Free Book "How to Obtain a Patent" and "Record of Invention" form. No charge for information on how to proceed. Communications strictly confidential. Prompt, careful, efficient service. Clarence A. O'Brien, Registered Patent Attorney, 5828 Security Bank Building (directly across street from Patent Office), Washington, D. C. See pages 172 and 173.

**AGENTS:** \$91.50 Weekly. Introductory specials in 57 styles, 40 colors New Insured Healers for men, women, children. You write orders. We deliver and collect. Free hose offer to every new customer. Other premiums for customers as well as agents. Bonus besides. No capital or experience necessary. Samples furnished. Write quick. No matter what you are now doing, you owe it to yourself to get this offer. Mathews, 7312, Cincinnati, Ohio.

**STOP!** Your chance is here. Chemical battery charger—Recharges any storage battery without electricity. Takes only a few minutes. Will not freeze nor corrode. Materials cheap and easy to obtain. Think of the great money-making possibilities here! Delay is expensive! Start now! Guaranteed formula with complete information only two dollars. Consulting Chemists, 245 N. Main St., Dayton, Ohio.

**MAKE money manufacturing and selling best mechanics' hand soap known.** No special equipment necessary. Materials easily obtainable. Four hundred per cent profit. Every garage, oil station, machine shop and automobile owner a customer. One round sample can, formula and full instructions two dollars. General Manufacturing and Sales Co., P. O. Box 833, Everett, Wash.

**MIRRORS Re-Silvered at Home.** Costs Less 5 cents per square foot; you charge 75 cents. Immense profits, plating autocrats, reflectors, tableware, stores. Refinishing metalware, etc. Outfits furnished. Write for information. Sprinkle, Piater 127, Marion, Ind.

**A DIFFERENT business,** worth remunerative. Learn privilege trading, small capital. Dept. M, Paul Kaye, 149 Broadway, New York.

**A MAIL-ORDER business** of your own, selling movie patrons all year anywhere; free circulars. Wonda, M, 31 Times Plaza, Brooklyn, N. Y.

**BATTERY Shop Equipment and Supplies** at Wholesale. Adams-Barr, Columbus, Ohio.

**FREE information** about mail-order business. Clever ideas make fortunes. Mail Order News, 260 Bristol Building, New York.

**FREE Advertising rates.** Newspapers, magazines. Pennell, Covington, Ky.

**\$50 WEEKLY.** Your own Business. Enormous Profits. Mail Order Plan Sample 50c. Suydam, 10748 112th St., Richmond Hill, N. Y.

**WIRE door mat machine** for sale; six dollars in wire will make ninety dollars in manufactured mats; easy to make, easy to sell. Profitable business for right man with small capital. J. L. Evans, Franklinville, N. Y.

**PATENTS Procured; Trade Marks Registered—**A comprehensive, experienced, prompt service for the protection and development of your ideas. Preliminary advice gladly furnished without charge. Booklet of information and form for disclosing idea free on request. Richard B. Owen, 30 Owen Bldg., Washington, D. C., or 41R, Park Row, New York.

**SUCCESS With Your Own Products—**Make them yourself. Formulas, Processes by experts. Trade-Secrets. Modern master methods. Catalog free. B. Thaxly Co., Washington, D. C.

**MAKE big money.** Safe and Lock Expert. Wayne Strong, 3697 1/2 Lan Franco St., Los Angeles, Calif.

**REPRESENTATIVES** selling direct to consumer can obtain information relative to plan which will substantially increase their income. Estru Products Company, 2903 W. Madison, Chicago.

**MONEY-MAKING Opportunities—**That big Mail Order and Agents' Monthly that is different—filled with plans, Formulas, and Valuable Money-Making Information. Three Months' trial subscription 25c (silver). Crittenden, 4132 West 21st Street, Chicago.

**TWENTY Big Money-Making Opportunities,** 10 cents. Fourteen Articles worth \$2.00 free. Lawrence Products Company, Beaver Dam, Wis.

**BUSINESS Financing.** Write Chas. W. Barrick, New Martinsville, W. Va.

**BUILD splendid business** making clipped glass number and name plates, signs, check-boards. Write for particulars. Simplex Utility Co., 1133 Broadway, New York.

**FORTUNE for you!** Manufacture and sell "Wizard Coal Saver!" New, Marvelous Discovery! Cut coal bills One-Half! Anyone can make! Simple; Cheap; Effective! Complete instructions only \$2.00! Leo J. Avard, Shenandoah, Pa.

**MAKE \$30 to \$100 a week Extra.** No experience or investment. No peddling. A permanent business. Lifetime opportunity. Joe Malek, 1269 Transportation Bldg., Chicago.

**23 MONEY-MAKING Ideas.** Mail order supply sources, 10c. Deaouth Company, Englewood, N. J.

**\$13,955.00 IN 4 months.** Wonderful Vapor Humidifier. All autos. One free to introduce. Critchlow, K-124, Wheaton, Ill.

**START your own Business.** Automobile Cleaning Station Retrimming Repair Cars. Interior Painting-Decorating of Homes. Manufacture Specialties. Learn these trades at Home. Modern Methods. Sent on approval. Devilda, Sheboygan, Wis.

**MAKE Big Money!** 15 Tested Formulas 25 cents. Handyman Instruction Sheet, 25 cents. All for 25 cents with other offers. J. Bucknam, 63 Court Street, Boston, Mass.

**MONEY-MAKING opportunity** for you. See our ad on page 136. Milburn Pancreatic Proof Tube Co., Chicago.

**CHILDREN'S Furniture** anyone can make—six patterns \$1.00. Doll's House, Dresser, Desk, Settee, Table, 25c each. Kiddie Cabinet, 305 West 143d St., New York.

**TATTOOING Supplies.** Complete Electric Outfits. Lowest Prices. Catalogue. "Waters," 865 Putnam, Detroit.

**NEW discovery** from Europe; will remove shine and gloss from old and worn clothing. Big profits. Exclusive territory. Trial package 25c. The Mann-Wood Co., Inc., Dept. B, 17 West 60th St., New York.

**\$30 A WEEK.** Mail Order business. Booklet tells how. Sample and plan 25c. Outfit furnished you free. Bradford Co., Dept. B, Shawnee, Okla.

**"NUSSHINE Silver-Gold Cleaner** agents desired, limited territory available. Good-housekeeping endorsement, sample free. Orchard Products, 1209 Tribune Bldg., New York.

**FEW responsible men** assisted in launching business by mail. Co-operative plan. Catalogs supplied your imprint. Orders filled direct from factory. Must have \$50. Postage. Colonial Cutlery Co., Warwick, N. Y.

**READ, heed, learn.** Mail Order Opportunity. Doubters hesitate. Doors act. Stamp brings details. Walter Anderson, Dept. 311P, Villa Park, Ill.

**150 MONEY-MAKING Plans** Free! Wolverine Bureau, (A-3), Muskegon, Mich.

**MAKE \$10 daily** at home, spare time, making mirrors and plating autos. Profitable anywhere. Instruction booklet free. Testimonials. W. Abell, 141 The Arcade, Cleveland, Ohio.

**GO into the Rug-Cleaning business.** Same method I am using myself. Plan and formula 50c. Good for \$10 daily. F. H. Fink, 1050 Curtis St., Toledo, Ohio.

**MAIL Order Booklet,** where to buy Books, Novelties, Specialties, 10c. Harry Teenie, Decatur, Ind.

**MAIL Order.** New plan, Practical, profitable and sure. Send for details. S. A. Van Auker, 34 Riehton, Detroit, Mich. Dept. B.

**HERE'S Your Opportunity.** Get into a little mail-order business of your own. Instructions \$1. Yarrington, Box 569, La-Crosse, Wis.

**POPCORN Poppers—**Money makers, lowest priced small machines. Northides Co., 1306 Fifth, Des Moines, Iowa.

**MECHANICS**, carpenters, painters, start furniture refinishing and handyman shop on nearby nothing; winning plan brings customers quickly. John Braceland, 1439 So. Ninth, Philadelphia, Pa.

**UNPATENTED Ideas Can Be Sold.** I tell you how and help you make the sale. Free particulars (Copyrighted). Write W. T. Greene, 810 Jenifer Building, Washington, D. C.

**RESPONSIBLE** manufacturer wants competent men to manage office and salesmen. \$300 to \$1,500 necessary; will allow expenses to Trenton if you qualify. Address Manager, 336 Forst Richey Bldg., Trenton, N. J.

**100,000 REPRESENTATIVES** Wanted! Sell by Mail, through Agents, or Direct! Detailed Information—25¢! None free. Surety Service, World Distributors, 351 Harvard St., Rochester, N. Y.

**ATTENTION!** You can have a business of your own. Establish and operate New System Real Estate Business, brokerage and insurance agency in your community. Office at home. Earn \$5,000 year. Representatives wanted everywhere. Send stamp free booklet. Hayes Realty Association, Cincinnati, Ohio.

**RESILVERING Mirrors—Genuine.** Guaranteed Trade-secret, 50c. Deluxe Chemical Service, Drawer "D," Park Ridge, Ill.

**I MADE \$30 a Week** Home. French Breadmaking, 15 years' experience; Free Booklet tells. Ashbrook 67, Marengo, Ohio.

**WHY work for others?** Make and sell your own goods. We show you how. Free book explains everything. National Scientific Laboratories, 1900-A Broad, Richmond, Va.

**MAKE Money** at home or on large scale, casting toys and novelties, particulars Free. New Specialty Co., 448 E. 79 st., New York.

**A WORTHWHILE Mail-Order Business** by new methods, quick sure, positive and big, is yours if you want it. Free circular gives latest information. MacRae, Publisher, 3805 Oregonian Building, Portland, Ore.

**IF you have a car**, are energetic, and desire to distribute the best selling automobile accessory on the market, address R. & C. Manufacturing Co., Parkersburg, W. Va.

**CHEMICAL Expert** furnishes Manufacturing Formulas and Processes with complete working directions. Reliable individual service only. No lists. Charges reasonable. Correspondence invited. Dr. Arthur Van-Heeden, 508 South Oakley, Chicago.

**LEARN** Hotype: Earn \$3,000 yearly; established 19 years; day, evening; cost \$200; including printing, \$350. Emory School, 204 E. 19th St., New York.

**COST \$5.00**, your profit \$104.75. Transferring Decalcomania letters on autos, trunks, bags etc. Send today for outfit or free samples. World Monogram, Dept. 73, Newark, N. J.

**MARBLE** mixing instructions, covering wood or cement flooring 1/2 in. thick, fire-proof, waterproof, low cost, sanitary, all colors. Particulars, 200 illustrations free. Chris. Mahler, Box 122, Huntington, N. Y.

**\$3,000 TO \$6,000** Yearly. Want it? Others are making it. Send check or money order today for our invaluable books "How to Sell Real Estate," \$3.00—and "How to Conduct Real Estate and Insurance Business," \$1.50. Absolute satisfaction guaranteed. Free circulars. Realty Book Co., Dept. 52, Cleveland, Ohio.

**FREE Book.** Start your own little Mail Order business; home employment essential. Beginner's Outfit furnished, including 500 circulars, samples, things to sell; you deal with Manufacturers. Also tell easy way to get Agents by mail to sell your novelties. Instructive Book free. Pier, 918 Cortland Street, New York.

**INVENTORS—Write** for our Guide Book, "How to Get Your Patent" and Evidence of Invention Blank. Send model or sketch of your invention for our free Examination and Instructions. Randolph & Co., Dept. 435, Washington, D. C.

**WE Start You in Business**, furnishing everything; men and women, \$20.00 to \$100.00 weekly operating our "New System Specialty Candy Factories" anywhere. Opportunity Lifetime; booklet free. W. Hillier Ragsdale, Drawer 4, East Orange, N. J.

**WANTED.** Patent Finance. Address W. C., Patent News, Washington, D. C.

**EARN \$10** daily silvering mirrors, plating and refinishing metalware, autos, chandeliers, bedsteads, headlights. Outfits furnished. E. Decie Laboratories, 1153 Broadway, New York.

**MAKE Money** at Home—making toys. We show you how. Send \$1 for complete working drawings and instructions. De-Kalb Designing Co., Decatur, Ga.

**GET Money** in Your Mail. "Lambert's Mail Order Secrets" contains successful methods never before published. \$1.00 post-paid. Particulars free. Leon Lambert, Wichita, Kans.

**SIGNS and Showcards** Easily painted with Letters Patterns. Large variety of Styles and Sizes. Sample for stamp. John Rahn, 22433 Greenleaf Ave., Chicago.

**LEARN** the collection business. Good income, quick results. Interesting booklet, "Skillful Collecting" free. National Collectors Assn., Lenoir St., Newark, Ohio.

**"WHAT to Invent for Profit"** free. Patent News-C, Washington, D. C.

**FREE Booklet** describes 52 plans for making \$20.00 to \$100.00 weekly in home or office business of your own. Downs Co., 2223 Myrtle, St. Paul, Minn.

**MANUFACTURE** Millerite! Ethyl-Super-Fuel Ingredient for Gasoline. Increases Power, Mileage—saves gas—easily mixed—profits great—valuable Formula Literature of this Lightning Electrolyte, Kor-Kit, Pro-Tex-U, Amazon Rubber Repair, and fifty other Biggest selling Specialties in all lines will be sent on request. Miller, Chemist, 1115 Grand Central Ave., Tampa, Fla.

**ENTER** a new business. Earn \$3,000 to \$6,000 yearly in professional fees making and fitting a foot specialty, openings everywhere, with all the trade you can attend to; easily learned by anyone at home in a few weeks, at small expense; no further capital required, no goods to buy, job hunting, soliciting or agency. Address Stephen-Laboratory, (1) Back Bay, Boston, Mass.

**SCHEMER**, Alliance, Ohio, prints Big Profit Schemes, one subscriber making \$25,000 from three; another \$10,000 from one. Try your luck. Three months, 30c; copy 10c.

**MAIL Order Business** is your opportunity. Breniser's Famous Handbooks teach how to start small, grow big. Sell merchandise, service, ideas; enormous profits. Spare time to begin. Get complete set, 11 books, \$2.00, and be posted. Breniser, 335 Walnut, Philadelphia. Descriptive Catalog and big batch interesting mail order information, 25c. None free.

**"HOW to Sell Patents"** free. Patent News-H, Washington, D. C.

**YOUR ship** will never come in unless you send it out. European Bonds, "The Venture of the Century," bought, sold cash or installments. Information without obligation. Frank O. Everett, 35 Wall Street, New York.

**MAKE** toys and novelties at home. Big profits. Instructions and illustrations, 25c. Astroline Company, Sharpsburg, Pa.

**CHEMICAL Expert** will furnish Formulas and Trade Secrets, All lines. Lists Free. W. L. Cummings, Ph. D., 228 Gordon Ave., Syracuse, N. Y.

**CLAIMS of Every Description** Collected. Fidelity Credit Co., 803 East Clay, Richmond, Va.

**PATENTBOOK**, 139 mechanical movements and illustrations, sent free. Labiere, 3 Parkrow, New York.

**GO INTO** the Crispette business. Everybody likes Crispettes. You can make a lot of money. We start you. Write for facts. Long Eakins, 1939 High St., Springfield, Ohio.

**INVENTIONS** fully protected two years \$15 total cost. Particulars free. Patent News-K, Washington, D. C.

#### TELEGRAPHY

**TELEGRAPHY—Both Morse and Wireless—taught** thoroughly and quickly. Tremendous demand. Big salaries. Wonderful opportunities. Expenses low; chance to earn part. School established fifty years. Catalog free. Dodge's Institute, H St., Valparaiso, Ind.

#### WANTED—BUSINESSES FOR SALE

**IF You Want to Sell Your Business** for Cash quickly and privately, we take the prospective buyer directly to you at our expense, no matter where located. We specialize in selling out-of-town businesses. If your business is worth \$5,000 or more, write us. The Mutual Security System, 68 W. Washington St., Chicago.

#### CHEMISTRY

**LABORATORY Apparatus**, Chemicals, Radio Supplies. List 4c. Chemical Apparatus Co., 4402 West End., Chicago.

**YOUR chemical problem** solved and working process furnished Fire Dollars. Write me. W. Steadman Richards, Consulting Chemist, address, Box 2402, Boston, Mass.

**TECHNICAL information**, analysis, formulas, trade secrets, Jacob Slayter, Chemist, 2525 East St., Davenport, Iowa.

**MASTER Practical Chemical Analysis** by my Chart Method, \$3.00. Your chemical problem solved, \$2.00. Henry Goldblatt, 3723 W. 16th St., Chicago, Ill.

#### FORMULAS AND TRADE SECRETS

**15,000 FORMULAS**; 800 pages; \$3.98. Money refunded if dissatisfied. Ideal Book Shop, 2511-H Foster, Chicago.

**START in Business**. Sell Piano and Furniture Polish. Used in Every Home. Make It Yourself. Directions and Formula \$2. S. T. Cole, 132 E. Eaton St., Bridgeport, Conn.

**LEARN** How to Make Fireworks. Send for formulas—15c. Frank Engel, 1924 Sturdevant St., Davenport, Iowa.

**BOOK** Containing 2,000 Valuable Formulas and Recipes, price \$1.00. E. Keshart, Box 34, Station Y, New York City.

**TESTED and Guaranteed formulas**, \$1.00 Chemical analysis for duplication. Roxbury Laboratories, 11 Williams St., Roxbury, Mass.

**WE solve Chemical problems**, furnish tested formulas or analyze your samples. Reasonable. Research Laboratories, Washington and Williams, Roxbury, Mass.

**MIRROR Formula**; 22 others, 25c. John M. Fisch, Sigourney, Iowa.

**ANY Formula**; 25c; 5 for \$1.00. Pittman's Lab., Parksville, Ky.

**FORMULAS**, Processes by experts. Trade-Secrets. Modern master methods. Catalog free. B. Thaxly Co., Washington, D. C.

**FORMULAS**, Chemical Analysis, etc. Douglas Chemists, 707 So. Laundale, Chicago.

**FORMULAS** The best Chemical Science can devise—Guaranteed Reliable Processes in all lines. Stamp brings big bunch valuable literature, interesting lists. Don't buy till you see what I can give you. 27 years supplying the best. Miller, Chemist, 1133 Grand Central, Tampa, Fla.

**500 FORMULAS—** including Luminous Paint—Renewing Dry Batteries—Mechanics' Soap—Gas Tonic—25c. Catalog Free. Ideal Book Shop, 2511-PM, Foster Ave., Chicago.

**BEVERAGES**, Syrups, Extracts, Flavors, Etc. Other good manufacturing specialties. Free information. The Formula Co., 1613 Queen Anne Ave., Seattle, Wash.

**CONCRETE** Waterproofing Processes, making Hard, Light Colored, Dampproof concrete building blocks. Concrete Machine Co., 5 Main St., St. Louis, Mo.

**WHY work for others?** Make and sell your own goods. We show you how. Free book explains everything. National Scientific Laboratories, 1900-A Broad, Richmond, Va.

**500 VALUABLE Formulas**, 25c. Circular Free. Harvey Teeple, Decatur, Ind.

**MAGIC Cloth—One Rub** keeps Snow or rain hurried windshield clear 24 hours. Big seller. Easily made. Guaranteed Trade-secret, 50c. Deluxe Chemical Service, Drawer "D," Park Ridge, Ill.

**10,000 FORMULAS**. A real Gold Mine of money-making ideas. Tells how to make almost everything under the sun. You can make and sell cosmetics, macilage, anti-freeze solutions, battery solutions, beverages, cheese, chewing gum, cleaning preparations, extracts, hair preparations, inks, bluing, leather polish, mirrors, perfumes, polishes, typewriter ribbons, carbon paper, washing powders, liquid soap, and hundreds of other profitable articles. Send No Money, just write a postal for "Healey's 20th Century Book of Formulas." Pay postman postage and \$4. Popular Mechanics Press, 200 E. Ontario St., Room 812, Chicago, Ill.

#### AGENTS WANTED

**AWAY Ahead of Every Thing Else!** That's "Zippo" as a seller. Show your sample, talk a minute and pocket your profit. A real Sure-Fire, He-Man Money-Getter that repeats—and sax. Boy. It actually sells on a ten second Show-Down. If we didn't know we had a proposition that any man could sell eight out of every ten calls, you can bet your sweet life we wouldn't spend money telling you about it. Karam-Smith, 612 F Street, Ft. Wayne, Ind.



**NO Dull Times in the Food Business.** Selling Federal Pure Food Products is the greatest, surest and safest business in the world today, and here is your opportunity to get into it. You can make \$3,000, \$5,000, \$10,000, or more per year—the only limit is your ability to take care of the business. You will need no experience or money to get into this business. Your \$20.00 starting order sent on trust. We teach you everything you need to know. We furnish you with license. No Dull Times, for the People Must Eat, and our food products are the fastest selling, surest and quickest repeat order goods in the world. Sell on sight in every home where food is used—repeat orders immediately and every week thereafter. A real big business all your own. Every new customer adds a great deal to your weekly income. Your business once established, has a market value just like a store and can be easily sold. The greatest money-making opportunity of your lifetime because you risk absolutely nothing, as we guarantee your sales, and we will not let you fail. Remember! Guaranteed! Best products, biggest sellers, surest repeat orders. No capital or experience is required. We furnish capital and everything necessary for you to become a Federal Distributor. Exclusive territory will be given honest men or women who write at once, Federal Pure Food Company, 2309 Archer Avenue, Dept. A, Chicago, Ill. Largest packers of Pure Food specialties in the world. Reference, any bank, Dun or Bradstreet rating agency, Express or Railway Company in America.

**MANUFACTURE** These World's Biggest Selling Specialties. A few dollars will start you making these in your own Home, Office or Shop. You'll have Agents and Specialty Salesmen Selling these for you everywhere. This you easily do with my Guaranteed Superior Manufacturer's Formulas and Plain Detailed Instructions for Saponal, Blue Crystal Queen of Soaps; New Way Fabric Mending Fluid; Amazon Self Vulcanizing Rubber Tire Weld Cement; Battery Charging Fluid; Parisian Bobbed Hair Liquid Marcelle; King's all-color Quick shining Shoe Paste; Cleo-Wonder No Water Hand Paste Soap; Thermolite, Radiator Anti-freeze Crystals; Masico Windshield Cloth; and many other New Unequaled sellers in all lines. Investment small, Quick Returns, Profits Great. State what interests you, enclosing stamp for valuable descriptive literature, addressing Miller, Chemist, 1706 Jetton-A, Tampa, Fla.

**DISTRICT Agents**—For Union Made pure wool suits and topcoats retailing at \$23.50, none higher. A remarkable line of 45 beautiful fabrics tailored by a large and well known old established firm. Sold only through our own stores and district agents. A real opportunity for any good man. Big money to start and chance for advancement. We furnish large sales outfit, 9x13 cloth samples. Men over 30 years of age with tailoring or clothing experience preferred. Can use ambitious spare-time men in smaller towns. Interested only in serious men who seek a future. Write for free samples and full information. Address J. C. Harvey, Box 99, Chicago.

**AGENTS Wanted, Agents—\$100 Weekly for Your Spare Time.** Radio is calling you. The biggest season in history is about to open. Let us show you how to make \$80 to \$125 per week working all or part time selling our marvelous five-tube radio set on 30 days' free trial direct from factory to user at a saving to your customer of about half, at the same time making a good profit for yourself. We want exclusive agents everywhere. No experience necessary. Write for proposition today. Metro Electric Co., 1243 S. Wabash Ave., Desk 575, Chicago, Ill.

**FREE—Get This Quick!** Chicago's Wonder Shirt line. Sell newest, stylish, snappy, Stylenor Shirts. Amazing values at low prices. Make \$100.00 weekly easy. Complete assortment of large scratches makes selling Stylenor Shirts a cinch. Experience or capital unnecessary. Be your own boss. We will show you how to build a big business of your own. We will deliver and collect. Exclusive territory open. Write today, for big free outfit. Stylenor, 81 W. Van Buren, Chicago, Ill. Dept. 560.

**AGENTS, Agents**—here's a live-wire sales proposition for you; easily earn \$10.00—\$75.00 weekly; article sells on sight to homes; repeats like wildfire; you can run out subagents and clean up; free folder explains. Broughton Adhesive & Socialty Co., 21 Lincoln Street, Boston, Mass.

**PATENTS.** Time counts in applying for patents. Don't risk delay in protecting your ideas. Send sketch or model for instructions or write for Free book "How to Obtain a Patent" and "Record of Invention" form. No charge for information on how to proceed. Communications strictly confidential. Prompt, careful, efficient service. Clarence A. O'Brien, Registered Patent Attorney, 5898 Security Bank Building (directly across street from Patent Office), Washington D. C. See pages 172 and 173.

**BIG Money Demonstrating "Jiffy Tire and Tube Repair Kit."** Contents 3 Self-Vulcanizing Tire Shoes; 3 marvelous Puncture Sealers; large Outfit Tube Patch Gum. Everything complete. Biggest value ever offered. We manufacture Nationally known "Jiffy Tire-Doh" and other high-grade accessories. Agents average \$80 to \$100 weekly. Write for exclusive territory and free sample. Chicago Tire Patch Co., 347 E. Garfield Blvd., Chicago, Ill.

**HALF a Minute Demonstrates My new patented powder puff; wonderful attention getter; no woman with 50c can resist it; gives you instant introduction everywhere, after which my automatic sales plan gives you two or more sales and profits, all with one demonstration; if your line is stale or overworked, get my plan today and put some new "pep" in your sales work. F. A. Koch, Dept. 70, 8718 Arcadia Avenue, Detroit, Mich.**

**AGENTS—Here's a New One.** "Best-ever Powdered Hand Soap." Sells like wildfire. Marvellous Discovery. Removes grease, paint, ink, oil, in fact anything from the hands. Cannot harm skin. 150% Profit. Great Repeater. Agents simply coin money. "Free Samples Get the Business." Write immediately. Bestever Products Co., 1945 E. Irving Park, Chicago.

**ONLY one sale a day means \$200 per month!** Marvellous new adding machine. Retail \$15.00. Work equals \$250 machine. Adds, subtracts, multiplies, divides, automatically. Computes feet and inches. Speedy, accurate, durable, handsome. Five-year guarantee. Offices, stores, factories, garages, lumbermen buy one to dozen. A fortune for live agents. Write quick for protected territory and free trial. Lightning Calculator Co., Dept. F, Grand Rapids, Mich.

**SELL Shirts and Overalls Direct to Wearer.** Big Profits. Work full or spare time. No experience required. Big variety Dress Shirts with splendid line Union-Made Work and Flannel Shirts, Overalls, Coveralls, Work Pants, Leather and Sheep-lined Coats. Write today for free selling outfit. The Nimrod Shirt Co., Dept. 8, 4922 Lincoln Avenue, Chicago.

**WHY work for others? Make and sell your own goods.** We show you how. Free book explains everything. National Scientific Laboratories, 1900-A Broad, Richmond, Va.

**SELL widely advertised Skat paste soaps, toilet soaps, Cleaners, polishes, etc.** New allowance and commission plan insures success. Skat Company, Hartford, Conn.

**\$8.50 TO \$20.00 daily pay.** Introducing New Invented Hosiery for men, women, children. 37 styles, 40 colors. Must wear or replaced free. Repeat orders sure. Nyland made \$395 in one month. Edwards, \$400.00. Mrs. Bone, \$445.25. Why not you? Even spare time work should pay you \$3 per hour. Your Pay Daily in advance. We deliver and collect. You spend all your time writing orders. No experience or capital needed. We furnish samples. All grades, colors, including silks. No matter what you are doing now, write for our offer. Maccohee Textile Company, Station 25612, Cincinnati, Ohio.

**AGENTS, Salesmen—Sell New Thermostatic Automatic Carburetor Control Attachment for Fords.** Big profit, full or part time. Burns 95% air. Doubles Mileage. Attached in 2 minutes. No drilling. Does automatically exactly what Ford manual says do by hand. Cadillac now using Thermostatic Carburetor Control under Blanche Heense. Write today. A. C. Blanche & Co., Dept. 805TX 602 Lake St., Chicago.

**WONDERFUL invention eliminates needles for photographs.** Preserves records. Abolishes scratching. Day's supply in pocket. \$20 daily. Sample on approval if requested. Everplay, Desk, B-12, McClurg Bldg., Chicago.

**\$50,000. PICTURE Man Friedman made** cashing. Beginners can make \$100.00 weekly with my sales talk. Experienced men make more. Free book "Profits in Portraits" explains. Samples Free. Picture Man Friedman, Dept. 8-B, 541 W. Lake, Chicago.

**AGENTS Wanted—Something New—Fyr-Fyter sells easily.** Makes a spectacular demonstration; car owners, homes, factories, stores, practically buy on sight. Our men make \$10 to \$50 a day. Exclusive territory to producers. If you wish to establish a business of your own with unlimited possibilities for making big money, write us today. Fyr-Fyter Co., 905 Fyr-Fyter Bldg., Dayton, Ohio.

**GREATEST temper-saving device!** Takes slack and kinks from telephone and electric iron cords. \$25 daily. Samples on approval if requested. Neverknot, Dept. 121, McClurg Bldg., Chicago.

**AGENTS—Make a dollar an hour.** Sell new kind of sharpeners. Sharpens all knives and tools quickly. Demonstrating sample free. Premier Mfg. Company, Dept. 61, Detroit, Mich.

**AGENTS: New Selling Plan!** \$1.25 premium free to every customer on a \$2.00 sale, consisting of 8-oz. Vanilla, 6-oz. Shampoo, 4-oz. Lemon Lotion. A big hit everywhere. Complete details free. Territory going fast. Write today. The C. I. Tegstad Company, Dept. 18T, 29 South Clinton St., Chicago, Ill.

**WHY work for others? Make and sell your own goods.** We show you how. Free book explains everything. National Scientific Laboratories, 1900-A Broad, Richmond, Va.

**64 MILES on 1 Gallon.** Scientific Gas Saver. All autos. One free to introduce. Critchlow, L-124, Wheaton, Ill.

**AGENTS make big money selling our household goods.** Webster Co., 522 Wrightwood, Chicago, Ill.

**\$100 A WEEK:** Agents, Crew Managers, sell Extracts, Toilet Articles, other necessities. Guaranteed line. Particulars free. Midwest Drug Co., 191 E. Naghten St., Columbus, Ohio.

**SELL Orange Blossom Perfume.** Costs you \$30.00 Gallon. Retail \$1.00 ounce. Superior Manufacturing Co., Oakland, Calif.

**CAN you sell to colored people?** Write, Eaton Co., Dept. 101, 2509 Second Ave., Birmingham, Ala.

**BE Independent.** Make—sell your own specialties. Immense profits. Catalog dependable Formulas, special selected Agents best sellers. Free. Lastro Co., 832 East Pershing, Chicago.

**AGENTS, no competition sell 25 cts. household necessities every woman wants, over 200% profit.** \$15.00 daily easy. Free sample. Franco, 309 S. LaSalle, Chicago.

**AGENTS—\$12 Daily Easy.** Introducing Largest Line New Style Guaranteed Hosiery. Cotton, Bal, heather, silk. Latest shades and colors. Alredale, Bunny, Congo, Gray-nude, Lightnude, 35 others. Special premiums to purchasers make sales easy. Ford Auto given to hustlers. Send for Proof of Profits—Free. M. H. Mathews, Station 58612, Cincinnati, Ohio.

**AGENTS Sell Spectacles.** Dobbins, 146 W. 27th St., Indianapolis, Ind.

**AGENTS—400 more active men to introduce Chieftain Guaranteed Tailored Shirts 3 for \$4.95.** Latest novelties, colors. Dickman, Illinois, in 3 weeks made \$589; Simton, Texas, in 12 days, \$219.00; Bend, Iowa, in 16 days, \$334.80. You should do as well. No experience or capital needed. We deliver and collect. Full working outfit Free. Cincinnati Shirt Company, Secy. 15812, Cincinnati, Ohio.

**BUILD splendid business making chipped glass number and name plates, signs, check-boards.** Write for particulars. Simplex Utility Co., 1132 Broadway, New York.

**SUCCEED With Your Own Products—Make them yourself.** Formulas, Processes by experts. Trade-Secrets. Modern master methods. Catalog free. B. Thaxly Co., Washington, D. C.

**ACTIVE men and women wanted as distributors and sales managers.** Exclusive territorial rights. Pays 150 to 250 per cent profit. Darn E-Z Laboratories, Department P.M., Dayton, Ohio.

**\$25.00 REWARD for any Corn Great Christopher Positive Corn Cure cannot remove.** Good for Warts, Bunions, Moles, Callouses. Price 35c. Sell Reliable Hair Food for Dandruff, Itching Scalp, Falling Hair and Premature Grayness. Absolutely guaranteed to grow hair. Price \$1.00. Agents wanted. Reliable Specialty Corporation, Buffalo, N. Y.

**AN Unusual Opportunity—Earn \$75.00 weekly and bonus taking orders for Nustile guaranteed hosiery.** Sample outfit furnished. Full or spare time. Write now. The Nustile Company, Dept. 1-12, Philadelphia, Pa.

**LEARN** a trade, "Silvering Mirrors," Big Profits. Complete Course \$1.00. Particulars for stamp. Write O-Soo-Easy Shoe Co., Dept. B, Harrisville, Penna., Richmond, Va.

**SELL**—Men's and Boy's O-Soo-Easy Shoes. Big sellers everywhere. Write O-Soo-Easy Shoe Co., Dept. B, Harrisville, Penna.

**PORTRAITS**, photo pillow tops, frames, sheet pictures, medallions, merchants' slams, food products, photo jewelry, guaranteed hose, toilet requisites, luminous crucifixes. Catalog 50 specialties free. 30 days' credit. Jas. C. Bailey Co., Desk A-12, Chicago.

**PROFITS** in selling Popular Mechanics Books. Make 100%. Buy books at 50 cents; sell them for twice as much. List of books with descriptions sent free upon request. Write for particulars. Popular Mechanics Press, 200 E. Ontario St., Room 812, Chicago, Ill.

**50c BRINGS** samples of three guaranteed sellers and my Big-Money proposition. Russell Johnson, Clarkfield, Minn.

**VEST Pocket Radio**—Amazing. Sure Seller. Not a toy. Retail \$1.50. Your price \$8.50 dozen. Sample \$1.00. 50 mite tuning. Satisfaction guaranteed. Triangle Mfg. Co., 506A W. 45th St., Chicago.

**200% BIG Repeat Necessity.** Write Sigler, 10897 Ashbury Ave., Cleveland, Ohio.

**FREE** \$1.25 Bamboo Fountain Pen to Hustlers. Send 25c for details so that you get Free Pen and quarter back. Co-operative, 1659 W. North Ave., Chicago.

**45 WEEK** easily made selling men's women's shoes to wearers. Samples furnished. Territory protected. Write now. Paramount Shoe Co., 627 Hiarod Ave., Youngstown, Ohio.

**WHY** work for others? Make and sell your own goods. We show you how. Free book explains everything. National Scientific Laboratories, 1900-A Broad, Richmond, Va.

**MAKES** Autos Run like on cool, moist night. Wonderful Vapor Humidifier. One free to introduce. Critchlow, M-124, Wheaton, Ill.

**CALIFORNIA** Dahlias on Laurel Branches are tremendous fall and holiday sellers. Millions were sold in Chicago last fall. Particulars. Unger Mfg. Co., 571 Harrison St., Chicago, Ill.

**STRETCHING** Kuff-Buttons, Reduces Laundry Bills. Marvelous Convenience for Automobileists, etc. Expands 3 inches. Big Profits for Demonstrators. Sample paid \$1.00. Sells on sight. Flexolinks, Sheboygan, Wis.

**AGENTS**—New Patent Device Just Out. Big seller needed every home, factory, store, garage. Millions will be sold. Sample 25c. The Handyholder Co., Box 305, Baltimore, Md.

**COLLAPSIBLE** Garment Hanger and folding steel Towel rack. See ad page 190. Big Xmas sellers. Samples to Agents 75 cents each. Gause Mfg. Co., Elmhurst, Ill.

**WINDOW** Sign Letters. One Thousand for \$9.75 Beautiful design. Perfect cut. Free samples, catalogue. Foll Sign Works, 812 W. 11th Street, Oakland, Calif.

**20th CENTURY** Specialties. Agents for Mail Order Men. Information 20c. F. G. Briggs, 67 Redlyn St., Rochester, N. Y.

**SELL** "Speed" the spot remover. Turn the bottle over and wipe away the spot—that's all. New, patented idea with irresistible appeal to men, women. Nothing else like it. No competition. Exclusive territory. Write now for proposition. Speed Co., 6 E. Lake St., Chicago, Dent. XXX.

**FIBRE** Brooms—detachable handles. fine finish. Good profits, repeat sales. The Fibre Broom People, 147 New Jersey Ave., Brooklyn, N. Y.

**MONEY-MAKING** opportunity for you. See our ad on page 136. Milburn Puncture Proof Tube Co., Chicago.

**AGENTS**—Increase your sales. 50c profit every dollar. Sales every home. Women must have it. Instructions for stamp. Sample and plan 25c. E. Wood, 84 Ryerson, Paterson, N. J.

**EVERYBODY** buys from Gibraltar representatives all over country taking order for famous Gibraltar line consisting of shirts, overcoats, raincoats, pants, hosiery, neckwear and other articles. Outfit representing full line free. Gibraltar Fashion Shop, 724 Roosevelt, Chicago.

**SALESMEN**—Four Square Suits reduced to \$9.99. Deposit \$3.00. Four patterns. Guaranteed two years. Write quick for free outfit. Stone-Field, MK 2554 Wabash, Chicago.

**MILLIONS** lost by forgery. Wonderful new \$3.00 Check Writer perforates, inks in three colors. Equals work of \$60.00 machine. Five-year guarantee. Full or side line. Protected territory. Write quick for details and free trial. Safety Devices Corporation, Dept. P, Grand Rapids, Mich.

**MEN**—Women in every town; sell household rubber goods. 100% profit; every woman buys. Catalog free. HP Kaler Rubber Co., 414 Broadway, New York.

**I'VE** sold shirts on the coast for over 5 years—must confess that your proposition cannot be equalled anywhere. Others have made similar statements. If you want the best shirt offer ever made write for more details to Supreme Shirt Co., 276-m Fifth Avenue, New York.

**AGENTS**—Best seller; Jem Rubber Repair for tires and tubes; superadhes vulcanization at a saving of over 800 per cent.; put it on cold, it vulcanizes itself in two minutes, and is guaranteed to last the life of the tire or tube; sells to every auto owner and accessory dealer. For particulars how to make big money and free sample, address Amazon Rubber Co., Philadelphia, Pa., Dept. 265.

**MARVELOUS** New Invention, 400% Profit. Liquid Quick Mend for hosiery and fabrics. Tremendous demand. Over hundred other fast sellers. Local and General Agents, J. E. Johnson Co., Dept. 436, 69 E. South Water St., Chicago.

**RADIO** Gas Lighters are biggest 25c sellers in country. Every gas user buys one or more instantly; 300% profit. Enclose \$1.00 sample dozen or \$10 gross, including selling plans. M. Masterlite Co., 110 East 23rd St., New York (Manufacturers famous Masterlite Pocket Cigar Lighter).

**PORTRAIT** Agents—Send for prices Pictures where improvement is necessary a specialty. Wickersham, 1018 N. Mayfield Ave., Chicago, Ill.

**CAN** you sell Ford size tires at \$3.50 each? Write for plan. Details free. American Accessories Co., Dept. 178, Cincinnati, Ohio.

**BIG** Money Selling Flavoring Extracts. Address Arthur Beers, Bradley Beach, N. J.

**EVERY** store uses signs. New changeable letter sign sells \$2.50. Profit \$1.75. One dozen daily easy. Write Maze Company, 2653 Oceola, Dept. P. N., Chicago.

**SELL** Amenz Shirts—Over 200 exclusive patterns; Made-to-Measure or Ready-Made. Largest commission 30% collected with order. We deliver, balance collect. Samples Free. Menzies Shirt Company, Dept. 11, 479 East Tremont Avenue, New York.

**110c WEEKLY** selling finest guaranteed union made to measure men's suits only \$12.50; boys' two-pants suits \$10.95. Six latest patterns that sell on sight. Also all-wool overcoats, vests, caps, riding breeches. Big commissions advanced. Free attractive outfit. Double Service Manufacturers, 1327-35 AP Washington, Chicago.

**WORLD'S** Largest Neckwear Manufacturer wants Salesmen Sell Direct. Remarkable opportunity. Commission 33%%. Complete line. Greatest Values. Write Beacon, 1059 Beaconwear Bldg., Boston, Mass.

**AGENTS**, men and women. Sell necessities. Every woman a user. Wonderful opportunity to make real money. Colonial Chemical Co., 711 Penn Avenue, Pittsburgh, Pa.

**SELL** every merchant our special line of Embossed Christmas Display Cards in appropriate Christmas colors and wordings. Ready for immediate delivery. Write today for new catalogue of 100 different signs. Artistic Sign Works, 799 Broadway, New York.

**AGENTS**—Write for Free Samples. Sell Madison "Better-Made" Shirts for large Manufacturer direct to wearers. No capital or experience required. Many earn \$100 weekly and bonus. Madison Co., 566 Broadway, New York.

**MAIL** Order or Local Business. New. Simple Plan gets Money Easily. Quickly. Steadily. Particulars Free. Edward Burke, 733 Nineteenth, Oakland, Calif.

**\$100 WEEKLY**—Pleasant Work: Apportioning local agents to introduce Mother Hubbard Foods. No canvassing; no delivering; no money invested. Mother Hubbard, 556 Congress, Chicago.

**GENERAL** Distributors, Agents, Salesmen, wanted for quick-selling automobile specialty. Can earn \$75.00 to \$100.00 weekly; permanent business; yields results right from start. Free folder explains. Atkinson Co., Mfgs., Cynthiana, Ky.

**SELL** Mione Cleaner and Polish. Restores factory lustre on pianos and furniture. Automobiles glisten. Cleans varnished, enameled, painted, nickel, or celluloid finish, and brass. Positively will not collect dust. Contains no acids. Amazing results. One can make one quart. No samples. Price \$1.00. Alice E. Smith, 1874 E. 20th, Cleveland, Ohio.

**AGENTS**, canvassers—Make \$15.00 daily, selling high-class, meritorious, patented, wonderful novelty; just out. Everybody buys immediately. Cognito Co.-4, Elizabeth, N. J.

**WE** pay \$18 a week, furnish auto and expenses to introduce our Soap and Washing Powder. Bass-Beech Company, Dept. A-12, Chippewa Falls, Wis.

**LARGE** Chemical Specialty Line for agents seeking profitable connections. Arthur Beck Company, Department 10, 4743 Bernard St., Chicago.

**FAMOUS** beauty parlor secrets just out; be independent—sell your own beauty preparations. Particulars free. Dwight Specialty Co., Dwight, Ill.

**E-Z TYPEWRITER** Cleaner. Rempe Mfg. Co., 2827 Myrtle, Oakland, Calif.

**AGENTS**—30% commission. Full line glove silk lingerie and guaranteed hosiery, mill to wearer; lowest prices. Get particulars. Wright Hosiery Mills, Philadelphia, Pa.

**AGENTS**—\$100 week; no experience; genuine gold leaf sign letters and script. Consolidated Co., 636 S. Dearborn, Chicago.

**SOMETHING** new—Presto Rubber Repair for tires, tubes; all rubber goods put on cold, no heat, acid or tools; vulcanizes itself in few minutes. Sells to auto owners and dealers, sample free. Pioneer Products Co., Dept. A, Rosbling, N. J.

**BIG** Money Selling New Household Cleaning Set. Washes and dries windows, Sweeps, scrubs, mops. All complete only \$2.95. Over half profit. Write Harner Brush Works, 132 3rd St., Fairfield, Iowa.

**LONG** handled Paint and Scrub Brushes. New Line. Greatest Time and Back Savers Known. Easy Sellers—Big Profits. Eastway, 1302 McCulloh, Baltimore, Md.

**AGENTS**—Stamping names on Pocket Key Protectors; sample Check with your name and address, 25c. Stamping Outfits, Emblem Checks, Check Fobs, Name Plates. Hart Mfg. Co., Desk 2, 303 Degraw St., Brooklyn, N. Y.

**AGENTS**: Big profits. Best and cheapest window letters made. Easily applied. Dime brings five samples. Particulars free. Stalbrite Co., 1115 Second Ave., New York.

**ORIENTAL** Perfumes bring 100% net profit. Good sellers and better repeaters. Remola Parfumerie, Inc., Woodlawn 10, Chicago.

**HOW** to operate Dyeing, Cleaning and Pressing Business. Complete Instructions \$2.00. Details for Stamp. Acheson, 2218 West Cary, Richmond, Va.

**AGENTS**—\$90 a Week—\$2 to \$5 an hour spare time. Make this with the celebrated line of Ho-Ro-Co Soaps, perfumes, toilet articles and specialties; over 200 items. Big profit makers. La-En-Strait Hair Dressing selling like hot cakes. Write for Free Sample Case offer. Ho-Ro-Co Mfg. Co., 792 Ho-Ro-Co Bldg., St. Louis, Mo.

**RIGHT** man can make \$150 to \$200 a week. Selling new product. Every Ford owner a real live prospect. Want state agents and salesmen. Territory going fast. Write at once to National Sales Co., Coin. Iowa.

**MAKE** \$150.00 to \$400.00 weekly selling the Start Bite switch for Ford Cars. To start car just retard spark lever. No floor button needed. Saves bendix and starter trouble. Demonstrator furnished. Write today for plan and proof of \$1,810.00 monthly profit. National Sales Company, Inc., Coin. Iowa.

**CHRISTMAS** Greeting Cards—Wholesale Prices. Big Profits. Manufacturer, 1235 Arch, Philadelphia, Pa.

**NEW** Marvelous Self-Lighting Pocket Cigar and Gas Lighters. No Friction. Sells on Demonstration. Sample 25 cents. Rapid Mfg. Co., 799 Broadway, New York.

**MAKE** \$125 Per Week—Sell Standard Closures for Fords and other cars. Lowest priced closure made. Gives sedan comfort for \$38.00. Easy to sell. Easily installed. Write today. Standard Closed Top Mfg. Co., 1512G Holmes St., Kansas City, Mo.

**EARN** \$45 to \$85 extra a week, selling beautiful shirts. Commission in advance. We deliver and collect. Write quick. Fashion Wear Shirts, Dept. S-941, Cincinnati, Ohio.

**BIG profits!** General distributors, Agents, Salesmen sell the new Wallace Combination Jack and Rim Tool! Every small car owner a positive customer. Sells on sight! Exclusive territory to workers. Act quick! Send for attractive proposition and sample tool. B. S. M. Sales Company, Dept. 916, Wrigley Bldg., Chicago.

**MECHANICAL necessities.** We manufacture popular \$1 devices. Used everywhere. Save trouble. Save money. Appealing appearance. Efficiency and utility obvious. 100% profit. 3 to 5 sold at a time. Easily carried. Enormous sales everywhere. Local managers wanted. Standard Products Co., 2931 Lawrence Ave., Chicago.

**TAILORING Agents—Our Guaranteed \$21.50 and \$31.50 all wool tailored to order suits are \$10 to \$20 cheaper than store prices. Commission in advance. Protected territory. Beautiful assortment 6x9 swatches free. J. B. Simpson, Dept. 1159, 843 Adams, Chicago.**

**BIG Profits with Exclusive Territory—\$50 to \$100 weekly easy.** More has often been made in one day's work. A hot or cold running water bath equipment for any home at only \$7.50. No plumbing or water works required. Investigate. Send no money. Write today. Sanitary Supply Co., 753 Allen Building, Toledo, Ohio.

**WALL and Auto Emblems—All Lodges—\$10 daily easy.** Every member buys. Absolutely new. No competition. Big, full, spare-time money maker. Write for free sample plan. Crafts Co., 3316A Lawrence Ave., Chicago.

**BLUE Flame Burner.** Cooking and heating. Tested two years. Territory going. Wise salesmen Tri-Won. P. E. Bennett, Room 660, 17 N. LaSalle St., Chicago, Ill.

**\$12 FOR 2 hours' spare time.** New line. Wall, Auto Emblems. No competition. Every member buys on sight. Biggest money maker. Free sample plan. Write! Crafts Co., 3309A Lawrence, Chicago.

**We Pay \$50 a Week and expenses and give a Ford Auto to men to introduce poultry and stock compounds.** Imperial Co., D. 23, Parsons, Kans.

**AGENTS—Mesco Corn and Callous Remover will build you a steady repeat business.** Send today for pocket-size trial outfit. The Moss Co., 264 Searle Bldg., Rochester, N. Y.

**CLEAN Up, now till Christmas.** Sweil Holiday Line. Wonderful Sellers. Big Margin. Hire Sub-agents. Catalog Free. Mission Factory PM, 519 N. Halsted, Chicago.

**AGENTS, \$45 a week—Finest line of silk hose you ever saw.** All styles and latest shades. Also other kinds for men, women, children. Must give satisfaction or new hose free. No collections or deliveries. Pay you daily. Write for samples. Parker Mfg. Co., Sample 1978, Dayton, Ohio.

**EARN \$2.00 an hour all or part time selling old established line of 240 everyday necessities.** Everyone guaranteed. Backed by million dollar organization. Two complete lines bring double profits. Particulars Free. City Dept. Furst McNeess, Freeport, Ill.

**INSURANCE Agents, fraternal agents, travel, appoint local agents, salary if experienced.** Old established sickness, accident, life. Popular monthly payment. Address National Insurance, Room 379, 3123 Troost Ave., Kansas City, Mo.

**65¢ PROFIT every dollar!** Minute demonstration makes sale. Homes, stores, offices, factories, etc. Big repeater. Free sample offer. Mallard Chem. Co., (A) 84, Louis, Mo.

**TIRED of Working for other people?** Without experience, training or capital I'll show you how you can become financially independent. Easy, pleasant work. \$100 profit every week. Free automobile. Write today for particulars. Albert Mills, Mgr., 4196 American Bldg., Cincinnati, Ohio.

**BRAND New Hosiery Proposition for men, women, children.** Must wear 12 months or replaced free. All styles, colors, and finest silk hose. Sell at less than store prices. Write for samples. Thomas Mfg. Co., Class 5562, Dayton, Ohio.

**AGENTS—Write for samples of our new Insured Hosiery.** Can't be beat. Finest you ever saw. Less than store prices. Auto furnished to travel in. Pay you daily. Write for territory. Wilkmt Hosiery Co., Dept. 778, Greenfield, Ohio.

**AGENTS—\$5 started me earning \$200 weekly, selling by Mail.** Outfits furnished. Free particulars. Peerless Service, 447, Waterville, Me.

**WANTED, several hundred men to represent manufacturer taking orders for shirts, raincoats, topcoats, sweaters, overalls.** Big commissions daily. Send for free sample outfit, Northern Sales Co., 219 Northern Office Bldg., Chicago.

**WHIRLWIND Seller—Big Profits—Sample ten cents.** Prall, Somerville, N. J.

**AGENTS, Two out of three buy Evernice Underwear.** Your chance to connect Right. Pays well. Particulars free. Art-silk, 146 West 37th Street, New York.

**MIRRORS Re-Silvered at Home.** Costs Less 5 cents per square foot; you charge 75 cents. Immense profits, plating apparatus, reflectors, tableware, stores. Refinishing metalware etc. Outfits furnished. Write for information. Sprinkle, Plater 128, Marion, Ind.

**AGENTS to demonstrate fast selling complete line automobile necessities.** Something to sell everybody. 100% profit and exclusive territory. Dahl Automotive Mfrs., Minneapolis, Minn.

**AGENTS—Make your own goods.** Sell local or by mail. Whirlwind seller. Enormous profit. Write quick. Particulars Free. Charles W. Hillman, Flatwoods, Va.

**WHY work for others? Make and sell your own goods.** We show you how. Free book explains everything. National Scientific Laboratories, 1900-A Broad, Richmond, Va.

**\$145.00 WEEKLY.** Wonderful Vapor Humidifier. All autos. One free to introduce. Critchlow, N-124, Wheaton.

**AN Opportunity never before presented.** Representatives wanted in every state in the U. S. A. and Canada, on a direct selling plan. No license required, no competition. Article a household necessity, fully guaranteed. Price within reach of all. Exclusive territory assigned. Particulars: Dundee Mfg. Co., Inc., 157 Summer St., Boston, Mass.

**DISTRICT Managing Agents, every town, can earn \$15-\$25 daily, with new automobile product; quick sales; repeat orders come fast; must sell this sub-agents, the trade and by mail; free folder explains; get it today.** Everything furnished to start going business. Boone Specialty Co., Boone, Iowa.

**AGENTS—Three big lines hosiery, silk underwear, men's shirts.** Liberal commissions. Send for free illustrated catalogs. Helix Co., 213ta Fourth Ave., New York.

**\$3.50 AUTOMATIC Adding Machine.** Excellent profits here for workers. No experiment, but old, reliable, meritorious proposition. Year after year seller. Write us, Bassett Company, 1458-P Hollywood Ave., Chicago.

**SELL By Mail! Big Profits! Books, Formulas, Novelties, Bargains.** Particulars Free! Elfoo, 523 South Dearborn Street, Chicago.

**AGENTS—N-R-G Laundry Tablets.** The old reliable money-maker for live agents. Millions sold—200% profit—sales waiting for you. Clothes washed spotlessly clean in 10 minutes without rubbing. Free samples. N-R-G Company, 230 W. Superior, Chicago.

**FREE Book, Start Little Mail Order Business.** Pier, 217 Cortland Street, N. Y.

**AUTOMOBILE Specialties.** Guaranteed formulas for all latest money makers. Lowest prices. Write for free lists, Muroby, Chemist, Tujunga, Calif.

**NO-WATER Hand soap.** Cleans dirtiest hands without water. Great Money-maker. Simple to make. Guaranteed Trade-secret. 5¢. Clover Laboratories, 2511-W, Foster, Chicago.

**GENUINE Gold Leaf Letters anyone can put on Store windows.** Guaranteed to never tarnish. Large Profits. Enormous Demand. Free Samples. Write today. Metallic Letter Co., 438-A North Clark, Chicago.

**AGENTS: Our gold-eyed Needle Cases are wonderful sellers; immense profits; \$50 to \$300 weekly; proof and particulars free; sample outfit 15¢; factory prices.** Paty Needle Co., 231 Davis Square, Somerville, Mass.

**MEN or Women Agents, Full or spare time, selling Stationery.** Every Man and Woman a customer. Sample outfit Free. Scheffer Stationery Company, 1308 Ewing St., Fort Wayne, Ind.

**300% PROFIT—Quick, easy seller.** Klen-Rite, New Clothes Washing Compound. No rubbing. Women simply amazed. Free premiums makes sales easy. Fast repeater. Distributing samples free. Everybody grabbing for territory. Write quick. Bestever Products Co., 1941-K11, Irving Park, Chicago.

**OPEN Toilet Goods Shop in your own home.** We furnish everything. Liebia's, Beaver Dam, Wis.

**SELL direct.** Shotguns, Rifles, Pistols, Revolvers, from catalog. Stoeger Incorporated, 224 East 42nd Street, New York.

**AGENTS—Steady income.** Large manufacturer of handkerchiefs and dress goods, etc., wishes representative in each locality. Factory to consumer. Big profits, honest goods. Credit given. Send for particulars. Freeport Mfg. Co., 59 Main St., Brooklyn, N. Y.

**AGENTS—good, steady income.** Exceptionally useful household article. The Handycap Company, Newark, N. J.

**FAST-SELLING, New Idea in Rugs.** Woven Oil Cloth, Sanitary, Durable. Beautiful colors. Send \$1.20 deposit for sample and details. Liberal profits. Guaranty Mail Order Co., Dept. PM, Clayton, N. J.

**PHOTO Medallions earn \$100 and more every week for our representatives.** Take orders for Famous P. & G. Photo Specialties—the quickest sellers and biggest profit-makers in the field. Includes Artroll Portrait Paintings—just like genuine oil paintings—Clock Medallions, Photo Medallions, Powder Compacts, etc. Don't wait—write Now! Pudlin & Goldstein, Dept. "A," 239 Bowers, New York.

**AGENTS: Make \$5 to \$10 Daily** introducing Ware's Iron Rust and Stain Remover. Everybody wants it; everybody buys. Just send name; we tell you how it is done. Vege-Lene Company, Desk 22, Warsaw, N. Y.

**MAKE \$10 to \$100 weekly.** Spare time, at home, 20 Successful plans, many require no canvassing or capital. Steady income assured. Particulars Free. Golding Publishing Co., 401 West 148th Street, New York City.

**\$20 PROFIT daily selling self-threading needles, needlebooks; cost 3-5¢ each; sell 25¢; three samples 25¢.** Catalog free. Needlebook Specialty Co., 661 Broadway, New York.

**AGENTS: \$300—\$500 monthly easy** taking orders for Morey Rim Tool, Autolets and trade buy on sight. M. Morey Rim Tool Company, Blisfield, Mich.

**BIG Money—fast sales; everyone buys gold initials for their auto; sell \$1.50, profit \$1.44.** Ten orders daily easy. Samples, information free. World Monogram, Dept. 16, Newark, N. J.

**FREE Booklet describes 52 plans for making \$20.00 to \$100.00 weekly in home or office business of your own.** Downs Co., 2322A Myrtle, St. Paul, Minn.

**NEW one-price line! Greatest yet!** Sensational values! Finest all-wool goods. \$23.50 for suit or overcoat. Nothing higher. Big commissions paid in advance. Earnings of \$20.00 a day sure. Only a few lines left to place. Don't delay. Write at once to Dept. 651, William C. Bartlett, Inc., 810 West Adams St., Chicago.

**ARE You Old at Forty? See our advertisement on page 185 of this issue.** The Electro Thermal Company, 2137 Main Street, Steubenville, Ohio.

**WHY work for others? Make and sell your own goods.** We show you how. Free book explains everything. National Scientific Laboratories, 1900-A Broad, Richmond, Va.

**USE No Liquid, Paste, Powder.** New Prepared Cloth Cleans all Metals—Just (1) Rub, (2) Retalis 25¢—Cost 10¢. "Sample Free." Nullife Metal, Hartford, Conn.

**FURNITURE refinishing, polishing, painting, handman shop; wonderful profits; start yours on nearly nothing.** John Israeland, 1457 So. Ninth, Philadelphia, Pa.

**A BIG income and a speedy seller are offered in our Felt Rug proposition.** Write now for particulars. Newark Felt Rug Co., 27c 16th Ave., Newark, N. J.

**A BUSINESS of your own.** Make and sell chipped glass name and house number plates, checkerboards, signs. Booklet Free. E. Palmer, Dept. 512, Wooster, Ohio.

**EARN \$10 daily** silvering mirrors, plating and refinishing metalware, autos, chandeliers, bedsteads, headlights. Outfits furnished. E. Deple Laboratories, 1133 Broadway, New York

**AGENTS—50% cash profit every sale with \$5 to \$10 commission on sure repeat business.** Live wires, men or women, build permanent income \$100 week up. Something new every man and woman uses. Write quick. Everett Co., Dept. 35, Sault Ste. Marie, Mich.

**EVERYBODY** Buys Davis' Nifty Toilet Goods Assortments. Useful, handsome gifts free to our customers. Over 250 high quality products. All repeaters. 100% profit. 25 years of success. Write! Davis Products Co., Dept. 56, Chicago.

**AGENTS**—\$60 to \$200 weekly putting up our Burnished Genuine Gold window letters; scripts. Experience unnecessary. Free samples. Premier Letter Co., 121 N. Francisco, Chicago.

**WONDERFUL!** Startling! Amazing! Our Ex-Cel Luminous Crucifix and Magical (Luminous) Necklace shine brilliantly in the dark. Sell on first demonstration. Big profits to you. Write for further particulars, or better still, send for sample and territory protection immediately. Crucifix \$1.50, Necklace \$1.00, postpaid. W. G. Hannan Co., Dept. B, 2589 So. State St., Chicago.

**LIVE** Agents Make \$10 Day selling Eureka Strainer and Splash Preventer for every water faucet. Takes on sight. Widely advertised and known. Get details today. A. B. Seed Filter & Mfg. Company, 73 Franklin, New York.

**AUTO** owner tire agent wanted each locality to use and take orders for handmade Mellinger fabric and cord tires; guarantee bond 8,000 and 12,000 miles (no seconds); shipped prepaid on approval; get your tires free; no capital or experience required; make \$100 to \$300 weekly. Write for wholesale prices and sample kit. Address, Mellinger Tire Co., Dept. 306, Kansas City, Mo. or Dept. 308, Philadelphia, Pa.

**EARN** big money fast applying gold initials to autos. Every owner buys—\$1.35 profit on \$1.50 sale—particulars and samples free. Write quick, Lithogram Co., Dept. 17, East Orange, N. J.

**ROBT. H. INGERSOLL** of \$1 Watch fame wants good men to sell his Dollar Strapping outfit, an ingenious invention for sharpening all makes of safety razor blades. Great Economic value. Meeting with nationwide approval. Easy to sell. Big repeat business. Agents having remarkable success. Full particulars. Robt. H. Ingersoll, 416C Broadway, New York City.

**SELL** the Livest, Quickest Selling Specialties Ever Known—Famous "Hawkeye" self-lighting pocket Cigar Lighters and Gas Lighters. Low Prices. Easily Demonstrated. Sell to Dealers. Employ Sub Agents. Exclusive Territory. Make over 100% Profit. P. Bernhardt, 143 Chambers Street, New York.

**MAN** in each town to plate auto parts, reflectors, bathroom fixtures, refinish beds, mirrors, chandeliers; by new method. No capital or experience required. Simple plan of manufacturing at home starts you in big money-making business. Outfit furnished. Free particulars and proofs. Gum Metal Co., Attn. H. Decatur, Ill.

**SEW**—THREADING Needles. Needle Books. Machine needles, find sales in every home. Fine side lines, easily carried. Big profits, sample and catalogues free. Prentice Lee, 145 East 23rd St., New York.

**AT** Last! Diamond Rival Discovered! Amazing blue white Rajah Gem astounds jewelry world and deceives experts! Beautiful Sample case Free! \$100 weekly! Write Quick! Rajah Diamond Co., Dept. F-7, Salisbury, N. C.

**YOU** can be your own boss with our Key-Check outfit. Good for \$5 a day stamping names on pocket key checks, fobs, etc. Sample check with your name and address, 20 cents. Pease Die Works, Dept. M, Winchester, N. H.

**AGENTS**, Distributors, Crew Men average \$60-\$100 with Harter Products; 10c brings sample of leader; money back if you wish; free folder shows how to start small and grow big. Act; Send today; big surprise awaits you. Harter Co., Bridgeport, Conn.

**AGENTS** make 500% profit handling auto monograms, window letters, transfers, novelty signs. Catalog free. Hinton Co., 1153 N. Wells St., Chicago.

**NEW** camera takes and finishes photos in one minute. Make money selling cameras or taking photos. Exclusive territory. Crown Co., Dept. 951, Norwalk, Conn.

**WILLIAMS'** No-Water Hand Soap. In tubes, has taken Auto owners by storm; washes dirtiest hands perfectly clean without water; easy demonstration makes quick sale. 150% profit. Williams Co., Dept. 265, Montclair, N. J.

**BIG** Money and Fast Sales. Every owner buys Gold Initials for his auto. You charge \$1.50; make \$1.35. Ten orders a day easy. Write for particulars and free samples. American Monogram Co., Dept. 40, East Orange, N. J.

**AGENTS**—Make a dollar an hour. Sell Mendets, a patent patch for instantly mending leaks in all utensils. Sample package free. Collette Mfg. Co., Dept. 404, Amsterdam, N. Y.

**AGENTS**: Big Money Monogramming by Transfer Method. Catalog Showing Over 50 Styles and Particulars Free. Motorists' Accessories Co., Mansfield, Ohio.

**INSTANT** Weld. Repairs largest punctures without cement or heat. Lenn's profit one day, \$55. Write quick. Free sample; territory going fast. Tourists' Pride Mfg. Co., Desk T, Minneapolis, Minn.

**\$60-\$200 A WEEK**. Genuine Gold Letters for store windows. Easily applied. Free samples. Liberal offer to general agents. Metallic Letter Co., 438-D North Clark, Chicago.

**200% PROFIT** selling Gem kettle bottoms. "The article with a dozen uses." Housekeepers buy on sight. Columbia Specialty Co., Box 73D, East Liverpool, Ohio.

**AGENTS**—Clever Invention! Inkspoon makes every pen a fountain pen. Fast office seller; big profit, demand increasing everywhere. Exclusive territory offered. Sample free. H. Marul Company, Tribune Bldg., New York, N. Y.

**TO** secure agents or salesmen or for selling (want) ads in largest newspapers and magazines. Price list No. 30 sent free. Ankrum Advertising Agency, 20 W. Jackson Blvd., Chicago, Ill. The largest classified advertising agency in the U. S.

**POLMET**—The Wonderful Polishing Cloth that cleans all metals without liquid, paste or powder. Approved by "Good Housekeeping" and "Modern Priscilla"—sells fast at 2c. Sample free. Gale & Co., Inc., 15 Edinboro St., Boston.

**WASH** Clothes the new way. Use the Torrent Automatic Washer. You will be delighted. Special offer to one in each locality. Storm Royalty Co., 3619 Enright Ave. St. Louis, Mo.

**WE** Start You Without a Dollar. Soaps, Extracts, Perfumes, Toilet Goods. Experience unnecessary. Carnation Co., Dept. 291, St. Louis.

**GET** Our Free Sample Case—Toilet articles, perfumes and specialties. Wonderfully profitable. La Derma Co., Dept. A, St. Louis, Mo.

**AGENTS**, both sexes, we manufacture and control new household article. Fast seller. Big profits. Exclusive territory. Write Now. Connolly, 123 Liberty St., New York.

**AGENTS**: 500% profit. "Happy Home Maker Shampoo" builds your own big business. Martin of Indiana made \$75.00 in one day. Missouri man made \$750.00 one month. Exclusive territory. Geo. A. Schmidt & Co., 224 W. North Ave., Chicago.

**EASY**, pleasant work for Merchants, Shop Men, Clerks, during spare hours; will add many dollars to their salaries. Also want persons who can give full time. Big wages assured. Novelty Cutlery Co., 67 Bar St., Canton, Ohio.

**MAIL-ORDER** Houses and Distributors; We pack French made beauty creams, face powders, perfumes, toilet preparations with your label. Chemist, 944A North Clark, Chicago.

**AGENTS** \$1. Retail \$3. Your Profit \$2. Wonderful, pocket Adding Machine with Magic Writing Pad. Particulars Free. Typewriter Supply, 905 Hersch Bldg., Pittsburgh, Pa.

**IF** you want good live agents—fellows who can get the business—ask me how others are doing it. I'll gladly render the necessary assistance. Geo. F. Baker, Mgr. Classified Advertising, Popular Mechanics Magazine, Chicago.

**"HOW to Sell Patents"** free. Patent News-O, Washington, D. C.

**EASY** Money Applying Gold Initials. Monograms on automobiles. Anyone can do it. Simply transferred from paper; takes 5 minutes. Make \$1.50 rest 5c. Samples free. "Balco," 1943 Washington, Boston, Mass.

**\$31.00 PROFIT**—with \$1.50 Outfit—Big Money—Easy Work. Selling Gold Monograms for Automobiles, Luggage, Windows, Wagons. No Experience. No License. "Samples Free." NuLife Monograms, Hartford, Conn.

**BECOME** our Associate in your town. Help merchants, doctors collect their bad accounts. You get them, we collect. Pay you daily. Men and women of character make \$50-\$100 weekly. Pleasant, dignified work. Steady, increasing profits. Hundreds now doing it. Get the facts. American Collection Associates, 27 Jay St., Schenectady, N. Y.

**AGENTS**: Handle a new necessity. Paintographs sell everywhere. Big Christmas demand. Write for Circular and Information today. Bradford Company, St. Joseph, Mich.

**AGENTS** Wanted in Every County in the U. S. A. for Electric Blankets, Bed Warmers, Caps and Warning Pads, Stretching, developing and Gymnasium tables. Wallace Electric Appliances, P. O. Box 147, Oakland, Calif.

**LARGE** Manufacturer Wants agents. Make \$100 weekly. Outfit free. Sell made-to-measure genuine Cravenette Gabardines, \$14.50. Whitecoats, \$12.50. Reversible Raincoats, \$9.75. Standard Raincoat Co., 131 W. 17th St., New York.

**BUSINESS** Guide with Free Legal Service Sells everywhere; Wells cleared \$1.185 in 25 days. Write for free outfit. Nichols Co., Naperville, Ill., Dept. 4B.

**EVERYBODY** uses Extracts. Sell Duo Double Strength Extracts. Complete line of household necessities. Big repeaters. Write today. Duo Co., Dept. E1, Attica, N. Y.

**MAGIC** polishing cloth. Polishes all metals. No polish needed. Guaranteed Formula. 50c. Clover Laboratories, 2511-P, Foster, Chicago.

**AGENTS** make \$100 week placing advertising Cigar Lighters with glass front. Every dealer wants one. Write for free plan. Drake Mfg. Co., Dept. M, Milwaukee, Wis.

**MAIL** Order Business. Excellent Side Line. No stock to carry. Details Free Hunt Co., Morrisville, Pa.

**AGENTS**—Make big money taking orders for furniture, house furnishings on easy payments; direct to user from big catalog; full or part time. One man made \$28.00 in an hour; another \$36.00 on one order; extraordinary opportunity for few good men in small towns to represent this 67-year-old house; new plan; experience unnecessary; no collections; we furnish everything free. L. Fish Furniture Co., Dept. A9, 2237 West Pershing Road, Chicago.

**\$35 A DAY**—Easy, selling our fast seller policy, which pays \$20 weekly sick benefit, \$40 weekly Accidental Benefit, \$500 natural death, \$1,000 accidental death, \$2,000 travel accidental death. Lowest premium rates. Biggest commissions. Large renewals. American Peoples Life, 1197, 159 N. State St., Chicago.

**FREE** Sample—"Rain Shield Winer" Retail \$1.00—cost 25c. Just invented. No Cloth—No Paste—No Attachment. Sold Clear and Rainy Days—(1) Rub keeps Windshield Clear 24 hours. Automobiles buy quickly. Riley made \$128—three days. Experience unnecessary. Wonderful Sideline. NuLife Corporation, Hartford, Conn.

**CALIFORNIA** Rosebuds selling like hot cakes. Agents raising money; new stuff. Big profits. Catalog free. Mission Factory PM 519 No. Halsted, Chicago, Ill.

**10,000,000 FORDS** need "Greater Grip" Fan Belts. Big Profit selling Dealers. Write quick. Teuscher Belting Co., St. Louis.

**MANUFACTURE** Chipped Glass Numbers; particulars Free. Beveridge, 168-22 Leugat Avenue, Jamaica, N. Y.

**300% PROFIT** selling Mitchell's Magic Marred Washing Compound. Men and women clearing hundreds weekly. Wonderful seller. Big repeater. Nature's mightiest cleanser. Free sample. L. Mitchell, D. 1302 East 61st Street, Chicago.

**DUSTLESS** Sponge Cloth. New Invention. (1) Rub—Dusts, Cleans and Polishes Automobiles, Furniture, Pianos. Retail \$ (50c)—Costs (10c). "Sample Free." NuLife Sponge, Hartford, Conn.

#### HIGH GRADE SALESMEN WANTED

**"YOUR Opportunity in a Great Industry."** That is the title of a book we have just prepared. It gives the full facts about one of the greatest money-making opportunities in the selling field today. Every specialty salesman in America owes it to himself to get and read this book. A copy of it is yours free for the asking. Write for it to Dept. 886, Goodwear Chicago, Inc., 814 West Adams Street, Chicago.

**SALESMEN**—Get this big sensational, order-getting shirt outfit Free. Sell Stylenor Shirts all year round. It's Chicago's Wonder shirt line. Advanced fall showing of smartest, snappy patterns. Large double swatches, low prices, quick service, makes shirt selling easy. Bellard of Texas made \$16.00 in two days. We deliver and collect. Write today for big free outfit. Strlemor, 81 W. Van Buren, Chicago, Ill., Dept. 650.

**MR. BRUSH Salesmen:** Old Established New York Brush Manufacturer requires the services of men in all territories to sell their extensive line of Sanitary Twisted in Wire Brushes. We pay larger commissions than any other Brush House in the country. Write immediately for proposition. Wire Grip Sanitary Brush Corp., 15 Mercer St., New York.

**A PAYING Position** Open to representative of character. Take orders shoes-hosiery direct to wearer. Good income. Permanent. Write now. Tanners Shoe Mfg. Co., 10-110 C Street, Boston, Mass.

**SALESMEN—Become Independent.** Own Your business, experience unnecessary selling our \$7,500 Accidental Death; \$50 Accident; \$25 Sick Weekly Benefits—\$12.50 Yearly. Other Amounts proportionate. Guaranteed steady income from renewals. \$250,000 Deposited Insurance Department. Universal Policy, Dept. A, Newark, N. J.

**ADVERTISING Salesmen** wanted to take orders for Auto Key Purse; new invention; sells to advertisers by thousands; commission 20%; sample by mail 25c. Novelty Cutlery Company, 523 McGregor Ave., Canton, Ohio.

**OUR line** entirely different; larger commissions. Quality merchandise. Prices right. Coffman Pencil Company, Cedar Rapids, Iowa.

**EASILY** make \$50 to \$100 weekly extra during your spare time. Season just opening up. Iowa Novelty Company, Box 1061, Cedar Rapids, Iowa.

**\$20 DAILY** Selling Ver-I-Ezy Men's Shoes direct. Sell relatives, friends, neighbors first. Low priced. Give real comfort, long service. You take orders, keep big commission. We ship and collect. Full or part time. Write now. Easy-Wear Shoe Company, Dept. 229, Indianapolis, Ind.

**TIRE Salesmen—Sell tires** and tubes direct from factory. Complete line, high quality, low prices. Liberal commission. Cable Rubber Co., Sandusky, Ohio.

**WE Want Good Men** to represent us. Sell to stores and mechanics our wonderful new hand soap, that cleans anything. Motorist Specialty Co., Dept. B-40, N. Wells St., Chicago.

**WANTED—Tailoring Salesmen,** make \$60 to \$125 per week. Biggest merchants in many towns have started with our line. We are the largest made-to-measure tailoring house in the country, furnishing elaborate sample equipments, including 500 all-wool fabrics. You make your own profits from \$8.00 to \$15.00 on each order. Guaranteed absolute satisfaction, perfect fit, best workmanship, or no sale. Write for our line and all accessories to be sent free. Tell us all about yourself. Address N. O. Perry, Sales Manager, Box 483, Chicago, Ill.

**SALESMEN** Wanted to handle New Safety Doorway Guards for Garages and Factories. Write today for territory. Thos. J. Coe, Dept. 6, 1905 Run View Drive, Endicott, N. Y.

**AUTOMOTIVE Specialty Salesmen.** Steady Profits. Results Guaranteed. Adams-Barr, Columbus, Ohio.

**A NATIONALLY Advertisized** musical concern wants local representative to follow up leads in this locality. Experience unnecessary. If you are satisfied with \$35 weekly at the start, interested in a permanent connection, write for free particulars and application. Leads furnished. A. F. Bloch, Pres., Dept. 107, New York City.

**EASY Selling Specialty.** Beautiful. Attractive. Appealing. Luminite Window Bulletin. Increase merchants' business 50% to 100%. Protected territory. \$8 commission on each \$20 sale. Thousands being sold; sells itself on demonstration. Display Products Co., Ltd., 106 Gibraltar Bldg., Kansas City, Mo.

**SPECIALTY Salesmen Full or Part Time.** \$15 to \$25 daily. Money in your pocket every night. We pay on repeats under most unique selling plan. Brand new patented article. Sells to 99 out of every 100 men on sight. Also real house to house item. E. Dickinson, 76 W. Monroe St., Suite 540, Chicago, Ill.

**SELL the Adjustable Price Tag—The Tag with a Hundred Changes!** Indispensable to all Stores. Easy to sell. Big profits. Sample \$2.00 set sent post free for \$1.00. Adjustable Price Tag Company, 236 Court Street, Los Angeles.

**MONEY-MAKING** opportunity for you. See our ad on page 136. Milburn Puncture Proof Tube Co., Chicago.

**SALESMEN** earn \$10,000 this year with fastest selling auto devices. Business with big future. Mishken, Indiana Harbor, Ind.

**IF You Think in Terms of \$1,000 Next Year,** Write us Now. Strong line for retail stores. Nationally advertised. Established concern. Best season now starting. Liberal weekly advance to producer. The Continental Co., 1922 Euclid, Cleveland, Ohio, Dept. 200.

**ACCEPTABLE Gift.** Ingalls "Ford" Irreversible steering stabilizer and combined shock absorber prevents shimmy, shock, vibrations. Drivers delight. Sells \$7.50. 100% Profit. Money back guarantee. Circular. "Nasco" D-34, 1661 Evans, Detroit, Mich.

**WONDERFUL,** newly invented Pricing System. All retail stores. Sells on sight. Tremendous demand! Big repeats. Write quick exclusive territory. Manufacturer, 250 Huntington, Boston, Mass.

**DISTRICT Manager.** Largest Eastern House. Suits, Overcoats \$23.25 factory to wearer. Largest commissions. Possibilities \$5,000 up. Boston Wholesale Clothing, 47 Beach, Boston, Mass.

**SELLS** for \$9.75. Prints ad on wrapping paper, envelopes, etc. \$4.00 commission. Send 10c for sample work. Automatic Ad-Stamp, Joplin, Mo.

**GOOD** salesman can secure exclusive territory for new patented Key Case. A big seller with big profits. Brand new. An opportunity for real producers to make big money. The Minnesota Specialty Co., 78 E. 3rd St., St. Paul.

**SALESMEN,** write for particulars of an interesting and profitable business, selling and operating aluminum refillable salesboard. Square Hole Board Co., 120 Schermer Ave., Newark, N. J.

**MINIATURE** Bowling Game and Gum Vender Combined. Lawful everywhere. Selling fast to all merchants. Operators buy in quantities. \$11.00 commission on \$27.50 sale. Honey Dew, 1322A Main, Kansas City, Mo.

**TIME-SAVER** Rubber Half Soles Becoming popular as rubber heels. Something new. Big seller. Quick money. Sells on sight all retail trade and direct. Outwears leather. Costs half. User attaches. No nails. Best season now starting. Time-Saver Co., 771 Arcade, Cleveland, Ohio.

**SALESMEN** Can make \$5.00 a day selling our Calendars, Pencils, Signs, Advertising Novelties, Yardsticks, Whistles, etc. Liberal terms. Sells entire year. Fine side line. Local and traveling agents. Model Calendar Co., Dept. 226, South Bend, Ind.

**SIDELINE** Salesmen—to sell an instant toothache relief remedy. Sold to Drugists, restaurants, poolrooms. About 40% profit. E. J. Leopold, Adrian, Mich.

**\$18.00 DAILY** representing established manufacturer; lumberjacks' sweaters, shirts, leather vests, raincoats, underwear direct to wearer. Outfit free. Counsel Corp., Dept. M2 208 N. Wells, Chicago.

**BEST Seller.** Jem Rubber Repair for tires and tubes; supercedes vulcanization at saving of over 80%; put it on cold, vulcanizes itself in two minutes, guaranteed to last life of tire or tube; sells to every auto owner and accessory dealer. Get particulars how to make big money and free sample. Amazon Rubber Co., Philadelphia, Pa. Dept. 510.

**HERE'S** big money-maker. Masterlite Pocket Cigar Lighter; something new in specialty field; sells instantly upon demonstration to consumers and dealers. Send 3c stamps for sample and selling plans. M. Masterlite Mfg. Co., 110 East 23rd St., New York. (Manufacturers well known Radio Gas Lighter.)

**SALESMEN,** part or full time. Brand new idea in window anti rattlers. Sells to every garage and accessory store. Good commission. Write today. Akeley Steele Co., Aurora, Ill.

**ACCESSORY, Oil and Tire Salesman—**We are now selling direct to dealers. Sample Free. Liberal Commissions. A corker—hurry for exclusive. Box 1091, Lincoln, Neb.

**MAKE \$100 Weekly** in spare time. Sell what the public wants—long-distance radio receiving sets. Two sales weekly pay \$100 profit. No big investment, no canvassing. Sharpe of Colorado made \$955 in one month. Representatives wanted at once. This plan is sweeping the country—write today before your county is gone. Ozarka, Inc., 126-B Austin Ave., Chicago.

**EARN \$100 weekly** in advance. Beautiful free Pocket size outfit. Superior \$12.50 Union Made Clothing—best on the market. Fit Guaranteed. Also raincoats and wool overcoats. Experience unnecessary. Prospects everywhere. Write F. Long, Superior Clothing Co., 1908 W. North Ave., Chicago.

**\$50 DAILY** Selling Salesboards—Make up to \$30 on single sale, selling largest, lowest priced line; no samples to carry; write for 3-color catalogue and full particulars. Lincoln Sales Co., Dept. E, 9 So. Clinton, Chicago.

**SALESMEN** to Sell Home Study course business handwriting; established twenty years. Managership and subagency rights worth six to ten thousand yearly to competent man. Iroquois Institute, 1639 Milwaukee Ave., Chicago.

**WHY** work for others? Make and sell your own goods. We show you how. Free book explains everything. National Scientific Laboratories, 1900-A Broad, Richmond, Va.

**ADVERTISING Salesmen,** write for particulars. Auto Accessory. Our name describes the article. Liberal commission. The Atargine Battery & Oil Guide Company, Fargo, N. Dak.

**TAKE** orders for coffee, sugar, flour, meats, canned goods, staple groceries; also paints, radio sets, tires, auto and tractor oils. No capital or bond required. We deliver and collect. Permanent business. Big pay. Write at once. Hitchcock-Hill Co., Dept. 50, Chicago.

**TRAVELING** Salesmen calling on retail stores wanted by large manufacturer to sell unique line of business-boosting articles. Year round, fast selling, main or side line. If not earning \$150 weekly, address Elgasser Works, 222 Charles St., Boonville, N. Y.

**\$50-\$200 A WEEK.** Genuine Gold Letters for store windows. Easily applied. Free samples. Liberal offer to general agents. Metallic Letter Co., 438-B North Clark, Chicago.

**EASY** to Sell Groceries, Paints, Lubricating Oils, from samples to consumers in towns and country. Prices meet all competition. No capital or experience necessary. Profitable, steady work. Commission advanced. Satisfaction guaranteed; 33 years in business. Write Lovelin & Browne Co., Wholesale Grocers, 1775 So. State, Chicago, Ill.

**FOUR \$7.50** sales to merchants net you \$28.00 daily. Sayers Systems, 2803 Sheffield Ave., Chicago, Ill.

**CALIFORNIA** Rosebuds selling like hot cakes. Agents coming money. Absolutely new. Big profits. Catalog free. Mission Factory SP, 579 No. Halsted, Chicago, Ill.

#### HELP WANTED

**BECOME** a Landscape Architect. Uncrowded profession of wonderful opportunity for money-making. Easily mastered by mail. Earn while you learn. Write for book. American Landscape School, 56-E, Newark, N. Y.

**\$35.00 WEEK.** Boys—men. Learn Automobile repairing. Sample lessons free. Franklin Institute, Dept. K-400, Rochester, N. Y.

**STEAMSHIP** Positions—Europe, Orient. Good pay. Experience unnecessary. No compulsory service. Send stamped addressed envelope for list. Box 30-X, Mount Vernon, N. Y. or Box 331-A, Santa Monica, Calif.

**MEN** wanting positions. Firemen, Brake-men, Colored train or sleeping-car Porters, write for application blank; experience unnecessary; first-class roads, no strikes; name position wanted. Railway Institute, Dept. 25, Indianapolis, Ind.

**MEN,** 18 up, wanting U. S. Mail Service jobs, \$142 to \$225 monthly. Steady. Experience or correspondence course unnecessary. Particulars free. Write P. Bradford, 112 N. 50th St., Philadelphia, Pa.

**\$158 MONTH.** Men, 18 up. Railway Postal Clerks, 25 coached free. Write immediately. Franklin Institute, Dept. K-16, Rochester, N. Y.

**SELL** personal stationery, name-address. Business and personal cards. Playing cards. New "process" engraving. Sells on sight. Commission in advance. Send \$1 for samples and complete selling outfit. Neff Co., 209 W. 35th St., New York.

**CALIFORNIA, Mexico.** Folders, Brilliant Colors, 18 assid Noted Scenes, 12 cents; with Villa Dollar; (Lists Seeing New York Photos, 2c). 43c Money Order. Studio, 1130 10th, San Diego, Calif.

**\$158 MONTH.** Railway Postal Clerks, 25 coached free. Write immediately. Franklin Institute, Dept. K-16, Rochester, N. Y.

**ARE** you old at forty? See our advertisement on page 185 of this issue. The Electro Thermal Company, 2137 Main St., Steubenville, Ohio.

**10,000 APPLICANTS** to operate Art. Gift Shops, Tea Rooms. Write for particulars. Unit Art Works, Dept. A2, 422 Lenox Ave., New York City.

**LOCOMOTIVE** Firemen for railroads nearest their homes—everywhere; beginners \$150-\$250 monthly; promoted, locomotive engineer, \$3,000-\$4,000 yearly. Best paying positions on railroads. Railway Association, Desk M1, Brooklyn, N. Y.

**MEN—Women**, 18 up. U. S. Government Jobs, \$95-\$250 month. List positions free. Write immediately, Franklin Institute, Dept. K-16, Rochester, N. Y.

**BUILD** splendid business making colored glass number and name plates, signs, check-boards. Write for particulars, Simplicx Utility Co., 1133 Broadway, New York.

U. S. Government Jobs, Railway Mail Clerks—Mail Carriers, \$1,700—\$2,700 year. Steady. Men 18 up. Sample coaching—free. Write immediately, Franklin Institute, Dept. K-16, Rochester, N. Y.

U. S. GOVERNMENT wants men, \$1,700—\$1,900 and up at start. Railway Mail clerk examination coming. Let our expert (former Government examiner) prepare you for this and also Rural Carrier, Post Office, Customs, Internal Revenue, and other branches. Write today for free booklet, Dept. 8, Patterson Civil Service School, Rochester, N. Y.

A REPRESENTATIVE Wanted take orders Bugs direct at Mill Prices. We deliver and collect. Exceptional opportunity now. Permanent weekly income. Seven wonderful quality rugs in Sample Case. Write Malsley-Payne Mfg. Co., 90110, Boston, Mass.

\$115-\$100 MONTHLY paid By Station—Office positions. Free passes; experience unnecessary. Write Baker, Supt. 41, St. Louis, Mo.

WHY work for others? Make and sell your own goods. We show you how. Free book explains everything. National Scientific Laboratories, 1900-A Broad, Richmond, Va.

**AGENTS:** \$11.80 daily pay (send for sworn proof) Introducing New Insured Hosiery, 57 styles, 40 colors, guaranteed seven months. No capital or experience required. You simply take orders. We deliver and collect for you can deliver, suit yourself! Credit given. Pay You Daily, monthly bonus besides. 1926 line now ready. We furnish samples. Spare time will do. Macabee Textile Company, Station 29012, Cincinnati, Ohio.

**MEN, Women**, 18 U. S. Government Life Jobs, \$1,140 to \$3,000 year. Steady work. Thousands Railway Mail Clerks—Clerks—Carriers, appointed every year. Postal Salaries just raised. Experience unnecessary. Common education sufficient. List positions and full particulars—free. Write today sure, Franklin Institute, Dept. K-3, Rochester, N. Y.

**FIREMEN, Brakemen, Baggage-men, Sleeping car, train porters (colored)** \$140—\$200. Experience unnecessary. 810 Railway Bureau, East St. Louis, Ill.

**SILVERING Mirrors**, French plate. Easily learned; immense profits. Plans free. Address, Wear Mirror Works, Dept. 34, Excelsior Springs, Mo.

**ALL men-women**, 18-60, wanting to qualify for Government Positions, \$140-\$225 monthly, local or traveling, write Mr. Oment, 101, St. Louis, Mo., immediately.

**FREE Book**, Start Little Mail Order Business. Piez, 218 Cortland Street, New York.

**OUR genuine gold window sign letters** are an excellent money-making proposition for handy men. Slann Sign System, Bethune Ave. E., Detroit, Mich.

**LINOTYPE** instruction; Earn \$60 weekly; cost \$300, including printing \$150; 1,000 have attended, Empire School, 208 E. 19th St., New York.

**STORIES, poems, plays, etc.**, are wanted for publication. Good ideas bring big money. Submit manuscripts or write Literary Bureau, 522, Hannibal, Mo.

**MEN** wanting forest ranger positions, \$1,500—\$2,400 year. Write for free particulars of exams. Mokane, B-21, Denver, Colo.

**EARN \$10 daily** silvering mirrors, plating and refinishing metalware, auto, chandeliers, bedsteads, headlamps. Outfits furnished. E. Decle Laboratories, 1133 Broadway, New York.

**FINGER Print Experts**—Excellent paying positions; particulars free. Finger Print Headquarters, 188 East 79th, New York.

**INVENTORS** desiring to secure patents should write for our book "How to Get Your Patent," tells our terms and methods. Send sketch for our examination and instructions without charge. Randolph & Co., Dept. 418, Washington, D. C.

**MAKE** money writing Photo-plays; details free to beginners. No correspondence course. Producer's League, 230 Walnut St., St. Louis.

**MEN** wanting forest ranger, railway mail clerk and other Gov't positions write for free particulars of exams. Mokane, Dept. B-21, Denver, Colo.

#### INFORMATION

**TECHNICAL** or Practical Information on any Mechanical, Electrical, or Chemical subject. \$1.00. Chicago Bureau of Standards, PM, 2905 W. Madison, Chicago.

**ALASKA** Pathfinder, illustrated magazine; three issues with year's privilege Alaskan information bureau, one dollar. Pathfinder of Alaska, Anchorage, Alaska.

**PRACTICAL** information on any Mechanical subject. \$1.00. Technical Research Bureau, 377 National Ave., Milwaukee, Wis.

**ADVICE** on any subject \$1.00. Universal Bureau, 3610 Enright, St. Louis, Mo.

**ELECTRICAL** Kinks on all phases of practical electricity are to be found in Popular Mechanics new book, "Electrical Kinks." There are 47 ideas on wiring, 45 on making electrical devices, 19 on lighting, 5 on transformers, 5 on motors, 8 on generators, 11 on switches, 22 on testing, 12 on repairing, 11 on battery manufacture and repair, 5 on telephones, and 9 on electrician's tools, 214 articles, 162 pictures. Send no money. Just write a postal asking for "Electrical Kinks." When the postman hands you the book, pay the few cents postage, and \$1.50 for the book. Popular Mechanics Press, Room 812, 204 E. Ontario St., Chicago, Ill.

#### BUSINESS SERVICE

**MAKE** 'Em Pay—My system will make them pay their bills. Write for the odd test. Literature free. Burleigh L. Horr, Horr Omelia Block, Rhineclander, Wis.

#### TYPEWRITERS AND SUPPLIES

**100 TYPEWRITERS** Free, Overstocked. Rent rebuilt Underwood or Remington \$3.00 month. If you pay its value in rental, we give machine free. Particulars free. Pittsburgh Typewriter Exchange, 945 Hersch Bldg., Pittsburgh, Pa.

**UNDERWOOD** Typewriters—only \$3.00 down. Easy monthly payments. Low prices at less than manufacturers. 10 days' free trial. Rebuilt, all worn parts replaced. Just like a new machine. 5-year guarantee. Write for big free catalogue C-151. Shipman-Ward Mfg. Co., 1519 Shipman Bldg., Chicago, Ill.

**TYPEWRITERS** All Makes. Save One-half. Thoroughly rebuilt in our factory to the famous "Young Process." Fully guaranteed. Free trial. We handle all standard makes. Cash or sold on easy terms. Write for catalog. Young Typewriter Co., Dept. 575C, Chicago, Ill.

**TYPEWRITERS—Standard** Makes; Wonderful Bargains; Guaranteed. Typewriter Sales Co., Ada, Okla.

#### PRINTING, ENGRAVING AND MULTIGRAPHING

**DISTINCTIVE** Printing! Samples for stamp. Franklinpress, B-52, Milford, N. H.

**GOOD** printing; Reasonable prices. Samples free. Riley-Zaur Company, 1517 S. 48th Court, Cicero, Ill.

**20 EACH** Hammermill Bond Letterheads, Envelopes, \$3.00. Sample. Midland Press, 343 West Hickory, Kankakee, Ill.

**200 PRINTED** Business Envelopes \$1.00. Commercial size. With name, business and address. Prompt service. List of 10 Big Dollar Specials Free. P. M. Kendall, Elmira, N. Y.

**100 LETTERHEADS**; 100 envelopes; 100 billheads; 100 business cards for \$2.75 cash. Noble Printing Co., Kendallville, Ind.

**GUMMED** Labels, with name, business and address, 500-2's; 3,000-\$1.00. Labels, Valhalla, New York.

**"NEARGRAVURE"**—500 each Letterheads, Envelopes, Billheads, \$6.66 postpaid. Rolldays, Knox, Ind.

**ADVERTISING** Pencils, "the kind that you want!" Buy direct; save middleman's profit. Samples free (no agents). Address R. Mustal & Co., 10-12 Lincoln St., Yonkers, N. Y.

**1,000 LETTERHEADS** or Envelopes \$2.95 Prepaid, Charles Champion, Wauwatosa, Wis.

**GUMMED** Labels! Interesting Samples Free! Edward Harrison, "Advertising Stickers," Baltimore.

**"LET Us Print For You."** Quality Printing at lowest prices. Pereira Bros., 796 Federal St., Chicago, Ill.

**\$3.00 DELIVERED**, 500 Watermarked Bond Letterheads, 8 1/2 x 11, and 250 envelopes, money with order. Job Printing Specialty. National Printing Company, Goshen, Ind.

**100 BOND** letterheads and 100 envelopes \$1.00. The Q. Shop, Hearing Springs, Pa.

**225 BOND** letterheads, envelopes, billheads, cards, \$1.25 each. Combination, \$1.00. Economic Press, Leonia, N. J.

We print Stationery, Booklets, Catalogs, Circulars, Samples. Commercial Press, Batavia, Ohio.

**250 LETTERHEADS**, 250 white envelopes printed and mailed \$3.00. Samples printing free. Sunco, Mohawk, N. Y.

**QUALITY** Printing! Reasonable Prices! Send for Free Standardized samples and prices. Folders, Circulars, Catalogs our specialty. Ernest Pantus, 525 South Dearborn, Chicago.

**1,000 LETTERHEADS** or Envelopes, \$3.00. Sent Prepaid, Samples Free. Monitor Press, Merrickville, Pa.

**500 MULTIGRAPH** Letters \$2.35 with printed head. Envelopes, Cards, bargains. Price list free. Carlson's, 8743 Essex Ave., Chicago.

**GUMMED** Labels, 500 name and address, 2 lines 3's, 3 lines 5's. Catalogue. Eastern Label Co., A. Clintonville, Conn.

**1,000 LETTERHEADS**, Envelopes, Cards, \$3.00 postpaid; 500, \$2.25. Samples Free. Artsevia Press, 68 Houghton, Worcester, Mass.

**PRINTING**. Lowest prices in America. Samples free. A. Pitt, Amana, Iowa.

#### PRINTING OUTFITS AND SUPPLIES

**COLT'S** Platen Press, 12x19 for printing, cutting and creasing, \$200. Milwaukee Specialty, 1710 34th St., Milwaukee, Wis.

**PRE-USED** Printing Presses, Type supplies. List for 2c stamp. Popular Bargains, Richland, Pa.

**COMPLETE** printing outfits, presses, type, ink, paper supplies. Write for Catalog. Press Co., C-11, Meriden, Conn.

**USED** Type Cheap! Moulton, 1410 E. 8th, Kansas City, Mo.

**PRINTING** Outfits, Presses, Type, Supplies. Stamp for information. Nicholas, M-116 High St., Boston.

**PRINTING** Outfits—Presses, type supplies, type novelties. Send stamp for catalogue. Model Press, York, Penna.

#### DUPLICATORS AND DEVICES

**YOU** can make 50 to 100 copies of a letter, notice, etc., at a cost of three cents on a Hoyer Quality Duplicator. Write for free trial offer. The Hoyer Duplicator Co., 14 S. Wells St., Chicago, Ill.

#### ADDING MACHINES

**FREE** Trial, Marvellous new Adding Machine. Adds, Subtracts, Multiplies, Divides, automatically. Work equals \$350.00 machine. Price only \$13.00. Speedy, durable, handsome. Five-year guarantee. Used by largest corporations. Write today for catalog and free trial offer. Lightning Calculator Co., Dept. E, Grand Rapids, Mich.

**NEW \$3.50** Automatic Adding Machine. Adds, Subtracts, Multiplies. Absolutely accurate. Capacity \$999,999.99. Fully guaranteed. 75,000 pleased users. Makes adding easy, positive, quick. Eliminates Mistakes. Saves Time. Postpaid \$3.50. Bassett Co., 1458 J. Hollywood Ave., Chicago.

#### MAILING LISTS

**BUSINESS** Producing Mail Order Buyers, Investors, Home and Spare Time Workers, Opportunity Seekers, Investors, Correspondence Students, Mechanics, Chauffeurs, Railroad Men, Agents by thousands or Millions, Manufacturers and 1,000 others. Details free. Advertising Service, Room 426, 26 Quincy, Chicago, Ill.

**GUARANTEED** mailing lists. Write for rates. French, 1963 E. Chase, Baltimore, Md.

**NEW** select list 10,000 prosperous North Dakota farmers, 100% correct, \$30.00 complete; \$4.00 per 1,000. Business Service Company, Bismarck, N. D.

**1,045 HOUSEWIVES'** Names and Addresses \$1.00. D. Ted Goertler, Dunlap, Neb.

**GUARANTEED** Mailing Lists \$3.00 Thousand. S. F. Battliff, Box 1673, Mobile, Ala.

**NAMES**—postcards—cuts. Ben Meyer, 35 West 31st, New York.

**GUARANTEED** Names, actual mail-order buyers, agents. \$5.00 thousand; 500, \$2.50. Demuth Company, Englewood, N. J.

2,240 CALIFORNIA Garages. Guaranteed. Entire list \$8.00. Murco Supply Tujunga, Calif. Box-3.

#### FOR SMOKERS

**THE Sweetest Smoke You Ever Had!** Something New! "Claychaum" pipes from Scotland. Special Clay, absorbs nicotine. Gives cool, dry smoke and conserves health. Colors beautifully. Well finished with smooth round edges. A new treat for the smoke connoisseur. Send only \$1.90 for 12. Mailed postpaid. Scotch Claychaum Pipe Company, Dept. 12-P, Laurel, Md.

**TOBACCO**—Chewing 30c pound. Smoking 25c pound. Plus Postage. Dick Chandler, Sharon, Tenn.

**HOMESPUN** Chewing and Smoking Tobacco—5 lbs. \$1.25; 10 lbs. \$2.50; 20 lbs. \$1.50. Hickory Ridge Farms, Mayfield, Ky.

#### FOR MEN

**1926 SHOP NOTES** now ready. Men in all walks of life find this annual volume worth many dollars. 393 articles, 519 pictures. Short cuts for all kinds of mechanical work. Ideas for farmers, mechanics, carpenters, masons, bricklayers, merchants, gardeners, school teachers, and home owners. Send No Money. Just ask for 1926 Shop Notes on a postal. Special—for a short time, we will give our Auto Tourist's book with 1926 Shop Notes. Sent C.O.D. for 98 cents. Popular Mechanics Press, 200 E. Ontario St., Room 812, Chicago, Ill.

**CARPENTERS.** Popular Mechanics Carpenters' Handbook is filled with ideas for those who like to tinker with tools, and for professional carpenters. 40 articles on saws and sawing, 17 on benches and bench equipment, 22 on doors and door hanging, 18 on lumber, 13 on mitering, 74 on tools and their care, 22 on shop equipment, and many others—366 in all, and 229 illustrations. Send No Money. Just write a postal. Pay postman postage and \$1.50. Popular Mechanics Press, Room 812, 200 E. Ontario St., Chicago, Ill.

#### BOATS AND LAUNCHES

**BEST** boating magazine six months \$1.00. How to build and sail. Back number and catalog of boatbuilding plans free. The Rudder, 9 Murray Street, New York.

**HUBBELL** Marine Coolers convert Ford engines into marine motors. Ford engine booklet free to boat owners. C. C. Hubbell, 4B East Ave., Norwalk, Conn.

**MAKE** 16' Rowboat. Blueprint 30c. Weesh-Uro, 31st Office, Detroit.

**BUILD** your own boat. Do your own concrete work. Two new books tell how to make 21 kinds of boats and 173 articles from concrete. Each book filled with pictures. Send No Money. Just write a postal and say, "Send Popular Mechanics Boat Book and Concrete Handbook." Pay postman postage and \$1. Popular Mechanics Press, Room 812, 200 E. Ontario St., Chicago, Ill.

#### RAZORS AND BLADES

**GILLETTE** style blades. Dozen 45 cents; 3 dozen \$1.25. Automatic stropper 75 cents. Genuine Auto-Strop razor, with strop 50 cents. F. Wallace Kutz, 152 Chamber St., Phillipsburg, N. J.

**NEW** blades for Gillette razor, 40 cents dozen. E. O. Mahan, Excelsior Springs, Mo.

**BLADES** resharpened 3c each. New Gillette type 40c dozen guaranteed. Standard Safety Razor, Pittsburgh.

#### FOR THE HOME

**ADDITION** and Multiplication table for home and office use (copyrighted). Conveniently arranged. Mistakes are costly. Save money and pep by using the table and having your sums correct. 25c each or four for \$1.00. P. O. money order preferred. Every home needs a table or two. Harry G. Little, P. O. Box 383, Marysville, Ohio.

**LOOMS**—Only \$9.90 and up. Big money in weaving Colonial Rugs, carpets, etc. from rags and waste material. Weavers are rushed with orders. Send for free Loom Book; it tells all about home weaving and quotes reduced prices and easy terms on our wonderful new looms. Union Loom Works, 489 Factory St., Bononville, N. Y.

**FURNITURE**; Make Furniture at Home. Popular Mechanics books tell how to make all pieces. "Mission Furniture and How to Make It, Book 1, Book 2, Book 3." Send No Money. Just write postal. Pay postman postage and \$3. Popular Mechanics Press, Room 812, 200 E. Ontario St., Chicago, Ill.

**MAKE** tables, chairs, book-racks, other furniture at home in spare time. We furnish complete plans and specifications anyone can use. Special—mahogany end table plans, 25c. The Practical Mechanic, South Haven, Mich.

**HOME** Mechanics. Ideas for all sorts of odd jobs about the house in "Home Mechanics," and "Popular Mechanics Handbook for Women." Over 700 discoveries useful to the whole family. Send No Money. Just write a postal. Pay postman postage and \$1. Popular Mechanics Press, Room 812, 200 E. Ontario St., Chicago, Ill.

#### DIAMONDS, WATCHES AND JEWELRY

**NEW** and Used Watches at Bargains. Ralph Pile, Main Street, Somerset, Pa.

#### ANTIQUES, WAR RELICS AND INDIAN GOODS

**RELICS** from Europe's battlefields. Weapons, medals, etc. Illustrated catalogue 2c (with sample War Photographs). Lieut. Welsh, 1889 Albany Ave., Brooklyn, N. Y.

**ANTIQUE** firearms, Indian relics, daggers, pewter, prints, china, glass, pottery, furniture. Catalogue free. Nagy, 8P South 18th Street, Philadelphia.

**GENUINE** Sioux Indian Costumes and Headwork. Buying direct from the Indian, our prices are reasonable. Write for complete price list. Lyon Curio Store, Clinton, Nebr.

**SEND** us for fine, new list Indian relics, antique firearms. F. E. Ellis, Webster Groves, Mo.

#### PHONOGRAPHS AND SUPPLIES

**REDUCTIONS** on quality phonograph equipment and Latest in Tuned Radio Frequency Sets. Salesmen Wanted. Superior Phonographs Co., Erie, Pa.

**BUILD** your own Phonograph. We furnish everything. Phonograph Parts and Radio catalog sent free. American Phonograph Co., 3742 Belmont, Chicago.

**BUILD** Your Phonograph. Spring Motors. Electric Motors, Tonearms, Amplifiers, Accessories. Latest Equipment also in Radio Mechanism and Cabinets. Catalog mailed for ten cents. Hoover Mfg. & Supply Co., 313 Baldwin Block, Indianapolis, Ind.

#### MUSIC AND MUSICAL INSTRUMENTS

**EVERYTHING** sold for Bands and orchestras—Saxophones, Banjos, Ukuleles, Drums, Trumpets, Violins, Reeds—All accessories. Salesmen wanted. Jay-Corn's instruments. Easy Payments. Repairing and Plating. Phonographs Repaired. Write for prices. Sternberg's Music Shoppe, 59 E. Adams St., Chicago.

**BAND** and Orchestra Instruments—All makes of new and used instruments sold, exchanged and repaired. Standard and popular music sold. Write today for catalog and Free subscription to "Musical Booster" magazine. "Deal with the Professional House." Crawford-Rutan Co., 1051 Grand Ave., Kansas City, Mo.

**"MUSIC** Composed" to words. Bauer Bros., (formerly of Sousa's Band), Oshkosh, Wis.

**VIOLIN**, Deep, Mellow, Soulful—on credit. Easy terms for wonderful instrument. Get details today. Gustav F. Henning, 2424 Gaylord St., Denver, Colo.

**VIOLINS**—Every inch handmade—real masterpieces. Get details. John Lehto, 935 4th, San Pedro, Calif.

**PIANO** Jazz! Teaches; Chimes, Negro Harmony, Player Piano Effects, Dischordant Blues, Etc. By Ear and Note. Postal brings free offer. Write "Piano Bill." Toronto, District 3, Can.

**AGENTS**—Sell Musical Instruments to your friends in your home town. Attractive proposition. Write Music House, Dept. P, 111 E. 14th Street, New York City.

**MUSIC** composed, melodies harmonized. Guaranteed instruction in harmony by mail. Jacobson, 2638 Milwaukee Ave., Chicago.

**I WANT** Song Poems. Casper Nathan, 3544 N. Racine, Chicago.

**WRITE** Songs. Big money and reputation. Write for information. J. Gordon Pub. Co., 291 N. Hayes Ave., Chicago.

**SING** Beautifully—quickly (without teacher). Write—Simplex Method. 4112M Hartford, St. Louis.

**SONG** Poem Writers—Have proposition. Ray Hibbler, DI, 2104 N. Keystone Ave., Chicago.

**SAXOPHONE** quickly taught by time-saving charts. Nothing like them. Musical training unnecessary. Particulars free. California Music Studios, 950 Dale St., Pasadena, Calif.

#### PATENT ATTORNEYS

**PATENTS, Trade-Marks, Copyrights.** Very reasonable. Sanders, 7 Rand McNally Building, Chicago, Ill.

**PATENTS** Procured; Trade Marks Registered—A comprehensive, experienced, prompt service for the protection and development of your ideas. Preliminary advice gladly furnished without charge. Booklet of information and form for disclosing idea free on request. Richard B. Owen, 30 Owen Bldg., Washington, D. C. or 41B Park Row, New York.

**PATENTS.** Time counts in applying for patents. Don't risk delay in protecting your ideas. Send sketch or model for instructions or write for Free book "How to Obtain a Patent" and "Record of Invention" form. No charge for information on how to proceed. Communications strictly confidential. Prompt, careful, efficient service. Clarence A. O'Brien, Registered Patent Attorney, 5888 Security Bank Building (directly across street from Patent Office), Washington, D. C. See pages 172 and 173.

**PATENTS**—Write for our Guide Books and "Record of Invention Blank" before disclosing inventions. Send model or sketch of your invention for Free Inspection and Instructions. Terms Reasonable. See advertisement on pages 174 and 175. Victor J. Evans & Co., 934 Ninth, Washington, D. C.

**LACEY'S** Patent Sense. Valuable book free. See ad page 177.

**PATENTS:** My fee in installments. Free personal advice. Frank T. Fuller, Washington, D. C.

**PERCY S. WEBSTER,** 203 Saving and Loan Building, Stockton, California. Long established organization. Send for free book on Patents.

**ESTABLISHED 1661.** Milo D. Stevens Company. Free booklet, Patents, Trade-Marks, Copyrights. Offices, Monadnock Block, Chicago; Barrister Building, Washington, D. C.

**PATENTS, Trade-Marks, Designs.** This firm has 27 years' experience and gives expert personal service at reasonable rates. We properly protect your invention. Write for free information and exact cost of procuring patent before proceeding. John H. Thomas & Co., 902 F St., N. W., Washington, D. C.

**PATENTS**—Send for form "Evidence of Conception" to be signed and witnessed. Form, fee schedule, information free. Lancaster and Allwine, Registered Patent Attorneys in United States and Canada, 221-Gary Bldg., Washington, D. C.

**PATENTS** and Trade-marks obtained. Prompt service. Write for our new book on patents. Established in 1889. D. Swift & Co., 369 7th St., Washington, D. C.

**MONROE MILLER,** Ouray Bldg., Washington, D. C. Patent Attorney; Mechanical, Electrical Expert. Free Blue Book gives candid advice.

**MILLIONS** spent annually for ideas! Hundreds now wanted! Patent yours and profit! Write today for free book—tells how to protect yourself, how to invent, ideas wanted, how we help you sell, etc. American Industries, Inc., 300 Kreage Bldg., Washington, D. C.

**PATENT** Procured. Prompt Service. Personal, careful and efficient service. Highest references. Moderate fees. Send sketch or model for actual search and advice. George P. Kimmel, Master of Patent Law, 54 M. Legal Bldg., Washington, D. C.

**PATENT** Book Free. Charles W. Lovett, Patent Attorney, Lynn, Mass.

**"INVENTOR'S** Advisor," the valuable Patent book with 139 mechanical movements and illustrations, sent free upon request. M.M. Labiner, Patent Attorney, 3 Parkrow, New York.

**PATENTS, Trade marks, copyrights.** Prompt, personal, reliable service. Over 36 years' active practice. Write for terms. Book free. Address E. G. Siggers, N. U. Bldg., 918 F Street, Washington, D. C.

**INVENTORS**—Write for our Guide Book, "How to Get Your Patent" and Evidence of Invention Blank. Send model or sketch of your invention for our prompt examination and instructions free. Randolph & Co., Dept. 430, Washington, D. C.

**INVENTORS:** Send sketch or model for advice and exact cost of patent. Ask for our Free book: "How to Obtain a Patent." Tells what every inventor should know. Established twenty-eight years. Highest references. Prompt service. Reasonable charges. Chandler & Chandler, 474 Seventh, Washington, D. C.

**PATENTS.** Booklet free. Highest references. Best results. Promptness assured. Send model or drawing for preliminary examination. Watson E. Coleman, Patent Lawyer, 644 G Street, Washington, D. C.

"INVENTORS' Guide" sent free on request; this book contains illustrations of patented inventions and gives valuable information and advice for all who have original ideas or improvements. Frank Ledermann, Registered Attorney and Engineer, Woodworth Bldg., 1712, New York.

**PATENTS**—Our book "How to Obtain a Patent" sent free upon request. Contains full information about patents, trade-marks and designs. If you will send us a sketch of your invention we will promptly make search of the Patent Office records and advise you as to patentability, our charge for the service being \$5.00. Prompt, efficient service with moderate charge. Over twenty years' experience. Bank and commercial references. Talbert & Talbert, Registered Patent Lawyers, 597 McGill Bldg., Washington, D. C.

**COMMERCIALIZE** your inventions according to My Cooperative Plan before patenting. Write for booklet, Ralph Burch, Patent Lawyer, Jenifer Building, Washington, D. C.

**PATENT** Application Blanks free to inventors. Patent News-D, Washington, D. C.

**FRED H. HAYN, M. E.**, formerly First Assistant, Examiner U. S. Patent Office, 23 years' exp. 1 W. Hellman Building, Los Angeles, Calif.

**HERBERT JENNER**, patent attorney and mechanical expert, 605 F Street, Washington, D. C. I report if patent is obtainable and exact cost. Send for circular.

**UNPATENTED** Ideas Can Be Sold. I tell you how and help you make the sale. Free particulars (Copyrighted). Write W. T. Greene, 806 Jenifer Building, Washington, D. C.

#### FOR INVENTORS

**PATENTS.** If you have an invention which you wish to patent you can write fully and freely to Munn & Co., for advice in regard to the best way of obtaining protection. Please send sketches, or a model of your invention and a description of the device, explaining its operation. All communications are strictly confidential. Our Handbook on Patents is sent free on request. This explains our methods, terms, etc., in regard to Patents, Trade Marks, Foreign Patents, etc. "Scientific American" contains Patent Office Notes, Decisions of Interest to inventors and particulars of recently patented inventions. Munn & Company, Solicitors of Patents, 623 Woodworth Building, New York; 524 Scientific American Bldg., Washington, D. C.; 413 Tower Bldg., Chicago, Ill.; 365 Hobart Bldg., 582 Market St., San Francisco, Calif.; 221 Van Ness Building, Los Angeles, Calif.

**PATENTS.** Time counts in applying for patents. Don't risk delay in protecting your ideas. Send sketch or model for instruction or write for Free book "How to Obtain a Patent" and "Record of Invention" form. No charge for information on how to proceed. Communications strictly confidential. Prompt, careful, efficient service. Clarence A. O'Brien, Registered Patent Attorney, 5898 Security Bank Building (directly across street from Patent Office), Washington, D. C. See pages 172 and 173.

**INVENTORS**—Write for our Guide Books and "Record of Invention Blank" before disclosing inventions. Send model or sketch of your invention for our free inspection and instructions. Terms reasonable. See advertisement on pages 174 and 175. Victor J. Evans & Co., 157 Ninth, Washington, D. C.

**LACEY'S Patent Sense.** Valuable book free. See ad page 177.

**PATENTS**—Send for booklet. Contains valuable information for inventors. Bank and commercial references. Prompt service, twenty years' experience. Talbert & Talbert, Registered Patent Lawyers, 558 McGill Building, Washington, D. C.

**PATENT** applications prepared, searches made, lowest fees. Strictly confidential. H. C. Chambers, Box 1544, Washington.

"**STRONGER** Patents for less money." Drawings, specification, claims \$20. Send half fee with sketch and description. Prompt, efficient action. American Patents Corporation, Barrister Building, Washington, D. C.

**PATENTS** wanted by manufacturers. Send description and number, Box 126, Dowagiac, Mich.

**COMPLETE** patent application papers, prepared, including one drawing, \$25; Canadian \$35; Amendments \$10; 20 years' experience. C. J. Williams, Consulting Patent Engineer, Pacific Bldg., San Francisco.

**PATENTED** or Pending Inventions Commercialized. Write for plan. C. J. Williams, Pacific Bldg., San Francisco.

**I SELL** Patents. Established in 1900. The only man in America who has spent the past 25 years exclusively at this work. An experience highly valuable to you, if you have a good patent to sell. Charles A. Scott, 773PM Garson Avenue, Rochester, N. Y.

**INVENTORS**—We will manufacture, assemble, and market your inventions. Write us. Koehler Machine Company, Monaca, Pa.

**PROPELLER** operated by Friction. Rotates 500 to 1,000 R.P.M. Right or Left. Working Model \$1.00. Bach, 65 Cooper Square, New York City.

**MECHANICAL** drawing from sketches. Confidential, neat accurate. Technical Research Bureau, 377 National Ave., Milwaukee, Wis.

**WILL** finance patent (good invention) for interest. F. A. c/o Patent News, Washington, D. C.

**HAVE** You an Invention? If so, write for our free book, "How to Get Your Patent," tells our terms and methods. Send model or sketch for our free examination and instructions. Randolph & Co., Dent, 141, Washington, D. C.

**GET** your own patents. Legal blanks, complete instructions \$1. Cutting Sons, Campbell, Calif.

**UNPATENTED** Ideas Can Be Sold. I tell you how and help you make the sale. Free particulars (Copyrighted). Write W. T. Greene, 807 Jenifer Building, Washington, D. C.

**INVENTORS.** Attention—Our monthly reports give latest developments toward Perpetual Motion. Save money, construct Perpetual Motion or any mechanical model with our standard parts. Write for information. Progressive Association, Box 86, Westville, Conn.

**SALES, Promoting, Exploiting, Correspondence** invited on good inventions. Commission 4%. Associated Inventors, Inc., District National Bk. Bldg., Washington, D. C.

**PATENTS** Procured; Trade Marks Registered—A comprehensive, experienced, prompt service for the protection and development of your ideas. Preliminary advice gladly furnished without charge. Booklet of information and form for disclosing idea free on request. Richard B. Owen, 30 Owen Bldg., Washington, D. C. or 41-B Park Row, New York.

**PATENTS:** My fee in installments. Free personal advice. Frank T. Fuller, Washington, D. C.

**INVENTOR'S Universal Educator**—contains 900 mechanical movements; 50 perpetual motions. Tells how to obtain and sell patents. Suggests new ideas. Explains how to select your attorney and avoid patent sharks. Price (revised edition) \$2.00 postpaid. Albert E. Dieterich, 621-Ouzay Bldg., Washington, D. C.

**INVENTIONS** fully protected two years, \$15 total cost. Particulars free. Patent News-G, Washington, D. C.

#### PATENTS FOR SALE

**MEASURING** device in canisters, bins, display cases for retailing tea, coffee, spices, sugar, etc. Time and money saver. Out-right or royalty. Christ Ritter, 1311 S. Galena, Freeport, Ill.

**WANTED** 6% Royalty on Banana Hanger. Fred Minder, Pawnee, Ill.

**PATENTS**—Clepsis; Musical Instrument; Tack Gauge; Sheet Music Turner; Disk Plow Scraper. Talbert & Talbert, McGill Bldg., Washington, D. C.

**OUTRIGHT** combination key ring and watch chain for belts. Moring and attachable. Model furnished. Marks Abrahams, 217 East 31st, Chicago.

**FOR Sale**—U. S. and Canada patent. Burglar-proof door lock; newly and cheaply constructed. Address Frank Rymars, 5432 Jonathon Ave., Springwells, Mich.

**MY** Invention Lubricates Dies. Will sell with royalty. Simple time saver and safety device. If interested write. D. Sweeney, 92 Coffey St., Brooklyn, N. Y.

**UNITED STATES** Patent for variable condenser, conceded but not yet issued; distinct improvement on existing rotary devices; both approximation and superposition of plates variable, first limited only by perfection of workmanship, as plates unformable and being square in shape exact graduation, hence exact tuning, possible. Ownership means distinct advantage over competitors to manufacturer high-grade sets. No sales agents need apply, but interested manufacturers invited to address inventor: Geo. J. Mahieu, Caixa 221, Rio de Janeiro, Brazil.

**FOR Sale** outright—United States and Canadian patent on Improved Window catch device. Burglar proof and absolutely reliable; easy and cheap to make. New Manufacturers, here's your chance to make money. What offers? Sam R. Wallen, Chase, B. C., Canada.

**FOR Sale**—Three Patents on a valve lifter. G. J. White, Oceanside, Calif.

**IMPROVED Toy**—Patent allowed—reasonably. Henry Claus, East Northport, N. Y.

**FOR Sale**—Patent on Improved Pie rack. Handy, room-saving. Sanitary, Kitchen Device. Address E. Suterli, Box 172, Elizabeth, Pa.

**FOR Sale**—Gas saver for Fords, gasoline engines. Make offer. J. L. Farmer, R 6, McKinney, Tex.

**IMPROVED** hack saw, allows a broken blade to be immediately re-inserted in frame. Particulars from Adam Fisher Mfg. Co., 3619-26 Enright Ave., St. Louis, Mo.

**OUTRIGHT**—Patent on filler for egg-shipping crates. Safety guaranteed. W. S. Palmer, c/o E. Campbell, 210 Grand Ave., Clark's Summit, Pa.

**FOR Sale**—Monkey Wrench. Patented Feb. 27, 1923. Patent No. 1,446,529. Serial No. 560,550. John Villani, 311 Melrose Street, Brooklyn, N. Y.

**PATENT.** Saw Set No. 1,519,592; best offer. Emil R. Peterson, Robbin, Minn.

**MR. MANUFACTURER,** Layman or veteran—Side Dump Scraper Hoist, loads wagons, does ditching. E. B. Hawkins, Applegate, Oreg.

**PATENTS** For Sale: To sell, buy or obtain patents, write Patent News-P, Washington, D. C.

**YOU** have a worth-while patent, haven't you? Why don't you tell our two million readers about it? Most of them are especially interested in patents and new inventions. Ask me to tell you how other inventors successfully sold their patents. Geo. F. Baker, Manager Classified Advertising, Popular Mechanics Magazine, Chicago, Ill.

#### SURVEYING INSTRUMENTS

**LARGEST** stock of new and used surveying instruments in the country direct from factory. Satisfaction guaranteed or money refunded. Wissler, 619 N. Broadway, St. Louis.

#### DRAWING INSTRUMENTS AND SUPPLIES

**IMPORTED** Drawing Instruments—Slide Rules. Highest Quality—Lowest Prices. Circulars free. Automotive Engineering Co. Box 1962, Indianapolis, Ind.

**DRAWING** Instruments, all grades; circulars. Prentissner, 36 West 88, New York.

**DRAFTING.** Learn Mechanical Drawing. Big demand for men to make accurate drawings to scale. This pocket-size, cloth-covered book starts you at the beginning and leads you by a series of simple lessons to the more difficult assignments that you would get in an architect's or engineer's office. Send No Money. Just write a postal for "A Practical Course in Mechanical Drawing." Pay postman postage and \$1. Popular Mechanics Press, Room 812, 260 E. Ontario St., Chicago, Ill.

#### MODELS AND MODEL SUPPLIES

**PATENTS.** Time counts in applying for patents. Don't risk delay in protecting your ideas. Send sketch or model for instructions or write for Free Book "How to Obtain a Patent" and "Record of Invention" form. No charge for information on how to proceed. Communications strictly confidential. Prompt, careful, efficient service. Clarence A. O'Brien, Registered Patent Attorney, 5898 Security Bank Building (directly across street from Patent Office), Washington, D. C. See pages 172 and 173.

**DIES, Tools** and General Manufacturing, Models and Manufacturing of new inventions or specialty. Logan Machine Co., 128 S. Clinton St., Chicago, Ill.



**MODEL Steam Engines, Boilers and Model Pipe line fittings, Model Making Supplies.** Send 20c for this year's illustrated catalogue and hand book. **Bathe Mfg. Co., Dept. D., 5214 Woodland Ave., Philadelphia.**

**HULT & CO., Model Makers, 625 W. Jackson, Chicago, Ill.** High grade Model and Experimental work on inventions of merit. **New Paris Made. Repair Work.**

**MODELS, experimental work for inventors. Confidential, reasonable. Technical Research Bureau, 377 National Ave., Milwaukee, Wis.**

**THE Modelmaker, a magazine for all interested in making working models. Sample 10 cents. Modelmaker, 123 Liberty St., New York.**

**CASTINGS for new model steam engine, 1" bore x 1" stroke. Send stamp for circular No. 7. Model Machine Shop, 417 East 71st St., New York City.**

**SPECIAL machine builders, tool and die makers, inventor's models, production work of all kinds. Dept. L, Quality Hardware & Machine Co., Ravenswood and Thorndale Avenues, Chicago, Ill.**

**WE make working models for inventors and do experimental work and carry a complete stock of brass gears and model supplies. Send for catalogue. The Pierce Model Works, Tinley Park, Ill.**

**WE Build Models, design, develop and manufacture articles in large or small quantities. Homeyer Mfg. Co., 1385 E. 17th St., Cleveland, Ohio.**

**PATTERN Making is a fascinating trade that pays good money. Popular Mechanics has helped many a young man into this trade by supplying the necessary instructions in "Pattern Making," by G. H. Willard, 312 Illustrations. Special chapters on moulding and core making. Send No Money. Just write a postal. Pay postman postage and \$1. Popular Mechanics Press, Room 812, 200 E. Ontario St., Chicago, Ill.**

#### MANUFACTURING

**METAL-CRAFT — Eventually — Metal-Craft. Competent Engineers, Designers and Producing Organization await your commands on dies, stampings, die-casting, deep pressing, screw-machine and wire products. Plating, Enameling, Burnishing, Assembling, Wrapping and Packing to your specifications. Large completely equipped plant which guarantees prompt, efficient service. It is not the quality of raw materials alone, nor the precision in manufacture, and not just the service rendered that has given Metal-Craft the good reputation they bear—but all of these, as a constant certainty. In Combination. Estimates promptly furnished. Metal-Craft Manufacturing Company, Chicago, Box 239-W.**

**WE design and build special machinery, tools, dies, jigs, and fixtures. Experimental work. Light stamping, quantity production. Reliable Machine Co., 400 West 23rd St., New York City.**

**WIRE goods made to order. Cooley Mfg. Co., 530 N. Western Ave., Chicago.**

**METAL Stampings, Dies and Special Machinery. Mail us your drawing or sample for estimate. Send for our free catalogue of Model Supplies. The Pierce Model Works, Tinley Park, Ill.**

**LIGHT stamping and manufacturing. Acme Tool Co., Mason City, Iowa.**

**OUR factory will make your models, manufacture your articles as well as build your tools, dies and fixtures. Standard Die & Specialty Co., 1932 Austin Ave., Chicago, Ill.**

#### MACHINERY, TOOLS AND SUPPLIES

**CONCRETE Building Block Machines and Molds. Catalogue free. Concrete Machine Co., 5 N. Main St., St. Louis, Mo.**

**NO. 60 Hald Auto Cylinder grinder, \$750.00; No. 2 Cincinnati Milling machine, \$275.00; 24" Hensly Shaper, \$325.00; 16"x8" Bradford Engine lathe, \$300.00; Barnes 20" Drill Press, \$55.00; 24" Woodworker Planer, \$175.00; 26" Band Saw, \$65.00. Terms to suit on single machine or complete shop. Complete line of machinery and supplies. Cincinnati Machinery & Supply Co., 218 E. Pearl St., Cincinnati, Ohio.**

**SPEED up. Extension geared wrench removes No. 4 Ford bearing in 2 minutes without hurting knuckles. Interchangeable socket. Labor and time saving tool for various jobs. \$2 Postpaid. George Thorn, Eleven-Forty Fairmount Ave., Philadelphia, Penn.**

#### ENGINES, MOTORS AND DYNAMOS

**ALTERNATING current, single phase sixty cycle motors complete with pulley and base. Century, Emerson, Wagner. Brand new in original crates. 1/2 H.P.—\$32.00; 3/4 H.P.—\$42.00. Many other bargains both new and rebuilt. Tell us your needs. Send for complete list. Hyre Electric Co., 815 MH South Dearborn Street, Chicago, Ill.**

**GUARANTEED 1/2 hp, 110 volt, 60 cycle, single phase, used motors with pulley at \$7.50, cash with order. We repair, rewind, electric motors and generators, etc. Bargains on electric fans. General Distributing Co., Security Storage Bldg., Duluth, Minn.**

**GOVERNORS for Gas and Auto Engines. Thousands of auto engines are now used to run shop or farm machinery. Send for our circular telling you how it is done. Candee-Smith Governor Co., 214 No. Los Angeles St., Los Angeles.**

**25-V. 8-AMP. generators connected to 220-V. 3-phase A. C. motor, \$23.00 to close out. Also other bargains. Queen City Electric Co., 1736 Grand Ave., Chicago, Ill.**

#### ELECTRICAL

**ENGINEERING Data: Pocket loose-leaf; Transformer practice; connections; diagrams. Electricians, Engineers, 25c coin. C. Homan, 181 Berkeley Place, Brooklyn, N. Y.**

**EXPERT Repairing of all kinds of Electric Motors. Send us your washing machine Motors, Vacuum Cleaners, Automobile starters and generators. Write for prices. Evert Electric Co., Racine, Wisconsin.**

**ELECTRICAL Devices such as bread toaster, grill, door opener, clock, engine, fire alarm, furnace regulator, furnace, lock, locomotive, and dozens of others are fully described and pictured in Boy Mechanic Book 1. You can make these for yourself with the crystal-clear instructions in this valuable book. Don't send a penny. Just write a postal and ask for Boy Mechanic, Book 1. When the postman hands you the book, pay the few cents postage and \$2. Popular Mechanics Press, Room 812, 200 East Ontario St., Chicago, Ill.**

#### BENDING MACHINES

**THE famous Hossfeld Wrenchless Universal Bender is the last word in bending machines; bends metal, cold or hot, into most any conceivable shape, including Eye-bolts and Automobile Spring Eyes. Bends up to 1" bars or 1 1/4" Pipe cold. Used by the largest corporations, yet so inexpensive that even a farm shop need not be without one. Send for circular. Hossfeld Mfg. Co., Box 344, Wisona, Minn.**

#### BLACKSMITHS

**BLACKSMITH Notice: Young smith or handy man make more money doing hard jobs easy. In job shop or factory be a Master Machine and Plow Blacksmith and Expert Tool Dresser. With Colored Temper Chart. All for One Dollar. Samples Free. W. M. Toy, Sidney, Ohio.**

#### ROOTS AND HERBS

**HERB Doctor Book—10 cents, 250 receipts for making herb medicines. Hazzard Company, Box 1, Vanderveer Park, Brooklyn, N. Y.**

**HORSERADISH is profitable. Grow it in your garden as a side line or gather the wild roots. New book tells how to find, how to dig, how to cultivate, how to prepare and bottle, how to find wholesale customers and how to sell at retail. All the information you need to start this easy and profitable business. Send 50 cents for the book, "Horseradish." Popular Mechanics Press, 200 E. Ontario St., Room 812, Chicago, Ill.**

#### FOR SALE MISCELLANEOUS

**GOOD Multigraphs with type, complete, \$58.00. J. L. Dees, Ada, Okla.**

**OVERCOATS \$5.00; Street Suits \$8.00. Slightly used; all sizes. Bargains. Wallace, 1834 North Halsted, Chicago.**

**HONEY, Michigan's best. Clover or Buckwheat. Five pounds \$1.60; Ten pounds \$2.75, delivered fourth zone—"with honey receipt book" (A gift suggestion.) Shady Lawn Apiaries, Milan, Mich.**

**SWAP!—Buy!—Sell! Anything!—Anywhere! 20-Word ad and 84 months subscription 50c. International-Opportunity, Brookings, S. Dak.**

**HONEY—clover, buckwheat, five pounds \$1.25, shipped C. O. D. Sootin, Liberty, N. Y.**

**PRINTING Presses, Type, Materials. Make easy money printing for self and others. Interesting circulars. Stamp. Watson, 30 Beekman St., New York.**

**CLOVER or Buckwheat Honey; Sorghum and Pure Maple Syrup. Highest quality, reasonable price. C. A. Crane, Racine, Wis.**

**ADDRESSOGRAPHS. Letter Folders, Multigraphs, Envelope Sealers, Duplicators, less than half price. Guaranteed. Pruitt Co., 117 No. Market, Chicago.**

**BUY—Exchange—Sell! Many of our readers have for sale or exchange the article you are looking for—and lots of them are looking for the very items you want to turn into cash. Get together! Let our two million readers know your wishes—they'll help you! Send your ad today to Geo. F. Baker, Manager Classified Advertising, Popular Mechanics Magazine, Chicago.**

#### WANTED—MISCELLANEOUS

**KIDDER Paraffin Medical Batteries. John Gormly, 410 E. Marshall St., Norris-ton, Pa.**

**MAIL us your discarded Jewelry, Gold, Crowns and Bridges, Watches, Diamonds, Silver, Platinum, and old False Teeth. Money promptly mailed. Goods returned if offer refused. United States Smelting Works, (The Old Reliable), Dept. 71, Chicago.**

**CASH Money for diamonds, old gold, platinum, silver, old watches, gold crowns, bridgework. Cash by return mail, 2020 S. Division, Grand Rapids, Mich.**

**CASH sent immediately for gold, silver, platinum, diamonds, watches, bridge-work, crowns, and all valuables. Satisfaction guaranteed. Dept. 50, Busch Products, 2340 Eighth Ave., New York.**

#### REAL ESTATE, FARM AND ORCHARD LANDS

**HERE'S your land! \$10 down and \$10 a month buys 20 acres of my best land in Cent. Mich. for \$400, or 10 acres for \$250. Write at once for free 48-page picture book. G. W. Swigart, P1239 1st Natl. Bank Bldg., Chicago.**

**100 ACRE Farm, 12 Cows, Horses, Calves, Poultry, Bull, machinery; well located, valuable woodland; good 8-room house, piped water, basement barn, silo. \$3,700 gets all, part cash. Details pg. 22 illus. 196 pg. Catalog, Free, Strout Farm Agency, 255-P, 4th Ave., New York City.**

**\$5.00 DOWN, \$2.00 monthly, buys 2 1/2 acres No. Michigan Fruit or Poultry Farm, Camp Site or Summer Home. \$100.00. Burt Lake, Cheboygan County. Finest hunting, fishing, boating, swimming. Good auto roads. Get free booklet and map. O. Hermann, 140 So. Dearborn St., Chicago.**

**ATTENTION—"Get acquainted." Cash for your property. Farm, Hotel or Retail Store, no matter where located; confidential service. Hayes' Business Agency, Cincinnati, Ohio.**

**PECAN-Orange-Fig Groves "On the Gulf" Monthly payments. Guaranteed care. Big, quick returns. Suburban Orchards, Dept. M, Biloxi, Miss.**

**WANT clear Montana ranch, fenced, improved. Box 423, Choteau, Mont.**

**\$5.00 DOWN, \$5.00 monthly; 10 acres unimproved poultry, fruit, stock, woodland; \$100; Ozarks. Fishing, hunting, trapping. Alvin Zimmermann, 1800 N. Fifth, Kansas City, Kans.**

**SELL your property quickly for cash, no matter where located. Don't pay big commission. Particulars free. Real Estate Salesmen Co., Desk B, Lincoln, Nebr.**

#### DOGS AND PETS

**RAISE guinea pigs. Pay better than poultry or rabbits; easy to raise; little space required. We guarantee market. Particulars and booklet how to raise free. Cavies Distributing Co., 3192 Grand Ave., Kansas City, Mo.**

**HUNDRED Hunting Hounds, Fur Catchers. Catalogue. Kaskaskennels, M32, Herrick, Ill.**

**WHITE Scotch Collies, Beautiful, Intelligent, pedigreed. Dept. P, Shomont Kennels, Monticello, Iowa.**

**POLICE Dogs. Blue ribbon stock. Circulars free. Land O'Lakes Kennels, Camden Station, Minneapolis, Minn.**

**RAT Terriers, Newfoundlands, St. Bernards, Police Dogs. We send on approval. Descriptive circular 10c. Fairview Farm, Elmore, Minn.**

**ENGLISH Bull Puppies, Catalogue ten cents. Triangle Kennels, Jackson Center, Ohio, Box 45.**

**BEAUTIFUL registered bull pups \$15. Bulldogs. 591 Rockwood, Dallas, Texas.**

**HUNTING Hounds Cheap; Trial. Dixie Kennels, R-1, Herrick, Ill.**

## PERSONAL

**SIMPLIFIED Psychological Guide.** Covering "All" Dispositions; Invaluable to Mother and Business; Particulars Free. C. Norton, (Psychologist), 171 S. 2nd, San Jose, Calif.

**IMPROVES Appearance!** Desire quickly corrects outstanding ears! Lawrence, 1238 South Thirteenth, Philadelphia.

**YOUNG-YOUNG** is the most inspiring, helpful and interesting Magazine Published, one copy will convince you. 3 months 25 cents. Geo. Stewart, 157 W. Sta. Barbara, Los Angeles, Calif.

**STOP Tobacco.** Remedy proven. Ten years success. \$1 prepaid. F. H. Fink, 1050 Curtis St., Toledo, Ohio.

**FREE—Stop using tobacco.** We will give free information how to conquer habit easily and permanently. Results guaranteed. Anti-Tobacco League, Box K, Omaha, Nebr.

**UNUSUAL Horoscope** Consisting of Extended four page Special Horoscope, and Astro Analysis. Send 50c and birthdate. Money returned if dissatisfied. Prof. Bolles, Box 125, Cranford, N. J.

**I CARRY** complete stock medicinal herbs. Indian Herb Medicine Book 10c. Information free. Shawnee, 145 West 112th Street, Chicago.

**TOBACCO or Snuff Habit** cured or no pay. \$1.00 if cured. Remedy sent on trial. Superior, Co., TP, Baltimore, Md.

**SEND 25c** and your date of birth for forecast of your vibrations for 1928. Arvel Synclaire, Numerologist, Box 25, Patton, Calif.

**DON'T** be a tobacco slave. Orsanin positively and quickly overcomes the habit, any form, or money refunded. Investigate. Orsanin Co., Box 503-D, Detroit, Mich.

**ASTROLOGY—Stars Tell Life's Story!** Send birthplace and 10c for test reading. M. Klemman, 373 William Ave., Winnipeg, Man.

## MISCELLANEOUS

**ARE you old at forty!** See our advertisement on page 185 of this issue. The Electro Thermal Company, 2137 Main St., Steubenville, Ohio.

**TOURIST** home auto body. Build yourself cheaply. Information free. Body Engineers, Webb City, Mo.

**MEXICAN** made pistole holsters, cartridge belts, lariats, sombreros, horse-hair goods; list free. Ingersoll Leather Co., 397 E. Main, Houston, Tex.

**MIRRORS** Re-Silvered at Home. Costs Less 5 cents per square foot; you charge 75 cents. Immense profits, plating auto parts, reflectors, tableware, stoves. Refinishing metalware, etc. Outfits furnished. Write for information. Sprinkle, Plater 288, Marion, Ind.

**BLUEPRINTS** For Building Seven Room Bungalow or Cottage \$3.00. Specifications \$1.00. M. Andrews, 309 5th Avenue, New York City.

**GENUINE** Rogers 1847 Silverware. 26-piece Silver Set. \$14.50. Send for catalog. Guarantee Specialty Co., 4823 Liberty Ave., Pittsburgh, Pa.

**MINERAL** Wealth under Foot. Learn to find it. Cash it in. Thousands profit, so can you. Information 10c. Baskett, Joulin, Mo.

**FORMS** to Cast Lead Soldiers, Indians, Marines, Trappers, Animals. 151 Kinds. Send 10c for Illustrated Catalogue. Henry Schlerke, 1031 72nd St., Brooklyn, N. Y.

**EARN \$3,000** yearly; course \$200; including printing, \$350; largest linotype school in existence; established 19 years; more than 1,000 have attended. Emidio School, 206 E. 19th St., New York.

**FREE Bargain Catalogue.** Watches, Jewelry, Radio Sets, Cameras, Etc. Address Louisiana Distributing Service, Harmon, La.

**CUTS** anybody can make. Simple, cheap process. \$1. Specimens, particulars, 2c stamp. M. Day, Windfall, Ind.

**ARTIFICIAL** Eyes. Booklet free. Denver Optic, 559 Barclay, Denver, Colo.

**HOMEOPATHIC** and Biochemic preparations sent postpaid to all parts of the world. Manual and booklets free. Halsey Bros. Co., 111 N. Wabash Ave., Chicago, Ill. Established 1835.

**CAN You Draw!** Make money at home. Something new. No canvassing. Sample and particulars 10c. "Straley," 1017 W. Mulberry, Springfield, Ohio.

**MAGIC mender** mends holes, cracks and breaks in anything, cooking utensils, all metals, enamel, wood, leather, etc. Waterproof and fireproof. Requires no heat nor soldering iron. Cheap and easy to make. This remarkable formula only \$1.00. Consulting Chemists, 245 N. Main St., Dayton, Ohio.

**10,000 FORMULARS.** A real Gold Mine of money-making ideas. Tells how to make almost everything under the sun. You can make and sell Cosmetics, mucilage, anti-freeze solutions, battery solutions, beverages, cheese, chewing gum, cleaning preparations, extracts, hair preparations, inks, blueing, leather polish, mirrors, perfumes, polishes, typewriter ribbons, carbon paper, washing powders, liquid soap, and hundreds of other profitable articles. Send No Money, just write a postal and ask for Henley's 20th Century Book of Formulae. When the postman hands you the book, pay the few cents postage and \$1. Money back if you are not delighted. Popular Mechanics Press, 200 E. Ontario St., Room 812, Chicago, Ill.

**DISCOVERIES** for farmers. 861 discoveries in "Popular Mechanics Handbook for Farmers." Tells how to make such useful devices as follows: portable greenhouse, fruit-picking ladder, tomato ripening device, land roller, exhaust water heater, ditch filler, self-closing garage door, barrel header, poultry water fountain, dump sled, manure scraper, combination rabbit hutch and poultry house, and hundreds of others. Don't send a penny. Just write a postal and ask for "Popular Mechanics Handbook for Farmers." When the postman hands you the book, pay the few cents postage and \$1, the price of the book. Popular Mechanics Press, Room 812, 200 E. Ontario St., Chicago, Ill.

**ELECTRICAL** Devices such as bread toaster, grill, door opener, clock, engine, fire alarm, furnace regulator, furnace lock, locomotive, and dozens of others are fully described and pictured in "Boy Mechanic, Book 1." You can make these for yourself with the crystal-clear instructions in this valuable book. Don't send a penny, just write a postal. Pay postage and \$2. Popular Mechanics Press, Room 812, 200 East Ontario St., Chicago, Ill.

**\$3,000 to \$5,000 a Year**

If you want to make at least \$3000 a year, send for our new, big catalogue FREE. Qualify for a big pay job in the automobile business after only 10 weeks' training in New York. Previous experience not necessary. You learn by doing actual work on passenger cars, truck and tractors. Thousands of successful graduates.

**FREE BOOK—Write today for large, illustrated catalogue**  
**STEWART AUTOMOBILE SCHOOL**  
225 West 57th Street Dept. 1759 NEW YORK CITY

**ELECTRICITY****FREE BOOK**

Send for it

**LEARN in 12 WEEKS**

Prepare for a good paying position in 12 weeks. Salaries from \$10 to \$25 a day not uncommon for Finlay trained men. Finlay Condensed Method, now in 23rd successful year, trains head and hand, combining practical shop work and intensive study. In 12 weeks we teach you HOW and WHY. Thousands of successful men have taken this short road to long pay. You have the same opportunity.

**EARN \$10 to \$25 a DAY**

Send for Finlay Catalog and full details on 12 weeks' course in Practical Electricity. Thousands of positions open. Enroll any time. Completely equipped shops and laboratories. Faculty of highly trained experts. Certificates awarded. Students assisted to positions. Success is calling you NOW. Write today and get the facts.

**FINLAY**  
**ENGINEERING COLLEGE**  
102 FINLAY BLDG., KANSAS CITY, MO.

**Physical Voice Culture****Results Guaranteed**

Improve your voice 100% the simple, easy, natural way by silent physical exercise in the privacy of your own home. The Physical Voice Culture method is ideally adapted to home study. It will improve your voice 100% or your tuition will be gladly refunded. You alone are the judge. Find out at once about the possibilities of your voice. Learn how to develop a strong, resonant, beautiful voice that will be the marvel of your friends and your key to success and fame.

**Free Book** containing absorbing true stories of what others have done. Send right away for this fascinating book and full information about Physical Voice Culture. Write today!

**PERFECT VOICE INSTITUTE**  
1922 Sunnyside Ave., Studio 13-59, Chicago, Ill.

**Make Art Objects Like These Yourself**

**Do This Profitable New Work At Home**  
You can easily make extra money at home in spare hours, decorating candlesticks, lamp shades, toys and novelty furniture. Many do it solely for artistic pleasure; thousands make fine incomes supplying enormous demand.

**Send for Free Book**

Tells how you can become a member of Fireside Industries, national organization of co-operative home-workers. Outfit furnished without extra cost. Send 1c for postage on beautiful book giving full details.

**FIRESIDE INDUSTRIES**  
Dept. 6612 Adrian, Michigan

# Quickly Learn to Play Hawaiian Guitar

## Play Like This Native



**Free**  
**\$18 Hawaiian**  
**Guitar when**  
**you enroll**



### Are You Popular? Do You Fit In This Picture?

Everyone likes popularity. It's great to be invited to many parties where young folks gather to have good times. Become an expert Hawaiian Guitarist and you will quickly become the center of attraction. It's an easy instrument to master with our short cut method of teaching.

## JAZZ Your Way to Popularity and Success

Jazz has taken the country by storm. Hawaiian Guitar jazz artists are popular and successful.

### Genuine \$18.00 Hawaiian Guitar Free

When you enroll as a student, you secure absolutely free a beautiful, full tone, genuine \$18.00 Hawaiian Guitar. We also furnish every bit of equipment so that it is not necessary for you to spend an extra penny outside of the cost of our course.

#### NEW INVENTION

### Kno-All Fingerboard Chart Quickly Teaches You How to Play and Read Notes

The newest invention of our chief Hawaiian instructor, which is exclusively used by us and which we call the "Kno-All Fingerboard Chart" quickly teaches you how to play and read notes. So simple is this device that anyone can understand it and begin to play immediately.

#### Diploma Given to Graduates

When you graduate, you get a beautifully engraved diploma and after graduation, we also give you six months' free service and consultation.

#### No Forming Class to Wait For

No forming class to wait for. Start your lessons at once and join the band wagon of success and popularity. Do it through the Hawaiian Guitar.

#### Rush Coupon for Free Book & First Free Lesson

Sign and mail coupon to us today. You will receive your Free Book, "How to Learn Hawaiian Guitar" and your first lesson free.

**Hawaiian Studio No. 529**  
**of New York Academy of Music**

100 Fifth Ave.  
New York

Bring the romantic, enchanting, entrancing and melodious strains of the great instrument of the Hawaiian Islands into your soul and you will soon become popular and successful. This short cut method of home instruction enables you to quickly master the Hawaiian Guitar, so that you will play as well as the Native Hawaiians.

Our staff of Hawaiian instructors have perfected a method of teaching that is simple that without any musical knowledge, you can quickly learn to play real music from notes. It is as simple as learning your A B C's and it will not be long before you will play latest Broadway hits such as, "Mamma Loves Papa, Papa Loves Mamma, Mamma Loves Papa, I Love You, Wonderful One, A-Reddy, When Lights Are Low," and any others of your choice long before you have completed our course.

There are only four simple motions to learn and then you will be able to play any music, whether it be popular, dance or classical. Almost from your first lesson you will be able to play love songs like Aloha Oe.

To help you get started and to promote in America the popularity of this wonderful instrument, we furnish absolutely free when you enroll as a student, a beautiful, full tone, genuine, \$18.00 Hawaiian Guitar. Only 1,000 free instruments will be given away, so if you want to get in on this free offer, write for particulars at once—you must act quickly.

### It's Easy to Understand Pictures Of Our Professors' Playing

Arthur Brisbane, the highest paid journalist in the world once said that "A single picture is worth a thousand words." He was right, for it stands to reason when you take your instrument in hand along with actual photographs of our professors in action as your guide, it is easy to imitate and do the right thing.



Along with our easy to read course we also supply you with diagrams and charts, as well as many pictures of our professors' playing. This enables you to imitate the pictures. Isn't this easy?

### Phonograph Records of Piece You Are Learning Included Free

As an additional guide, we also furnish you with phonograph records of our Hawaiian instructors' own playing of the piece you are learning. This practically brings our professors from our studio to your own home and enables you to listen to their playing just as if they were actually in front of you.



### First Lesson Free

So positive are we that you will become one of our students and a booster for our course, that if you write at once, we will send you absolutely free, without any obligation on your part, our first lesson which will enable you to see just what you can expect when you enroll. You will also receive our big book which gives full particulars about our course. Write for your book and your first lesson today. You will be one of the lucky ones to have a free Hawaiian Guitar reserved for you—write at once, because the number of gift Hawaiian Guitars are limited.

## PROOF

#### Expects to Play by Bed Time

Received my Guitar all O.K. and was delighted to see such a fine Guitar for the price. I have begun to study the first lesson and I think I will be able to play it by bed time tonight, or at least will try.—Mr. Orville Lee, 408 East Duane Ave., Knoxville, Tenn.

#### Getting Along Fine

The guitar is O.K. and am getting along nicely in spite of the fact that I can't read music.—S. Francis Schindler, 122 W. Green St., Pasadena, Cal.

#### Proud of Hawaiian Guitar

I am perfectly satisfied with your course. It is very simple indeed and above all, am proud of my Hawaiian Guitar. It is a beauty. Looking forward for the other lessons to come.—John L. Cahan, National Sanatorium P. O. Box 70, Yonkers, N.Y.

### RUSH THIS COUPON FOR FREE BOOK AND FIRST FREE LESSON

**Hawaiian Studio No. 529**  
**of New York Academy of Music,**  
**100 Fifth Avenue, New York.**

Please rush your book, "How to Learn Hawaiian Guitar" and my first free lesson. Also reserve a gift Hawaiian Guitar for me. This obligates me in no way whatever.

Name \_\_\_\_\_

Address \_\_\_\_\_

City \_\_\_\_\_

State \_\_\_\_\_

NOTE—This offer expires in 60 days





# Learn By Doing!

Every phase of all branches of

## ELECTRICITY

Taught By Actual Practice

In America's foremost institution for trade training.

Established 1902

### No Books Used

Individual Instruction. Start Any Day.

A SPECIAL and SEPARATE Course in Ignition, Auto Lighting and STARTER Systems.

Write for FREE 64-Page Catalog

**THE NEW YORK ELECTRICAL SCHOOL**  
44 West 17th Street NEW YORK CITY

Whatever Your Question;—be it the pronunciation of Fascista, the spelling of a puzzling word, the location of Esthonia, the meaning of soviet, realtor, vitamin, etc., this Supreme Authority—

### WEBSTER'S NEW INTERNATIONAL DICTIONARY

contains an accurate, final answer. 407,000 Words 2700 Pages. 6000 Illustrations.  
Regular and India-Paper Editions G. & C. MERRIAM CO., Springfield, Mass.  
Write for specimen pages, prices, etc., and FREE Pocket Maps, per Popular Mechanics.



## DO YOU LIKE TO DRAW?

It's Easy To Learn When Shown In The Right Way

Some of the cleverest cartoonists and comic artists in America today learned how to draw quickly—by following **CARTOONIST EVANS' SIMPLE AND EASY METHOD**. This school is recommended by foremost cartoonists because they know the students are handled right. If you like to draw, send 6c in stamps for **portfolio of cartoons and full details**. The course is **NOT EXPENSIVE**.

**The W. L. Evans School of Cartooning** 821 Leader Building CLEVELAND, OHIO

## WANTED—RAILWAY MAIL CLERKS

**\$1900 to \$2700 a Year for Life**

(ALL POSTAL PAY JUST RAISED)

Every second week off with full pay—no "lay-offs" because of strikes, poor business, etc.—sure pay—rapid advancement to higher positions. City and country residents stand same chance. Common sense education sufficient—no political influence.

### TRAVEL—SEE YOUR COUNTRY DON'T DELAY—ACT AT ONCE

Mail Coupon today—sure. Every day's delay means so much less chance of appointment from the next examinations—so do it at once.

Take this First Step for  
a U. S. Government Job  
Use Coupon Before You Lose It

#### COUPON

FRANKLIN INSTITUTE, Dept. K174 Rochester, N. Y.  
Kindly send me, entirely free of charge: (1) A full description of the position checked below; (2) Sample examination questions; (3) Free Sample Coaching; (4) A list of U. S. Government Jobs now obtainable; (5) Tell me how I can get the position here checked.

... Railway Mail Clerk (\$1900 to \$2700) ... Customs Positions (\$1140 to \$1860)  
... Postoffice Clerk (\$1700 to \$2100) ... Internal Revenue (\$1140 to \$1860)  
... City Mail Carrier (\$1700 to \$2100) ... Rural Mail Carrier (\$2100 to \$3300)  
... Income Tax Auditors ..... (\$2040 to \$3000)

Name .....

Address .....

Copyrighted material

If you want a job while training, I'll help get you one. Come to my big schools at Chicago, Cleveland or Detroit



What's the use of training for the old, overcrowded trades? If you're going to prepare for big-salaried jobs

Easiest, pleasantest work you ever saw! Your own boss, money and success yours from the very beginning. You can start with a "shoe-strinz." We prepare you in a few months to run a business of your own, to do any job. Common schooling, ability to use your fingers ALL YOU NEED! Free R. R. Fare to Chicago, Cleveland or Detroit for a limited time!



**Jobs at  
\$60 to \$125  
a Week!**

In a business where there are many times as many jobs as Experts, salaries are high, hours are easy, opportunities are everywhere! McCarrie-trained Graduates always get the preference—Dentists everywhere recognize the high-standing of our graduates. No books here—learn with tools and instruments. Start quick—get ready in a few months for your big opportunity! *Mail Coupon today!*

### RUBBER PLATES

Learn to make partial upper or lower plates with soldered, cast or wire clasps, with palatal bars; with lingual bars. McCarrie-trained Students learn to make full rubber plates of every type, including Vulcanite base-plates, padded gums, carved gums, etc.

### CROWNS

Here's only a small part of your practical training in Crown-work: Two-piece, seamless, open-face, Richmond, cast-base porcelain, Carmichael, split-pin, carved (swaged) cusp, cast cusp, etc.

### BRIDGE WORK

Complete training in both fixed and removable bridge-work. Interchangeable teeth, gold dummy, Sanitary, porcelain dummy jobs—Roach, Gilmore, Bischoff and all forms of cast-clasp work is taught—not with books but in actual Laboratory.

### METAL BASE DENTURES

Cast bases of Aluminum, gold, Watt's metal, etc., are included in your training. Both centrifugal and air pressure casting machines are used. Free Catalog contains complete list of subjects in course.

**FREE!**  
R. R. Fare  
TO  
Chicago  
Cleveland  
OR  
Detroit

# This Dental Laboratory Expert earns \$20 a day!

or a profitable business of your own GET INTO THE NEWEST PROFESSION—"Laboratory Dentistry." Biggest opportunity for success of the century, because there are ten times as many jobs as men to fill them, because there are a dozen cities crying for Laboratories for each EXPERT capable of operating one!

## 70,000 DENTISTS NEED LABORATORY WORK!

Only a few hundred Laboratories in all the U. S.—most of them in Chicago and New York. Dentists can't afford to do their own mechanical jobs. They can buy the services of a Laboratory Expert at \$3.00 an hour and sell their own time at \$6 to \$15 an hour. Dentists will encourage you to learn mechanical work, start a "Lab" of your own, give them quicker service than sending to Chicago or New York. Dentists can't wait and keep their patients waiting.

## WE HELP YOU OPEN A LABORATORY OF YOUR OWN!

Many of my graduates open a Laboratory of their own. To encourage more men to go into this wonderful profession, we will help you find a good location for your Laboratory, and help you make a success of it. Write for complete information on how you can find yourself in a profitable business of your own after you become a Dental Laboratory Expert.

## INTERESTING CATALOG—FREE!

Right this minute there are openings for 150 Dental Laboratory Experts in locations where they can do a business of \$5,000 to \$20,000 a year. But you can't cash in, take advantage of these OPPORTUNITIES until you're trained. Catalog tells you how quickly and easily you can get ready, how hundreds of others have SUCCEEDED! Tells you how you learn in a few months BY DOING ACTUAL LABORATORY JOBS under one of the world's greatest Mechanical Dentists! Brings you FREE R. R. Fare offer and other big inducements. Write for free Catalog today!

### EARN while you LEARN!

Day students make all or part cost of course by part-time night work. Night students can find plenty of good jobs to see them thru. We'll help you!

## McCarrie School of Mechanical Dentistry

1338 S. Michigan Ave. Dept. 2901-M Chicago, Ill.

### McCarrie School of Mechanical Dentistry,

1338 S. Michigan Ave. Dept. 2901-M, Chicago, Ill.

Without obligation, please send me your Free R. R. fare offer and free catalog with complete information about how I may become a Dental Laboratory EXPERT. How you will help me open a Laboratory, how you will help me find a job while I take my training, etc.

Name.....

St. No. or R. F. D. ....

City..... State.....



## Traffic Manager Boosts Salary 900%

"Within three months after enrolling for LaSalle training in Traffic Management," writes S. G. Ritchie, a Missouri man, "I was able to step into a better position at a 30 per cent increase. By working during some of my spare time I very easily completed the course, and you can judge of its benefits when I tell you that my present salary is 900 per cent higher than when I enrolled, and I can honestly credit LaSalle training with most of this. I could not possibly have secured or held my present position without the training I received from my course in Traffic Management."

### Send for Salary-Doubling Plan

Are you—like Ritchie—following a well-organized plan to double—triple—quadruple your salary? Or are you relying for advancement upon day-to-day experience? LaSalle offers a sound and practical salary-doubling plan which has added millions and millions of dollars to the earning power of its members. During only six months' time, for example, as many as 1,248 LaSalle members reported salary-increases totalling \$1,399,507. The average increase per man was 89 per cent.

If a successful career is worth a 2c stamp and two minutes of your time, check the field of advancement that appeals to you, fill in your name and address, and place the coupon in the mail TODAY.

### LaSALLE EXTENSION UNIVERSITY

The World's Largest Business Training Institution  
Dept. 1264-TR Chicago

Please send outline of your salary-doubling plan, together with a copy of "Traffic Management," also copy of "Ten Years' Promotion in One," all without obligation.

Traffic Management—  
How Traffic Men Make Money

### Other LaSalle Opportunities

The LaSalle Plan opens the way to success in every important field of business. Check below the opportunity that appeals to you.

- |  |  |
|--|--|
| <input type="checkbox"/> Business Management                       | <input type="checkbox"/> Personnel and Employment Management         |
| <input type="checkbox"/> Modern Salesmanship                       | <input type="checkbox"/> Banking and Finance                         |
| <input type="checkbox"/> Higher Accountancy                        | <input type="checkbox"/> Modern Business Correspondence and Practice |
| <input type="checkbox"/> Railway Station Management                | <input type="checkbox"/> Expert Bookkeeping                          |
| <input type="checkbox"/> Law—Degree of LL. B.                      | <input type="checkbox"/> C. P. A. Coaching                           |
| <input type="checkbox"/> Commercial Law                            | <input type="checkbox"/> Business English                            |
| <input type="checkbox"/> Industrial Management                     | <input type="checkbox"/> Commercial Spanish                          |
| <input type="checkbox"/> Modern Foremanship and Production Methods | <input type="checkbox"/> Effective Speaking                          |

Name .....

Present Position .....

Address .....

# Learn Furcraft

Learn by mail, evenings at home. Make up New Furs and Make Old Furs Like New. Learn Fur Repairing and Cleaning.

Learn our secret processes. Learn glazing, ironing and storage. Big demand, big need in every neighborhood. A wonderful uncrowded field. Investigate.

**\$3 an Hour!**

In Your Spare Time

or a real business now and later a big fur shop. Next month earnings start if you learn now. Men and women equally successful.



**Free Book**

Tells all about this greatest of Spare Time Money Makers. Big opportunity now in your neighborhood. Be first. Send at once for Free Book and get full details of this money-making business. No obligation. Write today.

**NORTHWESTERN FUR COMPANY**  
1779 Sunderland Building, Omaha, Nebr.



## Learn How to WRESTLE

In Your Own Home  
By Mail



Yes, learn to become an expert wrestler right in your own home, by mail, from the greatest wrestler the world has ever known. He an athlete, he strong, he healthy. Learn how to throw and handle big men with ease. Learn to defend yourself. All taught in our course of lessons, and illustrated with hundreds of charts and actual photographs by

**Farmer Burns and Frank Gotch**

Farmer Burns, "the great old man of the mat," taught Frank Gotch, the World's Champion, all he knew about wrestling, so Gotch said. He will now teach you Scientific Wrestling—Physical Culture—Jiu-Jitsu—Self Defense. Every man and boy in America, no difference what age, needs this wonderful course of lessons. Write today—your name, age and address on a postcard or letter brings you our fine book absolutely free.—no obligation of any kind. A splendid boon on wrestling and physical culture. Write today stating your age.

Farmer Burns School of Wrestling 9779 Range Bldg., Omaha

This  
Week  
the  
Book  
FREE

LET US TEACH YOU

## PHOTOGRAPHY

**At Home** This profitable high paying profession now taught by advanced methods.

**OPPORTUNITY—INDEPENDENCE—MONEY**

You can qualify for this profession in your spare time and start your own business in a short time. You learn the new SUCCESS method, by doing, under expert guidance.

**Genuine Professional 8x10 Camera—FREE**

Each student receives a genuine professional camera equipped with a professional anastigmat lens. Not a toy machine.

Write immediately for information on the guaranteed success course of study. Universal Institute, 620 Monadnock Bldg., Chicago, Ill.

## BE AN ARTIST

Comics, Cartoons, Commercial, Newspaper and magazine illustrating, Pastel, Water Colors, Portraits and Fashions. Our simple method quickly develops your talent in spare time. By Mail or Local Classes. Write for terms and list of successful students. ASSOCIATED ART STUDIOS, Dept. B, 100 W. 23rd St., NEW YORK



**Clear-Tone**

FOR

**DIMPLES**

Your skin can be quickly cleared of Pimples, Blackheads, Acne or any Eruptions on the face or body, Barbers Itch and Eczema, Enlarged Pores, Oily or Shiny Skin. CLEAR-TONE has been Tried, Tested and Proven its merits in over 100,000 test cases.

**FREE**

WRITE TODAY for my FREE Booklet—"A CLEAR-TONE SKIN" telling how I cured myself after being afflicted for fifteen years.

E. S. GIVENS

128 Chemical Bldg.

Kansas City, Mo.

# "When you *stop stammering* you'll succeed"

**U**NTIL you learn to talk smoothly and convincingly, all that you know about automobiles will not get you out of the shop and into the service department, Hank. No one has the patience or time to listen to a man who cannot say what he thinks, easily and quickly."

Henry Watkins felt miserable. He was a likable chap with his fair share of personality, brains and ambition, which only made his predicament more insufferable.

The affliction that his parents thought cute when he was a tot—which they thought he would outgrow—was making his life a failure. In his helplessness he felt like a man who has been sentenced to life imprisonment.

## *He sees his chance*

That night the words of this employer shut everything else from his mind. While glancing through the pages of a magazine he came upon an interesting story. It was the story of the work Benjamin N. Bogue was doing. "Why haven't I seen it before?" he asked, half aloud. Quickly he noted the address and wrote Mr. Bogue.

Within a few days a catalog and other pieces of literature arrived from Indianapolis. He looked at the photographs of the dormitories and classrooms of the Bogue Institute, of Indianapolis. He read some of the letters written by former students. . . . And he made his decision. One that was the turning point in his life.

## *Salary doubled*

He obtained a leave of absence and hurried to Indianapolis, anxious to be cured of his affliction as soon as possible. Under the personal supervision of Mr. Bogue, aided by a staff of assistants, he showed remarkable daily improvement. And in five weeks he was absolutely cured of stammering. He had learned how to speak correctly and convincingly.

It was a new Henry Watkins who returned to the old position. He had confidence in himself. His employer, quick to notice the change in him, placed him in the service department at double his former salary. . . . Henry's going ahead fast now.

He is only one of hundreds of men, women, boys and girls who have been cured of stammering at Bogue Institute. Benjamin N. Bogue, the founder of the Institute, stammered for twenty years. Then he worked out a new, easy method of curing himself which proved so



successful that he offered it to other stammerers.

At first he had only a small class of students, but his fame spread quickly. And he was compelled to open the Bogue Institute, of Indianapolis, not as a mail-order school, but as a resident school operated exactly like any other boarding school. This school, founded 1901, has grown steadily under the careful supervision of Mr. Bogue. The average student speaks easily and distinctly in from three to eight weeks.

Find out what the Bogue Institute can do for you. Mailing the coupon below will put you under no obligation whatsoever. By return mail you will receive complete information regarding this scientific, *guaranteed* cure for stammerers and stutters.

Or perhaps you know someone who stammers. Send us his name and we will get in touch with him without mentioning your part in the matter. The Bogue Institute can open up a new world of opportunity and happiness for anyone who stammers or stutters. Remember . . . stammering cannot be outgrown—but it can be cured.

**BENJAMIN N. BOGUE**  
6928 Bogue Building  
1147 N. Illinois St., Indianapolis, Ind.

Without obligation on my part, please send me full information regarding the Bogue Institute and the new scientific cure for stammerers and stutters.

Name.....

Address.....

# FASCINATING

... and perhaps you, like other ambitious men, due to the lack of money, time and education necessary to master *difficult* mechanical trades, wonder what *you* can get into *quickly* and make the most out of, *now!* Haven't you overlooked the very thing you are looking for?

For *there is* a profession begging for clean-cut, *earnest* men, like yourself! *Look into it!* 60,000 Moler graduates know Modern Barbering is easy to learn, inexpensive, *quicker* to earn, clean and FASCINATING! It pays *better* than you think! FIND OUT! Write for catalog B12

Address the branch of the MOLER SYSTEM OF COLLEGES nearest you  
(Street address not needed)

Chicago, Ill.  
New York, N. Y.  
St. Louis, Mo.  
Kansas City, Mo.  
Cincinnati, Ohio  
Cleveland, Ohio

Detroit, Mich.  
Denver, Colo.  
New Orleans, La.  
Omaha, Nebr.  
Milwaukee, Wisc.  
Atlanta, Ga.

Memphis, Tenn.  
Dallas, Tex.  
Houston, Tex.  
San Antonio, Tex.  
Minneapolis, Minn.  
Seattle, Wash.

Los Angeles, Calif.  
Salt Lake City, Utah  
San Francisco, Calif.  
Tacoma, Wash.  
Portland, Ore.  
Winnipeg, Man., Can.





## READ THIS!

"Washington School of Cartooning: I want to tell you that I am having a wonderful success. I have been with the Evening Times and Sunday Sun here. I am now working for myself and sure find all I can do. I FIND NO TROUBLE IN CLEANING UP IN THE NEIGHBORHOOD OF \$250 A WEEK. I have my own syndicate and am gradually branching out into a good field. I am sending you one of my sample proof sheets, also a write-up which I got while with the Evening Times. Thanking you for my success I remain,

Yours very truly,

R—P—"

# It's a Cinch **Earning** \$50 to \$250 a Week In **CARTOONING!**

At the top of this advertisement is reprinted a letter received from one of the many successful Washington School of Cartooning Students.

Why don't YOU earn big money as a cartoonist? YOU can learn *easily*—*quickly!*

### Learn **CARTOONING** at Home

Regardless of how little you know about cartooning now, you can easily qualify for a position in this attractive, high-salaried business. Our home-study method starts you at the simplest fundamental principles of cartoon-making and takes you through every branch of humorous and serious cartooning. You will be amazed at how quickly it teaches you to draw salable work. Many students of this method began to sell their drawings before they were half through their courses. The training paid for itself long before they finished it.

Learn cartooning this easy way. Enjoy the fascinating life of a successful cartoonist—easy hours, freedom from routine, your own boss, and \$3,000 to \$15,000 a year for this work that is play.

### Tremendous Urgent Demand for Cartoonists

Millions of dollars were spent last year on comic strips, political and sport cartoons, animated cartoons, etc. Thousands of new cartoonists are needed now to meet the ever-

increasing demand for this work. Never before have the opportunities in this fast-growing field been so many, so varied or so high-paying.

### Send for **FREE BOOK**

Learn more about the wonderful opportunities in Cartooning and details about this remarkable home-study method. A handsomely illustrated booklet has just been prepared which, upon request, will be sent to you without the slightest obligation. This booklet gives a thorough outline of the cartooning field and explains in detail this wonderful new method of teaching Cartooning. Send for it today! Washington School of Cartooning, Room 3012-C, 1113-15th St., N. W., Washington, D. C.



**WASHINGTON SCHOOL OF CARTOONING,  
Room 3012-C, 1113-15th St., N. W., Washington, D. C.**

Please send me, without obligation, your Free Booklet on Cartooning and full details of your home-study method of teaching Cartooning.

Name.....  
(Print Name Plainly)

Address.....

City..... State.....

(If under 16, please give age .....)

# Shake off your

**THERE ARE THOUSANDS UPON THOUSANDS OF BIG, IMPORTANT OPPORTUNITIES IN THE GREAT FIELD OF ELECTRICITY**

Don't envy the other fellow because he is getting the big things out of life! Chances are he had just as many, if not more, obstacles to overcome before he got on the road to Prosperity, Independence and Happiness. One thing is certain! He didn't get anywhere until he MADE UP HIS MIND to be a real success, and then ACTED! ACTION, applied in the RIGHT DIRECTION, will work wonders, and will surprise you with what it accomplishes for you.

The Electrical Field is the ideal field today. It offers big pay, a steady income and fascinating work. Big as it is, it will grow bigger and bigger and offer more amazing opportunities each year. Don't let Lack of Training or Lack of Decision keep YOU forever in the poor, unhappy, unsuccessful class. **SHAKE OFF THOSE SHACKLES—NOW!**

## **COMPLETE ELECTRICAL TRAINING**

**In 12 Happy Weeks at COYNE**

Only three short months—think of it! Then on to Independence and Happiness in the most interesting of professions. No one can hold you back once you get the thorough knowledge of Electricity that my course provides. I and my big staff of Expert Instructors take you step by step over the whole ground until everything about Electricity has been explained to you, and you yourself know what's what about Dynamos, Generators, Motors, Wiring, Lighting, Batteries, Currents, Circuits and thousands of other things that you couldn't very well get for yourself out of books. Remember, when you study at Coyne you work with your own hands on giant electrical apparatus in Coyne's Great Shops, right in the electrical center of the world. My newly-enlarged and simplified course is the result of 27 years' experience.

### **You Don't Need Advanced Education or Experience to Learn at Coyne**

My course in Electricity is a practical, LEARN-BY-DOING Course. Every Coyne student receives INDIVIDUAL and PERSONAL instruction, on COMPLETE electrical apparatus, under EXPERT INSTRUCTORS. Therefore, it doesn't matter what kind of work you've done in the past. It doesn't matter if you've never spent a day at high school or college. You don't need advanced education or experience to learn at Coyne.

### **Make Up Your Mind—ACT AT ONCE!**

Decide RIGHT NOW that you'll get ahead. I want to send you my Big FREE Book which tells all about my great, long established school. It also tells how thousands of fellows have pulled out of the rut and become well-to-do for life. For your own sake, see that "Better Times Coupon" on the opposite page, TODAY!

**HUNDREDS OF COYNE-TRAINED MEN  
EARN \$60 TO \$200 A WEEK**

*It stands to reason: There is no substitute for personal, practical training in great shops.*

Tune in on COYNE  
Radio Station WGES



Every COYNE Student receives individual and personal instruction on complete electrical apparatus.

# COYNE

**1300 West Harrison Street**

**H. C. LEWIS, President  
Department 9359**

# shackles!



# ELECTRICITY

**— Provides Bigger Pay, Steadier Jobs and More Thrilling Work!**

**EARN While You Learn at COYNE**

My wonderfully-organized EMPLOYMENT DEPARTMENT helps you to get a job to earn part or all of your expenses while training at COYNE, and assists you to a good job on graduation. Furthermore, it stands by you through life, without a penny of extra cost to you!

**WE ARE SPECIALISTS**

COYNE teaches only one thing—ELECTRICITY. Our instructors are not divided, nor is Electricity a sideline with us. We have SPECIALIZED in the teaching of ELECTRICITY for more than a quarter of a century.

Men who never before had the slightest knowledge of ELECTRICITY have become REAL ELECTRICAL EXPERTS and stepped into BIG PAY JOBS because of our advanced, simple, practical methods of training.

**2 BIG COURSES WITHOUT EXTRA COST IF YOU ACT AT ONCE**

If you send the Better Times Coupon right away, I'll give you, without a penny of extra cost, complete courses in Radio Electricity and Auto Truck and Tractor Electricity.



Student Winding a Stator



**H. C. LEWIS, President**  
Coyne Electrical School

**IT STANDS TO REASON: THERE IS NO SUBSTITUTE FOR PERSONAL, PRACTICAL TRAINING IN GREAT SHOPS**

**Get My Big FREE Book and Special Offer NOW!**



Be sure to send at once for my big FREE BOOK containing 151 actual photos of electrical operations and methods; also my special offer of 2 Big Courses without extra cost. Write today, sure, before this offer is withdrawn.

**Better Times Coupon**

H. C. LEWIS, President  
COYNE ELECTRICAL SCHOOL  
1300-10 W. Harrison Street  
Dept. 9359, Chicago, Ill.

Dear H. C.—You can just bet I want one of those big, handsome FREE 12x15 books, with 151 actual photographs printed in two colors. Send it quick, before the supply is exhausted. Be sure to tell me all about 2 Big Special Courses without extra cost.

Name.....

Address.....

Town..... State.....

# Electrical School

**ESTABLISHED 1899  
CHICAGO, ILLINOIS**



For  
Architects,  
Draftsmen,  
Carpenters,  
Contractors,  
Builders  
and all  
who expect  
to build

## BRAIN TOOLS

Men who work with their hands know that head-work gets them more money.

Brain tools make the tools in your tool box at least twice as effective, and the best brain tools you can get are good books—not just any books, but books which tell you the things you want to know, and do it instantly.

Carpenters make themselves contractors by learning how to estimate correctly. Contractors are able to handle bigger and more profitable jobs by learning how the big fellows do it, and architects and those who want to enter this highly paid profession earn more money by having facts and figures at their finger tips.

This brand new set of five handsomely bound books covering all phases of architecture, carpentry and building, enable you to get authoritative, specialized information in a moment. No tedious long hours of reading—no hard grinding study but instant reference to the vital facts. You don't waste a minute—the new jiffy index puts before your eyes, without wasted time, the things you want to know.

The most complete work of its kind we have ever published; nothing has been overlooked. Use of tools—building construction, heating, lighting, plumbing, architectural drawing, blueprint reading; in short, the most comprehensive and easily understood work of its kind.

### FREE Membership

Send now and we will include with these money making books a membership which entitles you to free consultation privileges with twenty highly paid experts. This alone is invaluable.

### These Books Sent FREE

Yes, this is true. We ship them to you without a penny of down payment. When you get them, look them over carefully—note how easy it is to find what you want to know—test the index in any way you want to and then, if after 10 days you agree that you have at hand a veritable mine of invaluable information, send only \$2.00 and keep the books. After that send us only \$3.00 per month until the small total of only \$19.80 is paid: You'll thank the day you sent for your set.

### Learning Means Earning

and here you have at hand information gathered from hundreds of experts, all for so small a sum you'll never miss the money. Use these books as others have done and you'll get many times their price in a few months. One job alone may repay you several fold. Send for your set today.

### FREE EXAMINATION COUPON

AMERICAN TECHNICAL SOCIETY, Dept. G919, Chicago, Ill. You may send me, entirely without obligation, this handsome set of 5 volumes—Architecture, Carpentry and Building. I am to have full ten days in which to look them over and decide if I want to keep them. After which I will either send them back or send \$2.00 down and \$3.00 per month until the special price of only \$19.80 has been paid.

Name.....

City..... State.....

Employed by.....

## MOVIES Believe the Bible

**See What It Teaches**

We sell wonderful religious movie films and real movie machines—so you can show movies at home. Some movie machines as low as \$3.75—others higher. Also fine assortment of comedy, western and feature films with an exchange service for home users.

Write for Big Free Catalog

**PARAMOUNT MFG. COMPANY** Dept. MA  
Boston, Mass.



## Be a Roofing Expert

**Earn \$300 to \$1000 Monthly!**

Why drudge your life away on a small salary job? Be independent! Get all the money you earn! Get into business for yourself! No trade today offers greater attractions than that of roofing expert—and you can easily master all details in a few weeks at home, during spare time. My course is complete, the result of a lifetime experience.

**NOT A SCHOOL**—but a thoroughly practical course of personal instruction by one who has been "on the job" a quarter of a century; a course which will fit you in a very short time, to go out and land the hundreds—yes, thousands,—of dollars' worth of work to be found right around your own town.

**EVERYBODY IS YOUR PROSPECT!** Every house has a roof, and every roof needs attention frequently. You don't have to hunt for business—start right in with your next door neighbor. **YOU CAN MORE THAN MAKE BACK THE COST OF YOUR COURSE ON YOUR VERY FIRST JOB.** Up to date methods and superior materials enable you to build a reputation which brings you all the work you can handle.

**FREE**  
ADVICE  
AND  
CONSULTATION

After you finish the course I don't forget you—you are free to call on me for advice at any time, about any job—best methods to follow, materials to use, etc.

**WRITE ME TODAY**—be the first in your town to get started in this big money-making business, the **ROOFING EXPERT**. Before some other fellow beats you to it. Write me today for full information. I will tell you how to get started in business for yourself at once.

**TOM W. SEAL, Director** 307 Delaware Street  
KANSAS CITY, MO.

## BARNEY GOOGLE



**PAID \$51,000**

in royalties. I will tell you how I wrote this world famous song. I will tell you how I wrote Follow the Swallow, That Old Gang of Mine, Don't Bring Lulu, and other song hits.

A poor boy who had never written a song before wrote "Yes, We Have No Bananas." In your mind may be the next song the world is waiting to sing. My book, "Secrets of Popular Songwriting," will help you. Sent postpaid for twenty-five cents.

**SONG WRITING 25¢**

Sent Postpaid for  
**BILLY ROSE, 161 W. 54th St., New York, Apt. C.**

## Make Money with Chickens

Learn how others do it! Double your profits this year—read America's most popular poultry magazine, **POULTRY TRIBUNE** shows how to get better hatches, stronger chicks, more eggs, better markets. **BIGGIEK POULTRY PROFITS**. It's the magazine with the beautiful colored poultry pictures. \$1.00 a year, 3 years for \$2.00. Subscribe NOW and get a copy of our **FREE BOOKLET** "How Hens Helped Run Our Farm," all based on actual experience of readers. Four months trial, without book, 25 cents. Send stamps or coin today. Poultry Tribune, Dept. 41 Mount Morris, Ill.



**"THERE'S MONEY IN IT"**

**AT HOME LEARN TELEGRAPHY AT HOME**

**MORSE AND WIRELESS**

**TEACH YOURSELF**

in half usual time, at trifling cost, with the wonderful Automatic Transmitter, **THE OMNIGRAPH**. Sends unlimited Morse or Continental messages, at any speed, just as an expert operator would. Adopted by U. S. Government, and leading Universities, Colleges and Telegraph Schools. 3 Styles. Catalog free. **OMNIGRAPH MFG. CO., 13-19 Hudson St., NEW YORK**

If you own a Radio Phone Set—and don't know the code—you are missing most of the fun.

# They Thought I Was Bluffing



## *When I Told Them I Learned Music Without a Teacher*

You could have heard a pin drop in the room! I had just finished playing Rubinstein's "Melody in F." My friends were actually dumbfounded. At last I was the center of attraction instead of a mere onlooker! It was just like a dream come true!

"Why, you didn't know a single thing about music not so long ago, Bob"—"How in the world did you ever do it?" A note of half envy, half admiration crept into their voices. "Yes," said Jim, "what sort of a trick have you played on us—I thought you weren't musically inclined." "Oh, he's been taking lessons for years and has kept it a secret"—followed Betty and Sue in rapid-fire succession. "You can't fool us though, you never learned to play that well without a teacher."

They were all wrong though. At first I didn't believe it was possible to learn music by mail. I thought I needed special "talent." But, thanks to a startling new simplified method, I soon discovered my mistake. It was simple as A-B-C, and actual

FUN learning. Each new lesson was better and easier than the last. Everything about them was so simple that a child of eight could understand it. Now I can play any piece of music—classical or jazz—and play real notes! I never have to refuse when I'm called upon to entertain. Now my life is just a joyous round of gay parties and admiring friends.

### Play Any Instrument

You, too, can now teach yourself to be an accomplished musician—right at home—in half the usual time through

this startling method, which has already shown 350,000 people how to play their favorite instrument. Forget that old-fashioned idea that you need special "talent." Just read the list of instruments in the panel, decide which one you want to play and the U. S. School will do the rest. And bear in mind no matter which instrument you choose, the cost in each case will be the same—just a few cents a day.

### Send for Our Free Booklet and Demonstration Lesson

If you are in earnest about wanting to play your favorite instrument—if you really do want to gain the proficiency in music that will add to your happiness, increase your popularity, and open the way to greater income—ask at once for the free booklet and valuable demonstration lesson. Getting them will cost you nothing and place you under no obligation. Right now we are making a Special Offer to a limited number of new students.

Now—before it's too late to gain its benefits—sign and send the convenient coupon. Instruments supplied when needed. Cash or credit. U. S. School of Music, 712 Brunswick Bldg., New York City.



U. S. SCHOOL OF MUSIC,  
712 Brunswick Bldg., New York City

Please send me your free book, "Music Lessons in Your Own Home," with introduction by Dr. Frank Crane, Demonstration Lesson and particulars of your Special Offer. I am interested in the following course:

.....  
Have you above instrument?.....  
Name.....  
(Please write plainly)  
Address.....  
City.....State.....

#### Pick Your Instrument!

Piano	Harmony and Com- position
Organ	Sight
Violin	Singing
Drums and Traps	Ukulele
Banjo	Guitar
Tenor	Hawaiian
Banjo	Steel
Mandolin	Guitar
Clarinet	Harp
Flute	Cornet
Saxophone	Piccolo
Cello	Trombone
Voice and Speech Culture	
Automatic Finger Control	
Piano Accordion	



## Be a Ship's Officer

Salary Up to \$412.50  
a month and expenses

### Learn Navigation

See the World  
in an Officer's  
Uniform.

In Only 24 Weeks  
Amazingly Quick, Easy, New Method En-  
dorsed by High Shipping Officials. Not  
Enough Trained Navigators to Supply  
Demand. Thousands of Openings. Rapid Advancement.

Be an officer in Great Lakes, Coastwise or Foreign  
trade. See the world. Men trained in Navigation are wanted  
at salaries up to \$412.50 per month and expenses. Advancement  
rapid. It used to require years to learn Navigation. But during  
the war Captain Warren Sheppard was detailed by U. S. Shipping  
Board to devise this quicker method. By cutting out all useless  
information, you learn in only 24 weeks in your own home.

Naval and Mercantile Shipping  
authorities endorse this method.  
No pupil has ever failed to pass  
examination for licenses. R. F.  
Grubbauch, 3rd Mate, S. S. Castle  
Point, writes:—"When I took  
your course a few months ago I  
knew nothing of Navigation.  
Now at age of only 24 I have  
my license." The youngest Cap-  
tain holding an unlimited Mas-

ter's license in the world, Captain  
Fred Higgins of S. S. Dorothy,  
21 years old, was Captain Shep-  
pard's pupil.

Learn more about this opportunity  
for red blooded young men  
to get big pay position for life.  
Write for free book telling of  
openings for Navigators. Special  
offer if you write quick.



## Get FREE BOOK

WORLD TECHNICAL INSTITUTE,  
Dept. L-10, 1415 G St., N. W., Washington, D. C.

Send me your FREE book telling about Captain Shep-  
pard's plan to teach me navigation and start me out as an  
officer aboard ship.

Name .....

Address .....

## The Poultry Business PAYS BIG!

Those who know how find it easy to  
make incomes of \$3,000 a year and  
more even on very small acreage. There  
is big money in poultry if you follow the  
right plan. Start as small as you  
like—grow fast.

### Write for FREE BOOK

Free Book, "How to Raise  
Poultry for Profit," by Harry  
Lamon, former Government  
Poultry Expert, tells all about his  
course. Shows you how to get  
started and how to succeed. Success  
positively guaranteed if you follow his  
methods. Send for your copy TODAY.  
National Poultry Institute  
Dept. 400-D, Washington, D. C.



## PLANS for Poultry Houses

All styles, 150 illustrations; secret of getting winter eggs,  
and copy of "The Full Egg Basket." Send 25 cents,  
INLAND POULTRY JOURNAL, Dept. 74 Indianapolis, Ind.

## Learn to Write

**BEGIN TODAY**  
WRITE  
FOR MY  
FREE  
BOOK

**BIG PAYING POSITIONS**  
are waiting for men and women who can write clearly  
and legibly. No matter how old you are or what  
kind of work you do,  
you can quickly learn to  
write well by the Tam-  
blyn Method.

**Send Today** for this  
free book  
showing by word and pic-  
ture what others have accom-  
plished by spare time practice  
in a few weeks. YOUR NAME  
elegantly written on a card if  
you enclose 2c postage. Address  
F. W. Tamblyn, 413 Ridge Bldg., Kansas City, Mo.

**FREE BOOK**

# Learn Autos in Los Angeles



## Jobs Open—\$40 to \$125 Week

IN a single day, over 300,000 autos crowd and jam only a small part  
of the downtown section of Los Angeles. In California alone there  
are about one million three hundred thousand autos—about 1/10th  
of all motor cars in the U. S.

That means business, prosperity and money for auto men. That  
means hundreds of auto jobs are open at big pay—\$40 to \$125  
per week; that garages, service stations, tire shops, ignition shops  
are needed. And that means success for you, if you'll make this  
opportunity yours NOW.

## YOU CAN BE AN AUTO EXPERT

National Automotive special, practical shop training makes it easy  
for you to become an auto expert. Since 1905, this great school has  
helped thousands of men to success. Tested training proved right  
for 21 years will help YOU make More Money.

## Earn While You Learn

Actual training practice on  
Packards, Cadillacs, Buicks,  
Fords, etc.; all types of batteries and  
electrical equipment; lathe  
and machine shop practice, etc. You learn every branch of auto  
mechanics at National, and learn it right. And we furnish spare-  
time jobs to earn living expenses while learning. FREE tools and  
equipment. No extras. Read all about National in our big, free  
illustrated catalog containing scores of pictures of our famous  
mechanical training departments. Read letters from National  
graduates who have easily doubled and tripled their former earn-  
ings. Find out how you, too, can be an auto expert in  
a short time, and earn big pay. Mail the coupon now.

### Paul Briggs Earns \$4,000 a Year

"I want to thank you for  
the big part National has  
played in helping me to a  
success in auto work. I am  
now assistant sales-man-  
ager, and will make \$4,000  
this year, which is more  
than I would have made in  
three years at my former  
work."

(Signed) Paul Briggs,  
728 E. 68th St., North,  
Portland, Oregon.

Training  
Headquarters  
for Auto  
Experts



## National Automotive

LOS ANGELES

ESTABLISHED 1905



NATIONAL AUTOMOTIVE SCHOOL  
Dept. 64, 4004 So. Figueroa, Los Angeles, Calif.

Please send me, absolutely FREE, your big, 84-page illustrated  
catalog, postage prepaid.

Name .....

Address .....

City .....



## “Why the Boss took a special interest in me”

**I** WORKED as hard and long as anybody, but somehow I didn't seem to be getting anywhere. Why, I don't think the Boss even knew me by name until he received a letter from the I. C. S. telling him that I was studying at home in spare time. He called me into his office immediately for a long talk and from that day he took a special interest in me and helped me to get ahead.

“I always feel safer in promoting an I. C. S. man,” he told me the other day, “because I once took an I. C. S. course myself. I know I can depend on the man who is ambitious enough to study his work at home in spare time.”

**H**OW do you stand when your employer checks up his men for promotion? Does he think of you? Is there really any reason why you should be selected?

Ask yourself these questions fairly. You must face them if you expect advancement and more money. For now, more than ever, the big jobs are going to men with special training.

There is an easy, fascinating way for you to get this special training right at home in spare time. One hour a day, spent with the I. C. S., will bring

you more money, more comforts, more pleasure, all that success means.

Don't let another priceless hour of spare time go to waste! Without cost or obligation, let us prove that we can help you. Do it today.

*Mail the Coupon for Free Booklet*

### INTERNATIONAL CORRESPONDENCE SCHOOLS Box 5540-E, Scranton, Penna.

Without cost or obligation, please tell me how I can qualify for the position or in the subject before which I have marked an X:

- | BUSINESS TRAINING COURSES  |   |
|--|---|
| <input type="checkbox"/> Business Management                     | <input type="checkbox"/> Salesmanship                                     |
| <input type="checkbox"/> Industrial Management                   | <input type="checkbox"/> Advertising                                      |
| <input type="checkbox"/> Personnel Organization                  | <input type="checkbox"/> Better Letters                                   |
| <input type="checkbox"/> Traffic Management                      | <input type="checkbox"/> Show Card Lettering                              |
| <input type="checkbox"/> Business Law                            | <input type="checkbox"/> Stenography and Typing                           |
| <input type="checkbox"/> Banking and Banking Law                 | <input type="checkbox"/> Business English                                 |
| <input type="checkbox"/> Accountancy (including C.P.A.)          | <input type="checkbox"/> Civil Service                                    |
| <input type="checkbox"/> Nicholson Cost Accounting               | <input type="checkbox"/> Railway Mail Clerk                               |
| <input type="checkbox"/> Bookkeeping                             | <input type="checkbox"/> Common School Subjects                           |
| <input type="checkbox"/> Private Secretary                       | <input type="checkbox"/> High School Subjects                             |
| <input type="checkbox"/> Spanish <input type="checkbox"/> French | <input type="checkbox"/> Illustrating <input type="checkbox"/> Cartooning |
| TECHNICAL AND INDUSTRIAL COURSES                                 |   |
| <input type="checkbox"/> Electrical Engineering                  | <input type="checkbox"/> Architect  |
| <input type="checkbox"/> Electric Lighting                       | <input type="checkbox"/> Architects' Blue Prints                          |
| <input type="checkbox"/> Mechanical Engineer                     | <input type="checkbox"/> Contractor and Builder                           |
| <input type="checkbox"/> Mechanical Draftsman                    | <input type="checkbox"/> Architectural Draftsman                          |
| <input type="checkbox"/> Machine Shop Practice                   | <input type="checkbox"/> Concrete Builder                                 |
| <input type="checkbox"/> Railroad Positions                      | <input type="checkbox"/> Structural Engineer                              |
| <input type="checkbox"/> Gas Engine Operating                    | <input type="checkbox"/> Chemistry <input type="checkbox"/> Pharmacy      |
| <input type="checkbox"/> Civil Engineer                          | <input type="checkbox"/> Automobile Work                                  |
| <input type="checkbox"/> Surveying and Mapping                   | <input type="checkbox"/> Airplane Engines                                 |
| <input type="checkbox"/> Metallurgy                              | <input type="checkbox"/> Navigation                                       |
| <input type="checkbox"/> Steam Engineering                       | <input type="checkbox"/> Agriculture and Poultry                          |
| <input type="checkbox"/> Radio                                   | <input type="checkbox"/> Mathematics                                      |

Name.....

Street.....

Address..... 3-6-24

City..... State.....

Occupation.....

Persons residing in Canada should send this coupon to the International Correspondence Schools Canadian, Limited, Montreal, Canada.

**The International Correspondence Schools are the oldest and largest correspondence schools in the world**

# Free Trial

## 14 Year Old Boy Learned In Short Time

"I have had my Xylorimba now for about three and a half months and in this short time I have learned to play well enough to be in an Orchestra. Any other instrument would take at least a year and a half to play. I have also played solos in public. I am fourteen years of age."

Russel Joseph,  
O'Fallon, Ill.

## Young And Old Enjoy The Xylorimba

"The Xylorimba is certainly easy to play. I am 63 years old and had no difficulty at all and my 16 year old son is making splendid progress, so you can see it is an instrument for young and old. We have used it in public on several occasions—at High School Class Play, Banquets, Chautauqua, and it always receives genuine praise. We have found the lessons you furnished very fine indeed."

Rev. George W. Brown,  
Nankin, Ohio



**In Your  
Own  
Home**

**A Year  
to Pay**

**Free  
Lessons  
With  
Every  
Instru-  
ment**

## Deagan Xylorimba

Become a crack Xylorimba player right in your own home. Easiest instrument to play. Everyone enjoys it—any one can learn to play it. We furnish you free with every instrument 14 complete lessons. Learn to play in a few hours. Many people are earning \$80 to \$200 a week. With this instrument you can play for profit or for fun. Deagan instruments furnish the "spice" of the music. Used exclusively in recording studios for phonograph records. Send coupon for full details of Free Trial and Easy Payment Plan.

### Easiest Instrument to Play

Due to scientific construction, the bars are extremely sensitive. When played pianissimo, you can get a softer, richer tone—without any "click" of the mallet—than with any other musical instrument known. A startling statement regarding a percussion instrument but a demonstration will prove it. It also has sufficient volume for use in a concert orchestra. Deagan instruments are world-renowned—used extensively in leading dance, theatre and concert orchestras, and for Radio Broadcasting. Yet the cost of the Xylorimba is no greater than the cost of any other good instrument.

J. C. DEAGAN, Inc., Dept. 1359  
Berteau and Ravenswood Ave., Chicago, Ill.

Gentlemen: Without obligation, please send me literature and full information regarding your Free Trial Deagan Xylorimba offer.

Name .....

Address .....

## Send Coupon Today!

Send coupon for full details of our Free Trial and Easy Payment Plan. No obligation.

**Easy to Carry** Tempered Aluminum Floor Rack and Resonators have reduced the weight (without in any way affecting its wonderful tone quality) so that the Xylorimba is as easily carried as other musical instruments.

J. C. Deagan, Inc., Dept. 1359  
Berteau & Ravenswood Ave., Chicago, Ill.





# Earn \$50 to \$200 a Week in RADIO

You can! Hundreds of ambitious men are already earning thousands of dollars in this wonderful new industry—you, too, can get your share. Mail coupon below for Free Book which describes fully the amazing money-making opportunities in Radio and tells you how YOU can earn from \$5,000 to over \$10,000 a year.

**T**HE astounding growth of Radio has created thousands of big money opportunities. Millions of dollars were spent during the past year on Radio, and thousands of young men are needed right now to meet the ever-increasing demand of work.

Men are needed to build, sell and install Radio sets—to design, test, repair—as Radio engineers and executives—as operators at land stations and on ships traveling the world over—as operators at the hundreds of broadcasting stations. And these are just a few of the wonderful opportunities.

## Easy to Learn Radio at Home in Spare Time

No matter if you know nothing about Radio now, you can quickly become a

Radio expert, by our marvelous new method of practical instruction—instruction which includes all the material for building the latest up-to-date Receiving Sets.

Scores of young men who have taken our course are already earning from \$75 to \$200 a week. Merle Wetzel of Chicago Heights, Ill., advanced from lineman to Radio Engineer, increasing his salary 100% *even while taking our course!* Emmett Welch, right after finishing his training, started earning \$300 a month and expenses. Another graduate is now an operator of a broadcasting station—PWX of Havana, Cuba—and earns \$250 a month. Still another graduate, only 16 years old, is averaging \$70 a week in a Radio store.

## Wonderful Opportunities

Hardly a week goes by without our receiving urgent calls for our graduates. "We need the services of a competent Radio Engineer." "We want men with executive ability in addition to Radio knowledge to become our local managers." "We require the services of several resident demonstrators"—these are just a few small indications of the great variety of opportunities open to our graduates.

Take advantage of our practical training and the unusual conditions in Radio to step into a big paying position in this wonderful new field. Radio offers you more money than you probably ever dreamed possible—fascinating, easy work—a chance to travel and see the world if you care to, or to take any one of the many Radio positions all around you at home. And Radio offers you a glorious future!

The National Radio Institute is one of America's Pioneer Radio Schools—established in 1914. Our course is an absolutely complete one which qualifies for a government first-class commercial license. It trains you for *bigger* paying jobs in Radio.

## Send for FREE RADIO BOOK

Learn more about this tremendous new field and its remarkable opportunities. Learn how you can quickly become a Radio Expert and make big money in Radio.

We have just prepared a new 48-page book which gives a thorough outline of



the field of Radio—and describes our amazing, practical training in detail. This Free Book, "Rich Rewards in Radio," will be sent to you without the slightest obligation. Mail coupon for it now!

For a short time we are offering a reduced rate to those who enroll at once. Act promptly and save money.

## National Radio Institute

Dept. 515-OB  
Washington,  
D. C.

NATIONAL RADIO INSTITUTE,  
Dept. 515-OB, Washington, D. C.

Please send me without the slightest obligation your Free Book, "Rich Rewards in Radio," and full details of your special Free Employment Service. Please write plainly.

Name.....

Address.....

City.....State.....

### PAY INCREASES OVER \$100 A MONTH

I am averaging anywhere from \$75 to \$150 a month more than I was making before enrolling with you. I would not consider \$10,000 too much for the course.  
(Signed) A. N. LONG,  
Greenburg, Pa.



### DOUBLES SALARY

I can very easily make double the amount of money now than before I enrolled with you. Your course has benefited me approximately \$5,000 over and above what I would have earned had I not taken it.

T. WINDER,  
Grand Junction, Colo.



### FROM \$15 TO \$80 A WEEK

Before I enrolled with you I was making \$15 a week on a farm. Now I earn from \$2,080 to \$4,420 a year, and the work is a hundred times easier than before. Since graduating a little over a year ago, I have earned almost \$4,000, and I believe the course will be worth at least \$100,000 to me.

(Signed)  
GEO. A. ADAMS,  
Tamaqua, Pa.



# These Mandolins FREE



Under the personal supervision of Professor Paul Bolognese you can now learn to play either the lute (flat) mandolin or the banjo mandolin. By way of celebrating his return to America, we are offering every one the opportunity to secure free one of the handsome mandolins pictured. No matter if you never had any previous musical training, you can learn to play this entrancing instrument—yes, you can learn at home in your spare time. The mandolin has played an important part in the musical world even before the days of *Roméo and Juliet*—today, with the ever-increasing demand for music that brings happiness, enchantment, popularity, the mandolin is even more popular than ever before. If you yearn for popularity, big money, or social success, you can quickly and easily realize your ambition by becoming a master of the mandolin. Your success will be assured if you will permit Professor Bolognese to teach you how.

## PICTURE and PHONOGRAPH RECORD METHOD ENABLES YOU TO PLAY IN 30 MINUTES

Our method of instruction is as near perfect as it has been possible for man to create a course of mandolin instruction whether the teaching be done by mail or in person. First of all, we furnish pictures and charts which show you exactly what to do. It is easy to imitate the pictures. We also furnish phonograph records of each lesson so that you may actually hear Professor Bolognese playing. This practically brings the professor to your own home, so that you can get that professional finish in your own playing. Besides the pictures, charts and phonograph records, we furnish easy-to-understand printed lessons which are as simple as A B C to understand. Authorities marvel at the simplicity and efficiency of our method. Students too write that they never realized that it was possible for anyone to learn such a marvelous method of instruction.

### DON'T SEND A SINGLE CENT

Be convinced. Investigate this offer today. Don't be one of the ones who puts things off, but make up your mind that you will write right away before you forget and not only miss the opportunity to learn how to play the mandolin, but you might also miss the opportunity to get a regular professional size \$18 instrument free when you enroll. There is no obligation in any way, therefore do not hesitate, but write this very minute for full particulars which will be sent to you absolutely free by return mail. You will be convinced that the mandolin can be quickly and easily mastered and it will not be long before you will be among our happy army of enthusiastic successful graduates. Remember, full particulars are yours, free for asking—write now.

New York Academy of Music, Studio 2026, 100 Fifth Ave., NEW YORK, N.Y.



## Travel—as a Davey Tree Surgeon

*An unusual opportunity for young outdoor men*

The work of the Davey Tree Surgeon carries him all over America; he sees the big cities as well as the beautiful country estates. To a few sturdy young men—who want a chance to grow—The Davey Tree Expert Company offers an exceptional opportunity. Even our present organization of nearly 600 Davey Tree Surgeons is not large enough to meet the constantly increasing demand for their services. Therefore we are selecting now a few young men to enter our employ. Those young men selected will be thoroughly trained by the company. If you are single, between 20 and 30 years old, a thorough American, healthy, with good practical education and able to furnish reference on request, you have a good chance to qualify. To those who make good we offer a permanent position in the Davey Company. Write for qualification blank to serve in place of personal interview. The Davey Tree Expert Co., 311 Federal Building, Kent, Ohio.



## SQUAB BOOK FREE!

Pigeons Printed in Natural Colors

Make money breeding squabs. Sold by millions. Start small, grow big. Start now. Read how our customers sell squabs for \$12 a dozen. We have been established for 25 years. Better look into this. Let us send you, at no cost to you, our big, illustrated freebook telling how to make money breeding squabs. Address

Plymouth Rock Squab Co. 634 H. St., Melrose Highlands, Mass.



# WANTED!

## U. S. RAILWAY MAIL CLERKS

STEADY WORK—NO LAYOFFS—PAID VACATIONS  
TRAVEL—SEE YOUR COUNTRY  
Common Education—Mail Coupon Today—SURE

## \$1900 to \$2700 Year

### Men—Boys 18 Up. Hundreds U. S. Gov't Jobs Obtainable

Franklin Institute, Dept. K181, Rochester, N. Y.  
Sirs: Send me, without charge: (1) Specimen Railway Mail Clerk Examination questions; (2) tell me how to get a U. S. Government job; (3) send list of places at which examinations will be held; (4) send copy of illustrated book, "How to Get U. S. Government Jobs."

Name.....  
Address.....

# NOW—A Shop Course in ELECTRICITY

## At Correspondence School Price!

Here is the greatest electrical news in years. Greer College for a limited time is offering the complete electrical course at a price that will give young fellows the chance they need—the chance to get the right start in this great, fast growing, money making profession—practical electricity. A resident school at the price of a correspondence course. Think what that means to you! You can now fit yourself for a big job with a big future and the training will take you only 12 short weeks.

### Wonderful Future in ELECTRICITY

You know what great strides electricity is making these days. Railroads all over the world are being electrified. High lines are carrying power into the farthest corners of civilization. Edison himself says electricity is in its infancy. What may we expect in the next ten years! You are standing right on the threshold of a great electrical age. Here is the chance of your lifetime to get in on the ground floor. Men who know are in great demand, and the need is growing faster all the time. Get into the game now while the field is uncrowded—while advancement is fast and sure. Learn to supervise other men's work, or to go into business for yourself. Now is the time.

#### The Practical Way to Start in the Electrical Business

The Greer electrical course offers the practical, sensible way to break into this wonderful field. Instruction is in charge of the former leading instructor of the U. S. Veterans Bureau Electrical Trade School, Chicago. You learn by the job sheet system, which was found so effective when the veteran's school was in operation. No time is spent in useless theories. Actual electrical problems are assigned from the first day. The course is made so interesting and practical that you will enjoy every minute.

#### Equipment—Finest Money Can Buy

No expense has been spared to make our equipment absolutely complete and up to date. We have over thirty kinds of motors—not toys—but real, working motors. We operate a high line in our shops, carrying 2500 volts, a shop up of 10 to 1 using other special features. We have an alternating current generator, something unusual in training shops. Our equipment and our methods make this the ideal place to learn the practical, money making art of electricity.

#### Now Is the Time

This winter is the ideal time to get your training. In 12 weeks you will be ready to start on a worthwhile job with a future. You will be just in time for the spring rush, when there will be more need for practical electricians than ever before. If you want to, you can start a shop of your own.

There are thousands of wonderful opportunities for men who really know the business and are not just "screw driver" electricians.

#### Free Employment Service

Our employment department will help you get started in the right job as soon as you finish training. If you need to earn money while learning, we will arrange a part time job to suit your convenience.

Night classes for men who are employed during daytime.

**Don't Delay a Minute** Send in this coupon and by return mail you will get full particulars of the remarkable offer which we are making for a limited time. Clip the coupon now and send it in.

**GREER COLLEGE**  
AUTOMOTIVE AND  
ELECTRICAL  
ENGINEERING

Dept. 1201-E, 2024 S. Wabash Ave.  
CHICAGO, ILL.

### CLIP THIS COUPON

ERWIN GREER, President  
Greer College—Electrical Division  
Dept. 1201-E 2024 S. Wabash Ave., Chicago

Please send me your FREE BOOK and offer for electrical course. It is understood that I am not obligated in any way.

Name .....

Address .....

# The Mighty Stories of History

Told in Fascinating Story Form

**T**HINK of being able to read — in easy story form — about all the stirring events that have made the world's history. Dr. Ridpath's eminent position as an historian is due largely to his wonderful flowing style, a style no other historian has ever equalled. Ridpath, the profound scholar, the authority among authorities, has written history so that it reads like a great novel. *He takes you with him through the life of the past.* Pick up Ridpath's History at any point and you will find a thrilling story — an account of some great historical occurrence that seems to happen before your eyes.

6000 Years of History



Joan of Arc Burned at the Stake



## Ridpath's History of the World

Including a Full Account of the World War

has long been recognized as standard authority. Ridpath is endorsed by Presidents of the United States, practically all college presidents, by a quarter of a million Americans who own and love it. **New Edition** of nine handsome Octavo volumes just off the press contains complete and accurate account of the World's history from the dawn of time through the Great World War to the present Administration. Ridpath covers every race, every time and holds you spellbound with his wonderful eloquence.

**HISTORY BOOK FREE** Send now for beautifully illustrated 46-page history book. Contains actual sample pages and pictures of Ridpath's History. Also we shall send you complete details of manufacturer's unusual direct low price offer and convenient easy terms. Learn about the special on approval offer. No obligation. Book is free. Tear off the coupon. Write your name and address plainly and mail now while you are thinking of it.

Ridpath Historical Society,  
1779 United Bank Bldg., Cincinnati, Ohio.

Please mail, without cost to me, the 46-page history book containing sample pages and pictures of Ridpath's History of the World. Also write me full details of your special low price and easy payment offer to readers of Popular Mechanics

Name.....

Address.....

## Earn \$80 a Week while learning this profession



A NEW way to break into the big paying selling game! You learn scientific selling by actual practice—coached at every step. You earn big money while you are training. Write at once for full details of this wonderful new plan.

### Traveling Salesmen

A. S. Inc. gives Complete service: Training, Coaching, locating profitable lines. Men without selling experience especially in demand. Men who want to see the world and travel in style. Men who want to get every dollar they really earn. Men who want to get into the big money class. If YOU are one of them write today for full details of this wonderful new plan. Applied Salesmanship, Inc., 1926 Sunnyside Ave., Dept. 13-59 Chicago

## FREE Electrical Training Book

Mail postcard for amazing FREE book on electricity. Shows you how to earn \$150 to \$600 a month in this immense field. Famous S & H shop-type training fits you quick at home for big jobs. Exclusive system. Lack of experience or education no bar. Write S & H Engineering Co., 1422 W. Monroe St., Dept. W-1, Chicago, Ill.

## "Your Opportunity in a Great Industry"

That is the title of a book we have just prepared. It gives the full facts about one of the greatest money-making opportunities in the selling field today. Every specialty salesman in America owes it to himself to get and read this book. A copy of it is yours free for the asking. Write for it to Dept. 885, GOODWEAR Chicago, Inc., 844 West Adams St., Chicago

## Big Money for You as an Automobile Mechanic

These four practical books, written by five well known teachers of automobile practice will teach you right in your own home during your leisure time just what you need to know about automobile troubles and repair. They will teach you automobile construction, maintenance and repair as experts know them and will help you to earn an expert's pay.

**Practical Automobile Library: Four Books—\$1.50 in 10 days and .2 monthly for 6 months—only \$13.50 in all!**

Hundreds of question-answering diagrams—hundreds of clearly-marked illustrations—make the books plain and readily understandable. All the explanations and descriptions are clear, simple, direct. Every chapter is packed with definite, step-by-step, how-to-do-it information. Here is your opportunity to enter a big pay field.

Sent FREE

Send No Money  
Mail the Coupon



## FREE EXAMINATION COUPON

McGraw-Hill Book Co., Inc., 370 Seventh Ave., New York

Send me for 10 days' free examination the New Practical Automobile Library. If satisfactory I will send you \$1.50 in 10 days and \$1.00 monthly until the special price of \$13.50 is paid. If not wanted, I will return the books at your expense.

Signed.....

Address.....

City and State.....

Position.....

Employer..... P. M. 12-1-25

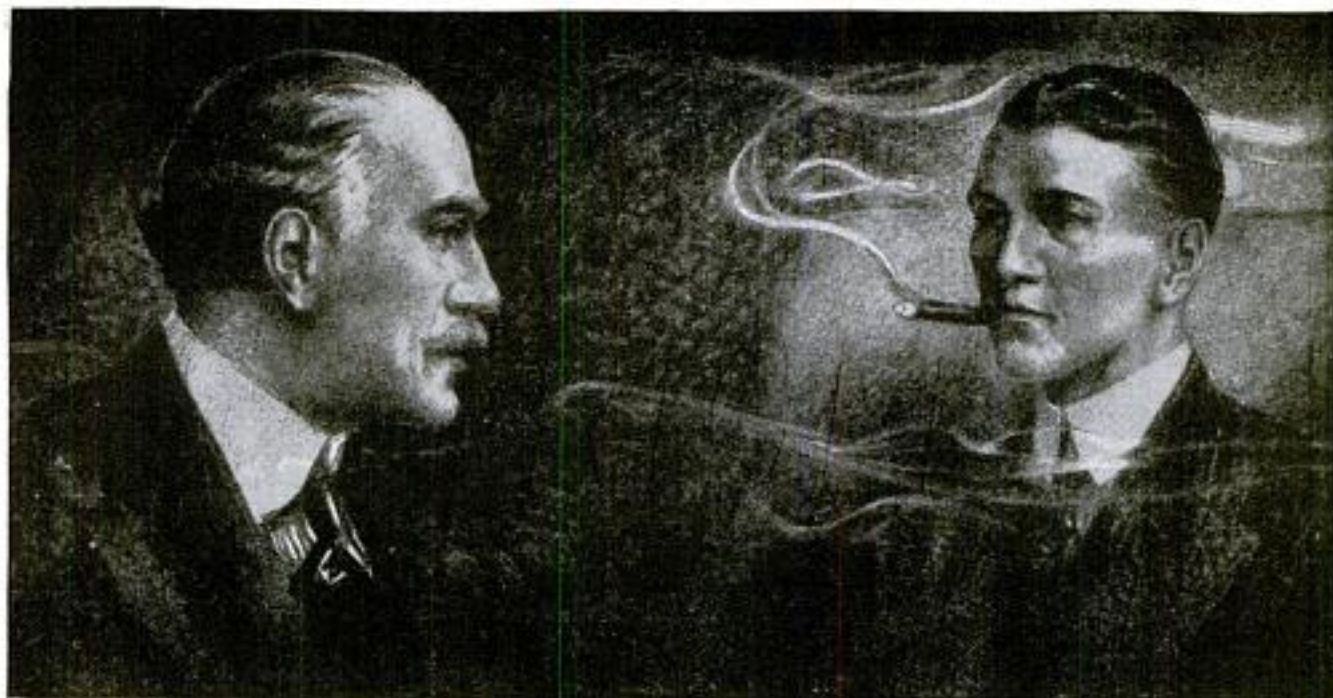

## Tobacco Is Hurting You

Look at the facts square in the face, Mr. Tobacco User. You may think tobacco is not hurting you.

That is because you haven't as yet, perhaps, felt the effects of the nicotine poison in YOUR system. For you know that nicotine, as absorbed into the system through smoking and chewing tobacco, is a slow working poison. Slow, yes—but sure.

Tobacco is lowering your efficiency. It slows a man down. Makes it harder for you to concentrate your mind on your work. You haven't near the amount of "pep" and energy you would have if you stopped using it. There's many a man twice as old as you in years who's twice as young in energy, simply because he lets tobacco alone.

Some day you will realize to what an alarming extent tobacco has undermined your system.

When your hands begin to tremble—  
and your appetite begins to fail—  
and your heart seems to "skip a beat" now and then—  
and slight exertion makes you short of breath—  
then you have a right to suspect that  
**TOBACCO** is getting the upper hand.

Any well-informed doctor will tell you that these are only a few of many symptoms of tobacco poisoning.

And YOU know that the use of tobacco in any form is an expensive, utterly useless habit. You know you ought to quit.

## Tobacco Habit Banished Let Us Help You

It doesn't make a particle of difference whether you've been a user of tobacco for a single month or 50 years, or how much you use, or in what form you use it—whether you smoke cigars, cigarettes, pipe, chew plug or fine cut or use snuff—**Tobacco Redeemer** will positively remove all craving for tobacco in any form in a very few days. Not the slightest shock to the nervous system. Your tobacco craving will usually begin to decrease after the very first dose—there's no long waiting for results.

**Tobacco Redeemer** contains no habit-forming drugs of any kind and is marvelously quick, scientific and thoroughly reliable.

It is in no sense a substitute for tobacco. After finishing the treatment you have absolutely no desire to use tobacco again or to continue the use of the remedy. It helps to quiet the nerves and make you feel better in every way.

**Results Guaranteed** A single trial will convince you. Our legal-binding, money-back guarantee goes with each full treatment. We will refund every cent you pay for the treatment if after taking it according to the easy-to-follow directions, it should fail to banish the tobacco habit completely.

**SEND Coupon for Free Proof** Let us send you our free booklet on the deadly effects of tobacco, together with testimonial letters from men all over the country telling how they have been absolutely freed from the tobacco habit by this simple home treatment. You could not ask for stronger proof that **Tobacco Redeemer** will free you from the habit than the evidence we will gladly send on request. Just mail the coupon—or a postal will do.

**NEWELL PHARMACAL CO.**  
Dept. 300 Clayton Station St. Louis, Mo.



## Free Book Coupon

**NEWELL PHARMACAL CO.**

Dept. 300 Clayton Station St. Louis, Mo.

Please send, without obligating me in any way, your free booklet regarding the tobacco habit and proof that **Tobacco Redeemer** will positively free me from the tobacco habit or my money will be refunded.

Name .....

Street and No. ....

Town..... State.....



## Choose as Your Profession Electrical Engineering

Electricity offers a brilliant future to the young man who is about to choose his career. Never before has there been such wonderful opportunity in this great field. Big paying positions in electrical work the world over are open to trained men—men who possess specialized, practical knowledge. Come to the School of Engineering of Milwaukee—one of the largest and best equipped electrical schools in America. Here you are trained in both theory and practice by a faculty of experts. You learn in large, finely equipped laboratories. If you have 14 high school credits or equivalent, you can become an Electrical Engineer with a Bachelor of Science degree in three years. If you lack these credits they can be made up at School of Engineering in a short, intensive Junior E. E. course.

**A Complete, Practical, Electrical Education**  
Learn by the thorough approved scientific methods which our twenty years of specialising enable us to give you. In addition to Electrical Engineering, the following complete courses are given: A. C. and D. C. Armature Winding—Electric Light, Heat, Power Wiring and Testing—Practical Electricity—Drafting—Electrotechnics—Commercial Electrical Engineering—Junior Electrical Engineering and Automotive Electricity.

## Earn While You Learn

By our special system you may earn part of your way while learning. Our Employment Department will help secure you a position to which you may devote a part of each day, spending the remainder at the school. This plan both solves the students' financial problems and provides splendid experience at the same time. Low tuition fee. Board and room reasonable. Daily Broadcasting WSOE, School Orchestra, Fraternities.

Winter Term  
Begins Jan. 4th

## Write for FREE Catalog

Write today for our free, illustrated catalog. Read about this wonderful institution and the great opportunities that lie before you. Find out about our specialized method of training and the details of our "Earn While You Learn" plan.

## SCHOOL of ENGINEERING of Milwaukee

Founded 1905

Dept. P. M. 1225 415 Marshall St. Milwaukee, Wis.

### SCHOOL OF ENGINEERING OF MILWAUKEE

Dept. P. M. 1225, 415-17 Marshall Street, Milwaukee, Wis.

Without obligating me in any way, please mail free 72-page illustrated book, "Electricity and the One Best Way to Learn It," and particulars regarding the course I have marked with an X.

- ..... Electrical Engineering.
- ..... Electrotechnics.
- ..... Commercial Electrical Engineering.
- ..... Junior Electrical Engineering.
- ..... Automotive Electricity.
- ..... Radio Sales, Service and Broadcasting.
- ..... Armature Winding.
- ..... Light, Heat, Power Wiring and Testing.
- ..... Practical Electricity.
- ..... Home Laboratory Service.
- ..... I am interested in your "Earn While You Learn" Plan.

Name..... Age.....

Address.....

City..... State.....

Education.....

## RADIO EXPERTS

EARN  
BIG  
MONEY

YOU CAN LEARN  
AT HOME



FREE!  
3 Tube Set

No other profession in the world offers the same big possibilities. Immense salaries await trained men in this fascinating, growing field. Fit yourself to be the radio expert of your own community. Thousands of men also needed in the great radio factories. I will quickly train you at home to be a radio expert. Write for all the facts today; learn how to get a wonderful 3-tube, receiving set free. Remember, we guarantee satisfaction or refund tuition.

WRITE TODAY  
A. G. MOHAUPT, Radio Engineer  
Radio Association of America  
Dept. A-12, 4513 Ravenswood Ave., Chicago

## I Made \$100,000

in less than five years as a

## REAL ESTATE SPECIALIST

Started during my spare time, with no experience and less than \$5 capital. If you want to learn the secret of my success and follow my money-making method, send your name and address at once to American Business Builders, Inc., Dept. AA 4412, 18 East 18th Street, New York.



## SAXOPHONE MUSIC

Just out—complete catalog FREE of latest jazz hits, also standard saxophone solos, duets, trios, quartets—2000 selections. Largest general dealers of saxophone music and supplies in the world. Expert repairing. Send for free catalog today.

FINDER & URBANEK, Dept. 1101-A, 1322 West Congress St., Chicago



## LEARN TENOR BANJO

**Banjoists!** Earn big money through Charles McNeil's famous Home Study Tenor Banjo Course. Same course as used by the Chicago Tenor Banjo Institute, in training professionals. Simple as A B C—yet has all technical requirements. Includes phonograph records played by Chas. McNeil, illustrating strokes, breaks, etc. Send for free booklet and full details.

CHAS. McNEIL, Director  
CHICAGO TENOR BANJO INSTITUTE  
Dept. 1359, 5029 N. Bernard St., Chicago, Ill.

## LEARN WATCHMAKING AND ENGRAVING

BY OUR PROFIT-SHARING PLAN  
OUR GRADUATES SUCCEED

One of our few students started in a very small way—now doing over \$30,000 a year. Another in Wisconsin, over \$10,000 the first year. Day or night classes. Call or write for FREE BOOK.

Chicago School of Watchmaking, Prof. 1191, 4844 Litch Ave., CHICAGO

**LAW** IN YOUR SPARE TIME  
Same course by correspondence as given for 15 years at classes of this college.  
**L. L. B. DEGREE CONFERRED.** 3 year university course prepares for bar exam. Money back guarantee. Low fee, easy terms, includes 1924 12 volume library, lectures, lessons, all expenses. Write for free book.  
HAMILTON COLLEGE OF LAW, G-12, 1412 S. Michigan Ave., Chicago

LEARN  
RADIO  
FREE

STUDY IN SPARE TIME AT HOME  
Earn a Diploma in Radio Engineering. Free Twin Superdon Set offer if you act now.  
Write  
AMERICAN RADIO ENGINEERS  
Dept. 125, Hearst Sq., Chicago, U. S. A.

**BE AN OFFICER IN THE U. S. COAST GUARD**  
\$1,700 up to \$7,500 Yearly. \$780 yearly at the U. S. Academy while training. You rank Ensign to Captain in Service. Age requirements, 18 to 24. Write Dept. 8 for information. Coast Guard Preparatory School, 4000 Ga. Ave., N. W., Washington, D. C.



## \$20 Value

### Take Your Choice

To every pupil taking our course we will give absolutely FREE with enrollment a superb \$20.00 Violin, Mandolin, Guitar, Ukulele, Hawaiian Guitar, Banjo, Banjo Mandolin, Tenor Banjo, Cornet or Banjo Ukulele.

# FREE

These high-class instruments are actually given away. They are free to pupils. Which one do you want? Which instrument do you want to learn to play? Send no money—just fill out and mail the coupon.

## Learn to Play AT HOME in Your Spare Time for Profit or Pleasure

### Everyone Loves Music

Our wonderful new system enables everyone to learn to play their favorite instrument in a few easy lessons. You can learn to play any of the instruments shown in a remarkably short time. Your spare time will do and **it only costs a few cents a week**. No charge for the instrument, just the lessons. That is your only expense. Why not mail the coupon today? You can be playing real music BY NOTE in a few short months if you do.

### Play by Note in 4 Lessons

This new system is very simple. Anyone can understand it. You can be playing standard note music in 4 lessons. We guarantee this. You pay nothing if you fail and only a few cents a week for the lessons while learning, nothing for the instrument you want. Every lesson is complete; you go along in easy steps. Learn to play either for your own pleasure or for profit. Do not wait longer to become a musician and be popular among your friends.

**Chicago Correspondence School of Music**  
Dept. 2 Lincoln Park P. O., Chicago, Ill.

### Your Success Guaranteed

This is the most remarkable offer you ever read. Just think—the instrument FREE, only a few cents a week for the lessons and your success guaranteed or money back. Why should you delay? You have everything to gain and nothing to lose. Send the coupon now while the Free Instruments Offer is good. We reserve the right to withdraw it at any time without notice. You may never have the same chance again. **Send the Coupon.**

*If you own a piano, organ or other musical instrument and want to learn to play it, write for special booklet and terms.*

### COUPON

**Chicago Correspondence School of Music**  
Dept. 2, Lincoln Park P. O., Chicago, Ill.

I want a.....FREE and learn how to  
play it by your easy method. Please send me full particulars and detailed information. This request does not obligate me in any way.

Name.....

Address.....

City.....

State.....

## A Great Book Free with this pay-raising library

For a short time only we will give every subscriber to the New Library of Machine Shop Practice a copy of French's Engineering Drawing—the greatest book on mechanical drawing ever written. This book makes drawing as plain as day—tells you all about instruments, plans and methods—and prepares you to handle any drawing job you will ever have to do. It comes to you absolutely free with

## Machine Shop Practice

9 volumes — 3065 pages — 3608 illustrations  
(A combined home study course and reference library)

The New Machine Shop Library is written for practical men. It gives you the best methods for every kind of machine shop work. It explains machine tools and their operation, drawing and design, tool work, gears and grinding, jigs and fixtures, automatic screw machines and their tools and all of the mathematics you will ever have to use. It is plainly written, completely illustrated—the very best kind of help to the machine shop man who wants to advance himself.

Sent  
**FREE**



No money down—  
only 7c  
a day

### FREE EXAMINATION COUPON

McGraw-Hill Book Co., Inc., 370 Seventh Ave., New York  
Send me for 10 days' free examination the New Library of Machine Shop Practice. If satisfactory I will send you \$1.50 in 10 days and \$2.00 monthly until the special price of \$19.50 is paid. If not wanted, I will return the books at your expense.

On receipt of my first payment of \$1.50 it is understood that I am to receive, free of charge, a copy of the second edition of French's Engineering Drawing.

Signed.....

Address.....

City and State.....

Position.....

Employer..... P.M. 12-1-25

## TELEGRAPH—RADIO

\$18 to \$35 a week while training for Radio and Telegraph Operator jobs at \$150 to \$300 per month. Write for particulars.

CHICAGO TELEGRAPH INSTITUTE

Dept. 1401 1238 S. Michigan Avenue, CHICAGO



### "BECOME A LIGHTNING TRICK CARTOONIST"

HERE MONEY CHALK TALKING. SEND \$100 FOR 30 DAY PROGRAM OF FREE DRAWINGS WITH INSTRUCTIONS BY A PROFESSIONAL CARTOONIST. SATISFACTION GUARANTEED. CIRCULAR FREE. BALDA ART SERVICE, QL OSHKOSH, WIS.



Repair autos at home and earn money. National's "Movie-graph" method makes it easy. You can soon make enough to come to California and have choice of many fine jobs now open or go into business for yourself.

### Send Now for "Movie-graph" Lessons —Make Money Right Away!

You can now begin at home to earn your way to Big Pay in automotive work. You can start immediately toward independence in this fascinating industry, where many of National's 16,000 graduates are earning \$50 to \$100 and more a week.

**Actual Training at Home!** These lessons are the same as practical work given National students for 21 years in our big \$1,000,000 plant. Now they have been put on paper—on "Movie-graphs"—in such a clear, simple way that you can instantly master them at home. No need to wait till you've saved up money to attend school. Send for these lessons, then earn your money while you learn. We show you how.

Over a million cars in California Motoring every day in the year! Truly the automotive man's paradise! We furnish free employment service. Why wait longer? Never has success been so easy. Every day's delay puts you farther from your goal. Mail the coupon today!

### Special Offer!

4 "Movie-graphs" \$1  
of Auto Repair  
Jobs for.....



Opportunities  
Are Thick  
Out Here!

## National Automotive

National Automotive School  
Dept. 394, 4004 South Figueroa St., Los Angeles, Calif.

CHECK ONE

- I enclose \$1 for the first four "Movie-graphs" of Actual Auto Repair Jobs.  
 Send FREE information on how I can earn money at home as an auto expert.

Name.....

Address.....

City..... State.....

## Learn

Take a W. A. C. Course in Applied Airplane Engineering. Many men earn \$2,000 to \$10,000 a year. Big Free outfit of airplane parts. Write for free catalog.

WESTERN AIRPLANE CORPORATION  
Dept. M12, Menashaek Bldg., Chicago, Ill.

## Aviation

## Bigger Pay in the Civil Service



WHEN everybody else is worrying about his job or looking for work, the U. S. Civil Service Employee is earning good, steady pay in a pleasant occupation of his own selection. **EARN \$1900 TO \$2700 A YEAR.** Let me train you to pass the U. S. Civil Service Examination with high rating so you will be eligible for one of the first positions open as a Railway, Postal Clerk or in Customs, Internal Revenue, Departmental Immigration, Postmaster, Post Office and Rural Branches. I have trained thousands who have successfully passed examinations. Money refunded if not offered a position within one year after receiving rating. Mail coupon or letter at once for our catalog.

### Patterson Civil Service School

Approved as a Correspondence School under the Laws of the State of New York  
Dept. 812, Rochester, N. Y.

Patterson  
Civil Service  
School  
Dept. 812,  
Rochester, N. Y.

Sir: Send me without charge your catalog describing this and other U. S. Government positions.

Name.....

Age.....

Address.....



From \$35 a week as a  
Garage Hand to  
**\$5000** a  
Year  
as a  
Draftsman



# Is He Smarter than YOU?

Do you want a man's size pay envelope? So did this man. Are you a little shy on book learning? This chap never finished eighth grade at school. But he looked the field over and chose the line nineteen out of twenty *Help Wanted* ads called for. He learned the line that's always in demand. He wrote to me in February. By the middle of May he was a draftsman. Today, my mail brought his photo and the statement, "I've been made Assistant to the Chief Draftsman at \$400 a month!"

**Six Months** is ample time for anyone to learn draftsmanship. It's longer than this man studied at home under me! And you need no "talent" for drafting. This student was a garage hand when he started my course! Smart? Yes. Smart enough to pick the *liest* line in all industry.



## Train at Home Under My Supervision

—and I'll have you right in the business of *drafting*—the first hour. There are no books. No theories. We put the tools in your hands, tell you what they're for, *illustrate* how they're used—and you *begin* to draft. I will have you so interested inside of a week—and so sure of yourself in a month or two—but you'll have to clip the coupon and get the introductory material to see what a pleasant and profitable course is waiting for you!

**You Suffer if You Wait  
MAIL THIS COUPON NOW**

**FREE**



**CHIEF DRAFTSMAN DOBE**

Div. 93-59, 1951 Lawrence Avenue, Chicago, Illinois

WITHOUT OBLIGATING ME send full information about the way you teach practical draftsmanship, your new, enlarged BOOK, and free tool offer.

Name.....Age.....

Address.....

P. O.....State.....

**Get  
the Better  
Things of Life**



**Your Own Home**  
Would you rather have a correspondence school "diploma"—or a draftsman's salary that will buy a HOME?



**Your Own Car**  
An "automotive expert" can repair a car—but a draftsman can OWN one.



**Leisure**  
A draftsman has leisure hours and the money to enjoy them!

**Let  
Ambition  
Guide You**

—but don't let it run away. There are many, many "schools" that teach most anything. Shoot for the line that is practical—profitable. Get the knowledge every industry needs and is willing to pay for.

**You Need Only the Will to Start**

We have everything required to put you in the high-pay class—*everything but your name and address*. If you clip the coupon now and mail it—we'll make the next move—by next mail!

REMEMBER, it's *supply and demand* that regulates everyone's pay. What good is a machinist if every shop has a *writing list* of willing men? What does a head crammed with electricity get you when electrical shops have signs up, "NO HELP WANTED"? But every industry is clamoring for draftsmen. (Just check this up in the *Want Ad* columns of any newspaper.)

**JOBS WAITING** all over U. S. Every industry uses blueprints by the thousands, as you know. The biggest concerns recruit their draftsmen from our offices. We haven't students enough to go 'round right now—and next Spring the shortage will be worse. Therefore: to induce action, I'll furnish tools without extra charge. So, clip coupon NOW.

# Be a BRICKLAYER

Make \$60 to \$90 a week

Learn this **Big Pay Trade**  
at Home in a  
**Few Short Months!**



**W. P. CISSSEL,**  
Vice President and  
Chief Instructor

**BRICKLAYING** is the best trade in the world for a man of ambition. First, because wages are so high; \$11 and \$14 a day for regular time; and \$20 and \$25 a day for overtime. Secondly, work is steady—because there is a shortage of 38,000 bricklayers.

And now you can learn this big pay trade at home—in spare time—by an amazingly quick, easy method known as "Job-Analysis". In a few short months I teach you MORE than the old time bricklayer learned during his four years apprenticeship. You build walls, panels, pilasters, jambs, piers, arches, corbels, etc., in your own cellar, garage, yard, shed or roof using bricks, mortar and trowel. You perform in your lessons, EVERY job which you will afterwards perform on the wall as a highly paid bricklayer. And you learn quickly and become more skillful than you could by the old time apprentice method because you don't have to "pick it up" as best you can. The pictures, diagrams, blue prints, charts and instructions are so clear that it is just as if I stood back of you, directing every movement; showing you every short cut; training your hands and eyes.

The lessons are easy to understand because of the many

diagrams and illustrations. You just get enough written instructions to make you quick and skillful; everything else is illustrated.

Furthermore: I teach you things the ordinary bricklayer doesn't know. How to read blue prints and plans; how to lay off buildings; how to buy materials; how to estimate; and other information designed to equip you to rise rapidly to Foreman, Superintendent, Estimator, Contractor or Builder—if you are ambitious.

### Free Book Explains

Send for free book "The Quick Way to Big Pay Every Day". It tells you why even the ordinary Bricklayer is always sure of steady work at big pay. And why my method equips you to rise rapidly to the higher stations in the building business. Read this free book. Then decide for yourself. But act quick. There is a special, short-time money-saving offer open right now. So mail coupon at once—W. P. Cissel.

**NATIONAL SCHOOL OF BRICKLAYING**

Dept. L 10  
9th & G Sts., N.W.  
Washington, D.C.



## Get YOUR FREE COPY

National School of Bricklaying, Dept. L 10  
9th & G Sts., N. W., Washington, D. C.

Send free book "The Quick Way to Big Pay Every Day" which explains how to become a bricklayer in only a few short months and how you train me at home—in spare time.  
(Write or print name clearly.)

Name.....

Address.....

City and State.....

# Play a Tune in 10 Minutes!

or Send It Back

No knowledge of music necessary. No expensive lessons or tiresome practice. Just pick up an "Instant Playing" Ukulele, Tenor Banjo or any stringed instrument you would like to play, press the numbered keys and before you know it you are playing tunes!

### Amazing New Invention

Revolutionizes stringed instrument playing. "Instant Playing" instruments give clearer, truer tones (not mechanical), are easier to finger and take all the work out of learning to play. Famous Vaudeville Star, Fritz Priganz, writes: "I learned to play a tune in 5 minutes and had never touched a stringed instrument before." John Matise writes: "Played tunes on the Guitar the same day and am delighted. Anyone can play." Leonard Cleary: "In only a few days I have had my money's worth in fun. It certainly is one fine instrument." Constance Seiler: "I was playing in four minutes."

### FREE Book

Send coupon for Free Book telling all about new "Instant Playing" instruments and how you can play in 10 minutes. Also Free Catalog of special bargains in musical instruments. No obligation. Send for this Free Book now! Your friends will be astonished at your learning to play so quickly. You will be popular and always sure of a good time.



Send this coupon for  
**FREE Book.**

**Ferry & Co.**  
Dept. 8779  
3224 N. Halsted St.,  
Chicago, Ill.

Send me Free Book on "Instant Playing" instruments and tell me how I can play tunes in 10 minutes. Also Free Bargain Catalog. No obligation.

Send Coupon  
Today!

Name.....

Address.....

City..... State.....

# BENNY LEONARD'S HOME COURSE OF MUSCLE AND BODY BUILDING

123 WEST 31st STREET, Dept. D, NEW YORK CITY

Write for FREE Booklet

## Practical Electrical Education

Learn by the thorough approved scientific methods which our twenty years of specializing enable us to give you.

Become a **Commercial Electrical Engineer** in one year, or learn an **Electrical Trade** in from three to six months. Light, Heat, Power, A. C. and D. C. Armature Winding, Automotive Electricity, Radio Included. Course unparalleled. Illustrated catalog FREE. Be sure to mention age and education.

**SCHOOL OF ENGINEERING OF MILWAUKEE**  
Dept. PM-1225A 425 Marshall St., Milwaukee, Wis.

# Painting Paper Hanging and Decorating

**\$100 PER WEEK AND UP  
EASILY EARNED**

A few weeks' training at this Big School will place you in the BIG MONEY CLASS.

**BIG OPPORTUNITY FOR AMBITIOUS MEN**

Send for our Big Free Catalog

**CHICAGO PAINTING SCHOOL** Dept. 411, 148 West  
Austin Ave., CHICAGO



DR. WM. STIVISON  
Dental Authority

# Make \$150 a Week Be An Expert Mechanical Dentist

## What a Mechanical Dentist Does

He does dental laboratory work, such as making plates, crowns, bridges, inlays, etc., from impressions taken by dentists and sent to him because he can save the dentist time and money. The mechanical dentist uses real dental tools just as I furnish in my school. You take them with you when you graduate. Some of the materials used are gold, silver, platinum, porcelain, rubber and aluminum. The work is interesting, clean, healthy, and best of all, a money maker.

## Dental Laboratory Experts Make Big Pay

There are thousands of dentists who do laboratory work that would gladly have an expert mechanical dentist do it if there was one handy. The busy dentist can make more money working in the mouth and can get plenty of work to do. Therefore, on account of the few trained mechanical dentists, they are always busy and get big money for their work. Instead of being an over-crowded field, it is becoming very popular.

## My Training Quick and Successful

Because I am a dentist and operate a clinic and commercial laboratory in connection with my school. I train you on work that is actually worn in the mouth—not thrown in the discard. You do work that the dentist needs and will ask you to do when you go to work for him or start a laboratory of your own.

The average student should complete the course in six months, but you are at liberty to stay as long as you like. I don't let you go until you know how to do the work. In other words, I won't let you fail.

## Individual Instruction

I show each student how an impression is made in the clinic. (See "In the Clinic.") Then he takes the impression into the laboratory and completes the work under my supervision. You get the advantage of watching the actual dental work done at this school, which helps you in your laboratory work.

Dentists know my training. Some even come to me for laboratory training themselves. My graduates get good jobs because of my method. **Jobs hunt them.**



In the Clinic

## In Business for Himself

One of my graduates who can earn more in one day than some people make in a week. Read his recent letter:

"After graduating from your school I got a job in a laboratory in St. Louis where I made \$300 a month. I am now in business for myself and doing better, and feel that I owe it all to you.

"Your clinic and laboratory training in school sure gives a student practical experience. When a man finishes your school he just can't help making good.

—W. J. Monkler.

## Makes Three Times as Much as He Did Before

"I came to you because dentists recommended your training. I want you to know that I am in charge of a laboratory in a five chair dental office and am making three times as much as I did before.

"Your teaching in clinic work and showing me how my finished work looked in your patients' mouths, has been a great help in holding down this big position.

"I am grateful to you and am sure that you being a dentist is the reason I am able to make good for you taught me what the dentists need.

—Jay Chamberlain.

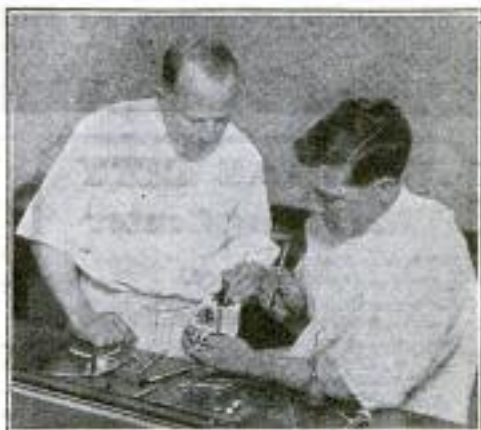

In the Laboratory

## A REAL OFFER

It will cost you no more to train here because I pay your railroad fare to Kansas City and locate you where living expenses are unusually low. I even furnish you with Real Dentists' Tools which are yours to take with you when you graduate.

## If You Want a Job While Learning

I will help you get it. If you need financial assistance, I will help you with it.

My latest book, "A Short Cut to Success," contains information of importance, and is sent absolutely Free to any one interested in Mechanical Dentistry. Just fill out the coupon. Mail it in today.

**STIVISON DENTAL INSTITUTE**  
505 McMillen Bldg. KANSAS CITY, MO.

Stivison Dental Institute  
505 McMillen Bldg., Kansas City, Mo.

Please send my copy of "A Short Cut to Success."

Name.....

Street..... R. F. D.....

City..... State.....



# Here's the New, Safe, Easy Way to LEARN FLYING



BY THE  
**SWEENEY  
SYSTEM  
OF  
PRACTICAL  
EXPERIENCE**

## KANSAS CITY The Flying Center

**Richards Field:**  
Official Army Flying Field.

**Commercial Flying:**  
300 Acres North Kansas City Field.

**Municipal Field:**  
\$500,000 set aside in new bond proposals  
for establishment of Municipal Field.

**Airplane Factory:**  
Million Dollar Plant to be built here by  
the famous Anthony Fokker.

**Sweeney School:**  
Complete Ground School and Air Pilot  
Course, three months' training.

5 Mechanics on the ground needed for  
one man in the air; big pay for skilled  
aviation mechanics and builders.

**Y**OUNG man, if you want to fly—or if you want to be an aviation mechanic—the new Sweeney Course, located on one of the great flying points of U. S. is your opportunity! I make certain before you ever actually fly that you have the real experience—the “feel” of the controls—the mastery of your plane—the sensation of dropping in an air pocket—by my marvelous real suspended airplane. Your ground school work is made intensely fascinating as well as practical by methods such as this.

When you have completed your ground school, when you can repair your motor, build wings, know every detail of the mechanical work, skilled pilots of national reputation take you up for hours of real flying!

## Work on 20 Airplane Motors

Liberty Twelves, Sturdevants, Gnomes, Hall-Scott fours and sixes, and other motors are part of the equipment you work with; real airplanes which you assemble and study; for example you learn to recover wings, etc.; this ground school teaches you thoroughly, makes you an expert aviation mechanic; in one part of the course you sit in the “suspended” or anchored plane and repair your motor while the propeller is whirling and while the plane is rising and falling as if in real action; then when you are ready for your “hours in the air,” skilled pilots take you in hand and qualify you.

## Skilled Airplane Mechanics Wanted

Now after years of preparation, aided by the best flyers in the world, I have perfected the system of teaching whereby in a short time you become a skilled mechanic, and also if you wish, a skilled pilot. The mechanical and repair work end of aviation, as well as airplane construction, is thoroughly taught you!

All the resources, skill, experience and reputation of the great Million Dollar Sweeney School insure that the Sweeney aviation course is the simplest, most efficient, most practical system in the world.

**LEARN TO FLY!** Aviation is no longer a mystery—no longer a hazard; no, it is a business growing greater and more important; you can qualify as a mechanic, or an engineer, or repair man, or builder; five men on the ground are needed for one man in the air, but if you want to become a pilot you easily master the work and can go into postal, government, or commercial work. Flyers are in demand, earning big money at fairs taking up passengers, etc. \$5 for a 10 minute flight is pretty fine pay! The building of the new million dollar Fokker plant here means liberal high paid employment for hundreds of aviation mechanics.

**SEND NAME TODAY** for full details of this aviation mechanical course and photographs of planes and equipment actually used; also full information as to the commercial end of flying and opportunities for young men.

## Sweeney School of Aviation

**LEARN A TRADE—**  
**Sweeney**  
AUTOMOTIVE & ELECTRICAL SCHOOL  
1231A SWEENEY BLDG. KANSAS CITY, MO.

## Send This NOW

**EMORY J. SWEENEY, President**  
1231A Sweeney Bldg., KANSAS CITY, MO.

Please send me full information about your aviation Course.

Name .....

P. O. ....

State..... Age.....



E. J. Sweeney  
PRESIDENT

# Sweeney Trained Men Cashing In! You can do it too

W. A. Hoffman, Shannon City, Ia., says: "I started with nothing; am now worth \$33,000. I've never been stuck on a job yet. Thanks to the SWEENEY AUTO SCHOOL." A. J. Hawkins, Meridian, Miss., says: "It was Sweeney's Wonderful Training that did it. Keep Six mechanics busy—just built \$5000 home—own my own car; wife has hers—money in bank." D. J. Klassen says: "Got a good education in the Automobile Line."



E. J. Sweeney,  
Kansas City, Mo.

Dear Sir:  
When I came to your school I paid my expenses out of my own pocket. I wanted to get my money's worth, and so I kept busy. Have been busy ever since and I found out it pays. I have not toiled in vain for the last eight years, for that's the time I have been in the garage business of my own. I feel satisfied that I could not have done any better anywhere else. I believe everybody that has an opportunity should not delay in getting a good education in the automobile line.

D. J. KLASSEN.

## Big Special Offer

Write me quick—I will  
make it easy for you to  
come to this **MILLION  
DOLLAR AUTO SCHOOL**  
—and come right away

If you have just enough determination to better yourself to clip the coupon or send a postcard and do it now. It will be your first step toward a big paying job or a business of your own. **ACT TODAY**—Get My Big Free Book and Amazing Offer.

## FREE CATALOG AND SPECIAL OFFER

Get my big FREE 64-page catalog. It shows hundreds of actual photographs of men at work in my magnificent new school. Tells all about wages, profits, opportunities in auto business. Explains step by step how you learn. Interesting letters from graduates telling how they made good. Shows how men come from all over the world to this big school. Makes you want to join the crowd. Tells everything you want to know. I will gladly send you a copy beautifully illustrated. I'll tell you how to get into business for yourself. No colored students accepted.

E. J. SWEENEY, President

LEARN A TRADE—

**Sweeney**  
AUTOMOTIVE & ELECTRICAL SCHOOL  
1231 SWEENEY BLDG. KANSAS CITY, MO.

The First Step Toward Success Is to Send  
for My Free Book, Just As These Men Did

# MEN WANTED

**JOBS  
PAY  
\$50  
a Week  
and up**

**COME RIGHT NOW.** If you are mechanically inclined, if you like to work with tools, you will learn under the "Sweeney System," by actually doing the work, everything about all kinds of automobiles, oxy-acetylene welding, vulcanizing, battery work, electrical work, aviation, building and repairing Radio sets. No experience or education needed. No books are used. You work on most complete gas engine and electrical equipment in any school in the world. Over \$200,000 invested. \$50,000 Radio Station WHB. You'll get dirty and greasy, but you'll learn by the "Sweeney System" that fits you for big pay jobs at \$50 a week and up, waiting for Sweeney trained men.

## Sweeney System of Practical Instruction

There's only one place where you can get this training—it's at the world-famous Sweeney Automotive and Electrical School of Kansas City. There's only one Sweeney School. There's only one "Sweeney System." No other school offers or can give you this training that not only trains you to all big paying jobs but saves you time and money. This training is making big money for 70,000 Sweeney Graduates. I estimate 20,000 of them own a good paying business.

## Learn a Good Trade

One that will pay you \$200 to \$500 a month and more. Get in the biggest business in the world—the Automotive Business. Make more money in 1926 than you ever dreamed possible. I want to prove that you can do what thousands of men just in your position have done as a result of "SWEENEY TRAINING." I say, take up the AUTO BUSINESS NOW. Learn it at SWEENEY'S—Kansas City, Mo.



MAIL THE  
COUPON  
TODAY

Union Station Plaza  
KANSAS CITY, MO.

Send this  
**NOW**

EMORY J. SWEENEY, President  
1231 Sweeney Bldg., Kansas City, Mo.

Please send me your Free 64-page catalog and special offer.

Name .....

P. O. ....

State..... Age.....

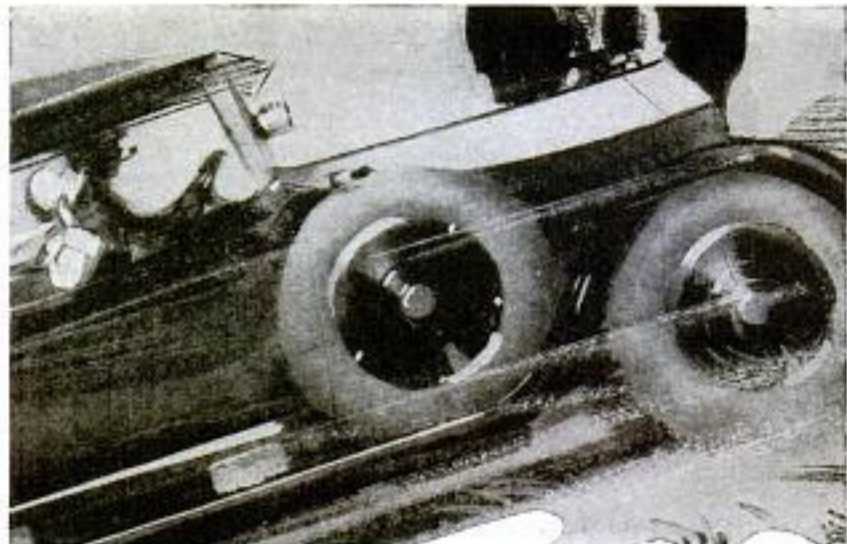
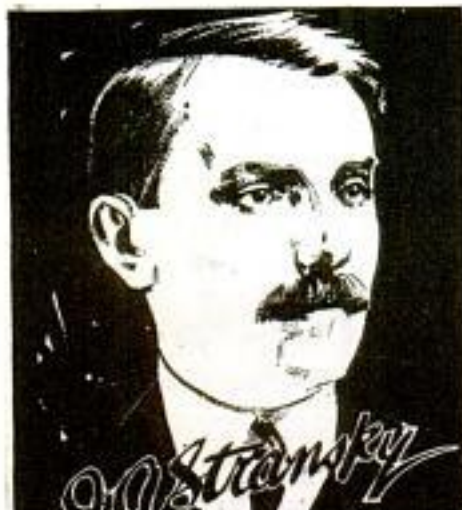

# Run Your Auto on **FREE AIR!**

An Amazing New Invention Makes It Possible Actually to Run Your Auto on FREE Air—and to Make a Splendid Income Besides Just Telling Your Friends About This Wonderful Little Device. Already It Is Being Used by Over a Million Satisfied Car Owners—on All Makes and Models of Cars. And Now the Inventor Will Send You a Sample at His Own Risk! Read His Offer Below.

**Earn \$250 to \$500 a Month!**

Here is one of the biggest inventions of the century—an invention almost as revolutionary as the invention of the auto itself—and it's making fortunes for agents and distributors. J. M. James made \$120 in one day. Vernon Gaines netted \$94 in eight hours. You can earn astonishingly big profits in full or spare time.

Imagine a car running 28½ miles on common, ordinary air—it doesn't seem believable, does it? This same car ran 27½ miles on a gallon of gasoline. But with the use of this amazing new device it did 56 miles on a gallon—a gain of 28½ miles, due simply to the introduction of Free Air.

This astounding new invention makes practically any car give twice its ordinary mileage a gallon—scores of car owners are reporting records of from 36 to 57 miles

and even 61 miles on a gallon of gasoline.

## Removes Carbon

The Stransky Vaporizer thoroughly vaporizes all your gasoline, giving it fully 50% more power! It also reduces spark plug trouble, prevents overheating, makes engine start easier, and prolongs life of motor. Most important of all, it removes carbon and keeps carbon from forming.

## Introductory Sample Offer

To introduce his new invention Mr. Stransky will send a sample at his own risk. Write him at once for his proposition. Just mail the coupon right now—today!

**J. A. Stransky  
Manufacturing Co.  
W-10 Stransky Bldg.  
Pukwana, S. Dak.**

**\$120 in  
One  
Day!**

**\$120 in One Day**  
I have found out that the Stransky will do what you said it would. I took forty orders in one day and wasn't out long. My Ford runs better than it ever did. I can save half the gas and it pulls better.—J. W. James.

**\$51 in One Hour**  
The results of one hour's work—17 men gave me orders for the vaporizers.—J. W. Cronk.

**Sold 32 to Yellow Taxi Co.**  
Yesterday I sold the Yellow Taxi Co. 32 vaporizers after they had tried one out for a week.—F. J. Munker, R. I.

**\$48 in 3 Hours**  
My gas bill has been cut nearly in half. I have removed every particle of carbon from my engine. I went out Saturday about 3 hours and secured 16 orders.—J. A. Williams.

J. A. Stransky Mfg. Co.,  
W-10 Stransky Bldg.,  
Pukwana, S. Dak.

Tell me how I can get samples of the Stransky Vaporizer at your risk. Also tell me how I can make from \$250-\$500 a month.

Name.....  
Street or R. F. D.....  
City.....State.....

# Learn How to BOSS the Job!



A view of one floor in the big Greer shops



**ERWIN GREER**  
President and  
Founder of the  
Greer Shops

Greer trained men are bossing shops in every part of the U. S. A. and in many foreign countries. They are getting the cream of the automobile jobs because they came here and made themselves *valuable men*. Many are in business for themselves and are making from \$10,000 to \$20,000 a year. How do they do it? By learning how to go after the big money—with Greer training. No previous experience necessary. You start at the very beginning and every step is made perfectly plain and easy.

## Let Me Prepare You for One of These Big Pay Jobs

- Automobile Repairmen  
—\$125 to \$250 per month
- Head Automotive Mechanic  
—\$150 to \$500 per month
- Automobile Salesmen  
—Up to \$20,000 per year
- Garage Owners  
—\$300 to \$5,000 per month
- Garage Managers  
—\$150 to \$350 per month
- Storage Battery Men  
—\$150 to \$300 per month
- Electrical Experts  
—\$175 to \$350 per month
- Truck and Tractor Men  
—\$6.00 to \$10.00 per day
- Tire Experts  
—\$150 to \$250 per month
- Repairmen  
—\$125 to \$250 per month

## The Greer Shop Plan

The Greer training plan is known throughout the auto trade as the efficient, quick way to start off in any line connected with autos, trucks or tractors. Real problems are worked out on real cars. We have specimens of every type of engine. Equipment used is not surpassed by any shop in the world. In addition to our own cars, trucks and tractors, there are from 75 to 100 customers' cars in our shops at all times, for overhauling and repairing. You do actual automotive jobs under the supervision of careful, expert instructors. You get the real, practical experience that fits you to become an expert. You, in turn will be fitted to supervise the jobs—and there is the big money for you. The knowledge you get by our method could not be learned by years of dirty, tedious apprenticeship.

## 24 Years' Experience Training Men

Our systems of training is the result of my 24 years' experience, fitting men for responsible positions in the auto field. The Greer Shops have been established practically as long as the auto business itself. Both have progressed side by side. We have kept up with every change and improvement. New equipment is being added whenever necessary—in order to keep thoroughly up to date.

## Now Is the Time to Start

Let's get right down to brass tacks. You know you are not satisfied to drift along with no future in sight. This training means everything to you and will take only 12 weeks or less. Right now is the best chance you will ever have. Get your training this winter and be ready for the spring rush.

## Greer Trained Men Are Needed

Everything points to the biggest year ever known in automobile history. Prosperity in the automobile business is here. Over 20,000,000 automobiles now in the United States. Over 4,000,000 new ones will be manufactured during 1925. Are you going to get your share of this prosperity? Here is your chance. You can't afford to wait. Send that coupon in the corner of the page right now and we'll mail you our big free book. It will give you many interesting facts about the auto business and will describe the Greer plan in detail.

## Free Employment Service

We help you get the right job when through training, and we stand back of you for life, with help and advice. You may return at any time you wish and "brush up" on any subject—free of charge.

## Earn While You Learn

If you need to earn money while in training, our employment department will arrange a part time job for you. There are evening classes for men employed in the daytime.

Fill in the coupon right this minute and send it in, so you will get our book without delay.

Address me personally, please.

ERWIN GREER, President.

Erwin Greer, President  
2024 S. Wabash Ave., Dept. 1201, Chicago

Please send me your FREE BOOK and offer. It is understood that I am not obligated in any way.

Name.....

Address.....



# DON'T Let Anybody Bully You

## LEARN SCIENTIFIC TRICKS OF PHYSICAL MASTERY

Don't pick scraps, but when you're right don't "back water." And don't worry about a man that's bigger and stronger than you are. By a few simple tricks you can have any assailant at your mercy quick as a flash. At last the astounding secrets of self-defense, used by the New York Police, are revealed in the marvelous, officially recognized system—

### Sgt. Wallander's Course

All Complete In

## PHYSICAL TRAINING MANUAL

By Sgt. A. W. WALLANDER, Commander Physical Training

### NEW YORK POLICE ACADEMY

This volume is a complete course in physical culture. Scores of gripping action photos showing just how to throw a bigger man and overpower him—how you disarm a hold-up thug—how to build up muscle—how to keep in fighting trim. Hundreds of health hints, too; care of the feet, prevention of colds, correct posture, how to walk without fatigue. This is the genuine book used by the New York Police Dept., now available to YOU for the first time!

**Easy to Learn** Let Sgt. Wallander give you his great secrets. A few hours of easy reading will make you master of these closely-guarded detective tricks. You'll hardly believe that such valuable knowledge could be learned so easily.

### ALL YOURS IN WORLD'S MOST AMAZING COURSE

**SEND NO MONEY.**—In Physical Culture and Police circles this volume is world-famous. You're lucky that you can get in on this short-time offer. Send immediately for your copy. You'll be a new man. You can learn how to be a great athlete. Don't delay. Don't send money now. Just send the coupon today. When volume arrives, pay the postman \$1.97, plus few cents postage. If you are not satisfied return volume and get money back.

**\$1.97**  
Plus  
Postage

SIEBEL PRESS, 34-Y W. 20th St., New York.

Please send me Sgt. Wallander's *Physical Mastery Course* as contained in the "Physical Training Manual." Upon arrival I will pay the postman \$1.97 plus a few cents carrying charges. It is understood that if I am not satisfied with this book, I will return it and my money will be refunded.

Name.....

Address.....

City..... State.....

(\$2.25 U. S. Cash with order in all other countries)

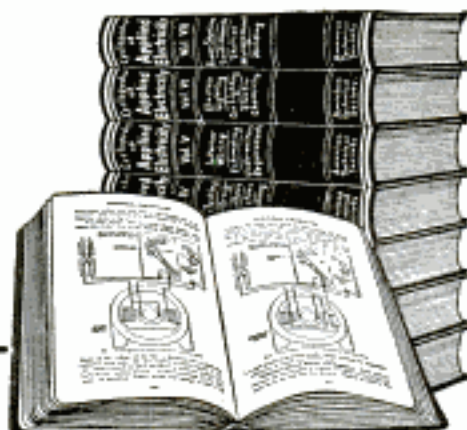

## ELECTRICITY FREE 8 BIG BOOKS SHIPPED

Here are the most interesting, the most practical books we have ever published on Electricity, wiring and equipment. Brim full of facts, photographs and explanations, so easy to understand that anyone can learn a lot about this money-making subject in almost no time.

Over 4000 pages, with diagrams, blueprints and everything else needed to make anyone an authority on Electricity.

Whether you want to qualify as an Electrical Contractor or merely wish to know the money-making possibilities of this important subject, you will welcome these books, especially on our

## No Money Offer

This plan brings this valuable information within the reach of everyone. You don't send us a single penny. You don't have to pay us anything—just send your name and address and we will send you the complete set of eight volumes, specially bound in Flexo covers.

Read them carefully; keep them ten days; find out anything you want to know, and then if you want to keep them, send only \$2.00, and \$3.00 per month until the special low price of \$29.80 is paid. There is no further obligation.

## American Technical Society Membership FREE

This is a great organization with over \$1,000,000 of resources which enables us to get the co-operation of the largest electrical manufacturers and dealers who have furnished us plans and photographs. If you send NOW for this new edition of our *Cyclopedia of Applied Electricity*, we will include a Consulting Membership in this great organization. Eighteen electrical experts will be ready to help you at all times. You can write or wire any time for special information. Answer will be sent to you promptly—without cost.

### Learn All About Electricity

Get these eight big books on this liberal offer and learn all the things you want to know about electricity. House wiring, motors, generators, spark coils and thousands of other subjects—all are fully covered. These complete and comprehensive electrical books are yours if you want them on this easy plan. Send for a set NOW; there's nothing to pay. You don't have to read the books through; the special index allows you to put your finger on the information wanted in a jiffy.

### For FREE Offer Use Coupon

**AMERICAN TECHNICAL SOCIETY,**  
Department E-919, Chicago, Ill.

I would like to look at the eight electrical books described above. Send them on your free offer. I will examine them carefully and return them in ten days, unless I like them; in which case, I will send you \$2.00 then, and \$3.00 per month until the total price of \$29.80 is paid. You are also to send me FREE Consulting Membership in the American Technical Society.

Name.....

Street.....

City and State.....

Reference.....



**EVEREADY HOUR  
EVERY TUESDAY AT 9 P. M.**

*Eastern Standard Time*

For real radio enjoyment, tune in the "Eveready Group," broadcast through stations—

WEAF New York	WCAE Pittsburgh
WJAR Providence	WSAI Cincinnati
WEEI Boston	WWJ Detroit
WTAG Worcester	WCCO Minneapolis
WFI Philadelphia	WOC St. Paul
WGR Buffalo	WOC Davenport
	KSD St. Louis

No. 764  
Portable  
22½-volt  
Vertical  
Price  
\$1.75



Eveready  
Columbia  
Ignitor  
"A"  
Battery,  
the  
proven  
dry cell  
for all  
radio  
dry-cell  
tubes  
1½ volts



No. 779  
22½-volt  
Large  
Vertical  
Price  
\$2.00



No. 771  
4½-volt  
Battery  
Price  
60 cents

No. 486  
45-volt  
Layerbilt  
Extra-  
large  
Vertical  
Price  
\$5.50



## For radio economy

EVEREADY Radio Batteries are noted for their long service and economical operation. They are made in different sizes and types so that every radio user can enjoy the economy and convenience to be had by fitting exactly the right Eveready to his receiver. Five of the dry-cell types of Eveready Radio Batteries are here illustrated and described to make it easy for you to decide just which will give the longest and most economical service on your set. A dealer near you sells Evereadys.

Manufactured and guaranteed by  
**NATIONAL CARBON CO., INC.**  
New York San Francisco

Canadian National Carbon Co., Limited  
Toronto, Ontario

**EVEREADY**  
**Radio Batteries**  
—they last longer

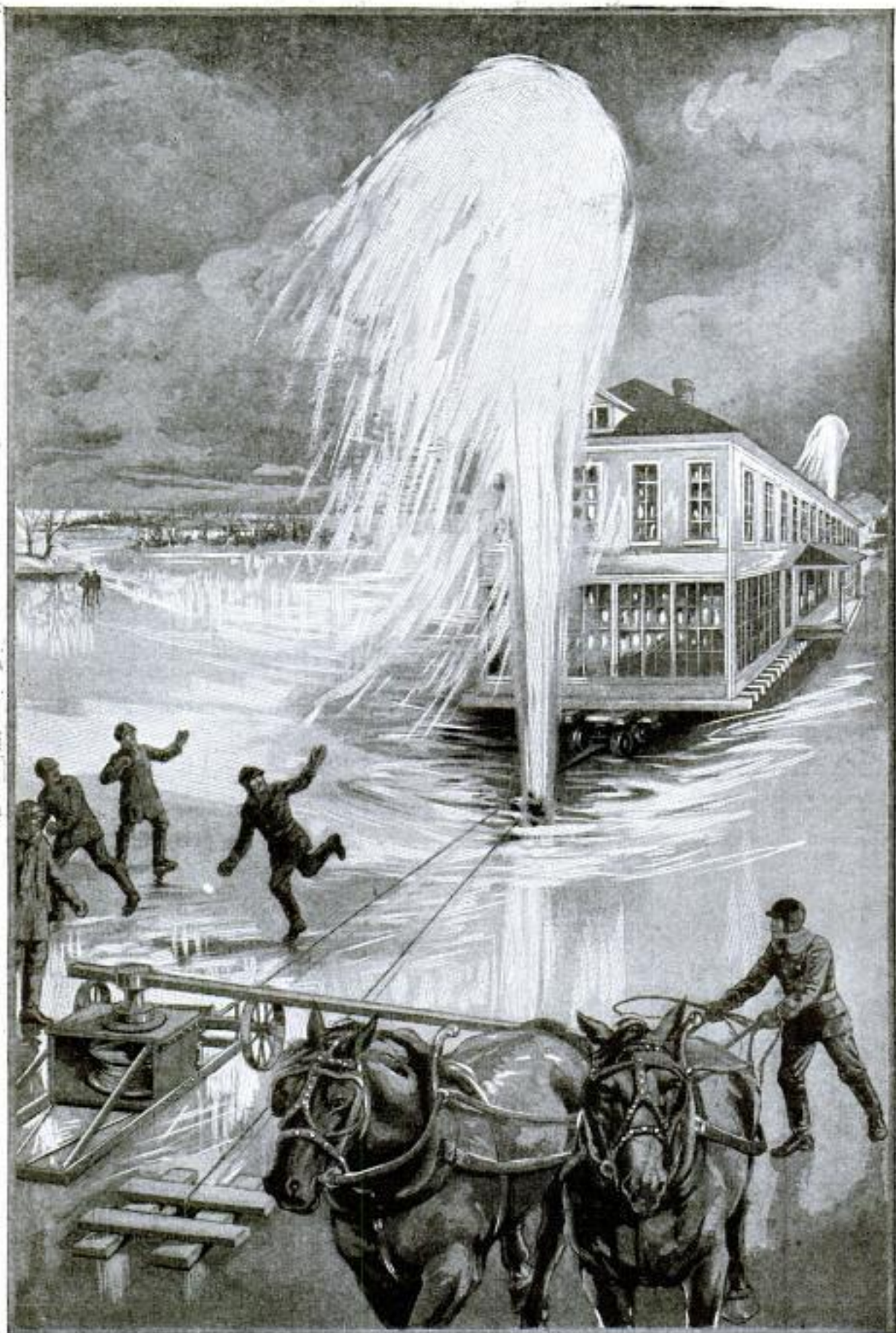

The Worst Scare in the Life of a Famous House Mover, When a Summer Hotel Being Moved over a Frozen Lake, Started toward the Bottom as the Fifteen-Inch Ice Bent—See Page 979

# Popular Mechanics Magazine

REGISTERED IN U. S. PATENT OFFICE

WRITTEN SO YOU CAN UNDERSTAND IT

Vol. 44

DECEMBER, 1925

493

No. 6



## How Divers Gambled Lives in Battle to Save "Sub" Crew

USING his bare hand to bridge a gap in a defective electrode, a deep-sea diver laboring over the wrecked submarine "S-51," 127 feet under the surface of the Atlantic, maintained the circuit through his body long enough for the current from the electrodes to burn a hole through a steel hatch. His feat was but one of many where the divers bet their lives against the sea in the frantic effort to discover whether life still remained in the lost ship.

From the time the first rescue crew reached the scene, a few hours after the submarine was sunk in collision with a passenger ship, until all hope for any of the crew left on board had been proved groundless, the pick of the naval and commercial divers of the country concentrated on the work. Going down alone or in pairs every time the sea was smooth enough to permit salvage operations, they fought their way through steel hatches and treacherous debris until every compartment was proven flooded and uninhabitable.

The depth and the intense cold made the work dangerous, while the menace of entangling air lines with the antenna wire and other wreckage added to the peril. Despite the danger, however, the divers crawled through hatches so small the bulky diving suits would hardly squeeze past, through flooded compartments where loose gear constantly threatened to trap them. William Lilja went down to close an air valve between the battery compartment, which was shattered by the collision, and the control room adjoining it. He found the only path through the wreckage was to crawl beneath the bunks in a space barely eighteen inches high. In some way he made the trip and closed the valve, then backed out

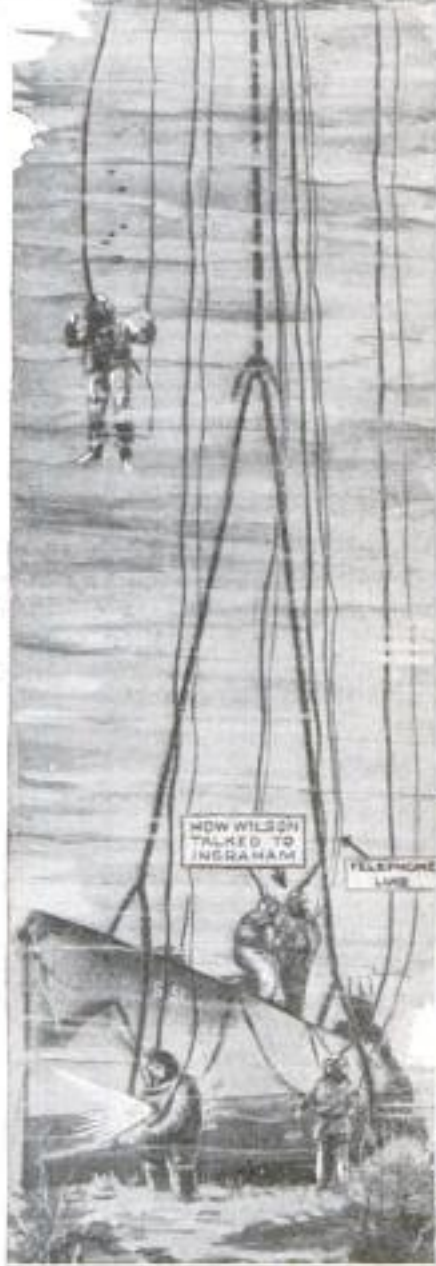

Trying to Raise a "Sub"

*Pacific & Atlantic Photos, Inc.  
25 Park Place, New York.*

*Kansas City Times 9/25/25*

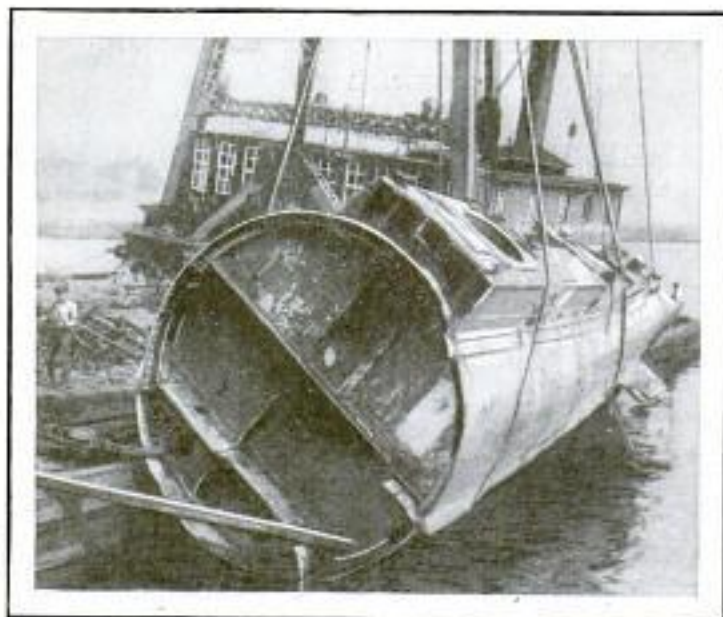

Cut through the Middle to Lighten the Load, Half of a Sunken Submarine Is Brought to the Surface by a Wrecking Crane

of the tunnel. The next diver going down found the tunnel entrance choked with rubber floor mats and other loose material which had washed in just after Lilja left.

William Reed, another famous diver, only three weeks out of the hospital after a siege of pneumonia, and still weak from the sickness, was the man who used his arms to bridge a gap for the current to melt a hole through the engine-room hatch and determine whether it contained air or water. If air bubbles had appeared, there would have been a chance that some men still lived behind the watertight bulkhead doors of the engine room. None, however, came, so the engine hatch was opened. Lilja was then sent down again to explore this compartment, after having studied an exact counterpart on the sister submarine "S-50," which stood by as a training school for the divers. Just as he started through the narrow opening, the diving light he carried failed. Another diver made the long trip to the surface and brought back a second light. Lilja dropped down the ladder, but as he reached the floor, the second light went out. Before him was a narrow passageway between the engines, but it was choked with loose gear. Unwilling to wait for another light, the diver felt his way along the tilted floor until he reached the motor room and found the watertight door, always kept hooked back when at sea, was unhooked and swinging in the water. Some man in the engine room had seen the wall of water coming after the accident and leaped through the door, struggling to push it shut after him, but

the water struck and drove him back. Lilja felt his way between the engines, found the ladder and got safely back to the surface, explaining that he had not waited for a third light because there was no time to waste.

To reach the wreckage 127 feet below the sea took only a few minutes, the diver with his 200 pounds of suit, including lead shoes and a lead belt, sinking easily through the water. Coming back, after from half an hour to an hour of work in the cold water, where the temperature was down to forty degrees, was another matter. If pulled up too rapidly, changing from the great pressure of the deep sea to normal air pressure at the surface, the diver's blood will mingle with air bubbles forced into the veins,

producing the dread disease called the "bends," which often results in death. To avoid this danger, the diver is drawn up a few feet at a time, and then left suspended for some minutes before going up another notch. It took an hour and a half to raise the divers from the submarine.

The only alternative to this slow process is to jerk the diver up quickly and rush him into a high-pressure room on the attending ship where a pressure equal to that at the sea bottom has been established. With a doctor and a nurse in attendance, the pressure is slowly lowered, until it is reduced to normal.

On one occasion it was necessary to lift two of the divers to the surface with this speed and send them to the pressure room. The salvage ship was rocking at anchor when the watch officer sighted a squall a few miles away. Had it struck while the divers were still in the submarine, the jerking of the ship would have parted their air lines and left them to die. The officer shouted a warning, and the divers were signaled by telephone to prepare for a quick ascent, which landed them under the doctor's care before the storm arrived.

Telephones have removed some of the danger from diving, and enabled the divers to perform better work. With two men on the sea bottom, they not only are able to direct the shifting of their lines from above, but, by talking to each other, can confer on the work. Two of the navy's most intrepid deep-sea men, J. W. Ingraham and R. C. Wilson, were the first to reach the "sub" after it had been located by an airplane flying overhead.

TEXAS "RUBBER"  
WATERPROOFS  
CLOTHING

545

High rubber prices have stimulated a revival of an industry in Texas by which a substitute for the natural product is derived from guayule, a plant growing wild and plentiful much like sagebrush. About seven per cent of its bulk is converted into a rubberlike substance by an extraction process, the material being used for waterproofing cloth and for making footwear. Four factories recently have resumed operations after ten years of intermittent activity. The guayule plant covers a considerable area of dry land in several counties in Texas and grows in abundance in Mexico. It is found also in Arizona.

TINY MOTOR BUILT  
BY BOY FITS  
ON RING

An electric motor, so small that it has been mounted on a ring, has been built by a St. Paul, Minn., high-school boy who devoted his spare time for six months to the task. It is only one-fourth inch high and weighs less than a quarter of an ounce. The armature was fashioned from a section of a nail and the drill used in fitting it, was left in the armature to form the shaft of the motor. Two and a quarter inches of wire were used in the armature and six inches on the field coils. The commutator was made of thin sheet bronze, attached to the shaft with shellac and a silk thread at each end. The brushes are about one-eighth of an inch long and were fashioned from Christmas tree tinsel. The motor runs at high speed on two volts and is nearly noiseless.



Eugene Reinbold  
215 McAlester Ave



Wide World Photos.

When Parisians Celebrate; One of the Floats in Parade in Observance of Birthday of Candle

BIRTHDAY OF CANDLE OBSERVED  
WITH PARADE OF FLOATS

572

The candle's importance in man's progress was recalled in Paris recently when a parade was held there in observance of the anniversary of its invention. The spectacle was featured by a number of fantastic floats, depicting improvements in lighting. During the thirteenth century, candlemaking was an important industry in Paris, the business being controlled by societies, one that worked in tallow and another in wax. Members of the guilds went from house to house, making a supply for their customers.

Street names placed on legible signs fastened to the curb, are the latest aid to drivers at night, as the headlights illuminate them when a car turns a corner. A further advantage is that, when they are used as a substitute for elevated signs, they save the expense of special posts.

Copyrighted Material

W-D Mailer Co.  
26 South St.  
Yonkers, N.Y.

Designed by Alfred Hayden

South of Ireland  
Kent.  
England.

884

**MOTOR BRIDGE ON ROUND PIERS HAS LITTLE VIBRATION**

Because of its great strength and attractive appearance, a circular-pier type of bridge with concrete buttresses, has

**RADIO BEACON WARNS SHIP WITH REVOLVING AERIAL**

Instead of warnings by flashing beacons, a radio lighthouse devised by Marconi broadcasts a wireless message from a revolving aerial. The signal not only apprises navigators of their danger, but enables them to determine their exact position even in dense fogs. Longer range and lower upkeep costs are advantages claimed for this useful adaptation of radio. The apparatus has been erected beside an old lighthouse tower, so that it is in an isolated spot, favorable for broadcasting. The aerial is revolved by means of a motor, while signals are being sent, the better to insure their reception. The transmitting outfit is housed in a separate shelter near the aerial. The station was inspected by a party of government scientists after studying the plans on Marconi's yacht.

533

Evening  
Railway  
158  
New York City



Round-Pier Automobile Bridge with Buttressed Concrete Roadway Intended to Support Heavy Weights with Little Vibration

been adopted by an eastern park commission for motor highways. The solidity of the structure is said to reduce the amount of vibration, increasing its safety. The piers are of stone blocks and form a contrast to the concrete part of the bridge, the underside of which resembles a vaulted ceiling.

**MANGER FOR MONKEYS IN ZOO PREVENTS WASTE OF FOOD**

Visitors at the zoo in Berlin, Germany, instead of being asked not to feed the animals, are encouraged to deposit nuts and other dainties in a hopper fastened outside of the cage. Besides preventing waste, the holder affords spectators the added amusement of watching the animals pick things out of the box. A monkey's face and directions for using the manger are stamped on the receptacle.



Placing Peanuts in Manger for Monkeys

**POTATO PATCH FULL OF POWER HENRY FORD DECLARES**

Alcohol sufficient to drive machinery necessary to cultivate the patch 100 years can be derived from one season's yield from an acre of potatoes, according to Henry Ford. The automobile manufacturer believes that we are coming to a time when we will grow our own fuel. Sawdust, apples, weeds and practically all forms of vegetable matter that can be fermented, are potential sources of power, Mr. Ford declares and asserts that electricity will be the kind of energy American cities of the future will be using for heat as well as light. Coal will be burned underground and converted into "white power" which will be sent by wires.

Monitor  
9/21/25  
Christian Science

Pacific + Atlantic

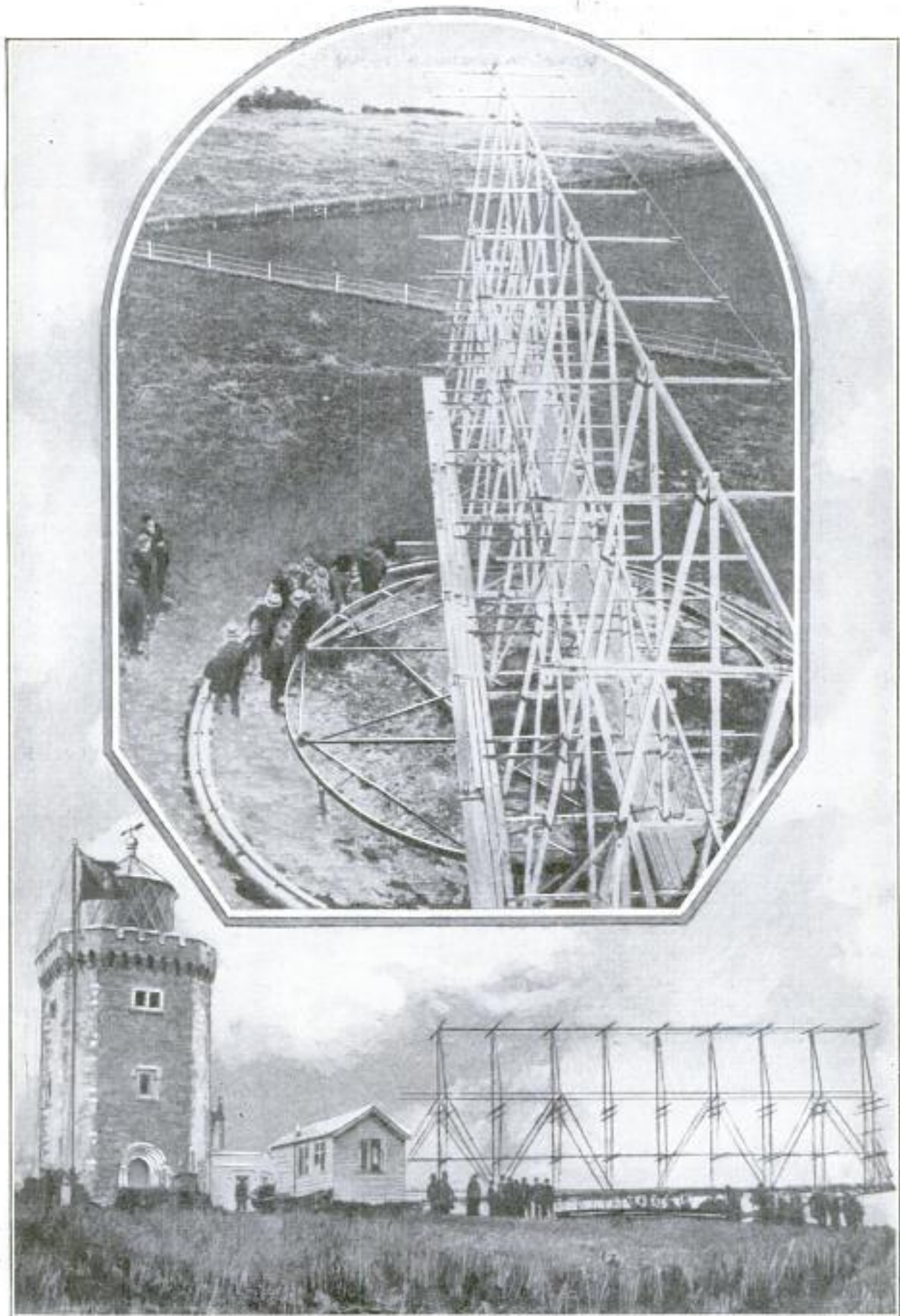

Views of the Radio "Lighthouse" from Which Signals Are Sent by Wireless, Giving Navigators Their Correct Positions in Fog; Upper Picture Shows Revolving Antenna and Track on Which It Runs

523



Zoo Elephant as Glass Tester: Four Pint Bottles Held Animal's Weight without Breaking or Cracking

### BOTTLES HOLD BIG ELEPHANT IN GLASS STRENGTH TEST

The strength of empty, half-pint glass bottles was demonstrated recently when four of them were used to support a wooden platform upon which a 13,000-pound elephant sat. None of the bottles was broken, although one of them was driven half an inch into the boards because of extra pressure at that point.

### THAW FROZEN MEAT BY ELECTRICITY

When meat is shipped long distances by steamer, it is often frozen to prevent spoiling. Thawing it out by natural means usually takes three or four days in summer and longer in winter, and affects the quality to such an extent that frozen beef, for instance, commands lower prices than that which has been merely chilled while in storage. These

disadvantages are said to be eliminated in a simple electrical "defrosting" process developed in Australia. It thaws the meat with electric current. The apparatus consists of a self-regulating transformer and a set of electrodes with connections which are set in the meat in such a way that more current passes through the solid flesh portions than through the thinner rib parts of the carcass, thus insuring uniform thawing throughout. But little current is used, attachment is made to a lighting socket, and the process is said not to damage the meat. An additional advantage is that only one day's hanging is required under this method.

499

### DITCH-SCRAPING PLOW CLEANS GUTTERS

Originally intended for digging flat-bottomed irrigation ditches, a scraper plow is adapted to cleaning out gutters before placing the concrete forms in street construction. It is built entirely of steel and is reversible so that earth can be thrown to either side. A guard prevents gouging into banks, and the edge is machined and of material that will scour in any soil, the manufacturers declare. Cuts of one-half or four to five inches are possible in one operation by adjusting the blade, and there is a lever by which the plow can be raised to clear obstructions.



Scraper Plow Cutting Street Gutter; Side Guard Prevents Damage to Curb

Inventory of A. U. Alcock, N. D. C. E. of Messrs Herbert Hill Cotte Proprietary Melbourne, Australia.

1501 Wazee St

Clinton + Held Co. St. 1501-4 Wazee St. Denver Colo.



525 Great Northern Railway Co.  
 W. B. Mills, Pres. Adv. Agent.  
 St. Paul, Minn.

POPULAR MECHANICS

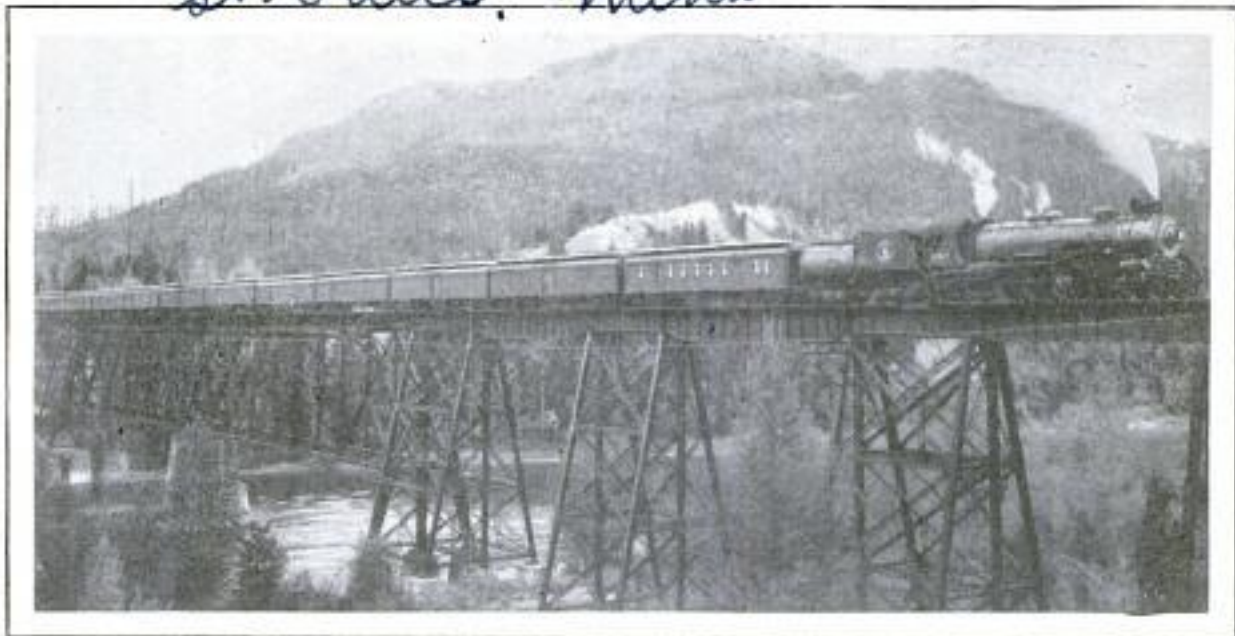

Moment's Halt for a Photograph; Engine That Thundered Halfway across Continent and Back with Heavy Trains in Record Performance for Single Locomotive

**SINGLE ENGINE HAULS TRAIN  
 THREE THOUSAND MILES**

525

The average distance traveled by one locomotive between division points is usually not over 200 miles, but an engine on a western road recently went over seventeen times as far in a practically continuous run from Seattle to St. Paul and back. The start was made at the coast city with a shipment of eighteen cars of silk. Fifty-two hours and thirty-five minutes later, the train and the same locomotive were in St. Paul, a distance of 1,789 miles. After an overnight stop, the same engine was attached to a mail train and sped back to Seattle. It arrived there in forty-seven hours and ten minutes, beating the schedule of the regular train by twenty minutes, with an average running time of about thirty-eight miles an hour. The total distance, 3,578 miles in ninety-nine hours and forty-five minutes, is said to

be a record for American railways. The engine was an oil burner, picked from stock, and was not equipped in any special way for the trip. The performance is considered all the more remarkable as the time included stops for water and fuel.

527

**"PHANTOM SHIP" IS MEMORIAL  
 TO WHALING INDUSTRY**

Evening passengers on a steamer between New Bedford, Mass., and New York City frequently see what appears to be a "phantom ship," visible for miles around, its masts and hull softly outlined in lights and a filmy flag fluttering at the staff.

It is the old whaleboat "~~Charles W. Morgan~~" docked at South Dartmouth, Mass., and was preserved as a memorial to the whaling industry. As the steamer salutes its forerunner, a man on the whaler returns the courtesy, by switching off the floodlights, leaving only the American flag illuminated.



Courtesy General Electric Company  
 Old Whaleboat "Charles W. Morgan" Outlined in Floodlights as Memorial to the Whaling Industry

Owned by Col. E. H. Green

467  
888  
W. H. Johnson Binding & Printing  
Co., 72 Columbia St  
POPULAR MECHANICS  
Seattle Wash.



Dipping the Fiber Cut-Outs into Vat of Hot Paraffin to Make Them Waterproof, and Full Side View of Decoys as They Appear When Floating; as the Real Ducks Circle about Them, the Lures Can Scarcely Be Seen Edgewise So That They Seem to Vanish, Further Exciting the Live Birds' Curiosity When They Appear to Bob Back



**LIGHTWEIGHT DUCK DECOYS  
MADE ON PRINTING PRESS**

Weighing, with its anchor, only half a pound, a duck decoy of paraffin-coated fiber, lightens the sportsman's pack and excites the curiosity of the wild birds as it seems to vanish and bob back again as they circle about it. This effect is secured, not by mechanical means, but by the flat shape of the decoy. From a full side view it appears to be a plump waterfowl resting upon the water, but it can scarcely be seen when looked at edgewise. The lures are manufactured from squares of jute fiber run through printing presses to impress the design and colors upon them. The hues are exaggerated and the models made in large size to attract the birds' attention. The forms are stamped out with a die then dipped into hot wax. Metal clips, used for attaching stiffening strips of wood in the neck and head, also serve as locks for the float. This is a piece of light cedar with an ounce of lead in one end for balancing, and at the other, a cotter pin for tying on the anchor line. The decoy offers little resistance to the wind and its motions are much like those of a live fowl. Being flat, the lures take little space in the boat.

**TINY MODEL OF MOTORCYCLE  
HAS MOVING PARTS**

So small that it easily can be carried in one hand, a model of a motorcycle displayed at a London exhibit, contains all parts necessary to locomotion. These are movable and illustrate what happens in the mechanism of a real motorcycle.



Motorcycle Model Is Complete Even to Rear-wheel Support and Has Parts That Move

Made by E. W. Slicker  
London, England.

**BIG GUN CARVED IN STONE  
HONORS WAR DEAD 510**

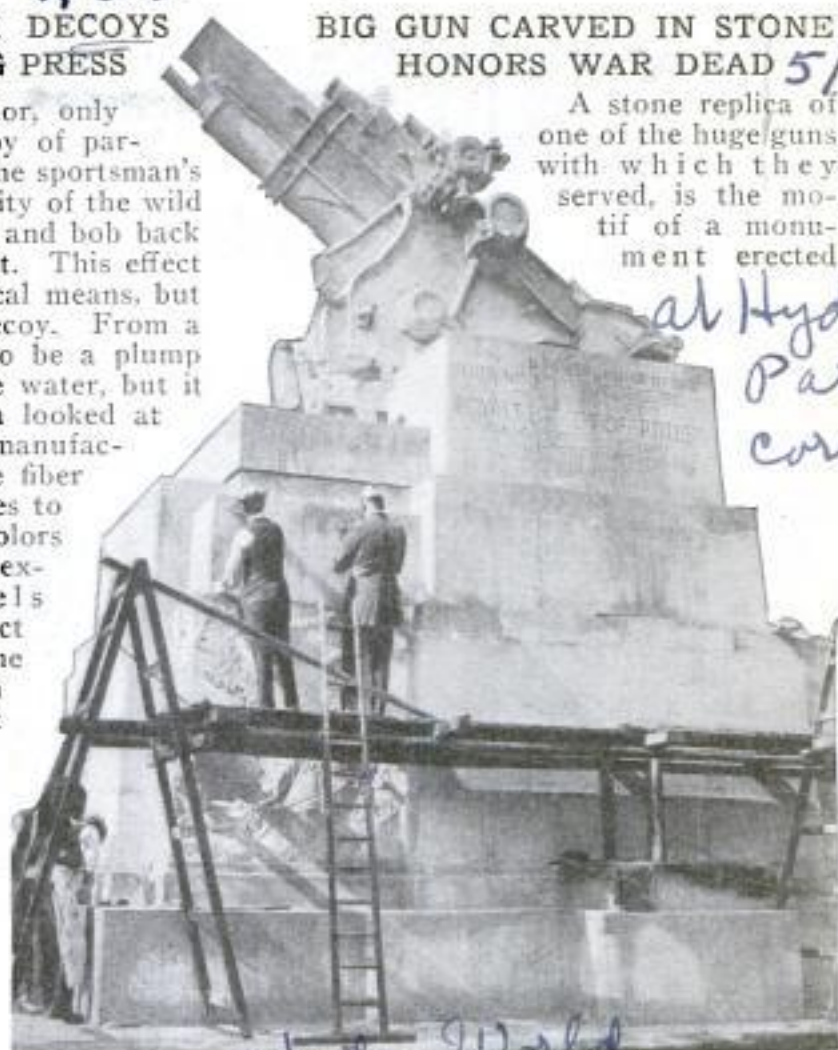

British Memorial to 49,076 Men of All Ranks of Royal Artillery Regiment Who Gave Their Lives in the Great War

A stone replica of one of the huge guns with which they served, is the motif of a monument erected

at Hyde Park corner

in London in honor of 49,076 British artillerymen of all ranks who gave their lives in the World War. The gun surmounts a ponderous base inscribed with the dedicatory legend and figures.

**PARKING SPACE IN BASEMENT  
SERVES BANK PATRONS 514**

Customers of a western bank are spared the trouble of circling the block to find a place to park their cars, for space has been provided in the basement of the building. Patrons ascend to the lobby by an inner staircase, admitting themselves with a special key furnished by bank officials. Other conveniences of this institution are check blanks with columns of figures at the left end, like those on a money order slip, indicating the amount of the check and preventing alterations, and an electrically protected deposit vault built into the front of the building, for merchants or others who wish to put in money after banking hours.

Central National Bank, Pasadena, Calif.

JOHNS

Good r...  
Pintail, V...  
Printed in...  
better th...  
shells, s...  
that the...  
pearanc...  
in any w...  
moving,

The 3...  
slides sr...  
float it...  
float mal...  
for differ...  
bottom c...  
Each d...  
Weight...

Retail...  
Retai



Stack...  
duct...  
are he...  
attache...  
the gr...  
water...  
dozen...  
bag. Pr...

Ove

501

# The Great Air Liner of the Future

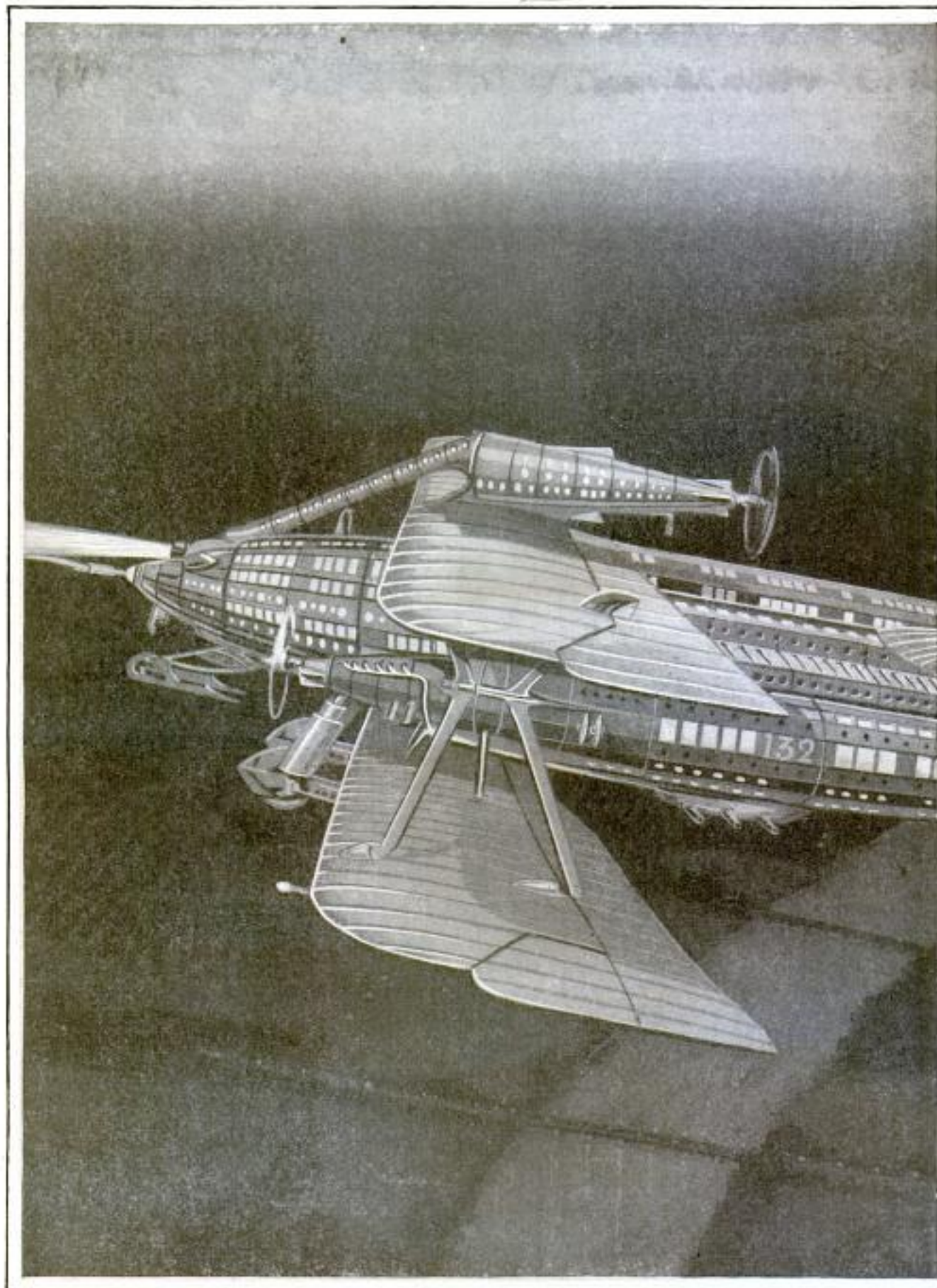

© 1917

With Space for Hundreds of Passengers, the Air Liner, It Is Predicted, Will Be Built Entirely of Metal and All Parts Will Be Inclosed Including the Motors

# as Described to British Association

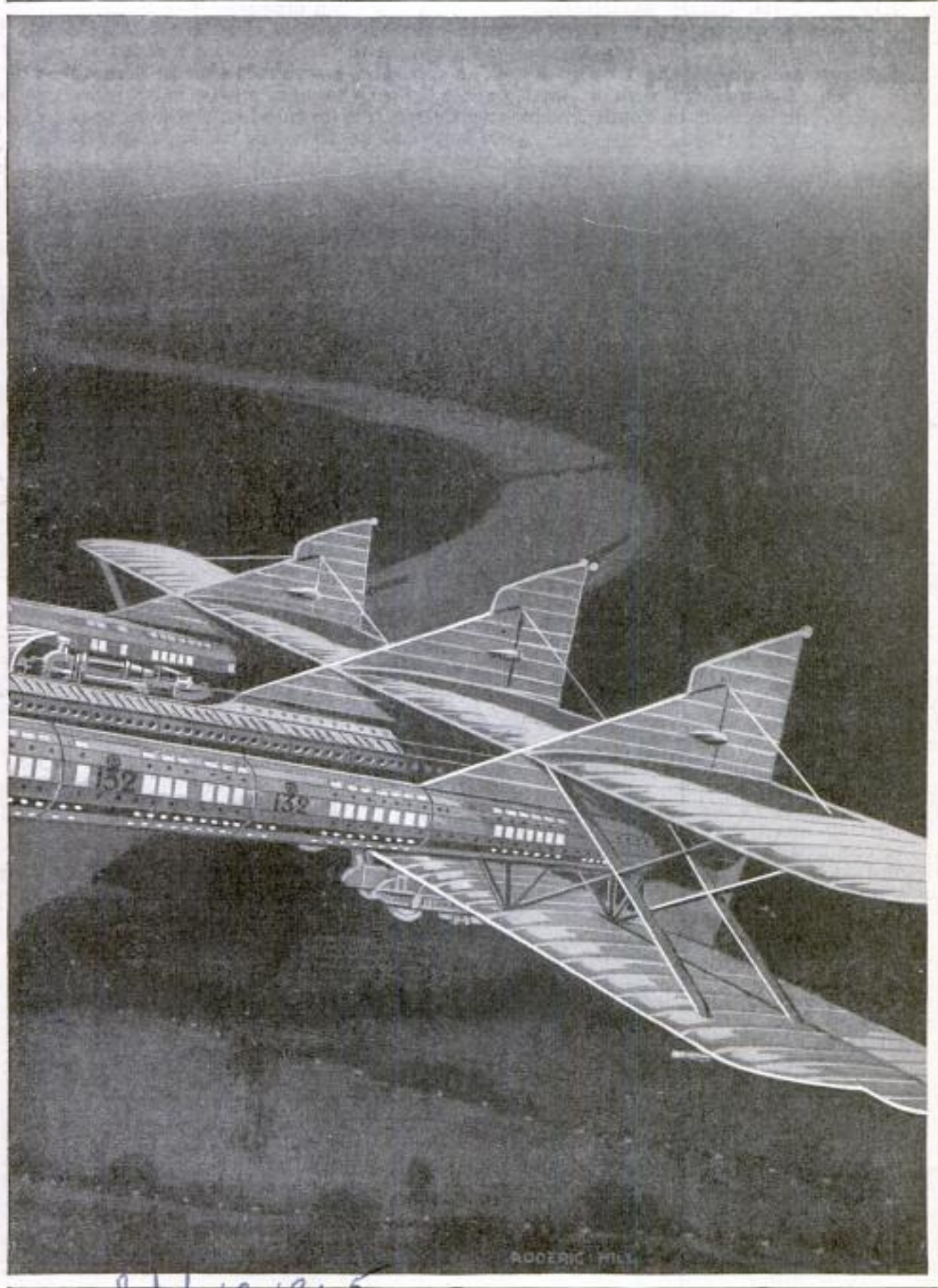

ADDERIC HILL

The Sphere

*Sept. 19, 1925*

An Artists Vision of the Great Transatlantic Air Liners of the Future Which Were Described by Speakers before a Recent Meeting of the British Association

Haynes Automatic Sounding machine

**AIR-OPERATED SHIP SOUNDER  
LESSENS MARINE HAZARDS**

3 2 8 Navigators are spared the trouble of taking repeated soundings with a hand lead line by an automatic depth finder

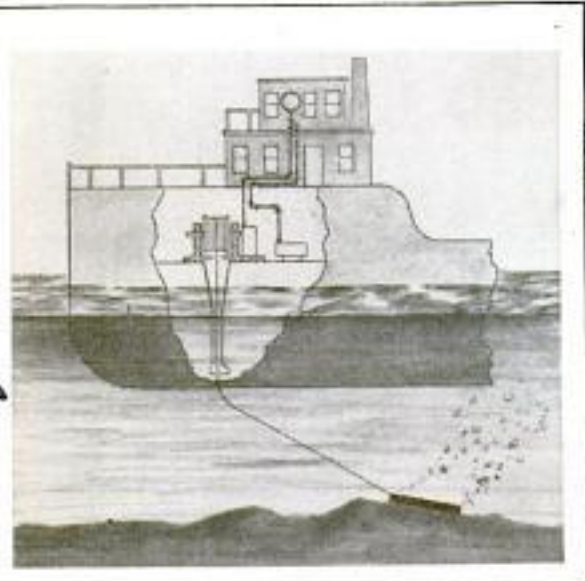

Diagram of Air-Operated Sounding Apparatus in Use, Automatically Registering Changes in Pressure

operated continuously by compressed air. It consists chiefly of a power-driven reel or drum carrying several hundred feet of armored hose with a special nozzle at the loose end to discharge air from a compressor. For instance, the navigator wishes to be advised when his craft reaches water 100 feet deep. The hose is lowered through a bottom outlet in the boat so that the nozzle will be at the required depth when moving forward at a fixed rate of speed. As soon as the end touches bottom, an electrical mechanism sounds an alarm and from that moment onward, depth is registered continuously by an index hand on a gauge as the pressure required to force air from the hose varies according to the depth. That is, water, twenty feet deep, will have twice the pressure of water ten feet deep; 100 feet deep, ten times as much as at ten feet. The hose is rigidly constructed to prevent crushing, and the armor plates of hard steel, arranged so that they do not interfere with the flexibility of the hose, keep it from

wearing out when dragged along the bottom. A steady supply of air is secured by admitting it to the hose from a reservoir. The apparatus may also be used to record speed, since the nozzle will hang more nearly straight down when the boat goes slowly and at an angle at high speeds, causing changes in its depth.

**GO HALFWAY AROUND GLOBE  
FOR TWO MINUTES' WORK**

56 To watch the eclipse of the sun, January 14, a party of scientists from the naval observatory in Washington, D. C., has gone to Sumatra in the Dutch East Indies. The phenomenon will last only two minutes, but in that time the observers hope to make motion pictures and color plates which will show more about the sun's gases and other features. The expedition has devoted three months to erecting their lookout station and telescope tower. Other parties from England, Germany and France, as well as one from Swarthmore college, will be at Sumatra. An Italian group will be stationed in Africa.

**496 COLLAPSIBLE RIMS FOR AUTOS  
SIMPLIFY TIRE REMOVAL**

Auto rims that fold in three segments, have been devised to lighten the task of removing or putting on tires. In fitting the casing, the longest section, which has a hole in it for the valve stem, is placed on the ground with the two shorter ones folded over it. These are lifted against the tire when it is in place and are held in circular position by a toggle joint which is secured by pressing on it with the foot. Little exertion is required to replace or remove the rim, and about the only precaution necessary is to see that the long segment is properly rested against the tire before snapping the toggle in place.



Collapsible Auto Rim in Position for Attaching Tire, the Large Segment on Ground

462 To eliminate waste in the industry, manufacturers of grindstones have agreed to reduce the number of sizes and types from 712,000 to 459,000, including whetstones and grinding wheels.

Chicago Herald-Examiner 9/25/25

Used by Detroit + Cleveland Navy Yards Co., Cleveland, O.  
From Compressed Air magazine  
Sept. 1925, p. 136

Williamport, Pa.  
Rim Corp.  
Collapsible  
Andet

GUIDE LINES SERVE AS POLICE IN DIRECTING TRAFFIC

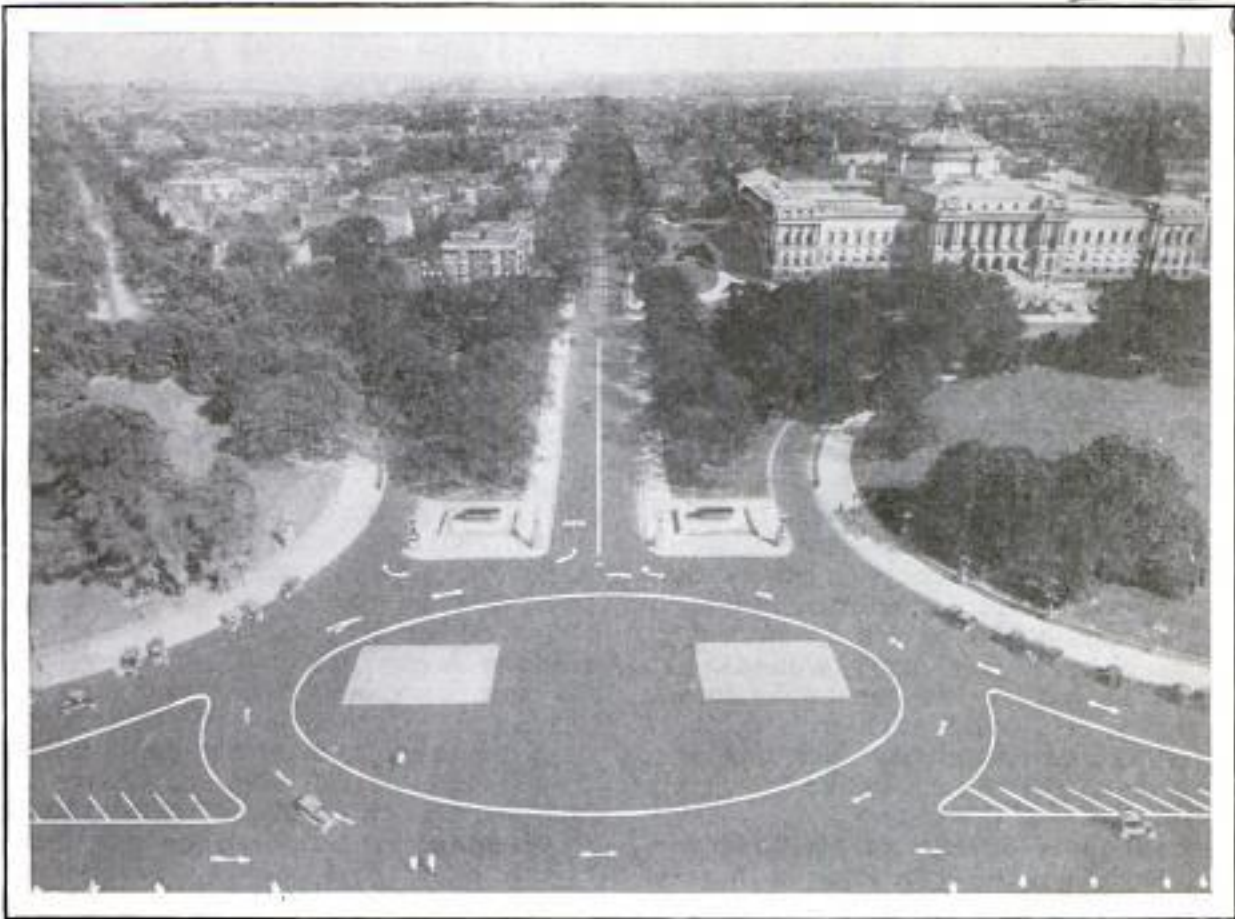

View of Plaza Taken from Dome of Capitol Building in Washington; Directions of Traffic, Parking Spaces and Forbidden Zones Are Plainly Marked in White Paint

Traffic guide lines and arrows, painted on the pavement of the Capitol plaza in Washington, D. C., serve as silent policemen, directing drivers which way to turn and where to park. Before the street had been mapped in this manner, the plaza was the scene of accidents almost daily, for traffic discharged from intersecting avenues into the circle made it a confused whirlpool of cars. The painted indicators perform the service of several policemen.

**GARDEN TRUCK GROWN FASTER UNDER ARTIFICIAL LIGHT**

Lettuce was grown from seedlings to heads in two to four weeks' less time than usual and sweet pea blossoms were produced four weeks earlier than was possible in daylight, by using powerful electric lamps to supplement the sunshine. The experiments were conducted by a plant-research institute with forty-eight lamps, each of 1,000 watts. They were suspended from a motor-driven crane and were moved over the greenhouse after dark. Other tests made in cellarlike rooms, to which no daylight was admit-

ted, showed that artificial illumination alone produced vigorous plants that matured earlier than under normal conditions. Nasturtiums grown under the lamps were found to last longer than those produced under natural light.

**WHOLE PACK OF CIGARETS IS HELD BY CASE**

Saving the trouble of carrying a few smokes in the cigaret case and the rest in the original carton, a case is being marketed that holds an entire package. Its top is held down by a spring and is opened by pushing a button on the face of the case. This lifts the cigarets and their pressure against the top forces it upward.



Borax was extremely rare and almost as precious as gold in early times.

Boyce-Thompson Institute for Plant Research  
Yonkers, N. Y.

Entered  
 Benjamin L. Hall  
 721 8th Avenue  
 Clark Park, Ill.

# WHAT YOU SHOULD DO WHEN YOU CUT YOUR FINGER

By DR. HERMAN N. BUNDESEN

Commissioner of Health, City of Chicago

376

WHILE cuts usually are not dangerous unless an artery or a vein is severed, they are likely to give considerable trouble if not properly treated. Over 600 persons die in the United States every year from the effects of cutting or piercing instruments, and many of the injuries were not at first considered serious.

Have the wound cleaned. That is the first and one of the most important steps. Always try to get someone to dress the cut for you. The cleansing should be done carefully so that no dirt or other source of infection is left in or introduced into the wound. If the skin is covered with grease or oil, remove this with benzine or alcohol (not wood alcohol). Green soap and water are sufficient in other cases. Rub away from the cut so that foreign matter will not be brushed into it.

The next step is to use an antiseptic. Iodine is good for many wounds. It should be put on with an applicator—a toothpick or a small stick with a bit of gauze twisted around it. Use this as a swab, dipping it into the iodine and gently brushing it over the injury.

Next, apply a strip of sterile gauze. Handle the gauze by the ends so that the fingers do not touch the part that is to come in contact with the wound. Lay the piece directly on the cut and then apply the bandage.

This should be wound firmly but not

too tight. With a little practice, you can learn to twist the cloth as you wrap it, so that it will not slip. Split the end for tying or use a cord or sew the bandage. Use no salves or ointments.

If a vein or artery has been severed, call or visit a doctor at once, and in the meantime endeavor to stop the bleeding. This can usually be done with a tourniquet, improvised from a handkerchief and a stick. Fold the handkerchief diagonally, bring the opposite corners up and spread them so the cloth will be nearly the same width throughout.

The important point to observe in using a tourniquet is the position of the wound. If an artery has been cut, which is indicated by intermittent spurts of bright-red blood from the wound, the tourniquet should be applied above the wound. When a vein is severed, the blood will flow evenly and will be darker, and the tourniquet is put on below the cut because blood in the veins flows back toward the heart. After tying the handkerchief in the proper position, insert the stick between two folds and turn it until the bleeding stops. Loosen the tourniquet slightly after a few moments to ease the strain and cleanse the wound, but twist it back again quickly.

The above applies to cuts on arms and legs only; for cuts on head, neck and trunk, a doctor should always be called.

## RADIO TUBES IN PHONOGRAPH PRODUCE BETTER TONE

Principles of the radio and talking machine are combined in a phonograph equipped with vacuum tubes that not only amplify the sound from the record, but also reproduce high and low notes ordinarily lost in the usual instrument. Instead of relying wholly on the action of the needle to give the tones, the improved apparatus transmits the vibrations with the aid of vacuum tubes into a loud speaker, so adjusted that sounds of from 20 to 18,000 vibrations per second are said to be

evenly produced. A jack allows use of the loud speaker with a radio receiver, and current also may be supplied from the batteries in the phonograph.

## LIMOUSINE TAXICAB PROTECTS DRIVER FROM COLD



Exterior of Luxurious Limousine Taxicab Which Adds to Comfort of Passengers and Drivers

Drivers are snugly protected from the weather in taxicabs a mid-western company has adopted to replace its open-front cars. As in a private auto of this type, the chauffeur is shielded by drop windows and front shield. The glass between driver and passenger is left.

535

Panatrophe

Brinsich-Balke-Collender Co,  
629 S. Wabash  
Chicago

Stuchens an  
Chicago  
Yellow Cab. Co. 581 W. Chicago



376



After Wound Is Washed, Prepare a Swab for Applying the Iodine by Rolling a Bit of Gauze on a Toothpick or Other Short Stick



Paint the Cut and Surrounding Area with Iodine; Do This Gently but Thoroughly, for the Idea Is to Keep the Wound Clean



Next, a Strip of Sterile Gauze Is Laid upon the Cut; Hold It by the Ends So as Not to Touch the Part Resting on Wound



There Is an Art in Applying the Bandage; by Twisting It as Indicated, It Can Be "Woven" on the Arm So It Will Not Slip



Split the End When Bandage Is On and Use the Parts for Tying; This Is Simpler than Use of Twine or Sewing



Applying Tourniquet; Put a Stick into Loop Formed in Handkerchief and Twist Until Pressure Pinches Blood Vessel Shut

Carthay Center  
 896 Beverly Hills, Calif.  
 509

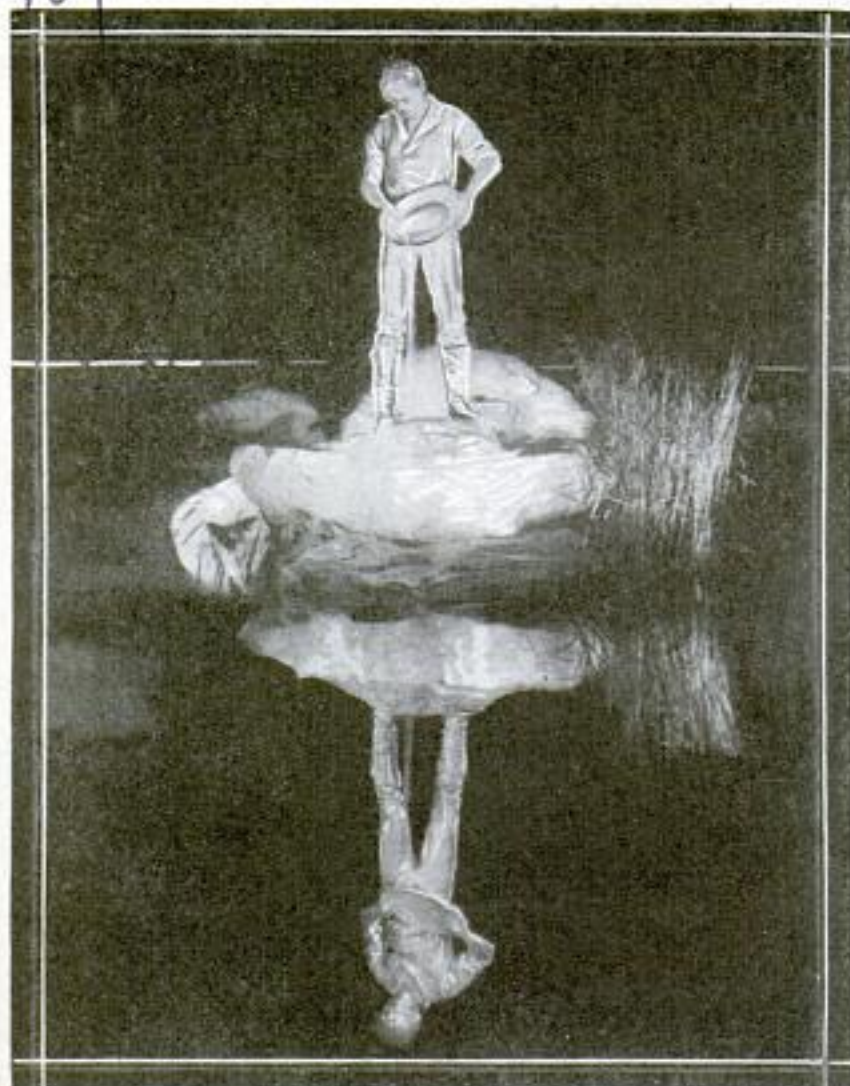

Bronze Statue of Daniel McCarthy, a California Pioneer, as It Appears When Illuminated at Night and Reflected in Pool

**DAYS OF GOLD RUSH RECALLED BY BRONZE MEMORIAL**

509 Days when gold seekers hunted hidden wealth with pick and shovel during the rush of '49 are suggested in a bronze statue of Daniel McCarthy, a California pioneer. The figure stands in a small park in Beverly Hills and is illuminated by floodlights at night. The subject is shown with a replica of a pan such as prospectors use to wash dirt from gold.

**LIVE SNAILS STORED FOR WINTER-FOOD SUPPLY**

54 Twenty million live, edible snails are annually collected and stored during the summer months in cold-storage depots in Paris to await the later demand for them. The temperature is

Pittsburgh Gazette  
 10/4/25

kept as nearly as possible to that of the average winter, to cause the snails to go to sleep in their shells so that they will be fresh when the cold season arrives, the only time when they are considered good for food. When the mollusks are caught, they are packed in wooden cases on layers of straw and taken to the storage houses. The traffic is confined to two varieties.

498  
**SIMPLE REFLECTOR MAKES DRAWING EASY FOR ALL**

With the aid of a reflecting instrument, inexperienced persons, young and old, are said to be able to draw cartoons, portraits, landscapes and other subjects with little difficulty. The apparatus consists of a jointed metal holder, adjustable to many angles and an eyepiece containing small mirrors to reflect the object on a piece of lined glass. The draftsman looks through this glass to his paper

below and, following the lines as a guide, copies the reflected image. The outfit is adapted to reducing or enlarging.

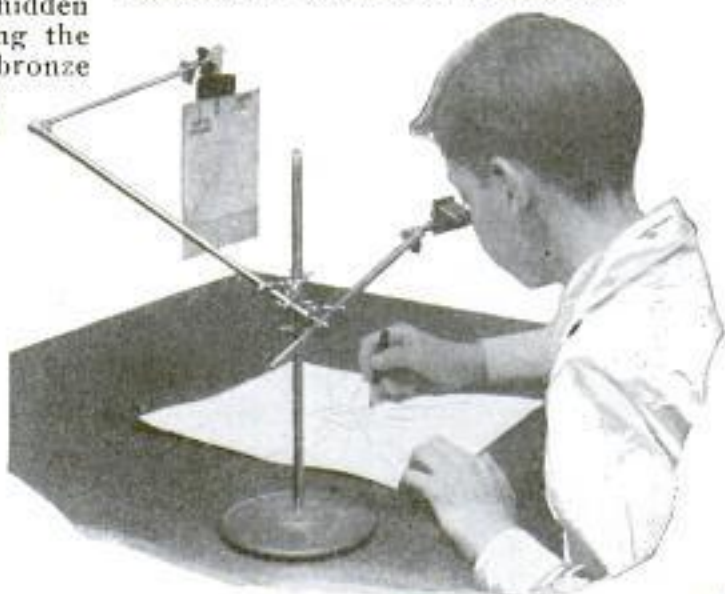

Drawing a Map with Aid of Reflector

The Davis Reflectograph Co.  
 1211 Exeter St. Cincinnati, O.

End of business  
 5/1/30

## UNDERGROUND PUMPS TO SAVE GREAT CATHEDRAL



Aerial View of St. Paul's and Glimpses of Repair Operations, Filling Piers with Liquid Cement

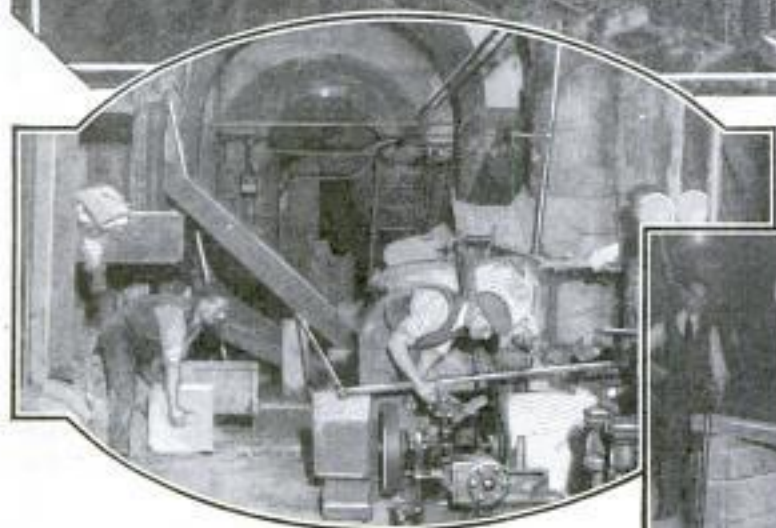

© London Daily Chronicle

Deep down in the vaulted crypt of St. Paul's cathedral, London, in the shadows of great men's tombs, an underground army of men has been at work on the risky job of pumping thousands of tons of liquid cement into the base of the piers which support the mighty dome, 400 feet above their heads. Great cracks, appearing in the pillars, have threatened the safety of the dome. It was feared that if the fissures were unchecked, many thousands of tons of masonry might come crashing down, an event that would undoubtedly have disastrous results, for the cathedral lies in the heart of London surrounded by offices, stores and public buildings. The exterior of the piers is solid masonry, but the interior is filled with loose material which has shifted and settled, causing the cracks. Several years ago, engineers engaged in the construction of an electric underground railroad running to the Bank of England, swung the line in a great curve to avoid disturbing the foundations of the cathedral. But

the base has been slowly settling. During the repairing operations, forty-nine holes were drilled sixteen feet deep into each pier. Through a tube inserted in each hole, liquid cement was injected. The noise of the pneumatic drills and the chugging of the cement pumps echoed so loudly through the aisles of the cathedral that guides, showing visitors about, had to speak with megaphones. Each hole was numbered and lettered and the pumping operations were supervised by another group of men, moving about, pencil in hand, among miles of coiled tubing, timber braces and tons of cement in bags. Great care has been taken not to disturb the tombs of famous men including that of Sir Christopher Wren, the builder of the cathedral. Memorial tablets, cut away to get at the piers, have been stored until they can be replaced.

An Canadian tracks Kansas City Mo  
9/22/25

456

### BRITISH PLAN TO RECOVER CHEMICALS OF DEAD SEA

Planning to extract the 30,000,000,000 tons of mixed salts suspended in the waters of the Dead Sea, British authorities in charge of the Palestine government have invited private firms to submit offers for the extracting concession. The salts of the world's lowest body of water, a thousand feet below the level of the Mediterranean, are estimated to include 10,000,000,000 tons of common salt, 20,000,000,000 tons of potassium chloride, the potash used in fertilizer, magnesium bromide and several other chemicals. The problem of recovery is said to be quite simple, in that no fires will be needed, the rays of the desert sun being strong enough to evaporate the moisture if the salt-charged waters are pumped into shallow settling tanks. The origin of the Dead Sea is a mystery to scientists. Fish cannot live in its waters, no sea birds hover over it, and there are no craft on it. Owing to the absence of fresh water, there is no vegetation on its shores, where bare rocks rise in frowning precipices. Geologists say the sea bed is the deepest sinkhole on earth, and was formed a million or more years ago. The Crusaders and early religious pilgrims gave the place a bad name, bringing back stories that the air above the sea was charged with poison gases, and its waters and shores were peopled with "frightfully hideous" monsters. There is evidence that at one time the level of the sea was much nearer that of the Mediterranean, but as it has no outlet the gradual evaporation of the water reduced the contents, and thereby increased the ratio of salts per gallon.



Jockey's Protective Fiber Helmet Fits Snugly and Does Not Interfere with Cap

### FIBER HELMET UNDER CAP PROTECTS JOCKEYS

Worn under the regular cap, a fiber helmet for jockeys is intended to protect the head in case of accidents. It is flexible enough to fit tightly without binding and does not interfere with the visor of the outer cap to shield the eyes. It can also be used by building workers and others to protect them from falling objects.

### BALLOON-TIRE CAR STEERS WITH TWO WHEELS

Believing that the ordinary auto-steering gear has too low a ratio for efficiently operating at high speed a car fitted with balloon tires, a middle-western company has devised a dual guiding system which has two wheels, one placed above the other, and two entirely independent gear ratios. The upper wheel operates the mechanism at a reduction of seven to one and is used for ordinary driving, while the lower, geared at fourteen to one, affords greater leverage, an advantage in driving at low speeds or while steering the car in or out of a parking space. Besides, it is asserted that the special gear promotes safety at high speeds.



Monster Coast-Defense Gun Mounted on Railway Carriage

### GIANT COAST-DEFENSE GUN RUNS ON RAILROAD

Mounted on a special railway carriage for quick moving, a fourteen-inch gun for the Pacific coast, fires a projectile weighing 1,400 pounds. The gun is said to be the largest unit in western coast defenses and was hauled overland by rail from the proving grounds at Aberdeen, Md., where it had undergone the regulation tests by government ordnance experts.

International  
Suggest Lehman, Mc Kay, McG  
Magara, Della, etc.  
Revere Motors Co., Ind. 500  
Loganport, Ind. 500

International Copyrighted material

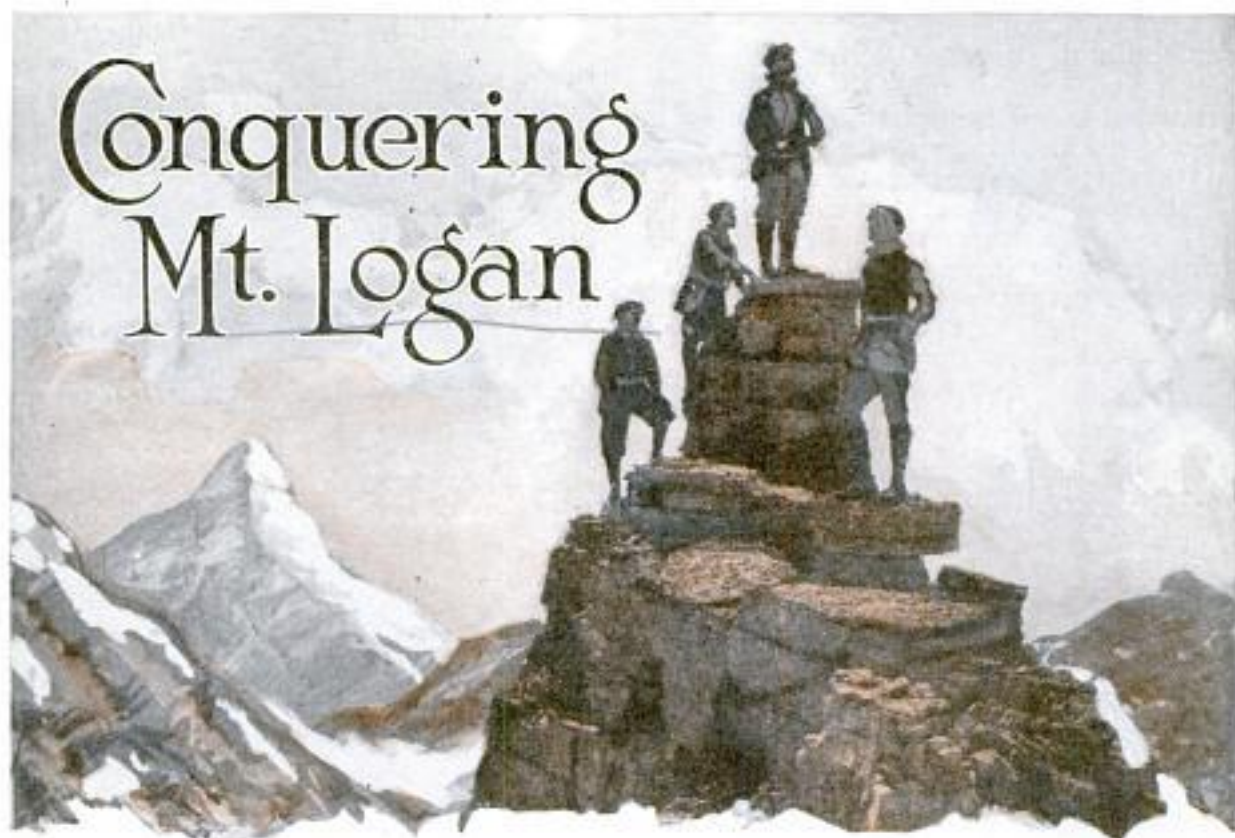

Photos Courtesy of Canadian Pacific R'y

**D**AZED from weeks of suffering, with hands and feet frostbitten, six explorers, with two Swiss professional Alpine climbers, last summer conquered the 19,850-foot peak of Mount Logan, the highest peak of Canada, Alaska and the Yukon.

Almost inaccessible in the heart of the northern wilderness, the mountain has defied conquest for years, and nearly claimed the lives of the eight before they finally crawled, on hands and knees, to its flat, triangular top, barely sixty feet across.

And as a climax to the adventure came a glimpse of the Ulloa circle—a series of rainbows forming a perfect circle, in which each saw a vastly magnified image of himself staring back from its center. Only one of the party—all enthusiastic mountain climbers—had ever heard of this queer apparition, first encountered on the Saxon mountain of Brocken, legend home of the witches of Germany, in 1780, and famed in story, along with the other witches of the mountain, in the Brocken scene of Goethe's *Faust*. The specter, which aviators frequently encounter when flying above misty clouds in the late evening, is sometimes a shadow of the observer thrown by the low-lying evening sun on a cloud bank, or more rarely an Ulloa circle, which, instead of

being a silhouette shadow, is an image reflected from ice particles in the air.

"The top of Mt. Logan was a raging hell such as I never expect to see again," Capt. A. H. MacCarthy, leader of the intrepid eight, said after his return in a report delivered before the Alpine club of Canada and the United States. "The thermometer registered thirty-three degrees below zero, and the wind was so terrific that we had to lie down and hold on to keep from being blown into space. The altitude had so affected us that we all were hardly conscious of what we were doing. If I had not reached the summit that day, I could never have considered going back again."

The eight had, after weeks of effort, succeeded in establishing an advanced base camp about 8,000 feet above sea level. From that they started, and for exactly three weeks, toiled up through the cold and snow to cover a distance of eighteen miles and climb the final 12,000 feet. Going down was even worse, three weeks and two days being taken for the descent, or a total of forty-four days to make thirty-six miles.

As they climbed miles above sea level in the glare of the midnight sun, "we suffered terribly from hallucinations and mental aberrations," Capt. MacCarthy explained. "As we groped upward, half out

of our minds from the effects of exposure and the high altitude, we saw nice warm barns and cozy farmhouses, peopled by comfortable families, resting on the crags around us, but for fear of being ridiculed and accused of wanting to rest, no one would mention what he saw, thinking that soon the others would see the same thing, mention it, and then we would all go in and get warm.



Mountain Climbers, Roped Together for Protection, Working across the Face of a Glacier, and, at Left, Climbing an Ice Precipice

"As we climbed, we established camp after camp, leaving covering and food and fuel to be utilized on our return. But when we came back, we were too dazed to be fully conscious of using the camps, so disturbed had our minds become. Each of the camps is there yet, for we hadn't energy enough to take them down and salvage the material.

"The altitude and the tremendous exertion required to lift each leaden foot and move it upward a step, left just energy enough to dig out shallow tunnels in the snow, sufficient to admit the

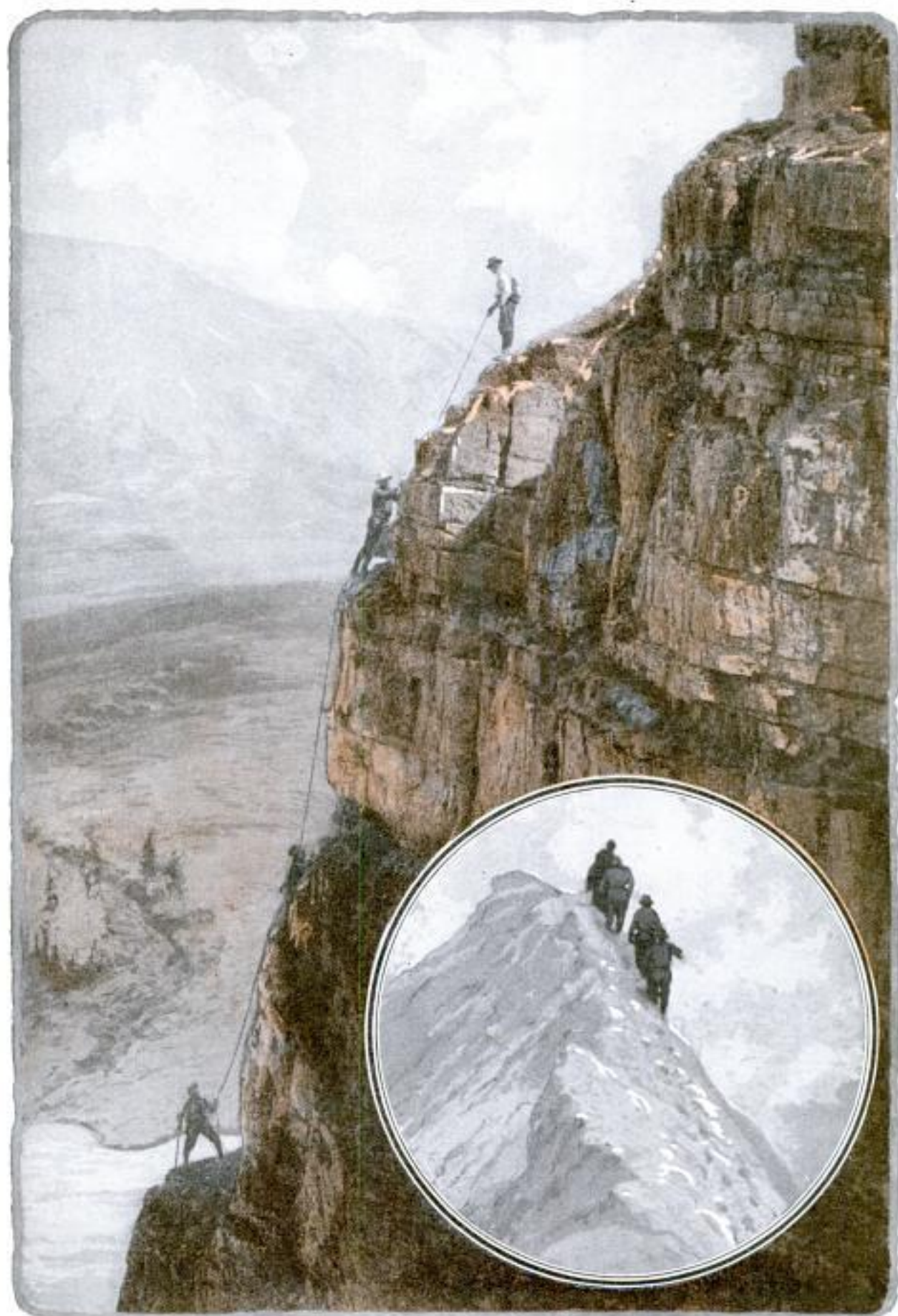

Scaling the Rocky Heights on the Way to the Snow Line, a Picture Taken on Mount Assiniboine, in the Canadian Rockies; Inset, a Typical Knife Ridge of Snow at the Peak



One of the Glacier Camps of the Mt. Logan Expedition, and, Left, Climbers Negotiating the Serrated Peaks of a Canadian Glacier

trunks of our bodies. We would crawl into these and doze and shiver.

"This went on for weeks in the chilly whiteness of the northern snow fields. Finally, just before we reached the summit of the topmost peak, the most dangerous ascent of all was encountered. For several hundred yards we had to crawl up a knife-edged ice ridge, with almost perpendicular drops of several thousand feet on either side.

"Suddenly the ridge spread into a flat triangle of snow, sixty feet across—the summit of Mt. Logan, seen for the first time by the eyes of men.

"As my head reached and peered over the flat triangle, I was startled by seeing a small rainbow with my exact photograph, greatly magnified, in its center. Knowing that the rest of the party had showed continued evidence of being off their mental balance, and realizing that I must be slightly off too, I was afraid to make any noise about it.

"But I clung on the ice against the wind and watched



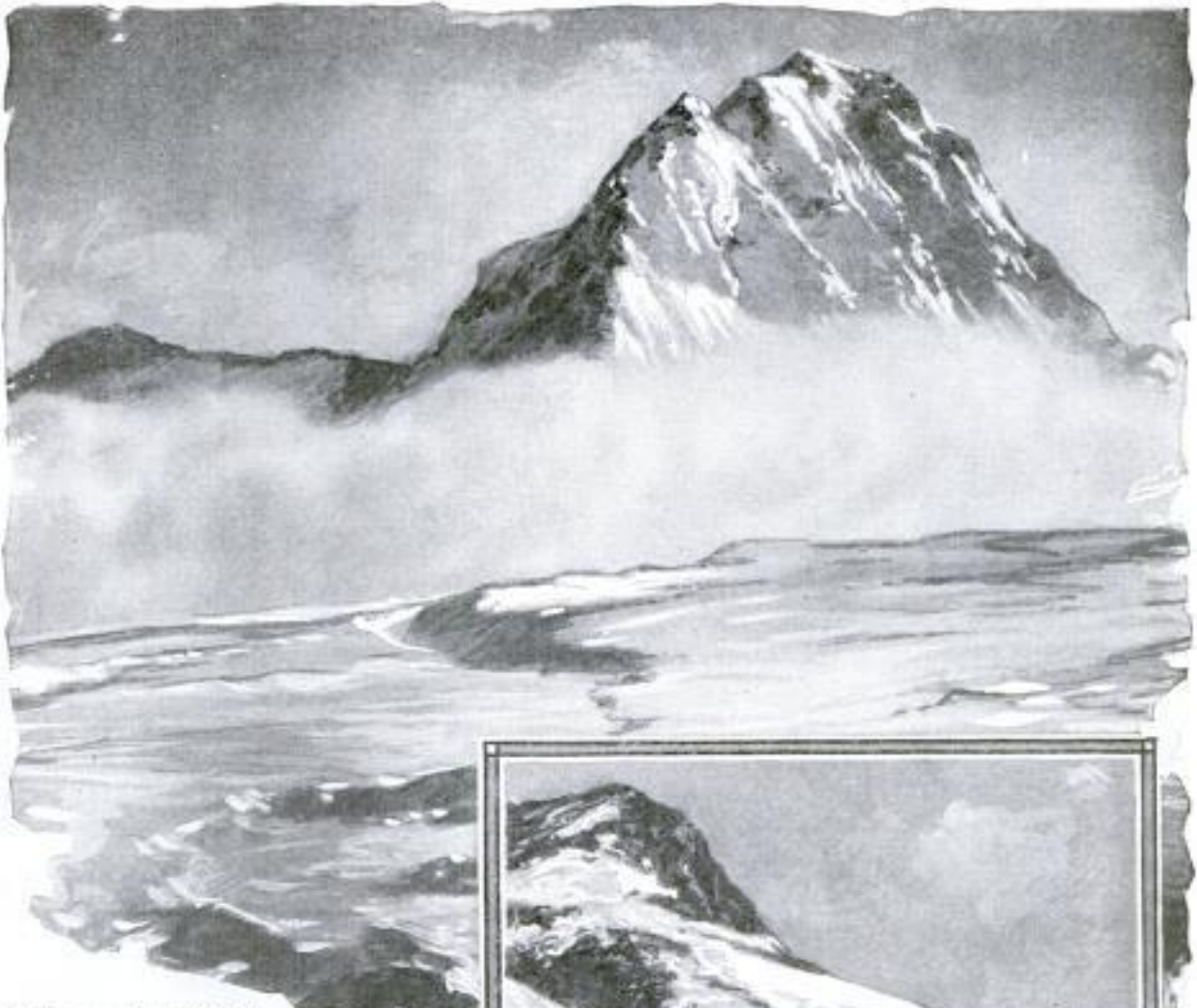

Mt. Logan Ice Field at Windy Camp, 16,800 Feet above the Sea and Still 3,000 Feet from the Lofty Summit, Seen Beyond; Gales Roared through This Valley Every Hour; at Right, a Bit of Difficult Climbing

the others come up and noticed a half-frightened look in each of their faces as they peked over the top. They, like me, were afraid to mention what they saw. But finally I mustered up courage and said: 'Men, do you see what I do in that rainbow,' and they all answered, 'Yes.' Then Col. Foster explained that it was a Brocken specter. I had never heard of such a thing before.

"The sight from the summit was spellbinding. We had to take our observations lying on our bellies and clinging on against the wind. The massive peaks below looked like pin points a few feet high. We were able to remain on that gale-swept height but fifteen minutes. Snow almost immediately joined the

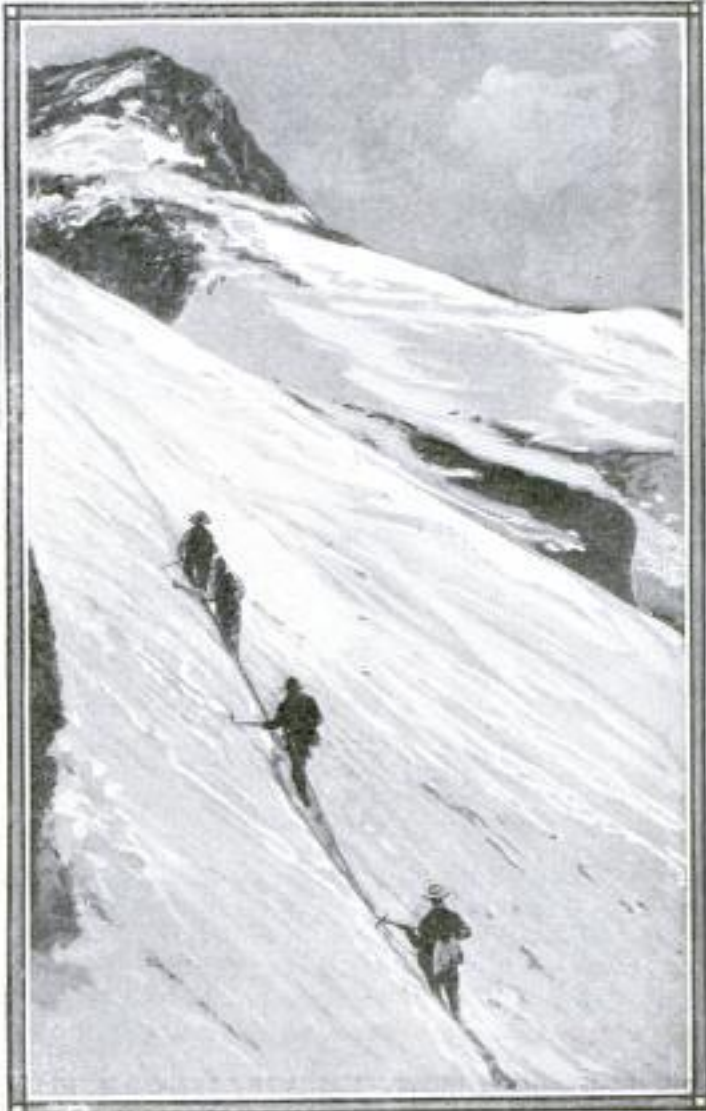

221

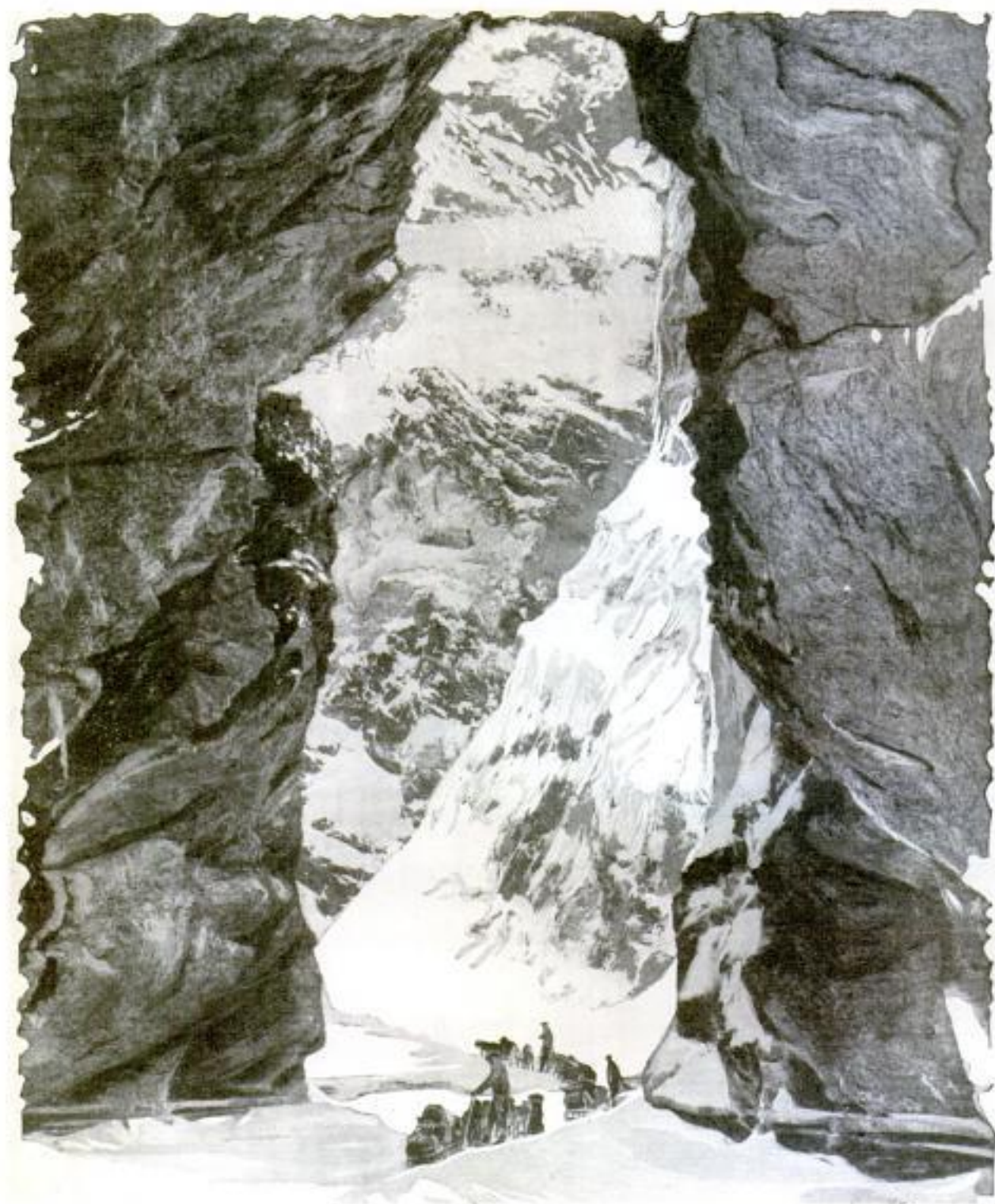

Mt. Logan Expedition Passing through the "Devil's Door," a Natural Rock Portal to the Heights Lying behind It

wind and formed the most terrific blizzard I have ever seen. Several days later when we reached the foot of the hurricane ridge, still more than 18,000 feet up, it seemed for the first time during our trip that the end for all of us was near. The men staggered into the camp, sat down and wouldn't move. I was the same way. We were just half conscious of life

and did not have one ambition left in the world. Blinded by snow, made half insane by the continuous exposure to high altitudes, we had reached the point where physical feeling ceases and a sort of false sense of comfort sets in. I know that if we had spent the night there, as we had intended to do, it would have been the sleep of peace for all of us. So after half

437

an hour of this stupor, I made the men move on. I knew that exertion was the only thing that would save us, and it did."

As the little band groped its way downward, tied together on two long ropes, one of the packers, who was leading on his rope, dropped from sight over an ice wall. MacCarthy went to the edge of the cliff and called again and again but received no answer until finally the packer, who had landed on a tiny snow ledge and been stunned by the fall, revived and shouted back. It took the entire seven men, weakened by their weeks of exertion, to pull him back to the surface. From the peak of the mountain, the trail led down to a glacial plateau with an elevation of 17,550 feet, and then back up a hard climb to a pass on the mountain col a thousand feet higher. About halfway up the exposed mountainside, as they climbed back to this point, the explorers were met by a hurricane.

"The temperature dropped rapidly," Col. Foster, one of the party, says. "Only with extreme difficulty could we keep any footing, the wind being strong enough to blow one over unless supported by crampons and ice axes. After nearly two hours' battling with the storm, the second rope, on which were MacCarthy, Carpe and Foster, reached the col, finding near there one member of the first rope, Read. He said the others on his rope were still down the slope, and MacCarthy, taking Read with him, immediately went back and found them in an extremely precarious position. It was only by heroic exertion on the part of MacCarthy and Taylor, the packer who had dropped over the ice cliff the day before, that loss of life was averted."

After struggling for twenty-three days to get back to the base camp, at the foot of the Yukon cascade, the explorers rested and recuperated and then tackled the task of getting back to civilization, represented by the village of McCarthy, eighty-two miles away. They decided to build two rafts and float down the Chitina river to the Nizina river, and then walk twenty-seven miles overland to the town.

### TEN THOUSAND PIGEONS RACE OVER HUNDRED MILES

Ten thousand pigeons were entered in a recent flying race from the stadium at

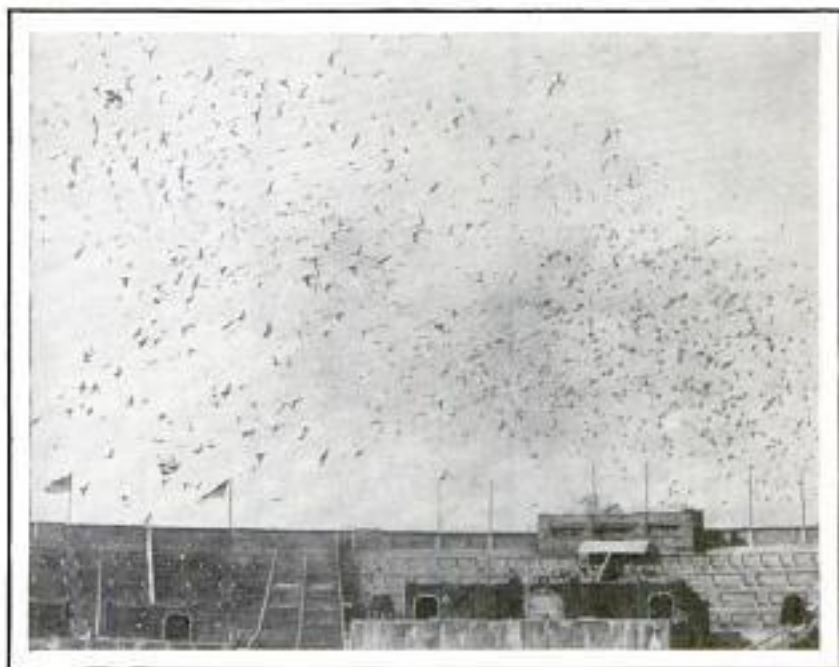

Clouds of Pigeons Circling over Wembley Stadium before Starting Their Race to Cardiff, Wales, 125 Miles Away

Wembley, Eng., to Cardiff, Wales, a distance of nearly 125 miles. As the birds were released, they circled over the amphitheater for a few moments before getting their bearings and starting off on the flight. Men were stationed at Cardiff to announce the arrival of the winners.

### PENCIL CARRIES FIVE LEADS OF DIFFERENT COLORS 443

Five leads, each of a different color, are carried in a recently marketed pencil for artists, draftsmen and others. The desired point is selected by turning a small drum located near an opening which exposes the contents of the magazine, and

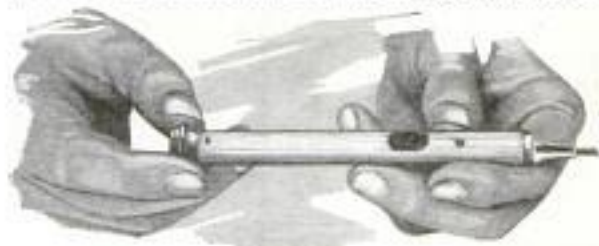

Pencil with Color-Indicator at Right

it is placed into position for use by twisting a knob at the end. The pencil is refilled with each color separately through a common opening.

*A. Aronson, 236 W. 55th St. New York*

*Price - \$1.50  
10 leads - 25¢*

Cmt. L. B. Tichenor  
 534 Findlay St.  
 906 POPULAR MECHANICS  
 Cincinnati, Ohio

Miller Brothers  
 101 Ranch  
 Maryland  
 Ohio

**FIRE-ALARM TRAINING SCHOOL**

**TEACHES CITIZENS**

413

The fire department of an Ohio town maintains a training school to teach the citizens the proper methods of sending in



Sign on Engine House to Call Attention to Citizens' Fire-Alarm Training School

alarms. Large signs on the engine houses call attention to the school, and the firemen act as instructors. The use of the telephone is discouraged in favor of the more expeditious way of relaying alarms directly from the street boxes. Since the system was established, the town has been free from serious fires.

**BRITISH PARLIAMENT HOUSES TURN INTO EPSOM SALTS**

The Houses of Parliament in London are being gradually turned into epsom salts by the action of fumes in the air on the magnesian limestone, of which they are built, according to Sir Frank Baines, British director of works, who has prepared plans for restoration of the more decayed portions. Over thirty-five tons of ornamental coping and other sculptured parts have fallen from the building during the last few years, and the condition has become so serious that, some months ago, warnings were posted along the famous luncheon terrace overlooking the Thames, advising visitors to sit near the river wall and keep away from the zone of falling stonework. Fumes from potteries located across the river are blamed for the chemical change in the stone, which is leading to its gradual dis-

integration. Dilute sulphuric acid from the pottery kilns is carried across the river and settles on the magnesian stone. The repairs contemplated will cost at least \$4,800,000, according to the estimates. The damage is particularly severe along the 940-foot river facade, where the wall was topped by a row of minaret-like spires.

**TURTLE DERBY ADDS THRILLS TO WILD-WEST SHOW**

407

Turtle races proved an exciting feature of a wild-west show in Oklahoma recently, drawing thousands of persons and bringing a prize of \$1,679 to an eight-year old boy, owner of the "dark horse" terrapin that unexpectedly won the finals in an elimination contest replete with thrills. Each lumbering contestant was numbered on the top of its shell, and the racers were started from a circular corral that could be raised on a pole support, permitting the turtles to dash simultaneously to the finish line, seventy-five feet away—if they chose. Many refused to start at all, or stopped abruptly when part way down the course, thus emphasizing the element of chance and adding zest to the betting. One, after a speedy trip, halted on the finish line, refusing to cross until its competitors, which had been far outdistanced by the first spurt, had all finished the race. Cowboys were dispatched throughout the countryside to collect turtles for the races, and more than 1,500 were entered. Second, third and fourth prizes, totaling nearly \$1,700, also were awarded.

**GUARD FITS INSIDE KEYHOLES TO PREVENT PICKING LOCKS**

151



Doors are made almost as secure as when fitted with cylinder or other safety locks by means of an expanding guard that is slipped inside the keyhole and grips the doorplate on the other side. It may be used either from the interior or exterior and is

provided with a hole for the attachment of a padlock to prevent its being pulled through the opening.

Keelock Mfg. Co. P. 210  
 Regener's Bldg. New York  
 300 Broadway

London Illustrated News 391  
 9/15/25

owned by P. J. Stephen, Jr. Ponca City, Okla.  
 Price \$1.00 per set in 1925

317 million

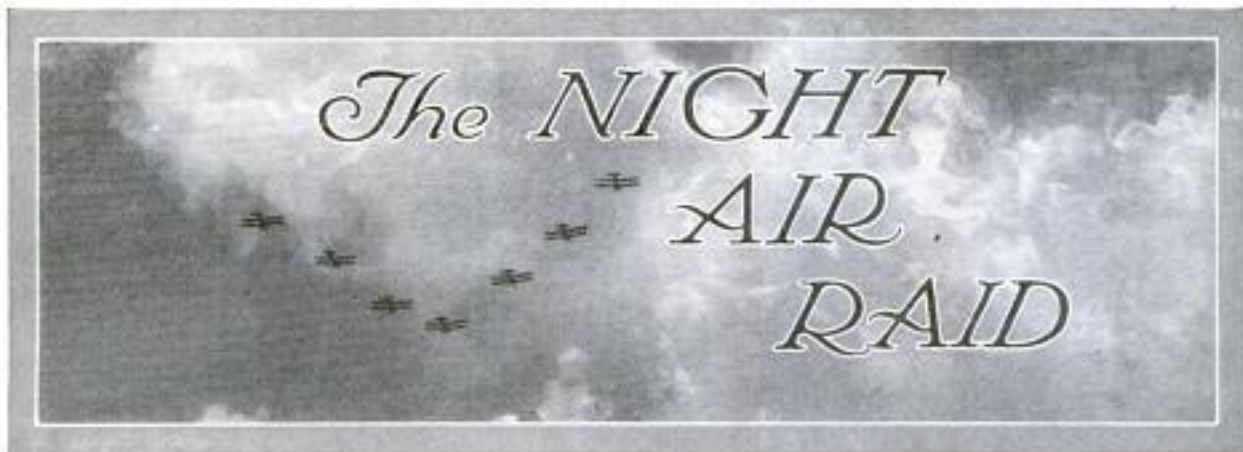

**Bombing Squadron, in Practice Flight, Sweeps Coast from Capital to New York, Showing It Is at Mercy of Superior Air Force**

Lieut By CORLEY McDARMENT *Esordon Hotel Washington D.C.*

IT was shortly before dusk. The army flying field near Norfolk, Va., was the scene of tense activity. Twelve giant bombing planes squatted upon the flying line with their motors turning over at idling speed. Presently, the mechanics began piling tool kits, handbags, thermos bottles and sandwiches into the rear compartments of the machines, while the officers gathered in a little circle and carefully read some final instructions.

It happened not very long ago, and scant notice was taken of it in the press, but some day, the official report of this remarkable and spectacular flight will be studied with utmost care, not only by aviators who already have become acquainted with its contents, but by others who are responsible for the safety of this country. On this particular night, two things were to be done. The first was to move the base of a bombing squadron over a distance of about 400 miles, and the second to raid cities along the Atlantic coast.

The start from Langley field was as interesting as the finish in New York. When the leader of the big nine-ship formation had completed his verbal instructions, the group of officers quickly scattered. Two of them started for each bombing plane. Two enlisted men, who had been standing beside the massive fuselages, began to climb aboard when they saw the officers approach, one into the nose and the other settled himself into the rear, where he fastened a wide belt around his waist, put on a pair of ear-phones and began turning little dials with tiny luminous lines on them. This man was the radio operator for his plane; the man in the nose was the bomber. He was to drop theoretical bombs on certain parts of the nation's vitals along the way.

When the two officers clambered over the broad wings, they made their way to the two seats just in front of the wings and between the two Liberty motors. After adjusting the safety belts, one of



City Lit Up at Night, Showing How the Towering Buildings Stand Out against the Blackness of the Horizon, Guiding or Offering a Target to the Airman

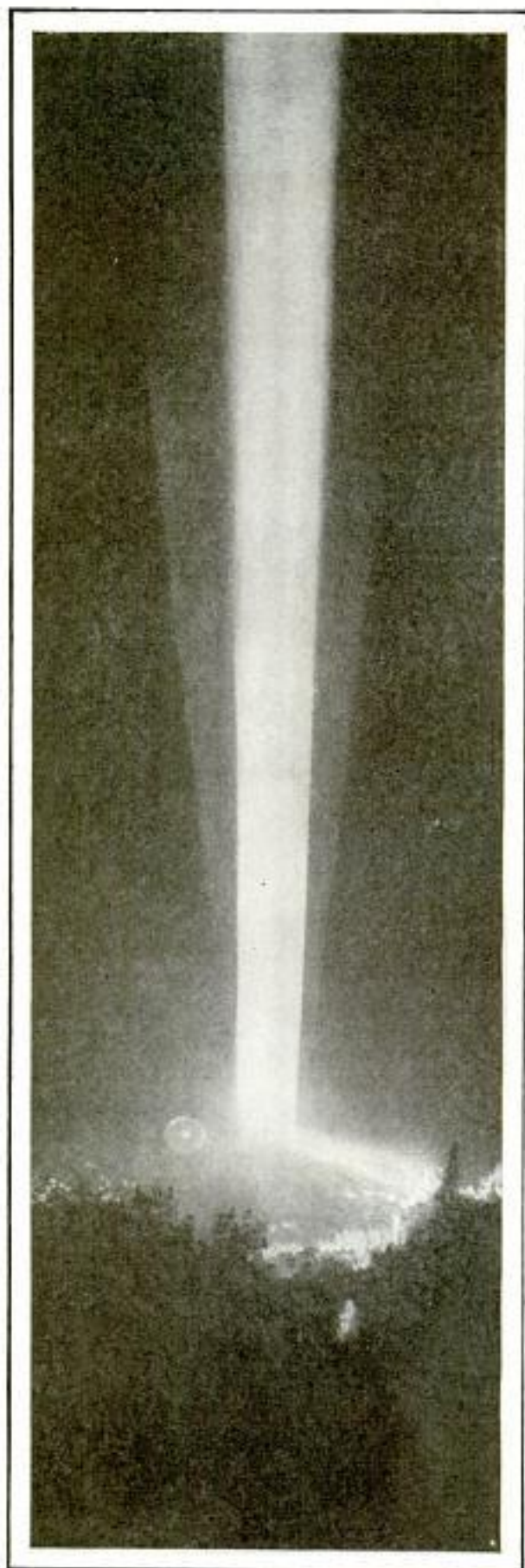

A Beam Shot Upward from a Portable Searchlight at Langley Field, Beckoning the Aviators to Return in Case of Trouble

them began to lay out several maps, fastened to thin boards, into the flood of the light in the cockpit. After getting the maps in order, he turned off the bright lights and left only a small dash globe burning, while the neat pile of maps was tucked down between the leather cushion and the side of the fuselage. This officer also leaned forward and looked at a small barrel-shaped chunk of metal that had a round window in it. Inside of the window, a little circular card swung slowly in liquid, but at each swing, the "E" of the compass card came back true to the center line. The officer scanned the heavens. He could scarcely make out the pointers of the Great Dipper, but he estimated the position of the North Star from them. He was the navigator. He was responsible for the direction of that one plane. As long as he followed the leader, his job was easy, but once out of the formation, his work was extremely delicate. Each plane had a navigation officer.

The other officer in each plane was the pilot. The pilots began warming up the motors at the same time. First one throttle was opened, then the other. When one engine's throttle was wide open, the ignition switches were snapped on and off to see if each was working. Several motors missed some on the left switches, but little heed was paid to it as the pilots knew from experience that a few minutes' flying would clean the plugs and all would be clear. But one thing each pilot watched with care was the flow of gasoline through the little glass tube along the center-section struts. This was most necessary, for the bombers worked on a forced-feeding system. A wind-driven pump sent the gasoline through the system, and a pump failure would be about as serious as running out of fuel.

By the time full darkness had come and before the moon had lighted the sky, all was in readiness to start the flight. The leader of the formation waved to the mechanics who were holding the ropes attached to the wheel blocks. The blocks were jerked away and the leading plane taxied slowly out into the middle of the field and swung her nose toward the north. The other planes labored clumsily out under bursts of first one motor then the other, and fell into line. A signal rocket went up from the leading plane and eighteen motors were opened wide. Slowly, but powerfully, the twin engines began stiffening up the formation as the 800 horsepower of energy took hold of the

Close View of a Great Twin-Motored Bombing Plane Which Took Part in the Night Raid on the Atlantic Coast; the Bomber Sits in the Nose Cockpit, the Pilot and Commander behind Him, and the Radio Operator in the Rear, Hidden Here by the Upper Wing

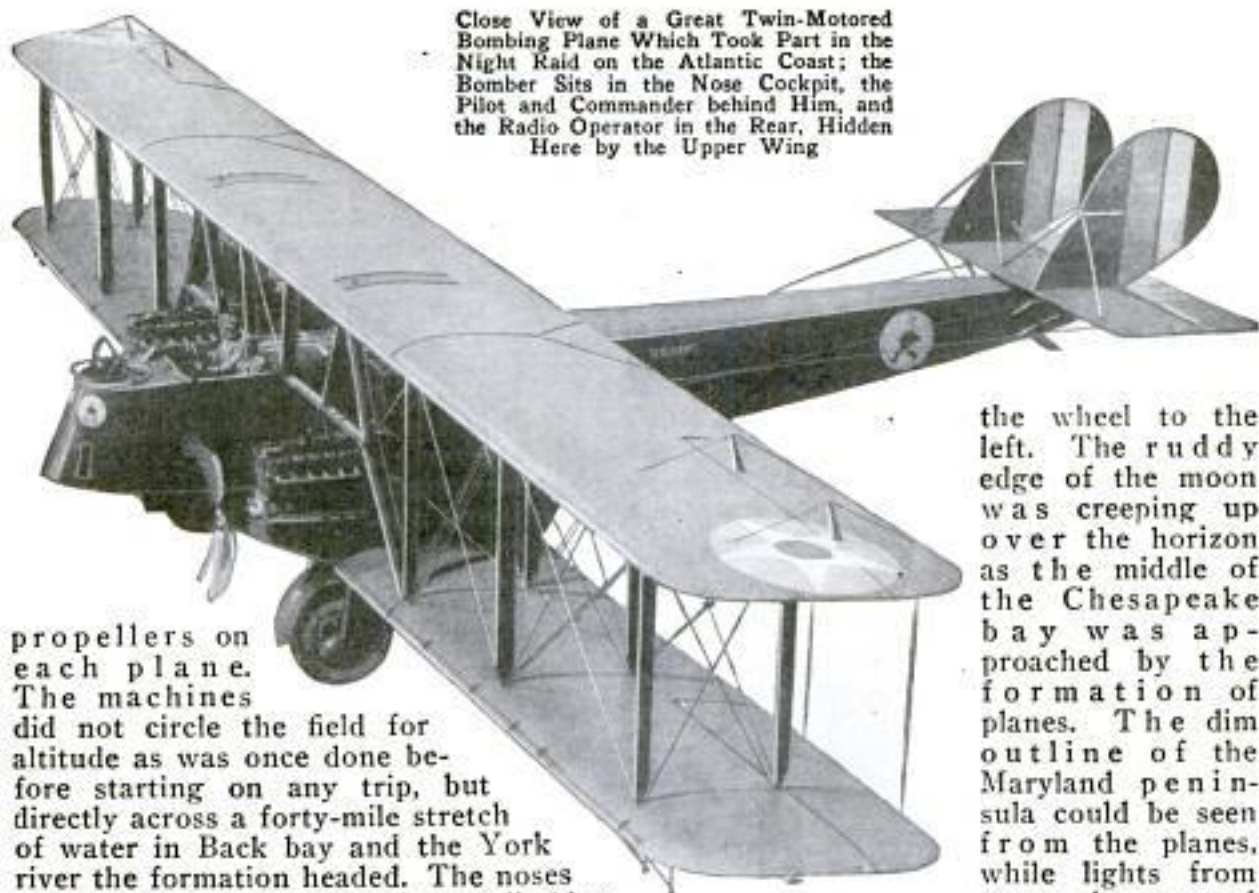

propellers on each plane. The machines did not circle the field for altitude as was once done before starting on any trip, but directly across a forty-mile stretch of water in Back bay and the York river the formation headed. The noses of the planes were inclined at a climbing angle. From each wing tip and tail, a bulb of light shone. As the night darkened, the exhaust pipes began to glow red and from each a trail of fire shot out like a comet's tail.

The leader of the formation had his own radio apparatus at hand. His ear-phones were inserted in his helmet and a speaking tube hung upon his breast, where it could be used without holding it in the hand.

The planes had ascended about half a mile when the leader tapped his companion on the arm and swept his hand toward the east. The navigator reached forward in the cockpit and pressed three times upon a switch key. The wing and tail lights on the plane blinked thrice. At that moment, the leader rolled the wheel of the machine a half turn to the right and pushed on the right rudder until the plane was cocked over at an angle of about thirty degrees; then he released the wheel and let it fly back into neutral of its own accord while the plane continued the bank. The course was being changed. All back along the line, the wing lights began tilting. The planes on the inside of the turn began to throttle down and float, while those on the outside speeded up to keep their positions. When the lead machine was headed due east, the pilot leveled up the wings with a slight roll of

the wheel to the left. The ruddy edge of the moon was creeping up over the horizon as the middle of the Chesapeake bay was approached by the formation of planes. The dim outline of the Maryland peninsula could be seen from the planes, while lights from towns, houses and

boats twinkled below as if mocking the stars above.

So far everything had gone along smoothly enough; too smoothly for the hasty preparations. The orders for the flight had been held up until it looked as if they would not come at all, and when they did finally come, the pilots wanted to take advantage of the moon during that part of the month.

Far behind the flight and to the southward, a single beam of light reached straight and still toward the Milky Way. The rumbling searchlight trucks were in action. The beam of light told the aviators the exact location of the flying field they had so lately left, and it beckoned them to return in case of trouble.

The leader of the flight smiled to himself as he saw how beautifully the planes were holding their places in the big V-shaped formation. He was contemplating the ease with which any such movement could be carried out at night, when suddenly a faint message began coming in from plane number four. The radio operator in the rear of the flag plane was on the same circuit with the leader and he immediately began to tune in on number four for better volume. Now the conversation was distinct:

"Left-hand motor is missing. Sounds like a frozen rocker arm. Believe I'll

have to drop out," came the message.

Then the leader spoke:

"Use your judgment. Don't take any chances."

"I'll go back and get another plane and, maybe, I can cut across the peninsula and catch you about Sandy Hook. Tell Lakehurst to keep out their lights."

"O.K.; we'll cruise along."

Plane number four blinked its lights three times. Number six flying directly behind, throttled down slightly to give room for a wide right-hand turn. Then the disabled plane swung out of formation and headed for the straight beam of light in the south. Number six closed up into the place occupied by number four and the flight continued. Away to the northwest, the sky showed a patch of dull light, somewhat like the coming dawn. It

"Don't try," commanded the leader, "no need to take any chances. Go back. You can get another plane and follow if you wish. The lights will be on along the way."

Plane number five blinked her lights twice. Number seven slowed up until five had banked to the left and swung out of line, then it closed up like number six had done on the right side, and the flight continued.

As the planes sailed out near the Atlantic shore line, ocean-going vessels could be seen. The freighters had their solitary lights fore, aft and upon the mast, but the passenger boats were lit up like a Broadway theater. The coast line was followed to Cape May, N. J. Here a spectacular thing occurred.

For some reason or other, the leaders of flights seem to play in bad luck. This



An Airplane Making a Safe Landing Guided by Its Own Wing-Tip Flares, Which Enable the Pilot to Determine the Smoothness of the Field and Level Out at the Correct Height above It

was Baltimore, the metropolis of the Chesapeake. The city was at the mercy of the air raiders. And away to the west a faint blotch of white on the horizon indicated Washington. On this city, a few well-placed bombs on large flat-topped government buildings could paralyze the whole army and navy. If every light in the capital were out, the city could be easily located by following up the silvery Potomac, and the white buildings of the city itself could not be mistaken on a moonlight night. The leader of the formation thought of the possibilities open to an enemy approaching the capital by air. He was wondering if such a thing would ever happen, when again a plane began speaking.

This time it was the pilot of number five, his plane being second behind the leader on the left.

"My ammeter is discharging—right-hand motor. Generator gone, but I can make it through on the batteries."

flight was no exception. When over Cape May, the leading plane developed motor trouble. The commander radioed that he would make a landing with the parachute and wing flares and try to find the trouble. He also directed the flight to continue on to New York.

The lead plane at once nosed down out of formation while plane number two moved up into first position, as is the custom. The formation then began a slow turning movement in order to remain in the vicinity to see how the leader fared on his forced landing.

From the former flag plane something black dropped beneath the fuselage, but it was black only a second or two. At once the object showed a streak of white fire, then suddenly the whole country for ten miles around was bathed in light almost as bright as sunlight. A parachute landing flare was paying for its keep. The pilots in the formation circling above could see their former leader banking to-



319

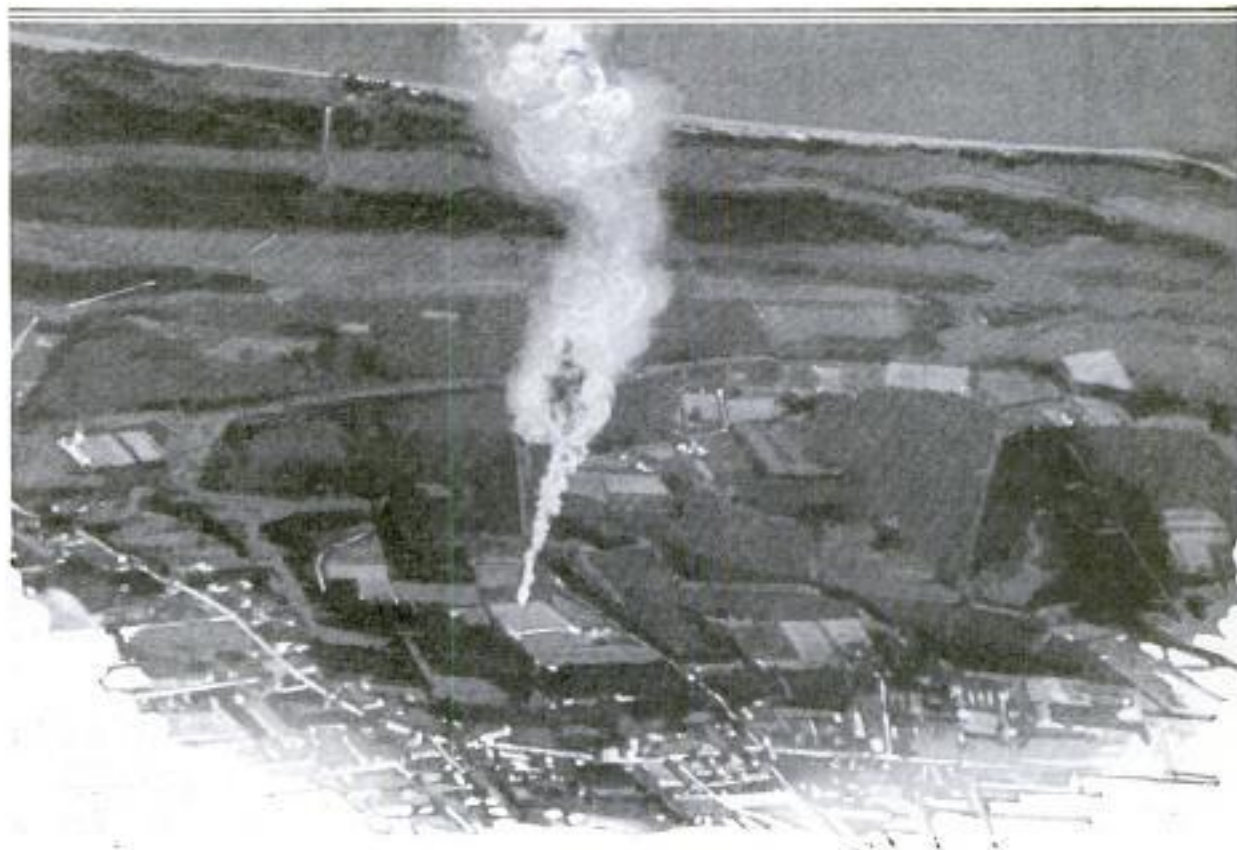

A Parachute Flare, Dropped from a Night Raider, Illuminates the Country for Ten Miles Around with a Brilliant White Glare, by Which the Aviator Can See to Pick a Safe Landing Spot

ward a large open field. Then the flare spent itself, and the blackness of the night became so thick, it could almost be cut with a cleaver. But it lasted only a few seconds.

Not far from the position where the descending plane was last seen, two great white fan-shaped beams of light burst forth, lighting the ground so that even the wheel tracks of vehicles could be discerned. The wing-tip landing flares on the disabled plane were paying for their ride.

The formation tarried until the plane had ceased rolling upon the ground, then turned northward and continued toward

New York. Lower New York bay was teeming with boats as the planes passed over; the streets were filled and every light burning as the bombers floated over Manhattan.

After they had cruised over the city for several minutes out of range of the searchlights and anti-aircraft defenses of the city, the formation struck out toward Long Island. The main formation had landed, and the planes had been taxied up on the line at the flying field on Long Island for about an hour and a half, when the other three planes came drifting in one after the other with their wing lights blinking against the stars.



Row of Small Fast Curtiss Pursuit Planes on the "Line." Waiting the Signal for the Squadron to Take the Air to Harry the Foe or Guard the Flight of the Huge Lumbering Bombers

Demonstrated at Curtiss New York Tribune  
and Mitchell Fields 9/24/25

Capper's Weekly

**SAFETY VANE ON PLANE WING GUARDS AGAINST TAILSPINS**

**SEWING MACHINE RANKS FIRST OF FARM CONVENIENCES**

Three out of every four airplane accidents are said to be caused by the engine

Sewing machines were found to be the most popular labor-saving devices in a typical country neighborhood surveyed in Ohio.

Examining Vane Which Automatically Rights the Airplane from Steep Angles to Prevent Tailspins



Eighty-eight out of a hundred families owned them, sixty-six had automobiles, sixty-three kitchen sinks, sixty-one oil or gas stoves, and fifty-five had washing machines. There were gas or electric irons in the homes of thirty-two, thirty-eight families had phonographs, twenty-two telephones, and twelve homes were equipped with bathtubs.

**FLOWER BASKETS ON LAMP-POSTS**

453 ADORN STREETS

Appearance of streets in a Pennsylvania city has been improved by baskets for flowers and vines attached to the lamp-posts. The plants are supported high enough above the pavement to be protected from vandals and do not obstruct the vision or interfere with the lights. Hundreds of these



A Bit of Green for the City Streets Is Furnished in This Lamp-Post Basket

**NECKLACE OF LIGHTS FOR LAKE**

One hundred and twenty-six bronze standards with pendant electric lamps, have been set about Lake Merritt, in Oakland, Calif. forming a "necklace of lights" around the basin, which formerly was an unsightly slough. Each standard was donated by a citizen. Installation expenses were met by the city.

"hanging gardens" give some of the streets the appearance of well kept parks.

Perfectly by Major J.C. Sprague, by writing Corp. 502.42nd St. New York and St. Louis

French airplane engineer.

ELECTRICITY BEATS STEAM IN TRAIN-HAULING RACE



Where Silent Power Defeated Steam; the Monster Locomotive in the Foreground Lost to the Electric Engine in the Rear in a Train-Hauling Race over Steep Grade

Steam bowed to electricity in a train-hauling competition on an eastern railroad. A seventeen and one-half mile climb over a steep grade was selected for the race and cars loaded with coal made up the trains. While the motor-driven engine hauled a 6,800-ton train at an average speed of a trifle over fourteen miles an hour, the steam locomotive made only about half that rate with a train weighing 600 tons less.

*International*

new passages did not cost the state a penny as all funds were taken from fees paid by tourists.

**WASHER HAS GEARLIKE TEETH TO HOLD NUTS TIGHTLY**

332

Lock washers with gear-shaped teeth, slightly turned up so that they dig into the softer metal when the nut is screwed down upon them, are said to prevent loosening in spite of jarring. They are manufactured in many sizes and for a wide variety of uses, and are much simpler than the use of special nuts with cotter-pin keys or the practice of putting two on one bolt. They are fashioned from thin, hard steel and are as easily put on as an ordinary washer.



**TUNNEL AT NIAGARA FALLS TO SUPPLANT STAIRWAY**

441

To replace the Beddell stairway leading to the "Rock of Ages" and the "Cave of the Winds" at Niagara falls, a 200-foot tunnel connecting with a shaft 167 feet deep has been constructed. The shaft was dug straight down from the surface of Goat island and contains two electric elevators, surrounded by a spiral stairway. The mouth of the tunnel opens directly upon the whirlpool and a peninsula built of rock removed from the excavations affords a close inspection of the falls. It has been named "Clearwater View." A structure on top of the shaft provides quarters for sight-seers as well as space for the elevator apparatus. The

Our Bureau of Information will answer all questions regarding articles appearing in this magazine.

*Hecker  
Chicago  
2515 N. Hecker Ave  
Chicago*

*Christian Science Monitor 9/2/25*

Used by The Consolidated Builders-Sway,  
 Esas Co, 130 E. 15th  
 914 POPULAR MECHANICS  
 new York City  
 Hyder - Wigham  
 Richardson,  
 Newcastle-on-Tyne Eng.  
 SHIP CARRIES HALF OF SELF  
 TO PASS THROUGH CANAL

**INHALER TO REVIVE FIREMEN  
 OVERCOME BY SMOKE**

468

To revive firemen and others overcome by smoke or gas, an emergency apparatus

Demonstrating Reviving Apparatus Which Uses Mixture of Carbon Dioxide with Oxygen; Man at Left Is Applying Pressure to Aid Breathing



new York City  
 American Atmos Corp.  
 105 W. 40th

40

Willard Milling Co.  
 Wilkes-Barre Pa.

474

**CORN FLAKES SERVE AS SNOW  
 IN WINTER MOVIE SCENES**

Flakes of white corn are sometimes used for snow in filming winter motion-picture scenes. A mill in Pennsylvania has received orders for large quantities of the product, and the manufacture of this material has become an important part of its business. The lightness and form of the flakes well suit them to the purpose, and their color, under the artificial lighting of the movie studios, makes the illusion still more realistic.

Twice as much power is required to stop an express train as to start it.

Because the Welland canal can accommodate boats of limited size only, nearly half of the 380-foot "Glenledi," built in England for service on the Great Lakes, was carried as cargo on the voyage across the Atlantic, so that the ship was only 236 feet long when it arrived here. The 144-foot center section, which was stored away, "knocked down," in the holds, was added after the ship had been cut in two following its passage through the canal. This plan of chopping-up steamers was not uncommon during the war when a number of ships in Great Lakes service were divided so they might pass through the

Welland locks and then be rejoined for duty on the ocean.

**RUBBER DISKS ON AUTO WHEELS  
 436 PREVENT SIDE SPLASH**

Revolving rubber disks with an oblong piece of the same fabric between them, to be attached to the outer side of auto wheels, have been devised by a French inventor as a solution of the mud-splashing problem. Being flexible, the shields are not damaged greatly if they strike the curb, nor do they retard the car.



Revolving Disks and Strip of Rubber at Bottom of Tires Keep Auto Wheels from Splashing

Pacific & Atlantic  
 223 Erie  
 Buffalo N.Y.

# Training Sleuth Hounds and War Dogs



Police Dog Showing His Teeth after Running Down Quarry, Who Wears Padded Canvas Armor for Protection

By HAROLD T. WILKINS

*Road, Cruxton, S. W. 7, London, Eng. Esq. 4, Crowhurst*

THE sharp ringing of a telephone bell, at midnight, startles the inmates of a quiet country house, deep in the heart of rural lanes and surrounded by wooded hills, many miles from a railroad depot. Jumping from bed, the owner of the house grasps the receiver and finds himself speaking to a police officer 400 miles away.

"Come at once. A murder has been committed here. Rush your bloodhounds by auto. Don't wait for a train."

The listener goes back to his room, and hurriedly dresses himself, after ringing up his chauffeur and telling him to get ready the auto. A swift toilet, a little food and drink thrust into a handgrip, and the owner walks quickly across lawns and walled fruit gardens to a block of clean-looking kennels. Inside are three magnificent coal-black mastiffs, with long pendulous ears, and deep, red-ringed eyes, shining like rubies.

They are pure-bred bloodhounds, highly trained, tenacious when hunting the trail of a wanted man, yet as gentle and affectionate as any puppy. Their natural quarry is man. Once these hounds are put on the trail, a murderer has an uncanny feeling that it is futile to try to es-

cape, since he may be tracked down to his very door.

Seventeen hours later the hounds are entering the streets of a busy Scotch seaport town. A severe frost, rendering the ground unfavorable for scenting, will put the bloodhounds' keen noses through a severe test.

The murderer has been traced to a spot on the cliffs where he has discarded some clothing. The owner takes his hounds to the spot, and they show true signs of their breed at once by walking with their noses to the ground. They sniff the articles discarded by the murderer, and cast around a little. The scarlet haws of their eyes gleam, and they are away.

The main road is followed for some distance, then the hounds leave it to cross a field. They trot through a wood to a cottage, but here they seem at fault and run about whimpering. A police officer knocks at the cottage door, and learns that, shortly after the murder, a man called and begged some water. Hearing this, the owner casts his hounds right and left round the cottage in order to pick up the scent. The bloodhounds run to and fro, persistently sniffing. A deep bloodcurdling bay breaks from one of them, in

which the others soon join, and they open out on a line beyond the wood. They cross fields at a short trot, and abruptly break off into undergrowth. Presently, the trail debouches on a high road, where it seems lost again, but the hounds, undaunted, keep steadily on, till they find the scent.

They lead the police across country roads and fields to a town and straight to the vicinity of a railroad depot, where all trace of the fugitive is completely lost. It is plain that the criminal has got clear away and is not hiding in the neighborhood. But the police have now got a working clue, and by vigorous action and the use of the telegraph and telephone are able to arrest the murderer, a few days later.

For police tracking, the vital part of the bloodhound's work is not so much that it may run a criminal to ground, as that it indicates the direction a criminal has taken after his crime, and gives the police a chance to wire or phone details and descriptions. Night and dawn are the best hours in which to put a bloodhound on the trail, since the scent is good, and criminals who rush across country, avoiding roads, seek the shelter of woods and undergrowth and fields, where the scent is caught and retained. On the other hand, in the towns the scent is soon broken and lost. If a police station has a bloodhound kennel, the chances of successfully tracking down a criminal immediately after the crime are immensely increased. The hound can be put on the scent while it is still fresh and undisturbed by vehicles, the police themselves, or sight-seers attracted to the scene of the crime. The bloodhound has to be highly trained for po-

Blank Cartridges Used to Accustom German Police Dog to Gun Fire during Strenuous Training

lice work, for every bloodhound cannot track. Its education is long and varied. It has to track its quarry through suburbs and across fields and footpaths where the trail is fouled, and it must be able to follow the scent on or off a leash. As soon as it reaches the trail, and the scent is good, it is put on a leash, consisting of twenty or thirty yards of strong rope, coiled to give play. Hot on the scent, the bloodhound will break into a fast trot requiring all the effort of the policeman to keep pace with it. The bloodhound's most remarkable characteristic is that it can follow a cold scent.

The bloodhound has a long and very interesting past, dating from the time



when it was first brought to England by William the Conqueror, who obtained it from the abbot of St. Hubert, in France. There are two strains of them—the black and the white. From the white is thought to be descended the old southern slave-hunting hound, heavily dew-lapped and slow-tracking, now almost extinct.

America's bloodhounds are the black and tan, southern foxhounds, used to trail escaping criminals over large tracts of sparsely inhabited country. A dash of ferocity is encouraged in these hounds, and they may show their teeth; yet one of them, over whose head was shot a notorious murderer fleeing from justice, was as gentle and affectionate as a child.

Great expense is attached to the maintenance of a kennel of bloodhounds. An adult hound, pure-bred and trained, may cost from \$200 to \$800, and their breeding renders them very liable to distemper. Collies and airedales have splendid noses for scenting, joined to greater intelligence, but for man tracking, the bloodhound, with its inherited qualities of indomitable perseverance, has no equal.

Few or no pure bloodhounds now exist in America, since, when they were imported here some years ago, they were crossed with other breeds to save them from distemper.

Hounds are not the only dogs used in police work. All over the world, English airedales, various breeds of European sheepdogs and terriers with their fine qualities of intelligence and powers of scent make good sleuths. German police employ airedales and the "Dobermann pinscher," a dog resembling a black-and-tan terrier. Los Angeles recently bought ten Alsatian dogs to be used on police-patrol work. They cost \$15,000. New York City at one time kept a brigade of highly trained police dogs, at first bloodhounds, then Belgian sheepdogs. These dogs went to the aid of people found ill on the streets, or lying on the ground frozen in winter, and they helped to make arrests. At present, dogs are not used there for police purposes.

The European continental police dog has a dual function. He is either an "executive" or a "sleuth dog." If the former, he accompanies the policeman on his night rounds, scouting in lonely roads, in the gardens of suburban houses or in parks.

Belgian Police Dogs Are Taught to Attack Bandits Who Waylay Their Victims by Pinioning Their Arms

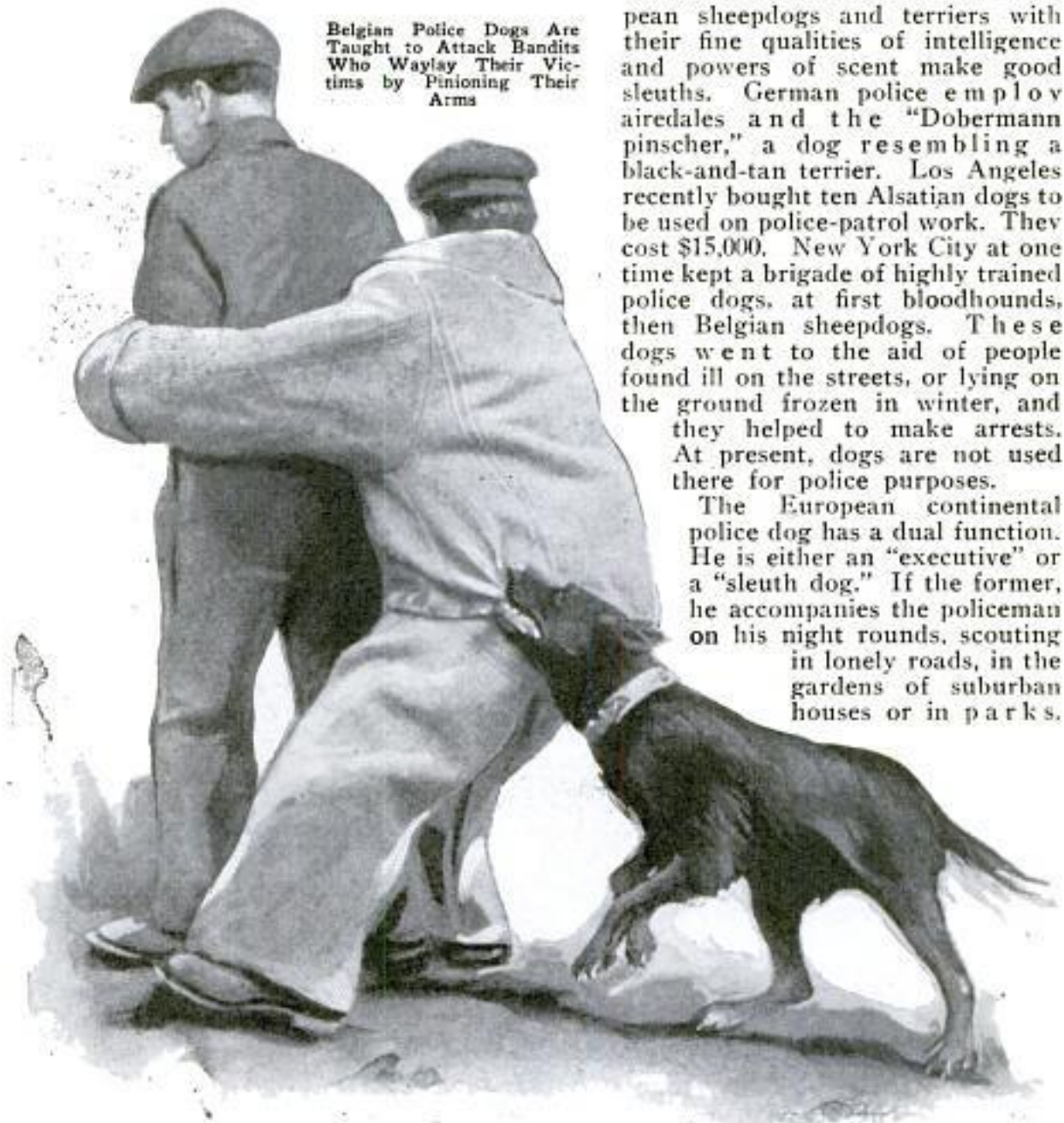

He warns the policeman of anything unusual or suspicious in the immediate neighborhood. Exceedingly savage and suspicious, the dog has to track down desperate characters, which he does to the extent of clearing out dangerous people in rough quarters of the towns.

If he has good scenting powers, and can run down cold trails, he becomes a sleuth dog, and is called in when the criminal has got clear away and the scent is bad. These sleuth dogs are kept at different centers where they can be telephoned for in emergency. They are taken in autos to the scene of the crime, and, like the bloodhound, give important clues to the whereabouts of the criminal, even if they do not always succeed in trailing him to his hiding place. Such a dog is trained to stop burglars escaping, which he does by jumping or swimming where a policeman would be hampered by his uniform. The German and Belgian law courts regard the work of the police dogs in tracking as contributory evidence in establishing guilt.

Belgian police dogs are prick-eared, smooth-coated sheepdogs of medium size, who accompany their masters on night rounds. They are treated kindly and never struck or whipped. Each kennel looks on an outside yard, surrounded by a high fence. The dogs cannot see each other, and bark incessantly, and as they

cannot see the public, they do not become accustomed to the sight of strangers. They bark whenever a person passes. On the dogs' collars are a series of sharp points to repel attacks. They are savage if they see policemen attacked, and are trained to leap at the attacker's throat, and throw him over. When the attendant is training them, he dons two thickly wadded suits and a heavy helmet and wire mask, but, even so, he often is severely bitten.

These canine detectives are doing some remarkable work today. At the castle of the Austrian prince von Fuerstenberg, at Salzburg, jewels of very great value were stolen in the night. No trace of the thieves could be found for some days, until police suspicion fell on the prince's valet. They put a police dog on his scent. The dog ran to a lonely part of the grounds of the castle, where was a disused well. Here, under boards, an empty jewel box, hidden by the valet, was found.

In England, conditions are different. A police dog can be sent into gardens, yards and around empty houses, while the policeman patrols the road. The animal can hear sounds 400 yards farther away than a man is able to do, and his senses are acute at night. He will give chase where a uniformed man could not pursue. English police dogs are trained after dark, when they are sixteen months old. They



Extended Order Drill of a Whole Platoon of German Police Dogs, Who Are Put through Mass Drills as Strict and Complicated as the Maneuvers of the Old Prussian Guards





Alsatian Dog Guarding Master's Hat and Wallet; Los Angeles Police Paid \$15,000 for Ten Trained Dogs of This Breed

are taken out on a lead of a double-swivel chain, and muzzled. If the night is wet, the dog wears a waterproof coat, which is carried on the policeman's belt. The dog starts his beat on the lead and his attitude tells the observant policeman what is passing in his mind. On lonely roads, the dog is off the lead and muzzled to save him from picking up poison. On the lead, he is not muzzled, so that, in emergency, he can use his teeth. These dogs are kenneled in comfortable quarters, with plenty of fresh air, pure water and clean straw. Their quarters are inaccessible to the public, to guard against the possibility of poison being thrown to them.

Alsatian police dogs, or German sheepdogs as they really are, are popular with the authorities. At the Crystal palace, London, a short time ago, they were put through severe tests. They had to track a man across scrub, grass land, miles of country and suburban roads, and ponds; pick him out of a crowd, help the policeman to arrest him, attack him if he attacked, and stop when the quarry did. They had quickly to respond to a recall, and stand fast against gunfire or blows with a stick.

A corps of airedales is used at Hull and Cardiff docks to aid the police in routing out pilferers from the recesses of labyrinthine warehouses.

A police dog, "Sauer," at De Aar, South Africa, succeeded a short time back in establishing the innocence of suspects, and



Taking a High Jump with Owner's Hat Still Grasped in His Mouth; These Dogs Can Spring on a Fugitive and Bring Him Down. Then Stand Guard at His Throat Until Help Comes

tracking down a native thief who had broken into and stolen money from a minister's house. The thief, in his escape, left the parson's portmanteau on the veldt. Twenty-five hours later, "Sauer" was given scent from this, and led two detectives to a gaol, where he barked at the door, and strained on the leash in his eagerness to get inside. In the prison yard, the dog made straight up to a prisoner, waiting trial on another charge. The native denied all knowledge of the offense, but when he was taken outside,

the dog picked him out from hundreds of other natives, and he was charged and sentenced.



Long, Floppy Ears and Deep-Sunken Eyes of the Pedigreed Bloodhound Give Him an Appearance of Great Wisdom

Before the war of 1914-1918, it was thought that dogs would have been of great use in finding and bringing back to ambulance stations wounded and missing soldiers. Accordingly many army staffs enlisted corps of highly trained dogs. But after the outbreak, it was discovered that ambulance dogs could not be used. A very remarkable part was, nevertheless, played by dogs in the World War.

The American war department formed training depots for dogs, which were to carry messages between outposts and batteries during heavy bombardments, when telephones were out of action, and human carriers certain of death. The British war office also set to work to train dogs. In their training quarters these dogs were within sound of the firing at the front, which it was thought would accustom them to the noise of warfare. Soldiers were schooled to handle the dogs, and after five weeks, went with them across the water to a French depot. The dogs were next drafted to sectional kennels behind the front, and then sent right into the firing zone.

Great patience and gentleness were necessary to accustom the dogs gradually to the noise of gunfire and the terrifying flash and scream of

shells. War dogs were and are trained to travel alone, carrying messages or food on their backs, along high roads, in and out of heavy motor traffic, over rough tracks, and past cook houses and other temptations. They have to ignore preferred food, and not dally to be patted and caressed by soldiers and civilians. They go through barbed-wire fences, leap over and creep through obstacles, swim dikes, ditches and rivers, pass through smoke barrages, dodge the pinging bullets of concentrated rifle fire, and finally enter and survive a hell of shellfire and bursting bombs which would be certain death to a man. A collie took a message to headquarters and saved

an infantry regiment cut off at Cambrai. Another dog carried telephone wire across exposed ground; a crossbred dog could detect the approach of gas long before human beings could do so; an airedale was trained to go on the roofbeams of a demolished house and act as a lookout. "Kust," a French war dog, warned his regiment that Germans were hidden in a wood. An American dog, blown up by a shell while carrying a message, came down on his four feet, grubbed about for his message and trotted off to deliver it.



"Mutt," an American Y.M.C.A. Dog Who Was Trained to Carry Packs of Cigarettes to Exposed Front Lines

# FORTY THOUSAND JEWELS ADD SPARKLE TO ARCH

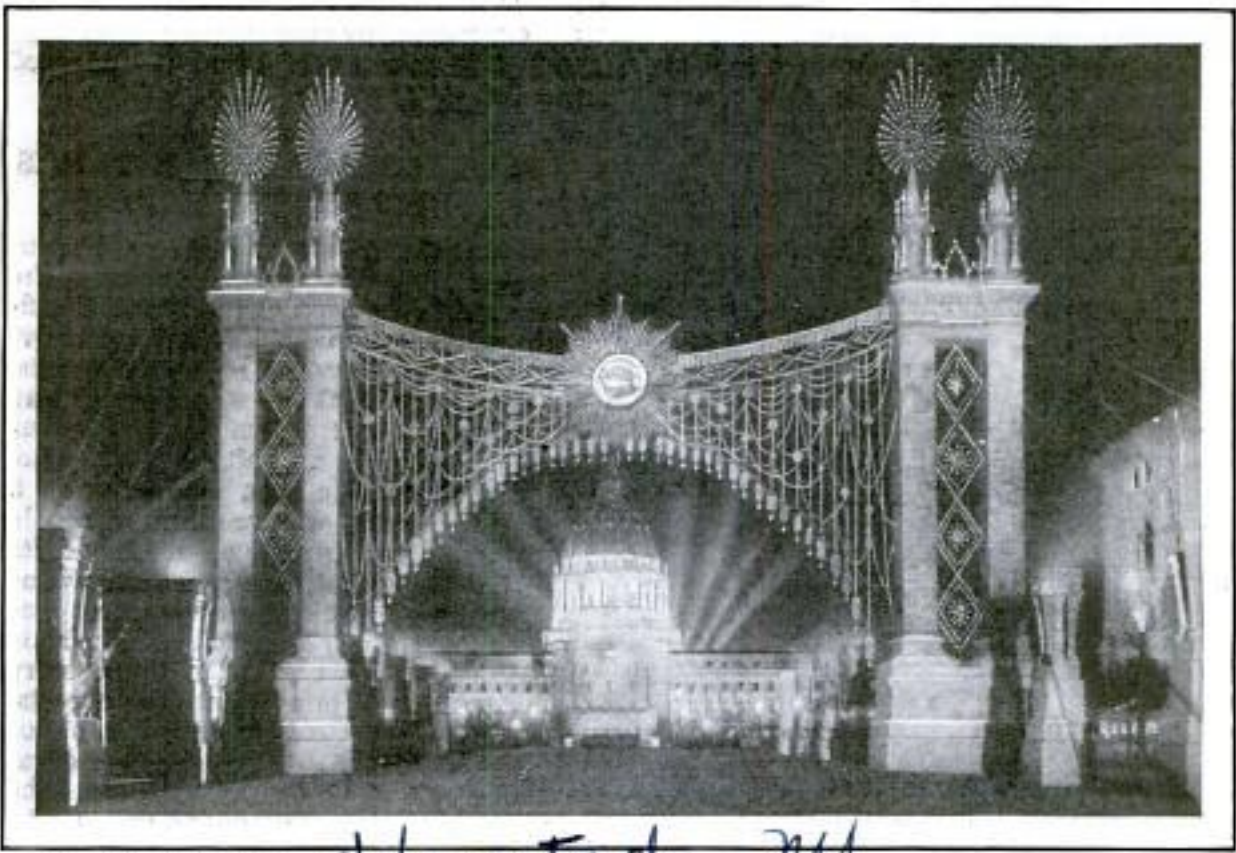

Courtesy General Electric Co. *Schenectady, NY*  
 Memories of the Exposition of 1915; the Arch of Jewels at San Francisco's Recent Diamond Jubilee; Back of It Is the City Hall Radiant under Floodlights

Beauties of the Panama-Pacific exposition of 1915 were recalled by a brilliant arch, studded with 40,000 glass jewels, one of the spectacular sets erected in San Francisco for the recent diamond-jubilee celebration in honor of the seventy-fifth anniversary of California's admission to the union. The arch, illuminated by floodlights at night, stood at the approach to the city hall which also was bathed in radiance and set off by a fan-shaped array of colored lights behind the dome.

**AIRPLANE-ENGINE VALUE DROPS TEN DOLLARS AN HOUR**

On the basis of a cost of \$10,000, the value of a modern airplane engine of 600 to 800 horsepower depreciates at the rate of \$10.60 for every hour it is in service, according to data collected by Archibald Black, a consulting air-transport engineer. The useful life of the motor is reckoned at 400 to 800 hours. When the mileage of the engine is considered, its term of service compares favorably with that of an automobile's power plant. A speed of 110 miles an hour is a modest average for an air motor, so that it can deliver

a total mileage of 44,000 to 88,000, with 110,000 as a possibility. This is considered approximately equal to six to twelve years of service from an automobile driven 7,500 miles a year.

**NAIL FOR BRICK HAS SPIRAL RIB TO PREVENT BENDING**



Hardened spiral ribs in a nail now on the market, are said to prevent bending when the fastener is driven into brick and also serve as anchors to keep it from becoming loose. In concrete or stone, a hole is usually drilled part way to give

the nail a start, after which it may be driven in with a hammer.

Wisconsin's first cheese factory was erected at Ladoga in 1864.

*Parke. Nelson Corp. 352 W. 13th St. New York*

457 **FISH ARE TRAINED TO EAT  
OUT OF HAND**

Through patience and generous feedings of bread, a Florida naturalist and his wife have tamed the fish in a lake near their home until the creatures will eat from their hands. The pets are bream, a yellowish-white fresh-water variety that sometimes attains a weight of twelve or fourteen pounds. Crumbs thrown on the water to watch the fish strike first attracted them. They seemed to expect this

experiments in photography. The best results were obtained between the hours of four and five in the afternoon. This was explained by the theory that less violet and ultraviolet light is reflected from the water at that time.

455 **BRINE FROM ICE-CREAM TANKS  
DAMAGES STREET PAVING**

Salt brine dumped from ice-cream containers on city streets will eat holes in the pavement, according to Wisconsin officials who made an investigation of paving failures near several ice-cream plants.

They found that salt would attack any kind of paving material, whether concrete, asphalt or brick. One Fond du Lac company, as a result, was required to repair the street in front of its plant, and a general warning was issued to all ice-cream makers and dealers not to throw salty water into the streets.

In the course of their investigations, the officials



In the Lower Photograph, a Fish Has a Piece of Bread in Its Mouth, and Above, One Is Resting on Its Mistress' Hand While Nibbling at the Food

when the visitors came for a daily swim. They soon learned to eat the bread from their benefactors' hands and even nibbled their toes. The taming period afforded opportunity for a number of interesting

found the street-railway companies, which use large quantities of salt in the winter to melt ice on their tracks, always have a considerable amount of paving repair to do in the spring.

Dr. E. Stollberg, Com.  
of Public Works  
Milwaukee, Wis



Like a Jagged Streak of Lightning in the Sky, the Switchbacks of the Spectacular New "Ladder to the Sky" Veer Back and Forth across the Mountain Face in Ever Ascending Angles

## Building a "Ladder to the Sky"

### Engineers Triumph over Nature in Unique New Highway in the Rockies, Opening Far-Reaching Vista to Automobile Tourists

*Road Mountain*  
IN the recently completed Broadmoor-Cheyenne mountain highway, Colorado offers the visiting motorist a road that is the most spectacular of any in the whole Rocky mountain country. The Pikes Peak region already had several scenic turnpikes known the world over for the exceptional engineering skill required in their construction and the grandeur of the vistas they open to those who traverse them.

It has remained, however, for this new "Ladder to the Sky," as some one has aptly termed it, to demonstrate what seemed the impossible in enabling the motorist to scale in safety heights previously deemed quite inaccessible except by trail. Today a zigzag scar across the head of the "The Sleeping Dragon," as the Indians named it from its strikingly suggestive form, graphically proclaims Cheyenne mountain another lofty peak man's vision and enterprise have brought into subjection to the autoist.

Surveying was started in November, 1923, and went on continuously until the following August when it was possible to begin construction work. The winter of

1924-1925 was so open that there was no interruption on account of unfavorable weather. When it was seen that by taking advantage of every minute of daylight and running two eight-hour shifts it might be practical to complete the highway by the end of the following summer, this plan was put into effect.

In the seven and a half miles from where one turns from suburban streets for the ascent, to the end of the road at the very top crest, there is a vertical rise of 3,000 feet and the summit is a little more than 9,200 feet high.

A feasible maximum grade was set at ten per cent with an average of seven and a half. On the "hairpin" turns of the switchbacks the pitch is reduced to three per cent. This with a radial width at the curves of thirty to forty feet insures the motorist safety and obviates the necessity of backing or loss of momentum. At these points and where there are dangerous declivities, real security is afforded either by stone walls not less than two feet thick and three feet high, or by heavy woven-wire fencing which is attached to iron posts set twelve feet apart and sunk



Broad Turns, Sloping Inward and Protected by Heavy Walls Make the Numerous Turns Safe

to two-thirds of their length in masonry footings. The roadway's minimum width of twenty-two feet makes it a comfortable and safe two-way thoroughfare.

Except on the first mile on the lower slopes of Cheyenne, where the job was chiefly a clearing and grading affair through a tree-covered area, construction involved a tremendous amount of blasting followed by rock removal by the steam shovel and big motor trucks. There were long stretches where a way had to be literally carved out of the overhanging cliffs and the debris filled in on the slopes below to accomplish the builders' purposes. Wherever the slope was so steep that the angle of repose, as the engineers term it, was impractical for a gravity embankment, cribbing was resorted to as a temporary hold and reinforced later with an outside masonry wall.

Thirty tons of dynamite and twenty tons of black powder were consumed in blasting the 100,000 cubic yards of rock that had to be moved. Compressed air for the drills was produced at a steam plant located just below "Hell's Gate," the first considerable blasting operation. A pipe line from this was extended as upward progress was made. Similarly a water main was kept up as the work advanced. Since no local supply could be found on the summit the pump house will have to continue indefinitely to function for this need. Telephone connections with the chief points of operation and the camps where workmen lived were maintained. The builders are particularly proud of the fact that while a few men have been seriously injured there have been no fatalities.

Officially the new turnpike starts where one branches off from the historic Cripple Creek stage road at a point where this begins to climb up and around the north shoulder of Cheyenne. This first swing to the south carries the motorist through a lovely bit of pine and spruce woods to an attractive toll-gate house of southwestern Pueblo Indian design. Then back and forth north-and-south tacks—to borrow a nautical term—carry one higher and higher through this belt of evergreen timber. The plains view opens ever wider with the ascent.

With mile two at an altitude of 7,530 feet we reach the granite cliffs and forbidding slopes of Hell's Gate and at mile five, "Devil's Saddle," whence the route works its way around this northeast shoulder to the summit nearly a thousand feet higher in a distance of a mile and a half.

*Bozart Rug Co. 369  
 Springfield St. Springfield  
 Mass.*

*Indian Trade Journal  
 August, 1925*

*Bozart Rug Co. 369  
 Springfield St. Springfield  
 Mass.*

**POPULAR MECHANICS**

**CARPET WOVEN OF PAPER YARN  
 RIVALS TEXTILE PRODUCT**

Rugs and carpeting of beautiful designs and a wide variety are now being woven of paper yarn made from woodpulp. They have no odor even in damp weather and can be washed and scrubbed. Paper from which fiber for the weaving is spun, is dyed while it is in the pulp stage, then turned into huge rolls weighing as much as 700 pounds each. It is next cut into narrow strips which are twisted into thread. This is given special treatment to prepare it for the weaving.



**MASK FOR DUSTY JOBS  
 GUARDS HEALTH**

Dust is kept from the worker's eyes, ears, nose and mouth by a mask that has an enveloping hood and skirt to cover the head and shoulders. Breathing is done through a mouthpiece protected by a fine copper screen and fitted with felt pads. A valve permits easy exhalation. Strong lenses of unbreakable glass protect the eyes from flying particles without interfering with the vision. The mask is manufactured in two types, one for general operations and another for use in spraying paint and similar jobs.



Face Mask Protecting Worker Cleaning Dusty Pit

Rope Support Attached to Revolving Arm That Moves with Horse, Saves Rider from Broken Bones

**ROPE SUPPORT FOR HORSEMAN  
 PREVENTS FALLS**

Candidates for the Pennsylvania state constabulary are saved from dangerous falls while learning to ride their horses by a rope support from a moving arm that follows the mount around the ring. It is attached to a wide belt about the rider's waist and is adjusted to keep him from falling to the ground in case he slips from the horse. A pole in the center of the ring holds the arm. With the rope, the rider can remount without stopping his steed.

**BATTLESHIP BOW FORMS  
 WAR MEMORIAL**

Commemorating the famous British naval raids on Zeebrugge and Ostend in 1918, the bow of the battleship "Vindictive," which led the raids, and was sunk at Ostend to obstruct German submarines, has been cut off, filled with cement, and set up on land beside the canal lock. The monument is complete with hawse pipes and anchors, and with it are mounted the "Vindictive's" propellers, and masts from the "Thetis" and "Intrepid," which also took part in the raid.

*The Engineering Products Corp. Inc.  
 64 Wall St. New York.*

*Illustrated London News  
 2/29/25*

Copyrighted material

461

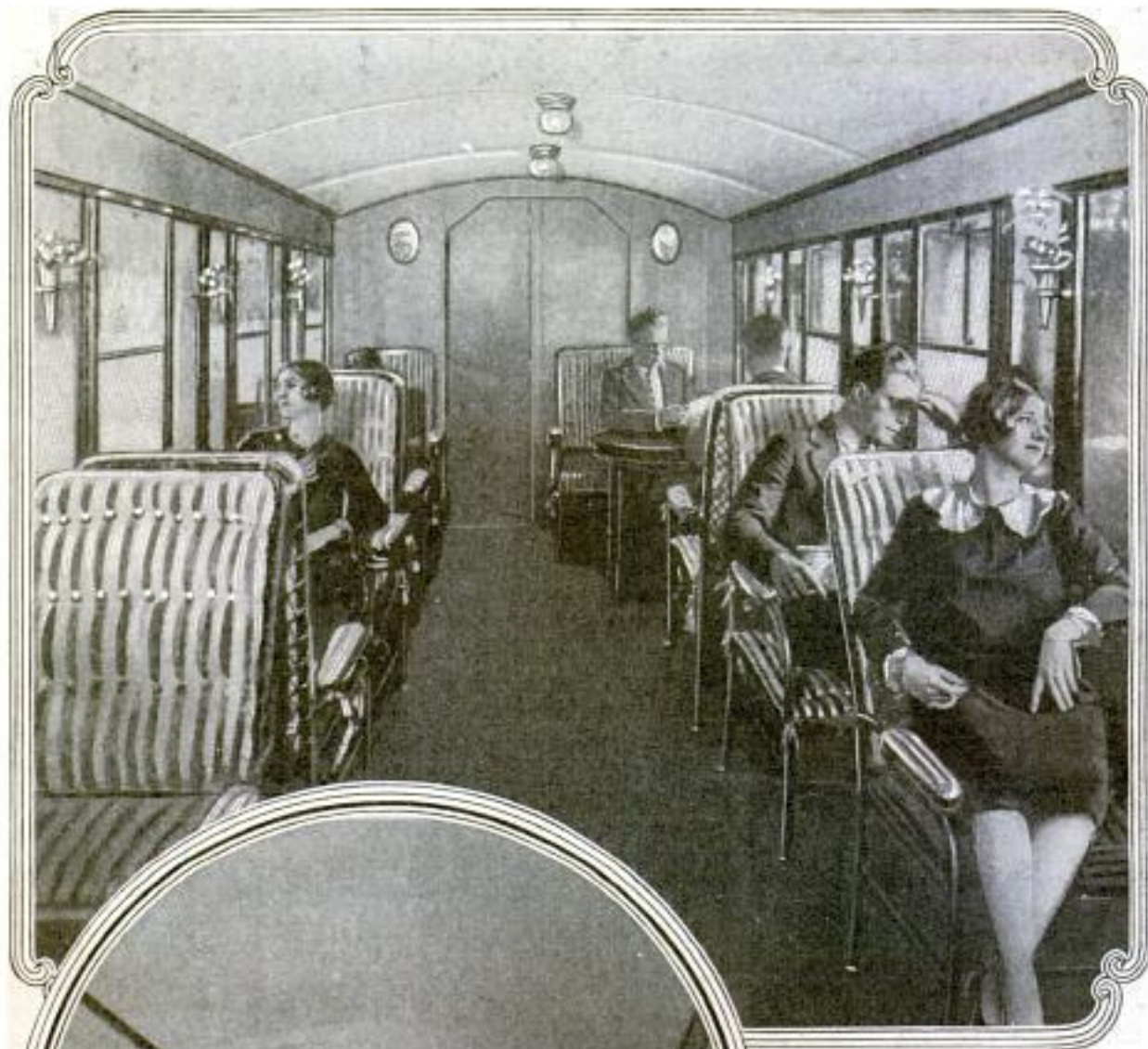

Inside the Comfortably Appointed Sitting Rooms and One of the Sleeping Compartments; the "N-1" Has Room for Twenty Persons in Its Forward Cabin. The Passenger Gondola, like the Hull of the Ship, Is Made Entirely of Duralumin and Is Connected to the Three Motor Units, toward the Rear, by a "Catwalk" through the Lower Part of the Ship's Body; Inflated with Hydrogen, the Dirigible Has a Gross Lifting Power of Nearly Twenty-Three Tons. Under Present Plans the Expedition Will Start from Rome, Fly to Norway, Thence to Spitzbergen Where the Explorers Will Hop Off across the Ice Pack over the Pole to Point Barrow, Alaska; Capt. Amundsen Believes That the Main Lap of 1,800 Miles Can Be Made in Forty-Five Hours



461



Will This Airship Open a New Era in International Trade? Side View of the "N-1" in Flight, Showing Control and Passenger Gondola and the Three Motor Shells

## Dirigible to Blaze Route over Top of World

Non-Stop, 1,800-Mile Flight across Arctic Ice Pack Planned by Norwegian Expedition in May

HAVING failed to reach the North Pole by airplane, Capt. Roald Amundsen and Lieut. Lincoln Ellsworth are planning another attempt for next May, this time in a dirigible. Their ship, the "N-1," built in Italy and purchased by Norway, is a semirigid, hydrogen-inflated craft, 347 feet long with a gas capacity of 640,000 cubic feet.

The pole is but one of the objectives of the proposed voyage, the last lap of which will be an 1,800-mile non-stop flight across the top of the world over the Arctic ice pack. This route is regarded as the true link between Europe and Asia, the short west passage to the Indies sought by Columbus, and engineers declare that, if it is successfully navigated by air, it may become the great aerial trade path of the future. It will shorten the journey between London and Hongkong approximately by half.

Capt. Amundsen has announced that he expects to complete the entire trip between King's Bay, Spitzbergen, and Point Barrow, Alaska, the major portion of the distance, in forty-five hours. The "N-1" has three motors with a combined horsepower of 750, developing a maximum

cruising speed of sixty-two miles an hour. Possessed of a high degree of elasticity because of its non-rigid construction, it is expected to withstand the strain and stress of Arctic gales, and since it can stay in the air, the crushing ice floes that all but conquered Amundsen on his last voyage, will be avoided.

Cabins and hull are of duralumin, the light, sturdy aluminum alloy. There is room for twenty passengers, and a complete set of atmospheric instruments and wireless will be carried, besides stores of rations sufficient to last for several months in case the ship should have to be abandoned.

Capt. Amundsen believes that there is no land at the pole, for soundings made on his last expedition showed that the water, at a point near the eighty-eighth parallel, was 12,000 feet deep. But between the pole and Alaska, there is believed to be a million square miles of territory never yet explored. Should it be found, it probably will be claimed for Norway, for the expedition is to fly under that flag. Included in the party will be Col. Umberto Nobile of Italy, the designer of the ship.





The Magic Carpet of Arabian Legend Which Bore Its Owner through the Air, Has Found a Modern Descendant in This Toboggan, Whose Inventor Has Perfected a Thrill for the Sport Lover

## Winter Sports Bring Red-Blooded Thrills

Passing of the Sedate Days of the Old-Time Sleigh Has Brought Grown-Ups into New, More Active Winter Sports

**T**HE old-time sleigh, with its body set off with landscape paintings and its horse with the string of jingling bells, has passed from the scene faster than its summertime companion, the side-bar buggy, but despite its eclipse, more grown-up Americans will go in for winter sports this year than ever before, in the opinion of the makers of skates, toboggans, skis and other winter-sports goods.

The family that used to take an evening ride through the moonlight in a one-horse cutter, or go for a bobsled party with some friends, is now out on the ice cutting figure eights, skiing over the hilltops or flying down a toboggan run. Throughout the snow belt, the thrills of winter sports have not only become popular, but have been made fashionable. Lake Placid and Saranac Lake rival St. Moritz, in Switzerland, and hardly a city in the northern states but has its ice rinks, toboggan slides, and, frequently, a winter carnival.

The sleigh went into oblivion along with the buggy, because the automobile offered more speed and thrills, but in its place has come the icyacht, whether sail or motor-driven. Either one, slipping over the glasslike ice of a lake, will give more speed than any motorist dares to extract from his automobile on the public road. There are no speed laws on the ice, and from sixty to eighty miles an hour is not at all unusual for an ice boat.

Skate sailing, now an organized sport, with regular tournaments and other features, offers the same thrill of high speed for the expert skater. Armed with a handy spread of canvas, and using his own body as a mast, the skater can skim over the ice at twenty or thirty miles an hour without effort.

Headed by transplanted Norsemen, skiing likewise has joined the list of popular sports, despite the difficulty of becoming an expert. Annual ski tournaments in New England and the northern middle west have made the sport popular.

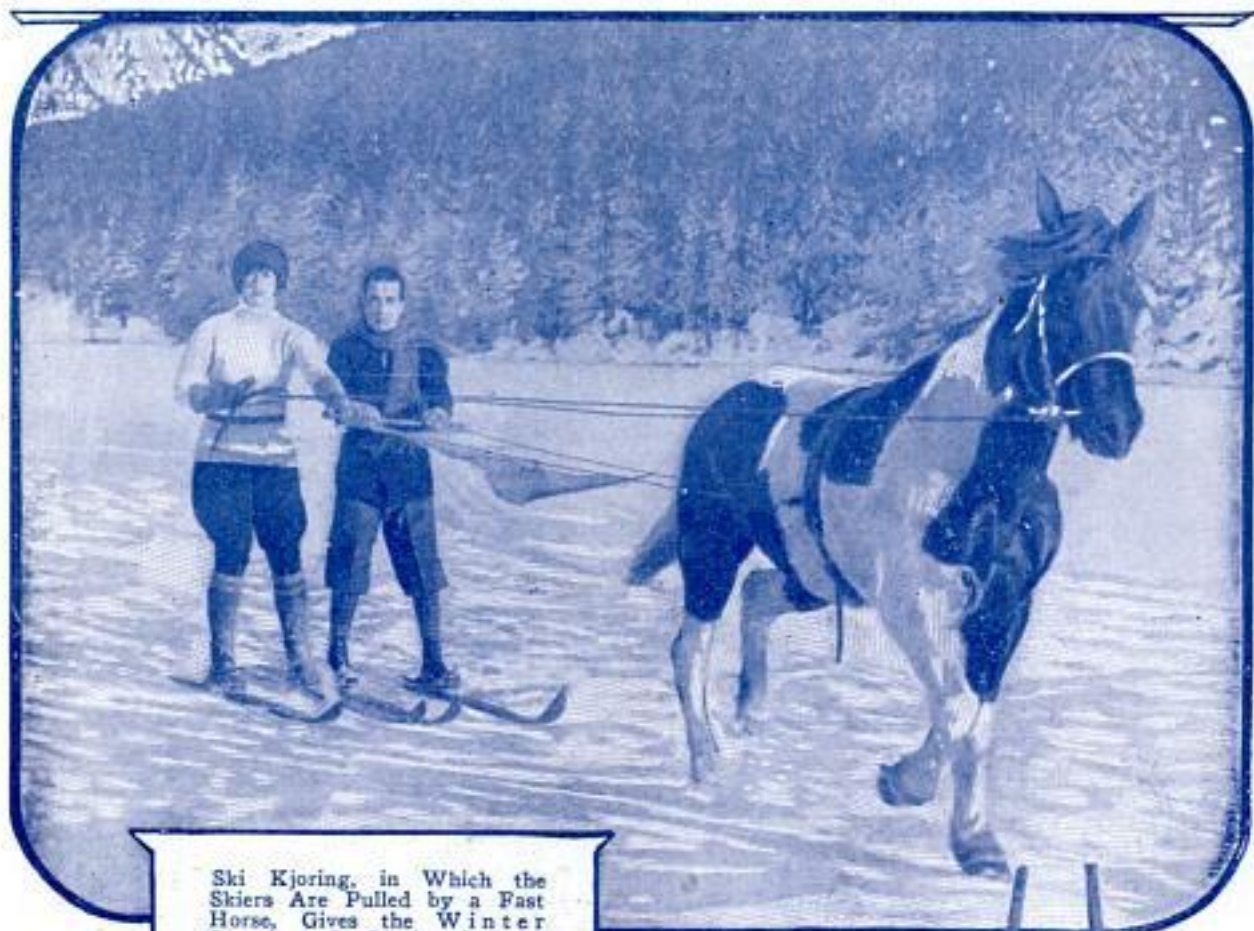

Ski Kjoring, in Which the Skiers Are Pulled by a Fast Horse, Gives the Winter Crowds at St. Moritz, Switzerland, Plenty of Exercise and a Fair Amount of Thrills, Particularly When Speed Races Are Run Off



Tossing a Girl in a Blanket, One of Quebec's Favorite Thrillers, Gives the Victim Plenty of Excitement, and Leaves the Tossers with Active Appetites; at Right, an Eighteen-Months-Old Skier Taking Her First Lesson at Mount Royal, Montreal



2923

Ice Hockey Is One of the Favorite Winter Sports at Quebec, Where the Rinks Are Busy All Day Long with Teams like These Schoolgirls; the Winter Carnivals in the Ancient Capital Have Made It a Famous Rendezvous for Sport Lovers from Both Sides of the Border, Who Go There to Skate, Ski or Enjoy the Great Toboggan Slide



Queen of the Inter-mountain Dog Derby at Ashton, Idaho, Miss Leona Mason, Enjoys Her First Ride on a Dog Sledge and Makes Friends with "Kazan," the Team Leader

Diogenes, Who Made His Home in a Barrel When Not Busy Hunting an Honest Man, Has Given His Name to This Unique Race, Which Requires the Skaters to Crawl through the Obstacles

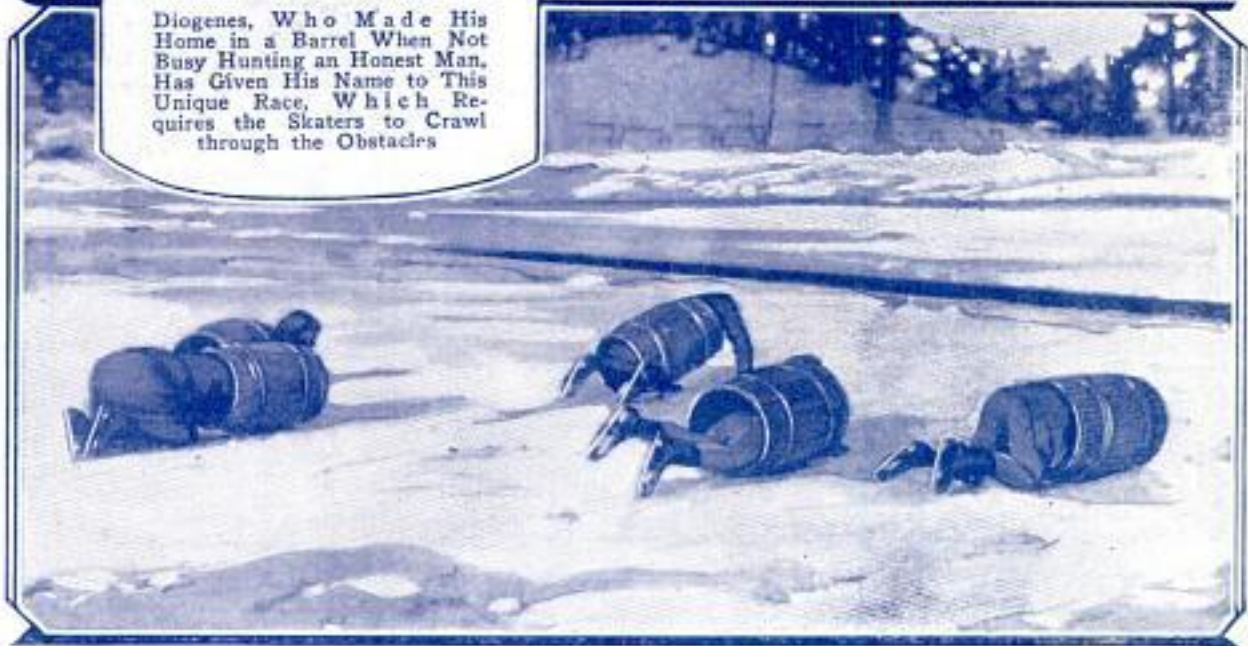



Montreal vies with Quebec for the title of Winter-Sports Home in Canada; the Fete de Nuit, on the Slopes of Mount Royal, overlooking the City, is a famous night pageant, with a myriad of colored fireworks bursting over the mountain slopes, while thousands of skiers and tobogganers storm the runs for the thrilling dash down the slopes



Ice Boating before winter gales, with speeds of sixty to eighty miles an hour, is full of breath-taking climaxes, not the least of which is a spill like this  
© U. & U.

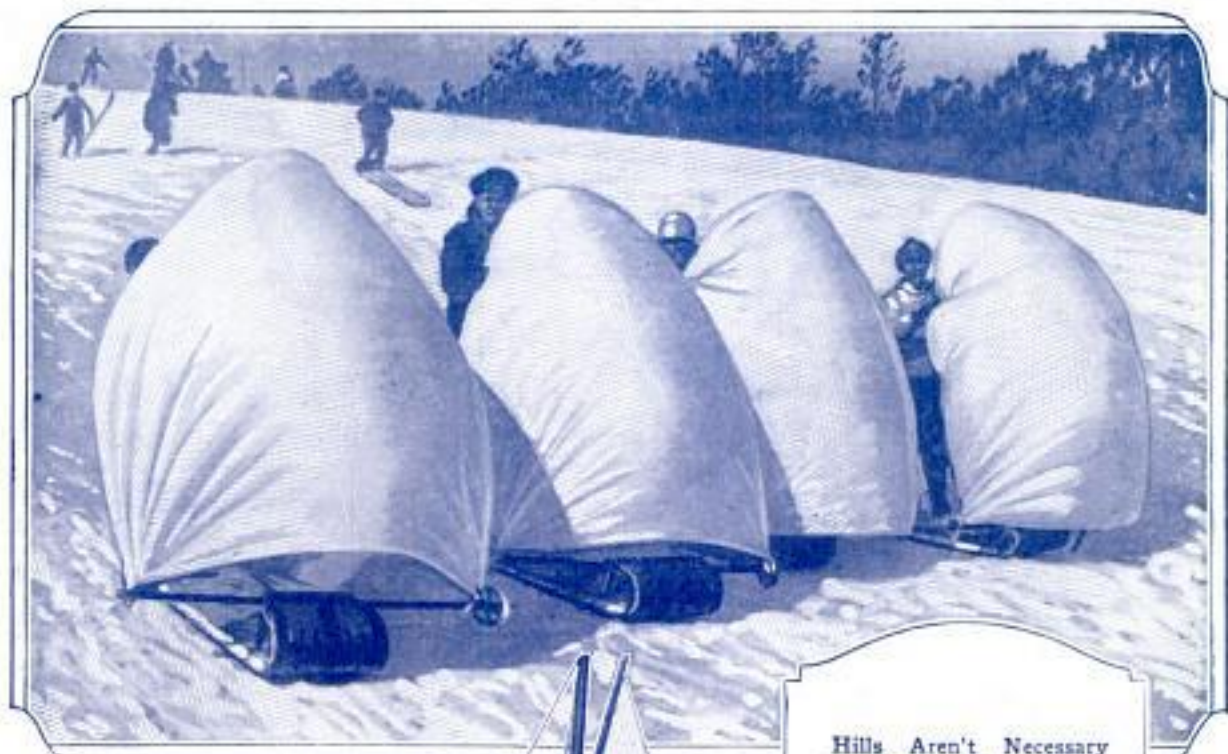

Hills Aren't Necessary to Get the Thrills of Tobogganing; Borrow a Sheet, Attach Two Corners to a Pole across the Front of the Sled, and on a Windy Day Stand Erect and Hold the Other Corners; the Wind Will Do the Rest

"Miss Milwaukee," Said to Be the World's Largest Iceyacht, Is Fifty Feet Long, Has a Mast Forty-Five Feet High and Carries 660 Square Yards of Canvas, Making Her Capable of Tremendous Speed; the Huge Craft Has Won Several Racing Trophies in Meets Held on Lake Pewaukee

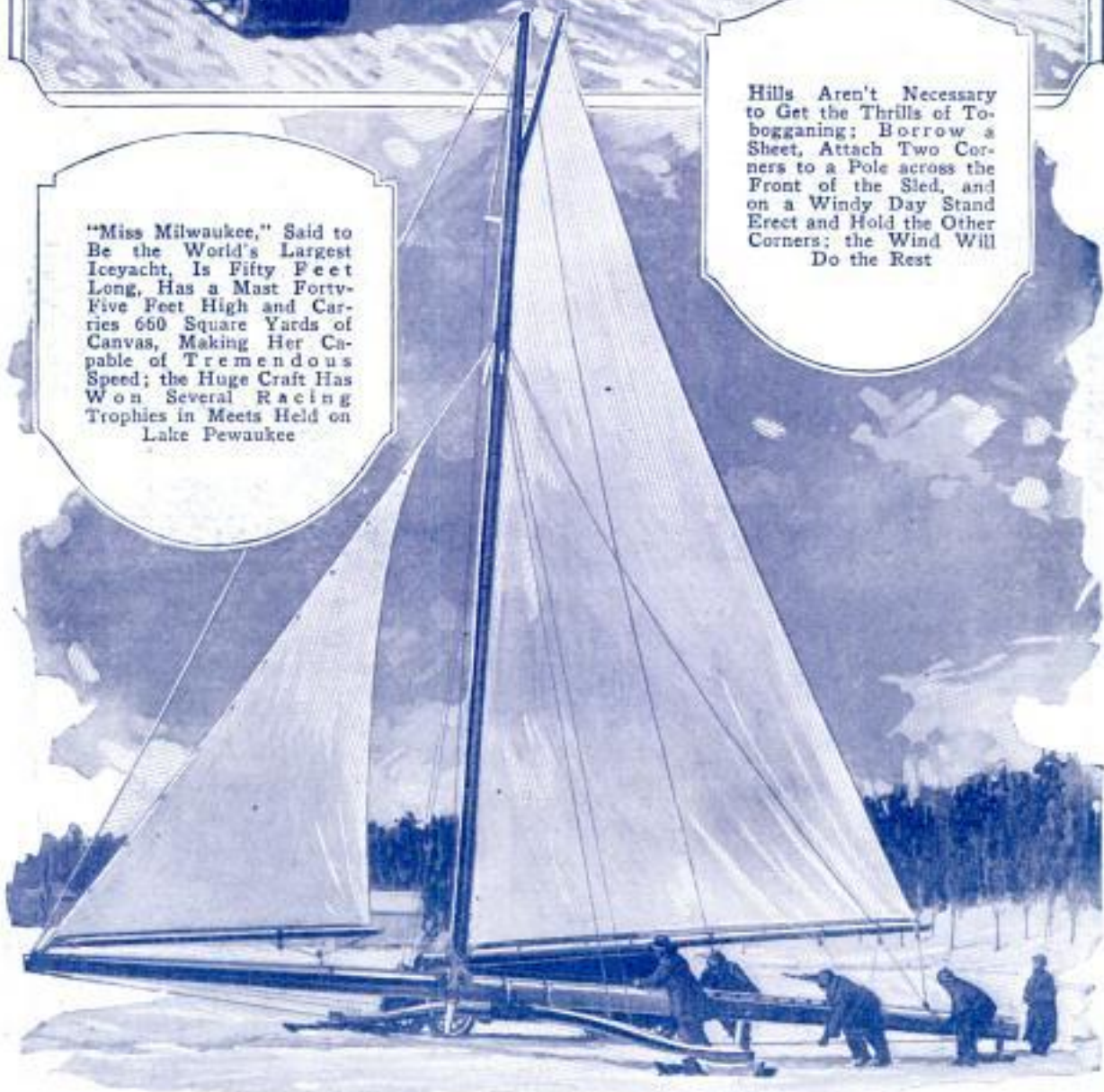

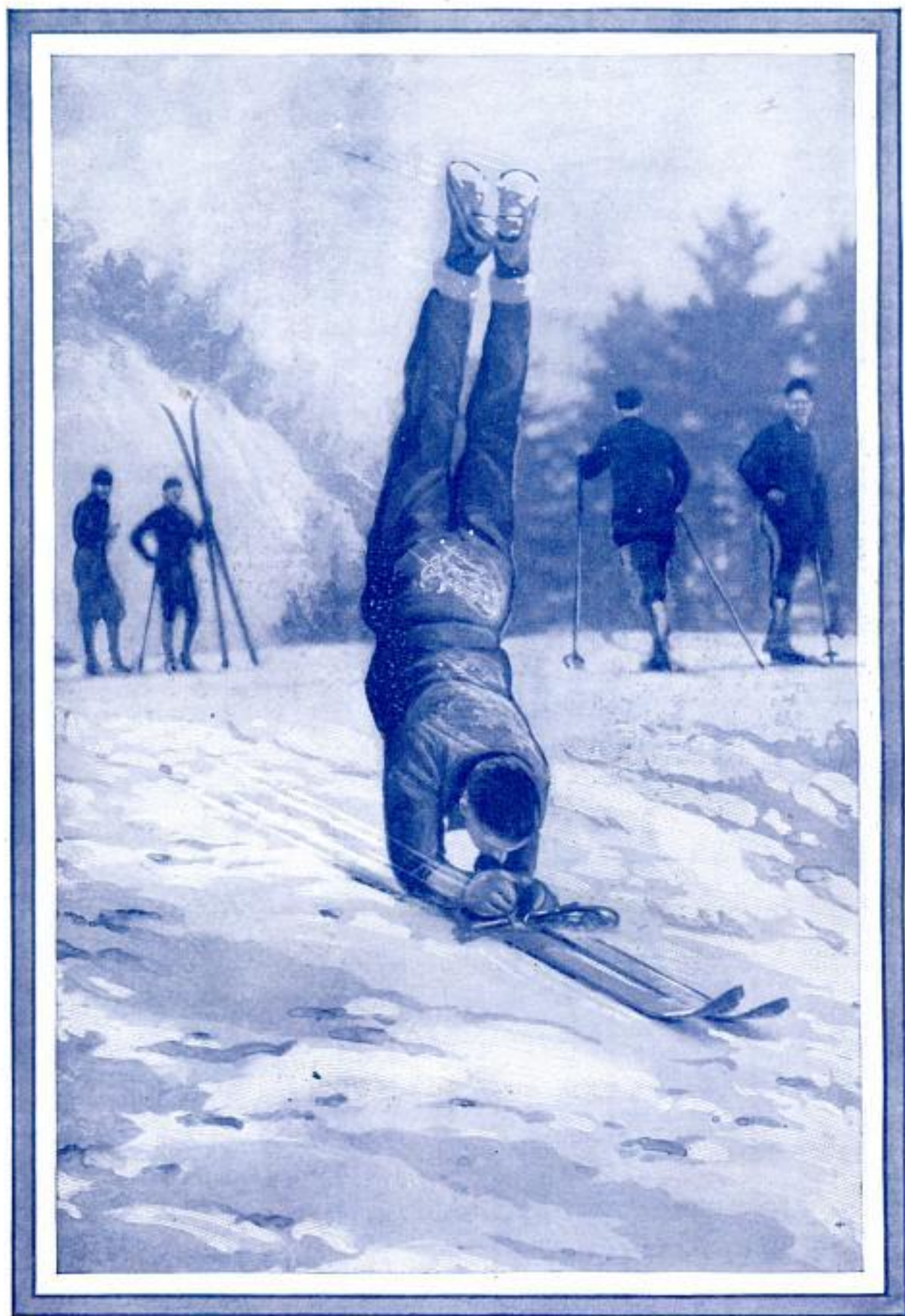

George Martin, University of Wisconsin Ski Expert, Has Discovered a New Thrill, Which Might Be Described as How to Keep from Growing Old; Fortunately the Snow Is Usually Soft



Smoky Gaston,  
of Yellowstone,  
Montana, 1923  
U. S. Champion  
Dog Racer and  
His Team  
Which Won the  
Coveted Title in  
the Famous  
American Dog  
Derby Run  
Each Year at  
Ashton, Idaho

© U. & U.



Climbing Mount Timpanogos, Utah, 13,000 Feet High, Is an Annual Fete at Provo, in Which as Many as 5,000 People Participate; the Climbers Then Slide down the Glacier at a Tremendous Rate of Speed

© U. & U.



Lake Placid and Saranac Lake, the St. Moritz of the United States, Are the Centers of Championship Skating in This Country; Fancy Skating, Illuminated by Flares Carried by the Skaters, Is a Night Feature at Saranac

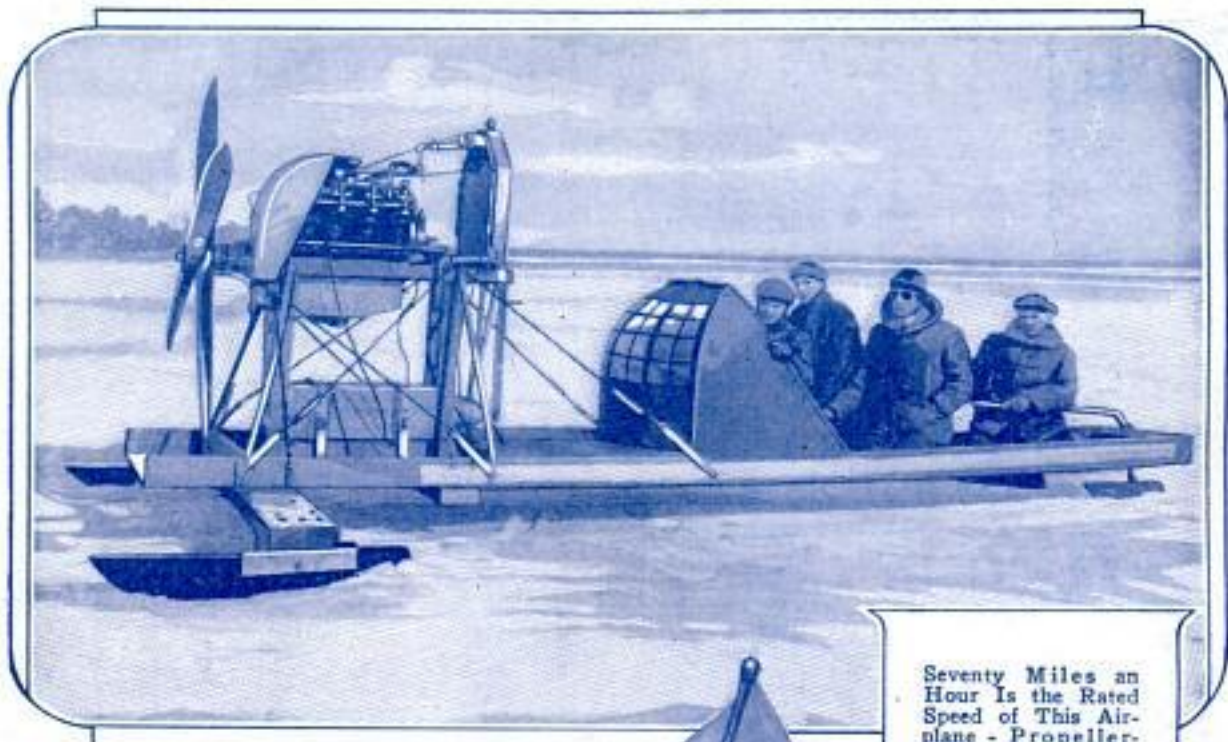

Seventy Miles an Hour Is the Rated Speed of This Airplane - Propeller-Driven Ice Boat, Designed by a Wisconsin Doctor



Wearing a Real Eskimo Costume, This Young Woman Enjoys Ski Sailing in Perfect Comfort at Lake Placid, and, in Event of a 'Tumb'e, the Well Padded Fur Clothes Take Most of the Shock Out of the Fall

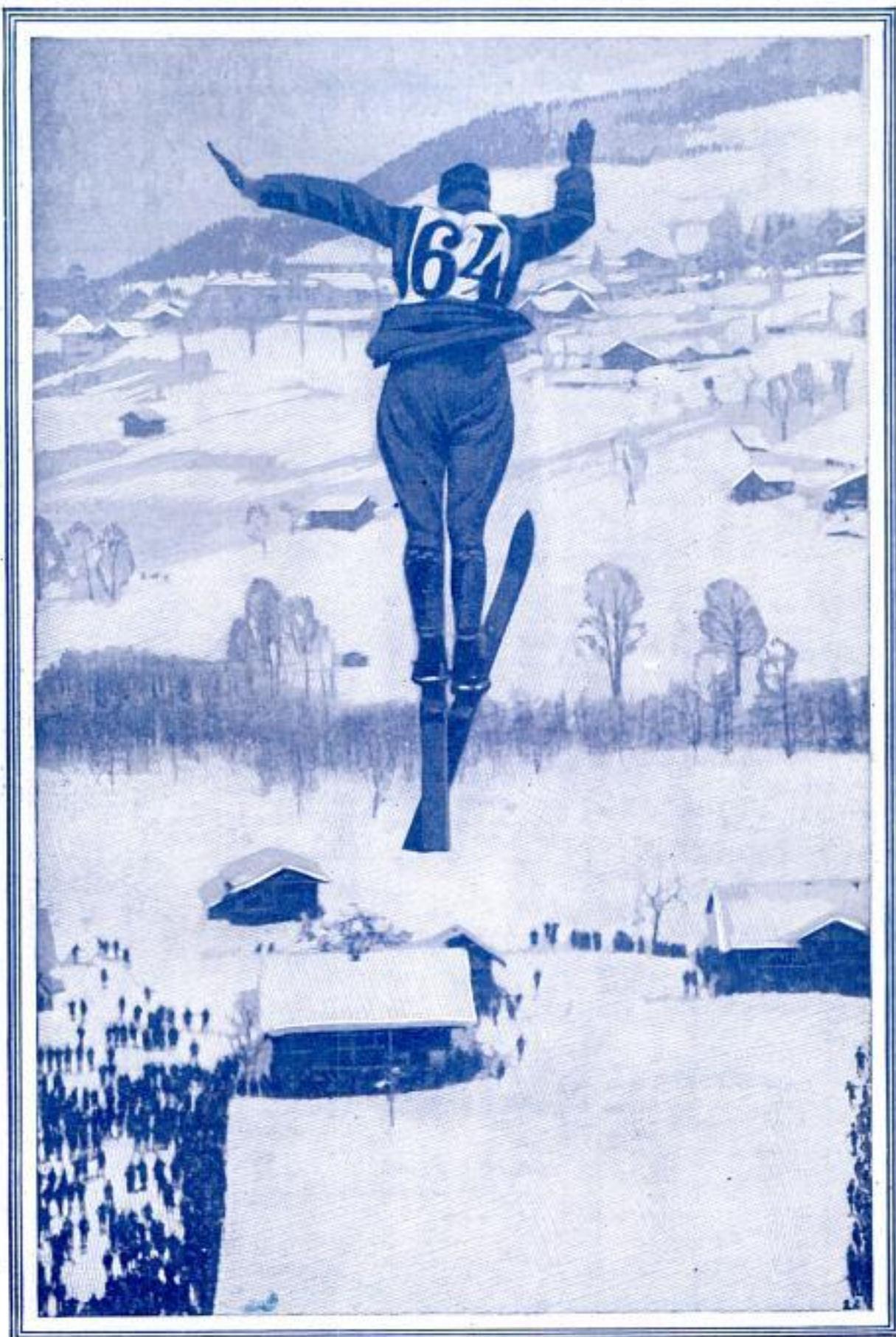

The Take-Off in the International Ski-Jumping Contest at the New Mattenburg Hill in the Alps; the Spectators Far Below Are Pressed Back Out of the Way as Rene Accola Takes the Air



The Famous Toboggan of Quebec, with Its Six Slides, and a View of a Part of the Thousands Who Throng It Each Day during the Winter Season; the Slide Is Nearly a Mile in Length



The Skate Sailors' Association Holds Regular Meets Each Winter at Which Its Members Demonstrate Their Skill in Gliding Gracefully over the Ice with a Strong Breeze to Keep Them Spinning Along; a Skilled Sailor Who Knows How to Manipulate His Sail Can Attain Remarkable Speed

© T. & T.

**CHURCH BELL CAST FROM COINS  
SERVED IN CIVIL WAR**

463

Molded out of coins contributed by soldiers during the Civil War, a church bell that announced services for Confederate captives, now reposes in the rooms of the Chicago Historical society. It was cast for the first religious chapel built at Camp Douglas, then a prison for southerners in what is now a busy section of Chicago. When the chaplain asked the government for funds to buy a bell, he was told that federal money could not be used for such a purpose. He appealed to the men of the camp, and the result was an outpouring of silver and copper coins. These were sent to a foundry in Massachusetts for molding. For fifty years following the war, the bell called worshipers to services at a church erected near the old camp site. When this congregation combined with another, the edifice was abandoned and the bell purchased for the historical society, where it now tolls the closing hour to visitors.

473

**WATER-DRIVEN RAILWAY CAR  
RUNS WITHOUT JERKS**

Carrying its own waterfall to propel a turbine, a railway car utilizing the principle of hydraulic power transmission has been developed in Sweden. The motive force is derived from an internal-combustion motor of the usual type, but instead of using gears or electric transmission, the motor actuates a centrifugal pump, forcing water under pressure to a turbine directly geared to the driving axle. The speed of the car is regulated by the height of the artificial "head" of water created by the pump, and a special advantage claimed is that jerks in starting and stopping are eliminated. A speed of fifty miles an hour has been attained with a 180-horsepower motor.

**COTTAGES FROM WINE CASKS  
FURNISH SUMMER HOMES**

Wine casks, rendered obsolete by prohibition, are being converted into summer homes for tourists at a camp on Lake Erie. Thirty-six of them were purchased



Wine Casks Made Over into Cottages Serve as Summer Homes for Tourists along Shores of Lake Erie

for \$25 each, a fraction of their original cost, and were placed on concrete foundations. Two windows were cut in the rear, a window and a door in front and a roomy dwelling provided by adding a screened-in front porch. The casks are eleven feet long, thirteen feet in diameter and weigh nearly 6,000 pounds. Each is fitted with a folding bed, folding table, kitchenette, ice box, toilet facilities, electric lights and running water. In the floor, which is two feet above the lower portion of the cask, is a trapdoor, opening upon a convenient storage space for baggage and supplies. The barrels were shipped, knocked down, to the camp where they were reassembled.

Camp owned by W. J. O'Neill, Vermillion, Ohio. Casks bought from Schuster Wine Co. Cleveland, Ohio.

**HIGH HEELS FOR MEN'S SHOES  
TO REMEDY FLAT FEET**

483

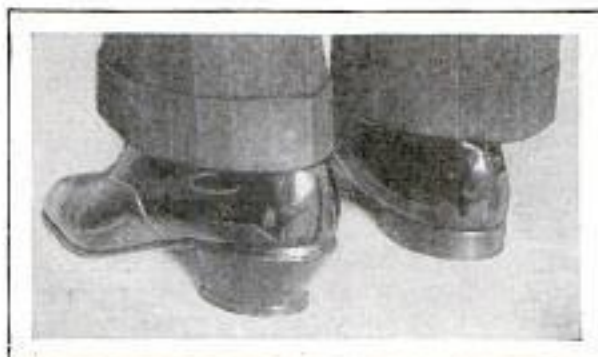

Paris Shoemakers Adopt High Tapering Heel for Men's Shoes; Compare with Ordinary Style at Right.

Heels of considerably greater height tapering to a much smaller bottom than those that are at present in vogue for men's shoes have been proposed from Paris. Manufacturers believe the change will benefit wearers afflicted with flat feet.

International

made by Mrs. Josephine  
 M. Foster, 123 & 108th St.  
 452 New York City



The Stars and Stripes in Crochet: Making It Consumed Spare Time of Six Years and It Contains 3,000,000 Stitches

**CROCHETED U. S. FLAG CONTAINS THREE MILLION STITCHES**

Seven feet wide and eleven feet long, a United States flag, crocheted by an eastern woman, contains 3,000,000 stitches. Work on it was started six years ago. The idea of crocheting the banner, to make it strong and durable, was suggested by seeing the tattered flags of some of the army divisions that had seen service overseas.

**THOUSAND DOLLARS A MINUTE TOLL OF FIRES IN U. S.**

Every time the clocks tick off a minute in the United States, property valued at more than \$1,000 goes up in smoke and flame. The nation's fire toll for 1924 was placed at \$548,000,000, a figure which gives this country a per-capita loss eleven times as great as that of the average for all the nations in Europe. Surveys by the National Fire Protection association and similar organizations indicate that incautious smokers and careless use of matches are the leading causes of fires. A property loss of \$70,000,000 was laid to

Chicago Daily News 9/28/25

those two sources alone in 1924. Nation-wide education and fireproof construction are being directed toward decreasing the annual fire toll. As an example of efficient building, Astoria, Oreg., is cited. Here there is but one frame structure in the business and residence district which was rebuilt after a disastrous fire in 1922.

**OLD LOGS SHOW ENDURANCE OF WOOD 480**

Under favorable conditions, wood appears to be as enduring as anything in the field of living or inorganic things, according to the New York state college of forestry. There are many frame buildings in this country that date from the beginnings of colonial history, but in the sacred temples of Japan are timbers 1,300 years old. Beams in Westminster hall, London, have lasted 1,000 years, while wooden objects that date back at least 3,500 years were found in Tutankhamen's tomb. Cypress stumps, not less than 20,000 years old and possibly 200,000, were dug up in Washington, D. C. One of the oldest specimens ever found is a log of a Sequoia tree.

Syracuse University

**SPOTLIGHT FOR AUTO TURNS AS CAR IS STEERED**

Attached by coil springs to the steering cross rod, a spotlight bracket, fitted to the front headlight post, swings as the car is turned so that the driver's way is always illuminated directly in front of the wheels. No drilling or alterations are necessary, the bracket being put on simply by taking off the nut that holds the headlight support.



and maker. Is W. Haman, 1401 W. Weller St. La Porte, Ind.

## "World Apart" Yields Giant Bones

Southern Argentina Once an Island, Explorer Says, after Finding Whale Relics Imbedded in Cliffs Far above Sea Level

THE southern part of South America was once a world apart, and, some fifteen million years ago, developed its own species of animal life, just as did Australia, according to Prof. Elmer S. Riggs, who recently returned after two years' exploration on behalf of the Field museum of natural history.

He brought back with him some 800 specimens of more than 100 different species of prehistoric animals, some of them stranger than anything seen in a nightmare. Among his finds are the hip bones of a twenty-five ton, ninety-foot long dinosaur; a prehistoric whale who left his carcass in a spot that has since risen from the sea floor to become a hill top several hundred feet above the water; great ground sloths and shell-backed glyptodons; creatures like camels, called macrauchenia, which had enormous taper-like snouts; toxodons, which looked something like hippos but had huge tusks; a huge birdlike flesh-eating creature with a head the size of a horse, and called by scientists a phorac'us; and a borhyaena, a carnivorous animal the size of a bear. Between 5,000,000 and 15,000,000 years ago these species, distinct from anything found elsewhere in the world, developed on what was then an island continent, according to Prof. Riggs. Along about the pleistocene period the seabed between their island and North America began to rise, until it eventually

formed a bridge, just as Asia was once connected with Alaska by a bridge over which the huge animals from the Gobi plateau came.

The South American species began to move northward, over a route which the Riggs expedition followed in unearthing their bones. Eventually, near what is now Tarija, Bolivia, they passed down over 12,000-foot mountain tops into a huge valley where they met the south-bound stream of northern animals, and here, in this secluded valley, occurred one of the strangest mysteries in history, for both northern and southern species died out and left their bones in such vast numbers that scientists have named the place "The Valley of the Bones of the Giants."

What caused their death, science has been unable to determine. Among the remains there is no trace of human bones or weapons, so it is apparent that the wholesale death was not due to invasion by human hunters. The skeletons of

animals which originated in Asia and North America mingle over the vast field with the bones of the distinct types from farther south, but that the two forces could have waged a war of extermination until they wiped each other out hardly appears possible. The condition of the fossils indicates that all the monsters died off at about the same period, indicating some natural catastrophe

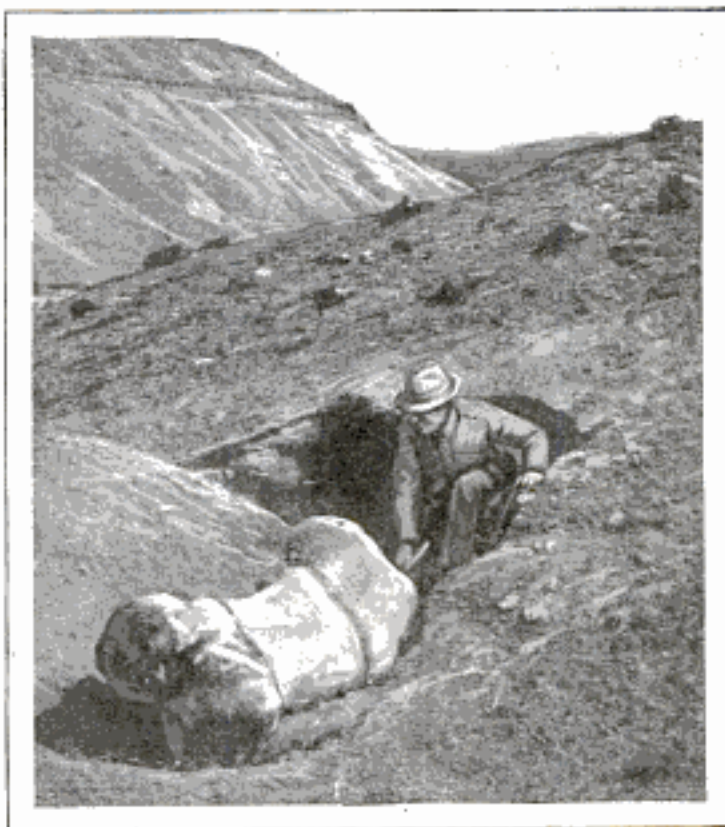

Digging a Dinosaur's Hip Out of the Hillside in the Valley of the Giants, South America's Relic Land

337

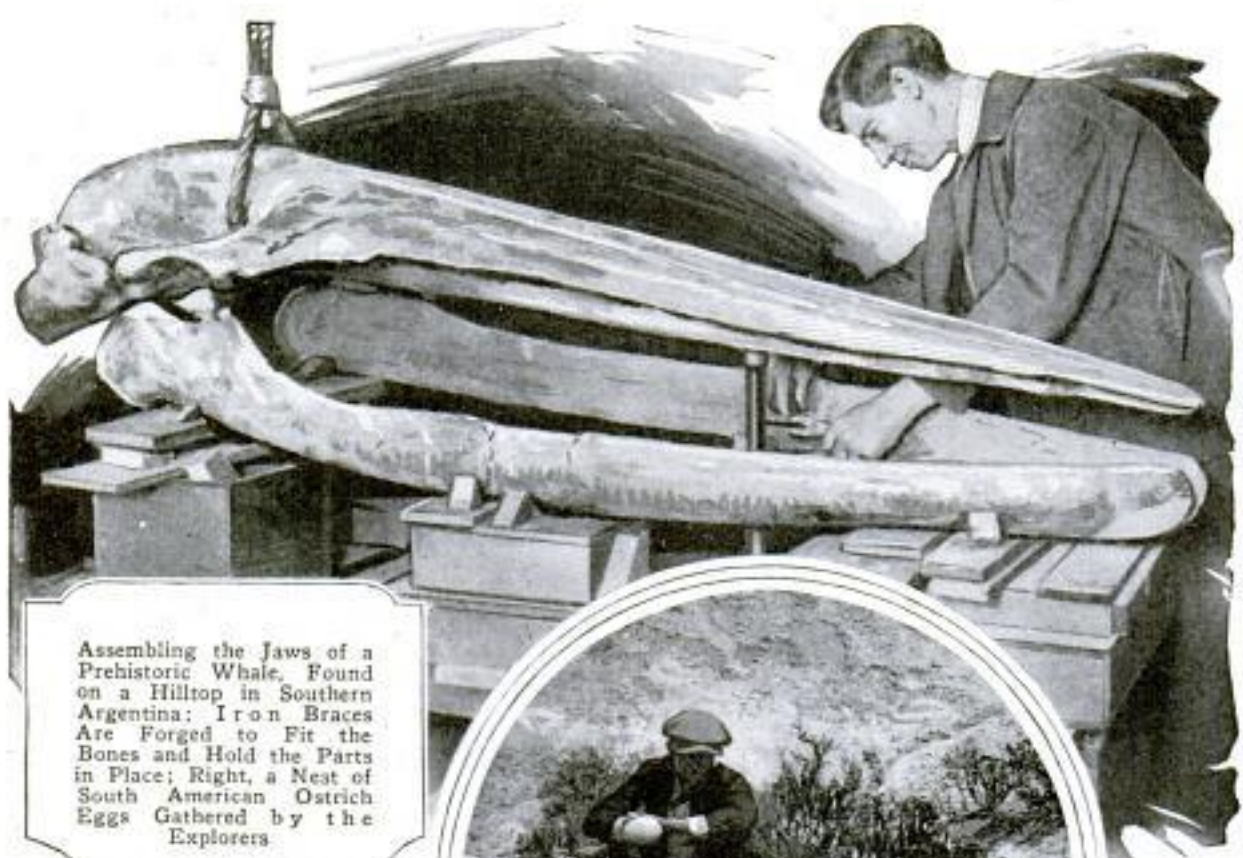

Assembling the Jaws of a Prehistoric Whale, Found on a Hilltop in Southern Argentina; Iron Braces Are Forged to Fit the Bones and Hold the Parts in Place; Right, a Nest of South American Ostrich Eggs Gathered by the Explorers



The Preparator of a Big Museum Must Be Both Blacksmith and Stone Cutter to Properly Assemble, Brace and Mount the Remnants of These Monsters; Right, One of the Dinosaur's Hip Bones



had engulfed the entire valley, either by flood, fire or disease.

The dinosaur bones discovered are important because one of them is the fourth largest ever found. It measures six feet seven inches and weighs 930 pounds. To handle the assembled piece after it had been put together in the museum, heavy block and tackle were required.

The preparing of the hundreds of specimens of such an expedition is in itself a huge task. The explorer must not only be an expert paleontologist to know what to bring back, but when he returns, must be a good blacksmith, cement mixer, stone cutter and several other things, to prepare his specimen.

As dug out of the ground, the bones are cracked and splintered by the several million winter frosts which they have undergone. The pieces are carefully wrapped and packed and shipped home. Arrived there, they are laid out and joined together, like matching up a jigsaw puzzle, and then with plaster of paris, hammer and chisel, drills and steel rods, the work of assembling the parts into a whole bone begins.

Holes are drilled in the fossilized rock and steel braces forged and hammered into shape to support the weight, while every missing part is replaced by a plaster filling and all cracks repaired. No effort is made to disguise the repairs and lead visitors into thinking the bone is whole, for the cement filling is left in its natural color, so that the spectator sees not only the bone as it looked when whole, but likewise the state in which nature, after millions of years' exposure, left it.

One of the richest fossil fields in South America was worked by the Riggs expedition in the San Bernardo hills of Chu-

but, where the dinosaur bones were found, and in the rocky cliffs along the sea coast of southern Argentina.

Here the rising of the former sea floor has created hills rearing 200 to 500 feet above the present sea level. Vast beds of fossilized oyster shells and other sea relics were found on top of these cliffs, and with them the bones of prehistoric whales.

Working the fossil beds was an unusually difficult feat. The tides there fluctuate more than fifty-seven feet between low water and high. Each receding tide washed down a bit of the cliff face, spreading the debris over the beach below. As the waters receded, the explorers hurried down and dug through the debris for bones, then hurriedly packed them up the hills and out of the way of the incoming sea. The finds here were particularly rich in marine life which flourished fifteen million years or more ago. The rising of the land, which eventually linked North and South America, likewise saved this bed of old-time sea life from destruction.



An Argentine Sheep Herder with His Dogs, Met on the Lonely Plains, and the Riggs Expedition Camp on the Pampas, from Which the Search for Fossil Remains Was Carried on by Automobile

Built by - Isus Petzely  
 944 1207 Island St  
 Alameda Calif

SINGLE-SEATER PYGMY AUTO  
 CROSSES CONTINENT

Weighing but 560 pounds, a small automobile, designed and built by a western mechanic, was driven from San Francisco



Tiny Auto That Made Cross-Country Journey and Can Develop a Speed of Eighty Miles an Hour

to New York to demonstrate its efficiency. The trip was completed in little more than a month. The car has a four-cylinder, three-speed, air-cooled motor and is equipped with electric lights, a self-starter and other features common to large autos. A speed of eighty miles an hour can be developed. The car cost \$2,000 to build.

DUTCH DRAINING ZUYDER ZEE  
 TO GET NEW FARMLAND

To add 1,350 square miles to the 13,000 square miles of Holland, the Dutch are spending \$185,000,000 on the reclamation of the famous Zuyder Zee. A mile and a half of dam, connecting the mainland with one end of Wieringen island, chiefly noted as the former home in exile of the crownprince of Germany, has already been completed, and work will start next spring on a seventeen-and-a-half-mile dike from the other end of the island to the eastern coast. The cost of the dikes alone is estimated at \$37,500,000, only a fraction of the total expenditure. Part of the balance represents revision of the defenses of Amsterdam, which at present are based on a flooding scheme whereby the waters of the Zuyder Zee can pass through breaks in the dikes and inundate all the surrounding country. The Zuyder Zee is a shallow arm of the ocean, ranging from 10 to 40 feet in depth. It supports a small fishing industry, and part of the cost of the enterprise will be spent in teaching the 3,000 fishermen along its shores to become farmers. The Zuyder Zee has long been a source of trouble to

the Dutch. In time of drought it has been necessary to admit salt water from it to the canal system of Holland, in order to preserve navigation in the north provinces. The salt water each year causes \$1,500,000 damage to soil and cattle. When the dams are completed, the Yssel which now flows into the Zuyder Zee, will empty into a fresh-water lake in the center of the reclaimed area, and each day, at low tide, flood gates will be opened to empty the excess lake water into the sea. If a drought occurs, the lake water will be used to maintain the canal levels, ending the damage from salt water. After the sea bottom is drained it will still be heavily impregnated with salt, and it is estimated that it will be two years before any crops can grow, and seven years before complete fertility, will be achieved.

GOGGLES MAKE ONION PEELING  
 A TEARLESS JOB

Goggles with snugly fitting pads about the lenses have been devised to protect the eyes when peeling onions, or to keep out fumes from cleaning fluids and dust while doing housework. The glass is



Close-Fitting Goggles Prevent Discomfort and Injury to the Eyes when Peeling Onions

clear to prevent interference with the vision, and the goggles are shaped to minimize discomfort if they have to be worn for long periods.

Very kind of cheap goggles  
 50 cents to a dollar.

4-cylinder air-cooled motor  
 2 speeds, 60-in. wheelbase  
 Wght. 560 lbs  
 speed - 65 m.p.h.  
 446  
 new York Times 9/27/25  
 (Clair Price)

Robert H. Montoye  
 Comb. from Chicago to guard of grade

**SUBMARINE CAN STAY UNDER TWO AND ONE-HALF DAYS** 438

Constructed at a cost of nearly \$4,500,000, the British submarine "XI," can re-

mountains of rock and minerals rest on a lighter substructure, while the crust beneath the sea, at least in the Indian ocean, is of much heavier material, so that the weight of the various areas remains the

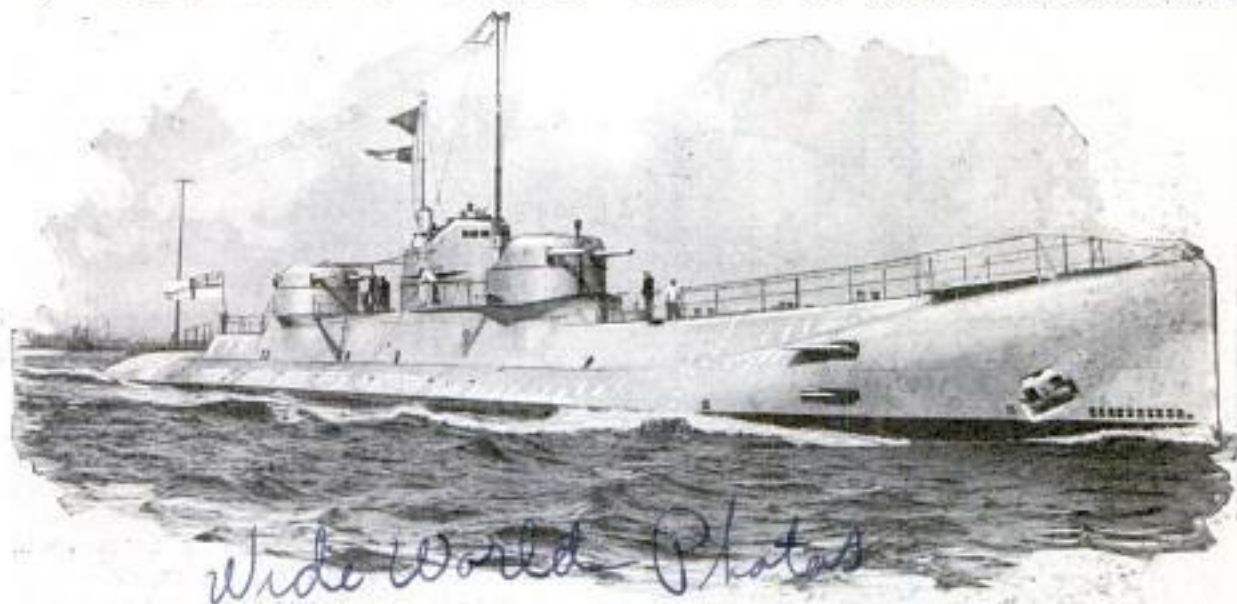

*Wide World Photos*

Latest Type of British Submarine, the "XI," a Powerful Fighter above as Well as below Water; It Cost \$4,500,000, Is 350 Feet Long and Carries a Crew of 121 Men

main submerged two and one-half days at a time and is capable of making voyages of 20,000 miles. It is of 3,500 tons' displacement, can turn in its own length, 350 feet, and carries a crew of 121 men. Other features of this dreadnaught of the underseas are being closely guarded.

*Dutch Geodetic Commission*  
**WEIGH FLOATING EARTH CRUST FROM A SUBMARINE** 497

To prove the last missing link in the geodesist's theory that the earth's crust is a floating shell which everywhere weighs the same, a Dutch scientist, Dr. Vening Meinesz, is making a trip from Holland to Java, by way of the Panama canal, in a Dutch submarine. He plans to make frequent tests of the crust formation under the Atlantic and Pacific to check observations he has already made under the Indian ocean. These indicate that the earth consists of a floating crust some sixty miles thick, which rests on an inner ball of rock and mineral. All of the earth's troubles, including earthquakes and volcanic eruptions, are believed due to falling rain, which carries millions of tons of silt to the ocean, and by upsetting the balance of the earth forces a readjustment. A hundred square miles of this sixty-mile thick crust, taken from any portion of the earth, will weigh the same as a similar area from any other portion, according to theories. The tall

same. The only link which remains to be proven concerns the crust under the major oceans.

**GARAGE ENTER AND EXIT SIGNS PHRASED IN MOTOR TERMS** 422

Instead of the usual words, "entrance" and "exit" or "drive in" and "drive out," a motor-service station in California has substituted the terms, "intake" and "exhaust." The novelty has appealed favor-



Signs Substituted for Usual "Enter" and "Exit" on Automobile Service-Station Doors

ably to autoists and others and helps advertise the station.

Manufacturers, seeking standard sizes, are making electric-light bulbs smaller, tipless and frosted inside to kill the glare

*Road Service Company in California*

*New York Times 9/20/25*  
*New York Herald Tribune 9/20/25*

433



Side View of Miter Gauge, Showing Folding Rule, Tables and Holes, and Using Instrument to Mark Rafter

### MITER FOR CUTTING RAFTERS SIMPLIFIES BUILDING ROOF

Correct angles and lengths for cutting rafters for roofs of any pitch are indicated automatically on a miter gauge intended to eliminate the task of mental calculations and figuring with an ordinary square. On one side of the instrument is printed a convenient table, the upper figures of which show the rise of the roof in inches, and below are corresponding figures that tell the length for common, hip or jack rafters in proportion to each foot of run. With the length of the rafter quickly determined by consulting the table, it is marked at the right angle for cutting with the aid of a folding rule attached to the miter. This is adjusted by inserting a pin in one of a series of holes to hold the free end locked.

### HENS SCARED BY AIRPLANES REFUSE TO LAY

Because airplanes, soaring over poultry farms in Burbank, Calif., frighten the hens so they refuse to lay, a delegation of chicken raisers has protested against further flying by commercial aviators over that neighborhood. The fowls seem to mistake the planes for hawks or other

birds of prey and flee for shelter, frequently leaving their nests and laying no eggs on days when the planes fly over the town. The farmers produced figures to show that there had been a material decrease in daily egg production since commercial aviation had become common.

### FOOT TOBOGGANS AFFORD NOVEL WINTER SPORT

Steel sandals, shaped like little toboggans with corrugated bottoms and turned-up tips, enable children to get greater fun from sliding on snow or ice and save wear on shoes. They are strapped on like roller skates, their wide, flat surfaces relieve ankle strain, and with the aid of the cor-

rugations, the wearer can take strokes or run to get a flying start for a long slide. They reduce the danger of tripping to a minimum and keep the feet from getting wet. Three sizes are manufactured for children from four to twelve years old.

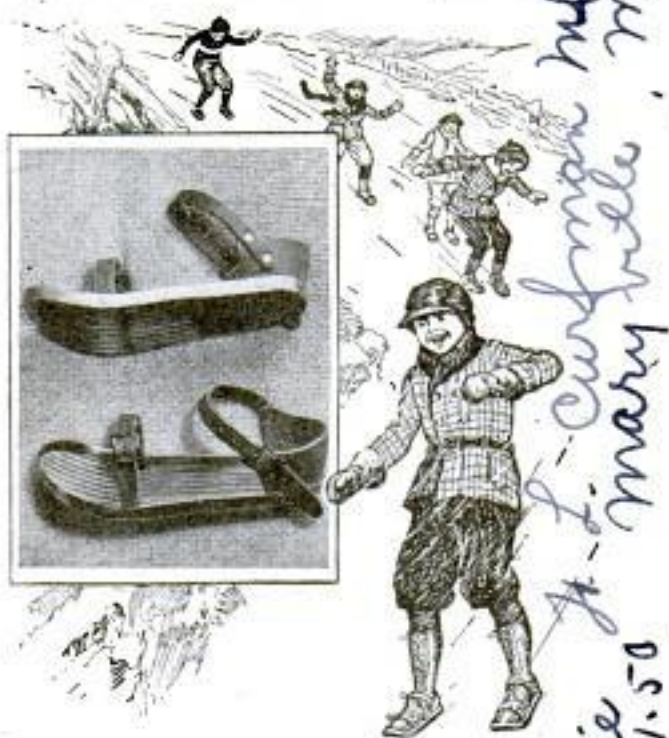

Corrugated Foot "Sleds" for Coasting down Hills

471

*J. L. Curdman mfg. Co.  
 Maryville, Mo.  
 Price \$1.50*

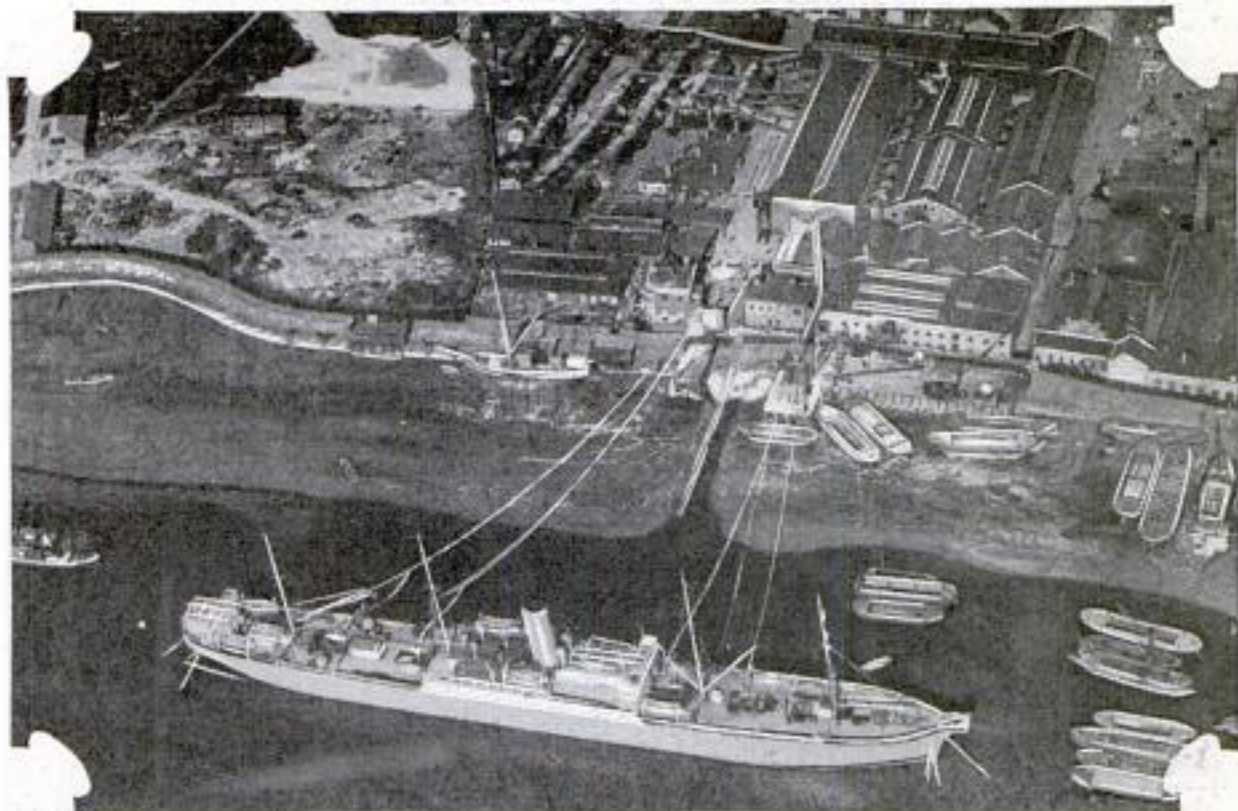

© U. &amp; U.

Cable Ship Loading 2,360 Miles of Permalloy Submarine Cable at Greenwich, England, for New America-Azores Link of the Direct Line to Italy

## “Four Millions on ‘Permalloy’—to Win!”

Once More of a Gamble than a Horse Race, New Transatlantic Cable Speeds Messages Five Times Faster than Before

By EARL CHAPIN MAY, *Sharon, Conn.*

**T**HIS is not a race-track yarn. It is the story of messages flashed along thousands of miles of track laid on the bottom of the seven seas. “Permalloy” is not a horse, but an alloy of about eighty per cent nickel and twenty per cent iron, which promises to revolutionize submarine-cable transmission.

Newcomb Carlton is president of the Western Union Telegraph company, one of the six big submarine-cable concerns. After thirty-four years in mechanical and electrical engineering he backed permalloy with \$4,000,000 of his company's money and his job. The bet and a new cable from New York to the Azores were laid last year. Carlton won. That new cable, the core of which was wrapped in permalloy, carried 1,700 letters per minute—five times more than any cable previously laid. Radio had challenged the cable, and the cable met the challenge.

Before Cyrus W. Field laid the first transatlantic cable in 1858, Europe and

America exchanged information only by mail or by word of mouth. About ten days elapsed between sending and receiving a message. The first official transatlantic cable message of twenty-one words was thirty-five minutes in transmission. The average speed of the 732 messages carried by that first cable was two words per minute. By 1894, improvements in sending and receiving devices and in cable construction and laying had increased the speed to 240 letters per minute.

The first around-the-world overland and underseas message, sent by President Theodore Roosevelt on July 4, 1903, made the circuit in twelve minutes. The second message, sent on the same day by Clarence H. Mackay, president of the Commercial Cable company, made the round trip in nine and a half minutes. These were “all clear” messages. On Aug. 21, 1911, the New York Times sent a straight message around the world in sixteen and a half minutes. Up to 1923,



This central copper wire carries the electric current. If it breaks, these flexible copper tapes carry the current around the gap.

This is the permalloy tape whose wonderful magnetic qualities keep the signals from jumbling. A thick covering of gutta-percha holds the currents to their path.

A wrapping of jute cushions the pressure of three miles of seawater.

Eighteen steel armor-wires protect the cable from injury.

Last of all a wrapping of tarred hemp cords, then the soft ooze of the ocean's floor.

combination, and its top transoceanic speed was 300 letters a minute, when Newcomb Carlton laid his own wires for his big bet on permalloy.

The laying really started ten years ago with experiments in the laboratory of the Western Electric company and by the American Telephone and Telegraph company. At the end of the ninth year, it was determined that the alloy now called permalloy automatically increased the magnetic effect of the current, sharpened the signals, and thus improved the cable's carrying capacity beyond anything previously known. Short-length tests showed a carrying capacity of 1,500 letters per minute.

In the spring of 1924, 120 miles of the permalloy cable were laid off the Bermuda islands. Under test conditions this piece of cable carried the required 1,500 letters per minute. But that did not necessarily mean that the same type of cable would do the same amount of work when laid on the floor of the Atlantic. And even if the new cable functioned at the profound depths to which it must be lowered, there was much doubt as to

its carrying capacity over great distances. And there was also the problem of sending and receiving messages at such an unprecedented speed. There have been a lot of surprise parties in the cable game. The first transatlantic cable was burned out by excess voltage

submarine cables averaged 250 letters per minute in transmission speed. In 1923, the Commercial Cable company increased its transatlantic speed to 300 letters per minute over a cable with an especially heavy copper core. During this period, cables had been duplexed and the old method of receiving by reading a magnified moving beam of light had been replaced by a siphon ink recorder. Automatic repeaters had been installed. There were many improvements in sending and receiving devices, but there was little change in cable construction until permalloy got its first try-out in 1924.

Prior to that time, practically every submarine cable consisted of seven strands of fine copper wire which constituted a conducting core smaller in diameter than a lead pencil. Three layers of insulating gutta-percha surrounded this core. Around these were spiraled first some jute fibers, then eighteen steel wires, wrapped in hemp. Radio was competing with this

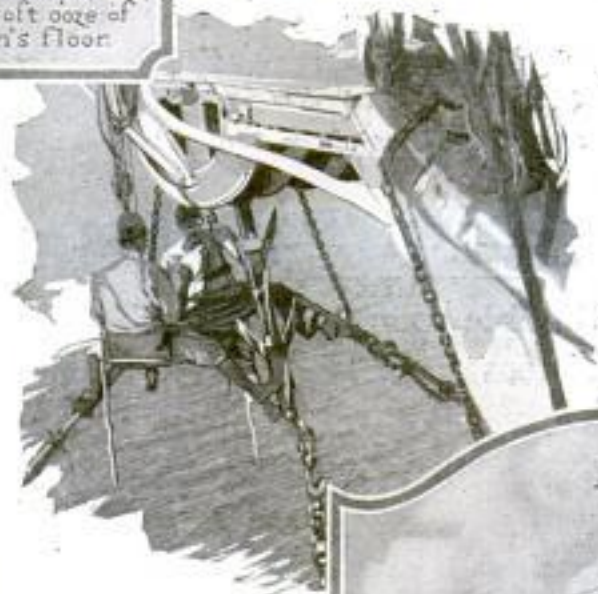

Top, Sections of Cable; Center, Cable Layers at Work at Sea, and, Right, the Cable-Laying Sheaves in the Ship's Bow



Copyright.

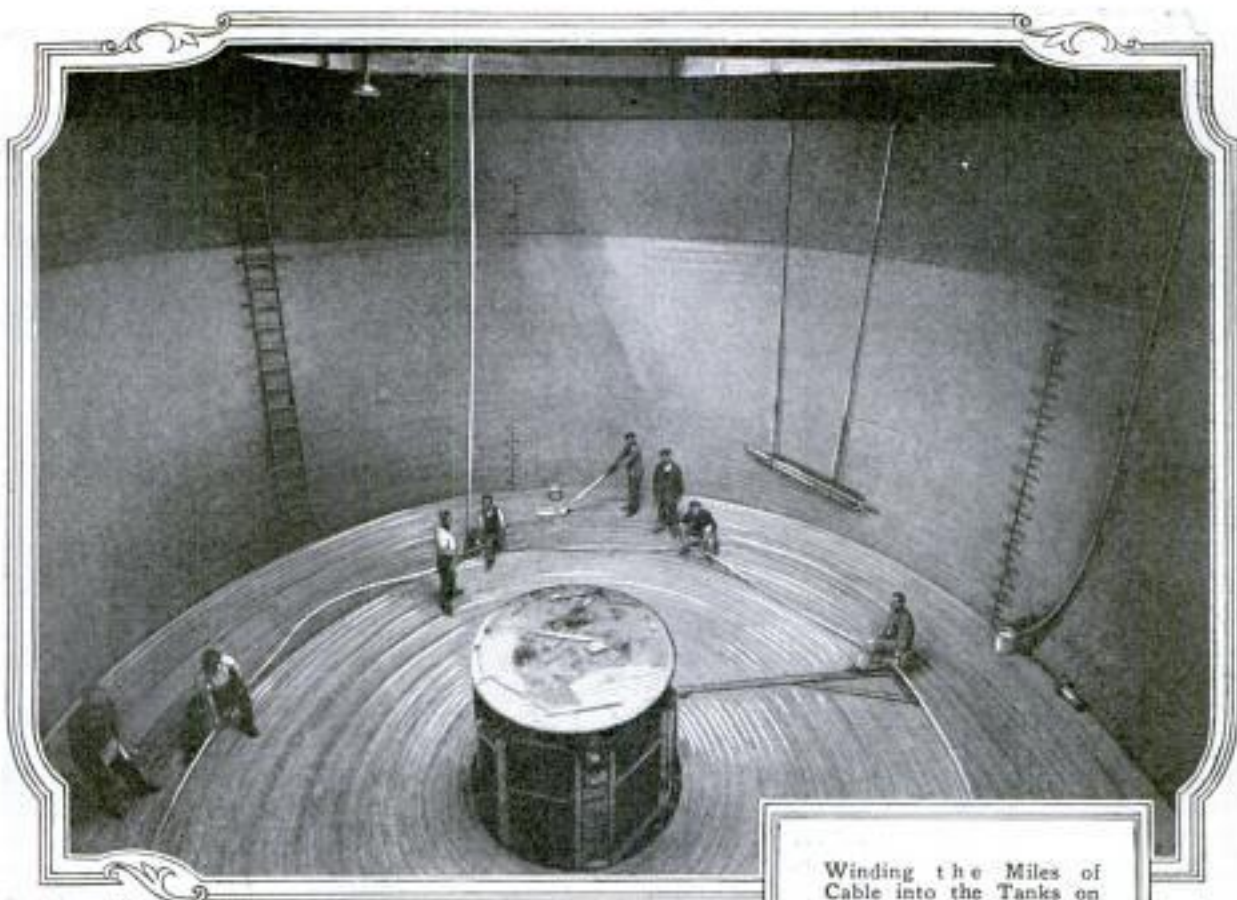

Winding the Miles of Cable into the Tanks on Board Ship, a Delicate Operation Since It Must Come Out Easily and Free of Kinks as the Ship Steams Ahead; Below Is the Receiving Apparatus Which Prints the Message as a Wavy Line

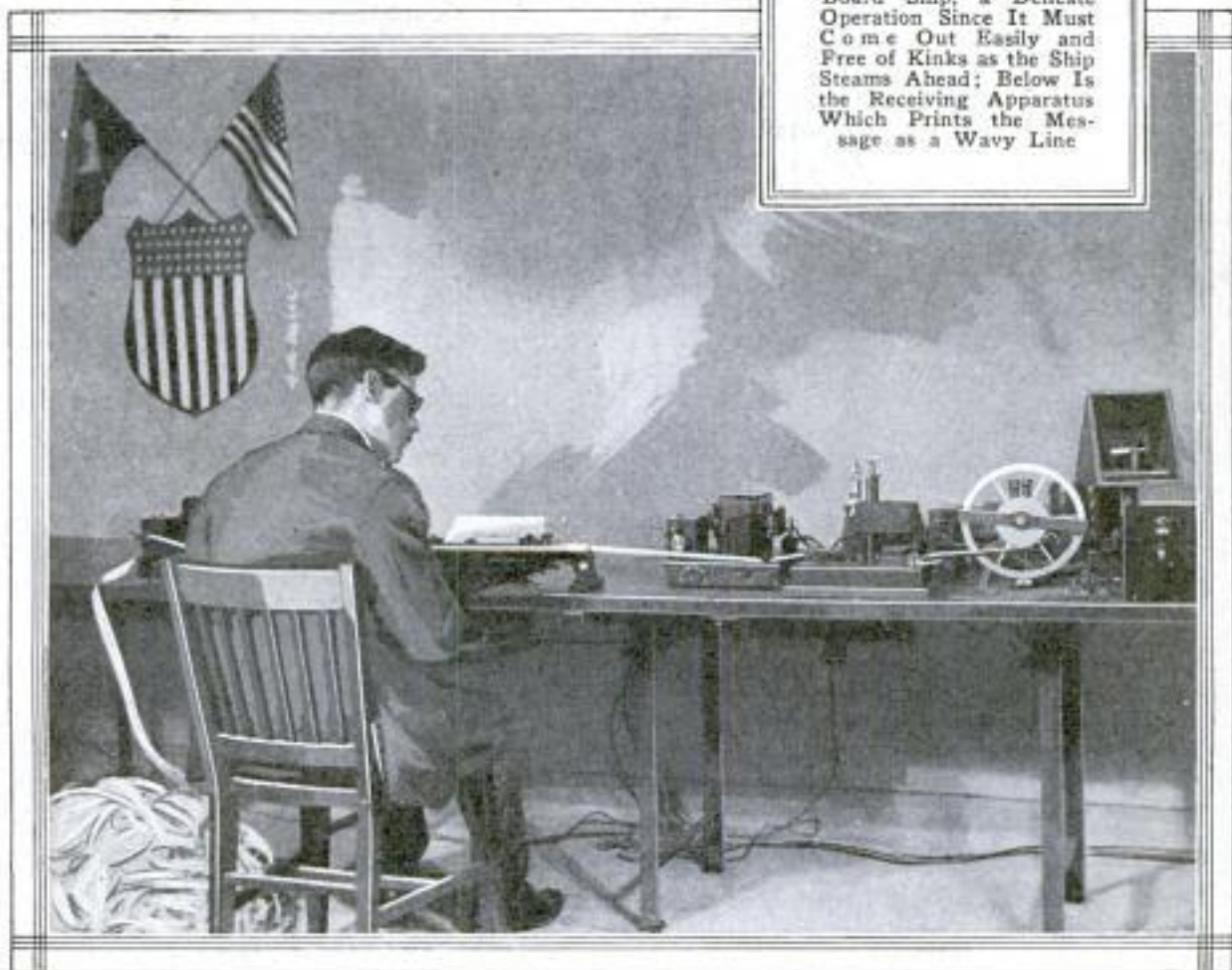



© U. & U.  
 Dragging the New York End of the Cable up the Beach After It Had Been Landed by Small Boats and Floating Buoys; the Land End Is Built Extra-Heavy to Withstand Wear and Tear

after a few weeks' use. That mistake cost \$2,000,000, which is equivalent to \$5,000,000 now. Cable people have to take chances. Carlton took a \$4,000,000 chance and ordered the construction and laying of 2,360 miles of his new permalloy cable from New York to the Azores.

The cable was manufactured in England, as most cables are, was loaded on the especially equipped cable ship "Colonia," and laid from the Azores to New York in September, 1924. On Sept. 23, it was tested and found to carry 1,700 letters per minute! The permalloy that turned the trick was a strip, six-thousandths of an inch thick, one-eighth of an inch wide and 10,000 miles long, spiraled around the cable's central core and imbedded in a special compound. This strip does the same amount of "boosting" for a submarine cable that the so-called Pupin coil is doing for the long-distance telephone.

While permalloy was coming into the submarine-cable field, new sending and receiving machines, operated on the typewriter principle, were introduced. Accurate, automatic dot-and-dash records came into vogue. Engineers kept pace with improvements in cable construction by improvements in these typewriter devices, until today, if one visits the New York cable office where the American end of the permalloy terminates, one sees a practical though somewhat mysterious product of engineering skill—six typewriters operated simultaneously by electric impulses from the Azores end of the cable.

To the general public the success of the new cable is a great boon. But a few years ago Americans were isolated

socially and economically. Now that we are among the world's most persistent globe trotters and have vast financial interests in almost every corner of the earth, a cablegram is no longer a novelty in Wahoo, Nebr. The tie-up between the telephone, telegraph and cable is complete. And every improvement in submarine-cable transportation, although inspired by competition with transoceanic as well as overland radio communication, makes it easier on the pocketbook of the inlander as well as for the exporter and importer along our thousands of miles of seacoast.

With increased cable speed came decreased cable tolls. In 1866, the commercial-cable rate across the Atlantic was \$100 for twenty words. The next year it was \$50. In 1884, it was twelve cents a word—twenty words for \$2.40. Then it went up to twenty-five cents a word. Now it is back to twenty cents a word for straight messages—although for deferred messages, on which delivery is guaranteed within five hours of sending, the rate is as low as five cents a word. Similar reductions have followed the building of competitive cables to other continents and the normal decreased overhead, due to improved methods of handling business.

Prior to the opening of the commercial Pacific cable in 1903, the commercial-cable rate from San Francisco to China was \$1.73 per word, via the Atlantic ocean, Europe and Asia. To the Philippines the rate was \$2.47, to Japan, \$1.88. The rates now in force across the Pacific are to China, eighty-eight cents; to the Philippines, eighty cents and to Japan, ninety-six cents. When the all-America systems entered Buenos Aires in 1882, the rate per



word was \$7.50, via Europe. In 1917, the rate to Buenos Aires and all principal cities in South America was reduced from sixty-five to fifty cents a word. On Sept. 12, last year, rates to Santo Domingo were reduced thirty-seven per cent.

Additional decreases will be in order as soon as there are enough cables to handle all business offered. We may even begin to manufacture cables on this side of the water although the British have a virtual monopoly of the business which requires a heavy initial investment.

Carlton won more than his \$4,000,000 bet when he laid his New York-Azores permalloy cable. He put permalloy permanently in the English vocabulary. In a year or so it will cease to be a proper name and will become just another word in everyday use. Since the first permalloy cable went into operation, the Western Union Telegraph company has closed another contract with the Telegraph Construction and Maintenance company of London for a second transatlantic permalloy cable. This one will cost about \$5,500,000, will be laid from New York via Newfoundland to Penzance and London, and will be in operation by August, 1926. It will have nearly double the capacity of the New York-Azores cable, which became a transatlantic cable through the completion of the link between the Azores and Europe by an Italian company.

The New York-London permalloy line, according to Mr. Carlton, will be equipped with a new type of receiving device which will still further revolutionize cable transmission. It has been possible for some time to transmit several messages over one cable simultaneously. But only recently has it been possible to pick up these messages while they were being transmitted. With the new receiving device, which resembles a revolving disk at which eight operators are seated, each operator can pick up words from his respective segment of the disk as they come in. That's just another tally for the cable.

Since the first permalloy cable was laid;

the Pacific cable board has closed contracts for the manufacture of a new cable to be laid in the Pacific ocean from Victoria, Can., to Suva, capital of the Fiji islands. The southern section of this cable, running from the Fanning islands to Suva, will be manufactured in London, and will be inductively loaded with permalloy.

German engineers are now in the United States making investigations which may lead to laying a permalloy cable from the Azores to Emden, Germany. This will link Germany with the New York-Azores permalloy, and will thus give us the first direct cable connection with Germany since the World War.

Mr. Carlton says there is nothing to fear, as far as submarine-cable interests are concerned, from radio competition. "We welcome such competition," he declares. "Inventions improve that which is worthy of survival; they do not destroy. With new devices to receive messages sent at stupendous velocity over cables that can and do transmit many messages simultaneously, the outlook for the cable has never been better."

Mr. Carlton has the figures to support his declaration.

In spite of the advent of radio, more than 35,000 miles of submarine cables have been laid during the past decade. More than 250,000 nautical miles of cables carry messages along the floors of the seven seas. They are all busy. Cable experts estimate that the 1926 New York-London cable of the Western Union Telegraph company will have a capacity of 100,000,000 words a year and will have all the business it can carry.

Communication is at the base of civilization. You will recall that Samuel Morse, father of the telegraph system, said before he died in 1872, "I am persuaded that whatever facilitates intercourse between the different portions of the human family will have its effect upon the guidance of sound moral principles to promote the best interests of man." Putting it another way, the more means

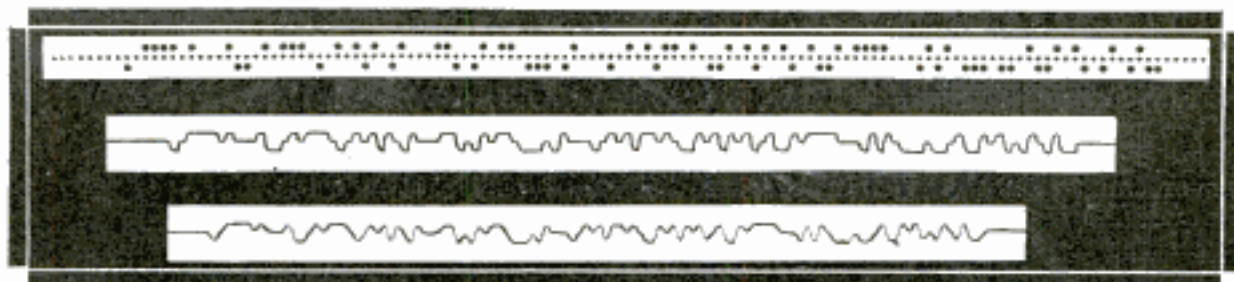

Top, Punched Sending Tape That Transmits Message; Clean-Cut Received Signals, in Center, with Sharply Defined Angles, and, Below, Ragged Reception Customary on Old-Time Cables

*Myr. Engineering Corp.,*  
 1305 W. Broadway  
 952 Long Beach, Calif.

*Bovite - American*  
 Armor Corp. 33 W. 34 St.  
 New York

of communication we have, the better it will be for us.  
 So, while the telephone reaches almost every farmhouse—whether the farmer owns a radio set or is just thinking about

**BULLET-PROOF METAL TO FOIL AUTOMOBILE BANDITS**

409 Automobile bodies of a bullet-proof metal that cannot be distinguished in appearance from the usual material have been constructed for police and other special uses. The metal is the same as that of which bullet-proof vests have been fashioned, and its efficiency lies in its ability to absorb the impact of a missile, allowing the vibrations to spread and thus preventing perforation. Unlike stiff, heavy armor plates, it can be cut or punched easily, and bodies constructed of it are well within the weight limits of the car's chassis, a sheet of the metal being only about one-sixteenth inch thick and weighing but two

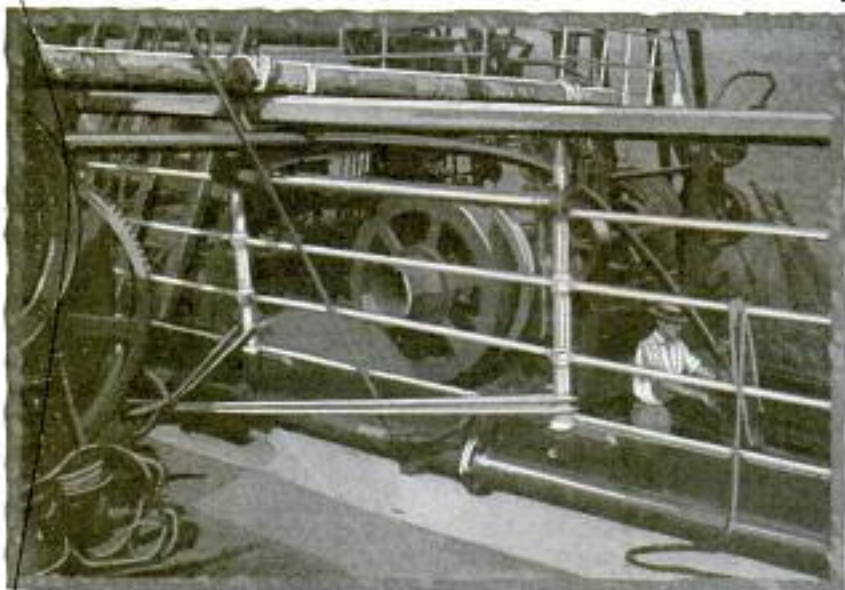

Deck Machinery of a Cable Ship, Showing the Drums and Other Apparatus Necessary to Pay Out the Miles of Cable Smoothly © U. & U.

buying one—and while the Western Union Telegraph company operates about 1,600,000 miles of land lines, and the Postal Telegraph company nearly 325,000, the cable companies are not overlooking any good bets to promote transmission of intelligence. And in making his \$4,000,000 bet, Newcomb Carlton did his important bit.

and one-half pounds to the square foot. It also has a surface that takes any kind of automobile finish.

**VANITY CASES FOR MEN'S USE HOLD PIPES AND KEY RINGS**

Pipe and tobacco pouch, an extra pack of matches and cigarets can be carried in a small "vanity" case for men, the latest London fad. Besides these articles, there is space for handkerchiefs, key ring, comb and nail file. Like the case for women, the top has a mirror.



"Vanity" Case as Smoker's Kit

**SMOKE DETECTOR FOR BOILERS OPERATED BY ELECTRICITY**

Electricity has been adapted further to public health and comfort in a smoke detector to warn boiler operators when their fires need attention to prevent soot and unpleasant fumes. The apparatus consists of two plates installed in one of the flues so that the gases pass between them. The units are connected to a sensitive recording instrument which is placed in convenient view of the furnace tender. As the density of the smoke increases, there is a corresponding rise in the conductive power between the plates, and the flow of current is registered upon a chart in the recording instrument. When the gauge reaches a certain point, the observer can tell that the chimneys are on the verge of smoking and at once can take steps to prevent it.

More than 793 distinct species of roses are known to science.

*new York Utility Bulletin 9/14/25*

*409*  
*no. 1 de l'epes*  
*metallurgique de compagnie.*

## 'GASSING' FRUITS AND FLOWERS KEEPS THEM FRESH

That fresh fruits and vegetables at Christmas, and other times out of season, will be common, is predicted by reason of a special preserving method developed in California. Some 200 tests already have demonstrated the success of the process. California pears, picked last year in August, were found to be ripe, fresh, full-flavored and sound, when they were opened in Indiana on Christmas

from contact with the fruit, thus averting decomposition. The process is simple. The product is graded as to size, then

each article, except grapes, cherries and other small fruits, is wrapped in tissue paper, just as in packing in the ordinary shipping container, but a metal case, holding twenty-four to forty-eight pounds, is used instead of a wooden box. When the container is filled, a per-

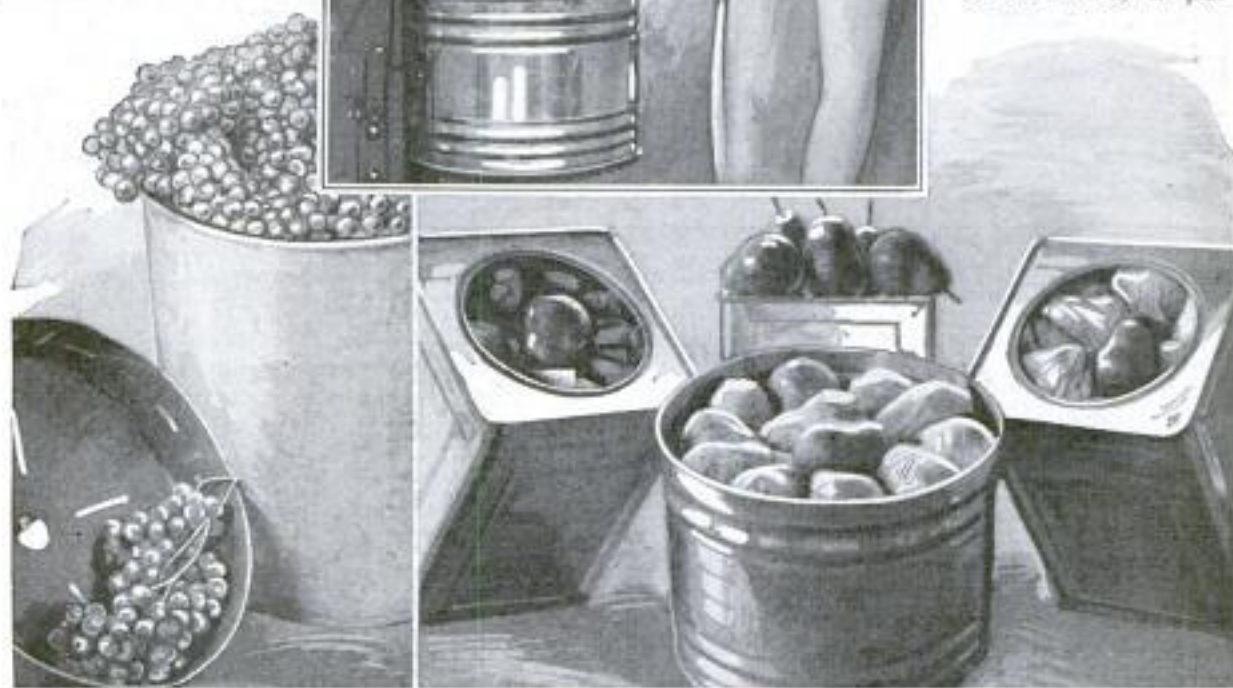

Metal Container in Press Ready for Sealing; Top Is Put On When Chemical Is Burning at Its Best; Below Are Samples of Fruit Packed for Treatment

day. Peaches packed in July this year were in the same condition as when put in their containers when they reached tables in London and Hamburg, forty to forty-five days later. Grapes, similarly treated and sent to London and Liverpool, were served at a banquet as fresh fruit just from the vines, although they had been in storage ten days and forty days at sea. A steamer load of fruits and vegetables has been sent around the world from San Francisco. The cargo will be carefully inspected by experts from the university of California on its return, to determine if there has been any decay during the 25,000-mile journey. The method is based on elimination of oxygen

forated cardboard shield is placed inside the package and over the fruit. On this shield is laid a slender pine stick, soaked in an inflammable composition. The stick is ignited, and when the composition on it is burning at its best, the lid is clamped down and the container hermetically sealed. The burning substance consumes all the oxygen leaving carbon-dioxide in its place, together with the nitrogen of the air. The cans are then stored or shipped at forty to fifty degrees.

The gas treatment is also applied to flowers, and is said to have the same beneficial effects, causing them to retain their color, fragrance and freshness although shipped long distances.

Cmh. Chester Lyndelle,  
Box 750, Brenton, N.J.

Mr. Du Toit  
Geologist  
University of Pretoria  
Dept.

954

POPULAR MECHANICS

### CAMERA TRAPS AUTO SPEEDERS BY DOUBLE EXPOSURE

49

Hidden in a clump of shrubbery where unsuspecting motorists could not see it, a camera proved an efficient "detective"

### RIVERS SOUGHT BY AIRPLANES TO FILL DRIED-UP LAKES

Airplanes are being used in a reclamation project in south central Africa, where flyers are seeking a way to divert rivers



What the Camera "Detective" Reported; Double Exposure Photograph Showing How Far Auto Went in One Second

in obtaining evidence against speeders. The drivers had been taking advantage of the fact that the law required policemen to follow a car for not less than half a mile before charging a violation of the ordinance. This gave the autoists a chance for bursts of speed through the parks, endangering pedestrians, but the distances were insufficient to permit motor police to make arrests. The camera solved the difficulty, and since officers were not present, drivers more readily fell into the trap. Attached to the instrument was an electric trip, a certain distance from the lens, to open the shutter which was set to register another exposure exactly one second after the first. Thus, two exposures were obtained on a single plate, giving the position of the car when it crossed the trip line and its place a second later. The distance between the two was measured by superimposing an accurately drawn scale, on a master plate, over the photograph. The speed of the car here illustrated was found to be between thirty and thirty-five miles an hour.

Popular Mechanics Magazine does not publish the name of maker or seller of devices described, but this will be furnished free by our Bureau of Information.

for refilling the dried-up lakes in the Kalahari desert. Great difficulties have been encountered in the work. The airmen had to carry their own supplies over a roadless country to their base of operations, ninety miles from the nearest town, and they face the ever-present danger of forced landings on the barren sands. Geologists and engineers are assisting in the task, and aerial photography is playing an important part in the survey. Should the lakes be filled again, scientists believe that the rainfall, which is now extremely scant, would be increased and the country made available

for white settlement. A large section of the territory already has been photographed and mapped from the air.

### LIGHT BULB USED TO COOK AND BAKE FOOD

485

Heat from electric-light bulbs is utilized to prepare food in a compact combi-



Demonstrating Electric Cooker Which Utilizes Heat of Light Bulb Attached to Socket in Side

nation cooker and baker. Warmth is retained by special insulation and the utensil, cylindrical in shape and occupying but little space, is not difficult to clean and requires little attention. It is said to be more easily repaired than other cookers.

Christian Science Monitor  
9/21/25

Show at Island Central  
Palace

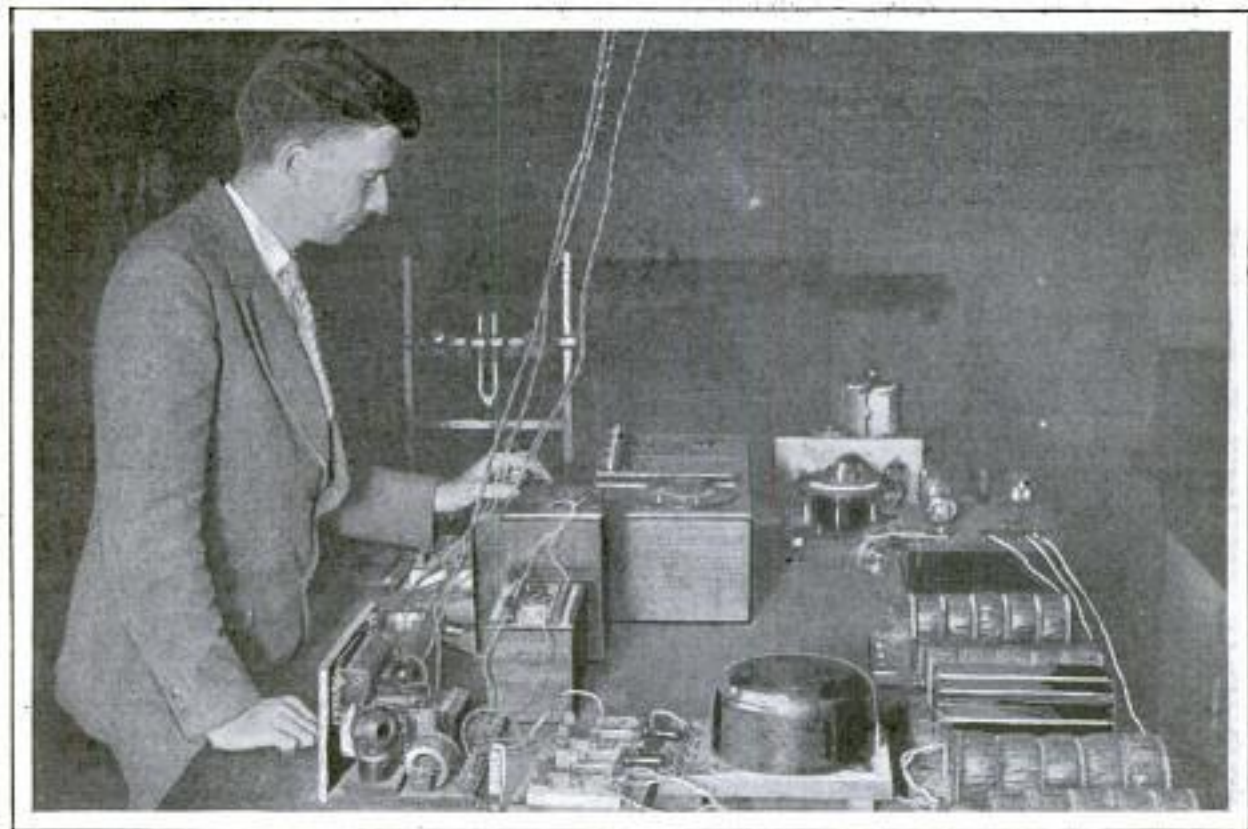

Small "Broadcasting" Station at Riverbank Laboratories Where Sounds Produced by Oscillations of Vacuum Tubes Are Transmitted to a Special Receiving Unit for Measurements of Hearing

## Exploring the Mysteries of the Ear

### Scientists Adapt the "Howl" of the Radio Vacuum Tube to Tests for More Accurate Measurements of Hearing

**I**MAGINE a grand piano, about half the size of a pea, with 20,000 tiny strings, each tuned to receive only one tone, and you have a rough picture of the inner ear, if the theory of some scientists is correct.

Dr. Frederick W. Kranz, an expert in physics, who, with associates at Riverbank laboratories, near Geneva, Ill., has been spending several years attempting to solve some of the riddles of the human ear, was talking as he demonstrated a testing apparatus he has devised for measuring hearing. It is, in effect, a small broadcasting station that utilizes the "howl" of the radio vacuum tube. The sound is adjusted to different frequencies by a control on the transmitter. The subject listens through a set of earphones similar to those on an ordinary receiver, except that a fine strip of platinum foil has been substituted for the usual diaphragm and coil. The intensity of the tone is changed by a set of switches, and the person taking the test causes the

howl to extend over a whole octave simply by moving a wooden bar back and forth. In this way, both loudness and pitch can be varied over a wide range at the same time, affording much more information about the hearing than could be gained simply from tuning forks, bells or whistles, which cannot be so regulated. The tests are made in a small room carefully insulated against disturbing sounds from the outside.

"Many persons do not realize it," Dr. Kranz continued, "but the human ear, in normal and healthy condition, is just as sensitive as the eye. If the sun made a noise when it comes up, you would be able to hear the dawn just as easily as you see it. Of course, the sight impression would be registered first because light travels much more rapidly than sound. Your ear is so alert that it can probably distinguish as many as 300,000 different tones, according to scientists who have measured the organ's sensitivity, and can distinguish between several at once. In this

371



through the bones. This test affords another measurement of hearing and shows what a marvelous sounding board the skull is.

"The ear consists of three parts, the outer, middle and inner. Sound vibrations enter the outside passage, strike the eardrum and are communicated to the inner ear by means of three little bones, the malleus, incus and stapes, the smallest bones in the body. Through them, the vibrations pass to the inner ear chamber. The location of those thousands of little 'strings,' which have been compared to those of a grand piano, is a point not yet clearly established and their nature is not understood. How do these strings keep in tune? Why do both ears stay alike? These, and many other questions about our hearing prove perplexing and are not satisfactorily answered. In fact, we know very little at all about the ear. You can go to a good

eye doctor and get glasses for almost any kind of ocular trouble. But deafness is not so easily remedied. In fact, if the difficulty lies in the inner or middle ear, there often is no known cure for it."

If you have normal hearing, you will be able to detect the tick-

respect, it is more wonderful than the eye, for even an artist cannot see the different colors that make up a mixture. The ear is so sensitive that in the case of a tone three octaves above middle 'c,' when the air particles move back and forth only a billionth of an inch, the sound still can be heard. Very little energy is represented in sound. In fact, it has been estimated that it would take 100,000,000 persons all talking at once to produce sufficient energy from their voices to boil a cup of water.

"Did you know that the bones in your head transmit sound?" Dr. Kranz disconnected the earphones and attached what appeared to be an ordinary telephone receiver with a flat-topped steel bar extending from the center. By pressing this to the head and to the teeth, the tones from the oscillator were heard. Speech was also audible through this strange receiver. "The vibrations are carried to the bar through an ordinary telephone circuit," Dr. Kranz explained. "Instead of being conveyed to the eardrum by the air, they are transmitted

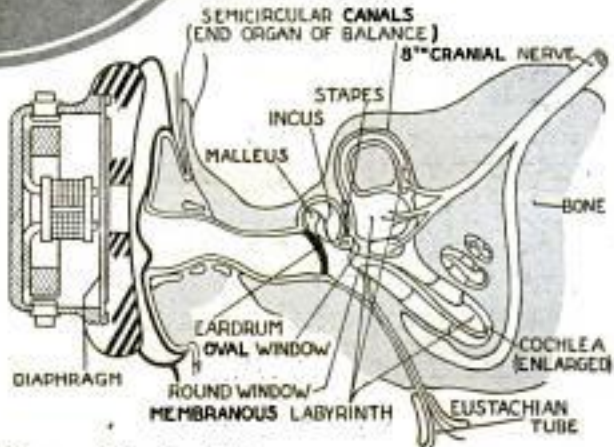

Diagram Showing Telephone Receiver Pressed to Ear and Inner Mechanism of Organ, with Large Models Used in Researches



ing of a watch held a foot, eighteen inches or even more away from the head, but such tests are not reliable, Dr. Kranz declares. Everything depends upon the conditions under which they are made, such as the size of the room, other noises and air currents. Even the slight disturbance produced by a small electric fan revolving at lowest speed interferes with the hearing. Tests in Dr. Kranz's laboratory showed that a tuning fork could be heard five seconds longer when the fan was not running.

"That demonstration indicates what a battle our ears are having against the distracting noises of everyday life," the physicist declared. "But we are accustomed to loud noises. In fact, you and I really talk a million times louder than is necessary for the ear to hear."

"Scientists have proved that some of our old theories about the way sound is transmitted to the ear are wrong. For instance, many persons declare that they can hear better in a subway or in other noisy places. What really happens is that people speak louder and listen more attentively under such conditions and

consequently they hear well, but not because the ear works more efficiently. Trumpets and other aids to the deaf are of value in some cases only because they amplify the sound, and you will notice that when you speak to a person using such a device you talk louder than ordinarily, and, of course, the deaf one is listening closely. People once believed that by stretching wires across a room that had poor acoustic properties, a speaker could be heard more distinctly. That theory has been entirely exploded. What occurred was that more people came to listen to the effect produced by the wires. Their bodies and clothing absorbed some of the troublesome echoes and so an improvement was probably noted, but it was in no way due to the wires."

For some unknown reason, the right ear, tests at Riverbank have shown, of the average person is more acute than the left, but there are wide differences in individual ears. For instance, the hearing may react normally under various tests, when suddenly, at the higher frequencies, it falls below the average sensitivity and then "comes back" at even higher tones. This defect has been most commonly noted in the left ear. It is interesting in this connection to observe that the human hearing mechanism's range of sound perceptibility extends far beyond ordinary musical and voice notes. The upper limit of audibility is approximately 20,000 cycles per second. The highest piano note, about the limit in music, is nearly 4,000 cycles and the range of ordinary speech is between 200 and 2,000 cycles per second.

Telephone engineers have devised electric filters for use on long-distance lines to eliminate the troublesome higher frequencies and thus improve the service.

If you get water in your ears while swimming, the effect may not be pleasant, but it is not dangerous unless the ear-

drum is perforated, allowing the liquid to enter the middle chambers and possibly cause infection.

"But the eardrum is a fairly substantial member after all and many persons' fears about injuring it are baseless," Dr. Kranz says. "It will heal in about a week if it is punctured, and it can be stretched back and forth, withstanding an amazing amount of strain. This flexibility probably explains why airplane rides at high altitudes may effect a temporary improvement in certain cases of deafness. There is a small tube or opening—the Eustachian tube—from the middle ear into the mouth. This equalizes the air pressure on both sides of the drum. When this opening gets filled up, the drum is pressed inward and partial deafness may



Testing a Doctor's Stethoscope by Listening to Sound Vibrations as They Pass through Subject's Head from Special Receiver



Listening with the Head; Sound Vibrations Are Transmitted through the Skull Bones from Receiver Bar

result. By ascending to high altitudes, the outer air pressure is reduced so that the drum has an opportunity to stretch back to normal position and the hearing receives a consequent benefit. The improvement is likely to be temporary only, however, if the tube still remains filled up. When the nose is blown violently, matter may be forced into this opening and into the ear, causing trouble. That is why persons suffering from severe colds sometimes complain of deafness, and why care



An Ear Test by Radio; Dr. Kranz, at Left, Changing Tone's Intensity While Subject Alters Pitch with Sliding Bar

should be exercised at all times in blowing the nose."

Besides being the organ of hearing, the ear serves as the balancer for the body, a direction finder and a pressure indicator, Dr. Kranz pointed out. Scientists believe that the ear, and not the stomach, is the true seat of seasickness. The delicate nerves of the organ become overworked while signaling the proper balance to a person on a pitching, tossing ship. This, in time, may produce nausea, headache and other attendant ills. Even hardened sailors are not immune from occasional attacks, but the system tends to become adjusted to the constant shift of balance. Tests on rats at the University of Illinois indicate how completely the nerves can become adapted to a special situation. A number of the animals, born and raised on a constantly moving platform arrangement, exhibited no signs of sickness due to the changing balance, while others, unaccustomed to the whirling, became affected in much the same way that persons react to seasickness. It was also observed that the rats which were used to the rotation had to become adjusted to "steady life" when taken from their revolving home. As a direction finder, the ear of the soldier now is called into important service in locating airplanes. Horn-shaped instruments that help to focus the sound of distant planes have been devised to aid him. To protect the ears of artillerymen from the heavy concussion of the big guns,

various appliances have been invented. One of the most effective was a simple rubber plug.

One of the interesting side issues of the ear experiments at Riverbank has been a test of physicians' stethoscopes. Sound is sent into the receiver with the vibrating bar, which is pressed against the head of a person who acts as a sort of transmitter for the vibrations. Another, wearing the stethoscope, presses the instrument to the other side of the "medium's" head and attempts to hear the sound as it is transmitted by the bones. Marked differences in the efficiency of various stethoscopes have thus been found.



**AIRPLANE WINGS SO STRONG  
MEN MAY WALK ON THEM**

Equipped with all-metal wings and body, a huge monoplane flying boat has been added to the British air service. It



Monoplane Flying Boat on Arrival in England from Copenhagen; Its Metal Wings Are Intended to Resist Damage from Heavy Storms and the Action of Sea Water

was built in Denmark, and one of its first trips was a non-stop run from Copenhagen to Felixstowe, Eng., a distance of nearly 700 miles by water and over 500 by air. Among the advantages claimed for its all-metal construction over fabric and wood, is that the wings are so strong and rigid, that men may walk on them.

488

**FUNDY'S TIDES TO GENERATE  
SUPER-POWER FOR EAST**

Approval by the voters of Maine in a recent election of a plan to harness the tides of the Bay of Fundy so that they will generate 500,000 horsepower of electrical energy, has paved the way for one of the biggest engineering feats in history. A storage area of 150 square miles will be formed, with the tidal currents each day filling it up anew. As the tides there range from eighteen to twenty-seven feet at different seasons of the year, there will always be a good head of water at the power house, with a maximum of 700,000 horsepower available at the time of highest tides. Passamaquoddy, an arm of the Bay of Fundy, is almost enclosed by a chain of islands, so that comparatively short dams between them will shut off the bay. At high tide the gates in the dams will be opened, permitting the ocean to rush in. As the tide turns, the gates will be closed and the water

will then escape through the power house into a lower pool, similarly dammed against the sea. At low tide, this lower pool will be emptied by opening its sluice gates. As the lower pool has an area of more than 50 square miles, the water flowing through the generator turbines will not appreciably affect its level, so that the head of the water, or difference between per and low levels, will remain fairly constant. The tidal power plant will

have an advantage over most fresh-water power houses in that there will be no unexpected spring floods to reckon with. The time of high tide and its height can be figured within a space of a minute or two and a fraction of a foot for any day of the year for years in advance. Whether the year be wet or dry, the Atlantic will always provide practically the same amount of water. Approval by the province of New Brunswick and the Canadian government also is necessary, since most of the storage pool lies in Canada.

420

**AUTO TOWLINE WITH SPRING  
ABSORBS SHOCKS**

Fitted with a strong shock-absorbing spring in the center, an auto towline now on the market is intended to withstand the sudden jerks that often break the ordinary line. This eases the jar on the auto and eliminates the necessity of frequent repairs when strands break, a job that often involves tying or untying hard knots. In addition to the spring, the line has worm-shaped hooks for quick and secure looping at the ends.



new York Times 7/27/25  
Robert L. Sluffe, Eastport, Me.

The Safety Hook Co. Minn.  
Two Harbors, Minn.  
\$7.50

maker. J. A. Cox  
 412. Malino St.  
 Los Angeles, Calif.

**REEL FOR CATCHING TUNA FISH  
 COSTS AS MUCH AS AUTO**

Fifteen hundred dollars, a sum sufficient to buy an automobile, is the price Zane Grey, the novelist, is reported to



Samples of Reels for Catching Tuna Fish

have paid for a reel to combat the game and weighty tuna fish. It is made with great precision, all parts being within one to one-half thousandth of an inch of the calculated measurements. It is constructed of a non-rusting, extremely strong alloy, and is controlled entirely by the right hand. The amount of "drag" on the line is regulated by a pilot wheel below the reel handle, so that friction with the water can be offset, thus reducing the chances of breaking the line and allowing the fish to escape. With one of these reels, the novelist has landed a 750-pound tuna; the inventor, in three and one-half hours, caught seven with a total weight of 810 pounds.

**ARMORED GUNNERS TO FIGHT  
 FUTURE SKY BATTLES**

With a view to protecting machine gunners in the exposed cockpits of big war planes from hostile bullet fire, suits of armor or revolving metal turrets have been proposed in England. Of the two suggestions, the former is looked upon with greater favor, as the armor would not interfere with the movements or vision of gunners when turning quickly to shoot at enemy fighters attacking in swift planes. The protecting equipment would consist of a bullet-proof helmet and a specially designed form of body armor. Machine-gun operators at their

Air Corps correspondent.  
 Contingent Edition  
 London Times

stations in the hull of a big bombing plane of the present type, offer a plain target either from above or from the sides, as their head, shoulders and sometimes more of their body are fully exposed.

**POST OFFICES IN CITY FLATS  
 TO SAFEGUARD MAIL**

Partly because mail left in boxes in city flat buildings is but little protected against theft, a suggestion of architects that apartment houses have their own post offices has been approved by the post-master-general. Under the proposed plan, a room would be provided for the purpose in the lobby or entrance, to which only postal authorities would have access. Mail would be distributed into lock boxes assigned to the various tenants.

Chicago Tribune 9/19/25

**EXTENSION TABLE FOR KITCHEN  
 HAS NO LEAVES**

Fitting flat against the wall when not in use, a folding kitchen table has no leaves. It is adjusted simply by raising it and pulling it out like a drawer. Fully extended, it provides sufficient space for five diners and is long enough to hold an ironing board. It is finished in white waterproof lacquer so that it can easily be kept clean, and since it collapses, the task of mopping the floor beneath it is simplified. It is especially intended for use in a breakfast nook or may be installed in the living room.



Leafless Kitchen Table Fully Extended and Folded Flat against the Wall

Utility Table Co.  
 Nashua, N.H.

Kansas City Times 9/12/25

386

Jid. Bits 9/19/25

Chicago agent. Sampson Electric Co., 2334 Wabash, Chicago

POPULAR MECHANICS 961

### DOORS COST HUNDRED DOLLARS TO OPEN OR CLOSE 31

It takes nearly half an hour to open or close the steel doors of some of the large hangars such as house the "Los Angeles"

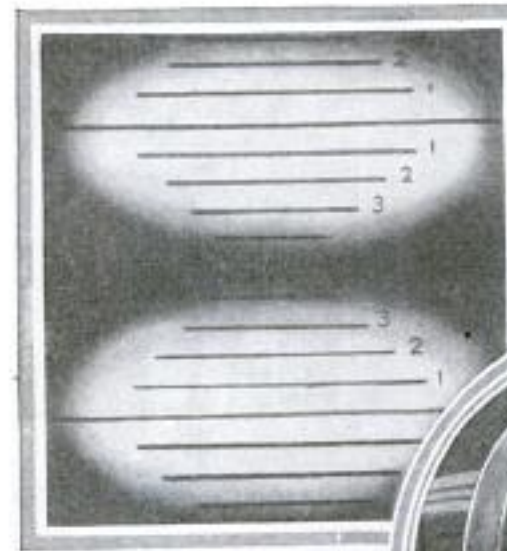

at Lakehurst, N. J., and the cost of the operation is about \$100. They run on steel tracks set on concrete foundations and are driven by electric motors. Although they protect the airships from damage from the storms and shield the interior of the hangar, they do not fit tightly against the ends as do ordinary doors. A space is left to prevent the formation of a vacuum inside the huge shed, and the serious consequences that might follow such an event.

### GAUGES FOCUS AUTO LIGHTS WITHOUT DARK ROOM 32

Auto headlights may be focused accurately, without elaborate dark-room or projection apparatus, by using two simple instruments now on the market. One is like a telescope, the large end of which is placed against the

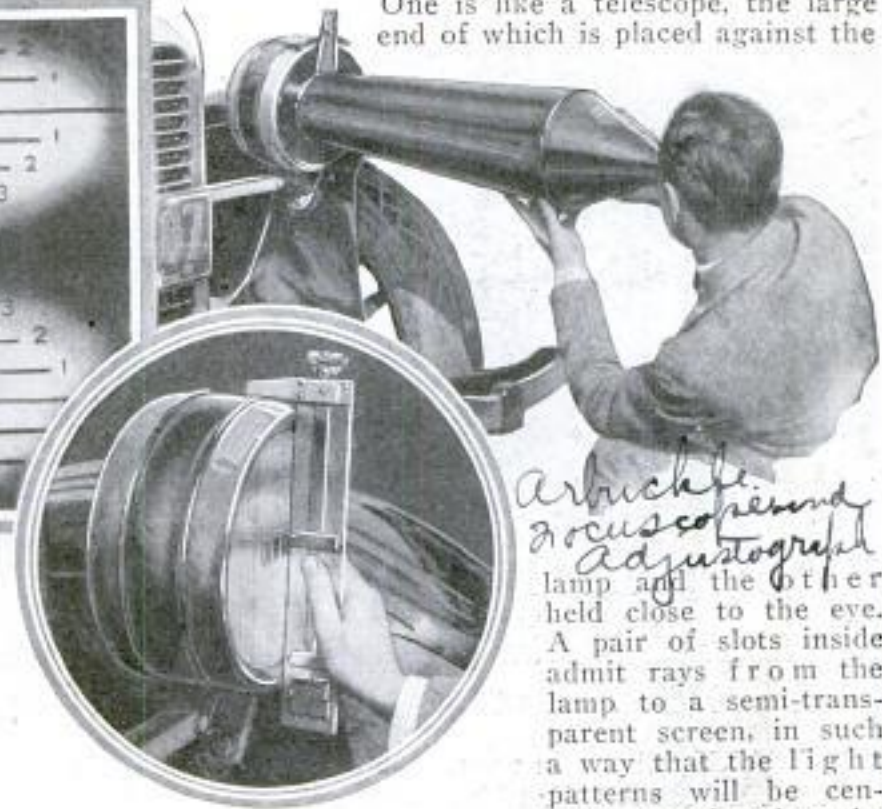

Testing Headlights with the "Telescope" and Gauge, and Pattern of Correctly Focused Rays

Arbuckle focuscope and adjustograph

lamp and the other held close to the eye. A pair of slots inside admit rays from the lamp to a semi-transparent screen, in such a way that the light patterns will be centered exactly when the beams are parallel, or, in other words, when the lamp is in proper focus. The other appliance is a measure for determining how much the light deviates from the horizontal. It is held against the front of the lamp and adjusted until a spirit level at the top, shows true horizontal. The exact tilt of the lamp will be indicated on a gauge below. For instance, if the reading is "3" on the down side of zero, the light beams will be tilted to the extent of three feet at a point 100 feet in front of the car. Proper adjustment of the lamp can be made as needed after this test.

### SAFETY-RAZOR BLADE STROPPER ROLLS IN HAND 414

Adapted to all kinds of safety-razor blades, a stropper now on the market consists of a small roller that is stroked back and forth on the palm of the hand. The whetting surface receives sufficient oil from the skin to aid in sharpening and the device is adjusted easily for different blades by bolts in the roller holder.



Sharpening Safety-Razor Blade in Stropper That Is Rolled over Palm of Hand

☐ We want all our readers to write us freely and often whenever they wish additional information on articles published in this magazine. Address Bureau of Information.

Wilson H. H. Co., Price \$1.00. 815 8.5th St., Dayton, Ohio.

Monogram Lens Corporation 52 Wabash St. New York City

257

90 metro. Mayer-Soldwin Corp. Buena Vista City, Calif.

# Exploring the Bottom of the Sea



Two Types of Diving Suits, Self-Contained, at Left, and with Air Hose to Surface, at Right, Showing the Grotesque Strides of the Divers as They Push Their Way against the Current

## Divers Battling Man-Eaters for Underwater Movies Find Them Less Dangerous than Barracudas—the Tigers of the Ocean

"A SHARK will circle around you and act unpleasant, just like a dog that doesn't know you, but he won't bite, unless you've done something to annoy him. At least, he won't bite immediately."

J. Ernest Williamson, inventor of the undersea movie, who has filmed the bottom of the ocean to reproduce many of Jules Verne's fantastic tales, is telling of his first shark fight, when he deliberately attacked a man-eater to furnish a thrill for the film.

"While the shark is making up his mind, you have a chance," Williamson continued. "But when a shark has got a taste of blood or a mouthful of flesh, he will go mad with desire and tackle anything. I've seen them come clean out of the water after a man or a piece of meat. When we want to show a fight between a shark and a man, we get a lot of fresh meat and bait the shark up to the attacking point by throwing him chunks of it."

"My first fight with a shark came in my first picture. I couldn't get the native divers down in the Bahamas to do it right. So, from the deck of the boat, I watched my shark in the clear water until he was, I knew, within range of the camera grinding away in the undersea chamber below. I dived down and came up under him,

grabbed his side fin and struck with a knife in the soft spot over his heart. Then my main idea was to get away, for if a shark lashes out once with his tail you're a goner. He can hand a terrific wallop, even in a weakened condition."

That was the first battle between shark and man ever filmed beneath the sea. Its filming was made possible by an invention of Williamson's father, a flexible steel tubing terminating in a five-foot steel chamber, with glass front, and called by the Williamsons, for want of a better name, "the hole in the ocean."

It does just that, punctures a hole in the water in which the cameraman and director can sit at ease and film the bottom of the sea, with its vast coral and seaweed forests, its sand-covered wrecks of long-lost ships, its troops of strange and brilliant fish, and the human actors who go down to perform before the camera.

The open end of the steel hole in the ocean is upheld by a boat, and down the tube pours fresh air for the men in the observation chamber below, so that they may work in ordinary clothes, unhampered by divers' helmets. The tube itself is made up of jointed sections, so that as many can be added as necessary to reach any desired depth. The observation cham-



ber is big enough to hold three men and the camera. With telephone connections to the divers working outside they are able to direct them, if desired. The front of the observation ball, like a huge funnel, projects from the rounded side, its outer opening being closed by a plate of glass thick enough to withstand the lashing of an angry shark's tail.

Most of the underwater films so far made were staged in the crystal-clear waters of the Bahamas, where sufficient light penetrates the sea to make possible photography by natural light at depths of thirty feet and more.

"As my ship, the 'Jules Verne,' travels along and moves our chamber under the sea when we go scouting for locations or interesting spots, it is as if we were taking the same kind of journey on land, except that we aren't jolted or coated with dust

Diver in a Self-Contained Suit Preparing to Drop to the Sea Bottom, Above, and a Movie Diving Girl and Diver Acting amid the Beautiful Coral Forests



257

and sand," Williamson says. "The scenery is just as varied, hills, valleys, even deserts. When we find a spot we want to work in, I telephone up and the ship anchors. We don't need to rest the steel chamber on the bottom. It can be suspended at any depth and remains motionless. There is no wave motion deep below the sea. We could work even in storms if the tube was not affected by the motion of the ship at the top. The ocean current, which we can see through the windows, 'blows' through the coral gardens and bends the coral fronds before it like a high wind. Most of the vegetation is animal and mineral, though occasionally the vegetable kelp or seaweed rises from great depths, its leaves reaching for the surface. We pass through jungles of colored stone,

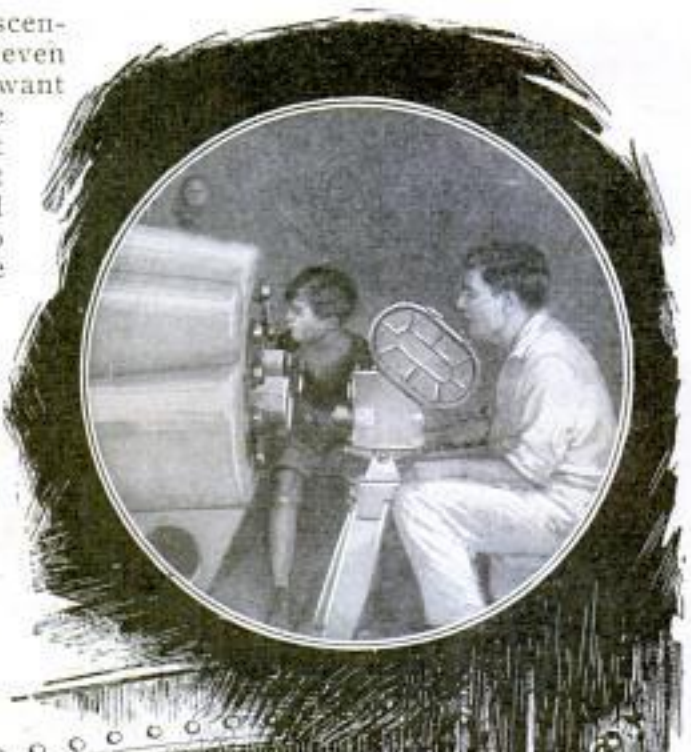

Inside the Steel Ball Where the Cameraman Works, and Divers in Self-Contained Suits Preparing to Leave a Sunken Submarine

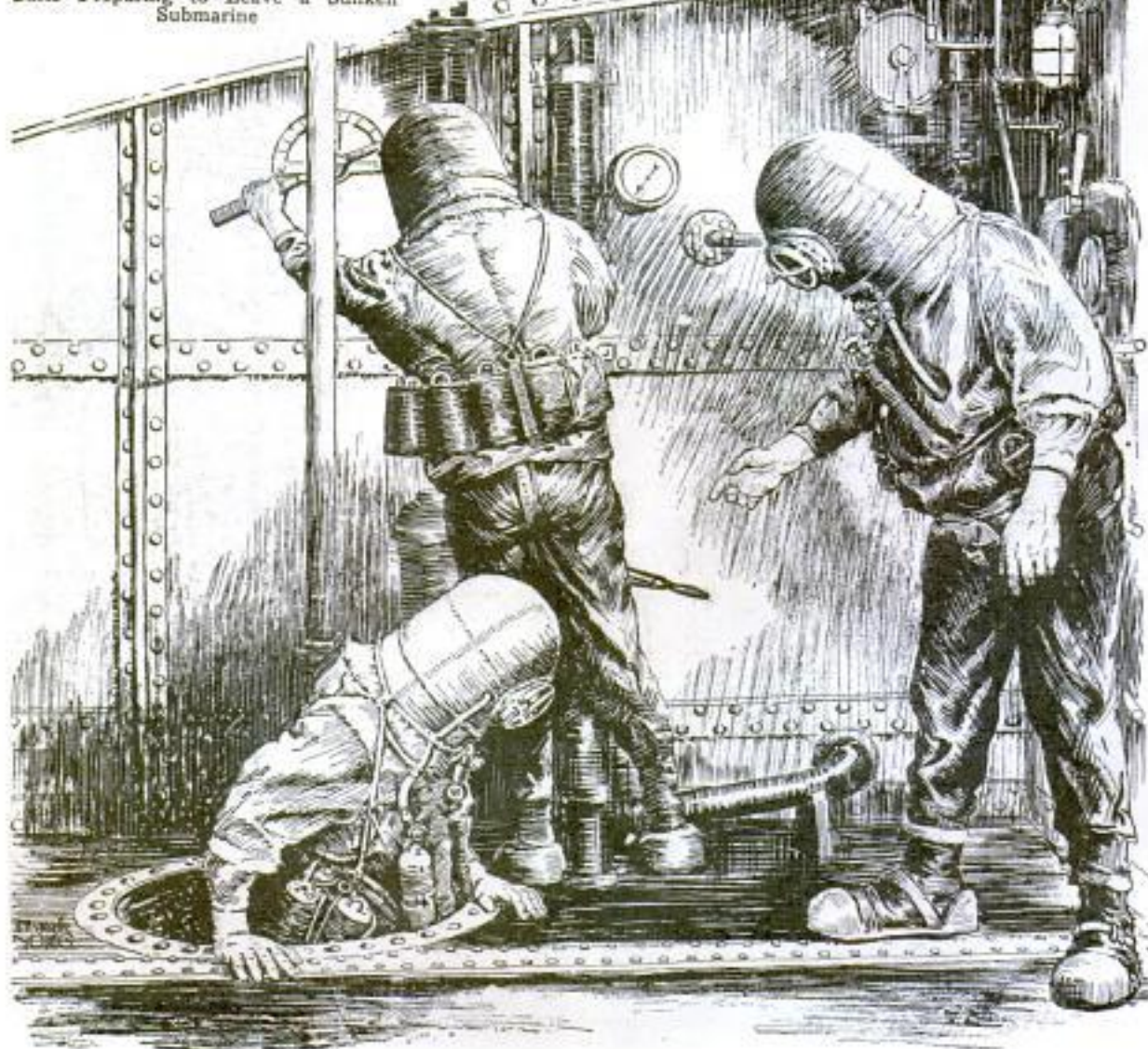

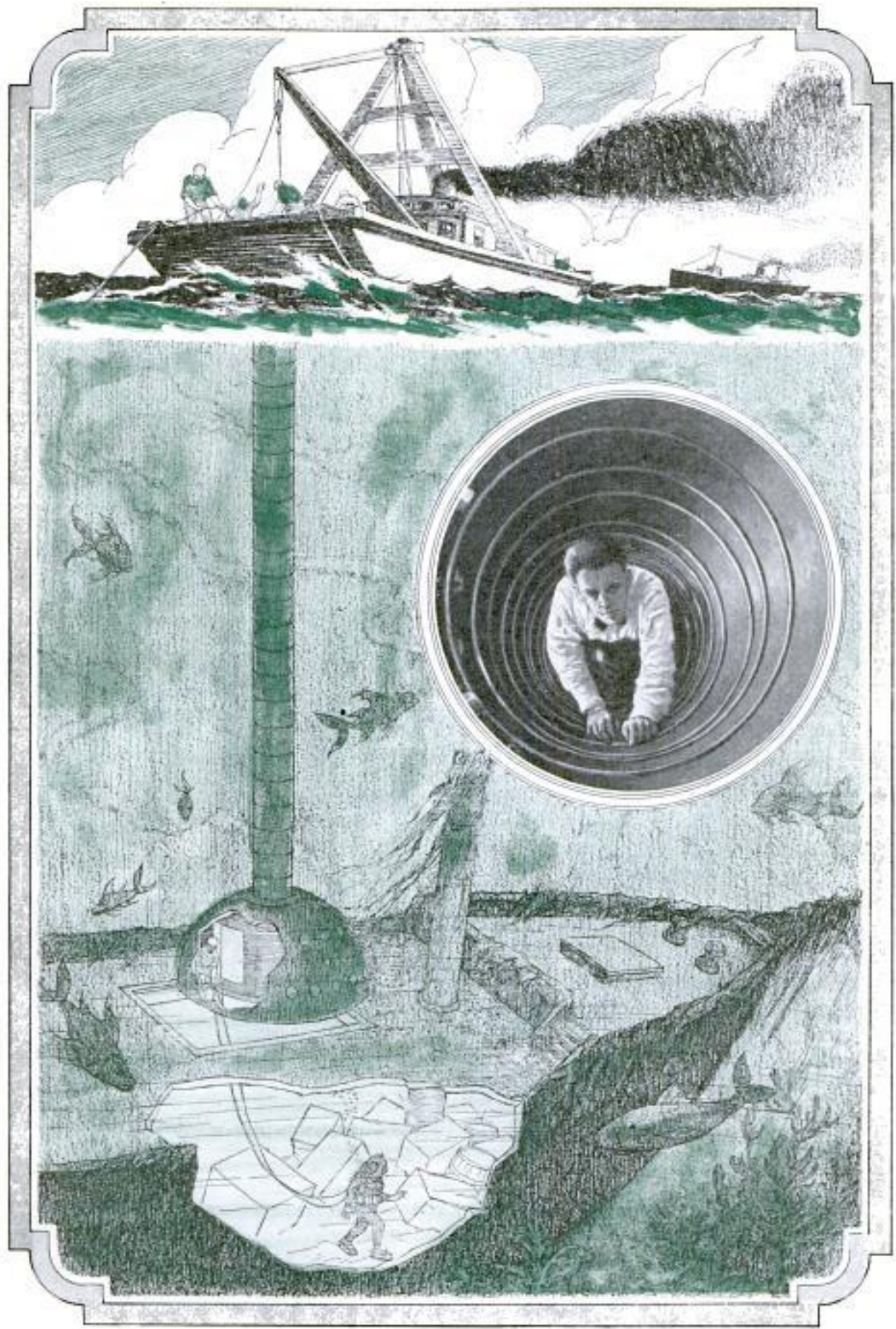

How the Hole in the Ocean May Be Used in Salvage Work, the Observers Guiding the Divers by Telephone; and a View down the Steel Tube Showing Williamson Climbing Up from the Camera Room

such delicate varieties of coral that they look like vegetation through interlacing marble arches, also coral columns so brittle they break at the impact with the tube.

"Fish swim through the forest isles in a constant procession, each species keeping to itself. There are hills, great rocks

of coral, and sandy valleys between. There are deserts where no life exists and where there is dark, deathlike silence. There are quiet places, very lovely, adorned with beautiful fronds of fan coral, with waving sea fans of magenta and gold, and sulphur-yellow mounds of coral. The sunlight scintillates down to us in millions of shafts like a rain of light."

The divers who work in the undersea pictures use a special type of outfit, called the "self-contained suit," which has no air hose, life lines or other connections with the surface. The only supply of air is what the man carries down with him, but this is continually purified by oxylithe, a chemical contained in a small tank inside the breast of the suit. There are two tubes connecting with the tank. One has a mouthpiece and is held between the teeth of the diver. The other leads from the tank up inside the large diving helmet, and terminates in an open end just above the diver's head. He inhales through the mouthpiece, and exhales through his nose, the used air being drawn back into the open tube and down through the chemical tank for purifying.

The dangers of the diving suit and of sharks are not the only perils encountered by the actors who go down under the sea. The tropical waters around the Bahamas



Breathing Apparatus of the Self-Contained Diving Suit, Above, and an Undersea Picture of a Giant Octopus Throwing Out a Cloud of Ink by Which He Blinds His Intended Prey



are occupied by barracudas—the “tigers of the sea”—giant morays and octopuses. The ordinary fish pay no attention to the chamber or its contents. They swim past the window in steady streams, and oc-

**BATTLE CRUISER IS CONVERTED INTO AIRPLANE CARRIER**

By adding a landing deck and other facilities, the British cruiser “Furious”



British Cruiser “Furious” as It Appeared after Being Converted into a Carrier for Navy Airplanes; the Top Deck Provides a Take-Off Space, and Storage and Repair Rooms Are Below

asionally come right up to the glass and peer at the camera for a close-up photograph.

“The morays are a species of sea eel, running as much as eight feet long, and with a poisonous, though not fatal bite,” Williamson says. “They can change their color at will to camouflage themselves as a bit of coral or rock. When we send the divers down they carry long iron-tipped spears, sharply pointed, to spear the morays with. I have had one fight with one of the big eels and have a healthy respect for them. The barracudas are the worst of the lot, though. They well earn their name of tigers of the sea. We never pick a fight with them, but often they pick one with us. The barracuda will attack just for the fun of it. It’s more dangerous than the shark because it doesn’t deliberate about biting, and with one bite, it can take off an arm or a leg.”

The hole in the sea has been used so far only for photographic purposes, but Williamson believes it may revolutionize salvage operations. By equipping the steel chamber with flexible steel arms and hands, considerable work could be done by the observer, he claims, or the present apparatus could be used as an observation point from which to direct divers by telephone.

has been converted into a carrier for navy airplanes. Besides space for the planes, the ship is provided with repair and storage rooms and is fitted as a floating service station for the craft of the air. While it is not as large as some other carriers, the cruiser’s speed is expected to prove a valuable aid when needed with the fleet.

**ELECTRIC HEATER FITS KETTLE FOR FRYING DOUGHNUTS**

Clamped to the edge of a metal kettle, a small electric stove is specially adapted for frying doughnuts. A control switch affords three changes of heat. The attachment is portable, uses a moderate amount of current and is said to reduce waste of the frying liquid.



Electric Heater Clamped to Doughnut Kettle below Chef’s Right Hand; Keeps the Frying Liquid at Cooking Temperature

*J. A. Campbell Co. Seattle, Wash.  
905 Western Ave.*



Rolling Bridge Span into Its Place upon Piers from Floating Barges, on Which It Was Towed After Old Span Had Been Removed; Both Jobs Required Only Six Hours

**BRIDGE SPAN ROLLED IN PLACE IN FOUR MINUTES**

Only four minutes were required to roll a double-track span, weighing many tons, into place during repair of a bridge over the St. John's river at Jacksonville, Fla. It was first lifted from the falsework, on which it had been supported, by pumping water from barges underneath, permitting them to rise and float the span. When it was towed into place, it was lowered by refilling the barges and was quickly set down on the concrete piers with the aid of rollers. The old span had been removed in the same manner with the order of procedure reversed.

**POISON GAS ROUTS BLACK ANTS FROM WIDESPREAD NESTS**

Poison gas has proved effective in fighting a species of big black ants that devour plants and bore out the cement between bricks in South American houses. The vapor is applied through a hose by a pump attached to a container for holding burning charcoal, upon which a powder that produces the poison gas is sprinkled. The tube is put in a hole leading to the ants' nest and the fumes forced into the network of passages to suffocate the inmates. In Buenos Aires, an ant colony that had dug a hole three feet deep

at one corner of a house and had made subterranean passages in a number of directions was successfully eradicated. Some of the tunnels were sixty yards long. This species of ant has been known to strip plants of leaves or devour them entirely in a few hours.

**PUMP PROOF AGAINST FREEZING LIFTS WATER ON CHAIN**



Operated either by hand or by power, a chain pump now on the market has no buckets or cups to clog up and freeze in cold weather. The water, lifted by the links, slips off when the pump is stopped. A capacity of five gallons a minute can be obtained by hand and eleven gallons by motor. The outfit will work in open or drilled wells with casings six inches in diameter or larger, and it is easily set up. Absence of valves, cylinders and other parts liable to get out of order, decreases upkeep costs, and the pump can be obtained in various sizes.

*Pacific & Atlantic*

*26 St. New York  
Cardinal Machinery Co. 252*

*New York Herald-Tribune  
2/11/26*

*395*

*The - Woman's Missionary  
Society  
Caroline B. Rubright Buenos Aires*

rev. A. L. Blakke,  
Iowa.

POPULAR MECHANICS

**HAY TAKES LESS TIME TO CURE  
IF CUT IN AFTERNOON**

404

Hay cut in the afternoon dries more quickly than it does when mowed in the morning, not only because the sun shines more warmly but because it contains less water, according to a plant physiologist. As a result of many tests, he declares that there may be a difference of forty per cent in the moisture content of plants between 10:30 a.m. and 1:30 p.m., when they contain the least. The reason he assigns for this, is that the leaf pores practically are closed during the night while the roots are absorbing moisture and consequently contain most water in the morning. Some of this is consumed in the life process of the plant during the forenoon. The time of cutting therefore seems important especially in the case of alfalfa and clover.



Carving Totem Po'e for Arkansas Indian Colony with Figures Representing Tribal Legends

*Jim Seary Sulphur Ark*

**POULTRY APARTMENT HOUSE  
IS FIVE STORIES HIGH**

402

By constructing a poultry house on the "skyscraper" plan, an English firm has provided space for a large number of fowls in spite of a limited ground area. Each of its floors contains five pens with roosts for 1,200 birds. The entire structure, five stories high, including a single-story addition at one end, is 1,000 feet long. Windows are arranged to admit abundant light and ventilation, and the whole house has been planned to encourage the hens to lay during the winter months.

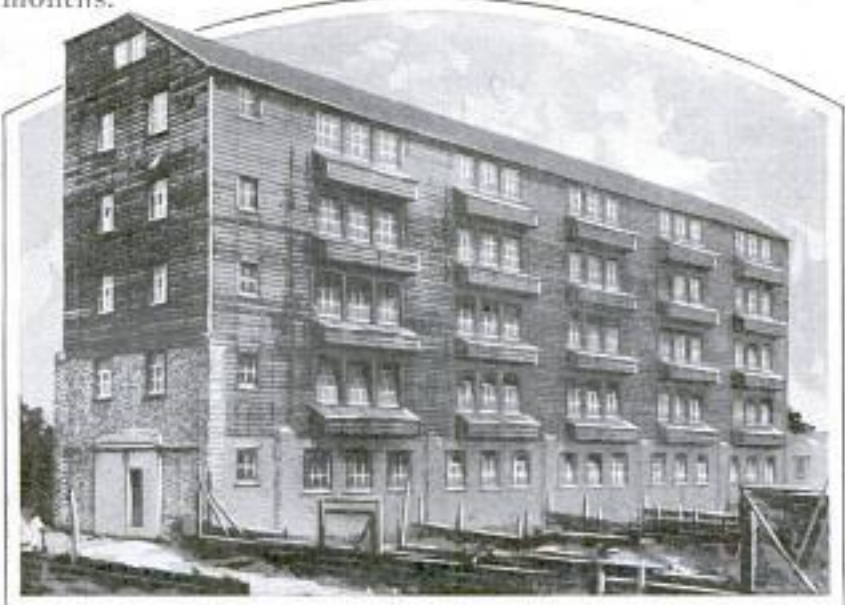

"Skyscraper" Poultry House with Windows and Nests Beneath. Designed to Increase Egg Production During Winter Months

**SKILLED TOTEM-POLE CARVER  
USES FIFTY CHISELS**

399

Depicting incidents in family and tribal history, a totem pole carved for an Indian colony in Arkansas by one of its members is much more skillfully fashioned than the poles of the Alaskan tribes. Its designer is said to have used more than fifty chisels in cutting the intricate figures that adorn the shaft. At the top is a replica of the head of the chief. Below are scenes describing episodes in the life of the Indian, until he "passes into the setting sun" with the arrival of the white man and the railroad. Even the tourists who visit the colony each summer are represented on the pole.

*Arkansas Colony.*

More than 600,000 persons are employed in the steel industry in the United States, and the value of material produced exceeds \$1,600,000,000 annually.

*at Paxton Hill London, England.*

Scheid Engineering Corp.

970

90

POPULAR MECHANICS

421

West St. New York

475

DEALERS SUPPLY INSECT PESTS TO COLLECTORS

Flies, fleas, beetles and other insects are the stock in trade of dealers who conduct a profitable business supplying specimens for collectors, schools, museums and sports outfitters. In Great Britain are several butterfly farms where caterpillars, eggs and the fully developed insects may be purchased at prices ranging from twenty-five cents to \$300 each for rare species. There are a number of dealers in fleas. Some specimens of these insects are said to be worth their weight in radium. A French collector not long ago paid \$5,000 for a particular kind of sea-otter flea. In Glasgow, Scotland, a dealer was kept busy supplying fleas to the city to help clear the sewers. It was found that the insects absorbed large quantities of a gelatinous substance that was obstructing the pipes. In Japan are a number of firms that

Star 9/14/25  
from  
Kansas City, Mo  
enclosed for review

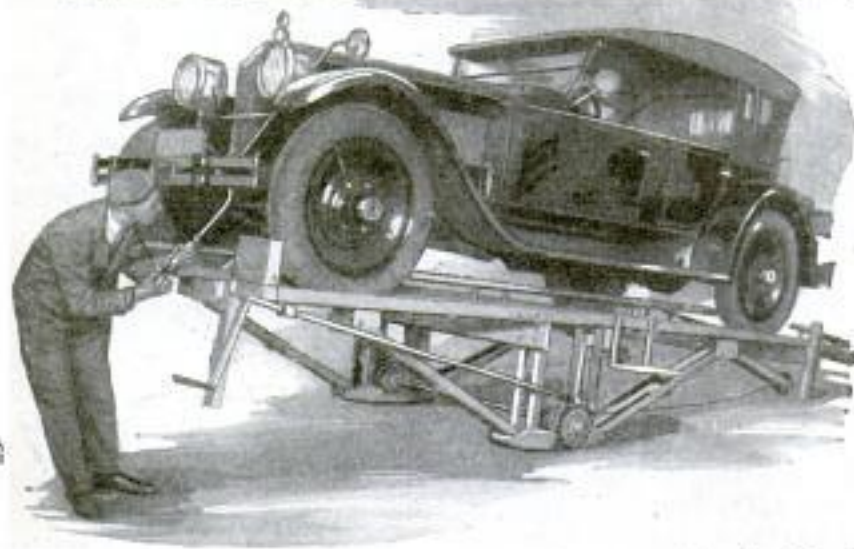
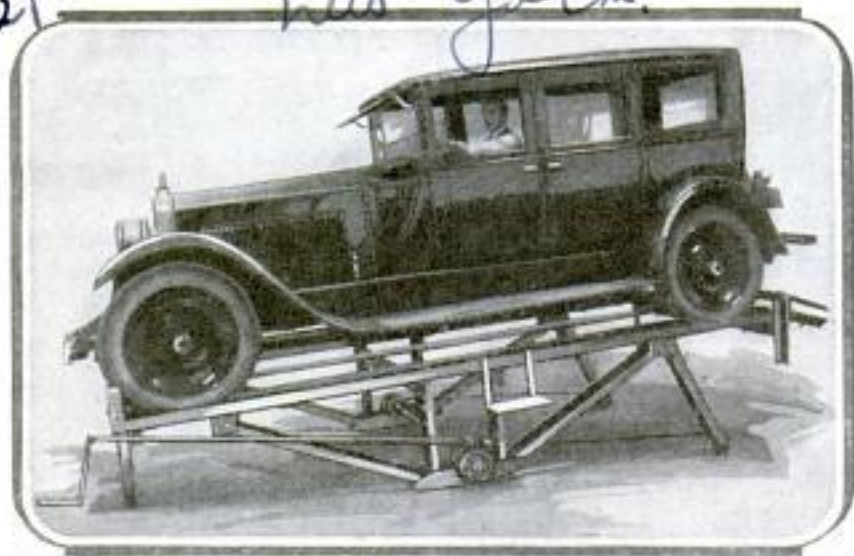

Automobile on Elevator Tilted Forward and Backward; Adjusting Crank Handle Is at Workman's Right; Blocks Keep Auto from Rolling

**AUTO ELEVATOR LIKE SEESAW SIMPLIFIES REPAIRING**

Automobiles are elevated and tilted to convenient angles backward or forward on an all-steel platform to lighten the task of making repairs, especially on parts under the body. Approaches to the stand are widened at the ends, permitting the driver to run his car upon the lift easily, and there are cleats to prevent slipping. The frame may be kept in a level position or is tilted by turning a crank at one side. This moves a wheeled support, prying the elevator up. Front and rear safety stops keep the car from rolling off. Besides these features, there are two powerful jacks at the forward end, an adjustable step to aid the repairman and a wide guardrail to steady the car. The platform has a capacity of three tons.

Goat's tallow and beech ash were the ingredients of the earliest kind of soap.

supply fireflies. They employ hunters who go forth at sunset to catch the flies in their damp haunts among the swamps.

**ELECTRIC GROOVER SAVES TIME ON WEATHERSTRIP JOBS**

Installation of metal weatherstripping is simplified by a portable electric tool that cuts grooves in less time than they can be done with a plane and with greater accuracy and uniformity. Its motor operates either with direct or alternating current at 110 volts, so that the lighting circuit can be used. Ball bearings and light weight contribute to the efficiency of the implement.



Wodack Electric Tool Corp., 23 S. Jefferson, Chicago

no Chicago agent.

421

large lift

Copyrighted material

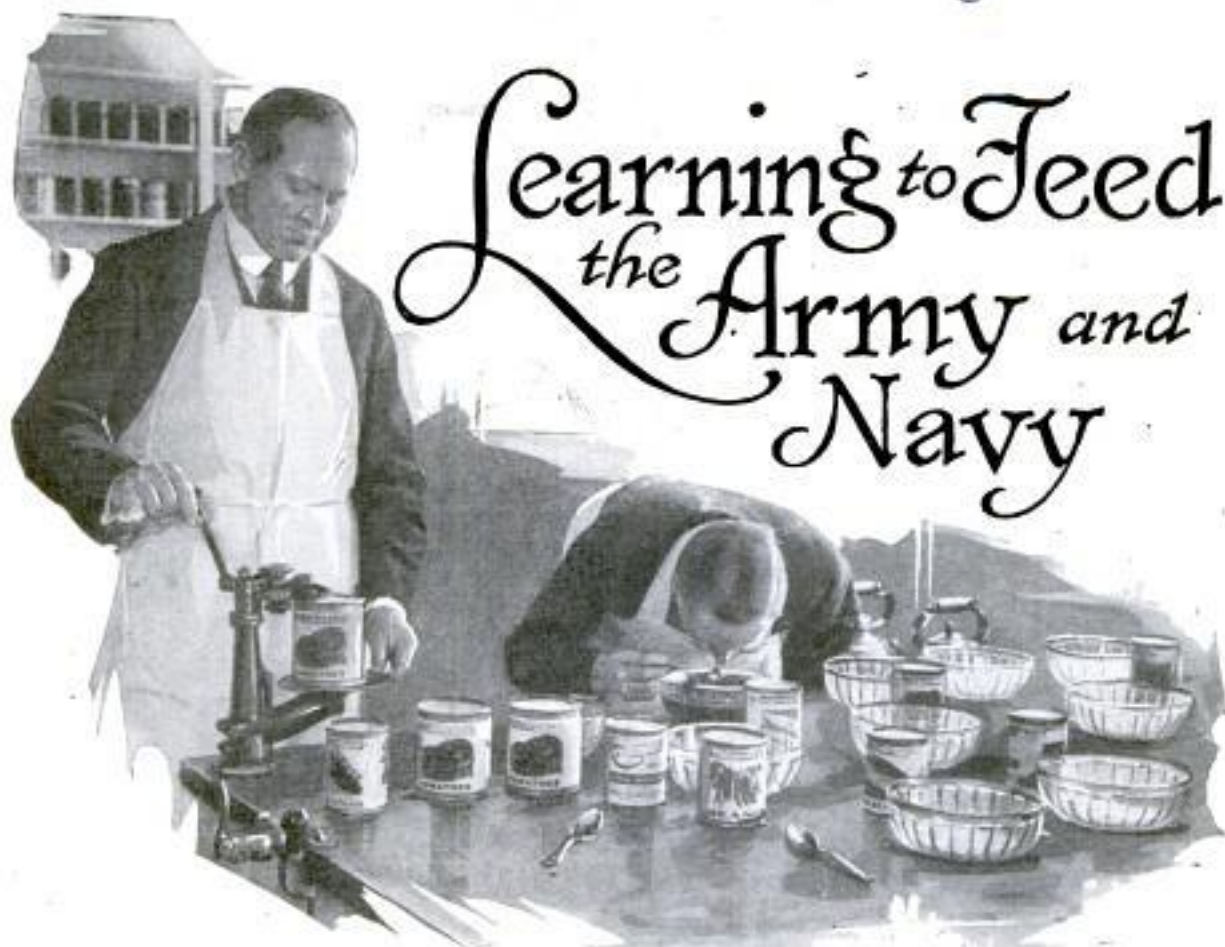

# Learning to Feed the Army and Navy

Army Officers Taking "Smelling Course," to Learn to Recognize Good and Bad Canned Goods by Their Odor, One of the First Lessons Given the Future Purchasing Officers

*J. Earle Miller*

THE world's best-trained military purchasing agents are being turned out at the Sixth Corps quartermaster depot, in Chicago, in the only school of its kind in the world—the Quartermaster Corps Subsistence school.

Its fame in the four years it has been in operation has spread so far that not only does the navy send officers to study side by side with those of the army, but foreign governments, notably the French, have availed themselves of the invitation to send students. And this fall, when the eleven months' term opened, the cavalry and artillery organizations sent officers to take the special course in hay and grain judging and buying.

Withal, the school remains a select affair, its present twenty-four students being about the limit the five instructors care to handle, in order to give each a fair share of individual attention.

There are classes in grading, testing and buying everything from hay through grain, wheat, flour, meats, coffee, tea, sugar, every known kind of canned goods, and on down the list to candy. In addition the graduates must know how to grind the wheat into flour and bake the

flour into bread; how to cut up a beef into chuck steak, round steak, sirloins, tenderloins and all the other parts; how to grade raw coffee beans, and then roast, grind and again grade the finished product by tasting the actual brew.

Some of the courses are titled: "Fresh and dried fruits and vegetables; canned fruits and vegetables; sugars, sirups and starches; canned meats and seafood; tobacco; soap; fish, eggs, salt, vinegar, gelatin, candles, matches, beverages, paper, cotton and jute bags; and dairy products, including canned and condensed milk and cheese. The school operates its own model cheese factory and also visits cheese plants and milk condenseries in Wisconsin. In between times all the flour for the entire army, with the exception of the San Francisco district and the Pacific possessions, is purchased through the Chicago corps headquarters and each sample tested by the students. The co-ordination of the purchasing office and the school is made easy because Col. Patrick W. Gurney, commanding officer of the quartermaster's depot, is likewise commandant of the school, the actual direction of which is entrusted to Lt. Col. Sherrard Coleman.

33



assistant commandant. The students also help roast all the coffee consumed by the army posts in fourteen middle-western states and test each sample purchased.

The equipment of the school is unusually complete. It includes such bulky machines as a self-contained flour mill; a coffee roaster and grinder; electric ovens for bread baking; all the latest electric or hand-operated kitchen appliances; an electric range; a complete chemical laboratory and an electric incubator where storage conditions in the tropics or on the Mexican border can be reproduced over periods of days or weeks, to test their effect on canned goods and other supplies. There are also several classrooms, one of which contains a writing machine for each student, as all school papers are required to be typewritten.

In addition to the school equipment, the huge plants of "Packing-town" are hardly a half mile away, and in them a regular course in meat buying and handling is given. Starting with classroom instruction around the skeleton of a cow, where the animal's anatomy is explained, the students move to the stock yards and learn the breeds and grades of the animals on the hoof. They then pass through the various killing and

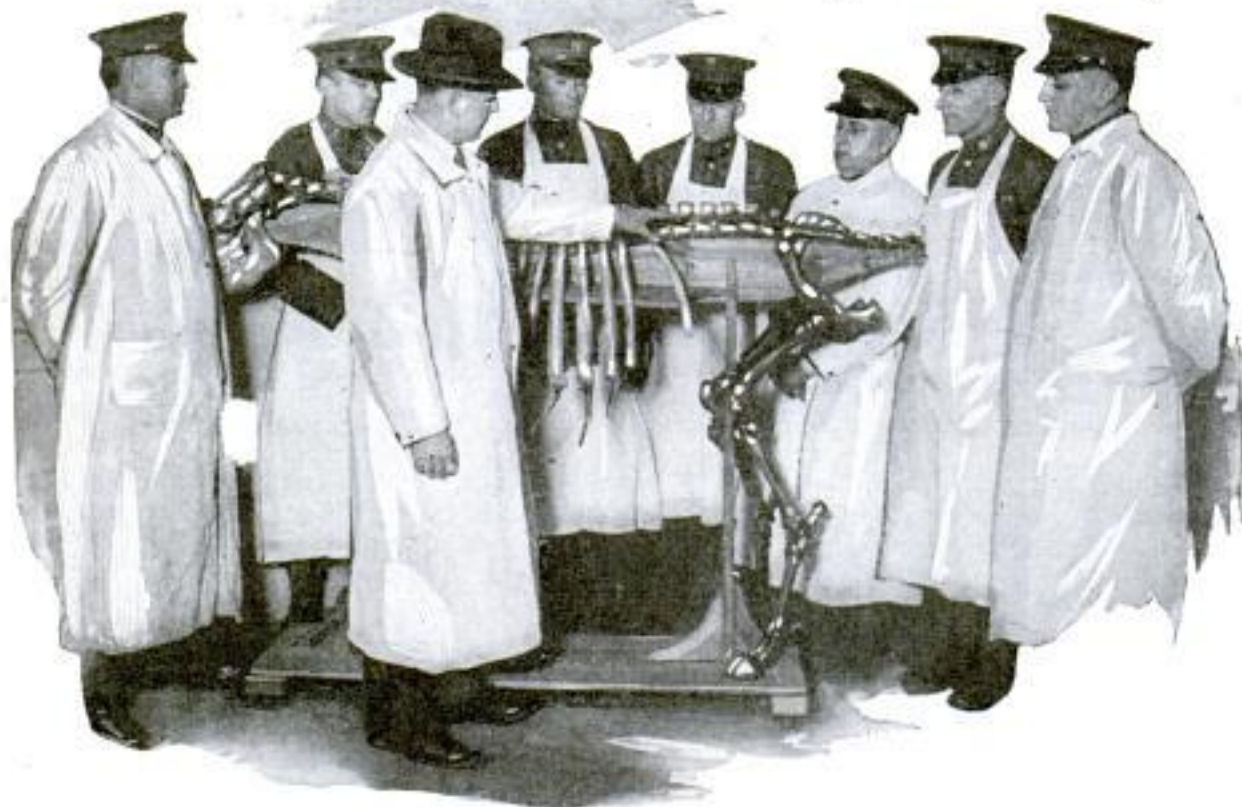

Top, Electric Bread Mixers and All the Latest Kitchen Appliances Are Used; Class in Anatomy, Getting First-Hand Information on Where to Look for Steaks and Roasts and Where Soup Bones Come From

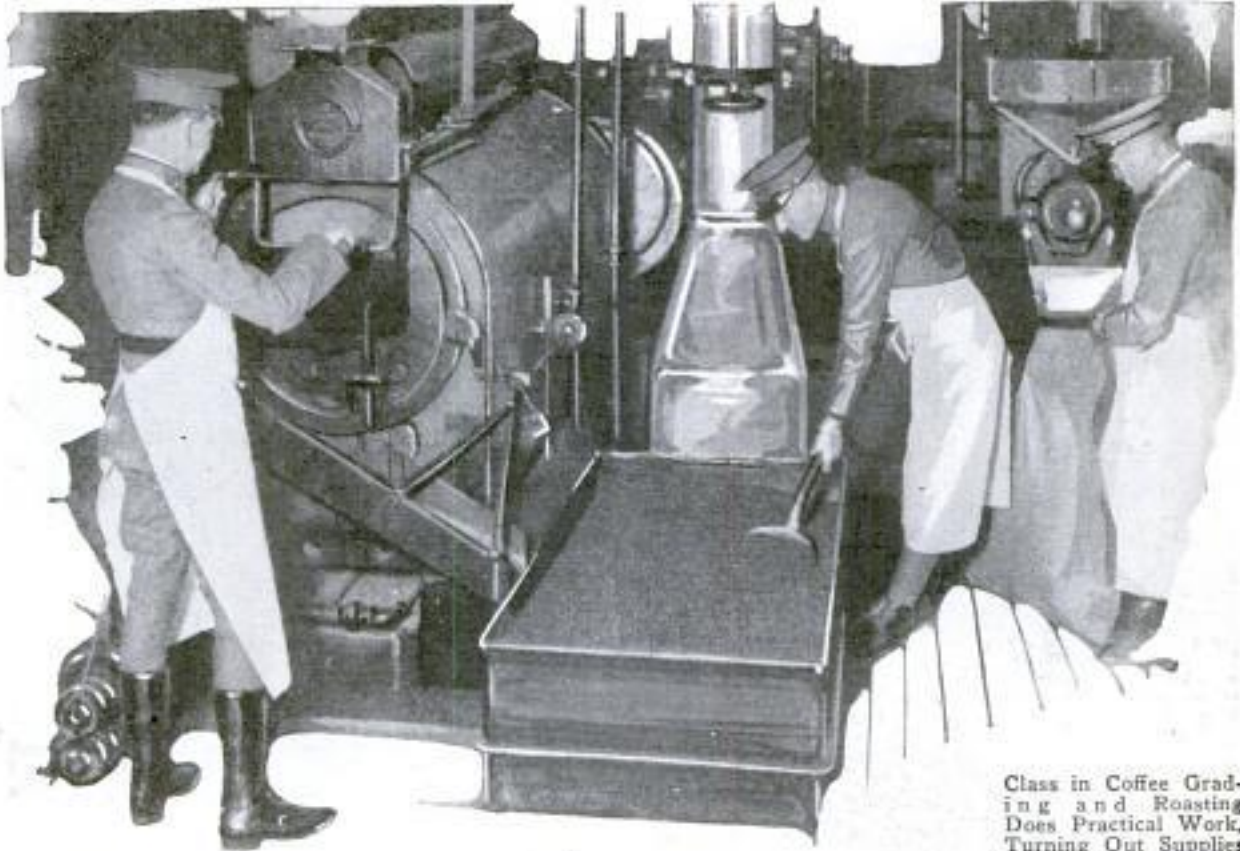

Class in Coffee Grading and Roasting Does Practical Work, Turning Out Supplies for Most Army Posts; Here Is the Roasting Oven and Sacker

dressing departments, and finally wind up in the refrigerator rooms, where they are taught to actually cut up the carcass.

Instruction in every branch is equally thorough. The meats and vegetables and fruits which go into canned goods are studied first from textbooks, next in actual visits to the canneries and finally by opening and testing cans purchased in the open market. Every student who completes the eleven months' course graduates with a highly gifted nose which can detect imperfections at one sniff.

The flour course is equally comprehensive. After the textbook lessons are learned, the class visits the Board of Trade—the world's greatest wheat mart—and studies the buying and selling of grain and the grading of samples which are displayed from each shipment handled there. Back at the school



A French Army Officer Sent to Chicago to Study American Army Feeding Methods Demonstrates His Skill with a Butcher's Knife during "Laboratory Work" in Packingtown

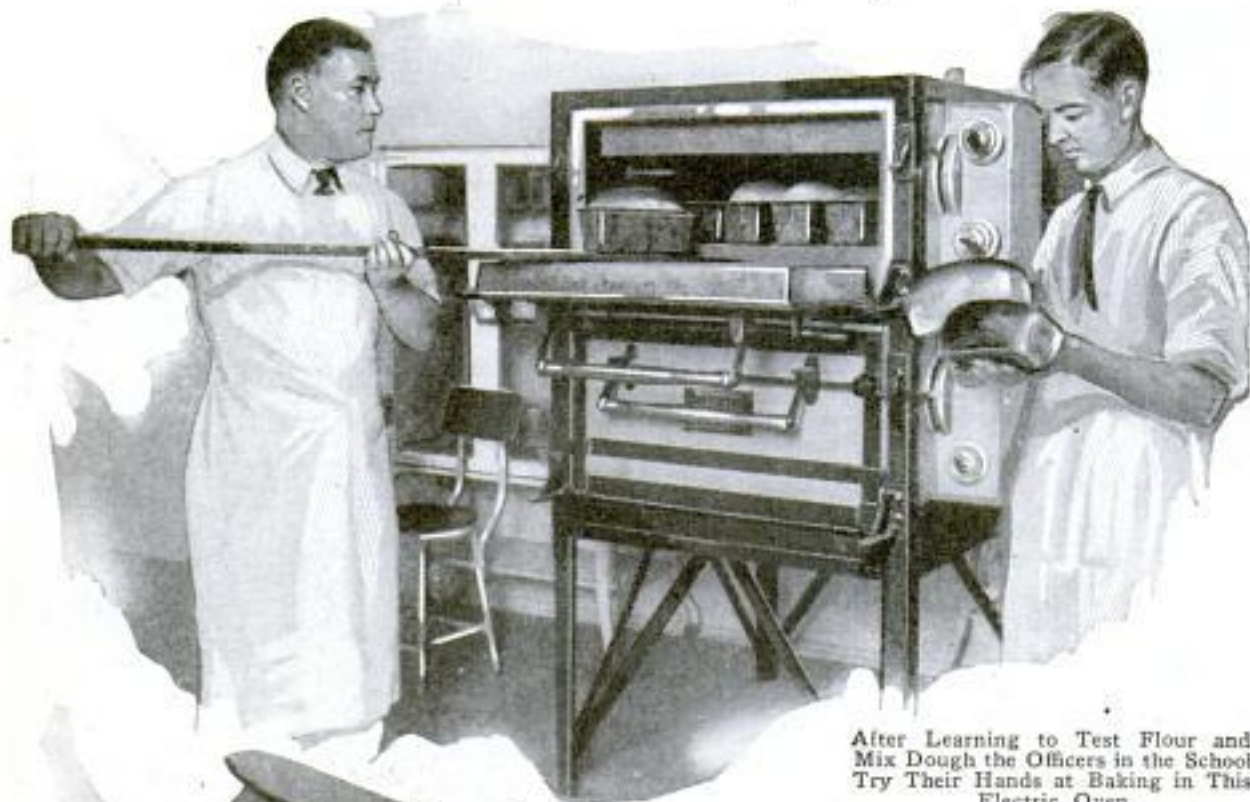

After Learning to Test Flour and Mix Dough the Officers in the School Try Their Hands at Baking in This Electric Oven

again, they learn to do the grading, then to grind the flour, and finally the chemical reactions which produce good bread dough, and how to bake the bread. Nothing is left to guesswork. When a student starts a flour test, he uses a measured amount of flour and draws the water for the dough from a graduated tube which will show just how many cubic centimeters the given amount of flour absorbs before it reaches the right consistency.

The baking course covers ordinary bread, rolls of various types and the sandwich bread which is baked in covered pans. Electric ovens are used in the laboratory, but in another department a regular army field oven is set up for actual experience under wartime conditions. The school carries in stock enough canned goods to outfit a good-sized grocery store, and a fancy one at that, for the supply includes not only the old reliable stand-bys, but rare foods in fancy glass jars and candies packed the same way. One discovery made when the school was first established



Latest-Model Kitchen Cabinets, and Aluminum Kettles and Pans, Are Used



four years ago was that existing textbooks on food did not fit the army and navy needs; so the faculty set to work to write their own. In four years more than thirty books have been completed, and another four years will be required to complete the task. Despite the deficiencies of existing texts, Maj. R. M. Littlejohn, under whose direction the school was built up, boasted that the library contains the best collection of works on subsistence in the world. Maj. Littlejohn, who completed his tour of duty at the school a few weeks ago, and was replaced by Lieut. Col. Coleman, established the practice of bringing in civilian experts to teach those courses for which qualified army men were not available.

The class which was graduated this summer contained twenty-four students, including nineteen army officers, ranging in rank from major down to lieutenant, and five navy officers, junior and senior-grade lieutenants, whose respective ranks are the equivalent of captain and major in the army. The small classes insure thorough teaching, and, despite their limited size, within a few years the various services will have a fairly large supply of trained purchasing officers, ready, in time of emergency, to organize the vast quartermaster's department needed in war.

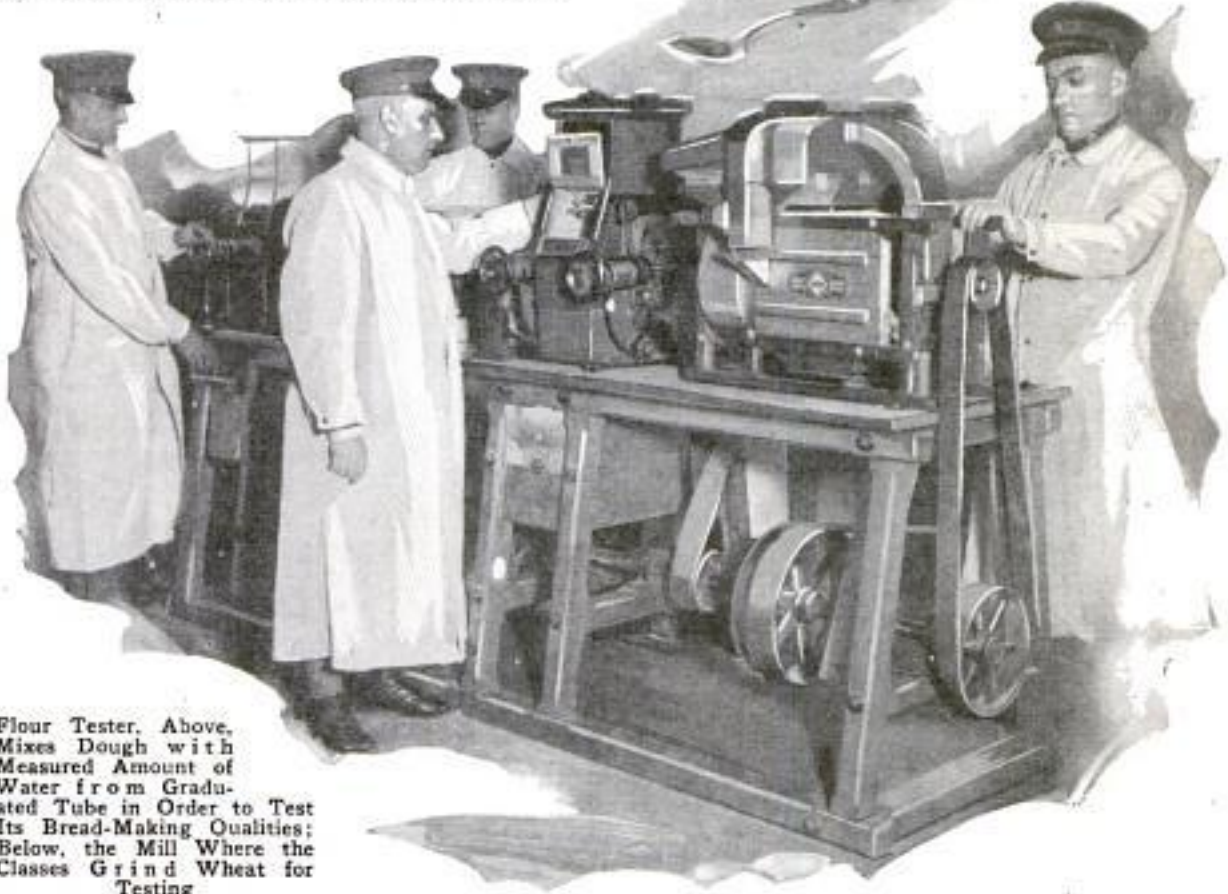

Flour Tester. Above, Mixes Dough with Measured Amount of Water from Graduated Tube in Order to Test Its Bread-Making Qualities; Below, the Mill Where the Classes Grind Wheat for Testing

*Department of Phonetics.*

**STREET LIGHTS OF CHINATOWN SHAPED LIKE PAGODAS**

Distinctive electric street lamps, erected by the merchants of Chinatown in San Francisco, reflect the oriental love of col-

an inclosed shell with two airplane wings. Long, freely moving stabilizers are suspended from the body like legs, and at the end of each is a boat-shaped "foot" filled with helium. These hold the plane up when at rest and merely touch the waves as it skims along.

*372*

*Emb. Arthur Benson, Box 422, A, Route 1, Gardena, Calif.*



Pagoda Street Lamps with Golden Bells and Dragons in San Francisco's Chinatown

or and symbolism. The globes are shaped like pagodas and are supported by two golden dragons. Golden bells are suspended from the six curved corners, and the sides of the lights are of orange glass. A rich color scheme for the lamps and posts adds to their attractiveness amid the fantastic surroundings of the shops, green meaning growth and life; gold, truth and red, good fortune.

**SOUNDS RECORDED FOR FUTURE ON DISKS OF BRASS**

*390*

Many of the sounds of the present age will echo for at least 10,000 years as a result of the work of Prof. Wilhelm Doegen of the state library in Berlin, who has compiled a collection of 2,500 "sound portraits" on master phonograph records of brass. During the World War, he visited many different army camps and prisons where he obtained records of the language sounds of nearly 250 different tribes and peoples, including many of the natives of Europe and Asia. These have been filed, together with reproductions of the text spoken by the native as delivered by an expert, and translated into English and German. Besides these records, front and profile photographs taken of each subject are included in the collection, which is open to the public. There are three copies of each master record and all are preserved in fireproof safes. Among them are a Mohammedan muezzin's call to prayer, Russian folk songs, Scotch ballads and an English interpretation of "Tipperary." Many forms of dialect have been recorded as well as addresses by famous men. Besides vocal records, the library includes animal, bird, and instrumental reproductions.

**FLASH-REFLECTING SPARK PLUG SHOWS MISSING CYLINDERS**

The core of a special spark plug, now on the market, is made of transparent material, so that explosions in the combustion chambers are reflected through them, and a glance at the motor when running will tell which cylinder is missing. The center may be renewed from time to time, and the plug is adapted to any auto, truck or tractor motor.



**PLANE MODELED AFTER FLEA TO CROSS OCEAN**

*428*

Patterned after a species of sea flea which jumps from wave to wave, an "ocean plane" has been built by a Russian engineer for a flight from Marseilles to Rio de Janeiro. The craft consists of

*Central Petroleum Cleveland Ohio Century Bldg.*

*Count de Haseenko for French government*

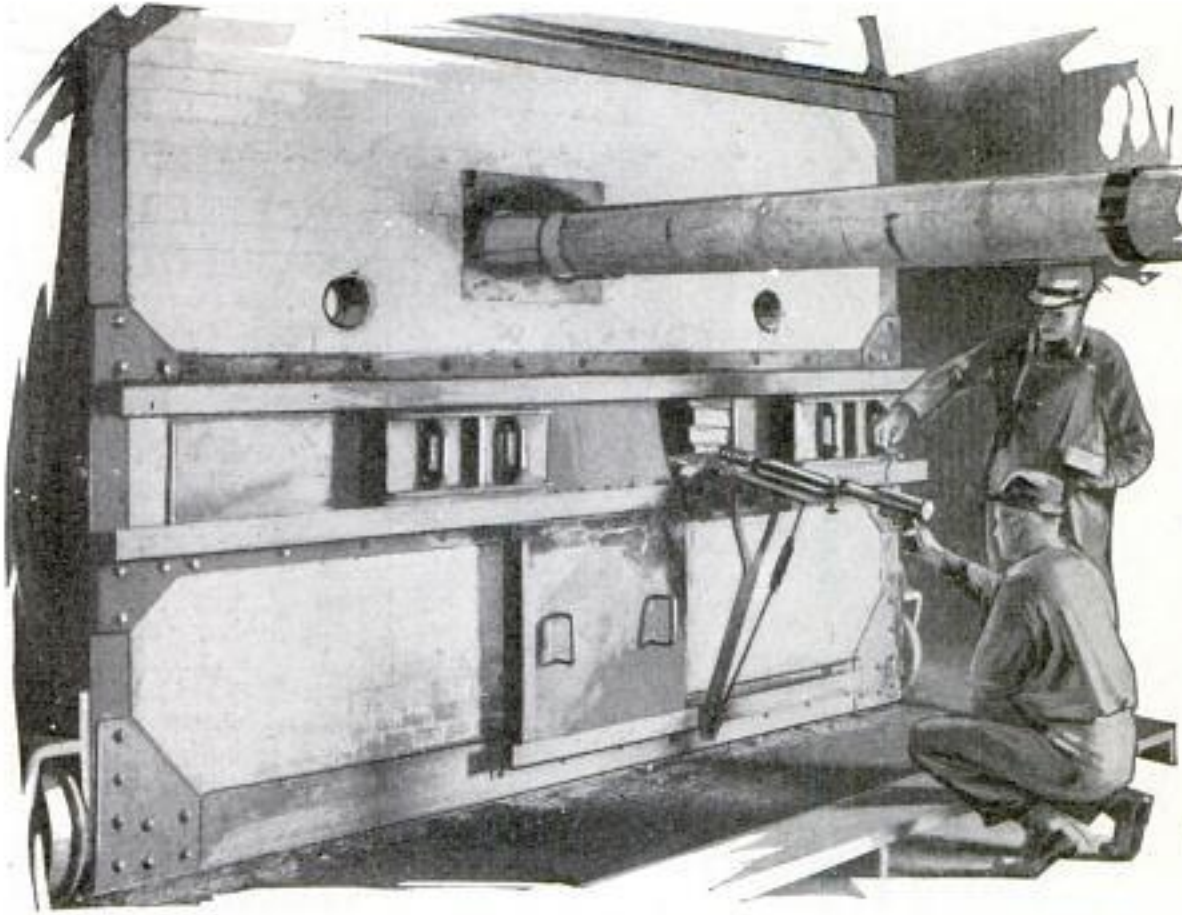

Shooting into Cement Kiln to Break Up Rings That Form When Powdered Rock Starts to Fuse under Intense Heat; Helper Is Placing Shells in the Magazine

**GUN FIRED INTO CEMENT KILN TO PREVENT CLOGGING**

Aside from the whaling industry, which uses guns for shooting the harpoons, cement manufacturing probably is the only field in which firearms are regular parts of the mechanical equipment. A special gun has been developed to aid one step in the cement-making process. It is a short-range affair with a one-inch bore, fires a slug weighing three ounces and is carefully adjusted to the kiln on a support for accurate aiming. Its purpose is to break up the "rings" that form on the inside of the huge mixers when the powdered rock, heated to between 2,500 and 3,000 degrees Fahrenheit, nears the fusing

point and makes white-hot clinkers which otherwise would choke the kiln.

**TWO-FILAMENT LIGHT BULB PROMOTES AUTO SAFETY**

Eliminating the necessity of dimming the automobile headlights, a two-filament bulb now on the market is said to prevent glare in a simpler and more effective way by directing the beams slightly downward. Between the filaments is a narrow space and one of them is set so that it depresses the rays and the other is in position for normal driving. Simply by switching from one filament to the other, the driver can direct the lights as occasion demands and always commands their full intensity.



Two-Filament Bulb for Auto Headlight, and Diagram Showing How Rays Are Directed Downward to Prevent Glare

Installed at plant of Johns Falls Portland Cement Co., Johns Falls, N.Y.  
 by Messrs. J. L. Smith & Co., Cleveland, O.

National Lamp Work, Inc. General Electric Co.

*Distinctive Awning Co.,*  
 5700 W. Santa Monica Blvd.  
 Los Angeles, Calif.  
 POPULAR MECHANICS  
 36<sup>978</sup> 6

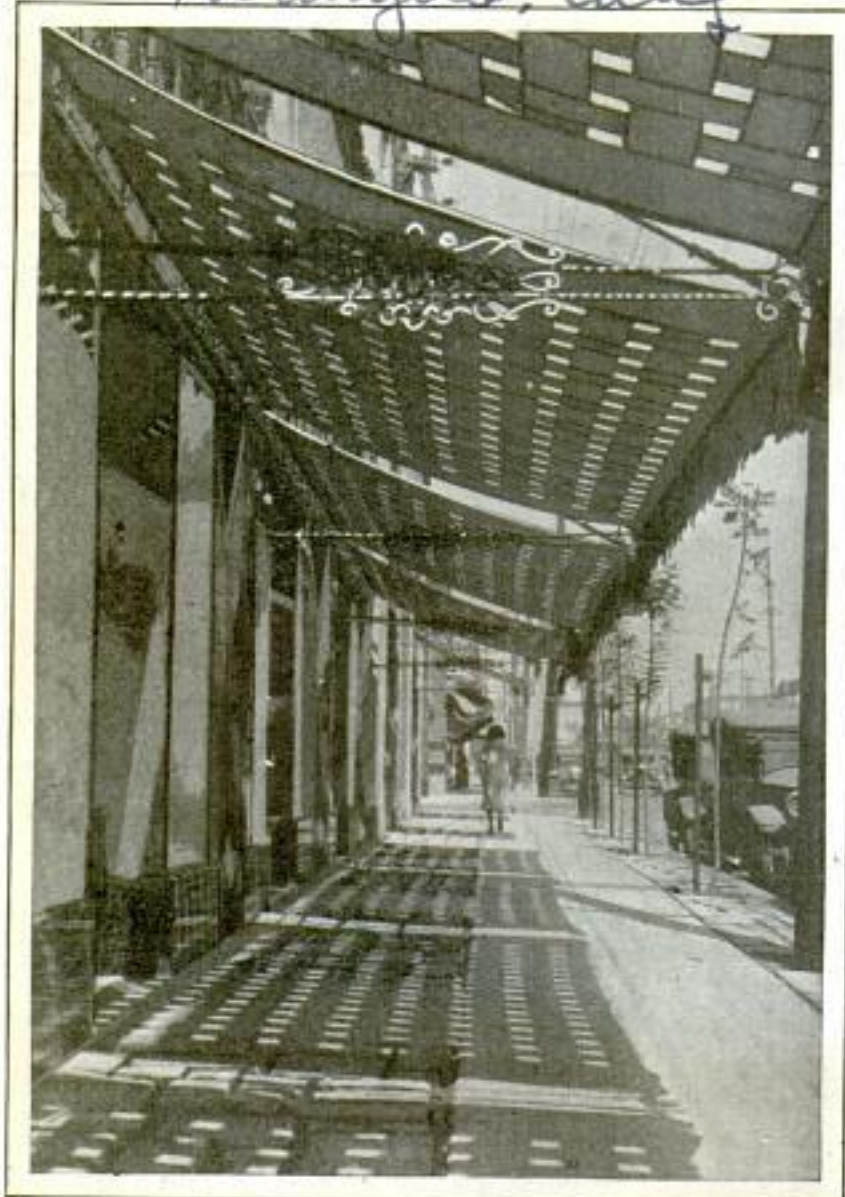

Canvas-Lattice Awning before California Shop Shades Windows and Casts Fanciful Patterns on Sidewalk and Walls

**CRISSCROSS CANVAS AWNINGS ADMIT MORE LIGHT**

Awnings of canvas strips, arranged in crisscross fashion, protect shop windows in Los Angeles yet permit more light to enter the store than is possible with the usual shade. The lattices are supported by specially designed fixtures to lend an artistic touch to the front of the buildings.

**FISH IN TANKS BECOME SEASICK ON LONG OCEAN TRIPS**

When certain species of fish for aquariums are shipped in tanks on steamers, they not only become seasick on long voyages, but the poisons they emit often bring death to their fellow tank passengers, according to Louis Mowbray, a well-

*gathers specimens for New York aquarium*

known collector. They are not bothered by big waves in their natural home, but the abrupt movements of the water in the tanks cause them to lose their sense of balance and they submit to the rolling of the ship. The symptoms are much the same as a human victim's. The fish cannot retain food, and the ejected matter must be removed to prevent other fish from becoming poisoned. To minimize seasickness as much as possible, Mr. Mowbray omits feeding the fish for two days before starting, and some are not fed during the entire journey. A few species must be given nourishment, or they will devour their companions. On trips from Florida waters with specimens for the New York aquarium, fresh water is pumped from the ocean and kept circulating through the tanks. In February, March and April, it becomes too cold when the steamer reaches Cape Hatteras and the pumps are shut off. Heated air is then forced into the containers, as tropical

fish become numb in water of a temperature lower than sixty-five degrees.

**RUBBER TAIL LAMPS FOR AUTOS KEEP BULB FROM BREAKING**

Attachable to the rear-lamp brackets or to the number plate, a molded rubber tail light that protects the bulb from breaking, because of ordinary vibration, has been placed on the market. It is said to be weatherproof and to prevent rattle.



There are openings for the red front and white side lights.

*Rubber Lamps, Ltd.*  
 59 Essex Portland  
 London, W.1. Eng.

*The County Chemical Co., Ltd. Rarmingham, Eng. Works,*

252 LaPlant - Choate  
Cedar Rapids, Iowa.  
POPULAR MECHANICS  
Chicago agent - W. B. Lower Co. 11 E  
979  
Harriman

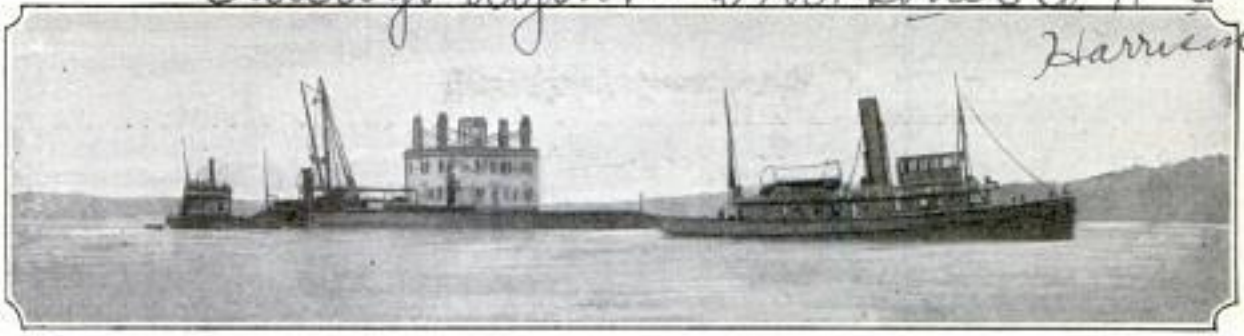

Taking an Old Colonial Mansion on an Eighty-Five-Mile Sea Jaunt to Reach a New Location at Rockport, Me.; Not Even the Chimneys Were Taken Down, Bracing Holding Them in Place

## Nothing Built Too Big to Move

Man Who Shifted Huge Department Store and Moved Entire Town Pines for a Mile-Long Building to Try His Skill

By J. EARLE MILLER

“**N**OTHING that man has ever built is too big to be moved with a team or two of horses, if you apply your power properly.”

Like the man who offered to lift the world if given a lever long enough, E. W. LaPlant, author of the above declaration and inventor of much of the equipment used by house movers, is ready to undertake any job, regardless of size. Having moved what is said to be the heaviest structure ever shifted by men—a 4,800-ton department store, in Montreal, Can.—he is pining for something bigger to tackle, preferably, he says, a building about a mile long, and the higher the better.

The Montreal department store wasn't much of a job, as he regards it, at least when compared to moving the entire town of Osborn, Ohio, consisting of 552 buildings, out of a valley and onto a hill-top, a mile and a half away. Osborn was a pleasant little village, with well shaded streets, and the new site was a barren plateau, so LaPlant lifted up some 400 ancient shade trees and took them along with the houses, planting each in its own yard, completing the reconstruction of the town. For sheer weight lifted

and moved the Canadian feat stands out as an engineering task without compare. The big building, seven stories high with a six-story addition, covered a plot forty by ninety feet in size, and in its main part reared 110 feet above the street. Built before the day of steel framework and hollow tile, its walls were sixteen inches thick, of concrete and brick, and the floors were solid twelve inches of cement, reinforced with steel. Its erection had preceded the time of caisson foundations and the 4,800-ton structure rested on a foundation of piles and cement mats. The new foundation, 310 feet away, was of the same sort, but in between lay a treacherous bed of quicksand.

To support the moving building over it, LaPlant was forced to sink caissons forty-

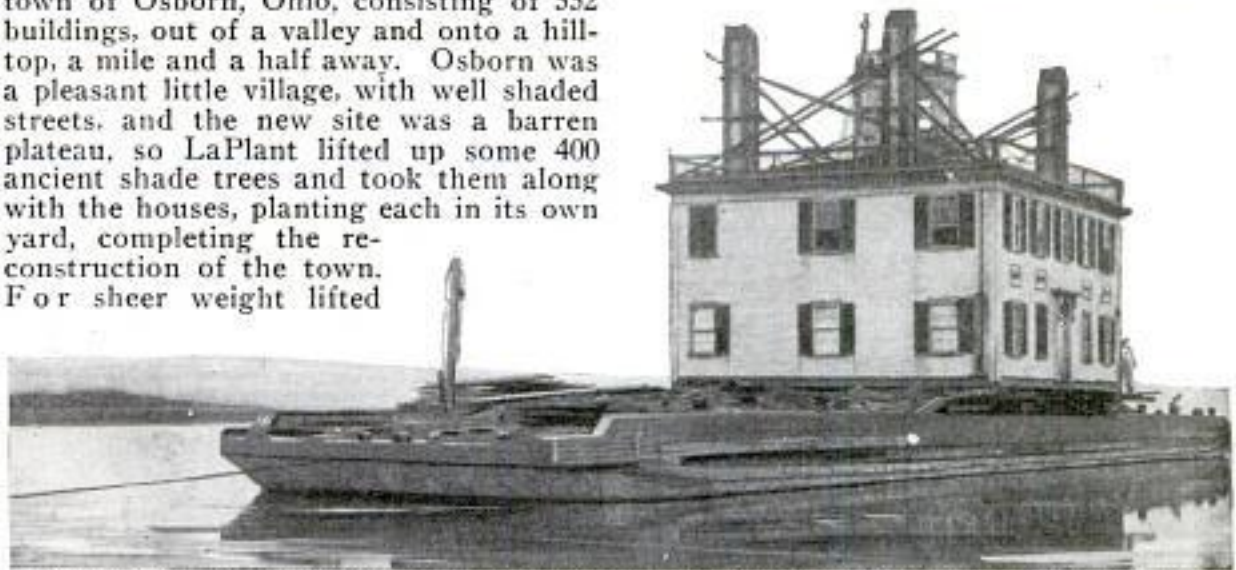

The Seagoing House Anchored to the Barge on Which It Was Moved; Two Tugs Took the Mansion, Which Was 120 Years Old, to Sea and Landed It Safely at Its New Site

25



When Houses Are Too Wide, the Mover Saws Them in Half, Moves the Sections and Then Rejoins Them

five feet to bedrock, and on them placed 350 tons of steel beams, topped by railroad rails on which the steel rollers moved.

Built against the stone wall of an adjoining building, the store formed a solid unit with its neighbor, but a row of powerful "push jacks," turned in unison, split the bond and slid the 4,800-ton mass away as easily as a toy building might be pushed by a human hand. A man stood at each jack,

with turning bar ready, and as LaPlant blew a whistle gave it a fraction of a turn, then moved the bar to the next hole and waited for the whistle blast.

Once free of the adjoining building, four horses, two at each of two capstans were hitched on. Moving on 800 steel rollers, between steel rails and steel-faced "shoes," the transportation of the building, LaPlant figured, would take 2,800 horsepower, but to be on the safe side he had provided 3,500 by multiplying the power of his four horses. Each capstan, with its sweep, twelve-inch drum and two horses exerted 150 horsepower, but by lacing the continuous pulling cable back and forth between pulleys at the building and pulleys attached to a row of "deadmen," the power of each horse was multiplied 875 times.

The actual moving, over a distance of 310 feet, was completed in nine hours, without a single crack in the building, so well was the load supported. Arrived at the new site, it was necessary to raise the structure on cribbing a distance of more than two feet

to permit the new foundations to be completed under it. A thousand steel jacks



Country Bridges Often Require Special Bracing to Prevent Their Collapse When a House Is Moved; the Front Rests on a Four-Wheel Movers' Truck

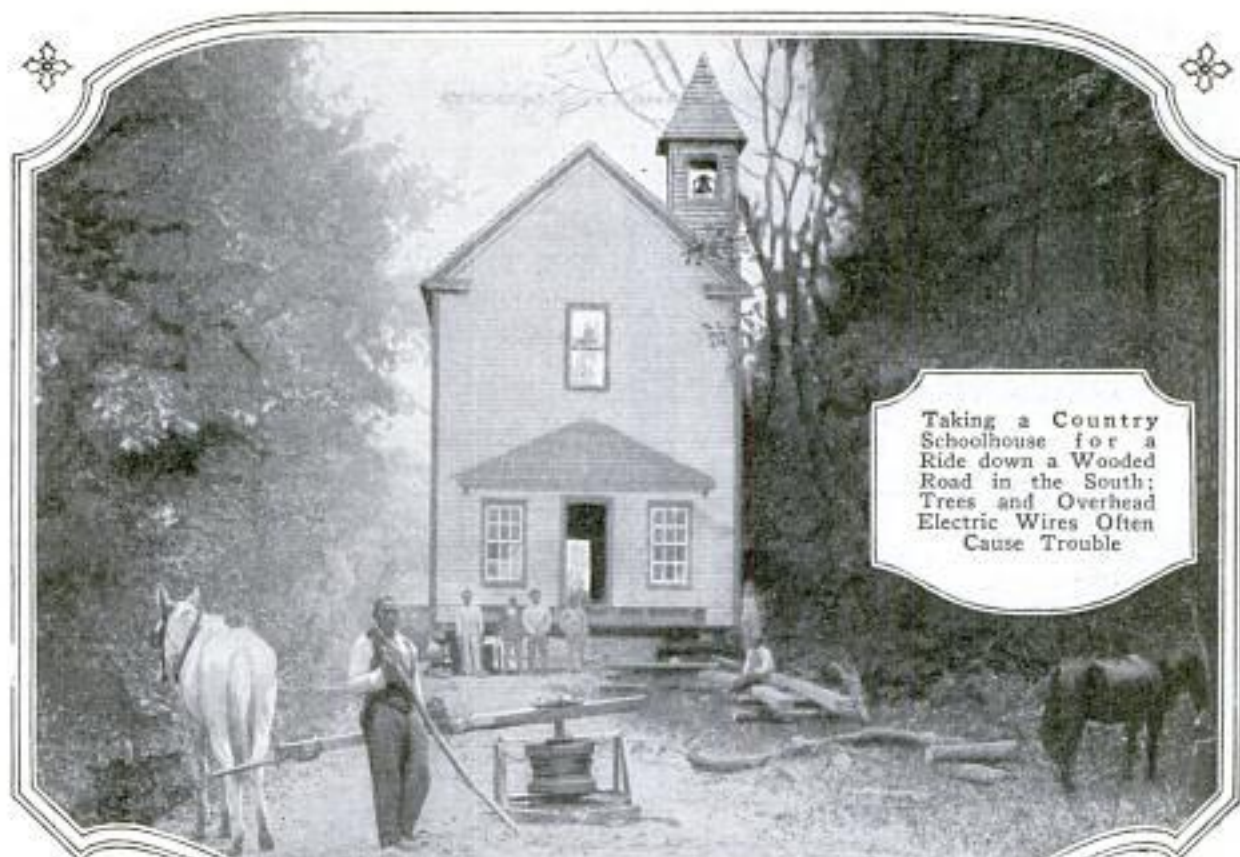

Taking a Country Schoolhouse for a Ride down a Wooded Road in the South; Trees and Overhead Electric Wires Often Cause Trouble

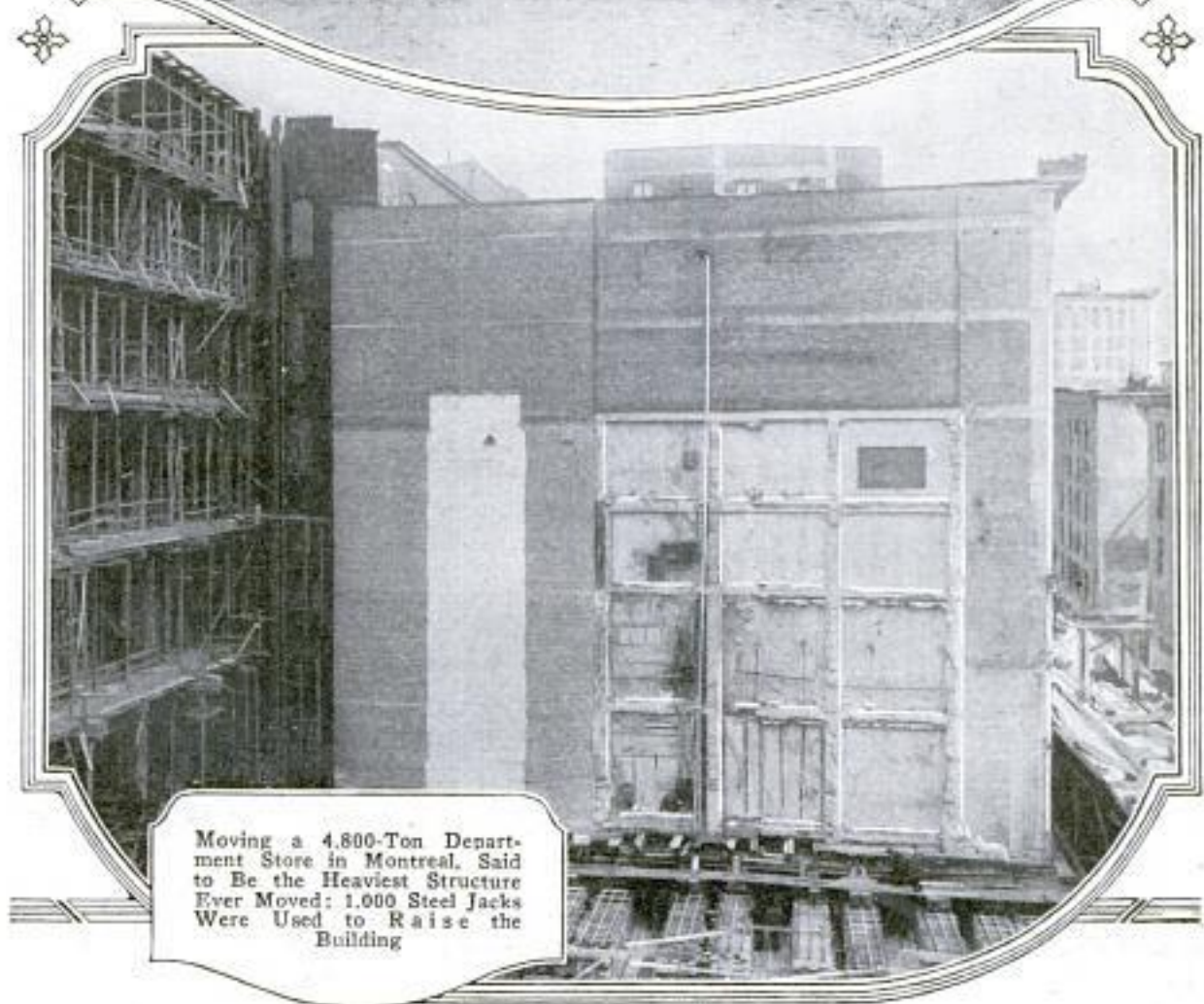

Moving a 4,800-Ton Department Store in Montreal. Said to Be the Heaviest Structure Ever Moved: 1,000 Steel Jacks Were Used to Raise the Building



were placed beneath the building, and with forty-two men moving down the lines, giving each jack a fraction of a turn as the whistle blew, the structure was lifted and blocked into place. Despite the great weight, when the time came to lower the building into place, it was planted on the head of a thin finishing nail, driven by the engineer to mark where the corner should rest.

"I never unload a building," LaPlant explains, "until the owner or his representative has driven a nail to mark where he wants it, and I have never seen a building too big to be unloaded on that exact spot."

Moving the town of Osborn to a new site a mile and a half from the old, and twenty-five feet higher was one of the biggest jobs ever undertaken. Osborn lay in a valley along the river above Dayton, and after the disastrous 1913 flood, the entire town site was purchased as part of a huge conservancy reservoir, which

was to store up flood water and pass it down to Dayton in reasonable quantities. The state at first intended to wreck the buildings, but later arranged to sell them to be moved to a new site, giving the old owners first chance to buy. A company was formed to undertake the moving and bids were asked.

"Between the old and new sites there was a swamp through which a road would have to be built, and nobody wanted to undertake a part of the job, and build that road for someone else to use later, so it was a question of bidding on the entire town," LaPlant recalled. "I got the contract and started to work on the road. It cost me \$18,000 before I was ready to move a single house. Two railroads through the valley were moving their

main lines back several miles to the hills and I bought carload after carload of the ol-

ties and laid a corduroy road with them, sixty feet wide, right through the swamp, staggering the tie ends to make a good job. With tractors and graders I scooped out a hillside and placed a foot and a half of dirt over the ties, and then rolled it down to make a solid roadbed.

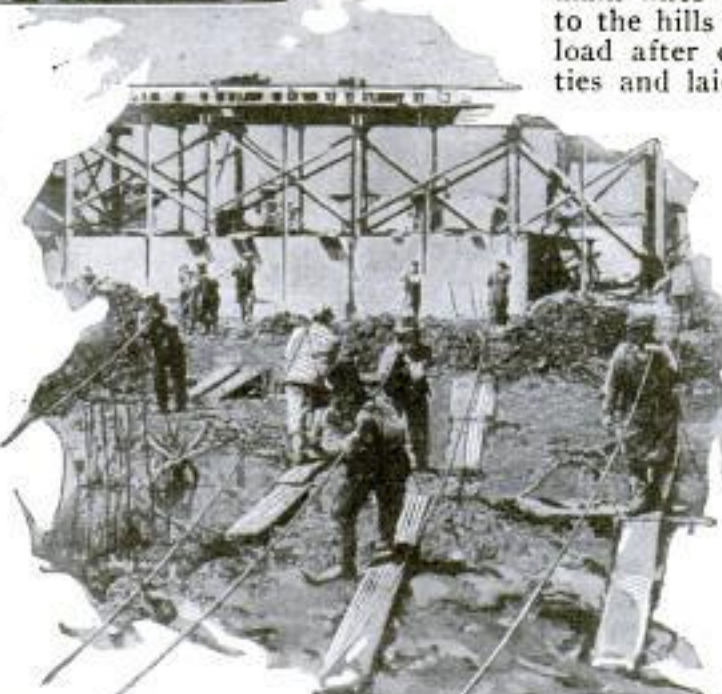

Tending the Steel Moving Rollers; Stretching the Cable to Multiply the Power, and Turning the Thousand Jacks to Raise the Big Montreal Department Store. Three Phases of a Record-Breaking Engineering Feat

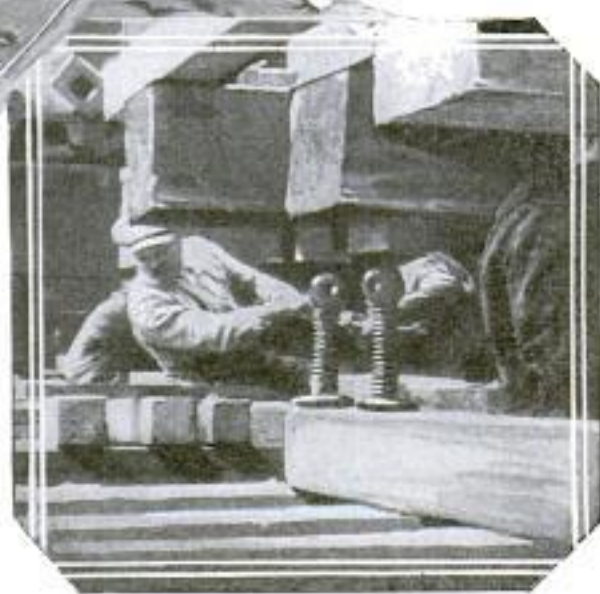



"When we once got things started moving, things moved fast. With a house or business block going up the hill in forty-five minutes, and the tractor coming back alone in less than that, we set the town down on the new site faster than all the workmen they could hire could dig the cellars and put in foundations. In fact, after I had moved the last one, we had to leave more than twenty buildings standing on cribbing, and it was three months after I finished the job before I got all my tools and equipment back.

"Most of the houses were occupied, and moving didn't interfere with the family life at all. When we got ready to start a house, my superintendent or I would go in and take a look around. If they had a piano or any other heavy furniture on rollers, which might run wild while going up the hill, we told them to put a piece of rag or an old stocking under each caster. That was just sufficient to keep the stuff from rolling. If there were pictures on the wall we gave them a twitch, and if they didn't come loose in our hands we let them stay there.

"The shade trees, more than 400 of them, were dug up as the houses were raised, and mounted on special trucks. When the tractor came along, it hitched one line to the house and another to the front yard tree and started off with both at the same time. If the owner wanted it, we put the tree down in the exact spot, in relation to the house, it had formerly occupied, or if he desired a change, we moved the trees around to suit."

For families in houses being moved to continue living in them during the journey is quite common, but in a moving job at Ferndale, Mich., a suburb of Detroit, winter before last, LaPlant not only moved seven brick business blocks as one unit, but furnished steam heat, water, gas, electric lights, telephone and sewer connections for the tenants, besides board-walk connections to their front doors.

The seven business buildings were part of a long row he moved to permit a street-widening project to go through. Owing to the fact that intersecting streets formed an odd angle, it was necessary not only to move the seven back some distance, but shift them around to a different angle. A boiler was set up in a shed at a point carefully calculated as halfway between one end of the buildings, as they stood, and the spot where the end would be at the new location. From the boiler a heavy armored hose ran to the buildings and tapped the steam pipes, the original cellar heating plants previously having



A Single Motor Truck Moved This Los Angeles Apartment House Twenty-Seven Blocks in the Night

been disconnected and the pipes plugged.

Gas and water connections were arranged in the same way, hose running from pipes laid to the vicinity of the boiler shed. A four-inch hose furnished sewer connections to the same spot, and the telephone and electric-light wires were manipulated from reels operated by men on the roofs.

In thirty-five years of work as a mover LaPlant has encountered many queer tasks, but one over which he still chuckles happened more than twenty years ago at his old home at Marshalltown. The Soldiers' Home there built a new power plant and the superintendent, an irascible old colonel, called for some one to come and wreck the old power-house

stack, a brick structure 170 feet high and eighteen feet in diameter at the base.

"He looked me over; snorted a time or two, and finally said," LaPlant recalls: "think you know enough to bring that stack down?" I said I thought so. He snorted again and said, 'we'll clean up the bricks, all you got to do is bring it down. How much do you want?'

"I told him \$500 would be the price and he snapped out 'Job's yours. When can you start?'

"Tomorrow.

"The next morning I went out with two men, some twelve by twelve-inch timbers, a few pieces of oak two-by-fours, a ten-gallon can of kerosene, a saw, sledge hammer and some cold chisels. The colonel stamped down the hill, looked over the outfit, and wanted to know, 'How the blue blazes' I expected to wreck the stack with that layout. I told him to leave it to me, and he marched back up the hill, while we started to work.

"I put the men to work with the sledge and chisels, cutting a hole a little over two feet high and about fourteen inches wide through the base of the smokestack, and while they worked I sawed the timbers up in two-foot lengths. As soon as the hole was ready, we stuck in two of the twelve-by-twelves, one on top of the other, and with a section of the two-by-four, which I had sawed out wedge shape, we drove them tight. As each timber and wedge went in, I oiled it well with kerosene, and then we started cutting out another hole alongside the first.

"Alternately cutting and wedging, always soaking the timbers well with the oil, we proceeded until, by mid-afternoon, we had cut halfway around the stack and were holding it up on the oiled timbers and wedges.

"I went up the hill and told the old colonel, if he wanted to see his stack fall down, to come along. When we got back, he looked over the job, and then at me. I walked down and touched a match to the oil-soaked timbers, applying the fire in a dozen places. With that big hole through the bottom there was a terrific draft up the 170-foot stack, and the flames roared. In just thirty-five minutes the timbering burned out and the stack came tumbling down. Labor and material costs on this \$500 job were about \$15.

"The worst scare I ever had," LaPlant continued as his mind wandered back over some of his difficult feats, "was up at Storm Lake a few winters ago. They had a big old, two-story wooden summer-resort hotel to be moved to a new location three miles down the lake. The woods and ravines prevented moving overland, so the only route open was to go down the ice in the winter.

"We watched and waited until tests showed fifteen inches of ice, and then eased the hotel out onto it. I didn't want to take any chances on losing a man in eighty feet of water under that ice, so we chained up the moving trucks in such a way that they would steer a fairly straight course without guidance, and set up the capstan



Starting to Move Seven Brick Business Blocks in One Unit in a Detroit Suburb; Heat, Light, Gas, Water and Sewer Connections Were Maintained

more than 800 feet down the lake. In moving, the cable from the capstan runs back to a pulley at the building, around it, and then to a deadman anchored somewhere ahead. You can run the cable back and forth over as many pulleys as you need to give any desired power. There was nothing on the lake to use as a deadman, so we cut twelve-inch square holes through the ice, tied the cable around the middle of a seven-foot timber, and poked it down into the water. By hauling the cable tight the timber would wedge across the bottom of the hole, under the ice, and afford a good anchorage.

"The ice, swept clear of snow by the wind, was smooth, and the old hotel came rolling along as fast as the horses, with well-calked shoes, could trot around the capstan. I had begun to think everything was lovely, when suddenly that ice let out a groan that could be heard for miles, and as we watched, the house began to go down. The whole ice sheet began to bend, and through the deadman holes we had passed, huge geysers of water shot up in the air. The ice kept giving and the hotel sinking until there was two feet of water lapping around the trucks. Then it stopped and the men, who had skipped for safety, began to come back. We started the team again and pulled up the grade over that bending ice until we were safe again."

**BUTTERFLIES IDENTIFIED BY ODOR**

Butterflies carry perfume, according to an English naturalist. The males of the large white garden butterfly diffuse the scent of balsam or lemon while those of a green-veined white species have a faint odor of verbena. Others smell of sweet briar, rose, violet, honeysuckle and carnation.



Greasing Auto with One-Hand Gun Operated as Pump

**RADIO CONTROLLED FOUNTAIN KEEPS TIME TO MUSIC**

400

Two illuminated fountains, which automatically synchronize their light and the movements of their waters with radio

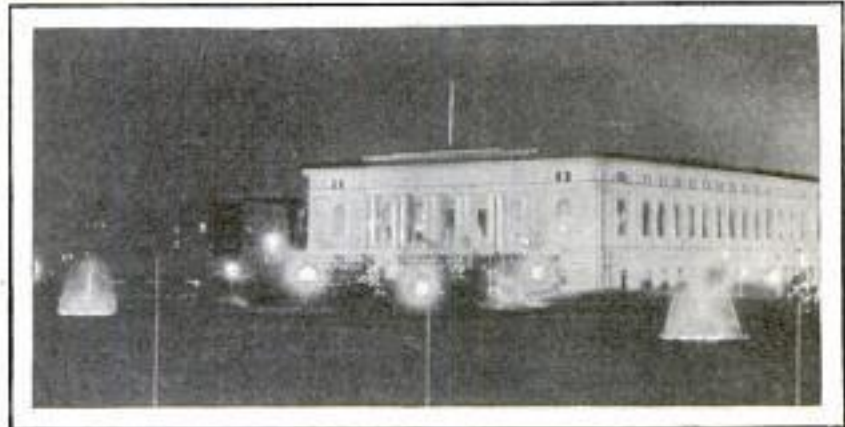

Illuminated Fountains Play in Foreground, While Changing Colors Rise and Subside in Harmony with Music from Radio

music, have been installed in the San Francisco civic center. By means of a special attachment, the tempo and the loudness of the tones modify or increase the force of the jets and change the lights, which are of four different colors. As the volume of the radio signals varies, the jets rise or fall and the lights shine through the spray so that the music selection is "reproduced" in color and motion.

363

**HIGH-PRESSURE AUTO GREASER, OPERATED WITH ONE HAND**

A high-pressure automobile lubricator now on the market is operated with only one hand and injects oil or grease into bearings with a force of 7,000 pounds. It works on the hydraulic principle by which the pressure exerted on a hinged handle is multiplied many times. The lubricant is carried in a can-shaped container, and the pumping mechanism is mounted on the top.

Smallest of the inmates of the London zoo are some mice tinier than bees.

W. Robertson & Son, Chicago  
 2013 Kanawha St.

*J.W. Taylor, The Naturalist, 5 Haringdon Ave. London, E.C.4, Eng.*

427



Army Anti-Aircraft Guns in Action, and Soldier Wearing a Cartridge Belt

Described by Mr. Robert J. P. ...  
 Research physicist, before allaying my ...  
 engineering study ...  
 Detroit 9/15/1918

**ARMY ANTI-AIRCRAFT GUN FIRES SIX SHOTS A SECOND**

Each spitting bullets at the rate of 100 shots every sixteen seconds at targets towed by airplanes, a battery of army anti-aircraft guns was tested at Fort Tilden recently. A number of hits were made, and officers expressed satisfaction at the results. Ballast of sand bags was used to help steady the guns.

**CHROMIUM-COATED AUTO LIGHT RESISTS WEAR AND TARNISH**

Auto headlamps and outdoor floodlight reflectors that are said to be as efficient as freshly silvered glass mirrors have been developed by using a coating of polished chromium. This metal, unlike aluminum,

silver or nickel, will not tarnish or corrode although subjected to constant exposure, and is so hard that gritty waste may be used in cleaning it without danger of scratching. It need not be coated with lacquer to protect it from the atmosphere; hence the full benefit of its brightness is obtained.

**LOOSE WRENCH TIGHTENS WITH CLOSE SETTING**

Equipped with a clamp that holds it in position while being manipulated, the jaws of a new wrench can be quickly released and locked in adjustment by moving the looped fastener with thumb and



finger. Owing to the design of the jaws, accurate setting of the tool is not necessary, as it takes hold of an object firmly when the handle is drawn in the direction of the turn. It is said the utensil saves much time because it can fit several pieces of work of slightly different sizes without need of change in adjustment.

Messrs. Dept. of ...  
 La ...  
 Box 3, ...  
 ...

Westinghouse Electric & Mfg Co,  
 East Pittsburgh, Pa

New York Times  
9/20/25  
E.E. True

**MYSTERY OF MOUND-BUILDERS IS PARTIALLY SOLVED** 448

Discovery of the decayed fragments of what were once gorgeous robes studded with pearls in one of the prehistoric mounds of southern Ohio recently, has furnished another link connecting the forgotten mound-building Indians with the Maya civilization which once flourished in southern Mexico and Guatemala. Opening what apparently was a royal burying mound, the investigators found skeletons both of warriors and of royal princes. Two of the skeletons were wearing helmets of beaten copper, one of the most prized metals of the ancients. The bodies likewise were surrounded by ornaments of silver and tortoise shell. The discoveries strengthen the theory that the prehistoric Indian tribes came under the influence of a superior civilization when Maya traders from the south invaded the territory east of the Mississippi in search of pearls and other valuables. These traders, it is believed, became leaders because of their superior knowledge of the crafts.

458

**SIX-WHEEL ALL-METAL TRUCK CARRIES HEAVY LOADS**

Built close to the ground to reduce lifting, a small metal truck carries 5,000 pounds and is specially suited to loads of different shapes and sizes such as paper rolls and barrels. Freight is loaded onto it from the side, curved extensions of the frame serving as inclines to assist in the operation. This arrangement also serves to prevent slipping while the truck is loaded.



Barrels Are Loaded On Easily from the Side without Danger of the Truck Slipping

Marion Tool Works  
marion, ind.

**GAS RANGE AND AIR FURNACE COMBINED IN ONE UNIT** 448

By lighting the burners and opening the oven of the ordinary gas range, the kitchen and near-by rooms can be warmed



Combination Gas Range and Furnace; Air Enters Opening at Lower Right, Is Heated and Passes Out through Upper Grating

on cool days when the regular heating plant is not in operation, but this method is costly, since the oven was intended to retain heat and not to be used as a furnace. A range now on the market has an air-heating unit, which, laboratory tests have shown, is highly efficient and, besides affording a serviceable furnace, gives extra cooking space. The heater is built as part of the stove and may be used with or without the other burners.

It is so arranged that a cold-air supply, admitted through openings in front and underneath, is thoroughly heated before it is emitted through holes in the top. Lids cover the holes of the air-warming unit, which is large enough to allow two or more cooking utensils to be placed on it.

Peoples Gas Light & Coke Co.  
122 St Michigan Ave  
Chicago

# Time and Money-Saving Tools



Roller Cabinet and Shelves Are Convenient to Sink



Cherry Stoner Works Like Punch, Pushing Pit through Hole in Cup



Handy Dish for Boiling Eggs, Washing Berries or Toasting Bread



Wooden Darning Holds Hose for Easy Mending



Steady Ball-Socket Mirror Cannot Fall Down



Four Infants' Bottles Sterilized at Once with This Simple Outfit



Left, a Tight-Fisting Rubber Cork with Metal Clips to Grip Rim of Bottle; Below, Shoe Protector That Prevents Scuffing When Driving Auto



Right, a Combination Gocart, Walker and Coaster Car with Adjustable Seat, Rubber Bumper and a Teething Surface on Hand Grip in Front



Anyone wishing further information on devices described in the editorial pages can

# for Woman's Workshop in Home



Holder for Steel-Wool Protects the Housewife's Hands and Aids Cleaning



Potato Mashers Usually Take Up Too Much Room; Here Is One That Is All Metal and Comes Apart for Easy Washing and Packing



For Tailors, Dress-makers or Housewives, a Pincushion Worn Like a Wrist Watch Is in Convenient Position



Hair Dries Quickly after Shampoo with Electric Brush

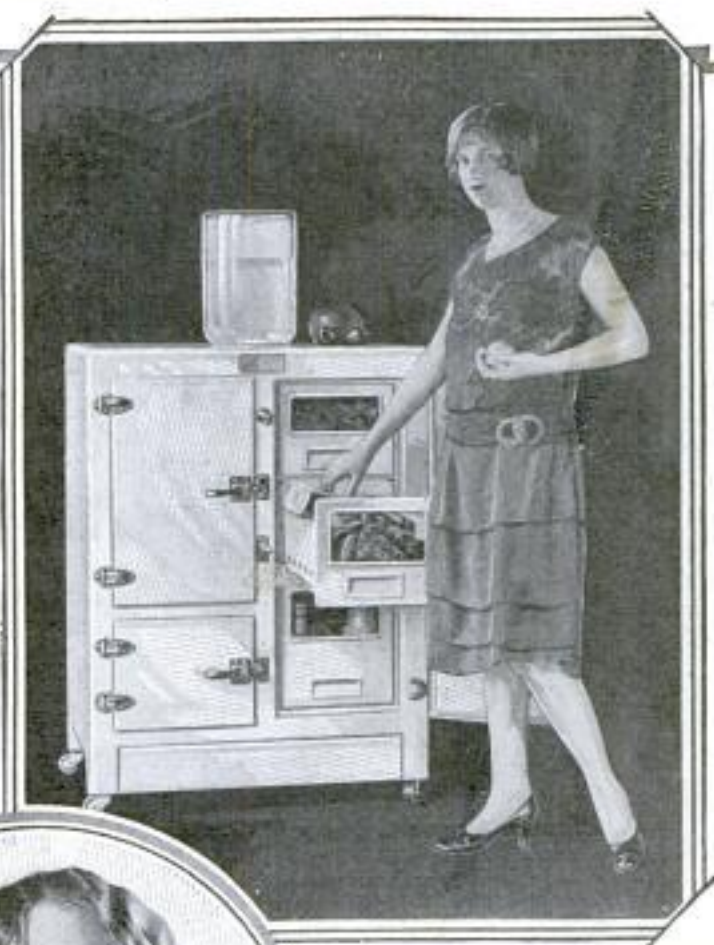

Sliding Drawers on This Refrigerator Eliminate Stooping to Get Contents at Back and Are Easily Cleaned; Water Bottle Fits in the Top



Fitted inside Pot, Strainer Is Out of the Way and May Be Removed Easily as Shown Above

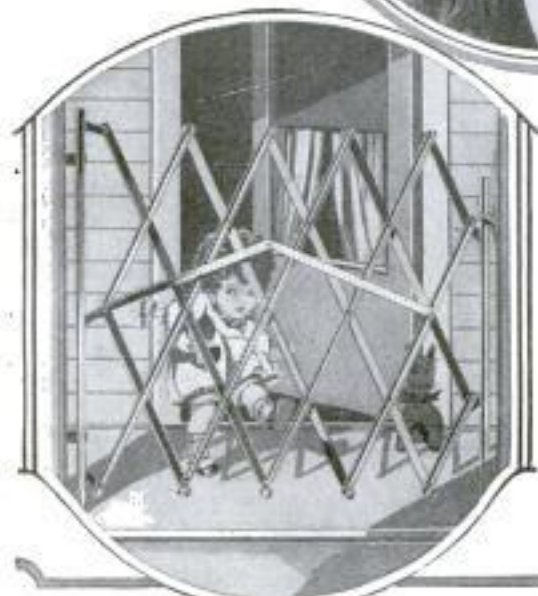

Just Press Handle of Implement Above and Pancake or Egg Is Turned Automatically

Right, Combination Shoe Buttoner, Ruler, Comb, Nail Cleaner, Screwdriver and Bottle Opener; Left, a Collapsible and Easily Adjusted Safety Gate for Children



**ELECTRIC MOTOR LAWN MOWER  
 RUNS FROM LIGHT CIRCUIT**



Electric Lawn Mower in Use; Current Cable Attached to Light Socket near House

Operated with current from the house-lighting circuit, an electric lawn mower has been devised to meet the needs of persons who want a power cutter but whose yards are not large enough to warrant investment in a large and complicated outfit. The supply cable is plugged into any light socket or electric outlet and pays out or takes up automatically on a reel to prevent its tangling up. A push of a button on the handle starts the motor. It cuts a twenty-one-inch swath.

**GENTILE FIRE TENDERS  
 HIRED IN ODD MARKET  
 FOR JEWISH HOLIDAYS**

Almost any Friday afternoon finds a half dozen or more Gentile women, each carrying a rolled-up apron, assembled in Goulston street, Whitechapel, London. They are "fire goyals," awaiting hire to light and tend fires, and perform other tasks, over Saturday in Jewish households, where that day is observed strictly as the Sabbath and the Hebraic prohibition against work is obeyed religiously. Their duties begin at sunset, Friday, and last until sunset, Saturday, the duration

of the Jewish Sunday. Many other odd labor markets are scattered over London. There are several exclusively for "sandwichmen" who carry boards displaying advertising legends. 9/12/25

**PHOTOS OF AIR EDDIES STUDIED  
 TO IMPROVE AIRPLANES**

To help builders design airplanes with less wind resistance, the aeronautical research committee of England has been taking photographs to determine what happens to air currents when they strike objects of different shape. The tests were carried out in a wind tunnel, brilliantly lighted by powerful arc lamps, and a smoke jet was introduced into the stream of air so that its movements would be registered. The current first was directed against a blunt block of wood, then the edges of the obstruction were rounded off in different ways, the camera recording the course of the air in each case. Study of the results, it is expected, will aid airplane designers in shaping parts that cannot be streamlined perfectly.

**ROUND SNOWSHOES FOR HORSES  
 AID TRAVEL IN ALASKA**

So they will not sink into deep drifts, horses in Alaska are fitted with round snowshoes which are chained to the hoofs. The animals are said to become accustomed quickly to the shoes and usually refuse to enter deep snows without them.



Fitting Horse with Snowshoes for Travel over Deep Drifts in Alaska

Information from  
 E. D. Winslow, Esq.  
 Sales Manager,  
 Canadian & Montreal  
 Hand Co.

369  
 H. H. Wallis Coldwell Lawn  
 Mower Co.  
 4139 W. Kingsie Chicago

397

368



338 Cmt. George H. Macy  
 4639 Montgomery Ave.  
 POPULAR MECHANICS 991  
 Bethesda, Md.



Dredge Used for Pumping Fossilized Deposits from Million-Year-Old Bed Where Myriads of Minute Sea Creatures Died Ages Ago to Form Material Valuable in Modern Industry for Insulation and a Hundred Other Purposes

## Turning Fossil Graveyard into Wealth

Curious Earth, Consisting of the Decayed Skeletons of Million-Year-Old Fossils, Is Valuable as Gold

**M**OST of us have never even heard of fossil meal, yet to the trades that use this material, it is as valuable as precious gems or nuggets of gold. A million years or more before the dawn of modern times, myriads of two-celled forms of life, known to science as diatoms, selected central Florida as their abode. These diminutive creatures of antiquity were probably the first to settle in the land of our last frontier because of its agreeable climate. For climatically ideal conditions are the one and only attraction that causes the curious diatoms to lash their moorings permanently in a locality. The average diatom is a veritable Tom Thumb of shell life. It would require 2,000,000 of them to occupy as much space as a one-inch cube. Under high magnification, they appear in the form of complicated and structurally beautiful snowflakes and willow leaves. These minute organisms grow and multiply rapidly in fresh spring water. They form skeletons, shields or shells as protective armor. Hundreds of thousands of years after their death, their shells decompose to form deposits that are called fossil meal, infusorial earth, kieselguhr or diatomite. This deposit is practically pure silica, and the peculiar hollow shape of the shells or skeletons and the abundance of air cells make the resultant product highly porous and extremely light. One of its most im-

portant qualities is its unequaled ability to resist the transmission of heat and cold. Science has demonstrated that air is the best distributor of heat and also the greatest barrier, on occasion, to heat transmission. Diatomite both keeps heat in and cold out. It is the best and cheapest material now used for lining cold-storage rooms and refrigerators. It is indestructible by fire, and is also very light, the fossil meal weighing only seven pounds per cubic foot. It is also particularly valuable for the soundproofing of modern buildings, as it can be mixed directly with plaster or cement. Besides, this remarkable material finds hundreds of uses in widely varied industries. There is a touch of romance in the discovery and utilization of fossil meal south of the snow line in sunny Florida. It was made during the World War, when diatomite was in keen demand especially for use in submarines. The British admiralty worked the deposits on the Isle of Skye, off the western coast of Scotland, to depletion. Finally, hearing that a settler in Florida had found deposits on his land which the United States geological survey had identified as fossil meal, the British authorities dispatched an expert to Florida to make a complete investigation. After an exhaustive search, a rich deposit of diatomite was located near Tabares. For patriotic reasons, an Eng-

Florida Diatomite Company, H.C. Brown, Pres.  
 Germantown, Fla.

lish lord bought this tract of land, and the expert, who had previously been superintendent of the Skye plant, developed a similar project on it. Just about the time the factory was finished, the armistice was signed and the demand for the material immediately abated. The British nobleman was killed during one of the last engagements of the war and the fossil-meal mine, with the rest of his property, was tied up in the courts.

The expert, however, decided to remain in Florida and to continue his quest for deposits of infusorial earth. For three years, he searched the highways and byways, the cultivated fields and the jungles of Lake county. His persistency ultimately was rewarded when he found "pay dirt" of fine diatomite near Clermont, and there a splendid plant has been built.

A special suction dredge is used in the reclamation work. It pumps the material to a sluiceway and deposits it in settling tanks as sludge. From these tanks, after precipitation has occurred, the material is drawn to large surface vacuum filters, and thence to a drying and calcining kiln. This kiln, of special construction, is fifteen feet in diameter and thirty-two feet high. The fossil meal is elevated to the top of the kiln and then descends through baffles in which it is exposed to temperatures as high as 2,500 degrees Fahrenheit. This burns out the organic material and eliminates all moisture. Subsequently, the residue is pulverized, screened and bagged, and sent to market.

### NAMES OF GARMENTS TRACED 415 TO MANY LANGUAGES

Study of costume terms reveals that the names of many garments, like the articles themselves, have had an interesting history and date from early times. In fact, the word "costume" itself is the same as "custom"—that which is customarily worn. The "cap," for instance, is a relic of the old "cappa," a cape with a hood. When the cape fell into disuse, the name was shortened to apply only to that portion that went over the head. The hero of Burns' poem explains the "Tam O'Shanter," and the term "pajamas" is of Hindoo derivation, the origin being "pae-jama" or leg clothing. "Coat" is from the Latin "cotta," a tunic; "jacket" sprang from "jaque," a short coat of mail and "jumpers" describe a garment which the wearer slips on, or into which he jumps. The "knickers" of today recall the wide breeches first worn in America by Dutchmen, who were called "knickerbockers" by Washington Irving. "Skirt" is allied to "shirt"; a "petticoat," originally worn by men, was, in French, a "petit cotte" or small coat; pinafore is something pinned before and "apron" is a contraction of "naperon" or cloth. "Kilts" got their name because they are kilted or tucked up; "frock" comes from the "froc" worn by French monks; "clog" was a wooden-soled shoe for use in mud, and "pumps" take their name from "pompe," a French word meaning ornament.

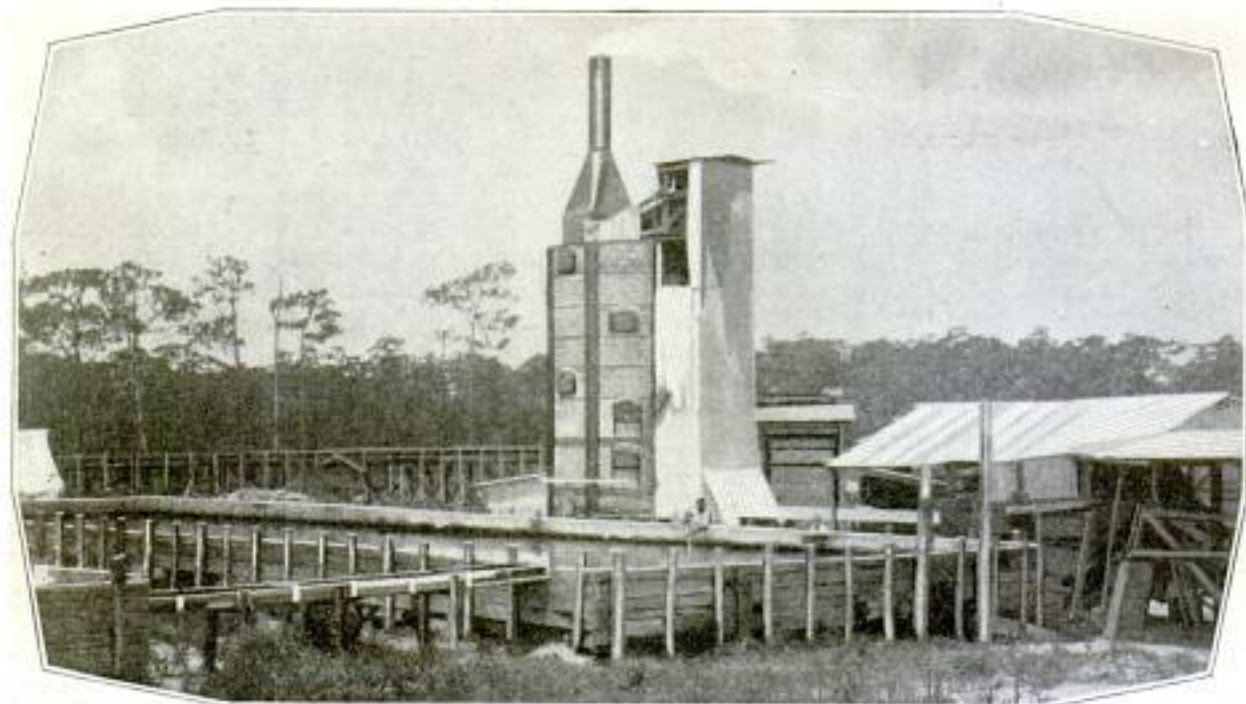

Vacuum Settling Tanks Where the Excess Moisture Is Removed, and, in Background, the Cooking Kiln Which Burns Out the Organic Material and Leaves the Pure Infusorial Earth

2842 Roscoe + Wallace Good  
Pasadena Calif.

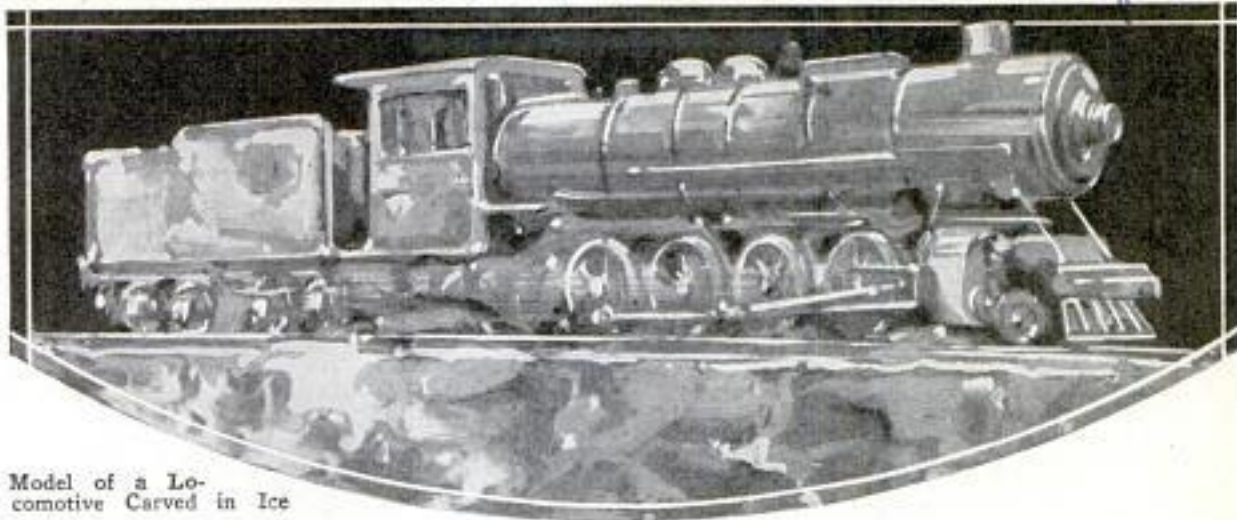

Model of a Locomotive Carved in Ice

## Toys Become Aids to Industries

Growth of Models as Helps in Selling Shown by High-School Boys' Rise to Factory Owners

**M**ANY men who love their work succeed in making play out of business, but two Pasadena boys have recently incorporated a business growing out of their play. The brothers, Roscoe and Wallace Good, eighteen and twenty years old, respectively, and only recently out of high school, are building a quarter-of-a-million-dollar factory to carry on a model-making industry which was founded in their backyard garage.

Starting with the building of ancient viking ships and sailing vessels, as toys, they turned out more than \$50,000 worth of commercial models in the family garage before they found need for larger quarters. Their output has ranged from small ornamental ship models to a ten-foot exact replica of an ocean liner, built for a western shipyard, and has included such widely diversified things as a half dozen street-car models and a complete model of the oil industry.

As boys, they whittled out their own toys, and then made the discovery that their little sailboats would readily sell for twenty-five cents each. That looked like an easy road to wealth, and when, a few years later, a real ship's model from their knives sold for \$12.50 they considered their fortune made. The war-time ship-building activities on the coast offered an opportunity to construct commercial ship models, and the two brothers, still in short trousers, began receiving orders from shipyards and ship owners.

After the war they branched into other fields and prepared to execute orders for

any kind of model work. Recently they completed a half dozen three-foot models of various types of street cars, ordered by the St. Louis car company for exhibition at the street-railway convention at Atlan-



Thirteen Feet High and Six Feet Wide, This Model Chair Is a Giant Instead of the Usual Miniature

2842

# POPULAR MECHANICS

Working Model of a Steel Gondola Car, Made to Scale, with All Parts Operating, and, Below, Roscoe and Wallace Good Working on a Model of a Steamboat, One of the Historically Accurate Boats Turned Out by Their Garage Play Shop Which Founded an Industry



Glass Model of a Return Tubular Boiler, at Left, Equipped with Glass Tubes, Shows the Exact Way in Which the Water Circulates

Working Model, Motor-Driven, of a Milk-Can Washer, Scrubs Miniature Cans and Helps Salesmen

tic City. The cars were exact replicas of the company's products. Another model recently completed was a sixteen-foot display, showing all the steps in the oil industry, a rush job for which they were allowed but one month's time.

Model building has opened up an entirely new field for clever mechanics who take pride in their skill. Dozens of industries are turning to models both for their advertising value and their ability to sell goods. Some of the models are very expensive. The Na-

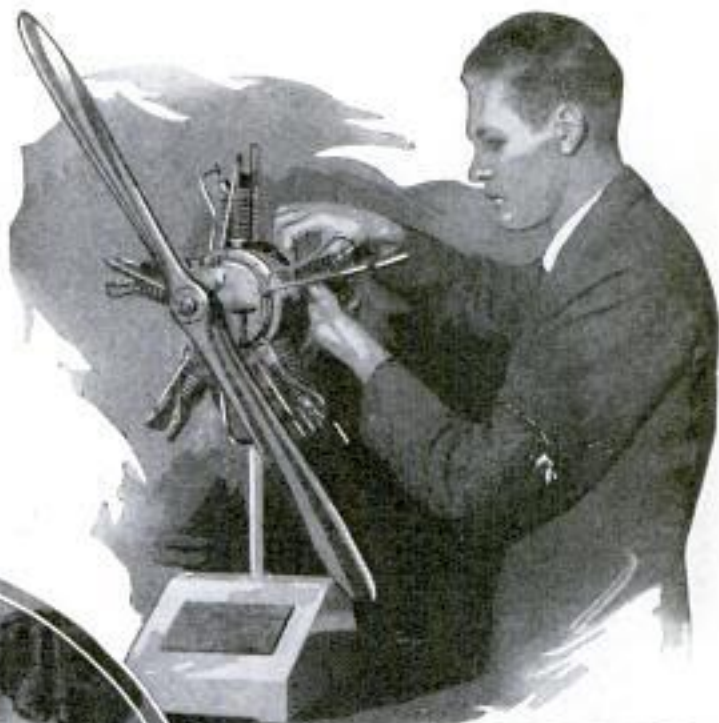

Three Widely Different Models, Each Built to Exact Scale; Above Is a Four-Stroke Aero Engine Displayed at a London Exhibition; at Left Is a Miniature Automobile Tank Truck, Used in the Delivery of Gasoline and Oils and Complete Even to Safety Devices; Below, Hospital Model That Can Be Taken Apart

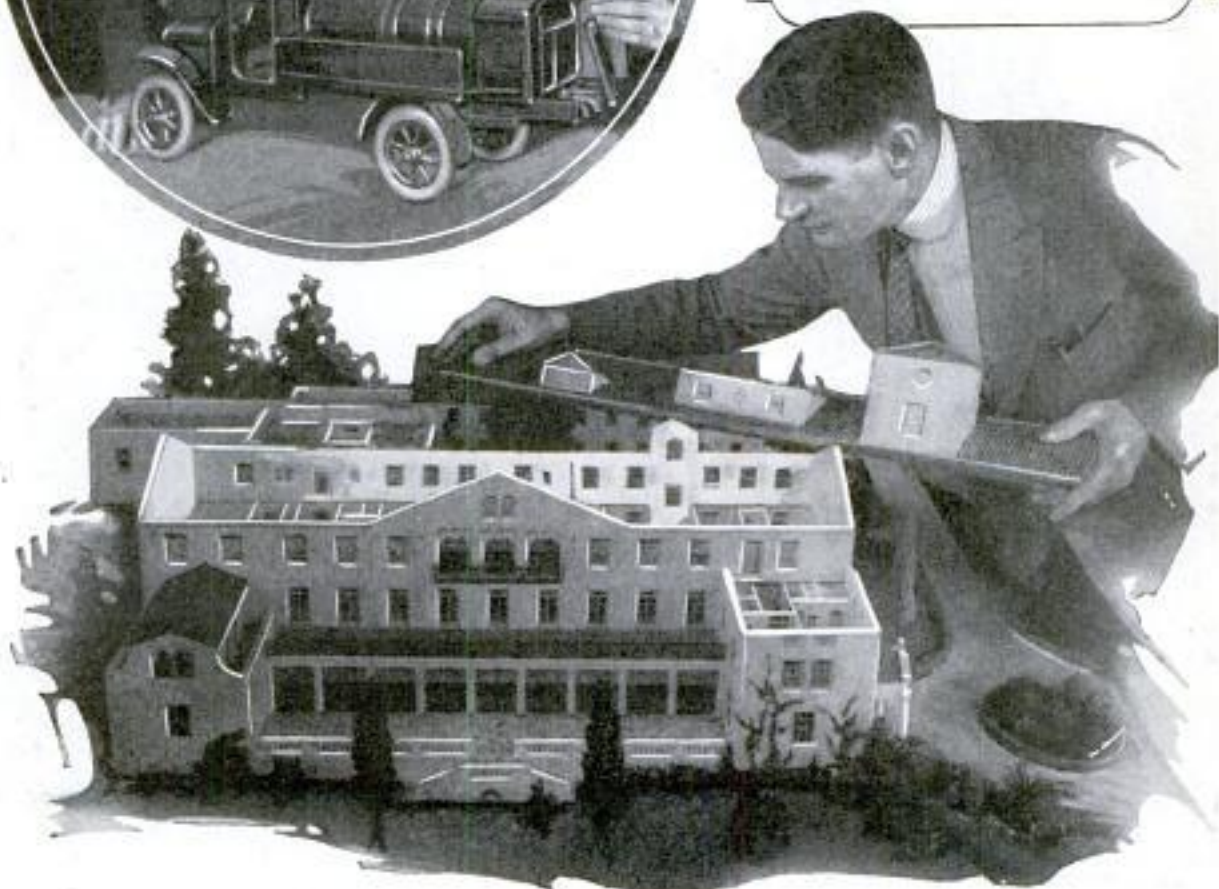



Contractor's House Model Used to Attract Buyers While the Full-Size One Is Being Built; Left, a Trowel So Big the Gods Might Have Used It to Lay the Cornerstone of Valhalla



Furnace Models, Above, Can Be Used to Explain the Workings of the Family Heating Plant to Prospective Customers without Taking Up Floor Space with Full-Size Exhibits; Right, the Largest and Smallest Boots at a Shoe Fair; the Big One, Said to Be the Largest Ever Made, Might Well Be Worn by the Workman Who Would Use the Trowel Above

tional Museum at Washington has a twenty-five-foot model of the liner "Leviathan" which cost \$25,000 to build. It was the work of German mechanics of the Hamburg-American line, and when the enemy-property custodian seized the assets of the line during the war, the model was taken over and later presented to the museum. The ship models displayed in steamship offices are usually from five to ten feet long, and cost anywhere from \$5,000 to \$15,000 to build.

Builders of railroad equipment, automobiles, trucks and large machinery are turning to models for use by their sales force. A salesman can pack an entire railroad outfit in a suitcase or two and go anywhere in the world to demonstrate his wares if he uses models which are exact replicas, built to scale, of the real equipment. In many of the finer automobile factories each new car design is executed in model form first, in order that its lines may be carefully considered and modified, if necessary, until the result is pleasing to the eye. A fortune in tool, jig and die making is thus often saved before the factory tools up for quantity production.

Plaster building models are likewise becoming common. Hardly a big building is erected any more without a plaster-of-paris

model first being executed from the architect's drawings, so that the owner can visualize its lines before ordering work to proceed.

Some progressive contractors who build houses for sale have adopted the model idea and erect models, often six or eight feet high, and complete to paint and hardware, and display them on the lot while



The Biggest Banjo Ever Built Is a Successful Working Model. Though It Requires Three Strong Men to Play It

2842



British Naval History Shown in Ship Models Owned by a Massachusetts Man; the Oldest Model Dates from King Alfred's Day; Below Is a Monster Teapot

the house is going up. They have found that people who stop to inspect the progress of the work often decide to buy after inspecting the completed model, with the result that a house built on speculation can be sold long before the walls are completed.

Even municipalities and states have turned to models in order to enable the voters to visualize proposed improvements. The state of Illinois built a complete working model of the locks and canals of the proposed lakes-to-the-gulf waterway and exhibited it at county and state fairs and exhibitions before the canal bonds were voted, and the city of Chicago has used models for the same purpose.

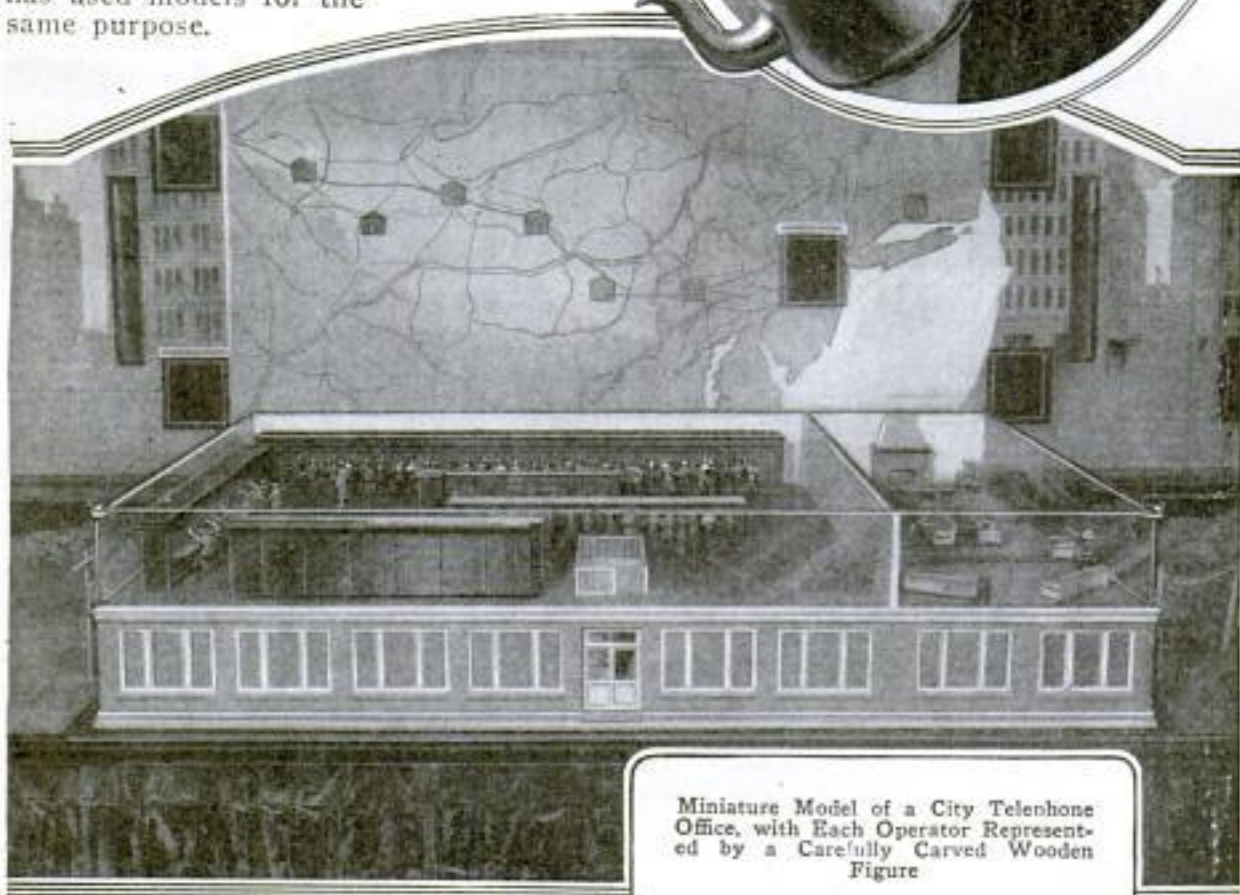

Miniature Model of a City Telephone Office, with Each Operator Represented by a Carefully Carved Wooden Figure



New York Times  
9/13/25

(drew. by J.P. Lunderback, Compton, Calif.)

POPULAR MECHANICS

PROHIBITION CHANGES METHOD OF POLISHING JEWELRY 294

Directly due to prohibition, a radical change in the method of manufacturing jewelry has been adopted, involving the substitution of a solution of soap-tree bark for sour beer in scratch brushing. This is a process for removing all loose gold from the finished article so that a clear, brilliant luster will result from polishing instead of a smoky surface which might cause purchasers to believe that the product was of inferior quality. Passage of the Volstead act made it impossible to obtain the right kind of beer for this process, so manufacturers sought a substitute. Bark of the soap tree, a shrub found in Central and South America, as well as licorice root, previously had been suggested, but the idea was scoffed at until jewelers were confronted with the necessity of finding something to take the place of beer quickly. The soapbark, in the ratio of two handfuls to two quarts of water, has been found cheaper and is said to produce better results than beer. The water soaks out the ingredients of the bark and produces an acid about the strength of the former liquid used.

BETTER LIGHT AND NO SOOT FROM KEROSENE LAMP 355

Brilliant light and a flame that remains centrally fixed in the chimney, no matter how much the lamp may be tilted, are advantages claimed for a kerosene lamp developed in France. Besides this, the chimney always remains cool and no soot forms even after long usage. The secret lies in supplying a large volume of air to the flame. This is done by a special design of chimney which has a brass top to draw out all burned gases before it can become heated. As a result of the perfect combustion, the lamp burns with a sootless flame.



Thirty million dozen eggs are exported from the United States annually.

Handled by M. Rene Brocard  
5 allée de la Source, Saint Leu



Inventor with Huge Four-Bladed Bit to Save Time in Oil-Well Drilling

FOUR-BLADED OIL-WELL BIT SAVES TIME IN DRILLING

For drilling oil wells, a bit that is designed to cut through hard shale without the necessity of frequent withdrawal for resharpening, has been patented by a California inventor. Externally, it is like the ordinary "fishtail" bit commonly used in the oil fields, but instead of only one blade, it has four steel cutters that project evenly at the bottom. A plunger actuates them so that they drop one-eighth of an inch at a time, presenting four edges at all times to the earth. The cutters are about forty inches long and the inventor asserts that they can be used without removal until thirty-two inches have been worn away, whereas the ordinary bit must be taken out when not more than one inch of its cutting surface has been dulled. This reduces the wear and tear on equipment as well as the expense and loss of time incident to frequent "pullings" of the old bits for resharpening. The complete drill is ten feet in length and weighs 1,600 pounds.

Austin C. Descarbons  
3140 m. Hudson Hwy

364  
Wm. Standard Oil Co  
+ California Petroleum Co  
Berkeley Calif  
Geo. F. Davis

Copyrighted material

~~Presk. Air Sencos, Inc Corporation~~  
~~North J. Mawanda N.Y.~~  
 1000 POPULAR MECHANICS ~~Long Island City N.Y.~~

**LIQUID GAS IN STEEL BOTTLES FOR FILLING AUTO TIRES**

382

Carbon-dioxide gas, the substance that puts the "fizz" in soda water, is now being

78 Aljiver St  
 North J. Mawanda N.Y.

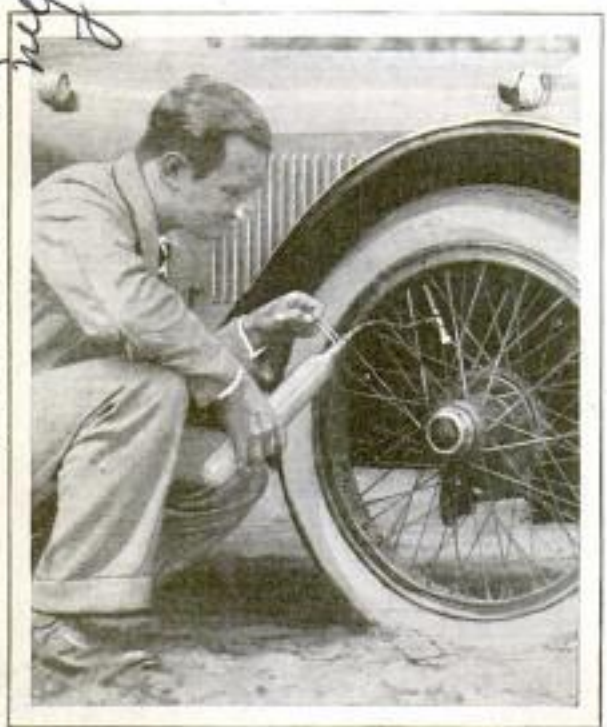

Filling Auto Tire from Bottle of Gas; Control Valve Is in User's Left Hand

used to jack up automobiles, inflate tires, grease bearings and extinguish fires. In liquid form, it is stored in steel bottles fitted with easily operated control valves. A turn of a small lever opens the outlet, and the gas, expanding instantly into a vapor, rushes forth at a pressure of 800 to 1,000 pounds to the square inch. This force is harnessed to a special jack to lift autos or heavy trucks, or to a grease "gun" which forces lubricant into the bearings. For filling tires, a small hose connects the valve to the bottle. It has a gauge arrangement so that the pressure can be regulated. The carbon dioxide is said to prolong the life of the rubber as it contains no air and will not cause the tire to oxidize. In case of a fire,

the gas is shot directly from the bottle upon the flames, cutting off the oxygen and quickly stopping combustion. The bottles are light, yet strong enough to withstand many times the pressure of the gas, which is non-poisonous.

398 Everetts Spring  
**PAPER MONEY, THOUGH RAGGED, BETTER THAN WORN GOLD**

Since the United States treasury redeems paper money at its face value but gold at its weight, a frayed and dirty bill may be worth more than a shiny coin of the same denomination in precious metal. Because gold wears away, the government has established what is known as the "legal limit of tolerance" beyond which the owner must stand a loss if he wishes to exchange his gold for other money. For instance, the standard weight of a new twenty-dollar gold piece is 516 grains. The "tolerance limit" is reached when abrasion has reduced the coin to 513.42 grains, which is the least weight at which the piece will be accepted for its stamped value. The wearing allowance provided for in tables at the mint is .086 grain a year on a double eagle-Silver, nickel and copper coins pass for their face value as long as recognizable, but the tendency of gold pieces to decrease in weight has cost banks and individuals many hundreds of dollars.

Bureau of Currency Washington

367  
**DIGGER PILES POTATOES IN ROW AND REMOVES VINES**

Drawn by a tractor or horses, a potato digger now on the market harvests the crop more quickly than is possible by hand or plow. It straddles the row and has a shovel in front, set deep enough to avoid cutting the tubers while removing them. Vines, grass and dirt fall away as they are carried on an endless chain belt to a shaker at the rear. A kicker attachment sweeps the refuse to one side, leaving the potatoes in a row so that they can be gathered quickly.



As Digger Is Drawn along by Tractor, Potatoes Are Piled in Row for Quick Gathering

Eureka Mower Co  
 Utica, N.Y.  
 Copyrighted material

Beacon Sencos,

# A Simple, Well-Designed Radio Cabinet

By EDWIN M. LOVE

THAT simplicity of construction can include beauty and durability is proved by the neat appearance and evident strength of this well-designed radio cabinet. Anyone handy with tools can build the cabinet at a very reasonable cost. While the ends and lid are paneled to avoid warping and shrinking, the joints are so easily made that no builder should have difficulty in suiting the methods to his own problem. It is designed to take a standard  $\frac{3}{8}$  by 7 by 26-in. panel. The inside dimensions are 9 by  $10\frac{5}{8}$  by  $26\frac{1}{2}$  in. This gives ample room for a good instrument arrangement without crowding. Pine may be used, but so little material is required that mahogany or other handsomely grained hardwood will increase the cost only slightly.

Build the panel ends first. Use 1-in. stock, cut 19 in. long and sized to  $\frac{3}{4}$  by  $1\frac{1}{2}$  in.; mark the best face and edge to

work from, and cut a groove,  $\frac{3}{8}$  in. wide and deep, in the edge  $\frac{1}{4}$  in. from the face side, to receive the panel. If no grooving tool is at hand, mark side lines and chisel out, making cuts across the grain every  $\frac{1}{4}$  in. before removing the chips. Make the depth accurate, so that the panel edge will brace against the groove bottom, holding the assembly rigid. From the same material, cut two rear stiles, 9 in. long. Make the front stiles in the same manner, using 2 by 2-in. stock sized to  $1\frac{1}{2}$  in.

Reserve a good face for the front of the cabinet. After grooving, cut the rabbet for the panel. Gauge the width and depth to  $\frac{1}{2}$  in., and tack a strip of wood along one line to guide the rabbet plane. If the plane slides outward, reducing the width of the rabbet at the bottom, trim to width with a chisel and use the plane again.

For the four end rails, use stock sized

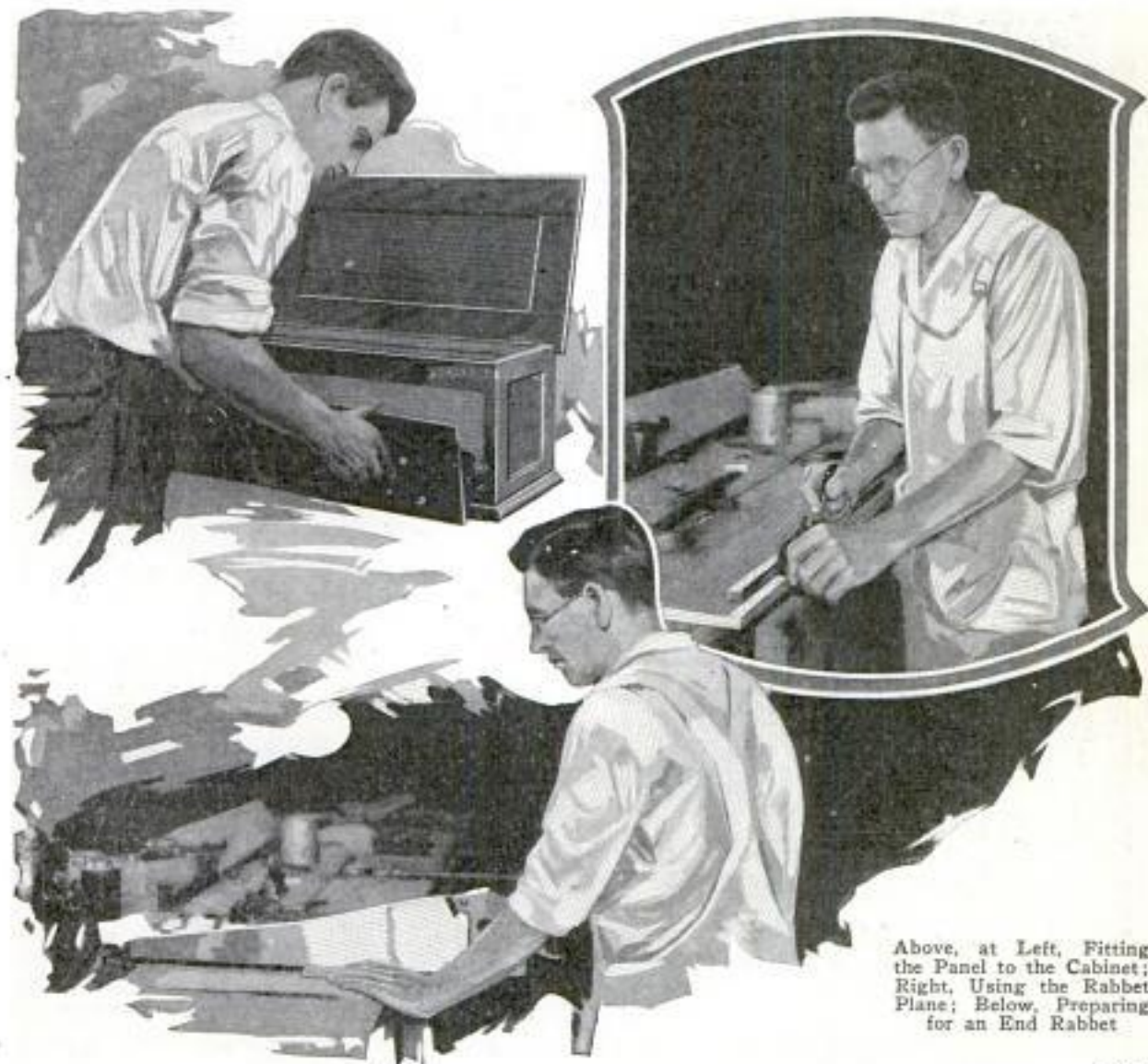

Above, at Left, Fitting the Panel to the Cabinet; Right, Using the Rabbet Plane; Below, Preparing for an End Rabbet

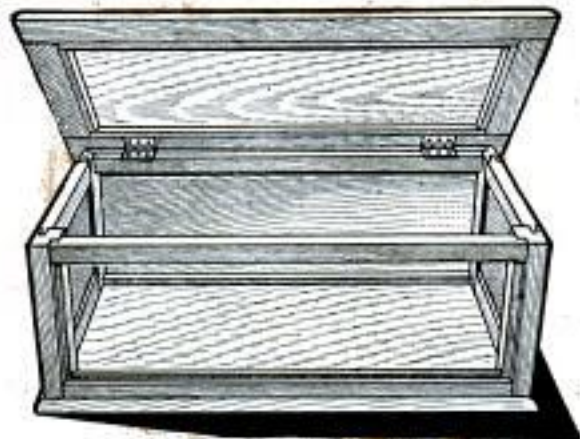
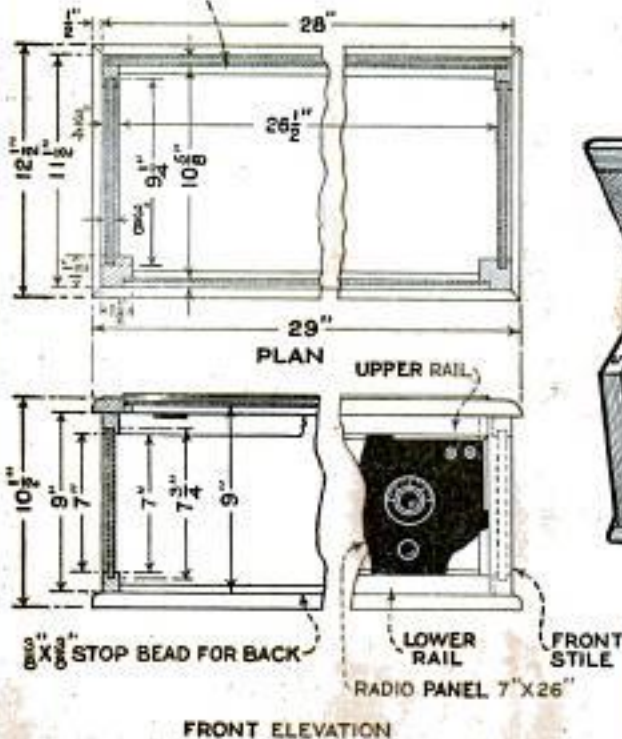
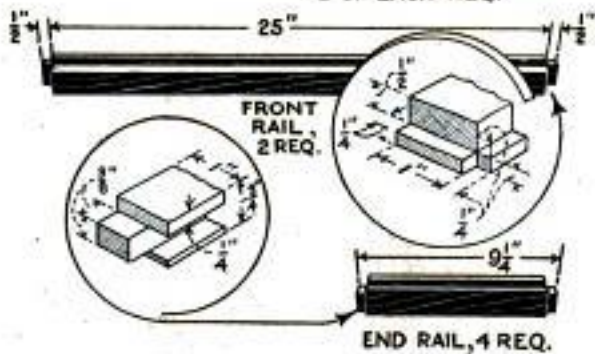
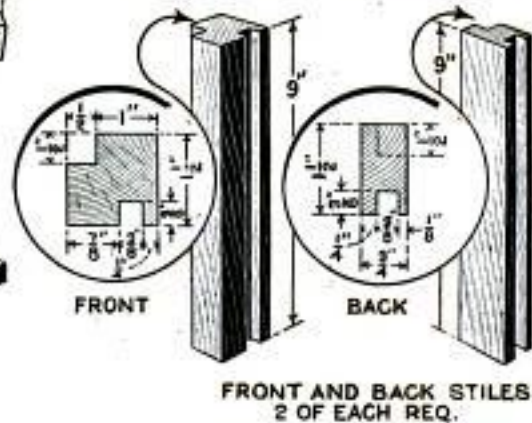
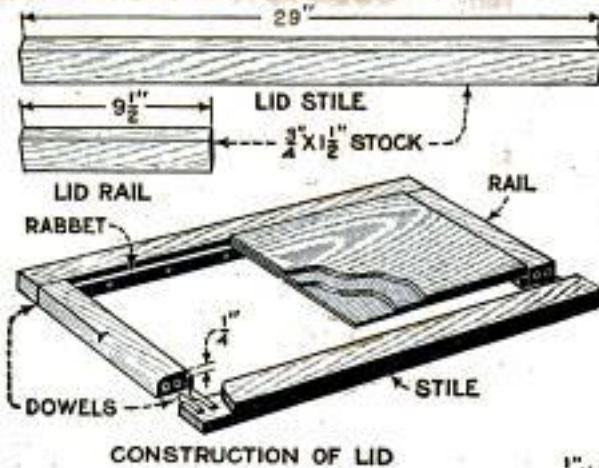

Details of Construction and Dimensions of Parts with Number Required of Each, and View of Assembled Cabinet

to  $\frac{3}{4}$  by 1 in., grooved in the edge  $\frac{1}{4}$  in. from the face. Cut these exactly  $9\frac{1}{4}$  in. long, and gauge the ends as if to continue the grooves across them. Square across both faces,  $\frac{3}{8}$  in. from each end, and with a backsaw rip both cheeks of the tenons, cutting the waste wood and "splitting the line." Lastly cut across the grain. Cut two pieces of  $\frac{3}{8}$ -in. three-ply panel veneer  $7\frac{3}{4}$  by  $9\frac{1}{4}$  in., the outside grain running horizontally. Bevel the edges and assemble with the rails, and front and rear stiles. If the panel or rail tenons are oversize, so that the joints will not close, reduce sufficiently to make the joints tight. Apply glue to the grooves, tenons and veneer edges, assemble, and clamp tightly. With a damp cloth wipe off any surplus glue. Drive  $\frac{3}{4}$ -in. brads from the outside stile faces through the rail tenons and the edges of the veneer, and clamps may be removed immediately. When dry, surface smooth.

The front rails are  $\frac{3}{4}$  by  $1\frac{1}{4}$  in., with a  $\frac{1}{4}$  by  $\frac{3}{4}$ -in. radio panel rabbet instead of the groove. Cut the stock 26 in., and on the back face of each end work a  $\frac{1}{4}$  by  $\frac{1}{2}$ -in. rabbet, leaving a flush tenon,  $\frac{1}{2}$  by  $\frac{1}{2}$  by 1 in., to fit in the front stile rabbets. Rabbet the back edges of the end panels, gluing and nailing to the rabbet, and clamp in the upper and lower front rails. If the joints have been accurately made, this assembly will stand almost square. Test this, and tack a strip diagonally over the top to brace the box.

The bottom is of 1-in. stock,  $12\frac{1}{2}$  in. wide and 29 in. long. If stock sufficiently wide is unobtainable, use a 12-in. board to which a strip has been glued and nailed. Countersink the nails deeply, square up the bottom, and round off the upper edges to a radius of  $\frac{3}{8}$  in. Rightly handled, the bottom is very easily attached to the box. Gauge a line on the underside,  $\frac{7}{8}$  in. from the ends and front, and start six-penny finish nails along these lines about 3 in. apart, the corner nails, which enter the stile ends, just pricking through the upper side. Lay on the box, adjust to equal projection all around, and tap the corner nails lightly to fix the position. Test the projection again, and if correct, drive all the nails home. Screws can be used instead of nails if desired, and in this case holes should be drilled.

The rails and stiles of the lid are  $\frac{3}{4}$  by



Cutting a Rabbet with a Chisel; the Bottom Is Trimmed by Holding the Chisel Flat

$1\frac{1}{2}$  in. The stiles are 29 in. long, the rails  $9\frac{1}{2}$  in. long. Bore two  $\frac{3}{8}$ -in. dowel holes, 1 in. deep, in the face edges of the stile ends, keeping the end holes  $\frac{3}{4}$  in. from the ends, and make mating holes in the rail ends. Assemble the lid by gluing in the dowel pins. Then nail a  $\frac{1}{2}$  by  $\frac{1}{2}$ -in. strip inside the frame,  $\frac{1}{4}$  in. from the top, forming a rabbet. Cut the panel  $3\frac{1}{2}$  by 26 in., beveling the edges slightly, so that when forced into the rabbet, the edges will form tight joints. Glue and nail from the underside. Round off the upper edges of the rails and stiles to a radius of  $\frac{3}{4}$  in., doing the rails first, since split corners on the stiles can be surfaced out when the stiles are rounded.

Nail to the bottom inside the back a  $\frac{3}{8}$  by  $\frac{3}{8}$ -in. strip for backing, and toenail the back to the bottom from behind. Also glue and nail a 1-in. strip of veneer to the inside upper edge of the back, to give hinge space.

Three inches from the ends mortise small brass hinges into the upper edge of the back. With the point of a knife, square across the edge. Use a hinge as a pattern for the length, and gauge the mortise depth equal to the thickness of the closed hinge. Make a number of saw cuts to the depth of the mortise and chisel out the waste wood. Drill holes for the screws to prevent spreading of the veneer

ply, and screw on the hinges. Now lay the lid, upside down, on the bench, and the box, upside down, on top of it. Shift around until an equal margin shows all around, and reaching down through the panel opening, mark the position of the hinges. Lift off the cabinet, cut a piece of cardboard the size of the half-hinge, and trace the holes on it. Using this as a pattern, locate the screw holes in the lid. Drill the holes, and attach the lid. If, when closed, the projection is not even all around, plug the screw holes with hardwood and try again.

Scrape off all the exposed glue and sponge the outside with a damp cloth to raise the grain and small bruises. When dry, sandpaper smooth, finishing with No. 00 grit. When sanding the joints, avoid rubbing across the grain, since the stain will bring out these scratches very strong-

ly. Stain as desired, and if the grain is open as in mahogany, use a paste filler rubbed off across the grain. When the stain is dry, give a coat of shellac, and follow with two or three coats of good varnish, rubbed down between coats with No. 00 steel wool or sandpaper. Rub down the last coat with pumicestone and water, using a felt pad or a roll of cloth, and finishing with rottenstone and water. A simpler, and very satisfactory finish is two coats of shellac, followed by two of wax. The wax tends to go white in the corners, but can easily be removed.

The radio panel can either be screwed into the rabbet or retained by a  $\frac{1}{4}$ -in. quarter-round, mitered around inside the rabbet and tacked with brads. A piece of felt glued to the underside or rubber feet at the four corners, will prevent the cabinet from marring its support.

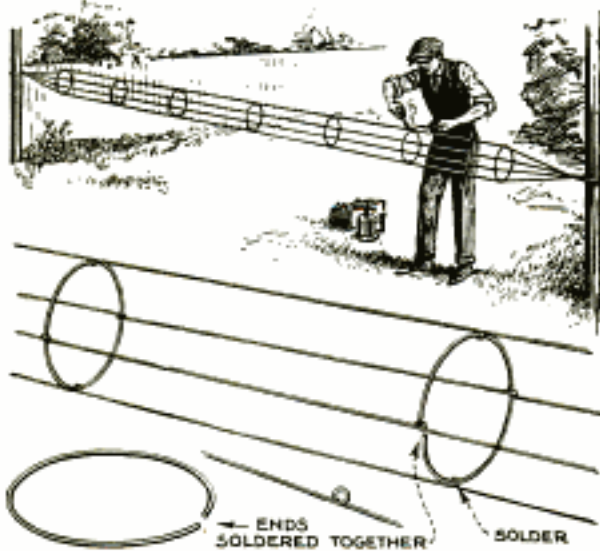

Supporting Antenna Wires between Posts Simplifies Building of Cage Aerial

### Simple Method of Building Large Aerial

A cage antenna is simple to build if the wires are supported above the ground as shown in the illustration. Two posts or trees, sufficiently far apart, serve as supports. Four, six or more strands of No. 18 bare copper wire may be used. Cut the strands of equal length and string them between the supports. Make a loop in each strand with a pair of pliers, at the points where the hoops are to be placed, as shown in the illustration. The hoops are formed of heavier copper wire, No. 8 or 10 being suitable for the purpose, and spaced about 6 ft. apart. Before joining the hoops together, thread them into the loops in the antenna wires, and then sol-

der the ends of the hoops together. Also solder each loop where it passes over the hoop, thus making a good electrical connection. The far ends of the strands are then twisted together and securely soldered, making a compact antenna.

### Logging Plate behind Dial Makes Tuning Easy

A disk of aluminum behind the dial makes a simple logging device. The older members of the family will be especially appreciative of the little device shown in the illustration. A disk of aluminum is cut in the form shown, and given a dull finish with a piece of emery cloth; it is then fastened to the panel by means of a locknut or screws. The disk should be large enough to extend above the dial when it is in position. This gives space



enough upon which the operator can easily pencil in the call letters of the various stations. The dial should be provided with a pointer as shown. It then becomes a matter of simply turning the pointer of the dial to the call letters of the station desired.—L. M. Curtis, Venice, California.

# Simple Alternating-Current Tube Receiver

By F. L. BRITTIN

NO A-battery is required for the receiver to be described in this article as it is operated by 110-volt a.c. house-lighting circuit. It was designed in Popular Mechanics' radio laboratory to satisfy the demand for a simple circuit adapted to the new a.c. tubes, and it has proved to be one of the most interesting sets we have developed. It is easy to tune, simple and inexpensive to build, and has good volume and range. In repeated tests, we have brought in stations within a radius of 1,000 miles with good volume on the horn, under difficult atmospheric conditions. If a B-battery eliminator is used instead of the usual B-battery, it becomes practically a no-battery set, the only one remaining being the small  $4\frac{1}{2}$ -volt C-unit that should last nearly a year without renewal. This puts the radio set in the same category as the reading lamp and the electric iron, in that all that is necessary is to plug into the nearest wall socket. The aerial and ground connections are the same as in any other set. Very little current is consumed in operating the receiver; a small step-down transformer being used to reduce the voltage to from  $3\frac{1}{2}$  to 5 volts, and taps provided for the various voltages. The 4-volt tap is used for this particular set. There are no rheostats to adjust, and having only two tuning controls, the set is easily operated.

Selectivity is due to the low-loss type of tuner unit and the new straight-line-frequency variable condenser used. This condenser gives a wider separation of the stations on the lower end of the dial, and makes tuning much easier in localities where many high-powered low-wavelength stations are on the air at the same time.

The rear-view photo of the completed set will give the reader an idea of the simple construction details. In the layout of the instruments on the front panel

and baseboard, only one a.f. transformer is shown in position; the other is to be mounted at the right, in the position indicated by the dots. The baseboard is

$\frac{1}{2}$  by 9 by 20 in. Mount the instruments on the base-

board first. The sockets are lined up as indicated, the socket

at the right being for the detector tube. It will be noted that the

.00025-mfd. grid condenser is provided with clips for the 2-

meg. gridleak, and that the unit is mounted on the grid post of this socket.

The seven binding posts are placed on a strip of bakelite,  $\frac{3}{16}$  by 1 by 7

in., and the strip is then mounted on two 1-in.

lengths of fiber or brass tubing, by means of long wood screws. The brass bracket supporting the two a.c. terminals on the bakelite strip is  $1\frac{3}{4}$  in. high, and the two binding posts are mounted on a strip of  $\frac{3}{16}$  by  $\frac{3}{4}$  by  $3\frac{1}{2}$ -in. bakelite. The bracket is fastened at the extreme right of the baseboard with a small wood screw.

The front panel is  $\frac{3}{16}$  by 7 by 21 in., the template for this panel is given, and the position of the holes to be drilled indicated. Four bakelite blocks,  $\frac{3}{16}$  by  $\frac{5}{8}$  by  $1\frac{1}{4}$  in., are drilled through the center to take a 6-32 flat-head brass machine screw. These blocks are then grooved at each end, as indicated, to support the a.c. busbar wires. These blocks are shown in position in the wiring diagram, and are to be mounted near the top of the front panel, at the rear. The straight-line-frequency variable condenser is placed at the left, the one-hole mounting making the assembly very easy. The open-circuit jack is mounted at the lower edge of the panel, and the tuner unit at the right. This unit is one of the pickle-bottle type, but any similar low-loss type can be used. The tickler coil is rotated with a dial mounted at the front of the panel. The connections to this coil are given in the wiring diagram. The front panel is fastened to the baseboard by means of two

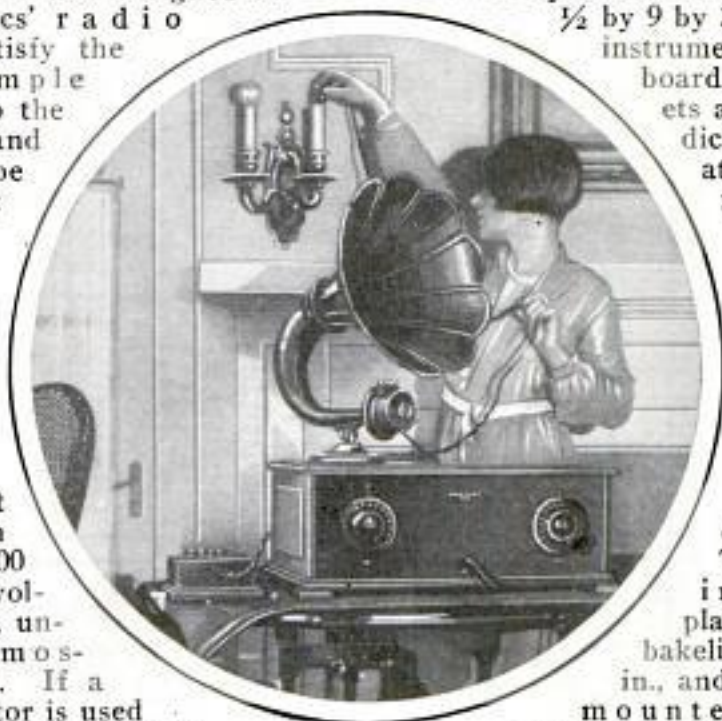

by means of long wood screws. The brass bracket supporting the two a.c. terminals on the bakelite strip is  $1\frac{3}{4}$  in. high, and the two binding posts are mounted on a strip of  $\frac{3}{16}$  by  $\frac{3}{4}$  by  $3\frac{1}{2}$ -in. bakelite. The bracket is fastened at the extreme right of the baseboard with a small wood screw.

The front panel is  $\frac{3}{16}$  by 7 by 21 in., the template for this panel is given, and the position of the holes to be drilled indicated. Four bakelite blocks,  $\frac{3}{16}$  by  $\frac{5}{8}$  by  $1\frac{1}{4}$  in., are drilled through the center to take a 6-32 flat-head brass machine screw. These blocks are then grooved at each end, as indicated, to support the a.c. busbar wires. These blocks are shown in position in the wiring diagram, and are to be mounted near the top of the front panel, at the rear. The straight-line-frequency variable condenser is placed at the left, the one-hole mounting making the assembly very easy. The open-circuit jack is mounted at the lower edge of the panel, and the tuner unit at the right. This unit is one of the pickle-bottle type, but any similar low-loss type can be used. The tickler coil is rotated with a dial mounted at the front of the panel. The connections to this coil are given in the wiring diagram. The front panel is fastened to the baseboard by means of two

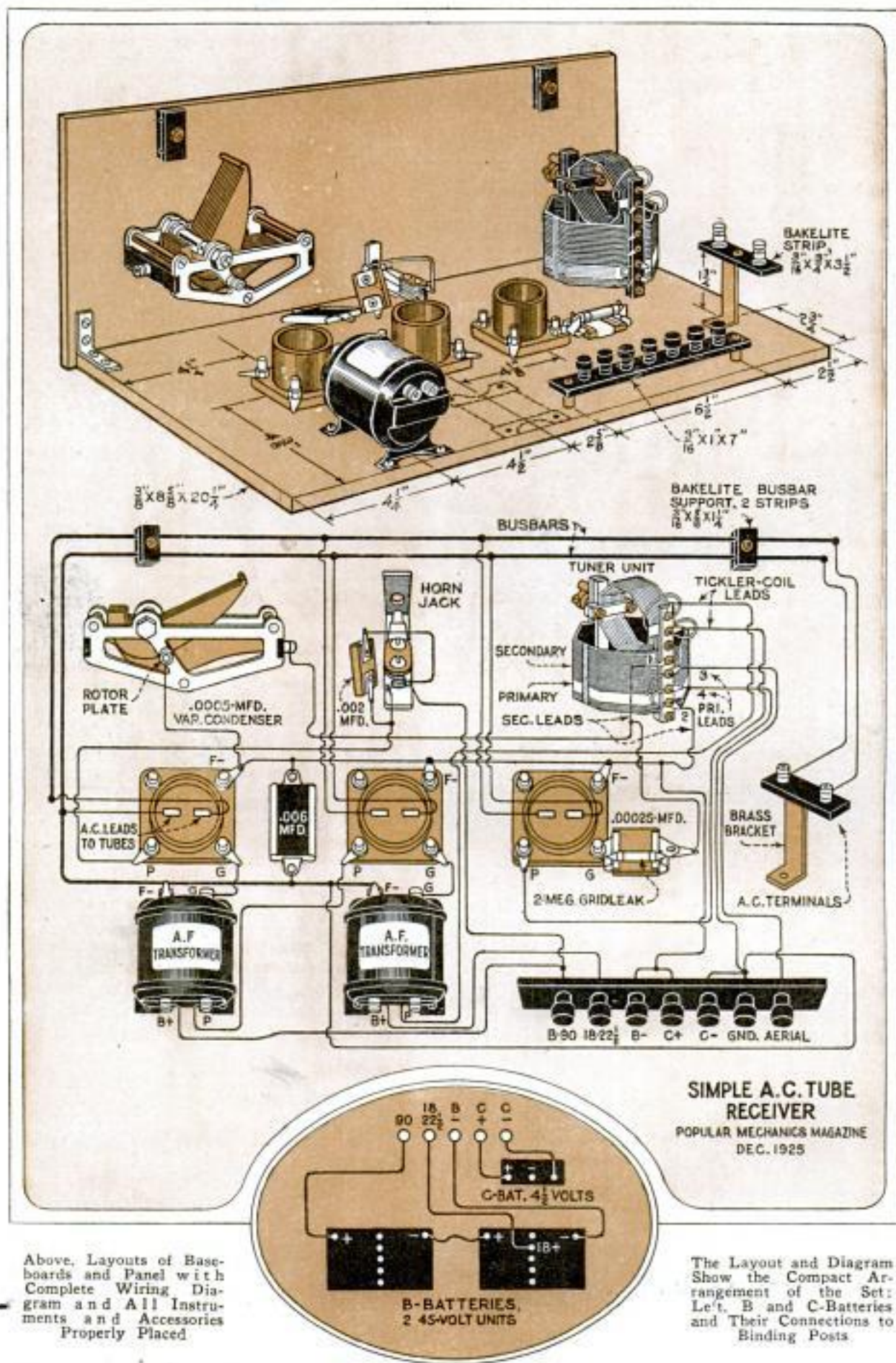

Above, Layouts of Baseboards and Panel with Complete Wiring Diagram and All Instruments and Accessories Properly Placed

The Layout and Diagram Show the Compact Arrangement of the Set: Let B and C-Batteries and Their Connections to Binding Posts



small angle irons. The set is now ready to be wired. The wiring diagram is extremely simple. Use soldering lugs under all terminals, and solder each connection carefully. No. 14 round tinned-copper busbar wire is used for the circuit, and either No. 10 or 12 busbar wire for the a.c.

on the front panel, and should be just long enough to reach the heater terminals on the tops of the tubes; small Fahnestock clips are used to connect the leads to the terminals. The B and C-battery connections are plainly marked in the diagram. Holes are drilled in the rear of the cabinet

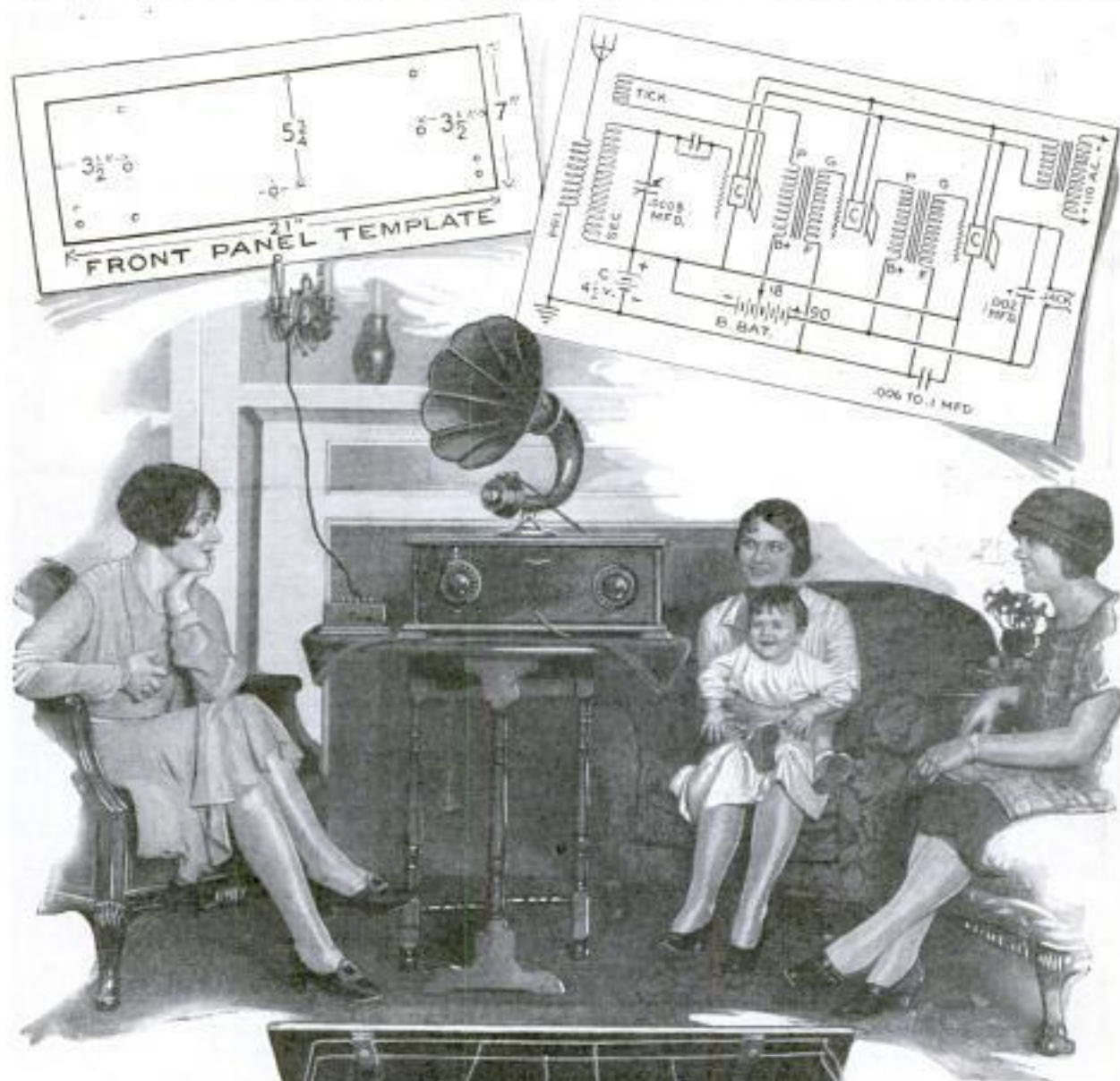

busbars. They may be covered with spaghetti tubing used where necessary to prevent shorts. Only the filament negative terminals on the tube sockets are used, the other filament posts being left blank.

Most of the other connections are standard for this type. Flexible rubber-covered leads are soldered to the a.c. busbars

Front-Panel Template and Schematic Wiring Diagram; Complete Instrument Connected to Lighting Fixture, and Rear View of Set

for the aerial, ground and battery leads, and also two holes for the leads from the step-down transformer; these leads should be long enough to place the transformer 1

ft. from the set, to prevent inductive hum. Now connect the set for operation and place the tubes in the sockets, switch on

the current and plug in the horn. In a few seconds the heater elements in the tubes will begin to glow, and if a drumming noise is heard, reverse the plug in the wall socket and rotate the condenser dial slowly until a station is picked up. The volume can then be adjusted with the tickler dial on the tuner unit. If the signals are not clear, reverse

the connections in the horn plug. The dials can be logged, and a station be picked up again at the same dialing.

We have prepared large blueprints of this circuit for those who wish them; send your request to Popular Mechanics' radio department, inclosing 10 cents to cover cost of mailing, and the blueprint will be forwarded at once.

#### MATERIAL LIST

- |   |   |
|---|---|
| <ul style="list-style-type: none"> <li>1 bakelite panel, 3-16 by 7 by 21 in.</li> <li>4 bakelite blocks, 3-16 by <math>\frac{3}{4}</math> by <math>1\frac{1}{4}</math> in.</li> <li>1 bakelite strip, 3-16 by <math>\frac{3}{4}</math> by <math>3\frac{1}{2}</math> in.</li> <li>1 bakelite strip, 3-16 by 1 by 7 in.</li> <li>1 baseboard, <math>\frac{1}{2}</math> by 9 by 20 in.</li> <li>1 three-circuit tuner unit, for broadcast wave bands, 225 to 550 meters.</li> <li>1 Karas straight-line-frequency condenser, .0005 mfd.</li> <li>1 open-circuit jack.</li> <li>2 small metal angle brackets.</li> <li>1 brass strip, 1-16-in. stock, <math>\frac{1}{2}</math> in. wide and 3 in. long.</li> <li>1 grid condenser, .00025 mfd., with gridleak clips.</li> <li>1 2-meg. gridleak.</li> <li>3 standard sockets.</li> <li>1 Dubilier micadon condenser, .002 mfd.</li> </ul> | <ul style="list-style-type: none"> <li>1 Dubilier micadon condenser, .006 mfd.</li> <li>2 Karas a.f. transformers, or any good make having a ratio not exceeding <math>3\frac{1}{2}</math> to 1.</li> <li>9 binding posts.</li> <li>2 McCullough a.c. amplifying tubes.</li> <li>1 McCullough a.c. detector tube.</li> <li>1 McCullough step-down transformer.</li> <li>1 C-battery, <math>4\frac{1}{2}</math> volts, large type.</li> <li>2 45-volt B-battery units.</li> <li>4 lengths No. 14 tinned-copper busbar wire.</li> <li>3 ft. flexible rubber-covered fixture wire.</li> <li>6 small Fahnestock clips.</li> <li>6 6-32 flat-head brass machine screws, <math>\frac{3}{4}</math> in. long.</li> <li>2 wood screws, <math>1\frac{1}{4}</math> in. long.</li> <li>30 tinned-copper lugs, long, round-hole type.</li> <li>4 ft. No. 10 or 12 copper busbar wire.</li> </ul> |
|---|---|

### Simple Markers Prevent Mixing Radio Wires

To prevent confusion, some method of marking the various leads in a radio set is essential, and, where the usual engraved

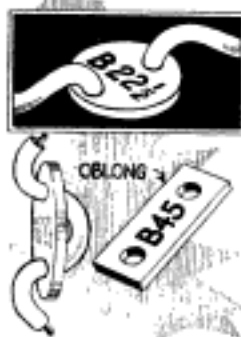

binding posts are not available or cannot be used, small cardboard or fiberboard disks, marked to suit, will be found very useful. Make the disks about the size of a quarter or half dollar. This form of terminal marking is especially necessary in portable sets where space is at a premium, and it becomes necessary to run the wires through partitions, from the batteries to the set. The illustration shows the method of using the disks.

### Improvements in Fixed Condensers

Some fixed condensers do not stay fixed, and capacities not uncommonly differ from those marked on the outside. In spite of warnings, the experimenter will solder wires directly to condensers of this type instead of to lugs fastened to the condensers by means of short brass machine screws. Manufacturers are making

every effort to improve these condensers. One type, for example, is incased in bakelite, which makes it moisture-proof. Older methods of impregnating condensers with paraffin or wax, using paper insulation and simply wrapping tinfoil and paper together, are no longer considered satisfactory for radio work. The condenser of today is clamped in a strong metal frame, the tension of which is fixed in a press while the capacity of the condenser is being formed.

### Rubber Band Makes Good Phone Connector

A rubber band can be used to connect two or more pairs of phones in series when connecting devices for this purpose are not available. The tips of the cords are held tightly together and the rubber band is wrapped around them. Stretch the band so that a tight contact is assured. This makes a better and easier connection than wire. Any number of phones can be connected in this manner, using a rubber band to connect each pair.



The illustration shows the method of connecting the terminals, and the phones should always be in series.

**By-Pass Condenser for Noisy B-Batteries**

A large by-pass condenser across the B-battery assures a uniform flow of current and eliminates the battery noises. There are several fixed condensers on the market for this purpose, the sizes most used being 1/2 or 1 mfd. When B-batteries are new, they are quite uniform, but after they have been in service for some time, the voltage, due to deterioration, becomes more or less unstable and produces noises in the phones or loud speaker that are annoying and make for poor reception.

**Increasing Volume on High Wave Lengths**

Many of the popular hookups lose volume on wave lengths over 450 meters. As there are now many stations using longer waves, it will be found of advantage to use a simple method of sustaining volume without distortion. An extra tube, rheostat and socket will be necessary. Most amateurs have these at hand and can quickly try the experiment. The illustration shows the method of adding the unit to either the dry-cell or standard type of socket. The extra tube is connected in parallel with the last stage of audio, in respect to the grid and plate connections only. The filament must be independently controlled. This makes the extra rheo-

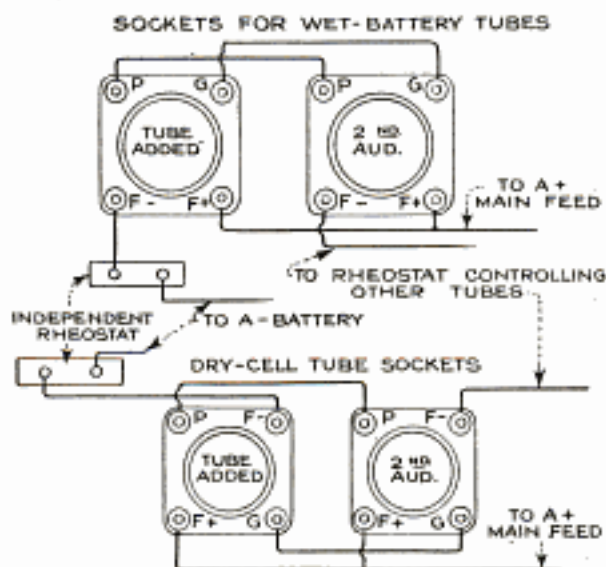

Adding One Tube in Parallel Increases Volume on High Wave Lengths

stat necessary. The experimenter will be agreeably surprised with the results obtained; volume is increased without introducing distortion.—L. H. Georger, Buffalo, N. Y.

*596-02*  
**Handy Radio Engraving Machine**  
Works from Light Socket

*135.00*

A handy engraving machine that operates from any electric-light socket supplying 110 volts either alternating or direct

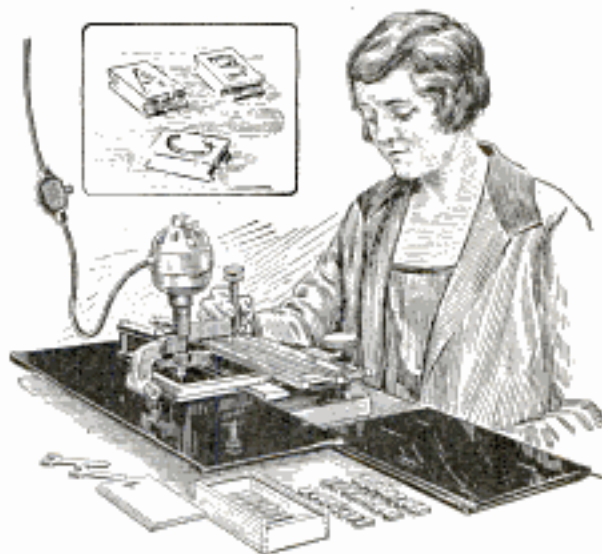

Handy Machine Simplifies Engraving of Radio Panels

current, has lately made its appearance on the market. It will engrave hard rubber, formica, or bakelite radio panels, as well as soft steel, brass or aluminum. The instrument will take panels of any width, and up to 14 inches in height.

The panel to be engraved is placed between the base and the work holder, against an adjustable squaring slide, and securely clamped in place by turning a large knurled screw at the front of the machine. Master letters, deeply cut in brass, are furnished with the machine, and these are arranged either in one, two or three lines on the table to form the word to be engraved on the panel, and clamped between two parallel strips. The letters are then traced with a stylus which is moved by the operator. This causes the cutter under the motor to engrave letters on the panel about one-third the size of the master letters. When the words are engraved the panel is removed and whitening is rubbed into the letters.

**Ammonia Water First-Aid Application for Spilled Battery Acid**

Ammonia water, quickly applied, will prevent damage from acid that may be dropped while taking a hydrometer reading. This is a timely hint for all those who are using wet-type storage batteries. A rubber mat or glass plate under the battery is always advised.

*Branch Tool Co., 508 Southpark Ave., Chicago*

# Radio Batteries, Their Care and Selection

By E. R. HAAN

**P**RACTICALLY every radio set today uses batteries in some form. If best results are to be obtained, the user must know something about them. He should know what kind of batteries to employ with the different types of tubes, and how they should be connected to get the most out of them. The best batteries will quickly lose efficiency if not properly cared for. Although there are several good B-battery eliminators, a substitute for the A-battery may be some time in arriving. Three kinds of batteries are used in radio sets; in practically all of

them two batteries are required, and many use all three. They are known as A, B and C-batteries. Each has its particular use and should be of the correct size and voltage recommended by the designer of the radio receiver.

The A-battery is for the purpose of lighting, or rather heating, the filament of the tube. We are all familiar with the 6-volt storage battery used for automobile lighting and ignition service. This type is used for standard tubes such as the UV-200 and C-300, which require 1 amp. of filament current, and the UV-201A and C-301A tubes requiring only  $\frac{1}{4}$  amp. These are known as 5-volt tubes, and a storage battery is the most economical means of operating them. The battery preferably should be incased in hard rubber, or similar material, but if the battery is built in a wood case, a rubber mat or glass plate should be provided to protect floors and rugs. The A-battery can be recharged at home, if house-lighting current is available.

Select a charger of quiet type and never permit the charge to fall below a specific-gravity reading of 1.200, which indicates that the battery is half discharged, the full-charge reading being 1.275. Keeping the battery fully charged means better reception and longer life for the battery. Provide a tall glass jar with a wide mouth in which to keep the battery tester. To take a



SYRINGE



HYDROMETER

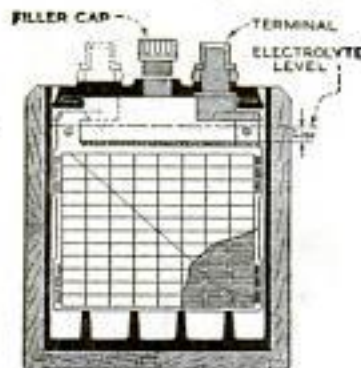

SECTION THROUGH TYPICAL BATTERY

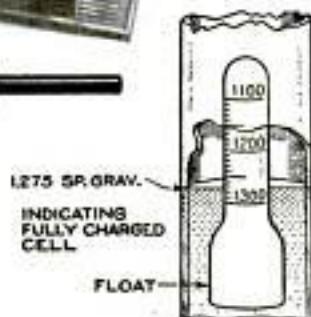

AVERAGE HYDROMETER READING



Hydrometer and How It Is Used to Test the Specific Gravity of a Battery to Ascertain Its Condition: Cross Section of Storage Cell, Showing Proper Electrolyte Level, and, Right, Wiping off Battery after Filling

reading, insert the hydrometer in the solution and draw up a sufficient quantity to raise the float. The reading is taken at the surface line. Carefully put back the solution after testing each cell, and wash off the hydrometer to free the rubber from acid. From time to time inspect the battery, to see that the plates are well covered with the solution. If low, add distilled water with the battery syringe. Never add acid. This is rarely necessary, and if required, it should be done at the service station.

When preparing to recharge the battery, remove the cap from each cell, and never overcharge the battery, as this is likely to buckle the plates and ruin it. When one does not intend to use the battery for a long period, it should be drained, and placed in dry storage at the battery station, or it may be kept full, but then a freshening charge should be given it once a month. Never keep the battery where the temperature is likely to fall below zero. When the battery reaches the full charge, gassing will take place, and the battery top will often be covered with a fine spray of the solution. Remove this with a cloth dampened with ammonia water, wipe dry and replace the caps. Keep a small quantity of vaseline on the battery terminals to prevent corrosion.

Dry cell A-batteries are used for tubes requiring less voltage. The C-12, WD-11 and WD-12 tubes require  $1\frac{1}{2}$  volts for each tube. The standard No. 6 dry cell is used for this purpose, and is connected as shown in

Fig. 1 for one tube. If two tubes are used, two dry cells are connected in parallel as in Fig. 2. The voltage remains the same, but the amperage is increased to take care of the additional tube. For each additional tube, another cell is required and the cells are connected in the same manner. Three dry cells are connected in series as shown in Fig. 3, the

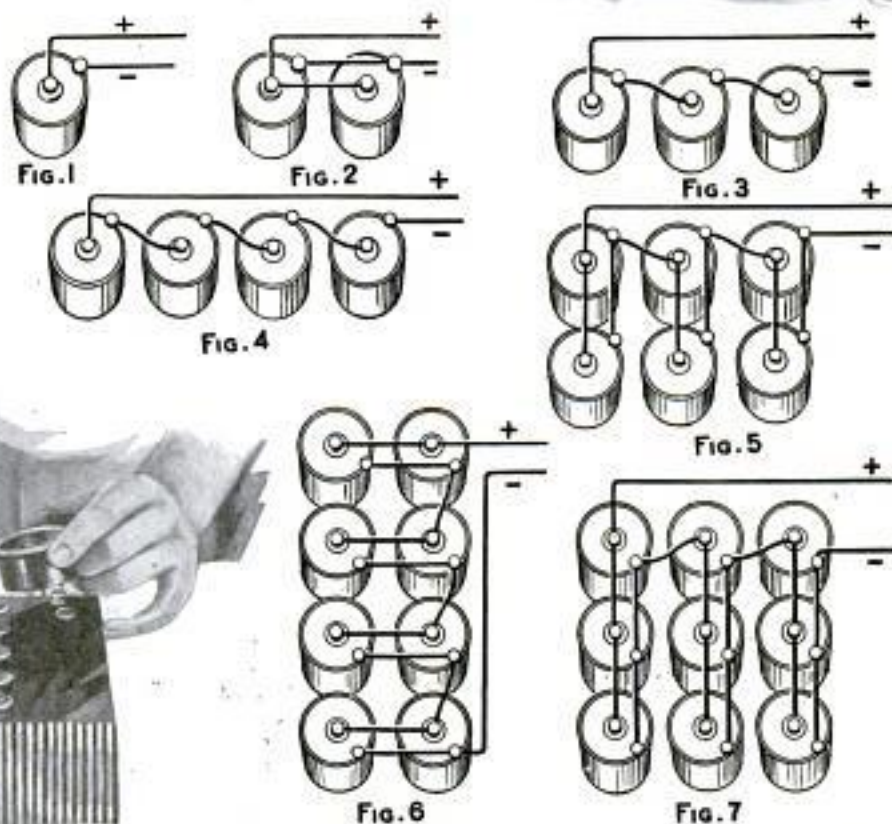

Testing B-Battery with Voltmeter; Diagrams Showing the Various Methods of Combining Dry-Cell Units for Radio Sets Employing One Up to Eight Tubes, and Above, Proper Manner of Making the Connections

positive of one cell being connected to the negative of the next. This raises the voltage to 4.5. This voltage is suitable for the low-current tubes, such as the UV-199 and the C-299, as these tubes draw only .06 amp. but operate on 3 volts. As many as four tubes can be operated on three dry cells connected in this manner. If five or six tubes are

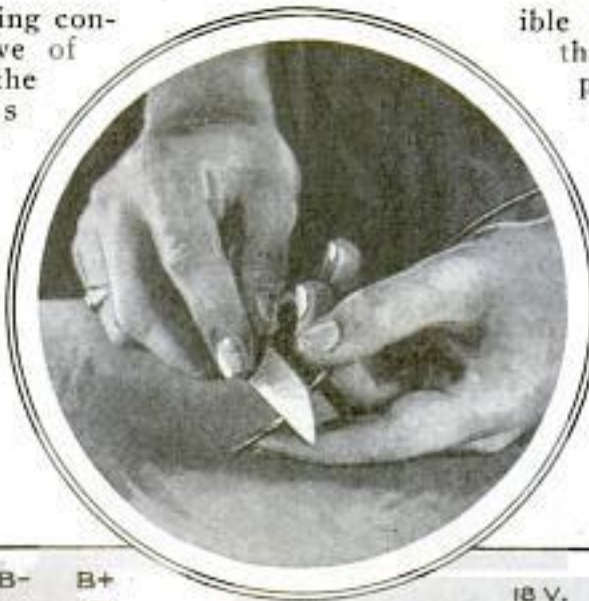

able the voice and music that you hear in the phones or horn, and their purpose must be understood if good results are to be maintained. They are to be had in two standard voltages, 22½ and 45; the sizes vary for different types of sets. Some are of the flat-block shape, and some are vertical and are used where space is limited, as

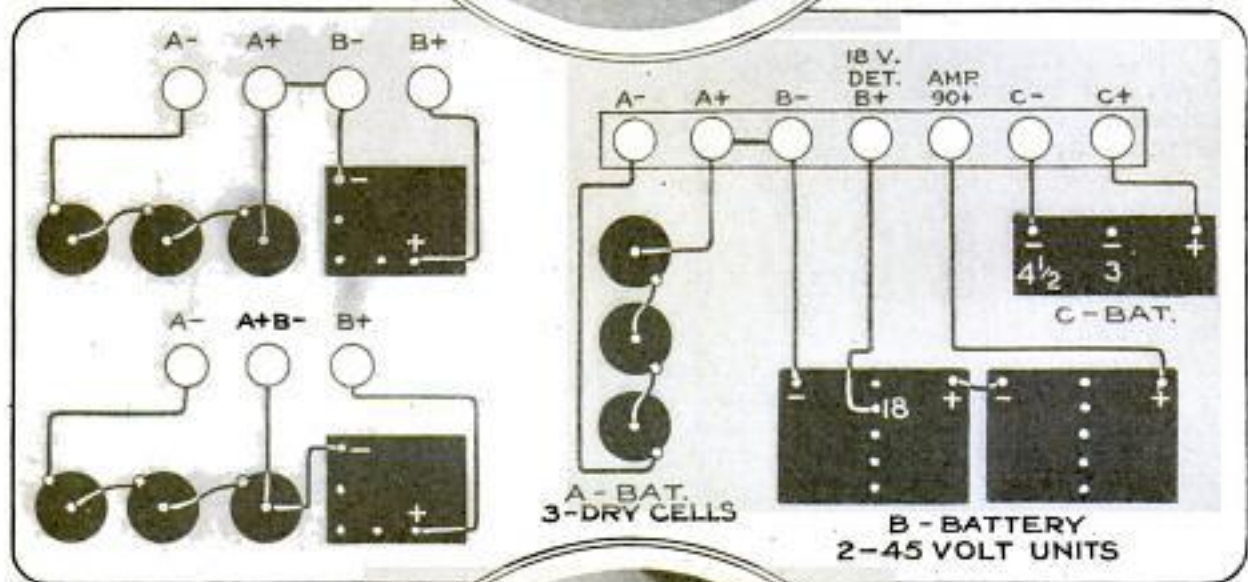

used, six dry cells should be connected in parallel-series, as shown in Fig. 5; this gives both increased voltage and amperage. The UV-201A and C-301A tubes can be operated temporarily with four dry cells connected in series as shown in Fig. 4, producing 6 volts. With two of these tubes, eight cells would be required connected in parallel-series as in Fig. 6, and for three tubes, 12 cells connected as in Fig. 7. This is about the practical limit with dry cells for these types of tubes, and the 6-volt storage battery is to be preferred. B-batteries are the units that really make aud-



Top, Scraping Insulation from Wire; Center, A and B-Battery Connections for One and Multi-Tube Sets, and Below, Seeing That Clamp Is Tight

in portable receivers. These batteries are connected in series to give the required voltage. The B or "plate battery" is called on for very little current, so the unit is made up of a number of small cells connected in series, and put in a box and covered with some insulating compound like sealing wax. One terminal of the B-battery is marked with a plus, or the word positive, and the other is marked with a minus sign or dash, indicating negative. Test the B-battery with a voltmeter having a scale reading up to 50 volts; test one unit at a time, and never subject the voltmeter to higher volt-

ages than it is intended for. One terminal of the voltmeter is marked positive. This is brought in contact with the positive terminal of the battery and the other terminal to the negative post on the battery to obtain the reading. This is an important test, when the receiver has suddenly lost its "pep," which often is caused by low-voltage B-batteries. When the voltage of a  $22\frac{1}{2}$ -volt unit has dropped to 17, it should be discarded for use in the plate circuit of the detector tube, but can still be used in series with other units on the amplifier-tube plates and is serviceable here until its voltage drops to 10. Some old B-batteries, however, cause a noise in the phones or horn, when their voltage becomes low, and should be discarded at once. The largest size B-units should be used whenever possible, as they last longer. They should be kept dry but away from heat. Renew the batteries from time to time, to keep them up to the maximum B-voltage specified for the set to maintain good volume.

Connecting A and B-batteries properly seems to puzzle a great many of our readers. It is really very simple, if the following rules are observed: Never connect the batteries to the set without first removing the tubes; use well-insulated, flexible wire, and keep the leads as short as possible; and scrape the insulation from the wire, being careful not to cut the strands. The exposed ends should be clean and bright. It is a good idea to apply a small amount of flux to these ends and coat them lightly with solder. Use heavy flexible auto-ignition wire for the A-battery leads, if a storage battery is used. If wingnut terminals are not provided on the battery, use heavy clips, and see that they make a good tight contact. The various battery groups, shown in the diagram on page 1012, are for the purpose of demonstration only, and, of course, do not apply in all cases, as in various sets the terminal arrangement differs. The connections at left are for a one-tube set of the UV-199 or the C-299 type; the B-battery is a  $22\frac{1}{2}$ -volt unit. The upper diagram shows the A and B-batteries connected together at the terminal strip, and the diagram below shows the same connection made at the batteries, only one terminal being used in the set.

The diagram at the right shows the same type of set with one or more amplifying tubes added. It will be noted that two 45-volt B-battery units are used, and the detector plate voltage is taken at either 18 or  $22\frac{1}{2}$  volts on the battery that carries the negative-B lead to the set. The other

45-volt unit is connected in series, and the amplifier voltage is taken off from the far end.

The C-battery will decrease the current drain on the amplifier tubes, and will about double the life of the B-battery. The common method of placing the C-battery in the circuit is to connect its negative side to negative F-posts on the a.f. transformers, and the positive side to the negative filament line at a convenient point. C-batteries in general use range from  $1\frac{1}{2}$  to  $4\frac{1}{2}$  volts; when the voltage has fallen to about 1 volt per cell, the unit should be replaced. An exhausted or low-voltage C-battery usually produces distorted signals. The C-battery will outlast a set of B-batteries, and renewal once a year is usually all that is required. Never buy batteries because they are cheap (they may not be cheap in the long run) and always request the dealer to test them for you when you buy them. Batteries often go dead on the dealers' shelves, and a test at the time of purchase protects not only the buyer but the seller as well.

#### Novel Battery Cable Eliminates Binding Posts

A battery cable that eliminates the binding posts in the set is now available. Various-colored, flexible insulated leads are incased in a fabric covering, and the battery ends are labeled for the different voltages. The opposite end of the cable terminates in a hard-rubber or composition block, the ends of the wires protruding just beyond this block. Two holes are provided for mounting the unit on the subpanel in the position shown. The battery leads of the circuit are then soldered to the terminals on the block, doing away with the usual binding posts in the set.

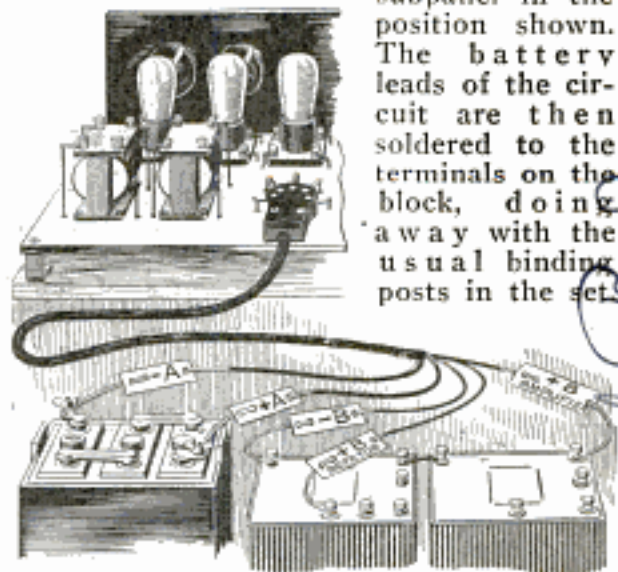

Battery Cable. Showing Labeled Leads to Batteries; Above, Terminal Unit in Position on Subpanel

4 ft. \$1.00  
8 ft. \$1.25

519. A

Howard B. Jones  
618 S. Canal, Chicago

### Clock Turns Receiver On and Off for Regular Broadcasts

A clock can be used for automatically turning the set on and off for receiving

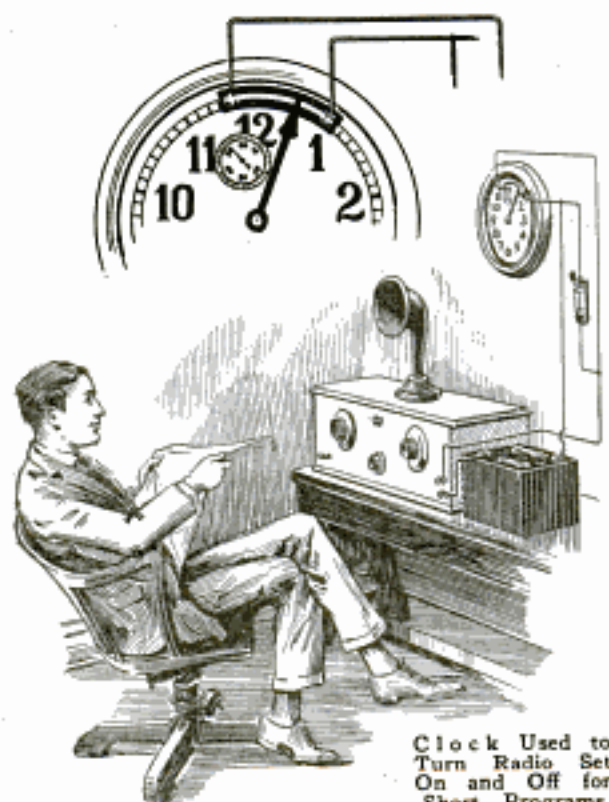

Clock Used to Turn Radio Set On and Off for Short Programs

regularly broadcast news bulletins, such as market and weather reports, or other short programs. This simple device permits the operator to go about other duties between broadcasts, with the assurance that the desired program will not be missed. A strip of insulating material is mounted on the face of the clock and carries a contact strip of thin metal that is held down during the passage of the minute hand. When depressed, the strip touches a suitable contact member also secured to the insulating strip. Wires lead from the contacts to the regular A-battery and to the receiving set itself as shown. A switch is arranged so that these wires may be short-circuited when it is desired to use the set for continuous programs. If the set is tuned in to a particular station and then left with the short-circuiting switch open, the radio clock will automatically turn on the filament at the desired periods as determined by the location and size of the contact strips on the face of the clock.—L. J. Lesh, Miller, Ind.

Keep batteries out of the sunlight, and in a cool spot. Heat shortens the useful life of a battery.

### Good Rheostats Are Necessary for Best Reception

The rheostat is an important piece of radio apparatus. It opposes the flow of electricity to the filaments of the tubes while the set is in operation. Without a rheostat, the filaments would soon be damaged beyond repair, because too much current would pass through and cause the thin thorium coating to disintegrate and flake off. This commonly occurs when rheostats are turned too far, and is the principal reason for tubes going dead.

In opposing the flow of current, the wire becomes warm, even hot if the tubes require considerable current. As the temperature rises, it causes the wire to expand. If the wire becomes hot enough to char the insulation on which it is wound, it becomes loose, adjacent coils touch each other, and the rheostat loses its smooth operation.

See that the wiping arm makes good contact on the resistance at all times. When turned to the extreme left, the wiper arm should leave the wire and come to rest on the insulated strip, breaking the circuit. Always select the proper type of rheostat for the kind of tube used and do not attempt to put too many tubes on one rheostat. When buying a rheostat, select one that is simple and compact. See that the winding is not defective, and that no part is missing. Many of the newer types are of the one-hole mounting variety, requiring only one hole in the panel.

### New Socket Equipped with Ball Grip

570-R for Tube Prongs \$1.25

A ball-grip socket is now available, which makes contact on the sides of the tube prongs without danger of corrosion

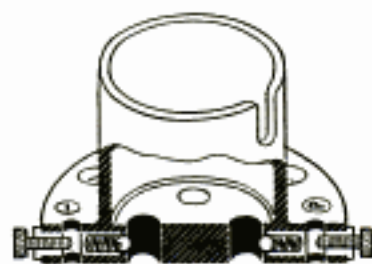

on the soldered tips. The spring construction maintains the thrust of the metal ball against the tube prong. No lugs or soldering is necessary. The wire is inserted in a hole in the bakelite form,

and the terminal screw is tightened. The balls and springs are of silvered phosphor bronze and all contact parts are insulated.

Quality Molded Products Inc. Change Place, Jersey City, N.J.





## A Comfortable Outdoor Sleeping Tent

By JAMES W. PEARL

**O**UTDOOR sleeping throughout the year is one of the best means of promoting health, and the construction of the porch bed shown in the photo has a uni-

versal appeal to all lovers of fresh air. From government surveys in Louisiana during the summer season and in Dakota during the winter, and from years of ex-

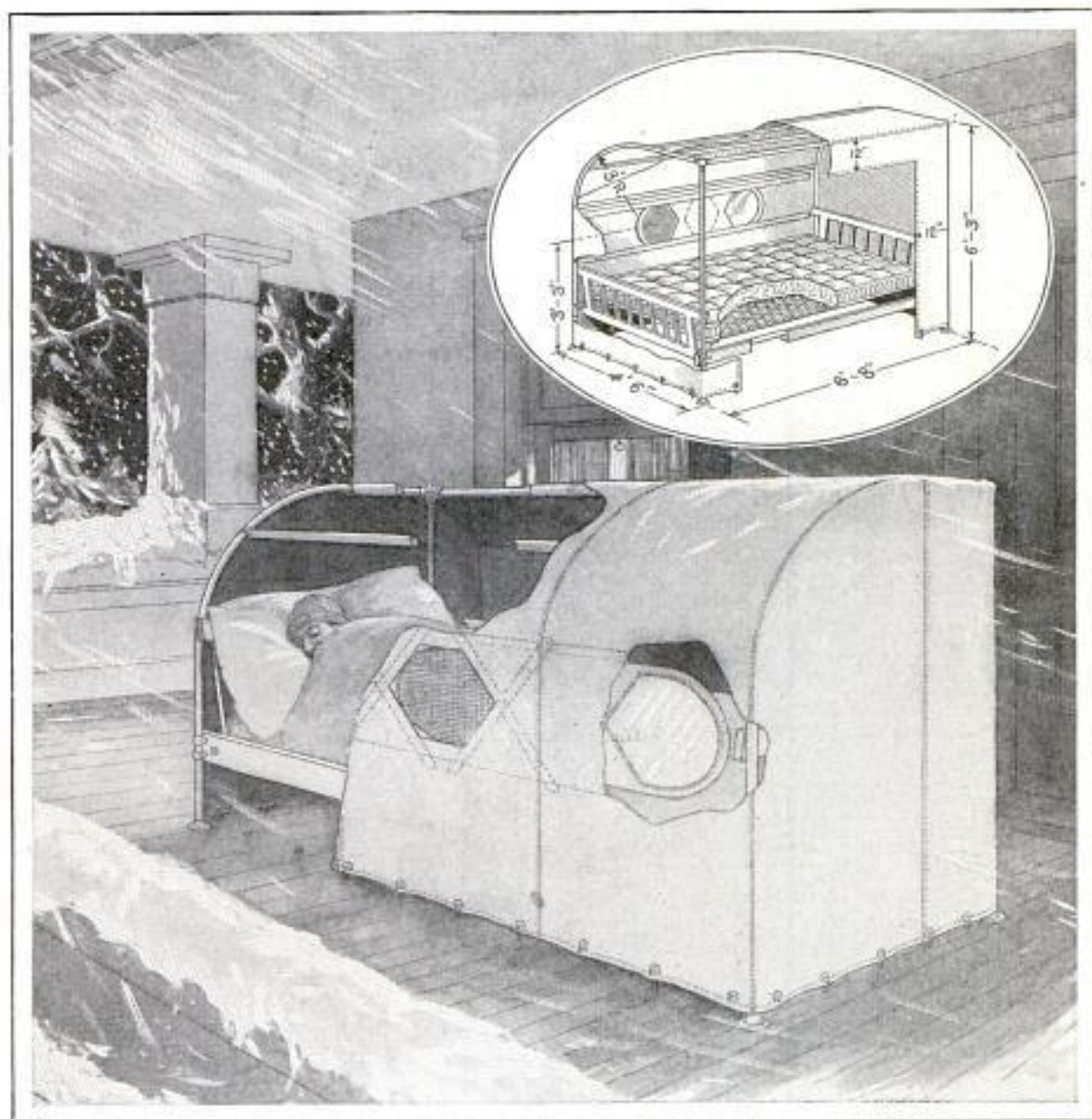

Tent Bed That Admits Plenty of Fresh Air, without Exposure to Drafts, Rain or Snow

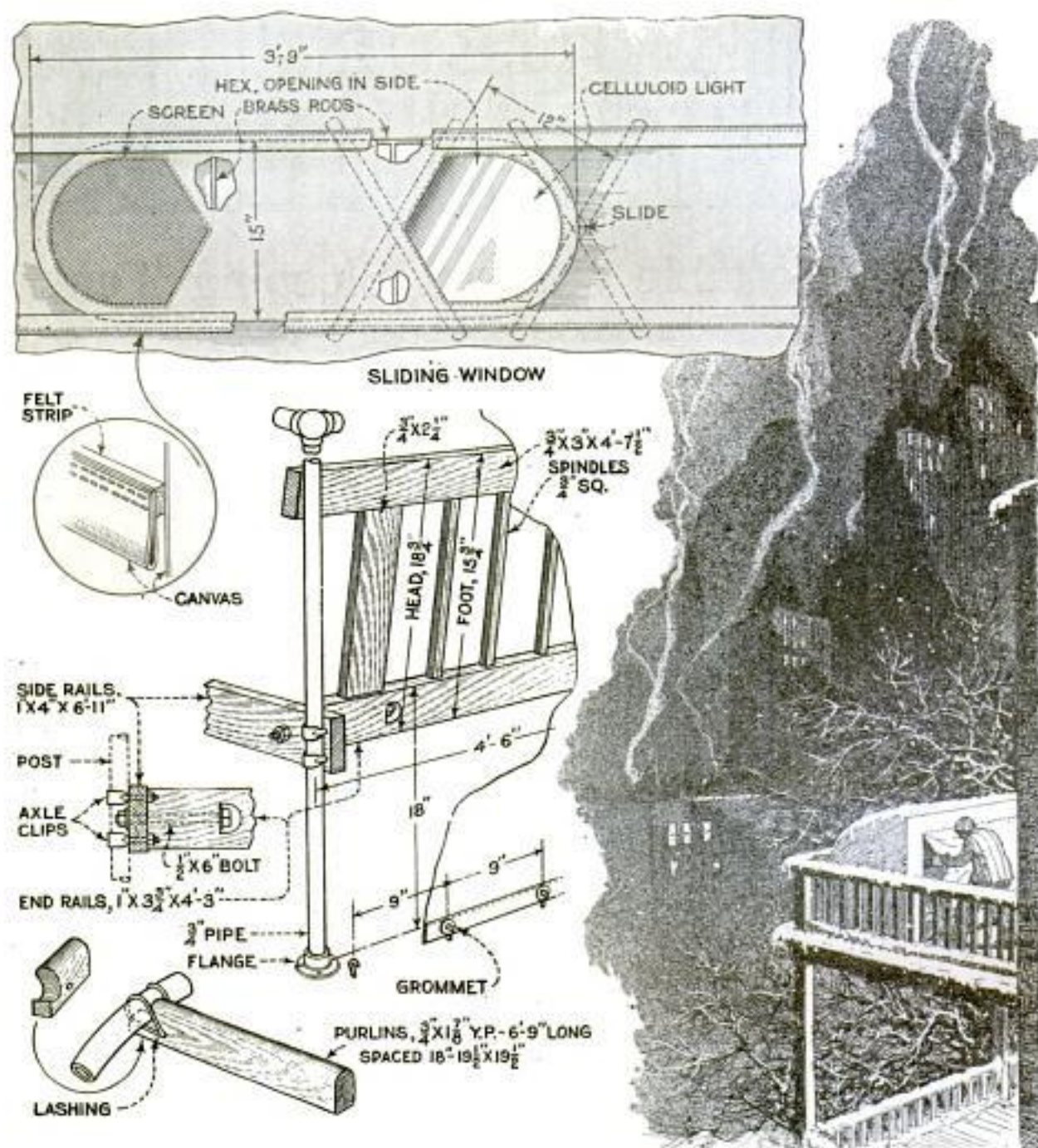

Constructional Details and Dimensions of the Sliding Window; Method of Attaching the Side Rails and Purlins to the Frame, and Use of Grommets to Hold the Canvas Down Tight

perience in tent life, the writer has collected ideas for the improvement of outdoor-sleeping accommodations, which are incorporated in this article. The covering of the tent is canvas and the fresh air will filter through the fabric at all times, while insects, drafts, rain and snow are excluded. The frame is secure in all kinds of weather, except storms of tornado character, so there is no danger of the tent collapsing while the occupant is sleeping.

The drawings show the construction and all the necessary dimensions so that anyone can build the tent and no difficulties will be encountered in assembling it. All

the irregularities on the outside of the pipes in the frame are removed by draw-filing so that chafing of the canvas will be minimized; ball-type pipe fittings are specified for the same reason. A 1-in. board with one edge dressed to a curve of 3-ft. radius, is firmly clamped in a vise to make a form for bending the longer pipes cold. Set one of the end frames up at the desired location of the booth and fasten it to the floor with heavy screws, flanges being provided on the lower ends of the frame as indicated. Hold the other end frame up in its approximate position and insert the top cross pipe into the fittings on both end

frames, which have a right and left thread, respectively, so that turning the cross pipe one way will screw it in. Screw the second end frame down to the floor. Bend the axle clips to fit the pipe, and attach the siderails to the frame at the proper height. Place the purlins, as shown, at intervals of about 18 in. from the top cross pipe and about the same distance from each other. These are lashed in position with strong fishline passed around the pipe and through a hole drilled near the end and bottom of the purlins. The upper edges of the purlins should be rounded so that they will not chafe the canvas. Round the corner holes to facilitate drawing the purlins tight without splitting them. The spindle and endpieces in the head and footrails are tenoned, mortised and glued into the top and bottom members of these rails, which are made to fit at either end of the booth. The head and footrails are attached to the siderails with a single-mortise machine bolt at each end at the bottom, and the extra length at the top rests against the pipe posts.

Three pieces of canvas, 28½ in. wide and 10 ft. 9 in. long, are required for the top and back; these are lapped and made into one piece by two or three lines of stitching through the laps, hemmed on both ends and provided with grommets, spaced about 9 in. apart in the hem along the bottom. Cut and hem the opening for the window with center on center line and about 39 in. above the floor, slotting the hem at the bottom so that it will be inside of the sash for shedding rain. Webbing, located as shown and stitched to the inside, provides guides for the sliding sash and forms a weather-proof contact with the outer canvas. Two and one-half widths of canvas, 6 ft. 9 in. long, are required for each end cover. They are lapped and sewed along the bottom and mitered at the upper front corner in the same way as the center section of the cover, and have tapes attached along the inside for tying to the front posts. All the canvas may now be placed on the frame, stretched tight, fitted and marked for the final seams along the rear posts, curve and top.

The window frame is formed of two brass rods bent to a U-shape, the ends of which are brought together in a ferrule and firmly soldered. Two brass upright rods of the same stock are soldered in place, as shown, to take the tension of the panes of canvas, celluloid and copper screen which are stretched in place and held by canvas or tape binding, securely

stitched. A curtain made of three widths of canvas, hung with hooks made of ⅜-in. soft brass wire at intervals of about 9 in. along the ridge pipe, and taped along the edges for tying to the corner posts, is provided for storm and winter protection. A standard-size spring, mattress, blankets and pillows complete the equipment.

### Cheap Watering Trough

A farmer who did not want to construct an expensive concrete watering trough for his cows used three old wooden tubs



Farmer Uses Three Wooden Tubs as a Watering Trough for His Cattle

connected by zinc channels. The water was supplied from a faucet and filled first one tub and then the second and third, as indicated in the illustration.—Frank Harazim, New York City.

### Hulling Black Walnuts

Allow the walnuts to lie on the ground under the tree until the outside hull is black and crusty. Then gather them up in baskets and run them through a corn sheller. This method will strip the shells from them almost as well as it can be done by hand and is much quicker, easier and cleaner. After being hulled, the walnuts should be kept in a dry place, not too many of them together.

### Re-Covering Auto Floorboards

Some time ago I bought a secondhand car. It had a rubber mat on the floor which was very badly worn, and after re-

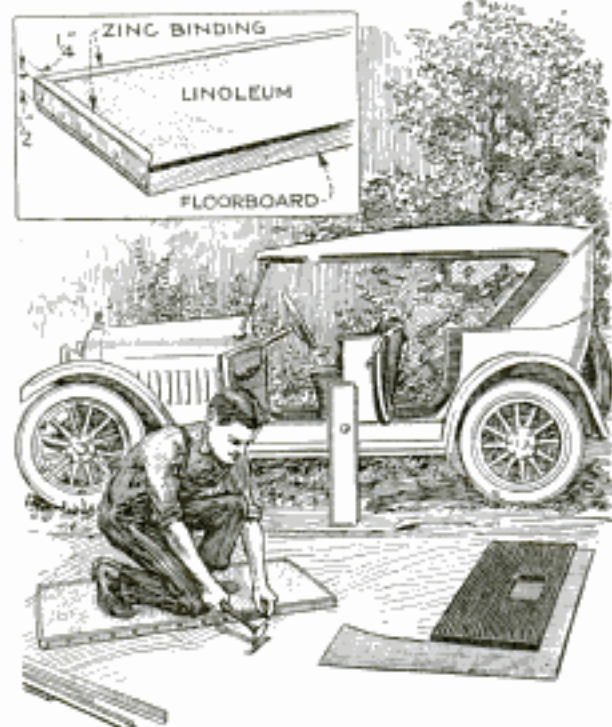

Covering Auto Floorboards and Running Boards with Linoleum Improves Their Appearance

painting the car the mat looked so shabby that I was dissatisfied with it. As I did not care to buy a new one, I decided to cover the boards with linoleum, using zinc strips along the edge to hold it in place. The running boards were also badly worn, so these too were re-covered to match the floor. I bought two thirds of a yard of inlaid linoleum, 6 ft. wide. Linoleum of this kind can also be had in brown, green or gray. I obtained a piece of sheet zinc, 10 in. wide and 30 in. long. Aluminum is a better material for this purpose, but it could not be obtained in sheet form at local hardware stores. The zinc was cut into strips, about  $\frac{3}{4}$  in. wide, and these were bent into the form of an angle by clamping them between two hardwood boards in a vise. One side of the angle was made  $\frac{1}{4}$  in. wide and the other about  $\frac{1}{2}$  in. wide. The floorboards were laid, top side down, on the back of the linoleum and marked with a pencil. All openings for the starter button, pedals and accelerator were also carefully marked. Each piece was cut out and tacked to its respective board with three or four tacks, placing them close to the edge so that the zinc binding would conceal the heads. The binding was applied as shown in the

drawing, the narrow side of the zinc on top and the wide side hanging down along the edge. The binding was tacked in place with small nails.

Applying linoleum to the running boards, these will have to be removed from the car. Do not try to remove the aluminum edging, as you will probably bend it and spoil its appearance. After the running boards are removed, it is easy to pull the old linoleum from under the edging and slip the new in. Trim the linoleum close to the wood and replace the boards. If your floorboards fit snugly, it will be necessary to plane a little off the edge of one of the boards to make room for the added width which is caused by the zinc binding. The square opening in the center of the floor through which the gear-shift and emergency levers project, should also be bound with zinc in the same manner as the edges of the boards.—Harold Jackson, Kankakee, Ill.

### Replacing Rope on Flagpole

When the rope on a flagpole or aerial mast breaks there is usually only one thing to do, namely, take the pole down and put on a new rope. In many cases this work can be avoided by fitting the head of the mast in the manner shown in the drawing. Then, if the rope breaks, it will usually be a comparatively easy matter to attach another by throwing the weighted end over the pulley. The two arms can easily be made from lengths of flat iron and should be spread about  $45^\circ$  apart. The spaces between the sheave and the sides of the slot into which it fits should be narrow, so that the rope will not get caught in it.

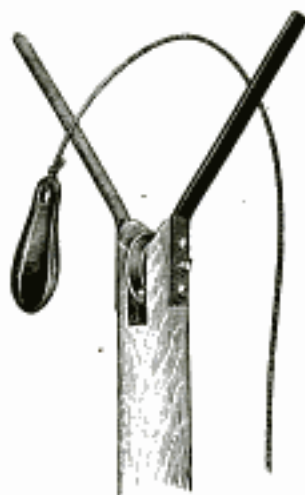

### Repairing Galoshes

Rubber galoshes wear out rapidly at the heels and are then usually discarded. It is, however, an easy matter to repair them. Cut two pieces of thin leather, place them over the hole, on both inside and outside, and nail them together securely. Galoshes repaired in this way have lasted several seasons.—Jane Vandervort, Tampa, Fla.

### Sawing Trees Single-Handed

By making a discarded inner tube do the work of his fellow sawyer, a timber feller in one of the largest logging camps in Oregon has boosted his monthly pay checks far above the average. One end of the tube is tied to



Use of an Old Inner Tube Eliminates One Man on a Two-Man Crosscut Saw in Felling Trees in Oregon Logging Camp, Boosting the Ingenious Inventor's Pay Check

a metal stake driven firmly into the ground on one side of the tree, while the other is looped over a hook substituted for one handle of a two-man crosscut saw, as shown in the photo. Then the sawman starts his work, the tube stretching on one stroke and pulling the saw back to its original position on the next.—Harold B. Say, Portland, Oreg.

### Sealing Wax from Dry Cells Used to Repair Doll

Sealing wax of worn-out dry cells can be easily removed and melted for future use. Before it becomes hard, form it into handy sticks. My little girl kept pushing the eyes out of her sleeping doll until I could not repair it again so that it would sleep. Therefore I put the eyes in position so that they were open and poured the head full of melted sealing wax obtained in this manner. When nearly hard, I added a little more and rounded it for the

top of the head so that the wig would glue on better. If the wax is put in too hot, the paint on the outside of the face may melt off. To prevent this, the face should be submerged in cold water while the hot

wax is poured in.—Mrs. Minnie Tarr Miller, Wells, Nev.

### Homemade Wire Brush Cleans Stovepipes

Cleaning stovepipes is an easy matter if the simple homemade device shown in the illustration is used. Cut two circular wooden blocks of  $\frac{3}{8}$ -in. material, about  $\frac{1}{2}$  in. less in diameter than the stovepipe. It is preferable that these blocks be round, but six-sided ones can be used. Cut three or more layers of screen wire into

disks about  $\frac{1}{4}$  in. larger than the pipe diameter and nail the screen between the blocks, which are then screwed together. Fasten the blocks to an old broom handle, and the cleaner is ready for use.—F. St. Boufanger, Alexandria, Louisiana.

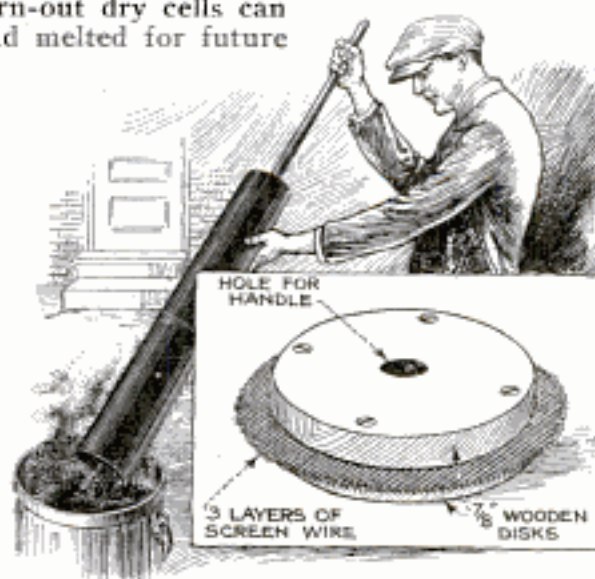

Cleaning Stovepipes Made Easy by Homemade Device

Ⓐ mixture that is too lean for starting the auto in winter can be used well in summer. Learn to adjust the carburetor to the season.

### Bending Pipe with Fire

A gas company has been using a novel method for bending gas mains to fit the grades in a hilly section. The length of pipe to be bent was first screwed up tight and a small pit dug under the pipe where the bend was to be made. A fire was then started in the excavation, and when the pipe was sufficiently heated, the weight of a man standing on the end of the pipe caused it to settle until it conformed to the grade of the trench.—Samuel E. Schofield, Indianapolis, Ind.



Novel Method of Bending Gas Mains in Trenches to Conform to Grades

kitchen wall and is as deep as the basement. The roof extends above the ground just enough to permit one to put the ice in or take it out, a small door being provided for this purpose. The bottom of the ice pit is covered with a layer of gravel, and a drain is provided to carry off the water, a screen being fitted over the drain to prevent any gravel from getting in. A floor is built on the same level as the kitchen floor, and if desired a small door may be provided

in the wall to permit entrance from the kitchen. A trapdoor is, of course, provided in the floor and is kept closed to keep the warm air from getting into the pit. A layer of heavy tar paper over this floor covers all the cracks and furnishes additional insulation. The refrigerator is simply an ordinary dumb-waiter which can be lowered into the ice pit. This opens into the kitchen and the lift is raised by means of a crank or counterweight. The usual dumb-waiter construction is used. This method provides a

### A Farm Ice House That Saves Ice and Work

In the ordinary farm ice house, the ice must be covered with straw or sawdust to insulate it against heat. However, this protective covering must be molested every day or two during summer when ice is taken out, to say nothing of the work of carrying the ice to the kitchen and the usual ice-box troubles. These objections are overcome by providing a combination ice house and refrigerator, as shown in the illustrations. The ice house, in this case, is built right against the outside

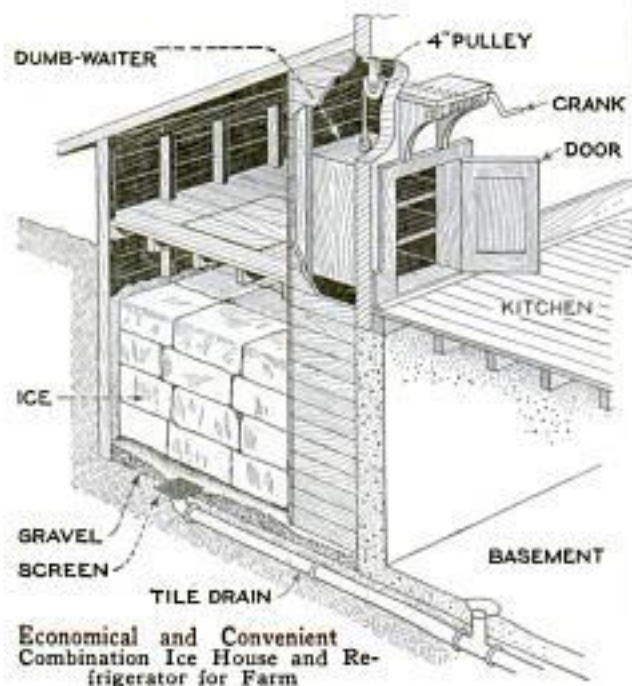

Economical and Convenient Combination Ice House and Refrigerator for Farm



lower temperature for the food than can be obtained in any refrigerator, and, besides, it is very saving of the ice. It has been found that a saving of approximately one-third of the ice is made.

☛ Newly mixed paint should never be used until it has been allowed to stand for 24 to 36 hours. Then it is strained through a screen a little finer than ordinary fly screen. It will be found that, by this means, the working qualities of any paint will be improved considerably.



## Snapshot Statuettes for Christmas Gifts

By Herbert C. McKay

THE field of arts and crafts offers a wide range of practical uses for the photograph. Little novelties may easily be made that have the sentimental value which always accompanies the photograph, and the obvious fact that they are handmade gives them an added value in the eyes of the recipient. The basis of all of these novelties is the photo statuette. These, in themselves, form very pleasing gifts and are quite in vogue.

The first step is to select a favorite photograph or to make one for this special purpose. In making the photograph, no attention need be given the background or any portion of the picture, aside from the figure itself and the immediate foreground near the subject's feet. The lighting should, of course, be the best possible so that the features will be reproduced distinctly.

The second thing is to be sure that the film will be suitable for enlarging. If a focusing camera is used, it should be very carefully focused and a stop not larger than f-8 employed. A full exposure should be given to insure good flesh values. A box camera may be used if the subject is placed in the full light of the sky on a bright day, but not in direct sunlight. When the film is developed, make or have made a direct print. This will show you if the pose is what you wanted, and it will also tell you whether the picture is good enough to make a satisfactory enlargement or not.

Now make an enlargement. The enlargement will usually be not less than 8 by 10 in. in size, although attractive little statuettes may be made in smaller sizes if desired. If you do not do your photographic work, explain to your finisher that the figure is all that you desire. This will enable him to disregard the background

and make a larger figure upon a given size of paper than he could otherwise do. If you have a definite size in view, give him this information and he can supply a figure of the height specified. This enlargement should be made upon paper which has a rough surface, such as is used in larger portrait work. It should also be cream, buff or India-tinted, and toned sepia. The reason for these points is that the figure will usually be colored and the cream and sepia tones in combination with the colors make a softer and more attractive effect.

When the enlargement is received, it is mounted upon wood as shown in Fig. 4. Three-ply paneling is the best material, but when it is not available, any thin wood of fairly close grain will serve very well. The best adhesive is glue. Paste and dry-mounting tissue do not serve as well when wood is used as a base. Fig. 4 shows the picture being glued to the board. The best results are assured by thinning glue with water and giving the wood a sizing coat, which is allowed to dry before the photograph with its coat of unthinned glue is applied. This operation may be done while the sizing coat is almost dry, but not quite, thus making it possible to remove roughness if the sizing coat was not properly applied.

When mounted, the whole thing must be subjected to pressure for some time, as glue sets slowly. This is done in a press such as that shown in Fig. 2. If this is not at hand, a pile of books, or even a few bricks piled upon a heavy board, will supply the necessary pressure. Two or three sheets of blotting paper should be laid over the photograph and under the board to insure uniform pressure. When the photograph is firmly set on the board and the glue is dry, it is ready for the saw.

The first step is to determine what portion of the figure is to be cut out and what part of the foreground will be allowed to remain to form the base. This will depend upon the subject. When this has been determined, the line to be followed should be faintly outlined in pencil. Then it is ready for the actual sawing. For this purpose a foot-power saw is preferable, but if this is not available a hand scroll-saw may be purchased for a dollar or so, and can be used quite successfully.

The figure is cut from the surrounding wood, carefully following all outlines or the pencil lines. In this operation, the table of the saw is tilted in order to bevel the edge of the figure (Fig. 3). By doing this, the edges will be inconspicuous and give the finished figure a more lifelike ef-

fect. When the figure is completely sawed out, the base is cut square. For this operation the saw table is set horizontally in order that the figure may stand upright when mounted upon its support.

When this is done, it will be seen that the edges of the paper have been raised a trifle. To leave the statuette this way would not only make the figure appear unfinished, but it would tend to make the gelatin strip from the paper support. Therefore, the edges should be smoothed, as in Fig. 1, with the finest sandpaper that can be obtained.

The next step is to drill the necessary holes in the figure. This is done from the face of the statuette, as this method will give less burring. The reverse would tear the paper base of the photograph instead

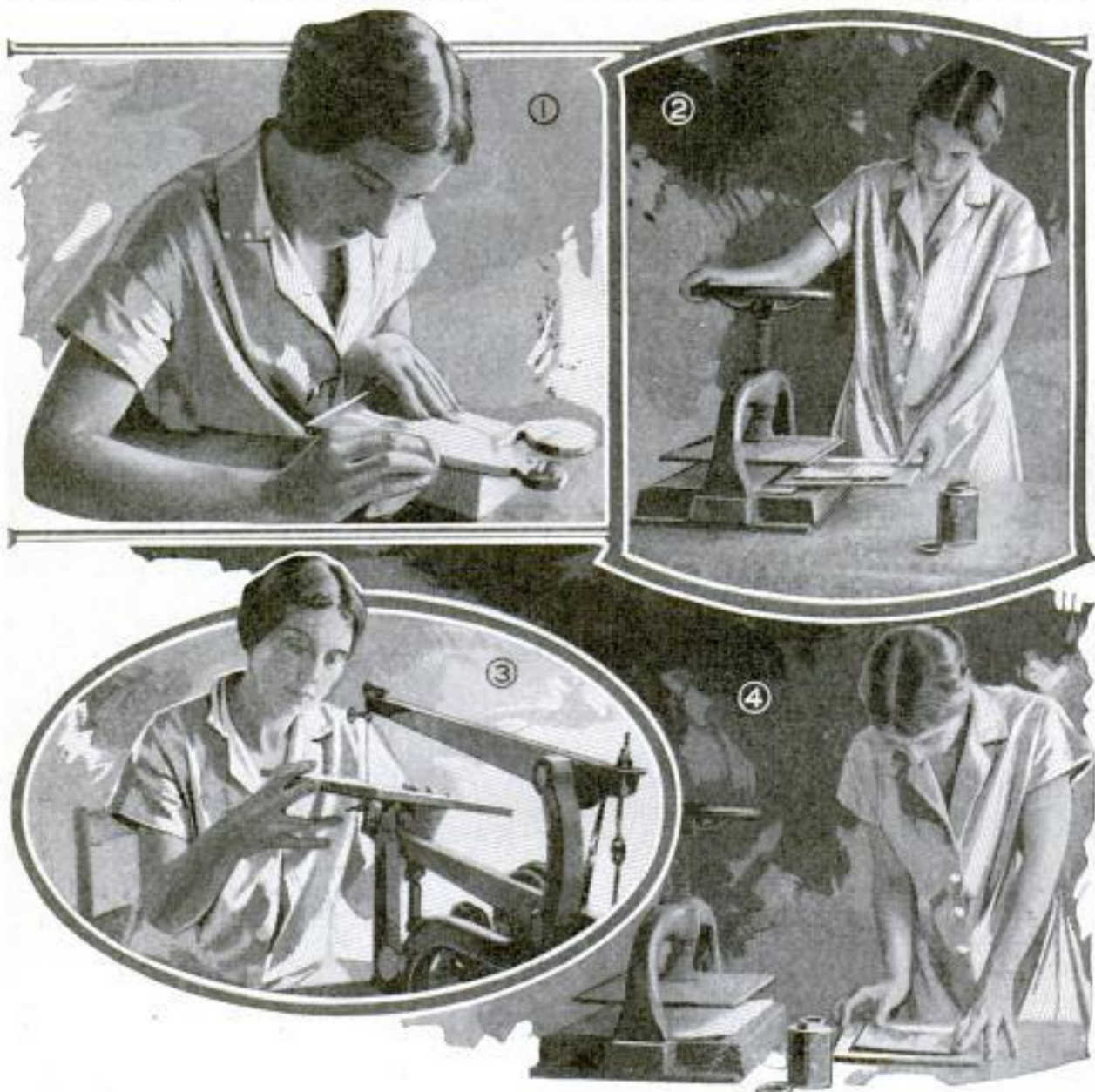

Upper Left, Sanding the Edges of the Figure; Upper Right, Pressing the Photo; Lower Left, Sawing Out; Lower Right, Gluing the Photo to the Wood



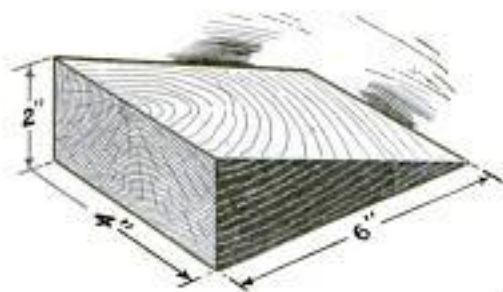

Fig. 5



BASE OF STATUETTE  
Fig. 6



Fig 7

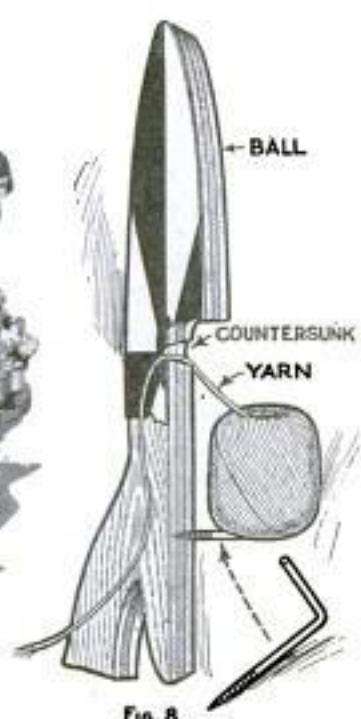

Fig. 8



CORK  
Fig. 9

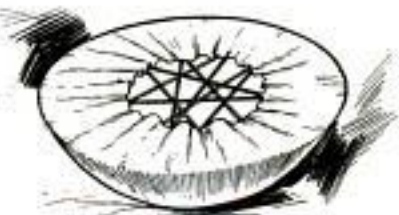

Fig. 10



Fig. 11 DRAW STRINGS

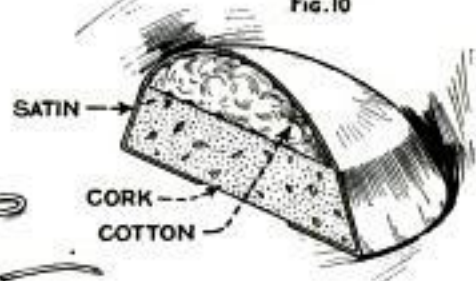

Fig. 12

Fig. 7. Staining the Edges of the Figure; Figs. 5 and 6 Show Different Bases; Fig. 8, Method of Mounting Tatting Yarn, and Figs. 9 to 12, the Making of a Cushion for the Sewing Companion



Various Statuettes and the Snapshots from Which They Were Made; Fig. 13, Tatting Stand; Fig. 14, Ash Tray; Fig. 15, Sewing Companion, and Fig. 16, a Trump Indicator

of cutting it smoothly. A board is placed beneath the figure to protect the worktable. This operation is shown in Fig. 20. The edges must then be colored. This may be done with thin stain or sepia drawing ink. A thin medium is desired in order that the tint may be carried to the very edge of the paper itself without any absorption stains showing upon the surface of the figure. Browns will harmonize with the colors of the photograph. This operation is best performed by using a small brush and by working from the back of the figure, Fig. 7. When this is done, the back of the figure is painted dark brown or black. This completes the



Above, Painting Design on Base; Right, Coloring Small Areas with the Aid of a Cotton-Covered Toothpick

figure, ready for the support, unless you desire to color it first. When the statuette is colored at this stage, it requires careful handling at later stages, to prevent soiling, but the operation is less difficult at this time.

As this work deals almost exclusively with human subjects, and as soft well-blended colors are desirable, the use of oil colors is recommended. The figure is laid upon the table and a few drops of the special medium supplied with photo oil colors are well rubbed into the surface of the paper. The necessary colors are squeezed out upon a small opal-glass plate and a small wad of absorbent cotton is rolled into shape. The color for one of the larger areas is determined and the cotton is lightly dipped into this color. It is then applied to the photograph, rubbing it all over the area and taking care

to stay within this area. This will give a rough, spotted coloring. Now, with a clean tuft of cotton, smooth this color out and carry it to the edge of the area. This is a simple operation which is easily mastered. It is shown in Fig. 19. Do not try to use brushes, as the effect will not be satisfactory; nor try to make heavy, intense colors. Tints look best upon photographs. Vivid colors are rare in nature. The details and small spots are colored by using a toothpick about which a small tuft of cotton has been closely wrapped. Take a bit of cotton between the thumb and index finger of the left hand. Grasp the toothpick between the thumb and index finger of the right hand. Place the point of the toothpick between the thumb and finger of the left hand; then thrust it into the cotton. Now twist the toothpick while squeezing the cotton, and you will have a small applicator with a firm cotton head. This is used to tint small portions of the figure. The eyes, jewelry, and so forth, are colored with a tiny brush and the color blended immediately afterward with a tuft of clean cotton. The



toothpick brush is shown in Fig. 18. After coloring, the statuettes must be allowed to dry for two or three days, as oil colors dry very slowly. Then the supports may be applied. For some figures, such as that shown in Fig. 13, a desk base is used. This is a wedge-shaped piece cut from 2 by 4-in. or other suitable timber. The construction is shown in Fig. 5. The figure for this base must be left long at the bottom, for it is not mounted upon the base, but screwed to the rear face of it.

The more usual base is shown in Fig. 6. This is a semicircular piece cut from thin wood. It is beveled as shown, in order to give a more finished appearance than a square edge. The statuette is either mounted upon this base, flush with the

rear edge, or it is set back of the base and screwed to the rear edge, depending upon the amount of foot room at the bottom of the figure. When the base is applied, it should be enameled. The color of the enamel used will depend upon the subject of the statuette, but in case of doubt, black will always be found attractive. It may be plain or relieved by an edging of contrasting color. The enamel is applied with a small brush, and the work must be carefully done. It may be desired to include some design. In that case, use a simple conventionalized design, since the vivid color of enamel does not lend itself particularly well to more elaborate designing.

When the base is dry the statuette is complete. If several figures are made at one time, the work will be simplified. Fig. 21 shows a group of figures that were made simultaneously, the whole being finished in but a trifle more time than would have been required for the production of any one.

While there are unlimited uses for this novelty, I will only take time to describe some typical examples, which will give you some idea as to the possible variety. You will then be able to originate your own ideas.

The first application of the idea is in making plain statuettes. These are novel, but have not the permanent attraction of the more utilitarian objects which are made upon the same basic idea. The illustrations do not do justice to real figures. This

their rich but subdued and soft coloring.

As I have stated, the size of the original photograph is of no consequence; neither is the pictorial quality. Fig. 13 shows a snapshot which is everything that a picture should not be, but is just as valuable for our purpose as if it were perfect. It will be noticed that two black spots indicate a torn emulsion due to careless laboratory work. This too is negligible. The same illustration shows a statuette made from this snapshot. The ball has been drilled, and the rear of the figure has a hook which supports a ball of tating thread. This arrangement is shown in Fig. 8. The base of the statuette is provided with a hook to hold the tating shuttle. The hole through the ball is countersunk to allow free passage for the thread. Whenever grandmother wants to tat, her shuttle is ready and when it is emptied, she may draw thread from the ball to refill it.

For special work, the figure may be posed, disregarding the background as usual. Fig. 16 shows us such a pose in the original. The pose is meaningless in this illustration, but reference to the picture immediately below at once makes the purpose clear. When this enlargement was cut out, a signpost with a cir-



Left, Coloring Large Areas of the Photo; Right, Drilling the Hole for the Yarn in the Tating Stand

is due to the fact that these figures were tinted, just as described herein, while for perfect reproduction by the press, any photographic subject should be in black and white and upon glossy paper. The originals, therefore, are very attractive in

cular head was left. This was painted white with show-card color, the bottom being left ragged to indicate the grass covering the base of the post. Pips from playing cards were cut out and glued to this post in four of five positions, the fifth

position was allotted to the "NT" monogram, indicating no trumps. The hand was drilled and an arrow cut from thin black celluloid was attached so that it would turn freely but stay in any position. This gives us a novel trump indicator which any bridge hostess would welcome as an addition to her tables. Ash trays are always in demand. They have replaced socks and handkerchiefs as gifts for men. For this reason, novelties are difficult to secure. To make an ash tray, pose the subject with the side to the camera. A ball, tray or other object is held in the hands to give the proper pose to the arms (Fig. 14). The doll is then cut out as

described. The object held in the hands is cut level to form a support. The base is made like the others, but full round instead of half round and beveled in the opposite direction. In this case, the black enamel was relieved by a red edging.

A sewing companion will be a pleasant surprise for the seamstress of the family. A favorite child is posed among flowers, as shown in Fig. 15. The doll is cut out as usual and the flowers gaily colored. The base is of the semicircular type. About its circumference are set posts for spools. These are made of nails, cut to proper length and with the points rounded. The base is completed by a pincushion. A thin, wide cork of the general shape shown in Fig. 9 is obtained. A satin cover is cut and a strong thread run about its circumference as shown. A tuft of cotton is placed over the top of the cork, the cover laid upon it and pulled around beneath the cork, and the drawing string pulled; this draws the cover tightly over the cork and cotton. The cover is then secured by cross sewing the edges

of the cover as shown in Fig. 10. The cross section of the completed cushion as shown in Fig. 12, and the details in Figs. 10 and 11 make the construction plain. As the cover is puckered beneath the bottom, the base should be somewhat

hollowed to allow the cushion to rest firmly. It is glued in place and the base is completed. In this case, the base was enameled green, the spikes green with red heads, and the cushion was covered with crimson satin. These colors were used to carry out the garden idea. One of the illustrations in the head of this article shows a desk companion. The base is of the design used in the tatting-thread holder,

and a memo pad is secured to the sloping surface. The hands of the figure are drilled so that when the pencil cord is threaded through them, it appears as if the figure were pulling upon this cord.

The lower illustration in Fig. 21 is an incense burner. The tray is a flat seashell, drilled and secured to the hand by means of a screw. The base has two oblique holes for the insertion of stick incense. In this case, the figure was specially posed for the work.

Similar ideas without number will occur to you. This will enable you to make novel gifts and, if you are so inclined, you should be able to make quite a bit of money by preparing these figures for neighbors and friends. For a 10-in. sewing companion the writer has received seven dollars and a half.

Cracks in plaster walls and ceilings can readily be repaired before paint or paper is applied by filling them with a stiff paste consisting of plaster of paris and whiting mixed with water.



Above, Various Poses of Same Child for Statuettes; Below, a Novel and Attractive Incense Holder, Posed by Subject in Costume

### Inner Tube Runs Toy Engine

Using air pressure instead of steam in a toy engine will run it at a far greater speed than is possible with steam. The



Old Inner Tube Used as an Air-Pressure Tank for Running Miniature Steam Engine

air-pressure tank is a piece of old inner tubing, about 14 in. long, with the ends tied with cord or cemented together, although a vulcanizing job is preferable. An air valve is provided, the core being removed so that the air can escape freely into a rubber tube connected to the steam engine. It would be better to have two valves, one with a core, which is used when the tube is pumped up, and the other without a core. It is also advisable to provide a pinchcock for the tube leading to the engine, so that the air can be shut off when desired. The rubber tank is pumped to about twice its normal size and will then run the engine for several minutes at considerable speed.

### Gasket for Old-Type Muffler Head

The exhaust pipe on the older model Fords slips into the front end of the muffler. Much smoking usually occurs at this point, and unless a good floor mat is in place, the fumes get into the car. This trouble can be prevented by using copper-asbestos ring gaskets, which are forced into the muffler head ahead of the ex-

haust-pipe end. The ring gaskets for the manifolds on the cylinder block are the right size to slip neatly into the muffler-head opening, but are rather thin and narrow for best results; several of them have to be used to be effective. A carburetor-flange gasket, if trimmed down and forced into the muffler head by the exhaust pipe, is better.—E. T. Gunderson, Humboldt, Iowa.

### Moving an Auto on Ice

An automobile, which was stalled on a stretch of icy road, because only one wheel had traction and the other spun freely due to the differential action, was moved by simply loosening the brake rod to the wheel on solid ground. By setting the brake on the other wheel to hold it tight, it was forced to slide on the ice while the wheel which was free furnished the driving power. If it is difficult to get at the brake rod, the wheel on the ice can be tied to the frame with a rope or skid chain, with the same result.—Harold E. Benson, Boulder, Colo.

### Necktie Rack Easily Made

In the design and construction of the necktie rack shown in the illustration an effort was made to produce an article of

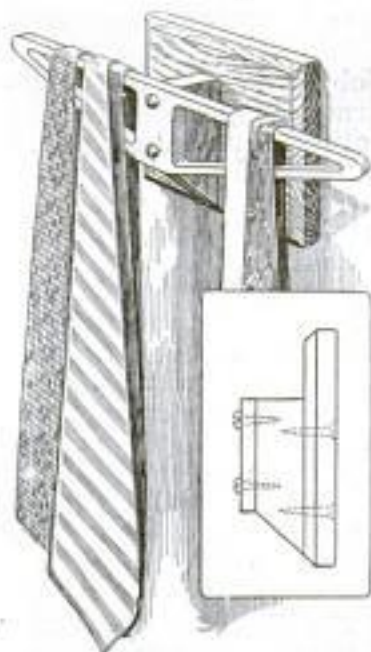

good appearance combined with simplicity and utility. The base is made from a piece of cypress,  $\frac{3}{4}$  by 5 by 8 in. in size, carefully squared and beveled. The post is a piece of 1-in. material, 4 in. long and 1 in. wide, tapered, commencing  $1\frac{1}{2}$  in. from the bottom, and fastened to the base with two No. 6,  $1\frac{1}{2}$ -in.

flat-head screws. The toe is placed with the end at the edge of the bevel on the base. The bar is  $\frac{1}{2}$  by  $2\frac{1}{2}$  by 16 in. in dimensions and made of cypress or white pine. It is not necessary to cut the open-

ings in it, but this is easily done with a coping saw and adds greatly to the appearance of the rack. The bar is fastened to the post with two No. 6 1-in. round-head screws, and care should be taken that it is kept parallel to the top of the base. When carefully sanded, stained and waxed or varnished, the rack will not disfigure the bedroom.

### First Aid to Frozen Plants

In spite of all precautions plants sometimes freeze accidentally. The following first-aid tip has saved several. Sprinkle the plant liberally with cold water. Then, after half an hour, let warm air enter the room gradually, but under no conditions should the plant be brought into a heated room. The whole process of revival should be spread over a period of one to two hours.—Stanley H. Phillips, Drummondville, Can.

### Making Old Pump Sanitary

In smaller towns and on farms there are scores of wells and pumps provided with drinking cups for general use. This is a real menace to the health of the community. A better method is shown in the drawing. Any pump can be converted into a sanitary drinking fountain by simply drilling a  $\frac{5}{16}$  or  $\frac{3}{8}$ -in. hole in the top of the spout. When drinking, pump slowly to avoid splashing, hold one hand under



Converting the Ordinary Pump into a Sanitary Drinking Fountain

the end of the spout as indicated and the water will bubble up out of the hole.—Leslie G. Roller, Cedar Rapids, Iowa.

### Removing Icicles from Flat Roofs

Icicles hanging from flat-roofed buildings are dangerous in windy or thawing weather. One of them, dropping several stories may mean death to someone below. With this dan-



Simple Device Is Pushed along a Flat Roof to Remove Icicles

ger in mind, a house owner made the scraper shown in the accompanying drawing. It is made of 1 by 3-in. lumber and is pushed along the roof as indicated so that the part extending underneath the eave will knock off the icicles.—L. B. Robbins, Harwich, Mass.

### Correcting Typed Papers

One of the greatest timesavers in my work as law stenographer is the following little trick for making corrections on legal papers that have already been stapled and provided with a manuscript back. Insert a sheet of paper in the typewriter in the ordinary manner. Then insert the bottom of the sheet on which you wish to make the correction between the sheet of paper already in the machine and the platen—that is, back of the paper in the machine—and roll the platen backward. This throws out the blank sheet of paper, and it is a matter of a moment to adjust the typed sheet so as to make the necessary correction. This saves the annoyance of taking the stapled sheets apart, as well as the chance of ruining the cover in doing so.—Rose R. Gilman, Boise, Idaho.

☞ When a three-cell flashlight battery becomes too weak to use, remove the lamp and substitute a two-cell lamp of the same shape and size. The cells can then be used and the lamp will give good light.

# Winter Car Ailments

A Little Time Spent in Preparing  
Save Much Trouble

By PAUL R.

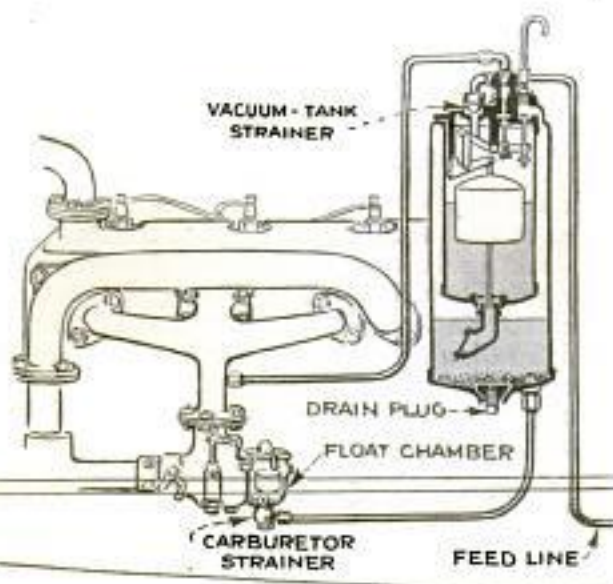

Above, Left, Kinks in the Gas Piping Should Be Fixed; Right, Various Points in the Fuel Lines Where Sediment May Collect; Below, Removing Generator-Brush Cover, and at Left, Removing the Strainer from the Carburetor

**A**UTOMOBILES are usually driven rather hard during the touring season, and many of the little jobs that the owner knows should be done to the car are put off until a "rainy day"—which often never comes. Before the cold weather sets in, however, these things should be attended to, unless the owner wants to have some trouble during the very worst time of the year for trouble hunting and fixing.

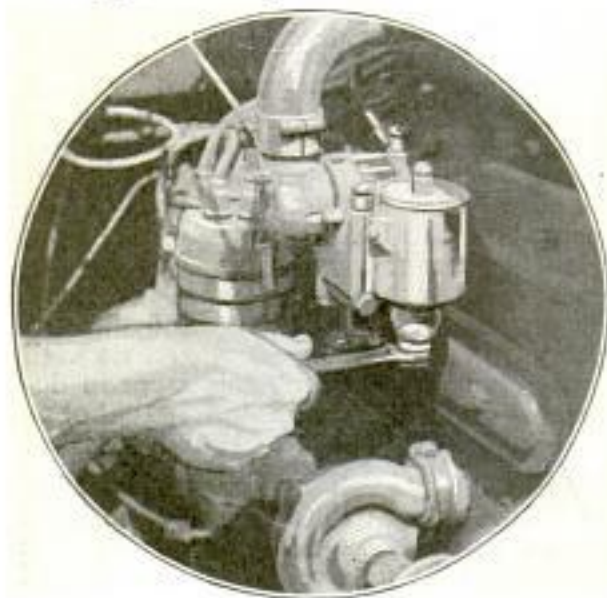

While there is no one part of the power plant that requires to be kept in good condition more than another, one part of the engine that usually is more neglected than another is the fuel-supply system. Many cars are driven thousands of miles, indeed, often for the entire life of the car, without the fuel system being cleaned once. No matter how careful the gasoline station is in the handling and distribution of the fuel, a certain amount of



# Are Easily Avoided the Car before Cold Weather Will Later in the Season

MALLONE

sediment is always present in the gasoline line, and if this reaches the carburetor, trouble almost certainly will result. The first thing to do, therefore, is to clean out the various strainers and traps with which the system is provided. In gravity-feed systems, such as is used on the Ford, there is a sediment trap under the tank, with a cock at the bottom. When the gas tank is nearly empty, this cock should

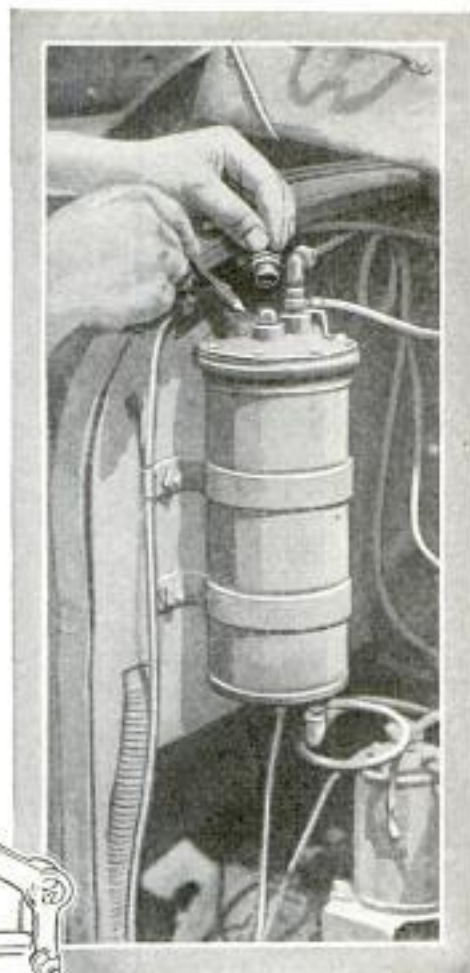
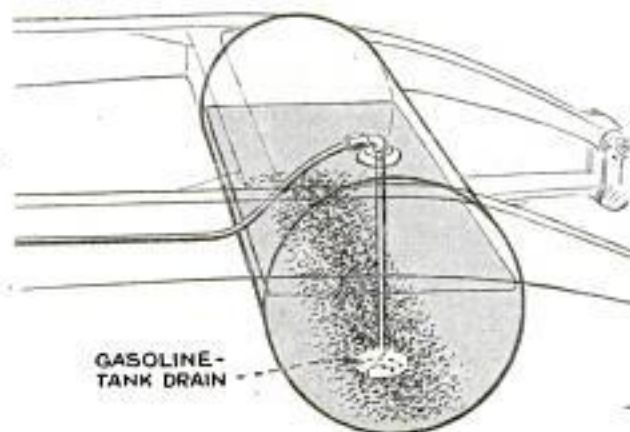

Above, Location of Gasoline-Tank Drain, and at Right, Position of Strainer on Inlet of Vacuum Tank; Left, See That All Gasoline Connections Are Tight; Below, Fill the Crankcase with the Proper Oil

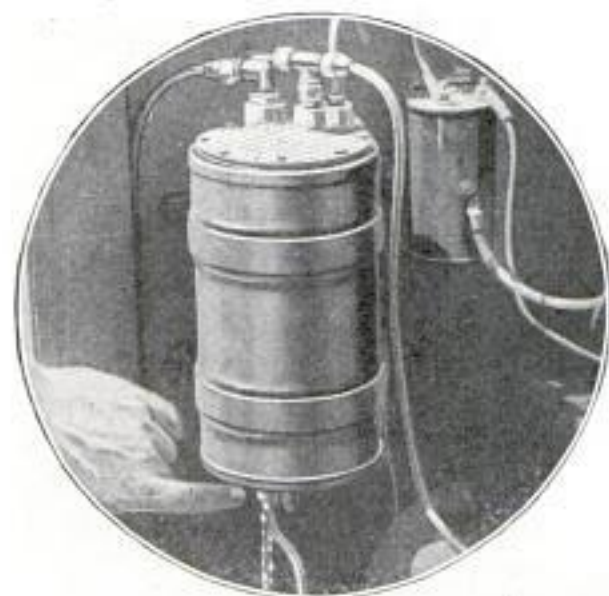

drawn from the tank by means of a vacuum tank, mounted on the front of the dash or on the engine. There is a strainer in the gasoline inlet of the vacuum tank also, which is reached by loosening the nut into which the gasoline-inlet elbow is screwed. This, too, must be removed and thoroughly cleaned. Nor should the plug at the

be opened, and the remainder of the gasoline in the tank drained out so as to flush out the trap. This should always be done at regular intervals, in any case, since if the trap fills up, the excess sediment will be carried over to the carburetor. Then every carburetor is supplied with a strainer in the gasoline inlet, and this also should be removed and thoroughly cleaned. In cars where the gasoline tank is located at the rear, the fuel is usually

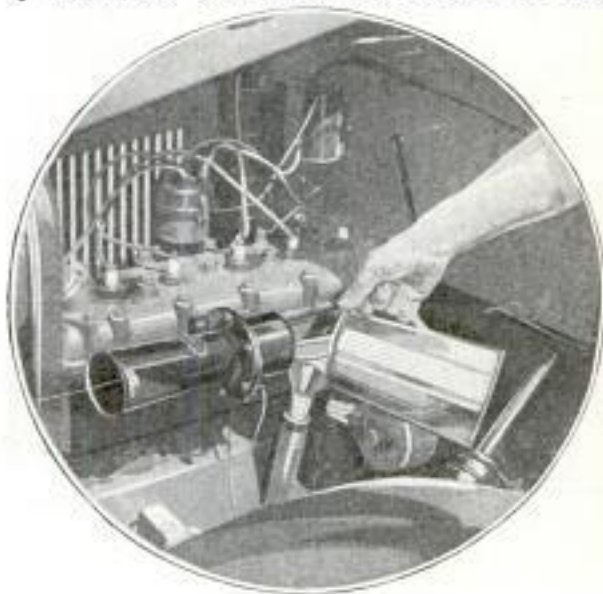

bottom of the vacuum tank be forgotten. Any sediment that may have accumulated in the bottom of the tank should be flushed out. The line leading from the gasoline tank to the rear, and the one leading from the bottom of the vacuum tank to the carburetor should be disconnected at both ends and blown out with a jet of compressed air, or flushed out with clean gasoline, so that any sediment that may have settled in the bends of the piping will be dislodged. The gas tank at the rear, of course, should be empty at the time this is done, and this provides an opportunity to flush out the gas tank through the plug in the bottom. Clean gasoline should be used for this operation.

Before piping is reconnected, it should be examined carefully for kinks and sharp bends that would obstruct the flow of gasoline to vacuum tank or carburetor. All bends should be as easy as possible, and if any kinks are found in the piping,

they should be removed carefully. When the pipes are reconnected, care should be taken that the joints are tight, and all joints on gasoline and vacuum lines must be examined to see that there are no leaks that would either waste gasoline or interfere with the proper operation of the vacuum system. If any doubt exists as to whether the vacuum-line joints are tight or not, a little gasoline, squirted around them while the motor is running, will betray any leaks, as the motor will pick up speed, due to the temporary enrichment of the mixture. Inlet-manifold joints that are suspected of leaking can be tested in the same way. The instructions given above apply to cars with a pressure-feed system also.

Since the motor does not start as readily in cold weather as in summer, greater demand will be made on the battery. The owner can avoid trouble in this respect by increasing the charging rate of the generator enough to take care of the increased drain on the battery. This is usually done, in the case of a third-brush regulated generator, by removing the cover over the brushes and moving the third brush in the direction of rotation of the armature when running. It is advised that the owner have this job done at the battery-service station, as it takes but a few minutes, and this will save the owner from getting mussed up and, perhaps, from moving the brush in the wrong direction. Lights are also used more in the winter than in summer, and this is the time to go over the lighting system. All wires that are chafed should be taped and waterproofed with shellac, rust cleaned

from the lamp sockets and connections, reflectors cleaned

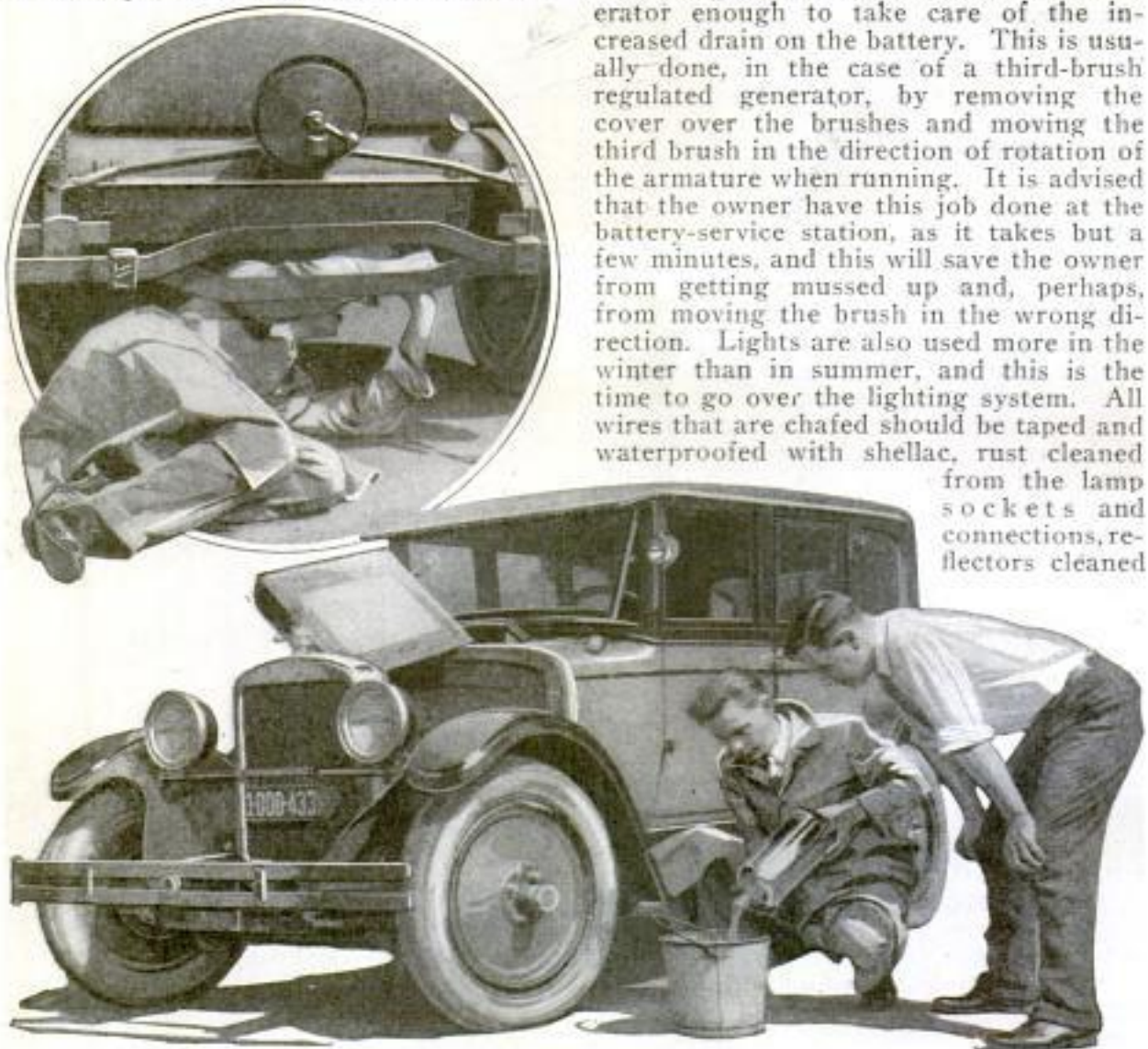

Draining the Gas Tank for Flushing; Below, Mixing Alcohol-and-Water "Dope" for the Cooling System

and lamps focused. The battery terminals should be cleaned of verdigris, tightened and coated with vaseline, and the starter cables examined and taped, if chafed.

Many motors demand a lighter oil in the engine in winter. The owner should find out from the agent for his car what oil he recommends for winter use, drain the crankcase and refill with the lighter oil, if this is advised. The oil in the transmission and differential also needs thinning, in many cars, and this must be attended to at the same time. If the lubricant used in the transmission and differential normally is steam-cylinder oil of the consistency of 600-W, it will only be necessary to thin this with an equal amount of medium engine oil. The manufacturer's recommendations, of course, form the best guide as to this, but they should not be neglected, if easy gear shifting and proper power are to be expected from the car, as oil in the transmission and differential casing that is too thick will not only absorb too much power, but will also make gear shifting harder.

If spring covers are fitted to the car, the springs themselves will need little or no attention, beyond the replenishment of the supply of lubricant, but the shackles should be thoroughly lubricated. If spring covers are not fitted, it is strongly recommended that the owner have a set put on the car, as they will prevent the rusting of the springs that is one drawback of winter driving, and will keep the car riding easily. If the owner does not wish to go to the expense of spring covers, however, he should see that the springs are thoroughly lubricated, and must keep this up throughout the winter.

The next thing for attention is the cooling system, and the first thing to do is to flush out the system thoroughly. Disconnect the lower radiator hose, and then, placing the nozzle of the hose in the radiator filler, allow the water to flow through the radiator until it flows clear; open the radiator drain cock also while doing this. Examine the condition of the radiator-hose connections and replace them if they are not in good condition. On many cars it is also possible to insure thorough flushing of the cylinder jackets by removing a drain plug in the side of the jacket, at the bottom. When flushed, the cooling system may be filled with an anti-freeze solution. Don't use a calcium-chloride solution in the system, as it will attack the metals in the engine. Use either an alcohol-water or an alcohol-glycerin-water solution, mixed as shown in the two accompanying tables.

The freezing point of the solution may be tested by means of an instrument similar to a hydrometer, but many of these are not reliable, and it is better to mix the solution exactly as specified to suit the weather it is expected to encounter.

The proportions of alcohol and water given in the tables must be kept constant, although the amounts can be varied. For example, instead of mixing 12 pt. of alcohol and 68 pt. of water for a freezing temperature of 18° above zero, one can take 6 pt. alcohol and 34 pt. water. The proportions given in the table will make a quantity of 10 gal., so it is easy to figure the proper proportion for any other quantity. In the alcohol-water table denatured alcohol is to be used.

In the alcohol-glycerin-water mixture the proportions are for wood alcohol,



Flush Out the Radiator Thoroughly to Clean It of Rust before Filling with the Anti-Freeze Solution

Temp.	Alcohol pt.	Water pt.
18	12	68
12	18	62
0	24	56
-9	27	53
-20	32	48

The proportions of alcohol and water given in the tables must be kept constant, although the amounts can be varied. For example, instead of mixing 12 pt. of alcohol and 68 pt. of water for a freezing temperature of 18° above zero, one can take 6 pt. alcohol and 34 pt. water. The proportions given in the table will make a quantity of 10 gal., so it is easy to figure the proper proportion for any other quantity. In the alcohol-water table denatured alcohol is to be used.

In the alcohol-glycerin-water mixture the proportions are for wood alcohol,

Copyrighted material

which has a lower boiling point than denatured alcohol, and is used to offset the higher boiling point of the glycerin. The straight mixture of denatured alcohol and water is recommended, as being easier

Temp.	Alcohol pt.	Water pt.	Glycerin pt.
29	5	68	6
9	10	60	10
-2	12	56	12
-11	13	54	13
-22	15	50	15

to make, and cheaper, except where the cooling system has a thermostat control, in which case the maker usually recommends the addition of glycerin. For losses by evaporation use 75 per cent alcohol to 25 per cent water, as the alcohol evaporates faster. Where glycerin, alcohol and water are used, only the alcohol need be replaced to compensate for evaporation. This does not apply, of course, to losses from leaks, or from boiling over. The loss should be made up with a solution corresponding to the original in these

cases. For a second filling of any of the solutions, the best plan is to take a hydrometer reading of the solution when first mixed, and keep subsequent fillings up to this, unless it is necessary to provide for a lower freezing point, when a fresh solution of higher alcohol content will be necessary.

The radiator covers should next be put in order for the season, and the hood cover, if this is employed. Radiator covers are a necessity for the winter season—no sensible driver will be without one—or, even better, a radiator shutter. The inside of the hood can be lined with thin sheet asbestos, fastened to the sheet metal of the hood with water glass (sodium silicate). This will take the place of the hood cover, and should close the ventilating louvers at the side of the hood. If the engine runs too warm during the milder weather with the louvers covered, slits can be cut in the asbestos to correspond with the openings in the hood.

### Force Pump Raises City Water



The third-floor tenant of a flat building complained to her landlord that the city water pressure was too low, and that sometimes the water wouldn't run at all. So an ordinary force pump was installed to pull the water up. This arrangement eliminated the trouble and the tenant has

plenty of water at all times.—Auguste Mathieu, Chicago, Ill.

### Determining Whiteness of Lead Paint

There are times when it is important to determine the whiteness of white lead paint, as for instance when one runs out of material and must use other brands. This is particularly true of the amateur craftsman who usually has only a small quantity on hand. The situation can be dealt with in the following way: Obtain a small piece of clear glass (or crystal-clear as it is called). Place a spot of the lead to be matched on one side with the

spots of the different brands beside it. Now turn the glass over and compare the whiteness of the different brands with that of the lead you have on hand.

### Concrete Makes Artistic Bridge

On the edge of a western town the sidewalk running from the main street to the cemetery, crosses a small ravine. A concrete bridge of unusual design and workmanship was built here. The side rails are made from poles, cut to shape and covered with concrete. Considerable care was used to have the two rails uniform in design. The crosspieces were matched, and the ends notched or rounded and



toenailed in place so that the pieces would not be of double thickness at any point. To add strength,  $\frac{1}{4}$ -in. wire mesh was wrapped about each piece and the ends were tacked down with small staples. This was covered with cement and allowed to harden. Today, many months after it was erected, this bridge is without a single crack.

☛ A small square of adhesive plaster placed over a cracked finger tip will relieve the soreness and hasten healing.

### Kitchen Utensils from Ice-Box Shelves

From an old discarded ice box I removed the shelves and found them useful for cooling breads, cakes and pies or anything requiring ventilation. After covering these shelves with paraffin paper they are fine for cooling drop candies. Delicious toast can be made quickly and in quantities by using one of these shelves placed on a hot cookstove as a toaster. By removing the top and one cross-piece of the stove, placing the shelf over a bed of coals and inverting a bread pan over it, you have an ideal broiler. It can also be used in the oven when doing slow baking, and no doubt, housewives under whose eyes this will come will find a great number of other uses for them while going about their duties.—Mrs Mattie A. Siegelman, Cairo, Ill.

### Use for Broken Steel Fence Posts

Broken steel fence posts make good brace arms at the top for preventing horses and cattle from reaching over and damaging the fence, and also are useful for chicken runs. The posts, which are usually made of angle iron, are cut off to 2-ft. lengths, and one flange is cut through about 15 in. from one end. The piece is then heated until red and bent to the angle shown. The pieces are bolted to the fence posts as in-

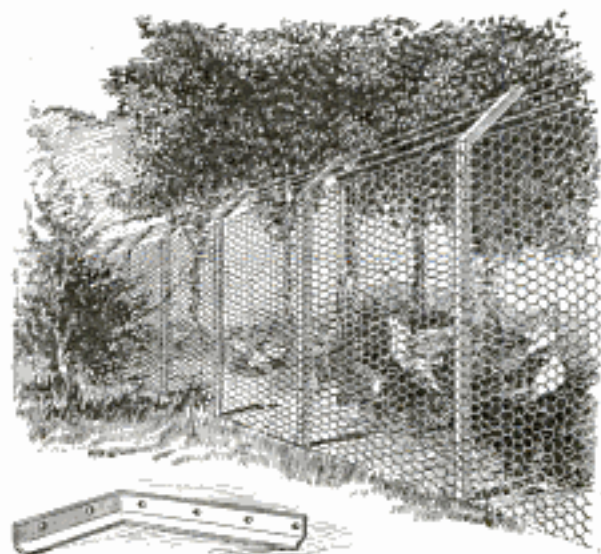

Angle Top on Fences Protects Them against Cattle and Prevents Chickens from Flying Over

indicated, and barb wire or 12-in. wire mesh is stretched over them.

### Flying a "Drinking-Cup" Kite

Flying kites will always be a popular boys' sport and a distinctly new type of kite, which has been found successful, is

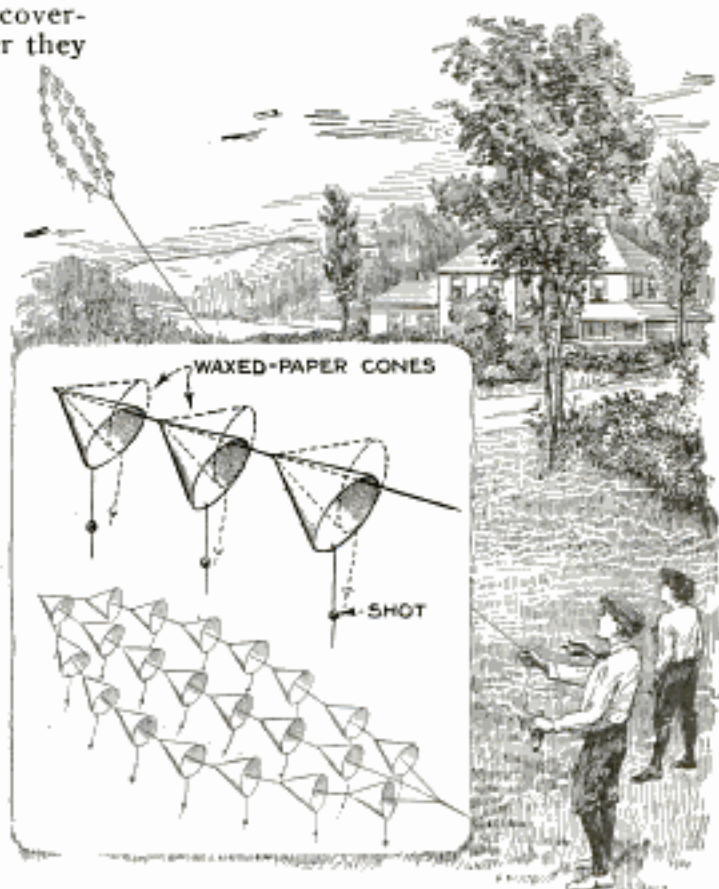

Kites Made from Cone Drinking Cups Fly Successfully

shown in the drawing. It is made from ordinary cone drinking cups, a number of which can be purchased for a few cents. The sharp end of the cone allows the kite to climb in the wind while a small lead shot, split and attached to a short length of thread, which is fastened to the rim of each cone as indicated, acts as a tail. Small round split fishline sinkers can be used instead of shot. The cones are strung at intervals along the line and the kite can be fashioned into various shapes, depending on the ingenuity of the builder. The "pull" of the kite increases with the number of cones used. The tow lines are threaded through the point of the cones.—John R. Malloy, Fort Worth, Tex.

### Meerschaum Cement

Quicklime added to the raw white of an egg until the mixture assumes the consistency of a thick cream, has been found to be a good meerschaum cement. As usual, it is necessary to thoroughly clean the surfaces to be cemented and the parts should be held in clamps for at least 24 hours.



Tourist Earns Traveling Expenses with Auto-Driven Grindstone

### An Auto-Driven Grindstone

A tourist who wished to make a living en route, mounted a grindstone on the back of his roadster, as shown in the photo, belted it to the brake drum of the left rear wheel when he wished to use it and proceeded to sharpen all the knives that needed attention in the neighborhoods he passed. The fender was removed but was used as a water guard over the stone, while another old fender was placed underneath to hold water. The drivewheel of the grindstone is 16 in. in diameter and has a 3-in. face. When the grindstone is to be used, the rear left wheel is jacked up, the other blocked, the belt put on and the motor properly throttled down.

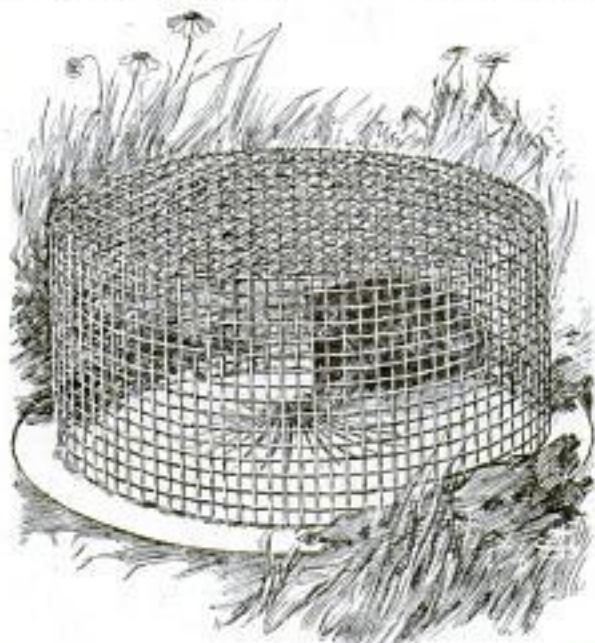

Cheap Burrow Trap Made of Sheet-Iron Base and Wire-Mesh Sides

### Baby-Proof Trash Holder

To protect the baby's fingers from sharp tin cans among kitchen rubbish, and also to prevent it from strewing the trash all over the kitchen when mother's back is turned, a baby-proof trash holder will be found of considerable usefulness. A 50-lb. lard can is obtained from the grocer or butcher, and a hole, about 6 in. in diameter, is cut in the center of the cover, the edge of the hole being turned over on the underside. The rubbish is thrown through this hole. A newspaper lining saves frequent washing and a few drops of disinfectant may be used to prevent odor, but this is not necessary if the pail is kept clean. It can be quickly washed by using an old mop and a little lye solution. A coat of paint and then a coat of enamel will make the appearance of the container unobjectionable so that it will be a most welcome addition to the kitchen.—V. S. Martin, Detroit, Mich.

### Easily Made Burrow Trap for Farm Is Adjustable for Various Animals

If you dislike the use of a steel burrow trap, here is one which will prove quite effective and is easy to make. Get a sheet of iron, about 4 ft. in diameter, and make a number of 4-in. cuts radiating from the center. Bend the sharp points up slightly to form an opening, from 1½ in. to 3 or 4 in. in diameter, according to the size of the animal you wish to trap. Make a cage of ¼-in. wire mesh, somewhat smaller than the sheet-iron base. Cut one strip for the side and either solder or splice the seam. Solder the side to the base and also provide a removable top of the same material. Set this over an active burrow and throw some earth over the edges of the base. The animals will eventually enter the trap, being able to pass up through the prong opening but not to go down again. It may take several days to get results with this trap, but when the animals come out, you may catch the whole family.—Dale R. Van Horn, Walton, Nebr.

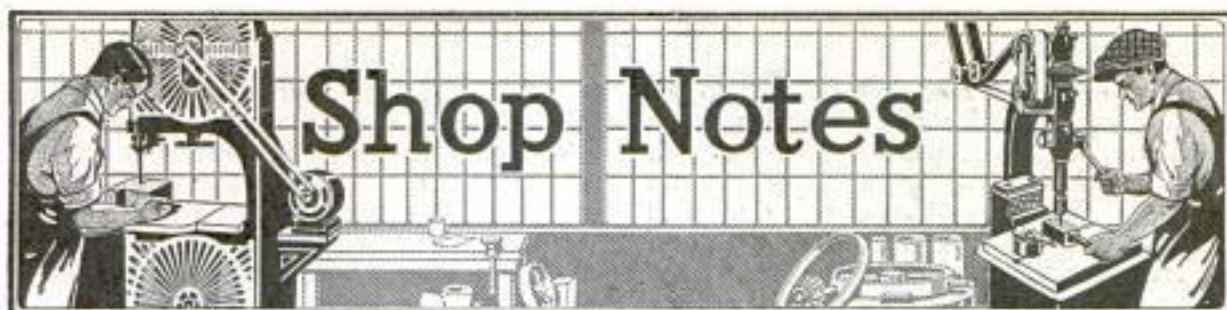

All Shop Notes published in 1924, in book form—Fifty Cents—from our Book Department

## A One-Man Barbed-Wire Winder

By J. R. KOONTZ

**H**ANDLING barbed wire is, at best, neither easy nor pleasant. To unroll it when building fence requires two men, and even then it is not done without much trouble. To rewind it when it is desired to change a fence or remove the wire is almost impossible, even when two men are doing the work, the usual custom being to roll a barrel along on the ground and wrap the wire around it.

We have here on the farm a contrivance that makes unwinding of barbed wire just an ordinary job for one man and is easy to build. In making this winder, you need two metal wheels from some discarded implement, or old buggy wheels will do. For an axle, a 40-in. length of pipe, of a size that will allow the wheels to fit on snugly, is used. Drill holes through the axle within an inch

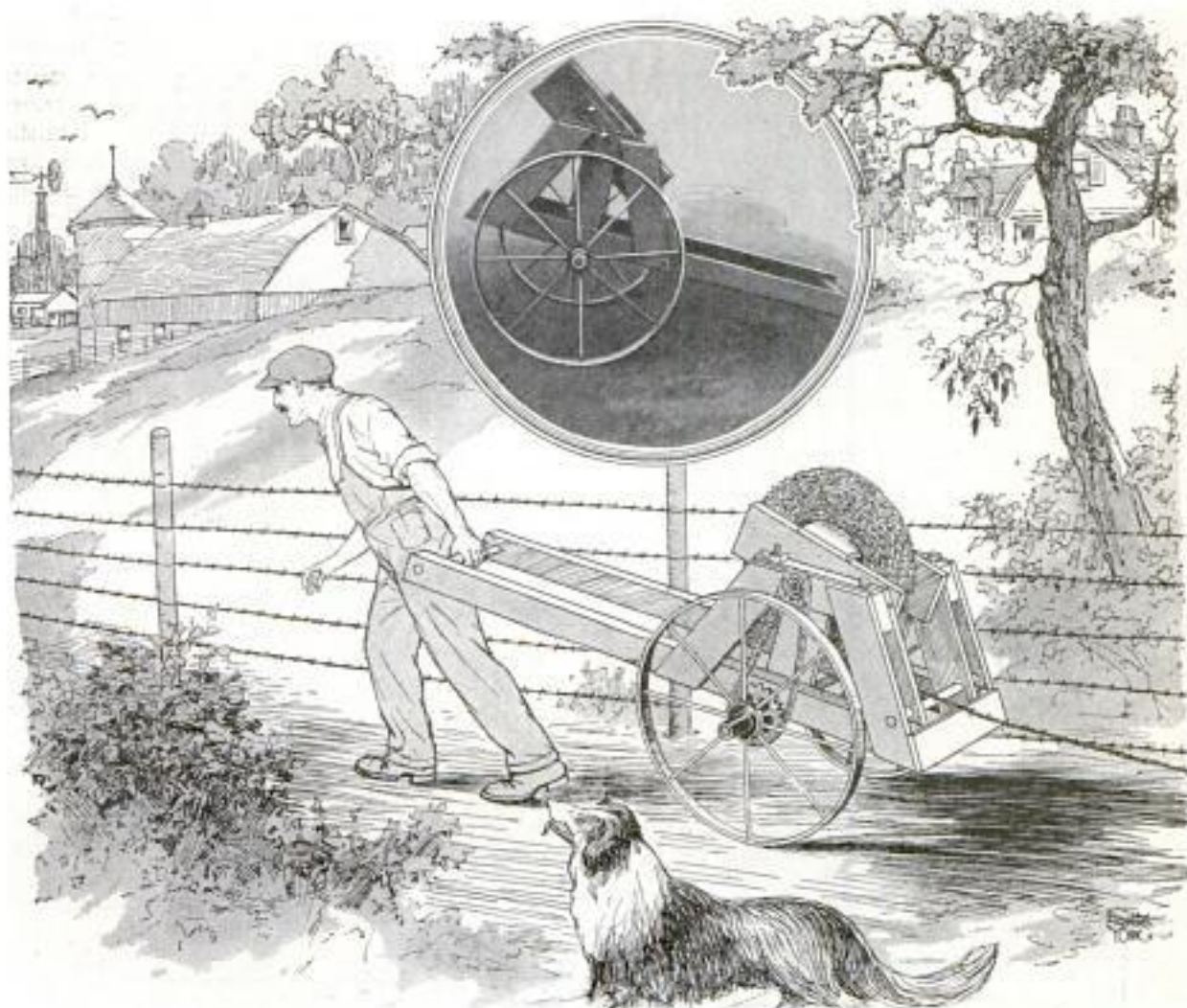

Homemade Barbed-Wire Winder That Can Be Operated by One Man and Is Very Useful on the Farm

from each end and also drill holes through the hub of the wheels in line with those in the axle. Then pass a bolt through both the wheels and the axle so that the latter will turn when the wheels do. The bearings are made from 12-in. strips of flat iron, 2 or 3 in. wide and  $\frac{1}{4}$  in. thick. These pieces are heated until red and one end is bent to fit around the axle loosely. Holes are drilled through these pieces to

permit fastening them to the wooden frame.

The construction and dimensions of the side frames are given in the detail drawing. Both sidepieces are nailed together at the back with crosspieces, and a hole is drilled through the end of each side-piece for the insertion of a length of broomstick, which serves as a handle. When completed, the frame is placed on

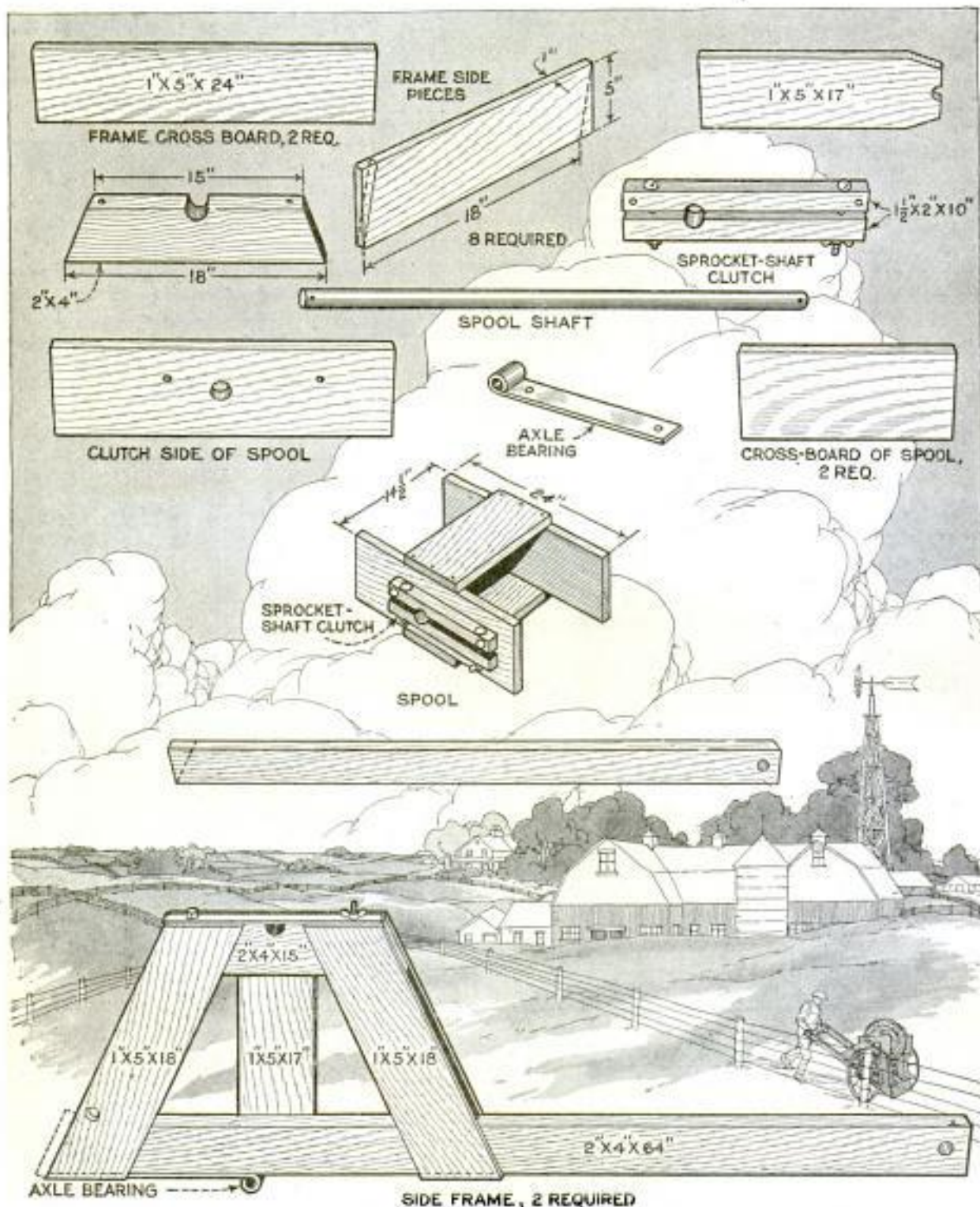

The Barbed-Wire Winder Is Built of Lengths of 2 by 4-in. Wood, Old Wheels, Sprockets, Chain and Pipe



the axle so that its front part is a little heavier than the rear, as otherwise it would tip backward when loaded with wire. The long sidepieces are then marked directly above the axle for the bearings. The reel shaft is mounted on the frame directly over the axle. This shaft also may be a length of pipe and a semicircular hole is cut in the top members of the frame in which the shaft is to rest, being held in place by strips of flat iron attached to the frame as indicated. A sprocket wheel is pinned to one end of the spool shaft and another to the axle, and a chain is provided so that the spool shaft will rotate with the wheels. A 7-tooth sprocket on the spool shaft and one of 16 teeth on the axle will give about the correct ratio.

The reel is fastened to the axle with a clutch arrangement made from a piece of 2 by 3-in. oak, 10 in. long, drilled to fit the shaft, and then sawed lengthwise through the center of the hole. The halves are held together with bolts and thumbnuts and one piece is screwed to the spool. When the nuts are tightened, the halves grip the shaft securely, and the reel turns with the shaft. When unwinding wire, the clutch is loosened.

A length of large iron rod or pipe should be provided just above the rear crosspiece for the barbed wire to strike on while winding so that the crosspiece will not be damaged. This roller should be pivoted so that it will revolve easily.

When the winder is completed, a coat of paint should be applied.

### Using an Old Touring Car for Delivery

The owner of this touring car, a specialist in repairing and sharpening lawn mowers, wanted to trade it in on a regular delivery truck for his business. He found, however, that, in the car dealer's estimation, it was worth practically nothing. Rather than take a heavy loss, he cut out the rear end as shown, faced the edge with wood, and now uses the space for carrying the mowers as he collects or delivers them. Several machines can be

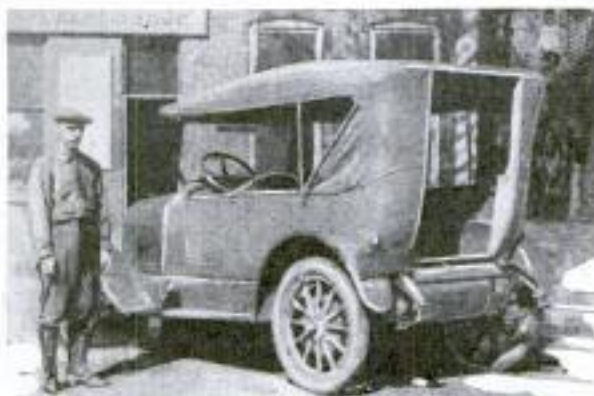

Opening in Rear End of Old Touring Car Converts It into a Delivery Truck

accommodated at one time and, as altered, the car serves as well as a regular truck.

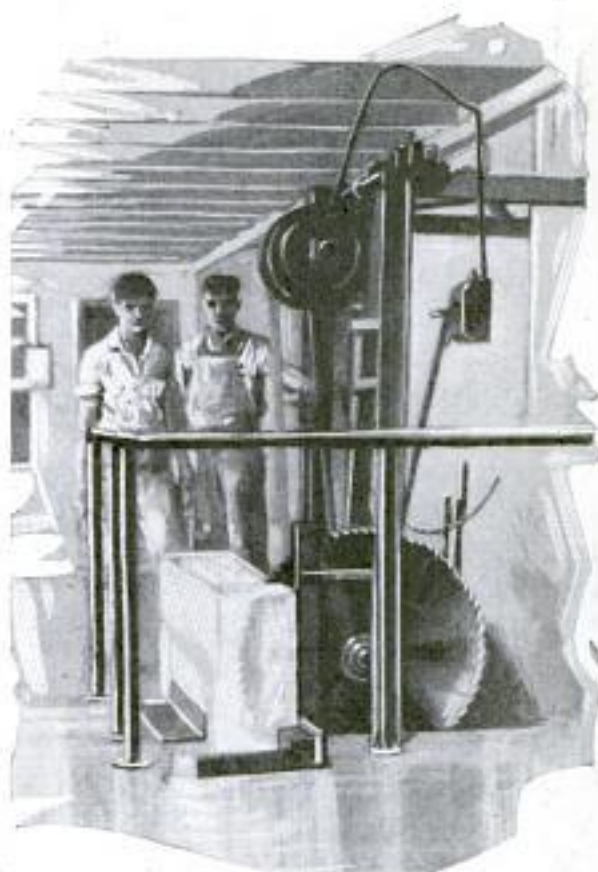

Swinging Ice Saw Cuts a 300-Lb. Cake in Four Seconds

### Swinging Saw Cuts Ice

At one of the ice stations in Austin, Tex., one finds a huge swinging saw rigged on a platform. The arrangement is not unlike a small bench swinging saw, except that the motor and wiring are protected from the flying ice particles and from moisture. The saw itself is 36 in. in diameter and will cut through a 300-lb cake of ice in four seconds. A guardrail makes the device safe and an adjustable block makes it possible to cut any size of cake.—Dale R. Van Horn, Walton, Neb.

### Belt for Model Conveyor

Having occasion, recently, to make a conveyor for a small model boiler house, I found old motion-picture film very suitable for the belt of the conveying machine. The holes on either side were

used to drive the belt by means of sprockets.—N. Sakata, Tokyo, Japan.

### Keeping Mortar Warm

During the winter months a contractor, who was erecting a large apartment build-



Novel Method of Keeping Mortar Warm

ing, found it necessary to provide heat to prevent the mortar from freezing and to keep the workmen as warm as possible. Being pressed to meet the completion date, which made it necessary for the work to go on without an interruption, a large number of electric heaters were used as shown in the illustration. The mortar was placed directly in front of the heater and the workman, standing near by, was also kept warm. The heaters were placed in shallow wooden boxes as indicated and hangers were provided on the back of these boxes, which enabled the workmen to hang them up on the guard board of the scaffold.

### Boring Straight Holes with Lathe

Lathe operators often have difficulty in boring straight holes in work held in the chuck, especially if the lathe is an old one and has had hard usage. The amount of taper is, of course, the same as that turned on the outside of the work, provided a perfectly rigid boring bar is used. The outside turning is easily straightened up by filing or by tapping the slide rest in or out as may be required. This is very laborious and inaccurate. It is, however, quite a simple matter to adjust the taper attachment to turn perfectly straight work, either by taking trial cuts or, bet-

ter still, by using a test indicator on a piece that is known to be straight. The hole may then be roughed out as usual, using the taper attachment for the finishing cut.—A. W. Burt, Swanton, Ohio.

### Welding Compound for Blacksmiths

An effective welding compound for the use of blacksmiths consists of borax, 1 lb., black oxide of manganese, 3 oz., and carbonate of iron, 1 oz. These ingredients, well mixed, will make about a hatful. I can take a piece of steel, lay it across a hot fire, burn it in two and then, after dipping both burnt ends in the mixture, weld the ends together so that the joint will be hardly noticeable and as strong as the original piece.—James Patton, Bedford, Indiana.

### Piston-Knock Detector

Locating engine knocks and looseness of bearings is an easy matter if the method indicated in the illustration is followed. An ordinary tire pump, having a single, large-size cylinder, is procured. The piston is removed and fitted with leather washers acting in both directions. A 5-in. length of  $\frac{3}{8}$ -in. pipe is threaded into the bottom of the cylinder. A right-angle reducing elbow and a nipple threaded to fit the spark-plug openings are provided. In use, the nipple is screwed into the spark-plug opening, the pipe fitted to the pump into the elbow, and the engine is turned over slowly until the pump handle is forced out, indicating a compression stroke with closed valves. Then, by working the pump handle back and forth rapidly, any piston knock is brought out very plainly, and if the lower pan is off and the connecting rod held firmly, a loose wristpin is detected. Also, any leakage past the pistons is immediately evident. Only slight practice with the tool enables a repairman to save quite some time in locating a knock that is uncertain when the motor is running.

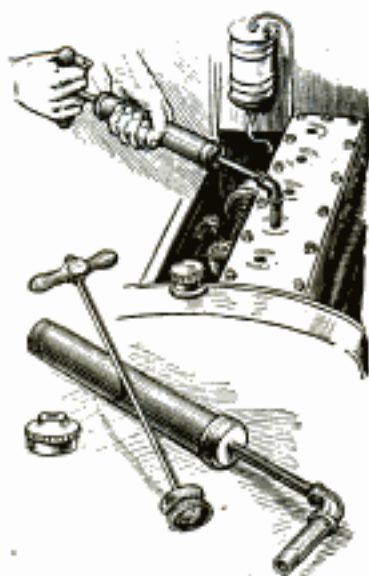

### Measuring Sewage Flow

One city uses celluloid toys in measuring the sewage flow of the smaller sewers. Bright-colored toys, dolls or animals, that are air-tight so that they will remain on the surface and can easily be seen, are dropped into the moving sewage at one manhole, at a certain observed instant, and the time of their appearance at the next manhole noted. The distance between the manholes in feet, divided by the time required for the toys to flow this distance in seconds, gives the velocity at which the sewage is moving in feet per second. The area of the wet cross section multiplied by the velocity gives the rate of flow in cubic feet per second, the usual unit of measurement.

### High Switch Is Reached by Swing Step

In the passageway of a shop, a switch on the wall near a corner was often broken accidentally by passing trucks. The switch could not be located at any other equally convenient place, still it was necessary to protect it. This was done by attaching it to the wall a few feet higher than its former location so that the trucks could not hit it. But as it was then impossible for a workman to reach it, a step had to be provided, of such design that it would not obstruct the passage. So a pivoted support of the kind shown in the drawing was attached to the wall, around the corner, where it was entirely out of the way. The support was made of a length of pipe and a length of solid rod, with a tee and an elbow fitting, arranged as shown in the detail. The solid rod was much heavier than the pipe part and automatically raised the support into a vertical position, as shown, when the workman had finished his job and stepped from it.—Harry Moore, Montreal, Canada.

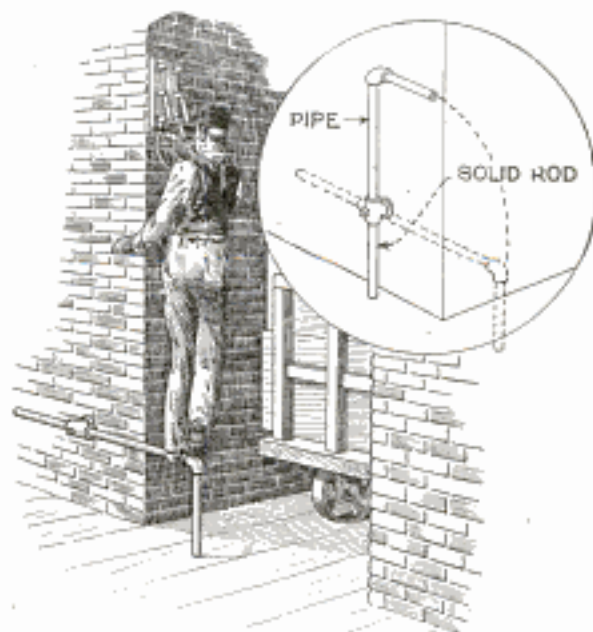

Pipe Step Enables Workman to Get at Switch and Swings Out of Way of Trucks

### Filling Locomotive Tanks

The ordinary drop spout to the locomotive water tank requires rather precise

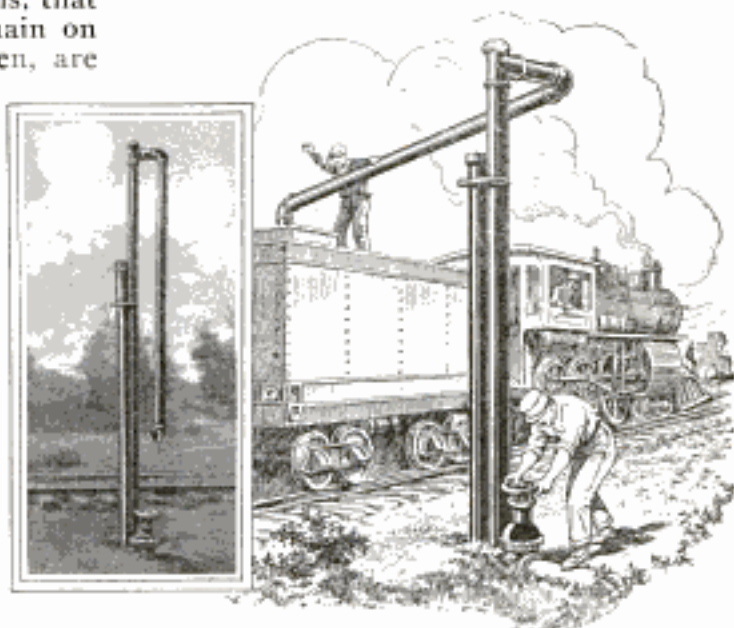

Water Pipe with Two Flexible L-Unions Facilitates Operation of Filling Locomotive Water Tank

“spotting” of the engine so that the intake hole in the tank will come directly under the spout. This sometimes necessitates the pulling forward and backing up several times in case of inaccurate air-brake operation. However, an engineer has arranged a pipe spout from an underground water line that eliminates this trouble. A perpendicular section of 4-in. piping connects with the underground supply line and stands 8 ft. high. Two L-unions and a short nipple connect another section 6 ft. long, on the extreme end of which is attached another L-union to turn the stream of water downward. The 6-ft. pipe spout leading to the tank swings freely and is raised to the engine tank as shown.

☛ Turpentine, or a solution of oxalic acid, applied to the tops of enameled letters on glass, and allowed to soak down through the cement, will loosen the letters so that they can be removed easily.

### Soldering Large Sheet-Metal Tanks

Soldering the seams of an 8,000-gal. oil tank proved quite a problem until the method of swinging it, as shown in the il-

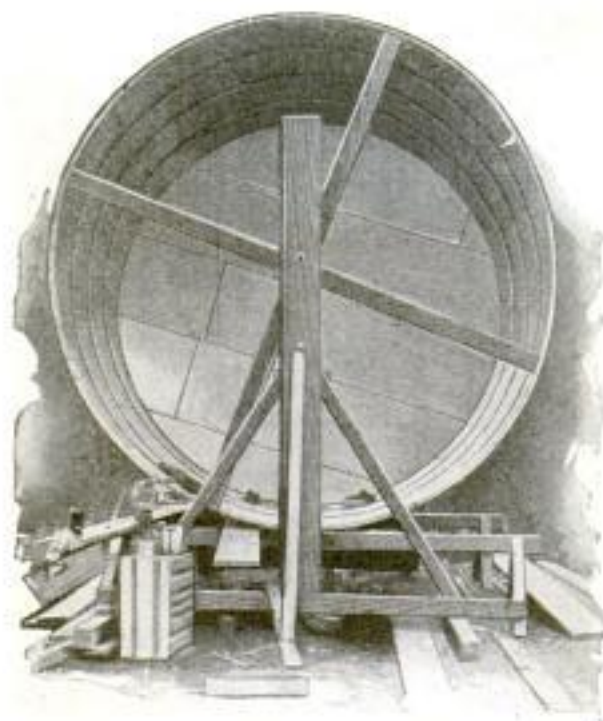

Suspending a Large Sheet-Metal Oil Tank to Facilitate Soldering the Seams

lustration, was devised. A well-braced frame of 2 by 4 by 2 by 8-in. stock was built so that the tank could be turned around to make soldering operations easy. A couple of boards were used to block the tank while the workman was inside.

### Freeing Frozen Bearings

Only those who have met with a badly frozen bearing such as a foot brake or clutch pedal on an automobile know what a difficult job it is to free it. The application of such penetrating oils as are now on the market is good, but it sometimes takes too long for it to reach the entire frozen surface. The following plan has been put to good use in a number of cases to hasten the action of the oil. Clean the exposed end of the bearing and apply the oil. While it is working in from one or both ends, drill a  $\frac{3}{16}$ -in. hole through the middle of the bearing and slightly into the shaft. If there is already an oil hole there, run a drill into it of a little larger diameter to make a clean bore. Then keep this hole filled with the oil. You will notice that it will work very fast from the middle toward both ends because it comes in contact with rust, which is dry and "thirsty." A constant pressure on the pedal by

means of a lever or jack will help in getting the first move on the shaft. After it begins to move, more oil and a back-and-forth pressure applied to the pedal will result in loosening it so that it can be removed, then polished and lubricated.

### Ringing Large Hogs

We have found, as has every other hog raiser, that the task of ringing large hogs is about as distasteful as anything we have to do on the farm. For several years, however, we have been using a simple device for holding hogs, which makes it an easy job to ring them. In a piece of metal pipe, 4 or 5 ft. long and from  $\frac{1}{2}$  to 2 in. in diameter, a hole is drilled near one end, only large enough to pass a piece of bailing wire through it, one end being fastened to the pipe as shown. The other end is passed through the pipe and securely fastened to a short stick, strong enough to hold a large hog. The wire should be of such length that, when the stick is shoved down against the end of the pipe, the wire will form a loop about 1 ft. in diameter. It is an easy matter to slip this noose over the hog's snout while it is feeding. The wire is then drawn up tight, letting go of the pipe and holding to the handle. The hog, when it finds that it is caught, will simply stand and pull

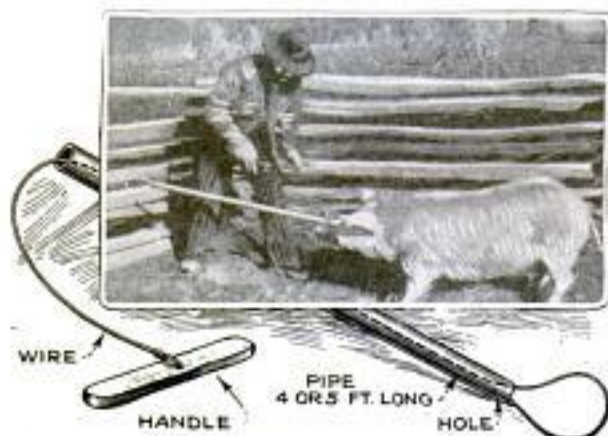

Easy Method of Holding Large Hogs While They Are Ringed

straight backward, and the harder it pulls the tighter the noose holds. If two men are working together, one can hold the handle and the other do the ringing. One man can do it alone, however, by fastening the stick to a fence, as shown in the photo.—P. C. Grose, McComb, Ohio.

☛ In winter time, bolt flat sheets of iron on the inside of the hood over the ventilation openings. This will keep the engine warm much longer than usual.

# Files and How to Use Them

## A Popular Mechanics Model Workshop Article

### Part II

**T**HERE are few mechanics' tools that demand more skill in their use than the file, and to make a file produce a true and smooth cut is an art that the budding machinist should cultivate on every possible occasion. Regarding the proper file to use for each purpose, there is, to some extent, a difference of opinion among mechanics. When filing a flat surface, many prefer a square file for the first rough filing, and finish the job with a flat or pillar file; others again will use a flat file for the whole operation.

The square file is universally useful, as it has more belly than other files and greater stiffness in the direction of pressure in proportion to its bearing surface on the work; besides, being narrow, it re-

quires less pressure to make it bite into the work. To file straight, it is necessary that the file hold the cut, with no slipping or sliding over the surface. With a wide, flat file, the pressure required to cause the file to bite and hold the cut becomes so great as to make straight filing difficult. The square file, on the other hand, requires little pressure, is easier to control, and responds to the touch and feel of the operator better than any other. The pillar file is, by some, preferred to the square and, in any event, is nearly equal to it.

The vise jaws, for filing, should be level with the worker's elbows, and, as this measurement varies from about 40 to 44 in., a good height for the vise is 42 in. This enables the file to be used with the full swing of the arms from the shoulder, avoiding the independent movement of the wrists and elbows as much as possible. For light work, the vise may be higher, so that the work can be seen to better advantage and the filer can stand erect.



Fig. 1. Position for Filing in Vise; Note That Vise Jaws Are at Height of Elbows

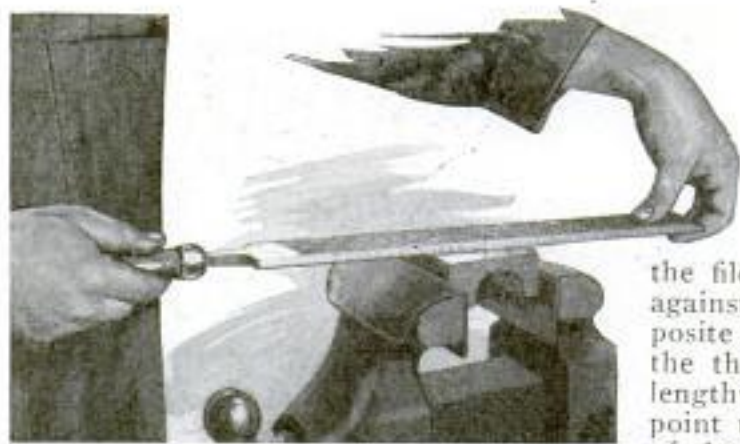

Fig. 2. Method of Grasping the File for Heavy Cross-Filing

When the jobs are heavy, the vise jaws should be lower than the elbow joint, so that the worker can stand farther away from the work and throw the weight of his body on the file.

When filing a surface flat, it is necessary to cross-file it, that is, to file in different directions until all file marks are removed and the desired amount of flatness attained, as at 1, Fig. 4. By changing the directions of the file strokes, the operator can see at all times just where the file is cutting. After testing the surface with the straightedge or square, if further filing is necessary, the new file marks

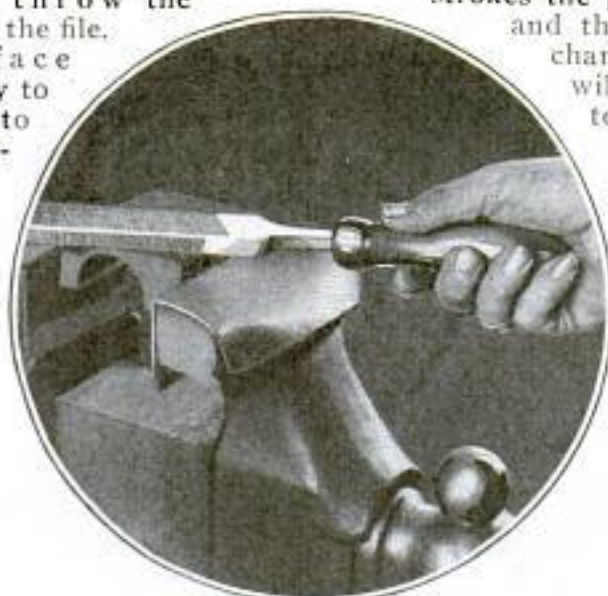

Fig. 3. How Handle of File Is Grasped with Right Hand

should always cross the old, so as to serve as an indication of the amount being removed. The last cross-filing is done with a file as fine as that to be used in finishing, so as not to leave any deep marks.

For filing of this character, hold the file so that the handle fits into and against the fleshy part of the palm, opposite the joint of the little finger, with the thumb along the top of the handle lengthwise. The ends of the fingers should point upward, or nearly in the direction of the filer's face. The point of the file should be grasped by the thumb and the first two fingers, with the ball of the thumb pressing on the top of the file. For heavy strokes, the thumb should be nearly in line with the handle, while for lighter

strokes the position of the thumb and the fingers may be changed so that the thumb will lie at right angles to the file. When holding the file with one hand, as is often necessary when filing small work, keep the butt of the handle in the palm of the hand as previously described, but turn the hand so as to bring the forefinger on top and lying along the handle, nearly in a lengthwise direction. These directions may seem unneces-

sary, but if the file is held properly, the operation of filing will be less fatiguing and more sure than if it is taken hold of "just any way."

To file a surface straight, especially a narrow one, is difficult and demands practice. When the file begins its stroke, the downward pressure of the left hand on the

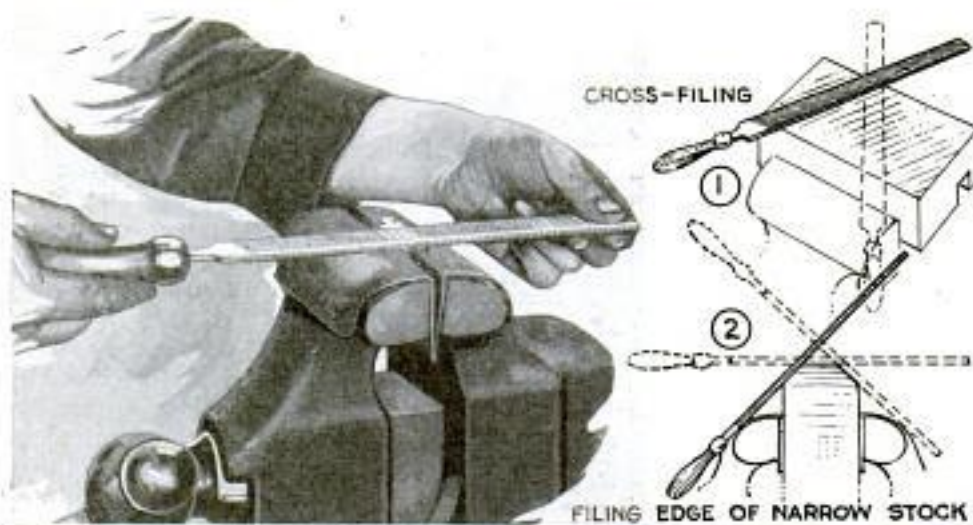

Fig. 4. Left, File Held for Light Cross Strokes; Right, Cross-Filing Work and Filing Narrow Stock

outer end of the file should be least, while the pressure of the right hand on the handle is greatest. As the file is driven across the work, the pressure on the left hand increases, while that of the right decreases. This is necessary because at the beginning of the stroke most of the file hangs over the work on the near side, while at the end of the stroke most of it overhangs on the other side. This variation of pressure becomes unconscious after some practice. When a large amount of metal is to be removed from a comparatively narrow surface, the file may be used as at 2, Fig. 4, to increase the bite of the file and decrease the area of cut, but this must not be done with a new file, or the teeth will be broken out. Narrow surfaces of this kind should be held as near the top of the vise as possible, to decrease vibration. Whatever the form of the work, the pressure on the file should be relieved on the return stroke so as to protect the teeth.

There is nothing so wearing on files as hard corners and spots on iron castings, and, even where the castings are pickled to remove the hard skin before filing, it will be found of advantage to go over the surfaces with an old file before starting the real filing. This will remove the sand and surface hardness left by the pickle, and will prolong the life of a good file. New files are covered with oil to keep them from rusting, and, while this is not objectionable for many uses, the oil should be thoroughly removed before the file is used on cast iron, as it will make it difficult for the teeth to bite. However, on fibrous material,

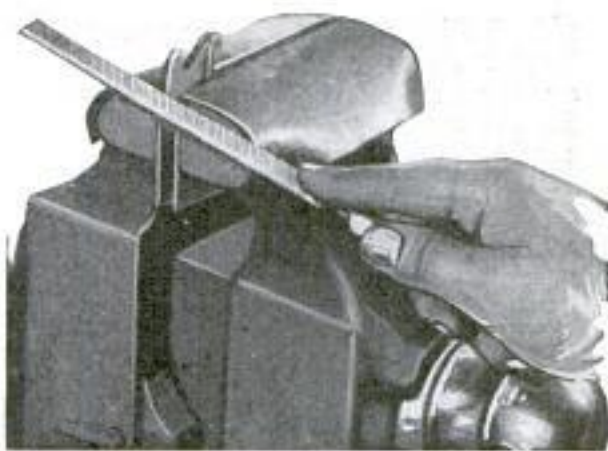

Fig. 5. How File Is Held When Taking Light Strokes with One Hand

a little oil is desirable, in fact, many workmen fill in the teeth with oil and chalk for use on iron and steel. This is especially to be recommended on fine files used for finishing these materials, as the chalk between the teeth prevents them from sinking so far into the surface, and prevents scratching.

Most mechanics, when filing a concave surface, use a half-round file for the roughing operation, and, while this is good, a square file is better, as it will "lie close" and make the surface straight crosswise with much less trouble. The

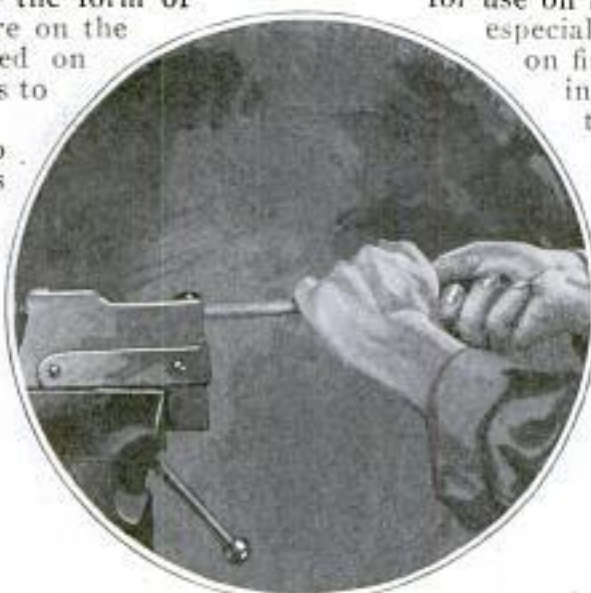

Fig. 6. When Outer End of File Cannot Be Held, the Grasp Is as Shown Above

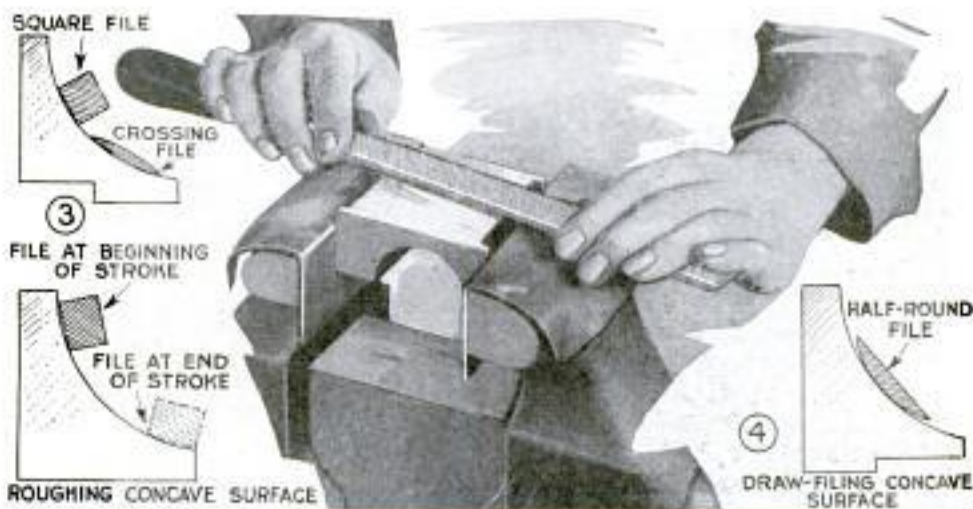

Fig. 7. Left and Right, Cross-Filing and Draw-Filing Concave Surfaces; Center, Draw-Filing Flat Surfaces

file is held straight across and swept around the surface while it is being advanced, sweeping it both ways so as to make the curve uniform (3, Fig. 7). Another good file for work of this kind is the crossing file, but one should be selected that has a radius of curvature greater than the work, so that it cuts only near the edges. This cutting on the edges is the important point in the use of the crossing or square files in curved work; it is surprising what a lot of metal the edges will remove. When the roughing is done, the work can be finished by draw-filing, using a half-round or crossing file with a radius less than that of the work (4, Fig. 7). If the work tends to become high in the center, use a scraper to ease it off, applying a little oil on the scraper if the work is of steel.

Convex surfaces are filed in somewhat the same manner. If the work cannot be held so that the file can be moved across the work at an angle to the axis of the

curve, the file should be moved straight across, giving it a little side motion to carry it around the curve and keep the latter uniform. It is preferable, usually, where it can be done, to file across the axis of the work, holding the file not quite at right angles to the axis, and making it go partly around the curve at each stroke, without any side motion. When the roughing is done, the curve is finished by draw-filing, if the grain of the work is to run across the curve, or by straight filing, if the grain is to run over the curve.

Draw-filing is done by holding the file at both ends and moving it sidewise over the length of the work. This removes the metal much more slowly than cross-filing, as the teeth are intended to cut when the file is moved in the direction of its length, but the surface, when the draw-filing is properly done, is left much smoother than by cross-filing. When draw-filing, the file is not held exactly at right angles to the work, but at a slight angle, so that the teeth will cut the metal instead of merely scratching it. This angle depends on the teeth of the file, and varies for different files. The pressure is relieved on the back stroke, just as in cross-filing.

Ordinarily, the file is longer than the surface on which it is used, but there are

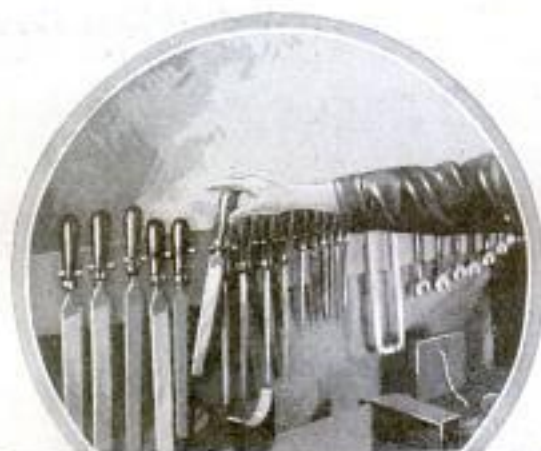

Figs. 8-11. Upper Left, Filing Convex Surface; Lower Left, File Holder for Broad Surfaces; Upper Right, Convenient File Rack; Lower Right, Chalking a File



occasions on which it is necessary to file a very broad surface, and, in these cases, the common methods of holding the file are useless. For work of this kind the tang of the file is often bent upward, and the ordinary handle used, but the special file holder shown in one of the illustrations is much better, as it enables more accurate work to be done.

Wherever possible, new files should be used on brass or bronze, before being used on cast iron, and on cast iron before being used on steel or iron, as keen cutting edges are required for the former. After they lose their keen cutting edges on brass, bronze or cast iron, they should be used, if convenient, on narrower surfaces of the same metals before being passed on for use on iron or steel. New files, especially those having double-cut teeth, are worn excessively when used on narrow surfaces. A good file should never be used on rough castings, as the scale is very hard, and ruins the teeth of the files in one or two passes over the surface. Files that are

useless for other purposes may often be used to advantage for removing this scale. Files should be arranged in a rack or drawer so that they cannot come in contact with each other. When they are carelessly thrown into a drawer with chisels, hammers and other tools, the teeth are apt to be damaged and obviously they will not give as long service as when they are properly stored. When particles of metal become lodged between the teeth, as happens when filing iron and steel, they should be removed at once, or they will scratch the work. This is most conveniently done with the "file card," a small steel-wire brush, or with a soft-wood stick, pushed along the teeth crosswise. This trouble is known as "pinning," and can be reduced to a great extent by rubbing chalk into the teeth of the file.

When using the Vixen files, mentioned in the first part of this article, the worker should not attempt to take all the cut off the material on the first stroke. Great strength or force is not required, but the file should be permitted to do its own

cutting, using only a light pressure. These files are made in flat, half-round, square, half-oval and pillar shapes, as well as special flat babbitt and flexible files. The latter are made without tangs and are attached to a special back. The files are cut on both sides, so that when

one side is dull it can be turned over and the other side used. The back may also be either straight or curved throughout its length, thus giving the file the convexity necessary on many classes of work. It is especially useful on automobile-body and other sheet-metal work. Another file of this character that is very useful is a utility file, with a regular cut on one side and a smooth cut on



Fig. 12. Cleaning Teeth of File with Card File, to Prevent Scratching Work

the other. The coarse side is used for wood, lead, solder and all soft metals, and the smooth side for the harder metals. The babbitt file is cut coarser than the regular files and is intended, as the name implies, for the soft metals only. The half-oval file is particularly adapted for filing the curved parts of auto bodies; it is made either straight or curved, and with or without a tang. The teeth are cut on one side only. The square and pillar files are used for the same work and in the same manner as the regular square and pillar files.

#### Using a Log Saw Properly

In using a two-man log saw in the common manner only about two-thirds of the blade is actually cutting, as this is all that the draw stroke permits. By drawing the stroke near one end of the saw part of the time and then changing to the other end, the saw will be kept in a more even set and sharpness, which makes it easier to file it.



Water Tank and Windmill Built on Top of a 40-Ft. Fir Tree Have Given Service for 14 Years

### Novel Windmill Tower

An Oregon farmer saved the expense of a tower when installing a water system by resorting to the clever arrangement shown in the photograph. A large fir tree was cut off about 40 ft. above the ground, and the tank and windmill were built on top. Although the tree is more than a hundred feet from the well, the power from the mill was successfully transmitted to the pump by means of wires run over pulleys and terminating in a walking beam, bolted to the pump handle. After 14 years of constant service the tree was found to be slightly decayed due to the fact that the bark had not been removed. But instead of wrecking the whole structure the farmer built a wooden tower under the tank, and the tree was sawed off.—R. Jensen, Silverton, Oreg.

One of the cheapest and most versatile of the mahogany stains is a solution of permanganate of potash and epsom salts in water; the depth of color is regulated by the strength of the solution and the number of applications.

### Temporary Woodworking Bench in Machine Shop

A machine shop is seldom equipped to do woodwork, yet this is sometimes necessary. It is almost impossible to use the regular workbench, as it is always rough, dirty and greasy so that the wood will be scratched and get oily and dirty. The vise cannot be used for the same reason. The writer was called on to do a little cabinetwork in a machine shop, and finding himself up against the above problem, arranged a temporary woodworking bench on the drill-press table. This can be done in a few minutes and is entirely satisfactory. Swing the drill-press table to one side and wipe it clean. Then wipe also the vise and place it on the table in a convenient position, fastening it down with clamps or bolts. The jaws of a drill-press vise are smooth so that the wood will not be scratched. Boards 4 to 6 ft. long can easily be held in this vise. One good feature of this device is that the table can be turned, raised and lowered to suit the worker's convenience.—Ed. Sundholm, Albert City, Iowa.

### Alternating and Direct-Current Tester

A handy tester for finding whether a current is alternating or direct can be made by taking a small bell-ringing transformer with a 6-volt secondary and connecting the primary winding in series with a 25-watt red lamp and the secondary winding to a small buzzer. On 110-volt direct current the lamp will light, and on alternating current of the same voltage the buzzer will ring. The transformer and buzzer can be mounted in a small wooden box, about 3 by 3 by 4 in. in dimensions, with a receptacle and a lamp mounted on the outside. The reason for the use of a red lamp is that the filament will glow also on alternating current but only slightly so that it is not noticeable through a red globe.—R. W. Kidwiler, Seattle, Wash.

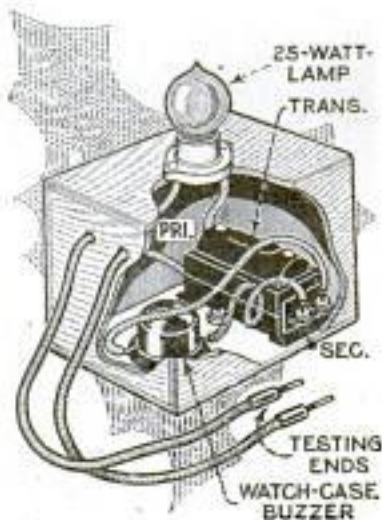

### High-Head Pumps Drain Cofferdams

High-head centrifugal pumps can seldom be used to unwater cofferdams because of the comparatively low heads to

1,800 amperes at 130 volts when babbitt bearings were used. The same load is now handled with a current of 1,200 to 1,300 amperes, which shows that the minimum reduction is about 25 per cent of the

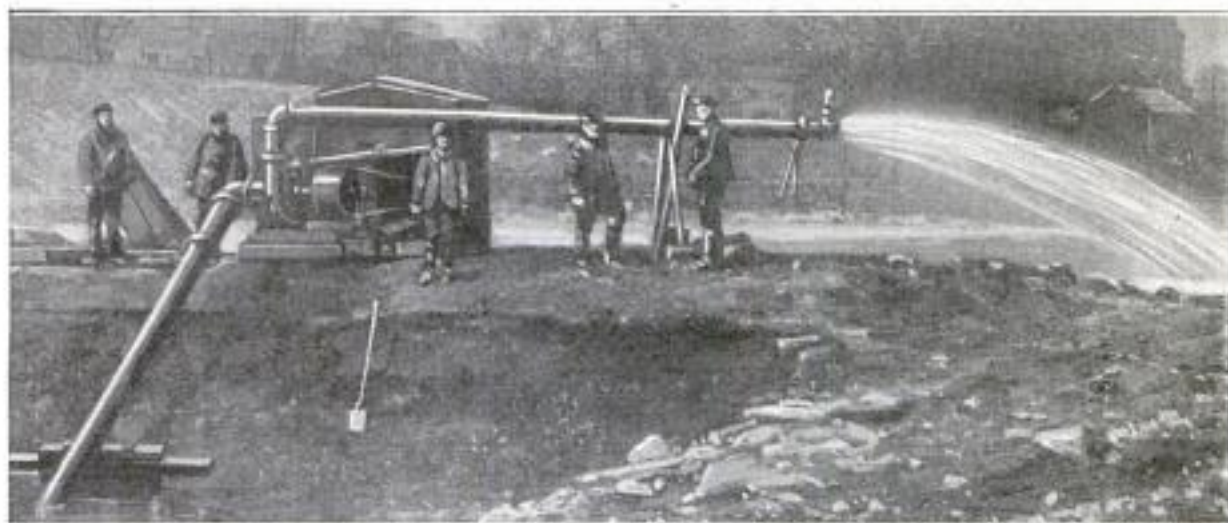

Using a Valve on Discharge Pipe Permits Employment of a High-Head Centrifugal Pump to Drain Cofferdams Where the Head against Which the Pump Works Is Low

be pumped against. Such pumps, when operated under low heads, generally throw so much water that they overheat the motor, sometimes burning out the windings. However, a high-head pump can be adapted to unwatering purposes, if no other is available, by attaching a valve to the end of the discharge pipe and keeping it shut until the working pressure is built up to a safe amount. The use of such a valve also permits the discharge to be cut off without stopping the pump.—Ivan E. Houk, Denver, Colo.

### Money Saved by Ball Bearings

Ball bearings cost more than babbitt bearings but have been found to pay back the difference in cost by power saving alone. In one plant it was clearly demonstrated that approximately 25 per cent less power was required after the installation of ball-bearing hangers and bearings. A report of this plant giving the particulars is as follows: "One section supplied by a direct-current generator required between 1,600 and

original load. The power saved per day is 468 kw.-hours, which in a year, at 2 cents per kw.-hour, means a saving of \$2,808. As this section of the plant takes about one-third of the total amount of power used, the saving from the use of ball bearings in the entire plant would be approximately \$8,424."—W. F. Schaphorst, Newark, N. J.

### Motor Drives Butcher's Slicing Machine

In our meat market we were slicing up approximately 150 lb. of bacon, 50 lb. of boiled ham and 30 lb. of smoked beef every day, requiring the continuous work of two men to do this on the slicer, which was operated by hand. Obviously, much labor and time could be saved by running it with an electric motor, and I immediately proceeded to install one as shown in the photo. I used a  $\frac{3}{8}$ -hp. machine and bolted it to the side wall. After calculating the proper speed, I found it necessary to use a  $\frac{3}{8}$ -in. pulley on the motor shaft and from this a belt was run to the flywheel on the slicer as indicated in the photo. —Leonard L. Bloch, New York City.

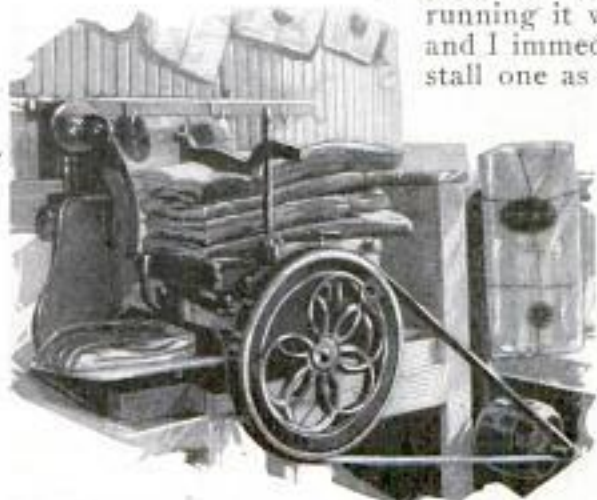

Electric Motor Bolted to Wall Runs Slicer

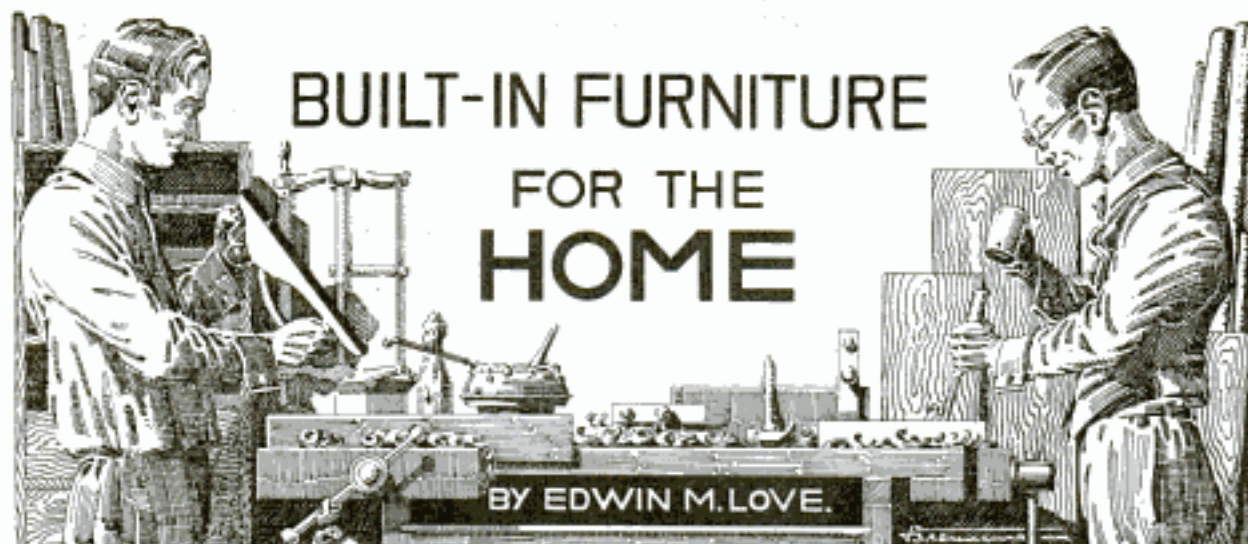

### Part XIII—Indirect-Lighting Fixtures

THE illustrations accompanying this article show an attempt on the part of the writer to give individuality to the lighting equipment in his home; an attempt that succeeded far beyond expectations. No chandeliers or brackets were used, but instead fixtures cast from plaster of paris were built into the walls. Eight of them were put in the living room, one on each side of the arched opening between the living room and the dining room, one each side of the large circle-top front window and mantel, and one each side of the piano position.

Fitted with 50-watt globes, they light the room brilliantly, yet without glare, giving a peculiarly restful light that casts no shadows. While the indirect-lighting results in slightly larger lighting bills than the direct, the saving of eyestrain more than offsets this disadvantage. In the interests of economy, four of the lamps can be turned off for family evenings at home, the other four giving sufficient light for reading newspaper print. Four fixtures in the dining room, a pair over the buffet and one on each of the adjacent walls, light

the room perfectly. Each consists of a bowl ornamented with conventional leaves in relief, within which the spherical light globes are almost entirely hidden, and a reflecting back let into the wall behind it. The reflector is enameled white, but the rest of the fixture is polychromed in old gold with touches of dull-blue and rose tints.

About 7 lb. of plaster of paris is required for making the molds, and about half that amount for each fixture. The writer made the molds and 12 fixtures in about 60 hours; but an appreciable amount of this time was lost in searching for the most efficient process and in smoothing defects due to a poorly finished mold. A bid from a local shop for the job was placed at \$75.

In making a mold, finish it as perfectly as possible, since a defect in the mold that might be removed, but is left, will reproduce itself in each of the fixtures, with a corresponding multiplication in the labor of smoothing them for finishing. For the bowl mold, procure an enamelware bowl, 8 in. in diameter and about  $3\frac{1}{4}$  in. deep. Cut a cardboard partition and prop it up

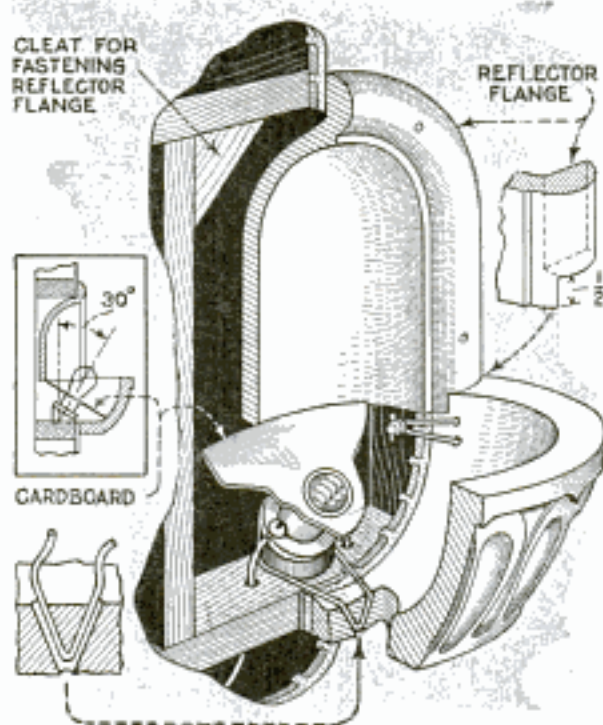

Sectional Assembly View, Showing Details of the Bowl Fastenings and Reflector Backing

in the bowl as shown in Fig. 1, keeping it at right angles to the top but  $\frac{1}{4}$  in. off center. In a suitable vessel, mix up enough plaster of paris of a thick, creamy consistency to almost fill the larger section of the partitioned bowl. Lubricate the latter with soft soap and cast against it a thick shell, gently shaking it out as

in the 12 divisions, grouping them in pairs with adjacent edges touching to form the center leaf ribs. Between the leaves leave stock,  $\frac{1}{2}$  in. wide near the upper part and widening to  $\frac{3}{4}$  in. near the narrow bottoms of the leaves. Carve in this stock the depressions showing the outlines of the leaves. Ignore the rim at the point of

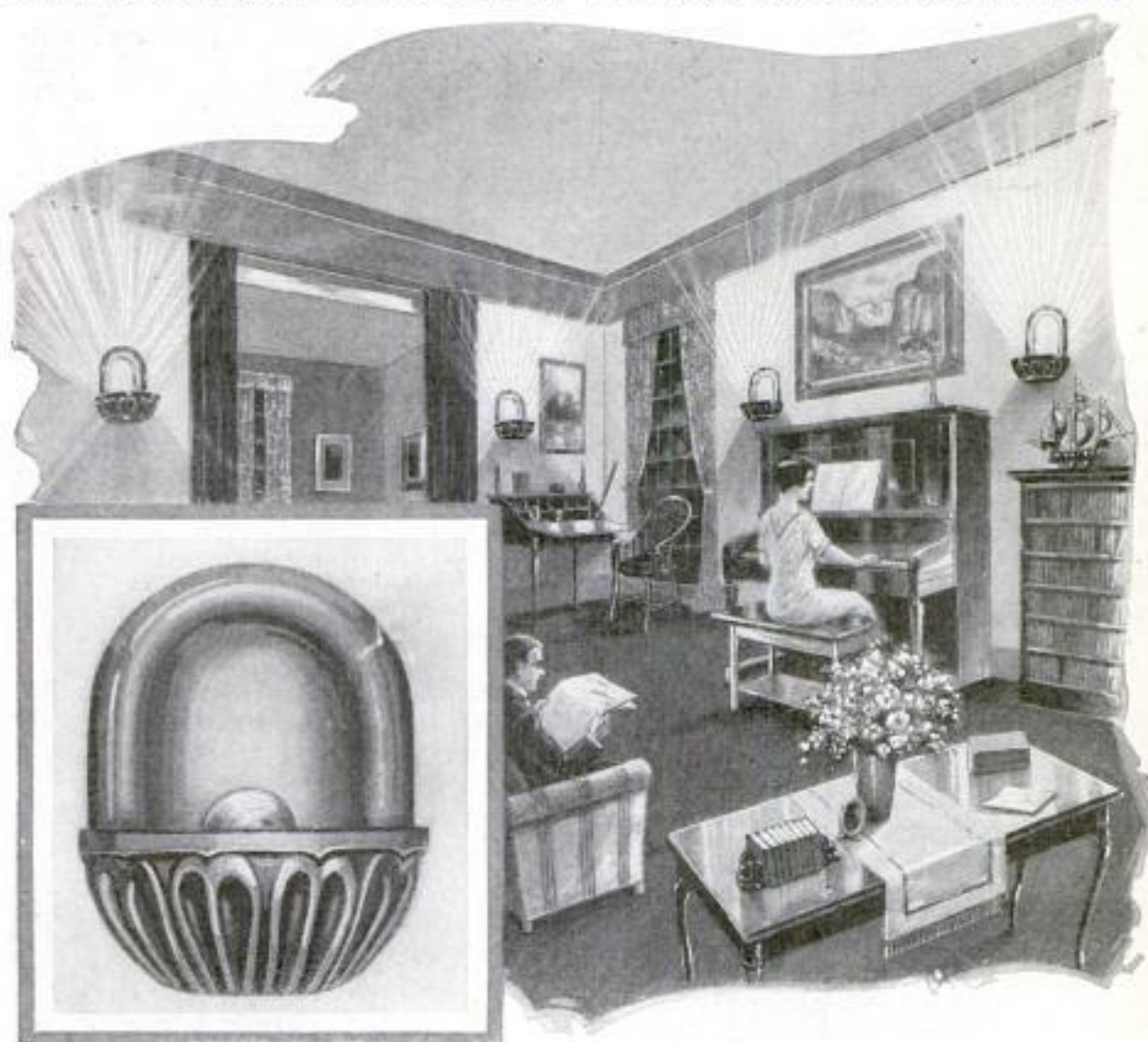

Indirect Lighting Fixtures That Can Be Made at Home and That Will Prove Both Effective and Novel

soon as it has set. This is a blank to be carved up for the mold to be cast on, in lieu of modeling the design in clay.

Lay it upside down on a board and saw through the diameter with a hacksaw, then point off the top and bottom into 12 equal parts. Using a narrow strip of cardboard as a straightedge, connect these points with pencil lines as shown in Fig. 2, and with dividers scribe two lines on the bottom,  $\frac{1}{4}$  in. from the outside and  $\frac{1}{4}$  in. apart. With a  $\frac{1}{4}$ -in. gouge, cut a shallow cove between these lines. Using a  $\frac{5}{8}$ -in. gouge, carve smooth depressions

the out-turned leaves shown in the detail. Smooth thoroughly with round-nose scrapers and sandpaper. Spare no pains to remove irregularities.

On a suitable board nail a block as backing for a vertical sheet of cardboard, as in Fig. 4, and put the blank upside down with the back against the cardboard. Shim it from the board  $\frac{3}{8}$  in. and separate from the cardboard with a small strip of the same material. Soap well, mix up a small amount of plaster of paris and water, and pour it over the blank. If quickly done with thin plaster, all depressions will

be neatly filled. Build up the thickness of the shell to about  $1\frac{1}{4}$  in.

Remove from the board. The blank is now held fast to the mold. Carefully chip away the plaster that ran under the edge

in Fig. 6, and  $3\frac{1}{2}$  in. from a long side as a center draw three semicircles, having radii of 2 in.,  $2\frac{1}{4}$  in. and  $3\frac{3}{4}$  in. These form the curves of the top. The straight sides are parallel to the center line, and the total length of the layout is  $6\frac{1}{2}$  in. Gouge out the depression as shown in the cross section, giving a depth of  $\frac{1}{2}$  in. Scrape and sandpaper smooth. The sides are almost vertical, being inclined outward only enough to give draft for pulling out the casting. Chisel off the center until it is  $\frac{1}{4}$  in. below the blank surface.

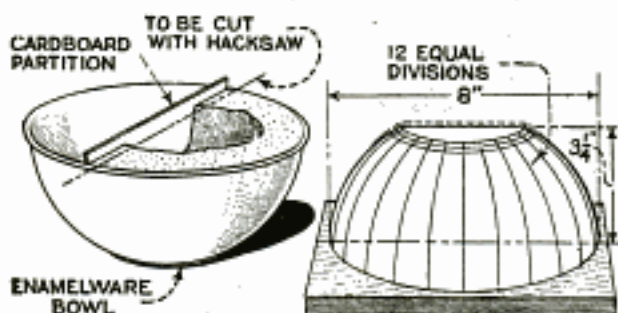

Fig. 1

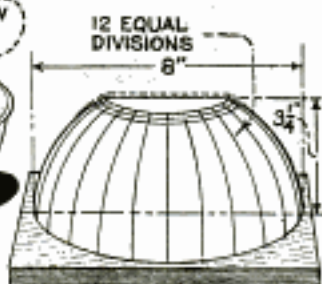

Fig. 2

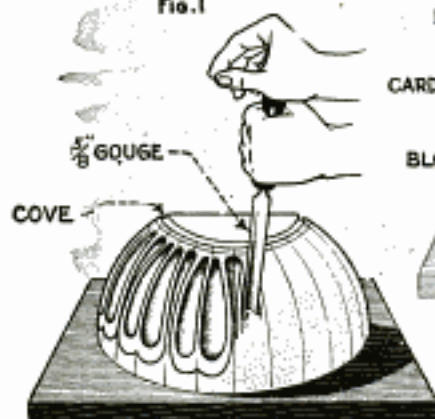

Fig. 3

CARVING DEPRESSIONS

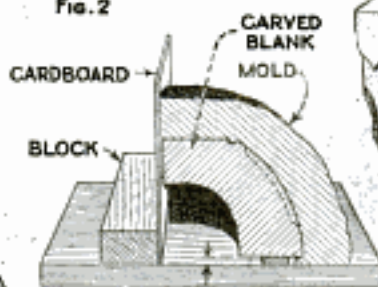

Fig. 4

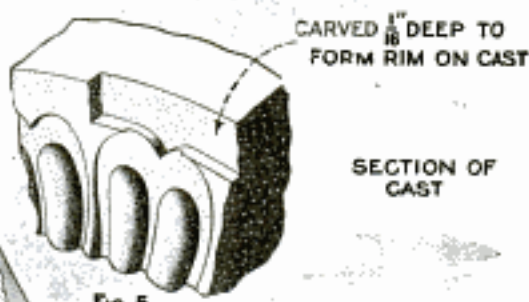

Fig. 5

SECTION OF CAST



SECTION A-A

Fig. 6

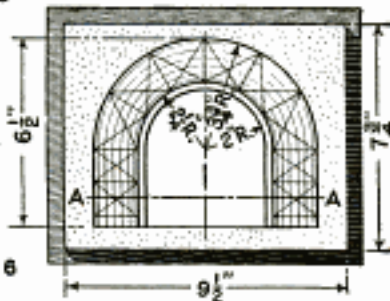

Details of the Making of the Model and Molds for the Bowl and Reflector; Also How the Wall Is Trimmed

of the blank, and tap the mold with a chisel handle, allowing the blank to fall at right angles to the bottom. Now carve out a rim depression  $\frac{1}{16}$  in. deep in the stock given the mold by raising the blank. Fig. 5. Cut the notches above the leaves for their out-turning points. Note that these are not simple "V"s but are curved tangent with the rim. Carelessness about such little details will result in a design void of character. Inspect the mold for air holes, tool marks and other defects, and sandpaper smooth. With a hacksaw, cut the mold in half, running the kerf down the center of the background between the two front leaves. Bore two  $\frac{3}{8}$ -in. holes in the edges and insert dowels in one piece to match those in the other.

The mold itself is carved for the back of the fixture. Drive shingle nails into a suitable board, leaving the heads projecting  $\frac{1}{2}$  in., and over them cast a rectangular blank,  $1\frac{1}{2}$  in. thick and  $7\frac{3}{4}$  in. wide by  $9\frac{1}{2}$  in. long. Draw a center line, as shown

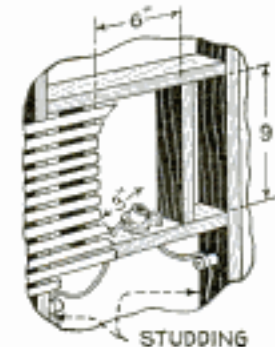

Fig. 7



DETAIL OF LEAF FORMATION

Fig. 8

The core for the reflector is made of two pieces of 2 by 3-in. pine rounded to an elliptical cross section with the upper ends also rounded off. Drive two nails through each into the plaster base to act as placing dowels. In the concave surface of the groove, using a  $\frac{1}{16}$ -in. round nose scraper ground on the point of a saw file, gouge six equidistant lines about  $\frac{1}{16}$  in. wide, as shown in the drawing; and scrape the radial lines and the three cross bands. Lastly sketch in the diagonals and scrape

them. Clean out thoroughly, put the core in place, and the mold is ready to use.

Prop the bowl-mold section on a box with suitable wedges and mix a small quantity of thin plaster. Soap the mold and pour in the plaster, covering the mold quickly and evenly. Build up to a thickness of 1 in. While the bowl sets, cast a back in the same manner. Smooth the back of the flange even with the mold and build the reflector to a thickness of about  $\frac{3}{4}$  in. However, it is better to have plenty of material at the joining of the reflector with the flange, so that in removing the cast the flange will not break off.

To remove the cast bowl, slip a chisel point in the mold joint and pry gently apart. Tap the mold lightly if necessary. Remember that a few extra seconds taken in removing the mold may save an hour of time repairing. Reassemble and cast another bowl. To strip the back mold, pry under the ends of the reflector core blocks and tap gently. This is likely to strip badly, leaving the raised bands rough, but this, fortunately does not seem to mar the appearance of the piece when polychromed. The whole effect of the bronze finish is that of beaten metal. Before making another cast, carefully scrape out all loose particles from mold and soap it.

When all the casts are made, go over them with sandpaper and plug all air spots with plaster. Scribe the back edges for the bowls to a flat surface and trim to the line. Smooth the flange edges of the reflector back and chisel away the excess stock. Drill four screw holes in the flange, as shown in the assembly detail. Drill  $\frac{1}{8}$ -in. holes  $\frac{1}{2}$  in. below the rim near the back of each bowl, starting each pair from the same hole in the front and making them diverge at the inside. Drill a pair in the bottom. Slip through each pair a loop of No. 20 copper wire, 10 in. long, and fill outside holes with plaster.

Since air-brush work in polychroming is far superior to hand-brush work, it is best to have an electrical shop equipped for such work put on the finish. It should not cost over 40 cents per fixture.

The wall holes for the fixtures must be trimmed previous to plastering. Cut a rod equal in length to the height of a

door and at the desired locations gauge marks on the studding. Cut in a trimmer 3 in. below the mark and another 9 in. above the first, and put in side trimmers 6 in. apart. The electric wires are brought up through the lower trimmer. After lathing, cut a pasteboard pattern with semicircular ends, 6 in. wide and 9

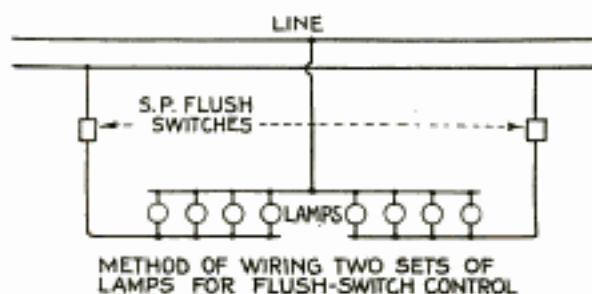

METHOD OF WIRING TWO SETS OF LAMPS FOR FLUSH-SWITCH CONTROL

Fig. 9

in. long, and trace the outline on the lath. Cut out with a compass saw. Porcelain cleat sockets, set inclining forward  $30^\circ$  from the vertical, are used. For the reflector-screw backing, nail soft wood cleats inside the openings and in the upper corners. Drive two six-penny nails in each side trimmer, hold a bowl in position and twist the upper wires around the nails. Wrap the bottom wires around the socket. Notch the reflector flanges to slip down inside the bowl  $\frac{1}{2}$  in. and screw in place. Cut a piece of glossy white cardboard or bristol board to fit around the socket, to close the hole in the fixture and prevent light from shining through the joint between the bowl and the wall.

Tone down the white enamel of the reflector by dipping a cloth in burnt ochre and rubbing it over the surface until the desired shade is obtained.

#### Flange on Rubber-Cutting Template Reduces Number of Accidents

Finding that an average of 125 injuries to fingers occurred monthly in cutting rubber with a knife and template, the safety manager of a Cudahy, Wis., factory suggested that all templates be fitted with flanges, as shown in the illustration. The suggestion was acted upon and the number of similar accidents after this change shows an average of only 20 a month.

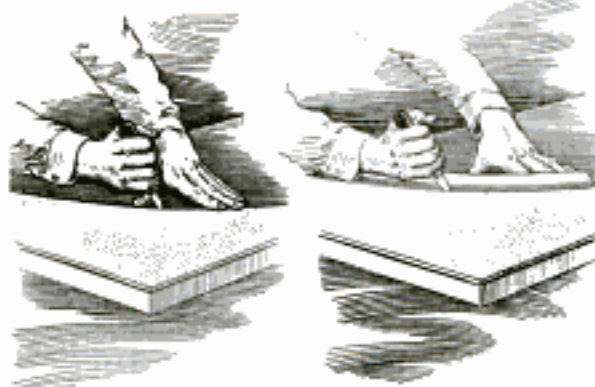

Dangerous and Safe Template for Use in Cutting Rubber and Other Fabrics

### Auto Stile over Farmer's Fence Saves Opening of Gates

Where a country road passed through a farmer's field and two gates had to be opened and closed every time a car passed,

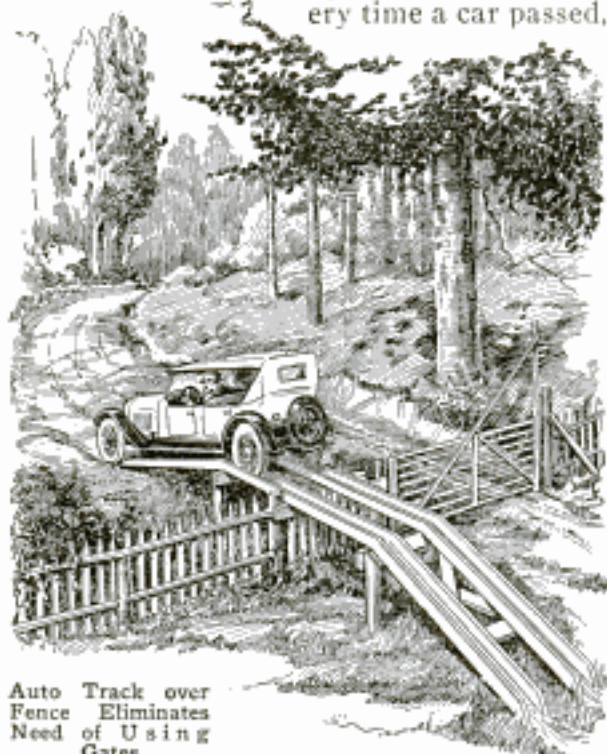

Auto Track over Fence Eliminates Need of Using Gates

which meant a considerable waste of time for the motorist, the stile shown in the drawing was found quite a timesaver. Two runs of 3 by 8-in. boards served as tracks and pieces of 2 by 6-in. material were spiked on the sides to prevent the wheels from slipping off. The whole track is, of course, securely braced and mounted on posts set in the ground. The stile makes it unnecessary to open and close the gates, and, besides, it is impossible for cattle to cross over on these tracks.—L. M. Jordan, Vredenburgh, Ala.

### Installing Oval Gasoline Tank on Old-Model Ford

Sometimes it is desired to replace the round gasoline tank on the older Ford touring cars with an oval one. However, as the oval tanks are much wider than the others some preliminary work is necessary to do the job. The flanges on the oval tank prevent its being moved ahead far enough on the frame for the bracket bolts to be replaced. The steel heel board, therefore, must be peened with a hammer at the right spots to make room for the tank flanges. Most of the peening must be done a little more than halfway down. Because of the flanges,

the sheet-iron panel back of the tank will not allow it to be dropped into place, even edgewise. A good plan is to place a jack with the base against the heel board and the top pressing on the rear panel just below the greatest bulge. The jack is then worked to push back the panel at the right spots. The heel board will not be bent by this method. The tank is dropped in place with the rear edge down, the front edge is pushed down and the bolt replaced. If this is not possible, remove the tank and repeat the bending of the rear panel or peening of the heel board.

### Taking Care of Belts

A belt for the tractor is not used very often nor very much at a time, and therefore it is likely to wear out more when not in use than otherwise. Generally a belt is either laid on the barn floor or allowed to hang in some dry shed. In either case it is not getting proper care, for it may be gnawed to pieces by rats or mice, and if kept in too dry a place, the rubberized fabric will become rotten and the belt will be ruined. Roll the belt up and tie it securely, then hang it in a dark cellar or cave. The darkness keeps the rubber alive and adds years of life to the belt.

### Increasing Safety of Freight Elevators

By standing too near the edge of the door on freight elevators many an employe has become the victim of an accident. After the landing gates are closed and the elevator rises, it happens occasionally that his foot is caught between the small floor overhang on the next landing and the rising elevator, resulting in serious injury. This danger can be prevented readily by attaching a curved guard of heavy sheet metal to the floor at each landing as shown in the drawing. As the elevator rises, the guard will push the worker's feet warning him to pull them in.—A. Bereskin, Winnipeg, Can.





302

# An Inglenook and Gray Shingles

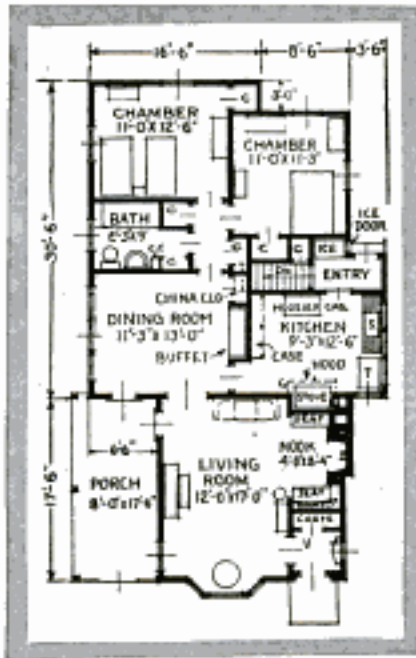

© Architects' Small House Service Bureau



Plan No. 5D25

**T**HIS five-room colonial bungalow won a first prize in a recent architectural competition for small houses. Commenting upon the design, the jury that made the selection said: "The winning plan presents a most interesting and convenient plan arrangement, in charming exterior of the colonial period adapted to a small home." Certainly this design has an unusually graceful character.

A splendid large living room with an inglenook, seats, a fireplace and bay window, practically all of glass, is one of the features of this home. Shingles stained a warm gray are suggested for the exterior wall surface, yet rough, wide siding might be used to good effect. The colonial entrance door with its fanlight and lantern is particularly distinguished. The door is recessed in its frame to obtain some degree of protection for the door and for an interesting shadow effect. Lattice on the porch is in keeping with the delicate detail of the door and the bay window. The outside chimney is of brick with an iron ornament.

The dining room is especially pleasant. If the built-in buffet and china closet are omitted, two feet can be added to the width of this room. The kitchen is built out a few feet beyond the living room, so

it can have both north and east windows. The stove stands in a special niche with hood above, and the refrigerator is placed in the side entry. The two bedrooms each have two exposures, insuring ventilation, sunlight and a pleasing outlook. The bathroom has a small closet for towels and a clothes chute to the laundry.

## Home Builders' Questions

**Q.** Can you put a tile roof on rafters that were designed for shingles? **A.** Not unless the rafters are deeper than necessary for shingles.

**Q.** What is meant by "frost level?" I find the term in the specifications. **A.** Frost penetrates to different levels below grade, depending on the climate. The lowest point reached in the course of a severe winter is called the "frost level."

**Q.** Is thermostatic control practicable and possible in a warm-air furnace? **A.** This type of heat control can be installed in connection with any kind of heating device. It is practical. It will help the uniform heating of your house and will often pay for itself through savings in fuel.

**Q.** Which is less expensive to build, a two-story house or a bungalow of the same accommodations? **A.** A two-story house costs less than a bungalow, assuming that the same accommodations are offered. The bungalow requires more excavation, foundation walls and roof than the other.

**Q.** What is the proper height for the kitchen sink above the floor? **A.** This dimension should be adjusted to the requirements of individuals using the sink most often. Do not set the sink too low. Two feet ten inches to three feet is about right for the average person.

**Q**UESTIONS regarding home building addressed to this magazine will be answered by the Architects' Small House Service Bureau of the United States, Inc., controlled by the American Institute of Architects and endorsed by the department of commerce, United States government. Blueprints, specifications and material lists for the bungalow shown above may be obtained at a nominal cost. Inclose self-addressed, stamped envelope for reply. If further information is desired send five cents and stamped envelope for a 24-page booklet explaining how the small home bureau functions and showing twelve sample plans.

# WHAT YOU WANT TO KNOW

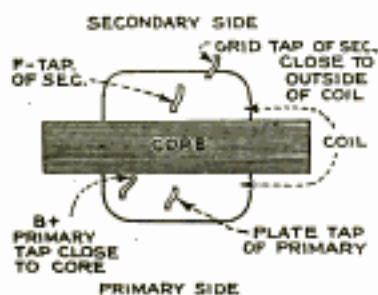

Fig. 1

side goes to the grid; the other to the filament negative. On the primary side, the tap close to the core goes to the B-positive, and the other to the plate. (See Fig. 1.)

**Q.** How can I use an outdoor aerial instead of the loop on my superheterodyne receiver? **A.** Use a variocoupler of the tapped type, with a .001-mfd. variable condenser in the manner shown in Fig. 2. No condenser is required across the secondary of the coupler, as it connects directly to the loop binding posts on the set and is tuned by the wavelength condenser in the set itself. If a three-tapped loop was used with your instrument, connect the secondary-coupler leads to the two outside loop posts on the set, and the center loop post to either of the outside posts with a short jumper wire.

**Q.** Please tell me what an underground antenna is, and how it is built. **A.** The length is the same as that ordinarily used for outdoor aeri-als. No. 14 rubber-covered wire is used. The far end of the wire is well insulated. The whole is buried about 1 ft. under ground, and the end used as a lead-in is brought to the surface directly under the window. Some experimenters shield the lead-in from the point where it leaves the ground to the binding post on the set by slipping it into lead pipe and grounding this pipe to prevent that part of the aerial from picking up energy from the air. This type of aerial is claimed to be practically non-directional and to be well suited for locations where static is annoying.

**Q.** I have been planning on building a reflex receiver, and some of my friends have told me they have had trouble with this type of set. What is the objection to this type of circuit, if any? **A.** The commonest difficulty encountered in reflex circuits is the control of oscillation, and tube oscillation results in loss of tone quality. With properly constructed apparatus, this difficulty can be eliminated.

**Q.** How can I make a variocoupler out of my variometer? **A.** This is very simple; all that is necessary is

**Q.** I have two a. f. transformers and the terminals are not marked. Please send me a diagram showing me how to pick leads. **A.** The secondary side can be determined by the fact that the taps are closer to the outside of the coil than on the primary side. The secondary tap close to the out-

side goes to the grid; the other to the filament negative. The same size wire can be used. The rotor now becomes the secondary and the stator the primary. The primary coil is then tapped off every five or ten turns to suit the builder.

**Q.** Please give me data for making toroid or "doughnut" coils. I have tried several methods and have had very little success. **A.** The doughnut coil is very difficult for the experimenter to make. Owing to the peculiar shape of the coil, special instruments are required for winding it successfully. These coils are not expensive and there are several good makes now on the market.

**Q.** I have been informed that the government is to lower all wavelengths for broadcasting, and for this reason I have been postponing the building of a set. When is this change to take place? **A.** While there has been some talk along these lines, there is no reason to believe that there will be a change this season. Almost any type of set now in use can be adapted to shorter waves, so it would not be wise to deprive yourself of the pleasure of the good programs of the coming season, waiting for a change that probably will not take place for some time to come.

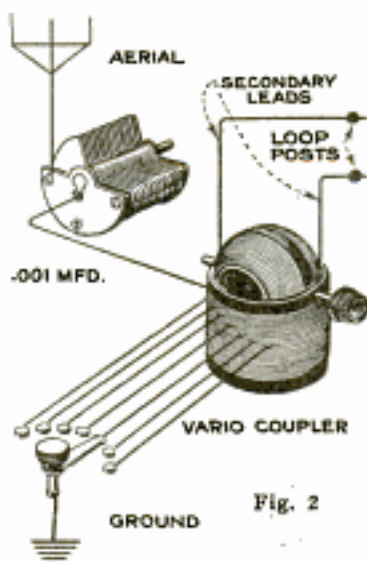

Fig. 2

**Q.** I am using a 10-to-1 a. f. transformer in the first stage and a 3½-to-1 in the second stage; is this correct? I do not get as clear signals as I believe I should; there is some distortion. How can I prevent this? **A.** High-ratio transformers will often cause distortion. Try 3½-to-1 ratio a. f. transformers in both stages. The transformer in the second stage could be of even lower ratio. When mounting transformers of some types, cores should be placed at right angles to prevent interaction. Grid and plate leads should always be as short as possible to get best results in receiving, and should never run parallel.

**Q.** Please send me a simple diagram showing how to make my set regenerative. **A.** You will find the diagrams in Fig. 3. The left sketch shows the usual method.

The plate current runs through a tickler coil, which is coupled to the tuner coil in the grid circuit. The tuner coil can be either a single inductance, or the secondary of a two-circuit tuner. The method given at the right is to tune the plate circuit with a variometer.

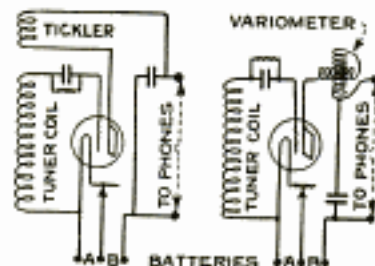
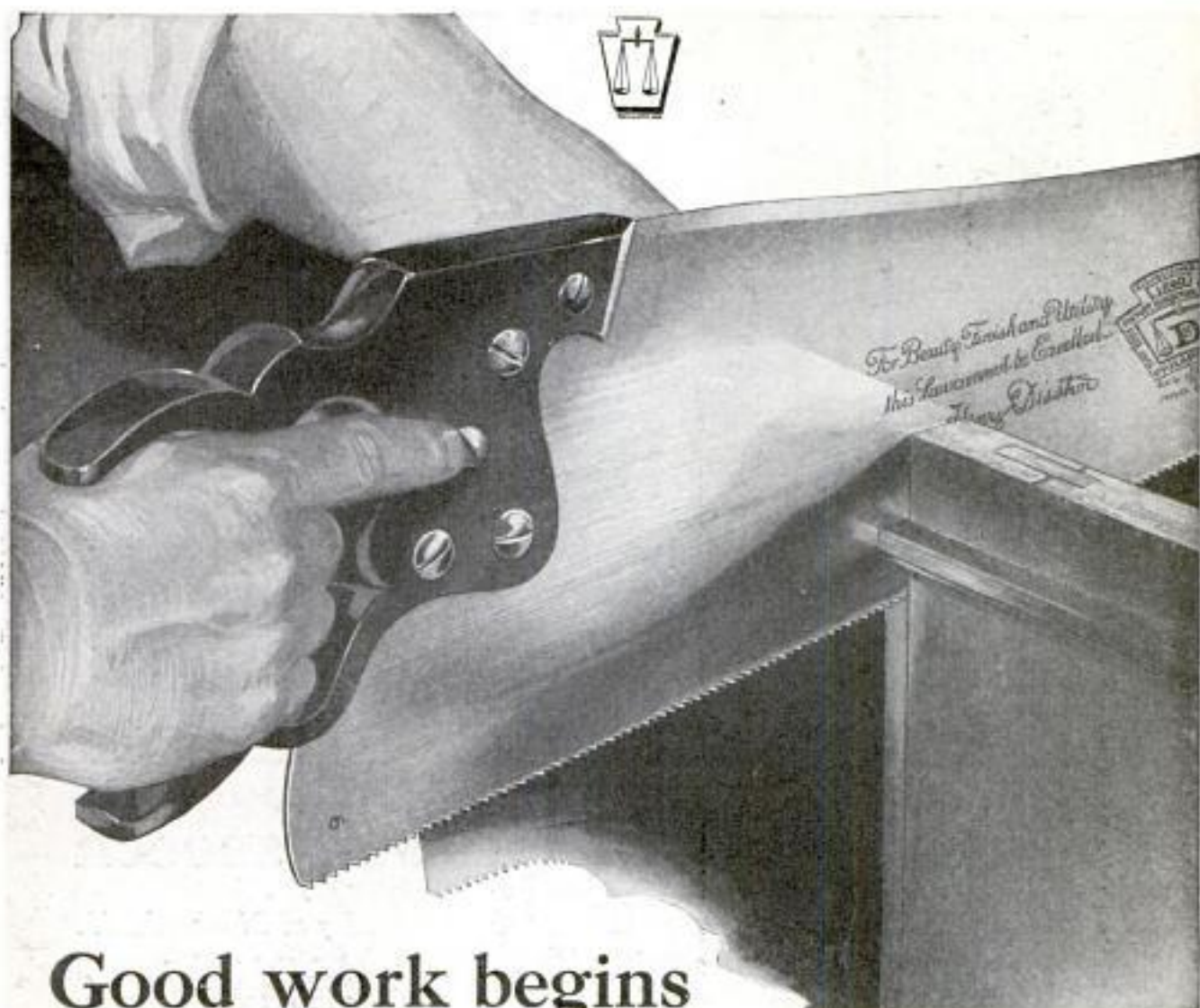

Fig. 3

**I**N accordance with the editorial policy of this magazine never to accept compensation in any form for what appears in our reading pages, and also to avoid all appearance of doing so, we are obliged to omit the name of the maker or the seller of any article described. This information, however, is kept on file and will be furnished free, by addressing Bureau of Information, Popular Mechanics Magazine, Chicago. [Editor.]



## Good work begins with the way the saw cuts

**N**O man can turn out good work unless the sawing is well done.

And for good sawing, easy and fast and clean, you must have a saw that *cuts*.

A saw such as Henry Disston figured out, years ago. A saw of Disston Steel, made by Disston-trained sawmakers.

The Disston Saw, everywhere, is "The Saw Most Carpenters

Use" because the carpenter chooses a saw for its cutting.

The Disston name on a saw means balance that works with hand and arm. It means the temper, spring, and edgholding that Disston Steel alone can give.

It means a saw that cuts—keenly, fast, and true.

Your hardware dealer, too, will tell you this about the Disston Saw.

### Ask Disston

Tell us what work you are doing, in wood, metal, stone, ivory, rubber, leather, cloth, fibre or other material. We will tell you how to saw it better and easier. Disston issues many books to aid saw users.

HENRY DISSTON & SONS, INC., PHILADELPHIA, U. S. A.

# DISSTON

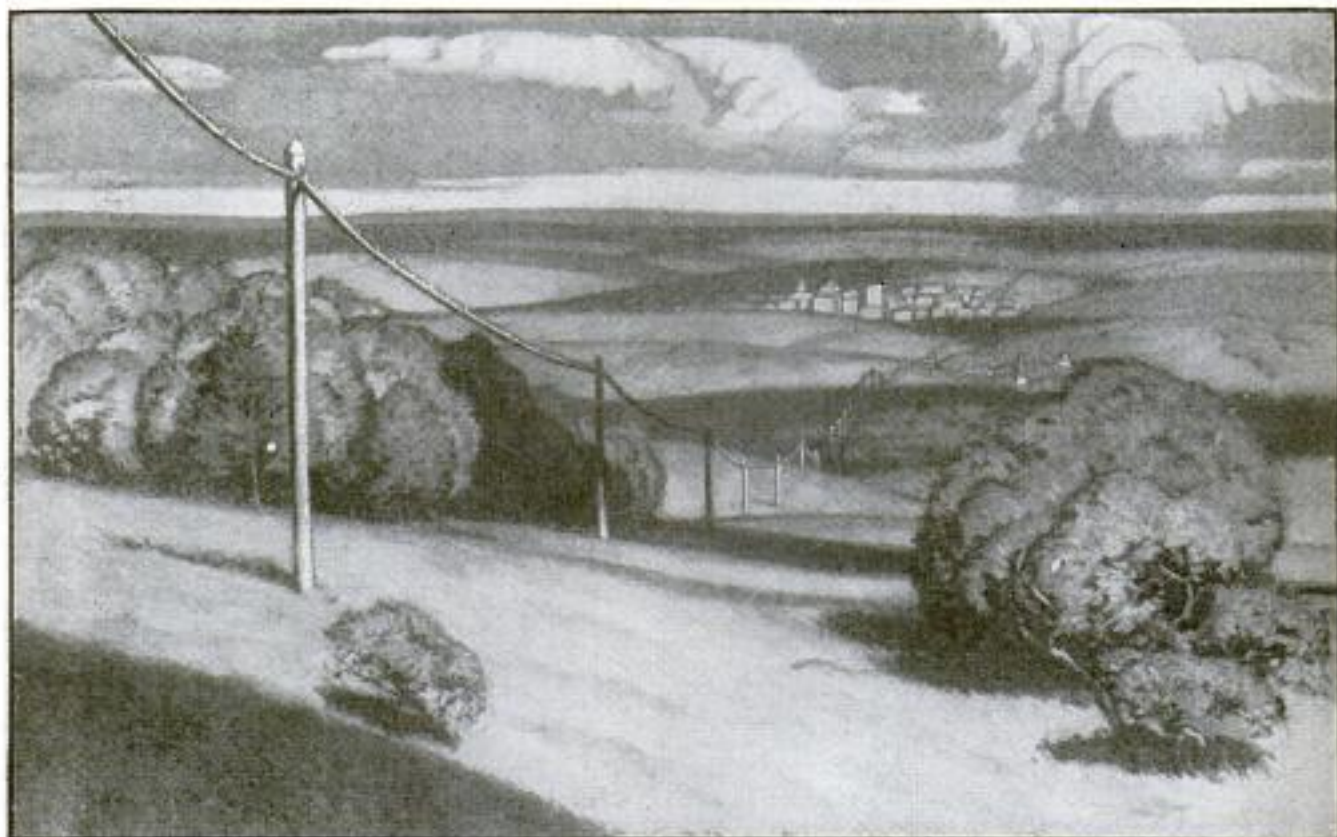

## Safeguarding the lanes of speech

The New York-Chicago telephone cable has been completed and is now in service. A triumph of American telephone engineering, the new cable is the result of years of research and cost \$25,000,000 to construct. Its first reach extended along the Atlantic seaboard, then steadily westward until this last long section to Chicago was put into service.

To the public, this cable means dependable service irrespective of weather conditions. It is now not likely that sleet storms, which at times interfere with the open wire type of construction with 40 to 50 wires on a pole, will again cut off the rest of the nation from New York or from the nation's capital as did the heavy

sleet storm on the day of President Taft's inauguration.

The new cable means speedier service, as it provides numerous additional telephone circuits and will carry a multitude of telephone and telegraph messages. It would take ten lines of poles, each heavily loaded with wires, to carry the circuits contained in this most modern artery of speech.

This cable, important as it is, is only one of the Bell System projects that make up its national program for better telephone service to the subscriber. It is another illustration of the System's intention to provide the public with speedier and even more dependable service.



**AMERICAN TELEPHONE AND TELEGRAPH COMPANY  
AND ASSOCIATED COMPANIES**

**BELL SYSTEM**

*One Policy, One System, Universal Service*

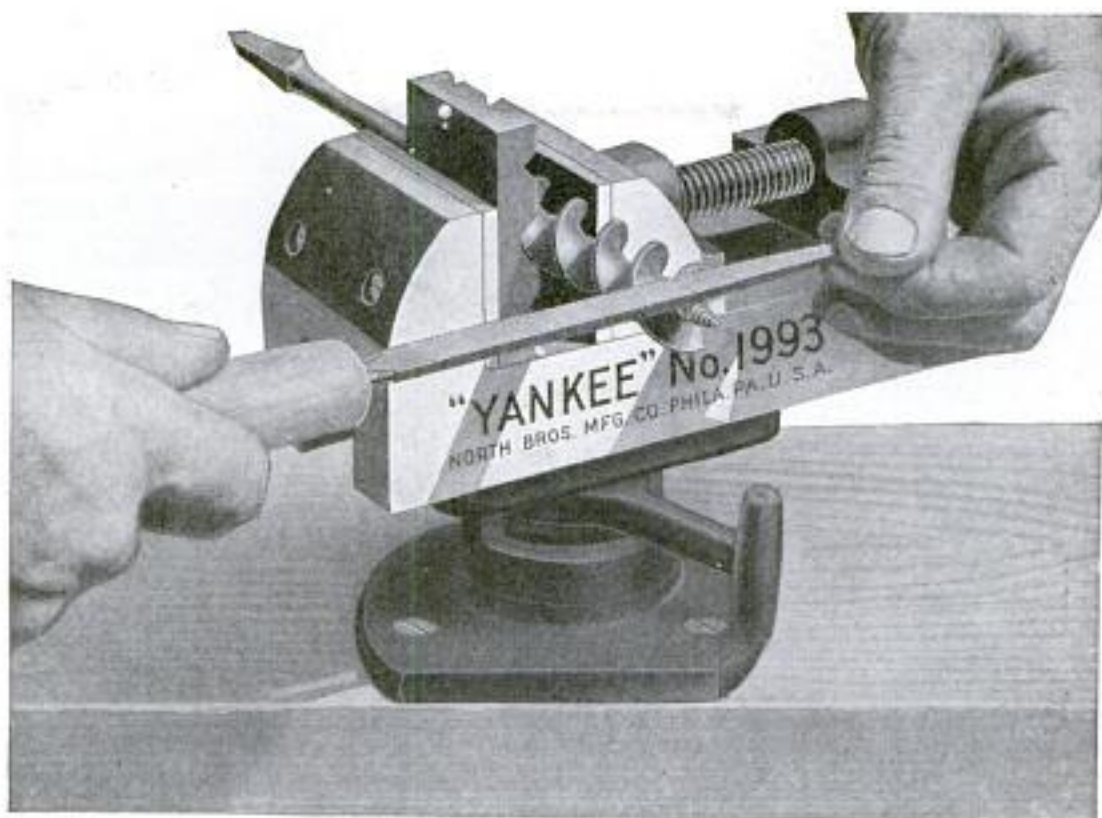

## The Handiest Vise in the World

You can do work with this "Yankee" Vise that is impossible with any other—and do it with speed, accuracy and ease.

Not only has a swivel base so you can turn it around in any position, but detaches from its base.

You don't have to remove work from vise until entire job is completed—simply lift vise, work and all, off base, and carry to drill press, milling machine, etc.

Sides, ends, bottom and top are machined true.

Hardened steel block with V-shaped grooves of various sizes holds round or irregular work.

You can get the size most convenient for your work.

No. 1991—Jaws open, 1½"

No. 1992—Jaws open, 2"

No. 1993—Jaws open, 2¾"

No. 1994—Jaws open, 4"

The gift of "Yankee" Tools is sure to be appreciated. Ask your hardware dealer to help you in your selection.

### "YANKEE"

#### Christmas Suggestions

- No. 30-A—Spiral Ratchet Screw Driver
- No. 41—Automatic Push Drill
- No. 1555—Ratchet Breast Drill
- No. 1431—Radio Drill
- No. 1992—Vise with Swivel Base
- No. 2100—Ratchet Bit Brace
- No. 105 & 106—Radio Tool Sets

Dealers everywhere sell "Yankee" Tools

*"Yankee" on the tool you buy means the utmost in quality, efficiency and durability*

Write for FREE "Yankee" Booklet

NORTH BROS. MFG. CO., Philadelphia, U. S. A.

# "YANKEE" TOOLS

*Make Better mechanics*

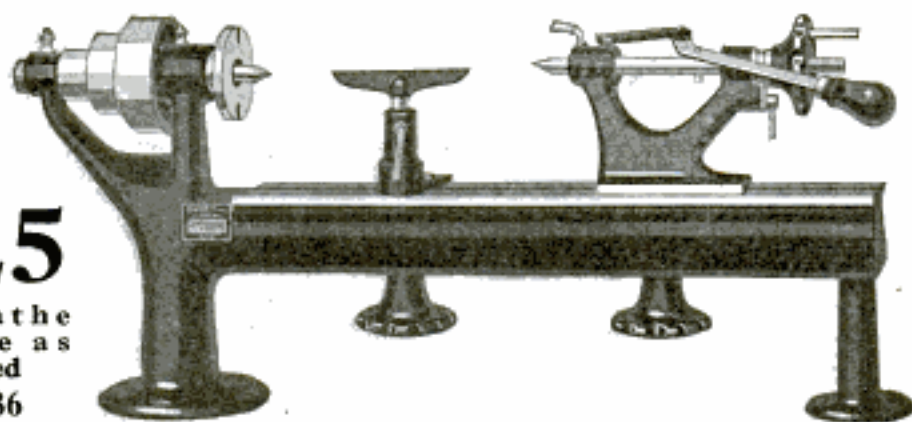
No. **125**Bench Lathe  
Complete as  
Illustrated  
Price \$36

## Turning and boring in your home shop

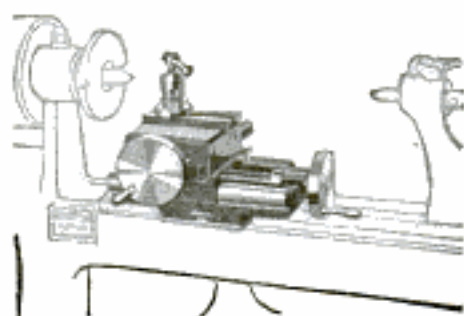
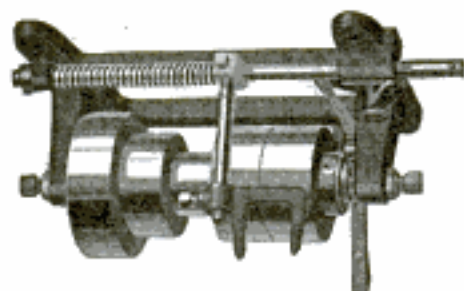
No. **132** Slide Rest  
Price \$16No. **130** Counter Shaft  
Price \$11

### Bench Lathe No. 494

Same construction as No. 125 above, but slightly larger. Length over all, 31 inches. Height, 11 $\frac{1}{2}$  inches. Swing, 7 inches. Extreme distance between centers, 18 inches. Weight, 36 pounds. Price, \$40.

**A**S soon as you set up this lathe on your work-bench, you are ready for all sorts of boring and turning jobs. Just the right size for a small workshop. Length over all, 25 inches; height, 11 $\frac{1}{2}$  inches; swing, 7 inches; extreme distance between centers, 12 inches. Weighs only 30 pounds.

Well made and finished with black and red enamel. The bed is milled. All working parts handsomely polished. Live spindle has a cone bearing to take up wear. Tail stock has screw and lever feed. Cone pulley has three steps—1 $\frac{1}{2}$ , 2 $\frac{1}{2}$  and 3 $\frac{1}{2}$  inches in diameter.

A complete line of attachments are available to fit this lathe, such as slide rest, lathe tools, compression check and collets, milling attachments, turret attachments, etc.

### Interesting Bench Lathe Booklet Free

Shows all the Goodell-Pratt Bench Lathes, also various attachments that enable you to do all sorts of turning, boring, milling, sawing jobs, etc. Gives the amateur mechanic many new and valuable hints for working out his ideas. A post card will bring you a copy of the booklet free. Just ask for the Goodell-Pratt Special Bench Lathe Booklet.

GOODELL-PRATT COMPANY  
GREENFIELD, MASS., U. S. A.

*Toolsmiths*

Makers of Mr. Punch

# GOODELL-PRATT

## 1500 GOOD TOOLS

# Sitting pretty on top of the world

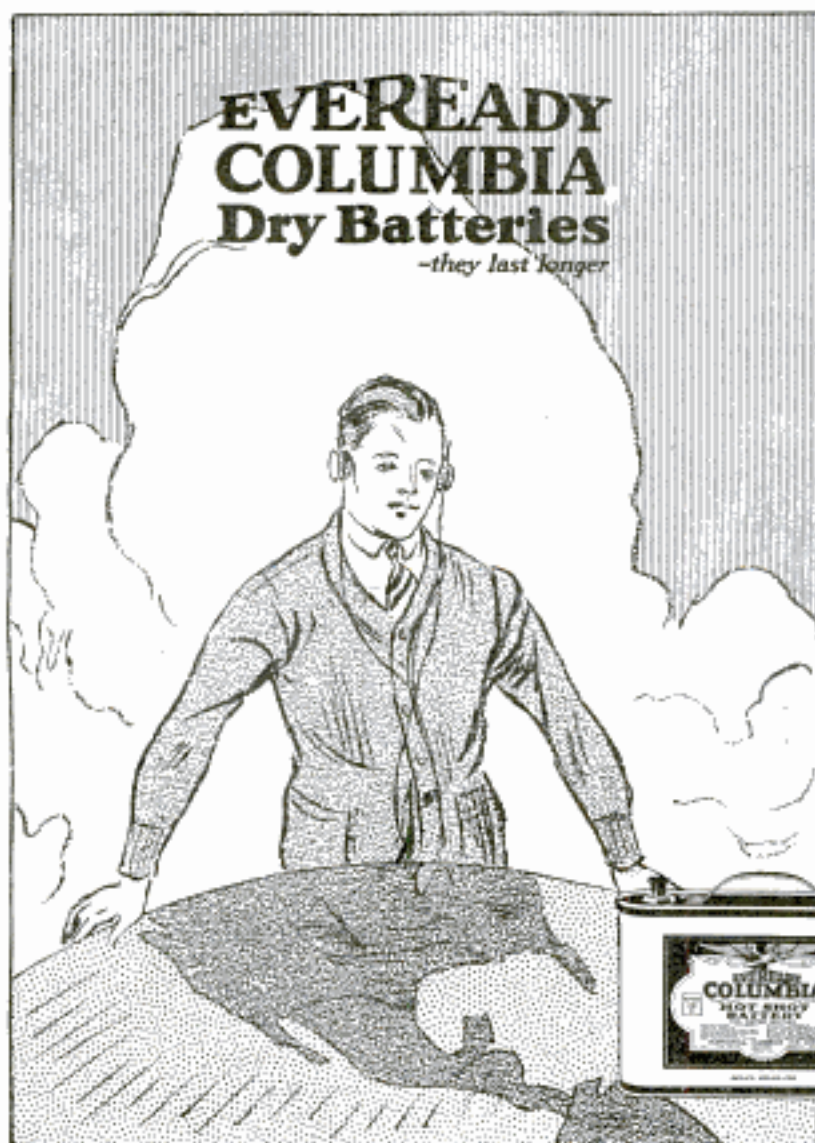

**EVEREADY  
COLUMBIA  
Dry Batteries**  
*-they last longer*

Popular  
uses  
include—

radio "A"  
gas engine ignition  
tractor ignition  
starting Fords  
firing blasts  
heat regulators  
doorbells  
buzzers  
ringing burglar  
alarms  
protecting bank  
vaults  
calling Pullman  
porters  
motor boat  
ignition  
telephone and  
telegraph  
lighting tents and  
outbuildings  
electric clocks  
running toys

Eveready  
Columbia Hot  
Shot Batteries  
contain 4, 5 or  
6 cells in a neat,  
water-proof  
steel case.



Fahnestock  
spring clip  
binding  
posts on  
Eveready  
Columbia  
Ignitor at  
no extra  
cost to you.

HOMES whose radio sets are battered with Eveready Columbia Ignitors have the pick of the programs of America. Eveready Columbias put you on top of the world by radio. They light the filaments of dry cell tubes day after day, night after night. Wise buyers always specify them, just as did the engineers who took this battery as the standard by which to design the dry cell tubes. That's why Eveready Columbias are as supreme for radio as they have been for years when used for ignition and hundreds of general uses. There is an Eveready Columbia dealer nearby.

*Manufactured and guaranteed by*

**NATIONAL CARBON COMPANY, INC.**  
New York San Francisco

Canadian National Carbon Co., Limited, Toronto, Ontario



## A Gift that Inspires Gratitude

**F**OR father or mother; for son or daughter; for teacher or pastor; for dearest friend.

This Christmas Portable may be had in our handsome Christmas package without extra charge. For sale by over 5,000 dealers and Remington branches everywhere. Easy payment terms, if desired. Write for illustrated booklet, "For You—For Everybody". Address Department 12.

REMINGTON  
TYPEWRITER COMPANY  
374 Broadway, New York

BRANCHES EVERYWHERE

# Remington Portable



# "American Flyer"

MINIATURE TRANSPORTATION SYSTEMS

ELECTRIC  
and  
MECHANICAL  
RAILROADS



No. 1434. Complete Train Outfit  
as illustrated with all accessories \$59.00  
and transformer, delivered . . .

## The Boys of America Designed This Train

The "ALL AMERICAN"—a New Wide Gauge Electric

When we started to build this NEW FEATURE TRAIN we asked hundreds of boys what they would like to have in a WIDE GAUGE Electric Train, that's why we say: "The Boys of America Designed This Train," because we have put into it just the "features" which make it the logical "first choice" of any boy who knows what a Big Electric Train should be like.

### Exclusive Features of the "ALL AMERICAN" Wide Gauge Train

1. Automatic Reverse. 2. Automatic Headlights, reverse as train reverses. 3. Heavy underframe with cow-catcher. 4. Real Automatic Couplers. 5. Two Electric Lights in cars. 6. Dome Light on car platform. 7. All cars lithographed on heavy steel (not painted). 8. Automatic Mail Bag Catcher with bags. 9. Car Roofs removable. 10. Vestibule Spring Doors, four sliding doors on baggage car. 11. Lowest Voltage Motors made, economical to operate. 12. Universal Track Terminal for accessories.

## There Are Lots of Other "American Flyer" Models

Sturdy Mechanical Trains for the smaller boys—"0" Gauge Electrics that any boy would be "tickled pink" to own—each the best in its class.

Show this advertisement to your toy dealer. Ask him to show you the new big "American Flyer"

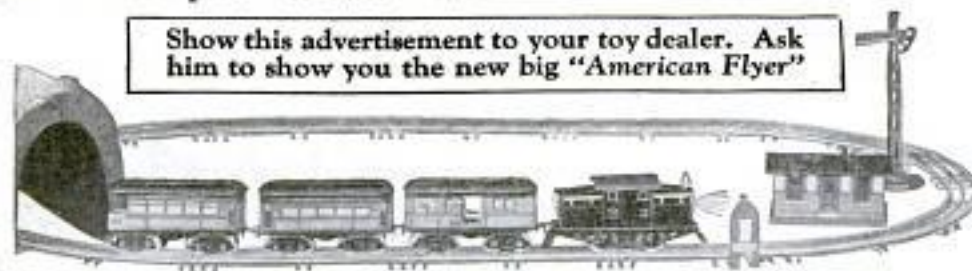

Train No. 1221—(No. 0 Gauge Track). Heavy pressed steel electric engine with headlight, 8 inches. Complete as shown, including tunnel, station, semaphore and automatic mail bag catcher. Double truck cars with disappearing couplers, 6 1/2

inches. Baggage car has sliding doors. Passenger car and observation car have interior electric lights. Eight pieces curved, six pieces straight track. Length of train 31 inches. Length of track 142 inches. **\$12.25**  
Weight 10 1/4 pounds. Price . . . . .

Train No. 13—Engine 7 inches. Equipped with piston rods and brake. Cars 5 1/2 inches. Baggage car has sliding doors. Ten pieces curved, two pieces straight track, two switches. Length of track 160 inches. Length of train 25 inches. Weight 5 pounds. Train can be switched from large oval to small oval by opening or closing both switches. Price **\$4.25**



Ask at the Toy Stores to see all the "American Flyer" Models—if you can't find the Outfit you want we will send you one from the factory, postpaid, on receipt of price. Our NEW 4-color Catalog is ready—it's quite an expensive book but we'll be glad to send you one. Just send us 4 cents in stamps to cover cost of mailing.

American Flyer Mfg. Co., 2233 South Halsted Street, Chicago

*Good Tools  
are a  
Mechanic's  
Strength*



**B.S.**

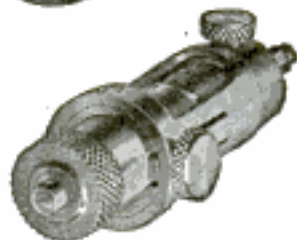
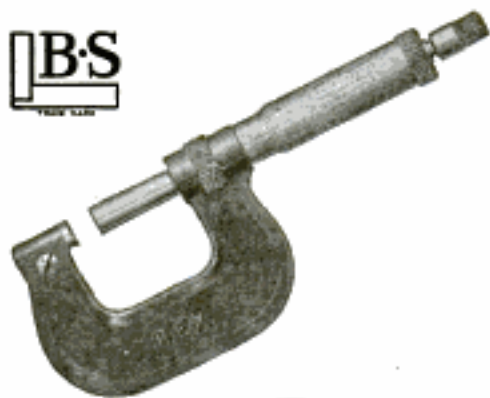

To be an expert mechanic you need not have the muscular development of a great athlete. Your strength lies in your tools and in your skill to use them. If you own a kit of good tools, you are prepared to try your skill with the best of mechanics. With poor tools your skill is hindered and you cannot do your best.

When your kit is Brown & Sharpe equipped, you can do better and quicker work.

*Write for Small Tool Catalog No. 29. It lists over 2,000 Brown & Sharpe Tools in which you will be interested.*

**BROWN & SHARPE MFG. CO.**  
PROVIDENCE, R. I., U.S.A.

**BROWN & SHARPE TOOLS**

*"Standard of the Mechanical World"*

**IVES Push Button Control**—stops and reverses  
the engine by a touch of the finger

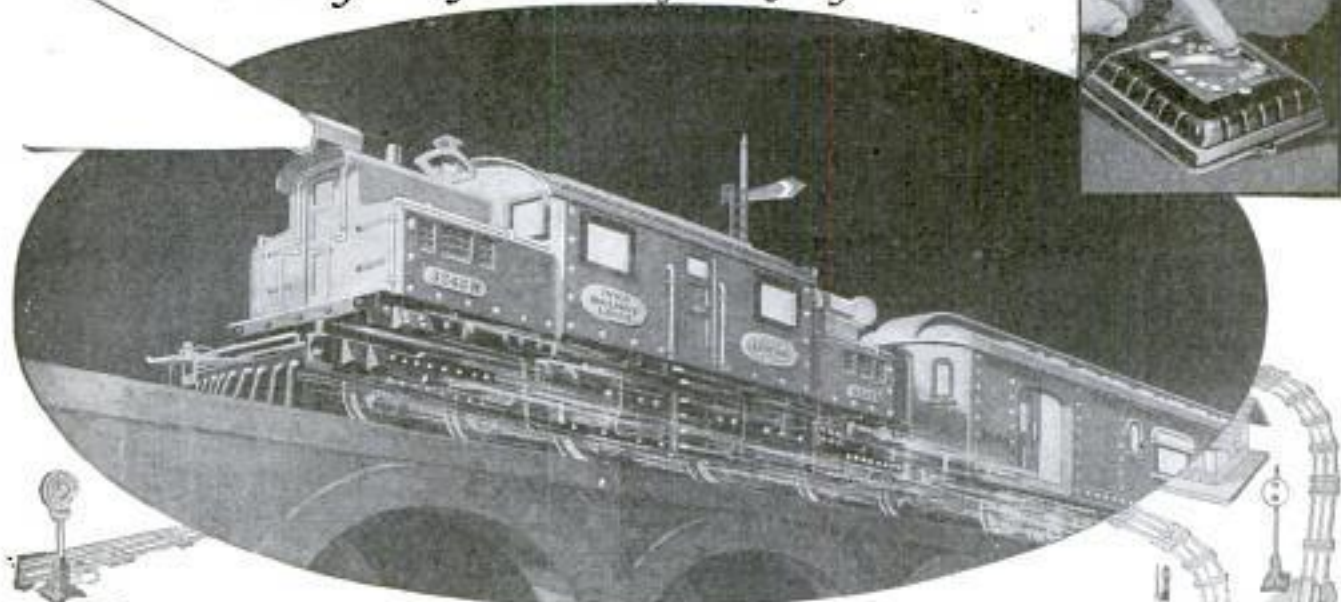

**Of course you want an  
electric train for Christmas!**

**But be sure you get a real one  
with all the 1925 improvements**

THERE are many new, exclusive features in the 1925 Ives Electric Trains that will bring you hours and days and weeks of wonderful fun. Probably the biggest one of all is the electric reversing locomotive that made such a big hit last year.

This year the noted Westinghouse engineers and skilled Ives workmen have so perfected the control switch that now you need not even move the lever. You set this control switch for the speed you want. Then just a pressure of your finger on the button—the engine stops! Another touch—it backs!

It's a great sensation to see your locomotive reverse itself electrically at any position on the track without touching it by hand. Remember, boys, no other trains but Ives have electric reversing locomotives with the automatic push button control. And this year you can have an Ives Electric Reversing Locomotive (Series R) on either 0-gauge or 2 $\frac{1}{4}$ -gauge track.

Ives Trains are exactly like the modern equipment of famous railroads. Cars are electrically lighted and attractively finished in every detail. Every locomotive has worlds of power. The small motors in

the lower-priced locomotives are as carefully made as the big ones and are as powerful in proportion to their size.

There is an almost endless variety of passenger and freight cars, electric target signals and semaphore signals with electrically-operated arms, bridges, tunnels, stations, and the efficient Ives Transformers. Prices range from the \$1.50 mechanical train to the big complete \$50 electric outfit.

**32-page Book in colors tells  
all about the new features**

Send for the 32-page book of Ives Trains and Accessories. It contains illustrations in colors of the full line and tells all about the new 1925 features exclusive with Ives. Mail the coupon today with 10 cents.

Toy, department, electrical, hardware and sporting goods stores sell Ives Trains. THE IVES MANUFACTURING CORPORATION, Dept. D-3, 198 Holland Avenue, Bridgeport, Conn.

**Speed me on my way  
to Bridgeport—I'll bring  
you the IVES Book**

THE IVES MANUFACTURING CORPORATION  
Dept. D-3, 198 Holland Avenue, Bridgeport, Conn.  
Please mail me your 32-page railroad book, illustrated in colors. I enclose 10 cents (U. S. stamps or coin).

Name .....

Address .....

City..... State.....

**IVES ELECTRIC AND MECHANICAL TRAINS**

# SARGENT

## PLANES



*Sargent Steel  
Block Plane  
No. 5206*

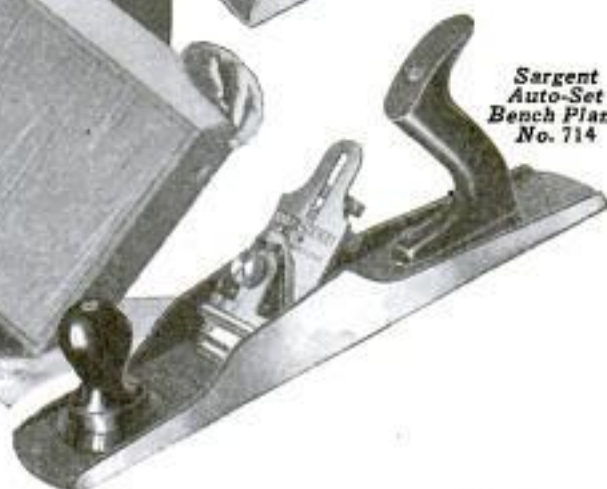

*Sargent  
Auto-Set  
Bench Plane  
No. 714*

## Be sure the planes you buy come up to Sargent standards

YOU may never have to put your plane to the tests that most carpenters give theirs. Nevertheless you want your work to have the finish that only the best of planes can give. The same qualities that make Sargent Planes the choice of carpenters should govern your selection.

**Sargent Construction:** Wear-resisting materials are used throughout. Chromium steel is used for the cutters—an unusually tough metal that takes a keen edge and holds it.

**Sargent Performance:** Absolute rigidity of cutter, even across and

against the grain or over knotty surfaces. Adjustments quickly and easily made. In the Sargent Auto-Set (the larger plane illustrated) the cutter can be removed, sharpened and replaced without changing original adjustment.

**Sargent Economy:** Sargent Planes are moderate in cost and prove a real economy by improving work and saving time. Seldom if ever do they need repair or replacement.

The two Sargent Planes shown here should be in every home and school workshop. See them at your dealer's. Write for booklet.

**SARGENT & COMPANY, Manufacturers**  
49 Water Street New Haven, Conn.



Sent  
for  
**\$2**  
XMAS  
GIFTS



**CG1**—Dinner ring; beautiful lace design, 18Kt. white gold, three blue-white diamonds and two French sapphires. Special price... \$42.50



**CG2**—Attractive Bow-Knot design ladies' ring of 18Kt. white gold set with a first quality blue-white diamond. Special price... \$22.00



**CG3**—Daintily pierced ladies' ring of 18Kt. white gold set with genuine perfect cut blue-white diamond. Special price... \$37.50



**CG4**—Genuine imported black onyx set with perfectly cut blue-white diamond; 18Kt. white gold pierced mounting. Special price... \$18.75



**CG5**—A genuine perfectly cut diamond, is set in this ladies' hand pierced mounting of 18Kt. white gold. Special price... \$11.75



**CG6**—Two perfectly matched blue-white diamonds; 18Kt. W. G. mounting to resemble two cut solitaire; sapphires on sides. Special price... \$57.50



**CG7**—Wedding ring of 18Kt. white gold, hand engraved with five perfectly cut, blue-white diamonds. Special price... \$30.00



**CG8**—Ladies' hand pierced mounting; 18Kt. white gold; large diamond in center and two matched diamonds on sides. Special price... \$100.00



**CG9**—Popular hand pierced ladies' ring of 18Kt. white gold; large, fiery first quality blue-white diamond. Special price... \$65.00



**CG10**—Men's serial design mounting, 18Kt. white gold; set with a perfectly cut blue-white diamond. Special price... \$75.00



**CG11**—Ladies' pocket watch; elegant wrist watch of solid 18Kt. white gold; highest grade 17 ruby and sapphire jeweled movement. Life time guarantee. Special price... \$20.00



**CG12**—Gentlemen's newest style mounting of 18Kt. white gold set with first quality blue-white diamond and two French blue sapphires. Special price... \$50.00



**CG13**—In this ladies' artistically carved hand pierced mounting of 18Kt. white gold is set a fine quality blue-white diamond. Special price... \$50.00



**CG14**—Two beautifully matched blue-white diamonds, set in beautiful hand pierced mounting, 18Kt. white gold. Price... \$36.75



**CG15**—Genuine blue-white diamond set in rarest cut; ladies' hand engraved mounting, 18Kt. white gold. Special price... \$75.00



**CG16**—Scraper pin; solid platinum top set with finest quality blue-white diamond, beautifully engraved; 14Kt. white gold pin. Special price... \$27.50



**CG17**—Beautiful Elgin watch; also this model Elgin watch hand engraved case, guaranteed twenty years. Hand lettered silver dial. Special price... \$16.50

**\$2 Brings Your Choice**

**NO RED TAPE—NO DELAY**

Simply send \$2.00 and your choice goes to you charges paid. You have ten days in which to decide. Money back instantly if you are not satisfied as to the quality and value.

**Ten Days' Free Trial**

Send only \$2.00 and your choice goes to you in handsome gift box all charges paid. Guarantee Bond attesting to quality and value accompanies each shipment.

**A Full Year to Pay**

Simply send \$2.00 and receive your selection, all charges paid. After trial pay balance in 12 monthly payments. 10% discount for cash.

**Free Royal Xmas Catalog**

The most complete Catalog ever published of Diamonds, Watches, Jewelry, Silverware, Cameras, Ivory Toilet Sets, etc., sent FREE. Prices from \$5.00 to \$1000—quality the highest. Ten days' trial and a full year to pay on everything you order from our \$2,000,000 stock. Send for your copy today. Dept. 1498.



**ROYAL DIAMOND & WATCH CO.**  
170 Broadway New York

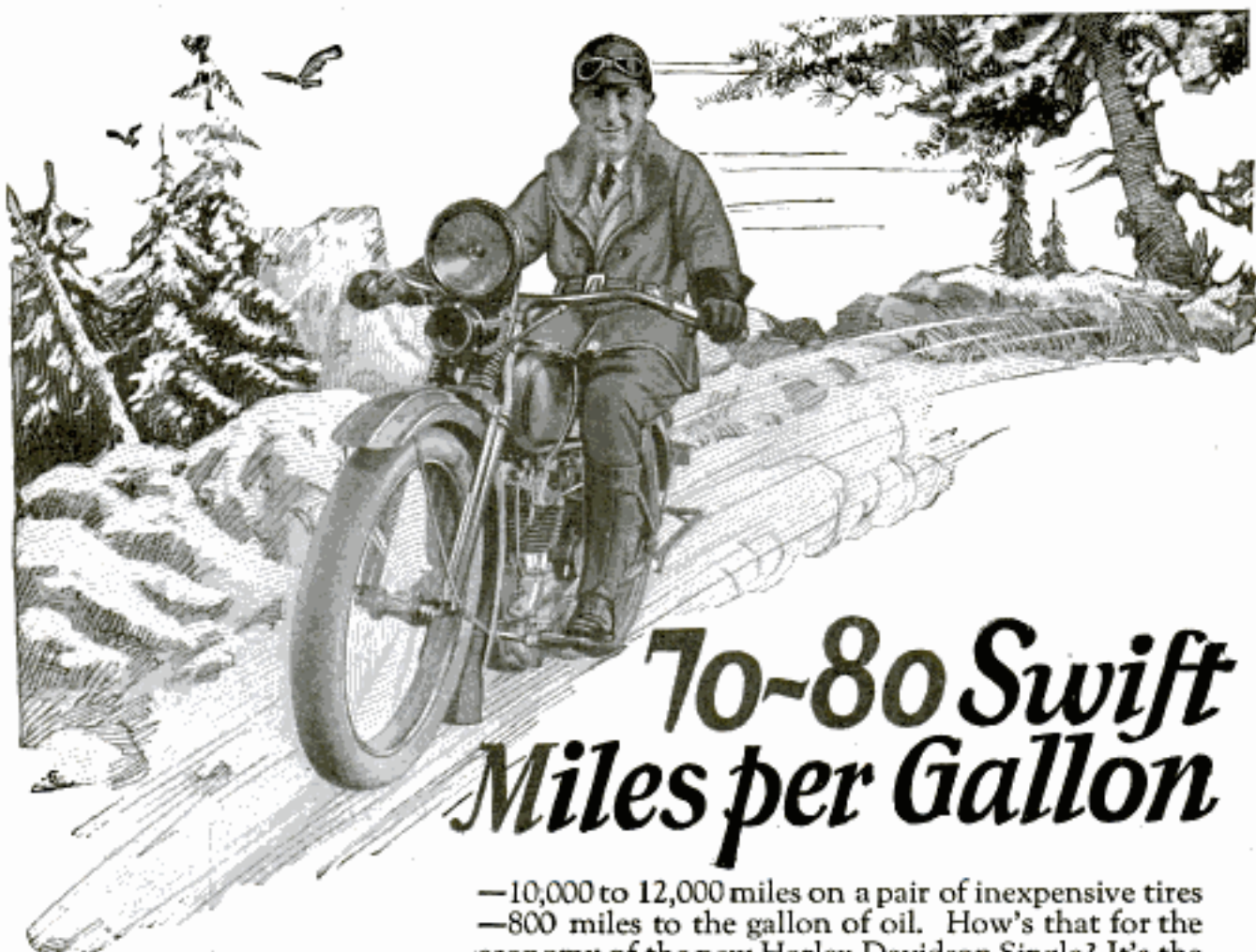

## 70-80 Swift Miles per Gallon

—10,000 to 12,000 miles on a pair of inexpensive tires  
—800 miles to the gallon of oil. How's that for the economy of the new Harley-Davidson Single? It's the type of motorcycle you knew would come some day.

Easy to ride—beginners learn within a city block. Easy to park. Easy to garage and care for.

And the performance! Ride it over trail or highway—on pleasure ride or hunting trip. See how swiftly and smoothly the Single hums over hills and through slush or mud. Ample power and speed!

Ride it to business. The saving in fares covers the operating costs and then some.

See the new Single at your Harley-Davidson Dealer's today. The low price will amaze you—and even that you can pay-as-you-ride.

**Mail the Coupon**

HARLEY-DAVIDSON MOTOR COMPANY  
Dept. P Milwaukee, Wisconsin

# Harley-Davidson The Motorcycle

Harley-Davidson Motor Company, Dept. P, Milwaukee, Wisconsin.  
Send me, FREE, interesting literature showing the new Harley-Davidson Single.

Name.....

Street or P. O. Address.....

City..... State.....



Money-making sales opportunities in open territories. Ask how others have made big successes selling Harley-Davidsons.

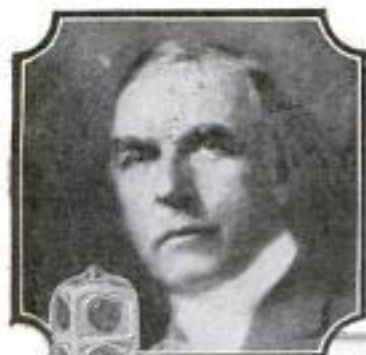

### The Late A. H. Smith

Famous President of the New York Central Lines, under whose direction the gigantic task of electrifying the road from New York City to Harmon, N. Y., was accomplished.

The boys who today are learning railroad principles by running their Lionel Model Railroads are fitting themselves to be America's transportation leaders of the future.

Lionel Automatic Train Control. The greatest achievement in model railroad engineering. Starts and stops trains automatically. Just one of the many wonderful realistic railroad devices in the Lionel line of Accessories.



## Lionel Trains and Real Trains Differ only in Size!

**WHEN** you wake up Christmas morning and see your own Lionel Model Railroad—

You'll be the happiest boy in town.

Lionel engineers are skilled in the art of developing electrically and mechanically perfect Model Trains and Railroad Accessories in exact reproduction of the latest big electric railroad devices.

For twenty-five years they have built Lionel Model Railroads, Multivolt Transformers and Model Railroad Accessories that *look like* real trains and *work like* real trains.

Lionel Standard Locomotives for 1925 are more powerful than ever. They are equipped with the wonderful "Three-point armature shaft bearing Super-Motor" and new reduction gearing that greatly increase hauling power and reduce current consumption.

Be sure to examine the great detail of Lionel Locomotives, Coaches and Accessories—the powerful 8-wheel, twin-motor locomotives for both Standard and "O" Gauge Track—real electric headlights—Lionel automatic couplers—the latest 6-wheel trucks on the largest Pullman

and observation cars—interior car lighting—everything that represents a real railroad.

Take father and mother to your store to see these amazing Lionel Model Railroads. Then you'll know and they'll know why more Lionel Railroads were sold last year than any other make. And remember: Lionel trains are lowest in price consistent with high quality—complete outfits from \$5.75 up. (Slightly higher in the far West.)

For sale at all good toy, hardware, sporting-goods, electrical and department stores.

### The LIONEL CORPORATION

Dept. D 48-52 E. 21st STREET  
NEW YORK CITY

The new Lionel catalog is a wonder book of model railroads—44 pages in actual colors. It shows the complete Lionel line. Send for it today—it's free.

LOOK FOR THE PATENTED LIONEL FEATURES



The Lionel Bell Warning Signal—As the train approaches the grade crossing, bell automatically rings—stops ringing as soon as train has passed. Steel construction throughout.



No miniature railroad is complete without the new Lionel Automatic Crossing Gates. Down goes the gate as the train approaches—up again when the train has passed. It works by itself—just like the real ones.



Lionel "Multivolt" Transformers—Ever-reliable power plants. Run all trains best. A type for every size train.

"STANDARD OF THE WORLD SINCE 1900"

# LIONEL ELECTRIC TRAINS

MODEL RAILROAD ACCESSORIES

## "MULTIVOLT" TRANSFORMERS

## Ozarka Senior Console—\$197.50 East of Rockies

*Complete with Tubes, Batteries and Speaker*



## If Your Radio Is Bought Right It Will Be a Life-Long Pal

**A** LITTLE more time, a little more care in making the selection in the first place generally tends to more lasting satisfaction.

Out of every 100 Ozarkas sold in 1922 only eight are not today in the hands of the original owners—this does not include 17 out of each 100 who have purchased later Ozarka models in newer type cabinets. If there is a single Ozarka that is not in active service today, we have never heard of it.

Without the Ozarka Service in charge of direct factory trained representatives, such a record would not be possible. Ozarka service can be had today in almost every country. Purchasers in South Africa, Alaska, Sweden, Newfoundland, New Zealand, and Japan all receive the same practical service as those in Canada, United States, Mexico and Cuba. Whenever you find the sign of the Ozarka long distance

# OZARKA

120 Austin Avenue P,  
Chicago, Illinois



YOU'LL KNOW  
THE MAN BY  
THIS BUTTON





goose, you'll find a man who knows Ozarka instruments perfectly.

If such service added more to your cost price it might be a matter to consider, but it doesn't. Quality for quality, you'll find Ozarka prices lower—four tube Ozarkas with built-in loud speakers retail for \$58.00—five tube with built-in speaker \$64.00, up to solid walnut console design, \$160.50.

Our nearest representative will gladly set up an Ozarka in your home, without any obligation whatever. He won't tell you what it will do—he will let you do all the tuning. With the Ozarka you must satisfy yourself as to distance, tone, volume, ease of tuning and selectivity.

More than this you will be very agreeably surprised at Ozarka prices—selling as we do, thru our own direct factory representatives, our selling expense is very low—we give Ozarka purchasers the benefit of it.

Where is there a value to compare with the one shown above—solid walnut cabinet (no walnut finish or veneer), imported English loud speaker of a marvelous tone, five tube instrument with 75 ampere Exide storage battery, 90 volts of Eveready "B" battery, 5 tubes, aerial equipment all erected and the price is only \$197.50?

## A Few More Men Are Needed to Sell Ozarka

In a great many counties we have the man we want. He is rapidly building up a permanent and profitable business of his own, because he has an instrument that will more than meet all competition. More than this, he is trained to back up his sales with the kind of service that counts.

Many well established Ozarka representatives started by giving us only their spare time—their evenings. If your county is open you can do the same.

The investment in cash is very small. The investment in time necessary for study is considerable. It requires patience, but the results have enabled many men to get out of the salary and time clock class.

Any previous sales experience is helpful but not necessary. We can and will teach you how to sell.

### Send for 84-Page Book— "The Ozarka Plan"

This book is entirely too expensive to be sent out on postal card requests. It will be sent FREE to any man who mails the coupon below and who is really anxious to improve his condition. Tell us about yourself, ask for Ozarka Plan No. 100 and don't fail to give the name of your county.

Ozarka  
Incorporated  
120 Austin Ave. P,  
Chicago, Illinois

Without obligation send book "Ozarka Instruments No. 200" and name of Ozarka Representative.  
 I am greatly interested in the FREE book "The Ozarka Plan" whereby I can sell your radio instruments.

# INCORPORATED

120 Austin Avenue P,  
Chicago, Illinois

Name .....

Address..... City.....

County..... State.....

# FATIMA

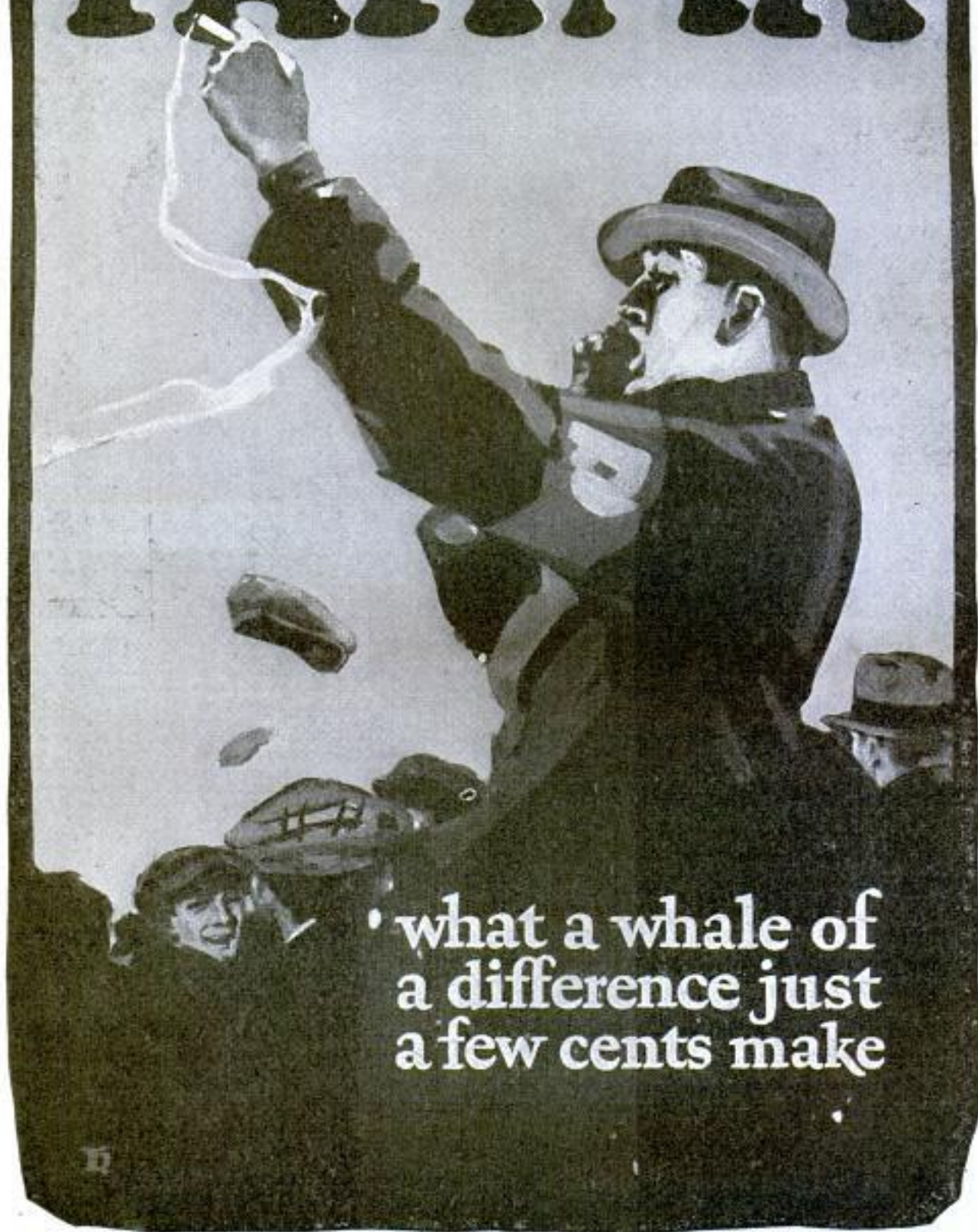

• what a whale of  
a difference just  
a few cents make

# KODEL RADIO

The Emblem of  Worth in Radio

## The Best that Radio Offers



**LOGODYNE**  
"BIG FIVE" **\$90<sup>00</sup>**

*Five tubes, self-balanced tuned radio frequency; sloping panel gold engraved; beautiful, massive, Adam brown mahogany cabinet; compartment for batteries; stations already logged for easy tuning.*

If the LOGODYNE Big Five excelled only in performance it would not be a KODEL RADIO.

But combining as it does the ultimate in good performance, a tone as mellow and true as a rare old music instrument, a cabinet artistry worthy of the old masters the LOGODYNE Big Five expresses the perfection required of the entire KODEL RADIO line—the best that radio offers.

**Free** Send for the new edition of our free booklet "The Secret of Distance and Volume in Radio". Gives helpful interesting information on radio operation.

**THE KODEL RADIO CORPORATION**  
517 East Pearl Street Cincinnati, Ohio

**WKRC**  
Owners of Kodel Broadcasting Station WKRC  
on the Alms Hotel. Send for program.



LOGODYNE "Big Five" Console Model—the Aristocrat of Radio; built-in loud speaker; compartment for batteries and charger a masterpiece in furniture design. **\$275**



LOGODYNE "Standard Five" Console Model—beautiful brown mahogany; built-in loud speaker; compartment for A and B batteries and charger..... **\$165**



LOGODYNE "Standard Five"—five tubes self-balanced tuned radio frequency; gold engraved panel and sub-panel; battery compartment; handsome brown mahogany cabinet..... **\$70**

KODEL "Gold Star" Models—Radio's greatest set values; **\$30**

Three Tube "Gold Star" Model. **\$20**

Two Tube "Gold Star" Model.. **\$12**

One Tube "Gold Star" Model... **\$6**

"Gold Star" Crystal Set..... **\$6**

# LOFTIS BROS. & CO. EST'D 1888

THE OLD RELIABLE ORIGINAL CREDIT JEWELERS  
Dept. G-894 108 N. State St., Chicago, Ill.  
Stores in Leading Cities

## DIAMONDS WATCHES

### CASH or CREDIT

#### FREE! Big Diamond Book

Big 132-Page Book, full of valuable information about Diamonds. Over 2000 illustrations of Diamond-set Jewelry. Watches, Wrist Watches, Silverware, etc. Sent Absolutely Free! Write today!



No. 59  
Pure White Diamond.  
18-k white gold.  
Special at \$60.  
\$5 down; then  
**\$1.25**  
a week



No. 825  
Blue-White Diamond. 18-k white gold prong ring. A bargain at \$137.50 \$13.75 down and  
**\$3.50**  
a week



No. 826  
Blue-White Diamond. 18-k white gold. Carved prongs. Price \$300. \$30 down and  
**\$7.50**  
a week

Our Diamonds are exquisitely beautiful, high-grade, QUALITY gems. Blue White, of dazzling brilliancy — the finest offerings of the European Diamond markets. Personally selected by our expert diamond buyers.



No. 49—"Wing" design, engraved Wrist Watch. Solid 18-k White Gold. \$7 Jewels, \$37.50. Delivered on first payment of **1.00** a week \$3.75, then . . . . .

**TERMS:** Goods delivered on first payment of one-tenth of purchase price; balance in equal amounts—payable weekly, semi-monthly or monthly, at your convenience. Satisfaction Guaranteed or Money Back



No. 827  
Blue-White Diamond. 18-k white gold. Special at \$37.50. \$3.75 down and  
**\$1.25**  
a week



No. 56  
Blue-White Diamond. 18-k white gold. A great value at \$150. \$15 down and  
**\$3.75**  
a week



No. 31  
Blue-White Diamond. 18-k white gold ring. \$200. \$20 down and  
**\$5.00**  
a week

Buy of LOFTIS, the Direct Importer. Select as many articles as you wish and charge all in one account. Catalog explains everything.

We invite comparison of quality and price. All Goods Delivered on First Payment



**WEDDING RINGS**  
No. 824—"The Elite" Wedding Ring. Solid 18-karat White Gold.  
**\$7.50**

The "Elite" all Platinum, \$25. With Diamonds: Three Diamonds, \$60; Five Diamonds, \$80; seven Diamonds, \$95; nine Diamonds, \$110; surrounded by Diamonds, \$225.

**High-grade Railroad Watches**  
Guaranteed to Pass Inspection  
HAMILTON No. 992, 21 Jewels. Adjusted to 5 Positions, G. F. case, guar. 20 years **\$55**  
ELGIN'S LATEST RAYMOND, 21 Jewels; 5 Adjustments. Runs 48 hrs. one winding **\$55**

#### 17-Jewel Elgin

No. 15—Green Gold, 17-Jewel Elgin Watch; 25-Year Quality Case; 12 Size, GHT Dial, \$30; \$3 down, then  
**\$1.00**  
a week



Send for the Loftis Catalog

**Radio Fans** Listen in off W. H. T. every Tuesday night from 7 to 7:30, every Friday night from 10 to 10:30, Central Standard time. Loftis Bros. & Co.'s hour of music.

# I MAKE \$25. A DAY with this Machine

That is what J. W. Fleming, Ind., wrote six months after we started him as an "American Universal" Floor Surfacing contractor. R. E. Wajnick, Texas, says, "I made \$30 in 8 hours." Don Arnold, Ind., says, "I have made as high as \$40 a day." Scores of others are doing as well or better. You, too, can make big money.

## SURFACING FLOORS

The electrically driven "American Universal" Floor Surfacing Machine does the work of six hand scrapers, earns you six men's pay. Field is unlimited, demand tremendous. Every newly laid floor must be surfaced; every old floor represents a resurfacing job. No experience necessary. Work is pleasant, interesting. Small amount starts you. Here's

### Your Big Opportunity

to be your own boss, to build a paying business, and make real money from the start. We help you, show you how and where to get work, furnish advertising, stationery, office forms, everything you need.

Write now for free details of this rare opportunity.

#### The American Floor Surfacing Machine Company

523 S. Saint Clair Street  
TOLEDO, OHIO

# DELTA

The Super Spotlight For Bicycles

"Young America's Choice"

## No. 37 BICYCLE SPOTLIGHT

PERMITS BICYCLIST TO RIDE THROUGH BLACKEST NIGHT IN PERFECT SAFETY

The rider whose bicycle is equipped with a Delta 37 does not fear hazardous road conditions or nights as dark as a "stack of black cats" for he has a powerful penetrating bright light of safety. Equals good auto spotlight. Head 4 1/2 inches in diameter. Improved bracket, fits any handlebar. Battery case mounts on all standard bicycle frames (fits on 18-in. Moto-Bike frame, inside triangle on either front or top bar). Operates on two dry cells. At your dealer or sent prepaid for \$3.75 complete (less batteries). In Canada \$5.00.

**DELTA ELECTRIC COMPANY, 100 Delta Block, MARION, IND.**  
Standard makes of Electric Bicycle Spotlights and Lamps, Motorized Spotlights, Auto Spotlights, Auto Ash Receivers, Electric Head Lamps, Radio Head-Phones, Flashlights and Flashlight Batteries

New York EXPORT DEPT. 30 Water St.      Chattanooga FAUCETTE-HUSTON CO.      San Francisco SANFORD BROS. 311 Mission St.

MADE FIRST—MADE BETTER—BUILDS MOST

*"I have been a Meccano Fan since I got my first set"*  
*Jackie Coogan*

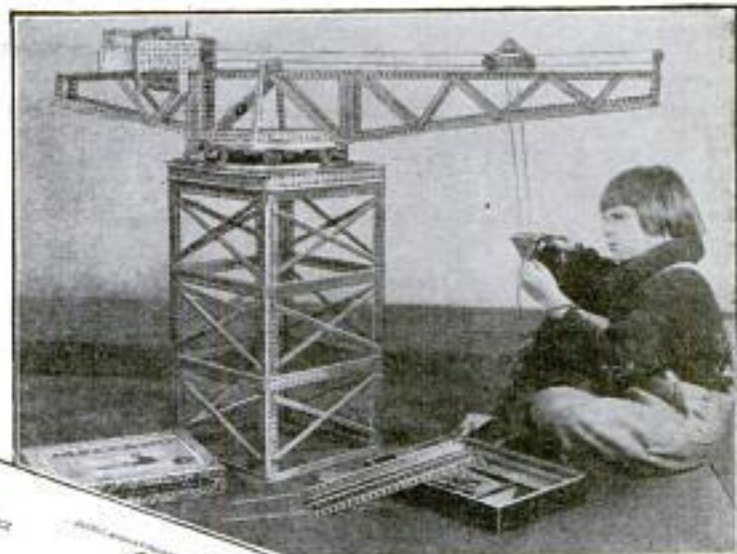

Having a choice of all construction toys, Jackie selected Meccano, the original and "The Daddy of them all". More than once Jackie has been known to dash off between pictures to finish a Meccano model which he has designed himself.

You, too, can share in this Meccano fun. You can build towers, cranes, bridges—anything you can think of. It's as easy as building with blocks.

### Made First—Made Better Builds Most

Meccano has such a great variety of parts—that's why it will build more models than any other toy. The parts are all made of shining steel and solid brass, and fit together perfectly. Other toys have copied some of these parts, but only Meccano has them all. Don't be fooled—to build *right* you must have the genuine

## MECCANO

### Engineering for Boys

In every Meccano outfit is a big book full of pictures of models. The fun begins as soon as you open your set. You can have a new toy every day for years without building the same one twice.

Yes, Jackie is enthusiastic about Meccano, and you fellows will be, too, when you get your outfit. Ask Dad to give you Meccano, and then—Oh Boy!



Meccano outfits are for sale by most toy stores. If your dealer cannot supply you, write us.

### Some Exclusive Meccano Features

Only in Meccano can you get these parts



Other toy parts may look like Meccano, but place them side by side and judge for yourself

### Meccano Price List

No. 00	Meccano Outfit.....	\$1.00
No. 0	Meccano Outfit.....	2.00
No. 1	Meccano Outfit.....	3.00
No. 1x	(has Electric Motor).....	5.00
No. 2	Meccano Outfit.....	6.00

and up to \$45.00

### Send for these two FREE Books



"The Magic Carpet"—that carries you to the wonderland of Meccano joy and model-building. Full of beautiful pictures.

"The Jackie Coogan Book"—an interesting story of Jackie's visit to the Meccano Headquarters and what he saw there.

Send us your name and address, together with the names and addresses of three of your chums, and the two books will be sent to you absolutely free. Put No. 12 after your own name for reference.

Meccano Company, Inc., Div. H-12, Elizabeth, N. J.  
 In Canada—Meccano Ltd., 45 Colborne St., Toronto

AS EASY AS BUILDING WITH BLOCKS



## DRYZ QUALITY SILVER FOXES BIG PROFIT MAKERS

**Absolute Guarantee Against Loss Backed by Guarantee Bond**

Old reliable firm. The only rancher giving a "Bond Guarantee." Big profits possible.

Never before to our knowledge has any Silver Fox Ranch been able to guarantee absolute returns backed by an Insurance Company.

**Do not invest in Silver Foxes until you have investigated our proposition thoroughly.** Possibilities of profit will startle you and the soundness and safety will be a revelation to you.

Silver Foxes produce one to ten young a year. We ranch them for you, giving you a profit without care or worry.

Silver Foxes have always proved to be an asset and money maker when added to farm or country estate.

Send for complete booklet, "A Treatise on Silver Foxes." Come in our office or phone Central 8050.

**DRYZ SILVER FOX RANCH, Inc.**

*The Best Known Ranch in the World*

Room 1809J, 360 N. Michigan Blvd., CHICAGO, ILL.



**MASTER  
WOODWORKER**

**Complete Woodworking Shop—  
Small Cost—  
Easy Payments**

A great opportunity for you to get a complete woodworking machine for home use, factory or construction use.

The "Master" is 12 machines in one. It does cross cutting, ripping, jointing, boring, sanding, dadoing, planing, plowing, mitering, rabbeting, molding, band sawing, mortising, tenoning, grinding, matching and stair routing.

Wonderfully speedy and accurate—sturdy and reliable. Lasts a life time—runs from a lamp socket.

Model No. 10 illustrated, rips 1" stock, cross cuts 2" stock. Three larger models for heavier work.

Costs little—sold on easy payments.

MASTER WOODWORKER MFG. CO.  
612 BRUSH ST., DETROIT, MICH.

Send  
for big  
description  
book

P. M. 12



**"No, Jim — I've stopped smoking. Gained six pounds in a week. You know how I used to smoke—a package of cigarettes and a cigar or two a day—it sure had some hold on me. But I'm cured—**

**took a scientific home tobacco treatment—fixed me up in two weeks.**

"Wasn't hard on me at all—noticed improvement the first day—I feel like a new man. It didn't interfere with my work—didn't leave any druggish after-effects—the money I saved in the last two weeks has paid for the treatment alone.

"Why don't you take it! It has cured men like you and me for over forty years—it is a doctor's individual prescription that sure fixes you up. Just send the coupon for full information NOW. No obligation. All correspondence is strictly confidential."



**A Doctor's  
Prescription**

**The Keeley Institute, Dwight, Ill.**

Please send me, without any obligation on my part, your free booklet which will tell me how to rid myself of the tobacco habit.

Name.....

Town.....

Street..... State..... P.M. 12

# Like a slap in the face

**H**E had failed to land the job. He had wanted it as he had never wanted anything before—and the President had seemed to like him at first, too. Then—what was it he had said? "Young man, personal appearance is of primary importance in a successful business career." What had he meant?

She hated to tell him, because it was such a personal thing.

\* \* \*

A great many men are inclined to have a grimy-looking skin, spotted with blackheads and dull in appearance. Few realize that this hinders their success in life. Pompeian Massage Cream helps you overcome this handicap by giving you a clean, ruddy complexion.

\* \* \*

**Clears the Skin:** Pompeian Massage Cream thoroughly cleanses the pores. It helps clear up blackheads and pimples by stimulating healthy circulation, and by keeping the skin clean and the pores open.

**Easy to Use:** After shaving or washing,

## YOUR DRUGGIST HAS IT

There's nothing quite so effective as doing the job yourself. Use Pompeian Massage Cream regularly at home—then you'll get the full benefit.



rub it in gently. Continue rubbing and it rolls out, bringing with it all the dirt and skin impurities. Result—a clean, healthy skin with clear, glowing color.

### Special Introductory Offer

$\frac{1}{3}$  of 60c jar for 10c

For 10c we send a special Trial Jar, containing one-third of regular 60c contents. Contains sufficient Pompeian Massage Cream to test thoroughly its wonderful benefits. Positively only one jar to a family on this exceptional offer.

The Pompeian Co., Cleveland, O., Dept. 29  
Gentlemen: I enclose a dime (10c) for  $\frac{1}{3}$  of a 60c jar of Pompeian Massage Cream.

Name \_\_\_\_\_

Address \_\_\_\_\_

City \_\_\_\_\_ State \_\_\_\_\_

For  
**Christmas**  
 an  
**Ingersoll**



The New Yankee  
 \$1.75

Dependable, as always,  
 but with many new fea-  
 tures of grace and beauty.  
 With luminous dial that  
 tells time in the dark, \$2.75

Wrist Radiolite  
 \$4.50



A serviceable  
 watch for women,  
 boys, girls, sports-  
 men, motorists, etc.

**Genuine KEYSTONE MOVIEGRAPH**

(PATENTED)

**SHOWS BIG SIZE MOVING PICTURES**  
**Safe for \$6.95** Non-Inflammable Safety Films  
 the Home Reel of Tom Mix Given FREE

The following reels are only a few in the film catalogue,  
 and are genuine, posed by the actors themselves. The  
 film is the same size as used in the theatre.

Charlie Chaplin in "Making Pies"  
 Wm. S. Hart in "Western Train Robbery"  
 Tom Mix in "The Battle on Horseback"  
 Also Slides, Drawing Slides, Theatre  
 Tickets, etc., included.  
**Machine and Reel of Film Complete for \$6.95**

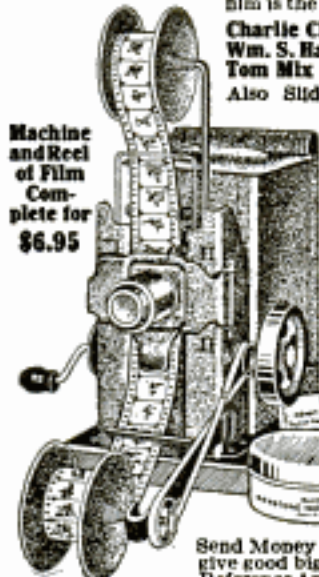

Every live boy should have  
 at home or club a Keystone  
 Moviegraph that shows  
 pictures the same as in the  
 movies with powerful  
 French lenses and con-  
 structed along professional  
 lines.

The electric cord is included  
 for connecting to any lamp  
 socket your electric bulb will  
 fit. Can also be had for any  
 Dry Cell Batteries for the  
 home without electricity.

Nothing to get out of  
 order. No compli-  
 cated parts. We have the  
 largest comedy  
 film service in the  
 country for home  
 machines.

Size of machine all set up  
 is 10" by 8". Weighs 4 lbs.

Send Money Order or check. Guaranteed to  
 give good big pictures or your money back.

Reference American Trust Co., Boston, Mass.

Order your machine today in time for Christmas

Price for Machine and  
 Reel \$6.95 complete,  
 prepaid in U. S. Genuine  
 Keystone Moviegraph Pat-  
 ented 1919, 1920, 1921.

**LIBBEY & NICHOLS**  
 Dept. P

100 Boylston St., Room 630, Boston, Mass.

**FREE** 1000 Illustrations **ELECTRIC FIXTURE CATALOG!**

Write today for your copy. Save  
 50% direct from Manufacturer.  
 No Middleman's Profit. OUR  
 SPECIAL: 8 Room Electric Set,  
 ready to hang, \$24.50—Other bargains.

UNITED LIGHTING FIXTURE CO.  
 83 Flatbush Ave. Dept. P, Brooklyn, N. Y.

**REDDING & COMPANY**

(Est. 1859) 9 West 23 St., N. Y. C.

Masonic Books, Monitors, Bibles,  
 Jewelry, and Lodge Supplies

Send for catalogue 3 of Books and Jewelry;  
 catalogue 4 of Lodge Supplies. No obliga-  
 tions. Mail orders promptly filled.

**SALESMEN  
 WANTED**

**To Sell Catholic  
 Art Calendar  
 for 1927**

Full or part time

**BIG PROFITS**

One of our salesmen made \$3000.00 in ten  
 months. Do not overlook this opportunity.

Send for Order Book, Samples, etc., at once.

**Extension Press Calendar Department**  
 Dept. B, 25 East Lake Street, Chicago, Ill.





019 the 9-inch Crescent Wrench that opens to three inches is a handy tool for everyone. With gift box and card, 75c



The Crescent Long Nose Plier is a favorite with radio fans and car owners. With gift box and card, 75c



The Crescent Wrench adds an extra note of dependable friendliness to any greeting. Eight inch size with gift box and card, 95c



**When these tools say  
"Merry Christmas"  
~ they really mean it!**

**YOU** will enjoy sending, and your friends will enjoy receiving the merry holiday greetings that go with Crescent Tools this Christmas. More than that Crescent Tools back up your good wishes with year after year of friendly dependable service.

You can buy singly or in sets to suit the individual taste of the recipient. Be sure to see these tools and greeting cards at your regular hardware or accessory store.

**Crescent Tool Company**  
210 Harrison St.                      Jamestown, N.Y.

*Originators of the Crescent Wrench*

**CRESCENT TOOLS**

# 500 PUNCTURES Yet Leaks No Air



More than 500 nails were driven into C. A. Milburn's newly invented inner tube and removed without loss of air—convincing proof that this tube is puncture-proof. It costs no more than ordinary tubes and increases mileage from 10,000 to 12,000 miles.

## Agents Wanted

To demonstrate and sell this wonder tube, Auto owners, regardless of the car they drive or what tires they use, *buy the minute they see the demonstration.* Our salesmen are coining money on our "Direct-from-Factory" sales plan. No capital required to start. No competition. Previous sales experience unnecessary. You can have a

### \$5,000 TO \$10,000 INCOME EACH YEAR

Depending on your own efforts. Get into your own business. Be your own boss. Sell Milburn Puncture-Proof Inner Tubes. Field unlimited. Every car owner a prospect. L. S. Knapp says, "My first few hours out sold eight tubes; no trouble at all to sell them." Hundreds of other letters like this on file.

**FREE TUBE** Send Coupon or write today for **Special Free Tube Offer** an complete details of our big money-making proposition. This is your opportunity—**NOW**. We refer you to any Chicago bank as to our reliability and financial rating. Mail coupon **NOW**.

C. A. MILBURN, Pres.  
**MILBURN PUNCTURE-PROOF  
TUBE COMPANY, Inc.**

4650 Shields Ave.,  
Chicago, Ill.

Milburn  
Puncture-  
Proof Tube  
Co., Inc.,  
4650 Shields Ave.,  
Chicago, Illinois

C. A. Milburn, Pres.:  
If the money-making  
opportunity is as big as you  
claim, I am interested in  
getting the facts, so that I can  
get a share of the profits selling  
Milburn Puncture-Proof Tubes. With-  
out obligation send me information  
about commission and **FREE TUBE**  
OFFER TO AGENTS.

**MAIL  
THIS  
COUPON  
NOW!**

Name.....

Address.....

City..... State.....

## CHRISTMAS GIFT!

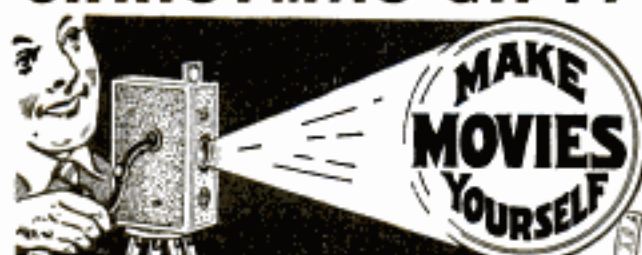

There's a wonderful thrill in taking your own motion pictures of interesting things where you live, of unusual scenes when you travel, of events everywhere.

### VICAM Movie Camera

STANDARD COMPLETE OUTFIT FOR TAKING AND SHOWING

takes high-grade, standard size pictures. Wonderful features—close-ups, stills, portraits, swift action. Can be loaded in daylight. Pictures can be projected on wall or sheet. **\$37** Including 2 Magazines

**WRITE FOR INTERESTING CATALOG** Send 10c in stamps for illustrated catalog describing marvelous Vicam Products.

Vicam Photo Appliance Corporation  
1224 Belmont Ave. Philadelphia, Pa.



Send  
Only

**10¢**

you may pay it \$1 per week. Make first payment only to postman when he delivers package. Send name and address at once. Our money back Watch guarantee protects you.

S. D. Deelite Co., 530 Broadway, New York

You Need Send Only 10c  
For This Latest Model  
Imported Jewelled  
Movement Watch

Runs 8 Days With One Winding  
Only a down payment of 10c re-  
quired and we make immediate  
shipment of this beautiful and  
serviceable watch.

**WE TRUST YOU**  
Shipment Same Day  
No References Needed

Elsewhere you would probably  
be required to pay upwards of  
\$16 for a full-jewelled open face  
8 Day watch of this quality.  
Our price reduced to \$12 and  
you may pay it \$1 per week. Make first payment only to postman when he delivers package. Send name and address at once. Our money back Watch guarantee protects you.

## 200 SHEETS AND 100 ENVELOPES \$1

POSTAGE  
PREPAID.

Amazing bargain high grade clear white bond paper smooth writing surface, size 6x7 inches. With envelopes to match **YOUR NAME AND ADDRESS PRINTED FREE** on every sheet and envelope in rich dark blue ink up to four lines. Our price does not allow variations. The type is Plate Gothic noted for its clearness and good taste a rich personal stationery you will be delighted to use. An ideal gift printed with your friends name. Write or print name and address exactly as you want it. Send \$1.00 west of Denver and outside of U.S. \$1.10. We prepay postage. Money refunded if not satisfied. Order today.

THE NATIONAL PRINT SHOP  
BOX 1483 DEPT. 14 WASHINGTON, D. C.



## SOFT SNAP FOR AGENTS

**GLAROFF Kills Headlight Glare.**  
Our representatives making from \$15 a day up to \$2000 yearly. Simple new device protects driver from glare of headlights and sun. Write for Special Free Offer. **GLAROFF MFG. CO. 805T East St., Sioux Falls, S. D.**

## \$25000 A WEEK!

Made with the new and improved  
"Krispy" Potato Chip Outfit.

Potato Chips the lunch of the hour. Everybody is eating them. One stand in small building sells \$100 worth in a week. Think of it! Grocers, druggists, pool rooms, cigar stands, tourists' counters, parks—all sell thousands of packages. Supply them. Get the big profits. Chips easily, quickly made at home. No experience necessary. Write today. Get a big profit fast growing business now. **SERVICE & EQUIPMENT CO., 905 Hoag St., Toledo, Ohio**

# A Corona for Christmas!



**H**OW would you like to wake up on Christmas morning and find that someone had given you this Corona? It's a regular honest-to-goodness typewriter, with standard keyboard, two-color ribbon, automatic reverse, stencil-cutter, variable line-spacer, and everything—just like the regular office machines, but not so big or heavy—you can carry it, easily.

Drop in at the Corona store and see it, or write us and we will mail you full particulars. Corona dealers accept used machines in trade.

CORONA TYPEWRITER COMPANY, INC.  
108 Main Street, Groton, N. Y.





## Drop a Christmas Hint!

Right now wives, mothers and friends are wondering what gifts to select for Christmas. Simplify their Christmas shopping by letting them know that a real Set of Genuine Irwin Auger Bits would just hit the mark with you.

There are no better bits made and there's a set that meets every requirement.

Irwin Home Set, 6 bits and case \$3.50

Irwin Handy Set, 10 bits and case 5.50

Irwin Carpenter Set, 13 bits and case 7.25

**THE IRWIN AUGER BIT COMPANY**  
Wilmington, Ohio

Hardware dealers everywhere sell genuine Irwin Auger Bits. The Irwin mark shown below is stamped on the shank of every Genuine Irwin Bit.



# The IRWIN Bit

REG. U.S. PAT. OFF.

*A necessity to every Boy Scout's equipment. LEEDAWL a Taylor Compass*

*If your Dealer cannot supply You, write*  
**Taylor Instrument Companies**  
ROCHESTER N.Y.  
Canadian Plant, Tyces Bldg. Toronto  
*There's a Taylor Style Thermometer for Every Purpose*

## DEFENDER Keyless LOCK

**NO KEYS TO LOSE!**

**No Springs! No Hinges! No Rivets!**

A strong, rustless padlock that will last a lifetime. Opened quickly day or night. You can easily change combination: 1024 to select from. If your dealer cannot supply you, send \$2.00 for most satisfactory lock you will ever own, or pay postman \$2.10. Money-back guarantee. SALESMEN WANTED.

**DEFENDER LOCK CO.**  
Dept. P.O. 68 CHH Street NEW YORK CITY



## FREE!

14-Kt. white gold filled wrist watches or beautiful men's watches, Dinner Sets, Cameras, Bags, Silverware, without a penny's cost to you for devoting a few hours of your spare time in selling our delicious high-grade candy to your friends and acquaintances.

Write today for our FREE Premium Book giving full information how you can secure one of these fine gifts.

**REPUBLIC TRADING CO.**  
25 W. Broadway New York, N. Y.

Dept. 269



# ERLA's New Audio Gives Marvelous Tone Curve

Exact laboratory tests show that no other audio gives such perfect reproduction. Note how uniformly and evenly all notes are amplified at frequencies from 32 to 10,000 cycles.

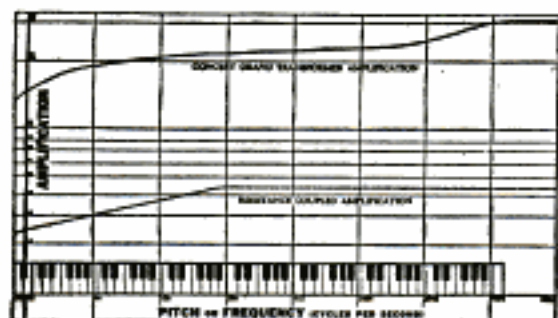

Note the smooth, even progression of the Concert Grand curve, revealing supreme uniformity of amplification, from lowest notes to highest in the musical scale.

**A**N amazing improvement has been made in audio amplification. A new transformer—the Erla Concert Grand—gives results far superior to any other system of amplification.

### Amazing improvement

Ordinary designs permit too much leakage to amplify properly at low frequencies. So we use the "quadriform type," heretofore unknown in radio work. In this design magnetic leakage is practically eliminated by providing twice as many paths for the magnetic field and by a better distribution of the core metal around the copper wire coils. Each of the four core units are complete magnetic circuits within themselves without breaks or joints to the main central core, and it will also be noticed that the central core section has a far greater area than conventional core types. The large area thus obtained reduces the effect of the direct "B" battery current on the pulsating voice currents and eliminates a cause of distortion common to transformers using smaller core sections.

The Concert Grand saves you money, too. Resistance coupling depends solely upon the tubes for amplification. Consequently they must be operated at maximum for efficiency, requiring more "A" battery current and higher plate voltage—135 to

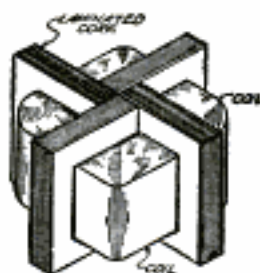

Note the quadruple core surrounding the coil, forming an almost perfect path for the flux within the coil. The core is a special grade of laminated silicon steel that provides highest permeability and lowest hysteresis loss, with consequent maximum conductivity in the magnetic circuit of the transformer. Price \$10. West of Rocky Mountains, \$10.50.

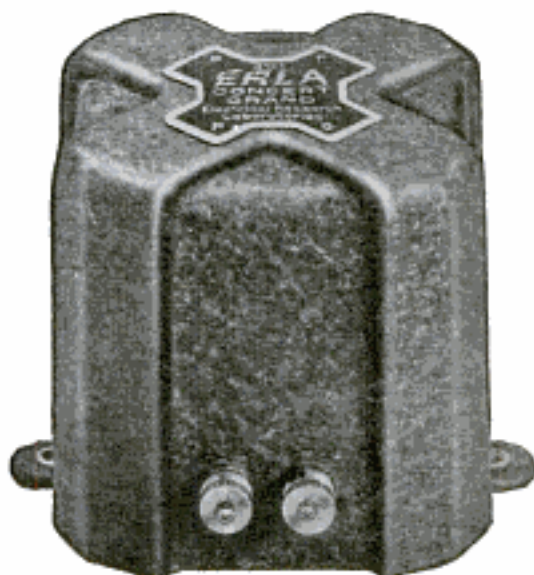

One-piece drawn steel shell provides perfect magnetic shielding. Finished in black crystalline lacquer and attractive in appearance.

150 volts. Filaments wear out more rapidly as a result and battery life is more than cut in half. The higher initial cost of Concert Grand amplification is therefore saved many times over, not only in improved performance but also in lowered upkeep cost.

### Booklet sent FREE

Get the Audio Grand at your dealer's today. See what a tremendous difference it will make in your set. If you wish to return the coupon, we will send you a new booklet giving the latest information on audio frequency amplification.

Electrical Research Laboratories  
Chicago, U. S. A.

Electrical Research Laboratories,  
2500 Cottage Grove Ave., Dept. 5-C, Chicago

Send me information about the Erla Concert Grand Audio. Also latest developments on audio frequency amplification.

Name .....

Address .....

City..... County..... State.....

# ERLA

# The Biggest Little Tools Made!



12" or 18"  
between  
centers;  
6" swing;  
speed range  
180 to 1750  
R. P. M.

## The *Baby Grand* Lathe

—with plain head as shown or with back-gear head. A practical, precision lathe for skilled mechanic or amateur. Arranged for wood turning, metal turning, or both. Not a toy!



## *Baby Grand* Grinder

6" high; wheels 4" dia.; 1/4" face. Will keep those edge tools in perfect cutting condition. Unusual value and serviceability combined with low price make this the biggest little grinder made.

## *Baby Grand* Drill

Practical  
Tools for Prac-  
tical Men

Capacity 0" to 3/4" drills. Wide speed range, versatility, handiness, plus a maximum of drilling efficiency make the Baby Grand supreme in its class. Comes complete with chuck as shown.



Write today for prices and complete information on the full line of Baby Grand Tools  
**The Watson Mfg. Co., 112 Watson Building Toledo, Ohio**

## HERE IT IS!

### The GREAS-OM-ETER System of Lubrication

Replace your old-fashioned grease cups. Cut your repair bills with the automatic

### GREAS-OM-ETER

Positive in action. No worry—always works. Endorsed by industrial plants, automobile operators, truck and tractor owners.

Price 75 Cents Each

THE GREAS-OM-ETER CORPORATION  
Sharon Building San Francisco

Salesman-Representatives Wanted.  
Write for Full Details.



## Mr. Brush Salesman

Unusual opportunity is offered for aggressive, ambitious, hustling men to represent an old established manufacturer of high grade, guaranteed, fastest selling line of Sanitary Twisted in Wire Brushes, sold direct to the Home. We have openings for experienced brush men as managers in all territories. We want live wire, energetic Go-Getters. We pay larger commissions than any other Brush House in the Country. If you want to earn some real money, it will pay you to write us immediately for our proposition.

WIRE GRIP SANITARY BRUSH CORP., 15 MERCER STREET, NEW YORK CITY

## Makes Old Ford a Tractor

We furnish everything for converting Ford Auto Chassis with Engine into a handy Farm Tractor. Just right for truck growers, small farms, nurseries, etc. Pulls 16" Plow, Discs, Seeds, Cultivators; Runs Belt Machinery. We also build Garden Tractors.

Handles Easily  
Turns in 18' Circle



Write for Free Particulars.

SHAW MFG. CO.,

Dept. F Galesburg, Kansas

## MOTORCYCLES

Price \$10 and up purchased through our Co-Operative Plan for as low as \$1.00 down and \$1.00 per week

Indians Harley-Davidsons Ace  
Henderson and Clevelands

Motorcycles shipped to all parts of the world

WALKER-INDIAN CO., 188 Mass. Ave., BOSTON



## BUILD SHIP MODELS!

Easy to build and sell. Plans and instructions: Pirate Ship, 52c—Viking Galley, 42c—Magellan's "Victoria," 77c—Hudson's "Half Moon," 92c—Chinese Junk, 47c—or all for \$2.90.

RICHTER & STROESSER, 405A Eleventh Ave., Milwaukee, Wis.

**AUTOMATIC HYDRO OIL BURNER \$295**  
INSTALLED COMPLETE, 220 GALLON  
FUEL TANK, THERMOSTATIC CONTROL

A few large city distributorships still open

Automatic Hydro Oil Burner Co., 512 McKerchey Bldg., Detroit, Mich.

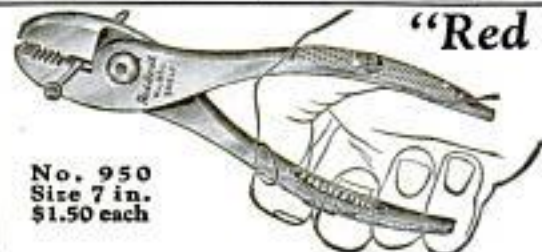

No. 950  
Size 7 in.  
\$1.50 each

## "Red Devil" Slip Joint Plier Makes a Multitude of Jobs Easy

Has adjustable jaws of great strength, a side cutter, pipe grip and screw driver. A tool for all around handiness. Nickel plated. Mechanic's handy tool booklet free.

SMITH & HEMENWAY CO., INC.

Mfrs. of "Red Devil" Tools, 122 Coit St., Irvington, N.J.

TRADE MARK

REG.

# WURLITZER

SUPREMACY IN MUSICAL INSTRUMENTS



## Learn to Play

You are always popular and sure of a good time if you can play some musical instrument. By yourself, with your friends around the piano, in orchestras or bands,—there is no end to the pleasure music will give you. And there is no easier way to earn money in your spare time. Choose your instrument now and let Wurlitzer help you buy it and learn to play it.

## Try Any Instrument in Your Own Home At Our Expense

You may now have any known musical instrument for a week's free trial in your own home. There is no obligation to buy—no expense for the trial. You may return the instrument at the end of a week if you decide not to keep it.

### Monthly Payments

The Wurlitzer plan makes it easy for you to own the instrument you want. Payments are conveniently arranged in small monthly sums—a few cents a day will pay.

Wurlitzer instruments are known everywhere for their unusual tone quality and excellence of workmanship. They are used by the greatest

professional musicians, bands and orchestras. Harry L. Jacobs of Sousa's Band, Brooke's Marine Band, and Chicago Grand Opera says: "I am proud to be the owner of one of your new cornets. It is positively superior to anything I have had in all my years of cornet playing."

### Easy to Buy

Thousands of amateur musicians are playing on Wurlitzer instruments. Many of them could not have bought except through the Wurlitzer selling plan. Wurlitzer is the world's greatest music house, with stores and dealers in all parts of the country. But no matter where you live you will receive the same service by mail as though you lived next door to the factory. Send the coupon today.

## Send for Free Catalog

The greatest musical catalog ever published. Over 3,000 articles—every known instrument described and illustrated—many of them shown in full color. Gives you all details of the Wurlitzer plan. Send coupon now.

The Rudolph Wurlitzer Co., Dept. 1779

117 E. 4th St., Cincinnati 329 S. Wabash Ave., Chicago  
120 W. 42nd St., New York 250 Stockton St., San Francisco

Send me absolutely free, your new illustrated catalog of musical instruments. Also tell me how I may try any instrument in my own home at your expense and how the Wurlitzer plan makes it easy for me to buy. No obligation.

Name \_\_\_\_\_

Address \_\_\_\_\_

City \_\_\_\_\_

State \_\_\_\_\_

Instrument \_\_\_\_\_

(State instrument in which you are interested.)

# \$10,000 a Year to Distributors \$5,000 a Year to Salesmen

Anyone, anywhere, can now secure almost miraculous results from Chlorine Gas.



The Chloronado gives you, at home, or when traveling, the healing gas now used by the most modern hospitals and physicians.

## Selling the Chloronado

Chlorine Gas is taking the country by storm. Prevents and kills colds and other respiratory diseases by destroying their bacteria, to which all are exposed daily. Doctors, Sales Organizations, Banks, Telephone Cos., Insurance Cos. and individuals buy on sight. Every sale means many repeats. Everyone sells his friends.

Generates the same gas used by President Coolidge, Senators, Congressmen, Lawyers; men and women in every walk of life. The Chloronado gives marvelous results; thousands satisfied.

### Inexperienced Men and Women Coining Money; Chloronado is Needed Everywhere

It is the first scientific chlorine gas generator for the home, saving costly hospital treatments and medical attendance. Sells like wild-fire because urgently needed in every home.

Choice territory open to live salesmen and distributors. The opportunity to join a fast-growing sales organization, with real cooperation backed by national advertising and circularizing campaign. Write—better wire—today for details.

**CHLORONADO LABORATORIES CO.**

439 E. Fort St.

Detroit, Mich.

You Want This Proposition—Write Today!



## AGENTS Big Money Quick!

### COMBINATION KING RADIO WONDER

First combination tube and crystal set ever made. Turn of a switch and either tube or crystal works as desired, or both together. 1000 Miles or more on headphones—loud speaker on locals. Two complete sets in one for only \$10.95 retail. Get my wonderful money making plan and special price to you.

W. F. RICHARDSON, MFR.  
128-32 W. Kinzie St., Chicago

Books on all subjects are sold by Popular Mechanics Press, 200 East Ontario Street, Chicago, Illinois.

## NO JOKE TO BE DEAF

—EVERY DEAF PERSON KNOWS THAT



I make myself hear, after being deaf for 25 years, with these Artificial Ear Drums. I wear them day and night. They stop head noises and ringing ears. They are perfectly comfortable. No one sees them. Write me and I will tell you a true story how I got deaf and how I make you hear. Address



Artificial Ear Drum

**GEO. P. WAY, Artificial Ear Drum Co. (Inc.)**  
80 Hoffman Bldg., 2539 Woodward, Detroit, Mich.

## How to Straighten Bow and Knock-kneed Legs!

Improve your personal appearance by using the new patent "Lim-Straitner," Model 18. Corrects bow and knock-kneed legs safely, quickly and permanently at home. No costly operation or discomfort. Is worn at night. Easy to adjust; its result will save you soon from further humiliation and will improve your personal appearance 100 per cent. Write today for copyrighted Physiological and Anatomical book and experience of others without obligation. Enclose a dime for postage.

**M. TRILETY, Specialist** Dept. 1306 BINGHAMTON, N. Y.



# \$16 a Day is my offer to You!

If you want to make \$16 to \$25 a day, if you want to be your own boss, if you want to build up a business of your own that will pay you enormous profits, if you want an Essex closed car absolutely free, then write me today for the details of my startling offer.

### Your Opportunity

I need right now 500 more representatives—men or women—to call upon friends and neighbors and others, and write orders for Jennings Guaranteed Hosiery. My hosiery is sweeping the country like wildfire. No other hosiery like it. All styles, sizes and colors for men, women and children, and at prices to fit every purse. Every member of every family a prospect. And, I'm offering

you the chance to cash in on this enormous, growing demand.

### Big Money for You

I furnish you free outfit and new, exclusive selling plan that brings big orders and big profits. \$2 to \$5 an hour should be easy if you follow my instructions. No limit to what you can make. Part time or full time.

This is the chance of a lifetime. Let me tell you how easy it is for you to make \$16 a day—\$100 a week—and besides get an Essex closed car absolutely free. Get started. Send the coupon NOW.

**The Frank B. Jennings Co.**  
Dayton, Ohio  
Hose N-61  
Frank B. Jennings  
Dayton, Ohio

Tell me about your offer of \$16 a day and how I can get an Essex closed car free.

**Mail this Coupon Now—Today**

Name.....  
Address.....

### Essex Given Coach

I have a wonderful plan that will bring you this wonderful car without cost to you. You'll be surprised to see how easy you can get it. Write for details.





Save on the price, and get a FIVE year guarantee

All tools, cover, etc., included

Copyright 1925  
Shipman-Ward Mfg. Co.

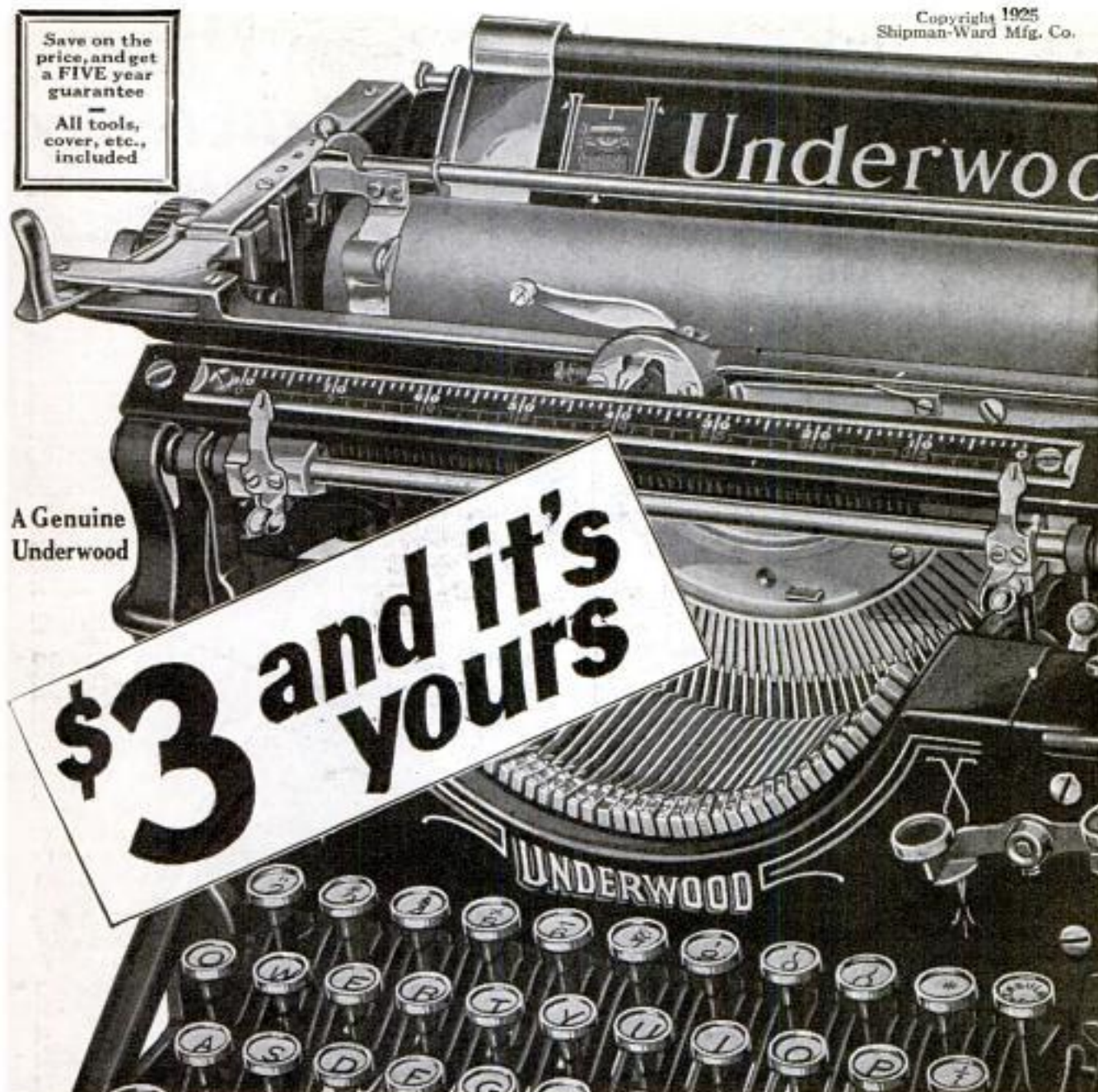

A Genuine Underwood

**\$3 and it's yours**

## Own a Typewriter!

**Act NOW, and Get a FREE Trial of this ACE of Writing Machines!**



Speak up, if you want one! Underwood typewriters are so popular this lot we're completing now won't be long in selling! Rebuilt from top to bottom—*every single worn part replaced*. New typewriters are guaranteed for a year; we guarantee this one *five years!* That's our Better-Than-New Guarantee. And we guarantee a big saving!

You can learn to write on this standard keyboard Underwood in a day. In a week, you'll feel lost without it! The free trial will *prove* it. Our rebuilt plan gives you the *best* machine and a *big* saving!

Don't send a cent, but do get our

special offer—valuable book on typewriting—*free*.

### Pay Like Rent

Three dollars puts this Underwood in your home—small monthly payments soon make it yours for good if you want to keep it—but send no money now. Just get our offer. Clip and mail coupon. There's no excuse now for not owning a typewriter—and the finest make! We include all tools, cover, etc., all complete, all ready to write. Write us now. Deal direct; we are the largest factory of the kind.

Get our catalog free; quotes lowest prices and most liberal terms in exist-

ence. We'll send a manual free, too; it contains valuable instruction for learning rapid typing, useful pointers for all who use a typewriter.

## FREE NEW BIG BOOK ON TYPEWRITERS

SHIPMAN-WARD MFG. CO.

2129 Shipman Bldg., Chicago

Please send FREE, full offer, catalog, typing manual, and outline your free course in Touch Typewriting.

Name .....

St. or RFD .....

P.O. ....

## Three Times and a Friend for Life

Try Barbasol just three times—according to directions. You'll never use anything else for shaving. No brush. No rub-in. No after-smart. 35c and 65c tubes.



The Barbasol Co.  
Indianapolis Ind.

Please mail me your Free Trial Tube of Barbasol.

Name.....

Address.....

P.31-13-25

For Modern Shaving

## 66 Miles on 1 Gallon

Wonderful Vapor Humidifier

For All Make Autos. Spare or full time. Agencies Wanted Everywhere

**1 FREE TO INTRODUCE BIG PROFITS to any MAN WITH CAR**  
CRITCHLOW, Inventor, C-111, WHEATON, ILLINOIS

Information on any book free. Write Popular Mechanics Press, Chicago, Ill.

## "A COMPLETE WORKSHOP ALL IN ONE"

### AT A REMARKABLE LOW PRICE

Consists of lathe directly driven by 1/2 HP fully-enclosed motor. No belts, countershafts, slippage and no trouble. Left side of motor carries 6" dia. fast cutting emery wheel, will sharpen anything. High grade hardwood work-bench with drawer; 6" quick acting steel vise and famous American Scroll Saw. Use motor to drive any other machinery.

### The AMERICAN SCROLL SAW

Represents the last word in the saw design. You will be delighted with its smooth and square cut; its sturdy mechanical design; cuts wood 1" and metal 1/4" thick. Sold under our "Money-back Guarantee", and with or without motor. "TO TRY IT—IS TO BUY IT". Write today for details of our Band, Circular Saws, etc.

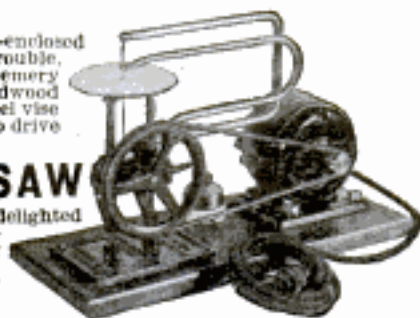
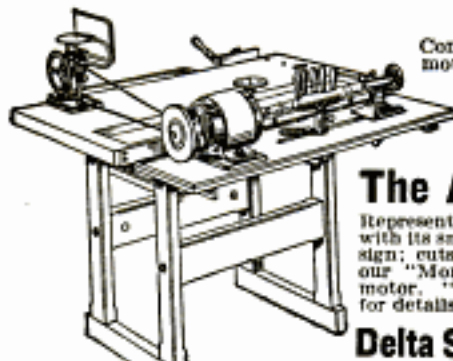

Delta Specialty Co., Dept. A-101 858 Third Street Milwaukee, Wis

PATENTED AUG. 21-25

## Play Right Away on this Jazzy Sax

No Knowledge of Music Necessary—Sweet Jazzy Tone

# 87 Songs Free

You can play this beautiful imported Jazzy Sax without practice. No difficult scales and keys. Play by easy numbers or by ear (or by notes if you wish). Not a toy—but a real musical instrument! Made of metal, handsome, gleaming, polished finish. Looks like regular saxophone—20 in. long. Clear, ringing tones and delightful harmony. Will make you popular at parties, dances, entertainments—everywhere. No need to spend \$50 or more when you can own a Jazzy Sax for a trifle.

H. A. King writes: "Received Sax in afternoon and placed lead in 2-piece orchestra same night."

H. M. Vinton writes: "Could play several old airs within an hour."

Made of solid metal 20 in. long.

**\$5.98**

Big book of 87 Songs, and full directions absolutely FREE with each Jazzy Sax on our special limited offer. But you must get your order in at once! Mail coupon TODAY.

SUPPLY LIMITED

## Send No Money

Just fill out the coupon below. When the Sax and FREE book of 87 Songs arrive, pay the postman only \$5.98 plus a few pennies postage. Play the songs right away. You don't risk a penny. Satisfaction guaranteed or money refunded. But the supply is limited, so don't delay. Mail coupon today.

—Send This Coupon Today—

FERRY & CO., 1224 N. Halsted Street Dept. 9779, Chicago, Ill.

Please send me at once your Jazzy Sax and FREE book of 87 Songs. On arrival I will deposit \$5.98 plus postage with the postman. If I am not satisfied, I will return all within 3 days and you will refund my money.

Name.....

Address.....

City..... State.....

Information on any book free. Write Popular Mechanics Press, Chicago, Ill.

**INSTALL YOUR OWN**

**FREE PLANS**

**HOT WATER HEATING PLANT CUT-TO-FIT**

**GUARANTEED**

Complete Hot Water Plants ready for shipment. Outfits as low as \$202.

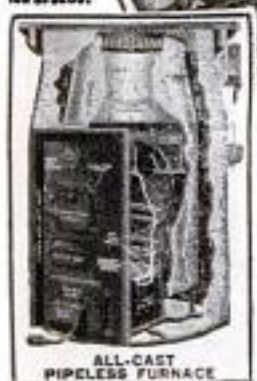

ALL-CAST PIPELESS FURNACE

# PLUMBING and HEATING

**→ SAVE HALF ←**

**By our New Easy Method and Lowest Wholesale Prices.**

Mail the coupon for our **FREE Bargain**

Catalog. Gives illustrations, complete descriptions, sizes and wholesale prices on Heating Outfits of all kinds, Water Supply Systems, Complete Bathroom Outfits and Plumbing Supplies, Fittings, Pipes, etc. All at wholesale. Send today for your copy.

**50 Years and Million Dollar Plants**

behind our bonded guarantee. Every Hardin-Lavin System is figured to eliminate long runs of piping, to save valuable time and unnecessary materials and expensive labor. We furnish Heating Plants or Plumbing Outfits cut-to-fit at the factory for the exact job and we thread and mark all the larger pipes. Any Handy Man with our simplified plan and new easy method can do the installing.

**MAIL COUPON TODAY**

We have saved economical buyers hundreds of thousands of dollars. Everything you get from us is guaranteed highest quality, Grade A merchandise with new, exclusive features.

**HARDIN-LAVIN CO.**

ESTABLISHED 1876

When in Chicago Visit Our New Plant at  
**107-17 West Pershing Rd., CHICAGO**



**HARDIN-LAVIN COMPANY,**  
107-17 West Pershing Rd., Chicago, Ill.

Gentlemen: Please send me your **FREE BARGAIN CATALOG** with special wholesale prices. I am interested in:

- Water Supply System
- H. W. Htg. Plant
- Sts. Htg. Plant
- Pipeless Furnace
- Warm Air Furnace
- Bathroom Outfit

NAME.....

ADDRESS.....

P. O. ....STATE.....

Self-Filler **DE LUXE** Style Pen

**"INDEPENDENT"**

All the best features of a Fountain. Lasts longer. Writes smoother. Improves handwriting. Eliminates fatigue. **GUARANTEED.**

**\$2.00**  
By Mail

**14 Kt. White Gold Point Chased Rubber Holder. Lever Filler. Pocket Clip.**

Your Name in Gold Inlay, 25c.

Write for Pen Catalog. Agents Wanted.

**J. C. Ulrich & Co., 161 Washington St., New York**  
Knows the World Over for 46 Years.



**—Writes Peter Werner, III, Sell Madison "Better-Made" Shirts for Large Manufacturer Direct to wearer. No capital or experience needed. Many earn \$100.00 weekly and bonus.**

**Write for Free Samples**

**MADISON SHIRT MILLS, 562 Broadway, New York**

Oh How Lovely!

**AGENTS**

Saleswoman—Salesmen!  
Make big money taking orders for our beautiful Dress Goods, Fills, Wash Fabrics and General Yard Goods. Large Book of Fabric Samples illustrated to Agents. Write under:  
**National Imp. & Mfg. Co., 573 Broadway, Dept. 6, N.Y. City**

1000 ACTUAL FABRIC SAMPLES

**General Electric Company, Schenectady, New York**

**DEAFNESS IS MISERY GOOD HEARING A JOY**

Millions of people know that, but Multitudes of persons with defective hearing and Head Noises are again enjoying conversation, go to Theatre and Church because they use Leonard Invisible Anti-septic Ear Drums, which are Tiny Megaphones fitting in the Ear entirely out of sight. No wires, no batteries, no head piece. They are Unseen Comforts and inexpensive. Write for booklet and sworn statement of the inventor who was himself deaf.

**A. O. LEONARD, Inc., Suite 161 70 5th Ave., New York**

Hand Forged Razor Steel Blades, No. 57

**Direct at Factory Prices**

This \$2 KNIFE \$1.18 Postpaid  
Hand Forged Razor Steel Blades Handy shaped Blade makes this knife best for mechanics, sportsmen and farmers; light but strong; re-sharpened easily. Stag handle. German silver finish; blades file tested, hand forged from razor steel and warranted.

Sample \$1.18 3 for \$3.00 Postpaid.

Send for our 100-page List and "HOW TO USE A RAZOR" **FREE**

**MAHER & GROSH CO., 106 A St., Toledo, Ohio**

# Let cold radiators get HOT



**A**IRID Air Valves are attached easily to any steam radiator without tools—need no adjusting—never leak—make no noise. Sold at heating and plumbing stores. Only \$1.60.

**AIRID**  
AIR VALVES  
make cold radiators HOT

#### AMERICAN RADIATOR COMPANY

1812 Elmwood Ave., Buffalo, N. Y.

Send me a trial Airid (one only). (Guaranteed 5 years.) (This will be mailed C. O. D., or enclose check or money order for \$1.60.)

Name .....

Address .....

## NEW VEST POCKET ADDING MACHINE

**ADDS - SUBTRACTS  
MULTIPLIES - DIVIDES**

Does all the work of a \$300.00 machine, yet fits the vest pocket. Easy to operate—does any kind of figuring in a jiffy. The neatest and best constructed portable adding machine made.

**\$2.95**

**Counts Clear Up to 999,999,999**

Total visible at all times. A pull of the finger clears it. Invaluable to anyone who uses figures. Saves many times its cost by preventing mistakes.

**10 Days' Trial** Send no money. Just same and address and we will send machine postpaid. Pay postman on delivery \$2.95. Use it 10 days to prove it does all we claim. Your money back if not perfectly satisfied. Don't be fooled by cheap imitations. Order your Ve-Po-Ad now from this ad.

Reliable Adding Machine Corp., Dept. 49  
184 W. Washington St., Chicago, Ill.

**AGENTS**

Here's a money maker. Everybody wants one. Splendid profit. Write for special offer.

**BRISTLES OR BADGER HAIR**

When you select a Shaving Brush for its "business end" it will of course be a **WHITING-ADAMS**

**VULCAN RUBBER CEMENTED**



**WHITING-ADAMS** Shaving Brushes are made from selected bristles and Badger Hair only. The "business end" of every Whiting-Adams brush is full and bushy, carries a copious lather that works in easily and softens the beard quickly. Naturally the bristles "stay put"—that's expected.

*Every hair is permanently  
imbedded in hard rubber—*

**VULCAN RUBBER CEMENTED**

**WHITING-ADAMS  
BOSTON**

Brush Manufacturers for 117 years and the largest in the World

**Taxidermy  
Book  
FREE.**



Write Today.

**Stuff Beautiful**

**Birds.** Learn by mail to stuff and mount all kinds of birds, animals, fish and game heads, make rugs, tax skins. Mount your own specimens and make money preserving for others. Men, Women and boys learn easily and quickly. Success guaranteed or no tuition. Write today for our wonderful FREE book "How to Learn to Mount Birds and Animals." **N.W. School of Taxidermy, 1779 Elwood Bldg., Omaha, Neb.**

**Beautiful HOUSES \$900  
and BUNGALOWS**

**CAN BE BUILT FOR AND UP**

This and many others in my new book, **Building Plans for Modern Homes**, will save you hundreds of dollars. One of the most complete and comprehensive books of plans ever published by any architect. New edition just off the press. Nearly 600 floor plans and photographs of Colonial houses, bungalows, etc., costing from \$200 up; gives sizes and cost to build. Sent postpaid for \$3.00.



**FREDERICK H. COWING  
ARCHITECT  
101 Tremont St., BOSTON, MASS.**

**Relieve  
rheumatic pain!**



Keep muscles and joints limber and free from stiffness. Absorbine, Jr. rouses the blood to renewed action and brings quick relief from soreness. Don't fear to rub—it cannot burn.

**\$1.25 a bottle at your druggist's  
W. F. Young, Inc. Springfield, Mass.**

**Absorbine Jr.** THE ARTIFICIAL LUBRICANT

## Save Money on New or Used Auto Parts!

15 years of progress has made our stock of new and used accessories and replacement parts the largest in the world. We can furnish you with anything from a Cotter-Pin to a complete Power Plant.

**FREE! CATALOG**  
of Parts Both

**NEW AND USED**

The most complete catalog ever issued. Chockfull of bargains. Save 30% to 50% on your purchases. Buy from Warshawsky. Every item guaranteed to be just as represented.

**WRITE TODAY**  
**SURE!**

**A FEW SPECIAL BARGAINS IN NEW REPLACEMENT PARTS**  
Prices quoted are F. O. B. Chicago

Ford Cylinder Heads, New..... **\$3.75**  
Ford Cylinder Blocks, New. Complete with rings, wrist pins, pistons, bushings..... **\$20.00**  
Ford Counter Balance Crank Shafts. A \$19.00 value..... **\$12.50**  
New.....  
Ford Triple Seal Pistons, New. Up to .005 oversize. Complete with wrist pins and bushings. Per set..... **\$5.00**  
Ford Gas Savers, New. 2-in. manifold, \$3.50 value..... **\$1.00**  
Ford Water Pump..... **\$2.50**  
New.....  
Genuine Chevrolet Pistons, New. Up to .005 oversize..... **\$1.00**  
Nu-Life Ring Expanders..... **5c**  
New.....  
Miles Piston Rings, New..... **40c**  
All sizes. A \$1.25 value.....

**WARSHAWSKY & CO.**

"World's Largest Car Wreckers and Replacement Parts House."

No Branches

No Branches

1915 So. State St., Dept. P. M. 12 Chicago, Ill.

**AGENTS** SELL THE **OVERSIZED**



**JOHNSON RED PEN**

Each pen is hand-made and ink-tested in our own factory.

**FIVE-YEAR GUARANTEE** with each pen.

\$7.00 VALUE for ..... **\$3.50**

Send for **AGENT'S SAMPLE** at \$1.75 C.O.D., plus postage, and complete literature, or send for literature only.

Johnson Pen Co., Dept. P.M., 117 S. First St., Rockford, Ill.

**MEN** NEW LINE **BIG MONEY**

World's fastest seller is Everbrite Stainless Steel Cutlery. Agents make \$65 to \$125 weekly. Commissions in advance. We deliver and collect. Wonderful samples and case furnished. Don't waste time on slow sellers. Get in on this world beater. Write for agents' offer—today!

**E. B. STAINLESS STEEL CUTLERY COMPANY**  
37 W. Van Buren St., Chicago, Ill. Dept. 36



**EASY \$100 a Week**

**FUGO**  
**FIRE EXTINGUISHER**

Unusual opening for live agents in every locality. Make \$500 or more a year—*easy*. Fugo—the instantaneous automatic fire extinguisher—is needed and wanted in every home, store, theatre, garage, shop, school, automobile, etc. Cheapest fire protection available today. Within reach of all.

**1 Qt. Size \$5.00** **2 Qt. Size \$7.50**

Recharged in a *flap*  
Amazing 20-second demonstration clinches sale—each one sold sells others. Territory going fast. Write at once for wonderful proposition that will make you big money.

**THE NATIONAL FORMETAL CO.**  
245 St. Clair Ave., N. E. Cleveland, Ohio

Every boy in  
America will be  
thrilled with  
The New Erector  
the world-famous  
construction toy!

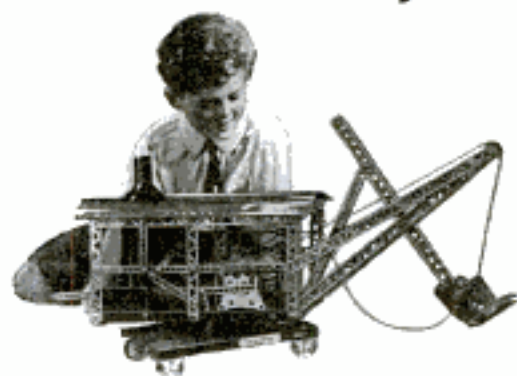

**WHEN** a boy has an Erector Set he can make working models of steam shovels, concrete mixers, locomotives, draw-bridges, hundreds of engineering toys. The powerful Erector electric motor makes them whiz and go.

Erector exclusive features are:—It's square girders; curved girders; steam shovel; new Erector boiler; dredge bucket; giant fly wheel. Other Erector features are:—It's perforated strips; a great assortment of gears and hundreds of other genuine perfect mechanical parts for a boy to build a new toy every day.

Sign this coupon and I will send my new free book about the new Erector, "One Thousand Toys in One," also the Mysterious Gilbertscope, a present that amuses everyone.

*Super Erector No. 7—\$10*

**THE** most popular Erector Set—contains powerful electric motor, new Erector boiler, steam shovel, base plates, curved girders, assortment of gears—473 parts, builds 533 models—with 64-page manual in colors. Packed in wooden chest. Price \$10. Other Erector Sets from \$1.00 to \$50.00.



**A. C. GILBERT CO.**

111 Blatchley Ave., New Haven, Conn.

Please send your free book, "1,000 toys in 1" and also the Gilbertscope to the following address.

Name.....

Street.....

City..... State.....

Copyrighted material



Men's Sizes \$5  
Boys Sizes \$4

## Practicoat

MEASURED by any rule, the Practicoat passes the test of manly looks, snug fit and long wear. That's why practical men wear it in the shop, office and home.

Its \$5 price is an achievement of modern standardization and quantity production; its ironclad guarantee makes your satisfaction certain.

If your dealer does not carry the Practicoat, order through us.

AMERICA'S  
GREATEST  
KNIT JACKET  
VALUE

*Manhattan*  
KNITTING MILLS  
8-14 West 30th Street,  
New York City

MYERS ELECTRIC IRON CORD HOLDER

A wonderful invention. Keeps cord out of way while ironing. Grips the ironing board. Tested and approved by Good Housekeeping Institute.

AGENTS WANTED

Sample 50 cents postpaid.

C. A. MYERS CO.  
6339 Woodlawn Ave., Chicago, Ill., U. S. A.

### CLASS RINGS & PINS

Largest Catalog Issued—FREE

Samples loaned class officers. Prices \$2.20 to \$8.00 each. No order for class, society, club emblems too large or too small. Special designs made on request.

METAL ARTS CO., Inc., 7705 South Ave., Rochester, N. Y.



"If I hadn't been all through it myself, I wouldn't have the assurance to say to you 'cheer up.'"

ERICKSON.



Those who wear them say:  
**ERICKSON LEGS** are Wonderful  
because they do not chafe, overheat or draw end of stump.

If you have had a recent amputation send for new booklet on TEST LEGS for beginners.

E. H. ERICKSON CO.  
38-A Washington Av. N.  
MINNEAPOLIS - MINN.

## FREE! NEW MONEY SAVING BOOK



Ranges Buy direct from factory! Save 1/4 to 1/2 on your stove, range or furnace. Take advantage of the biggest SALE in our 25 years. Kalamazoo quality is the highest; prices are at bedrock. This is the year to

buy. Send for our big, new catalog—it's full of new ideas, new features, new models.

200 bargains in heating stoves, gas ranges, combination ranges, coal ranges, furnaces, both pipe and pipeless, and household goods. Cash or easy payments. 30 days' trial. Money-back guarantee. Twenty-four-hour shipment. 500,000 pleased customers.

Furnaces \$59.95 Up



Write today for Your FREE Book Now Ready  
KALAMAZOO STOVE CO., Mfrs.  
391 Rochester Avenue,  
Kalamazoo, Michigan

**"A Kalamazoo Direct to You"**

## 4 DAYS' IN ROME Brought Phillips \$200



Four Days' Easy Work in Rome, Ga., brought T. G. Phillips \$200 profit. And he is just one of hundreds who have cleaned up the biggest money of their lives demonstrating an amazing new kind of fire gun, which smothers fire at a distance of 25 feet. McPhail made \$1140 in 4 months. Clement made \$62.70 in 1 day. This new gun requires no pumping and creates from one quart of liquid over 500 quarts of fire-quenching gas. It sells cheaper and gets a bigger commission than other extinguishers. One demonstration often sells a dozen—your profit \$50 or more. Write quick for free selling outfit offer. We furnish cars to producers, besides giving free radio and cash bonus. Write for full details.

WELDON MANUFACTURING CO.  
Dept. 712 Grand Rapids, Mich.



## WHITE FLAME

BURNERS make your old kerosene lamps and lanterns give a brilliant white light better than electricity or gas. Doubles your light. Saves oil. NO MANTLE TO BREAK. Guaranteed Safe and Reliable. Delights every user. Send now for complete sample postpaid 50 cents, stamps or coin. 3 for \$1.25. Money Back if Not Satisfactory. Live Representatives Wanted. Exclusive Territory.

WHITE FLAME LIGHT CO., 68 Clark Bldg., Grand Rapids, Mich.



This Scientific  
Device is easily  
attached to  
Furnace Door



## CROWN FUEL SAVER and SMOKE ABATER

Less Coal, More Heat

Mix red hot oxygen  
with coal gases over

the furnace fire bed and save 20% on your coal bill! That is the CROWN guarantee—20%—but it often saves much more! Balmly warmth from your heating plant and savings soon pay its cost.

The CROWN brings the fuel to the top—where it belongs and will do the most good. 10 years' successful use. Thousands now pleasing owners. Cheaper grade fuels can be used.

**WRITE TODAY** for a full detailed description of the CROWN—information for everyone buying fuel for dwelling or industrial plant.

**DISTRIBUTORS WANTED!**

A splendid business opportunity—write at once.

C. F. S. Co., 412 N. 10th Street, Richmond, Ind.

Sole Canadian Distributor:

33 St. Vincent St. Montreal, Canada

# 1/2 SAVED

on all Standard  
Typewriters

10  
Days  
Trial



At last—World's Best Typewriters with every modern writing feature at positively lowest prices and on easiest terms ever offered.

## Young Process Re-Manufactured

The "Young Process" is a perfected and standardized process of completely re-manufacturing typewriters—they are completely torn down, frame enameled, plated parts renickled, new platens, feed rolls and new parts wherever a replacement will make it a better machine, so as to give satisfactory typewriter service in writing qualities and appearance like new. Our catalog explains and illustrates this wonderful process which actually saves you fifty dollars.

## A Year to Pay 5 Year Guarantee

You can buy any standard typewriter on easy payments—so small you will never miss them—the typewriter will easily pay for itself while you benefit by having the use of it. Why wait when you can have 10 days trial without obligation to buy unless satisfied?

Every machine is backed by our iron-clad FIVE YEAR GUARANTEE—and will give satisfactory service for many, many more years. Let us prove this to you.

## Free Typewriter Book

Be sure to clip free catalog coupon and mail it today and we will be glad to send full information about the Young Process of Remanufacturing and the wonderful offer we can make to you at this time.

**YOUNG TYPEWRITER CO.**  
654 W. Randolph (Estab. 1911) Chicago, Ill.

## Mail Coupon Today

Young Typewriter Co. Dept. 110C, Chicago  
Send me your free illustrated catalog. This is not an order and does not obligate me in any way.

Name .....  
Street .....  
City ..... State .....

**10 SEND ONLY**  
**NO MORE**  
**TO PAY**

We Will Send You a Full Cut,  
ONE CARAT

### Corodite Diamond

NO C. O. D.—NOTHING TO BUY OR SELL  
NO STRINGS ATTACHED TO THIS OFFER

We make this remarkable offer so that every lover of beautiful jewelry can have the opportunity of comparing a Corodite Gem side by side with a Genuine Diamond. We want you to see with your own eyes the fiery flashing beauty of this Gorgeous Gem. CORODITE DIAMONDS are double polished and have the true diamond 132 facets. So closely do they resemble the genuine that even lifelike experts are astonished. The illustrations above show how beautiful a CORODITE looks when mounted in a ring. Send your name and address and 10c in coin or stamps to help cover cost of handling to us Today. Your Corodite will come Fully Prepaid by return mail.

**E. RICHWINE CO., Dept. B-69 19 W. Jackson Blvd. CHICAGO, U. S. A.**

**COUNTER**  
**Eveready**  
**SALESMAN**

**MAKES YOU \$5,000 A YEAR**

Scores of men making \$5,000 a year and more. EVEREADYS in big demand in confectionery, drug, grocery, cigar stores, waiting rooms, newsstands, hotels, cafeterias, restaurants, poolrooms, barber shops, soft drink parlors, etc.

**WE GUARANTEE AGENTS**  
100% to 150% profit on every deal. \$12 initial investment starts you—buys 12 Evereadys (with sales-attracting 1-11 attachment, 25c each extra). Complete investment averages from \$100-\$300, depending on number of EVEREADYS put out. Profits quickly pay back your investment. Sell or lease EVEREADYS, then keep merchants supplied with stork (salted peanuts, candies, nut meats, etc.) Daily repeat orders. Our contract with big national specialty houses enables you to buy all your supplies wholesale—in separate bags or bulk.

**WHOLE OR PART TIME** Volume steady business and big profits in short time. Nothing else the EVEREADY—automatic—easy sell—no books, clips or stickers. **ACT NOW**—for exclusive rights in your community. Dealers: If no "Eveready" distributor has called—permit \$1.00. 30 days must prove claims or full refund.

**THE INTERSTATE CO., 2406 E. 9th Pl., CLEVELAND, O.**  
(Reference: Midland Bank, Cleveland)  
OR—start on "sheepskin" with new EVEREADY Metal Easel Display—just out—write for details!

## THAT WET BOILER PIT CAN BE MADE DRY!

MAKE and keep your cellar walls, floor and boiler and drain pits thoroughly dry by filling the cracks and coating the surface with Smooth-On No. 7, the only practical water-proofing material that can be effectively applied from inside and bonds perfectly on wet or dry surface. Excellent also for patching concrete floors, water-proofing garage, stable and wash-room floors, brick walls, cisterns, septic tanks, water troughs, fountains, fish ponds, swimming pools, manure pits, etc.

Requires about 25 lbs. Smooth-On per 100 sq. ft. of surface and you can do the work yourself.

Sold in 5 and 10-lb. cans and 25, 50 and 100-lb. kegs

**SMOOTH-ON MFG. CO.**  
Dept. 61  
574 Communipaw Ave., Jersey City, N. J.



Write for  
**FREE BOOK**

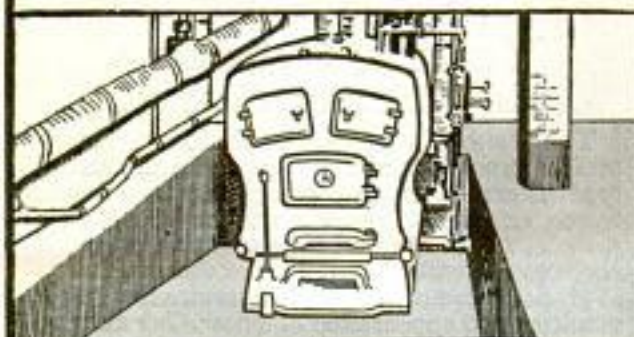

Do it with  
**SMOOTH-ON No 7**

## WHAT EVERY MASON WANTS

We have Masonic books and lodge supplies for Blue Lodge, Chapter, Commandery, Scottish Rite, and Shrine.

Our Rituals Are Used the World Over. Send for free catalog of books and rituals for Masons, Odd Fellows, Knights of Pythias, Knights of Columbus, Elks, etc.

**EZRA A. COOK, Publisher, Inc.**  
1350 N. Clark St., Dept. M, Chicago, Ill.



## Make \$60 to \$100 A WEEK

**New 300 Candle Power Lamp—Burns 96% Air**

Introduce wonderful patented invention. Burns only 4% fuel—cheap kerosene or gasoline. Uses less than wick lamps. Greatest advancement in lighting of the age. Table lamps, wall lamps, hanging lamps, lanterns. Powerful, brilliant, soft, restful white light—like daylight. Brighter than a score of wick lamps. No Smoke—No Soot—No Odor.

**FREE Outfit Offer** Easy to earn big Money. No experience—no capital required. Work all or spare time. Simply take orders. We deliver and collect—pay you big commission same day. Vlyian of Minn. made \$400 in 39 days. Green of N. Y. made \$33 in one day. Hundreds making \$10 to \$40 a day. Get territory quick. Big season now on. Write today for Free catalog and special agents offer.

**THE AKRON LAMP COMPANY**  
112 Lamp Building Akron, Ohio



## MEET LLOYD HOBSON

Then read what he writes about his

# CARNES ARM

"I can play the violin and will have my picture taken playing it. I can also write with it and will sign my name to this letter." \* \* \* \* \*

"I am going to hang some paper in a day or two. I have not tried anything yet but what I have accomplished and I think I can hang the paper." \* \* \* \* \*

Mr. Hobson's right arm is off 6 inches below the shoulder. He says he would now miss his artificial arm as much as he did his natural arm before he bought a Carnes.

**FREE CATALOG**—Let us send you our catalog filled with pictures and letters of actual uses of the Carnes arm.

**CARNES ARTIFICIAL LIMB CO.**  
68 Carnes Bldg., 904 East 12th St., KANSAS CITY, MISSOURI



A Home and Car with Tyler Profits

**AGENTS \$8 to \$20 A DAY**

No Experience Necessary

"I paid for my home and bought a car with Tyler profits," writes Jos. H. Boorem. You too can make big money selling "Handiest tool in the kitchen." Indorsed by *Good Housekeeping*. Easy to sell. Liberal Profit. No experience necessary. Our Plan assures success. Write today. The Tyler Mfg. Co. Dept. M-4. Muncie, Indiana

## Wonderful New Plan for AGENTS

Easy to Make \$90 a Week



Men and Women! Write me today and

by this time next week I can place you in a position to make \$2.00 to \$3.00 an hour in your spare time, up to \$15.00 a day full time. Thousands of our representatives are making that and more with our New plans. Simply introduce and take orders for famous **World's Star Hosiery and Underwear** sold direct from mill to home—a complete line for whole family. Permanent customers and repeat orders make you steady, big income. No capital required.

**Write Quick** It's a chance to make thousands of dollars. Your profits begin at once. Exclusive territory. No experience needed. Write today and I'll send all facts and tell how to start **Free**. (Established 30 years.)

**World's Star Knitting Co.**  
282 Lake St. Bay City, Mich.







# Elto

(Designed and built by Ole Evinrude)

## Quick Detachable Rowboat Motor

Powerful, Light Weight, Speedy, Quiet Running, Practically Vibrationless. Starts on a quarter turn. Easily carried with you anywhere you go. No rowing, no work, no bother. Just ride and enjoy the greatest of water sports. Slow down for fishing. Speed up for racing. Great power.

Write for **FREE** Catalog describing all the new features, especially the famous Propeller Pump. Only Elto has it. Write today.

**ELTO OUTBOARD MOTOR CO.** Dept. AA  
Ole Evinrude, Pres.  
Manufacturers Home Bldg., Milwaukee, Wis.



## Do Your PRINTING

Cards, stationery, circulars, labels, paper. Complete **Outfit \$8.85** up, Rotary Jobber, \$150. Card Cutters \$5. Save Money. Print for others, big profit. Easy with rules sent. Write for catalog presses, type, paper, cards, ink, etc. **THE PRESS CO., L-37, MERIDEN, CONN.**

## SHAW MOTOR ATTACHMENT MAKES YOUR BIKE A MOTORCYCLE!

A high grade 2 1/2 H. P. motor attachment quickly clamped on any bike frame. Speed 4 to 40 miles an hour. 90 to 125 miles per gallon of gas.

**Special Low Price Now!** Write today for Complete Description and Special Low Prices on SHAW Motor Attachments and the SHAW Complete Motorbicycle. **SHAW MANUFACTURING COMPANY** Dept. 37  
Galesburg, Kansas



# Free SUIT OFFER

By Our New Plan

Made to Order Now

## Send No MONEY

our unbeatable values, classy styles and perfect tailoring, we make this introductory **free** suit offer. Our new plan enables you to get one of our fine, made to order suits, in any style you like without spending money.

**AGENTS Earn \$9 to \$18 DAILY WANTED** Cash for you besides Free Suit for spare time showing our wonderful samples to neighbors and friends, we show you how, perfect on low folks buy on sight, get cash and **FREE SUIT**. No experience needed. Biggest sample outfit, agents wholesale prices, real wool pieces, fashion styles, tape measure, simple directions. **WRITE AT ONCE** for **FREE** suit offer and Free sample outfit.

**PROGRESS TAILORING CO., Dept. M-216, CHICAGO**



10 MONTHS TO PAY



N-107. 18K White Gold Dinner Ring, artistically hand-carved and pierced design. 7 AA1 Quality Blue-white Diamonds. \$64.50

Now you can give that worthwhile Xmas Gift, and still remember everyone. Send only \$2.—we'll open your charge account—and your choice of these Xmas Specials will come for approval and 15 DAY TRIAL. Convince yourself of its exceptional value—if satisfied, pay balance in 10 monthly payments. Otherwise return, and your deposit will be sent back.

**Special Xmas Service**  
Our Charge Account Plan is simple, easy, convenient and confidential.  
**MAIL YOUR ORDER TODAY**



N-108. Ladies Spreadtop Cluster. 18K White Gold; 7 AA1 Blue-white Diamonds mounted to resemble big solitaire. \$55



N-109. Gents 18K White Gold Spreadtop Ring. AA1 Blue-white Diamond. \$57



N-110. Friendship Gift—Ladies 18K White Gold Ring. 3 AA1 Blue-white Diamonds. \$42.50



N-112. Ladies 18K White Gold Ring. 7 Triangular cut Blue Sapphires; AA1 Blue-white Diamond. \$62.50



N-113. A Bargain—18K White Gold Lace-work design. AA1 Blue-white Diamond. \$29.50



N-114. Ladies 18K White Gold Floral and Scroll Design. AA1 Blue-white Diamond and regular-cut Diamond on each side of shank. \$52.



N-115. 14K White Gold Rectangular Wrist Watch set with 4 Regular-cut Blue-White Diamonds and 4 Blue Sapphires. 15 Jewel Movement. \$42.50

N-116. Same Watch without diamonds and sapphires. \$24.95



It's **FREE** Complete booklet; over 3,000 appropriate Xmas Gifts in Diamonds, Watches, Jewelry, Silverware and Toilet Sets—all priced low. 10 Months to Pay on Everything.

AUTHORIZED \$1,000,000.

# L.W. SWEET INC.

65-T 1660 BROADWAY, NEW YORK

## Better Shaves More Shaves

With the wonderful new James Stroppler you can now treat yourself every morning to a "head-barber" shave.

It gives you the kind of shave you hoped to get from your blades, not one or two mornings, but every morning.

Your favorite store has them in stock or will get them for you.

Ready in Gillette, Gem, Ever-ready, Enders, Auto Strop and Durham Duplex types. Price \$2.00.

Valuable booklet on "Better Shaving" sent free.

**DUDLEY FREEMAN COMPANY**  
80 Boylston Street BOSTON



## MAKE YOUR Ford INTO THIS Sport Car—Save \$50 to \$150 with Red-i-Kut Life-Size Patterns \$5.00

Famous sure-fit RED-I-KUT life-size patterns and picture instructions show how you can easily convert your Ford into this Fast, Saucy, Sport Car as thousands have done, with easily obtained materials. No need to lay up the car. Rear seat folds making 4-passenger car. Look at Wilfred Eng's. Eng says: "I took me 3 Sundays to build it and I sure am proud to hear them say, 'He built that snappy sport car.' I never cut any steel or did any work before but we can't go wrong with Kuempel patterns. St. Louis, Mo.



The Lark life-size patterns for each part of the body as you can't go wrong, picture instructions and CONICAL DISK WHEEL PATTERNS. Only \$3.00 delivered. \$4 extra brings patterns for Jiffy Top and Green windshield. 22 cup RHO Steel for Lark 220 complete. Estimate West 213. Order now while we can make good delivery, and really enjoy these wonderful days in your Lark. Klean, Clean, Up-to-the-minute. You can build it. Over 11,000 in use. Don't hesitate. "Swing Lo" Underlying Iron, no frame cutting kind. \$6.50. Only \$4.99 when ordered with Lark patterns. Send for more manual of other distinctive sport body patterns from \$5.00 up—"REO" Steel "Swing-Lo" Iron, Tops and Windshields. ORDER RIGHT NOW. KUEMPEL CO., 67 Kuempel Bldg., Guttenberg, Iowa

Easy-to-Understand Instructions

The "Lark" Class—Snap



## Tire AGENTS WANTED

Use and introduce MELLINGER CORD TIRES  
**15,000 MILES GUARANTEED**  
Lowest Wholesale Prices in America. Shipped prepaid on approval. Make big money all or part time. No capital or experience. Sample sections furnished.

**YOUR TIRES FREE!** Simply send name today for valuable FREE BOOK; tells how thousands have gone into big business. SPECIAL AGENTS' OFFER. Wholesale Prices and FREE SAMPLE KIT. Write nearest address.  
**MELLINGER TIRE & RUBBER CO.**  
PHILADELPHIA, PA. Dept. 1915 KANSAS CITY, MO.



## You and This New Machine Can Earn \$500 a Month



Operate a Tire Repair Shop

70,000,000 Tires in use. America's greatest opportunity for men with small capital. We furnish everything—\$100 and up. Easy payments. We train you FREE right at home. Start making money at once. Write today for Free Book of Opportunity.

Haywood Tire Equipment Co. 1344 S. Oakley, Chicago

## DON'T PAY RETAIL PRICES FOR YOUR BUMPER! \$7.50

WE SELL DIRECT FROM FACTORY TO CONSUMER BUMPERS LISTING AT \$20.00, FOR



Garage Owners—Auto Owners—Ford Owners

OUR CYCLONE BUMPERS AND BUMPERETTES ARE BEAUTIFULLY POLISHED NICKEL DOUBLE BAR—LOOP-END-SPRING-Steel. Each bar is 1 3/4" wide x 5/16" thick, has black enameled spring steel back-bar, also black enameled clips, for all cars, guaranteed for wear and just as we represent them to be. Best constructed and finest bumpers and bumperettes on the market. Also single bar loop-end bumpers fully nickel-plated with fittings complete for Fords and Chev. \$4.75 each. Salesmen wanted. Reference—Duren and Bradstreet and Drexel State Bank, Chicago.

**CYCLONE MFG. & SALES COMPANY, 1108 S. Michigan Avenue, CHICAGO**

f. o. b. Chicago. Bumperettes to match. \$9.50

## Roofing Book FREE



World's

## Best Roofing at Factory Price

Don't buy Roofing of any kind until you get our big Free Roofing Book, describing full line of Edwards Famous "Tighttoote" Galvanized Roofings, Sidings and Ceilings, and our lowest factory prices. Then see for yourself how much we save you by selling direct and saving you all in-between dealers' profits.

## EDWARDS "REO" Metal Shingles

Absolutely rust proof. By our patented "Tighttoote" process, edges as well as sides of metal sheets are heavily coated with zinc—not a space the size of a pin point exposed to weather. Fire and lightning proof. Outlasts three ordinary roofs. Forever wind and weather proof. Need no repairs—and all roofing expense. Patent INTERLOCKING SENCE makes water tight seams—all nail heads covered—no chance for rust or leaks.



## EDWARDS Galvanizing Test

Edwards "Tighttoote" Galvanized Roofing can be bent, twisted or struck by lightning, and the galvanizing will not crack or flake. Bend it or hammer it—you can't loosen or scale the galvanizing. No other galvanized roofing can withstand this test.

Low Priced Garages

Wide variety of styles, all sizes of Portable Fireproof Metal Garages. Lowest prices ever made. Postal brings Big Garage Catalog free.

Write Today for free samples and proof that we can save you a lot of money on any kind of roofing siding or ceiling you may need. Ask for Roofing Book No. 100.

**THE EDWARDS MFG. CO.,**  
1200-1250 Butler St., Cincinnati, O.

FREE Samples & Roofing Book

**Make Your Tires**  
**PUNCTURE-PROOF**  
IN ONE MINUTE  
**Agents**  
AND  
**Distributors**  
**Wanted**

**580**  
NAIL & SPIKE  
PUNCTURES  
WITH NO  
AIR LOSS

**25¢**  
PER TIRE  
IN  
VARIOUS  
SIZES

**GALACITE** will repair a puncture in ONE MINUTE without taking the tire off the wheel rim; and in addition it will make the tire Puncture Proof for life. GALACITE seals instantly and permanently, punctures, leaks, porous places and leaky valves. No more flat tires, no more getting out and changing tires in a hot sun. No soiled clothes. A scientific laboratory product. Tested in every part of the United States. Backed by a MONEY BACK GUARANTEE to do everything we claim. Guaranteed not to injure tube, valve or tire; on the contrary it preserves and lengthens the life of tube and tire, often

**INCREASING TIRE MILEAGE FROM 10,000 TO 12,000 MILES**

Take a hammer and drive as many nails into a tire as you wish. 50—100—500. It makes no difference. GALACITE seals the punctures permanently, as soon as they are made. We guarantee it for one year, but it will last indefinitely.

**CAR OWNER AGENTS WANTED**  
**EARN \$5,000 TO \$10,000 A YEAR**

**TREMEUDOUS PROFITS.** Agents and Distributors everywhere to demonstrate and sell to car owners, critics, filling stations. Work all or spare time in your own home town or traveling. GALACITE sells itself. Every customer becomes so enthusiastic that he helps you sell his friends. A revolutionary invention that will make you independent. You can also manufacture and sell GALACITE PUNCTURE PROOF INNER TUBES.

**ACT QUICK SEND NO MONEY.** Just your name and address will bring complete particulars by return mail. Get this information right now. Test it out. Get started while the field is still uncrowded.

**C. F. JOHNSON & CO.** Dept. 940, 39 W. Jackson Blvd., CHICAGO, ILLINOIS, U. S. A.  
\*Galacite Trade Mark Reg. Copyright 1925

**WORLDS OF HEAT**  
**RADIANT**  
**KEROSENE**  
**OIL HEATER**

**Everbrite**

Burns 8 to 10 hours on gallon of Coal Oil. Turns on like gas—cheaper—cleaner—more comfortable than coal or wood fire. No wick—no smoke—no odor. Will heat the whole house in coldest weather. Portable—may be moved from room to room. Simple; turns up and down—off and on like city gas. Thousands in Happy Homes everywhere. Handsome, durable—gives intense heat.

**FREE** Simply send name today for circular and full details how it works and amazing offer.

**EVERBRITE STOVE CO.** 4212 Gateway Station  
KANSAS CITY, MO.

**18 Million Cars**  
need it! Three devices in one!  
Big Seller! I want an exclusive  
representative in your section.  
Opportunity to make \$10.00 to  
\$50.00 daily selling the new Electric  
Quick-Start and Gas Saver. No  
capital required. Write Quick!  
W.W.Kutsche, Inventor Dearborn, Mich.



**MOTORCYCLES**  
**LESS THAN HALF COST**

See, Indian, Cleveland, Harley-Davidson, Henderson Motorcycles and Sidecars, new, used and rebuilt. Rider Agents Wanted. Write for FREE trial offer, agent's free outfit and big bargain bulletin. New American Bicycles in different styles and colors. Write for illustrated catalog giving our money saving prices.

**AMERICAN MOTOR CYCLE CO.**  
2047 W. Chicago Ave., Dept. 1229, Chicago



**Get an Ideal**  
**Model Aeroplane**  
**for Christmas!**

Model Aeroplane building is the most interesting thing you ever tackled. Shows you how big aeroplanes are constructed; how they fly. Ideal Models are true copies of real aeroplanes; the ones you see and read about; have parts and fittings like big ones and are guaranteed to fly in the air, when correctly built. **Any bright boy can build one.** Ideal Construction Outfits make building easy. They contain all parts needed to build a dandy Model Aeroplane; including plans, charts, diagrams and careful instructions. Here are several popular models; select yours now, get it for Christmas, and have a good time building and flying it.

**This is the Famous DE HAVILLAND**  
**"Round-the-World Flyer"**



Complete Construction Outfit with everything needed, including rubber tire Glac wheels, carved propeller, aluminum and veneer cowling, formed ribs, all other parts and fittings, and careful directions. Complete 3-ft. Outfit..... **\$7.50**

**This is the Popular J N 4 D-2 Curtiss Training Plane**



A perfect 3-ft. duplicate of this wonderful training plane. Complete Construction Outfit, including all parts and materials, plans and careful instructions, telling exactly how to build the entire model aeroplane... **\$7.00**

**Other Construction Outfits**

N C-4 Naval Seaplane; 4 1/2 foot model of the Navy Plane which crossed the Atlantic Ocean.....	<b>\$10.00</b>
Nieuport Monoplane; 3 ft. model of this famous French Scout plane.....	<b>6.00</b>
Bleriot, or Yawb Monoplane; 3 ft. model of either of these graceful flyers.....	<b>5.00</b>
Coill Peell Racing Airplane Capable of flying 1800 feet.....	<b>4.50</b>
Improved Three-foot Racer Ready for flying in 15 minutes. (West of Denver, Colo., and in Canada, prices are 50c higher.)	<b>3.00</b>

Ask your Dealer for these Model Aeroplane Construction Outfits. If unobtainable, we will fill your order upon receipt of price.

<b>Plans for</b> <b>Model Aeroplanes 25c</b>	<b>Catalog of</b> <b>Parts and Supplies 5c</b>
Complete Scale Drawings and Building-Flying Instructions for any of the above Model Aeroplanes, sent postpaid for 25c.	48 pps. describing the above Model Aeroplanes, and many flying toys; listing hundreds of parts and supplies for model builders; sent prepaid for 5c.

**The AIRPLANE**  
**Any Boy Can Build!**

**Every Boy's**  
**Own**  
**Airplane**



The simplest-to-make model airplane there is—3 1/2 ft. wing spread; flies beautifully. All parts ready formed; needs only fastening together without nails or wire. Anyone can do it in 2 hours. Has beautiful parts and fittings. Just like a real monoplane.

Price, Complete \$4.00  
West of Denver, Colo., and in Canada, \$6.50  
Ask Your Dealer, or Order Direct

**Ideal Aeroplane & Supply Co.**  
408 West Broadway, New York

## Yes—A Pair of Brand New, Shining, Nickered, Hardened Steel SKATES Attached to Strong, Com- fortable, Smart, Athletic SHOES



For only **\$5.00**  
Pre-paid

Skates are a clean cut, snappy design from the famous Winslow Skate Mfg. Co., made in the most up-to-date style for hockey and all round skating, and firmly attached to strong calf-skin athletic shoes with just the right medium high heel and the firm ankle support strap necessary to make skating easier and more comfortable. The lacing extends way down to the end of the toes, enabling you to adjust shoes perfectly for the snugest support combined with comfort. This skate-shoe outfit will make your skating far, far better than the old clamp-on skates. If you have never worn shoe-skates, you'll be surprised to see how much better you get along. Check, money order, or C. O. D. Money back if not thoroughly satisfied. Shoes and skates complete for less than the price of ordinary shoes—a real buy! Men's and boys' shoe sizes from 3½ to 11½. Women's and girls' sizes from 3½ to 8½. Sporting goods catalog free.

**IVER JOHNSON SPORTING GOODS CO.**  
10 Cornhill, Boston, Mass.

## 30 DAYS FREE TRIAL



Direct From Factory  
to You At Less Than Dealer's Cost

### THIS WONDERFUL COAST-TO-COAST METRODYNE SUPER FIVE 5 TUBE RADIO SET

Will be shipped anywhere in the U. S. for 30 days FREE trial. Test it yourself in your own home and if you do not agree that it is the Greatest Radio Set in the Country, RETURN IT TO THE FACTORY. We don't want your money unless you are completely satisfied.

The Metrodyne has the latest and most efficient Tuned Radio Frequency Circuit. Approved by America's leading Radio Engineers. Easy to operate. Dials can be logged. Tune in your favorite stations instantly on the same dial numbers every time. No guessing.

Mr. Howard of Chicago said "while 5 Chicago Broadcasting Stations were on the air I tuned in 17 out-of-town Stations, including New York and San Francisco on my loud speaker horn, very loud and clear, as though they were all in Chicago."

Thousands of satisfied and happy users everywhere

**PRICE—COMPLETELY ASSEMBLED ONLY**

Compare it with any \$100 or \$150 set. The results will really surprise you. Don't buy a radio set until you learn more about our liberal 30 days FREE TRIAL OFFER.

**\$48.50**

Write Today for Free Information

**METRO ELECTRIC COMPANY**  
1243 S. Wabash Avenue Dept. 64 CHICAGO, ILL.

## SPENLO Shaving Brush and Cream Combined

"The Handy Handle  
Holds the Cream"



Just wet the Brush, then press the bottom like you do with an oil can and instantly work up a Rich Creamy Lather that makes shaving a real pleasure.

### A Bully Christmas Gift

Just send \$2.00 for a SPENLO Brush of imported French Bristles or \$3.00 for a Brush of blended Badger hair. Guaranteed satisfactory. A tube of SPENLO Shaving Cream FREE with each Brush.

**SPENGLER-LOOMIS MFG. CO.**  
1311 Garland Bldg. CHICAGO, ILL.

## AGENTS' NEW SPARK PLUG Visible Flash



**Just Out—Amazing Invention—  
Beacon Lite Spark Plugs.** You see the flash of each explosion in the cylinders. Tells which are firing right. Greatest improvement in spark plugs since gas engines were invented. Wonderful gas savers. Agents coin money.

**\$90 A WEEK**

Easy to make with new sure-fire plans. Sells on sight to every auto owner. Phillips, Ont., writes "Sold 2 dozen today, 3 dozen yesterday. Rush 10 dozen." Write for special Free Demonstrator Offer and FREE deal to introduce these wonder spark plugs in your territory. Write quick—today.

**CENTRAL PETROLEUM COMPANY**  
1032 Century Building Cleveland, Ohio

## Makes Pumping Up Tires Unnecessary



Line up with big money. The Harbor "Airlox" Valve Cap is a proven success. Air-tight. Eliminates all troubles due to under-inflation: tests life of tire. Positive necessity to auto owners. Doubles tire mileage. Tested and approved by leading auto manufacturers. \$1.95 a week for hostlers. Unlimited demand. No competition.

**FREE SAMPLES TO AGENTS**  
to use and introduce in exclusive territories. Immense uncrowded field. Don't hesitate. Write today for facts and FREE SAMPLES.

**AIRLOX RUBBER CO.**  
2512-14 W. Monroe St., Dept. 8057 Chicago, Ill.

## Your Coat and Vest can be Matched with new Trousers



Save the price of a new suit. We match hundreds of coats and vests satisfactorily every day. Every pair tailored to your measure. 60,000 patterns. We submit sample of cloth for your approval. Just mail your vest or a sample of the suit to

**MATCH PANTS COMPANY**  
Dept. 2-A, 36 W. Randolph Street, Chicago  
Enclose return postage if vest is sent.

## UTAH LOUDSPEAKER

Ours is the strongest guarantee! Use it 10 days. If not the finest you ever heard, return it and get your money. Dealers Everywhere.

**Utah Radio Products Co.** Dept. 50, 1427 S. Michigan Ave. CHICAGO, ILLINOIS

## MOTORCYCLES

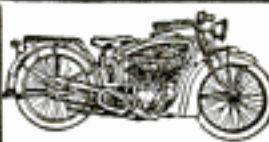

**RELIABLE STANDARD MAKES** that you can DEPEND on. Enjoy the thrills of experience of going wherever you like—when ever you like. The price is within your means—\$55 to \$85 less than others. These machines are strictly used, thoroughly overhauled or rebuilt. Send for catalogue. **MYEROW BROS.** 15 Berkeley St. Boston, Mass.



Ernest Pechin  
Cornet Virtuoso  
Uses a Conn

## How to Win Success in Music

Begin with the right instrument. This is the advice of the world's foremost artists. Conn instruments, used and endorsed by the most successful players, are easier to play, most beautiful in tone, perfect in scale; reliable in action—possess many exclusive features, yet cost no more than others.

Free Book by Sousa and nine other famous artists on "Success in Music," helps you choose the instrument for your talent. Send now for your copy and details of Free Trial, Easy Payments on any Conn instrument.

C. G. CONN, LTD.  
1231 Conn Bldg. Elkhart, Ind.

**CONN**  
BAND  
INSTRUMENTS  
WORLD'S LARGEST MANUFACTURERS

## To Hang Up Things In the Boy's Room MOORE PUSH-PINS

Glass Heads—Steel Points

Moore Push-less Hangers

Scientifically Hold Heavy Things

10c pkts. Everywhere

MOORE PUSH-PIN CO., Philadelphia, Pa.

## DOES YOUR BOAT LEAK?

Send for our Booklets, "How to make Your Boat Leakproof," and "Marine Glue—What to Use and How to Use It."

### JEFFERY'S MARINE GLUES IN ALL THE VARIOUS GRADES

Any old boat so long as the frames are in fair condition can be made watertight by following the instructions in the above booklets.

For sale by all Yacht, Boat and Canvas Supply Dealers; Hardware, Paint and Oil and Sporting Goods Dealers.

L. W. FERDINAND & CO.

156 Kneeland Street Boston, Mass., U. S. A.

## SEND NO MONEY 2 Genuine Diamonds 4/100 Each

Cut Stones, No Chips

SOLID GOLD \$25

Terms if desired (6 mos. to Pay)  
Outside U. S. cash with order  
14 kt. White gold top. Gold  
Emblem (any Lodge) or any  
Initial (Old English), yellow or  
white gold, Inlaid in Genuine

## HOPE RUBY

Also, in Black Onyx

Send size of finger and ring This  Reg. Trade Mark  
will be sent for inspection. Guarantees you genuine diamonds.

Send for Free Catalog **B H C M S W** Any Letter  
BUFFALO JEWELRY MFG. CO., "THE MAIL ORDER HOUSE" Dept. P  
501 Washington St. BUFFALO, N. Y.



New  
No. 6132

# Great *New* Invention for seekers of Health Power Beauty



Elco Health Generators at last are ready for you! If you want more health—greater power to enjoy the pleasures and delights about you, or if more beauty is your desire—write! Ask for the book on these inventions which has just been prepared. It will be sent to you without cost. It tells you how Elco Health Generators aid you in leaving the lethargy and hopelessness of bad health and weakness behind forever. Re-vitalize yourself. Bring back energy. Be wholly alive. Write today!

10 Days Free Trial—Write for FREE BOOK

## Elco Electric Health Generators

These great new inventions generate *High Frequency Violet Ray, Mechanical Vibration, Medical Electricity and Ozone.* Combined or separate.

They operate on the electric light in your home or on their own motive power at less than 50 cents per year. Elco Health Generators are positively the only instruments which can give you in one outfit Electricity, Violet Ray—Vibration and Ozone—the four greatest curative agents. Send coupon below. Get the Free Book NOW!



### For All These:

Rheumatism	Asthma
Gout	Hay Fever
Lumbago	Sore Throat
Neuralgia	Catarrh
Sciatica	Deafness
Headache	Insomnia
Neuritis	Pain
Nervousness	Development
Circulation	Skin Disease
Weakness	Pimples
Paralysis	Scalp Disorders
Eye Trouble	Obesity

## MAIL the COUPON for FREE Book!

Do not put this paper down without sending the coupon. Don't go on as you are with pains and with almost no life and energy. You owe it to yourself to be a better man or woman. You were put here to enjoy life—not just to drag through it. So do not rest another day until you have put your name on the coupon here. That will bring the whole story of these great new inventions. Do it today—now.

Health  
Power  
Beauty

### Lindstrom & Company

30 West Lake Street. Dept. 13-59, Chicago, Ill.

Please send me your free book, "Health—Power—Beauty" and full information on your 10-day Free Trial Offer.

Name .....

Address .....



## "ATKINS"

### A "Lifetime" Saw for Your Home

THINK of this beautiful saw of genuine "Silver Steel", the finest saw material originated and perfected by ATKINS laboratories—made to last a lifetime. Tempered and taper-ground by ATKINS patented processes so that it always cuts easier and faster.

Of course such tools are cheaper when you consider the time and material and temper you save. You can buy this genuine ATKINS No. 53 Saw at good hardware stores for only \$3.45—in Canada and west of the Rockies for \$3.65.

No matter how you use saws—from the biggest mill saws to tiny jewelers' saws—it will pay you to LOOK FOR THE ATKINS NAME ON THE BLADE. Ask for our new folder—"The Saw in the Home"—sent free.

E. C. ATKINS & CO. Est. 1857  
Dept. P. INDIANAPOLIS, U. S. A.

Leading Manufacturers of Saws, Saw Tools,  
Saw Specialties and Machine Knives

# ATKINS

## SILVER STEEL SAWS

*A new Parks!*

Cabinet  
Shop  
Special  
No. 7

\$250



### Make a real shop in your basement!

This handy Parks woodworker is complete shop equipment in itself. With it you can do all sorts of cabinet work. Make toys, furniture, radio cabinets—anything. Built for close, accurate work, yet small enough to fit in a corner of your basement. Operates from light socket. Has motor, rip and cut-off circular saw, jointer and bandsaw. Add lathe and shaper at slight extra cost. A real machine ideal for home use. Send for circular.

The Parks Ball Bearing Machine Co.  
1500-1540 Knowlton Street, Cincinnati, Ohio  
Canadian Factory: 200 Notre Dame East, Montreal, Can.

# PARKS

## WOODWORKING MACHINES



You can get yourself no  
Better Christmas Gift

than  
A Gerstner Tool Chest

Ideal for Toolmakers and Machinists

Write for free catalog

*Gerstner Sons*

424 Columbia St., DAYTON, OHIO

BURN YOUR NAME ON TOOLS

WITH THE  
**ARKOGRAF**

PROTECT YOUR TOOLS FROM THEFT

Write with electricity any name or design on the hardest and finest tools and instruments, or any metal, like writing on paper with pen or pencil. Complete outfit \$3.50—Postpaid America. Interesting illustrated circular free. Write today. Agents wanted. ARKOGRAF PEN CO., 1171 E. Stark St., Portland, Oregon



## TURN WASTED TIME INTO MONEY!

Every Purchaser Finds Numerous Uses for the  
**Torit Acetylene Torch No. 13**

Uses Acetylene only.

No oxygen or air pressure is required. Tips suck in air. Simply connect to Presto auto tank, light gas, and the outfit is put to work.

Beats anything you ever tried for soldering, heating or light brazing.

Outfit consists of 4 tips for different kinds of work, soldering copper, 5 feet tubing, tank connection, and full instructions.

ST. PAUL WELDING & MFG. CO., 177 W. 3rd St., St. Paul, Minn.



\$7.50

# \$5 DOWN Buys Any Latest Model WITTE Engine

Now, more than ever, the need for economical, dependable power is felt by the producer who is faced with ever-increasing labor costs. WITTE Throttling Governor ENGINES answer this important question perfectly—now an economical, dependable power plant is within the reach of everyone.

Today the WITTE ENGINE sells at the lowest price in history. Into this WITTE has gone the ripe experience of more than 42 years of engine building—over 100,000 users all over the world have placed upon it their stamp of approval. You, too, can put a WITTE on your place, secure in the knowledge that represents the



## The WICO Magneto

—the most perfect system of high tension ignition known. Makes starting easy, even at 40 below zero—sure performance in any climate or temperature. Not affected by rain, hail, snow or sleet. The perfect replacement for old-style battery-equipped engine.

**Makes all Jobs Easy and Cheap**—No need to do the hard, back-breaking work—no need to pay high prices for poor labor—you can show \$1,000.00 more profit every year you have a WITTE working on your place. Investigate now!

All Sizes, 2 to 25 H-P. Easy Terms. Scrap the Old One—Pay a Little Down on the New Witte!

Ask for Our Big **FREE ENGINE BOOK** or if interested, ask for our Log and Tree Saw, 3-in-1 Saw Rig or Pump catalog.—ED. H. WITTE.

## WITTE ENGINE WORKS

(FOUNDED IN 1870)

1744 WITTE BLDG., KANSAS CITY, MO.  
1744 EMPIRE BLDG., PITTSBURGH, PA.  
1744 WITTE BLDG., SAN FRANCISCO, CALIF.

Up to 10 H-P.

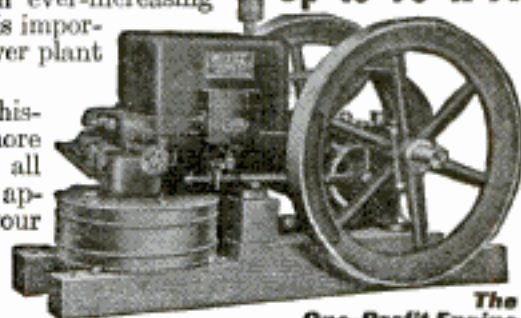

The One-Profit Engine

## The WITTE Throttling Governor

the original and leader of the throttling-governor type. An even steady speed with a big surplus of power for the heavy loads. The minimum in fuel consumption—the WITTE ENGINE burns kerosene, gasoline, gas-oil, distillate or gas at a fuel cost of less than 2c an hour per H-P. Simple, trouble-proof and guaranteed for a lifetime of hard work. Completely equipped with WICO Magneto, speed and power regulator and throttling governor.



Standard of Power



## Fibre-Lite Limbs

AND BRACES \$35 TO \$175

GREAT INVENTION. MAKES WORK EASY. **\$100 WEEK SAVES WEAK LIMBS** WORMAN CO.



AGENTS WANTED  
252-P HENNEPIN AVE.  
MINNEAPOLIS, MINN.



## STOP FORD CRANKSHAFT END-PLAY!

**C-A ADJUSTABLE BEARING** corrects and prevents end-play without removing motor. Eliminates many troubles. Easy to install—simply drop pan. Only \$3.75. Ask your dealer or send prepaid by ADJUSTABLE BEARING CO. Dept. P BRAZIL, IND.

## Get Boice Prices on These Three Bargains!

The logical place to get lowest prices with highest quality on small bench machines is from Boice, the World's largest makers. Whatever you build, there's a Boice machine to do your work: Circular Saws (6 sizes), Band Saws, Jointers (4 sizes), Lathes and Jig Saws. Write today for literature and prices on all Boice machines before you buy!

### 8" Bench Lathe

Does turning, drilling, threading, sawing, sanding, grinding and jig sawing in wood or soft metals. Swings 8". Capacity 20" between centers.



### Handisaw Model 3

Does all your ripping, mitering, grooving, sanding, grinding and drilling with ease and accuracy. Table 14"x16". 8" diameter saw cuts 2 1/2" stock. Dadoes 3/4"x 1 1/4" deep. Cuts mouldings.



### 14" Band Saw

Table 12"x14" tilts 45 degrees. Saws 7" stock. Uses blades 1/4" to 1/2" wide. Bronze bearings.

1/4 H.P.	MOTORS	1/3 H.P.
\$11.95	Standard make, new, 110 V. 60 cycle, single phase, A. C. 1750 R. P. M. with cord, plug and 1 1/2" flat or grooved pulley. Bronze bearings. Both motors guaranteed 100% overload. These special offers not listed in regular price list. Made for immediate acceptance only. Prices F.O.B. Toledo. Cash with order only. Satisfaction guaranteed. Send TODAY!	\$13.95

All Boice machines sold with or without motor

W. B. & J. E. BOICE, Dept. P.M. 12-A, Toledo, Ohio



## Reduce Motor Speed WITH IXL

**FREE BOOK** Every inventor and experimenter should know about IXL Speed Reducers. Most efficient, compact and safe device for reducing motor speeds. May be built into machines where speed reduction is required, or used in shop transmission in place of belts, chains and open gearing. Large variety of sizes and reductions.

Send for your copy of our big FREE book today.

We Make Cut Gears of all kinds, Micarta Pinions, Micarta Timing Gears, Flexible Couplings, Speed Reducers, Special Machinery

**FOOTE BROS. GEAR & MACHINE CO.**  
229-238 N. Curtis St., Chicago, Ill.

Gentlemen: Please send me a copy of your free Speed Reducer Book.

Name.....  
Address.....  
City..... State..... 123-0

## "WONDER" Cold Pipe and Tubing Benders

Do Not Crack, Flatten or Crimp the Pipe

Hand and Motor Operated

**14 SIZES OF MACHINES**

What It Costs to Bend Pipe Our Way. Per Bend

1" Pipe.....	5c	4" Pipe.....	25c
2" Pipe.....	10c	6" Pipe.....	60c
3" Pipe.....	15c	8" Pipe.....	\$1.00

SEND FOR CATALOGUE

American Pipe Bending Machine Co.  
59 Pearl Street BOSTON, MASS.

## ALUMINUM SOLDER

SOLDERS ALUMINUM of any description. NO ACIDS OR FLUX NECESSARY. For home, shop and garage use. Your tool kit is not complete without HAMILTON LEAD CO. ALUMINUM SOLDER. (Name on every bar.) Send 25c for 2 six inch bars, or \$1.00 for 9 bars; postpaid.

**HAMILTON LEAD CO., HAMILTON, OHIO**



## Don't Be a Slave

Be independent and make big profits with the

## BEISSER KEY MACHINE

You can start a business of your own, no experience necessary. Only machine that will make first keys without taking lock apart. Makes a dozen duplicate keys per minute.

Write Today for Full Particulars

**BEISSER KEY MACHINE CO.**  
407 Fort Street, East Detroit, Michigan



## REDUCED PRICES ON ENGINES

Now—big save on most practical farm engine ever built—the famous **OTTAWA**. Low cash prices—easy terms—on all sizes 1½ to 22 H. P. Each engine pull big surplus of power. Easy starting. You must be satisfied or money refunded. 30 days trial. 10-year guarantee.

**FREE BOOK** "How to Know Better Engines." Write for your copy now. A postcard will do.

**OTTAWA MFG. CO.**  
531-D King Street, OTTAWA, KANS.  
Desk 531-D, Magee Bldg., PITTSBURGH, PA.

Direct from Factory





## The New Sypher

More for the money than ever built before. Length over all, 30 in. Between centers, 14 in. Swing over bed, 7½ in. Includes counter shaft. Bronze taper bearings. Weight 60 pounds. Absolutely accurate. Time payments if desired. Write today for circular.

**\$60**

The Sypher Mfg. Co. Dept. D Toledo, Ohio



## CALCULATIONS

Office, School, Store and Shop can be instantly made with the **Midget Slide Rule**. It gives the answer to any problem involving fractions, mixed numbers, decimals, whole numbers, roots, powers, Logs, and Trig. Functions. Thousands of these rules are used by Accountants, Engineers, Clerks, Students, etc. It is the most versatile calculator ever invented. If you have any factoring to do, order a Midget Slide Rule on trial. Made of aluminum with figures on white celluloid. Size 4". Price with Instruction Book, \$1.50. Leather Case, 50c extra. Catalogue Free. Sent C. O. D. if desired.

Your money back if you are not satisfied.

**GILSON SLIDE RULE CO., Niles, Mich.**

## CUT WINTER FUEL THE EASY WAY

RUNS EASY NO BACKACHES WEIGHT ONLY 45 LBS. EASILY CARRIED SAW DOWN TREES



The farmer's best helper for 40 years. Thousands save money and backaches every year. YOU CAN TOO. Send for free catalog showing low prices. Address Dept. 115.

**FOLDING SAWING MACHINE CO., 2633 S. State St., CHICAGO, ILL.**



## PILLIOD Tool Cases Excel

Machinists, Tool Makers and Carpenters find them most satisfactory in construction, appearance, service and price. Immediate shipment. Booklet describing 20 styles on request.

**THE PILLIOD LUMBER CO.**  
Dept. 1 Swanton, Ohio



## Buchstein's Fibre Limb

is soothing to your stump—strong, cool, neat, light. Easy payments. Braces for all deformities.

**D. BUCHSTEIN CO.**  
610 3rd Ave., So., MINNEAPOLIS, MINN.

Send for Catalogue Today

## AGENTS 500% PROFIT

## GENUINE GOLD LEAF LETTERS

guaranteed to never tarnish. Anyone can put them on stores and office windows. Enormous demand, large profits. Paul Clark says: Smallest day \$28.70. R. L. Reel made \$920 in two months. Write today for free sample and liberal offer to general agents.

**METALLIC LETTER CO., 433-B N. Clark St., CHICAGO**





Price  
**\$1 75**

Complete with  
aerial, ground  
wire and single  
headphone.

**\$5.00**

with double  
headphone.

**\$7.50**

## HOWE RADIO RECEIVER

—A Practical Crystal Set—

For a Worthwhile

### CHRISTMAS PRESENT

"Grown-ups" as well as the "Young Folks" will appreciate the HOWE—especially in homes where there is no Radio or where an extra *Head Phone Set* can be used independently. The HOWE brings in loud and clear all stations within a 25-mile radius and has good selectivity. Installation very simple—complete instructions furnished.

250,000 Now in Use

If your dealer is "out," we will ship either the Receiver alone or one of the "Complete Sets" on receipt of price.

Howe Products Co. 128 N. Green St. CHICAGO

## LATEST WHOLESALE RADIO CATALOG

**FREE** TODAY for big 64-page book explaining liberal proposition paying agents \$60 to \$100 a week and how to get latest radio goods at Wholesale. *Live dealers and agents wanted.*

STANDARD RADIO CO., 1402 Walnut St., Kansas City, Mo.

## Music Master Radio Receivers—

10 models \$50—\$400, unsurpassed for beauty and tone quality.

Music Master Corporation, 128-130 N. Tenth St., Philadelphia

## RADIO "MIDGET" CONNECTORS



for quick and easy connection of wires in assembling sets, or connecting phones in series. Screws hold wire tight; no soldering. Fans buy them by dozen @ \$1.00 or three samples 25c post paid.

ILLINOIS RADIO CO., 800 S. 4th St., Springfield, Ill.

## FARAWAY RADIO



**\$22.50**

Gets stations  
Far and near  
Loud and Clear

FARAWAY Radio Sets are amazing values at bargain prices. Users get stations from New York to Frisco—loud and clear. Operate with either dry cells or storage batteries. Beautiful cabinet finished in mahogany with new platinum-finished panel. **SATISFACTION GUARANTEED.** Don't pay \$100 to \$150. Write for our money-saving plan and literature.

2 Tube Set - \$22.50  
5 Tube Set - \$35.50

Dealers-Agents: Biggest possibilities you ever heard of. Write for plan and territory quickly. The Faraway Radio Co., P.O. Box 819, Dept. T-1, Cincinnati, O.

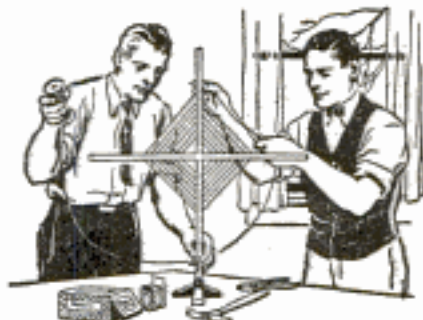

*A good loop  
is easy to build*

**M**ANY radio fans prefer to build their own loops. Of course, the most important part of the loop is the loop wire, and only special loop wire will give the best results with your set.

Why not use the wire used by prominent loop manufacturers for their loops? Belden Loop Wire is made of 60 strands of No. 38 wire combined with 5 strands of No. 36 specially treated wire. This special loop wire will not stretch, sag or kink, making a rigid loop that gives excellent results.

Specify Belden Loop Wire. Ask your dealer for it, today!

Our illustrated **FREE** booklet describes Belden Litz Wire. For special coils and radio equipment, use Belden Litz Wire. Send the coupon!



# Belden

Send for Free Illustrated Booklet

Belden Manufacturing Company,  
2306-G So. Western Ave., Chicago.

Please send me your latest illustrated booklet, free, describing Belden Radio Products and their use in radio work.

Name .....

Address .....

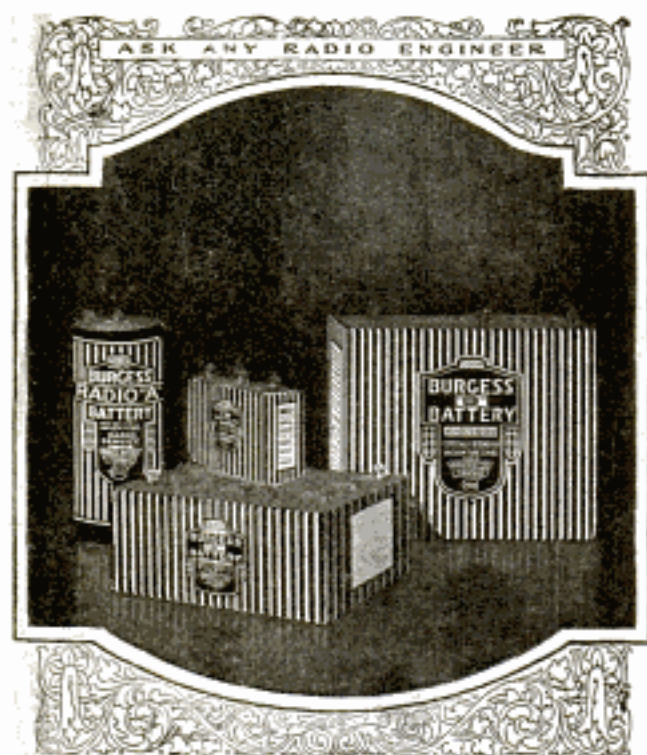

## Contributors to your radio entertainment

**V**ERY probably hidden away in the cabinet of your receiving set, the batteries you use are nevertheless surrendering their power unseen and unheard.

And to be able to contribute their energy and to add to the complete efficiency of your receiving equipment, those batteries must combine every desirable factor and formula known in the electrochemical field.

Such Batteries are Burgess—products of the Burgess Laboratories—products which have been used by practically every famous explorer, the majority of amateurs and the leading radio engineers.

That's why when you use Burgess Radio 'A', 'B' and 'C' Batteries you are using batteries which assure the utmost dependability, longer life and complete satisfaction.

**BURGESS BATTERY COMPANY**  
GENERAL SALES OFFICE: CHICAGO

Canadian Factories and Offices:  
Niagara Falls and Winnipeg

**BURGESS RADIO BATTERIES**

## 21 Jewel ~ Extra thin STUDEBAKER

The Insured Watch



Sold direct from the factory at a saving of 50%.

SENT FOR  
**\$1.00**  
DOWN!

Only \$1.00! The balance in easy monthly payments. You get the famous Studebaker 21 Jewel Watch—insured for a lifetime; 8 adjustments, including heat, cold, isochronism and 5 positions—choice of 60 new Art Beauty Cases in green gold, white gold or yellow gold effects. Latest thin models.

**Chain Free!** For a limited time we are offering a beautiful Chain FREE!

**Write** For FREE Book Send today for wonderful Studebaker Book of Advance Watch Styles and our \$1.00 Down Offer—FREE!

**STUDEBAKER WATCH CO.**  
Dept. N12 South Bend, Indiana  
Canadian Address: Windsor, Ontario

## THIS WONDERFUL INVENTION



converts any ordinary cook stove into a gas stove. OXO-GAS is made from kerosene and air. Cheaper, cleaner and more efficient than coal. Responsible distributors wanted.

**GLORIA LIGHT CO.**  
111-12 N. May St. Chicago, Ill.

## Como Duplex Transformers

"The World's Standard for Push Pull Amplification"

Use them in your set and you will realize why they are continually specified by leading Radio Engineers. The fact that they are widely copied is proof of their superiority. "Take no chances—use Como."

\$18.50 per matched pair at leading dealers. Send for literature.  
Como Apparatus Corp., Manchester, New Hampshire



Popular Prices—Remarkable Results

No better loops at any price. Quantity production keeps prices low. Handsome, convenient and efficient.  
**LINCOLN 4-POINT TAPPED LOOP . . . \$8.00**  
Built for any circuit where it is desired to vary the inductance of the loop. Exceptionally fine for Superhets.  
**LINCOLN CENTER-TAPPED LOOP . . . \$6.50**  
For any set employing radio frequency amplification. For certain Superhets requiring a center tap. If your dealer cannot supply you, order direct, giving your dealer's name. Write for illustrated catalog P.M.

**LINCOLN RADIO CORPORATION, 224 N. Wells St., Chicago**

*The wonderful performance of these CROSLLEY Radios will be duplicated this year—and with these New Prices they should be Radio's best value!*

### Crosley 2-Tube 51 Regular

This efficient little set uses any make of tubes. Nearby stations on loud speaker, long range on headphones.

**Now \$14.75** was \$18.50



### Crosley 3-Tube 52 Regular



For a less expensive 3-tube set the Crosley 52 Regular cannot be surpassed at the new low price.

**Now \$25** was \$30

### Crosley Super-Trirdyn Regular

In the Super-Trirdyn, 3 tubes do the work of 5. Matchless performance. Beautifully finished solid mahogany cabinet.

**Now \$45** was \$50

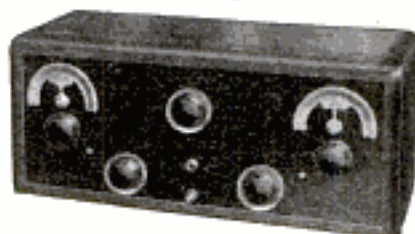

#### Crosley Trirdyn Has Brought Him 178 EKKO Stamps and KZKZ Manila, Philippine Islands

"In all I have logged 208 stations and received 178 EKKO stamps. The farthest I have received is 7,000 miles, which is Manila, Philippine Island (KZKZ). I have received one Alaska Station and four California stations."

LEO CASSELL, Indianapolis, Ind.

#### Easy Tuning is a Feature of the Crosley Trirdyn

"My little daughter, two and a half years old, is a real radio fan. For an honest fact, she can tune in the most powerful stations and get some music."

L. F. INFANGER, Rome, N. Y.

#### Hot Weather Did Not Keep This Crosley Trirdyn Owner Home

"During hot weather I bring in New York, Schenectady, Detroit, Omaha, Cincinnati, Cleveland, New Orleans, Denver, St. Louis, and Atlanta on any night. No matter how many stations are broadcasting in Chicago I can always pick up 10 to 20 outside stations on my set."

ORVILLE G. DAILY, Chicago, Ill.

#### 35 States in the Union Report to This Crosley Trirdyn Owner

"Here is a list of States from which I have received verification stamps—from one or more stations in each state. I have also heard Scotland during international test."

JOHN H. PUTHOFF, Akron, Ohio

#### Lives in Lawrenceburg, Ind.—Listens to U. S. with a Crosley 2-Tube 51

"I received program under normal conditions from New England States including Canada, the Western Coast and as far South as Florida and Texas."

EDGAR F. FREST, Lawrenceburg, Ind.



### The Famous MUSICONE

This marvelous loud speaker—well on its way to REPLACE HALF A MILLION HORN TYPE SPEAKERS by January 1st—substantially reduced because of assembly improvements developed by Crosley engineers. Reproduces all tones—without distortion. Crosley patented unit, not cone, secret of its amazing perfection.

**Now \$14.75**  
was \$17.50

# CROSLLEY · RADIO

BETTER · COSTS LESS

THE CROSLLEY RADIO CORPORATION, Dept. 15, CINCINNATI

*These prices do not include accessories. Add 10% to all prices West of the Rockies*

# Take a Year to Pay FOR YOUR DIAMONDS

## WATCHES ~ JEWELRY

### Send No Money Down!

# First Payment Next January

### SPECIAL XMAS SALE!

Every reader of this magazine should come to us for their jewelry because we give the most for the money and treat our customers with the greatest of courtesy. We were established 46 years ago and are absolutely reliable.

**LOWEST PRICES; EASIEST TERMS**  
Thousands of satisfied customers say this is so. Our store is full of wonderful Xmas gifts, so is our big catalog.

**MONEY BACK GUARANTEE; FREE TRIAL**  
You get a gold bond full value guarantee with each purchase. If you are not satisfied and return the purchase, we return your money.

**YOU GET 8% INCREASE ON EXCHANGES**  
When you exchange a diamond for a larger one, we allow you 8% per annum more than you paid for it.

<b>\$197.00 A CARAT</b> The greatest diamond value ever heard of. Guaranteed worth \$225 a ct.	<b>ORDER FROM THIS BARGAIN LIST</b>
Carat — \$28.00	Carat — \$147.75
Carat — \$49.25	Carat — \$197.00
Carat — \$65.65	Carat — \$244.25
Carat — \$73.75	Carat — \$383.00
Carat — \$90.50	Carat — \$494.00

No. CS1 **Price \$37**



**\$1 Deposit: \$3 A Month**  
It is amazing to be able to get this gorgeously beautiful cluster of 7 sparkling, brilliant, blue-white, genuine diamonds set in platinum, in this solid gold ring, or only \$37. It's worth \$60.

No. CS13 **Price \$25**



**\$1 Deposit: \$2 A Month**  
All the colors of the rainbow flash and sparkle most attractively from the best quality genuine color-white diamond set in this handsomely designed 18 Kt. solid gold ring. It makes a splendid present.

**No. CS8—\$22**



**\$1.00 Down \$1.75 a Month**  
**ELGIN or WALTHAM**  
Your choice of famous Elgin or Waltham movement in this full 12 size, attractively engraved, gold filled case. Guaranteed a fine time-keeper. It comes in a handsome gift case, and the gold filled chain and knife are included absolutely free.

No. CS3 **\$37**



**\$1 Deposit \$3 a Month**  
Latest style, engraved and pierced 18 Kt. solid white gold mounting, set with brilliant, blue-white, genuine diamond, which flashes and sparkles with the colors of the rainbow.

No. CS4 **\$49**



**\$1 Deposit \$4 a Month**  
Extra fine quality, brilliant, blue-white, genuine diamond, full of fire and sparkle, set in artistically designed 18 Kt. solid gold ring, having 2 dark blue sapphires in shanks. Easily worth \$75.00.

No. CS39 **\$61**



**\$1 Deposit \$5 a Month**  
This is one of the most beautiful mountings we have ever come across. It is exquisitely designed. The gorgeously beautiful blue white diamond is full of fiery sparkling colors.

No. CS35 **\$119**



**\$9 Deposit \$9 a Month**  
Four sparkling brilliant small diamonds are set in the sides of this attractive ring. The large diamond in the hexagon top is set off by 2 triangular dark blue sapphires.

**No. 38 \$37**



**\$1 Deposit \$3 A Month**  
Ladies small, fashionable wrist watch, 14 Kt. solid gold case, with 15 jeweled movement, set with 4 diamonds and 4 sapphires. Former price, \$50. You save \$13.

**4 Diamonds & 4 Sapphires**

No. CS40 **\$69**



**\$3 Deposit \$5.50 a Month**  
The 7 beautiful blue-white sparkling, brilliant genuine diamonds comprising this big cluster are set in solid platinum in the handsome ring. It looks like a solitaire of large size.

No. CS34 **\$89**



**\$5 Deposit \$7 a Month**  
Extra large size cluster of 7 best quality fiery brilliant diamonds set in solid platinum in this beautiful mounting, which is engraved all around. Has 2 dark blue sapphires.

No. CS27 **\$61**



**\$1 Deposit \$5 a Month**  
Man's 14 Kt. solid green gold heavy-weight ring, attractively engraved in popular style, set with a genuine diamond that flashes and sparkles in a most attractive and fascinating manner.

No. CS 42 **\$55**



**\$1 Deposit \$4.50 a Month**  
Three large diamonds and 2 smaller diamonds and 2 triangular dark blue sapphires are set in this latest style, attractively engraved diamond ring.

**14 Karat Solid Gold \$19**



**\$1.00 DEPOSIT \$1.50 A MONTH**  
Stylish 14 Kt. solid gold wrist watch with 15 jeweled movement. Worth \$30. Extra sterling silver bracelet free.

**No. 11**

**TEAR OUT AND MAIL!**

**SEND NO MONEY**

STERLING DIAMOND & WATCH CO., Inc.  
1540 Broadway, Dept. P-2057, New York, N. Y.

GENTLEMEN: I HAVE SELECTED NUMBER \_\_\_\_\_

Please mail it to me by parcel post, C. O. D. the small deposit and I will pay the postman when he hands me the package.

I enclose \$\_\_\_\_\_ as a deposit to show my good faith. Please send the article size \_\_\_\_\_ direct to my home for me to wear on free trial.

Do not send any jewelry now but send your big bargain catalog to me showing thousands of diamond, watch jewelry, silverware and toiletware bargains for me to choose. Send the List of Premiums so I can Choose My Gift.

NAME \_\_\_\_\_

LOCAL ADDRESS \_\_\_\_\_

CITY AND STATE \_\_\_\_\_

# FREE PREMIUMS

Every purchaser who answers this advertisement will receive from us absolutely free of charge, a choice of many valuable premiums. A list of free gifts will be sent to you when we receive the coupon. Choose premium you prefer.

**THIS IS THE MOST LIBERAL OFFER EVER MADE.**

We want to add thousands of new customers to our business this month and will give you a premium if you order from us.

**WRITE FOR CATALOG**

If you want something not shown in this advertisement, it is in our catalog. Thousands of bargains in diamonds, watches, wrist watches, jewelry of all kinds, silverware, toilet sets, etc. Mail coupon.



**STERLING DIAMOND & WATCH CO.**  
Square Deal Credit Jewelers—Diamond Importers—Estab. 1879  
1540 BROADWAY Dept. P-2057 NEW YORK  
**MAIL FREE PREMIUM COUPON**

Greater selectivity, range, power, beauty and simplicity—*at lower cost!* SEE NOTICE



**NOTICE!** Enormous demand for the celebrated Miraco Ultra-5 (resulting from its many enthusiastic users so highly recommending it to their friends) has enabled us to add hosts of newly new features, latest refinements and up-to-the-minute improvements such as you might expect to find only on the newest sets selling at much higher prices. So the improved New Ultra-5 for 1936 is even a better set—a more beautiful set—a more selective and more powerful set—incredible as this may sound—for less money than ever before.

Built like—looks like—and it performs like a \$200 set

**MIRACO RADIO GETS 'EM COAST TO COAST**

Reports from Ultra-5 users everywhere come into for us to add. These are typical of the many in our files and which we receive daily.

**HEARS CALIFORNIA TO EUROPE**

Enclosed is a partial list of the stations I received with the Miraco Ultra-5: KBD, WESH, WHAV, WEAF, WLW, WCRD, WHB, WOB, WJAZ, WOC, WHAS, WMT, CKAC, KFIS, WGB, WLAB, KFAR, WFLA, WWS, WCAP, WTAR, WJL, KFKA, WAAW, WTAM, WOAL, WBOE, WCCO, KDKA, WJAP, WMC, CNRO, WLS, WEI, WRB, WMB, KFSF, WFL, WFK, WWL, WFLA, WAF, WLY, CBS, WEE, WCAE, WEO, WRC, WYOM, WJED, WGB, WAIN, WCAL, WER, WEN, WMAQ, WEX, WLS, WQAW, WOO, WOS, CPAC, Sheffield (Ex-1) Paris (France), Carl H. . . . Washburn, Wis.

**MONTANA HEARS CALIFORNIA TO IRLAND**

I am more than pleased with the Ultra-5 Receiver. I have 30 stations on my record in 20 days time including KDKA, WCAE, KFIR, WFC, WCC, WJAZ, WEAF, WEM, WGM, WCAL, WLW, CAM, WAF, WLY, WLS, KAKS, KQOW, WCCO, WOC, WCAE, WHO, WCCA, WQAW, CPAC, WQAL, WOS, WCKY, KPPU, KBB, KPO, KFAA, WMOR, CKY, WCCP, WMAQ, WJAP, WGN, KJR, WHI, WOS, WMC, WJL, WGAN, KKT, WGW, WLW, WOC, WBB, WFAI, WJAZ, KGO, WCAF, KSAC, WTAP, KRRI, KFKA. On February 19th at 12:15 o'clock I received Ireland—the distance being several thousand miles. Richard. . . . Conestown, Mont.

**WEST VIRGINIA HEARS AUSTRALIA**

Got 2-KB Wellington, Australia, plain last night at 12:45 A. M. over the Ultra-5 Miraco you sold me. I am delighted and would not trade for any instrument in town. Geo. . . . Glenn Ferris, W.Va.

**PENNSYLVANIA HEARS CALIFORNIA VERY LOUD**

I received the Ultra-5 Set, set it up on directions called for, and received Dallas, TEXAS, first station. Will list a few of the stations received in two lists: KDKA, WFAE, WOB, WQAW, WLS, WTAM, WCAE, WLW, WOO, WJY, WJS, KFI, KSI, WWJ, WHN, WEX. It is very easy for me to receive Los Angeles, California, loud enough to be heard in any room in the house. W. E. . . . Uniontown, Penn.

**CALIFORNIA GETS NEW YORK ON LOUDSPEAKER**

I have got stations from coast to coast without any trouble at all on Ultra-5, WTAM, Cleveland, Ohio, comes in on loudspeaker nearly as loud as the nearby stations do. I have brought in on loudspeaker with ample volume to hear all over the room stations WEAF, N. Y.; KDKA, Pittsburgh, Pa.; WHY, N. Y.; CHCA, Ottawa, Kan.; Cincinnati: WCCO, St. Paul, Minn.; WLS, Chicago, Ill. . . . Duarte, Cal.

**GETS COAST TO COAST AND CANADA**

I received my Ultra-5 radio from you and I can say it is a wonder. We have received stations from coast to coast and also Canada. Orie E. . . . Leona, Iowa.

*"Astoundingly Selective!"*  
**The Powerful New MIRACO Ultra-5**  
[FIVE TUBE OUTFIT IN BEAUTIFUL MAHOGANY CASE]

Now only **\$59.50** Retail

The amazing coast to coast reception (on the loudspeaker) and international receiving range of the famous Miraco Ultra-5 in the hands of its multitudes of pleased users—as voluntarily reported by them to us in writing—offers proof of performance which makes further claims by us superfluous. Send for plenty of this proof—and our remarkable Special Offer. Make or save money on sets and supplies!

Remember that one of America's oldest and most reliable manufacturers of quality sets completely builds, thoroughly tests and factory guarantees each Miraco. That longer experience and immense production make possible such money-saving prices. Bear in mind that this big, beautiful, powerful and clear-toned Miraco Ultra-5 is the latest, improved model. That it has a beautifully gold-etched genuine Formica panel with large Bakelite knobs equipped with gold filled indicators for very fine tuning. That it is even more selective, more powerful and is capable of getting greater distances due to exclusive use of "Duofomers" (ultra low-loss inductance coils—the newest achievement in radio engineering). "B" battery consumption is minimized and oscillations are controlled on all wavelengths by a new patented feature, the "Counter-Balancer." Flexibly wired (to prevent broken connections). Has an adjustment for different length aerials, only two rheostats, a cut-out switch, wiring concealed under Formica baseboard and other features of costless sets. Comes in a handsome hand-rubbed mahogany cabinet. Unbeatable value!

An instrument thoroughly tested and approved by radio's highest authorities and one which anyone can easily connect, operate and "log." Works on storage or dry batteries. Literature describes other latest improvements—use coupon.

Send for Special Offer

**Other Miraco Long Distance Sets \$13.75 up retail**



Wonderfully improved new models in one-tube and three-tube Miraco Long Distance Sets also ready at lower prices! New Miraco R-3 at only \$27.35 (retail) operates loudspeaker on distant stations. New one-tube Model R is also a record-breaker for distance at \$13.75 (retail). All Miraco sets work on storage or dry batteries, are easily connected and operated. Unmatched values! Let testimony of users convince you. Write for literature and Special Offer—use coupon.



**AGENTS! DEALERS!** Write for the new Miraco proposition. Nation-wide use and popularity of Miraco sets, coupled with their amazingly low prices, make them wanted everywhere. Easy to sell—due to their wonderful tone, volume and distance-getting ability. Only necessary to order one set for demonstration.

**All the Proof you want is waiting for You!**

Reports from hosts of users in every state prove Miraco sets—at rock-bottom factory prices—out-perform sets costing up to three times as much. Send for latest literature, AMAZING SPECIAL OFFER and plenty of additional testimony from users leaving no doubt that "Miraco Radio Gets 'em Coast to Coast."

Send coupon for free bulletins AND AMAZING SPECIAL CASH-SAVING OFFER

**MIDWEST RADIO CORPORATION**  
Pioneer Builders of Sets, 407-K E. Eighth St., Cincinnati, O.  
Send free literature, SPECIAL OFFER and all particulars regarding Miraco Sets. ( ) Dealer ( ) Agent ( ) User  
NAME.....  
ADDRESS.....

## EFFICIENCY

That Meets the Requirements of Eminent Radio Engineers

Apex Vernier Dials are more than mere "knobs." In reality they are instruments endowed with an ultra degree of efficiency. Their rich elegance of finish lends a touch of striking attractiveness to any set. Precision of production and of operation makes a good set a better set—providing a greater range of selectivity—positiveness of control—and utmost simplicity of tuning in most difficult stations. Ratio 12 to 1. Clockwise or counter clockwise. No back lash. Royal Brass Finish 4-inch \$2.00—3½-inch \$1.65. Satin Silver Finish 4-inch \$2.50—3½-inch \$1.90. DeLuxe Gold 24 (K) Finish 4-inch \$3.50—3½-inch \$2.50. Your dealer has them. If not, order direct.

**APEX Rheostat Dials** are as essential to successful operation and pleasing appearance as are Apex Vernier Dials. Royal Brass Finish—75c. Satin Silver Finish—85c. DeLuxe Gold (24K)—\$1.00.

**APEX ELECTRIC MFG. CO.**  
Dept. 1201  
1410 W. 59th St. CHICAGO



**FREE** Diagram, Templates, Instructions for building Calcaterra's 5 tube Tuned **RADIO FREQUENCY** Set for \$55  
Write **KELLOGG SWITCHBOARD & SUPPLY CO., Chicago, Illinois**

**PREMIER  
WONDER**  
Only \$34<sup>50</sup>



Brings opera—symphony—syncopation—melody—oral selections—into your home just as actual as though the artists and instruments stood in your very presence.

A Marvellous Radio Instrument in a Magnificent Cabinet at the Factory Price Users everywhere enthuse over its realistic performance—wonderful tone quality—selectivity—distance—volume. Buy this exceptional radio direct from the factory at wholesale price. Test it in your home.

Illustrated Circular G-3 sent Free. Ask for it.

**SPORT RADIO WORKS, AURORA, ILL.**

**Save 20 to 50%  
FREE RADIO CATALOG**

**LATEST  
IN  
HOOK-UPS  
AND  
RADIO**

Get the lowest rock-bottom prices on radio parts, sets, kits. New free Radio Catalog and Guide brimful of standard, reliable, guaranteed goods. Over 100 latest hook-ups and illustrations. Be sure to get this thrifty book before you buy. It puts money in your pocket. Saves you as much as half on a set. Also please include name of radio fan. Send letter or postal NOW.

**THE BARAWIK COMPANY**

103-168 S. Canal St., Chicago, U. S. A.

**FREE**  
64 Page Catalog  
of Radio  
Bargains



The World's Largest Exclusive Radio Mail Order House Will Send You This Wonderful Book FREE

Contains thousands of bargains in radio sets, semi-finished sets and radio kits of all styles, sizes and approved circuits. Beautiful models of latest designs and types. Elaborate console models with loud speakers built right in cabinets of genuine mahogany and walnut. All sets guaranteed. Coast to coast receiving range. Also contains everything in radio supplies including batteries, chargers, loud speakers, transformers, condensers, rheostats and any other parts you may want for improving your set or building a new one. Guaranteed saving to you of 1/4 to 1/2.



American Radynola

**AMERICAN  
RADYNOLA**  
5 TUBE SET  
\$29.50

**World's Best 5 Tube Set**  
Fully built and wired. Beautiful mahogany cabinet. Sliding panel design. Finest low-loss condensers, coils and sockets. Baffle board, panels and dials. Regular \$75.00 value. Price \$29.50. Transportation charges extra. Shipping weight 25 lbs.

Set with all accessories including tubes, loud speaker, storage battery, "B" batteries, aerial and ground equipment—\$59.75. Shipping weight 100 lbs. Complete instructions with set.

Satisfaction Guaranteed. Send for Catalogue Today!

**RANDOLPH RADIO CORP.**  
159 N. UNION AV. Dept. 194 CHICAGO, ILL.

**COAST TO COAST RADIO—Low Price**



**IMPERIAL 5 Tube Set**

Latest, most advanced type 5 tube tuned radio frequency receiver. Greater range, power, selectivity and perfect tone. Why pay more when you can't get more than the new IMPERIAL gives you? Write at once for full particulars of this new, better radio receiver and low price.

SIMPLEX CO., 2035 S. Michigan, Dept. 21, Chicago

**SOLDERALL**

METAL IN PASTE FORM



The only convenient metal solder

Every Electrical Connection needs Solderall for perfect reception

25¢

The SOLDERALL CO., NEWARK, N.J.

**Take Your Profit From Now On**  
300% advance on Crude Rubber drives Mr. Car owner to have his Tires repaired, instead of buying new ones.  
**EASY TO LEARN** We give you instructions Plants \$100 and up  
Our free Catalog tells you how to save 50% on a plant we have near you. Instruction Book for a \$1.00 bill.  
Equipment Exchange, 118 E. 11th St., Los Angeles, Calif.



**THIS CLEAR, POWERFUL  
6 POWER VEST POCKET  
TELESCOPE**  
with glove leather case \$2

Only 3¼ in. long! Easily slips in vest pocket, yet powerful, precise, adjustable to either eye, six full magnifications, and brings distant objects close without objectionable "trembling" of higher power glasses. Nothing cheap in appearance or action. Guaranteed satisfactory by us and by maker, or money back at once. Handsome black baked-in enamel finish. Five first glass lenses by Wollaston. Check, money order or C.O.D. \$2.00 prepaid, including five limp leather case.

**BOSTON SPORTING GOODS CO.** Dept. P, 80 Baystate St. BOSTON, MASS.



**Starrett**

*Why are  
Starrett  
Graduations  
So Easy  
To Read*



One thing you'll find all mechanics agreed on—the ease and rapidity with which you can read any Starrett Tool.

Examine your Starrett Steel Rule for instance and see how plainly and distinctly it is marked. The Starrett Graduating Process (our own, exclusively) cuts figures and graduations deep into the steel. No uncertainty about your measurements! Even under a powerful magnifying glass the markings are perfect. Also, the comparative lengths of the various lines and the

weight of the lines help to make it easier to read **accurately**.

Write for a free copy of the Starrett Catalog and you'll find the rule exactly suited to the needs of your work. Spring Tempered, Semi-Flexible, Heavy, Light, Stainless, Hook, Shrink, Blacksmith's, Carpenter's—they're all shown in the Catalog. Ask for No. 23 "AP."

**THE L. S. STARRETT CO.**

World's Greatest Toolmakers  
Manufacturers of Hacksaws Unexcelled  
Steel Tapes—Standard for Accuracy  
ATHOL, MASS.

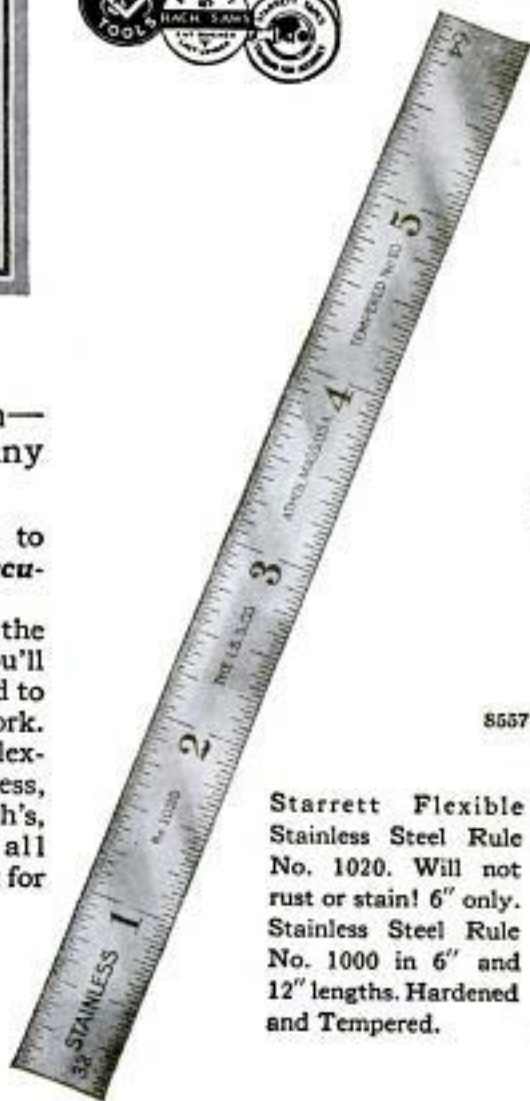

8557

Starrett Flexible Stainless Steel Rule No. 1020. Will not rust or stain! 6" only. Stainless Steel Rule No. 1000 in 6" and 12" lengths. Hardened and Tempered.



The crack Shine-All team of St. Joseph, Mo.—one of the fastest basketball teams in America

## These all-college stars make a record on **Keds**

Trademark Reg. U.S. Pat. Off.

**I**NDDEPENDENT basketball champions of Missouri—finishing the National A. A. U. Tournament with but a single defeat—victors over the national independent champions!

That's the record of the famous Shine-All team—composed of former college stars. And this team wears Keds!

Keds soles are full of life—built to absorb shocks and jolts—remarkably tough. Durable canvas uppers protect against twists—yet are light and comfortable. A special Feltex innersole absorbs perspiration—keeps the feet cool.

Keds are made *only* by the United States Rubber Company—the name Keds is on every one. All popular styles—prices \$1.25 to \$4.50.

Our Keds Hand-book of Sports is full of interesting information on games, sports and dozens of other subjects. Sent free if you address Dept. 87J, 1790 Broadway, New York City.

United States Rubber Company

They are not Keds  
unless the name  
Keds is on the shoe



"COMET"  
The special Keds  
basketball shoe



**\$100 to \$200 Per Week**

**We Teach You How to Make It**  
Money—big money—is waiting for you to come and get it. No matter where you live nor what your experience, we teach you how to make money.  
*Special Proposition Open Now*

**Fireite Sells on Sight**  
TRADE MARK

Fireite amazes everyone who sees it used. A single demonstration often makes a dozen sales. It has saved many thousands of dollars of property damage. Men, women and children are astounded and fascinated by the ease with which it puts out an alarming fire. It is no exaggeration to state that Fireite is one of the easiest to demonstrate and fastest sellers ever made. Why? Because it is so simple a child can use it with one hand. **It always works**—(wonderful secret composition). No pump nor mechanism. Beautiful and long lasting. The low price is within the means of everyone—50% less than most others. Sold to every home, school, garage, factory, office, store, hotel, etc., wherever shown.

**AGENTS and MANAGERS WANTED**  
In All Territory Not Taken  
You can make big money using all or part of your time. We supply everything for your success. This is an **unusual opportunity** for a sound, substantial, permanent income. Write for our agent's—or manager's—special proposition today!

**FIREITE CO., Dept. 2, Masontown, Pa.**

**NEW MARVELOUS ONE - MINUTE CAMERA**  
Takes and finishes pictures inside the camera in one minute. Agents wanted. Exclusive Territory. Make money selling these wonderful cameras or taking photos or both. Six different models. Photos 4x6, 5 1/2x3 1/2, 3x4 1/2, 2 1/2x3 1/2, 2 1/2x1 1/2, 1 1/2x1 1/2 inches. No experience necessary. Any one can operate these cameras. Write today for special offer.  
**CROWN MINUTE CAMERA COMPANY, Dept. 940, NORWALK, CONN.**

**SPORT BODIES for FORD and CHEV. 490 at \$34.50 UP**  
Life-size paper patterns—You can build your own body at small cost. We are manufacturers and our quantity production enables us to quote exceptional low prices. Our unique shipping methods save you 73% in FREIGHT CHARGES. Send at once for free particulars on Central Bodies. Our Book: "HOW TO BUILD A FORD RACER" sent anywhere on receipt of 25c in cash or stamps. **WRITE TODAY!**  
**Central Auto Supply Co. Dept. 120, Louisville, Ky.**

The Famous **KON-VER-TER SLIDE RULE**  
Instantly adds, subtracts, divides, multiplies, converts fractions or decimals of an inch. Gives sines, co-sines, versed sines, co-versed sines, tangents, co-tangents, secants, co-secants of angles directly. Gives square roots, squares, cube roots, cubes and fifth roots and powers of all numbers. Logarithms, co-logarithms, anti-logarithms. Instructions with rule. De-Luxe Model \$3. Cash or C. O. D.  
**NEW ENGLAND NOVELTY CO.**  
Dept. A. WAKEFIELD, MASS.

**Lighting Fixtures**  
**READY TO HANG**  
(Direct from the Manufacturer)  
Completely wired, including glassware. Send for New Catalogue No. 27. Just reduced prices.  
*Special proposition to DEALERS.*  
**ERIE FIXTURE SUPPLY CO.**  
STA. A. ERIE, PA.





# UNLIKE ALL OTHERS!

ONE TO SIX PUMP-STROKES COMPRESSES AIR TO ANY SHOOTING-FORCE DESIRED

Three Strokes for Ordinary Shooting



## The BENJAMIN

This illustration shows an inch block of wood (double size) penetrated to different depths by a Benjamin Air Rifle using one to six charges of air.

*This is a Feat No Other Air Rifle Can Duplicate*

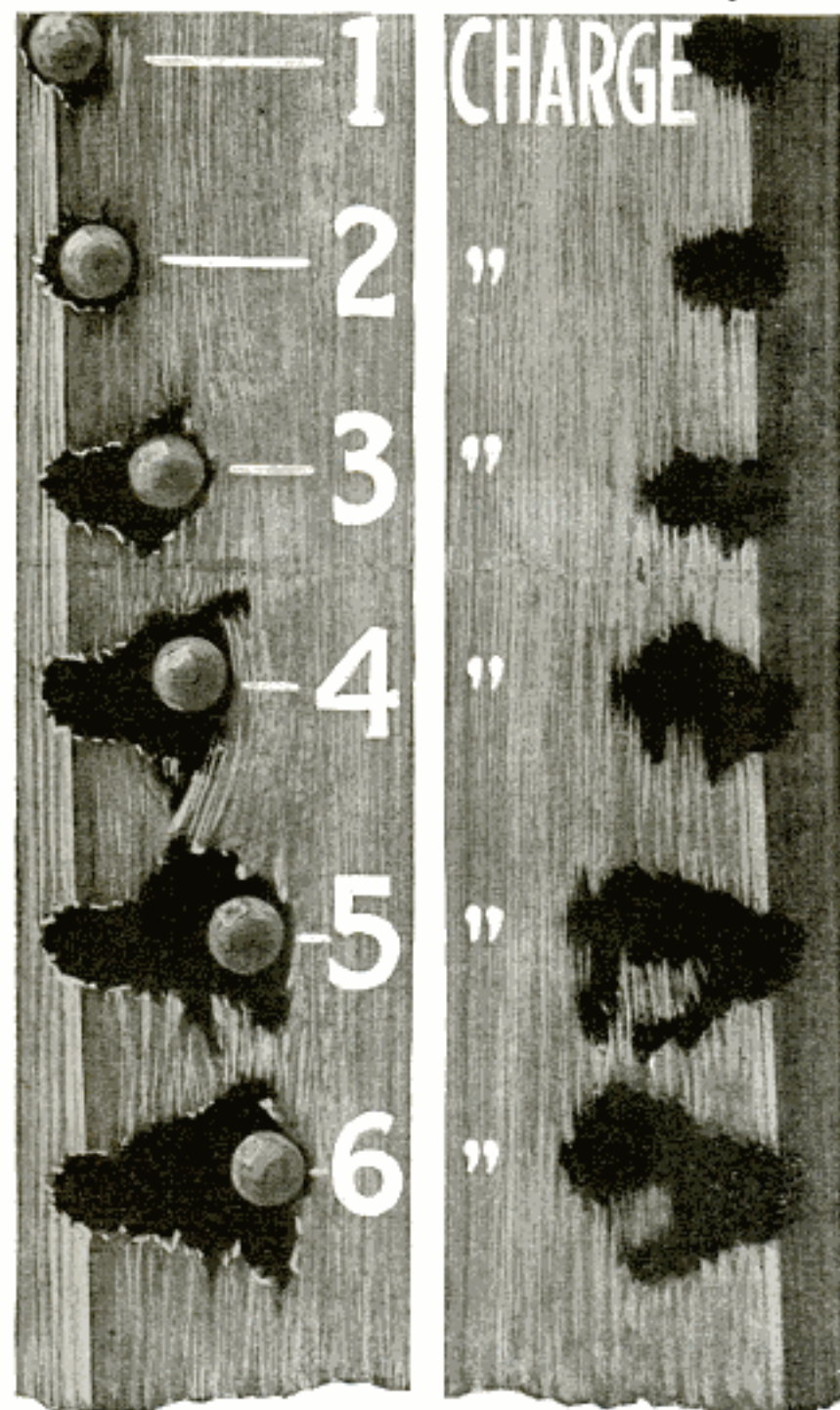

is the gun you have been looking for. For target practice and for hunting rabbits, squirrels, gophers, rats and frogs it has no equal. It is the most powerful, accurate and reliable compressed air rifle made. It has a far greater shooting range than any other. Imagine bringing down rabbits with an air rifle! You can do it with a Benjamin.

### The BENJAMIN

is the ONLY PUMP GUN MADE using compressed air, SIMILAR TO AIR DRILLS AND HAMMERS. It does not lose shooting force after long use. The BENJAMIN is the only air rifle with the shooting force under the operator's control. It can be loaded to shoot weak or powerful as desired, from one to six strokes of the pump giving all the power wanted. It is absolutely safe; accidental discharge is impossible. Furthermore, after being charged with air, it is ready for instant use at any time after the shot is placed in the barrel.

### The BENJAMIN

is mechanically perfect. It is the only air rifle not requiring frequent repairs, customary in all spring-guns.

Price **\$5<sup>00</sup>** Post-paid

Canvas Case \$1.00

Write for descriptive folder giving full details of this wonderful air rifle.

## BENJAMIN

AIR RIFLE & MFG. CO.  
651 N. Broadway  
ST. LOUIS, MO., U. S. A.

Pacific Coast Representative  
THAYER & BOWER  
Los Angeles, Cal., & San Francisco, Cal.

# Look

sent on



Men in every walk of life  
now wear Strap Watches

Adjusted to the Second  
Adjusted to Temperature  
Adjusted to Isochronism  
Adjusted to Positions  
21 Ruby and Sapphire Jewels  
25 Year Gold Strata Case  
Your choice of Dials  
(Including Montgomery R. R. Dial)  
New Ideas in Thin Cases

# Approval

## The 21 Jewel Santa Fe Special

We will send this famous watch, express prepaid, for you to examine, to inspect, to admire, to approve without one penny advance payment. Examine the watch and be convinced it's the best watch buy you ever saw. Just a small payment down, the balance in easy MONTHLY payments. You use the watch while paying for it.

### Save $\frac{1}{3}$ to $\frac{1}{2}$ of Your Money

By purchasing this Famous Santa Fe Special Watch. Not only are you saving money from the present day prices of watches, but you can still secure the "Santa Fe Special" Watch, at the same low prices and terms that have made our watches famous.

### Ladies' Wrist Watches

Artistic, dependable ladies' wrist watches—perfect timepieces, beautiful hand engraved cases in white or green gold. Send for New Watch Book and see the new shapes and designs. Sent on approval and sold on payments.

### Write for "Santa Fe" Watch Book

Clip the coupon, fill out and receive the FREE WATCH BOOK just off the press. All the newest watch case designs in white or green gold, fancy shapes and thin models are shown. Read our easy payment offer. Wear the watch 30 days FREE. Watch sent for your examination and approval without a penny down. Nothing to risk. See the watch before you buy.

Write for New Book Today and Select Your Watch.  
Mail Coupon.

### SANTA FE WATCH COMPANY

C-6 Thomas Building, Topeka, Kansas  
(Home of the Great Santa Fe Railway)

### JUST OUT!

Send for our New Watch Book—Just off the press. It will post you about watch styles and values. Send for it today—It's FREE.

**FREE BOOK COUPON**

Santa Fe Watch Company,  
C-6 Thomas Building,  
Topeka, Kansas.

Please send prepaid and without obligation your New Watch Book Free, explaining your "No Money Down" Offer on the Santa Fe Special Watch.

Name.....

Address.....

State.....

## LUMINOUS PAINT

**Make Your Watches, Clocks, Etc., Visible by Night**

The very latest discovery in the scientific world (Luminescence) practically revolutionizes the watchmaking industry, revealing it perfectly visible in the dark. **THE DARKER THE NIGHT, THE MORE BRILLIANT IT SHINES.** Quite simple to use. Approach—you can do it. A little applied to the dial of your watch or clock will enable you to tell the time by night. You can read the push buttons or switch plates of your electric lights, switch boxes, and irremovable clock articles; make your own Luminescent Cigarettes, Luminescent Keweenaw, etc. Small bottle, price 25c. Larger sizes, 50c and \$1 postpaid.

JOHNSON SMITH & CO., Dept. 460, RACINE, WIS.

## Serpent's Eggs

Box contains 12 eggs. When lit with a match, each one gradually betrays itself into a snake several feet long, which curls and twirls about in a most life-like manner.

Price per box, 10c postpaid, 3 for 25c.

## CIGARETTE MAKER



Roll your own and save money. Makes them better and quicker besides saving more than half. Use your favorite brand of tobacco. Neat, useful and handy. Pocket size, weighs 1/2 oz. Made entirely of metal, nickel-plated. Price 25c postpaid.

## MIDGET BIBLE

**GREAT CURIOSITY** Smallest Bible in the World. Size of a postage stamp. 200 Pages. Said to bring good luck to the owner. A genuine work of art. Must be seen to be appreciated. These good little Bibles sell them to friends, church acquaintances, etc. Price 15c each, 3 for 40c, 12 for \$1.35, 100 for \$7.50. Also obtainable in Leather Binding, with gold edges. Price 50c each, 3 for \$1.25, \$4.50 per doz. Magnifying Glass for use with Midget Bible, 15c.



## STAGE MONEY

With a bunch of these bills, it is easy for each person of limited means to appear prosperous by flashing a roll of these bills at the proper time and peeling off a genuine bill or two from the outside of the roll, the effect created will be found to be all that can be desired. Prices, postpaid: 40 Bills 20c, 125 for 50c, or \$3.50 thousand postpaid.

## Wonderful X-Ray Tube

A wonderful little instrument producing optical illusions both surprising and startling. With it you can see what is apparently the back of your fingers, the back of a lead pencil, the interior of a pipe stem, and many other similar things. A mystery that no one has been able to satisfactorily explain. Price 10c, 3 for 25c, 1 dozen 75c. Johnson Smith & Co.



**Good Luck Ring**  
Quaint and Novel Design

A VERY striking and mysterious ring. Silver finish, skull and crossbones design, with two brilliant, flashing gems sparkling out of the eyes. Said by many to bring Good Luck to the wearer, hence the name. Good Luck Ring. Very unique ring that you will take a pride in wearing. **ONLY 25 CENTS.**

Address orders for all goods on this and opposite pages to **JOHNSON SMITH & CO.**

Dept. 460 RACINE, WIS.

A Deluxe Edition of our new 1925 CATALOG mailed on receipt of 25c. Handsome cloth binding. Only book of its kind. 420 pages of all the latest and best books, curiosities, puzzles, games, sporting goods, interesting books, curiosities in seeds and plants, etc., unobtainable elsewhere. Remit by Money Order, Check, Coin, Stamps, etc. Stamps of foreign countries also accepted.

## BLANK CARTRIDGE PISTOL

Protection against Burglars, Thieves & Dogs

Prices **50c**  
**\$1.00**



Well made and effective; models on latest type of Revolver; appearance alone is enough to scare a burglar. When loaded it may be as effective as a real revolver without danger to life. It takes standard .22 Cal. Blank Cartridges obtainable everywhere. Price 50c, superior quality, \$1.00 postpaid. Blank Cartridges, by express, 50c per 100. Holster (Cowboy type) for Blank Cartridge Pistol, 50c. Johnson Smith & Co., Dept. 460, Racine, Wis.

**BOYS! BOYS! BOYS!**

## THROW YOUR VOICE



Into a trunk, under the bed or anywhere. Lots of fun fooling the teacher, policeman or friends.

## THE VENTRILLO

a little instrument, fits in the mouth out of sight, used with above for Bird Calls, etc. Anyone can use it.

Never Fails. A 32 page book on ventriloquism, the Ventrillo, ALL FOR 10 CENTS

## Exploding Cigarettes



JUST LIKE ORDINARY CIGARETTES, BUT SUCH REAL STARTLERS! The box contains ten genuine cigarettes of excellent quality. They appear so real, but when each cigarette is about one-third smoked, the victim gets a very great surprise as it goes off with a loud BANG! A great mirth provoker yet entirely harmless. Price 25c per box.

## Popular Watch Charms



Very pretty little curiosities and decidedly novel. Filled with Magnifying Lenses that enlarge the picture to a very surprising degree; in fact, it seems almost incredible that a clear picture could be possible in such a small compass, and how sharp and distinct they show up when you look through. Come in assorted views—Actresses, Views of Panama Canal, Lord's Prayer in type, etc.

## Mystic Skeleton

A jointed figure of a skeleton 14 in. in height, will dance to music and perform various gyrations and movements while the operator may be some distance from it.

10c + pd.

## NEW BOOK ON ROPE SPLICING

Useful Knots, Hitches, Splices, etc. A most practical handbook giving complete and simple directions for making all the most useful knots, hitches, hitches, splices, etc. Over 100 illustrations. All about wire rope attachments, hitches, blocks, tackle, etc. 37 Heraldic Knots illustrated. Of great value to mechanics, riggers, carpenters, boatmen. Price 20c ppd.

## MAGIC FLUTE

Wonderfully Sweet Toned and Musical The Magic Flute, or Harmonicon, is a unique and novel musical instrument that is played with nose and mouth combined. There is just a little knack in playing it which, when once secured allows a little practice will enable you to produce very sweet music that somewhat resembles a flute. There is no fingering, and once you have mastered it you can play all kinds of music with facility and ease. When played as an accompaniment to a piano or any other musical instrument, the effect is so charming as it is surprising.

Post Paid 25c

## K.K.K.

Everything about the Ku Klux Klan told in a clear, fearless manner. Book tells all—How it started and was oppressed in 1871—The New Ku Klux Klan—How Organized—How Members are Enrolled—Oath of the Klan—Questions for Candidates—Creed—Objects of the Order—Obedience—Fidelity—Pledge of Loyalty—Ku Klux Klan and the Masons—The Jews—The Masons—Head K. of C. Oath—The Negro Ku Klux Klan, etc., etc. Latest and most complete book on the Klan published. Price 35c, Postpaid, Stamps or Coin

## LOOK 35¢ LOOK

Wonderful instrument. Greatest thing yet. Nine separate articles in one. Everybody delighted with it. Odd, curious and interesting. Lots of pleasure as well as very useful. It is a double Microscope for examining the wonders of nature. It is also an Opera Glass, a Stereoscope, a Burning Lens, a Reading Glass, a Telescope, a Compass, a Pocket Mirror, and a Laryngoscope—for examining eye, ear, nose and throat. It is worth all the cost to locate even one painful cinder in the eye. Folds flat and fits the pocket. Something great—you need one. Don't miss it. Sent by mail, postpaid. **Only 35c or 3 for \$1.00**

## 25 CENTS BABY TANK

Go on backward or forward by its own power. Nothing so new. What makes it go is a mysterious force. It crawls along, overcoming obstacles as like the larger Tanks. Performance of most amazing stunts. Runs ten times longer than most mechanical toys. Handsomely finished and unobtainable elsewhere. Piped in natural colors. 25c postpaid.

## Female SEX Indicator 25c Male Sex Indicator

Hold the MAGIC INDICATOR over a man's hand—instantly it moves in a straight line, backward and forward. Hold it over a woman's hand and it describes a complete and continuous circle. The same action can be obtained over a letter written by a man or woman, etc. It is foolproof; no hint. We have never been able to figure out how it does, but we've never seen it fail. Many novel and startlinging tests may be performed with the Sex Indicator. For example, similar results may be obtained with animals, cats, dogs, rabbits, even birds, chickens, geese, etc. Also used to determine the sex of children and birds, etc. In fact it is sold as a patented sex tester in Europe. Price 25c, or 3 for 65c, ppd. JOHNSON SMITH & CO., Dept. 460, RACINE, WIS.

# THE TEDDY CAMERA



**Takes and Finishes an Excellent Photograph on a Card 3 1/2 x 2 in One Minute**

It is the newest method of photography in which skill and experience are not necessary. Not a plate nor a film camera, but a camera that produces the complete picture. Does not use silver plates, film, or darkroom. All the troubles of picture-taking in the ordinary manner are swept away. It eliminates all the fuss and trouble and, above all, there is *No Waiting*, for you actually see the finished picture in *One Minute*. You merely place the cards in the camera, press the shutter, drop the card into the automatic developing tank attached to the camera, and in *One Minute* you have a Complete Picture all finished and ready to show. It is so simple and easy that any child who can use its hands can take good pictures. The camera weighs little more than half a pound, and measures about 4 1/2 x 3 1/2 inches, easy to carry, and in *One Minute* you have a Complete Picture all finished and ready to show. It is so simple and easy that any child who can use its hands can take good pictures. The camera weighs little more than half a pound, and measures about 4 1/2 x 3 1/2 inches, easy to carry, and in *One Minute* you have a Complete Picture all finished and ready to show.

\$2.50

every about and always ready to take and finish a picture in one minute. The lens is of high grade, universal focus, needs no adjustment, and takes clear and brilliant pictures at any distance. The Shutter works perfectly and responds to very slight pressure. It loads in broad daylight. The Developing Tank is attached to the Camera and holds a single solution that develops, tones and fixes the picture in one minute with absolute certainty and with no care or attention on the part of the operator; it cannot be over-developed. Produces a picture 3 1/2 x 2 inches. Send today and have the never-fading pleasure of making excellent pictures of your family, friends or neighbors, your home or your domestic pets. Price of Camera Complete with Developer and Package of Cards, \$2.50 Postpaid. Extra packages containing Cards 15 cents per package; extra Developing Solution 25 cents. All prices are postpaid to any address in the world.

## Every Boy His Own Toy Maker

Greatest boys' book written. Tells how to make a Pinhole Camera, a Canoe, model Railroad, a Telephone, Boomerang, Telegraph Instrument, Box Kite, Talking Machine, Microscope, Electric Motor, Electric Door Bell, Water Wheel, Paddle Boat, a pair of Skis, a Dog Sled, Bird House, Rabbit Yard, etc. 64 pages, 150 illustrations. PRICE, 10c postpaid; 3 for 25c.



10 Cts.

## INVISIBLE INK

The most confidential messages can be written with this ink, for the writing **Makes No Mark.** Cannot be seen unless you know the secret. Invaluable for many reasons. Keep your postals and other private memorandums away from prying eyes. Great fun for playing practical jokes. Only 15c a Bottle; 3 for 40c.



# JAPANESE ROSE BUSHES

## The Wonder of the World

Japanese Rose Bushes bloom all the year round. Just think of it. Six weeks after planting the seed, the plants will be in full bloom. It may not seem possible, but we positively guarantee it to be so. They will bloom every ten weeks, Summer or Winter, and when three years old the bush will be a mass of roses, bearing from five hundred to a thousand roses on each bush. The flowers are in three shades—white, pink, and crimson. The plants will do well both in and out doors. We guarantee at least three bushes to grow from each packet of seed. Price, 10c packet, 3 pkts. for 25c postpaid.

## Kissing Permit

A handsome metal badge, nickel plated, that you can wear, giving you fun out of all proportion to its trifling cost. PRICE 10c each, 3 for 25c, or 12 for 75c postpaid.



## False Mustache

Here you are, boys! Just the thing for a little harmless masquerading. On and off in a twinkling. Lots of fun putting one on in a crowd of friends. The sudden transformation is astonishing. Fine for private theatricals, minstrel shows, charades, tableaux, etc. Changes your appearance beyond recognition. PRICE 10c, 3 for 25c postpaid.



# Microphone Transmitter Button

You can easily make a highly sensitive detector by using this Transmitter Button to collect the sound waves. You can hold your own outfit without buying expensive equipment. It is simple and inexpensive. You can install it in your home and have conversations held all over the house. You can connect to different rooms of a hotel. This outfit was used by secret service operatives during the war. It is being used on the stage. It is ultra-sensitive and is the greatest invention in microphones. You can connect the button almost anywhere—card board boxes, store rooms, safe cabinets, on the wall behind a picture frame, etc. Button is as light and small it cannot be detected. Persons can be overheard without suspecting it. You can listen to an conversation in another room. A deaf person in the audience can hear the speaker. Connected to phonograph, piano or other musical instrument, music can be heard hundreds of feet away. Buttons may be used to receive telephone transmissions of long wires as old line "talk-up" when retired also will. The ideal microphone for radio use; carries heavy current and is extremely sensitive. Amplifies radio signals. Caution: other similar uses will suggest themselves. Experimenters find the Button useful for hundreds of experiments along the lines of telephones, amplifiers, loud speakers, etc. Many interesting stunts may be devised, such as holding the button against the throat or chest to reproduce speech without sound waves. \$5.00 is given to anyone who sends in a new suggestion for the use of the Button providing the manufacturers find it suitable for use in their literature. PRICE \$1.00 POSTPAID ANYWHERE.

\$1.00 POST-PAID



# MAGICIAN'S OUTFIT

Apparatus and Directions for a Number of Mysterious Tricks Enough for an Entire Evening's Entertainment **ANYONE CAN DO THEM 75c**



It is great fun to give your friends. Get this Magician's Cabinet, and you will be the cleverest fellow in your district. It contains the apparatus for seven dramatic tricks, including: The Disappearing Rose, that, when placed on the lapel of your coat, vanishes from sight at will; the Magic Vase and Ball Trick in Wooden Ball is placed inside, and upon replacing the lid has disappeared and is found in someone else's pocket; The Magic Ball with which you can apparently cut your finger almost in two; the Wonderful Card Trick in card is placed in an envelope, and when open an entirely different card (secretly is found); The Disappearing Coin Box a coin is placed in the little wooden barrel and, when opened, vanishes, is found to have vanished entirely, or can be made to change into a coin of another denomination; The Famous Disappearing Penny Trick; The Glass Goblet and Vanishing Coin Trick is coin is dropped into a glass of water, and when the water is poured out the coin has vanished. With the tricks described above, we send full printed instructions for performing each trick, so that anyone can readily perform all the tricks to the great amusement of their friends or the public. Any boy of ordinary intelligence, with this Cabinet of Tricks in his possession, can give a parlor entertainment not inferior to any regular magician. Besides the tricks contained in the Cabinet, there are many other little amusements fully explained with full instructions, for which you can easily make or procure the necessary apparatus. This unexcelled Cabinet of Tricks for ONLY 75 CENTS POSTPAID TO ANY ADDRESS.

## Great Fire Eater

Most Sensational Trick of the Day! With the Fire Eater in his possession any person can become a perfect salamander, apparently breathing fire and ejecting thousands of brilliant sparks from his mouth, to the horror and consternation of all beholders. Harmless fun for all times, seasons and places. If you wish to produce a decided sensation in your neighborhood don't fail to procure one. We send the Fire Eater with all the materials, in a handsome box, the cover of which is highly ornamented with illustrations in various colors. Price of all complete only 30 cents, postpaid.



## SQUIRT ROSE

25c A REAL STARTLER. This is the most popular of all squirt tricks. The flower in your coat looks so fresh and sweet that everyone is tempted to inhale the delightful perfume. Then is the moment to press the bulb. Good! Dissonant! Don't they jump? There is a very long rubber tube that easily reaches to the pocket of your coat or trousers, and the bulb is large enough to make a dozen shots with one loading. PRICE 25c each, or 3 for 65c postpaid.



## PISTOL, OPERA & FIELD GLASS

PRICE POSTPAID, \$1.00 It is made in the shape of and looks like a regular Automatic Pistol. No one is likely to stop and ask you whether it is real or not. This is likely to prove itself very handy in an emergency. On pressing the trigger it opens up, as shown in the illustration at the right, revealing nine most useful articles—Opera and Field Glass, Telescope, Mirror, Magnifying Glass and Burning Lens, Reading Glass, Sun Disk, Sun Compass, etc. In the handle of the revolver there is a place for various pocket necessities, such as First Aid Articles, Buttons, Pins, etc. The Pistol is of sheet metal, bleed finish, that can be carried comfortably in pocket. PRICE \$1.00.



**GOLD TEETH** You know how fashionable it is to have gold crowns—if you can afford it. These gold-finished shells fasten over your real teeth and look like very wealthy girls. Can be slipped on and off in an instant. Get some and surprise your friends. PRICE 5 Cents Each, 3 for 15c, or 50c for 1 doz., postpaid.

## SURPRISE MATCHES

More fun than fighting with your wife. Look just like ordinary matches. Put up in boxes just like regular Safety Matches. As the victim tries to light one he gets quite a surprise. PRICE 10c per box, 3 boxes for 25c postpaid, 12 for 75 cents.



## SEEBACKSCOPE

By merely placing this clever instrument to your eye, you can see what is going on behind your back, and sometimes you see very interesting things when no one thinks you are looking. Why it is just like having eyes at the back of your head. PRICE ONLY 25 Cents Postpaid, 3 for 50 cents.



# The "Little Giant" Typewriter

A First Class Writing Machine For \$1.50 A perfect little typewriter for \$1.50. There are two kinds of persons who would like to use a typewriter but whose needs and brains do not warrant the expense attached to the purchase and use of a fifty or seventy-five dollar machine. To such persons we confidently recommend our Little Giant. It is strongly made, but simple in construction, so that anyone can quickly learn to operate it, and write as rapidly as they would with pen and ink. The letters of the alphabet are 10, and the punctuation marks look together. With this machine you can send your best and typewritten love letters, address envelopes, make out bills, and do almost any kind of work not requiring a large, expensive machine. With each typewriter we send a tube of ink and full printed instructions for using the machine. Price complete \$1.50 by mail postpaid to any address in the world.

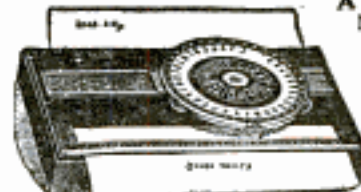



# PA INVENTORS.

**JUST  
ACROSS  
STREET  
FROM  
U.S. PAT.  
OFFICE.**

At the right is a view of my drafting and specification offices where a large staff of experienced experts are in my constant employ. All drawings and specifications are prepared under my personal supervision.



## PROTECT YOUR IDEAS Take the First Step Today

If you have a useful, practical, novel idea for any new article or for an improvement on an old one, you should communicate with a competent Registered Patent Attorney AT ONCE. Every year thousands of applications for patents are filed in the U. S. Patent Office. Frequently two or more applications are made for the same or substantially the same idea (even though the inventors may live in different sections of the country and be entirely unknown to one another). In such a case, the burden of proof rests upon the last application filed. Delays of even a few days in filing the application sometimes mean the loss of a patent. So lose no time. Get in touch with me at once by mailing the coupon on the opposite page.

### Prompt, Careful, Efficient Service

This large, experienced organization devotes its entire time and attention to patent and trademark cases. Our offices are directly across the street from the U. S. Patent Office. We understand the technicalities of patent law. We know the rules and requirements of the Patent Office. We can proceed in the quickest, safest and best ways in preparing an application for a patent covering your idea. Our success has been built on the strength of careful, efficient, satisfactory service to inventors and trademark owners located in every state in the Union.

**Clip this Coupon and Mail**

# TENTS

## Write for these FREE BOOKS

**NO CHARGE  
for Information**

**On How to  
Proceed!**

The books shown here contain valuable information relating to patent procedure that every inventor should have. And with them I will also send you my "Record of Invention" form, on which you can sketch your idea and establish its date before a witness. Such evidence may later prove valuable to you. Simply mail the coupon and I will send you the books, and the "Record of Invention" form, together with detailed information on how to proceed and the costs involved. Do this NOW. No need to lose a minute's time. The coupon will bring you complete information entirely without charge or obligation.



### STRICT SECRECY PRESERVED

All communications, sketches, drawings, etc., are held in strictest confidence in strong, steel, fireproof files, which are accessible only to authorized members of my staff. Feel free to write me fully and frankly. Your case will have my personal attention. It is probable that I can help you. Highest references. But **FIRST**—clip the coupon and get my free books. Do **THAT** right now.

## Clarence A. O'Brien

Registered Patent Attorney

Member of Bar of: Supreme Court of the United States; Court of Appeals, District of Columbia; Supreme Court, District of Columbia; United States Court of Claims.

Practice confined exclusively to Patents,  
Trademarks and Copyrights

### FREE COUPON

CLARENCE  
A. O'BRIEN

Registered  
Patent Attorney

7098 Security Savings and  
Commercial Bank Bldg.,  
Washington, D. C.

Please send me your free books, "How to Obtain a Patent," and "Invention and Industry," together with your "Record of Invention" form without any cost or obligation on my part.

Name .....

Address, .....

.....  
(Important: Write or Print name clearly)

**It Now!**

# PATENTS TRADE-MARKS AND COPYRIGHTS

## Have You An Idea?

### Our Offer: FOR THE PROTECTION OF YOUR INVENTION YOUR FIRST STEP

Before disclosing an invention the inventor should write for our blank form

#### "RECORD OF INVENTION"

This should be signed and witnessed and returned to us together with model or sketch and description of the invention for INSPECTION and INSTRUCTIONS

*No Charge for the Above Information*

**Our Four Books Mailed  
Free to Inventors**

*Our Illustrated Guide BOOK*

#### How to Obtain a Patent

Contains full instructions regarding U. S. Patents. Our Methods, Terms, and 100 Mechanical Movements illustrated and described.

#### Our Trade Mark Book

Shows value and necessity of Trade Mark Protection. Information regarding *Trade Marks and unfair competition in trade.*

#### Our Foreign Book

We have Direct Agencies in Foreign Countries, and secure Foreign Patents in shortest time and lowest cost.

#### Progress of Invention

Description of World's Most Pressing Problems by Leading Scientists and Inventors.

*We Regard a Satisfied Client as our best advertisement, and furnish anyone, upon request, lists of clients in any state for whom we have secured patents.*

**Highest References—Prompt Attention  
—Reasonable Terms**

## VICTOR J. EVANS & CO.

### PATENT ATTORNEYS

Main Offices: 956 9th St., N. W., Washington, D. C.

*Opposite U. S. Patent Office*



Our New York Office  
Suite 1007 Woolworth Bldg.



Our Philadelphia Office  
Suite 714-15 Liberty Bldg.



Our Washington Office  
Victor Building





# PATENTS TRADE-MARKS AND COPYRIGHTS

## IMPORTANT

TO HAVE YOUR CASE MADE SPECIAL AND AVOID DELAY YOU SHOULD HAVE YOUR CASE MADE SPECIAL IN OUR OFFICE to secure protection, save correspondence and secure early filing date in Patent Office. To secure special preparation of your case send \$25.00 on account with model or sketch and description of invention.



MAIN OFFICE, VICTOR J. EVANS & CO.—VICTOR BUILDING, WASHINGTON, D. C.

*Our Lawyers Practice in all U. S. Courts and defend Clients in Suits involving Patents, Trademarks and Copyrights*

All Communications and Data Strictly Confidential. Interference and Infringement Suits Prosecuted

OUR ORGANIZATION OFFERS PERSONAL SERVICE By Experienced Patent Lawyers, Solicitors and Draftsmen

**FREE  
COUPON**

**VICTOR J. EVANS & CO.  
PATENT ATTORNEYS**

NEW YORK OFFICES  
1007 Woolworth Bldg.

CHICAGO OFFICES  
1114 Tacoma Bldg.

PHILADELPHIA OFFICES  
714-715 Liberty Bldg.

PITTSBURGH OFFICES  
514 Empire Bldg.

SAN FRANCISCO OFFICES  
Hobart Bldg.

MAIN OFFICES: 956 9th Street, N. W., WASHINGTON, D. C.

Gentlemen: Please send me *Free of Charge* your books as described on preceding page.

Name .....

Address .....



Our Chicago Office  
Suite 1114 Tacoma Building



Our Pittsburgh Office  
Suite 514 Empire Building



Our San Francisco Office  
Suite 1010 Hobart Building

# PATENTS

TRADE MARKS · DESIGNS · FOREIGN PATENTS

## MUNN & CO. PATENT ATTORNEYS

*Associated since 1846 with the Scientific American*

672 WOOLWORTH BUILDING  
New York City

523 SCIENTIFIC AMERICAN BLDG.  
Washington, D. C.

412 TOWER BUILDING  
Chicago, Ill.

365 HOBART BUILDING  
San Francisco, Cal.

220 VAN NUYS BUILDING  
Los Angeles, Cal.

*Books and Information on Patents and Trade Marks by Request. Associates in All Foreign Countries.*

### Have You An Invention?

If so the WORLD PROGRESS will send you upon request sample copy Free containing SUGGESTIONS TO INVENTORS as to Inventions Needed. We invite manufacturers to address us regarding inventions they want.

Subscription for one year 60 cents

WORLD PROGRESS PUB. CO., Inc.  
Room 203 Victor Bldg. WASHINGTON, D. C.

### PATENTS

C. L. PARKER  
Formerly Member Examining  
Corps, U. S. Patent Office  
PATENT LAWYER  
MCGILL BLDG.  
WASHINGTON, D. C.

Patents, Trade Marks, Copyrights, Patent Litigation  
Pamphlet of instructions sent upon request



### PATENTS

Send us sketch or model for advice and exact cost of patent. Our book "How to Obtain a Patent" sent free. It tells how to apply for Patents, Trade Marks, Foreign Patents, Copyrights, etc.; gives information on Patent Procedure; tells what every inventor should know. Thousands of inventors, who are our clients, are our reference.

CHANDLEE & CHANDLEE, 25 Years' Experience  
473 7th St. Washington, D. C.



### GEARS ALL KINDS SMALL

The most accurate made and prices reasonable. We carry a complete line of gears in stock for immediate shipment. Can also quote on special gears of all kinds. Send us your inquiries.

WRITE FOR CATALOGUE.

CHICAGO STOCK GEAR WORKS  
105-109 S. Jefferson St., CHICAGO

# PATENTS

Booklet Free Highest References  
Promptness Assured Best Results

Send drawing or model for preliminary examination of Patent Office records.

## ALL BUSINESS GIVEN PROMPT AND PROPER ATTENTION

Listed Patent Lawyer in the latest editions of the Rand-McNally Directory of Bankers and Attorneys, of Chicago, Ill.; The Baggott & Ryall Directory of Attorneys, New York City; the United Lawyers' List of Attorneys, published in Chicago, Ill.; The Lawyers and Bankers Quarterly, published by the Legal Directory Publishing Company of St. Louis, Mo.; the American Lawyers Annual, Cleveland, Ohio.

**WATSON E. COLEMAN,**  
REGISTERED PATENT LAWYER

644 G Street, N. W., Opp. U. S. Pat. Office  
**WASHINGTON, D. C.**

# PATENTS

## To the Man with an Idea

I offer a comprehensive, experienced, efficient service for his prompt, legal protection and the development of his proposition.

Send sketch, or model and description, for advice as to cost, search through prior United States patents, etc. Preliminary advice gladly furnished without charge.

My experience and familiarity with various arts frequently enable me to accurately advise clients as to probable patentability before they go to any expense.

*Booklet of valuable information and form for properly disclosing your idea free on request. Write today.*

Richard B. Owen, Patent Lawyer  
9-303 Owen Bldg., Washington, D.C.  
41-E Park Row, New York City

## TRADE-MARKS REGISTERED

## BLUE BOOK ON PATENTS

gives instructive information and candid advice.

MONROE E. MILLER, PATENT LAWYER  
411-2 Ouray Building WASHINGTON, D. C.  
ELECTRICAL AND MECHANICAL EXPERT

## PATENTS

As one of the oldest patent firms in America we give inventors at lowest consistent charge, a service noted for results, evidenced by many well known Patents of extraordinary value. Book, Patent-Sense, free. Lacey & Lacey, 846 F St., Wash., D.C. Estab. 1869.

## PATENTS

Trade Marks, Copyrights, Patent Litigation Handbook with illustrations, 100 mechanical movements. Sent free on request.

ALBERT E. DIETERICH  
formerly member examining corps U. S. Patent Office  
PATENT LAWYER and SOLICITOR

621-A, Ouray Bldg.  
27 Years' Experience Washington, D. C.

## Wanted—Inventions

A large manufacturing corporation making small metal products and having world-wide connections, wishes to secure inventions or patents covering devices of metal having large market possibilities, if properly exploited. Liberal arrangements and absolute protection.

Address:

"MANUFACTURER,"

Care POPULAR MECHANICS MAGAZINE, CHICAGO, ILL.

## YOU CAN NOW LEARN HOW TO INVENT!

- How to develop your imagination
- How to develop your ideas
- How to get the facts you need for inventions
- How to keep legal records of ideas
- How to use scientific principles of mechanics
- How to avoid wasting time on impractical inventions
- How to apply for a patent
- How to organize a company
- How to protect your rights
- How to market a patent

and hundreds of other vitally important facts which EVERY successful inventor knows and uses. A remarkable new, and much needed course which can be studied in spare time, at home.

## Make Your Ideas Pay You a Fortune

You can now learn how to train your mind along scientific inventive lines. No longer need you let your mind wander in unprofitable fields. You can learn how to think of worth-while ideas and make your ideas pay you money. The trouble with most people is that they do not know what to do with their ideas. Millions of dollars go to waste because of these undeveloped ideas. Now for the first time you can learn to harness your thoughts and make them work for you! One little invention, properly developed, may make you independent for life!

## You Are Born an Inventor Develop your ability



Raymond F. Yates

## Edison Says

"Invention is a Science and Should Be Taught as a Profession."

Invention is like trying to build a bridge without knowing engineering. This is the first course in practical invention that has ever been devised. Now you can take Edison's advice and actually learn HOW TO INVENT—how to make invention a profession! In simple, easy-to-understand language, you are told how successful inventors work; you learn how to use the secrets of invention that convert a simple little idea into money.

## Amazing Book On Inventive Science Free

Fortunes have been made by men who have thought of a "little" idea in a flash—the bottle top, the crimped hairpin, the thin lead automatic pencil, the snap fastener—earned fortunes, yet there are as many fortunes lost by inventors who did not know just what to do about their ideas. A wonderful book explaining this wonderful new course written by 14 practical inventors has been prepared and will be sent free to those genuinely interested. If you have ever had an idea for an invention, or if you would like to become a spare-time or professional inventor, and if you would like to know what to invent, send in your name at once on the coupon or a postal NOW! Only a limited number of these books are available for free distribution.

BUREAU OF INVENTIVE SCIENCE  
Dept. 312, Wisner Bldg. ROCHESTER, N. Y.

Bureau of Inventive Science, 312 Wisner Bldg., Rochester, N. Y.

Please send me your free book "The Science of Invention."

Name.....Age.....  
Address.....  
City.....State.....

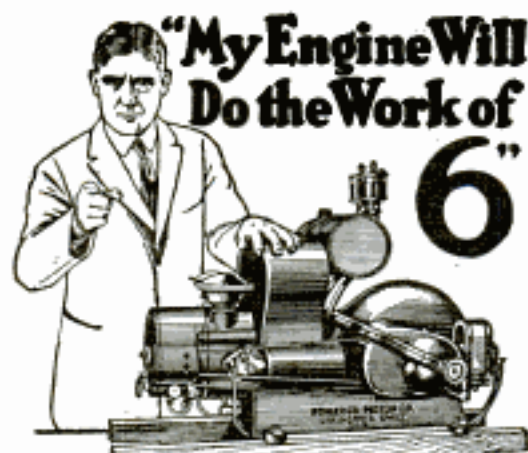

### Try This Remarkable Engine

**FREE** The Edwards Farm Engine sells direct to you at low factory price. No other engine like it. 1½ to 6 H. P. in one engine. Change power while running. Efficient at all powers.

#### Fits Every Farm Job

Pumps, saws, grinds, cuts ensilage, runs spray rig, concrete mixer, washer—anything up to 6 H. P. Portable. Burns kerosene or gasoline. No cranking. All moving parts enclosed. Work it anywhere without fastening down. Endorsed by thousands of users.

**Clarence Rutledge, of Ontario, says:** "Have given my Edwards four years' steady work and like it fine. Runs 28-inch wood saw, 8-inch grinder, ensilage cutter and does all chores. Have had ten other engines. The Edwards beats them all." Write now for full description of Edwards Engine, low factory price and details of free trial offer.

**EDWARDS  
FARM  
ENGINE**

**For Special  
FREE TRIAL  
Mail Coupon  
Now**

EDWARDS MOTOR CO.  
218 Main Street, Springfield, Ohio  
Without obligation, send complete description of engine, also free trial offer.

Name \_\_\_\_\_  
Address \_\_\_\_\_

### SHOW IT—and IT'S SOLD



The Handy Knife Sharpener is the fastest selling home necessity ever offered.

Everyone a prospect. Sells for \$1.00, your profit 65c. Free deliveries. Guaranteed.

Morgan Mfg. Co., Dept. G, 443 S. Dearborn, Chicago

## U.S. PATENTS



### DON'T LOSE YOUR RIGHTS TO PATENT PROTECTION

Before disclosing your invention to anyone send for blank form "EVIDENCE OF CONCEPTION" to be signed and witnessed. A sample form together with printed instructions will show you just how to work up your evidence and establish the same before filing application for patent. As registered patent attorneys we represent hundreds of inventors all over the United States and Canada in the advancement of inventions. Our schedule of fees will be found reasonable. The form "Evidence of Conception," sample, instructions relating to obtaining of patents and schedule of fees sent upon request. Ask for them—a post card will do.

PATENTS AND TRADE MARKS  
**LANCASTER & ALLWINE**

Registered Patent Attorneys in U. S. and Canada.  
480 Ouray Bldg., WASHINGTON, D. C.  
Originators of forms "Evidence of Conception."

### You Can Save \$35.00



\$4.45 and up

Recover it yourself.

Custom tailor made to fit all makes and models. Roof

and quarters sewed together, with rear fasteners, welts and tacks, complete. Anybody can put it on. Give name, year, model number of your car. Catalog FREE. Agents wanted.  
LIBERTY TOP & TIRE CO. Dept. I, Cincinnati, O.

### AGENTS!!!

300 to 500% PROFIT

Goods have Fine Appearance. Good Quality. Sells easy, and agents make big money. Write today for FREE CATALOGUE AND SAMPLES.

National Soap Company  
512 W. Huron St., Dept. D-4, Chicago

## INVENTORS PROTECT YOUR IDEAS

Send for our Guide Book, **HOW TO GET A PATENT**, and Evidence of Invention Blank, sent Free on request. Tells our terms, methods, etc. Send model or sketch and description of your invention for INSPECTION and INSTRUCTIONS FREE. TERMS REASONABLE. BEST REFERENCES.

**RANDOLPH & CO.**  
300 Victor Bldg., WASHINGTON, D. C.

NAME \_\_\_\_\_

STREET \_\_\_\_\_

CITY \_\_\_\_\_ STATE \_\_\_\_\_

# Nestler Rubber Fusing Stations

An opportunity is offered one man in each community to secure the sole and exclusive right to operate the famous Nestler Rubber Fusing Process of servicing pneumatic tires. Unlike any other method on earth. The Nestler method is the perfected and only known way of successfully retreading pneumatic auto or truck tires, including all sizes of balloon tires. Every car owner needs Nestler Service. Nestlerized repairs outlast the tire. No previous experience necessary. We teach you the business in two weeks or less. Moderate capital required. Big profit on each tire you do. Here is your opportunity to have a permanent and highly profitable business in your own name. Remember only one man can secure this profitable franchise in each community. Act now if you want to be that man. Write today for two interesting books describing the Nestler Rubber Fusing Process and the methods that are being employed by Nestler licensees everywhere to build up prosperous businesses.

**NESTLER RUBBER FUSING CO., Inc.**

Dept. H, 245 West 55th Street, New York City

## New Kind of OIL BURNER

Through a recent discovery of Pat Schaefer's, a practical mechanic of more than 30 years' experience, oil burners have been perfected to a degree never before thought possible. And Pat Schaefer will send to any one this new oil burner for 30 days' trial in any stove, range, or furnace with the understanding that if it does not give satisfaction it costs you nothing. Now you can be free from the worry of coal shortages, strikes and high prices—the dirt, smoke, soot, ashes and drudgery of coal and wood. Find out full details of this wonderful invention and how you can get it in your own home for free trial. No obligation. Agents interested in making \$10 to \$25 a day should write for free sample case, cash bonus and free territory offers. Oliver Oil Burner Corporation, 210 Chestnut St., Dept. W-130, St. Louis, Mo.

**\$6**

**CASH WITH ORDER**



16 inches over all, C to C, 4"x11" swing bed is machined and centers accurately. Shipping weight, 13 pounds, also made in larger sizes.

**SYPHER MFG. CO., Dept. L, Toledo, O.**

Books on all subjects are sold by Popular Mechanics Press, 200 East Ontario Street, Chicago, Illinois.

**30 DAYS FREE TRIAL**



### MUSIC LOVERS

Here is your opportunity to have a beautiful new piano, try it free for thirty days, and then pay for it by small monthly payments. Our illustrated Catalog explains this and shows you how to save as much as \$200 on our "factory-to-home" plan. It tells you how our "sweet toned" Schmoller & Mueller Pianos and Player Pianos are made and guaranteed for 25 years. Every piano is backed by our resources of over \$2,000,000. Don't delay. Send for this catalog today.

**SCHMOLLER & MUELLER PIANO CO.**

Dept. 115

Omaha, Neb.

Please send me catalog and plan.

Name .....

Address .....

## Easy to Play Easy to Pay



**BENNIE KRUEGER**

Director Bennie Krueger and his Orchestra. One of America's Best Dance Bands.

The reason all the great saxophone players of the country prefer the

**BUESCHER**  
*True Tone*  
**SAXOPHONE**

is because it is perfectly in tune and produces a beautiful tone without any skillful trick lipping or fingering. And that is also the reason that amateurs prefer the Buescher once they have tried and compared it with other instruments.

## You Can Play This Wonderful Instrument

There is no mystery about it. No special talents required. If you can whistle a tune or beat time to music, then there is music and rhythm within you and the Buescher Saxophone will quickly bring it out and develop it for the entertainment of yourself and others. \*Saxophone music is the most beautiful of all and will give you greatest pleasure.

**Try It In your Own Home Six Days FREE Before You Decide**

Try a Buescher, any instrument you choose, in your own home. Six Days FREE. Surely this is a most liberal offer. You are not obligated to keep the instrument if it does not suit you. We take the risk. If you like the instrument and decide to keep it, pay a little each month. Play as you pay. Get the details of this wonderful plan. Clip the coupon below. Send it for the free literature. It's your first step toward musical success. Send it today.

**BUESCHER BAND INSTRUMENT CO.**

Everything in Band and Orchestra Instruments  
1264 Buescher Block Elkhart, Ind.

**free**  This 64 page book tells about the various models, with pictures of professionals using them. Send for a copy of this wonderful

## SAXOPHONE BOOK

**Clip the Coupon NOW!**

**Mail**

**BUESCHER BAND INSTRUMENT CO.**  
1264 Buescher Block, Elkhart, Indiana

Gentlemen: Without obligation to me, send your beautiful book "The Story of the Saxophone" Check here  If you prefer other literature describing other band or orchestra instruments, check below.

Cornet  Trumpet  Trombone  Tuba

Mention any other .....

Write plainly, Name, Address, Town and State in Margin Below

## TRUE TONE QUALITY



**T**HIS Super-Amplifier was chosen for its tone quality by the Radio Laboratory of Popular Mechanics, for use in a set they described as "the most perfect toned receiver we have ever listened to." It will pay you to read the article, "Perfect Tone Six Is Ideal for Music Lovers" in the November Number. And for 10c the Radio Department of Popular Mechanics will send you a blue print of the "Perfect Tone Six."

Superlative tone quality is to be had in only one way—by the use of Resistance Coupled Amplification. The newest Audio Amplifiers are of this latest approved type. It has already been adopted by more than a dozen far-sighted set manufacturers, and thousands of set owners are following suit.

The Daven Super-Amplifier—the first offered the radio public—was developed by the pioneers in resistance coupled amplification. It gives you tone quality of unbelievable purity, all the volume you could wish for and longer life for your "B" batteries.

It is the Aristocrat of Amplifiers—a compact unit—as easy to connect as a battery. If you wish to assemble your own, the Daven three stage kit containing all essentials is available.

Furthermore, you may use two Daven High-Mu Tubes and a Daven Power Tube and have the volume increased over fifty per cent. These tubes are designed expressly for resistance coupled amplifiers and are another evidence that Daven the Pioneer is Daven the Leader.

*The Sine of Music*  
**DAVEN RADIO CORPORATION**

*Resistor Specialists*

Reg. U. S. Pat. Off.

Newark

New Jersey

.....CLIP THIS COUPON.....



### RESISTOR MANUAL

The Handbook of Resistance Coupled Amplification. At Best Radio Dealers 25c. Direct by mail, postpd. 30c.

**DAVEN RADIO CORPORATION,**  
158-160 Summit St., Newark, N. J.

Please send me the following on Resistance Coupled Amplification:

- Resistor Manual. 30c is enclosed.  
 Complete Catalogue (free).

Name.....

Address.....

For Dealers: Send your letterhead or card, or this coupon, and we will have our nearest distributor communicate with you.

**THE BIG LITTLE THINGS OF RADIO**

## "Twice the range and more volume on this indoor aerial!"

—says a Youngstown, O. Fan

### Effarsee

ANTENNAE  
REG. U. S. TRADE MARK  
PATENT PENDING

Equip your set with a new EFFARSEE and watch your old distance records go! Thousands of unsightly, inefficient outside wires have been replaced with this new scientifically designed antenna.

### Increases Selectivity! Cuts Down Static!

You never have trouble separating stations with an EFFARSEE, and it eliminates local interference—reception with EFFARSEE is reception at its best.

Type IXL contains 1000 feet of copper wire; type BXL, slightly smaller; both models equipped with special fixed condensers. Write for testimonials of enthusiastic users.

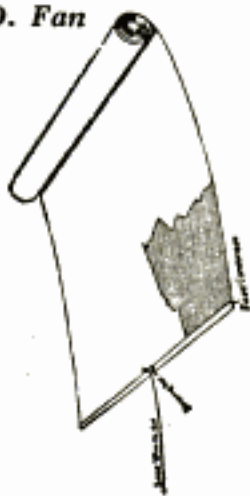

Type IXL (Large).....\$4.00  
Type BXL (Small).....\$2.50  
At any radio dealer or write direct

**THE FISHWICK RADIO CO.**

139 Central Parkway

Cincinnati, O.

## FREE two unusual RADIO CATALOGS



FOR "FANS"

**O**UR new 64-page Radio Catalog including all the best and latest Kits, Parts and Accessories for broadcast receiving sets. Lowest prices in the country!

More than 1,000,000 fans and hams make our store their headquarters—get these books and find out why

FOR "HAMS"

**N**EW 32-page booklet of army and navy transmitting apparatus and miscellaneous specials for "hams" such as W. E. Choke Coils, Generators, Resistance Boxes, etc.

Write for either or both

509 South State Street

**RADIO CHICAGO SALVAGE STOCK STORES**

Dept. P.M.6 Chicago Ill.

*No matter what circuit—  
Far, Far Better Results  
with*

# KARAS

**Orthometric Condensers and Harmonik Transformers**

Karas instruments have been tested and recommended by leading technical editors for use in all types of sets from the most elaborate supers to the simplest low loss 3-tube receivers. The most exacting home set builders, the country over, demand Karas Transformers and Condensers—and will use nothing else. Nothing can take the place of these scientifically designed, precision instruments. Use them in your next set—or improve your present set by installing them. It's easy to do—the results will be worth many times the cost.

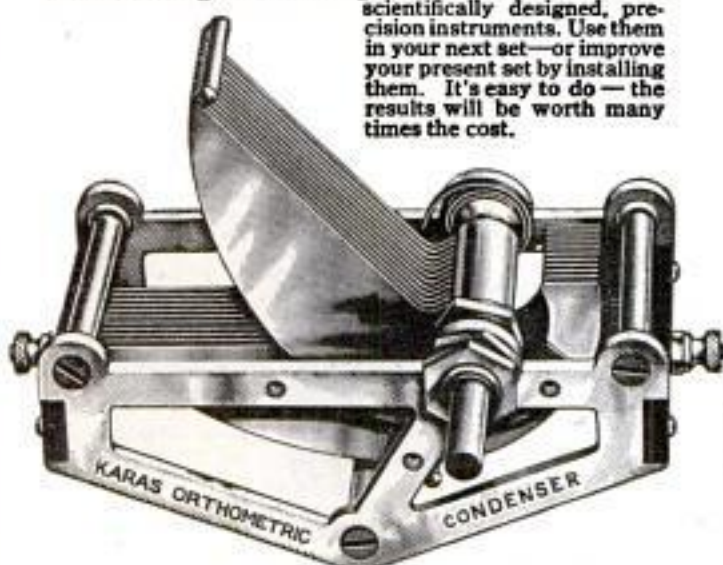

### Spreads Stations Evenly Over the Dial —No Crowding Whatever

The Karas Orthometric Condenser positively separates all adjoining wavelengths by EQUAL distances on the dial—giving you full benefit of the 10 Kilocycle frequency separation fixed by the government. Ordinary condensers jam 70 of the 100 Government allotted wavelengths into the first 30 points on the dial—even straight-line-wavelength condensers crowd 57 of them below 30. But with Karas Orthometrics, each point on the dial corresponds to one of the 100 allotted wavelengths. The result is marvelous simplicity in tuning—and better, clearer reception—all side bands without interference.

### Brings in KDKA at 53

Not at 17—or 28, but at 53 where it belongs, leaving lots of room for the 52 wavelengths that must come in below it. The Karas Orthometric is a "precision job"—entirely of brass. Every joint soldered. Plates patent-levelled and securely bridged.

*If your dealer is out of Karas Instruments*

### Order Direct on This Coupon

Most good dealers everywhere sell Karas parts. If your dealer happens to be one who doesn't, we will supply you direct at no trouble on your part—on our 30-day money back guarantee. Just fill in and mail this coupon at once. Send no money. You can pay the postman on delivery.

**KARAS ELECTRIC CO.,** 4048 N. Rockwell Street  
CHICAGO, ILLINOIS  
*For more than 20 years makers of PRECISION Electrical Apparatus*



### For Long Distance with Big Volume and Keen Musical Quality

Karas Harmoniks deliver perfect music with loads of volume from stations one to two thousand miles distant. DX broadcasting becomes really enjoyable. "Fishing" for distant stations is only a matter of finding programs you want to hear—not straining to catch only the bare announcement and making up a list of call letters.

Even from far away points, Karas Harmoniks bring out full, round musical tones. All the vital harmonics and rich overtones are fully retained. Low bass notes pour forth, rich, sweet, sonorous.

If you want music like this, you must have Karas Harmoniks in your set. Get a pair TODAY! The best transformer money can buy.

**Karas Electric Co.,**  
4048 N. Rockwell St., Chicago

I enclose \$..... for which please ship me, postage paid, the instruments checked below. It is understood that I have the privilege of returning these goods, for full refund, within 30 days, if they do not prove entirely satisfactory.

..... Karas Harmonik Audio Transformers. (\$7.00 each)

..... Karas Orthometric Condensers: Size.....  
(23 plate \$7 ea.; 17 plate \$6.75 ea.; 11 plate \$6.50)

Name.....

Address.....

If you send cash with order, we'll send package postpaid

**\$48<sup>58</sup>** POSTPAID  
Kit PK 9215  
Range 3500 Miles

## 4-Tube ROBERTS

Superior to most other sets  
REGARDLESS OF  
NUMBER OF TUBES!

**FOR QUICK ACTION!** To get you started dealing with us, we have slashed the prices on this most popular kit. But your order will have to be sent by November 30 when our regular catalog price will again be in effect.

Combines principles of Reflex, Neutralization, Tuned Radio Frequency, Regeneration (without blooming), and Push-Pull Amplification. Smooth-working—easily tuned—non-howling—non-radiative—non-squealing. Guaranteed absolutely to give entire satisfaction.

See what Doubleday, Page & Co., through Mr. Arthur H. Lynch, Editor of their magazine, "Radio Broadcast," say about the Radio Broadcast's sensational 4-Tube Knock-Out set developed by Walter Van B. Roberts: "Tubes by tube, dollar for dollar, result for result, we will stack it up against any receiver for home construction ever described by any radio publication and gamble that it comes out winner. It is the best we have ever seen—and we have seen and operated almost every type made and used during the past twelve years. It has pulled in forty-six stations on a lead speaker with two tubes, using an indoor antenna. Its signals have been heard through the air more than a quarter mile. It is not merely the best four-tube receiver, but the best by a very good margin."

### CUSTOMERS PRAISE IT!

**Special Features** Great volume—Utmost clearness—Sweetness of tone—Highly selective—Cheap to build—Easy to operate—Receives great distance—Does not radiate or cause squealing in your neighbors' receivers—Low cost of upkeep. The best 4-Tube set for home construction ever produced.

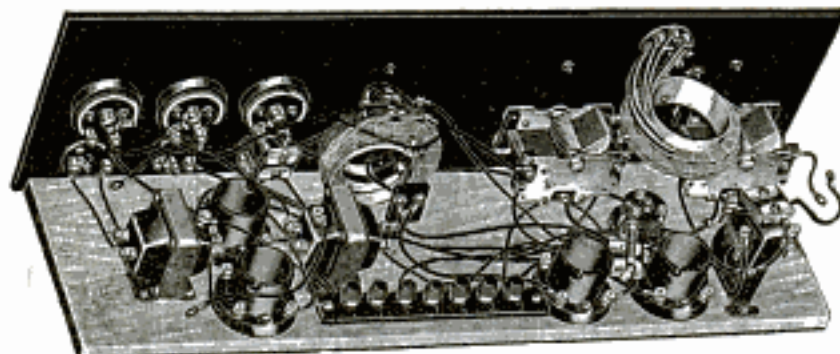

### SEE WHAT YOU GET—BEST QUALITY

All parts highest grade—advertised, well-known, reliable, dependable—fully guaranteed by manufacturers and ourselves. Look at these brands. You cannot get a better kit! Fine 7x34x5 mahogany finish cabinet, drilled and engraved Bakelite-Diflecto panel, five-ply laminated baseboard, Sylvania's Roberts' coils, 2 Hammarlund low loss variable condensers, 3 E-Z Teen vernier dials, Thordarson transformer, pair Modern push-pull transformers, 3 Percent rheostats, 4 Bell Bakelite low loss sockets, Jones Improved single-circuit jack, Jones Improved double-circuit jack, Cutler-Hammer inductance switch, Smilser filament switch, Electro-Grid leak, Milco grid condenser and mounting, 2 Milco fixed condensers, Ampex grid-densifier, 7 Aristocrat binding posts, binding post strip, complete set "No-Sod-er" connecting wires, hardware, blueprint and instruction sheets. You can assemble in only three hours or so. Satisfaction positively guaranteed or money back.

List price, \$64.69; our regular catalog price, \$48.58—Special price to Nov. 30, only \$43.58. ORDER DIRECT FROM THIS AD—ON APPROVAL—NO MONEY IN ADVANCE—SHIPPED SUBJECT TO EXAMINATION WHEN REQUESTED—WE PAY TRANSPORTATION—24-HOUR SHIPMENT—SATISFACTION OR MONEY BACK. Foreign customers will please remit with order and include enough for transportation and insurance which we don't pay.

Send for **BIG CATALOG—36 Pages—FREE**

Filled with big bargains in Kits, Parts and Accessories. Send today!

**RADIO SPECIALTY COMPANY, Kit Div. 163Z, 2455 Greenwich Street, NEW YORK**

Our New Method of Wiring—Perfectly Simple  
—No Radio Knowledge Needed

**"No-Sod-er"**  
MAKES SET-BUILDING EASY

No solder—No bare wires—No poor connections—No dissatisfaction. No tools needed except a common screw-driver and common pliers. All connections are made by the use of our flexible, insulated eyeletted connecting wire in place of bus bar or wire, and solder. And in a fraction of the time usually required when using the old fashioned way. And when the job is done it is neat and connections are tight.



**OLD TUBES MADE  
GOOD  
AS NEW**

An ideal  
Xmas gift—  
one that will  
be appreciated  
and kept.

**\$3<sup>65</sup>** This latest Laboratory product will recondition any old, run-down, even worthless tubes, as long as the filament still lights. Makes them good as new in few minutes' time. Cost but few cents more than new tubes! Simple, efficient, practical Big money-saver. Operates on either A. C. or D. C. 110-120 Volts. Model No. 20 for U V 201 A. (C 301 A. etc.) and all similar types. Model No. 10 for U V 199 (C 299, etc.) and all similar types. Bound to do the work on our

### Money-Back Guarantee

You cannot lose! Act quick on this special short-time introductory price—sent Postpaid with full directions on receipt of \$3.65. (\$3.85 in Canada and foreign count less.) Be sure to state Model No. wanted. Our guarantee refund price protects you. Send now.

**MACK LABORATORIES**

710 Cass St. CHICAGO, ILL.

**MACK RECONDITIONER**  
"THE CURE FOR RUN-DOWN TUBES"

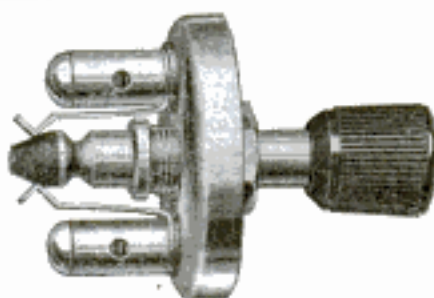

FROST-RADIO

## Improve your set with this switch

A FROST-RADIO No. 608 Push-Pull Battery Switch will greatly improve your set's appearance and its operation—save your batteries—lengthen the life of your tubes. Metal frame—bakelite knob—single hole mounting. Your dealer has No. 608 in stock. Ask for this neat, compact, dependable push-pull switch, and install it on your set.

List Price 30c **RMA** Pacific Coast Price slightly higher

**HERBERT H. FROST, Inc.**  
314 W. Superior St. CHICAGO  
New York Cleveland Kansas City Los Angeles



# Free to Motorists

on trial

Amazing New Auto Invention - the Marvelous WESCO - a Boon to Motorists!



## Makes Autos Run 60 Miles to a Gallon of Gasoline!

I don't care what mileage you are making—how many so called gas savers you have used. I know what the WESCO does. I want you to try it Free. Just try it, that's all I ask. It's the strongest argument I know. Auto owners all over the country report that it cuts their gas bill in half or less.

Many cars with this device attached have made from 40 to 60 miles on a gallon. It removes every particle of carbon from the



motor, increases power and pep, eliminates spark plug troubles and prevents overheating. Car owners everywhere marvel at the amazing new performance of their cars—the smoother running qualities, quicker pick-up and greater power on hills. Best of all this remarkable little device works automatically—is self regulating and can be easily attached without tapping or drilling by anyone in five minutes.

# I Pay You to Try It!

So sure am I that the WESCO will amaze and delight you, as it has thousands of others, I offer to send one for FREE TRIAL on your own car, entirely at my own risk and expense. The WESCO has been put to the most severe tests imaginable. It is giving daily satisfaction on thousands of cars throughout the country and on autos generally throughout the world. The world was waiting for WESCO. It has met with instantaneous success.

Owners report such tremendous mileage increases and such a wonderful reduction in gasoline consumed, that I have no hesitation in offering you one for your own car on Free trial. In

addition, I will guarantee to pay you should it fail. I take your word for it. I trust you implicitly. So confident am I of what the WESCO will do that I ask only an opportunity to prove it. I ask you to believe nothing. Just try it. I take all the risk. Send the coupon today. Put the WESCO on your car and try it thoroughly for ten days. Prove for yourself that all my claims are true. In the remote possibility that it should fail to satisfy you, simply return it and I will pay you for your trouble.

I could not make such an unheard-of offer unless absolutely confident of satisfactory results. I know what it will do. I mean what I say. Mail the coupon below for FREE proof today.

### AGENTS WANTED

**\$250.00 to \$600.00 a Month**

I want men and women in every locality to take care of the enormous demand for the WESCO. SURE QUICK PROFITS EVERY DAY. Nearly every owner buys on demonstration. Every satisfied customer sends you more. Enormous advertising campaign creating hundreds of new prospects daily. Be first in your territory to cash in on this big success. You can sell a whole delivery truck fleet as easily as one car owner. Merchants or farmers equip all cars, trucks and tractors with WESCO. Easy to install. SELLS LIKE HOT CAKES. Get a WESCO on your own car, start cashing in today. ACT NOW.

### Saves 1/2 on Gas Bills

**PAYS FOR ITSELF EVERY FEW DAYS**

Yes, that's what users report. They say it pays for itself nearly every day and keeps on giving perfect satisfaction month after month. I want you to prove its amazing performance on your own car. If you are not delighted in every way, if it has not lived up to every claim I make, remember, it costs you nothing. I will even pay you for trying it.

Auto owners the world over say my marvelous WESCO cuts their gasoline bills from one-third to one-half, and they wouldn't be without it. I am confident you, too, will be amazed and delighted. My FREE offer allows you to try it without risk on your part. It won't cost you one penny unless it does all and more than I claim. Sending the coupon costs you nothing. It obligates you in no way. Just fill out and mail at once. The wonders accomplished on your own car will convince you.

**SEND NO MONEY.** Simply mail me the coupon. Tell what car you want the WESCO for. Give name as well as yearly model. I have equipped thousands of cars satisfactorily to cut gasoline consumption, save time, trouble and money. I want to equip yours. I take all the risk. Just try WESCO and be convinced. Mail coupon today and begin saving on your gasoline bills. If you have some spare time learn how easy it is to make big money with this article.

**JIM MAY, President**  
**Western Specialty Co.**  
**162 May Building, Sioux Falls, S.D.**

### Sells Like Hot Cakes

**Sold 61 in 2 Days**

"I am sure your Wesco will sweep O. K.; have 61 orders in two days." M. L. ROCKETT, California.

**Sold 10 Before Noon**

"I have given the Wesco a good tryout and am well pleased with it." T. E. HARRINGTON, Louisiana.

**8 in One Day**

"I have sold eight today!" J. C. MURPHY, Georgia.

**It Sells Itself**

"You were right when you said the Wesco sells itself. I have placed every one I ordered. Your article will make me independent."

P. M. VONKARLOVITZ, Texas.

### MAIL COUPON TODAY

Mr. Jim May, Pres.  
 Western Specialty Co., 162 May Bldg.  
 Sioux Falls, South Dakota

Attention: JAS. A. MAY, President. I would like to try out a Wesco Gas Saver and Carbon Remover at your risk. If not satisfactory, after fair trial—I to be the sole judge—you will pay me for trying it out on my own car. Without obligation, send me information, telling me how I can get a Wesco Free and how I can become your agent and make big money selling Wesco Gas Savers and Carbon Removers.

PRINT NAME PLAINLY

Name.....  
 Name of Car..... Yearly Model.....  
 St. or R. F. D.....  
 Post Office.....  
 State.....

### Ends Carbon Trouble

The WESCO saves many dollars in annual repair bills. It saves the costs of carbon removing, prevents crank case dilution and fouling of front plug. Stop paying out good money to burn out carbon. Leave it to WESCO.

**60 Miles per Gallon**

"Tried a Wesco on a Ford and averaged 60 miles per gallon after removing the carbon."

BERNARD J. KOOP, North Carolina.

**Would Not Sell for \$50.00**

"I am getting about 42 miles on a gallon regularly with Wesco. Wouldn't take \$50.00 for it."

A. KISHALL, Ohio.



**STRONGFORT**  
The Perfect Man

health, cheerfulness and success. It will show you how to eliminate from your system, in a very short time, the distressing disorders which have made you feel yourself a misfit in the scheme of humanity; how to build up your body, strengthen ALL your vital organs, and you'll feel the thrill of new life coursing through your veins. It will teach you how to become FIT physically and mentally; fit for business, for society, for the home, a power among men, a pleasing personality to women. What I have done for others I can do for YOU. I GUARANTEE IT.

### Get My FREE Book—Don't Send One Cent

It's a startling revelation of undisputed facts about the human body that will open your eyes to new visions of life and happiness and success. It will show you how to eliminate from your system, in a very short time, the distressing disorders which have made you feel yourself a misfit in the scheme of humanity; how to build up your body, strengthen ALL your vital organs, and you'll feel the thrill of new life coursing through your veins. It will teach you how to become FIT physically and mentally; fit for business, for society, for the home, a power among men, a pleasing personality to women. What I have done for others I can do for YOU. I GUARANTEE IT.

Send for the Free Book Now. It's FREE. Fill out the coupon. Don't delay. SEND IT TODAY.

**LIONEL STRONGFORT** Physical and Health Specialist For Over 25 Years.

Dept. 84, NEWARK, NEW JERSEY, U. S. A.

**FREE CONSULTATION**

Mr. Lionel Strongfort, Dept. 84, Newark, N. J.

Please send me absolutely free your BOOK on the "Promotion and Conservation of Health, Strength and Mental Energy." I have marked (x) before the subjects in which I am most interested.

..... Colds	..... Increased	..... Weak Eyes
..... Catarrh	..... Height	..... Weak Heart
..... Asthma	..... Pimples	..... Poor Circulation
..... Hay Fever	..... Insomnia	..... Round Shoulders
..... Headache	..... Short Wind	..... Lung Troubles
..... Thinness	..... Constipation	..... Muscular Development
..... Rupture	..... Indigestion	..... Nervousness
..... Lumbago	..... Nervousness	..... Rheumatism
..... Flat Chest	..... Rheumatism	..... Great Strength

Name .....

Age.....Occupation .....

Street .....

City.....State.....



### BIG VALUE FOR 10 CTS.

6 songs, words and music; 25 Pictures Pretty Girls; 40 Ways to Make Money; 1 Joke Book; 1 Book on Love; 1 Magic Book; 1 Book Letter Writing; 1 Dream Book and Fortune Teller; 1 Cook Book; 1 Base Ball Book, gives rules for games; 1 Toy Maker Book; Language of Flowers; 1 Morse Telegraph Alphabet; 12 Chemical Experiments; Magic Ace Table; Great North Pole Game; 100 Conundrums; 3 Puzzles; 12 Games; 30 Verses for Autograph Albums. All the above by mail for 10 cents, and 2 cents postage.

ROYAL SALES CO., Desk 142, Norwalk, Conn.

### FLY

Young man learn aviation. Build this classy plane and learn to construct and operate aircraft. Use your motorcycle engine or our "Meteor" 20 h. p. motor. We furnish parts very reasonable to build this wonderful little "Meteorplane," the World's first successful motorcycle engine airplane. Send \$3.50 for complete set of blue prints and parts list of this latest Model M-T-2.

IRWIN AIRCRAFT CO.  
126 O Street, Sacramento, Cal.

## WRITE FOR THIS

Diamond and Sapphire Flexible Bracelet

\$15.50

Annual Catalog  
**K. BURNS & SON**  
DIAMOND IMPORTER & CUTTERS

LADIES SOLID GOLD DIAMOND RING

Genuine blue white diamond onyx ring. Perfect cut. 14K, white or green gold, richly carved and hand pierced. Special

\$4.95



When you buy from K. Burns & Son you buy direct from the importer and cutter, saving yourself 3 profits.

### Ladies' Diamond Ring



Fine full cut blue white diamond of rare brilliancy set in 14 K. white gold ring beautifully carved and pierced.....

\$9.50

### Love Bird Diamond Engagement Ring

Large Perfect cut diamond of rare brilliancy. 18 K. white gold Love Bird mounting. We will send this ring to you with the privilege of examination.....

\$48.00



### 14 K. Solid Gold Ladies' Wrist Watch



Jewel adjusted. Guaranteed dependable time-keeper. Platinum finished dial. Beautifully engraved design.

\$11.50

Blue sapphire crowned.....

### Diamond Mounted Bar-Pin

14 K. pure solid white gold of great beauty. Artistic Lace work design. Greatest value ever offered....

\$6.50



### Diamond and Sapphire Flexible Bracelet

Handsomely pierced lace work design. 14 K. solid white gold, platinum faced. Two oblong shape synthetic blue sapphires and a full cut genuine blue white diamond.....

\$15.50

Write today for our free catalog

**K. BURNS & SON**  
641 Broad Street NEWARK, N. J.



**9 BOOKS FOR 25 CENTS** Each book has 32 pages full of riddles, tricks, games, etc. This is a Special Introductory Offer. No stamps are used to it. Just send 25c. coin or stamps and the entire set will be sent to you, postage prepaid. This is all you pay. This is a SPECIAL OFFER and will be withdrawn when the first million sets are sold. Send your order in immediately, if you want to be the lucky owner of one of these sets. SHERWOOD & COMPANY, Publishers, 213 State St., Racine, Wisconsin



### RADIO RING

Made from your finger! This expensive ring with glittering many facet stones is a complete radio set. Guaranteed to bring in loads of clients whenever you see or mention back. Mail name address 50 cents in full payment to Mr. Poe, ROSS MERCHAND CORPORATION P. O. Box 307, Station 1, New York City

### ARE YOU SELF-CONSCIOUS? DO YOU STAMMER?

You must overcome Self-Consciousness—Mental Fear—Embarrassment to succeed in the business and social world. Send 10c for amazing booklet, "Road to Poise and Achievement." Tells how thousands have conquered Self-Consciousness in a very short time. SEYMOUR INSTITUTE, 56 W. 45th St., Dept. 1, New York City

**Build a Boat** Popular Mechanics Boat Book tells how to make 21 kinds of boats and canoes. Fully illustrated. You can build a boat any time of the year. Many do the building in winter. Price 50 cents. POPULAR MECHANICS PRESS, Popular Mechanics Bldg., Rm. 712, Chicago, Ill.

## Big Money This Winter

### FILE AND SET SAWS BY MACHINE

The Foley Automatic Saw Filer will give you a profitable business this winter. F. V. Mosher, 1121 Jefferson St., Waterloo, Iowa, writes:

"Your Filer and Setter arrived O. K. and I expect the first week's revenue to return the cost to me in full."

You can do the same. With a Foley Filer you can sharpen a saw in 5 minutes—perfectly. No experience necessary—makes you an expert filer.

Write for Free  
Circular  
about Foley  
Saw Tools

**FOLEY  
SAW TOOL  
COMPANY**

914 E. Lake St.  
Minneapolis,  
Minn.



## Make Your FORD a Closed Car

Limo weather-proof sections change your 1923-24-25 Ford Touring or Roadster into classy limousine-style closed car in a jiffy. Doors open from outside. Siding front panels for ventilation. Three-ply double covered veneer frames. Color matches your top; quickly installed. Guaranteed. Low priced. Write for prices.

**BUOB & SCHEU** P80 Webster Street, Cincinnati, O.

## Interlox

MASTER SLIDE RULE

Takes accurate inside or outside measurements

MASTER RULE MFG. CO., 841-43 E. 136th St., New York

Deniers and Agents: request attractive proposition

Works fast. Slides in and out quickly. Durable made of brass trimmed boxwood. Any length 2 to 8 feet, 20 cents per lineal foot. If not at dealer's, send postpaid.

## Bodies of Rare Beauty for Fords

At Factory Prices!

**\$22.75 and Up**

Write for Circular A-2 showing this Model and others.

**SPORT BODY WORKS**  
AURORA, ILL.



This model in grey prime, \$39.50

## \$9.95 RAINCOAT FREE

The Peter Falor Co., 31 Traders Bldg., Kansas City, Mo., is offering a \$9.95 Raincoat to men who will take orders. If you want one of these fine Raincoats, be sure to write them today.

**AGENTS WANTED**



## CRESCENT Wood Working Machines

are adapted for use wherever there is wood work to be done. Small machines for use on the bench, large machines for general factory use. Send today for circular of machines in which you are particularly interested. For the small shop, Bench Joister, Bench Saw Table No. 12, 20 inch Band Saw. For larger factories, Band Saws, Saw Tables, Shapers, Jointers, Variety Wood Worker, Planers, Planers and Matchers, Disk Grinders, Cut Off Table, Swing Saws, Boreers, Hollow Chisel Mortisers, Tenoners, Universal Wood Workers.

The Crescent Machine Co. 93 Columbia Street  
Lectonia, Ohio, U.S.A.



## Must Men Fear 40?

**M**EDICAL authorities agree that 65%, or nearly two-thirds, of all men past middle age, are afflicted with a disorder of the prostate gland. Here is the known cause for many of the ailments commonly ascribed to declining years—including aches in back, feet and legs, frequent nightly risings, sciatic pains, nervousness and lack of vitality. But now, science knows that thousands suffer needlessly.

For a well-known American scientist has discovered a remarkable new drugless hygiene that usually restores the prostate gland to its normal functioning. Already it has been used by more than 15,000 men—Doctors, Statesmen, Teachers, Bankers, Lawyers, men in every walk of life—with amazing results.

"I know too plainly the effects of prostate gland disorder when it is allowed to continue unabated," says the scientist mentioned above. "I know of the operations and the common saying among many that the average life after this operation is only two or three years. That is why I am doing everything possible to let people know of this important discovery."

## FREE BOOK

If you have prostate trouble, if you suffer with any of the ailments mentioned above, you should not lose a day in finding out about this wonderful new method.

If you will mail the coupon below you will get, in plain wrapper, a free copy of an interesting book describing this new method. It contains facts every man should know. But send immediately, for the edition of this book is limited; address .



**THE ELECTRO THERMAL COMPANY**  
2152 Main Street, Steubenville, Ohio

Please send me Free, and without obligation, a copy of your booklet, "Why Many Men Are Old at 40." Mail in plain wrapper.

Name.....

Address.....

City..... State.....

Western Office—Dept. 21-T, 711 Van Nuys Bldg., Los Angeles, Cal.

## Be a Boy Chemist with

REGISTERED TRADE MARK  
**CHEM-CRAFT**  
THE CHEMICAL OUTFIT

Have more fun than you've ever had before; make soap, ink, dyes and paints; test water, foods, soil and metals, and do lots of other wonderful chemical experiments. Astonish your friends with tricks of chemical magic; make magic inks and paper; experiment with chemical sorcery and produce many magical changes. Any boy who uses Chemcraft does better in his science studies, and knows more about chemistry than most people.

Chemcraft is the outfit for you. More and better experiments, more chemicals and apparatus, the best chemistry set on the market. Don't accept a substitute—insist on Chemcraft.

Five dandy outfits to choose from:—No. 0—**75c**; No. 1—**\$1.50**; No. 2—**\$2.50**; No. 3—**\$5.00**; and No. 4—**\$10.00**. Each complete with safe chemicals, apparatus and book of experiments. Sold in all toy departments, or sent prepaid upon receipt of price, if more convenient. (West of Denver, Colo. and in Canada, add 10%).

### Big Book Free!

Write at once for your copy of The Boy's Handbook of Chemistry; 150 pages of experiments, formulae, interesting chemical information, money making suggestions, and catalog of supplies.

The Porter  
Chemical Co.  
113 Washington St.  
Hagerstown, Md.



## This Tenor Banjo

WORTH  
**\$18**

Learn  
in 30  
Minutes

**FREE**



When you enroll we want to present you with one of these wonderful, delightful instruments. We want to help every music lover attain success. No musical knowledge is necessary. Learn in 30 minutes. Our picture method shows you, and you imitate. We start your popularity, success and fame by supplying you with a handsome instrument. Under personal supervision you will be given the benefit of Prof. Pitt's 22 years' experience as director of Glee and Instrumental clubs of New York University. We furnish photos of the professor along with phonograph records for each lesson, together with our printed and illustrated easy-to-read course. It is easy to learn. We guarantee to teach you.

### DON'T SEND A SINGLE CENT

Just drop us a line—telling you are interested in receiving full particulars, and to reserve one of our regular \$18.00 full size professional pit tenor banjos for you. Write now for free book and sample lesson.

N. Y. ACADEMY OF MUSIC

Studio 19X, 100-5th Avenue, New York, N. Y.

## MEN \$75 Every Week

### I Show You How



Hundreds earn amazing profits selling finest shirts ever offered at \$4.95 for three. You can make \$15 to \$15 every day making calls in garages, offices, factories, etc. They sell fast on sight.

**FREE Samples—Send Name** J. E. Harris earned \$40 in half an hour. Hundreds earn big incomes. Simply send name for FREE outfit. But act quick. Address: Charles H. Hoop, CINCINNATI, OHIO

FASHION WEAR SHIRT COMPANY Dept. 5-351

**Foot Pains** go in 5 minutes if you wear FAIRYFOOT CUSHIONS. Must help or no pay. Write to FOOT REMEDY CO., 22nd St. & Millard Ave., Dept. 28, Chicago, Ill.

## HIGH GRADE KNIFE \$1.00 "HIS" Christmas Gift

REPRESENTATIVE wanted to introduce novelty knives and razors. Permanent employment and exclusive territories. If you are earning less than \$1200 yearly let us show you how to make more.

INTRODUCTION OFFER. This full size knife, with any desired design, mailed for \$1. Name and address added for 25 cents extra. Every man or boy will appreciate this beautiful knife, blades of finest steel. Handles clear as glass and unbreakable. Length 3 1/4 inches. Every knife guaranteed perfect.

NOVELTY CUTLERY CO.  
667 Bar St., Canton, Ohio



## ONLY Read This Wonder Offer \$2.50

We challenge you to beat this. The famous Little Hustler Motor, with switch (runs on single dry cell) our No. 914 Emery and Buffing wheel 4 1/2" high, double pulley, finish nickel and gray, and spiral spring belt with three connectors, and 25c book "Electricity and Magnetism."



Regular Price, \$3.25  
Our price, **\$2.50**  
until Dec. 31,

Knapp Electric Corp.

Dept. 109  
Port Chester, N. Y.

## ADDING MACHINE VEST POCKET SIZE



ADDS  
SUBTRACTS  
MULTIPLIES  
DIVIDES

**\$2.50**

**NEW** Does Work of \$100 Machine. Total Visible at all Times.

**FREE TRIAL—Send No Money**

Anyone Can Operate It. Guaranteed for Life Just write "Send me a Baby Calculator" and give your name and address. We will ship it immediately, all charges prepaid. On delivery pay postman \$2.50. You can return it after 10-day trial for full refund if the Baby Calculator is not the greatest time and labor saver you ever used. This is the lowest priced practical calculating machine made. Order today. **BABY CALCULATOR SALES CO.** P. O. Box 1118, Dept. 9, Chicago, Illinois

### AGENTS

Every business firm, man or woman, will buy the Baby Calculator on sight. BIG COMMISSION.

## \$150 to \$300 MONTHLY PROFITS EASILY MADE WITH ONE DAY BATTERY CHARGING

Here's your **BIG CHANGE** to add \$1500 to \$3000 a year to your income. An HB One Day Battery Charger recharges auto and radio batteries in one day or less. Requires no expert attention. Thousands in use endorsed by leading battery makers. Just \$35 cash puts an HB One Day Battery Charging outfit in your shop, complete ready to operate. 30 days free trial on money back guarantee. Long easy terms on balance, more than paid by your big monthly battery charging profits. HB users everywhere making big money—you can, too. Write today for free bulletin.

**HOBART BROS. CO.** Box M-120 TROY, OHIO

**ONE DAY BATTERY CHARGING MAKES YOUR SHOP PAY PROFITS**



Fastest Cutting

Saws Fifteen Cords  
a Day!

Men—  
Let Me Send You My  
Greatest LOG SAW Offer!

ONLY  
\$39

Puts the OTTAWA  
Working for YOU!

It's easier now than ever before to own this fastest-cutting, easiest-moved, most powerful Log Saw. Now, you can make big money sawing firewood, stove-bolts, ice, shingle timber, etc. Write today for full details of this most wonderful offer. Know how easy it is to make big money sawing fifteen cords of wood a day with no hard work.

350 Saw Cuts a Minute—

nearly six each second. Just think of it—now you have a log—in a few seconds it's all sawed up into lengths you can use—without any hard work! The OTTAWA has balanced crank shaft, power force feed, friction clutch.

Make BIG MONEY—

Wood selling at \$3 a cord brings owner \$45 a day. Saw your own wood—go into the wood business. Don't let the lack of ready money stop you. Remember, we sell on very easy terms. More in use than all others combined.

"I average \$20 profit a day with my OTTAWA."—J. Schill, New York. "My OTTAWA has earned \$700 for me."—S. Grossman, Wisconsin. "I can make more money with the OTTAWA than by farming."—D. Gott, Missouri.

## OTTAWA 4.H.P. LOG SAW

30 Days to Try—one whole month to use the OTTAWA at your own sawing. Shipped on trial only—backed by 10-year guarantee. Prove to yourself how easy you can saw 15 cords or more a day—at a cost of 13¢ a cord.

To Save You Freight—and get your machine to you a few days after you order, I ship from: Ottawa, Kans.; Pittsburgh, Pa.; St. Paul, Minn.; Albany, N. Y.; Memphis, Tenn.; Indianapolis, Ind.; Pueblo, Colo.; Ft. Worth, Texas; Portland, Ore.; San Francisco, Cal.

Send me your name and address on postcard today, so I can send you my wonderful new edition of the "Wood Sawing Encyclopedia." Educational, instructive. Be sure to investigate—will help you to make big money.

**HARRY OVERMAN, Pres. OTTAWA MFG. CO.**

1742-P Wood St., Ottawa, Kans. Room 1742-P, Magee Bldg., Pittsburgh, Pa.

Wood  
Sawing  
Encyclo-  
pedia



## RED, BLACK, GREEN OR PURPLE New Unbreakable Fountain Pen

Sells for Only \$1.25

Agent's Sample 67 cents

Guaranteed 2 Years

Ideal Xmas Gift

Comes in Holly Boxes

\$5,000 a year easily made.  
We will show you how.

Latest  
Improved  
Point

Writes  
Like a \$7  
Pen

**FREE**

New and unusual Mail  
Order Distributing Plans and  
Large Wholesale Specialty Cata-  
log showing best sellers from all parts  
of the world. Money refunded if not pleased.

Mark Check and Fill Out at Once

**F. SPORS & CO., 350 Main St., Le Sueur Center, Minn.**

- Send Sample C.O.D. 67c, plus few cents postage.  
 Send 12 Assorted Colors C.O.D. \$6.42, plus few cents postage.  
 Send Catalogue, no obligation on my part.

Name \_\_\_\_\_

Address \_\_\_\_\_

## Own A Business Like This

**STUDY** the picture below. The wide-awake owner of this flourishing Harley-Davidson Motorcycle business built it up from scratch in a few years. He had no more to start with than you have.

If you are ambitious you can take over a Harley-Davidson franchise—perhaps in your home town—and handle all our local motorcycle business. We furnish you with leads and "tips", supply you with dealer helps, and assist you in closing sales. You profit handsomely on both sales and service. And you'll like the business.

Here is the opportunity to make some real money at last. Investigate it to the very bottom. Send us the coupon and get all the facts.

Harley-Davidson Motor Co.  
Dept. P Milwaukee, Wis.  
Show me how I can make some real money in the  
Motorcycle business. Also send me the free, interest-  
ing literature about your new models.

Name \_\_\_\_\_ State \_\_\_\_\_  
Address \_\_\_\_\_  
City \_\_\_\_\_



### Harley-Davidson The Motorcycle

## The Coil that is Built for a Circuit

Price: \$4.00

The B-T Torostyle is designed for a circuit,—the circuit the patented B-T "Counterphase" which employs the only efficient method of oscillation control. A set built with B-T Torostyles is equally efficient on all wave lengths.

Ask a B-T Dealer about the Torostyle,—"the toroid that's different."



B-T TOROSTYLE FOR EASY WIRING

### "The Best We Ever Tested"



2.2 to 1, \$5.00  
4.7 to 1, 5.75

Better Tuning, 80 pages of hook-ups and helps sent for 10c. Literature on B-T Products free.

says a leading laboratory. Superior tone quality is the outstanding feature of the B-T "Euphonic" audio transformer. Hear a set equipped with these transformers and you'll appreciate the better quality.

Case and brackets arranged to permit mounting in any position with terminals in proper position. This feature eliminates howling and distortion due to crossed or too close leads.

**BREMER-TULLY Mfg. Co.**  
532 S. Canal St. CHICAGO, ILL.

## Free Wonder Radio

hookup. You don't need to know anything about radio to build the best set known if you have our simple plans. Send stamped, addressed envelope for free diagram.

Songbird Transformer Works, 1507 West 58th St., Chicago



## Ready Reference for Roof Framing

Gives lengths of common, hip, valley and jack rafters and figures to use on the square for the following pitches:  $\frac{3}{4}$ ,  $\frac{1}{2}$ ,  $\frac{1}{4}$ ,  $\frac{1}{2}$ ,  $\frac{3}{4}$ ,  $\frac{1}{2}$ . Also octagon rafters for same pitches and scale for polygon cuts up to ten sides. Helpful, time-saving booklet for everyone to have. Price 50c. Money returned if not as represented.

E. OEHRLER 521 South 26th Ave., Omaha, Neb.



ONLY  
**\$37.50**  
Prepaid

## Get this KISMET 5-Tube Set at FACTORY PRICE!

An amazing bargain! This latest Kismet Receiver gives you a 5-tube T.R.F. circuit, wonderful for distance and volume. Genuine Bakelite insulation. New type straight line condensers. Beautiful sloping panel; two-tone walnut finish cabinet with battery compartments. A precision instrument in a masterpiece of cabinet-craft! You risk nothing!

Every set guaranteed free from mechanical defects—money refunded if set does not work. Sent to you prepaid, \$37.50. Send for complete Radio Catalogue. VAN-ASHE RADIO CO., 208 N. 10th St., ST. LOUIS, MO.

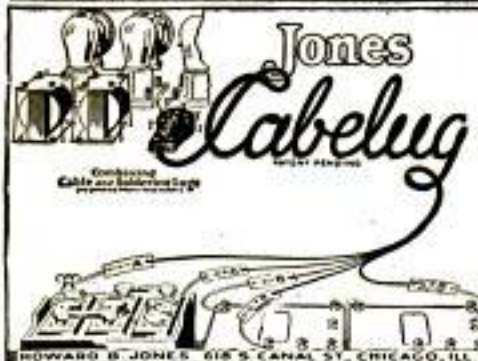

## Build Your Radio Right

with a 4 or 8 foot CODED CABLE Equipped with SOLDERING LUGS and anchor to hold cable. (No binding posts necessary.)

At your dealer or sent postpaid

**HOWARD B. JONES**

618 S. Canal Street

CHICAGO

4 Foot  
**\$1.00**

8 Foot, \$1.25

**\$200**  
**SELECTIVITY**  
 for  
**\$8.50!**

The Ferbend WAVE TRAP is not a "toy." Construction, material and workmanship equal to that of the finest receiving sets.



## Make Every Night Silent Night!

### TRAP OUT THE INTERFERENCE

Selectivity—which is merely the ability to cut out interference—is usually the dominating difference between very expensive sets and the moderately priced ones. Why pay \$50.00 to \$200.00 extra for increased selectivity, when for \$8.50 you can get a FERBEND WAVE TRAP which will tune out interfering stations, no matter how troublesome.

### Add a Ferbend Wave Trap to Your Set

You will find it a valuable addition. It is designed and manufactured complete by us, after years of careful experimenting. It is not to be confused with imitations hastily assembled from ordinary parts. The price is \$8.50. Shipment is made parcel post C. O. D. plus a few cents postage. If you prefer, you can send cash in full with order and we will ship postage prepaid. Send us your order today.

## FERBEND ELECTRIC COMPANY

415 W. Superior St.  
 CHICAGO

Descriptive Folder  
 on Request

FERBEND  
 Wave Trap

## RADIO DEALERS WANTED!

If you are the type of dealer who hustles after business, who isn't content to wait for trade to come in but who takes sets out to demonstrate, can talk and sell quality merchandise, and knows Radio values, we have a big proposition for you. Are you that dealer?

### 50% DISCOUNT TO DEALERS

We manufacture a complete line of high grade receivers and sell to dealers at 50% discount. We are distributors for more than 225 Nationally advertised lines.



**FREE** Write today for amazing offers, new 112-page catalog and regular monthly catalogs quoting below-the-market prices on latest merchandise—all free, Everything in Radio for less.

**AMERICAN RADIO MFG. CO.**  
 1416 McGee St. Kansas City, Mo.

Radio **The LIFELONG ONLY 4.95**



**CRYSTAL VARIOMETER RECEIVER**

Now you can have this genuine variometer tuned crystal receiver for only \$4.95 ready to hook up to any electric light socket. We guarantee, by following factory instructions, that you can listen in on stations from 1 to 30 miles away and hear perfectly. Why wait when you can have this amazing set now for only \$4.95? Or \$6.70 complete with ear phones. Send No Money. Just pay postman small C. O. D. Charges after approving this amazing Radio. Take no chances but send your order for the famous Lifelong Radio today on an absolute guarantee of success.

**THE LIFELONG RADIO COMPANY**  
 3787 East Avenue E. Cleveland, Ohio

## The Loud Speaker Sensation!



Design Patented

## The KODEL MICROPHONE LOUD SPEAKER

An exact replica of the transmitting microphone used in broadcasting stations.

The efficient KODEL SOUND UNIT, with an ingenious new snail-shell horn, mounted inside the microphone case, produces a remarkably clear, full-toned volume, with every note as rich and true as when it enters the transmitting microphone in the studio. Non-vibrating tone chamber absolutely eliminates distortion.

\$15 Model incorporates new Kodel, Jr. unit; with large Kodel unit, \$20. **\$15.00**

Radio dealers everywhere have them.

**THE KODEL RADIO CORP.**  
 517 E. Pearl St. Cincinnati, O.

Manufacturers of Kodel Radio Receivers and Accessories, and Homecharger Battery Chargers.

**WKRC**

Owners of Kodel Broadcasting Station WKRC. Send for program

# REX



**For your  
B battery  
eliminator**

**R**EX answers the eliminator problem. The B Battery eliminator equipped with Magnatron Rex tubes works day in and day out—silently and economically.

Magnatron Rex is the product of long research by the oldest exclusive manufacturers of thermionic valves in the country. It has been designed primarily and only for eliminator work.

Magnatron and Excellence have come to mean one and the same thing. Impartial laboratories and radio engineers throughout the country have certified this. Their reports explain why Magnatrons in your set will make it function better.

Your dealer has the Rex as well as the other Magnatrons. Ask him today! They list for only \$2.50.

Write for your **FREE** copy of "Pot Pourri—a snappy review of mirth and music," to Dept. P. M. CONNEWY ELECTRIC LABORATORIES, Magnatron Building, Hoboken, N. J.

West Coast supplied from complete stocks carried by Pacific Radio Laboratories, 256 So. Los Angeles St., Los Angeles, Calif.



# MAGNATRONS

## Diamonds Here at 60% of Market Price

Free Bulletin lists diamonds as low as \$60 per carat, also Gems of Finest Quality at higher per carat charges, but proportionately Low Bargain Prices. This 3/4 less 1-16 carat correctly cut diamond, a snappy blazer solitaire at \$68.50. This 75 year patent largest Diamond Banking Firm in all the world lends money on diamonds. Thousands of unpaid loans and other bargains. Many from big cash deals direct with European Diamond Cutters. Must sell NOW.

**WHY PAY FULL PRICES**

*Costs Nothing to See*

Any Diamond sent for absolutely free examination at our risk. No obligation. No cost to you. Latest Listings—Unpaid Loans. Sent Free. Describes Diamond Bargains in Detail, gives cash loan values guaranteed. Explains unlimited exchange privilege. Write Today for your copy of Diamond Bargain List. Postal card will do.

Jos. De Roy & Sons, 1939 De Roy Building  
Only Opposite Post Office Pittsburgh, Pa.



\$68.50  
3/4-1/16  
Carat  
Correctly  
Cut



Pioneers in the Radio Industry

### Collapsible Garment Hanger

big space-saver for crowded wardrobes and closets in homes, hotels and business places. Occupies no more space than one hook. Made of best of steel. Nothing to wear out, endorsed by all users. Makes a fine Xmas present. Now send \$1.00 for sample, oxidize finish. Satisfaction guaranteed or money back without question.

B. D. GAUSE MFG. COMPANY, ELKHART, IND.

## Mohawk Radio

5 TUBES—JUST ONE DIAL TO TUNE

## Palmolive Shaving Cream

"5 New Delights for Men"



Cabinet size, 30" high, 30" long, 15" wide. Panel sizes, 30" x 15" to 17" x 20". Price \$21.50  
Very neatly designed, without fasten, only held in place by support when open.

## RADIO CABINETS AT REMARKABLE PRICES FOR RADIO BUILDERS—FOR RADIO OWNERS

*Here is Just What You Have Been Looking for*

A real console type cabinet at a cost within reach of all. These cabinets are made of selected gumwood with 5-ply walnut veneer doors and top, of sturdy construction. Two-tone effect, with doors for battery compartment. All wires concealed. Just the cabinet for the Popular Mechanics Circuit as illustrated on pages 829-30-31-32, November issue.

Order Early for the Holidays

LOEB EQUIPMENT SUPPLY CO., 618-620-622 West Lake Street, CHICAGO



Cabinet size, 30" long, 14" wide, 30" high  
Price \$18.00  
Most practical cabinet made for batteries, etc. Walnut finish only.





## "That Musical Pal of Mine"

If you want to make this Christmas a Merry Christmas, ask old Santa to bring along a Hohner Harmonica — and "tune in" on happiness.

No other gift, regardless of price, offers greater possibilities for clean, wholesome fun, entertainment and musical training. With the aid of the New Instruction Book, containing charts, pictures and favorite musical selections, anyone can quickly learn to play a Hohner Harmonica.

Order a Hohner for every member of the family this Christmas and make the "joyful season" last the whole year 'round. If your dealer cannot supply you with the Free Instruction Book write M. Hohner, Inc., Dept. 181, 114 East 16th Street, New York.



## BIG BUSINESS OPPORTUNITY

ABOUT \$5000 ANNUAL INCOME ON EACH \$1000 INVESTED. Responsible Company offers new exclusive advertising proposition having unlimited possibilities. Opens a new and necessary field. Assures advertising at the selling point. PROTECTED TERRITORY. Experience unnecessary. NATIONAL KEI-LAC CO., 1868 Locust St., St. Louis, Mo.



## File Your Next Saw With a Plumb

And you will then know both ease and speed of filing.

Plumb Files are of special taper, perfectly cut with keen edges that stand up. The edge of a Saw File is the life of the File.

Three Files do all your work:

The 5½" for fine Saws 10 to 12 point where a short stroke is all you can use.

The 7" is designed for a long sweeping stroke. Use this on your 6 to 10 pt. Saws.

The 8" is for your largest Saws. Use with a rigid stroke.

Plumb design, steel, cutting and temper solve your filing troubles. Try your hardware dealer. If he does not have them send 75c (stamps will do) and we will mail you all three Files at once.

Fayette R. Plumb, Inc.  
4821 James St., Philadelphia



# We'll Allow You \$20 on your Old Radio Set Whether 1-2-5 Tube or Crystal Set

Now you can get a real Radio Set with an allowance of \$20 on any old set you have, even a crystal set. We offer this allowance on our 5 Tube Henderson set only, to introduce this wonderful "Master of the Air." Fully Guaranteed in every way and your money back if not perfectly satisfied after 10 days' trial.



**5 Tube  
Henderson**  
Coast to Coast  
Very Selective

Beautiful Mahogany Cabinet. For Clear Tone—Simplicity of Operation—Selectivity and Distance it masters the air. In big demand. Supply Limited. Regular \$100 value. Our price \$85 with \$20 allowance you pay. **NET \$65.00**

This includes A and 2 B Batteries—Load Speaker—Plug—5 Guaranteed Tubes—Aerial—Insulators—ground wire and clamp.

**CLARATONE  
SPECIAL**  
5 Tube Tuned  
Radio Frequency



A Beautiful Model—Famous in Chicago for its simplicity of operation and volume. A coast to coast set of high quality. Special price complete, including all accessories. **\$59.00**



**Amerex Improved  
5 Tube Radio Set**

The Biggest 5 Tube Value on the market today! Regular Value \$30. Beautiful hardwood cabinet of latest design, fancy panel and quality condensers, coils and sockets. **\$25.79**

etc. Large production permits our low price of.....

**Head Phones**

Guaranteed in every way. Regular \$5.00 value—our price only..... **\$1.89**



**GENUINE  
WONDER  
TUBES**

Guaranteed. Will replace free for any defects if tube still lights. U. V.-199 or B 201A type. Each..... **90c**



**Storage Battery**  
100 Hour 6 Volt in Rubber Case, with Handle. Fully charged and guaranteed 2 years. **\$10.75**  
Special Price.



**QUALITY "B"  
BATTERIES**  
Nationally Advertised Battery. Gives longer service, produces new life in set. 45 Volt Flat..... **\$2.62**  
22 Volt..... **\$1.40**



**Loud  
Speaker**  
Airline \$6.49  
Wonders \$3.75

Rich black finish with adjustable unit.

**ORDER DIRECT from This Adv.**

Save 50%—Our guarantee covers every item and protects you. Money refunded if not satisfied. Write order plainly. Send money order or bank draft for 1/4 of total order, pay balance on delivery plus shipping charge.  
References—Any bank or Commercial Agency—  
Foreman National Bank—Chicago.

**Warshawsky & Company, Inc.**  
1915-31 S. State St. Dept. PM13 CHICAGO

**SM**  
**Silver  
Six**



**HERE IS  
THE SET YOU WANT**

Designed by McMurdo Silver, Assoc. I. R. E. It is unsurpassed for Selectivity and Sensitivity—operates on either a loop or antenna. Ease of control allows the use of one, two or three dials as desired. The "SIX" will out perform anything except a laboratory-built super-heterodyne. You can assemble this new receiver yourself, in just a few hours using only the parts supplied in the kit.

**Send 50c**  
for complete  
building  
instructions on  
the Silver Six.



*It's easy to Build*

**FREE** Complete description of McMurdo Silver's latest circuit designs. Write today!

**SILVER-MARSHALL, Inc.**  
112 S. Wabash Ave., CHICAGO

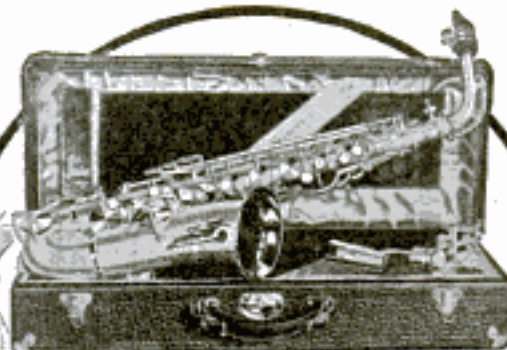

**"KING" Saxophones**

Built Acoustically Correct

**KING** Saxophones and Band Instruments are built to the most exacting standards in the industry. Every instrument is true to pitch, easy to play and has a beautiful quality of tone.

Free Trial—Easy Payments

You can have 10 days free trial to prove to your own satisfaction that a "King" is all that is claimed—and easy payments are extended in purchasing. Other instruments are accepted as part payment.

Send for Catalog. The New King Catalog will tell you how "Kings" are built, explain the various exclusive features which make "Kings" the finest instruments you can obtain.

**THE H. N. WHITE CO.**  
5211-70 Superior Ave. Cleveland, Ohio

**THE H. N. WHITE CO.**  
5211-70 Superior Ave., Cleveland, Ohio

Kindly send me free without obligation your latest catalog on \_\_\_\_\_ (Instrument)

Name \_\_\_\_\_  
Address \_\_\_\_\_  
City \_\_\_\_\_ State \_\_\_\_\_

**\$351.00**

**Cleared  
in one day  
(Aug. 1925)  
by W.H. Adams  
Dayton, Ohio**

V. A. Marini, Santa Cruz, Cal. (Nov. 1924) reports \$11,275 sales in 3 months. J. Gordon of New Jersey says \$4000 profit in two months. Alexander of Penn. \$3000 profit in four months. Ira Shook, Flint \$365 in one day. Bram, bought one outfit then 10 more within a year. Patillo, Ocala, writes: "Crispettes all you claim and then some." John W. Culp, South Carolina, writes, "Everything going lovely. Wrappers lying all over. It's a good old world after all." Perrin, \$380 in 1 day. Mrs. Lane, Pittsburgh, 8000 packages in

one day. J. R. Bert, Ala. "only thing I ever bought that equaled advertisement."



## WE'LL START YOU IN BUSINESS

Furnish secret formulas, raw material, and equipment. Very little capital required; no experience needed.

## Build Paying Business of Your Own

No limit to the sale of Crispettes. Everybody likes them. It's a delicious food confection made with or without sugar. Write me for facts about a business that will make you independent. Start now, in your own town.

## Profits \$1,000 a Month Easily Possible

Send postal for illustrated book of facts. In contains enthusiastic letters from others—shows their places of business, tells how and when to start, and all information needed. Free. Write now!

### LONG-EAKINS COMPANY

1228 High Street

Springfield, Ohio

## THE WOTEN, GASOLINE ENGINE

2 CYCLE, 3-PORT

Aircooled and Watercooled. Nearly One-Half H. P. in five pounds. Handiest little engine ever made. Ideal wherever power is needed. Complete line of small gasoline and steam engines, dynamos, motors, batteries, battery chargers, etc. CATALOGUE FREE.

### DYNAMIC MANUFACTURING CO.

First Nat'l Bank Bldg., Dept. 6 Chicago

## TOSTWICH

THE GREATEST  
PROFIT-MAKER

The Tostwich brings amazingly big profits and sales wherever installed—a patented process—makes sandwiches taste 100% better than ever before. Full information without obligation to you—write today.

THE TOSTWICH CORPORATION  
Dept. 1778, 846 No. Michigan Ave., Chicago.

## AUTO BODIES—RADIO SETS

SEND FOR THE INTERNATIONAL CATALOG, our net price 1926. Full line of RADIO SETS; and auto bodies for Fords at Wholesale Prices. Save big money by buying Direct from Factory.

INTERNATIONAL BODY WORKS, 914 W. Ohio St., Dept. 7, CHICAGO, ILL.

## The De Luxe

The Machine That Cheats the Printer

Price \$12.50 Big Profits

Here it is, boys! Look it over. The selling Wonder of the Century. Handle a live one and climb the ladder of success. The machine pays for itself faster and over each year. It prints the merchant's "ad" automatically on roll wrapping paper in one or two colors as you pull the paper. Guaranteed for five years. \$25.00 per day easy. Write for proof today.

Woodworkers Mfg. Co., Racine Ave. & Cortland St., Chicago.



# LOOK! FOR ONLY \$1 DOWN YOU CAN SECURE AT ONCE ANY BEAUTIFUL GIFT!

**SURPRISE** and delight your loved one with a really beautiful gift! A dollar's all you need at Bales! Send a dollar—mention gift desired. That's all! Prompt shipment made. Charges prepaid, under our MONEY BACK GUARANTEE! If fully satisfied pay balance NEXT YEAR 10% monthly, TEN FULL MONTHS TO PAY! ORDER NOW. AVOID THE LAST MINUTE RUSH.



X80—Gorgeous 18Kt. white gold dinner ring. Three fine blue-white diamonds, two blue sapphires. \$48.50  
\$1 down; \$4.75 monthly



X81—14Kt. white gold ladies' solitaire. White gold prongs. Specially selected fine quality blue-white diamond. Only \$65.00  
\$1 down; \$6.40 monthly



X82—New design ring, 18Kt. white gold. Two square cut blue sapphires; large, fine quality diamond in center. \$57.50  
\$1 down; \$5.65 monthly



X83—18Kt. white gold pierced and engraved ring. Cluster seven fiery brilliant genuine diamonds platinum set. \$52.50  
\$1 down; \$5.15 monthly



X84—This wrist watch—double jewel for value! Solid white gold case set with four fine genuine diamonds, two specially cut blue sapphires. Blue sapphire winding stem—silk grain ribbon. Wonderfully accurate 15-jewel guaranteed movement. \$42.50. \$1 down; \$4.15 monthly



X85—Delicately pierced and engraved ring of 18Kt. white gold, fine quality blue-white diamond. Only \$37.50  
\$1 down; \$3.65 monthly



X86—Massive gentleman's belcher cluster, 14Kt. solid gold. Seven fine accurately cut genuine diamonds, platinum set. \$55.00. \$1 down; \$5.40 monthly



X87—Genuine gold ring exquisitely pierced and engraved. Fine quality blue-white diamond; two blue sapphires. \$49.50  
\$1 down; \$4.85 monthly

**FREE CATALOG**—If the gift you have in mind isn't in this "ad," send AT ONCE for complete catalog illustrating in natural colors most complete assortment of Diamonds, Rings, Watches, Silverware, etc., in America! Our prices as Direct Diamond Importers and wholesale jewelers defy comparison. **MOST LIBERAL TERMS EVER OFFERED! ALX FOR CATALOG NO.**



X88—18Kt. gold white gold only 18Kt. Genuine onyx and genuine fine diamond set in white gold. Only \$26.50  
\$1 down; \$2.50 monthly

## O. F. BALE & CO.

ESTABLISHED 1888

21-40 Maiden Lane, New York

Please Mention Popular Mechanics

Copyrighted material

# Big 3 ft. Telescope

Has unusually powerful lenses—magnifying over 8 times. Makes people and objects miles away seem close. Brings new pleasures to home, farm, camp, travel sport. See moon and stars as never before. New Ferry "Wonder" telescope has 5 sections—opens out over 8 ft. long, measures 12 inches closed. Big, strong and powerful yet light, compact, easy to carry. Body and draws fully brass bound with smoothed edges. Body covered with black leatherette, draws made of special, smooth, English fibre, easy to slide in and out. Brass safety caps at each end to keep out dust. Powerful lenses are special clear achromatic European optical glass.

## Free

**YES ABSOLUTELY FREE!** Handsome leatherette covered Carrying Case light, strong, complete with strap. Case is 12 in. long, 2 1/2 in. in diameter. Protects from dust and damage. Handy for farmers, auto tourists and hikers.

3 ft. long open  
12 in. long closed  
FIVE SECTIONS  
8-power Lenses

Read These Letters

Thousands of Delighted Users

"I am delighted with the 'Wonder' telescope. Today I have been watching submarines 3 miles off the coast."

—Philip Brush "I can see across the Mississippi 3 miles and see people fishing."

—M. L. Thorn. "I am nearly 80 years old and if I could not get another would not take \$10.00 for it."

—A. R. Walker "I can tell time on the church clock 5 miles away."

—Edward Foster. "Could tell color of aeroplane 4 miles away."

—Mrs. L. M. Yarbrough. "I saw a Light House 18 miles away."

—Clyde Scribner. "Can see men working 7 miles away."

—S. M. Gearhart. "I could see windmill more than 4 miles away."

—Raymond Goswami.

## Send No Money

Sign and mail coupon below and Ferry Wonder 3 ft. Telescope with free Carrying Case will come by return mail. Pay postman special bargain price of \$1.85 plus few cents postage. Satisfaction guaranteed or your money back. Send coupon today!

FERRY & CO., Chicago, Ill.

Ferry & Co., Dept. 1779  
3224 N. Halsted St.,  
Chicago, Ill.

Send me 3 ft. Ferry Wonder Telescope and Free Carrying Case. I will pay postman \$1.85 plus postage on arrival. If I am not satisfied you will refund my money.

Name \_\_\_\_\_

Address \_\_\_\_\_

City \_\_\_\_\_ State \_\_\_\_\_

Catalog of Things You Want Sent Free

## Preferred by Experts Best for Handy Men

Trying to nurse along an old style Blotorch on present-day, low-grade fuels is a discouraging task. You'll appreciate the ready performance and hot flame of the Turner No. 45. The Turner patented Super-heating Burner Baffle and heater plug was specially designed to gasify present-day gasoline or kerosene.

### TURNER BLTORCH

Safe as a Candle

Absolutely safe; it can't explode. The patented Automatic Safety Valve prevents bursting pressure. The patented Twin Needle Control obviates enlarged orifice, a trouble that often renders the ordinary blotorch useless. The patented, seamless, solderless, leakproof Brass Tank has but one opening and that above fuel line—no leaks from soldered connections. The Pistol Grip fits any hand comfortably. Only a Turner has these features.

Fearlessly Guaranteed.

Order from your dealer or write us direct, \$8.25 postpaid.

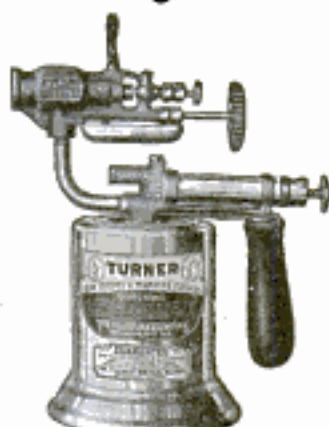

No. 45 — 1 Quart

\$8.25

Postpaid

THE TURNER BRASSWORKS  
Industry Ave. Sycamore, Ill.

The World's Largest, Exclusive Manufacturers of Bltorches, Firepots and Brazers

## Milwaukee Inventor Explains 10c per Gal. Gasoline Offer

"Running a light car with my Vitalizer is equivalent to buying gas at 10c a gallon," says the Milwaukee inventor who guarantees most astonishing results from the use of his remarkable device. Not only more mileage, but increased power and quicker "pickup," are guaranteed to any Ford or Chevrolet owner who wishes to try a sample free for ten days. Just send your name and make of car to the Motor Vitalizer Co., 540 Van Buren St., Dept. 13-59, Milwaukee, Wis. Send no money. Pay no C.O.D. Promise nothing except to try it. Write at once.



## SALESMEN WANTED

We want twenty-five men who are calling on Ford dealers, filling stations, accessory stores and garages to sell patented radiator caps and gasoline tank caps on com-

mission. These articles are new, well advertised and our men are making good money.

State territory covered

CRARY PRODUCTS CORPORATION  
1638-C4 Penobscot Bldg. DETROIT, MICHIGAN



SILENT  
MODEL No. 8

\$1

A WEEK  
AND IT'S  
YOURS

WORLD'S ONLY BALL-BEARING TYPEWRITER

## 10 DAYS FREE TRIAL

*Remarkable New Special Low Price Offer*

SEND NO MONEY.  
NO RED TAPE.  
NO OBLIGATION  
WHATSOEVER

EVERYONE should own a good typewriter. To command attention your letters must be typewritten. No matter what your business is you need a dependable typewriter. It is the best investment you can possibly make. The Ball Bearing L. C. Smith is the finest typewriter ever made—used by such nationally known corporations as Standard Oil Co., Du Pont Powder and the largest railroads. The U. S. Government has bought over 50,000 of these wonderful ball-bearing typewriters. *Our Special Offer* Now Makes it Possible For Everyone to Own one of these long-wearing, ball bearing machines. Never before has such a remarkable offer been made on the genuine Silent Ball Bearing Model No. 8 L. C. Smith. The world's finest typewriter for over twenty years. *Now is the time if you want one*—we may never be able to make this offer again though *we are the world's largest exclusive dealers in L. C. Smith Typewriters.*

### 10 DAYS' FREE TRIAL!

Don't send us a penny—just mail the coupon. We will promptly ship the typewriter to you for *ten days' free trial*. We depend entirely upon the typewriter to sell itself—no one will urge you to buy. If you don't think it is the finest typewriter you ever saw and the fastest and easiest running machine you ever used—*return it at our expense* and we will be quite satisfied. You won't want to part with it. We ask you to deposit \$3. with your express agent to be sent to us *after ten days* as a first payment. *The express agent will return your \$3. to you if for any reason you return the typewriter to him within ten days.* If you decide to keep it you send us *only a dollar a week* until the balance of our special low price is paid.

### A LIFETIME BARGAIN

We offer you the lowest price ever made on this wonderful machine—late style—up-to-date—highest quality rebuilt—with a five year guarantee. You cannot buy a typewriter at anywhere near our price that will give you as many years of satisfactory service.

### FREE TO YOU NOW!

*A Complete Course of Lessons on Touch Typewriting; Tools; and Waterproof Cover; Complete Operating Instructions;* all given with your machine. This is the easiest typewriter to operate and learn. You can learn to use it in a day with our instructions.

Send the coupon now before this offer is withdrawn.

**SMITH TYPEWRITER SALES CORP.**  
11c-360 E. Grand Ave., Chicago, Ill.

**Smith Typewriter Sales Corp.**  
11c-360 E. Grand Ave., Chicago, Ill.

Ship me the L. C. Smith Typewriter. I will deposit \$3 with the express agent on arrival subject to 10 days' trial. If I keep it I will send you \$1 a week until the \$63.20 balance of the special \$66.20 price is paid. The title to remain in you until then. It is understood that I have 10 days in which to examine and try the typewriter. If I choose not to keep it, I will repack and return it to the express agent. You are to give your standard 5-year guarantee.

Name.....  
Address.....  
Occupation.....  
Employed by.....

FREE TRIAL COUPON →

Sent On  
**FREE**  
TRIAL  
NO MONEY  
DOWN

**Just Name and Address  
Brings You This Liberal Offer.**

**D**ON'T send a penny! Your name and address brings to your home this wonderful New Model Aladdin Lamp for ten days FREE Trial absolutely at our risk. Amazingly powerful, steady, white light from common kerosene (coal-oil); no odor, no noise, smoke or spattering. Simple, safe, clean, easy to handle; no pumping up, no pressure.

**BEATS ELECTRIC OR GAS — Burns 50 Hours on One Gallon**

**Think of It!** This wonderful new Aladdin light beats electricity or gas at a fraction of a cent an hour. Tests by U. S. Government and 35 leading universities show Aladdin light is ten times as strong as light from ordinary kerosene lamps. Five times as efficient as the best round wick open flame kerosene lamp. Soon saves its cost. Light nearest to sunlight of all artificial lights. Over seven million satisfied users. Your simple request brings you full particulars of our liberal 10 day Free trial offer, and how you can secure one without cost. Write Quick.



**Agents Wanted!**

**Make \$200 to \$500 a Month**

Become our distributor for this light that sells on sight. Needed and wanted everywhere. Big waiting demand. No capital or experience necessary. Get details quick of this most unusual big-money opportunity for either men or women—spare or full time.

**Get Your's  
FREE**

**MANTLE LAMP CO., 300 Aladdin Bldg., Chicago, Illinois**

*Largest Kerosene (coal-oil) Mantle Lamp House in the World.*

Cal. 30



**U. S. ARMY KRAG CARBINES**

All carbines have the new model 1898 stocks. The barrels, actions and parts are either new or have been refinished by the Government, and equal to new **\$15**

**W. STOKES KIRK** New — in sizes from 32 waist to 40 waist. Strong light weight wool. Made for the Home Guards **\$1.50** Parcel Post Extra  
SEND 10 CENTS FOR OUR NEW CATALOG  
1627-PM North 10th Street, PHILADELPHIA, PA.



**WADE  
BENCH  
LATHE**

**AMATEUR MECHANICS, REPAIR SHOPS, INVENTORS, STUDENTS**

A real machine tool for the home work bench—capacity 4" dia. x 12" length. For Metal—Wood—Composition Materials—Turning—Facing—Boring—Drilling—Welding—Tapped—Cutting. Accurate—Strong—Quiet—Compact. 500-cm has travel entire length of bed. Lead screw inside bed. No. 1 Lathe, plain headstock, \$28.00. No. 2 Lathe, back-gear headstock, \$38.00. Complete line of accessories at equally low prices. Write for free catalog—just out.

**THE GEROLD CO., Dept. P-17, 120 Liberty St., New York**

**Winter's Biggest Money Maker** — start a profitable business of your own — Only \$16.50 monthly pays for your complete One Day Battery Charging equipment.

**\$150 to \$300 Profit Monthly from One Day Battery Charging**

No special experience necessary to operate — Successful Manufacturers since 1893  
Write for full particulars — No obligation — **HOBART BROS. COMPANY**  
More HB's are in use than any other make. Box M 12 Troy, Ohio.



**\$35** Complete Outfit as illustrated



Delivery Paid East of the Mississippi

**\$38** Delivery Paid West of Miss.

**MECHANICS  
BENCH SAW**

With this saw you can make your own repairs in shop, home, farm or garage. Makes a clean edge on the toughest wood—no planing necessary. Rips, cross-cuts, bevvels, miters, mortises, tenons, or grooves. Attach to any lamp socket. Weight only 61 lbs. Will cut up to 1 1/4" All metal. Saw size 6 in. Table 10x13, base 7x11 height 7 in. Table tilts for bevveling 5 degrees left 10 degrees right.

**Saw Table** Can be purchased with 6-inch saw for **\$22.50**  
Delivery paid East of Mississippi.  
**\$24.50** Delivery paid West of Mississippi.

**Motor** This heavy duty motor can be furnished separately for delivery paid East of Mississippi. **\$12.90** Delivery paid West of Mississippi. Complete with Cord, Plug and flat or grooved Pulley. Guaranteed 50% Overload. Special Prices on Quantities of 10 or Over.

**PAUL J. DEVITT, 1101-1107 So. 2nd St., Phila., Pa.**

**WRITE FOR OUR NET PRICE BUILDERS' HARDWARE CATALOG**

*The slow 2-ampere battery charger is as obsolete today as the old "one-lunger" of 1903*

*Buy nothing but an up-to-date 5-ampere charger!*

*The New Improved*  
**5 AMP. A & B**  
**GOLD SEAL**  
**HOMCHARGER**  
**\$19.50**



Over 500,000 already in use

**Charges 150% Faster!**

**Better Because:—**

New micrometer adjustment, hinged lid, and carrying handle.

No bulbs to buy or break.

Can be used anywhere—contains no acids or other harmful liquids to spill.

Approved by underwriters—trouble-proof, shock-proof and fireproof.

Beautiful cabinet in maroon and gold.

**Free** Write for new edition of our instructive booklet on radio operation "The Secret of Distance and Volume in Radio."

It takes only one-third as long to charge a battery with the New Improved GOLD SEAL HOMCHARGER. The big, healthy 5-ampere charging rate does away with the long bothersome waits that were necessary when the obsolete slow 2-ampere charger was the best that radio offered.

The New Improved GOLD SEAL HOMCHARGER charges 150% faster—will charge your battery overnight! And it charges both A and B batteries without additional equipment.

Don't let anybody sell you a slow 2-ampere charger—they are obsolete—out-of-date. You need a modern charger with a full 5-ampere rate. Insist on the GOLD SEAL HOMCHARGER.

**The Kodel Radio Corporation**  
 517 East Pearl Street Cincinnati, Ohio

**WKRC**

Owners of Kodel Broadcasting Station WKRC on the Alms Hotel. Send for program.



*Adjusted to Temperature  
Adjusted to Isochronism  
Adjusted to Positions  
Adjusted to the Second  
21 Ruby and Sapphire Jewels*



## WONDERFUL QUALITY AND STYLE

Whether you want a lady's watch so small and dainty it becomes a piece of jewelry, or whether you want a watch made strong, sturdy and dust-proof for

miners, loggers and cement mill workers, you will find it in the new Burlington catalogue—and at a remarkably low price, considering QUALITY.

## 21 JEWEL BURLINGTON

Yes, every Burlington watch for men has 21 jewels. The Burlington quality is exactly the same in the heavy service watch as it is in the very thin aristocratic model. Superior quality distinguishes the Burlington. We are proud of this distinction. Every owner is equally proud of it.

**Burlington Watch Co. Dept. 13-59**  
19th and Marshall Blvd., Chicago, Ill.  
Canada: 62 Albert St., Winnipeg

Please send me your new watch catalogue and prices, also your special \$1.00 down offer.

Name \_\_\_\_\_

Address \_\_\_\_\_

## SPECIAL OFFER

Burlington quality has made it possible for us to sell you a high-grade watch for \$1.00 down and the balance in small monthly payments. Do not buy before you see our new catalog and read our special offer. Write for it today.





# 60 MILES ON A GALLON OF GASOLINE

## TESTS SHOW FORD CAN RUN 60 MILES ON A GALLON

The amazing fact that a Ford can run 60 miles on 1 gallon of gasoline was recently brought to light through tests conducted by America's foremost engineers, where it was shown that a gallon of gasoline contains sufficient heat units which if properly atomized and mixed with air would give this additional mileage. Great strides have already been made in this direction by the recent invention of a simple attachment which can be installed in a few minutes without any alterations to the motor. It is common for Ford Owners to make from 40 to 44 miles per gallon after this marvelous device is attached.

## MOST WONDERFUL INVENTION TODAY BRINGS JOY TO FORD OWNERS

### Starts Ford Instantly

Starting a Ford Car in cold or zero weather is something every Ford Owner dreads—everybody realizes that difficult starting is an abuse on the starter and battery. Thousands of Ford Cars are "laid up" during the Winter just for these reasons. This great difficulty has been overcome. The SUPER positively starts a Ford Car instantly in the coldest weather.

### Marvelous Device

The SUPER is no trick affair—requires no mechanical adjustments and contains all the scientific principles of carburetors costing \$20 to \$35 and in its natural action uses up every particle of unused gasoline and breaks it up into a perfect vapor. The hitherto impossible is now realized by the SUPER.

### Everybody Satisfied

#### Saves 3 to 7 Dollars Per Month

The best investment I ever made. The SUPER is saving me from three to seven dollars each month, besides putting new life into my motor.

A. H. WORRA, Iowa.

#### Makes 44 Miles Per Gallon

I have tried the SUPER and the results of the experiment are satisfactory. One quart of gasoline run my Ford 11 miles over improved roads which is just about again as far as I could run with the plain Ford Carburetor.

G. E. YODER, Penn.

#### Finds That Our Claims Are Correct

I find that your claims for increased mileage are correct and that a big saving is made by your SUPER. In fact, the best device I have met with in that line.

M. J. VAN LEEUWEN, Mass.



The Heart of the Motor

### Eliminates Oil Pumping in Front Cylinder

What a wonderful relief to Mr. Ford Owner when he realizes that he can run his car without the motor pumping oil in the front cylinder. Sounds like an awful lot to expect of any device, but that is what the SUPER does and this is only one of its many advantages because it puts real efficiency into any Ford Car.

### Complete Combustion

The SUPER is so designed that it takes advantage of the present Ford Carburetor and properly atomizes the light as well as the heavy elements of the fuel, converting every atom of gasoline and kerosene into power preventing liquid fuel from passing into the cylinders, thus avoiding carbon formation and oil dilution.

### Easy to Sell

#### Sells Like Hot Cakes

This is a recent letter from one of our distributors: "Enclosed find draft for 200 more SUPERS, rush as I need them badly. I sold and banked \$104.00 in one day. Hope to sell 1000 SUPERS next month."

A. W. LEONARD, Penn.

#### Making Big Profits Every Noon

I have been working the SUPER at noon only. Yesterday noon I made more money with the SUPER than I did at my 11 hours' hard work in the factory all day.

J. L. LEHNER, Wis.

#### Had No Previous Selling Experience

This letter shows what ambition does: "I sold six SUPERS in less than 2 hours tonight. I think it's a pretty good start—for it's the first thing I ever sold."

E. MANGOLD, Ind.

## \$60.00 TO \$150.00 PER WEEK EASY

You just can't help making Big Money selling the SUPER because a trial sells itself and soon everyone in the neighborhood get talking about this marvelous device. Men like Leonard, Shaw, Manner, Kinsley, Peters, Sands, Beck and Hall are not exceptional salesmen, but just the type of men that saw an opportunity and were quick to grasp it when within reach. No previous selling experience is necessary, just a little ambition on your part to make money is all we ask and we will extend the same opportunity to you. Spare time will pay you well. If you can devote your entire time so much the better, because the SUPER is a whirl-wind seller and takes hold in a locality like wildfire.

### Men Wanted Everywhere To Introduce

We want distributors in all parts of the country to take orders and deliver the SUPER and to look after the repeat business that is bound to follow and to such distributors we are willing to assign territory. You do not have to own a Ford to take up this proposition but if you have a Ford it is easier to explain its many advantages. However a Trial of the SUPER convinces the most doubtful person and tells a wonderful story.

### A REAL FUTURE HERE

**WEEKS SUPER CARBURETOR CO.**

426-1592 Eleventh St., Milwaukee, Wis.

**MAIL TODAY**  
**WEEKS SUPER CARBURETOR CO.**  
 426-1592 Eleventh Street, Milwaukee, Wis.  
 GENTLEMEN: Please mail me full free particulars about your wonderful invention.  
 Name .....  
 St. or R. F. D. ....  
 Town .....  
 County .....  
 State .....



No Christmas gifts are more appreciated than those the donor makes himself—by hand

## The Right Finish for Christmas Gifts of Wood

IT'S the finish that counts, after all. No matter how skillfully you make home-made furniture, it takes the right kind of finishing to give that professional touch that makes you proud of your craftsmanship.

You will want the new Johnson Book on Wood Finishing. Gives complete instructions for finishing all kinds of woods—hard or soft—old or new. Tells how to stain wood artistically—everything you want to know about wood finishing. It's Free—just use the coupon below.

## JOHNSON'S WOOD DYE

With Johnson's Wood Dye inexpensive soft woods such as pine, cypress, fir, birch, etc., can be finished so they are as beautiful and artistic as expensive hard woods. Comes in oil and spirit in 17 beautiful shades, among the most popular of which are:

- |                        |                       |
|------------------------|-----------------------|
| No. 131—Walnut         | No. 126—Light Oak     |
| No. 123—Dark Oak       | No. 124—Golden Oak    |
| No. 127—Brown Mahogany | No. 129—Dark Mahogany |

Johnson's Wood Dye is easy to apply. It goes on smoothly and will not rub off or smudge. Penetrates deeply, bringing out the beauty of the grain. Dries ready for the finish coat in four hours.



Stores displaying this sign carry a full line of Johnson's Artistic Wood Finishes. They will gladly give you a Free copy of the Johnson 25c Book on Wood Finishing.

### FREE — this valuable book



Get this beautiful 25c Book on Wood Finishing absolutely FREE. Contains color charts, covering capacities, and hundreds of practical suggestions for the man who wants to make his home more artistic, cheery and inviting.



S. C. JOHNSON & SON, Dept. P. A. 12, Racine, Wis.  
"The Wood Finishing Authorities"  
(Canadian Factory—Brantford)

Please send me Free your 25c Instruction Book on Home Beautifying and Wood Finishing.

My Dealer Is .....

My Name .....

Address .....

City and State .....

# Send for this RADIO BOOK FREE

The World's Largest Exclusive  
Radio Mail Order House Will Send  
You This Wonderful Book FREE

64 illustrated pages containing thousands of bargains in radio sets, semi-finished sets and radio kits of all styles, sizes and approved circuits, 5-tube sets as low as \$29.50. Beautiful models of the very latest designs and types. Elaborate console models with loud speakers built right in cabinets of genuine mahogany and walnut. All sets guaranteed. Coast to coast receiving range. Also contains everything in radio supplies, including batteries, chargers, loud speakers, transformers, condensers, rheostats and any other parts you may want for improving your set or building a new one. Guaranteed saving to you of  $\frac{1}{3}$  to  $\frac{1}{2}$ .



# 1926 Catalog of RADIO BARGAINS Save $\frac{1}{3}$ to $\frac{1}{2}$

## AMERICAN RADYNOLA

### 5 TUBE SET

# \$29<sup>50</sup>

## The Biggest 5-Tube Value on the Market

Positively the world's greatest 5-tube radio bargains. Regular \$75.00 value. Our large quantity production enables us to sell this set for only \$29.50, fully built and wired in beautiful mahogany cabinet of latest design with sloping Bakelite panel of Satin finish, handsomely etched and engraved as illustrated. Constructed of the finest low-loss condensers, coils and sockets. Bakelite baseboard panel and dials. Price for set only **\$29<sup>50</sup>**. Transportation charges extra, shipping weight 25 lbs.

This set with all accessories, including the famous American Bell loud speaker with adjustable unit, 2-45 volt "B" batteries, one guaranteed 100 Ampere Hour storage "A" battery, cable for battery connection, 5-201A tubes, Aerial and ground equipment, and everything complete ready to set up and operate. Nothing else to buy. Price **\$59<sup>75</sup>**. Transportation charges extra. Shipping weight 100 lbs.



## Order Direct from This Page! Save About One-Half!

Order direct from this page. Save  $\frac{1}{3}$  to  $\frac{1}{2}$ . Our guarantee protects you. Money cheerfully refunded if you are not satisfied. Write your order and prices plainly. Send post office money order or bank draft for full amount to insure safety. Refer to any bank or commercial agency regarding our reliability.

### SEMI-FINISHED 5-TUBE RADIO FREQUENCY SET

\$18<sup>75</sup>

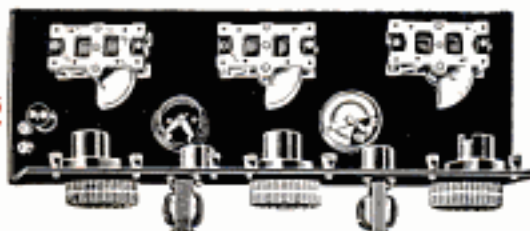

This special offer is astounding the radio world. Coast to coast reception on loud speaker. Low loss condensers and sockets. Highest quality transformers. Bakelite rheostats. All wiring concealed under baseboard. 7x18 panel—fits into any standard 7x18 cabinet. Complete instructions for operating. Guaranteed saving to you of \$50.00. Price of set all mounted, \$18.75. Cabinet of same model as American Radynola pictured above \$5.65 extra.

You must have our catalog no matter what set or kit you want. Our line is complete and includes all popular sets, such as Super-Heterodyne, Neutrodyne, Ultradyne, Reinartz, Regenerative, Radio Frequency, Browning-Drake, B. T. Nameless and all other latest circuits. Kits, sets and parts manufactured by all well known manufacturers such as Frost, Howard, Baldwin, Brandes, Western Electric, Columbia and others.

Our semi-finished sets come with all parts mounted on panel and baseboard ready for wiring. Do not fail to send for our catalog. Remember—we are the largest exclusive radio mail order dealers in the world and carry the best of everything in radio. We save you  $\frac{1}{3}$  to  $\frac{1}{2}$  on the following kits. Detailed descriptions appear in our catalog.

### SEMI-FINISHED 8-TUBE SUPER-HETERODYNE

\$43<sup>75</sup>



World's Famous 8-tube Super-Heterodyne. Fully mounted on panel and baseboard. Comes completely assembled ready to wire and operate. We have testimonials from thousands of builders of this set. Some have received foreign stations on loop aerial. Unsurpassed in volume and tone quality. Low-loss straight line frequency condensers, vernier dials, finest quality rheostats. Matched Columbia long wave transformers. Requires only three screws for attaching panel and baseboard and set is ready to operate. 7x30 panel. Price of set only \$43.75.

Requires following accessories to complete this set: 7x30 cabinet, 8-201A tubes for storage battery operation or No. 109 tubes for dry cell operation. 100 Ampere hour storage battery, 2-45X "B" batteries, loud speaker, center tapped loop aerial. All these items are listed in our catalog at a tremendous saving.

Complete Parts for  
**BEST'S 45-KILOCYCLE  
SUPER-HETERODYNE**  
Genuine Remler Parts **\$49<sup>50</sup>**

Catalog includes list of broadcasting stations, general radio information and facts about our free service division. Write for it today.

**NEUTRODYNE**  
Genuine licensed Neutrodyne kit of parts, come fully assembled on the panel and baseboard with complete instructions. ready to wire. Price, **\$29.75**

**COCKADAY**  
3-tube Cockaday kit of parts, fully assembled on panel and baseboard, ready to wire. Price, **\$15.85**

**AMBASSADOR**  
3-tube, 3 circuit tuner. Lowloss. Litz wire. Complete parts. Price, **\$19.95**

**ULTRA-AUDION**  
One-tube Ultra-Audion. Wizard of radio. Fully assembled and ready to wire, with instructions **\$6.70**

**RANDOLPH RADIO CORPORATION**  
159 N. Union Ave. Dept. 177 Chicago, Illinois



Instantly  
Adjustable  
3 Ways

This  
Amazing New Razor

**FREE Xmas Gift!**  
**To Every Man in America**  
**No More Blades to Buy!**

**H**ERE'S the most marvelous razor in history—built on a unique, new principle. Cuts each whisker on the *diagonal*. Slides instead of pulling. Reduces beard resistance 45% and gives the keenest, slickest shaves you ever saw. Kriss-Kross is adjustable—really 3 razors in one. A flip of the finger converts it from diagonal position into a regular T-shape safety—or makes it horizontal like the old-style straight edge.

**365 SHAVES A YEAR FROM ONE BLADE**

With your Kriss-Kross razor, we'll give you 5 special-processed blades—a *lifetime supply*. Follow my instructions and those 5 blades will give you keen, velvety shaves *forever*. No more bother and expense of buying new blades! No more "raking" with dull ones! With the Kriss-Kross combination I offer to keep you in razor blades for life!

This amazing offer is made possible by the new Kriss-Kross stropper, an invention even more startling than Kriss-Kross razor. It is so remarkable that it seems hardly fair to call it a *strop*. Rather it is a *blade rejuvenator*—a *super stropper*. Until you've tested its uncanny ingenuity yourself, you'll never know how sensational it really is.

**CHRISTMAS SERVICE COUPON**

RHODES MFG. CO.  
Dept. W-370, Pendleton & Cozens Aves.,  
St. Louis, Mo.

Please send me details of your free Xmas Razor offer and information about the Kriss-Kross stropper that makes blades last indefinitely. No obligation on my part.

Name.....

Address.....

City..... State.....

Check here if you are interested in becoming an authorized Kriss-Kross representative.

Kriss-Kross strops your blade on the *diagonal* just like a master barber. Also strops from *heavy* to *light*. Pressure decreases automatically until a jig flies up to tell you that your blade is ready with the *keenest edge that steel can take!*

Kriss-Kross prolongs the life of any-make blade, single or double-edge, for months and even years. Embodies seven mechanical features that have baffled inventors for years. Solves your blade problem for all time. Saves \$5 to \$15 the first year—is guaranteed for ten—will last a lifetime!

**Send Gift Coupon Today!**

This sensational introductory offer of a free razor is strictly limited to 30 days. Send the coupon at once! Get the details of our generous Xmas gift offer and find out all about these two amazing Kriss-Kross inventions. No obligation! Just mail the coupon today.

Never  
Sold in  
Stores



**Agents!**

**Make Big Money Giving This Razor Away!**

Here's the most sensational opportunity to make real money you ever dreamed of. Free Introductory Razor brings Kriss-Kross representatives \$10-\$20 an hour. F. Niehaus made \$66 in one day. C. F. Conklin got \$22 in 2 short hours. Others average \$125 to \$300 a week.

We have a wonderful new sales plan that brings amazing bonus profits while you sleep. Nothing like it ever originated before. One simple little sale often goes on working for you, piling up big extra profits that are "pure velvet." K. D. Ralph made \$380 bonus one month. You can do the same.

**Spare Time Workers Office and Factory Men**

can make \$5-\$10 extra a day just showing Kriss-Kross Stropper and free razor to friends and fellow-employees. And every man wants to buy, whether he is running a bank or digging ditches.

Write for details at once. See how you, too, can reap enormous profits with Kriss-Kross. But act quickly. Check the bottom line of the coupon and mail it to-day!

World's Largest Manufacturers of Mechanical Stropers

**KRISS KROSS**  
RHODES MFG. COMPANY  
Dept. W-370, Pendleton & Cozens Aves., St. Louis, Mo.

*Strop*  
*per*