

POPULAR MECHANICS

MAGAZINE

WRITTEN SO YOU CAN UNDERSTAND IT

REGD. TRADE MARK GREAT BRITAIN No. 418425

REG. U.S. PAT. OFF.



SEE PAGE 711

Copyrighted material

Right in your hand!



Opportunity-Independence-Money

A McSweeney trained man can go anywhere and make big money—the practical experience that the McSweeney Graduate Shops give you—no one can take away from you. The training is a key to success anywhere—because McSweeney trained men are in demand anywhere there are automobiles—and automobiles are everywhere.

YOU, TOO, CAN MAKE BIG MONEY

Down in Tennessee, Walter Creekmore makes as high as \$20.00 a day. Fred Pendley was made chief mechanic in a Tennessee shop working on Packards and Cadillacs. George Smith is making \$800.00 a month in Ohio.



J. H. McSweeney,
President,
Dept. 144
McSweeney Auto-
motive and Electrical
Training Shops,
1815 E. 24th St.,
CLEVELAND, O.
9th and Walnut Sts.,
CINCINNATI, O.
517-521 South Laflin St.,
CHICAGO, ILL.

Dear Mac: Send me full details of your SPECIAL tuition offer and your FREE 65-page book.

Name.....
Address.....

SPECIAL
Tuition offer
includes Board
and Railroad
fare.

MAIL THIS
COUPON
for my
FREE BOOK
"Mac"

TWO MONTHS' TRAINING

A little thing to do—A big thing to accomplish

The McSweeney Graduate Shops give you an experience in two short months, that would be difficult for you to get in a lifetime, merely working some place.

The McSweeney system is not a course in book study, but a period of intensive but easy training. It is an actual experience in the McSweeney shops, where equipment is modern and complete with automobiles, trucks, tractors and stationary engines.

SEND FOR FREE BOOK

All the information, all the detail, of the McSweeney training plan, is contained in a handsome illustrated book, that is yours for the asking. It tells how McSweeney-trained men are earning big money. A few minutes now, while you think of it, and a 2c stamp will bring to you, this interesting story, and show you how you can travel anywhere, make big money, and be independent.

If you have the desire to succeed—if you have the slightest ambition—you can not afford not to investigate McSweeney methods. Don't put it off. Follow your impulse and send in this coupon right away. Give McSweeney the chance to lay this key to bigger things right in the palm of your hand.

McSWEENEY AUTO
and
TRACTOR
GRADUATE SHOPS

Cincinnati Chicago
Cleveland

Write the nearest one

RCA

announces

three new power tubes *for greater volume*

RCA announces three important new Radiotrons. Their contribution to radio progress is *greater power*. They mean greater volume on dry batteries — and greater volume on storage batteries. They mean better tone, because they mean volume of sound *without distortion*.

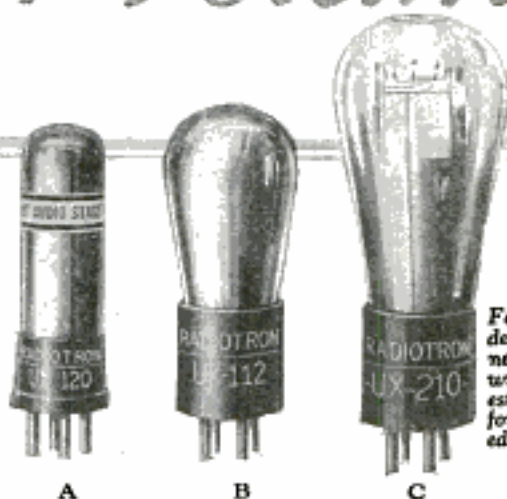

For technical description of the new Radiotrons, write to the nearest RCA office for the illustrated booklet.

- A—New Radiotron UX-120—for great volume on dry batteries . . . \$2.50
 B—New Radiotron UX-112—Similar to Radiotron UV-201-A, but several times as powerful . . . \$6.50
 C—New Radiotron UX-210—A super-power tube several times as powerful as UX-120 . . . \$9.00



Radiotron

AN RCA PRODUCT

RADIO CORPORATION OF AMERICA • CHICAGO • NEW YORK • SAN FRANCISCO

Equip your set with Balkite Radio Power Units

*They provide unfailing, uniform
current for both circuits*



U. S.
Patent
May 27,
1924

Balkite

Battery Charger

This popular battery charger is entirely noiseless. It can be used while the radio set is in operation. Charging rate 2.5 amperes. Operates from 110-120 AC 60 cycle current. Special model for 50 cycles. Also for 25-40 cycles with 1.5 ampere charging rate.

Price \$19.50

West of Rockies, \$20
In Canada, \$27.50



U. S.
Patent
May 27,
1924

Balkite

Trickle Charger

Charges both 4 and 6 volt radio "A" batteries. Will furnish more current than is used for 6 dry cell or 2 storage battery tubes, if used only while the set is in operation. If allowed to "trickle" charge continuously will also furnish enough current for as many as 8 dry cell or storage battery tubes. Size 5 1/2 in. long, 2 1/2 in. wide, 5 in. high. Operates from 110-120 AC 60 cycle current. Special model for 50 cycles. Price \$10

West of Rockies, \$10.50
In Canada, \$15

Equip your set with Balkite Radio Power Units. They improve and simplify radio reception. With their use your current supply is unfailing and always exactly what is required for each circuit.

The Balkite Battery Charger is entirely noiseless and can be used while the set is in operation. The Balkite Trickle Charger is especially adapted to sets of small "A" current requirements. It enables owners of sets now using dry cells to make a most economical installation. Balkite "B" II eliminates "B" batteries and supplies plate current from the light socket. It fits any set. The new Balkite "B" at \$35 is especially designed to serve sets of 6 tubes and less.

Noiseless—No bulbs—Permanent

All Balkite Radio Power Units are entirely noiseless in operation. They have no moving parts, no bulbs, and nothing to adjust, break or get out of order. Each is a permanent piece of equipment with nothing to wear out or replace. They require no other attention than the infrequent addition of water. They require no changes or additions to your set.

Manufactured by

FANSTEEL PRODUCTS COMPANY, Inc.
North Chicago, Illinois

FANSTEEL
Balkite
Radio Power Units



U. S.
Patent
May 27,
1924

Balkite "B"

Eliminates "B" batteries. Supplies plate current from the light socket. Operates with either storage battery or dry cell tubes. Keeps "B" circuit always operating at maximum efficiency. Requires no attention other than adding water twice a year.

Will serve sets requiring not more than 20 milliamperes at 90 volts — practically all sets of 5 tubes or less, and most 6 tube sets. Occupies about same space as 45 volt dry "B" battery. Operates from 110-120 AC 60 cycle current. Special model for 50 cycles.

Price \$35

In Canada, \$49.50



U. S.
Patent
May 27,
1924

Balkite "B" II

Same as the new Balkite "B" but will fit any set including those of 8 tubes or more. Operates from 110-120 AC 60 cycle current. Special model for 50 cycles.

Price \$55

In Canada, \$75

The Gould Unipower is equipped with a special Balkite Radio Power Unit

BALKITE BATTERY CHARGER • BALKITE TRICKLE CHARGER • BALKITE "B" • BALKITE "B" II

Popular Mechanics Magazine

200 E. Ontario Street, Chicago, U. S. A.

H. H. WINDSOR, Founder

H. H. WINDSOR, Jr., Editor and Publisher

London: Hachette & Co.,
16-17 King William Street, Charing Cross, W. C. 2

Paris: Hachette & Co.,
111 Rue Reaumur

Melbourne: Gordon & Gotch
509-513 Little Collins St.

ISSUED MONTHLY

SUBSCRIPTION:

SINGLE COPY, 25 CENTS

In United States and its possessions, also Canada, Cuba, and Mexico, per year, postpaid - \$2.50

To all other countries in the Postal Union 3.00

All subscriptions are discontinued at expiration. Please examine the date printed on your wrapper.

Entered as Second Class Matter Sept. 15, 1903, at the Post Office at Chicago, Illinois, under Act of March 3rd, 1879.

Entered as Second Class Matter at the Post Office Department, Canada.

Published monthly by POPULAR MECHANICS CO.

Copyright, 1925, by Popular Mechanics Co.

Copyright in Australia. Copyright in France

Vol. 44

Contents for November, 1925

No. 5

Airplanes

aid explorers in Brazil 786

boy nearly upsets plane stealing ride 822

for Arctic flights impractical 761

Airships—hitching post for dirigible is padded 768

Alcohol—German alcohol can't replace gasoline 799

Amusements—water dip roller coaster 720

Arctic Regions

bluegrass and winged snails found in 816

midnight sun photographed 707

lone adventurer faces dangers of 790

Automobile—belt and snowshoes for auto 752

Automobiles—Equipment and Supplies

adjustable bed 743

watch on steering wheel promotes safety 727

Automobiles—Fuel—gas tank filler on dash 805

Automobiles—Lighting—box for extra bulbs 810

Automobiles—Safety Devices—auto signal winks warn-
ing 766

Aviation

aviators seek riddle of birds' flight 766

flight for airway regulated by sun 721

Baby Carriage—folds up for auto 784

Bamboo—American-grown 765

Bats—enemies of insects, friends of mankind 785

Birds

eggs gathered by thousands in rowboats 789

feeding and housing birds help destroy insects 777

Black Hills, South Dakota—"ice mine" in 810

Boats and Boating—non-sinkable 767

Boots and Shoes—shoes half-soled at home 752

Butterflies

farm hatches by electricity 822

mystery in their trek 743

Candy—"all-day-sucker" sticks a new industry 744

Caterpillars—plague of, laid to bird feeding 701

Chemistry—miracles of years revealed at chemists'
meeting 814

Clamps—plierlike 799

Climbers—climbing shoes make work platform 824

Clocks—"elastic" marble clock cases 778

Cloth—electroplating for 748

Compressed Air—cold air flow from oil well runs
pumps 737

Copyholder—to aid typists 728

Crime—science, the modern Sherlock Holmes 729

Cutters—bolt cutter set at an angle 801

Derricks—skill of derrick men tested in placing statue 737

Diamond—price of, raised by high labor 741

Efficiency—science aims to make work easier 722

Electric Battery Charger—magnet charger on battery 749

Elephants—cold cured by inhaling vinegar 792

Enamel—produced by snails 785

Fiber—carpets from string beans 727

Fire Apparatus—sliding sled on fire ladder aids rescues 719

Fireplaces—made air furnaces by heating system 814

Fishing

adjustable fish rod holder 736

college for fishermen 807

Fruits—peaches pitted by machine 762

Germs—grown on farm to supply schools 736

Glass—reinforced, for auto windshields 823

Gold

lighter, bulkier to aid art 721

Golf

aluminum sole on golf shoes 814

photos taken through glass to study golf poses 800

waterproofed golf clubs make wood like metal 806

Grains—found in Egyptian tombs well preserved 761

Great Lakes—unwritten tales of the inland seas 793

Guns (Ordnance)—finder for anti-aircraft gun 792

Heating Plant—on roof in movie palace 761

Horses—snowshoes built for 719

Hotels—hotel above office building 777

Household Devices 812

Houses—home builders' page 879

Hygiene—perils in drinking cup 824

Atlas—don't throw away your 745

Insects—pick birthdays to conform to weather 803

Insulin—extracted from fish 766

Iodine—pocket pencil iodine holder 777

Iron—wealth from low-grade ore promised 820

Jerusalem—glories of old, at Philadelphia fair 743

Lace—trees yield substitute 728

Lasso—champion proves skill balanced on head 805

Libraries—Paris war library has 30,000 books 762

Life Saving—how to save gas, shock and drowning
victims 762

Lighthouses—graves of Canadian heroes marked by 811

Loading and Unloading—self-unloading auto truck 802

Lobsters—colored by dyeing their food 764

Locomotives

boy's dream of "waterless" locomotive realized 792

electric locomotive as long as three cars 784

Locusts—African locusts grow large 717

Mail Box—automatically signals mail's arrival 717

Maps—map serves as city guide 708

Matches—are waterproofed 801

Metals—foils rolled so thin they become transparent 802

Motor Truck—extension truck tail light 778

Motorcycle—stunts by police thrill crowds 759

Moving Picture—the world's most hazardous pro-
fession 769

Moving Picture Photography—four-ton camera takes
five thousand pictures a second 717

Moving Picture Projectors—pistol shaped 823

Music—getting in tune with ourselves 779

Nails—most dangerous implements in industry 776

Nature—engineering feats of nature 738

Needles—history traced for centuries 801

Pacific Ocean—survey of to enlarge food supply 740

Painting—painting clouds for weather forecasts 803

Paleontology—footprints of dinosaur found on rock 741

Photography—photos done in seven minutes on air-
plane 704

pressure, signs and movements of pianist 789

produces organ tones by means of reflectors 751

Plants—cannibal plant eats itself 806

Police—puzzle picture tests police memory and vision 749

Poitics—kings still in power 764

Printing—film used instead of type 727

Prison—seen from air looks like wheel 810

Purse—rubber purse for bathers fits on wrist 737

Radio

carries voices over ocean 709

fixed condenser aids in sharp tuning 833

vision of the future 705

Annapolis. 753

see

see street map

[Continued on Page 4]

This One



ZBWT-SH8-ZCSA

*de Bicycle
Power Series 854*

AMATEUR MECHANICS

| | | | |
|--|-----|--|-----|
| Radio Aerials | | | |
| erecting single wire aerial on flat roof | 834 | Advertising—moving sign on highway | 841 |
| thrills in life of men who build towers | 790 | Automobile Driving—saving the gas | 844 |
| Radio Apparatus | | Bees—watering honey | 842 |
| condenser suits any circuit | 827 | Carpet Beater—guard for | 848 |
| lead-in kept from grounding by bracket insulator | 833 | Chairs—handy study | 852 |
| lock switch protects batteries | 833 | Clothes Hangers—rubber bands on prevent garment | |
| shock-proof plug locks cord tips | 835 | from slipping off | 857 |
| switching battery from set to charger | 835 | Concrete—using tin cans in concrete walls | 853 |
| Radio Application | | Containers | |
| making use of in business | 815 | for grinding compounds | 857 |
| sound waves from the brain picked up by radio | 784 | handy water made from inner tube | 850 |
| wireless phones on trains | 776 | Doors—novel hay | 857 |
| Radio Battery | | Electric Batteries | |
| automatic battery connector | 838 | assembling sets | 842 |
| how to avoid making mistakes when wiring set | 834 | recharging dry cells | 858 |
| Radio Broadcasting—world's radio roof held cause of | | solutions that "charge" storage batteries | 852 |
| fading | 811 | Fireplace—redecorating old | 850 |
| Radio Construction | | Fishing | |
| adjusting tuned-plate circuits | 834 | automatic mechanical fisherman | 851 |
| busbar wire contains own solder | 835 | making case for fish rod | 841 |
| clean jacks improve reception | 835 | Funnel—for gas tank | 857 |
| proper potentials for vacuum tubes | 833 | Furnaces—conserving furnace heat | 858 |
| spacing wire on coils | 833 | Hedge Trimmers—improving hedge shears | 851 |
| Radio Loop—how to make tapped collapsible loop | 825 | Hose—using garden hose in winter | 840 |
| Radio questions and answers | 880 | Icebox—inclosed storm window makes "icebox" | 849 |
| Radio Receivers | | Incubators—feather duster | 841 |
| perfect tone six | 829 | Kitchen Utensils—cutting board for kitchen cabinet | 850 |
| inexpensive crystal set | 836 | Ladder—combination stepladder, washtub stand and | |
| Radio Tubes—repair that saves tube with loose base | 833 | ironing board | 839 |
| Railroads—greatest rail hazard ended by automatic | | Motorcycles—making power-driven ice bicycles | 854 |
| switching | 752 | Newspapers—container | 842 |
| Rats—carnation substitutes for cheese as bait for rats | 824 | Organ (Musical)—repairing bellows | 841 |
| Recreation—children build houses with wooden blocks | 767 | Oven—baking, made from tin can | 849 |
| Religions—census of, in 1926 | 719 | Popcorn—sheet-iron sheller | 843 |
| River—giant blast turns river into new channel | 717 | Soap—shaving, for washing machine | 851 |
| Roads | | Stains—removing sugar stains from clothes | 842 |
| lime keeps dirt roads firm | 811 | Tables—adjustable kitchen worktable | 843 |
| shields to mark all roads | 719 | Umbrellas—holding umbrella on suitcase | 858 |
| Safety Devices and Measures | | Weeds—burning off dry | 858 |
| humps in road give warning at crossing | 806 | | |
| net guards bridge workers from falls | 727 | | |
| white crosses are warning spots at auto death spots | 790 | | |
| Sailors—form human tree on ship's crossarms | 801 | | |
| Saws and Sawing Rigs—one-man portable rail saw | 728 | | |
| Scaffold—raised by foot and quickly adjusted | 799 | | |
| Science—solving mysteries | 817 | | |
| Searchlights—used to lure moths to death | 823 | | |
| "Shenandoah"—what happened to? | 711 | | |
| Ships | | | |
| fire ends career of useless wartime | 736 | | |
| magnet-fixed motor on hull turns ship in dock | 719 | | |
| Sleds—brakes on runners prevent coasting accidents | 740 | | |
| Slot Machines—for stationary | 785 | | |
| Smoke—screen used to aid fleeing bootleggers | 740 | | |
| Sound—echo sounder shows depth under ship | 708 | | |
| Statue—struck by lightning mended by steeplejacks | 776 | | |
| Street Cleaning—giant magnet road sweeper picks up | | | |
| nails and iron | 710 | | |
| Street Traffic Regulation | | | |
| flashing hands halt autos | 761 | | |
| auto stop sign of prism glass | 768 | | |
| Suction Grip—shaving brush suction grip clings to any | | | |
| surface | 802 | | |
| Swimming—channel crossed five times beats most | | | |
| swimmers | 783 | | |
| Tanks—non-explosive oil | 741 | | |
| Taste—lost at very high altitudes | 790 | | |
| Telephone—longest phone cable | 816 | | |
| Testing | | | |
| for slippery floors | 751 | | |
| meter tests bridge spans | 785 | | |
| Tin Foil—pictures in colored | 816 | | |
| Tires | | | |
| air scales for auto tires | 751 | | |
| inner tube of three layers | 824 | | |
| tire tool of great leverage fits all split rims | 789 | | |
| Tools—set of seven tools in one | 810 | | |
| Toys—motor-driven building toys | 710 | | |
| Transportation—models tell story of | 721 | | |
| Treasure Trove—mystery of pirate's treasure still un- | | | |
| solved | 720 | | |
| Typewriter—Holland scene done on | 743 | | |
| United States Naval Academy—Four Years at Annap- | | | |
| olis—fourth year | 753 | | |
| Upholstering Tool—web stretcher | 822 | | |
| Vacuum Cup—for auto valves | 783 | | |
| Ventilation—two-way auto ventilator for closed car | 776 | | |
| Warfare—army and navy war colleges train battle | | | |
| chiefs | 778 | | |
| Weather—forecast of severe winter based on weather | | | |
| cycles | 710 | | |
| Whale—battle witnessed by explorer | 744 | | |

SHOP NOTES

| | |
|--|-----|
| Asphalt—removing from cement | 870 |
| Automobiles—Equipment and Supplies—auto dash | |
| box and desk | 864 |
| Automobiles—Repairing | |
| lining up cotter holes | 870 |
| removing Ford front spring perches | 878 |
| restoring brake bands | 861 |
| Block and Tackle—safeguarding | 866 |
| Built-in Furniture for the Home—Part XII—Seats | 875 |
| Chutes—spherical carriers for office messages | 861 |
| Clamps—increasing size of | 863 |
| Clips—tag clip for radiator pipes | 878 |
| Concrete—sand pan protects concrete floor | 865 |
| Drills—repair for worn keyhole | 866 |
| Electric Wiring—tester for determining negative wir- | |
| ing line | 861 |
| Excavating Machine—used as pile driver | 874 |
| Fire Apparatus—portable fire barrel | 878 |
| Garages—Equipment and Supplies—combined auto | |
| stairway and elevator | 862 |
| Gearing—removing stubborn gears | 863 |
| Grinders—lathe grinder made from electric fan | 866 |
| Hacksaw—frame takes fine and coarse saws | 865 |
| Holders—for grinding chisels | 874 |
| Hooks—non-slip hook on chain | 877 |
| Lubrication—filling small grease gun | 871 |
| Motor Truck—dumping body on farm truck | 859 |
| Planing Machine—extension tool on small planer | 870 |
| Printing—built-up printers chase | 866 |
| Pumps—old windmill rigged up to run field pump | 871 |
| Rust—preventing on small steel instruments | 874 |
| Safety Devices and Measures—holder for shop goggles | 872 |
| Sifter—springs aid gravity sand screen | 863 |
| Tables—combined bookcase and drawing table | 865 |
| Testing—fuses and lamps | 864 |
| Tires—old casings make unloading mat | 869 |
| Track—giant revolving track for bull wheel | 873 |
| Turning Machinery—work too large for lathe | 862 |
| Valves—refitting Corliss valves | 872 |
| Varnish and Varnishing | |
| clear varnish for enamel | 866 |
| spar varnish will toughen paint | 870 |
| Welding | |
| building 2 kw. spot welding set | 867 |
| carbon prevents spelter and filler rod from spread- | |
| ing | 871 |
| Wrenches—universal jointed socket wrench | 873 |

DRAKE'S PRACTICAL MECHANICAL BOOKS

THEY WILL RAISE YOUR PAY—

ORDER ON 5-DAY TRIAL

The books listed below will perfect you in your chosen trade—pave the way to the big positions. Written in non-technical language—easy to read and understand. *Every book covers its subject completely.* An entire course of instruction condensed into one volume. Your choice sent postpaid—you benefit 5 days—money refunded in full if not entirely satisfactory. Order direct from this page.

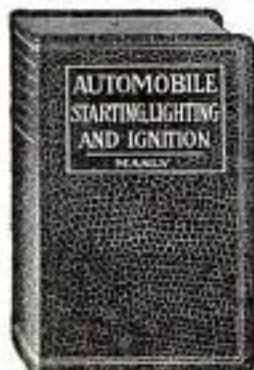

Automobile Books

Automobile Starting, Lighting and Ignition, by Manly... 700 pp. \$3.00
Brookes' Automobile Handbook. \$2.00
Ford Motor Car, Truck and Tractor, by Manly... Cloth \$1.50
Automobile Battery, Care and Repair, by Manly... Leatherette \$2.00
Motorcycle Handbook, by Manly \$1.50

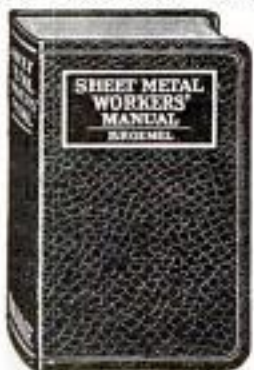

Shop Practice Books

Sheet Metal Workers' Manual... \$2.00
Oxy-Acetylene Welding and Cutting... Cloth \$1.25
Slide Rule and Logarithmic Tables. \$2.00
Handbook for Millwrights... Cloth \$2.00
Machine Shop Practice... Cloth \$2.00
Mechanical Drawing and Machine Design... Cloth \$2.00

ORDER DIRECT FROM THIS PAGE—ON OUR MONEY-BACK PLAN

The books listed above are only a few of the many in our catalogue, which you will receive promptly after filling out and mailing us the attached coupon. For quick action order direct from this page—cross name of each book wanted and send in with price quoted. We prepay postage and send books on our money-back plan.

FREDERICK J. DRAKE & CO.
PUBLISHERS

1008 Michigan Ave., Chicago
Drake Books Are For Sale at All Book Stores

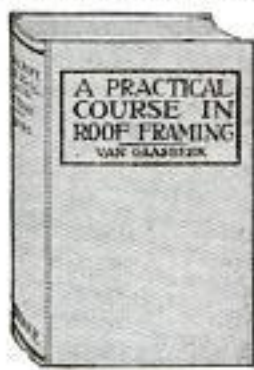

Carpentry Books

Cloth Binding
Modern Carpentry, 2 vols. \$1.00
The Steel Square, 2 vols. \$3.00
Modern Estimator... \$1.50
Timber Framing... \$2.00
Builder's Architectural Drawing... \$2.00
Concrete... \$1.50
Practical Bungalows... \$1.00
Roof Framing, by Van Gasbeek... \$1.50

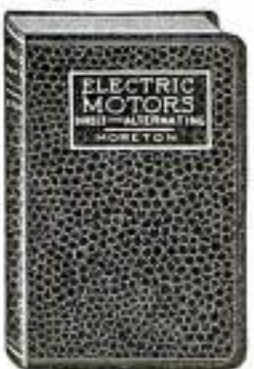

Electrical Books

Telephony, Including Automatic Switching, by Smith, 450 pp. Leatherette \$2.50
Practical Applied Electricity... \$2.00
Wiring Diagrams and Descriptions. \$1.50
Armature and Magnet Winding... \$1.50
Electric Motors, D. & A. \$1.50



Painting and Decorating

Ross Crane Book of Home Furnishing and Decoration... Cloth \$3.00
House Painting Methods with the Brush and Spray Gun, by Vanderwalker. Cloth... \$2.00
Interior Wall Decoration, by Vanderwalker... Leatherette \$4.00
The Mixing of Colors and Paints, by Vanderwalker... Cloth \$2.00
A Show at Sho' Cards... Cloth \$4.00
Sign Painting, by Atkinson... Cloth \$4.00
Strong's Book of Design, Leatherette \$4.00
Modern Painter's Cyclopaedia. Cloth \$2.00
Automobile Painting... Cloth \$1.50
New Hardwood Finishing... Cloth \$1.50

Steam Engineering

Swingle's Handbook for Steam Engineers and Electricians, Leatherette... \$4.00
Examination Questions and Answers for Marine and Stationary Engineers, Leatherette... \$2.00
Steam Boilers... Leatherette \$2.00
Swingle's Catechism of Steam, Gas and Electrical Engineering, Leatherette \$1.50

Modern Languages

By Prof. P. S. Allen, U. of Chicago
French without a Teacher... Cloth \$1.25
Spanish without a Teacher... Cloth \$1.25
German without a Teacher... Cloth \$1.25
Everyday French... \$1.25
Everyday Spanish... \$1.25

FREDERICK J. DRAKE & CO.
1008 Michigan Avenue
Chicago, Ill.

GENTLEMEN:—Please send me free, postage paid, your illustrated catalogue which lists and describes 200 Practical Mechanical Books for Home Study.

My name is

and my address

Mail Coupon For Free Catalogue
Your Guide to Home Study

WANTED: Men to Keep Pace with R. B. Cook

In 1919 R. B. Cook was a bookkeeper—holding down a one-track job. In 1923—four years later—he was sales manager of the B. A. Railton Company, Chicago; and ever since that time has successfully directed a sales force of more than seventy salesmen, many of them with twenty years' experience.

"To the casual observer," writes R. A. Railton, General Manager of the B. A. Railton Company, "his rise might seem unusually rapid, but we view it as the natural result of his being prepared for the big opportunity when it came."

CHICAGO



"Worth More Than \$10,000"

(So writes R. B. Cook, the employee)
"The advancement I have made during the past five years was made possible thru your splendid training and the various services which I have used with much profit. Two years ago I wrote you saying that I would not part with the knowledge LaSalle training has brought me for \$10,000. Today I can say I would not part with it for many times that amount."

(Signed) R. B. COOK, Chicago.

"You Are Rendering Our Organization a Distinct Service"

(So writes R. A. Railton, the employer)
"In training a half million men, your institution has made a valuable contribution to business. I feel that in bringing to our attention a man with the training and capabilities of Mr. Cook, you are rendering our organization a distinct service."
(Signed) R. A. RAILTON, Chicago.



When a young man can advance in four years from a routine job to the position of Sales Manager of one of the big wholesale houses of Chicago—without any pull except his own initiative—there must be a reason. There is a reason. It's summed up in the LaSalle salary-doubling plan. What that plan has done for R. B. Cook it can do for any man sincerely ambitious to increase his earnings.

Advance, by this Plan, to Bigger Pay!

Here is the story of a pace-maker—a man who refused to let handicaps obstruct his progress—a man who acts and makes money by this simple principle: *to capitalize his every resource.*

Handicapped by ill health—which kept him in a hospital during four years of his boyhood—R. B. Cook, a Chicagoan, bridged the gap in his education by day and evening study, which gave him a sound foundation for LaSalle home study business training.

Starting as a bookkeeper, in 1919, he enrolled for LaSalle training in Modern Business Correspondence and Practice.

"Before I was half way thru my training," writes Mr. Cook, "I was promoted to Collection Manager, with an increase of 50 per cent in salary. Later I became Credit Manager of another concern. This move was a very decided promotion."

"My next advancement was to the position of Office Manager. In each of these positions I was successful. This fact paved the way to my present position. Two years ago I was offered a post as Assistant Credit Manager with my present concern. Within two years I was made General Sales Manager, which position I now hold."

Five years of *consistent progress*—that is the record of Mr. Cook, who has recently enrolled for LaSalle training in Business Management. Paragraph by paragraph, line by line,

he takes up each assignment, asking himself how he can turn each business principle into profits for his company. A single idea—so he writes—which he got from his very first assignment—resulted in savings of many thousands of dollars for his firm.

Send for Salary-Doubling Plan

You are eager for success. You wish to enjoy the rewards which come inevitably to the man who fits himself for responsibility.

But before you can reap those rewards, you must make yourself more profitable to the business which employs you. By no other method can you possibly succeed.

Cook's experience clearly shows the way—a way illuminated by the careers of thousands of LaSalle-trained men. During only six months' time, for example, as many as 1,248 LaSalle members reported definite salary-increases totalling \$1,399,607, an average increase per man of 89 per cent.

The details of the LaSalle *salary-doubling plan* will be sent you for the asking. Whether you adopt the plan or not, the basic information it will place in your hands, without cost, is of very real and definite value.

Balance the two minutes that it takes to fill out the coupon against the rewards of a successful career—then clip and mail the coupon NOW.

LASALLE EXTENSION UNIVERSITY

The World's Largest Business Training Institution

CLIP AND MAIL

LASALLE EXTENSION UNIVERSITY

Dept. 1164-R

Chicago

I shall be glad to have details of your salary-doubling plan, together with complete information regarding the opportunities in the business field I have checked below. Also a copy of "Ten Years' Promotion in One," all without obligation.

- | | | | |
|---|---|--|--|
| <input type="checkbox"/> Business Management: Training for Official, Managerial, Sales and Departmental Executive positions. | <input type="checkbox"/> Law: Training for Bar; LL. B. Degree. | <input type="checkbox"/> Industrial Management; Factory Management: Training for positions in Works Management, Production Control, Industrial Engineering, etc. | <input type="checkbox"/> Modern Business Correspondence and Practice: Training for position as Sales or Collection Correspondent, Sales Promotion Manager, Mail Sales Manager, Secretary, etc. |
| <input type="checkbox"/> Modern Salesmanship: Training for position as Sales Executive, Salesman, Sales Coach or Trainer, Sales Promotion Manager, Manufacturer's Agent, Solicitor, and all positions in retail, wholesale, or specialty selling. | <input type="checkbox"/> Commercial Law: Reading, Reference and Consultation Service for Business Men. | <input type="checkbox"/> Modern Foremanship and Production Methods: Training for positions in Shop Management, such as that of Superintendent, General Foreman, Foreman, Sub-Foreman, etc. | <input type="checkbox"/> Business English: Training for Business Correspondents and Copy Writers. |
| <input type="checkbox"/> Higher Accountancy: Training for position as Auditor, Comptroller, Certified Public Accountant, Cost Accountant, etc. | <input type="checkbox"/> Traffic Management—Foreign and Domestic: Training for position as Railroad or Industrial Traffic Manager, Rate Expert, Freight Solicitor, etc. | <input type="checkbox"/> Personnel and Employment Management: Training in the position of Personnel Manager, Industrial Relations Manager, Employment Manager, and positions relating to Employee Service. | <input type="checkbox"/> Commercial Spanish: Training for position as Foreign Correspondent with Spanish-speaking countries. |
| <input type="checkbox"/> Expert Bookkeeping: Training for position as Head Bookkeeper. | <input type="checkbox"/> Railway Station Management: Training for position of Station Accountant, Cashier and Agent, Division Agent, etc. | | <input type="checkbox"/> Effective Speaking: Training in the art of forceful, effective speech, for Ministers, Salesmen, Fraternal Leaders, Politicians, Clubmen, etc. |
| <input type="checkbox"/> C.P.A. Coaching for Advanced Accountants. | <input type="checkbox"/> Banking and Finance: Training for executive positions in Banks and Financial Institutions. | | |

NAME _____ PRESENT POSITION _____ ADDRESS _____

BUILDERS TRADE GUIDES



4 Vols. \$6

AUDELS CARPENTERS AND BUILDERS GUIDES—4 VOLS. \$6

Inside Information for Carpenters, Builders, Joiners, Building Mechanics—all Woodworkers. **1600 pages; 3700 diagrams; flexible; pocket size.** Short-cut instructions, new methods, ideas, solutions, plans, systems—money saving suggestions. An easy progressive course for the apprentice. A practical daily helper and Quick Reference for the master worker. A Helping Hand to Easier and Better Work and Better Pay. To get this aid for yourself, simply fill in and mail the FREE COUPON below.

INSIDE TRADE INFORMATION ON:
 How to use steel square; How to file and set saws; How to build furniture; How to use mitre box; How to use chalk line; How to use rules; How to make joints; Carpenters' arithmetic; Mensuration problems; Estimating strength of timbers; How to set girders and sills; How to frame houses and roofs; How to estimate costs; How to build houses, barns, garages, bungalows, etc.; How to read and draw plans; Drawing up specifications; How to excavate; How to use settings 12, 13 and 17 on the steel square; How to build hoists and scaffolds—skylights; How to build stairs; How to put on interior trim; How to hang doors; How to lay floors; How to paint.

"Audels Guides worth four times their price—handy too as I carry them in pocket for reference." W. J. Bates, Knoxville, Pa.



4 Vols. \$6

AUDELS PLUMBERS AND STEAMFITTERS GUIDES—4 VOLS. \$6

A new set—just out! A practical, illustrated, Reference Library and Study-Course for Master Plumbers, Journeymen and Apprentice Steamfitters, Gas Fitters and Helpers, Sheet Metal Workers, Draughtsmen, Master Builders, Engineers and all Building Trade Students. **1670 pages; 3642 diagrams; flexible; pocket size.** Guides explain all the principles, advances and short cuts of the Plumbing and Heating trade. Contains instructions on how to figure and estimate jobs. Use FREE COUPON below to examine, without obligation, this valuable work.

INSIDE TRADE INFORMATION ON:
 Soldering, tinning. Joint wiping, bending, beating. Pipe—iron—steel, threading. Mathematics, tables, physics. Materials—iron, steel, copper, brass, lead, tin, antimony. Sheet metal—galvanized—plate. Sanitation, syphonage, tanks. Drainage, sewage, purification. Fixtures—bath—kitchen. Pipe fittings, soil pipe, tools. Laying out work. Roughing. Screwed fittings, flanges, joints. Pipe bending, examples. Elbows. Heating, ventilation, refrigeration. Water supply, mains, wells, tanks. Gas-fittings. Underwriters. Sheet metal work, problems, methods, brazing, heating, lead burning. Welding, various welds, methods. Blacksmithing, forges, tools.

"Audels Guides are practical, easy to understand, reliable. Cover the field in plain language." W. F. Arringer, Annapolis, Md.



4 Vols. \$6

AUDELS MASONS AND BUILDERS GUIDES—4 VOLS. \$6

A new, complete, illustrated trade reference library, for Bricklayers, Cement Workers, Plasterers, Tile Setters and Stone Masons, including a practical outline of Steel Construction. **1100 pages; 2067 diagrams; flexible; pocket size.** A practical Trade Assistant explaining modern methods of masonry construction. Easy to understand and apply. A reliable and authentic reference work and study-course for Master Journeyman and Young Mechanic. Use FREE COUPON below and find out for yourself, without obligation, whether this set will benefit you.

INSIDE TRADE INFORMATION ON:
 Bricklaying, tools, materials; Brick designs, patterns, bonds; Setting frames and foundations; Mortars, scaffolds, estimating; Mortars and mortar mixing; Tile setting, mosaic, hollow tile; Straight edge test, walling; How to figure brick work; Safe loads, piers, chimneys; Boiler settings, anchors, fire stops; Labor tables; Concrete, forms; How to figure concrete work; Stucco—on old and new buildings; Plastering; Plasterers agreement; Plastering on various surfaces; Stonemasonry; Cutting, finishing, estimating stone; Derricks, rigging; Steel construction; Fire proof; How to read blue prints.

"Audels Masons Guides are the best books on the subject. Have laid brick 12 years and am able to judge." H.A. Bennett, Corlies, Pa.



PRACTICAL ELECTRICITY — 1 VOL. \$4

Audels Handy Book of Practical Electricity is a simplified Ready Reference and Study Course in one pocket size, leather bound volume—for Engineers, Professional Electricians and Students. **1040 pages; 2600 diagrams; flexible red leather bound.** A reliable authority and handy helper for every electrical worker. Contains important and valuable wiring diagrams, calculations, machine sketches, helps on maintenance and repair. Use this FREE COUPON today and find out, without obligation, how this handy book will help you in your daily work.



Complete in one handy, red leather bound volume

1040 Pages 2600 Diagrams

INSIDE TRADE INFORMATION ON:

Electro-Therapeutics, X-Rays, Shocks, Welding, Brazing, Radio Hook-ups, Motion Pictures, Telephone, Telegraph, Cranes, Bells, Elevators, Pumps, Tools, Ship Drive, Railways, Vehicles, Automobile Electric Systems, Ignition, Generation, Lighting, Plant Management, Power Plans, **Armature Winding**, Repairing, A. C. Motors and Apparatus, D. C. Motors and Apparatus, Alternator Construction, Dynamos, Wiring Diagrams, Sign Flashers, Cable Splicing, **Power Wiring**, Outside Wiring, Switches, Lighting, Rectifiers, Converters, Transformers, Fuses, Circuit Breakers, Rheostats, Electro Plating, Electrolysis, **Storage Batteries**, Magnetism, Electrical Energy, Conductors, Insulators, Static, Dynamic, Radio Electricity, Applications, Ready Reference and Index Covering the entire field of Modern Electricity.

Learn More and You Will Earn More!

Know your job and you'll never be without one. The skilled man is always in demand. Knowledge is power. Learn your trade thoroughly by easy reading. This coupon is your opportunity for advancement and better pay. You risk nothing in sending for Audels Guides for free examination. Send it NOW!

FREE EXAMINATION COUPON

THEO. AUDEL & CO.,
 65 W. 23 ST., NEW YORK CITY

Please mail me for free examination the books marked (x) below. If I find them satisfactory, I agree to mail \$1 in 7 days, on each set ordered, and to further mail \$1 monthly on each set until I have paid the purchase price.

4 CARPENTERS GUIDES \$6 4 PLUMBERS GUIDES \$6

4 MASONS GUIDES \$6 1 ELECTRICIANS HANDY BOOK \$4

NAME

ADDRESS

OCCUPATION

EMPLOYED BY.....

Plenty of Well Paid Drafting Jobs!

Look!



ARCHITECTURAL DRAFTSMAN — Thoroughly competent draftsman and designer for large apartment house work in Philadelphia; at least one year's work to start immediately; salary \$75 to \$85 per week. In reply state briefly experience, age and soonest date available.

I'll Train You to Fit In!

Could YOU make good in one of these jobs? Would you like to? If you would, write me today!

Only skilled men are wanted. No chance for the man who wants to learn "on the job." I can train you at home. I have trained thousands of others. Many are earning \$3500 a year — and more.

Right now is the time to learn this trade. More and more draftsmen will be needed. My training is the practical kind. It fits you to make good right from the go. I know what other Chief Draftsmen want because I have hired and worked draftsmen for 25 years. I'll train you until you are ready to hold down a good steady, well paid job.

No Extra Charge for Drafting Outfit

As soon as you decide to take my training, I send you a complete Drafting Outfit, just like the one I use myself. It comes as part of your course. No extra charge. Everything is just what you need, both for your course, and for your BIG JOB later: The "Chief's Own" Drafting Table, fine set of drafting instruments, 24-inch T square, triangles, French Curve, drafting board, rule, pencils, ink, paper and thumb tacks. These are all necessary in my course, because I teach you on practical work. That's the way to learn drafting.

WriteQuick for Great Special Offer

I'll go the limit, to help earnest, ambitious men to fill jobs like those advertised above. I'll even give you a chance to earn your training without cash outlay. Write me at once for details of this exceptional offer.

Money doesn't count. If you have vim and determination, I'll give you your chance to get ahead. Put it all up to me.



Write me today—or just send the coupon.

Chief Draftsman Dobe
1951 Lawrence Ave., Div. 93-58 Chicago, Ill.

Chief Draftsman Dobe, 1951 Lawrence Ave., Div. 93-58 Chicago, Illinois

Send me your Great Special Offer open now to ambitious men. Also your book, "Successful Draftsmanship." No obligation on my part.

NameAge.....

Address

Post Office State.....

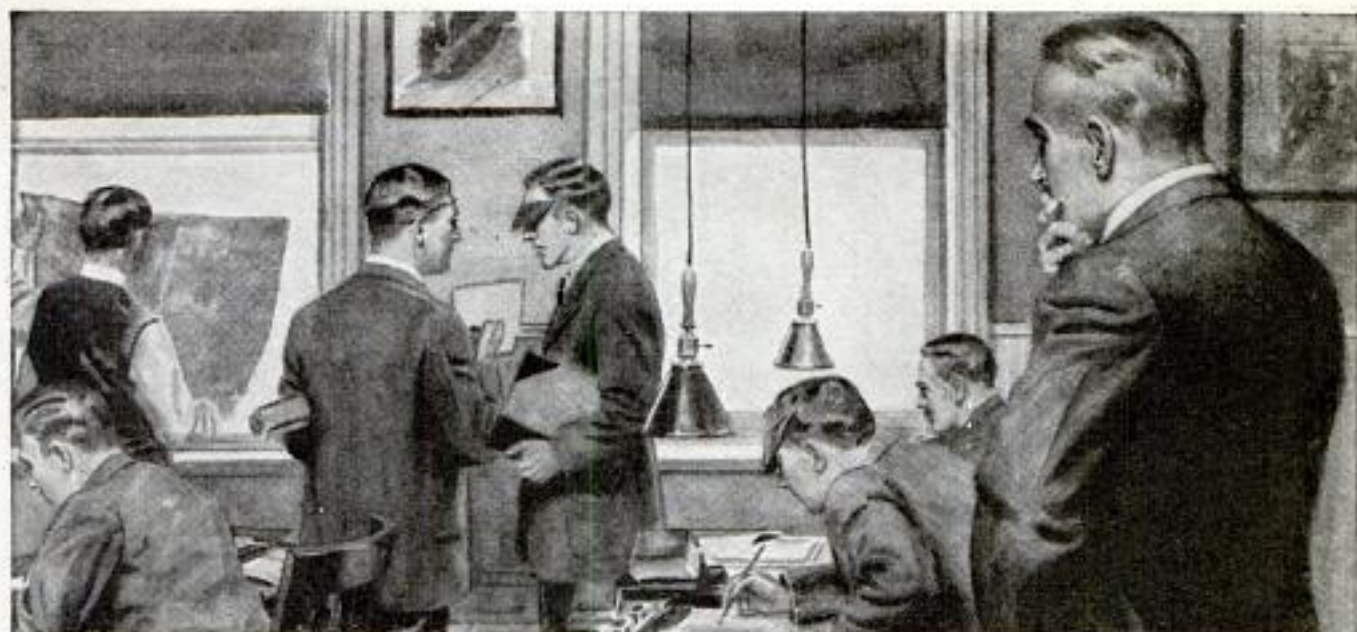

“Which Man Shall I Promote?”

THERE is probably no one problem in business that gives an employer so much concern as this—“Which man shall I promote?”

He must not—he *dare* not—take chances when a position of responsibility is open. The success of his department, his business, his very reputation, depends on his ability to pick men.

In every office, in every factory, the problem always is the same.

Many, many men. Old men, young men, men of middle age. A score, a hundred ordinary routine workers.

But how few whose vision of the business, or whose aptitude for it, extends beyond the narrow limits of their own particular job! How startlingly few who are equipped to handle bigger work when Opportunity calls!

What does your employer think of *you* when a good position is open? Does he pass you by as just an ordinary routine worker, or does he say—“There’s a man I can depend on because he’s training himself to handle bigger work?”

Do not try to delude yourself. Your employer knows more about you than you sometimes think. He’s constantly checking up on your work, your ability, your ideals, your aspirations. Stored away in the back of his

mind, or filed away in black and white, are his impressions of the kind of man *you are* and the kind of man *you want to be*.

There is no better way to get out of the rut and lift yourself above the crowd than to take up a home-study course with the International Correspondence Schools. An hour a day—the odds and ends of spare time that now go to waste—will qualify you for promotion.

Just mail the coupon and we will gladly send you booklets describing any of the courses listed below.

INTERNATIONAL CORRESPONDENCE SCHOOLS

Box 5535-E, Scranton, Penna.

Without cost or obligation, please tell me how I can qualify for the position or in the subject before which I have marked an X:

BUSINESS TRAINING COURSES

- | | |
|--|---|
| <input type="checkbox"/> Business Management | <input type="checkbox"/> Salesmanship |
| <input type="checkbox"/> Industrial Management | <input type="checkbox"/> Advertising |
| <input type="checkbox"/> Personnel Organization | <input type="checkbox"/> Better Letters |
| <input type="checkbox"/> Traffic Management | <input type="checkbox"/> Show Card Lettering |
| <input type="checkbox"/> Business Law | <input type="checkbox"/> Stenography and Typing |
| <input type="checkbox"/> Banking and Banking Law | <input type="checkbox"/> Business English |
| <input type="checkbox"/> Accountancy (including C.P.A.) | <input type="checkbox"/> Civil Service |
| <input type="checkbox"/> Nicholson Cost Accounting | <input type="checkbox"/> Railway Mail Clerk |
| <input type="checkbox"/> Bookkeeping | <input type="checkbox"/> Common School Subjects |
| <input type="checkbox"/> Private Secretary | <input type="checkbox"/> High School Subjects |
| <input type="checkbox"/> Spanish <input type="checkbox"/> French | <input type="checkbox"/> Illustrating <input type="checkbox"/> Cartooning |

TECHNICAL AND INDUSTRIAL COURSES

- | | |
|---|--|
| <input type="checkbox"/> Electrical Engineering | <input type="checkbox"/> Architect |
| <input type="checkbox"/> Electric Lighting | <input type="checkbox"/> Architects' Blue Prints |
| <input type="checkbox"/> Mechanical Engineer | <input type="checkbox"/> Contractor and Builder |
| <input type="checkbox"/> Mechanical Draftsman | <input type="checkbox"/> Architectural Draftsman |
| <input type="checkbox"/> Machine Shop Practice | <input type="checkbox"/> Concrete Builder |
| <input type="checkbox"/> Railroad Positions | <input type="checkbox"/> Structural Engineer |
| <input type="checkbox"/> Gas Engine Operating | <input type="checkbox"/> Chemistry <input type="checkbox"/> Pharmacy |
| <input type="checkbox"/> Civil Engineer | <input type="checkbox"/> Automobile Work |
| <input type="checkbox"/> Surveying and Mapping | <input type="checkbox"/> Airplane Engines |
| <input type="checkbox"/> Metallurgy | <input type="checkbox"/> Navigation |
| <input type="checkbox"/> Steam Engineering | <input type="checkbox"/> Agriculture and Poultry |
| <input type="checkbox"/> Radio | <input type="checkbox"/> Mathematics |

Name.....

Street.....

Address..... 3-6-24

City..... State.....

Occupation.....

Persons residing in Canada should send this coupon to the International Correspondence Schools Canadian, Limited, Montreal, Canada.

The International Correspondence Schools are the oldest and largest correspondence schools in the world

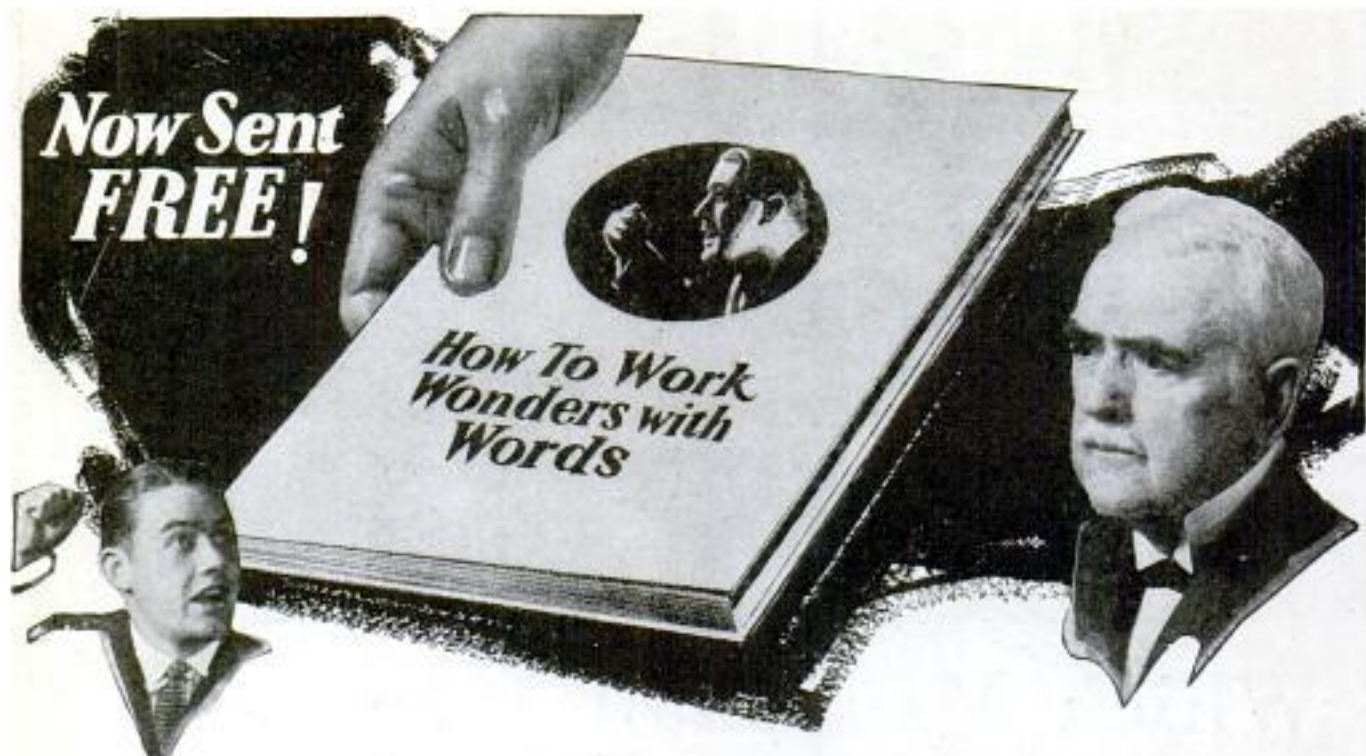

Not Only Men Who Have Made Millions Send for this Astonishing Book *—but Thousands of Others!*

Many successful business men have sent for this amazing book NOW MAILED FREE. Such men as Walter C. Ford, of the Ford Manufacturing Company; C. F. Bourgeois, President of Robischon and Peckham Company; H. B. McNeal, President of the Telephony Publishing Company; and many other prominent, prosperous business executives, are unstinting in their praise of it. But don't think it is only for big men. Thousands of young men have found in this book the key to advancement in salary and position, popularity, standing, power and real success.

Today business demands for the big, important, high-salaried jobs, men who can dominate others. It is the power of forceful, convincing speech that causes one man to jump from obscurity to the presidency of a great corporation. Another from a small, unimportant territory to the sales manager's desk. Another from the rank and file of political workers to a post of national prominence as a campaign speaker. A timid, self-conscious man to change almost overnight into a popular and much-applauded after-dinner speaker.

EITHER YOU BECOME A POWERFUL SPEAKER—OR YOUR TRAINING IS FREE

You are shown how to conquer stage fright, self-consciousness, timidity, bashfulness and fear—those things which keep you silent when men of lesser ability get what they want by the sheer power of convincing speech. You are told how to bring out and develop your priceless "hidden knack"—which will win for you advancement in position and salary, popularity, standing, power and real success. This simple, easy, sure and quick training is guaranteed to do this—or it will not cost you a single penny.

ONLY 15 MINUTES A DAY REQUIRED

There is no mystery about the power to work wonders with words. It makes no difference how embarrassed or self-conscious you now are when called upon to speak. Certain principles will show you how to rise head and shoulders above the mass and make yourself the dominating figure in any gathering. How to rise to any occasion and demand what you want with

force, vigor and conviction. Give only fifteen minutes a day in the privacy of your own home and you can accomplish all this in a few short weeks.

MAKE THIS FREE TEST

If you will fill in and mail the coupon at once you will receive this remarkable new book, "How to Work Wonders with Words," which gives you an amazing test by which you can determine for yourself in five minutes whether you are one of the seven men out of every nine who possess the "hidden knack" of powerful speech, but do not know it. Decide for yourself if you are going to allow fifteen minutes a day to stand between you and success. Thousands have found this to be the biggest forward step of their lives. If it has played such an important part in the lives of many big men, may it not in yours?

WHAT 15 MINUTES A DAY WILL SHOW YOU

How to address business meetings
How to propose and respond to toasts
How to make a political speech
How to tell entertaining stories
How to write better letters
How to enlarge your vocabulary
How to develop self-confidence
How to acquire a winning personality
How to strengthen your will power
How to be the master of any situation

NORTH AMERICAN INSTITUTE

Dept. 1358, 3601 S. Michigan Ave., Chicago, Illinois

NORTH AMERICAN INSTITUTE, Inc.

Dept. 1358, 3601 S. Michigan Ave., Chicago, Ill.

Please send me FREE and without obligation my copy of your famous book, "How to Work Wonders with Words."

Name.....

Address.....

City.....State.....



Play Your Way to Greater Popularity with the fascinating HAWAIIAN GUITAR

Play all the
LATEST HITS
just as the
Hawaiians do

\$15
HAWAIIAN GUITAR
with Genuine Seal Grain
Fabrikoid Cover

FREE
when you
enroll

Be the most popular member of your set. Get in on all the good times. Play all the new song and dance hits. Entertain your friends—or play professionally. Be in demand everywhere. We will help you.



Learn Quickly and Easily in Spare Time at Home

Even if you don't know one note from another, our method is so simple, plain and easy that you begin a piece your first lesson. In half an hour you can play it! You study in spare time—when you like—as long as you like. And your lessons are always before you to refer to at any time.

Complete Conservatory Course

You get 52 complete printed lessons. Nothing is omitted. Pictures explain every move. And no matter how little you know about music, no matter if you have never touched a musical instrument, our easy picture method will make you an accomplished player.

Only 4 Motions to Learn

Then you can play any music—popular songs, classical, old-time melodies, native Hawaiian airs—or real jazz—separately or with accompaniment. You'll never be lonesome when you can play the Hawaiian Guitar. By our simple method you learn—and learn quickly. No waiting for class to form—you can begin now.

Our Native Hawaiian Instructors Will Show You How

You receive expert instruction from such world-famous players as Kolomoku, Kalaluki, Ferera and Seville. They quickly teach you the secrets of this fascinating instrument. And remember—the services of these gifted native masters of the Hawaiian Guitar are obtainable only through this old-established New York Conservatory.

New Invention Makes It Easy

Our course includes a marvelous invention which helps you to make rapid progress. You will be astonished how quickly you learn to play this popular musical instrument, the Hawaiian Guitar, just as the Hawaiians do!

Our Written Guarantee

Anyone can play the Hawaiian Guitar. We guarantee in writing to teach you. The success of 45,000 students backs up our claim. Like them, you can soon be a full-fledged player, your popularity established and constantly increasing, a professional career ahead of you if you desire. And we coach and advise you after graduation—with no extra expense.

Pay as You Play

We make it easy for you to obtain the many advantages of this big Conservatory. You start with a small first payment—then pay while learning. It comes to only a few cents per lesson. And bear in mind—your only investment is the moderate cost of your lessons—we furnish everything else.

This Sweet Toned Hawaiian Guitar FREE

This sweet-toned Hawaiian Guitar would cost you at least \$15 in any music store without the genuine Seal Grain Fabrikoid Case. We give you the entire outfit free when you enroll, including everything necessary to carry on your studies and play the instrument. We can do this because we make them in huge quantities in our own factory.

**First Hawaiian
Conservatory of Music, Inc.**
9th Fl., Woolworth Bldg.,
Dept. 48 New York

Approved as
a Correspondence School
Under the Laws of the
State of New York



No
Extras
—We
Furnish
Everything

Including
the Free
Hawaiian
Guitar
in genu-
ine Seal
Grain
Fabrikoid
Case
—picks,
steel playing
bar and 52
pieces of
music.

Other
Courses

Famous
teachers con-
duct our
courses in
Tenor Ban-
jo, Violin,
Mandolin,
Banjo-
Ukulele,
Ukulele.

This is the Popularity Coupon ~ MAIL IT NOW

First Hawaiian Conservatory of Music, Inc.
Dept. 48, 9th Floor, Woolworth Bldg., New York, N. Y.

Please mail full information about your 52-lesson
Hawaiian Guitar Course. I am not obliged to
enroll unless I want to.

Name

Address

City

State



H.A. McCARRIE

Be a Dental Laboratory Expert!

**My Graduates
Are Successful!**

Let McCarrie train you

My Students Did These Jobs!



Lingual (Tongue) Bar Plate
Used where all the back (posterior) teeth are missing. The gold clasps help to hold the plate in place, and the gold bar provides additional strength and room for the tongue.



Full upper plate, ordered by Dentist where patient has lost all upper teeth.



Lower removable bridge, needed where molars are missing on one side only.

What Is Dental Laboratory Work?

Successful, busy Dentists no longer make their own plates, crowns, bridges, etc. They send "impressions" to a Dental Laboratory where the work is done by EXPERTS. Gold, silver, porcelain, rubber are some of the materials used. The work is pleasant, interesting, easy.



Laboratory of Glen Davis

In Tennessee—a McCarrie graduate. "I encourage my graduates to go into business for themselves and I help them succeed."



"Earnings four times larger"
"I am still with Dr. Medina, doing all his work and making good. My earnings are four times larger than before I entered your school. Thank you for assisting me to this fine position."
J. CARRILES.



"Course intensely practical."
"Any man who wants to become a first class mechanical dentist can do so at your schools. You teach by making the student do actual work."
E. SCHNEIDER.
(Penn.)



Deutschman of So. Dakota.
"I now have a good job working for New York Dentists. I like my work fine. Thank you very much for helping me."



"I can say frankly that I appreciate your good help and cooperation. Any man in earnest can master mechanical dentistry at your school."
Harry D. Stone,
(Montana.)

**Be McCarrie Trained
If You Would Be
Successful!**

**Many McCarrie Graduates Earn
\$65 to \$125 A Week!**

Don't crowd into the old over-crowded trades. Before you decide which line of work to go into—look into the **Dental Laboratory business**. You'll find it's an interesting, easy, WELL-PAID Mechanical profession—easily learned in a few months in my big schools at Chicago, Detroit and Cleveland. You'll discover there's a brighter future, bigger opportunities to make real money in "Mechanical Dentistry," because 70,000 busy Dentists **must** send their Laboratory jobs to Experts, specialists.

LEARN QUICK THE McCARRIE WAY!

I have successfully trained many men and women with only common schooling and no previous experience. No text-books, no classes in my schools. You learn here by doing actual Dental Laboratory jobs on standard materials, with standard tools which I supply without extra charge. Individual, personal instruction only.

R. R. FARE FREE to Chicago, Detroit, Cleveland

—to every student who enrolls. Actually Free, because I have not raised the price of tuition a penny since announcing this offer. For a limited time also, I am supplying every student with a complete outfit of new tools and materials. Tuition within reach of the untrained fellow who wants to get ahead. Easy terms.

Mail COUPON for FREE CATALOG. Specify
Offers, Complete information, Don't wait.
Send today!

JOBS — or a Laboratory of Your Own!

Very little capital needed to go into business when you have McCarrie training. My instruction includes training in Laboratory methods and management. When you finish, we will help you find a good location for a Laboratory of your own, help you start, help you make a success of it. Or if you prefer a job at good pay, we give you absolutely free the services of our Employment Department which has placed many of my graduates in fine positions.

A JOB While You Train

My schools are located in three wonderful cities where we can always help you find a spare-time job if you must "work your way through." We maintain a special employment department to find positions for my students. So don't hesitate because you haven't ready cash in your pocket. Show me you're willing and ambitious and I'll go the limit for you.

H. A. McCarrie, Director
McCarrie Schools of Mechanical Dentistry
1338 S. Michigan Ave., Dept. 2801-L, Chicago.
I want to know more about the Dental Laboratory business, your schools and training. Also send me your special offers mentioned in POPULAR MECHANICS (without cost or obligation).

Name.....

St. No.....

City..... State.....

McCarrie Schools of Mechanical Dentistry

1338 S. Michigan Ave., Dept. 2801-L, CHICAGO

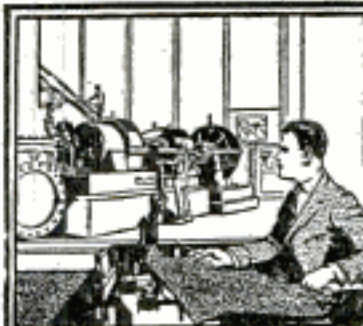

Be Superintendent of an Electrical POWER PLANT



Own Your Own Electrical REPAIR SHOP

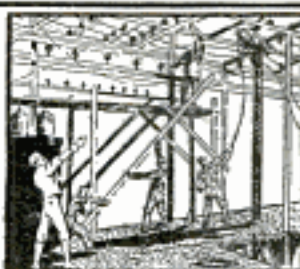

Boss Electrical Construction Jobs



Be an Electrical CONTRACTOR

Train At Home
for a fine
ELECTRICAL
JOB and
a big **RAISE**
IN
PAY!

If you're now earning less than \$40 a week

—if you want to be an **ELECTRICAL EXPERT**—if you want to step quickly into the class of men earning from \$60 to \$250 a week—**write me at once!** This million dollar school offers ambitious fellows their big opportunity to learn every branch of Electricity at home in spare time by a new, practical **JOB-METHOD**.

Learn Electricity Quick by Dunlap "Job-Method"

My students make rapid progress because I train them on actual Electrical jobs with standard-sized tools and materials which I supply without extra cost. The first half of my training is **APPLIED ELECTRICITY**—a complete course in itself. In the second half I give you Electrical Engineering subjects. I give you Electrical Drafting, Radio, Automotive Electricity, and many other valuable subjects, all for one small price, and on easy terms.

EARN MONEY WHILE Learning

Early in your training I give you special instruction in house-wiring, Radio-building, Electrical Repair Work, etc. I show you how to get spare-time work—work you'll be well paid for.

The American School

is chartered under the laws of Massachusetts, as an educational institution **NOT FOR PROFIT**. Established 29 years. Over 200 Executives, Engineers, and Educators have prepared the texts used in these wonderful home-study courses.

Get My Pay-Doubling Offer!

Before you put your time and money into home-training, you want to know if it will lead to a better job and bigger pay. **I will answer that in plain English.** Get my catalog, my wonderful new guarantee, my sensational offers—quick! Before you enroll for any home-training, get the facts about my training, so you can compare it intelligently with others.

Write me today!

Chief Engineer **DUNLAP**, Electrical Division

AMERICAN SCHOOL, Dept. E-874
Drexel Ave. & 58th St. CHICAGO



\$10 Motor—4 Big
Outfits Given to
every Student
Not a Penny Extra Cost



Chief Engineer Dunlap

23 Training Built by NOTED ENGINEERS

This is not a one-man, one-idea school. 23 famous Engineers and Executives of the following corporations and universities helped me make Dunlap-training complete and up-to-date.

1. General Electric Co.
 2. Commonwealth Edison Company
 3. Crocker-Wheeler Co.
 4. Cutler-Hammer Mfg. Company
 5. American Telephone & Telegraph Co.
 6. Westinghouse Electric & Mfg. Co.
 7. Western Electric Co.
 8. Underwriters Laboratories, Inc.
 9. Columbia University
 10. Dartmouth College
 11. Massachusetts Institute of Technology
 12. Lehigh University
 13. University of Vermont
- AND MANY OTHERS

4 big

Electrical Outfits Given!

Costly, standard, full-size tools, materials and equipment. The man-size motor of the same type as the big-fellows in a power plant. Not a toy, but a regular power-motor. Runs on Alternating or Direct Current, or 32-volt farm electric system. Comes to you knock-down. It's part of your job to wind the armature and assemble it. That's the way you learn every branch of Electricity by the Dunlap Job-Method.

MAIL COUPON TO DAY

Chief Engineer Dunlap
AMERICAN SCHOOL, Dept. E-874
Drexel Ave. & 58th St., Chicago

I want to be an Electrical Expert. Please rush guarantee, job-service facts, complete information, money-saving offers.

Name.....

St. No.....

City..... State.....



DRAWING *is a way* to FORTUNE

Ali Hafed, a Persian farmer, sold his acres to go out and seek his fortune. He who bought the farm found it contained a diamond mine which made him fabulously rich. Ali Hafed overlooked the great opportunity at his door to go far afield in search of wealth—which illustrates a great truth.

DO YOU LIKE TO DRAW?

If you do it is almost a certain indication that you have talent, a talent which few possess. Then don't follow Ali Hafed's example and look farther for fortune. Develop your talent—your fortune lies in your hand!

Earn \$200.00 to \$500.00 a Month and More

Present opportunities for both men and women to illustrate magazines, newspapers, etc., have never been exceeded. Thousands of publishers buy millions of dollars' worth of illustrations every year. Illustrating is the highest type of art—pleasant work, yielding a large income.

THE FEDERAL COURSE IS A PROVEN RESULT GETTER

It is the only Home Study Course which has been built by over fifty nationally known artists—Sid Smith, Neysa McMein, Norman Rockwell, Clare Briggs, Charles Livingston Bull and Fontaine Fox among them.

FREE—"A ROAD TO BIGGER THINGS"

If you like to draw you should read this free book before deciding on your life's work. It tells about illustrating as a highly paid, fascinating profession and about the famous artists who have helped build the Federal Course. Just tear out this ad, write your name, age, occupation and address in the margin, mail it to us and we will send you your copy of the book and the sample lesson free. Do it right now while you are thinking about it.

**Federal
School
of Illustrating**

1113 Federal School Bldg.

Minneapolis, Minn.

WANTED-MEN TO LEARN RADIO



\$75 to \$200 a Week

Right now, everywhere, big, easy money is being made in Radio. Field unlimited. You can master radio quickly at home in spare time. No previous experience necessary. Now is the time to enter this new, uncrowded field.

1,000 Mile Receiving Set—FREE

Our new home-study methods make everything about radio amazingly simple. No other course like it. Makes you expert on radio operation, repairs and installations of all kinds. Send for literature telling all about opportunities and how we give 1,000 mile receiving set FREE. Don't miss this big offer—ACT. Write now for big free book.

Radio Association of America
4513 Ravenswood Ave., Dept. A-11 Chicago

I POSITIVELY GUARANTEE that you can produce wonderful, sweet music in three days and quickly play popular and classical selections.



Complete Outfit
Sent on
Trial

No notes
to read.
No theory
practice.

Just three short, simple lessons revealing every secret of my 15 years' success as a professional saw musician. Amaze your friends with this sensation of radio, waltzville, orchestra and lodge entertainment. Send 10c for phonograph record of two beautiful Musical Saw solos which also entitles you to complete information about my special introductory offer of Saw, Bow, Hammer, and Rezin, FREE with Course of Instruction.

MUSSEHL & WESTPHAL
251 West Water St. Fort Atkinson, Wis.

LAW

STUDY AT HOME

Become a lawyer. Legally trained men win high positions and big success in business and public life. Be independent. Greater opportunities now than ever before. Big corporations are headed by men with legal training. Earn \$5,000 to \$10,000 Annually. We guide you step by step. You can train at home during spare time. Degree of LL.B. conferred. LaSalle students found among practicing attorneys of every state. We furnish all text material, including fourteen-volume Law Library. Low cost, easy terms. Get our valuable 108-page "Law Guide" and "Evidence" books FREE. Send for them NOW. LaSalle Extension University, Dept. 13364-L, Chicago. The World's Largest Business Training Institution.

Welding

Mr. Mechanic, be in demand! Expert welding is in demand in every part of the world. Earn top wages, or go into business for yourself. We train you at Home, in your Shop, or on the Job. "Kerr's Training Course for Welders" is a thorough course in practical experience, covering all metals. It trains you in WHAT TO DO, WHY IT IS DONE, and HOW TO DO IT. Write at once for information (state if you own or have access to a welding outfit). **KERR'S WELDING SCHOOL, Dept. 2, Box 1313, Los Angeles, Cal. (3)**

Buchstein's Fibre Limb

is soothing to your stump—strong, cool, neat, light. Easy payments. Braces for all deformities.

D. BUCHSTEIN CO.
610 3rd Ave., So., MINNEAPOLIS, MINN.

ZIP-ZIP

THOUSANDS of boys are made happy with this wonderful Zip-Zip shooter, something every boy wants and never gets tired of. Zip-Zip shooter is scientifically and practically made: boys, if you like hunting and outdoor sports, get a Zip-Zip shooter with plenty of pep and force and learn that quick and sure aim. If your dealer happens not to have them, order from us. Zip-Zip shooter complete 3.00 or three for \$1.00; send stamps, coin or money order.

AUTOMATIC RUBBER CO., Dept. 44, Columbia, S. C.

After Death—What?

That's the mystery. But don't get excited. You don't need to worry if you play the game square. You were given a good body to care for on earth. You were told to spread happiness, but *keep your body clean*.

Are you doing it? You are not. You've gone in for every possible kind of self-indulgence. You never stop to consider the consequences. Are you playing the game square? You're cheating both your Maker and yourself.

HOW TO LIVE

Cut it out, men! Why not be square shooters? Don't you realize what it means to you? Do you know you will really enjoy life better and live longer? Sure, you have to give up some things, but think what you get in return. I would give up a dime to get a dollar any day. The difficulty is, you are so chuck full of germs and decayed tissue by now, it would take you years to even get back to normal.

But listen, fellows. There's a short cut. I found it. I've been showing others how to take it for nearly 15 years. And not only do I chase those disease bugs out of you, and clean all that rotted tissue out of your body, but I put good, solid tissue—live, animated tissue—in its place. I build out your shoulders—I deepen your chest—I strengthen your back—I give you arms and legs like pillars. I teach you how to breathe so that your lung capacity is doubled. Every time you take a breath, you draw rich, pure oxygen down into every last minute cell of your lungs. This loads your blood with red corpuscles, which fly around your body in jig time, clearing the cobwebs out of your brain, toning up your liver, your kidneys and the muscles of the very organs themselves. In less than no time you'll feel the thrill of life shooting up your old spine. You'll feel like fighting a wild cat. You will have the flash to your eye and the snap to your step that will make people stop and say: "There goes a real he-man. Boy! but he has pep."

Is it worth it, fellows? You can bet your Sunday socks it's worth it. And the best of it is, it's a sure bet that you'll get it. Remember, I don't just promise these things. I guarantee them. Can you beat that? Try and do it.

Are you with me? Of course you are. Well, let's ride.

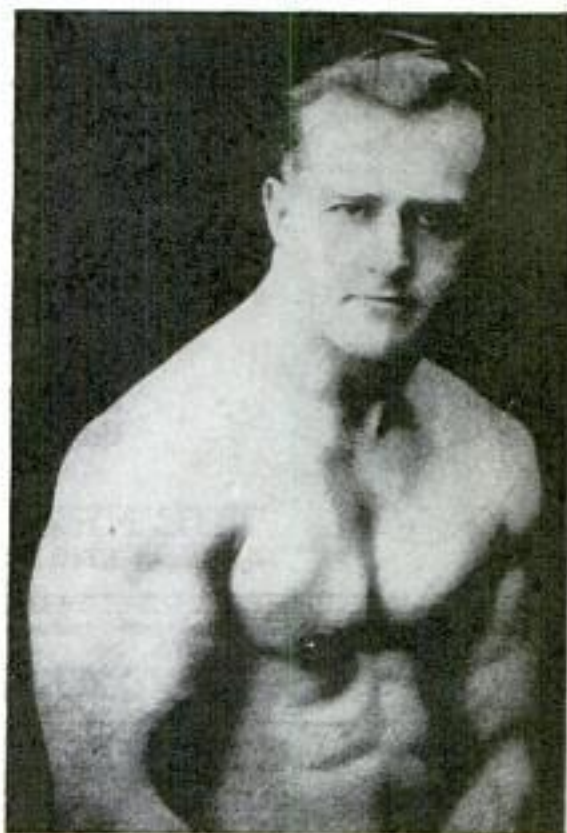

EARLE E. LIEDERMAN
The Muscle Builder

Author of "Science of Wrestling and Jiu Jitsu", "Muscle Building", "Secrets of Strength", "Here's Health", etc.

Send For My New
64 Page Book
"Muscular Development"
It Is FREE

What do you think of that? I don't ask one cent. And it's the peppiest piece of reading you ever laid your eye on. I swear you'll never blink an eyelash till you've turned the last cover. And there are 48 full-page photos of myself and some of my prize-winning pupils. This is the finest art gallery of strong men ever assembled. And every last one of them is shouting my praises. Look them over. If you don't get a kick out of this book, you had better roll over—you're dead.

Come on, then. Take out the old pencil and sign your name and address to the coupon. Snap into it. Do it now. Tomorrow you may forget. Remember, it's something for nothing and no strings attached—no obligation. GRAB IT!

EARLE E. LIEDERMAN
Dept. 2011, 305 Broadway, NEW YORK CITY

**It
Is
F
R
E
E**

**DON'T
SEND ONE
PENNY
—
YOUR
NAME AND
ADDRESS
ON A
POSTAL
WILL DO**

EARLE E. LIEDERMAN
Dept. 2011, 305 Broadway, New York City.

Dear Sir: Please send me, absolutely FREE and without any obligation on my part whatever, a copy of your latest book "Muscular Development."

Name.....

Street.....

City..... State.....

(Please write or print plainly)

Learn By Doing!

Every phase of all branches of

ELECTRICITY

Taught By Actual Practice

In America's foremost institution for trade training.

Established 1902

No Books Used

Individual Instruction. Start Any Day.

A SPECIAL and SEPARATE Course in Ignition, Auto Lighting and STARTER Systems.

Write for FREE 64-Page Catalog

THE NEW YORK ELECTRICAL SCHOOL
44 West 17th Street NEW YORK CITY

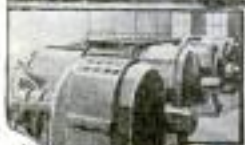

Ludwig
YOUR MARK

Trap Drummers! With one of the new Ludwig Trap Drum outfits you will be able to make from \$75 to \$200 a week. Nearly all famous drummers use Ludwig equipment. Write us today for full information on all outfits. **LUDWIG & LUDWIG, The World's Largest Manufacturers of Percussion and Rhythmic Instruments, Drum Makers to the Profession, 1611 N. Lincoln St., Dept. 1358, Chicago, Ill.**

Learn Advertising at HOME

The highest paid men in the world are advertising men. You can learn easily and quickly at home during your spare time. Bigger opportunities now in advertising than ever before. Tremendous demand for our graduates at big pay.

Send for FREE Book. Giving interesting information and vital facts—just what you want to know about advertising. Write today!
PAGE-DAVIS SCHOOL OF ADVERTISING
Dept. 1358 3601 Michigan Ave., Chicago, U. S. A.



DO YOU LIKE TO DRAW?

It's Easy To Learn When Shown In The Right Way

Some of the cleverest cartoonists and comic artists in America today learned how to draw quickly—by following **CARTOONIST EVANS' SIMPLE AND EASY METHOD**. This school is recommended by foremost cartoonists because they know the students are handled right. If you like to draw, send 6c in stamps for **portfolio of cartoons and full details**. The course is **NOT EXPENSIVE**.

The W. L. Evans School of Cartooning 821 Leader Building CLEVELAND, OHIO

LAW IN YOUR SPARE TIME
Same course by correspondence as given for 15 years at classes of this college
L. L. B. DEGREE CONFERRED, 3 year
University course prepares for bar exam. Money back guarantee
Low fee, easy terms, includes 1924 12 volume library, lectures, lessons, all expenses. Write for free book.
HAMILTON COLLEGE OF LAW, G-H 2412 S. Michigan Ave., Chicago

ARE YOU SELF-CONSCIOUS? DO YOU STAMMER?

You must overcome Self-Consciousness—Mental Fear—Insecurity to succeed in the business and social world. Send 10c for amazing booklet, "Road to Poise and Achievement." Tells how thousands have conquered Self-Consciousness in a very short time. **SEYMOUR INSTITUTE, 56 W. 45th St., Dept. PM11, New York City**



WANTED!
U. S. RAILWAY MAIL CLERKS

STEADY WORK—NO LAYOFFS—PAID VACATIONS
TRAVEL—SEE YOUR COUNTRY
Common Education—Mail Coupon Today—SURE

\$1900 to \$2700 Year
Men—Boys 18 Up. Hundreds
Gov't Jobs Obtainable

Franklin Institute, Dept. J 181, Rochester, N. Y.
Sirs: Send me, without charge: (1) Specimen Railway Mail Clerk Examination questions; (2) tell me how to get a U. S. Government job; (3) send list of places at which examinations will be held; (4) send copy of illustrated book, "How to Get U. S. Government Jobs."

Name.....
Address.....



Where Shall We Mail Your Copy of this Book—FREE

Remarkable new book on Salesmanship just off the press will be mailed to you without cost or obligation

THE contents of this amazing new book — just published by the National Salesmen's Training Association — will prove a revelation to every man who is interested in making real money—and to those who realize the tremendous possibilities for high earnings in the selling field.

Thirty thousand copies of this book will be mailed free without cost or obligation to those who send for it while the supply lasts—and there is no time like the present for you to fill in the coupon below.

FULLY EXPLAINS NATIONAL DEMONSTRATION METHOD

Thousands have wondered why N. S. T. A. Members invariably make good, in a big way, right from the start, even though they have had no former selling experience, or why salesmen who have just plodded along with indifferent success quickly begin to outstrip their brother salesmen after becoming members of the Association.

Among other things, this remarkable free book explains just why success comes rapidly and surely to those who enroll for this amazing System of Salesmanship Training.

There are too many victims of that vicious superstition that "salesmen are born and not made," but after reading "Modern Salesmanship," you will realize the utter fallacy of that foolish notion.

QUICK SUCCESS THROUGH N. S. T. A. TRAINING

EMPLOYERS

are invited to write to the Employment Dept. of the N. S. T. A. No charge for this service to you or our members. Employers are also cordially invited to request details about the N. S. T. A. Group Plan of instruction for entire sales forces. Synopsis and charts sent without obligation.

Whether you have had selling experience or not, it makes no difference. The N. S. T. A. System of Salesmanship Training will enable you to become a Master Salesman in an amazingly short period of time. It will teach you, in your spare time, at home, the fundamental rules and principles of selling—how to approach different types of prospects to get their undivided attention—certain ways to stimulate keen interest—ways to overcome objections, batter down prejudices, outwit competition, and make the prospect act.

Step by step this Training takes you through every phase of Salesmanship. Every underlying principle of sales strategy is made as simple as A B C. Through the National Demonstration Method, you get actual experience on practically every type of sales problem that may ever present itself. And through the instruction in Character Analysis, you will become an expert in reading character on sight—a valuable asset for any salesman.

JUST MAIL THE COUPON THE BOOK IS FREE

To fill in and mail the coupon will not obligate you in any way, but it, undoubtedly, will show you the way to be a "star" salesman. No matter what you may think now, it can only be a thought and it will pay you to let us send you this valuable and interesting book.

While this is before you, fill in and mail the coupon and get it into the mail some time today.



National Salesmen's Training Association

Dept. S-12, N. S. T. A. Building, Chicago, Ill.

National Salesmen's Training Ass'n, Dept. S-12, N. S. T. A. Building, Chicago, Ill.

Without cost or obligation you may send me your free book, "Modern Salesmanship," and all I promise to do is to read it through carefully.

Name.....

Address.....

City.....State.....

Age.....Occupation.....



Quick Easy Way to Learn Drawing

How you can earn big money in Commercial Art, Illustrating, Designing or Cartooning, without being a "genius," and regardless of your present ability.

Never was there such a need for artists as today! Business revitalized needs thousands. Illustrated catalogs, advertisements, posters, circulars, trade-mark designs—countless pieces of art work are needed by the busy business world. 48,868 periodicals are published in America—every one of them needs the services of at least two artists for each issue. You can't begin to realize the gigantic amount of art work that must be done—and the demand is increasing daily. Big money is gladly paid—and big money is waiting for anyone with foresight enough to prepare for this pleasant profession. Through our quick, easy method of teaching, YOU can earn \$40 to \$100 a week as an artist, regardless of your present ability.

Learn in Spare Time

This simple method is like a fascinating game. No matter how little you may know about drawing, no matter whether people tell you, "you have no talent," no matter what your present ability may be—if you can write we can teach you to draw. The quick method simplifies everything—all the red-tape, "art for art's sake" teaching and superfluous theory is taken out and in its place is put definite, practical instruction so that you will make money in the art game. The course is the work of an expert—an artist of over 35 years' practical experience. And all your instruction is under his personal supervision.

Write for Interesting Free Book

An interesting and handsomely illustrated booklet, "Quick Easy Way to Become an Artist," has been prepared and will be sent to you without cost if you mail the coupon below. Mail coupon NOW for this attractive free book and full details about our Special Offer of a FREE ARTIST'S OUTFIT to every new student. No obligation whatever. Address Washington School of Art, Inc., Room 3011-C, 1115-15th St. N. W., Washington, D. C.

WASHINGTON SCHOOL OF ART, Inc.

Room 3011-C, 1115-15th St. N. W., Washington, D. C.

Please send me, without obligation, free book, "How to Become an Artist," together with full particulars of Free Artist's Outfit Offer to every new student.

Name

(State whether Mr., Mrs. or Miss)

Address

City..... State.....

YOU Can Be a Dental Laboratory Expert

Make Up to \$150 A Week This Expert Is Stivison Trained



He Can Earn More in one day than the average Mechanic does in a week. He got it the same way you will get it if you select the

Stivison Way

Personal Instruction to Each Student in One Big School for Mechanical Dentists. Students are taught on Patients' work that is actually used. **Only Modern Methods Taught.** Thousands of dentists need Laboratory Experts.

Stivison Trained Graduates

Always in Demand Jobs Hunt You. Every Dentist does Laboratory Work that he would gladly have done by an expert and pay Big Prices.

Real Dentist's Tools are furnished and Instructions given by Real Dentists on work that Dentists need.

Our attractive Illustrated Catalog tells of many others who are earning big money and how easy you may be able to get into the Big Pay Class. If you live in Maine or California, it costs no more for you than it does for one living in Mo. or Kas., because WE PAY YOUR R. R. FARE TO KANSAS CITY. WE FURTHER ASSIST YOU in paying your TUITION by allowing You to Earn While You Learn. Bear in mind, the Catalog is Free and no man ever got in the Big Pay Class by wondering what he should do. Decide now and write for this "Short Cut to Success" today.

STIVISON DENTAL INSTITUTE

501 McMillen Bldg.

Kansas City, Mo.

WRITE for big book on wrestling. Tells secrets you've always wanted to know.



Learn How to WRESTLE

In Your Own Home

By Mail

Yes, learn to become an expert wrestler right in your own home. By mail, from the greatest wrestlers the world has ever known. Be an athlete, be strong, be healthy. Learn how to throw and handle big men with ease. Learn to defend yourself. Learn from the World's Champions.

Farmer Burns and Frank Gotch Secrets

Farmer Burns, who taught Frank Gotch—trainer of SEVEN World's Champions, will teach you Scientific Wrestling—Physical Culture—Jiu-Jitsu and Self-Defense. Write today for big wrestling book, illustrated with many fine pictures—shows holds and secret tricks used by champions. Tells how easy it is to learn the marvelous breaks, falls and holds that make you an expert. Send today for this wonderful book. Enclose only 10c to help cover cost of wrapping and postage. Be sure to state age. No obligation.

Farmer Burns, 1778 Ry. Exch. Bldg., Omaha, Neb.

Send Now for Farmer Burns' Book

LEARN AUCTIONEERING

At World's Original School. Successful Auctioneers make big money. Write today for free catalog and important information.

Carey M. Jones National School of Auctioneering
8 N. Sacramento Boulevard Chicago, Illinois

"STAMMERING

Its Cause and Cure"

You can be quickly cured if you stammer. Send 10 cents, coin or stamps, for 288 page cloth bound book on Stammering and Stuttering. It tells how I cured myself after Stammering and Stuttering for 20 years. BENJAMIN N. BOGUE
6927 Boque Building, 1147 N. Hill St. Indianapolis

MINSTRELS Musical Comedies and Revues, with full instructions for staging. You can stage your own show with our books. Full line of plays, stage songs, crossfire, monologues, afterpieces, vaudeville acts and make-up. CATALOGUE FREE.
T. S. Denison & Co., 623 S. Wabash Ave., Dept. 19, Chicago

22 YEARS OF SUCCESS

CHICAGO TECHNICAL COLLEGE



FROM THIS RECOGNIZED COLLEGE OF ENGINEERING

a Home-Study Course in

DRAFTING

Everything today is built from drawings made by Draftsmen. Industry calls for 50,000 new men yearly. Draftsmen work hand in hand with the architect, the engineer, the designer, the builder. And thus many men rise from such positions to be heads of great contractors' organizations, directors of railroads, chief engineers—responsible positions commanding very attractive salaries.



Mr. Bjarne C. Dahl

DRAFTING HALL OF FAME

Mr. Bjarne C. Dahl says: "Your training has sure been valuable to me. At 26 years of age I was earning \$300.00 a month. And now, at 28, I am Architectural Engineer for J. Morgan, Architect, in California. The Chicago Technical College gives the finest technical training one can get, being the most thoro and practical. Am going to Honolulu in September to inspect a big building project there for my firm."

NOTICE—A well established Placement Bureau assists both graduates and undergraduates to find positions.

FREE TRIAL LESSON

Prove your fitness and liking for one of industry's highest paid professions. We want you to know what Drafting is like... how readily you can progress... how we train and teach you by mail. So, before you enroll... FREE... without cost or obligation... we send you a trial lesson to study in your own home.

Within Ten Months Increase Your Income

No special training or talent is required. In 10 months' time or less... we can train you... at home, in your spare hours... to be a good Draftsman.

And remember this: In Drafting a big income is open to every properly trained man. Thousands today are earning \$35 to \$100 per week. The reason is simple: Good Draftsmen are in constant demand.

Book of Facts FREE

We will send you a 40-page Book. It tells you all about Drafting... and our courses. What prominent men say... where Draftsmen are employed... their salaries... their opportunities... what our students have done and are doing... how many have increased their salaries even before finishing their courses... how many hold high-sal-

aried executive positions today. Tells how 34 instructors give you from this recognized 22-year-old college a practical, short, home-study course.

The Coupon Below Means Money to You

Find out what Drafting may mean to you... mail that coupon. Here is a field in which you can work and win.

We make the test easy, for, with no obligation, we send you a trial lesson FREE. Note the fairness of this offer, the absence of exaggerated promises.

\$25 Outfit Included

When you enroll, you will need drafting instruments; so, included in the cost of the course, is a \$25 "lifetime" set. If you have instruments, credit will be allowed. Note that we do not claim to give you these instruments "free". Tuition is low, payments easy.

In Chicago—Earn While You Learn

Those who can come to Chicago will find opportunity to earn living expenses in part-time positions, outside of school hours, while attending day or evening classes at the College.

Chicago Technical College, founded 1904, is known as one of America's oldest and largest schools of specialized engineering. Over 1000 men enroll in resident day and evening courses yearly.

Diplomas in Civil, Mechanical and Electrical Engineering and Architecture granted after two years. Degree of B. S. conferred after three years in the day course. Short courses offered in Drafting, Plan Reading, Estimating, etc. Evening classes for day workers.

If interested in attending Day or Evening Classes at the College in Chicago write for 72-page "Blue Book"—mailed free.

Send Today for FREE Trial Lesson
Fill Out the Attached Coupon NOW

Chicago TECHNICAL College

Drafting—Engineering—Electricity—Architecture... all branches

Chicago Technical College,
Dept. 1130, 118 E. 26th St., Chicago, Ill.

Name.....

Send me, without cost or obligation, your
FREE Trial Lesson and your 40-page Book
of Facts about Drafting.

Address.....

City and State.....



An Easy Way to Learn PHARMACY AT HOME

Graduate pharmacists are always in demand. The work is interesting and pleasant and salaries are good. Many young men open drug stores of their own and become independent.

There's an easy way to learn pharmacy right in your own home in spare time, without losing a day or a dollar from your present work.

The International Correspondence Schools course in Pharmacy supplies the knowledge which it will be necessary for you to have in order that you may pass your State Board Examination.

Just mark and mail the coupon printed below to the International Correspondence Schools, Box 5537-E, Scranton, Pa., and full particulars about the Pharmacy Course or any other work of your choice will come speeding to you by return mail.

INTERNATIONAL CORRESPONDENCE SCHOOLS Box 5537-E, Scranton, Penna.

Without cost or obligation, please send me full information about the subject before which I have marked an X in the list below:

TECHNICAL AND INDUSTRIAL COURSES

- | | |
|--|---|
| <input type="checkbox"/> PHARMACY | <input type="checkbox"/> Civil Engineer |
| <input type="checkbox"/> Chemistry | <input type="checkbox"/> Surveying and Mapping |
| <input type="checkbox"/> Automobile Work | <input type="checkbox"/> Mine Foreman or Engineer |
| <input type="checkbox"/> Navigation | <input type="checkbox"/> Steam Engineer |
| <input type="checkbox"/> Agriculture and Poultry | <input type="checkbox"/> Gas Engine Operating |
| <input type="checkbox"/> Mathematics | <input type="checkbox"/> Wireless <input type="checkbox"/> Airplane Engines |
| <input type="checkbox"/> Electrical Engineering | <input type="checkbox"/> Architect |
| <input type="checkbox"/> Electrician | <input type="checkbox"/> Contractor and Builder |
| <input type="checkbox"/> Mechanical Engineer | <input type="checkbox"/> Architectural Draftsman |
| <input type="checkbox"/> Mechanical Draftsman | <input type="checkbox"/> Concrete Builder |
| <input type="checkbox"/> Machine Shop Practice | <input type="checkbox"/> Structural Engineer |
| <input type="checkbox"/> Railroad Positions | <input type="checkbox"/> Plumbing and Heating |

BUSINESS TRAINING COURSES

- | | |
|--|---|
| <input type="checkbox"/> Business Management | <input type="checkbox"/> Salesmanship |
| <input type="checkbox"/> Industrial Management | <input type="checkbox"/> Advertising |
| <input type="checkbox"/> Personnel Organization | <input type="checkbox"/> Better Letters |
| <input type="checkbox"/> Traffic Management | <input type="checkbox"/> Foreign Trade |
| <input type="checkbox"/> Business Law | <input type="checkbox"/> Stenography and Typing |
| <input type="checkbox"/> Banking and Banking Law | <input type="checkbox"/> Business English |
| <input type="checkbox"/> Accountancy (including C.P.A.) | <input type="checkbox"/> Civil Service |
| <input type="checkbox"/> Nicholson Cost Accounting | <input type="checkbox"/> Railway Mail Clerk |
| <input type="checkbox"/> Bookkeeping | <input type="checkbox"/> Common School Subjects |
| <input type="checkbox"/> Private Secretary | <input type="checkbox"/> High School Subjects |
| <input type="checkbox"/> Spanish <input type="checkbox"/> French | <input type="checkbox"/> Illustrating <input type="checkbox"/> Cartooning |

Name.....
Street.....
Address.....

City..... State.....

Occupation.....

Persons residing in Canada should send this coupon to the International Correspondence Schools Canadian, Limited, Montreal, Canada

**QUIT WISHING
AND WAITING
EARN**

\$3500 to \$5000 a Yr.

**LEARN
MECHANICAL DENTISTRY**

*Three Months'
Training
Will Qualify
You for
Success.*

*2500 More
Dental Mechanics
Needed Now
and Demand
Is Increasing.*

YOU LEARN BY DOING

We train each student individually—no classes whatever—using the tools of the trade and you learn on regular dental work. But we do not make the **serious** mistake of depending on practical work alone. You are given definite theoretical training as well.

FREE PARTIAL SCHOLARSHIPS

Send today for Free Catalog No. 2, outlining Scholarship Offer, how students "Learn by Doing" actual work through practical, individual instruction, day or evening sessions, and how you can "Earn while Learning."

BODEE DENTAL INSTITUTE

Established 30 years.

New York
126 W. 52d St.

Philadelphia
1305 N. Broad St.

Buffalo
501 Washington St.

Brooklyn
85 Court St.

ELECTRICAL Course for men of ambition and limited time.
Over 4000 men trained.

Condensed course in Theoretical and Practical Electrical

ENGINEERING including the closely related subjects of Mathematics and Mechanical Drawing taught by experts. Students construct motors, install wiring, test electrical machinery. Course complete

IN ONE YEAR

Prepare for your profession in the most interesting city in the world. Established in 1893. Free catalog.

BLISS ELECTRICAL SCHOOL
221 Takoma Ave. WASHINGTON, D. C.

Study
AT
Home

Become More Efficient

Courses in *Mathematics, Chemistry, Psychology, Education, Business* and 40 other subjects command either High School or College credit. Start any time.

The University of Chicago
15 Ellis Hall CHICAGO, ILL.

BE AN ARTIST

Comics, Cartoons, Commercial, Newspaper and Magazine Illustrating, Paste Crayon Portraits and Fashion. Our simple method quickly develops your talent in spare time. By Mail or Local Classes. Write for forms and list of successful students. ASSOCIATED ART STUDIOS, Dept. B, 100 W. 23rd St., NEW YORK

LEARN WATCH REPAIRING

You can learn by our modern and original system of instruction every part of the **Watch Repairing Trade** at home as good or better than at a shop. You can earn money while learning and secure a well paying position or start in business after completing our course of instruction. Good watch repairers are always in demand and earn from \$50 to \$75 per week. For particulars apply to the **Wisconsin School of Watch Repairing**
166 Mason St., MILWAUKEE, WIS.

ELECTRICITY

Complete Study Course and Pocket Library \$10

SHIPPED FREE



A set of **HAWKINS GUIDES** is a good friend to the electrical worker. It tells you how to do any job the right way—without guessing or taking chances.

Hawkins Guides put the facts about modern electrical engineering at your finger tips, making your chances for advancement in the electrical field unlimited.

HAWKINS GUIDES INCREASE YOUR PAY



Electricity is king! It is the great ruling force—transportation, communication, light, heat, power—almost every modern activity is dependent on electricity. Industry is demanding electrical men that know their jobs!

Hawkins Guides teach you all you need to know about electricity in easy, step-by-step lessons. Daily spare time reading of the Guides will greatly increase your value to yourself and your employer in a few weeks. Hundreds of our friends have written us and told us this!

READERS OF HAWKINS GUIDES KNOW HOW



"You can't stump him on an electrical job." "He certainly knows his business." "Certainly have to hand it to him for knowing how."—These are the things employers say about our friends who are readers of **Hawkins Guides**. No matter what question or problem comes up the Ready Reference Index enables you to give an expert answer at once.

HAWKINS STARTS YOU WHERE OTHERS LEAVE OFF

Don't work any longer at low wages when easy reading of **HAWKINS GUIDES** will give you the money-making knowledge of the expert! Easy daily reading of the Guides will teach you in a few months what it has taken the expert a lifetime to learn!

With **HAWKINS GUIDES** in hand you have a running start to success in the electrical field. You will actually begin where others left off!



NOW!

This coupon is your golden opportunity. Tear it out—send it now!

FOR EXAMINATION!

REAL ELECTRICAL EDUCATORS

"Hawkins Guides at \$10 are the best investment I have ever made. Am able to take up almost any electrical job and have never gone to an electrical school."—**B. Roessler, Oenaville, Texas.**

AS EASY AS A. B. C.

"Everything in Hawkins Guides is very plain and anybody can read and understand them as easy as A. B. C."—**J. Knight, Tobyhanna, Pa.**

OTHER READERS SAY

"Worth ten times their price." "Helped me to two raises in four months." "Better than a school of instruction." "Studied them when I was laid up and got further ahead than if I had been on the job."

Hawkins Guides Explain These Points So You Can Easily Understand:—

Magnetism—Induction—Experiments—Dynamometers—Electric Machinery—Motors—Armatures—Armature Windings—Installing of Dynamometers—Electrical Instrument Testing—Practical Management of Dynamometers and Motors—Distribution Systems—Wiring—Wiring Diagrams—Sign Flashers—Storage Batteries—Principles of Alternating Currents and Alternators—Alternating Current Motors—Transformers—Converters—Rectifiers—Alternating Current Systems—Circuit Breakers—Measuring Instruments—Switch Boards—Wiring—Power Stations—Installing—Telephone—Telegraph—Wireless—Bells—Lighting—Railways. Also many Modern Practical Applications of Electricity and Ready Reference Index.

Hawkins Guides—10 POCKET SIZE NUMBERS

Each number easy to carry around and read in spare time. Big type and clear diagrams. Easy to study and learn. Durable, flexible binding—gold edges. 3,500 pages—4,700 illustrations. Shipped free for examination. Pay only \$1 a month if satisfied. Price of set, complete, \$10.



EXAMINE GUIDES FREE! \$1 PER MO.

Let the Guides themselves demonstrate their practical value to you—as a study course, reference work and complete electrical library. You are the judge. Simply send this coupon. No obligation unless you are entirely satisfied. Tear out on dotted line—fill in—mail it NOW!

FREE EXAMINATION COUPON

Theo. Audel & Co., 65 W. 23rd St., New York City

Please send me (postpaid) for my approval **Hawkins Electrical Guides**, 10 numbers (price \$1 each). If satisfactory I will mail you \$1 in 7 days and further mail \$1 monthly until purchase price of \$10 is paid.

Name.....

Address.....

Occupation.....

Employed by..... 11 T 30



High School Course in Two Years!

You Want to Earn Big Money!

And you will not be satisfied unless you earn steady promotion. But are you prepared for the job ahead of you? Do you measure up to the standard that insures success? For a more responsible position a fairly good education is necessary. To write a sensible business letter, to prepare estimates, to figure cost and to compute interest, you must have a certain amount of preparation. All this you must be able to do before you will earn promotion.

Many business houses hire no men whose general knowledge is not equal to a high school course. Why? Because big business refuses to burden itself with men who are barred from promotion by the lack of elementary education.

Can You Qualify for a Better Position

We have a plan whereby you can. We can give you a complete but simplified high school course in two years, giving you all the essentials that form the foundation of practical business. It will prepare you to hold your own where competition is keen and exacting. Do not doubt your ability, but make up your mind to it and you will soon have the requirements that will bring you success and big money. YOU CAN DO IT.

Let us show you how to get on the road to success. It will not cost you a single working hour. Write today. It costs you nothing but a stamp.

American School

Dept. H-874, Drexel Ave. and 58th St., Chicago

American School

Dept. H-874, Drexel Ave. and 58th St., Chicago

Send me full information on the subject checked and how you will help me win success.

- | | |
|-----------------------------|---------------------------|
|Architect |Business Law |
|Building Contractor |Lawyer |
|Automobile Engineer |Machine Shop Practice |
|Automobile Repairman |Mechanical Engineer |
|Civil Engineer |Shop Superintendent |
|Structural Engineer |Employment Manager |
|Business Manager |Steam Engineer |
|Cert. Public Accountant |Foremanship |
|Accountant and Auditor |Sanitary Engineer |
|Bookkeeper |Surveyor (& Mapping) |
|Draftsman and Designer |Telephone Engineer |
|Electrical Engineer |Telegraph Engineer |
|Electric Light & Power |High School Graduate |
|General Education |Wireless Radio |
|Vocational Guidance |Undecided |

Name

Address

Learn Furcraft

Learn by mail, evenings at home. Make up New Furs and Make Old Furs Like New. Learn Fur Repairing and Cleaning. Learn our secret processes. Learn glazing, ironing and storage. Big demand, big need in every neighborhood. A wonderful uncrowded field. Investigate.



\$3 an Hour!

In Your Spare Time

or a real business now and later a big fur shop. Next month earnings start if you earn now. Men and women equally successful.

Free Book Tells all about this greatest of Spare Time Money Makers. Big opportunity now in your neighborhood. Be first.

Send at once for Free Book and get full details of this money making business. No obligation. Write today.

NORTHWESTERN FUR COMPANY
1778 Sunderland Building, Omaha, Nebr.

LEARN WATCH REPAIRING

Be a watchmaker—you can learn this profitable trade by correspondence in a few weeks in your own home by the DeSelms Chart System. After you complete the course you will know a watch from A to Z. You will know just what the matter is and how to repair it. When you graduate you will be a practical watchmaker and repairer and competent to fill any position. Positions for our graduates. Ask for our Free Book. It explains our system and terms.



THE DeSELMS WATCH SCHOOL
LOGANSPORT, INDIANA

"BECOME A LIGHTNING TRICK CARTOONIST"

MAKE MONEY CHECK TALKING. SEND \$1.00 FOR SNAPPY PROGRAM OF TRICK DRAWINGS WITH INSTRUCTIONS BY A PROFESSIONAL CARTOONIST. SATISFACTION GUARANTEED. CIRCULAR FREE. BALDA ART SERVICE, Q.L. OSHKOSH, WIS.

Learn Mechanical Dentistry

Most profitable profession today. Intensive 3 months' course. We guarantee to teach you. Practical instruction; individual attention; unequalled curriculum. Lowest co-operative tuition fee. Tools and materials free when you enroll. Write for Free Catalog NOW! N. Y. School of Mechanical Dentistry, Dept. F-63, Penn Arcade, 147-153 W. 33rd St., N.Y.

STAMMERING

easily, permanently corrected. Win happiness and success. Ask for full information and special phonograph record. Send dime for postage. 153 Scimmon Ave., The LEWIS INSTITUTE, Detroit

TELEGRAPHY

(Morse and Wireless) and RAILWAY ACCOUNTING taught thoroughly. Big salaries; great opportunities. Oldest, largest school. Endorsed by Telegraph, Railway, Radio, and Government officials. Expenses low—opportunities to earn large portion. Catalog free. DODGE'S INSTITUTE, Jones St., Valparaiso, Ind.

Clear-Tone

The Wonder-Working Lotion

Used like toilet water. Is positively recommended for quickly and permanently removing

PIMPLES, BLACKHEADS,

Acne Eruptions on the face or body, Barbers Itch and Eczema, Enlarged Pores, Oily or Shiny Skin. Endorsed by druggists, physicians, skin specialists, barbers, and over 100,000 men and women test cases, who succeeded with Clear-Tone after failing with everything else.

FREE Write today for my FREE Booklet, "A CLEAR-TONE SKIN," telling how I cured myself after being afflicted for fifteen years.

E. S. GIVENS, 128 Chemical Building, Kansas City, Mo.



I Was Afraid of This New Way to Learn Music

— Until I Found It Was Easy As A-B-C

Then I Gave My Husband the Surprise of His Life

"DON'T be silly, Mary. You're perfectly foolish to believe you can learn to play music by that method. You are silly to even think about it. Why, it claims to teach music in half the usual time and *without a teacher*. It's impossible."

That is how my husband felt when I showed him an ad telling about a new way to learn music. But how I *hated* to give up my new hope of learning to play the piano. When I heard others playing, I envied them so that it almost spoiled the pleasure of the music for me. For *they* could entertain their friends and family. . . *they* were musicians. I had to be satisfied with only hearing music.

I was so disappointed. I felt very bitter as I put away the magazine containing the advertisement. For a week I resisted the temptation to look at it again, but finally I couldn't keep from "peeking" at it. It fascinated me so much that finally, half-frightened, half-enthusiastic, I wrote to the U. S. School of Music—without letting my husband know.

Imagine my joy when the course arrived and I found that it was as easy as A. B. C. Why, a mere child could master it! My progress was wonderfully rapid and before I realized it, I was rendering selections which pupils who study with private teachers for years can't play. For through this short-cut method, all the difficult, tiresome parts of music have been eliminated and the playing of melodies has been reduced to a simplicity which *anyone* can follow with ease.

One day not long after my husband came to me and said, "Mary, don't laugh, but I want to try learning to play the violin by that wonderful

method. You certainly proved to me that it is a good way to learn music."

So, only a few months later Jack and I were playing together. Now our musical evenings are a marvelous success. Every one compliments us, and we are flooded with invitations. Music has simply meant everything to us. It has given us Popularity! Fun! Happiness!

If you, too, like music . . . then write to the U. S. School of Music for a copy of the booklet "Music Lessons in Your Own Home," together with a Demonstration Lesson, explaining this wonderful new easy method.

Don't hesitate because you think you have no talent. Thousands of successful students never dreamed they possessed musical ability until it was revealed to them by a wonderful "Musical Ability Test." You, too, can learn to play your favorite instrument through this short-cut method. Send the coupon. The Demonstration Lesson showing how they teach, will come AT ONCE.

Pick Your Course!

| | |
|-------------------------|------------------|
| Mandolin | Flute |
| Drums and Traps | Harp |
| Harmony and Composition | Cornet |
| Sight Singing | Cello |
| Ukulele | Hawaiian |
| Piccolo | Steel |
| Trombone | Guitar |
| Saxophone | Voice and Speech |
| Piano | Culture |
| Organ | Automatic |
| Violin | Finger |
| Banjo | Control |
| Clarinet | Piano |
| | Accordion |

Address the U. S. School of Music, 711 Brunswick Building, New York.

Instruments supplied when needed, cash or credit

U. S. SCHOOL OF MUSIC.

711 Brunswick Bldg., New York City

Please send me your free book, "Music Lessons in Your Own Home," with introduction by Dr. Frank Crane, Demonstration Lesson and particulars of your Special Offer. I am interested in the following course:

Have you above instrument?.....

Name.....
(Please Write Plainly.)

Address.....

City.....State.....

LEARN CARTOONING

Successful cartoonists earn big salaries. Many of the most popular cartoonists of today learned to draw in their spare time, at home, through the Landon Course of Cartooning and now earn \$75 to \$200 or more per week.



The Landon Picture Chart Method of teaching ORIGINAL drawing makes cartooning easy to learn. Hundreds of sketches like the above explain every step in creating ORIGINAL heads, figures, animals, etc. Send 6c in stamps today for sample Landon Picture Chart and full explanation of this wonderful course, also long list of successful Landon students and information showing possibilities for you. *Please state your age.*

The Landon School, 738 National Building, Cleveland, Ohio

Former Students Who Are Now Successful Comic Strip Artists

BLOSSER—Now drawing "Freckles and His Friends."
BYRNES—Now drawing "Reg'lar Fellers."
BRANNER—Now drawing "Winnie Winkle."
LOCHER—Now drawing "Cicero Sapp."
TAYLOR—Now drawing "Mom 'n Pop."
EDWINA—Now drawing "'Cap' Stubbs."
CRANE—Now drawing "Washington Tubbs II."
ETHEL HAYS—Now drawing "Flapper Fanny."
PAUL FUNG—Now drawing "Gus & Gussie."
KNICKERBOCKER—Now drawing "This and That."

New 1926 Catholic Art Calendar

NOW READY

Printed in Four Beautiful Colors 14 pages, actual size 9x17 inches. Order today.

Price 40c each; 3 for \$1.00; \$3.90 per dozen

Specialty Salesmen write for our special proposition

EXTENSION PRESS, 915 Le Moyne Bldg., 25 E. Lake St., Chicago, Ill.

Comedies, Dramas, Musical Comedies and Revues, Minstrel Choruses, Songs, Blackface Plays, Everything for Burnt Cork Shows and All Amateur Entertainments, Monologs, Dialogs, Speakers. **CATALOGUE FREE.**
T. S. DENISON & CO., 623 So. Wabash, Dept. 9, CHICAGO

PLAYS

Vaudeville Acts
How to Stage a Play
Make-up Goods

LUCKY SAW ROLLED GOLD
 "Answers questions, solves problems" says the Old Carpenter. A beautiful charm of pocket piece. Rolled gold. Highly polished. Fastening, amusing. Full instructions for use. Money back guarantee. Send 1c now for Lucky Saw to "LUCKY JOE" CO., 152 W. 42 St., New York, Room 1423A.

Information on any book free. Write Popular Mechanics Press, Chicago, Ill.

No Better Christmas Present for \$2.50

than a year's subscription to

Popular Mechanics Magazine

Containing 4500 Pictures and 3600 Articles

Much of it Interests Everybody

Most of it Interests Anybody

All of it Interests Somebody

Order through your Newsdealer or address the Publisher

POPULAR MECHANICS COMPANY

200 East Ontario Street, CHICAGO, ILL.

A PERFECT LOOKING NOSE

Can Easily Be Yours

Trades Model No. 25 corrects now ill-shaped noses quickly, painlessly, permanently and comfortably at home (excepting cases caused by improper bone structure). It is the only adjustable, safe and guaranteed patent device that will actually give you a perfect looking nose. Over 90,000 satisfied users. For years recommended by physicians. 16 years of experience in manufacturing Nose Shapers is at your service. **Model 25 Junior** for children. Write for testimonials and free booklet, which tells you how to obtain a perfect looking nose.

M. TRILETY, Pioneer Nose-shaping Specialist
 Dept. 2476 Binghamton, N. Y.



"THERE'S MONEY IN IT"

AT HOME

LEARN TELEGRAPHY

AT HOME

MORSE AND WIRELESS

TEACH YOURSELF

in half usual time, at trifling cost, with the wonderful Automatic Transmitter, **THE OMNIGRAPH**. Sends unlimited Morse or Continental messages at any speed, just as an expert operator would. Adopted by U. S. Government, and leading Universities, Colleges and Telegraph Schools. 3 Styles. Catalog free. **OMNIGRAPH MFG. CO., 13-19 Hudson St., NEW YORK**
 If you own a Radio Phone Set—and don't know the code—you are missing most of the fun.



WANTED

RAILWAY POSTAL CLERKS
 CITY CARRIERS—POST OFFICE CLERKS

\$1700 to \$2700 Year
 (All Postal Pay Just Raised)

MEN—BOYS, 18 UP

Steady work. No layoffs. Paid vacations
 Travel—See Your Country

Common education sufficient. Mail coupon today—SURE!



MAIL CLERKS

FRANKLIN INSTITUTE, Dept. J-174, Rochester, N. Y.

Send me without charge, (1) Specimen Railway Postal Clerk Examination questions; (2) List of government jobs open to men, 18 up; (3) Send free sample coaching; (4) Send free illustrated book, "How to Get U. S. Government Positions,

Name.....

Address.....



Be a Machine Draftsman—earn \$60 to \$150 a week.



Be a Structural Draftsman—earn \$60 to \$200 a week.



Be an Architectural Draftsman—earn \$60 to \$150 a week.



Be an Electrical Draftsman—earn \$50 to \$125 a week.



Be an Auto Draftsman—earn \$60 to \$125 a week.

3 Drafting Lessons Actually FREE!

to prove you can LEARN AT HOME, IN YOUR SPARE TIME!

We have invented a new, simplified way to teach Drafting—the first real improvement in Drafting home-instruction in history. We want you to see it, try it—without one penny of cost or obligation. We want to show you how we get away from the copying methods used in the past. See how we make you think, solve problems, do actual drafting room jobs from the first lesson!

FREE Job Service

Our employment department will help place you in a good job. Demand exceeds the supply. No charge for nation-wide employment service. Read want-ads for Draftsmen every day in Chicago Tribune or any big city paper—see the opportunities for yourself—and get ready for them.

MAIL COUPON TODAY!

Draftsmen Wanted \$60 to \$200 a week!

70,000 fine jobs advertised this year. Get ready to fill one. Get out of the rut. Make something of yourself. Plan your future in Drafting. Even if you have only common schooling, even if you know nothing of Drafting, we guarantee to make you a real Draftsman or to refund your money! Special surprise offer right now to the first 500 men who answer this ad—reduced price, easy terms. Coupon brings complete information.

A New, Rapid, Easier Training

Copying drafting lessons prepares you to be only a "tracer." This new "Job-Method" gives you actual drafting-room jobs in a new one-step-at-a-time way. With pictures which you can understand almost without reading the "lessons." And that is why American School-trained Draftsmen can qualify for a good job at big pay when they graduate.

Win Success Through Drafting

Drafting is easy, fascinating work. Short hours. Big pay. And the Draftsman is always in line for promotion for executive positions. This training is Complete. It includes high-school subjects (if you need them) and all the Engineering and Mathematics required of Drafting Experts.

Coupon Brings Three Lessons Free!

Get them. Test your own ability to learn Drafting and get ready for a fine job and big pay. Coupon also brings surprise offer, and complete information about your opportunities for success in Drafting.

Mail It Today!

CHIEF DRAFTING ENGINEER,
AMERICAN SCHOOL,
Dept. D-874, Drexel Ave. & 58th St., Chicago

Rush 3 Free Drafting Lessons, Surprise offer, complete information, money-back guarantee, etc., to prove I can become a real draftsman at home in spare time.

Name.....

Street No.....

City..... State.....

Complete Costly Drafting Outfit GIVEN!

You need a fine outfit like this to do precise, neat Drafting. Not one penny of extra charge for this complete, valuable, high grade outfit. Imported instruments. Table, board, mahogany-edge T square, triangles, ink, thumb-tacks, etc., everything you will need. Retail value \$20. Coupon brings this Free Offer.

CHIEF DRAFTING ENGINEER
AMERICAN SCHOOL
Dept. D-874
Drexel Ave. & 58th St., CHICAGO

BOYS

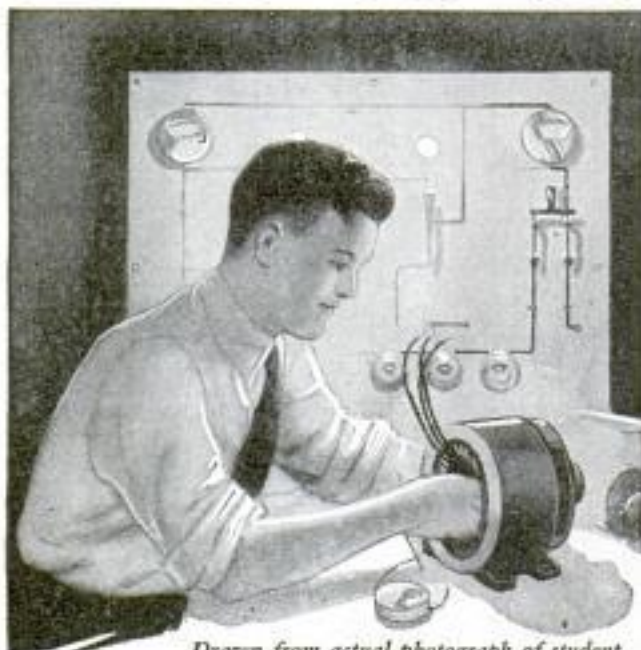

Drawn from actual photograph of student doing spare time electrical work

Learn Electricity Make Big Money

How would you like to earn two or three dollars every evening after school and prepare yourself for

a fine big job at the same time? Here's the opportunity of a lifetime for you fellows who like Electricity. Begin right now to prepare yourself for a regular man's size job in this fascinating field. Your chances for a big success are simply wonderful—the pay is big (thousands of men earn \$70 to \$200 a week) and advancement comes swift and sure.

I Will Train You at Home

With my easily earned, spare time Electrical Course I will train you at home like I have trained hundreds of other boys who are now big successful men. It will not interfere with your school work and you can earn more than the small cost of the course doing odd electrical jobs in your spare time. The Course pays for itself. I will show you how to get this work and how to do it. Some of my boy students make \$10 to \$15 a week this way.

Tools, Apparatus and Radio Course —Given Without Extra Charge

Send me the coupon below and I will tell you all about the big outfit of tools, apparatus and instruments and a new Radio Course that I am giving to my students for a limited time. I will send you my big interesting Electrical Book and a sample lesson, too—all Free. You will be tickled with the things I will send you Free. Mail the coupon right now.

L. L. COOKE, Chief Engineer
Chicago Engineering Works
Dept. O-18 CHICAGO

Use This "FREE BOOK" Coupon

L. L. COOKE, Chief Engineer,
Chicago Engineering Works,
Dept. O-18 2150 Lawrence Avenue, Chicago
Send me your Big Outfit Offer, your big Electrical Book, Sample Lesson and particulars of your Electrical Course and Extra Radio Course. This will not obligate me in any way.

Name.....

Address.....

This Coupon only for use of boys 15 years old or more.

Look What This Boy Is Doing

"Although the School term is coming to a close, and I am pretty busy with my examinations, I manage to keep up with my electrical studies and work.

"I guess I forgot to tell you I am now in business for myself. Am doing fine, but owe it all to you. If it had not been for your Course, I, being under age, could not have secured my license in this town. But I got it, and now have all the work I can do, averaging \$20 to \$30 a week, this spare time work.

"I went out on a job tonight after school, on which I made \$3 and brought home another on which I made \$2.50—\$5.50, for 4 hours' work and no material furnished by me."
ROBERT SMITH,
1215 Chestnut St.,
Greenville, N. C.

ART

We Teach COMMERCIAL ART

Meyer Both Company, maintaining the most widely known Commercial Art Studios in the World, offers you a practical training based upon 25 years' success in producing over a quarter million commercial drawings for leading advertisers.

Many of the full page illustrations appearing in leading national magazines are drawn by Meyer Both Trained Artists.

Our graduates are filling attractive positions in every section of the country. Home study instruction.

GET FACTS BEFORE YOU ENROLL IN ANY SCHOOL

Ask the advertising manager of the leading newspaper in your locality about us. Send 4c in stamps for illustrated book telling of the success of our students, and the unusual opportunity for both men and women in this attractive profession.

MEYER BOTH COMPANY

Dept. 16
Michigan Ave. at 20th St.
CHICAGO, ILL.

NOTE—To Art and Engraving Firms: Secure practical artists among our graduates. Write us.

Music Lessons WITH ACCREDITED SCHOOL At Home

Any Instrument Write for our complete course you are interested in: Violin, Cornet, Mandolin, Guitar, Banjo or Reed Organ—and we will send FREE CATALOG. SEND for it NOW!

University Extension Conservatory, 198 Siegel-Myers Bldg., Chicago

Complete Conservatory Course by Mail

Wonderful home study music lessons under great American and European teachers. Endorsed by Paderewski. Master teachers guide and coach you. Lessons a marvel of simplicity and completeness.

Learn Watchwork, Jewelrywork and Engraving.

A fine trade commanding a good salary, and your services are always in demand. Address **Horological,** Dept. P, Bradley Institute, PEORIA, ILL., for our latest catalog.



SHORTHAND IN ONE MONTH

Boyd—the Wonderful, New, Easy System. Writers hold World's record, 100 to 150 words a minute in 30 days guaranteed. New Principles—dilatation first week. Best for Court Reporting and Secretaries. Also Typewriting, Bookkeeping and Commercial Law. Send today for Catalog and Money-Back Guarantee. CHICAGO HOME STUDY SCHOOLS, 802 Reaser Block, CHICAGO, ILLINOIS

500 Quarts of Fire Gas from One Quart of Liquid



A new kind of gun—a fire gun—amazes everyone who sees it. For when a little valve is released 500 quarts of fire-destroying gas is produced from one quart of liquid. You can actually stand 25 or 30 feet away from a fire and by directing this stream of liquid at the base of the fire it quickly smothers the flames with its blanket of gas.

No Pumping

One of the most remarkable features of this new fire gun is that it requires no pump like old-fashioned fire extinguishers. Consequently, it does not jam or get out of order in the emergency of fire. All you have to do is to turn a valve and hold the gun steady. You can hit a spot no bigger than a quarter, quite different from the pump gun that is bound to weave and splatter with every stroke.

Harmless, Stainless Liquid

Yet, with the amazing power of this gun to put out fires, it is absolutely harmless to human beings. You can turn its spray directly on furniture, rugs, draperies, clothing and furnishings without damaging them one bit—without even leaving a stain. Think what a great thing this wonderful invention makes for homes, offices, factories, schools and all other buildings. An instant protection against fire—one that is absolutely harmless and can be used by a child—one

that puts out every kind of fire including celluloid, gasoline, kerosene and other fires that water only makes worse.

Agents, Salesmen Needed

The *inventor* of this wonderful gun wants salesmen, agents and spare time workers in every part of the nation to demonstrate it and is willing to pay them well. Already thousands of these guns have been sold and other men are making \$200 a week in full time and \$50 to \$100 a week in spare time.

Besides giving you free territory and free selling outfit, the inventor of this gun will furnish to producers free automobiles so that they can cover a bigger territory and make more money. By writing quick you will get full terms of this amazing offer.

Mail Coupon for Free Selling Outfit Offer

Do not hesitate a day. This wonderful invention is doubling and tripling the earnings of other men. La Barr actually made \$131 in one day. Clement

made \$62.70 in one day. McPhail made \$1,140.10 in four months. Even if you can only work in spare time here is a wonderful opportunity to make \$5, \$10 or \$20 a day extra. Simply mail coupon below and you will get full details of this amazing new product and our offer to representatives. Get the coupon in the first mail.

WELDON MANUFACTURING CO. DEPT. 711 GRAND RAPIDS, MICH.

Weldon Manufacturing Co.
Dept. 711, Grand Rapids, Mich.

Send me at once full details of your amazing new fire gun and how I can get your free selling outfit and free territory. I am not obligated.

Name.....

Address.....

City.....State.....

**AGENT MAKES \$131
IN ONE DAY**

Automobiles Furnished Producers

This Tenor Banjo FREE

WORTH
\$18



When You Enroll

This handsome full size, professional tenor banjo is yours when you enroll. We want to make one thousand new friends this month. We want to present one of these wonderful, delightful instruments as a gift to each of one thousand readers of this magazine—and here's why. Before becoming a professor, and a lover of music, particularly the tenor banjo, Prof. Six yearned and yearned for the possession of a genuine, professional instrument, the same kind used by the big, successful professionals of the world. Now we want you to succeed. We want to help every music-lover that we can, attain success, and this gift offer is made to pave the way for you, and no previous musical knowledge is necessary.

We have another surprise for you! Not only do we start you on the way to popularity, success and fame by supplying you with an instrument that you can compare to any used or displayed in your town, but under personal supervision you will be given, by mail, the benefit of Professor Harry S. Six's twenty-two years' experience as director of Glee and Instrumental clubs of New York University. We don't just send you a lot of printed words and instructions and trust to luck that you will catch on. Our method is different and has proven to be the simplest devised by man—that is why we claim you'll be able to play in thirty minutes. Put us to the test.

Learn in 30 Minutes With My Picture Method

Arthur Brisbane, the highest paid journalist in the world, once said that "a single picture is worth a thousand words." He was right, for it stands to reason, when you take your instrument in hand along with the actual photographs of our professor in action as your guide, it is easy to imitate and do the right thing. But that is not all.

Phonographic Records Free

We also furnish as an additional guide, phonographic records of our professor playing the piece you are learning, along with our thorough, printed and illustrated, easy-to-read course.

Doesn't that sound easy? It is easy. If you could sit at our desk and see the letters and telegrams from our pupils you would be convinced that we have perfected the simplest, yet most highly efficient course to insure your mastery of the tenor banjo.

Don't Send a Single Cent

Investigate offer today. Don't put off until tomorrow, because you might forget and miss this wonderful opportunity. It might be the turning point in your career. Don't send a single cent. Just drop a line—use coupon or postal card will do—telling you are interested in receiving full particulars about course and to reserve one regular eighteen dollar, full size professional tenor banjo for you, which is offered as a gift.

Act quickly, because there may not be enough gift banjos to go around for the million or more readers of Popular Mechanics. This does not obligate you in any way. There (see, do not hesitate—put in your reservation now, this very minute. You will soon join our happy army of enthusiastic finished tenor banjo musicians.

EARN BIG MONEY

Hundreds have started orchestras and are making money.

FREE BANJO COUPON

New York Academy of Music
Studio 18-100 Fifth Ave., New York

Please rush all free information relative to your Tenor Banjo Course and reserve a gift banjo for me. This obligates me in no way whatever.

Name.....

Address.....

City..... State.....

Make Money Taking PICTURES



Tremendous, big-paying opportunities are open for ambitious men in Modern Photography. This is the picture age. Magazine and newspaper publishers buy thousands of photographs each year. Every manufacturer sends out high priced pictures of his products. Every home wants portraits. Photography is a business running into millions of dollars each year. And there is a great shortage of trained photographers.

Get \$100 for Flood Pictures

"I took pictures of a flood and sold them for \$100. I have been able to buy my house and lot from the sale of pictures."

C. M. COLE,
Washington.

\$97 in Two Days!

"I made \$285 in December. Went out two days last week on home portrait work and made \$97!"

A. G. HUGHES,
Kentucky.

EARN \$3,000 TO \$10,000 A YEAR

Hundreds of men are earning big money and establishing their own businesses. Even during spare time, while training, you can make \$75 a week easily—no matter where you live!

AMAZING NEW EASY METHOD

I show you, at home, how to do the kind of work turned out by the big studios in New York and Chicago! I show you how to make big money within 30 days! C. M. Cole bought a home with money he had made when only half way through his training. So well do I know what I can do for you that I guarantee under bond to return every cent of your tuition if you are not thoroughly satisfied.

PROFESSIONAL VIEW CAMERA FREE!



Write at once for Free Camera Offer—I give you, free, a splendid professional view camera. You will be astonished and delighted. This offer open for short time only—so act quick! No obligation.

INTERNATIONAL STUDIOS, INC., Dept. 1353
3601 Michigan Ave. CHICAGO, U. S. A.

BE A JAZZ MUSIC MASTER

PLAY PIANO BY EAR

Play popular song hits perfectly. Hum the tune, play it by ear. No teacher—self-instruction. No tedious dig-dog daily practice—just 20 brief, entertaining lessons, easily mastered.

At Home in Your Spare Time

Send for FREE BOOK. Learn many styles of bass and syncopation—trick endings. If 10c (coin or stamp) is enclosed, you also receive wonderful booklet "How to Entertain at Piano"—and many new tricks, stunts, etc.

NIAGARA SCHOOL OF MUSIC,
Dept. 794 Niagara Falls, N. Y.

Send for this Free Book

Minstrel Show Guide

350 End-men's Jokes, 26 Songs, 9 Complete Sketches, 8 Monologues, 4 Stump Speeches, besides Complete instructions on stage and program arrangements, rehearsals and "make-up," from beginning to end. Price 15c post paid.

J. C. DORN, 701 S. Dearborn Street, Dept. 39, CHICAGO, ILL.

ELECTRICITY

COMPLETE COURSE FOR HOME STUDY \$10

Hawkins Electrical Guides, 10 Numbers \$10. Complete home study course with questions and answers. Teaches entire subject of practical, modern electricity. Plain language, clear diagrams, 3500 pages, 4700 illustrations. Authentic, highly endorsed—help you to better position and pay. Examination Free. \$1 a month if satisfied. Here is your opportunity. Send this coupon today!

THEO. AUDEL & CO., 85 West 23rd St., NEW YORK CITY

Please send me free examination coupon and full particulars about Hawkins Electrical Guides.

Name.....

Address..... 11T30



Joke All-You Want About This New Way To Be Popular —

But Read What Albert Mead and Thousands of Former
Wall Flowers Say About It!

By Albert Mead

I USED to think a fellow was crazy to try a stunt like this. It seemed positively ridiculous to think that anyone could become popular by learning to dance. And what's more, I couldn't believe that learning to dance by mail was possible—especially in a case like mine where I didn't know one step from another!

So every time I saw an advertisement like this, I just laughed. And I took great delight in poking fun at some of my friends who were taking this new course.

But it wasn't long before I saw that the joke was on me. Slowly my friends seemed to be drifting away from me. They were always "going to a party"—always having "barrels of fun." I was left out of the fun. Even the girls with whom I used to be so chummy, began to pass me by.

Well, I'm only human after all. So, the next time I saw an ad of Arthur Murray's, the famous dancing authority, in a magazine I gave it a chance. I read it through and when I saw that I didn't have to buy anything—that I could learn all about the short-cut to popularity from a Free 32-page book, I mailed the coupon.

And that started it. The illustrated free book that came by return mail was so convincing and the free test lesson was so simple that I felt sorry to have hesitated all these months. I eagerly sent for Mr. Murray's complete course.

A Great Surprise

And I received the greatest surprise of my life the day the lessons arrived. I opened the first page—and right then and there—before I was really aware of what I was doing—I was actually doing one of the steps. In a few minutes I had mastered that step. It was real fun to follow the simple diagrams and instructions.

The following few evenings I was mastering the Waltz, the Fox Trot, and other delightful new steps. It seemed so easy—so perfectly natural. And the remarkable thing about it is that I needed no music or partner. It seemed as if Mr. Murray himself were standing by my side gently directing, gently pointing out the right way or the wrong way to dance. And before I realized it, I was practically through with the course. I could hardly wait for a chance to dance at a real "affair."

My big chance came the following Saturday night. It was the annual class re-union dance. All my former

class-mates and their "best" girls were present. Jeanne was my partner.

The music started. I rose with a thrill. Jeanne was wonderfully light and easy to lead. We glided across the floor like professional dancers.

The band played. I led Jeanne gracefully around the room, interpreting the dance like an expert, keeping perfect harmony with the music.

The "old gang" stared at us in amazement. They couldn't believe their eyes! The transformation was too sudden for them. I laughed to myself and Jeanne's smile of understanding thrilled me.

When the music stopped we found ourselves in the midst of a group of smiling, friendly, admiring faces. It was a complete triumph. And to think that just a few weeks before I couldn't dance a step!

FREE 32-Page Booklet and Test Lesson

You too, can quickly learn dancing at home, without music and without a partner through Arthur Murray's remarkable new method.

Send today for Mr. Murray's wonderful free 32-page book and the free Test Lesson which shows how easy his method is. You'll enjoy the booklet immensely because it tells all about Mr. Murray himself, how he became private instructor to the "400," how he devised his easy home-study dances, how he taught over 250,000 people to dance by mail, and particularly how he can teach you to become a graceful, versatile, popular dancer in a few enjoyable evenings. And the free Test Lesson will amaze you!

Get this free book and read it carefully. Send for your copy now. Mail the coupon at once. Please enclose 10c to cover postage and printing. Arthur Murray, Studio 522, 801 Madison Ave., N. Y.

ARTHUR MURRAY, Studio 522,
801 Madison Avenue, New York City

Please send me a free copy of your 32-page book on dancing. Also your free Test Lesson. I enclose 10c to cover cost of postage and printing.

Name

Address

City State



Former Bricklayer Now Earning \$12,000 a Year

"When I enrolled with the International Correspondence Schools, I was a bricklayer and I didn't know a thing about blueprints. Today I have my own contracting business and I am able to figure the most difficult jobs and execute them to the satisfaction of everyone concerned. My income is between \$12,000 and \$15,000 a year. It certainly was a lucky day for me when I sent in that I. C. S. coupon."

That's a true story of what just one student of the International Correspondence Schools has done. There are thousands of others. Every mail brings letters from men and women telling of increases in income and salary due directly to spare-time study.

One hour a day spent with the I. C. S., in the quiet of your own home, will prepare you for success in the work you like best.

Mail the coupon for Free Booklet

INTERNATIONAL CORRESPONDENCE SCHOOLS BOX 5536-E SCRANTON, PA.

Explain, without obligating me, how I can qualify for the position, or in the subject, before which I mark X.

- | | | |
|---|---|---|
| <input type="checkbox"/> ARCHITECT <input type="checkbox"/> Architectural Draftsman <input type="checkbox"/> Contractor and Builder <input type="checkbox"/> Building Foreman <input type="checkbox"/> Concrete Builder <input type="checkbox"/> Structural Engineer <input type="checkbox"/> Structural Draftsman <input type="checkbox"/> Plumber and Steam Fitter <input type="checkbox"/> Heating and Ventilation <input type="checkbox"/> Plumbing Inspector <input type="checkbox"/> Foreman Plumber <input type="checkbox"/> Sheet Metal Worker <input type="checkbox"/> CIVIL ENGINEER <input type="checkbox"/> Surveying and Mapping <input type="checkbox"/> Reading Architects' Blue Prints <input type="checkbox"/> ELECTRICAL ENGINEER <input type="checkbox"/> Electric Lighting and Rys. <input type="checkbox"/> Electric Wiring <input type="checkbox"/> Telegraph Engineer <input type="checkbox"/> Telephone Work <input type="checkbox"/> MECHANICAL ENGINEER <input type="checkbox"/> Mechanical Draftsman <input type="checkbox"/> Toolmaker <input type="checkbox"/> Machine Shop Practice <input type="checkbox"/> CHEMIST <input type="checkbox"/> Pharmacy | <input type="checkbox"/> Navigation <input type="checkbox"/> SALESMANSHIP <input type="checkbox"/> ADVERTISING <input type="checkbox"/> Window Trimmer <input type="checkbox"/> Show Card and Sign Painting <input type="checkbox"/> BUSINESS MANAGEMENT <input type="checkbox"/> Private Secretary <input type="checkbox"/> Business Correspondent <input type="checkbox"/> BOOKKEEPER <input type="checkbox"/> Stenographer and Typist <input type="checkbox"/> Higher Accounting <input type="checkbox"/> COMMERCIAL LAW <input type="checkbox"/> Common School Subjects <input type="checkbox"/> Mathematics <input type="checkbox"/> GOOD ENGLISH <input type="checkbox"/> ILLUSTRATING <input type="checkbox"/> Railway Mail Clerk <input type="checkbox"/> CIVIL SERVICE <input type="checkbox"/> Mining Engineer <input type="checkbox"/> Gas Engine Operating <input type="checkbox"/> STATIONARY ENGINEER <input type="checkbox"/> Textile Overseer or Supt. <input type="checkbox"/> TRAFFIC MANAGER <input type="checkbox"/> AUTOMOBILES <input type="checkbox"/> AGRICULTURE <input type="checkbox"/> Poultry Raising | <input type="checkbox"/> French <input type="checkbox"/> Spanish <input type="checkbox"/> Banking |
|---|---|---|

Name _____
 Present Occupation _____ Business Address _____ 3-6-24
 Street and No. _____
 City _____ State _____

Persons residing in Canada should send this coupon to the International Correspondence Schools Canadian, Limited, Montreal, Canada.

Here's the career for YOU



Get into this wonderful, big-paying profession. Hundreds of openings now in Motion Picture Camera Work, Portrait and Commercial Photography. Learn at home. Big money while learning.

Earn Up To \$250 a Week



High salaried positions everywhere or, open your own studio. My business averages \$700 to \$1000 a week," writes Michael Gallo. Others doing equally well. Even spare time work pays up to \$75 a week!

CAMERA FREE

to students. Your choice of real Motion Picture Camera taking standard professional film used by all theatres, or 5x7 View Camera, latest model, genuine anastigmat lens.

Send for Book

Tells all about Professional Photography and how to make big money quickly. Also details of Free Camera Offer. Write today. NOW!

New York Institute of Photography
143 West 36th St., New York 18 (Dept. 49)



NOTE:

If you prefer to come to our New York or Chicago Studios for personal instruction, day or evening classes, write for Catalog R-46 to nearest address: 341 West 36th St., New York, or 630 So. Wabash Ave., Chicago, Ill.

Learn to Mount Birds



Learn at home by mail, to mount birds, animals, game heads; tax furs, make rugs and robes. Complete lessons. Easily and quickly learned by men, boys and women.

FREE Write today for Free Taxidermy Book. Tells all about it. Every Sportsman, Hunter, Trapper and Nature lover should know this wonderful fascinating art. Have your trophies. Big profits. Success guaranteed. Our school is 20 years old - 75,000 graduates. Investigate today. Write for Free Book.

Northwestern School of Taxidermy 9778 Elwood Bldg., Omaha, Neb.

STAMMER

If you stammer attend no Institute until you get my large FREE book "STAMMERING, Its Origin and The Advanced Natural Method of Treatment." Ask for special tuition rate. Established 22 years. Write today.

MILLARD INSTITUTE OF NORMAL SPEECH
2317 Millard Building MILWAUKEE, WISCONSIN

LEARN PIANO TUNING AT HOME

With our TUNE-A-PHONE Action Model, tools, charts and lessons you learn easily and quickly. Earn big money. Esth. 1898. Money-back Guarantee. Diploma given. Low tuition; easy terms. Write today for our FREE book, "Winning Independence." Miles Bryant School of Piano Tuning, 49 Bryant Bldg., Augusta, Mech.

LEARN WATCHMAKING

and become independent. We help you secure a position. Easy to learn. Send for FREE CATALOG.

ST. LOUIS WATCHMAKING SCHOOL, Dept. 5, ST. LOUIS, MO.



Wonderful, new device, guides your hand; corrects your writing in few days. Big improvement in three hours. No inlures. Complete outline FREE. Write C. J. Orment, D-34; St. Louis, Mo.

PLUMBERS & STEAM FITTERS

A new set—just out! A practical, illustrated, Reference Library and Study-Course for Master Plumbers, Journeyman and Apprentice Steamfitters, Gas Fitters and Helpers, Sheet Metal Workers, Draughtsmen, Master Builders, Engineers and all Building Trade Students. This valuable set of handy, pocket-size Guides explains in practical, concise language and well-done illustrations all the principles, advances and short cuts of the Plumbing and Heating trade—based on modern practice. Contains careful, detailed instructions on how to figure and estimate various jobs. Use FREE COUPON below to examine, without obligation, this valuable work.



AUDELS PLUMBERS & STEAMFITTERS GUIDES - 4 Vols. \$6

1670 Pages—3642 Trade Illustrations

\$6 A Set

\$1 PER MO.

A NEW SET JUST OUT!

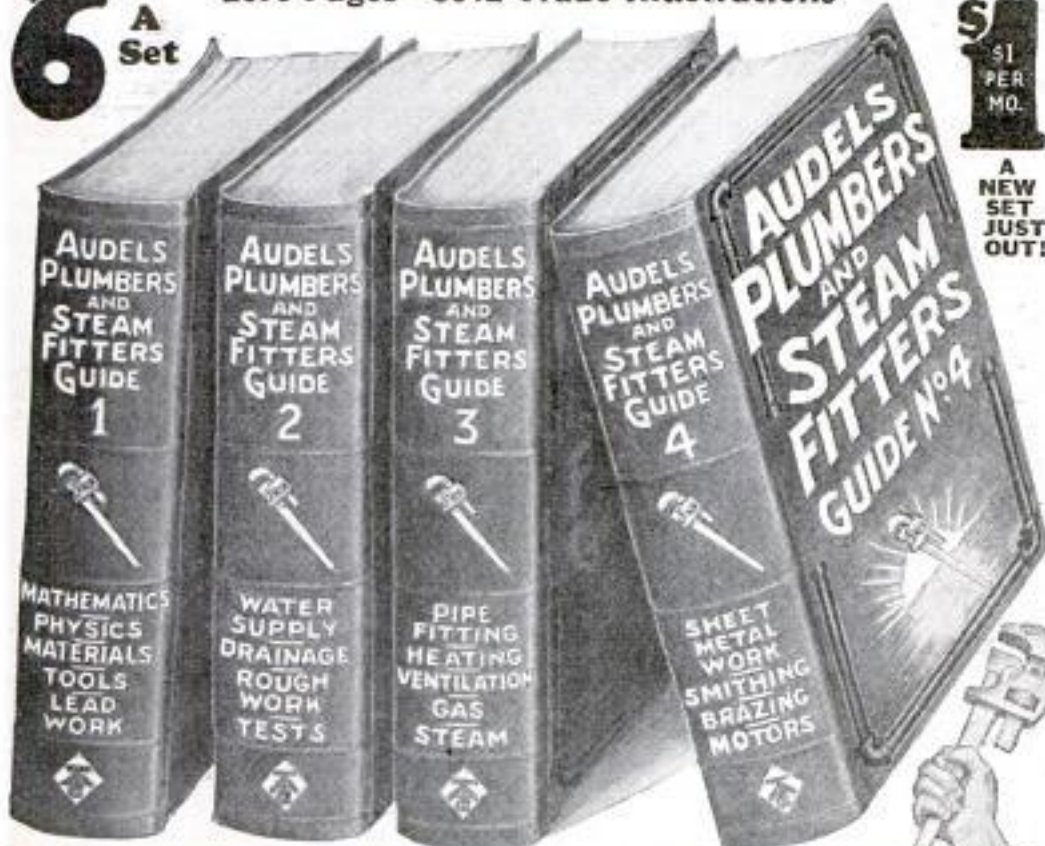

INFORMATION

Guides give complete instructions and practical modern data on the following important subjects:

MATHEMATICS—symbols, arithmetic, measurement, trigonometry, tables.

FUSION—specific gravity, pressure, expansion, hydraulics, pumps.

MATERIALS—iron, steel, copper, brass, lead, tin, antimony, bismuth, zinc, spialitan.

SHEET METAL—lead, tin, plate, galvanized, brass, bronze.

PIPE—wrought iron, steel welded, threads, tests, tubes.

TOOLS—square, level, plumb bob, scriber, caulking, tap borer, pipe threading, torches, fire pots, etc.

SOFTENING—soft soldering, tinning.

JOINT WIPING—preparing joint, wiping, lugging solder.

BENDING—distortion, tools used, hot and cold bends.

HEATING—lead flashing, gutter covers, etc.

SANITATION—cold water supply, siphonage, air pockets, circulation, etc.

HOUSE DRAINAGE—sewer, drain, stacks, traps, venting.

SEWER DISPOSAL—purification, cesspools, septic tanks, filter beds, disposal.

FIXTURES—bath, lavatory, shower, urinal, kitchen, storage tanks.

PIPE FITTINGS—tube, spigots, laying length, cast and fittings.

ROTATING IS—lay-out for work, drainage, piping methods.

ACCESSORIES—valves, cocks, valve grinding, flange, tubing, turned fitting.

SOIL PIPE—joints, packing, caulking, wrought pipe, tools.

SCREWED PIPE FITTINGS—diameters, forged, malleable brass, bends, joints, flanges.

DRAINAGE FITTINGS—recessed joints, properties of.

PIPE FITTINGS—threading off-sets, elbows, pipe bending, assembling.

HEATING AND VENTILATION—steam, low pressure, vapor systems, vacuum, hot water, circulation, furnace.

REFRIGERATION—simplest compression, management of machines, various methods.

WATER SUPPLY—wells, city main, pressure, piping methods, tanks, repairs.

GAS AND GAS FITTING—producer, testons, fittings, pressure, flow, underwriters requirements.

SHEET METAL WORK—geometry, problems, patterns, shearing, bench machines, wiring, burring, edging, tucking.

BRAZING—heating methods, brazing copper, lead burning.

WELDING—oxidation, various methods, blow pipe, thermite.

BLACKSMITHING—force, firing, bending, rivet work, forming, welding, tempering.

Pocket Size—Easy to Carry and Read FLEXIBLE BINDINGS—GOLD EDGES

These great self-educators teach the plumbing, heating and steamfitting trade in an easy step-by-step manner. There are thousands of practical examples, covering the entire trade—as well as new methods, new ideas, efficiency plans, short cuts, time and money saving suggestions. A practical and valuable Daily Helper on every plumbing job. Every point made clear with easily read text and clear illustrations and diagrams.

Complete Course for Home Study and Reference

Audels Plumbers and Steamfitters Guides give you, at a low price COMPLETE inside trade information and instruction. You can gain a thorough, practical knowledge of the trade by half an hour a day of easy reading. The definitions, tables, diagrams, descriptions, explanations, rules, sketches and illustrations will be found easy to follow and to apply to daily work.



Send No Money—Nothing to Pay Postman!

Send coupon now—today! Not a cent to pay until you have examined books. No obligation unless satisfied. This is your big opportunity for advancement.

FREE
EXAMINATION
COUPON

THEO. AUDEL & CO., 65 W. 23d St., New York.
Please send me (postpaid) for free examination, AUDEL'S PLUMBERS and STEAMFITTERS GUIDES, 4 numbers. If satisfactory, I will send you \$1 within 5 days and \$1 monthly until \$6 is paid.

Name.....

Address.....

Occupation.....

Reference..... 11T30



IN DRAWING CARTOONS

Why spend your time doing work that is drudgery, and get little money for it when you can enter this well paid profession? You can learn cartooning at home with this amazing easy method, which teaches you to draw cartoons that sell. You can also earn while you learn.

A steady income—\$3000 to \$15,000 a year—your own boss—easy hours—no off seasons—that's the life of a good cartoonist. Right now you may be earning only a pitifully small salary—but with this training you can easily be on easy street—*independent*. There's always a demand for good cartoonists.

Easy to Learn Cartooning At Home in Spare Time

There is a knack about learning cartooning which you can master in your spare time with this simple home study method. It starts you at the very beginning—on simple fundamental principles—then takes you through every branch of humorous and serious cartooning. You will be surprised how quickly you can draw cartoons that will sell. Many earn even while learning.

Send for Free Book

Get this handsomely illustrated booklet which gives the details of this remarkable home study course in Cartooning. Gives thorough outline of the cartooning field and market for cartoons. Shows how to become a cartoonist. No obligation. Send for it today.

Washington School of Cartooning, Room 3011-C 1113—15th St., N. W. Washington, D. C.
WASHINGTON SCHOOL OF CARTOONING

Room 3011-C, 1113—15th St., N. W., Washington, D. C.
Please send me without obligation, your Free Booklet on Cartooning, and full details of your home study method of teaching Cartooning.

Name..... (Print Name Plainly)

Address.....

City..... State.....
(If under 14 please give age)

Be a Plumber!

Earn Big Money Good Plumbers Are In Demand

Work the year around—GET BIG PAY—Apprenticeship requires 4 years. This is not necessary. The Kansas City School of Plumbing offers the PRACTICAL METHOD to learn all branches of the trade quickly. LEARN in 8 to 12 WEEKS—REAL PLUMBERS TEACH YOU. LEARN to do any job—step right into a big pay job or start a Shop of your own. The Plumber modernizes the Home. Plumbers can earn more in one day than some folks make in a week. Be a Plumber. Write for information, LOW TUITION Fee and opportunities offered. Do it today.

KANSAS CITY SCHOOL OF PLUMBING
2030 Troost Avenue KANSAS CITY, MO.



MUSIC LESSONS FREE

You can read Music like this quickly

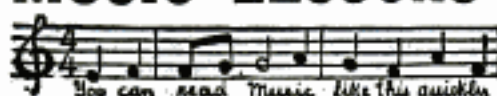

IN YOUR OWN HOME

Piano, Organ, Violin, Mandolin, Guitar, Banjo, etc. Beginners or advanced players. One lesson weekly. Illustrations make everything plain. Only expense about 2c per day to cover cost of postage and music used. Write for FREE booklet which explains everything in full.

AMERICAN SCHOOL OF MUSIC, 51 Lakeside Building, CHICAGO

LAW Personal Instruction By Mail

Be a lawyer or law trained business man. Qualify to earn \$2,500 to \$15,000 a year. University methods. TUITION LOW. EASY TERMS. Text books furnished. Practical and authoritative non-resident course. Endorsed by bench and bar. Prepares for bar or business. Over 60,000 students. PERSONAL INSTRUCTION. Guarantee to coach free any graduate failing to pass bar exams. SPECIAL REDUCED TUITION OFFER now in force. Write today for particulars and book on law FREE.

AMERICAN CORRESPONDENCE SCHOOL OF LAW
Dept. 1358 3601 Michigan Avenue, CHICAGO

PIANO JAZZ

By Note or Ear, With or without music, short Course. Adult beginners taught by mail. No teacher required. Self-instruction Course for Advanced Pianists. Learn 259 styles of Boss, 684 Syncopated Effects, Blue Harmony, Oriental, Chime, Movie and Café Jazz, Trick Endings, Clever Breaks, Space Fillers, Sax Stars, Triple Bass, Wicked Harmony, Blue Obligato, and 247 other Subjects, including Ear Playing. 133 pages of REAL Jazz, 25,000 words. A Postal brings our FREE Special Offer.

Waterman Piano School, 1826 W. Adams St. Los Angeles, Cal.

"Your Opportunity in a Great Industry"

That is the title of a book we have just prepared. It gives the full facts about one of the greatest money-making opportunities in the selling field today. Every specialty salesman in America owes it to himself to get and read this book. A copy of it is yours free for the asking. Write for it to Dept. 871.

GOODWEAR Chicago, Inc., 844 West Adams St., Chicago

YOU CAN OIL PAINT

Amazing new method teaches men or women to earn after first lesson. OIL PAINTING photos—portraits, landscapes or art subjects. Earn \$15 to \$174 and more a week. OIL PAINT GIFT GIVEN. Send now for free illustrated book. PICTORIAL ART STUDIOS, Inc., Dept. MP, 2781 No. Clark St., Chicago

STOP GROPING IN THE DARK

Be Yourself—Get
Into Your Stride—
MAKE GOOD!



All men-women, 18 to 65 wanting to qualify for Government Positions, \$140-\$300, traveling or stationary—Write Mr. Ozment, 111 St. Louis, Mo., immediately.

Can you fix it?



New books have "jiffy index," making all facts instantly available. You find anything you want to know in a moment.

These books tell how

HERE are the most interesting, the most practical books we have ever published on automobile construction, operation and repairs. Brimful of facts, photographs and explanations so easy to understand that anyone can learn how in almost no time.

Over 2500 pages, with diagrams, blueprints and everything else needed to make anyone an authority on automobiles.

Whether you want to qualify as garage owner, auto repair expert or merely wish to know how to keep your own car 100% efficient, you will welcome these books, especially on our

No Money Offer

This plan brings this valuable information within the reach of everyone. You don't send us a single penny. You don't have to pay us anything—just send your name and address and we'll send you the complete set of 5 volumes, specially bound in Flexo covers.

Read them carefully; keep them 10 days; find out anything you want to know, and then if you want to keep them, send only \$2.00 then and \$3.00 per month until the special low price of \$19.80 is paid. There is no further obligation.

American Technical Society Membership Free

This is a great organization for the publishing and spreading of specialized knowledge—we have over a million dollars of resources, enabling us to get the cooperation of the largest automobile manufacturers and dealers, who have furnished us plans and photographs. If you send NOW for this new edition of Automobile Engineering, we will include a Consultation Membership in this great organization.

Eighteen automobile experts will be ready to help you at all times. You can write or wire any time for special information. Answers will be sent to you promptly—without cost.

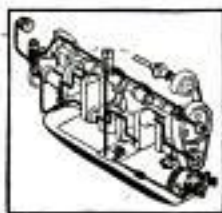

Modern Oiling System

Don't Hesitate

There are no strings to this offer—it means just what it says. Send name and address on the coupon and ALL of the five books—the complete set—will be sent to you for examination.

Remember one fact only which you can find in these books may save you an expensive repair or help you to a better job.

Learn All About Autos

Get these five big books on this liberal offer and learn all the things you want to know about autos.

Carburetors, engines, springs and spring suspension, brakes, 4-wheel drives, lubrication systems—all are fully covered.

These complete and comprehensive auto books are yours if you want them on this easy plan. Send for a set NOW; there's nothing to pay.

Jiffy



Index

You don't have to read the books through; the index enables you to put your finger on the information wanted in a jiffy.

For Free Offer, Use Coupon

American Technical Society,
Spec. Dept. A-819, Chicago, Ill.

I would like to look at the 5 Auto Books described above. Send them on your FREE offer. I will examine them carefully and return them in 10 days unless I like them; in which case I will send you \$2.00 then and \$3.00 per month until the total price of only \$19.80 is paid. You are to also send me Free Consulting Membership Certificate in the American Technical Society.

Name.....

Street.....

City.....

State.....

Employed by.....

Daring

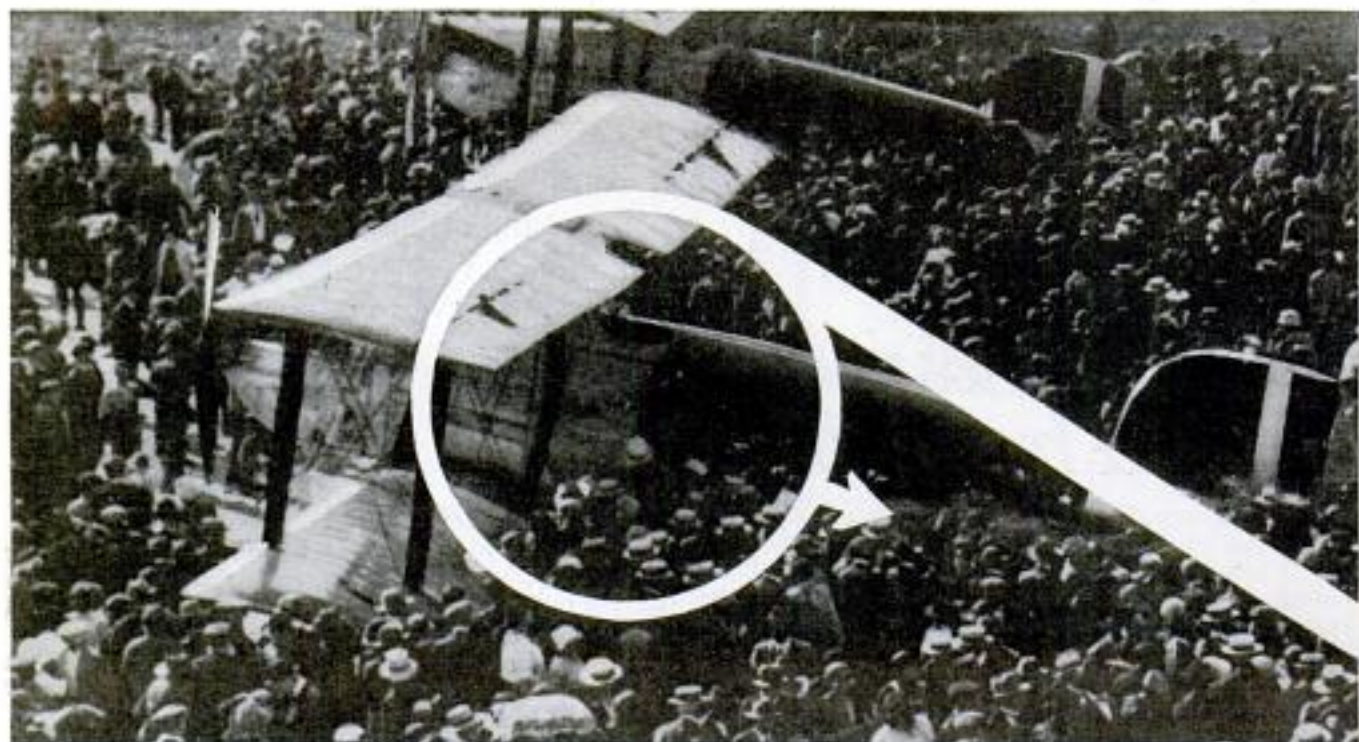

Aviation Experts in Big Demand!

Big Money—Popularity—Thrills! That's What This Fascinating New Profession Offers You! Right Now Aviation Experts Are in Big Demand. Here's an Amazingly Quick, New, Easy Way to Qualify, for One of These Jobs That Will Pay \$4,000—\$10,000 A Year!—Right in Your Own Home in Spare Hours.

BIG, vivid, virile—Aviation offers courageous young men the most astonishing opportunity in America today! Training in this fascinating work pays big rewards in excitement, adventure and popularity, as well as sensational money. Just imagine yourself directing the destinies of air-pilots and being pointed out by your friends as an Aviation Expert!

Never were the opportunities in this thrilling profession greater than at this moment. Aviation is still in its infancy. It stands today where the automobile industry stood 25 years ago. Its de-

velopment will create vast opportunities as surely as the automobile business made millionaires out of Henry Ford, and the Dodge Bros.! The big thing is to get in on the ground floor—right now while the field is new and uncrowded.

Get into this great, thrilling profession now—before the world at large wakes up to its amazing possibilities. Get your share of the tremendous sums that are going to be paid to Aviation Experts within the next few years. The field is opening up bigger every day. Act quickly or this surprising opportunity will slip out of your grasp before you know it.

Young Men Needed in Aviation

Easy To Become An Aviation Expert— \$75-\$400 Weekly

Now—you can quickly train for one of these exciting, highly paid jobs through a new, sure, easy method of basic training. The study of Aviation is almost as fascinating as the actual work itself. That's what makes it so easy to learn. Every Lesson sent you is packed full of vital interest. You get so absorbed that you actually forget you are studying—it doesn't seem like work at all—and once you start, you simply can't get enough of it. You'll hardly be able to wait until you, too, can begin playing your part in America's great conquest of the air.

Students Learn Quickly From Experienced Men

Only an hour of spare time a day will give you the basic training in a surprisingly short time. One student, S. F. McNaughton, Chicago, says: "Your lessons are like a romance, and what is more, after one reading, the student gets a thorough under-

standing. One never tires of reading them." James Powers, of Pennsylvania, writes: "I am indeed surprised that such a valuable course can be had from such practical men at so little cost."

That's the secret of the success of the American-trained student. They learn from practical skilled men who know the flying game from A to Z. These experts guide you carefully through your training, step by step. They select your lessons, blue prints, bulletins, etc. They give you all the inside facts and details that are essential to your success. Every lesson is clearly explained and easy to understand—and they are always glad to answer special questions and help you in every way possible.

Send for Big FREE Book on Aviation

Send the coupon below for new, free book just out "Opportunities in the Airplane Industry." It is vitally interesting, reads like a romance and will tell you things about this amazing profession that you never even dreamed of. This book is so gripping, so brimful of astonishing facts that it could easily sell for a dollar. We are offering a limited number free. Get yours before the edition is exhausted. Write today.



AMERICAN SCHOOL OF AVIATION Dept. 1358, 3601 Michigan Ave., Chicago, Ill.



Aeroplane Inspector
\$75 a Week

Aeronautical
Engineer
\$300 a Week

Aeronautical
Instructor
\$150 a Week

Aeroplane
Builders
\$200 a Week

Qualify for one of these big pay jobs—the Aviation Industry will be waiting for trained men to fill them.

Aeronautical Instructor
\$60 to \$150 per week
Aeronautical Engineer
\$100 to \$300 per week
Aeronautical Contractor
Unlimited Profits
Aeroplane Repairman
\$60 to \$75 per week
Aeroplane Mechanician
\$40 to \$60 per week
Aeroplane Inspector
\$50 to \$75 per week
Aeroplane Assembly
\$40 to \$65 per week
Aeroplane Builders
\$75 to \$200 per week

These are just a few of the amazing opportunities that aviation will offer to young men of daring and foresight.

MAIL THIS TODAY

American School of Aviation,
Dept. 1358, 3601 Michigan Ave.,
Chicago, Ill.

Without any obligation, please send me Free book "Opportunities in the Airplane Industry," also information about your Course in Practical Aviation.

Name

Address

City..... State.....

I'll Make You A Human Dynamo

YOU know how the aviator looks over his machine before taking off. You have seen the automobile racers tuning up before the get-away. At every railroad station you have observed the engineer and fireman oiling up the locomotive, and examining the bearings. In the power house and in the shops constant inspection and supervision is given dynamos and everything that runs and wears or is likely to get out of order.

How About the Human Machine —How About YOU?



STRONGFORT
The Perfect Man

What attention have you paid to your body? Have you seen to it that every part, every organ, every muscle was kept fit and strong, ready to function, either in performance or in warding off illness and the inroads of disease? Or have you, through ignorance or laziness or sheer neglect, permitted it to become rusty, faulty, weak, rheumatic, catarrhal, tubercular, debilitated, despised—a wreck ready for the junk heap—a reject such as no one respects nor admires?

Let's Get Together

Don't stand by and see your body go on down to destruction and perdition. Stop right where you are and get your bearings. Let's get together—you and I—and see what we can save—see if we can't put you on your feet again and make a 100 per cent man out of you.—I'll make you a human dynamo. I've done it with almost countless thousands—I can do it with you. Let's look facts right in the face. You tell me your story—then I'll tell you how I can and will help you.

Get My Free Book

It's a startling revelation of undisputable facts about the human body that will open your eyes to new visions of life and happiness and success. It will show you how to eliminate from your system, in a very short time, the distressing disorders which have made you feel yourself a misfit in the scheme of humanity; how to build up your body, strengthen ALL your vital organs, and feel the thrill of new life coursing through your veins. It will teach you how to become FIT physically and mentally; fit for business, for society, for the home, a power among men, a pleasing personality to women. What I have done for others I can do for YOU. I GUARANTEE IT.

Send for the Book Now. Fill out the coupon and enclose a 10c piece (one dime) to help pay postage. Don't delay. SEND IT TODAY.

LIONEL STRONGFORT, Physical and Health Specialist For Over 25 Years.
Dept. 65, NEWARK, NEW JERSEY, U. S. A.

FREE CONSULTATION

Mr. Lionel Strongfort, Dept. 65, Newark, N. J.

Please send me absolutely free enlightenment on the Promotion and Conservation of Health, Strength and Mental Energy. I enclose a ten cent piece (1 dime) to help cover postage and have marked (x) before the subjects in which I am most interested.

- | | | |
|-----------------|-------------------|---------------------------|
| Colds | Increased | Weak Eyes |
| Catarrh | Height | Weak Heart |
| Asthma | Pimples | Poor Circulation |
| Hay Fever | Insomnia | Round Shoulders |
| Headache | Short Wind | Lung Troubles |
| Thinness | Constipation | Muscular Development |
| Rupture | Indigestion | Great Strength |
| Lumbago | Nervousness | |
| Flat Chest | Rheumatism | |

Name

Age..... Occupation

Street

City..... State.....

STOP USING A TRUSS

Do Away With Steel And Rubber Bands

FREE TRIAL



Inner surface is made adhesive to secure the FLAPAO-PAD firmly to the body, keeping the FLAPAO continually applied and the pad from slipping. No straps, buckles or springs attached. Soft as velvet—easy to apply.

It's the Non-Slipping, yet Non-Rigid Pad and What is Within It That Counts

FREE to 5,000 Truss Sufferers

To the extent of 5,000 sufferers who may apply I will send, ABSOLUTELY FREE, a sufficient quantity of the Flapao to positively convince them that this is the only logical, commonsense way of treating rupture. Flapao is a highly astringent medication placed within the Flapao-Pad and being absorbed through the skin, creates a wonderful feeling of relief and at the same time tends to strengthen the weakened muscles and thus permanently close the rupture opening. The process of recovery is natural, so you'll have no use for a truss—you can throw it away forever! Old and young have testified under oath that the Flapao-Pads cured their rupture—many of them long-standing, aggravated cases—without delay from work. Patent allowed in U. S. and foreign countries. Awarded Gold Medal at Rome and Grand Prix at Paris.

Send No Money—for a sufficient quantity of the Flapao is sent without charge to enable you to give it a thorough test; you pay nothing for this trial now or ever. Write for it and full information today. Address: Flapao Laboratories, Block 1427 St. Louis, Mo.

Weight and Health

Can Be Restored in as short a time as 10 days. To prove that you can be rid of thinness, that tired feeling, sleepless nights, nervousness, and regain normal weight, health and vitality I send you Hilton's Vitamines absolutely free and post-paid to anyone who will write me. No cost. No obligation. If it cures you, makes you strong and gain weight, I will appreciate your telling others. That's all I ask. Simply send me your name and prove that you can feel and look 10 years younger. W. W. HILTON, 748 Gateway Station, Kansas City, Mo.

No Joke to be Bald



Grow
New
Hair
Quick

Let Me PROVE It To You FREE

What I accomplished on my own head, pictured above, I believe I can do for you, provided you are under 45 years of age and loss of hair was not caused by burns or scars. Anyhow, I must succeed or you pay nothing. No apparatus—my home treatment is simple, quick and inexpensive. SEND NO MONEY, just your name and address and I will mail you full information with PHOTOGRAPHS, NAMES and ADDRESSES of men and women who have successfully used my treatment for dandruff, falling hair and particularly for baldness. Write Now. A postal will do. VREELANDS, 1931 E. 40th St., Cleveland, O.

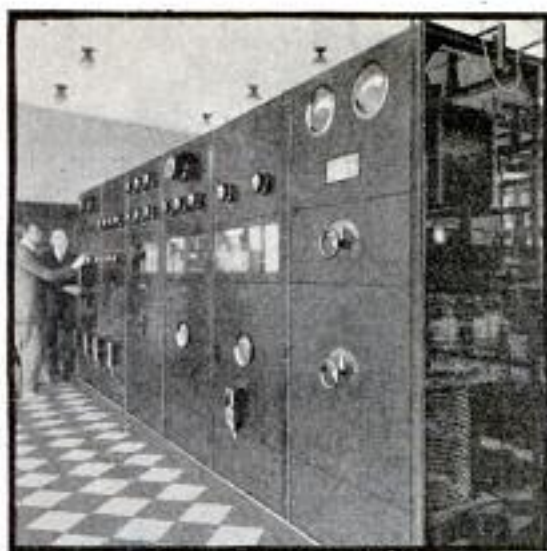

\$50. to \$250. a week
IN WORK THAT IS
ALMOST ROMANCE

Be a Radio Expert

Get into the great new Big-Pay Industry—Radio. If you're earning a penny less than \$50 a week, clip coupon now. Send for AMAZING FREE BOOK. Be a Radio Expert, and draw down big money for the easiest and most fascinating work in the world. Positions everywhere. Thoroughly-trained men are in big demand. Need for Radio Experts in every community. Short hours. BIG PAY. Free book gives all the facts. Astonishing opportunities—thousands of them! Every day N. R. I. trained men are taking good places in the Radio field. Free book tells all about their success. Send for it now!



Learn Quickly and Easily AT HOME

Master Radio Engineers will show you how to qualify quickly and easily at home, for Radio's fine jobs. We guarantee to train you successfully. Lack of experience no drawback—common schooling all you need. Our tested, clear methods make it easy for you. Send coupon now for free proof.

Instruments Given with Course

All instruments shown here and many others given to students for practice work while learning. Receiving sets, from simple kind to thousand mile receiver, an UNEQUALLED OFFER. Many other big features for limited time only.

Famous Training That "Pays for Itself"

Spare time earnings are easy in Radio. Increase your income almost from the start through practical knowledge we give you. This is the famous practical training that pays its own way.

PROOF



Operates WMAQ

"Accepted a position with Chicago Daily News—Station WMAQ. My income practically doubled, thanks to your free course."

Kenn Kimball, Chicago.



Gets Big Job

"Just been made Sales Manager of this Radio concern—a big raise in pay. Regret I did not take course sooner."

R. E. Jones, Bay City.

Get This Amazing Book

Most amazing book on Radio ever written—full, interesting facts about this great field and how we prepare you and help you start. You can do what others have done. GET THIS BOOK.

Send Coupon

Send coupon today for special limited offer, including all instruments—you'll get full particulars by return mail.

National Radio Institute

Dept. 15NB, Washington, D. C.

You get all of these

MAIL THIS NOW

NATIONAL RADIO INSTITUTE Dept. 15NB, Washington, D. C.

Without obligating me in any way, send me your free book, "Rich Rewards in Radio," and all information about your practical, home-study Radio course.

Name.....

Address.....

Town.....State.....

Radio Needs Trained Men

ORIGINATORS OF RADIO HOME-STUDY TRAINING

Established 1914

Find out
why~

"The **COOKE**
Trained Man
is the
Big-Pay Man"
in **ELECTRICITY**

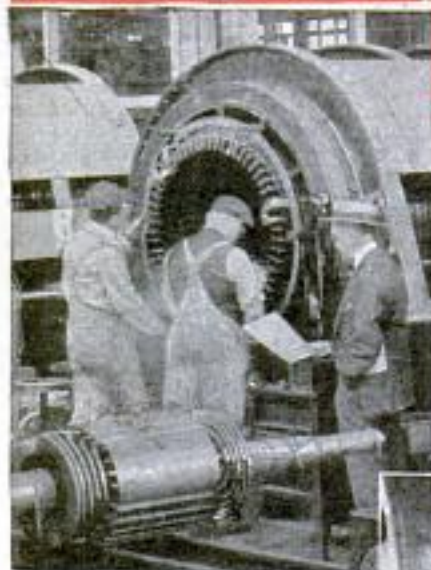
**Knew Nothing About
Electricity When He
Enrolled — Now Makes
\$75 to \$150 a Week**

"When I enrolled with you I didn't know the first thing about Electricity. But your lessons were so easy I advanced quickly — today I make \$75 to \$150 a week doing electrical work. I am sure glad to be a "Cooke" Trained Man."
— Emil Tokarz, Fort Grande Hotel, R. No. 206, Detroit, Mich.



**These Men are
Making Big Money!**

\$90 a Week in Radio

"I am now busy in Radio, and have averaged \$90 a week clear since last February, when I started my own store. My success is due entirely to your training. I wouldn't take \$100,000 for it."
— D. G. Plank, 611 Fourth St., Woodland, Calif.

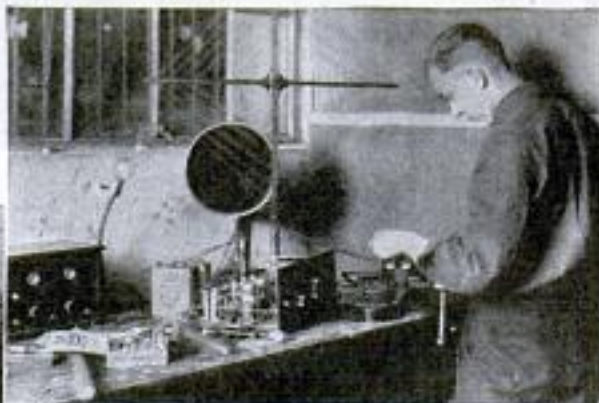

**Jumps from \$20 to \$60 a Week
— and Just Started**

"I used to work hard in a shop for only \$20 a week. Now I am a graduate of your wonderful school, and making \$55 to \$60 a week. And the beauty of it is that I am just starting. Your Training will make a Big-Pay Man out of anyone who will study your Course and follow your instructions."

— Theo. Fedoronko, Trafford, Penna.

Thousands of Cooke Trained Men Earn \$3500 to \$10,000 a year

Be a "Cooke" Trained Man Yourself!

You want to make big money! You want to earn more than a mere \$20 or \$30 a week! Of course you do. Then get into Electricity, the field of big pay and bigger opportunities. I'll train you at home—in your spare time. You work just as you are working now—at your same old job. But you learn Electricity every day,

in an easy,
simple, unfor-
gettable way
—by doing.

And—

5 BIG OUTFITS to work with

NOT TOYS, BUT
REAL HONEST-TO-
PETE TOOLS &
APPARATUS.
NOT A PENNY
EXTRA FOR
ALL THESE!



Every "Cooke" student will tell you he doesn't see how I can possibly afford to give so many wonderful and big outfits.

You Earn as You Learn!

That's the way I teach Electricity—so that you can make extra money as you go along. That's why my Course is Practical. That's why my students are successful. That's why the "Cooke trained man is the Big-Pay Man," everywhere, and always. \$40 a week is just an ordinary salary in Electricity. \$70 to \$200 a week is what thousands of Cooke Trained Men are earning.

Money Back if Not Satisfied

That's my Guarantee. And you're to be the judge and jury, all in one. If you're not satisfied you get your money back—every cent of it. And back of me in this Guarantee stands the Chicago Engineering Works, a \$2,000,000 Illinois Corporation.

Nothing Like "Cooke" Training

Don't confuse other Courses with mine. Don't be satisfied with anything but "Cooke" Training, the course with 10,000 boosters. There is nothing like it anywhere. It stands by itself—alone in this field. This is the Training that Electrical men are praising—the Training that Electrical concerns recommend to their employees, that the American Association of Engineers has endorsed 100% after a thorough investigation.

Before you select any Course, find out about "Cooke" Training with its 16 guaranteed features and its long record of proven success.

If You Are Earning Less Than \$70 a Week—Mail Coupon TODAY!

Don't wait a minute! Find out today why "The Cooke Trained Man is the Big-Pay Man" everywhere! Find out how Cooke Training will help you boost your pay! Mail the Coupon for my big book of proof, pictures and Pay-Raising FACTS. Do it NOW!

L. L. Cooke, Chief Engineer

Chicago Engineering Works, Inc.

Dept. 18 2150 Lawrence Ave., Chicago, Ill.

FREE BOOK COUPON

L. L. Cooke, Chief Engineer,
Chicago Engineering Works,
Dept. 18, 2150 Lawrence
Avenue, Chicago, Illinois

Mr. Cooke:

I want to know why the "Cooke" trained man is the "Big Pay" man in Electricity. Send me your big FREE Book with other information. This does not obligate me in any way.

Name.....

Address.....

City.....State.....



Swear Off Tobacco



Tobacco Tells on Nervous System



Tobacco Ruins Digestion

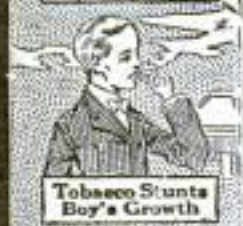

Tobacco Stunts Boy's Growth



Tobacco Robs Man of Vitality



Tobacco Steals from You the Pleasures, Comforts, Luxuries of Life

Tobacco Habit Banished Let Us Help You

Quick Results

Trying to quit the tobacco habit unaided is often a losing fight against heavy odds, and may mean a serious shock to your nervous system. So don't try it! Make the tobacco habit quit you. It will quit you if you will just take Tobacco Redeemer according to directions.

It doesn't make a particle of difference whether you've been a user of tobacco for a single month or 50 years, or how much you use, or in what form you use it. Whether you smoke cigars, cigarettes, pipe, chew plug or fine cut or use snuff—Tobacco Redeemer will positively remove all craving for tobacco in any form in a few days. Your tobacco craving will usually begin to decrease after the very first dose—there's no long waiting for results.

Tobacco Redeemer contains no habit-forming drugs of any kind and is marvelously quick, scientific and thoroughly reliable.

Not a Substitute

Tobacco Redeemer is in no sense a substitute for tobacco, but is a radical, efficient treatment. After finishing the treatment you have absolutely no desire to use tobacco again or to continue the use of the remedy. It helps to quiet the nerves, and will make you feel better in every way. If you really want to quit the tobacco habit—get rid of it so completely that when you see others using it, it will not awaken the slightest desire in you—you should at once begin a course of Tobacco Redeemer treatment for the habit.

Results Absolutely Guaranteed

A single trial will convince the most skeptical. Our legal, binding, money-back guarantee goes with each full treatment. If Tobacco Redeemer fails to banish the tobacco habit when taken according to the plain and easy directions, your money will be cheerfully refunded upon demand.

Let Us Send You Convincing Proof

If you are a slave of the tobacco habit and want to find a sure, quick way of quitting "for keeps" you owe it to yourself and to your family to mail the coupon below or send your name and address on a postal and receive our free booklet on the deadly effect of tobacco on the human system, and positive proof that Tobacco Redeemer will quickly free you from the habit.

Newell Pharmacal Company
Dept. 300, Clayton Station, St. Louis, Mo.



Free Book Coupon

NEWELL PHARMACAL CO.,

Dept. 300, Clayton Station, St. Louis, Mo.

Please send, without obligating me in any way, your free booklet regarding the tobacco habit and proof that Tobacco Redeemer will positively free me from the tobacco habit or my money will be refunded.

Name.....

Street and No.....

Town..... State.....



Send for this Free Book!

A FASCINATING BOOK of Detective stories that shows how ordinary boys and men have won nationwide fame, thousands of dollars in rewards, and important official positions by solving finger print mysteries!

“... Shortly before midnight a young couple slipped away from the dance. They sought out a long, low, rakish roadster. With powerful headlights picking out the path, it moved cautiously through the parking space and out onto the high road.

“Early next morning—a farm boy found the girl’s dead body crumpled in the wayside ditch. Concealed in the bushes at the side of the road lay the boy’s lifeless body, also shot from behind.”

Who had committed the murder?

Read the rest of the story on page 15 of our new Finger Print book. Find out how the murderers were traced, tried and convicted, and how a certain finger print expert solved five murder mysteries and secured 97 convictions in less than a year.

Find out how you can become a Finger Print Expert.

Thirteen Thrilling Stories of Mystery and Achievement

Thirteen stories of crime, daring robberies, mysterious murders, thrilling escapes. You’ll enjoy “Snowflakes,” a great dope story—“The Invisible Finger Print,” a blackmail mystery.

In “Foiled,” a true account of a great political coup, you’ll read of the astounding rise of a young country photographer who saved the Mayor of his city and was later appointed to the most important identification position in the state.

You’ll read of men who achieved fame, big rewards and important positions in a short time through the study of finger prints.

Any man who can read and write can become a finger print expert.



PARTIAL LIST

Graduates U. of A. S.
Recently appointed
Finger Print Experts
of these
States, Cities and
Institutions.

State of Iowa
State of Idaho
State of Colorado
St. Paul, Minn.
Columbus, Ohio
Detroit, Mich.
Pittsburgh, Pa.
Great Falls, Mont.
Idaho Falls, Idaho
East Lansing, Mich.
Schenectady, N. Y.
Lorain County, Ohio
El Paso, Texas
Galveston, Texas
Houston, Texas
Lincoln, Nebr.
Everett, Wash.
Ogden, Utah
Butte, Mont.
Pueblo, Colo.
Albany County Feniten-
Albany, N. Y. [diary
Wilkes Barre, Pa.
Livingston, Mont.
Alhambra, Calif.
Tulsa, Okla.
Havana, Cuba

Finger Print Experts Needed!

More and more the detection of crime resolves itself into a problem of identification. Trained men are needed every month to fill the new positions that are created. Records show that University of Applied Science graduates get first choice at the big positions. Listed below are some of the city and state bureaus to which U. of A. S. men have been appointed.

You can learn finger print identification in a few months in your spare time—at home.

Send the Coupon!

This book cannot be bought at any newsstand or bookstore—but it will be sent to you FREE if you write to us at once. Thirty-two pages, illustrated in color with weird crime pictures. This book explains your opportunities in the finger print world—shows how you can get your training in a few months—tells how you can get a professional finger print outfit free. Write for this book today.

University of Applied Science
1920 Sunnyside Ave., Dept. 13-58 Chicago, Ill.

University of Applied Science, Dept. 13-58
1920 Sunnyside Avenue, Chicago, Ill.

Please send me free your 32-page illustrated book “Finger Prints.” I understand that there is absolutely no obligation. Also tell me how I can become a finger print expert by studying a few months in spare time—and how I can get a professional finger print outfit free.

Name.....

Address.....

City..... State.....

**Just
Out!**



Be an Automobile Mechanic!

There's big money in this field—Get in on it now while you have the chance. Trained auto men are wanted!

The demand for trained men in the automobile field is far greater than the supply.

More than 15,000,000 automobiles are in use in this country now, and every week the figures grow larger.

There are not enough trained automobile service and repair men to keep up with this steady growth.

If you are not satisfied with your present earnings, look into this proposition NOW.

Just Published PRACTICAL AUTOMOBILE LIBRARY

Four Books—\$1.50 in 10 days and \$2 monthly for 6 months—only \$13.50 in all!

These four practical books, written by five well known teachers of automobile practice will teach you right in your own home, during your leisure time, just what you need to know about automobile troubles and repair. They will teach you automobile construction, maintenance and repair as experts know them and will help you to earn an expert's pay.

Step up to a Big-Pay Auto Job

Hundreds of question-answering diagrams—hundreds of clearly-marked illustrations—make the books plain and readily understandable to any man with the mechanical instinct. All the explanations and descriptions are clear, simple, direct. Every chapter is packed with definite, step-by-step, how-to-do-it information.

Examine This New Library Free

No money down Small monthly payments

These books were written specially for self-instruction by men who have trained thousands of automobile operators and garage men. Examine the library for 10 days free. Just fill in and mail the attached coupon.

If you find the books what we say they are, send us \$1.50 in 10 days and \$2 monthly for only six months. If you do not want the books, send them back at our expense. It costs you only a postage stamp to take a look at the books. Act now!

FREE EXAMINATION COUPON

McGraw-Hill Book Co., Inc., 370 Seventh Ave., New York

Send me for 10 days' free examination the New Practical Automobile Library. If satisfactory I will send you \$1.50 in 10 days and \$2.00 monthly until the special price of \$13.50 is paid. If not wanted, I will return the books at your expense.

Signed

Address

City and State

Position

Employer P. M. 11-1-25

BE A FOREMAN!



Step out of the ranks—be a modern factory foreman. Today, the foreman who **knows** his job commands high wages and is in direct line for promotion to the big executive jobs. Samuel Vauclair, president of the Baldwin Locomotive Works and hundreds of other great industrial leaders climbed from foremanship right up to the top of the ladder.

The big leather lugged foreman is **gone**—replaced by the foreman who **knows** how to get greater efficiency from men and machines, who **knows** the **drum** and one thing that employers pay well for.

Train yourself at home for a foreman's job. Just a few minutes' study each evening is required. Robert Grimshaw, M. E., has prepared a book "The Modern Foreman." It is really a **complete course** in foremanship for it teaches in a practical way, everything you must know to become a highly paid foreman. The book is so successful in training men, that such concerns as Collier-Brammer Co., American Sheet and Tin Plate Co., Sisson Machine Co., Westinghouse Electric Co., have bought this book for their foremen and factory workers.

Just send us your name and we'll send you "The Modern Foreman." Keep it 5 days. If at the end of that time you do not think it will teach you to become a highly paid foreman with unlimited opportunities for advancement, return the book at our expense. Other- wise remit \$2.50. You can't lose. Send your name today.

THE GREGG PUBLISHING CO., 20 West 47th Street, NEW YORK

A FILE

NOT A FILE

Stop Forgetting

Make Your Mind an index from which you select facts, figures, names, faces. Develop concentration, self-control; overcome bashfulness, forgetfulness.

Write today for **FREE** memory and concentration test and illustrated booklet, "How to Remember."

PROF. HENRY DICKSON
Dept. 70511 Evanston, Ill.

BIG MONEY IN POULTRY

Now's the time to get into the poultry business. This Fall eggs will jump way up in price. You can start small. Handsome profits in spare time. Free book tells all about our new, up-to-date, money-making poultry course, prepared by experts, and about our remarkable plan of close, careful, individual assistance. Write for a copy today.

National Poultry Institute, D-4, 480-C, Washington, D. C.

BE A RAILWAY TRAFFIC INSPECTOR

Earn Up to \$250 Per Month Expenses Paid

MEN ARE WANTED to enter this fascinating profession. Splendid opportunities; travel or remain near home. Pleasant, outdoor work; meet big railway officials.

START AT \$110 PER MO.

Expenses paid, after 3 months' spare-time study at home. Any average man can qualify.

You Take No Risk!

For over seven years we have secured a position for practically every graduate, paying at least \$110 per month and expenses. Those few not securing positions had their money refunded. You can succeed—advance rapidly! Send coupon at once for full details. Positions waiting for graduates!

**Standard Business Training Institute
Buffalo, N. Y.**

**Standard Business Training Inst.
Buffalo, N. Y.**

Send me, entirely free, Booklet No. D-63, giving full particulars about course in Railway Traffic Inspection.



Name

Street

City



Fourteen Years a Conductor— Then Salesmanship and \$700 a Month

Do you know the quickest way to make dreams come true?—It's the salesmanship way.

For out in the *selling* field, if a man makes good, "raises" come to him automatically—and many times a year. There was C. A. Thomas, for example.

Thomas, a California man, had been a conductor on a railroad for fourteen years. "One day," said Mr. Thomas, telling of his experience, "I came in on my passenger run and never went out again. Instead, I undertook to sell real estate. The first month I did not make a sale. I saw that I needed something to help me, and I believed I would find it in LaSalle's training in Modern Salesmanship. You can judge for yourself the aid it gave me when I tell you that the next month I cleared \$700, and last month I averaged better than \$67 a day throughout the month. . . ."

J. J. Graney writes of similar success. He was a mail carrier when he enrolled with LaSalle.

"I have not worked nearly so hard since I have been selling," writes Graney, "but have increased my earning power about 400 per cent. During September I earned \$225, October \$500, November close to \$700, and I expect to make \$1,000 this month."

Were these men—and hundreds of others—merely "lucky"?

Men privileged to master Salesmanship thru the LaSalle Problem Method will tell you that their success was far from luck; it was the logical result of knowing the hows and whys of their profession.

Whether or not you have had experience in selling—that is not important. The point is that any man of average intelligence who will follow the LaSalle *salary-doubling plan* can quickly multiply his earnings. And this fact applies with doubled force to the man now in the field who is sincerely

striving to increase his volume, to really *sell* in dozens of places which he is now forced to leave without an order.

The complete story of the LaSalle *salary-doubling plan*, which thousands of men have followed with such gratifying results, is outlined in a fascinating book entitled "Modern Salesmanship." This book tells clearly the opportunities in the selling field—points the way to a quick mastery of the very methods whereby the big producers top the list year after year, earn big five-figure salaries. The information contained in this book is of priceless value to the man seriously ambitious to make a real success in the selling field. And—the coupon brings it to you, *free*. If your future is worth a two-cent stamp and two minutes of your time—place the coupon in the mail TODAY.

— — — — CLIP AND MAIL — — — —
LASALLE EXTENSION UNIVERSITY

The World's Largest Business Training Institution
Dept. 1164-SR Chicago

I should be glad to receive an outline of your *salary-doubling plan*, together with a copy of "Salesmanship in a Nutshell," also copy of "Ten Years' Promotion in One," all without obligation.

**Modern Salesmanship—
Salesmanship in a Nutshell**

Other LaSalle Opportunities

The LaSalle plan opens the way to success in every important field of business. Check below the opportunity that appeals to you.

- | | |
|--|--|
| <input type="checkbox"/> Business Management | <input type="checkbox"/> Banking and Finance |
| <input type="checkbox"/> Traffic Management | <input type="checkbox"/> Modern Foremanship and Production Methods |
| <input type="checkbox"/> Higher Accountancy | <input type="checkbox"/> Personnel and Employment Management |
| <input type="checkbox"/> Railway Station Management | <input type="checkbox"/> Expert Bookkeeping |
| <input type="checkbox"/> Law—Degree of LL. B. | <input type="checkbox"/> Business English |
| <input type="checkbox"/> Commercial Law | <input type="checkbox"/> Commercial Spanish |
| <input type="checkbox"/> Industrial Management | <input type="checkbox"/> Effective Speaking |
| <input type="checkbox"/> Efficiency | <input type="checkbox"/> C. P. A. Coaching |
| <input type="checkbox"/> Modern Business Correspondence and Practice | |

Name.....

Present Position.....

Address.....

\$86⁷⁵ A Week or More

Be A — Detroit Trained Man!

\$86.75 is just an average weekly profit for Earl Hatfield (Dayton, Ohio) in his garage. He writes us that it is a poor week when he doesn't make **more** than that. At 19 years of age, a farmer boy, he came to Detroit, the Auto Center, and learned the auto business at this great School.

Now he has a fine business near his home, is independent, making good money. He is just one of many who have done the same. These successful "Michigan State" trained men are just plain fellows, no brighter nor better educated than you. Practical training at the factory-endorsed school started them to success.

Make Big Money Too—Learn Autos in Detroit

The Auto business offers unlimited opportunities. Autos are increasing faster than repair shops or mechanics can keep up with them. Think of the repair work on 18,000,000 cars. There are not nearly enough trained men to do this work. You too, can be a skilled mechanic and auto electrician and **EARN BIG MONEY**. Experience isn't necessary. If you are mechanically inclined come to Detroit now, to this great auto trade School, known and endorsed throughout the world. Become a trained man and go back to your home town. Work as a mechanic, or start a garage of your own. Farm managers also can increase their profits greatly by knowing auto mechanics.



Come to Detroit, the heart of this great business. Here you have wonderful advantages. Learn on up-to-date, new equipment. All types of cars, engines, axles, transmissions, electrical systems. New Packard Straight Eight with four wheel brakes, Packard Twin Six, new Buick with four wheel brakes, Oakland (four wheel brakes), Cadillac Eight, Hupmobile, Reo, Oldsmobile, G. M. C. Truck, Hudson, Overland, and many others.

Each instructor is a master. A thorough course that slight nothing. Visit the great auto plants. These big companies approve our School. Get **FACTORY-ENDORSED TRAINING** at Detroit, the Auto Center.

Read What Factories Say:

THE STUDEBAKER CORPORATION OF AMERICA

"We do not know of a better automobile school than the MICHIGAN STATE."

HUDSON MOTOR CAR COMPANY

DETROIT, MICH., U.S.A.

"This school is thought very highly of by the automobile men of Detroit, and is considered one of the best equipped and most efficient schools in the country. You will make no mistake in attending the M. S. A. S."

DODGE BROTHERS

INCORPORATED
DETROIT, U.S.A.

"We believe the Michigan State Automobile School of this city to be an exceptionally high class school, and no doubt a diploma from this school would assist materially in obtaining employment with high class automobile dealers."

PACKARD MOTOR CAR CO., DETROIT

"We do not believe you would make any mistake in attending this school if you wish to become thoroughly experienced in the automobile business."



BUICK MOTOR COMPANY

"We believe the MICHIGAN STATE AUTO SCHOOL, Detroit, would best meet your requirements, as its course in technical training is most thorough and complete in every detail."

Good Positions Open

The demand for trained men is greater than the supply. We cannot fill all the calls we get. Look into any garage that is run by trained men—everybody busy, earning big money. These opportunities can be yours too, with "Michigan State" training.

Learn in a Few Weeks—Start Now

A thorough training in Detroit at the "Michigan State" fattens your pay envelope if you are working for others, or puts more profit in business for yourself. You can take a full **Automotive Course in 12 weeks**, or our big **Master Course in 30 weeks**. Or specialize in any of its money-making branches; you can be an Auto Electrician, a Battery Man, Welder or Machinist. Jobs for all these men are offered to us daily. **Free Course in Business, Garage Management and Selling** given to all our students. Classes always open. Plan now to come. Write today for outline of Courses. A letter or post card will do, or use the coupon on the opposite page. **Do it Today!**

MICHIGAN STATE

311 Auto Building

Detroit, Michigan

Learn Autos Where Autos Are Made

Copyrighted material

Made by Hatfield AND Many Others

"Michigan State"

graduates are making money

in every corner of the world. 20,000

graduates. 700 students here now. Come to Detroit, a

fine city. Big business, pleasant climate all year 'round.

Auto Business Leads. The Auto industry now leads all

industries in the world, in value of production. There are

more autos than telephones. 269 cars to every service station.

This shows as plain as ABC **where the big chance**

is today. Ambitious men with training are wanted.

No Experience Needed

If you are mechanically inclined we can train you in a few weeks for a better job or a business of your own. No experience is needed. A few weeks of real training will save you years of time. Get into work you like and earn big money. We can start you to success as we have so many others. Thousands of men, no smarter than you, are making big money today because they saw the chance and learned this business right.

18,000,000
Automobiles in U.S.

One Car to Every
6 People

269 Cars to Every
Repair Shop

Thousands more Trained
Men are Needed

FREE Management Course

Business Course by Packard service manager is free to all students. Teaches how to locate a garage, about equipment, systems, financing, selling, advertising. Worth \$100.00 alone. No extra charge.

EARL HATFIELD



Earn while you learn if necessary

Some students work evenings to pay their way. Others work days and take our evening classes. Ask us about this and explain your circumstances fully when writing. Your letter will receive a personal reply from the President of the School, with advice on the best way for you to get your training. We have helped 20,000 men to succeed and we can help you too. Don't delay a day longer. Write at once.

(Colored students not enrolled, except for our Home Study Course)



Student learning the Packard
Straight Eight

Send the Coupon

Get all the interesting facts. They will open the way to a bright future for you. Write a letter or post card or use this coupon. Full information will be sent, including (1) Auto School News (2) Booklet "Who are the best Judges of an Auto School?" and (3) Complete Chart of Courses. Write today sure.

A. G. ZELLER, President.

HOME STUDY COURSE FREE

For students who can not come to Detroit at once we have a fine Home Study Course. You can start to learn at home. Then come here later with no extra charge for the Home Study Course. It will help you to get a garage job right away. Write for full information about this and explain your circumstances.

Mail Coupon To-day

Michigan State Automobile School 311 Auto Building
DETROIT, MICH.
Send me FREE and without obligation complete information about Detroit-training to make the most money.

Name.....

Street or R. F. D.....

City..... State.....

I am interested in { 12 Weeks' Auto Course.
30 Weeks' Master Course.
Home Study Course.

AUTOMOBILE SCHOOL

3729 Woodward Avenue Detroit, Michigan

The Factory Endorsed School



"I'm going to raise his salary"

"I've had my eye on him for some time and I know he can handle bigger work."

"He studies those I. C. S. textbooks every chance he gets, and I want to tell you it has made him a valuable man for this business."

"I'm going to raise his salary and give him that new job we were talking about. I wish we had more men like him."

How do you stand when your employer checks up his men for promotion? Does he pass you by as just a routine worker, or does he think of you as a man who is ambitious to get ahead? Won't you be far more likely to get the promotion if he knows you are studying at home and are really preparing yourself to handle bigger work?

Think it over. Then act. It takes only a moment to mark and mail the coupon and find what the International Correspondence Schools can do for you, yet that one simple little step may be the means of changing your whole life. "Do it now."

The
I. C. S.
is the oldest
and largest
correspondence
school in the
world

INTERNATIONAL CORRESPONDENCE SCHOOLS

Box 5538-E, Scranton, Penna.

Without cost or obligation, please tell me how I can qualify for the position or in the subject before which I have marked an X:

BUSINESS TRAINING COURSES

- | | |
|--|---|
| <input type="checkbox"/> Business Management | <input type="checkbox"/> Salesmanship |
| <input type="checkbox"/> Industrial Management | <input type="checkbox"/> Advertising |
| <input type="checkbox"/> Personnel Organization | <input type="checkbox"/> Better Letters |
| <input type="checkbox"/> Traffic Management | <input type="checkbox"/> Show Card Lettering |
| <input type="checkbox"/> Business Law | <input type="checkbox"/> Stenography and Typing |
| <input type="checkbox"/> Banking and Banking Law | <input type="checkbox"/> Business English |
| <input type="checkbox"/> Accountancy (including C.P.A.) | <input type="checkbox"/> Civil Service |
| <input type="checkbox"/> Nicholson Cost Accounting | <input type="checkbox"/> Railway Mail Clerk |
| <input type="checkbox"/> Bookkeeping | <input type="checkbox"/> Common School Subjects |
| <input type="checkbox"/> Private Secretary | <input type="checkbox"/> High School Subjects |
| <input type="checkbox"/> Spanish <input type="checkbox"/> French | <input type="checkbox"/> Illustrating <input type="checkbox"/> Cartooning |

TECHNICAL AND INDUSTRIAL COURSES

- | | |
|---|--|
| <input type="checkbox"/> Electrical Engineering | <input type="checkbox"/> Architect |
| <input type="checkbox"/> Electric Lighting | <input type="checkbox"/> Architects' Blueprints |
| <input type="checkbox"/> Mechanical Engineer | <input type="checkbox"/> Contractor and Builder |
| <input type="checkbox"/> Mechanical Draftsman | <input type="checkbox"/> Architectural Draftsman |
| <input type="checkbox"/> Machine Shop Practice | <input type="checkbox"/> Concrete Builder |
| <input type="checkbox"/> Railroad Positions | <input type="checkbox"/> Structural Engineer |
| <input type="checkbox"/> Gas Engine Operating | <input type="checkbox"/> Chemistry <input type="checkbox"/> Pharmacy |
| <input type="checkbox"/> Civil Engineer | <input type="checkbox"/> Automobile Work |
| <input type="checkbox"/> Surveying and Mapping | <input type="checkbox"/> Airplane Engines |
| <input type="checkbox"/> Metallurgy | <input type="checkbox"/> Navigation |
| <input type="checkbox"/> Steam Engineering | <input type="checkbox"/> Agriculture and Poultry |
| <input type="checkbox"/> Radio | <input type="checkbox"/> Mathematics |

Name.....
Street..... 3-6-24
Address.....
City..... State.....
Occupation.....
Persons residing in Canada should send this coupon to the International Correspondence Schools Canadian, Limited, Montreal, Canada.

Be Fit—Make Good

You would be a better and happier man—

if you were only able to "knock the block off" of the man or the thing that stands in your way. AND YOU CAN! It's all just a matter of having **PHYSICAL VIGOR AND FITNESS.**

My unusual System of Muscle Building and Promoting Physical



Fitness is giving men new bodies for old. I am taking run-down, peppy, forlorn men and women under my wing, studying their condition, and instructing them by mail, at their own homes, all over the world, how to get the pink of physical perfection they are after.

BENNY LEONARD'S

HOME COURSE OF MUSCLE AND BODY BUILDING (AND BOXING)

Most of them are young or middle-aged men who were getting prematurely old until I took them in hand. Many are studying my course to learn the **MANLY ART OF BOXING AND SELF DEFENSE.**

Many are getting **BIGGER MUSCLES**—huskier bodies—larger limbs—heavier necks, arms, chests—as a result of the scientific steps of development which I am pointing out to them. And many are forging ahead in business as a result of renewed pep and vitality, the singing, tingling body, which my physical culture course has given them.

Remember—that I didn't always have the perfect body I now have—once I was skinny and weak. I achieved the **Lightweight Championship of the World** as a result of first **BUILDING BODILY PERFECTION** for myself. What I did for myself I can do for YOU.

It is impossible to tell you all about my methods, here. If you'll just send me your name and address, I will send you, free of charge, my wonderful booklet, "Now I Can Tell You," which tells you just why you should enroll under my personal instruction. Let me send you this free booklet—write for it **NOW—THIS MINUTE**—there's no obligation.

BENNY LEONARD, Undefeated Lightweight Champion of the World—123 W. 31st St., Dept. 11-N, New York, N. Y.

Send NOW—for my free booklet—no obligation.

Stop Making Mistakes in English

Wonderful new way to improve your English. No rules to learn. No hard study. Grammar, spelling, punctuation, and expression, taught in 15 minutes a day—at home. Self-correcting feature makes it fascinating as a game. Write today for Free Book "How to Speak and Write Masterly English" and 15 minute test which you can take in your own home. The answers are given so that you can tell at once just where you stand. Address



SHERWIN CODY SCHOOL OF ENGLISH
511 Searle Building ROCHESTER, N. Y.

SAVE
TIME



Secure Better Illustrations

USE AN ALL METAL

PANTOGRAPH

for roughouts, layouts, enlargements, reductions, checking proportions, etc.

Simple Adjustable Permanent Economical

Sent postpaid on receipt of \$3.50

only Money refunded if not satisfactory.

DRAWING-AIDE CO.

206 Caxton Bldg., Cleveland, O.

WANTED

RAILWAY MAIL CLERKS



\$1900 FIRST YEAR

Raise to \$2700

Travel—See the Country
MEN, BOYS—18 UP
LIFE JOB

Mail Coupon Today Sure

FRANKLIN INSTITUTE
Dept. J170, Rochester, N. Y.

First! Send me at once, free of charge, Sample Railway Mail Examination questions and coaching lessons, list of other U. S. Government positions now obtainable and free book describing them.

Name.....
Address.....

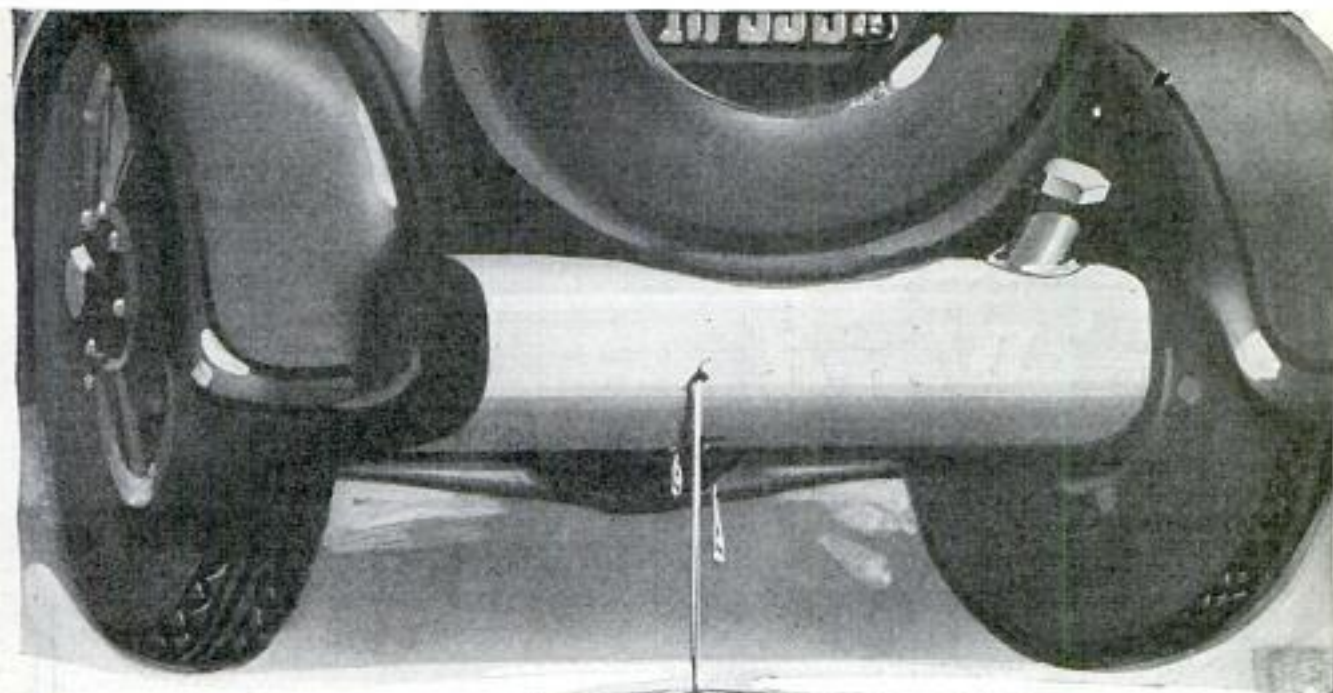

You're Losing Half Your Gasoline!

FOR every ten gallons you buy you are losing five! That's a startling statement, but true.

You are getting just half the power, half the mileage you should get out of your gasoline! For now an amazing new invention—a ridiculously simple little device—makes practically any car give twice its regular mileage!

57 Miles on a Gallon

With this wonderful new invention auto drivers in all parts of the country have chalked up records of from 37 to 57 miles on a gallon of gasoline. Every day we hear of some new record—some difficult feat such as pulling a car through deep sand, or up a mountain, on half the usual gas.

Here's how this amazing new invention works. Your carburetor is adjusted to make starting easy—it gives a rich mixture to start a cold engine. But once your engine gets heated up, the mixture is far too rich, resulting in faulty explosion. Half the gasoline is drawn into the cylinders in a raw state and, instead of exploding, it burns. This causes a heavy deposit of carbon.

But with this startling little device in your car all this is changed. As soon as the engine warms up, this device automatically begins to admit a much larger volume of air, thoroughly vaporizing all the gasoline, giving it fully 50% more power—breaking it up so that it explodes instead of burning!

A Carbon Remover

Not only does this invention save you half your gasoline, but it also removes carbon, saving you

the expense and time of having your carbon scraped out—a job costing from \$5 to \$25.

The Stransky Vaporizer is absolutely automatic and self-regulating. It has no springs, shutters, diaphragms or delicate parts to get out of order. It requires no adjustment—you can attach it in three minutes. And it will lengthen the life of any car.

Introductory Sample Offer

To introduce this new invention in your community, Mr. J. A. Stransky, the inventor, will send a sample at his own risk. Write at once for his proposition. The price is so low that all your neighbors will want to order through you, giving you a generous profit.

Send the request blank for full details of our amazing offer.

J. A. Stransky Manufacturing Co.
P-10 Stransky Bldg.
Pukwana So. Dakota

AGENTS Earn \$120 a Day!

This is one of the greatest propositions of the century for agents—over twenty million people want this amazing little device! J. M. James made \$120.00 in one day. J. A. Williams made \$48.00 in three hours. Vernon Gaines made \$94.00 in one day. One demonstration brings from five to twenty orders. Ideal for spare time workers. Splendid opportunity for distributors and managers. Write at once for sample offer.

J. A. STRANSKY, Inventor,
at address below.



J. A. Stransky Mfg. Co.,
P-10 Stransky Bldg., Pukwana, So. Dakota
Please send me full details of your special introductory offer.

Name

Address

City.....State.....

Will You Take These Men's Word For It?



\$700 in 24 Days "Thanks to you, I made \$700 in 24 days in Radio," says F. G. McNabb, 848 Spring St., Atlanta, Ga. "I recommend your course to all."

These three and thousands of other men earning \$70 to \$200 a week, recommend this training to you!

\$1000 a Month John J. Innes, 1133 Fourth Ave., Astoria, L. I., now earning \$12,000 a year, recommends the course. "It alone is responsible for my success."

START NOW Be an

ELECTRICAL EXPERT

LEARN TO EARN

\$3500 to \$10,000 a Year

Don't you keep on working for only \$25 or \$35 a week. Get into Electricity. Thousands of Cooke Trained Men who knew nothing about it a short time ago are now earning \$70 to \$200 a week in the Electrical Business—and they don't work half as hard as you do. Why stick to your small pay job? Why stick to a line of work that offers no chance—no promotion—no big pay? Get into the world's greatest business. Electricity needs you. I'll show you how to do it. Get ready for the big pay job now.



L. L. COOKE, Chief Engineer, who has trained thousands of men for Big-Pay Jobs in Electricity.



\$9,000 a Year Auto Electricity pays W. E. Penos, Albany, Ore., over \$3,000 a year. 53 men enrolled for this training on his advice.

Electrical Experts Are in Big Demand Even ordinary electricians—the "screw driver" kind—are making big money, but trained men—Electrical Experts who get the top salaries—are needed more now than ever before. Thousands of Cooke Trained Men easily earn \$3,500 to \$10,000 a year. That's the kind of a job you want—where you can plan and boss and supervise the work of others or go into business for yourself. Get started towards one of these big-pay jobs now. Learn to earn \$70 to \$200 a week—you can do it with Cooke Training—recommended by more than ten thousand successful graduates. Just mail the coupon below.

Employment Service—No Extra Charge I will train you for a big-pay job and then help you get it without extra charge. Hundreds of employers look to me for the electrical men they hire. Last year I placed over one thousand men at big raises in pay. Hundreds of others were promoted by their employers through the help of my Vocational Service and other hundreds went into business for themselves with the help of my Special Business Training. Mail coupon for big free book which contains this service and 14 other features, many of which can't be had anywhere else.

have to be even a high school graduate. As Chief Engineer of this big 2 million dollar institution operating one of world's greatest Training Schools, I know just what training you need to make a success in electricity. Let me give you that training with my simplified complete home course—the world famous "Cooke Training"—built on my own 20 years of engineering experience with the help of nearly 50 other engineers. Learn to earn \$70 to \$200 a week; only spare time needed.

My Training Pays for Itself You can start earning extra money a few weeks after you start my training. I give you special instruction for doing simple electrical jobs in your spare time—show you how to get these jobs and tell you what to charge. Many of my students make as high as \$25 a week extra this way while studying. My course more than pays its own way.

Your Satisfaction Guaranteed I am so sure I can make you a big success in Electricity, just like I have done for the men whose pictures you see here and thousands of others who now boast my training, that I will guarantee your satisfaction with a signed, money-back guarantee bond. If my training doesn't satisfy you after you have finished, you get back every penny you pay me. A two million dollar institution stands back of this guarantee.

Get Started Now—Mail Coupon Get my big free book—"The Vital Facts about Electricity." Read about the success of hundreds of other men—men who recommend this training and whose names and addresses are given in my book. (Get the real dope about your opportunities in Electricity. See how easy it is to get started on the road to jobs that pay \$70 to \$200 a week. Don't deny yourself this chance to make big money. Get the facts now—Mail Coupon at once for facts and my guarantee.)

**L. L. COOKE, Chief Engineer,
CHICAGO ENGINEERING WORKS, Inc.
Dept. 513
2150 Lawrence Ave.,
Chicago, Illinois**

- 5 WONDERFUL WORKING OUTFITS—Given without extra charge!**
- 1 LABORATORY AND EXPERIMENTAL OUTFIT. Complete material for interesting experiments.
 - 2 BELL AND ALARM OUTFIT. Electrical apparatus—material and tools—a complete installation kit.
 - 3 ELECTRIC LIGHTING OUTFIT. Switches, Wire, Lamps, etc.
 - 4 ELECTRIC POWER OUTFIT. The famous "Cooke" Motor and other apparatus.
 - 5 TRANSFORMER OUTFIT. Complete parts for building and winding.



The 'Cooke Trained Man' is the 'Big Pay' Man!

ENGINEERS' ASSOCIATION ENDORSES COOKE TRAINING

The American Association of Engineers, with 15,000 College and Practical Engineer Members, has approved Cooke Training and the C. E. W. 100%. Their printed and publicly distributed report of their investigation is the only endorsement of a school they have ever issued. Full details of this endorsement sent with my free book.

L. L. COOKE, Chief Engineer,
CHICAGO ENGINEERING WORKS,
Dept. 513

2150 Lawrence Ave., Chicago, Illinois
Send me at once, without obligation, your big illustrated book and complete details of your Home Study Course in Electricity, including your outfit and employment service offers.

Name.....
Address.....
Occupation.....

Classified Advertisements

WORLD'S BEST WANT AD MEDIUM

Advertisements in this section, 25 cents per word, each insertion, minimum 10 words, payable in advance. To be inserted under proper classification in December issue, copy should be in our office October 18th.

ADVERTISING AGENCIES

TO secure agents or salesmen or for selling farms and reaching investors, use classified (want) ads in largest newspapers and magazines. Price list No. 29 sent free. Ankrum Advertising Agency, 20 W. Jackson Blvd., Chicago, Ill. The largest classified advertising agency in the U. S.

ADVERTISE in 24 Big Sunday Newspapers, 24 words \$15.00. Catalog listing 1,000 leading Dailies, Weeklies, Magazines, 4c stamps. Union Advertising, Baltimore Bldg., Chicago.

YOUR 25-word advertisement in 56 Eastern Newspapers only \$2.60. Shaw, 221A Northeast, Washington, D. C.

ADVERTISING in all magazines and newspapers at publisher's lowest rates. Rate Book free. Taylor's Advertising Service, Dept. F, Freeport, Ill.

25 WORDS—355 Rural Weeklies, \$14.20. Ad-Meyer Agency, 4112-M Hartford, St. Louis.

1,000 LIVEWIRE Salesmen names; remit \$10.00, will send by return mail. C. Bloor, 413 Clymer Ave., Morrisville, Pa.

FREE. Advertising rates. Newspapers and magazines. Pennell, Covington, Ky.

FOR ADVERTISERS

ADVERTISING 222 Magazines .08c word. \$6.00 inch, \$45.00 page. Sample 10c. 171 Magazines, 5,000 Newspapers, 28 words \$180.90. Inch, 98 words, \$620.60. 28 words 100 magazines, 100 newspapers, \$3.00 inch \$12.00. Diamond Advertiser, Norton, Mass.

CATALOGUES, Booklets and Sales Literature, Planned Written and Printed, Reliable Work. Write Requirements. National Merchants Company, 4342 North Lehigh, Chicago.

HOUSE Distributing. Sign Tackling. Mailing Lists. Agents, Housewives, Farmers, Buyers. John Smelter, 2342 West 19th, Chicago.

I WRITE letters, folders, booklets, complete followup for manufacturers, mail-order dealers. Long experience. Write for details. L. Taylor, Box M14, Freeport, Ill.

ADVERTISE in 300 country newspapers, 28 words \$10. Keator, Hartford Bldg., Chicago.

25 WORDS, 88 magazines, \$1.00; Thrice \$2.00. Inch display \$2.00; Thrice \$3.40. Smith's Service, 1194, Wenzelhoe, Wash.

PHOTOGRAPHS made from sketches or ideas. Photos for artists. Struckettis, 749 Dundas, London, Ont.

WE Create Letters that get results. Write us. Demuth Company, Englewood, N. J.

MAILING Lists for Illinois, \$3.00—1,000. Janata, 1927 So. 49th Ave., Cicero, Ill.

CIRCULARIZE guaranteed lists. Agents names \$3.00, 1,000. Pennell, Covington, Ky.

COMBINATION Winner 125 Monthlies, Thrice, 10c word; \$8.00 inch. Interstate, Munising, Mich.

SALES PROMOTION

\$30 TO \$50,000 Daily Sales developed during 36 years for clients by my direct-mail plans, copy, campaigns. A \$25,000 annual volume increased ten-fold in twelve months. Another, from an initial expenditure of \$720 developed in four years sales by mail of half million yearly. Ten years Sales Promotion Manager Larkin Co. Submit sales problems for free diagnosis. James C. Johnson, 118A Woodbridge Ave., Buffalo.

STRONG copy based on sound plans. Outline your project for free analysis and plan. P. Wyeross Company, Lansdowne, Penna.

AUTOMOBILE SUPPLIES

MIRRORS Re-Silvered at Home. Costs Less 5 cents per square foot; you charge 75 cents. Immense profits, plating auto-parts, reflectors, tableware, stoves, Refinishing metalware, etc. Outfits furnished. Write for information. Sprinkle, Plater 77, Marion, Ind.

MILLERITE-ETHYL-Super-Fuel Ingredient for Gasoline. Increases Power and Mileage—Saves Gas. Make it yourself by my simple Formula and clean up five to fifty thousand a year. This and eighteen other High Class Automobile Specialties described in the valuable literature I'll send you upon request—Hurry! Exclusive Territory! Miller, Chemist, 1109-1111 Grand Central, Tampa, Fla.

IGNITION Parts for any car. Dist. points \$2.00 pair, any car. Dist. head \$2.50, any type. Rotors, Coils, Condensers, Resistance units. For any ignition. Gen. and starting motor. Brushes, all kinds. Quick service, no waiting. Bradley Auto Electric Service, Hancock and Indiana Ave., Philadelphia.

Send for bargain list of Auto supplies, including AC and Champion Spark Plugs, Kelly Lamp Works, Oak Park, Ill.

DISTRIBUTORS and Representatives Wanted everywhere. Exclusive territory. Kelly Automatic Roadite, Ford, Chevrolet, Overland and all others. John B. Kelly, 5958 Washington Blvd., Chicago, Ill.

AUTOMOBILE Parts—New and Used Parts for all cars. You can save 25 to 75% buying from us. Satisfaction guaranteed. Free Catalogue to repairmen. Century Parts Company, 4105 Olive St., St. Louis, Mo.

VULCANIZING Auto Tires is a Paying Business on account of new tires advancing. We have Plants near you from \$100 up. We save you 50%. Catalog Free. Instruction Book \$1. Equipment Exchange, 108 East 11, Los Angeles, Calif.

PLANS and Instructions for new, worthwhile Auto accessories and specialties you can manufacture. Morton, 3937A Tracy, Kansas City, Mo.

MAGNETOS, Starters, Generators, Ignition systems, spark plugs, parts, repairing. Meinert Magneto Co., 1759 E. 21st St., Cleveland, Ohio.

AUTOMOBILES

PATENTS. Time counts in applying for patents. Don't risk delay in protecting your ideas. Send sketch or model for instructions or write for Free book, "How to Obtain a Patent" and "Record of Invention" form. No charge for information on how to proceed. Communications strictly confidential. Prompt, careful, efficient service. Clarence A. O'Brien, Registered Patent Attorney, 5897 Security Bank Building (directly across street from Patent Office) Washington D. C. See pages 140 and 141.

AUTOMOBILES: 753 Ideas on repairing and improving, in Popular Mechanics three new books: Auto Repairman's Handbook, Auto Owner's Handbook, Auto Tourist's Handbook. Send No Money. Just write a postal. Pay postman the postage and \$1.50. Popular Mechanics Press, Room 811, 200 E. Ontario St., Chicago, Ill.

COMPRESSORS—only \$16.50 monthly. Fully automatic, lighting or power lines operate. Special prices. Hobbarths, Troy, Ohio.

PATENTS: My fee in installments. Free personal advice. Frank T. Fuller, Washington, D. C.

DYKE'S Automobile and Gasoline Engine Encyclopedia. Latest edition contains information on repairing and adjusting every part of all motor cars now in use. Tells how to find out what is wrong and how to fix it. Mechanics everywhere depend upon this compendium to keep them up-to-date. Send No Money. Just write a post card. Pay postman the postage and \$8. Popular Mechanics Press, Room 811, 200 E. Ontario St., Chicago, Ill.

AUTOMOBILE SUPPLIES, ACCESSORIES AND HOUSEHOLD GOODS WANTED

100,000 REPRESENTATIVES Wanted! Sell by mail, through Agents, or Direct! Detailed Information—25c! None free. Surety Service, World Distributors, 551 Harvard St., Rochester, N. Y.

FOR FORD OWNERS

CALIFORNIA tops for Ford and Chevrolet roadster and touring cars. Economical, pleasing, closed car comfort. Simple installation. Quality high. Price low. Write factory today. Kospet Auto Top Company, Bellefonte, Ill.

UNDERSLING with "RKO" Swing Lo Irons. See "Red-I-Kut" ad page 135.

1/2-1-1/2 KW, 110-volt Electric current from your Ford. Equipment easily attached. Write, Duplex Manfg. Co., Myerstown, Pa.

DELIVERY Bodies for Ford Model T. Chassis with inclosed Cab. Suitable for Contractors, Grocersmen and Farmers. Three styles. Price \$37.50. Write Daniel Zimmerman, Craigville, Ind.

GUARANTEED. Ford size spark plugs, set (4) \$1.00 postpaid. Made by, Benj. Jordan, 280A Shelton Ave., New Haven, Conn.

SEND dime for information how to change genuine Ford bands through inspection plate. Cross, Geneva, Ind.

MOTORCYCLES, BICYCLES AND SUPPLIES

1923 HARLEY-DAVIDSONS, \$168; 1922, \$118; 1921, \$111; 1920, \$85; 1919, \$65; 1917, \$50; 1916, \$45; 1915, \$40; 1914, \$35. Guaranteed. Money refunded if not satisfied. Circular free. Wisconsin Cycle Sales Co., 726 National Ave., Milwaukee, Wis.

NEW Cleveland Motorcycles, Fully Equipped, \$95.00 delivered. Equipment, Inc., 563 Boulevard, Long Island City, N. Y.

DON'T buy a Bicycle Motor Attachment until you get our prices. Shaw Mfr. Co., Dept. 27, Galesburg, Kans.

USED parts for all motorcycles, cheap. State wants. Schuck Cycle Co., 1922 Westlake, Seattle, Wash.

USED Harley-Davidson Parts 40% to 80% Discount. Tower Cycle Co., 4385 North Florissant, St. Louis, Mo.

NEW and used parts for Motorcycles and Bicycles. Get our prices on parts needed. Kingshighway Motor Co., 1166 N. Kingshighway, St. Louis, Mo.

SEND for Bargain Bulletin. All makes of rebuilt motorcycles at lowest prices. Used parts half-price. Ash Motor Corporation, Rochester, N. Y.

AVIATION

LEARN to Fly with experienced teachers. Former students of ours are now flying the mail. Others are with Ford. Our course includes Dual Instructions (with teacher), Solo Flying (without teacher), and Aerobatics. Average time required to solo, 6 to 7 hours. No bond required. Partridge, Inc., 3515 West 83rd Place, Chicago. Post Graduate Course in night flying.

SPECIAL Offer, "Airslinger," 300 ft. flights guaranteed; 40c postpaid. Big model catalog, airplanes, boats and supplies, 5c postpaid. W. Phipps Company, 367 Wilson Avenue, Brooklyn, N. Y.

JOIN the Gary Flying School and take your International Certificate! Captain J. A. Yonge, war and commercial pilot of ten years' experience, offers a complete flying course on entirely new lines. Considerable "solo" flying time and advanced air instruction are two special features. Write now for information. Gary Flying School, Gary, Ind.

CAPTAIN J. A. YONGE offers an instructive correspondence course at \$12.50 for ten lessons on Theory of Flight, Flying, Construction, etc. Write for information. Gary Flying School, Gary, Ind.

"HIGHLIGHT" Replacement Wings for Jenny or Canuck Light Planes. Complete and "knockdown." Plans for Builders. Flying Instruction, \$100. Circular Free. Aviation Engineering Co., Lawrence, Kan.

EARN \$3,500 to \$10,000 a year. Learn Airplane Engineering Now at Home. The World Flyers were Airplane Engineers. Write for free catalog. Western Airplane Corporation, Dept. K-11, Monadnock Block, Chicago.

PATENTS. Time counts in applying for patents. Don't risk delay in protecting your ideas. Send sketch or model for instructions or write for Free Book "How to Obtain a Patent" and "Record of Invention" form. No charge for information on how to proceed. Communications strictly confidential. Prompt, careful, efficient service. Clarence A. O'Brien, Registered Patent Attorney, 5897 Security Bank Building (directly across street from Patent Office), Washington, D. C. See pages 140 and 141.

TEN lessons in the air of twenty minutes each will make you a pilot by our advanced method of training. This, together with our five weeks shop course at \$100.00, makes America's oldest aircraft factory the most popular flying school. Work after class hours guaranteed. Heath Airplane Company, Chicago, Ill.

ANNOUNCEMENT Extraordinary. Blueprints giving detailed constructional specifications for making latest type "Aerodrive" "Ice Couch," Fast Boat, Speedy Scooter, Likewise Specifications for converting Ford motor into Aviation engine, only \$2.50 (easily worth \$5). Price list Aircraft Supplies, Propellers, etc., 5c. Ostergaard Aircraft, 4271 North Narragansett, Chicago.

AIRPLANES, Motors, Parts, Supplies. Prompt shipment, honest dealings. Learn to fly with us. Enroll any time. Write for Full catalogue, Nicholas-Beasley Airplane Co., Marshall, Mo.

PATENTS: My fee in installments. Free personal advice. Frank T. Fuller, Washington, D. C.

AVIATION Fans: Send one dollar for beautiful pair sterling silver wings, mounted on bar pins with safety catch, and identification card issued by National Flyers' Association. Thousands being worn by pilots' aviation mechanics, and aero enthusiasts. Wallace Aero Company, Bettendorf, Iowa.

28 H. P. two-cylinder Lawrence Airplane Engine, is just the thing for light sport plane. Only cost you \$75.00 complete with new mahogany long propeller, Duplex Zenith Carburetor, Philbrin ignition system switch, etc. Cost the Government almost a thousand dollars. We have everything for aviation. Wire, write or telephone your orders. Crawford Airplane Co., Venice, Calif. Phone 62889.

NEW nine-cylinder Gnome aeroplane engine \$15. Albert Lashaw, Clarion, Mich.

HEATH propellers represent the most efficient method of aerial drive. Each propeller individually designed for the particular work to be done, as laid out by America's oldest aeronautical engineers. Propeller catalog 4c; send blueprints \$2.00. Redial goggles \$2.90. Heath Airplane Company, Chicago, Ill.

MOTORS: Curtiss OX-6 Class A (under Fifty Hours) for Plane, Sea-Sled, Motor boat, etc., \$140.00. All Motor and Plane Stores at Best Prices. Send for Catalogue. Monumental Aircraft Co., 339 N. St. Paul Place, Baltimore, Md.

LEARN Aviation! Flying, Mechanical, and Homestead courses. Special opportunity now. Send 25c for catalog and details. Varney Aircraft Co., Peoria, Ill.

28 HORSEPOWER airplane motors, new and slightly used; \$100 and \$125. Propellers \$2.00 to \$25.00. Leather coats \$10.00 and \$12.50. Smith Machinery Co., Box 133, Houston, Tex.

THE American School of Aviation announces a new correspondence course in Mechanics of Aviation. A thorough training in Practical Aeronautics. American School of Aviation, Dept. 1861, 3601 Michigan Ave., Chicago, Ill.

LEARN to Fly! Write for booklet. Robertson Aircraft Corp., Anklam, Mo.

WELDING AND SOLDERING

ALUMINUM Solder. Guaranteed to Solder Aluminum Sheet or cast. No flux. Will solder any metal to Aluminum. Send 50c for sample. Gardner Co., Box 267, Lomax Park, Pasadena, Calif.

PLATING EQUIPMENT

PLATING generators. Barred platers. Specially priced. Ideal for factories or plating shops. Write Hobart, Troy, Ohio.

BOOKS AND PERIODICALS

HYPNOTISM easily learned. Lessons guaranteed. Postpaid \$1.10. Smith Pub. Co., Dept. 3, Springfield, Mass.

THE United Extension Library desires ten thousand New Members. Popular novels. Eminent authors. Year \$1.00. 73 Maple St., Columbus, Ohio.

B & M RELOADER'S Handbook. A textbook on handloading and complete catalog. Contains clear instructions for loading cartridges, bullet descriptions, powder tables, ballistic tables and general data. Describes B & M scope sights, cleaning rods, loading tools, and rifle sights. Upwards of two hundred pages in loose-leaf form. Price only 50 cents, and that amount refunded on your first \$5.00 order. Belding & Mull, 826 Osceola Road, Phillipsburg, Pa.

PHILOSOPHY and Phenomena of Spiritualism. The author relates his thirty years' personal experience with spirits while in and out of his body. Led by them through the Spirit world, he visited Heaven and Hell and found many convincing proofs of Life after Death, and Spirit return. 500 pages, \$3.25. Franklin A. Thomas, Author, Malden, Mass.

LAMPS. Make your own lamps and shades. Popular Mechanics crystal-clear books on this subject are filled with designs and photos. All sorts of lamps, from floor lamps to dining room domes. Send No Money. Just write a postal. Pay postman postage and \$2. for the two books. Popular Mechanics Press, Room 811, 200 E. Ontario St., Chicago, Ill.

"MASTER KEY" Success Wonderful 410 Pages, Cloth, \$2.50 Mind Reading 60c. Happiness 30c. Hypnotism 30c. Barren lists (all subjects) 10c. Phipps Library, 1014 Belmont, Chicago.

HYPNOTISM Amuses, Astounds, Insures health, wealth, happiness. 25 Easy Lessons \$1.00. "Mindreading" (any distance), wonderful, 50c. Success guaranteed. Popular Institute, N430 Milwaukee Ave., Chicago.

WHERE'D Cain get wife? Where is hell? What is soul? 62 pages 50c. Jabe Studio, Los Angeles.

"COLORS and Rhythms." About 100 pages. Chromo-therapeutics. Marvelous Scientific Knowledge. Illustrations. Deluxe \$2.00; Plain \$1.00. Dept. M. Stevens, 242 Powell, San Francisco, Calif.

BRYANT'S latest book, 224 pages, opposing "Evolution," postpaid \$1.60. First Edition, over 200 pages, 75c. Two best Articles, 20c. Stephen O. Bryant, Bethany, Mo.

"AMATEUR Electrician" 64 pages (illustrated). "Toymaker Book" (illustrated), "Ford Joke Book"—all for 25c. G. Elson, Bowling Green, Ohio.

INDUSTRIAL Alcohol. Wright's book. Full directions for making drawings, \$2.50. Spoon & Chamberlain, 120 P. M. Liberty Street, New York, N. Y.

FREE—Send for my Newthought, Self-culture, Occult, Mystic and Scientific book literature. Martens Publisher, Burlington, Iowa.

MENTAL and Spiritual Healing: All Schools and Methods. Why pay \$100 to learn to heal? Technique complete \$3.50. International Book Concern, Los Angeles.

GLIDER—Complete instructions with drawings and dimensions in Boy Mechanics, Book 1. In addition, directions for making nearly 1,000 other useful and interesting devices. Send No Money. Just write a postal. Pay postman \$2 and the postage when book arrives. Popular Mechanics Press, Room 811, Chicago, Ill.

SNOWSHOES, How to Make and Use Them. Make your own from crystal-clear instructions in Boy Mechanics, Book 2. Many illustrations show how Indians make snowshoes. Also directions for making ice boats, bob-sleds, merry-go-round for the lev-monoplane glider, and many other outdoor devices. Send No Money. Just write a postal. Pay postman postage and \$2.60. Popular Mechanics Press, Room 811, 200 E. Ontario St., Chicago, Ill.

PICTURES AND POSTCARDS

BEAUTIFUL pen-written visiting cards, wedding announcements, invitations, certificates and diplomas filled in, beautiful Christmas cards, reasonable. E. F. Aber, Penman, Lock Box 491, Dearborn, Mich.

JOIN Popular Friendship Club. World's best. Exchange view postcards, letters, stamps. Enthusiastic members everywhere. Fascinating pastime. Membership two months, 10c; six months, 25c; one year, 50c. Oliver Gandy, Crisfield, Md.

75 BEAUTIFUL Art Pictures and Bathing Beauties 25c (coin). Photo Sales Co., 3212 Rixton, Suite 400, Detroit, Mich.

SEE San Francisco, California. Twenty-five beautiful Postcards. Quarter. Mott, 520 Clementina, San Francisco.

TWELVE excellent photographic postcards of your favorite movie stars fifty cents. Macfarlane Studio, 5332 Santa Monica, Hollywood, Calif.

TRUE-BLUE, Old reliable, 17 years. Exchange cards, letters stamps. Year, \$1; half, 50c; quarter, 25c; booklet, 10c. Ed. Erlson, Elroy, Wis.

"ARTISTIC Hand Made." Roll and six translucent pictures 25c. Reprints 3c. Art Studio, Dallas, Tex.

JOIN Live Postcard Club; Membership lists including Catalog, 10c. Harvey Teeple, Decatur, Ind.

GAMES, ENTERTAINMENTS AND PLAYS

PLAYS, musical comedies and revues, minstrel music, blackface skits, vaudeville acts, monologs, dialogs, recitations, entertainments, musical readings, stage handbooks, make-up goods. Big catalog free. T. S. Denison & Co., 623 So. Wabash, Dent. Ill., Chicago.

VENTRILOQUISM taught almost anyone at home. Small cost. Send 2c stamp today for particulars and proof. George W. Smith, Room 8-30, 125 N. Jefferson Ave., Peoria, Ill.

PLAYS, Minstrels, Musical Comedies, Vaudeville Acts, Monologues, Make-Up, Wigs, Catalogue "D" Free. Banner, 1061 Market St., San Francisco, Calif.

100 LIGHTNING Chalk Talk Stunts \$2.00. Cartoonist, 2925 Euclid, Kansas City, Mo.

NOVELTIES, CURIOS, ETC.

UNIQUE Fortune Telling Device! Interesting! Entertaining! Answers Questions Accurately. Easily Operated. Fun for Everybody. Appropriate Prize or Gift. One Dollar. Schenck Novelty Company, Box 959, Denver, Colorado.

LOOK! New catalog and French novelty 25c. Ruth, Box 202, Morris, Ill.

MAGIC TRICKS, BOOKS AND JOKER NOVELTIES

MAGIC—Tricks, Books and Supplies. For Amateurs as well as the great professionals. Anyone can learn through our instructions. Feature Acts in Mind Reading, Spiritualism, Rope Ties, etc. Large Illustrated Professional Catalog, 20c. Chicago Magic Co., 140 S. Dearborn St., Dept. B, Chicago, Ill.

AMAZE and Mystify your friends! Easy to learn. New Book, "33 Card Mysteries" and big 1925 Catalog Magic and Novelty, postpaid 10c. Lyle Douglas, Station A, Dallas, Texas.

FREE with \$25 order die box. Send 20c for our large catalogue of tricks, wigs, seasonal escapes. Oaks Magical Co., Dent. 548 Oshkosh, Wis.

125 CARD Tricks, Explained and Illustrated, 25c. Big illustrated trick catalog, 10c. American Sales Co., Trick Dept., Springfield, Ill.

TRICKS, Magic, Gazing Globes, Catalogue free. Otto Waldmann, 1450 First Ave., New York.

BOOKS, Secrets, Magical novelties. Home work everywhere. Catalogue free. Singer, 315 Hanover, Wis.

MAGIC goods, cards, books, novelties, tricks. Catalog free. C. Fenner, 2401 Jefferson, Louisville, Ky.

SEVEN Magical Delusions and Catalog— 25c. Gilmazieo, Morgan Park, Ill.

MAGIC for Beginners. Some of the most startling of stage illusions are fully explained in Boy Mechanics, Book 1. Full directions for making apparatus and for performing such tricks as: escape from a padlocked box, startling electrical illusions, snikt hand that answers questions, making the spirits play a violin, and many others. Get this book now and mystify your friends. Send No Money. Just write a postal. Pay postman \$2 plus postage. Popular Mechanics Press, Room 811, 200 E. Ontario St., Chicago, Ill.

STAMP COLLECTING

STAMPS, 4c-4c-10 each. Josiah Babcock, St. Joseph, Mich.

STAMPS—\$1,000.00 sacrificed for cash. Richards, Box 56, Shadyside, Ohio.

SNAPS—200 different stamps, 10c; 60 different United States Stamps, 12c. With each order we give free our price list of sets, packets, albums, etc., and our pamphlet which tells "how to make a collection properly." Queen City Stamp Company, Room 38, 604 Race, Cincinnati, Ohio.

ALTHOUGH thousands more were printed than in any previous year, unprecedented sales of Scott's Postage Stamp Catalogue, 1926 Edition, (out Oct. 10) will soon make copies very hard to get. This edition contains more than 1,500 pages—it lists, describes, illustrates type, gives color, watermark and perforation of every stamp ever issued by any government in the world to date of going to press. Also prices at which they may be bought, used, or unused from the Scott Stamp & Coin Co. Order from your Dealer—\$2.00 cloth, \$2.50 with thumb index, or we will supply you at this price plus forwarding (wt. 2 lbs.) if dealer is out of stock. New 50% Approvals. We now offer a greatly enlarged line of 50% approvals. Our World-wide connections enable us to offer approvals which are in a class by themselves for quality, value and desirability. State countries you prefer; references required. Scott Stamp & Coin Co., 33 West 43rd Street New York, N. Y. Philatelic Headquarters since 1869.

ARABS! Bandits! Head-Hunters! Egypt (sphinx); Malay (tiger); Benadir (elephant); Tunis (arab); Turkey (sacred mosque); Belgium (showing battle between angel and "old horns"); Congo (head hunter)—All of these mysterious and remarkable stamps are contained in our Famous Phantom Packet—55 fine varieties (40 approval applicants only) for eight cents. Nothing like it; order at once! Pacific Stamp Co., Box 138, Helena, Mont. Extra! Send us with your order for the Phantom Packet at 8c, the names of three of your friends who collect stamps; and we will give you, free of charge, a scarce set of 11 diff. Albania—bandit land!—cataloguing over \$1.50. Supply limited; write immediately!

PERSLA—ancient land of Arabs, massacres and mysteries! Packet 25, all different Persia, including scarce and high values; also set unused Red Cross stamps and fine packet 50 different, including Nyassa, Kenya, Gold Coast. Entire lot 16c to approval applicants furnishing references. Scarce Havli stamp, free if ordered immediately. Send 6c for Mexican Revolution bill and big price lists. Russian coin 7c; Two different South American coins 16c. Stamps—all different 4 Tanganyika 16c; 4 Kenya 12c; 6 Mozambique 8c; 5 Irish 6c; 5 Nyassa 6c; 7 Borné 16c; 4 Liberia 10c; 17 Mexico 11c; 50 Spain 12c. C. D. Reimers, 904 Flatiron, Fort Worth, Tex.

ANCHERS \$\$\$ Outfit—only 12c! Fine triangle stamp; set German stamps with (pre-war) value forty million dollars (interesting!); perforation gauge, mm. scale; small album; 2 approval sheets; airmail set; scarce stamp from smallest republic on earth; newspaper set; packet good stamps from Travancore, Johore, Dutch Indies, etc. Entire outfit for 12c to approval applicants! (Nice pocket stock book, value 25c, with every order!) Ancher Stamp Co., 148½ Clerk St., Jersey City, N. J.

FAMOUS Fenway Outfit. All for 12c; triangle stamp; small album; 250 hinges; 5 large French Colonials; 2 special deliveries; Airmail set; Red Cross set; Fantastic Fenway Packet containing 55 different, including Abyssinia, Azores, Cape of Good Hope, Bosnia, Crete, Congo, etc. This wonderful outfit and 16-page price list only 12c; to new approval applicants. Fenway Stamp Co., 161 Massachusetts Ave., Boston, Mass.

THE "Magnificolus" 10c Packet. Contains over 108 Stamps from Iceland, African Congo, Cape of Good Hope, Hindustan, New South Wales, Cochín, (Rajah, with bumper-shot watermark), Mozambique Pictorial, and many other stamps from the hidden parts of the world; Also Perforation Gauge and Scale; Also Snappy Lists to approval applicants. Imperial Album, 96c postpaid. Collections Bought, Paym Stamp Co., 945 Vista Drive, Los Angeles, Calif.

500 FOR 25c mixed stamps from 40 different countries, Australia, North, Central, and South America, Africa, China, Japan, British, French Colonies, War Issues, Russia, etc., also 500 stamp hinges, pocket approval book, perforation gauge, and 5 United States stamps issued from 1861 to 88. Biggest bargain ever offered to approval applicants. Satisfaction guaranteed or money back. Hussman Stamp Co., Dept. PM, St. Louis, Mo.

ARMENIA, complete set 16 values catalogue, \$1.14 for only 12c to approval applicants sending good reference. J. L. Nelson Theological Seminary, Alexandria, Va.

\$10.00 FOR 25c. A choice assortment of 500 all different stamps guaranteed to catalogue over \$10.00 offered to approval applicants for only 25c. Edgewood Stamp Co., Milford, Conn.

MYSTIC'S "Mysterious" Packet! Contains stamps from the lands of cannibals, heathens, sun worshipers, and wild savages. Included are Kenya and Uganda, Persia, Africa, Dutch Indies, Gold Coast, Federated Malay States, Eritrea, Nyassa, Travancore, Siam, Congo, etc. This wonderful packet containing 103 all different (mostly unused) for only 8 cents to approval applicants. Mystic Stamp Co., Dept. 8, Camden, New York.

STAMP Collectors Outfit only 25c. includes 32-page book "How to Collect Stamps" Album (illustrated), 100 Hinges, 110 different stamps from Comoro, Guinea, Hejaz, Iraq, Sudan, Zanzibar, etc.; also "free stamps" coupon. For new customers only. Harry Ioor, 801 State Life Bldg., Indianapolis, Ind.

5 AIRMAIL—20 unused 4c, 1,000 different 98c, 500 different 38c. Both \$1.25. Buckey, 528 Alameda, Dayton, Ohio.

200 FOREIGN, bank, U. S. precancelled 35c. Boy's and Girl's competition prizes. Montauk Stamp, Baldwin, N. Y.

20 DIFFERENT, Turkey 8c. Approvals. Fryrear, 1111 4th Ave., Cedar Rapids, Iowa.

FREE—500 Different Stamps, to Approval Customers, Rio Grande Stamp Company, Box 881, Brownsville, Tex.

WONDER Packet—500 varieties, all-over world, postpaid, 69c. China, \$5. Temole, 60c. Invisible approvals. For reference. Reb. 6339 Ada Street, Chicago.

200 DIFFERENT stamps, set triangles, set animal stamps, other sets, U. S. Packet, blank approval book, 40 pages stamp bargains, \$4.00 value for only 25c to applicants. 1,000 Hinges, 9c; 100 U. S., 25c; 500 diff., 45c. Hawker Stamp Co., Cedar Rapids, Ia.

FREE RR set to approval applicants. Postage 4c. Park Houghton, Dayton, Ohio.

25 DIFFERENT Persia, 19c. Iowa Stamp Co., Cedar Rapids, Iowa.

FIFTY fine different British Colonies stamps, 35c. Duroso, 25 Mulberry, New York City.

SURPRISE Packet—Contains variety foreign stamps free for 2c postage. Gray Stamp Company, Toronto, Can.

UNITED STATES—55 different (special issues, etc.), 10c; Borné Rhinoceros and 105 different, Foreign, Hinges, etc., 10c. Moxley, Bloomfield, Mo.

ALL Different: 11 Albania 11c; 16 Armenia 18c; 21 Mozambique 21c; 19 White Russia 16c; 19 Iceland 10c. Fred Jackson, Montana, Calif.

\$1.00 WORTH OF Stamps for 3c. Hull, 14 West 101st, New York.

110 DIFFERENT Stamps, many unused, high values, free to collectors requesting our Net Approvals. Postage 2 cents. Christensen, Milwaukee, Wis.

CURIOSITY Packet, 104 unused in blocks 12c. Big 20-page list, set Air Mail Free. Burger, 21 Cambridge, Dayton, Ohio.

THE \$1 Big Beauty Packet—25 stamps only, but all rare—50c to approval applicants. Cheap at \$1. Money back guaranteed. Cedric W. Lomont, Delaware, Ohio.

FRENCH Colonies Free—Jungles, Tigers, Native Chief 2c postage. Empire Stamp Company, Toronto, Canada.

1,000 MIXED U. S. and Foreign Stamps 25c. Phil. Lundstedt, Cape Cottage, Maine.

BRITISH Colonial Stamps are safe investments. Selections sent on approval. Reference required. H. Braun, 95 Charles St., Jersey City, N. J.

1,000 STAMPS all different \$1.00, 100 different French Colonies 25c. List Free. Claud Denney, Box 315, Dallas, Tex.

BEST one-cent approvals in America. F. P. Hand, 1117 So. 60th St., Philadelphia, Pa.

STAMPS Free—Ask for money-saving approvals. John P. Bergesen, Cedar Falls, Ia.

100 DIFFERENT stamps, postage 3c. Glenwood Stamp Co., 30 Athol St., Springfield, Mass.

FREE—25 Different Portuguese Colonials, to Approval Applicants. 2c Postage. Lightbown's, Osborne Road, Southsea, England.

APPLY for our Superior Approvals and receive absolutely free 100 different foreign postage stamps. W. Streiberger, 506 DuBois St., Union City, N. J.

105 CHINA, etc., stamp dictionary, list, 2c. Album (500 illustrations), 3c. Bullard, Sta. A. Boston.

UNITED STATES Stamps, Complete stock Postage, Dept's., and Revenues. Price list free. Voorhes, 7 So. Dearborn St., Chicago.

"EXHIBITION," "War Prisoners," "Airmail," "Pictures," "Eagles," "Dues"; six sets unused, different countries, five French, five British, five Portuguese Colonies, Packet Dutch Indies, 100 different foreign, 15c to approval applicants. Deering, 38 Fairmount, Marlborough, Mass.

500 STAMPS, 17c. Includes Finland, Piume triangle, Ceylon, Guatemala, Australia (swan), Dominican Republic, New Zealand, etc. To approval applicants, 17c. Plenty U. S. Elmer, 15 School Street, Boston, Mass.

55 DIFFERENT United States 10c. Valuable approvals at 60% discount. Seidenberg, Baroda, Mich.

NET Approvals. Premium to new applicants sending reference. Tower Stamp Co., 42 Westville St., Dorchester, Mass.

110 NEW Europe All Different, a wonderful collection cataloguing several dollars, free to collectors requesting our Net Approvals. Postage 2 cents. Badger Stamp Co., Milwaukee, Wis.

ROYAL Surprise Packet, 10 French Col., 10 British Col., 10 Port. Col., Small Album, 250 Hinges, Perforation Gauge and Millimetre Scale and a packet of 100 Diff. Stamps all for 10c to new approval applicants. Royal Stamp Company, 6929 Broadway, Dept. P, San Antonio, Texas.

24 VARIETIES Cuban stamps, 10 cents. List of 6,000 low-priced stamps free. Address Chambers Stamp Co., 111P, Nassau St., New York City, N. Y.

STAMPS, 100 all different, Postage 2c. Lists free. P. M. Quaker Stamp Co., Toledo, Ohio.

FREE! Loose Leaf Postage Stamp Album at rate of 8 pages each month given with subscription to monthly Journal. Send 3c stamp for prospectus. United Stamp Co., Marquette Bldg., Chicago, Ill.

STAMPS, 50 varieties, Africa, Brazil, Peru, Cuba, Mexico, etc., 10c. 50 different U. S. 25c; 1,000 mixed, 40c; 1,000 hinges, 10c. List free. C. Stegman, 5948 Cote Brillante, St. Louis, Mo.

PACKET of 23 stamps, no two countries alike. Packet hinges. Set of \$1 and \$2 U. S. Rev., all for 5c. P. M. Miami Stamp Co., Toledo, Ohio.

20 UNUSED stamps free. All different. Postage, 2c. P. M. Fisk Stamp Co., Toledo, Ohio.

ZAMBESIA, Zanzibar, Abyssinia, Herzegovina, Allenstein stamps, menagerie collection, album, 10c. Liberty, 3874 Arsenal, St. Louis, Mo.

1,000 DIFFERENT \$1.00, 50 French Colonies 15c; 100, 50c. Fred Onken, 630 79th Street, Brooklyn.

FREE! 20 Diff. large, showy picture stamps for a request for my 1, 2 and 3c approvals; also the higher priced desirable stamps at 50% discount. Chas. Thomas, 1412 N. 16th St., Philadelphia, Pa.

1,000 DIFFERENT genuine stamps, only \$1.00. Guaranteed satisfactory or money back. Nickles, 2939 Rodman, Washington, D. C.

FOREIGN Stamp Collection Sent Free. Cornish Co., Schenectady, N. Y.

FREE, Hungary Charity No. 565 to 567 and a surprise packet given to those requesting for my 1, 2 and 3c approvals and also my 50% discount and better. Chas. W. Schmidt, 327 Benner St., Wissinoming, Philadelphia, Pa.

STAMPS on approval—¼c up. Free Premium. Herbert Keigwin, Middletown, N. Y.

STAMPS sent on approval at 70% discount. Reference required. Emory Renoll, Haver, Vt.

FREE—50 varieties to approval applicants sending 2c. Richard P. Lamprecht, Valparaiso, Ind.

FREE! 10 beautiful Rhein-Ruhr stamps to approval applicants. Penna Stamp Co., Manor, Pa.

PENNY Approvals that Satisfy. Neil Gronberg, Box 5441, Philadelphia, Pa.

RARE COINS

OLD Money Wanted. Will pay \$100.00 for 1894 Dime, 8c. Mint., \$50.00 for 1913 Liberty Head Nickel (not Buffalo). Big premiums paid for all rare coins. Send 4c for Large Coin Folder. May mean much profit to you. Numismatic Co., Dept. H, Ft. Worth, Tex.

100 WAR coins. Curious designs. 75c; 20 large foreign bills 25c; 10 Confederate bills 35c; Revolutionary War Currency 1776 30c; 10 historical medals 50c; War Medal 50c. Retail catalogue free. Nagr, 8P South 18th, Philadelphia.

GET Profit and Pleasure in collecting Old Coins. Send 10c for Sample Old Coin, together with my Large Illustrated Coin Catalogue. You'll be delighted with it. Send for it right now. B. Max Mehl, Professional Numismatist, Mehl Bldg., Dept. P, Fort Worth, Texas. Largest Rare Coin Firm in U. S.

OLD Coins, Large Spring Selling catalogue of coins for sale free. Catalogue quoting prices paid for coins, ten cents. William Hessler, 101A Tremont Street, Boston, Mass.

\$2 TO \$500 Each Paid for hundreds of Old or Odd Coins. Keep All Old Money. It may be very valuable. Send 10 cents for Illustrated Coin Value Book, 4x8. Get Posted. Guaranteed Prices. We Buy and Sell. Clarke Coin Office, LeRoy, N. Y.

10 OLD coins, all different \$1.00. 30 coins from 30 different countries \$1.00. Monroe Half-Dollar, unscrubbed, \$1.00. List free. Claud Denney, Box 315, Dallas, Tex.

SELL foreign coins, European bonds, money, etc., by mail from home. Profitable business. Literature free. Giant beginner's outfit \$1.00. "Oldest in the Line." Hirscher, 79 Wall St., New York.

CALIFORNIA gold Quarter 27c; Half 52c; 1841 Jackson cent 20c; \$188.50 Confederate money 75c. A. Wylie, Wheaton, Ill.

OLD Money Wanted. Will pay Fifty Dollars for nickel of 1913 with Liberty Head (not Buffalo). We pay cash premiums for all rare coins. Send 4c for large Coin Circular. May mean much profit to you. Numismatic Bank, Dept. H, Fort Worth, Tex.

UNITED STATES Large Cent and bargain Price List 10c. ARTY, Box 483, Muskogee, Okla.

UNITED STATES and Foreign Money. Medals, Catalogue and Villa Bill 10 cents. Alexis Mengelle, Colorado Springs, Colo.

CALIFORNIA gold, 3/4 size, 27c; 3/8 size, 53c; three-cent-piece and catalogue, 10c. Norman Shultz, Colorado Springs, Colo.

FOR BOYS

BOYS and Girls: Christmas Money Given. Send name and address. We will send you 50 sets Christmas Seals. Easily sold 10 cts. a set. You keep \$2; send us \$3. Be first in your neighborhood. We trust you. Many earned \$10 last Christmas. Write at once. Mistletoe Seal Co., Dept. 56, Brooklyn (R) N. Y.

BOOKS—"Amateur Electrician" (illustrated), "Teymaker," "Ford Jokes," all for 25c. "Boxing Instructor" (illustrated) 25c. 74 American Songs, with music, 25c. Big package Pocket Perfume, 10c G. Elsen, Bowling Green, Ohio.

MODEL Airplanes. Build your own. Enjoy flying them. Full instructions, pictures, and dimensions in Boy Mechanic Book 4. 1349 articles, 1320 pictures. Send No Money. Just write a postal. Pay postman postage and \$2. Popular Mechanics Press, Room 811, 200 E. Ontario St., Chicago, Ill.

BOYS and Girls Earn Xmas Money. Write for 50 Sets St. Nicholas Christmas Seals. Sell for 10c a set. When sold send us \$3.00 and keep \$2.00. No Work—Just Fun. St. Nicholas Seal Co., Dept. 43, Brooklyn, N. Y.

EARN \$2.00. Be First in your Town. Write now for 50 sets Christmas Seals. Sell for 10c a set. When sold send us \$3.00 and keep \$2.00. Trust you till Xmas. Newbecker Bros., 961 E. 23d St., Dept. 88, Brooklyn, N. Y.

AUTOMOBILE—Make your own motor car, toy size, operated with motorevele engine. Any boy can make it. Costs little aside from engine. Full directions with drawings and dimensions in the Boy Mechanic, Book 3. Send No Money, just write a postal. Pay postman postage and \$2. Popular Mechanics Press, Room 811, 200 E. Ontario St., Chicago, Ill.

CAMERAS AND PHOTO SUPPLIES

PHOTOGRAPHIC equipments and accessories of every description are listed and illustrated in our 228-page catalogue. It will pay you to secure a copy which is issued free, as our prices are low. We also deal in used goods which are sold under the same guarantee as new goods. Ask for our Bargain Book. Central Camera Co., Dept. K-99, 112 S. Wabash Ave., Chicago, Ill.

FILMS Developed Free. Glossy prints, year 'round prices, 2 1/4 x 3 1/4 3c; 2 1/4 x 4 1/4 4c; 3 1/4 x 5 1/4 5c. Free enlarging coupons with all orders. Dept. 80, Baldwin Studio, St. Louis, Mo. No stamps.

MODERN Photography in all its branches now taught by mail. New Successful Method. Students earning \$300.00 while learning. Big opportunity. Write for particulars and unusual offer open for short time. Dept. 1331, International Studios, Inc., 3601 Michigan Ave., Chicago.

FILMS Developed, Special Trial Offer. Any Size Kodak film developed 5c, prints 3c each. Trial 8x10 Enlargement in handsome folder 40c. Overnight Service. Roanoke Photo Finishing Co., 209 Bell Ave., Roanoke, Va.

SUPERIOR quality finishing. Trial offer: Any size 6 exposure roll developed and printed, 25 cents. One only 8x10 enlargement unmounted from negative, 35 cents. Carkhuff Photo Finishing Co., 2129 W. Van Buren St., Chicago.

HAVE You a Camera? Write for Free sample of our big magazine, showing how to make better pictures and earn money. American Photography, 116 Camera House, Boston, 17, Mass.

KODAK Films—Special trial offer; your next kodak film developed, 5c—prints, 2c each. Moser & Son, 1817 St. James Ave., Cincinnati.

ENORMOUS Profits From Camera! An Income From a Camera, kind of pictures 100 firms want, 12 issues P-8 Bulletin, all \$2. Particulars, stamp. Press Studios, Walton, Neb.

BETTER Photo Finishing. Send one roll film and 15c for trial offer. Moore's Photo Studio, Abstead, N. H.

MAKE photographs quickly, without plates. New process, saves money. Instructions \$1.00. Samples 10c. Satisfaction guaranteed. Koch's Studio, Colbran, Colo.

PORTRAITS in all grades. Send for price list. Pictures where improvement is necessary a specialty. Wickersham, 1018 N. Mayfield, Chicago, Ill.

KODAKS, 3 1/4-5 1/2 \$9; with astigmat lens \$15. Kodaks exchanged. Ray, 296 5th Ave., New York.

DEVELOPING, Printing. Roll of six fifteen cents. Satisfaction Guaranteed. Universal Supply Co., Auburn, N. Y.

SIMPLIFIED Photo-engraving. Line and half-tone cuts easily made. Particulars 2c. Horton & Fisher, Princeton, Ill.

MOTION PICTURES

SEPT spring motor Movie Camera, new, worth \$150, with leather case only \$40—Home Projector, 1,000-foot reels, \$30. Motor-driven salt case Projector \$110. 4,000 reels of Movie Films, 7,500 lantern slides. Ray, 296 5th Ave., New York.

FILM—Million Feet for Sale. Cowboy—Drama—Comedy and Feature Specials. Mix—Hart—Chaplin and best Movie Stars, \$3.00 per reel up. Genuine List Free. We Supply the World. Dept. G, Monarch Films, Memphis, Tenn.

DON'T fail to send for the big Free Bass Book of Cinema Apparatus. The Cyclopaedia of M. P. Cameras and Projectors. Get in the game that has made thousands independent. Write or wire for your copy. Bass Camera Company, 105 N. Dearborn St., Chicago, Ill.

\$35.00 PROFIT nightly. Small capital starts you. No experience needed. Our machines are used and endorsed by government institutions. Catalog free. Atlas Moving Picture Company, 482 Morton Bldg., Chicago.

\$\$\$ FOR Ideas. Photoplay plots accepted any form; revised, criticized, copyrighted, marketed. Advice free. Universal Scenario Corporation, 208 Security Bldg., Santa Monica and Western, Hollywood, Calif.

MOVIE films, 1,000 ft. reels. Complete stories, \$2.50 each; shipped anywhere on receipt of remittance with order. Independent Films, 177 Golden Gate Ave., San Francisco, Calif.

FILMS of every kind and character. Comedies—Westerns—Andy Gump Cartoons—Educational and Special Feature Subjects. Rock Bottom Prices. Wonderful Guaranteed List Free. Dixie Film Co., P. O. Box 407, Memphis, Tenn.

NEW and Rebuilt Machines for Big Theatres—Schools—Churches—Travelling Shows. Also Films—Supplies and Complete Theatre Equipments. Bargain List Free. Monarch Theatre Supply Co., Dept. F, Memphis, Tenn.

MAKE money writing photoplays; details free to beginners. No correspondence course. Producers League, 230 Wainwright, St. Louis.

MOVIE Films Price List free. Donald Elder, 589 Broadway, Chelsea, Mass.

SCENERY TO RENT

SETTINGS for Opera, Plays, Minstrels. Plush drops. Address Amelia Grain, Philadelphia.

EDUCATIONAL AND INSTRUCTION

YOU can have a business profession of your own and earn big income in service fees. A new system of foot correction; readily learned by anyone at home in a few weeks. Easy terms for training; openings everywhere with all the trade you can attend to. No capital required or goods to buy, no agency or soliciting. Address Stephenson Laboratory, 1 Back Bay, Boston, Mass.

LEARN modern expert barbering at home. Practice on the family, friends. Hair-cutting, shingling, bobbing, shaving, honing, stropping razors. Easily learned by any one. Practical scientific instruction course complete for \$1 (bill) or money order same instructions as given by all barber colleges. Used everywhere. Foster, Expert Barber, 613 E. 60th St., Chicago, Ill.

MEN Needed as freight traffic managers. Positions at \$150 to \$300 and up monthly open to those willing to learn. No matter where you live, your age and education, a few months of study at home will prepare you. Freight Traffic Training School, 615 Merrill Building, Milwaukee, Wis., Established 1912.

WOOD-WORKING for Amateur Craftsmen is a pocket-size book that starts you with wood-working tools and leads you by a series of easy and interesting lessons to the point where you can undertake some of the more difficult cabinet work. Send No Money. Just write a postal. Pay postman postage and \$1. Popular Mechanics Press, Room 811, 200 E. Ontario St., Chicago, Ill.

PRACTICAL Psychology Teaches Hypnotism, Personal Magnetism, Magnetic Healing, Auto-Suggestion, Cure Habits and Disease. Easy Lessons. Send for Booklet, 4 cents stamp. Fernando, Dept. M, Springfield, Mass.

AMATEUR cartoonists. Make money at home by mail. Complete working plan \$1.00; particulars stamp. Smiths Service, Wenatchee, Wash.

USED educational matter of all kinds. Sold on repurchase basis. Big saving. Money-back guarantee. List free. (Courses bought.) Lee Mountain, Pisgah, Ala.

HIGH School—College courses. Correspondence. Diplomas granted. Humphrey, Valleygrand Bldg., Alhambra, Calif.

MAKE Big Profit Weekly promoting Auto Shows without capital. Complete plan by successful promoter \$1.00; worth \$5.00. Hanser, Telicity, Ind.

GREAT Strength easily obtained; Great Illustrated booklet, 10c, tells how. Prof. Dreyer, Box 1850-P, Chicago.

FREE Book. Start little Mail Order business. Pier, 219 Cortland Street, New York.

SHORTHAND in four evenings. Arthol course seven dollars. Sent approval. Particulars, Holfreund's College Stratford, Ontario, Can.

WORLD-ROMIC System, Masterkey 5,000 languages. Primers \$1.98. Chinese, French, Spanish—Languages, 8 West 40th, New York.

SKI-MAKING and Running. Fully treated in a series of crystal-clear articles in Boy Mechanic, Book 3. Tells how to make your own skis, how to run and jump, how to climb hills or travel on level ground. Send No Money. Just write a postal. Pay postman postage and \$2. Popular Mechanics Press, Room 811, 200 E. Ontario St., Chicago, Ill.

DISCOVERIES for farmers. Popular Mechanics Handbook for Farmers tells how to make portable greenhouse, fruit-picking ladder, tomato ripening device, land roller, exhaust water heater, ditch filler, self-closing garage door, barrel header, poultry water fountain, dump sled, manure scraper, combination rabbit hutch and poultry house, and hundreds of others. Don't send a penny. Just write a postal. Pay postman postage and \$1. Popular Mechanics Press, Room 811, 200 E. Ontario St., Chicago, Ill.

ARTIFICIAL Marble sanitary flooring instructions, ornamental casting, concrete, plaster, papier-mache decorations, garden furniture, statuary. Rubber-moulds, 16 years' instructing the public, particulars and 200 illustrations free. Chris Mahler, Huntington, N. Y.

"WHAT to Invent for Profit" free. Patent News-N, Washington, D. C.

SHOWCARD Writers, Artists—Mix 500 beautiful colors. Book gives proportions plain English. \$1.00 prepaid. Money refunded. Art Book Publisher, 2633-35 College, Indianapolis, Ind.

USED educational matter bought, sold, exchanged. Handling, 799 Broadway, New York.

USED educational matter. Lowest prices; terms. Catalog free. Mention Subject. Economy Educator, 440-A Sansome, San Francisco.

LINOTYPE instruction; largest, oldest school in existence; established 19 years; 1,000 have attended; course \$290; including printing, \$350. Empire School, 206 E. 19th St., New York.

DOUBLE Entry Bookkeeping mastered in 60 hours with 8 keys; guaranteed; diplomas. International Bookkeeping Institute, Dept. 8, Springfield, Mo.

RADIO OUTFITS AND SUPPLIES

CEDAR Radio Cabinets—Manufacturers of Radio Cabinets, built from cedar, Cedar cabinets finished in Cedar or Walnut. We also make cabinets up from Gum, Birch, African Mahogany and American Black Walnut. We sell direct to the consumer which gives you the profit enjoyed by the dealer. These cabinets are remarkably low priced, considering finish, quality, construction, etc. All our cabinets are built to suit your requirements. Send panel sizes for prices; also state kind of cabinet desired. Mannheim Wood-Working Co., Mannheim, Pa.

PORTABLE Radio Receiver. Build your own. Full directions with illustrations given in Boy Mechanic, Book 4. Hundreds of other useful articles telling how to make all sorts of things. Send No Money. Just write a postal. Pay postman postage and \$2. Popular Mechanics Press, Room 811, 209 E. Ontario St., Chicago, Ill.

BIG money made repairing burnt-out Radio Tubes. Instruction \$1.00. Duck Mfg. Co., Freeport, Ill.

RADIO Bargains. Send for free catalogue. Wm. Wambach, 23 Dover St., Paterson, N. J.

FREE marvelous radio hookup. With our plans you can build a radio like the one picked by us as the very best regenerative hookup known. Send addressed, stamped envelope for free diagram. Songbird Transformer Works, 1507 West 58th St., Chicago.

RADIO Soldering Tool—Works from 6-volt Battery; Size 7 inches long; retails \$1.00. Sample fifty cents. Arko, 885 Mass. Ave., Cambridge, Mass.

CRYSTAL Radio Receiving Sets. 50c Each. Guaranteed. Dozen \$2.50. Tru-Bu Supply, 106 Lake Ave., Rochester, N. Y.

200,000 SATISFIED customers hear distant stations on Lambert Crystal Sets. Copyrighted plans \$1.00. Complete kit and plans \$5.00. Leon Lambert, 539, Wichita, Kans.

PLAN Free. How to make Radio set for 10 cents. Al Day, Jamaica, N. Y.

TRADE AND TECHNICAL SCHOOLS

CHICAGO Technical College offers short, intensely practical courses in Drafting and Engineering—civil, mechanical, electrical, structural—Architecture, Building, Construction, Plan Reading, etc. Courses fitted to your needs. No time wasted. Instructors are experts. Graduates in demand at big salaries. Opportunities for part-time work while studying. Day and evening classes, 22nd year. Enter any time. No special preliminary training required. Low tuition—easy terms. Write for 52-page illustrated Blue Book, describing opportunities open to our graduates. Chicago Technical College, 25 Chicago Tech. Building, Chicago.

\$12.70 To \$25.00 Per Day—that's what my students earn. I train men in a few weeks to be expert Sign Painters, Auto Painters, Paper Hangers, Decorators. No Mail Course. All practical work. Write H. Glick, Department 156, for free catalog. Chicago Painting School, 148 West Austin Avenue, Chicago.

GET a Foreman's Job in any trade. Train yourself to earn more money. Become an expert Blue Print Reader. You can do it in spare time. My training will give you advancement in a few weeks. Write now—tell me what trade you want—I will send my plan at once. Carroll Ramsey, 165 Drexel Bldg., Philadelphia, Pa.

TELEGRAPHY—Both Morse and Wireless—taught thoroughly and quickly. Tremendous demand. Big salaries. Wonderful opportunities. Expense low; chance to earn part. School established fifty years. Catalog free. Dodge's Institute, Fern St., Valparaiso, Ind.

BUSINESS OPPORTUNITIES

OPPORTUNITY of a lifetime. Something entirely new. A remarkable permanent-wave hair-curling preparation. Works like magic. Guaranteed. Make it yourself for almost nothing. Every girl and lady wants it. Practically sells itself. Can you imagine anything else with such enormous possibilities? This superb formula with complete information only \$25, and we trust you. As a special introductory offer, good only until Nov. 10, we submit the following exceptional terms: Send \$3 with order and balance after you have sold \$1,000 worth. Could anything be more liberal? Your big opportunity is here now. Think! Will you grab it or let it pass? Consulting Chemists, 245 N. Main St., Dayton, Ohio.

PATENTS. Time counts in applying for patents. Don't risk delay in protecting your ideas. Send sketch or model for instructions or write for Free Book "How to Obtain a Patent" and "Record of Invention" form. No charge for information on how to proceed. Communications strictly confidential. Prompt, careful, efficient service. Clarence A. O'Brien, Registered Patent Attorney, 5897 Security Bank Building (directly across street from Patent Office), Washington, D. C. See pages 140 and 141.

AGENTS: \$11.80 daily cash (send for sworn proof). Introducing New Insured Hosiery, 57 styles, 40 colors, guaranteed seven months. No capital or experience required. You simply take orders. We deliver and collect (or you can deliver, suit yourself). Credit given. Pay You Daily, monthly bonus besides. Winter line now ready. We furnish samples. Spare time will do. Maroche Textile Company, Station 25811, Cincinnati, Ohio.

GREAT Discovery: Coeur D'Alene Composition Gold-like Nuggets fool them all. They have the weight, color and look like the genuine article. Are you looking for something different? Think this over. These Nuggets attract attention—quick sales—big profits—inexpensively compounded and will wear forever. Formula and complete copyrighted manufacturing directions, also four other valuable formulas mailed for \$1.00. (No stamps.) Western Specialties Laboratory, 902 Hastings Ave., Coeur D'Alene, Idaho.

BE your own broker and secure a State contract on our Tool Post Lathe attachment with exclusive patented features for grinding lawn mowers without removing the reel, sharpening scissors, skates and making keys. Every machine shop a prospect. Write for catalog and descriptive literature. Brown Machinery Company, Greenville, Tenn.

MIRRORS re-silvered at Home. Costs less 5 cents per square foot; you charge 75 cents. Immense profits, plating autogaps reflectors, tableware, stores. Refinishing metalware, etc. Outfits furnished. Write for information. Sprinkle, Plater 127, Marion, Ind.

ESTABLISHED manufacturing business for sale, producing truck and automotive products of unquestionable merit and demand, including full set dies, patents etc., with or without modern one-story brick building and equipment. Box 438, Streator, Ill.

BIG Money with every mail; 96% Profit. Exact method we use; Particulars for Stamp, Banner, 1222 E. 49th, Los Angeles, Calif.

COLLECT Your own Bad Debts. Six Dimes (60c) brings you six collection letters that get the CASH; makes friends. Interstate Sales Company, Box 700, Minneapolis, Minn.

UNPATENTED Ideas Can Be Sold. I tell you how and help you make the sale. Free particulars (Copyrighted). Write W. T. Greene, 810 Jenifer Building, Washington, D. C.

POPCORN Poppers—Money makers, lowest priced small machines, Northside Co., 1306 Fifth, Des Moines, Iowa.

RESPONSIBLE manufacturer wants competent men to manage office and salesman, \$300 to \$1,500 necessary; will allow expenses to Trenton if you qualify. Address Manager, 536 First Richey Bldg., Trenton, N. J.

OPPORTUNITY Seekers—Make extra money. Spare time business. Catalog free. Busy Bee Service, 154 East 170th, New York.

100,000 REPRESENTATIVES Wanted! Sell by Mail, through Agents, or Direct! Detailed Information—25c! None free. Surety Service, World Distributors, 551 Harvard St., Rochester, N. Y.

MAKE \$20 daily selling new self-inking Bamboo fountain pens. Write today for full particulars. F. Dobronsky, 1875 Third Avenue, New York City.

ATTENTION! You can have a business of your own. Establish and operate New System Real Estate Business, brokerage and insurance agency in your community. Office at home. Earn \$5,000 year. Representatives wanted everywhere. Send stamp free booklet. Hayes Realty Association, Cincinnati, Ohio.

FREE information about mail-order business. Clever ideas make fortunes. Mail Order News, 369 Bristol Building, New York.

ARE you old at forty? See our advertisement on page 50 of this issue. The Electro Thermal Company, 2137 Main St., Steubenville, Ohio.

MANUFACTURE new, fast-selling novelties, toys, preparations, mail order, agents' goods. Free list reliable plans, patterns, processes, commercial information. Manufacturer's Bureau, 3937A Tracy, Kansas City, Mo.

SIGNS, Cards, Banners Easily Painted with Letter Patterns. Samples for Stamp. Corwin Adv. Service, Lockport, N. Y.

25 MONEY-MAKING Ideas. Mail Order supply sources. 14c. Deouth Company, Englewood, N. J.

RESILVERING Mirrors—Genuine. Guaranteed Trade-secret. 50c. Deluxe Chemical Service, Drawer "D," Park Ridge, Ill.

I MADE \$30 a Week Home. French Breadmaking, 15 years' experience; Free Booklet tells. Ashbrook 67, Marengo, Ohio.

WHY work for others? Make and sell your own goods. We show you how. Free book explains everything. National Scientific Laboratories, 1909-A Broad, Richmond, Va.

INVESTMENT Opportunity. Inventor of device of great importance sugar industry is desirous making connection with responsible party able to furnish capital. Write Mulet, 125 McKinley Ave., Glendale, N. Y.

MAKE Money at home or on large scale, casting toys and novelties, particulars free. New Specialty Co., 448 E. 79 st., New York.

150 MONEY-MAKING Plans Free! Wolverine Bureau, (A-2), Muskegon, Mich.

START your own Business with small capital. Learn automobile cleaning, Re-trimming, Repainting—Interior Refinishing and Decorating of Homes—Standard trade Methods Easily Learnt at Home—Write today. Dewilde, Sheboygan, Wis.

GET Money in Your Mail. "Bertrand's Way" guaranteed to pay. 50c postpaid. Robert D. Bertrand, Rochester, N. Y.

START a typewriter ribbon manufacturing business; enormous demand. Machine and supplies. Bargain. Adams, 136 West 8th, Kansas City, Mo.

PATENTED Card Case For Sale. Proven success. Cases now being sold by Largest Printing, Embossing and Stationery Houses. Owing to other large Business Interests, cannot devote my time to this. Superior Manufacturing Co., 1427 Chestnut St., Kansas City, Mo.

HUSTLERS wanted to publish our almanac locally. We furnish the almanac—you sell the advertising. Big profits. Particulars free. Davis-Smith Co., 186 Lincoln St., Boston 11, Mass.

A WORTHWHILE Mail-Order Business by new methods, quick sale, positive and big, is yours if you want it. Free circular gives latest information. MacRae, Publisher, M805 Oregonian Building, Portland, Ore.

DRAWING Instruments, all grades; circulars. Preuthner, 36 West 88, New York.

PUT yourself in business with little or no investment. Unlimited money-making possibilities. First time offered to public. Free information. Franklin Sales System, Bremer Areal St. Paul, Minn.

PATENTS Procured; Trade Marks Registered—A comprehensive, experienced, prompt service for the protection and development of your ideas. Preliminary advice gladly furnished without charge. Booklet of information and form for disclosing ideas free on request. Richard B. Owen, 30 Owen Bldg., Washington, D. C., or 41-R Park Row, New York.

SUCCEED With Your Own Products— Make them yourself. Formulas, Processes by experts. Trade-Secrets. Modern master methods. Catalog free. B. Thaxly Co., Washington, D. C.

\$100. WEEKLY up. We want experienced Radio men to operate branch assembling plants. Part or whole time. Barfield Radio Co., 13 Tillery Street, Dept. M, Brooklyn, New York.

START your own business. Circular free. French, 1903 E. Chase, Baltimore, Md.

COMPANIES organized. Financing. Write, Box 8-209, 311 Fifth Avenue, New York.

REMODEL vases. New! Easy! Make money. Instruction, quarter. Mack's, Norwood, Mass.

IF you have a car, are energetic, and desire to distribute the best selling automobile accessory on the market, address R. & C. Manufacturing Co., Parkersburg, W. Va.

YOU Want Money? Hundred of millions dollars being spent in advertising every year. Get some of this. Our book, "Local Advertising Schemes" shows you how to sell advertising in any town or city; how to originate ideas of your own for getting the coin; how to persuade others; how to earn easy living. Price only \$1.00. Brault, Davis, Ill.

FINANCIAL success can only be obtained in the manufacturing business. Trade and Professional work made easy. For 62-page Catalog send dime (or stamps), to cover postage, etc. Lanes National, Syracuse, N. Y.

MINIATURE Furniture, anyone can make; six pattern \$1.00. Doll's House, radio cabinet 25c each. Kiddie Cabinet, 305 West 143d St., New York.

MAKE Big Money manufacturing, selling wonderful new auto polish—formula \$1 bill. Chemist, Box 2241, Portland, Ore.

BUILD splendid business making chipped glass number and name plates, signs, check-boards. Write for particulars. Stimlex Utility Co., 1133 Broadway, New York.

INVENTIONS fully protected two years \$15 total cost. Particulars free. Patent News-K, Washington, D. C.

FREE Book. Start your own little Mail Order business; home employment evenings. Beginner's Outfit furnished, including 500 circulars, samples, things to sell; you deal with Manufacturers. Also tell easy way to get Agents by mail to sell your novelties. Instruction Book free. Pier, 978 Cortland Street, New York.

INVENTORS—Write for our Guide Book, "How to Get Your Patent" and Evidence of Invention Blank. Send model or sketch of your invention for our free Examination and Instructions. Randolph & Co., Dept. 435, Washington, D. C.

WE Start You In Business, furnishing everything; men and women, \$30.90 to \$100.00 weekly operating our "New System Specialty Candy Factories" anywhere. Opportunity lifetime; booklet free. W. Hillier Ragsdale, Drawer 4, East Orange, N. J.

WANTED, Patent Finance. Address W. C., Patent News, Washington, D. C.

EARN \$10 daily silvering mirrors, plating and refinishing metalware, autos, chandeliers, bedsteads, headlights. Outfits furnished. E. Deede Laboratories, 1133 Broadway, New York.

MAKE Money at Home—making toys. We show you how. Send \$1 for complete working drawings and instructions. DeKalb Designing Co., Decatur, Ga.

GET Money in Your Mail. "Lambert's Mail Order Secrets" contains successful methods never before published. \$1.00 postage. Particulars free. Leon Lambert, Wichita, Kans.

SIGNS and Showcards Easily painted with Letters, Patterns. Large variety of Styles and Sizes. Sample for stamp. John Rahn, 42133 Greenview Ave., Chicago.

LEARN the collection business. Good income, quick results. Interesting booklet, "Skillful Collecting" free. National Collectors Assn., Long St., Newark, Ohio.

"WHAT to Invent for Profit" free. Patent News-C, Washington, D. C.

FREE Booklet describes 52 plans for making \$20.00 to \$100.00 weekly in home or office business of your own. Downs Co., 2323 Myrtle, St. Paul, Minn.

MAIL Order Booklet, where to buy Books, Novelties, Specialties, 10c. Harvey Toombs, Decatur, Ind.

\$10.00 A WEEK; made at home with our \$10.00 potato chip outfit; we work with you. General Sales Co., Muncie, Ind.

CHEMICAL Expert furnishes Manufacturing Formulas and Processes with complete working directions. Reliable individual service only. No lists. Charges reasonable. Correspondence invited. Dr. Arthur VanHeeden, 508 South Oakley, Chicago.

LEARN Hints: Earn \$3,000 yearly; established 19 years; day, evening; cost \$200; including printing, \$350. Empire School, 206 E. 12th St., New York.

MANUFACTURE Doll Beds at home. Instructions. Sample \$1.75. Sprinzer, 415 South Lawndale, Kansas City, Mo.

COST \$5.00, your profit \$104.75. Transferring Decalcomania letters on autos, trunks, bags etc. Send today for outfit or free samples. World Monogram, Dept. 73, Newark, N. J.

MARBLE mixing instructions, covering wood or cement flooring 1/2 in. thick, fire proof, waterproof, low cost, sanitary, all colors. Particulars, 200 illustrations free. Chris. Mahler, Box 122, Huntington, N. Y.

TRIPLE Your Sales! Learn New Secrets of Selling. Large Free Folder Explains. Cutler Limited, Reading, Pa.

\$50 A WEEK Evenings. Mail Order Business. Booklet Tells How. Sample and plan 25c. Free—9 articles worth \$5. R. Bradford Co., Shawnee, Okla.

\$2,000 TO \$8,000 Yearly. Want it? Others are making it. Send check or money order today for our invaluable books "How to Sell Real Estate," \$3.00—and "How to Conduct Real Estate and Insurance Business," \$1.50. Absolute satisfaction guaranteed. Free circulars. Realty Book Co., Dept. 52, Cleveland, Ohio.

GOLD, Silver, and Colored Sign Letters for windows, automobiles, trucks. Make them yourself with our Process and Letter Patterns. Fast Sellers. Big Profits. No Experience. Stamp brings actual sample. Witterling, 1144 Pleasant Street, Oak Park, Ill.

GO into the Crispette business. Everybody likes Crispettes. You can make a lot of money. We start you. Write for facts. Long Eakins, 1959 High St., Springfield, Ohio.

MANUFACTURE Millerite! Ethyl-Super-Fuel Ingredient for Gasoline. Increases Power, Mileage—saves gas—easily mixed—profits great—valuable Formula Literature of this, Lightning Electrolyte, Kor-Kit, Pro-Tex-U, Amazon Rubber Repair, and fifty other Biggest selling Specialties in all lines will be sent on request. Miller, Chemist, 1115 Grand Central Ave., Tampa, Fla.

ENTER a new business. Earn \$2,000 to \$8,000 yearly in professional fees making and fitting a foot specialty, openings everywhere, with all the trade you can attend to; easily learned by anyone at home in a few weeks, at small expense; no further capital required, no goods to buy, job hunting, soliciting or agency. Address Stephenson Laboratory, (1) Rock Bay, Boston, Mass.

SCHEMER, Alliance, Ohio, prints Big profit Schemes, one subscriber making \$25,000 from three; another \$10,000 from one. Try your luck. Three months, 30c; copy 10c.

MAIL Order Business is your opportunity. Brenner's Famous Handbooks teach how to start small, grow big. Sell merchandise, service ideas; enormous profits. Spare time to begin. Get complete set, 11 books, \$3.00, and be posted. Brenner, 335 Walnut, Philadelphia. Descriptive Catalog and big batch interesting mail order information, 25c. None free.

"HOW to Sell Patents" free. Patent News-H, Washington, D. C.

YOUR ship will never come in unless you send it out. European Bonds, "The Venture of the Century," bought, sold cash or installments. Information without obligation. Frank O. Everett, 35 Wall Street, New York.

MAKE toys and novelties at home. Big profits. Instructions and illustrations, 25c. Astrolite Company, Sharpsburg, Pa.

CHEMICAL Expert will furnish Formulas and Trade Secrets. All lines. Lists Free. W. L. Cummings, Ph. D., 228 Gordon Ave., Syracuse, N. Y.

CLAIMS of Every Description Collected. Fidelity Credit Co., 802 East Clay, Richmond, Va.

PATENTBOOK, 139 mechanical movements and illustrations, sent free. Labinez, 3 Parkrow, New York.

BATTERY Charging pays big profits using Constant Potential. Only \$16.50 monthly. Write Wilhoit, Troy, Ohio.

TELEGRAPHY

TELEGRAPHY—Both Morse and Wireless—taught thoroughly and quickly. Tremendous demand. Big salaries. Wonderful opportunities. Expenses low; chance to earn part. School established fifty years. Catalog free. Dodge's Institute, H St., Valparaiso, Ind.

WANTED—BUSINESSES FOR SALE

IF You Want to Sell Your Business for Cash quickly and privately, we take the prospective buyer directly to you at our expense, no matter where located. We specialize in selling out-of-town businesses. If your business is worth \$5,000 or more, write us. The Mutual Security System, 68 W. Washington St., Chicago.

CHEMISTRY

LABORATORY Apparatus, Chemicals, Radio Supplies. List 5c. Chemical Apparatus Co., 4402 West End., Chicago.

YOUR chemical problem solved and working process furnished Five Dollars. Write me. W. Stedman Richards, Consulting Chemist, address, Box 2402, Boston, Mass.

TECHNICAL information, analysis, formulas, trade secrets, Jacob Stryker, Chemist, 2525 East St., Davenport, Iowa.

CHEMICAL Catalogue for Experimenters, 5c. George Ott, 1218 Chestnut, Reading, Pa.

FORMULAS AND TRADE SECRETS

MAKE Big money by making automobile polisher Formula. Guaranteed 50 cents. Address, H. Randall, Rochester, N. Y.

CONCRETE Waterproofing Processes, making Hard, Light Colored, Damp-proof concrete building blocks. Concrete Machine Co., 5 Main St., St. Louis, Mo.

WHY work for others? Make and sell your own goods. We show you how. Free book explains everything. National Scientific Laboratories, 1900-A Broad, Richmond, Va.

NEW Real Money Getter, Liquid Finzer Nail Polish, Exclusive Territory Right, Formula, Instructions \$10. L. Second, 858 E. 58th St., Chicago.

FORMULAS, Processes by experts. Trade-Secrets. Modern master methods. Catalog free. B. Thaxly Co., Washington, D. C.

MY formula—"The Little Orphan Annie" for your home. Twenty-five cents. C. S. Rattan, 411 O'Farrell St., San Francisco, Calif.

FORMULAS The best Chemical Science can devise—Guaranteed Reliable Processes in all lines. Stamp brings big bunch valuable literature, interesting lists. Don't buy till you see what I can give you. 27 years supplying the best. Miller, Chemist, 1133 Grand Central, Tampa, Fla.

500 FORMULAS—, including Luminous Paint—Renewing Dry Batteries—Mechanics' Soap—Gas Tonic—25c. Catalog Free. Ideal Book Shop, 2511-PM, Foster Ave., Chicago.

BEVERAGES, Syrups, Extracts, Flavors, Etc. Other good manufacturing specialties. Free information. The Formula Co., 1613 Queen Anne Ave., Seattle, Wash.

BESTALL Chemical Wood Stone—For public building, kitchen and bath room flooring. Can be molded into dolls, souvenirs and novelties. Circular Free. Maxlin Chemical Co., Maxlin Building, New Castle, Ind.

1,000 SHAVES from one razor blade. Secret 25c. Barber, Box 1278, San Francisco.

FORMULAS—Reliable for manufacturing newest, long profit specialties. Baxter, 2657A Trace, Kansas City, Mo.

SAWDUST and Chemicals make Sanitary flooring. Profitable business. Directions \$1.00. Universal Supply Co., Auburn, N. Y.

10,000 FORMULAS. A real Gold Mine of money-making ideas. Tells how to make almost everything under the sun. You can make and sell cosmetics, muckilage, anti-freeze solutions, battery solutions, beverages, cheese, chewing gum, cleaning preparations, extracts, hair preparations, inks, blueing, leather polish, mirrors, perfumes, polishes, typewriter ribbons, carbon paper, washing powders, liquid soap, and hundreds of other profitable articles. Send No Money, just write a postal for "Hendley's 20th Century Book of Formulas." Pay postman postage and \$4. Popular Mechanics Press, 200 E. Ontario St., Room 811, Chicago, Ill.

MAGIC Cloth—One Rub keeps Snow or rain blurred windshield clear 24 hours. Big seller. Easily made. Guaranteed Trade-secret, 50c. Deluxe Chemical Service, Drawer "D," Park Ridge, Ill.

1,000,000 FORMULAS, 1,016 pages, \$1.98. 500 Formulas Free if you order quick. Ideal Book Shop, 2511-PM, Foster Ave., Chicago.

AGENTS WANTED

NO Dull Times in the Food Business. Selling Federal Pure Food Products is the greatest, surest and safest business in the world today, and here is your opportunity to get into it. You can make \$3,000, \$5,000, \$10,000, or more per year—the only limit is your ability to take care of the business. You will need no experience or money to get into this business as we send you our handsome \$15.00 Sample Case on Trust and teach you everything you need to know. We furnish you with license. No Dull Times, for the People Must Eat, and our food products are the fastest selling, surest and quickest repeat order goods in the world. Sell on sight in every home where food is used—repeat orders immediately and every week thereafter. A real big business all your own. Every new customer adds a great deal to your weekly income. Your business once established, has a market value just like a store and can be easily sold. The greatest money making opportunity of your lifetime because you risk absolutely nothing as we guarantee your sales, and we will not let you fail. Remember! Guaranteed! Best products, biggest sellers, surest repeat orders. No capital or experience is required. We furnish capital and everything necessary for you to become a Federal Distributor. Exclusive territory will be given honest men or women who write at once. Federal Pure Food Company, 2309 Archer Avenue, Dept. A, Chicago, Ill. Largest packers of Pure Food specialties in the world. Reference, any bank, Dun or Bradstreet rating agency, Express or Railway Company in America.

FREE—Get This Quick! Chicago's Wonder Shirt line. Sell newest, stylish, snappy, Stylenor Shirts. Amazing values at low prices. Make \$100.00 weekly easy. Complete assortment of large swatches makes selling Stylenor Shirts a cinch. Experience or capital unnecessary. Be your own boss. We will show you how to build a big business of your own. We will deliver and collect. Exclusive territory open. Write today, for big free outfit, Stylenor, 81 W. Van Buren, Chicago, Ill. Dept. 560.

SELL Women's Fashion Shoes. Castle-Blair representatives earn \$50 a week as side line—\$500 a month full time—\$3 an hour spare time. No sample shoes to lug around. No delivering or collecting. Most liberal commissions in cash in advance. Our 65 New York and Paris styles in pictures talk. "Automatic" sample outfit makes sales easy. Free! First to qualify from each locality awarded valuable territory right. Write at once. Castle-Blair, Inc., 318 S. Michigan Blvd., Dept. C-210, Chicago.

AGENTS, salesmen, Demonstrators, you will have the devil's own time trying to find a better seller than "Sippo." If there was such a thing we'd have it! Splendid profit on 50c "Go-Getter" repeat article that sells on ten-second demonstration. Works While You Watch It! Demonstrates value while others waste time making claims. New Discovery! Greatest scientific triumph of the age. It's the berries. Haven't room to tell our story here. Write immediately. Karam-Smith Co., 6011-P Street, Fort Wayne, Ind.

AGENTS—\$90 a Week Easy. This big pay and a great opportunity for ambitious men and women. Experience not needed. We have thousands of customers on our line to be supplied. 200 household necessities at rock bottom prices. We need representatives right here to take charge of territory and handle this business. Deal with regular customers—Make big money every day. Write quick for territory and Free Outfit Offer. Ho-Ro-Co Mfg. Co., 791 Ho-Ro-Co Bldg., St. Louis, Mo.

AGENTS Wanted—Something New—Fyr-Fyter sells easily. Makes a spectacular demonstration; car owners, homes, factories, stores, practically buy on sight. Our men make \$10 to \$50 a day. Exclusive territory to producers. If you wish to establish a business of your own with unlimited possibilities for making big money, write us today. Fyr-Fyter Co., 904 Fyr-Fyter Bldg., Dayton, Ohio.

MILLERITE: Here it is! You've read about this New Wonderful Ethyl-Super-Fuel ingredient for Gasoline—Increases Mileage—Saves Gas—Knocks Carbon—Easily Mixed from my simple Formula—profits great—\$5,000.00 to \$50,000.00 for you if you hurry! Don't pass this by you'll be sorry—but send today for full descriptive literature of this and other valuable Formula Lists describing latest, biggest, selling specialties in all lines as Mendit, Fabric Mending Cement, Marcel Permanent Hair Curling Fluid; Denta-perl Tooth Whitener; Balloons and other thin dipped rubber goods; Plynox—few drops kills roachful flies; Amazon Self Vulcanizing Repair; Pro-Tex-U only Guaranteed Fire Extinguisher; Pure Food Products; Toilet, Medical, Household, Automobile Office Specialties—latest in all lines. 27 years supplying the best in Formulas and manufacturing information. Highest References. Miller, Chemist, Tampa, Fla.

\$8.50 TO \$20.00 daily easy. Introducing New Insured Hosiery for men, women, children. 57 styles, 40 colors. Must wear or replaced free. Repeat orders sure. Nyland made \$375 in one month. Edwards, \$160.60. Mrs. Bone, \$445.25. Why not you? Even spare time work should pay you \$3 per hour. Your pay daily in advance. We deliver and collect. You spend all your time writing orders. No experience or capital needed. We furnish samples. All grades, colors, including silks. No matter what you are doing now, write for our offer. Maccabee Textile Co., Station 25611, Cincinnati, Ohio.

PATENTS. Time counts in applying for patents. Don't risk delay in protecting your ideas. Send sketch or model for instructions or write for Free book "How to Obtain a Patent" and "Record of Invention" form. No charge for information on how to proceed. Communications strictly confidential. Prompt, careful, efficient service. Clarence A. O'Brien, Registered Patent Attorney, 5897 Security Bank Building (directly across street from Patent Office) Washington, D. C. See pages 140 and 141.

IT'S Easy to Sell a \$15 Dress for \$6.75. 75 Red-hot Paris and New York styles ready for Fall. Silk, Flannels, Kashas, Balloons. Prices \$6.75 to \$19.95. Carlton Agents are getting 30% repeat orders. Full time good for \$75 to \$250 a week. Part time earnings \$5 an hour. Biggest, fastest growing concern selling women's stylish dresses house-to-house. No deposit for sample line. Exclusive territory. Act quick for biggest money maker of the year. Carlton, Inc., Dept. 353-A, 337 S. Franklin St., Chicago.

BIG profits! General Distributors, Agents, Salesmen sell the new Wallace Combination Jack and Rim Tool! Every small car owner a positive customer. Sells on sight! Exclusive territory to workers. Act quick! Send for attractive proposition and sample tool. B. S. M. Sales Company, Dept. 1359, Wrigley Bldg., Chicago.

THREE Unmatchable Values—New novel, nickel plated. All have line, form, tone-class. Sell at either 25c or 15c each. Qualit, dainty candlestick handle—cigarette ash tray with holder—extinguisher. Combination safety match box holder and pipe holder. Combination pipe reamer and pipe stand. Sold in gross lots only—\$9.50 the gross. 3 samples for 25c silver, and 4 cents stamps. 2 strange Mystical Novelties included—Free. Caldwell Novelties, Inc., Bloomfield, N. J.

HALF a Minute Demonstrates My new patented powder puff; wonderful attention getter; no woman with 50c can resist it; gives you instant introduction everywhere, after which my automatic sales plan gives you two or more sales and profits, all with one demonstration; if your line is stale or overworked, get my plan today and put some new "pep" in your sales work. F. A. Koch, Dept. 70, 8718 Arendia Avenue, Detroit, Mich.

AGENTS—Best sellers; Jen Rubber Repair for tires and tubes; supersedes vulcanization at a saving of over 800 per cent; put it on cold. It vulcanizes itself in two minutes, and is guaranteed to last the life of the tire or tube; sells to every auto owner and accessory dealer. For particulars how to make big money and free sample, address Amazon Rubber Co., Philadelphia, Pa., Dept. 505.

AGENTS—Here's a New One, "Best-ever Powdered Hand Soap." Sells like wildfire. Marvelous Discovery. Removes grease, paint, ink, oil. In fact anything from the hands. Cannot harm skin. 150% Profit. Great Repeater. Agents simply raking money. "Free Samples Get the Business." Write immediately. Besterer Products Co., 1945 E. Irving Park, Chicago.

SELL Christmas Cards. All Your Friends Use Them. Make your Christmas money. Engraved cards exclusively; best value in design, quality and price. Customer's name printed or engraved. Good commission. No money needed. Write for selling outfit and particulars at once. No replies considered after Nov. 20, or outside of U. S. Knight & Co., Box M-76, Riverton, N. J.

SELL Shirts and Overalls Direct to Wearer. Big Profits. Work full or spare time. No experience required. Big variety Dress Shirts with splendid line Union-Made Work and Flannel Shirts, Overalls, Coveralls, Work Pants, Leather and Sheep-lined Coats. Write today for free selling outfit. The Nimrod Shirt Co., Dent. 8, 4922 Lincoln Avenue, Chicago.

WHY work for others? Make and sell your own goods. We show you how. Free book explains everything. National Scientific Laboratories, 1900-A Broad, Richmond, Va.

SELL widely advertised Skat paste soaps, toilet soaps, Cleansers, polishes, etc. New allowance and commission plan insures success. Skat Company, Hartford, Conn.

AGENTS—Mosses Corn and Callous Remover will build you a steady repeat business. Send today for pocket-size trial outfit. The Moss Co., 253 Searle Bldg., Rochester, N. Y.

IF You Want \$96 a Week, a Big, Permanent business, an honest company and an Essex coach without a cent of expense, write now. I need 100 men and women quick to take orders for Jennings hosiery. Don't delay. Send post card now for details. The Frank B. Jennings Co., Dept. J-521, Dayton, Ohio.

AGENTS, \$45 a week. New guaranteed hosiery for men, women, children. Must give satisfaction or new hose free. Full line of silk hose, Latest styles and shades. Write for samples. Parker Mfg. Co., Sample 1178, Dayton, Ohio.

INCREASE your present earnings selling Gre-Solvent to mechanics, automobilists, farmers, housewives. Millions cans used yearly. Instantly removes grease, grime with benefit to the skin. Standard 20 years. We take risk first shipment if you are the right man. Choice territory going fast, nation-wide campaign. The Utility Co., Inc., 632 West 44th St., New York.

AGENTS. Write for free catalogue. Winter House Dresses, Hosiery, Underwear, Blankets, Flannel Nightgowns, Novelties, etc. Economy Sales Co., Dept. 473, Boston, Mass.

RADIO Calls You, Agents: \$80 to \$125 weekly all or part time selling nationally known 5-tube radio set on 30 days' free trial direct from factory. Customer saves half. Big profit to agent. No experience necessary. We want exclusive agents everywhere. Write at once. Metro Electric Co., Dept. N-1, 1243 S. Wabash Ave., Chicago, Ill.

AN Opportunity never before presented. Representatives wanted in every state in the U. S. A. and Canada, on a direct selling plan. No license required, no competition. Article a household necessity, fully guaranteed. Price within reach of all. Exclusive territory assigned. Particulars: Dundee Mfg. Co., Inc., 157 Summer St., Boston, Mass.

AGENTS—every locality—demonstrate and sell new idea in Soap for daily use. Easy sales—fast repeater. 100% profit. Make \$60-\$85 a week. Write Dept. PM, Motor Tool Specialty Co., Lytton Bldg., Chicago.

\$70.00 TO \$150.00 weekly. Ladies Smart Style Made-to-measure hats sell on sight. Latest Paris and New York models. No money required for stock. Write for samples and territory wanted. Smart Style Milliners, Dent. 55, Cincinnati, Ohio.

DISTRICT Managing Agents, every town, can earn \$15-\$25 daily, with new automobile product; quick sales; repeat orders come fast; must sell thru sub-agents, the trade and by mail; free folder explains; get it today. Everything furnished to start going business. Boone Specialty Co., Boone, Iowa.

AGENTS—Three big lines hosiery, silk underwear, men's shirts. Liberal commissions. Send for free illustrated catalogs. Helly Co., 2132a Fourth Ave., New York.

IPTHEYGO Kuff Buttons. Reduces Laundry-Bills, operates automatically, marvelous convenience to motorists, etc. Durable New Invention that sells on sight. Sample pair \$1.00. Live agents wanted. Flexo Copm, Sheboygan, Wis.

AGENTS—\$14.85 daily in advance. Send for sworn proof. Introduce Finest line of Guaranteed Hosiery you ever saw. Auto Furnished. Best selling plan known. 106 styles and colors. Beats store prices. Spare time satisfactory. No capital or experience necessary. Samples furnished. Wilkitt Hosiery Co., Dept. 2078 Greenfield, Ohio.

NEW Marvelous Self-lighting Gas lighter. Sells on demonstration. Sample 25c. Gross \$10. Rapid Mfg. Co., 799a Broadway, New York.

WHY work for others? Make and sell your own goods. We show you how. Free book explains everything. National Scientific Laboratories, 1900-A Broad, Richmond, Va.

\$110 WEEKLY selling finest guaranteed union made to measure men's suits only \$12.50, boys' two-pants suits \$10.95. Six Latest Patterns that sell on sight. Also all-wool overcoats, vests, caps, riding breeches. Big commissions advanced. Free attractive outfit. Double Service Manufacturers, 1327-35-AF, Washington, Chicago.

AGENTS: Handle a new necessity. Paintographs sell everywhere. Big Christmas demand. Write for Circular and information today. Bradford Company, St. Joseph, Mich.

AGENTS: New Selling Plan! \$1.25 premium free to every customer on a \$2.00 sale, consisting of 8-oz. Vanilla, 6-oz. Shampoo, 4-oz. Lemon Lotion. A big hit everywhere. Complete details free. Territory going fast. Write today. The C. I. Tegstad Company, Dept. 18P, 29 South Clinton St., Chicago, Ill.

65c PROFIT every dollar! Minute demonstration makes sale. Homes, stores, offices, factories, etc. Big repeater. Free sample offer. Mallard Chem. Co., A. St. Louis, Mo.

SALESMAN, Tailoring, \$100-\$150 week selling hand-tailored, union, made-to-measure suits, overcoats, \$25.50-\$28.50. Commissions advanced. Wood & Co., 451 So. Wells, Chicago.

NEW one-price line! Greatest yet! Sensational values! Finest all-wool goods. \$23.50 for suit or overcoat. Nothing higher. Big commissions paid in advance. Earnings of \$20.00 a day sure. Only a few lines left to place. Don't delay. Write at once to Dept. 646, William C. Bartlett, Inc., 850 West Adams St., Chicago.

AGENTS our new Co-operative plan, makes you a partner in our business and pays you profits, the same as stockholders; the most liberal plan in the United States today. \$25 to \$75 weekly easily made. H. & G. Rubber Co., Dept. 841, Pittsburgh, Pa.

WE pay \$48 a week, furnish auto and expenses to introduce our Soap and Washing Powder. Buss-Beach Company, Dept. A42, Chippewa Falls, Wis.

AGENTS: \$60 a week selling guaranteed hosiery for men, women, children. Must wear 12 months or replaced free. All styles and colors, including finest line of silk hose. Mrs. McClure makes over \$2,000 a year. Mrs. Schurman averages \$60 a month working spare time. Write for sample outfit. Thomas Mfg. Co., Class 5402, Dayton, Ohio.

AGENTS—Big Seller—\$20 a Day Easy selling Taylor Caps—made-to-measure—every man buys—some want 2 or 3 caps. Samples Free and Cap Free to good agents. Write quick for fast money making proposition. Address Taylor Cap Manufacturers, Dept. 8-8, Cincinnati, Ohio.

BECOME our Associate in your town. Help merchants, doctors collect their bad accounts. You get them, we collect. Pay you daily. Men and women of character make \$50-\$100 weekly. Pleasant, dignified work. Steady, increasing profits. Hundreds now doing it. Get the facts. American Collection Associates, 27 Jay St., Schenectady, N. Y.

MIRRORS re-silvered at Home. Costs less 5 cents per square foot; you charge 75 cents. Immense profits, plating autographs, reflectors, tableware, stoves. Refinishing metalware, etc. Outfits furnished. Write for information. Sprinkle, Plater 128, Marion, Ind.

\$12 FOR 2 hours spare time. New line. Wall, Auto Emblems. No competition. Every member buys on sight. Biggest money maker. Free sample plan. Write! Crafts Co., 3312-A Lawrence, Chicago.

DISTRIBUTORS wanted for the Marvelous Radio Gas Lighters and Master-Lite Pocket Clear Lighters; big money makers. Write immediately for full particulars and selling plans. M. Masterlite Co., 110 East 23rd St., New York.

FORD Owners: Guaranteed short proof magnets post oiling system forces oil higher than any other. Agents wanted in every county of every state. First order from county entitles you to territory which is now open. Make big money. Sells at sight. Send five dollars for oiler with visible dash feed; two dollars and fifty cents for plain visible at breather cap. Big discount to agents after you have secured agency. J. H. Bertram Mfg. Co., Picabo, Idaho.

AGENTS—See my money making proposition on page 161, this issue. W. F. Richardson.

AGENTS Wanted in Every County in the U. S. A. for Electric Blankets, Bed Warmers, Caps and Warming Pads, Stretching, developing and Gynasium tables. Wallace Electric Appliances, P. O. Box 147, Oakland, Calif.

\$10 DAILY, manufacturing plate glass signs, name plates, glass novelties. Outfits furnished. Barter, 3837A Tracy, Kansas City, Mo.

LARGE Manufacturer wants agents. Make \$100 weekly. Outfit free. Sell made-to-measure genuine Cravenette Gabardines, \$14.50. Whipcords, \$12.50. Reversible Raincoats, \$9.75. Standard Raincoat Co., 131 W. 17th St., New York.

CHRISTMAS Greeting Cards—Wholesale Prices. Big Profits. Manufacturer, 1215 Arch, Philadelphia, Pa.

IF We Give You shoes made-to-your measure in any one 60 leather, 50 different styles, will you keep them, wear them, show them to your friends as sample of our \$10 Made-To-Order shoes to sell at \$6.85? Advise us today. Your complete outfit will go forward absolutely free at once. Dent, 1875, Tailor Made Shoe System, 45 S. Wells, Chicago.

RED Devil Ant Exterminator. Guaranteed. Sells to every home and farm. Agents wanted. Sample to destroy four ants' beds, 35c. Covacevich Supply Co., Brownsville, Tex.

LATEST design adjustable leather link belts. Artex Company, 494 Milwaukee Ave., Chicago.

AGENTS and Distributors wanted for guaranteed 30c Crystal Radio Receiving set. Exclusive territory. Sample 50c. Write today! Tru-Bin Supply, Dept. A, 110 Lake Ave., Rochester, N. Y.

BUSINESS Guide with Free Legal Service Sells everywhere; Wells cleared \$1,185 in 35 days. Write for free outfit. Nichols Co., Nanerville, Ill. Dept. 4B.

EVERYBODY uses Extracts. Sell Duo Double Strength Extracts. Complete line of household necessities. Big repeaters. Write today. Duo Co., Dept. El, Attica, N. Y.

BENS'Discovery. New, Original, 200% profit. Get details and Free sample. Ames-Paxton, 6824 South Green, Chicago.

AGENTS: \$100 a Week Paid To Men Who will help me in spare time in local assembly of amazing new kind of 5 tube radio set. I show you how. Demonstrator set given free. No capital needed. Write quick for details of work. Frank Condon, Dept. G-N, 2032 Prairie Ave., Chicago.

WONDER fluid charges batteries instantly. Chance to make fortune selling to garages and dealers. Gallon free to agents. F. & M. Sales Co., 2069 Eastern Ave., Cincinnati.

MAGIC polishing cloth. Polishes all metals. No polish needed. Guaranteed Formula, 50c. Clover Laboratories, 2511-P, Foster, Chicago.

QUICK Seller. Foot powder thousands need. Big commission. Dr. Cordingley, Clinton, Ind.

ARE You Old at Forty? See our advertisement on page 88 of this issue. The Electro Thermal Company, 2137 Main Street, Steubenville, Ohio.

MAKE \$20 Daily selling Changeable letter Window Signs to merchants. Experience unnecessary. Send for free sample offer. Maze Company, Dept. P. O., Norwood Station, Chicago.

NOW is the time for you to make big money selling our products to Radio, Electrical, Hardware, Drug Stores, etc. Quick seller. High class goods. Melodiah Laboratories, Independence, Mo.

MARVELOUS New Invention, 400% profit. Liquid Quick Mend for hosiery and fabrics. Tremendous demand. Over hundred other fast sellers. Local and General Agents, J. E. Johnson Co., Dept. 435, 69 E. South Water St., Chicago.

AGENTS, Salesmen—Sell New Thermo-static Automatic Carburetor Control Attachment for Fords. Big profit, full or part time. Burns 95% air. Doubles Mileage. Attached in 2 minutes. No drilling. Does automatically exactly what Ford manual says do by hand. Cadillac now using Thermo-static Carburetor Control under Biameke license. Write today. A. C. Blanche & Co., Dept. 805PX 692 Lake St., Chicago.

SELLS for \$9.75. Prints ad on wrapping paper, envelopes, etc. \$4.00 commission. Send 10c for sample work. Automatic Ad-Stampers, Joplin, Mo.

AGENTS—\$14.50 Daily Easy—Your pay every day—Monthly bonus besides—Introducing and demonstrating Chiefly Guaranteed Shirts. No investment or capital needed. Just write orders. Reliable money maker. Repeat orders certain. Send for free samples and full working outfit. Cincinnati Shirt Company, Secy. 15811, Cincinnati, Ohio.

AGENTS make \$100 week placing advertising Clear Lighters with glass front. Every dealer wants one. Write for free plan. Drake Mfg. Co., Dept. M, Milwaukee, Wis.

GREATEST temper-saving device! Takes slack and kinks from telephone and electric iron cords. \$25 daily. Samples on approval if requested. Neverknot, Dept. 111, McClurg Bldg., Chicago.

\$50,000. PICTURE Man Friedman made canvassing. Beginners can make \$100.00 weekly with my sales talk. Experienced men make more. Free book "Profits in Portraits" explains. Samples Free. Picture Man Friedman, Dept. 8-A, 541 W. Lake, Chicago.

INSYDE Tires in your old casings give from 3 to 5 thousand miles more service. Positively prevent punctures and blowouts. Used over and over again. Low priced. Big money saver. Agents wanted. Write for terms. American Accessories Co., Dept. 478, Cincinnati, Ohio.

AGENTS: Two out of three buy Everette Underwear. Your chance to connect Right. Pays well. Particulars free. Artalk, 446 West 57th Street, New York.

FREE sample outfit, \$18.50 suits, \$3.00 profit. Whirlwind seller. Write Desk 9, Chicago Super-Built Garment Co., Box 433, Chicago.

MAKE \$5 daily. Whirlwind seller. Imported Bamboo Fountain Pen. Free sample. B. Mohler, 416 S. Dearborn, Chicago.

AGENTS: Signs for stores, offices. Entirely new. Liberal inducement to workers. World Signs, M, 166 W. Washington, Chicago.

MAIL Order or Local Business. New. Simple Plan gets Money Easily, Quickly, Steadily. Particulars Free. Edward Burke, 733 Nineteenth, Oakland, Calif.

300% PROFIT selling Mitchell's Magic Marvel Washing Compound. Men and women clearing hundreds weekly. Wonderful seller. Big repeater. Nature's mightiest cleanser. Free sample. L. Mitchell, D, 1302 East 61st Street, Chicago.

AGENTS—Sell every man. Over 200% profit. No competition. Write quick. P-dly Co., Dept. A. K., Miami, Ark.

AGENTS: How to get a Free Suit and real cash commissions daily selling our High Quality, Low Price Ready-to-Wear Men's and Boys' Suits and Overcoats. We undersell stores. For Free Sample Outfit, Write H. W. High Co., 306 So. Franklin, Dept. 602, Chicago.

CASH in on sensational evolution publicity. 50c book on evolution selling like wildfire. 150% profit. Write quick. Bender Press, 143 Chambers, New York.

AGENTS—Sideline Men. Sell Genuine snag-proof overall suit and work pants. A wonder garment. Sells on sight. Write for particulars. Nedmae Merc. Co., Camden, N. J.

\$10 DAILY. Foods, extracts, toilet preparations, big soap offer. 300 fast sellers. Women—men. Permanent business. New catalogue. Freight paid on \$20 orders. Western Products Co., 628 N. Oakley Blvd., Chicago.

MAIL Order Business. Excellent Side Line. No stock to carry. Details Free Hunt Co., Morrisville, Pa.

AGENTS—Sell Musical Instruments to your friends in your home town. Attractive proposition. Write Music House, Dept. P, 111 E. 14th Street, New York City.

AGENTS—Increase your Income. "Science of Selling" postpaid for 50c. Leland Publishing Company, Oakland, Calif.

AGENTS—Make big money taking orders for furniture, house furnishings on easy payments; direct to user from big catalog; full or part time. One man made \$28.00 in an hour; another \$56.00 on one order; extraordinary opportunity for few good men in small towns to represent this 67-year-old house; new plan; experience unnecessary; no collections; we furnish everything free. L. Fish Furniture Co., Dept. A9, 2337 West Pershing Road, Chicago.

\$3.50 AUTOMATIC Adding Machine. Excellent profits here for workers. No experience, but old, reliable, meritorious proposition. Year after year seller. Write us. Bassett Company, 1458-P Hollywood Ave., Chicago.

AGENTS—30% commission. Full line glove silk lingerie and guaranteed hosiery, mill to wearer; lowest prices. Get particulars. Wright Hosiery Mills, Philadelphia, Pa.

AGENTS—Sell Electric Hairclippers to barbers and hairdressers. Good sideline, easy seller. One sale, day's wages. Norstrom Electric Co., 2537 Sheffield Ave., Chicago.

BE independent. Make-sell your own specialties. Immense profits. Catalog dependable Formulas, special selected Agents best sellers, free. Lustris Co., 832 East Pershing, Chicago.

20th CENTURY Specialties. Agents for Mail Order Menus, Information 20c. F. G. Briggan, 67 Bostyn St., Rochester, N. Y.

AGENTS, sell spectacles. Big pay; experience unnecessary. I help you. Dobbins, 146 West 27th St., Indianapolis, Ind.

SELL Lock Guards. Particulars free. Sample ten cents. Dow Mfg. Co., West Lebanon, N. H.

AGENTS—Wonderful new seller. Todd Company, 19 1/2 East Second, Cincinnati.

FREE Book. Start Little Mail Order Business. Pier, 217 Cortland Street, N. Y.

AUTOMOBILE Specialties. Guaranteed formulas for all latest money makers. Lowest prices. Write for free lists. Murphy, Chemist, Tulunga, Calif.

SELL by Mail Order. at home spare time. No Capital. O. Quaint, 5142 W. 25th St., Cicero, Ill.

AGENTS—N-R-G Laundry Tablets, the old reliable moneymaker for live agents. Millions sold—200% profit—sales waiting for you. Clothes washed spotlessly clean in 10 minutes without rubbing. Free samples. N-R-G Company, 230 W. Superior, Chicago.

\$15.00 DAILY in advance. No competition. No investment. Get exclusive territory on Rhinestone Initial Buckles; clean up. Chaston Novelty Co., 600 Blue Island, Dept. 40, Chicago.

SELL By Mail! Big Profits! Books, Formulas, Novelties, Bargains, Particulars Free! Effen, 523 South Dearborn Street, Chicago.

AGENTS: \$100 Week. No experience. Genuine Gold Leaf Sign Letters and Script. Consolidated Company, 636 South Dearborn, Chicago.

GENERAL Distributors. Agents. Salesmen, wanted for quick-selling automobile specialty; can average \$75.00 to \$100.00 weekly, selling direct, to the trade, thru subagents; lifetime opportunity for men looking for a No. 1 sales proposition; permanent business that yields results right from the start. Free folder explains. Addison Co., Mfgs., Cynthia, Ky.

PRISM Binoculars 8x to 20x. Sell on Sight. Good Discounts. B. & L. Optical Wks., 208 E. 58th St., Chicago.

NO competition. Nine out of ten buy. Big profits. Nothing else like it. Exclusive territory. Write for selling plan. Speed Co., 6 East Lake, Chicago, Dept. XX.

MORE men and women sell consumers direct striking health-preserving household necessity, enamelled, nickeled, quickly demonstrated. Easily earn \$40 week. Prepaid delivery. Write for free sample plan. Tri-Caddy, Freeport, Ill.

EARN \$30 to \$100 Weekly in spare time. No experience or investment. Local or mail order. A lifetime opportunity. Joe Malek, 1269 Transportation Bldg., Chicago.

DEMONSTRATE "Outsize" aluminum hip-suspenders. Grip shirt seams without tearing. Shirt down, pants up. Belt unnecessary. Enormous seller at 25c. Five pair, \$1.00; dozen, \$1.80; 72, \$9.00; 144, \$14.40. Woods, Suite 1563, 705 Olive, St. Louis, Mo.

AGENTS. \$240 a month. Brand New Selling Outfit. Finest line Christmas Cards you ever saw. All designs patented. Nothing else like it. No competition. No selling experience needed. Write for sample outfit. Sunshine Studios, Dept. 250, Dayton, Ohio.

AGENTS—\$300 monthly easy. Everybody wants "Life of Bryan." Best terms. Credit given. Freight paid. Free outfit. Willmore Book Co., Conns Bldg., Chicago.

NATURE treatment. "Wonder Generator"; makes own electricity; no batteries; used for aches, pains, massage, falling hair; wonderful seller; sample furnished; circular free. Science, 17-A, 110 W. 14th Street, New York.

NO-WATER Hand soap. Cleans dirtiest hands without water. Great moneymaker. Simple to make. Guaranteed Trade-secret. 50c. Clover Laboratories, 2511-W. Foster, Chicago.

WHY work for others? Make and sell your own goods. We show you how. Free book explains everything. National Scientific Laboratories, 1900-A Broad, Richmond, Va.

SUCCESS With Your Own Products—Make them yourself. Formulas, Processes by experts. Trade-Secrets. Modern master methods. Catalog free. B. Thaxly Co., Washington, D. C.

BUILD splendid business making chipped glass number and name plates, signs, checkboards. Write for particulars. Simplex Utility Co., 1133 Broadway, New York.

PORTRAITS, photo pillow tops, frames, sheet pictures, medallions, merchants' signs, food products, photo jewelry, guaranteed hose, toilet requisites, luminous crucifixes. Catalog 50 specialties free. 30 days' credit. Jas. C. Bailey Co., Desk A-11, Chicago.

OPEN Toilet Goods Shop in your own home. We furnish everything. Liebig's, Beaver Dam, Wis.

REAL Money selling a great new Health Invention generating Violet Ray, Vibration, Electricity and Ozone. Exclusive Territory now open. Write today Lindstrom & Co., 30 W. Lake St., Dept. 92-58, Chicago.

PENNANTS and Pillows: Colleges, Schools, Clubs, Lodges, Students and agents get busy. American Pennant Co., 66 Hanover St., Boston, Mass.

AGENTS: Our gold-eyed Needle Cases are wonderful sellers; immense profits; \$50 to \$200 weekly; proof and particulars free; sample outfit 15c; factory prices. Paty Needle Co., 231 Davis Square, Somerville, Mass.

AGENTS—Make a dollar an hour. Sell new kind of shavers. Sharpens all knives and tools quickly. Demonstrating sample free. Premier Mfg. Company, Dept. 60, Detroit, Mich.

WONDERFUL invention eliminates needles for phonographs. Preserves records. Abolishes scratching. Day's supply in pocket. \$20 daily. Sample on approval if requested. Everday, Desk. B-11, McClurg Bldg., Chicago.

MEN or Women Agents. Full or spare time, selling Stationery. Every Man and Woman a customer. Sample outfit Free. Scheffer Stationery Company, 1308 Ewing St., Fort Wayne, Ind.

AGENTS—An Unusual Opportunity! Brand new hosiery proposition; earnings \$50 to \$75 weekly; full or spare time; you write orders, we deliver and collect. Special monthly bonus; sample outfit furnished. The Nustle Company, Dept. 1-11, Philadelphia, Pa.

300% PROFIT—Quick, easy seller. Kien-Rite. New Clothes Washing Compound. No rubbing. Women simply amazed. Free premiums makes sales easy. Fast repeater. Distributing samples free. Everybody grabbing for territory. Write quick. Bestever Products Co., 1911-K11, Irving Park, Chicago.

AGENTS: Earn \$10-15 daily; quick cash sales; free goods plan with each sale; free folder tells how. Write Eureka Rug Co., Fairfield, Ill.

EARN \$2.00 an hour all or part time selling old established line of 240 everyday necessities. Everyone guaranteed. Backed bars free. City Dept. Furst McNeess. Profits million dollar organization. Two complete lines bring double profits. Particulars, Ill.

REPLATE brass worn-off Automobile parts, Reflectors, Bath Room Fixtures, Worn Spoons, Forks, etc., with pure silver. Look like new. Use U-Kan-Plate Polish. Positively no mercury. \$1.00 half pint. Postpaid. Satisfaction Guaranteed. Agents wanted. Dept. A, U-Kan-Plate Co., Philadelphia, Pa.

AGENTS Wanted to advertise our goods and distribute to consumer; 90c an hour; write for samples. American Products Co., 4195 American Bldg., Cincinnati, Ohio.

WHY work for others? Make and sell your own goods. We show you how. Free book explains everything. National Scientific Laboratories, 1900-A Broad, Richmond, Va.

SELL direct. Shotguns, Rifles, Pistols, Revolvers, from catalog. Stoeger Incorporated, 224 East 42nd Street, New York.

BIG profits. Rapid seller. Household sample and sales plan for dime. Merry Specialties, Dent. 2, Somerville, N. J.

GENUINE Gold Leaf Letters anyone can put on Store windows. Guaranteed to never tarnish. Large Profits. Enormous Demand. Free Samples. Write today. Metallic Letter Co., 438-A North Clark, Chicago.

QUICK, easy sales; splendid profits and sure repeat orders handling Carefree Lingerie. Start small, grow big with tremendously successful plan. Sincere men and women seeking real money-making opportunity write Gartfeld Manufacturing Company, 119 N. Fourth, Philadelphia.

AGENTS—Steady income. Large manufacturer of handkerchiefs and dress goods, etc. wishes representative in each locality. Factory to consumer. Big profits, honest goods. Credit given. Send for particulars. Freeport Mfg. Co., 59 Main St., Brooklyn, N. Y.

AGENTS—good, steady income. Exceptionally useful household article. The Handicap Company, Newark, N. J.

FAST-SELLING. New Idea in Rugs. Women Oil Cloth. Sanitary, Durable, Beautiful colors. Send \$1.25 deposit for sample and details. Liberal profits. Guaranty Mail Order Co., Dept. PM, Clayton, N. J.

MAKE \$3.00 An Hour Taking Orders for Pie Crimpers, Nu-Style Egg Rollers, Knife Sharpeners, Wonder Wrenches, Jiffy Egg Beaters and 30 Other Big Profit Sellers. Agents' Outfits Free. Write Quick. General Products Co., Dept. T-C, Newark, N. J.

PHOTO Medallions earn \$100 and more every week for our representatives. Take orders for Famous P. & G. Photo Specialties—the quickest sellers and biggest profit-makers in the field. Includes Artful Portrait Paintings—just like genuine oil paintings—Clock Medallions, Photo Medallions, Powder Compacts, etc. Don't wait—write Now! Puddin' & Goldstein, Dept. "A," 259 Bowery, New York.

AGENTS: Make \$5 to \$10 Daily introducing Ware's Iron Rust and Stain Remover. Everybody wants it; everybody buys. Just send name; we tell you how it is done. Vege-Lene Company, Desk 22, Warsaw, N. Y.

MAKE \$10 to \$100 weekly. Spare time, at home. 20 Successful plans, many require no canvassing or capital. Steady income assured. Particulars Free. Golding Publishing Co., 461 West 118th Street, New York City.

MAKE \$15.00 daily selling "Fixit" Rubber Repair (Liquid Rubber) for tires and tubes. Sensation of 1925. Fastest seller. Big money maker. Sample free. Marquette Rubber Co., 2125BB Wolfram St., Chicago.

\$20 PROFIT daily selling self-threading needles, needlebooks; cost 3-5c each; sell 25c; three samples 25c. Catalog free. Needlehook Specialty Co., 661 Broadway, New York.

AGENTS: \$200—\$500 monthly easy taking orders for Morer Rim Tool. Automobile and trade buy on sight. M. Morry Rim Tool Company, Hillsfield, Mich.

BIG Money—fast sales; everyone buys gold initials for their auto; sell \$1.50, profit \$1.44. Ten orders daily easy. Samples, information free. World Monogram, Dept. 15, Newark, N. J.

SOMETHING new—Proto Rubber Repair for tires, tubes; all rubber goods put on cold, no heat, acid or tools; vulcanizes itself in few minutes. Sells to auto owners and dealers, sample free. Pioneer Products Co., Dept. A, Rosbling, N. J.

FREE Booklet describes 52 plans for making \$20.00 to \$100.00 weekly in home or office business of your own. Downs Co., 222A Myrtle St. Paul, Minn.

EVERYBODY buys from Gibraltar representatives all over country taking order for famous Gibraltar line consisting of shirts, overcoats, raincoats, pants, hosiery, neckwear and other articles. Outfit representing full line Free. Gibraltar Fashion Shop, 724 Roosevelt, Chicago.

NEW Specialty Costs 16c. Sells for 50c. Real \$1.00 Value. 50 Other Htz Profit Sellers. Agents' Outfit Free. Write Quick. General Products Co., Dept. 7-N, Newark, N. J.

Why work for others? Make and sell your own goods. We show you how. Free book explains everything. National Scientific Laboratories, 1900-A Broad, Richmond, Va.

USE No Liquid, Paste, Powder. New Prepared Cloth Cleans all Metals—Just (1) Rub. Retail 25c—Cost 10c. "Sample Free." NuLife Metal, Hartford, Conn.

EVERY Autoist will buy Auto Mitten Dusters. 200% Profit. Free Sample Offer. National Fibre Broom Works, St. Louis, Mo.

FURNITURE refinishing, polishing, painting, handyman shop; wonderful profits; start yours on nearly nothing. John Straceland, 1457 So. Ninth, Philadelphia, Pa.

NEW Embossed Letter Display Cards for stores and offices; quick sales, big profits, repeat orders. Embossed Letter Card Co., 2120 E. 14th St., Cleveland, Ohio.

NEW Idea Windshield Cleaner; Medicated-Felt beats rubber all hollow; one rub, presto! entire windshield stays clear 24 hours. One agency sold 40,000. Security Mfg. Co., Dept. 62, Toledo, Ohio.

A BIG income and a speedy seller are offered in our Felt Rug proposition. Write now for particulars. Newark Felt Rug Co., 276 10th Ave., Newark, N. J.

A BUSINESS of your own. Make and sell chipped glass name and house number plates, checkboards, signs. Booklet Free. E. Palmer, Dept. 512, Wooster, Ohio.

EARN \$10 daily silvering mirrors, plating and refinishing metalware, autos, chandeliers, bedsteads, headlights. Outfits furnished. E. Decle Laboratories, 1133 Broadway, New York.

AGENTS—50% cash profit every sale with \$5 to \$10 commission on sure repeat business. Live wires, men or women, build permanent income \$100 week up. Something new every man and woman uses. Write quick. Everett Co., Dept. 35, Sault Ste. Marie, Mich.

EMBOSSING Display Signs Mean Big Money, and independence for you. Sell every merchant. Make 250% profit. This proposition is different. Write and see why. Artistic Sign Works, 799 Broadway, New York.

EVERYBODY Buys Davis' Nifty Toilet Goods Assortments. Useful, handsome gifts free to our customers. Over 250 high quality products. All repeaters. 100% profit. 25 years of success. Write! Davis Products Co., Dept. 56, Chicago.

AGENTS—\$60 to \$200 weekly putting up our furnished Genuine Gold window letters; scripts. Experience unnecessary. Free samples. Premier Letter Co., 121 N. Francisco, Chicago.

WONDERFUL! Startling! Amazing! Our Ex-Cel Luminous Crucifix and Medal (Luminous) Necklaces shine brilliantly in the dark. Sell on first demonstration. Big profits to you. Write for further particulars, or better still, send for sample and territory protection immediately. Crucifix \$1.50, Necklaces \$1.00, postpaid. W. G. Hannan Co., Dept. B, 2589 So. State St., Chicago.

\$300 FIRST Two Weeks—made by Weiland, Johnstown, Pa., selling "Slide-O-Graf Jr." Novel, effective—sidewalk advertisement projector. Sells fast, big non-competitive field. \$14 Profit every sale. Stand-out Slide Corp., 207 W. 48th St., New York.

LIVE Agents Make \$10 Day selling Eureka Strainer and Splash Preventer for every water faucet. Takes on sight. Widely advertised and known. Get details today. A. B. Seed Filter & Mfg. Company, 73 Fremont, New York.

WTO owner tire agent wanted each locality to use and take orders for handmade Mellinger fabric and cord tires; guarantee bond 8,000 and 12,000 miles (no seconds); shipped prepaid on approval; get your tires free; no capital or experience required; make \$100 to \$300 weekly. Write for wholesale prices and sample kit. Address, Mellinger Tire Co., Dept. 300, Kansas City, Mo. or Dept. 300, Philadelphia, Pa.

EARN big money fast applying gold initials to autos. Every owner buys—\$1.35 profit on \$1.50 sale—particulars and samples free. Write quick. Lithogram Co., Dept. 17, East Orange, N. J.

ROBT. H. INGERSOLL of \$1 Watch fame wants good men to sell his Dollar Scrooping outfit, an ingenious invention for sharpening all makes of safety razor blades. Great Economic value. Meeting with nationwide approval. Easy to sell. Big repeat business. Agents having remarkable success. Full particulars. Robt. H. Ingersoll, 470C Broadway, New York City.

BIG Money Selling New Household Cleaning Set. Washes and dries windows, Sweeps, scrubs, mops. All complete only \$2.95. Over half profit. Write Harper Brush Works, 132 3rd St., Fairfield, Iowa.

\$31.00 PROFIT—with \$1.50 Outfit—Big Money—Easy Work. Selling Gold Monograms for Automobiles, Luggage, Windows, Wagons. No Experience. No License. "Samples Free." NuLife Monograms, Hartford, Conn.

AGENTS: \$65 to \$100 a week. High grade all wool suits made to measure \$25 and \$30. Biggest comm. in advance. Money back guarantee. Free sample outfit. Write A. B. Ferrin, Mgr., Box 1097, Chicago.

SELL the Latest, Quickest Selling Specialties Ever Known—Famous "Hahway" self-lighting pocket Cigar Lighters and Gas Lighters. Low Prices. Easily Demonstrated. Sell to Dealers. Employer Sub Agents. Exclusive Territory. Make over 100% Profit. P. Bernhardt, 148 Chambers Street, New York.

AGENTS—Make a dollar an hour. Sell Mendets, a patent patch for instantly mending leaks in all utensils. Sample package free. Collette Mfg. Co., Dept. 404, Amsterdam, N. Y.

MOST Wonderful Seller. 96c Profit every dollar. No stock to carry. License unnecessary. Sample free. Mission Factory PM, 519 No. Halsted, Chicago, Ill.

MAN in each town to plate auto parts, reflectors, bathroom fixtures, refinish beds, mirrors, chandeliers; by new method. No capital or experience required. Simple plan of manufacturing at home starts you in big money-making business. Outfit furnished. Free particulars and proofs. Gun Metal Co., Ave. H, Decatur, Ill.

SELF-THREADING Needles. Needle Books, Machine needles, find sales in every home. Fine side lines, easily carried, big profits, sample and catalogue free. Practice Lee, 145 East 23rd St., New York.

AT Last! Diamond Rival Discovered! Amazing blue white Rajah Gem astounds jewelry world and deceives experts! Beautiful Sample case Free! \$100 weekly! Write Quick! Rajah Diamond Co., Dept. F-7, Salisbury, N. C.

YOU can be your own boss with our Key-Check outfit. Good for \$5 a day stamping names on pocket key checks, fobs, etc. Sample check with your name and address, 20 cents. Pease Die Works, Dept. 34, Winchester, N. H.

AGENTS, Distributors, Crew Men average \$60-\$100 with Harker Products; 10c brings sample of leader; money back if you wish; free folder shows how to start small and grow big. Act; Send today; big surprise awaits you. Harker Co., Bridgeport, Conn.

AGENTS make 500% profit handling auto monograms, window letters, transfers, novelty signs. Catalog free. Hinton Co., 1133 N. Wells St., Chicago.

NEW camera takes and finishes photos in one minute. Make money selling cameras or taking photos. Exclusive territory. Crown Co., Dept. 251, Norwalk, Conn.

WILLIAMS' No-Water Hand Soap. In tubes, has taken Auto owners by storm; washes dirtiest hands perfectly clean without water; easy demonstration makes quick sale. 150% profit. Williams Co., Dept. 265, Montclair, N. J.

BIG Money and Fast Sales. Every owner buys Gold Initials for his auto. You charge \$1.50; make \$1.35. Ten orders a day easy. Write for particulars and free samples. American Monogram Co., Dept. 40, East Orange, N. J.

SELL Lightbrite Electric Signs. They make you big money. We finance you. Price kills competition. Write for information. Modern Sign Co., Inc., 5721 Woodward Ave., Detroit, Mich.

ARTICLE costs 5c, sells quickly for 60c. Particulars free. Bags, 3229 Archer Ave., Chicago, Ill.

GOLD-LEAF Sign Letters; make and sell; 1,000% profits. Particulars. Johnston Co., Quincy, Ill.

ONLY one sale a day means \$200 per month! Marvelous new adding machine. Retail \$15.00. Work equals \$350 machine. Adds, subtracts, multiplies, divides, automatically. Computes feet and inches. Speedy, accurate, durable, handsome. Five-year guarantee. Offices, Stores, factories, garages, lumbermen buy one to dozen. A fortune for live agents. Write quick for protected territory and free trial. Lightning Calculator Co., Dept. F, Grand Rapids, Mich.

AGENTS, both sexes, we manufacture and control new household article. Fast seller. Big profits. Exclusive territory. Write Now. Connolly, 123 Liberty St., New York.

AGENTS—Write for Free Samples. Sell Madison "Better-Made" Shirts for large Manufacturer direct to wearer. No capital or experience required. Many earn \$100 weekly and bonus. Madison Mfgs, 511 Broadway, New York.

AGENTS: Big Money Monogramming by Transfer Method. Catalog Showing Over 50 Styles and Particulars Free. Motorists' Accessories Co., Mansfield, Ohio.

INSTANT Weld. Repairs largest punctures without cement or heat. Lem's profit one day. \$50. Write quick. Free sample; territory going fast. Tourists' Pride Mfg. Co., Desk T, Minneapolis, Minn.

\$40-\$200 A WEEK. Genuine Gold Letters for store windows. Easily applied. Free samples. Liberal offer to general agents. Metallic Letter Co., 438-D North Clark, Chicago.

200% PROFIT selling Gem kettle bottoms. "The article with a dozen uses." Housekeepers buy on sight. Columbia Specialty Co., Box 130, East Liverpool, Ohio.

AGENTS—Clever Invention! Inkspoon makes every pen a fountain pen. Fast office seller; big profit, demand increasing everywhere. Exclusive territory offered. Sample free. H. Marul Company, Tribune Bldg., New York, N. Y.

To secure agents or salesmen or for selling (want) ads in largest newspapers and magazines. Price list No. 30 sent free. Ankrum Advertising Agency, 20 W. Jackson Blvd., Chicago, Ill. The largest classified advertising agency in the U. S.

POLMET—The Wonderful Polishing Cloth that cleans all metals without fluid, paste or powder. Approved by "Good Housekeeping" and "Modern Princes"—sells fast at 25c. Sample free. Gale & Co., Inc., 15 Edinboro St., Boston.

WASH Clothes the new way. Use the Torrent Automatic Washer. You will be delighted. Special offer to one in each locality. Storm Royalty Co., 3610 Enright Ave., St. Louis, Mo.

WE Start You Without a Dollar. Soaps, Extracts, Perfumes, Toilet Goods. Experience unnecessary. Carnation Co., Dept. 201, St. Louis.

GET Our Free Sample Case—Toilet articles, perfumes and specialties. Wonderfully profitable. La Derma Co., Dept. A, St. Louis, Mo.

AGENTS: 500% profit. "Happy Home Maker Shampoo" builds your own big business. Martin of Indiana made \$75.00 in one day. Missouri man made \$750.00 one month. Exclusive territory. Geo. A. Schmidt & Co., 236 W. North Ave., Chicago.

EASY, pleasant work for Mechanics. Shop Men. Clerks, during spare hours; will add many dollars to their salaries. Also want persons who can give full time. Big wages secured. Novelty Cutlery Co., 67 Bar St., Canton, Ohio.

MAIL-ORDER Houses and Distributors: We pack French made beauty creams, face powders, perfumes, toilet preparations with your label. Chemist, 944A North Clark, Chicago.

AGENTS \$1. Retail \$3. Your Profit \$2. Wonderful, pocket Adding Machine with Magic Writing Pad. Particulars Free. Typewriter Supply, 905 Hersch Bldg., Pittsburgh, Pa.

If you want good live agents—follows who can get the business—ask me how others are doing it. I'll gladly render the necessary assistance. Geo. P. Baker, Mgr. Classified Advertising, Popular Mechanics Magazine, Chicago.

"How to Sell Patents" free. Patent News-O, Washington, D. C.

EASY Money Applying Gold Initials, Monograms on automobiles. Anyone can do it. Simply transferred from paper; takes 5 minutes. Make \$1.50, cost 5c. Samples free. "Ralo," 1043 Washington, Boston, Mass.

FREE Sample—"Rain Shield Wiper" Retails \$1.00—cost 25c. Just invented. No Cloth—No Paste—No Attachment. Sold Clear and Rainy Days—(1) Rub keeps Windshield Clear 24 hours. Automobiles buy quickly. Riley made \$198—three days. Experience Unnecessary. Wonderful Sideline. Nullife Corporation, Hartford, Conn.

CALIFORNIA Rosebuds selling like hot cakes. Agents earning money; new stuff. Big profits. Catalog free. Mission Factory P.M. 519 No. Halsted, Chicago, Ill.

10,000,000 FORDS need "Greater Grip" Fan Belts. Big Profit selling Dealers. Write quick. Teuscher Belting Co., St. Louis.

MANUFACTURE Chipped Glass Numbers; particulars Free. Beveridge, 166-22 Lecest Avenue, Jamaica, N. Y.

AGENTS—Make \$100 weekly selling nationally advertised "Cathaspirin." Large demand. Big repeater. Easy sales. Write today for special offer. Cathaspirin Co., Chillicothe, Ohio.

DUSTLESS Sponge Cloth. New Invention. (1) Rub—Dusts. Cleans and Polishes Automobiles, Furniture, Pianos. Retails (50c)—Costs (16c). "Sample Free." Nullife Sponge, Hartford, Conn.

HIGH GRADE SALESMEN WANTED

AUTOMOBILE Ash Tray Free. No other tray like it! Puts out fire by conduction. Better, handsomer. More useful, than higher-priced ones. We do not send this tray free unless it accompanies samples of several other articles that we wish to introduce to earnest, producing salesmen. All samples that we will send are either nickel plated or colored glass, with nickel plated attachments. All of these, including the free automobile tray, are packed in a dollar package. This package contains the following: The Caldwell Automobile Tray—(free). Three new style ash trays, for home or office use. The sizes are 5, 4 1/2 and 2 1/2 inches in diameter. "A Wipe-pats out the fire" on all three. One dainty 2 1/2 inch. Candlestick handle ash tray. One Combination pipe stand, and pipe reamer. One protector, for coffee pot, and percolator handles. Two spoon holders, for holding different sized spoons, on hot cooking utensils. Handy while stirring. All the foregoing sent for a one dollar bill. (Wrap securely.) Satisfaction guaranteed or money back. Do not send the dollar unless you are a seller desiring to sell and make unusual profits. Caldwell Novelties, Inc., Bloomfield, N. J.

SALESMEN—Get this big sensational, order-getting shirt outfit free. Sell Style-mor Shirts all year round. It's Chicago's Wonder shirt line. Advanced fall showing of smartest, snappy patterns. Large double swatches, low prices, quick service, makes shirt selling easy. Bellard of Texas made \$48.00 in two days. We deliver and collect. Write today for big free outfit. Stylemor, 81 W. Van Buren, Chicago, Ill., Dept. 660.

MR. BRUSH Salesman—Old established New York Brush Manufacturers require the services of men in all territories to sell their extensive line of Sanitary Twisted Wire Brushes. We pay larger commission than any other Brush House in the country. Write immediately for our proposition. Wire Grip Sanitary Brush Corporation, 15 Mercer St., New York.

SALESMEN sell phenomenal advertising specialty. Metcalf's commission \$72 one sale. Another man made \$120 in 3 hours. Change on auto dash with oil change warning. For sample, write Klapp Printing Company, Omaha, Neb.

BEST Seller. Jem Rubber Repair for tires and tubes; supersedes vulcanization at saving of over 800%; put it on cold. vulcanizes itself in two minutes, guaranteed to last life of tire or tube; sells to every auto owner and accessory dealer. Get particulars how to make big money and free sample. Amazon Rubber Co., Philadelphia, Pa., Dept. 563.

WANTED—Tailoring Salesmen, make \$60 to \$125 per week. Biggest merchants in many towns have started with our line. We are the largest made-to-measure tailoring house in the country, furnishing elaborate sample equipments, including 500 all-wool fabrics. You make your own profits from \$8.00 to \$15.00 on each order. Guaranteed absolute satisfaction, perfect fit, best workmanship, or no sale. Write for our line and all accessories to be sent free. Tell us all about yourself. Address N. O. Perry, Sales Manager, Box 483, Chicago, Ill.

SALESMAN—I have an opening for the best boiler compound and belt dressing man in the country to fill position as sales manager. Must be able to show he has successfully sold both products himself, and evidence that he can procure salesmen that can market these specialties. The right man can make a permanent and profitable connection with a substantially rated corporation manufacturing these two products. Address in confidence, H. H., 1246 W. 74th St., Cleveland, Ohio.

"YOUR Opportunity in a Great Industry." That is the title of a book we have just prepared. It gives the full facts about one of the greatest money-making opportunities in the selling field today. Every specialty salesman in America owes it to himself to get and read this book. A copy of it is yours free for the asking. Write for it to Dept. 872, Goodwear Chicago, Inc., 844 West Adams Street, Chicago.

MAKE \$100 Weekly in spare time. Sell what the public wants—long distance radio receiving sets. Two sales weekly pay \$100 profit. No big investment, no canvassing. Sharpe of Colorado made \$953 in one month. Representatives wanted at once. This plan is sweeping the country—write today before your county is gone. Ozarka, Inc., 128-Q West Austin Ave., Chicago.

SALESMEN: Become Independent. Own Your Business, experience unnecessary selling our \$7,500 Accidental Death, \$50 Accident, \$25 Sick Weekly Benefits, \$12.50 Yearly. Other amounts proportionate. Guaranteed steady income from renewals, \$250,000 Deposited Insurance Department, Universal Policy, Dept. A, Newark, N. J.

\$20 DAILY selling "World's Greatest Foot-Comfort Shoes" direct to men or boys. Quick sellers everywhere. Low priced. Just take orders; we mail shoes direct. Big cash profit and repeats. Territory protected. Best season now. Write quick, Dept. 229, Easy-Wear Shoe Co., Indianapolis, Ind.

TIME Saver Rubber Half Soles becoming popular as rubber heels. Something new. Big Seller. Quick money. Sells on slight all retail trade and direct. Outwears leather. Cost Half. User attaches. No nails. Best season now starting. Timesaver Co., 771 Arcade, Cleveland, Ohio.

SALESMEN for new patented padlock—no keys—cannot be picked—combination easily changed—steady position—future. Write Defender Lock Co., Dept. P. P., 68 Cliff Street, New York.

SALESMEN—35c article eliminates automobile accidents; over 400% profit. Sample free. French, 625 Buder Bldg., St. Louis, Mo.

SALESMAN: If You Think In Terms Of \$6,000 The First Year Write Me Personally. Strong line for retail stores. Nationally advertised. Established concern has unusual opportunity. Liberal weekly advance to producer. Geo. R. Williams, Mgr., Dept. 200, 1922 Euclid Avenue, Cleveland, Ohio.

SALESMEN earn \$10,000 this year with fast selling auto device. Business with big future. Mashken, Indiana Harbor, Ind.

SIDELINE Salesmen—Earn \$100 a month. Every merchant uses salesbooks. Commission 20%, payable in full on acceptance of order. Write for samples, Crane Co., Box 305, Canistota, N. Y.

SALESMEN Wanted—To interview furniture and department stores in their locality on a special proposition for reliable manufacturer. You can earn \$100 a week or more in full or spare time on commission. Interesting, steady work. Write today for full particulars. The Marvel Company, Hammond, Ind.

COLLECTS Money from the Dead-Beats. Retails \$5.00—Cost \$1.00—Profit \$4.00. "New Method." Every Storekeeper, Doctor buys Quickly. Wonderful Money Getter. Federal Association, Hartford, Conn.

\$20.00 DAILY. New patented auto radiator shutter. Real winter proposition. Fastest seller ever invented. Quantity price 45c; retails \$1.50. Jones, 800 N. Clark, Chicago.

MEN—Working Garage Trade For brake reeling machine, new invention; costs one-fifth other devices. Does perfect job in half usual time. Sells on demonstration; big money making opportunity. Write Bear Manufacturing Co., Rock Island, Ill.

\$10.00 DAILY easy. We start you in auto accessory business. No investment, no experience necessary. Exclusive territory. Motor Products Co., 1760 Lunt Ave., Chicago.

GASOLINE Cost Cut 50%. Car owners can now get just twice the mileage as formerly by using a new type vacuum feed invented by Robert Martin of Chamberlain, S. D. This invention automatically doubles mileage for Ford cars and trucks and adds tremendous power. It filters all gasoline used and removes all carbon. Put on or taken off in five minutes. Any owner can secure free trial of this new device by writing Robert Martin, 819 Somers Bldg., Chamberlain, S. D.

SALEMEN—\$10 to \$20 a day easy. No experience necessary. Big fall shirt line now ready at prices to meet competition everywhere. Everything from work shirts to silk shirts, including latest plain and knitted bottom flannel shirts and blouses. Also complete Boys' Line, 24-Hour Service. Wonderful opportunity spare or full time for live workers. Sheridan Shirt Co., Dept. 14, 702 W. Roosevelt Rd., Chicago.

SIDELINE Salesmen—To sell an instant toothache relief remedy. Sold to druggist, restaurants, poolrooms, etc., 25% commission. F. J. Leopold, Adrian, Minn.

WHY work for others? Make and sell your own goods. We show you how. Free book explains everything. National Scientific Laboratories, 1909-A Broad, Richmond, Va.

SALESMEN Make Big Money Selling Our Business Blotter Cards. Free Information. Kelly Specialty Co., Dept. A, Fairbault, Minn.

SIDELINE Salesman—To introduce newest thing in fountain pens. Free sample. Sells on sight. \$3 an hour easily. Write for particulars. Liberty Co., Dept. S, Great Northern Bldg., Chicago.

SELL Men's High Top Boots and Waterproof Quality Work Shoes Factory to Wearer. Our new sales manual will put you in the big earning class in twenty-four hours. Write for free copy today. Carson Shoe Co., Essex Station, Boston, Mass.

SALESMEN—Four Square Suits reduced to \$9.99. Deposit \$3.00. Four patterns. Guaranteed two years. Write quick for free outfit. Stone-Field, LK2554 Wabash, Chicago.

EARN \$100 weekly in advance. Beautiful free Pocket size outfit. Superior \$12.50 Union Made Clothing—best on the market. Fit guaranteed. Also raincoats and wool overcoats. Experience unnecessary. Presents everywhere. Write P. Long, Superior Clothing Co., 1908 W. North Ave., Chicago.

ADVERTISING Salesmen, write for particulars. Auto Accessory. Our name describes the article. Liberal commission. The Atalgance Battery & Oil Guide Company, Fargo, N. Dak.

ADVERTISING Pencils—High grade, big line ready; sight sellers. Big commissions. Pocket samples. Main or sideline. North American Pencil Works, Dept. 2, 126 So. Clinton, Chicago.

MEN, stop chasing rainbows. Sell something which every one must have. Sell shoes. Experience not necessary. Write now. Dept. 53, Acme Shoe Company, Hudson, Mass.

EASY Selling Specialty. Beautiful. Attractive. Appealing. Luminite Window Bulletin. Increase merchants' business 50% to 100%. Protected territory. 88 commission on each \$20 sale. Thousands being sold; sells itself on demonstration. Display Products Co., Ltd., 106 Gibraltar Bldg., Kansas City, Mo.

OUR Legal Guide and Salesman's Instructor will mean money to you. One Dollar. Geo. Stewart, 157 W. Santa Barbara, Los Angeles, Calif.

SELL and operate Sales Board. Write for particulars of this interesting and profitable business. Square Hole Board Co., 120 Scheerer Ave., Newark, N. J.

TAKE orders for coffee, sugar, flour, meats, canned goods, staple groceries; also paints, radio sets, tires, auto and tractor oils. No capital or bond required. We deliver and collect. Permanent business. Big pay. Write at once. Hitchcock-Hill Co., Dept. 50, Chicago.

ADVERTISING Specialty Salesmen: Increase your income by selling Advertising Pocket Knives. Customers use from 100 to 5,000 each season, and you receive a liberal commission. Novelty Cutlery Company, 522 McGregor Ave., Canton, Ohio.

\$15.00 DAILY Easy. Sensation of 1925. It's new, just out. "Fixit" Rubber Repair for Tires and Tubes. Fastest seller, and biggest money maker in America. Act quick. Sample free. Marquette Rubber Co., 2323A Wolfram St., Chicago.

EASY to Sell Groceries, Paints, Lubricating Oils, from samples to consumers in towns and country. Prices meet all competition. No capital or experience necessary. Profitable, steady work. Commission advanced. Satisfaction guaranteed; 53 years in business. Write **Loverin & Browne Co., Wholesale Grocers, 1775 So. State, Chicago, Ill.**

FOUR \$7.50 sales to merchants net you \$20.00 daily. Sayers Systems, 2803 Sheffield Ave., Chicago, Ill.

CALIFORNIA Rosebuds selling like hot cakes. Agents coin money. Absolutely new. Big profits. Catalog free. Mission Factory 8P, 519 No. Halsted, Chicago, Ill.

\$50 DAILY Selling Salesboards—Make up to \$33 on single sale, selling largest, lowest priced line; no samples to carry; write for 3-color catalogue and full particulars, Lincoln Sales Co., Dept. E, 212 N. Sheldon, Chicago.

TRAVELING Salesmen—calling on retail stores wanted by large manufacturer to sell unique line of business-boosting articles. Year round, fast selling, main or side line. If not earning \$150 weekly, address Elmer Works, 222 Charles St., Bloomville, N. Y.

SALESMEN Wanted: Auto Key Purse, New Invention, Wonderful side-line. Low price, long life advertising specialty. Wide Awake Advertisers will use thousands. Commission 20%. Novelty Cutlery Co., 522 McGregor Ave., Canton, Ohio. Established 1879.

\$60-\$200 A WEEK. Genuine Gold Letters for store windows. Easily applied. Free samples. Liberal offer to general agents. Metallic Letter Co., 438-B North Clark, Chicago.

HELP WANTED

AGENTS: \$11.30 daily cash (send for worn proof). Introducing New Insured Hose, 57 styles, 40 colors, guaranteed seven months. No capital or experience required. You simply take orders. We deliver and collect (or you can deliver, suit yourself). Credit given. Pay You Daily, monthly bonus besides. Winter line now ready. We furnish samples. Spare time will do. Marchoe Textile Company, Station 26011, Cincinnati, Ohio.

FIREMAN, Brakemen, Baggage-men, Sleeping car, train porters (colored) \$140-\$200. Experience unnecessary. 810 Railway Bureau, East St. Louis, Ill.

RAILWAY Mail Clerks—\$1,900-\$2,700 year. Men 18-35. Particulars free. Franklin Institute, Dept. J-16, Rochester, N. Y.

MEN: We will establish you in a permanent business paying big income. Your credit is good for merchandise; people must buy every day. No special experience necessary. Write today for free booklet "McCommon's System." McCommon & Co., Factory M18, Winona, Minn.

A PAYING Position Open to Representative of Character. Take orders Shoes—Hosiery direct to Wearer. Good income. Permanent. Write now, Tanners Shoe Mfg. Co., 9-410 C Street, Boston, Mass.

RAILWAY Mail Clerks—City Carriers. \$1,700-\$2,700 year. Men 18-35. Steady. Common education. Sample examination coaching free. Write today, Franklin Institute, Dept. J-16, Rochester, N. Y.

\$170-\$225 MONTHLY. Railway Postal Clerks, Postoffice Clerks, Carriers, \$145-\$192 month. Customs, Internal Revenue, Departmental Clerks, \$1,500 up. Information free. Chicago Civil Service College, Box 226-A, Kesner, Chicago.

MEN, 18 up, wanting U. S. Mail Service jobs, \$142 to \$225 monthly. Steady. Experience or correspondence course unnecessary. Particulars free. Write P. Bradford, 112 N. 50th St., Philadelphia, Pa.

WHY work for others? Make and sell your own goods. We show you how. Free book explains everything. National Scientific Laboratories, 1909-A Broad, Richmond, Va.

ALL men-women, 18-60, wanting to qualify for Government Positions. \$140-\$225 monthly, local or traveling, write Mr. Orment, 101, St. Louis, Mo., immediately.

LARGEST custom shirt manufacturers selling through agents direct to consumer, desire additional salesmen. No capital nor experience required. Samples free. Write today, Hudson Valley Mills, 580 Broadway, New York City.

FREE Book, Start Little Mail Order Business. Pier, 218 Cortland Street, New York.

BIG Raise in Postal Salaries, Become Railway Postal Clerks (\$158-\$225 month). City Carriers—Postoffice Clerks (\$142-\$192 month). Rural Carriers (Average \$175-\$225 month). Men 18 up. Steady work. Life positions. Vacation. Common education sufficient. Sample coaching and full particulars free Franklin Institute, Dept. J-3, Rochester, N. Y.

U. S. GOVERNMENT wants men, \$1,700-\$1,900 and up at start. Railway Mail clerk examination coming. Let our expert (former Government examiner) prepare you for this and also Rural Carrier, Post Office, Customs, Internal Revenue, and other branches. Write today for free booklet, Dept. 8, Patterson Civil Service School, Rochester, N. Y.

RAILWAY Mail Clerks. \$1,900-\$2,700 year. Men 18-35. Particulars free. Write today, Franklin Institute, Dept. J-16, Rochester, N. Y.

BUILD splendid business making chined glass number and name plates, signs, checkerboards. Write for particulars. Simplex Utility Co., 1133 Broadway, New York.

LOCOMOTIVE Firemen for railroads nearest their homes everywhere; beginners \$150-\$250 monthly; promoted, locomotive engineer \$1,000-\$4,000 yearly. Best paying positions on railroads. Railway Association, Desk M1, Brooklyn, N. Y.

MACHINISTS wanted who wish highly to increase their income through the famous new "Record-Stellite-Toothed." Write to: G. F. Ruddle, 747 E. 130th St., New York, N. Y.

\$1,700-\$2,100 YEAR. Mail Carriers, Men, 18-35. Sample examination coaching free. Write today sure Franklin Institute, Dept. J-16, Rochester, N. Y.

RAILWAY Postal Clerks, \$1,900-\$2,700 Postoffice Clerks, Carriers, \$1,700-\$2,300 annually. Thousands appointments annually. Many other lifetime openings. Common education sufficient. Experience unnecessary. Particulars free. Chicago Civil Service College, Box 226-A, Kesner, Chicago.

BOYS-MEN: Learn Auto Repairing. Make \$30.00 week. Sample lessons free. Franklin Institute, Dept. J-400, Rochester, N. Y.

WANTED—Confidential correspondents everywhere; secret service. Write Association American Detectives, Department 105, Bandon, Ore.

A REPRESENTATIVE wanted take orders Runs direct at Mill Prices. We deliver and collect. Exceptional opportunity now. Permanent weekly income. Seven wonderful quality rugs in Sample Case. Write Malsley-Payne Mfg. Co., 90419, Boston, Mass.

\$115-\$400 MONTHLY paid by Station—Office positions. Free passes; experience unnecessary. Write Baker, Supt. 41, St. Louis, Mo.

SILVERING Mirrors, French plate. Easily learned; immense profits. Plans free. Address, Wear Mirror Works, Excelsior Springs, Mo.

OUR genuine gold window sign letters are an excellent money-making proposition for handy men. Stamm Sign System, Bethune Ave. E., Detroit, Mich.

LINOTYPE instruction; Earn \$60 weekly; cost \$200, including printing \$250; 1,000 have attended. Empire School, 206 E. 19th St., New York.

STORIES, poems, plays, etc., are wanted for publication. Good ideas bring big money. Submit manuscripts or write Literary Bureau, 322, Hannahal, Mo.

MEN wanting forest ranger positions, \$1,500-\$2,400 year. Write for free particulars of exams. Mokane, B-21, Denver, Colo.

EARN \$10 daily silvering mirrors, plating and refinishing metalware, auto, chandeliers, bedsteads, headlights. Outfits furnished. E. Deale Laboratories, 1133 Broadway, New York.

FINGER Print Experts—Excellent paying positions; particulars free. Finger Print Headquarters, 188 East 79th, New York.

INVENTORS desiring to secure patents should write for our book "How to Get Your Patent," tells our terms and methods. Send sketch for our examination and instructions without charge. Randolph & Co., Dept. 418, Washington, D. C.

MAKE money writing Photo-plays; details free to beginners. No correspondence course. Producer's League, 220 Wainwright, St. Louis.

MEN wanting forest ranger, railway mail clerk and other Gov't positions write for free particulars of exams. Mokane, Dept. B-23, Denver, Colo.

MEN to build radio sets in spare time. Leon Lambert, 539-H, Wichita, Kans.

INFORMATION

ALASKA Pathfinder, Illustrated magazine, three issues with year's privilege Alaskan information bureau, one dollar. Pathfinder of Alaska, Anchorage, Alaska.

PRACTICAL information on any Mechanical subject, \$1.00. Technical Research Bureau, 377 National Ave., Milwaukee, Wis.

ADVICE on any subject \$1.00. Universal Bureau, 3010 Enright, St. Louis, Mo.

DISCOVERIES of value to men in all walks of life, are to be found in Popular Mechanics Shop Notes for 1924 and 1925. Full directions for making such articles as: electric pump for farm, leather pulley, boring and turning attachment for small lathe, barrel hoist and rack for garage, price ticket printer for stores, special attachments for hand grinder, hydraulic ram, film drying cabinet, and hundreds of others. Send No Money. Just write a postal. Pay postman postage and \$1. Popular Mechanics Press.

BUSINESS SERVICE

BUSINESS Aids, Books, Formulas, Novelties, Stationery. North Pacific Distributing Co., Box 167, Seattle, Wash.

DELAWARE Incorporator. Charters; Fees Small; formula. Chas. G. Guyer, 901 Orange St., Wilmington, Del.

TYPEWRITERS AND SUPPLIES

FRESH Ribbons, Black Record, Visible Makes, 55 cents, Two for \$1.00. Typewriter Supplies, 7927-29 Colfax Ave., Chicago.

UNDERWOOD Typewriters—only \$3.00 down. Easy monthly payments. Low prices at less than manufacturers. 10 days' free trial. Rebuilt, all worn parts replaced. Just like a new machine. 5-year guarantee. Write for big free catalogue C-151, Shipman-Ward Mfg. Co., 1518 Shipman Bldg., Chicago, Ill.

TYPEWRITERS, all standard makes, \$10 up. Fully guaranteed. Free trial. Write for complete illustrated lists. Northwestern Typewriter Exchange, 121 N. Francisco Ave., Chicago.

SIMPLEX Typewriters \$5. Remingtons \$12. Adding Machines \$2.95. Catalog 5c. Demos, 114 Ford St., Providence, R. I.

TYPEWRITERS \$1-\$35. Motorcycles \$5-\$50. New Victrolas \$13. Send cash. Agents wanted. Knight's, 1512 Locust, St. Louis, Mo.

TYPEWRITERS All Makes. Save One-half. Thoroughly rebuilt in our factory to the famous "Young Process." Fully guaranteed. Free trial. We handle all standard makes. Cash or sold on easy terms. Write for catalog. Young Typewriter Co., Dept. 375B, Chicago, Ill.

PRINTING, ENGRAVING AND MULTIGRAPHING

BETTER Printing: Lowest Prices! Office, Factory, Forms a specialty. Convincing Samples. Shattuck-Williams, Aurora, Ind.

PRINTING. Lowest prices in America. Samples free. A. Pitt, Amara, Iowa.

5,000 AD. Slips 3 1/2 x 5 1/2, \$5.00. All Clearers, Folders, Stationery lowest prices. Elegant Samples Free. Good's Printery, Harrisonburg, Va.

"LET Us Print For You." Quality Printing at lowest prices. Perela Bros., 296 Federal St., Chicago, Ill.

PERSONAL Stationery—200 sheets paper, 100 envelopes, postage prepaid, \$1.25; cash with order; samples. The Quality Press, 209 Auburn St., Ithaca, N. Y.

ADVERTISING Pencils, "the kind that you want!" Buy direct; same middleman's profit. Samples free (no agents). Address S. Mustal & Co., 10-12 Lincoln St., Yonkers, N. Y.

GUMMED Labels! Catalog Free! Edward Harrison, "Printing Rubber Stamps," Baltimore.

\$3.00 DELIVERED. 500 Watermarked Bond Letterheads, 8 1/2 x 11, and 250 envelopes, money with order. Job Printing Specialty, National Printing Company, Goshen, Ind.

250 BOND Letterheads 8 1/2 x 11, 250 Envelopes \$3.00, 500 Bond Letterheads and Envelopes \$4.50. J. R. Weeks, St. David's Road, Schenectady, N. Y.

COMMERCIAL outfit—500 Bond Letterheads, Envelopes, Billheads, Cards, \$8.98. Pleasing Printing, Stark Press, 782 Portland, Rochester, N. Y.

DRAWINGS and cuts made to order. "Cressman," Washington, N. J.

EVERYTHING Printed! Samples for stamp. Franklin Press, B-32, Milford, N. H.

500 Envelopes, Noteheads, ruled or unruled; Shipping Tags, Statements, choice \$2.50; 1,000 at \$3.50, prepaid, cash with order. Beebe Printery, Pennsylvania, Wis.

100 BOND letterheads and 100 envelopes \$1.00. The Q. Shop, Roaring Springs, Pa.

GUMMED Labels—3,000 \$1.00. Catalogue 2c. MacTazart, 1233 Arch, Philadelphia, Pa.

250 EACH Hammermill Bond Letterheads, Envelopes, \$3.00. Samples. Midland Press, 543 West Hickory, Kankakee, Ill.

225 BOND letterheads, envelopes, billheads, cards, \$1.25 each. Combination, \$4.00. Economic Press, Leonia, N. J.

WE print Stationery, Booklets, Catalogs, Circulars, Samples. Commercial Press, Batavia, Ohio.

250 LETTERHEADS, 250 white envelopes printed and mailed \$3.00. Samples printing free. Sunco, Mohawk, N. Y.

QUALITY Printing! Reasonable Prices! Send for Free Standardized samples and prices. Folders, Circulars, Catalogs our specialty. Ernest Fantus, 525 South Dearborn, Chicago.

1,000 LETTERHEADS or Envelopes, \$3.00. Sent Prepaid, Samples Free. Monitor Press, Morrisville, Pa.

500 MULTIGRAPH Letters \$2.35 with printed head, Envelopes, Cards, bargains. Price list free. Carlson's, 8743 Esser Ave., Chicago.

250 LETTERHEADS 250 white envelopes delivered printed \$3.00. Eastern Label Co., V. Clintonville, Conn.

20-LB. Bond Letterheads, 6% envelopes, Billheads, Statements; \$3.00 thousand. Low quotations on all good printing. Service Press, Middletown, N. Y.

GUMMED Labels, 500 name and address, 2 lines 35c, 3 lines 55c. Catalogue. Eastern Label Co., A. Clintonville, Conn.

QUALITY Printing, anything; estimates furnished. Adamee, 180 Harman St., Brooklyn, N. Y.

250 BOND Letter Heads (8 1/2 x 11), Envelopes or cards, \$1.50; 500, \$2.25. Geo. Pfeiffer, Hackensack, N. J.

1,000 LETTERHEADS, Envelopes, Cards, \$3.00 postpaid; 500, \$2.25. Samples Free. Artservis Press, 68 Houghton, Worcester, Mass.

1,000 LETTERHEADS or Envelopes, \$2.95. Prepaid, Samples, Advance Printers, Wauwatosa, Wis.

PRINTING OUTFITS AND SUPPLIES

PRINT your own cards, stationery, circulars, paper, etc. Complete outfits \$8.85; Job Presses \$12, \$35; Rotary \$150. Print for others; big profit. All easy, rules sent. Write for catalog presses, type, paper, etc. Press Company, A-11, Meriden, Conn.

PRE-USED Printing Presses, Type supplies. List for 2c stamp. Popular Bargains, Richard, Pa.

PRINTING OUTFITS, Presses, Type, Supplies. Stamp for information, Nicholas, M-110 High St., Boston.

PRINTING OUTFITS—Presses, type supplies, type novelties. Send stamp for catalogue. Model Press, York, Penna.

DUPLICATORS AND DEVICES

YOU can make 50 to 100 copies of a letter, notice, etc., at a cost of three cents on a Hoyer Quality Duplicator. Write for free trial offer. The Hoyer Duplicator Co., 14 S. Wells St., Chicago, Ill.

STENCIL Duplicator—\$1.00, \$3.50, \$4.00. Clear Printing, Typewriting, Handwriting, Returnable. Primos Specialty Co., 3-M, Primos, Pa.

ADDING MACHINES

ADDING MACHINE for \$1.25. All metal with case, for desk or pocket; Adds, subtracts. Capacity 999,999,999. Simple and accurate. Postpaid. Ernest C. Gosnay, 295 Broadway, New York.

FREE Trial, Marvelous new Adding Machine. Adds, Subtracts, Multiplies, Divides, automatically. Work equals \$350.00 machine. Price only \$15.00. Speedy, durable, handsome. Five-year guarantee. Used by largest corporations. Write today for catalog and free trial offer. Lightning Calculator Co., Dept. E, Grand Rapids, Mich.

NEW \$3.50 Automatic Adding Machine. Adds, Subtracts, Multiplies. Absolutely accurate. Capacity 999,999,999. Fully guaranteed. 75,000 pleased users. Makes adding easy, positive, quick. Eliminates Mistakes, Saves Time. Postpaid \$3.50. Bassett Co., 1458 J, Hollywood Ave., Chicago.

MAILING LISTS

AGENTS' Names neatly typewritten from our one day old inquiry letters. Price right. C. World, 160 W. Washington, Chicago.

GUARANTEED Mailing Lists. Write for rates. French, 1903 E. Chase, Baltimore, Md.

NATIONAL up-to-date guaranteed mailing lists. John Clarke, 5 Trumbull, New Haven, Conn.

GUARANTEED Names, actual mail-order buyers, \$5.00 thousand, 500, \$2.50. Demuth Company, Englewood, N. J.

2,200 CALIFORNIA Garages. Guaranteed. Entire list \$8.00. Murco Supply Tujunga, Calif. Box-3.

NAMES—postcards—cuts. Ben Meyer, 35 West 31st, New York.

UP to date list \$5 per 1,000 names. J. E. Mallinson, Carolina, B. I.

FOR SMOKERS

FREE Trial—3,000 London-made, fine Italian brucere pipes. Product of House of Comoy, London. Comoy's have installed in each "Right-O!" pipe our Caldwell (Pat. Pdg.) trap tube—that traps moisture and impurities. Delivers to smoker clean smoke. Takes the "bite" out of tobacco. Prevents foul-tasting pipe juices from entering the mouth. No filters, cartridges, or absorbents used. Easy to clean. Its action surprising to smokers. The most healthful pipe to smoke. To smoke this pipe is to adopt it. We want reliable men to smoke and recommend the "Right-O!" pipe. Do not send any money! Write and say: "Send me 'Right-O!' pipe for a two weeks' trial. I will smoke the pipe and following this free trial I will either return the pipe or send you two dollars in full payment for it. I am to be judge." Please send names and addresses of two or more local pipe smokers. The "Right-O!" pipe is a good value. It is made on honor—and sold on honor. High-class solicitors wanted to sell these pipes at a higher price than this introductory price. Caldwell Novelties, Inc., Bloomfield, N. J.

THE Sweetest Smoke You Ever Had! Something New! "Clayschaum" pipes from Scotland, Special Clay, absorbs nicotine. Gives cool, dry smoke and conserves health. Colors beautifully. Well finished with smooth round edges. A new treat for the smoke connoisseur. Send only \$1.00 for 12. Mailed postpaid. Scotch Clayschaum Pipe Company, Laurel, Md.

HOMESPUN Chewing and Smoking Tobacco—5 lbs. \$1.25; 10 lbs. \$2.50; 20 lbs. \$4.50. Hickory Ridge Farms, Mayfield, Ky.

FOR MEN

CARPENTERS. Popular Mechanics Carpenters' Handbook is filled with ideas for those who like to tinker with tools, and for professional carpenters. 40 articles on saws and sawing, 17 on benches and bench equipment, 22 on doors and door hanging, 18 on lumber, 13 on mitering, 74 on tools and their care, 22 on shop equipment, and many others—366 in all, and 229 illustrations. Send No Money. Just write a postal. Pay postman postage and \$1.50. Popular Mechanics Press, Room 811, 200 E. Ontario St., Chicago, Ill.

BOATS AND LAUNCHES

BUILD your own boat. Do your own concrete work. Two new books tell how to make 21 kinds of boats and 173 articles from concrete. Each book filled with pictures. Send No Money. Just write a postal and say, "Send Popular Mechanics Boat Book and Concrete Handbook." Pay postman postage and \$1. Popular Mechanics Press, Room 811, 200 E. Ontario St., Chicago, Ill.

MAKE 16' Rowboat. Blueprint 30c. Weedon-Pro, 31st Office, Detroit.

BOATS: Prepare now to build your own boat for next season's use; substantial saving guaranteed. Bow, Sail, Speed, Hydroplanes, Runabouts, Cruisers. Send 25c for 64-page Catalog. Brooks Boat Co., Inc., Rust Ave., Saginaw, Mich.

RAZORS AND BLADES

GILLETTE style blades, all new. Dozen 45 cents; 3 dozen \$1.25. Automatic shaver 75 cents. F. Wallace Katz, 132 Chamber St., Philadelphia, N. J.

OPTICAL GOODS

BINOCULARS. Binoculars, Binoculars! A glass for every use and every pocketbook. 58 styles, 4 to 24 power, \$9.50 to \$106.00. Guarantee of absolute satisfaction or money back. Get the Geneva price list first. Send for descriptive circular today. Geneva Optical Co., 41 Linden St., Geneva, N. Y.

144 NEW Megaphos Prism Binoculars 8x. Worth double, \$19.50 each. Subject examination and trial. B. & L. Optical Wks. 3 E. 38th St., Chicago.

RUBBER STAMPS

MUSIC stamps, rubber type catalog 2-c. W. Karstaedt, Dayton, Ohio.

FOR THE HOME

LOOMS—Only \$9.90 and up. Big money in weaving Colonial Rugs, carpets, etc., from rags and waste material. Weavers are rushed with orders. Send for free Loom Book; it tells all about home weaving and quotes reduced prices and easy terms on our wonderful new looms. Union Loom Works, 489 Factory St., Boonville, N. Y.

GRANDFATHER'S Clock Works, \$3.00. Build your own case; Instructions free; make good profits selling your friends. Clock works with chimes for old or new cases. Write for full particulars. Clock Co., Buffner St., Philadelphia.

HOME Mechanics. Ideas for all sorts of odd jobs about the house in "Home Mechanics," and "Popular Mechanics Handbook for Women." Over 700 discoveries useful to the whole family. Send No Money. Just write a postal. Pay postman postage and \$1. Popular Mechanics Press, Room 811, 200 E. Ontario St., Chicago, Ill.

FURNITURE; Make Furniture at Home. Popular Mechanics books tell how to make all pieces. "Mission Furniture and How to Make It, Book 1, Book 2, Book 3." Send No Money. Just write postal. Pay postman postage and \$5. Popular Mechanics Press, Room 811, 200 E. Ontario St., Chicago, Ill.

MAKE tables, chairs, book-racks, other furniture at home in spare time. We furnish complete plans and specifications anyone can use. Special—mahogany end table plans, 25c. The Practical Mechanic, South Haven, Mich.

DECORATIVE Metal articles. It's easy to make your own book ends, desk sets, paper knives, blotting pad corners, stationery racks, desk calendars, arts-crafts jewelry, tie racks, watch fobs, photo holders, book marks, drawer pulls, hinges, and many other articles from brass and other metals by simply following the crystal-clear instructions in Popular Mechanics book, "Metal Work and Etching." Send No Money. Just write a postal. Pay postman postage and \$1. Popular Mechanics Press, Room 811, 200 E. Ontario St., Chicago, Ill.

DIAMONDS, WATCHES AND JEWELRY

MAGIC Costume Ring—Gold, Silver, tricolor Stone turns at will red, blue or green. Patented. Popular price. Beautiful card model free. Cognito Co., 4, Elizabeth, N. J.

ANTIQUES, WAR RELICS AND INDIAN GOODS

ADDITION and Multiplication table for home and office use. Conveniently arranged. Mistakes are costly. Save money and pay by using the table and having your sum correct. 35c each or four for \$1.00. P. O. money order preferred. Every home needs a table or two. Harry G. Lillie, P. O. Box 385, Marysville, Ohio.

SEND 5c for fine, new list Indian relic antique firearms. F. E. Ellis, Webster Groves, Mo.

PHONOGRAPHS AND RECORDS

REDUCTIONS on quality phonograph motor, tone outfits and cabinet hardware. Agents wanted for Tuned Radio Frequency Sets. Superior Phonograph Company, Erie, Pa.

BUILD your own Phonograph. We furnish everything. Phonograph Parts and Radio catalog sent free. American Phonograph Co., 3752 Belmont, Chicago.

BUILD Your Phonograph. Spring Motors, Electric Motors, Tonearms, Amplifiers, Accessories. Latest Equipment also in Radio Mechanism and Cabinets. Catalog mailed for ten cents. Hoosier Mfg. & Supply Co., 313 Baldwin Block, Indianapolis, Ind.

MUSIC AND MUSICAL INSTRUMENTS

EVERYTHING sold for Bands and orchestra—Saxophones, Banjos, Ukuleles, Drums, Trumpets, Violins, Reeds—All accessories. Salesmen wanted. Jay-Corn's Instruments, Easy Payments, Repairing and Plating. Phonographs Repaired. Write for prices. Sternberg's Music Shoppe, 29 E. Adams St., Chicago.

ROLLS, Records, \$1.50 Dozen; 81cents used. Buy, Sell, Exchange. Also 65 note rolls. Standard Music Exchange, 39 E. Randolph, Chicago.

BAND and Orchestra Instruments—All makes of new and used instruments sold, exchanged and repaired. Standard and popular music sold. Write today for catalog and Free subscription to "Musical Booster" magazine. Deal with the Professional House, Crawford-Rutan Co., 3051 Grand Ave., Kansas City, Mo.

PLAY piano by Ear. A Sound System. Postal brings full particulars and Free Booklet. No obligations. Boucher's Harmony Studio, 127 Metcalfe St., Ottawa, Can.

VIOLIN Bow Finger Rest \$1.00. Makes proper holding of bow easy. Protects bow from any wear. Indispensable to Violinists. H. L. Johnson, Yarmouth, Me.

TRUMPETS—Cornets. Easy terms. Particulars free. Kenneth Klugh, Ridgway, Pa.

VIOLINS—Handmade Masterpieces. Easy terms. Illustrations free. Kenneth Klugh, Ridgway, Pa.

PORTABLE Phonographs. Finish Mahogany. Very Easy to Carry. Formerly Sold for \$35.00. Sent Direct from Factory \$16.75. Schubb & Co., 1208 Fifteenth St., Detroit, Mich. Agents Wanted.

PIANO JAZZ: teachers Ear Playing, Negro Harmony, Player Piano Effects, Chimes, Blues, Chords, Sweet Harmony. Particulars Write "Piano Bill," Toronto, D. 3, Canada.

MUSIC Composed. Send words. Louis Soboloff, 14 Bradley St., New Haven, Conn.

MELODIES harmonized, music composed. Guaranteed Instruction in Harmony by mail. Jarnhem, 2638 Milwaukee Ave., Chicago.

"MUSIC Composed" to words. Bauer Bros., (formerly of Sousa's Band), Oshkosh, Wis.

VIOLINS. Deep, Mellow, Soulful—on credit. Easy terms for wonderful instrument. Get details today. Gustav F. Henning, 2424 Gaylord St., Denver, Colo.

VIOLINS—Genuine hand-made; sweet, soulful, mellow, yet powerful. Instruments of finest tonal quality. Free trial. John Lehto, 925 14th St., San Pedro, Calif.

WRITE Songs. Big money and reputation. Write for information. J. Gordon Pub. Co., 201 N. Hoyle Ave., Chicago.

SING Beautifully—quickly (without teacher). Write—Simplex Method, 4112M Hartford, St. Louis.

I WANT Song Poems. Casper Nathan, 2311 N. Racine, Chicago.

SONG Poem Writers—Have proposition. Ray Hübeler, D1, 2104 N. Kerstone Ave., Chicago.

PATENT ATTORNEYS

PATENTS—Our book "How to Obtain a Patent" sent free upon request. Contains full information about patents, trade-marks and designs. If you will send us a sketch of your invention we will promptly make search of the Patent Office records and advise you as to patentability. Our charge for the service being \$5.00. Prompt, efficient service with moderate charge. Over twenty years experience. Band and commercial references. Talbert & Talbert, Registered Patent Lawyers, 597 McGill Bldg., Washington, D. C.

PATENT Procured. Prompt Service. Personal, careful and efficient service. Highest references. Moderate fees. Send sketch or model for actual search and advice. George P. Kimmel, Master of Patent Law, 54 L, Legal Bldg., Washington, D. C.

PATENTS. Time counts in applying for patents. Don't risk delay in protecting your ideas. Send sketch or model for instructions or write for Free book "How to Obtain a Patent" and "Record of Invention" form. No charge for information on how to proceed. Communications strictly confidential. Prompt, careful, efficient service. Clarence A. O'Brien, Registered Patent Attorney, 5897 Security Bank Building (directly across street from Patent Office), Washington, D. C. See pages 140 and 141.

INVENTIONS Patented: Trade-marks Registered; reasonable charges; prompt service; plain advice; request particulars. Jaynes & Jaynes, 709 Kellogg, Washington, D. C.

LACEY'S Patent Sense. Valuable book free. See ad page 144.

PATENTS—Write for our Guide Books and "Record of Invention Blank" before disclosing inventions. Send model or sketch of your invention for Free Inspection and Instructions. Terms Reasonable. See advertisement on pages 142 and 143. Victor J. Evans & Co., 934 Ninth, Washington, D. C.

PATENTS. Trade marks, copyrights. Prompt, personal, reliable service. Over 36 years' active practice. Write for terms. Book free. Address E. G. Siggers, N. U. Bldg., 918 F Street, Washington, D. C.

"STRONGER Patents for less money." Drawings, specification, claims \$20. Send half fee with sketch and description. Prompt, efficient action. American Patents Corporation, Barrister Building, Washington, D. C.

PATENTS procured: Trade Marks Registered. A comprehensive, experienced, prompt service for the protection and development of your ideas. Preliminary advice gladly furnished without charge. Booklet of information and form for disclosing idea free on request. Richard B. Owen, 29 Owen Bldg., Washington, D. C., or 41-R Park Row, New York.

PATENTS: My fee in installments. Free personal advice. Frank T. Fuller, Washington, D. C.

PATENTS, Trade-Marks, Designs. This firm has 27 years' experience and gives expert personal service at reasonable rates. We properly protect your invention. Write for free information and exact cost of procuring patent before proceeding. John B. Thomas & Co., 392 F St., N. W., Washington, D. C.

MONROE MILLER. Ouray Bldg., Washington, D. C. Patent Attorney; Mechanical, Electrical Expert. Free Blue Book gives candid advice.

ESTABLISHED 1864. Milo D. Stevens Company. Free Booklet, Patents, Trade-Marks, Copyrights. Offices, Monadnock Block, Chicago; Barrister Building, Washington, D. C.

PATENTS and Trade-Marks obtained. Prompt service. Write for our new book on patents. Established in 1889. D. Swift & Co., 369 7th St., Washington, D. C.

MILLIONS spent annually for ideas! Hundreds now wanted! Patent yours and profit! Write today for free book—tells how to protect yourself, how to invent. Ideas wanted, how we help you sell, etc. American Industries, Inc., 500 Kroeger Bldg., Washington, D. C.

INVENTORS—Send for form "Evidence of Conception" to be signed and witnessed. Form, fee schedule, information free. Lancaster and Allwine, Registered Patent Attorneys in United States and Canada, 221 Quay Bldg., Washington, D. C.

COMMERCIALIZE your inventions according to My Cooperative Plan before patenting. Write for booklet. Ralph Birch, Patent Lawyer, Jenifer Building, Washington, D. C.

PATENT Application Blanks free to inventors. Patent News-D, Washington, D. C.

FRED H. HAYN, M. E., formerly First Assistant, Examiner U. S. Patent Office, 23 years' exp., I. W. Hellman Building, Los Angeles, Calif.

INVENTORS—Write for our Guide Book, "How to Get Your Patent" and Evidence of Invention Blank. Send model or sketch of your invention for our prompt examination and instructions free. Randolph & Co., Dent, 430, Washington, D. C.

PATENTS. Booklet free. Highest references. Best results. Promptness assured. Send model or drawing for preliminary examination. Watson E. Coleman, Patent Lawyer, 614 G Street, Washington, D. C.

"INVENTORS' Guide" sent free on request; this book contains illustrations of patented inventions and gives valuable information and advice for all who have original ideas or improvements. Frank Ledermann, Registered Attorney and Engineer, Woodworth Bldg., 1712, New York.

INVENTORS: Send sketch or model for advice and exact cost of patent. Ask for our Free book: "How to Obtain a Patent." Tells what every inventor should know. Established twenty-eight years. Highest references. Prompt service. Reasonable charges. Chandler & Chandler, 474 Seventh, Washington, D. C.

HERBERT JENNER, patent attorney and mechanical expert, 605 F Street, Washington, D. C. I report if patent is obtainable and exact cost. Send for circular.

PERCY S. WEBSTER, Savings and Loan Building, Stockton, California. Long established organization. Send for free book on Patents.

UNPATENTED Ideas Can Be Sold. I tell you how and help you make the sale. Free particulars (Copyrighted). Write W. T. Greene, 805 Jenifer Building, Washington, D. C.

"INVENTOR'S Advisor," the valuable Patent book with 139 mechanical movements and illustrations, sent free upon request. M. M. Labiner, Patent Attorney, 3 Parkrow, New York.

PATENT Book Free. Charles W. Lovett, Patent Attorney, Lynn, Mass.

FOR INVENTORS

PATENTS. If you have an invention which you wish to patent you can write fully and freely to Munn & Co., for advice in regard to the best way of obtaining protection. Please send sketches, or a model of your invention and a description of the device, explaining its operation. All communications are strictly confidential. Our Handbook on Patents is sent free on request. This explains our methods, terms, etc., in regard to Patents, Trade Marks, Foreign Patents, etc. "Scientific American" contains Patent Office Notes. Derivations of interest to inventors and particulars of recently patented inventions. Munn & Company, Solicitors of Patents, 623 Woolworth Building, New York; 524 Scientific American Bldg., Washington, D. C., 413 Tower Bldg., Chicago, Ill.; 366 Hobart Bldg., 532 Market St., San Francisco, Calif.; 221 Van Nuys Building, Los Angeles, Calif.

PATENTS—Our book "How to Obtain a Patent" sent free upon request. Contains full information about patents, trade-marks and designs. If you will send us a sketch of your invention we will promptly make a search of the Patent Office records and advise you as to patentability. Our charge for the service being \$5.00. Prompt, efficient service with moderate charges. Over twenty years' experience. Bank and commercial references. Talbert & Talbert, Registered Patent Lawyers, 582 McGill Bldg., Washington, D. C.

PARTNER wanted for developing of revolutionary invention, concerning production of electrical power. Lorenz Meckl, 6117 Epworth Blvd., Detroit, Mich.

PATENTS Wanted by Manufacturers. Send Description and Number, Box 126, Dowagiac, Mich.

WANTED to hear from inventors with patents on automobiles. Auto accessories, signal devices novelties, electric devices and formulas. S. B. Disenza, U-C Specialty Co., Hartford, Conn.

I SELL Patents. Established in 1909. The only man in America who has spent the past 25 years exclusively at this work. An experience highly valuable to you. If you have a good patent to sell. Charles A. Scott, 775PM Garson Avenue, Rochester, N. Y.

OBTAIN your own Patent. Complete instructions and application material \$5. Inventors' Service Bureau, 189 N. Clark, Chicago.

MECHANICAL drawing from sketches. Confidential, neat accurate. Technical Research Bureau, 377 National Ave., Milwaukee, Wis.

INVENTORS—Write for our Guide Books and "Record of Invention Blank" before disclosing inventions. Send model or sketch of your invention for our free inspection and instructions. Terms reasonable. See advertisement on pages 142 and 143. Victor J. Evans & Co., 137 Ninth, Washington, D. C.

LACEY'S Patent Sense. Valuable book free. See ad page 144.

PATENTS. Time counts in applying for patents. Don't risk delay in protecting your ideas. Send sketch or model for instructions or write for Free book "How to Obtain a Patent" and "Record of Invention" form. No charge for information on how to proceed. Communications strictly confidential. Prompt, careful, efficient service. Clarence A. O'Brien, Registered Patent Attorney, 5897 Security Bank Building (directly across street from Patent Office), Washington, D. C. See pages 140 and 141.

WILL finance patent (good invention) for interest. P. A., c/o Patent News, Washington, D. C.

HAVE You an Invention? If so, write for our free book, "How to Get Your Patent," tells our terms and methods. Send model or sketch for our free examination and instructions. Randolph & Co., Dent, 144, Washington, D. C.

GET your own patents. Legal blanks, complete instructions \$1. Cutting Sons, Campbell, Calif.

UNPATENTED Ideas Can Be Sold. I tell you how and help you make the sale. Free particulars (Copyrighted). Write W. T. Greene, 805 Jenifer Building, Washington, D. C.

PATENTS procured; Trade Marks Registered. A comprehensive, experienced, prompt service for the protection and development of your ideas. Preliminary advice gladly furnished without charge. Booklet of information and form for disclosing idea free on request. Richard B. Owen, 39 Owen Bldg., Washington, D. C. or 41-B Park Row, New York.

INVENTIONS fully protected two years, \$15 total cost. Particulars free. Patent News-G, Washington, D. C.

PATENTS: My fee in installments. Free personal advice. Frank T. Fuller, Washington, D. C.

MONROE MILLER, Ouray Bldg., Washington, D. C. Patent Attorney; Mechanical, Electrical Expert. Before proceeding, read free Blue Book.

INVENTOR'S Universal Educator—contains 900 mechanical movements; 50 perpetual motions. Tells how to obtain and sell patents. Suggests new ideas. Explains how to select your attorney and avoid patent sharks. Price (revised edition) \$2.00 postpaid. Albert E. Dieterich, 621 Ouray Bldg., Washington, D. C.

COMPETENT Engineers will furnish you Certified Engineer's Report showing cost of manufacture of each part of your invention. K. M. Keller & Co., Consulting Patent Engineers, City Center Bldg., Philadelphia, Pa.

PATENTS FOR SALE

FOR Sale outright—United States and Canadian patent on Improved Window catch device. Burglar proof and absolutely reliable; easy and cheap to make. Now, Manufacturers, here's your chance to make money. What offers? Sam R. Wallen, Chase, B. C., Canada.

FOR Sale—Patent No. 1,550,634; Wooden Collapsible Garment Hanger and Patent pending on instrument; Double indicator, designed for Pool and Billiard players to keep score of points. It hangs from ceiling upon the pool table. Numbers visible all around. Write A. Pollock, Box 153, 529-531 Clinton St., Brooklyn, N. Y.

OUTRIGHT or Royalty—Newly patented radiator cap and motor combined. C. Butler, 484 Wash. St., Placerville, Calif.

MANUFACTURERS of light machinery! Material shoveling machine will save millions; will you investigate No. 1, 512, 844 particulars. Paul Groshek, Glen Massey, New Zealand.

TWO inventions for sale on woodworking tool. Address John Szako, 2014 Fifth Ave., New York City.

NOVELTY for women. Mail order proposition. Sell for \$1.00 each, cost to manufacture 10 to 15 cents each. Patent, together with about 800 finished articles ready to sell, for \$85.00. Good reason for selling. W. F. Sprengnether, 14 N. Ninth St., St. Louis, Mo.

FOR Sale outright. My Patent 1,536,167, Fruit Gatherer. Made of canvas, receives apples shaken from the tree without bruising, saving time and expense. Wm. G. L. T. item, Burkhammon, W. Va.

AUTOMATIC gas burning furnace fire starter; starts coal quickly without use of kindling, charcoal or inconvenience. Householder delighted, buy on sight. Make offer. D. Terney, 9925 Chemist, Detroit, Mich.

WATERLESS Finger Moistener. Essential Office Device. Outright. Alexander Mark, 2130 Baltimore Ave., Chicago.

PATENT 1,550,504. Adjustable Wrench. Stable, simple. Outright or royalty. Yashuhiko Nagano, 837 Geary St., San Francisco, Calif.

PATENT Applied for. A marketable invention for sale at moderate price—A powerful Air Vacuum for cleaning woolsen suits. Make offer. W. Acosta, c/o Gen. Delivery, Chicago, Ill.

IMPROVEMENTS in mixing air with fuel gases, proven successful for stoves and furnaces. H. Stever, 311 So. Jackson, Danville, Ill.

1,520,464. Cardboard Toy. Fascinating. Outright sale preferred. Anson K. Pearce, Gustine, Calif.

DIRIGIBLE Headlight Patent, for Fords, outright or royalty. R. Webster, 7152 Gower Ave., Philadelphia, Penn.

PATENT on the Kwik-Tite shade holder; no screws, simple in construction; shade can be placed or displaced quickly by slight operation of the hand. Redding Metal & Heating Works, P. O. Box 1552, New Haven, Conn.

TOY—Patent Pending. Reasonable. Henry Claus, East Northport, New York.

MR. MANUFACTURER. Layman or veteran—Side Dump Scraper Hoist, loads wagons, does ditching. E. B. Hawkins, Applegate, Oreg.

COMBINED Hoe and Rake Tool for gardens. Will sell outright for \$4,000.00. Release on reasonable royalty basis. Add. Micajah Harris, 8 Chestnut St., Flushing, N. Y.

PATENTS For Sale: To sell, buy or obtain patents, write Patent News-P, Washington, D. C.

YOU have a worth-while patent, haven't you? Why don't you tell our two million readers about it? Most of them are specially interested in patents and new inventions. Ask me to tell you how other inventors successfully sold their patents. Geo. F. Baker, Manager Classified Advertising, Popular Mechanics Magazine, Chicago, Ill.

SURVEYING INSTRUMENTS

LARGEST stock of new and used surveying instruments in the country direct from factory. Satisfaction guaranteed or money refunded. Wisler, 619 N. Broadway, St. Louis.

DRAWING INSTRUMENTS AND SUPPLIES

IMPORTED Drawing Instruments—Slide Rules. Highest Quality—Lowest Prices. Circulars free. Automotive Engineering Co. Box 1662, Indianapolis, Ind.

DRAFTING. Learn Mechanical Drawing. Big demand for men to make accurate drawings to scale. This pocket-size, cloth-covered book starts you at the beginning and leads you by a series of simple lessons to the more difficult assignments that you would get in an architect's or engineer's office. Send No Money. Just write a postal for "A Practical Course in Mechanical Drawing." Pay postman postage and \$1. Popular Mechanics Press, Room 811, 200 E. Ontario St., Chicago, Ill.

MODEL AND MODEL SUPPLIES

PATENTS. Time counts in applying for patents. Don't risk delay in protecting your ideas. Send sketch or model for instructions or write for Free Book "How to Obtain a Patent" and "Record of Invention" form. No charge for information on how to proceed. Communications strictly confidential. Prompt, careful, efficient service. Clarence A. O'Brien, Registered Patent Attorney, 5897 Security Bank Building (directly across street from Patent Office), Washington, D. C. See pages 149 and 141.

MODELS, experimental work for inventors. Confidential, reasonable. Technical Research Bureau, 377 National Ave., Milwaukee, Wis.

PATTERN Making is a fascinating trade that pays good money. Popular Mechanics has helped many a young man into this trade by supplying the necessary instructions in "Pattern Making," by G. H. Willard, 312 illustrations. Special chapters on moulding and core making. Send No Money. Just write a postal. Pay postman postage and \$1. Popular Mechanics Press, Room 811, 200 E. Ontario St., Chicago, Ill.

THE Modelmaker, a magazine for all interested in making working models. Sample 10 cents. Modelmaker, 122 Liberty St., New York.

MODELS and patterns made, light manufacturing. Oil Runner Patent for Sale. H. W. Hathorn, Mason City, Iowa.

CASTINGS for new model steam engine, 1" bore x 1" stroke. Send stamp for circular No. 7. Model Machine Shop, 417 East 71st St., New York City.

SPECIAL machine builders, tool and die makers, inventor's models, production work of all kinds. Dept. L. Quality Hardware & Machine Co., Ravenswood and Thornside Avenues, Chicago, Ill.

WE make working models for inventors and do experimental work and carry a complete stock of brass gears and model supplies. Send for catalogue. The Pierce Model Works, Tinley Park, Ill.

DIES, Tools and General Manufacturing. Models and Manufacturing of new inventions our specialty. Logan Machine Co., 126 S. Clinton St., Chicago, Ill.

WE Build Models, design, develop and manufacture articles in large or small quantities. Homner Mfg. Co., 1385 E. 17th St., Cleveland, Ohio.

MANUFACTURING

METAL-CRAFT — Eventually — Metal-Craft. Competent Engineers, Designers and Producing Organization await your commands on dies, stampings, die-casting, deep pressing, screw-machine and wire products. Plating, Enameling, Burnishing, Assembling, Wrapping and Packing to your specifications. Large completely equipped plant which guarantees prompt, efficient service. It is not the quality of raw materials alone, nor the precision in manufacture, and not just the service rendered that has given Metal-Craft the good reputation they bear—but all of these, as a constant certainty. In Combination, Estimates promptly furnished. Metal-Craft Manufacturing Company, Chicago, Box 239-W.

RUBBER articles made to specifications. Rozelle Rubber Laboratories, 401 East 15th, Kansas City, Mo.

METAL-WORKERS. Popular Mechanics New Lathe Handbook, and the Drilling and Thread Cutting Handbook make a most valuable combination for anyone interested in metal work. 560 ideas, 510 illustrations. Send No Money. Pay postman postage and \$1. Popular Mechanics Press, Room 811, 200 E. Ontario St., Chicago, Ill.

CORPORATION established 1913 wants one article for manufacture and sale royalty basis; have complete factory National sales organization. Langmotor Corporation, 185 N. La Salle, Chicago.

LARGE foundry desires meritorious articles suitable for Malleable Iron production. Consideration given both patented and unpatented specialties. Box One, Hertel Station, Buffalo, N. Y.

MANUFACTURING. Models, Dies, Stampings, Brass Work, one or thousands. Baum's Metal Specialties, Kansas City, Mo.

WANTED articles to manufacture, either on royalty basis or outright purchase. H. L. Cook, Aurora, Ill.

ELECTRIC heating elements designed, manufactured. Chas. Olsson, 1371 Forest Home Ave., Milwaukee, Wis.

WE design and build special machinery, tools, dies, jigs, and fixtures. Experimental work. Light stamping, quantity production. Reliable Machine Co., 400 West 23rd St., New York City.

WIRE goods made to order. Cooley Mfg. Co., 530 N. Western Ave., Chicago.

METAL Stampings, Dies and Special Machinery. Mail us your drawing or sample for estimate. Send for our free catalogue of Model Supplies. The Pierce Model Works, Tinley Park, Ill.

LIGHT stamping and manufacturing. Acme Tool Co., Mason City, Iowa.

OUR factory will make your models, manufacture your articles as well as build your tools, dies and fixtures. Standard Die & Specialty Co., 1932 Austin Ave., Chicago, Ill.

MACHINERY, TOOLS AND SUPPLIES

CONCRETE Building Block Machines and Molds. Catalogue free. Concrete Machine Co., 5 N. Main St., St. Louis, Mo.

NO 60 Heald Auto Cylinder grinder, \$75.00; No. 2 Cincinnati Milling machine, \$275.00; 24" Handy Shaper, \$325.00; 16"x8" Bradford Engine lathe, \$300.00; Barnes 26" Drill Press, \$57.00; 24" Woodworker Planer, \$175.00; 26" Band Saw, \$65.00. Terms to suit on single machine or complete shop. Complete line of machinery and supplies. Cincinnati Machinery & Supply Co., 218 E. Pearl St., Cincinnati, Ohio.

GRIDLEY Automatic Screw machines, Fitchburg low swing production lathe. One lot of light and heavy lathes; machinery every description; must sell. Refiner Elevator Works, Kansas City, Mo.

EXTENSION geared wrench removes No. 4 Ford bearing in 2 minutes without hurting knuckles. Labor and time-saving tool for various jobs. \$2 Postpaid. George Thorn, Eleven Forty Fairmount Ave., Philadelphia, Pa.

WATCH or Instruments maker. Precision Lathe with attachments, complete with guarantee. Standard parts. Express Company permits examination. Special \$48.50. Chicago Jewelers Tool Works, Chicago.

SHAW Garden Tractor—Plows, seeds, cultivates, runs belt machinery, cutter bar attachment. See page 416 September issue this magazine. Literature free. Shaw Manufacturing Company, Department C, Galesburg, Kans.

ENGINES, MOTORS AND DYNAMOS

ENGINES—6 H. P. Vertical "Novo" gas and gasoline—New—\$150.00. 150 H. P. 3 cylinder Vertical "Weber" gas engine—excellent condition—\$2,000.00. Ideal Electric, Mansfield, Ohio.

GUARANTEED 1/2 hp. 110 volt, 60 cycle, single phase, used motors with pulley at \$7.50, cash with order. We repair, rewind, electric motors and generators, etc. Bargains on electric fans. General Distributing Co., Security Storage Bldg., Duluth, Minn.

25-V. 8-AMP. generators connected to 220-V. 3-phase A. C. motor, \$25.00 to close out. Also other bargains. Queen City Electric Co., 1726 Grand Ave., Chicago, Ill.

ALTERNATING current, single phase, sixty cycle, new General Electric motors with pulley—1/2 H.P. \$9.00; 1/4 H.P. \$13.00; 1/2 H.P. \$29.85; 3/4 H.P. \$41.00; 1 H.P. \$51.00. Many other bargains both new and rebuilt. Tell us your needs. Send for our complete price list. Hyre Electric Co., 615 So. Dearborn St., Chicago.

BRAND new 1 KW Westinghouse, 32 volt, 1,150 speed, light and power Generators at \$48.00 each. 25% cash, balance C.O.D. General Distributing Co., Security Storage Bldg., Duluth, Minn.

1/2 HP motors, Alternating and Direct. Bargains. V. M. Nussbaum & Co., Fort Wayne, Ind.

ELECTRICAL

ENGINEERING Data: Pocket loose-leaf; Transformer practice; connections; diagrams. Electricians, Engineers. 25c. coln. C. Homan, 123 Berkeley Place, Brooklyn, N. Y.

BENDING MACHINES

The famous Hossfeld Wrenchless Universal Bender is the last word in bending machines; bends metal, cold or hot, into most any conceivable shape, including Eye-bolts and Automobile Spring Eyes. Bends up to 1" bars or 1 1/2" Pipe cold. Used by the largest corporations, yet so inexpensive that even a farm shop need not be without one. Send for circular. Hossfeld Mfg. Co., Box 344, Winona, Minn.

BLACKSMITHS

BLACKSMITH Notices: Young smith or handy man make more money doing hard jobs easy. In job shop or factory be a Master Machine and Flow Blacksmith and Expert Tool Dresser. With Colored Tempering Charts. All for One Dollar. Samples Free. W. M. Toy, Sidney, Ohio.

FOR SALE—MISCELLANEOUS

ABOUT 100 complete universal draft regulators with clock attachment. Cheap. Opportunity for man with some leisure to turn small investment to big profit. Investigate. Cosine, 51 Carson, Newburg, N. Y.

HONEY, Michigan's best. Clover or Buckwheat. Five pounds \$1.60; Ten pounds \$2.75, delivered fourth zone. Shady Lawn Apiaries, Milan, Mich.

BEAUTIFUL polished and engraved Alaska Ivory; 15 years collecting; must sell. Bargain to interested. Call or write Miss Bessie E. Morris, 1605 Broadway, Alameda, Calif.

BARREL Lots Slightly Damaged Crockery, Hotel Chinaware, Cookingware, Glassware, etc. Shipped Direct From Factory to Consumer. Write for Particulars. E Swasey & Company, Portland, Me.

FOR sale, rope tightener outfit; can be made by hand; very little capital needed; send for sample. Schumann Mfg. Co., Johnstown, N. Y.

PRINTING Presses, Type, Materials. Make easy money printing for self and others. Interesting circulars. Stamp. Watson, 30 Beekman St., New York.

ADDRESSOGRAPH, Letter Folders, Multigraphs, Envelope Sellers, Duplicators, less than half price. Guaranteed. Pruitt Co., 117 No. Market, Chicago.

BUY—Exchange—Sell! Many of our readers have for sale or exchange the article you are looking for—and lots of them are looking for the very items you want to turn into cash. Get together! Let our two million readers know your wishes—they'll help you! Send your ad today to Geo. F. Baker, Manager Classified Advertising, Popular Mechanics Magazine, Chicago.

WANTED—MISCELLANEOUS

MAIL us Jewelry, New or Old, Diamonds, Unused Postage Stamps, Bonds, Old Gold, Platinum, Magnetite, Points, Mercury, Watches, Pearls, Silversware, Dental Gold, False Teeth, Most Anything; Any Quantity. Cash Sent Immediately, Ten Days Return Privilege. Confidential. Ohio Smelting Co., 315 Hippodrome Bldg., Cleveland, Ohio.

CASH Money for diamonds, old gold, platinum, silver, old watches, gold crowns, bridgework. Cash by return mail, 2020 S. Division, Grand Rapids, Mich.

KIDDER Faradic Medical Batteries. John Gornaly, 410 E. Marshall St., Morris-town, Pa.

CASH sent immediately for gold, silver, platinum, diamonds, watches, bridge-work, crowns, and all valuables. Satisfaction guaranteed. Dept. 50, Busch Products, 2360 Eighth Ave., New York.

REAL ESTATE, FARM AND ORCHARD LANDS

\$5.00 DOWN, \$2.00 monthly, buys 2 1/2 acres No. Michigan Fruit or Poultry Farm, Camp Site or Summer Home. \$100.00. Burt Lake, Chelveygan County. Finest hunting, fishing, boating, swimming. Good auto roads. Get free booklet and map. O. Hermann, 140 So. Dearborn St., Chicago.

ATTENTION—"Get acquainted." Cash for your property. Farm, Hotel or Retail Store, no matter where located; confidential service. Hayes' Business Agency, Cincinnati, Ohio.

100 ACRE Farm, 12 Cows, Horses, Calves, Poultry, Bull, machinery complete; well located, valuable woodland; good 8-room house, piped water, basement barn, silo. \$3,700 gets all part cash. Details on 22 illus. 194 pg. Catalog. Free. Strout Farm Agency, 255-P, 4th Ave., New York City.

\$100 CASH Secures 60 Acres, 6 Cows, Horses, Crops, Poultry, machinery; on main highway, markets at door; level fields, good water, timber, loads fruit; good 6-room house, running water, 50 ft. barn. Bargain at \$1,500, only \$300 required. Details on 8 illus. Catalog Supplement. Free. Strout Farm Agency, 255-P, 4th Ave., New York City.

HERE'S your land! \$10 down and \$10 a month buys 20 acres of my best land in Cent. Mich. for \$400 or 10 acres for \$250. Write at once for free 48-page picture book. G. W. Swigart, P1259 1st Nat. Bank Bldg., Chicago.

PECAN-Orange-Fig Groves "On the Gulf" Monthly payments. Guaranteed care. Big, quick returns. Suburban Orchards, Dept. M, Biloxi, Miss.

WANT clear Montana ranch, fenced, improved. Box 423, Choteau, Mont.

\$5.00 DOWN, \$5.00 monthly; 10 acres unimproved poultry, fruit, stock, woodland; \$100; Ozarks. Fishing, hunting, trapping. Alvin Zimmermann, 1800 N. Fifth, Kansas City, Kans.

SELL your property quickly for cash, no matter where located. Don't pay big commission. Particulars free. Real Estate Salesmen Co., Desk B, Lincoln, Neb.

ROOTS AND HERBS

HERB Doctor Book—10 cents. 250 receipts for making herb medicine. Hazard Company, Box 1, Vanderveer Park, Brooklyn, N. Y.

DOGS AND PETS

RAISE guinea pigs. Pay better than poultry or rabbits; easy to raise; little space required. We guarantee market. Particulars and booklet how to raise free. Covles Distributing Co., 3102 Grand Ave., Kansas City, Mo.

WHITE Collie dogs. Handsome Pedigree Stock. Cheap. Mrs. John Hincliffe, Lisbon, Ohio.

"ELEVEN Box Traps"; blueprint 30c. Weesho-Uco, 31st Office, Detroit.

BEAUTIFUL registered bull pups \$15. Bulldogs, 501 Rockwood, Dallas, Texas.

RELIABLE Rabbitry, Flemish Giants, New Zealand, Belgian Hares, Maikrans Rabbitry. New Bethlehem, Pa.

HUNDRED Hunting Hounds, Fur Catchers, Catalogue, Kaskaskensels, M32, Herick, Ill.

GERMAN police pups and grown dogs for sale. Veri-Best Police Dog Kennels, Portland, Ind.

PERSONAL

DON'T be a tobacco slave. Orsanin positively and quickly overcomes the habit, any form, or money refunded. Investigate. Orsanin Co., Box 503-D, Detroit, Mich.

ASTROLOGY—Stars Tell Life's Story! Send birthplace and 10c for test reading. M. Kleman, 373 William Ave., Winnetka, Ill.

CORRESPOND for pleasure and profit. Join best Exchange. Membership 25c. List 10c. Popular Exchange, Windsor, N. C.

LEGAL Advice by Mail! Reliable and Confidential. Satisfaction Guaranteed. Information Free. Emmons and Emmons, Lawyers, Canton, Ohio.

LEARN to write Inspirational stories, poems, etc., for Magazines. Copy of Magazine and full particulars 25 cents. Geo. Stewart, A-2, 157 W. Sta., Barbara, Los Angeles, Calif.

YOUR Horoscope—Individual service; no printed forms. Character analysis, finance, love, marriage, etc. \$3. One year's future prospects \$8. Both for \$5. Satisfaction guaranteed. Data required: hour, date and place of birth. Cedric W. Lemont, Delaware, Ohio.

UNUSUAL Horoscope—Six pages, 2,500 words, consisting of extensive four-page Special Horoscope, Astro-Analysis, and two-page valuable guide giving daily and monthly advice covering entire year. Send 50c and birthdate. Money returned if dissatisfied. Prof. Bolles, Box 125, Cranford, N. J.

TOBACCO or Snuff Habit cured or no pay. \$1.00 if cured. Remedy sent on trial. Superba, Co., TP, Baltimore, Md.

SEND 25c and your date of birth for forecast of your vibrations for 1928. Arvel Synclare, Numerologist, Box 25, Patton, Calif.

STOP tobacco, cigarettes. Guaranteed Remedy on trial. Helle Company, 4158 Gladwin, Detroit.

MISCELLANEOUS

GENUINE Rogers 1847 Silverware. 26-piece Silver Set, \$14.50. Send for catalog. Guarantee Specialty Co., 4823 Liberty Ave., Pittsburgh, Pa.

MINERAL Wealth under Foot. Learn to find it. Cash in thousands profit, so can you. Information 10c. Buskett, Joplin, Mo.

KNITER Owners Save More Money. T. S. Burns, Salem, Ill.

MEXICAN made pistol holsters, cartridge belts, lariats, sombreros, horse-hair goods; list free. Ingersoll Leather Co., 307 Fannin, Houston, Tex.

CUTS anybody can make. Simple, cheap process. \$1. Specimens, particulars, 2c stamp. M. Day, Windfall, Ind.

ARTIFICIAL Eyes. Booklet free. Denver Optic, 559 Barclay, Denver, Colo.

HOMEOPATHIC and Biochemic preparations sent postpaid to all parts of the world. Manual and booklets free. Halsey Bros. Co., 111 N. Wabash Ave., Chicago, Ill. Established 1855.

PEARLS and Slugs. Pearl Hunters should send their pearls and slugs by registered mail or express to Herbert H. Verross, Fresh Water Pearls, Box 407, Pittsfield, Ill.

ALL Wool Yarn for sale by manufacturer at great bargain. Samples free. H. A. Bartlett, Harmsong, Me.

EARN \$5,000 yearly; course \$200; including printing, \$350; largest linotype school in existence; established 19 years; more than 1,000 have attended. Empire School, 205 E. 19th St., New York.

SURE-CATCH Fish Hooks get every fish. Enormous profits. Wonderful Seller. Fish Hook Co., Windfall, Ind.

ARE you old at forty? See our advertisement on page 80 of this issue. The Electro Thermal Company, 2137 Main St., Steubenville, Ohio.

FORMS to Cast Lead Soldiers, Indians, Marines, Trappers, Animals, 151 Kinds. Send 10c for Illustrated Catalogue. Henry Schlercke, 1034 72nd St., Brooklyn, N. Y.

WATCHES. Where Did Our Watches Originate? Popular Mechanics book, Time and Its Measurement, tells where and how. Learn how the Chinese keep time, how musical watches are made, how to make a 24-hour watch, and how modern watches are made. All this and much more in "Time and Its Measurement" by James Arthur. Send No Money. Just write a postal. Pay postman postage and \$1.50. Popular Mechanics Press, Room 811, 200 E. Ontario St., Chicago, Ill.

SHOP Notes. We have a few back numbers of Shop Notes for those who wish to complete a set. The following issues are available. 1908, 1912, 1913, 1914, 1916, 1917, 1919, 1920, 1921, 1922, 1923, 1924, 1925. Single copies are 50 cents each. Special price of \$6 for complete set. Send No Money. If you order 2 or more, just write a postal giving the dates you want. Pay postman for books, and postage. Popular Mechanics Press, Room 811, 200 E. Ontario St., Chicago, Ill.



SILENT
MODEL No. 8

\$1

A WEEK
AND IT'S
YOURS

WORLD'S ONLY BALL-BEARING TYPEWRITER

10 DAYS' FREE TRIAL

Remarkable New Special Low Price Offer

SEND NO MONEY.
NO RED TAPE.
NO OBLIGATION
WHATSOEVER

EVERYONE should own a good typewriter. To command attention your letters must be typewritten. No matter what your business is you need a dependable typewriter. It is the best investment you can possibly make. The Ball Bearing L. C. Smith is the finest typewriter ever made—used by such nationally known corporations as Standard Oil Co., Du Pont Powder and the largest railroads. The U. S. Government has bought over 50,000 of these wonderful ball-bearing typewriters. *Our Special Offer* Now Makes it Possible For Everyone to Own one of these long-wearing, ball bearing machines. Never before has such a remarkable offer been made on the genuine Silent Ball Bearing Model No. 8 L. C. Smith. The world's finest typewriter for over twenty years. *Now is the time if you want one*—we may never be able to make this offer again though *we are the world's largest exclusive dealers in L. C. Smith Typewriters.*

10 DAYS' FREE TRIAL!

Don't send us a penny—just mail the coupon. We will promptly ship the typewriter to you for *ten days' free trial*. We depend entirely upon the typewriter to sell itself—no one will urge you to buy. If you don't think it is the finest typewriter you ever saw and the fastest and easiest running machine you ever used—*return it at our expense* and we will be quite satisfied. You won't want to part with it. We ask you to deposit \$3. with your express agent to be sent to us *after ten days* as a first payment. *The express agent will return your \$3. to you if for any reason you return the typewriter to him within ten days.* If you decide to keep it you send us *only a dollar a week* until the balance of our special low price is paid.

A LIFETIME BARGAIN

We offer you the lowest price ever made on this wonderful machine—late style—up-to-date—highest quality rebuilt—with a five year guarantee. You cannot buy a typewriter at anywhere near our price that will give you as many years of satisfactory service.

FREE TO YOU NOW!

A Complete Course of Lessons on Touch Typewriting; Tools; and Waterproof Cover; Complete Operating Instructions; all given with your machine. This is the easiest typewriter to operate and learn. You can learn to use it in a day with our instructions.

Send the coupon now before this offer is withdrawn.

SMITH TYPEWRITER SALES CORP.
200-360 E. Grand Ave., Chicago, Ill.

Smith Typewriter Sales Corp.
200-360 E. Grand Ave., Chicago, Ill.

Ship me the L. C. Smith Typewriter. I will deposit \$3 with the express agent on arrival subject to 10 days' trial. If I keep it I will send you \$1 a week until the \$63.20 balance of the special \$66.20 price is paid. The title to remain in you until then. It is understood that I have 10 days in which to examine and try the typewriter. If I choose not to keep it, I will repack and return it to the express agent. You are to give your standard 3-year guarantee.

Name.....
Address.....
Occupation.....
Employed by.....

FREE TRIAL COUPON →



Do You Want This Job?

MEN 18 TO 45

Become City and Rural Mail Carriers

\$1700 TO \$3300 YEAR

Many Other U. S. Gov't Jobs Now Obtainable

STEADY WORK. PAID VACATION. COMMON EDUCATION SUFFICIENT. PULL UNNECESSARY.

MAIL COUPON—TODAY SURE

Coupon
Franklin
Institute
Dept. J320
Rochester, N. Y.

Send me, WITH-
OUT CHARGE, (1)
Your Copyrighted
Civil Service Book, (2)
Tell me how to get a position
as City or Rural Mail
Carrier at \$1700 to \$3300 a
year, (3) Send free sample exam-
ination coaching.

Name.....

Address.....

Whatever Your Question;—be it the pronunciation of Fascista, the spelling of a puzzling word, the location of Esthonia the meaning of soviet, realtor, vitamin, etc., this Supreme Authority—

WEBSTER'S NEW INTERNATIONAL DICTIONARY

contains an accurate, final answer. 407,000 Words, 2700 Pages, 6000 Illustrations.
Regular and India-Paper Editions. G. & C. MERRIAM CO., Springfield, Mass.
Write or specimen pages, prices, etc., and FREE Pocket Maps, per Popular Mechanics.



Learn



Take a W. A. C. Course in Applied
Airplane Engineering. Many men earn
\$2,000 to \$10,000 a year. Big Free out-
fit of airplane parts. Write for Free catalog.

WESTERN AIRPLANE CORPORATION
Dept. 311, Hanadcock Bldg., Chicago, Ill.

Aviation



INSTALL YOUR OWN
FREE PLANS
HOT WATER HEATING PLANT
CUT-TO-FIT GUARANTEED

Complete
Hot Water
Plants
ready for
shipment.
Baffle as
low as \$200.



PLUMBING and HEATING

→ SAVE HALF ←
*By our New Easy Method
and Lowest Wholesale Prices.*

Send the coupon for our FREE bargain catalog which explains our new easy method of installing factory-fitted Heating Plants and Plumbing Systems. During 50 years, we have saved our customers hundreds of thousands of dollars in the cost of Heating Plants, Furnaces, Plumbing Outfits and Supplies and Water Systems.

FREE Planning Service Send us rough sketch of your

rooms and we will figure the wholesale cost of Heating Plant designed especially to fit your home. We will show you kinks and wrinkles where you can make savings that will surprise you. With our simplified plans and new easy method you can do the installing. We loan tools FREE.

Mail Coupon for FREE Money-Saving Catalog

Every Hardin-Lavin System is guaranteed highest quality, grade A material and is backed by our million dollar plants and Bonded Guaranty. Our wholesale Bargain Catalog tells the whole story.
SEND FOR FREE COPY

HARDIN-LAVIN CO.

ESTABLISHED 1876

When in Chicago Visit Our New Plant at
107-17A West Pershing Rd., CHICAGO

HARDIN-LAVIN COMPANY,
107-17A West Pershing Rd., Chicago, Ill.

Gentlemen: Please send me your FREE BARGAIN CATALOG with special wholesale prices. I am interested in:

Water Supply System Hot. Htg. Plant Warm Air Furnace
 H. W. Htg. Plant Pipeless Furnace Bathroom Outfit

NAME.....

ADDRESS.....

P. O..... STATE.....





W. P. Cissel
VICE PRESIDENT AND
CHIEF INSTRUCTOR

**Drop Everything
for this
Big Pay Trade
Learn at Home**

Be This New Kind of Brick Mason and Get \$66⁰⁰ week to \$12,000 year Your Job Is Waiting for You Prepare for It At Home in 30 minutes a day!

Don't Work for Low Pay. Don't Stay in an Insecure Job. Don't Remain where There is No Future. This Special "Job-Analysis" Method Not Only Fits You to be a \$11.00 to \$14.00 a Day Brick Mason. It Also Equips You For the Higher Stations in the Building Field—Foreman, Superintendent, Contractor, Builder.

BRICK Masonry (bricklaying) is the best trade of all for a man with ambition. First—because the wages are so high—\$1.25 to \$1.75 an hour—\$11.00 to \$14.00 a day—for regular time. And \$1.87½ to \$2.62½ per hour for overtime.

Secondly—the future is brighter in this line than in any other for the man who will learn the things the ordinary bricklayer neglects. The man who can read blue prints and plans; who can make estimates; who can lay out a building; who can make contracts; needn't stop at the \$14.00 a day mark. He is the kind of man who fills the higher jobs—who becomes foreman, superintendent, contractor or builder. His starting pay of \$60, \$75 or \$90 a week may easily grow to an income of \$12,000 a year.

Make Your Money Like I Made Mine

I started as a bricklayer. Then studied blue print and plan reading, estimating and building. I spent long years "picking up" the knowledge I give you in a few short months.

I rose to foreman and superintendent, became an executive with a building firm, then used my knowledge to get into the building business for myself—the best paying business on earth—with practically no capital. I retired well off. Then decided to teach others to succeed as I did.

Learn By Doing

In your own home, in 30 minutes a day, I teach you to do every job the bricklayer does on the wall. You learn by **DOING**; in your collar, shed, garage, yard or on your roof. You use bricks, mortar and trowel. You build walls, corners, angles, jamba, piers, pilasters, arches, lintels, etc. in your studies—by my Job-Analysis Method—just as you will afterward do when you are a big pay Brick Mason.

But that isn't all. After you learn ALL that a brick mason knows, I teach you the other things that the ordinary brick mason never learned. For I want to see you go to the very top—as have so many of the boys I have trained.

Be Foreman, Builder, Etc.

I teach you how to read blue prints and plans; how to estimate; how to select

materials; how to lay off an entire building; how to superintend the erection of any kind of brick work, residence, apartment house, store, office or factory; and how to "get in" for yourself as contractor or builder. I teach you the things you need to know to be a success in the building business—the business in which bright men make fortunes so quickly.

FREE Booklet Explains

This amazingly quick, easy method is

explained in an interesting book which I want to send you **FREE**. It is called "The Quick Way to Big Pay Every Day." It shows you what my course covers; how complete it is; how easy it is to learn; how rapidly you can prepare to take your place on the wall. It shows how badly bricklayers are needed now and probably will be for the next 50 years. It shows how the big contractors and builders are clamoring for more bricklayers than they can possibly get and how they want us to do our part in preparing our students quickly.

It shows what experienced bricklayers think of this course—a course which they would have been glad to have had when they began to learn their trade. For it would have enabled them to become bricklayers in a few months instead of the four years required by the old errand-running, time wasting apprenticeship methods. And it would have taught them many things that a great number of them don't know yet; things that might have put them at the very top in the building business.

This free book will open your eyes as to the opportunities that exist in this big pay field—whether you decide to stay "on the wall" or whether you have the ambition that will take you still higher.

Iron-Clad Guarantee

Book shows our Ironclad guarantee which makes the course cost you absolutely nothing unless after studying it you are thoroughly satis-

Send for this
FREE BOOK
It Is An
"Eye Opener"

fied. You don't risk anything—you gain everything.

The book is free—it doesn't obligate you to a thing—and you'll not be bothered by a personal solicitation. So **Clip the Coupon Now and Mail at Once**. It will be the most profitable thing you ever did in your life.—W. P. Cissel.

**NATIONAL SCHOOL
OF BRICKLAYING,
Security Saving and
Commercial Bank Bldg.**

Dept. K-10
Washington, D. C.

**Send for
Your
FREE
COPY!**



W. P. Cissel,
Chief Instructor; The National School of
Bricklaying, Dept. K-10,
Security Saving and Commercial Bank Bldg.,
Washington, D. C.

Send me your **FREE** book on "The Quick Way to Big Pay Everyday," which tells all about how to become a bricklayer and how you train me at home in my spare time.

(Write or Print Name Clearly)

Name.....

Address.....

City.....State.....



Brain Tools

Men who work with their hands know that headwork gets them more money.

Brain tools make the tools in your tool box at least twice as effective, and the best brain tools you can get are good books—but just any books, but books which tell you the things you want to know, and do it instantly.

Carpenters make themselves contractors by learning how to estimate correctly. Contractors are able to handle bigger and more profitable jobs by learning how the big fellows do it, and architects and those who want to enter this highly paid profession earn more money by having facts and figures at their finger tips.

This brand new set of five handsomely bound books covering all phases of architecture, carpentry and building, enable you to get authoritative, specialized information in a moment. No tedious hours of reading—no hard grinding study but instant reference to the vital facts. You don't waste a minute—the new jiffy index puts before your eyes, without wasted time, the things you want to know.

The most complete work of its kind we have ever published; nothing has been overlooked. Use of tools—building construction, heating, lighting, plumbing, architectural drawing, blueprint reading, in short, the most comprehensive and easily understood work of its kind.

FREE Membership

Send now and we will include with these money saving books a membership which entitles you to free consultation privileges with twenty highly paid experts. This alone is invaluable.

These books sent FREE

Yes, this is true. We slip them to you without a penny of down payment. When you get them, look them over carefully—note how easy it is to find what you want to know—test the index in any way you want to and then, if after 10 days you agree that you have at hand a veritable mine of invaluable information, send only \$2.00 and keep the books. After that send us only \$3.00 per month until the small total of only \$19.00 is paid. You'll thank the day you sent for your set.

Learning Means Earning

and here you have at hand information gathered from hundreds of experts, all for so small a sum you'll never miss the money. Use these books as others have done and you'll get many times their price in a few months. One job alone may repay you several fold. Send for your set today.

FREE EXAMINATION COUPON

AMERICAN TECHNICAL SOCIETY, Dept. G819, Chicago, Ill. You may send me, entirely without obligation, this handsome set of 5 volumes—Architecture, Carpentry and Building. I am to have full ten days in which to look them over and decide if I want to keep them. After which I will either send them back or send \$2.00 down and \$3.00 per month until the special price of only \$19.00 has been paid.

Name.....
 City..... State.....
 Employed by.....



Play this Jazzy BANJO UKULELE!

Complete instructions and a strumming pad FREE with every Banjo Ukulele. Easy to learn—very simple to play. **SEND NO MONEY.** Pay postman \$3.98 and postage when delivered. No more to pay!

Play all the latest song hits immediately—Become popular—Win friends. Wonderful professional instrument—Made of fine Mahogany-varnish wood. Pure tones.

SINCERE STUDIOS
 24 East 21st St.
 Dept. 72 New York



Free Lessons with Banjo "Uke"

BOYS SEND FOR FREE COPY

of the "Meccano Magazine." Full of news that boys like—stories, contests, articles on engines, airplanes, bridges, model-building, etc. **WRITE TODAY.**

MECCANO MAGAZINE P.O. Box 264 ELIZABETH, N. J.

Make Money with Chickens

Learn how others do it! Double your profits this year—read America's most popular poultry magazine, POULTRY TRIBUNE shows how to get better batches, stronger chicks, more eggs, better markets, BIGGER POULTRY PROFITS. It's the magazine with the beautiful colored poultry pictures. \$1.00 a year, 3 years for \$2.50. Subscribe NOW and get a copy of our FREE BOOKLET "How Hens Helped Run Our Farm," all based on actual experiences of readers. Four months trial, without book, 25 cents. Send stamps or coin today. Poultry Tribune, Dept. 41 Mount Morris, Ill.



Stop that ITCH



Are you a sufferer from skin diseases, rashes, pimples, skin afflictions, or eczema in any form? Do you long for that calm, cool sensation that comes when itch is taken away? Then try the soothing D. D. D. prescription. Let us send you a

Trial Bottle FREE

This famous antiseptic prescription is a wash, composed of well known healing ingredients—thymol, oil of wintergreen, etc. Gives instant relief from that burning, itching torture. The very moment it touches the skin, the itch is gone!

D. D. D. Prescription

Send your name and address for a generous trial bottle of D. D. D. The first touch from this trial will give you instant relief no matter how long you have suffered. Free Trial Bottle sent postage prepaid. No obligation. Write today. A postal will do.

D. D. D. Co., 3845 Ravenswood Ave., Dept. 1778, Chicago

Bigger Pay in the Civil Service



WHEN everybody else is worrying about his job or looking for work, the U. S. Civil Service Employee is earning good, steady pay in a pleasant occupation of his own selection. **EARN \$1900 TO \$2700 A YEAR.** Let me train you to pass the U. S. Civil Service Examination with high rating so you will be eligible for one of the first positions open as a Railway Postal Clerk or in Customs, Internal Revenue, Departmental Immigration, Postmaster, Post Office and Rural Branches. I have trained thousands who have successfully passed examinations. Money refunded if not offered a position within one year after receiving rating. Mail coupon or letter at once for our catalog.

Patterson Civil Service School
 Approved as a Correspondence School under the Laws of the State of New York
 Dept. 811, Rochester, N. Y.

Patterson Civil Service School
 Dept. 811, Rochester, N. Y.

Send me without charge your catalog describing this and other U. S. Government positions.

Name.....
 Age.....
 Address.....

How Would You Like \$33,000?

W. A. Hoffman made this amount by writing for this Free Book

Thousands of men lifted out of the rut by reading this book. Thousands of men just like you who date their success from the time they wrote me for this big free book. Thousands of men who now own their business, running garage, tire shop, welding shop, repair shop, men making over \$10,000 a year, give this book credit for starting them on the road to success. Thousands and thousands of others holding down good jobs, expert mechanics, drivers, foremen, inspire you by their example to FIND THE SHORT CUT TO SUCCESS in the pages of this free book. ALL I ASK—

Are You Mechanically Inclined?

Do you like to drive a car? Do you like machinery? Then send for this book. It's yours for the asking. You don't know the opportunities in the automobile business until you investigate. You must find out the facts about the Sweeney System for with SWEENEY TRAINING you can step into the ranks of skilled mechanics any time, earn and Bank Big Money. Read Hoffman's letter. I estimate 20,000 Sweeney Men own their own business.

\$50 A WEEK AND UP

With over 17 MILLION automobiles running, the demand for mechanics, demonstrators, chauffeurs, truck drivers, garage men, etc., is greater than ever before. Countless opportunities in cities and towns and even remote places. Grab one of these good jobs now. Make real money; own your own business anywhere, or travel where you like, sure of good, interesting, high paid jobs.

FREE CATALOG AND SPECIAL OFFER

Get my big FREE 64-page catalog. It shows hundreds of actual photographs of men at work in my magnificent new school. Tells all about wages, profits, opportunities in auto business. Explains step by step how you learn. Interesting letters from graduates telling how they made good. Shows how men come from all over the world to this big school. Makes you want to join the crowd. Tells everything you want to know. I will gladly send you a copy beautifully illustrated. I'll tell you how to get into business for yourself. No colored students accepted.

E. J. SWEENEY, President

LEARN A TRADE—
Sweeney
 AUTOMOTIVE & ELECTRICAL SCHOOL
 1131 SWEENEY BLDG. KANSAS CITY, MO.

You do the
actual
 work—
 you don't
study
 Books

Shannon City, Ia.

Dear E. J.:

Since going to your school I have done fine. Started with nothing, and am now worth about \$33,000. I think that is fine, don't you, for a small town of 300 population? I have never been stuck on a job yet, thanks to the Sweeney Auto School.

W. A. HOFFMAN.



You cannot get the
 "SWEENEY SYSTEM OF
 PRACTICAL TRAINING"
 anywhere except at the
 SWEENEY AUTO
 SCHOOL,
 Kansas City,
 Missouri

To save time and money and be properly trained you must come to the famous trade school, the MILLION DOLLAR SWEENEY SCHOOL. I have helped 70,000 men to success. The way to learn is easy. You don't need any experience; age makes no difference. I am making a *Special Offer*. That is why you should not delay.

This Coupon Brings FREE Book

EMORY J. SWEENEY, President
 1131 Sweeney Building, Kansas City, Mo.

Send me free, without any obligation, your 64-page catalog and Special Offer!

NAME.....

P. O.....

STATE..... AGE.....

"Strength Magazine" IS FREE TO YOU FOR THE MERE ASKING



One of the
Many Illustrations

Get Your FREE Copy NOW

You will spend many an enjoyable and profitable hour with it. You'll be benefited in a great number of ways, and thankful that we acquainted you with this great magazine. Don't turn this page without first clipping the coupon and mailing it to us. Then within a few days your Strength Magazine will be delivered to your door and you will be extremely glad to receive it.

SEND NO MONEY and

Don't hesitate to send the coupon for there is positively no catch in it.

Strength is FREE to You

USE THIS FREE COUPON

The Milo Publishing Company is giving you a copy of October "Strength" FREE. In order to get this free copy, there is nothing you have to pay—nothing to buy—nothing to do except fill in the coupon below and send it in to us. This big, interesting magazine will then be mailed to you free of charge and postage cost. We are not even going to ask you to look it over or read it, for we know that when you get it in your hands you will be interested and eager to see its contents.

Strength is Wonder- fully Illustrated

There are pictures of beautifully formed women, muscular men, athletes, strongmen, and those who have found health and happiness in its pages.

Strength's Reading Matter is Interesting, Healthful and Writ- ten by Experts

There are articles on the cause and cure of all diseases and ailments. These articles will make your life happier and healthier. There are articles for women as well as men—articles for amateur athletes, future strongmen, acrobats, and the physical perfection seekers.



BEGIN TODAY
WRITE FOR MY
FREE BOOK

Learn to Write

BIG PAYING POSITIONS
are waiting for men and women who can write clearly and legibly. No matter how old you are or what kind of work you do, you can quickly learn to write well by the Tashlyn Method.

Send Today for this showing by word and picture what others have accomplished by spare time practice in a few weeks. **YOUR NAME** elegantly written on a card if you enclose 2c postage. Address: **F. W. Tashlyn, 418 Ridge Bldg., Kansas City, Mo.**

FREE BOOK

Be a REAL ESTATE SPECIALIST

Starting in my spare time with no experience and less than \$5 capital, I made a fortune in less than five years as a real estate specialist. If you want to learn the secret of my success and follow my money-making method, send your name and address at once to American Business Builders, Dept. AA-4411, 18 E. 18th St., New York. They send full information free, telling you how you can build up an independent, profitable business of your own by using my amazingly successful system.

What Shall I Be?



DECIDE THIS QUESTION ONCE FOR ALL!

WEALTH—POWER—HAPPINESS—all the worthwhile things of life—depend upon the right choice of occupation. Expert Vocational Guidance of the right kind now available to everybody. Write for free information today.
BUREAU OF VOCATIONAL RESEARCH
530 Broadway Dept. 430 NEW YORK CITY

FREE Trial!

In your own home—

Become a crack Xylorimba player right in your own home. Easiest instrument to play. Everyone enjoys it—anyone can learn to play it. We furnish you free 14 complete lessons. Learn to play in a few hours. Earn \$80.00 to \$200.00 a week. Deagan instruments are world-renowned—used extensively in leading dance, theatre and concert orchestras, and for Radio Broadcasting. Yet, the cost of the Deagan Xylorimba is no greater than the cost of any other good instrument.



DEAGAN XYLORIMBA

With this instrument you can play either for profit or for fun. Deagan instruments furnish the "spice" of the music. Used exclusively in recording studios for phonograph records.

Free Lessons—A Year to Pay

Our free trial and easy payment plan make it easy to learn at home. Send coupon below for illustrated literature and details of our special free trial offer.

SEND THIS COUPON

J. C. DEAGAN, Inc., Dept. 1358
Berteau and Ravenswood Avenues, Chicago, Ill.

Gentlemen: Without obligation, please send me literature and full information regarding your Free Trial Deagan Xylorimba offer.

Name

Address

THE MILO PUBLISHING CO. P. M. No. 6
2745 N. Palethorp St., Philadelphia, Pa.

Gentlemen: Please send me immediately and without any obligation on my part, a FREE COPY of your great magazine "Strength."

Name

Address

City..... State.....

SAXOPHONE MUSIC REPAIRS SUPPLIES

FitsU DeLUXE SAXOPHONE CORD

FREE!

We serve 150,000 Saxophonists. We supply nearly every music shop in America with its Saxophone Music and Accessories. Now, in order to tell other Saxophone fans all

about F. & U. music publications, and complete line of supplies, we make a sensational offer

This \$1 new type lightning-adjustable DeLuxe Cord, absolutely free with every order from this page amounting to \$1 or over!

May be ordered separately at \$1, postage paid. Most popular instantly adjustable Saxophone cord made.

Only one to a customer during this offer.

Sax Accessories

- F&U Reeds, per doz. \$1.50 up
Silk Braid Cord. 75c
Fast Glue Cement 25c
Hard-rubber Mouthpiece \$3.00 to \$5.00
Pads in sets \$1.50
Springs in Sets. \$2.50

Send for world's biggest Catalog of Saxophone Accessories Free

The Radio Collection

of Saxophone Solos with Piano accompaniment. Four collections, Popular Classics, Popular Ballads, Operatic Melodies and National Songs and Hymns. Edition after edition have been sold. An exclusive Saxophone publishers, as the largest in America, you can depend on F & U music. Each collection, we pay postage. **Biggest Value Ever Offered, each 60c, 4 for \$2.00**

Saxophone Repairing

Isham Jones, Rudy Windheft, Ross Gorman, Paul Biese, Clyde Doerr and all the great geniuses of the Saxophone insist on a clean Saxophone for their solo work. They have their instruments overhauled 2 to 4 times a year and you should too. Only expert instrument-makers in our repair department. Estimates on request.

How to Order

We pay the postage. Order from your dealer or direct from us by mail. Terms, payment with order or C. O. D. Satisfaction guaranteed or money refunded.



Master-built Reed Trimmer

New — simple — sure — lasting. The greatest invention since Saxe. Low in price and guaranteed to do PERFECT WORK. Pays for itself over and over again by saving your good reeds. Trims as much or as little as you wish without frizzling. Order one and get the FitsU Cord Free.

Introductory Offer.

\$1.50

The Jazz-E-Sax Album

A simple, practical Saxophone collection which will make you an Artist—compositions with a punch. Contains Piggie Wiggle, Laf-'N Sax, Slip-'N Sax, Polly Woggle, Rube-'N Sax, Tong-'N Sax, Slap-'N Sax, Break-'N Sax, Kitten Scamper. Designed to make it easy for you to master these wonderful selections. DeLuxe Cord free with any order over \$1.00. Price, postage paid.

\$1.60

The Business Saxophonist

By Cragun, formerly band instructor at the University of Chicago and the world's greatest Saxophone teacher. Discloses the "tricks of the trade" which have made Jones,

Biese, Doerr and others great. Simple, clear, easy to understand. Actually a home-study post-graduate course—worth \$100, say great Saxophonists.

20 lessons, devices, not theory. Intended to develop your ability to make money with the Saxophone. Not an ordinary book or method, but the world's greatest instruction book. Special introductory price, postage paid. **\$10**

Saxophone Band Music

Published for 16 Saxophones and Piano. For Quartets, Sextets, etc. All possible combinations. World's greatest collection of Saxophone music, 27 separate numbers, each 75c to \$1.00.

Write for complete list

Sax Melody Album

A collection of melodious gems, easy to learn, easy to play, easy to memorize. For the beginner and the advanced player. Especially desirable for teaching. 10 selections, with piano accompaniments. Postage paid **\$1.30**

Biggest Saxophone Catalog of Accessories and Music FREE!
Send for it TODAY!

Everything listed here for sale by your dealer.



Finder & Urbanek—"F. & U."—1322 W. Congress St., Dept. 1001-A, Chicago



50% 100% 150% 200%

Promoted Over 35 Candidates

Accountancy Brings 200% "Raise"

6 MONTHS 12 MONTHS 18 MONTHS 24 MONTHS

"When I enrolled for LaSalle training in Higher Accountancy," writes J. L. Trudell, a Michigan man, "I was doing the simplest kind of clerical work. I had had no previous bookkeeping experience. Before completing half the course—within a period of about eight months—three promotions brought me to be Assistant to the Chief Accountant. Within another year I was given entire charge of accounting, over about thirty-five assistants. The first of the year I was promoted to be Director of Advertising with present earnings nearly 200% more than when I first enrolled. I am very grateful for LaSalle training."

Send for Salary-Doubling Plan

Are you—like Trudell—following a well-organized plan to double—triple—quadruple your salary? Or are you relying for advancement upon day-to-day experience? LaSalle offers a sound and practical **salary-doubling plan** which has added millions and millions of dollars to the earning power of its members. If a successful career is worth a 2c stamp and two minutes of your time, check the field of advancement that appeals to you, fill in your name and address, and place the coupon in the mail TODAY.

LASALLE EXTENSION UNIVERSITY
The World's Largest Business Training Institution
Dept. 1164-HR Chicago

I would welcome details of your salary-doubling plan, together with copy of "Accountancy, the Profession that Pays," also a copy of "Ten Years' Promotion in One," all without obligation.

Higher Accountancy
Training for positions as Auditor, Comptroller, Certified Public Accountant, Cost Accountant, etc.

Other LaSalle Opportunities

LaSalle opens the way to success in every important field of business. If more interested in one of the fields indicated below, check here:

- | | |
|---|--|
| <input type="checkbox"/> Business Management | <input type="checkbox"/> Modern Business Correspondence and Practice |
| <input type="checkbox"/> Modern Salesmanship | <input type="checkbox"/> Modern Foremanship and Production Methods |
| <input type="checkbox"/> Traffic Management | <input type="checkbox"/> Personnel and Employment Management |
| <input type="checkbox"/> Railway Station Management | <input type="checkbox"/> Expert Bookkeeping |
| <input type="checkbox"/> Law—Degree of LL.B. | <input type="checkbox"/> Business English |
| <input type="checkbox"/> Commercial Law | <input type="checkbox"/> Commercial Spanish |
| <input type="checkbox"/> Industrial Management Efficiency | <input type="checkbox"/> Effective Speaking |
| <input type="checkbox"/> Banking and Finance | <input type="checkbox"/> C. P. A. Coaching |

Name.....
Present Position.....
Address.....

**\$100⁰⁰ EARNED BY YOUNG
ARTIST IN 2 DAYS**

Well-trained artists earn splendid incomes. The Federal home-study Course is a proven result—etier. If you like to draw, send in stamps for 56-page book "Your Future." State your age and present occupation.

FEDERAL SCHOOL OF COM'L DESIGNING
610 Federal Schools Building
Minneapolis, Minn.

FREE Electrical Training Book

Mail postcard for amazing FREE book on electricity. Shows you how to earn \$150 to \$600 a month in this immense field. Famous S & H shop-type training fits you quick at home for big jobs. Exclusive system. Lack of experience or education no bar. Write S & H Engineering Co., 1422 W. Monroe St., Dept. N-1, Chicago, Ill.

TELEGRAPH—RADIO

\$18 to \$35 a week while training for Radio and Telegraph Operator jobs at \$150 to \$300 per month. Write for particulars.

CHICAGO TELEGRAPH INSTITUTE
Dept. 1301 1338 S. Michigan Avenue, CHICAGO



FREE Book on Deafness

Write today for 168 page FREE book giving full particulars and testimonials from hundreds of grateful users whose hearing has been restored by use of our "little wireless phones for the ears."

Wilson Common-Sense Ear Drums require no medicine but effectively replace what is lacking or defective in the natural ear drums. They are simple devices, which the wearer easily fits into the ears where they are invisible. Soft, safe and comfortable.

WILSON EAR DRUM CO., Incorporated
132 Todd Building LOUISVILLE, KY.



Men Wanted TO COME TO DETROIT AND Learn a Trade AT THE DETROIT SCHOOL OF TRADES

Endorsed by Contractors, Builders and Manufacturers

Come to Detroit. Enroll in our School. Learn one of these high paying trades and your success in life is assured. We teach you on the actual work. You use the tools: not books.

| | | |
|-------------|-------------------|-------------------|
| Bricklaying | Electrical | Auto Mechanics |
| Plastering | Paper Hanging | Auto Trimming |
| Plumbing | Painting and | Metal Finishing |
| Carpentry | Decorating | Auto Painting |
| Estimating | Sign Painting | (Duco-Zapon) |
| and | Show Card Writing | Acetylene Welding |
| Contracting | Auto Striping | — and — |

SPECIAL CUSTOM SHOP COURSE

Why work for low wages when you can make from \$9.00 to \$14.00 per day at any of these trades after a short practical training at our School? Reasonable tuition rates.

RETURN COUPON

DETROIT SCHOOL OF TRADES,
217-221 Woodward Ave., Dept. 1125-A, Detroit, Mich.
Please send me without obligation on my part full information regarding your School of Trades.

Name.....
Address.....
City and State.....
Trade interested in.....
We have no facilities for negroes

The World Needs ELECTRICAL EXPERTS

THREE 100,000 H.P. GENERATORS IN THE LARGEST POWER PLANT
IN THE WORLD

Here is your chance to break into the field of unlimited opportunities by training 8 to 12 weeks in our shops

WE are entering a marvelous electrical age. Look all about you at the progress Electricity is making. All over the country steam railways are being electrified. High lines are carrying light and power into the remotest corners of civilization. Wonderful new uses of electricity are coming in so fast that nothing surprises you any more. You take everything as a matter of course, perhaps overlooking what electricity means to you. This force which is changing our entire world offers you the big chance of your lifetime. You can have the thrill of big achievement, and the big pay that goes with it, by starting in now while the business is growing so fast. We have only *beginners* to find the uses of electricity. Try to imagine the number of uses in ten more years!

We Teach You the Money Making End of Electricity

We do not depend on books and theories. Most of the instruction is by practice on real equipment. Real electrical problems are solved, going from the very simplest to the most complicated. We use the time-proven job sheet plan, with expert supervision on all the way,—the kind that develops *your own* ability and inventiveness.

This new Electrical Department of Greer College formerly belonged to the U. S. Veterans Bureau, on Karlov Ave., Chicago. Their entire electrical equipment

is now installed in the Greer Shops. Mr. Fred W. Butler, who organized the school for the Government, has come to Greer College to continue in charge of the course. He has supervised all installing, and has added many new pieces of equipment to bring everything up to the minute in completeness. For instance: we have not just one or two makes of motors, but *over thirty*—every kind you will need to know when you get out on a practical job. This school can boast of an alternating current generator. We operate a high line in our shops carrying 2300 volts, a step-up of 10 to 1. No expense has been spared in making this course absolutely complete, but at the same time simple to understand. It is not necessary that you know anything about Electricity to start with. You need only be interested in it and in making a worthwhile future for yourself.

Take Electrical Course, Auto Course or Both

The Greer Automotive Course fits you for any line connected with autos, trucks or tractors. Men who need a knowledge of both Electrical and Automotive Engineering may take both courses at the former price of one.

FREE EMPLOYMENT SERVICE helps you to get jobs while learning and after.

**ERWIN
GREER**
President
Dept. 1101
2024 S. Wabash
Ave.,
CHICAGO

GREER

COLLEGE
**AUTOMOTIVE
& ELECTRICAL
ENGINEERING**

Dept. 1101, 2024 South Wabash Avenue, CHICAGO

Send this coupon
NOW for catalogue
with full information
and special offer.
Don't delay.

Please send me FREE
BOOK concerning auto
and electrical courses
and special offer for im-
mediate action. I under-
stand that this request does
not obligate me in any way.

Name.....

Address.....

\$1.00 DELIVERS to Your Home

Complete Outfit

Violet Ray

ONLY \$1.00 brings this complete, scientific Violet Rays outfit to you. Treat yourself and family at home, save delay, costly doctors and medicines. Thousands use Violet Rays at home to relieve pain and sickness. The identical outfits doctors have bought from us for years and with which they successfully treat many ailments, including those listed below.

QUICK RESULTS—No Medicine

Violet Rays work quickly. It's scientific, goes after the cause. That's why results are quick, permanent. Dr. Duncan, Kewanee, Ill., writes, "Violet Rays is the finest thing I ever used to relieve pain, treatments are so pleasant all my patients like it." Use it yourself at home, you save Doctor's bills.

BEAUTY AID EARN CASH

Brings natural, magnetic beauty of health, no dieting, exercise or drugs. FREE book tells in detail how high priced beauty specialists use it to improve scalp and skin.

Men, women, without experience earn liberal profits in spare time showing Violet Rays to neighbors. Proves results first demonstration. Sells on sight. Get attractive offer and wholesale prices now.

SEND FOR FREE BOOK

Explains how Nikola Tesla discovered Violet Rays, how it works, why it heals. Tells what doctors and plain folks accomplish in conquering pain, disease and nervous trouble with Violet Rays.

Reveals Marvelous Scientific Discovery Shows charts of human body, explains where pains start, how to banish them. Offered FREE for a limited time only, to introduce Violet Rays. Send for FREE copy.

Check Your Ailment Below for Free Advice Here is a partial list of ailments successfully treated with Violet Ray:

| | | | |
|--------------|--------------|-------------|----------------|
| Catarrh | Eye Diseases | Lumbago | Skin Diseases |
| Chills | Falling Hair | Nervousness | Sore Throat |
| Cold | Hay Fever | Neuritis | Sprains |
| Constipation | Headache | Paralysis | Tonsillitis |
| Croup | Goitre | Piles | Whooping Cough |
| Eczema | Insomnia | Rheumatism | Asthma |

Mail Coupon—Send No Money

VI-REX COMPANY
211 S. Peoria St. Dept. 211 Chicago

Please send me without cost or obligation your free book describing your VI-REX Violet Ray outfits, and details of your \$1.00 offer.

Name _____

Address _____

City _____ State _____

5 TUBE GUARANTEED RADIO

Get Special Offer

BIG POWERFUL MIRACO Ultra 5

Uses everywhere report it gets program coast to coast, Canada to Gulf, loud and clear on speaker; outperforms \$100 to \$250 sets. Many \$59.50 hear Europe, marvelous value. Let users' testimony convince you. Retail

FACTORY PRICES—SAVE 1/3 TO 1/2. Smaller Sets \$13.75 up, retail. FREE Literature on latest 120 5 tube models. Agents new low prices and (Dealers) SPECIAL OFFER!! Write!

MIRACO RADIO GETS 'EM COAST TO COAST

MIDWEST RADIO CORPORATION
Former Builders of Sets
407-B-E 8th St., Cincinnati, Ohio

BE A REPORTER!

Learn most fascinating of all professions. Romance, thrills, travel. Meet prominent people. Solve Mysteries. Good positions open. Good pay. We train you quickly. Write National School of Journalism (Not Inc.), Dept. P-1, Six N. Michigan Boulevard, Chicago, Illinois.

LEARN RADIO FREE STUDY IN SPARE TIME AT HOME Earn a Diploma in Radio Engineering. Free Twin Superdon Set offer if you act now. Write AMERICAN RADIO ENGINEERS Dept. 25, Hearst Sq., Chicago, U. S. A.

NO MORE BALD HEADS



WHEN our VACUUM CAP is used a few minutes daily. We accept no pay until you have tried the Cap 60 days and are satisfied. The Vacuum Cap is an appliance that draws the blood to the Hair Roots and starts a new healthy crop of hair. It stops Dandruff, stops the hair from falling out.

Bought by Doctors and men who know that it is the only reasonable HAIR GROWER known to science. No Drugs Used. Write for application blank, testimonials and booklet on "HAIR," sent sealed in plain envelope. FREE.

THE MODERN VACUUM CAP CO.
N-559 BARCLAY, DENVER, COLO.

Beautiful Complexion in 15 Days



Clear your complexion of pimples, blackheads, whiteheads, red spots, enlarged pores, oily skin and other blemishes. I can give you a complexion soft, rosy, clear, velvety beyond your fondest dream. And I do it in a few days. My method is different. No cosmetics, lotions, salves, soaps, ointments, plasters, bandages, masks, vapor sprays, massage, rollers, or other implements. No diet, no fasting. Nothing to take. Cannot injure the most delicate skin. Send for my Free Booklet. You are not obligated. Send no money. Just get the facts.

DOROTHY RAY, 646 N. Michigan Blvd., Suite 128, Chicago

BOW LEGS?

OUR GARTER (Pat'd)

Makes Trousers Hang Straight

If Legs Bend In or Out, Self Adjustable, Free Booklet—Plain Sealed Envelope

THE T. GARTER CO. Dept. 2, New London, New Hampshire

Foot Pains go in 5 minutes if you wear FAIRYFOOT CUSHIONS. Must help or no pay. Write to FOOT REMEDY CO., 22nd St. & Millard Ave., Dept. 28, Chicago, Ill.

Factory to Rider

Saves \$10 to \$25 on the Ranger Bicycle you select. You can have your choice of 44 Styles, colors and sizes. Delivered free on approval, express prepaid, for 30 DAYS' FREE TRIAL. Bicycles, \$21.50 up, \$5 a Month if desired. Possession and use at once on our Liberal Easy Payment plan. Parents often advance first payment.

Tires best quality, at factory prices, express prepaid. Lamps, wheels and equipment, low prices. Send No Money, do business direct with makers.

Mead CYCLE COMPANY DEPT. A-109 CHICAGO

Write today for free Ranger Catalog, factory prices and marvelous easy payment terms



Everything
You need to know
about Electricity
in these 8 big books

Read This NO MONEY Offer

Here is an amazing offer—an offer that will astonish you by its liberality and the opportunity it gives you to prove to yourself its value—without your having to pay a single penny.

We want every earnest man, every one who has a spark of ambition in his make-up, to see these 8 big wonder books on electricity and to know how he can be helped to bigger pay, bigger earnings and a larger place in life by having all these facts at his finger tips.

This is the sole reason for making our startling offer—an offer which, as never before, brings these 8 big books within the reach of everybody

We Ship FREE

Yes, it's true; simply send us the coupon with your name and address plainly written and we will ship ALL the books promptly, with no obligation whatever except your promise to look them over carefully and read what you have time for. Keep them for ten full days, satisfy yourself of their wonderful value before you decide whether or not you want to keep them. After you have seen their tremendous value and have noted how clearly and simply everything is explained, you can send us only \$2.00 and then only \$3.00 a month until the special low price of \$29.80 is paid. There is nothing further to pay us, no membership fee, no special charges to us of any kind.

Most Complete Electrical Books We Ever Published

We give you our word for it that we have never written or printed a more complete set of books on electricity; thousands of facts are clearly stated and hundreds of subjects are fully covered.

| | |
|-------------------|-------------------|
| Electric Lighting | Electric Railways |
| Storage Batteries | Switchboards |
| Wiring | Magnets |
| Radio | Coils |
| Power Stations | Motors |
| Signal Systems | Dynamos |

The above are only examples of the completeness and thoroughness of these modern books. Even Electrical Engineers find them of great value.

American Technical Society Membership

This is a great organization for the dissemination of special knowledge—we have over a million dollars of resources, all of which are back of this offer which includes, if you take advantage of it now—

Free Consultation Membership

Twenty experts are ready to answer your questions and help you to qualify for a Better Job or Bigger Pay where you are.

Have you ever had such an opportunity before—did you ever hear of so liberal an offer?



Don't Hesitate

WRITE NOW. There are no strings to this offer at all; it is an honest plan offered to honest, ambitious men, to help them help themselves. Remember that one fact alone in these books, and having it at your finger tips, may mean hundreds of dollars to you. This is not an exaggeration, but a plain statement of fact.

Send for your books NOW. You may never have another opportunity. You may never see this offer again.

For Free Offer Use Coupon

FREE SHIPMENT COUPON

American Technical Society, Special Dept. E-819, Chicago, Ill.
I would like to look at the 8 books described above. You may send them to me on your Great Offer. I will examine them carefully and return them in ten days—or if I like them I will send \$2.00 then and \$3.00 per month until the low price of only \$29.80 is paid. You are to include Free Consulting Membership to the American Technical Society.

Name.....

Street.....

City..... State.....

Employed by.....

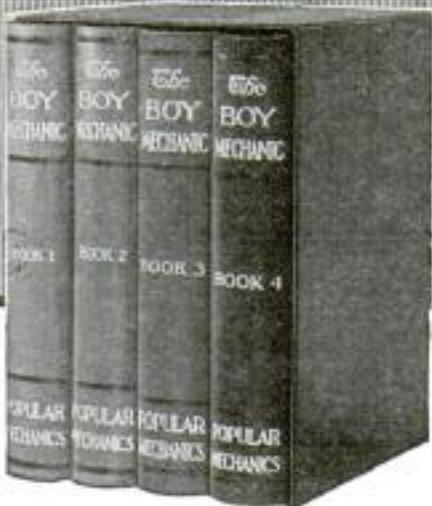

3,849
Ideas

3,917
Pictures



It's Fun To Make Things

Let the other boys wonder how you can make so many interesting things. Make your own motor sled. Make your own radio. Make your own skis and snowshoes. You can learn how to make almost anything that any boy could want by following the pictures and the simple directions in

The Boy Mechanic Library

And just think of it, there are nearly 4,000 separate articles in the four beautiful volumes! Some of the most fascinating subjects are listed below.

How To Make Things — How To Do Things

| | | |
|------------------|-----------------------|---------------------|
| Boats | Carpentry | Electrical devices |
| Winter sports | Painting | Photography |
| Camping | Toys | Music |
| Ice boots | Fishing | Outdoor games |
| Water sports | Fruit growing | Stoves |
| Toboggans | Entertainments | Furnaces |
| Tents | Automobile | Wireless |
| Skis | House decorations | Tricks |
| Indian snowshoes | Drafting | Puzzles |
| Skating | China painting | Bicycle |
| Gymnasium | Decorative metal work | Flowers |
| Wind wagons | Furniture making | Hunting |
| Motor sleds | Farming | Kites |
| Radio | Poultry | Metal working tools |
| Magic | Models | Secret locks |
| Trapping | Laboratory helps | Swings |
| Pets | Household helps | Sleds |
| Leather work | Wood working | Power devices |

Learn how to make things to sell. Learn how to make things to enjoy yourself. Buy the complete library, including Book 1, Book 2, Book 3 and Book 4.

SEND NO MONEY Four Books for only

Simply sign your name and address to the attached coupon and mail it at once. When the postman delivers the books to your door, pay him the price of the books and the few cents postage. That is all.

\$7

POPULAR MECHANICS PRESS
Popular Mechanics Building, Room 711, Chicago, Ill.
***** Mail The Coupon Today *****

Popular Mechanics Press,
Popular Mechanics Building, Room 711, Chicago, Ill.

Please send me at once C. O. D. The Boy Mechanic Library comprising Book 1, Book 2, Book 3, and Book 4. I will pay the postman \$7 and the few cents postage.

Name.....

City.....State.....

Street No. or R. F. D.....

If you want individual books at \$2 each, check the numbers of the books you want: 1 2 3 4



Big Money in Autos



Which School for You?

Yes, You Can Earn \$2000 to \$8000 a Year In Auto Business—BUT You Must Have Practical Training and Experience To Get These Big-Pay Jobs.

Can you learn how to run a locomotive by reading a book? Then how can you expect to become a skilled auto mechanic or electrician by a similar method?

You must have the practical training and experience that is required of the man who "makes good on the job."

The National gives you this training. Twenty-one successful years have proved that through our practical system of training you can become a big pay auto expert. Our million-dollar investment assures you of the newest, most modern, most complete equipment in America. Thousands of successful graduates now earn two, three, four and five times their former salaries, own profitable garage businesses, or operate money-making service stations.

Now we offer you the same opportunity; and give you this advice. You want to earn more money, you want to own your own business, you know you can succeed in the great money making auto business—NOW CHOOSE the school that will make your success a certainty.

Train in Sunny California the Land of Opportunity

Summer all year. Beaches—movie studios—mountains close by. Over 1,500,000 autos in State. Cities growing amazingly. Scores of opportunities for you to get big pay and succeed.

Send at once for our big, illustrated auto book. See for yourself what wonderful training advantages you will get at National. Learn firsthand from facts and figures which prove that in California there are more big pay jobs and more opportunities to make money in your own business than elsewhere.

The coupon below will offer you your greatest opportunity, will show you the way to sure, certain success. Clip it NOW, and mail it. It costs you nothing to learn the facts.

National Automotive School
Los Angeles, California
Mail Coupon

National Automotive School
Dept. 51, 4004 So. Figueroa Street,
Los Angeles, California

Please send me, absolutely free, your big, 84-page illustrated Auto Book.

Name.....

Address.....

City..... State.....

**FREE
AUTO
BOOK**



Young outdoor men wanted



To a few sturdy young men—lovers of fresh air and sunshine—who want to get away from the grind of indoor work—John Davey's national organization, The Davey Tree Expert Company, offers an exceptional opportunity. Constantly increasing demand will create a limited number of openings. These young men selected will be thoroughly trained by the Company and given a permanent position if they make good. If you are single, between 20 and 30 years of age, free to travel, healthy, industrious, having a good practical education, and able to furnish satisfactory references, you have good chance to qualify. Pay is good at start, advancement assured on merit. We want only men who desire permanent employment in a growing organization and will accept only clean, sturdy young men, thorough Americans, not afraid of vigorous outdoor work. Fill out the coupon and mail it promptly—before the few available openings are all spoken for by other men.

THE DAVEY TREE EXPERT CO., Inc.,
295 Federal Bldg., Kent, Ohio

I believe I am qualified for employment as a member of the Davey Organization in the profession of Tree Surgery. Please send qualification blank to serve in place of a personal interview.

Name

Address

Be a Popular Favorite— Play the TENOR BANJO

45,000 successful students back up our claim that you can play a piece in 30 minutes by following our printed instructions. Study in leisure time at home. Begin at once.

Picture Lessons Make It Easy

You can't fail to learn—pictures explain every move. You don't have to be able to read notes. We teach you, in our large New York conservatory, by mail.

Play for Fun or Money

Get in on parties. Entertain your friends. Be popular. Play at dances. Earn money in spare time.

Write for Special Offer

\$18 TENOR BANJO, in genuine Seal Grain Fabrikoid Case, FREE when you enroll. Write for special offer and guarantee.

FIRST HAWAIIAN CONSERVATORY of MUSIC, Inc.
9th Floor, Woolworth Building, Dept. 160
New York, N. Y.

Approved as a Correspondence School Under the Laws of the State of New York

\$18 TENOR
BANJO
with case
FREE
When You Enroll



Low Prices—
Easy Terms!

\$3,000 to \$5,000 a Year

If you want to make at least \$3000 a year, send for our new, big catalogue FREE. Qualify for a big pay job in the automobile business after only 10 weeks' training in New York. Previous experience not necessary. You learn by doing actual work on passenger cars, truck and tractors. Thousands of successful graduates.

FREE BOOK—Write today for large, illustrated catalogue

STEWART AUTOMOBILE SCHOOL

225 West 57th Street Dept. 1758 NEW YORK CITY

LEARN WATCHMAKING AND ENGRAVING



**BY OUR PROFIT-SHARING PLAN
OUR GRADUATES SUCCEED**

One of our Iowa students started in a very small way—now doing over \$10,000 a year. Another in Wisconsin, over \$10,000 the first year. Day or night classes. Call or write for FREE BOOK

Chicago School of Watchmaking, Dept. 1001, 4844 Lincoln Avenue, CHICAGO

WANT WORK AT HOME?

Earn \$18 to \$20 a week RETOUCHING photos. Men or women. No selling or canvassing. We teach you and furnish WORKING OUTFIT given with each enrollment. Limited offer. Write today.
Aircraft Studios, Dept. 50, 3509 Sheridan Rd., Chicago

FREE 48 CHRISTMAS SEALS

in colors. Given FREE with 4 months' subscription to our magazine, full of good stories. Household Departments, etc. Big Bargain. All for 20 cents.

ILLUSTRATED COMPANION, Dept. X-24, New York City

How to Straighten Bow and Knock-kneed Legs!

Improve your personal appearance by using the new patent "Lim-Straiter," Model 18. Corrects now Bow and Knock-kneed legs safely, quickly and permanently at home. No costly operation or discomfort. Is worn at night. Easy to adjust; its result will save you soon from further humiliation and will improve your personal appearance 100 per cent. Write today for copyrighted Physiological and Anatomical book and experience of others without obligation. Enclose a dime for postage.

M. TRILETY, Specialist Dept. 1308 BINGHAMTON, N. Y.



Robert Connelan, world's champion Professional 3 cushion player, one of the experts who contributes to this successful system.

You can now become an expert billiard player. A group of past and present champions have prepared a short cut method of teaching that any layman can easily master. After completing these five simple lessons you can easily become the champion of your neighborhood and possibly go after national honors. These lessons start with the October issue of Sportlife Magazine. There will be one complete lesson in each of the next five issues. It will pay you to subscribe for the next five issues for these all-champion billiard lessons alone—and besides this, you get up-to-the-minute articles, advice and a digest of the world's sport activities. The side lights and tips on your favorite sport will make you a better athlete and perhaps a champion.



Sportlife is issued monthly and each issue is covered by an acknowledged authority in his respective field, thereby ensuring the pages of Sportlife with authentic articles written by the greatest authorities. Many timely photographs of various sport events are also included—you see the world's stars in action.

Rank coupon today along with a dollar bill for five issues and start with the first billiard lesson in the October issue. Mail now before the supply of this issue is exhausted.

**Sportlife, 501 Macfadden Building,
1926 Broadway, New York**

Enclosed please find one (\$1.00) dollar for which kindly send me the five issues of Sportlife containing the all-champion easy method billiard course, to begin with the October issue.

Name

Address

City State

Heat Fountain Fits Any Stove!



PAT SCHAEFER

No longer do you have to depend on an uncertain supply of high priced coal. No longer do you have to contend with the soot, ashes, smoke and grime of dirty coal and wood. No more fires to kindle and tend. Pat Schaefer unconditionally guarantees to give you a new heating satisfaction without a change to your present furnace or stove—with a money back guarantee and a free trial privilege of his wonderful discovery.

Does Away with Coal and Wood for any Stove or Furnace



Mr. Schaefer's discovery has brought an already standard oil burner to a degree of perfection never before anticipated and as a result makes possible an offer never before made—actual trial of a wonderful heating invention in your own stove or furnace with the understanding that unless it gives you heating satisfaction it costs you nothing.

Fits Any Stove or Furnace

This new burner will be sent to any one for trial in their own home. It comes in sizes to fit any

heating stove, cooking range or furnace. No holes to drill. No changes whatever. Easily installed in a few minutes. Burns ordinary kerosene in stoves and furnace oil in furnaces. Already tried in thousands of homes—some with perfect satisfaction where the temperature is 20 to 40 degrees below zero. Yet it can be regulated to any degree of heat wanted, for mild Fall and Spring days, by the simple turn of a valve.

Cheap, Clean, Simple

Mr. Schaefer's invention really makes it possible to burn gas in any stove—by combining air with ordinary kerosene or fuel oil. This gas burns with an intense, hot, clean flame. There are no ashes, smoke, or soot—no noisy motors. The cost of operation is very small. It is absolutely safe and will last a lifetime. Mr. S. K. Pedro of South Carolina writes: "Beats all other burners seen in this country. A sensation." Mr. Geo. Flynn of Michigan writes: "It is cleaner, cheaper, hotter and steadier than coal or wood."

Now, and for all time, do away with household drudgery and dirt. Eliminate the thousands of steps that coal and wood necessitate.



30 Days' Free Trial

Send immediately for special low introductory price and 30 days' trial offer. Interesting book included which tells of the different types of Mr. Schaefer's burners and how you can install one in your own stove or furnace. Act now. Fill out and mail the coupon immediately to



OLIVER OIL BURNER CORPORATION

210 Chestnut St. Dept. P-130, St. Louis, Mo.

AGENTS AND SPARE TIME WORKERS \$250,000 Already Paid!

and only a start has been made. Spare time workers, full time workers, agents and salesmen, here is an unprecedented opportunity to cash in on a nation-wide slide of this wonderful invention. One agent made more than \$215 in one day. One made \$1000 in one month. The demand for oil heat for both heating stoves and furnaces is nation-wide. Heretofore, price alone has prevented millions from adopting it. Now, with the perfected Oliver—selling at a fraction of the cost of other oil burners—every home can afford the luxury of oil heat. Olivers also fit cooking ranges giving you all-year round sales. Spare time workers can realize tremendous profits right in their own neighborhoods. Write at once for free sample case and free territory plan, or check the coupon and mail it immediately to W. A. Schaefer, The Oliver Oil Burner Corporation, Dept. P-130, St. Louis, Mo.

Oliver Oil Burner Corporation,
Dept. P-130, 210 Chestnut St., St. Louis, Mo.

Send me your free book and special free trial offer. I am interested in your offer, without obligation to myself. I am interested in a burner for

() Heating Stove () Range () Furnace

Name.....

Address.....County.....

City.....State.....

() If interested in selling check in square here.

My Boys Are on the Road to Fame and Fortune



"Best Thing I EVER Saw"

"I never undertook anything in my life with such an ambition as I did your Course, owing to the fact that it is the best thing that I have ever had the good fortune to become familiar with. Heartiest and sincere congratulations for this mighty good work."

TOMMY GALSON,
Wilkes Barre, Pa.
(Leading Contender for the Bantamweight Title.)

JIMMY DE FOREST

World's Greatest Trainer

Will Make You a Finished Boxer

My course starts at the very beginning and teaches you all the fundamentals of boxing. It embodies all I know based on my 35 years' experience, during which time I have trained more champions and real contenders than any other man living or dead. All the tricks I taught Dempsey, Firpo, Joe Gans, Pal Moore and a host of others are embodied in this one and only complete course in Boxing. Every blow, every defense, every trick, and new angle in ring strategy is explained and illustrated, so that anyone can readily understand and master them in a remarkably short time.

20 Weeks All You Need

In 20 short weeks you can be a finished boxer ready to take your place along with the best of the lads who are real drawing cards for bouts at the big fights. Soon thereafter, by applying the principles I teach you, your name will rank as one of the clever boxers of your locality. My boys who a year ago were unheard of, are now fast approaching the championship titles and several of them are actually contenders.

You May Be One of the Lucky Boys I Will Train FREE

Every six months I select from each of the weight divisions the boys who make the best showing with my course. I pay their railroad fare and expenses to my Long Branch, N. J., training camp and finish off their training in person and without cost. Then I will sign them for bouts at Tex Rickard's New Madison Square Garden, the Polo Grounds, Yankee Stadium or some other big New York Club. This offer is open to everyone who takes the Jimmy DeForest Boxing Course by Mail.

Send for My Remarkable Book "The Golden Age of Boxing"

Every page of this fascinating 64 page book is brimful of action. It contains numerous photos of great ring battles and champions and scenes at my training camp. It explains how I teach boxing so successfully by mail. It shows some of the special picture charts I use in my instructions. It contains a complete outline of my course, week by week. It is a volume you will want to keep for a permanent record. Send 10c to cover cost of mailing and postage and I'll send you a copy at once. Opportunity is knocking at your door. NOW is the time to ACT. Mail the coupon TODAY to Jimmy DeForest, 347 Madison Ave., New York City.

JIMMY DEFOREST BOXING COURSE,
347 Madison Ave., Box 695, New York City.

Gentlemen—Enclosed find ten cents, for which please send me your book, "The Golden Age of Boxing," without obligation on my part.

Name.....

Street No.....

City.....State.....



Old Age

AND THE AMAZING POWER OF COMMON HEAT

Why are many men old at 40 and many young at 70? When should the crumbling process of age show itself? What is actually meant by "gland surgery"? Why are severe bladder weakness and chronic constipation so frequently connected with lessened vital strength?

Prostatitis—the frequent answer to these questions—is readily understood when stripped of its medical nomenclature. In a new book a well-known scientist—member of four national scientific societies—deals with astounding new facts about the power of common heat, which, when used a new way, often surpasses surgery in that it often produces amazing results in seven days!

This new hygiene is simple almost beyond belief, but results are remarkable. Thousands of tests have been made. Instance after instance is cited—supported by much medical opinion.

Now FREE! In the interests of men past 40 this book in 24-page form is now Free. Write at once for a copy. You are not obligated in any way.

THE ELECTRO THERMAL COMPANY
2151 Main Street Steubenville, Ohio
Western Office: Dept. 21-S, 711 Van Nuys Bldg., Los Angeles, Calif.



Make Your
FORD
a Closed Car

Limo weather-proof sections change your 1923-24-25 Ford Touring or Roadster into classy limousine-style closed car in a jiffy. Doors open from outside. Sliding front panels for ventilation. Three-ply double covered veneer frames. Color matches your top; quickly installed. Guaranteed. Low priced. Write for prices.

BUOB & SCHEU P80 Webster Street, Cincinnati, O.

LEARN PHOTOGRAPHY!

Earn \$200 to \$500 monthly. Or start your own business. Photography and Photo-Engraving taught by largest college of its kind in world. Established 1893. Big demand for graduates. Write for booklet. Illinois College of Photography, Box 4115, Effingham, Ill.

NO JOKE TO BE DEAF

—EVERY DEAF PERSON KNOWS THAT



I make myself hear, after being deaf for 25 years, with these Artificial Ear Drums. I wear them day and night. They stop head noises and ringing ears. They are perfectly comfortable. No one sees them. Write me and I will tell you a true story how I got deaf and how I make you hear. Address



GEO. P. WAY, Artificial Ear Drum Co. (Inc.)
80 Hoffman Bldg., 2530 Woodward, Detroit, Mich.



WANTED

U.S RAILWAY MAIL CLERKS

\$1900 to \$2700 a Year

MANY GOVERNMENT POSITIONS

City Mail Carriers

Rural Carriers

Customs Clerks

City Postal Clerks

Clerk at Washington, D. C.

Short hours Rapid Advancement
Pleasant Work Permanent Employment
Long Vacation With Pay

MEN—BOYS, 18 UP

Fill out and mail the attached coupon
now. Act at once.

FRANKLIN INSTITUTE

Dept. J178 Rochester, N. Y.

Kindly send me entirely free of charge
(1) a full description of the position
checked below; (2) Free specimen
coaching; (3) Free copy of book,
"Government Positions and How to Get
Them"; (4) A list of U. S. Government Jobs
obtainable; (5) Tell me how to get the position
checked.

..... Railway Mail Clerk (\$1900-\$2700)
..... Post Office Clerk (\$1700-\$2100)
..... City Mail Carrier (\$1700-\$2100)
..... Rural Mail Carrier (\$2100-\$3300)
..... Clerk at Washington, D. C. (\$1140-\$1860)

VALUABLE COUPON

NAME

ADDRESS



LEARN TENOR BANJO

Charles McNeil, one of the world's
greatest banjoists—8 years with Isham
Jones' Recording Orchestra—now offers you his famous
Home-Study Course.

This is your opportunity! For the first time in the history
of musical instrument teaching, we are offering a practical
up-to-date Home Study Course on the world's most popular
instrument today—the tenor banjo. Charles McNeil,
the man who devised this Course, is the first man to ever
play a tenor banjo—in fact, he helped to develop it.

This is the same Course used so successfully by the Chicago
Tenor Banjo Institute in training professional banjo artists.

Easy to Play the McNeil Way!

This course can now be yours. Just as if Charles McNeil
were actually sitting at your elbow teaching you the correct
finger positions—chords, melody, harmony, etc., etc.

The McNeil Home Study Course for the tenor banjo is
suitable for beginners, advanced students and professional
artists. An "A" to "Z" course—includes everything you
will ever need to know about tenor banjo playing. Includes
photograph records played by Charles McNeil, illustrating
jazz strokes, breaks, etc.

Send coupon for free booklet and full details
on this latest Home Study Course

Chicago Tenor Banjo Institute

Dept. 1358
5029 N. Bernard St., CHICAGO, ILLINOIS

Charles McNeil, Director, Chicago Tenor Banjo Institute,
Dept. 1358, 5029 N. Bernard St., Chicago, Illinois.

Dear Sir:—Without obligation please send me your free
booklet with full details on your new Home Study Course.

Name

Address

State

Beginner. Advanced Student. Professional Artist



1,000 Hotel Positions Open!

HOTELS, restaurants, clubs, apartments, everywhere need trained
men and women. Over 70,000 high-class positions paying up to
\$10,000 a year are open each year in the hotels of the United States.
In 1924 the Hotel Business was America's largest industry in new
construction. Nearly a billion dollars worth of NEW HOTELS
AND RESTAURANTS built this year will need over 60,000 trained
men and women. Hotels start you at salaries up to \$3,500 a year,
with your living. At any time you have your choice of over 1,000
hotel positions open.

You can have one of these high-class big-pay positions, with luxurious apart-
ment and meals and fascinating work. No previous experience necessary. The
Lewis Schools guarantee to give you the valuable knowledge that it has taken
some of the most successful hotel men years to obtain—men who are now making
\$2,000 to \$50,000 a year. We train you by mail in your spare time at home with the
Lewis Simplified Study Plan, and put you in touch with big opportunities. Our
students employed, our methods endorsed by leading hotel men everywhere.

Send today for FREE BOOK. "YOUR BIG OPPORTUNITY," showing
how we can train you for one of these splendid positions in 20 weeks or less, and
explaining our Money-Back Guarantee.

LEWIS HOTEL TRAINING SCHOOLS,

Clifford Lewis, Pres.

Room Y-385

Washington, D. C.

FREE BOOK COUPON

LEWIS HOTEL TRAINING SCHOOLS Room Y-385 Washington, D. C.

Send me without obligation the Free Book "YOUR BIG OPPORTUNITY."

Name

(Please Print)

Address

City

State

Your Chance to be a NAVIGATOR

**Start as Officer at \$150 a Month Plus
All Expenses — Captain Sheppard Trains
You at Home in 24 Weeks—Our Students
Now on Every Sea**

Captain Sheppard, world-famous nautical expert, 40 years' sailing experience, will train you at home, as he has already successfully trained hundreds of others—in twenty-four weeks or less—for a career at sea. Start as First, Second or Third mate, Pilot, or Ship's Master at \$150 a month and up—all expenses paid. Thousands of opportunities waiting NOW—our new merchant marine needs men who know navigation faster than they can learn by the old methods. Fine chance for advancement in uncrowded field. See any foreign country of your choice; live in luxury on floating hotel; meet best people; always something new—thrills, adventure, excitement, romance.

The Course That Uncle Sam Uses

Captain Sheppard's course has won highest praise of important naval officials and is now in use by the Educational Division of the U. S. Navy for enlisted men. Hundreds of our students have qualified for big-pay jobs in short time. Free book tells all about plan and the amazing opportunities awaiting you on the seven seas. Clip coupon—satisfy yourself—NOW.

Get FREE BOOK!

**The World Technical Institute,
Dept. K-10, 925 Fifteenth Street
Northwest, Washington, D. C.**

Send me your FREE book telling about Captain Sheppard's plan to teach me navigation and start me out as an officer aboard ship.

Name

Address



FLY

Young man learn aviation. Build this classy plane and learn to construct and operate aircraft. Use your motorcycle engine or our "Meteor" 20 h. p. motor. We furnish parts very reasonable to build this wonderful little "Motorplane," the World's first successful motorcycle engine aeroplanes. Send \$1.50 for complete set of blue prints and parts list of this latest Model M-7-2.
IRWIN AIRCRAFT CO.
126 O Street, Sacramento, Cal.

BIG NOVELTY BARGAIN! 10c

Throw Your VOICE

Into a trunk, under the bed or anywhere. Lots of Fun fooling the Teacher, Policeman or Friends. **Barrels of Fun.**

THE VENTRILO—

a little instrument—fits in the mouth out of sight, used with above for Bird Calls, etc. Sent with full instructions; anyone can use it. NEVER FAILS. Also a 32-PAGE BOOK ON VENTRILOQUISM. Formula for Secret Writing, 12 Money Making Secrets and the marvelous

NOVELTY X-RAY WONDER

With it you can apparently see the bones in your fingers, lead in pencil, etc.; lots of fun with this outfit. Also 10 Big Magic Tricks Free with every order. All the above Novelties 10c by prepaid mail for

Ventrilo Company, Dept. 309, Norwalk, Conn.

LARGEST and OLDEST Mail Order House in Connecticut



We have a wonderful new copyrighted system of teaching note made by mail! To every pupil taking this course we will give free a \$20 superb Violin, Tenor Banjo, Ukulele, Hawaiian-Guitar, Banjo, Mandolin, Banjo-Ukulele, Banjo-Mandolin, Cornet or Banjo-Guitar absolutely free. Also teach Piano and Organ. Very small charge for lessons only. Your lessons will teach you several pieces. Over 100,000 successful players. We guarantee satisfaction or no charge. Complete outfit free. Write today. Dept. 218. No obligation.
Slingerland School of Music, Lincoln Park P. O., Chicago, Ill.

TOSTWICH THE GREATEST PROFIT-MAKER

The Tostwich brings amazingly big profits and sales wherever installed—a patented process—makes sandwiches taste 100% better than ever before. Full information without obligation to you—write today.
THE TOSTWICH CORPORATION
Dept. 1778, 648 No. Michigan Ave., Chicago.



Gold Mine of Ideas for the HOME

Discoveries made by home owners, including dozens of devices that will be useful about every home. There are 329 of them and every one has been tested and is practical. Popular Mechanics New

Home Mechanics Handbook No. 1 should be in every home.

329 Discoveries—203 Illustrations EASY TO MAKE

You may know what you want, but do you know the best way to make it? This book tells how other folks have made the dozens of devices that make a home a good place to live. It tells how to make such articles as follows:

SEND NO MONEY

Just write us that you want a copy of Home Mechanics SPECIAL: With it we will send the Auto Repairman's Handbook, containing 334 money, time-and labor-saving ideas for repairing all makes of cars. 337 illustrations. Indispensable to every one who works on his own car. When the two books arrive pay postman only 98c. Money refunded if you do not think them worth many times this special price. Write at once to get both books.

POPULAR MECHANICS PRESS
711 Popular Mechanics Bldg. CHICAGO, ILL.

366 SHORT CUTS FOR CARPENTRY WORK

Popular Mechanics New Carpenter's Handbook is filled with illustrated short cuts and improved methods for doing all sorts of carpentry work and odd jobs. Each idea was discovered by a practical man in the course of his work. Each idea is practical, a time-saver, a money-saver. The 229 Pictures are so clear that in many cases, the picture itself explains the short cut. This new book is a book for professional carpenters, for amateurs, and for boys. It is destined to be just as popular as the many other handbooks published in recent months. This new book is beautifully bound in golden brown cloth, is a handy size, and sells for the remarkably low price of \$1.50.

Send No Money Simply write a postal saying that you want Popular Mechanics New Carpenter's Handbook. It will be sent C. O. D. and you may pay the postman the price of the book and the few cents postage when he delivers the book to you. If you live outside the U. S. or if you are not at home when the postman delivers your mail, send \$1.50 with your order.

POPULAR MECHANICS PRESS
Room 711, Popular Mechanics Bldg., 200 E. Ontario Street, Chicago, Ill.

ELECTRICITY

Give me 12 Short Weeks of
Your time **HERE** at **FINLAY'S**
then **SUCCESS** for **YOU**

That's all the time I ask—just 12 short, pleasant weeks and your undivided attention. You CAN get Bigger Pay and take your place in this fascinating, pulsating field of Electricity. Come to Kansas City—"The Heart of America." Come to the famous Finlay Engineering College, where head and hands are trained for Success in the easiest, most natural and most practical way. Previous electrical experience not necessary. If you have a common school education or its equal, you can enroll NOW. The Finlay Engineering College CAN and WILL train you for Bigger Pay. The Electrical field is begging for men—trained men—men who don't need a boss. The Big Pay jobs in Electricity must have men whose hands are rightly trained to do the bidding of minds that know. You can be that kind of an electrical expert if you train at Finlay's.

Earn \$10 to \$25 a Day

Unusual earnings? Not for Finlay Trained Experts. Top salaries are the rule for them. Read about C. J. Larsen and J. A. Borst. Their earnings beat that and they're not exceptions. There are hundreds of Finlay men just like them. **SUCCESS**—of course you can get it. Give me 12 short weeks of your time. I'll prove what Finlay Training can do for you.

TWO FINLAY SUCCESSES



C. J. Larsen

Christian J. Larsen, formerly Chief Engineer Kansas City Telephone Co., now with Automatic Electric Co., Chicago. Work largely confined to studies concerning several European projects now under way. Proud to hold a Finlay Diploma.

J. A. Borst, with Thomas E. Murray Company, Red Bank, N. J. Doing electrical drafting and designing on new East River Plant of New York Edison Co. (Largest Power Plant in the world, capacity 1,000,000 H. P.) Has



J. A. Borst

New Building New Equipment

Our new building recently completed gives ample shop and laboratory space. Complete, up-to-the-minute and new equipment. Faculty of highly trained experts. Unusual features not found elsewhere. 23 years of successful training is your assurance of success. Send for free catalog and complete information.

Employment Department

We do not guarantee positions. We are always glad to assist worthy graduates in getting good positions. We continually have requests for trained men.

Decide NOW

Take the first step this minute. Send for Free Book and all information on 12 weeks' course in Practical Electricity. Use the coupon, send a post card or write to 100 Finlay Bldg. You can save money.

NO FREE OFFERS

You want training at lowest Possible Cost.

FINLAY TRAINING COSTS YOU LESS

Get The Real Facts

SEND FOR FREE BOOK

100 Finlay Bldg., Kansas City, Mo.

Dear Sir:—Please send me your Free Book on your 12 weeks' course in Practical Electricity.

Name.....

Address.....

Town.....

State.....



**I Will Train You
for
BIG PAY**

Finlay Engineering College, founded in 1903, is not a mere "school." It is a real institution of learning where earnest, sincere men are prepared for the profession of Engineering in all branches. To be able to say you are a Finlay Trained man carries the authority of higher knowledge. I have trained engineers for 23 years. Practical, fundamental Training—That's what you get here. The result is supreme confidence which only right training and true ability give. Finlay Graduates are successful. You want Success and Big Pay. I can train you for them. Give me 12 short weeks of your time. I have no FREE OFFERS—no free railroad fare or board, but I give practical training at lowest cost to you—and Success.

Henry Finlay
PRESIDENT

MR. E. H. WITTE, PRES., MILLION DOLLAR WITTE ENGINE CO., says: "We have employed many of your students in the various departments of our factory, building WITTE ENGINES. Have found that the training received at your hands has been extremely beneficial to them. We not only want to compliment you on your new buildings, but particularly upon the reputation you have made in teaching men."

BIG DENTON ENGINEERING AND CONSTRUCTION COMPANY say:—"We are constantly on the lookout for capable, well trained and educated young men who can fill positions in a satisfactory manner in our construction and machinery departments. We have had several of your graduates in our employ during the past 10 years and in every case have been particularly pleased with the work they have done and results obtained. We therefore wish to take this opportunity of telling you how highly we regard the courses you are giving in the practical application of electricity. We believe that your splendid method of training and teaching young men the fundamentals of electricity, together with practical applications of electricity to all forms of machinery and equipment, is preparing these young men for undertaking responsible positions with electrical concerns. We thank you for your co-operation and assure you of our desire to aid you in placing your graduates whenever we need men."

FINLAY
Engineering College

100 Finlay Bldg.

Kansas City, Mo.

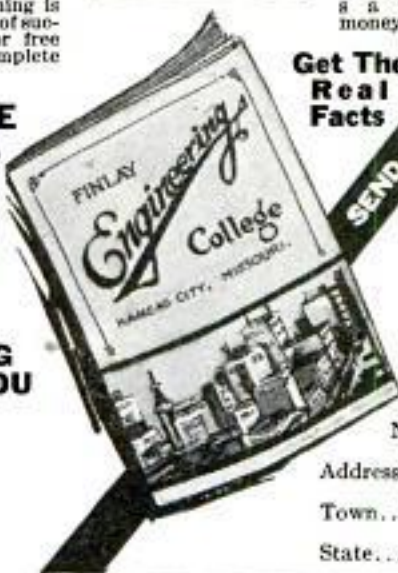

BARBERING

Now One of the Highest Paid Professions! \$90 to \$150 Every Week!



Easy to Learn—Quick

to Earn! That's BARBERING for YOU! And the best part of it all is this—scientific barbering, as taught the modern MOLER way, makes YOU a Master Barber in a short course of intensive training, at small expense! You soon step out as your own Boss, if you wish, in your own Shop, which we will gladly help you equip.

MOLER Graduates are Always Busy! MOLER trained Men are always given the preference, for they alone possess the valuable, thorough MOLER training in the application of all the latest scientific Barbering methods, including the Electric hair cutter, the mechanical massage, and the latest vogue in ladies' hair bobbing. MOLER also gives special training in ladies' marcelling and an easy practical course in the treatment of skin diseases.

EARN WHILE LEARNING!

"Where there's a Will there's a Way" to earn BIG pay! Write to the nearest MOLER College, there is one near you, and learn how you can earn while you learn the barber trade. Ask for the new FREE MOLER Barbering Booklet B11. Find out HOW MOLER helps you help yourself AFTER you graduate, as well as BEFORE! Find out why MOLER Men are making DOUBLE the money others made last year, before Ladies' Shingle Bobbing became so popular. You're NEXT in line for big pay—the MOLER way. Send Coupon TODAY!

Moler System of Colleges

30 Branches in United States and Canada

New York, N. Y.
Chicago, Ill.
St. Louis, Mo.
Kansas City, Mo.
Cincinnati, Ohio
Cleveland, Ohio
Detroit, Mich.
Denver, Colo.

Omaha, Nebr.
Milwaukee, Wis.
New Orleans, La.
Atlanta, Ga.
Memphis, Tenn.
Dallas, Tex.
Houston, Tex.
San Antonio, Tex.

Los Angeles, Cal.
San Francisco, Cal.
Fresno, Cal.
Sacramento, Cal.
Winnipeg, Can.
Seattle, Wash.
Portland, Ore.
Minneapolis, Minn.

MOLER SYSTEM OF COLLEGES

Address Nearest Branch

(Street Address NOT Needed)

Please send me without obligation on my part your Booklet B11.

Name

Address

City.....State.....

Play a Tune



On Your Favorite Stringed Instrument!



in 10 Minutes!

No Knowledge of Music Necessary
No Tiresome Practice

Now you can pick up your favorite stringed instrument and play a tune almost instantly, even if you don't know one note of music. These wonderful "Instant Playing" Instruments take all the work out of learning to play. No expensive lessons. No complicated musical signs and symbols. Play by numbers instead of notes (or by notes if you wish). Just press the numbered keys and you are playing tunes. Hundreds are playing "Instant Playing" Instruments who could never learn the old way.

Amazing New Invention

This is not merely a system of instruction—it is a new device invented by a musician, Prof. James F. Reed, that revolutionizes stringed instrument playing. "Instant Playing" Instruments give clearer, truer tones, are easier to finger and anybody can play. Famous Vaudeville Star, Trixie Friganza, writes: "I learned to play a tune in 3 minutes and had never touched a stringed instrument before." John Matise wrote: "Played tunes on the Guitar the same day and am delighted. Anyone can play." Leonard Cleary: "In only a few days I have had my money's worth in fun. It certainly is one fine instrument." Constance Sedler: "I was playing in four minutes."

Send for Free Book

Tells all about new "Instant Playing" Instruments and how you can play in 10 minutes. Also Free Catalog of special bargains in musical instruments. No obligation. Send for this Free Book now! Your friends will be astonished at your learning to play so quickly. You will be popular and always sure of a good time. Send coupon today.



Choose Your Instrument

What is your favorite stringed instrument? Send for this Free Book, and choose the one you would like to play. You can play it in 10 minutes! Send coupon now!

FERRY & Co. Dept. 8778, 3224 N. Halsted St., Chicago, Ill.

Send me Free Book on "Instant Playing" Instruments and tell me how I can play tunes in 10 minutes. No obligation.

Name

Address

City.....State.....

PIANO JAZZ BY "PIANO BILL"

Teaches: Player Piano Effects, Chimes, Blues, Sweet Harmony Effects, Snappy Chord Combinations, Etc. 15 Easy lessons. Written so that you can understand them. Drop a card today for free information. Write "PIANO BILL," TORONTO 2, CANADA.

Information on any book free. Write Popular Mechanics Press, Chicago, Ill.



BIG VALUE FOR 10 CTS.

6 songs, words and music; 25 Pictures Pretty Girls; 40 Ways to Make Money; 1 Joke Book; 1 Book on Love; 1 Magic Book; 1 Book Letter Writing; 1 Dream Book and Fortune Teller; 1 Cook Book; 1 Base Ball Book, gives rules for games; 1 Toy Maker Book; Language of Flowers; 1 Morse Telegraph Alphabet; 12 Chemical Experiments; Magic Age Table; Great North Pole Game; 100 Conundrums; 3 Puzzles; 12 Games; 30 Verses for Autograph Albums. All the above by mail for 10 cents, and 2 cents postage.

ROYAL SALES CO., Desk 120, Norwalk, Conn.

"I Made J. E. Raymond a Success"

He's boss of his department. He's happy, contented, sure of his future. He earns \$3500 a year. He has unlimited opportunities before him. And he credits his success to my training.

"Let Me Do the Same for You"

the same training and friendly help that these men had. You study at home. No interference with your present job. The cost is small—the results certain. Make the decision NOW, to become a trained man, a man with a highly paid trade.

Draftsmen NOW in Demand at Good Salaries

Draftsmen are needed everywhere—thousands of them. Look at the Want-Ad columns of any big city paper. Thousands and thousands of jobs open for trained men. But only skilled men are wanted. No chance for the man who wants to learn on the job. You have got to get your training outside, if you want to get into this highly paid trade.

A tremendous era of prosperity is just ahead. More and more draftsmen will be needed. Now is the time to get started. Don't delay and miss out. Write me at once so I can tell you all about my wonderful method of learning drafting. It's easy, quick, fascinating—a short-cut method which I developed during years of handling draftsmen on practical work.

Great Special Offer

Write me at once for the extra special offer I am making to men who start their training at once. I'll tell you how you can become a Dobe trained draftsman, without any cash outlay. I want men with the "pep", vim, ambition and determination to succeed. Such men can't help but win out with the training, and help, and personal co-operation I am willing to give. Mail the coupon right away. Let's get together and plan your future for success.

Chief Draftsman Dobe, 1951 Lawrence Avenue, Div. 13-58 Chicago, Ill.

My Guarantee

I guarantee to train you and continue that training until you occupy a position as a practical draftsman. I guarantee to give you my personal attention, not only as a teacher, but as a friend and advisor until you are in a position where you no longer need my help.

Chief Draftsman Dobe, 1951 Lawrence Ave., Div. 13-58 Chicago, Illinois

Send me your Great Special Offer open now to ambitious men. Also your book, "Successful Draftsmanship." No obligation on my part.

Name.....Age.....

Address.....

Post Office.....State.....

Dobe's Home Training Insures Success

My method of teaching is the gradual outgrowth of years' experience handling draftsmen on practical work. You learn by doing. You get the practical experience while taking my course. Many of my students earn much more than the price of the course by doing outside work while training.

No Extra Charge for this Outfit



Here are the tools of your trade. A regular working outfit like I use myself. I send it to you without any extra charge. It's yours to keep — to use all through your course, and later "on the job."

Hawaiian Guitar

FREE

Worth
\$18

When You Enroll

This Hawaiian Guitar expert and professor wants the opportunity to welcome you as a student so you will quickly learn how to play a Hawaiian Guitar—yes, you will be able to play just like the native Hawaiians. To get you started and help your musical success, which will bring you popularity, you will receive a beautiful Hawaiian Guitar, the same as the one pictured, free when you enroll. Our short cut method of instruction will enable you to play a piece almost from the first lesson. Rush coupon for full particulars today and we will reserve a gift Hawaiian Guitar for you.



Play Quickly

With our short cut method of instruction you will quickly learn how to play Hawaiian Guitar, which will bring you popularity and social success. You learn to play from notes. If you never had any musical training, you will quickly get on, because our nine experts have perfected a course of home instruction which is as simple as learning A, B, C's.

Picture and Phonograph Record Method Easy

We don't depend upon printed lessons only for your success, but we also furnish pictures of our professors playing, diagrams, charts and phonograph records for each lesson. This practically brings our professors from our studio to your own home and enables you to listen to their playing just as if they were actually in front of you. To prove this is easy, we will send you your first lesson free. Rush coupon now.

HAWAIIAN STUDIO No. 528
of New York Academy of Music
100 Fifth Avenue, New York, N. Y.

Please rush your Free book, "How to Learn Hawaiian Guitar," and my first free lesson. Also reserve a gift Hawaiian Guitar for me. This obligates me in no way whatever.

Name.....

Address.....

City..... State.....

Make Arts-Crafts Lamps



Some make them for pleasure, and some make them for sale.

For either purpose, these cloth-covered, illustrated books will be a wonderful aid. They tell just how to make 33 kinds of lamps for table and wall. The directions are so clear that even boys can make the lamps with these books.

Arts-Crafts Lamps, How to make them Lamps and Shades in Metal and Art Glass The two Arts-Crafts Lamp Books . . \$2

Either book alone, \$1

Send No Money—just write a postal

Popular Mechanics Press

Popular Mechanics Building
Room 711 Chicago, Ill.

Choose as Your Profession

ELECTRICAL ENGINEERING

Electricity offers a brilliant future to the young man who is about to choose his career. Never before has there been such wonderful opportunity in this great field. Big paying positions in electrical work the world over are open to trained men.

B. S. Degree in 3 Years

Come to School of Engineering of Milwaukee. Here you are trained in both theory and practice by a faculty of experts. You learn in large, finely equipped laboratories. If you have 14 high school credits or equivalent, you can become an Electrical Engineer with a Bachelor of Science degree in 3 years. If you lack these credits they can be made up in our Institute of Electrotechnics in a short, intensive course.



A Complete, Practical, Electrical Education

Learn by the thorough approved scientific methods which our twenty years of specializing enable us to give you. In addition to Electrical Engineering, the following complete courses are given: A. C. and D. C. Armature Winding—Electric Light, Heat, Power Wiring and Testing—Practical Electricity—Drafting—Electrotechnics—Commercial Electrical Engineering—Junior Electrical Engineering and Automotive Electricity.

EARN WHILE YOU LEARN

You can earn money to help defray your expenses while learning. Our wonderful co-operative plan brings an Electrical Career within the reach of every ambitious man. Our Free Employment Department secures positions for those students who wish to earn part or all of their expenses. In addition, the Department will help you get a good position in the Electrical Industry when your training is completed. The new Student's Loan Fund offers financial aid to worthy men. Daily Broadcasting WSOE.

Fall Term Opens Nov. 9th

Big Book FREE Mail the coupon today for our big new illustrated catalog. Mention the course that interests you most and we will send you special information. Read about the school that trains men for practical and quick success. See how easy it is for you to get the training that will enable you to step to a splendid position and a handsome income. Mail the coupon right NOW. No cost or obligation.

SCHOOL of ENGINEERING of Milwaukee

Dept. PM 1125 415 Marshall St. Milwaukee, Wis.

SCHOOL OF ENGINEERING OF MILWAUKEE,
Dept. PM 1125, 415 Marshall St., Milwaukee, Wis.

Please send me your free illustrated catalog; also details of your "Earn-While-You-Learn" plan.

Name.....

Address.....

City.....State.....

Age.....Education.....

Course wanted.....

**EVEREADY HOUR
EVERY TUESDAY AT 9 P. M.**

Eastern Standard Time

For real radio enjoyment, tune in the "Eveready Group." Broadcast through stations—

| | | | |
|------|--------------|------|-------------|
| WEAF | New York | WSAI | Cincinnati |
| WJAR | Providence | WWJ | Detroit |
| WEEL | Boston | WCCO | Minneapolis |
| WFI | Philadelphia | WOC | St. Paul |
| WGR | Buffalo | WCTS | Davenport |
| WCAE | Pittsburgh | | Worcester |

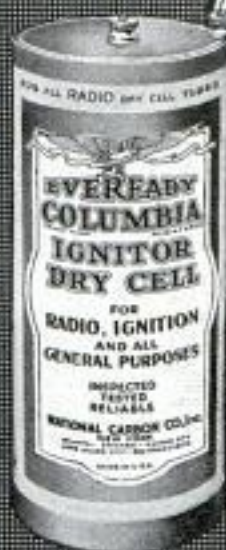

*Eveready
Columbia
Ignitor
"A"
Battery,
the
proven
dry cell
for all
radio
dry cell
tubes
1½ volts*

ALWAYS RELIABLE

EVEREADY Radio Batteries are always uniform and reliable! Evereadys perform the same, everywhere, for everybody, needing no skill, calling for no experimentation, wasting no time, saving you money. Trouble-proof, wonderful Evereadys. There is an Eveready dealer nearby.

Manufactured and guaranteed by
NATIONAL CARBON CO., INC.
 New York San Francisco
 Canadian National Carbon Co., Limited
 Toronto, Ontario

EVEREADY Radio Batteries

-they last longer



*No. 766
22½-volt
Large
Horizontal
Price
\$2.00*



*No. 486
45-volt
Layerbilt
Extra-
Large
Vertical
Price
\$5.50*

812

Wide World Photos, 229 W. 43rd St., New York City.

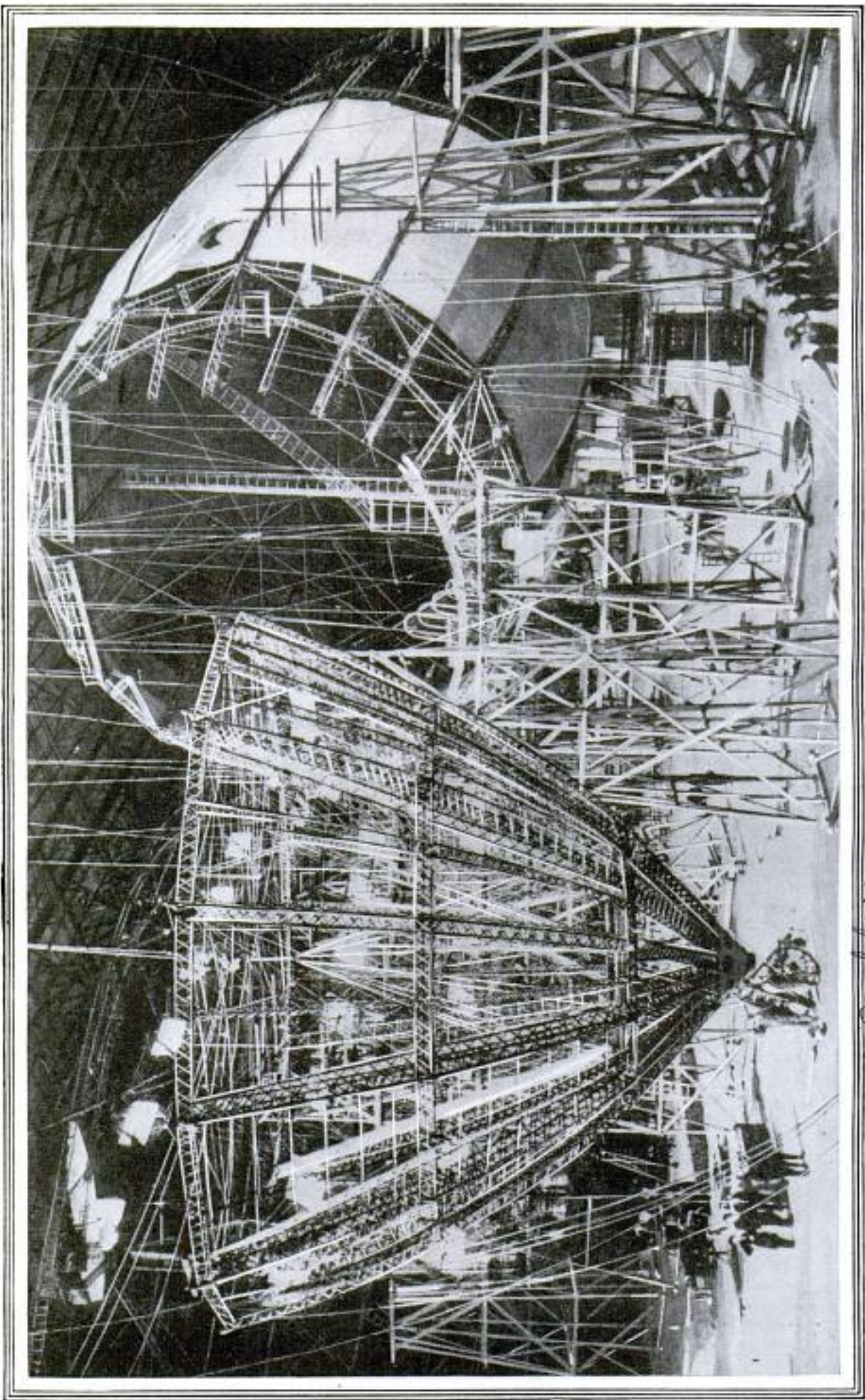

A New Nose for the Great British Dirigible "R-33," Which Was Torn from Its Mooring Mast and Blown to Holland in a Gale, Was Assembled on the Ground and Then Raised by Cables and Riveted to the Main Frame of the Airship—See Page 711

Military

1519 Connecticut Ave
Washington, D. C.

Popular Mechanics Magazine

REGISTERED IN U. S. PATENT OFFICE

WRITTEN SO YOU CAN UNDERSTAND IT

Vol. 44

NOVEMBER, 1925

No. 5

Radio Vision of the Future

331

Experiments Forecast the Time When You Will Both Hear and See by Wireless

By S. R. WINTERS

"WE will now broadcast the 'Follies'." This terse announcement, in the near future, will mean that you will not only hear the singing and comedy but see the actors and actresses amid all their splendor of stage scenery.

The attachment of a special lamp to the radio-vision machine of C. Francis Jenkins, whereby a living subject is illuminated, signifies that a dancer, speaker or other personality may now be seen as well as heard by radio. The Jenkins laboratories, having recently successfully demonstrated the transmission and reception by radio of a Dutch windmill from a standard motion-picture film, it was but a single step to the sending and receiving of the direct image of a living subject.

In his original demonstration of radio vision, Mr. Jenkins had planned to transmit the scene of a dancing girl from his laboratories to the homes of Secretary of Commerce Herbert Hoover and Col. Paul Henderson, former second assistant post-master-general. However, these plans were thwarted at that time, chiefly because he was not equipped with the special type of lamp which he has just installed. Now, it is possible to place a person before a motion-picture camera and transmit the likeness of this individual by radio with quite the facil-

ity that a scene from a motion-picture film is sent and received by the invisible radio waves.

The transmission of the reflection of light from living subjects in action differs from still pictures only in that they are more rapidly formed, that is, sixteen pictures are transmitted in one second instead of one photograph within five or six minutes. Therefore, with the addition of the special lamp referred to, the radio-vision machine remains unchanged. The combination lens-disks-prismatic rings for drawing the lines of the picture and the use of a rare metal for converting light values into electrical values are necessary, just as in the case of the transmission of the motion picture of the windmill.

Similarly, at the radio-vision receiving station, the equipment used is identical with that employed in the original demonstration. For instance, there is a multi-tube receiving set, together with a cabinet,

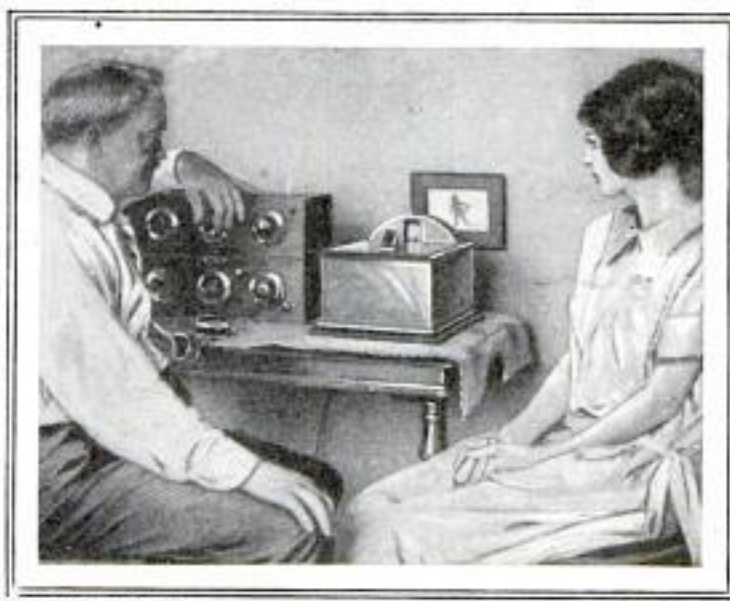

© Harris & Ewing
Compact Radio-Movie Outfit for Home Can Be Attached to the Regular Radio Receiver to Pick Up Broadcast Movies

in the top of which is found a miniature white screen upon which the motion picture is projected. Then, too, there are the usual prismatic rings or lens-disks, duplicating those in use at the transmitting station. The "cold-light" lamp, invented by Prof. D. MacFarlan Moore, serves the highly es-

Harmon. 92 (see Sept. 1925. 410)

C. Francis Jenkins, 1519 Connecticut Ave
Washington, D. C.

705
Copyrighted material

sential function of changing the electrical values back into picture values, after which they are outlined on the miniature screen.

Upon the threshold of this remarkable achievement of the direct transmission and reception of the likenesses of living subjects by radio, Mr. Jenkins indulges in a bit of prophecy: "When this radio service to the eye has been developed to the extent now attained by radio service to the ear, a new era will, indeed, have been ushered in, when distance will no longer prevent our seeing our friend as easily as we hear him.

"President Coolidge may then look on the face of the King of England as he talks with him; or upon the countenance of the President of France when exchanging assurances of mutual esteem.

"The general staff of our navy and army

waves, but they can look upon these unfamiliar places by means of this same instrumentality.

"And from our cozy firesides, we stay-at-homes can watch the earth below as a great dirigible, like the 'Los Angeles,' carries our flag and radio-vision machine on a transcontinental flight over the mountains and plains, the cities and farms, the lakes and forests, of our wonderful country.

"In due course, then, folks in California and in Maine, and all the way between, will be able to see the inaugural ceremonies of their president, in Washington; the army and navy football games at Franklin field, Philadelphia, and the struggle for supremacy in our national sport, baseball.

"Educationally, the extension worker in our great universities may then illustrate his lectures, for the distant student can see as

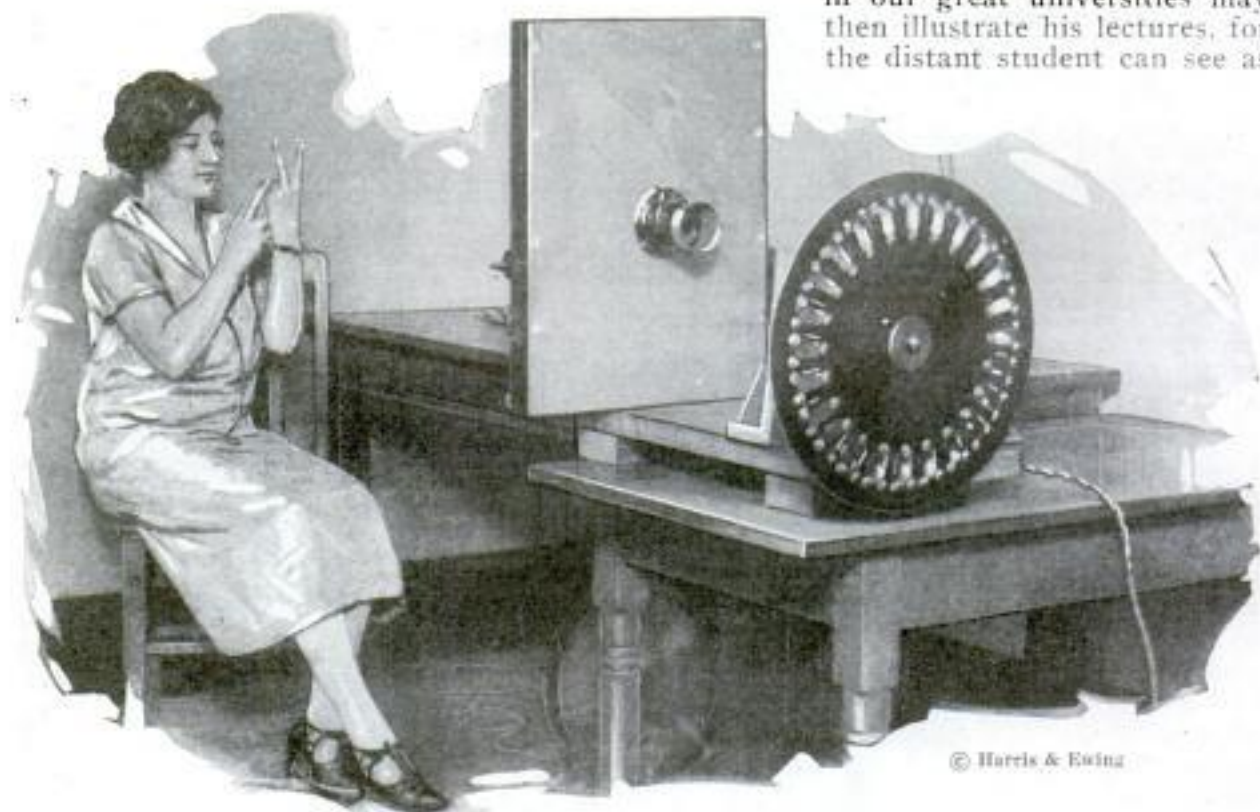

Radio Vision, by Which Reflection of Young Lady Demonstrating Deaf and Dumb Language Is Caught by Big Camera Lens, Projected through the Revolving Lens, Changed to Electricity and Broadcast

may see at headquarters all that a lens looks upon as it is carried aloft in a scouting airplane over battle front or fleet maneuvers.

"Radio amateurs may see as well as hear verbal description of the bleak, desolate regions in the vicinity of the North Pole, as Donald MacMillan searches for strange and undiscovered lands. That is, radio amateurs will not only be able to converse with members of this polar expedition by means of the invisible radio

well as hear him by radio. It is not a visionary, or even a difficult thing to do.

"The radio-vision machine, transmitting and receiving living and moving objects, will come to the fireside as a fascinating teacher and entertainer, without language, literacy or age limitation; a visitor to the old homestead with photoplays, the opera, and a direct vision of world activities, without the hindrance of muddy roads or snow blockades, making farm life still more attractive."

Taken over Ellesmere Island.

GLORY OF ARCTIC MIDNIGHT SUN SHOWN BY PHOTO

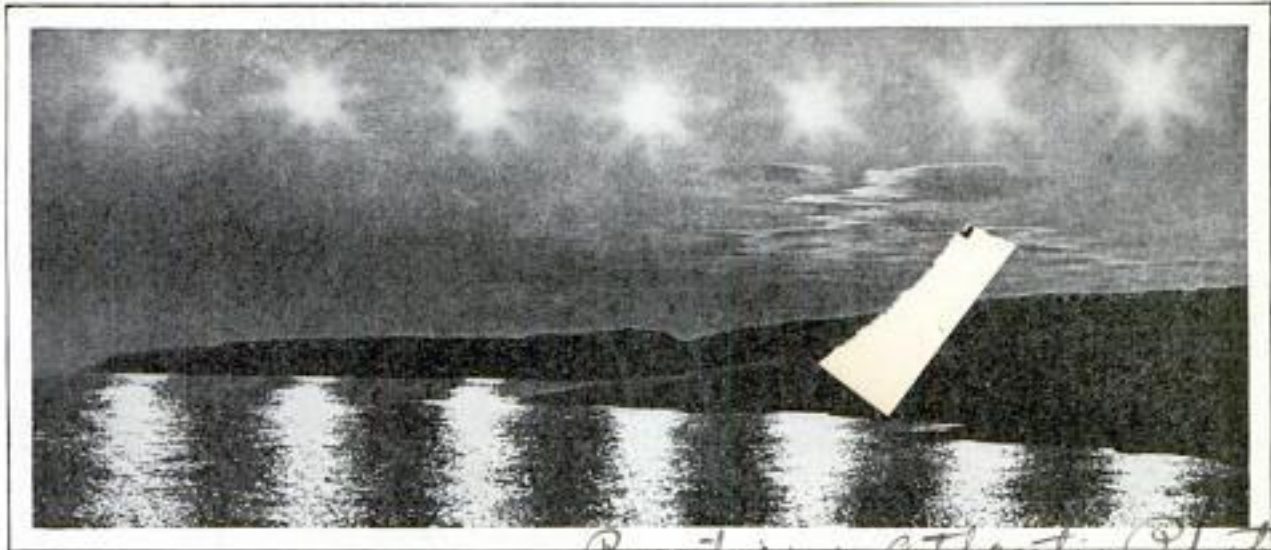

Pacific & Atlantic Photos.

Footlights of the Northern Sky, Successive Stages of the Midnight Sun Taken on Single Plate by Making Seven Exposures at Intervals of Twenty Minutes Each

By making exposures at twenty-minute intervals, a photographer with the Mac-Millan expedition obtained seven successive views of the midnight sun. A body of open water in the foreground heightened the effect, as the reflections were clearly registered although the hills in the scene were reduced to black masses because the exposures obliterated all details.

380

CATERPILLAR PLAGUE IN PARK LAID TO FEEDING BIRDS

Because too many persons fed the sparrows, the birds failed to eat insects' eggs, and a plague of caterpillars resulted in a London park. That was the explanation given by one of the keepers, who with several associates, was kept busy during the months of June and July fighting the pests. Each morning, attendants visited the park and swept up the caterpillars. Six bucketfuls were gathered in half an hour from one small section of the park.

Hyde Park

FOUR-TON CAMERA SNAPS FIVE THOUSAND MOVIES A SECOND

370

More than 150 times as fast as the human eye, a movie camera used by the British government in studying the effects of armor-piercing shells can record pictures at the rate of 300,000 a minute. It weighs four tons, took four years to build and cost approximately \$70,000. Forty lenses on a revolving disk turn before the camera aperture, the disk itself whirling 125 times a second. The actual time exposure of each picture is one sixty-thousandth of a second. Highly sensi-

tized film is run on a drum at the rate of 18,000 feet a minute. One of the problems that faced the builders of the instrument was how to keep the film on the holder at such high speed. The solution was found by perforating the drum with small holes and placing an apparatus inside to suck the film tightly to the drum. Intense light is necessary to take pictures at such high speeds and difficulties encountered at speeds above 3,000 exposures a second have not yet been solved completely. Not long ago, a film taken by this camera was exhibited in a private theater in London. It depicted a glass globe breaking under a charge of powder. Each minute particle was seen plainly.

144.

AUTOMATIC MAIL BOX SIGNALS DROPPING OF LETTER

Because rural-mail carriers are no longer required to raise the signal flag when they deposit letters in the farmer's roadside box, a southern postmaster has invented a box which automatically signals the arrival of mail and saves useless trips from the house to the box. When the postman inserts the letter through the swinging flap, the lower end of the flap presses a trip which operates springs. They raise the white flag as a signal.



Rural Mail Box Signal Co., Burlington, N. C.

*New York Tribune 9/19/25
Quoted from The Daily Mail, London, Eng.*

160 State St.
Boston, Mass.

**ECHO SOUNDER
SHOWS DEPTH
UNDER SHIP**

343 Adopted first as a somewhat doubtful experiment, the echo method of sounding is reported to have proved successful on many different kinds of vessels. Big liners like the "Leviathan" and the "Mauretania," as well as small coast-guard ships, are using it regularly, and scientists declare that it has several distinct advantages over older methods, such as, increased rapidity, lower operation cost and greater accuracy. The outfit employs

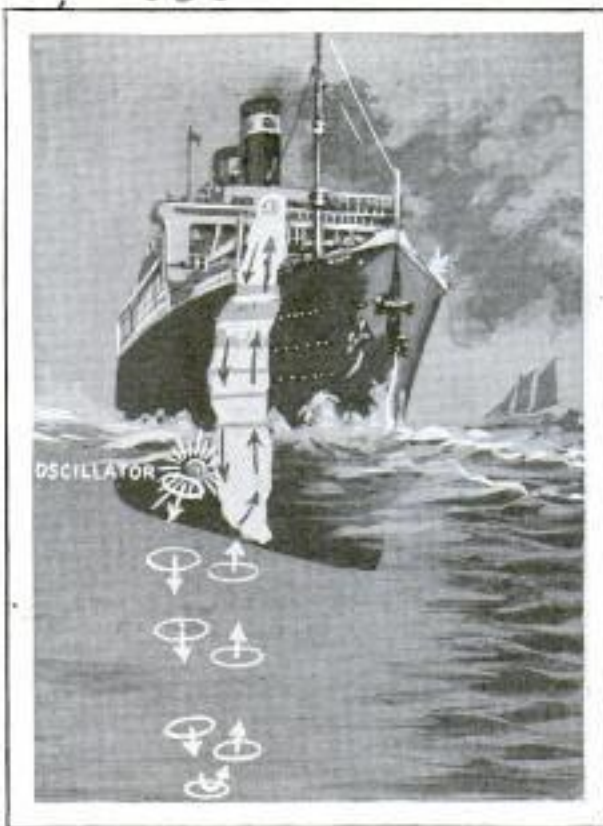

Diagram of Echo-Sounding Installation; Arrows Indicate Impulses Striking Bottom and Returning

no lead or line and consists chiefly of an electric transmitting unit which sends sound vibrations through the water. As they rebound from the ocean's floor, they are registered on a receiver in the ship. The depth of the water is determined by noting the lapse of time between the sending and receiving of the signals. The apparatus is set into operation simply by pressing a button. The results are registered visually so that the navigating officer can determine the depth as easily as he can tell time by looking at a clock.

**AUTOBUS, TRAMWAYS, BATEAUX DE LA S.T.C.R.P.
RAYONNENT DANS 52 DIRECTIONS**

The image shows a large, rectangular map of Paris with a complex network of lines representing transit routes. Below the map is a list of destinations, each with a corresponding button. A person wearing a hat and a fur-lined coat is shown from the side, pointing at one of the buttons on the list. The list includes various locations like 'Gare d'Orléans', 'Gare de Lyon', etc. There is also a small inset box with text in French and English.

Using the Animated Map That Directs Paris Visitors; a Push on the Button Opposite Name of Intended Destination, Lights Up Section Where It Is Located and Shows the Route

356 *Electric*
**PUSH ON BUTTON
LIGHTS MAP THAT
SERVES AS GUIDE**

By simply pressing a button, strangers in Paris are directed to their destinations by means of an animated map. It is painted on translucent glass and is illuminated with electric lights. A list of the principal points of interest is shown at the bottom, and opposite each is a button. When this is pushed, the section of the map in which the place is located, lights up, showing how it can be reached. The guide gives directions for more than fifty different points. They are indicated by symbols in the left-hand corner of the frame and corresponding letters on the map. Besides these, there is a schedule showing when conveyances leave for the various places.

*Edw. J. Landras
Inventor, Paris Rapid Transit System*

North German Line Columbus. 286
 Chief Radio Operator
 Radiophone Carries Voices over Ocean
 Telephone

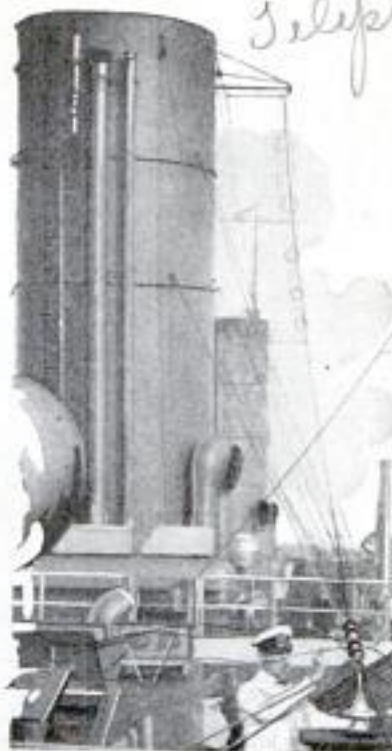

Wireless-Phone System of S. S. "Columbus" Has Four-Wire Aerial, Running Length of Ship

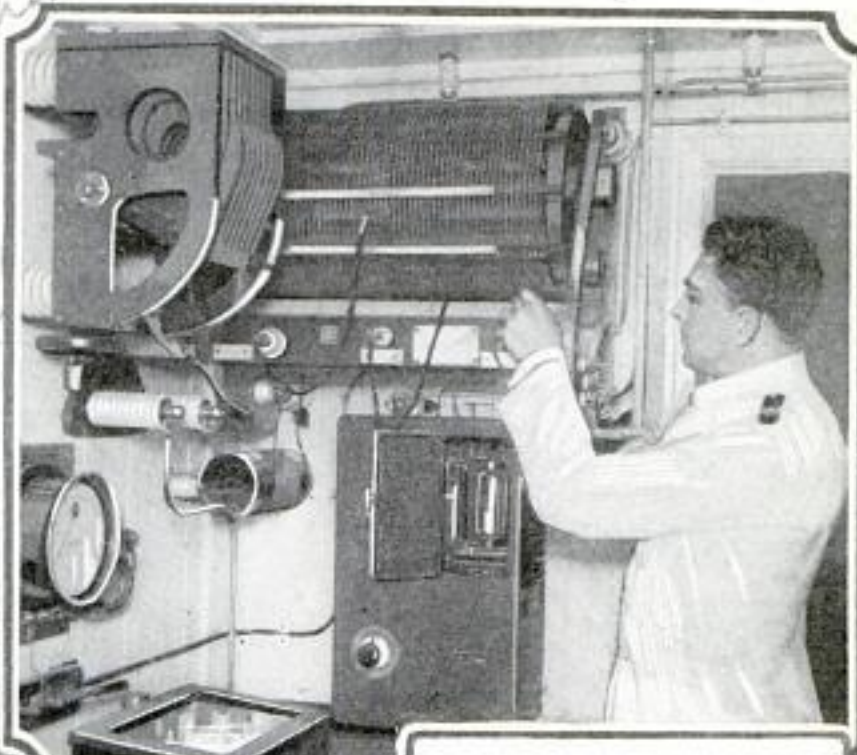

Steamer's Antenna Tuning Coil Is of Tapped Construction and, to Afford Greater Selectivity, a Huge Specially Designed Condenser, Seen at the Upper Left, Is Employed

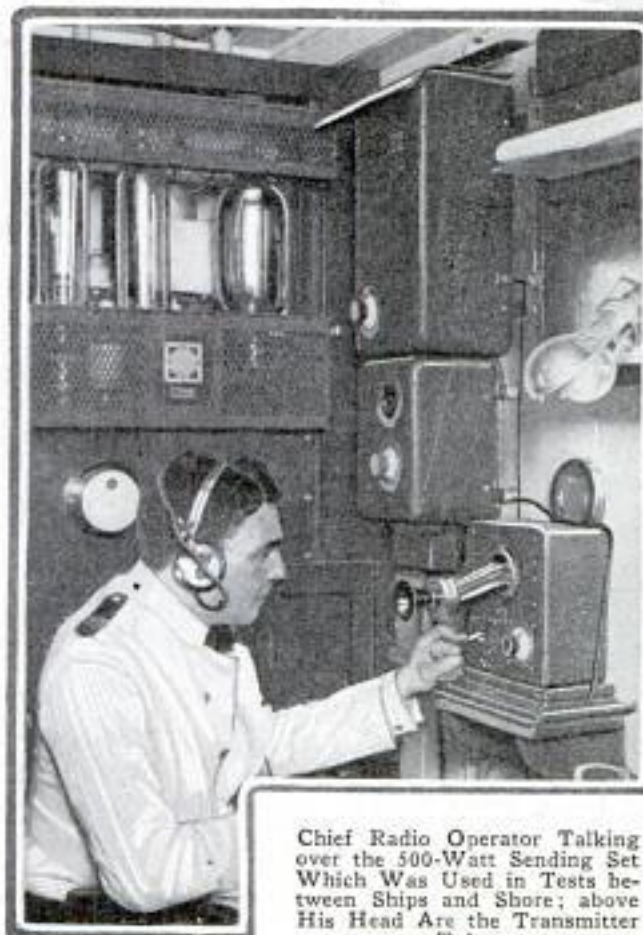

Chief Radio Operator Talking over the 500-Watt Sending Set Which Was Used in Tests between Ships and Shore; above His Head Are the Transmitter Tubes



Receiving Set Used Four Tubes, One Stage of Tuned Radio Frequency, Detector and Two of Audio; Sending and Receiving Were Done Together, Interference Being Avoided by the Use of Wavetraps, Taking In - Coming Messages a Few Meters above or below the Transmitter

Electric Controller Mfg. Co.
2700 E. 76th St.
710

New York
Herald Tribune
9/10/25

POPULAR MECHANICS

GIANT MAGNET ROAD SWEEPER PICKS UP NAILS AND IRON

With a powerful magnet suspended from the rear of a five-ton automobile

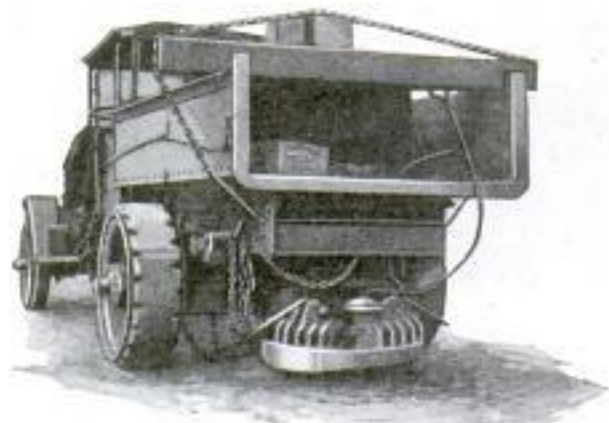

Powerful Magnet on Motor Truck for Clearing Roads of Nails and Pieces of Metal

truck, more than 600 pounds of nails, tacks, bolts and pieces of scrap iron were removed from a seven-mile stretch of the Yellowstone trail, affording motorists great saving and relief as the puncture hazard was eliminated. The truck was driven back and forth, the magnet, four inches above the surface of the roadway and supplied with current from seventy-two cells of the locomotive storage type, lifting jagged bits of metal from the loose stone covering with ease. Many of them were so small that persons walking slowly along the road could not see them.

FORECAST OF SEVERE WINTER BASED ON WEATHER CYCLES

Basing his prediction on a study of writings before scientific records were kept as well as the weather reports over a long period, Father Gabriel, the astronomer-priest of France, declares that the winter will be as severe as those of 1553 and 1740. The lunar-solar cycle of 744 years, he says, is divided into two periods of 372 years each and four of 186 years. The weather follows these periods, he thinks. He made researches in ancient writings to learn of the seasons before official weather bureaus were established. Other astronomers also have observed that hard winters seem to occur in cycles.

MOTOR-DRIVEN BUILDING TOYS HELP DEVELOP TALENT

Model hoists, derricks, cable carriages and other construction units, operated by a tiny electric motor that obtains power from the lighting circuit, are intended to develop a boy's mechanical genius besides amusing him, since they actually function. For instance, the hoist has brake bands and lever, ratchets, pawls, gears and guards like those of the unit a contractor uses. The motor requires no transformer and ball bearings are grease-packed, providing for automatic lubrication. Included in the assortment, is a model clamshell bucket like that used

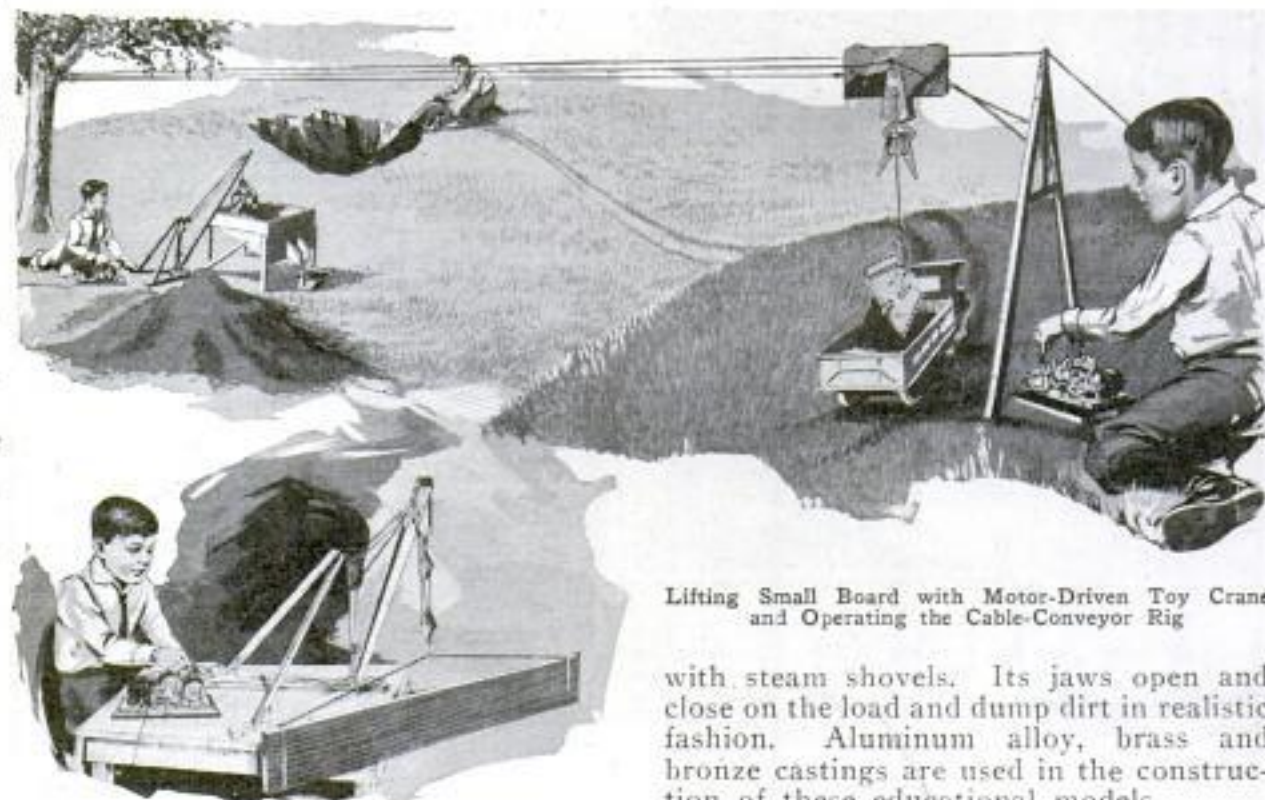

Lifting Small Board with Motor-Driven Toy Crane and Operating the Cable-Conveyor Rig

with steam shovels. Its jaws open and close on the load and dump dirt in realistic fashion. Aluminum alloy, brass and bronze castings are used in the construction of these educational models.

Iron model - Noble Mfg. Co. Hartford, Conn.
249 Pearl St.

339

261



The Three Parts into Which the "Shenandoah" Broke When the Great Airship Was Torn Apart by a Terrific "Line" Squall While Flying over Ohio on Her Ill-Fated Western Trip

What Happened to the "Shenandoah"?

Navy Still Believes in Usefulness of Lighter-Than-Air-Craft and Will Continue Experiments to Develop Them

UNDAUNTED by the wrecking of America's first native-built Zeppelin, the "Shenandoah," with the loss of fourteen lives, the navy is prepared to continue experiments with the huge airship "Los Angeles" and to build another and bigger fighting craft to replace the lost "Daughter of the Stars," provided congress appropriates the necessary funds.

While two investigating boards were still delving in the ruins of the big ship, wrecked by a "line" squall over the hills of southeastern Ohio, Secretary Curtis D. Wilbur declared he had not lost faith in the ultimate triumph of lighter-than-air ships as adjuncts to the fleet.

"They have shown too much promise to be discarded," he declared, "and at the same time have not altogether proven themselves. Further experiments, along the lines of those already made, are necessary before we can say

that the Zeppelin-type ship is or is not a success."

Weeks before the "Shenandoah" disaster, plans had been made to build a second great naval air station at San Diego, Calif., and transfer both the "Shenandoah" and the "Los Angeles" to the west coast.

Specifications also had been prepared for a super-ship, more than 100 feet longer than the "Shenandoah," and with nearly three times her gas capacity, to cost about \$6,000,000. If congress provides funds for this program, these plans will be modified to take advantage of the lessons learned in the loss of the first American-built Zeppelin.

Contrary to all newspaper reports about the accident, the "Shenandoah's" failure, in the opinion of the navy department, was due neither to a change in the water-recovery system nor to the elimination of ten of the original eighteen helium-gas escape

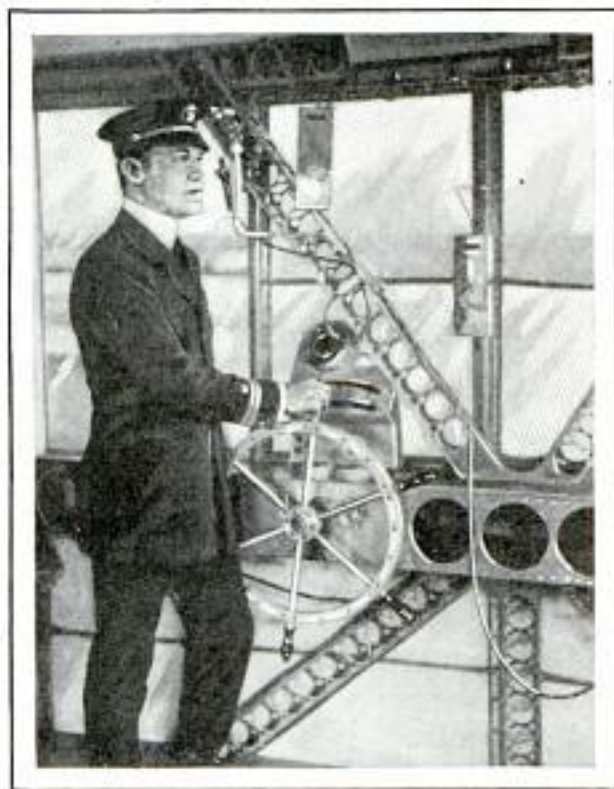

The Control Car in Which Twelve Men Perished When It Was Wrenched from the Bag

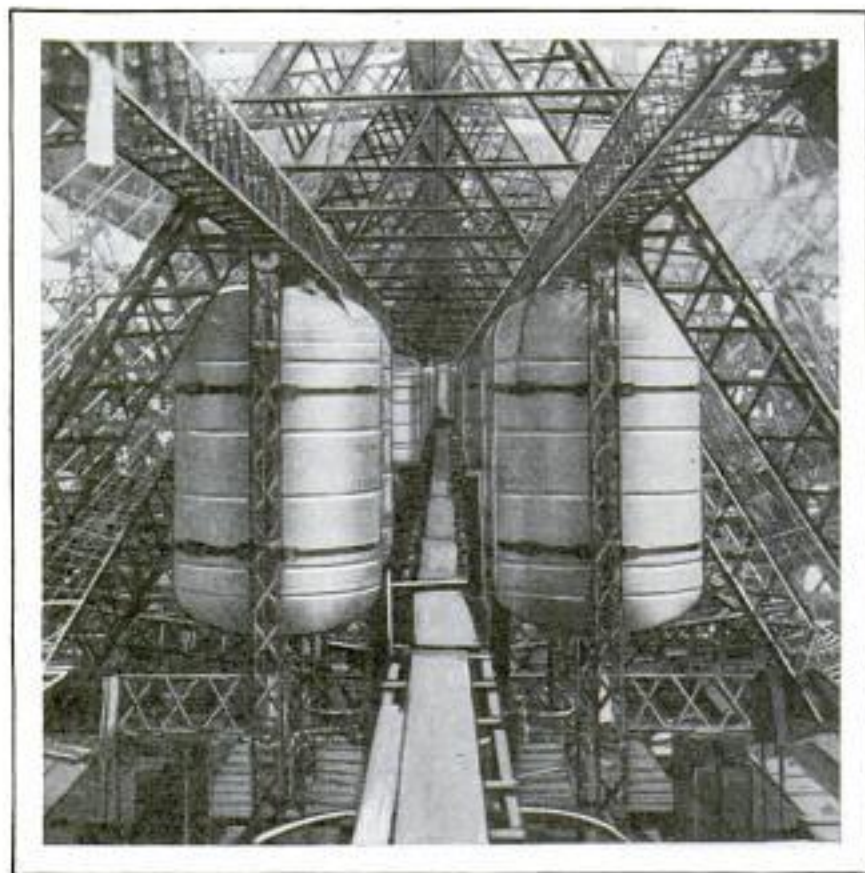

The Narrow "Cat Walk" down the Keel, and Some of the Huge Duralumin Gasoline Tanks; Bunks for the Crew Were Interspersed between Them

valves, a theory suggested by Capt. Anton Heinen, German adviser in the construction of the ship.

Instead, according to reports made to Secretary Wilbur by Rear Admiral Charles W. Dyson, naval constructor and head of an independent investigating board representing the navy secretary, the ship broke because of the failure of the lugs used to fasten longitudinal brace wires to the girders of the frame. While the ship was cigar-shaped, she was not round, but was formed by connecting the longitudinal ribs, running the length of the ship, with short girders, so that the exterior, after the aluminum-painted cotton cover was in place, presented a series of flat facets. The space between each pair of ribs and each pair of adjoining girders formed a rectangle, and this was braced by two crossed steel wires, attached at the ends by duralumin lugs of a somewhat broad V-shape. Duralumin, the material of which the girders and ribs, gasoline tanks and other metal parts of the ship was made, is a composition of aluminum, copper and manganese, with the tensile strength of mild steel and only one-third of its weight.

Survivors testified that as the ship plunged up and down in the terrific cur-

rents of the line squall, rising and falling from 3,000 to 7,000 feet at a single pitch, they heard several sharp sounds, which they described as resembling the breaking of fiddle strings. Examination of the wreckage disclosed that a number of the lugs holding the steel brace wires had torn out the four rivets which held them to the frame, while the ends of others, where they were drilled for the wire fastening, had snapped off.

With these wires gone the rigidity of the frame would have disappeared and the ribs and girders might as well have been hinged together, since there was nothing left to prevent their folding up like the sides of a paste-board box after top and bottom have been removed. Whether the

wires snapped before the control car dropped off, carrying Commander Lansdowne and eleven others of the fourteen victims to their death, may never be known, but the actual breaking up of the

DIRIGIBLE FATALITIES

Other airship accidents included in aerial history are:

December 21, 1923, French dirigible "Dixmude" fell in the Mediterranean after having presumably been struck by lightning, and the officers and crew numbering fifty-two men, were lost.

February 21, 1922, the giant army dirigible "Roma," crashed to earth in flames near the Hampton roads army base.

January 29, 1921, the British dirigible "R-34," was wrecked at her base by a strong wind. No fatalities.

August 24, 1921, the dirigible "ZR-2" met with disaster over the Humber river, England. Forty persons, including sixteen Americans, lost their lives.

July 15, 1919, British airship "NS-11" fell into the North sea with a loss of twelve lives after being struck by lightning.

September 9, 1913, Zeppelin "L-1" destroyed off Heligoland with loss of fifteen lives.

October 13, 1913, Zeppelin "L-2" exploded over Johannisthal airdrome, killing twenty-eight.

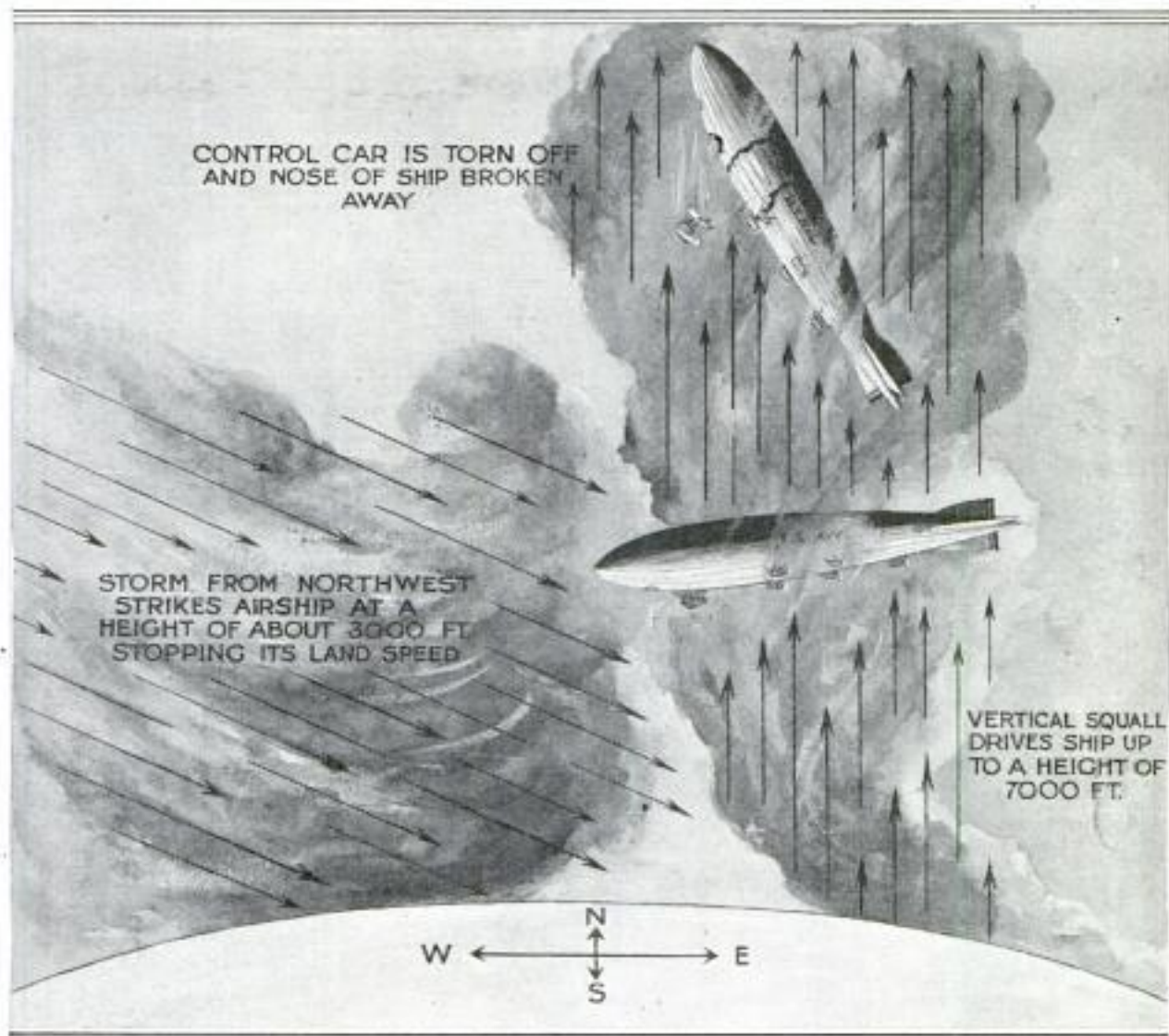

Artist's Diagram of the Line Squal, a Vertical Fountain of Air Moving at Tremendous Speed, Which Hurled the 680-Foot Ship 7,000 Feet above Ground and Broke Its Back

hull and the loss of the control car, were separate and distinct accidents, though both were due to the same causes.

The recording barometer, which was recovered after having been taken away by the souvenir hunters, shows that the hull broke up at an altitude of 7,000 feet, after shooting 5,000 feet into the air at a terrific pace.

The construction was designed to take care of average flying conditions, and had proved successful in several storms, but it was not built to stand the strain of plunging almost straight up in the air, or straight down. When the ship got more than twenty or thirty degrees out of level, the strain on the control-car guy wires became too great and they tore loose, and the struts quickly followed.

Newspaper reports quoting members of the crew as saying that the water-recovery system had been changed, over the protests of Commander Lansdowne,

and that in making the change two tubular girders were cut, are denied by the navy department and by Capt. Steele, commander of Lakehurst air station. A new water-recovery system, which extracts water from the exhaust gases of the motors and returns the liquid to canvas ballast bags to offset the loss in weight through the burning up of the gasoline consumed, was being tested out on the forward engine on the starboard side, but the other four engines all were operating with the old system, which had been in use on previous flights.

The elimination of ten of the original eighteen escape valves for helium gas likewise was not a factor in the accident, in the opinion of naval officers. As built, each of the eighteen gas bags had its separate safety valve, which released gas when heat or rapid ascent expanded the helium to the point where there was danger of bursting the bag. To get away

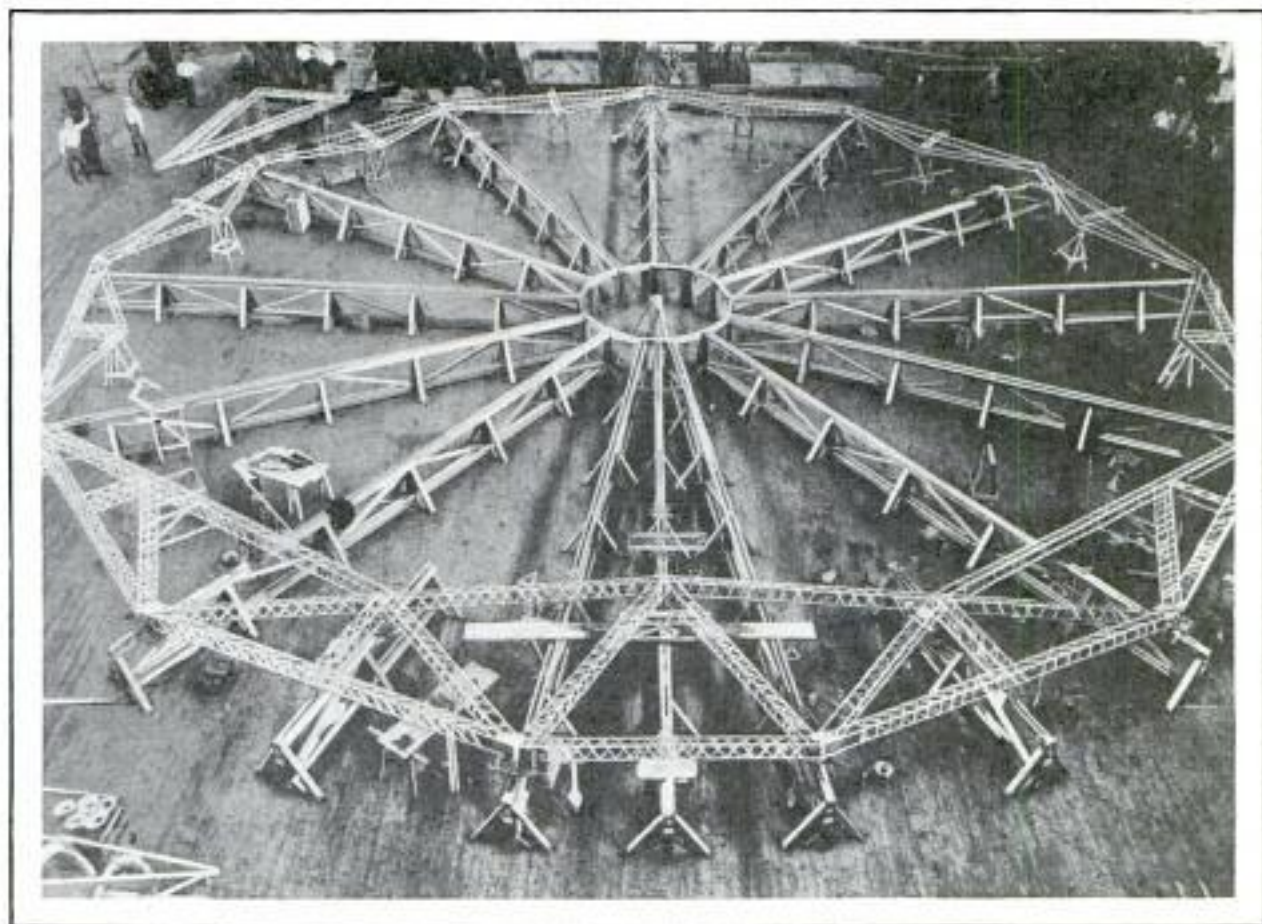

Assembling a Midship Frame of Duralumin Girders; These Frames, Spaced at Short Distances, Were Linked by the Longitudinal Ribs, and the Whole Braced by High-Tension Steel Wires

from the high rate of leakage incident to so many valves, ten were eliminated and eight left. The eighteen bags were all connected by tubes, however, and those without valves exhausted through the tubes into the bags which had valves. The system had been thoroughly tested, and worked successfully, according to Capt. Steele and other officers.

When the ship broke up, the forward end, some 150 feet in length, rode away as a free balloon, and was navigated to the ground by the seven men who had been in their bunks along the "cat walk," the narrow runway down the keel. With the assistance of a farmer, who snubbed a trailing rope around a tree, the nose section was tied down, with all gas bags intact, upsetting reports that some had burst. In fact, it was necessary to borrow the farmer's shotgun and shoot the bags full of holes before the ship could be safely secured to the tree.

After the control car had broken off and the nose departed on its wild ten-mile cruise, the remainder of the ship, 530 feet in length, began to break up. A section of about eighty feet amidships crumbled and dropped away, carrying with it the two forward power cars, to one of which

the new water-recovery system had been fitted. That left some 450 feet still in the air, with three power cars and engines running. Despite the fact that three propellers were working, the storm was so great that this section, after blowing some distance, swung around and started toward earth, moving backward or tail first. It swept down through the trees on a wooded hillside, and eventually struck in an open meadow. As it grazed the ground two of the power cars, situated on either side not far back of the broken end where the midship section had torn away, were knocked off and fell some distance from the wreckage. The other power car, situated near the tail, remained under the ruins.

Lieut. W. W. Richardson, chief photographer of the bureau of aeronautics, was the senior officer on this section. When the storm struck the ship, he was asleep in his bunk at frame eighty, or about 300 feet from the stern of the ship. In his testimony before the investigating board he told how the 680-foot craft began to pitch violently, shooting down at an acute angle into the trough of the giant air waves, and then pitching, nose up, for thousands of feet on the crest of a rising

357

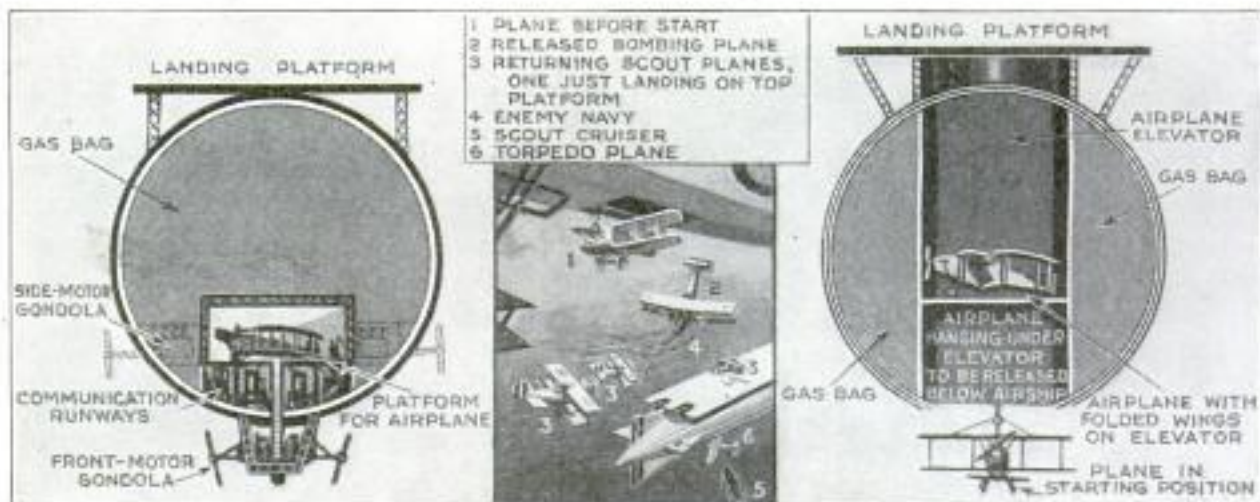

Details of Plan Proposed by British Admiralty to Use Zeppelins as Motherships for Planes, Launching Them through Bottom, with Broad Landing Platform Built on Top of Gas Bag

air current. He crawled out of his bunk and had started to make his way toward the stern when the break-up began. The angle at which the ship was rising and falling was so acute that, as he clung to the bunk rods with both hands, at times his feet were hanging in air, and at others, as the stern sank, he was flat on the cat walk, holding his body back with hands braced above his head.

Whether the accident could have been avoided may always remain a mystery, since every one in the navigating cabin, where the control instruments were located, perished. Aviation experts agree, however, that the ship was not built to withstand the strains she encountered. The only thing that might have saved the "Shenandoah" would have been a better weather-report system, which would have announced the storm in time for the ship to steer around it.

The ship, officials admit, was out of date and actually obsolete before she was built, but represented the best that was available to the navy at that time. She

was based on plans made by American officers from a German Zeppelin brought down in the American sector in France, in 1918. The German ship in turn represented German craft of about the year 1916, and the Zeppelin builders had already, at the time of that vessel's loss, progressed considerably beyond her design, and have gone even farther in the passenger-carrying ship "Bodensee," built after the armistice.

The navy, however, took the German designs, improved on them in so far as possible, and with the assistance of Capt. Heinen, a German Zeppelin builder brought over for the purpose, built the "Shenandoah." The German builders who came over with the "Los Angeles," built for the navy in Germany, declared the "Shenandoah" was too long and unwieldy, and pointed out that the "Los Angeles" was a bigger ship, though shorter, because her greater diameter gave her a larger gas capacity.

Summing up the defects of the ship, the aircraft engineers agree in general

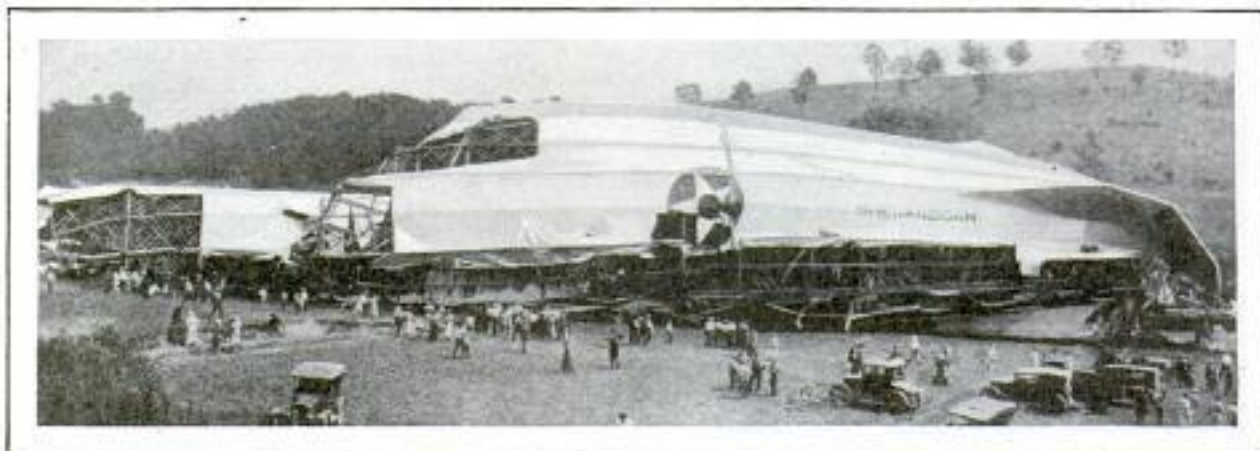

Wreckage of the 450-Foot After Section of the "Shenandoah," Which Landed Safely with More Than a Dozen of the Crew After the Nose Broke Loose and the Center Section Collapsed

that, while more graceful than the "Los Angeles" because of her longer and slimmer lines, her length was too great in proportion to the diameter, and too unwieldy for the same reason. They also agree that, in the future, control cars should be rigidly attached to the hull, and that the longitudinal bracing should be improved.

What effect the loss of the navy ship

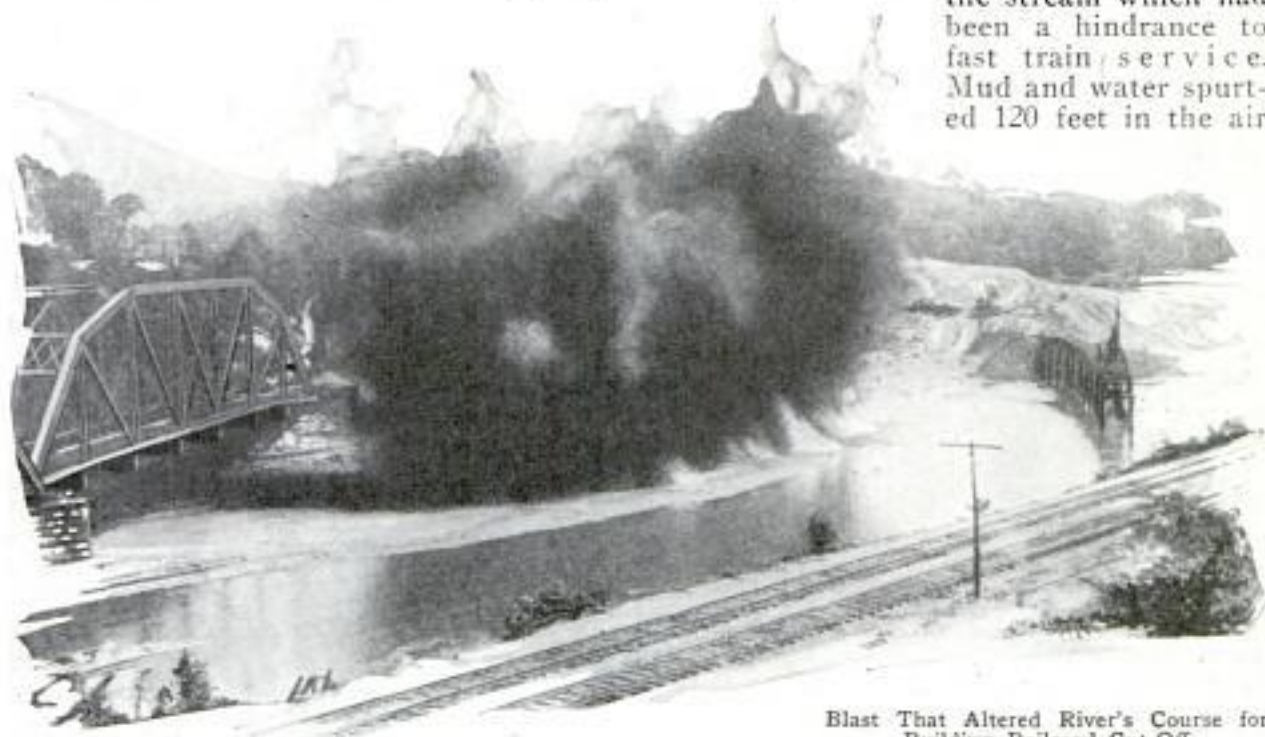

Blast That Altered River's Course for Building Railroad Cut-Off

will have on projects for commercial aircraft lines remains to be seen. Negotiations were on foot at the time of the disaster to lease the "Los Angeles" to a private company, headed by John Hays Hammond, Jr., the inventor of the wireless-controlled boat.

In accordance with the terms by which the "Los Angeles" was built in Germany, she cannot be used for military purposes but only for experimental work; so it was proposed to rent her to the private company for a commercial air line between New York and Chicago, the navy supplying the operating crew and benefiting by the experience gained.

Plans also are on foot for a ship of the "Shenandoah's" size, or larger, built entirely of metal, even to a metal skin, instead of the cotton covering of present Zeppelins, and designs have been brought to America by Capt. Karl L. Leps, of Munich, Germany, a former associate of Count Zeppelin's, for a non-rigid airship, 950 feet long, equipped with ten motors and carrying a 700-foot Pullman-like gondola, with room for 300 passengers.

GIANT BLAST TURNS A RIVER INTO NEW CHANNEL

How explosives aid in the conquest of nature was graphically illustrated when a 1,700-pound charge of dynamite, in a few seconds, altered the course of the Schuylkill river at Port Clinton, Pa., permitting a railroad access to the town. The blast helped cut off a U-shaped curve in the stream which had been a hindrance to fast train service. Mud and water spurted 120 feet in the air

when the charge was fired; then the river obediently turned into the new path cut for it. The man-made channel is 1,200 feet long and reduces the length of the river nearly 2,000 feet.

REDWOOD LOG FOUND IN SAND AS GOOD AS GOLD MINE

Lumber valued at \$3,000 and thirty circular dining-table tops, each worth \$75, were cut from a redwood log found partly buried in the sand by an Oregon man, who declared that the discovery was almost as good as a gold mine. Two days' work with team and scraper were required to unearth the huge log, which was eight feet in diameter and fifty feet long. According to the rings, it was 527 years old and had lain in the same place for many years before anyone had thought it worth the trouble to remove it.

☐ In certain parts of Africa, the locusts attain a length of four inches and feed on mice.

20 miles north of Reading, Pa.

George Walker Cannon Beach, Ore.

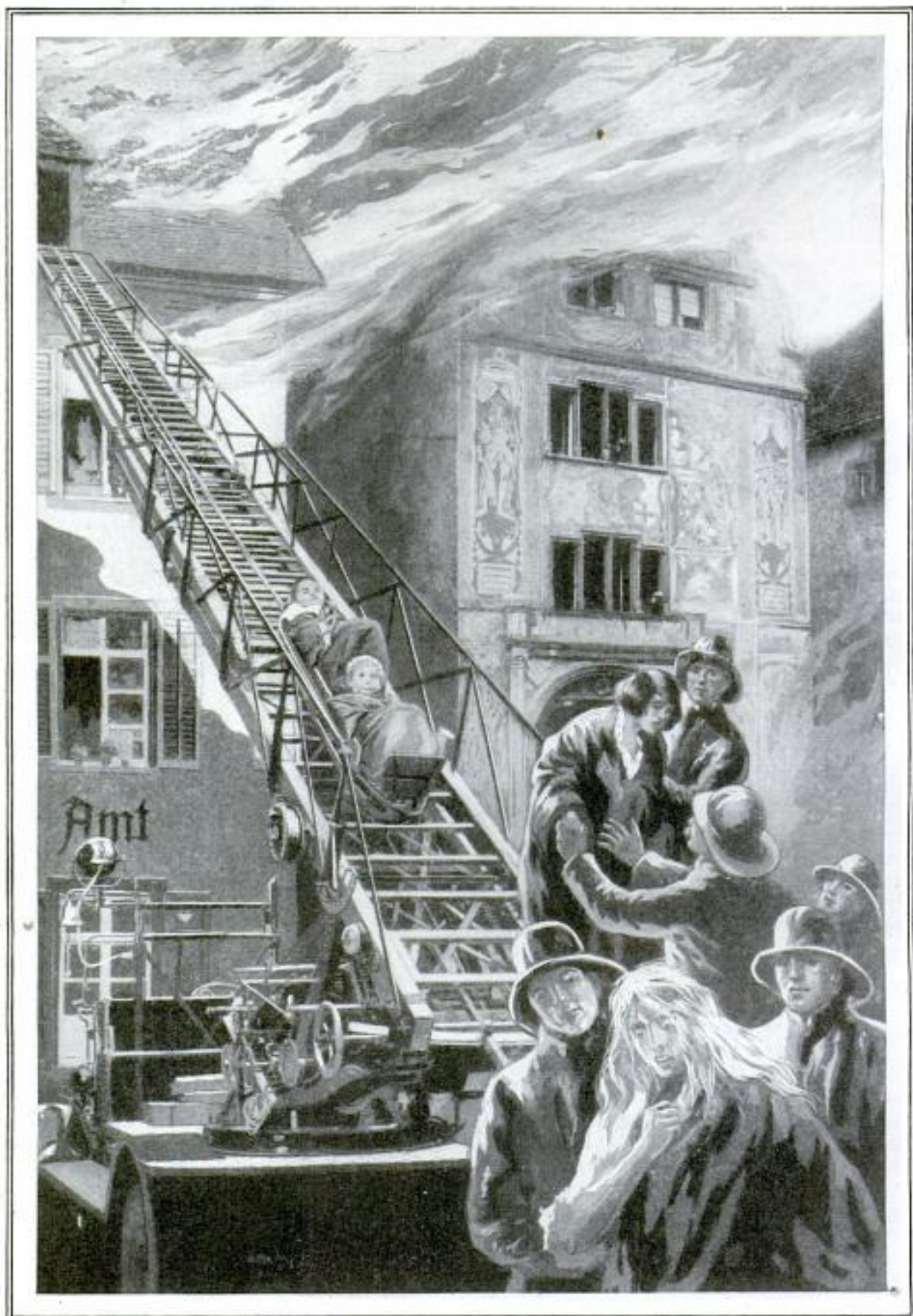

Ending the Difficulty of Getting an Invalid or Fire-Crazed Person down the Tall Fire Ladders, a Newly Invented Cable Car Uses the Ladder Rungs for a Runway

SLIDING SLED ON FIRE LADDER AIDS IN RESCUES 16

Attachable to any ladder but specially adapted to that used with the fire apparatus, a sled and cable arrangement quickly assists persons to the ground and may also be used for hauling up water buckets or fire extinguishers. The car has side guards, straps and footboards and may be used for two children or one adult. It slips down the ladder and is drawn back and kept from falling by means of a cable controlled at the top. In a test, a family of four persons was taken from a floor nearly seventy feet above ground in seven minutes.

283

CENSUS OF RELIGIONS TO SHOW CHURCHES' GAIN OR LOSS

How many men and women in the United States are church members; how many children are enrolled in Sunday schools; the number of ministers; value of church property—these and many other facts are to be gathered next year at the taking of the religious census for the entire country. This is done every decade, just as the general census is taken, years ending in six being chosen for the task. To get the desired information, the government sends out two sets of questionnaires through the census bureau. One calls for data concerning the church itself, and the other relates to the minister, priest or rabbi in charge of each congregation. The report of the last religious census taken in 1916, is available in the larger libraries.

New York Times 8/23/25

SHIELDS TO MARK ALL ROADS AS AID TO AUTOISTS 236

After many years in which state and city governments and automobile clubs have borne the principal burden of highway marking, the United States has now started to mark most of the chief roads in the country with a uniform shield sign. This will usually bear the number of the road, the name of the state and the initials "U. S." The public-roads commission is in charge of the installation and maintenance of the signs.

Sample Shields Government Is Preparing to Mark Principal Auto Highways for Guidance of Motorists



Es. E. Mac Donald, Chairman Joint Board Inter. State

MAGNET-FIXED MOTOR ON HULL TURNS SHIP IN DOCK 220

Steering ships into narrow slips or docks frequently results in damage to the

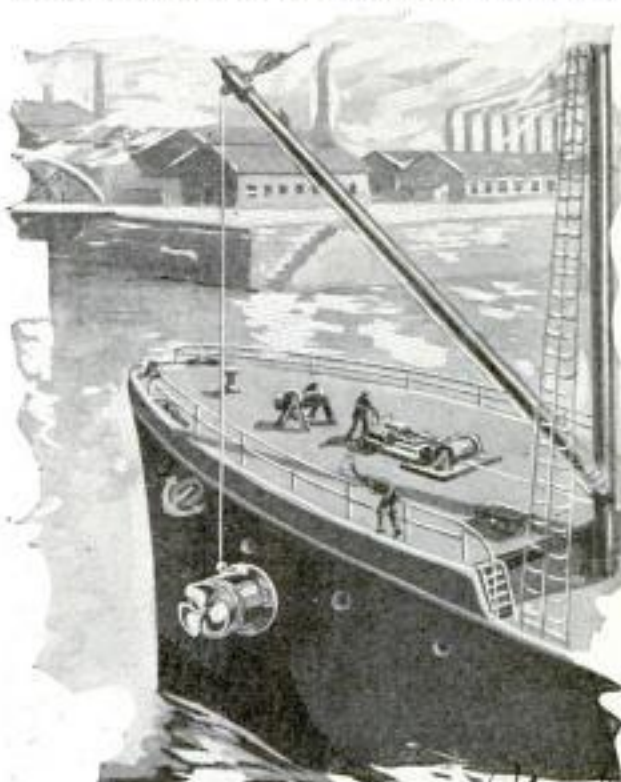

Courtesy T. Bernard Percy, Propeller Attached to Iron Side of Ship by Magnet for Use in Docking

397a - bridge

hulls from bumps against the wharfing of sidewalls. A remedy, called the "limpet," has been devised. It consists of a small propeller, with a portable motor, which is attached to the iron hull with an electromagnet under the water line. With several of them in use at various points of the ship, the craft can be steered easily.

Road U.S. London Eng

SNOWSHOES BUILT FOR HORSES TO CROSS MOUNTAINS

Boards about a foot square were fastened to horses' feet to serve as snowshoes while the animals were being taken over the mountains for construction work on a highway between Idaho and Montana. The shoes prevented the horses from sinking into the drifts, enabled them to travel with less fatigue and they learned to use them quickly.

new York Times 5/17/25

Chambers Highway

346 ROLLER-COASTER WATER DIP — ADDS THRILL TO RIDE

Delights of the "chute the chutes" and the scenic railway are combined in a roller coaster at Wembley, Eng., in a pool of water placed at the bottom of one of the steep descents. The car shoots down the incline and across the tank before ascending the next grade. Spray is thrown to either side, and, looking into the basin from the top, passengers get the impression that they are about to

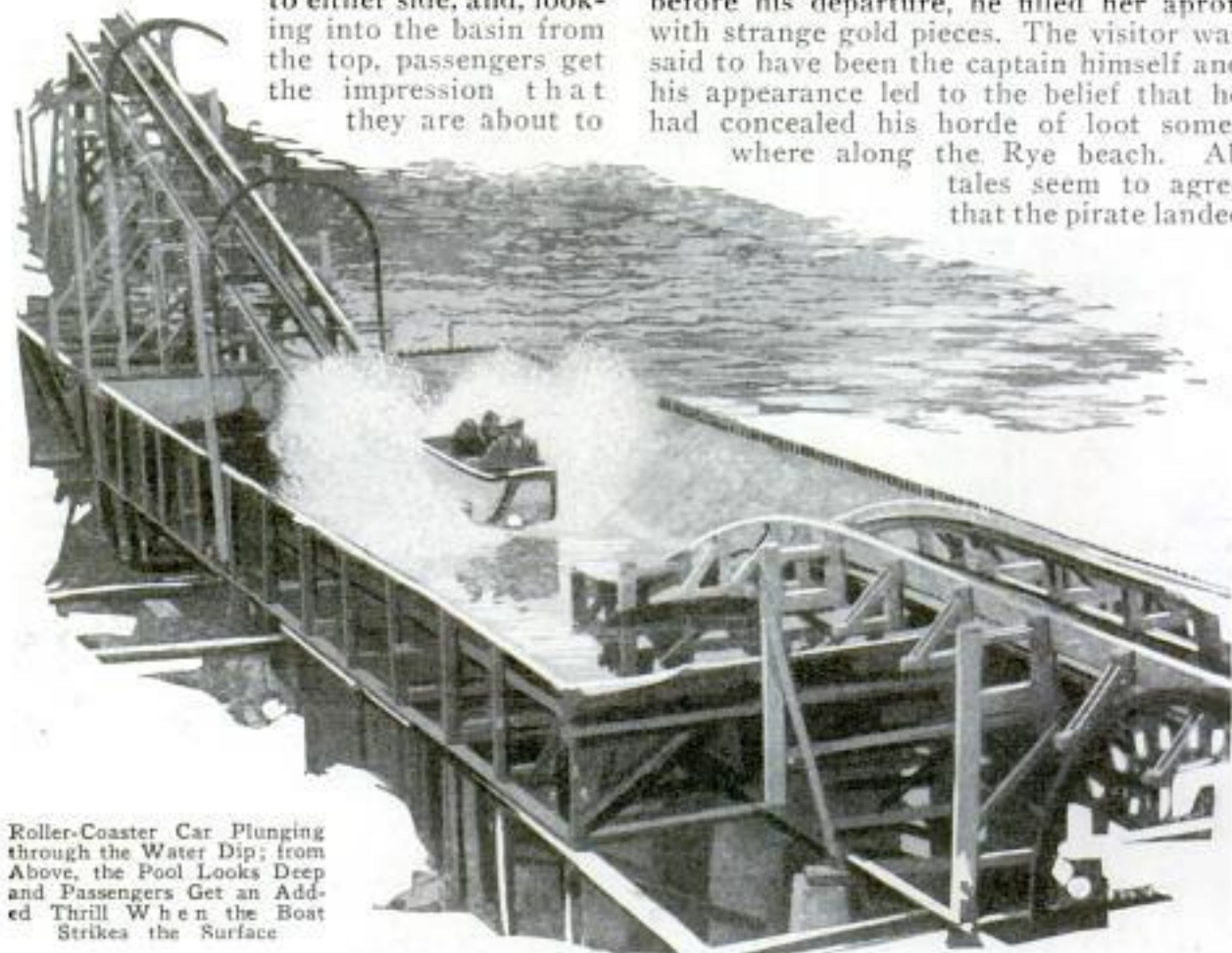

Roller-Coaster Car Plunging through the Water Dip; from Above, the Pool Looks Deep and Passengers Get an Added Thrill When the Boat Strikes the Surface

fall into a deep pool. In reality, the tracks are placed just a few inches below the surface so there is no danger of the car leaving the rails.

329 MYSTERY OF PIRATE'S TREASURE IS STILL UNSOLVED

Although some historians maintain that Capt. Kidd did not bury any treasure, but spent all before his death, the popular belief that one of his chests of gold lies imbedded in the sands somewhere near New York persists in spite of the fact that repeated searches have disclosed no trace of it. All stories agree that a Negro slave helped him hide the box and was then killed and buried on top of it by the fierce pirate. Several years ago, laborers

digging near the Andre monument in Sleepy Hollow, unearthed the headless skeleton of a colored man that had been long interred. The bones were reputed to be those of Capt. Kidd's murdered slave, but the treasure was not found. Another tradition relates that one stormy night, a mysterious stranger, evidently a sailor, begged shelter from a farmer's wife near Rye, N. Y. The next morning, before his departure, he filled her apron with strange gold pieces. The visitor was said to have been the captain himself and his appearance led to the belief that he had concealed his horde of loot somewhere along the Rye beach. All tales seem to agree that the pirate landed

on a "dark and rainy autumn night" and that the black slave carried a stout coffin in which was inclosed the treasure. Another account has it that a fisherman of Great South Bay, L. I., dreamed three successive nights that, at a certain spot near by, Capt. Kidd's doubloons lay buried. He arose before daybreak and rowed his boat to the place. Next morning, he was found lying unconscious across his own doorstep. His boat was never found, but the spade, still wet and with sand clinging to it, was discovered in a graveyard miles away. When revived, he declared that he had no recollection of what had happened after he started to dig, or how he returned to his home. The notorious adventurer's gold is said to have been hunted more frequently than any other hidden treasure.

Chicago Daily News

8/31/23

Copyrighted material

Washington, D.C.

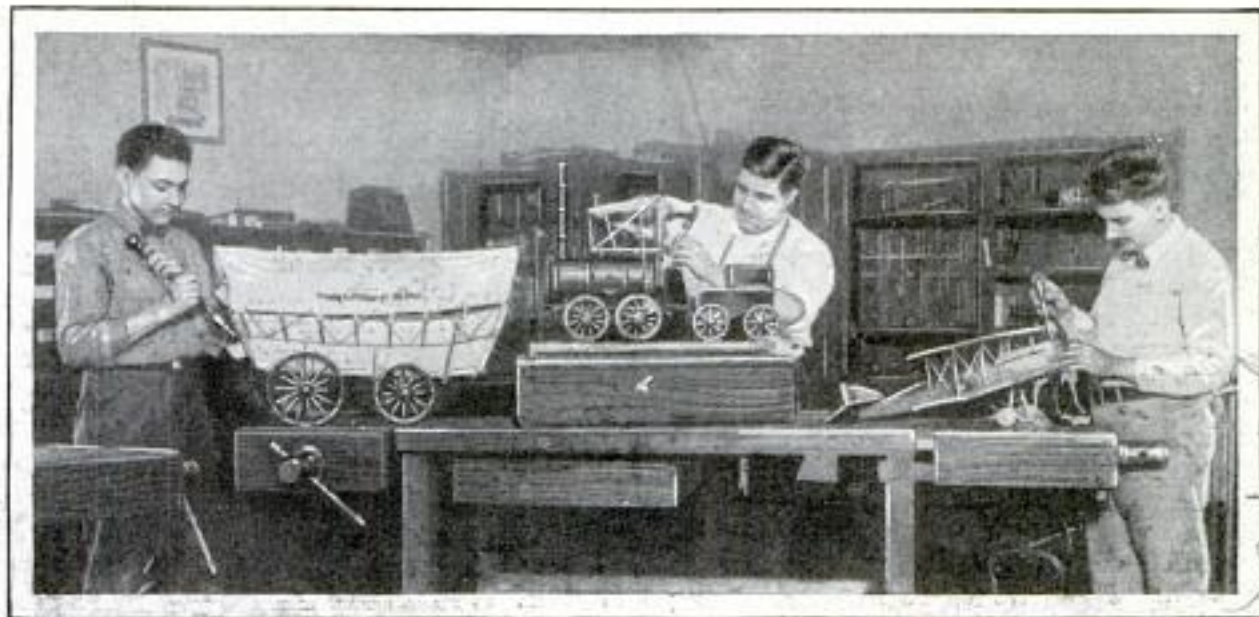

Preparing Models of Prairie Schooner, Early Locomotive and Airplane for Display at Smithsonian Institution to Illustrate Progress in Methods of Transportation from Pioneer Days to the Present Time.

STORY OF TRANSPORTATION TOLD IN MODEL DISPLAY

Man's progress in developing better ways of transportation is graphically shown by a display of models in the Smithsonian Institution. The exhibit goes back to the days of the plodding prairie schooner, carries the story through the evolution of the locomotive from the first crude types, and shows modern methods by a diminutive airplane. Each model has been constructed with a view to accuracy and emphasis on important stages in the history of travel.

LIGHTER, BULKIER GOLD SEEN AS AID TO ARTS

Credited among the accomplishments of Benvenuto Cellini, famed Italian goldsmith, and one of the secrets that died with him, a process for treating gold to make it lighter in weight but greater in volume has been rediscovered and patented by an eastern metallurgist. The method, it is expected, will effect a saving of eight to eighteen per cent in the weight of articles manufactured of gold, and the metal will also withstand tarnish and

stains. Greater use of gold in jewelry and a saving in millions yearly are anticipated from the process.

WONDER LIGHT FOR AIRWAY IS REGULATED BY SUN

Lighting automatically at sundown and going out at dawn, an acetylene beacon installed at the London terminal aerodrome at Croydon, helps direct craft to and from the fields and requires practically no attention. It operates on the same principle as the smaller beacons set along the airways in this country to guide flyers with the night mails. A so-called sun valve controls the supply of gas which is taken from a storage tank in the base. This valve is so sensitive to light that it closes in the morning and opens again at night or whenever darkness occurs for some other reason. Renewal of the gas tank is about the only work that need be done and one container holds a supply sufficient for several weeks.

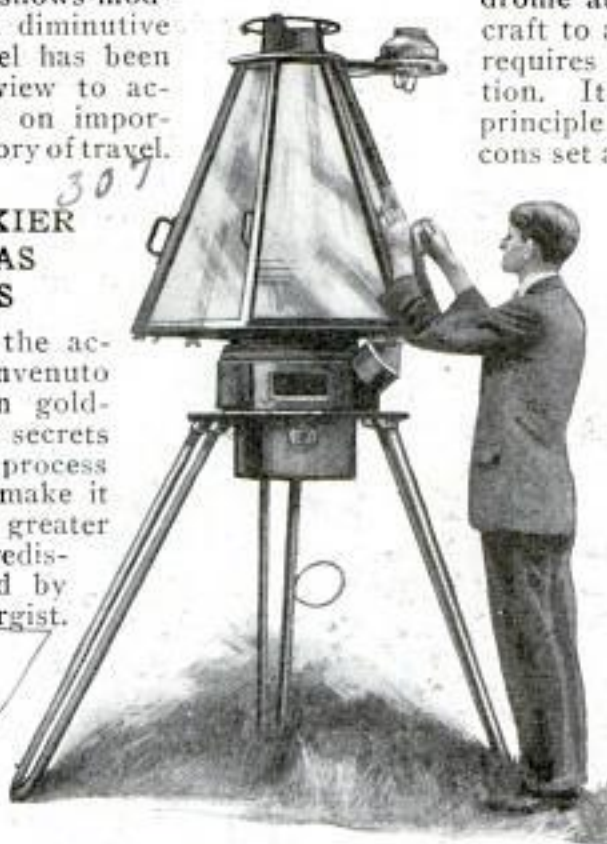

Automatic Beacon at English Air Field; Light-Sensitive-Control Valve at Right

Irish wolfhounds are the tallest dogs in the world.

no other information

*Victor Navignon,
General Plate Co.,
Attleboro, Mass.*

To Make Your Work Easier

8-11 A. M. Washington D. C. Sunday, W. C. 2

New Science Aims to Reduce Fatigue, Fit Square Pegs in Round Holes and Remedy Faults in Human Mechanism

By FENN SHERIE

London, Eng.

102

SINCE history has shown that many a poor student has attained greatness in the world, a new science has been developed in England designed to make work easier, fit "square pegs in round holes" and remedy the faults of the human mechanism.

In the past, the list of illustrious dunces includes such names as Napoleon, Wellington and Cecil Rhodes. It is obvious, therefore, that the school report is of comparatively little value in determining ability. Realizing this, the scientist has approached his subject from a new angle. His tests are to learn not what a youngster has done in the past, but what he is capable of doing in the future.

Some young persons develop a distinct leaning toward a certain trade or profession at an early age, while others, though revealing no definite bent, may have their talents hidden beneath the surface. Generally speaking, it is fairly easy to ascertain whether a youngster possesses what is known as a literary mind or a mechanical mind (these are the two main classifications into which most people may be divided), but when it comes to testing specific abilities the task is more difficult.

Here, for instance, is a young man about to start on a career. He has shown no particular aptitude at school, but thinks he would like to be an engineer.

Now it may be that he has a natural talent for things mechanical; his imagination may have been fired by something he has seen or read about the romance of engineering; or he thinks he ought to be an engineer because his father was one.

The scientist has to find out whether the boy is a potentially successful

engineer, and, if so, what branch of it he should take up. Having studied the youngster's school report and interviewed him in a friendly manner concerning his hobbies, the examiner now endeavors to ascertain his standard of general intelligence.

He sets him a number of questions, each of which has a definite purpose. Some of them are such amusing "posers" that readers may like to try them on their friends.

For example, to test the youngster's clearness of thought, a typical problem is this:

"Draw a triangle unless there are more days in the week than there are months in the year, in which case draw a circle."

The average boy of fourteen should be able to do this with ease.

As a test of common sense, the youth is asked to examine a number of statements and see if he can find anything wrong with them. Here are two examples:

(i) "The horse obeys his master because his eyes magnify, so that his master seems to the horse to be much larger than himself."

(ii) "John James, who had married his widow's sister, used to say that if a man had a bad sister it was his misfortune, but if he had a bad wife it was his fault."

The fallacies in the above sentences are explained at the end of this article.

The next questions are formulated with the object of measuring imaginative power. Here is one:

"If people had no teeth, how would their life be different from what it is now?"

One bright youngster replied to this: "All of us would have to use scissors to cut our nails!"

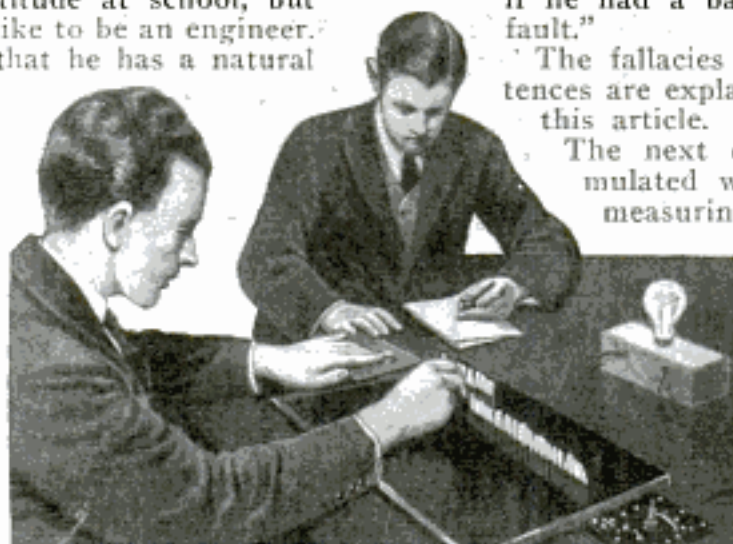

Divided-attention test for locomotive engineer in which he taps rapidly with two fingers of the left hand, the taps being automatically recorded, while with the right hand he endeavors to move a number of pegs quickly from one place to another; at intervals the examiner lights the electric light and the examinee is supposed to stop all work while he extinguishes it by pressing a switch with his right hand.

Of the several ingenious questions propounded as a test of ability to reason, the following is a typical one:

"My brother writes: 'I have walked from Byford wood today, where yesterday I had the misfortune to break a limb.' Can you guess from this which limb he probably broke—right arm, left arm, right leg, or left leg?"

The intelligent answer to this is, of course, "probably the left arm—since he walked and wrote a letter so soon after the accident."

According to his answers to a large number of such questions a youngster's ability to think, reason, and act can be gauged with remarkable accuracy.

In order to make the intelligence tests fair to those who have not the gift of expressing themselves in words, there are also a number of non-verbal tests, similar to those illustrated on page 726.

Next the examiner passes on to tests by which physical and mental capacities are measured together. For example, he produces a tray and a number of oblong strips, as illustrated on this page. He spreads the strips upon the table and informs the youth that, at a given signal, he has to pack the

strips into the tray. If the boy is casual, careless, hasty or unsystematic, he will probably commence to pack the strips as shown in (a). The examiner then waits to see how long it takes him to realize the futility of this method—or, rather, lack of method—and remedy his mistake.

The boy of normal mechanical intelligence will probably set about the task with some sort of system, trying first to fit each strip, in turn, into a given space

until he finds the right one. The boy of high mechanical intelligence, however, will commence by laying the strips upon the table in a row. He may then discover that they are graded at different lengths—see (b)—and this will enable him

to fit them into their positions with great rapidity.

Here is another interesting test. The boy is handed a tray containing a number of simple mechanical objects—such as a bicycle bell, a door lock, and so on—in pieces, and he is requested to assemble them. By watching his methods of going to work and timing the various operations, a great deal of valuable information may be obtained.

Similar tests have been devised to assist employers. Hitherto the selection of a worker has been decided by a brief interview, and his natural ability gauged by guesswork. The scientist supplements this inter-



A TEST FOR "MECHANICAL INTELLIGENCE"
The applicant is required to stow the ebonite strips into the tray as neatly and quickly as possible.



(a) An unsystematic worker usually commences the task in the manner depicted above.

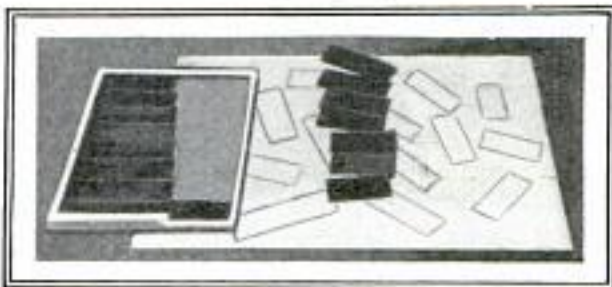

(b) A worker of high "mechanical intelligence" moves the apparatus to within easy reach, and stows the strips in order of size.

view with practical tests which have been tried and proved by experience. A famous firm of dressmakers recently had occasion to select a number of "learners" and began by studying the special abilities required, and then proper tests were devised. In the case of embroidery workers, one was for judgment of equal distances. It was carried out by means of cards upon which were printed a number of lines, some parallel and others diverging. Another consisted in showing the applicants a number of colored drawings of flowers and asking them to sort them, according to their personal tastes, into good, bad and indifferent.

To test the co-ordination of hand and eye and hand and image (or, in other words, to find whether a girl could aim straight with regularity), the candidate was given a sheet of squared paper and a pencil. A metronome was set in motion, beating one stroke to the second, and the girl was told to make a dot at the corner of every other square, keeping time with the "ticker." Next she was given a pin and the test was repeated—only this time she had to prick upward from beneath the paper.

To measure speed of movement and determine a girl's resistance to distraction (the latter is an important quality, for work girls will chatter to one another), a perforated zinc sheet was used. The girl was given a needle to which was attached a string and told to sew through the holes,

up and down, with one hand above and the other below the frame. After a little preliminary practice, the girl was told to carry out the operation as fast as possible and the time occupied in completing a line was noted. The test was now repeated in exactly the same manner, except that the examiner, after giving the word "go,"

commenced to converse with the girl, asking her questions about her school, her hobbies and so on. According to the increase in the time taken, her resistance to distraction can be measured.

For each different branch of industry a special set of tests has to be devised. In dressmaking, the test for speed of work consists of tying a number of knots in a piece of wool in a given time (twenty knots a minute is good speed), while that for lightness of touch consists of folding fine tissue paper, making as few creases as possible. One of the most im-

portant tests for weavers is to ascertain their ability to notice discrepancies in patterns. This is carried out by means of a series of cards bearing designs similar to those shown on this page.

Some of the common-sense tests may be formulated so that they have a direct application to the particular job for which the candidate applies. Here is an example: A big laundry recently had a vacancy for a girl clerk to deal with orders which came by post and telephone. Among the questions put to her was this:

"Ten minutes after the van has left to

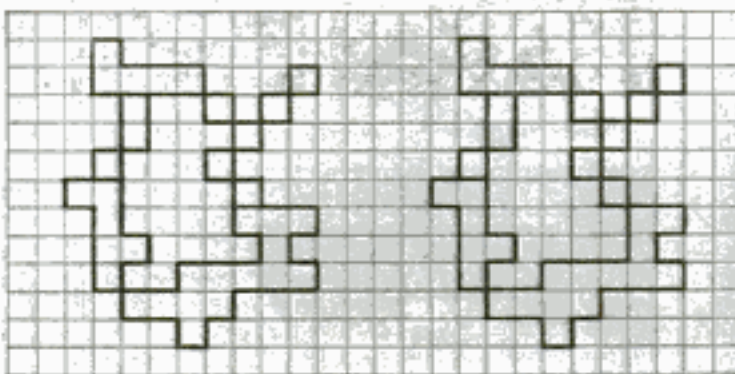
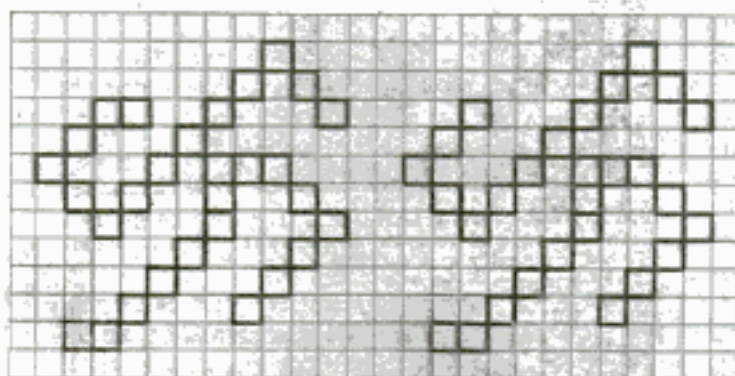
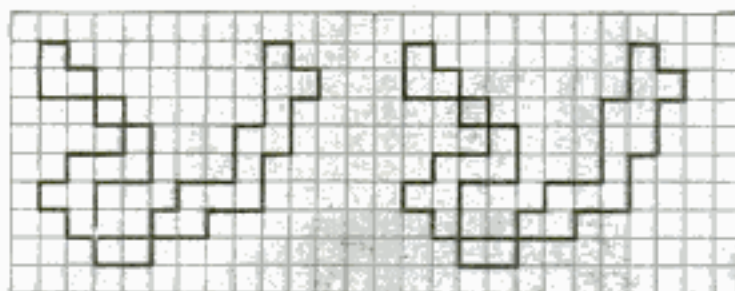

ALMOST AS BAD AS "CROSS-WORDS"!

A test applied to weavers. In each of the above pairs of patterns there is a slight difference. Can you find it? Nine seconds are allowed for each pair.

collect the washing in a certain district you receive a telephone message from an important new customer on the round, requesting that some linen be collected on that day. What would you do?"

Comparatively few applicants thought of the correct answer to this, which is: "Telephone to the house of one of your regular customers where you know that the roundsman is due to call and ask them to oblige you by telling him, when he arrives, to ring you up."

Another branch of the new science is that which aims to study workers and working conditions with a view to remedying faults in the "human mechanism" of industry. Big employers often feel that there is something wrong in their offices or workshops, yet are unable to trace the cause. For example, a firm of caterers recently complained that they were suffering very heavily from breakages of crockery at their various branches.

The cause was noise and nerves. The investigators found the key to the whole situation when during a rush period, in which there was a babel of voices calling and repeating orders, the girls began to show signs of irritation. In the hurry and scurry some of the orders were forgotten or mistakes were made, and consequently the shouting from one department to another increased in volume and the nervous tension grew worse.

Now there is nothing more infectious than irritability, and it was found that it was almost invariably at the time when the girls' nerves were "on edge" that they suffered from involuntary—and sometimes unconscious—dislocation of mind and muscle. In other words, they dropped things, and were not always able to understand how these accidents occurred. The trouble was remedied by the installation of a system of indicators. The worker requiring a particular article now

simply presses a button, and a signal appears in the service room indicating what is required. Not only have the breakages been reduced (in some cases by as much as seventy-five per cent), but the workers are happier and suffer far less fatigue. Moreover, the amount of goods handled has increased over thirty per cent.

However simple or elementary a job may be, there are always right and wrong ways of doing it, and the scientist aims to discover the best methods. Industrial workers are like golfers. Some of them take to the game naturally; others require a lot of training, but all of them have a better chance of success if they take a few lessons from an expert. At any rate, they will find a shorter cut to the right way without a great

deal of experiment, and they will avoid the many pitfalls which arise from the formation of bad habits.

The best method of doing a specified job is found by studying scientifically the movements of the first-class operator and teaching these motions to those who are less deft. This is done, in many cases, by making what is known as a "chronocyclograph." A small

electric light is attached to the wrist of the best worker and his movements are photographed by means of a special camera. The resultant picture shows the movement of the hands as a series of lines. These are copied in the form of a wire model, which in the hands of a teacher can be used for instructing the other workers.

The importance of eliminating waste movement, and thereby reducing fatigue, may not be generally realized. Yet, to quote a single instance, investigations made recently in the packing department of a margarine factory revealed that while the best worker was able to wrap a pat of margarine in four distinct motions, another girl, though not the poorest worker among them, seemed to find it necessary to make over twenty-four motions in the same process.

Much has been said and written about the monotony of certain tasks. But, says



MOVING THIMBLES RAPIDLY FROM ONE PEG TO ANOTHER

A test for speed of larger movements as required in wool embroidery.

18.2 the scientist, it must be remembered that monotony is not always disagreeable. Walking is a monotonous exercise, but many people derive pleasure from the rhythm it provides. Similarly, if rhythm

for dirt, another for coal, and so on. Similar experiments and improvements have been made in other industries with surprising results, but it is pointed out that unless the new science is applied

under the direction of an expert, the results will probably be unsatisfactory and may even be harmful. It is said that a certain laundry proprietor introduced a phonograph to keep his workers lively and happy. As he had anticipated, the girls instantly began to work in time with the music. But he had overlooked the fact that they were engaged on a number of different

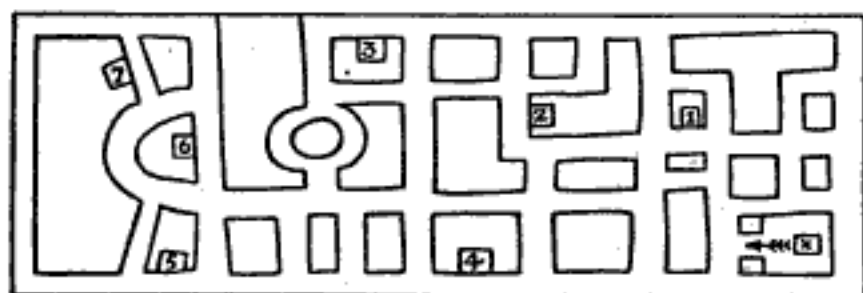

ARE YOU ABLE TO PLAN AHEAD?

Here is a street map, with houses indicated by numbers. Imagine that you have to drive the car "X" from the garage in the right-hand lower corner to each of the houses in numerical order. It is imperative, however, that you must always turn to the LEFT (never to the right), and must pass each house on your left.

can be introduced into working movements, monotony will be greatly reduced. This theory has been tested and proved in a number of different spheres of activity, perhaps the most remarkable of which was a coal mine.

Careful observation of the methods of the best workers revealed that they used a comparatively slow stroke of the pick in getting coal, and a faster one when working upon dirt. The best workers were those who instinctively employed a steady rhythmic movement. But these steady plodders were in the minority, and there seemed very little likelihood of their fellow workers discovering their secret—or even taking the trouble to do so.

The examiners, therefore, set out to train the less expert workers to use their picks in time with a metronome. As soon as they got into the swing, the metronome was withdrawn, and it was found that the rhythmic beat was maintained. The result was that, apart from the reduction of fatigue and the awakening of a new interest in a hitherto monotonous job, the output actually increased by sixteen per cent.

The mining association has taken the matter up. Investigations are now being made to discover improvements in miners' lamps in order to avoid eye strain. Scientists have also ascertained the average weight of material that the average worker can lift on a shovel with regular motion and a minimum of fatigue, and are now having the shovels made in accordance with these findings, that is, one size is designed

occupations each of which required a different natural rhythm. What suited the washers did not please the ironers, and what the ironers liked nearly sent the folders frantic. The scheme is now abandoned, and each girl is encouraged to make her own music.

The fallacies in the sentences on page 722 are as follows:

(i) If the horse's eyes magnify, they magnify everything else in the same proportion, so that if he sees a man big he also sees another horse big, and sees his own body big.

(ii) If a man has a widow he is dead.

348 SPEEDING UP PATENTS

Although 1,900 more applications and 30,000 more amendments were received at the patent office during the last fiscal year as compared to the year before, 16,000 fewer cases were awaiting action at the close of the period, according to the patent commissioner's report.

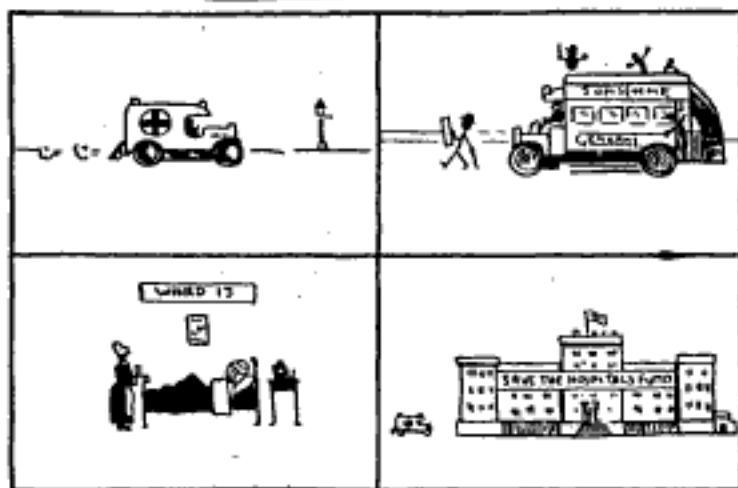

A SIMPLE INTELLIGENCE TEST

Indicate the logical sequence of the above set of pictures. You should be able to do this in six seconds.

**FILM FOR TYPE
 USED IN PRINT
 PROCESS**

267

By a special application of the principles of photography, two London men have devised a printing process which eliminates the use of metal type. The basis of the invention is a "master" film on which the different characters usually carried in the printer's font or produced by a machine, have been photographed. Using a keyboard like that of a typewriter, the symbols can be projected rapidly to a sensitized base where they are rephotographed, and another film is the result, resembling the original but bearing only the matter which is to be published. The printing then may be completed by various methods already in use. The camera which projects the symbols from the master film is focused automatically, and by adjusting the lens, an infinite variety of type can be obtained as well as a wide range in column widths, spacing and other details, all of which may be decided upon and executed in a few seconds by the manipulation of small levers.

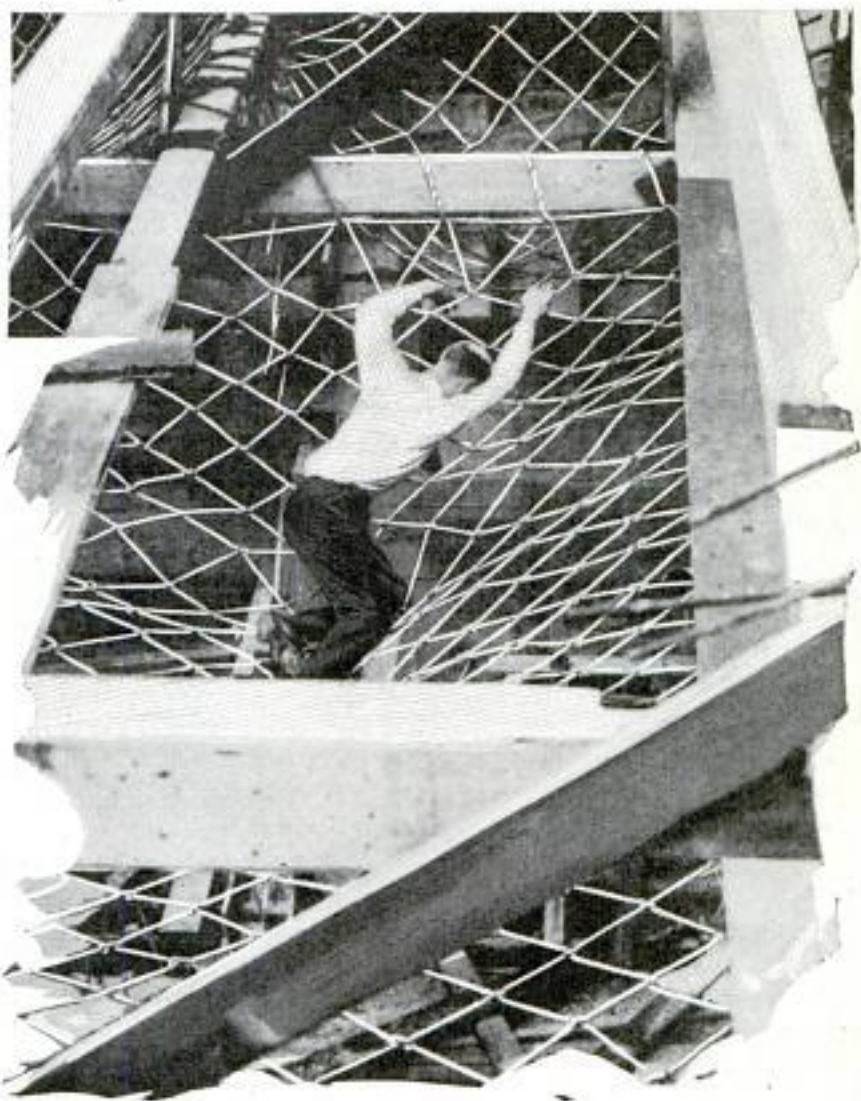

Saved from Death by a Life Net Stretched between Beams during Work on Lofty Philadelphia-Camden Bridge to Protect Builders

**NET GUARDS BRIDGE WORKERS
 FROM SERIOUS FALLS**

277

Following the recommendation of the coroner, life nets have been attached to the Philadelphia - Camden suspension bridge at various places where workmen are engaged, to protect them from fatal falls, should they slip from beams or girders. The nets are constructed of stout mesh and can easily be moved to different locations as work on the bridge progresses.

Patton, Phila.

CARPETS FROM STRING BEANS

227

Fibers beaten from string-bean pods are being spun into a coarse thread by Austrians and placed in competition with hemp and cotton for many commercial purposes. The yarn is described as hard and very strong. After being bleached and printed, it is being employed in making carpets, curtains, upholstery, etc.

Patented in Budapest

**WATCH ON STEERING WHEEL
 PROMOTES AUTO SAFETY**

264

For the motorist whose car has no clock, a watch holder clamped to the steering wheel keeps the timepiece in plain view and eliminates the hazard that attends one-hand driving while removing the watch from the pocket and putting it back. Spring fasteners on the sides of holder permit easy insertion.



*Coffey Mfg. Co
 Centralia, Ill.*

Crime

Science—the Modern Sherlock Holmes

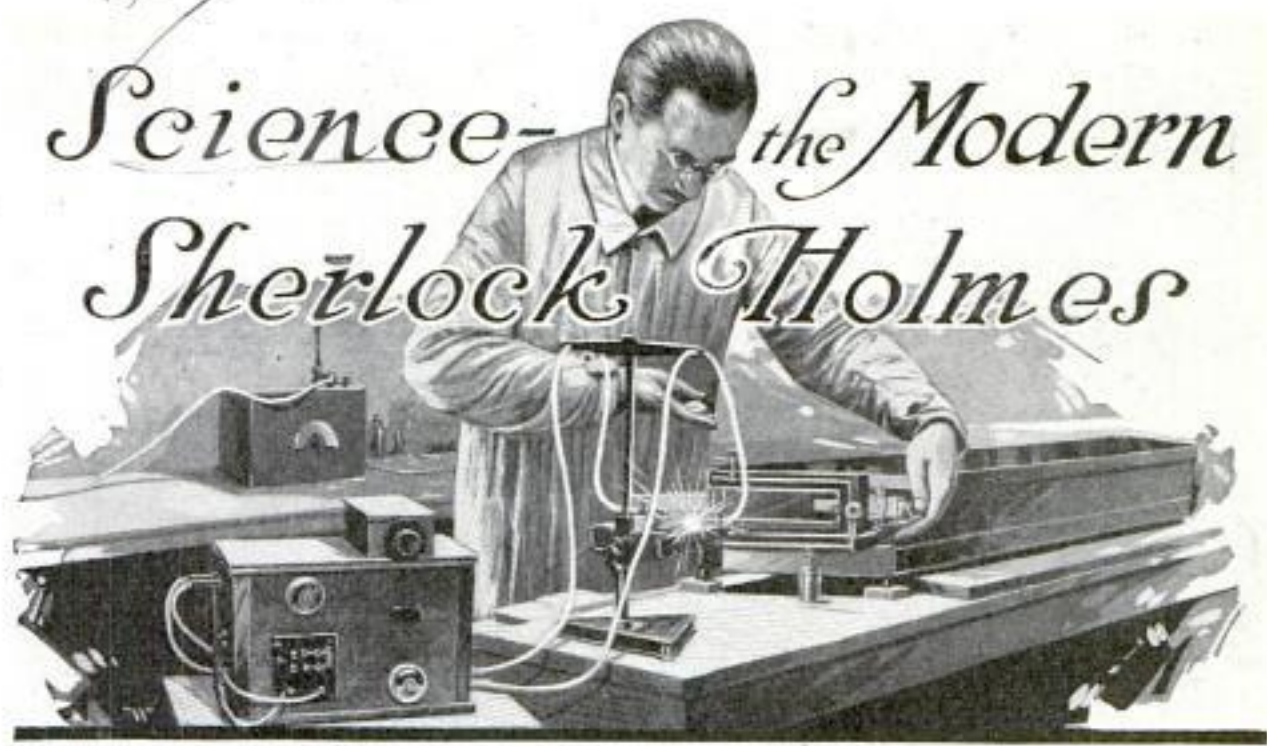

Paris Detective Analyzing Material by Reducing It to Ashes, Placing These between Two Electrodes, and Photographing with the Spectroscope the Spark Passing through the Gap

By NORMAN C. McLOUD

*St. Paul St
Baltimore, Md*

WHEN the housebreaking assassin of Paris pauses in his work and places his coat on a chair, he starts a chain of research which may lead to the gallows. In this simple act, the criminal fails to reckon with the spectroscope, with which the French police follow the blindest trails.

In placing his coat, the malefactor disregards the possibility that lint from the garment may cling to the upholstery of the chair. To the Paris police the fine threads supply a clue of the utmost worth. Under the mystic eye of the spectroscope, the thread may reveal the identity of the garment from which it came. If the threads match the coat of the man under suspicion, the police have made a forward step in placing responsibility.

In essential details, the spectroscope is composed of a dark chamber containing a prism and a plate holder. On the outside, there is a lens for projecting images through a narrow crack at one end of the chamber. Gathered by the lens and passing through the crack, the light crosses the prism before reaching the photographic plate. The action of the prism causes the rays to be produced on the plate in the form of a spectrum, with bands of varying width which correspond to the individual colors.

The uses of the spectroscope are manifold. An assassin fires a bullet, which

passes through the body of his victim and is lost. The only record of its passage is a hole in the window shade through which it disappeared. Two suspects arrested both possess pistols, but one uses copper-covered bullets and the other plain lead. The Paris detectives cut a square from the window shade, reduce it to ashes, and with the spectroscope analyze the ash to determine whether the hole was made by lead or copper. Any fragments of the bullet attached to the edges of the hole are too minute to be seen even with the most powerful microscope, but the spectroscope detects their presence and determines the kind of material.

France, and Italy, lead the world in the application of new scientific discoveries to police work. The higher police officials are all college graduates and specialists in certain lines of work. The advancement of scientific criminology on the continent has proceeded much farther than in America because of the custom of requiring a suspect to prove his innocence, rather than forcing the state to prove his guilt, still prevails in some of the old-world countries. The system gives the police officers wide latitude in introducing any kind of evidence, and the continental courts have helped them by accepting every new advance in scientific work. The Bertillon system was adopted abroad

75

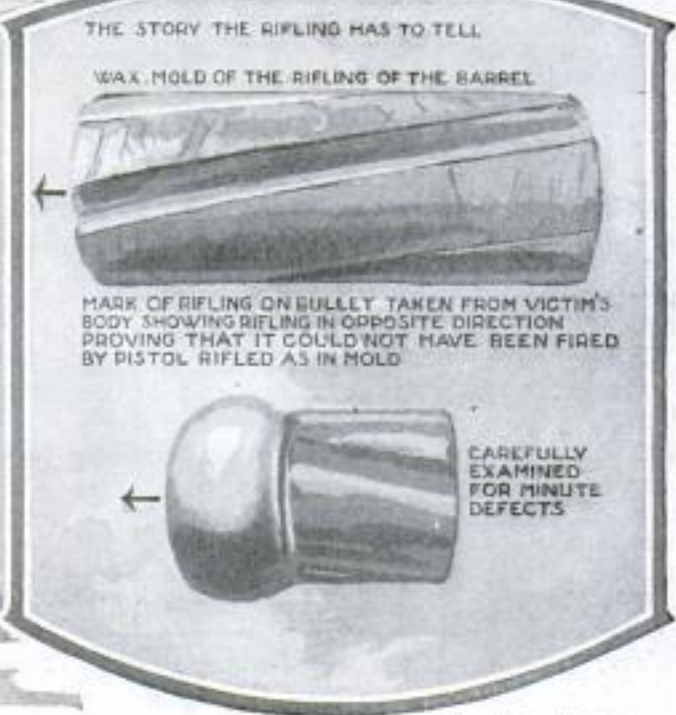
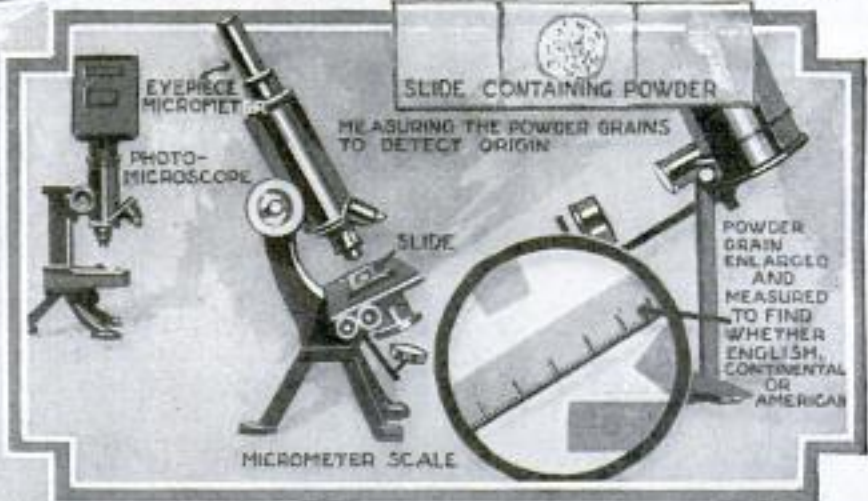
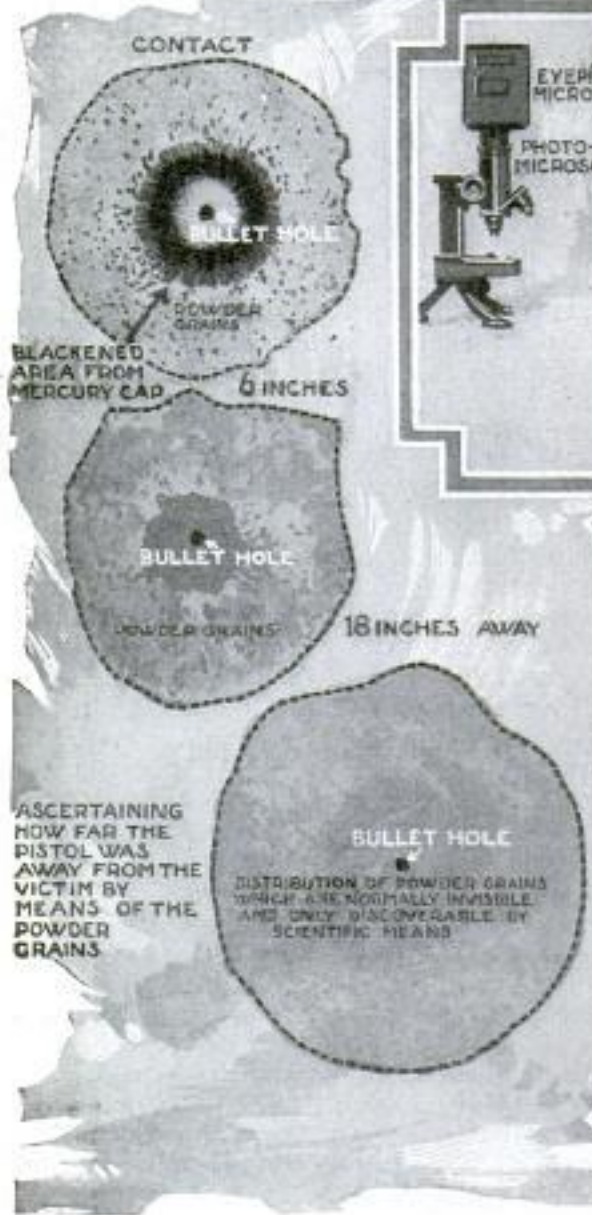

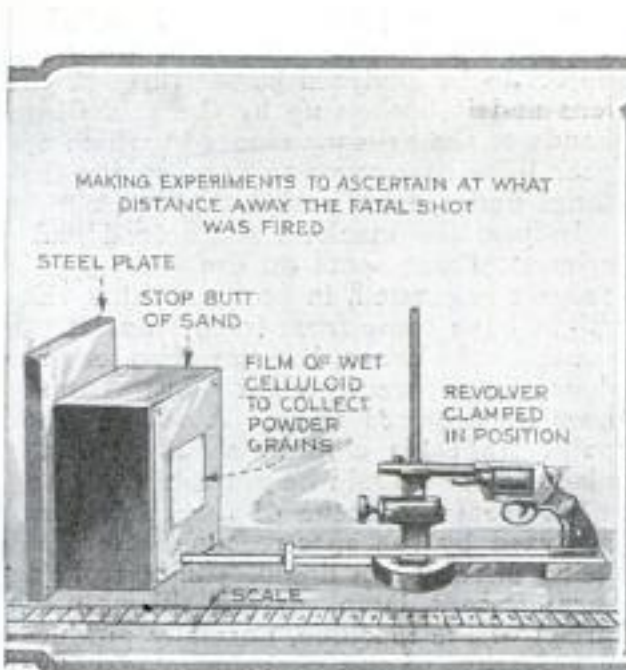

SECTION OF CAST OF PISTOL BARREL

| | |
|---|----------|
| A | 1 .050" |
| | 2 .1025 |
| | 3 .0515 |
| | 4 .1025 |
| | 5 .0525 |
| | 6 .105 |
| | 7 .053 |
| | 8 .103 |
| | 9 .050 |
| | 10 .1045 |
| | 11 .0475 |
| | 12 .102 |

SECTION OF BULLET FROM CORPSE

| | |
|---|----------|
| B | 1 .050" |
| | 2 .105 |
| | 3 .040 |
| | 4 .103 |
| | 5 .050 |
| | 6 .106 |
| | 7 .045 |
| | 8 .100 |
| | 9 .050 |
| | 10 .1027 |
| | 11 .055 |
| | 12 .105 |

MEASUREMENTS OF THE BARREL PROVE THE BULLET COULD NOT HAVE BEEN FIRED FROM IT

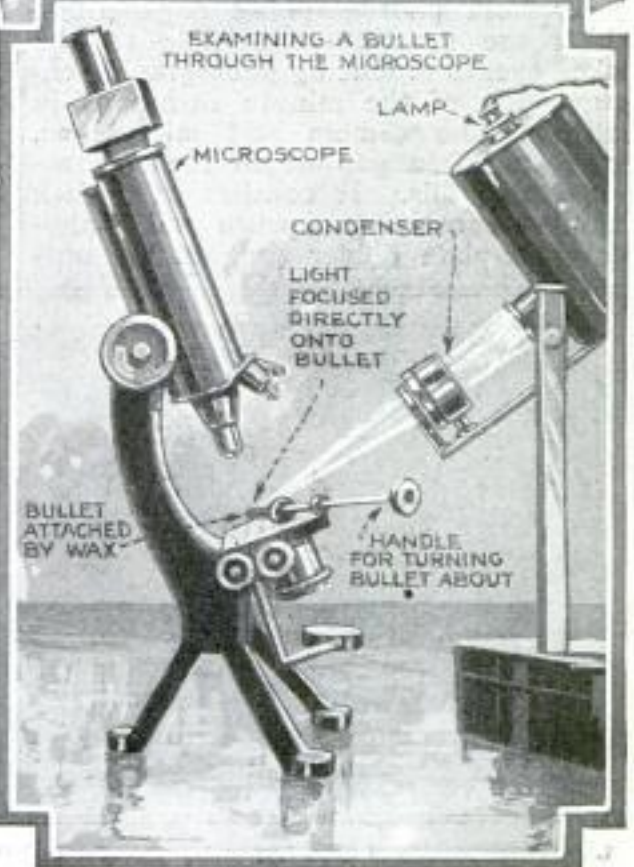
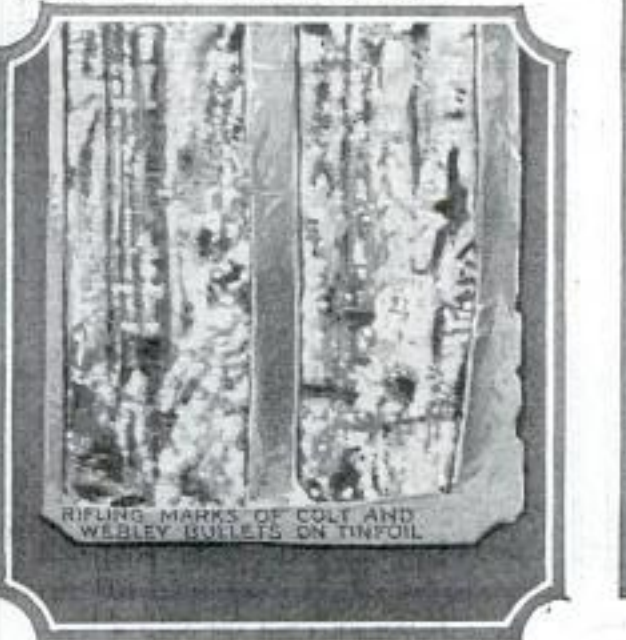



Photograph of Wanted Man Reconstructed on Ruled Paper from Numbers Transmitted by Telegraph

years before it was first recognized by American courts.

One of the most important parts of Paris police headquarters is the large chemical laboratory and photographic department. Special cameras have been developed by experts for every kind of work, from photographing fingerprints, which are practically invisible to the naked eye, to producing photographic enlargements of the minute variations in bullets. The camera and microscope, however, left a gap which the spectroscope now fills. It consists of a dark chamber containing a prism and a photographic-plate holder and, on the out-

side, a lens for projecting light through a narrow aperture. The light from the object to be analyzed passes through the lens and is broken up by the prism into bands of the primary colors in which appear lines that serve to identify the material under examination.

In use, the machine has solved many crimes. Paint spots on the clothes of a suspect suggested, in one case, that they might have come from fresh paint at the scene of the crime, but the prisoner produced an apparently good alibi to explain how he acquired them. A small bit of paint from his clothes, a bit from the place where he said he got the spots, and a bit from the scene of the crime were analyzed by the spectroscope, after first being dissolved in liquid. Light from an incandescent lamp, passed through the prism of the machine, normally produces a spectrum of the seven primary colors, but as each paint vial was inserted between light and prism there were changes in the spectrum to correspond to the nature of the color in the paint. The samples from the scene of the crime and from the prisoner's clothes produced the same spectrum, while the sample from the spot where the man claimed he rubbed against the paint showed an entirely different appearance. Faced with the irrefutable evidence, he confessed.

One of the interesting stories in the Paris police records concerns the attempted sale of a painting fraudulently attributed to a famous artist who had died some years before. Members of his family brought suit to stop the dealer attributing the painting to the dead painter, charging it was unfair to his memory to call the work his. Art critics agreed the style was similar and that the painting

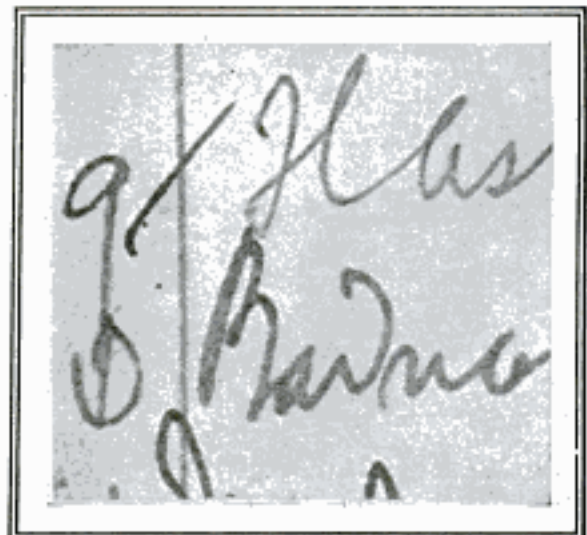
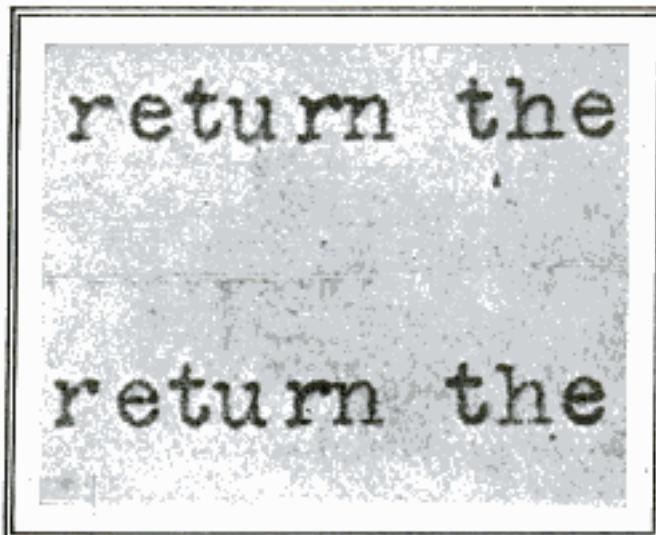

Left, Enlargements of Two Typewriter Samples in Which the Same Mechanical Fault Convicted a Black-mailer in England; Right, Chemical Ink Tests Which Saved an Accused Doctor from Conviction

75

Testing Substances to Determine if They Are Identical by Listening with a Sensitive Radio Receiver to Find Whether They Have the Same Electrical Conductivity

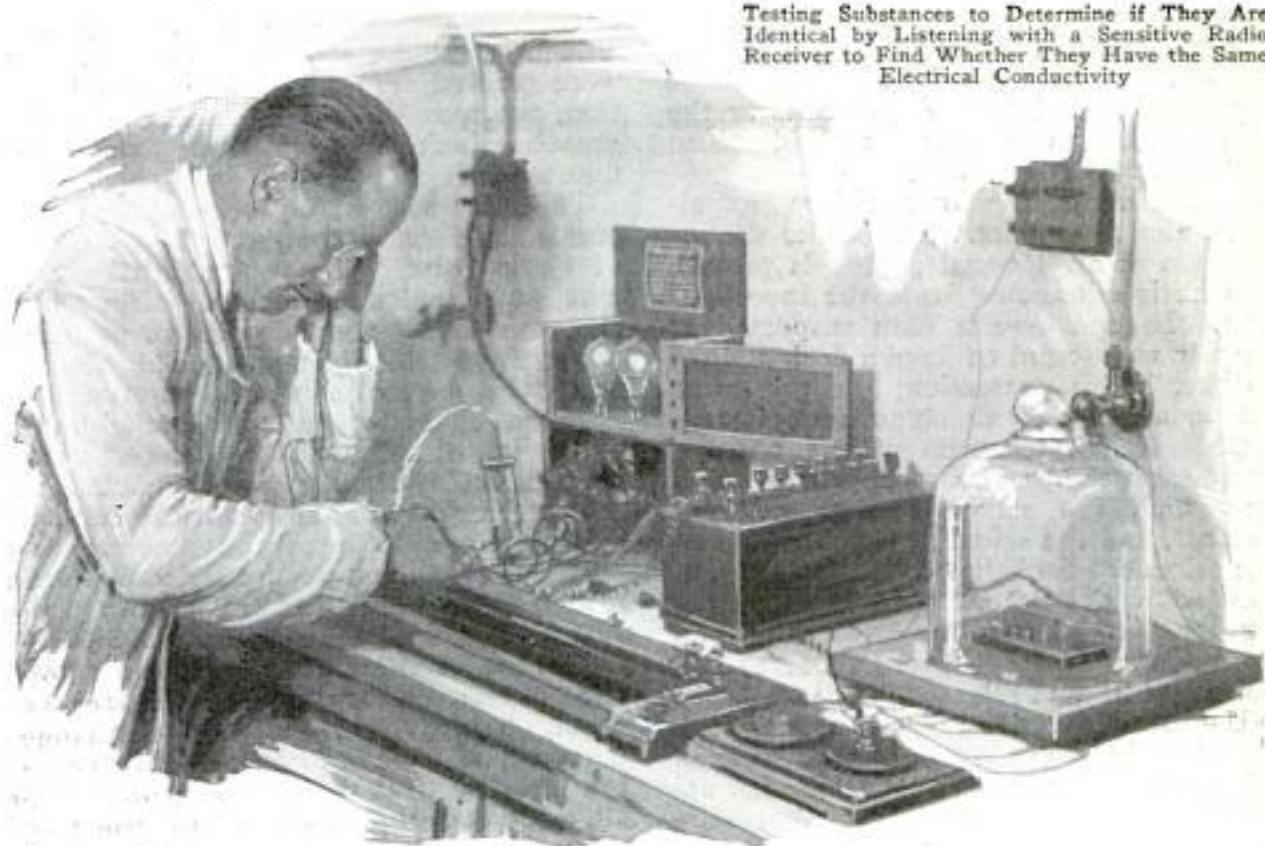

either was the work of the man named or a very good imitation.

The police were called in, and after investigation, learned the dead painter always used yellows of special composition in which the foundation was antimony of lead. With the point of a knife they lifted a tiny yellow fleck from the questioned painting, dissolved it in liquid, rendered it volatile by inserting two electrodes in the solution and passing a current through them, and then submitted it to the spectroscope. The resulting photograph disclosed a spectrum that was indisputably that of cadmium, with antimony of lead totally lacking, and the sale of the painting as the work of a famous master was prevented.

News that a murder has been committed in Paris brings a special squad to the scene from the police. Until they reach it, nothing is

touched. In the squad are five men, three of them photographers, one a specialist in searching for fingerprints and the fifth a draftsman skilled in reproducing the scene of the crime in exact detail. Upon arrival one investigator examines the lock of the room before they enter and another photographs any fingerprints he finds. Inside, they photograph everything that may be important, both in ensemble and in detail. One of the three cameras is a

special outfit for fingerprints alone, another takes the broad views of the room and surroundings, and the third is for close details. While the photographers work, the draftsman is busy measuring and sketching an exact plan of the house or apartment, with positions of every piece of furniture, the body, weapons and other objects shown.

Every object in the room which the criminal might

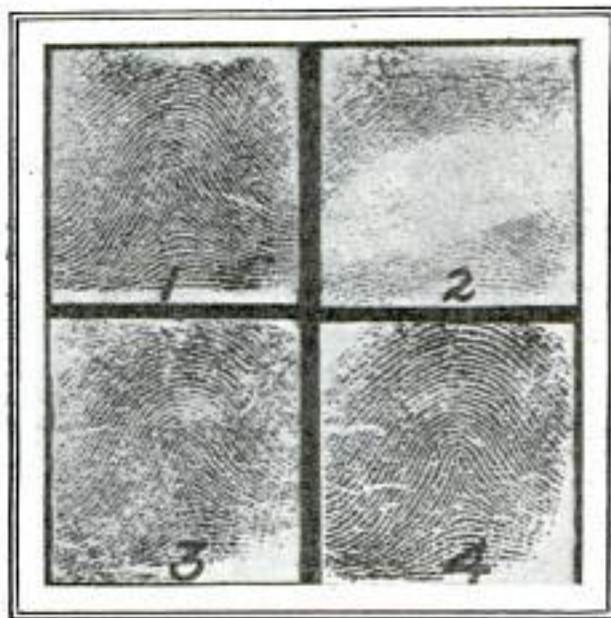

Proving Fingerprints Are Permanent; (1) Original; (2) after a Burn; (3) While Healing; (4) Healed

45 have touched is carefully examined for fingerprints, and if any are found, is photographed. In a single year the police bureau obtained 2,300 fingerprints at the scenes of various crimes and identified 123 criminals from them.

The work of the bureau does not always aim to convict. Sometimes the innocence of an accused person is proved, and he is eliminated from the investigation. In one case, a man suspected of murder was found to have a flesh-stained hatchet in his possession, and the crime was committed with some such instrument. Near the scene of the murder, however, a scrap of newspaper was found on which the slayer had cleaned his hatchet, and the scientific examination of the prisoner's tool showed it had last been cleaned with cloth. The examination further showed that the flesh stains on the prisoner's hatchet were those of salt pork, and he was released.

Use of ultraviolet rays in police work also has been perfected by the French scientists. These rays, outside the normal spectrum revealed by a prism, have the property of exciting certain substances into fluorescence, or causing them to illuminate themselves. Thus the rays, ordinarily invisible to the eye, become visible. Because of their peculiar properties, they can detect forgeries which defy the usual methods. In one case where French government bonds had been paid, then stolen from the government vaults, altered and presented for payment again, the rays disclosed where the original date of payment had been washed out with

chemicals and a new date substituted. The original ink with which the bonds were printed responded to the illumination, whereas the forged date contained grease which kept it from becoming fluorescent.

This first test merely showed that the bonds had been altered, and the necessity of finding the criminal remained. One man was under suspicion. The only clue was an ink-stained piece of blotting paper, found in his home. The blotter and stains were dissolved in water, and a fragment of the forged bond date with the greasy ink dissolved in another test tube.

Platinum electrodes were inserted in each tube and a small electrical current passed through them, the amount depending, of course, on the resistance furnished by the dissolved ink. With delicate headphones, the scientist listened to the sound of the current. If one liquid had offered more resistance than the other, proving the inks were not the same, there would have been a singing sound in the phones. But there was no sound at all, since both liquids offered the same resistance, and this proof that the ink found in the blotter in the suspect's home and the ink used on the forged bonds were the same, was accepted.

One of the most unusual of modern developments owes its origin to New York, where a special plastic material has been used successfully to reconstruct the features of a skeleton.

Recently, the police in this manner, restored a dead man to such lifelike reality that friends recognized and named him.



General View of the Chemical Laboratory of the Paris Detective Bureau Where Many of the Amazing Crime Solutions Which Have Made the French Police Famous Were Worked Out

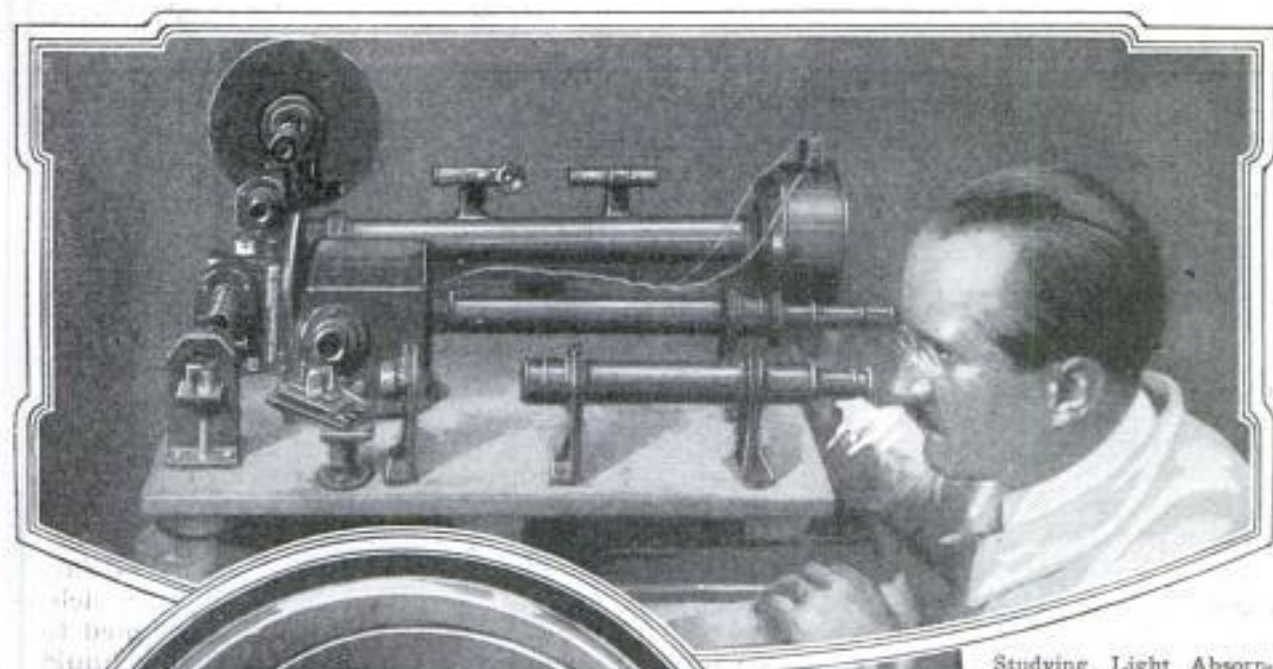

Studying Light Absorption of Two Samples of Paint, the Operator, Above, Determines Whether the Stain on a Criminal's Clothes Was Made at the Crime Scene

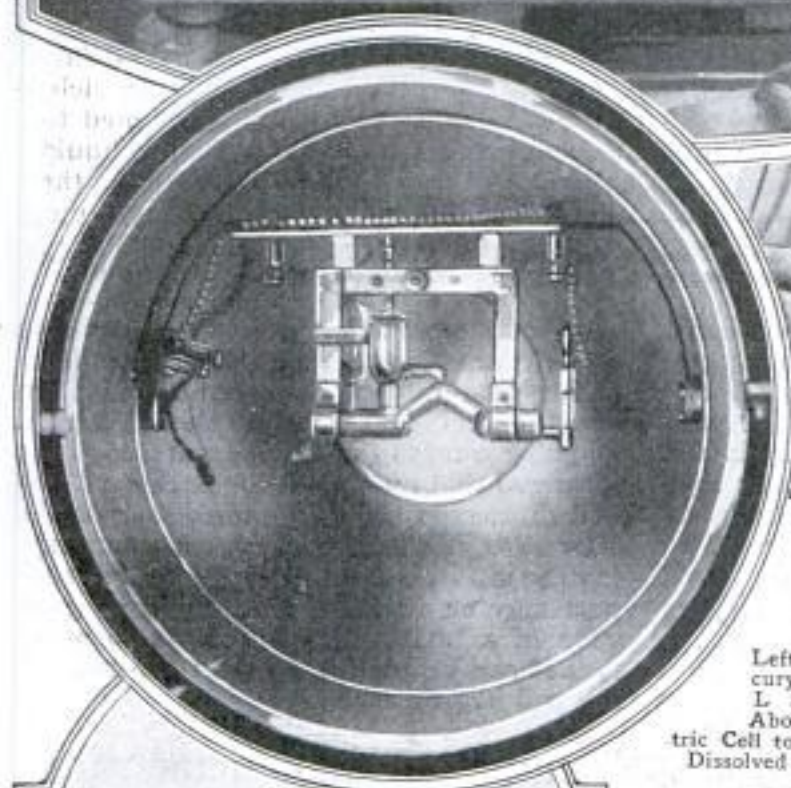

Left. Mercury - Vapor Lamp; Above, Electric Cell to Identify Dissolved Samples



Face Reconstructed with Plastic Material on Skeleton Found in New York, Leading to Identification of the Murder Victim; Above, French Detective Examining Falsified Bonds under Ultraviolet Rays, a Method Which Proved They Had Been Stolen

FIRE ENDS CAREER OF USELESS WAR-TIME FLEET

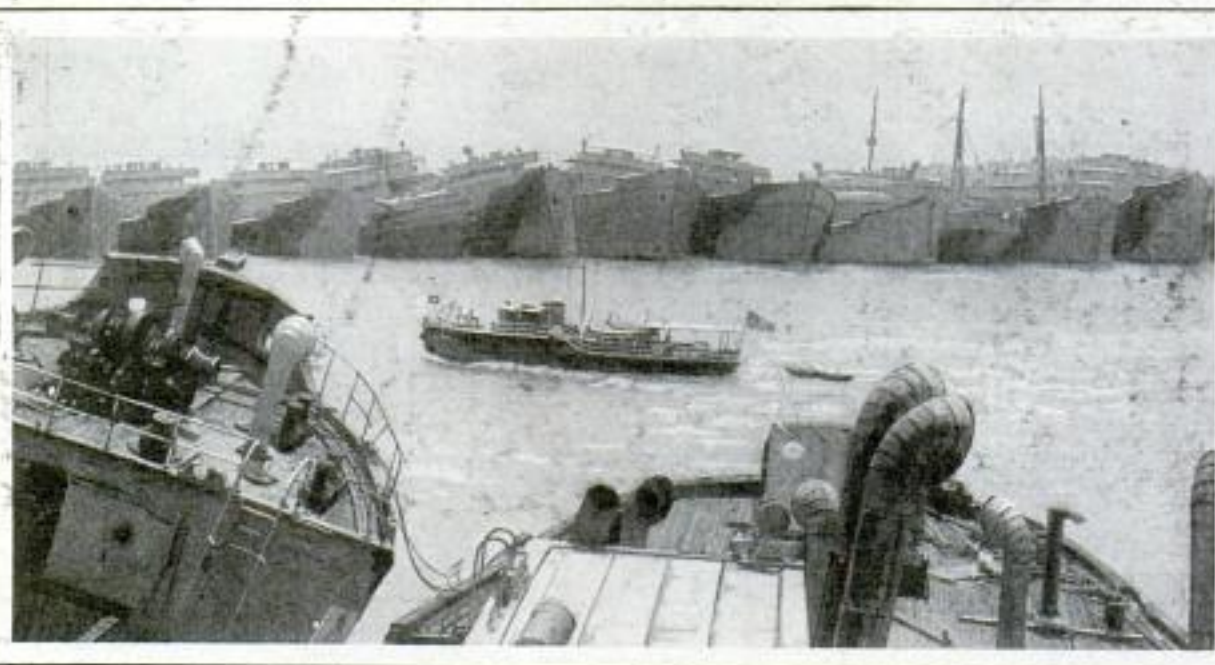

Rotting Hulls of War-Time Emergency Wooden Fleet in Potomac River Before Torch Was Applied to Clear Passage; a Government Inspection Boat Passing between the Rows of Ships

Built to meet emergencies of the World War, but never in service, a fleet of wooden ships in the Potomac river near Tidewater, Va., was burned to clear the passage. Inspection showed that the hulls had rotted and fallen into such disrepair that restoration was impractical. Much of the equipment was salvaged, however.

ADJUSTABLE FISH-ROD HOLDER
KEEPS REEL FROM MUD

Fitted with a clamp that holds the fishing rod in angular or horizontal positions,

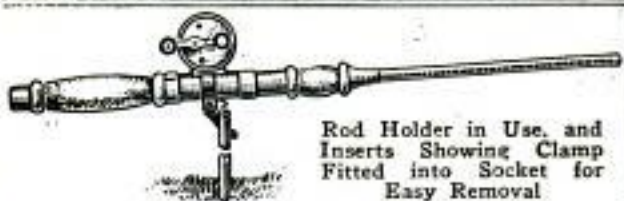
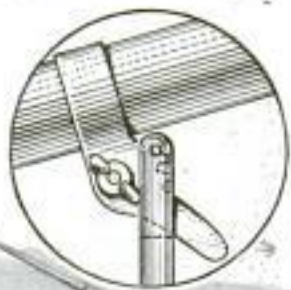

Rod Holder in Use, and Inserts Showing Clamp Fitted into Socket for Easy Removal

a spiked support that is easily thrust into an earthen bank, keeps the pole from falling into mud or sand that might damage the reel, and relieves the fisherman when he wants to rest. The fastening is so arranged that an upward or backward pull will disengage the rod immediately while a forward jerk has no effect. Accompanying the outfit, is a clamp by which the support may be attached to the seat or gunwale of a boat. The holder is so small that it can be tucked away in a corner of the rod bag or case.

260

GERMS ARE GROWN ON FARM
TO SUPPLY SCHOOLS

Germ farming is the business of a Dallas, Tex., citizen. The minute organisms are grown in cultures and sold to scientific bodies, hospitals, druggists and schools. The owner of this singular enterprise spent several years studying and teaching in a medical school, but ill health compelled him to give up his position, so he started the business of germ culture as a means of livelihood. Nearly all the commoner species are kept on hand, and rare ones are grown to order. Students frequently visit the laboratories to study these organisms.

*Mr. Atty's Saunders
Especially of the material
Letter retd*

*Kiefer Kempt Rod Holder Co
1626 Carll St. Cincinnati Ohio*

Moore lease near El Paso,
drilled by N.W. Co.

COLD-AIR FLOW FROM OIL WELL RUNS PUMPS AND ENGINES 29 **SKILL OF DERRICK MEN TESTED IN PLACING BRONZE STATUE 26**

Searchers for oil in Scurry county, Tex., failed to find the cherished flow after digging a deep well recently, but a blast of intensely cold gas rushed out at a reputed rate of 4,000,000 to 6,000,000 cubic feet daily at a pressure of 250 pounds. At first, it was thought that a new supply of helium had been found, but analysis showed that the gas was mostly nitrogen. But the owners harnessed the flow, directed it into an ordinary steam boiler and obtained pressure sufficient to operate an engine used in drilling other wells near by. As a precaution, the boiler was buried, leaving only a pressure gauge showing. A line was tapped off from the main conduit and led to a shallow well not far away which was producing only a small quantity of oil. The pressure of the air stream was directed down into the casing and the well was thus made to "pump itself." Some of the air was used to operate a turbine generating electricity for the works. The gas was so cold that workmen quickly cooled water for drinking simply by holding a cup at a leaky joint in one of the pipes.

Hoisting a heavy bronze statue of Gen. Sam Houston upon a high base erected at



Swinging Huge Bronze Statue of Gen. Sam Houston to Its Position on High Stone Pedestal Arch with Strong Derrick

the entrance to a park in Houston, Tex., enabled derrick operators to demonstrate their ability to perform exacting as well as rough tasks. Care had to be taken not to damage the masonry, and the huge figure, said to be the second largest equestrian statue in the United States, also demanded skillful handling of guide ropes and derrick before it was finally lowered to the correct position on its support. Two men, stationed on the arch, directed the operators below.

Popular Mechanics Magazine does not publish the name of maker or seller of any device described in its pages, but this information is kept on file and will be furnished free by addressing our Bureau of Information.

RUBBER PURSE FOR BATHERS FITS ON WRIST. 175

Bathers may carry money, keys or other articles with little danger or inconvenience in a small rubber purse that fits snugly about the wrist. It fastens with a strong snap, is watertight, the manufacturers declare, and has no parts that are likely to catch and tear.



Nepstune Rubber Mfg. Co.
Ch. Wington

*Entrance of Hermann Park
Houston, Texas.*

3442

Keystone View Co. Inc
91-7th St New York

Engineering Feats of Nature That Rival



The Lightning Grasshopper, Above, Is South America's Glorified Version of Our Lightning Bug; It Has a Wing Spread of Three Inches

The Spider Web, Above, Glistening in the Morning Dew, Is a Triumph of Engineering; No Two Webs Are Ever Alike, Since Their Shape Is Always Determined by the Location of the Twigs to Which They Are Fastened; the Bees Are Equally Skilled Engineers; the Angles of a Comb Are So Exact They Use the Least Possible Material

A Rook's Nest Built on the Lightning Rod of a Lofty Church Spire in England and Anchored Only to an Ornamental Ball; It Has Survived the Hardest Wind and Rainstorms

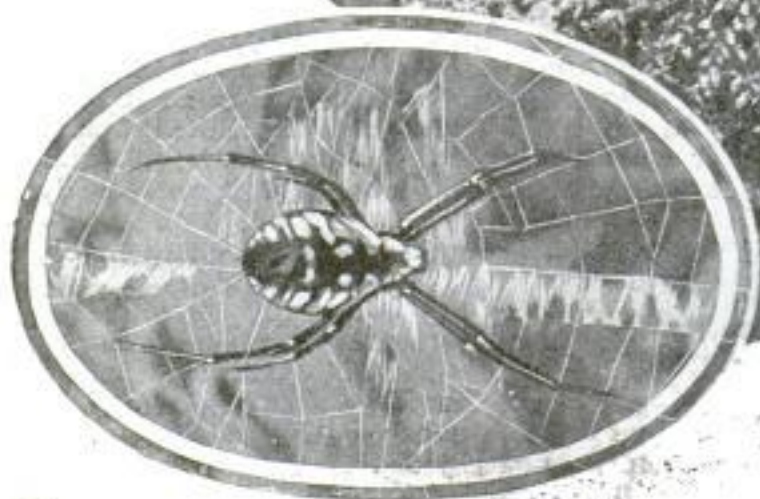

An Orb-Weaver Spider with His Cart-Wheel Web, Pronounced by Scientists to Be Geometrically Perfect; It Consists of an Outer Web of Untretchable Silk and an Inner Web of Sticky Material on Which Insects Get Stuck

the Greatest Achievements of Mankind



Mason Wasp, a Pottery Master Building a Jug of Clay in Which to Hatch Its Eggs, Top Left, and, Above, the Nest of the Social Wasps, Which Live in the Columbia Jungles; It Is Three Feet Long and White

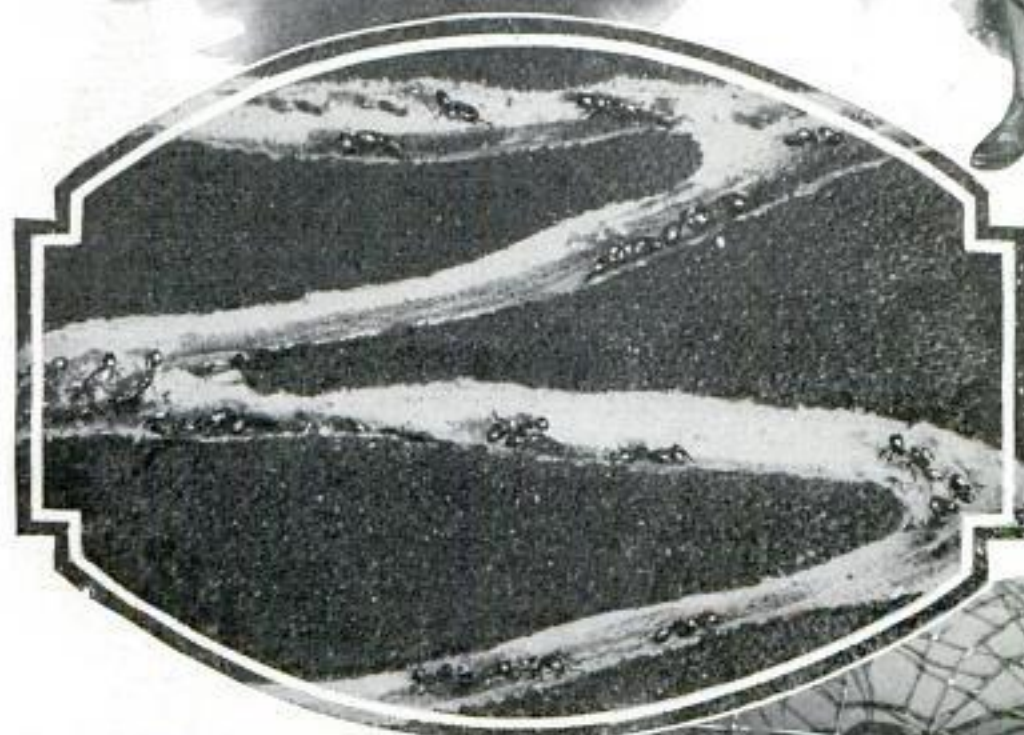

Minute Insects, Magnified Hundreds of Times, Become Movie Actors before a New Micro - Photographic Camera Which Turns Them into Giants on the Screen; Right, a Caterpillar Suspending Itself by a Thread from a Leaf Weaves a Basket Home



SMOKE SCREEN USED TO AID BOOTLEGGERS' FLIGHT

Bootleggers have adapted the smoke screen, an efficient weapon of war, to the

Test of an Auto Smoke Screen at Boling Aviation Field, illustrating how it would aid fleeing bootleggers

automobile so that dense white clouds of vapor can be ejected from the rear of a speeding car, obscuring the vision of pursuers and giving the fugitives time to dart into side streets or lanes. The dispensing apparatus is concealed in such a way that it is entirely unnoticeable except when in operation.

SURVEY OF PACIFIC IS SOUGHT TO ENLARGE FOOD SUPPLY

Coasts and waters of the Pacific ocean can feed the world, scientists estimate, and partly to conserve this huge food supply and to learn more about the vast wonderland under the waters, it is urged that a thorough survey of the Pacific be made. The undertaking is in line with the project in which various nations of the world are now engaged—that of making a new map of the globe. A seagoing vessel, with a wide cruising radius and with a specially trained crew and personnel, would have to be provided for the task. One of the most important phases of the work would be sounding the ocean's bottom so that an accurate map of its bed could be prepared, the location of fishing grounds determined and the rights to use them fixed. Variations of

temperature, the density, acid and salt content of the water, and other factors, are known to affect the migrations of fish, and all these matters would be studied during the survey. Col. E. Lester Jones, director of the United States coast survey, points out that the Pacific was not known to the nations of Europe until about four centuries ago and that today it is in a sense a "new world" 10,000 miles wide at the broadest part, with an area of 70,000,000 square miles, in places over five miles deep, lined here and there with active volcanoes, swept by currents that act as a "climatic balance wheel" for many regions and that flow a third of the

circumference of the world. With the aid of the latest instruments for deep-sea surveying, it is believed that the submarine plateaus, ridges and valleys of the Pacific could be exactly mapped.

BRAKES FIXED TO SLED RUNNERS PREVENT COASTING ACCIDENTS

Automobiles have made the sport of coasting more hazardous in many communities and to prevent accidents, an effective brake attachment has been invented that can be fitted to almost any sled. It consists of a pair of sharp, curved spikes, one for each runner, and fixed to the rear. They rest flat when not in use but turn downward toward the surface by pressure on a lever arrangement in front. This may be operated either with the feet or hands and at the same time acts as a brace to keep the coaster from sliding off at a sudden stop.



Coaster with Brakes, Lever in Front, and Bottom View of Protruding Spikes

314

Washington, D.C.

284

2631

New York Times

8/23/25

and ...
 195 County Road, N.Y.

PRICE OF DIAMOND IS RAISED BY HIGH LABOR COST 320

Diamonds are sold at an average price of \$16 a carat at the mines in South Africa, while purchasers pay from fifteen to twenty times as much for the cut gem in this country. The rarity of fine stones, an expert says, is but one factor of the high price. The great amount of high-grade labor expended to turn the raw stone into a finished gem, is the main item. The cutting process involves the constant risk of spoiling the entire stone. A first step consists in cleaving the specimen with the grain, and requires great care and skill. Small ends are recut into brilliants, while the gem itself is faceted on top and bottom. The next process involves the lapping of the remaining facets, which requires more time than the cutting and causes the stone to lose from one to two thirds of its weight.

Tribune 8/30/25 New York

NON-EXPLOSIVE OIL TANK DEFIES INTENSE HEAT 345

To demonstrate the fireproof qualities of an oil tank, the inventor built a fire of excelsior packing soaked with gasoline beneath it. Although the tank contained inflammable liquid, it did not explode. The container was fitted with special valves and was thoroughly insulated. Its use promises greater safety in shipping oils.



Hudson Maxim with Rock Bearing Dinosaur Footprint Probably Made 10,000,000 Years Ago

FOOTPRINT OF DINOSAUR FOUND ON ROCK THIRTY FEET DEEP 351

A footprint of a dinosaur, plainly outlined in a piece of soft rock, was discovered recently thirty feet below the surface, where workmen were excavating on the property of Hudson Maxim, the famous inventor, at Lake Hopatcong, N. J. Mr. Maxim estimated that the impression must have been made something like 10,000,000 years ago.

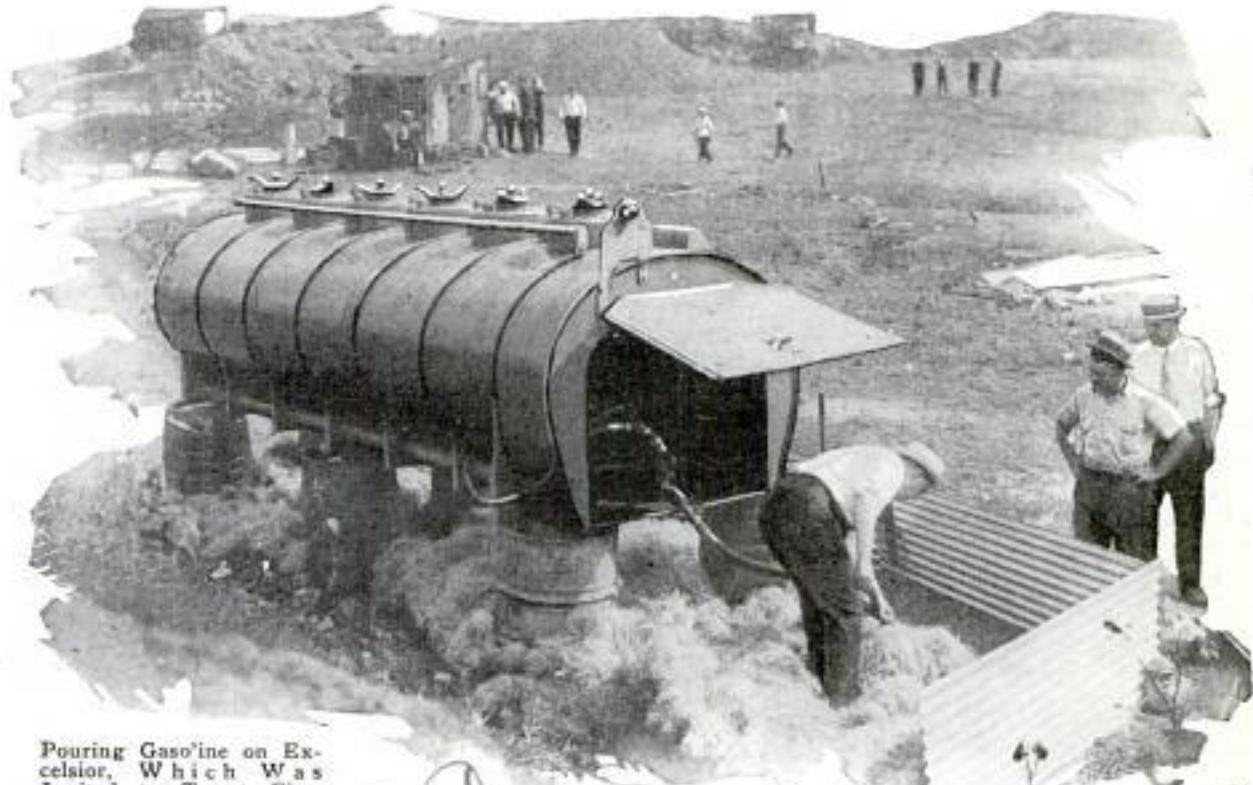

Pouring Gasoline on Excelsior, Which Was Ignited to Test Fireproof Qualities of Tank

Rev. A. W. Scripps - no address

Demonstrated at Corona - Queens - N.Y.

246

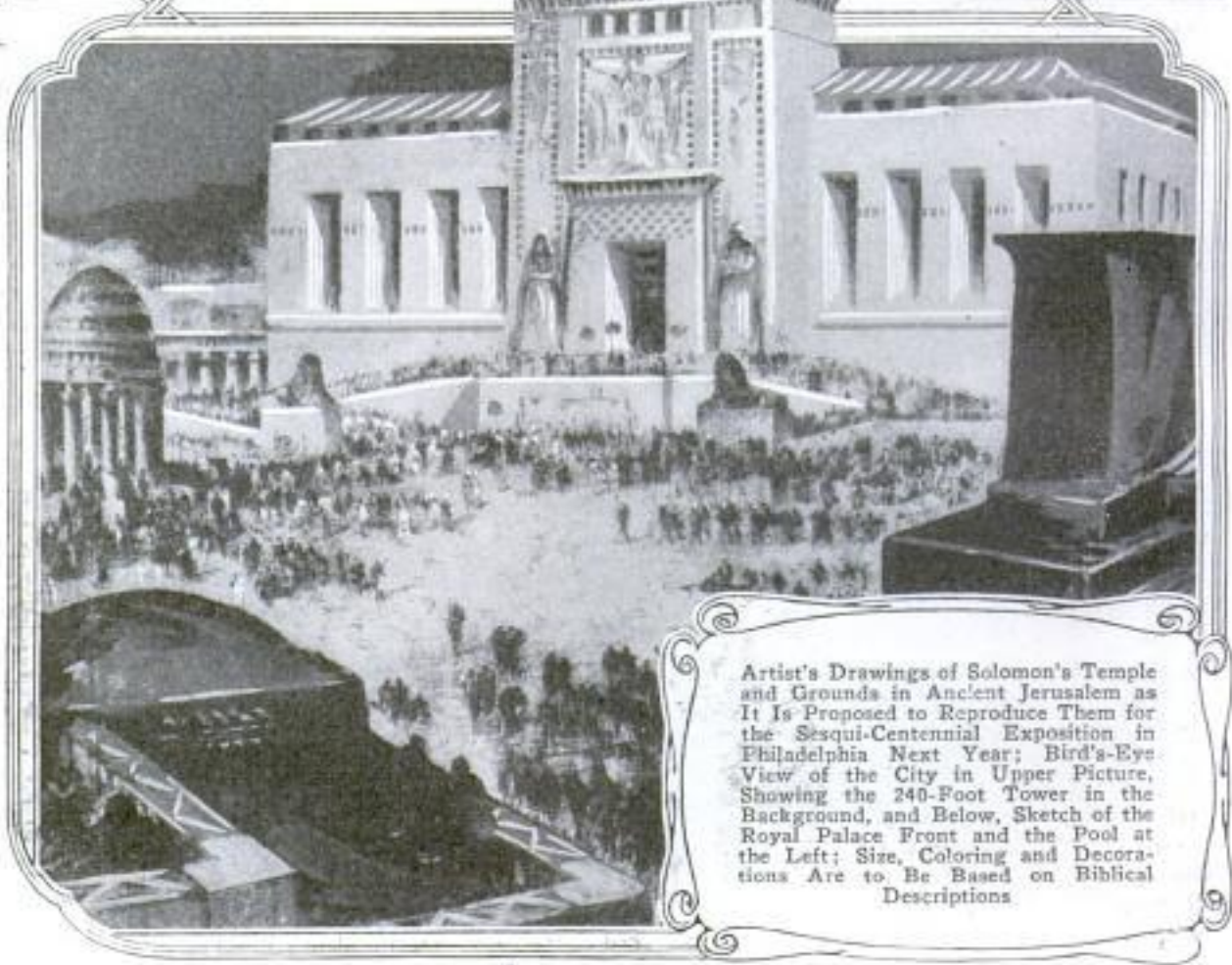
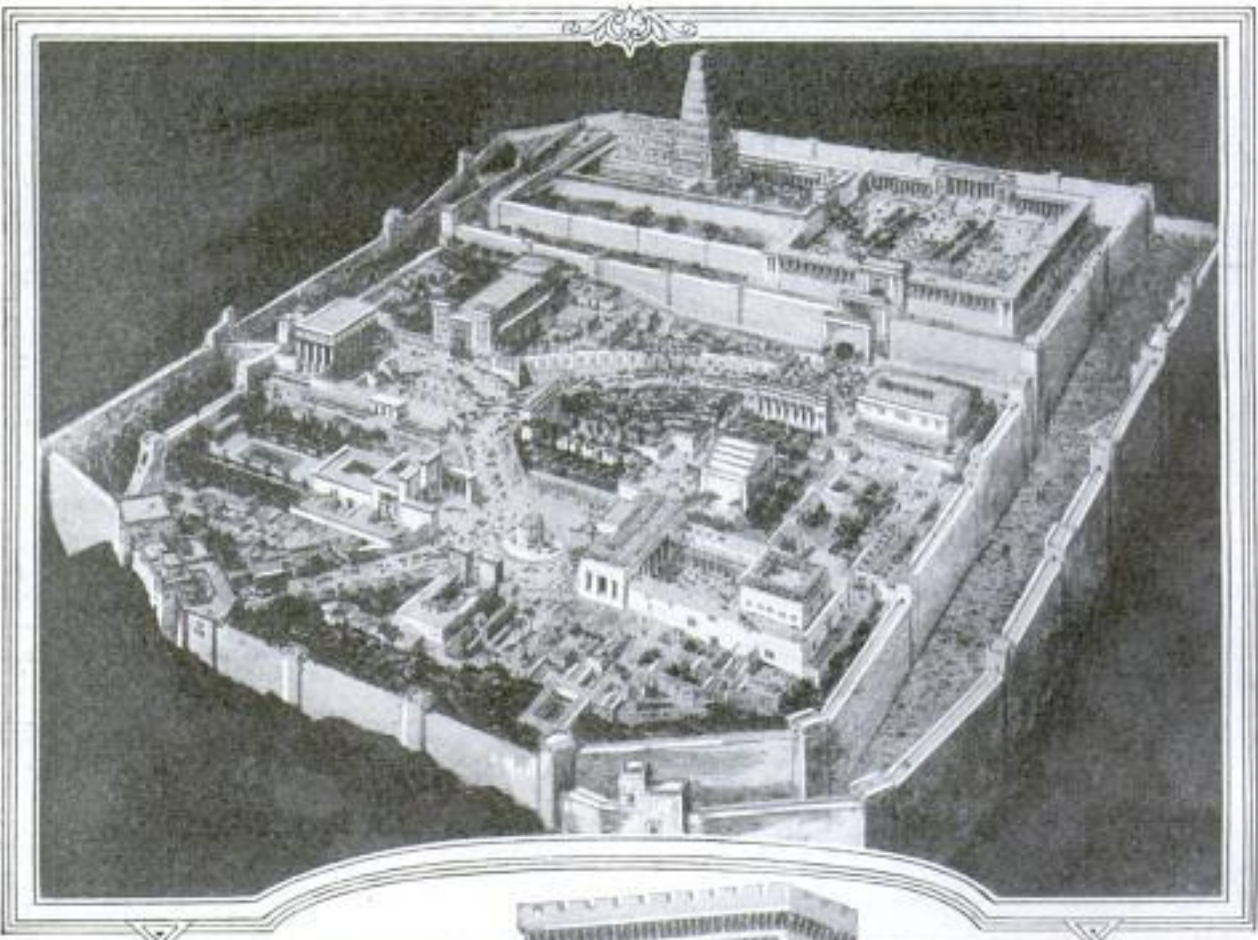

Artist's Drawings of Solomon's Temple and Grounds in Ancient Jerusalem as It Is Proposed to Reproduce Them for the Sesqui-Centennial Exposition in Philadelphia Next Year; Bird's-Eye View of the City in Upper Picture, Showing the 240-Foot Tower in the Background, and Below, Sketch of the Royal Palace Front and the Pool at the Left; Size, Coloring and Decorations Are to Be Based on Biblical Descriptions.

Pacific & Atlantic

358

**GLORIES OF OLD JERUSALEM
TO LIVE AGAIN AT FAIR**

Modeled closely after Biblical descriptions and other data scholars have discovered, reproductions of King Solomon's temple, the pool, the palace he built for one of his wives who was the daughter of a pharaoh, and other edifices that graced Jerusalem in ancient times, are to be shown at the Philadelphia exposition in 1926. One of the outstanding features of the city will be the 240-foot tower of the temple. The entire project is expected to cost nearly \$3,000,000.

**MYSTERY IN BUTTERFLIES' TREK
FROM TROPICS TO ARCTIC**

Each year swarms of butterflies, known as "painted ladies," are seen crossing the sea from France to England on a 4,000-mile journey from northern Africa to Iceland. How they find their way and how fresh broods appear yearly, although the butterflies never have been seen traveling back from the north, are mysteries. It has been suggested that they return in swarms at night or fly back alone as individuals, thus escaping notice, but there is no evidence of this. Another curious feature of the migration is that the butterflies which begin the flight probably are not the same that reach the northern destination for eggs are laid on the way, these hatch into caterpillars and become butterflies that move on toward the north, maintaining a sort of relay race. They arrive in France in May, then cross the channel into England, and, still heading northward, reach Iceland in July.

**ADJUSTABLE BED FOR TOURISTS
FITS OPEN OR CLOSED CARS**

Easily put up or taken down, a full-sized bed utilizes the auto cushions for a mattress and may be used with touring or closed cars. Two rails support the bed and are fastened to the back of the seats. A canvas extension, attached to the front of the car by straps, provides room for the feet. The bed is high enough to give the occupants the benefit of ample ventilation through the windows of the car.

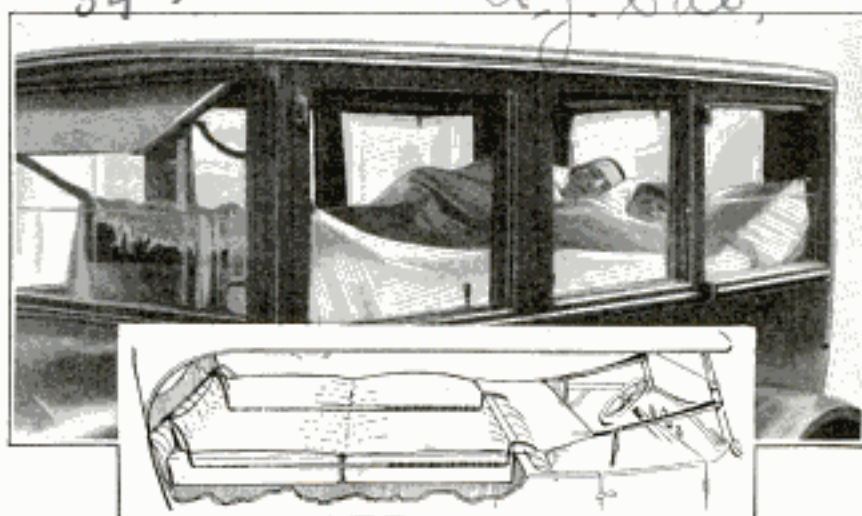

Bed in Use, and Diagram Showing Rails



What Typewriter Keys Will Do under an Artist's Fingers—a Dutch Scene in Letters and Figures

**ARTISTIC SCENE IN HOLLAND
DONE ON TYPEWRITER**

Executed entirely on a portable typewriter, a scene in Holland is the work of a Dutch artist. Figures and letter characters both were used, and contrasting shades were achieved by superimposing a number of symbols to make lines of the heaviness required.

Rotterdam, Holland.

C.B. Williams, Chief Entomologist
Egyptian Ministry of Agriculture

Waterloo Specialty Mfg. Co.,
108 E 5th St. Waterloo Iowa.

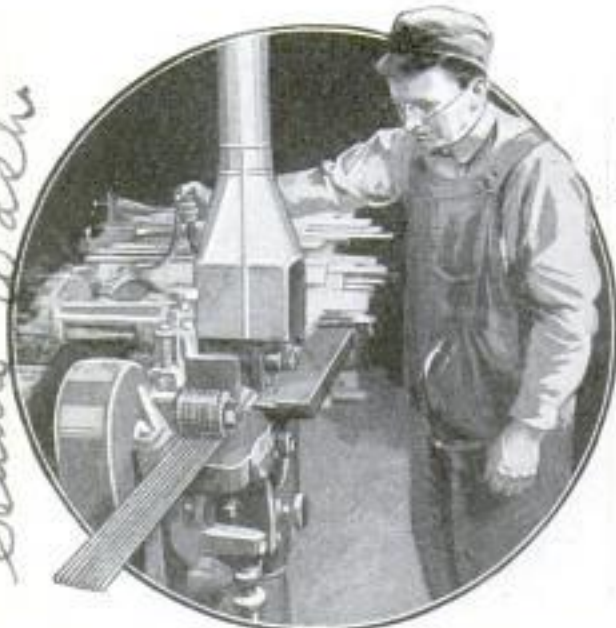

Finishing "All-Day-Sucker" Sticks on Cutter with Capacity of 50,000 an Hour

MAKING OF "ALL-DAY-SUCKER" STICKS IS NEW INDUSTRY

To meet the demand for sticks to hold the popular "all-day sucker" and similar confections, an automatic cutter which converts boards into sticks at the rate of 50,000 an hour has been devised. By a simple adjustment, it can be turned into a saw mill for the manufacture of skewers, leadpencil stocks, spools, rulers, tags and

other wooden articles. It uses wooden strips three inches wide and a quarter of an inch thick. These are reduced to fourteen thin round pieces which are cut into four and one-half-inch lengths and packed for delivery to confection makers.

WHALE BATTLE IN POLAR SEAS WITNESSED BY EXPLORER

During one of Scott's antarctic cruises to study the finback whales, the rare appearance of which in the waters near the Falkland Islands, threatened the existence of the islanders, one of his assistants witnessed a stirring battle between a sixty-foot finback and a number of killer whales. The smaller species are armed with strong, sharp teeth, grow from twenty to thirty feet long and are exceedingly ferocious. They tear pieces of flesh a yard long from their larger adversary, slash its lips and enter its mouth, ripping out its tongue. The ocean's surface becomes red with blood over long stretches after such a conflict. The killer whale usually lives on smaller fish and remains around the mouths of rivers lying in wait for its prey, but occasionally is found miles out to sea, hunting and attacking the largest whales without fear. One scientist found parts of thirteen dolphins and fourteen other victims inside a killer seventeen feet long.

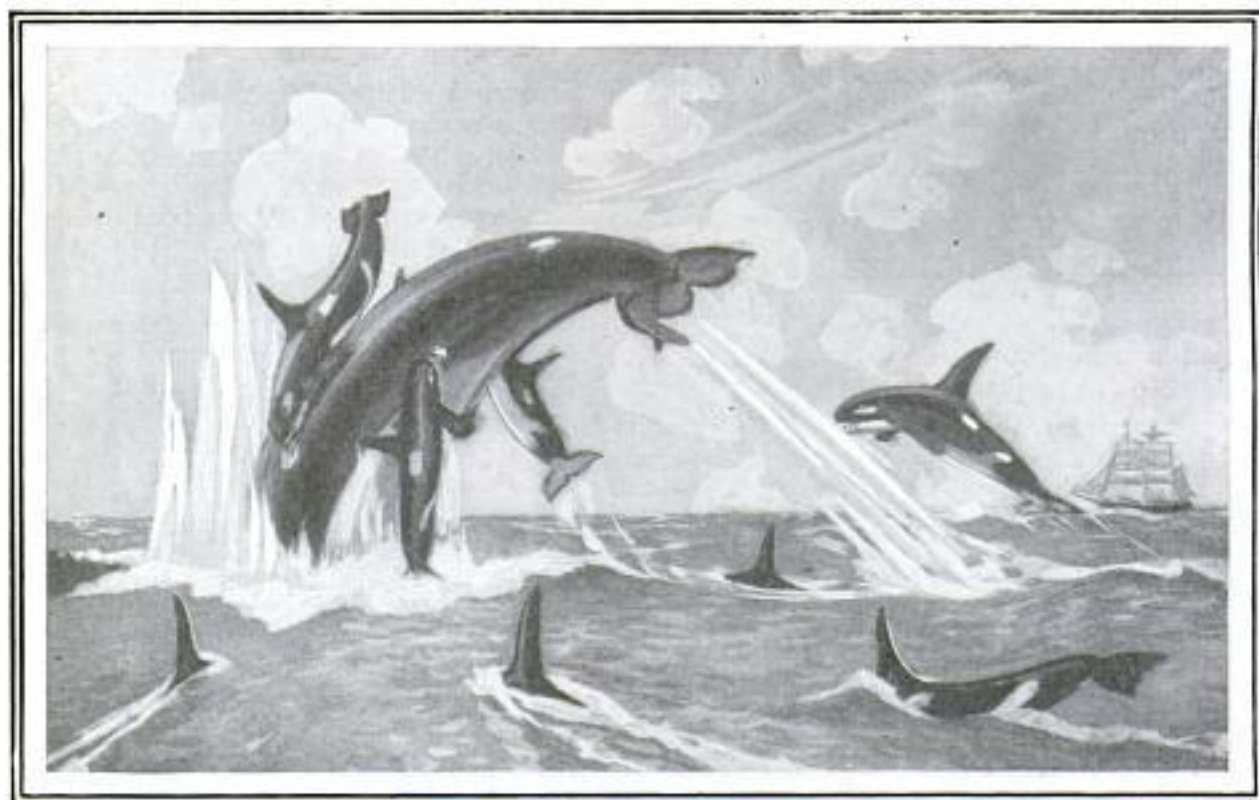

Artist's Drawing of Savage Battle between Killer Whales and Monster Finback in Antarctic Sea; Attackers with Their Sharp Teeth, Ripping Blubber from Their Larger and Almost Helpless Adversary

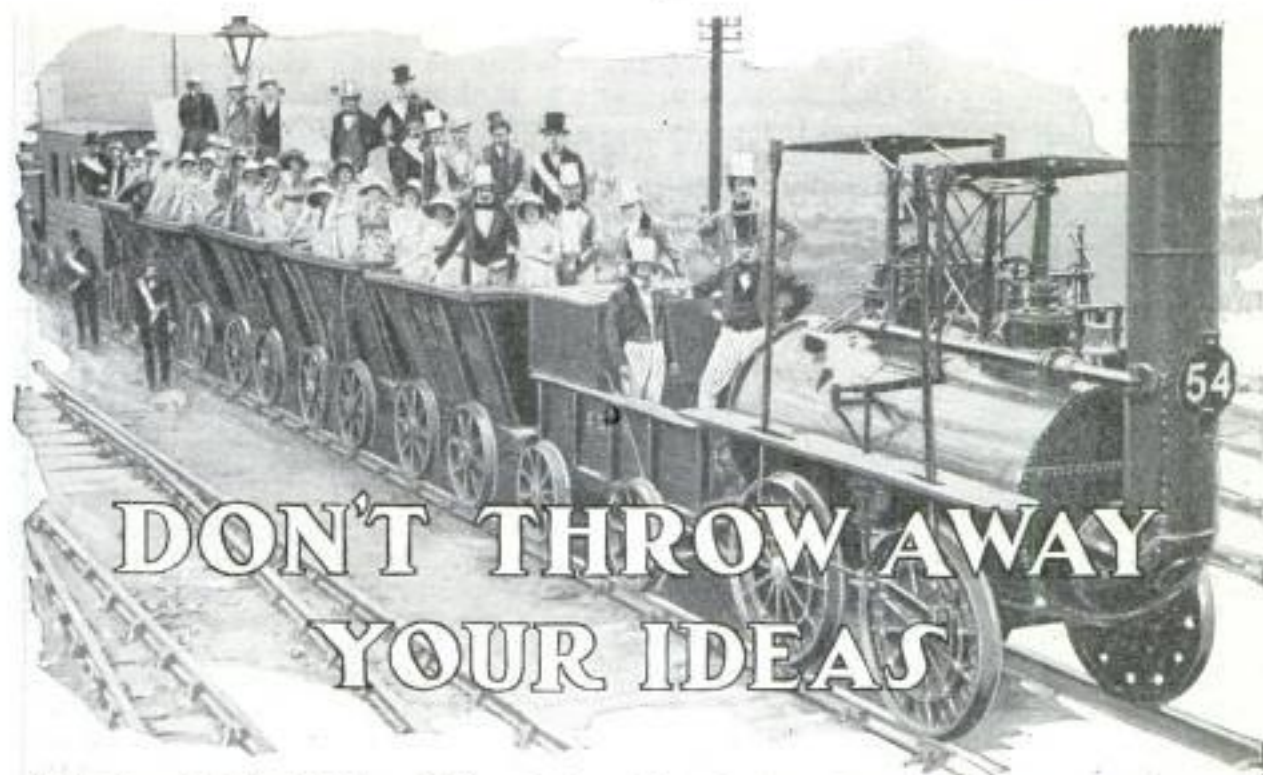

DON'T THROW AWAY YOUR IDEAS

Early Type of Railroad Engine, Hauling Replica of First Train on Hundredth Birthday of Railroading, Celebrated in England This Year

By LEO T. PARKER

MANY of the most valuable patents have been issued on little things, the courts having held that simplicity is the highest trait of genius.

For example, the rubber-covered button of an ordinary hosiery supporter was, during the life of the patent, the source of a princely income for its inventor. This invention merely consisted in covering the commonly used metal button with rubber. Ordinarily the mere change of the material from which a well-known article is made, is not the subject of a valid patent, but in this instance new and useful results were accomplished by the substitution. Not only was the inventor granted a patent, but it was upheld in later legal controversies.

The rubber-tipped lead pencil netted its inventor something over \$100,000 before the patent was, for technical reasons, finally declared invalid. This invention consisted merely in securing an eraser to the end of a lead pencil. Previous to this invention lead pencils were common, as also were rubber erasers, but the use of the two articles in combination with each other was new.

Another valuable patent on an exceedingly simple invention was that of the metal shoe-heel plate which was used so extensively a few years ago to prevent "run over" heels. This invention is the simple application of a curved metal plate

to the outer edge of the heel of a shoe. The selling price of the plate was trifling, but its cost was saved many times over by eliminating the shoemaker's bill for repairing worn heels. Its use, therefore, was economical and for giving it to the world, the inventor received the sum of almost \$150,000.

Paralleling the heel-plate patent, from the viewpoint of large profits as well as similarity of usage, is the metal toe-plate invention, by which boot and shoe wearers were benefited because the toe of their footwear was not so quickly "kicked out." This patent netted its inventor about \$75,000.

The glove and automobile-curtain snap fastener that is in universal use today, was fought through the courts to the ultimate victory of its inventor, who reaped a golden harvest of many thousands of dollars. It is a simple invention, but saves time. The anti-skid chain for automobiles ran its full seventeen years as a valid patent and a very conservative estimate of the earned profits from its sales, in this country alone, is \$5,000,000.

Another interesting fact is that so many inventions have sprung from hobbies. The father of photography was an army officer; of the electric motor, a bookbinder's clerk; the inventor of the telegraph was a portrait painter; of the Jacquard loom, a dressmaker.

Attorney-at-Law
905 Burke Alley, 123 E 6th St.

Examine this.

A farmer tinkered up the typewriter; a poet, the sewing machine; a cabinet-maker, the cotton gin; a coal miner, the locomotive. The telephone was the after-school work of a teacher of the deaf; the well-known disk talking machine, the result of a clothing salesman's night work; the wax-cylinder phonograph, the work of a lawyer's clerk; the type-casting machine, of a grocer. A physician made the first pneumatic tire because his small son was a wheel-chair invalid. The hand camera was invented by a bank clerk; the film roll, by a country preacher; the motion picture, by a stenographer.

The steam automobile was the plaything of a photographic-dryplate maker; the dry-blast steel process, the brain child of a preacher's son; the tunneling shield, of an editor; the stock ticker, of a dentist.

The long-distance telephone loading coils were figured out by a professor of mathematics; bicycle-repair men made the first man-carrying airplane; a soldier, the wireless telegraph; a druggist's clerk, the audion tube for broadcasting daily news, stock quotations, grand opera, etc., and of the loud-speaking telephone.

That has been the story of almost every

great invention. Each has been the result of some one's riding a hobby—a kindly soul tinkering around with what the neighbors were pleased to call his "crazy" idea.

It is noticeable that a new thing, in most cases, originates in a single brain, usually the brain of a poor man. It is not the product of great wealth and a great laboratory. Money only develops; it never originates because money never works in a woodshed. Not infrequently an invention has been suggested by some trivial event which would have passed unnoticed had not a man with an observant mind pondered it.

It was an accident that gave us the telephone. Dr. Alexander G. Bell twisted a screw one-fourth of a revolution and thereby gave us one of the marvels of all ages, but he had no idea at the time what it meant. Dr. Bell was at the time seeking some method of making speech visible by means of light flashes. He was working with a contrivance another man had invented with the idea of carrying speech to a distance by means of an electric current and a wire. The current used was intermittent. When Dr. Bell turned the screw, he closed the gap and made the current constant, which is the principle of the telephone.

He did not realize the value of what he had done until he was demonstrating to some friends that he could talk from the garret to the cellar. The next morning, in order to protect his discovery, he obtained a patent on his invention. At three o'clock the same day another man appeared and sought a patent for the same idea. The difference of a few hours lost him a hundred million dollars.

It was an accident that put George Westinghouse on the track of his chief invention. While on a railway journey he was importuned by a poor woman to buy a magazine. He read in it an article describing a compressed-air borer used in a mountain tunnel, which gave him a clue to his automatic air brake.

Bath towels were accidentally discovered by a towel manufacturer whose machinery got out of order and tangled the threads intended for a smooth product. After readjusting his machine, the man picked up the spoiled material, wiped his hands on it



Alexander Graham Bell, Inventor of the Telephone, Opening the First New York-Chicago Long-Distance Line in 1892



One of the First Automobiles to Cross the Continent Halts in a Mountain Valley to Be Inspected; the Lady at the Left Wears the Motoring Cap Which Was Chic in That Day and Age

and found it more effective than the smooth, so he patented it and made a machine which would tangle the threads.

Sometimes a patent can be obtained on an extremely simple invention which apparently does not present patentable features but which nevertheless has large money-making possibilities. Generally a patent may be obtained on any new device capable of performing new and useful functions. Furthermore, inventors may rest assured that simplification of any well-known invention or device, whereby it is rendered capable of performing its work with greater efficiency, is practically a safe foundation for a valid patent. It pays to protect your ideas and therefore it is advisable to carefully prepare detailed drawings and descriptive matter from time to time at every stage of improvement of the invention, so that priority rights may be proved in any later legal controversies. Moreover, it is good policy to secure two or more trustworthy friends to sign and date the papers, and as further proof, the inventor may appear before a notary public and have the papers sealed.

These are very important protective methods, particularly while an inventor is proceeding to bring the invention to a state of perfection, but simply to have drawings and descriptive papers of an already perfected invention signed, dated and witnessed and then "pigeonhole" the invention is not good practice.

The courts have repeatedly held that an inventor cannot obtain a patent if, after perfecting and reducing an invention to practice, he fails, for an unreasonably long period, to take steps to give it to the public or file an application for a patent,

until some other inventor proceeds in good faith to invent and patent it. It is true that an inventor is entitled to a reasonable time to perfect an invention before applying for a patent, but what period of time may be decided by the courts to be reasonable, depends entirely upon the circumstances of the case. Sickness, poverty and other similar excuses have been held to be insufficient.

In other words, an inventor who secretes his perfected and operative invention, ordinarily cannot obtain a patent against a later inventor who acts in good faith and diligently proceeds to patent and market the invention. But, of course, so long as the invention is new, and is not patented by any other person, it may be hidden away for an indefinite period without destroying or in any way affecting the inventor's chances of obtaining a patent.

If, however, an inventor permits his invention to be described in a printed publication or to be placed on public sale for two years prior to filing an application for a patent, a valid patent cannot be secured. Such public use or sale for two years is an absolute bar to a patent, unless it can be proved that the public use is an experimental one.

Patents may be subdivided into classes of machines or improvements, articles of manufacture, compositions of matter, chemical processes, mechanical processes and designs.

A new composition of matter is patentable. For example, a housewife may invent a new salad, cooking recipe, clothes whitener, baking powder, flavor, candy recipe or any mixture of old and well-known ingredients by which new and ad-

vantageous results are accomplished. All of these things are patentable, and many fortunes have been accumulated from incomes received through just such inventions. But the average individual is not familiar with this phase of the patent laws, and, therefore, very often has a comfortable income within his grasp without profiting by the opportunity.

The courts have held that a valid patent may be obtained on a mixture of the identical ingredients previously and commonly mixed together, provided the proportions are sufficiently different to produce a composition whereby new and useful results may be accomplished. Furthermore, if the steps and method of mixing the ingredients are original, and never before have been applied, a process patent may be obtained as well as a composition patent.

Design patents are another source of extraordinary and sometimes unexpected profits for observant persons who have some ability to invent ornamental and attractive shapes, forms, and figures. A design patent relates to the exterior appearance of an article, which must be the result of at least a degree of inventive genius. Many persons believe that design patents issue to designers solely, but this is not true. Moreover, some of the most valuable and desirable profit-earning patents have been designs that were issued on such common articles as inkwells, dolls,

hats, clothing, etc., which may very easily have been patented by any individual possessed of average intelligence and ability combined with the knowledge that such things are patentable.

So, therefore, many valuable inventions, which might have been the means of producing a greatly needed and much desired income, have been permitted to remain unprotected and unpatented simply because the inventors were misinformed or unfamiliar with the fact that a patent could have been obtained.

Notwithstanding these facts, some of the most valuable patents are simple improvements on well-known devices, but as a rule, such inventions require considerable inventive ability to perfect and are being sought for by a large number of persons. After the invention, however, almost everybody will say, "Well, isn't that simple."

354. ELECTROPLATING FOR CLOTH

By electroplating cloth with a film of aluminum, the fabric is made waterproof without making it impervious to air as it becomes when rubber, wax or rosin is used for the coating. This process originated during the war and was first tried in treating khaki for aviators' uniforms. It has since been improved and one factory is said to waterproof 36,000,000 yards of cloth yearly in this manner.

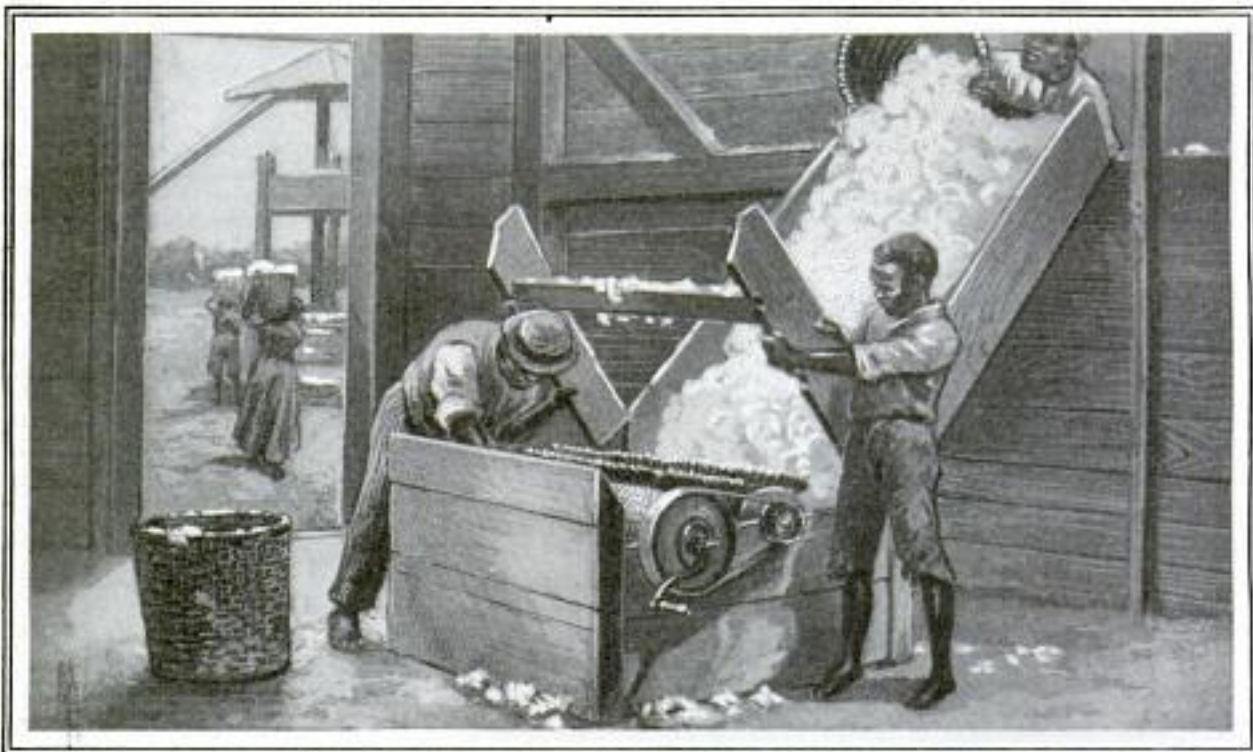

One of the First Working Models of Eli Whitney's Cotton Gin, an Invention Hailed with Dismay by the Cotton-Field Workers, Who Believed It Would Rob Them of Their Jobs

William Esorham Rice -
New York State Civil
Service Commissioner

323 749

PUZZLE PICTURE TESTS POLICE MEMORY AND VISION

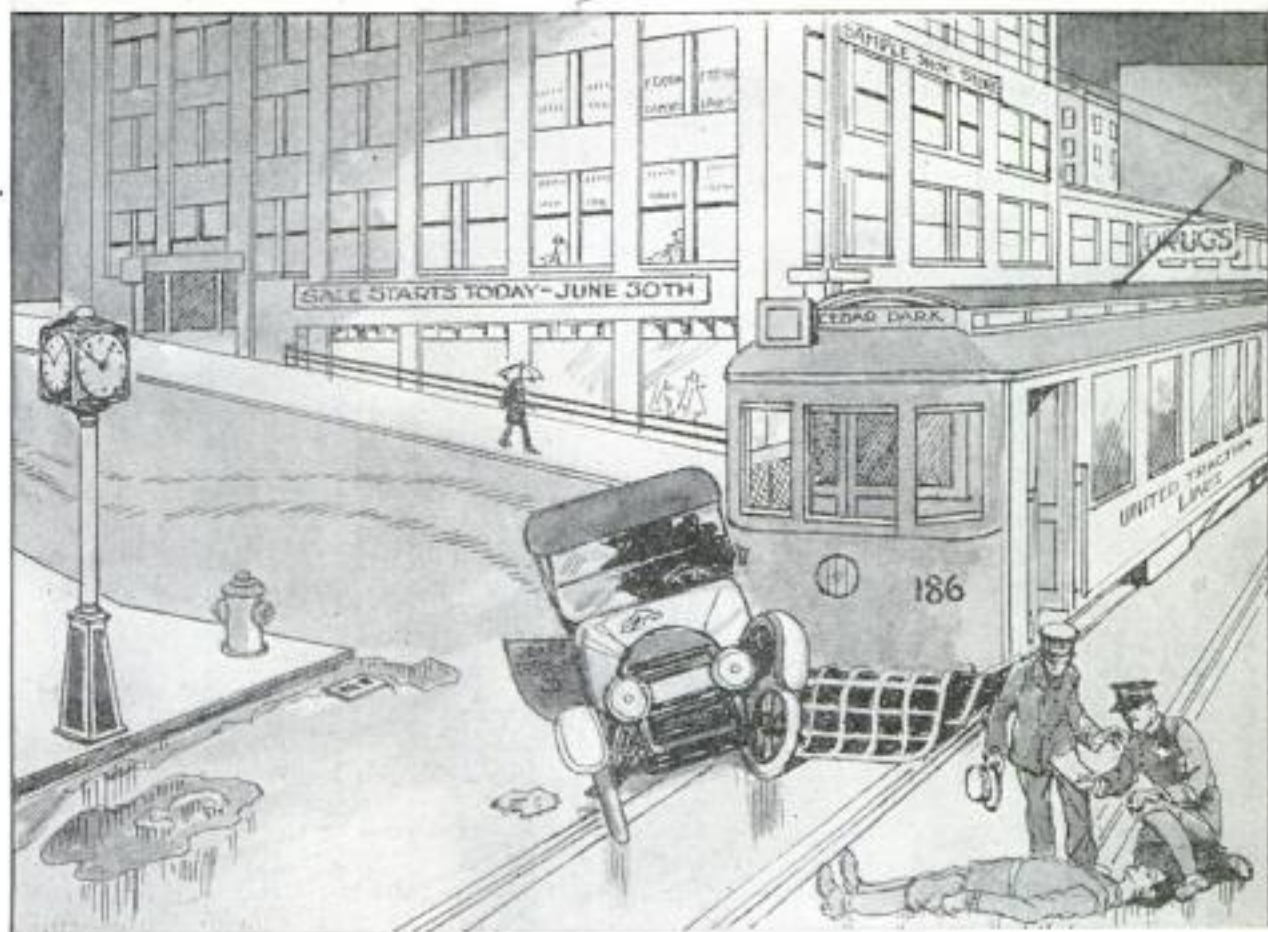

After Studying This Picture for Three Minutes, Police Candidates Are Asked Ten Questions about What They Saw, to Test Their Quickness, Accuracy and Memory

To test the quickness of perception, accuracy and memory of candidates for police departments, the bureau of public personnel administration at Washington has prepared pictures showing a collision of a street car and an automobile. The would-be policeman is allowed to study the print for three minutes and may take any notes that he wishes. At the end of the time, he is asked questions about the things he saw, such as, "On what street was the auto being driven?"; "What was the number on the street car?"; "What shows reckless driving on the part of the chauffeur?" The queries, ten in all, must be answered in fifteen minutes, and the applicant is graded according to the replies. The test has been found useful in that it indicates if the candidate is naturally alert and precise or is unlikely to notice the significant facts of such an accident. Another observation problem consists in allowing the competitor a three-second glance at an automobile license plate, the average time an officer or a pedestrian has to look at a tag under ordinary traffic conditions. He then attempts to write down the number correct-

ly. In tests for automobile drivers, ten photographs illustrating dangerous or objectionable situations are shown the candidates, and they are asked to tell the hazardous feature in each.

MAGNET CHARGER ON BATTERY NEEDS LITTLE CURRENT 2788

Quickly attached to a six-volt storage battery by clips that fasten on the terminals, a simple charger for Ford magnetos can be used in the car, if the flywheel is removed, or on the magnets separately.

It requires no other connections, and is said to use less current than is required for the headlights. Hence, it may be run for several hours without weakening the battery. The usual connections do not have to be disturbed, as the clips are large enough to fit over the regular wiring. Charging can be done in five minutes, it is said, and the apparatus is constructed to last a lifetime.



Horton Electrical
Instruments
Manchester, Conn.
Copyrighted material

Chicago

Motorcycle Stunts by Police Thrill Crowds

276



The "Dust Spin," a Sharp Turn on Dirt Course, Done at the Risk of a Severe Fall

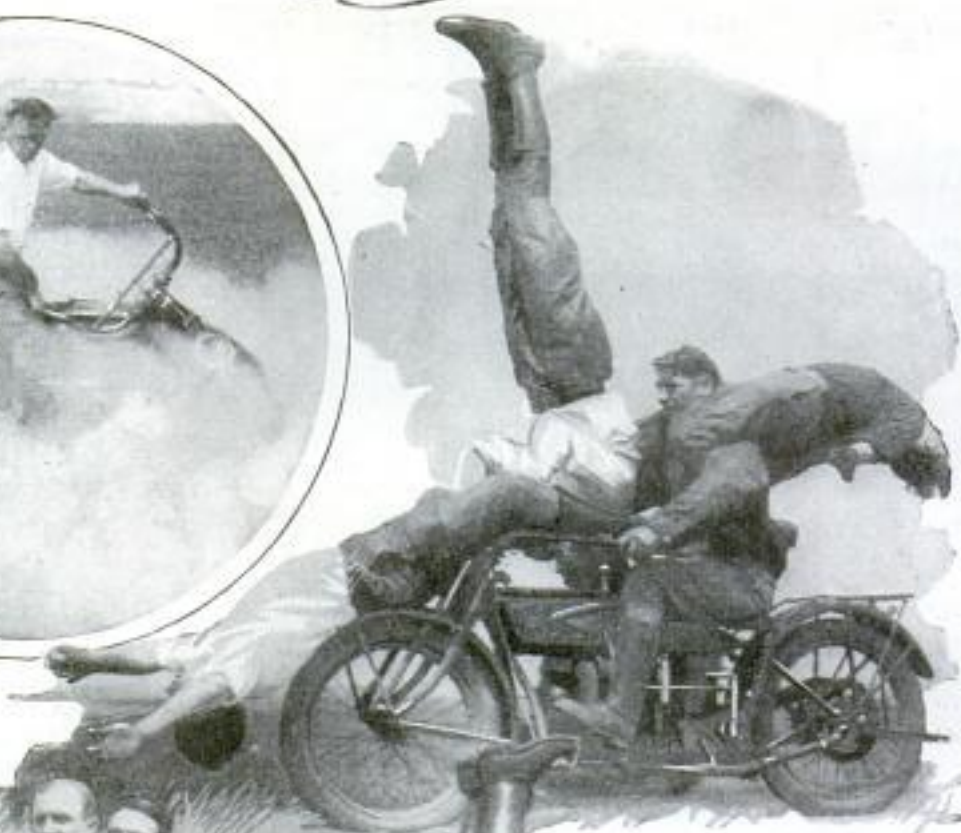

Although Hampered by Three Passengers in Dangerous Postures, Driver Runs at High Speed



Keeping the Balance Tests Skill in Standing Ride, but Men Are Ready to Jump If Accident Happens



Where Teamwork Counts; If Rider Swerves His Machine Suddenly, Other Performers Are Likely to Fall

**PIANO PRODUCES ORGAN TONES
BY MEANS OF REFLECTORS**

What some musicians declare is the most remarkable improvement in the piano since it was first used in the early part of the eighteenth century, consists in the addition of a fourth pedal and a series of "reflectors," by which the vibrations of the strings can be built up into tones resembling those of an organ. Tremolo effects and the "giggle" of the saxophone can also be produced according to the inventor, who declares that the modification adapts the piano not only to better interpretation of jazz music, but also to improved rendition of the works of the masters, since it permits shadings not possible with the ordinary instrument. The notes do not fade and die away after being struck as in the usual piano, but may be sustained and even increased in volume or allowed to escape with almost any degree of softness.

— 340

**AIR SCALE FOR AUTO TIRES
MAKES FILLING EASY**

An air scale which automatically fills automobile tires to any desired pressure and then stops, is the latest filling-station device for the aid of motorists. The scale has a beam and movable weight, like any weighing machine, except that it is inclosed behind glass in a dust-proof case. To operate the scale, the motorist turns a knob until the weight on the beam reaches the mark indicating the air pressure he wants. The chuck at the end of the hose, suspended from a counterbalanced arm, is then applied to the tire valve in the usual way. When the pressure in the tire reaches the point set by the scale, the air is automatically turned off. Besides eliminating the trouble of halting the filling several times to test the air pressure with a gauge, the device is said to be much more accurate, since the large-size scale is built with the same precision as other weighing apparatus of the type employing a graduated balance.

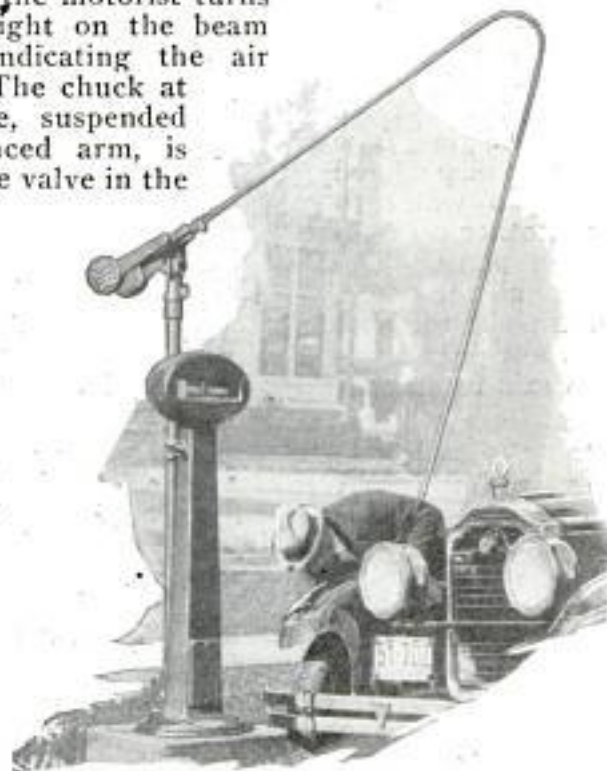

Filling Tire from Air Hose with Scale That Shuts Off at Desired Pressure.

**TESTER FOR SLIPPERY FLOORS
TO REDUCE ACCIDENTS** — 25

More than 250 persons in the United States are killed every week as the result of falls, according to government statis-

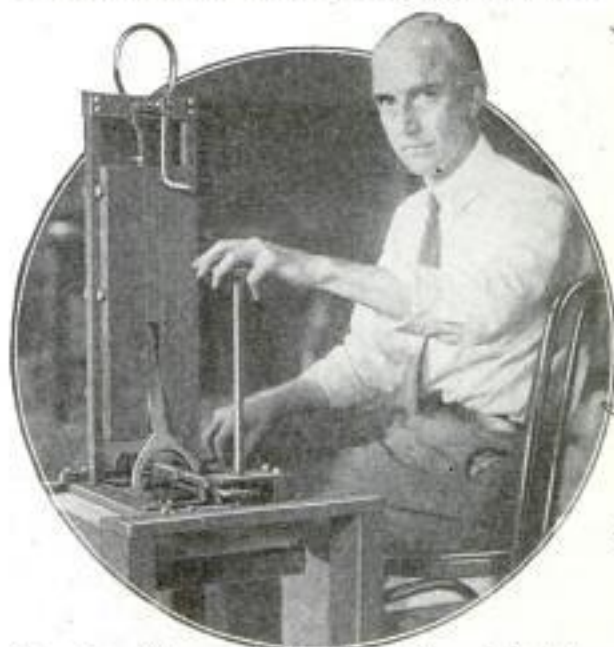

Measuring Slippage of Sample of Floor Material on Tester at Bureau of Standards

tics, while thousands suffer minor injuries. Many of these accidents are due to slipping on sidewalks, floors and other surfaces commonly encountered in the day's work. As a means of determining the hazard presented by various kinds of materials under such conditions, the bureau of standards is testing an apparatus devised to measure slippage. It consists of a lever arrangement resting upon a sample surface which is smoothed to different degrees for the experiment. Pressure is applied by a ratchet mechanism, tending to cause the lever to slide more or less according to the amount of force exerted upon it.

One of Denmark's cabinet members is a woman; she acts as minister of education.

*U. S. Bureau of Standards
Gov. B. Hunter
lev-*

no patent number

*The Air-Scale Co., 810 B. roadway
Toledo, Ohio 810*

**SHOES HALF-SOLED AT HOME
 — WITH WATERPROOF GLUE**

259

With waterproof glue and a set of clips furnished in a small repair box, shoes can be half-soled without going to the cob-



Home Shoe-Repair Outfit with Sole Glued On, and Held by Special Clamps

bler. The old bottom is partly peeled off or removed entirely and the surface roughened for an application of glue. The new sole, cut to fit the shoe, is also coated with the adhesive, soaked in water to soften it and then given another application before being fitted in place. The special clamps attached around the edges, hold the sole from slipping while the glue is drying. The substance not only binds the sole to the shoe but is said to make it waterproof.

267

**GREATEST RAIL HAZARD ENDED
 BY AUTOMATIC SWITCHING**

Riding and braking by hand "wild" freight cars while they are being switched in the big classification terminals, is regarded as about the most dangerous job in railroading. But the perils of the "humps," as the yards are called, have been greatly minimized through an invention of a railroad official for controlling the cars by sets of levers from a tower

instead of having to mount the roofs and turn the brake wheel. Under the new system, the switches are operated by electro-pneumatic devices, and the cars are stopped or slowed down as desired by "retarders" on the rails instead of brakes. These retarders pinch in upon the wheels of the car, effecting the same result as a brakeman on top, but the whole task is performed from the security of the tower where the operator commands a full view of the yards. Increase of twenty-five to forty-five per cent in performance of a yard is possible by using the tower, the inventor declares, accidents are reduced to a minimum and the number of men to a job is reduced thirty-five per cent.

**BELT AND SNOWSHOES FOR AUTO
 FIT IT FOR WINTER TRAVEL**

2518

Traction belts, similar to tank treads, and sled runners, which can be attached to the wheels and frames of automobiles to give them a firm track in winter and to keep them from sinking into drifts, are said to enable the cars to make speeds of fifteen to eighteen miles an hour on otherwise impassable roads. Even deep snow packs that block traffic for other vehicles may be successfully traversed by machines fitted with the winter treads, which cannot be injured by contact with bare ground or wood or concrete surfaces. The attachments are also of great assistance to cars operating in country where roads are often covered with large mounds of shifting sands. In sections where ice and snow impede the progress of fire-fighting equipment, application of the traction belts to the apparatus is claimed to make possible ordinary speeds in responding to alarms. The treads can be fitted to the



Ready for Winter Trips, Auto Fitted with Caterpillar Tread Behind and Runners in Front

cars in a short time, and when in place, prevent skidding, sideslipping and racing of the engine caused by churning of the wheels in deep snow.

(C) W. George Barnum, Inc. 1918
 1000 North Dearborn St. Chicago, Ill.
 1000 North Dearborn St. Chicago, Ill.

Taken over by West Coast
 new station Wis.

West Coast
 H. H.

General Railway Signal Co., Rochester, N.Y.
 Signal Co., St. Louis, Mo.
 Signal Co., St. Louis, Mo.
 Signal Co., St. Louis, Mo.
 Signal Co., St. Louis, Mo.



Cadets in the New Aeronautical Course, in Which Every Future Naval Officer Is Required to Qualify as a Flyer, Show Their Lesson Charts to Assistant Secretary Robinson, of the Navy

FOUR YEARS AT ANNAPOLIS

IV—Finishing the Making of “An Officer and a Gentleman”

BEGINNING of a midshipman's final year at the naval academy is one of the biggest events in any boy's life. As soon as the retiring first class has received its diplomas from the hands of either the president of the United States or the secretary of the navy, the old second class becomes the first, with all the privileges and honors appertaining thereto. Every second-class man, on that graduating day, goes to the exercises with his first-class ring in his pocket, and as soon as the new ensigns are officially commissioned the entire new first class dashes to Dewey basin, the small boat harbor, and dives in en masse to baptize the rings.

The final year at the academy starts off with another summer cruise, and by the time the men return late in August from their third trip, they have seen a good part of the world, visited most of the capitals of Europe, been sight-seeing in quaint old-world ports, looked in on South America, traveled back and forth through the Panama canal, and looked over the Pacific coast of their own country.

When the academic year opens in the fall there is no relaxation in the duties of the upper class. The members still make their own beds, sweep their own floors, and must keep everything in their rooms in the same spick and span fashion as before.

The same grind of lessons, always a bit stiffer than the year before, and of drills and exercises occupy the time of the midshipman in his first-class year. But with his increased rating, he also acquires new responsibilities. He is responsible for the conduct of the men of the lower classes at his mess table, and is frequently called on to assume executive positions, such as being placed in charge of crews at boat drill and on other occasions.

As spring nears, his final round of examinations, and “boning” to make up in studies in which he is weak, keep him busy, but not too busy to prepare for the big event of graduation. June week is an endless round of activities. There is his “farewell ball,” the visits of friends and relatives, the return of old grads, now wearing the insignia of officers of the navy, and, on the last day, with thousands looking on, the graduating class, wearing full-dress white uniforms, receives its diplomas, and henceforth are full-fledged officers too.



Above, Class in Navigation, on the Summer Cruise, Takes a Daily Lesson in "Shooting the Sun" to Determine the Ship's Position; Right, the Ship's Bugler Blows Taps as a Signal That Lights Must Be Put Out



Summer Cruising to Fascinating Foreign Ports Is Not All a Pleasure Trip, for When Coaling Time Comes, the Future Officers Must All Fall To and Fill the Ship's Bunkers, Then Wash Down and Re-paint the Vessel

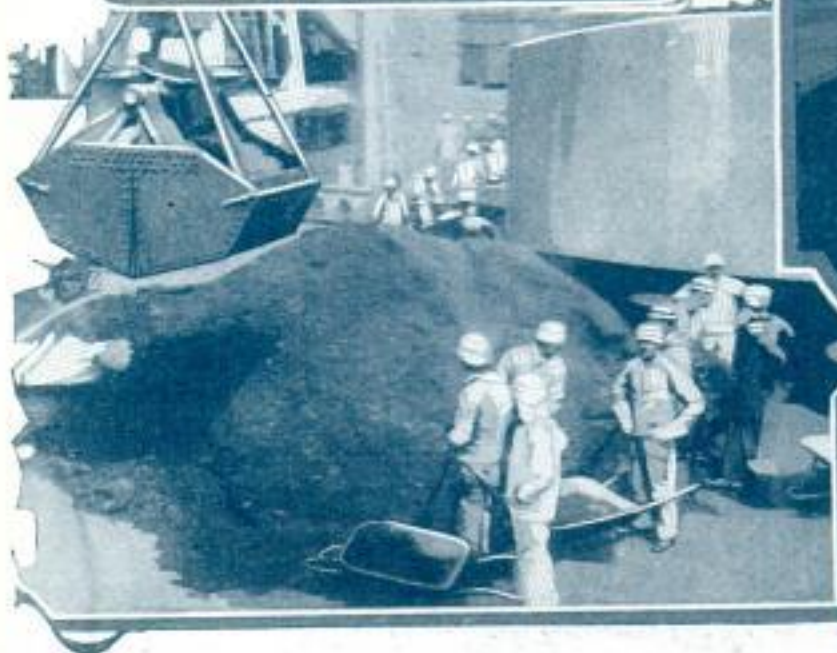

Spotless White Uniforms, Caps and Shoes Must Pass a Rigid Examination on the Summer Cruises Before Visitors Are Received Aboard or a Party Goes Ashore; the Navy Is Always Watchful of the Impression Its Men Make in Foreign Ports and Emphasizes the Necessity of Upholding the Dignity of the Service

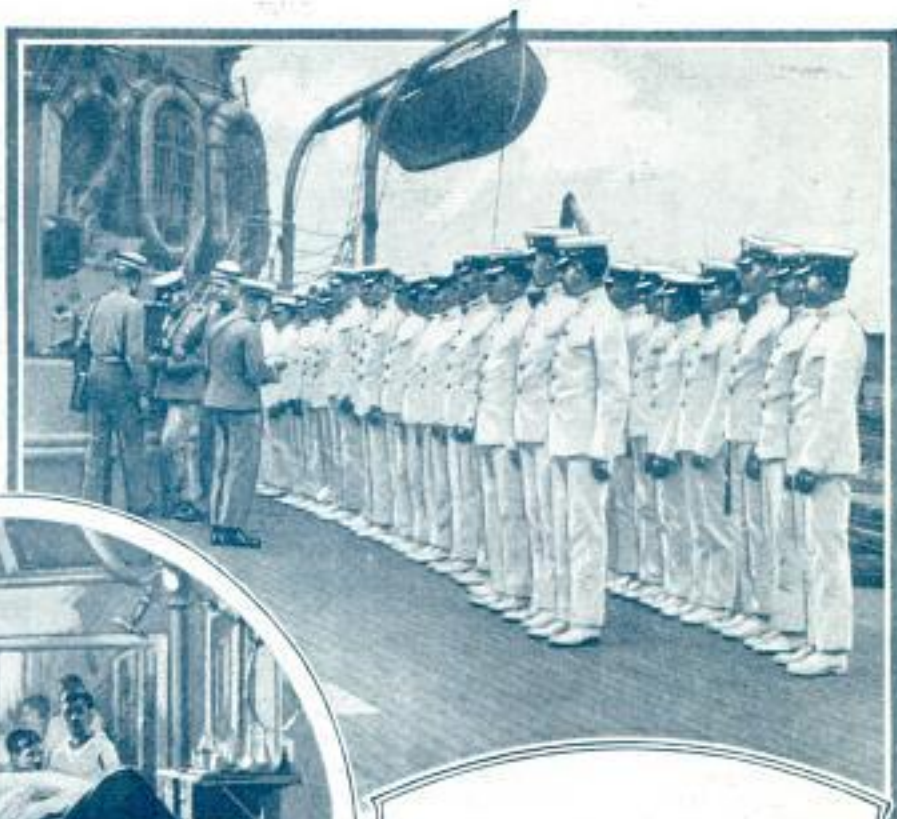

The Ship's Barber Shop, at Left, Helps the Middies Prepare for Inspection; Below, a Motor Launch, Returning to the Fleet at Anchor in Port during the Summer Cruises, Offers an Opportunity for the Midshipmen with Cameras to Photograph Their Ship as Part of the Picture Record of the Trip

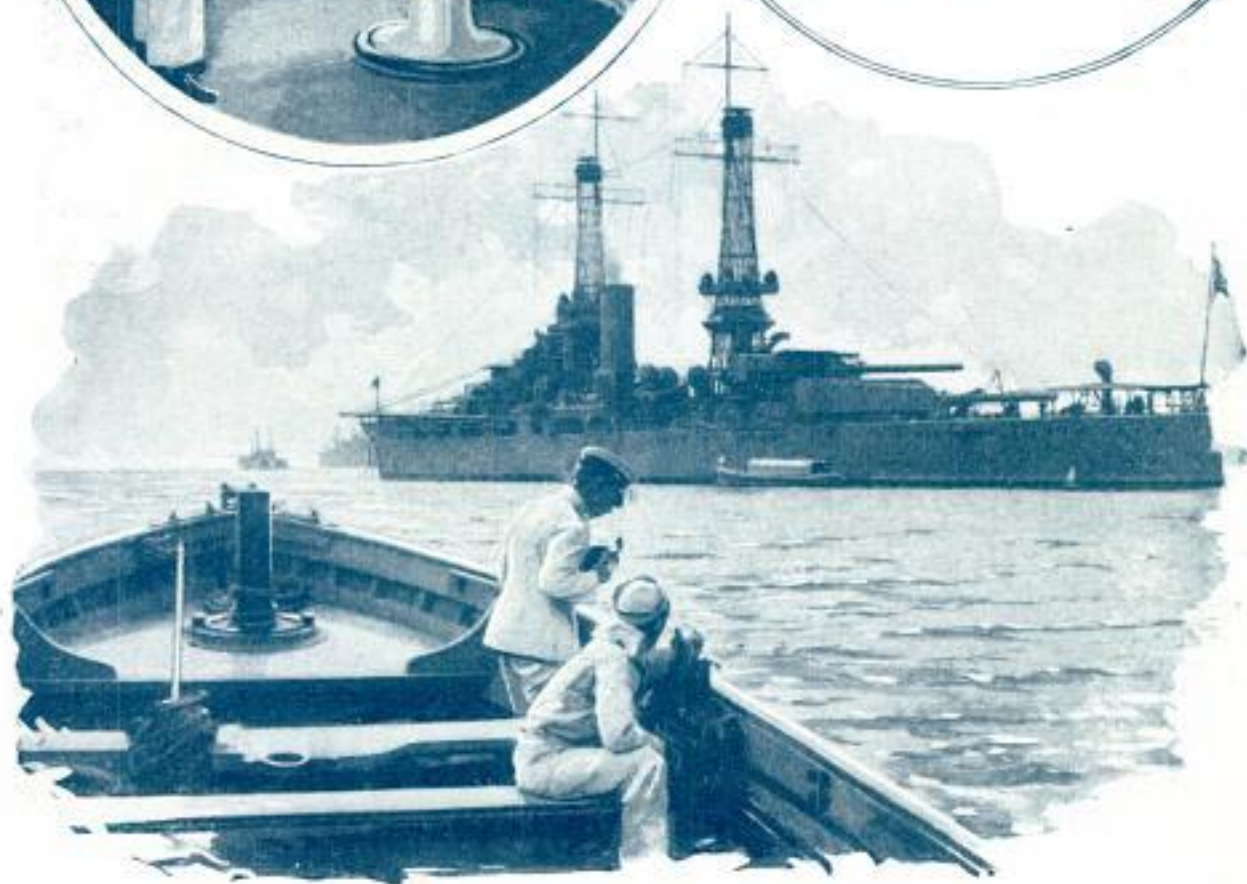

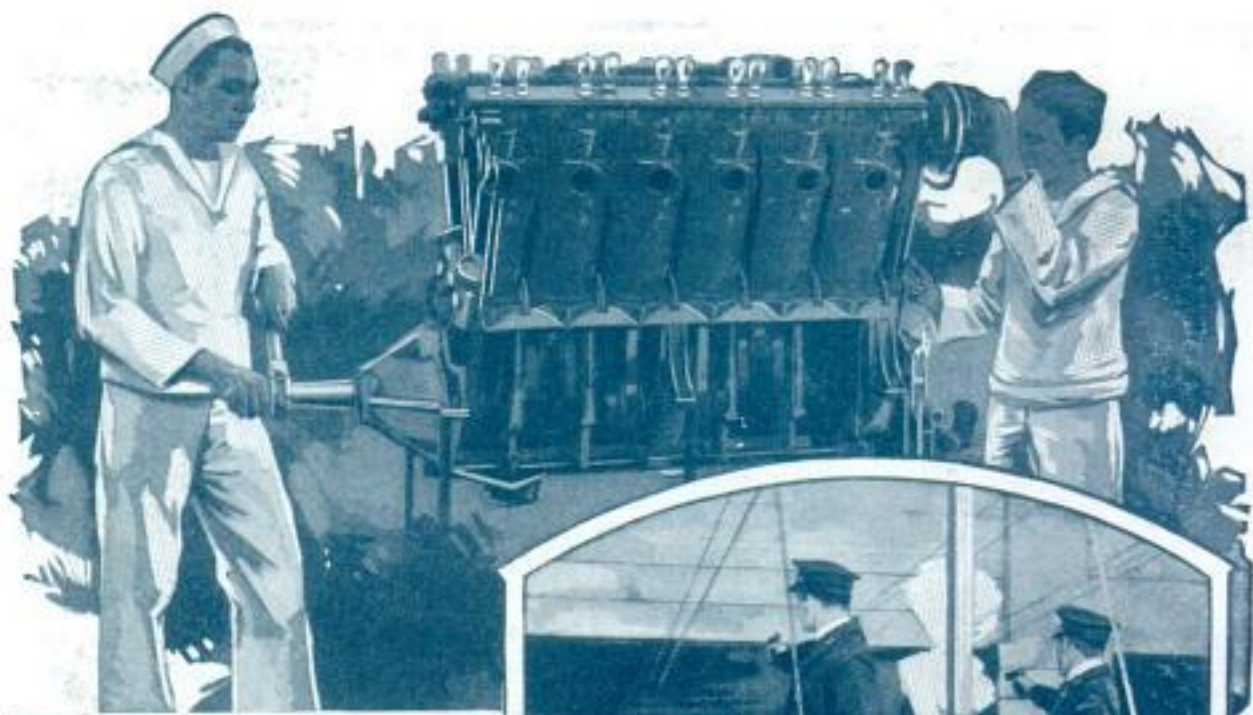

Cut-Out Liberty Engine, Above, Used in Aviation Classes, Has Electric Lights to Show the Firing Order; Right, Pistol Practice Teaches the Regulation Stance in Firing Sideways

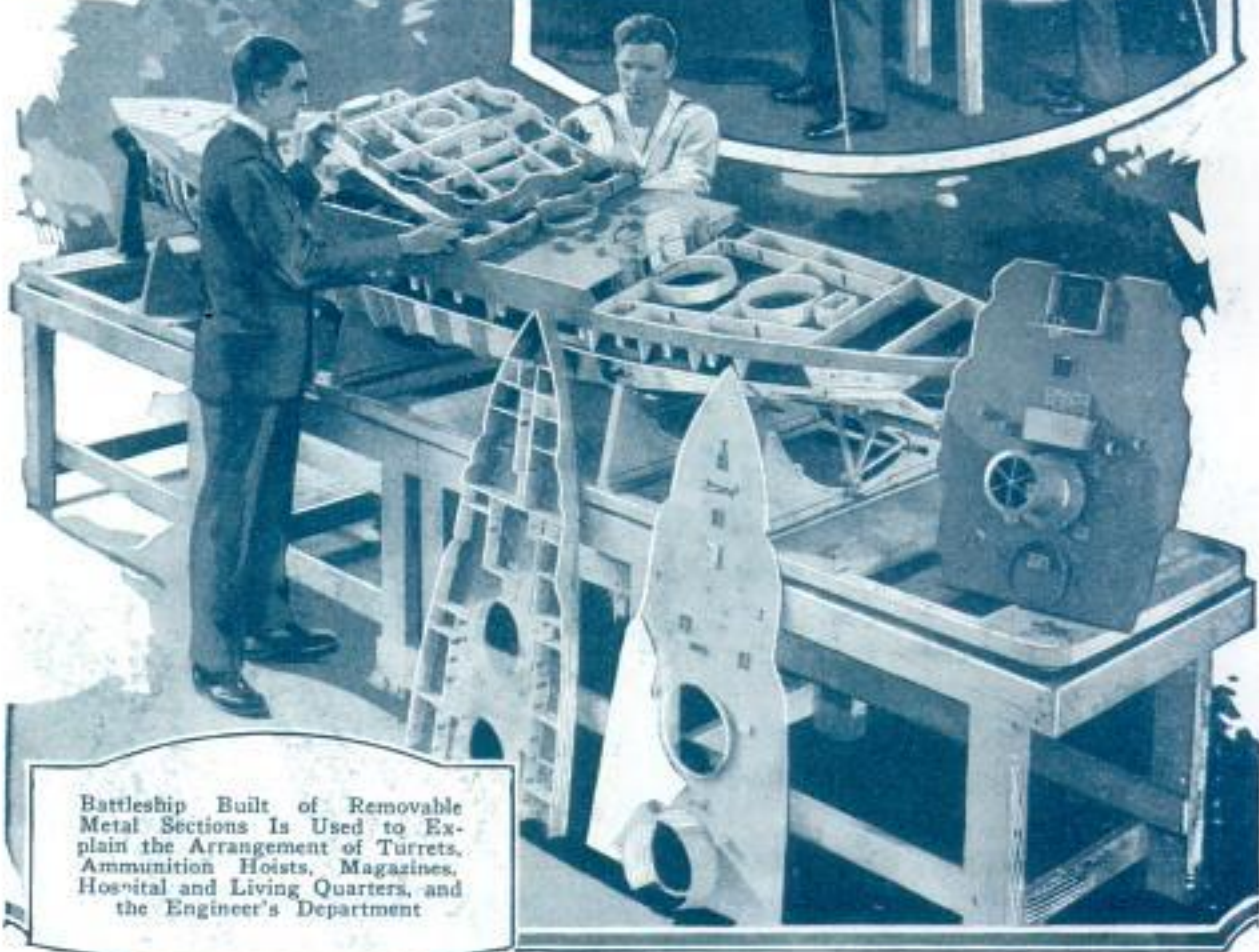

Battleship Built of Removable Metal Sections Is Used to Explain the Arrangement of Turrets, Ammunition Hoists, Magazines, Hospital and Living Quarters, and the Engineer's Department

167

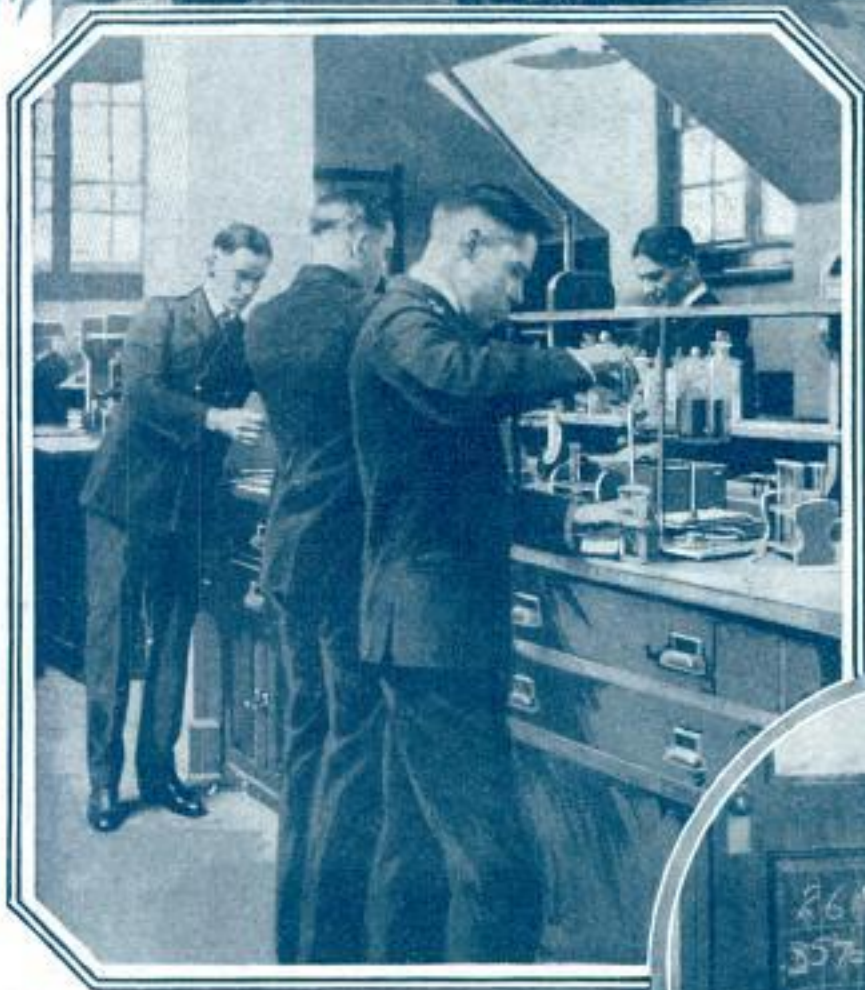
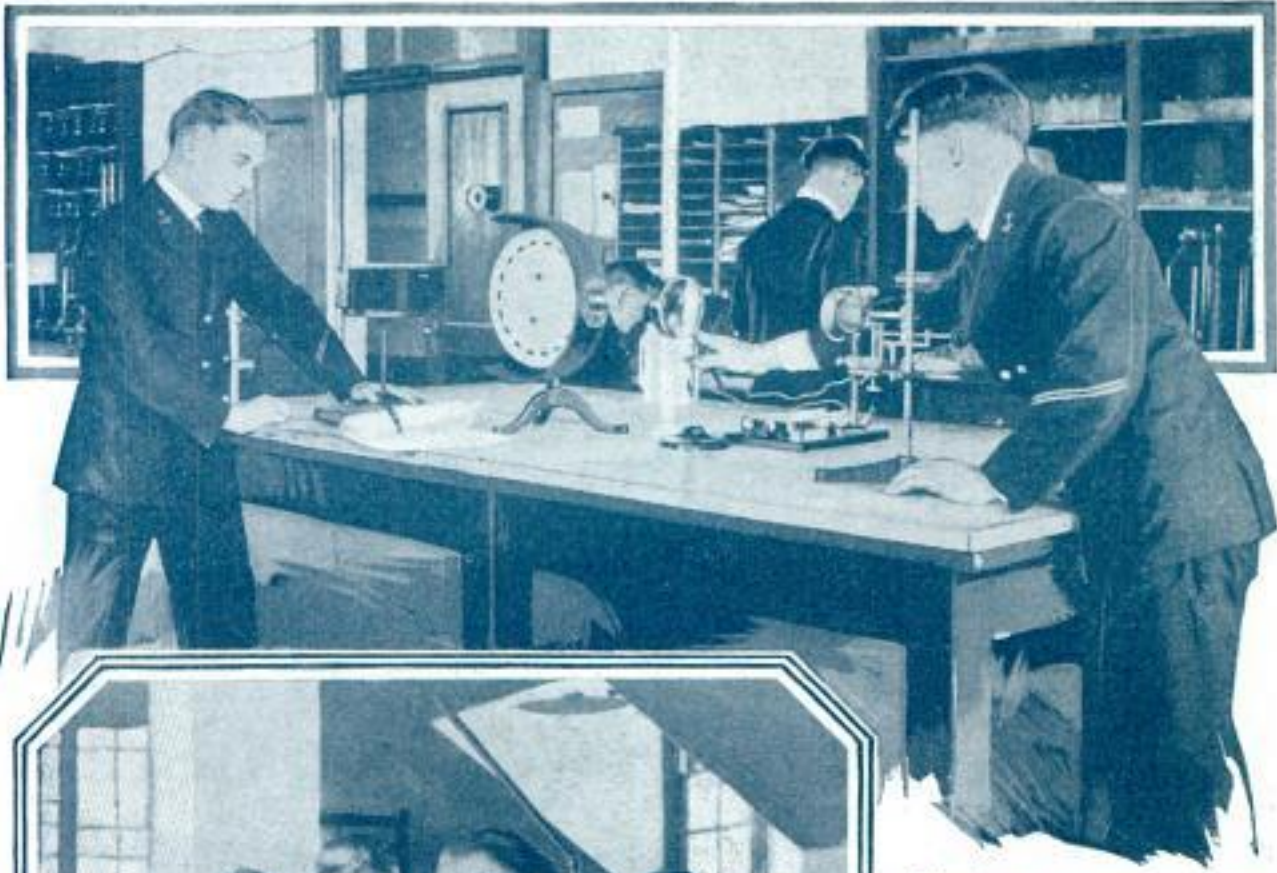

Physics and Chemistry Are Subjects in Which Every Cadet Must Qualify. Since Both Enter to a Large Degree into the Making of Ships, Guns and Ammunition, and Their Operation and Use; the Two Laboratories Are Equipped with the Latest Devices; Above Is Apparatus Used in a Study of Light Refraction, a Subject Closely Allied to the Use of Instruments in Determining a Ship's Position at Sea, and at the Left Is a View of the Chemical Laboratory, with a Group of Second-Class Men Carrying Out a Difficult Experiment



Hazing Has Been Abolished at the Naval Academy as a Result of Several Unfortunate Incidents, but There Are Certain Privileges Still Allowed the First-Class Men in the Days Just before Graduation. One Is to Order a Plebe to Appear Each Morning during the Last Month of the Academy Year and Chalk Up on the First-Class Man's Door the Number of Days Remaining until June Week and Graduation Day; to the Upper Class Also Is Delegated Considerable Responsibility over the Younger Boys during the Last Year

16^a

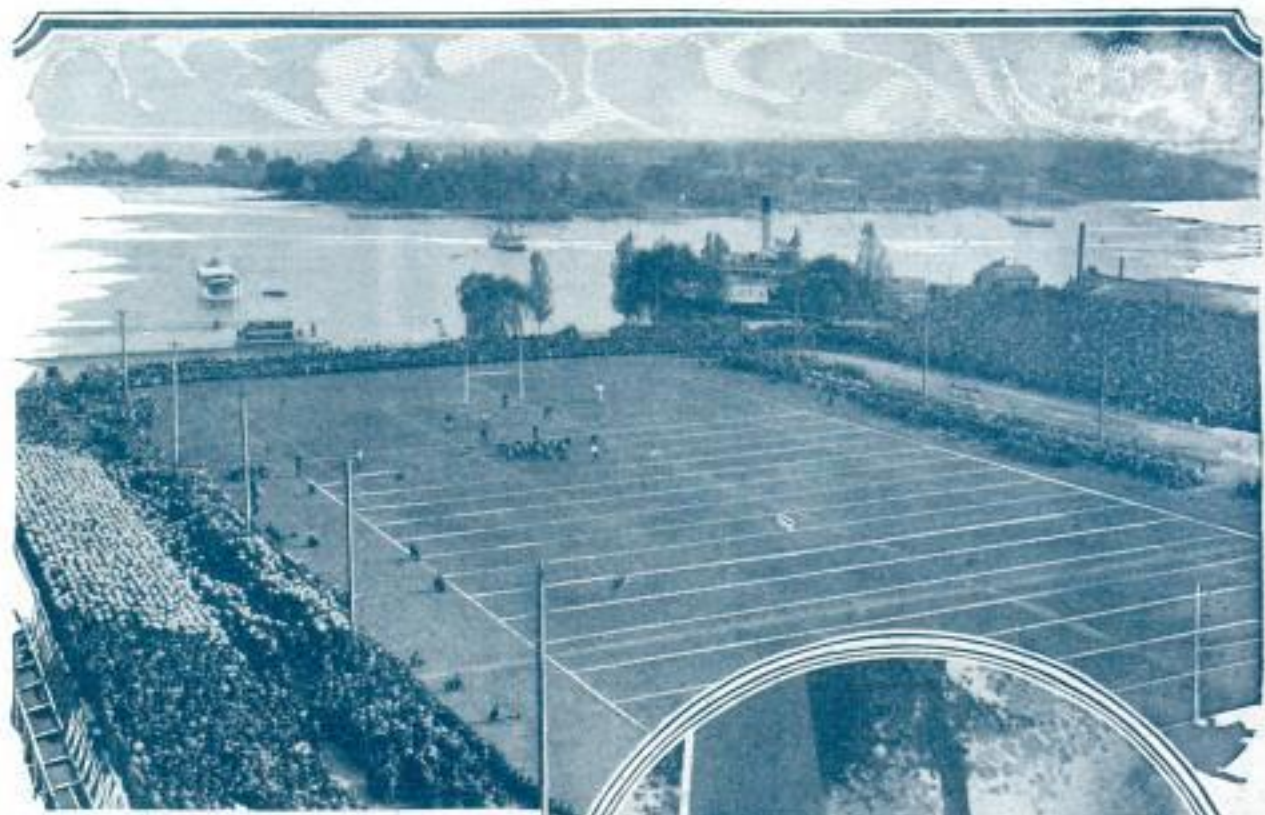

The Athletic Field, with Its New Steel Stands, Built from Metal Salvaged from a Battleship Scrapped under the Washington Arms-Limitation Treaty, Provides a Splendid Stage for Football and Other Contests; Right, Middies Cheering a Football Victory

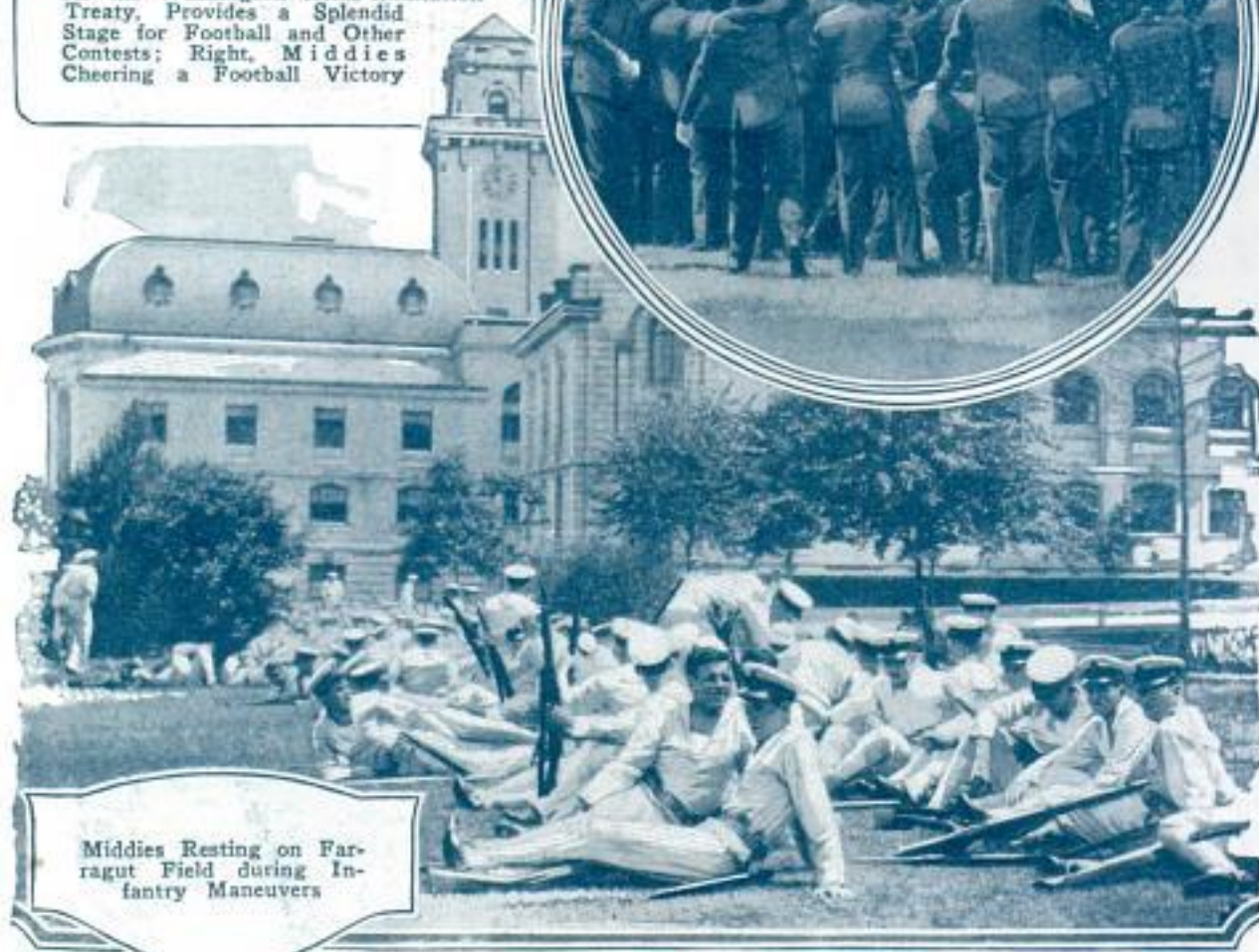
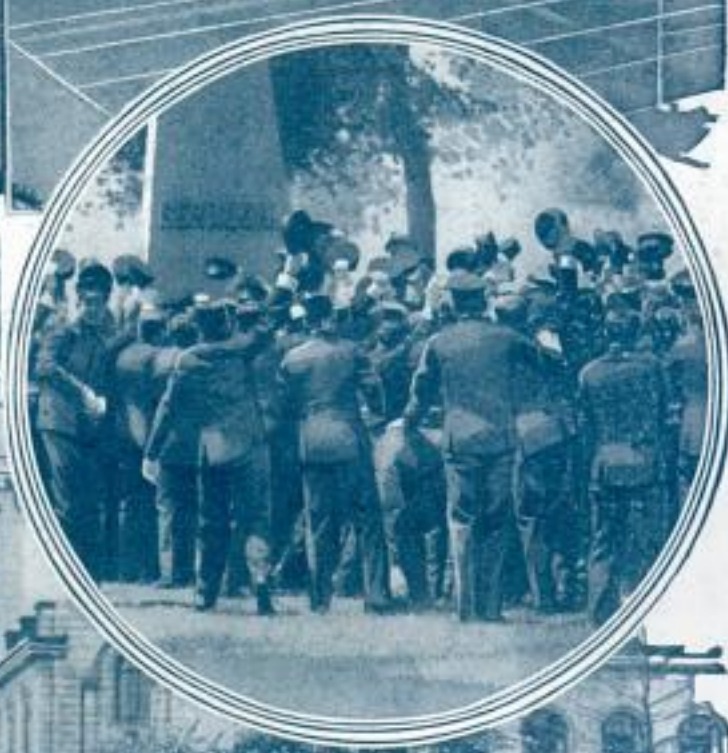

Middies Resting on Faragut Field during Infantry Maneuvers

167



With a Plebe to Wind the Phonograph, Two Upper-Class Men Enjoy a Dance in Quarters Decorated with a Picture of "THE" Girl and a "Quiet" Sign Which Apparently Has Been "Borrowed" from Some Sleeping Car.

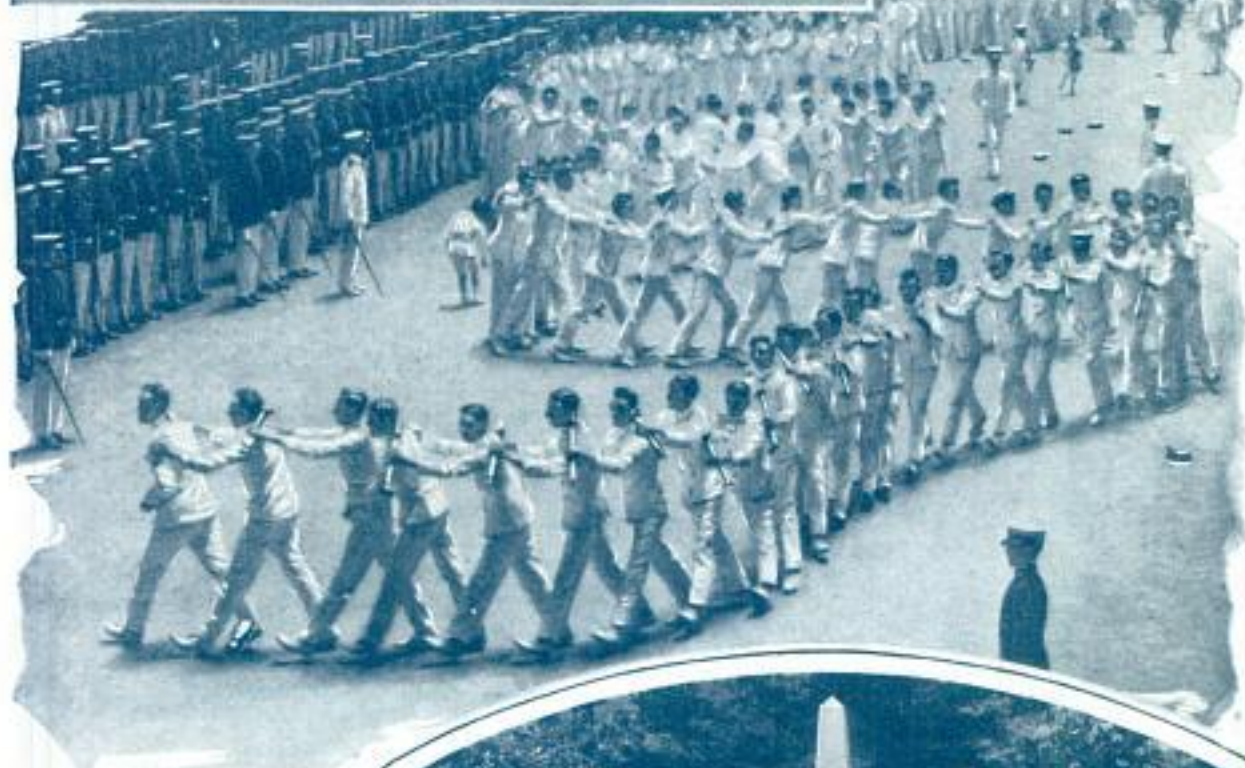

The Snake Dance of the Happy Graduates, Diplomas in Hand, Comes Winding Out of Dahlgren Hall as the High Spot of Graduation Week; the New Ensigns Wind In and Out before the Envious Lower-Class Men, Chanting as They Go the Greatest Song in Four Years of Academy Life, "No More Rivers to Cross"; at the Right Is Another View of the Final Triumph of the Newly Made Ensigns before They Depart for a Long Home Leave While Awaiting Assignments





Presentation of the Colors. When a Pretty Girl Entrusts the Stars and Stripes and Academy Flag to the Company Which Has Won the Honor of Guarding Them by Being the Best at Drill; the Company Commander Salutes the Fair Donor with a Kiss; Insert, Chapel in Which Is Buried John Paul Jones



With Diploma in Hand, the New Ensign Has the Epaulettes of His Rank Fastened in Place

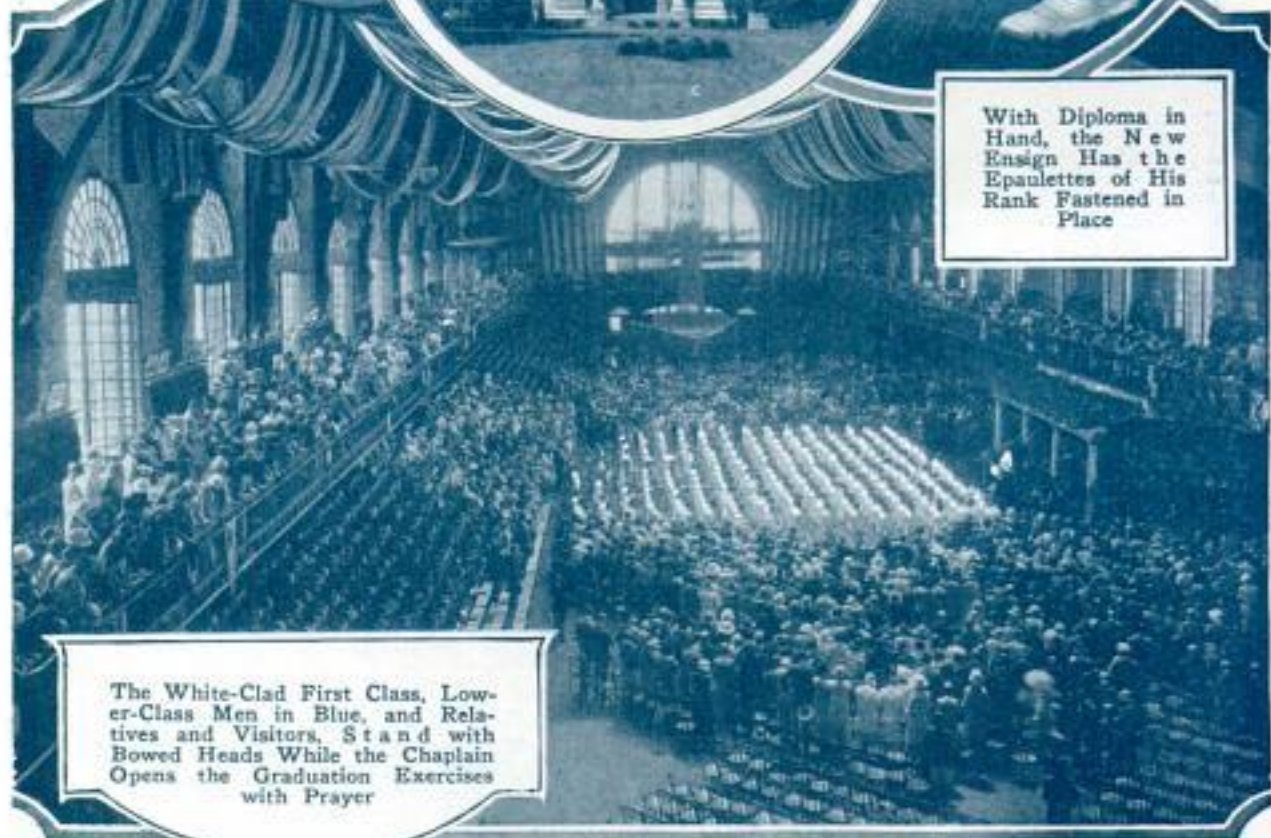

The White-Clad First Class, Lower-Class Men in Blue, and Relatives and Visitors, Stand with Bowed Heads While the Chaplain Opens the Graduation Exercises with Prayer

New York Times

8/21/25 POPULAR MECHANICS

761

PLANES FOR ARCTIC FLIGHTS HELD IMPRACTICAL

280

Dirigibles, not airplanes, must be used if an aerial survey of the arctic regions is to be successful, according to Donald B. MacMillan, who was compelled to abandon that part of his expedition to the north. From his and Amundsen's experience, he was convinced that the uncertainty of landing places and the unreliability of caches of fuel and food made travel by airplanes exceedingly hazardous. For that reason, and because adverse weather had set in earlier than had been expected, he advised that further exploits by naval planes be discontinued this year. "A fjord is free today and icebound tomorrow," was one of the explorer's radio messages from the far north. "A cache under such conditions, is not a help but a menace, for, if depended upon and a plane arrives out of fuel, destruction is the inevitable result. The lighter-than-air machine can do the work and should do it at the earliest opportunity." Naval officers declare that the dangers of venturing into the arctic regions with a dirigible such as the "Los Angeles" are tremendous. They point out that if the big gas bags get weighted with snow or ice from frozen mist and rain, they might never return. On their advice, the naval airships were not allowed to fly to the polar regions in search of Amundsen and Ellsworth when it was feared that they were lost last summer.

GRAINS FOUND IN EGYPTIAN TOMBS WELL PRESERVED

186

Wisps of wheat and barley placed in royal tombs to sustain the Egyptian rulers on their journeys after death, as well as flowers and funeral garlands, are often found in excellent state of preservation by scientists exploring ancient ruins. A collection of objects of this kind was presented to the University of Chicago recently by Prof. James H. Breasted. Dates, olives and pomegranates were also among them, indicating the preserving power of Egypt's exceedingly dry climate.



Prof. James H. Breasted with Centuries-Old Samples of Grain Found in Egyptian Tombs

Pacific Atlantic

FLASHING HANDS HALT AUTOS AND SPEED TRAFFIC

191

For night service especially, sets of colored-light



Traffic Policeman Using Hand Lights, and Close View of Signal Set in Position

signals, strapped to the hands of traffic police, aid in giving signals clearly. Current is supplied from a small battery. A red lamp is on one side and a green on the other, so that the policeman may flash practically all the signals displayed by the usual traffic tower.

HEATING PLANT IS PUT ON ROOF IN NEW MOVIE PALACE

A radical departure in heating systems has been made by the new Capital theater in London by placing the huge gas-fired boilers on the roof of the building. By the use of gas instead of coal, the need for fuel storage is obviated, and instead of using the basement and part of the first floor for heating equipment, this valuable space is freed for other uses. The system is put in operation by turning on and lighting the gas and starting the pumps and fans. Thereafter the plant operates automatically. Local authorities commend the innovation as an aid in reducing the smoke nuisance in the city.

mention Clarence G. Dick
 mention 'man' every night
 State Utility Bulletin
 New York Times

PEACHES ARE QUICKLY PITTED BY AUTOMATIC MACHINE

238

Peaches are pitted by a patented machine just seven times faster than by

old methods, according to Pacific-coast experts after watching tests. The peaches are run down a chute to a girl operator who feeds them into an arm protruding from the machine. From then on, there is no human touch. The fruit is ridded of its stone, which is taken away in one conveyor, while the meat is delivered by means of another.

224

Letter retd. 10/20/20



Automatic Peach Pitter Seven Times Faster than Human Hands

PARIS WAR LIBRARY HAS THIRTY THOUSAND BOOKS

Started as a reading refuge for the American expeditionary force, the war library in Paris has been continued and has increased until it now has 30,000 books.

The place is a memorial to the war dead. Much research matter of commercial and political value is being accumulated. Efforts are made to clear propaganda from the facts, as an aid to Americans trying to build commerce overseas.

New York Times 8/9/20

HOW TO SAVE GAS, SHOCK AND DROWNING VICTIMS

By Dr. HERMAN N. BUNDESEN

Commissioner of Health, City of Chicago

19 *5*

DROWNING, lightning, electric shocks and poisonous gases claim more than 12,000 lives in the United States every year, according to figures compiled by the National Safety council. Drowning alone caused nearly 7,000 deaths last year, and of those killed by gas, a large number were victims of the auto's exhaust with its invisible poison that strikes a person down before he is aware of its presence. Death is often the penalty paid for the practice of running the motor in a closed garage or crawling under the car and breathing the fumes.

While carelessness frequently is the cause of hundreds of these fatalities, it is only half the tragedy, for scores of victims are given up for dead when, as a matter of fact, they are alive and could be saved by prompt and proper application of artificial respiration. In practically every case of drowning, shock or gas poisoning, there is a possibility of restoration. Therefore, artificial respiration should be continued for at least four hours without interruption.

Never pause to drag or carry the patient far, or to fan him, give him

water or loosen the clothing. If it is a case of drowning, don't waste time trying to empty the water out of the victim. Start artificial respiration at once.

If the person has suffered an electric shock, carefully free him from the current, using wood, rope, cloth or rubber if necessary to touch him or the wires, and avoid contact with his skin or puddles of water. In gas-poisoning cases, carry or drag the person to fresh air. Do not expose him to cold outside atmosphere or try to walk him about. The method of artificial respiration to be followed is the same in all three situations.

Even after natural breathing has been started, the patient should be carefully watched, for in gas and shock cases, especially, there is a likelihood that the breathing may stop before full restoration. Strong, black coffee may be given when consciousness has been regained. Whisky or brandy should not be used. Above all, do not get excited. It's a good plan to count ten before you do anything. That gives you an opportunity to collect your wits. Keep calm, start artificial respiration immediately and keep at it.

Bringing "Dead" to Life After Four Hours

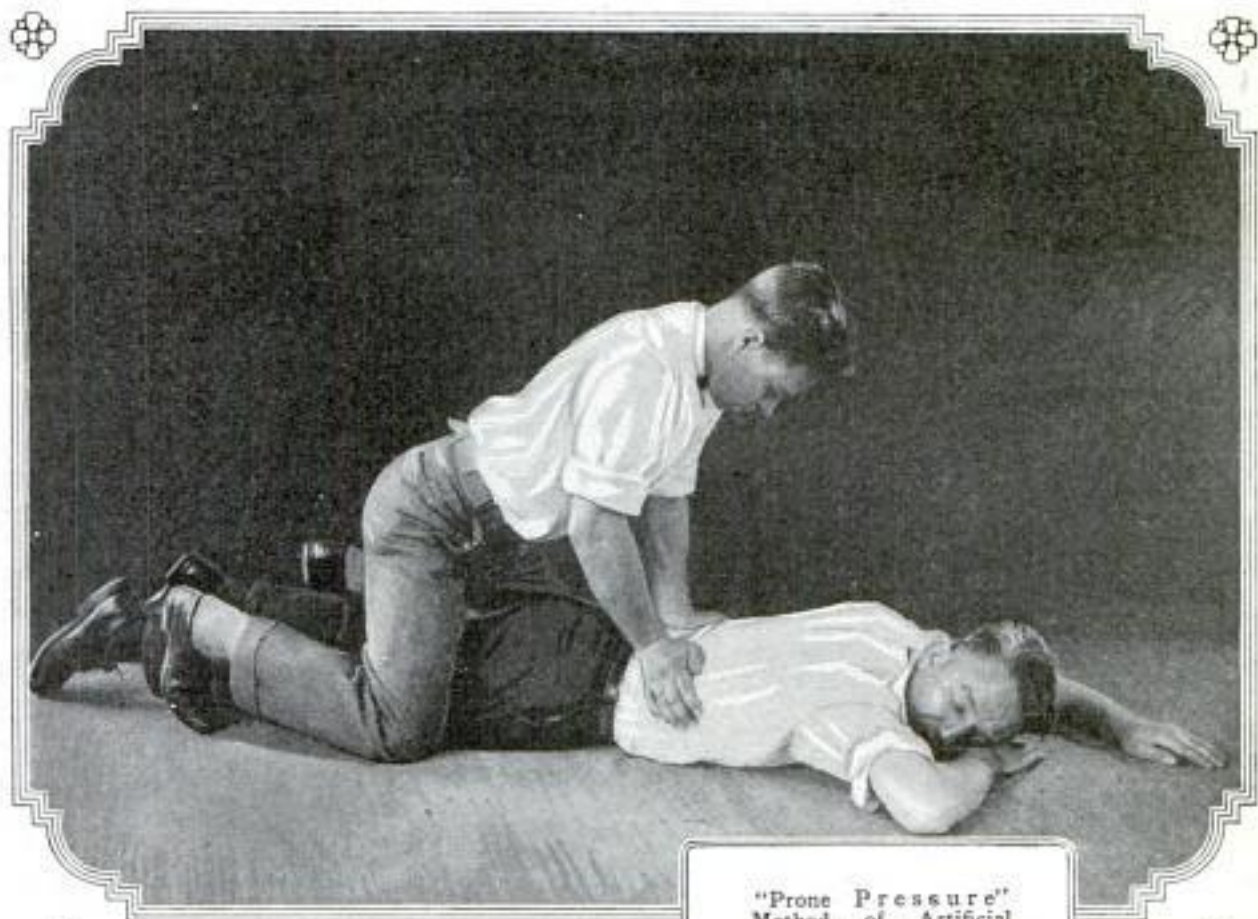

"Prone Pressure"
 Method of Artificial
 Respiration; Victim Is
 Laid on Stomach, Head
 Propped on Arm and
 Turned So Mouth Is
 Unobstructed; Rescuer
 Presses Downward,
 with Palms Close To-
 gether, on Victim's
 Back, and Counts
 Slowly While Pressing;
 at Count of Four, He
 Releases Pressure,
 Giving Lungs Oppor-
 tunity to Take in Air;
 Then Repeats Process



New York Times

PHOTO DONE IN SEVEN MINUTES ON SPEEDING AIRPLANE

In seven minutes, after the exposure was made, a finished print was prepared,

and Eastman, Kodak Co.,
Rochester, N.Y.



Aviators Examining Print of Exposure Developed in Seven Minutes on Airplane; Two of the Cylinder Carriers in Foreground.

dried and ready for mounting, by photographers in the army air service recently. They used a special paper, which has been devised for quick results in aerial work. The entire job was done while the flyers were aloft, and when the print was developed, it was placed in a cylinder and dropped on the front lawn of an interested witness of the performance. An ordinary airplane camera and other equipment were used.

MANY KINGS STILL IN POWER DESPITE WORLD WAR

While the world's eighty-three governments employ thirty-six presidents, some fifteen reigning kings and queens are left in spite of the changing styles in rulers

produced by the World War. In Europe, kings retain their thrones in England, Italy, Spain, Belgium, Holland, Jugoslavia, Norway, Denmark and Sweden, while Iceland is ruled by King Christian X and Egypt by King Fuad I. Cambodia, a French protectorate, Mesopotamia, the Hedjaz, Nepal and Siam are also governed by kings. Only two emperors, George V of England, who bears that title as ruler of India, and Yoshihito of Japan, survive the evolution in governments. Among other exalted personages are the viceroy of India, a regent in Hungary, a state head in Esthonia and a chief executive in China. Bulgaria has a czar, an amir is the head of the Afghanistan state, a maharajah presides over Bhutan, a bey in Tunis and a sultan in Zanzibar. Although many of the titles are ancient, practically all present-day rulers are new at their jobs. The oldest, in point of reigning time, is Prince John II of Lichtenstein who ascended the throne in 1858. Queen Wilhelmina of the Netherlands succeeded to the throne in 1890 and King Alfonso XIII of Spain in 1886.

Heads of all other governments came into power in the twentieth century, and only in the United Kingdom, Norway, Sweden, Denmark, Italy, Belgium, Japan, Bhutan, Cambodia, Morocco, Nepal, Zanzibar and Siam, had the present rulers ascended to the throne before 1914.

3350

LOBSTERS COLORED TO TASTE BY DYEING THEIR FOOD

Lobsters may be colored to any hue desired, to suit the particular scheme of dinner decoration simply by putting coloring matter in their food, according to a well-known German scientist. He discovered that they turn red after they are boiled because of the action of the heat upon a chemical in their shells.

Dr. Kornfeld.
Berlin, Germany

Experiments conducted by U. S. Army Service Engineering Division, McCook Field, Dayton, Ohio.

American-Grown Bamboo for Every Purpose

Government Scientists Find Many Species of It May Be Profitably Cultivated in United States

By UTHAI VINCENT WILCOX

Washington, D. C. Jackson Park

BEFORE so very long, bamboo may figure largely in the life of the average American. It will not be an imported bamboo; it will come from newly planted forests, from farms and from the back-yard garden. This is the prediction of government scientists who have started the ball rolling through experimental plantings and cultivation. They have found a large part of the United States ideally suited for the growing of many species of bamboo.

This strange grass has an almost unlimited number of uses. The manufacturer, the sportsman, the contractor and builder, the engineer, the paper manufacturer, and the epicure who loves good things to eat, all will derive benefits from it. Bamboo grows wild in China, Japan, India, Ceylon and Java. In the last-named country, only a little larger than Cuba and with a population of 30,000,000, bamboo is so much a part of the life

with long stringers. It also lends itself to artistic trellises, for bean poles, pea stakes, fishpoles, fruit poles and hay-curing racks. Down in Florida, where much of the experimentation has been carried on, one grove is a mecca for fishermen.

Home-grown bamboo can be used for tool handles and clothes-drying poles and clothes-line props. It can be used as well for water-carrying pipes running from a well or



Glimpses of Three Widely Different Uses to Which the Strange Grass Is Well Adapted; Picnic in Bamboo Grove; Top, Reinforcing Concrete with Split Stalks; Bottom, Edible Shoots

of the natives that it is doubtful whether they could long exist without it. One of the proved possibilities of American-grown bamboo is light fences made of the poles and then tied together

poles for rugs, carpet beaters and reinforced-concrete posts. The government is starting boys' and girls' bamboo clubs for the growing of the grass. Bamboo and poultry were

a spring. By punching out the cross walls with a sharp tool, ten-foot pipe sections can be obtained and with a bit of bicycle tubing they can be easily joined together, thus giving a flexible water pipe. There are many miscellaneous uses, such as chicken coops, chicken yards, spray rods for orchards, tool and book racks, portiere rods.

*Barbour Lathrop Lyon Playd contrapuc; isos
iron traiden, Saramach, isos*

228 766

found to make an ideal combination. A grove not only furnished protection from

aid the science. Not long ago, it was thought that a rigid-wing glide, such as



Bamboo Roots Ready for Planting Contain What Corresponds to Potatoes' Eyes, and Shoots Come Out Thickly

the sun and wind but easy roosting places. Hawks and other birds do not molest the chickens that run about in the groves. It is also true that the poultry are sympathetic toward the giant grass, the bamboo growing where the chickens are found to do the best, thirty-five feet and higher.

In the far east, it was early discovered that the tender shoots of the bamboo tasted good. They are eaten very much the same as asparagus and taste sweet and delightful. Bamboo shoots are known to most persons who are familiar with the chop-suey dishes, but there are many other methods of preparing them.

In almost all parts of the south and the west bamboo will grow well. Extreme cold and frost are its enemies. It is able to stand a little of the latter but hardly any of the former. In Georgia, where bamboo also has been grown experimentally, the groves, like the redwoods of California, have a strange fascination for all who come near. They seem to whisper of the mysteries of the east.

AVIATORS SEEK KEY TO RIDDLE OF HOW BIRDS GLIDE

Will man ever be able to glide through the air on artificial wings as easily as the eagle? Is the low-powered airplane feasible or is the conquest of the sky to be written in terms of faster and faster motors? Following the second aviation meeting in France where gliders and craft with tiny engines were demonstrated, airmen asked these questions again, and the study of birds' flight is being renewed to

various birds employ, could never be imitated by man. But in 1922, Boussoutrot remained in the air five minutes without a motor and almost immediately afterward a German aviator, Hentzen, astounded the world by circling in the air for three hours in an engineless plane. In the spring of 1924, another German, Schultz, flew without motor for eight hours, forty-two minutes and nine seconds on the Baltic coast. Besides these tests of endurance, distance records also have been made. In 1923, Botsch, a German pilot covered nearly twelve miles by utilizing the effect of ascending

air currents and carefully manipulating his motorless glider. The "internal structure" of the winds is still a mystery to man. By means of further experiments, aviators hope to make greater progress in harnessing the breezes without the aid of engines, just as birds do in soaring.

AUTO SIGNAL LIKE HUMAN EYE WINKS ITS WARNING

Modeled after the human eye, a stop-and-turn signal for the rear of the auto



winks rapidly, calling the attention of an approaching driver to the proper sign. Controlled by the brake pedal and switch buttons on either dash or steering wheel, it has a brilliant red center, corresponding to the pupil, and rolls in the direction of the letter "R" or "L" as desired, these symbols being placed below to indicate right or left turns. For instance, if the driver is to steer right, the "R" is illuminated by pressing one button, the eye looks at the signal and at the same time begins to wink rapidly, which cannot fail to attract immediate notice. If a stop is to be made, the word lights up and the eye gazes straight ahead.

Insulin is now being extracted from certain fish at a cost one-fifth of that of the product a year ago.

Calif.
Bakersfield
201

296

**NON-SINKABLE BOAT
CANNOT TIP OVER**

Air chambers arranged as a series of steps form the bottom of a new safety boat, preventing tipping and reducing friction. The spaces are divided into six independent compartments, each of which has a brass deck plate that may be lifted off so that a pump can be inserted for removing water or when



Boat Carrying Party of Four, and View of Stern Showing Arrangement of Air Chambers

repairs are necessary. An outboard motor fits in a specially designed well, which also holds the gasoline tank and batteries. The boat is built in various sizes and is said to be capable of carrying a relatively heavy load in spite of its light draft, and is practically non-sinkable. From twelve to fifteen miles an hour against wind can be made with a four-horsepower motor, the manufacturers declare.

PLAY IS MADE AN ACHIEVEMENT IN WORKMANSHIP

Besides having the fun of building their own playhouses, children are given training that improves their mechanical and domestic instincts with patented wooden blocks used in an outdoor kindergarten in California. Some of the pieces are a yard long. They are slotted and cut so that they interlock with little trouble and are suited to the erection of little houses of two or three rooms with windows, doors and roofs like those of

a real home. Besides the houses, furniture is also constructed from the blocks. The units are light in weight, smoothed to prevent splintering, thus avoiding hurts to the youthful builders, and cannot easily be broken. An added point claimed in their favor is that they teach young children to overcome fear and give them valuable physical exercise, as in building the playhouses, they have to climb up to put on the roof.

Broad Oaks School, Pasadena, Calif



Kindergarten Children Lay Mental Foundations That Aid in Future Home Making While Building Their Own Three-Room Playhouse and Furniture with Interlocking Wooden Blocks

no information available on makers of blocks.

Acme Newsfeatures, 461 - 8th Ave, New York City

HITCHING POST FOR DIRIGIBLE IS PADDED TO PROTECT BAG

Lined with soft padding and attached to an outer framework by means of

Padded "Scarf Mount" for Top of Mooring Mast to Secure "Los Angeles" Nose; It Connects with Buoy on Dirigible



springs, the top of the mooring mast for the "Los Angeles" at Fort Leavenworth, Kans., is intended to ~~simplify~~ simplify the task of anchoring the huge bag and to protect the envelope from jars and scratches. The piece is called a "scarf mount" and a buoy on the airship is fastened to it when making a landing.

Chicago Evening Post, 8/25/15

SOLOMON'S GOLD MINE IN PERU ACCORDING TO EXPLORER

Ophir, land of rich gold mines that supplied metal for the decorations of King Solomon's temple, was in South America according to Dr. von Hauch of Vienna, who has been exploring the forests of Peru. The fabled country has been the subject of speculation for years and has been variously located in Arabia, India or South Africa. In support of his theory, the Vienna explorer declares that he found an Indian tribe of 300 whose features bore a Jewish cast and whose language contained many words like those of the ancient Hebrew. The name

Solomon had been given to a number of men in the tribe, and legends were told him of a race of seafaring men who landed on the banks of the river Hualla and carried away quantities of gold ore.

They called the region around the river Ophira. Dr. von Hauch believes that the strangers may have been King Solomon's sailors and that the three years' absence of his fleet mentioned in Biblical accounts is explained by the long journey to Peru. Columbus believed that he had found the source of Solomon's riches when he set foot on the West Indies. The African theory is based on the discovery of ancient mines among ruins south of the Zambesi river and a seventeenth-century writing to the effect that one was the Abyssinian mine from which the Queen of Sheba obtained most of the gold she gave King Solomon.

AUTO STOP SIGN OF PRISM GLASS SAVES LIGHTS

Self-illuminating traffic stop signs installed in Washington, D. C., are lettered in prismatic glass so that they reflect the light that shines on them and need no electric bulbs. They are said to be more conspicuous in the daytime than the usual marker with its dark-red sign.



Stop Sign Lettered in Prism Glass Is Intended to Reflect the Light, Requiring No Electric Bulbs

Inspector. G. W. Brown, Washington Police

Standard

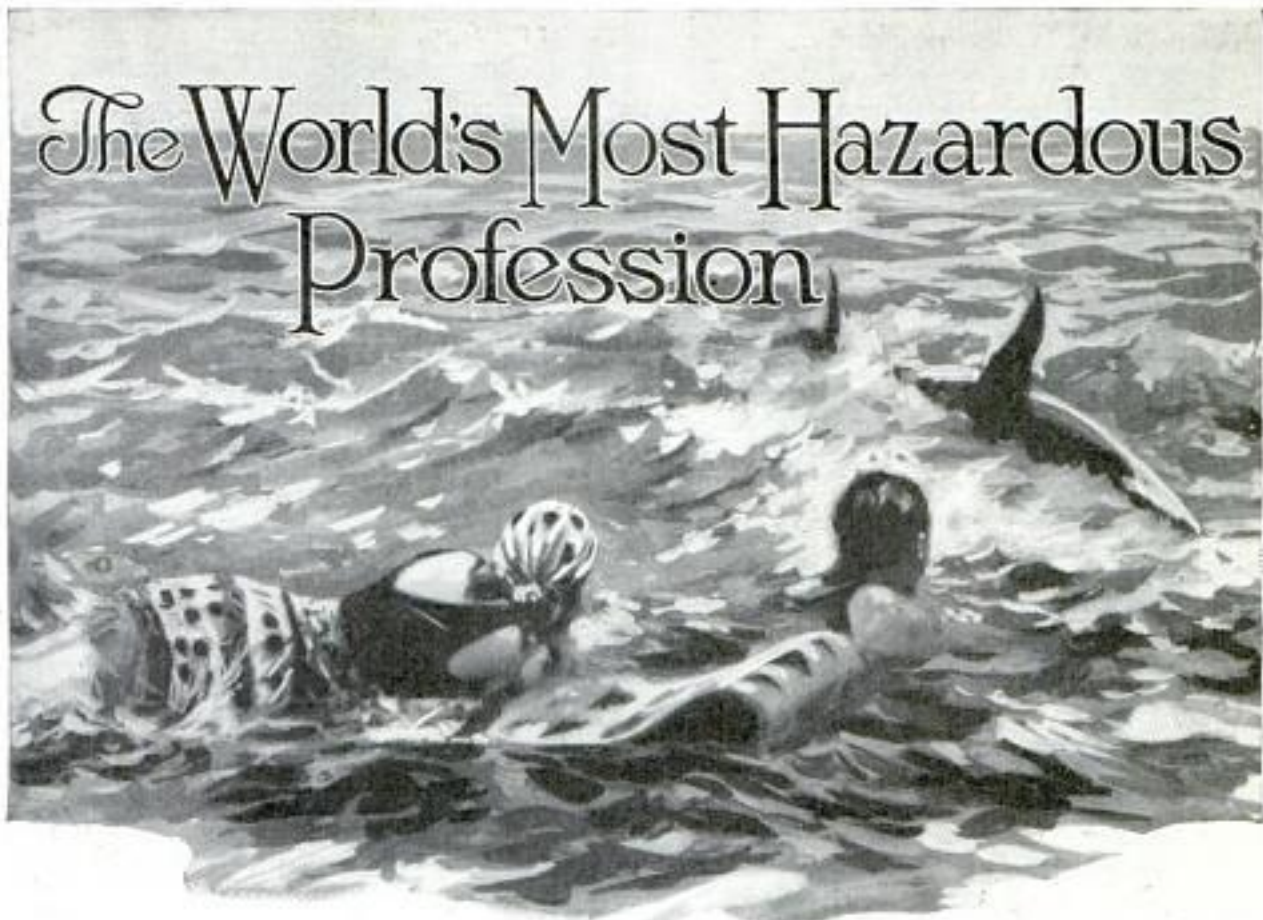

Attacking a Shark with Only a Knife to Save the Star from Death, Is All in the Day's Work for a Movie-Stunt Man, Doubling for a High-Priced Male Actor

By FRED GILMAN JOPP

*Picture 207 S. Berendo to
Los Angeles
Calif*

SPEEDING across the screen, flickering pictures had been unfolding the story of an auto chase and the leap of the hero into the villain's car.

"Good show," commented one as he left.

"Great," rejoined his companion, "but that fellow who leaped into the car—I wonder if he wasn't hurt?"

"Hurt nothing," the other scoffed. "That leap was impossible even for a man who was fool enough to try it. What you saw was just a good piece of trick photography, nothing else."

What the last speaker didn't know, and what the other sensed, was that the scene was not only real, but that the actor who staged the leap had broken his neck doing it. But the camera had shot the scene, the film went to the cutting room, and the actor to the hospital. Trimmed and titled, the scene showed nothing of the serious accident, and the film went out to the theaters while the stunt man's broken neck slowly knit together again, held by a leather harness.

Trick photography has been credited with many a death-defying scene for

which some unknown stunt man, doubling for a famous star, has paid with bruises, broken bones and even death. The stunt which cost Richard Talmadge his broken neck was classed as simple, so easy that it went off perfectly through two rehearsals, only to fail in the actual taking of the picture. As Talmadge later described it, the jump was almost fool-proof, just a running leap, a left corkscrew twist in mid-air, and he would land on the seat of the speeding car, with his arms wrapped about his head to protect his neck. But when the scene was actually "shot," the car went just a bit faster than before, and all the elaborate timing failed.

Yet, despite the hazards of the calling, Hollywood is full of good stunt men, ready to take any kind of a risk to earn the high salaries the movies pay. Their ranks are recruited from aviators, auto-race drivers, professional acrobats, human flies, circus performers and just plain dare-devils who gravitate into the business. They plan their stunts carefully, analyze the risks and plot, and time every movement in advance, yet often the



A Calculated Fall Which Will Be a Success if the Rehearsed Plan Has Allowed for All the Unexpected Dangers; Right, a Stunt Man Getting off a Motor Bus, a Method Not Recommended for the Average Passenger

unforeseen happens, and another actor goes to the hospital or the morgue.

Omar Locklear, famous aviator and one of the greatest stunt men the movies ever had, was likewise one of the most careful. He figured his tricks out in advance on paper, charting every move every moment, and then rehearsed them carefully. Yet, in his final stunt, he neglected to reckon on the glare of the powerful arc lights in which he was to spin his plane, and the machine crashed and literally buried its nose in the ground.

"Curly" Stecker, famous as a trainer of movie animals, braved death thousands of times in the cages of lions and tigers, yet, at last, "Charlie," a meek-mannered but gigantic elephant, sat down on him, and he finally died of his injuries after battling for a year in the hospital.

Sometimes the accidents are not fatal. Then the actors are patched up and come back for more. George Carrossella, a lion trainer in a movie zoo, is literally covered from head to foot with scars of scratches raked by the animals' claws, yet still carries on. Day after day he dives through trapdoors only inches ahead of his five lions, and with attendants standing ready with revolvers and specially designed crowbars made to pry the lion's jaws from a human meal.

Dick Grace, one of the Hollywood stunt actors, last winter was hired to double for a famous woman star in a scene where he was to have a flimsy ballet dress, soaked with gasoline and alcohol, burned off his body.



148

The first step in staging the episode was to call Grace's doctor to the lot and have him lay out his tools and bandages, preparatory to patching up the actor's forthcoming burns.

The scenario called for the star to be seated at a table in a dance-hall balcony with a group of intoxicated men near by. One of the men was to light a cigar and toss the flaming match into the folds of the ballet gown. The star was then to run screaming across the balcony and down the stairs where the hero would smother the flames in his coat.

When the time came, Grace's costume was soaked with inflammable liquids, and at the signal of cameras, the property man threw the match. In an instant Grace was a human torch. The fire spread faster than had been anticipated, the flames leaping ten feet above his head. With an agonized bound he cleared the balcony stairs and raced for the open, all thought of the scene gone in the desperate desire to run away from the torturing flames.

An assistant director grabbed him and threw him down, rolling him in an overcoat and beating out the flames with his hands. The ballet costume was completely burned away and most of the stunt man's body was black and charred. From the neck to the waist, his back had lost all skin

and was seared through the flesh. Aids hurried him to the room where the doctor stood ready with a pail of gasoline in which to wash the burns. The gasoline burned with such intense pain that the victim twice fainted before the washing was over. He had lost 720 square inches of skin, and most of the burns were of the third degree—the worst imaginable. Yet, in eleven days he was out of the hospital and in a few weeks was again working.

Many Have Stopped a Run-away Team under the Spur of Necessity, but a Stunt Man Must Do So Deliberately; Below, a Method of Escape Good When a Film Is Needed, but Unpleasant to Actor

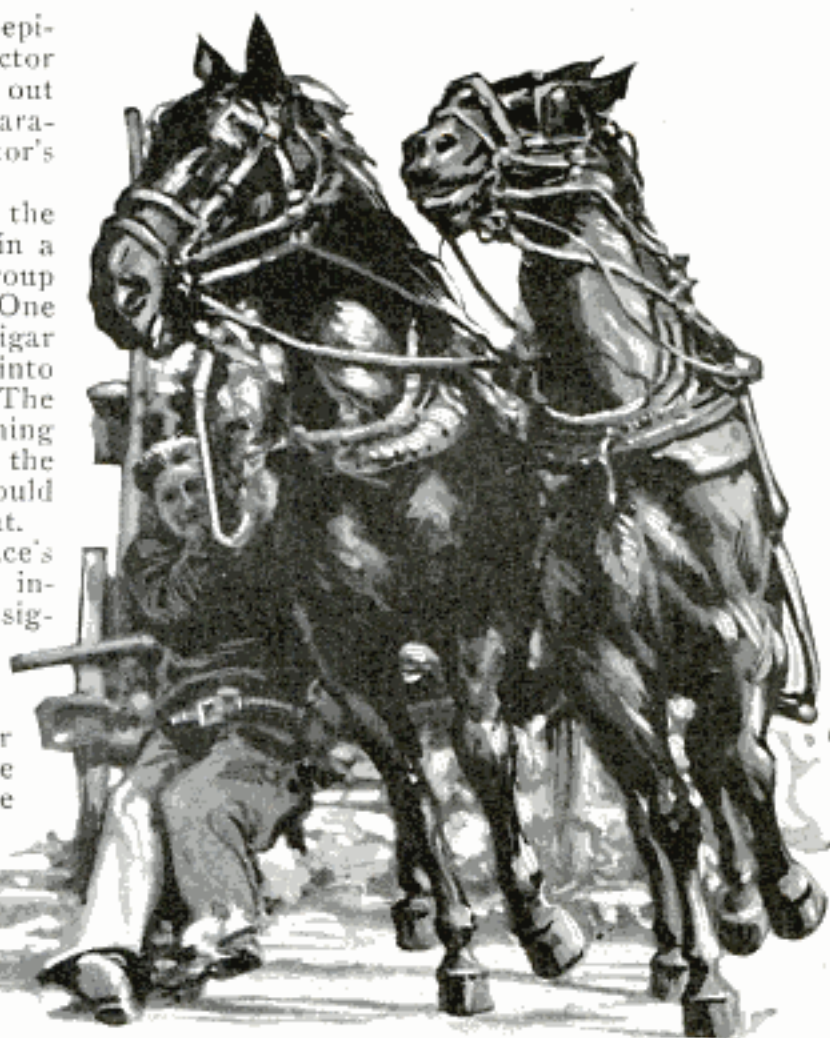

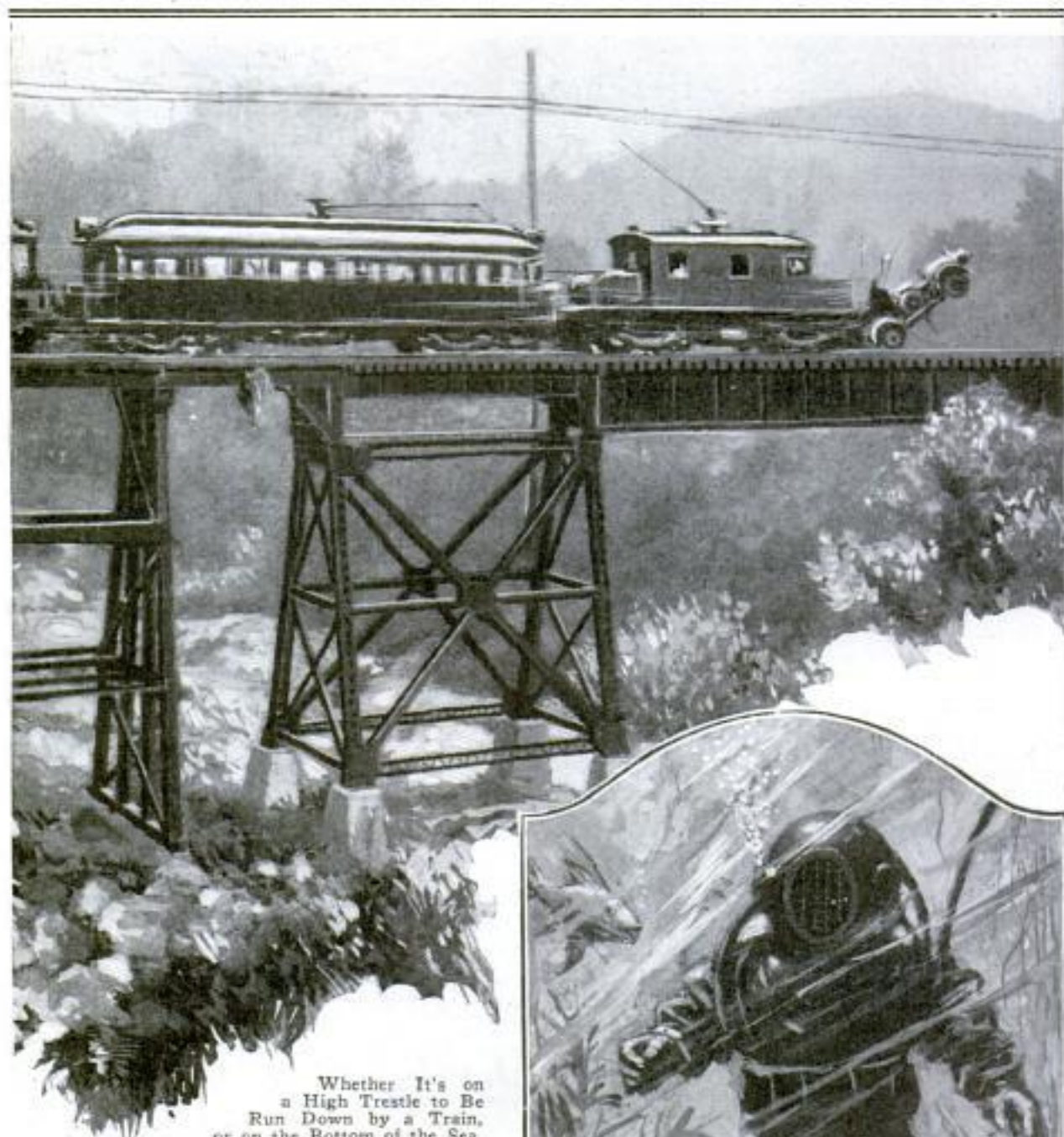

Whether It's on
a High Trestle to Be
Run Down by a Train,
or on the Bottom of the Sea,
the Stunt Man Is There

Bob Rose, another "careful" stunt man who calculates every risk in advance, on one occasion barely escaped with his life in a runaway dash with a six-horse stagecoach on a steep mountain road. The horses obtained for the scene were wild and only half-broken. Rose started the drive and the picture was going well, when the onlookers saw him climb down from his seat and edge out onto the whiffle-tree, where he tried to guide the horses with one hand and replace a partly slipped bolt with the other. At that very moment one of the leading horses stumbled and the entire team of six piled up in a struggling, kicking heap, with



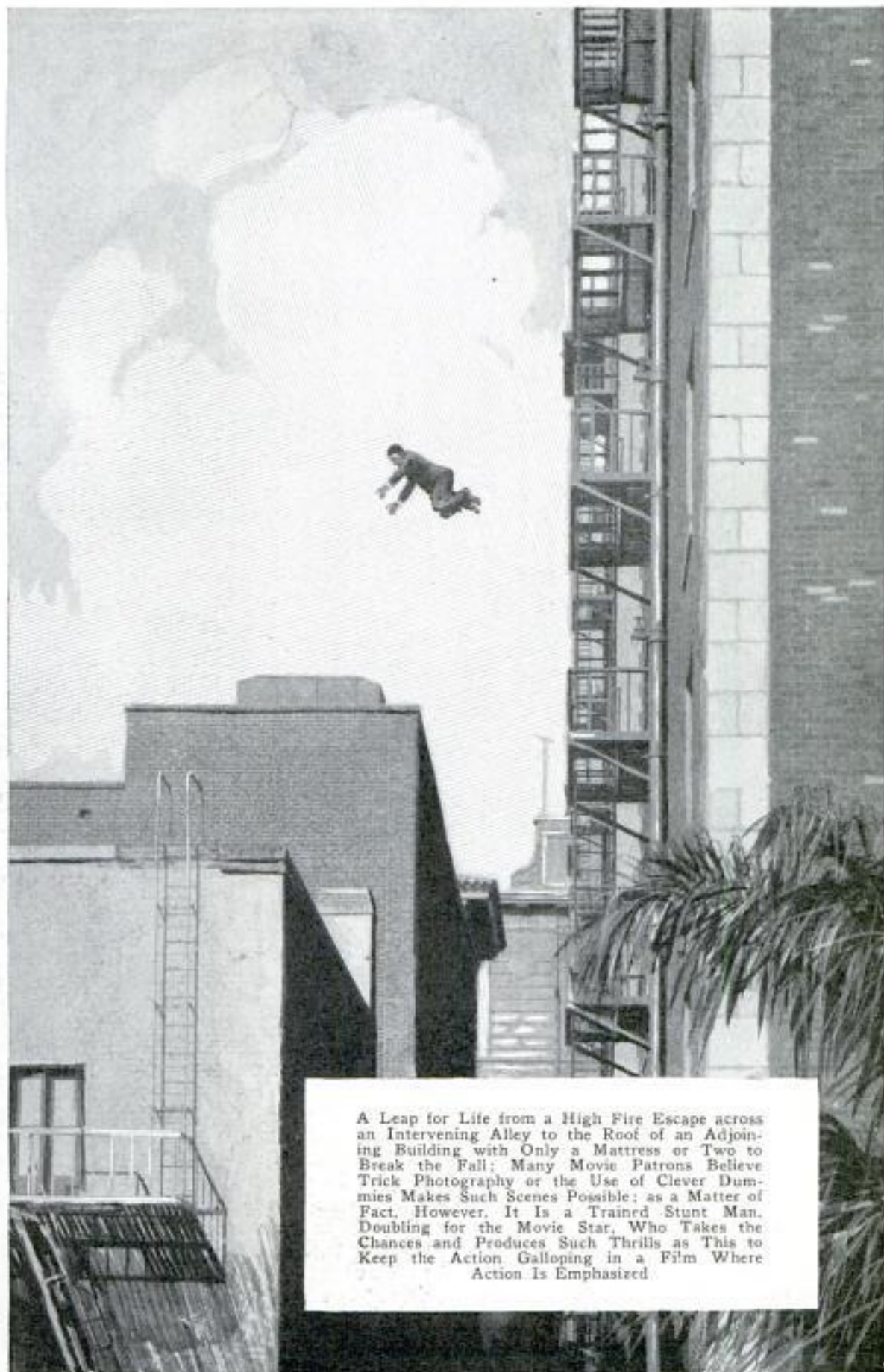

A Leap for Life from a High Fire Escape across an Intervening Alley to the Roof of an Adjoining Building with Only a Mattress or Two to Break the Fall; Many Movie Patrons Believe Trick Photography or the Use of Clever Dummies Makes Such Scenes Possible; as a Matter of Fact, However, It Is a Trained Stunt Man, Doubling for the Movie Star, Who Takes the Chances and Produces Such Thrills as This to Keep the Action Galloping in a Film Where Action Is Emphasized.

148

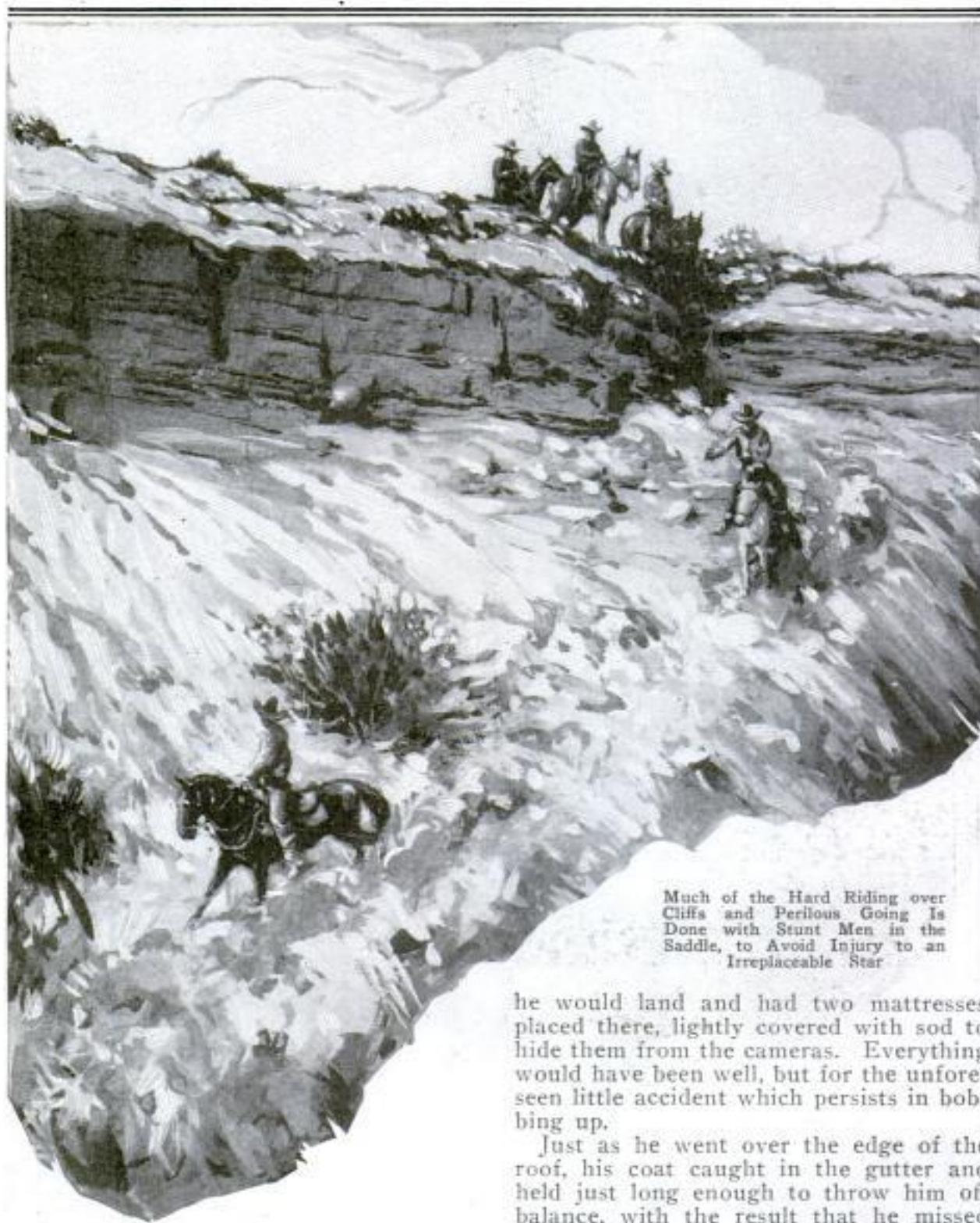

Much of the Hard Riding over Cliffs and Perilous Going Is Done with Stunt Men in the Saddle, to Avoid Injury to an Irreplaceable Star

Rose somewhere beneath. Yet, when the animals were untangled, the stunt man crawled out, badly bruised and cut but able to stand.

"Well, that's that," he remarked, and, walking to his car, climbed in and drove home.

Gene Perkins, hired to slide down a steep corrugated-iron roof and fall forty feet to the ground, had an equally narrow escape from death. He figured out where

he would land and had two mattresses placed there, lightly covered with sod to hide them from the cameras. Everything would have been well, but for the unforeseen little accident which persists in bobbing up.

Just as he went over the edge of the roof, his coat caught in the gutter and held just long enough to throw him off balance, with the result that he missed the mattresses and landed, head first, on the hard ground forty feet below.

He was picked up unconscious and started for the nearest doctor, but on the way recovered consciousness, called for a drink of water, and then insisted on being driven back to the lot to complete the day. Not long afterward he lost his life trying to drop from an airplane to the roof of a moving train.

Bert Grace, who is not only a stunt man, but an airplane pilot as well, handled a

148

plane for Tom Mix last year in a forest-ranger picture. Flying over the dense redwood forests one day, with no landing spot within many miles, the engine suddenly cut out and went dead. The only place to come down was a small forest glade, and Grace headed for that, yelling to Norman Devoe, the cameraman, who was standing in the rear cockpit cranking his

A Leap like This, into a Moving Auto, Cost a Stunt Man a Broken Neck, Which, Happily, Later Healed; Animal Men, Center, Risk Life Daily in the Cages with the Lions and Tigers; Below, Jumping Cliffs or from Peak to Peak Is All in the Day's Work



camera, to sit down and prepare for the crash. Devoe refused and kept on turning the crank until the plane struck. Both were thrown clear of the wreckage, and Devoe still had the crank of the camera, which had been torn off by the impact, in his hand. The film box escaped damage with the only pictures ever taken from a place of a crash.

Another famous stunt man, staging a movie fight with the star, went through two rehearsals and the filming of a scene in which he was thrown from a platform, a mattress below breaking the fall. During a continuation of the fight, he tripped and plunged over the edge, missed the mattress and broke his neck.



STATUE STRUCK BY LIGHTNING MENDED BY STEEPLEJACKS

Following damage by a bolt of lightning, a stone statue of Miles Standish, fourteen feet high and several tons in weight, at Duxbury,



Head of Miles Standish Statue after Its Removal by Steeplejacks for Repairing

Mass. was taken down by steeplejacks for repairs. The figure was removed in sections, as the head and the left arm already had been broken off by the bolt.

NAILS ARE MOST DANGEROUS IMPLEMENTS IN INDUSTRY

That nails are the most dangerous implements in industry is indicated by figures gathered in New York. In one year, compensation was made for 1,338 accidents due to nails and, using New York City's average of thirty mishaps daily from this cause, there are nearly 18,000 such injuries yearly in the state. From a list of 150 reports, thirty-seven such accidents were classed as infections with loss of time and forty-five, while not involving poisoning, compelled the sufferers to stop work. Thousands of accidents, it is believed, are never reported. According to officials, the nail hazard is becoming serious, and its importance is increased by the fact that almost every part of the human body is liable to "attack." This is illustrated by reports such as, "stepped on nail in floor"; "nail in guardrail tore his scalp"; "nail flew from box while loading

truck, infected wound on nose"; "nail in bench tore leg"; "fell down and nail punctured stomach." A nail-elimination week has been recommended by the labor department during which all loose nails and those protruding where they are likely to endanger persons, would be removed.

WIRELESS PHONES ON TRAINS SEND WAVES FROM ROOFS

Passengers using a wireless-telephone system installed on trains in Germany literally talk through the roof. Electric waves are radiated through the tops of the cars and are communicated to telegraph wires along the track. The messages then speed to receiving apparatus at a terminal or way station and are relayed by long-distance telephone to the proper person just as an ordinary conversation is handled. The procedure is reversed when a person in the country wishes to talk with some one on the train. During a demonstration of the system, a business man talked with his office in Hamburg while a train was speeding toward Berlin.

TWO-WAY AUTO VENTILATOR AIRS CLOSED CARS

An added convenience for the closed car is provided in a ventilator that both draws out the used air and admits a fresh supply through a set of openings next to the exit ducts. This arrangement is especially satisfactory when the weather is too cold to permit lowering the door panes in



Ventilator Installed: Arrows Indicate Incoming Air; Smoke Pours through Other Apertures

comfort and when passengers are smoking. A fine screen keeps dust and dirt from entering with the current from the outside.

256

024

*new york state
department of labor*

Chicago Auto Ventilator Co. 3507 Grand Blvd. Chicago

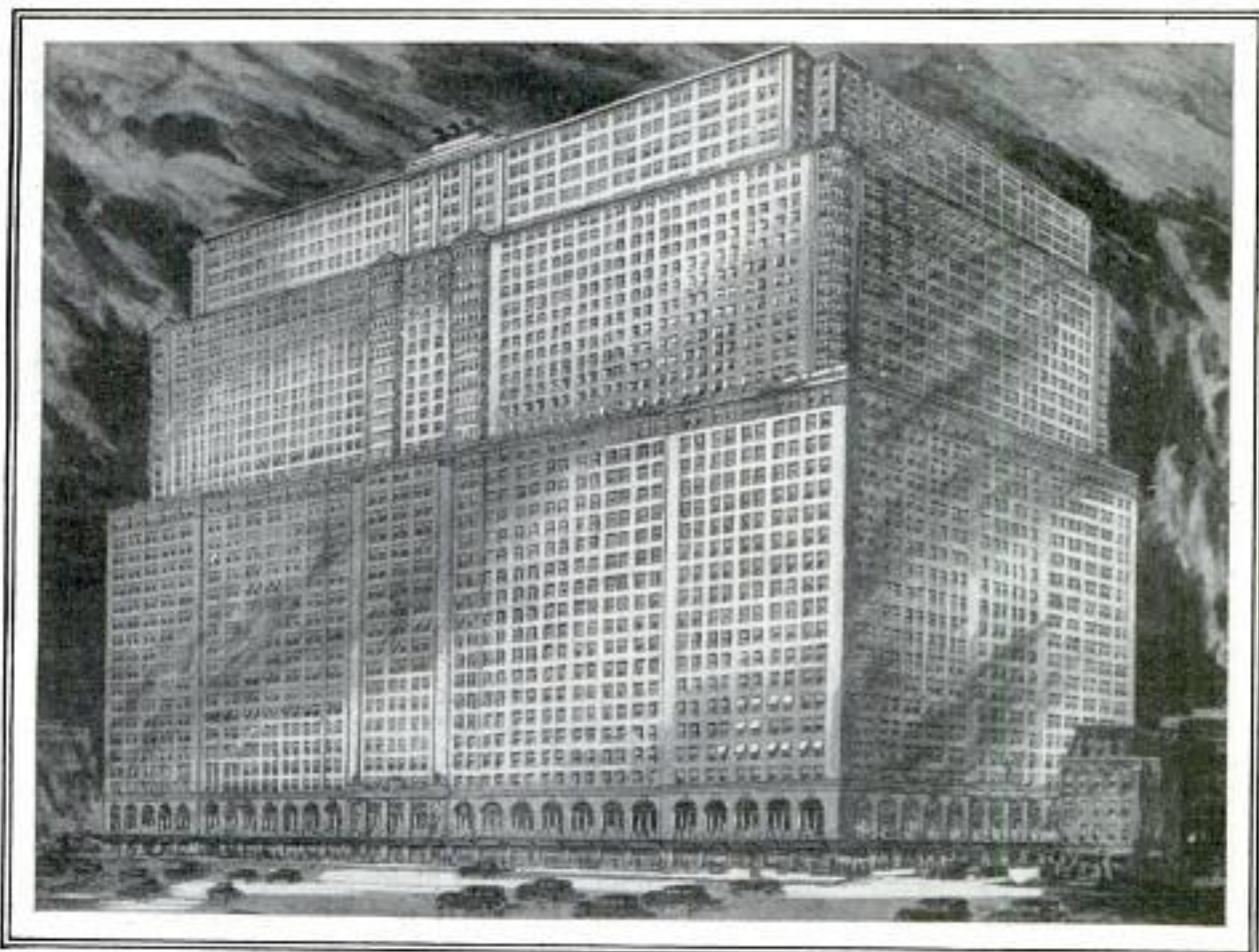

The First Twenty-One Stories of This \$40,000,000 Building Planned for Chicago, Will Be Devoted to Offices, the Upper Floors to a 4,000-Room Hotel

HOTEL ABOVE OFFICE BUILDING TO BE FREE OF NOISE

Street clamor will not greatly bother guests of a hotel planned for Chicago, since its 4,000 rooms are to be placed on top of a twenty-one story office building, according to architects' plans. The entire structure, costing about \$40,000,000, will be thirty-nine stories high and will also contain a huge convention hall with seats for 25,000 persons and emergency accommodations for 10,000 more. It will occupy an entire block.

FEEDING AND HOUSING BIRDS HELP DESTROY INSECTS

Attracting birds by feeding, and by building houses for them, has practical rewards, according to the department of agriculture. In the eastern United States, birds average little more than one pair to the acre but in park areas and in suburban and residential districts, the number easily can be increased to ten pairs to the acre. This has been done at Golden Gate park, San Francisco, with 404 pairs to forty acres; at Olney, Ill., with seventy pairs to eight acres, and at

Chevy Chase, Md., where there are 224 pairs to twenty-three acres. Higher records have been made elsewhere. An example of the value of birds in combating insects is cited from Germany. On one estate where 2,000 nests had been provided, but few trees suffered from the oak-leaf roller.

POCKET-PENCIL IODINE HOLDER PREVENTS SPILLING 152

Iodine is carried in solidified form in a convenient glass pencil-shaped container that fits the pocket and is ready for instant use when needed. There is a small rod which slips inside the outer case and on this, the chemical is fastened so that the piece is used as a dauber and no bottle or cork is needed. This arrangement prevents spilling, and the holder, being of thick glass, will not break easily.



Boston and Chicago, 61 Hancock St. Boston, Mass.



The University of Wisconsin's Combined Bands, Season of '23-24, E. W. Murphy Conductor. Typical of the smartly Uniformed Groups of Players Whose Snappy Music Kindles College Spirit

Getting in Tune with Ourselves

How Community, School and Industrial Bands and Orchestras Are Uniting the Nation through Music

By EARL CHAPIN MAY, *Sharon, Conn.*

YOU might not think that Gary, Ind., and Boston, Mass., had much in common, nor that Los Angeles, Calif., and Waterville, Me., were striking the same stride, but they do. They are thinking and acting on the same plane in matters musical, because public-school bands and orchestras are bending the musical twigs in the way they should grow, and the young things are growing all together.

Gary, you know, is a steel town largely inhabited by folks of foreign blood. It is one of our thousands of melting pots. But the Gary public schools are famous for many forward steps. One of these is the

selection of H. S. Warren as bandmaster. Maj. Warren knows the heart of a child, and how to make a musician out of an urchin. Any son—or daughter for that matter—of any of the 12,000 families in Gary can begin studying for a musical career when he enters grade school. He has an hour's instruction and practice, free each school day. After a few months' individual efforts he is promoted to membership in a junior band, then to a senior band and finally to the crack Gary schools band, official representative of the city and envy of all the boys and girls. That's in Gary.

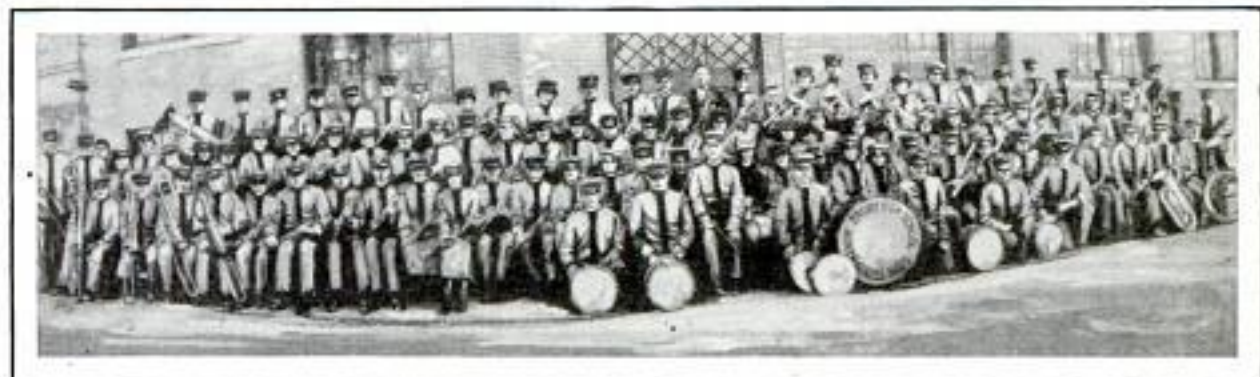

Winners of First Place at Last Year's Eastern-States Exposition Musical Contest, the Drury High-School Band of North Adams, Mass., James Morley Chambers Conductor

Morton High-School Symphony Orchestra of Richmond, Ind., Directed by J. E. Maddy, Plays Difficult Classical Music with Perfect Ease



Not so long ago, about all any school was supposed to teach in New England was the four R's—Reading, 'Riting, 'Rithmetic and Religion. It's different now. There are more than 300 supervisors of music in the Massachusetts public schools. Thousands of large and small cities in various parts of the country celebrated national music week, May 3 to 9. But in Boston they wound it up with a grand New England band and orchestra conclave in which 2,000 boys and girls participated.

The juvenile bands assembled and played, severally, on historic Boston Common, then paraded, with brilliantly uniformed drum majors 'n ever'thing, to the Boston arena. There, after various individual orchestras and bands had played to an audience of 8,000, the massed orchestras and bands performed with thrilling effect under the baton of the veteran bandmaster, Frederick Neil Innes. And the silver cup donated by the Boston Kiwanis, for the organization that overcame the greatest obstacles to attend the conclave, went to the Waterville, Me., high-school orchestra, directed by Dorothy H. Marden, supervisor of music. The boys and girls had raised the money to make the journey by giving a concert, and had chartered a bus for the round trip of 400 miles.

Across the continent, the supervisor of music of the Los Angeles elementary schools assembled nearly 2,500 boys and girls for an outdoor spring concert. In 131 orchestras massed on that occasion, there were 1,300 violins, nineteen cellos, fifty-two flutes, sixty-three clarinets, 115 saxophones, 171 cornets, twenty-five trom-

bones, nine French horns, 127 sets of bells, 151 drums and 291 pianos.

This public-school band and orchestra movement which holds so many possibilities for juvenile development, is found in nearly every state in the Union. "Maryland, My Maryland," is true to its traditions. Almost every county in that state has its public-school music supervisor.

There are more than 300 such supervisors in the state of New York. Boys' band contests are held in Central Park, Manhattan, each spring. The famous Drury high-school band of North Adams, Mass., has been the guest of New York city, where in one day it played three concerts, broadcast twice and was received on the city-hall steps by Mayor Hylan. About half of the young musicians are girls, and on the march the band follows the lead of a drum majorette!

Young as they are, these juvenile players are not entirely tyros. The Morton high-school symphony orchestra of Richmond, Ind., under the direction of J. E. Maddy, gave the 1922 music supervisors' national conference at Nashville, Tenn., a treat by rendering the difficult overture to Wagner's "Tannhauser" with professional skill. A little later, the same organization of boys and girls played with equally good effect Tschaiakowsky's "Symphonie Pathetique" before another music supervisors' conference in Cleveland. When a hundred high-school orchestra pupils won approval by playing the "Priests' March" from Mendelssohn's "Athalia" at a similar conference in Davenport, Iowa, they



A Competitive Spirit Encourages the Musicians to Do Their Best and Regard Practice Periods as Sport

were applauded as much for their ability as for the fact that a lot of the youngsters who sat on the chairs provided for them could not touch the floor with their feet.

Down at Winston-Salem, N. C., C. D. Kutshinski, director of instrumental music, is in charge of more than 200 trained band boys. The city has purchased 100 of the instruments they use. In 1917, a public-school instructor in mathematics decided to see what he could do about enlivening the local school-band movement in Evansville, Ind. From a standing start he developed four high-school and ten elementary bands, well equipped and well taught, in the short space of five years.

Up at St. Cloud, Minn., there exists a schoolboys' band with over 200 members. And they can play, too. Citizens and visitors to the resort town of Lake Geneva, Wis., have seen 1,100 Wisconsin boys and girls participating in a state band tournament. The sixty members of the Jordan high-school orchestra of Salt Lake City are pretty well known throughout Utah. These are only a few of many thousand examples that might be cited of the active interest in juvenile bands and orchestras. The thing is catching because it is based so largely on the psychology of competition.

There are few normal boys and girls who do not hate to practice on the cornet, clarinet, trombone or tuba in the woodshed, or on the violin, cello, flute or piano in the front parlor—if they have to practice alone. But let them get into

competition with each other and it's quite a different story. Music supervisors and public-school instructors are taking advantage of this human trait. Once get a bunch of musical youths in a practice room together and let them fight for places of honor and the trick is turned. Fishing and baseball and even skating and football are neglected for the steady bucking of scales and intervals or the one time monotonous scraping away on exercises.

Each instrumental musical organization of any size is divided into sections. There are first and second-violin sections, as well as the cello, bass, woodwind and drum sections for the orchestras. There are woodwind sections—meaning piccolo, flute, clarinet and other reed-instrument sections—and alto, tenor, baritone, trombone, bass and drum or percussion sections for the bands.

Each section has its "first chair." The first chair is the honor position for each section. Ranking these coveted first-chair positions is that of concert master of the orchestra or assistant director of the band. Above the concert master or assistant director is the supreme master, the director. The whole organization is based on the law of progression. Supervisors and instructors know this. So, at stated intervals there are competitions. Each section, then each member of each section, plays a specified selection or part of a selection upon which all have been given a chance to practice individually at home. The other members of the band

285-
782

or orchestra decide, by raising of hands, whether each contestant shall go up or down the social musical scale.

When the competition is carried into county, state and nation, the members of each organization rally around its flag, spurred on by local pride. When the members of the different Rockford, Ill., high-school bands, for example, know there is to be a national school-band contest in Chicago, and that only those selected by the bandmaster of the Rockford schools can make the first band and hence participate in the Chicago contest, they buckle down and work their hardest. That's what the members of the first high-school band of Fostoria, Ohio, did before they got into the "First," after which they won the Ohio state band contest prize and captured first prize and \$1,000 at the national contest.

That healthy normal desire to excel in any honorable endeavor kept a regiment of Wisconsin boys and girls at hard practice until the Elkhorn band walked away with a first prize and the Richland Center band with another—after which all the competing boys and girls went home and began practicing for the next annual tournament. What happens in Illinois, Ohio or Wisconsin, happens in half of these United States each year. We have a very marked and commendable attack of "banditis" in America and the results are evident on every hand.

Music can go a very long way toward Americanization of both the foreign-born and natives of this country. Music comes

pretty close to being a universal language, because it gives aspiring youth a ready means of self-expression. As one expert phrases it: "Music is invaluable as a mental disciplinarian. No subject taught in our public schools requires such promptness and accuracy in the solving of problems. All children have more or less latent musical ability and this side of their natures should be developed."

Dr. John James Tigert, United States commissioner of education, maintains that music is the first Americanizing force with which the foreigner comes in contact, and that it holds a safe and strong regenerative power during the individual's hours of rest and recreation. William Arms Fisher, who was prominent in putting over the last New England band and orchestra conclave, believes every child has a right to education in music, at public expense.

The good work does not stop with bands and orchestras. You will find it in the increased number and improved technique of choral societies, who were given new life by the community singing of the World War period. The recently organized Associated Glee clubs of America, with headquarters in New York, is perpetuating our college glee clubs, which have a decidedly meritorious mission in life although some of us may poke fun at them.

And so it goes throughout the land. The several hundred thousand members of the General Federation of women's clubs and the national and State Federa-



"Kid Band," Organized by the Author at Rochelle, Ill., in the Early 'Nineties, Was a Forerunner of the Town's Present Concert Organization of Thirty Pieces

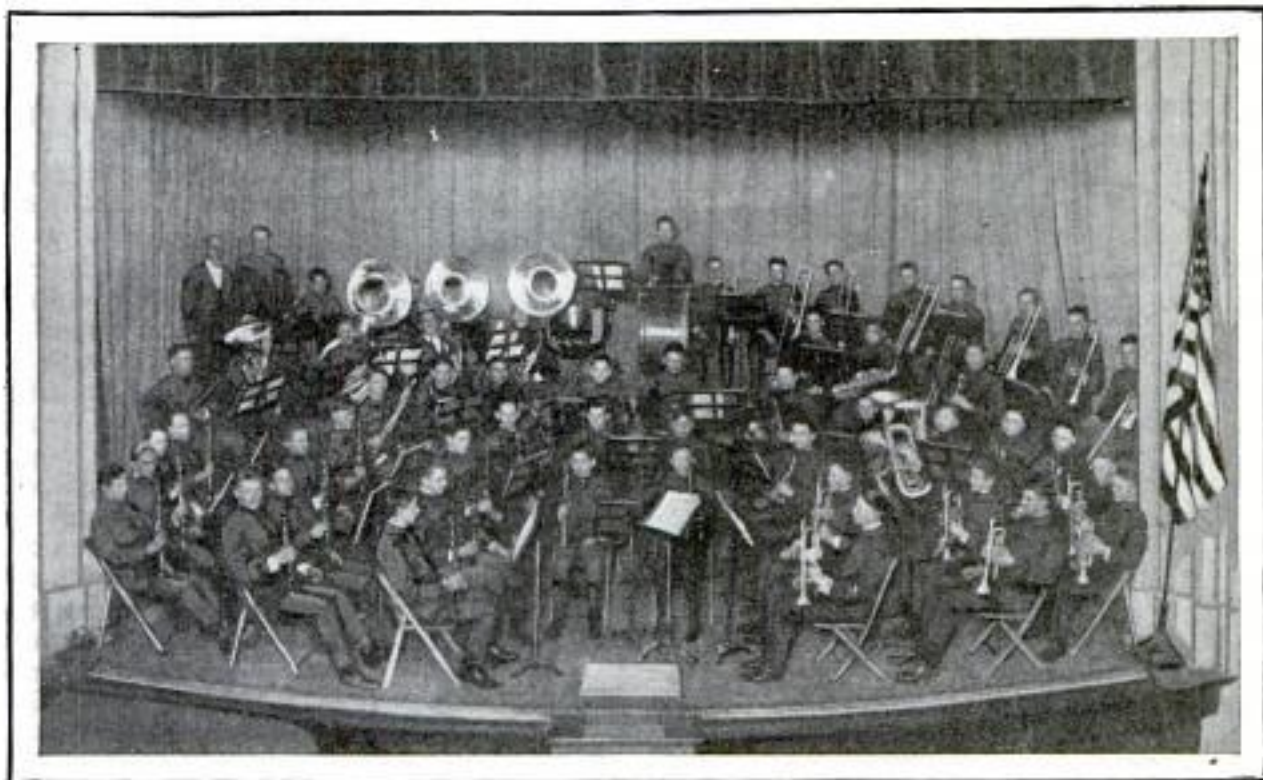

Gary, Ind., High-School Band, a Powerful Factor in Harmonizing Diverse Elements among the Youth and Adults of One of America's Vigorous Melting-Pot Cities

tions of music clubs are sponsoring local music clubs independent of educational institutions. The several thousand Chatauqua towns have juvenile music classes during each Chatauqua week.

We cannot win wild youths to lawful ways by courts, jails and prisons, but we

can keep them in the moral familyfold, or bring them back if they have strayed away, by a love for music. Give us ten years more of the current harmony in and out of our schools, and as a nation we can go "singing to our destiny" without any fear for the future.

290.

CHANNEL CROSSED FIVE TIMES BEATS MOST SWIMMERS

It is about twenty miles as the crow flies between Dover and Calais, where the English channel swims have been made or attempted. The water at its warmest is usually under sixty degrees Fahrenheit. Swift tides sweep the course for over five hours in each direction, carrying the swimmer far from his objective and making the actual distance he must negotiate, forty miles or more. These are obstacles every swimmer is trained to meet, but the one, and often deciding, factor that spells defeat or victory is just luck. The channel is notorious for its swift weather changes. High waves are likely to be lashed up at any time. Those who know the demands of the undertaking declare that the best equipped swimmer would be doomed to failure if the weather is unfavorable. Waves defeated Gertrude Ederle after she had been swimming seven hours. So far, only five swimmers, all men, have swum the channel.

The first was Capt. Matthew Webb, who later lost his life in the rapids at Niagara. He accomplished the supposed impossible feat in twenty-one hours and forty-five minutes. The record was made by Enrico Tiraboschi, who did the distance in sixteen hours and thirty-three minutes.

Vac Cup
VACUUM CUP FOR AUTO VALVES LIFTS THEM FOR GRINDING

Raising valves on the motor to a position where they can be ground, is simplified by the use of a stick with a little rubber cup on the end that forms a vacuum when it is pressed tightly down upon the top of the valve. In practice, the tip should be moistened slightly with water and then squeezed on with force enough to exclude all the air from under the cup.



New York Times 8/28/25

Mr. H. J. d. goss, Greenawald
Price \$1.00.

Head of Dept
of Neurology
and Psychiatry
metaphysique

**BABY CARRIAGE THAT FOLDS UP
CAN BE USED IN AUTO**

Infants ride in safety and comfort, and mothers are spared trouble and worry, by

**SOUND WAVES FROM THE BRAIN
PICKED UP BY RADIO**

Transmission of sound waves from one brain to another is foreseen as a result of experiments by Prof. Ferdinando Cazzamali

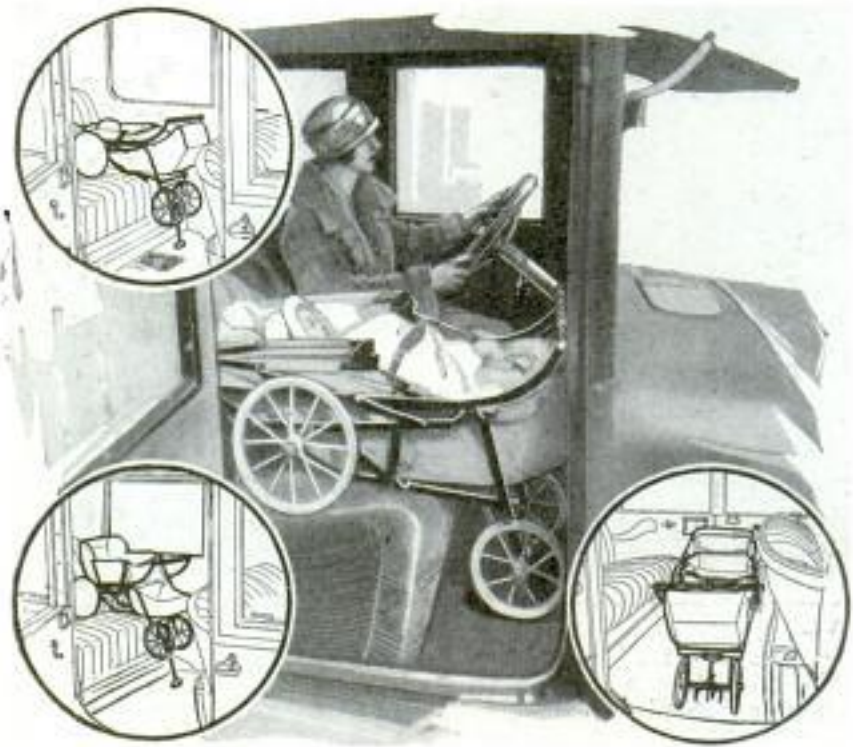

Folding Baby Carriage Inside of Auto, Arranged for Reclining, and Inserts Showing Other Ways of Disposing of It

using a folding carriage that fits as a chair or crib inside the automobile or may be placed back of the front seat in a large car. It is adjusted to rest securely on the cushions, no attachments being needed to hold it in place, and the baby may recline or sit up. The cart opens up automatically to full size when it is taken out. When it is collapsed, it is said to be about the size of a suitcase and, being made of light material, is easily carried.

of the university of Milan, who is reported to have heard sounds issuing from a human brain through a radio receiver operating on short waves. Highly excited persons or those suffering from nervous diseases were used in conducting the tests. The patient was placed in a thoroughly insulated cabinet. Sounds heard through the receiver ranged from signals like those of ordinary wireless messages to whistling. Similar results were obtained by using hypnotized persons, and in every case, the noises ceased when the subject was restored to normal condition. Prof. Cazzamali declares

it might be possible for waves sent out from one brain to be picked up by another under a like stress.

**ELECTRIC LOCOMOTIVE AS LONG
AS TRAIN OF THREE CARS**

Weighing 372 tons, developing 5,000 horsepower, and 117 feet in length, a giant electric locomotive can pull a train of freight cars one and one-half miles in length. In spite of its enormous bulk, it can attain a speed of thirty-five miles an hour. Some engineers believe that the engine foreshadows the type that will supplant the present steam locomotive.

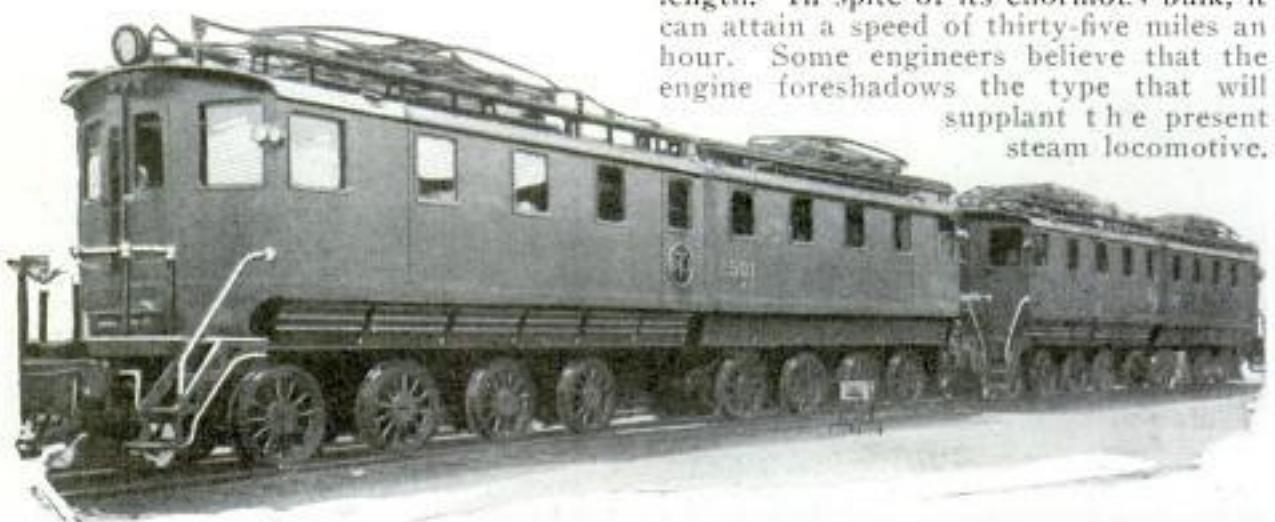

Huge Electric Locomotive Which Can Pull a Freight Train a Mile and a Half Long

L. K. K. O.

BATS AS ENEMIES OF INSECTS ARE FRIENDS OF MANKIND

Widely regarded as an omen of bad luck, and disliked because it is supposed to become entangled in a person's hair, the bat is in reality a valuable servant to man because it devours amazing quantities of harmful insects. While it clings to walls and roofs in dark places during the daytime, it is not blind, as is popularly believed, but has small beadlike eyes, almost hidden by the soft fur with which it is clothed, and has such a highly organized nervous system that it is sometimes said to possess a "sixth sense." Its keenness of touch is extraordinary; taste, hearing and sense of smell likewise being acute. Scientists say that, if man were as highly developed in these particulars as the bat, we would be capable of marvelous exploits. They are about the only mammals that fly, and were once called "flitting mice." Comprising about 450 species, they are found in almost every part of the world except extremely cold regions. In the tropics, some kinds are so large that they attain a wing spread of five feet. The dreaded vampire variety that sucks the blood of animals and of man, is found in the warmer countries and some tropical varieties eat cultivated fruits, but the numbers of these dangerous and destructive species are small compared with the many harmless ones which benefit mankind.

328

METER TESTS BRIDGE SPANS AS AID TO SAFETY

So that engineers may measure accurately the load bridges can bear safely, an inventor has devised a meter arrange-

294

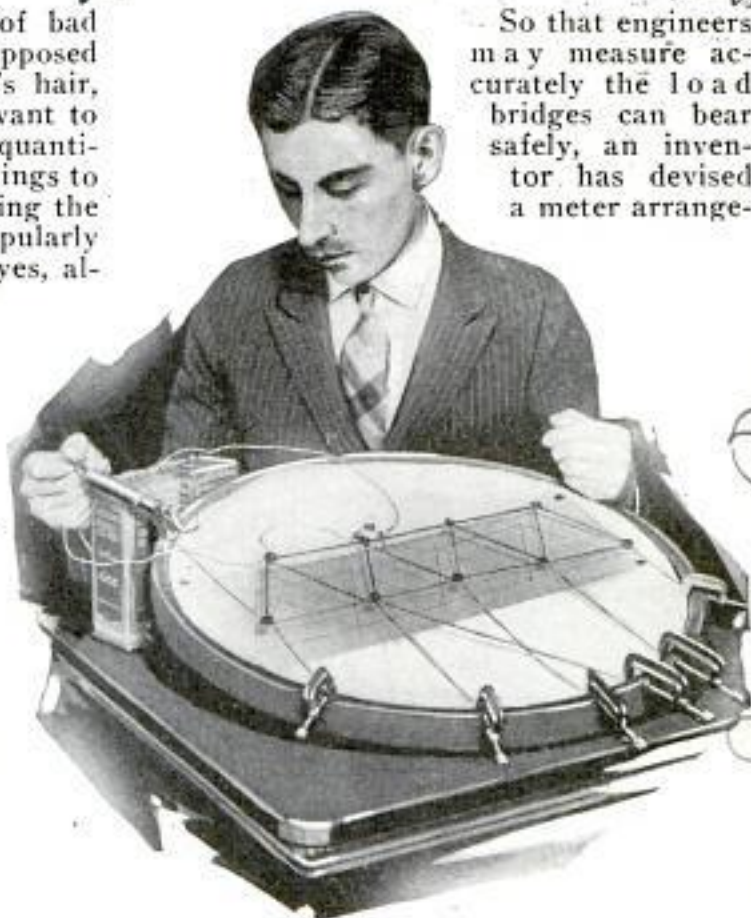

Inventor and His Meter for Measuring Strain Bridge Spans Can Bear Safely by Pulling on Models Clamped to a Rack

ment that uses models of the actual spans. A replica of the part to be tested is placed upon a surface like the top of a drum and is fastened by wires attached to clamps screwed to the rim of the board. The model is set directly over a drawing executed in exactly the same size. Strain is then applied by pulling on one end, the amount being registered on a small spring scale, and the "give" of the little span is indicated by the variation from the lines of the drawing. At the breaking or danger point, a small electric bulb in the center of the board lights up.

*Morris Berman
Inventor
638 Stone Ave. Brooklyn, N.Y.*

SLOT VENDER FOR STATIONERY AIDS LETTER WRITERS

Two sheets of writing paper and a stamped envelope are supplied from a vending machine at the drop of a coin in the slot, saving special trips to post office or drug store for stamps and simplifying the task of preparing the letter. The flap of the envelope is fitted over the sheets, so that all three come out of the machine at the same time and are easily separated.



265

ENAMEL PRODUCED BY SNAILS WITHSTANDS AGE

As a substitute for Japanese enamel in decorating boxes, vases and imitation antiques, a gelatinous substance produced by some of the larger varieties of snails is said to resist age and give a brilliant surface when hard. It is also well suited to dyeing while in a soft state and only experts are said to be able to tell it from the more costly oriental substance.

334

Stewart Stationery Vending Machine Co., 510 W. 6th St., Los Angeles, Calif.

95

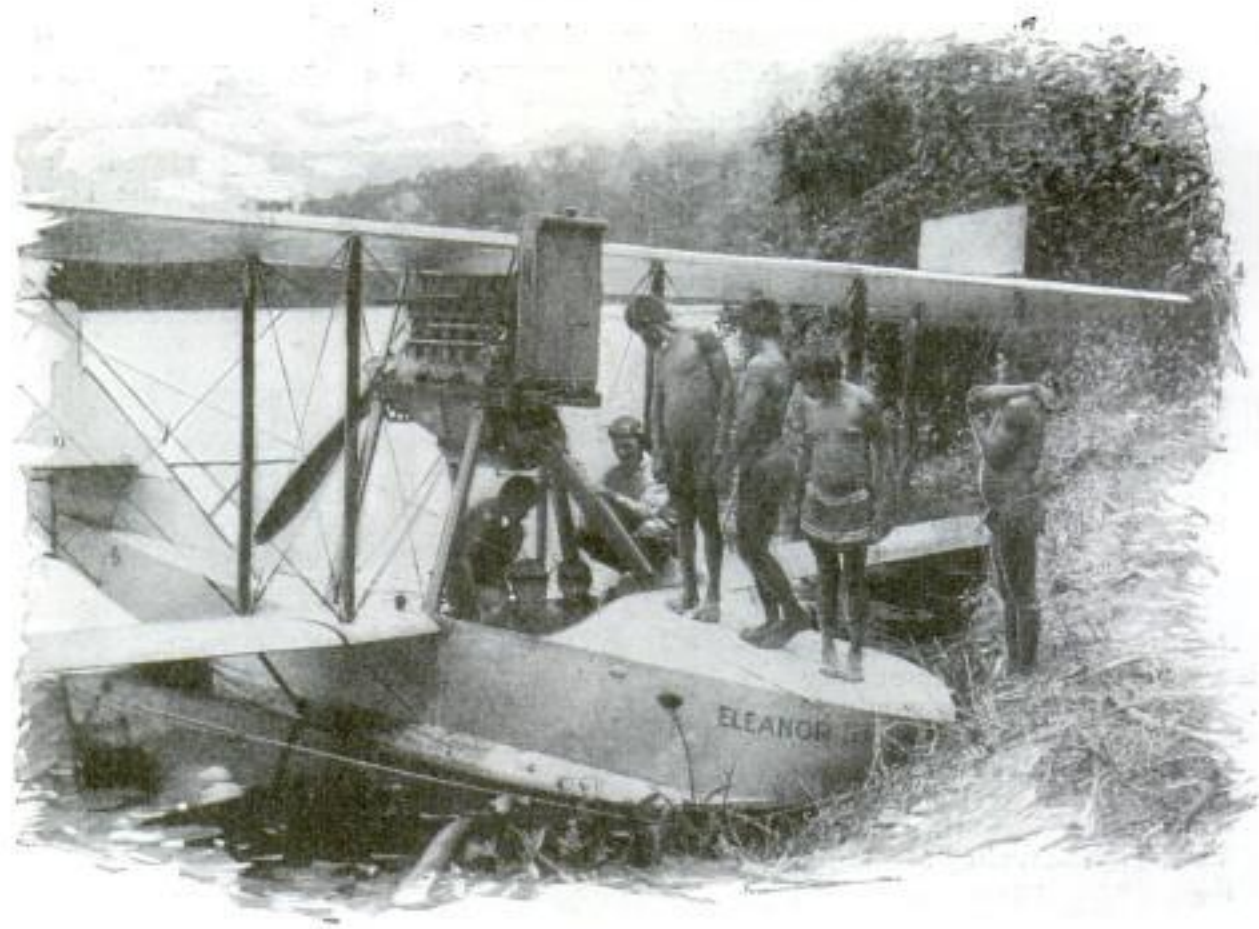

Airplanes Aid Explorers in Brazil

By H. A. BRUNO

HHEAD-HUNTING Indians, who infest the Parima mountains in Brazil and are noted for their ability to shoot poisoned arrows, have been made peaceable by a "White Winged God" which showered gifts from the skies. This deity was what is known in civilized countries as a flying boat, and the gifts were glass beads, pocketknives, etc., dropped by means of small red parachutes.

Two daring airmen, Capt. A. W. Stevens of the army air service and Lieut. Walter Hinton, former naval aviator, of "NC-4" fame, who were attached to the Dr. A. Hamilton Rice expedition, have returned to America after piloting their ships so efficiently that they, practically, made possible the success of the expedition.

Lieutenant Hinton, racked by recurrent malaria, nauseated and dizzy, stuck to the controls of the plane and flew it to the source of the Parima river, while his associate, Capt. Stevens, using an aerial camera, photographed and mapped almost 1,000 miles of terrain, including 120 miles never before explored by white men.

It is interesting to note that the Indians

were really responsible for the use of aircraft by Dr. Rice. The eminent explorer was in the same territory in 1920 endeavoring to find the source of the Orinoco river, which rises in the Sierra Parima. On this occasion there were no planes to assist in the work, with the result that the expedition withdrew after being violently attacked by the Indians.

Upon returning to New York, Dr. Rice immediately began preparations for his recent successful trip, by communicating with aircraft concerns and with the government. Just about this time, Capt. Stevens astounded the world by breaking the two-man altitude record. He ascended in an army airplane, piloted by Lieut. John A. Macready, to a height of six miles above Dayton, Ohio, and with his aerial camera took a photograph of the entire city on one plate.

Doctor Rice had been planning to do a great deal of aerial survey work and upon his request the government willingly gave Capt. Stevens leave of absence to go on the expedition to Brazil. In an interview given out before the expedition sailed from New York, Dr. Rice said:

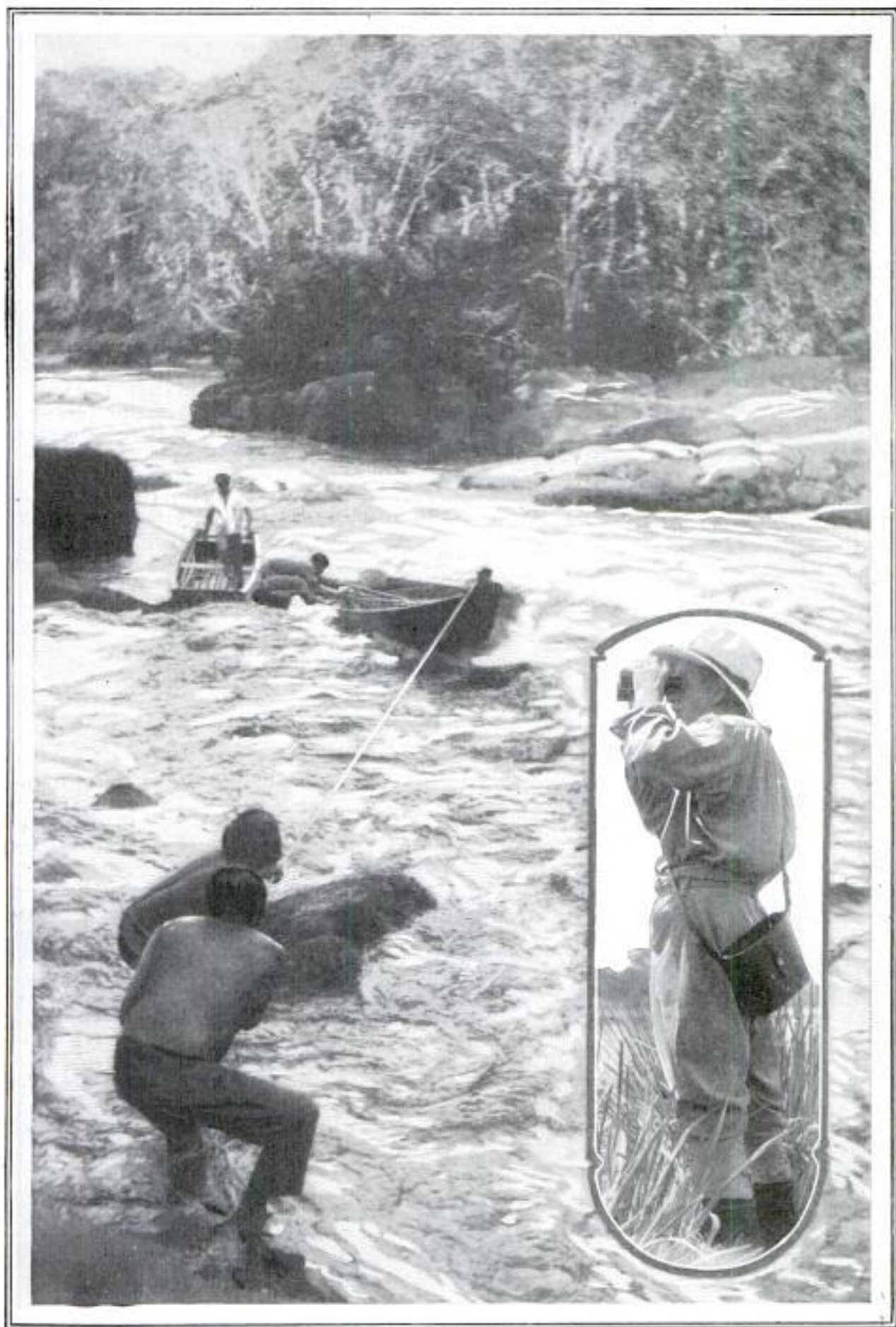

Hauling the Boats through the Rapids of the Rio Parima, the New River Explored by the Party, and Dr. Hamilton Rice, Leader, Looking through His Glasses to Map the Day's Journey

95

"The advantages of aerial photography as an auxiliary to exploratory and geographical surveys are the much enlarged area of territory that may be gone over in a given time and the covering of districts otherwise inaccessible. Those regions where the natives are so hostile or the physical obstacles so great as to effectually bar progress or ingress to domain which it is desired to penetrate, the airplane passes over easily and quickly."

The plane was shipped in knockdown form by boat to Brazil and was assembled at Manaos, near the Amazon river, by friendly natives under the supervision of Mechanic John Wilshusen and Lieut. Hinton, who had made an air trip to Rio Janeiro three years before and so was familiar with tropical flying.

Hard luck visited the airmen very soon after the expedition assembled. Wilshusen became ill with fever and the responsibility of taking care of the plane fell to the pilot and photographer. Almost all the members of the expedi-

tion had tropical fever. It proved fatal to Dr. Koch-Grunberg, the German explorer, who died at Vista Allegra.

The plane was used as a scout for the main expedition. Dr. Charles Bull, former Harvard athlete and classmate of Dr. Rice, went ahead of the main party with seventy gallons of gasoline, traveling naked with the natives, living on the same food, and being burned to almost their hue. He proved that a white man can live under the same conditions as an Indian.

The expedition traversed the Negro from its junction at Manaos with the Amazon to the place where its main branch becomes the Branca; followed this until the next major branch, where it becomes the Uraricoera and thence headed for the final division, where the river changes again to the Parima.

At the latter spot the last gasoline depot was established by Dr. Bull and with cheery wishes of good luck, the airmen flew 120 miles farther into the jungle than the hardest explorers ever had been. That they had laid aside their revolvers to carry more gasoline and increase the



Listening In to Music from Pittsburgh in a Camp at the Headwaters of the Amazon; the Same Set Was Used to Report Progress; Above, Dr. Rice Measuring a Five-Foot Two-Inch Maku Indian

*Kingston
B. W. C.
789*

distance they might fly over a country where they knew hostile Indians with poison-tipped arrows lurked is known to few.

According to Capt. Stevens, the flying boat was in the air 174 hours and during

BIRDS' EGGS ARE GATHERED BY THOUSANDS IN ROWBOATS 3369

Natives of the West Indies reap a rich harvest once a year when booby birds, a species of the gannet, lay their eggs on the

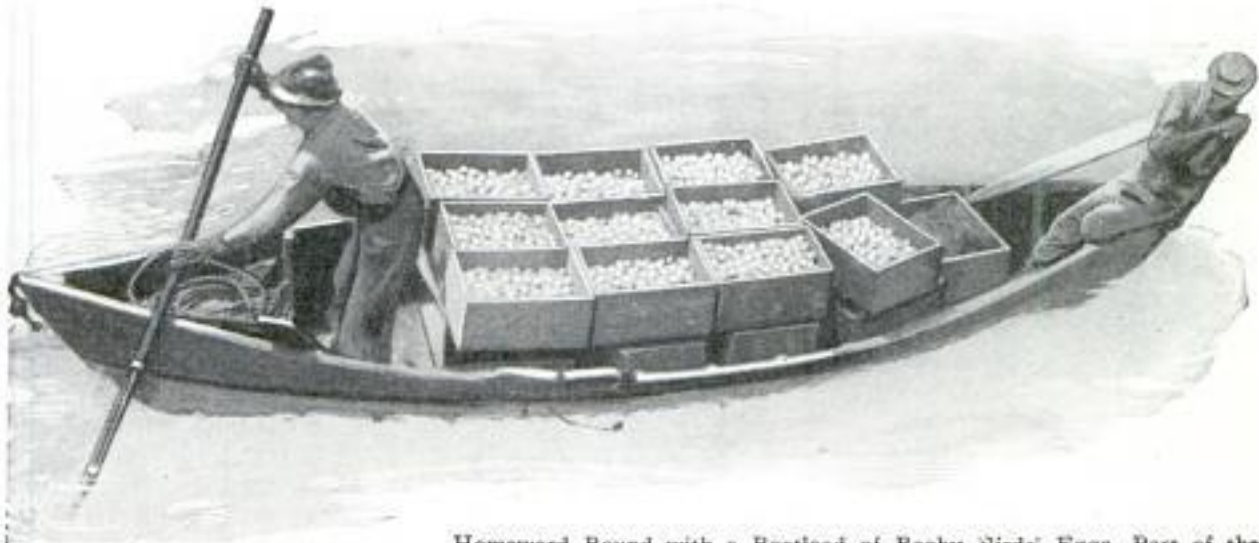

Homeward Bound with a Boatload of Booby Birds' Eggs, Part of the Annual Harvest Gathered by Natives of the West Indies

this time covered about 12,000 miles. There were no serious accidents, but several humorous incidents connected with the air work. The friendly natives were at first very much afraid of the White Winged God, but later their curiosity overcame their fear and they stared with primitive awe as Lieut. Hinton turned on the motor and summoned a mighty wind and thunder which bent the jungle foliage before its cooling blasts. The first time this experiment was tried, the natives took to their heels and would not come back until the motor was switched off. Later both Stevens and Hinton were able to induce them to work harder during the day by promising to turn on the cooling wind at nightfall.

Snakes bothered the airmen considerably. Although the flying boat was moored in the river, the tropical foliage drooped over the wings and various poisonous reptiles found their way into the cockpit. It is quite possible that a record for an unusual air cargo was created when Lieut. Hinton discovered himself fifty miles from his base with an eight-foot boa sunning itself in the hull of the boat. The noise of the motor seemed to soothe the snake, but a quick slash with a machete ended its reverie.

Upon returning from one of their many hazardous trips, the flyers would gather around the portable radio set with which the expedition was equipped and listen to radio concerts in America.

rocks along the beaches. The birds come by the hundreds of thousands and but feebly resist the egg seekers who row their boats close to the nests. Frigate birds also prey upon the boobies, eating the fish they have caught. The stupidity of the victims under attack, earned for them their derisive name.

TIRE TOOL OF GREAT LEVERAGE FITS ALL SPLIT RIMS 3369



Drop - forged steel jaws which are held to the split rim with hardened screws are used in a patented tire tool. The leverage exerted by one movement of the long handle forces half of the rim downward and forward so that the casing may be removed or mounted. It is said that the tool will contract and expand all split rims, including those for balloon tires.

Often applying 3,000 pounds of pressure to the keys in a minute, a pianist in the same time reads 1,500 signs and makes 2,000 finger movements.

Donney Forge & Tool Works, Allentown, Pa.

WHITE CROSSES ARE WARNING AT AUTO DEATH SPOTS

As a forceful warning to reckless automobile drivers, the state of Ohio is mark-



To Remind Motorists Day and Night of the Folly of Reckless Driving, White Crosses Mark Scene of Fatal Accidents

ing its highways with large white wooden crosses wherever a fatal auto accident has occurred. So-called "death corners" are expected to have the appearance of cemeteries. Even at night, the white paint will show through the darkness as a reminder to the speeder.

LONE ADVENTURER FACES DANGERS OF ARCTIC TRIP

Relying on his ability as a hunter for food and clothing, Maj. "Lookie" Burwash of Toronto, a government explorer has started alone for a two years' trip across the northern extremities of Canada. His route will lead from the delta of the Mackenzie river along the shore of the Arctic ocean and finally to Chesterfield inlet of Hudson bay. His only aid is his rifle. He carries no supplies of food. The journey will take him through Bathurst inlet, where a number of white men were murdered by unfriendly Eskimos a few years ago. The object of his solitary expedition is to examine the conditions of the natives who inhabit that part of Canada and the varieties of wild life that are found there. He will also observe soil and mineral conditions and make a complete report to the Canadian government when he has finished the trip. In 1922, he explored Baffin island and is the only white man to have crossed it.

THRILLS IN LIFE OF MEN WHO BUILD RADIO TOWERS

145

A series of remarkably lofty radio towers have recently been erected by the British post office, at Hillmorton, to flash messages direct to Australia and India. Up the center of the main mast, which is 820 feet high, crawls a small electric elevator, and a vivid idea of the height of this tower is impressed upon the mind when it is realized that the elevator takes twelve minutes to ascend from the ground to the summit.

near Oughby Eng.

blow, the girders and latticework of the towers sway gently to and fro.

The men who built these towers of steel, far transcending in height the skyscraper, endured great physical hardship. Rains and cold winds made this work difficult and hazardous for often they could not descend from their lofty construction stage where they were hammering, riveting or painting, with only a narrow steel girder between them and death.

So far above the earth are these aerial masts, that clouds often veil the tops from the eye of the observer gazing up from below, and if he stands on the top of the tower, looking down from that dizzy height, he sees only a floor of clouds into which the slender steel mast vanishes earthward. Strangely, these tall towers are not based directly upon the earth, but rest upon a ball, so that when the winds

It cost \$75,000 to erect one only of these mast towers, and altogether, \$200,000 has been spent on the equipment of this radio station.

At an altitude of 19,000 feet, during the climb to reach the summit of Mt. Everest, the adventurers are said to have lost their sense of taste, onions and peppermints seeming practically without flavor.

145

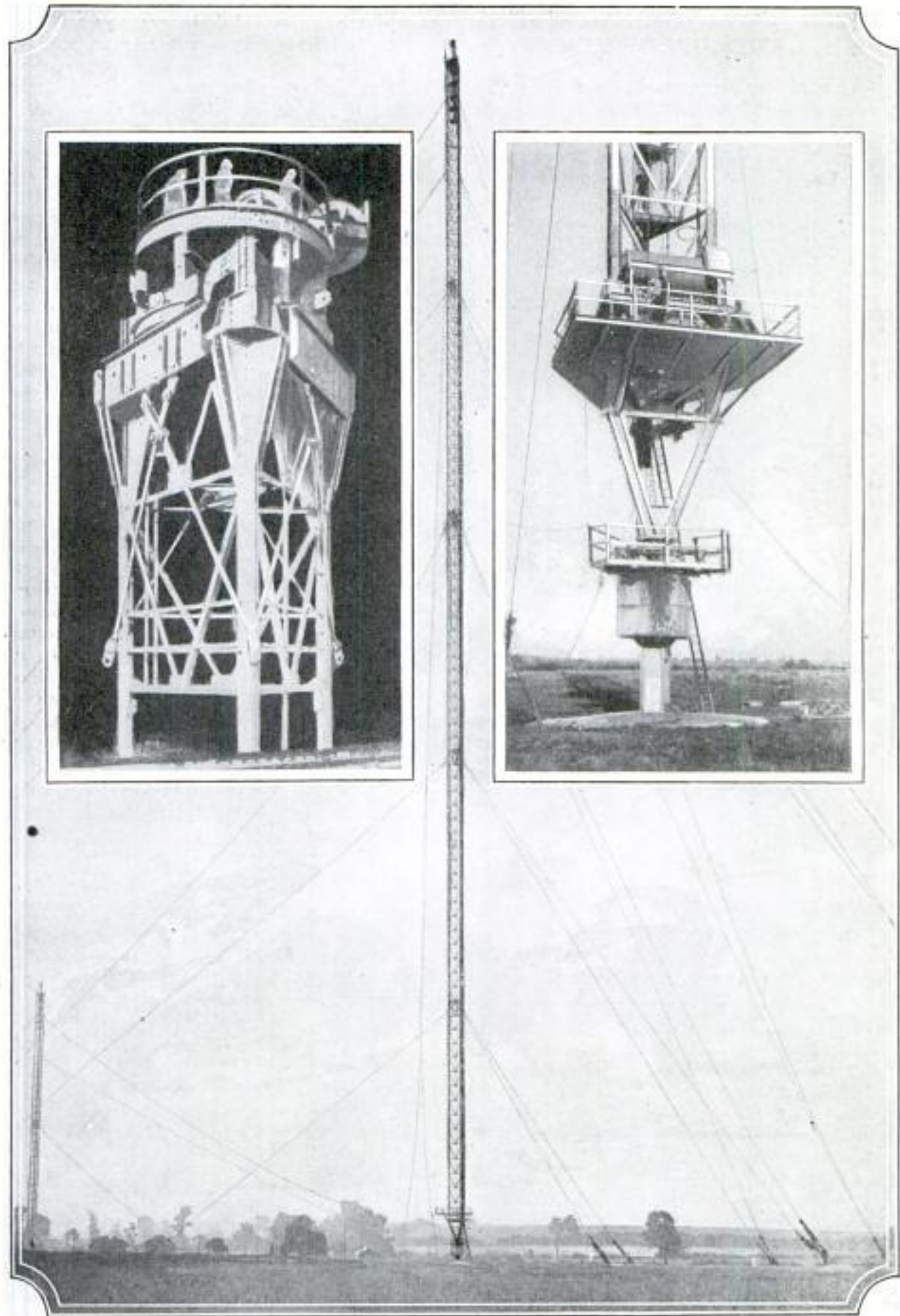

Courtesy Postmaster-General, London, England

Radio Tower, 820 Feet High, near Rugby, England; Tip of the Mast in Left Insert, and at Right, the Bottom. Showing Platform and Elevator That Climbs to Top in Twelve Minutes

Capt. H. S. Welkins, Esq., 4, Crowhurst
 Road, Brixton, S.W. 9, London, Eng.

Copyrighted material

FINDER FOR ANTI-AIRCRAFT GUN TELLS HEIGHT OF PLANES

As an aid to determining the range on speeding airplanes, a telescope-shaped

*Tests conducted at Fort Tilden 268
Rochaway N.Y. by Coast Artillery
Co. 1st Air Service 8/17/23*



Soldiers Using Special Finder to Gauge Height of Moving Airplane Targets during Tests with Anti-Aircraft Guns

finder that records the height of the targets has been devised for use with anti-aircraft guns. It is attached to a large tripod so that it can be set up quickly and carried about and is operated after the fashion of the range finder of battleships. Its chief difference is that it measures altitudes instead of horizontal distances.

BOY'S DREAM OF "WATERLESS" LOCOMOTIVE IS REALIZED

322

Elimination of the lonely little water-tank towns of the western desert is declared possible as a result of tests recently completed with a new 1,000-horsepower locomotive built in the Baldwin shops. It is powered with a new type of Diesel engine, invented by Carl H. Knudsen, a Norwegian engineer who came to America twenty years ago as an immigrant boy. The engine differs radically from other Diesels in that it completely expels all burnt gases, leaving no dead gas in the cylinder under compression, and it likewise has a supercharger which increases the power output by maintaining a pressure on the intake above that of the at-

*Locomotive works
Broad + Spring Garden
Phila*

mosphere. The 1,000-horsepower unit stands but four feet seven inches high, is twelve feet long, and weighs but forty-five pounds per horsepower, so that it makes possible an unusually powerful railroad locomotive in much less space than the usual steam type requires. The chief field for the locomotive is said to be on hauls where the task of supplying water for steam making is difficult.

With the elimination of water, the entire tender capacity can be devoted to fuel oil. In tests, one of the locomotives pulled over 1,800 tons on a grade and handled 3,000 tons on a level road. By changing the low-ratio freight gearing, it can be adapted for passenger work with a speed of seventy-five miles.

292
ELEPHANT'S COLD CURED WITH BAG OVER TRUNK

When circus elephants catch a cold, inhaling boiling vinegar sometimes proves effective as a cure. The "medicine" is administered by placing it in a canvas container, shaped like a feedbag and tied securely to the animal's trunk. Whether the elephant wants it or not, it must inhale the beneficial fumes.



Bag Containing Hot Vinegar Placed over Trunk, Compels Elephant to Inhale Fumes for Cold

Keystone

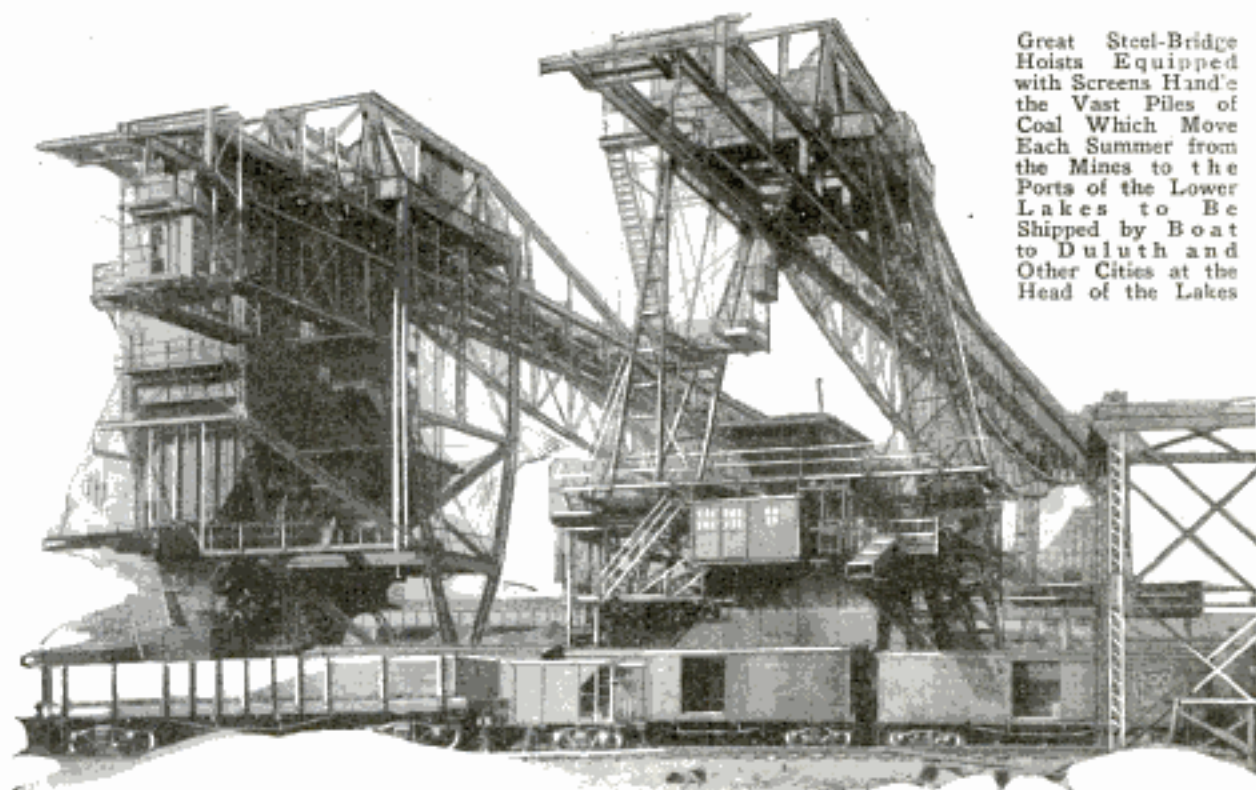

Great Steel-Bridge Hoists Equipped with Screens Handle the Vast Piles of Coal Which Move Each Summer from the Mines to the Ports of the Lower Lakes to Be Shipped by Boat to Duluth and Other Cities at the Head of the Lakes

Unwritten Tales of the Inland Seas

Adventures and Thrills Mark Lives of Sailors Who Ply the Great Lakes, and Mystery Surrounds Fate of Hundreds

By J. EARLE MILLER

OUTFITTING of several treasure-hunting expeditions on the Great Lakes during the past summer has revived interest in the many tragedies of the inland seas. Scoffed at by deep-water sailors as a "mill pond," the Great Lakes have probably claimed, in the last hundred years, a greater toll in ships and cargo than any other area of equal size.

At least three expeditions are planning to hunt some of the lost ships of Lake Michigan alone. The passenger ship "Westmoreland," sunk near the straits of Mackinac several years ago with \$100,000 in its safe, is the chief prize sought.

Despite the fact that a ship is rarely more than half a day's run from land, great-lakes navigation offers perils that are not encountered on the ocean. The very narrowness of the inland seas is a danger from which the boat in mid-ocean is free, since the lake skipper in a storm is always almost on a lee shore. The famous fishing schooners on St. George's bank in the Atlantic have been featured in innumerable stories because of the danger and hardships they suffer in the path of

the transatlantic liners. But in the narrow confines of Whitefish bay, at the lower end of Lake Superior, fogs are just as bad as on the Atlantic fishing banks, and more huge steel ships, with bellowing foghorns, pass in a single hour than the ocean pathway will see in a week.

For skill in navigation, the masters of the iron, coal and wheat freighters which ply the upper lakes are said to be without a peer, yet all their sailing is done without the use of sextant or any of the usual navigating instruments. Knowing the speed of their ships, and with a good compass and clock, they will sail the darkest or foggiest night through waters so crowded that a dozen or more 600-foot freighters may be within hearing at one time. Starting from the harbor light at Duluth or one of the other upper lake ports, they can go all the way to the lower lakes with little more than dead reckoning as a guide. Given the ship's speed, they will sail a certain course for so many hours or minutes, then turn to the next, and raise lighthouse or reef buoy at the exact place and time it was expected.

*Emb. Ethel Vincent Wilson
Takoma Park, Washington, D.C.*

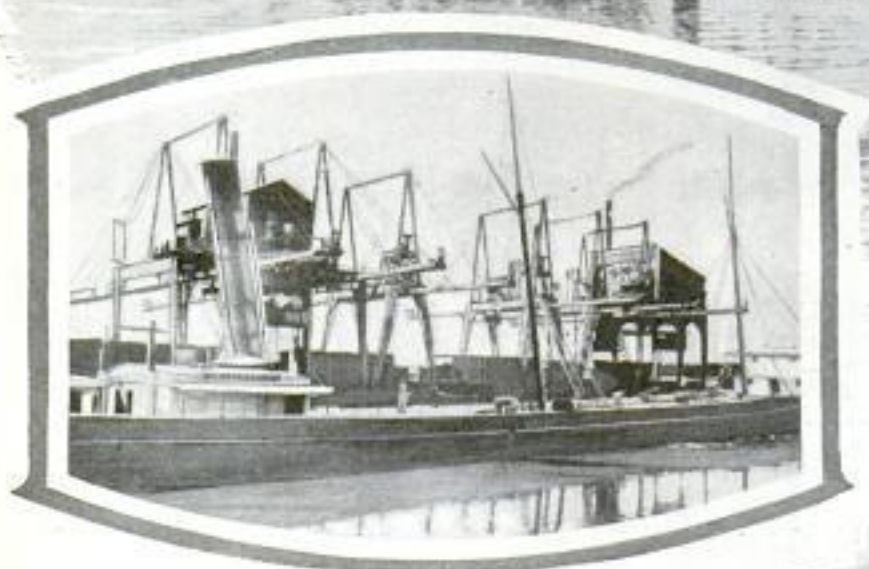

Above, the First "Fast Plant," Introduced with a New Type of Boat; the Unloading Buckets Dipped through the Hatches and Brought Up the Ore; Right, One of the Unloading Bridges Which Went Out When the Lake-Type Steamship with Its Huge Hatchways Came In

The bulk of the lake traffic is carried by the huge freighters which bring iron ore to the steel mills and carry back coal for the northwest. Next to the steel trade comes the wheat movement. The ships are peculiarly a lake development, and hold the world's records for low cost and efficiency in handling cargo. A 600-foot steel freighter, with its engines set far aft and its bridge in the very bow, leaving a long expanse of open deck between, has been loaded with more than 12,000 tons of ore in sixteen minutes, and has unloaded its cargo in less than half a day. An ocean freighter of the same capacity would have required not hours, but days to handle the same amount of cargo.

The lake boats are unique in that the loading and unloading equipment is all built on the dock, and the ship itself is



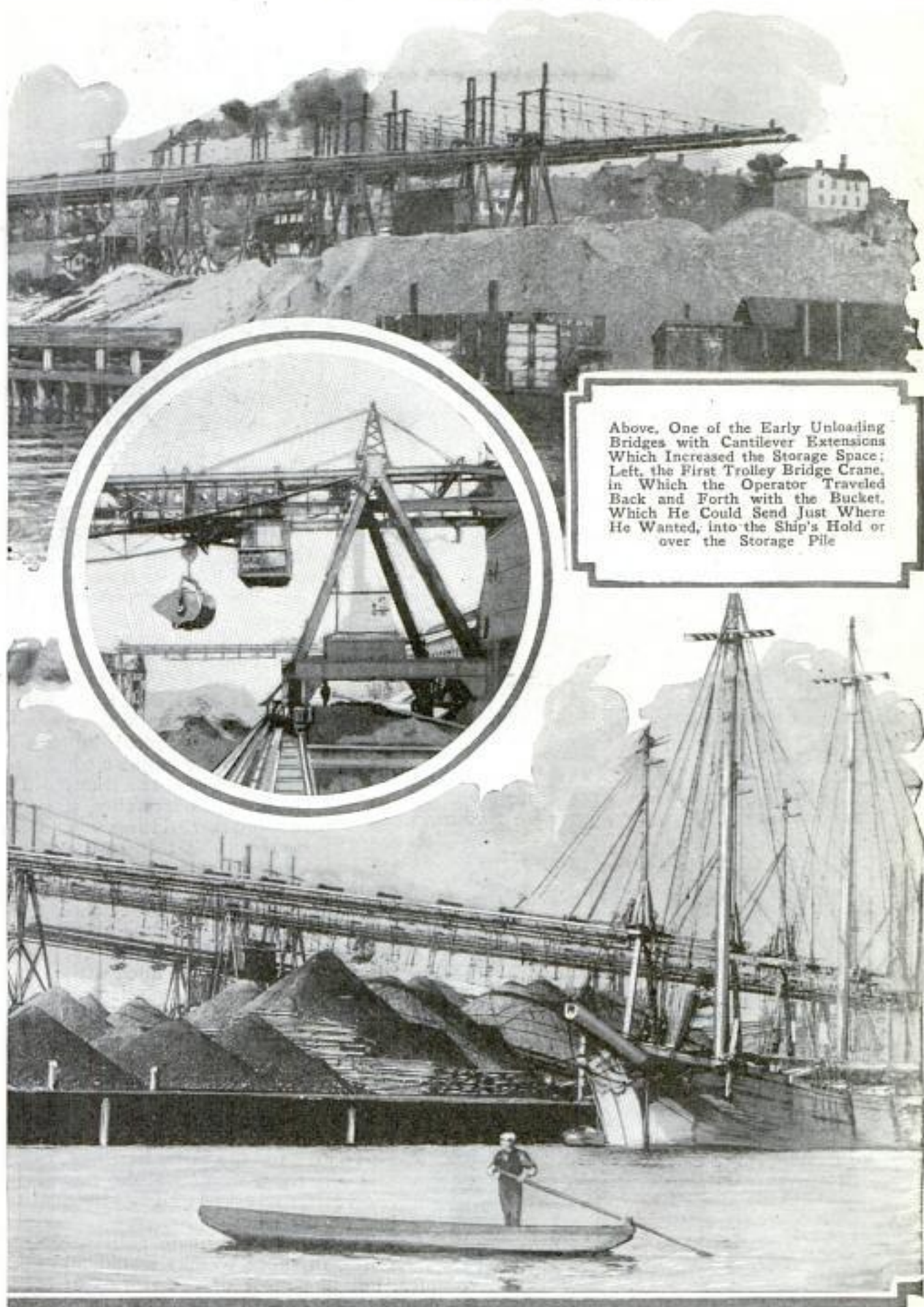

Above, One of the Early Unloading Bridges with Cantilever Extensions Which Increased the Storage Space; Left, the First Trolley Bridge Crane, in Which the Operator Traveled Back and Forth with the Bucket, Which He Could Send Just Where He Wanted, into the Ship's Hold or over the Storage Pile

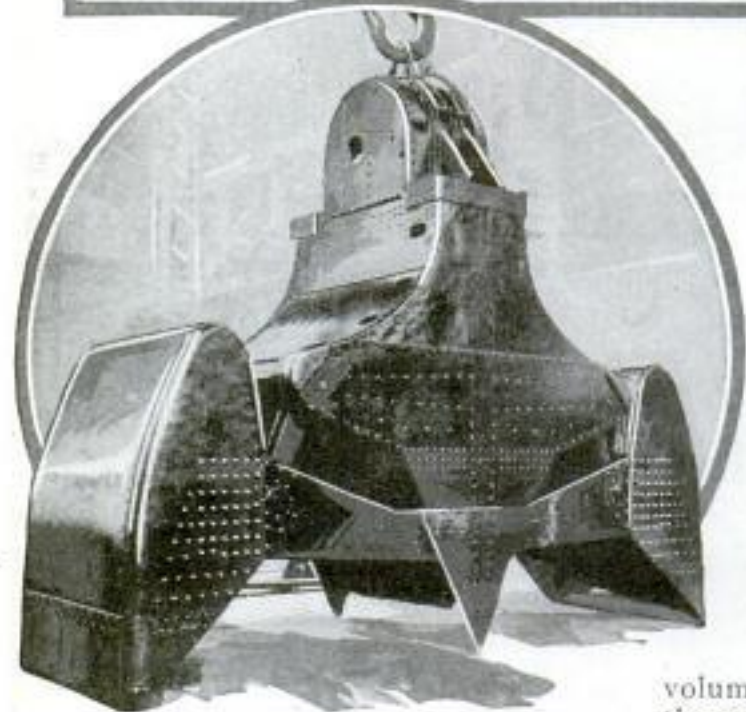
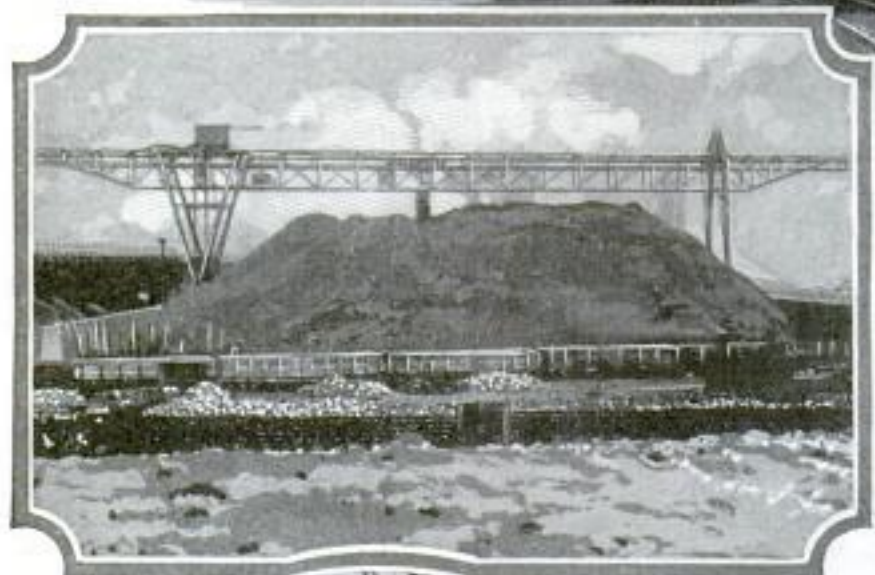
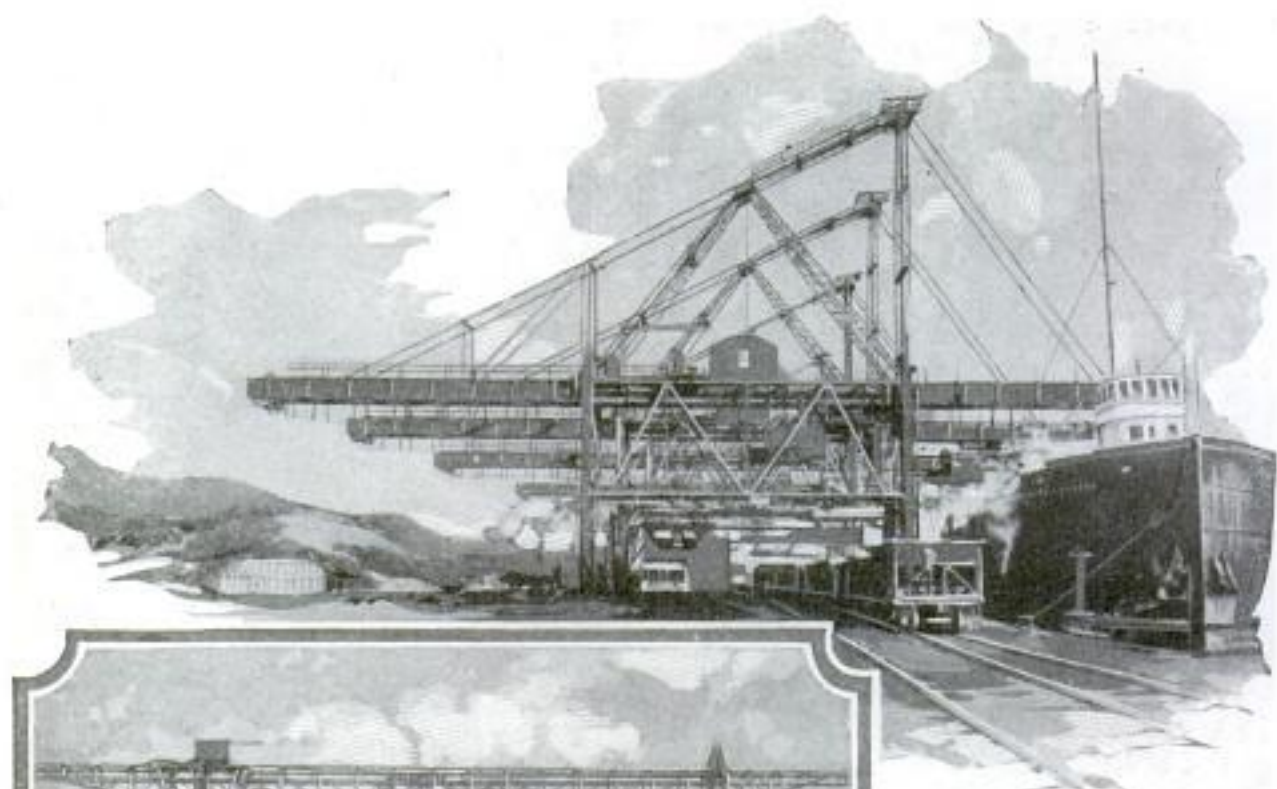

Improved Unloaders and Giant Bridge Cranes, with Ten-Ton Buckets, Followed, Emptying Ships Faster

simply an enormous bin, pierced by rows of huge loading hatches, and with a propelling engine at one end and steering wheel at the other. There is no more ungainly-looking craft in the world, but they handle with such remarkable ease that, in confined stretches, a double row of them will move up and down the

stream as closely packed, in proportion to their size, as automobiles on Fifth avenue or Michigan boulevard.

As far back as the records go, the story of the lakes is filled with tales of disaster—263 vessels and seventy-nine lives lost in 1851, 100 vessels and 200 lives in 1883; 285 disasters and 135 lives in the single month of October, 1886, and twenty-nine vessels and thirty-nine lives in two days in the following month; and similar records for the years between, and since. The year 1860 saw 382 vessels wrecked and 578 lives lost on the lakes.

The tales of heroism and suffering in those wrecks would fill volumes, but like most of the stories of the men who go down to the inland seas, they remain unwritten. A few years ago



Previous to 1880, Donkey Engines Hoisted the Ore and Men Carted It to the Storage Piles in Wheelbarrows



Tramway Machines, to Left, Displaced the Wheelbarrows, and Sent Their Steam-Operated Buckets Direct into the Hold, to Be Filled by Shovelers; Transfer Cars, Above, Capable of Moving Many Buckets to the Blast Furnaces, Were the Next Step to Meet the Incessant Speeding Up of the Mills

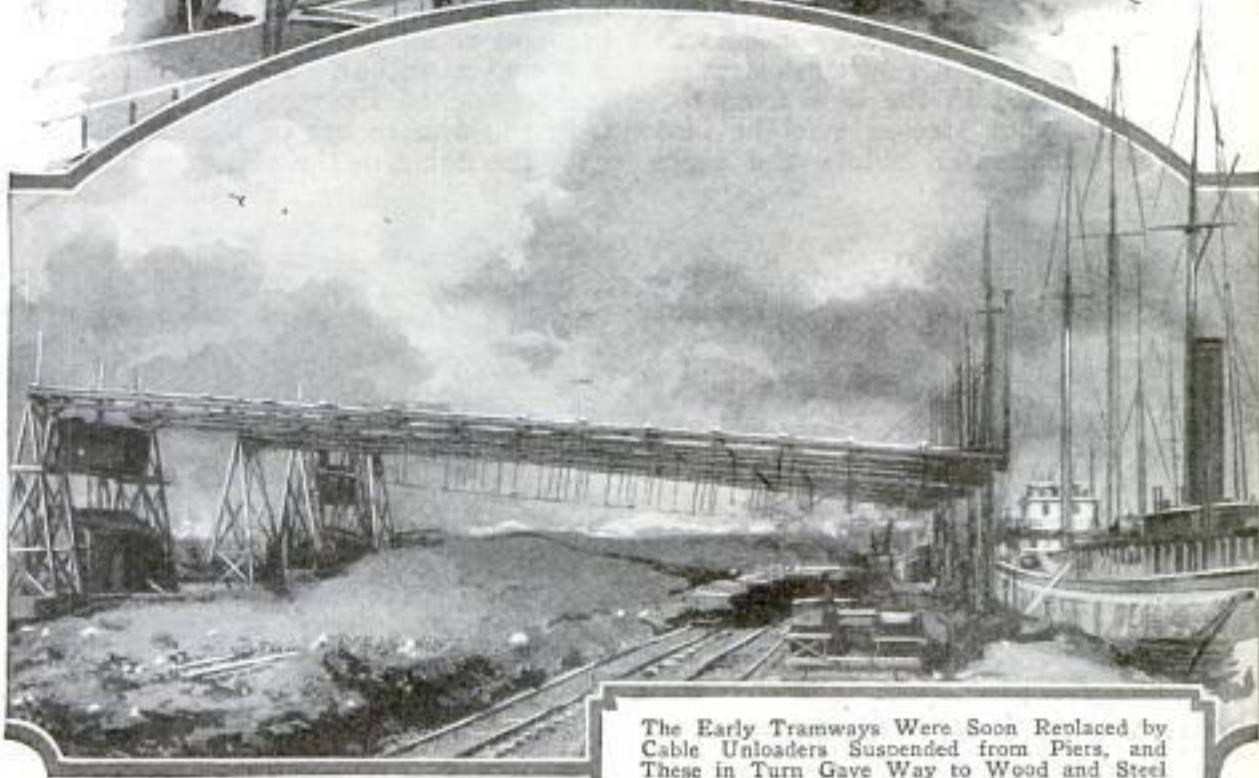
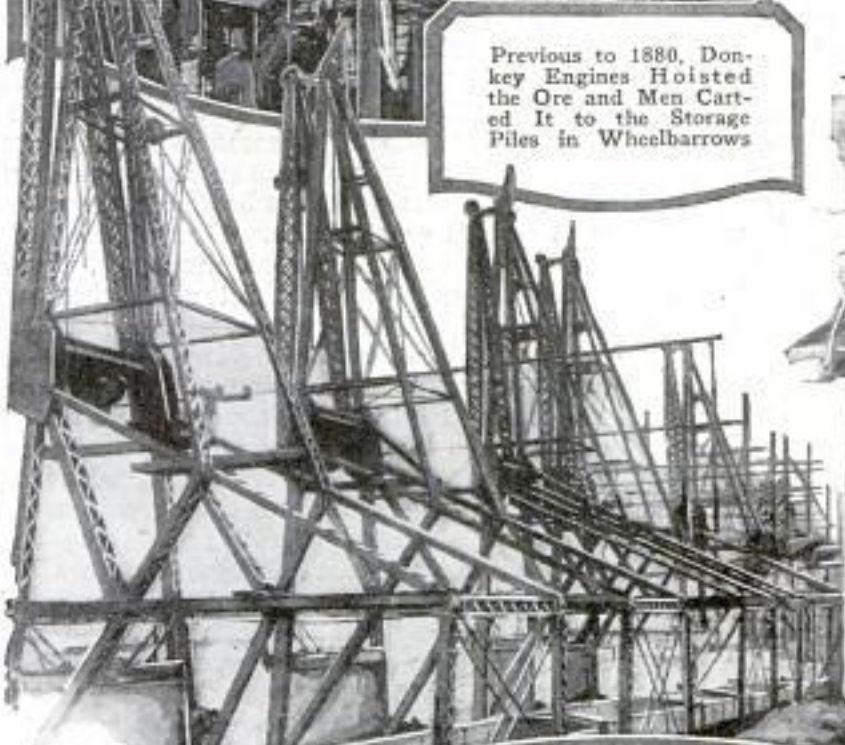

The Early Tramways Were Soon Replaced by Cable Unloaders Suspended from Piers, and These in Turn Gave Way to Wood and Steel

a Chicago captain who went up the lakes each season to bring back a cargo of Christmas trees set out with his schooner, expecting to reach the city just a few days before the holiday. He was caught in a December gale. A few days later Christmas trees began to wash ashore, and from that day nothing has been learned about the fate of his ship or where she sank. Yet the next year his wife and daughter chartered another schooner, and brought back the usual cargo.

One of the most famous mystery disasters on the lakes is that of the "Chicora," which sailed from Milwaukee on January 21, 1895, bound for St. Joseph, Mich., and was never heard from. Somewhere on the trip of eighty miles across the lake she went down with her crew of twenty-four, caught in a howling gale, and only a bit of wreckage, washed ashore days later, was ever found. In the great storm of Nov. 17-18, 1885, when twenty-nine boats were lost in forty-eight hours, the crew of the steamer "Arizona" were victims of one of the strangest pranks ever played.

The "Arizona" had left Marquette, Mich., with a cargo of acid in carboys and 900 barrels of oil. Six miles out, with the gale raging, a carboy was wrenched from its fastenings and broke, the acid immediately taking fire. The engineer gave the ship full steam ahead before he was driven to the deck, and the captain turned back toward the harbor. Other carboys and the barrels of oil caught fire, and as the steamer raced into the harbor she was a blazing torch, only her speed protecting the crew gathered in the bow from the flames. The pilot steered straight into the stone breakwater, while the crew

jumped ashore, but the masterless ship then sheered off and, with flames pouring from her sides and a full head of steam turning the propeller, chased the sailors over the wall.

The growth of the freighters has kept pace with the expansion of the steel industry. Constant improvement eventually produced the freighter of today, and the unloading equipment. The ore is dumped from the mine cars into hopper bins at the loading ports and flows by gravity into the ship. At the other end huge unloading machines dip into the hold, each one biting up seventeen tons of ore at a grab.

The men who command the huge freighters grew up on the lakes, and in most cases their fathers before them were lake sailors or captains. One of the oldest in point of service on the lakes, Capt. C. E. Moody, has retired from the ore trade and in summer commands a big excursion boat on Lake Michigan. As a boy he was present when the dead from the "Lady Elgin" wreck, one of the worst disasters in lake history, were brought in, and his own father went down with his ship near the straits of Mackinac more than half a century ago. The "Lady Elgin," on a trip from Milwaukee to Chicago with 350 passengers and a crew of thirty-five, had left the latter city on her return trip in the early evening, but because of the gale, was making slow progress when, at two o'clock in the morning, a schooner, deep-loaded with lumber and running without lights, crashed into and sank her. The schooner eventually reached Chicago, badly damaged, with the first report of the disaster, but with the name of the victim unknown.

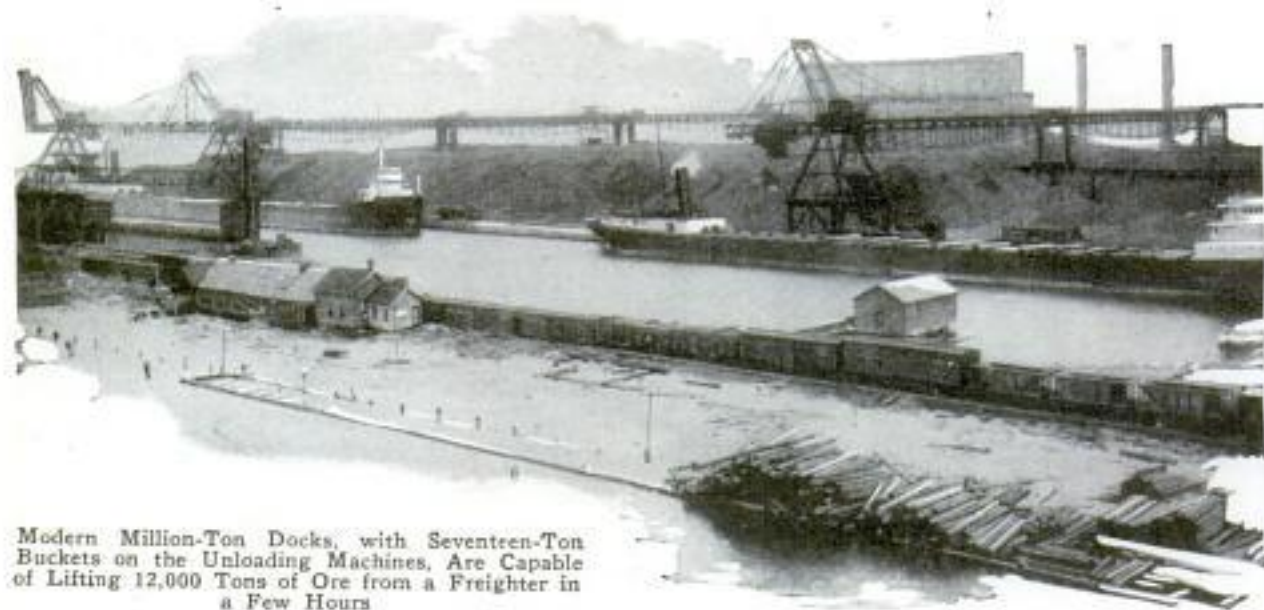

Modern Million-Ton Docks, with Seventeen-Ton Buckets on the Unloading Machines, Are Capable of Lifting 12,000 Tons of Ore from a Freighter in a Few Hours

Paper 8/18/25

Moulton Ladder Mfg Co.
790
2-40 Harding St

POPULAR MECHANICS

GERMAN ALCOHOL
CAN'T REPLACE
GASOLINE 2

While the flow of cheap, synthetic alcohol from Germany has had a pronounced effect on the wood-product industry, those who have studied the situation declare that it will not replace gasoline as auto fuel. The refiner's cost for gasoline may be as low as six cents while the manufacturing cost of synthetic alcohol is placed at not lower than ten cents a gallon. By the time the latter product bears its share of railroad freight, retailer and jobber profits, its price to the consumer will approximate that of gasoline or be higher. It has only half the heat value of gasoline and its efficiency is low with engines operating on the compressions now in use.

PLIERLIKE CLAMP
AID TO HOME
WORKER 258

For various mending jobs about the house, and for the use of workmen in several trades, a clamp shaped like a pair of pliers and having a strong spring that keeps the jaws together, saves time, leaves both hands free to do other work and fits in difficult positions. In gluing, for instance, it may be attached to the surfaces that are being mended and left until the adhesive is dry, and the bother of adjusting a screw clamp is saved. For upholstery and repairing furniture, building radio sets, frames and patterns, the tool has special uses. It is manufactured in several sizes that will suit light and heavy work within the range of the implement.



Mending Photograph Plate Holders Is Simplified by Using Clamp Plier to Keep Edges Together

Knape + Vogt
Grand Rapids, Mich

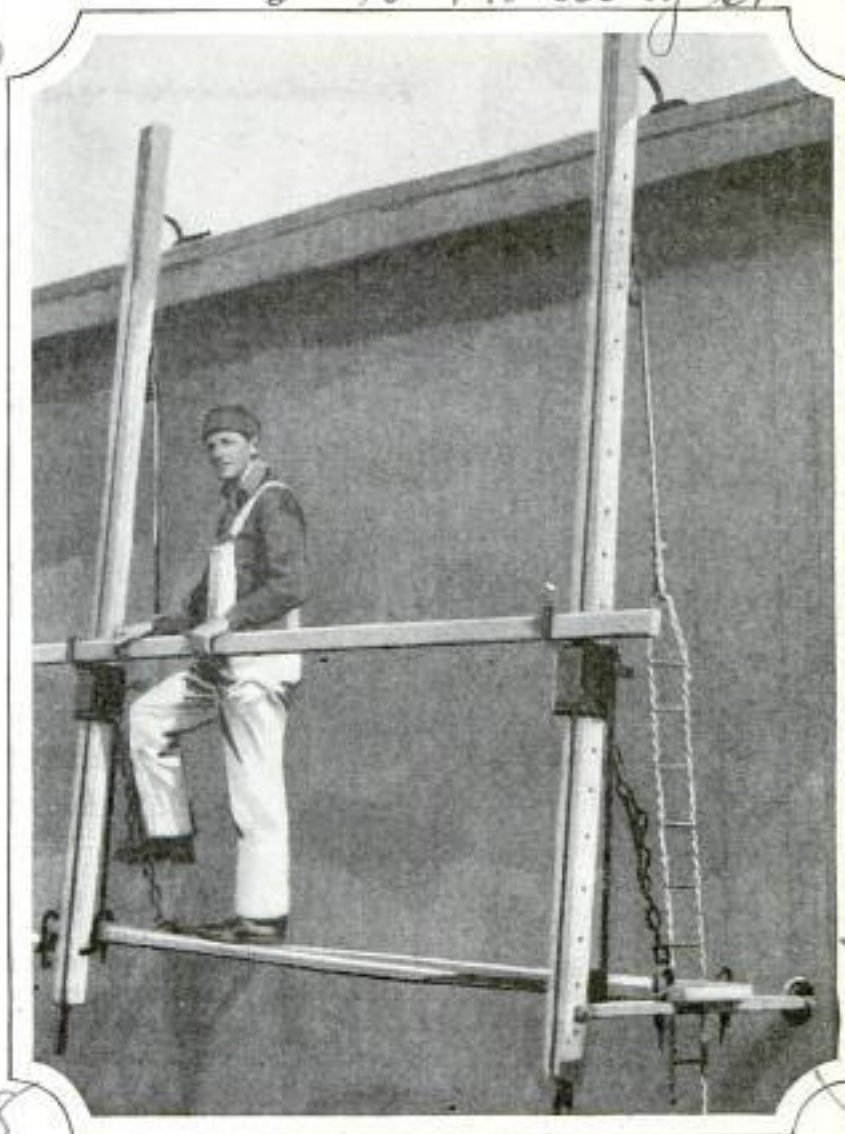

Workman Raising Scaffold by Foot While Supporting Weight on Crossbar Which Guards Him from Falling; Special Clamps Hold Bottom Board

SCAFFOLD IS RAISED BY FOOT
AND QUICKLY ADJUSTED 273

Fitted with a special balancing device, a patented scaffold for painters, carpenters and other workmen is raised or lowered by foot pressure. It is put up in little time, special roof connections being used which require no boards, cornice hooks, triangles or ladders. The uprights are twenty feet long and have extension parts for greater lengths. The guard rail across the scaffold and the platform on which the workers stand are so arranged that they can be locked securely at any desired height.

Wm. E. W. Clough
337 Pine St. Fall River, Mass

my
is
Dunham
Barnstable
Mass



PHOTOS TAKEN THROUGH GLASS
TO STUDY GOLF POSES

HOW far apart should the feet be in making a golf drive? Are the eyes on the ball? What happens when the club hits the sphere? These and other questions, frequently discussed by players, have been answered by the camera in various photographic studies, but some of the fine points of the game have been revealed in a more novel and helpful way

by taking the pictures through a glass platform with the camera directly below the player, so that the demonstrator's face, hand positions and feet would be emphasized. The distortions that resulted only served to call attention to the points that were to be studied especially. In addition to the "stills," a slow-motion movie, showing the swing from its start to completion, caught the player's action even to the facial expression.

NEEDLES' HISTORY TRACED FOR CENTURIES

235

Latest figures show that the United States leads the world in the manufacture of machine-made needles. Twenty-two processes are required in the making of each of these humble, but highly useful domestic tools. Needles are known to have existed long before Christianity, bronze specimens having been found in Mexican, Roman and Greek ruins. They were first made of bone and ivory and later of metals, the first type being pierced with an eye and the latter simply turned over in a loop at one end to carry the thread. A Moor, driven from Spain by religious persecution, first brought this article to England, in its wire shape. Earlier they had been imported from that country, 12,000 of them being included in the marriage portion of one king's daughter according to old records. However, as a practical implement, pins are of more recent development, but in the shape of highly-jeweled ornaments they have been known from time immemorial, and were prized gifts of the ancient rulers to their favorites.

3151

BOLT CUTTER SET AT AN ANGLE REACHES DIFFICULT PLACES

With cutting jaws set at an angle of thirty degrees, a long-handled bolt clipper reaches difficult places such as the underside of an automobile mudguard with ease. Powerful leverage is easily exerted by the long grips and the tool withstands heavy service.



H. R.

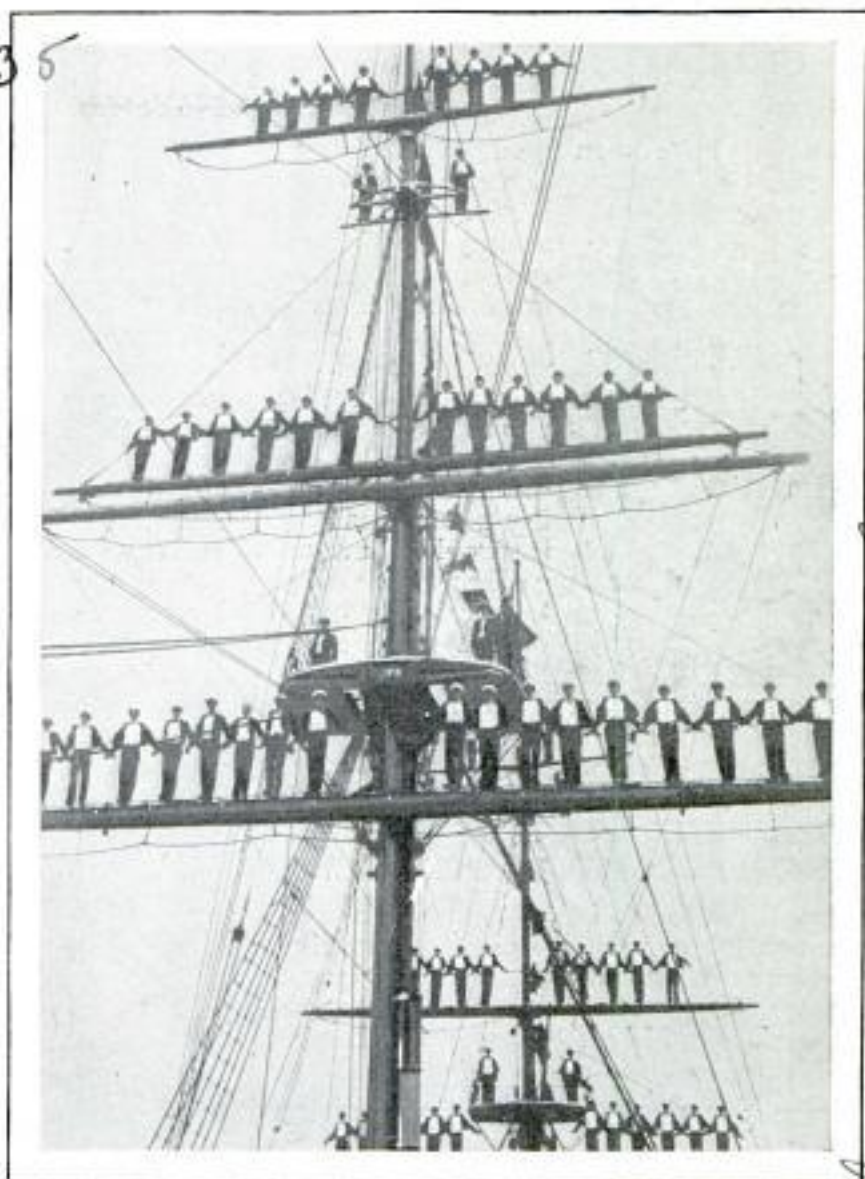

British Naval Cadets Balanced on Masts of Sailing Vessel, a Training Stunt for Steadying Nerves, Testing Agility and Courage

SAILORS FORM HUMAN TREE ON SHIP'S CROSSARMS

Cadet officers of the British navy undergo a rigorous course of training to fit their bodies and their minds for the duties of their future positions. A drill was given recently on a training ship in which the embryo admirals, most of them without support other than that of the hands of their neighbors, posed on the huge crossarms of the vessel to form a "ship tree with human branches."

MATCHES ARE WATERPROOFED

Matches which can be dipped in water without spoiling have been produced, it is claimed, by putting rubber latex into the tip material. The mixture is then vulcanized. The lighting power is retained even after the matches have been in water for some time.

England. Worcester, English. Chemical Trade

18
L. W. M. M. Messay
Engineer. July. 1924.
Copyrighted material

A. K. Iron Co, Inc.
 34 802 Madison Ave
 New York City

POPULAR MECHANICS

242

SHAVING-BRUSH SUCTION GRIP
 CLINGS TO ANY SURFACE

Shaving brushes may be kept upright after they have been filled with lather by thrusting the handle into a clip held at any angle by a rubber suction grip. The latter is attachable to glass, wood or metal. It is claimed for the clip that it saves much of the disorder of the shaving stand and that it provides an excellent way of keeping the brush out in the air and light where it may

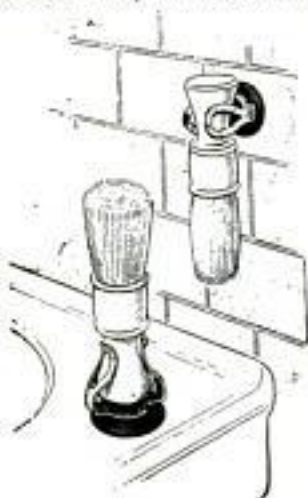

dry in a sanitary manner, or standing upright without slipping on a wet surface while one is shaving.

METAL FOILS ROLLED SO THIN
 THEY BECOME TRANSPARENT

Metal can be rolled so thin one can see through it like a pane of glass, according to claims of a German scientist for a process of making foil that he has discovered. By his method, the report says, a block of gold or other metal can be reduced to the thinness of one-millionth

Dr. Karl Mueller
 Physical Research Bureau
 Berlin, Germany

part of a centimeter and still retain its elasticity. The practical value of the discovery, it is asserted, is in the radio, telephone and musical industries. An easy study of the atomic structure of metals is also afforded.

219.

SELF-UNLOADING AUTO TRUCK
 SAVES TIME AND MONEY

Time, labor and money are saved for haulers of loose loads, like coal and gravel, by a motor truck which has a conveyor fed from the side of the car. The vehicle, it is claimed, is particularly good for work in narrow and crowded streets and alleys of cities, because the driver need not back the truck into position but simply drives alongside the point of delivery. The conveyor normally is upright against the side of the motor body. When it is let down, the load pours onto it and is carried into the waiting bin or cellar by a moving pan. Power for driving the conveyor is supplied by a sprocket wheel and chain connected with gearing on a shaft driven by the truck motor.



Power Conveyor on Coal Truck Delivering the Load Direct into the Basement Bin, Eliminating Shoveling and All Rehandling, and, Above, the Conveyor Folded Up When Not in Use

Chas. Henry Parkmann
 2514 W. Huron and
 Kutscha, 5622 S. May St. Chicago

Copyrighted material



One of Daily Cloud Paintings Made by M. Pierre Fleury at Paris for Use in Future Comparisons of Sky Conditions and Colors as a Means of Predicting the State of the Weather

Painting Clouds for Weather Forecasts

Artist Sits All Day with Nothing to Do but Make Scientifically Accurate Pictures of Skies

VISITORS strolling along the Quai d'Orsay in the shadow of the Eiffel tower in Paris, may notice at any time of the day a black-bearded man in military uniform seated on a platform over the street with brush and palette in hand and easel before him, looking not at the city stretched below but at the skies above. This is M. Pierre Fleury whose title is "painter of clouds attached to the Office National Meteorologique."

His is a strange occupation, stationed on that lonely elevation with throngs of persons passing below while he executes rough sketches to be turned later into finished paintings of the white voyagers of the sky. M. Fleury is an artist of no small reputation, although but twenty-five years old, and his work has already been seen and favorably received at more than one exhibition in the French capital. Now he devotes his entire attention to fixing on canvas the delicate tints of the clouds as they pass over his head.

When completed, his paintings are used by the

weather experts to make predictions of the state of the weather, the possibilities of rain, or the chances of its being fair and warmer on the following day. The French weather-forecasting system is based on the aspect of the heavens, and meteorologists are able by comparing M. Fleury's paintings with similar canvases of the past to make their predictions. This system is said to give remarkably accurate results, and Col. Delcambre, director of the French weather bureau, is desirous not only of extending the system throughout France, but of establishing similar observatories in every country of the world in order to effect an interna-

tional organization to prophesy conditions several days in advance. But to achieve the best results in indicating the condition of the upper air, science was at a loss, for photography in black and white alters values and photography in colors—a difficult technical process—is often treacherous. So science turned to art.

M. Fleury laughs when asked the



M. Fleury at Work Painting His Daily Sky Record for the Meteorological Bureau at Paris



Photograph of a Tornado, Taken by an Alert Photographer at David City, Nebr., Showing the All-Destroying Funnel

reason for his employment in this capacity. "It is very simple," he explains, "Photography is incapable of capturing the numerous tints of every cloud. That is why science has found itself under obligation to make an appeal to art. As for myself, though scientific in effect, I am in my work none the less the artist."

A cloud passes, and he returns with alertness to his work lest one of these celestial fugitives might slip past him. The work that he is doing now will never hang in museums or galleries—scientific exactitude rather than artistic effect is his aim—but Pierre Fleury is satisfied, because he appreciates that he is aiding in a great work, that scientists in observatories await his finished canvases, and that navigators of the sea and air depend for their very lives on his technical ability.

"Nebulous masses," says an expert of the French weather office, "are not divided haphazardly. They constitute vast mobile groupings, whose organization has been well defined in four different sectors—the front, or anterior portion; the body, or central portion; the margin, or lateral portion; and the train, or posterior por-

tion—presenting characteristic aspects of the heavens. The problem of the prevision of the weather resolves itself into a study of these groupings and their evolution."

Anyone can do much of his own weather predicting by studying the clouds. Their height, size and shape are all dependent upon moisture, temperature and the motions of the atmosphere. Sighting past any fixed object it is possible to determine the direction of movement of a cloud bank and decide whether, if it contains rain, it is coming in your direction, going away, or will pass to one side or the other. High clouds are the result of much cooling, and therefore cannot contain sufficient moisture to yield any appreciable amount of rain or snow. Low-lying, dense cloud banks, on the other hand, may usually be taken to mean stormy weather. A good way to determine the height of a cloud is by its brightness. The higher they go the easier the sun penetrates them, and therefore the lighter they become.

Banks of massy clouds, of variegated shades ranging from white to deeper colors, typical of warm summer days and appearing usually in the early afternoon, are of the type called by the weather observers "cumulus," and may mean rain or thunder gusts. They are broken and irregular, and quite different from the broad, fleecy "nimbus" clouds of spring days. The more common thunderstorm clouds are the dark threatening masses called "cirrus." The cloud formations take many different shapes. Cumulus rolls, long-drawn masses which move forward with a rolling motion in advance of an oncoming wedge of cool air are one of the types which may develop local thunder showers, since they invariably contain much moisture, while their rolling movement in advance of the cold air indicates considerable agitation and changing conditions which will release the rain.

Fogs, the lowest form of clouds, offer another sign to be used in interpreting the weather. They are the result of the cooling of the ground-surface air to a temperature below its dewpoint. Then, the excess moisture forms the fog cloud. Rising fogs indicate clear weather ahead, while a descending cloud promises rain.

Rufus H. Inallinson
in Congress?
London

**INSECTS PICK OWN BIRTHDAYS
TO CONFORM TO WEATHER** 23 2

If the weather is bad, the small egger moth can postpone its own birthday for days, months or years, according to observations just made by a British scientist. The cocoon of this type of insect is ordinarily due to open in February, but if the weather is inclement the birth is usually postponed for twelve months. Moths have been known to emerge successfully after being imprisoned for eleven years. Another case of the way in which nature can suspend life is cited by the same authority. He declares that when a wood is cut over, the next season a profusion of foxglove springs into bloom, proving that the seeds have long been dormant under the heavy growth until sunlight touched them into life.

**GAS-TANK FILLER ON DASH
SAVES MOVING SEAT** 23 4

Filling the tanks of autos which have their gas containers under the front seat may now be accomplished without trouble through a dashboard appliance. This is a combination of a filling entrance and

gauge. The gasoline runs from the dash fill through a pipe under the floorboards and up into the usual opening in the tank. Conveniences claimed for the accessory



Filling the Auto Tank through Dashboard Opening Eliminates the Trouble of Lifting the Cushions

are that the driver need not leave his seat or guess at the amount of gas received.
Price - \$12.50.

LASSO CHAMPION PROVES SKILL BALANCED ON HEAD 240

In training for a recent western rodeo, a champion cowboy performed the difficult feat of standing on his head, balancing with one hand, and roping three motorcycle policemen with a lariat

wielded by the other hand. The officers then showed their prowess when seven of them rode on one cycle, a stunt they later demonstrated to thousands in a police-game program.

Standing on His Head and Balancing with One Hand, Cowboy "Roped" Three Speeding Motorcycle Policemen at Rodeo



Leonard Stroud

J.C. Evans Co. 2005 1/2 Cadby St. Dallas, Texas

536-18th Ave
New York N.Y.

206

CANNIBAL PLANT EATS ITSELF IN DIET OF OUTER LEAVES



Cannibal plants from the tropics are being imported into the United States for hothouse cultivation. The

Specimen of Cannibal Plant Growing on Bark

growth, known as the "air plant," attaches itself to the bark of trees. Two leaves,

veined like those of the cabbage, first appear and grow to some length. Then a second pair sprout, and promptly start to feed on the first, which soon die, and the process is repeated indefinitely. If the outer leaves of this curious plant are torn off, it cannot live.

WATERPROOFED GOLF CLUBS— MAKE WOOD LIKE METAL

Wooden golf-club heads are made almost as hard as ivory and proof against water by treating them in a pressure tank with a chemical that fills the pores. First, the heads, of seasoned persimmon wood, are placed in a retort and subjected to a vacuum process to draw out the air and moisture. They are then put in a tank and the chemical, in molten state, is forced into the wood under high pressure. Then the heads are dried and hardened. It is reported that a splinter of maple, after being filled with this material, becomes so hard that it can be driven through a one-inch plank. The waterproofing process, it is said, prevents the heads from shrinking away from the shaft or plates, increases the driving power and greatly prolongs the club's life, neither rainy weather nor a winter in a dry locker having any effect on it.

HUMPS IN ROAD GIVE WARNING AT CROSSING

Using concrete bumps in the road to warn motorists that a railroad crossing is ahead, a new safety device being tried out on a California highway has proved highly successful. Two risers, a couple of inches high and a few feet apart, are placed across the pavement at a safe dis-

tance from the railroad tracks. As an automobile passes over them two distinct bumps are recorded as a signal to the driver that there is danger ahead. Autoists have rapidly learned the meaning of the bumps and instinctively slow down and look for trains.

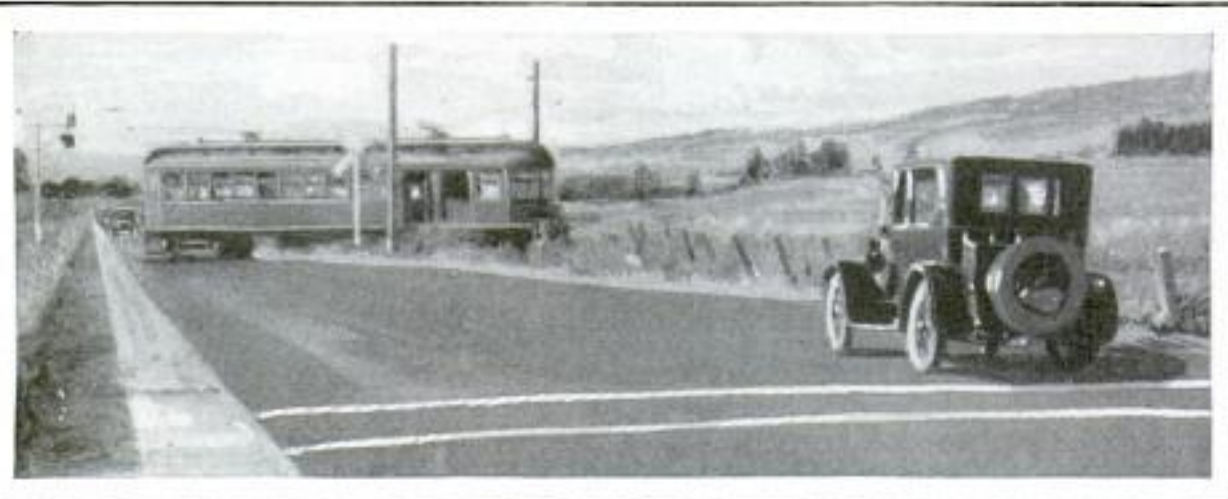

Two Concrete Risers across the Pavement Warn Autoists of a Rail Crossing Ahead, for Even if He Fails to See Danger Signs, the Sharp Jars Put Him on His Guard

Between Petaluma and Santa Rosa, Calif.

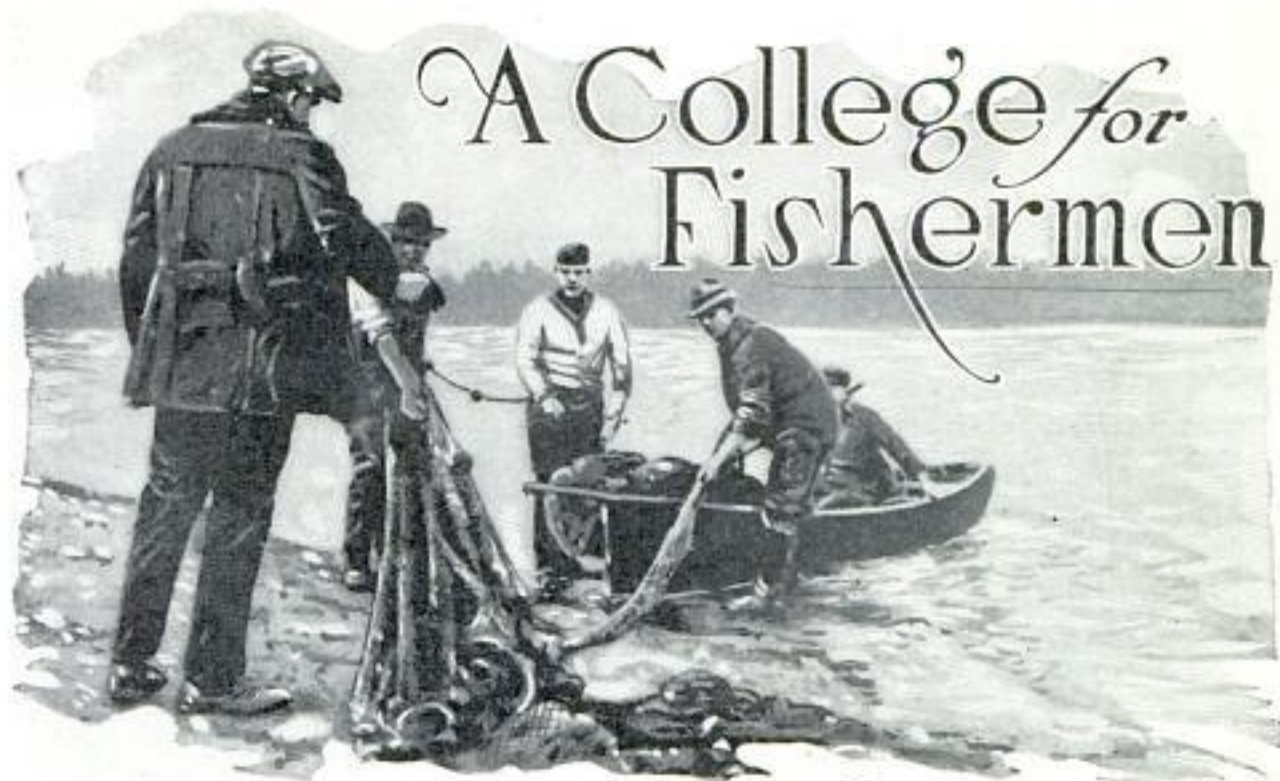

Fishery Class at the University of Washington Loading Their Haul Net into the Boat Preparatory to a "Laboratory" Lesson in Fish-Catching, Part of the Course Carried Out at Seattle

By ROBERT H. MOULTON

THE business of fishing is one of the oldest in the world, and as now conducted seems a rather fixed industry. In other words, the fisherman goes out in his boat, drops his seine overboard, hauls it in, takes from it what he can use, and that is all there is to it. What, therefore, could a fisherman learn from a college whose purpose is to teach him how to fish?

This question has been answered by the College of Fisheries of the University of Washington. Established six years ago, it has already proved an unqualified success. It has shown that, while the whims of the sea and the vagaries of the always wandering schools of fish largely control the prosperity of the commercial fisherman, nevertheless the fisheries may be regulated, the habits of the fish studied, and much of the uncertainty of the harvest of the sea converted into a reasonable sureness of output every year.

The principal justification for the establishment of the college was the fact that the fishing industry of the North American continent is the most important in the world. In the United States, including Alaska, its production amounts to almost 3,000,000,000 pounds annually, valued, as it leaves the fishermen's hands, at approximately \$100,000,000. Canada is the second most important fishing country in the

world, with products valued annually at more than \$30,000,000, while those of New Foundland total almost as much. The total value of the world's fisheries is computed at \$560,000,000. In the United States the industry uses 8,750 vessels of 240,000 net tons, and employs 191,000 men, women and children.

Much of our fishery resources is, however, either totally neglected or little utilized, simply because of the lack of trained men. The college supplies these men, and teaches them the best methods not only of operating the industry, but of preserving and conserving the natural product which forms the basis of that industry.

The older and more experienced students form the bulk of the salmon inspection force of the National Cannery association. Special instruction is given all who are considering engaging in the canning or packing of fish or any other branch of the fisheries industry. The four-year course leads to the degree of bachelor of science in fisheries.

Students are taught the fundamentals of commercial fisheries, how to outfit for the work, how to operate for each variety of food fish, and how to prepare the fish for market. They are also taught to conserve the resources of their own or any other state, by surveys of the available

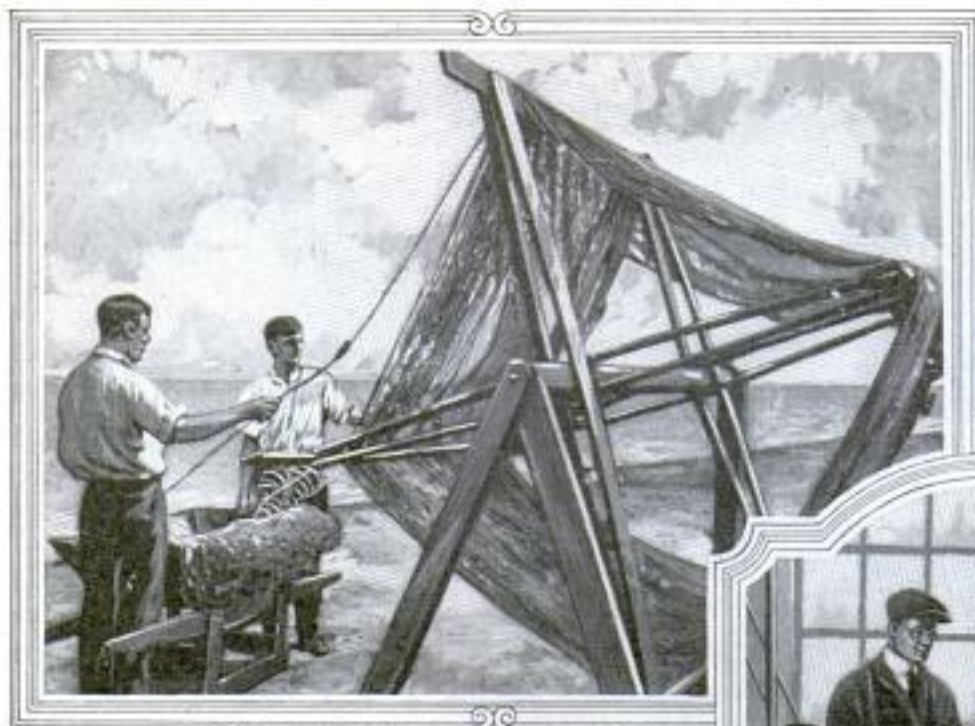

Practical Instruction in Winding a Wet Net on the Drying Reel, at Left, and, Below, a Fryer in Which Sardines Are Cooked in Oil before Being Canned, Another Lesson Taught in the Canning Plant

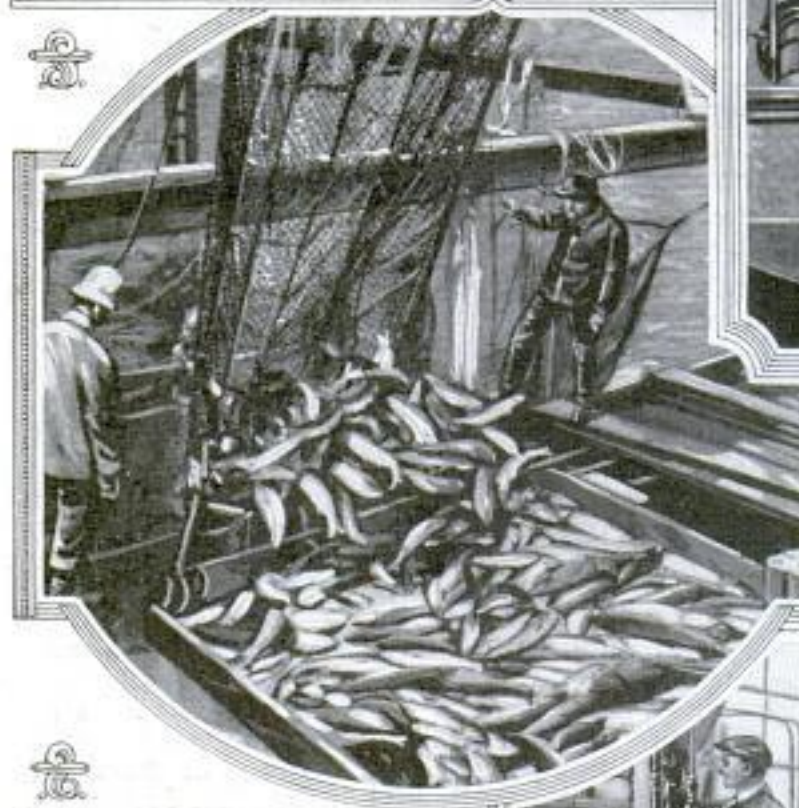

Left, Bailing Salmon from a Fish Trap; Students Are Taken to the Fishing Grounds to Watch and Assist in the Actual Operations, Getting Their Knowledge of the Business at First Hand

Part of the Steam Plant and Reports for Cooking Salmon; Here the Students Operate the Latest and Most Modern Devices in Preparing the Product for Market; the School is Equipped Throughout to Teach Not Only the Theory of Preparing Sea Food for Sale, but to Instruct the Pupils in Actual Work

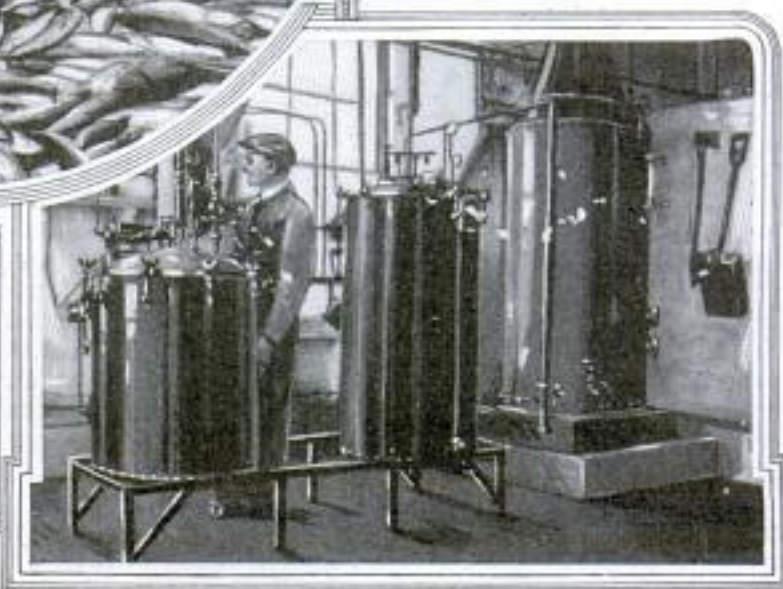



Microscopic Animal and Plant Life Hauled Up in a Fine-Meshed Net, for Study of the Food of the Fish; Center, Seining in the College Fish Pond; and, at Bottom, Small Salmon Being Dipped from the Rearing Ponds Preparatory to Transfer to Other Waters

waters and their fish supply, by the proper planting of fish and by the establishment of rules whereby the supply can be conserved, both for the commercial fisheries and for anglers.

In the fish-culture course, instruction is given in the artificial and natural methods of hatching and rearing fishes, mollusks and crustaceans. To make this work as practical as possible, a laboratory has been fitted up with troughs for the handling of salmon and trout eggs, batteries of shad and whitefish jars have been installed, while tidal boxes and other equipment are available. Several cement ponds for rearing fish have been constructed on the grounds and are in operation all the year round.

Since its establishment, the faculty and students of the college have worked on a number of problems of vital interest in connection with fisheries. The discovery of a process for canning crab meat was the first problem taken up and carried to

a solution, the results being published in 1921. During the season of 1922 some eight or ten new plants, using this process, were established in Alaska and on Puget sound. These plants packed some 15,000 cases valued at approximately \$500,000, a clear gain in our material wealth, as the common crab in Alaska waters previously had not been utilized commercially to any extent. In 1923 more plants were working on this crab and the much larger king crab, the existence of which at various places along our coast already had been established. The king crab is the one packed by the Japanese canners, who have controlled our market for a number of



years. It is probable that the newly established plants and others projected will in the near future produce in the neighborhood of 100,000 cases a year.

Es - m - 3 mfg Co
 810 309-6th Ave
 new York
POPULAR MECHANICS
SET OF SEVEN TOOLS IN ONE
ALSO USED AS RULER.

2 made by Frank Beck,
 Highway Supervisor
 of Lawrence County
 in W. Va. & Pearfish
 ter tool being marketed to the radio,
 mechanical, electrical and automobile
 trade. Of two pieces, hinged in the
 middle, the tool is a three-inch ruler when
 closed and a six-inch ruler when opened.
 Various parts in the two sections combine
 to make a wrench for bolts, an insulation
 and wire cutter, a wire stripper and
 cleaner, a pipe wrench, a screwdriver
 and a countersink.
 24'

166
 154 in small quantities.

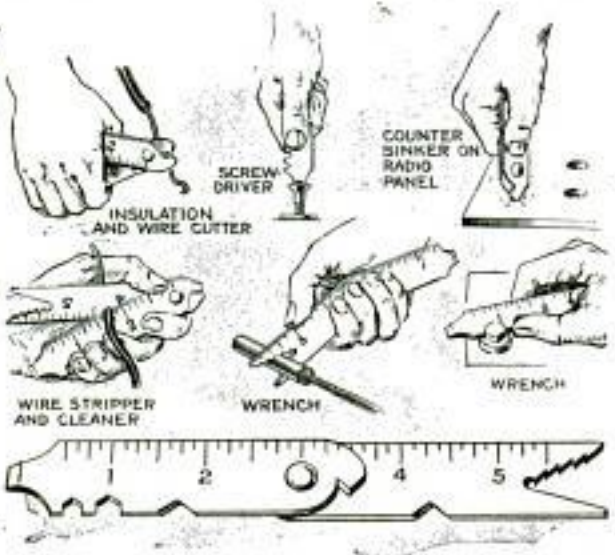

Versatile Ruler and Some of Its Uses

"ICE MINE" IN BLACK HILLS

Highway workers in South Dakota have made an interesting discovery of an "ice mine." The men went to a cliff of naturally terraced limestone alongside the road they were building with the object of obtaining rock for a crusher. After digging several feet, they encountered a formation which resembles a stone wall with the mortar replaced by ice. Apparently the dirt had been washed away by some subterranean flow of water, which had since congealed.

Sanford, N.W. section

274 **PRISON SEEN FROM AIR LOOKS LIKE HUGE WHEEL**

Constructed in the shape of huge wheels, some of the buildings of the prison at Copenhagen, Denmark, resemble units of a ponderous machine when viewed from the air. The arrangement

utilizes space and also provides room for a number of small exercise yards between the "spokes." Here the inmates may take their daily walks. The small inclosures simplify handling the prisoners.

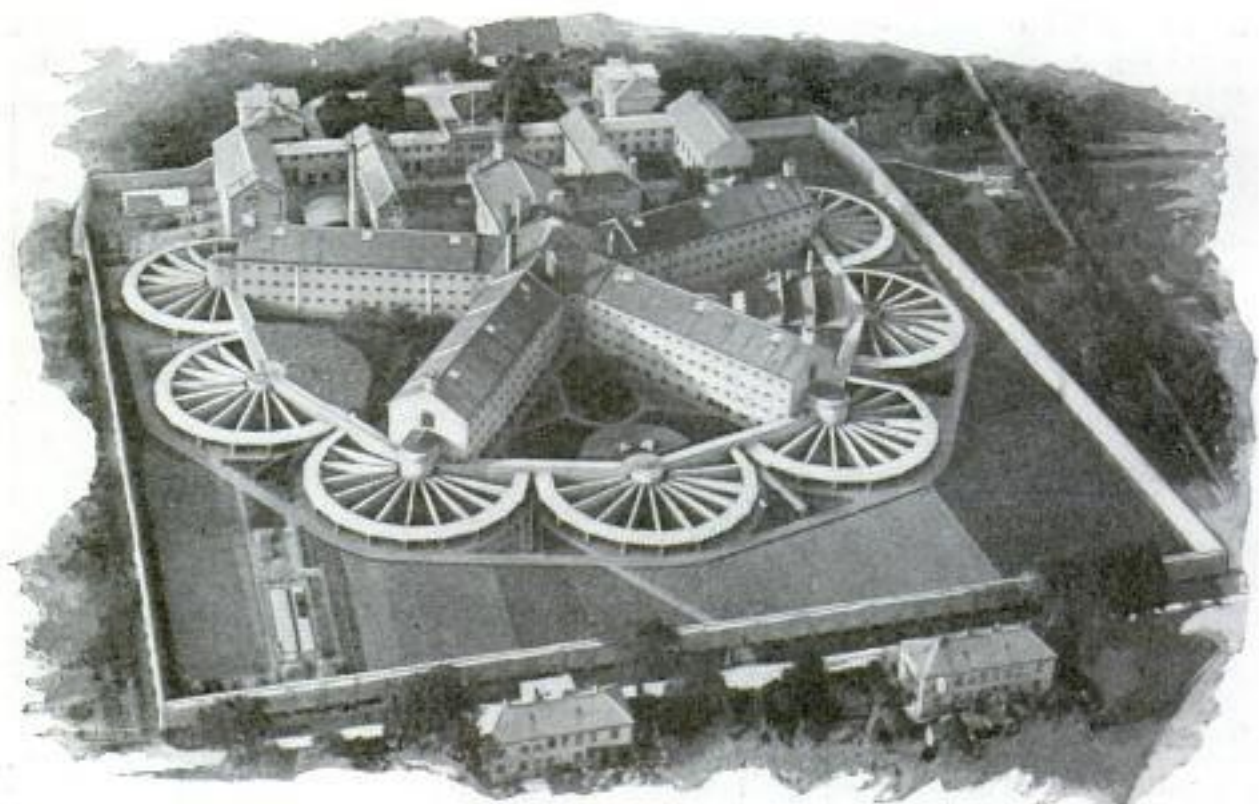

Air View of Copenhagen Prison, Where Buildings Radiate from Central Axis to Simplify Management, and Additions, Resembling Gigantic Wheels, Provide Small Exercise Yards for Inmates

8/24/25

WORLD'S RADIO 'ROOF' HELD CAUSE OF 'FADING' 298

As a result of recent investigations by the naval research laboratory and the Carnegie institution, Curtis D. Wilbur, secretary of the navy, has announced that the nearest approach to the key of unsolved radio problems, such as fading and other difficulties, has been made and many of these troubles, it is expected, will be practically eliminated. The findings will be of benefit chiefly to commercial radio and indicate that a high-frequency short-wavelength station costing only \$60,000 will have greater range and give better service than some of the present high-power stations that cost as much as \$2,000,000 and have correspondingly high upkeep costs. The experiments bear out the theory that there lies above the earth at an altitude of 100 miles or more, what is known as the "ceiling" of the sky, a layer acting as a deflecting surface for electromagnetic waves and under which they are guided around the world in somewhat the same way that whispers are reflected in the domes of the capitol building in Washington and in St. Paul's cathedral in London. This ceiling rises and falls, as atmospheric conditions vary and its exact location and extent have not yet been determined. Further experiments are being conducted for these purposes. In the early stages of short-wave transmission work, it was found that signals could be picked up at distances of forty or fifty miles and then disappeared as though followed up, only to be picked out of the air again several hundred miles farther away. This zone of quiet became known as the "skip" distance. By comparing data furnished by many broadcasters, it was found that there was a relation between the earth's magnetic field, the frequency of the waves used, the skip distance and the height of the sky ceiling. Later experiments have shown the existence of two waves, it is reported, one of them arriving by way of the earth and the other by the upper layer.

3354.

Pigeon lofts have been installed at a number of towns in California by a large corporation to house homing birds that will be used by its salesmen to carry orders, etc., to the main office.

St. Joseph News Press 5/25/25

GRAVES OF CANADIAN HEROES MARKED BY LIGHTHOUSE 239

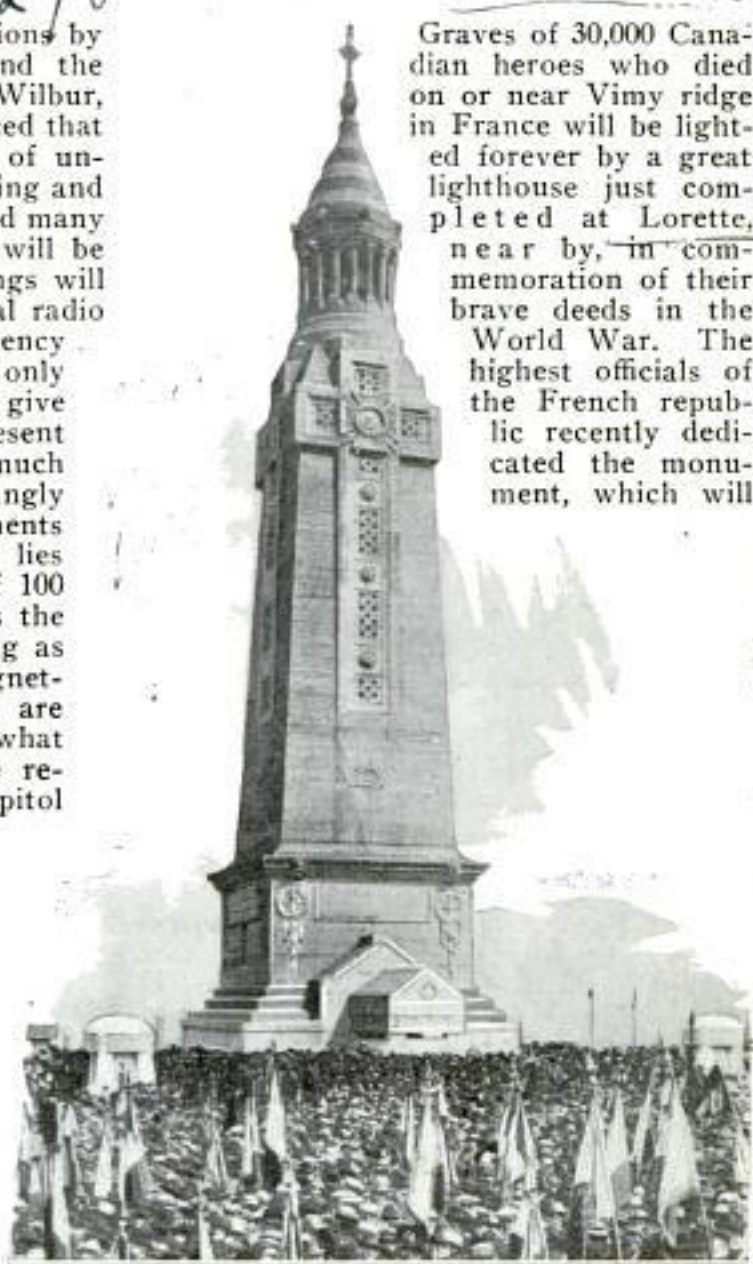

Graves of 30,000 Canadian heroes who died on or near Vimy ridge in France will be lighted forever by a great lighthouse just completed at Lorette, near by, in commemoration of their brave deeds in the World War. The highest officials of the French republic recently dedicated the monument, which will

Beacon Monument at Lorette, France, in Memory of Thirty Thousand Canadian Soldiers Who Died at Vimy Ridge

also serve as a beacon for night air service, its light being visible for sixty miles.

LIME KEEPS DIRT ROADS FIRM

Experiments of engineers have developed, it is claimed, that mixture of two to five per cent of hydrated lime with the top surfacing of country dirt roads has ended excessive rutting and clinging of the clay to feet of animals and tires of autos, after rainfalls. The clay and lime mixture does not stick. Instead it tends to smooth out and pack down more quickly than does untreated surfacing. The roads also respond more readily to dragging.

University School of Engineering Copyrighted material

Reported in Agricultural Lime News Bulletin, Washington, D.C. National Lime Association

3470

Time and Money-Saving Tools



Rough, Bronze-Covered Rubber Mitt Protects Hands When Scouring Pans



Steel Spring, Attached to Hinge, Closes Doors Quickly; at Right, a Durable, Flexible Broom That Raises Little Dust and Has Renewable Filler



Simple Rotary Dishwasher That Spins the Dirty Plates in Boiling Soap and Water



Tea Kettle Cannot Slip off Faucet When Hung on Easily Adjusted Holder; Right, Interchangeable Bathroom Fixture and Its Socket Screwed to Wall

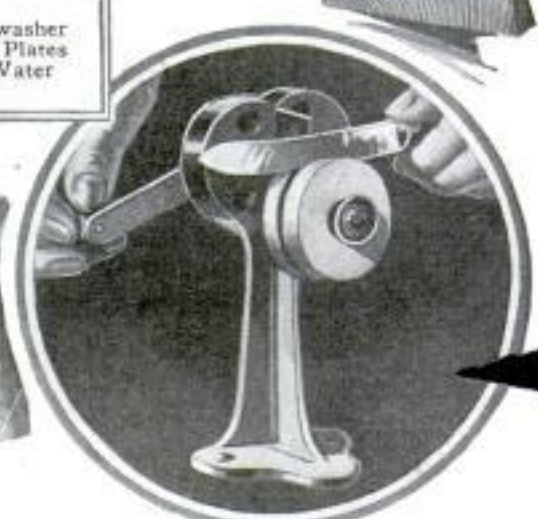

Grooved, Rotary Grinder That Quickly Sharpens Kitchen Knives, Shears and Other Implements

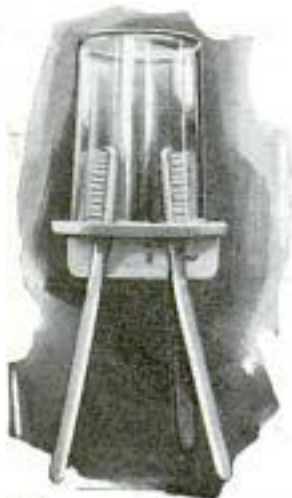

Toothbrushes Collect Germs if Left Exposed; This is Avoided in Metal Holder Attached to Wall or Cabinet with Shelf for Drinking Glass to Be Turned Upside Down over Them; Above, Fruit-Jar Sealer Straightens Caps, Insuring Air-Tight Fit



Stove Lifter, Tack Puller, Hammer, Fish Sealer and Screwdriver are Combined in This Single Tool

3470

for Woman's Workshop in Home



Just Twist Top of This Case for Workbasket to Proper Hole and Size of Needle Desired Is Ejected



Left, Driver for Putting Screws in Difficult Places, It Holds to Slot with Tiny Jaws; the Rope Holder Above, Eliminates Need of Knots as Ends Are Put through Holes and the Thumbscrews Secure Line



Lamp-Socket Electric Cooker Which Prepares Whole Meal at the Same Time

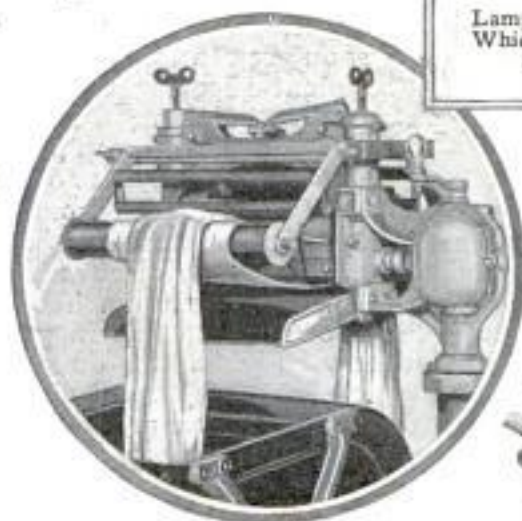

Safety Guard for the Wringer Carries Clothes on Endless Canvas Belt. Is Easily Attached and May Be Left On; Right, Stove Polish Is Put Up like Dental Cream Avoiding Stained Hands



Lid with Insulated Handle Fits Different-Sized Pans

© C. A. Oldroyd



Removable Heels Are Slipped into Locking Plates So That Rubber or Leather May Be Worn and New Ones Put On



A Sturdy Lining That Fits inside the Trousers Pocket and Is Attached as Shown in the Insert, for Those Who Carry Large Quantities of Loose Change



obtain it by addressing Bureau of Information, Popular Mechanics Magazine, Chicago.

Benneth Heater
814 Sydney

Article by Henry
Schubert - *ratios*
Business

POPULAR MECHANICS

**FIREPLACE MADE AIR FURNACE
BY HEATING SYSTEM**

233

Making a hot-air furnace out of the ordinary open fireplace is the work of a

Fireplace Fitted as Furnace: Diagram Shows How Cold Air, Drawn into Tubes, Is Heated

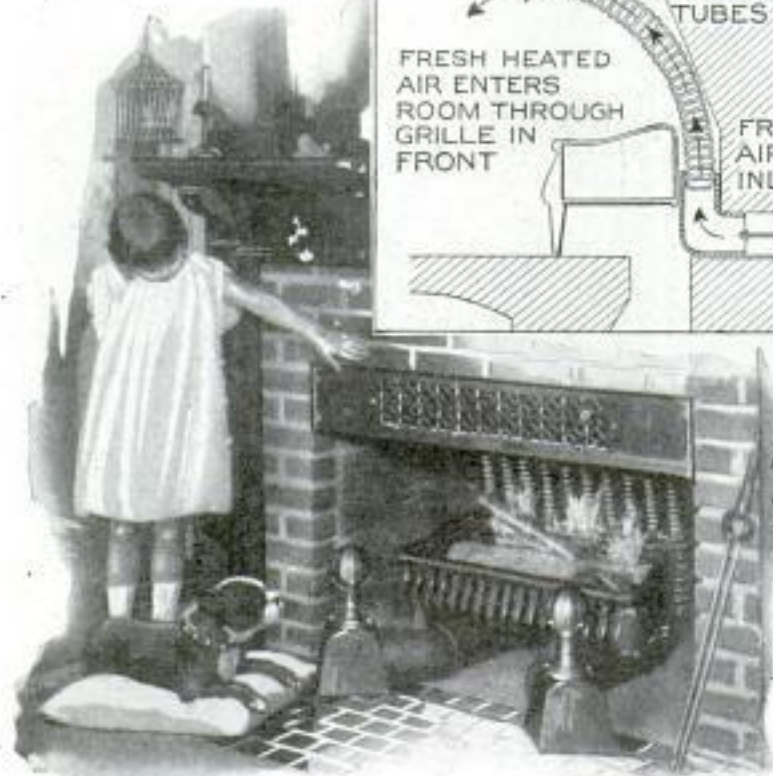
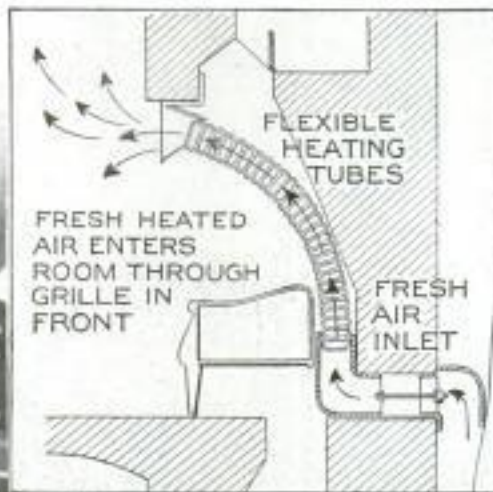

**MIRACLES OF YEAR REVEALED
AT CHEMISTS' MEETING**

What has been done by chemists in the past year in finding new means of combating disease and extending life, improving foods, using the energy in gasoline more efficiently and making lubricating oil oilier, was told at the recent meeting of the American Chemical society.

Now it is possible at least in the laboratory, to make artificial rubber, starting with acetylene from calcium carbide, a mineral substance made from lime and coal, into a glue, and finally into a material that may some day become an automobile tire. A way to avoid deaths from illuminating gas has been found by treating it with a substance of which red pepper is the base. Gas so treated burns just as well, but anyone breathing it is soon seized with such violent sneezing that he has to rush out of the gas-laden atmosphere. A crystalline dextrose has freed America from a

sugar famine, and the raw material comes from the old corn field. New discoveries of the effect of neutral salts upon hides will mean millions of dollars in saving to the tanning industry. Five million dollars an ounce is the cost of a substance called "radon," 180,000 times as active as radium, which will make the treatment of cancer cheaper. True, it costs more than radium, but its increased activity makes its use less costly. Contrary to the popular theory that rust is caused by iron united directly with oxygen, burning just as wood or coal except more slowly, it has been definitely proved that electricity generated by the chemical action of water and air causes the corrosion. So the chemists proceeded to take the air out of water by boiling it, subjecting it to the action of a vacuum or by running it through scrap iron. The result is that the water does little harm thereafter to the pipes through which it passes. This will mean much to the steam plants of the country.

see July, 1925 p. 40.

tetraethyl lead

heating appliance recently marketed. Cold air is drawn in from the outside through pipes leading into the base and irons. Then it passes under the fire, through flexible copper tubes and a top manifold, and thence into the room. The air is never touched by flame and is kept clean and pure. The system also is said to end the heavy drafts that open fireplaces usually produce.

ALUMINUM SOLE ON GOLF SHOE HELPS PREVENT SKIDDING

241

Flexible aluminum soles are being made for golf shoes, to keep them from slipping. Punched from sheet metal, the soles are sliced in three places, to afford grip on the ground. A set weighs less than two ounces but is said to wear a whole season.



Chas. W. George Esq. 90 George St. Highfield New, Tipton View Road Chesterfield England

Copyrighted material

Making Use of Radio in Business



Clerks in County Bank Receiving and Listing Latest Government Market Reports by Radio from Remote-Control Station of Arlington Navy Yard near Washington



Blackboard Bulletin and Radio Receiver with Loud Speaker in Country Business Office and, at Upper Right, Corner of Remote-Control Station in Bureau of Agricultural Economics Department Where Crop and Market Reports Are Broadcast



Radio Now Keeps the Farmers Posted on Daily Prices

Miss Madeleine Paver
 816 Seattle (2111) 254th St
 Wash. POPULAR MECHANICS

9/12/20

**PICTURES OF COLORED TIN FOIL
 START NEW ART FAD**

255

By combining artistic ability with colored tin foil, a western woman has



Artist and One of Her Designs in Colored Tin Foil against a Dark Background

created a new fad. Starting with a background of black tin foil, other colored pieces of the same material are cut into desired shapes and pasted on the backing. The finished pictures are said to be life-like and colorful.

BLUEGRASS AND WINGED SNAILS FOUND IN ARCTIC REGIONS

321

Explorers are correcting the popular conception of the polar areas as abounding only in ice and bleak stretches of snow. Radio dispatches from Dr. Walter A. Koelz, in charge of the scientific unit of the MacMillan expedition, state that poppies, dandelions and buttercups were gathered beside the glaciers and that within a few minutes' walk of Etah, Greenland, far north of the Arctic circle, fifty specimens of flowering plants were found. In places, Kentucky bluegrass had formed a thick carpet, while timothy grew luxuriantly. All the land plants were practically stemless, however, since any part extending above the scant snow covering would be frozen off. Even willows and birch trees grow only a few inches high. In the waters were found myriads of a species of jelly fish, and winged snails that propel themselves and float on the surface with the aid of their queer appendages. Another interesting aquatic animal was the liparis, resem-

Chief naturalist

Report to National Geographic Society

bling the bullhead. It attaches itself to the rocks with its fins, and considerable force is required to dislodge it. Varieties of rare birds; kelp that grows to be twenty feet long and is commonly mistaken for animal life, and brilliantly colored lichens in shades of orange and purple, were also found. Swarms of bullbirds were disturbed by the airplanes, their frightened cries bearing a resemblance to the laughter of maniacs.

**LONGEST PHONE CABLE LINKS
 CHICAGO AND NEW YORK**

After seven years' work and at a cost of \$25,000,000, the world's longest telephone cable has been completed. It links Chicago and New York City and is 861 miles in length. Freedom from almost all storm hazard and a lightening of present wire loads were the objects of the new line. Five hundred telegraph messages and 250 phone conversations can be handled at the same time. About 717 miles are above ground, on poles, and 144 miles in underground conduits. The total weight of the 447,000 miles of wire used is about 34,750,000 pounds. Other cables are being constructed from Chicago to St. Louis and between New York and Cleveland by way of Albany and Buffalo.

BOX FOR EXTRA AUTO BULBS PREVENTS BREAKAGE

How to carry safely extra bulbs for the headlights, is a common problem among motorists. A French inventor has offered



Auto Headlight-Bulb Carrier Has Rounded Ends and Center Holder That Keep Contents from Shaking

a solution in a small box, the center part of which contains two sockets into which the bulbs are screwed securely, so that they cannot roll around or jar. The ends of the carrier are shaped to fit the contents, and simplify packing it away among other luggage in the automobile.

Inquiries to Frederic W. Delano, '6

Inventor by L. Capeta Avenue Paris



SOLVING MYSTERIES

Wealthy Man Finds Laboratories to Explore Realms of Light and Sound and Advance World of Science

By PAUL PADDOCK

"THE world is full of mysteries and the greatest adventure is life itself," said Col. George Fabyan, to explain his reason for founding one of the most unusual laboratories in the world on his estate at Geneva, Ill. "We are faced on every hand with fascinating puzzles," he continued.

"For instance, there is a scientist in our laboratory who spends a lot of time blowing bubbles and crushing them under pressure so that he can study the shape of the resulting molecules. They seem to be of a rather fixed pattern, which is a clue that, perhaps, the 'angle of force' engineers talk so much about is one of sixty degrees.

"Do you know why a bee makes a buzzing sound? One of my staff has been working on this problem for two years but has not quite solved it. When you slap a mosquito remember this problem, for those that have empty stomachs are the only ones that can be heard."

Col. Fabyan's interest in science is

the result of his efforts to develop a secret code for use in his business. As a boy he worked in a lumber yard and rode the cattle ranges of the west. Later he became a salesman and head of a great cotton firm. In perfecting his cipher, he consulted with experts. Their explanations of how ciphers and codes were started, how they were solved and their importance in history, fired Col. Fabyan's imagination. He delved into all the literature he could find on the subject and discovered that some of the scientists of

the sixteenth and seventeenth centuries, who wrote in ciphers because they feared persecution, had performed experiments with light, sound, and other phenomena. Their apparatus was crude and their conclusions uncertain, but their efforts led Col. Fabyan to try to work out some of their experiments himself. In an old barn, he fitted up a shop, and as his tests progressed, it

Opportunity!

"THE day of the explorer did not end with Columbus and Balboa. The man with a desire to become a great discoverer has opportunities in the fields of science as great as that of the French and Spanish adventurers of four hundred years ago. There is no boundary and no limit to the awards awaiting those who solve the countless mysteries facing mankind. In medicine, chemistry, electricity, the possibilities have scarcely been even scratched. New and revolutionary sources of power and its application remain to be discovered."—Col. Fabyan.

became necessary to call in experts to help. In a few months, the barn had to be enlarged. Other buildings were erected. Men were induced to join the colony of scientists and the laboratory now occupies a score or more of buildings and more than a hundred persons are employed in its various departments. There are no bosses, time clocks or schedules.

"When I can actually see a thing work, I can understand it better," says Col. Fabyan. "Watch this flame." He



Forty Curves Representing Tone Vibrations Can Be Drawn at Once by Turning the Crank of This "Synthesizer," a Riverbank Product for Studying the Mysteries of Sound

for the undertaking is non-commercial. The utmost freedom is given the workers to pursue their studies as they wish.

This spirit of independence is reflected in the style of the buildings. One appears to be a series of separate rooms piled in blocklike fashion so that each has ample light and ventilation. In addition, this form of construction allows the entire building to be easily enlarged or altered at any time. Here is what is known as the "Parlor de Junk," a large room devoted to the collection and remodeling of articles from all over the country. The proceeds of the sale of these things go to the maintenance of the laboratory as does the income from the farm.

Near this structure is another laboratory, distinguished by its eagle-capped tower, a memorial to the late Prof. Wallace Clement Sabine, of Harvard university, who was technical adviser on aircraft to the allies during the war. In this building, is what has been called the strangest room in the world, a subterranean sound chamber where a war upon noise is now being carried on.

takes a bunch of keys, rattles them, and the light dances, keeping time to the keys' jingle and responding in the same way to the clap of the hands, a result of the effect of sound waves on a sensitive apparatus that regulates the supply of gas to the burner. Peer through a little telescope apparatus and you will see the vibrations of a tuning fork translated into waves of light. Did you know that your head was a sounding board? The visitor is invited to sit in a chair and put his fingers in his ears. A telephone receiver with a protruding metal hammer is pressed to the different bones in his skull and he hears the conversation of a man who is speaking into a transmitter in a distant room.

"Doctors know a lot about our eyes, but the ear is almost a mystery to us," Col. Fabyan points out, as he explains that this test is one that is used in connection with a special phase of the work, which has as its object discovery of the cause of deafness and ways to cure it.

In another room is a pulley-testing apparatus. It consists of a twelve-inch pulley with open sides attached to an electric motor to measure the amount of wind resistance. At 1,750 revolutions per minute, the resistance is fifty-four ounces. Then disks are fitted over the sides of the pulley to shield the spokes. At 1,770 revolutions per minute the resistance is only

three ounces. As a result it is estimated that there would be a saving of one dollar a year on every pulley of the size used in the test—if the sides were closed.

Upstairs, an army rifle has been rigged to a light-proof cabinet in such a way that, when it is fired, a picture is taken of the vibrations of the sounds as they spread over a model of a room or auditorium inserted in the cabinet. By this means, builders are able to determine the acoustic properties of churches, theaters and other structures before they are completed, saving costly errors in construction and disappointed owners.

Passing to the sound chamber, the visitor sees men at work preparing various kinds of plasters in search of a mixture that will be sound-absorbent, durable, easily applied and commercially practical. When they have made a sample, they will test it in the chamber which is entered through heavy doors like those of a refrigerator. Speech is almost impossible, for words are smothered in their own echoes that bound back from the high walls and ceiling. It is explained that the room is entirely cut off from surrounding areas by means of an air space and special insulation. The temperature

varies but a few degrees the year round although there is no artificial



Recording Turns on Pulley Tester; Dutch Windmill for Grinding Feed, and Studying Bell's Vibrations in Mercury



cooling or heating. At one end of the room is a set of organ pipes, seventy-three in all, from the big ones that make sixty-four vibrations per second to the tiny ones with 4,096 vibrations in the same period. There are also four smaller sets of pipes like miniature organs, one at each side of the room, and a wooden cabinet resembling that of a steam bath. In the center are two huge steel reflectors attached to a steel pole.

In making the tests, the observer enters the cabinet, closes the door so that only his head is exposed, that his clothing may not absorb any of the sound. By means of an electrical switchboard at his side, he can cause any one of the pipes to play. With a stop watch, he counts the number of seconds required for the vibrations to die away. If double the volume of sound is desired, or greater ratios, the small organs are used, one at a time, then two, three or four, using the same pipe on each.

The sample of material that is to be

154

E. W. Davis
Super. Mine Experiment
Station

tested has been placed in an opening in one of the walls. It is shielded by an iron door until the first readings are made. Then the door is opened, the pipe sounded again, and the difference in the time required for the vibrations to pass away indicates how much sound has been absorbed. Another observer is stationed at the opposite side of the sample in an insulated test chamber. He listens in the same way to detect how much sound passes through the sample. The men who perform these tests have been subjected to rigid ear tests, and the two work together in order that the readings of one may be checked against those of the other.

Besides the laboratories, there is the farm to superintend, a small-sized zoo, including monkeys, deer, bears and rare birds, and there is a Dutch windmill Col. Fabyan purchased from a farmer several miles away, and rebuilt both for ornamental purposes and to grind coarse meal and feed used on the farm.

The joy of scientific exploration alone is sufficient justification for his work. Col. Fabyan believes, and declares that one of the things that keeps him young is the lure of the unknown just around the corner.

"Many people wonder why we seem to be spending so much time and equipment on work that seems to have no direct relation to everyday life," he replies when asked what is the purpose of the laboratories. "The same question might be asked of every inventor and scientist. For the answer, we have to wait and see.

"Franklin didn't know what would result from his experiment with the kite and string, but we see it today. The importance of scientific discovery is increasing. Civilization, I believe, is nearing or has reached

a peak. My idea is illustrated in the coal industry. What is going to happen when it takes one and a half dollar to dig a dollar's worth of coal? The same situation is approaching in other industries.

"You answer, 'science will find a way out.' Well, maybe it will. At any rate, for the future of civilization, scientists should be given every encouragement!"

WEALTH FROM LOW-GRADE ORE PROMISED BY NEW PROCESS

Regarded as of extreme importance to the future of the steel industry, an improved process for extracting iron is promised from experiments conducted at the university of Minnesota. ~~Instead of melting the ore and running the impurities off as molten slag, this method burns up everything but the iron itself and the silica in a specially modeled furnace.~~ A mechanical process later separates the materials. This system is called "metallizing" and its chief value lies in the fact that it can be adapted to low-grade ores, the kinds that carry only twenty-five to forty-five per cent iron or less. At present, only the richer ores, averaging more than fifty per cent iron content, are being shipped from the Lake Superior district. With an average consumption of from 40,000,000 to 65,000,000 tons a year, the supply cannot be expected to last much longer than thirty years, geologists estimate. Hence, the iron and steel industries, with their millions of capital invested in mining machinery and equipment, would be likely to move to richer fields, such as those in Brazil, Cuba or Newfoundland, when the better ores in this country are gone, but the "metallizing" process will make available the billions of tons of low-grade ores that abound in Minnesota and other ranges. The cheapest fuels can be burned in the turnace.

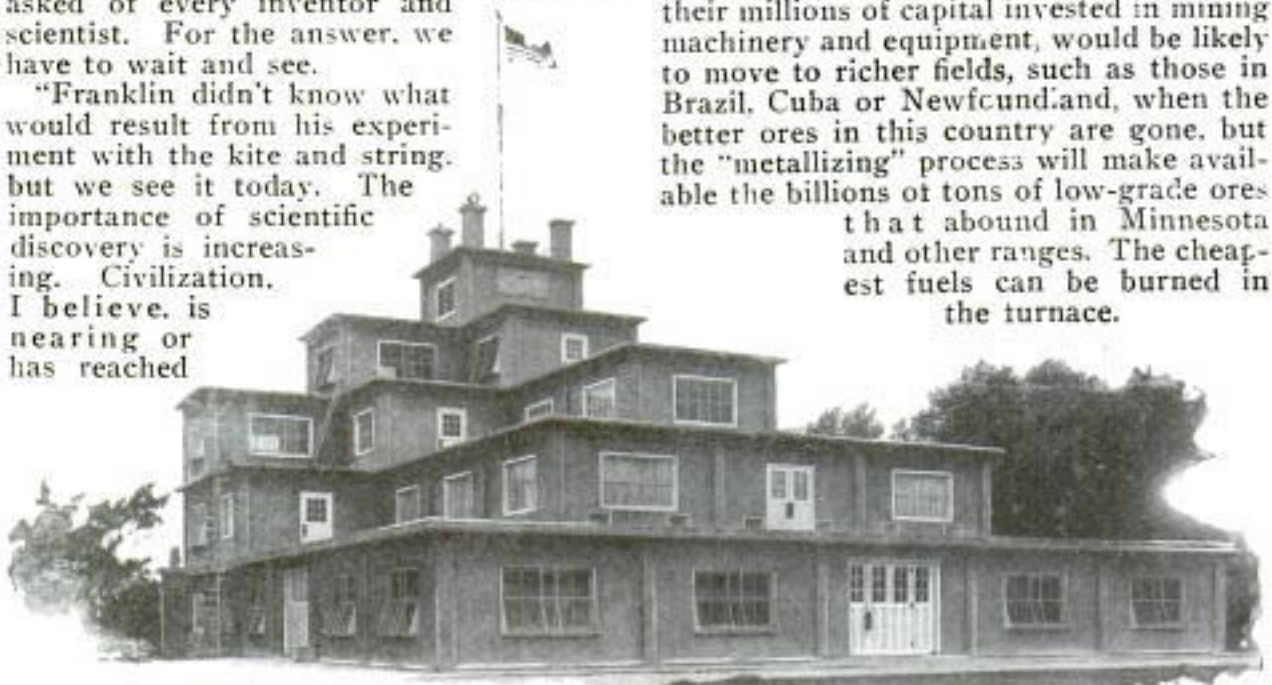

The Garage Which Grew into a Series of Laboratories; Upper Floors, "Stepped-In" to Admit Light on Three Sides, Were Added to the Lower Story Originally Built for Autos

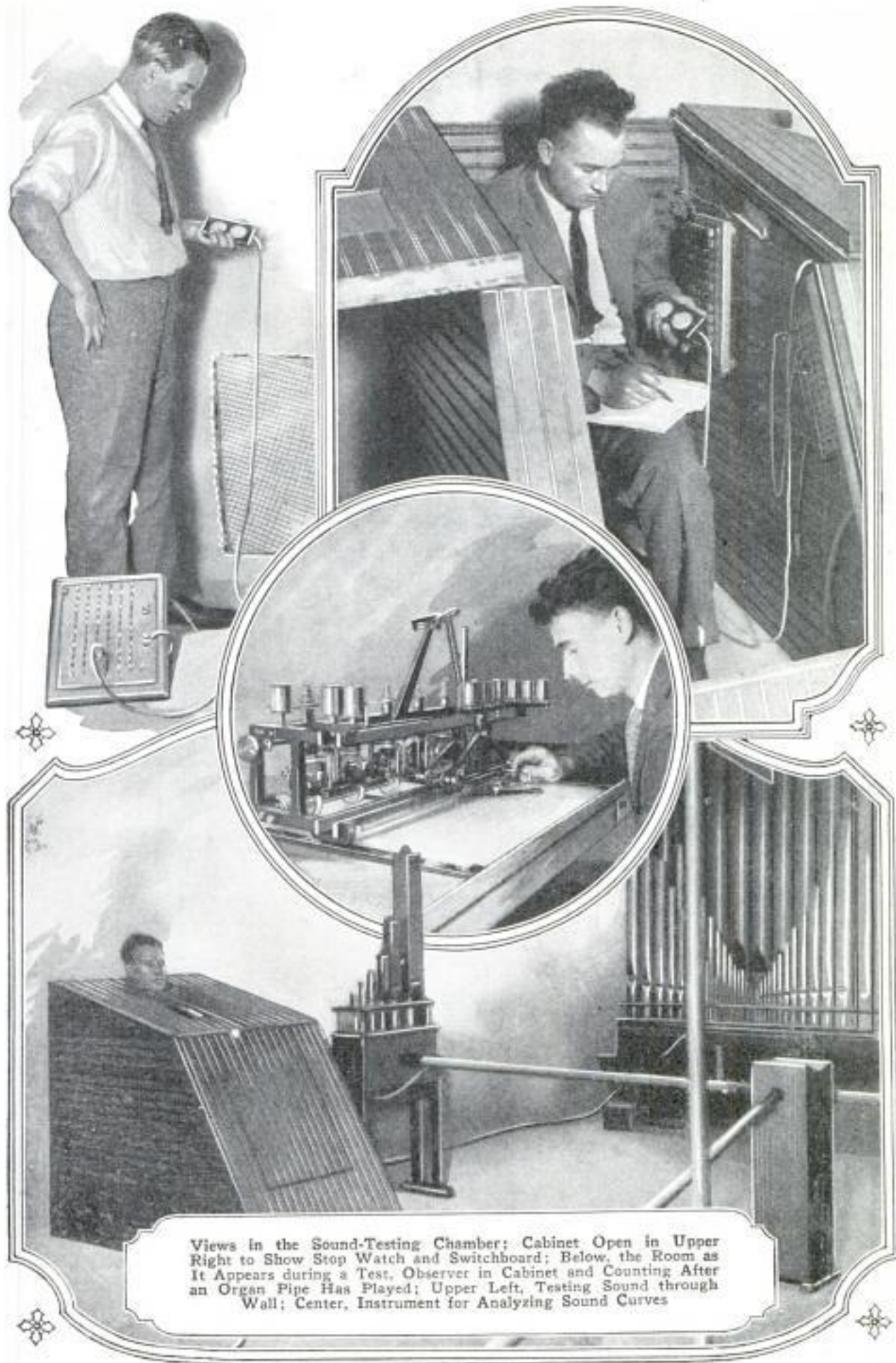

Views in the Sound-Testing Chamber; Cabinet Open in Upper Right to Show Stop Watch and Switchboard; Below, the Room as It Appears during a Test, Observer in Cabinet and Counting After an Organ Pipe Has Played; Upper Left, Testing Sound through Wall; Center, Instrument for Analyzing Sound Curves

Salt Lake City

Los Angeles

201

258

BOY NEARLY UPSETS PLANE STEALING RIDE ON WING

A seventeen-year-old boy "hoboing" his way across the continent nearly wrecked an airplane at Las Vegas, Nev., recently when he boarded the wing to steal a ride to Los Angeles. As the plane took the air, it swept around in a dizzy fashion, with one wing much lower than the other. While the pilot, Maj. C. C. Moseley, of the California national guard air service, fought for control, his passenger, Sergeant Wood, was amazed to see a boy's head stick up over the end of the wing. The lad, Jack Richman, of Milwaukee, had caught the bumper under the end of the wing as

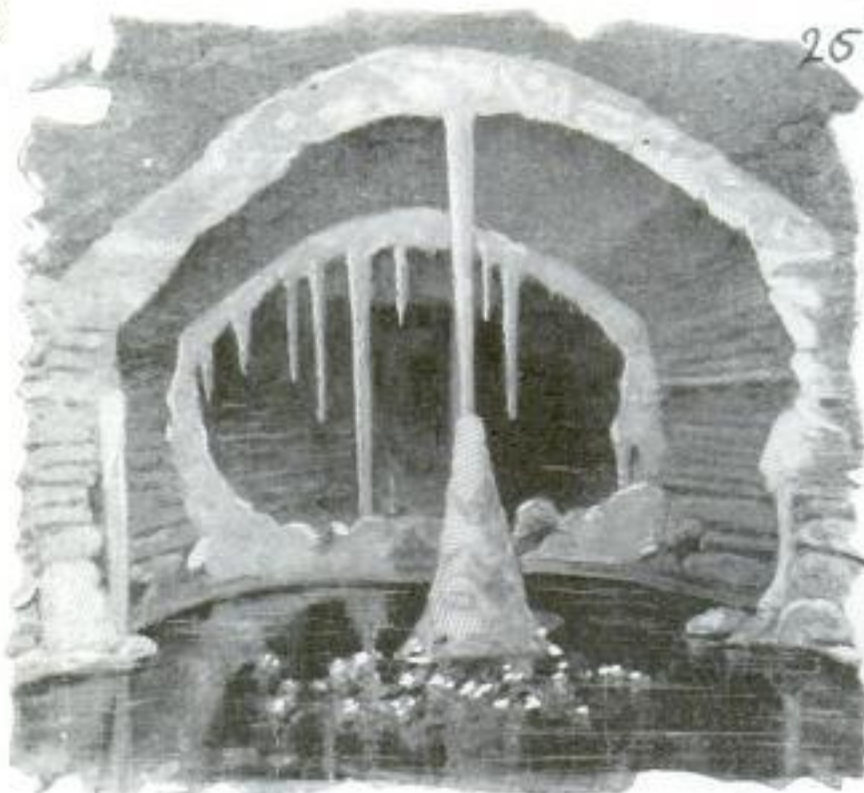

Cave with Water Bottom and Imitation Icicles, in Which Hardy Types of Butterflies Are Hatched by a California Butterfly Grower

BUTTERFLY FARM HATCHES ITS COCOONS BY ELECTRICITY

Breeding butterflies under artificial conditions is the occupation of a California farmer. His incubator is an electric oven, with the humidity regulated to suit the type of cocoon being hatched. On the farm he grows plants and flowers suited to the palate of the flying beauties. For hardier butterflies, demanding cooler air and ample moisture, a cave is provided.

WEB STRETCHER SPEEDS UPHOLSTERERS' WORK

Straps of upholstered furniture are fastened, with a saving of time, labor and material, by a portable stretcher which is said to enable one man to do the webbing for a crew of fifty upholsterers who ordinarily must do this work themselves. The strips of material are carried on a drum, uniform tension being maintained by the operation of a wheel that locks the drum.



Web Stretcher Places Upholstery Straps in Minimum Time and Maintains Constant Tension

the plane took off. When the pilot's attention was attracted to the cause of the trouble, he motioned for the lad to crawl in toward the plane, and the boy succeeded in raising himself up on the wing and then clambered in close to the fuselage, where his weight would not destroy the balance of the machine. He rode the 300 miles to Los Angeles clinging to the wing struts. In the first few miles the terrific blast from the propeller whipped his shirt to shreds, and he arrived on the coast with his back badly sunburned. An old army shirt was supplied by the major, and the boy, who said it was his first airplane ride, announced that after looking around the coast towns, he would start beating his way back east again. His only explanation of the wild ride was that he and a chum had been put off a train at Las Vegas, and the aerial journey looked like the easiest, if not the safest or most comfortable way to continue the trip to

the coast.

Owner: Schwader, 201 W Illinois, Los Angeles, Calif

Northwestern Upholstery Co
505

2111 W. J. E.

Minneapolis
copyrighted material

SEARCHLIGHTS USED TO LURE MOTHS TO DEATH

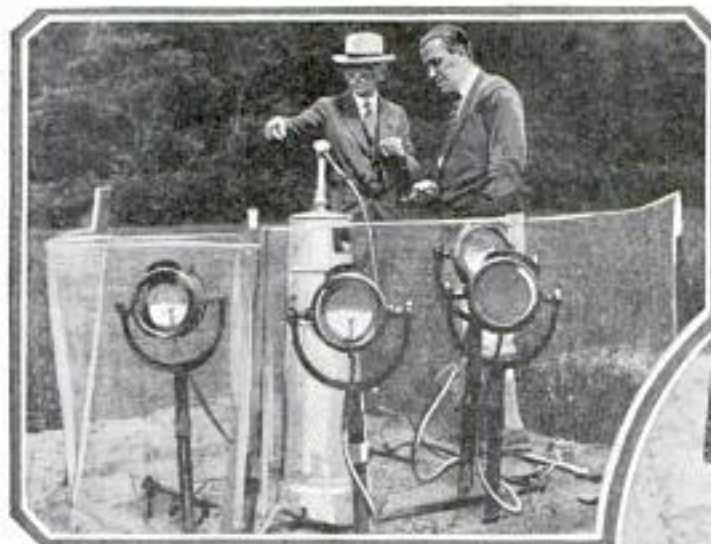

Auto Headlights and Glue-Coated Screen Mesh Used to Lure Cranberry Moths to Their Death

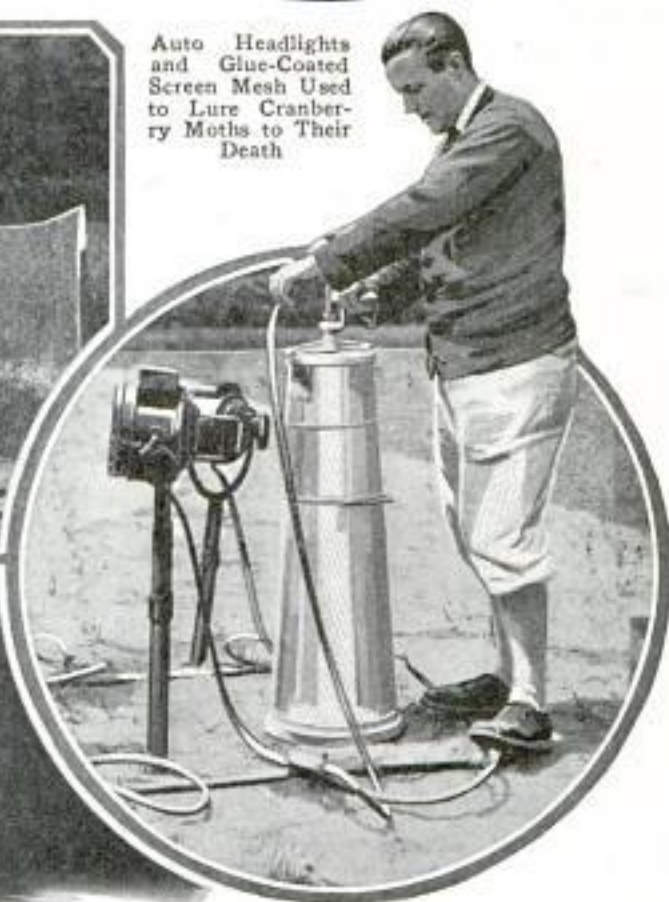
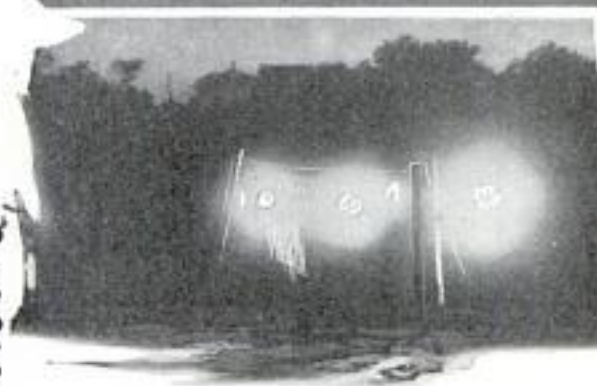

Pyralis and other pests killed by the searchlights
 used by the Cranberry Growers Association

Cranberry growers are using acetylene searchlights to lure fruit-worm moths to their death, as a result of the discovery of one bog owner. Like others, he had suffered great loss from the pests, which killed the budding blossoms and left their larvae to grow in the newly forming fruit. The ordinary cure is to flood the bog or spray the plants with poison, both costly methods. Four auto headlights, using acetylene gas, were set up in the center of a four-acre field. Around them was erected a mesh of fine wire, coated with glue. At sunset the lights were turned on and the moths obeyed their primitive instinct to speed to the gleam. In the morning millions of them were found sticking on the screen dead.

226

pounds was suspended from the ceiling, then lifted 24 feet and allowed to swing down. It hit the front end of the chassis a terrific blow but no damage was done to the windshield. In another test, a block of wood and metal weighing three and three-fourths pounds was hurled at the glass from a few feet away. The pane was cracked badly but did not shatter.

"GUN" PROJECTOR SHOWS FILM LIKE MAGIC LANTERN

Scenes cut from any standard motion-picture film may be thrown upon the screen, without bothering with complicated apparatus, by means of a small projector supplied with current from a lighting plug. It is provided with a gun grip for easy handling and steadying. To show motion pictures, the nozzle part is detached and the lamp combined with a special camera arrangement. Reels up to twenty-five feet in length can be run.



Price - \$15.00

REINFORCED GLASS FOR AUTOS ENDS WINDSHIELD DANGER

Plate glass, reinforced with fine parallel wires two inches apart, is being tested with good results by an auto manufacturer seeking to minimize danger to drivers from broken windshields. A car equipped with the wired glass was anchored to the shop floor. A block of lead weighing 248

Stutz Motor Co.
 Capitol Ave + 10th
 Indianapolis, Ind.

Nicam Photo Machine Corp. 1224 Cambridge Ave. Philadelphia, Pa.

Made in *Vadstena*

203 CLIMBING SHOES CLASP POLE AND MAKE WORK PLATFORM

Climbing shoes are used by steeplejacks in Sweden, forming an aerial platform on which the worker stands when he reaches the height desired. Two curved irons, with leather straps attaching them to the ankles and insteps of



Climbing Irons Which Become Standing Platform When the Wearer Stops to Do Work on Pole

the climber, hug the telephone or telegraph pole in a circle. The end of each is pointed and sinks into the wood. This point of contact, plus the weight of the man on the other side, digs the irons into the pole at two points, and, it is claimed, makes climbing and working much safer and more comfortable than the old-fashioned irons.

248

PERILS IN DRINKING CUP EVOKE WARNING FROM U. S.

With a million sufferers in the United States every day from respiratory diseases which may be spread by the common drinking cup or glass, the public-health service recently issued a special warning to beware putting the lips to a container

which someone else has used, unless it has first been well sterilized.

All but two of the states have passed laws banishing community use of drinking vessels, and they have been forbidden for several years on trains and steamers in interstate commerce, but in spite of this fact, many people, the government says, defeat the law by failing to insist on its enforcement.

Some cities, the bulletin states, have passed ordinances forbidding the use of glasses at soda fountains, but in others, the receptacles are rinsed again and again in the same water until the wash itself becomes more dangerous than the used glass. Citing the Ohio laws as an excellent example of good sanitation, the public health service points out that they provide a soda-fountain glass or other publicly used container must, after each use, be first washed in cold water, then in hot water with soap or suitable cleansing powder, or exposed to live steam, boiling water or hot air for not less than five minutes, then rinsed in clear cold water and drained. If hot air is used to kill the germs, the law provides the temperature must not be less than 260 degrees. Heat is about the best sterilizer known, and boiling water will kill most germs within five minutes.

Motor tourists should provide separate drinking cups for each member of the party, the health service adds, and care should be taken to keep them clean.

2333

INNER TUBES OF THREE LAYERS SEAL UP PUNCTURES

Self-sealing inner tubes for automobiles and motorcycles have been placed on the



market by an English firm to eliminate the need for patching and to give longer life to the casings. They contain no fluid or sticky substance of any kind but have a tread

portion of three layers so adjusted that the hole made by a nail or similar article is automatically closed up when it is withdrawn. They are said to be little more expensive than those of the usual kind.

(Fragrant carnations have been used with success as a substitute for cheese as bait for catching rats in Los Angeles.

P. J. Cogler & Co. Ltd
Melano Works
Edinburgh

J. Cogler & Co. Ltd
Melano Works
Edinburgh

Copyrighted material

How to Make a Tapped, Collapsible Loop

By E. R. HAAN

AFTER several unsuccessful efforts to increase the selectivity of his 6-tube radio-frequency set, located within a mile from two powerful Chicago broadcasting stations, both of which could be found all over the dial when in operation, making it impossible to tune in outside stations, the owner resorted to a tapped loop and found that this eliminated all his trouble. With another receiver having one stage r.f. amplification, the stations on lower

of standard size. This obviously meant that there was too much inductance. So a tapped loop was used, and it was found that these stations could be brought in near the center of the dial. The effect was that these stations could be separated at points farther apart on the dial than usual when they are brought in on the lower end, which gave a result similar to that obtained with the new straight-line frequency condensers.

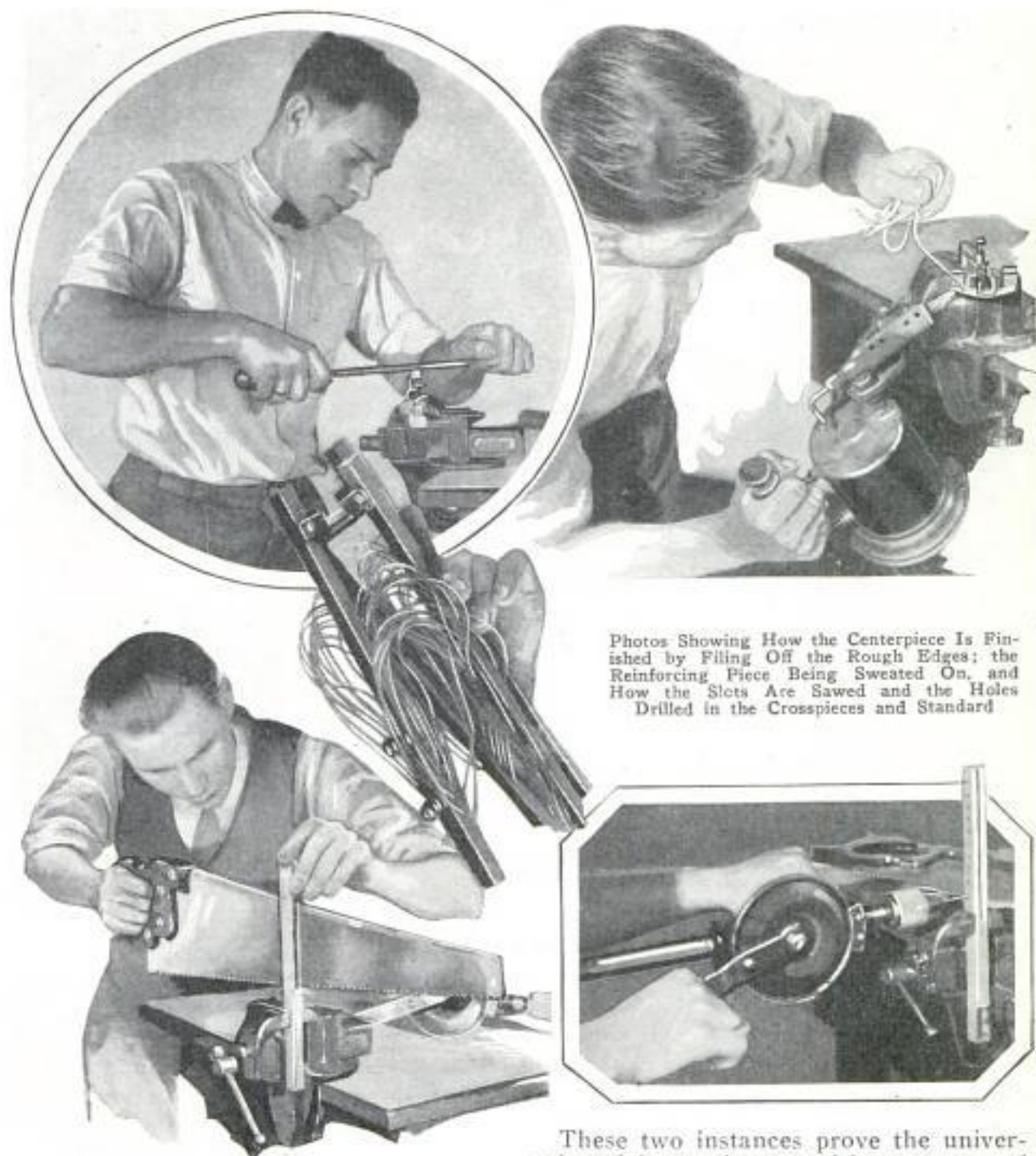

Photos Showing How the Centerpiece Is Finished by Filing Off the Rough Edges; the Reinforcing Piece Being Sweated On, and How the Slots Are Sawed and the Holes Drilled in the Crosspieces and Standard

wavelengths than 275 meters could not be brought in on the dial when using a loop

These two instances prove the universal usefulness of a tapped loop on sets of these types, so if you have experienced similar troubles, a tapped loop is the

remedy. The simplest loop to make is one having a rigid frame on which to wind

pieces with a small panel saw, as shown in the lower left-hand photo, and a similar slot

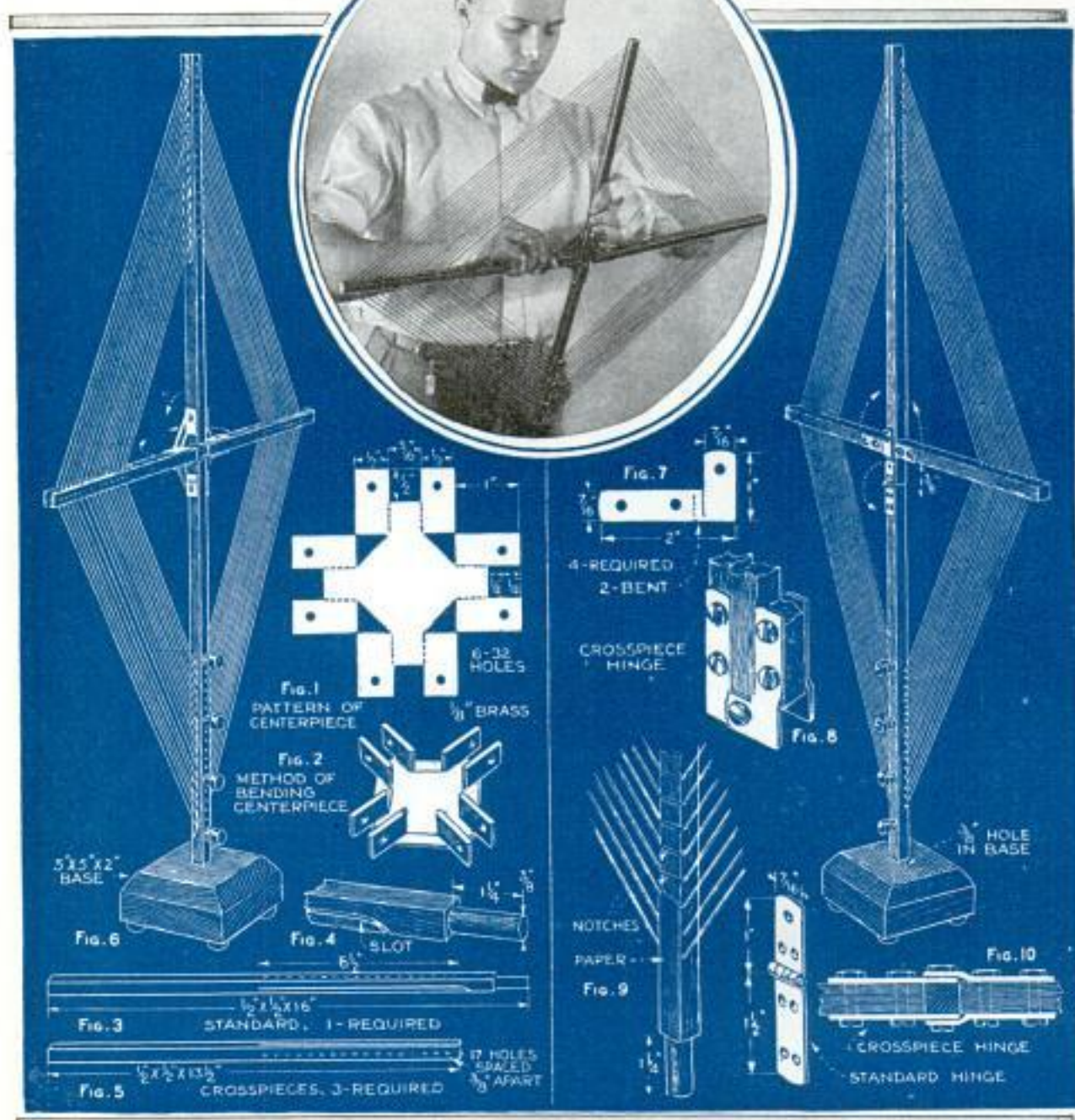

Above, the Proper Method of Opening the Loop; Each Half of the Blueprint Shows a Pancake Style of Loop with Different Folding Features and Method of Attaching the Wire

the wire, but many people desire a loop that can be folded and carried around conveniently with portable sets, and therefore consider it worth the extra trouble to make it collapsible.

The three crosspieces, Fig. 5, and the standard, Fig. 3, are made of strong $\frac{1}{2}$ -in. stock, preferably oak. A distance of $6\frac{1}{2}$ in. is marked off from one end and 17 small holes, spaced about $\frac{3}{8}$ in. apart, are drilled through them, care being taken to keep the holes in line. Saw slots, $6\frac{1}{2}$ in. long, are cut in the ends of the cross-

is cut in the standard with a keyhole saw, starting the cut about 3 in. from the end, as shown in Fig. 4. This end is rounded to fit accurately in the hole drilled in the base, shown in Fig. 6. The center-piece is cut from $\frac{1}{8}$ -in. sheet brass. Cut the pattern exactly according to the dimensions shown in Fig. 1 and bend it along the dotted lines as shown in Fig. 2. Before bending, it is heated to a dark red and cooled quickly in water, whereupon the bending can be done easily and without danger of breaking the piece. An

extra piece of brass of the same stock is sweated to the back of the centerpiece to reinforce it, as shown in the upper right-hand photo. Rough edges can be removed with a file. The three crossarms and the standard are fitted on the centerpiece and holes are drilled through both centerpiece and crosspieces for 6-32 round-head screws on which the crosspieces pivot. It will be noted that these holes are indicated in the pattern, Fig. 1, but are not drilled until the centerpiece and crosspieces are assembled.

Get a spool of 100 ft. of loop wire and proceed to wind it on, which is done in the following way: Drive a small pin, about $\frac{3}{8}$ in. long, in the inside hole on each crosspiece, put a knot in the wire about one foot from the end, slip the wire into the slot of the standard and then in the slots of the crosspieces, drawing it up tightly. Continue thus, driving a pin in each piece and then slipping the wire in and drawing it tight until the end is reached, which is knotted so as to draw the wire taut when slipped into the slot in the standard for the last time. All the pinholes can be filled up with wood filler. Four holes are drilled through the standard, between the pins, to receive binding posts. Solder lugs are put under the nuts on the underside of the binding posts, and the beginning and end of the loop are connected to the first and last binding posts, while taps, taken off at the third and fifth turns from the outside end, are connected to the other two binding posts. The taps should be well soldered to the lugs and to the loop wire, which is bared for $\frac{1}{2}$ in. The base is made of 2-in. wood, a $\frac{3}{8}$ -in. hole being drilled in its center to receive the standard, and

rubber-head tacks driven into the bottom to prevent it from marring polished surfaces. The loop can be folded as shown in the center photo, and its size when folded is indicated by the hand holding it. When

Using a Nail Set to Drive the Small Pins into the Holes



set up, the loop should have a slight bow in the opposite direction from that in which it is folded, to prevent it from collapsing. Stain should be applied

to the wood before the wire is wound on and the pinholes retouched again after they have been filled with wood filler.

Figures 7 to 10 show a similar loop, the folding arrangement of which is somewhat simpler. In this case the standard is hinged to the top with a narrow hinge and the sidepieces with the specially made hinges shown in Figs. 7, 8 and 10. Four of these are required, two being bent as indicated by the dotted lines in Fig. 7 to slip over the corresponding portion of the other two when the loop is up. There must also be a slight bow in this loop to prevent it from collapsing. The tautness of the wires keeps it up when past the center. The method of attaching the wires on the loop is shown in Fig. 9.

Condenser Suits Any Circuit

A convertible condenser that can be adapted to any circuit is now available. For a short-wave set all but two plates of the condenser can be removed. If the inductance coil in the receiver is a little too large or too small, the condenser plates can be changed so that the circuit may be perfectly balanced. In the common type of five-tube set using tuned r.f. amplification, one or more condensers may tune out of line; in such cases, the plates of

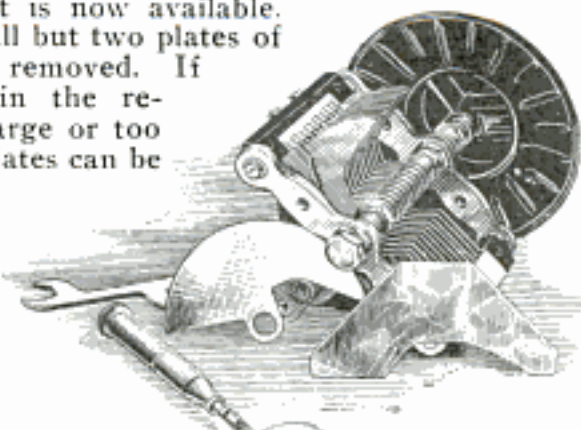

Condenser with One Plate of Each Kind Removed

this instrument can be changed to make all stages tune alike. The condensers are manufactured in the following sizes:

the 23-plate with a capacity of .0005 mfd., the 17-plate of .00035 mfd., and the 13-plate .00025 mfd. All three can be converted to lower capacities but not above their rating. They are of the one-hole mounting type, and the plates are quickly changed with a small wrench furnished with each instrument.

The Crest Radio Corp. 5 n Wabash Chicago

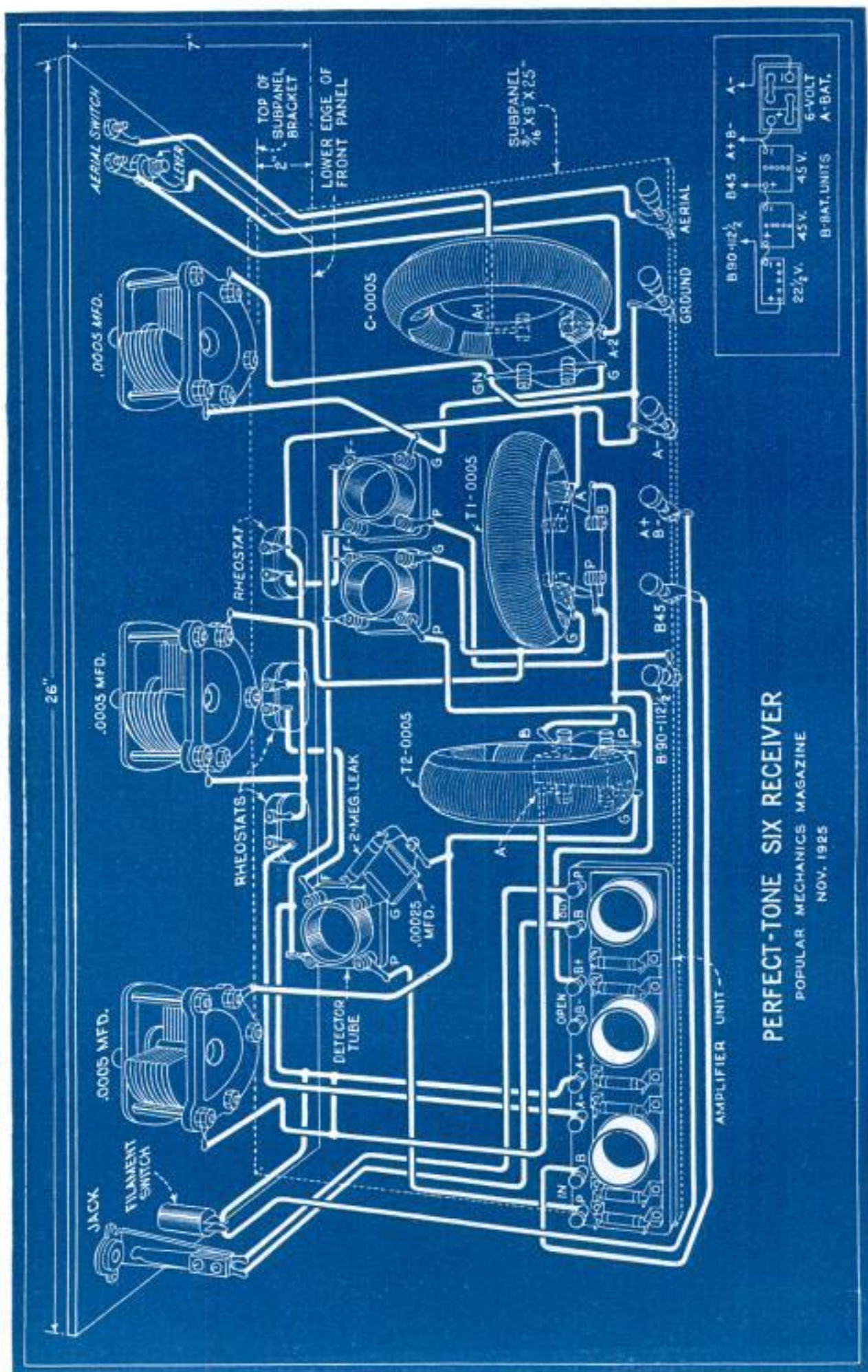

PERFECT-TONE SIX RECEIVER

POPULAR MECHANICS MAGAZINE

NOV. 1925

PERFECT-TONE SIX IS IDEAL FOR MUSIC LOVERS



WITHOUT a doubt the most perfectly-toned receiver we have ever listened to is the simple six-tube set recently developed in the Popular Mechanics radio laboratory. The deep, low notes of the organ and bass viol, as well as the higher notes of the flute and piccolo are faithfully reproduced with a full-throated volume and clarity that is surprising. The voice is so natural that one would believe the speaker to be in the same room.

This set was developed with the sole idea of obtaining tone quality; but it is also selective, and has a range equal to that of any good six-tube receiver. The cost to build is only \$63.50, exclusive of the tubes and batteries. This cost is figured on the high-grade materials always necessary to produce good results. The instrument is easy to tune and log, as the three dials are rotated practically in step, and, once the rheostats are set, there are no readjustments to make. The standard units used, make the set easy to build, even for those who have had little or no experience. The circuit is the tuned r.f. type with resistance-coupled a.f. amplification. Close tuning is due to the type of r.f. amplification used. It is a well-known fact that the coupler and r.f. coils themselves act as pick-up devices of broadcast signals. This is the main cause of

what is known as broad tuning. The new toroidal or "doughnut" coils as they are often called, are not subject to outside influences, as the magnetic

field is self-contained, resulting in sharp tuning and less interference. The coils have proved their value in this set. The tonal quality is due in a large measure to the resistance-coupled type of a.f. amplification used. This amplifier comes in a complete unit ready to mount on the subpanel and there are only seven connections to make. Good volume and pure tone without distortion are obtained by this form of amplification. It also eliminates tube noises and is economical in its demands on the B-battery. The rear-view photo shows the simple layout of the instruments on the subpanel. This panel, of bakelite, is $\frac{1}{8}$ by 9 by 25 in. in dimensions and is mounted on metal brackets, one at each end. These brackets come flush with the front edge and are provided with holes for mounting the front panel. A third bracket is mounted in the center at the rear. As the brackets come in pairs, the builder can use a brass strip or fiber rod of the same height for the center support and save the cost of the extra pair. The brackets support the subpanel 2 in. above the bottom of the cabinet and are fastened to the subpanel with two 6-32 brass machine screws, $\frac{1}{2}$ in. long. The amplifier unit is mounted at the left rear, with the terminal posts toward the front. This

unit may be reversed if desired; it is fastened to the subpanel with four round-head 6-32 brass machine screws, $1\frac{1}{4}$ in. long.

The detector-tube socket is lo-

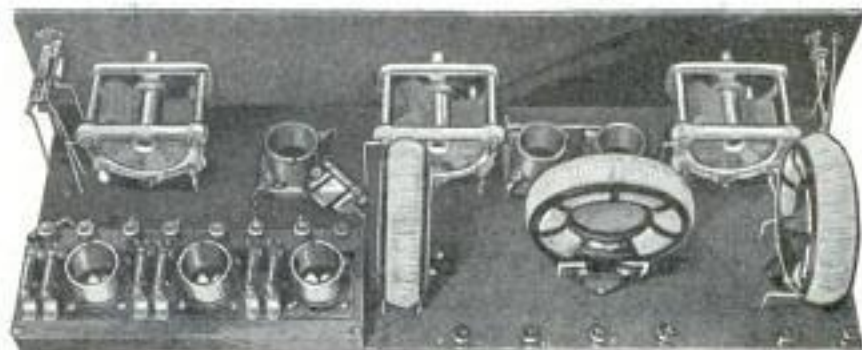

Rear View Showing the Instrument Layout and the Method of Running the Wires through the Subpanel

diagram, the T₂0005 coil at the right of the amplifier unit, the T₁0005 in the center, either alined with the first or at right angles to it, and the C0005 at the right. The sockets for the r.f. tubes are placed in front of the center coil. The binding posts for the aerial, ground and battery connections are mounted at the rear edge of the subpanel, behind the coils. This completes the layout of the subpanel. The bakelite front panel is $\frac{3}{16}$ by 7 by 26 in., a standard size, and the instrument arrangement is very simple. The condensers are of the low-loss type, .0005-mfd. capacity. The rheostats used are of the carbon-pile variety and take very little room on the front panel, below the subpanel. When laying out this panel, it is a good plan to make a template of bristol board. Measuring $2\frac{1}{8}$ in. from the lower edge of the panel, draw a line to represent the top



cated directly in front of this unit with the grid condenser and leak mounted on the grid post of the socket. The doughnut coils are then placed according to their type, as shown in the blueprint

of the subpanel. The holes for the rheostats are located 1 in. above the lower edge of the panel, one at the center and the other two spaced $4\frac{1}{2}$ in. on either side. The condensers are placed at a height that

will permit them to clear the subpanel; this distance will depend on the type of condenser used. The center condenser should be on a line with the center rheostat. The condensers on either side are fastened at the same height, and



punch or scribe. When the instruments have been mounted on this panel, it is ready for mounting on the subpanel. Holes countersunk for two 6-32 flat-head brass machine screws (black-japanned if possible) are used to hold the front panel to the subpanel brackets. The set is now ready to be wired. The

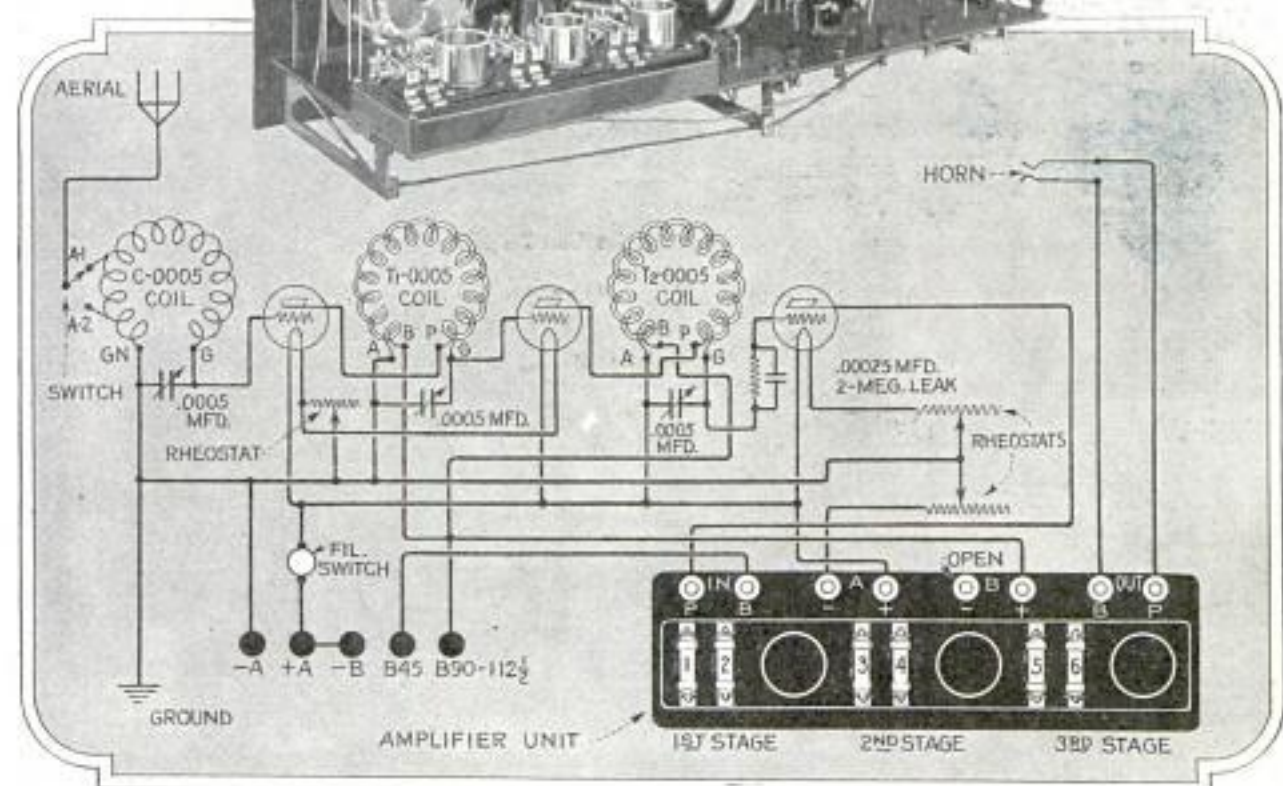

Schematic Diagram Showing the Simplicity of the Amplifier Connections; Above, Rear View, Showing Sub-panel Brackets and Wiring Details

should be spaced exactly 9 in. from center. The front-view photo of the set in the cabinet shows the position of the aerial switch at upper left. This switch lever, with two contact points, is for the purpose of obtaining the equivalent of a short or long aerial. The connections are clearly shown in the large circuit diagram. The horn jack is shown at the upper right, and the push-pull filament switch below. After the positions of the various instruments have been located, cut the cardboard to the exact size of the panel. Clamp this template to the panel and point off the location of the various holes to be drilled with a center

reader will note that holes are drilled in the subpanel near each instrument terminal; the No. 14 round tinned-copper busbar wire used for the circuit is bent with a small pair of pliers so as to drop down through the holes from the terminals and run in direct line under the subpanel, coming up at the proper point to complete the connection. The large wiring diagram gives all the wires above the subpanel for the purpose of clearly showing the circuit from point to point. When the wiring is run below, the result is more direct and shorter leads, and neater appearance above. When running the wires below the subpanel, some are dropped

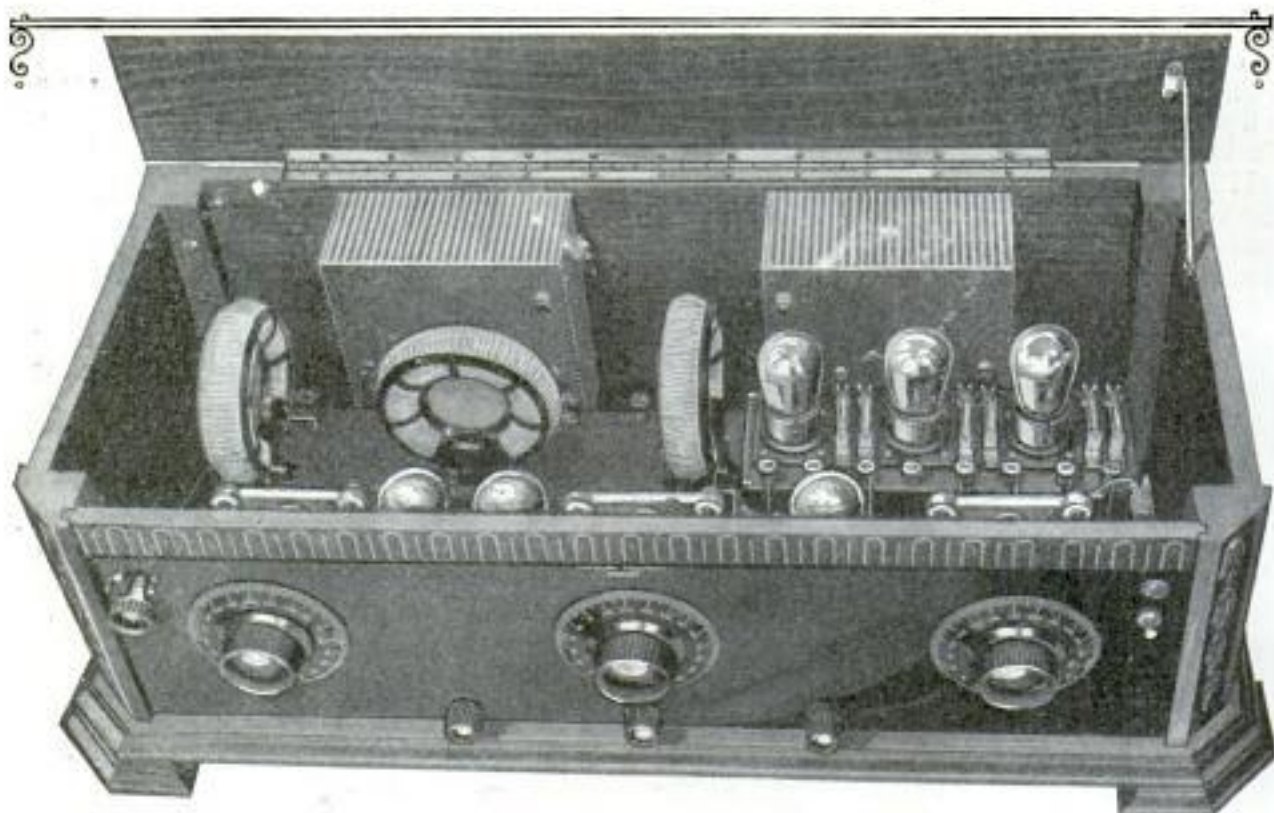

The Completed Instrument, Showing How the B-Batteries Can Be Included in the Cabinet if Desired

lower than others so as to prevent shorts. No insulation is used on the busbar wire, so care must be taken that the wires do not touch. Stranded rubber-covered wire is used for the lead from the positive A-battery terminal to the filament switch; this lead can be seen in the rear-view photo above the schematic diagram, as it is threaded through the supporting brackets. Rubber-covered wire is also used for the lead from the output post, P, on the amplifier unit, to the horn jack. The B-battery consists of two 45-volt units and one 22½-volt unit. They are connected as shown in the blueprint diagram. The positive A and negative B-leads are connected together and run to the A-positive terminal on the subpanel. Six UV-201A or C-301A tubes are used. For the aerial use one wire from 80 to 100 ft. long, including the lead-in, and a ground con-

nection to a near-by water pipe. A good horn should be used, as a poor one will not bring out the real value of the set.

To operate the receiver, plug in the horn and place each dial at, say 50, light the tubes, and turn up the rheostats until a faint swishing is heard in the horn. Rotate the dials in step until the station comes in clearly, then readjust the rheostats for proper volume. The rheostat on the right will regulate the volume after the other rheostats have been adjusted properly. It will be found that the dial readings will be about the same, if each dial is adjusted so that it reads 100 when all condenser plates are in.

Blueprints for this set may be obtained from the Radio department, Popular Mechanics Magazine, 200 E. Ontario St., Chicago. Inclose ten cents to cover postage and packing. Specify blueprint No. 102.

MATERIAL LIST

- | | |
|---|---|
| 1 bakelite panel, 3-16 by 7 by 26 in. | 1 Dubilier grid condenser with gridleak clips. |
| 1 bakelite panel, ¼ by 9 by 25 in. | 1 cartridge-type gridleak, 2 meg. |
| 1 pair Benjamin brackets. | 4 flat-head brass machine screws, 6-32, ½ in. long. |
| 1 set No 43 Thorola doughnut coils for .0005-mfd. condensers. | 12 round-head brass machine screws, 6-32, ½ in. long. |
| 3 variable condensers, .0005-mfd., low-loss type. | 4 round-head brass machine screws, 6-32, 1¼ in. long. |
| 3 dials, 4 in. | 2 B-battery units, 45 volts each. |
| 1 Daven super-amplifier unit complete. | 1 B-battery unit, 22½ volts. |
| 1 open-circuit jack. | 12 lengths No. 14 round tinned-copper busbar wire. |
| 1 push-pull filament switch. | 3 ft. stranded rubber-covered fixture wire. |
| 3 Bradleystats. | 38 tinned soldering lugs, long round-hole type. |
| 1 switch lever. | |
| 2 contact points with stops. | |
| 6 binding posts. | |

Fixed Condenser Aids in Obtaining Sharp Tuning

Those who have difficulty in tuning their sets sharply enough to eliminate some near-by interfering station, will find that a fixed condenser connected in series with the aerial will help considerably, although it will reduce the signal strength. Use either a .0001, .00015 or .00025-mfd. instrument. Try all three values until one is found that gives best selectivity and greatest volume. Sharp tuning is necessary in congested districts, and it is sometimes helpful to have both a short indoor aerial and the usual outdoor type, the shorter aerial being used so that sharper tuning may be obtained on local stations.

Lead-In Kept from Grounding by Bracket Insulator

A neat and effective mounting for the lead-in wire is provided by a new insulator, which is fitted with a long rust-proof



534-U.
 bracket. Almost everyone who has erected an aerial knows what a job it is to bring the lead-in down to the set without having it touch the building at some point where it might ground the aerial when wet. The usual method of keeping the wire from the side of the building is to use any lengths of stick that are available, but this makes an unsightly job, as well as a poor one

from the standpoint of insulation. The bracket illustrated not only provides a neat way to do the job, but also insulates the wire properly.

Spacing Wire on Coils

To correctly space wire on coils, start the coil with a thread or light string, winding the wire and string alongside each other on the form, and keeping a stiff tension. After the coil has been wound, the thread or string can be removed, and the turns of wire will be correctly spaced.

Unless proper grid-bias batteries are used vacuum tubes should not be operated on potentials higher than 100 volts, because there is then considerable danger of burning out the transformers.

Simple Repair That Saves Tube with Loose Base

Tubes will often break loose at the joint between the metal base and the glass. Tubes in this condition will very likely be ruined when changed from one socket to another, if not repaired at once. A simple remedy is to wrap a strip of adhesive tape around the joint three or four times, carefully stretching the tape at each turn so as to fit tightly over the top of the metal base and the glass, as shown in the sketch. After wrapping, hold the tube in the closed hand, pressing tightly on the tape for a few moments, to heat the tape and make the support solid. This will save the tube for future use.—L. B. Robbins, Harwich, Mass.



Lock Switch Protects Batteries from Unnecessary Use

To prevent careless operation or tampering when the owner of a receiving set is absent, a lock switch has been devised which retains its key until the circuit is properly turned off. This arrangement eliminates needless drain on the batteries and saves the tubes from being accidentally left burning, since the operator cannot take the key with him on leaving the set

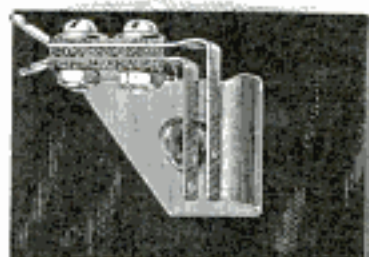

without first shutting off the current. The switch is for installation on the inside of the panel and resembles a jack. A guard is provided to prevent the insertion of a pencil, plug or similar object in attempts to work the lock without the key. Any number of keys may be furnished for the same switch, so that several persons may operate a set equipped with the device.

Kilbourne & Clark Mfg. Co
 101 Spokane St. Wash.
 Seattle, Wash.

Erecting Single-Wire Aerial on Flat Roof

Erecting an aerial on a flat gravel, asphalt or composition roof of an apart-



Simple Method of Erecting Single-Wire Antenna on Apartment-House Roof

ment house is frequently a problem, as no place can be found to attach supports with nails or bolts. The problem may be solved, however, by building two A-supports of light lumber, with a crosspiece of heavy wire to hold the legs the proper distance apart. The supports should be spaced two or three feet outside the insulators at either end of the aerial, and the supporting wires led over the grooves formed by the junction of the legs of the A's, and then down to the nearest projecting plumbing vent pipe. Almost every apartment-house roof is studded with plumbing vents, and it will usually be possible to find two sufficiently far apart to wire the supporting wires to.

Adjusting Tuned-Plate Circuits

The operation of tuned radio-frequency circuits, requires selective but firm adjustments of the movable, or tickler coil, which is in the plate circuit of the detector tube. In such circuits the tuning of this coil is much more critical than is generally supposed, if the best results are to be obtained, and therefore it is necessary to provide a support which will permit the coupling to be changed very slightly when nec-

essary, and that will hold this adjustment regardless of the jars or movements to which the radio cabinet or set may be subject. The illustrations show two methods of arranging the adjustment of the tickler coil in the Roberts' scheme, which has proved satisfactory. The right-hand drawing shows a micrometer adjustment which is sufficiently rapid in its movement to meet any tuning conditions over the entire band of frequencies used in present broadcasting. This method permits the three coils of the unit to lie flat on the bottom of the cabinet in the rear of the panel. The upper coil, or the plate tickler, is adjusted by the knob, screw, springs and brass angle piece, as indicated. A few turns of this arrangement will move the coil up or down with rapidity.

The arrangement at the left shows a scheme that is somewhat slower in operation but extremely sensitive and stable. The tickler coil is attached to a brass rod which slides through a hole in the support and which is moved ahead by the screw and knob that work against the end of the rod. A piece of spring, fitting firmly against the coil will keep the tension even so that the coil will move closer to

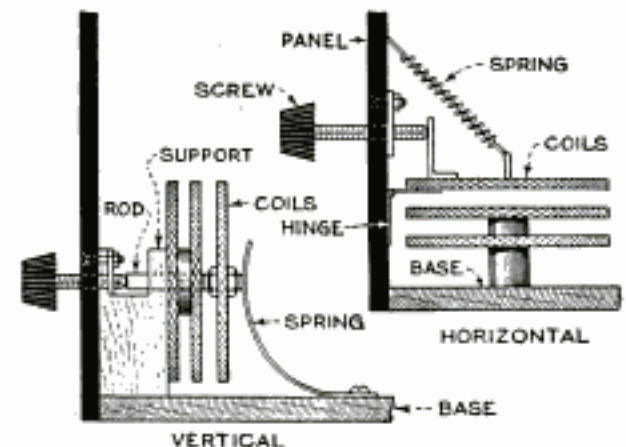

Two Simple Methods of Fitting a Sensitive Adjustment to Tickler Coils

the secondary coil when the screw is withdrawn.—B. F. Dashiell, Washington, D. C.

☞ To avoid making mistakes when wiring a radio set it is an excellent idea to use different kinds of color of insulated wire for the A-battery leads and for the B-battery leads so that they can be readily distinguished.

*L. S. Beach Mfg. Co.
127 Sussex St.
Newark, N.J.*

Clean Jacks Improve Reception

Clean jack contacts are necessary for good reception. These little springs gather dust and corrode slightly making a poor path for the weaker signals. Much of the frying and crackling noises can be traced to this cause. An easy method of cleaning them is to insert a small piece of fine sandpaper between the contacts and pull it back and forth a few times. Emery paper should not be used for this purpose, as it leaves a metallic deposit that will cause leakage and losses. A small camel's-hair brush will aid in keeping the jacks free from dust.

Switching Battery from Set to Charger

Everyone knows that a storage battery should be kept as completely charged as possible; to make sure this is done, it is necessary that some simple and convenient means be used to change the battery

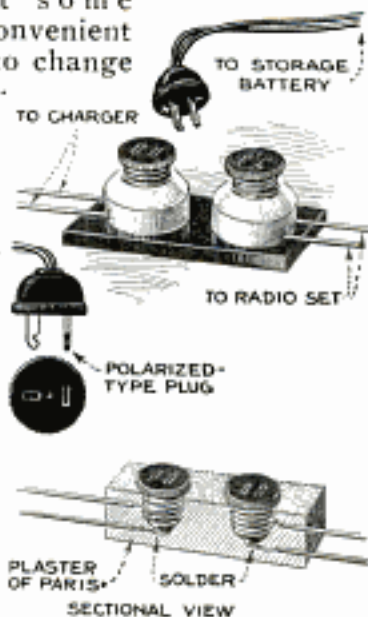

from the set to the charger and back again. A simple double-throw, double-pole switch is commonly used for this purpose, but is not altogether satisfactory, as it is unsightly, and unsafe on account of shorts. A

closed snap switch does not answer either, as it is not rugged enough and may be accidentally thrown. An ideal arrangement can be made by fastening two sockets to a block as shown in the illustration, the cap and plug being notched or otherwise marked to show the polarity if they are not of the polarized type. If no extra sockets are at hand, wires may be soldered to the screw halves of the plugs; wires and plugs are then placed in a small cardboard box and the box filled with plaster of paris. If this method is used, the polarity of the wires must be determined and marked on the outside of the box before sealing with the plaster. A switching device of this type has none of the objectionable features of the knife switch, and makes a neat assembly.—C. N. Bourgholtzer, New York City.

Shock-Proof Plug Locks Cord Tips 495-

Cords from the headset or from the loud speaker are quickly and securely fastened in a plug that is designed to afford efficient electrical contact and has no metal parts exposed, thus giving protection against shock. As the tips are inserted, they are automatically locked in place, but may be released instantly simply by pulling them to one side. The plug is insulated to withstand the voltage required by loud speakers, and is said to relieve the strain on the cords and soldered connections.

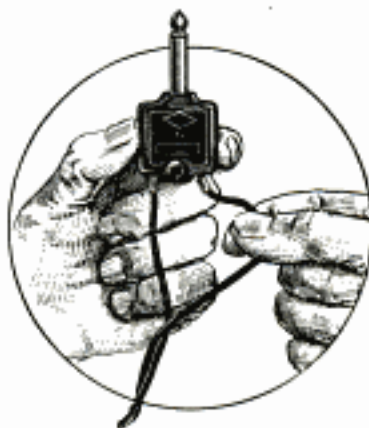

New Busbar Wire Contains Its Own Solder

A new busbar wire containing its own solder has just made its appearance in England. The wire is of the tinned-copper type familiar to all radio builders, but on close examination it is found to be drawn in a double T-section, a solder compound being contained in the side grooves, as shown in the enlarged sectional view.

To form a joint, the ends are simply brought together; the point of junction is moistened with a little flux, and a hot iron applied. Under the influence of the heat, the solder coatings unite immediately and form a joint. Very neat work is the result as shown by the example of wiring at the right in the illustration.

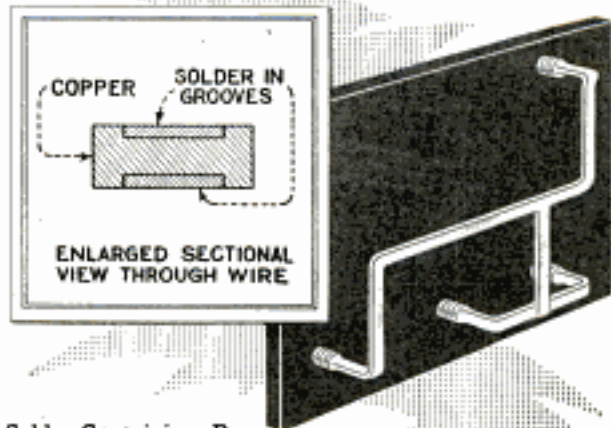

Solder-Containing Bus Wire and Sample of Work Done with It

*555-R
Res Engineering Co. Ltd.
2 Ravenhill Square W.C. 6. Eng.*

Inexpensive Crystal Receiver

By WILL H. BATES

THIS simple, selective crystal receiver will bring in the broadcast programs within a range of 35 or 40 miles, and can be built for less than \$1, exclusive of the headphones and the aerial and ground supplies. No variable condenser is used, yet the set will separate the local stations. This is of particular advantage in the larger cities, where several stations are on the air at the same time, and the average crystal receiver will not tune sharply enough to give satisfaction.

For local stations, a few turns of bell

tated with the finger as indicated in the illustration. It is mounted on the wooden support, detailed in the upper left-hand corner. The shaft is a 1½-in. brass machine screw, and if an old discarded rheostat is available, its shaft, or that of a switch, will serve.

As the coil is turned, the taps are brought in contact with a thin spring-brass strip on the baseboard. The details of the primary coil are clearly shown, and the winding is very simple. The form for the coil is the sawed-off end of a large spool, 1¾ in. in diameter. Holes are drilled in the edge for 20 burned-off matches, equally spaced. For the coil No. 22 d.c.c. magnet wire is used. Leave 1 in. or more at the beginning and wind over one spoke, under two spokes, and so on, for two complete turns. At the start of the third run insert a wood wedge to form a flat

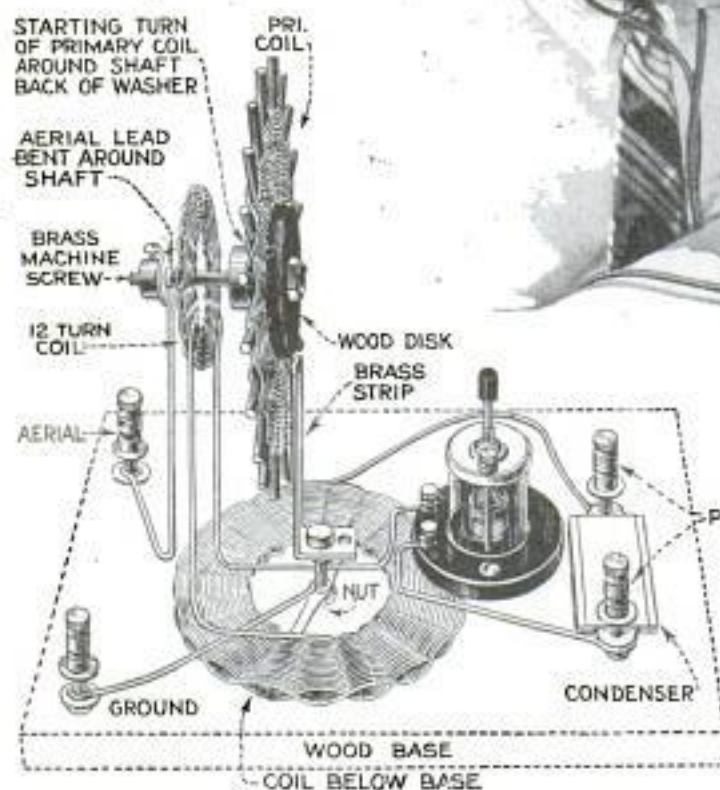

View of Receiver in Use, Details of Parts and Connections, and Circuit Diagram

wire around the room behind the molding will answer for the aerial, and a wire clamped to a water pipe makes an ideal ground. The revolving coil makes the set easy to tune. This primary coil is ro-

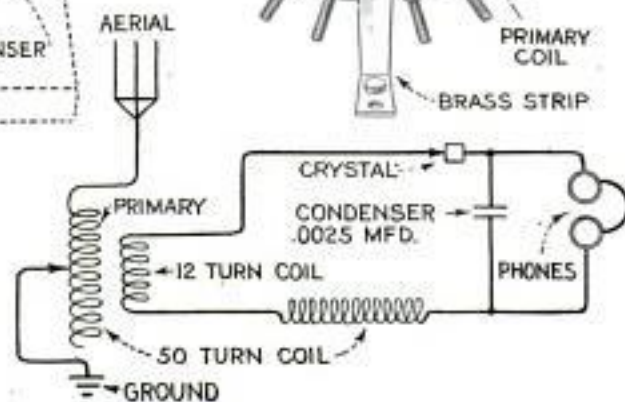
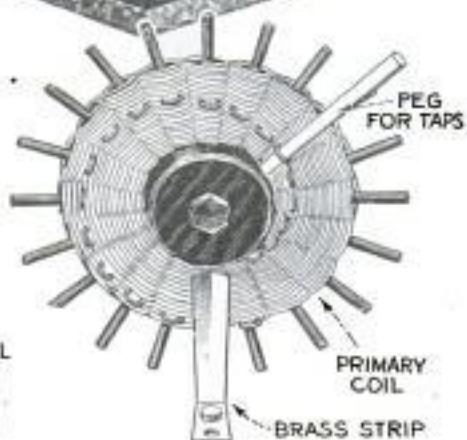

loop in the wire, as shown. When the turn is completed remove the peg. Every second turn on the coil will now bring the over-one turn on the adjoining spoke, and the peg is again inserted in the same way, thus advancing the taps in a spiral to the outer edge of the coil and forming 20 in all. The winding is then continued a part of the way around the coil, clipped and secured around one of the spokes. This end of the wire is not connected in the circuit; the loops are then scraped free of insulation and the spokes withdrawn from the coil. Heavy thread or light string is used to bind the coil, threading it in and out of the openings left by the spokes and tying the ends. The spokes are then replaced and the unit is complete and ready for mounting.

The starting wire of this coil is bared and looped around the shaft back of the wood disk, a large nut and washer holding it in place. The aerial wire is brought up through the base and looped around the shaft at the rear of the support, and held in place with a lock bearing and washer. The wooden baseboard is $\frac{1}{4}$ by 7 by 7 in. and rests on four $\frac{1}{2}$ -in. strips tacked around the outer edge, so as to allow the larger secondary coil clearance underneath it.

The secondary coil, in two sections, is wound on a form made from the remainder of the spool, the rim of which is drilled to take 19 nails, as shown. The smaller section has 12 turns and is mounted directly back of the primary, and supported by its lead wire but not

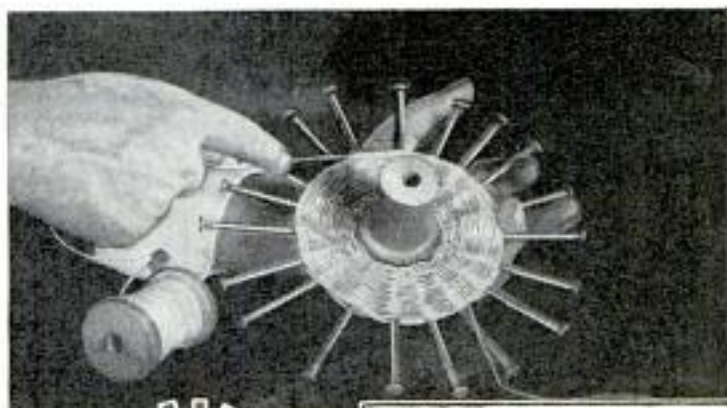

Winding Secondary Coil, and, Below, Rear View of Completed Set

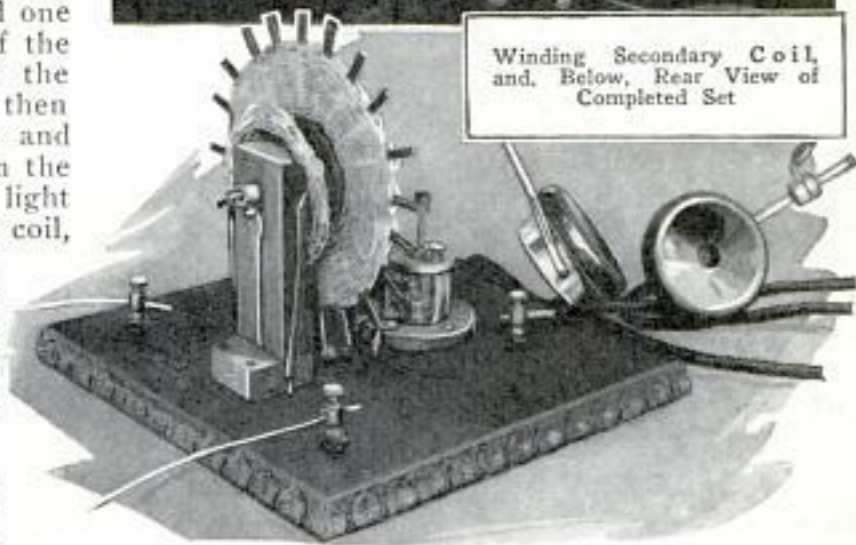

taken through the baseboard to the inside turn of the larger coil, and the outside end of the small coil to one side of the crystal detector. Both sections of the secondary are wound with No. 22 d.c.c. wire, the method of winding being over two spokes, and under two. Leave a start and finishing end about 8 in. long, remove from the form and sew together as before. The second section of the secondary has 50 turns, and is made in the same way. It is supported below the baseboard by a thin strip of wood; the author used a paper soda straw. The brass machine screw that supports the spring-brass strip also holds the supporting

MATERIAL LIST

1 baseboard, $\frac{3}{4}$ by 7 by 7 in.
 2 wood strips, $\frac{1}{4}$ by $\frac{1}{2}$ by 7 in.
 2 wood strips, $\frac{1}{4}$ by $\frac{1}{2}$ by 6 in.
 1 wood block, $\frac{1}{2}$ by $1\frac{1}{4}$ by $1\frac{1}{4}$ in.
 1 piece of wood, $\frac{1}{2}$ by $1\frac{1}{4}$ by 3 in.
 1 crystal detector.
 1 .0025-mfd. condenser.
 4 binding posts.

1 piece of thin spring brass, $\frac{3}{8}$ in. wide and $2\frac{1}{2}$ in. long.
 1 brass machine screw, $1\frac{1}{2}$ in. long, with nut to fit.
 3 small washers.
 1 small bearing with set screw.
 1 large spool, $1\frac{1}{4}$ in. in diameter at ends.
 1 small spool No. 22 magnet wire.

touching the shaft, spaghetti tubing being used to strengthen the supporting leads. The inside lead of the small coil is

strip for the large secondary and forms the grounding terminal from the primary through the metal strip. The brass con-

tact strip is bent to form a $\frac{1}{2}$ -in. mounting piece drilled for the machine screw, and mounted on the baseboard so that it will make good contact with the primary taps when the coil is rotated.

The .0025-mfd. condenser is mounted across the phone posts, under the baseboard. The outside end of the large secondary coil is connected to one phone post, and the other phone post is connected to the other side of the crystal

detector, completing the instrument. Connect the ground, aerial and phones, and the set is ready for operation.

To tune the instrument, put the headphones on, turn the primary coil slowly and adjust the crystal detector until a signal is heard. When a sensitive point on the crystal is located, the station will come in clearly. Once this sensitive spot is located, other stations can be tuned in by merely turning the coil.

Automatic Battery Connector

Usually the radio experimenter finds it necessary to take a set out of the cabinet a great many times to make the changes needed to get it working right, and it is annoying and temper-trying to fish in the back of the cabinet to make and unmake the battery connections in the cramped space. There is always the danger of short-circuiting, if the connections on the batteries have not been taken off first. Also, not infrequently, soldered connections are knocked loose.

The accompanying illustrations show a simple, yet effective way of eliminating the need of disconnecting the batteries when the set is to be taken out of the cabinet.

The materials required are easily obtained: a strip of hard rubber or formica, 6 in. long, $\frac{1}{2}$ in. wide and $\frac{1}{4}$ in. thick; another piece of the same material, 6 in. long and $\frac{3}{8}$ in. square; ten binding posts; two pieces of hard-rubber tubing, $\frac{1}{2}$ in. in diameter and about $1\frac{1}{2}$ in. long, and five pieces of thin spring brass, $\frac{3}{8}$ in. wide and $1\frac{3}{8}$ in. long.

Drill the two hard-rubber strips as indicated at the top in the illustration. The holes nearest the ends of each piece are to be used in fastening them down. Mount five binding posts on top of the

wide piece as shown, with soldering lugs underneath or above, as you prefer. (Ordinary brass or nickelplated nuts and bolts can be used instead of the binding posts.)

Next drill a hole in each of the spring-brass pieces and mount them, as shown in the sectional view, on the square rubber piece, as wide as the back of the cabinet is thick, being used between the strips and the binding posts. The first-mentioned piece of hard rubber is fastened to the baseboard, being held up by the rubber tubing at each end. The other piece is fastened to the back of the cabinet, at such a height that the springs will be pressed in close contact with the heads of the binding-post screws. This position being found, holes

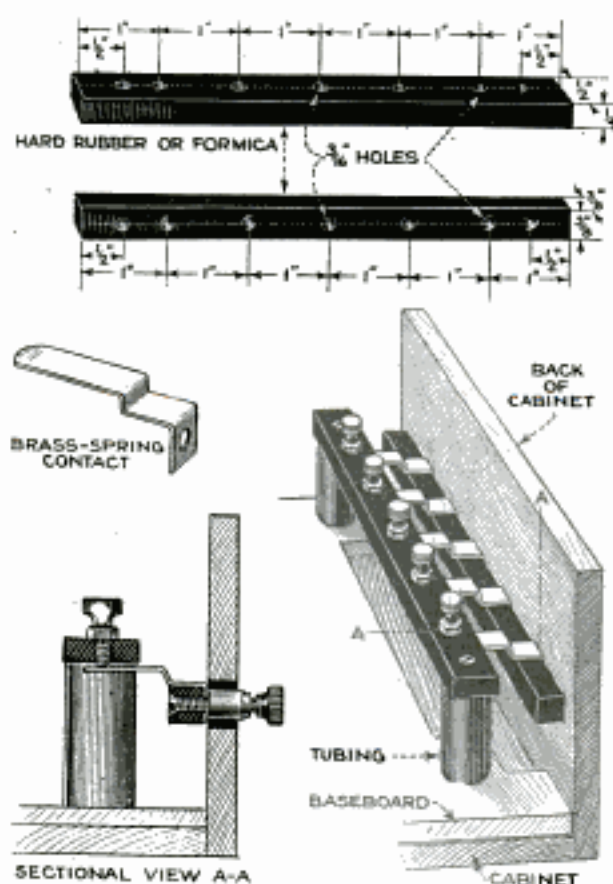

Simple Device for Automatically Connecting Batteries to Cabinet Receiver

are drilled in the back of the cabinet, large enough to take the binding posts and collars without touching. The binding posts will project outside the cabinet, and connections from the batteries are made there. Cut out enough of the baseboard to clear the springs when the set is taken from the cabinet. The installation of this connector means a little more work, but it will pay in the long run in time saved. There is nothing to disconnect when taking the set out. When it is put back, connections are automatically made.—Albert Chenicek, Chicago.



Combination Stepladder, Washtub Stand and Ironing Board

By E. E. SCOTT

CONSIDERABLE space can be saved in the small house or apartment by combining the ironing board, washtub stand and stepladder, as shown in the photos and illustrations. The article has only four movable parts and can be folded to dimensions which permit it to be stored behind a door or in any other out-of-way place.

Spruce wood, $\frac{3}{4}$ in. thick and dressed on all four sides, is used, as it is strong and light. The sides of the ladder proper,

part 3, and the bottom of part 1 should be mortised, $\frac{1}{4}$ in. deep, to receive the steps, as it is important that they should be securely anchored to insure the safety of the person using the ladder. It will be noted that the bottom step is in part 3 and the other three in part 1. The detail of the upper end of the sides of part 1 indicates the cut-out portion of this part, while the drawing of the ladder set up as an ironing-board support shows how these sides project into the slot formed by the sides of part 2 and the inner strip having the notches,

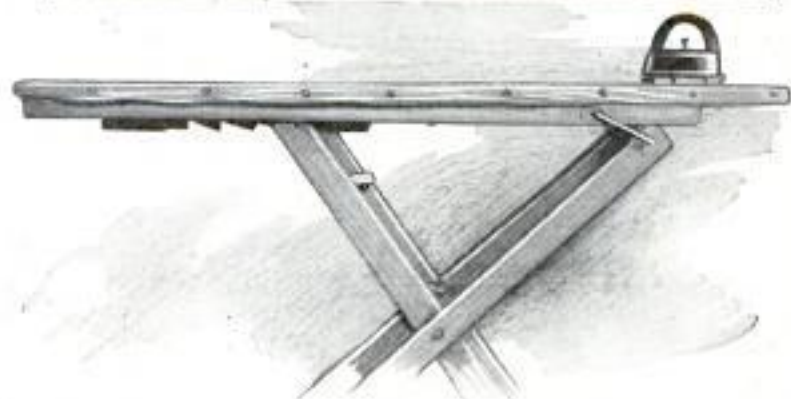
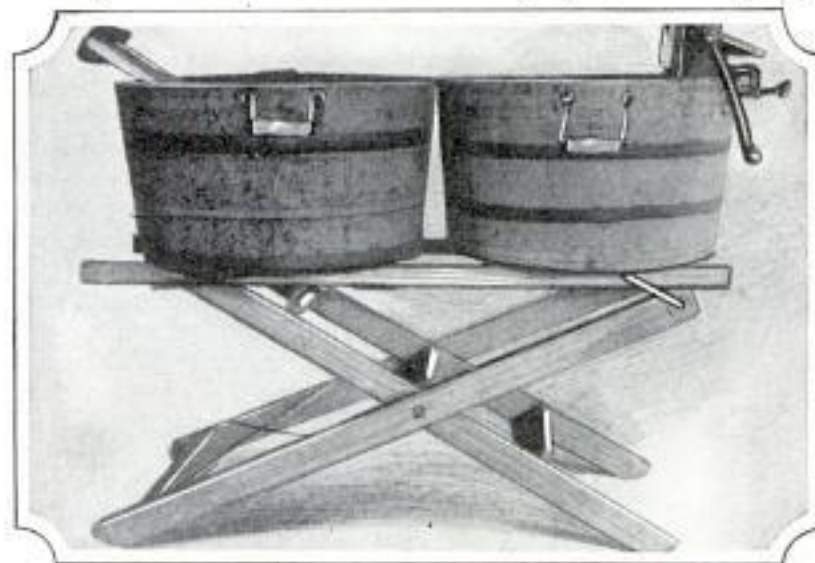

A Three-Purpose Household Utility Which Can Be Used as a Stepladder, Washtub Stand and Ironing Board, Helping Save Space in a Small Home or Apartment

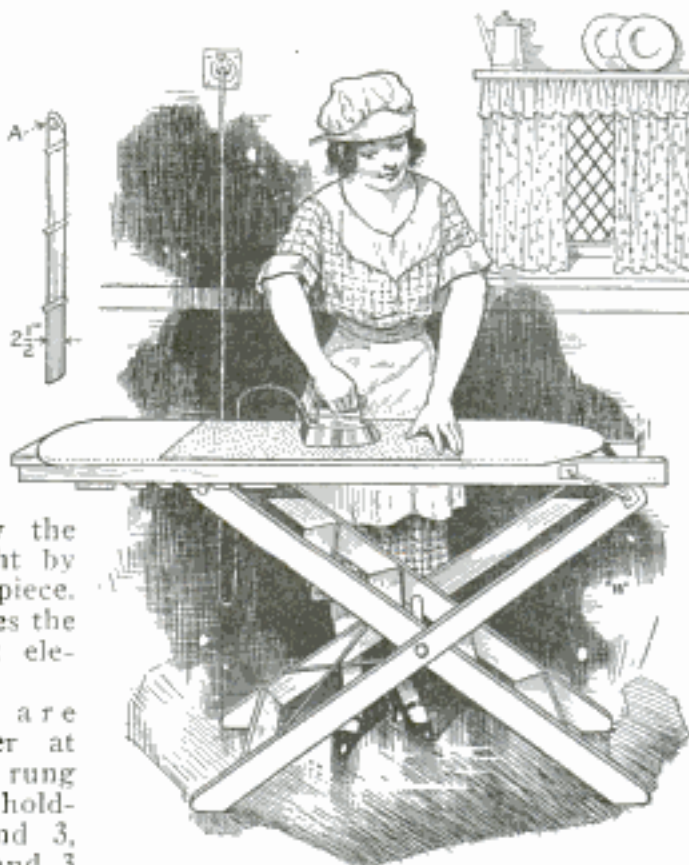
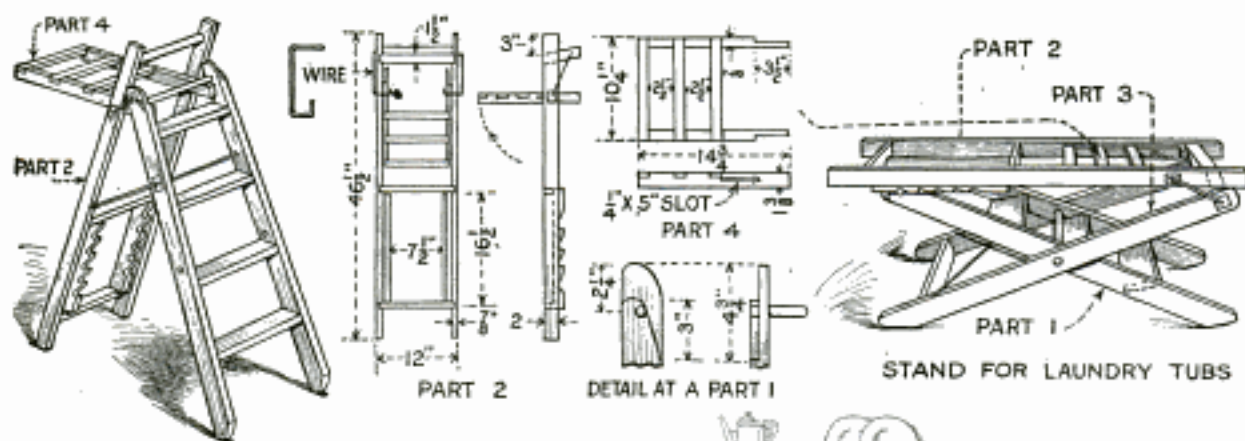

Rigid in Construction and Substantial Throughout, This Ironing-Board Support Is Very Strong and Quickly Adapted to Its Other Uses

and also how the rung is caught by this notched piece. Each notch gives the top a different elevation.

The parts are hung together at two points, the rung in the center holding parts 1 and 3, while parts 2 and 3 are connected by two links of $\frac{3}{16}$ -in. steel wire, bent as shown in detail of part 2. The straight end projects through the sides of part 3 and into the $1\frac{1}{2}$ -in. piece shown in part 2, which serves as the top step. This piece is screwed to the top of part 2 and projects so that part 3 can pivot on it as shown. It is important that each of these wires be of the same length and that they be inserted at the same distances from the end of the sidepieces, or the parts will not fold together properly nor will they stand level when used as a stepladder. The pail support, part 4, slides on these wires, and when in use, is pushed under the top rung of part 1. When assembling the various parts, it is well to use numerous screws to insure a rigid and safe ladder. Do not omit the wire braces shown at the bottom of part 3, nor those shown

in upper left-hand assembled view, which hold the legs when the device is used as a stepladder. At all points where holes for the various wire parts are made, a heavy tin reinforcement should be tacked on to reduce wear to a minimum. The finished piece should be given two coats of good

paint or valspar varnish as a protection against water that occasionally may be spilled upon it.

Using Garden Hose in Winter

Keep the garden hose connected to a faucet in the cellar to fill the water pan of the furnace quickly, and to spray the ashes before sifting them. This will keep the dust down and prevent hot coals from being thrown up against wooden partitions and starting fires. The spraying should be done while the ashes are still in the furnace pit, and only a little water is needed. Too much water will make the ashes "muddy" and make it almost impossible to properly sift them.—Stanley H. Phillips, Drummondville, Can.

*Harry C. Lorey
of Newark, N.J.
Sunday Call
Newark, N.J.*

Making Case for Fish Rod

Get a large cane, such as is used to roll rugs on, and saw it off about 4 in. longer than the fishing rod. Split it down the center, cut out all the joints, and clean and smooth the inside with sandpaper. A handle can then be riveted to one of the halves. Now glue the sections together again and wrap the case with heavy thread, in the way a fly rod is wrapped. In one end of the case a cork is glued, and a loose cork is used in the other. If desired, the completed case may be enameled or varnished to make a better appearance. —Max K. Hortin, Oakley, Utah.

Moving Sign Attracts Attention

Many highways are lined with colored display signs of about every description. Growing accustomed to the more ordinary ones, it takes a decided departure to command attention. Just west of Omaha, Nebr., on one of the main roads, one may see a whirling red and black sign that announces ice-cold pop, gas and oil just around the bend. The sign itself is conspicuous, but the colors add to this considerably. Closer investigation shows the mechanism to be extremely simple. Two can covers, cut from 1-gal. cans, are soldered to a heavy strip of tin. To this a small bushing or tube is also soldered to form a bearing for the spike which is driven

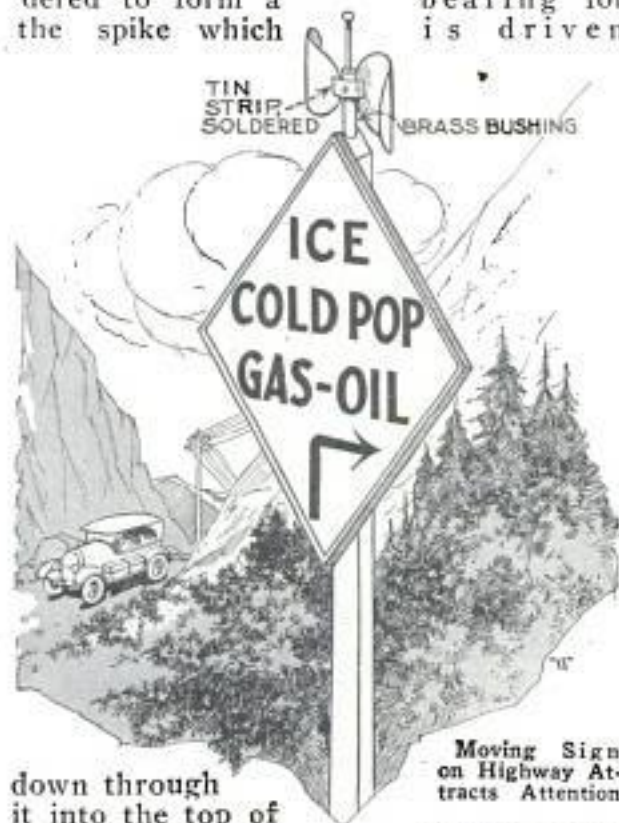

down through it into the top of the support. The will turn in a light breeze.

Moving Sign on Highway Attracts Attention

curved covers

Novel Feather-Duster Incubator

A New Jersey chicken breeder has succeeded in hatching a record number of eggs in the novel homemade incubator



Novel Incubator Consisting of Feather Dusters and Electric Lamp

shown in the photo. It consists of an ordinary wooden box divided by a partition. The eggs are placed in one section covered by a board, to which four feather dusters, with the handles cut off, are attached as shown. An electric lamp, inclosed in a guard, is set centrally between the dusters, the cord passing through a hole in the cover. The heat of the lamp is retained by the dusters and, when the eggs are hatched, the new-born chicks have an artificial hen sitting on them. The other section provides an open-air yard where the older chicks may be fed and exercised.

Repairing Organ Bellows

I was called upon to clean and repair a small church organ here, and found the rubber bellows cloth worn threadbare in many places, which made the instrument very difficult to play. New cloth could not be had except at the factory in Illinois, and I knew it to be very difficult to put in place satisfactorily. So I tried the following scheme, which has proved entirely successful after two years' use: I cleaned the bellows thoroughly with gasoline, and when dried, gave it a coating of rubber cement.—M. A. Carty, Bremerton, Wash.

Newspaper Container

Newspapers are often thrown on porches regardless of the weather. A good container which will prevent them



Container for Newspaper Protects It from the Weather

from being blown away, or from being soaked, is shown in the drawing. It is simply a 1-ft. length of conductor pipe, closed at one end and fastened to the wall horizontally by means of sheet-metal straps. It is painted white and it is an easy matter for the carrier to roll up the newspaper and slip it into the container.

Assembling Battery Sets

Users of dry-battery sets for ignition on boats, gas engines, etc., commonly prefer sets contained in a metal or heavy cardboard case because they are compact and waterproof. They cost more, of course, than separate cells, but it is not necessary to discard the whole battery because one or more units are exhausted. Remove the waterproof compound, replace the dead cells by new ones, remelt the compound and pour it back into place. The owner of a fleet of pleasure boats uses this method entirely, with the result that the original battery cases last indefinitely.

Removing Sugar Stains from Clothes

Sugar spots on silk or crepe dresses are difficult for the home cleaner to remove as gasoline will not dissolve them and water leaves rings or destroys the color. To

avoid these difficulties, cut down the bristles of a discarded toothbrush to approximately half their normal length. Stretch the spotted portion of the garment over the ironing board and brush across the grain of the fabric. The brushing will loosen and remove the sugar, if this is perfectly dry, and will also raise the nap so that the spot cannot be detected. Even though some of the sugar may remain in the fabric, it will not become apparent again until the garment is dampened and pressed the next time.

Watering Honey Bees

Honey bees require much water during the hot summer months. They will fly miles for a drink, but setting out of vessels filled with water near the apiary is not quite satisfactory, as many bees will drown in them. This danger is entirely eliminated by providing the novel drinking fountain shown in the photo. A small keg is filled with water and provided with a brass stopcock. This is opened so that the water will only drip on a board and keep it moist. Of course, an air hole is drilled in the bung. The bees collect in numbers, drinking up the water without any danger of drowning. A 5-gal. keg



Drinking Fountain Which Waters Bees without Any Danger of Drowning Them

needs refilling only twice a week and will supply water for 50 hives.

An Adjustable Kitchen Worktable

A resourceful housekeeper made her kitchen labors lighter by providing herself with a novel worktable, which can be adjusted to any suitable height when sitting or standing. It also can be taken

apart in a moment and tucked away in the corner of a closet until it is needed again. Besides, it is serviceable as a bedside



holds the rod securely at any height desired. This rod is flattened at the upper end, bent over at right angles and two holes are drilled through it so that it can be screwed to the



Convenient Kitchen Table Can Be Adjusted to Any Desired Height and Is Collapsible, Which Permits It to Be Stored Away in a Small Space

table in the sick room, because the top can be slipped over the bed so that it is convenient and accessible to the patient. A strong metal tripod of the kind used for music racks serves as the base. Into the tubular upper portion of this tripod is slipped a metal rod of suitable length and a thumbscrew at the upper end of the tube

underside of the table top. The latter is built up of thin, light boards nailed to three cleats. The top should be about 2 ft. wide and 3 ft. long. The upper surface of the table may be enameled, if desired, or at least should be covered with a washable fabric such as oilcloth.—P. C. Grose, Lakewood, Ohio.

Sheet-Iron Popcorn Sheller

Shelling popcorn with the fingers becomes a long and laborious task if quantities sufficient for planting are to be removed from the cob. A simple and efficient sheller is easily made from a piece of sheet



iron, 11 in. long and 2½ in. wide. It is first laid flat and perforated with a spike, a number of holes being punched and left so that the metal around them protrudes as in a grater. The strip is then bent to fit around the cob, the unpunched part of the metal serving as a handle. By turning the ear inside this holder, the kernels are easily and quickly removed.

When an egg shell is cracked, the white usually comes out when the egg is boiled. This can be prevented by wrapping the egg in tissue paper. As soon as the paper gets wet it will seal the crack.



Saving the Gas

By JAMES TATE

"HELLO, Bill," called John Jackson, familiarly called "J. J." by his friends, to a motorist who had just driven up to the curb in front of his garage, "I haven't seen you since you got the new car. How does she run?" "Oh, so-so," replied Bill. "Only so-so?" asked J. J.: "the Speedwell's a good boat; shouldn't have any trouble with it as early as this. You've had it about three months, haven't you? Thought so. Well, what seems to be the trouble?" "Oh, she takes too much gas," said Bill; "not such an awful lot, y'understand, but more than I figure she should."

"Wait just a minute," said John, "I'll get my coat and take a little ride with you. Need a little fresh air, I guess, and you have time to take me for a mile or two."

"But I want you to look over the car and see what you can do for it," said Bill. "All right, but let's take a little ride first," said John, "I'll look over the car when we come back." John climbed in, Bill stepped on the starter, and the car moved down the street with a whirl of gears.

After an absence of about an hour, the pair reappeared,

and when they reached the garage curb, Bill was about to shut off his engine when J. J. stopped him, reached over to the steering wheel and retarded the throttle control to the limit, listened to the engine for a few seconds, then climbed out, lifted the hood, and with a screwdriver, adjusted the throttle control until the engine was running to his satisfaction; did a few mysterious things to the carburetor, shook his head after listening to the engine and then seemed to undo them again. Finally he closed the hood. "Well, what's the matter with it?" said Bill. "There's nothing the matter with the car," said J. J. "It's your own fault if you're using too much gas." "My fault? You're crazy," said Bill; "why, I've been driving a car for five years. Think I don't know how to drive?" "Calm down, Bill,"

replied John, "you are no better or worse than a million others, but the fault none the less is yours. Come into the office, where we can be comfortable, and I'll clear up the trouble for you."

"In the first place," said J. J., after they were comfortably seated at the desk and the

blue smoke had started curling up toward the ceiling, "your engine was idling too



fast. You don't need to have it idling at 500 or 600 revolutions a minute. Keep it ticking over at the slowest speed possible without having it stop whenever you throw out the clutch. Of course, with a new engine, you have to idle it fairly fast for the first few hundred miles, because if you don't, it may stop whenever the clutch is thrown out, but you should have experimented with the throttle control as the engine became loosened up, and kept reducing the idling speed until you could reduce it no longer. Sometimes a new car may be getting an over-rich mixture, and one of the first things the owner of a new car should do, after the engine is pretty well run in, is to have the service station for his particular make of carburetor go over the setting of the jets and see that the mixture is not too rich. It was not so in your case; you saw me try a leaner mixture, but the original setting was about as lean as the engine will stand now. After this, however, watch your idling speed.



Adjust the Carburetor to Get the Slowest Possible Idling Speed without Letting the Engine "Die"; Let the Engine Run Quite Fast for a Few Moments While Closing the Garage, to Reach the Proper Temperature for Running Right

"Now, when you came over here, you had just taken the car out of your garage, hadn't you?"

Thought so. The motometer on your radiator showed a very cool engine, too cool, in fact. When you first take your car out in the morning, or at any other time of the day, give the engine time to warm up. Let it run fairly fast while you are closing the garage doors and keep it running so for a few minutes before you let in the clutch and drive off. A cold engine is inefficient, and is not only wasteful of gasoline, but also hard on the oil, because of excessive leakage of the gas past the pistons and into the crankcase. Another thing that not only wastes the gas, but also contributes to crankcase dilution, is the way you use your choke. You pulled the choke all the way out when you stepped on

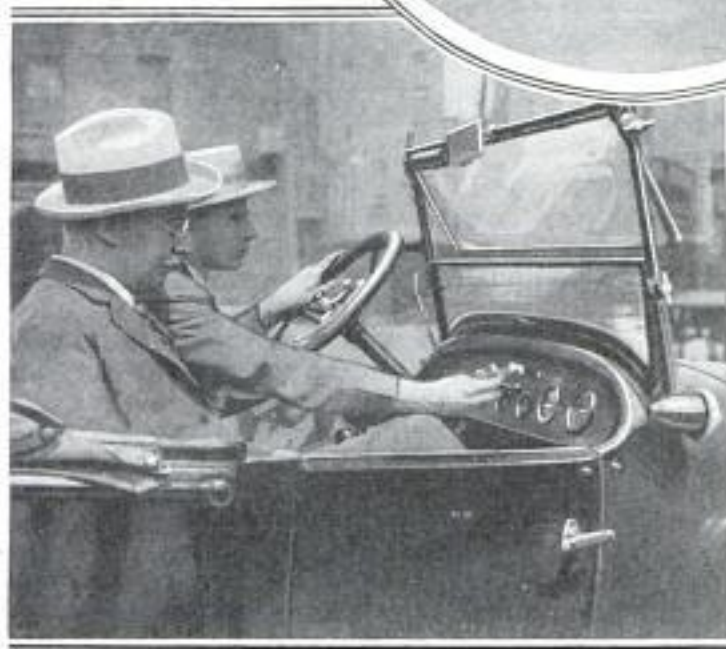

Push the Choke In as Soon as Possible after Starting as the Engine Will Then Run Better and Consume Less Gas

the starter, then you pushed it in about halfway, which was all right, but you allowed it to stay halfway out until you had driven about five miles down the boulevard. I very often do the same thing



Just About Twenty Miles an Hour Is the Most Efficient and Economical Driving Speed for Most Cars; on Rough Roads Use the Hand Throttle Instead of the Foot Accelerator to Save Gas



—forget all about it somehow—but forgetting these little things is what wastes the gasoline. Push your choke all the way in as soon as you possibly can after starting, and you'll find it easier on both your engine and your pocketbook.

"How long have we had the new traffic lights? About two years, isn't it? Have you ever seen them before? No, I'm not foolish. Judging from the way you drove today you'd think you didn't know where any one of them was until you were right on top of it. You've been driving long enough around town to know the position of every stop sign and traffic light in it, and yet you dash up to the very corner and then slam on your brakes as though you had only seen the sign or the light one second before you applied the brakes. Four times you had just entered a block when the traffic lights at the other end turned against you, and yet you didn't slacken your speed until you had to come to a full stop in a distance of about ten feet. Good job your brakes are still good, although I don't know how long they're going to keep good, with the abuse they get. You could have coasted along with the clutch disengaged for a full half block

at all of those intersections. Your engine would then have been running merely at idling speed, you'd have saved some wear on your brake linings, and it would not have cost you a second's time, because you would have had to come to a stop at the corner for a minute or two anyway.

"I noticed, too, when we got in that jam down at East boulevard, that you kept applying your foot brake to keep from getting too close to the fellow ahead. Now, under some circumstances, it is good driving to apply the brake without declutching, but this time it wasn't so good. You were held behind that car for nearly three blocks, and all that time your engine with its high idling speed, was running at a rate corresponding to a car speed of about 15 miles an hour, while you were holding the speed of the car down to about 10



with the brake. Why not slip the clutch every now and then, keeping the engine running as slow as possible? That would accomplish the same result, and save gasoline as well as the brakes. When I say slip the clutch, I mean slip it deliberately, and that means throwing it out, not slipping it the way you do all the time without knowing it. What do I mean? You rode all the time we were out with your foot on the clutch pedal, and if you have been driving this car for three months in that manner, I'll bet your clutch has been slipping half the time. That means that your engine had to run faster than necessary to make up for the clutch slipping—more wasted gasoline, and a worn-out clutch in a short time if you

keep it up. Every time you started after a stop, you waited until the car was running at about 10 miles an hour before you changed from first speed into second, and you seemed to want to hit 20 miles

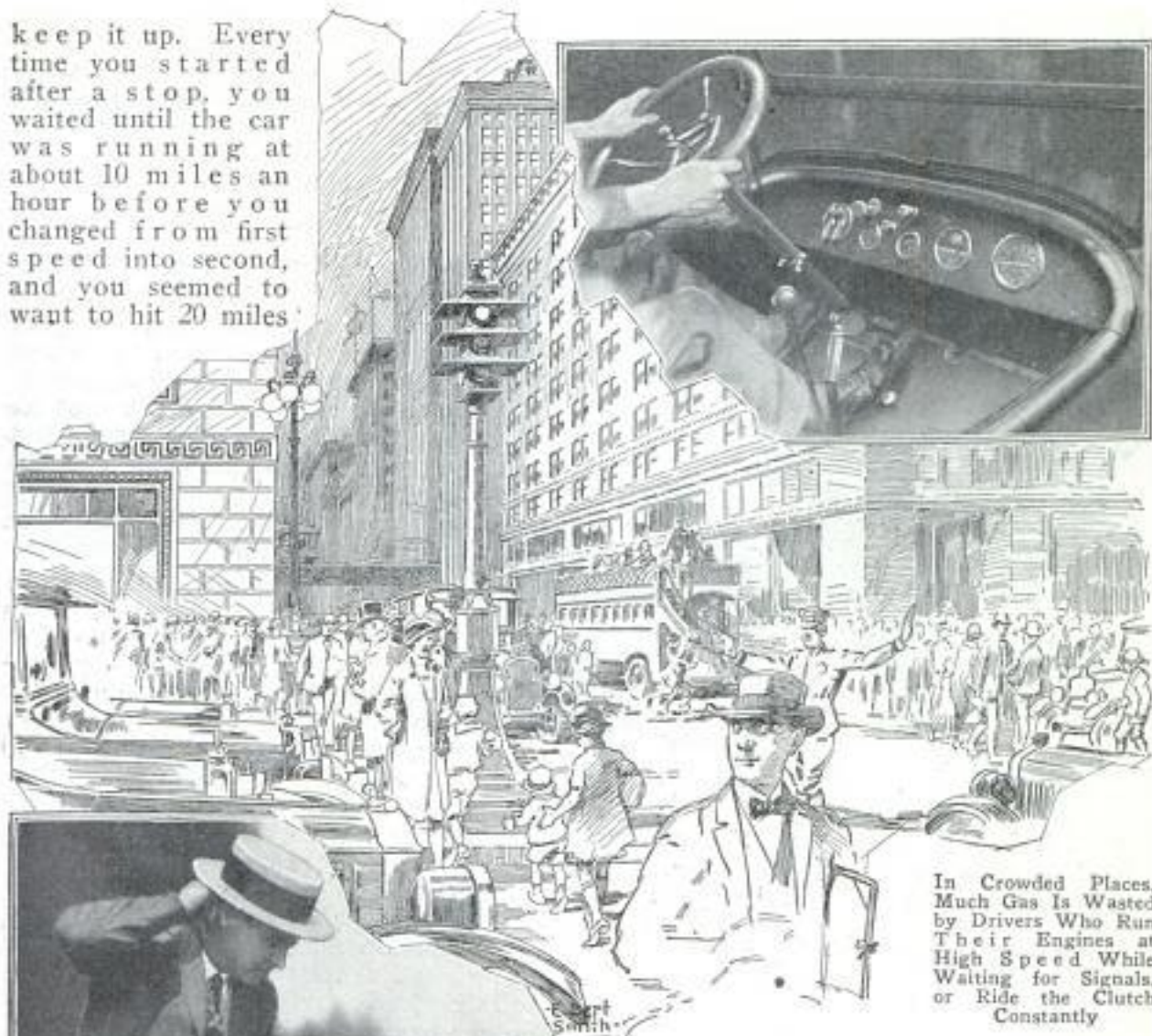

In Crowded Places, Much Gas Is Wasted by Drivers Who Run Their Engines at High Speed While Waiting for Signals, or Ride the Clutch Constantly

low gear to get the same speed as in high? Get into high gear as soon as possible after starting, and you'll save gas, but do not try to improve on this advice by starting always from second, as many drivers do. Low gear was not put into the car to give the maker's assembly department something to do, but for a purpose, and that is, to give the engine a 'toehold' when starting the car from a dead stop. Sure, you can start from second—I can start a car on high gear—but it isn't good for the engine nor for the clutch. Another thing; don't race the engine unnecessarily. I noticed that you did this sometimes, especially when you threw out the clutch before you eased your foot on the accelerator.

"Did the maker of your car fit it with automatic spark control? I don't think he did, or else you wouldn't have a spark-control lever on the wheel, but for all the use you make of it, it might as well not be there. Oh, I know you use it to retard the spark when you start the engine, but half the time you don't advance it imme-

He Used So Much Gas That He Thought the Gas Tank Leaked

an hour in second before you changed into high. Did you ever stop to figure that the engine has to run a lot faster in

diately, and then, when you have advanced it, you neglect it altogether. You ought to learn to adjust the spark to the speed of the engine and the road conditions. For instance, when we were going up the hill at Center street, you kept the spark ad-



Keep the Tires Inflated to the Proper Pressure to Reduce "Rolling Resistance"

vanced all the way, when the engine would have pulled better, and need not have been run so fast, with the spark retarded somewhat.

"I'm pretty nearly through now, Bill; there's only one more thing. When we got out in the country, and you saw that nice stretch of concrete road, you 'let her out' to between 55 and 60 miles an hour. Sure, you wanted to show me what she could do, but, by the way, you have to go over to Centerville every other day, don't you? That's 60 miles. You do it in less than two hours? I thought so. Let me give you a bit of advice. In the first place, that means a speed of over 50 miles an hour out on the road, taking into consideration the time you lose in traffic here in town. Now, you want to be considered a good driver, don't you? Well, the first thing a good driver remembers is, never to lose control of his car, and you have lost that, very often, if you are traveling over 50 miles an hour. Just think that over. In the second place, there is a certain speed at which an engine performs most economically, and that is around 20 miles an hour, or, say, from 20 to 25. If you stick to 25 miles an hour on your trips you'll not only save gasoline, but strange to say, you'll find that in most cases you make just as good time. Next time you go over there, just choose a moderate speed and stick to it; when you have to reduce it for traffic, or to increase it slight-

ly to pass another car, get back to it as soon as possible. Watch the speedometer and keep as close to the mark as you can, and then come in and tell me if you lost any time over your previous trips and how much gasoline you used. And say, when you run over that stretch of rough road near Centerville, take your foot off the accelerator and use your hand throttle control. The bumping jogs your foot up and down and feeds the gas to the engine in gulps when you use the foot on a road like that, while the hand throttle feeds the gas steadily and evenly.

"Another thing, Bill; keep your tire pressure up to the standard recommended by the makers. What experts call the rolling resistance of the tire depends to a great extent on the pressure carried, and even a slight departure from the proper pressure means a great increase in the rolling resistance. This means, again, that the engine has to exert more effort to start the car and keep it going, and that takes more gas.

"I guess that's all for now, Bill. No, you don't owe me anything. It took me a long time to find out all these things, and I guess I've wasted just as much gasoline in my early driving days as you have. You can pay me back by passing the dope along to the next friend you drive with, when you see him make the same mistakes. So long, old man, and thanks for the ride."

Guard for Carpet Beater

A guard made from an old piece of leather belting and fastened to the handle of a carpet beater, as shown in sketch, will protect the knuckles while beating a carpet or rug, as it prevents them from coming in contact with the rough carpet. Where much work of this kind is to be done this guard will be appreciated.



Keeping Insects from Spotting Painted Surfaces

Most amateurs usually hold off painting jobs in and about the home until warm weather. This may be good practice in one way, but at that season of the year the newly painted surfaces are very attractive to insects and if they get on the paint—as they naturally do—the appearance is ruined. A good method of preventing this and particularly valuable when painting seats, arbors and other garden furniture, especially if they are painted white or some light color, is the addition of $\frac{1}{2}$ pt. of cedar oil to every gallon of paint. This oil will not injure the paint in any way. Very little turpentine should be added to the paint, if it is ready-mixed. The cedar oil is so effective that it more than justifies the slight expense incurred. Its odor will be objectionable to the insects, and the paint will have a chance to dry before it can be spotted, which it cannot fail to be if no precaution has been taken to keep the pests away.—L. H. Georger, Buffalo, N. Y.

Storm Window Inclosed with Strips Makes Neat Winter "Icebox"

By using two tapered strips of wood and a board on the kitchen-window sill, when the winter storm sash is attached, considerable space can be provided for cooling food, etc. The photo clearly shows how this is arranged. The sidepieces are 8 in. wide at the base and the shelf is mortised into the lower edges. Cleats form a seat for the edge of the sash, while wingnuts hold it in place.



Novel Baking Oven Made from Tin Can

A small oven, which has proved satisfactory for baking pies, cakes, potatoes, apples and other things with a one-burner gas plate, can readily be made from a large tin box, as shown in the illustration. The circular cover was fastened to one side with a hinge to form a door, the hinge being bolted to both door and side with small stovebolts. In this case a 5-lb. soda can was

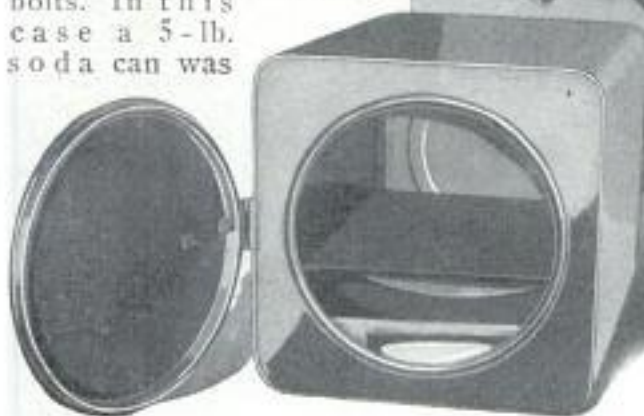

used, which measured $9\frac{1}{2}$ by $9\frac{1}{2}$ by $11\frac{1}{2}$ in., outside dimensions, and had an opening 7 in. in diameter. A 7-in. square hole was cut in the side to be used as a bottom.

Two pieces of tin were bent over to form right-angle brackets and bolted to the sides to support a sheet-metal shelf on which the baking tins are placed. As the door opening is only 7 in. in diameter and consequently the shelf cannot be more

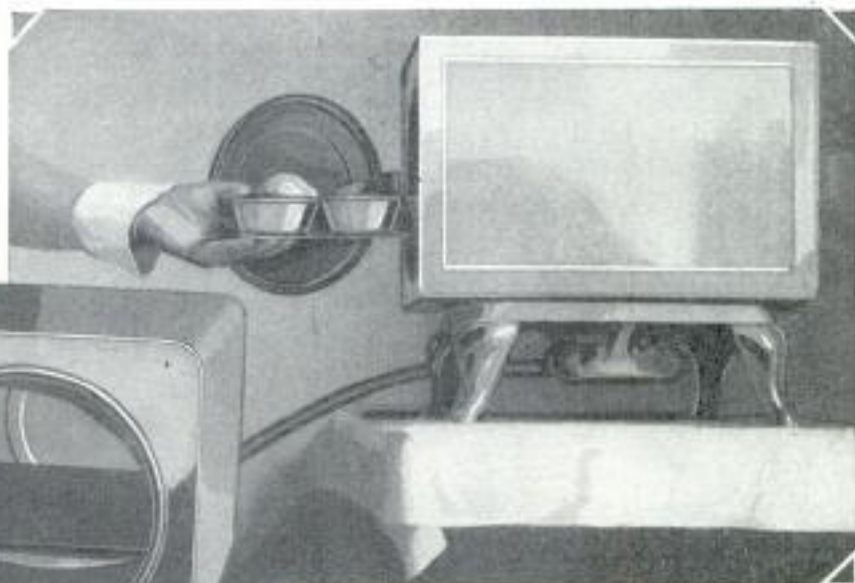

This Simple Oven, Made from Tin Can and Fitted with a Shelf and a Hinged Door, Is Efficient for Ordinary Baking; Heat Is Supplied by a Gas Plate

than about $6\frac{1}{4}$ in. wide, the supporting brackets should extend a little into the door opening.—H. E. Bethe, Green Bay, Wisconsin.

Handy Water Container

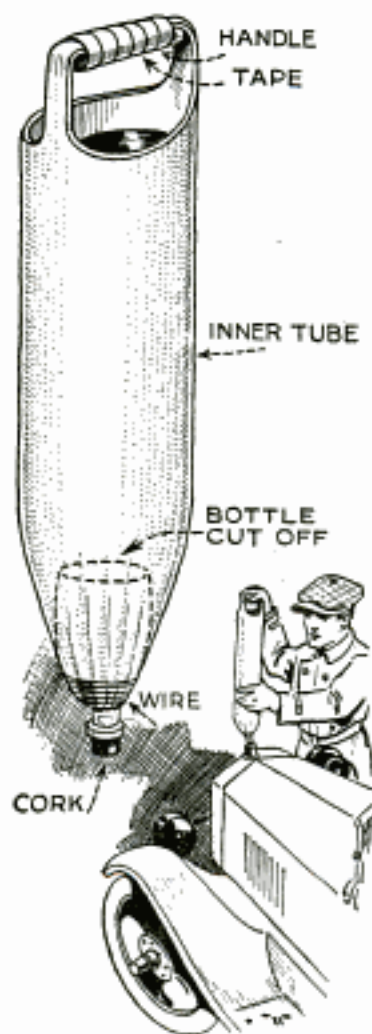

edge filed smooth. A short piece of wood serves to stiffen the handle, and ordinary tape is used to bind them together. The container can be rolled up and stowed under the back seat.—F. S. Root, Fall River, Mass.

Redecorating the Old Fireplace

Bringing the old tile and golden-oak fireplace and mantle up to date is a problem faced in many old homes. It may be easily and effectively done by means of one of the new plastic paints now on the market. Gezzo may be used for this purpose. It can be obtained at any store selling art supplies. In the case of one fireplace with an ornate mirror over the mantle and pillars of oak on either side of the tile-faced grate, the mirror was removed and the pillars torn out, leaving the front plain. Tile, which had loosened or were out of place, were replaced. Then the wood and tile were carefully washed to remove all dust and smoke both on the outside and around the grate. The plas-

tic paint, which comes in white powder form, was mixed to a medium-thick consistency, and as a Caen-stone finish was desired, it was tinted with a yellow-ocher oil paint thinned with turpentine. The resultant mix was applied to the entire surface. While still wet, the paint was stippled with an ordinary stippling brush and marked into blocks by means of a nail and straightedge. Over this, a glaze, which comes with the paint, was applied to make it washable and also to give the effect of light and shade produced by real Caen stone. The wall around the grate was glazed to produce a smoky hue. The result was most pleasing and the work was all done by the owner of the home. Any desired shade and finish can be produced with this paint.

Cutting Board for Kitchen Cabinet

In order to avoid unsightly marks on her kitchen furniture, every housewife will insist on a special board on which to cut bread, meat, fruit, vegetables, etc. Ordinarily, this board is kept separate from the cabinet or table, but it will be found much more convenient if it is hinged to the edge of either, as shown in the illustration. The attachment is easily made and provides a simple method of swinging the board into position for use or out of the way when not needed.

A piece of $\frac{3}{8}$ -in. iron rod, about 20 in. long, is obtained; also a piece of $\frac{1}{8}$ by 1-in. flat iron, about 10 in. long. The latter is bent over at right angles at the ends and the ends then drilled to receive the $\frac{3}{8}$ -in. rod. The flat piece is attached to the underside of the cutting board by means of wood screws, and the rod to the table or cabinet, as shown. When needed, the board is swung up on the table, and after use, it is turned over and pushed back to the position indicated by the dotted lines. A spring clip on the side of a cabinet will keep the board from slamming against the cabinet and marring its finish.—Jas. H. Rodgers, Toronto, Can.

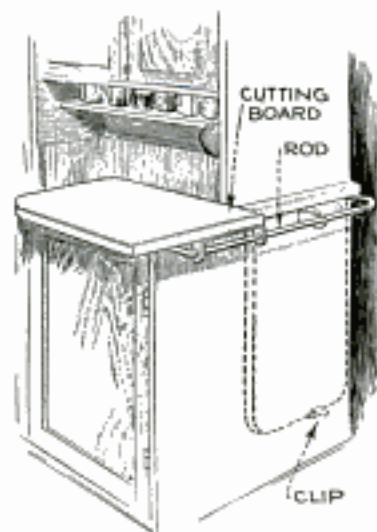

A. H. Abbot & Co., 208 S. Wabash, Chicago

Improving the Hedge Shears

Everyone who has used the 6 to 8-in. hedge shears has found them impractical for removing canes of advanced growth, since the shears slip. This trouble may be overcome, without decreasing the usefulness of the shears for regular work, by filing notches in one blade as follows: Mark one blade, its entire length, at $\frac{1}{2}$ -in. intervals. At each mark place the corner of a flat file on the cutting bevel and file notches at least $\frac{1}{8}$ in. deep. I make a business of trimming trees and shrubs. Several years ago, while attempting to trim an overgrown privet hedge with a new pair of shears I became disgusted and applied my file, and have filed notches in every shear I have used since.—John W. Farmer, Kansas City, Mo.

Shaving Soap for the Washing Machine

It is quite difficult to cut soap shavings thin enough for the washtub so that they will soon dissolve and work into lather quickly. With the aid of the cutter shown in the illustration, however, this can be done easily. The tool is made in the following way: Get a piece of 2 by 4-in. pine, 18 or 20 in. long; drill several holes slantingly through one side, and chisel out the material between them to make one rectangular slot. Then provide a plane bit and a wooden wedge to hold the bit in place. The surface should, of course, be sandpapered smooth to prevent getting splinters into the hand or fingers. If an old wooden plane is obtainable, it can be used simply by adding a handle as shown. In

An Old Plane Fitted with Handle
Makes Thin Soap Shavings

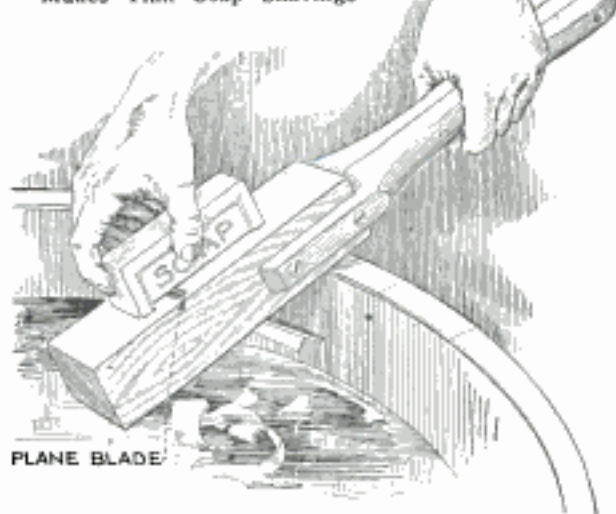

either case, soap shavings can be cut so thin that they are nearly transparent.—E. D. Fahling, Tama, Iowa.

Automatic Mechanical Fisherman

This automatic fisherman, made from an old window-shade roller and three tin-can lids, will hook and play a fish until

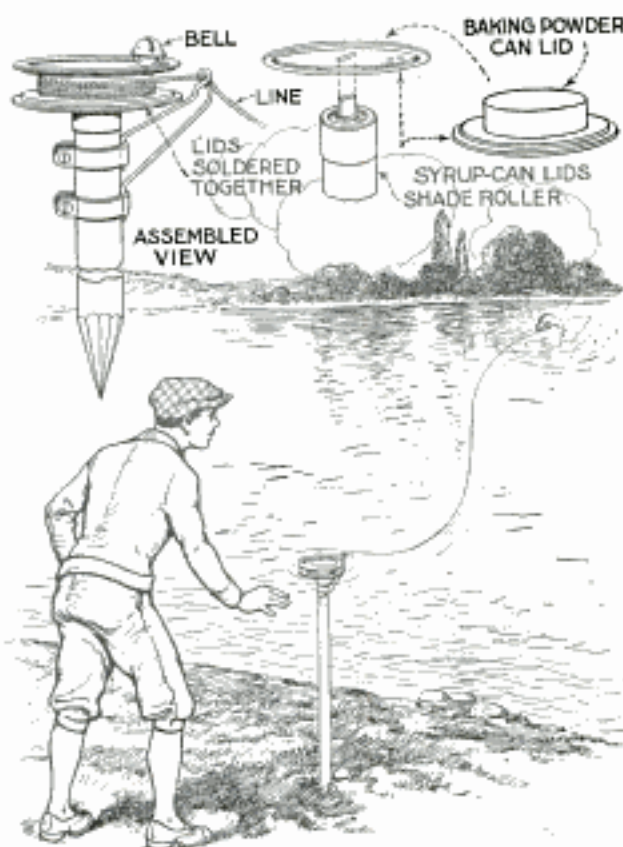

With This Mechanical Fisherman the Fish Is Hooked
and Played Automatically

the fisherman gets there. Its construction is clearly shown in the upper details of the illustration. The lids are soldered together to form a reel for the fishline and this reel is in turn soldered securely to the square pin on the end of the shade roller. A little bell may also be fastened to the top of the reel to give an alarm when a fish is caught. The lower end of the shade roller is pointed so that it can be pushed into the bank to stand solidly. A wire bracket, with a small eye, is clamped to the roller just under the reel, to serve as a guide for the line, as shown in the left-hand detail.

The end of the line is tied to the reel and wound around it a few times, then pulled out until the tension of the spring is quite strong. Then the catch is allowed to lock, and the line is cast out. About one turn of the line should be left on the reel to take up the shock when the fish bites. When the fish pulls the line the catch releases, giving a sudden jerk, which hooks the fish. The catch will not lock again as long as the fish keeps on fighting.—A. Perrault, Vancouver, Can.

Handy Study Chair Is Easily Made

Almost everyone is familiar with the common type of desk chair used in most high schools and colleges. The table or



The Common Type of Desk Chair Can Be Improved by Providing an Arm That Swings Out of the Way When Not Needed

desk part is simply a flat board mounted on the right-hand side to serve as a writing board. The disadvantage of these chairs is that the writing board is made a fixed attachment and therefore is in the way when not needed. An improvement is shown in the photos and the detailed illustration. The board is hinged to a member pivoted to the chair arm so that the whole can be swung over and dropped on one side of the chair. The construction is simply and fully explained in the drawing.—W. C. Harris, Brooklyn, N. Y.

Solutions That "Charge" Storage Batteries

Changing the solution in a storage battery does not charge it. An investigation has recently been made at the bureau of standards of certain solutions which were said to charge batteries instantly, or in a short time as compared with the usual process. These tests have shown that batteries containing these solutions, contrary to the claims made for them, behave exactly in accordance with well-established laws of electrochemistry.

Analysis revealed that these solutions

contain 38 to 42 per cent of sulphuric acid which is about the amount in the ordinary electrolyte of an automobile battery when charged. In some of them were found also significant amounts of sodium or magnesium as well as coloring matter. The sodium may have been added as soda, lye, or Glauber salts; the magnesium as Epsom salts. The use of sodium sulphate (Glauber salts) in batteries is an old story. It was suggested more than 35 years ago, but various authorities since that time have stated that such material is without beneficial effect. This has been confirmed by the bureau's recent experiments,

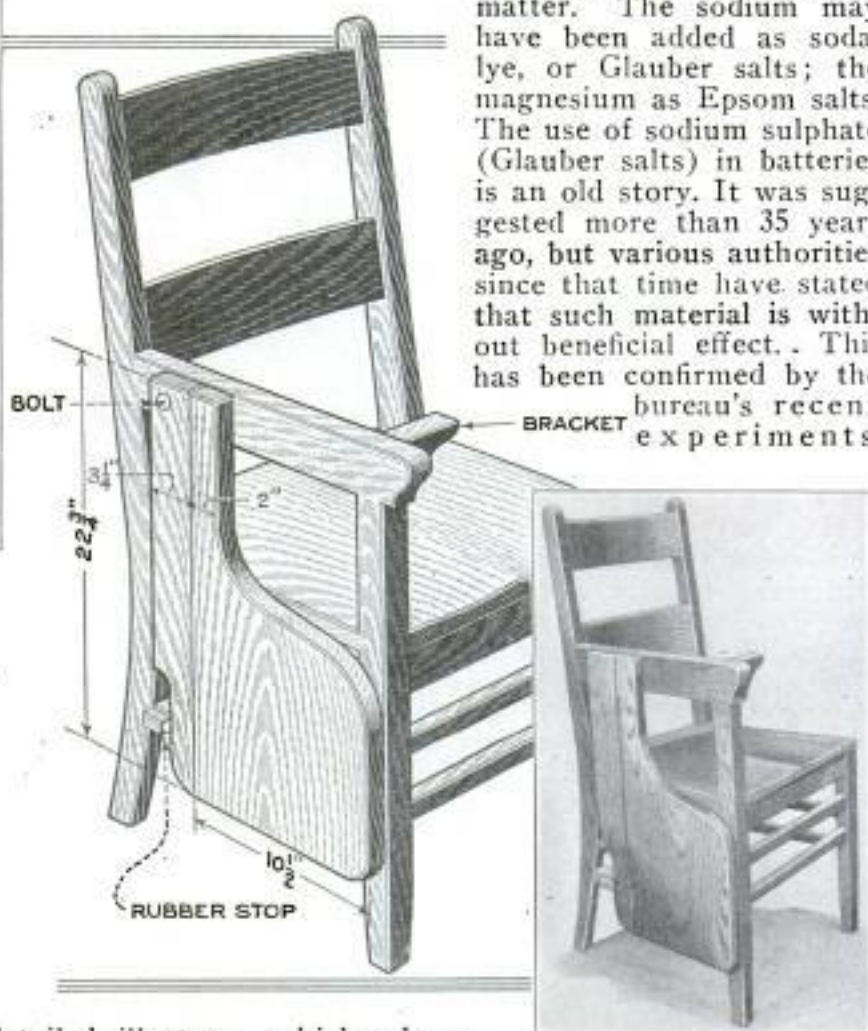

which show that the rate of sulphation of plates is entirely unaffected by even 4 to 5 per cent of Epsom or Glauber salts.

Comparison was made between batteries containing these solutions and similar batteries containing electrolyte of sulphuric acid of equivalent strength. No essential differences were shown in the charging, the voltage, the efficiency, or the temperature. When a battery is said to be charged, it is understood that the battery is fully charged. A battery which is almost completely discharged may have nearly the same voltage as one that is charged. In this condition it may be able to operate the starter of an automobile, but this fact cannot be taken as evidence that the battery is fully charged. It takes as long to charge completely a battery containing one of these solutions as to charge a similar battery containing the ordinary electrolyte.

The indiscriminate addition of these solutions to a battery is not advisable, although in some cases no great harm may be done. If the solution is used to replace the electrolyte of a completely discharged battery, as is usually the case, the battery may be spurred on to give a little more current because the plates retain a surplus of active material. When the battery is recharged again by an electric current, however, the specific gravity will rise much too high. This is because the acid formed at the plates by the charging current is added to the acid already present in the solution. In the bureau's experiments it rose to 1.365. This is not desirable, because the local action or self-discharge within the battery is materially increased. A battery containing one of these solutions lost 47 per cent of its charge in four weeks as compared with 8 per cent which was lost by a similar battery with the ordinary solution. Batteries containing solution of higher than normal specific gravity often give less capacity at high rates of discharge—as when cranking the engine of an automobile—depending upon the behavior of the negative plates. The higher the specific gravity of the electrolyte the more injurious is the action upon the separators. It is a well-recognized principle in battery operation that acid should be added only to replace that which may have been spilled, or in rare instances to adjust the specific gravity to the required standard after the completion of a full charge.

Although the materials and coloring matter, considered individually, may be harmless, the disadvantages in using such solutions more than offset any temporary gain. The usual electrolyte

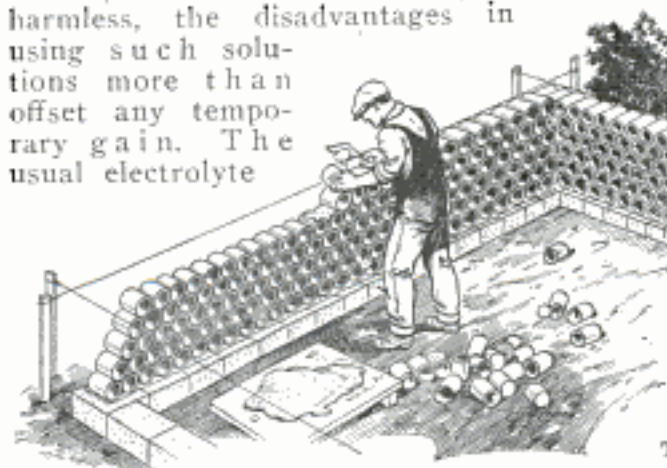

of pure sulphuric acid and water, adjusted to the proper specific gravity, is believed to be the best.

☛ When tying a number of sheets of paper together make holes with an awl and pull the string through with a hook.

Using Tin Cans in Concrete Walls

Old tin cans, usually thrown away, can be used to advantage in masonry work,

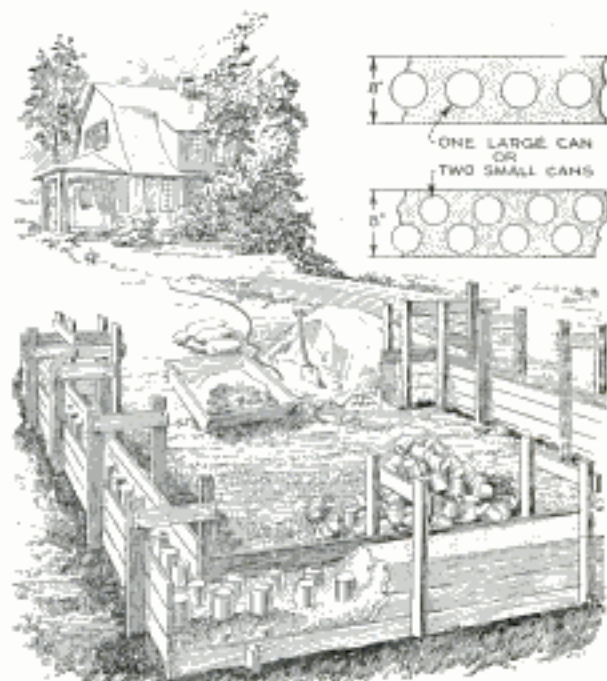

Old Tin Cans Imbedded in Concrete Foundation of Garage Lower Its Cost

such as walls and foundations. This construction provides air spaces in the wall which mean better insulation against heat and cold, but, of course, does not make so strong a wall as solid concrete. Yet, for small buildings, it has sufficient strength. There are two methods of using the tin cans, as shown in the two drawings. In the first, only a few tin cans are

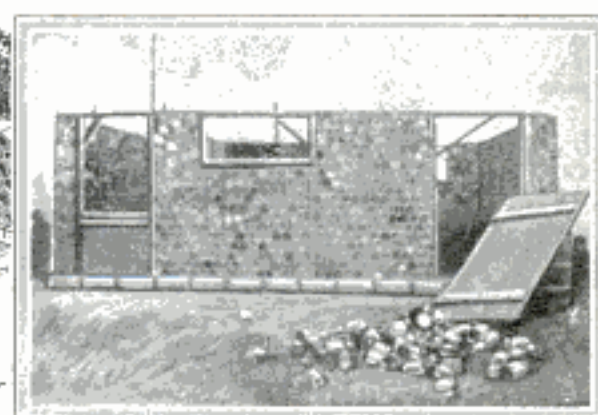

This Wall Consists of Tin Cans Laid Horizontally, with Mortar to Hold Them Together

set up vertically while the concrete is poured around them. In the latter method, the tin cans are laid horizontally and mortar is used to hold them together. When finished a coating of cement, plaster or stucco is applied to the outside.—B. D. Gause, Elkhart, Ind.

Making a Power-Driven Ice Bicycle

Latest Winter Diversion for the Youngsters with Homemade Device Found Thrilling But Safe

By L. B. ROBBINS

WHEN snow-filled roads make the use of the bicycle impossible and outdoor sport seems limited, it is time to build the fast ice speeder shown in the drawings. It is simple in design and the parts can readily be obtained, so that anyone who has a little mechanical skill can build it. A motor wheel, such as used with bicycles and children's autos, provides the power. On smooth ice it is possible to make 35 to 40 miles per hour, and with a fair wind behind much greater speed can be expected.

Practically all the parts necessary in the construction of this device can be picked up at any garage or automobile junk yard. The body consists of a 2-in.

Any auto headlight with a vertical support can be used.

About 6 in. behind the first hole drill a $\frac{3}{4}$ -in. hole for the steering-runner post. A few inches behind this, say about 1 ft. from the front edge of the board, a storage-battery box or a box for dry cells is attached. This battery is to furnish current for the headlight and for a horn or bell, if desired. Next, measure 2 ft. from the front end and drill a $\frac{1}{2}$ -in. hole through the board from edge to edge, taking care to drill it through the exact center and at right angles to the edges. A long bit, the kind used by electricians, will have to be used for this purpose. A piece of $\frac{1}{2}$ -in. iron rod, 28 in. long and threaded at both ends, is pushed through this hole, to project 9 in. on either side. The footboards, to which the brakes are attached, are bored through and pivoted on these projections, and consist of two pieces of 1-in. hardwood, about 1 ft. long and 8 in. wide. Round the back end of each and screw on a semicircular piece of

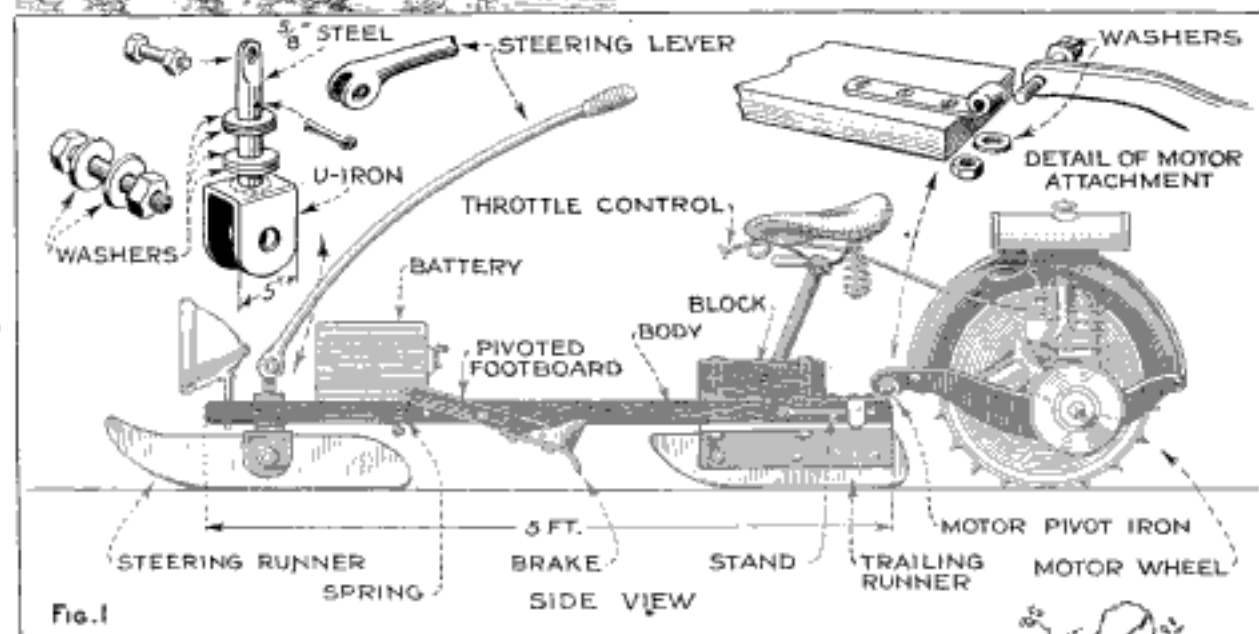

plank, 5 ft. long and 10 in. wide, planed smooth on both sides. The corners are rounded slightly and both sides and edges are given a thorough application of linseed oil to protect the wood against the weather. Drill a hole through the center of the plank, about 1 in. from the front end. This is for the headlight post.

Side View of the Ice Bicycle, Showing Details of Steering Equipment, Motor-Wheel Pivot Support, and Other Parts



Motor. Bugg. Stratton Co., 1047 Long St., Milwaukee, Wis.

thin sheet metal to make a heel guard, then tack a piece of rubber matting on the top side for treads. Nuts are driven on the threaded ends to hold the footboards on and a couple of washers are used between the footboards and the body to prevent binding. Small coil springs are attached to the front edge of the foot-

Top View Showing How the Footboards Are Pivoted, Details of Runner Construction and Their Dimensions

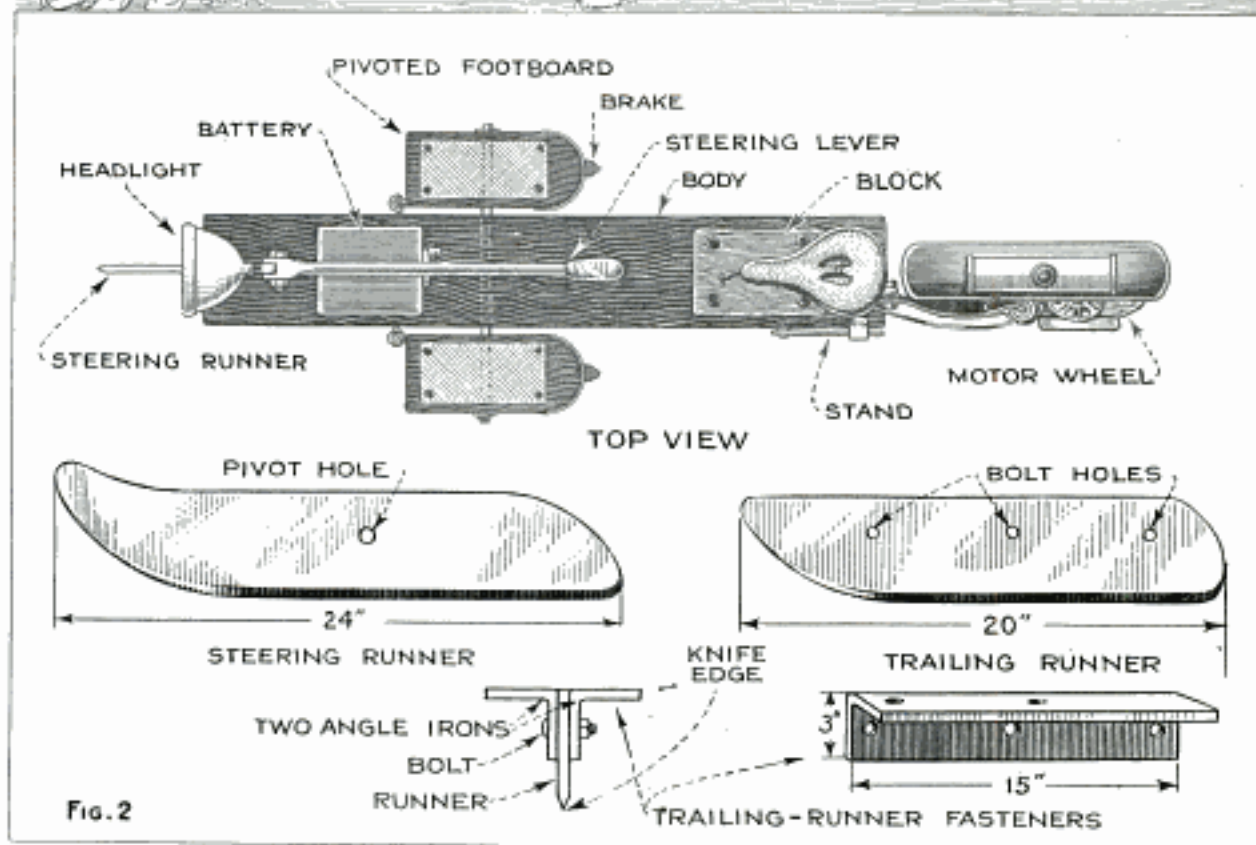

boards and to the body, as indicated, to hold them up against normal foot pressure. Underneath the footboards, at the rear, a piece of steel rod, bent down sharply and ground to a sharp point, is screwed on, to act as a brake, as shown in Fig. 3.

The motor-wheel attachment (see Fig. 1) consists of a piece of flat steel about 10 in. long, with one end bent over to form an eye, $\frac{1}{2}$ in. in diameter. Three holes are drilled through the flat portion and it is bolted to the plank, about 2 in. from the left edge, so that the eye projects slightly over the rear end of the plank and turns upward. Then cut a block of wood,

1 ft. long, 4 in. deep and 6 in. wide, and place it on the bank 6 in. from the rear end, in the position indicated in Figs. 1 and 2. Toenail it to the plank temporarily and drill a vertical hole in each corner, through both block and plank, leaving the permanent fastening until later.

The runners are shown in Fig. 2. They are made from sheet steel, $\frac{3}{8}$ in. thick and 6 in. wide. The steering runner is 24 in. long and the trailing runner 20 in. As will be noted, the steering runner is turned up slightly at the front so that it will be sure to ride over small obstructions. Drill a $\frac{1}{2}$ -in. pivot hole through the center of

the steering runner and three similar holes, in line and slightly nearer the top edge, in the rear runner. Then grind the bottom edges of the runners to a knife-edge. The steering mechanism is shown in Fig. 1. It consists of a U-shaped piece of flat steel, $\frac{1}{2}$ in. between sides and drilled so the runner will fit inside of it

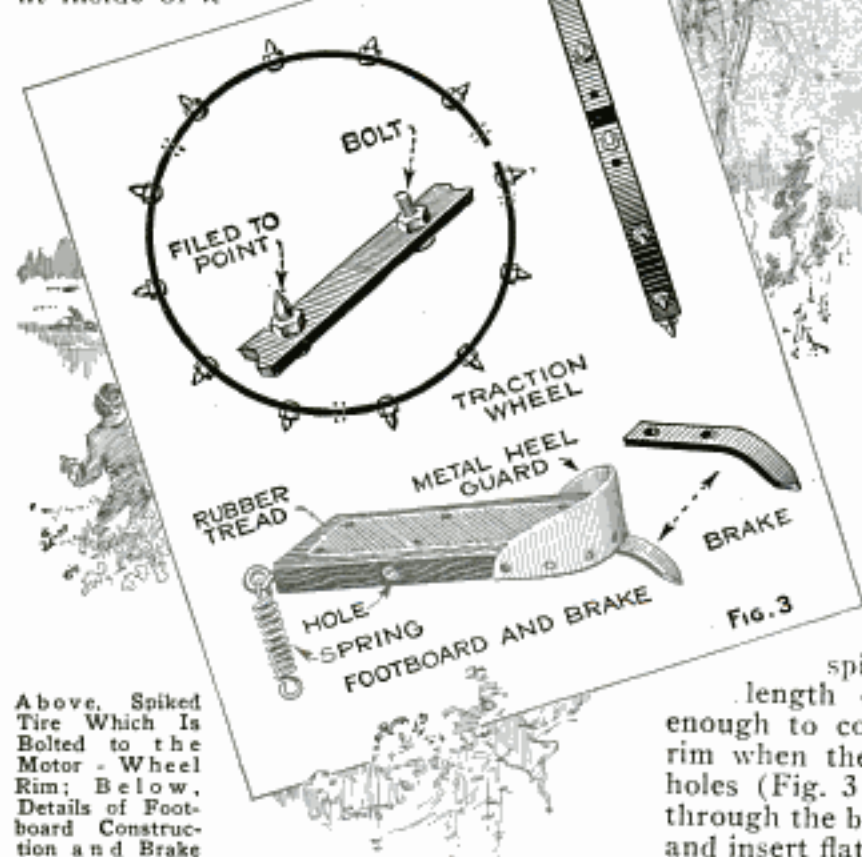

Above, Spiked Tire Which Is Bolted to the Motor Wheel Rim; Below, Details of Footboard Construction and Brake

and pivot on a short bolt through the holes shown. The post is a piece of $\frac{5}{8}$ -in. round steel riveted vertically into the top of the U-iron and flattened at the top. Place two washers over the U-iron, push the post through the hole in the plank, then place two more washers over the plank and drill the post for a cotterpin to prevent end play as much as possible. The end of a length of curved steel tubing or rod, which is used for the steering lever, should be split and drilled to bolt loosely over the flattened end of the post. This makes a flexible joint. Push a bicycle handlebar grip on the end.

The trailing runner is bolted between two steel angle irons 15 in. long and 3 in. wide on each leg, as shown in Fig. 2. This assembly is placed under the plank so the front ends of the angle irons are directly below the front of the block and in the exact center. Four holes are then drilled in the angles to coincide with the four

holes in the block. The block and runner irons can now be fastened solidly to the plank with four long bolts. Remove the nails from the block and drill a hole for a bicycle saddle post, at an angle through the block and plank, as shown. A small metal wedge driven in snugly will prevent the post from turning.

At the rear end, on one edge, pivot a short piece of round iron so that it can be turned down to keep the speeder upright when standing still. A spring clip holds this up when not in use. The body assembly is now completed. Give all wood and exposed metal a coat of bright paint and connect the headlight to the battery, using a switch to cut off the current when not used.

Traction for the motor wheel is provided by a spiked tire. This consists of a length of $\frac{1}{4}$ -in. flat steel, wide enough to conveniently fit in the wheel rim when the tire is removed. Drill 18 holes (Fig. 3 shows only some of them) through the band, at equal distances apart, and insert flat-head steel bolts, $\frac{3}{4}$ in. long, with heads on the inside. Run thin nuts down tightly on the outside and then file each bolt to a point, as in Fig. 3. Bend the strip to a circular shape to fit around the wheel and drill a hole near each end and two at other convenient points, and fasten the strip to the rim with bolts, similar holes being drilled in the rim. Attach the motor wheel to the pivot iron at the rear of the plank with a bolt just as it would be attached to a bicycle. Run the flexible throttle control through the saddle springs (see Fig. 1) to the front. Now, with the tank filled, you are ready for a trial. Set the spark and throttle and run along a few feet on the ice until the motor starts. Then step aboard the plank and seat yourself on the saddle, placing your feet on the footboards. Steer just as though riding a bicycle, but be careful to make wide turns as a short one might lead to a bad spill. To stop abruptly, shut off the motor and press down on the footboards with the heels.

Containers for Grinding Compounds

Suitable containers for holding grinding compound, soapstone, polishing materials and other powdered stuff in the garage, are rather hard to find, but one mechanic solved the difficulty in an ingenious way and at no cost. Talcum-powder tins with perforated tops, which can be picked up in any home, are the containers used. These are held in a simple rack on the back of the bench, and are much handier than any of the usual open-top tins, as the material can be sifted out of the perforations in as small quantities as required, without waste. Flat tobacco tins will serve the same purpose if holes are punched in the hinged tops.—G. A. Luers, Washington, D. C.

Handy Funnel for Gas Tank

In many autos the filling spout of the gasoline tank is between the tire rack and the back of the car, leaving a space only about 6 in. wide.

When gasoline must be poured into the tank from a can this proves to be very awkward, even if a funnel of the ordinary type is used. The illustration shows how I overcame this difficulty. I obtained a gallon can that formerly had contained hair tonic; this was 8 in. long,



3 in. wide and 12 in. high. I cut the height down to 5 in. and slit the cut edge so as to make a number of small "ears." A piece of baling wire was then bent around the edge and the ears bent over it as shown in the detail. A handle made of baling wire completed the device. This is much more easy to pack in the car than a funnel of the ordinary kind, and gasoline can be poured into it quite easily without danger of spilling it over the rear of the car. In addition to this, when the cap is in place on the can spout it serves as a pail for carrying water or oil in emergency.—William Calvert, Vickery, Texas.

Novel Hay Door Saves Work

Instead of providing his barn with the usual doors which swing open or slide



Projecting Gable with Trapdoor on Barn Makes It Easier to Take In Hay

downward on tracks, a Nebraska farmer used the trapdoor shown in the photo. The gable is extended and the bottom is divided in the middle, each half forming a door which swings downward and is drawn up in place again with two ropes operated by the team that lifts the hay into the mow. The projection is 10 ft. square and 16 ft. high from floor to peak. Its roof is merely a continuation of the upper part of the hip roof. The carrier track continues along the ridge to the end of the projection and when the doors are lowered a chute or mow is formed which takes the hay in. The owner declares this type of construction is superior to the method commonly used in that it is handier, the opening can be closed easier and the walls of the projection form adequate anchorage for the extended track.—Dale R. Van Horn, Walton, Nebr.

☞ To prevent dresses and coats hung on ordinary hangers from slipping off, twist rubber bands around each arm of the hanger about 1 in. from ends; these provide friction enough to overcome the tendency to slip.

Conserving Furnace Heat

Considerable heat is radiated from the furnace in the basement where it is not needed so much as in the rooms above. A

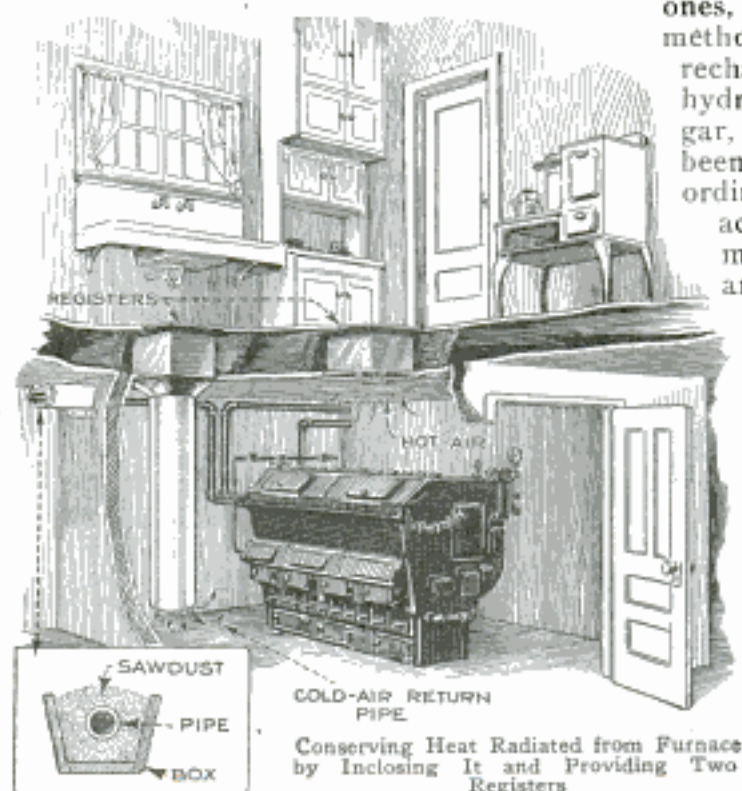

simple method of turning this waste to account is shown in the illustration. Walls are built around the furnace forming a small room and two registers are provided in the floor above, as indicated. One of these has a length of galvanized-iron pipe extending under it nearly to the basement floor. All steam or hot-water pipes running along the ceiling in the basement are packed in sawdust as in the lower left-hand detail, if they are not already wrapped with asbestos. The heat given off by the furnace passes up through one register and the colder air in the room above returns into the furnace room through the other register.—Walter J. Wilhelm, Randolph, N. Y.

Burning Off Dry Weeds

Recently I noticed workmen along the highway using a novel and practical method of burning off dry weeds and grass. An old tire was first set afire and slowly dragged along by means of a wire, about 12 or 15 ft. long. One man stood by with a fire extinguisher in case the blaze should spread too far or come too near the fence.—M. M. Fishback, Orange, California.

Recharging Dry Cells

Many times I have thrown away old dry cells even though the outward appearance of the cells was similar to fresh ones, with the zinc cover intact. Several methods had been used in an attempt to recharge them, including the addition of hydrochloric acid, common salt, vinegar, and sal-ammoniac solution. All had been highly praised, but I got no extraordinary results from any. One of the active salts in the dry cell is sal ammoniac. This deteriorates with time and use. To restore the chlorides to the ammonium form, common ammonia water, very strong, should be added. The sealing wax is broken from the top of the cell and ammonia added. When the paste has absorbed this, add more. Do this two or three times. Then place the cell in a warm oven to drive out excess water. Pour melted sealing wax over the paste as before. Flashlight cells, with scarcely enough power to cause a bulb to glow, treated in this manner, will light the bulb practically as efficiently as new cells and it will be found that in many cases they will last almost as long.—Clyde E. Volkers, Terre Haute, Ind.

Holding Umbrella on Suitcase



Tourists and travelers who find it inconvenient to carry an umbrella along with a suitcase will appreciate the holder for it shown in the illustration. Two narrow strips, of the shape indicated, are cut from a discarded inner tube and slits are cut through one side of the suitcase. The ends of the strips are inserted in the slits and the umbrella can then be inserted under them, where it will be held securely.



Shop Notes

All Shop Notes published in 1924, in book form—Fifty Cents—from our Book Department

Dumping Body on the Farm Truck

By J. R. KOONTZ

OF all the various kinds of bodies that have been designed for the farm truck the handiest is the dumping body, and it is not a difficult matter to build one. That shown and detailed in the illustrations was made at a cost of less than \$18 for materials, all the work being done by the farmer himself except some blacksmithing.

As the body usually gets extremely hard usage it must be substantially built, and for this reason, the frame is made of two

pieces of 3 by 5-in. timber, 6 ft. 8 in. long, across which are bolted at equal intervals four pieces of 2 by 4-in. stock, 3 ft. 10 in. long. The width of the frame is the same as that of the truck chassis, which varies in different makes.

The floor, sides and endpieces are made of 1 or 1¼-in. lumber, preferably cypress. Three boards of 7-in. width are used for the sides, which are held in place securely by means of braces made of 1-in. flat iron, ¼ in. thick, bent to the shape shown in

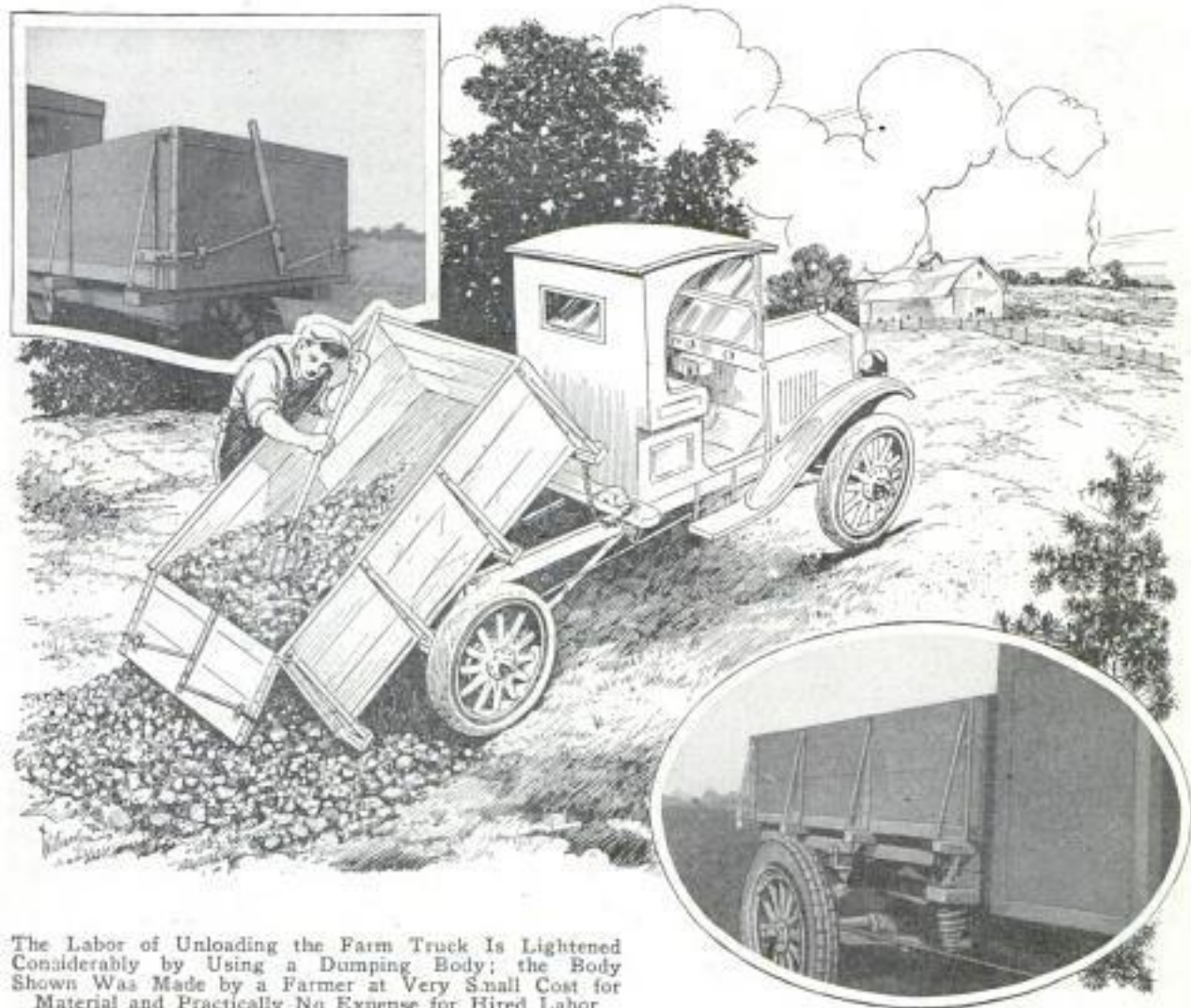

The Labor of Unloading the Farm Truck Is Lightened Considerably by Using a Dumping Body; the Body Shown Was Made by a Farmer at Very Small Cost for Material and Practically No Expense for Hired Labor

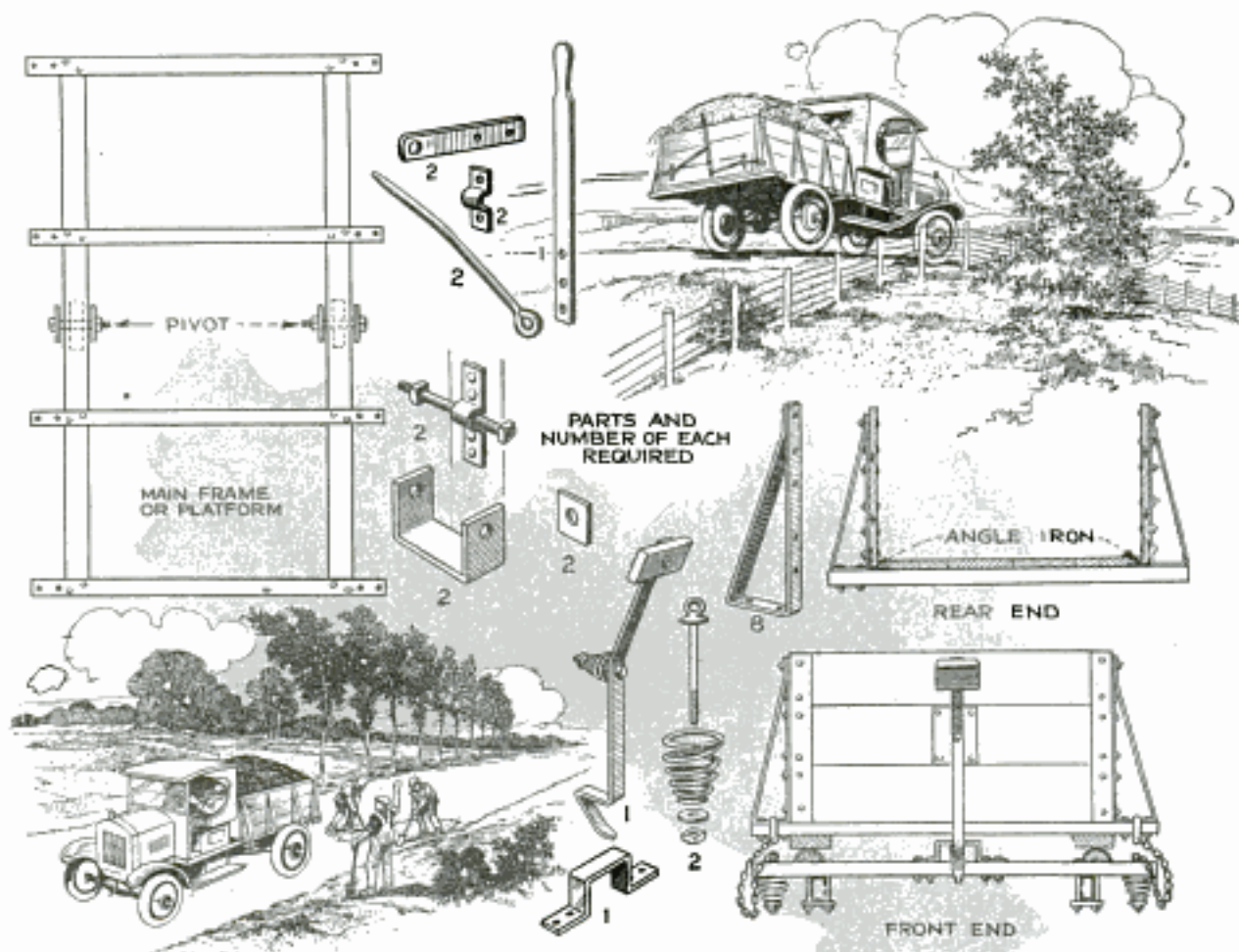

Construction of Body Frame, Side and Floor, Latch on Front Endpiece and Locking Device on Rear Gate, with Details of Necessary Metal Parts

the detail and drilled to receive $\frac{1}{4}$ -in. bolts, two for each board. These braces are also bolted to the ends of the crosspieces, which project on each side of the body. It is advisable to use an ordinary washer and a lock washer before tightening down the nuts, to prevent the latter from loosening from vibration. A length of angle iron with 3-in. flanges is run under each side, as shown, to support the floorboards between the crosspieces.

The front end and the floor are put on in the same way. The rear endpiece is made separately, being reinforced by strips of flat iron, 4 in. wide, screwed to the inside. It is hinged to the top of the sidepieces and opens at the bottom as shown. The latch consists of an old lifting lever from a harrow, or other machine, and other metal parts shown in the upper details, the number required of each being specified. The body is pivoted at its center on the truck chassis, as will be explained later, and therefore, a latch must be made to hold it down at the front end. To provide this latch, a piece of 2 by 5-in. wood, 3 ft. 10 in. long, is bolted to the truck chassis as shown in the front view.

A piece of $\frac{1}{2}$ -in. flat iron is bent over to form a catch for the latch, which engages with it as indicated. The latch is made of the same stock, is bent in the center and has a $\frac{1}{4}$ -in. hole drilled through it for a $\frac{1}{4}$ -in. bolt; a coil spring is slipped over the bolt between the latch and the body to keep the latch closed while traveling. This bolt passes through the front end, iron plates being bolted on either side to reinforce the end. To open the latch, the upper end is pushed in; a weight may be bolted to this end if desired in order to make manipulation of the latch easier. It is necessary to fasten two chains to the front crosspiece of the body and the ends of the 3 by 5-in. pieces carrying the catch, and coil springs are provided to take the shock of the load when it is dumped. Rubber cushions, made from pieces of old solid tires, are provided to absorb the jolt when the box is pushed back in position after the load has been dumped.

The pivots underneath the frame of the body are then put on. They should be placed 42 in. from the front end or exactly in the center of the body. Two pieces of

$\frac{1}{2}$ -in. iron are bent to a U-shape and $\frac{3}{4}$ -in. holes are drilled through both ends. These pieces are welded to the chassis, care being taken to locate them accurately. Bolting them to the chassis is not advisable, as the holes drilled for this purpose would weaken it greatly. Two bolts, $\frac{3}{4}$ -in. in diameter are fastened to the underside of the 3 by 5-in. timbers, and are held with strips of $\frac{1}{2}$ -in. flat iron, which serve as bearings. One piece is used to prevent the bolt from wearing into the wood and the other to hold it in place. Holes are drilled through both of these pieces so that they can be bolted to the frame securely. When finished, an application of creosote or paint will help to improve the appearance of the body and protect the wood from the weather.

Restoring Brake Bands

Brakes that squeak are not necessarily in need of relining. The noise is often due to dirt and grit imbedded in the brake lining and can be removed by scrubbing the lining with gasoline or kerosene and a wire brush. However, some brake linings, which have been neglected for a long time and consequently have the surface glazed and impregnated with grit, cannot be thoroughly cleaned in this way, and it is necessary to apply dressing. A large service station uses a mixture of powdered rosin and castor oil with satisfactory results. The rivet heads holding the lining should be below the surface so that they will not touch the drum. It may be necessary to use a punch and hammer to set the rivets back. If new rivets are needed use only copper rivets.

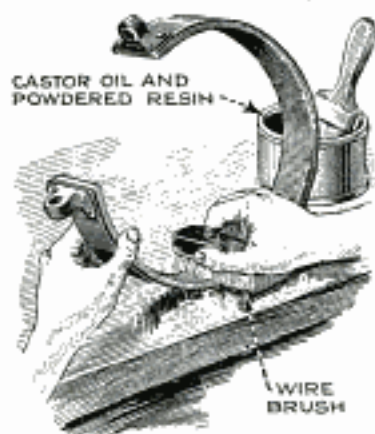

Tester for Determining Negative Wiring Line

Finding the negative line of a house-lighting circuit is an easy matter with the aid of a tester made in the following way: Get a burned-out auto lamp with a tip, and two short lengths of covered wire. These are soldered to the metal contacts, if the lamp is of the double-filament type, or one wire is soldered to the single contact and the other to the side of the ferrule, if a single-contact lamp is used. The lamp is then immersed in a dish of saturated salt water and the tip is clipped off with a pair of pliers or shears, which makes a small opening. The lamp being evacuated of air, brine will enter it until it is practically full, and it will not run out again. To use the tester place the terminals on the live lines to be tested. Gas bubbles will appear on the negative filament support.—J. G. Brown, Evanston, Ill.

Spherical Carriers for Office Messages

In a Kansas City automobile concern a novel method of carrying requisitions from the parts department on the second floor to the office on the first floor, is used. A trough, about 100 ft. long, is run from the upper desk to one below, as shown in the illustration, with sufficient pitch to cause the hollow balls of light metal used as containers to roll down easily. The balls are cut through in the middle and the two halves are held together by means of a coil spring, as shown in the detail. A flat spring at the lower end of the trough checks the speed of the balls just before they reach a wire basket where they are taken out. The last ball is painted red so that the clerk downstairs will know that the containers accumulated should be carried back to the upper floor.

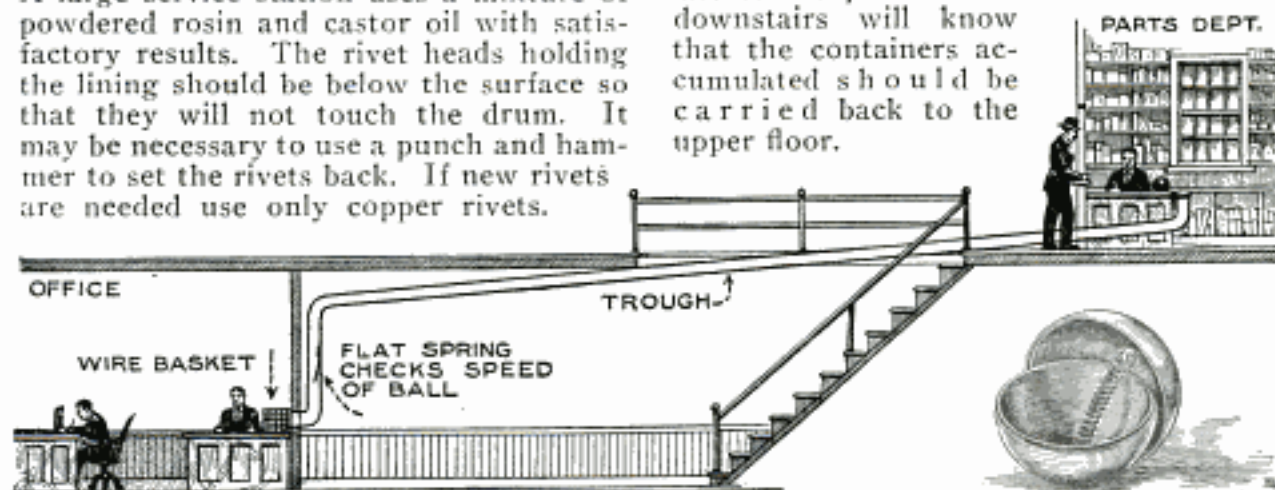

Novel Method of Carrying Requisitions and Messages from the Second Floor to the First Floor in Spherical Containers Rolled Through a Trough

Combined Auto Stairway and Elevator

By installing the moving platform shown in the illustration instead of an

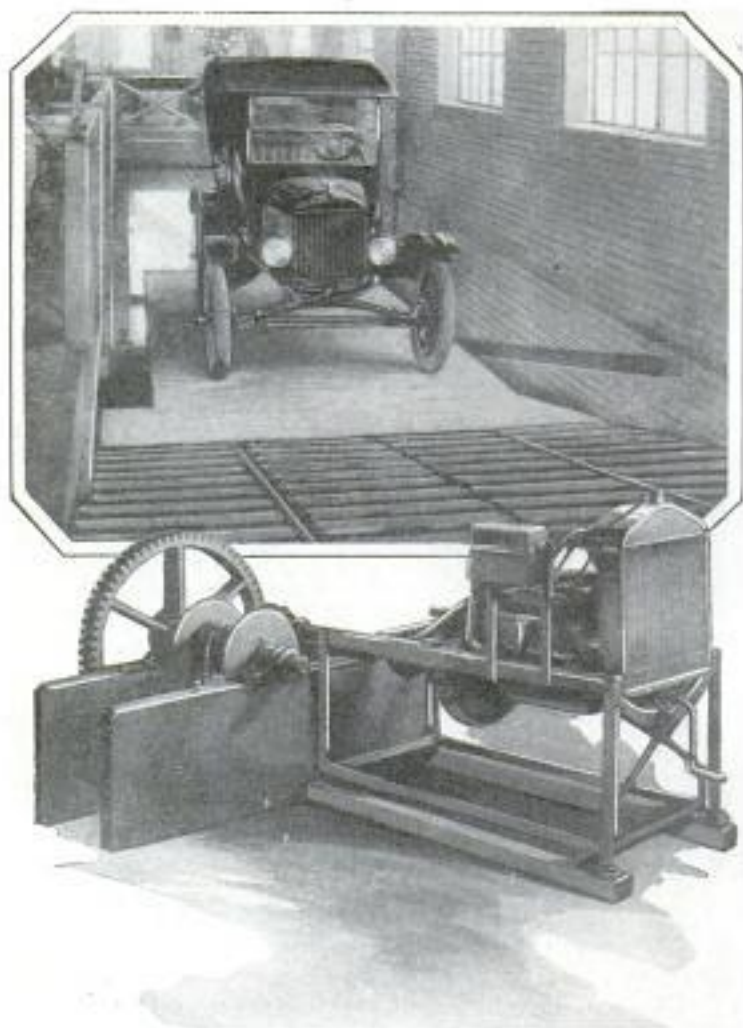

Combination Inclined Run and Elevator from First to Second Floor of Garage

elevator for raising autos from the first to the second floor of his garage, a southern automobile dealer saved nearly \$1,000 in initial expense and \$70 a month in operating cost. An incline of 15° grade leads from the driveway at the street level to the upper floor and is in most cases easily negotiated by cars that can run under their own power. For autos that are wrecked, there is a platform at the lower end of the incline and level with the floor, onto which they are pushed and the whole then pulled up by means of a winch driven by an old auto engine. The platform is provided with wheels, which run on tracks, as shown in the upper photo. The lower photo shows the engine and the drum on which the hoisting cable is wound.—Archie Richardson, Decatur, Georgia.

Turning Work Too Large for Lathe

A mining company high in the mountains of a western state had a breakdown of their hoisting engine, the crankshaft of the double-cylinder hoisting engine snapping off short at the crank disk. A new shaft was ordered immediately, but in spite of all efforts a long delay resulted. When the shaft finally arrived, it was found that the pins were larger than the old ones, in fact so large that the brasses would have had to be bored out entirely in order to make them large enough to fit the crankpins. Having a 24-in. lathe in the mine shops, the crankpins were turned down to a suitable diameter by adopting the method shown in the illustration. Centers were laid out on the crank heads opposite the centers in the crankpins, and the whole was supported by and bolted to wooden blocks that were bolted to the shears. The right-hand disk was clamped to the tailstock, which was left free on the lathe bed. A plain angle toolholder was made as shown in the drawing and bolted to the lathe faceplate. The carriage was then backed away from the headstock and the tool set in its holder, after which the carriage was fed in the regular way, the tool revolving instead of the work. The tool was fed by tapping it inward, and, while this meant careful caliper-ing, it saved the time necessary to provide a fine adjustment.

The center in the headstock was used only when setting up the work, then removed.—A. A. Stafford, Reno, Nev.

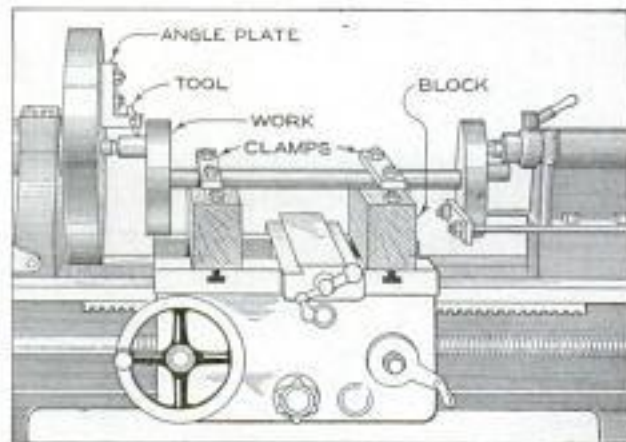

Lathe Setup for Turning Crankpins of Hoisting-Engine Crankshaft

Springs Aid Gravity Sand Sifter

Contractors handling small jobs of cement work usually employ a sloping or gravity-type screen for sifting sand. The sand is shoveled onto the upper end of the screen and, while sliding downward, sifts through, leaving the pebbles and other foreign matter to roll off at the lower end. However, if the sand is damp, it slides slowly, and the workman must then scrape the screen with a shovel to force the sand through. This naturally wears out the screen and necessitates occasional re-covering, and besides is time-wasting and annoying. By bolting two discarded auto-spring leaves on the upper end of the sifter, as shown in the drawing, a Wisconsin contractor eliminated the necessity of scraping the screen. The weight of the sand when thrown onto the upper end of the

screen causes the springs to vibrate, tossing the sand up and down so that it sifts through the screen readily. The sifter is supported at the rear by a frame of $\frac{3}{4}$ -in. pipe, the springs being attached to the top

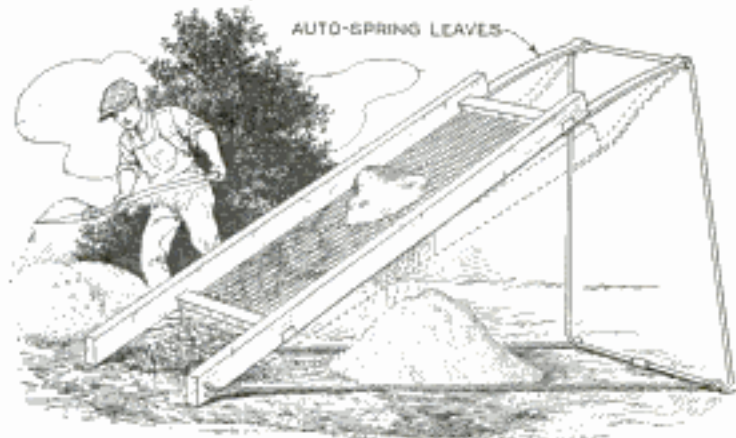

This Sifter, Being Supported on Auto Springs, Will Let the Sand through the Screen, Even if It Is Damp

as indicated, and two chains at the bottom keep it from slipping down.

Increasing Size of C-Clamps

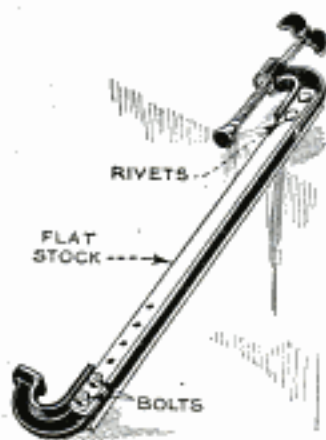

The range of the average-size C-clamp can be extended to accommodate any width of work, by cutting it in half and joining the parts with two strips of flat iron or steel, which are fastened by means of rivets and $\frac{3}{8}$ -in. bolts, as shown in the illustration. At the screw end, only two holes are drilled through both strips and clamp, but at the other end a number of equidistant holes are drilled in the strips so that work of many sizes can be accommodated in the clamp.—M. J. Quoits, Philadelphia, Pa.

Dentist's Cement for Mechanics

Few mechanics are aware that dental supplies are often useful to them. The cement used by dentists for crown, bridge and gold-inlay work is waterproof, resists corrosion, does not shrink or expand, and has great strength and hardness. The powder and liquid components are easily mixed by the amateur at the time of using, and a hard "set" is obtained in a few

minutes. It is very useful in cementing glass to glass for use under water, though it is desirable to allow it to set before immersion. The cement is valuable also for many other uses.

Removing Stubborn Gears

After considerable use, gears or wheels on tractors and other heavy machinery often become set so that it is very difficult to remove them.

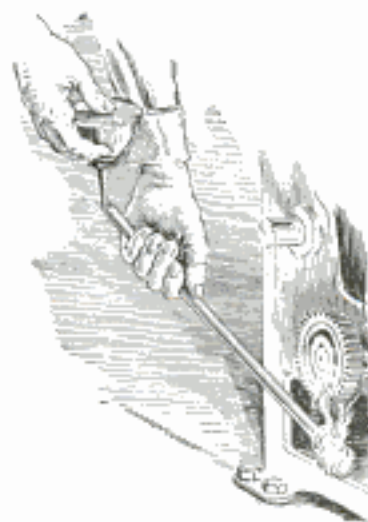

However, they can usually be loosened very easily by the method shown in the illustration. A length of ordinary $\frac{1}{2}$ -in. pipe is wrapped with burlap or cloth at one end, and this is soaked with kerosene and lighted. The flame is held under the gear, and a few drops of kerosene occasionally dropped into the upper end of the pipe with an oilcan to keep the flame burning. When water sizzles on the gear it usually can be easily removed.

How-
ever,
they
can
usu-
ally
be
loos-
ened
very
easily
by
the
method
shown
in
the
illustration.
A
length
of
ordi-
nary
 $\frac{1}{2}$ -in.
pipe
is
wrapped
with
burlap
or
cloth
at
one
end,
and
this
is
soaked
with
kerosene
and

S. S. White Dental Mfg. Co. 211 S. 12th St. Phila. Frank Supply Co. 4753
Broadway, Chicago.

Testing Fuses and Lamps

For an all-around tester, the one shown in the illustration is easy to make and will be found to be of considerable usefulness.

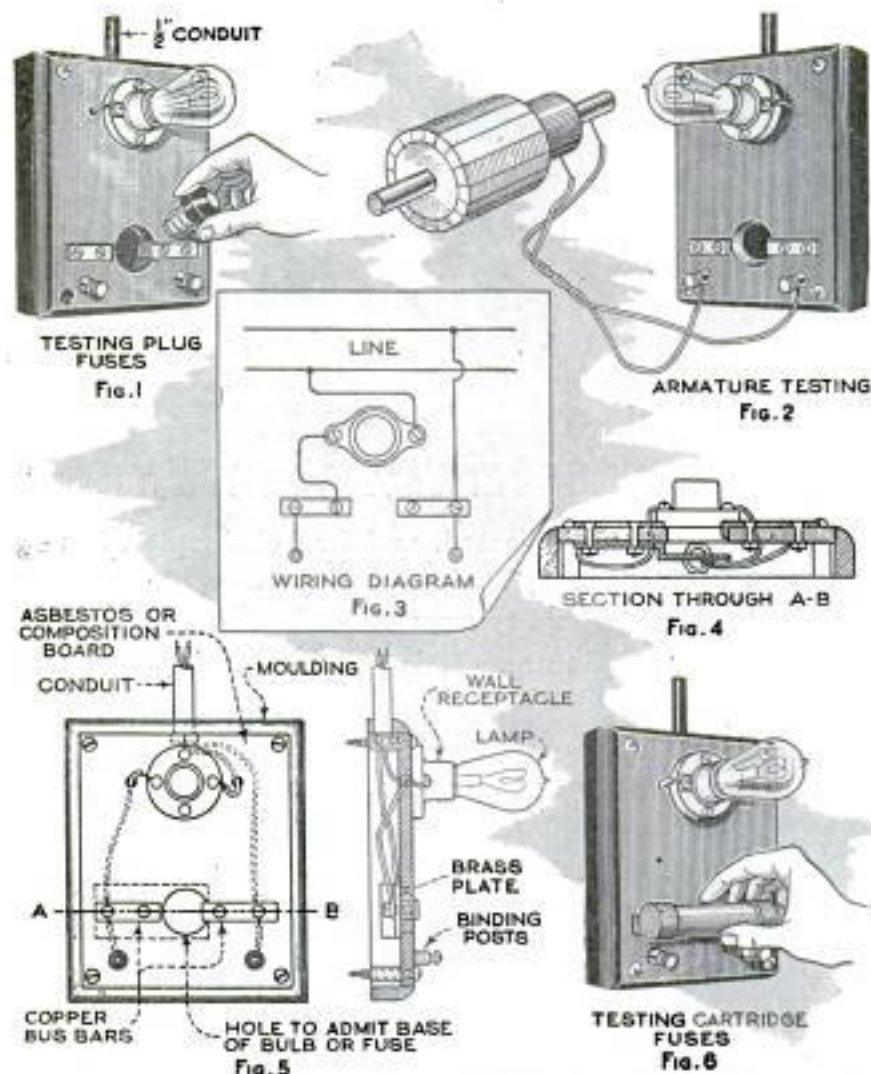

Convenient Board for Testing Fuses, Lamps and Armatures Eliminates All Danger of Short Circuits

The board can be made of almost any material on hand; I used asbestos board. When mounted on the wall on wooden

cleats, it can be bordered by quarter-round molding. A hole, large enough to admit plug fuses, is drilled near the bottom, as shown, and a bus bar is screwed down on either side, one being bent over to project into the hole so that it touches the screw shell of a fuse or lamp, while the other is connected to a brass plate directly underneath the hole; this plate must make contact with the center terminal of the fuse or lamp. A wall socket is mounted on the board and connected to the bus bars as shown in Fig. 3. The connections to the lines are also shown. In use, a lamp is screwed into the socket and the fuse or bulb to be tested is inserted into the hole as in Fig. 1. If it is in good condition, the lamp in the socket will light. A pair of radio binding posts are also fastened to the board near the bottom, and are connected to the bus bars so that leads for testing armatures and other work can be attached as shown in Fig. 2. Fig. 4 gives the sectional view, showing the arrangement of bus bars, and Fig. 5 shows how the board is wired. Fig. 6 shows how cartridge fuses are tested. This type of tester is safe, as all connections are

made on the back of the board thus eliminating possibility of short circuits.—W. W. Parker, Lead, S. Dak.

Auto Dash Box and Desk

Drivers of Reo trucks will find a box enclosure for the gasoline tank of considerable convenience as it provides a place for keeping order books, delivery sheets, pencils, shipping tags, and also affords a good surface to write on. The box is made of 1-in. boards and the slanting top, consisting of two parts, is hinged as shown in the drawing. The box itself has no wooden bottom as the gas tank serves the purpose. It must be fitted around the tank snugly and any small openings between the tank and the box may be filled

with waste. The ends of the box are fastened to the dash with angle irons.

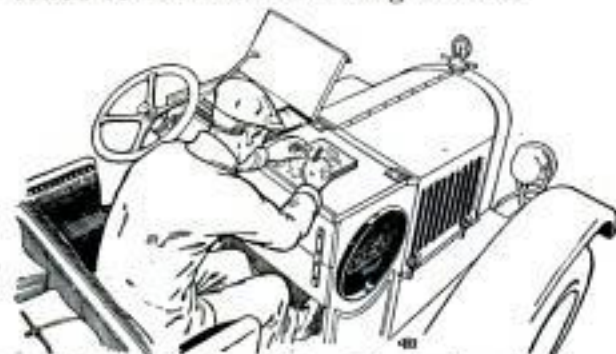

Desk on Box around Gasoline Tank on Truck

Sand Pan to Receive Oil Drip Protects Concrete Floor

Oil has a pronounced tendency to disintegrate concrete. It is not satisfactory merely to wipe off the oil now and then, but it should be prevented from getting in contact with the concrete. If a tank or auto crankcase leaks, fix the leak or provide a shallow pan, filled with sand, for the oil to drip into. It is still better to provide a pit in the garage, which not only eliminates the above-mentioned trouble, but also makes it easy to get at the parts underneath the car when these must be removed or adjusted. The idea, of course, applies to all places where oil leakage occurs.

Hacksaw Frame Takes Fine and Coarse Saws

Users of hacksaws are aware of the difficulty of starting a diagonal cut on flat metal. If a coarse blade is used it is liable to slip sideways or break the teeth before the cut is started. This annoyance is not experienced with a fine-tooth saw, which is well adapted for starting a cut, but is too slow to go right through the piece. The double saw holder illustrated is of advantage for such work in a small shop. Two end-pieces, made of $\frac{1}{2}$ -in. round stock, and one piece of $\frac{1}{4}$ -in.

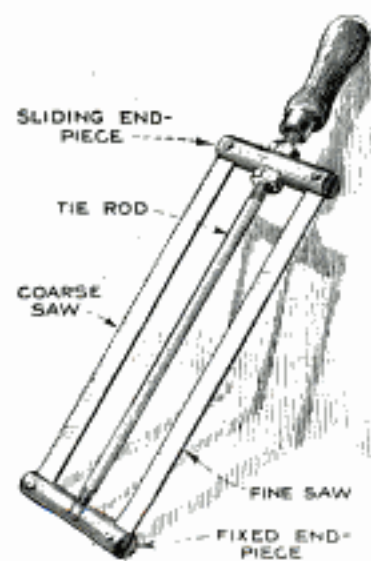

rod as a tie piece, are the essential parts of the frame. One end piece is tapped in the center and slotted on top and bottom to take the saw blades. The other end piece is similarly treated but the central hole is clearing size. On one side a fine-tooth saw is held and on the other a coarse one, the former for starting and the other for cutting. Both saws are tightened up by a nut on one side, a nut on the other side locking the adjustment.—Harry Moore, Montreal, Can.

Draftsman's Cabinet Combines Bookcase and Drawing Table

The illustration shows a draftsman's homemade cabinet, which combines a bookcase, storage bin and a drawing table in one compact unit. The upper section contains handbooks, catalogs and instru-

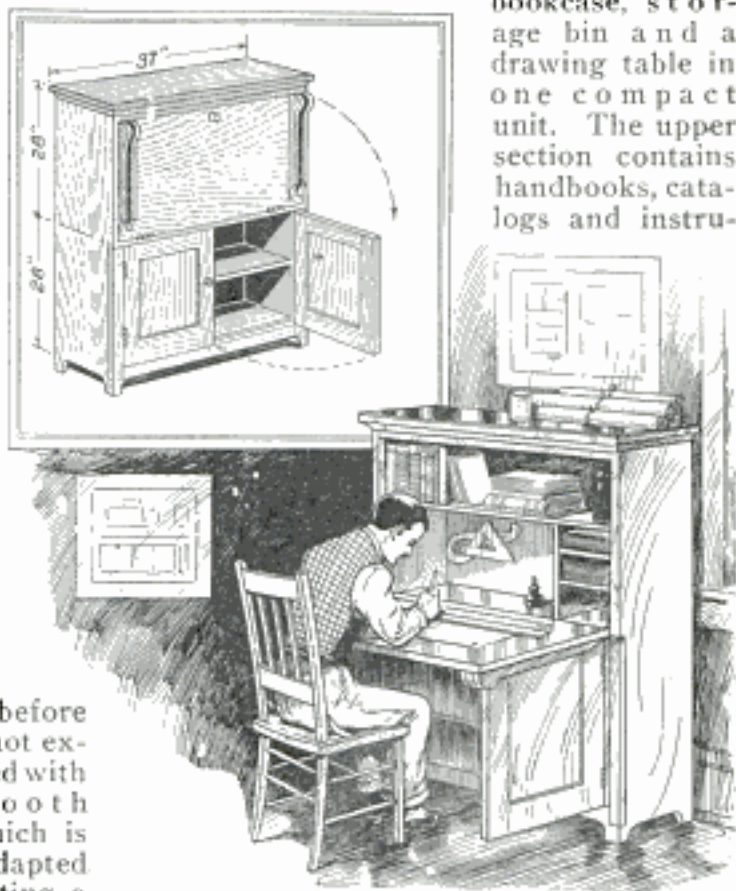

Convenient Draftsman's Cabinet, the Upper Door of Which Serves as a Drawing Board

ments, while the lower section accommodates standard-size rolls of tracing cloth and drawing paper. A drawing board, hinged at the bottom, closes the upper section, and is held in its closed position by a latch. In use, the board is lowered and rested on the doors of the lower section. The drawing board is reinforced by double cleats at the ends, the space between them being such that the edges of the doors fit snugly in it and hold the board securely. With this arrangement there is no need for the draftsman to remove his drawing and put it away for protection; he only needs to lift the board up.—C. Nye, New York City.

☞ To bleach gum shellac, which is naturally dark, it is subjected to the action of chlorine, and when the treatment is overdone the gum becomes insoluble in alcohol. To render it soluble, first moisten the gum with ether equal to about .05 of its weight, and allow the gum to swell in a closed vessel until its solubility is restored.

Lathe Grinder Made from Electric Fan

In a small hardware-manufacturing plant the absence of a lathe grinder pre-

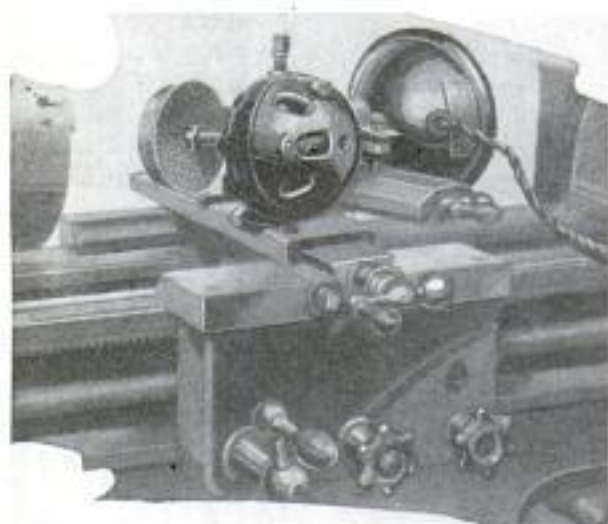

Improved Lathe Grinder Made from Electric Fan Proves Satisfactory

sented quite a problem in grinding a cylindrical punch-press die. Observing an electric fan standing idle in the office, the toolmaker visioned the grinder. The fan guard and blades were removed, the shaft lengthened to hold the grinding wheel, and the arrangement then fastened to the lathe as shown in the photo. So satisfactory was this improvised grinder that in three hours the die was completed and the punch press again in operation.—D. B. Hoag, Kansas City, Mo.

Built-Up Printers' Chase Is Very Substantial

Some time ago, I was working in a printing office where only homemade cast-iron chases were available, which would



not stand up to the work. There were several that showed signs of having been welded, and when rush jobs came along of a certain size, it was invariably the case that the chase required was broken. In order to overcome this difficulty, I designed a chase that would last a

lifetime. It is made laminated, being built up of three layers of $1\frac{1}{2}$ in. by $\frac{1}{4}$ -in. cold-rolled steel. Each piece was sawed off to its proper length, care being taken to have the ends square. The three parts of each side were clamped firmly together, drilled and reamed to suit No. 1 drill rod, of which the rivets were made. Then the whole frame was assembled and riveted. The upper outside edge was rounded as shown, and the locking seat milled in one long side. The inside edges were draw-filed smooth and square.—E. N. Davey, Vancouver, Can.

Clear Varnish for Enamel

To make clear varnish for enamel, add 2 qt. of denatured alcohol to 4 gal. of damar varnish, and shake well. The resulting varnish will have a rather dark appearance, but it will look clear on the enamel. The alcohol removes the opalescence of the damar varnish, leaving a clear, transparent liquid, and also causes the varnish to dry harder than it would otherwise do, damar being a soft-gum varnish.—A. A. Kelly, Malvern, Pa.

Safeguarding Block and Tackle



Unless some provision is made to safeguard the workman's hand on block and tackle of the type shown in the illustration, he is apt to place

his hand on the cable, which will draw it into the pulley and considerable injury is possible. To prevent this, a piece of tubing or old pipe can be arranged in a crosspiece as shown. This will not only safeguard the hand but will also help in manipulating the tackle.—Auguste Mathieu, Chicago, Ill.

When the keyhole in the end of the drill-chuck screw is worn, drill a hole in the other end of the screw and broach or cut it out square to fit the key.

Building a Two-Kilowatt Spot-Welding Set

A Practical Shop Utility Which Has Wide Usefulness
and Can Be Made by Anyone

By ARTHMAN N. CAPRON

FOR welding light sheet iron, small rods, etc., a 2-kw. spot-welding outfit will be found very useful in the average small shop. The design is simple, no difficult castings are required, and when in operation, it does not cause any disturbance on the line by unbalancing the phases, owing to the special construction of the core.

It is to be kept in mind that the electrical capacity of the average small shop's supply line is practically limited to about 2 kw., so that no spot-welding work should be attempted that requires a heavier current. The electrical characteristics of this transformer are such that the current on a dead short circuit of the

secondary coil will be limited to about 2 kw., and if this condition is kept up, the secondary coil will get red-hot and begin to melt. Hence care must be taken not to overheat it. The design is for use only with 110-volt, 60-cycle, alternating current. The maximum contact area of the tips is equivalent to a $\frac{1}{4}$ -in. circle, and the maximum thickness of material to be welded is $\frac{1}{4}$ in. The potential at the copper tips is 3 volts and the current approximately 600 amperes. On heavy stock, say of $\frac{1}{2}$ -in. thickness, a $\frac{1}{4}$ -in. iron rivet is used, and this rivet is welded to the material, resulting in strong joints.

The central core on which the coils are wound is built up from strips of transformer iron, 4 in. wide. This is 30 or 32-gauge japanned silicon steel and can be obtained at the larger electrical concerns. The object of the japan finish is to prevent eddy currents in the core. The central core strips are 14 in. long and are staggered 2 in. at each end so that the yoke strips can be pushed between. The over-all dimensions of the central core are 4 by 2 by 16 in.; it is riveted in the center to hold its position solidly, is wound with one layer of friction tape, except the ends, 2 in. being left bare, and then a coat of varnish is applied over the tape. When dry, a strip of $\frac{1}{8}$ -in. micanite is placed around the tape.

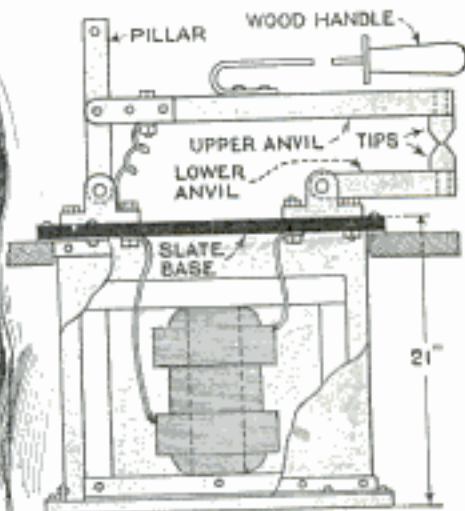
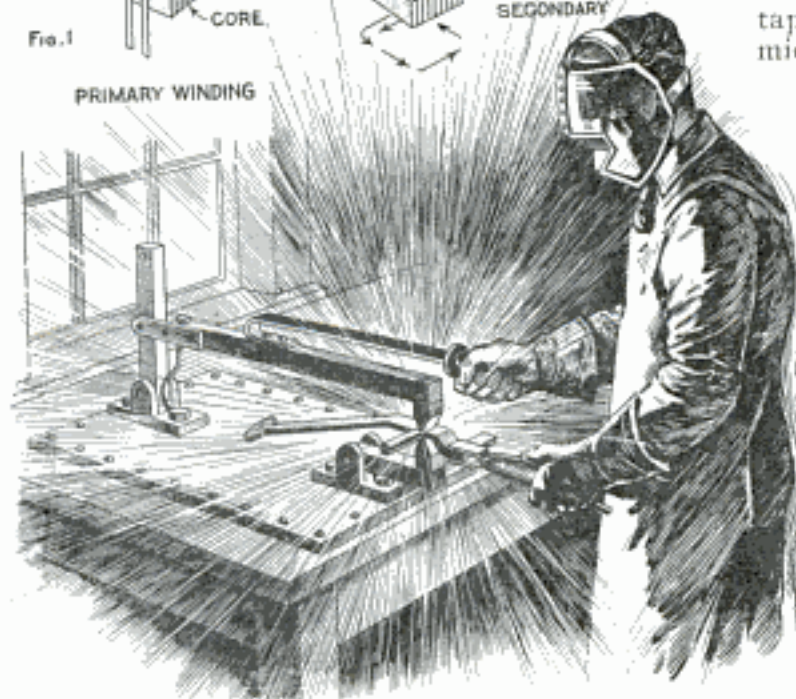
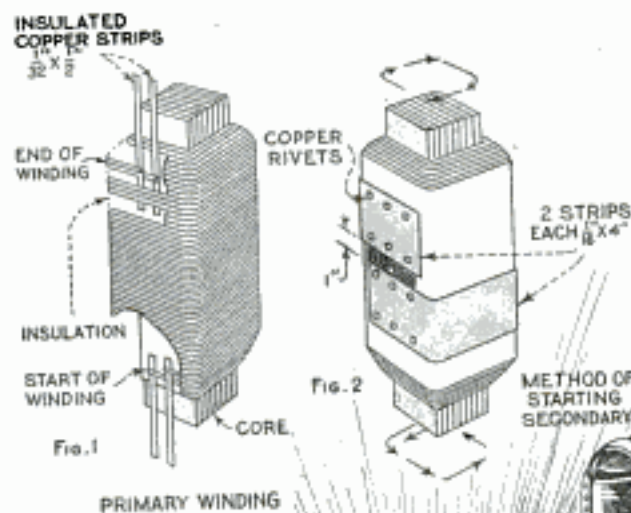

METHOD OF MOUNTING
TRANSFORMER UNDERNEATH
BENCHTOP
Fig. 3

All Kinds of Light Welding Work in the Small Shop Can Be Done Efficiently with This Homemade Electric Spot-Welding Outfit of Two-Kilowatt Capacity, Designed to Operate only on 110-Volt, 60-Cycle A.C.

*Allegany Steel Co
Parachuck, Pa*

*Manufactured by
Electrical Supply Co
114 S. West Chicago*

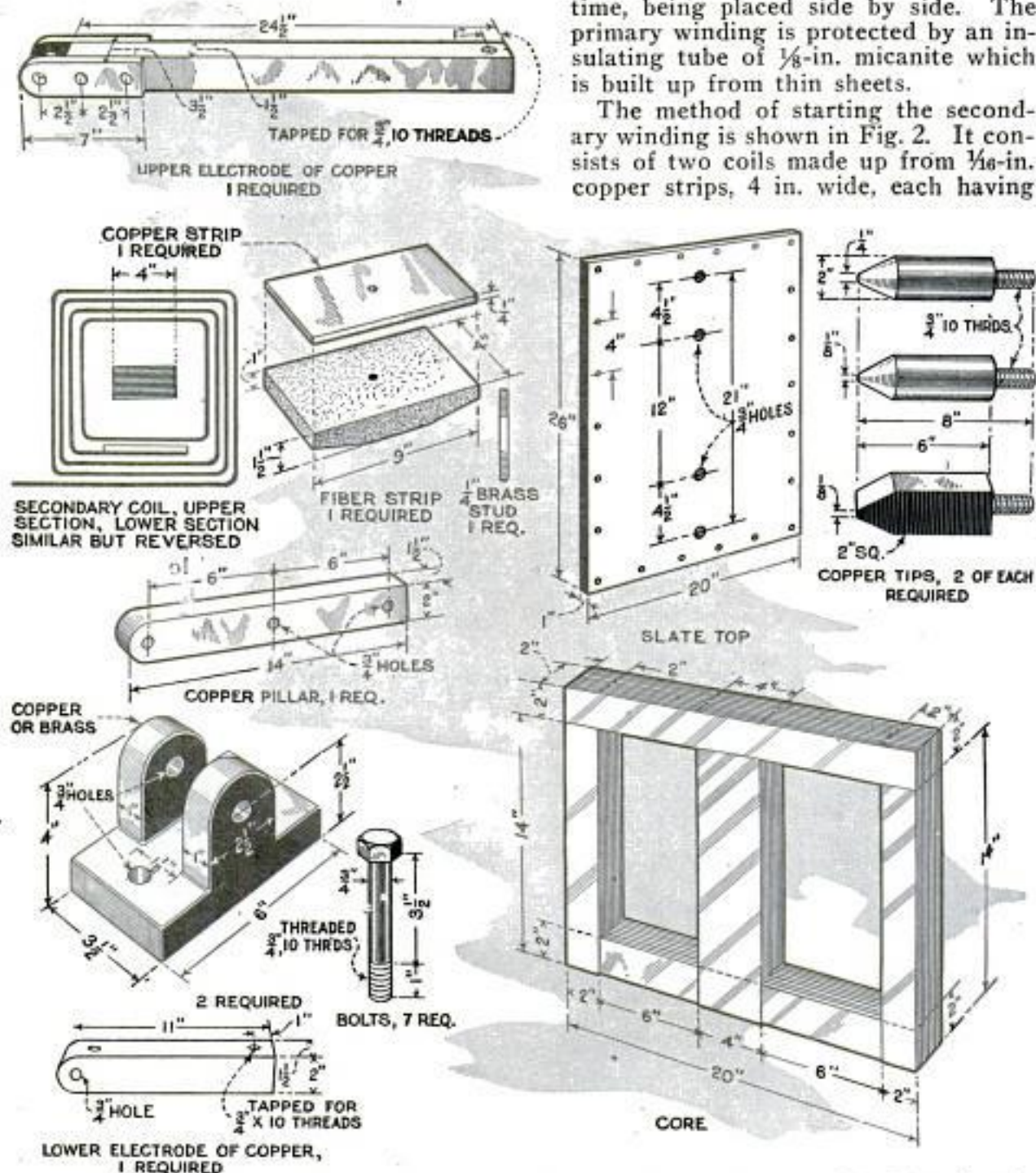

Constructional Details of Transformer Core, Slate Base, Method of Winding Secondary Coils, Dimensions of Anvils, Anvil Supports, Welding Tips and Fiber Clamp for Holding Ends of Secondary Winding in Place

Next comes the primary winding. It consists of two parallel coils each having 220 turns of No. 12 d.c.c. magnet wire. The method of winding it is shown in Fig. 1. It is advisable to wind a layer of tape over each layer of the primary coil to prevent the possibility of a short circuit, or if desired, the layers can be given a coat of black asphaltum varnish and baked. The ends of each winding are securely soldered to two 3/2 by 1/2 by 6-in. insulated copper strips, as indicated. Both the primary coils are wound at the same

time, being placed side by side. The primary winding is protected by an insulating tube of 1/8-in. micanite which is built up from thin sheets.

The method of starting the secondary winding is shown in Fig. 2. It consists of two coils made up from 1/8-in. copper strips, 4 in. wide, each having

three turns, which are insulated from each other with a layer of 3/64-in. micanite, 4 1/4 in. wide. The two secondary coils are wound in opposite directions, as indicated by the arrows, and are connected in series, which is done by riveting and sweating the inside ends of both coils to a 9-in. strip of 1/4-in. flat copper, 4 in. wide. A 3/4-in. hole is drilled and tapped in the center of this strip for a stud, as shown in the sectional view of this coil. After the coils are wound, a fiber strip, 1 1/2 by 4 by 9 in., with a hole

MATERIAL LIST

| | |
|---|--|
| 100 lb. 30 to 32-gauge transformer iron. | 1 $\frac{3}{4}$ by 5-in. brass stud and nut. |
| 660 ft. No. 12 d.c.c. magnet wire. | 40-in. length 2 by 2 by $\frac{1}{2}$ -in. angle iron. |
| 240 sq. in. $\frac{3}{8}$ -in. mica made up of thin sheets. | 40-in. length 2 by 1 by $\frac{1}{4}$ -in. channel iron. |
| 216 sq. in. 1-16-in. mica made up of thin sheets. | 8 $\frac{1}{4}$ by $3\frac{1}{2}$ -in. bolts and nuts. |
| 4 copper strips, 1-32 by $\frac{1}{2}$ by 8 in. | 4 $\frac{3}{4}$ by $1\frac{1}{2}$ -in. bolts and nuts. |
| 1 copper strip, $\frac{3}{4}$ by 4 by 9 in. | 1 piece 1-in. slate, 20 by 26 in. |
| 24 ft. copper strips, 1-16 by 4 in. | 1 piece 1-in. asbestos slate for base (size to suit). |
| 50 in. hard-drawn copper bar, 2 by $\frac{1}{2}$ in. | 24 $\frac{3}{4}$ by 2-in. round-head bolts and nuts. |
| 7 $\frac{3}{4}$ by 6-in. bolts, 10 threads, with nuts. | 1 pt. asphaltum varnish. |
| 32-in. length of hard-drawn copper bar, 2 in. square. | 1 roll $\frac{1}{2}$ -in. friction tape. |
| 16-in. length round hard-drawn copper bar, 2 in. in diameter. | 3 by $\frac{3}{8}$ -in. copper strip for conductors. |
| 1 piece fiber, $1\frac{1}{2}$ by 4 by 9 in. | 16 $\frac{3}{4}$ by 2-in. copper washers with $\frac{1}{4}$ -in. hole. |
| | 1 double-pole, single-throw, fused knife switch, 25 amp. |

drilled through the center, is slipped over the projecting stud and a nut driven on; the purpose of this is to hold the finishing ends of the secondary down securely and also to make a neat-appearing job. The assembled view of this holder is not shown in the drawing. The outer ends of the secondary winding are connected to the two anvils by means of conductors, which consist of four strips of $\frac{1}{16}$ -in. copper, 4 in. wide. These conductors are bolted and then soldered to the ends of the secondary winding and also to the supports of the anvils, as shown in Fig. 3. A similar conductor is later coiled between the upper-anvil support and the anvil itself, permitting it to be moved readily. These conductors, which must be able to carry 600 amperes, are made up of strips to make them flexible.

The transformer proper is now completed, and the two outside cores and the yokes are built up of transformer iron. The ends of these parts are staggered 2 in. to dovetail nicely, and the dimensions are all given in the lower-right corner of the detail drawing. The whole core assembly is fastened together securely at the top with two 20-in. lengths of channel iron, one on each side of the upper yoke, and clamped together with bolts, which are run through both channel irons and the yoke, three or four holes having been drilled for this purpose. The lower yoke is similarly clamped between two 20-in. lengths of angle iron, which are also bolted to a slate base. The channel iron and angle-iron clamps are not shown. Although it is not necessary, the transformer may be inclosed in a sheet-metal case, which the builder can design. It should be perforated to allow free circulation of air to keep the transformer cool. The most convenient mounting for the transformer is directly underneath the benchtop, as shown in Fig. 3, as it will then be entirely out of the way and will not be damaged easily.

It is necessary to provide a 1-in. slate top on the bench to prevent burning the bench when welding. This piece, with all the dimensions, size of holes and their spacing, is shown in the upper-right detail. The anvil clamps and pillar are made of hard-drawn copper-bar stock, $1\frac{1}{2}$ in. thick and 2 in. wide, and their exact construction, length and location of holes to be drilled and tapped, etc., are clearly indicated in the details, as well as the construction of the anvil-pivot supports and the welding tips. A steel handle with a wooden handgrip projecting well out and away from the upper electrode is provided so that the worker can manipulate the upper anvil easily. As will be noted, the upper anvil can be pivoted on the pillar at two points, spaced 6 in. apart, to accommodate various sizes of work. A double-pole, single-throw knife switch, of 25-ampere capacity, with fuses of this capacity, is provided in the primary circuits.

Old Casings Make Good Unloading Mat

Made of discarded tire casings, the mat shown in the drawing is an excellent landing pad upon which barrels or other containers may be allowed to fall from trucks without injury. Obtain three old casings and cut two of them through once. Coil these inside the other, cut off surplus, and bind with wire as shown.



☐ To use a lathe bed as a substitute for an anvil on small jobs quickly destroys its accuracy.

Removing Asphalt from Concrete by Burning

Many workmen spend hours using tools to remove asphalt from joints between concrete slabs or from concrete surfaces, but all this labor can be saved by pouring gasoline over the asphalt and igniting it. This is a rapid method, far cheaper than the other process, and one that does not



Burning Off Asphalt Coating on Concrete with Gasoline

damage the concrete. To remove all the old asphalt may call for repeated applications of gasoline. It is, of course, far better and safer to repeat the process than to try to do it all at once. It is also necessary to avoid a continuous fire to prevent the concrete from being damaged. Care must be taken if this method is used in concrete reservoirs, which are covered with wooden roofs. Plenty of ventilation must be provided before the gasoline is ignited. The accompanying photo shows the removal of several tons of asphalt from a reservoir surface by this method. In this case one man was able to remove a 1/2-in. coating of asphalt from a surface area of 15,000 sq. ft. in two days, the treatment leaving the surface perfectly clean.—George F. Paul, Chicago, Ill.

Lining Up Cotter Holes

After discarding one or more shims to take up a bearing, a mechanic is sometimes tempted to place undue strain on the bearing bolts or studs in order to properly line up the holes for cotter pins as the cotter hole does not always align with the castellations of the nut. The next time you are confronted with such a situation, do not take a chance of stripping the thread or breaking the stud, but remove the nut and place under it one of the shims just discarded. You will find that in almost every case this will furnish the exact thickness needed to fill the space, and the nut can then be tightened

up properly. The portion of shim extending beyond the nut can be removed with a chisel or knife, or it can be torn off easily with a pair of pliers.

Extension Tool on Small Planer

In the small shop where the largest planer is too small to permit large work to go through the uprights, it becomes necessary to use an extension tool of some kind. A common bar tool is generally used, which does the job by taking light cuts, on account of the spring in the bar. However, when machining a piece of work similar to the one shown, it is nearly impossible to make a first-class job, especially when cutting the angles, with such a bar extension, and a more rigid tool is required. Such a tool is shown in the illustration. It fits onto the four regular bolts in the planer tool block. A stud is screwed into the clapper box above the clamp bolts, and two set-screws are fitted into the upper part as shown, to tighten two cast-iron blocks between the clapper bar and the extension tool. After the regular

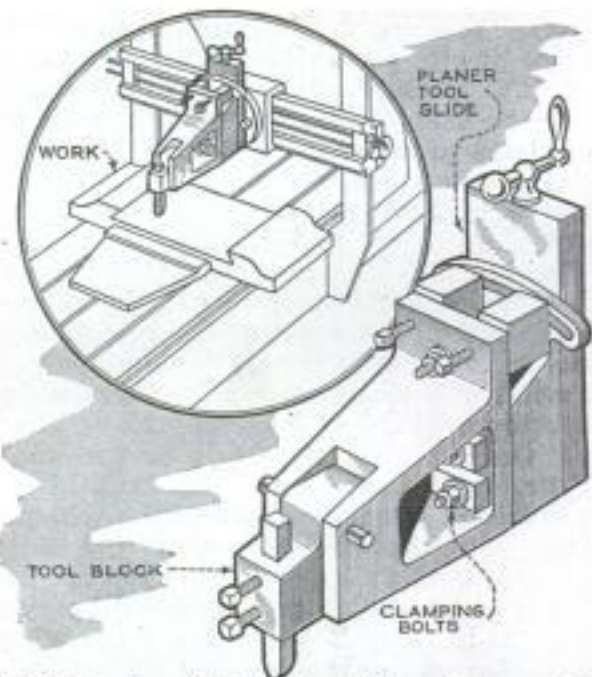

Rigid Extension Tool on Small Planer Increases Its Range of Work

clamps have been tightened, the nut on the stud is tightened, which takes the strain off the taper pin in the clapper box. The tool box on the outer end of the extension tool is fitted with a taper pin.—R. W. Laing, Fergus, Can.

☐ A little spar varnish in exterior oil paint will toughen it and increase its luster.

Old Windmill Parts Rigged Up to Run Field Pump

In the plains states, it is almost necessary to have water in the pasture, and it usually does not pay to pipe it there from the windmill. One farmer who had to pump by hand each day

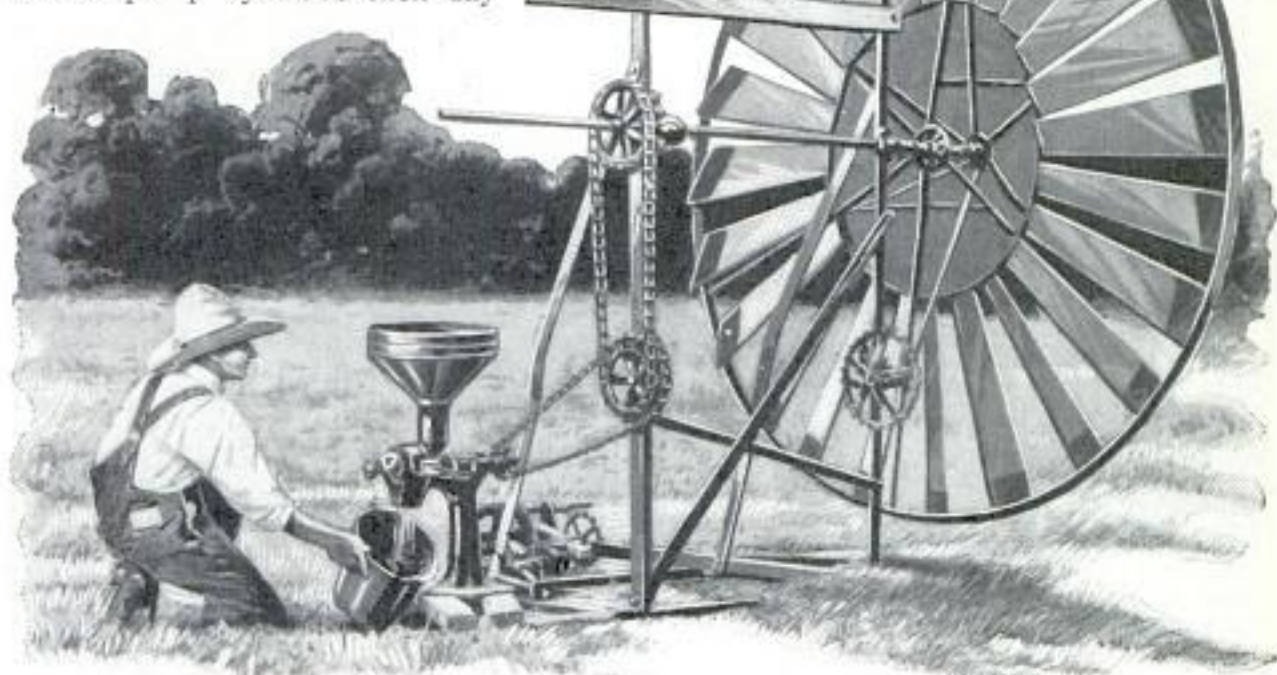

Farmer Uses Parts of an Old Discarded Windmill to Run Pump in Pasture for Watering His Cattle

rigged up the parts of an old discarded windmill to do the work for him. The arrangement was found entirely satisfactory and saved much labor.

Carbon Prevents Spelter and Filler Rod from Spreading

In many jobs of brazing or welding, the spelter or welding material spreads over finished surfaces, necessitating its removal by extra machining after the weld is completed. In a recent production job

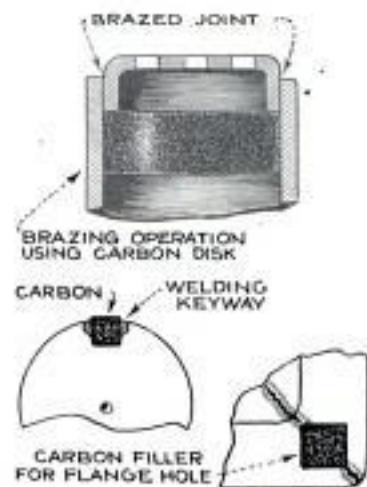

of brazing heads into steel tubing, the trouble was evident at the first attempt. To avoid the spread of the spelter inside the tube, a stopper or disk of some kind was necessary, and as heat-resistant material was

required metal could not be used. A carbon disk was suggested by the welding department and found successful. This department had used carbon successfully before. The filling of worn keyways and the repair of drilled flanges, for instance, had been accomplished with the aid of protecting carbon fillers, closing the key slot or the holes in these flanges. Arc-light carbons and carbons from dry cells can be used to advantage for this purpose.—G. A. Luers, Washington, D. C.

Filling Small Grease Gun

A good method of filling small grease guns is to remove the plunger and rear cap, and clamp them vertically in a vise. The grease first is forced into the casing of the gun with a paddle, and then it is pushed down on the plunger until some of it appears at the end of the spout. Place the thumb over the spout and pull the casing off. By holding the thumb over the opening the grease is prevented from being sucked back when the plunger is removed. This drives all the grease which has been placed in the gun solidly to the front end. The remainder of the gun is then filled and the plunger replaced.—E. T. Gunderson, Jr., Humboldt, Iowa.

Handy Holder for Shop Goggles

Even the boss of the shop may be caught going to the emery wheel and doing a touch-up job of grinding without taking the trouble of slipping on the goggles. How-

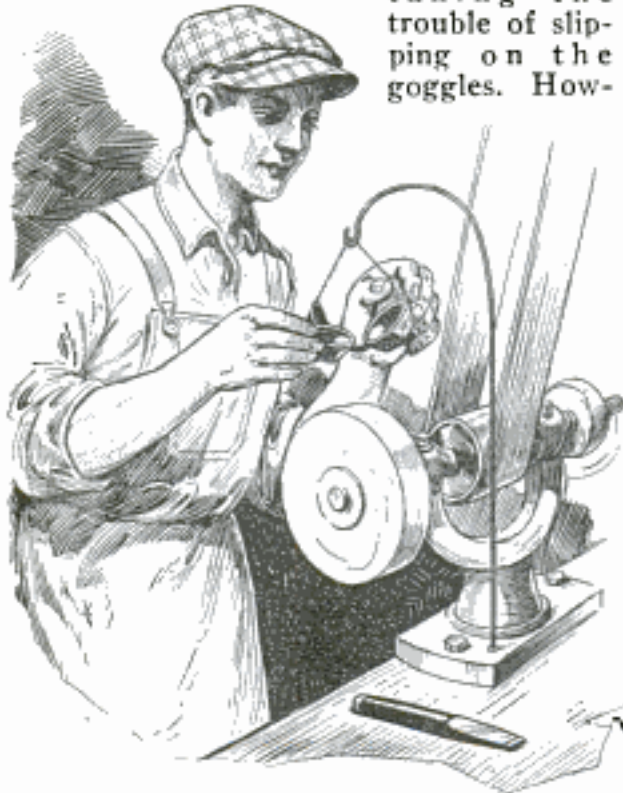

Convenient Holder for Goggles over Emery Wheel Reminds Worker to Use Them

ever, eyesight is too valuable to risk in that way and by hanging the goggles right over the emery wheel, they cannot easily be forgotten as they must be removed before starting to grind. Such a reminder is illustrated herewith. A steel rod or length of heavy wire is attached to the grinder frame as shown, bent over and formed into a hook at the end to hold the goggles. — Hiram E. Barber, Olney Springs, Colo.

Refitting Corliss Valves

To put old Corliss valves in shape to work as well as new valves it is necessary to re-turn them so that their diameter is the same as the newly bored chamber, less whatever clearance is allowed. For steam valves this is very simple; it is only necessary to move over the centers in the ends so that the solid part of the valve will clean up to the required size. This is possible because most steam valves are made with a bearing on the underside only, the top portion being cut away as shown in the drawing. The dotted line shows the circle around the new center.

The centers may be moved over by chipping and recountersinking, or, if they are very large, a hole for a plug 1 in. in diameter may be drilled and tapped. A steel plug is screwed into this hole and the center accurately laid off on the plug. The new center need not be more than $\frac{1}{8}$ in. from the old one in most cases. The caliper of the valve may be facilitated by screwing a stud into the casting opposite the solid portion so that the tool will cut on the stud at the same time as on the casting. The exhaust valves usually have a cylindrical portion at each end, as shown in the drawing, which fits the chamber bore closely. It is obvious that, if we turn the exhaust valve with the cylindrical ends in the same manner that we did the steam valves, we will no longer have this end to guide the rotation of the valve. The ends of the valves should be centered as before. At each end a shoulder is turned for shrinking on a bushing. This bushing should not be less than $\frac{3}{8}$ in. in thickness finished. Bushings are made and shrunk on and the valve turned up as if it were a new casting. The bushings may be of pipe, or they may be forged. In case the end is very wide it is easier to make two narrow rings than one wide one. In any case the rings should be bored on the inside before shrinking on. While for the best results the chambers should be bored, it is sometimes found that the valves are worn much more than the chamber or have been scored by water or other foreign matter. If the nature of the service is such that the engine cannot

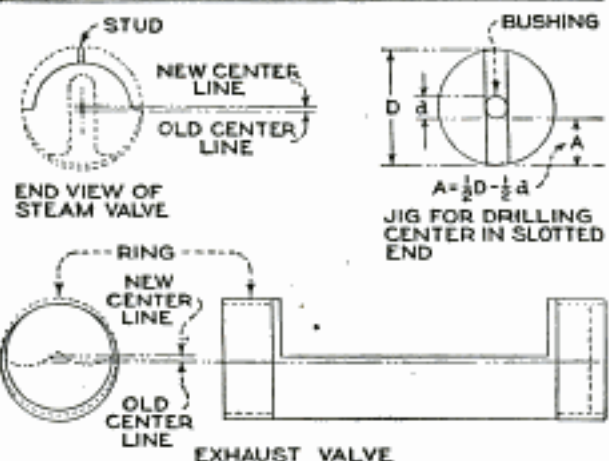

Two Types of Corliss Valves and How They Can Be Repaired; Above, Right, Center-Drilling Jig

be shut down long enough to bore the chambers and refit the valves, the economy of the engine may be improved by truing up the valves as described. In this case the ends, the part of the valve which

moves on solid metal, should be relieved so that the working portion can wear to a good fit in a short time. In putting the center in the slotted end, it is absolutely essential that the center be exactly in the middle of the slot. To obtain this result a bushing may be turned up in the lathe to a good fit in the slot and a hole for a

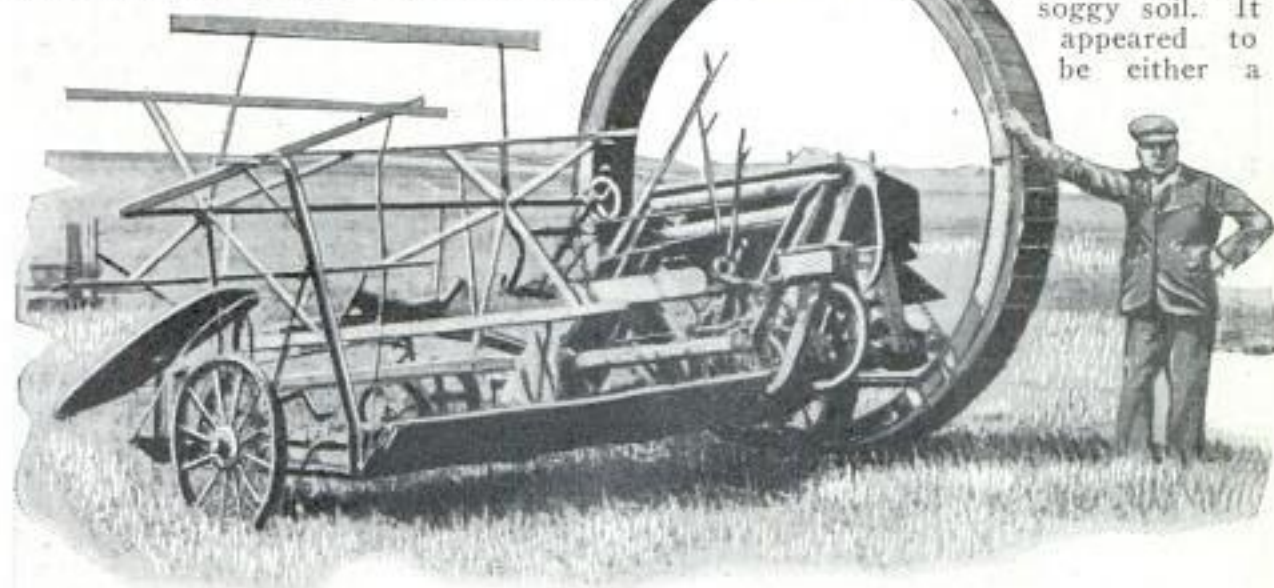

Many a Wheat Crop Has Been Saved by Using This Giant Wooden Wheel, Which Serves as a Track for the Binder Bull Wheel When the Soil Is Soggy

Giant Revolving Track for the Binder Bull Wheel

One summer, when the grain was ready to be harvested, it had rained so much that it was impossible to move the binder over the soggy soil. It appeared to be either a

$\frac{1}{4}$ -in. drill put through the center of the piece while it is still in the lathe. This bushing is located at the correct position in relation to the length of the slot by measuring as shown. The other center can be laid off by ordinary means.

Universal-Jointed Socket Wrench

There are many bolts or nuts on a car on which the regular socket wrench cannot be used with any degree of speed, because it has to be removed and replaced repeatedly. A universal-jointed socket wrench can easily be made from old steering knuckles or brake-rod clevises, as shown in the illustration.

The clevises or knuckles are screwed into an iron block from opposite sides as shown, forming a joint that enables the wrench to be used in any suitable position.—Robert H. Neill, Toledo, Ohio.



case of harvesting with hand scythes or losing all the grain. However, the wheel shown in the photo solved the problem. It is merely a huge wooden wheel without spokes and wide enough for the bull wheel to travel in smoothly. There is a rim 2 or 3 in. high to keep the bull wheel from slipping out. In use, the bull wheel is jacked up high enough to slip the track under it, and the machine is then ready to travel. This method saved many a crop.—Wm. J. Douglass, Missouri Valley, Iowa.

Feeding Poultry Salt

Most amateur poultrymen have been led to believe that salt added to the ration of their flock would be likely to result in death to all fowls that ate it. Salt in too great quantities is injurious to them but a limited amount is almost essential to their welfare. A Wisconsin poultryman who follows the advice of experts in feeding dry mash, has found that the judicious addition of salt causes an increase in egg production up to 25 per cent. It was found that if the dry mash was salted as one would salt vegetables for the table, a healthy thirst was stimulated and this caused the birds to drink larger quantities of water.

Excavating Machine Used as Pile Driver

The accompanying photo shows how a drag-line excavating machine can be used as a pile driver. The drag-line bucket was removed, the pile-driver leads were fastened to the end of the drag-line boom, swung into position, and lowered until the bottoms of the leads had pushed into

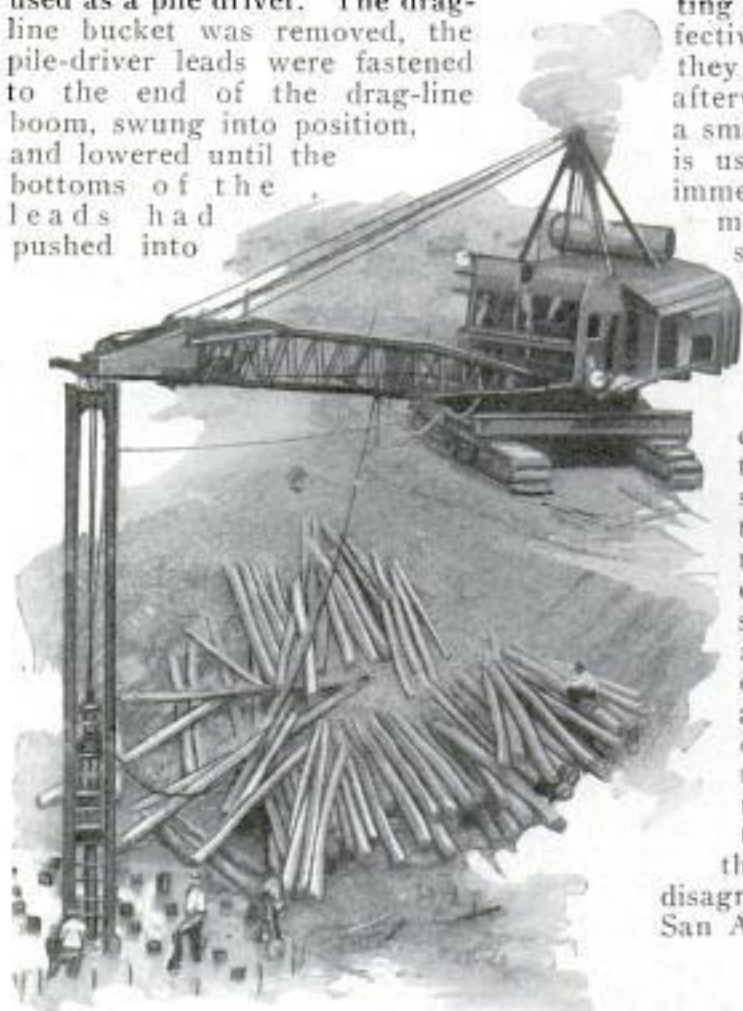

Using a Drag-Line Excavating Machine for a Pile Driver

the gravel far enough to be held firmly. Piles were swung into place with the drag-line load cable, and were driven 18 ft. into gravel at the rate of one every 12 minutes.—Ivan E. Houk, Denver, Colo.

Preventing Rust on Small Steel Instruments, Wire and Rods

After small steel instruments are made they soon rust from handling and some quick efficient method must be used to prevent this. There is a great difference in peoples' hands in the way they cause steel to rust, some having such "rusty" fingers that steel rusts very quickly after they have handled it. When small steel instruments or other articles are finished they should be immersed in a bath of gasoline, to which a very small amount of gas-engine cylinder oil has been added.

(This should be the lowest-grade, dark-colored oil, as the higher grades often contain a trace of acid.) After the bath the instruments are spread out on some absorbent material, such as a sheet of blotting or other clean paper. This will effectively prevent them from rusting and they should not be touched with the hands afterward. For very small instruments a small pan having a perforated bottom is used to hold the instruments while immersing them in the bath. Instruments that have been soldered into shanks or handles should be washed in boiling water and dried before they are immersed in the gasoline-oil bath. This method is also valuable for makers of music wire and small steel rods, etc. The coils of wire should be immersed in the bath and hung up to dry. A very small amount of oil is mixed with the gasoline so that the wire will not assume an oily appearance when dry. After the coils are dry they should be dusted with powdered talc and wrapped up. Steel rods that are dipped in this manner, laid away in a box and dusted over with powdered talc, will remain bright indefinitely. Foreign manufacturers of music wire have used air-slaked lime to dust the wire with for years, but the talc is just as effective and far less disagreeable to handle.—J. H. Downie, San Antonio, Texas.

Holder for Grinding Chisels

Grinding a true bevel on the cutting edge of a chisel or plane iron is usually an



expert's job, but with the aid of the simple rig shown in the illustration, anyone can do it. The device consists of two blocks hinged on one side and provided with a clamp, taken from an old plane, on the other side, so that the upper block can be set at the proper grinding angle. A metal plate is screwed to an upright beveled block with two coach screws, and the chisel is clamped under this plate.

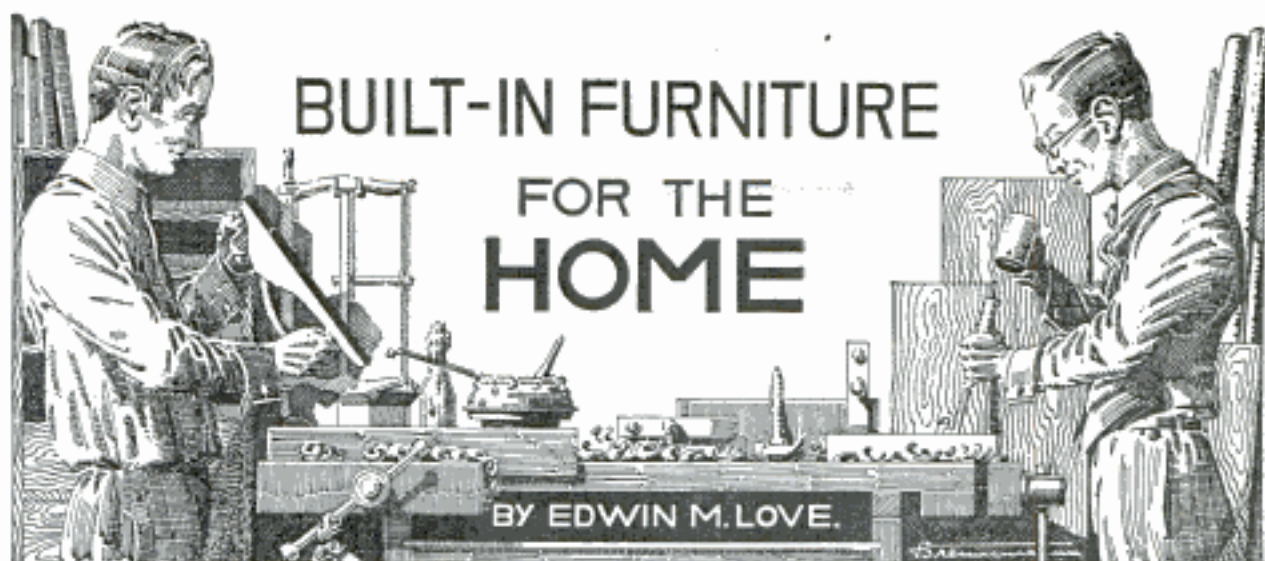

Part XII—Seats

SEATS are among the most adaptable and useful of all built-in furniture. They can be built between a pair of bookcases, or between a writing desk and a bookcase, or at the sides of a fireplace, or they may be made portable and finished to match the trim of the room. A pair of the latter type placed at right angles to the fireplace in a large room make for an atmosphere of cozy comfort.

The ends of the portable seat are of $1\frac{1}{4}$ by 10-in. stock, glued up in the rough form indicated by the heavy lines of the layout diagram. On this blank, lay off $1\frac{1}{2}$ -in. squares as shown, and carefully point off the intersections of the curved outline with the squares. Through these points draw the outline, either by use of a large irregular curve or by driving in brads around which thin strips of wood can be sprung to guide the pencil. If a bandsaw is not available, saw out with a compass saw and smooth the edges with spokeshave, rasp and sandpaper. In using the rasp, do not file straight across, dragging the rasp back and forth like a saw, but stand facing the edge of the work and push away from the body while making the stroke from right to left, lifting the rasp on the return stroke. There are four advantages to this. The

shearing cut is smoother and faster; a cut is taken over an appreciable length of the curve, tending toward a smoother outline; there is less likelihood of rocking the file and thereby working an irregular round on the edge; and lastly, as the file teeth incline forward and therefore hardly cut on the backstroke, waste of energy and needless dulling of the rasp are avoided.

While the gain for housing of the seat and back may be laid out in the same manner as the outline, it is better to wait until

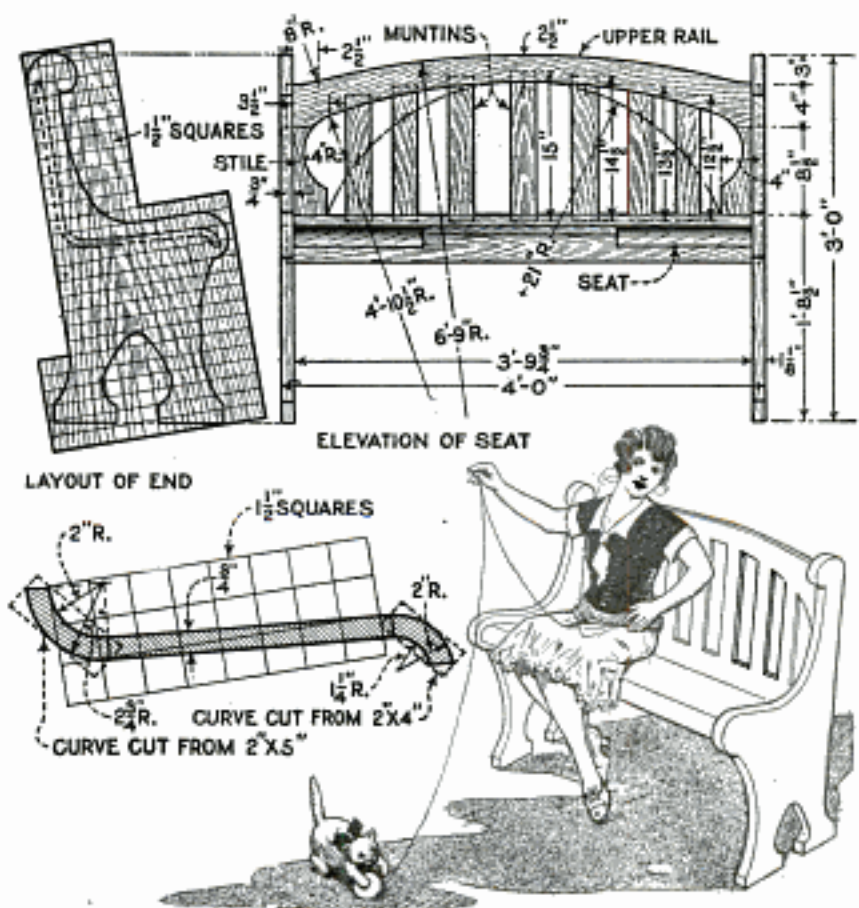

Particularly Adapted for Use on the Porch, This Portable Seat Is Both Substantial and Attractive

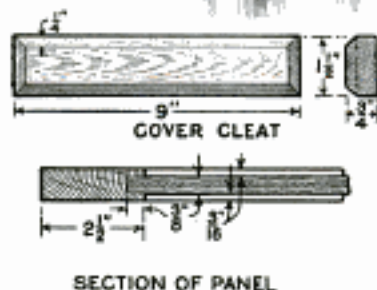
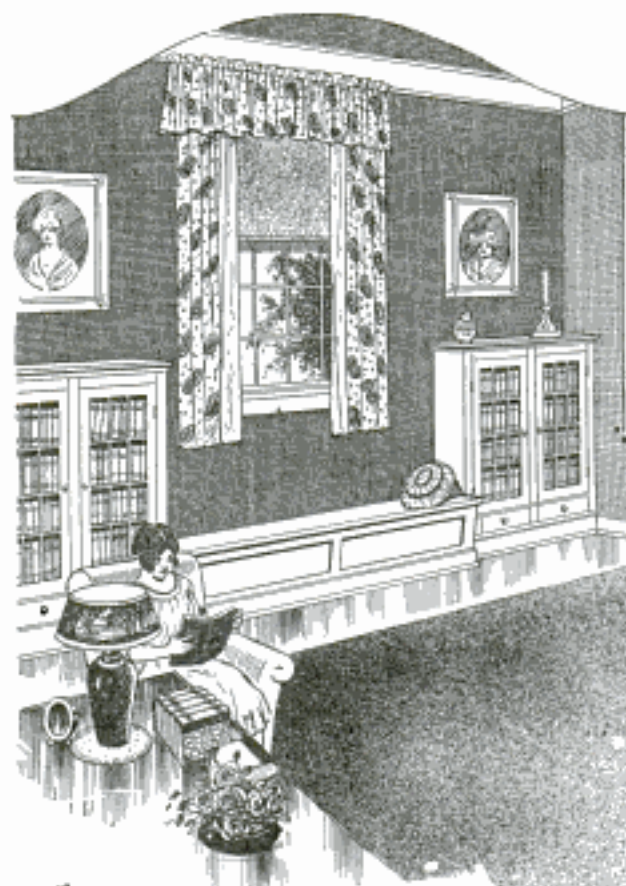

6 ft. 9 in., and $2\frac{1}{2}$ in. from this curve, at the center, strike another arc having a radius of 4 ft. $10\frac{1}{2}$ in. Cut end stiles of 1 by 6-in. stock, $8\frac{1}{2}$ in. long, and lay in position at each end of the rail, as shown in the elevation. Measure $3\frac{1}{2}$ in. from the line gauged on the ends of the rail. From this point on the inner curve of the rail, setting the compasses to 4 in., strike off an arc on the 4 ft. $10\frac{1}{2}$ -in. radius, and, with this point as a center, draw the curve of the stiles. Draw a radius of the top curve through this point on the rail also, and extend it until it intersects with a prolongation of the gauged line; then, with this as a center, draw the reverse curve for the top of the rail. Round

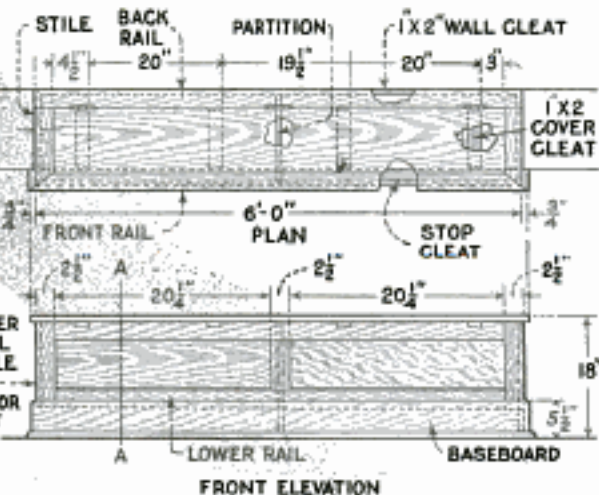
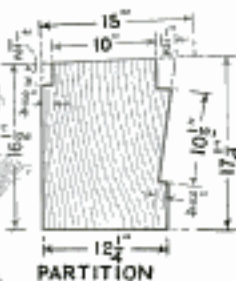

A Built-In Seat, between the Bookcases or along the Windows of the Living Room, Improves the Appearance Considerably, Provides Extra Seating Capacity and Furnishes a Desirable Chest

they are assembled, when the ends may be used for scribing the gains and an exact fit assured.

On the ends of the pieces of 2 by 5-in. stock lay out the curve shown in the section, using a radius of 2 in. for the inside and $2\frac{3}{4}$ in. for the outside. Work out the curve very carefully, afterward sandpapering the inside smooth by the use of a curved sanding block. Make the front roll with radii of $1\frac{1}{4}$ in. and 2 in., using the piece of 2 by 4-in. material. The straight section is of 1 by 12-in. stock, sized to a width of 11 in. This is joined to the rolls with $\frac{3}{8}$ -in. hardwood dowels spaced 6 in. apart.

Stock 1 by 8 in. is required for the upper rail of the back. Cut it to a length of 3 ft. $11\frac{1}{4}$ in., and gauge back from the ends $\frac{3}{4}$ in., representing the inside faces of the seat ends. Lay out for the upper edge of the rail an arc with a radius of

off the upper edge of the rail by first accurately chamfering the corners.

As the elevation shows, the stiles are reduced to a width of 4 in. Fit to the lower ends of the stiles a rail of 1 by 2-in. stock, sized to $1\frac{1}{2}$ in. in width. Dowel the joints, and assemble the back on trial. Locate the mortises for the slats or muntins, which are made of hardwood, $\frac{3}{8}$ by $1\frac{1}{2}$ in. net. These are not spaced evenly. The centers are obtained by striking an arc terminating at the inside corners of the lower rail and stiles and rising to touch the inside edge of the upper rail, having a radius of 1 ft. 9 in. This arc is divided into eight equal sections, and the muntins are centered on them. Square across both rails from the lower, take the back apart, and dig the mortises to a depth of about 1 in. Assemble, this time with muntins in place and every joint glued. Dowel the lower rail to the back round of

the seat with dowels spaced 6 in. Drive four six-penny finish nails into the back of each end through the ends of the rails

essary cuts on the bottom and back. Nail solidly in place and glue and nail the front panel to them.

MATERIAL LIST

Portable Seat

- 1 piece, 1¼ by 10 in. by 12 ft., pine or fir, S+S, sanded.
 - 1 piece, 1 by 8 in. by 4 ft., pine or fir, S4S, sanded.
 - 1 piece, 1 by 12 in. by 4 ft., pine or fir, S4S, sanded.
 - 1 piece, 1 by 2 in. by 4 ft., pine or fir, S4S, sanded.
 - 1 piece, 2 by 5 in. by 4 ft., pine or fir, S4S, sanded.
 - 1 piece, 2 by 4 in. by 4 ft., pine or fir, S4S, sanded.
 - 1 piece, ¾ by 2 in. by 8 ft., maple or birch, S+S, sanded.
- Cost of material, about \$5.
Time to build, about 24 hours.

Built-In Seat

- 1 piece, 1 by 3 in. by 16 ft., pine or fir, S4S, sanded.
 - 1 piece, 1 by 3 in. by 14 ft., pine or fir, S4S, sanded.
 - 1 piece, 2 by 2 in. by 6 ft., pine or fir, S4S, sanded.
 - 1 piece, 1 by 10 in. by 12 ft., pine or fir, S4S, sanded.
 - 2 pieces, 1 by 2 in. by 10 ft., pine or fir, S4S, sanded.
 - 1 piece, ¾ in. by 1 ft. 6 in. by 3 ft., 3-ply veneer.
 - 3 butterfly (surface) hinges; 1 flush lid lift.
- Cost of material, about \$3.25. Time 12 hours.

and stiles housed in, and set them for puttying. Remove all glue spots and bruises before finishing.

The stationary seat is designed to be built between two bookcases or some similar combination. It is 15 in. wide, 1 ft. 6 in. high, and 6 ft. long. The seat slopes toward the back ¼ in., making for comfort, and the bottom of the front is let back to give heel room.

Build the front panel of 1 by 3-in. stock, sized to 2½ in. in width. The stiles are 13 in. long, the rails 5 ft. 7 in., and the muntin, fitting between them in the center, is 8 in. long. Groove all ⅜ in. deep, centering the groove on the face edges, for housing the panels of ⅜-in. three-ply panel veneer. These are cut 8⅝ in. by 2 ft. 8⅞ in. Assemble by doweling the joints.

The top frame is of different construction. The back rail is cut 6 ft. long, and the stiles are butted against it. Note that the frame projects over the front panel ¾ in., necessitating the returns on the stiles shown in the plan. The front rail and stiles are joined by doweled miters.

Measure up from the floor 1 ft. 4½ in. and level a line full length of the seat. Guiding on this, nail up a 1 by 2-in. cleat. Nail to the floor a like cleat, keeping the front edge 12¼ in. from the plaster, or in line with the baseboard backing of the cabinets between which the seat is being built. Now shape the 2 by 2-in. stop cleat as shown in the cross section and glue and nail it to the upper rail of the front panel. Make the center partition out of 1 by 12-in. stock, widened with 1 by 2-in. material, and make the two ends of the seat exactly like it, except that the stop-cleat notch is omitted, the cleat butting inside the ends. Tack the partition and ends in place and test the fronts to see if they line, taking them down to make nec-

The fitting of the top frame is rather difficult. Measure the exact length between the cabinets or walls at the ends of the seat, using two rods, and transfer this length to the frame. Then scribe a piece of cardboard to fit each cabinet, and trace the outlines on the ends of the frame. After cutting, slip it into place, and scribe the back rail to the plaster; or if preferred, nail in place and cover the wall joint with a small molding.

Run one straight length of baseboard through for both cabinets, or if the seat is built in a plastered corner, miter the base around the free end. Nail the base shoe to the floor rather than to the baseboard, for if the latter is done, shrinkage of the base will lift the shoe from the floor, making an open joint.

Non-Slip Hook on Chain

The tension on open chain hooks in many cases bends them out of shape and causes them to unhook, but with the simple arrangement shown in the illustration this objectionable feature is entirely eliminated. Instead of loosening as the tension increases, it is locked even more securely. This is accomplished by putting the hook on the second link from the end and slipping the last link over the hook, which is bent outward as indicated. The dotted lines show the position of the links while the last one is slipped over to lock it. It is obvious that tension holds the lock link tightly.

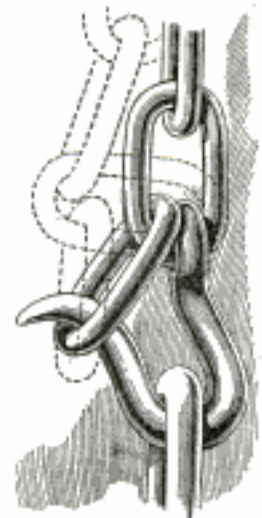

Portable Fire Barrel

In a large lumber yard where barrels of water were set out along lumber stacks for extinguishing beginning fires, it was



Wheeled Trucks for Water Barrels in Lumber Yard Help to Prevent Large Fires

found on one occasion that the flames could not be controlled because it was impossible to carry water fast enough in the fire buckets from the barrels. So the barrels were mounted on wheels, as shown in the illustration, so that the whole barrel could be taken to the blaze. A hoop was made of $\frac{1}{2}$ by $1\frac{1}{2}$ -in. flat iron to fit over the lower end of the barrel. At opposite sides wheel bearings are welded to the hoop to take 24-in. lumber-truck wheels. A tongue with which to draw or push the cart was then attached.—L. M. Jordan, Vredenburgh, Ala.

Removing Ford Front-Spring Perches

When Ford front-spring perches must be removed from the axle, they are often found to be a tight fit or rusted in place. With the axle in place on the car, they are rather difficult to drive up, because short hammer swings only can be taken, and to raise the front end of the car or remove the axle is difficult unless the proper hoist is at hand.

A good method is to place a jack or block under the lower end of the perch, after removing the nut, and raise enough to lift the wheel on that side. Then hammer on the upper side of the axle near the

perch. Hammering on the axle is not as effective as on the end of the perch when the axle is removed from the car, but with the axle in place it adds part of the weight of the car to the hammer blows. To prevent burring of the lower end of the perch, the radius rod can be dropped, on the new style cars, and the nut replaced flush with the end of the perch. This will allow the perch to be driven up about $\frac{5}{16}$ in. before the nuts need be removed. They are then unscrewed and the castellated end will straighten out the threads. This upward movement will break the rust, and the rest of the removal will be fairly easy. Plenty of penetrating oil or kerosene poured about the upper end of the perch will help in loosening it.—E. T. Gunderson, Jr., Humboldt, Iowa.

Tag Clip for Radiator Pipes

In a warehouse where material is often heaped temporarily on the floor, advantage was taken of the hot-water pipes on the walls for holding metal tags containing a description of the goods immediately below. These tags at first were simply wired to a pipe but as this meant trouble when they had to be changed or moved to another position, the clip shown in the photo and illustration was devised. It consists of two pieces of spring wire, one bent to form a hook and the other to form a catch. To attach the clip the hook

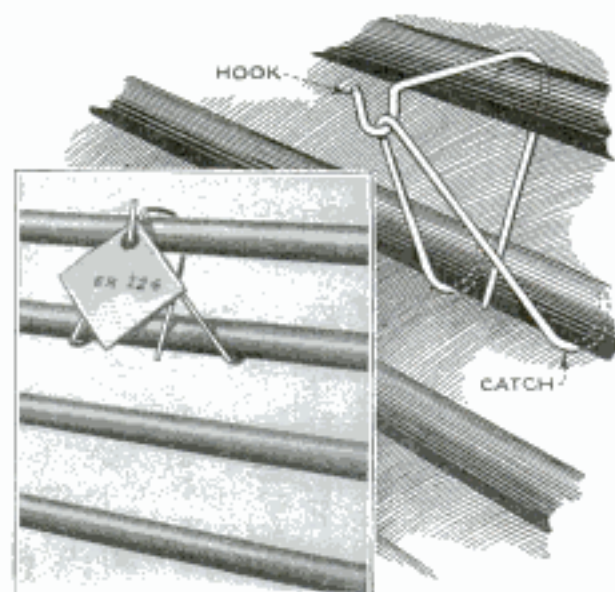

Safety Clips for Radiator Pipes Hold Tags Identifying Material Stored on Floor Below

is first put on one pipe and the catch pulled down and sprung under the pipe below as indicated in the illustration.—Hary Moore, Montreal, Can.

Six-Room Home—Hollow Tile and Stucco



Plan No. 6B20



© Architects' Small House Service Bureau

SIMPLICITY of design is the keynote of this modern English cottage. The direct arrangement of this plan provides a roomy interior without loss of valuable space.

Here is a step-saving, space-saving plan difficult to improve upon. Special thought has been given not only to the use of standard lengths of lumber, but to the use of stock millwork as well. This means a saving in building costs.

The house is planned to be built of hollow tile walls on concrete footings, with stucco exterior and brick base course. The house is planned to face west or south, but for other facings the plan should be reversed.

The basement is planned for excavation below kitchen, sleeping porch, rear chamber and dining room only. A full basement can be provided if desired.

Special features of the house are a lattice-inclosed pergola porch, a fireplace of simple, inexpensive design in the living room, an arched opening between living room and dining room, and French doors, if desired.

This house provides six rooms and bath. A breakfast table with seats are in the nook in the kitchen. A sliding door between the kitchen and the rear entry is a feature that will be found highly desirable and convenient.

Home Builders' Questions

Q. I am building a new home and am undecided as to the finishing of the floors. They are to be hardwood. Some people say that they should be finished with shellac, while others say to use varnish. Which is the better way? **A.** Shellac may be used on floors only where they are almost completely covered with rugs. In other words, shellac will not stand wear. Put on three coats of the finest varnish you can buy.

Q. I note the construction of one of the houses you illustrate is "trowel marked stucco." Just what is meant by this? **A.** Stucco is a plastic material that may be modeled freely. Customarily it is finished smooth. However, it is possible to secure a rough finish in various different ways, one of which is by putting the stucco on with a trowel and not smoothing it afterward. The finish will therefore bear the marks of the trowel.

Q. What is the usual charge made as commission on second mortgages and contracts for deed? **A.** Various commissions are charged on this kind of paper, depending upon the size of the mortgage and what the current market is for money. The exact amount of commission is often a matter of bargaining. In some districts the going rate of discount on a contract for deed is 4 per cent per 1,000. Thus a \$5,000 contract would be discounted \$200.

Q. Is there much difference in expense between a gas fireplace and one in which coal is burned? **A.** The difference is made up largely by the difference in expense between the metal pipe to vent the gas heater and the masonry stack necessary to carry off smoke. This amount is not great enough to be made the basis of choice. If you can afford a fireplace, build the one you like best.

Q. Can casement windows be made water-tight? Are they more expensive than double hung windows? **A.** Casement windows can be made perfectly water-tight, especially if they are of the out-swinging type. Weather stripping is of great assistance. Casement windows of the out-swinging type generally cost more than double hung windows, since the screens and storm sash must be of wood to match the finish woodwork.

QUESTIONS regarding home building addressed to this magazine will be answered by the Architects' Small House Service Bureau of the United States, Inc., controlled by the American Institute of Architects and indorsed by the department of commerce, United States government. Blueprints, specifications and material lists for the house shown above may be obtained at a nominal cost. Inclose self-addressed, stamped envelope for reply. If further information is desired send five cents and stamped envelope for a 24-page booklet explaining how the small home bureau functions and showing twelve sample plans.



Q. I am building a battery charger and wish to determine the polarity of the supply line. Please tell me some simple method of doing this.



Fig. 1

A. If the polarity of the circuit is not known, hold the exposed ends of the wires in a glass of water in which some common salt has been dissolved. Be sure to keep the ends of the wires separated. Gas bubbles will appear about the ends of the wires but the greater amount of bubbles appear on and about the wire that is connected to the negative side of the circuit. (See Fig. 1.)

Q. Will a wavetrapp give me greater selectivity? I am using the ultra-audion circuit, and find it very good but not as selective as I would like.

A. Yes a wavetrapp will give you greater selectivity. You will find a good wavetrapp described on page 999 in the June, 1925, Popular Mechanics.

Q. Can I use a gas pipe for a ground? What size of wire should I use for my receiver ground? **A.** Gas pipes should never be used as a ground, because they are often insulated at the meter, and then there is always a chance of static discharge, igniting a leak. A cold-water pipe serves best, as it has fewer joints, and leads more directly to the earth. Use No. 14 insulated wire for the ground lead, and attach it to the pipe with a good ground clamp.

Q. I have a six-tube receiver using the UV-199 tubes. When anyone walks across the room, or the set is jarred in any way, there is a growling noise in the horn. What is the cause of this and how can I remedy it? **A.** This noise is caused by the tube vibrating in the socket. The tubes must be mounted in rubber-cushioned sockets, or small squares of sponge rubber must be placed under the corners of the cabinet.

Q. What is a phusiformer? Does it take the place of the usual r.f. transformer? **A.** The phusiformer is another form of r.f. amplifying transformer, which has a primary and secondary winding with adjustable coupling.

Q. What is the difference between a regenerative set and a non-regenerative receiver? **A.** In the non-regen-

erative receiver the a.f. signals from the plate are made to actuate the telephone receivers, and no use is made of the r.f. pulsations. In the regenerative receiver the r.f. current is put to work by being fed back to the grid circuit. The effect obtained is greatly strengthened signals.

Q. I have a B-battery that makes a crackling sound in the horn; is there any way to eliminate this without getting a new battery at once? **A.** Sometimes the B-battery will break down, and cause jumpy reception, and horn noises. This can be partially remedied by placing a .001 to .006-mfd. condenser across the B-battery.

Q. Can a diode tube be used instead of a crystal in a reflex receiver? **A.** Yes; this tube contains but two elements, is stable in operation, and requires no adjustments, as is the case with a crystal.

Q. Can a sodion tube be used as an amplifier? **A.** The sodion tube is a detector only. Literature covering this tube can be obtained from any radio dealer.

Q. I have just finished a crystal receiver. Can I use an ordinary telephone receiver with this set? **A.** No; use good standard 2,000-ohm receivers.

Q. I have a five-tube set using two steps of tuned r.f., a detector and two steps of a.f. amplification. It gives good results on stations within 1,000 miles but I would like to build a set having a greater range. Would you suggest the superheterodyne? **A.** The superheterodyne still holds first place in radio receivers, having a consistent range of about 3,000 miles when properly constructed. It is easy to operate, and has loud-speaker volume on all stations within the range of the set.

Q. I purchased a three-tube receiver several months ago and have been getting good results up to this time, when for no apparent reason the set went dead. I know very little about radio and live some distance from anyone who could help me. The set works on dry batteries and I have put in new batteries, but this did not help. Where should I look for the trouble? **A.** The trouble may be caused by a defective tube, a short circuit in the set or aerial; broken or loose connections, broken loud-speaker or phone cord, poor contact of the springs in the tube sockets or jacks. Possibly you did not connect the new batteries correctly.

Q. Can a gap be arranged in the ground lead for a lightning arrester? Please give me a diagram for installing an arrester of this type. **A.** A gap can be built in flat-type porcelain cleats, but the better plan is to obtain a good protecting device approved by the underwriters, and connect it as shown in Fig. 3.

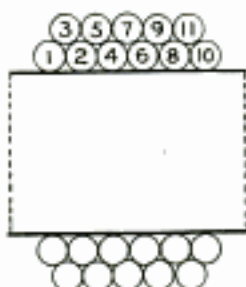

Fig. 2

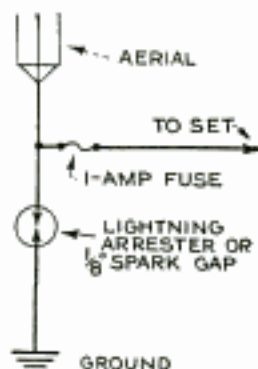

Fig. 3

IN accordance with the editorial policy of this magazine never to accept compensation in any form for what appears in our reading pages, and also to avoid all appearance of doing so, we are obliged to omit the name of the maker or seller of any article described. This information, however, is kept on file and will be furnished free, by addressing Bureau of Information, Popular Mechanics Magazine, Chicago. [Editor.]

You know
what your saw
should do—



YOUR saw should make a straight clean cut, fast and easy.

Suppose, instead, it binds, chatters, spoils your work, wastes your time?

Then you are ready for a real tool-user's saw—the kind worked out by Henry Disston.

He trained his own saw-makers, made his own steel. Made a saw that holds its edge, cuts keenly, is always ready.

Ask for the Disston Saw by name; it is "The Saw Most Carpenters Use."

In it you will find the steel, the balance, taper, and spring, that will make your work easier and better.

Henry Disston & Sons, Inc.
Philadelphia, Pa., U. S. A.

DISSTON

Ask Disston

Tell us what work you are doing, in wood, metal, stone, ivory, rubber, leather, cloth, fibre or other materials. We will tell you how to saw it better and easier. Disston issues many books to aid saw users.

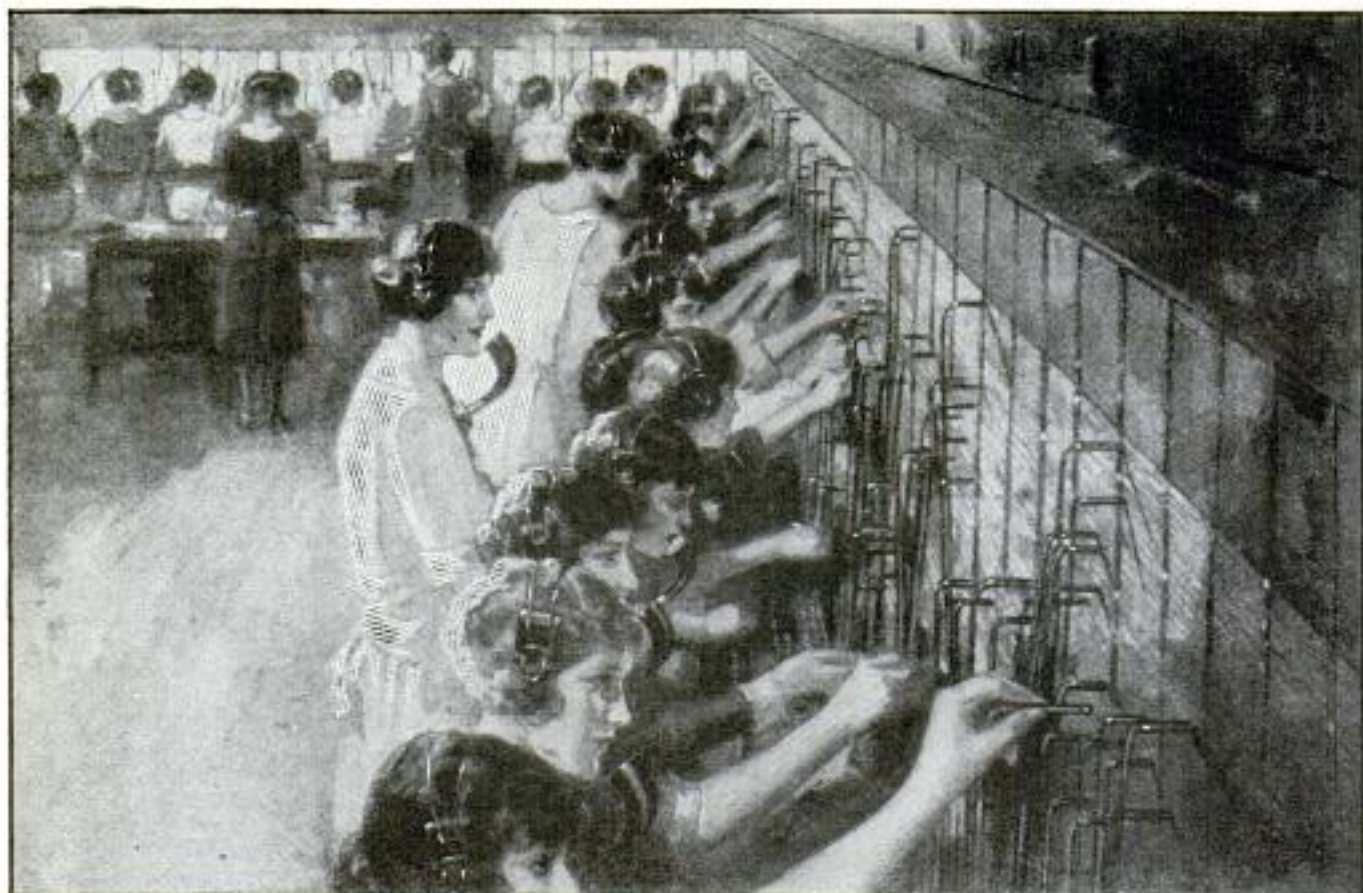

Service cannot stop

The telephone, like the human heart, must repair itself while it works. The telephone system never rests, yet the ramifications of its wires, the reach of its cables and the terminals on its switchboards must ever increase. Like an airplane that has started on a journey across the sea, the telephone must repair and extend itself while work is going on.

To cut communication for a single moment would interrupt the endless stream of calls and jeopardize the well-being and safety of the community. The doctor or police must be called. Fire may break out. Num-

berless important business and social arrangements must be made.

Even when a new exchange is built and put into use, service is not interrupted. Conversations started through the old are cut over and finished through the new, the talkers unconscious that growth has taken place while the service continues.

Since 1880 the Bell System has grown from 31 thousand to 16 million stations, while talking was going on. In the last five years, additions costing a billion dollars have been made to the system, without interrupting the service.



**AMERICAN TELEPHONE AND TELEGRAPH COMPANY
AND ASSOCIATED COMPANIES**

BELL SYSTEM

One Policy, One System, Universal Service

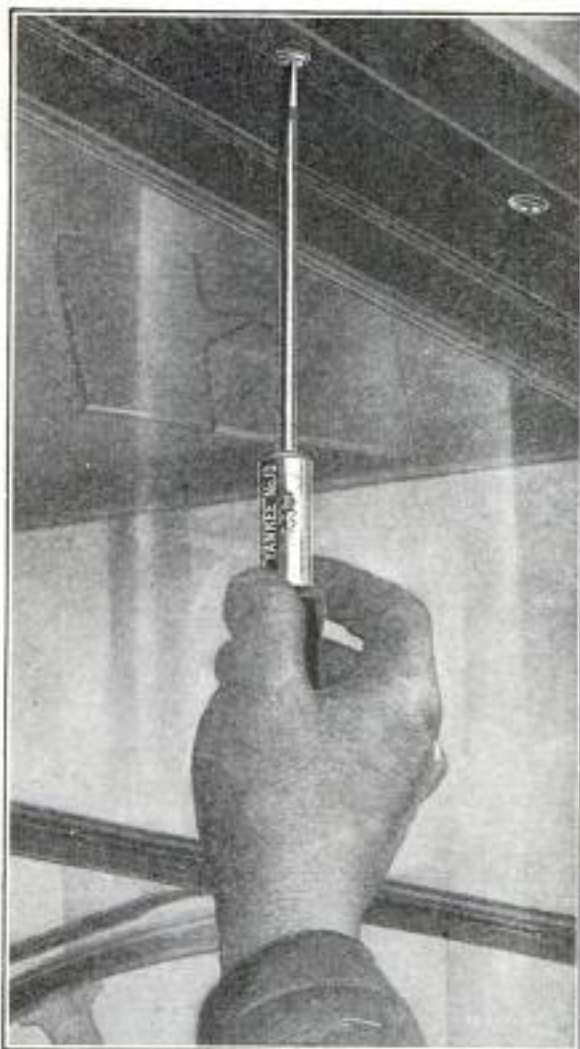

No. 10—(Illustrated).
Blade lengths, 2,
3, 4, 5, 6, 8, 10
and 12 inches.

No. 11—Same as No. 10,
except that
Ratchet Shifter
moves across in-
stead of parallel
to barrel.

No. 15—(Illustrated). Has
handy knurled
thumb turn for
starting small,
wobbly screws.
Blade lengths, 2,
3, 4, 5, 6 and 8
inches.



Let the "YANKEE" Ratchet *do the work*

Driving (or drawing) screws on visor as shown above, requires you to stretch upwards to do the job.

What a big help it is to have a "Yankee" Ratchet Screw-driver No. 10. All you need do is to set the little Ratchet Shifter, and turn to and fro. The "Yankee" Ratchet does what your muscles would otherwise have to do, and saves your time.

"YANKEE" Ratchet Screw-drivers Right and Left Ratchet; and Rigid

It's like winding your watch to use them. Your first grip need not be relaxed until screw is in, or out. All the tiresome grip-and-let-go is done away with.

Some other "Yankee" Tools

Ratchet Breast Drills
Ratchet Hand Drills

Ratchet Bit Brace
Ratchet Bench Drills

*"Yankee" on the tool you buy means the utmost in quality,
efficiency and durability*

Dealers everywhere sell "Yankee" Tools

NORTH BROS. MFG. CO., Philadelphia, U. S. A.

"YANKEE" TOOLS

Make Better mechanics



This seal on the tool you buy assures you of the highest tool quality

BROWN & SHARPE Inspection insures tools which *must* be right

So exacting are the requirements of Brown & Sharpe inspection that no product leaves the factory until it is as nearly mechanically perfect as men can make it. The maintenance of such high standards for nearly 100 years has brought to Brown & Sharpe Tools their reputation of dependable accuracy.

Brown & Sharpe Small Tool Catalog No. 29 lists over 2000 different tools. Write for your copy today.

BROWN & SHARPE MFG. CO.
PROVIDENCE, R. I., U.S.A.

BROWN & SHARPE TOOLS

"Standard of the Mechanical World"

Is your radio on Main Street?

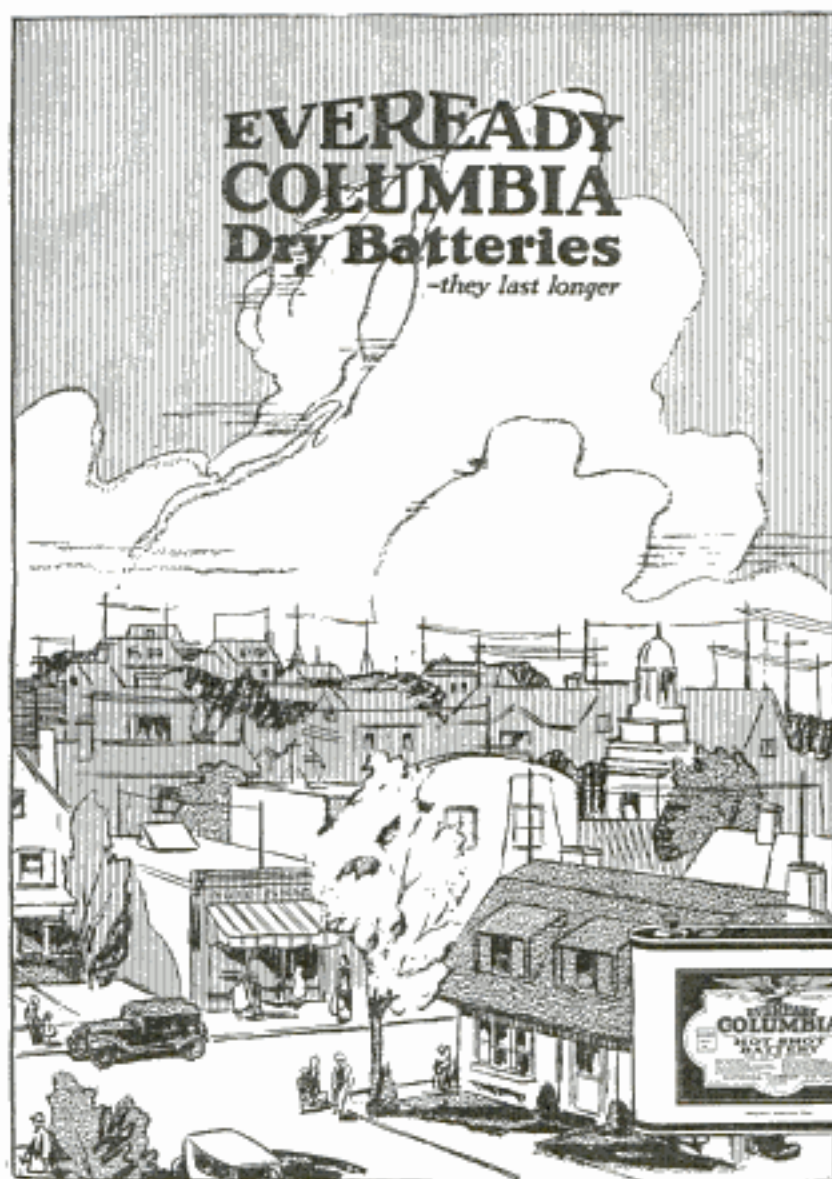

Popular uses include—

radio "A"
gas engine ignition
tractor ignition
starting Fords
firing blasts
heat regulators
doorbells
buzzers
ringing burglar
alarms
protecting bank
vaults
calling Pullman
porters
motor boat
ignition
telephone and
telegraph
lighting tents and
outbuildings
electric clocks
running toys

Eveready Columbia Hot Shot Batteries contain 4, 5 or 6 cells in a neat, water-proof steel case.



Fahnestock spring clip binding posts on Eveready Columbia Ignitor at no extra cost to you.

LIGHT the filaments of your dry cell tubes with Eveready Columbia Ignitors and put your radio on Main Street. No matter where you live, these remarkable batteries are always available. A good receiver, genuine dry cell tubes and Eveready Columbia Dry Batteries make a trio that's good for endless hours of entertainment direct from the Main Streets of the nation. Eveready Columbias are independent of all other sources of current. They're reliable, safe, convenient, economical. The world's standard dry cell, for radio and hundreds of other uses too, about home and office, farm and factory. Insist on Eveready Columbias. There is an Eveready Columbia dealer nearby.

Manufactured and guaranteed by

NATIONAL CARBON COMPANY, INC.
New York San Francisco

Canadian National Carbon Co., Limited, Toronto, Ontario

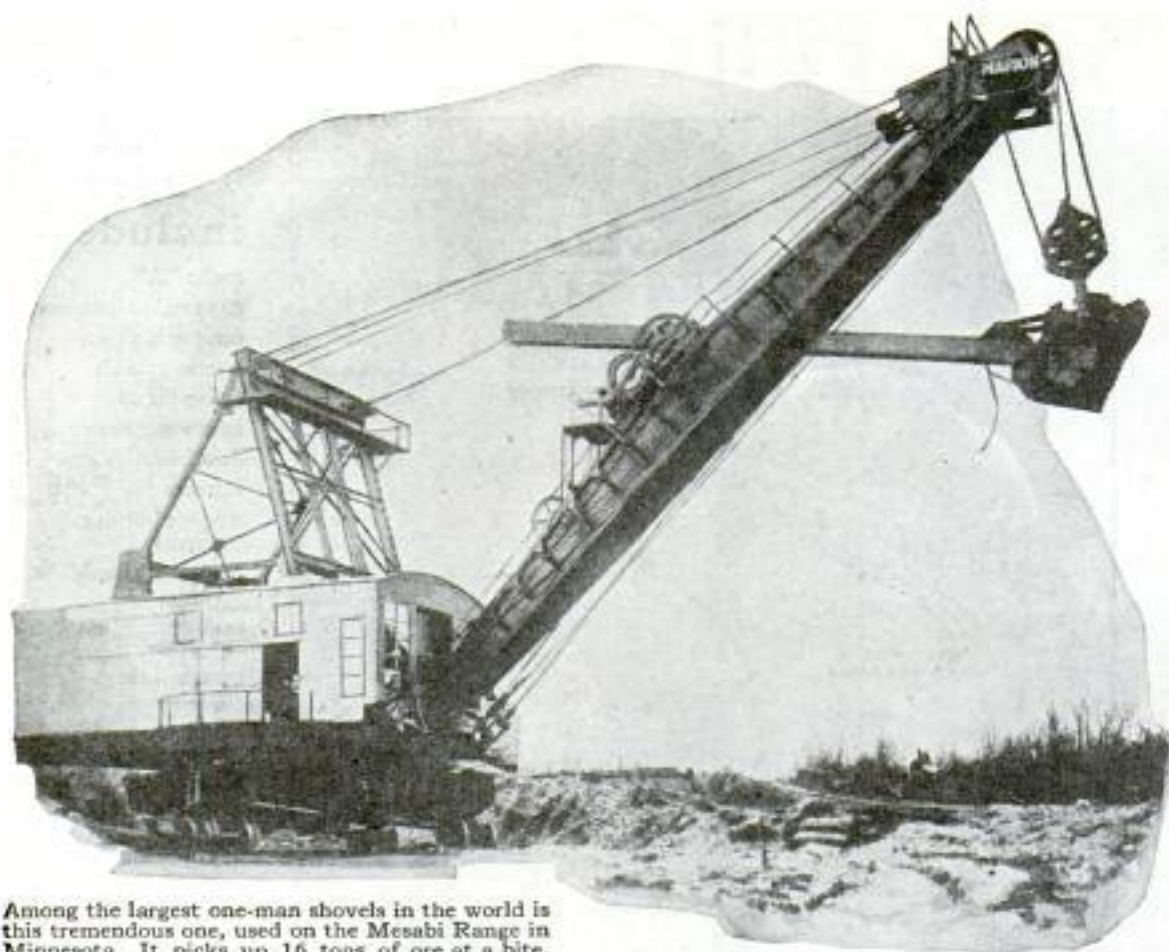

Among the largest one-man shovels in the world is this tremendous one, used on the Mesabi Range in Minnesota. It picks up 16 tons of ore at a bite, which it deposits in a car—all in less than a minute.

A day's work at every gulp



Surgeons use a tiny G-E MAZDA lamp when they examine an ear. Miners use G-E motored hoists to remove tons of ore from a mine. Wherever there is difficult work to be done you will find that the General Electric Company makes something electrical that will help.

A hand shovelful of ore weighs 21 pounds, and a man can handle 200 shovelfuls in an hour. But here is a giant that picks up, in one gulp, more than a man can shovel in a day!

And the G-E motors that animate the giant never get tired.

GENERAL ELECTRIC

IVES Push Button Control - stops and reverses
the engine by a touch of the finger

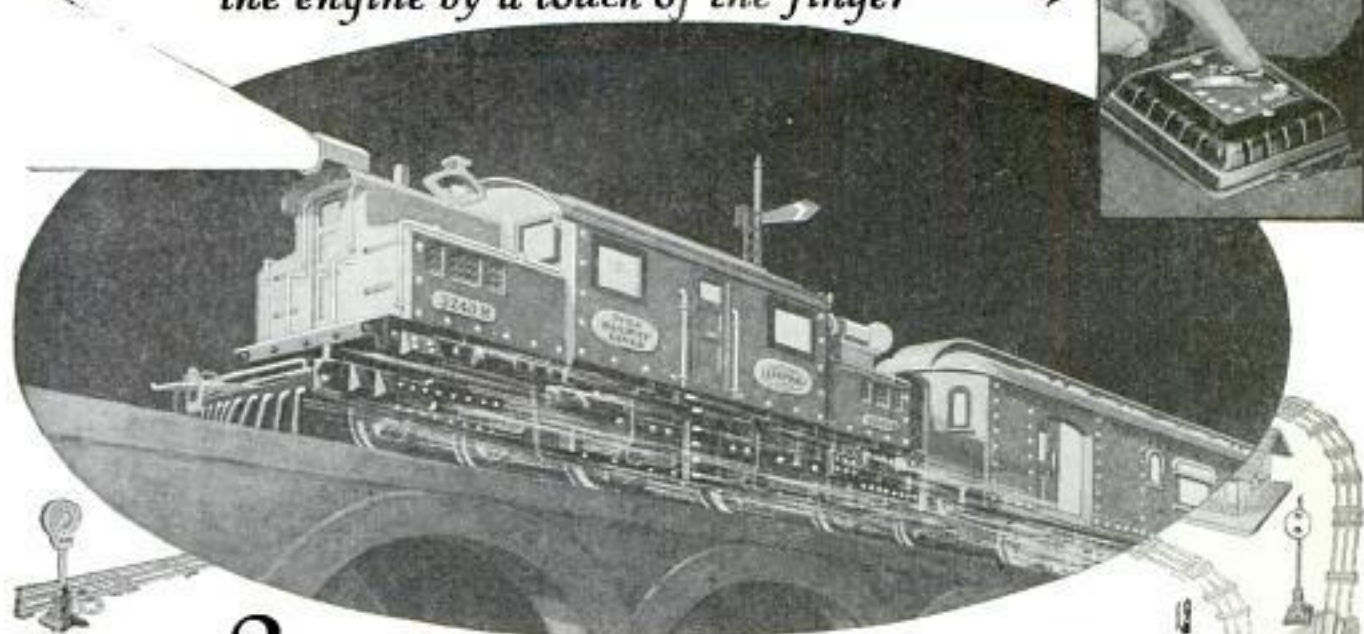

Fun? you bet - more than ever before
Just see the wonderful new features
of the 1925 Ives Electric Trains

THE boy who gets a 1925 Ives Electric Train for Christmas will have the most realistic, up-to-date and powerful train in all the world.

The Ives electric reversing locomotives (Series R) are the only locomotives that reverse electrically by a touch of your finger. You set this control switch for the speed you want. Then just a pressure of your finger on the button—the engine stops! Another touch—it backs!

Only Ives Trains give you these up-to-date improvements

It's a great sensation to see your locomotive reverse itself electrically at any position on the track without touching it by hand. Remember, boys, no other trains but Ives have electric reversing locomotives with the automatic push button control. It isn't a crude mechanical device on the locomotive or track, but a real electric automatic control operated from the switch. And this year you can have an Ives Electric Reversing Locomotive on O-gauge or 2 1/4-gauge track.

Ives trains are exactly like the modern equipment of famous railroads.

THE IVES MANUFACTURING CORPORATION
Dept. D 2, 198 Holland Ave., Bridgeport, Conn.

Cars are electrically lighted and attractively finished in every detail.

Every locomotive has worlds of power and a strong chassis so it can pull long trains at express speed. The motors in the lower-priced locomotives are as carefully made as the big ones and are as powerful in proportion to their size.

There is an almost endless variety of passenger and freight cars, electric target signals and semaphore signals with electrically-operated arms, bridges, tunnels, stations, and the efficient Ives Transformers. Prices range from the \$1.50 mechanical train to the big complete \$50 electric outfit.

32 - page book in colors tells all about the new features

Send for the new 32-page book of Ives Trains and Accessories. It contains illustrations in colors of the full line and tells all about the new 1925 features exclusive with Ives. Mail the coupon today with 10 cents. Toy, department, electrical, hardware and sporting goods stores sell Ives Trains.

**Speed me on my way
to Bridgeport - I'll bring
you the IVES Book**

"Fast Mail Coupon"

THE IVES MANUFACTURING CORPORATION
Dept. D 2, 198 Holland Ave., Bridgeport, Conn.

Please mail me your new 32-page railroad book illustrated in colors. I enclose 10 cents (U. S. stamps or coin).

Name

Address

City State



IVES ELECTRIC AND MECHANICAL TRAINS



E. H. HARRIMAN
America's Master
Railroad
Organizer

Wide-awake boys, operating their Lionel Model Railroad Systems today, are preparing to be the railroad leaders of the future.



LOOK
FOR THE
PATENTED
LIONEL
FEATURES

"Why, It Looks Real!"

Of course a Lionel Railroad looks real.

It is real. The only difference between Lionel and real trains is the size.

Lionel Engineers take care of that. They design and build Lionel Railroads electrically and mechanically perfect, so that they run like real railroads. They work from the engineers' drawings and blueprints of real railroad locomotives, coaches, freight cars, signals, crossing gates and the many other railroad accessories.

Lionel Model Railroads are way beyond ordinary "toy railroads." They are valuable educators. They are helping American boys to learn how real railroads are run, how the passengers and freight of the nation are transported.

Running a Lionel Model Railroad is exactly like running a real railroad.

Lionel Automatic Train Control. The greatest achievement in model railroad engineering. Starts and stops trains automatically. Just one of the many wonderful realistic railroad devices in the Lionel line of Accessories.



This wonderful realism can be found only in Lionel Model Railroads and Accessories. That's why American boys buy more Lionel Trains than any other make. That's why Lionel has been "Standard of the World" since 1900.

Lionel Model Railroads and Accessories are displayed at all of the best stores. Take father and mother with you to see them and remember: Lionel trains are lowest in price consistent with high quality—complete outfits from \$5.75 up.

Write today for your copy of the beautiful new 44-page Lionel catalog illustrated in actual colors. It shows the complete Lionel line. Sent free on request.

The LIONEL CORPORATION

Dept. D 48-52 E. 21st STREET
NEW YORK CITY



Be sure to send a post card today for this wonderful 44-page catalog, beautifully illustrated in 4 colors. It is FREE.



No miniature railroad is complete without the new Lionel Automatic Crossing Gate. Down goes the gate as the train approaches—up again when the train has passed. It works by itself—just like the real ones.



Lionel "Multivolt" Transformers—Ever-reliable power plants. Run all trains best. A type for every size train.

"STANDARD OF THE WORLD SINCE 1900"

LIONEL ELECTRIC TRAINS

MODEL RAILROAD ACCESSORIES

"MULTIVOLT" TRANSFORMERS

21 Jewel Santa Fe Special

on credit

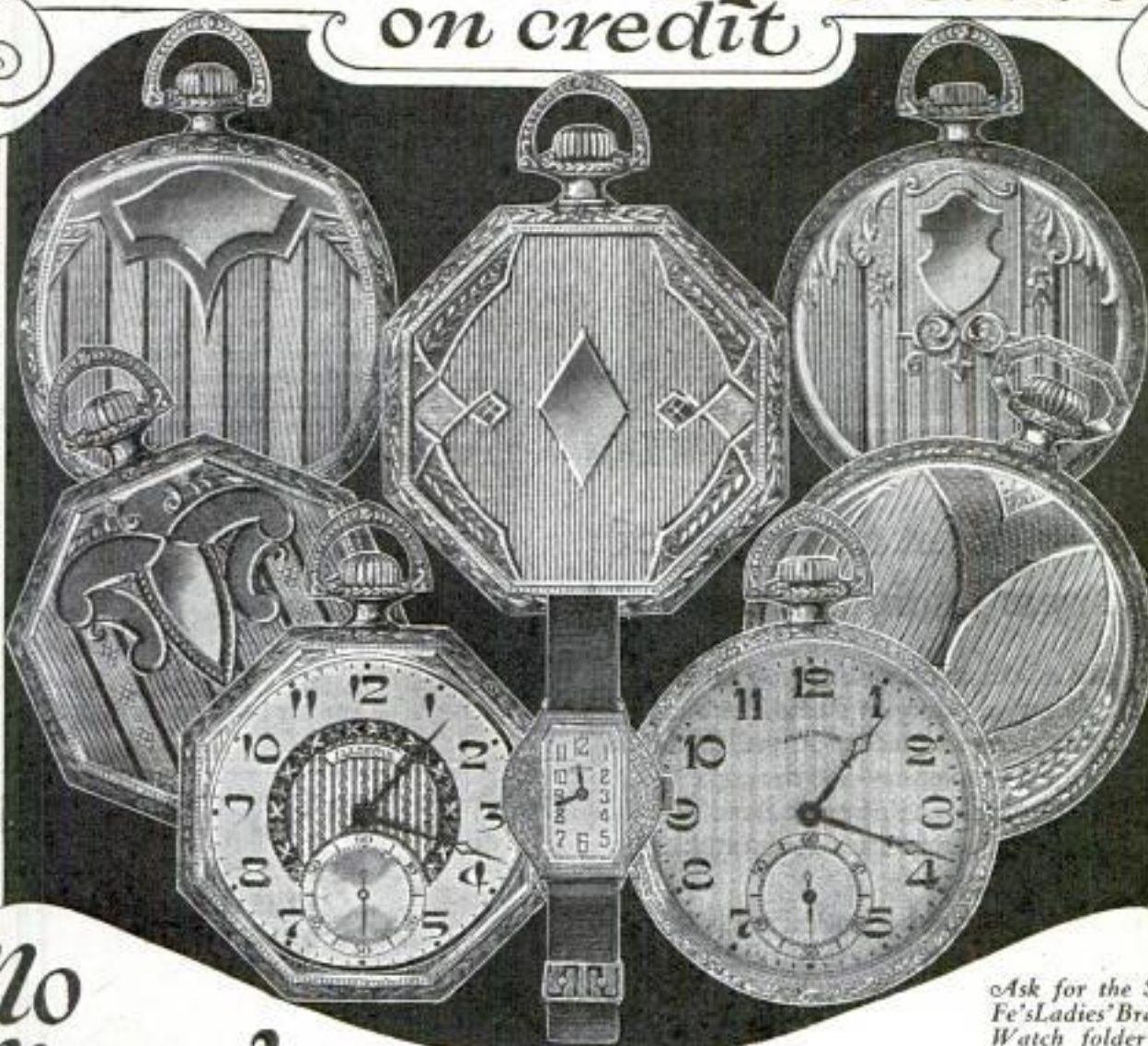

**No
Money
Down**

WE will send this famous watch direct to you, express prepaid on FREE Approval. Examine watch and be convinced it's the best watch buy you ever saw. You save $\frac{1}{3}$ to $\frac{1}{2}$ your money by purchasing a Santa Fe Special Watch. We trust you—wear watch while paying for it.

Ask for the Santa Fe's Ladies' Bracelet Watch folder and Diamond folder.

Mail Coupon for FREE Watch Book →

Clip the coupon, fill out and receive the FREE WATCH BOOK. All the newest watch case designs in white or green gold, fancy shapes and thin models are shown. Read our easy payment offer. Select the watch you would like to see, we will send it to you on approval, express prepaid. Wear the watch 30 days FREE—return at our expense if not fully satisfied.

SANTA FE WATCH COMPANY

Dept. B-6, Thomas Building Topeka, Kansas
The Home of the Great Santa Fe Railway

SANTA FE WATCH CO.,
Dept. B-6, Thomas Building,
Topeka, Kansas

Please send prepaid and without obligation your Watch Book Free, explaining your "No Money Down" Offer on the Santa Fe Special Watch.

Name.....

Address.....

ASK . . ANY . . RADIO . . ENGINEER



Burgess Batteries operate the receiving sets of radio-equipped mail planes

An every night adventure of Burgess Radio Batteries

ONE of the reasons why you should always buy Burgess Radio Batteries is that the batteries used by air-mail pilots—battleships—explorers—and the majority of recognized radio engineers—are evolved in the Burgess Laboratories and manufactured in the Burgess factory.

These batteries are identical with the batteries sold by your dealer and thousands of other good dealers everywhere.

BURGESS BATTERY COMPANY

GENERAL SALES OFFICE: CHICAGO

Canadian Factories and Offices: Niagara Falls and Winnipeg



BURGESS RADIO BATTERIES



FREE book

Shows how to get—greater distance, more volume, amazing selectivity, finer tone

Science has discovered a new principle in radio amplification . . . a striking new development that is bringing unheard of results. This principle is founded upon a new kind of coil—the Eria Balloon Circlord. It brings 4 distinct improvements. These are explained in a fascinating book just published and being mailed free.

Edition limited—Write today

Get this book and read about this newest scientific radio principle. See the many different circuits in which it may be used. Find out how you can turn your present set into the latest example of radio engineering—and at a remarkably small cost. There are only a limited number of these books, so you must write immediately.

Address **Electrical Research Laboratories**
2500 Cottage Grove Ave., Dept. 5-24 Chicago, Ill.

FAMOUS 'COAST TO COAST' MIRACO GUARANTEED

RADIO'S-FACTORY PRICES
SAVE 1/3 TO 1/2

Uses everywhere report Miraco Radios get programs coast to coast on loud speaker; outperform sets three times as costly. Many hear foreign countries. Radio's most amazing value is guaranteed factory-built, factory-tested long distance sets—let testimony of users convince you.

MIRACO RADIO GETS 'EM COAST TO COAST

Powerful New Multi-tube Miraco gets long distance on loud speaker. Set, ONLY \$27.35

FREE! Literature on latest improved 1 to 5 tube models, new low prices, testimony of users and SPECIAL OFFER. Write.

MIDWEST RADIO CORP'N
Pioneer Builders of Sets
407-C E. 8th St., Cincinnati, Ohio



AGENTS DEALERS Write!



RADIO TUBES

All Types—Guaranteed

\$1.50 Each

ACME PRODUCTS CO., Dept. 110

903 Broad St., Newark, N. J.

18,000,000 CARS

need it! Three devices in one! Big Seller!

I want an exclusive representative in your section. Opportunity to make \$10 to \$50 daily selling the new Electric Quick-Start & Gas Saver. No capital required. **Write Quick!**

W. W. KUTSCHE, Inventor Dearborn, Mich.



New Foot Accelerator

A revelation in auto-driving comfort. Foot presses a rubber roller which instantly adjusts itself to the foot, eliminating jerky feed, jumpy engine, wear on car and loss of gas. Immensely popular with lady drivers—adds to foot comfort in driving—no friction on sole of shoe—no wear. Makes astonishing difference in driving. Easily attached to any car. Try it. Return if not delighted, and we return money without question. We are responsible. Mailed postpaid for \$1.00. Order today giving name and year of car, or send for circular.

P. I. MILLER CO.

Box 807, Station C., Los Angeles, California



FREE!

NEW MONEY SAVING BOOK



Ranges Buy direct from factory! Save **\$37⁷⁵** $\frac{1}{4}$ to $\frac{1}{2}$ on your stove, range or furnace. Take advantage of the biggest SALE in our 25 years. Kalamazoo quality is the highest; prices are at bedrock. This is the year to

buy. Send for our big, new catalog—it's full of new ideas, new features, new models. 200 bargains in heating stoves, gas ranges, combination ranges, coal ranges, furnaces, both pipe and pipeless, and household goods. Cash or easy payments. 30 days' trial. Money-back guarantee. Twenty-four-hour shipment. 560,000 pleased customers.

Furnaces **\$59⁹⁵** Up



Write today for Your **FREE Book Now Ready**
KALAMAZOO STOVE CO., Mfrs.
391 Rochester Avenue,
Kalamazoo, Michigan



"A Kalamazoo Direct to You"

21 Jewel ~ Extra thin STUDEBAKER

The Insured Watch

Sold direct from the factory at a saving of 50%.

SENT FOR

\$1.00 DOWN!



Only \$1.00! The balance in easy monthly payments. You get the famous Studebaker 21 Jewel Watch—insured for a lifetime; 8 adjustments, including heat, cold, isochronism and 5 positions—choice of 60 new Art Beauty Cases in green gold, white gold or yellow gold effects. Latest thin models.

Chain Free! For a limited time we are offering a beautiful Chain FREE!

Write For **FREE Book** Send today for wonderful Studebaker Book of Advance Watch Styles and our \$1.00 Down Offer—FREE!

STUDEBAKER WATCH CO.
Dept. P12 South Bend, Indiana
Canadian Address: Windsor, Ontario

-m-m-m-m-m-boy!

The lure of jazz is yours with a Buescher Saxophone. Young folks are enamored by its tantalizing tunes. They love that syncopation.



Free!

This 64 page book tells about the various models with pictures of professionals using them. Send for copy of this wonderful Saxophone Book

This is the Buescher C Melody

Tantalizing Tunes

If you want to be popular - if you want to be admired - favored, get this wonderful instrument. At home, at parties, everywhere, you will always be welcome with your

BUESCHER True Tone SAXOPHONE

You don't have to "study" the Saxophone as you do other instruments. There is no practice drudgery. Three lessons sent free give you a quick easy start.

Easy To Play - Easy To Pay

You can learn to play a Buescher. If you can hum a tune, if you can beat time, you can learn to play most any Buescher instrument. And if you are "talented" or "gifted" you may become famous.

TRY IT SIX DAYS, FREE

Try a Buescher, any instrument you choose, in your own home. 6 Days FREE. This is a most liberal offer. Places you under no obligation. We take the risk. If you like the instrument and decide to keep it, pay a little each month. Pay as you play. Mail coupon for full details.

BUESCHER BAND INSTRUMENT CO.

Everything in Band and Orchestra Instruments
1064 Buescher Block Elkhart, Ind. 289

Clip the Coupon NOW!

Mail

BUESCHER BAND INSTRUMENT CO.
1064 Buescher Block, Elkhart, Indiana

Gentlemen: Without obligation to me, send your beautiful book "The Story of the Saxophone". Check here If you prefer other literature describing other band or orchestra instruments, check below.

Cornet Trumpet Trombone Tuba

Mention any other

Write plainly, Name, Address, Town and State in Margin Below

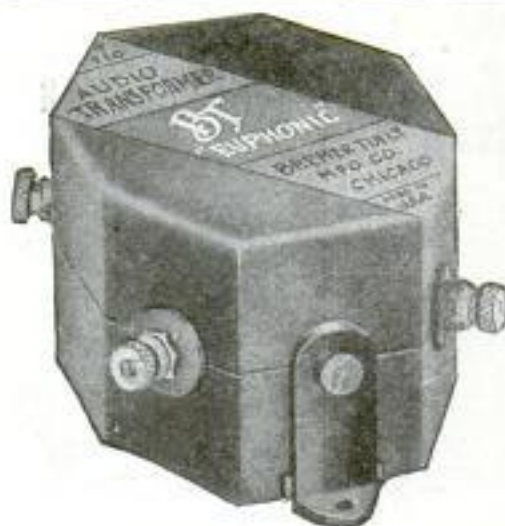

For Fidelity to Tone

USE

B-T "Euphonic"

The B-T "Euphonic" Transformer sets a new standard. It is not only *superior in tone quality* but offers the first real *improvement in mechanical construction* in years.

All experienced set builders know of the distortion and howling caused by **LONG LEADS** and **CROSSED WIRES**.

The adjustable legs of the Euphonic allow mounting *either side up, above or below* sub-panel, so you can bring your terminal connections where needed for *short leads and no crossed wires*.

The Euphonic is the result of the *20 years' radio experience* of Harry A. Bremer, who built his first wireless apparatus in 1905.

The B-T Euphonic is unsurpassed.

Two ratios, 2.2 to 1, **\$5.00**—4.7 to 1, **\$5.75**

The New B-T Circuit— The "Counterphase"

The "COUNTERPHASE" circuit with B-T Torostyle Transformers and Tandem Condensers offers the *first practical 6-tube set with three stages of radio frequency and only two tuning controls*.

This means *long-distance loud-speaker* operation with only *a short indoor antenna*.

The Counterphase is built under exclusive B-T patents covering a variable control of oscillations *over the complete broadcast range*.

Whether you build your own or buy a factory-built set you cannot beat the Counterphase.

The 6-tube Kit (2 Tandem Condensers, 4 Torostyle Transformers, wires, double resistance, 2 mikro 'mike condensers, blue prints and instructions) **\$38.00**.

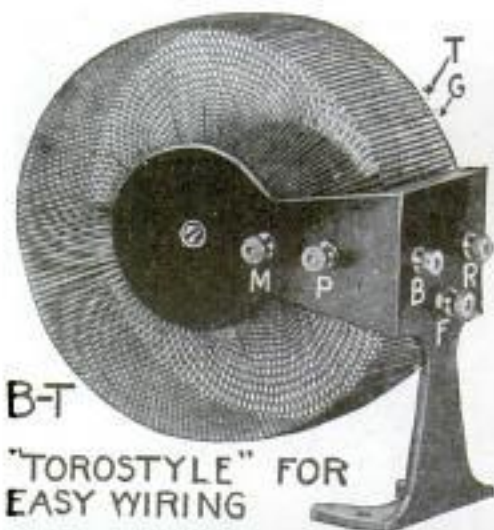

WHAT'S NEW IN RADIO

"Better Tuning" is the biggest dime's worth you ever bought in radio. Contains new circuits, tuning information, and all the latest ideas in Radio are discussed. Send 10c in coin or stamps today. Circulars free.

Bremer-Tully Mfg. Co. 532 S. Canal St.
CHICAGO, ILL.

The SHOE of CHAMPIONS!

KEDS help win World and National Championships



The ORIGINAL CELTICS—National Professional Basketball Champions. These famous stars always wear Keds.



America's champion handball player and the New York State handball champion wore Keds in winning their titles.

AMERICA'S fastest basketball team—the champion handball player of the country—National and Olympic singles and doubles tennis champions—Olympic soccer champions (in training)—these are just a few of the victorious athletes who wear Keds.

These men and women champions know that they must have a shoe built to give the most in speed, comfort and wear.

They know—

—that Keds soles are full of life and spring and remarkably tough, that they

have a sure grip that makes possible starting and stopping without slipping.

—that the uppers are of durable canvas—strong enough to support the foot and protect against twists and sprains—yet light and comfortable. And that there's a special Feltex innersole to absorb perspiration and keep the feet cool.

Keds are made of the world's finest rubber—grown on our own plantations. Keds frequently outwear two and three pairs of ordinary canvas rubber-soled shoes!

But remember—not all canvas rubber-soled shoes are Keds. Keds are made only by the United States Rubber Company, and the name Keds is put on every shoe. They come in all popular styles—prices \$1.25 to \$4.50.

The Keds Hand-book of Sports is full of interesting information on games, sports, how to make things and dozens of other subjects. Sent free if you address Dept. 770, 1790 Broadway, New York City.

United States Rubber Company

*They are not Keds
unless the name
Keds is on the shoe*

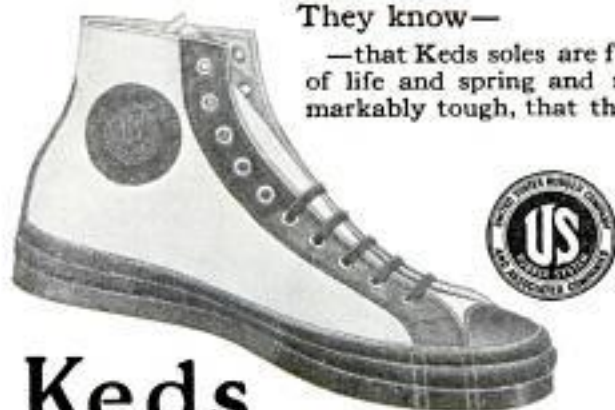

Keds

Reg. U. S. Pat. Off.

The Keds basketball shoe

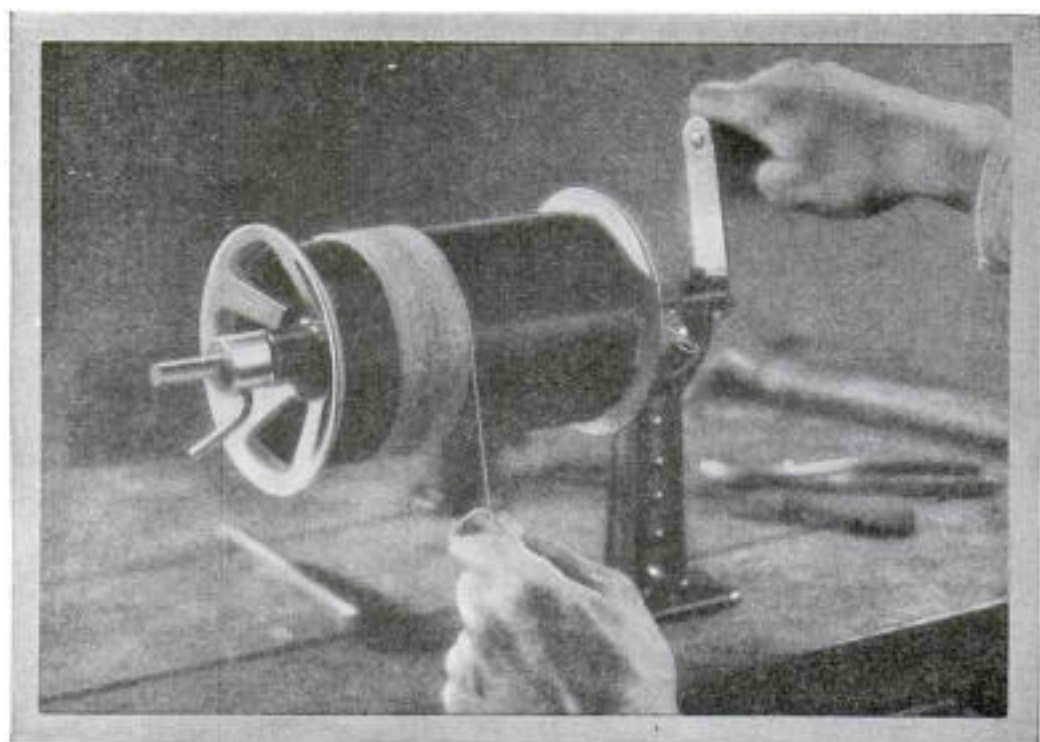

For the fan who "winds his own"

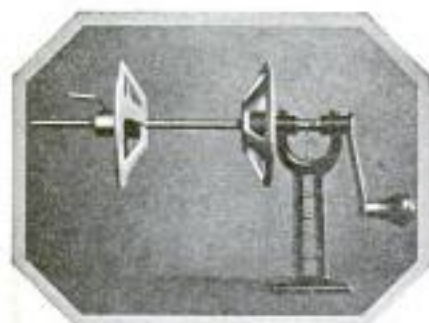

No. **695**

Coil Winder

Price, **\$4.20**

YOU set builders who are winding tubular coils, inductance coils, and transformers for superdyne and neutrodyne circuits can do an expert job with this Goodell-Pratt Coil Winder. You can do the job at your own bench, a job worthy of the highest class professional, at a fraction of the cost.

Holds any cylinder of cardboard, bakelite or fibre up to $4\frac{3}{4}$ inches in diameter and 7 inches in length. The outer aluminum driving disc is adjusted to the cylinder length by a sliding collar which can be locked at any point on the spindle with a thumb screw. The outside face of this collar is cut at an angle, affording a cam action against the button on the disc hub, which exerts a continual tightening effect on the cylinder. And because both discs are cone-shaped, the cylinder is centered automatically.

The spring wound around the spindle prevents it from turning backward and releasing the tension on the coil wire. If unwinding becomes necessary, merely raise the loop end of the spring.

Nicely finished in red and black enamel and natural aluminum, with all exposed steel parts well polished. Length over all, $14\frac{1}{2}$ inches; weight, 3 pounds.

Other tools for radio builders. Write for special radio tool folders, which show all the Goodell-Pratt radio tools, many of which are new and exclusive Goodell-Pratt inventions.

GOODELL-PRATT COMPANY, Greenfield, Mass.
Makers of Mr. Punch

GOODELL-PRATT

1500 GOOD TOOLS

A Real Long Range Crosley Receiving Set, \$9.75

Do not assume from its very interesting price that this very unusual Crosley set is a toy. Its impressive performance alone entitles it to serious consideration.

Heretofore, the \$10 radio was designed only for local reception. Now the Crosley Pup extends the entertainment radius to 1500 miles under ordinary conditions. Place it beside some costly multiple-tube set and operate the dials. Both tune through local stations sharply. Both get the same programs with equal ease and clarity. Both let you tap the infinite enjoyment coming through the air. There is only one difference—the Pup operates with head phones instead of a loud speaker.

The Pup is the newest Crosley set with a price that reflects the volume-production economies of the world's largest builder of radios. It is substantially constructed and permanent in every regard. Its design is an improvement of the famous Crosley one tube set with which Leonard Weeks of Minot, N. D., heard the Mac-Millan Polar Expedition while the rest of America listened in vain.

Almost overnight the Pup has become the most popular Crosley set ever offered. It is being bought for youngsters whose curious fingers cannot resist the lure of dials and switches; for the cook, the maid, the old folks back home, and for shut-ins. Traveling men are selecting it because of its easy portability, and radio enthusiasts to have an inexpensive check on their larger sets. Hear it once—and you will own one too!

In addition to the Pup, there is a Crosley for every price and preference. Operating 1, 2 and 3 tubes, these are encased in handsome Crosley-built cabinets and range in price up to the Super-Tridyn Special which retails for \$60. Each will deliver the superlative performance that has made the word "Crosley" a hall mark of radio perfection in millions of homes throughout the world.

THE CROSLLEY RADIO CORP. CINCINNATI, OHIO

Owning and operating W L W, first remote control super-power broadcasting station

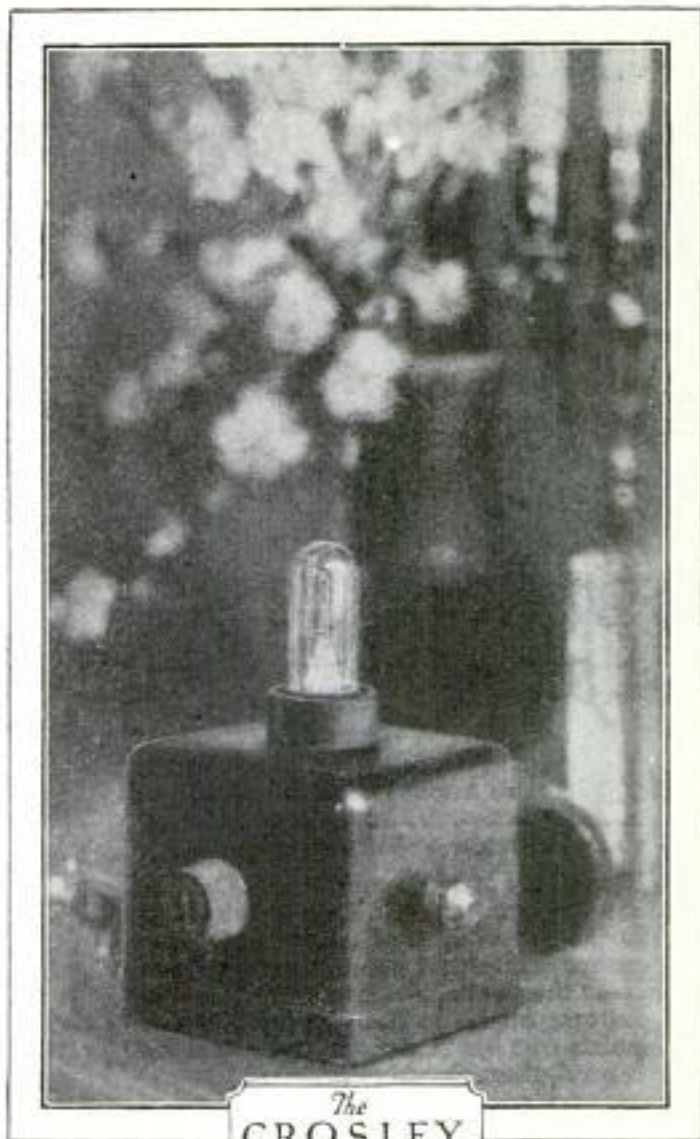

The
CROSLLEY
Pup - \$9.75

Crosley manufactures receiving sets which are licensed under Armstrong U. S. patent No. 1,113,149 and priced from \$9.75 to \$60.00 without accessories. None of the prices quoted include batteries, tubes, headphones, etc. Add 10% to all prices west of the Rocky Mountains.

Crosley De Luxe Combination
Musicone De Luxe - \$27.50
Super-Tridyn Special - 60.00
Console Table - 25.00
Complete - 112.50



Crosley 3 Tube 52S.D.
Mahogany finished cabinet, sloping panel. Holds all batteries - \$32.50



Crosley Super-Tridyn Regular
More compact than the Special Model—but exactly the same superb performance - \$50.00



Crosley Super-Tridyn Special
Matchless performance and exquisite beauty combined. Solid mahogany cabinet with popular sloping panel, \$60.00



Crosley 2 Tube 51S.D.
True long range set, easy to tune and handsome in appearance, \$25.00



CROSLLEY · RADIO

B E T T E R · C O S T S L E S S

Copyrighted material



And then he got a story in the Post

HIS wife knew he could write, but somehow he had always lacked the confidence or initiative to try.

Two years ago she gave him a Corona for Christmas, and, little by little he began to write. His first attempts were rather crude and promptly came back from the publishers. But he persevered. Editors began to take an interest—to point out his faults. A story was accepted, then another.

And at last he had a thrill of seeing his name in the Saturday Evening Post. He had arrived.

Is there someone in your family who should be developing a talent for writing? Get him a Corona—the standard typewriter for writers—portable, sturdy, easy to use. The latest model has the standard, single shift keyboard, and may be purchased or rented on easy monthly terms.

Look for Corona in your phone book or write the Corona Typewriter Company, Inc., 108 Main Street, Groton, N. Y.



CORONA

STANDARD KEYBOARD

LEPAGE'S mends for keeps



COMPARED to the value of the article mended, the cost of the glue you use is practically nothing. Then while you are about it, why not use the best glue—LePage's? Have the satisfaction of knowing that the article is mended *for keeps* and that it won't come apart in a little while and have to be mended over again. Insist on LePage's.

LEPAGE'S GLUE

Self-Filler DE LUXE Style Pen

"INDEPENDENT"

All the best features of a Fountain Pen. Looks longer. Writes smoother. Improves handwriting. Minimum fatigue. GUARANTEED.

14 Kt.

White Gold Point.
Chased Rubber Holder.
Lever Filler. Pocket Clip.

Your Name in Gold Inlay, 25c.

Write for Pen Catalog. Agents Wanted.

J. C. Ullrich & Co., 161 Washington St., New York

Known the World Over for 40 Years.

\$2.00

By Mail



Do Your PRINTING

Cards, stationery, circulars, labels, paper. Complete Outfits \$8.85 up, Rotary Jobber, \$150. Card Cutters \$3. Save Money. Print for others, big profit. Easy with rules sent. Write for catalog presses, type, paper, cards ink, etc. THE PRESS CO., L-37, MERIDEN, CONN.

For Permanence and Economy

Everlastbestos Flooring

PERMANENT—Laid over old floors or in new buildings. It has great wear-resistance, the result of a perfected formula and highest quality ingredients.

ECONOMICAL—Its first cost is the last and is surprisingly low.

ATTRACTIVE—Because of its fine texture and smooth, soft sheen. Three pleasing colors—red, buff and gray. Seamless—jointless—easy to clean—sanitary.

Used everywhere in homes for kitchens, bathrooms and in business buildings, factories, schools and theatres.

Write for catalog and free sample

EVERLASTBESTOS FLOORING CO.

Dept. P, 95 North Street, Rochester, N. Y.



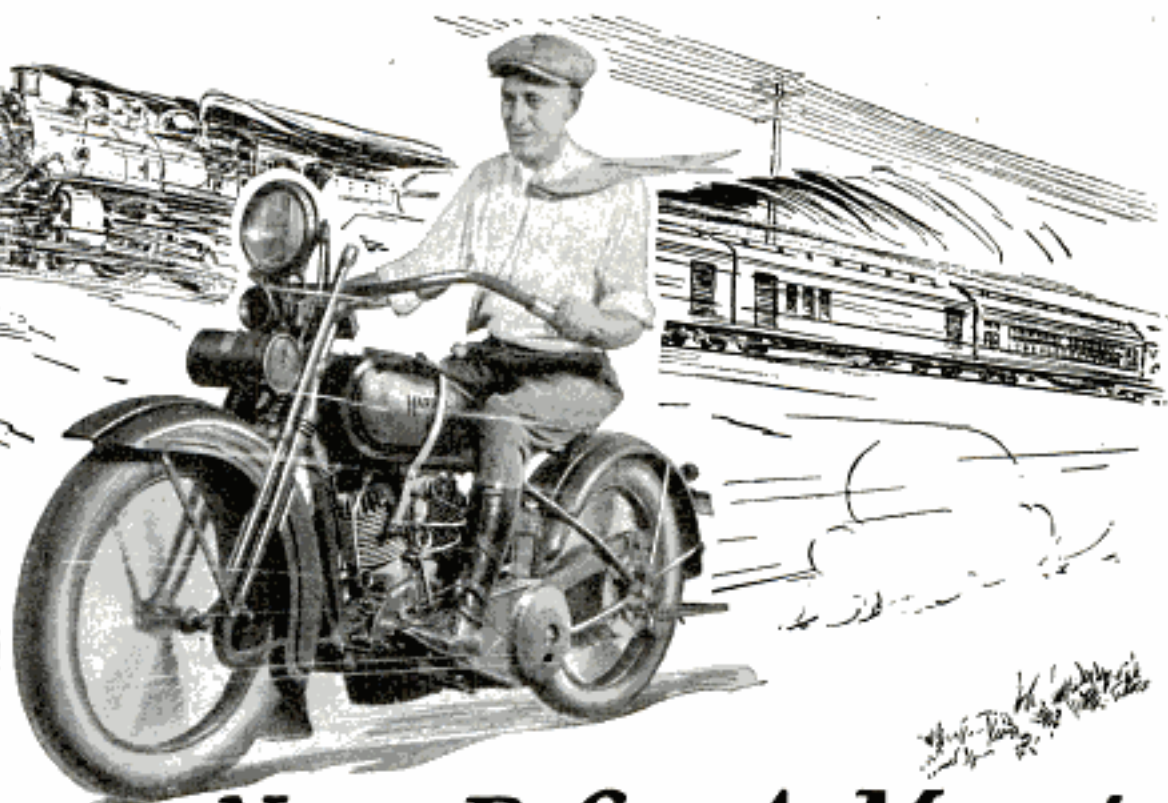

Never Before A Mount Like The "Twenty-Six"

MILES are happy minutes when you ride the "Twenty-Six". You glide along like the wind. Such eager power at your command! Such easy mastery of every road condition!

Harley-Davidson engineers have certainly outdone themselves in designing this great motorcycle. It has sixteen striking improvements.

Riding is believing. Just take a "Twenty-Six" over the Thrill Trail. Your dealer will be glad to arrange that treat for you. Ask him about the easy Pay-As-You-Ride Plan, too.

Money-making sales opportunities in open territories. Ask how others have made big successes selling Harley-Davidsons.

Harley-Davidson The Motorcycle

Mail the Coupon

Harley-Davidson Motor Co., Dept. P, Milwaukee, Wisconsin

Send me FREE, interesting literature showing the new 1926 Big Twin Harley-Davidsons in actual colors.

Name

Address..... City.....



Build and Fly Your Own 3-ft. Model Aeroplanes!

It's the most interesting fun you ever had. Shows you how big machines are built, because these are true models of real 'planes. You can fly your model too, right from the ground, under its own power. Any bright boy can build one. Ideal Scale Drawings and Building-Flying Instructions show exactly how to do it; and Ideal Model Aeroplane Construction Outfits contain everything needed. Get your outfit now and build a model aeroplane before Christmas!

This is the Well-Known JN 4 D-2 Curtiss Training Plane



A perfect 3-ft. Model of this popular machine, with parts and fittings just like the big one. Guaranteed to fly when correctly constructed. Complete Construction Outfit, containing everything needed to build the model, with full directions. **\$7.00**

This is the Famous DE HAVILLAND "Round-the-World Flyer"



An exact 3-ft. model of one of the planes which completed the world-circling flight. Will rise from the ground under its own power and fly in the air, when correctly constructed. Complete Construction Outfit containing everything needed to build the model, with full directions. **\$7.50**

(West of Denver, Colo. and in Canada, add 50c to these prices.)

Ask Your Local Dealer for These Ideal Model Aeroplane Construction Outfits or we will supply them postpaid, upon receipt of prices listed.

Send 5c for 48 p.p. Catalog containing pictures and descriptions of these Outfits and Flying Toys, including the popular Every-Boy's Airplane. Also lists hundreds of parts and supplies for Model Aeroplane Builders. Send 5 cents in stamps for a copy now.

IDEAL AEROPLANE & SUPPLY CO., 408 W. Broadway, New York

Beautiful HOUSES \$900 and BUNGALOWS

CAN BE BUILT FOR AND UP

This and many others in my new book, Building Plans for Modern Homes, will save you hundreds of dollars. One of the most complete and comprehensive books of plans ever published by any architect. New edition just off the press. Nearly 600 door plans and photographs of Colonial houses, bungalows, etc., costing from \$200 up! gives sizes and cost to build. Send postpaid for \$3.00.



FREDERICK H. COWING ARCHITECT
101 Tremont St., BOSTON, MASS.

Amaze Your Friends With Chemical Tricks

The Boy's Hand Book of Chemistry

Price 15 Cents

Write secret letters with invisible ink; pour blue, brown and black liquid from a glass of water; make a magic pitcher of bluing; make your own magic writing paper, your own ink and dyes. It's all easy if you have Chemcraft Junior—the pocket Chemical outfit. Get yours now. Order right away and get a FREE Copy of The Boy's Handbook of Chemistry; 150 pages of experiments, formulae, interesting chemical information, money-making suggestions and catalog of supplies.

BOTH
Porter Chemical Co.
113 Washington St.
Hagerstown, Md.

25¢
POSTPAID



Elto

(41)

(Designed and built by Ole Evinrude)

Quick Detachable Rowboat Motor

Powerful, Light Weight, Speedy, Quiet Running, Practically Vibrationless. Starts on a quarter turn. Easily carried with you anywhere you go. No rowing, no work, no bother. Just ride and enjoy the greatest of water sports. Slow down for fishing. Speed up for racing. Great power.

Write for FREE Catalog describing all the new features, especially the famous Propello Pump. Only Elto has it. Write today.

ELTO OUTBOARD MOTOR CO., Dept. AA
115 Riverside Plaza
Manufacturers Home Bldg., Milwaukee, Wis.



RAISE BELGIAN HARES

NEW ZEALAND REDS—Chinchillas—Flemish Giants
MAKE BIG MONEY—We supply stock and pay you following prices for all you raise: Belgian Hares \$5 each—New Zealand \$3 each—Chinchillas \$4 each—Flemish Giants \$5 each. 32-page illustrated book, catalog and contract, also copy of *Fur Farming magazine*, tells how to raise skunk, mink, fox, etc., for big profits, all for 10c. Address

OUTDOOR ENTERPRISE CO., Box 25, Holmes Park, Mo.

Big Money This Winter FILE AND SET SAWS BY MACHINE

The Foley Automatic Saw Filer will give you a profitable business this winter. L. C. Miller, 19 Grand St., Jamaica, N. Y. writes:

"I have filed 1600 saws with your Foley Filer and am busy from morning to night, owing to the reputation I have made for doing good work with your tools. People for 300 miles around—even from W. Virginia—send me their saws."

You can do the same. With a Foley Filer you can sharpen a saw in 5 minutes—perfectly. No experience necessary—makes you an expert filer.

Write for Free Circular about Foley Saw Tools

FOLEY SAW TOOL COMPANY

914 E. Lake St.
Minneapolis, Minn.

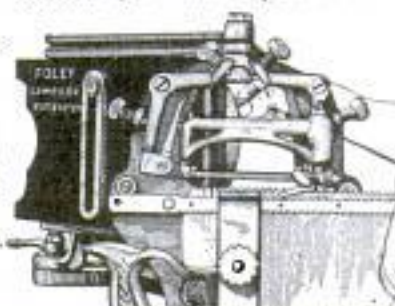

Send for this RADIO BOOK FREE

The World's Largest Exclusive
Radio Mail Order House Will Send
You This Wonderful Book FREE

64 illustrated pages containing thousands of bargains in radio sets, semi-finished sets and radio kits of all styles, sizes and approved circuits, 5-tube sets as low as \$29.50. Beautiful models of the very latest designs and types. Elaborate console models with loud speakers built right in cabinets of genuine mahogany and walnut. All sets guaranteed. Coast to coast receiving range. Also contains everything in radio supplies, including batteries, chargers, loud speakers, transformers, condensers, rheostats and any other parts you may want for improving your set or building a new one. Guaranteed saving to you of $\frac{1}{3}$ to $\frac{1}{2}$.



1926 Catalog of RADIO BARGAINS

Save $\frac{1}{3}$ to $\frac{1}{2}$

AMERICAN RADYNOLA 5 TUBE SET

\$29⁵⁰

The Biggest 5-Tube Value on the Market

Positively the world's greatest 5-tube radio bargains. Regular \$75.00 value. Our large quantity production enables us to sell this set for only \$29.50, fully built and wired in beautiful mahogany cabinet of latest design with sloping Bakelite panel of Satin finish, handsomely etched and engraved as illustrated. Constructed of the finest low-loss condensers, coils and sockets. Bakelite baseboard panel and dials. Price for set only \$29⁵⁰. Transportation charges extra, shipping weight 25 lbs.

This set with all accessories, including the famous American Bell loud speaker with adjustable unit, 2-45 volt "B" batteries, one guaranteed 100 Ampere Hour, storage "A" battery, cable for battery connection, 5-201A tubes, Aerial and ground equipment, and everything complete ready to set up and operate. Nothing else to buy. Price \$59⁷⁵. Transportation charges extra. Shipping weight 100 lbs.



Order Direct from This Page! Save About One-Half!

Order direct from this page. Save $\frac{1}{3}$ to $\frac{1}{2}$. Our guarantee protects you. Money cheerfully refunded if you are not satisfied. Write your order and prices plainly. Send post office money order or bank draft for full amount to insure safety. Refer to any bank or commercial agency regarding our reliability. All kits described on this page shipped prepaid East of Rockies (except Canada). American Radynola and the 5-tube Radio Frequency receiver shipped charges collect.

SEMI-FINISHED 5-TUBE RADIO FREQUENCY SET



\$18⁷⁵

This special offer is astounding the radio world. Coast to coast reception on loud speaker. Low loss condensers and sockets. Highest quality transformers. Bakelite rheostats. All wiring concealed under Bakelite baseboard. 7x18 panel—fits into any standard 7x18 cabinet. Complete instructions for operating. Guaranteed saving to you of \$50.00. Price of set all mounted, \$18.75. Cabinet of same model as American Radynola pictured above \$5.65 extra.

You must have our catalog no matter what set or kit you want. Our line is complete and includes all popular sets, such as Superheterodyne, Neutrodyne, Ultradyne, Reinartz, Regenerative, Radio Frequency, Browning-Drake, Super-Heterodyne Reflex and all other latest circuits. Kits, sets and parts manufactured by all well known manufacturers such as Frost, Howard, Baldwin, Brandes, Western Electric, Columbia and others.

Our semi-finished sets come with all parts mounted on panel and baseboard ready for wiring. Do not fail to send for our catalog. Remember—we are the largest exclusive radio mail order dealers in the world and carry the best of everything in radio. We save you $\frac{1}{3}$ to $\frac{1}{2}$ on the following kits. Detailed descriptions appear in our catalog.

SEMI-FINISHED 8-TUBE SUPER-HETERODYNE



\$43⁷⁵

World's Famous 8-tube superheterodyne. Fully mounted on panel and baseboard. Comes completely assembled ready to wire and operate. We have testimonials from thousands of builders of this set. Some have received foreign stations on loop aerial. Unsurpassed in volume and tone quality. Low-loss straight line frequency condensers, vernier dials, finest quality rheostats. Matched Remler or Columbia long waved transformers. Requires only three screws for attaching panel and baseboard and set is ready to operate. 7x30 panel. Price of set only \$43.75. Requires following accessories to complete this set: 7x30 cabinet, 8-201A tubes for storage battery operation or No. 199 tubes for dry cell operation. 100 Ampere hour storage battery, 2-45V "B" batteries, loud speaker, center tapped loop aerial. All these items are listed in our catalog at a tremendous saving.



Catalog includes list of broadcasting stations, general radio information and facts about our free service division. Write for it today.

NEUTRODYNE

Genuine licensed Neutrodyne kit of parts, come fully assembled on the panel and baseboard with complete instructions. Guaranteed ready to wire. Price \$29.75

COCKADAY

3-tube Cockaday kit of parts, fully assembled on panel and baseboard, ready to wire. Price \$15.85

REFLEX

4-tube Reflex does the work of 7. Fully assembled on panel and baseboard, ready to wire. Price \$38.65

ULTRA-AUDION

One-tube Ultra-Audion. Wizard of radio. Fully assembled and ready to wire. Price \$6.35 with instructions

RANDOLPH RADIO CORPORATION

159 N. Union Ave. Dept. 111 Chicago, Illinois

For Expert or Handy Man The Turner No. 45 Is Best

\$8²⁵

Postpaid

It permits you to do your best work because all the hazards and troubles common to ordinary blowtorches have been eliminated by Turner patented features. Over 50 years' experience have enabled us to perfect a blowtorch that is safe, fast, convenient and durable.

TURNER BLOWTORCH

"Safe as a Candle"

There are eleven patented improvements. The Super-heating Burner Baffle and heater plug that perfectly gasifies present day kerosene or gasoline; the separate Adjusting and Cleaning Needle that gives freedom from orifice trouble; the Automatic

Safety Valve that prevents explosions; the seamless, solderless, leakproof, polished brass tank with but one opening and that above fuel line; the Pistol Grip that fits any hand perfectly, and other features. **FEARLESSLY GUARANTEED.**

If your dealer can't supply you, write us direct.

THE TURNER BRASS WORKS
Industry Ave., Sycamore, Ill.

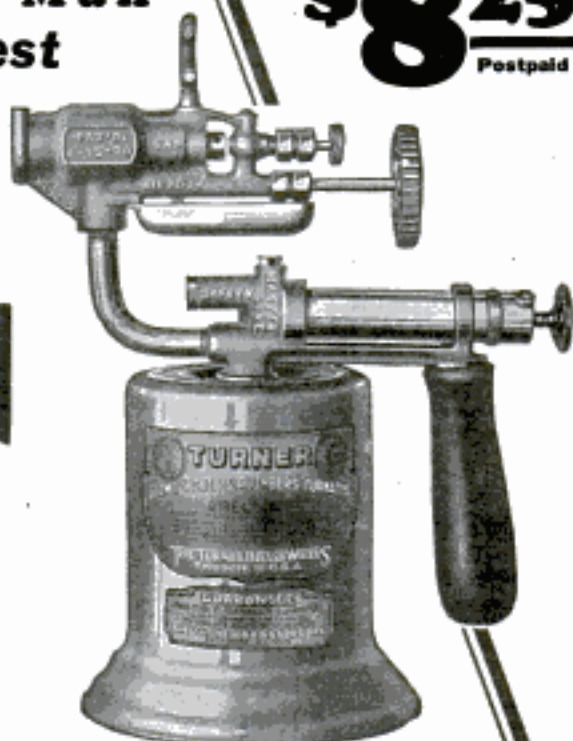

The World's Largest Exclusive Manufacturers of Blowtorches, Firepots & Brazers.

21 Jewels!

\$1 DOWN

Nothing less than 21 Ruby and Sapphire jewels is good enough for the Burlington masterpiece.

Quality and Style

Adjusted to second—temperature isochronism—positions, 25 year gold strata case, in 100 designs. Unsurpassed quality, rock-bottom prices. \$1 down brings your choice. Balance in small monthly sums.



Send for FREE Book Write today for FREE Burlington Watch Book Find out about this big special offer made for a limited time!

Burlington Watch Company Dept. 13-58
19th Street and Marshall Boulevard Chicago, Illinois

To Fasten Up Pictures, Charts and Other Things

MOORE PUSH-PINS

Glass Heads—Steel Points

Moore Push-less Hangers

For the Heavier Articles

10c pkts. Everywhere

MOORE PUSH-PIN CO., Philadelphia, Pa.



High Quality Long Life
Right Prices
These are found in all Gerstner
TOOL CASES AND CHESTS
for Machinists and Toolmakers.

A postal brings free catalog
Gerstner & Sons

423 Columbia St., DAYTON, OHIO



The Famous **KON-VER-TER SLIDE RULE**

Instantly adds, subtracts, divides, multiplies, converts fractions or decimals of an inch. Gives sines, co-sines, versed sines, co-versed sines, tangents, co-tangents, secants, co-secants of angles directly. Gives square roots, squares, cube roots, cubes and fifth roots and powers of all numbers. Logarithms, co-logarithms, anti-logarithms. Instructions with rule. De-Luxe Model \$3. Cash or C. O. D.

NEW ENGLAND NOVELTY CO.
Dept. A. WAKEFIELD, MASS.

DOES YOUR BOAT LEAK?

Send for our Booklets, "How to make Your Boat Leakproof," and "Marine Glue—What to Use and How to Use It."

JEFFERY'S MARINE GLUES
IN ALL THE VARIOUS GRADES

Any old boat so long as the frames are in fair condition can be made watertight by following the instructions in the above booklets.

For sale by all Yacht, Boat and Canvas Supply Houses; Hardware, Paint and Oil and Sporting Goods Dealers.

L. W. FERDINAND & CO.

156 Kneeland Street Boston, Mass., U. S. A.



My Engine Will Do the Work of 6



Write now for facts about this wonder engine. Same engine gives 1½ to 6 H. P. Gasoline or kerosene. Portable, light, and free from vibration. Requires no anchorage. Easy starting—no cranking. Pumps, saws, grinds and does all chores. Plenty of power for every purpose.

Low Factory Price—Free Trial Offer

Tremendous value. Thousands of satisfied users. Write now for details and free trial offer on this amazing engine.

Edwards Motor Co., 118 Main St., Springfield, Ohio



Copyrighted material



What's the Difference Between 20 Feet?

Theoretically, no difference at all. Twenty feet is twenty feet. *Actually* it depends on how the measurement is taken. A woven tape may say 20 feet when as a matter of fact the correct reading should be 19 feet, 11 $\frac{7}{16}$ inches. That's because the fabric stretches every time you pull the tape taut to get a reading. And you never can be sure of stretching it alike two times running.

Use a Starrett Steel Tape and you can rely absolutely on the truth of your measurements. No shrinking. No stretching. No guessing at fractions of an inch, for Starrett Tapes are accurately and plainly graduated. The steel bright lines and figures show up well against the jet black background. To lessen chances of misreading your measurement, the foot figure is placed alongside each inch mark, giving the correct reading in feet and inches at a glance. Closer measurements—faster work and longer service go with every Starrett Steel Tape.

Your hardware dealer will show you the different Starrett Tapes made for Machinists, Builders, Surveyors and Mechanics of all sorts. Ask to see the Patented Push Button Handle Opener—a Starrett feature that saves time, finger nails and cuss words.

THE L. S. STARRETT CO.

World's Greatest Toolmakers
Manufacturers of Backsaws Unexcelled
Steel Tapes—Standard for Accuracy
ATHOL, MASS.



Starrett Steel Tapes

Catalog No. 23 "AP"
sent free on
request



8431



"ATKINS"

Always Saves YOU Time,
Labor and Money

WHEREVER timber is cut, "ATKINS" means the *only* cross cut saw that is "Segment Ground" to cut easier and faster, the *only* saw made of "Silver Steel" to hold its edge longer and give added service and value.

Remember—it saves time, labor and money to buy an ATKINS Silver Steel Segment Ground Cross Cut Saw—a saw you can depend upon.

It will pay you to look for the ATKINS name on the blade of any saw for cutting wood or metal. It means the finest materials, tempering and workmanship—greater value in service and satisfaction.

Ask YOUR Hardware Dealer for genuine ATKINS Saws. We will gladly send you our booklets, "The Saw on the Farm" or "The ATKINS Cross Cut Saw Book."

E. C. ATKINS & CO. Estab. 1857
Dept. P INDIANAPOLIS, U. S. A.

Leading Manufacturers of Saws, Saw Tools, Saw Specialties
and Machine Knives.

ATKINS

SILVER STEEL SAWS



A new Parks!

Cabinet Shop
Special No. 7

\$250

as illustrated
with motor



You ought to have this handy Parks in your shop!

A compact, complete machine designed just like a big production outfit at one-fifth the cost. Nothing extra to buy. Motor is included, operating from any light socket. Fits in a corner of your basement. Does any kind of cabinet and joinery work. Circular saw, jointer and ban/saw on permanent all-steel frame. Add lathe, shaper and other attachments at small cost. You can make money with this Parks! Write for circular.

The Parks Ball Bearing Machine Co.
1500-1540 Knowlton Street, Cincinnati, Ohio
Canadian Factory: 200 Notre Dame East, Montreal, Can.

PARKS

WOODWORKING MACHINES



SHOP FIGURING

can be quickly done on the Midget Slide Rule. It adds, subtracts, multiplies and divides fractions and decimals. Gives lettered and numbered drill sizes. Also gives size of drill to use for any size hole with any thread. In addition to the above the "Midget" is a complete general purpose slide rule. Get one and become an expert with figures. Many shops have purchased these rules for their Machinists and Draftsmen. The engine-divided scales are on white celluloid, mounted on aluminum and are grease and water proof. Diameter 4". Price with complete instructions, \$1.50. Leather case 50c extra, each or C. O. D.

Satisfaction Guaranteed. Catalogue Free.
GILSON SLIDE RULE CO., Niles, Mich.



PILLIOD

Tool Cases Excel

Machinists, Tool Makers and Carpenters find them most satisfactory in construction, appearance, service and price. Immediate shipment.

Booklet describing 20 styles on request.

THE PILLIOD LUMBER CO.
Dept. 1 Swanton, Ohio



SERVISTEELE TAP AND DIE SET, ONLY \$3.75

FOR THE HOME—THE FARM—THE WORKSHOP

Our No. 32 Automobile Set furnished in our highly finished chestnut box contains 3 each taps and dies (1-4, 5-16, 3-8, 7-16 and 1-2"), in the S. A. E. thread, 1 die stock, and one tap and reamer wrench.

Our No. 31 Set is the same as No. 32 except that the thread is U. S. E. instead of S. A. E. You are purchasing a splendid set at a very low figure.

Send us your order at once and be one of our many satisfied customers. Let us also send you our circulars illustrating our full line of tools.

Worcester Steel Products Co., Dept. 40, 25 Union St., Worcester, Mass., U. S. A.

See that long nose!

For bending wire, for reaching small nuts, pins or screws in a tangle of delicate machinery or a maze of radio parts this new Crescent Long Nose Plier is perfect. It's a powerful wire cutter.

Retail 75c

CRESCENT TOOL CO.
210 Harrison St., Jamestown, N. Y.
Originators of the Crescent Wrench



Crescent Tools will have a special Christmas appeal this year. Look for the Crescent Tool Counter at your regular hardware or accessory store.

CRESCENT TOOLS

BURN YOUR NAME ON TOOLS

WITH THE ARKOGRAF

PROTECT YOUR TOOLS FROM THEFT
Write with electricity any name or design on the hardest and finest tools and instruments, or any metal, like writing on paper with pen or pencil. **Complete Outfit \$3.50**—Prepaid Anywhere today. Agents wanted. **ARKOGRAF Pen Co., 1171 E. Stark St., Portland, Oregon**



WONDERFUL "AWL FOR ALL"



This little tool is a marvel. Will mend anything from thin fabrics up to heavy shoe and harness leathers. Worth its weight in gold. Easily carried in the pocket ready for any emergency. **Only \$1 postpaid.** Special terms to agents. Big money maker. Write today for territory. **C. A. MYERS COMPANY, 6139 Woodlawn Avenue, CHICAGO, ILL., U. S. A.**

TURN WASTED TIME INTO MONEY!

Every Purchaser Finds Numerous Uses for the
Torit Acetylene Torch No. 13

Uses Acetylene only.
No oxygen or air pressure is required. Tips suck in air. Simply connect to Presto auto tank, light gas, and the outfit is put to work. *Beats anything you ever tried for soldering, heating or light brazing.*

Outfit consists of 4 tips for different kinds of work, soldering copper, 5 feet tubing, tank connection, and full instructions. **ST. PAUL WELDING & MFG. CO., 177 W. 3rd St., St. Paul, Minn.**



\$7.50



Better than a stone for sharpening knives, axes, and tools.

As useful in the car as around the home and shop.

Here's Your "All-Work" File

All you need is this one file for every filing job you ever have.

Made by Plumb. Double-cut one side for fast, coarse work; single-cut side for fine work and finishing.

Sharpens tools, knives, implements; files iron, steel, wood, copper, brass, hard rubber, fibre. Fine for radio work.

Actually two files and a forged handle to control your stroke. With a sheath to protect the teeth in tool box or kit.

Get it today and your troubles with files are over!

35¢ at your dealers
or by mail (40¢
West of Rockies)

Sold by most hardware dealers. Send us the cost (stamps will do) if your dealer can't supply you.

FAYETTE R. PLUMB, Inc.
4819 James St. Philadelphia



PLUMB
DOUBLE LIFE

Hammers Hatchets
Files Sledges Axes



This is "Big Money Year" for WITTE Log Saw Owners!

YOU can make big profits with the one-profit WITTE Log and Tree Saw clearing up timbered land, sawing wood for fuel, doing power jobs, etc. Write me and I'll show you how.



Saws 'em down in a hurry. "Felled fifty 18-inch trees in less than 5 hours," says Earl McBurney of Iowa.

The WITTE Log and Tree Saw has made thousands of dollars for users all over the country. Ask for their names and addresses.

The standard of power saws. Weighs only 38 lbs. at handles. Only three minutes to change from Log Saw to Tree Saw. Saws level to the ground.

Burns Kerosene, Gasoline, Gas-Oil or Distillate. All purpose outfit that can be used for other farm power work as needed.



Completely equipped with WICO Magneto, Speed and Power Regulator, Throttling Governor and 2 Fly Wheels.

Easy Terms. Lifetime Guarantee. Sold direct from factory to you—a factory with 55 years record of honest building. Ask for our big free Log and Tree Saw catalog, or if interested, for our Engine and Pump catalogs. No obligation.

ED. H. WITTE, Pres.

WITTE ENGINE WORKS 6744 Witte Bldg., KANSAS CITY, MO.
6744 Empire Bldg., PITTSBURGH, PA.
6744 Witte Bldg., SAN FRANCISCO, CALIF.

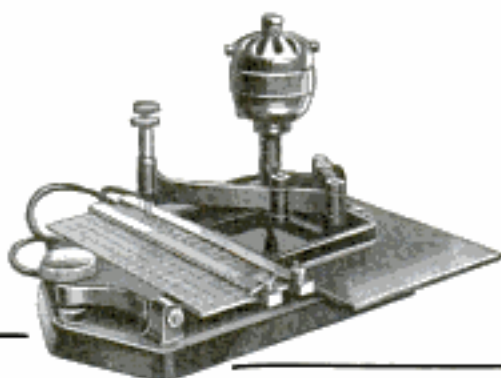

Rapid Engraving Machine For Engraving Radio Panels

Easy to operate. Will increase Radio Dealer's income

A low price engraving equipment for engraving the words used on radio panels, trade-marks, and border and corner designs. Will engrave on Hard Rubber, Bakelite, Aluminum and other soft metals. PRICE OF COMPLETE EQUIPMENT \$135.00.

Will earn several dollars an hour engraving panels for amateurs building their own sets.

Branch Tool Co., Dept. P, Forestdale, R. I.

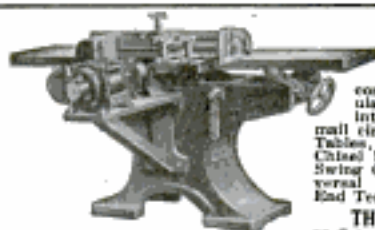

CRESCENT Wood Working Machines

continue to steadily increase in popularity. Tell us just what you are interested in and we shall be glad to mail circular. Band Saws, Jointers, Saw Tables, Planers, Planers & Matchers, Hollow Chisel Mortisers, Boreers, Disk Grinders, Swing Cut Off Saws, Cut Off Table, Universal Wood Workers, Shapers, Single End Tenoners.

THE CRESCENT MACHINE CO.
93 Columbia St. Lectoria, Ohio, U. S. A.

DYNA-MOTOR

As a dynamo it will operate induction coils, light lamps, charge storage batteries, electroplate, etc. makes an ideal machine for experimenting. As motor they will operate heavy models, energy wheels, and other appliances.

16 Watt \$6.50 32-Watt \$8.00
Dyna-Motor Dyna-Motor
65 to 200 Watt Dynamos, Armatures, Commutators, Patches, Parts for Schools and Students.

Send for Catalog
LOOMIS ELECTRIC COMPANY
1427 N. Artesian Ave. CHICAGO, ILL.



SARGENT PLANES

See them at your hardware store.

Write for booklet.

SARGENT & CO., 49 Water Street, New Haven, Conn.



WADE BENCH LATHE

AMATEUR MECHANICS, REPAIR SHOPS, INVENTORS, STUDENTS
A real machine tool for the home work bench—capacity 4" dia. x 12" length. For Metal-Wood-Composites. Materials—Turning—Facing—Boring—Drilling—Winding—Thread Cutting. Accuracy—Strong—Quiet—Compact. Slide-rest has travel entire length of bed. Loaders inside bed. No. 1 Lathe, plain headstock, \$28.00. No. 2 Lathe, back-gearing headstock, \$38.00. Complete line of accessories at equally low prices. Write for free catalog—just out.

THE GEROLD CO., Dept. P-36, 120 Liberty St., New York.

ONE Easy Payment

Puts This

13" x 5' Quick Change Gear
Screw Cutting

SOUTH BEND LATHE in Your Shop

We ship any size Lathe you need upon receipt of first payment—then you pay balance in convenient monthly installments which the Lathe itself will save and earn for you.

Prices of Popular Sizes

| | Quick Change Gear Lathes | Standard Change Gear Lathes |
|--------------------|-----------------------------|--------------------------------|
| 9" x 3' Lathe..... | \$241.00 | \$211.00 |
| 11" x 4' "..... | 288.00 | 248.00 |
| 13" x 6' "..... | 368.00 | 316.00 |
| 15" x 7' "..... | 447.00 | 392.00 |
| 16" x 8' "..... | 498.00 | 438.00 |
| 18" x 10' "..... | 721.00 | 656.00 |

33,000 NOW IN USE

in U. S. and in 64 Foreign Countries. Free Catalog shows 96 styles, all sizes. Select just the Lathe you want. Write for Free Catalog today.

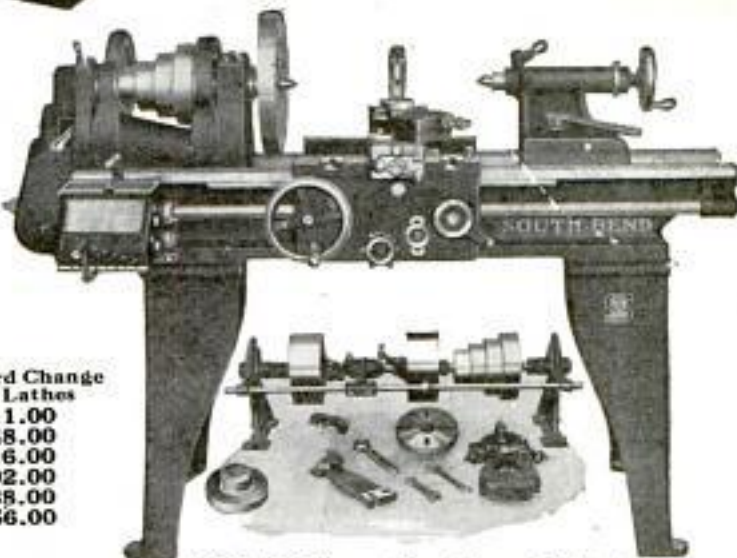

13" x 5' Quick Change Gear Screw Cutting Lathe
Price \$354

SOUTH BEND LATHE WORKS 805 East Madison St. SOUTH BEND, IND.



The New Sypher

Is lathe value plus—more for the money than ever built before. Length over all, 30 in. Between centers, 14 in. Swing over bed, 7 1/4 in., includes counter shaft. Bronze taper bearings. Weight 60 pounds. Absolutely accurate. A real job. Write today for circular.

\$60

The Sypher Mfg. Co. Dept. D Toledo, Ohio

"WONDER" Cold Pipe and Tubing Benders

Do Not Crack, Flatten or Crimp the Pipe

Hand and Motor Operated

14 SIZES OF MACHINES

What It Costs to Bend Pipe Our Way. Per Bend

1" Pipe..... 5c 4" Pipe..... 25c

2" Pipe..... 10c 6" Pipe..... 60c

3" Pipe..... 15c 8" Pipe..... 1.00

SEND FOR CATALOGUE

American Pipe Bending Machine Co.

59 Pearl Street BOSTON, MASS.

REMINGTON PORTABLE TYPEWRITER Dealers and Branches Everywhere



Ask your dealer for "Red Devil" No. 444, 7 1/2, or send us \$1.25 and we'll send it to you postpaid. Mechanic's tool booklet free.

It's a Plier, It's a Wrench, It's a Whole Tool Kit

"Red Devil" Giant-Grip No. 444, no bigger than an ordinary plier and just as well balanced, has solved many of the plier and wrench troubles. Lays parallel on all sizes of nuts up to 3/4". Moves the most stubborn nuts or bolts, even when they are rusted. It does its work without damage. Nothing to get out of order.

SMITH & HEMENWAY CO., INC.
Mfrs. of "Red Devil" Tools, 122 Coit St., Irvington, N.J.

One "POLLY" in Place of Ten Wrenches

One "Polly" Wrench takes the place of ten solid end wrenches. A set of only three "Polly" Wrenches will fit every job you have—a complete wrench equipment. Save space, time and labor. No other wrench like it. Instantly adjusted, jaws lock automatically and cannot spread. Light and easy to handle, but unusually strong and durable. Fully Guaranteed.

Sizes 6, 9 and 12 inch; 85c. \$1.25 and \$1.75—or complete set in case \$2.85. From dealers or direct from us.

GELLMAN MFG. CO.

Dept. 15

ROCK ISLAND, ILL.



Polly
WRENCH
SET OF 3
FITS ALL NUTS

ALUMINUM SOLDER

SOLDERS ALUMINUM of any description. NO ACIDS OR FLUX NECESSARY. For home, shop and garage use. Your tool kit is not complete without HAMILTON LEAD CO. ALUMINUM SOLDER. (Name on every bar.) Send 25c for 2 six inch bars, or \$1.00 for 9 bars; postpaid.

HAMILTON LEAD CO., HAMILTON, OHIO



LUMINOUS PAINT

Make Your Watches, Clocks, Etc., Visible by Night

The very latest discovery in the scientific world, Luminous, practically unobtainable elsewhere as an exorbitant price, we have at last succeeded in producing the remarkable LUMINOUS PAINT, which, applied to the surface of any article, emits rays of white light, rendering it perfectly visible in the dark. THE DARKER THE NIGHT, THE MORE BRILLIANT IT SHINES. Quite simple to use. Approx—you can do it. A little applied to the dial of your watch or clock will enable you to tell the time by night. You can coat the push buttons or switch plates of your electric lights, match boxes, and innumerable other articles; make your own Luminous Crucifers, Luminous Rosaries, etc. Small bottle, price 25c. Larger size, 50c and \$1 postpaid. **JOHNSON SMITH & CO., Dept. 448, RACINE, WIS.**

Serpent's Eggs Exploding Cigarettes

Box contains 12 eggs. When lit with a match, each one gradually hatches itself into a snake several inches long which curls and twists about in a most lifelike manner. Price per box, 10c postpaid, 3 for 25c.

CIGARETTE MAKER



Roll your own and save money. Makes them better and quicker besides saving more than half. Use your favorite brand of tobacco. Neat, useful and handy. Pocket size, weighs 34 oz. Made entirely of metal, nickel-plated. Price 25c postpaid.

MIDGET BIBLE

GREAT CURIOSITY Smallest Bible in the World. Size of a postage stamp—200 Pages. Said to bring good luck to the owner. A genuine work of art. Must be seen to be appreciated. Make good money selling them to friends, church acquaintances, etc. PRICE 15c each, 3 for 40c, 12 for \$1.25, 100 for \$7.50. Also obtainable in Leather Binding, with gold edges. Price 50c each, 3 for \$1.25, \$4.50 per doz. Magnifying Glass for use with Midget Bible, 15c.



STAGE MONEY

With a bunch of these bills, it is easy for each person of limited means to appear prosperous by flashing a roll of these bills at the proper time and peeling off a genuine bill or two from the outside of the roll, the effect created will be found to be all that can be desired. Prices, postpaid: 40 Bills 20c, 125 for 50c, or \$3.50 thousand postpaid.

Wonderful X-Ray Tube

A wonderful little instrument producing optical illusions both surprising and startling. With it you can see what is apparently the bones of your fingers, the lead in a lead pencil, the interior opening in a pipe stem, and many other similar illusions. A mystery that no one has been able to satisfactorily explain. Price 10c, 3 for 25c, 1 dozen 75c. **Johnson Smith & Co.**



Good Luck Ring

Quaint and Novel Design

A VERY striking and uncommon ring. Silver finish, skull and crossbones design, with two brilliant, flashing gems sparkling out of the eyes. Said by many to bring Good Luck to the wearer, hence its name, Good Luck Ring. Very unique ring that you will take a pride in wearing. **ONLY 25 CENTS.**

Address orders for all goods on this and opposite pages to **JOHNSON SMITH & CO.**

Dept. 448 RACINE, WIS.

A DeLuxe Edition of our new 1925 CATALOG mailed on receipt of 25c. Handsome cloth binding. Only book of its kind, 420 pages of all the latest tricks in magic, the newest novelties, puzzles, games, sporting goods, interesting books, curiosities, in needs and gifts, etc., unobtainable elsewhere. Remit by Money Order, Check, Coin, Stamps, etc. Stamps of foreign countries also accepted.

BLANK CARTRIDGE PISTOL

Protection against Burglars, Tramps & Dogs

Prices 50c \$1.00 Post-paid



Well made and effective; loaded on latest type of Revolver; appearance alone is enough to scare a burglar. When loaded it may be as effective as a real revolver without danger to life. It takes standard .32 Cal. Blank Cartridge obtainable everywhere. Price 50c, superior quality, \$1.00 postpaid. Blank Cartridges, by express, 50c per 100. Holston (Cowboy type) for Blank Cartridge Pistol, 50c. **Johnson Smith & Co., Dept. 448, Racine, Wis.**

BOYS! BOYS! BOYS!

THROW YOUR VOICE

Into a trunk, under the bed or anywhere. Lots of fun fooling the teacher, policeman or friends. **THE VENTRILO** a little instrument, fits in the mouth out of sight, used with above for Bird Calls, etc. Anyone can use it. Never Fails. A 32 page book on ventriloquism, the Ventrillo, ALL FOR 10 CENTS

Never Fails. A 32 page book on ventriloquism, the Ventrillo, ALL FOR 10 CENTS

K.K.K.

Everything about the Ku Klux Klan told in a clear, fearless manner. Book tells all—How it started and was oppressed in 1871—The New Ku Klux Klan—How Organized—How Members are Enrolled—Oath of the Klan—Questions for Candidates—Creed—Objects of the Order—Obedience—Fidelity—Pledge of Loyalty—Ku Klux Klan and the Masons—The Jews—The Masons—Real K. of C. Oath—The Negro Ku Klux Klan, etc., etc. Latest and most complete book on the Klan published. Price 35c, Postpaid. Stamps or Coin

LOOK 35 Look

Wonderful instrument. Greatest thing yet. Nine separate articles in one. Everybody delighted with it. Odd, curious and interesting. Lots of pleasure as well as very useful. It is a double Microscope for examining the wonders of nature. It is also an Opera Glass, a Stereoscope, a Burning Lens, a Reading Glass, a Telescope, a Compass, a Pocket Mirror, and a Laryngoscope—for examining eye, ear, nose and throat. It is worth all the cost to locate even one painful cinder in the eye. Folds flat and fits the pocket. Something great—you need one. Don't miss it. Sent by mail, postpaid. **Only 35c or 3 for \$1.00**

25 CENTS BABY TANK

Goes backward or forward by its own power. Nothing to tow it. What makes it go is a mystery. It crawls along, overturning obstacles just like the larger Tanks. Performances of most amazing "stunts." Runs ten times longer than most mechanical toys. Handsomely finished and constructed in natural colors. 25c postpaid.

Female SEX Male Sex Indicator

Hold the MAGIC INDICATOR over a man's hand and it moves in a straight line, backward and forward. Hold it over a woman's hand and it describes a complete and continuous circle. The same action can be obtained over a letter written by a man or woman, etc. It is fascinating! Nothing. We have never been able to figure out how it's done but we've never seen it fail. Many novel and entertaining facts may be performed with the Sex Indicator. For example, similar results can be obtained with animals, cats, dogs, rabbits, over birds, chickens, canaries, etc. Also used to predetermine the sex of chickens and birds, etc. In fact it is sold as a patented sex tester in Europe. Price 25c, or 3 for 65c, postpaid. **JOHNSON SMITH & CO., Dept. 448, RACINE, WIS.**



JUST LIKE ORDINARY CIGARETTES, BUT SUCH REAL STARTLERS! The box contains ten genuine cigarettes of excellent quality. They appear so real, but when each cigarette is about one-third smoked, the victim gets a very great surprise as it comes off with a loud BANG! A great ninth proverb yet entirely harmless. Price 25c per box.

Popular Watch Charms

ONLY 15c 3 for 40c; \$1.35 doz.

Very pretty little curiosities and decidedly novel. Fitted with Magnifying Lenses that enlarge the pictures to a very surprising degree; in fact, it seems almost incredible that a clear picture could be possible in such a small compass, and how sharp and distinct they show up when you look through. Come in assorted views—Actresses, views of Panama Canal, Lord's Prayer in type, etc.

Mystic Skeleton

A jointed figure of a skeleton 14 in. in height, will dance to music and perform various gyrations and movements while the operator may be some distance from it. **10c & pd.**

NEW BOOK ON ROPE SPLICING

Useful Knots, Hitches, Splices, etc.

A most practical handbook giving complete and simple directions for making all the most useful knots, hitches, rigging, splices, etc. Over 100 illustrations. All about wire rope attachments, lashing, blocks, tackles, etc. 37 Hermetic Knots illustrated. Of great value to mechanics, riggers, carpenters, boatmen. Price 20c postpaid.

MAGIC FLUTE

Wonderfully Sweet Toned and Musical

The Magic Flute, or Human-voice, is a unique and novel musical instrument that is played with nose and mouth combined. There is just a little knack in playing it which, when once acquired after a little practice, will enable you to produce very sweet music that somewhat resembles a flute. There is no fingering, and once you have mastered it you can play all kinds of music with facility and ease. When played as an accompaniment to a piano or any other musical instrument, the effect is as charming as it is surprising.

Post Paid 25c

THE TEDDY CAMERA



Takes and Finishes an Excellent Photograph on a Card 3 1/2 x 2 in One Minute

It is the newest method of photography in which skill and experience are not necessary. Not a plate nor a film covers, but a camera that produces the complete picture. Does not use either plates, film, or dark-room. All the troubles of picture-taking in the ordinary manner are swept away. It eliminates all the mess and trouble and, above all, there is No Waiting, for you actually see the finished picture in One Minute. You merely place the card in the camera, press the shutter, drop the card into the automatic developing tank attached to the camera, and in One Minute you have a Completed Picture all finished and ready to show. It is so simple and easy that any child who can use its hands can take good pictures. The camera weighs little more than half a pound, and measures about 4 1/2 x 3 inches, easy to carry about and always ready to take and finish a picture in one minute.

\$2.50

carry about and always ready to take and finish a picture in one minute. The camera is of high grade, universal focus, needs no adjustment, and takes clear and brilliant pictures at any distance. The Shutter works perfectly and responds to very slight pressure. It leads in broad daylight. The Developing Tank is attached to the Camera and holds a single solution that develops, tones and fixes the picture in one minute with absolute certainty and with no care or attention on the part of the operator. It cannot be overdeveloped. Produces a picture 3 1/2 x 2 inches. Send today and have the never-fading pleasure of making excellent pictures of your family, friends or neighbors, your house or your domestic pets. Price of Camera Complete with Developer and Pack of Cards, ONLY \$2.50. Extra packages sensitized Cards 75 cents per package; extra Developing Solution 25 cents. All prices are postpaid to any address in the world.

Every Boy His Own Toy Maker



Greatest boys' book written. Tells how to make a Pinhole Camera, a Canoe, model Railroad, a Telephone, a Loosening Telegraph Instrument, Box Kite, Talking Machine, Microscope, Electric Motor, Electric Door Bell, Water Wheel, Paddle Raft, a pair of Skis, a Dog sled, Bird House, Rabbit Yard, etc. 64 pages, 150 Illustrations. PRICE, 10c postpaid; 3 for 25c.

INVISIBLE INK

The most confidential messages can be written with this ink, for the writing Makes No Mark. Cannot be seen unless you know the secret. Invaluable for many reasons. Keep your postals and other private memorandums away from prying eyes. Great fun for playing practical jokes. Only 15c a Bottle; 3 for 45c.



JAPANESE ROSE BUSHES



The Wonder of the World
Japanese Rose Bushes bloom all the year round. Just think of it. Six weeks after planting the seed, the plants will be in full bloom. It may not seem possible, but we positively guarantee it to be so. They will bloom every ten weeks, Summer or Winter, and when three years old the bush will be a mass of roses, bearing from five hundred to a thousand roses on each bush. The flowers are in three shades—white, pink, and crimson. The plants will do well both in and out doors. We guarantee at least three bushes to grow from each packet of seed. Price, 10c packet, 3 pkts. for 25c postpaid.

Kissing Permit

A handsome metal badge, nickel plated, that you can wear, giving you fun out of all proportion to its trifling cost. PRICE 10c each, 3 for 25c, or 12 for 75c postpaid.



False Mustache

Here you are, boys! Just the thing for a little harmless macquerading. On and off in a twinkling. Lots of fun putting one on in a crowd of friends. The sudden transformation is astonishing. Fine for private theatricals, minstrel shows, charades, tableaux, etc. Changes your appearance beyond recognition. PRICE 10c, 3 for 25c postpaid.



Microphone Transmitter Button



You can easily make a highly sensitive microphone by using this Transmitter Button to collect the sound waves. You can build your own outfit without buying expensive equipment. It is simple and inexpensive. You can install an outfit in your house and hear conversations being held all over the house. You can connect up different rooms of a house. This outfit was used by secret service operators during the war. It is being used to this day. It is unsurpassed and is the greatest invention in microphones. You can mount the button almost anywhere—card board boxes, stove pipes, still radiators, on the wall behind a picture frame, etc. Button is so light and small it cannot be detected. Persons can be overheard without suspecting it. You can listen in on conversations in another room. A deaf person in the audience can hear the speaker. Connected to phonograph, piano or other musical instrument, music can be heard hundreds of feet away. Button may be used to receive telephone transmissions from cables on old line "talk-up" when nothing else will. The ideal microphone for radio use carries heavy current and is extremely sensitive. Avoids radio signals. Countless other similar uses will suggest themselves. Experimenters find the Button useful for hundreds of experiments along the lines of telephones, amplifiers, loud speakers, etc. Many interesting stunts may be devised, such as holding the button against the throat or chest to reproduce speech without sound waves. \$5.00 is given to anyone who sends in a new suggestion for the use of the Button providing the manufacturer find it suitable for use in their literature. PRICE \$1.00 POSTPAID ANYWHERE.



\$1.00 POSTPAID

MAGICIAN'S OUTFIT

Apparatus and Directions for a Number of Mysterious Tricks Enough for an Entire Evening's Entertainment

ANYONE CAN DO THEM 75c



It is great fun mystifying your friends. Get this Magician's Cabinet, and you will be the cleverest fellow in your district. It contains the apparatus for seven fast and easy tricks, including The Disappearing Rose, that, when placed on the top of your coat, vanishes from sight at will; the Magic Van and Ball Trick; the Wooden Ball in Pencil Tray, and upon releasing the lid has disappeared and is found in someone else's pocket; The Magic Nail with which you can apparently cut your finger almost in two; the Wonderful Card Trick in card is placed in an envelope, and when opened an entirely different card altogether is found; The Disappearing Coin Box & coin is placed in the little wooden barrel, and, when opened again, is found to have vanished entirely, or can be made to change into a coin of another denomination; the Fantastic Disappearing Penny Trick; The Glass Ball and Vanishing Coin Trick in coin is dropped into a glass of water, and when the water is poured out the coin has vanished. With the tricks described above we send full printed instructions for performing each trick, so that anyone can readily perform all the tricks to the great amusement of their friends or the public. Any boy of ordinary intelligence, with this Cabinet of Tricks in his possession, can give a parlor entertainment not inferior to some regular magicians. Besides the tricks contained in the Cabinet, there are many other tests and illusions fully explained with full printed instructions, for which you simply make or procure the necessary apparatus. This unexcelled Cabinet of Tricks for ONLY 75 CENTS POSTPAID TO ANY ADDRESS.

Great Fire Eater

Most Sensational Trick of the Day!
With the Fire Eater in his possession any person can become a perfect salamander, apparently breathing fire and ejecting thousands of brilliant sparks from his mouth, to the horror and consternation of all beholders. Harmless fun for all times, seasons and places. If you wish to produce a decided sensation in your neighborhood don't fail to procure one. We send the Fire Eater with all the materials, in a handsome box, the cover of which is highly ornamented with illustrations in various colors. Price of all complete only 30 cents, postpaid.



SQUIRT ROSE

25c
A REAL STARTLER. This is the most popular of all squirt tricks. The flower in your coat looks so fresh and sweet that everyone is tempted to inhale the delightful perfume. Then is the moment to press the bulb. Good-bye! Don't they jump? There is a very long rubber tube that easily reaches to the pocket of your coat or trousers, and the bulb is large enough to make a decent shot with one loading. PRICE 25c each, or 3 for 65c postpaid.



PISTOL, OPERA & FIELD GLASS

PRICE POSTPAID, \$1.00
It is made in the shape of and looks like a regular Automatic Pistol. No one is likely to stop and ask you whether it is real or not. Thus it is likely to prove itself very handy in an emergency. On pressing the trigger it opens up, as shown in the illustration at the right, revealing nine most useful articles—Opera and Field Glass, Telescope, Mirror, Magnifying Glass and Burning Lens, Reading Glass, Sun Dial, Sun Compass, etc. In the handle of the revolver there is a place for various pocket necessities, such as First Aid Articles, Buttons, Pins, etc. The Pistol is of sheet metal, blued finish, that can be carried comfortably in pocket. PRICE \$1.00.



GOLD TEETH

You know how fashionable it is to have gold crowns if you can afford it. These gold-butabut shells lace over your real teeth and look like very wealthy fittings. Can be slipped on and off in an instant. Get some and receive your friends. PRICE 5 Cents Each, 3 for 15c, or 50c for 1 doz. postpaid.



SURPRISE MATCHES

More fun than fighting with your wife. Look just like ordinary matches. Put up in boxes just like regular Safety Matches. As the victim tries to light one he gets quite a surprise. PRICE 10c per box, 3 boxes for 25c postpaid, 12 for 75 cents.

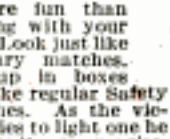

SEEBACKSCOPE

By merely placing this clever instrument to your eye, you can see what is going on behind your back, and sometimes you see very interesting things when no one thinks you are looking. Why it is just like having eyes at the back of your head. PRICE ONLY 25 Cents Postpaid, 3 for 50 cents.



The "Little Giant" Typewriter

A First Class Writing Machine For \$1.50
A perfect little typewriter for \$1.50. There are the thousands of persons who would like to use a typewriter but whose needs and incomes do not warrant the expense attached to the purchase and use of a fifty or seventy-five dollar machine. To such persons we confidently recommend our Little Giant. It is strongly made, but simple in construction, so that anyone can quickly learn to operate it, and write as rapidly as they would with pen and ink. The letters of the alphabet 1 to 10, and the punctuation marks being together. With this machine you can send your best girl typewriter her letters, address envelopes, make out bills, and do almost any kind of work not requiring a large, expensive machine. With each typewriter we send a tube of ink and full printed instructions for using the machine. Price complete \$1.50 by mail postpaid to any address in the world.





PA INVENTORS.

**JUST
ACROSS
STREET
FROM
U. S. PAT.
OFFICE.**

At the right is a view of my drafting and specification offices where a large staff of experienced experts are in my constant employ. All drawings and specifications are prepared under my personal supervision.



PROTECT YOUR IDEAS Take the First Step Today

If you have a useful, practical, novel idea for any new article or for an improvement on an old one, you should communicate with a competent Registered Patent Attorney AT ONCE. Every year thousands of applications for patents are filed in the U. S. Patent Office. Frequently two or more applications are made for the same or substantially the same idea (even though the inventors may live in different sections of the country and be entirely unknown to one another). In such a case, the burden of proof rests upon the last application filed. Delays of even a few days in filing the application sometimes mean the loss of a patent. So lose no time. Get in touch with me at once by mailing the coupon on the opposite page.

Prompt, Careful, Efficient Service

This large, experienced organization devotes its entire time and attention to patent and trademark cases. Our offices are directly across the street from the U. S. Patent Office. We understand the technicalities of patent law. We know the rules and requirements of the Patent Office. We can proceed in the quickest, safest and best ways in preparing an application for a patent covering your idea. Our success has been built on the strength of careful, efficient, satisfactory service to inventors and trademark owners located in every state in the Union.

Clip this Coupon and Mail

PATENTS

Write for these FREE BOOKS

NO CHARGE
for Information

On How to Proceed!

The books shown here contain valuable information relating to patent procedure that every inventor should have. And with them I will also send you my "Record of Invention" form, on which you can sketch your idea and establish its date before a witness. Such evidence may later prove valuable to you. Simply mail the coupon and I will send you the books, and the "Record of Invention" form, together with detailed information on how to proceed and the costs involved. Do this NOW. No need to lose a minute's time. The coupon will bring you complete information entirely without charge or obligation.



STRICT SECRECY PRESERVED

All communications, sketches, drawings, etc., are held in strictest confidence in strong, steel, fireproof files, which are accessible only to authorized members of my staff. Feel free to write me fully and frankly. Your case will have my personal attention. It is probable that I can help you. Highest references. But **FIRST**—clip the coupon and get my free books. Do **THAT** right now.

Clarence A. O'Brien

Registered Patent Attorney

Member of Bar of: Supreme Court of the United States; Court of Appeals, District of Columbia; Supreme Court, District of Columbia; United States Court of Claims.

Practice confined exclusively to Patents, Trademarks and Copyrights

FREE COUPON

CLARENCE A. O'BRIEN

Registered Patent Attorney

7097 Security Savings and Commercial Bank Bldg., Washington, D. C.

Please send me your free books, "How to Obtain a Patent," and "Invention and Industry," together with your "Record of Invention" form without any cost or obligation on my part.

Name

Address

(Important: Write or Print name clearly)

It Now!

PATENTS TRADE-MARKS AND COPYRIGHTS

Have You An Idea?

Our Offer: FOR THE PROTECTION OF YOUR INVENTION YOUR FIRST STEP

Before disclosing an invention the inventor should write for our blank form

"RECORD OF INVENTION"

This should be signed and witnessed and returned to us together with model or sketch and description of the invention for

INSPECTION and INSTRUCTIONS

No Charge for the Above Information

**Our Four Books Mailed
Free to Inventors**

Our Illustrated Guide BOOK

How to Obtain a Patent

Contains full instructions regarding U. S. Patents. Our Methods, Terms, and 100 Mechanical Movements illustrated and described.

Our Trade Mark Book

Shows value and necessity of Trade Mark Protection. Information regarding *Trade Marks and unfair competition in trade.*

Our Foreign Book

We have Direct Agencies in Foreign Countries, and secure Foreign Patents in shortest time and lowest cost.

Progress of Invention

Description of World's Most Pressing Problems by Leading Scientists and Inventors.

We Regard a Satisfied Client as our best advertisement, and furnish anyone, upon request, lists of clients in any state for whom we have secured patents.

*Highest References—Prompt Attention
—Reasonable Terms*

VICTOR J. EVANS & CO.

PATENT ATTORNEYS

Main Offices: 956 9th St., N. W., Washington, D. C.

Opposite U. S. Patent Office



Our New York Office
Suits 1007 Woolworth Bldg.



Our Philadelphia Office
Suits 714-15 Liberty Bldg.



Our Washington Office
Victor Building



PATENTS TRADE-MARKS AND COPYRIGHTS

IMPORTANT

TO HAVE YOUR CASE MADE SPECIAL AND AVOID DELAY YOU SHOULD HAVE YOUR CASE MADE SPECIAL IN OUR OFFICE to secure protection, save correspondence and secure early filing date in Patent Office. To secure special preparation of your case send \$25.00 on account with model or sketch and description of invention.

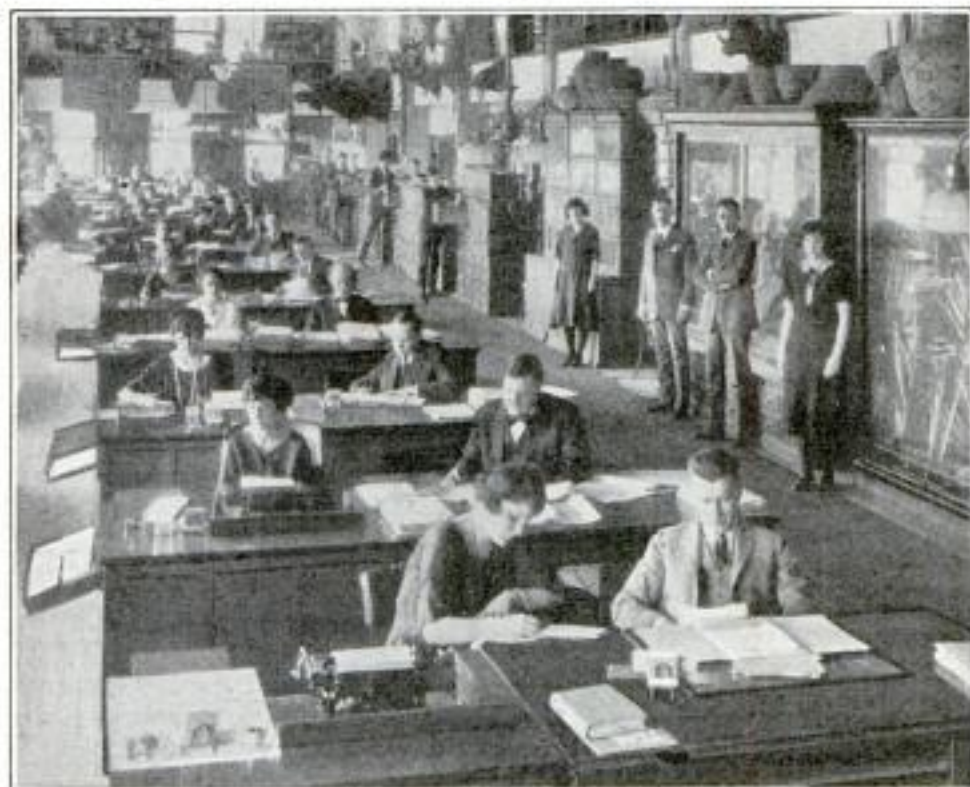

MAIN OFFICE, VICTOR J. EVANS & CO.—VICTOR BUILDING, WASHINGTON, D. C.

Our Lawyers Practice in all U. S. Courts and defend Clients in Suits involving Patents, Trademarks and Copyrights

All Communications and Data Strictly Confidential. Interference and Infringement Suits Prosecuted

OUR ORGANIZATION OFFERS PERSONAL SERVICE By Experienced Patent Lawyers, Solicitors and Draftsmen

**FREE
COUPON**

**VICTOR J. EVANS & CO.
PATENT ATTORNEYS**

NEW YORK OFFICES
1907 Woolworth Bldg.

CHICAGO OFFICES
1114 Tacoma Bldg.

PHILADELPHIA OFFICES
714-715 Liberty Bldg.

PITTSBURGH OFFICES
514 Empire Bldg.

SAN FRANCISCO OFFICES
Hobart Bldg.

MAIN OFFICES: 956 9th Street, N. W., WASHINGTON, D. C.

Gentlemen: Please send me *Free of Charge* your books as described on preceding page.

Name

Address



Our Chicago Office
Suite 1114 Tacoma Building



Our Pittsburgh Office
Suite 514 Empire Building



Our San Francisco Office
Suite 1010 Hobart Building

PATENTS

TRADE MARKS · DESIGNS · FOREIGN PATENTS

MUNN & CO. PATENT ATTORNEYS

Associated since 1846 with the Scientific American

672 WOOLWORTH BUILDING
New York City

523 SCIENTIFIC AMERICAN BLDG.
Washington, D. C.

412 TOWER BUILDING
Chicago, Ill.

365 HOBART BUILDING
San Francisco, Cal.

220 VAN NUYS BUILDING
Los Angeles, Cal.

Books and Information on Patents, and Trade Marks by Request. Associates in All Foreign Countries.



PATENTS

Send us sketch or model for advice and exact cost of patent. Our book "How to Obtain a Patent" sent free. It tells how to apply for Patents, Trade Marks, Foreign Patents, Copyrights, etc.; gives information on Patent Procedure; tells what every inventor should know. Thousands of Inventors, who are our clients, are our reference.

CHANDLEE & CHANDLEE, 25 Years' Experience
473 7th St. Washington, D. C.

Have You An Invention?

If so the WORLD PROGRESS will send you upon request sample copy Free containing SUGGESTIONS TO INVENTORS as to Inventions Needed. We invite manufacturers to address us regarding inventions they want.

Subscription for one year 60 cents

WORLD PROGRESS PUB. CO., Inc.
Room 203 Victor Bldg. WASHINGTON, D. C.

PATENTS

C. L. PARKER
Formerly Member Examining
Corps, U. S. Patent Office
PATENT LAWYER
MCGILL BLDG.
WASHINGTON, D. C.

Patents, Trade Marks, Copyrights, Patent Litigation
Pamphlet of instructions sent upon request

INVENTORS

who derive largest profits know and heed certain simple but vital facts before applying for Patents. Our book Patent-Sense gives those facts; sent free. Write **LACEY & LACEY, 646 F St., Washington, D. C. Established 1869.**

TOBACCO OR SNUFF HABIT CURED OR NO PAY

Any form QUICKLY conquered. NO LONG WAITING. Costs small sum if it cures. Harmless. Sent on approval.
DR. C. M. SIMPSON, 104 W. 44th St., Cleveland, O.

PATENTS

Booklet Free Highest References
Promptness Assured Best Results

Send drawing or model for preliminary examination of Patent Office records.

ALL BUSINESS GIVEN PROMPT AND PROPER ATTENTION

Listed Patent Lawyer in the latest editions of the Rand-McNally Directory of Bankers and Attorneys, of Chicago, Ill.; The Baggott & Ryall Directory of Attorneys, New York City; the United Lawyers' List of Attorneys, published in Chicago, Ill.; The Lawyers and Bankers Quarterly, published by the Legal Directory Publishing Company of St. Louis, Mo.; the American Lawyers Annual, Cleveland, Ohio.

WATSON E. COLEMAN,
REGISTERED PATENT LAWYER

644 G Street, N. W., Opp. U. S. Pat. Office
WASHINGTON, D. C.

U.S. PATENTS



SEND FOR THIS FORM

DON'T LOSE YOUR RIGHTS TO PATENT PROTECTION

Before disclosing your invention to anyone send for blank form "EVIDENCE OF CONCEPTION" to be signed and witnessed. A sample form together with printed instructions will show you just how to work up your evidence and establish the same before filing application for patent. As registered patent attorneys we represent hundreds of inventors all over the United States and Canada in the advancement of inventions. Our schedule of fees will be found reasonable. The form "Evidence of Conception," sample, instructions relating to obtaining of patents and schedule of fees sent upon request. Ask for them—a post card will do.

PATENTS AND TRADE MARKS



Registered Patent Attorneys In U. S. and Canada.

480 Ouray Bldg., WASHINGTON, D. C.

Originators of forms "Evidence of Conception."

PATENTS

To the Man with an Idea

I offer a comprehensive, experienced, efficient service for his prompt, legal protection and the development of his proposition.

Send sketch, or model and description, for advice as to cost, search through prior United States patents, etc. Preliminary advice gladly furnished without charge.

My experience and familiarity with various arts frequently enable me to accurately advise clients as to probable patentability before they go to any expense.

Booklet of valuable information and form for properly disclosing your idea free on request. Write today.

Richard B. Owen, Patent Lawyer
9-303 Owen Bldg., Washington, D.C.
41-E Woolworth Bldg., New York City

TRADE-MARKS REGISTERED

PATENTS

Trade Marks, Copyrights, Patent Litigation Handbook with illustrations, 100 mechanical movements. Sent free on request.

ALBERT E. DIETERICH
formerly member examining corps U. S. Patent Office
PATENT LAWYER and SOLICITOR

621-A, Ouray Bldg.

27 Years' Experience Washington, D. C.



GEARS ALL KINDS SMALL

The most accurate made and prices reasonable. We carry a complete line of gears in stock for immediate shipment. Can also quote on special gears of all kinds. Send us your inquiries.

WRITE FOR CATALOGUE.

CHICAGO STOCK GEAR WORKS
105-109 S. Jefferson St., CHICAGO

Seal Rupture With a Quarter

Now you can throw away forever steel bands, chafing leg straps and other heavy makeshift devices. For a well known American scientist has found a new easy way to support rupture treated by means of a wonderful little invention weighing less than 1-25 of an ounce. Not only do you do away with the objectionable pressure and tight strapping, but you eliminate the "coming down" of rupture—when running, straining, exercising, standing, etc.—which too frequently leads to strangulation. So good has been the success of this wonderful device that it is being referred to ruptured people for free inspection. Simply drop a postcard or letter requesting free literature to **NEW SCIENCE INSTITUTE, 2118 Clay Street, STEUBENVILLE, OHIO**



BLUE BOOK ON PATENTS

gives instructive information and candid advice.

MONROE E. MILLER, PATENT LAWYER
411-2 Ouray Building WASHINGTON, D. C.
ELECTRICAL AND MECHANICAL EXPERT

INVENTORS PROTECT YOUR IDEAS

Send for our Guide Book, **HOW TO GET A PATENT**, and Evidence of Invention Blank, sent Free on request. Tells our terms, methods, etc. Send model

or sketch and description of your invention for **INSPECTION and INSTRUCTIONS FREE. TERMS REASONABLE. BEST REFERENCES.**

RANDOLPH & CO.
300 Victor Bldg., WASHINGTON, D. C.

NAME _____

STREET _____

CITY _____ STATE _____

\$1 Brings your Choice of these 3 Big Specials

Buy From Us and Save Money

Simply pin a dollar bill to this ad, put it in an envelope with your name and address and Mail It Today. Your choice of these exceptional values will come Prepaid for a 15 Day Trial. If you can duplicate your purchase for less money anywhere, send it back and your dollar will be returned. If satisfied pay balance in ten equal monthly payments.

No Red Tape—Prompt Delivery
Transactions Confidential
Rush Your Dollar Today



A10 Beautifully hand-carved 18K White Gold Ladies Ring. 3 Genuine sparkling, blue-white Diamonds. Price \$37.50

\$1.00 Down; \$3.65 a Month

A11 Rectangular style 14K Solid White Gold Wrist Watch set with 4 Genuine, brilliant, Blue-white Diamonds, 4 blue sapphires. Guaranteed 16 Jeweled Movement. Price \$42.50

\$1.00 Down; \$4.15 a Month.

A12 Gent's 12 size 17 jewel Guaranteed Elgin Watch, 14K Gold Filled Engraved Case guaranteed for 25 yrs. Complete with gold filled Knife and Chain. Price \$37.50. \$1.00 Down; \$3.65 a Mo.

FREE

A complete Booklet with over 3,000 other big bargains in Diamonds, Watches and Jewelry.

Send for it.
10 Months to Pay on Everything.

AUTHORIZED CAPITAL \$1,000,000.

L.W. SWEET INC.

Dept. 65-S 1660 BROADWAY, NEW YORK

SQUAB BOOK FREE!



Squabs are selling at highest prices ever known. Greatest market for 20 years. Make money breeding them. No mixing feed, no night labor, no young to attend. Start small, grow big. Start now. Read how our customers sell squabs for \$12 a dozen. We have been established for 24 years. Better look into this. Let us send now, at no cost to you, our big, illustrated free book telling how to make money breeding squabs. Address

Plymouth Rock Squab Co., 634 H. St., Melrose Highlands, Mass.



I Made \$21.00 In Five Hours

—Writes Peter Werner, III, Sell Madison "Better-Made" Shirts for Large Manufacturer Direct to wearer. No capital or experience needed. Many earn \$100.00 weekly and bonus.

Write for Free Samples

MADISON SHIRT MILLS, 511 Broadway, New York

New Magnetic Discovery Builds Health



Add 10 to 20 years to your life with the aid of

Vit-O-Net Magnetic Health Blanket

Be in top-notch physical condition—and stay there! The Vit-O-Net Electro-Magnetic Blanket the greatest health discovery in recent years. You can now have a tremendous reserve of real vitality. No longer will you feel nervous, fagged out or dull. Vit-O-Net gives you a new life—new power. Eliminates wastes and dissolves congestions responsible for scores of ailments. It adds years to your life.

Vit-O-Net Magnetic Health Blanket

Used by Greatest Hospitals and Physicians

For treatment of Rheumatism, Neuritis, Nervousness, Catarh, Eczema, Blood Pressure, Kidney trouble, etc. Frequently successful after all other methods fail. Helps to restore health. Pays for itself over and over again.

Read these — "I can attribute my good health to the help of Vit-O-Net." "Received greater benefit from Vit-O-Net than from treatments costing \$1,600.00." "No words can express my love for my blanket." "Would not take \$500.00 for it or do without it for nerves." "I am an entirely new man."

Get Free Health Document! Tells why 90% of diseases are caused by improper elimination. Reveals valuable health secrets you ought to know. Write for your copy today!

Representatives Wanted

Vit-O-Net Mfg. Co. 4195 Ravenswood Avenue
Desk 5115, Chicago, Ill.

EASY \$100 a Week

FUGO FIRE EXTINGUISHER

Unusual opening for live agents in every locality. Make \$500 or more a year—easily. Fugo—the instantaneous automatic fire extinguisher—is needed and wanted in every home, store, theatre, garage, shop, school, automobile, etc. Cheapest fire protection available today. Within reach of all.

1 Qt. Size \$5.00 2 Qt. Size \$7.50

Recharged in a Jiffy

Amazing 20-second demonstration (live) each one sold sells others. Territory going fast. Write at once for wonderful proposition that will make you big money.

THE NATIONAL FORMETAL CO.
243 St. Clair Ave., N. E. Cleveland, Ohio

AGENTS!!!

300 to 500% PROFIT

Goods have Fine Appearance, Good Quality. Sells easy, and agents make big money. Write today for FREE CATALOGUE AND SAMPLES.

National Soap Company
512 W. Huron St., Dept. D-3, Chicago

WHITE FLAME

BURNERS

make your own house lamps and lanterns give a brilliant white light better than electricity or gas. Doubles your light. Saves oil. NO MANTLE TO BREAK. Guaranteed Safe and Reliable. Delights every user. Send now for complete sample postpaid 25 cents, stamps or coin. 3 for \$1.25. Money Back if Not Satisfactory. Live Representatives Wanted. Exclusive Territory.

WHITE FLAME LIGHT CO., 63 Clark Bldg., Grand Rapids, Mich.

REALLY EARNS WHILE HE LEARNS

"I work only four hours a day and average \$60.00 a week," writes Geo. W. McHaney, Tyler salesman, who spends part of his time studying. Later reports: "I made 14 demonstrations, resulting in 12 sales in one hour today (\$9.50 profit)." Hundreds making big money selling Ideal Fiber Cutter "handiest tool in the kitchen." So can you. No experience necessary. No heavy samples to lug. Easy to sell. Write today.

AGENTS

The Tyler Manufacturing Co., Dept. M-3 Muncie, Ind.

INSTALL YOUR OWN**FREE PLANS****HOT WATER HEATING PLANT
CUT-TO-FIT****GUARANTEED**

Complete Hot Water Plants ready for shipment. Outfits as low as \$200



ALL-CAST PIPELESS FURNACE

**PLUMBING
and HEATING****→ SAVE HALF ←**
*By our New Easy Method
and Lowest Wholesale Prices.*Mail the coupon for our **FREE Bargain**

Catalog. Gives illustrations, complete descriptions, sizes and wholesale prices on Heating Outfits of all kinds, Water Supply Systems, Complete Bathroom Outfits and Plumbing Supplies, Fittings, Pipes, etc. All at wholesale. Send today for your copy.

**50 Years and Million Dollar Plants**

behind our bonded guarantee. Every Hardin-Lavin System is figured to eliminate long runs of piping, to save valuable time and unnecessary materials and expensive labor. We furnish Heating Plants or Plumbing Outfits cut-to-fit at the factory for the exact job and we thread and mark all the larger pipes. Any Handy Man with our simplified plan and new easy method can do the installing.

MAIL COUPON TODAY

We have saved economical buyers hundreds of thousands of dollars. Everything you get from us is guaranteed highest quality, Grade A merchandise with new, exclusive features.

HARDIN-LAVIN CO.

ESTABLISHED 1876

When in Chicago Visit Our New Plant at
107-17B West Pershing Rd., CHICAGO**HARDIN-LAVIN COMPANY,**
107-17B West Pershing Rd., Chicago, Ill.Gentlemen: Please send me your **FREE BARGAIN CATALOG** with special wholesale prices. I am interested in:

- | | | |
|--|---|---|
| <input type="checkbox"/> Water Supply System | <input type="checkbox"/> Stns. Htg. Plant | <input type="checkbox"/> Warm Air Furnace |
| <input type="checkbox"/> B. W. Htg. Plant | <input type="checkbox"/> Pipeless Furnace | <input type="checkbox"/> Bathroom Outfit |

NAME.....

ADDRESS.....

P. O.....STATE.....

\$15 A DAY EASY

I have thousands of customers all over the world on my big line of over 200 household necessities. I need representatives in every territory, all or spare time, to handle this business, take orders and make big money under my new plan of distribution. Real necessities at rock bottom, money saving prices is the secret of my agents' success. No capital or experience needed. Write quick for Free Outfit Offer.

Ho-Ro-Co Mfg. Co., 531 Ho-Ro-Co Bldg., St. Louis, Mo.

\$10 A DAY EASY

McDonald made \$68 in one week! Hampton made \$7.65 in 4 hours—just wearing this beautiful Hand-Tailored Taylor Cap.

FREE CAP FOR YOU. I want to give you a **FREE** cap. Your friends will be delighted with its class, style and fit and you will make a generous profit taking their orders. Finest materials and workmanship. Choice of 5 styles and 25 fine waterproof fabrics. Send your name right away for details. Write at once.J. W. TAYLOR, Pres.
TAYLOR CAP MANUFACTURERS, Dept. 55-5, CINCINNATI, O.**I Offer You \$100 a Week**

Without experience, training or capital you can establish a big business for yourself. Be your own boss, work when you please, spare time or full time, and make from \$25 to \$100 a week.

Ford Auto Given

We want men and women to represent us. Wonderful plan. 350 Household Necessities direct from factory to home. We provide all instructions and equipment including automobile. Write quick for offer.

AMERICAN PRODUCTS CO., Dept. 4316 Cincinnati, Ohio.

**NEW MARVELOUS ONE-MINUTE CAMERA**

Takes and finishes pictures inside the camera in one minute. Agents wanted. Exclusive Territory. Make money selling these wonderful cameras or taking photos or both. Six different models. Photos 4x6, 3 1/2x5 1/2, 3x4 1/2, 2 1/2x3 1/2, 2x3 and 1 1/4x2 1/4 inches. No experience necessary. Any one can operate these cameras. Write today for special offer.

CROWN MINUTE CAMERA COMPANY, Dept. 940, NORWALK, CONN.

CLASS RINGS & PINSLargest Catalog Issued—**FREE**

Samples loaned class officers. Prices \$2.00 to \$8.00 each. No order for class, society, club emblems too large or too small. Special designs made on request.

METAL ARTS CO., Inc., 7705 South Ave., Rochester, N. Y.

Hand Forged
Razor Steel
Blades, No. 57**A GENUINE \$2 KNIFE
FOR
\$1.18 POSTPAID****Direct at Factory Prices**This \$2 KNIFE \$1.18 Postpaid
Hand Forged Razor Steel Blades
Handy shaped B i n d e makes this knife best for mechanics, sportsmen and farmers; light but strong; re-sharpened easily. Stag handle. German silver finish; blades file tested, hand forged from razor steel and warranted.

Sample \$1.18 3 for \$3.00 Postpaid.

Send for our 100-page List and **FREE**

"HOW TO USE A RAZOR"

MAHER & GROSH CO., 106 A St., Toledo, Ohio

GENUINE Sent for \$2.00 DIAMOND RINGS

\$2.00 Brings the Most Sensational Price Smashing Diamond Ring Offer Ever Made

Each of these rings is set with guaranteed, perfect cut, blue-white, fiery diamond of first quality; mountings are of 18 kt. white gold, hand engraved in the latest designs.



No. 5
First quality, blue-white diamond set in 18 K. white gold disc, 3 4 ct. size, 18 K. white gold mounting.
Price **\$79.90**

Ten Days Free Trial
Simply send \$2.00 and your choice comes to you all charges paid. If for any reason whatsoever you are not satisfied at the end of ten days, return the diamond ring to us and your deposit will be refunded. A legal bond as to quality and value accompanies each ring. After trial pay balance in 12 monthly payments.

NO RED TAPE—NO DELAY

FREE BOOK OF GEMS
Most complete jewelry catalog ever published of diamonds, watches and jewelry—newest designs at lowest prices. A full year to pay for everything you order from our \$2,000,000 stock.
Established 1895
Address Dept. 1467



No. 10
Dinner ring set with five large diamonds and four French blue sapphires in 18 Kt. solid white gold ring. Price **\$67.50**



No. 15 Perfect cut, diamond center, four French blue sapphires; 18 K white gold ring. Price **\$42.50**

ROYAL DIAMOND & WATCH CO.
170 BROADWAY NEW YORK

'Wonderful New Plan' for AGENTS Easy \$90 a Week



Men and Women! Write me today and by this time next week I can place you in a position to make \$2.00 to \$5.00 an hour in your spare time, up to \$15.00 a day full time. Thousands of our representatives are making that and more with our **New plans.** Simply introduce and take orders for famous **World's Star Hosiery and Underwear** sold direct from mill to home—a complete line for whole family. Permanent customers and repeat orders make you steady, big income. No delivering or collecting. No capital required.

Write Quick It's a chance to make thousands of dollars. Your profits begin at once. Exclusive territory. No experience needed. Write today and I'll send all facts and tell how to start **Free.** (Established 30 years.)

World's Star Knitting Co.
281 Lake Street Bay City, Mich.



"If I hadn't been all through it myself, I wouldn't have the assurance to say to you 'cheer up.'"

ERICKSON.

Those who wear them say: **ERICKSON LEGS are Wonderful** because they do not chafe, overheat or draw end of stump.



If you have had a recent amputation send for new booklet on **TEST LEGS** for beginners.
E. H. ERICKSON CO.
38-A Washington Av. N.
MINNEAPOLIS • MINN.

My Agents Make \$60 to \$200 Weekly



Full or spare time all my agents declare that the Carlton line is the biggest and best money maker of all. It's so easy to sell

CARLTON DRESSES

The new line is a winner. Latest Paris and New York styles in silk and wool from \$6.75 to \$19.95. Coats \$22.50 up. Exclusive models. Sell on sight.

Sample Outfit FREE

No samples to lug—no deposit—no investment for you. I give you portfolio of beautiful, large art plates, so perfect, so life-like that you don't need a lot of selling talk.

Write Today Get in line Now. I make it easy for you to get the BIG money. I back you up with all the resources of this company until you are a success. Address Z. Dicker, Pres. Carlton, Inc., Dept. 261-A, 337 S. Franklin St., Chicago, Ill.

Make \$60 to \$100 A WEEK

New 300 Candle Power Lamp—Burns 96% Air



Introduce wonderful patented invention. Burns only 4% fuel—cheap kerosene or gasoline. Uses less than wick lamps. Greatest advancement in lighting of the age. Table lamps, wall lamps, hanging lamps, lanterns. Powerful, brilliant, soft, restful white light—like daylight. Brighter than a score of wick lamps. No Smoke—No Soot—No Odor.

FREE Outfit Offer Easy to earn big Money. No experience—no capital required. Work all or spare time. Simply take orders. We deliver and collect—pay you big commission same day. Vivian of Minn. made \$400 in 39 days. Green of N. Y. made \$35 in one day. Hundreds making \$10 to \$40 a day. Get territory quick. Big season now on. Write today for **Free** catalog and special agents offer.

THE AKRON LAMP COMPANY
111 Lamp Building Akron, Ohio

AGENTS 500% PROFIT

GENUINE GOLD LEAF LETTERS

guaranteed to never tarnish. Anyone can put them on stores and office windows. Enormous demand, large profits. Paul Clark says: Smallest day \$28.70. H. L. Reel made \$920 in two months. Write today for free sample and liberal offer to general agents.

METALLIC LETTER CO., 433-B N. Clark St., CHICAGO

Oh How Lovely!

AGENTS

Saleswomen—Salesmen!

Make big money taking orders for our beautiful Dress Goods, Fibre, Wash Fabrics and General Yard Goods. Large Book of Fabric Samples furnished to Agents. Write today.

National Imp. & Mfg. Co.
573 Broadway, Dept. G, N.Y. City

1000 ACTUAL FABRIC SAMPLES

AGENTS YOUR SUCCESS GUARANTEED

\$75.00 A WEEK

Fastest money ever made with greatest seller ever known — 2-in-1, world's only hot water bottle, ice bag, and fountain sprig combination. One minute demonstration positively makes a sale. No capital nor experience necessary. Write immediately for revolutionizing sales plan. The Lobl Manufacturing Company, Dept. 63 Middleboro, Mass.

3-1

COUNTER
Eveready
SALESMAN



MAKES \$5,000 A YEAR
YOU

Scores of men making \$5,000 a year and more, EVEREADYS in big demand in confectionery, drug, grocery, cigar stores, waiting rooms, newsstands, hotels, cafeterias, restaurants, poolrooms, barber shops, soft drink parlors, etc.

WE GUARANTEE AGENTS

100% to 150% profit on every deal. \$12 initial investment starts you—buys 12 Evereadys (with sales-attracting 10) attachment, 25c each extra. Complete investment averages from \$100-\$200, depending on number of EVEREADYS put out. Profits quickly pay back your investment. Sell or lease EVEREADYS, then keep merchants supplied with stock (salted peanuts, candies, nut meats, etc.) Daily repeat orders. Our contract with big outlet specialty houses enables you to buy all your supplies wholesale—in separate bags or bulk.

(Patent applied for)

WHOLE OR PART TIME Volume steady business and big profits in short time

Nothing else like EVEREADY—automatic—easy refill—no books, clips or stickers. **Hurry—ACT NOW**—for exclusive rights in your community.

Dealers: If no "Eveready" distributor has called—remot \$1.00, 10 days must prove claims or full refund.

THE INTERSTATE CO., 2404 E. 9th Pl., CLEVELAND, O.

(References: Midland Bank, Cleveland)

OR—start on "shoestring" with new EVEREADY Metal Kiosk Display—just out—write for details!

REDUCED PRICES ON ENGINES

Now—big sale on most practical farm engine ever built—the famous OTTAWA. Low cash prices—easy terms—on all sizes 1 1/2 to 22 H. P. Each engine pull big surplus of power. Easy starting. You must be satisfied or money refunded.

30 days trial. 10-year guarantee.

FREEBOOK—"How to Know Better Engines." Write for your copy now. A postcard will do.

OTTAWA MFG. CO.

531-D King Street, OTTAWA, KANS.

Desk 531-D, Magee Bldg., PITTSBURGH, PA.

Direct from Factory



Lighting Fixtures
READY TO HANG

(Direct from the Manufacturer)

Completely wired, including glassware. Send for New Catalogue No. 27. Just reduced prices.

Special proposition to DEALERS.

ERIE FIXTURE SUPPLY CO.
STA. A. ERIE, PA.

FREE BARGAIN CATALOGUE, WATCHES, JEWELRY, RADIO SETS, CAMERAS, ETC. ADDRESS Louisiana Distributing Service, Harmon, Louisiana

NEW VEST POCKET ADDING MACHINE

ADDS - SUBTRACTS
MULTIPLIES - DIVIDES

Does all the work of a \$300.00 machine, yet fits the vest pocket. Easy to operate—does any kind of figuring in a jiffy. The neatest and best constructed portable adding machine made.

\$2.95

Counts Clear Up to 999,999,999

Total visible at all times. A pull of the finger clears it. Invaluable to anyone who uses figures. Saves many times its cost by preventing mistakes.

10 Days' Trial Send no money.

Just name and address and we will send machine postpaid. Pay postman on delivery \$2.95. Use it 10 days to prove it does all we claim. Your money back if not perfectly satisfied. Don't be fooled by cheap imitations. Order your Ve-Po-Ad now from this ad.

Reliable Adding Machine Corp., Dept. 48
184 W. Washington St., Chicago, Ill.

Here's a money maker, Everybody wants one. Splendid profit. Write for special offer

AGENTS



Hello Boys!
Here's the biggest thrill you ever had
The New Erector
the world's greatest toy!

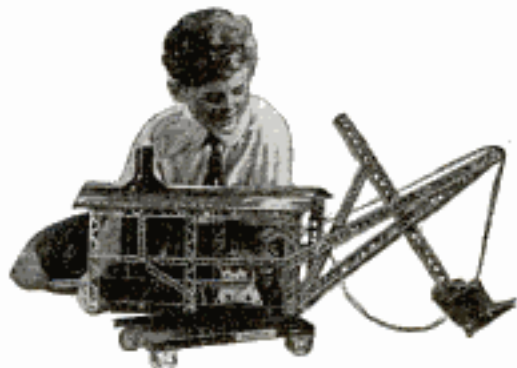

WHEN a boy has an Erector Set he can make working models of steam shovels, concrete mixers, locomotives, drawbridges, hundreds of engineering toys. The powerful Erector electric motor makes them whiz and go.

Why the new Erector is the World's Greatest Toy. Erector contains more parts and builds more models than any other toy. Erector exclusive features are: Its square girders; curved girders; steam shovel; new Erector boiler; dredge bucket; giant fly wheel. Other Erector features are: Its perforated strips; a great assortment of gears and hundreds of other genuine perfect mechanical parts for a boy to build a new toy every day.

Sign this coupon and I will send my new free book about the new Erector, "One Thousand Toys in One," also the Mysterious Gilbertscope, a present that amuses everyone.

Super Erector No. 7—\$10

THE most popular Erector Set—contains powerful electric motor, new Erector boiler, steam shovel, base plates, curved girders, assortment of gears—473 parts, builds 533 models—with 64-page manual in colors. Packed in wooden chest. Price \$10. Other Erector Sets from \$1.00 to \$50.00.



A. C. GILBERT CO.
110 Blatchley Ave., New Haven, Conn.

Please send your free book, "1,000 toys in 1" and also the Gilbertscope, to the following address.

Name

Street

City.....State.....

DIAMONDS \$2⁰⁰ DOWN

No. 1. The "Butterfly" Fiery blue white perfect cut diamond. 18k. white gold hand engraved and pierced ring. \$32.50—\$2 Down—only **\$1.50 a week.**

No. 2. "Vassar". Artistically pierced lace work design. 18 k. white gold. Perfect cut blue white diamond. \$37.50—\$2 Down—only **\$1.00 a week.**

No. 3. "Cluster". 7 fine white diamonds set in platinum. Resembles \$750 solitaire. 14k green gold. Rare beauty. \$32.50—\$2 Down—only **\$1.50 a week.**

No. 4. "Luxor". Man's 14k. green gold massive ring. 18k. white gold top. Fiery blue white diamond. \$57.50—\$2 Down—only **\$1.50 a week.**

FREE
Write for Catalog.
Diamonds
Watches Jewelry
\$10 to \$1000
on easy terms.
Wonderful values

TEN DAYS' FREE TRIAL
Easy for you to own or give as a gift any of these handsome rings. **Simply send \$2.** We will send ring you select on 10 days' trial. **Only if satisfied, make weekly payments until balance is paid.** If you do not agree it is an **amazing bargain**, return ring within 10 days and we will refund your \$2. **You take no risk.**

Address
Dept. B-26

BAER BROS. Co.

6 MAIDEN LANE, NEW YORK. Established 1890

Guarantee
Bond with
Every Ring.

ARMY COMPASSES

At a Bargain Price Worth \$5

Genuine U.S. Army Engineer Pocket Compasses. 2" diameter. Jewel bearing. Illuminated needle for night use.

GUARANTEED NEW AND PERFECT

ONLY \$1³⁵ Post Paid ORDER NOW



Supply is limited. We are closing out all our army goods at sacrifice prices. Get our list. These compasses, secured from Engineer's Corps, are representative of the big bargains we offer.

MICHIGAN TENT & AWNING CO., Mail Order Dept.
1753 Lysander Street Detroit, Michigan

Free SUIT OFFER

By Our New Plan Made to Order. Now

Send No MONEY

To secure boosters for our unbeatable values, classy styles and perfect tailoring, we make this introductory **free** suit offer. Our new plan enables you to get one of our fine, made to order suits, in any style you like without spending money.

AGENTS Earn \$9 to \$18 DAILY WANTED

Cash for you besides Free Suit for spare time showing our wonderful samples to neighbors and friends, we show you how prices so low folks buy on sight, get cash and **FREE SUIT**. No experience needed. Biggest sample outfit, agents wholesale prices, real wool pieces, fashion styles, tape measure, simple directions. **WRITE AT ONCE for FREE** suit offer and Free sample outfit.



PROGRESS TAILORING CO., Dept. L 216, CHICAGO

HIGH GRADE KNIFE \$1⁰⁰

REPRESENTATIVE wanted to introduce novelty knives and razors. Permanent employment and exclusive territory. If you are earning less than \$150 yearly let us show you how to make more.



NOVELTY CUTLERY CO.
667 Bar St., Canton, Ohio

"HIS" Christmas Gift

INTRODUCTION OFFER. This full size knife, with any desired design, mailed for \$1. Name and address added for 25 cents extra. Every man or boy will appreciate this beautiful knife. Blades of finest steel. Handles clear as glass and unbreakable. Length 3 1/4 inches. Every knife guaranteed perfect.

MOTORS

\$1.50 to \$5.50

Many styles and models. Low prices for high quality. Send 6c to pay postage for big catalog.

Knapp Electric Corporation Dept. 109, Port Chester, N. Y.
Established 1890

FREE 1000 Illustrations ELECTRIC FIXTURE CATALOG!

Write today for your copy. Save 50% direct from Manufacturer. No Middleman's Profit. **OUR SPECIAL: 8 Room Electric Set**, ready to hang, \$24.50—other fixtures.

UNITED LIGHTING FIXTURE CO.
83 Flatbush Ave. Dept. P Brooklyn, N. Y.



Just Out GREEN, RED, SELLS FOR \$1.25. SAMPLE 67c

Unbreakable Trio Self-Filling Fountain Pens



Guaranteed for 1 year. "It makes Carbon Copies"

Money refunded if you don't think it's the best pen you ever wrote with. Finished in beautiful green or red. Send for wholesale quantity price list and distributing plans. **F. SPORS & CO., 337 Main St., Lesueur Center, Minnesota**



NOW—a world famous Remington on

5 DAYS FREE TRIAL

Write today for details of how you can now get a world famous rebuilt Remington by our new Free Trial and Easy-to-Pay Plan. It looks and writes like new. Our 45-year reputation and guarantee are your protection. Here is a real bargain—don't miss it.

AMERICAN WRITING MACHINE Co.
Dept. 601, Newark, N. J.

THIS WONDERFUL INVENTION



converts any ordinary cook stove into a gas stove. OXO-GAS is made from kerosene and air. Cheaper, cleaner and more efficient than coal. Responsible distributors wanted.

GLORIA LIGHT CO.
111-11 N. May St. Chicago, Ill.

Taxidermy Book FREE.

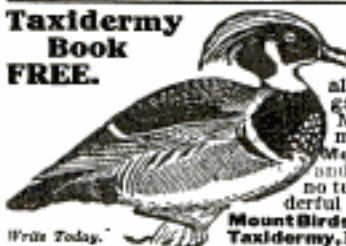

Stuff Beautiful Birds.

Learn by mail to stuff and mount all kinds of birds, animals, fish and game heads, make rugs, tan skins. Mount your own specimens and make money preserving for others. Men, Women and boys learn easily and quickly. Success guaranteed or no tuition. Write today for our wonderful FREE book "How to Learn to Mount Birds and Animals." N.W. School of Taxidermy, 1778 Elmwood Bldg., Omaha, Neb.

Write Today.

SAVE YOUR BODY

Conserve Your Health and Efficiency First

"I would not part with it for \$10,000"

So writes an enthusiastic, grateful customer. "Worth more than a farm," says another. In like manner testify over 100,000 people who have worn it.

The Natural Body Brace

Overcomes WEAKNESS and ORGANIC AILMENTS of WOMEN and MEN. Develops erect, graceful figure. Brings restful relief, comfort, ability to do things, health, strength.



For Boys and Girls Also

Wear it 30 Days Free at Our Expense

Does away with the strain and pain of standing and walking; replaces and supports misplaced internal organs; reduces enlarged abdomen; straightens and strengthens the back; corrects stooping shoulders; develops lungs, chest and bust; relieves backache; curvatures, nervousness, ruptures, constipation, after effects of Flu. Comfortable, easy to wear.

Keep Yourself Fit Write today for illustrated booklet, measurement blank, etc., and read our very liberal proposition.

HOWARD C. RASH, Pres., Natural Body Brace Co.
223 Rash Building • • SALINA, KANSAS

Great New Invention
for seekers of
Health Power Beauty



Elco Health Generators at last are ready for you! If you want more health—greater power to enjoy the pleasures and delights about you, or if more beauty is your desire—write! Ask for the book on these inventions which has just been prepared. It will be sent to you without cost. It tells you how Elco Health Generators aid you in leaving the lethargy and hopelessness of bad health and weakness behind forever. Re-vitalize yourself. Bring back energy. Be wholly alive. Write today!

10 Days Free Trial—Write for FREE BOOK



These great new inventions generate *High Frequency Violet Ray, Mechanical Vibration, Medical Electricity and Ozone.* Combined or separate.

They operate on the electric light in your home or on their own motive power at less than 50 cents per year. Elco Health Generators are positively the only instruments which can give you in one outfit Electricity, Violet Ray—Vibration and Ozone—the four greatest curative agents. Send coupon below. Get the Free Book NOW!



For All These:

| | |
|-------------|-----------------|
| Rheumatism | Asthma |
| Gout | Hay Fever |
| Lumbago | Sore Throat |
| Neuralgia | Catarrh |
| Sciatica | Deafness |
| Headache | Insomnia |
| Neuritis | Psoriasis |
| Nervousness | Development |
| Circulation | Skin Disease |
| Weakness | Furunculosis |
| Paralysis | Scalp Disorders |
| Eye Trouble | Obesity |

MAIL the COUPON for FREE Book!

Do not put this paper down without sending the coupon. Don't go on as you are with pains and with almost no life and energy. You owe it to yourself to be a better man or woman. You were put here to enjoy life—not just to drag through it. So do not rest another day until you have put your name on the coupon here. That will bring the whole story of these great new inventions. Do it today—now.

Health Power Beauty

Lindstrom & Company

30 West Lake Street. Dept. 13-58, Chicago, Ill.

Please send me your free book, "Health—Power—Beauty" and full information on your 10-day Free Trial Offer.

Name

Address



Men's Sizes \$5
Boys Sizes \$4

Practicoat

MEASURED by any rule, the Practicoat passes the test of manly looks, snug fit and long wear. That's why practical men wear it in the shop, office and home.

Its \$5 price is an achievement of modern standardization and quantity production; its ironclad guarantee makes your satisfaction certain.

If your dealer does not carry the Practicoat, order through us.

AMERICA'S
GREATEST
KNIT JACKET
VALUE

Manhattan
KNITTING MILLS
8-14 West 30th Street,
New York City



STOP FORD CRANKSHAFT END-PLAY!

C-A ADJUSTABLE BEARING corrects and prevents end-play without removing motor. Eliminates many troubles. Easy to install—simply drop pan. Only \$3.75. Ask your dealer or mail prepaid by ADJUSTABLE BEARING CO., Dept. P BRAZIL, IOWA.

FREE SAMPLE OUTFIT!

SIX MILLION DOLLARS Profits made by Rawleigh Retailers last year! Get into the big money making class. Establish your own business. Sell necessities. Enormous demand. Easy sales, profits big, no experience needed. Backed by largest Company of its kind in the world. Best Localities being chosen fast. Write quick for free sample offer. Get busy!

The W. T. RAWLEIGH Co.,

Dept. IL 8262
FREEPORT
ILL.



Different from all others—the NEW BENJAMIN

AIR RIFLE

Made on a different principle from all other Air-Rifles.

The Benjamin is really a strong air-pump used to compress the air in the air chamber to any degree of power desired. From one to six strokes of the pump give all the force necessary. Each additional stroke gives increased power. The Benjamin works on the same principle as all air-drills and air-hammers—with this difference:

You control the shooting force as you desire. Look at this block of hardwood. It shows how Benjamin power is regulated as you wish.

You can't have accidents with a Benjamin. It's safe, always, because you control the power. The Benjamin never loses shooting force, and has no springs to get out of order or shake your aim. Write us for an interesting folder about this wonderful air-gun.

If your dealer does not handle same, send direct to factory—

(PRICE \$5)
(POSTPAID)

BENJAMIN AIR-RIFLE & MFG.
CO., 415 N. Broadway, St. Louis, Mo.

Ask your
dealer for
demon-
stration.

Pacific-Coast
Representatives
TRAYLOR &
BOWEN
Los Angeles
Calif., and
San Francisco
Calif.



MOVIES Believe the Bible

See What It Teaches

We sell wonderful religious movie films and real movie machines—so you can show movies at home. Some movie machines as low as \$3.75—others higher. Also fine assortment of comedy, western and feature films with an exchange service for home users.

Write for Big Free Catalog

PARAMOUNT MFG. COMPANY Dept. MA
Boston, Mass.

SHOW IT—and IT'S SOLD



The Handy Knife Sharpener is the fastest selling home necessity ever offered.

Everyone a prospect. Sells for \$1.00, your profit 65c. Free deliveries. Guaranteed.

Morgan Mfg. Co., Dept. G, 443 S. Dearborn, Chicago

Ranger \$5 a Month

Finest bicycle built—44 Styles, colors and sizes. Factory-to-Rider prices. FREE delivery, express prepaid on 30 Days Free Trial. Cash or easy payments. Bicycles, \$21.50 and up.

Tires, lamps, wheels and equipment at half usual prices. Send no money. Write today for big catalog, special factory prices, free trial plan and marvelous offers.

MEAD CYCLE COMPANY
DEPT. A-109 CHICAGO

Write today for free
Ranger Catalog, fac-
tory prices and mar-
velous easy payment terms



Interlox

MASTER SLIDE RULE
Takes accurate inside or
outside measurements

MASTER RULE MFG. CO., 841-43 E. 136th St., New York

Works fast. Slides in and out quickly. Durable made of brass trimmed boxwood. Any length 2 to 8 feet, 20 cents per lineal foot. If not at dealer's, send postpaid.

Dealers and Agents:
request attractive proposition

\$100 to \$200 Per Week

We Teach You How to Make It
 Money—big money—is waiting for you to come and get it. No matter where you live nor what your experience, we teach you how to make money.
Special Proposition Open Now

Fireite *Sells on Sight*
 TRADE MARK

Fireite amazes everyone who sees it used. A single demonstration often makes a dozen sales. It has saved many thousands of dollars of property damage. Men, women and children are astounded and fascinated by the ease with which it puts out an alarming fire. It is no exaggeration to state that Fireite is one of the easiest to demonstrate and fastest sellers ever made. Why? Because it is so simple a child can use it with one hand. It always works—(wonderful secret composition). No pump nor mechanism. Beautiful and long lasting. The low price is within the means of everyone—50% less than most others. Sold to every home, school, garage, factory, office, store, hotel, etc., wherever shown.

AGENTS and MANAGERS WANTED
 In All Territory Not Taken
 You can make big money using all or part of your time. We supply everything for your success. This is an unusual opportunity for a sound, substantial, permanent income. Write for our agent's—or manager's—special proposition today to the Fireite Co., Dept. 2, Masontown, Pa.

SEND FOR THE INTERNATIONAL CATALOG

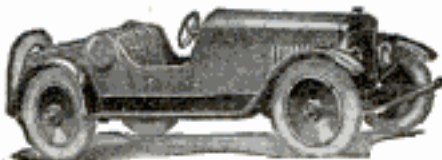

Our net price list. Full line of auto bodies and accessories for Ford and Wholesale Prices. Save big money on bodies by buying Direct from Factory.

FOR FORD—Prices from \$27.85 up. Factory to consumer direct—Pay Only One Profit.

International Body Works, 914 W. Ohio Street, Dept. 7, Chicago, Illinois

SHAW MOTOR ATTACHMENT
MAKES YOUR BIKE A MOTORCYCLE!

A high grade 2 1/2 H. P. motor attachment quickly clamped on any bike frame. Speed 4 to 40 miles an hour. 90 to 125 miles per gallon of gas. **Special Low Price Now!** Write today for Complete Description and Special Low Prices on SHAW Motor Attachments and the SHAW Complete Motorcycle. **SHAW MANUFACTURING COMPANY**
 Dept. 37 Galesburg, Kansas



\$3.87 FREE

SOLID gold effect case guaranteed 25 years. Richly engraved. Accurate. Railroad model. Backed by million dollar factory. **SEND NO MONEY** Pay postman's bill on arrival. Money back guaranteed. **BRADLEY, F-652, NEWTON, MASS.**

CHAIN AND KNIFE
 Also Good Luck Ring if you order NOW!

MOTORCYCLES



RELIABLE STANDARD MAKES that you can **DEPEND** on. Enjoy the glorious experience of going wherever you like—when ever you like. The price is within your means—25% to 50% less than others. These machines are slightly used, thoroughly overhauled or rebuilt. Read for outposts. **MYEROW BROS.,**
 15 Berkeley St. Boston, Mass.

The Best Friend on the Road

A great traveling companion, this Barbasol. No tools to pack except the good old razor. No brush. No rub-in. And a real head-barber shave! 35c and 65c tubes.



The Barbasol Co.
 Indianapolis Ind.

Please mail me your Free Trial Tube of Barbasol.

Name.....

Address.....

P.M.-11-25

For Modern Shaving

Mix "Red Hot" Oxygen
 with gases over furnace fire bed

FURNACE DOOR →
 CROWN FUEL SAVER

Guaranteed saving of 20% in fuel—often saves much more. Fool-proof; trouble-proof; expense-proof. Use less fuel—get much more heat with the

Crown Fuel Saver and Smoke Abater

Burns smoke—mixes red hot oxygen with gases over fuel bed to complete combustion. Brings fire to top, where it does most good. On market 10 successful years. Write today for descriptive circular.

Distributors Wanted — Write for special proposition. Big field—Good business opportunity.

C. F. S. Co., 411 N. 10th Street, Richmond, Ind.

Please Mention Popular Mechanics

GET FACTORY PRICES ON GALVANIZED ROOFING



EDWARDS "REO" Metal Shingles

Absolutely rust-proof — edges as well as sides. Not the space of a pin point exposed to weather. Also fire and lightning proof. Reduce insurance. Outlast building. Need no repairs — end all roofing expense. Easy to lay — one man can do the work — hammer and nails only tools needed. Lay over old shingles if desired. Patent Interlocking Device makes water tight seams — all nail heads covered — no rust or leaks possible.

Exclusive "Tightcote" Process

Put all Edwards Galvanized Roofing in a class by itself. Bend, twist, strike it with a hammer as much as you like — you can't loosen or scale off the galvanizing — due to our "TIGHTCOTE" process which practically makes zinc covering a part of the metal sheet. No other galvanized roofing can withstand this test.

FREE Roofing Book Don't buy roofing until you get our big free book, describing Edwards famous "Tightcote"



Roofings, Sidings, and Ceilings, and our lowest factory prices. We sell you direct and save you in-between dealers' profits. Write for Roofing Book No. 162.

Low-Priced Garages

Lowest prices on Ready-Made Fire-Proof Steel Garages. Set up any place. Send postal for Garage Book showing styles.



Corrugated



Patent Side Lock
No nail heads in sight or exposed to the weather



Brick Siding



THE EDWARDS MFG. CO. CINCINNATI, O.
1100-1150 Butler St.

Makes pumping Up Tires Unnecessary



Line up with big money. The Hughes "Airox" Valve Cap is a proven success. Air-tight. Eliminates all troubles due to under inflation lasts life of tire. Positive necessity to auto owners. Doubles tire mileage. Tested and approved by leading auto manufacturers. \$100 a week for hustlers. Unlimited demand. No competition.

FREE SAMPLES TO AGENTS
to use and introduce in exclusive territories. Immense uncrowded field. Don't hesitate. Write today for facts and FREE SAMPLES.
AIROX RUBBER CO., Dept. 805P Chicago, Ill.
2512-14 W. Monroe St., Dept. 805P Chicago, Ill.

Tires With 500 Nail Holes Leak No AIR

A new puncture-proof inner tube has been invented by a Mr. J. Y. Milburn of Chicago. In actual test it was punctured 500 times without the loss of air. This wonderful new tube increases mileage from 10,000 to 12,000 miles and eliminates changing tires. It costs no more than the ordinary tube. Mr. Milburn wants them introduced everywhere and is making a special offer to agents.

Write Mr. J. Y. MILBURN
335 West 47th St., Chicago

MILBURN-PUNCTURE PROOF TUBE

Make Your Ford Ride Like a Pullman



Remove the shocks and shakes of ruts and bumps and uneven roads. Your Ford will roll along over any road as tho it were a boulevard when equipped with



Shock Rebound Absorbers

Scientifically designed and built to give the benefit of opposing action of double coil springs,—the only principle which successfully accomplishes the desired result. The outside spring absorbs the shocks; the inside spring smoothes the rebound. Direct suspension permits free and easy action of leaf spring, as designed by Ford engineers. No extra strain on any part of car. Eliminates vibration. Makes car run smoothly.

Quickly and Easily Attached: No holes to drill,—nothing to change from present Ford design. No special tools required.

Dealers and Agents Wanted

Dealers and Agents wanted in every community to demonstrate and sell this wonderful accessory. Get a set for your car today;—show them to your neighbors and they'll want them. Write today for full particulars and special sales proposition to Dealer-Agents. THE EDWARDS BROS. CO., 511 Main St., Leipsic, Ohio

Price \$19.75
Per set
Special Discount to Dealers and Agents

SPORT BODIES for FORD and CHEV. 490 at \$34.50 UP

Life-size paper patterns—You can build your own body at small cost. We are manufacturers and our quantity production enables us to quote exceptional low prices. Our unique shipping methods save you 75% in FREIGHT CHARGES. Send at once for free particulars on Central Bodies. Our Book: "HOW TO BUILD A FORD RACER" sent anywhere on receipt of 25c in cash or stamps. WRITE TODAY!

Central Auto Supply Co. Dept. 120, Louisville, Ky.



PROTECT YOUR LIFE

Autoists Marvelous, new, patented anti-glare goggles exclude headlight glare. Make night driving pleasant and safe. Worn with or without glasses. Shipped immediately, postpaid, on receipt of \$1. Money-back guarantee. Agents—Enormous incomes being earned. Territories Protected. Wildfire sales. Write today.

FAIRMONT OPTICAL MFG. COMPANY
35C Kneeland St., BOSTON, MASS.

SOFT SNAP FOR AGENTS

GLAROFF Kills Headlight Glare. Our representatives making from \$12 a day up to \$3000 yearly. Simple new device protects driver from glare of headlights and sun. Write for Special Free Offer.

GLAROFF MFG CO., 805P Rad St., Sioux Falls, S. D.

Tire AGENTS WANTED

Use and introduce MELLINGER CORD TIRES
15,000 MILES GUARANTEED
Lowest Wholesale Prices in America. Shipped prepaid on approval. Make big money all or part time. No capital or experience. Sample sections furnished.

YOUR TIRES FREE! Simply send name today for valuable FREE BOOK; tells how thousands have gone into big business. SPECIAL AGENTS OFFER! Wholesale Prices and FREE SAMPLE KIT. Write nearest address.

MELLINGER TIRE & RUBBER CO.
PHILADELPHIA, PA. Dept. 1915 KANSAS CITY, MO.



Make Your Tires PUNCTURE-PROOF
IN ONE MINUTE

580
NAIL & SPIKE
PUNCTURES
WITH NO
AIR LOSS

Agents AND DISTRIBUTERS **25¢** PER TIRE
Wanted

GALACITE * will repair a puncture in ONE MINUTE without taking the tire off the wheel or rim; and in addition it will make the tire Puncture Proof for life. GALACITE seals instantly and permanently, punctures, leaks, porous places and leaky valves. No more flat tires, no more getting out and changing tires in a hot sun. No soiled clothes. A scientific laboratory product. Tested in every part of the United States. Backed by a MONEY BACK GUARANTEE to do everything we claim. Guaranteed not to injure tube, valve or tire; on the contrary it preserves and lengthens the life of tube and tire, often

INCREASING TIRE MILEAGE FROM 10,000 TO 12,000 MILES

Take a hammer and drive as many nails into a tire as you wish, 50—100—500, it makes no difference. GALACITE seals the punctures permanently, as soon as they are made. We guarantee it for one year, but it will last indefinitely.

CAR OWNER AGENTS WANTED
EARN \$5,000 TO \$10,000 A YEAR

TREMENDOUS PROFITS. Agents and Distributors everywhere to demonstrate and sell to car owners, garages, filling stations. Work all or spare time in your own home town or traveling. GALACITE sells itself. Every customer becomes so enthusiastic that he helps you sell his friends. A revolutionary invention that will make you independent. You can also manufacture and sell GALACITE PUNCTURE PROOF INNER TUBES.

ACT QUICK SEND NO MONEY. Just your name and address will bring complete particulars by return mail. Get this information right now. Test it out. Get started while the field is still unoccupied.

C. F. JOHNSON & CO. Dept. 241, 19 W. Jackson Blvd.
CHICAGO, ILLINOIS, U. S. A.
*Galacite Trade Mark Reg. Copyright 1925



"Make America Musical"

The Hohner Harmonica is endorsed by musical and educational authorities as the logical instrument with which to encourage children to learn music by playing it.

"The Harmonica was the first instrument I ever knew" says Irving Berlin, nationally known composer and music publisher.

"It is natural that a healthy youngster should take to the Harmonica, and from the Harmonica it is but a step to another musical instrument and a musical education. It will not surprise me if the Harmonica becomes a most important factor in making America a more musical nation."

Anyone can quickly learn to play a Hohner Harmonica with the aid of the Free Instruction Book, procurable at all dealers. If your dealer is out of copies, write M. Hohner, Inc., Dept. 181, New York.



BOYS & GIRLS EARN XMAS MONEY

We trust you. Write for 20 sets Christmas Seals. Sell at 20 cents a set. Return us \$2.00. Keep \$2.00 yourself. Easy to earn \$10 before Christmas. **F. B. WARNER COMPANY,** 90 Chambers Street, Department T29, New York City

MOTORCYCLES

LESS THAN HALF COST

Ace, Indian, Cleveland, Harley-Davidson, Henderson Motorcycles and Sidecars, new, used and rebuilt. **Rider Agent Wanted.** Write for FREE trial offer, agent's free outfit and big bargain bulletin. **New American Bicycles** in different styles and colors. Write for illustrated catalog giving our money saving prices.

AMERICAN MOTOR CYCLE CO.
2047 W. Chicago Ave., Dept. 1129, Chicago

AGENTS NEW SPARK PLUG Visible Flash

Just Out—Amazing Invention—Beacon Lite Spark Plugs. You see the flash of each explosion in the cylinders. Tells which are firing right. Greatest improvement in spark plugs since gas engines were invented. Wonderful gas savers. Agents coining money.

\$90 A WEEK

Easy to make with new sure-fire plans. Sells on sight to every auto owner. Phillips, Ont., writes "Sold 2 dozen today, 3 dozen yesterday. Rush 10 dozen." Write for special **Free Demonstrator Offer** and **FREE** deal to introduce these wonder spark plugs in your territory. Write quick—today.

CENTRAL PETROLEUM COMPANY
1031 Century Building Cleveland, Ohio

WANTED! TIRE SALESMEN

Experienced men who have been working for big companies and who want to make more money.

BEARCAT CORDS

are the smarter looking, longer wearing, better quality, guaranteed tires that 25,000 Chicago motorists demand. Popular wherever shown. Sold to dealers. Write for proposition which will give you bigger, always-increasing income.

SIMPLEX TIRE & RUBBER CO.
2035 S. Michigan Ave., Dept. 20, Chicago



MAKE YOUR Ford INTO THIS Sport Car—Save \$50 to \$150 with Red-i-Kut Life-Size Patterns \$5.00

Famous easy-fit **RED-I-KUT** life-size patterns and piece instructions show how you can easily convert your Ford into this Fast, Sporty, Sport Car in thousands of ways, with easily obtained materials. No need to lay up the car. Rear seat folds making 4-passenger car. **Look at Wilfred Eno's.** Eno says: "It took me 2 Sundays to build it and I sure am proud to hear them say, 'We built that snappy sport car.' I never cut any steel or did any wood-work before but we can't go wrong with Kumpel patterns." St. Louis, Mo.



The Lark life-size patterns for each part of the body so you can't go wrong, feature interlocking and **CONICAL DISK WHEEL PATTERNS.** Only \$3.00 delivered. 24 extra bracing patterns for Jiffy Top and Cozum wind-shield. 22 extra **RKO Steel** for Lark \$10 complete. Extreme West \$13. Order now while we can make good delivery, and really enjoy these wonderful days in your Lark. **Keen, Gleasy, Up-to-the-minute.** You can build it. Over 11,000 in use. Don't hesitate. "Swing Le" Underlating Irons, no frame casting kind, \$6.59. Only \$4.99 when ordered with Lark patterns. Send in coin for new manual of other distinctive sport body patterns from \$3.50 up—"RKO" Steel "Swing-Le" Irons, Tons and Windshields. **ORDER RIGHT NOW.** **KUMPEL CO.,** 66 Kuempel Bldg., Gettensberg, Iowa

The "Lark" Class—Snap

Easy-to-Understand Instructions

\$5.00

38-inch Easy Riding Seat

Yes—A Pair of Brand New, Shining, Nickeled, Hardened Steel SKATES Attached to Strong, Comfortable, Smart, Athletic SHOES



For only **\$5⁰⁰**
Pre-paid

Skates are a clean cut, snappy design from the famous Winslow Skate Mfg. Co., made in the most up-to-date style for hockey and all round skating, and firmly attached to strong calf-skin athletic shoes with just the right medium high heel and the firm ankle support strap necessary to make skating easier and more comfortable. The lacing extends way down to the end of the toes, enabling you to adjust shoes perfectly for the snuggest support combined with comfort. This skate-shoe outfit will make your skating far, far better than the old clamp-on skates. If you have never worn shoe-skates, you'll be surprised to see how much better you get along. Check, money order, or C. O. D. Money back if not thoroughly satisfied. Shoes and skates complete for less than the price of ordinary shoes—a real buy! Men's and boys' shoe sizes from 3½ to 11½. Women's and girls' sizes from 3½ to 8½. Sporting goods catalog free.

IVER JOHNSON SPORTING GOODS CO.
10 Cornhill, Boston, Mass.



At Last! A Perfect Stropper

The James Stropper puts a keen-cutting edge on your blade that makes every shave a pleasure. It holds the blade at the right angle, so that the strop "whips" the original bevel from edge to edge. No skill is needed. Just a few pulls and the job is done. Makes your blade last for months.

There is a James Stropper for every type of safety razor. Send \$2.00 with Coupon.

FREE—15 days' Trial Guarantee
MAIL COUPON TODAY

DUDLEY FREEMAN COMPANY
80 Boylston Street, Boston

Name.....

Address.....

Dealer.....

I use a.....razor.

Nestler Rubber Fusing Stations

An opportunity is offered one man in each community to secure the sole and exclusive right to operate the famous Nestler Rubber Fusing Process of servicing pneumatic tires. Unlike any other method on earth. The Nestler method is the perfected and only known way of successfully retreading pneumatic auto or truck tires, including all sizes of balloon tires. Every car owner needs Nestler Service. Nestlerized repairs outlast the tire. No previous experience necessary. We teach you the business in two weeks or less. Moderate capital required. Big profit on each tire you do. Here is your opportunity to have a permanent and highly profitable business in your own name. Remember only one man can secure this profitable franchise in each community. Act now if you want to be that man. Write today for two interesting books describing the Nestler Rubber Fusing Process and the methods that are being employed by Nestler licensees everywhere to build up prosperous businesses.

NESTLER RUBBER FUSING CO., Inc.
Dept. S, 245 West 55th Street, New York City

10,000,000 AUTOS EACH A PROSPECT FOR THE L-W GLARE SHIELD

Protects Eyes from Glare of Oncoming Headlights. Easily Attached and Neatly Made. Send \$2.50 for sample. AGENTS WANTED. MAKE BIG MONEY. Write for Agents' Proposition. **GREEN BROTHERS COMPANY, 120 High St., Boston, Mass.**

REDDING & COMPANY

(Est. 1859) 9 West 23 St., N. Y. C.

Masonic Books, Monitors, Bibles,
Jewelry, and Lodge Supplies



Send for catalogue 3 of Books and Jewelry;
catalogue 4 of Lodge Supplies. No obligations. Mail orders promptly filled.



Saw Table Can be purchased with 6-inch saw for.....
Delivery paid East of Mississippi. \$22.50
\$24.50 Delivery paid West of Mississippi.

Motor This heavy duty motor can be furnished separately for \$12.90 delivery paid East of Mississippi. \$13.90 Delivery paid West of Mississippi. Complete with Cord, Pulley and flat or grooved Pulley. Guaranteed 10% Overload. Special Prices on Quantities of 10 or Over.

PAUL J. DEVITT, 1101-1107 So. 2nd St., Phila., Pa.

MECHANICS BENCH SAW

With this saw you can make your own repairs in shop, home, farm or garage. Makes a clean edge on the toughest wood—no planing necessary. Rips, cross-cuts, bevels, miters, mortises, tenons, or grooves. Attach to any lampsocket. Weight only 61 lbs. Will cut up to 1¼" All metal. Saw size 6 in. Table 10x13, base 7x11 height 7 in. Table tilts for beveling 5 degrees left 10 degrees right.

WRITE FOR OUR NET PRICE BUILDERS' HARDWARE CATALOG

Build the phenomenal new type radio with this amazing kit

Everyone wants one of these revolutionary receivers that are amazing engineers. You may build your own in a surprisingly short time from this remarkable kit. Free book that tells how.



The new Erla Circlloid Five Factory-Built Kit—as you receive it. Ready-cut, flexible, solderless leads and charts enable you to wire it in an evening.

Price, \$49.50

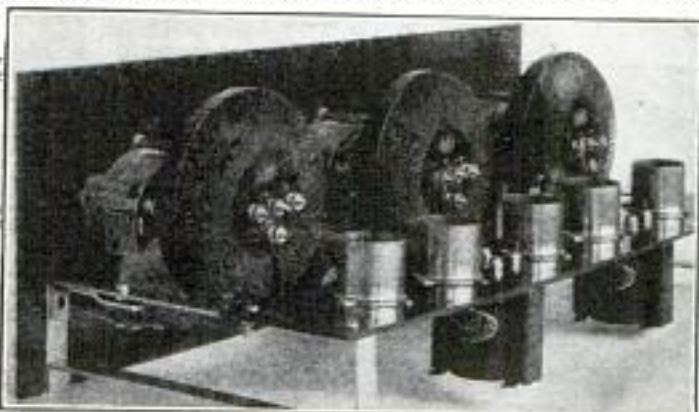

HERE is an easy way to have the new radio that is astonishing radio fans everywhere. You make a big saving and have the fun of building your own set besides.

The amazing new inductance principle found in these kits belongs to Erla alone. No other set, regardless of price, can offer it to you. It is based on a different kind of coil—the Erla *Balloon *Circlloid. Four striking advantages result:

1. **Greater Distance.** Circlloids have no measurable external field to affect adjacent coils or wiring circuits. This makes possible higher amplification in each stage, with increased sensitivity and greater range.
2. **More Volume.** Higher r. f. amplification enables Circlloids to bring in distant stations scarcely audible in ordinary sets with volume enough to fill an auditorium.
3. **Increased Selectivity.** Circlloids have absolutely

DEALERS—Exclusive franchises are available to high class dealers in localities still open. Write or wire immediately. *Trade Mark Registered

no pickup qualities of their own. Only signals flowing in the antenna circuits are built up.

4. **Finer Tone Quality.** The self-enclosed field positively prevents stray feed-backs between coils. Hence no blurring or distortion. Tones are crystal clear.

Write for free information on kit—also book. See how a few minutes of fun will give you the newest and most phenomenal set known to radio science. Examine it at any Erla dealer's, or send the coupon for full information, illustrations and diagrams contained in the remarkable book, "Circlloid Hookups."

Electrical Research Laboratories,
2500 Cottage Grove Ave.,
Dept. 5B, Chicago, U. S. A.
Send me the new book explaining Circlloid principle and hookups.



Name

Address

City.....County.....State.....

CLASS 25¢ PINS

BUY DIRECT FROM THE MAKER
CATALOG FREE



Either pin shown made with any 3 letters and 2 figures. 1 or 2 colors enamel. Silver plate 25¢ ea. \$2.50 doz. Sterling silver, 40¢ ea. \$4.00 doz.

BASTIAN BROS. CO.

3490

630 Bastian Bldg., Rochester, N. Y.



2534

DON'T BURN COAL

use cheap oil

New remarkable invention does away with coal or wood and saves money, time and labor. Simply sets in firebox of any range, heating stove or furnace. Most economical and lowest priced Oil Burner on market. Burns 90% air, 4% cheap oil and gives three times the heat of coal. Easy to install and operate. Absolutely safe. No noise, dirt or odor. Sold on money-back guarantee. 30 days free trial and special low price to first user in each locality. Write for free book on Home Heating. Agents: Write for sample offer and protected territory.



OKAY MFG. CO., Dept. 187 East St. Louis, Ill.



DARCHE "CALL-ME" ELECTRIC ALARM AND LIGHT CLOCK

Will ring until you get up and STOP it. No home complete without one. Can be used as an "alarm clock" or "mantel clock." With a little effort on your part you can get one.

FREE OUR OFFER TELLS YOU HOW

Agents, here is a big money-maker, no competition, sells on sight. A good punch board proposition. Write today for our descriptive literature. An ideal GIFT for any occasion. Mahogany finish. Size 10 1/2 x 8 1/2 x 4.

Darche Mfg. Co., 641 Washington Blvd., Chicago

Make More Money

with our new Household Cleaning Device. It washes and dries windows, sweeps, cleans wall scrubs, mops. Complete outfit costs less than brooms. Over half profit to agents.

Write
Harper Brush Works
278 3rd St., Fairfield, Iowa



PRICES SLASHED FOR QUICK ACTION!

But your order will have to be sent by November 30 when our regular catalog price will again be in effect.

4-Tube ROBERTS Spl. \$43⁵³ Postpaid
 Superior to most other sets REGARD- Kit KY 9215
 LESS OF NUMBER OF TUBES! Range 3500 Miles

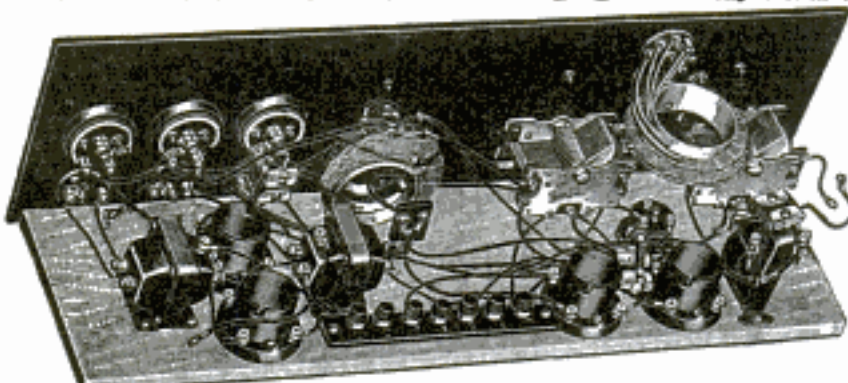

SEE WHAT YOU GET—BEST QUALITY

All parts highest grade—advertised, well-known, reliable, dependable—fully guaranteed by manufacturers and ourselves. Look at these brands. You cannot get a better kit! Fine 7x24x8 mahogany finish cabinet, drilled and engraved Bakelite-Dialcote panel, five-ply laminated baseboard, Hickley's Roberts' coils, 2 Hammarlund low loss variable condensers, 3 E-Z Tons variable dials, Thordarson transformer, four Modern push-pull transformers, 3 Percent rheostats, 4 Bell Bakelite low loss sockets, Jones Improved single-strut jack, Jones Improved double-strut jack, Cutler-Hammer inductance switch, Smilcar filament switch, Electrolytic grid leak, Niles grid condenser and mounting, 2 Niles fixed condensers, Amplex grid-denser, 7 Aristocrat binding posts, binding post strip, complete set "No-Solder" connecting wires, hardware, blurring and instruction sheets. You can assemble in only three hours or so. Satisfaction positively guaranteed or money back.

List price, \$64.00; our regular catalog price, \$48.50—Special price to Nov. 30, only \$43.53. ORDER DIRECT FROM THIS AD—ON APPROVAL—NO MONEY IN ADVANCE—SHIPPED SUBJECT TO EXAMINATION WHEN REQUESTED—WE PAY TRANSPORTATION—24-HOUR SHIPMENT—SATISFACTION OR MONEY BACK (Foreign customers will please remit with order and include enough for transportation and insurance which we don't pay.)

Send for **BIG CATALOG—36 Pages—FREE**

Filled with big bargains in Kits, Parts and Accessories. Send today!

RADIO SPECIALTY COMPANY, Kit Div. 163Y, 245L Greenwich Street, NEW YORK

Combines principles of Reflex, Neutralization, Tuned Radio Frequency, Regeneration (without blooping), and Push-Pull Amplification. Smooth-working—easily tuned—non-howling—non-reradiative—non-squealing. Guaranteed absolutely to give entire satisfaction.

See what Doubleday, Page & Co., through Mr. Arthur H. Lynch, Editor of their magazine, "Radio Broadcast," say about the Radio Broadcast's sensational 4-Tube Kit—Out Set developed by Walter Van R. Roberts:

"Tune for tube, dollar for dollar, result for result, we will stack it up against any receiver for home construction ever described by any radio publication and gamble that it comes out winner. It is the best we have ever seen—and we have seen and operated almost every type made and used during the past twelve years. It has pulled in forty-six stations on a loud speaker with two tubes, using an indoor antenna. Its signals have been heard through the air more than a quarter mile. It is not merely the best four-tube receiver, but the best by a very good margin."

CUSTOMERS PRAISE IT!

Special Features Great volume—Utmost clearness—Highly selective—Cheap to build—Easy to operate—Receives great distance—Does not radiate or cause squealing in your neighbors' receivers—Low cost of upkeep. The best 4-Tube set for home construction ever produced.

Our New Method of Wiring—Perfectly Simple
 —No Radio Knowledge Needed

"No-Solder"

MAKES SET-BUILDING EASY

No solder—No bare wires—No poor connections—No dissatisfaction. No tools needed except a common screw-driver and common pliers. All connections are made by the use of our flexible, insulated eyeletted connecting wire in place of bus bar or wire, and solder. And in a fraction of the time usually required when using the old fashioned way. And when the job is done it is neat and connections are tight.

Save Money on New or Used Auto Parts!

15 years of progress has made our stock of new and used accessories and replacement parts the largest in the world. We can furnish you with anything from a Cotter-Pin to a complete Power Plant.

FREE! CATALOG
of Parts Both

NEW AND USED
The most complete catalog ever issued. Check full of bargains. Save 30% to 80% on your purchases. Buy from Warshawsky. Every item guaranteed to be just as represented.

WRITE TODAY
SURE!

A FEW SPECIAL BARGAINS
IN NEW REPLACEMENT PARTS
Prices quoted are F. O. B. Chicago

| | |
|--|---------|
| Ford Cylinder Heads, New | \$3.75 |
| Ford Cylinder Blocks, New. Complete with rings, wrist pins, pistons, bushings. | \$20.00 |
| Ford Counter Balance Crank Shafts. A \$19.00 value. | \$12.50 |
| Ford Triple Seal Pistons. New. Up to .005 oversize. Complete with wrist pins and bushings. Per set | \$5.00 |
| Ford Gas Saver. New. 2-in. manifold, \$3.50 value | \$1.00 |
| Ford Water Pump. | \$2.50 |
| Genuine Chevrolet Pistons. New. Up to .005 oversize. | \$1.00 |
| Nu-Life Ring Expanders. | 5c |
| Miles Piston Rings, New. | 40c |
| All sizes. A \$1.25 value. | |

WARSHAWSKY & CO.

"World's Largest Car Wreckers and Replacement Parts House."

No Branches 1915 So. State St., Dept. P. M. 11 Chicago, Ill.

Bodies of Rare Beauty for Fords

At Factory Prices!
\$22.75 and Up

Write for Circular A-2 showing this Model and others.
SPORT BODY WORKS
 AURORA, ILL.



This model in grey prime, \$39.50

You and This New Machine Can Earn \$500 a Month



Operate a Tire Repair Shop
 20,000,000 Tires in use. America's greatest opportunity for men with small capital. We furnish everything—\$100 and up. Easy payments. We train you FREE right at home. Start making money at once. Write today for Free Book of Opportunity.

Haywood Tire Equipment Co. 1344 S. Oakley, Chicago.



\$15,000 a year earned by State Agent Easing, of Texas; \$5,000 a year by District Agent Hubbell, of Iowa. If interested in Agency write today. Good territory open. Big Money.

WORLDS OF HEAT RADIANT KEROSENE OIL HEATER

Burns 8 to 10 hours on gallon of Coal Oil. Turns on like gas—cheaper—cleaner—more comfortable than coal or wood fire. No wick—no smoke—no odor. Will heat the whole house in coldest weather. Portable—may be moved from room to room. Simple; turns up and down—off and on like city gas. Thousands in Happy Homes everywhere. Handsome, durable—gives intense heat.

FREE Simply send name today for circular and full details how it works and showing offer.

EVERBRITE STOVE CO. 210 Gateway Station KANSAS CITY, MO.



Apex Vernier Dials

are constructed on exhaustively tested and truly scientific principles and are engineered

to meet the precise requirements of experts—consequently they more than meet the expectations of the average radio user. They bring in distant stations with alacrity and positiveness seldom encountered and provide control and accuracy essential to full radio enjoyment. They impart a degree of elegance that creates a marked improvement in the appearance of any set. Clockwise or counter clockwise.

Royal Brass Finish, 4 in. \$2.00; 3 1/4 in. \$1.65
Satin Silver Finish, 4 in. 2.50; 3 1/4 in. 1.90
DeLuxe Gold (24K) 4 in. 3.00; 3 1/4 in. 2.50

Apex Rheostat Dials

are little brothers to Apex Vernier Dials. Accurate, handsome—a necessity to satisfactory operation and beauty of appearance.

Royal Brass Finish 75c Satin Silver Finish 85c
DeLuxe Gold (24K) \$1.00

If your dealer is unable to supply you, order direct from us.

Apex Electric Mfg. Co.
1410 W. 59th St., Dept. 1101, CHICAGO

Como Duplex Transformers

"The World's Standard for Push Pull Amplification"

Use them in your set and you will realize why they are continually specified by leading Radio Engineers. The fact that they are widely copied is proof of their superiority. "Take no chances—use Como."

\$12.50 per matched pair at leading dealers. Send for literature.
Como Apparatus Corp., Manchester, New Hampshire

LATEST WHOLESALE RADIO CATALOG

FREE Simply send name
TODAY for big
48-page catalog
of latest radio goods at Wholesale.
Live dealers and agents wanted.

STANDARD RADIO CO., 102 East 13th, Kansas City, Mo.

RADIO CATALOG

NEW
1925-1926
EDITION

Contains nationally
advertised High
Quality Sets,
Parts and Kits.

Western Radio Co. MFG
136 W. Lake St. Chicago, Ill.



Make your set safe with a Belden Battery Cord



DO away with the old messy jumble of battery wires behind your set and substitute a Belden Radio Battery Cord. It has five rubber-covered, cotton insulated wires, each color-coded, and enclosed in a compact brown braid. Every set owner improves his set by using one of these handsome cords.

Eliminate the danger of short circuits between battery wires and the possibility of burned-out tubes.

All leading radio dealers carry Belden Radio Battery Cords. They are distributed in individual cartons, plainly marked for your protection. Be sure you specify Belden. It is your safe-guard for quality.



Belden

Send for Free Illustrated Booklet

Belden Manufacturing Company,
2306-F So. Western Ave., Chicago.

Please send me your latest illustrated booklet, free, describing Belden Radio Products and their use in radio work.

Name

Address

30 DAYS FREE TRIAL



Direct From Factory
to You At Less Than Dealer's Cost

THIS WONDERFUL COAST-TO-COAST METRODYNE SUPER FIVE 5 TUBE RADIO SET

Will be shipped anywhere in the U. S. for 30 days FREE trial. Test it yourself in your own home and if you do not agree that it is the Greatest Radio Set in the Country, RETURN IT TO THE FACTORY. We don't want your money unless you are completely satisfied.

The Metrodyne has the latest and most efficient Tuned Radio Frequency Circuit. Approved by America's leading Radio Engineers. Easy to operate. Dials can be logged. Tune in your favorite stations instantly on the same dial numbers every time. No guessing.

Mr. Howard of Chicago said "while 5 Chicago Broadcasting Stations were on the air I tuned in 17 out-of-town Stations, including New York and San Francisco on my loud speaker horn, very loud and clear, as though they were all in Chicago."

Thousands of satisfied and happy users everywhere

PRICE—COMPLETELY ASSEMBLED ONLY
Compare it with any \$100 or \$150 set. The result will really surprise you. Don't buy a radio set until you learn more about our liberal 30 days FREE TRIAL OFFER. **\$48.50**

Write Today for Free Information

METRO ELECTRIC COMPANY
1243 S. Wabash Avenue Dept. 38 CHICAGO, ILL.



Popular Prices—Remarkable Results

No better loops at any price. Quantity production keeps prices low. Handsome, convenient and efficient.

LINCOLN 4-POINT TAPPED LOOP . . . \$8.00

Built for any circuit where it is desired to vary the inductance of the loop. Exceptionally fine for Superhets.

LINCOLN CENTER-TAPPED LOOP . . . \$6.50

For any set employing radio frequency amplification. For certain Superhets requiring a center tap. If your dealer cannot supply you, order direct, giving your dealer's name. Write for illustrated catalog P.M.

LINCOLN RADIO CORPORATION, 224 N. Wells St., Chicago



No. 31 Radio Table
15"x31"x29" high

\$22.50. Any of them can be furnished with built-in loud speaker. The most attractive line on the market for the price.

Radio Cabinet Dept.—Express Body Corporation
50 Lake Street Crystal Lake, Illinois

A Rigid, Substantial Table

Just the thing for your radio set. Made of selected fir wood. Comes in natural wood only, ready for finish. Color card with instructions for finishing with each shipment. Price \$3.50, cash with order, or we will ship c. o. d.

Get our illustrated circulars, showing many kinds of radio cabinets, from \$1.50 up to be furnished with built-in loud

FREE

64 Page Catalog of Radio Bargains



The World's Largest Exclusive Radio Mail Order House Will Send You This Wonderful Book FREE

Contains thousands of bargains in radio sets, semi-finished sets and radio kits of all styles, sizes and approved circuits. Beautiful models of latest designs and types. Elaborate console models with loud speakers built right in cabinets of genuine mahogany and walnut. All sets guaranteed. Coast to coast receiving range. Also contains everything in radio supplies including batteries, chargers, loud speakers, transformers, condensers, rheostats and any other parts you may want for improving your set or building a new one. Guaranteed saving to you of 1/3 to 1/2.



American Radynola

AMERICAN RADYNOLA 5 TUBE SET \$29.50

World's Best 5 Tube Set
Fully built and wired. Beautiful mahogany cabinet. Sloping panel design. Finest low-loss condensers, coils and sockets. Bakelite baseboard, panels and dials. Regular \$75.00 value. Price \$29.50. Transportation charges extra. Shipping weight 25 lbs.

Set with all accessories including tubes, loud speaker, storage battery, 6" batteries, aerial and ground equipment—\$59.75. Shipping weight 100 lbs. Complete instructions with set.

Satisfaction Guaranteed. Send for Catalogue Today!

RANDOLPH RADIO CORP.
159 N. UNION AV. Dept. 122 CHICAGO, ILL.

A SUPERIOR RADIO AT A LOW PRICE!

Premier
Wonder

\$34.50

Wonderful Tone Quality
Distance—Selectivity—Volume

Buy this high grade radio direct from the factory at wholesale price. All parts high grade. Test it yourself. The set is guaranteed. Write for Illustrated Circular G-8.

SPORT RADIO WORKS, Aurora, Ill.



UTAH LOUDSPEAKER

Ours is the strongest guarantee! Use it 10 days. If not the finest you ever heard, return it and get your money. Dealers Everywhere.

Utah Radio Products Co. Dept. 50, 1427 S. Michigan Ave. CHICAGO, ILLINOIS

A Jefferson Tube Rejuvenator

will keep your radio tubes like new. At leading Radio Stores **\$7.50**

JEFFERSON ELECTRIC MANUFACTURING COMPANY
501 So. Green Street, CHICAGO, Ill.

Mohawk Radio

5 TUBES—JUST ONE DIAL TO TUNE

SOLDERALL

METAL IN PASTE FORM



The only convenient metal solder

Every Electrical Connection needs Solderall for perfect reception **25¢**

The SOLDERALL CO., NEWARK, N.J.

Preliminary Announcement

ALL-AMERICAN RADIO RECEIVERS

There will be available this fall a limited number of radio receivers, produced and wired complete in the new ALL-AMERICAN factory and bearing the name ALL-AMERICAN.

They will embody all the genuine improvements of the past year in radio reception—multistage control through two 360° dials, tonal beauty through Rauland-Lyric and distance and selectivity through ALL-AMERICAN Straight-Line-Frequency TUNING. Yet the price will be low, being based on next year's extensive production.

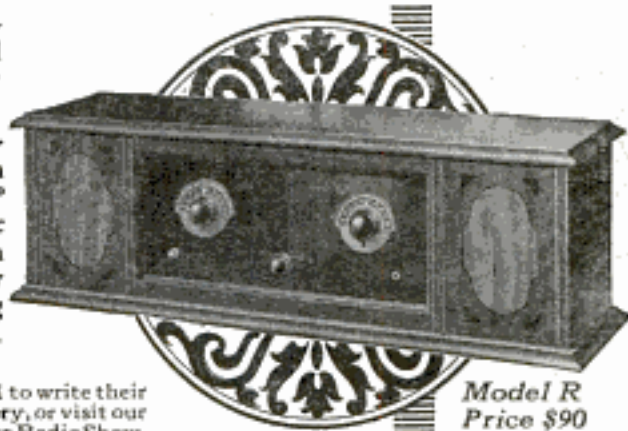

Model R
Price \$90

Dealers are invited to write their jobbers or the factory, or visit our booth at the Chicago Radio Show.

ALL-AMERICAN RADIO CORPORATION, E. N. Rauland, Pres., 4221 Belmont Ave., Chicago, U.S.A.

RMA

OWNING AND OPERATING STATION WENR—266 METERS

ALL-AMERICAN

Pioneers in the Radio Industry

Save 20 to 50%
FREE RADIO CATALOG

**LATEST
IN
HOOK-UPS
AND
RADIO**

Get the lowest rock-bottom prices on radio parts, sets, kits. New free Radio Catalog and Guide brimful of standard, reliable, guaranteed goods. Over 100 latest hook-ups and illustrations. Be sure to get this thrifty book before you buy. It puts money in your pocket. Saves you as much as half on a set. Also please include name of radio fan. Send letter or postal NOW.

THE BARAWIK COMPANY

103-168 S. Canal St., Chicago, U. S. A.

FREE two unusual
RADIO CATALOGS



FOR "FANS"

OUR new 64-page Radio Catalog including all the best and latest Kits, Parts and Accessories for broadcast receiving sets. Lowest prices in the country!

FOR "HAMS"

NEW 32-page booklet of army and navy transmitting apparatus and miscellaneous specials for "hams" such as W. E. Choke Coils, Generators, Resistance Boxes, etc.

More than 1,000,000 fans and hams make our store their headquarters—get these books and find out why

Write for either or both

509
South
State
Street

RADIO CHICAGO
SALVAGE STOCK
STORES

Dept.
P.M.6
Chicago
Ill.

Please Mention Popular Mechanics

AGENTS
Big Money Quick!

**COMBINATION KING
RADIO WONDER**

First combination tube and crystal set ever made. Turn of a switch and either tube or crystal works as desired, or both together. 1000 Miles or more on headphones—Loud speaker on Locals. Two complete sets in one for only \$10.95 retail. Get

my wonderful money making plan and special price to you.
You Want This Proposition—Write Today!

W. F. RICHARDSON, MFR., 128-32 W. KINZIE ST CHICAGO



Washington Jewelry Co., Boston, Mass.

Amplifies! Beautifies! Clarifies!**The NEW Burns "MEL-O-TONE" Loud Speaker****10-Days' Trial
Absolutely FREE!****Send NO Money!****Great
Acoustic
Achievement!****Super-
Sensitive
Unit!****75c Plug
Included FREE!***"Floods the
Home with
Mellow-
tone"*

MARVELOUS Super-sensitive Unit. Patented electro-magneto coil construction with **PRECISION** adjuster to regulate reception from faintest whisper to thunderous **VOLUME** that will fill an auditorium. Stands 22 inches high. Bell is 14 inches and made of lustrous jet black Pyralin, in graceful flower petal design. What a beauty it is! Worthy of the finest homes! The sound conduit is polished aluminum, **non-vibrating, non-resonating**, eliminates harsh raspy sounds. Mounted on swivel—swings smoothly in all directions. A \$50 Speaker in construction and appearance. **OUR PRICE**.....

\$22⁵⁰**Send NO Money! Pay NOTHING to Postman! 10-Days' Trial FREE!**

We want you to **SEE!** to **HEAR!** to **ENJOY!** it!—before paying a cent. **\$4** A MONTH
If satisfied after 10-Days' Trial, you may pay \$22.50 cash, or on our **Nationally Famous Charge Account Payment Plan:—\$1 WEEKLY...**



2 Generations of Honorable Dealings

**WASHINGTON
JEWELRY Co.**

Importers and National Mail Order House
Largest Distributors of "MEL-O-TONE" Loud Speakers

365 Washington Street, Boston, Mass.
For prompt attention address **RADIO DEPT. 126**

Gentlemen: Please send me \$22.50 Burns "MEL-O-TONE" Loud Speaker with 75c Plug included FREE. I enclose NO money, and pay NOTHING to Postman. If I am satisfied, after 10 DAYS' TRIAL, I have the privilege of paying cash or at the rate of \$4.00 monthly. Otherwise, I shall return it.

NAME.....

ADDRESS.....

Please write **PLAINLY!** Tear this coupon out **NOW!** If you wish to tell us something about yourself, it will be appreciated. Pop. Mch. 11-25.

TO own the Burns "MEL-O-TONE" Loud Speaker is to give friends and family real **ENJOYMENT** when listening to broadcasts. Makes good concerts **BETTER.** It amplifies **CLEARLY, FAITHFULLY, SWEETLY** the beautiful strains of the violin; stirring airs of bands; snap and pep of jazz music; thrilling notes of opera singers; natural inflections of the orator; delightful richness of concert music. We have sold hundreds to "fussiest" Radio Fans—and they are Delighted with the Burns "MEL-O-TONE" Loud Speaker!

ORDER YOURS TODAY! Send NO Money. This Amazingly Liberal Offer for Limited time only! Send coupon NOW!

NOTE! Eminent Radio Scientists endorse the Horn type Loud Speaker. The curved throat and wide mouth produce *concentrated volume, directional volume, greater volume* than the Non-horn type which diffuses sound. Try the Burns and test the truth of this **FACT** yourself.



Vigilance

Constant vigilance is the price of uniformity and constant vigilance is maintained over Magnatrons. That is why Magnatrons are uniform, and uniformly good.

The Magnatron DC-201A, DC-199, and DC-199 (large base) now list for only \$2.50 each.

Connewey Electric Laboratories, Magnatron Bldg., Hoboken, N. J.

MAGNATRONS



The Traffic Cop of the Air

Add a **Ferbend Wave Trap** to your Radio Set and "Police" your reception. Guaranteed to tune out any interfering station. The original and only successful **Wave Trap**. Best paid on receipt of \$8.50 or C. O. D. plus postage. *Send for Free Booklet.* Ferbend Electric Co., 15 E. So. Water St., Chicago

Wave Trap

ULTRADYNE

Model L-2
Famous Superheterodyne

Write for interesting booklet on the famous Ultradyne.

Phenix Radio Corp.
114-E East 25th St., New York City

Silver Six

SM

YOU SAVE 50%

Radio "A" and Auto World Batteries are famous for their guaranteed quality and service. Based by years of successful manufacture and thousands of satisfied users. Equipped with Solid Rubber Case, an insurance against acid and seal leakage. You save 50 per cent.

2-Year Guarantee Bond in Writing

WORLD Battery swears "all their friends." That's our best proof of performance. Send your order in today.

Solid Rubber Case Radio Batteries

6-volt, 100 Amperes... \$18.25
6-volt, 120 Amperes... \$13.25
6-volt, 140 Amperes... \$14.00

Solid Rubber Case Auto Batteries

6-volt, 11-Plate... \$18.25
6-volt, 13-Plate... \$13.25
12-volt, 7-Plate... \$16.00



Approved!

Listed as Standard by Leading Authorities including Radio News Laboratories, Popular Science Institute of Standards, Popular Radio Laboratories, Radio Broadcast Laboratories, Radio in the Home and Lab., Inc.

Radio Station W S B C

Set your Radio Dials at 210 meters for the new 1000 watt World Storage

Battery Station, W S B C, Chicago, Ill. Watch for announcements. **Send No Money.** Just state battery wanted and we will ship day order is received, by Express, C. O. D., subject to your examination on arrival. **Extra Offer:** 5 per cent discount for cash in full with order. Buy now and get a guarantee battery at 50 per cent saving to you.

World Battery Company, Dept. 6, 1219 So. Wabash Ave., Chicago, Ill.



HERE IS THE SET YOU WANT

Designed by McMurdo Silver, Assoc. I. R. E. It is unsurpassed for Selectivity and Sensitivity—operates on either a loop or antenna. Ease of control allows the use of one, two or three dials as desired. The "SIX" will out perform anything except a laboratory-built superheterodyne. You can assemble this new receiver yourself, in just a few hours using only the parts supplied in the kit.

Send 50c

for complete building instructions on the Silver Six.



It's easy to Build

FREE Complete description of McMurdo Silver's latest circuit designs. Write today!

SILVER-MARSHALL, Inc.
110 S. Wabash Ave., Dept. E. CHICAGO

Have you a cold radiator



AIRID Air Valves make cold radiators hot. Attach easily to any steam radiator without tools—need no adjusting—never leak—make no noise. Sold at heating and plumbing stores. Only \$1.60.

AIRID

AIR VALVES

make cold radiators **HOT**

AMERICAN RADIATOR COMPANY

1812 Elmwood Ave., Buffalo, N. Y.

Send me a trial Airid (one only). (Guaranteed 5 years.) (This will be mailed C. O. D., or enclose check or money order for \$1.60.)

Name

Address

FREE Diagram, Templates, Instructions for building Calceaterra's 5 tube Tuned **RADIO FREQUENCY** Set for \$55
Write **KELLOGG SWITCHBOARD & SUPPLY CO., Chicago, Illinois**

CORONA PORTABLE ADDING MACHINE

Does everything any adding machine can do yet costs only one-fourth to one-half as much! Really portable—weighs only 16 lbs. Covers no more desk space than an ordinary letter-head. Built by the Corona Typewriter Co. Send now for free booklet.
Portable Adding Machines Sales Co., Dept. 1778, 343 S. Dearborn St., Chicago

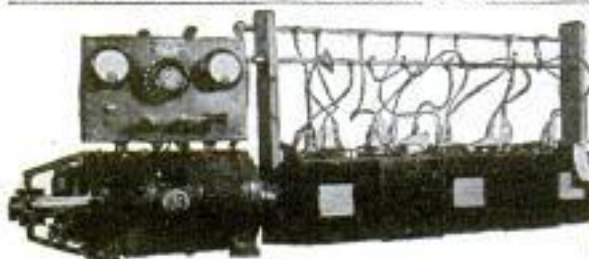

PATTERN-MAKING

for Those Who Should Know

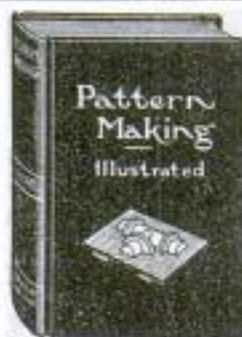

Compiled by **G. H. WILLARD**, a pattern maker of many years' experience, for those who wish to increase their pay—or those who wish to enter this well-paying occupation. Filled to the covers with helpful shop-kinks and actual working information. Practical instructions written in plain language, which anyone can easily read and understand. Learn at home—in your spare time. Bound in cloth, 224 pages, 312 illustrations, diagrams and working drawings, etc.

Tells About Pattern making as a trade—The Tools—Wooden Joints—4 chapters on Turning—2 chapters on the Circular Saw—2 chapters on Machine Tools—3 chapters on Single Tools—Crooked Patterns—2 chapters on Large Pattern Work—Cross-Head Guide Patterns—Sweep work—Pipe work—Stove pattern work—Molding—Machine Work—Molding Pattern Work.

CORE MAKING AND MOLDING

Part II explains the simple and complicated problems in core making and molding which every good pattern maker should know. **Tells about**—Core making, simple and complex—principles in Molding—Loam Patterns—Loam Molds.

Everyone following this trade or intending to enter it should have this remarkable book. The price is so low that anyone can afford to buy it. Those who have it, wouldn't be without it.

SEND NO MONEY Just write a postal. Pay postman postage and \$1 when he hands you book.
POPULAR MECHANICS PRESS

200 E. Ontario St., CHICAGO

286 Ideas for Drivers

19 ideas on oiling and greasing
16 ideas on starting balky cars
22 ideas for road emergencies
18 ideas on radiator repairs
15 ideas on handling gasoline
33 ideas on lights and ignition
24 ideas for tire repairs
9 ideas on foiling thieves
12 ideas on caring for springs
8 ideas on non-skid equipment
16 ideas for the home garage
6 ideas on cleaning cars
10 ideas on non-freezing solutions
78 ideas on miscellaneous repairs

—This book will be worth more than twice its cost to you.

It tells how to apply chains easily when your wheels are sunk deep in mud or sand. It tells how to lock your car so that a thief cannot steal it. It tells how to judge a second-hand car. It tells how to quiet squealing brakes. It tells how to stop the rattling of car doors.

SEND NO MONEY Simply write a postal and say, "Send me the Auto Owner's Book." Special with the Auto Owner's book, we will give you the Auto Tourist's Handbook. When the postman hands you the two books, deposit with him only 98 cents and pay the few cents postage. Address your postal to

POPULAR MECHANICS PRESS
Room 507, Popular Mechanics Bldg., Chicago, Ill.

\$150 to \$300 PROFIT MONTHLY FROM HB ONE DAY BATTERY CHARGING

Only \$35 cash starts you in a moneymaking battery charging business of your own with this complete HB One Day Charging outfit. Easy monthly terms let your profits pay for equipment. HB users easily clear \$150 to \$300 monthly profits from battery service alone. No experience needed to operate an HB 30 days free trial on your shop on absolute moneyback guarantee. Universal demand for One Day Battery Service insures your success. Write for free bulletin 26.

HOBART BROS. CO. Box M11 TROY, OHIO

MORE HB ONE DAY BATTERY CHARGERS ARE IN USE THAN ANY OTHER MAKE

1/2 **SAVED** on all Standard Typewriters

**10 DAYS
TRIAL!**

At Last—
World's Best
Typewriters
with every
modern writing
feature
at positive-
ly lowest
prices and on
easiest terms ever offered.



A Year to Pay—5 Years Guarantee

Standard machines so perfectly **Re-Manufactured** by the exclusive **Young Process** that they look and write like brand new. Our exclusive, distinctive process makes possible better typewriters at lower prices.

**FREE BIG ILLUSTRATED
TYPEWRITER BOOK**

Write now. See our amazing typewriter bargains. Read what users say and the unusual service we will give you. Don't wait—write today.

YOUNG TYPEWRITER COMPANY
654 West Randolph Dept. 11.B Chicago, Ill.

NEW TOPS

Send 10c in stamps for estimates and samples. State name and year of car.

Glass Enclosures,
Winter Tops, Curtains,
Radiator Covers, etc.

Comfort Auto Top Co., 1527 Germantown Ave., Phila.

WANTED AGENTS—Easy to Earn \$25.00 a Day Selling This New PATENTED TIRE MOCCASIN

Without the aid of cement or heat our patented semi-cured rubber vulcanizes itself to the tire. Everybody buys tires—and everybody has them repaired. You can sell one of these to every car owner. One of our agents sold nine hundred in one day.

No Experience Necessary Send \$1 for full size moccasin and full details. Money refunded if not satisfied.

PERFECTION RUBBER PRODUCTS CORP.
Factory and Gen'l Offices: 825 So. Meridian St., Indianapolis, Ind. Dept. C
Reference: Fletcher Am. Loan National Bank.

A *Baby Grand* Lathe in YOUR Home or Shop

An accurate, high grade tool for doing the most fascinating, educational and profitable class of work.

Make the Things You Want of metal, wood or other material, on this thoroughly practical machine built for honest service by experienced lathe builders and sold at a popular price direct from factory to user.

POSITIVE MONEY-BACK GUARANTEE

We also make Drills, Grinders,
Accessories, Tools and Supplies.

The Watson Mfg. Co., Toledo, Ohio

111

Watson
Bldg.

Write today
for illustrated
folder giving
complete
description
and prices.



BARBERING

**Now One of the Highest Paid
Professions! \$ 90 to \$ 150
Every Week!**



**Easy
to
Learn—
Quick**

to Earn! That's BARBERING for YOU! And the best part of it all is this—scientific barbering, as taught the modern MOLER way, makes YOU a Master Barber in a short course of intensive training, at small expense! You soon step out as your own Boss, if you wish, in your own Shop, which we will gladly help you equip.

MOLER Graduates are Always

Busy! MOLER trained Men are always given the preference, for they alone possess the valuable, thorough MOLER training in the application of all the latest scientific Barbering methods, including the Electric hair cutter, the mechanical massage, and the latest vogue in ladies' hair bobbing. MOLER also gives special training in ladies' mannequing and an easy practical course in the treatment of skin diseases.

EARN WHILE LEARNING!

"Where there's a Will there's a Way" to earn BIG pay! Write to the nearest MOLER College, there is one near you, and learn how you can earn while you learn the barber trade. Ask for the new FREE MOLER Barbering Booklet B. Find out HOW MOLER helps you help yourself AFTER you graduate, as well as BEFORE! Find out why MOLER Men are making DOUBLE the money others made last year, before Ladies' Shingle Bobbing became so popular. You're NEXT in line for big pay—the MOLER way. Send Coupon TODAY!

Moler System of Colleges

30 Branches in United States and Canada

New York, N. Y.
Chicago, Ill.
St. Louis, Mo.
Kansas City, Mo.
Cincinnati, Ohio
Cleveland, Ohio
Detroit, Mich.
Denver, Colo.

Omaha, Nebr.
Milwaukee, Wis.
New Orleans, La.
Atlanta, Ga.
Memphis, Tenn.
Dallas, Tex.
Houston, Tex.
San Antonio, Tex.

Los Angeles, Cal.
San Francisco, Cal.
Fresno, Cal.
Sacramento, Cal.
Winnipeg, Can.
Seattle, Wash.
Portland, Ore.
Minneapolis, Minn.

MOLER SYSTEM OF COLLEGES

Address Nearest Branch

(Street Address NOT Needed)

Please send me without obligation on my part your Booklet B.

Name

Address

City..... State

DIAMONDS WATCHES & JEWELRY 12 MONTHS TO PAY

Send No Money Pay The Post Man

No. 4 \$1 Down: \$4 A Month

The sparkling, brilliant, blue white, genuine diamond set in this handsomely engraved popular style ring is much larger than usual for the price. It flashes with all the colors of the rainbow. Everybody will think that you paid at least \$75.00 for it. Two dark blue sapphires are set in the shanks and add style and beauty.

No. 4
\$49

No. CS2 \$1 Down: \$5 A Month

Great big cluster of seven sparkling, brilliant blue white, specially selected diamonds set in solid platinum in this handsomely engraved 18 kt. solid white gold ring. Two triangular, dark blue sapphires give the proper touch of style. It looks like a 2 carat solitaire worth \$1,000.00.

No. CS2
\$61

FREE

Every purchaser who answers this advertisement will receive a valuable premium. The premium list will be sent as soon as we receive coupon.

No. 8 \$22 \$1 DEPOSIT \$1.75 A MONTH ELGIN OR WALTHAM



Man's full 12 size, open faced model, fancy engraved watch with your choice of either of the world-famous Elgin or Waltham movements. They are cased in this handsome gold filled case which will wear like solid gold. The Waltham and Elgin movements are positively guaranteed both by the factory and ourselves. They are accurate time keepers. FREE: We will give away, absolutely free, a handsome gold filled chain and knife to match. They come in a fine gift case, and make an unexcelled present.

STERLING DIAMOND & WATCH CO., Inc.
1540 Broadway Dept. 2029P New York

TEAR OUT & MAIL

STERLING DIAMOND & WATCH CO., Inc.
1540 Broadway, Dept. 2029P New York, N. Y.

- Please send it to me by parcel post C. O. D. and I will pay the small deposit to the mailman when he hands me the package.
- I enclose \$..... as a deposit. Please mail the article to me direct to my home.
- Don't send the ring or watch, but mail a copy of your big free catalog to me, which shows thousands of diamond, watch and jewelry bargains for me to select from.

Name

Local Address

City and State

YOURS WITHOUT COST

Popular Mechanics will furnish you with either its world-famed

Popular Mechanics Super Eight

—the last word in Radio

(cabinet, engraved and drilled panels, voltmeters and parts, including full set of blue prints)—or a



Ranger "Motorbike"

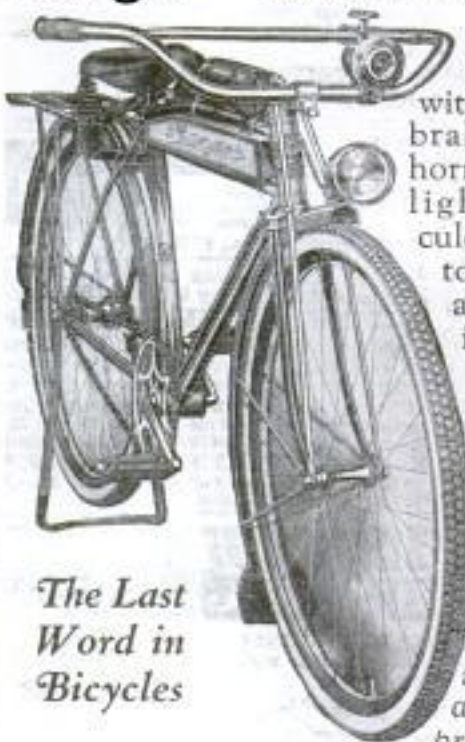

The Last Word in Bicycles

fully equipped with coaster-brake, hand horn, electric light, Hercules carrier, tool tank and tools, in your choice of 18, 20, or 22-inch frame, finished in golden brown and white all charges prepaid, for

a little of your spare time taking a few subscriptions to POPULAR MECHANICS in your community.

Drop us a postcard today, with your name and address and two references, for full details of this Remarkable Offer, and subscription outfit FREE. Address

Popular Mechanics Magazine
Room 408, 200 East Ontario Street
CHICAGO, ILLINOIS

Make Home Lovely for Christmas This Easy Way

YOUR dreams of a lovelier, cozier home can come true before Christmas! Whether it's a new home, a room or a spot here or there you wish to brighten, do it by the Larkin Better Homes Credit Plan, the happiest way in the world.

See all the suites, rockers, lamps, rugs, curtains, silverware, etc. in the beautiful Larkin Catalog—your copy FREE for the asking.

Mail
Coupon
for your
FREE
Catalog

Larkin Co. Inc. BUFFALO, N. Y.
Peoria, Ill.
Chicago, Ill.
Gentlemen: Please send me at once your new Fall Catalog No. 219 with all details of your Better Homes Easy-Payment Plan. 11

Name.....

Street and No.....

P. O. State.....

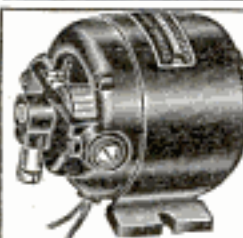

Large Quantity—Brand New
Robbins-Meyers Small Motors
at practically 50% Saving
ROBBINS-MEYERS SMALL MOTORS
about 1/20 H. P. 110 volts. \$6.00 Each
Universal.
GENERAL ELECTRIC SMALL MOTORS
about 1/20 H. P. 110 volts. \$6.00 Each
1050 R. P. M. Universal.
Finest mechanically and electrically constructed
motor ever built for its size. Quiet run-
ning. Larger sizes always in stock.
WEXLER ELECTRIC MOTOR CO.
Dept. P, 196 Centre St. New York City

THE WOTEN, GASOLINE 2 CYCLE, 3-PORT ENGINE

Aircooled and Watercooled. Nearly One-Half H. P. in five pounds. Handiest little engine ever made. Ideal wherever power is needed. Complete line of small gasoline and steam engines, dynamos, motors, batteries, battery chargers, etc. CATALOGUE FREE.

DYNAMIC MANUFACTURING CO.
First Nat'l Bank Bldg., Dept. 6 Chicago

Prevent Tooth Decay and Bad Breath by using a Flossy

IT'S up to your druggist to sell the genuine "Flossy." Do not accept the common dental floss—it is wasteful, unsanitary and will surely cut your gums like toothpicks. Next time at the drug store buy the latest, most scientific, important new article, "The Ivory Flossy," for cleaning the 30 pockets between your teeth where 90% of all decay and pyorrhea begins.

Look At Your Own Teeth

and you will see yellowish food packings between them—the cause of bad breath and decay. Toothpicks cut the gums.

Brushing cleans outside only. Dental floss used by hand is a crime best known by those who use the new "Flossy" with its simple bite. Preferred by dentists everywhere. Big surprise awaits you to see what "Flossy" finds after the most thorough brushing. If your druggist doesn't carry "Flossy" send us his name and a dollar bill and we'll send it direct. Leather pocket case free with first order. Makes ideal gift for meretricious women.

Order by Mail
FLOSSY DENTAL CO., East 10, EVANSTON, ILL.



AUTOMATIC HYDRO OIL BURNER \$295

INSTALLED COMPLETE, 220 GALLON
FUEL TANK, THERMOSTATIC CONTROL

A few large city dist. dealerships still open

Automatic Hydro Oil Burner Co., 511 Mc Kerchey Bldg., Detroit, Mich.



Reduce Motor Speed WITH IXL

FREE BOOK

Every inventor and experimenter should know about IXL Speed Reducers. Most efficient, compact and safe device for reducing motor speeds. May be built into machines where speed reduction is required, or used in shop transmission in place of belts, chains and open gearing. Large variety of sizes and reductions.

Send for your copy of our big FREE book Today.

We Make Cut Gears of all kinds, Mica Pinions, Mica Timing Gears, Flexible Couplings, Speed Reducers, Special Machinery

FOOTE BROS. GEAR & MACHINE CO.

215 N. Curtis St., Chicago, Ill.

Gentlemen: Please send me a copy of your free Speed Reducer Book.

Name.....

Address.....

City..... State.....

Sent On
FREE
TRIAL
NO MONEY
DOWN

**Just Name and Address
Brings You This Liberal Offer.**

DON'T send a penny! Your name and address brings to your home this wonderful New Model Aladdin Lamp for ten days FREE Trial absolutely at our risk. Amazingly powerful, steady, white light from common kerosene (coal-oil); no odor, no noise, smoke or sputtering. Simple, safe, clean, easy to handle; no pumping up, no pressure.

BEATS ELECTRIC OR GAS — Burns 50 Hours on One Gallon

Think of It! This wonderful new Aladdin light beats electricity or gas at a fraction of a cent an hour. Tests by U. S. Government and 35 leading universities show Aladdin light is ten times as strong as light from ordinary kerosene lamps. Five times as efficient as the best round wick open flame kerosene lamp. Soon saves its cost. Light nearest to sunlight of all artificial lights. Over seven million satisfied users. Your simple request brings you full particulars of our liberal 10 day Free trial offer, and how you can secure one without cost. Write Quick.

Get Your's
FREE

MANTLE LAMP CO., 300 Aladdin Bldg., Chicago, Illinois

Largest Kerosene (coal-oil) Mantle Lamp House in the World.

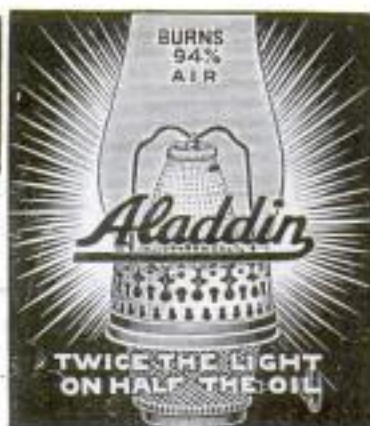

Agents Wanted!
Make \$200 to \$500 a Month

Become our distributor for this light that sells on sight. Needed and wanted everywhere. Big waiting demand. No capital or experience necessary. Get details quick of this most unusual big-money opportunity for either men or women—spare or full time.

**We Help You Build
This Paying Business**



ARE you the man that will grasp this splendid opportunity to get into the motorcycle business? The Harley-Davidson 1926 models are arousing more interest in motorcycling than ever. We receive inquiries from everywhere daily.

You can cash in on all this live interest by becoming a Harley-Davidson Dealer. We furnish you with all the "leads" from your territory, and we help you build a successful business.

All you need is enthusiasm, a genuine desire to get ahead in this world, and a small amount of capital.

If you are the type of man who wants to run his own business, and be independent, send us the attached coupon and we will explain our interesting plan in detail.

**Harley-Davidson
The Motorcycle**

Harley-Davidson Motor Co., Dept. P, Milwaukee, Wis.

Tell me how I can get into the profitable motorcycle business with your help. Also, send me free illustrated booklets.

Name

Address

City

Books on all subjects are sold by Popular Mechanics Press, 200 East Ontario Street, Chicago, Illinois.

**\$200—\$400
Monthly Income to Start!**

New Plan for Permanent Business

Men needed now—who want future prosperity as well as big immediate income. This means both. \$200-\$400—more—monthly income to start. Constant increases. Permanent business of your own. Better than owning retail store. Remarkable training, constant help, *insure* success. Previous experience not essential. You become local partner-representative of world's greatest shoe merchants. Sensationally successful new plan. Quick advancement open to men accepted now. Rush reply. Get complete proposition. Nothing like it ever offered. Address:

Feltman & Curme Shoe Stores Co., Inc.
Dept. 5 118 S. State St., Chicago
World's largest shoe merchants; 73 stores, in all principal cities

Don't go
into the
woods
without the CEEBYNITE
a Taylor Compass



If your Dealer cannot supply You, write

Taylor Instrument Companies

ROCHESTER, N.Y.

Canadian Plant, Tycoo Bldg Toronto

There's a Taylor Byke Thermometer for Every Purpose

\$68
3/4-3/16
Carat

\$142
1-3/32
Carat
Accurately
Cut

\$55
Close set
Cluster
Solitaire

JOS. DE ROY & SONS
PITTSBURGH, PA.

Diamonds Here at 60% of Market Price

See this 1 less 3/32 carat absolutely correctly cut, snappy, brilliant solitaire diamond in handsomely designed mounting, at just \$142. Also many other bargains in our big lists.

Never in three-quarters of a century in the diamond business, have we offered such bargains as we do now compared with prevailing prices. Diamonds right now at rock-bottom even in regular market. Yet ours are but a fraction of market prices. The opportunity of a lifetime. Buy now—the trend is already upwards, but, our cash prices for unpaid loan diamonds left on our hands are but a fraction of their real value.

Why Pay Full Prices Costs Nothing to See

This diamond banking house, X century old, rated more than \$1,000,000.00, takes this way of turning into cash the diamonds on which money was loaned and not repaid. Also other special advantage buys—many from big cash deals direct with European diamond cutters.

Send for Latest Bargain List

Radically different from a catalog. Every gem fully and minutely described. Any gem sent you on approval without slightest obligation to buy. Write now. The very stone you wish may be in this present list at a price that will amaze you. Send this coupon now.

JOS. DE ROY & SONS

Only Opposite Post Office

1938 DeRoy Bldg., Pittsburgh, Pa.

References by permission:
Bank of Pittsburgh—N. A.
Merchants National Bank
Union Trust Co., Pitts-
burgh, Pa. Your bank
can look us up in mer-
cantile agencies.

JOS. DE ROY & SONS

1938 De Roy Bldg., Pittsburgh, Pa.

Gentlemen: Please send me, absolutely free and prepaid, your new bargain list of diamonds, watches and other jewelry. It is distinctly understood that I assume no obligation of any kind.

Name _____

Address _____

\$59
2 Ct.
Show
Diamond
Cluster

\$100
3/4 less 3/16
Carat
Blue-White

\$189
1-3/32 Ct
Blue-
White

As Low As \$60 a Carat for Diamonds

You Can Save \$35.00



\$4.45 and up

Recover it yourself.

Custom tailor made to fit all makes and models. Roof

and quarters sewed together, with rear fasteners, wells and tracks, complete. Anybody can put it on. Give name, year, model number of your car. Catalog FREE. Agents wanted.

LIBERTY TOP & TIRE CO., Dept. I, Cincinnati, O.

MEN NEW LINE BIG MONEY



World's fastest seller is Everbrite Stainless Steel Cutlery. Agents make \$65 to \$125 weekly. Commissions in advance. We deliver and collect. Wonderful samples and case furnished. Don't waste time on slow sellers. Get in on this world heater. Write for agents' offer—today!

E. B. STAINLESS STEEL CUTLERY COMPANY
37 W. Van Buren St., Chicago, Ill. Dept. 35

AGENTS SELL THE OVERSIZED



JOHNSON RED PEN

Each pen is hand-made and ink-tested in our own factory.

FIVE-YEAR GUARANTEE with each pen.

\$7.00 VALUE for **\$3.50**

Send for AGENT'S SAMPLE at \$1.75 C.O.D. plus postage, and complete literature, or send for literature only.

Johnson Pen Co., Dept. P.M., 117 S. First St., Rockford, Ill.

DIVINE RED DEVIL Water Motors

Simple—strong—durable. Wonderful little workers for all sorts of household and shop uses. Thousands in use. For all light power purposes. Attaches to faucet.

Two sizes: 4'—\$4.25
6'—\$6.75

The higher the water pressure the more work they do.

Send today for catalogue.
Divine Water Motor Company
Utica, N. Y.



See
What's
Going On!

Carry a clear, accurate, powerful
Vest-Pocket TELESCOPE
\$2.00 (Genuine Wollansak)

Postpaid, with Limp Leather Case

A powerful, precise, monocular, quickly and accurately adjustable to either eye. Brings distant objects close, in full detail, without the "vibration" present in higher power scopes or binoculars. Handsome black baked-in enamel with non-slip grip. Guaranteed both by this company and by maker, one of the finest lens builders in the world. Fits any vest pocket (only 3 3/4 in. long) yet has full six magnifications. Glove leather case included. A handsome, practical 'scope for your own use, or for a gift. Money back if not thoroughly satisfied. Check, money order, or C. O. D. \$2.00 postpaid.

Boston Sporting Goods Co., Dept. P., 80 Bay State St., BOSTON, MASS.

Floor Surfacing Pays Big Profits



THIS MACHINE EARNS YOU

Young men, middle aged men, and older men whom we started in the Floor Surfacing business with American Universal Floor Surfacing Machines make from \$25.00 to \$40.00 and more per day and get all the business they can handle. They are men from factory, store and office jobs who saw only endless drudgery ahead for them as wage earners. They wanted a chance to "get somewhere," to make real money, to be their own bosses and to build a future for themselves and their families. They saw that chance in the Floor Surfacing game and grabbed it. Most of them were "greenhorns" at this business, but they had ambition, energy and good sound "horse-sense," and that is all any man needs to succeed as an American Universal Floor Surfacing contractor.

\$25⁰⁰
Per Day

Every New Floor Must Be Surfaced Every Old Floor Needs Resurfacing

There is surfacing work to be done in every new and old business or residence building in your town. Think man, what that means! Have you energy and "get-up" enough to go out and get the business that is waiting for you on every hand?

Would you don a pair of overalls and guide an electrically driven American Universal Floor Surfacing Machine over a floor for \$25.00 to \$40.00 a day, until you can build up enough business to hire others to do the work for you? If you can and will do so we can help you get into a business that is not overcrowded, that is easy to manage and operate, easy to build and enlarge; a business that

requires very little capital, almost no operating expense and one that can be made to pay big, handsome profits from the very first day you start. No town or community is too small. We can show you successful floor surfacing contractors in villages of 100 people.

No Experience Necessary

Any intelligent man can learn to operate the electrically driven American Universal Floor Surfacing Machine in half an hour, and with a few days' practice, can actually do the work of six men scraping by hand. And with the American Universal you can do better, smoother and more uniform and beautiful work than any man living could ever do by hand.

Write Now for Particulars. Send your name and address to us today with just a note saying, "Tell me how I can get into the floor surfacing business." We'll send you full information about the wonderful opportunity open to you. We'll tell you all about the American Universal Machine, what it does, how it works, what it costs, and give you letters, facts and figures that will cause you to do some tall thinking. Do it right now before you lay this book aside.

The American Floor Surfacing Machine Co. 523 S. St. Clair Street TOLEDO, OHIO

Cal. 30



U. S. ARMY KRAG CARBINES

All carbines have the new model 1898 stocks. The barrels, actions and parts are either new or have been refinished by the Government, and equal to new **\$15**

Wool Breeches New — in sizes from 32 waist to 40 waist. Strong light weight wool. Made for the Home Guards . . . **\$1.50** Parcel Post & Extra

W. STOKES KIRK SEND FOR OUR COMPLETE CATALOG 1627-PM North 10th Street, PHILADELPHIA, PA.

**Buy Now
Pay Later**

Get Boice Prices Before You Buy!

Boice offers you greater values in circular saws, band saws, lathes and jointers at lower prices with a positive money-back guarantee. Write for literature, prices and the Boice "E-Z" Pay Plan before you buy.

14" Band Saw

Table 12"x14", tilts full 45 degrees; saws 7" stock; uses blades 3/16" to 1/2" wide. Bronze bearings throughout. All these machines are driven by a 3/4" to 1 1/2" H. P. motor attached to light socket.

Turns wood or soft metal. Swings 8" max. over bed. 20" between centers. 3/8" hole thru spindle. Can be fitted with jig saw, circular saw and sand disc attachments. 3" scroll chuck, 1/2" drill chuck and arbor for grinding or buffing.



8" Bench Lathe

Junior Saw

Does all your ripping, mitring, grooving, moulding, sanding, grinding and drilling with ease and accuracy. Table 10" x 13". Saws 2 1/4" stock. Dadoses 3/8" x 3/8". Sold with or without motor and base.

1/4 H. P. Motor, \$11.95

Standard make, new. 110 V, 60 cycle, single phase A. C. 1750 R. P. M. with cord, plug and 1 1/2" flat or groove pulley. Bronze bearings. Guaranteed 100% overload.

1/3 H. P. Motor, \$13.95

These special offers not listed in regular price list. Made for immediate acceptance only. Prices F. O. B. Toledo. Cash with order only. Satisfaction guaranteed. Send Today!

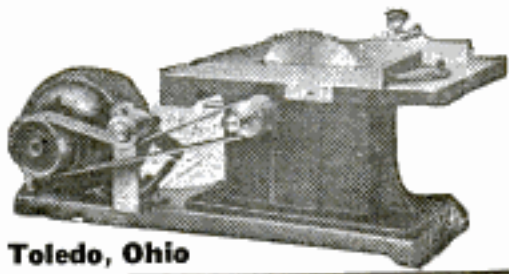

W. B. & J. E. BOICE, Dept. P. M. 11A, Toledo, Ohio

STOP LEAKS! REPAIR BREAKS! MAKE LOOSE PARTS STAY TIGHT!

Smooth-On No. 1

STOPS leaks and repairs breaks in pipes, furnaces, boilers, smoke pipes, hot air ducts, radiators, tanks, busted water jackets, etc., with one simple application.

Keeps bolts, nuts, grease cups, etc., from loosening and dropping off—makes loose handles tight—joins wood, metal or glass to each other tightly—holds on iron, brass, lead, aluminum, etc., and requires no previous experience to get good results.

For quick, cheap, lasting joints and repairs and stopping many nuisances in every home, automobile and workshop, Smooth-On is in a class by itself.

Get Smooth-On No. 1 in 7-oz., 1-lb. or 5-lb. tin at any hardware store and write for the free book.

SMOOTH-ON MFG. CO.
574 Communipaw Ave., Dept. 37
JERSEY CITY, N. J.



Write for
FREE BOOK



MOTOR BARGAINS



\$13⁵⁰

for this
big
guaranteed
 $\frac{1}{4}$ H. P.
110 Volt
AC Motor

Has many exclusive features. We guarantee to satisfy or return your money.

Grinder and Buffer, \$20

6" and 7" wheels, fan-cooled motor, dust-proof. Send cash with order. Guaranteed to give satisfaction or money refunded (less return charges).

Write for dealers' and quantity discounts.

Northwestern Electric Co.
410-420 S. Hoyne Avenue, Chicago



A Queer Way

of doing business, you may say, yet—

We urge you "don't buy—yet"—let us first prove the claims made for this unique shaving cream. Accept, please, a 10-day tube free.

TELLING customers not to buy your product may appear an odd selling philosophy. Yet that is the way we brought Palmolive Shaving Cream to top place in its field. We urge you not to buy it. But to start using it at our expense. Will you grant us that courtesy? We'll thank you if you will.

Immeasurably different

Palmolive Shaving Cream is based on new principles of skin care and beard softening.

8 men in 10 who try it, stay with it. A great many of its users were won from rival preparations. You'll find these 5 new shaving joys unknown before.

- 1—Multiplies itself in lather 250 times.
- 2—Softens the beard in one minute.
- 3—Maintains its creamy fullness for 10 minutes on the face.
- 4—Strong bubbles hold the hairs erect for cutting.
- 5—Fine after effects due to palm and olive oil content.

10 Shaves Free

Now in justice to yourself, and in courtesy to us, please accept a 10-day tube free.

To add the final touch to shaving luxury, we have created Palmolive After Shaving Talc—especially for men. Doesn't show. Leaves the skin smooth and fresh, and gives that well-groomed look. Try the sample we are sending free with the tube of Shaving Cream.

TEN SHAVES FREE

and a can of Palmolive After Shaving Talc

Simply insert your name and address and mail to Dept. B 1097, The Palmolive Company (Det. Corp.), 3702 Iron Street, Chicago, Ill.

Residents of Wisconsin should address The Palmolive Company (Wis. Corp.), Milwaukee, Wis.



"SON, That's the Toughest, Best Cutting Bit You Can Buy"

That was the advice of an old carpenter to his nephew just starting out to learn the trade.

He had learned through years of experience that Irwin Bits cut clean holes quickly and easily, and that they had the strength and toughness to endure hard service for years. When his nephew asked for advice on tools, his first recommendation was that he buy a complete Carpenter Set of Irwin Bits. That's good advice for any man who uses tools.

Ask your hardware dealer to show you Irwin Auger Bits in sets. If he should not handle them, send us his name. We will gladly send you an interesting booklet on the use, care and selection of bits.

Irwin Home Set, 6 bits and case . . . \$3.50
Irwin Handy Set, 10 bits and case . . . 5.50
Irwin Carpenter Set, 13 bits and case . . . 7.25

THE IRWIN AUGER BIT CO.
Wilmington, Ohio

Hardware dealers everywhere sell genuine Irwin Auger Bits. The Irwin mark shown below is stamped on the shank of every Genuine Irwin Bit.

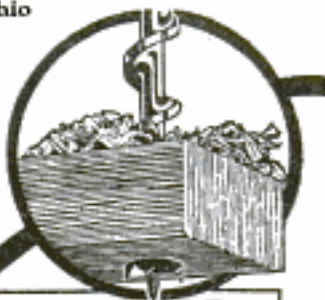

The IRWIN Bit

REG. U.S. PAT. OFF.



This shows the Carpenter Set in the Borse.

LOFTIS

BROS. & CO. EST'D 1858

DIAMONDS WATCHES

Special Christmas Bargains!

Special values for buyers of Christmas gifts—lowest prices on Diamond Rings, Watches, Jewelry, Silverware, etc. Easy credit terms—pay one-tenth down, balance in 9 months. Goods delivered on first payment. Order today!



Narrow style rings. Brilliant, blue white diamonds set in 18-K white gold mountings

Satisfaction guaranteed or money back

No. 832 \$125

No. 834 \$100

No. 833 \$37.50

No. 835 \$100

A Diamond Ring makes the perfect Christmas gift.

17-Jewel Elgin—No. 15—Green gold, Elgin Watch 25-year quality case; 12 size; gilt dial; \$100's \$30.45 down and \$1 week

Wrist Watch—14-K white gold, hand engraved case, Fancy trim, etc. Silver dial, High grade 15-Jewel movement, \$90. \$3 down and \$1 a week

FREE! Big Catalog Shows 2,000 bargains in highest quality jewelry. Sent absolutely free—no obligation. Write today!

Stores in Leading Cities **LOFTIS BROS. & CO.** Est'd The Old Reliable Original Credit Jewelry
Dept. F894 108 N. State Street Chicago, Ill.

Radio Fans

Listen in on W. H. T. every Monday night from 7 to 7:30, every Friday night from 9:30 to 10, Central Standard time. Loftis Bros. & Co.'s hour of music.

DEAFNESS IS MISERY GOOD HEARING A JOY



Millions of people know that, but Multitudes of persons with defective hearing and Head Noises are again enjoying conversation, go to Theatre and Church because they use Leonard Invisible Antiseptic Ear Drums, which are Tiny Megaphones fitting in the Ear entirely out of sight, No wires, no batteries, no head piece. They are Unseen Comforts and inexpensive. Write for booklet and sworn statement of the inventor who was himself deaf.

L. O. LEONARD, Inc., Suite 161 70 5th Ave., New York

\$9.95 RAINCOAT FREE

The Peter Falor Co., 30 Traders Bldg., Kansas City, Mo., is offering a \$9.95 Raincoat to men who will take orders. If you want one of these fine Raincoats, be sure to write them today.

\$25000 A WEEK!

Made with the new and improved "Krispy" Potato Chip Outfit.

Potato Chips the lunch of the hour. Everybody is eating them. One stand in small building sells \$100 worth in a week. Think of it! Grocers, druggists, pool rooms, cigar stands, tourists' counters, parks—all sell thousands of packages. Supply them. Get the big profits. Chips easily, quickly made at home. No experience necessary. Write today. Get a big profit fast growing business now.

SERVICE & EQUIPMENT CO., 905 Hoag St., Toledo, Ohio

Mr. Brush Salesman

Unusual opportunity is offered for aggressive, ambitious, hustling men to represent an old established manufacturer of high grade, guaranteed, fastest selling line of Sanitary Twisted Wire Brushes, sold direct to the Home. We have openings for experienced brush men as managers in all territories. We want live wire, energetic Go-Getters. We pay larger commissions than any other Brush House in the Country. If you want to earn some real money, it will pay you to write us immediately for our proposition.

WIRE GRIP SANITARY BRUSH CORP., 15 MERCER STREET, NEW YORK CITY



FREE

140-page Book full of life-size ruled forms, each one completely filled in. The answer to problems of accounting and record keeping for any business or profession.

Send for this FREE Book today
John C. Moore Corporation
(Established 1839)
3035 Stone St., Rochester, N. Y.

MOORE'S LOOSE LEAF SYSTEMS
In Use In More Than
300,000 Offices



"Been on a vacation Bill?"

"No, Jim - I've stopped smoking. Gained six pounds in a week. You know how I used to smoke—a package of cigarettes and a cigar or two a day—it sure had some hold on me. But I'm cured—

took a scientific home tobacco treatment—fixed me up in two weeks.

"Wasn't hard on me at all—noticed improvement the first day—I feel like a new man. It didn't interfere with my work—didn't leave any druggish after-effects—the money I saved in the last two weeks has paid for the treatment alone.

"Why don't you take it! It has cured men like you and me for over forty years—it is a doctor's individual prescription that sure fixes you up. Just send the coupon for full information NOW. No obligation. All correspondence is strictly confidential."



A Doctor's Prescription

The Keeley Institute, Dwight, Ill.

Please send me, without any obligation on my part, your free booklet which will tell me how to rid myself of the tobacco habit.

Name.....
Town.....
Street..... State..... PM-11



New Invention Stops Ford Shimmy in 15 MINUTES!

The way those front wheels shake and shudder over bumps is enough to loosen a man's eye teeth. Keeps you on edge every minute. Might as well loosen the car, too. Wears tires, loosens bearings, weakens wheels, and starts squeaks all over the car.

NEW INVENTION

Steady-Boy, amazing new device, replaces entire steering connections between steering post and front wheels in 15 minutes. Anyone can do it. Stops all signs of "shimmy" and side play even on the roughest roads. Makes "one-thumb" steering as smooth as highest priced car made.

FULLY GUARANTEED

Steady-Boy is unconditionally guaranteed. It will outlast your Ford car. Nationally known 43 year old company behind it.

FREE TRIAL

Order one today. Try it 2 weeks. See the amazing difference. Then, if not delighted and satisfied in every way, return Steady-Boy at our expense. Your money refunded immediately and no questions asked. Now reduced from \$10.00 to \$7.50 due to volume demand. Send no money. Simply pay postman. 15 minutes later get the greatest driving comfort you have ever known. Relax! Take the strain off your nerves and off your car, too! Enjoy yourself! Mail coupon now!

MOON BROS. MFG. CO. Dept. P-20, 4900 McKissock Ave. ST. LOUIS, MO.

STEADY-BOY

Keeps Your Ford on the Road

MOON BROS. MFG. CO.
Dept. P-20, 4900 McKissock Ave., St. Louis, Mo.

Send me a Steady-Boy. I will pay postman \$7.50 plus few cents postage. If I return it after 2 weeks' trial you will refund my money promptly.

Check here if you want only descriptive literature.

Name.....
Address.....
City..... State.....

FORD OWNERS
GARAGE MEN MECHANICS, ETC.
FREE SPARE TIME OFFER

Steady-Boy sells quick. You can sell every Ford owner in spare time. If you really look for buyers you can make \$30 a day—\$20 easily!

AGENTS
Jones Made \$22 in 2 Hours

This St. Louis mechanic sold 6 in 2 hours! Your profits are generous. One buyer tells another. Sales soon grow into a steady business. Two good sales plans. Represent us. Get big extra money. Almost no capital required. Wonderful sales helps free. Mail coupon for details of free Steady-Boy plans for representatives and spare time workers. Territories going fast. Act at once.



India, like the rest of the world, sends to this country for **NICHOLSON FILES**

Tradition and iron-clad custom permeate the commercial as well as the private life of the people of far away India.

NICHOLSON Files, because of their outstanding superiority, years ago broke through tradition. The turbaned merchants sell them from Baluchistan to Burma, and the people demand them for everyday and industrial use.



And a rule as rigid as India's caste system is that the NICHOLSON trade mark shall always be stamped on the tang.

NICHOLSON FILE CO
Providence, R. I., U. S. A.

Just Out 13th Edition A NEW AND GREATER **Dyke's Automobile Encyclopedia**

Entirely Rewritten, Rearranged and Illustrated
Greatly Enlarged; 1238 Pages, 4143 Illustrations

A Practical Book for Everybody



The Repairman will find this book a ready reference and guide.

The Auto Owner will know how to diagnose troubles and know when repairs are done right.

The Student learns the fundamental principles, the key to a successful repairman.

This Book Will Teach You to Become

An Expert Automobile Repairman, not only on testing, adjusting and repairing engines, carburetors, clutches, rear axles, differentials, tires, etc., but an Electrical Expert on ignition, generators, starting motors, storage batteries, etc. Diagnosing any trouble will be easy.

Don't wait—Order Now!

Cloth \$6.00 — Limp American Morocco \$7.50 Postpaid

Popular Mechanics—Book Dept.
200 E. Ontario St. Chicago

HOW TO MAKE DEVICES FOR OUTDOOR WINTER SPORTS

Motor-Driven Sleds and Ice Boats—Coasting Bobsleds and Toboggans—Skis—Gilders—Ice Yachts with Boat Book, 98c.

Send No Money. Just write a postal.
Popular Mechanics Press, Room 710, 200 E. Ontario St., Chicago

419 IDEAS On METAL WORKING

A most wonderful collection of practical short cuts and labor saving ideas for working metal is in the New book,

Everybody's Handbook of Machinist's Kinks

Successful machinists everywhere contributed their most valuable discoveries to this gold mine of ideas. Like the other Popular Mechanics books, this one is filled with pictures that make the ideas clear and easy to duplicate.

287 ILLUSTRATIONS

A faint idea of the contents of this new book may be obtained from the following brief tabulation of a part of the subjects covered:

| | | |
|-------------------------------|-------------------------|---------------------------|
| Special shop equipment | Scribers | Pulley repair |
| Erecting machines | Machinist parts | Handling bearings |
| Machine repairs | Special bolts | Gear fitting and mounting |
| Special machinist's tools | Screws for special jobs | Belting belts |
| Special gauges | Sharp formulas | Special jigs and fixtures |
| Micro-meters for special work | Templates | Special jigs and fixtures |
| | Teaching methods | Drafting kinks |
| | Shafting kinks | |

Every article "Written so you can understand it." Every article tells how to make or do some job with metal or metal machinery.

Send No Money Just drop us a postal and say, "Send me the New Everybody's Handbook of Machinist's Kinks." When the postman hands you the book, deposit the price and pay the few cents postage. Your money back if you are not delighted.

SPECIAL With this valuable new book, we will give our popular Drilling and Thread Cutting Handbook.

You may have the two for the unusually low price of **\$1.98**
POPULAR MECHANICS PRESS
Room 711, 200 E. Ontario Street, CHICAGO, ILL.

She hated to tell him



OF late her brother seemed much discouraged. He was being left out of things—dances, dinners—and somehow "the girl" never had an open date. His sister knew the cause.

She hated to tell him, because it was such a personal thing.

* * *

Nearly all young men are inclined to have a grimy-looking skin, spotted with blackheads and dull in appearance. Few realize that this hinders their success in life. Pompeian Massage Cream helps you overcome this handicap by giving you a clean, ruddy complexion.

Clears the Skin: Pompeian Massage Cream thoroughly cleanses the pores. It helps

clear up blackheads and pimples by stimulating healthy circulation, and by keeping the skin clean and the pores open.

Easy to Use: Rub it in; rub it out. After shaving or washing, rub it in gently. Continue rubbing and it rolls out, bringing with it all the dirt and skin impurities. Result—a clean, healthy skin with clear, glowing color.

Special Introductory Offer

1/3 of 60c jar for 10c

For 10c we send a special Trial Jar containing one-third of regular 60c contents. Contains sufficient Pompeian Massage Cream to test thoroughly its wonderful benefits. Positively only one jar to a family on this exceptional offer.

YOUR DRUGGIST HAS IT

There's nothing quite so effective as doing the job yourself. Use Pompeian Massage Cream regularly at home—then you'll get the full benefit.



The Pompeian Co., Cleveland, O., Dept. 28
Gentlemen: I enclose a dime (10c) for 1/3
of a 60c jar of Pompeian Massage Cream.

Name _____

Address _____

City _____ State _____

A Good Bookcase

for the price of a good book!



\$2.75 Per Section
without Doors

With Disappearing Glass Doors **\$3.50** Per Section

On Approval—Direct to User

Lundstrom

IT GROWS WITH YOUR LIBRARY

SECTIONAL BOOKCASE

Endorsed by Over 100,000 Users

Made for and universally used in the finest homes and offices throughout the country. Made in sections of different sizes, combining utility, economy and attractive appearance. Price complete as shown above, with top, base and three book sections with non-binding, disappearing, felt-cushioned glass doors, beautifully finished in plain golden oak, \$15.00; without doors, \$12.75. In quartered oak, or in imitation mahogany, with doors, \$17.50. In genuine mahogany, with doors, \$23.50. Other styles at correspondingly low prices. **Shipped direct from factory ON APPROVAL** at a considerable saving TO YOU. Write for catalog No. 21.

The C. J. LUNDSTROM MFG. CO., Little Falls, N. Y.
Manufacturers of Sectional Bookcases since 1899

RADIO SET FREE

5 TUBE



AND \$100 A WEEK JUST SHOWING IT TO FRIENDS

The Ambu Institute has perfected the finest 5 tube set ever made. Out-performs all others and sells for half store prices. We need men to represent us in every territory and will give demonstrator set free when you have taken six orders from your friends.

READ! Your set is certainly a wow! It performs better than any you've heard. Took orders for 500 sets. My profit \$212. Can sell 50 more this season easy. I'm out for a big profit.

R. MASON
Michigan

FRANK CONDON, Dept. 208, 2632 Prairie Ave., Chicago, Ill.

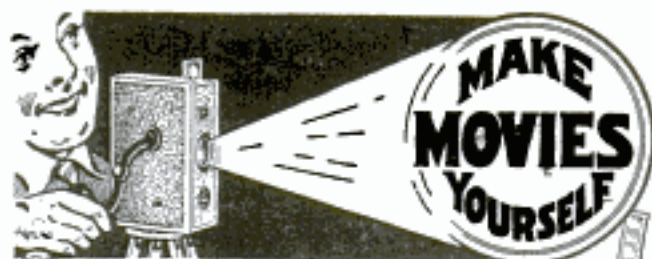

There's a wonderful thrill in taking your own motion pictures of interesting things where you live, of unusual scenes when you travel, of events everywhere.

VICAM STANDARD Movie Camera

takes high-grade, standard size pictures. Wonderful features—close-ups, stills, portraits, swift action. Can be loaded in daylight. Pictures can be projected on wall or sheet. **\$37** Including 2 Magazines

WRITE FOR INTERESTING CATALOGS
Send 10c in stamps for illustrated catalogs describing marvelous Vicam Products.

Distributors and Agents Wanted

Vicam Photo Appliance Corporation
1224 Belmont Ave. Philadelphia, Pa.

ADDING MACHINE

VEST POCKET SIZE



ADDS
SUBTRACTS
MULTIPLIES
DIVIDES

\$2.50

NEW Does Work of \$100 Machine. Total Visible at all Times.

FREE TRIAL—Send No Money

Anyone Can Operate It. Guaranteed for Life Just write "Send me a Baby Calculator" and give your name and address. We will ship it immediately, all charges prepaid. On delivery pay postman \$2.50. You can return it after 10-day trial for full refund if the Baby Calculator is not the greatest time and labor saver you ever used. This is the lowest priced practical calculating machine made. Order today.

AGENTS

Every business firm, man or woman, will buy the Baby Calculator on sight. BIG COMMISSION.

BABY CALCULATOR SALES CO.
P. O. Box 1118, Dept. 3, Chicago, Illinois



STOP! BUYING RAZOR BLADES

SEND NO MONEY!

JIFFY Safety-Blade Stropper

makes old blades keen as new. Improves new ones. Easy to use. Omit blades handle for all blades, double horsehide strop, large tube Jiffy Strop-dressing. **Send money—** just name and address. On delivery, pay postman \$1.50 and postpaid. Money back if not all we claim. Order today! **AGENTS WANTED!** C. A. Blumman Strop Co., 3738 S. Spring Ave., St. Louis, Mo.

FIELD GLASS

Genuine Chevalier only **\$6.98**

Amazing value, imported French Air Force, Army and Navy field glass. See distant objects as if they were close. Wonderful glass for nature study, races, hiking, touring and all sports. Powerful achromatic lenses, 21 line objective, large field, strong illumination. Special shaped eye pieces. Opens 7 1/2 in.—closed 6 1/2 in. Handsome case and shoulder straps included free. A life-time bargain.

Send No Money Send only name and address. When the'd glasses are delivered deposit with Postman our special low price of **\$6.98** plus postage. (Regular \$15.00 value) case and straps included free. Satisfaction guaranteed or money refunded. Send at once. Bargain Catalog FREE.

FERRY & CO., 3224 N. Halsted, Dept. 9778, Chicago

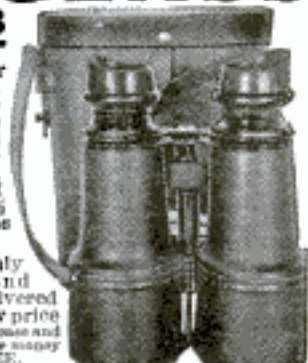



MEET LLOYD HOBSON

Then read what he writes about his

CARNES ARM

"I can play the violin and will have my picture taken playing it. I can also write with it and will sign my name to this letter." * * * * *

"I am going to hang some paper in a day or two. I have not tried anything yet but what I have accomplished and I think I can hang the paper." * * * * *

Mr. Hobson's right arm is off 6 inches below the shoulder. He says he would now miss his artificial arm as much as he did his natural arm before he bought a Carnes.

FREE CATALOG—Let us send you our catalog filled with pictures and letters of actual uses of the Carnes arm.

CARNES ARTIFICIAL LIMB CO.
68 Carnes Bldg., 904 East 12th St., KANSAS CITY, MISSOURI



The New KING Saxophone Catalog

SHOWING latest models and many improvements, telling how KINGS are made and many other features of interest to professional or amateur saxophonists—is ready for distribution. If you play or are interested in learning to play a saxophone or any other band instrument send the coupon below stating what instrument you play or wish to play.

KING Instruments embody the finest craftsmanship and best materials of any made today—this catalog will tell you exactly how KINGS are made by THE H. N. WHITE CO.

5211-69 Superior Ave.
Cleveland, O.

The H. N. White Co., Cleveland, O.
5211-69 Superior Ave., Cleveland, O.
Gentlemen: Please send me free your latest catalog on _____ (Instrument)

Name _____

Address _____

City _____

State _____



AGENTS

Here is a Ford Gasoline Tank Cap that "lifts out." It can't stick. It can't leak. It has a non-splashing vent. It is just the thing for the new Ford models as well as the old. It sells for only 35 cents. Long discounts to Agents who mean business. State Territory. Made by manufacturer of famous "Crary Radiator Cap,"—the locking wing cap, that is removed by pinching the wings.

Write for details—or send \$1.50 for samples of both articles.

CRARY PRODUCTS CORPORATION
1638-C3 Penobscot Bldg.,
DETROIT, MICH.

Make \$75 to \$150 a Week No Experience Necessary FREE BOOK

Shows and Teaches You How to
SELL OUR MONEY-MAKING LINE

Methods explained in this book now making thousands of dollars for our representatives. You can turn these ideas quickly into big profits for yourself. Easy to read. Plain, simple explanations. You learn quickly.

UNIQUE SELLING PLAN—
MILLIONS OF PROSPECTS

No collecting—no delivery—no capital needed. You deal with a large, financially responsible manufacturer.

Write for FREE Booklet and full details.
M. F. BRONNER, Pres. Dept. B
Box 123, Essex Postal Station, BOSTON, MASS.



PIMPLES

Blackheads—Acne Eruptions

Now Are Easily Removed at Home at a Small Cost!

Banish those unsightly blemishes easily and quickly by using "CLEAR-TONE"—a simple home treatment that has cured chronic cases of long years standing. Use like toilet water. Leaves the skin clear, smooth and without a blemish. Has made many friends with men, women and children. Elegant for men after shaving. If you have **Pimples, Blackheads, Acne Eruptions** on the face or body, Bar-

FREE!

Send name today for FREE Booklet, "A CLEAR-TONE SKIN," telling how I cured myself after being afflicted for 15 years. And I know every embarrassment one has to endure with a bad complexion. **\$1,000 GOLD CASH SAYS I CAN CLEAR YOUR SKIN OF THE ABOVE BLEMISHES.**

E. S. GIVENS

729 Chemical Building

KANSAS CITY, MO.

bers Itch, Eczema, Enlarged Pores, Oily or Shiny Skin—never mind how bad—"CLEAR-TONE" has cured the worst cases I ever saw. Endorsed by druggists, physicians, skin specialists, barbers and over 100,000 Men and Women test cases, who succeeded with "CLEAR-TONE" after failing with everything else.



DON'T Let Anybody Bully You

LEARN SCIENTIFIC TRICKS OF PHYSICAL MASTERY

Don't pick scraps, but when you're right don't "back water." And don't worry about a man that's bigger and stronger than you are. By a few simple tricks you can have any assailant at your mercy quick as a flash. At last the astounding secrets of self-defense, used by the New York Police, are revealed in the marvelous, officially recognized system—

Sgt. Wallander's Course

All Complete In

PHYSICAL TRAINING MANUAL

By Sgt. A. W. WALLANDER, Commander Physical Training

NEW YORK POLICE ACADEMY

This volume is a complete course in physical culture. Scores of gripping action photos showing just how to throw a bigger man and overpower him—how you disarm a hold-up thug—how to build up muscle—how to keep in fighting trim. Hundreds of health hints, too; care of the feet, prevention of colds, correct posture, how to walk without fatigue. This is the genuine book used by the New York Police Dept., now available to YOU for the first time!

Easy to Learn Let Sgt. Wallander give you his great secrets. A few hours of easy reading will make you master of these closely-guarded detective tricks. You'll hardly believe that such valuable knowledge could be learned so easily.

ALL YOURS IN WORLD'S MOST AMAZING COURSE

SEND NO MONEY.—In Physical Culture and Police circles this volume is world-famous. You're lucky that you can get in on this short-time offer. Send immediately for your copy. You'll be a new man. You can learn how to be a great athlete. Don't delay. Don't send money now. Just send the coupon today. When volume arrives, pay the postman \$1.97, plus few cents postage. If you are not satisfied return volume and get money back.

\$1.97
Plus
Post-
age

SIEBEL PRESS, 34-X W. 20th St., New York.

Please send me Sgt. Wallander's *Physical Mastery Course* as contained in the "Physical Training Manual." Upon arrival I will pay the postman \$1.97 plus a few cents carrying charges. It is understood that if I am not satisfied with this book, I will return it and my money will be refunded.

Name.....

Address.....

City..... State.....

(\$2.25 U. S. Cash with order in all other countries)

New Speed Way Shop

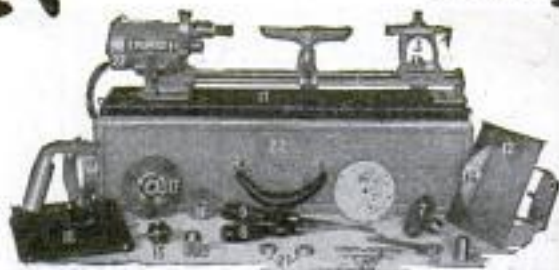

Six Complete Motor Driven Tools

A compact metal and woodworking outfit for mechanics, householders and "handy" men. Driven by famous SpeedWay motor which is easily detached, giving you a Portable Electric Drill. Tools quickly interchangeable.

Saw, Lathe, Grinder, Buffer, Cleaner, Drill

Attaches to any lamp socket. All packed under pressed steel case (No. 22 above) with lathe bolted to platform 25 in. x 6 in.

Check the Numbers on the Photograph

- | | | |
|-----------------|-------------------------|-----------------------------------|
| 1. Lathe Bed | 9. Gauge Chisel | 17. 4-in. Wire Brush |
| 2. Tool Rest | 10. Universal Wrench | 18. Tool Case |
| 3. Tail Stock | 11. Base 25 in. x 6 in. | 19. Drill Handle |
| 4. Centers | 12. Saw Table | 20. Drill Bits |
| 5. Chuck | 13. 6-in. Circular Saw | 21. Nut and Washer |
| 6. Spur Center | 14. 2-in. Wheel | 22. Steel Corner |
| 7. Face Plate | 15. Arbor and Flanges | 23. The Well Known SpeedWay Motor |
| 8. Parting Tool | 16. Cloth Buffer | |

Only \$10 Down—Easy Payments

Five minutes after receipt you can have the chips flying. Pay as you enjoy it. Use the SpeedWay Shop for pleasure or profit.

Write Today For Full Information

Every tool in the "Shop" is high grade, for regular work. A money maker for the small job man. Get full particulars. Write today.

ELECTRO-MAGNETIC TOOL COMPANY

DEPARTMENT 1358

1830 South 52nd Ave., Cicero, Illinois (Adjoining Chicago)



LEARN Silver Fox Farming

Mail course now obtainable in a new uncrowded field. Condensed, practical, no written answers required. Special introductory price \$25 to first purchaser in each county.

DUFFUS SILVER FOX CORP.
Dept. 9, 38 W. 34th Street, N. Y.

Learn Mechanical Drafting

How to make working drawings. A complete course for boy or mechanic. Thousands have learned the business from "A Practical Course in Mechanical Drawing". Write a postal for it today. Send no money. Pay postman postage and 98c. Popular Mechanics Press, Room 710, 200 E. Ontario St., Chicago, Ill.

Mathematics Made Easy by ROPP'S CALCULATOR AND SHORT-CUT ARITHMETIC

Shows the Answer as Quickly as a Watch shows the Time to all Problems likely to occur in the Office, Store, Shop, Bank, Farm, or Factory.



Over 2,000,000 Sold
Explains and simplifies every principle in Arithmetic, Mechanics, and Mensuration.

PRICES POSTPAID
Desk Size...\$1.50
Leatherette, Pocket Size...\$1.00
Pocket Size, Cloth...\$0.50
Pocket Size, Paper...\$0.35

Popular Mechanics Book Dept., 200 E. Ontario St., Chicago

With a **FIVE** Year
Guarantee by the
Rebuilders!

Pay Like Rent!
We Trust You

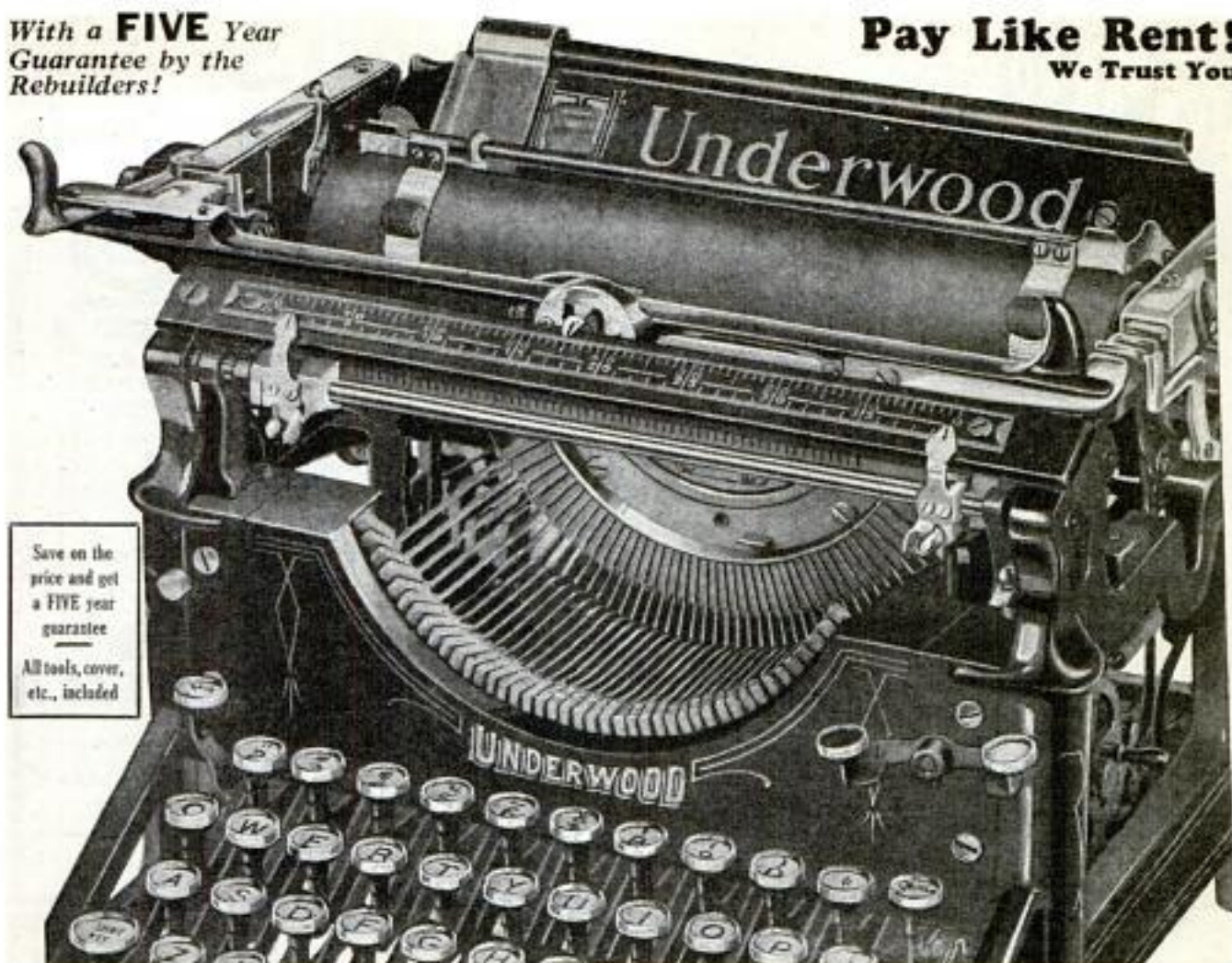

Save on the
price and get
a **FIVE** year
guarantee

All tools, cover,
etc., included

THREE DOLLARS!

That's All That Stands Between YOU and This Genuine UNDERWOOD!

Here's that Underwood you didn't think you could afford! You needn't pay \$100—or anything like it! You don't have to buy it on the chance you're going to like it—a full week's thorough test is free for the asking! Three dollars and you keep it. Monthly payments you'll never feel nor miss—and it's yours forever *with a five-year guarantee.*

Why try to do without a good typewriter when this is a typewriting age? Why be content with a second-class machine when you can just as easily own a genuine, spirited Underwood? The Shipman-Ward plan was made for you; it's ready to serve you now; it offers a convenience and a saving many of the largest business houses are not too proud to take!

A New Plan—10-Day Trial

If thought of the *expense* has held you back—get your Underwood now! The expressman will bring it for your own actual try-out. There'll be nobody at hand to urge its purchase; sit down and let it sell itself.

We have just put through a new lot of several hundred Underwoods. They are beautiful writing machines—in sparkling condition—every one stands ready for a long life of service—complete with tools, cover, book, etc.

The Shipman-Ward organization was first to realize that the big cost of high-grade typewriters was due to the way they

were sold. By selling direct, we avoid a long round-about of expense, and this saving we pass along to you. Do something about this offer now. No money is wanted, no deposit need be sent, just fill in the coupon and mail it.

FREE! The coupon below brings the free typewriter book that acquaints you with the Shipman-Ward plan and offer! It tells how we rebuild these wonderful Underwood typewriters in the largest factory of its kind in the world, and we will quote you the lowest prices and best terms in existence. We will also include free, the new Typewriting Manual.

Mail to SHIPMAN-WARD MFG. CO. 2128 Shipman Bldg., CHICAGO

Please send full offer, with Typewriting Manual FREE, prices, terms, etc., and full information about your FREE course in Touch Typewriting. All without obligation. This is NOT an order.

Name.....

St. or R. P. D.....

P. O..... State.....

\$351.00
Cleared
in one day
(Aug. 1925)
by W.H. Adams
Dayton, Ohio

V. A. Marini, Santa Cruz, Cal. (Nov. 1924) reports \$11,275 sales in 3 months. J. Gordon of New Jersey says \$4000 profit in two months. Alexander of Penn. \$3000 profit in four months. Ira Shook, Flint \$365 in one day. Bram, bought one outfit then 10 more within a year. Patillo, Ocala, writes: "Crispettes all you claim and then some." John W. Culp, South Carolina, writes, "Everything going lovely. Wrappers lying all over. It's a good old world after all." Perrin, \$380 in 1 day. Mrs. Lane, Pittsburgh, 8000 packages in

one day. J. R. Bert, Ala. "only thing I ever bought that equaled advertisement."



WE'LL START YOU IN BUSINESS

Furnish secret formulas, raw material, and equipment. Very little capital required; no experience needed.

Build Paying Business of Your Own

No limit to the sale of Crispettes. Everybody likes them. It's a delicious food confection made with or without sugar. Write me for facts about a business that will make you independent. Start now, in your own town.

Profits \$1,000 a Month Easily Possible

Send postal for illustrated book of facts. In contains enthusiastic letters from others—shows their places of business, tells how and when to start, and all information needed. Free. Write now!

LONG-EAKINS COMPANY

1128 High Street Springfield, Ohio

BOYS AND GIRLS CHRISTMAS MONEY GIVEN

Send name and address. We will send you 50 sets Christmas Seals. Easily sold 10 cts a set. You keep \$2; send us \$3. Be first in your neighborhood. We trust you. Many earned \$10 last Christmas. Write at once.

MISTLETOE SEAL CO., Dept. 56, Brooklyn, (R) N. Y.

Let us recommend the best books to study on any subject. POPULAR MECHANICS PRESS, Chicago, Illinois

AGENTS Some Set At \$2.00 Looks Like \$5.00 Worth Gives You \$1.05 Profit!

With Our Great Introductory Offer

Giving These \$1.25 Dress-Making Shears FREE



With each sale of our wonderful 11 piece Toilet Article Assortment for only \$2.00. TOTAL STORE VALUE \$4.60

\$21.00 a Day PROFIT on only TWENTY Sales



MY! HOW THEY SELL!

You get the attention with the free Shears. Walter Harris sold 800 boxes in six weeks. Profit over \$100 a week. You can do this too.

Act Now! Sell like hot cakes year round. A baby could sell Lucky 11. Don't wait a minute. Save time. Send \$1.75 for complete outfit including display case. At least write for circulars explaining our unique plans, including 30 other packages. **ACT NOW!**

E. M. DAVIS CO., Dept. 5635, CHICAGO, ILL.

AGENTS—SALESMEN



Stop Here—newest invention out—selling like wild-fire. Chlorine Gas taking the country by storm. The Chlorinator is the first and only Chlorine Gas for home or individual use. Generates the same gas as used by President Coolidge and other officials in Washington. Chlorine Gas destroys the bacteria of adult and childhood diseases to which all are exposed daily. Any person, anywhere can now use Chlorine Gas with perfect safety and almost marvelous results with the Chlorinator. Simple to use—easy to sell—needed in every home. Also sell to Doctors, Dentists, banks, offices and factories.

\$100 WEEKLY AND UP

The opportunity of a lifetime—make money right and left. Every sale means ten repeats. Selling experience or capital not necessary. Not sold in stores. Exclusive territory to permanent salesmen. Hurry—don't delay—write quick for details. Address:

HUBERT MYERS LABORATORIES
171 Erie Street TOLEDO, OHIO



Console Style

\$1250
List

Mathiesen's Loop Aerials

Four Styles

MASTER CONSOLE. Wound single; open 40 x 21, folded 22 x 4 x 5.

BABY CONSOLE. Wound double; open 30 x 14, folded 15 x 4 x 5.

MASTER STANDARD. Wound single; open 34 inches square; folded 22 x 4 x 5.

BABY STANDARD. Wound double; open 24 inches square, folded 15 x 3 x 5.

ALL LOOPS have green Silk covered Wire, Nickel Trimming, and solid Mahogany Frames and have Three Taps. If your jobber or dealer cannot supply you, write and we will give the name of our nearest dealer.

MATHIESEN-SANDBERG CO.

5249 Ravenswood Ave.

CHICAGO



Standard Style

\$1250
List

How I Earn Money at Home

And in This Way Make Up for George's Shrinking Salary

Every Wife or Self-Supporting Girl Can Use Extra Money—Many Are Now Making It Themselves—Right at Home—How Auto Knitting Pays Three Ways

By MARY WHITMAN

"MY dear, you should have seen her at church this morning. She looked positively 'dowdy.' It's a shame. Mary used to be such a well dressed girl—until she married that bank clerk. I should think he'd feel—"

"Sh-h-h! She's on this car. Over behind you. She might hear."

But I had heard and my face flushed red with resentment and shame. It was true—I did look "dowdy"—and I knew it.

I got off the street car at the next corner and walked the remaining blocks to my home—and George. My cup of bitterness had spilled over, and I needed a few minutes to choke back my tears that wanted to run down my burning cheeks.

I didn't want to make George feel worse than he did already about our money situation. My husband is one of the "white collar men" whose salaries haven't kept pace with the mounting cost of living. I had sometimes hinted to George that I would be glad to take my old position again, but he had always vetoed the idea strenuously.

But the bitter experience of this Sunday morning was too much. I resolved as I walked home I was going to find a way to make extra money for clothes.

When I got home I was prepared to be cheerful as usual, but George was comfortably smoking and absorbed in his Sunday paper, and his contentment somehow irritated me terribly. To make matters worse he held up the magazine-picture section of the paper as I came into the room, and remarked that he had never seen the girls wear "such good-looking duds as they do this year."

I lost my temper, snatched the paper from him and cried, "If you like to see nice clothes so much, why don't you buy your wife some of them?"

Then I rushed to my room, still carrying the magazine section of the paper, shut the door, and threw myself across the bed for a good cry. George came and knocked and spoke to me, but I wouldn't let him in.

After a while I sat up, and idly began to turn the pages of the paper I had taken away from George. All of a sudden I sat up straighter and gasped. A woman was looking out of the page at me, holding a bank check in her hand, and across the top of the page were the words, "How I Make Money—Right at Home—Auto Knitting Pays Three Ways."

That night I mailed the coupon from that advertisement of The Auto Knitter Hosiery Company.

To make my story short, I found their prospectus so convincing and reasonable that I sent for and received the wonderful little machine, the Auto Knitter.

While George was at the bank, I used it every minute I could spare from my housework. At the end of a month I sent my first shipment of soft, warm, well-knit wool socks to the company's hosiery department. By return mail came a check in payment.

Well, I kept on knitting socks—but after a little while not many of them went to the company, for when I let my friend Gracia into my secret and showed her the socks, she immediately exclaimed: "I know where we can sell them right here in town and nobody need even know who made them." It worked out fine. I sold them and soon had calls for more. I found I could make more money selling them in this way than I could sending my standard socks to the company.

Then one day, as we were ready to go out, I presented myself before George in a pretty, new accordion-pleated frock which I had seen advertised in Park & Taylor's sale and a fancy little sweater I had made up myself with the aid of the Auto Knitter.

His mouth opened wide and he just stared at me in admiration. Finally, he managed to say: "Where did you get them, Mary?"



"It turned spare hours into extra dollars"

"I earned them myself," I replied brightly, not just sure how he would take the news.

"The sweater, too?" he inquired, and I knew he was thinking what an extravagant lot such a sweater must have cost.

"Well, the sweater—" I answered, "the sweater I really made myself!"

"But, Mary, I didn't know you could knit like that!"

"I couldn't by hand, George," I replied, "but I learned to do it another way."

George looked for a moment as if I had stolen my new things. But then I made him sit down and listen to my story.

Then I took the light, portable Knitter out of the closet and showed George how it worked. I had had enough practice by that time, so that I made a sock so quickly that George's

eyes almost dropped out of his head.

"And you say the Company's hosiery department will buy the socks from you?" he asked.

"Yes," I replied, "they will take my entire surplus of standard socks at a guaranteed price, but the best of it is that I can sell my work right here at home and make even more than by sending it to the company, to say nothing of the money I can save by making our own knitted wear just as I made this sweater."

George was certainly astonished, said he had no objection to my continuing the work. In fact, he was secretly proud of my ability. So I kept right on making clever little knitted articles for my daughter, socks for George and knitted novelties for home sale. When spring and summer came I took up the knitting of fancy, sport and golf stockings, so that I really had very little knitting to sell to the company, although they helped me in every way, even sending me a booklet telling how to build up my own home knitting business.

Now, I can have the pretty things I want for myself, for Helen and for the house—and I don't have to feel "guilty" when I buy them, because I am not obliged to touch a cent of what I call "the family money"—the money that George makes.

Whenever I hear a woman complaining about the high cost of living and clothes, I always try to tell her how the Auto Knitter will help her to make and save money at home in spare time.

No matter where you live, I feel sure that you want to know all about the Auto Knitter that has meant so much to us. By all means write to The Auto Knitter Hosiery Company at once and find out about this home industry waiting for you. Find out what others have done with the aid of the Auto Knitter and what it offers you. Send your name and address on the coupon below—no obligation of any sort. The Auto Knitter Hosiery Company, Inc., Dept. 21811, 630 Genesee Street, Buffalo, N. Y.

The Auto Knitter Hosiery Co., Inc.
Dept. 21811, 630 Genesee St., Buffalo, N. Y.

Send me full particulars about Making Money and Saving Money at Home with the Auto Knitter, telling how Auto Knitting Pays Three Ways. I enclose 2 cents postage to cover cost of mailing, etc. It is understood that this does not obligate me in any way.

Name.....

Street and Number.....

Postoffice..... State.....

Cultivate Your Musical Bump

Roger Kahn of Kahn
Symphonic Dance
Orchestra, N. Y.

Charles Straight of
Straight's Orchestra
Chicago

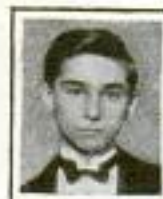

Free Trial; Easy Payments on Any Conn Instrument

ENTERTAIN yourself and your friends; make big money playing whole or part time, if you choose, with a Conn saxophone. Easiest to play, beautiful in tone, perfect in scale, reliable action—chosen by foremost artists for its exclusive features, yet costs no more than others. You'll learn to play it quickly.

Send coupon for free book, "Success in Music and How to Win It," by Sousa and others, and details of trial offer on any instrument. Remember Conn is the only maker of every instrument used in the band.

CONN
BAND
INSTRUMENTS
MUSIC MARKET MANUFACTURERS



C. G. Conn, Ltd., 1131 Conn Bldg.
Elkhart, Indiana

Please send "Success in Music" and details of trial offer on

.....Instrument

Name.....

St. or R. F. D.....

City, State..... County.....

Keep Out Cold Drafts, Dust and Gases



ACME No-Draft Mats for Fords and Chevrolets

Tough rubber mats with slots lined with sheep's hide—wool attached. Sides of slots press tight against levers. No trouble to install. Just lay in position around pedals. Cannot interfere with operation of car.

Price **\$1.35** by Parcel
Per Set Post Prepd.

Specify model or year of car. One size fits all Fords up to 1926 models. If your dealer does not have them—

Order a Set Today—Drive in Comfort This Winter

THE ACME SALES COMPANY
334 Lakeside West Cleveland, Ohio

DELTA



The Super
Spotlight
For
Bicycles

"Young
America's
Choice"

No. 37 BICYCLE SPOTLIGHT

PERMITS BICYCLIST TO RIDE THROUGH
BLACKEST NIGHT IN PERFECT SAFETY

The rider whose bicycle is equipped with a Delta 37 does not fear hazardous road conditions or nights as dark as a "stack of black cats" for he has a powerful penetrating bright light of safety. Equals good auto spotlight. Head 4 1/2 inches in diameter. Improved bracket, fits any handlebar. Battery case mounts on all standard bicycle frames (fits on 18-in. Moto-Bike frame, inside triangle on either front or top bar). Operates on two dry cells. At your dealer or sent prepaid for \$3.75 complete (less batteries). In Canada \$5.00.

DELTA ELECTRIC COMPANY, 100 Delta Block, MARION, IND.

Standard makers of Electric Bicycle Spotlights and Lamps, Motorcycle Spotlights, Auto Spotlights, Auto Ash Receivers, Electric Hand Lenses, Radio Head-Phones, Flashlights and Flashlight Batteries

New York
EXPORT DEPT.
30 Water St.

Chattanooga
FAUCETTE-HUSTON CO.

San Francisco
SANFORD BROS.
311 Minna St.

When the Loos Brothers Sing from W.E.B.H.

Robert Loos sits at home and hears them as naturally as though they were singing in the same room.

For over 30 years
makers of
PRECISION
Electrical Apparatus.

Karas Harmonik Transformers

Amplify Radiocast Music with Absolute Fidelity!

No sooner had Karas Harmonik Transformers been introduced than letters began to pour in from all over the country. Exacting set builders could not restrain their enthusiasm.

"Now I know radio as I never knew it before."

So Mr. E. M. Lubeck of Kokomo, Indiana, expressed himself. "Karas Harmoniks bring in every voice and every instrument as distinctly as one could get them in the room," wrote the Rev. Wm. Stelhorn of Columbus, Ohio. "I consider your transformer a real musical instrument. Like a good violin, it has fine tonal qualities at all pitches covering the musical scale." That was the comment of Mr. Walter Krause of 7807 Burnham Ave., Chicago.

These few reports—picked at random from scores of letters—tell you more convincingly than we can tell you, the wonderful results YOU can obtain through installing Karas Harmonik Transformers in your set.

Here, for your enjoyment, is an audio transformer, scientifically designed to reproduce through your speaker *all* of the beauty of radiocast music—exactly as it is rendered in the studio.

High, low, and medium audio frequencies are amplified to an equal degree. Sonorous bass notes pour forth from the speaker in full strength and rich tone quality. The vital harmonics and rich overtones are brought out in their true beauty by this marvel of audio transformers.

Dear Sirs: I take great pleasure in praising your wonderful Karas Harmonik Transformers. I am using two of them in a three-tube Low-Loss set which I built. I have two brothers singing from Edgewater Beach, WEBH Station. Well, their singing comes in so natural and clear that at times we think they are right in the same room with us. They also tell me mine is the clearest set they have ever heard.

Robert Loos, 1640 N. Leavitt St., Chicago, Illinois

All last season, home set builders—the most discriminating class of radio enthusiasts—bought Karas Harmoniks and enjoyed a musical quality of radio reception that owners of factory-built sets knew nothing about.

If YOU want the utmost musical enjoyment that radio has to offer, get a pair of Karas Harmonik Transformers at once. It is

very simple to install them or, if you don't care to do it for yourself, any radio repair man will do it for you at small expense. Why not make up your mind right now to have the best music your set is capable of giving?

Most good radio dealers carry Karas Harmoniks. If your dealer is out of them, order direct of us. Send no money, just pay the postman \$7.00 each on delivery.

Karas Electric Co., 4047 N. Rockwell St., Chicago, Ill.

Please send me pairs of Karas Harmonik Audio Frequency Transformers. I will pay the postman \$7 apiece, plus postage, on delivery. It is understood that I am privileged to return the transformers any time within 30 days if they do not prove entirely satisfactory to me, and my money will be refunded at once.

Name

Address

if you send cash with order we'll send Transformers postpaid.

Make FURNITURE at Home

You Can Do It in Spare Time—It's Easy

THE simple designs in furniture are, after all, the most attractive. And the best of the easily-made styles have been gathered into "Popular Mechanics Furniture-Making Books." These books are filled with pictures that show you how the finished piece looks, and how to lay out, saw, and put together the various parts. You are also told how to finish your furniture in the most attractive ways. Nowhere else will you find instructions more clear. Nowhere else will you find such a marvelous assortment of simple designs to select from. Think of it! 142 different designs, including all the pieces of furniture and the different styles of lamps you need to make your home a pleasant place to live.



142 Pieces

**Complete
Instructions
and Designs**

Popular Mechanics Furniture-Making Books

Tell How to Make These 142 Pieces of Furniture and Lamps

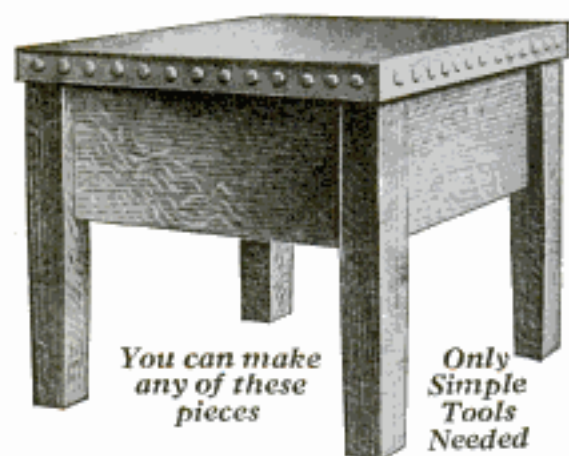

You can make
any of these
pieces

Only
Simple
Tools
Needed

Betco
The turning of oak
How to make black wax
40 styles of chairs, beginning with
the Egyptian style made 500
years before Christ
Piano bench
A shaving stand
A waste paper basket
A cigarette pedestal
A princess dresser
A sideboard
A window seat
A plant stand
A bedside medicine stand
A hall chair
A side chair
An arm chair
A book case
A lamp stand
Extension dining table
An oak-bound cedar chest

A dresser for child's playroom
Arts and crafts oil lamp
China closet
An oak bedstead
A footstool
A library set in pyro-carving
A grille with pedestals to match
A lady's writing desk
A telephone stand and stool
An oak medicine cabinet
Home-made mission chair
A lamp stand and shade
A porch chair
A tabouret
A Morris chair
A mission book rack
A substantial library table
A mission candlestick
A low-back mission chair
A magazine stand
A lawn swing
A portable table
A combination billiard table and
davenport

Easily made book shelves
A black case tabouret
A Roman chair
A roll top desk
A pyrographer's table
A piano bench
A library table
A princess dresser
A sewing box
A fern stand
A wardrobe
An oak table
A book trough
An oak serving table
An umbrella stand
A chafin-dish buffet
A writing desk
A music rack and book stand
A dictionary and magazine stand
A leather back arm chair
A wall shelf
A pedestal
A magazine rack
A ball tree

One-light portable lamp
Two-light portable lamp
Four-light chandelier
Dining-room dome
Reading lamp
Pulver or den lantern
Lantern
One-light portable
Shade for droplight
Four-light chandelier
One-light bracket
Piano lamp
Newel post lamp
Electric candle sconce
One-light bracket
Droplight
Reading lamp No. 1
Reading lamp No. 2
Square dining-room dome
Mission chandelier
Desk light
Droplight No. 3
Chandelier
Hexagonal library lamp
Hexagonal dome
Lamp No. 1
Lamp No. 2
Lamp No. 3
Lamp No. 4
Conventional patterns
The butterfly design
The pyramid design
An oak buffet
Oak stain
A plain oak hall clock
A rocking chair

A curved back arm chair
A plate rack
A tool for marking dowel holes
A magazine table
A waste paper basket
A writing desk
A couch with cushions
Shade for dining room
How to bend wood
A smoking stand
A china closet
A leather-covered footstool
Arts-crafts mantel clock
A music stand
Wall case with mirror
A table for the den
A burlap-covered seat
A quarter-sawn oak settee
A screen
A mission book rack
A round extension table
An arm dining chair
A hall bench
A sewing table
A side chair
Another piano bench
Another screen
A folding card table
A magazine stand
A tabouret
A porch swing
A foot warmer
Plate rack
A mission sideboard

This valuable set known as "Popular Mechanics Furniture-Making Books," includes the five volumes of which thousands have been sold:

1. Mission Furniture and How to Make It, Book 1
2. Mission Furniture and How to Make It, Book 2
3. Mission Furniture and How to Make It, Book 3
4. Lamps and Shades in Metal and Art Glass
5. Arts-Crafts Lamps and How to Make Them

Send No Money

Don't send a penny (if you live in the U. S.). We want you to have these valuable books in your hands before you make any deposit. When the postman hands them to you, pay the postage, and deposit \$4.95 for the five books. If you are not delighted with your purchase, we will promptly refund the entire purchase price. Nothing could be fairer than that. Just write a postal and say, "Send me the Popular Mechanics Furniture Making Books." Single books, \$1 each.

POPULAR MECHANICS PRESS
Room 12, 200 East Ontario St., Chicago

IDEAL BOOKS For Manual Training Courses

Men and boys, alike, find these books to be marvels of simplicity and fascination. Boys just starting manual training courses, will find in these books instructions and designs that will make their work both interesting and profitable, for the pieces so clearly described may be readily sold at a good profit.

33 Lamps to Choose From



**Save Half the Cost
of Furnishing
Your Home**

*It's Fun to Make Things.
It's Profitable to Make
Furniture and Lamps*

The New 21 Jewel Burlington "Bull Dog"

for

Rough Service

HERE is the ideal watch for rough service. A masterpiece—with 21 ruby and sapphire jewels—handsome, sturdy, 100% dust proof—and it comes in a heavy 14 karat Gold Strata case. Adjusted to the Second—to Temperature—to Isochronism—to Positions. Built for absolute accuracy under all conditions and so strong in every part that it practically removes all chances of breakage. Note the tight fitting extra cap placed over the movement making it doubly dust proof! No matter what your work is—whether firing on a locomotive, working in a mine, on a farm or in a lumber camp, this is the watch for YOU—and you will be astonished to find such a wonderful watch so low priced!

Rock Bottom Price

Easy Payments — Sent on Approval

This masterpiece among watches is sold direct to you, at our rock bottom price, on easy monthly payments. And it is sent on approval. No obligation to buy unless you are perfectly satisfied. When you can so easily secure a watch that you can absolutely depend upon under all conditions, why deprive yourself of this great satisfaction one day longer than necessary?

Mail the coupon below for our free book and liberal offer! Do it NOW! It costs you nothing to FIND OUT!

Beautiful Burlington Book

"An Education in Watches"

Sent Free!

Don't choose ANY watch until you have seen this beautiful book. It contains in colors the most complete and varied assortment of watch styles and exquisite designs ever shown under one cover! In addition to the "Burlington Bulldog" you will find the new Burlington Supreme, in many beautiful shapes and in white and green gold; the new 18 karat gold Lady Burlington—the new square strap watches for men—special watches for doctors, nurses, etc., in fact, a watch for everyone! You will also learn from the Burlington Book just how to judge the real value of a watch and how to avoid purchasing watches that are over priced. You owe it to yourself to FIND OUT! Remember—the book is free. Just fill out the coupon and mail it TODAY!

BURLINGTON WATCH COMPANY,

93-58, 19th St. & Marshall Blvd., Chicago

Canadian Address: 62 Albert Street, Winnipeg, Manitoba

Please send me [without obligation and prepaid] your free book on watches and full explanation of your liberal approval offer on the Burlington Watch.

Name

Address

Big 3 ft. Telescope

Has unusually powerful lenses—magnifying over 8 times. Makes people and objects miles away seem close. Brings new pleasures to home, farm, camp, travel, sport. See moon and stars as never before. New Ferry "Wonder" telescope has 5 sections—opens out over 3 ft. long, measures 12 inches closed. Big, strong and powerful yet light, compact, easy to carry. Handy and draws fully brass bound with knurled edges. Body covered with black leatherette. Drawings made of special, smooth finish fibre, easy to slide in and out. Brass safety caps at each end to keep out dust. Powerful lenses are special clear achromatic European optical glass.

Free

YES ABSOLUTELY FREE! Handsome leatherette covered Carrying Case light, strong, complete with strap. Case is 12 in. long, 2 1/2 in. in diameter. Protects from dust and damage. Handy for farmers, auto tourists and bikers.

3 ft. long open
—
12 in. long closed
—
FIVE SECTIONS
—
8-power Lenses
—
Read These Letters
Thousands of Delighted Users

"I am delighted with the 'Wonder' telescope. Today I have been watching submarines 3 miles off the coast."

—Philip Brush "I can see across the Mississippi 3 miles and see people bathing."

—M. L. Thorn. "I am nearly 80 years old and if I could not get another would not take \$10.00 for it."

—A. R. Walker "I can tell time on the church clock 5 miles away." —Edward Foster. "Could tell color of aeroplane 4 miles away." —Mrs. L. M. Yarbrough. "I saw a Light House 18 miles away." —Clyde Scribner.

"Can see men working 7 miles away." —S. M. Gearhart. "I could see windmill more than 4 miles away." —Raymond Cosanova.

Send No Money

Sign and mail coupon below and Ferry Wonder 3 ft. Telescope with free Carrying Case will come by return mail. Pay postman special bargain price of \$1.85 plus few cents postage. Satisfaction guaranteed or your money back. Send coupon today!

FERRY & CO., Chicago, Ill.

Ferry & Co., Dept. 1778
3224 N. Halsted St.,
Chicago, Ill.

Send me 3 ft. Ferry Wonder Telescope and Free Carrying Case. I will pay postman \$1.85 plus postage on arrival. If I am not satisfied you will refund my money.

Name _____

Address _____

City _____ State _____

Catalog of Things You Want Sent Free



\$66 A DAY

IS EASY When You Give This Razor FREE

That's what H. R. King made in just 8 hours! And \$10 of it just rolled into his hands while he was waiting for gas at a filling station! No wonder salesmen everywhere say this amazing new razor is the greatest money-getter ever seen!

Kriss-Kross is absolutely unique—3 kinds of razors in one! Most unusual invention ever patented. No man can see it without wanting to own it instantly. And you give it to him absolutely FREE! Think of it!

Amazing Extra Profits, Too

We have originated a startling new bonus plan that brings you surprising extra profits. Nothing like it under the sun. K. D. Ralph made \$368.50 extra one month above his regular, big earnings. You just make one simple little sale and it often goes on working for you, piling up a big money-bonus while you sleep. We can't explain the plan here—others might copy it. Once you get the inside facts, you'll be simply astounded. Write us without a moment's delay! No obligation. Just send a postal today!

RHODES MANUFACTURING CO.
Dept. S-370, Pendleton & Cozens Ave., St. Louis, Mo.

FROST-FONES

Best for Your
Radio
Receiving Set

A new model—No. 174 FROST-FONES— with wonderfully light aluminum shells and featherweight headband. Sensitive—powerful—low in price—superb quality.

FROST-FONES

will greatly improve the operation of your radio receiving set and enable you to get more pleasure and satisfaction from its use.

FROST-FONES

are light in weight, give clearest reception, and are famous for their tone quality.

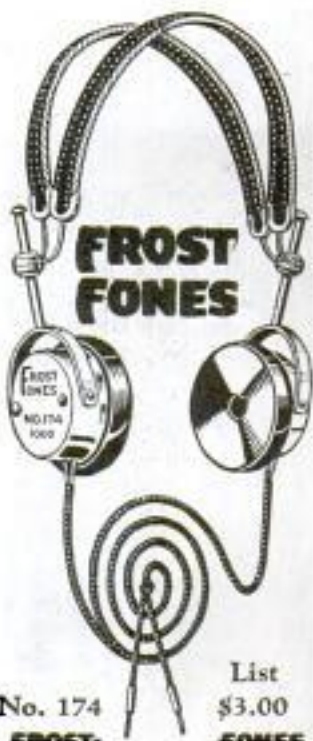

No. 174 FROST-FONES List \$3.00

HERBERT H. FROST, Inc.

314-324 West Superior Street, Chicago

New York Cleveland Kansas City Los Angeles
Export Office: 314 West Superior Street, Chicago

**Sale
Price
Now!**



**\$1
Down**

Lamb Collar Submarine Coat

Combination Raincoat and Warm Overcoat

Men! Here is the most practical coat ever made, at a bargain price and only \$1.00 down! Broad shawl collar of best quality 4x beaverized lamb skin; and warm plaid blanket body and sleeve lining. Outer fabric is rippled submarine cloth with a coating of rubber between making coat absolutely stormproof. Smart stylish double breasted belted style with two large patch pockets with flaps and two muff pockets. Strapped sleeve. Length 44 inches. Tan only. Sizes 34 to 46.

6 Months to Pay

Have this serviceable combination coat *and never miss the money!* Six months to pay our bargain price! Send only \$1.00 now—when you get the coat you'll say it's the greatest garment you ever saw. Then if perfectly satisfied take six months to pay for it!

Order by No. W-18. Terms \$1.00 with the coupon, \$1.85 a month. Total price only \$11.95.

Elmer Richards Co., Dept. 1778
West 35th St., Chicago

I enclose \$1.00. Send Submarine Coat No. W-18. If I am not delighted with the coat I may return it and get my money back. Otherwise I will pay the bargain price on your terms; \$1 with coupon and only \$1.85 monthly. Total price \$11.95.

Size
Wanted.....

Name.....

Address.....

Post Office..... State.....

I have lived in this town..... yrs. And before that I lived in.....

For..... yrs. Age..... Own Rent Nationality or Color.....

Married Present Occupation.....

Employers Name.....

Give names of merchants who know you personally

Name..... P. O. Box or Street Address.....

Name..... P. O. Box or Street Address.....

If you have ever bought goods on credit by mail, tell us from whom. If there is anything else you wish to tell us about yourself, write on a piece of paper and enclose it with this coupon. But the coupon alone, fully filled out will do. That's all we want to know and we're ready to ship the coat at once. No red tape. No C. O. D.

Our Reference: First National Bank of Chicago.

**No
C. O. D.
to
Pay**

**Send the Coupon
And Only \$1.00 Now!**



Unlike Some Music OZARKA Service Satisfies Every Owner—

IN radio, when one selection does not please, you simply tune it out and pick up another broadcasting station. If it is a question of unsatisfactory volume or tone in your instrument then it becomes an entirely different matter.

You have certain very definite ideas in mind as to what you want your radio to do. Will you allow us to make a few suggestions regarding a plan whereby you can settle the radio question?

Select the instruments which you think might answer. Have a demonstrating instrument

brought to your home. Let each salesman, in turn, make the necessary battery connections. Let him tell you how to operate it but do all the tuning yourself.

You'll buy the instrument then, based on your own operation. You'll size up each one for

- ease of tuning
- distance received
- volume
- tone
- selectivity
- price.

OZARKA

120 Austin Avenue P,
Chicago, Illinois



**YOU'LL KNOW
THE MAN BY
THIS BUTTON!**

OZARKA Senior S-IComplete With All Accessories
Including Hi-Power Speaker**\$125.00**West of Rockies, \$137.50
Canada, \$180.00

There still remains one very important question to settle—the matter of service. No matter what anyone tells you sometimes little things may go wrong. The best radio salesman often knows nothing of correcting radio troubles—satisfy yourself.

Our Ozarka representative in your community will gladly put an Ozarka in your home for such a test. More than this, you will find that he is a thoroughly trained mechanic on our instrument. He has gone through a complete course of study under Ozarka Engineers, the men who designed and perfected the Ozarka.

3187 such men today can correct any trouble which may occur on any Ozarka instrument—more men are being factory trained daily. You wouldn't buy an instrument blindly—then don't buy service the same way. Any radio instrument is only as satisfactory as the quality of service behind it.

Our Book No. 200 shows the full Ozarka line from \$75.00 to \$197.50, complete with all accessories.

A Few More Men Are Needed

In a great many counties we have the man we want. He is rapidly building up a permanent and profitable business of his own because he has an instrument that will more than meet all competition. More than this, he is trained to back up his sales with the kind of service that counts.

Many well established Ozarka representatives started by giving us only their spare time—their evenings. If your county is open you can do the same.

The investment in cash is very small. The investment in time necessary for study is considerable. It requires patience, but the results have enabled many men to get out of the salary and time clock class.

Any previous sales experience is helpful but not necessary. We can and will teach you how to sell.

Send Coupon for FREE Book!

The 84-page "Ozarka Plan" is entirely too expensive to be sent out on postal card requests. It will be sent FREE to any man who mails the coupon below and who is really anxious to improve his condition. Tell us about yourself, ask for Ozarka Plan No. 100 and don't fail to give the name of your county.

**Ozarka
Incorporated**
120 Austin Ave. P.
Chicago, Illinois

Without obligation send book "Ozarka Instruments No. 200" and name of Ozarka Representative.

I am greatly interested in the FREE book "The Ozarka Plan" whereby I can sell your radio instruments.

INCORPORATED

120 Austin Avenue P,
Chicago, Illinois

Name.....

Address..... City.....

County..... State.....

Fastest Cutting

Saws Fifteen Cords
a Day!

Men—
Let Me Send You My
Greatest LOG SAW Offer!

ONLY
\$39

Puts the OTTAWA
Working for YOU!

"I average \$20 profit a day with my OTTAWA."—J. Schill, New York. "My OTTAWA has earned \$700 for me."—S. Graham, Wisconsin. "I can make more money with the OTTAWA than by farming."—D. Goff, Missouri.

It's easier now than ever before to own this fastest-cutting, easiest-moved, most powerful Log Saw. Now, you can make big money sawing firewood, stove-holts, ice, shingle timber, etc. Write today for full details of this most wonderful offer. Know how easy it is to make big money sawing fifteen cords of wood a day with no hard work.

350 Saw Cuts a Minute—

Make BIG MONEY—

nearly six each second. Just think of it—now you have a log—in a few seconds it's all sawed up into lengths you can use—without any hard work! The OTTAWA has balanced crank shaft, power force feed, friction clutch.

Wood selling at \$3 a cord brings owner \$45 a day. Saw your own wood—go into the wood business. Don't let the lack of ready money stop you. Remember, we sell on very easy terms. More in use than all others combined.



OTTAWA 4.H.P. LOG SAW

30 Days to Try—one whole month to use the OTTAWA at your own sawing. Shipped on trial only—backed by 10-year guarantee. Prove to yourself how easy you can saw 15 cords or more a day—at a cost of 15¢ a cord.

To Save You Freight—and get your machine to you a few days after you order, I ship from: Ottawa, Kan.; Pittsburgh, Pa.; St. Paul, Minn.; Albany, N. Y.; Memphis, Tenn.; Indianapolis, Ind.; Pueblo, Colo.; Ft. Worth, Texas; Portland, Ore.; San Francisco, Cal.

Send me your name and address on postcard today, so I can send you my wonderful new edition of the "Wood Sawing Encyclopedia." Educational, instructive. Be sure to investigate—will help you to make big money.

HARRY OVERMAN, Pres. OTTAWA MFG. CO.

1742-P Wood St., Ottawa, Kans. Room 1742-P, Magee Bldg., Pittsburgh, Pa.



Cuts Up Branches



Cuts Down Trees Level With Ground

Wood
Sawing
Encyclo-
pedia

The De Luxe The Machine That
Price \$12.50 Big Profits Cheats the Printer

Here it is, boys! Look it over. The selling Wonder of the Century. Handle a live one and climb the ladder of success. The machine pays for itself over and over each year. It prints the merchant's "ad" automatically on roll wrapping paper in one or two colors as you pull the paper. Guaranteed for five years. \$25.00 per day cost. Write for proof today. Woodworkers Mfg. Co., Racine Ave. & Cortland St., Chicago



Why Not Solve Your Saw
Problems With This Regular Tool?

You will like its sturdy mechanical construction. It will saw wood, fibre, bakelite 1" and metal 1/4" thick. Sold also without motor. We carry a complete line of bench woodworking machinery. For details write to DELTA SPECIALTY CO. Dept. A-2 858 Third St., Milwaukee, Wis.



\$150 to \$300 PROFIT MONTHLY FROM HB ONE DAY BATTERY CHARGING

Right now is your best chance to start a money-making battery charging business that will make \$150 to \$300 monthly clear profits. Winter brings greatest demand for HB One Day Battery Charging. Only \$35 cash brings complete HB equipment on 30 days' free trial with money-back guarantee. Easy monthly terms let you pay balance from your big battery charging profits. No experience needed. The lowest priced complete One Day Battery Charging equipment on the market. HB owners everywhere making big money, you can too. Write today for free bulletin 11A.

HOBART BROS. CO. Box M-110 TROY, OHIO

MORE HB ONE DAY BATTERY CHARGERS ARE IN USE THAN ANY OTHER MAKE



Do-All Bench, Wood and Metal Working Machines

Are designed to handle a large variety of work, both small and large, in metal as well as wood and all other materials. Being used in Manual Training Schools, Cabinet Shops, Monogram Manufactories, Metal

Model 15
Combina-
tion
Jig Saw
Drill
Press and
Filing
Machine

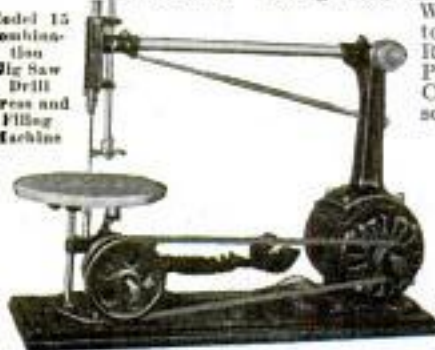

Workers, Sign Manufactories, Electric Shops, Radio Manufactories, Photographers, Art Craftwork of every description.

Send for Descriptive
Circular and our
Liberal Offer for the
months of
October and November

DO-ALL APPLIANCE CO., 859 N. Franklin St., Chicago

Manufacturers of The Do-All Combination Fruit Juice Extractor, Cream Whipped, Egg Beater and Knife Sharpener.



Agents Wanted

Model 11
Circular Saw
Table 11x15 1/2
6-Inch Blade

60 MILES ON A GALLON OF GASOLINE

TESTS SHOW FORD CAN RUN 60 MILES ON A GALLON

The amazing fact that a Ford can run 60 miles on 1 gallon of gasoline was recently brought to light through tests conducted by America's foremost engineers, where it was shown that a gallon of gasoline contains sufficient heat units which if properly atomized and mixed with air would give this additional mileage. Great strides have already been made in this direction by the recent invention of a simple attachment which can be installed in a few minutes without any alterations to the motor. It is common for Ford Owners to make from 40 to 44 miles per gallon after this marvelous device is attached.

MOST WONDERFUL INVENTION TODAY BRINGS JOY TO FORD OWNERS

Starts Ford Instantly

Starting a Ford Car in cold or zero weather is something every Ford Owner dreads—everybody realizes that difficult starting is an abuse on the starter and battery. Thousands of Ford Cars are "laid up" during the Winter just for these reasons. This great difficulty has been overcome. "The SUPER positively starts a Ford Car instantly in the coldest weather."

Marvelous Device

The SUPER is no trick affair—requires no mechanical adjustments and contains all the scientific principles of carburetors costing \$20 to \$35 and in its natural action uses up every particle of unused gasoline and breaks it up into a perfect vapor. The hitherto impossible is now realized by the SUPER.

Everybody Satisfied

Saves 3 to 7 Dollars Per Month

The best investment I ever made. The SUPER is saving me from three to seven dollars each month, besides putting new life into my motor.

A. H. WORRA, Iowa.

Makes 44 Miles Per Gallon

I have tried the SUPER and the results of the experiment are satisfactory. One quart of gasoline run my Ford 11 miles over improved roads which is just about as far as I could run with the plain Ford Carburetor.

G. E. YODER, Penn.

Finds That Our Claims Are Correct

I find that your claims for increased mileage are correct and that a big saving is made by your SUPER. In fact, the best device I have met with in that line.

M. J. VAN LEEUWEN, Mass.



*The
Heart
of the
Motor*

Eliminates Oil Pumping in Front Cylinder

What a wonderful relief to Mr. Ford Owner when he realizes that he can run his car without the motor pumping oil in the front cylinder. Sounds like an awful lot to expect of any device, but that is what the SUPER does and this is only one of its many advantages because it puts real efficiency into any Ford Car.

Complete Combustion

The SUPER is so designed that it takes advantage of the present Ford Carburetor and properly atomizes the light as well as the heavy elements of the fuel, converting every atom of gasoline and kerosene into power preventing liquid fuel from passing into the cylinders, thus avoiding carbon formation and oil dilution.

Easy to Sell

Sells Like Hot Cakes

This is a recent letter from one of our distributors: "Enclosed find draft for 200 more SUPERS, rush as I need them badly. I sold and banked \$104.00 in one day. Hope to sell 1000 SUPERS next month."

A. W. LEONARD, Penn.

Making Big Profits Every Noon

I have been working the SUPER at noon only. Yesterday noon I made more money with the SUPER than I did at my 11 hours hard work in the factory all day.

J. L. LEHNER, Wis.

Had No Previous Selling Experience

This letter shows what ambition does: "I sold six SUPERS in less than 2 hours tonight. I think it's a pretty good start—for it's the first thing I ever sold."

E. MANGOLD, Ind.

\$60.00 TO \$150.00 PER WEEK EASY

You just can't help making Big Money selling the SUPER because a trial sells itself and soon everyone in the neighborhood get talking about this marvelous device. Men like Leonard, Shaw, Manner, Kinsley, Peters, Sands, Beck and Hall are not exceptional salesmen, but just the type of men that saw an opportunity and were quick to grasp it when within reach. No previous selling experience is necessary, just a little ambition on your part to make money is all we ask and we will extend the same opportunity to you. Spare time will pay you well. If you can devote your entire time so much the better, because the SUPER is a whirl-wind seller and takes hold in a locality like wildfire.

Men Wanted Everywhere To Introduce

We want distributors in all parts of the country to take orders and deliver the SUPER and to look after the repeat business that is bound to follow and to such distributors we are willing to assign territory. You do not have to own a Ford to take up this proposition but if you have a Ford it is easier to explain its many advantages. However a Trial of the SUPER convinces the most doubtful person and tells a wonderful story.

A REAL FUTURE HERE

WEEKS SUPER CARBURETOR CO.
426-1532 Eleventh St., Milwaukee, Wis.

MAIL TODAY
WEEKS SUPER CARBURETOR CO.
426-1532 Eleventh Street, Milwaukee, Wis.

ENTRANCE: Please mail me full free particulars about your wonderful invention.

Name

St. or P. O.

Town

County

State

FREE—Valuable Instruction Book on Wood Finishing

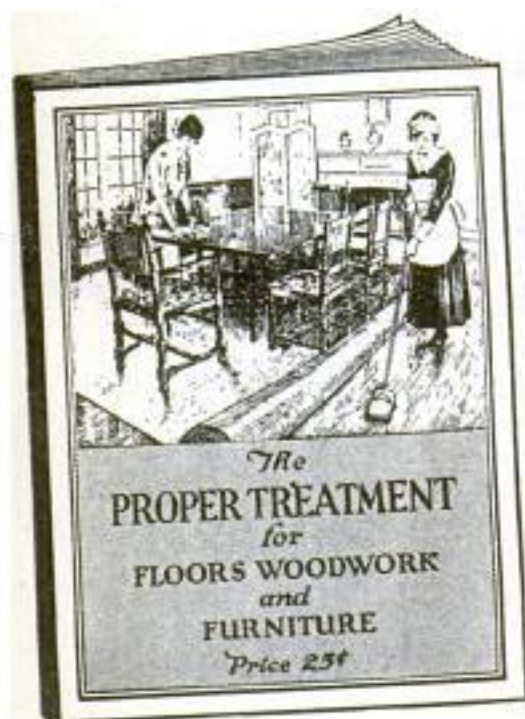

It tells how inexpensive soft woods such as pine, cypress, birch, fir, etc., may be finished so they are as beautiful and artistic as expensive hard woods.

Tells how you can easily put furniture, floors and woodwork in perfect condition. How to finish wood in beautiful stained effects with Johnson's Wood Dye and in up-to-date enamel effects with Johnson's Enamel.

How to Get it—FREE

Ask your best paint or hardware dealer for a FREE copy of the Johnson 25c Book on Wood Finishing. If your dealer cannot furnish this Book—mail the coupon to us, giving the name of your dealer, and we will gladly send you a copy free and postpaid.

JOHNSON'S WOOD DYE

Penetrating

| | | | |
|---------------|----------------|---------------|---------------|
| Dark Oak | Light Oak | Walnut | Bog Oak |
| Fumed Oak | Golden Oak | Mission Oak | Flemish Oak |
| Dark Mahogany | Light Mahogany | Weathered Oak | Early English |

Johnson's Wood Dye is very simple to apply—it goes on easily and quickly without a lap or a streak. Dries in four hours and will not rub off or smudge—penetrates deeply, bringing out the beauty of the grain without raising it. All shades of Johnson's Wood Dye may be easily lightened or darkened.

Johnson's Wood Dye is a *dye* in every sense of the word. It penetrates so deeply that the natural wood color is not disclosed. Like most first class products Johnson's Wood Dye answers one purpose only—it *dyes* the wood; a finish must be applied over it—we recommend Johnson's Varnishes or Johnson's Polishing Wax.

S. C. JOHNSON & SON, Dept. P. A. 11,
"The Wood Finishing Authorities"
RACINE, WIS.

Please send me free and postpaid, a copy of the Johnson 25c Instruction Book on Wood Finishing and Home Beautifying, "The Proper Treatment for Floors, Woodwork and Furniture."

Name.....

Address.....

City and State.....

Dealer's Name.....

The Symbol of the Specialist

The sign at the right distinguishes the Wood Finishing Specialist from the ordinary paint store. Stores displaying this sign carry a full line of Johnson's Artistic Interior Wood Finishes. They will gladly give you a FREE copy of the Johnson 25c Book on Wood Finishing and are competent to give advice on the proper finishing of wood.





**Chesterfield's popularity
is securely founded on
the bed rock of quality**

SUCH · POPULARITY · MUST · BE · DESERVED

LIGGETT & MYERS TOBACCO Co.

WURLITZER

TRADE MARK REGISTERED
THE WORLD'S LARGEST MUSIC HOUSE



Try Any Wurlitzer Instrument in Your Own Home

EXAMINE it, show it to your friends, play it as much as you wish. A week's free trial—no obligation to buy. We make this liberal offer because we want you to see for yourself this superior quality of Wurlitzer instruments, the result of 200 years' experience. Noted musicians praise them for unusual tone quality, artistic workmanship and ease of playing. They are used in the finest bands and orchestras throughout the country.

Easy Payments

If you decide to buy, payments are arranged in small monthly sums. A few cents a day pays for your instrument. Special offers on complete musical outfits. Buy direct from Wurlitzer and save money.

SEND FOR New Catalog

The greatest musical catalog ever published! Over 3,000 articles—every known instrument described and illustrated; many of them shown in full colors. Gives you lowest prices and all details of Free Trial, Easy Payment plan. All sent FREE—no obligation. Just clip coupon and mail today.

Clip and Mail

THE RUDOLPH WURLITZER CO., Dept. 177

117 E. 4th St., Cincinnati 120 W. 42nd St., New York

329 S. Wabash Ave., Chicago; 250 Stockton St., San Francisco

Send me, absolutely free, new illustrated catalog, with prices and details of Free Trial Easy Payment plan. No obligation.

Name

Address

City

State

Instrument

(State instrument in which you are interested)