

DECEMBER

RADIO DRAMA VS. STAGE THRILLS

25 CENTS

N.S.E.

POPULAR MECHANICS MAGAZINE

WRITTEN SO YOU CAN UNDERSTAND IT

REG. TRADE MARK GREAT BRITAIN No. 410428

REG. U.S. PAT. OFF.

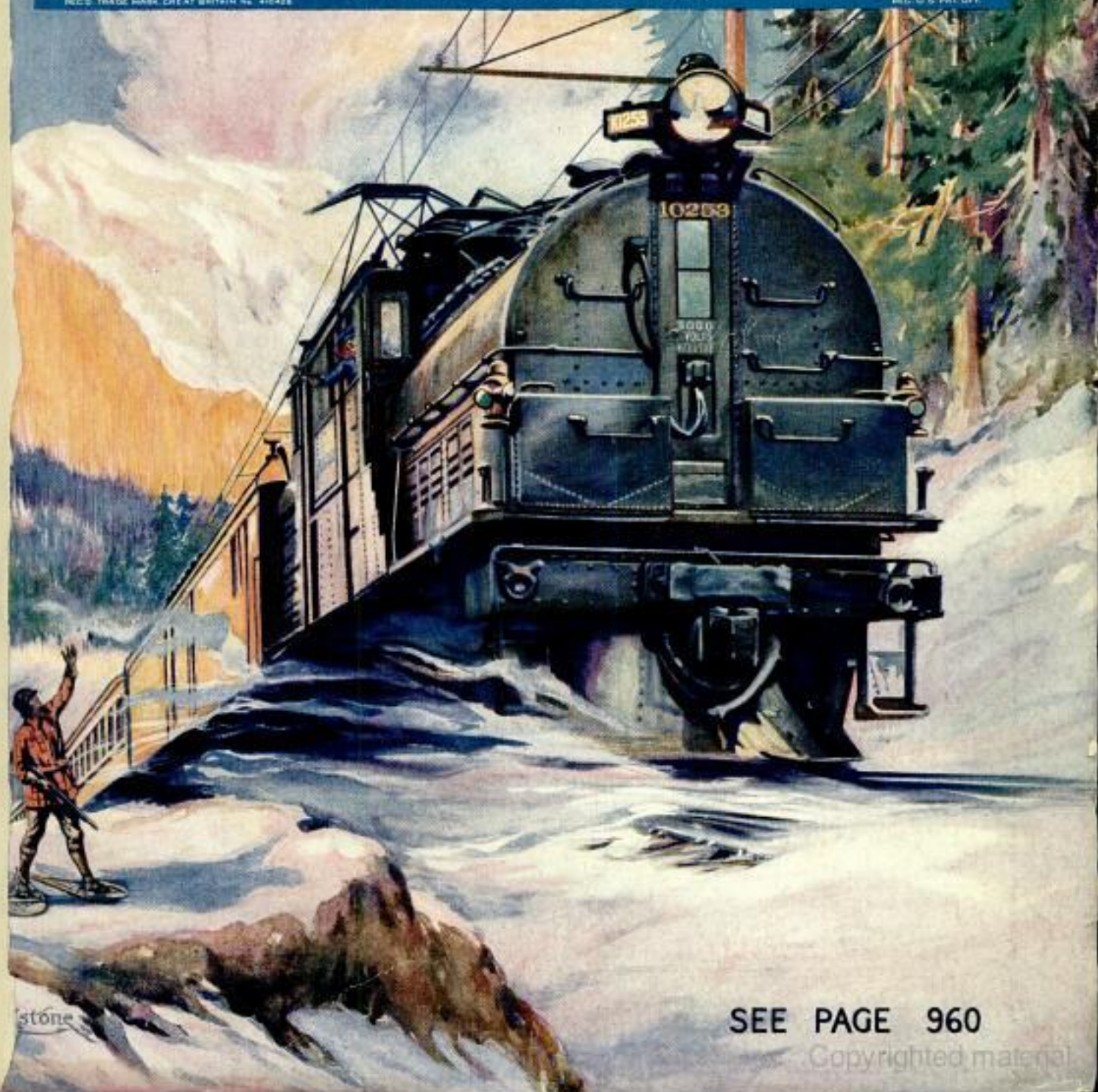

Stone

SEE PAGE 960

Copyrighted material

Pick Your Job - I'll Train You!



Eight Weeks in Either of my Schools and You step into the Big Pay Class

This Will Start You On The Road to Independence

Get out of the rut of underpaid, no advancement jobs—get into the auto game—the field of unlimited opportunities—of big pay—of independence. Thousands of jobs are open, paying from \$150 to \$500 a month on salaries—and the sky is the limit if you go into business for yourself.

McSweeney Trained Men Are In Demand

A man who has completed the course taught in either of my schools finds the doors of the automobile, tractor and battery businesses open to him. "McSweeney Trained" means a real job at real money. Thousands of my former students who now own their own business won't hire any but McSweeney trained men. They know!

You Learn by Doing Actual Jobs

You can't learn any profession out of books, you can learn why, but never how. I teach you both the why and the how by doing actual jobs on the most modern equipment. That's why you can walk out of my schools into big paying jobs.

\$86,000 Made by a McSweeney Trained Man Last Year!

A. J. Beall, Jr., Morgantown, W. Va., made \$86,000 last year with his garage and service station. Geo. W. Smith, W. Alexandria, O., makes over \$800 a month. Thousands of others are making from \$50 to \$150 a week.

Aren't You Just as Good as They Are?

Would you admit to anyone, even to yourself, that these men are any brighter or cleverer than you? I know them—and I'll bet they aren't—the only difference is that they know how. Spend eight weeks in either of my two big schools and I'll teach you the same things that have made them big money makers.

Decide Today — Your Entire Future Lies in the Balance

The right decision today will either start you on the road to success, or will leave you in the ranks of the underpaid. Make your decision, fill in the coupon today!

McSweeney Auto, Tractor and Electrical Schools

Dept. 1411

McSweeney Building
CLEVELAND, OHIO
CINCINNATI, OHIO

Address Either School

R. R. Fare and Board FREE

For a limited time only, I am offering a special low tuition rate, including Free R. R. Fare and Board. Get full particulars by sending coupon today.

J. H. McSweeney, Pres., Dept. 1411, McSweeney Auto, Tractor & Electrical Schools, McSweeney Bldg., Address either Cleveland or Cincinnati

Dear Sir: Send me your big catalog and full information about your Special limited offer.

Name

Address

No facilities for colored students.



YAY—a touchdown!

Mickey over the line! Listen to 'em cheer! 'Ray—Mick! Thousands at the game. Hundreds of thousands listening in! Everybody's eager—excited—keeping young with new enthusiasms. Listening in!

It's great to get every word from the field—just as sharp and distinct as if you stood beside the announcer. It's great to get music that comes from miles away, every tone and overtone mellow and clear. And these are the things that are making the fame of Radiola Regenoflex.

The Regenoflex is simple to operate. It is non-radiating—doesn't disturb your neighbor's program. It is selective—gets the station you want without interference. It is sensitive—gets big distances on the Loudspeaker. But most important is the new tone quality so real that it doubles the fun of getting the game!

"There's a Radiola for every purse"

Radio Corporation of America

Sales Offices:

233 Broadway
New York

10 So. La Salle Street
Chicago, Ill.

433 California Street
San Francisco, Cal.

Radiola

REG. U.S. PAT. OFF.

Radiola Regenoflex
with compartments to hold the batteries; with 4 Radiotrons WD-11 and Radiola Loudspeaker. Complete except batteries and antenna.. \$191
Same without Radiotrons and Loudspeaker.. \$150



This symbol of quality is your protection.

Want a Radiola this Christmas?

A gentle hint does wonders. Send us the name of the relative who doesn't know what to get you, and we'll mail to him—or her—a book about all the Radiolas from \$35 to \$425. It may help.

Or send for the booklet yourself for Christmas ideas.

RADIO CORPORATION OF AMERICA
Dept. 5112 (Address office nearest you)
Please send a Christmas booklet on Radiolas to

Name _____
Street _____
City _____ P.O. _____
State _____



EUS2-XTW-ZKHB

HAPPY PLANNING TIME:

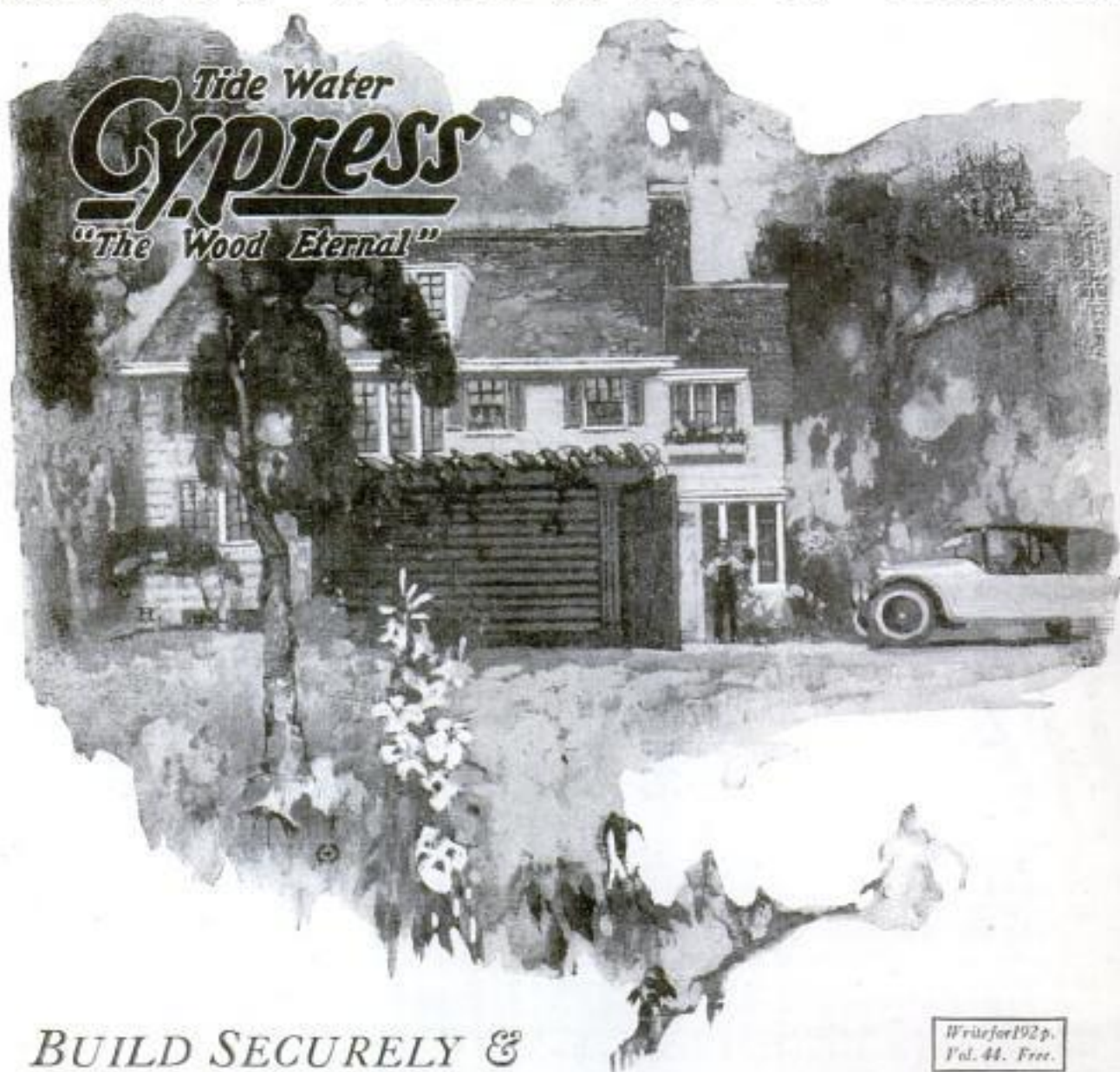

BUILD SECURELY &

Write for 192 p.
Vol. 44. Free.

when you celebrate the demise of Mr. Decay-Germ you may well consider it "a successful funeral." He "had a bad influence"—and his habits were costly. He ended his destructive career by his folly in attacking your *new* Colonial Home, built entirely, and *for keeps*, and with *beauty* as well as *utility*, of genuine

"Tidewater" Cypress, "The Wood Eternal."

Mr. Decay-Germ tried the impossible, and "died on the job." But—the lesson is—

Be sure you get genuine "Tidewater," the true swamp Cypress from within 200 miles of the sea.

Better send for **Free Copy** of Vol. 44, 192 pages, 96 pictures, Double Plan Sheet Supplement, Full Specifications for Entire House and Equipment. Also 3-sheet Special Colonial Art Supplement by a famous artist. Entire book exclusively designed. Write

SOUTHERN CYPRESS MANUFACTURERS' ASSOCIATION



1219 POYDRAS BUILDING, NEW ORLEANS, LA.

OR 1219 GRAHAM BUILDING, JACKSONVILLE, FLA.



Insist on Trade-marked "TIDEWATER" CYPRESS. Accept no other.

Bicycle, Ride on Stationary Test Muscles 940
Cable, Greater Speed in Messages 918
Popular Mechanics Magazine

200 E. Ontario Street, Chicago, U. S. A.

H. H. WINDSOR, Founder

H. H. WINDSOR, Jr., Editor and Publisher

London: Hachette & Co.,
15-17 King William Street, Charing Cross, W. C. 2

Paris: Hachette & Co.,
111 Rue Reaumur

Melbourne, Australia
The Australasian News Co.

Freight Car Unloader 940

ISSUED MONTHLY

SUBSCRIPTION:

SINGLE COPY, 25 CENTS

In United States and its possessions, also Canada, Cuba, and Mexico, per year, postpaid - \$2.50

To all other countries in the Postal Union - 3.00

All subscriptions are discontinued at expiration. Please examine the date printed on your wrapper.

Entered as Second Class Matter Sept. 15, 1903, at the Post Office at Chicago, Illinois, under Act of March 3rd, 1879.

Entered as Second Class Matter at the Post Office Department, Canada.

Published monthly by POPULAR MECHANICS CO.

Copyright, 1924, by Popular Mechanics Co.

Copyright in Australia. Copyright in France

Bread, baking to test flour classes, gold coated 944
 Vol. 42 Contents for December, 1924 No. 6
Furniture, without nails 958

Accidents—persons blinded in industrial accidents	986
Advertising	
revolving sign on water tank advertises theater	983
waste steam used in advertising	892
Aeronautics—one-man blivver plane	925
Automobiles	
cost more than furniture	911
wallpaper finish for auto bodies	975
Automobiles—Driving	
auto hazard in green sunshades avoided by changing color	926
spare wheel at rear of car aids parking	892
Automobiles—Equipment and Supplies	
folding rear windshield	974
motor heat meter	990
twin roller bearings absorb shocks	903
Automobiles—Fuel	
valve adjusters save gas	903
Automobiles—Ignition	
fat spark no aid to motorists	924
Automobiles—Lighting	
bulb has two filaments	905
lights turned up or down by knob on steering wheel	981
night driving made safe by running-board lights	925
stop light run by drop of mercury	958
Automobiles—Lubrication	
grease-filled shackle bolt nut eliminates squeaky springs	992
touch of button oils chassis fitted with lubricator tank	939
Aviation	
fog-piercing ray to guide fliers	918
glider in air nine hours	959
making the air safe for fliers	977
skeleton adopted as symbol by fliers	886
with the new mosquito fleet	906
Barbers—shop on auto	941
Baseball—every move in game shown on screen	966
Bells—church, made of alloy of aluminum	904
Bicycles—water bicycles for river carnivals	949
Board—made of mixed minerals fireproof	987
Boring Machinery—hole cutter for wood and metal used like wrench	939
Bread—whole wheat bread made directly from grain	937
Brushes—fit water hose	982
Building	
green lumber reduces cost by using calked seams	947
schoolhouse moved on canal barges	981
Buttons—needle finding, saves cloth	894
Camera—built for queen's doll house	911
Canaries—taught by phonograph to sing like nightingales	939
Carving—egg cups carved from bits of coal	916
Cigaret—slot machine	883
Cinders—oil burners cause shortage	987
Clock—without a face	887
Coal—big deposits found in arctic	883
Compass	
airplane compass guides fliers	986
in ring for electrical tests	967
Concrete—"lumber" to cut building costs	928
Crime—beating burglar at own game	896
Cuff Links—expanding	982
Department Stores—date book for appointments	905
Diamonds—found on farm in S. Africa	982

Diesel Engine—in locomotive hauls train 100 miles	926
Dogs—collies trained to pull with pony	919
Dynamite—used to destroy lake crib	891
Efficiency—Industrial—making weather for workers aids quality of products	946
Eggs—where yolks get color	967
Electric Power	
power of two handfuls of coal	981
tasks done with electricity	975
Elevators—speed set by machine	888
Explosives—safety powder for blasts in mines	948
Eyes	
eyeshades like lashes shield against sun	903
gold-coated glasses admit light but halt glare	949
Fire Protection—gas well fires put out with snuffer	959
Fulton, Robert—statue saved from wreck of station	956
Furniture—vanishing, fixed on door	980
Garages—Equipment and Supplies	
frames for tilting autos on side for repairing	895
Gauges—with handle and lock clamp for measuring holes	974
Gloves—tailoring leather for gloves	921
Gold—world's, flowing to America	913
Golf—night golf with luminous balls played on lighted course	884
Grass—growing by electricity	891
Guns—safety of shotgun depends on skill in making	956
Gyroscope—yacht held steady by stabilizer	910
Hats—paper hat parasol for men	912
Heat—of breath able to release power to lift tons	888
Heaters—electric coal burner saves fuel	927
Hoists—hoisting tower on auto	948
Hotels—housekeeping on gigantic scale	950
Household Devices	
Hydroelectric Power—over the mountains with white coal	960
Liberty Bell—Alabama village laid out in shape of bell	985
Life-Saving—policemen swim in full uniform in life-saving stunts	895
Life-Saving Apparatus—lever release for launching lifeboats	986
Loading and Unloading	
tipple turns coal cars over	991
unloading freight cars with detachable steel chutes	940
Magnet—magnetic rod picks up bolts and bits of metal	949
Mars—eggs not boiled on the planet Mars	908
Masks—air-filter mask for painters	967
Mats—moss matting a substitute for linoleum and cork	926
Microscope—pocket, with strong lens	905
Models—yacht modeling teaches seamanship	983
Motorcycle—single-wheeled motorcycle carries rider on rim	918
Mount Everest—new climb to conquer	889
Moving Picture Photography	
arrow thriller in movie made by turning-camera backward	957
when the movie camera won't lie	969
Mower—craft cuts river weeds	974
Music—twenty-seven centuries old on tablet	917
Naval Warfare	
British fleet outlined in lights	975
phantom ships aid naval gunners	909
Navigation—undersea survey of Gulf may aid in forecasting weather	957
Ornament and Decoration—goldplated stones on skyscraper	887

606 - buy your hole cutter, Wood or metal 939.

Blackboard 891 [Continued on Page 4] *Coal Burner, Electric 927* *Hole Cutter*

939

DRAKE'S PRACTICAL MECHANICAL BOOKS

THEY WILL RAISE YOUR PAY—

ORDER ON 5-DAY TRIAL

The books listed below will perfect you in your chosen trade—pave the way to the big positions. Written in non-technical language—easy to read and understand. **Every book covers its subject completely. An entire course of instruction condensed into one volume.** Your choice sent postpaid—you benefit 5 days—money refunded in full if not entirely satisfactory. Order direct from this page.



Automobile Books

- Automobile Starting, Lighting and Ignition, by Manly. [Pub. Jan. 1924.] 700 pp. Leatherette \$3.00
- Manly's Automobile Handbook, 1924 Edition. Leatherette \$2.00
- Truck and Motor Car, Truck and Tractor, by Manly. Cloth \$1.50
- Starting and Lighting Troubles, Remedies and Repairs, by Manly. Leatherette \$3.00
- Automobile Battery, Care and Repair, by Manly. Leatherette \$2.00
- Automobile Catechism and Repair Manual. Leatherette \$1.50
- Tires and Vulcanizing, by Tufford. Cloth \$2.00
- Gas and Oil Engine Handbook. Cloth \$1.50
- Automobile Upkeep and Care, by Manly. Cloth \$1.50
- Motocycle Handbook, by Manly. Cloth \$1.50

Shop Practice Books

- Sheet Metal Workers' Manual. Leatherette \$2.00
- Oxy-Acetylene Welding and Cutting. Cloth \$1.25
- Slide Rule and Logarithmic Tables. Leatherette \$2.00
- Handbook for Millwrights. Cloth \$2.00
- Modern Blacksmithing. Cloth \$1.25
- Machine Shop Practice. Cloth \$2.00

ORDER DIRECT FROM THIS PAGE—ON OUR MONEY-BACK PLAN

The books listed above are only a few of the many in our catalogue, which you will receive promptly after filling out and mailing us the attached coupon. For quick action order direct from this page—cross name of each book wanted and send in with price quoted. We prepay postage and send the books on our money-back plan.

FREDERICK J. DRAKE & CO.

PUBLISHERS

1008 Michigan Ave., Chicago

Drake Books Are For Sale at All Book Stores

Mail Coupon For Free Catalogue
Your Guide to Home Study

- Mechanical Drawing and Machine Design. Cloth \$2.00
- Pattern Making. Cloth \$1.50

Carpentry Books

Cloth Binding

- Modern Carpentry, 2 vols. \$3.00
- The Steel Square, 2 vols. \$3.00
- Wooden Boat and Shipbuilding. \$1.50
- Modern Estimator. \$1.50
- Timber Framing. \$2.00
- Builder's Architectural Drawing. \$2.00
- Concretes. \$1.50
- Practical Bungalows. \$1.00
- Low Cost Homes. \$1.00
- Roof Framing, by Van Gasbeck. \$1.50
- Stair Building and Hand Railing. \$1.50

Electrical Books

- Telephony, Including Automatic Switching, by Smith. [Pub. Jan. 1924.] 500 pp. Leatherette \$2.50
- Practical Applied Electricity. \$2.00
- Alternating Current. \$1.50
- Electric Motor Control Systems. \$1.50
- Wiring Diagrams and Descriptions. \$1.50
- Electrical Tables and Data. \$1.50
- Armature and Magnet Winding. \$1.50
- Modern Electrical Construction. \$1.50
- Modern Electric Illumination. \$1.50
- Electricians' Operating and Testing. \$1.50
- Motion Picture Operation. \$1.50
- Drake's Electrical Dictionary. \$1.50
- Electric Motors, D. & A. \$1.50
- Electrical Measurements and Meter Testing. \$1.50
- Drake's Telephone Handbook. \$1.50
- Easy Experiments. Cloth \$1.25
- Wireless Telegraph and Telephone Handbook. Cloth \$1.25
- Telegraphy Self-Taught. Cloth \$1.25

Steam Engineering

- Swingle's Handbook for Steam Engineers and Electricians. Leatherette \$4.00
- Examination Questions and Answers for Marine and Stationary Engineers. Leatherette \$2.00
- Steam Boilers. Leatherette \$2.00
- Swingle's Catechism of Steam, Gas and Electrical Engineering. Leatherette \$1.50

Painting Books

- The Mixing of Colors and Paints, By Vanderwalker. Cloth \$2.00
- Scene Painting and Bulletin Art. Cloth \$4.00
- A Show at Sho' Cards. Cloth \$4.00
- Sign Painting. Cloth \$4.00
- Strong's Book of Designs. Cloth \$4.00
- Strong's Art of Show Card Writing. Leatherette \$4.00
- Signist's Alphabets. Cloth \$4.00
- Modern Painter's Cyclopedia. Cloth \$1.50
- Automobile Painting. Cloth \$2.00
- Estimates, Costs and Profits, Painting and Decorating. Cloth \$1.50
- New Hardwood Finishing. Cloth \$1.50
- The Amateur Artist. Cloth \$1.50
- New Stencils. Cloth \$1.25
- Chalk Talk and Crayon Presentation. Cloth \$1.25

Farm Books

- Farm Mechanics. Cloth \$1.25
- Farm Buildings. Cloth \$1.25
- Farm Engines. Cloth \$1.25
- Traction Farming. Cloth \$1.50

Business and Reference Books

- Better Business Letters. Cloth \$1.00
- Better Business English. Cloth \$1.00
- Better Advertising. Cloth \$1.00
- Finger Prints Simplified. Cloth \$1.25
- Practical Bricklaying. Cloth \$1.25
- Practical Instruction for Detectives. Cloth \$1.00
- Practical Plumbing. Cloth \$1.50
- Hot Water Heating. Cloth \$1.50
- Elementary Chemistry. Cloth \$1.50
- Courses in Civil Service. Cloth \$1.50
- Cyclopedia of Recipes. Cloth \$1.50
- American Star Speaker. Cloth \$1.50

Modern Languages

- By Prof. P. S. Allen, U. of Chicago
- French without a Teacher. Cloth \$1.25
- Spanish without a Teacher. Cloth \$1.25
- German without a Teacher. Cloth \$1.25
- Everyday French. \$1.25
- Everyday Spanish. \$1.25

FREDERICK J. DRAKE & CO.
1008 Michigan Avenue
Chicago, Ill.

GENTLEMEN:—Please send me free, postage paid, your illustrated catalogue which lists and describes over 100 Practical Mechanical Books for Home Study.

My name is

and my address

Neglect of Home-Study Training Cost This Man \$47,424!

How much are you paying to stay untrained?

The other day we received a letter which every man working for a living ought to read—whether he's making \$20 a week or \$200. Here it is:

"During the forty years that I have been working, my salary has averaged less than twenty-four dollars per week with the exception of the last two years while I have been acting as foreman of a department. I made good in this position on a small scale and saw, thru the failings of others, what would happen to me unless I found a way to train for larger responsibilities.

"I had read of correspondence courses and began searching for that which I thought would benefit me. I found it in the LaSalle Modern Foremanship course, and benefited by it, my salary being nearly doubled, and I was promoted from foreman to factory superintendent.

"This happened in a period of about ten months, and by devoting only about four or five hours per week to the studies.

"I am now enrolled as a member of the Industrial Management Efficiency course, and find the work very interesting and beneficial. It can be applied every day in the factory, and brings results.

"I regret that I put it off to so late a day in life to reap the benefits I am now enjoying, and can truthfully say to younger men that if they would only profit by the experience of others they can gain more knowledge thru one year's training by LaSalle methods than can be obtained in ten years' practical experience by hard work."

SHERMAN C. WOOD, Maryland.

We quote the above letter not because Mr. Wood is now making a staggering salary as a result of his training, but because it illustrates so clearly the principle behind LaSalle training.

Here is a man who all his life had accepted the thought that he was compelled to work for little or nothing.

For one thousand, nine hundred and seventy-six weeks the writer of this letter *paid at least \$24 a week for the doubtful privilege of staying in the ranks of untrained men.*

Can anyone doubt that training would have doubled his salary just as easily when he was thirty-eight years younger—when he could attack his work with the abundant energy of a younger man?

Yet his neglect of this one main avenue of business progress cost him—leaving simple and compound interest out of the reckoning—the appalling sum of \$47,424—a fortune in itself.

**If You Could Use \$47,424,
Pause Before You Turn This Page**

Perhaps you are now making quite as much as Wood—perhaps more. Perhaps, on that account, you may think that Wood's experience does not apply to YOU.

But if training in Higher Accountancy—or Modern Salesmanship—or Business Management—or Law—or Business Correspondence—or any of a dozen other branches of business could change your forty-eight dollars into *\$96 a week*—and if you now **NEGLECT** to advance yourself thru the training you need—will you not find it difficult, thirty-eight years from now, to explain to those who are dear to you why you threw away—not \$47,424, but *fully \$95,000?*



We're not going to moralize. We're not even going to cite you any of the thousands of letters from men who have not merely doubled but tripled and quadrupled their incomes thru home study training under the LaSalle Problem Method. We have the letters. We will show them to you, if you like. But understand, please, that they would not *alter* the facts—they would merely *emphasize* them.

Below this text there's a coupon.

We believe that if you will re-read that letter from Sherman C. Wood and will face your problem of advancement squarely, you will not turn this page until you have clipped the coupon, filled it in, and by placing it in the nearest mail-box placed *yourself* on the road to real success.

LaSalle Extension University

The Largest Business Training Institution in the World
Dept. 1264-R Chicago, Illinois

Upon request, the book, "Ten Years' Promotion in One," and material completely descriptive of the course and service that interests you, will gladly be sent without cost or obligation. Indicate your choice by checking, and write below your name and address.

- | | |
|---|--|
| <input type="checkbox"/> Business Management | <input type="checkbox"/> Modern Business Correspondence and Practice |
| <input type="checkbox"/> Modern Salesmanship | <input type="checkbox"/> Modern Foremanship and Production Methods |
| <input type="checkbox"/> Higher Accountancy | <input type="checkbox"/> Personnel and Employment Management |
| <input type="checkbox"/> Law—Degree of LL.B. | <input type="checkbox"/> Expert Bookkeeping |
| <input type="checkbox"/> Traffic Management | <input type="checkbox"/> Business English |
| <input type="checkbox"/> Railway Station Management | <input type="checkbox"/> Commercial Spanish |
| <input type="checkbox"/> Commercial Law | <input type="checkbox"/> Effective Speaking |
| <input type="checkbox"/> Industrial Management Efficiency | <input type="checkbox"/> C. P. A. Coaching |
| <input type="checkbox"/> Banking and Finance | |

Name.....

Present Position.....

Address.....

CARPENTERS

GUIDES THAT SOLVE PROBLEMS

A Complete Course in Practical Carpentry and Building Work

POCKET SIZE—
FLEXIBLE
COVERS—
3100 ILLUSTRATIONS
— 1600
PAGES

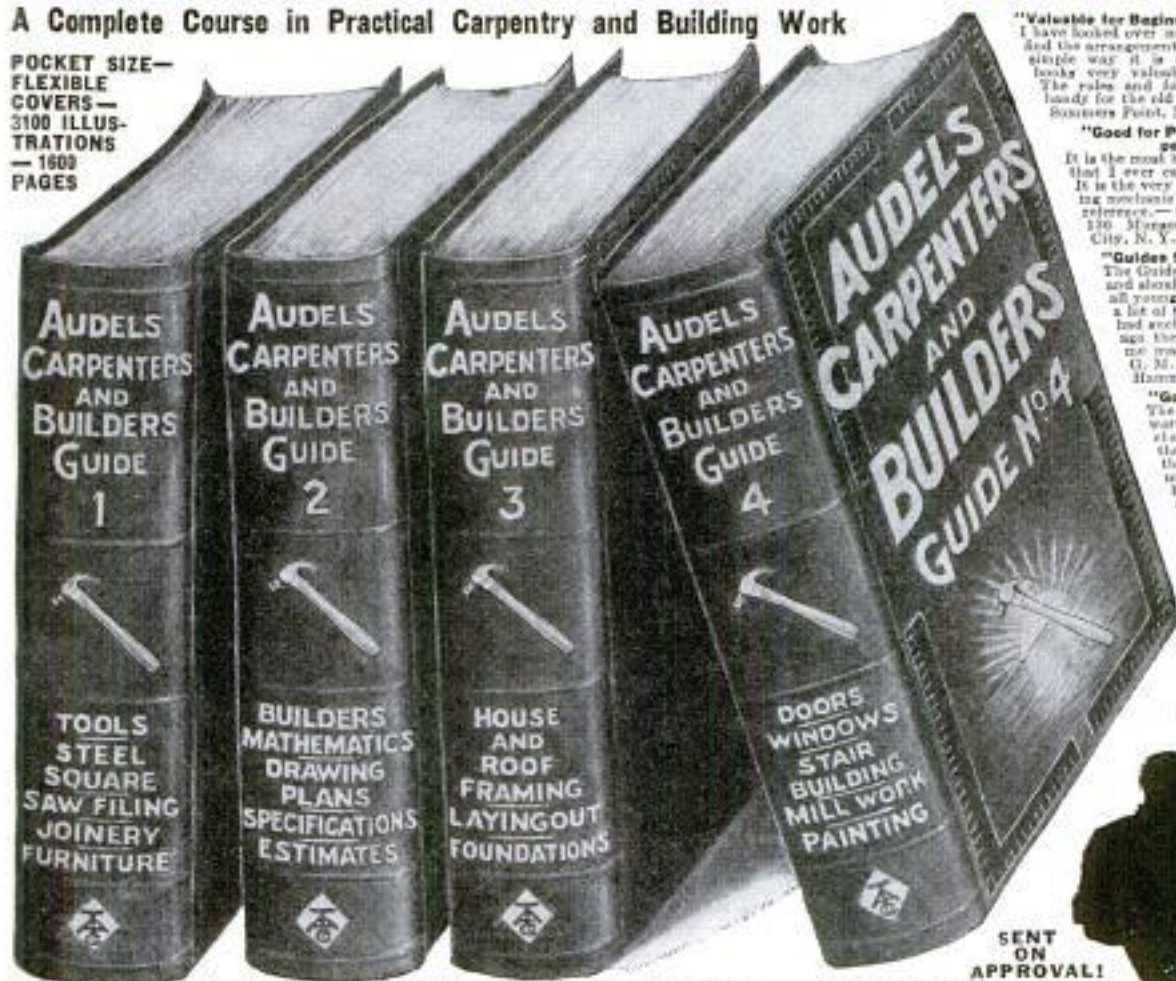

"Valuable for Beginners or Old Timers"
I have looked over our Audel Guides and find the arrangement of subjects and the simple way it is explained make the books very valuable for the beginner. The rules and formulas are right handy for the old timers.—Ross Smith, Somers Point, N. J.

"Good for Professional Carpenters"
It is the most handy reference work that I ever came in contact with. It is the very thing that the building mechanic needs every day for reference.—George H. Watson, 130 Morgan St., Long Island City, N. Y.

"Guides Save Hard Knocks"
The Guides are truly woodwork and should be in the hands of all young carpenters as well as a lot of the older heads. If I had such information 20 years ago they would have saved me many a hard knock.—G. M. Nicholson, R. R. 1, Hammond, Ind.

"Good for Amateurs"
The books are surely worth more than the purchase price; especially as they serve as a guide to the nonprofessional like myself who is trying to build himself a home at the least expense.—Otto F. Schaefer, P. O. Box 147, Westmont, Ill.

\$1

PER MONTH



SENT ON APPROVAL!

NEW IDEAS—MODERN METHODS—SHORT CUTS

This course, "Audel's Guides for Carpenters and Builders," consists of 4 handy volumes of over 1500 pages with thoroughly illustrated charts, diagrams, graphs, pictures with calculations for every job from making the excavation to constructing the entire building. You will find these new Guides most complete and comprehensive in addition to being both timely and practical. There are 3700 actual examples of efficient construction work with new methods, ideas, solutions, plans, systems, short

cuts, time and labor saving suggestions, new ways that cover the entire theory and practice of the subject illustrated by sketches and forms all specific and practical. Audel's Guides give you the short cut, professional information you want. No need to guess or take chances. Every day you have before you in this set the exact, practical, useful information that will help you with every job that comes up in your daily work.

HOW To Handle the Job That Puzzles YOU

There are thousands of examples of modern construction and building work—new methods, new ideas, proved efficiency plans, short cuts, time saving suggestions, new ways that cover the entire theory and practice of modern carpentry. Every point is easy to read and understand and clearly illustrated with sketches and forms. Inside Trade Informa-

tion for Carpenters, Builders, Joiners, Building Mechanics and all Woodworkers on—Care and Use of Tools—How to Use the Steel Square—File Saws—Make All Kinds of Joints—Draw and Read Plans—Write Specifications—Make Estimates—How to Frame Roofs and Houses—Lay Out Work—Put in Foundations—Full Instruction on In and Outside Building Work—Stair Building—Saw Mill Work—Practical Painting—Thousands of Short-Cuts that save time and money—Information usually obtained only by hard experience.

NO MONEY!

MERELY SEND COUPON AND LOOK THE SET OVER AT AUDEL'S RISK

THEO. AUDEL & CO., 72 5th Avenue, NEW YORK CITY
Send me for free examination Audel's Carpenters and Builders Guides, if satisfactory I will send you \$1 within 5 days and mail \$1 monthly until \$5 is paid.

Name.....
Address.....
Occupation.....
Employed by.....
Reference.....
12-1-30

FREE

EXAMINATION

Not a cent to pay until you see the books. No obligation to buy unless you are satisfied. Fill in coupon in pencil. Send now—today—get this great help library for carpenters and builders.

Learn Electricity

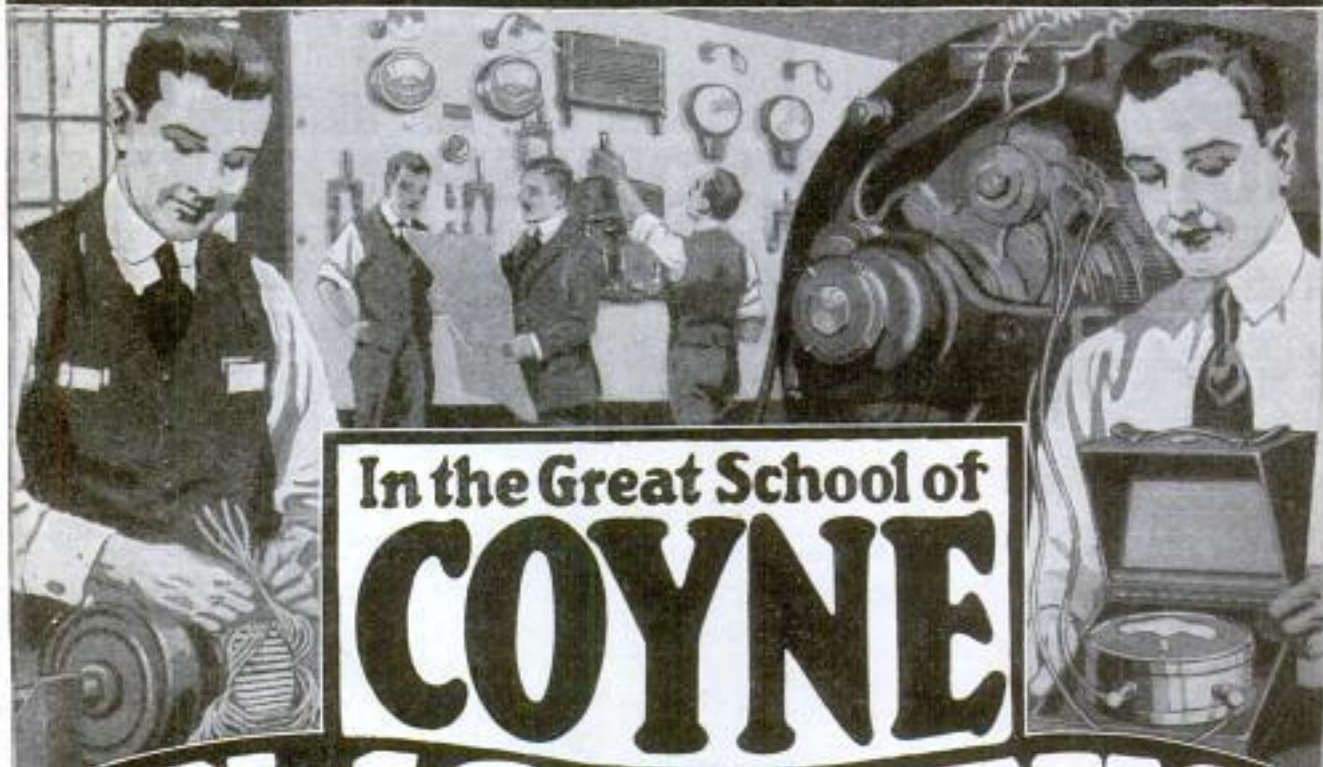

In the Great School of

COYNE

IN 12 WEEKS

EARN \$60 TO \$200 A WEEK

Why work at dull uninteresting work, at low pay, with no future? In 12 weeks I will train you for a big pay job where you can command \$60 to \$200 a week as a COYNE TRAINED MASTER ELECTRICAL EXPERT or you can go in business for yourself with very small capital and make up to \$15,000 a year. Men trained as I train them are in demand everywhere. The great development of the Electrical Industry makes the demand for trained men tremendous. Big opportunities and advancement for those who prepare now. The Coyne school was founded 26 years ago and my thousands of SUCCESSFUL GRADUATES are living proofs of what my training can do for ANY AMBITIOUS man. Many of these fellows will tell you in my big free book what Coyne has done for them.

COMPLETE ELECTRICAL TRAINING IN 12 WEEKS

I train you thoroughly on the greatest outlay of ACTUAL ELECTRICAL machinery ever assembled in any school. You work with your hands on all kinds of Electrical apparatus, door bells, house wiring, armatures, switchboards, dynamos, everything to make you an all around ELECTRICAL EXPERT. This REAL WORK with REAL tools, on REAL machinery trains you many times FASTER, many times MORE THOROUGH than trying to learn in the field or by books or lessons.

No Books, No Lessons, No Classes —You Do Actual Work!

I do not attempt to teach you by books or lessons. I train you to work with your head and hands on the same kind of Electrical Machinery used in power houses, industrial plants and on the outside, under actual working conditions, with instructors at your side. I have no classes, every student gets individual training.

Free Radio and Auto Course

For a short time only I am including ABSOLUTELY FREE my big new Radio Course and Auto, Truck and Tractor Electrical Course.

COYNE ELECTRICAL SCHOOL

1300-1310 W. Harrison St., Dept. 135-9, Chicago, Ill.

You Don't Need Education or Experience

You don't need a lot of schooling to master my course. You don't have to be a high school graduate or even a grammar school graduate. My method of instruction is clear and plain, and yet thorough, and if you can understand plain English I will make you an electrical expert even though you haven't a lot of education or any previous electrical experience.

Coyne Trains You for Life

You get a free life scholarship which enables you to stay longer than the required time if you care to, or you may return at any time to take up new work. I am constantly adding to my school to make it the most modern at all times.

Earn While You Learn

My employment department will assist you to a part time job where you can make a good part of your living expenses while training, and they will assist you to get a BIG PAY job on graduation.



H.C. LEWIS, President

Get My Free Book

This big handsome new book just off the press is 12x15 inches—shows actual photographs of my big shops. Cost me a dollar to print, but it's yours FREE if you mail coupon. You owe it to yourself to get the facts.

Dear Sir:—Please send me absolutely FREE your big new book and full particulars of your special offer of two extra courses FREE.

H. C. LEWIS
President
COYNE
Electrical School
1300-10
W. Harrison St.
Dept. 135-9
Chicago, Illinois

Dear Sir:—Please send me absolutely FREE your big new book and full particulars of your special offer of two extra courses FREE.

Name.....

Address.....

Text.....

Mail.....

MAIL THIS COUPON NOW!



"Don't tell me you never had a chance!"

"Four years ago you and I worked at the same bench. We were *both* discontented. Remember the noon we saw the International Correspondence Schools' advertisement? That woke me up. I realized that to get ahead I needed special training, and I decided to let the I. C. S. help me. When I marked the coupon I asked you to sign with me. You said, 'Aw, forget it!'"

"I made the most of my opportunity and have been climbing ever since. You had the same chance I had, but you turned it down. No, Jim, you can't expect more money until you've trained yourself to handle bigger work."

There are lots of "Jims" in the world—in stores, factories, offices, everywhere. Are *you* one of them? Wake up! Every time you see an I. C. S. coupon your chance is staring you in the face. Don't turn it down.

Right now more than 180,000 men are preparing themselves for bigger jobs and better pay through I. C. S. courses.

You can join them and get in line for promotion. Mark and mail the coupon, and find out how.

INTERNATIONAL CORRESPONDENCE SCHOOLS

Box 5656-D, Scranton, Penna.

Without cost or obligation, please tell me how I can qualify for the position or in the subject before which I have marked an X:

BUSINESS TRAINING COURSES

- | | |
|--|---|
| <input type="checkbox"/> Business Management | <input type="checkbox"/> Salesmanship |
| <input type="checkbox"/> Industrial Management | <input type="checkbox"/> Advertising |
| <input type="checkbox"/> Personnel Organization | <input type="checkbox"/> Better Letters |
| <input type="checkbox"/> Traffic Management | <input type="checkbox"/> Show Card Lettering |
| <input type="checkbox"/> Business Law | <input type="checkbox"/> Stenography and Typing |
| <input type="checkbox"/> Banking and Banking Law | <input type="checkbox"/> Business English |
| <input type="checkbox"/> Accountancy (Including C.P.A.) | <input type="checkbox"/> Civil Service |
| <input type="checkbox"/> Nicholson Cost Accounting | <input type="checkbox"/> Railway Mail Clerk |
| <input type="checkbox"/> Bookkeeping | <input type="checkbox"/> Common School Subjects |
| <input type="checkbox"/> Private Secretary | <input type="checkbox"/> High School Subjects |
| <input type="checkbox"/> Spanish <input type="checkbox"/> French | <input type="checkbox"/> Illustrating <input type="checkbox"/> Cartooning |

TECHNICAL AND INDUSTRIAL COURSES

- | | |
|---|--|
| <input type="checkbox"/> Electrical Engineering | <input type="checkbox"/> Architect |
| <input type="checkbox"/> Electric Lighting | <input type="checkbox"/> Architects' Blue Prints |
| <input type="checkbox"/> Mechanical Engineer | <input type="checkbox"/> Contractor and Builder |
| <input type="checkbox"/> Mechanical Draftsman | <input type="checkbox"/> Architectural Draftsman |
| <input type="checkbox"/> Machine Shop Practice | <input type="checkbox"/> Concrete Builder |
| <input type="checkbox"/> Railroad Positions | <input type="checkbox"/> Structural Engineer |
| <input type="checkbox"/> Gas Engine Operating | <input type="checkbox"/> Chemistry <input type="checkbox"/> Pharmacy |
| <input type="checkbox"/> Civil Engineer | <input type="checkbox"/> Automobile Work |
| <input type="checkbox"/> Surveying and Mapping | <input type="checkbox"/> Airplane Engines |
| <input type="checkbox"/> Metallurgy | <input type="checkbox"/> Navigation |
| <input type="checkbox"/> Steam Engineering | <input type="checkbox"/> Agriculture and Poultry |
| <input type="checkbox"/> Radio | <input type="checkbox"/> Mathematics |

Name.....
Street.....
Address..... 3-6-24

City..... State.....

Occupation.....
Persons residing in Canada should send this coupon to the International Correspondence Schools Canadian, Limited, Montreal, Canada.

Be ^{B.W.} a Cooke Trained

5 Thousand Million Dollars Spent Every Year for Upkeep

EARN
\$3500 to
\$10000
A YEAR

The World's Biggest Business Needs You!

Think of it! Five BILLIONS every year for *upkeep alone!* No matter where you live this tremendous field offers unlimited opportunities EVERYWHERE. The Auto Industry needs trained AUTO EXPERTS. It needs YOU!

GET YOUR SHARE

Mail the coupon. Let me show you how I train you for positions paying \$75 to \$200 a week. My "JOB-WAY" training has prepared hundreds of men *just like yourself* for quick, brilliant success in the Auto business. Let me show you how it can fit *You* for BIG PAY jobs.

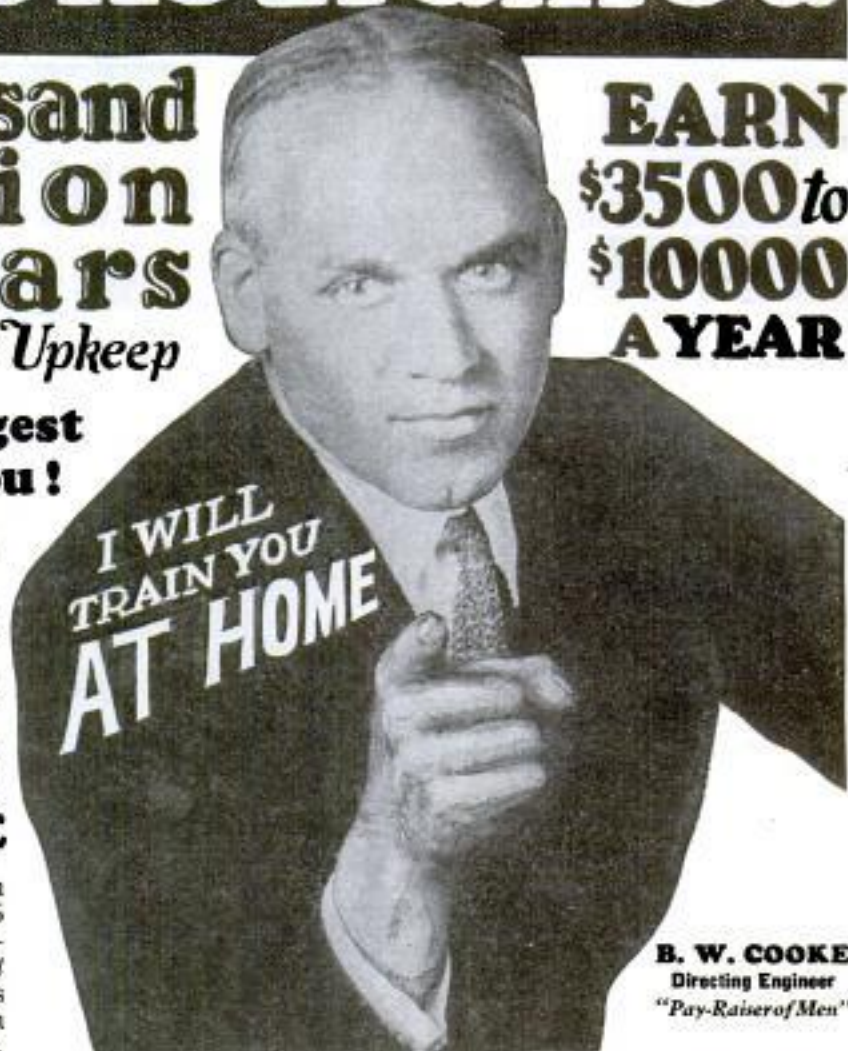

B. W. COOKE
Directing Engineer
"Pay-Raiser of Men"

You Don't Need to Leave Home

I mean it! I guarantee it! If you don't find it's true, I'll give you my training *absolutely free!* Keep your job. Stay home. Save hundreds of dollars. Read my free book. See how "JOB-WAY" is most practical, most thorough, easiest learned, BEST Auto training—*by far.* As Directing Engineer of the great Chicago Auto Shops, I *know* what training you need—and I give you THAT TRAINING! I insist that you become a BIG PAY EXPERT. Students' letters in my free book will *prove* to you that you need not leave your doorstep!

See What I Can Do For You!

Start to Make Money Quick Like These Men!

In my files are letters from hundreds of enthusiastic boosters of the "JOB-WAY." Many had not a day's Auto Experience before enrolling. Others had as high as 10 to 15 years' Auto Experience. Read what a few of them say:—

"Am already making \$50 to \$60 a week in my new shop. Will make \$75 to \$100 soon," writes M. J. Morrison, Parkersburg, W. Va., who had not a day's experience before enrolling.

"Wouldn't take \$1000 for what I have learned," says Chris. F. Baden, Spangle, Wash., who has finished only half my training so far.

"Have been in the Auto business for eleven years, but find I still have lots to learn about Autos," writes Fred Wood, 41 Norway Ave., Toronto, Canada, Auto Mechanic with 5 years' experience before enrolling.

"I give your course all the credit for being in business for myself and making what I am today," writes 20-year old Harry Carter, R. L., Lima, Ohio, who had no previous Auto Experience.

"Job-Way" Costs Many Nothing Earn While You Learn

Nearly all my students earn real money long before they're half way through my training. Many make more in ONE MONTH than the entire cost of my training. Get my book. I'll show you how to do this too. I give you Free life-time service from my Employment Department also.

Clip Coupon Now.

Auto Expert!

With My Training You Can Go Into Business!

15 Million Autos, Trucks, Tractors on roads today. Thousands and thousands more made every year. Opportunities for Cooke-trained Auto Experts are *Endless*. Every Cooke-trained man is assured of a big, successful future. Very little capital needed. Rich prizes reward the Auto Expert who knows and is trained to give better service, as I will train you! My book will show you why.

No Other Training Like

TRADE MARK **JOB-WAY** REGISTERED

Not Book Learning—It Is Practical

Remember this—"Job Way" training is not books! I don't give you big, thick volumes full of old, dry-as-dust, rubber-stamp, technical matter. Takes months and months to get out a book. I train you with *Tools and Illustrated Jobs*, and practical talks just as though I were standing right beside you. You simply sit back and absorb all the important Automotive knowledge that I and my Engineering Staff have gained through many years of experience. It is modern, practical, personal training that you get from me.

Training Complete in Every Detail

I believe in doing *ONE* thing—and doing it well. I teach automotive work. Not a dozen different things.

My training includes all Electrical work, ignition, starting, lighting, welding, brazing, vulcanizing, etc.—also Business Course, Salesmanship, Advertising, Buying, How to Keep Simple Books—everything to make you an auto expert—also Free Monthly Magazine, also 2 free outfits. Nowhere else can you get all this money-making training. Nowhere else can you get the original, genuine, copyrighted "JOB-WAY" training.

Experience, Education Not Needed!

I don't care how little schooling you have, I will make you a successful Auto Expert or refund your money! Boys and men of all ages have become Garage owners and managers, Superintendents, Foremen, Auto Experts, BIG PAY executives, with Cooke "JOB-WAY" training behind them. My book will prove to you that I will fit you to take advantage of the many wonderful opportunities of the great Auto Business!

Read My Guarantee!

Ten guarantees in my big free Auto Book. No. 1 is: "I guarantee to refund every cent of your money if after receiving my training you are not absolutely satisfied." This and nine other wonderful guarantees make my "JOB-WAY" course the training for you! Be sure to get my book and read all 10 guarantees—the most amazing protection offered by any school on earth!

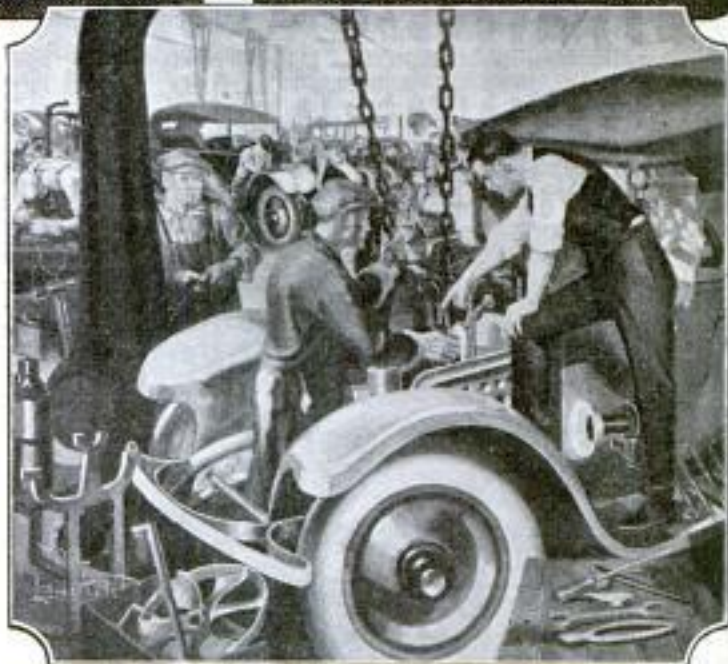

Make \$75 to \$200 a Week!

Don't sell your time for a penny less! You don't need to when you have this wonderful training. There are hundreds of big-pay positions open right now, waiting for Cooke-trained Auto Experts. There are opportunities waiting for YOU. Just read my book. See how many opportunities there are to start a business where \$3,000 to \$15,000 a year and more can easily be made. No other business is growing so fast, or offers you so many big opportunities.

Get My Big Book Quick!

It Is Crammed Full of Dependable, Proven FACTS!

I will send it to you without one penny of cost. Read all the facts, find out about the demand for Cooke-trained Auto Experts. Let me tell you how easily and quickly you, too, may become an Auto Expert. Special offer right now to ambitious men. Coupon brings complete information. *Mail it today!*



FREE!
Big
Repair
Outfits

Auto Book
free

Tools and Test Bench Equipment FREE! Many Auto Tools and more gifts. See my MARK MONEY shortly after starting my training. Mail now, post paid for \$2.00!

MAIL THIS COUPON FOR FREE AUTO BOOK

B. W. COOKE, Directing Engineer
CHICAGO AUTO SHOPS, Dept. 916, 1916 Sunnyside Ave., Chicago, Ill.
Send me FREE Auto Book and proof that I can become an Auto Expert at home in spare time. Also send your special offer of 2 FREE outfits.

Name.....
Address.....
City.....
State.....
Occupation.....
Age.....

Address Me Personally **B. W. Cooke** Directing Engineer
CHICAGO AUTO SHOPS
1916 Sunnyside Avenue, Dept. 916 Chicago

\$90
Drafting Course
Drawing Table
Drawing Instruments

ALL
FREE

Mail Free Coupon Below

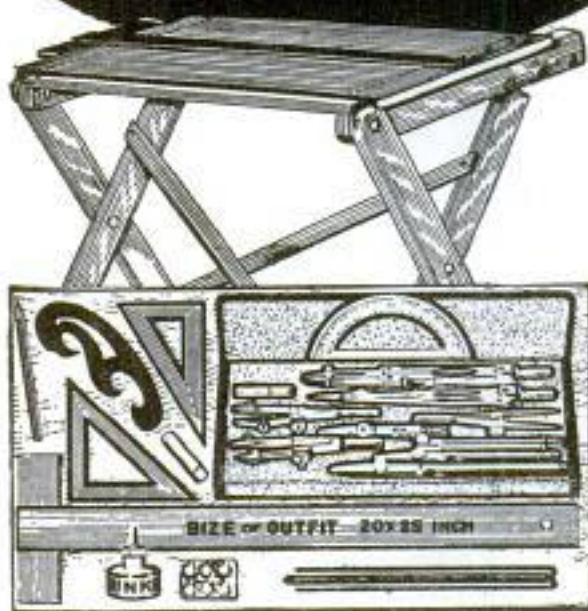

Complete Set of Drawing Instruments delivered at once. Yes, I will give you complete drawing outfit, a regulation "Chief's Own" drawing table and, besides, give you an opportunity to get a \$90 drafting course free of all money cost to you. The instruments I give are in a handsome high class, plush lined folding case. They are regular draftsman's working instruments. Besides I will give you absolutely free, a 20 x 25 inch drawing board, a 24 inch T square, a 12 inch rule, a supply of drawing paper, two triangles, a French curve, pencils, erasers and thumb tacks as soon as you become my student.

Salaries up to
\$250 to \$300
Per Month

There is an urgent demand for skilled draftsmen. Companies are issuing calls every day for men to fill positions paying up to \$250 to \$300 a month. Work is light, pleasant and profitable; a trained draftsman can be reasonably sure of having a good job all the time.



"I instruct you personally!"
 DOBE, Chief Draftsman

Chief Draftsman Will Instruct You Personally

I am Chief Draftsman of a large and well known firm. I have been doing the highest paying expert drafting work for a quarter of a century and I know just the kind of training that is demanded from men who get big salaries. I train you by giving you actual, practical work, the kind you must be able to do to hold a permanent, big paying position. I give you my individual instruction. If your work is right, I will advance you rapidly. If it is wrong, I will show you where and make you do it right, and do all I can to make you an expert draftsman and designer in a short time.

Write Today Without Fail!

I Guarantee
 to train you until you
 are holding a position
 paying up to \$250
 and \$300 month.



Chief Draftsman,
 Engineers' Equipment Co., Div. 13-59
 1951 Lawrence Ave., Chicago, Illinois
 Without any obligation on me whatsoever,
 please, mail your book, "Successful Drafts-
 manship" and full particulars of your liberal
 "Personal Instruction" offer to a few students.
 It is understood that I am obligated in no
 way whatsoever.

Send Coupon
For New Book

Put your name and address on the coupon or a letter or a post card and send it to me today. I will send you absolutely free and postpaid, my new book "Successful Draftsmanship," and [the great special offer that I am now making, on which you get the complete Draftsman's Working Outfit absolutely free. You assume no obligations of any kind in sending in the coupon. Get in line for a big paying position. Getting the book and full particulars of the special offer is the first step.

Chief Draftsman, Engineers' Equipment Co.
 1951 Lawrence Ave., Div. 13-59 Chicago, Ill.

Name

Address



I Guarantee, You
A Job
AND
A **50% Raise!**

If you are now earning less than \$40 a week, I will guarantee you an Electrical job after you finish my training—guarantee you at least 50% more pay under bond, or refund every cent you pay for tuition. You can get this guarantee only from AMERICAN SCHOOL, the 27 year old, million dollar educational institution.

Go Into ELECTRICITY!

The world's greatest, fastest growing, most fascinating industry will pay you \$3500 to \$12,000 a year when you are an ELECTRICAL EXPERT trained to BOSS electrical construction or electrical power plants, to direct the work of ordinary electricians. Prepare for these positions, at home in your spare time, with Dunlap JOB-METHOD training, the most complete and up-to-date home instruction in Electricity.



Chief
Engineer
Dunlap

You Get
**4 Electrical
Outfits**

Dunlap JOB-METHOD training is built around four complete Electrical outfits which I send you without extra charge. With these valuable instruments, tools and materials, you learn by doing actual Electrical jobs. You get the theory while getting the practice. My JOB-METHOD of instruction makes it easy for you to understand the most difficult subjects.

22 Electrical Engineers

from Westinghouse, General Electric, Commonwealth Edison, Western Union and other great corporations helped me to build this wonderful home-study training. So in every department of Electricity you get your training from a *specialist* and an *authority!* These executives know what training you need to hold down the BIG-PAY positions in Electricity, and they give you just that training.

BOSS Electrical Jobs at \$70 to \$200 a Week!

New projects in Electricity total hundreds of millions of dollars. No other industry offers such a golden future to *trained* men, trained as I train you. Electricity rewards not only the occasional genius like Edison and Steinmetz. This giant business also pays rich prizes to thousands of men who master electrical principles as I help you master them in my JOB-METHOD instruction.

Mail Coupon Get \$63 Scholarship FREE!

AMERICAN SCHOOL organized NOT FOR PROFIT, gives you the benefit of royalties, profits and other savings. Write me at once and save \$63 cash. Get the facts and take advantage of my GUARANTEED JOB and RAISE offer. Get the facts about your chances in the Electrical business. Get my big, free catalog, see for yourself how quickly and easily you can get ready for Big Pay!

CHIEF ENGINEER DUNLAP
Electrical Division

American School
Dept. EE-974, Drexel Av. and 58th St.
CHICAGO

Make This Training Pay for Itself!

Don't let lack of ready money or anything else prevent you from getting my training. As early as your eleventh lesson I train you to do Electrical and Radio jobs in your spare time—to earn enough money to pay for this course and have some left over.

Chief Engineer Dunlap
American School, Electrical Division
Dept. EE-974, Drexel Ave. and 58th St.
CHICAGO

Please rush free book, guarantee of a job and 50% raise, \$63 Free Scholarship offer and complete information.

Name.....

St. No.....

City..... State.....



Only a
Part
of
Outfit

Dunlap Guarantees You a Job And a Raise!

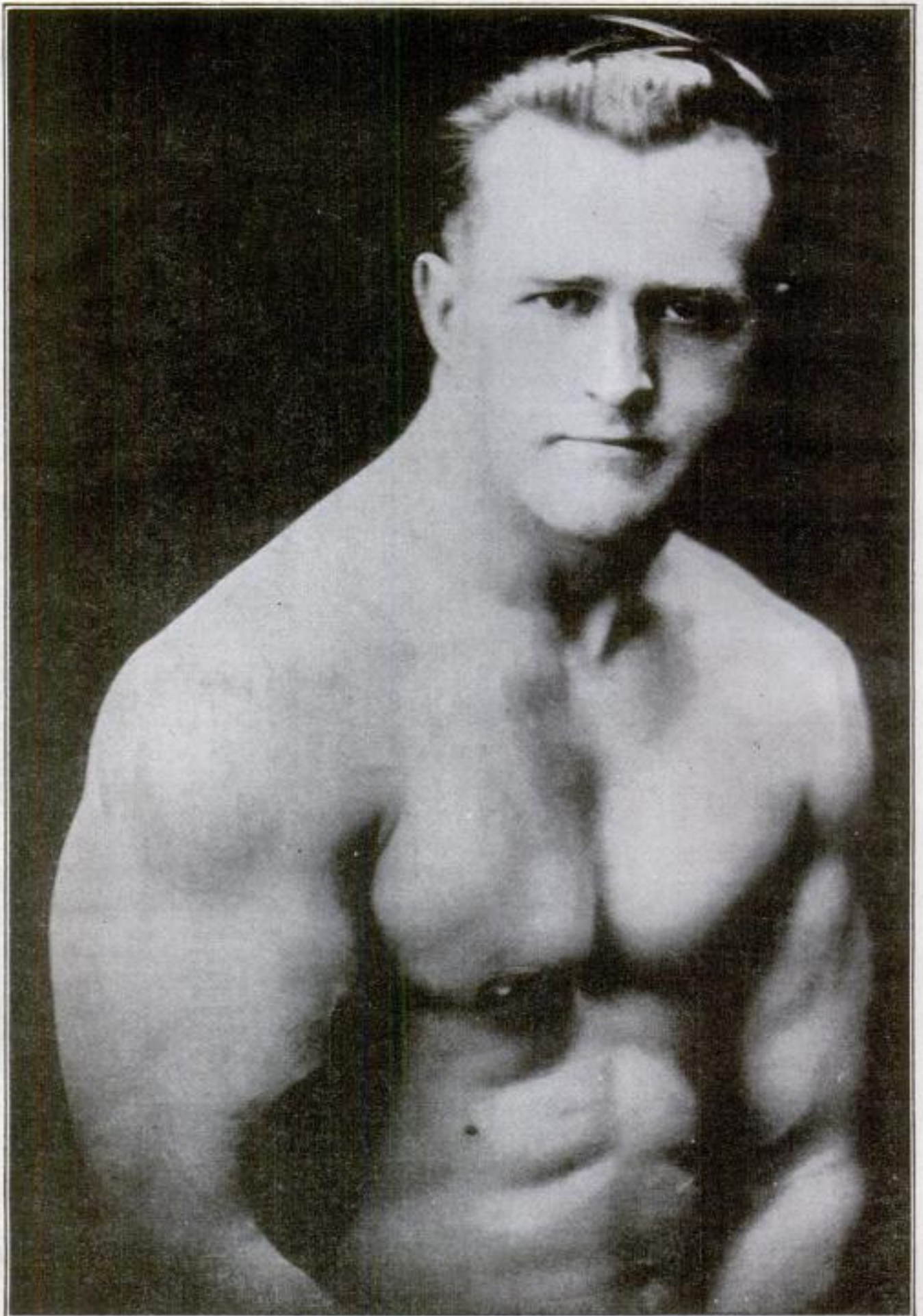

EARLE E. LIEDERMAN, *The Muscle Builder* Copyrighted material
Author of "Science of Wrestling," "Muscle Building" and "Here's Health"

Pills Never Made Muscles Wishing Never Brought Strength

NO one can paste muscles onto your arms and shoulders. If you wish a strong, healthy body, you must work for it. And if you don't have one, you are doomed to a life of misery.

Modern science has taught us that we must keep our bodies physically fit or our mental powers will soon exhaust themselves. That is why the successful business man resorts to golf and other active pastimes.

Examine Yourself

Do you have the strong, robust body that keeps you *fit* at all times to tackle the daily tasks confronting you—always looking for bigger things to do? Do you jump out of bed in the morning full of pep; with a keen appetite and a longing to enter the day's activities? Do you finish your daily tasks still thrilling with pep and vitality? Or do you arise only half awake and go through a languid day?

PEP UP!

Don't let it get you, fellows. Come on out of that shell and make a real *he* man of yourself. Build out those skinny arms and that flat chest. Let me put some real pep in your old backbone and put an armor plate of muscle on you that will make you actually thrill with ambition. I can do it. I guarantee to do it. I will put one full inch on your arm in just 30 days and from then on, just watch 'em grow. This is no idle boast. It's the real works. A genuine guarantee. Come on now. Get on the job and make me prove it.

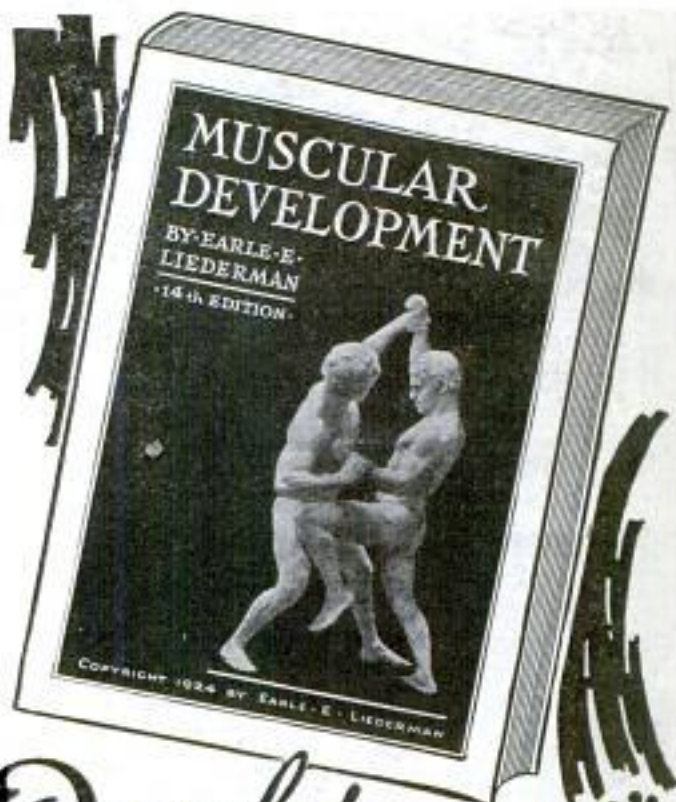

Send For My New
64 Page Book

"Muscular Development"

IT IS FREE

It contains forty-three full-page photographs of myself and some of the many prize-winning pupils I have trained. Some of these came to me as pitiful weaklings, imploring me to help them. Look them over now, and you will marvel at their present physiques. This book will prove an impetus and a real inspiration to you. It will thrill you through and through. All I ask is 10 cents to cover the cost of wrapping and mailing and it is yours to keep. This will not obligate you at all, but for the sake of your future health and happiness, do not put it off. Send today—right now, before you turn this page.

EARLE E. LIEDERMAN
Dept. 2012, 305 Broadway, New York City

EARLE E. LIEDERMAN

Dept. 2012, 305 Broadway, New York City

Dear Sir:—I enclose herewith 10 cents for which you are to send me, without any obligation on my part whatever, a copy of your latest book, "Muscular Development." (Please write or print plainly.)

Name.....

Street.....

City..... State.....



I GUARANTEE

to give you personal, individual training in every branch of Dental Laboratory work, to make you expert in a few months!

\$3.00 an Hour
 \$20.00 a Day
 \$125.00 a Week
 \$500.00 a Month
 \$6000 to \$10,000 a Year

Get ready for these Jobs!

Where else can you earn such large salaries after only a few months of training? My training is the quickest way to BIG PAY. At my schools you become Expert in EVERY BRANCH of Dental Laboratory work, not merely skilled in some one part of it. That is why you will read letters in my book from McCarrie graduates telling of winning wonderful successes and enormous salaries.

Open a Laboratory!

That's the big thing my students and graduates aim for—a business all their own! Remember when you are a McCarrie-trained Dental Laboratory Expert IT TAKES VERY LITTLE CAPITAL to open a Laboratory of your own. So I say to my students and to you—train at my schools as the shortest road to a business of your own, good for profits of \$6,000 to \$15,000 a year.

Get This Book Quick!

It will show you how to pull yourself out of the rut, how to lift yourself out of small pay, hard work into the fascinating, professional life of the well paid Dental Laboratory Expert. You need this book if you are earning less than \$75 a week and want to make something of your future. Coupon brings it, mail it today!



H. A. McCarrie, Director, McCarrie Schools of Mechanical Dentistry,
1338-1340 S. Michigan Ave., Dept. 1501-L, Chicago

Send me your three free offers and your Book without cost or obligation. Tell me about the Dental Laboratory business and the training you give at your schools.

I attach letter stating the kind of work I am interested in while training at your schools.

.....Name

.....St. No.

.....City.....State

Be a Dental Laboratory EXPERT!

With my training any fellow with a little mechanical ability can become a Dental Laboratory Expert *in a few months!* Here is a growing, uncrowded business calling for more experts than it can find—men trained as I will train you to make Crowns, Plates, Bridges, etc., for Dentists. This work is interesting, clean, easy. Salaries \$75 to start up to \$125 and more per week for EXPERTS. Why don't you investigate the wonderful opportunities of this profession and break away from poorly paid *harder* work?

"Work your way thru McCarrie School"

In Chicago (and Detroit) any ambitious fellow can *with my help* find a well paid position which will enable him to attend my schools evenings. Hundreds now at my schools, hundreds who have graduated have done this. Others go to my schools days and work evenings.

Day or Evening Instruction

Don't let lack of ready money keep you back. *I will help you.* When you mail coupon for complete information, be sure and tell me what kind of work you are interested in, so I can arrange to place you at once when you arrive.

This picture shows how I train my students. No classes, no text-books. You learn on actual "cases" from ethical practical Dentists, you learn with standard instruments on actual materials at my schools. Individual, personal instruction, intensive methods, enable you to become expert in every branch of Dental Laboratory in only a few months. My schools at Chicago and Detroit are the largest and best equipped Dental Laboratory schools in the world, and my graduates are the most successful.



This is Not a "Correspondence" School. You Learn Here by Doing Actual Dental Laboratory Jobs

FREE 1. R. R. Fare to Chicago or Detroit
2. \$80 SCHOLARSHIP
3. COMPLETE OUTFIT

In order to encourage more men to go into Dental Laboratory work and meet the big demand from Dentists and Laboratories *I am making extraordinary inducements right now!* Even if you have only common schooling, no matter what your age, get all the facts about this wonderful business and my remarkable offers *quick*.

Coupon brings complete information, mail it or write immediately.

Address, H. A. McCARRIE, Director

McCarrie Schools of Mechanical Dentistry

Dept. 1501-L, 1338-40 So. Michigan Ave., Chicago

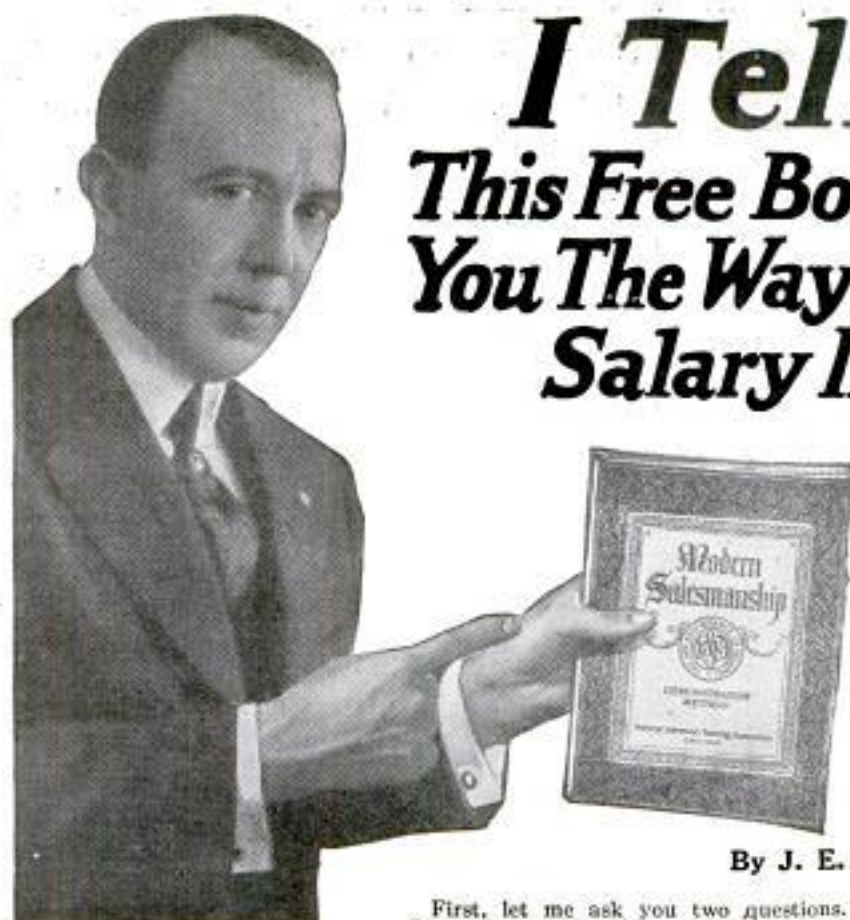

I Tell You This Free Book Will Show You The Way to Amazing Salary Increases

I only ask that you risk two cents on the strength of my word that the contents of this amazing book will show you the way to a prosperity that you never dreamed possible, in a fascinating field that you never thought of entering. This book is now free. Read my offer.

By J. E. GREENSLADE

READ!

\$12,000 a Year

A. H. Ward, Chicago, held a small-pay job. Now he averages \$12,000 a year as a salesman.

\$100 a Month to \$100 a Week in Only 3 Months

H. D. Miller, another Chicago boy, was making \$100 a month as stenographer in July, 1922. In September, 3 months later, he was making \$100 a week as a salesman.

\$150 to \$500 a Month

W. P. Clenny, of Kansas City, Mo., stepped from a \$150 a month clerkship into a selling job at \$500 a month. In one month he made \$850.

\$6,500 a Year

M. V. Stephens, of Albany, Ky., was making \$25 a week. He took up this training and now makes five times that much.

Small Pay to Big Earnings

J. H. Cash, of Atlanta, Ga., exchanged his \$75 a month job for one which pays him \$500 a month. Now Sales Manager at \$10,000 a Year

O. H. Mallroft, of Boston, Mass., stepped into a \$10,000 position as a SALES MANAGER—so thorough is this training. All these successes are due to this easy, fascinating and rapid way to master certain invincible secrets of selling.

EMPLOYERS

are invited to write to the Employment Dept. of the N. S. T. A. We can put you in touch with just the men you need. No charge for this service to you or our members. Employers are also cordially invited to request details about the N. S. T. A. Group Plan of instruction for entire sales forces. Synopsis and charts sent without obligation.

First, let me ask you two questions. One: Do you consider that you are as intelligent as the average mail-clerk, farm-hand, office clerk, mechanic, or bookkeeper?

Second: If you suddenly found yourself with all the money you needed to spend, wearing the best clothes, living in a fine neighborhood, driving a good car and belonging to the best clubs—but having to make good in a job that paid \$10,000 a year, would it scare you? There are men to whom \$10,000 a year is so much that the idea of earning it themselves never occurs to them. They will always be in routine jobs at low pay. Their dreams will never come true. But yours will if you will absorb what I am going to tell you.

Now, in one quick step you can enter the field where opportunities in your favor are ten to one—the Selling field. You know that Salesmen top the list of money-makers—that the salesman is his own boss—that his work is fascinating, interesting and highly profitable! But the thing you doubt is your own ability. All right, but you can become a first-class money-making salesman in an amazingly easy way.

Proof That Salesmen Are Made —Not "Born"

The story of six men who once thought salesmen were "born," who did not believe they were "cut out for selling," is on this page.

Thousands of men like these six men who formerly thought salesmen were "born," are now enjoying magnificent earnings in the selling field. They were bookkeepers, mechanics, farmers, clerks—even doctors, lawyers and ministers—but in a few months after writing to the National Salesmen's Training Association they were out in the field selling—and making more money than they had ever hoped to make.

Sounds remarkable, doesn't it? Yet there is nothing remarkable about it. Salesmanship is governed by rules and laws. There is a certain way of saying and doing things, a certain way of approaching a prospect to get his undivided attention, a certain way to overcome objections, batter down prejudice, and overcome competition.

Just as you learned the alphabet, so you can learn salesmanship. And through the NATIONAL DEMONSTRATION METHOD—an exclusive feature of the N. S. T. A. System of Salesmanship Training—you gain actual experience while studying.

Years of Selling Experience in a Few Weeks

The N. S. T. A. System of Salesmanship Training and Employment Service will enable you to quickly step into the ranks of successful salesmen—will give you a big advantage over those who lack this training. It will enable you to jump from small pay to a real man's income.

Remarkable Book, "Modern Salesmanship," Sent Free

With my compliments I want to send you a most remarkable book, "Modern Salesmanship."

It will show you how you can easily become a Master Salesman—a big money-maker—how the N. S. T. A. System of Salesmanship Training will give you years of selling experience in a few weeks; how our FREE Employment Service will help select and secure a good selling position when you are qualified and ready. And it will give you success stories of former routine workers who are now earning amazing salaries as salesmen. Mail the coupon today. It may be the turning point in your life.

National Salesmen's Training Association
Dept. 12-W 53 W. Jackson Blvd. Chicago, Ill.
National Salesmen's Training Association
Dept. 12-W, 53 W. Jackson Blvd., Chicago, Ill.

I simply want to see the facts. Send me free your book, "Modern Salesmanship," and Proof that I can become a Master Salesman.

Name.....
Address.....
City.....State.....
Age.....Occupation.....



An Easy Way to Learn PHARMACY AT HOME

Graduate pharmacists are always in demand. The work is interesting and pleasant and salaries are good. Many young men open drug stores of their own and become independent.

There's an easy way to learn pharmacy right in your own home in spare time, without losing a day or a dollar from your present work.

The International Correspondence Schools course in Pharmacy supplies the knowledge which it will be necessary for you to have in order that you may pass your State Board Examination.

Just mark and mail the coupon printed below to the International Correspondence Schools, Box 3657-D Scranton, Pa., and full particulars about the Pharmacy Course or any other work of your choice will come speeding to you by return mail.

INTERNATIONAL CORRESPONDENCE SCHOOLS Box 3657-D Scranton, Penna.

Without cost or obligation, please send me full information about the subject before which I have marked an X in the list below:

TECHNICAL AND INDUSTRIAL COURSES

- | | |
|--|---|
| <input type="checkbox"/> PHARMACY | <input type="checkbox"/> Civil Engineer |
| <input type="checkbox"/> Chemistry | <input type="checkbox"/> Surveying and Mapping |
| <input type="checkbox"/> Automobile Work | <input type="checkbox"/> Mine Foreman or Engineer |
| <input type="checkbox"/> Navigation | <input type="checkbox"/> Steam Engineer |
| <input type="checkbox"/> Agriculture and Poultry | <input type="checkbox"/> Gas Engine Operating |
| <input type="checkbox"/> Mathematics | <input type="checkbox"/> Wireless <input type="checkbox"/> Airplane Engines |
| <input type="checkbox"/> Electrical Engineering | <input type="checkbox"/> Architect |
| <input type="checkbox"/> Electrician | <input type="checkbox"/> Contractor and Builder |
| <input type="checkbox"/> Mechanical Engineer | <input type="checkbox"/> Architectural Draftsman |
| <input type="checkbox"/> Mechanical Draftsman | <input type="checkbox"/> Concrete Builder |
| <input type="checkbox"/> Machine Shop Practice | <input type="checkbox"/> Structural Engineer |
| <input type="checkbox"/> Railroad Positions | <input type="checkbox"/> Plumbing and Heating |

BUSINESS TRAINING COURSES

- | | |
|---|---|
| <input type="checkbox"/> Business Management | <input type="checkbox"/> Salesmanship |
| <input type="checkbox"/> Industrial Management | <input type="checkbox"/> Advertising |
| <input type="checkbox"/> Personnel Organization | <input type="checkbox"/> Better Letters |
| <input type="checkbox"/> Traffic Management | <input type="checkbox"/> Foreign Trade |
| <input type="checkbox"/> Business Law | <input type="checkbox"/> Stenography and Typing |
| <input type="checkbox"/> Banking and Banking Law | <input type="checkbox"/> Business English |
| <input type="checkbox"/> Accountancy (Including C.P.A.) | <input type="checkbox"/> Civil Service |
| <input type="checkbox"/> Nicholson Cost Accounting | <input type="checkbox"/> Railway Mail Clerk |
| <input type="checkbox"/> Bookkeeping | <input type="checkbox"/> Common School Subjects |
| <input type="checkbox"/> Private Secretary | <input type="checkbox"/> High School Subjects |
| <input type="checkbox"/> Business Spanish <input type="checkbox"/> French | <input type="checkbox"/> Illustrating <input type="checkbox"/> Cartooning |

Name.....
Street.....
Address.....

City..... State.....

Occupation.....

Persons residing in Canada should send this coupon to the International Correspondence Schools Canadian, Limited, Montreal, Canada

WEALTH, HONOR, RICHES

Do not depend upon opportunity or intellectual brilliancy of any kind, because it is well known that uneducated people often acquire great wealth, while cultured and talented people remain in poverty.

Again, they do not depend upon capital, because many men with capital lose what they have, while others with no capital acquire phenomenal wealth.

Whatever finds a place in human experience is the result of the operation of natural laws, and the determining factors are therefore within your own control.

This may seem "too good to be true," but if you will consider that by the touch of a button or the turn of a lever science has placed almost infinite resources at the disposal of man, it becomes evident that there may be still other laws not generally known which contain even greater possibilities.

We have published a Remarkable little book, giving the conclusions of science concerning these laws, which we will send upon request. If you want to underwrite success on a magnificent scale, send for it.

MASTER-KEY INSTITUTE

214 Howard Bldg.,

ST. LOUIS, MO.

BE AN ARTIST

WE CAN TEACH
YOU DRAWING in
your own home during your
spare time. Twenty-five years of
successful teaching proves our ability.
Artists receive large salaries.

Write Today for Art Year Book

SCHOOL OF APPLIED ART
ROOM NO. 2, BATTLE CREEK MICH.



LEARN WATCH REPAIRING



You can learn by our modern and original system of instruction every part of the Watch Repairing Trade at home as good or better than at a shop. You can earn money while learning and secure a well paying position or start in business after completing our course of instruction. Good watch repairers are always in demand and earn from \$30 to \$70 per week. For particulars apply to the Wisconsin School of Watch Repairing
166 Mason St., MILWAUKEE, WIS.

"STAMMERING

Its Cause and Cure"

You can be quickly cured if you stammer. Send 10 cents, coin or stamps, for 288 page cloth bound book on Stammering and Stuttering. It tells how I cured myself after Stammering and Stuttering for 20 years. BENJAMIN N. BOGUE
6916 Bogue Building, 1147 N. Ill. St. Indianapolis

30 Days' Free Trial

Select from 44 Styles, colors and sizes, famous Ranger bicycles. Delivered free on approval, express prepaid, at Factory Prices. You can easily save \$10 to \$25 on your bicycle. Prices \$21.50 and up. \$5 a Month on any Ranger if desired. Parents often advance first deposit. Boys and girls can easily earn small monthly payments. Pay as you ride.

Best quality, at factory prices, express prepaid. Tires, lamps, wheels and equipment, low prices. Send No Money, do business direct with us.

MEAD CYCLE COMPANY
DEPT. 106 CHICAGO

Write today for free Ranger Catalog, factory prices and marvelous easy payment terms.



Choose Your Favorite Musical Instrument



Master any Musical Instruments

Piano	Cello
Organ	Harmony and Composition
Violin	Sight Singing
Drums	Ukulele
and Taps	Guitar
Banjo	Hawaiian
Tenor	Steel Guitar
Banjo	Mandolin
Mandolin	Harp
Clarinet	Corset
Flute	Piccolo
Saxophone	Trombone
Voice and Speech	Culture
Automatic Finger	Control

Learn to Play at Home This Quick Easy Way

Remarkable new short-cut method teaches you how to play any musical instrument. As easy as A, B, C! No tricks—no "stunts"—no monotonous exercises! Yet you learn from regular music!

ALL your life you've wanted to play a musical instrument. And now at last—you can realize your ambition! Just choose your favorite instrument—the piano, the violin, the saxophone, whatever it may be—and then let the U. S. School of Music prove that you can learn to play it in an amazingly short time—*right in your own home—and without any private teacher.*

Amazingly Simple Method

Even if you don't know one note from another—even if you have never touched a musical instrument in your life before—this remarkable *Print-and-Picture* method will enable you to master music with astonishing ease and rapidity.

There are no tricks—no stunts—no long tedious exercises—no dull, monotonous finger practice. Everything is clearly explained and simplified so that you get all the essentials of a through musical education—in short-cut fashion.

Some of our most successful students say that this home course in music is real fun—more fascinating than the most enjoyable game! For you study when you please—and as much as you please—in your spare time. You go fast or slow—it doesn't make a bit of difference because there isn't any expensive private teacher to pay. The cost is the same in every case—a few cents a lesson.

How To Be Popular

If you can play a musical instrument—you will never feel "alone in a crowd." For as you dash off the latest song hit—or play some lovely melody from a well-known classic—you will be the very center of attraction. You will be flooded with

invitations. You will meet influential people. The sooner you start upon this path to popularity—the sooner will you find a brighter and happier life.

FREE BOOKLET EXPLAINS NEW METHOD

Send for our interesting *Free* booklet—it will give you all the details of this remarkable course. Don't hesitate because you think you have no talent. Thousands of our most successful students never dreamed they possessed the slightest musical ability until it was revealed to them by our wonderful "Musical Ability Test." Now many of them earn big incomes in bands, or orchestras, as music teachers, church organists, vaudeville artists, etc. Others use their music solely for personal pleasure and for the entertainment of their friends. But once you see how quickly and easily you can learn to play your favorite musical instrument through this startling easy way—you will not let another day slip by without sending for the course. So send for the *Free Book Now*. Mail the coupon to-day. U. S. School of Music, 712 Brunswick Bldg., New York.

U. S. SCHOOL OF MUSIC,
712 Brunswick Bldg., N. Y. C.

Please send me your free book, "Music Lessons in Your Own Home," illustrated folder and particulars of your special offer. I am interested in the following course:

(Name of Instrument or Course)

Name _____
(Please Write Plainly)

Address _____

City _____ Stat. _____

No More Wallflowers!

You Can Now Learn to Be a Popular
Dancer in One Evening. Here's How:

YOU can have a good time at the next party you go to—don't sit by and envy others. You can learn to dance the latest steps—overnight—without music or partner. Dance every step like a professional—and become absolutely at ease on any ballroom floor. Arthur Murray, instructor to the Vanderbilts, is willing to give you the same high class instruction for almost nothing. 250,000 have already taken advantage of this offer.

It doesn't make any difference whether you know one step from another—even if you never danced before—you can learn in a few hours. Mr. Murray is so positive of this that he is willing to send you five lessons FREE as proof.

Five Lessons FREE Coupon

ARTHUR MURRAY, STUDIO 342
801 Madison Ave., New York City

Send the FIVE FREE LESSONS. I enclose 10c (stamps or coin) to pay for the postage, printing, etc.

Name.....

Address.....

City..... State.....

He will tell you free: (1) The Secret of Leading; (2) How to Follow; (3) How to Gain Confidence; (4) A Fascinating Fox Trot Step; (5) A Lesson in Waltzing. Enclose 10c to cover the cost of printing and postage, and the lessons will be sent to you by return mail. No obligation. Surprise your friends. Write today to

ARTHUR MURRAY
Studio 342
801 Madison Avenue
NEW YORK CITY



LAW STUDY AT HOME

Become a lawyer. Legally trained men win the highest positions and biggest success in business and public life. Be independent. Greater opportunities now than ever before. Big corporations are headed by men with legal training. Earn \$5,000 to \$10,000 Annually.

We guide you step by step. You can train at home during spare time. Degree of LL. B. conferred. LaSalle students practicing law in every state. We furnish all text material, including fourteen-volume Law Library. Low cost, easy terms. Get our valuable 108-page "Law Guide" and "Evidence" books free. Send for them NOW.

LaSalle Extension University, Dept. 1264-L Chicago
The World's Largest Business Training Institution

Music Lessons

WITH ACCREDITED SCHOOL
At Home

Any Instrument Write naming course you are interested in: Violin, Cornet, Mandolin, Guitar, Banjo or Reed Organ—and we will send FREE CATALOG. SEND for it NOW!

Complete Conservatory Course by Mail
Wonderful home study music lessons under great American and European teachers. Endorsed by Paderewski. Master teachers guide and coach you. Lessons a marvel of simplicity and completeness.

University Extension Conservatory, 37 Siegel-Myers Bldg., Chicago

TELEGRAPHY

(Morse and Wireless) and RAILWAY ACCOUNTING taught thoroughly. Big salaries; great opportunity. Oldest, largest school. Endorsed by Telegraph, Railway, Radio, and Government officials. Expenses low—opportunities to earn large portion. Catalog free. DODGE'S INSTITUTE, Jones St., Valparaiso, Ind.

ENCYCLOPEDIA BRITANNICA

in the New Form—at a saving of 46 per cent
Write for full details
THE ENCYCLOPEDIA BRITANNICA, Inc.
342 Madison Ave., New York City

LEARN CARTOONING

Successful cartoonists earn big salaries. Many of the most popular cartoonists of today learned to draw in their spare time, at home, through the Landon Course of Cartooning and now earn \$75 to \$200 a week.



The Landon Picture Chart Method of teaching ORIGINAL drawing makes cartooning easy to learn. Hundreds of sketches like the above explain every step in creating ORIGINAL heads, figures, animals, etc.
Write today for Sample Landon Picture Chart, long list of successful Landon students and full information showing possibilities for you. Please state your age.
The LANDON SCHOOL, 738 National Building, CLEVELAND, OHIO

Four Successful Landon Students From One Village

Here is the record of four boys—all from Nappanee, Ind. (2200 population)—who, after taking the Landon Course, won national reputations:

Merrill Blosser is now nationally famous as creator of "Freckles and His Friends."

Henry Maust's work appears in Saturday Evening Post, Cosmopolitan, etc.

Francis Parks, following their advice, is now a cartoonist for the Omaha News.

Fred Neher is comic artist with the Universal Feature Co.

MECHANICS!

TAKE THIS HELPING HAND TO BETTER PAY

Hundreds of Engineers, Electricians and Machinists write us that this Set, **Audels Engineers & Mechanics Guides**, has been the means of quick advances in grade, position and pay.

Audels

\$1
PER
MO.
FREE
EXAMI-
NATION

Engineers and Mechanics Guides

Guides Tell you all about:

THEORY, PRACTICE and OPERATION of ALL Steam Engines; UNIFLOW and POPPET VALVE ENGINES and LOCOMOBILES, Locomotive-Marine Engines; Turbines; Rotary Engines—the Indicator—Lubrication—PRACTICAL MANAGEMENT. GAS, GAS ENGINES—Aeroplanes and Aetation—HOW TO SELECT AN ENGINE. STEAM ENGINE rules and formulae. Steam Boilers; Heat-Combustion; Fuel and Flue Gas Analysis—CO₂ Recorders—Construction of all types of Boilers—Mechanical Stockers—Oil Burners—Setting—Chimneys—Mechanical Draught—HOW TO SELECT A BOILER—BOILER DESIGN based on A.S.M.E BOILER CODE—OPERATION FIRING. Pipes, Fittings—Heating and Ventilation—Refrigeration—Cooling Towers—Condensers—Distilling Apparatus—Elevators—Cranes—Ropes and Cables—Splicing—Practical Electrical Engineering as an aid for engineers and electricians in obtaining a license—ready reference index, covering entire field of Modern Electricity.

Every Engineer, Mechanic and Electrical Worker will find real help in these books. Daily problems are quickly solved. Short cut methods are explained that save time and labor. Complete, up-to-date information on modern engineering practice is clearly given. Fifteen minutes a day of study will prepare you quickly for a better job and better prospects.

**Pocket Size
Flexible Covers**

**8 Numbers, \$12
FREE EXAMINATION
\$1 a Month
8754 Illustrations
4750 Pages**

"With the help of your Set, I am holding a position of chief engineer, and am under 21."—J. F. Hoffman, Columbia City, Ind.

No obligation to buy unless you are satisfied. Not a cent to pay until you see the books. Use coupon now and start on the way to better pay.

**FREE
Exam-
ination**

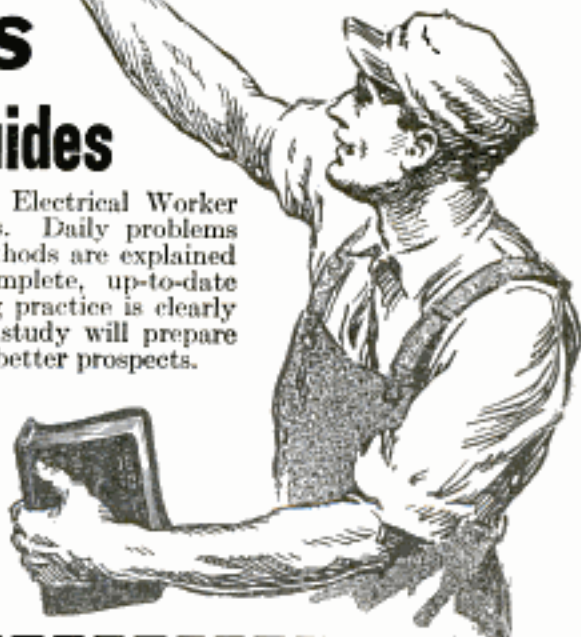

THEO. AUDEL & CO., 72 Fifth Ave., New York

Send me for free examination, AUDELS ENGINEERS AND MECHANICS GUIDES—8 Numbers, \$12. If satisfied, I agree to send \$1 in 5 days, and \$1 a month until paid.

Name.....

Address.....

Occupation.....

Employed by.....

Reference.....

12-T-30

DON'T SLAVE

→ **EARN!**

\$3500 to \$5000 a Year



3 Months' Training

Will Qualify You for Success in the Professional Trade—

MECHANICAL DENTISTRY

Unequaled Opportunity for men who like to use tools. Right now 2,500 more Dental Mechanics are needed and the demand is rapidly increasing. Approximately 56,000 practicing Dentists in the U. S. and only about 4,000 full-fledged Dental Mechanics.

You Learn by Doing

We train each student individually—no classes whatever—using the tools of the trade and you learn on regular dental work. But we do not make the serious mistake of depending on practical work alone. You are given theoretical training as well so that you become familiar with both the theory and practice of Mechanical Dentistry and with the methods and terms used throughout the profession.

Bodee-Trained Men Lead the Field Unequaled Curriculum

For over 30 years Bodee Schools have been the chief source of supply for well-trained Dental Mechanics and the Dental Profession is constantly calling for graduates of this institution. Just ask your own dentist to examine the curriculum with you. Compare also the moderate cost of this course with the charges of other schools.

FREE PARTIAL SCHOLARSHIPS

In order to meet the urgent demand for the men we train, we are offering for a limited time Free Partial Scholarships. Be sure to ask immediately for this exceptional offer: It will very much reduce the cost of your training. Remember, this offer will be discontinued soon—so act NOW while it is still in effect.

SEND FOR CATALOG AND SCHOLARSHIP OFFER

Catalog No. 2 fully describes the field and why the demand. Shows how students "Learn by Doing" actual work through practical, individual instruction, day or evening sessions. Shows how you can "Earn while Learning." This catalog is your First Step to Success in Mechanical Dentistry. IT IS FREE. SEND FOR IT TODAY.

BODEE DENTAL INSTITUTE

136 West 52d Street, NEW YORK

PHILADELPHIA
1305 No. Broad St.

BUFFALO
1226 Main St.

BROOKLYN
85 Court St.

YOU CAN PLAY IT IN 30 MINUTES
40,000 successful students back up our guarantee that you can play a piece in 30 minutes by following our printed instructions. You get this \$18.00 TENOR BANJO, FREE, as soon as you enroll for 52-easy lessons. New low prices and easy terms!

PICTURE LESSONS MAKE IT EASY
You can't fail to learn because the pictures explain every move. You don't have to be able to read notes. Better than oral instructions. We teach you in the largest conservatory, by mail.

PLAY FOR FUN OR MONEY
Don't be a wallflower. Get in on parties. Entertain your friends. Be popular. Play for dances, etc. Form an orchestra. Our 52 lesson course will make you an expert. Earn money in spare time.

WRITE FOR SPECIAL FREE OFFER
Famous teachers will explain how we can positively teach you to play. You get the free \$18.00 Tenor Banjo with the first lesson. Pay while you play. Write for other special courses under famous teachers for Hawaiian Guitar, Violin, Banjo Ukelele, Ukelele.

FIRST HAWAIIAN CONSERVATORY OF MUSIC, Inc.
Woolworth Bldg., Dept. 60, New York, N. Y.

ELECTRICAL ENGINEERING

Course for men of ambition and limited time. Over 4000 men trained. Condensed course in Theoretical and Practical Electrical including the closely related subjects of Mathematics and Mechanical Drawing taught by experts. Students construct motors, install wiring, test electrical machinery. Course complete.

IN ONE YEAR

Established in 1893. Prepare for your profession in the most interesting city in the world. Free catalog.

BLISS ELECTRICAL SCHOOL
104 Takoma Ave. WASHINGTON, D. C.

Anyone CAN LEARN

No talent or experience necessary. Fascinating work. Pays big money. Complete instruction book tells about Alphabets, Colours, How to Make Points, Show Cards, Window Board and Wall Signs, Ready made letters, Gilding, Tricks of the Trade, also gives 100 Alphabets and Designs. Book bound in flexible imp. leather, gold edges, and four full bearing Show Cards. Post. Sent postpaid \$3.00, C. O. D. 10c ex. Globe Pub. Co., 57 Ross St. Dept. 50, N. Y. City

EARN MONEY IMMEDIATELY—
WE FURNISH EQUIPMENT TO START!!

LEARN ACCOUNTING

Bryant & Stratton NEW Training System fits you to earn BIG money. Learn in your own home. Short course for everybody. New method TELLS HOW and SHOWS HOW. Full credit given in our Chicago school for all work under OUR NEW TRAINING SYSTEM.

WRITE TODAY!
BRYANT & STRATTON BUSINESS COLLEGE
116 S. Michigan Ave. Dept. 5 Chicago, Ill.

Joy-STOMACH for SUFFERERS

I positively guarantee Macerated Wheat to relieve the worst cases of stomach trouble and banish constipation or it costs you nothing. Soothing to a weak stomach as a poultice to inflammation. Stays down and nourishes. Testimonials without number. My reputation of 25 years backs my guarantee. Write for proof.

BYRON TYLER 172 Gibraltar Bldg. KANSAS CITY, MO.



\$1000 REWARD For the Capture of This Man

CONVICT 6138, escaped from the State Penitentiary; Name, Charles Condray; Age, 37; Height, 5 ft. 8 in. Weight, 141 pounds; Hair, light brown; Eyes, gray.

Easy enough to identify him from his photograph and this description, you may say — but, Condray took the name of "Brown", dyed his hair, darkened his skin, grew a mustache, put on weight and walked with a stoop. Yet, he was captured and identified so positively that he knew the game was up, and returned to the penitentiary without extradition.

How was it accomplished? Easy enough for the Finger Print Expert. They are the specialists, the leaders, the *cream* of detectives. Every day's paper tells their wonderful exploits in solving mysterious crimes and convicting dangerous criminals.

More Trained Men Needed

The demand for trained men by governments, states, cities, detective agencies, corporations, and private bureaus is becoming greater every day. Here is a real opportunity for YOU. Can you imagine a more fascinating line of work than this? Often life and death depend upon finger print evidence—and big rewards go to the expert. Many experts earn regularly from \$3,000 to \$10,000 per year.

Learn at Home in Spare Time

And now you can learn the secrets of this science at home in your spare time. Any man with common school education and average ability can become a

Finger Print Expert in surprisingly short time.

Free Course in Secret Service

For a limited time we are making a special offer of a *Professional Finger Print Outfit, absolutely Free, and Free Course in Secret Service Intelligence.* Mastery of these two kindred professions will open a brilliant career for you.

Write quickly for fully illustrated free book on Finger Prints which explains this wonderful training in detail. Don't wait until this offer has expired—mail the coupon now. You may never see this announcement again! You assume no obligation — you have everything to gain and nothing to lose. Write at once — address

University of Applied Science

Dept. 13-59 1920 Sunnyside Ave. Chicago, Illinois

UNIVERSITY OF APPLIED SCIENCE

Dept. 13-59, 1920 Sunnyside Avenue, Chicago, Illinois

Gentlemen:—Without any obligation whatever, send me your new, fully illustrated, FREE book on Finger Prints and your offer of a FREE course in Secret Service Intelligence and the Free Professional Finger Print Outfit.

Name.....

Address.....

Age.....



Men Needed in Electricity

NO PROFESSION offers greater opportunity to-day than Electricity. Salaries of \$12 to \$30 a day are not uncommon and the opportunity for advancement is unlimited.

As Forrest Crissey said recently in *The Saturday Evening Post*—"The demand for electrical work is increasing immensely and electrical contractors assert that the supply of electrical workers cannot overtake the demand for several years."

Now is the time to prepare for a good position in this profitable, interesting profession. You can study right at home in spare time through the International Correspondence Schools—just as so many other men have done. The I. C. S. Electrical Courses have been endorsed by Thomas A. Edison and Charles P. Steinmetz—the late electrical wizard of the General Electric Co.

Just mark and mail the coupon printed below and full information about Electrical Engineering, Electric Lighting, Electric Wiring, Electric Railways, Radio or any other work of your choice will come to you by return mail.

Mail the Coupon To-day

INTERNATIONAL CORRESPONDENCE SCHOOLS BOX 5658-D SCRANTON, PA.

TEAR OUT HERE
Explain, without obligating me, how I can qualify for the position, or in the subject, before which I mark X.

<input type="checkbox"/> ELECTRICAL ENGINEER	<input type="checkbox"/> CHEMICAL ENGINEER
<input type="checkbox"/> Electrician	<input type="checkbox"/> Pharmacy
<input type="checkbox"/> Electric Wiring	<input type="checkbox"/> SALESMANSHIP
<input type="checkbox"/> Electric Lighting	<input type="checkbox"/> Show Card and Sign Painting
<input type="checkbox"/> Electric Car Running	<input type="checkbox"/> RAILROAD POSITIONS
<input type="checkbox"/> Heavy Electric Traction	<input type="checkbox"/> ILLUSTRATOR
<input type="checkbox"/> Electrical Draftsman	<input type="checkbox"/> DESIGNER
<input type="checkbox"/> Electric Machine Designer	<input type="checkbox"/> BUSINESS MANAGEMENT
<input type="checkbox"/> Telegraph Expert	<input type="checkbox"/> Private Secretary
<input type="checkbox"/> Practical Telephony	<input type="checkbox"/> Business Correspondent
<input type="checkbox"/> MECHANICAL ENGINEER	<input type="checkbox"/> BOOKKEEPER
<input type="checkbox"/> Mechanical Draftsman	<input type="checkbox"/> Stenographer and Typist
<input type="checkbox"/> Toolmaker	<input type="checkbox"/> Cert. Public Accountant
<input type="checkbox"/> Machine Shop Practice	<input type="checkbox"/> Traffic Management
<input type="checkbox"/> Gas Engineer	<input type="checkbox"/> Commercial Law
<input type="checkbox"/> CIVIL ENGINEER	<input type="checkbox"/> GOOD ENGLISH
<input type="checkbox"/> Surveying and Mapping	<input type="checkbox"/> Common School Subjects
<input type="checkbox"/> Reading Architects' Blue Prints	<input type="checkbox"/> CIVIL SERVICE
<input type="checkbox"/> METALLURGY	<input type="checkbox"/> Railway Mail Clerk
<input type="checkbox"/> ARCHITECT	<input type="checkbox"/> STATIONARY ENGINEER
<input type="checkbox"/> Architectural Draftsman	<input type="checkbox"/> Textile Overseer or Supt.
<input type="checkbox"/> PLUMBING AND HEATING	<input type="checkbox"/> AGRICULTURE <input type="checkbox"/> Spanish
<input type="checkbox"/> Sheet Metal Worker	<input type="checkbox"/> Navigator <input type="checkbox"/> Math's 's
<input type="checkbox"/> Automobiles	<input type="checkbox"/> Poultry Raising <input type="checkbox"/> RADIO

Name _____

Present Occupation _____ Business Address _____ 3-6-24

Street and No. _____

City _____ State _____

Canadians may send this coupon to International Correspondence Schools Canadian, Limited, Montreal, Canada

Drawing Easily Learned



Haven't you often wished that you could draw cartoons, illustrate some idea, sketch some pretty face, etc.? You can do all of these things. One of America's most famous Cartoonists and Illustrators has developed a great, simple system for success in all branches of Commercial Art. This system has revolutionized the entire theory of drawing. It means that drawing can be as easy for you as writing—much simpler than learning shorthand, bookkeeping or typewriting. We are now placing this original system for learning Drawing, Art and Cartooning, consisting of 34 lessons with over 500 illustrations, within reach of every one. If you will devote a few hours each week to the Course, WE ABSOLUTELY GUARANTEE that you will learn to draw and draw well before you have half finished the Course. If we fail to make this claim good, we will refund every cent paid us. By eliminating a large office force for answering correspondence, expensive catalogs, etc., we are enabled to make a price of \$2.98, the cheapest price ever known for a high-grade home study course. Many have sent us letters similar to that of Robert P. Davis, of Detroit, who wrote: "I can't see how you ask so little, when others with inferior Courses get from \$30 to \$60 for theirs. It is more than I expected."

Learn to draw. It is a big asset, no matter what field you are in.

Send No Money

Just order the Course, and on arrival pay the postman only \$2.98 plus a few cents postage, payment in full for the entire Course and Free Drawing Outfit. If not entirely satisfied, return within five days and we will REFUND MONEY. Address

FREE If you order the Course at once, we will include a drawing outfit, consisting of artist's pencils, pens, paper, erasers, thumb tacks, etc., enabling you to go to work without any additional cost.

Lederer School of Drawing, Dept. 368-C, Chattanooga, Tennessee
Orders from outside the U. S. are payable \$3.24 cash with order.

LEARN WATCHMAKING AND ENGRAVING



ALSO JEWELRY REPAIRING BY OUR PROFIT-SHARING PLAN

OUR GRADUATES SUCCEED

One of our best students started in a very small way—now doing over \$25,000 a year. Another in Wisconsin, over \$18,000 the first year. Day or night classes. Write for FREE BOOK.

CHICAGO SCHOOL OF WATCHMAKING Dept. 29 4844 Lincoln Ave., CHICAGO

Can you afford to

STAMMER?

OR STUTTER?

It ruins many chances for promotion. Send postage for large free book "The Correction of Stammering and Stuttering." Methods successful for over a quarter-century. THE LEWIS INSTITUTE, 33 Lewis Bldg., 155 Stinson Av., Detroit, Mich., U.S.A.

A FILE



Stop Forgetting

Make Your Mind an index from which you select facts, figures, names, faces. Develop concentration, self-control; overcome bashfulness, forgetfulness.

Write today for FREE memory and concentration test and illustrated booklet, "How to Remember."

PROF. HENRY DICKSON
Dept. 70512 Evanston, Ill.

NOT A FILE



PIMPLY SKIN made WELL

When a few applications of this wonder-working lotion has cleared faces of pimples, **FREE blackheads, acne eruptions on the face or body, barbers itch, eczema, enlarged pores, oily or shiny skin**, you can realize why CLEAR-TONE has been tested and approved in over 100,000 Test Cases. The simplicity of the treatment, and *The Story of How I Cured Myself* are all explained in my free booklet, "A Clear-Tone Skin." Write for your copy today and learn of the results gotten by thousands of men and women.

E. S. GIVENS, 128 Chemical Bldg., Kansas City, Mo.

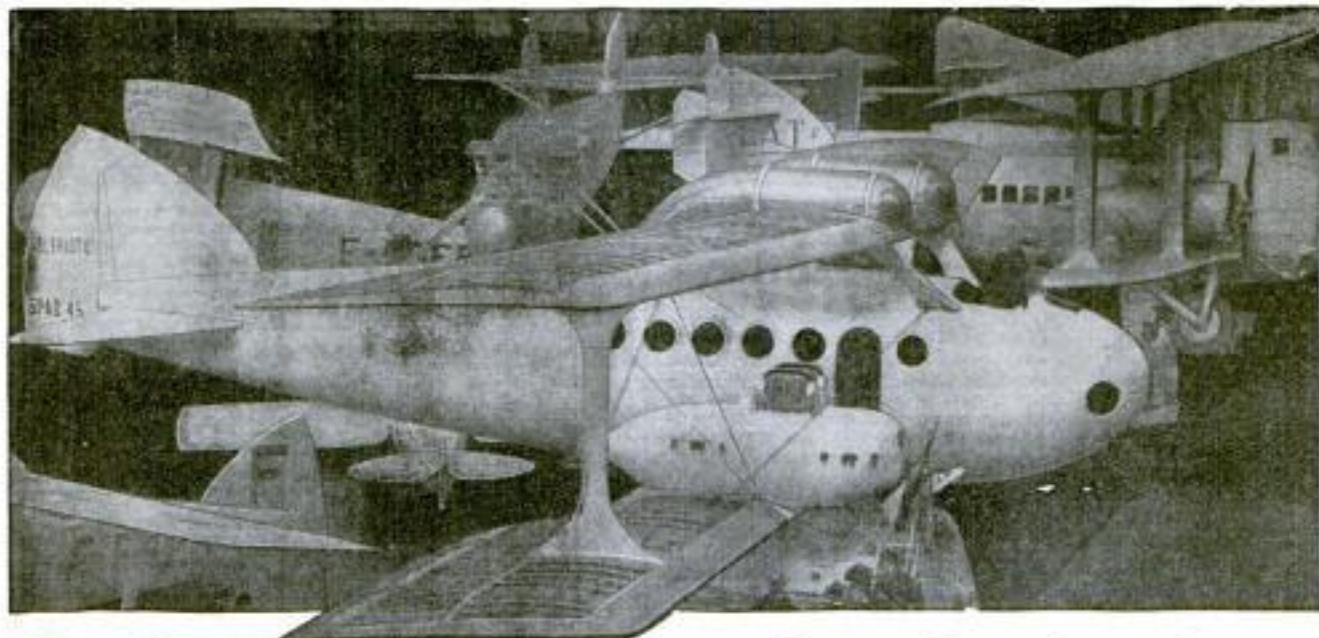

Quick Success in Aviation Fascinating—Daring—Big Paying

To young men of daring, no other field of work will offer such a fascination, such high pay, nor such opportunities for quick success as the field of Aviation. As yet, aviation is practically in its infancy. NOW is the time to get in.

Amazing Opportunities in Airplane Industries

In the automobile industry and in the moving picture business hundreds of men got rich by getting in at the start. They made their success before others woke up. Today, these lines offer no greater opportunities than a hundred and one others. BUT AVIATION IS NEW. Get in while the opportunity is big. All over the country there will be a clamor for trained men. It will not be a question of pay, but of getting capable men.

**Here are Real Positions
—\$50 to \$150 Per Week**

Aeronautical Instructor, Aeronautical Engineer, Aeronautical Contractor, Airplane Repairman, Airplane Mechanician, Airplane Inspector, Airplane Salesman, Airplane Assembler, Airplane Builder



View in an Airplane Factory

A Sure and Easy Way to Learn Aviation—at Home



A New Job—The Aerial Postman

The study of aviation is almost as fascinating as the actual work. Every lesson is full of interest. That is why it is easy to learn aviation. You do not have to make yourself study—it is like reading an in-

teresting book that tells you things you have always wanted to know. Only one hour each evening will give you the basic training in a surprisingly short time. You need only a common school education.

One of my students, James Powers, Pa., says, "I am indeed surprised that such a valuable Course can be had from such practical men for so little cost."



A New Seven-Passenger Airplane

Personal Instruction by Experienced Men

Men who have had actual experience give you personal attention. They select the lessons, lectures, blueprints and bulletins. They tell you things that are essential in everyday practice. Each lesson is easy to read and understand.

BIG BOOK FREE
of Opportunities

Send coupon below for New Book, just out, "Opportunities in the Airplane Industry." It is interesting and instructive. It will show you many things you never knew before about aviation. Due to shortage of paper we could get only a limited supply of these books—send the coupon before they are all gone.

AMERICAN SCHOOL OF AVIATION
3601 Michigan Avenue, Dept. 13-59, Chicago, Ill.

AMERICAN SCHOOL OF AVIATION
3601 Michigan Ave., Dept. 13-59, Chicago, Ill.

Without any obligation, send me your Free Book, "Opportunities in the Airplane Industry," also information about your Course in Practical Aeronautics.

Name

Street

City.....State.....

EARN UP TO \$250 per mo. POSITION GUARANTEED

BE A RAILWAY TRAFFIC INSPECTOR



Hundreds of successful inspectors earn good money, in highly confidential positions, with many opportunities for advancement. Many more are needed; railroads (steam and electric) are constantly looking to us for trained men!

Fascinating Work

W. A. Judson states: "I find Traffic Inspection the best chance to travel and see the country. There are no end of chances for advancement."

Another graduate, J. A. Smallick, says: "I do not think a quicker or greater return can be found for money invested."

This wonderful new profession is open to any man of average intelligence. The work is interesting, ever-changing, healthful, out-doors, with chances to travel or remain near home.

Unlimited Opportunities

A. A. Quintana, another graduate, says: "I have been working in my present position for over a year and the manager is well satisfied with my work and I have already received an advancement in salary."

J. W. Mensinger states: "My work must be satisfactory as my wages have been increased. There are great opportunities for first-class inspectors and my advice to anyone wishing such a position is that he will make no mistake in securing a training in your school."



A. A. Quintana



J. W. Mensinger

Start at \$110 per Mo. EXPENSES PAID

POSITION GUARANTEED

Prepare at home in spare time. After completing course in three months (average time) we secure you a position paying at least \$110 a month or refund all you have paid.

There are hundreds of openings. You take no risk! The training is easily mastered; the cost is moderate; terms if desired.

Mail coupon for free Booklet No. D-63, giving full information.

Standard Business Training Inst., BUFFALO, N. Y.



MAIL TODAY

Standard Business Training Inst., Buffalo, N. Y.

Send me, entirely free, Booklet No. D-63 giving full particulars about course in Railway Traffic Inspection.

Name.....

Street.....

City.....

Learn to Write

I Teach by Mail

I can make a good penman of you at your home during spare time. No matter where you live or how poorly you now write. My simplified system can show thousands the way to good penmanship during the next twenty-five years — it CAN and WILL do the same for YOU.

My beautifully illustrated 32-page Book "How to Become a Good Penman" FREE!!

It contains many beautiful specimens of penmanship showing what others have accomplished by the Tamblin System, with testimonials and general information about our courses. (Your name elegantly written on a card if you enclose stamp for postage.) Ladies taught as successfully as men. Write Today. Address

F. W. TAMBLIN
418 Ridge Blvd. Kansas City, Mo., U. S. A.



21 Jewels

Nothing less than 21 Ruby and Sapphire Jewels is good enough for the Burlington masterpiece.

Quality and Style

Adjusted to the second temperature—each jewel—position. 25 year Gold Strata Case, in 100 exquisite designs. Only \$1 down. Balance in small monthly payments. Send for free book.

Burlington Company Watch
18th Street and Marshall Boulevard
Dept. 93-59 Chicago, Illinois



DRAW FACES

Make folks smile while you make big money for yourself. Our Cartooning and Commercial Art Course enables you to EARN AS YOU LEARN. Individual criticisms by a nationally known cartoonist given on each lesson. Write today for outline of course and our special plan for enabling you to earn as you learn.

THE OHIO SCHOOL OF COMMERCIAL ART
1719 Euclid Ave. Cleveland, Ohio



MEN WANTED

Prepare as **Firemen, Brakemen, Electric Motormen, and colored Train Porters.** Hundreds put to work—good wages to start on. No experience necessary. 500 more wanted. Name position you want.

RAILWAY INSTITUTE, Dept. 40, INDIANAPOLIS, IND.

Comedies, Dramas, Musical Comedies and Revues, Minstrel Choruses, Songs, Blackface plays, Everything for Burnt Cork Shows and All Amateur Entertainments. Monologs, Dialogs, Speakers. **CATALOGUE FREE.**

PLAYS Vaudeville Acts
How to Stage a Play
Make-up Goods

T. S. DENISON & CO., 623 So. Wabash, Dept. 9, CHICAGO

BE A JAZZ MUSIC MASTER

PLAY PIANO BY EAR

Play popular song hits perfectly. Hum the tune, play it by ear. Self-instruction—no teacher required. No tedious dig-dog daily practice—just twenty brief, entertaining lessons which you master.

At Home in Your Spare Time
Send for FREE BOOK. Learn many styles of bass and arpeggiation—trick endings. 6c stamp brings interesting CHART also.

NIAGARA SCHOOL OF MUSIC
Dept. 722, Niagara Falls, N. Y.

Send for this Free Book



BARBERING

Now One of the
Highest Paid
Professions!

**\$90 to \$150
Every Week!**



William McClintock, President Master Barbers' Ass'n of Chicago and proprietor of the highest priced rented shop in the world, says, "My son, who learned at Moler's, is top man in my shop every week. I gladly recommend the Moler System as the proper place for men to become successful barbers."
—WM. McCLINTOCK.

**BE A "WHITE-COLLAR" MAN—
Earn \$90-\$150 a Week—CLEAN Money!**

What's the use of doing dirty, greasy, hard work, when you can NOW make TWICE as much money in a manly profession that is CLEAN, profitable and full of opportunities?

**Easy to Learn—
Quick to Earn!**

That's BARBERING for YOU! And the best part of it all is this—scientific barbering, as taught the modern MOLER way, makes YOU a Master Barber in a short course of intensive training, at small expense! You soon step out as your own Boss, if you wish, in your own Shop, which we will gladly help you equip.

See the World, Too!

Or, if you prefer, we will help you step into a real job, with good pay the first day, after you graduate. Ocean Liners, crack trans-continental passenger trains, big luxurious hotels and skyscrapers all over the world, as well as thousands of Barber Shops everywhere, demand MOLER trained men.

**MOLER Graduates
Are Always Busy!**

MOLER trained Men are always given the preference, for they alone possess the valuable, thor-

ough MOLER training in the application of all the latest scientific Barbering methods including the Electric hair cutter, the mechanical massage, and the latest vogue in ladies' hair bobbing. MOLER also gives special training in ladies' marcelling and an easy practical course in the treatment of skin diseases.

**Earn While
Learning!**

"Where there's a Will there's a Way" to earn BIG pay! Write to the nearest MOLER College, there is one near you, and learn how you can earn while you learn the barber trade. Ask for the new FREE MOLER Barbering Booklet B. Find out HOW MOLER helps you help yourself AFTER you graduate, as well as BEFORE! Find out why MOLER Men are making DOUBLE the money others made last year, before Ladies' Shingle Bobbing became so popular. You're NEXT in line for big pay—the MOLER way. Send Coupon TODAY!

MOLER SYSTEM OF COLLEGES

30 Branches in United States and Canada

New York, N. Y.
Chicago, Ill.
St. Louis, Mo.
Kansas City, Mo.
Cincinnati, Ohio.
Cleveland, Ohio.
Detroit, Mich.

Denver, Colo.
Omaha, Nebr.
Milwaukee, Wis.
New Orleans, La.
Atlanta, Ga.
Memphis, Tenn.

Dallas, Tex.
Houston, Tex.
San Antonio, Tex.
Seattle, Wash.
Tacoma, Wash.
Spokane, Wash.



"The XXth Century," "Oriental Limited" and other crack trans-continental trains carry barbers.



The Majestic, Leontan and U. S. Shipping Lines all carry barbers.

**NEXT!
For BIG Pay**

Mail THIS

MOLER SYSTEM OF COLLEGES

← Address Nearest Branch
(Street Address NOT Needed)

Please send me without obligation on my part your Booklet B.

Name.....
Address.....
City.....State.....



High School Course in Two Years!

You Want to Earn Big Money!

And you will not be satisfied unless you earn steady promotion. But are you prepared for the job ahead of you? Do you measure up to the standard that insures success? For a more responsible position a fairly good education is necessary. To write a sensible business letter, to prepare estimates, to figure cost and to compute interest, you must have a certain amount of preparation. All this you must be able to do before you will earn promotion.

Many business houses hire no men whose general knowledge is not equal to a high school course. Why? Because big business refuses to burden itself with men who are barred from promotion by the lack of elementary education.

Can You Qualify for a Better Position

We have a plan whereby you can. We can give you a complete but simplified high school course in two years, giving you all the essentials that form the foundation of practical business. It will prepare you to hold your own where competition is keen and exacting. Do not doubt your ability, but make up your mind to it and you will soon have the requirements that will bring you success and big money. **YOU CAN DO IT.**

Let us show you how to get on the road to success. It will not cost you a single working hour. Write today. It costs you nothing but a stamp.

American School

Dept. H974, Drexel Ave. and 58th St., Chicago

American School

Dept. H974, Drexel Ave. and 58th St., Chicago
Send me full information on the subject checked and how you will help me win success.

- | | |
|-----------------------------|---------------------------|
|Architect |Lawyer |
|Building Contractor |Machine Shop Practice |
|Automobile Engineer |Photoplay Writer |
|Automobile Repairman |Mechanical Engineer |
|Civil Engineer |Shop Superintendent |
|Structural Engineer |Employment Manager |
|Business Manager |Steam Engineer |
|Cert. Public Accountant |Foremanship |
|Accountant and Auditor |Sanitary Engineer |
|Bookkeeper |Surveyor (& Mapping) |
|Draftsman and Designer |Telephone Engineer |
|Electrical Engineer |Telegraph Engineer |
|Electric Light & Power |High School Graduate |
|General Education |Fire Insurance Expert |
|Vocational Guidance |Wireless Radio |
|Business Law |Undecided |

Name

Address

We Teach COMMERCIAL ART

Meyer Both Company, the largest Commercial Art Organization in the World offers you a practical training based upon twenty-five years of success. This nationally known organization each year produces and sells to advertisers over 15,000 commercial drawings. This well paid profession equally open to men and women. Home study instruction.

Get Facts Before You Enroll in Any School

Ask the Advertising Manager of the leading newspapers in your city about Meyer Both Company—let them tell you about us. Send four cents in stamps for illustrated book telling of the success of our students.

MEYER BOTH COMPANY Department of Art Instruction

CHICAGO, ILLS.

Michigan Ave. at 20th St. Dept. 16

Note—To Art and Engraving Firms: Secure artists among our graduates. Write us.

LEARN WATCHMAKING

and become independent. Good-paying positions secured. Easy to learn. Send for FREE CATALOG.

ST. LOUIS WATCHMAKING SCHOOL, Dept. 5, ST. LOUIS, MO.

STUDY AT HOME

Directed by

The University of Chicago

Courses in English, History, Chemistry, Business, Education, Mathematics, Psychology, and 35 other subjects command credit toward a Bachelor degree. Begin any time. Address 15 Ellis Hall, University of Chicago, Ill.

STAMMER

If you stammer attend no Institute till you get my large FREE book entitled "STAMMERING, Its Origin and The Advanced Natural Method of Treatment." Ask for special tuition rate and a FREE copy of "The Natural Speech Magazine," published monthly in the interest of those afflicted with stammering, stuttering and other speech impediments. Largest, best equipped and most successful school in the world for the cure of stammering. Established 20 years. No sing-song or time-beat. Write today. Millard Institute of Normal Speech, 2317 Millard Bldg., Milwaukee, Wis.

MUSIC LESSONS FREE

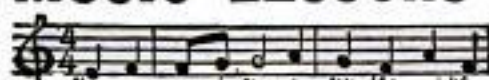
 IN YOUR OWN HOME
You can read music like this quickly

Piano, Organ, Violin, Mandolin, Guitar, Banjo, etc. Beginners or advanced players. One lesson weekly. Illustrations make everything plain. Only expense about 20¢ per day to cover cost of postage and music used. Write for FREE booklet which explains everything in full.

AMERICAN SCHOOL OF MUSIC, 51 Lakeside Building, CHICAGO

Wanted Men and Women to Learn Photography!

Photographers and Photo-Engravers earn \$200 to \$500 a month. The field is uncrowded. Learn these profitable and fascinating professions. Taught by largest and best college of its kind in the world. Established over 30 years. Demand for our graduates far exceeds supply. Good positions secured. Tuition and living expenses low.

Get this FREE Book! Write today for free book describing wonderful opportunities in this field.

Illinois College of Photography, Box 4124, Effingham, Ill.

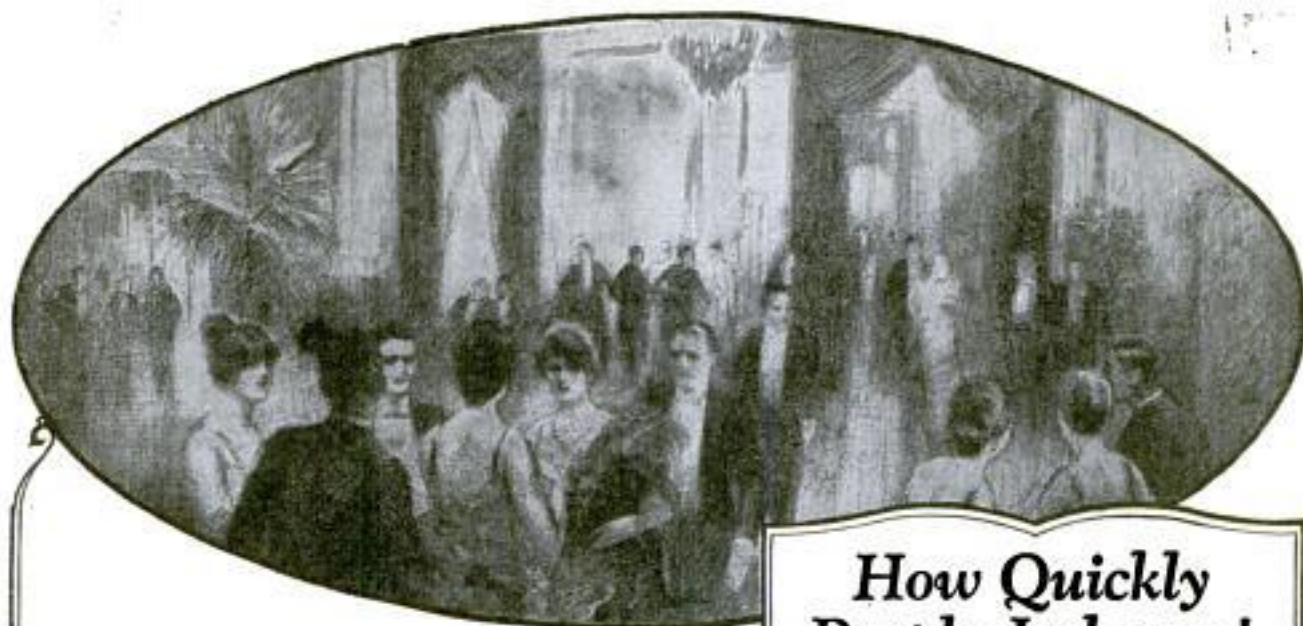

"The Supreme Authority"

WEBSTER'S NEW INTERNATIONAL DICTIONARY

The Merriam Webster

Wherever the importance of correct, forceful English is appreciated, there you will find this standard authority—in office, home, and study. A complete reference library in dictionary form is this one big volume, equivalent in type matter to a 15-volume encyclopedia.

Thousands of the new words people are using are here among the 407,000 vocabulary terms. The biographical section gives you information about 12,000 famous men and women. There are 32,000 geographical entries. Over 6,000 fine illustrations. Surely it is a work you must have—and now is the time to get it for you may secure with it the

1924 Atlas — Free

This splendid Reference Atlas of the World is offered without charge to those who order now. It contains 146 pages—96 pages of colored maps with all recent changes in the countries of the world, new census figures, parcel-post guide, etc. This free Atlas and the great Merriam Webster will be

Delivered for \$1.00

on approved orders and you may remit for the dictionary in easy monthly payments thereafter. Send the coupon to-day and get the booklet "The Magic of Words", free, and full information about our present special offer.



G. & C. MERRIAM COMPANY
Dept. S., Springfield, Mass.

How Quickly People Judge us!

Before we have spoken a dozen words in social conversation, the men and women whose respect we prize have passed judgment upon us. Accuracy and power of expression win their admiration; errors and uncertainty lose it. The same standard is accepted in the world of business and the professions. Our use of English determines our success. That is why intelligent men and women draw constantly on the highest authority of English expression—WEBSTER'S NEW INTERNATIONAL DICTIONARY.

**Read this Interesting Booklet
It is Yours on Request**

"The Magic of Words"

There is magic in words rightly used and this booklet tells, with many interesting illustrations, a story about what words can accomplish. It gives you also information you will be glad to have about The Merriam Webster.

**The Coupon Brings
Your Copy Free**



G. & C. Merriam Company,
Dept. S., Springfield, Mass.

Please send me, without cost or obligation, the illustrated booklet "The Magic of Words" and full information about Webster's New International Dictionary and your special Free Atlas offer.

Pop. Mech. 12-21

Name _____

Street _____

City and State _____



\$95 an Hour!

"Every hour I spent on my I. C. S. Course has been worth \$95 to me! My position, my \$5,000 a year income, my home, my family's happiness—I owe it all to my spare-time training with the International Correspondence Schools!"

Every mail brings letters from some of the thousands of I. C. S. students telling of promotions or increases in salary as the rewards of spare-time study.

What are you doing with the hours after supper? Can you afford to let them slip by unimproved when you can easily make them mean so much? One hour a day spent with the I. C. S. will prepare you for the position you want in the work you like best. Yes, it will! Put it up to us to prove it. Mark and mail this coupon now!

INTERNATIONAL CORRESPONDENCE SCHOOLS Box 5660-D, Scranton, Penna.

Without cost or obligation, please tell me how I can qualify for the position or in the subject before which I have marked an X:

BUSINESS TRAINING COURSES

- | | |
|--|---|
| <input type="checkbox"/> Business Management | <input type="checkbox"/> Salesmanship |
| <input type="checkbox"/> Industrial Management | <input type="checkbox"/> Advertising |
| <input type="checkbox"/> Personnel Organization | <input type="checkbox"/> Better Letters |
| <input type="checkbox"/> Traffic Management | <input type="checkbox"/> Show Card Lettering |
| <input type="checkbox"/> Business Law | <input type="checkbox"/> Stenography and Typing |
| <input type="checkbox"/> Banking and Banking Law | <input type="checkbox"/> Business English |
| <input type="checkbox"/> Accountancy (Including C.P.A.) | <input type="checkbox"/> Civil Service |
| <input type="checkbox"/> Narcissism Cost Accounting | <input type="checkbox"/> Railway Mail Clerk |
| <input type="checkbox"/> Bookkeeping | <input type="checkbox"/> Common School Subjects |
| <input type="checkbox"/> Private Secretary | <input type="checkbox"/> High School Subjects |
| <input type="checkbox"/> Spanish <input type="checkbox"/> French | <input type="checkbox"/> Illustrating <input type="checkbox"/> Cartooning |

TECHNICAL AND INDUSTRIAL COURSES

- | | |
|---|--|
| <input type="checkbox"/> Electrical Engineering | <input type="checkbox"/> Architect |
| <input type="checkbox"/> Electric Lighting | <input type="checkbox"/> Architects' Blue Prints |
| <input type="checkbox"/> Mechanical Engineer | <input type="checkbox"/> Contractor and Builder |
| <input type="checkbox"/> Mechanical Draftsman | <input type="checkbox"/> Architectural Draftsman |
| <input type="checkbox"/> Machine Shop Practice | <input type="checkbox"/> Concrete Builder |
| <input type="checkbox"/> Railroad Positions | <input type="checkbox"/> Structural Engineer |
| <input type="checkbox"/> Gas Engine Operating | <input type="checkbox"/> Chemistry <input type="checkbox"/> Pharmacy |
| <input type="checkbox"/> Civil Engineer | <input type="checkbox"/> Automobile Work |
| <input type="checkbox"/> Surveying and Mapping | <input type="checkbox"/> Airplane Engines |
| <input type="checkbox"/> Metallurgy | <input type="checkbox"/> Navigation |
| <input type="checkbox"/> Steam Engineering | <input type="checkbox"/> Agriculture and Poultry |
| <input type="checkbox"/> Radio | <input type="checkbox"/> Mathematics |

Name.....
Street.....
Address..... 3-6-24

City..... State.....

Occupation.....

Persons residing in Canada should send this coupon to the International Correspondence Schools Canadian, Limited, Montreal, Canada.

Do You Make Mistakes in English?

Every time you speak or write you show just what you are. Mistakes in English reveal you as a person who lacks education and refinement. Lack of language power prevents you from presenting your thoughts in the strongest possible way. No matter what you do, real command of English will help you to your goal. Stop making mistakes in spelling, punctuation, pronunciation, increase your vocabulary.

WONDERFUL INVENTION

Only 15 minutes a day with Sherwin Cody's new invention—and you can actually SEE your English improve. It teaches by HABIT—makes it easier to do the RIGHT way. Wonderful self-correcting lessons include Spelling, Punctuation, Grammar, and Expression.

FREE BOOK ON ENGLISH AND 15 MINUTE TEST Lack of language power may easily be costing you thousands of dollars every year. See what Mr. Cody can do for you. It costs nothing to find out. Mail a postal card or letter this very minute for free book "How to Speak and Write Masterly English," and 15 Minute Test, which you can take in your own home. It will prove a revelation to you. WRITE NOW. Address

Sherwin Cody School of English, 512 Searle Building, Rochester, N. Y.

LEARN WATCH REPAIRING

Be a watchmaker—you can learn this profitable trade by correspondence in a few weeks in your own home by the DeSelms Chart System. After you complete the course you will know a watch from A to Z. You will know just what the matter is and how to repair one. When you graduate you will be a practical watchmaker and repairer and competent in all your positions. Positions for our graduates. Ask for our Free Book. It explains our system and terms.

THE DeSELMS WATCH SCHOOL
23 Perry Street ATTICA, INDIANA



Learn Expert Auto Painting



There is Big Money in auto painting and refinishing. Our Home Study Course in Practical Auto Painting will enable you to do the finest work and earn big money, or come here for training under our experts. Wonderful opportunity.

FREE circular tells all about this big new business. Be first. Write quick.

CHICAGO COLLEGE OF AUTO PAINTING
Dept. 124, 140 S. Dearborn St., CHICAGO, U.S.A.

FREE Finger Print Outfit

Everything you need to gain practical experience in finger print work while you are training to become a great Finger Print Expert. The Big Money Finger Print Experts and secret service men are the ones who know the finger print branch of this profession. Easy to learn in spare time at home. Write now for Free Offer.

U. S. SCHOOL OF FINGER PRINT, 7003 North Clark Street, Dept. 13-59, CHICAGO

"BECOME A LIGHTNING TRICK CARTOONIST"

MAKE MONEY QUICK TALKING. SEND \$1.00 FOR SNAPPY PROGRAM OF TRICK DRAWINGS WITH INSTRUCTIONS BY A PROFESSIONAL CARTOONIST. SATISFACTION GUARANTEED. CIRCULAR FREE. BALDA ART SERVICE, Q1, OSHKOSH, WIS.

Cheapest Way to Go

to work or school and recreation is on a Ranger bicycle. You can have your choice of 44 Styles, colors and sizes, 30 DAYS FREE TRIAL. Express prepaid. Factory-to-Rider bicycles from \$21.50 up. \$5 a Month if desired. Saved time and carfare easily meets the small monthly payments. Parents often advance first payment.

Tires best quality, at factory prices, express prepaid. Lamps, wheels and equipment, low prices. Send No Money to business direct with satisfaction.

MEAD CYCLE COMPANY
DEPT. 108 CHICAGO

Write today for free Ranger Catalog, low prices and marvelous easy payment terms.

NOTICE—All men, women, boys, girls, 17 to 65, willing to accept Government Positions, \$117-\$300 monthly, traveling or stationary write Mr Ozment, 111, St. Louis, Mo AT ONCE

Play Tenor Banjo Like a Professional

Learn at Home—In Your Spare Time

Your Way to Success and Popularity

Prof. Harry S. Siz was for 22 years head of Glee and Instrumental Clubs of N. Y. University. His method enables you to play real music the first day.

FREE
\$18.00 Tenor Banjo
when you
enroll



Shortly after you enroll, you will play tenor banjo like a professional. Our method of teaching you to read notes is as easy as A B C's. You quickly win your way to success and popularity. When you stop to think that artists as Paul Whiteman, Vincent Lopez and an endless chain of others have become independently wealthy through music, doesn't it make you stop and think—doesn't it make you wish that you, too, could have all these pleasures?

Musicians become internationally famous and travel all over the world. They receive invitations from heads of nations. You can enjoy the same success, perhaps in a smaller way in your own home town, because tenor banjoists are in demand, both as professionals and for home entertainment. Be popular in your set and receive invitations. Answer this advertisement at once and secure a genuine, full tone, professional size tenor banjo free with our course when you enroll as a student in our academy. Our method of home instruction is so easy, you will play real music the first day.

**Learn Quickly With Our
Picture Method**

Arthur Brisbane, the highest paid journalist in the world, once said that "a single picture is worth a thousand words." He was right, for it stands to reason when you take your instrument in hand along with actual photographs of our professors in action as your guide, it is easy to imitate and do the right thing. All you have to do is put the pictures before you and copy them—just the same as you would if you were sitting in our studio and getting personal instruction.



Our Professors' Phonograph Records FREE

We also furnish as an additional guide, phonograph records of our professors playing the pieces you are learning along with our thorough printed and illustrated, easy-to-read course. This plan in reality and almost in actuality brings our professors to you in your own home. You have the opportunity to hear them play the piece you are learning, and you can accompany them with the aid of your own phonograph.

Learn to Play for a Few Cents a Day

Regardless of the size of your purse, you cannot afford to miss this opportunity. There is no reason why you need hesitate to send for particulars because the payments are so small that they really amount to a few cents per day. Every student who enrolls at once will also secure a handsome, full tone, professional size tenor banjo free with the course when they enroll. You will be surprised how much we give you for a very little money.

No Forming Class to Wait For

**Rush Coupon
for FREE
Information
Booklet**

Send in coupon at once and receive full particulars. You can enroll immediately and get full benefit of the complete New York Academy of Music course without waiting for a forming class. There are no delays whatsoever. You start your lessons at once.

NEW YORK ACADEMY OF MUSIC
Studio 1120, 212 Fifth Ave., NEW YORK, N. Y.

**We Furnish Everything Including
Tenor Banjo**

When you enroll for our tenor banjo course, we start you off by presenting you with an \$18.00, full professional size, tenor banjo. We furnish every bit of equipment including a picture of the fingerboard with all the notes placed in their proper positions. You get six months' free service after you graduate and have received your diploma. Send for free particulars today.

Don't Send a Single Cent

Investigate today. Don't put off until tomorrow because you might forget and miss this wonderful opportunity. It might be the turning point in your career. Don't send a single cent. Use coupon or postal card will do—telling you are interested in receiving full particulars and to reserve a regular eighteen dollar, full size, professional tenor banjo for you. Act quickly.

**New York Academy of Music,
Studio 1120 212 Fifth Avenue, New York, N. Y.**

Please rush all information relative to your tenor banjo course and reserve a gift \$18 full tone professional size tenor banjo for me. This obligates me in no way whatever.

Name

Address

City..... State.....

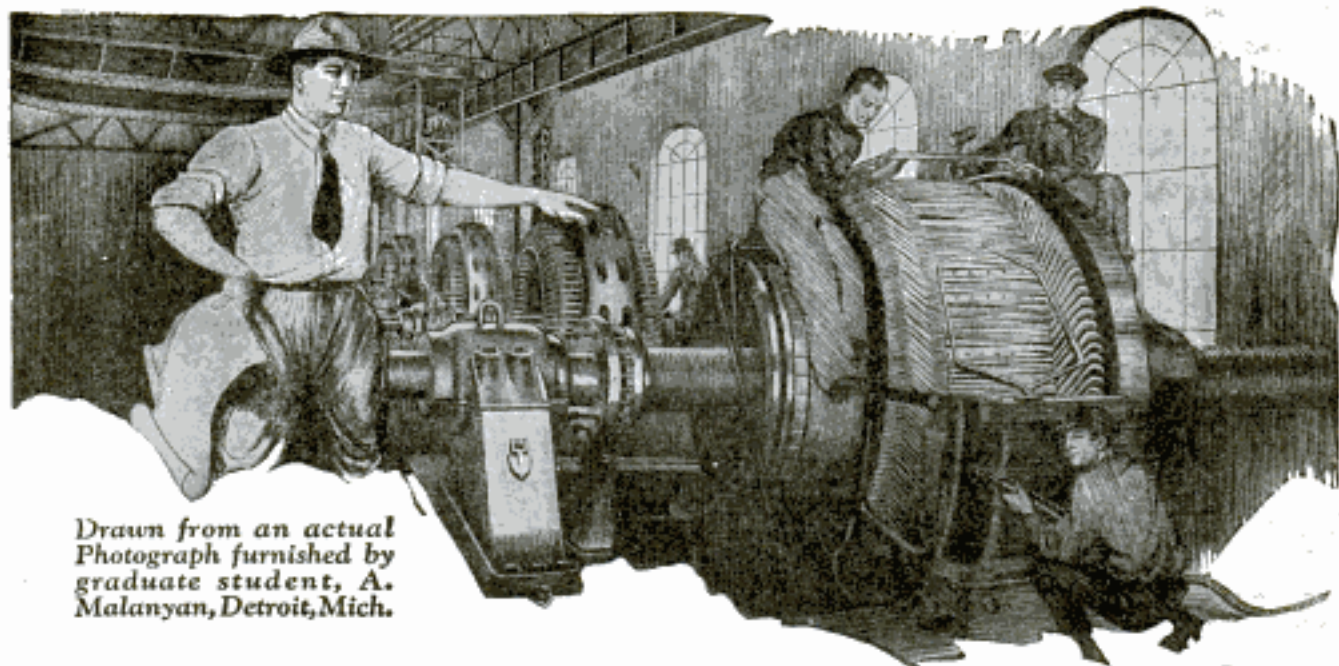

Drawn from an actual Photograph furnished by graduate student, A. Malanyan, Detroit, Mich.

You Too, Can Get the Big Jobs

"Cooke" Trained Men Earn \$3500 to \$10,000 Yearly in Electricity

Now you earn \$20 or \$30 or \$40 a week. In the same six days as an Electrical Expert you can make \$70 to \$200 and make it easier—not work half so hard. Why then remain in the small-pay game, in a line of work that offers no chance, no big promotion, no big income? Fit yourself for a "Bossing" Job—be an "ELECTRICAL EXPERT."

Be An Electrical Expert

Today even ordinary Electricians—the "screwdriver" kind—are making money—big money. But it's the trained man—the man who knows the whys and wherefores of Electricity—the "Electrical Expert"—who is picked to "boss" the ordinary Electricians—to boss the Big Jobs—the jobs that pay.

\$3500 to \$10,000 a Year

Get in line for one of these "Big-Pay Jobs" by enrolling now for my easily-learned, quickly-grasped, right-up-to-the-minute, Spare-Time, Home-Study Course in Practical Electricity.

Age or Lack of Experience No Drawback

You don't have to be a High School Graduate—it isn't even necessary that you should have finished the grades. As Chief Engineer of the Chicago Engineering Works, I know exactly the kind of training you need, and I will give you that training. My Course in Electricity is the most simple, thorough, successful and practical in existence, and offers every man, regardless of age, education or previous experience, the chance to become, in a few short months, an "Electrical Expert" able to make from \$70 to \$200 a week.

Earn While You Learn

With me you do practical work—at once. In my first few lessons I show you how to make money doing Electrical work in your spare time. (Over half of my students are paying for their course in this way.) I show you, also, how to get started in business for yourself, and then I help you to get started.

Electrical Outfit FREE

To do spare time work you'll need tools, etc. These I give you—FREE—a whole kit, including measuring instrument, a real electrical motor (no toy) and other things—the greatest value ever given by any School.

Your Satisfaction Guaranteed by a Million Dollar Institution

I absolutely guarantee to return every penny paid me in tuition if, when you have finished my Course, you are not satisfied in every way with my instructions. And back of me, in my guarantee stands the Chicago Engineering Works, a million dollar institution.

Nothing Like "Cooke" Training Anywhere

"Cooke" training is different because it's the most practical and most successful. It's best because it's backed up by the greatest Service to students ever known. It's this Service, plus "Cooke" training, that makes the "Cooke" trained man the "Big Pay" man everywhere. Become a "Cooke" Trained Man yourself, and earn \$12 to \$30 a day—\$70 to \$200 a week—\$3,500 to \$10,000 a year.

Investigate! Mail Coupon

Get the Vital Facts. Let me send you free my big new book on The Future of Electricity. Let me tell you more about the big demand for "Cooke" trained Electrical Experts. Sign and send me Coupon below.

L. L. COOKE, Chief Engineer
Chicago Engineering Works, Inc.

Dept. 19, 2150 Lawrence Ave., Chicago

L. L. COOKE, Chief Engineer,
Chicago Engineering Works
Dept. 19, 2150 Lawrence Ave.
Chicago, Ill.

You may send me, entirely free and fully prepaid, a copy of your book, the "Vital Facts" and particulars about your Home Study Course in Electricity

Name.....

Address.....

Occupation.....

The "Cooke" Trained Man is the "Big Pay" Man

Classified Advertisements

WORLD'S BEST WANT AD MEDIUM

Advertisements in this section, 25 cents per word, each insertion, minimum 10 words, payable in advance.
To be inserted under proper classification in January issue, copy should be in our office November 18th.

ADVERTISING AGENCIES

TO secure agents or salesmen or for selling farms and reaching investors, use classified (want) ads in largest newspapers and magazines. Price list No. 30 sent free. Ankrum Advertising Agency, 20 W. Jackson Blvd., Chicago, Ill. The largest classified advertising agency in the U. S.

25 WORDS—353 Rural Weeklies \$14.20. Ad-Meyer Agency, 4112-M Hartford, St. Louis.

25 WORDS—151 Weekly Newspapers \$6.40. Information free. Shaw, 221A Northeast, Washington, D. C.

\$15.00 OBTAINS Expert Plan and Resultful copy for newspaper, magazine or direct-mail advertising. No charge when publication advertising is \$100. Martin Advertising Agency, 1402 Broadway, New York.

FOR ADVERTISERS

IMMEDIATE Results or two extra weeks free. Advertisement 21 leadlag newspapers two weeks only 30c word. Affiliated Newspapers, Bedford Bldg., Chicago.

CLASSIFIED seventy magazines, 3c word; three Sc. Smith's Service, 1194 Wematchee, Wash.

ADVERTISING Cuts, any wording, designed and made free. Ad-Lines, 3009 Kenwood, Indianapolis, Ind.

USE Letters, Booklets, Circulars to Increase Business. Send Problems and \$5.00 Retainer. Satisfaction Guaranteed. Duffy, 232 Sixth Avenue, Brooklyn, N. Y.

35 WORDS seventy magazines \$1.00. Thrice \$2.50. Smith's Service, 1194, Wematchee, Wash.

ADVERTISE in 24 Big Sunday Newspapers, 24 words \$15.00. Catalog listing 1,000 leading Dailies, Weeklies, Magazines, 4c stamps. Union Advertising, Baltimore Bldg., Chicago.

ADVERTISE, hundred magazines, three issues, 10c word. Pennell-Company, Covington, Ky.

MAILING List, 30,000 guaranteed mail order buyers names. Write. John Smelter, 2342 West 19th, Chicago.

SALES PROMOTION

\$50 to \$50,000 Daily Sales developed during 30 years for clients by my direct-mail plans, copy, campaigns. A \$25,000 annual volume increased ten-fold in twelve months. Another, from an initial expenditure of \$720 developed in four years sales by mail of half million yearly. Ten years Sales Promotion Manager Larkin Co. Submit sales problems for free diagnosis. James C. Johnson, 118A Woodbridge Ave., Buffalo.

STOP—Look and Listen! I write sales letters that command attention, and compel action. \$3 a letter. Robert Hoagland, 1217 West 47 Street, Kansas City, Mo.

PULLING Letters, booklets written. Send problem. Blake Whiting, Branford, Conn.

SUCCESSFUL Sales Letters. For \$3 I will write you one that will have to bring results. Write—today, giving us particulars. Robert Hoagland, 1217 W. 47th, Kansas City, Mo.

AUTOMOBILE SUPPLIES

RETIRED from business. Write for bargain list. Nat Arnold, 1800 Pitkin Ave., Brooklyn, N. Y.

CARBON-X makes sluggish motors peppy. It satisfies. Write for booklet "Why Is Carbon?" C-P Sales Company, Box 1953, Chicago.

"TRICK" Valve Adjuster and Silencer. New one-piece adjuster for all motors. No tools. 24 for \$1.00. C. E. Richardson, 5 Albee Building, Washington, D. C.

GUARANTEED Spark Plugs \$12.00 per hundred. Sample 25c. Kelly Lamp Works, Oak Park, Ill.

A WRENCH and plier wonder—answers every need. Does away with end wrenches. Ideal for car, home and business. Should be in every tool kit. Money back if not satisfied. Sent postpaid on receipt one dollar. Order Today. Ames-Battigan Body Co., 9083 Grand River, Detroit, Mich.

MILLERITE-ETHYL-Super-Fuel Ingredient for Gasoline. Increases Power and Mileage—Saves Gas. Make it yourself by my simple Formula and clean up five to fifty thousand a year. This and eighteen other High Class Automobile Specialties described in the valuable literature I'll send you upon request—Hurry! Exclusive Territory!! Miller, Chemist, 1109-1111 Grand Central, Tampa, Fla.

COMPRESSORS, Air Twin Cylinder, Fully Automatic. Only \$20 monthly. Postal brings full information. Hobartsons, Troy, Ohio.

AUTOMOBILE Parts—Used parts for most any car at half factory list prices. Allen, Briggs, Buick, Cadillac, Chalmers, Chevrolet, Dodge, Dort, Grant, Hudson, Hupmobile, Oakland, Overland, Oldsmobile, Reo, Studebaker and many others. Send list of parts wanted. Century Auto Parts Co., 4105 Olive St., St. Louis, Mo.

AUTO and Truck Parts. Save 25-80%. New and used motor, gears, axles, bearings, springs, generators, \$10 up. New Zenith, Johnson, Rayfield, Stromberg carburetors, \$7.50 up; new waterproof Simms and Berling magnetos, \$15; Ford retopping, \$4-\$6; other cars, \$12 up. Brightman Auto Exchange, 321 Windsor Ave., Hartford, Conn.

AUTO Parts at cut prices! All kinds of new and used, for all cars. Engines, Clutches, Transmissions, Axles, Radiators, Magnets, Generators, Batteries, Shafts, Gears, Bearings, Springs, etc., etc. If you have never known the house of Warschawsky, you had better write us and get acquainted. Think of buying the Shaler lens for 85c a pair, and rims for any car at \$2.00 each. Windshields from \$8.00 to \$10.00. Spotlights \$1.75. Welding outfits at a low price. Specify make and model of car when writing. "Ask for Bargain List." Warschawsky & Co., 1935 S. State St., Chicago, Ill.

BARGAINS—Radiators—Sport Bodies built to order—send sketch. All standard makes radiators furnished at bargain prices. State make and model. We guarantee satisfaction. Independent Radiator Co., 1119 Wabash Ave., Chicago.

VULCANIZERS, tools, materials, supplies, tires, tubes direct from factory. Miller-Anderson Rubber Works, Anderson, Ind. Dept. P. M. 2.

BIG Profits in Eight Hour Battery Service. Only \$16.50 monthly. Postal brings particulars. Hobartsons, Troy, Ohio.

AUTOMOBILE SUPPLIES, ACCESSORIES AND HOUSEHOLD SPECIALTIES—WANTED

NATIONALLY Known advertiser, supplying thousands of agents, desires to hear from manufacturers of good automobile or household specialties sold readily by canvassers; articles requiring little demonstration and possessing unusual merit, that sell on sight. We want leaders. What have you? Kimo Mfg. Co., Buffalo, N. Y.

DISTRIBUTOR entire state of Pennsylvania desires Automobile Supplies and Accessories of real merit. Pennsylvania buys 1-12 of all Automobiles made. Controls names of one million Automobile Owners including Retail Stores, Service Stations, Garages and Individuals. Do you want Your Product featured vigorously to this list of a Million Prospective Buyers? If so submit for consideration sample, full details and Best-Rock Prices based on State Wide Distributor's Service. James C. Johnson, 118B Woodbridge Ave., Buffalo.

AUTOMOBILES

PATENTS—Write for our Guide Books and "Record of Invention Blank" before disclosing inventions. Send model, or sketch and description of your invention for our free Examination and Instructions. Highest references. Reasonable terms. See advertisement on pages 164 and 165. Victor J. Evans & Co., 185 Ninth, Washington, D. C.

AUTO Top Trimming Course. Particulars 10c. Madison Leach, Mt. Sterling, Ky.

POTENTIAL Battery Charging Brings added business, bigger profits. Costs \$18.50 monthly. Write us. Hobartsons, Troy, Ohio.

PATENTS. Write for my free Guide Books "How to Obtain a Patent" and "Invention and Industry" and "Record of Invention" blank before disclosing inventions. Send model, or sketch of your invention for instructions. Promptness assured. No charge for above information. Clarence A. O'Brien, Registered Patent Lawyer, 589 Security Bank Building, directly across street from Patent Office, Washington, D. C. See pages 162 and 163.

DYKE'S Automobile Encyclopedia, 13th edition, new, greater than ever, entirely rewritten and rearranged. Contains greatest array of automobile facts ever published in one volume. Separate books containing same information cost \$21. Over 1200 pages and 4100 illus. Cloth \$6. Flex. Amer. Morocco \$7.50 postpaid. Popular Mechanics Book Dept., 205 E. Ontario St., Chicago.

SAFETY device for automobiles complete with instructions ready to install. Absolutely thief proof. Fits any make old or new including Ford. With our device, the owner alone can start his own motor. Every combination entirely different from another. No thief can work it. Endorsed by automobile experts. State make on your order. \$4.50 postpaid. George Salrach, Box 106, Evanston, Wyo.

FOR FORD OWNERS

FORD Repair Book Free: A very complete and well illustrated book explaining how to make repairs on most every part of your Ford. We offer this book free with a nine months' subscription to Ford Owner and Dealer Magazine—at only \$1.00. Everyone interested in the Ford car should read this big magazine of about 200 pages monthly. It clearly explains the things you want to know about cutting down the cost of operation, the engine, ignition, transmission, carburetor, etc. Send today and get the valuable Repair Book Free. Ford Owner and Dealer Magazine, 545 Montgomery Bldg., Milwaukee, Wis.

CAN You sell an article that demonstrates easily and effectively? Agent-demonstrators wanted everywhere. H. F. Geist, Oak Park, Ill.

CALIFORNIA Tops for Ford Roadster and Touring. Stylish—Noiseless. Cool in Summer. Warm in Winter. Easily installed. High Quality. Low Prices. Write Factory Today. Koupet Auto Top Company, Belleisle, Ill.

"AUTOMATIC" Airburner." Ford Cars. Particulars. Parlaw Sales Co., 4420 So. Francisco Ave., Chicago.

FORDSPEED speedster bodies; sport Coupe body. See Ad. Page 171.

UNDERSLING with "RKO" Swing Lo Irons. See "Red-i-Kut" ad page 155.

FORD Owners—Stop grinding valves. 25,000 miles guaranteed. Replacement parts \$5.00. Three Ring Valve Co., Suite A808, 974 Broad St., Newark, N. J.

2½ MORE volts than any ordinary Ford Timer. More power, more pep, better pick-up, and instant starting. Wipe Timer Brush—replaces roller in any standard Ford Timer. Smooths out worn timer shells. Positive contact—strong, steady spark—uses no oil or grease. Highest grade carbon steel tip, or wearing surface, is harder than glass. Helps keep spark plugs clean. Eliminates much carbon and coil trouble. Sent prepaid for 75c. Fully guaranteed. Order one today. 4 A Products Company, Mfrs., Department A, Denver, Colo.

PROFITABLE Business Quickly built. One Day Battery Service, \$16.50 monthly. Write us. Hobartsons, Troy, Ohio.

FORD Battery Cables complete with Non-Corrosive Connectors. Anyone can attach. Sent Postpaid for \$1.00. Agents Wanted. Hiawatha Sales Company, Atchison, Kans.

MOTORCYCLES, BICYCLES AND SUPPLIES

SEND for our Bargain Bulletin and Money Saving Message. It will save you money on Motorcycles, Side Cars, Motor Wheels, Repair Parts and Accessories. Some used parts at less than half. Cleveland and Ace Motorcycles our specialty. See our ad on page 157. American Motor Cycle Co., 2043-5-7 W. Chicago Ave., Chicago.

BICYCLES—all sizes \$10; Coasters \$12.50; Tandems \$25; Triplet \$30; Unicycles \$20; Bucking Bronco \$35. McDougald, 300 N. Wells, Chicago.

USED parts for all motorcycles, cheap. State wants. Schuck Cycle Co., 1922 Westlake, Seattle, Wash.

USED Motorcycle Bargains; Lists free. Seeber-Hofheins, Buffalo, N. Y.

1922 **HARLEY-DAVIDSONS**, \$135; 1921, \$115; 1920, \$85; 1919, \$65; 1917, \$50; 1916, \$45; 1915, \$40; 1914, \$35. Guaranteed. Money refunded if not satisfied. Circular free. Wisconsin Cycle Sales Co., 726 National Ave., Milwaukee, Wis.

DON'T buy a Bicycle Motor Attachment until you get our new catalogue and prices. Also runs washers, pumps, and shop machinery. Shaw Mfg. Co., Dept. 27, Galesburg, Kans.

OVERSTOCKED—200 Used Motorcycles. Must be sold at once. We have Harley-Davidsons, Indians, Hendersons, Excelsiors, Cleavelands. Write for our Bargain List. Myerow Brothers, Dept. B, 15 Berkeley St., Boston, Mass.

SEND for big list of slightly used motorcycles on the easy payment plan. Howard Cycle Co., Trenton, N. J.

AVIATION

AVIATORS' leather coats \$12.50. Aeroplane propellers \$3.00 up. Motors, 28 to 200 H.P. and parts for same. Fuselages, wires and fittings for Standards. Smith Machinery Company, Box 153, Houston, Texas.

LEARN to fly this fall or winter. Special course! Special price! Write for catalog. Varney Aircraft Co., Peoria, Ill.

NEW JN4-D's crated, complete, \$1,000.00. Perfect condition. Used JN4-D's in splendid flying condition all ready to take off. \$800.00. Flying tuition \$100.00 extra. Boost for aviation! Send \$1.00 for beautiful pair of sterling silver wings mounted on bar pin. Wallace Aero Company, Bettendorf, Iowa.

HEATH propellers represent the most efficient method of aerial drive. Each propeller individually designed for the particular work to be done, as laid out by America's oldest aeronautical engineers. Propeller catalog 4c; Kied blueprints \$2.00; Jersey aviator helmets 95c; Resistal goggles \$2.99. Heath Airplane Co., Chicago, Ill.

SPEEDY motorcycle motored aerosed drawings \$1.00. Fuselage \$40.00. Motors \$76.00. Frederick Burke, 2599 Maplewood Ave., Chicago.

COMPLETE Scale Plans, with Building-Flying Instructions for following 3-ft. Model Aeroplanes, 25c each postpaid; JN4D-2; De-Havilland; N.C.-4; Curtiss Tractor; Bleriot; Nieuport or Taube Monoplanes; Cecil Peoli Racer. Complete 48 pp. catalog, 5c. Ideal Airplane Co., 165 1/2 Spring Street, New York.

PATENTS. Write for my free Guide Books "How to Obtain a Patent" and "Invention and Industry" and "Record of Invention" blank before disclosing inventions. Send model or sketch of your invention for instructions. Promptness assured. No charge for above information. Clarence A. O'Brien, Registered Patent Lawyer, 589 Security Bank Building, directly across street from Patent Office, Washington, D. C. See pages 162 and 163.

AIRPLANES, Flying Boats, Motors, Aircraft Supplies. New 80 H. P. LeRhone Rotary Motor \$77.50; Balloon Baskets \$50; OX5 Motor \$400; Zenith Carburetor \$12.50; Compass \$15; Unshatterable Goggles—Jumbo \$2.50; wide-vision \$5; Leather Helmets \$4.50; 26x4 Wire Wheels \$6.50; Cord Tires, Slightly Used, \$3; Moderately Used \$2; New Tubes \$2; Airplane Cloth, 65c Yd. Floyd Logan, 714 W. Superior, Cleveland, O.

SEND 10c for our latest aeronautical catalog, listing a complete line of airplane goods at reduced prices; also special bargain sheet on overstocked material. Ford and Motorcycle airplane circular 4c each. Heath Airplane Co., Chicago, Ill.

THE American School of Aviation announces a new correspondence course in Mechanics of Aviation. A thorough training in Practical Aeronautics. American School of Aviation, Dept. 1865, 3601 Michigan Ave., Chicago, Ill.

OPPORTUNITY is at your door. Learn Airplane Engineering Now. The World Flyers were Airplane Engineers. Write for free catalog. Western Airplane Corporation, Dept. K, Monadnock Block, Chicago.

TWO-SEATER Sportford. Efficient and Economical. Complete planes and parts for Builders. Blueprints and Instructions, \$5. Motorcycle Engine Monoplane Plans, \$2.50. Circular Free. Aviation Engineering Co., Lawrence, Kans.

TEN lessons in the air of twenty minutes each will make you a pilot by our advanced method of training. This together with our five week shop course at \$100.00 makes America's oldest aircraft factory the most popular flying school. Work after class hours guaranteed. Heath Airplane Co., Chicago, Ill.

BOYS get a three-foot model aeroplane free. Nothing to sell. Write to Aero Shop, 3950 Hurbit Ave., Detroit, Mich.

WELDING AND SOLDERING

ACETYLENE Brazing and Soldering Torches, \$2.00. Light welding and lead burning torches, \$7.00. Postage prepaid upon receipt of price. Marshall Mfg. Co., Kansas City, Mo.

BOOKS AND PERIODICALS

CURIOUS Books, Unique Novelties, Stunning Pictures, Samples, 10 cents Prepaid. Linds, 214 W. 34th Street, New York.

ENCYCLOPAEDIA Britannica, India Paper, Harvard Classics, most any Encyclopaedia half publisher's price. Dalton Riggs, Crilly Bldg., Chicago.

HYPNOTISM easily learned. Lessons guaranteed. Postpaid \$1.10. Smith Pub. Co., Dept. 3, Springfield, Mass.

SHORTHAND in Eight Hours. Complete book instructions "Modern Shorthand" \$2.25 postpaid. Wonderful, scientific, lightning speed. Anything in the language written after eight hours' study. Maitland Studio College, Stratford, Ontario, Canada.

BOOK of Great Secrets 35c. C. B. Dynes, 705 E. 12th St., Muncie, Ind.

"MASTER KEY" \$2.50. Bargain Catalogues (All subjects) 10c. (Books Wanted.) Phelps Library, 1914 Belmont, Chicago.

DIRECTIONS for Building Imitation Marble Front Houses and for Manufacturing Tomb-Stones and Monuments from White Cement. Read my book on Fancy Concrete. Price \$1. Peter De Linds, Zion, Ill.

PRACTICAL Psychology Teaches Hypnotism, Personal Magnetism, Magnetic Healing, Auto-Suggestion, Cure Habits and Disease, Easy Lessons. Send for Booklet, 4 cents stamps. Fernando, Dept. M, Springfield, Mass.

RADIO, electrical, engineering magazines, Everything. What's wanted? List free! Toepf Magazine Agency, Middletown, N. Y.

WHAT is the soul? 15 pages, 15c. Jabe Studio, Los Angeles.

HYPNOTISM wins your wishes. Controls, amuses, astounds. 25 Easy Lessons \$1.00. "Mindreading" (any distance), wonderful. Success guaranteed, 50c. Popular Institute, D1014 Belmont, Chicago.

HYPNOTISM—Thorough course with illustrations. Scientific, complete. Price only 25c. Astrolite Company, Sharpsburg, Pa.

HOW To Run a Lathe, a new 160-page book containing 250 illustrations. Price 25 cents, postpaid. See our Advertisement on page 206 for Easy Payment Plan on Lathes. South Bend Lathe Works, Dept. C, South Bend, Ind.

SECOND-HAND Books, Gathered in New England Sold by Mail, Low Prices. Advise Subject Wanted. Old Coins Bought and Sold. Address H. M. Grant, No. 83 Empire Street, Providence, R. I.

"A ROAD Map of Success": This valuable booklet will help you discover and develop your strong points and overcome your weak ones and propel you successward. Send 25c today for your copy. Golden Lantern Book Shop, 1914 Hennepin, Minneapolis, Minn.

NATIONAL Fun Review two months and Premium Package 10c. "Sadny," 225 East 119th St., New York.

WRITERS: Study at home; 30 text books; criticism and advice regarding markets for manuscripts. Catalogue free. Correspondence invited. James Knapp Reese (former editor The Editor), 50 Alexander Bldg., Franklin, Ohio.

INDUSTRIAL Alcohol, Wright's book. Full directions for making drawings. \$2.50. Spoon & Chamberlain, 120 P. M. Liberty Street, New York, N. Y.

FREE—Send for my Newthought, Self-culture, Occult, Mystic and Scientific book literature. Martens Publisher, Burlington, Iowa.

"NATURE'S Finer Forces": Vibrations; Lights; Color-tones; Electromagnets; Odicuras; Radio; Coldlights; Inventions; Wonderful Opportunities; Fifty Lessons; Marvellous Cures; Illustrated. Satisfaction Guaranteed. 270 pages, \$2.00. DeLuxe \$3.00. M. Stevens, 243 Powell, San Francisco, Calif.

176 PRACTICAL Subjects, how to master any of them. A new booklet giving reliable advice on how to study 176 subjects at home is free. Write your name and address on a postal and say, Send me "An Easy Way to Master 176 Practical Subjects" and mail to Popular Mechanics Press, Room 867, Popular Mechanics Building, Chicago, Ill.

PICTURES AND POSTCARDS

WILD Game Pictures for your den, office or home; natural surroundings; thirty-six subjects; send for descriptive circular. Neumann & Lick, Gardiner, Mont.

TWENTY Beautiful "Colorview" post cards 15c and full particulars how to get others free. Mutual Supply Co., Bradford, Pa.

SET imported Art Studios, Six Cents (Stamps), Golden State Sales Service, Seal Beach, Calif.

IMPORTED oil painted postcards 6 for 25c. Fred Park, % Billboard, New York.

BOYS—Beautiful Xmas cards hand painted. Send film, 3 dollars doz. W. Taylor, 1025 New Westminster, B. C.

IMPORTED Art Study Cards, 25 for \$1.00. Samples 25 cents. A. Rossberg, 1592 Eastern Parkway, Brooklyn, N. Y.

JOIN Live Postcard Club; Membership lists including Catalog, 10c. Harvey Teeple, Desatur, Ind.

ART Photos, 180 Miniature Samples, \$1.00. Garvey Photos, Randolph, Mass.

IMPORTED Art Study Cards, 100 assortment \$2.00; 50, \$1.25; 15, 50c. 14 Karat Gold Self-Filling Fountain Pens, \$1.50. Your name engraved free. John Ruze, Importer, 347-PM East 73rd Street, New York.

JOIN—Old Reliable Card Club. Trial Membership 10c. Riverside Club, 1408e Meriden, Washington, D. C.

DECORATE your den with pictures; your snapshot, landscape or marine, made into a beautiful solid oilpainting, 10 x 12; only 5 dollars. W. Taylor, 1925 New Westminster, B. C.

JOIN Popular Friendship Club. Exchange view postcards with our enthusiastic members everywhere. Fascinating pastime. Membership two months 10c; six months 25c. Cliver Gandy, 24 Calendar, Providence, R. I.

SURPRISE your Sweetheart, Friends, Relatives. Post Cards Free. Stamp for Particulars. Mailing-Letter Service, Box 1718, Honolulu, Hawaii.

EXCHANGE Postcards! Extremely entertaining, fascinating, instructive pastime. Year's membership \$1. Six months, 50c. List 10c. Join now. Popular Exchange, Windsor, N. C.

75 BEAUTIFUL Art Pictures and Bathing Beauties 25c (coin). Photo Sales Co., 6275 Pingree, Suite 391, Chicago, Ill.

AMES, ENTERTAINMENTS AND PLAYS

VENTRILLOQUISM taught almost anyone at home. Small cost. Send 2c stamp today for particulars and proof. George W. Smith, Room M-913, 125 N. Jefferson Ave., Peoria, Ill.

100 LIGHTNING Chalk Talk Stunts \$2.00. Cartoonist, 2925 Euclid, Kansas City, Mo.

LEARN Trick Cartooning, Instructions \$1.00. Particulars Free. Footlight Cartoonist System, Portsmouth, Ohio.

DADS—A complete blueprinting outfit for your child. They can print photograph negatives, drawings, leaves, etc. Educational as well as entertaining. Sent postpaid for \$1.00. Trenton Blueprinting Agency, Post Office Box 443, Trenton, N. J.

PLAYS, musical comedies and revues, minstrel music, blackface skits, vaudeville acts, monologs, dialog, recitations, entertainments, musical readings, stage handbooks, makeup goods. Big catalogue free. T. S. Denison & Co., 623 So. Wabash, Dept. 11, Chicago.

CHALK Talk Programs and Supplies. Big List Free. Balda Art Service, Dept. 38, Oshkosh, Wis.

NOVELTIES, CURIOS, ETC.

BRASS Buddha \$1 up, Incense Burners \$3 up, Oriental Curiosities, are latest house ornaments. We can supply anything Oriental. Photos and description on application. Agents wanted. Oriental Curio Store, Box 413, Hongkong, China.

BOYS—Brainracking, nervebreaking, mystifying paper puzzle forming bow-tie. Puzzle with instructions, only twenty-five cents. Alton Walker, 1630 Humboldt, Manhattan, Kans.

MYSTERIOUS Novelties, when dropped into water, expand twice original size, turning into fish, flowers, animals. Pretty Package twelve, assorted, 15 cts. Heinemann, 7242 Pingree, Chicago.

MAGIC TRICKS, BOOKS AND JOKER NOVELTIES

WE are headquarters for entertainers—Magical goods—stage illusions—Sensational Escapes—Novelties—Jokes—Ventriloquist figures—Mindreading—card tricks. Large 224 Page Illustrated catalog and the book Bargain Magic 25 cents. Write today. Heaney Magic Co., Berlin, Wis.

MAGIC goods, cards, books, novelties, tricks. Catalogue free. C. Fenner, 2401 Jefferson, Louisville, Ky.

THREE Card Tricks, big Magic book, Magic catalogue, all for ten cents. Magico, 400 North State, Chicago.

250 MAGIC Tricks 10 cents. Lowe, Box 287, Spokane, Wash.

TRICKS, puzzles, jokes, magical apparatus, plays, stage supplies, mind-reading, sensational escapes, large illustrated professional catalog, 10c. Oaks Magical Co., Dept. 548, Oshkosh, Wis.

SEVEN Magic Effects, Four Catalogs—2c. Gilmagico, Morgan Park, Ill.

SPIRIT Medium's Table Lifting—mystifying trick—complete, with instructions, 10c. "50 Magic Tricks," (Illustrated), 10c. G. Elser, Bowling Green, Ohio.

AMAZE and Mystify your friends: New 64-page Copyrighted Book tells how. "33 Card Mysteries" just published, including New 1924-5 Catalog of 300 Mystifying Magical effects, prepaid 10c. Send now! Lyle Douglas, Station A, Dallas, Texas.

200 KINDS of Iron, Wood and Wire Puzzles. Leader and Illustrated folder 10c. Western Puzzle Works, C. St. Paul, Minn.

MAGIC—Tricks, Books and Supplies. For Amateurs as well as the great professionals. Anyone can learn through our instructions. Feature Acts in Mind Reading, Spiritualism, Rope Ties, etc. Large Illustrated Professional Catalog, 20c. Chicago Magic Co., 140 S. Dearborn St., Dept. B, Chicago, Ill.

STAMP COLLECTING

MYSTIC'S "Mysterious" Packet! Contains stamps from the lands of cannibals, heathens, sun worshippers, and wild savages. Included are Kenya and Uganda, Persia, Africa, Dutch Indies, Gold Coast, Federated Malay States, Abyssinia, Nyassa, Travancore, Siam, Congo, etc. This wonderful packet containing 105 all different (mostly unused) for only 8 cents to approval applicants. Mystic Stamp Co., Dept. 8, Camden, New York.

\$2.00 FOR 12c! 100 different Newroups, Catalogued \$2.00 Red Cross set, Airplane set, Perforation gauge, Millimetre scale, Fine wallet, 5 approval sheets, 250 hinges, scarce packet from Nyassa, Abyssinia, etc., price list and approvals—all for 12c to approval applicants. Atlanta Stamp Co., Box 532, Atlanta, Ga.

START a Stamp Collection—70 different stamps from 70 different foreign countries, including Africa, Asia, Australia, Europe, West Indies, etc. Our pamphlet which tells "How to make a collection properly," and price list of albums, packets and sets all for only 16 cents. Queen City Stamp Co., Room 51, 404 Race St., Cincinnati, Ohio.

BOYS! Have you ever owned a nice, shiny, new pair of steel stamp tongs? Lakerlew offers: Famous "Confiscated" set of Bulgaria (stamps that nearly started a war); set of new Germany with (pro-war) face value over forty million dollars; perforation gauge; small album; packet 100 different from Argentina, British Guiana, etc., etc.—and last but not least, a dandy pair of stamp tongs! The entire big outfit only 15c to approval applicants! Lakerlew Stamp Co., 238 Columbia Street, Toledo, Ohio.

ANCHER'S \$\$\$ Outfit—only 12c! Five triangle stamp; set German stamps with (pre-war) value forty million dollars (interesting!); perforation gauge, mm. scale; small album; 2 approval sheets; small set; scarce stamp from smallest republic on earth; newspaper set; packet good stamps from Travancore, Johore, Dutch Indies, etc. Entire outfit for 12c to approval applicants! (Nice packet stock book, value 25c, with every order!) Ancher Stamp Co., 148 1/2 Clerk St., Jersey City, N. J.

FAMOUS Fenway Outfit — 2 triangle stamps, small album, 5 blank approval sheets, 250 hinges, perforation gauge, 3 large French Colonials, 2 special delicacies, annual set, red cross set, packet 55 different, including Abyssinia, Azores, Cape of Good Hope, Bosnia, Crete, Congo, etc., 16-page price list, all for 12c to new approval applicants. Fenway Stamp Co., Fenway Station, Boston, Mass.

STAMPS sent on approval at 70% discount. Reference required. Emsey Renolt, Hanover, Pa.

PARAMOUNT 10c Outfit! Contains: air mail set; stamp from smallest republic; famous "confiscated" set of Bulgaria; 2 triangle stamps; perforation gauge, millimetre scale, ruler; stamp from most savage country on earth; set 3 large Crete revolutionary; 2 scarce Hayti, catalogued (1923) \$2.00; big price list; packet from Dutch Indies, Argentina, Bosnia-Herzegovina, British Guiana, Chile, Guatemala, Luxembourg, Newfoundland, Siam—all for 10c to approval applicants! Paramount Stamp Co., 1540 Broadway, New York, N. Y.

BOYS! Bet you haven't got a single stamp from the Irish Republic! We offer this month only to approval applicants: Packet of 100 different from Cape of Good Hope, San Marino, Fiume (triangle), Travancore, Malay (tiger), Guatemala, Congo (Savage), etc., etc.; also a fine set of 5 diff. Ireland Perforation gauge and mm. scale, and 250 peelable hinges—all for eight cents! Supply limited, order at once. Paul Revere Stamp Co., Watertown, Mass.

NYASSA Giraffes and packet of 52 different scarce stamps, Fiume Triangle, large \$1.00 U. S. Rev., millimetre scale, perforation gauge and ruler for only 9c. To introduce our Sudden Service approvals. Fennell Stamp Company, Dept. P, Fullerton Bldg., St. Louis, Mo.

BRITISH Colonies, 55 Different, 15c. Breeze, 90 Kemper, Wollaston, Mass.

HALF cent Approval Sheets. Many unused, Sam Josephson, Bremerton, Wash.

BEST one-cent approvals in America, F. P. Hand, 1117 South 60th St., Philadelphia, Pa.

GENUINE Mexican \$5 Bill and 20 different unused stamps for a dime, 1,000 foreign mission stamps for 35 cents. B. Nagle, 1101 Marion, Reading, Pa.

FREE—50 varieties to approval applicants sending 2c. Richard P. Lamprocht, Valparaiso, Ind.

100 DIFFERENT foreign 3c. Walter Oliver, 811 Richmond, Buffalo, N. Y.

TEN different Stamps 25c. Dursa, 25 Mulberry, N. Y. City.

1,000 DIFFERENT Stamps \$1.00. Nagy, 23 South 18th, Philadelphia.

STAMP Packets given for old books, What have you? R. Edgerton, Box 661, Fresno, Calif.

100 DIFFERENT Stamps, many unused, high values, free to collectors requesting our Net Approvals, Postage 2 cents. Christensen, Milwaukee, Wis.

FREE! Foreign Coins, Nice Packet, All Different. Enclose Dime for Postage, Etc. Russell Long, 1104 Willow St., Lebanon, Pa.

KENYA, Antigua, Montserrat, Syria, Iraq, Nyassaland, Palestine and many other fine British, French, Portuguese Colonials in Pennsylvania Packet of 89 different for 25c. Request approvals when ordering and receive beautiful, scarce set of Azerbaijan Free, Penna. Stamp Co., Manor, Pa.

TEN Large Shiny Stamps Free; Also list of sets; Postage 2c. We buy Stamp Collections. Paym Stamp Co., 915 Vista Drive, Los Angeles, Calif.

FREE—Dandy foreign packet, including White Russia, British Guiana, Newfoundland, Dutch Indies, Travancore, Etc., to approval applicants sending 2c. Acme Stamp Company, Rock Island, Ill.

BRUNEL: 2 varieties—beautiful pictorials—7c postpaid. Allison, Angola, Ind.

50 STAMPS from Czech-Slovakia, 50 Poland, 50 Bavaria, 25 Bulgaria, 25 Roumania, 12 Bosnia, 12 Montenegro, 15 Persia, 22 Chili, 14 Brazil, 10c each, 200 Austria, 25c; 50 Jugo-Slavia, 35c. Postage Extra. All in good condition. Rowland Hill Stamp Co., 3675 Washington St., San Francisco.

50 VAR. Scandinavian 10c. Try my one-cent approvals, N. Gronberg, 1012 S. 52 Philadelphia, Pa.

FREE Foreign Coins, Nice Packet, All Different. Enclose Dime for Postage, Russell Long, 1104 Willow St., Lebanon, Penn.

FIFTY British, French and Portuguese Colonials only fifteen cents to net approval applicants, Davies Stamp Co., Box 108, Toledo, Ohio.

SUPERB Newfoundland Stamps sent on approval. References please. Rev. Butler, St. Georges, Newfoundland.

PREMIUM with anything you need on approval. Glegh, 1505 Scott, Houston, Texas.

200 DIFFERENT Stamps 10c approvals, Midwest Stamp Company, Kemper Bldg., Kansas City, Mo.

AIRPLANES—Lithuania — Nos. 408-414 — Net 30c. F. Buffham, Lake Ave., Racine, Wis.

100 NEW Europe, All Different, a wonderful collection cataloguing several dollars, free to collectors requesting our Net Approvals. Postage 2 cents. Badger Stamp Co., Milwaukee, Wis.

WONDER Offer, 50 Diff. Stamps, 2 Cuba Mags, 2 Egypt pictures, 1 Cameroon Tiger Stamp, Pope Stamp Company, Dept. M, Detroit, Mich.

30 DIFFERENT Sweden 10c; 30 different Denmark 10c; 25 different Poland 10c; 100 different Hungary 15c. B. H. Carlton, 366 W. 80, Temple, Salt Lake, Utah.

200 DIFFERENT stamps from many countries, catalog value about \$4.00; only eight cents to approval applicants, H. W. Myers & Co., 915 Florida St., Richmond, Calif.

500 STAMPS including Congo, Ceylon, Australian (swan), Guatemala, Dominican Republic and triangle stamp for 15c to approval applicants. Elmer, 39 Court St., Boston.

FREE—25 different U. S. Stamps with 60% approvals to reliable parties, 75 different U. S. Stamps 25c. C. Seidenberg, Merion, Wis.

2,000 DIFFERENT stamps \$5.35; 1,000, \$1.45; 500, 45c; 300, 25c. Michael, 5353 Calumet, Chicago.

BIG Stamp Outfit 10c. Walter Oliver, 813 Richmond, Buffalo, N. Y.

35 DIFF. Neurope free to request for my 1, 2, and 3c approvals, and also my 50% discount. Chas. W. Schmidt, 3227 Benner St., Wissinoming, Philadelphia, Pa.

61 DIFF. U. S., including Harding Imperforated, 25c. 100 Diff. Foreign, 500 Hinges, 12c. Mountain City Stamp Co., Box 235, Mannington, West Va.

4 MINT sets, including "Poland Eagles," hinges, 300 different, premium, French colonies, 2c. Deering, Newton St., Marlborough, Mass.

2,000 DIFFERENT \$5.00; 1,000, \$1.50; 500, 50c; 300, 25c. Fred Onken, 630 79th Street, Brooklyn.

50 DIFFERENT Scandinavian stamps 10c and a free packet of different English or Canadian stamps. Phil. Lundstedt, Cape Cottage, Maine.

LARGE packet beautiful French, Portuguese and British Colonials, only 10c to approval applicants. Trigg, 419 Bush, Houston, Texas.

FREE! Dandy premium packet to approval applicants sending 2c. Lyman Stamp Co., Davenport, Iowa.

115 DIFFERENT, including Air Mail, Charity, Abyssinia, Nyassa, stock book, hinges, etc., only 12c to approval applicants. Parke Stamp Co., Housatonic Ave., Bridgeport, Conn.

FREE Packet containing stamps from Paraguay, Newfoundland, Canada, etc., to applicants for our 50% and 60% sheets; enclose 2c postage. Geo. Flagg, 270 Wyoming Ave., Melrose, Mass.

1,000 DIFFERENT stamps, \$1.00. Think of it!—30 stamps for 1 cent! The finest 1,000 variety packet, at this price, we ever saw. Satisfaction guaranteed or money back. C. E. Nickles, 3091 Rodman, Washington, D. C.

APPROVALS for more advanced Collectors. Discounts to 80%. Reference. International, 2117 Regent Pl., Brooklyn, N. Y.

SEND 25c for Approvals and gift, imported direct. Arthur S. Cram, Lock Box 191, Hillsboro, N. H.

NET Approvals. New applicants 20 free stamps. Reference required. Tower Stamp Co., 42 Westville St., Dorchester, Mass.

YOUR name with reference brings my frequent circular series of packets, sets, etc. Also novel approval service, 100 fine varieties 10c to approval applicants. Donald Holmes, 3080 Woodland, Kansas City, Mo.

STAMPS on approval at 60% discount. References please. J. A. Flaten, Fertile, Minn.

FREE—Two Sets Nyassa. Also 20 diff. British Colonies, Barbadoes and Jamaica pictorials and packet of hinges for a request for my 1, 2, 3c net approvals. None better. Charles T. Egner, 4821 Frankford Avenue, Frankford, Phila., Pa.

FREE Packet to Approval Applicants. References. Prospect Stamp Co., 185 Annette Street, Toronto.

THOUSAND Different \$1.50. Fifty British Colonies 15c. Free Packet to Approval Applicants, Sending References. Packet List Free. Reid, 605 Yonge Street, Toronto.

200 DIFFERENT stamps 10 cents to approval applicants. Ogd Stamp Co., 261 W. Dakota, Pasadena, California.

BARGAINS! 100 unused all different stamps, only 5 cents, another 1,000 mixed stamps from Europe, Asia, Africa, etc., 20 cents. Nielsen, 3244 Whipple St., Chicago, Ill.

SEND for Price List No. 15 of Packets, Sets and Supplies. Approvals for Beginners. Inwood Stamp Company, 213 Inwood Avenue, Upper Montclair, N. J.

FREE! Three cent orange, red Canada 1872 unlisted guide dot. Variety to applicants for approval selections. E. E. Goodchild, 116 Sherbrooke West, Montreal, Canada.

1,000 DIFFERENT stamps \$1.00; 100 Portuguese Colonies 50c; Approvals 60%. Martel, 306 Station "C," Montreal, Canada.

105 CHINA, etc., stamp dictionary, list, 2c. Album (500 illustrations), 3c. Bullard, Sta. A, Boston.

BIG Variety Packet Foreign Stamps Free for 2c postage. Gray Stamp Company, Station E10, Toronto, Canada.

BIG \$1.00 outfit and premium to approval applicants 10c. Buckley, 712 Bowen, Dayton, Ohio.

FRENCH Colonies Free.—Pretty Picture Set, Native Chiefs, Tigers, 2c Postage. Empire Stamp Company, 342 Lippincott, Toronto, Canada.

20 UNUSED stamps free. All different. Postage, 2c. P. M. Fisk Stamp Co., Toledo, Ohio.

STAMPS on approval 1/4 cent up. Free Premium. Herbert Kaigwin, Middletown, N. Y.

DANZIG Free.—Nice Set Danzig Stamps with Biggest Lists issued, 2c postage. Midland Stamp Co., Station E2, Toronto, Canada.

HAVE you an Abyssinia in your collection? 3 varieties 5c. 1,000 all different stamps \$1.00. Approvals sent upon request. Edgewood Stamp Co., Milford, Conn.

24 VARIETIES Cuban stamps, 10 cents. List of 6,000 low-priced stamps free. Address Chambers Stamp Co., 111P, Nassau St., New York City, N. Y.

STAMPS, 100 all different. Postage 2c. Lists free. P. M. Quaker Stamp Co., Toledo, O.

158 GENUINE Foreign Stamps. Mexico War Issues, Venezuela, Salvador and India Service, Guatemala, China, etc., only 5c. Finest approval sheets 50 to 60%. Agents Wanted. Big 72-p. Lists Free. We Buy Stamps. Estab. 29 years. Hussman Stamp Co., Dept. 54, St. Louis, Mo.

FOREIGN Stamp Collection Sent Free. Cornish Co., Schenectady, N. Y.

FREE! Loose Leaf Postage Stamp Album at rate of 8 pages each month given with subscription to monthly Journal. Send 2c stamp for prospectus. United Stamp Co., Marquette Bldg., Chicago, Ill.

STAMPS, 50 varieties, Africa, Brazil, Peru, Cuba, Mexico, etc., 10c. 50 different U. S., 25c; 1,000 mixed, 40c; 1,000 hinges, 10c. List free. C. Stegman, 5948 Cote Brillante, St. Louis, Mo.

ZAMBESIA, Zanzibar, Abyssinia, Herzegovina, Allenstein stamps, menagerie collection, album, 10c. Liberty, 3974 Arsenal, St. Louis, Mo.

PACKET of 23 stamps, no two countries alike. Packet hinges. Set of \$1 and \$2 U. S. Rev., all for 5c. P. M. Miami Stamp Co., Toledo, Ohio.

FREE—20 Luxemburg stamps to general collectors requesting my net approvals. Reference required. J. de Jong, 539 West 162nd St., New York City, N. Y.

FREE—100 different to approval applicants. F. M. Gillespie, 1302 S. Madison St., Bloomington, Ill.

RARE COINS

OLD Money Wanted. Have you an odd or old coin or bill? It may be worth several dollars. Get posted. Send 4c for Coin Circular. May mean much profit to you. Send now. Numismatic Bank, Dept. H, Post Worth, Texas.

SPECIAL Free Offer.—1,000,000 German Marks in Banknote Currency given away Absolutely Free of Charge with every 25c order for 20 Russian Czar Pre-War Roubles. Our Foreign Department buys and sells Bonds and Currencies of Germany, Poland, Austria, Hungary and Russia. Send 25c order today and receive our latest Market letter and quotation list of all Central European securities. Public State Bank, Dept. 800, Roosevelt Road, Chicago, Ill.

\$2 TO \$500 Each paid for hundreds of Old or Odd Coins. Keep all Old Money; it may be very valuable. Send 10 cents for Illustrated Coin Value Book, 4 x 6. Get Posted. Guaranteed Prices. Clarke Coin Company, C. St., LeRoy, N. Y.

44 DIFFERENT foreign coins \$1.00. Post-paid. Otto Oddehon, Independence, Mo.

RARE Coins, Medals, United States and Foreign Paper Money. New Catalogue and Villa Bill 10c. Alexis Mengelle, Box 387, Colorado Springs, Colo.

10 FOREIGN Copper Coins, Different, and German Bill—25c; 100,000 German marks—10c; California Gold 1/4—27c; 1/2—53c; Magic Bill Book and 3 Bills—25c; Price Lists and Wild Cat Bill—6c. Al. E. Domsall, Richmond, Ind.

OLD Coins, Large Fall Selling catalogue of coins for sale free. Catalogue quoting prices paid for coins, ten cents. William Hestlein, 101A Tremont Street, Boston, Mass.

40 OLD coins, all different, \$1.00. 100 different coins \$2.00. 500 different Germany and Austria Bills \$2.50. Claud Denney, Box 315, Dallas, Texas.

CALIFORNIA gold quarter 27c; half 52c; Jackson cent 15c; Continental bill 40c; proof 3c, 25c. A. Wylie, Wheaton, Ill.

100 FOREIGN coins 50c. Revolutionary War bills 25c, 15 foreign bills 25c, 10 Confederate bills 25c, German Iron cross \$1.00, Austrian cross 60c, 5 Roman coins 50c. Catalogue free. Nagy, 33P South 18th, Philadelphia.

CALIFORNIA gold, 3/4 size, 27c; 1/2 size, 53c; three-cent-piece and catalogue, 10c. Norman Shultz, Colorado Springs, Colo.

GET Profit and Pleasure in collecting Old Coins. Send 10c for Sample Old Coin, together with my Large Illustrated Coin Catalogue. You'll be delighted with it. Send for it right now. B. Max Mehl, Professional Numismatist, Mehl Bldg., Dept. P, Fort Worth, Texas. Largest Rare Coin Firm in U. S.

\$1.00 BRINGS Pound of Samples; Bonds, Banknotes, Coins; 10 countries; 57 varieties; 100 pieces. Agents Cleaning Up. Hirscher, 78 Wall St., N. Y.

FOR BOYS

SCHOLARSHIPS available Boy's Prep School to athletes and musicians. Box 926, Stamford, Conn.

MOUTH-ORGAN Instructor (116 big pages), 25c. Eighteen good selections of music, including "Mocking Bird," with complete instructions for playing immediately. Thousands sold. Order today—become popular. 150 Song Parodies, 10c. 55 Famous Songs (with music), 10c. G. Elsen, Bowling Green, Ohio.

BOYS! 200 Feet Fine Film with 2,000 Theatre Tickets, \$1.65, Postpaid Anywhere. Northern Theatre Supply, Duluth, Minn.

GIRLS—Boys, Earn Xmas Money. Write for 50 Sets St. Nicholas Christmas Seals. Sell for 10c a set. When sold send us \$3.00 and keep \$2.00. No Work—Just Fun. St. Nicholas, 2814 Glenwood Rd., Dept. 43, Brooklyn, N. Y.

CAMERAS AND PHOTO SUPPLIES

PHOTOGRAPHIC equipments and accessories of every description are listed and illustrated in our 228-page catalogue. It will pay you to secure a copy which is issued free, as our prices are low. We also deal in used goods which are sold under the same guarantee as new goods. Ask for our Bargain Book. Central Camera Co., Dept. E-88, 112 S. Wabash Ave., Chicago, Ill.

FILMS Developed Free on trial roll. Prints 3c each. Desk E. The Camera Co., Oklahoma City, Okla.

\$350.00 **BUSCH** 3-inch celestial telescope, tripod, etc. 70X Vion celestial telescope outfit, Graflexes, cameras, lenses, binoculars sold and exchanged. Liberal allowance for high-grade foreign and domestic firearms. National Camera Exchange, 7th and Marquette, Minneapolis, Minn.

35 NEW Camera Kinks and Photo Fads 50c. Circulars free, Greenhalgh, Box 278, Indianapolis, Ind.

5 x 7 **ENLARGEMENT** 25c. Send Negative. J. Frey, 53 Walnut St., Newark, N. J.

BECOME a "Colorist." Earn money Coloring Photographs at home. Instruction Free. Your own photo hand-painted Free. Radiographic Studio A, Drawer 417, Los Angeles, Calif.

SIX 5 x 7 enlargements from your favorite negative for \$1.10 C. O. D. Mounted in Art Folders \$2.00. Simple enlargement, mounted, 25c. David N. Essick, Ankeny, Iowa.

POCKET Kodaks \$2.50 to \$3. Besser Speed Camera, F 4.5 lens, 35c. Kodaks exchanged. Write for bargain price list. H. Ray, 324 Fifth Ave., New York.

MODERN Photography in all its branches now taught by mail. New Successful Method. Students earning \$300.00 while learning. Big opportunity. Write for particulars and unusual offer open for short time. Dept. 13-36, International Studios, Inc., 3801 Michigan Ave., Chicago.

HAVE You a Camera? Write for Free sample of our big magazine, showing how to make better pictures and earn money. American Photography, 116 Camera House, Boston, 17, Mass.

FILMS Developed, Special Trial Offer. Any 816 Kodak film developed 5c, prints 3c each. Trial 6x10 Enlargement in handsome folder 40c. Overnight Service. Roanoke Photo Finishing Co., 209 Bell Ave., Roanoke, Va.

SUPERIOR quality finishing and enlarging. Trial offer: Any size 6 exposure roll developed and printed, 25 cents. 8x10 enlargement unmounted, 30 cents. Carthuff Photo Finishing Co., 2129 W. Van Buren St., Chicago, Ill.

BIG Money Saved on Photographic Lenses and Apparatus—goods exchanged; repairing done. Ralph J. Golsen, 1128 Argyle St., Chicago, Dept. P.

KODAK Films—Special trial offer; your next kodak film developed, 5c—prints, 2c each. Moser & Son, 1817 St. James Ave., Cincinnati.

ENORMOUS Profits from Small Camera. Write for Details. Press Studio, Box 132, Lincoln, Nebr.

MOTION PICTURES

FILMS and Machines for sale. Stamps for list. National Film Brokers, 3907 Summit, Kansas City, Mo.

FILMS rented and sold. Moving Picture Projectors sold at lowest prices. Movie Camera \$40.00. Triped \$20.00. New Motor Driven Suit Case Projector \$75.00. Write for Bargain Price-List. A. Ray, 324 Fifth Ave., New York.

FILM—Million Feet for Sale. Cowboy—Drama—Comedy and Feature Specials. Mix—Hart—Chaplin and best Movie Stars. \$3.00 per reel up. Genuine List Free. We Supply the World. Dept. G, Monarch Films, Memphis, Tenn.

BIG Money Nightly—Good assortment. Complete Outfits, installment plan. Splendid Home Outfit, \$25.00. Good Movie Camera, \$25.00. Ralph J. Golsen, Dept. M, 1128 Argyle St., Chicago.

DON'T fail to send for the big Free Bass Book of Cinema Apparatus. The Encyclopedia of M. P. Cameras and Projectors. Get in the game that has made thousands independent. Write or wire for your copy. Bass Camera Company, 105 N. Dearborn St., Chicago, Ill.

WONDERFUL Opportunities for Making Fortunes in this Business. No Experience needed. Complete Theatre Outfits sold on Easy Terms. Free Catalog. Monarch Theatre Supply Co., Dept. P, Memphis, Tenn.

\$35.00 PROFIT nightly. Small capital starts you. No experience needed. Our machines are used and endorsed by government institutions. Catalog free. Atlas Moving Picture Company, 482 Morton Bldg., Chicago.

\$\$\$ FOR Ideas. Photoplay plots accepted any form; revised, criticized, copyrighted, marketed. Advice free. Universal Scenario Corporation, 200 Security Bldg., Santa Monica and Western, Hollywood, Calif.

AMERICA'S Greatest Fortunes made in the Motion Picture business. We furnish complete theatre equipment on easy payments. Openings everywhere. Catalog free. Monarch Theatre Supply Co., Dept. A, 724 So. Wabash Ave., Chicago, Ill.

MAKE money writing photoplays; details free to beginners. No correspondence course. Producers League, 230 Wainwright, St. Louis.

ELECTRICITY—Make it yourself with our auto generator. Write for particulars. Monarch Theatre Supply Co., Dept. 7, 724 So. Wabash Ave., Chicago.

SCENERY TO RENT

SETTINGS for Opera, Plays, Minstrels. Push drops. Address Amelia Grain, Philadelphia.

EDUCATIONAL AND INSTRUCTION

VIC'S Selfwriter wonderful asset in teaching writing. \$1. Vic Hansen, Wallace, Idaho.

AUTO, Boilermaker drafting courses \$30; also **Clarinet**, Honery, Roseto, Pa.

MEN wanted for Automotive Work. We train, place you on a good job when graduated. Western Automotive School, 1269 Arona, Denver, Colo.

MODEL Engineering. An indispensable book for Modelmakers, Inventors and Experimenters. Descriptive circular free. Lightning Method Publishers, Box 999, Long Beach, Calif.

SCHOLARSHIPS available Boy's Prep School to athletes and musicians. Box 926, Stamford, Conn.

USED educational matter bought, sold, exchanged. Bulletin free. Instruction Correspondence Exchange, 1968 Broadway, New York.

SHOWCARD writing made easy. Instruction book and complete outfit \$1.09. D. Gale, (Removed to) 618 Madison Ave., Albany, N. Y.

CARTOONING and Comic Art made easy. Get Kite's adjustable comic models to draw from; wonderful help. Write Kite, Barberston, Ohio.

WORLD-ROMIC System. Masterkey to All Languages. Primers, \$1.94; Chinese, French, Spanish, Pronunciation-Tables, 30c. Dictionaries, \$1.98. Languages, 8 West 40th, New York.

WE buy and sell Used Educational Matter, Old Gold, Jewelry, Postage Stamps, Gold Teeth, Bonds. Handling, 799 Broadway, New York.

ROPP'S Calculator and Short-cut Arithmetic shows the answer as quickly as a watch shows the time to all problems likely to occur in office, store, shop, bank, farm or factory. Price, pocket size, paper 35 cents; cloth 50 cents; leatherette \$1. Desk size, cloth \$1.50 postpaid. Popular Mechanics Book Dept., 205 E. Ontario St., Chicago.

HOW To Run a Lathe, newly revised 160-page book, 250 illustrations, over 1,000,000 copies now in use. Price 25 cents postpaid. See advertisement page 206 for Easy Payment Plan for South Bend Lathes. South Bend Lathe Works, Dept. C, South Bend, Ind.

"SIGN Painting Simplified" teaches you this big paying trade. Beautifully illustrated book and working outfit \$1. Sign-Book Shop, 910 N. 18th St., St. Louis, Mo.

RAILROAD Postal Clerks start \$133 month, railroad pass. Send stamps for questions. Columbus Institute, E-2, Columbus, Ohio.

YOU can have a business profession of your own and earn big income in service fees. A new system of foot correction; readily learned by anyone at home in a few weeks. Easy terms for training; openings everywhere with all the trade you can attend to. No capital required or goods to buy, no agency or soliciting. Address Stephenson Laboratory, 1 Back Bay, Boston, Mass.

CARTOONISTS—Improve your style by following the work of the greatest cartoonists found in the bound volumes of Cartoons Magazine. Three volumes, each covering six months, Jan.-June 1919 to Jan.-June 1920, inclusive. 1200 cartoons, 900 pages to a volume, 7 by 9½ in., 3 in. thick. New books, durable and attractive binding. Sold separately at \$2 per vol. postpaid. Supply limited. Send at once. Popular Mechanics Book Dept., 205 E. Ontario St., Chicago.

USED educational matter, books, etc., bought, sold, rented and exchanged. Big list free. Lee Mountain, East Chattanooga, Tenn.

ARTIFICIAL Marble sanitary flooring instructions, ornamental casting, concrete, plaster, papier-mache decorations, garden furniture, statuary, Rubber-moulds. 15 years' instruction the public, particulars and 250 illustrations free. Chris Mahler, Huntington, N. Y.

DRAFTING, Tool Designing and Mathematics taught by mail; combined course or separate subjects. Harding School, Box H, Highland Park, Mich.

STUDY Patent Solicitation. Become Patent Attorney. Full particulars, Patent Law, Jordan, Minn.

USED Educational Matter; save over half. Bargain catalogue 1,000 courses free. Used courses bought. Students' Exchange, Dept. A, 47 West 42nd St., New York.

"WHAT to Invent for Profit" free. Patent News-N, Washington, D. C.

DOUBLE Entry Bookkeeping mastered in 60 hours with 8 keys; guaranteed; diploma. International Bookkeeping Institute, Dept. 8, Springfield, Mo.

BOOKKEEPING in a Week, \$2 complete. Deakes, 1337 Walton Av., New York.

RADIO OUTFITS AND SUPPLIES

\$55.00 **WESTERN** Electric speakers \$20.00. Write for other Bargains. East Wright, Cole Camp, Mo.

RADIO Game, Log. Map, Score Sheets, Instructions, Etc. Only 35c. Agents Wanted, 918 Garrick, Chicago.

BUILD Your Radio. Complete line of radio equipment. Money saving prices. Complete sets or units ready for assembly. Send ten cents for catalog. Hoosier Manufacturing & Supply Co., 310 Baldwin Block, Indianapolis, Ind.

CASH in on Radio! Build and sell sets for us. No trouble to earn \$5 an hour in spare time at home. Auburn Radio Co., Dept. J, Cincinnati, Ohio.

RADIO WORLD: National Illustrated Weekly. Solves all radio troubles. List stations, advance programs for full week. Great Q. and A. Dept. All dealers. Specimen Copy, 15c. \$4 year; \$3 six months, \$1.50 three months. Special: \$1 for 8 issues. Radio World, 1493 Broadway, N. Y.

DON'T scrap your crystal or tube set. Wonderful volume with our amplifiers \$8.00. Theodore Burwell, Middletown, N. Y.

BLUR Generators, new 6-volt maximum output 22 amp., 2000 r. p. m., with cutout suitable charging A-battery. Government surplus, \$10.00. Cook County Sales, 2456 Calumet, Chicago.

NAVY Battery Dynamotors, 12/350V, 12/500V, 24/1500V. Bargains. Klengle, 561 East 81th, New York.

BUILD a four tube Super-Heterodyne, the most powerful four tube set possible to make. Easily made from standard parts obtainable anywhere. Complete instructions and drawing 50c. Guaranteed or your money refunded. Johnson & Wentink Mfg. Co., 3225 Sheffield Ave., Chicago, Ill.

IT'S a Knockout! Harkness Reflex. Better than 3 tube receiver. No whistles or squeals. Very selective. Complete parts \$35.00 postpaid. Lewis Homes, Princeton, Ill.

DEALERS—Write for illustrated catalog reliable radio merchandise. Bossiter-Manning Corp., 1830 Wilson Ave., Chicago, Ill.

GENTLE "Radiotron" Tubes \$1.40 Postpaid. MacTaren, Dept. PM-1, Onset, Mass.

500 **MILE** Crosley Receiver, Tube, Phones \$19.50 Postpaid. Catalog 5c. Curtis, 1109 Eighth Ave., Fort Worth, Texas.

RECHARGING Radio Batteries in Eight Hours pays big profits. Particulars free. Radio Hobart, Troy, Ohio.

RADIO tubes repaired like new \$2.00 all makes. New tubes \$3.00. Types 201A-200-109-12; written guarantee with each tube. Radio Tube Manufg. Co., Dept. 10, 154 Nassau St., New York City. Mail orders promptly filled.

2,650 MILES Distance with one tube. Any Novice understands our Simplified Instructions, including Panel Layout and Photo 25c. Vesco Radio Co., Box PM-117, Oakland, Calif.

TELEGRAPHY

TELEGRAPHY—Both Morse and Wireless—taught thoroughly and quickly. Tremendous demand. Big salaries. Wonderful opportunities. Expenses low; chance to earn part. School established fifty years. Catalog free. Dodge's Institute, H St., Valparaiso, Ind.

TRADE AND TECHNICAL SCHOOLS

BE a Bricklayer. Attend a School conducted by building contractors, who are interested in increasing the number of bricklayers. Day course is four months and fee which student pays \$100.00. Night class is six months for which student pays \$60.00. This Association helps students get work after they finish course. Send for catalogue. Associated Building Employers of Michigan, 112 A. B. E. Building, Grand Rapids, Mich.

GET a Foreman's Job in any trade. Train yourself to earn more money. Become an expert Blue Print Reader. You can do it in spare time. My training will give you advancement in a few weeks. Write now—tell me what trade you want—I will send my plan at once. Carroll Rumsey, 165 Drexel Bldg., Philadelphia, Pa.

LEARN Sign Painting, Decorating, Paper-hanging, Marbling, and Graining—Auto Painting. Practical course takes only few weeks. Write for Free Book and Special Offer. Chicago Painting School, Dept. 9159, 150 W. Austin Ave., Chicago.

BUSINESS OPPORTUNITIES

MONEY-MAKING propositions, plans, information, magazines, only 10c postage. Chartley Press, Chartley, Mass.

START a business of your own. Sell goods under your own private brand. Todiet articles, food products, household specialties. Tremendous profits. Big repeat business. We supply everything needed. Write for our attractive proposition. National Scientific Laboratories, 208 Monroe, Richmond, Va.

PATENT applications filed guarding priority, \$20 drawing; deferred \$15. Caveat advantages; basic protection. Inventors' Service, 11 Broadway, New York.

EARN money at home spare time or evenings. No peddling. Permanent. Work in your own home. Write Downs Co., 2323 Myrtle, St. Paul, Minn.

I SUPPLY mail order books, imprint catalogs. Send 10 cents for details. P. Dorf, 711 So. Dearborn St., Chicago, Ill.

A TEA Room or Cafeteria will make you a fortune—you can operate one of your own or manage one for others. We teach you in a few weeks and put you in touch with positions and money-making opportunities—earn \$5,000 a year—be independent. Write today for book "Pouring Tea for Profit." Lewis Tea Room Institute, Bureau A-31, Washington, D. C.

I MADE \$100,000 as Real Estate Specialist. Free information tells how. American Business Builders, Dept. A4412, 1133 Broadway, New York.

MONEY Silvering Autolights, Radiators, Mirrors, tableware, stoves, Outfits. Methods Free. Sprinkle Plaster, 287 Marion, Ind.

NEW Mail Order plans in "Business Progress" each month. Three months' trial subscription, 25c. 734 Cherry, Kansas City, Mo.

MAKE Big Money Manufacturing Vanilla in your own home. Sell to homes, stores, bakeries, hotels. Guaranteed Formula \$2.00. Richard C. Stark, 1216A College St., Bowling Green, Ky.

FOR methods of making money, no merchandise; start a business. Write Department M, Paul Kaye, 149 Broadway, New York.

MANUFACTURE Polishes. (Full Auto Accessory line). Plate Auto-parts-Paint Automobiles. Complete Instructions \$2.00. Details stamped envelope. N. Boricke, 427 Carroll St., Akron, Ohio.

AMATEUR Artists, Make money by mail; plan quarter. Smith, 1194 Wenatchee, Wash. 120 **MONEY-MAKING** Plans Free! Wolverine Bureau, G-8, Muskegon, Mich.

LEARN Tartaric Mirror Silvering. It pays big! Long, closely guarded secret. Particulars free. Wm. Barstow, 514 23rd St., Oakland, Calif.

WANTED—A wide-awake man in each town who is looking for proposition which will increase his income. Should be mechanically inclined. Small investment. Majestic Co., Huntington, Ind.

MECHANICS, Manufacture at home. Investigate. 415 South Lawndale, Kansas City, Mo.

START in business for yourself. Five successful plans. \$1.00. W. Carlson, 8239 S. Morgan St., Chicago.

HOME Work Opportunities; particulars free. Nielsen, 39 N. 2 W., Provo, Utah.

AGENTS: \$11.80 daily in advance (send for sworn proof) Introducing New Insured Hostlers—47 stripes—35 colors—guaranteed seven months—Winter line now ready—No capital or experience required—You simply take orders—We deliver and collect for you can deliver, suit yourself. Credit given—Pay You Daily—Monthly bonus besides. We furnish samples—spare time will do. Maccoche Textile Company, Room 25812, Cincinnati, Ohio.

POPULAR Scherer, Alliance, Ohio, teaches mail-order business and prints big profit schemes; one subscriber making \$25,000 from three; another \$10,000 from one. Try your luck. Year, 12 copies, 384 pages, only \$1; 3 months, 50c.

3,384 **MONEYMAKING** Plans, Formulas, Trade-Secrets. "Encyclopedia Business Opportunities." 2 Volumes 98c. "Ideal," 5501-V12, North Robey, Chicago.

THE Great Wheat Secret—New book showing the cause of market swings in wheat and how to anticipate them. Contains unequalled secret and method for traders, millers, speculators. Eye-Opening folder free. Write today. Market Forecaster Co., Dept. A, 1016 Baltimore Ave., Kansas City, Mo.

CEMENT Masons, Plasterers, Contractors. Build successful business, stuccoing old and new buildings with Everlastone Indestructible Stucco; also installing Corkstone Floors over worn-out flooring. Write immediately for agency proposition. Everlastone Corporation, 825 W. Pratt St., Baltimore, Md.

PATENTS procured; trade marks registered. A comprehensive, experienced, prompt service for the protection and development of your ideas. Preliminary advice gladly furnished without charge. Booklet of information and form for disclosing idea free on request. Richard B. Owen, 39 Owen Bldg., Washington, D. C., or 2274-B Woodworth Bldg., New York.

BOOKS Explaining Mail Order Business; Circulars Free. Harvey Teeple, Decatur, Ind.

I STARTED a mail order business with only a formula and \$2.90 and ran a wonderfully successful business. Send for "How I Started a Mail Order Business." It's free. J. G. Packard, The Formula Man, Pittsburg, Kans.

SUCCESSFUL selling plans and 450 formulas for salable articles. 50c. Postland Service, Norwalk, Conn.

SLOT Machines—Headquarters for Premium Machines. 1016 Germantown Ave., Philadelphia.

A \$12.00 **DARCHE** "Call-Me" Electric Alarm Clock free. Write us for particulars. Darche Mfg. Co., 643 Washington, Blvd., Chicago, Ill.

24 MONEY-MAKING Plans Free. DeKort, 255 Clay St., Paterson, N. J.

SUCCEED With Your Own Products—Formulas by Experts. Manufacturing Processes. Trade Secrets. Different. Dependable. Profitable. Interesting Catalog Free. B. Thaxly Co., Washington, D. C.

GET in the "Home Made Cookie Business." Start at Home. Build large business. Profitable, permanent employment, whole family. Walland, Box 4338, Sta. B, Kansas City, Mo.

BE first in your town to make this combination household article—stool, step ladder, bench, writing table, easel, stand, etc. Easily made by any carpenter or handy man. Drawings \$1.00. Home Equipment Co., Drawer 923, Butler, Penna.

EARN \$60.00 Weekly Contracting without experience or equipment. Free Instruction. Greenhagh, 3090 Kenwood, Indianapolis, Ind.

PUBLISH small mail order magazine; sample, plan, free. Harvey Teeple, Decatur, Ind.

\$3,000 TO \$6,000 Yearly. Want it? Others are making it. Send check or money order today for our invaluable books "How to Sell Real Estate," \$3.00—and "How to Conduct Real Estate and Insurance Business," \$1.50. Absolute satisfaction guaranteed. Free catalogs. Realty Book Co., Dept. 52, Cleveland, Ohio.

START a Mail Order Business; Particulars Free. A. Ehrke, Box 42, W. Park Sta., Cleveland, Ohio.

MANUFACTURE New Fast Selling articles. Free list of plans, patterns, molds. B. Barter, 3931 Tracy, Kansas City, Mo.

PATENTS—Write for our Guide Books and "Record of Invention Blank" before disclosing inventions. Send model or sketch and description of invention for examination and instructions. No charge for the above information. See advertisement on pages 164 and 165. Victor J. Evans & Co., 192 Ninth, Washington, D. C.

SIGNS, Cards, Banners, Easily Painted with Letter Patterns. Samples Free. Outdoor Adv. Service, Lockport, N. Y.

100,000,000,000 GERMAN Mark free with 100,000 Polish Mark for 60c. 10,000 Austrian Kronen 35c, and 10,000 Hungarian Kronen 50c. Don't send us any money, but write for Dealer's Terms. Arrow Sales, 1748 North Park Ave., Chicago.

PATENTS. Write for my free Guide Books "How to Obtain a Patent" and "Invention and Industry" and "Record of Invention" blank before disclosing inventions. Send model or sketch of your invention for instructions. Promptness assured. No charge for above information. Clarence A. O'Brien, Registered Patent Lawyer, 589 Security Bank Building, directly across street from Patent Office, Washington, D. C. See pages 162 and 163.

START Business—Make, Sell Auto Polishes, Wall Paper Cleaner, 3c Coffee substitute, Salves, Liniments, Cements, Silvering Mirrors. 150 selected formulas, etc., and Digest three months 25c. Digest, Grand Rapids, Mich.

ENTER a new business. Earn \$3,000 to \$6,000 yearly in professional fees making and fitting a foot specialty, openings everywhere, with all the trade you can attend to; easily learned by anyone at home in a few weeks, at small expense; no further capital required, no goods to buy, job hunting, soliciting or agency. Address: Stephenson Laboratory, (1) Back Bay, Boston, Mass.

MECHANICS and Repair Shops—Get into a profitable business for yourself by establishing an Authorized Simplicity Cylinder Grinding Station, reconditioning automobiles, trucks and tractors. Also become direct factory representative. \$600.00 investment required—installment plan. Be the first in your community to get our plan. Write—Simplicity Mfg. Co., Port Washington, Wis.

MANUFACTURE Millerite! Ethyl-Super-Fuel ingredient for Gasoline. Increases Power, Mileage—saves gas—easily mixed—profits great—valuable Formula Literature of this, Lightning Electrolyte, Kor-Kit, Pro-Ter-U, Amazon Rubber Repair, and fifty other Biggest selling Specialties in all lines will be sent on request. Miller, Chemist, 1115 Grand Central Ave., Tampa, Fla.

DOLLARS! Dollars!—1,700 Money Making Plans free. Goldberg's, Rockville, Conn.

EVERYONE knows of the remarkable success of the 10c Stores. Now come the 25c and 50c Mail Order Business. Write for free circular. Taber Bros., 311 Fifth Avenue, New York.

MONEY-MAKING Plans 60. Hundreds of Formulas. Wholesale Directory. All for \$1.00. Particulars free. G. Genner, 726 Julia, Jacksonville, Fla.

START a Real Business of your own! Write for full particulars concerning a liberal proposition. Monarch Specialties Co., 425 North Leamington, Chicago.

"HOW to Sell Patents" free. Patent News-H, Washington, D. C.

GET Money in Your Mail. "Lambert's Mail Order Secrets" contains successful methods never before published. Particulars free. Leon Lambert, 539-D Kaufman Bldg., Wichita, Kans.

METAL Articles Manufactured. We specialize in stamping, drilling and assembling. Inventions financed, patents obtained. Address with description or sample. Barritt & Bates, A-1821 Berceau Ave., Chicago, Ill.

MAKE money with your camera. Lancaster-B, Box 438, Los Angeles.

INCH Display Advertisement 186 Magazines Year \$50. Wood's Popular Services, Atlantic City (N. J.)

ATTENTION! You can have a business of your own. Establish and operate New System Real Estate Business, brokerage and insurance agency in your community. Office at home. Earn \$5,000 year. Representatives wanted everywhere. Send stamp free booklet. Hayes Realty Association, Cincinnati, Ohio.

MAKE Money at Home—making toys. We show you how. Send \$1 for complete working drawings and instructions. Dekalb Designing Co., Decatur, Ga.

UNPATENTED Ideas Can Be Sold. I tell you how and help you make the sale. Free particulars (Copyrighted). Write W. T. Greene, 810 Jennifer Building, Washington, D. C.

INVENTORS—Write for our Guide Book, "How to Get Your Patent" and Evidence of Invention Blank. Send model or sketch of your invention for our free Examination and Instructions. Randolph & Co., Dept. 435, Washington, D. C.

EXCEPTIONAL Opportunity for sales Manager capable of handling state distribution. Marvelous new Adding Machine. Retail \$15. Work equals \$350 machine. Tremendous possibilities. Unlimited Profits. Write quick for details. Lightning Calculator Co., Dept. B, Grand Rapids, Mich.

MAIL Order Business is your opportunity. Brenner's Famous Handbooks teach how to start small, grow big. Sell merchandise, service, ideas; enormous profits. Spare time to begin. Get complete set, 11 books, \$3.00, and be posted. Brenner, 335 Walnut, Philadelphia. Descriptive Catalog and big batch interesting mail order information, 25c. None free.

I MADE \$20 a Week Home. French Breadmaking. 15 years' experience; Free Booklet tells. Ashbrook 47, Marengo, O.

CHEMICAL Expert will furnish Formulas and Trade Secrets. All lines. Lists Free. W. L. Cummings, Ph. D., 228 Gordon Ave., Syracuse, N. Y.

MAKE toys and novelties at home. Big profits. Instructions and 200 Illustrations. 25c. Astrolite Company, Sharnsburg, Pa.

WE Start You in Business, furnishing everything; men and women, \$30.00 to \$100.00 weekly operating our "New System Specialty Candy Factories" anywhere. Opportunity Lifetime; booklet free. W. Hillier Hagdale, Drawer 4, East Orange, N. J.

DOLLARS Yearly in your Backyard. No mushroom dope. Particulars free. Metz, 313 East 89th, New York.

PUBLISH a Monthly Magazine. We will tell you how. Very interesting, profitable. Information free. P. M. Lutz Printing Co., York, Pa.

EARN \$10 daily silvering mirrors, plating and refinishing metalware, autos, chandeliers, bedsteads, headlights. Outfits furnished. E. Decie Laboratories, 1133 Broadway, New York.

"WHAT to Invent for Profit" free. Patent News-C, Washington, D. C.

MARBLE mixing instructions, covering wood or cement flooring 1/2 in. thick, fire-proof, waterproof, low cost, sanitary, all colors. Particulars, 200 Illustrations free. Chris Mahler, Box 125, Huntington, N. Y.

LEARN the collection business. Good income, quick results. Interesting booklet, "Skillful Collecting" free. National Collectors Assn., Long St., Newark, O.

PATENTBOOK, 139 mechanical movements and illustrations, sent free. Labinere, 3 Parkrow, New York.

GOLD Window Sign Letters. Manufacture them at home. Unlimited profits and business opportunities. Complete instructions and patterns. No experience required. Particulars, Wiltedring, 1144 Pleasant Street, Oak Park, Ill.

WANTED—BUSINESSES FOR SALE

IF You Want to Sell Your Business for Cash quickly and privately, we take the prospective buyer directly to you at our expense, no matter where located. We specialize in selling out-of-town businesses. If your business is worth \$5,000 or more, write us The Mutual Security System, 68 W. Washington St., Chicago.

CHEMISTRY

16-PAGE catalogue for chemists and experimenters, 5c. George Ott, 1218 Chestnut St., Reading, Pa.

MANUFACTURING Processes, Formulas, Research. Robert Henderson, Consulting Chemist, Madison, Maine.

YOUR chemical problem solved and working process furnished Five Dollars. Write me. W. Stedman Richards, Consulting Chemist, address, Box 2492, Boston, Mass.

TECHNICAL information, analyses, formulas, trade secrets. Jacob Shlyter, Chemist, 2325 East St., Davenport, Iowa.

FORMULAS AND TRADE SECRETS

500 FORMULAS, including Luminous Paint—Renewing Dry Batteries—Mechanics' Soap—Gas Toxic—25c. Catalog Free. Ideal Book Shop, 5501-P12, North Robey, Chicago.

FORMULAS The best Chemical Science can devise—Guaranteed Reliable Processes in all lines. Stamp brings big bunch valuable literature, interesting lists. Don't buy till you see what I can give you, 27 years supplying the best. Miller, Chemist, 1113 Grand Central, Tampa, Fla.

NEW; Different; Make—sell Extracts, Flavors, Beverages, Syrups, etc. Lists—valuable information free. Meriden Co., 3322 White Bldg., Seattle, Wash.

1,000,000 FORMULAS, 1,616 pages, \$1.98. 500 Formulas Free if you order quick. Ideal Book Shop, 5501-M12, North Robey, Chicago.

BEAUTY Clay formula with selling plan 25c. R. Yarrington, Box 560, La Crosse, Wis.

10,000 SELECTED chemical, technological and practical recipes and processes, including hundreds of so-called trade secrets for every business, alphabetically arranged in one large volume of 800 pages. Price \$4 postpaid. Popular Mechanics Book Dept., 260 E. Ontario St., Chicago.

FIFTEEN Ink Formulas, 10c (coin). R. E. Brang, Broadheadville, Pa.

COLD Cream—Never Turns Rancid. Formula Dollar Bill. Guaranteed. Alchemist, 57 Saratoga, Yonkers, N. Y.

AGENTS WANTED

START a business of your own. Sell goods under your own private brand. Toilet articles, food products, household specialties. Tremendous profits. Big repeat business. We supply everything needed. Write for our attractive proposition. National Scientific Laboratories, 251 Monroe, Richmond, Va.

GENUINE Gold Leaf Letters anyone can put on Store windows. Guaranteed to never tarnish. Large Profits. Enormous Demand. Free Samples. Write today. Metallic Letter Co., 434-A North Clark, Chicago.

DUSTLESS Sponge Cloth. New Invention. (1) Rub—Dusts, Cleans and Polishes Automobiles, Furniture, Planes. Retail (50c)—Costs (15c). "Sample Free." NuLife (18) Sponge, Hartford, Conn.

NO Dull Times in the Food Business. Selling Federal Pure Food Products is the greatest, surest and safest business in the world today, and here is your opportunity to get into it. You can make \$3,000, \$5,000, \$10,000, or more per year—the only limit is your ability to take care of the business. You will need no experience or money to get into this business as we send you our handsome \$15.00 Sample Case on Trust and teach you everything you need to know. No Dull Times, for the People Must Eat, and our food products are the fastest selling, surest and quickest repeat order goods in the world. Sell on sight in every home where food is used—repeat orders immediately and every week thereafter. A real big business all your own. Every new customer adds a great deal to your weekly income. Your business once established, has a market value just like a store and can be easily sold. The greatest money making opportunity of your lifetime because you risk absolutely nothing as we guarantee your sales, and we will not let you fail. Remember! Guaranteed! Best products, biggest sellers, surest repeat orders. No capital or experience is required. We furnish capital and everything necessary for you to become a Federal Distributor. Exclusive territory will be given honest men or women who write at once. Federal Pure Food Company, 2309 Archer Avenue, Dept. A, Chicago, Ill. Largest packers of Pure Food specialties in the world. Reference, any bank, Dun or Bradstreet rating agency, Express or Railway Company in America.

CALIFORNIA Rosebuds selling like hot cakes. Agents coinng money; new stuff. Big profits. Catalog free. Mission Factory P.M. 519 No. Halsted, Chicago, Ill.

\$6 TO \$15 Daily—Year Around Position, monthly bonus besides. Groby made \$499.50 in 30 days, Cregan \$443.03, Whiteside, \$435.00, Babey \$392.00, Bickel \$339.91. No experience or capital required. Exclusive patented necessity—millions of prospects, homes, stores, schools, factories, auto and truck owners. Spare time satisfactory. We deliver and collect also carry accounts. Cash in on our advertising and approval by National Board and big users. Our original new plans produce results. Write quick for full details. The Fyr-Fyter Co., 445 Fyr-Fyter Bldg., Dayton, Ohio.

AGENTS: \$12.85 daily—Introducing "Kui-Ezy" Self-Sharpening Shears. Cut to the end. Automatic. Guaranteed 20 years. Not for sale in stores. Every housewife interested. Quick startling demonstration makes sales easy. Spare time workers make enormous profits. No capital or experience needed. Write quick for demonstrating outfit. Macoshee Manufacturing Company, Shear 15412, Cincinnati, Ohio.

300% PROFIT: Whirlwind Seller. Tremendous repeater. "Kleanrite." Marvelous Discovery. Washes clothes without rubbing. Premiums for customers. Sells 20c. You make 15c. Free samples make easy sales. Write quick. Bestever Products Co., 1941-K12 Irving Park, Chicago.

AGENTS: \$40 a week selling guaranteed hosiery for men, women and children. Must wear 12 months or replaced free. Write for sample outfit. Thomas Mfg. Co., Class 162, Dayton, Ohio.

MAKE 10,000 miles without a puncture. Insody Tyres positively prevent punctures and blowouts. Double tire mileage, any tire, old or new. Use over and over again. Low priced. Agents wanted. Write for terms. American Accessories Co., Dept. 378, Cincinnati, Ohio.

AGENTS—Men and Women. \$5 Million women are anxiously waiting to buy the 3 In 1 Hot Water Bottle—Icebag—Fountain Syringe combination. Commissions daily. No delivering. Write for startling money making plan. 3-In-1, Middleboro, Mass.

150% PROFIT on Eradium Luminous Crucifix. Shines in the dark—sells itself. Our agents making \$75.00 to \$100.00 a week. Write Pioneer Corp., 6301 Yale Ave., Chicago.

YOU can make \$100 a week selling our new specialties: Ivoryplak and Lykoff Paintings—also complete line of Photo Novelties. 60% profit. Experience unnecessary. Perry Photo Novelty Corp., Sec. PM-12, 1793 Jerome Ave., New York.

IF you can sell hosiery and want the largest commissions, 100% repeaters, guaranteed quality, most complete hosiery line in the country, write Dept. 12, Munch Hosiery, 110 E. 23d St., New York.

\$10 DAILY, more to real workers. Marvelous new polishing cloth sells like hot cakes to housewives, automobilists, musicians, merchants, everybody. 100% profit. Popular price. Big repeater. Samples 2c. Write for Money-Coining plan. Denmae Co., 317-E Madison Ave., New York.

MILLERITE: Here it is! You're read about this New Wonderful Ethyl-Super-Fuel Ingredient for Gasoline—Increases Mileage—Saves Gas—Knocks Carbon—Easily Mixed from my simple Formula—profits great—\$5,000.00 to \$50,000.00 for you if you hurry!! Don't pass this by you'll be sorry—but send today for full descriptive literature of this and other valuable Formula Lists describing latest, biggest selling specialties in all lines as Mendit, Fabric Mending Cement, Marcel Permanent Hair Curling Fluid; Denta-perl Tooth Whitener; Balloons and other thin dipped rubber goods; Flynox—few drops kills roachful flies; Amazon Self Vulcanizing Repair; Pre-Tex-U only Guaranteed Fire Extinguisher; Pure Food Products; Toilet, Medical, Household, Automobile Office Specialties—latest in all lines, 27 years supplying the best in Formulas and manufacturing information. Highest References. Miller, Chemist, Tampa, Fla.

WE want one ambitious man in each county as Sales Representative. Our salesmen make big money taking orders for the Cole Visible Gasoline Gauge. Only scientifically accurate gasoline gauge that fits on instrument board—always in sight—prevents short measure—stops running out of gas—low price—in class by itself—sells on sight. \$10 to \$20 a day for six to eight hours. You get your pay in advance. We deliver and collect. Commissions paid on repeat orders. Exclusive territory. Capital not necessary. Write The Stemo Engineering Co., 203 Webb St., Dayton, Ohio.

AGENTS—300% Profit. New specialty sells for 50c. Real \$1.00 value. Thirty other wonderful sellers. New inventions, all household necessities. Sample outfit free. Write today. General Products Co., Dept. 17W, Newark, N. J.

SELL every merchant Embossed Display Signs. 300% Profit for you. Means a fortune for workers. Write today for territory. Details free. Sample free. Artistic Sign Works, 799 Broadway, New York.

PEARLS will bring you \$1,000 from now until Christmas. You offer real values and get big commissions in advance. Write right now. International Products, Suite FX, 398 Broadway, New York.

FREE—Twelve big money-making opportunities. Enclose stamp. Lawrence Products Company, Beaver Dam, Wis.

\$300.00 A MONTH to distribute everyday household necessity in rural and small town districts. No money needed. Million dollar firm behind it. Write for particulars and state territory desired. B. M. Johnson, 611 W. Lake, Chicago.

AGENTS, sell 1925 Catholic Art Calendars. Samples 40c. Demen, 114 Ford St., Providence, R. I.

AGENTS—make \$15 daily selling men's neckwear direct to wearer. Write to-day. Continental Mercantile Co., 54-58 Canal St., New York.

MARVELOUS Radio Gas Lighter—lights instantly, sells instantly, easily demonstrated, good for 10,000 lights; retails 25c, costs \$10 gross, \$25 profit. Send \$1.00 for sample dozen with self-selling plans. Mastelite Co., 110 East 23rd, New York.

WONDER Radio—The talk of the country. Lark Tube Set, range 1,000 miles, beautiful panel, size 7 by 1 1/2. \$25 to \$30 daily for you; samples \$8; special prices to distributors. International Radio Co., 152 W. 42d, N. Y.

BIGGEST season on! Take orders for fraternal and monogrammed leather goods, belt buckles, emblem jewelry. Quickest, easiest, profitable Xmas year-round sellers. We deliver. Crafts Company, 436 Como Bldg., Chicago.

\$10 A DAY easily earned taking orders for our big line quality soaps, perfumes, toilet goods, extracts, spices, foods, tinsels, jewelry, remedies, novelty needle books, rubber goods, etc. Men and women write for big offer. Catalogs, outfit free. Western Products Co., Dept. 41, 606 N. Oakley, Chicago.

\$5.00 AN hour for your spare time. New proven success. Send dime for full particulars. K. Roths, 3949 Metropolitan, Chicago.

AGENTS: Newly invented pocket roller sells to every man you meet. \$10.00 to \$30.00 daily easy. The Pocket Roller Co., 3042 No. Troy, Chicago.

CLEAN UP \$100.00 weekly with our marvelous Christmas packages selling from 50c to \$3. Great crew manager's proposition. Postal brings unique plans. Davis Products Co., Dept. 56, 1311 Carroll, Chicago.

AGENTS, Make Big Money, selling new auto invention. Hoffenberg's sold 900 in 2 months. Profit \$2700. For full particulars write Stransky Co., Dept. Z-12, Pakwan, S. Dak.

AGENTS, Salesmen, Demonstrators, you will have the devil's own time trying to find a better seller than "Zippo." If there was such a thing we'd have it. Splendid profit on 30c "Go Getter" repeat article that sells on ten second demonstration. Works While You Watch It. Demonstrates value, while others waste time making claims. New discovery! Greatest Scientific Triumph of the age. It's the berries. Haven't room to tell our story here. Write immediately. Karam-Smith Co., 612 Bozart St., Ft. Wayne, Ind.

EARN money at home spare time or evenings. No peddling. Permanent. Work in your own home. Write Downs Co., 2323A Myrtle, St. Paul, Minn.

WE pay \$18 a week, furnish auto and expenses to introduce our Soap and Washing Powder. Buss-Beach Company, A-42, Chipewa Falls, Wis.

AGENTS: \$15-\$20 daily selling "Swing-up," the great accident preventer. Every auto driver wants one. 100% profit. Free offer. Industrial Development Corp., Dept. 22, Bridgeport, Conn.

\$50,000 PICTURE Man Friedman made canvassing. Beginners can make \$100.00 weekly with my sales talk. Experienced men make more. Free book "Profits in Portraits" explains. Samples Free. Picture Man Friedman, Dept. 8-B, 541 W. Lake, Chicago.

AGENTS: Sell Roberts Lightning Mixer (Patented) Direct. Every housewife wants one. Retail \$1.00. Over 100% profits. Big money opportunity. Employ sub-agents, men, women. Write for Protected Proposition free now. National Co., 286 Cambridge, Mass.

GOODYEAR Mfg. Co., 1740 Goodyear Bldg., Kansas City, Mo., is making an offer to send a handsome raincoat free to one person in each locality who will recommend it to friends. Write today.

WONDERFUL Invention eliminates needles for photographs. Preserves records. Abolishes scratching. Day's supply in pocket. \$29 daily. Sample on approval if requested. Everplay, Desk B-12, McClurg Bldg., Chicago.

PORTRAITS, photo pillow tops, frames, sheet pictures, medallions, merchant's signs, food products, rubber aprons, guaranteed hose, toilet requisites, luminous crucifixes. Catalog 50 specialties free. 30 days' credit. Jas. C. Bailey Co., Desk A-12, Chicago.

AGENTS, Salesmen—Sell New Thermo-static Automatic Carburetor Control Attachment for Fords. Big Profits, full or part time. Burns 95% air. Doubles Mileage. Attached in 2 minutes. No drilling. Does automatically exactly what Ford manual says do by hand. Cadillac now using Thermo-static Carburetor Control under Bianche license. Write today. A. C. Blanche & Co., Dept. 730C, 692 Lake St., Chicago.

AGENTS, both sexes, we manufacture and control new household article. Fast seller. Big profits. Exclusive territory. Write now. Connolly, 123 Liberty St., New York.

AGENTS: Write for free catalog. 200 sure sellers. Wearing apparel, Novelties, etc. Economy Sales Co., Dept. 212, Boston, Mass.

A BUSINESS of Your Own—Make and Sell Chipped Glass Name and Number Plates, Checkerboards, Signs. Large Booklet Free. E. Palmer, 512, Wooster, Ohio.

\$50.00 DAILY taking orders beautiful guaranteed embroidered (two colors) washable table cloth. \$2.95. Also raincoats, sweaters, leather coats, hosiery, etc. Bargain prices. We deliver. Service Mfg. Co., Box 770, Dept. 40, Chicago.

AGENTS—\$100 a week for full time; \$25 to \$50 spare time. Equipment and car free. Exclusive territory. Sound permanent proposition. A rare opportunity, but you must act quickly. Write for particulars today sure. American Products Co., 1987 American Bldg., Cincinnati, Ohio.

\$5 TO \$15 daily—(Sworn Proof) Introducing New Guaranteed Hosiery—Must wear or replaced free—No capital or experience required—You simply write orders—We deliver and collect—Your Pay Daily. Spare time satisfactory. Macoshee Textile Company, Room 5812, Cincinnati, Ohio.

TURN your spare time into dollars selling Polmet Polishing Cloth that cleans all metals without liquid, paste or powder. Retail \$25. Our agents say it sells like "hot-cakes." Prove it yourself with free sample sent on request. F. C. Gale Co., 122 Edinboro St., Boston.

AGENTS! Profit with first order selling shirts. Factory to wearer. \$50 to \$100 weekly. Write Swanton Sales Co., Dept. 12, 1270 Broadway, New York.

YOU can sell every merchant in town our changeable signs. Large profits; easy sales. Write for territory now. Changeable Sign Co., 581 East 102nd, Cleveland.

150% PROFIT—New Fast Seller. Powdered Hand Cleaner. "Sample Free." Best-ever. 1941-C12 Irving Park, Chicago.

ALUMINUM House Numbers Sell Quickly. Good Profits. Write for Sample. Manufacturers' Agents. Post Office Box 964, Waterbury, Conn.

MOST Wonderful Seller. 86c profit every dollar. No stock to carry. License unnecessary. Sample free. Mission Factory PM. 519 No. Halsted, Chicago, Ill.

\$60-\$200 A WEEK. Genuine Gold Letters for store windows. Easily applied. Free samples. Liberal offer to general agents. Metallic Letter Co., 438-D North Clark, Chicago.

EVERYBODY Needs and Buys the "Business Guide." Wells cleared \$1,150 in 35 days. Send for sample. It's Free. Nichols Co., Dept. 4B, Naperville, Ill.

FREE Sample. "Rain Shield Wiper." Retail \$1.00—costs (25c). Just Invented. No Cloth—No Paste—No Attachment. Solid Clear and Rainy Days. (1) Rub keeps Windshield Clear (24) hours. Automobiles buy quickly. Riley made \$198 three days. Experience unnecessary. Wonderful Sideline. NuLife Corporation, Hartford, Conn.

AGENTS: \$11.80 daily in advance (send for sworn proof) Introducing New Insured Hosiery—47 styles—35 colors—guaranteed seven months—Winter line now ready—No capital or experience required—You simply take orders—We deliver and collect (or you can deliver, suit yourself). Credit given—Pay You Daily—Monthly bonus besides. We furnish samples—spare time will do. Maccochem Textile Company, Room 25612, Cincinnati, Ohio.

START a business of your own. Sell goods under your own private brand. Toilet articles, food products, household specialties. Tremendous profits. Big repeat business. We supply everything needed. Write for our attractive proposition. National Scientific Laboratories, 251 Monroe, Richmond, Va.

AGENTS Wanted—Sales Representatives to handle fast selling line to residences, offices, stores and factories; work up a big business. Write for territory. Indiana Mfg. & Electric Co., Dept. 5, Marion, Ind.

BIG Profits. 50 Fast Sellers. Rubber Specialties—Everybody needs and buys; \$50 Weekly easily made. B. & G. Rubber Co., Dept. 674, Pittsburgh, Pa.

AGENTS: Big Earnings! Selling greatly needed Radio feature. Newly patented. Low price. Tremendous Market. Nationally advertised. Radio Equipment, 20 H. Stuart, Boston, Mass.

MONEY Shining Autolights, Radiators, Mirrors, tableware, stoves, Outfits. Methods Free. Sprinkle Plaster, 287 Marion, Ind.

AGENTS: Sell two shirts for price of one. Walton Duplex shirts are reversible. Make \$15-\$25 daily. We deliver, collect. Write for "Your Opportunity." Walton-Duplex Co., 522 Brooks Bldg., Chicago.

FREE Samples 100 Hosiery, Neckwear styles and colors. Free ties and hosiery to Customers. Highest Commission. 10% Bonus. The Lexington Co., Dept. 1500, Lexington, Ky.

NEW one-price line of men's clothes. Sensational values. \$23.50 for a suit or overcoat. Finest all-wool goods. Big commissions paid in advance. Earnings of \$20.00 a day sure. Write at once to Dept. 130, William C. Bartlett, Inc., 850 West Adams St., Chicago.

AGENTS—Something new. Wonderful invention. Food Owners wild over it. Distributors profit 300%. Thirty-day trial offer. Write K. Super, 1304 Fondular, Milwaukee, Wis.

AGENTS—You can make \$1.00 per sale, selling our line of Wringer and Dust Mops to the housewife. Ten to Twenty sales per day. Samples—Wringer Mop \$1.00—Dust Mop \$1.50—Both \$2.50 Postpaid. The E. & N. Mfg. Co., Delphos, Ohio.

GREAT opportunity for hustlers to clean up with Sattler Automobile signals. Every auto driver buys on sight. Wonderful for closed and open cars. Simple construction. Retail \$1.25. Substantial discount to agents. Particulars free. Write or wire today. Hans Sattler, Sheboygan, Wis.

AGENTS, Sell guaranteed spark plugs \$12.00 per hundred. Sample 25c. Kelly Lamp Works, Oak Park, Ill.

NEW line. Big Profits. Quick Sales. No stock to carry. Clean up before Christmas. Holycoft, 7420 Moneta, Los Angeles, Calif.

WHY Sell for Other Agents? Pocket Both Profits! Deal direct with manufacturers. "MP" specialties for home, for auto, nationally preferred. Join "MP" army of jiffy sales, gewitz profits, customers reordering constantly. Free outfit, credit, snappy assistance start your dollars piling. Your territory may be untaken—write this hour: Moto Products Company, 1332 Milton, Grand Rapids, Mich.

SAFE! Owl Self-Shining Stove Polish Agents make money and friends. Ready? Owl Polish Factory, Scranton, Pa.

CREW Managers—Distributors—Magic Washing Compound. Your name on package. Sells Fast. Great Repeater. 300% Profit. Samples with your name on furnished free. Besco, 1943-W, Irving Park, Chicago.

BIG Profits. New \$3.50 Automatic Adding Machine. Quick Sales. No competition. Ten daily easy. Absolutely accurate. Fully guaranteed. Pocket size. Business people everywhere positive customers. Exclusive territory to workers. Act quick. Bassett Company, 1458-A Hollywood Ave., Chicago.

SELL Komik Display Cards, Prize tickets, card holders, display stands, etc. Big Demand. Komik Advertising Co., Cambridge, Ohio.

\$3.00 AN Hour Easy—all or spare time—no capital or experience required—homes, churches, stores will buy the "Diamond Light"—300 Candle Power—beats electricity—burns kerosene or gasoline—lamps, lanterns—write for free outfit offer. The Akron Lamp Company, 432 Lamp Bldg., Akron, Ohio.

ANY man handy with paint brush can start furniture refinishing, job painting and handman business on nearly nothing; mostly all profit. Winning plan brings money quickly. John Bruceland, 1457 So. Ninth, Philadelphia, Pa.

MEN wanted to repair and refinish old Window shades any color. No brushes used. Be your own boss. Write Home Service Co., Superior, Wis.

SELL Magic Mending Fluid. Hosiery and Garments mended without thread. Withstands washing, boiling and ironing. Good profits. Akynes, 734 Major, B, Salt Lake, Utah.

AGENTS—N-R-G Laundry Tablets, the old reliable money-maker for live agents. Millions sold—200% profit—sales waiting for you. Clothes washed spotlessly clean in 10 minutes without rubbing. Free samples. N-R-G Company, 782-B, N. Franklin, Chicago.

AGENT for Ford Accessory. Capital unnecessary. No freezing, no boiling in any climate, running or standing. Cheap and practical. Anyone can install. Weighs under pound. Thousands making good. Millions demanding it. Winter is best time to sell—distributors make money fast. Write to Airlock Products, 703 Willow Street, Long Beach, Calif.

AGENTS—Best seller; Jen Rubber Repair for tires and tubes; supersedes vulcanization at a saving of over 500 per cent; put it on cold. It vulcanizes itself in two minutes, and is guaranteed to last the life of the tire or tube; sells to every auto owner and necessary dealer. For particulars how to make big money and free sample, address Amazon Rubber Co., Philadelphia, Pa., Dept. 505.

AGENTS—Marvelous new invention. Automatic fire alarm to protect the home. Saves lives. Sells on demonstration. No competition. You make 150% profit and can easily earn \$100 a week. Dee Electric Co., 4683 N. Racine, Chicago.

MAIL order business; big profits; no stock to carry; we furnish everything; particulars free. J. M. Hunt Company, Morrisville, Pa.

AGENTS—Sell "Instant Shine" Metal Polishing Cloths, 25c; costs 8 1/2c. Sample free. Instant Shine Polish Co., Albany, N. Y.

NEW Idea. Easy Way Plan Going Over Top Big. Men, Women, Boys, Girls working it make \$2.00 to \$5.00 daily for few hours' easy work. No experience. For quick action send 25c for working samples and instruction, refunded. Free: Pretty Oriental Novelty, Thalinger, Dept. 1, 3025 Enright Ave., St. Louis, Mo.

AGENTS—Men and Women, sell useful articles for the home, 100% profit. For catalog and prices, P. Miller, Box 3, Tremont Station, New York.

AGENTS—\$15 a day. Easy. Quick Sales. Free auto. Big weekly bonus. \$1.50 premium free to every customer. Simply show our beautiful 7-piece solid aluminum handle cutlery set. Appeals instantly. We deliver and collect. Pay daily. New Era Mfg. Co., 863 Madison St., Dept. 21-BQ, Chicago.

LIVE Agents Make \$10 Day selling Eureka Strainer and Splash Preventer for every water faucet. Takes on sight. Widely advertised and known. Get details today. A. R. Seed Filter & Mfg. Company, 73 Franklin, New York.

NO Steamy, Foggy Eye glasses or wind shields from hot or cold weather if cleaned with Audrey's Stay-Clear. Sample 25c. Audrey's Agent Supply, Box 2091, Louisville, Ky.

SUCCEED With Your Own Products—Formulas By Experts. Manufacturing Processes. Trade Secrets. Different. Dependable. Profitable. Interesting Catalog Free. B. Thaxly Co., Washington, D. C.

MAKE Big Money Easy in your spare time. Double profits. New Self-Wringing Mop. Eastway Company, 405 St. Paul, Baltimore, Md.

AGENTS: Experience unnecessary. Sell Men's, Women's, Children's hosiery to consumer. 16c to \$1.50 Pair. Big Profits. Samples furnished. Write Banner Hosiery, 182 No. LaSalle, Chicago.

AGENTS: Our guaranteed all wool tailor made suits and coats at \$31.50 are \$20 cheaper than store prices. Fall line greatest ever. Easy to sell, we train you. Comm. in advance. Write for great new sales plan. J. B. Simpson, Dept. 1020, 843 Adams, Chicago.

DON'T be an agent—Get my System and hire agents. Particulars free. Bazaar, 701 E. 47th St., Chicago, Ill.

BIG Money Now—Sells faster than ever—hard times improve sales. Darn E.-Z. Universal fabric Cement finds a buyer in every home, office, store and factory. New selling plan with every order. Darn E.-Z. Laboratories, Dept. P.M., Dayton, Ohio.

FREE Goods: Agents' headquarters; wholesale, any quantity, soaps, shampoos, creams, perfumes. Fastest selling combinations. Quickest money. \$20 daily. American Preparations, Park Place, New York.

SELL Union Label All-Wool Made-to-Measure Suits direct to wearer for \$24.50. Scott System Wholesale Tailors, 99M, Bedford Street, Boston.

MAKE \$15 daily just taking orders for wonderful new coat; retails \$45.00. Rain-proof Mfg. Co., Parkersburg, West Va.

THE Agent's Buyers' Guide tells where to buy everything. Copy, 50c. Wilson, Publisher, 1409 Broadway, New York.

AGENTS—\$40 to \$200 weekly putting up our Burnished Genuine Gold window letters. Experience unnecessary. Free samples. Premier Letter Co., 121 No. Francisco, Chicago.

DISTRIBUTORS Wanted—Men and Women. Staple Product. Quick Seller. Big Profit. Waxoline Laboratories, 549 West Quincy Street, Chicago, Ill.

\$300 FIRST Two Weeks—made by Weigand, Johnstown, Pa., selling "Slide-O-Graf Jr." Novel, effective—sidewalk advertisement projector. Sells fast, big non-competitive field. \$14 Profit every sale. Standard Slide Corp., 207 W. 48th St., New York.

SAFETY Comfort Seat for Cleaning windows, sells to every home and building where windows must be cleaned. Prevents damage and accidents. Big profit; quick sales. No competition. Super-Set Mfg. Co., Dept. 46, 503 Fifth Avenue, New York.

AGENTS—No experience or capital necessary selling rubber goods demanded everywhere. Fancy Aprons, Women's Necessities, Baby Goods, Household Specialties, etc. Big Profits. Write American Rubber Products Company, Dept. 308, Pittsburgh, Pa.

\$1-NECESSITIES—98c—Profit. Catalog—Dime. Moxe Mfg., 1234 Clay, Paducah, Ky.

AGENTS Wanted—To distribute new Drug Preparation. Write for Territory. Walvern Co., 2340 Fullerton Ave., Chicago.

ANY man can easily make big money by addressing Consolidated Co., 632 South Dearborn, Chicago.

AGENTS Wanted. Men and Women. Exclusive territory. Marvelous new camera takes and finishes pictures inside camera in one minute. Wonderful opportunity. Crown Co., 909 Romax Bldg., New York.

AGENTS: Big Profits, Gold Sign Letters. Easily Applied. Samples free. Liberal offer to General Agents. Inter-State Sign, 2953 Armitage Ave., Chicago.

EMBOSSED Window Sign Letters, 1,000 for \$9.75 1 1/2 inch, 2 1/2 inch, 4 inch assorted. All guaranteed non-tarnishable and perfect cut. A bargain of course. 100,000 in stock. Poff Sign Works, 1965 Telegraph Ave., Oakland, Calif.

MANUFACTURE New Fast Selling Articles. Free list of plans, patterns, molds. K. Barter, 3837 Tracy, Kansas City, Mo.

MONEY from start. Household necessity. Invisible adhesive. Mends any cloth. Sensational seller. Repeats. Exclusive territory. Carson Supply Co., 332 Shubert Bldg., Kansas City, Mo.

AGENTS, make \$20 a day selling novel advertising specialty. Every business man uses it. All or part time. Better than 40% commission. No investment required. It sells itself. Write for particulars. Commonwealth Specialty Co., 329 Main Street, Webster, Mass.

\$75 A WEEK. Man or Woman Wanted with ambition and industry to distribute Rawleigh's Household Products to steady users. Several fine openings in nearby cities and towns. We train and help you so you can make up to \$100 a week or more. No experience necessary. Pleasant, profitable, dignified work. Write to-day. W. T. Rawleigh Co., Dept. IL-8253, Freeport, Ill.

START a business of your own. Sell goods under your own private brand. Toilet articles, food products, household specialties. Tremendous profits. Big repeat business. We supply everything needed. Write for our attractive proposition. National Scientific Laboratories, 251 Manne, Richmond, Va.

PATENTS. Write for my free Guide Books "How to Obtain a Patent" and "Invention and Industry" and "Record of Invention" blank before disclosing invention. Send model or sketch of your invention for instructions. Promptness assured. No charge for above information. Clarence A. O'Brien, Registered Patent Lawyer, 539 Security Bank Building, directly across street from Patent Office, Washington, D. C. See pages 162 and 163.

TWELVE Beautiful Dollar Knit Ties. Special \$4 per Dozen. Sent C. O. D. M. Zolin Co., 191 Farwell, Milwaukee, Wis.

AGENTS Wanted—Sell Treado, prepared rubber for filling holes in heels and soles or breaks in uppers of rubbers, tires, etc. Apply with knife, no cement, no soiled hands. Big profits, repeat sales. Treado Co., 238 East 45th St., New York City.

AGENTS: \$50.00 Weekly Selling New Specialty; every merchant buys; sample 25c. H. A. Johnson, 1721 Almie St., Chicago.

AGENTS—Sell the Latest, Latest, Quickest selling specialties ever known. Make 200% profit. No competition. Practically every man and woman buys from two to six on sight. They can't resist. Act now. Get the Cream. Send 50c for three samples, one of which retails for \$1.00. Hamilton Novelty Mfg. Co., 220-222 North State Street, Chicago.

ADVERTISING Novelty Pencils and Watch Charms with Microscopic Views enlarged 500 Times, 25c seller. Three Assorted Samples and Catalogue sent for 25c. Grandefeld, 1238 Theriot Ave., Bronx, New York.

ARE you old at forty? See our advertisement on page 192 of this issue. The Electro Thermal Company, 2137 Main St., Steubenville, Ohio.

IRONWEAR Suits \$13.50. Never wear out. Working suits with style that sell. Get our agency. Good income. Write Ironwear Co., 293 Chauncey, Boston.

FOLD-UP-CHAIR Converts any chair into highchair for baby. Agents wanted immediately. Ganger Company, 3125 Essex Road, Cleveland.

\$1.00 BRINGS Pound of Samples: Bonds, Banknotes, Coins; 10 Countries; 57 varieties; 100 pieces. Agents Clearing Up. Hirschbill, 70 Wall St., N. Y.

AGENTS—Men and Women. 35 Million women are anxiously waiting to buy the 3 in 1 Hot Water Bottle—Irish—Fountain Syringe combination. Commissions daily. No delivering. Write for startling money making plan. Lobl Manufacturing Corporation, Middleboro, Mass.

WANT Distributing Agents for Hanslick, the new original powdered handsoap. Removes grease, grime, ink, paint, and most anything from the hands without injury to skin. Every mechanic and auto-owner, everybody who gets his hands dirty, will be a customer. Great opportunity for hustler to get in business. Full information and sample free. Solar Products Company, A-124 West Lake, Chicago.

BOBBED hair has increased our sales. Crew-managers can make \$8.00 per day. Kingsbury Company, Fort Wayne, Ind.

AT last! Complete home products. Folks want guaranteed specs, extracts, cocoa, baking powder, toilet articles, soaps, famous Edrings Herb Tablets. Catalogue. Jet. Pharmaceutical Company, Allentown, Pa.

\$20 PROFIT daily selling needlebooks; costs 2c-5c each; sells 25c, value 50c; three samples 25c. Catalogue Free. Needlebook Specialty Co., 661 Broadway, New York.

AGENTS: 500% profit. "Happy Home Maker Shampoo" builds your own big business. Martin of Indiana made \$75.00 in one day. Missouri man made \$750.00 one month. Exclusive territory. Geo. A. Schmidt & Co., 228 W. North Ave., Chicago.

AGENTS, \$20 daily easy selling household necessity every woman wants. New invention reduces price. Big profit. Flagley & Halpen, 303 Cherry Street, Dept. 5, Philadelphia, Pa.

EXCLUSIVE agents \$225 weekly. Genuine gold letters for store windows. Free samples; selling instructions. Chicago Window Sign System, 6226-A Kimbark Avenue, Chicago.

AT Last! Diamond Rival Discovered! Amazing blue white Rajah Gem astounds jewelry world and deceives experts! Beautiful Sample case Free! \$100 weekly! Write Quick! Rajah Diamond Co., Dept. F-7, Salisbury, N. C.

BRING Home the Bacon—selling Stuart's Stain Remover. Removes ink, iron rust, grass and fruit stains. Write for free samples and terms today. C. H. Stuart & Co., 5967 Broadway, Newark, New York.

AGENTS—Sell Gloss Oil Veneer—The Wonder Polish. Cleans and polishes cars, furniture, etc. Sells in every home. Get your field at once. Duo Co., Dept. G1, Attica, N. Y.

"HOW to Sell Patents" free. Patent News-O, Washington, D. C.

ONE Dozen New Blades for Gillette Razor 50c Postpaid. Agents' Prices Only with Order. Hurry. Smith's Service, 1194, Wenatchee, Wash.

PORTRAIT Agents! Get busy on the biggest profit proposition you've ever seen! The new sensation in the portrait field—Artall Portrait Paintings—exactly like oil paintings. Easy, big seller, great for "repeats." A "clean-up" in combination with famous P. & G. Photo Medallions. Write now. Puddin & Goldstein, Dept. "A," 259 Bowery, New York.

ABSOLUTELY free box Bassett's Native Herbs sent to introduce. For Constipation, indigestion, headache, rheumatism. Big money selling, all or part time. Established 1878. Bassett, Dept. 8, Columbus, Ohio.

AGENTS—Wonderful opportunity, newest line Perfumes, Creams, Compacts, Soaps, Extracts, Remedies, Jewelry. Protected territory. Catalog free. Van Ogden, Inc., 1918 VanBuren, Chicago.

\$35.00 PROFIT on \$1.50 Outfit; Gold Monograms for Automobiles, etc. National, Station D, Brooklyn, N. Y.

YOUNG Men who want to make their spare time pay from \$29 to \$50 a week are offered an opportunity to sell an article which every man buys on sight, made by Ingersoll, the dollar watch man; retails for \$1; you don't need to be a salesman; merely to show it to sell; big profits, quick sales and constant repeat business. Write today. Robt. H. Ingersoll, 470 Broadway, Dept. 208, New York.

AGENTS—Coin money selling our new fabric table cover; needs no laundering, housewives wild about them; send for free offer. Mfg., Box 67, Medford, Mass.

"PEPPY-PORTER" Products—Necessities in every household. List of Formulas, Labels, Free. Monarch Specialties Co., 423 North Leasington, Chicago.

MAIL-ORDER Houses and Distributors: We pack French made beauty creams, face powders, perfumes, toilet preparations with your label. Chemist, 944A North Clark, Chicago.

MAKE extra money. Xmas postal folder, tag combination packs, 10th season. Sell 25c. Sample 15c. Big profits. Ufert, 133 West 15th, New York.

WE Pay \$36 a Week and expenses and give a Ford Auto to men to introduce poultry and stock compounds. Imperial Co., D-23, Parsons, Kan.

NEW Invention. Cleans whole house from cellar to attic, inside and out. All complete only \$2.95. Over 100% profit. Write Harper Brush Works, 324 Grimes St., Fairfield, Iowa.

PUMSO. The fastest selling product on the market. Nothing else like it. Something entirely new. Make Big Money. Used by every auto-driver, mechanic, and necessary to every household. Repeat orders. A twenty-five cent article. Quick sales. Big Profits. Pumso Manufacturing Company, 128 West 15th St., New York City.

AGENTS: Imported Champagne baskets containing six bottles genuine French perfume. \$1 value for \$1.00. Sample postpaid 75c. Free particulars. Thayer, 729 E. Wabash, Chicago.

AGENTS' Side Line: Good Profits; New Novelty Game Just Out. Sensational Hit. Sample 35c. Kahn (Manufacturer), 99 Nassau Street, New York City.

SELL Beautiful \$7.00 Red and Black Oversized hand made Fountain Pens for \$3.50. Cost you \$1.75. With bonus \$1.55. Post card brings full details. or C. O. D. sample, at wholesale price. Johnson Pen Co., 117 So. First St., Rockford, Ill. Dept. F.

DASH control Gas Reserve Valves for Fords; \$25.00 to \$50.00 per day permanent income established; customers do the selling. Write today. The Will-Burt Co., Orrville, Ohio.

AGENTS—Be independent, make big profit with our soap, toilet articles and household necessities. Get free sample case offer. Ho-Ro-Co., 2725 Dodder, St. Louis, Mo.

\$8 TO \$16 daily easy—New Patented Cutlery and Carving Set—You take orders—We deliver and collect—Your Pay Daily—No experience necessary—Not for sale in stores—Full or spare time. Macroebe Company, Stand 11012, Cincinnati, Ohio.

AGENTS wanted by Manufacturer of exclusive Novelty Knitted Sport Dresses and other knitted fabrics, selling direct to consumer. Attractive commission—large sample outfit free. Straightline Mills, Inc., 266 Broadway, New York City.

AGENTS and Side Line Salesmen wanted to sell the Easy Fill Gasoline Tank Cap and Gauge for Fords. A big proposition for live men. Write today. Easy Fill Cap Co., 929 Lawrence Ave., Chicago.

CAN you sell to colored people? Write, Eston Co., Dept. 101, 2590 Second Ave., Birmingham, Ala.

JEFFORDS sold 25 cans his first 4 hours; profits \$7.50. Hundreds of others doing as well, or better. Particulars and sample free. Write today. The Mallard Chemical Company, Dept. EX, Saint Louis, Mo.

\$8.00 TO \$20.00 per day. A wonderful seller. Any man, woman, boy or girl can make big wages Selling Crimp Grip Clothes Line Fasteners. It is a perfect rope holder and can be used for many purposes. Crimp Grips are a simple, time-saving device. They last a life time and will not rust; it holds the line tight, and saves time on wash days. Every buyer is a booster. Send 50c for Mounted Sample and one pair of Crimp Grip Clothes Line Fasteners. Write for particulars. Crimp Grip Company, Belvidere, Ill.

\$25.00 A DAY Easy! Best Line of Brushes on the market. 90 varieties, including famous Auto Fountain Washer. Excellent territory available. Write immediately. Philadelphia Brush Co., Dept. 25, Vineland, N. J.

WILLIAMS No Water Hand Soap. In tubes, has taken Auto owners by storm; washes dirtiest hands perfectly clean without water. Easy demonstration makes quick sales; 150% profit. Williams Co., Box 265, Montclair, N. J.

BIG Money selling new Household cleaner. Washes and dries windows, Sweeps, scrubs, mops. Complete outfit less than brooms. Over 100% profit. Harper Brush Works, 132 3rd St., Fairfield, Iowa.

AGENTS clear \$50.00 weekly selling Opaline Portraits. Expense money advanced. Credit given. Big line now ready. Samples and Catalog free. Consolidated Portrait Co., Desk 2, Chicago.

AGENTS—Steady income. Large manufacturer of handkerchiefs and dress goods, etc., wishes representative in each locality. Factory to consumer. Big profits, honest goods. Credit given. Send for particulars. Freeport Mfg. Co., 59 Main St., Brooklyn, N. Y.

SELL Shirts and Overalls direct to wearer. Big profits. Work full or spare time. No experience required. Big variety dress shirts with splendid line Union-made work and flannel shirts, overalls, coveralls and khaki pants. Write today for free selling outfit. The Nimrod Shirt Co., Dept. 8, 4712 N. Kedzie Ave., Chicago.

AGENTS—Steady income. Exceptionally useful Household Article. Handycap Co., Newark, N. J.

AGENTS Our new Fire Extinguisher sells for \$4.95 with big commissions. Mechanically perfect—can't leak. Exclusive territory. Free outfit. Write. Nichols Co., Naperville, Ill., Dept. F. 1.

AGENTS—line up with better Felt Rugs now. Our new rug novelties increase your income. Here's your chance! Newark Felt Rug Co., 27C, 16th Ave., Newark, N. J.

SPIRAL Curtain Rods and large line wire and metal specialties; get our latest price list. Hunt Mfg. Co., Box 1652P, Paterson, N. J.

AGENTS: Men and women, in spare or full time, make big money selling household necessities. Every home a prospect. Quick sales, big profit. Territory open. Write for particulars. Judd & Leland Manufacturing Company, Box 21, Clifton Springs, N. Y.

WONDERFUL Miniature X-Ray shows bones in fingers, lead in pencil, etc. Sells itself. Simply show it, everybody buys. Immense profit. Sample ten cents. Particulars free. Rialto, 1612-P Fitzgerald Bldg., New York.

AGENTS—Make \$25.00-\$100.00 weekly selling Comet Sprayers and Autowashers to Farmers and Autoists. All brass. Throws continuous stream. Established 30 years. Particulars free. Rusler Co., Johnstown, Ohio, Box C48.

WONDERFUL Scientific Discovery—"Sapphires," Blue White; also one Changeable Color, \$3 per carat. Fire, Goldens, others \$2. Rival Diamonds. Any kind of ring wanted—will quote wholesale. Wrist Watches, Pearl Ropes, Imitation Diamonds, Rings, Wand Agents, Pauer (Importer), 152 Dewitt, Buffalo, N. Y.

HEATING with oil is in its infancy. Get in while the getting is good. Our burners make good. Agents wanted. Exclusive rights. Economy Oil Burner Co., 718-720 Second St., Webster City, Iowa.

SELF - THREADING Needles. Needle Books. Machine needles, find sales in every home. Fine side lines, easily carried, big profits, sample and catalogues free. Prentice Lee, 145 East 23rd St., New York.

AGENTS make 500% profit handling auto monograms, window letters, transfers, novelty signs. Catalog free. Hinton Co., 1153 N. Wells St., Chicago.

AGENTS—Three neckties, boxed singly \$1.00. Retail \$2.00, cash with order. Maxwell, 401 Searle Bldg., Rochester, N. Y.

MAKE \$10.00 to \$25.00 daily selling our Standard Books, Bibles and Testaments. Easy to sell. Big profits. Permanent position for responsible producers. Write National Book & Bible House, Desk 1, 36 S. State, Chicago, Ill.

BIG Money Selling Gold Initials. Quick Sales. Every Car Owner Buys. You Charge \$1.50—Make \$1.44 Every Sale. Your Profit \$20 Daily. No License. No Experience. "Samples Free." NuLife (0) Monogram Company, Hartford, Conn.

AGENTS—Write for Free Samples. Sell Madison "Better-Made" Shirts for large Manufacturer direct to wearer. No capital or experience required. Many earn \$100 weekly and bonus. Madison Mills, 564 Broadway, New York.

AGENTS—\$10 to \$25 daily. No investment. Free outfit. Best values. Largest commissions. World Raincoat Co., 639-B Morris Park Ave., New York.

AGENTS—\$75.00 Weekly Selling Nustle Guaranteed Hosiery direct to wearer. Your pay daily in advance, we deliver and collect. All styles and colors. No experience necessary. Special extra monthly bonus. Sample outfit furnished. Write for particulars. Nustle Hosiery Mills, Dept. 175, Philadelphia, Penna.

EVERYBODY Buys new, instant stain and rust remover. For clothing, table linen, etc. Fine premium with every sale. Big, Quick Profits. Free Outfit. Write today. Christy, 51 Union, Newark, New York.

AGENTS—Make a dollar an hour. Sell Mendels, a patent patch for instantly mending leaks in all utensils. Sample package free. Collette Mfg. Co., Dept. 401, Amsterdam, N. Y.

10,000,000 FORDS need "Teuscher" fan belts. 50% profit selling dealers; 250% selling owners. Write quick. Teuscher Belting Co., St. Louis.

BIG profits selling our practical patented specialties. Write for particulars. Welch Brothers Co., North Chicago, Ill.

CASH in on this quick seller. Wingo cleared \$1,480 with Never Fail Razor Sharpener in six weeks; Purdy, \$14.50 first day. Applewhite, also inexperienced, six orders in thirty minutes. No end to ready buyers. Exclusive territory for quick workers. Be first. Address Never Fail Company, 166 Allen Bldg., Toledo, Ohio.

AGENTS. Household necessity. Sells rapidly. Large Profit. Square deal. Premier Mfg. Co., Dept. 813, Detroit, Mich.

START a business of your own. Sell goods under your own private brand. Toilet articles, food products, household specialties. Tremendous profits. Big repeat business. We supply everything needed. Write for our attractive proposition. National Scientific Laboratories, 251 Monroe, Richmond, Va.

BIG Profits with Exclusive Territory—\$50 to \$100 weekly easy. More has often been made in one day's work. A hot or cold running water bath equipment for any home at only \$7.50. No plumbing or water works required. Investigate. Send no money. Write today. Sanitary Supply Co., 721 Allen Building, Toledo, Ohio.

AGENTS—Good salary and commission selling "Ratskyl" new rat and mouse exterminator; ready for use; no bait required; non-poisonous; rodents die outside premises; no odor. Empire Specialties Co., 1549 N. Wells, Dept. 301, Chicago, Ill.

EASY, pleasant work for Mechanics, Shop Men, Clerks, during spare hours; will add many dollars to their salaries. Also want persons who can give full time. Big wages assured. Novelty Cutlery Co., 67 Bar St., Canton, Ohio.

POLMET—The Wonderful Polishing Cloth that cleans all metals without liquid, paste or powder. Approved by "Good Housekeeping" and "Modern Priscilla"—sells fast at 25c. Sample free. Gale & Co., Inc., 15 Edinboro St., Boston.

AUTO owner tire agent wanted each locality to use and take orders for handmade Mellinger fabric and cord tires; guarantee bond \$,000 and 12,000 miles (no seconds); shipped prepaid on approval; get your tires free; no capital or experience required; make \$190 to \$290 weekly. Write for wholesale prices and sample kit. Address, Mellinger Tire Co., Dept. 200, Kansas City, Mo.

AGENTS—Cleer Invention! Inkopson makes every pen a fountain pen. Fast office seller; big profit, demand increasing everywhere. Exclusive territory offered. Sample free. H. Marul Company, Tribune Bldg., New York, N. Y.

AT Last—World's Greatest Adding Machine. Almost human. Retail \$15; work equals \$300 machine. \$500 monthly easily made, demonstrating to stores, offices, garages, factories. Simple, easy; adds, subtracts, multiplies, divides automatically. Speedy, accurate, durable, handsome. Five year guarantee. Tremendous demand, amazing profits. Liberal trial offer. Protected territory. Write quick. Lightning Calculator Corp., Dept. F, Grand Rapids, Mich.

GET Our Free Sample Case—Toilet articles, perfumes and specialties. Wonderfully profitable. La Derma Co., Dept. A, St. Louis, Mo.

AGENTS—Stamping man on Pocket Key Protectors; sample check with your name and address, etc. Stamping Outfits, Emblem Checks, Check Fobs, Name Plates, Hart Mfg. Co., Desk 2, 363 Degraw St., Brooklyn, N. Y.

125% CLEAR profit selling neckties; 2 samples \$1.00; satisfactory or money refunded. Raymond Mfg. Co., 152nd St. and Madison Avenue, New York.

MAKE \$17 daily—Finest Extracts, Food Products, Toilet Preparations, Household Necessities. Credit: Sample Case Free. Write for amazing offer. Perkins Products, B-6, Hastings, Nebr.

AGENTS: Big Money Monogramming by Transfer Method. Catalog Showing Over 50 Styles and Particulars Free. Motorists' Accessories Co., Mansfield, Ohio.

AGENTS: Big Profits, Best and cheapest window letters made. Easily applied. Dime brings five samples. Particulars free. Stalbrite Co., 1115 Second Ave., New York.

MAKE \$25 to \$50 Week, representing Clow's Famous Philadelphia Hosiery, direct from mill—for men, women, children. Every pair guaranteed. Prices that win. Free book "How to Start" tells the story. George Clow Company, Desk 31, Philadelphia, Pa.

YOU can be your own boss with our Key-Check outfit. Good for \$5 a day stamping names on pocket key checks, fobs, etc. Sample check with your name and address, 20 cents. Pease Die Works, Dept M, Winchester, N. H.

INSTANT Weld. Repairs largest punctures without cement or heat. Lenn's profit one day. \$76. Write quick. Free sample; territory going fast. Tourists' Pride Mfg. Co., Desk T, Minneapolis, Minn.

EARN \$10 daily silvering mirrors, plating and refinishing metalware, autos, chandeliers, bedsteads, headlights. Outfits furnished. E. Dele Laboratories, 1135 Broadway, New York.

AGENTS sell Wolverine Laundry Soap. Wonderful repeater and good profit maker. Free Auto to hustlers. Wolverine Soap Co., Dept. B37, Grand Rapids, Mich.

EVERYBODY uses extracts. Sell Duo Double Strength Extracts. Complete line household necessities. Big repeaters. Write today. Duo Co., Dept. E1, Attica, N. Y.

PATENTED Cigar Lighters with Glass Advertising Front. Also Electric Cigar Moisteners. Wonderful Sellers. No Competition. Big Steady Profits. Proof, Cuts, Sales Plan Free. Drake Mfg. Co., Dept. M, Milwaukee, Wis.

BIG Money and Fast Sales. Every owner buys Gold Initials for his auto. You charge \$1.50; make \$1.35. Ten orders a day easy. Write for particulars and free samples. American Monogram Co., Dept. 40, East Orange, N. J.

IF you want good live agents—fellows who can get the business—ask me how others are doing it. I'll gladly render the necessary assistance. Geo. F. Baker, Mgr. Classified Advertising, Popular Mechanics Magazine, Chicago.

AGENTS—Send for free sample "Fretnot"—washday wonder. You can clear at least \$20 to \$100 weekly, according to spare or whole time. You don't have to talk; if she doesn't buy at sight, leave sample; she will be looking for you long before you are able to make the rounds again. Samples furnished free. Premiums for your customers. Exclusive territory. Credit given. Empire Specialties Co., 1549 N. Wells, Dept. 101, Chicago.

BUILD permanent business. Men's, Women's, Children's guaranteed shoes direct to wearer. A. P. Condon, Sales Manager Allen Shoe Co., 110 Summer, Boston.

WE Start You Without a Dollar. Soaps, Extracts, Perfumes, Toilet Goods. Experience unnecessary. Carnation Co., Dept. 201, St. Louis.

TO secure agents or salesmen or for selling farms and reaching investors, use classified (want) ads in largest newspapers and magazines. Price list No. 30 sent free. Ankrum Advertising Agency, 20 W. Jackson Blvd., Chicago, Ill. The largest classified advertising agency in the U. S.

AGENTS—Men and Women. Establish permanent business. 34c money order brings can of Gray Crystals, a wonderful Gray and Stew Improver. Try it and convince yourself. Every Store and Home a prospect. New product with big future. Exclusive territory to live representatives. Smith & Gray, Manufacturers, Guinda, California.

WONDERFUL! Startling! Amazing! Our Ex-Cel Luminous Crucifix and Magical (Luminous) Necklaces shine brilliantly in the dark. Sell on first demonstration. Big profits to you. Write for further particulars, or better still, send for sample and territory protection immediately. Crucifix \$1.50, Necklaces \$1.00, postpaid. W. G. Hanson Co., Dept. B, 57 E. 18th St., Chicago.

SELL the Livest, Quickest Selling Specialties Ever Known—Famous "Railway" self-lighting pocket Cigar Lighters and Gas Lighters. Low Prices. Easily Demonstrated. Sell to Dealers. Employ Sub Agents. Exclusive Territory. Make over 100% Profit. P. Bernhardt, 148 Chambers Street, New York.

EARN big money fast applying gold initials to autos. Every owner buys—\$1.35 profit on \$1.50 sale—particulars and samples free. Write quick. Lithogram Co., Dept. 17, East Orange, N. J.

HIGH GRADE SALESMEN WANTED

AGENTS: Our guaranteed all wool tailor made suits and o'cuts at \$31.50 are \$29 cheaper than store prices. Fall line greatest ever. Easy to sell; we train you. Comm. in advance. Write for great new sales plan. J. B. Stimpson, Dept. 1021, 843 Adams, Chicago.

IF you are ambitious, not afraid of work, satisfied to make \$60 to \$125 per week, I can show you how. I have given hundreds of clean-cut earnest men heretofore making \$20 to \$25 a week the opportunity of achieving such results. I can do the same for you. Opportunity often knocks but once; heed it. Write me today. M. P. Bronner, Box 123, Essex Postal Station, Boston, Mass.

SALESMEN: Moccasin Footwear Made over Shoe-Shaped Lasts sells quickly for Street—Sport and Workman's use. Write for Manufacturers' Illustrated Book and leather samples. Large immediate commissions. Investigate this. Moccasin Footwear Company, 508 Fifth Avenue, New York.

FOUR \$7.50 sales to merchants net you \$20.00 daily. Savers Systems, 2803 Sheffield Ave., Chicago, Ill.

SALESMEN Wanted—To interview furniture and department stores in their locality on a special proposition for reliable manufacturer. You can earn \$100.00 a week or more, in full or spare time, on commission. Interesting, steady work. Write today for full particulars. The Marvel Company, Hammond, Ind.

MANUFACTURER of power specialties has several territories open for men calling on power plant trade. No other will be considered. If you are willing to work and are anxious to make some real money, answer with full particulars regarding self, which will be treated confidential. The Colossus Company, Inc., Box 71, Shreveport, La.

START a business of your own. Sell goods under your own private brand. Toilet articles, food products, household specialties. Tremendous profits. Big repeat business. We supply everything needed. Write for our attractive proposition. National Scientific Laboratories, 208 Monroe, Richmond, Va.

A PLUNGE into Prosperity. That about describes your affiliation with the Alexander Publicity Film sales organization. Some representatives earn \$25,000 a year. Attractive proposition. Field large, receptive. 35% average profit for you. If earning less than \$50 daily write for plan and book "Salesmen, Roll Your Own." Alexander Film Co., 3189 S. Broadway, Denver, Colo.

EVERY Ford Owner in the World Wants This! The Hamer Visible Vaporizer guarantees increased mileage (3 to 8 miles per gallon), more power (20% and better), quicker pickup, no carbon, smooth running motor, less heat, longer life, more driving comfort. Sells \$4.50; your commission, \$3. Exclusive territory. Details and proofs. Visible Vaporizer, Dept. 19, Chamberlain, S. Dak.

SIDE LINE salesmen make \$100 to \$200 monthly selling Insto Hand Cleanser to grocers, drug stores, garages and shops. Attractive proposition to retailer makes Insto easy to sell. Write for particulars. W. A. Marsh, Westfield, N. Y.

SALESMEN wanted as exclusive distributors on a new, marvelous pocket cigar lighter selling to stores. Write immediately for particulars and selling plans. Masterlite Co., 110 East 25th St., New York.

SALESMAN: If you think in terms of \$6,000 the first year write me personally. Strong line for retail stores. Nationally advertised. Established concern has unusual opportunity. Liberal weekly advance to producer. Geo. R. Williams, Mgr., 1922 Euclid Avenue, Cleveland, Ohio, Dept. 290.

SALESMEN—Sell Four Square suits, \$12.50. All wool overcoats \$19.50. Make \$3.00 to \$5.50 each sale. Five different patterns of cloth. Complete line, coats, vests, pants, riding pants, slip-ons, overcoats, caps. Three-day delivery. Write today. Stone-Field Corporation, X-2556 S. Wabash Ave., Chicago.

SALESMEN to make \$24 a day selling Rainbow Electric advertising signs. A real proposition for real salesmen. Every merchant a prospect. Every sale a \$4 profit. Sample outfit complete for \$2.50; six for \$12. Sales guaranteed. Exclusive territory when you earn it. Rainbow Electric Sign Co., 451 E. 86th St., New York.

MR. BRUSH Salesman: Old Established New York Brush Manufacturers require the service of men in all territories to sell their extensive line of Sanitary Twisted Wire Brushes. We pay larger commission than any other Brush House in the Country. Write immediately for our proposition. Wire Grip Sanitary Brush Corp., 15 Mercer St., New York.

SALESMEN: Sell guaranteed shoes for men, women and children below store prices. \$75.00 weekly easy. We deliver, collect. K-W Shoe Company, 4048 Harrison, Dept. 20, Chicago.

SALESMEN and District Managers to sell constantly used, repeating building specialties to factories, public institutions and building owners of all kinds. Products established over twelve years among thousands of largest users, including U. S. Government. Immediate, big earnings and promotion with \$100,000.00 company to ambitious capable men. Write at once. The Colcraft Company, 871 W. 70th, Cleveland, Ohio.

ESTABLISHED national concern manufacturing high grade household specialty offers openings as managers to men who can organize specialty salesforce; exceptional earnings. Kitchen Kraft Company, West Bend, Wis.

SALESMEN make \$75 week, no investment, no deliveries. Envelope Sealer, retails \$3.50, sells on demonstration. Kendall Sealer Co., Dept. B-31, Jaffrey, N. H.

SALESMEN who are interested in putting themselves on permanently profitable basis should write us today. This is strictly business—not a "get-rich-overnight proposition." Product nationally advertised. Exclusive territory to high-grade men. CFSCO, 15 N. 10th St., Richmond, Ind.

SALESMAN: Wonderful new office specialty, sells 50 cents. Can you organize sales, employ salesmen? Big opportunity. Write Robinson Co., 250-36 Devonshire St., Boston.

DISTRIBUTORS—Screw-holding Screw Driver. Handiest Tool ever invented. Unlimited market. Tremendous demand! Big repeat earnings! Write Coburn Tool 736A, Boylston, Boston, Mass.

DISTRICT MANAGERS—Wonderful envelope sealer, seals 3500 hour! Retail \$4 only! Big repeats. Tremendous profits. Consolidated Co., Dept. QG, 100 Boylston, Boston, Mass.

EXCLUSIVE State Distributor—Big earnings. Newly invented pricing system, retails \$4.50. Tremendous demand! Big repeats! Millen Mfg., Dept. RG, Colonial Bldg., Boston, Mass.

WANTED—Tailoring Salesmen, make \$60 to \$125 per week. Biggest merchants in many towns have started with our line. We are the largest made-to-measure tailoring house in the country, furnishing elaborate sample equipments, including 500 all-wool fabrics. You make your own profits from \$8.00 to \$15.00 on each order. Guaranteed absolute satisfaction, perfect fit, best workmanship, or no sale. Write for line and all accessories to be sent free. Tell us all about yourself. Address N. O. Perry, Sales Manager, Box 483, Chicago, Ill.

ASTOUNDING invention. Fords use kerosene, start instantly. Mileage doubled. Big profit. Super, 1306 Fondular, Milwaukee, Wis.

SALESMEN—Sell "Amenz" made-to-measure and ready made shirts; wonderful features; highest commissions. Samples Free. Meinan Shirt Co., 481-J East Tremont Ave., New York.

EXCLUSIVE State Distributor, \$10,000 yearly. Newly invented pricing system, retails \$4.00. Tremendous demand! Big repeats! Millen Mfg., Dept. XE, Colonial Bldg., Boston, Mass.

DISTRIBUTORS, \$10,000 yearly. Amazing new invention seals 3,500 envelopes hour! Retail \$4 only. Tremendous demand! Consolidated Co., Dept. Z.O., 100 Boylston, Boston, Mass.

SALESMEN Wanted—Local or traveling, part or full time, to sell calendars, fans, fly swatters, brushes, rulers, etc. Our two hundred stock design paraffined signs, ice cards, etc., for all merchants. Fine side line. Liberal commissions. The Harrison Co., Union City, Ind.

A WONDERFUL Seller! Any man, woman, boy or girl can make big wages. Some agents make from \$8.00 to \$20.00 per day. Crimp Grip Clothes Line Fasteners are a simple, time-saving device for holding a rope—also used for many other purposes. It pays for itself quickly in time saved on wash days. No knots—it fastens and releases quickly. Every home a prospect. Every housewife who uses Crimp Grips—and there are thousands of them—is a booster. There is but one Crimp Grip. Write for particulars, or send 50c for one pair and a mounted sample, with full particulars to agents. Crimp Grip Company, Belvidere, Ill.

WERE You Ever Offered a Grocery Store? Our proposition is better. You can handle flour, canned goods, dried fruit, coffee and entire line of groceries as well as radio sets, paints, roofing and automobile oils and tires with no rent to pay; no money invested, take large orders from samples. Goods are guaranteed and proven quality. Selling experience not necessary. Steady, profitable work for "workers." Address Hitchcock-Hill Co., Dept. 236, Chicago, Ill. Reference: Any bank or Express company.

DOES Your Trade Use Salesboards? Send for free catalog. Finest and largest ever published. Big commissions! Lincoln Sales Co., Dept. L, 212 N. Sheldon, Chicago.

BEST Seller, Jem Rubber Repair for tires and tubes; supersedes vulcanization at saving of over 800%; put it on cold, vulcanizes itself in two minutes, guaranteed to last life of tire or tube; sells to every auto owner and accessory dealer. Get particulars how to make big money and free sample. Amazon Rubber Co., Philadelphia, Pa., Dept. 510.

THE Jackson Mfg. Co., 1331 16th St., Denver, Colo., has salesmen clearing as high as \$85.00 daily selling their newly patented auto specialty. Write them for free sample and particulars.

DISTRICT Managers Wanted—Appoint Local Agents for us in your locality. No canvassing or delivering. \$100.00 weekly easily made. Commissions advanced. Bob Russell, A-2387 Archer, Chicago, Ill.

MEN—Women—Sell rubber aprons and rubberized goods, direct from manufacturer; every woman buys—100% profits—big sales. Get our proposition first. P. M. Bresler Co., 414 Broadway, New York.

SALESMEN sell sales and order books, auto, reg. rolls and bill ladings. Large demand. Liberal commission. Wirth Sales Book Co., Dept. PM, Chicago.

\$60-\$200 A WEEK. Genuine Gold Letters for store windows. Easily applied. Free samples. Liberal offer to general agents. Metallic Letter Co., 438-B North Clark, Chicago.

MAKE \$100 Weekly in Spare Time. Sell what the public wants—long distance radio receiving sets. Two sales weekly pays \$100 profit. No big investment, no canvassing. Sharpe of Colorado made \$955 in one month. Representatives wanted at once. This plan is sweeping the country—write today before your county is gone. Ozarka, 802 Washington Blvd., Chicago.

SALESMEN—Become Independent. Own your business; experience unnecessary; selling our \$7,500 Accidental Death, \$50 Accident, \$25 Sick Weekly Benefits; \$12.50 yearly; other amounts proportionate. Guaranteed steady income from renewals. \$250,000 deposited Insurance Department. Registration Dept. A, Newark, N. J.

TRAVELING Salesmen calling on retail stores wanted by large manufacturer to sell unique line of business-boosting articles. Year round, fast selling, main or side line. If not earning \$150 weekly, address Ebaser Works, 222 Charles St., Bloomville, N. Y.

SALESMEN—Side line pays five to ten dollars a day taking orders for Specialty printed gummed advertising and Match Box Stickers. Write for proposition, samples, etc., today. Beardley's Printery, Rock Island, Ill.

\$4.00 PROFIT on Every \$5.00 sale. "Free Sample"—New Specialty. (Money Getter.) Every Storekeeper, Doctor buys quickly. Experience unnecessary. Territories open. Box 595, Hartford, Conn.

SALESMEN Can make \$5.00 a day selling our Calendars, Pencils, Signs, Advertising Novelties, Yardsticks, Whistles, etc. Liberal terms. Sells entire year. Fine side line. Local and traveling agents. Model Calendar Co., Dept. 226, South Bend, Ind.

CALIFORNIA Rosebuds selling like hot cakes. Agents coinng money. Absolutely new. Big profits. Catalog free. Mission Factory SP, 519 No. Halsted, Chicago, Ill.

HELP WANTED

HOME Employment—New fascinating easy work, experience unnecessary. Egyptian Art Craft (copyrighted) enables anybody to immediately make hundreds of original beautifully designed art pieces from Silk, Cotton, or Paper. Complete working outfit with instructions sent postpaid for 25c. Archibald Co., 246C, 5th Avenue, New York City.

HOTELS Need Trained Men. Nationwide demand for high-salaried men; past experience unnecessary. We train you by mail and put you in touch with big opportunities. Big pay, fine living, interesting work, quick advancement; permanent. Write for Free Book, "Your Big Opportunity." Lewis Hotel Training Schools, Suite A-351, Washington, D. C.

MEN: We will establish you in a permanent business paying big income. Your credit is good for merchandise people must buy every day. No special experience necessary. Write today for free booklet "McComen's System." McComen & Co., Factory M48, Winona, Minn.

U. S. GOVERNMENT Life Positions. Over 20,000 positions filled yearly. Steady work. Men—women, 18 up, \$1140 to \$2300 year. Railway Postal Clerks—City Carriers—Clerks, etc. Pleasant work. Influence unnecessary. Common education sufficient with our coaching. Experience unnecessary. List positions obtainable—Free. Write immediately. Franklin Institute, Dept. S-3, Rochester, N. Y.

MONEY Silvering Mirrors, Autolights, Radiators, tableware, stoves, Outfits. Methods Free. Sprinkle Plater, 288, Marion, Ind.

\$12 MONTH. Railway Postal Clerks. 25 coached free. Write immediately. Franklin Institute, Dept. S-19, Rochester, N. Y.

FIREMEN. Brakemen, Baggage-men, Sleeping car, train porters (colored) \$140-\$200. Experience unnecessary. 810 Railway Bureau, East St. Louis, Ill.

LOCOMOTIVE Firemen for railroads nearest their homes—everywhere; beginners \$150-\$250 monthly; promoted, locomotive engineer, \$3,000-\$4,000 yearly. Best paying positions on railroads. Railway Association, Desk M1, Brooklyn, N. Y.

PERSONS Wishing Change of Work. Write Scott Wilkerson, Mills Bldg., Washington, D. C.

MEN. Railway Postal Clerks. Steady, \$1600-\$2300 year. 25 coached free. Write immediately. Franklin Institute, Dept. 8-19, Rochester, N. Y.

AGENTS: \$11.80 daily in advance (send for sworn proof) introducing New Insured Hose—47 styles—35 colors—guaranteed seven months—Winter line now ready—No capital or experience required—You simply take orders—We deliver and collect (or you can deliver, suit yourself). Credit given—Pay You Daily—Monthly bonus besides. We furnish samples—spare time will do. Macebee Textile Company, Room 26012, Cincinnati, Ohio.

MEN: Chance to earn money. Experience unnecessary. Schlitz Co., 3703 Haverford, Philadelphia.

MEN—Women, 18 Up. Get Government Jobs, \$95-\$192 month. List positions free. Write immediately. Franklin Institute, Dept. 8-19, Rochester, N. Y.

BECOME a Landscape Architect. Uncrowded profession of wonderful opportunity for money-making. Easily mastered by mail. Earn while you learn. Write for book. American Landscape School, 56-E, Newark, N. Y.

MEN wanting positions firemen, brakemen, colored train or sleeping car porters, write for application blank; experience unnecessary, first class roads, no strike. Name position wanted. Railway Institute, Dept. 35, Indianapolis, Ind.

GOVERNMENT Railway Postal Clerks, \$133-\$192 monthly. Many other openings, \$1400 upward. Full information free. Write immediately. Chicago Civil Service College, A-11 Kesner, Chicago.

MEN to Build Radio Sets for use in spare time. Leon Lambert, 529-H Kaufman Bldg., Wichita, Kansas.

HUNDREDS Jobs. Become Expert Automobile Repairmen. \$30 week. Sample lessons free. Franklin Institute, Dept. 8 400, Rochester, N. Y.

BE a Forest Ranger, Postal Clerk or Carrier. Steady positions. Particulars free. Write Mokane, Dept. A-12, Denver, Colo.

CLERKS: for Government Postal and other good positions \$1400-\$2300 yearly. Experience unnecessary. Full particulars free by writing G. W. Robbins, Civil Service Expert, 411 Burchell Bldg., Washington, D. C.

GET a United States Government Position. Good Pay, Short Hours, Vacation, Sick Leave, Pension, etc. Prepare for Railway Mail, Post Office, Customs House, Internal Revenue, Rural Carrier or other branches. Examination all the time. Common education sufficient. Let our expert (Former U. S. Civil Service Secretary-Examiner) train you. Guaranteed Preparation. Write today for Free Booklet. Patterson Civil Service School, Dept. 8, Rochester, N. Y.

MEN—Age 18-40, wanting Railway Station-Office positions, \$115-\$250 month, free transportation, experience unnecessary. Write Baker, Dept. 41 Wainwright, St. Louis.

\$50-\$200 A WEEK. Genuine Gold Letters for store windows. Easily applied. Free samples. Liberal offer to general agents. Metallic Letter Co., 438-C North Clark, Chicago.

FINGER Print Experts—Excellent paying positions; particulars free. Finger Print Headquarters, 188 East 79th, New York.

SILVERING Mirrors, French plate. Easily learned; immense profits. Plans free. Address, Wear Mirror Works, Excelsior Springs, Mo.

OUR genuine gold window sign letters are an excellent money-making proposition for handy men. Stann Sign System, Bethune Ave. E., Detroit, Mich.

MAKE money writing Photo-plays; details free to beginners. No correspondence course. Producers' League, 230 Wainwright, St. Louis.

INVENTORS desiring to secure patents should write for our book "How to Get Your Patent," tells our terms and methods. Send sketch for our examination and instructions without charge. Randolph & Co., Dept. 418, Washington, D. C.

RAILWAY Postal Clerks. \$1600 to \$2300 year. Men 18 up. Steady work. Common education sufficient. 25 coached free. Write immediately. Franklin Institute, Dept. 8-19, Rochester, N. Y.

EARN \$10 daily silvering mirrors, plating and refinishing metalware, autos, chandeliers, bedsteads, headlights. Outfits furnished. E. Deele Laboratories, 1133 Broadway, New York.

ALL men, women, boys, girls, 17 to 65, willing to accept Government Positions, \$117-\$250 traveling or stationary. Write Mr. Crogent, 101 St. Louis, Mo., immediately.

STORIES, poems, plays, etc., are wanted for publication. Good ideas bring big money. Submit manuscripts or write Literary Bureau, 322, Hambohl, Mo.

INFORMATION

CORRECT, detailed, expert information, advice, promptly. Any subject, \$1.00. International Information Institute, 15 Moore Street, New York.

BUSINESS SERVICE

DELAWARE Incorporator. Charters; Fees Small; forms. Chas. G. Guper, 901 Orange St., Wilmington, Del.

TYPEWRITERS AND SUPPLIES

SIMPLEX Typewriters \$5.00; Famous, \$5.00; Remington, \$12.00. Circulars stamp. Dimeo, 114 Feed St., Providence, R. I.

TYPEWRITERS All Makes. Save one-half. Thoroughly rebuilt in our factory by the famous "Young Process." Fully guaranteed. Free Trial. We handle all standard makes. Cash or sold on easy terms. Write for Catalog. Young Typewriter Co., Dept. 502C, Chicago, Ill.

TYPEWRITERS—\$20 up. Easy payments. Free trial. Payne Company, Rosedale, Kans.

TYPEWRITERS All Makes; real bargains; guaranteed. Dees Typewriter Sales Co., Ada, Okla.

UNDERWOOD Typewriters — only \$3.00 down. Easy monthly payments. Low prices at less than manufacturers. Low prices at less than manufacturers. 10 days' free trial. Rebuilt, all worn parts replaced. Just like a new machine. 5-year guarantee. Write for big free catalogue C-151, Shipman-Ward Mfg. Co., 1519 Shipman Bldg., Chicago, Ill.

TYPEWRITERS, All makes, \$15 up. Guaranteed. Write for our bargain price list and Free Trial offer. Department 16. Manufacturers Typewriter Clearing House, 193 N. Dearborn Street, Chicago.

TYPEWRITERS, all standard makes, \$10 up. Fully guaranteed. Free trial. Write for complete illustrated lists. Northwestern Typewriter Exchange, 121 N. Francisco Ave., Chicago.

TYPEWRITING

MANUSCRIPTS, anything, accurately typewritten, 50c M. Author's Service, Bradford, Conn.

PRINTING, ENGRAVING AND MULTIGRAPHING

1,000 CIRCULARS. Good Paper, 6 x 9, \$4.00; 9 x 12, \$7.00. Jupiter, Lancaster, Ohio.

FOOTE Prints anything. Send copy for estimate. Free Sample and price list. Foote Printing, 5706 Hainforth, Cleveland, Ohio.

HAMMERMILL Bond—100 letterheads, 100 envelopes, 50 notesheets, \$1.00. Samples Free. Opportunity Publishing Co., Dunick, N. Y.

500 LETTERHEADS — Envelopes \$5.00. G. Open, 196 Warren St., Watertown, Wis.

1,000 LETTERHEADS or Envelopes, \$3.00. Sent Prepaid. Samples Free. Monitor Press, Morrisville, Pa.

EMBOSSING Business Stationery. Samples for Stamps. Daniels Company, Pittston, Pa.

50 NAME Cards 20c; with address, 30c. E. Shepard, Rome, N. Y.

PICTURES Make Printing Powerful. Cut Catalog 10c. "Superior," 1825 Roosevelt, Indianapolis.

ENVELOPE special—100, name and address printed 50 cents. Postpaid. Guy Sherman, Clinton, Iowa.

PERSONAL Greeting Cards—25 Beautiful "Steel engraved" Christmas cards, printed with your name, \$1.50, envelopes included. Order early. Cole Bros., 400 South Halsted, Chicago.

250 FINE 8 1/2 x 11 bond letterheads or 6 1/2 bond envelopes, \$2.00; 500 either, \$2.60; 500 business cards, \$1.90. Todd Printing Co., 19 East Second Street, Cincinnati, Ohio.

GUMMED Labels! Advertising Stickers! Interesting Samples Free! Brush, Auburn, Neb.

5,000 — 12-PAGE — 3 x 6 Folders \$25. Arthur Marchener, Sinking Spring, Penna.

5,000 HAMMERMILL Bond Letterheads, \$14.00; 10,000 — \$24.00; 25,000 — \$56.50; 50,000 — \$108.00; 100,000 — \$213.00. 8 1/2 x 11 20lb. Envelopes to match, same price. William W. Webb, Salisbury, Md.

WE print Stationery, Booklets, Catalogs, Circulars. Samples. Commercial Press, Batavia, Ohio.

FREE Card Case with your name engraved in gold on case with each calling card order. 20 cards 30c; 100, 60c. Christmas cards a specialty. Samples free. Mail Order Printing Co., 3702 Oregon, St. Louis, Mo.

5,000 THOUSAND 20 lb. Hammerrill Bond Letterheads \$15.00. Printing Samples Free. Commercial Printing Company, 7052 N. Clark St., Chicago.

"NEARGRAVURE" Stationery—It's Different—Class—Moderate prices. Solidus's, Knox, Ind.

225 BOND letterheads, envelopes, billheads, cards, \$1.25 each. Combination, \$4.00. Economic Press, Leola, N. J.

200 PRINTED 8 1/2 x 11 Hammerrill Letter-heads, Envelopes, Billheads or Business Cards \$1.00. Postpaid. Race Printery, Hudson, N. Y.

250 LETTERHEADS, 250 white envelopes, printed and mailed, \$3.00. Samples printing free. Sunco, Mohawk, N. Y.

QUALITY Printing! Reasonable Prices! Send for Free Standardized samples and prices. Folders, Circulars, Catalogs our specialty. Ernest Fantus, 525 South Dearborn, Chicago.

GILT lettered Advertising-Pencils for you. Buy direct; save entire middleman's profit. Samples free (no agents). Address S. Musial & Co., 10-12 Lincoln St., Yonkers, N. Y.

250 BOND Letterheads, 250 Envelopes, \$3.00. Samples. Midland Press, 543 West Hickory Kankakee, Ill.

BOND Letterheads—\$2.00 per 500. Small size \$1.50. Placé, Harding, Mass.

MULTIGRAPHING. Prices lowest; let us quote. Printing. Walter Miller, Berwick, Pa.

PRINTING OUTFITS AND SUPPLIES

COMPLETE printing outfits, presses, type, ink, paper supplies. Write for Catalog. Press Co., C-11, Meriden, Conn.

PRINTING Outfits—Presses, type supplies, type specialties. Send stamp for catalogue. Model Press, York, Penna.

PRE-USED Printing Presses, Type and supplies. List for stamp. Popular Bargains, Richland, Pa.

DUPLICATORS AND DEVICES

"MODERN" Duplicators save Time, Labor, and Money. Gets business. Reproduces Typewritten or Panned Letters, Drawings, Lessons, Music, Menus, Bids, Notices, Specifications, Maps or anything in one or more colors. Prints Two per minute. Special Sale On 30 Days' Free Trial. \$8.60 delivered. Booklet Free. J. E. Durkin-Reeves Co., Ridgway, Pa.

STENCIL Duplicating Outfit—Typewriting, Handwriting. \$2.50, \$3.00, \$4.00 Sizes. Returnable. Primos Specialty Co., 3-M Primos, Pa.

COMPLETE Multigraphing outfit—30—cheap. Habben, 816-18 Chestnut, St. Louis, Mo.

YOU can make 50 to 100 copies of a letter, notice, etc., at a cost of three cents on a Hoyer Quality Duplicator. Write for free trial offer. The Hoyer Duplicator Co., 11 S. Wells St., Chicago, Ill.

ADDING MACHINES

NEW \$2.50 Automatic Adding Machine. Adds, Subtracts, Multiplies. Absolutely accurate. Capacity 9999,999.99. Fully guaranteed. 75,000 pleased users. Makes adding easy, positive, quick. Eliminates Mistakes. Saves Time. Postpaid \$3.50. Bassett Co., 1458-B Hollywood Ave., Chicago.

FREE Trial. Marvelous new Adding Machine. Adds, Subtracts, Multiplies, Divides, automatically. Work equals \$35.00 machine. Price only \$15.00. Speedy, durable, handsome. Five-year guarantee. Used by largest corporations. Write today for catalogue and free trial offer. Lightning Calculator Co., Dept. E, Grand Rapids, Mich.

MAILING LISTS

RANCHERS, Stockmen make good customers. List \$5 Per Thousand. Adv'g Matter Distributed. James Mathews, Twin Falls, Idaho.

FOR SMOKERS

CIGAR Bargains. 50 44's or White Owls \$3.35; 50 Harvesters, 81 Products or Admirations \$4.50. Prepaid in U. S. A. Economy Bulletin free. Richard Lavery, Asbury Park, N. J.

200 LUCKY Strikes, Camels, or Chesterfield Cigarettes \$1.35. 600 divided into thirds or all one brand, \$3.95. Holland, 53 Woodward Ave., Boston 19, Mass.

CIGAR Smokers! Factory to Smoker System Saves You Half; write for particulars and special offer. Montrose Cigar Factory, Dept. F, 4004 Montrose Ave., Chicago, Ill.

FOR MEN

CHRISTMAS Special! Genuine Calabash Pipes \$2.00 prepaid. Booms, 5909 Wakefield, Cleveland, Ohio.

ARE You Old at Forty? See our advertisement on page 192 of this issue. The Electro Thermal Company, 2137 Main Street, Steubenville, Ohio.

200 LUCKY Strikes, Camels, or Chesterfield Cigarettes \$1.35. 600 divided into thirds or all one brand, \$3.95. Holland, 53 Woodward Ave., Boston 19, Mass.

CHRISTMAS Suggestion! Men's Imported Handkerchiefs, Warranted Pure Linen, 50 cents Each; Six \$2.75. Postage and Insurance Extra. Irish Manufacture. Alexis Mengelle, Box 387, Colorado Springs, Colo.

BOATS AND LAUNCHES

16-FOOT Rowboat—easily made. Construction blueprint 20c. Weesko-Uco, 31st Office, Detroit, Mich.

BOATS that always go are propelled by Ford Engines. Ford engine booklet free to boat owners. Harry Bider, 201B East Avenue, South Norwalk, Conn.

SPEED boat for small engine. Plans and directions 25 cents. Free catalog of boat plans and books. The Rudder, 9 Murray Street, New York City.

NEW Boat Book telling how to make 21 kinds of boats. Also many other helpful ideas for those who like boats. Profusely illustrated. 50 cents. Popular Mechanics Press, Room 897, Popular Mechanics Building, Chicago, Ill.

RAZORS AND BLADES

MILLER'S Safety Razor Sharpening Machine. The most attractive, most durable, easy to operate and fool proof. It sharpens any make of safety razor blades. Yes! It sharpens the blades. Any man or woman can make from \$100.00 to \$300.00 a month above expenses. Write for Catalog and prices. Sanitary Sharpening Machine Inc., 1905-A Main Street, Kansas City, Mo.

FORTY new Gillette style blades \$1. Money back guarantee. Johnson Specialty Co., Box M193, Cleveland, Ohio.

BLADES Resharpener 3c, any make. Guaranteed Service. Standard Safety Razor Corp., Pittsburgh, Pa.

SAFETY Razor Blades, Gillette style, 50 cents dozen. Wm. Wagner, Fargo, N. Dak.

OPTICAL GOODS

BINOCULARS. Binoculars, Binoculars! A glass for every use and every pocketbook, \$12 to \$60. 4 to 20 power. Guarantee of absolute satisfaction or money back. Get the Geneva price list first. Send for descriptive circular today. Geneva Optical Co., 41 Linden St., Geneva, N. Y.

FOR THE HOME

GRANDFATHER Clock Works, \$5.00. Build your own case; Instructions free; make good profits selling your friends. Clock works with chimes for old or new cases. Write for full particulars. Clock Co., Ruffner St., Philadelphia.

LOOMS—Only \$9.90 and up. Big money in weaving Colonial Rugs, carpets, etc., from rag and waste material. Weavers are rushed with orders. Send for free Loom Book; it tells all about home weaving and quotes reduced prices and easy terms on our wonderful new looms. Union Loom Works, 480 Factory St., Boonville, N. Y.

CONCRETE Handbook, for the Amateur. We have just published a book describing 173 ways of using concrete in the home, shop and on the farm, with full directions for doing these things yourself with ordinary tools. 138 illustrations. It is "written so you can understand it." Price 50 cents, postpaid. Popular Mechanics Book Dept., 206 E. Ontario St., Chicago.

HOME Mechanics, Attention! We specialize in unusual cabinet hardware and mechanical devices for home furniture construction; copper chest, tinning, transfer designs, knock down chests, tea wagon wheels, sawtooth wheels, wood and silk lamp shades, bridge lamp arms and electrical fixtures, cane and reed, porcelain table tops, upholstery supplies, finishing materials, office chair and typewriter desk fixtures, casters, steel rails for wood beds, locks, hinges, catches, dowels, customer books, smoking stand trimmings, etc. Most complete line entire country this class material. Send ten cents stamps for Tenth Annual Catalog "Hard-to-Get" materials. Thurston Manual Training Supply Company, Anoka, Minn.

HOME Mechanics—A new Popular Mechanics Handbook containing 329 discoveries that will be of value to anyone who has a home. 96 pages—203 illustrations. 50 cents. Popular Mechanics Press, Popular Mechanics Building, Room 897, Chicago, Ill.

FOR more heat from less fuel, less work tending the furnace; even, steady heat at all times—attach the Crown Fuel Saver to your furnace. This inexpensive device is guaranteed to make a coal-saving of at least 20% or your money refunded. Write for booklet. C.F.S.CO., 15 N. 10th St., Richmond, Ind.

DIAMONDS, WATCHES AND JEWELRY

CALIFORNIA Abalone Blister Pearls, Pins—rings, Dollar Each. Winona Products Company, 525 West Santa Barbara, Los Angeles.

ANTIQUES, WAR AND INDIAN RELICS

FOR Dens; Relics, collected from Europe's Battlefields. Illustrated Catalogue and sample War Photos 25c. Lieut. Welsh, 2117 Regent Pl., Brooklyn, N. Y.

WANTED—Furniture, clocks, glass, china, lamps, anything old. Wm. Longmeyer, 85 E. Genesee St., Buffalo, N. Y.

INDIAN Made Baskets, Blankets, Beads, Curios. Catalog. Gilham, Kelseyville, Calif.

SEND 5c for fine, new list Indian relics, antique firearms. F. E. Ellis, Webster Groves, Mo.

PHONOGRAPHS AND RECORDS

PERFECTION Phonograph-Radio combination tonearms, motors, hardware, highest quality, lowest prices. Free catalog. Federal Supply Company, Indianapolis, Ind.

BUILD your own phonographs. We can supply you with motors, tone arms and all accessories at wholesale prices. Write for catalogue AX. Pleasing Sound Phonograph Co., 204 East 113th St., New York, N. Y.

BUILD Your Phonograph. Spring Motors, Electric Motors, Tonearms, Amplifiers, Accessories. Latest Equipment also in Radio Mechanism and Cabinets. Catalog mailed for ten cents. Hoosier Mfg. & Supply Co., 313 Baldwin Block, Indianapolis, Ind.

EDITH Portables and Table Phonographs at Cost. Circulars upon request. A. E. Shearer Mfg. Co., Station E, Box 9, Cleveland, Ohio.

BUILD Your Own Phonograph with Our Help—Save Half. The Choralion Aristocratic Phonograph is unexcelled. Plays any record. Finest motors, tone arms, case materials cut to fit, ready to put together and blueprint and full instructions furnished at small cost. Satisfaction guaranteed. Write for catalog. Choralion Phonograph & Radio Co., 945 5th Street, Elkhart, Ind.

SAVE money; Finest quality Phonograph Builders' Equipment. Instructions, Catalogue. Superior Phonoparts Co., Erie, Pa.

BUILD your own Phonograph. We furnish everything. Write for Phonograph and Radio Parts Catalog. American Phonograph Co., 3752 Belmont, Chicago.

MUSIC AND MUSICAL INSTRUMENTS

PIANO Jazz; teaches Ear Playing, Negro Harmony, Chimes, Player Effects, Blues, Cabaret, Vamping, Heavy Bagtime and many Jazz Combinations. Particulars for Post Card. Write "Piano Bill," Station C, Toronto, Can.

BAND and Orchestra Instruments Exclusively. We sell and exchange Buescher Saxophones and other instruments, Vega Banjos, Ludwig Drums and supplies, Pencil Clarinets, Violins and Supplies. We do repair work on all band and orchestra instruments. Write today for complete Free Catalog and list of used and rebuilt instruments, including free subscription to Musical Booster Magazine. "Deal with the Professional House." Crawford-Rutan Co., 1651 Grand Ave., Kansas City, Mo.

VIOLINS—I make 'em; sweet, Soulful, mellow-toned, instruments of highest tonal quality. Get details now. John Lehto, 925 14th St., San Pedro, Calif.

BARGAIN: \$86 Lyon Hoaly Mandolin, \$50 buys it. Raymond Kerst, Wapakoneta, Ohio.

SACRIFICE Large Stock new musical instruments. Saxophones, trumpets, banjos, violins, etc. Bugles, \$4.25. Write for low prices, mentioning instrument. Winn School of Music, 2117 Regent Pl., Brooklyn, N. Y.

I WANT Song Poems. Casper Nathan, 1232 Bryn Mawr, Chicago.

WRITE Songs. Big money and reputation. Write for information. J. Gordon Pub. Co., 201 N. Hoyne Ave., Chicago.

"**MUSIC** Composed" to words. Bauer Bros., (formerly of Sousa's Band), Oshkosh, Wis.

VIOLINS. Deep, Mellow, Soulful—on credit. Easy terms for wonderful instrument. Get details today. Gustav P. Henning, 2421 Gaylord St., Denver, Colo.

CORNETISTS—Trombonists—Saxophonists—Clarinetists. Get "Free Pointers." Name instrument. Virtuosi School, Concord, Mass.

PATENT ATTORNEYS

PATENT Secured. Prompt Service. Personal, careful and efficient service. Highest references. Moderate fees. Send sketch or model for actual search and advice. George P. Kimmel, Master of Patent Law, 54-L Loan and Trust Bldg., Washington, D. C.

EDWARD C. SARNETT, formerly a Principal Examiner U. S. Patent Office, 516 McGUIRE Building, Washington, D. C.

PATENTS for Inventions. Long experience, highest grade work, rates reasonable, best references. Advice as to patentability. Wm. Ashley Kelly, 41 Park Row, New York.

PATENT applications prepared, prosecuted (simple inventions)—total fee, \$25. \$15 down. A. M. Bonner, Olympia, Wash.

PATENT Application Blanks free to inventors. Patent News-D, Washington, D. C.

INVENTORS having ideas to patent should write for my booklet telling how to sell and safeguard your inventions at lowest cost. Ralph Burch, 500 Jennifer Building, Washington, D. C.

INVENTORS, before applying for Patent, send for our free circular "Advance Confidential Service for Inventors" designed to save you money and increase your opportunities for success. Custon Guay Engineers, 30 Sixteenth Street, Southeast, Washington, D. C.

PATENTS Procured; Trade Marks Registered—A comprehensive, experienced, prompt service for the protection and development of your ideas. Preliminary advice gladly furnished without charge. Booklet of information and form for disclosing idea free on request. Richard B. Owen, 30 Owen Bldg., Washington, D. C., or 2276-B Woodworth Bldg., New York.

CASH for the better patents and pending patents. Write promptly. American Patents Corporation, Barrister Building, Washington, D. C.

MILLIONS spent annually for ideas! Hundreds now wanted! Patent yours and profit! Write today for free book—tells how to protect yourself, how to invent, ideas wanted, how we help you sell, etc. American Industries, Inc., 509 Kresage Bldg., Washington, D. C.

PATENTS. Trade-Marks, Copyrights, and Patent Litigation. Write for advice and instructions how to proceed, costs, etc. Hand Book with illustrations of 100 Mechanical Movements sent free on request. Albert E. Dieterich, Patent Lawyer and Solicitor, 621-B Ouray Bldg., Washington, D. C.

MONROE MILLER, Ouray Bldg., Washington, D. C. Patent Attorney; Mechanical, Electrical Expert. Free Blue Book gives candid advice.

PATENTS. Trade-Marks, Designs. This firm has 27 years' experience and gives expert personal service at reasonable rates. We properly protect your invention. Write for free information and exact cost of procuring patent before proceeding. John H. Thomas & Co., 902 F St., N. W., Washington, D. C.

INVENTORS—Send for form "Evidence of Conception" to be signed and witnessed. Form, fee schedule, information free. Lancaster and Allwine, Registered Patent Attorneys in United States and Canada, 221 Ouray Bldg., Washington, D. C.

H. F. LOWENSTEIN, Registered Patent Attorney, Technical expert. McLachlen Building, Washington, D. C.

PATENTS, patent litigation, trademarks, copyrights. Handbook of instructions "How to protect inventions" free on request. R. H. Pravel, Patent Attorney, formerly of the U. S. Patent Office Examining Corps, Room 503 McLaughlin Bldg., Washington, D. C.

PATENTS and Trade-Marks obtained. Prompt service. Write for our new book on patents. Established in 1889. D. Swift & Co., 309 11th St., Washington, D. C.

ESTABLISHED 1864. Milo B. Stevens & Company, Registered Attorneys (No. 830), Patents—Trade Marks—Copyrights. Full information upon request. Moderate fees. Offices: Barrister Building, Washington; Leader Building, Cleveland; Monadnock Block, Chicago.

THE PATENTOMIE. Impartial advice to inventors and manufacturers. Mailed on request. Anderson & Son, Patent and Trade Mark Lawyers, Established 1865, 625 F St., Washington, D. C.

PATENT SENSE—"The book the inventor keeps." Free. See Lacey ad page 136.

PATENTS—Write for our Guide Books and "Record of Invention Blank" before disclosing inventions. Send model or sketch of your invention for Examination and Instructions. No charge for the above information. See advertisement on pages 164 and 165. Victor J. Evans & Co., 934 Ninth, Washington, D. C.

PATENTS. Write for my free Guide Books "How to Obtain a Patent" and "Invention and Industry" and "Record of Invention" blank before disclosing inventions. Send model or sketch of your invention for instructions. Promptness assured. No charge for above information. Clarence A. O'Brien, Registered Patent Lawyer, 589 Security Bank Building, directly across street from Patent Office, Washington, D. C. See pages 162 and 163.

UNPATENTED Ideas Can Be Sold. I tell you how and help you make the sale. Free particulars (Copyrighted). Write W. T. Greene, 806 Jenifer Building, Washington, D. C.

INVENTORS: Send sketch or model for free opinion concerning patentable nature and exact cost of patent. Book "How to Obtain a Patent," sent free. Tells what every inventor should know. Established twenty-eight years. Highest references. Prompt service. Reasonable charges. Chandler & Chandler, 474 Seventh, Washington, D. C.

TRADEMARKS \$25; Design patents \$35; Copyrights \$5; Booklet Free; 20 years' experience. Sanders, Registered Patent Attorney, 7 Rand-McNally Building, Chicago.

PATENTS—Send for Booklet. Contains valuable information for inventors. Our charge for search of Patent Office records \$5.00. Prompt service, twenty years' experience. Talbert & Talbert, 508 McGill Building, Washington, D. C.

INVENTORS—Write for our Guide Book, "How to Get Your Patent" and Evidence of Invention Blank. Send model or sketch of your invention for our prompt examination and instructions free. Randolph & Co., Dept. 430, Washington, D. C.

"**INVENTOR'S Advisor**," the valuable Patent book with 139 mechanical movements and illustrations, sent free upon request. M. M. Labiner, Patent Attorney, 3 Parkrow, New York.

PATENTS. Booklet free. Highest references. Best results. Promptness assured. Send model or drawing for preliminary examination. Watson E. Coleman, Patent Lawyer, 641 G Street, Washington, D. C.

PATENTS. Trade marks, copyrights. Prompt, personal, reliable service. Over 38 years' active practice. Write for terms. Book free. Address E. G. Siggers, N. U. Bldg., 918 F St., Washington, D. C.

HERBERT JENNER, patent attorney and mechanical expert, 606 F Street, Washington, D. C. I report if patent obtainable and exact cost. Send for circular.

"**INVENTORS' Guide**" sent free on request; this book contains illustrations of patented inventions and gives valuable information and advice for all who have original ideas or improvements. Frank Ledermann, Registered Attorney and Engineer, 15-P Park Row, New York.

PERCY S. WEBSTER, Savings and Loan Building, Stockton, California. Long established organization. Send for free book on Patents.

PATENTS. My fees in installments. Advice book free. Frank Fuller, Washington, D. C.

FOR INVENTORS

PATENTS. If you have an invention which you wish to patent you can write fully and freely to Munn & Co., for advice in regard to the best way of obtaining protection. Please send sketches, or a model of your invention and a description of the device, explaining its operation. All communications are strictly confidential. Our vast practice, extending over a period of seventy-eight years, enables us in many cases to advise in regard to patentability without expense to the client. Our Hand-Book on Patents is sent free on request. This explains our methods, terms, etc., in regard to Patents, Trade Marks, Foreign Patents, etc. "Scientific American" contains Patent Office Notes, Decisions of Interest to Inventors and particulars of recently patented inventions. Munn & Company, Solicitors of Patents, 623 Woolworth Building, New York; 524 Scientific American Bldg., Washington, D. C.; 413 Tower Bldg., Chicago, Ill.; 366 Hobart Bldg., 582 Market St., San Francisco, Calif.; 221 Van Nuys Building, Los Angeles, Calif.

WANTED—Inventors' Experimental work, wood, metal patterns, Machine work, rubber mill under one roof. Send drawings. Miller-Anderson Rubber Works, Anderson, Ind. Dept. P. M.-2.

CASH for the better patents and pending patents. Write promptly. American Patents Corporation, Barrister Building, Washington, D. C.

UNPATENTED Ideas Can Be Sold. I tell you how and help you make the sale. Free particulars (Copyrighted). Write W. T. Greene, 806 Jenifer Building, Washington, D. C.

HAVE You an invention or patent for sale on cash or royalty basis? Do you wish to buy a practical, money-making invention? Write us definitely what you have or want. We bring seller and buyer together. Address Western Security Co., 301 Hammbal, Mo.

PATENTS wanted. Must have merit. Ross, 52 Vanderbilt Ave., New York City.

INVENTORS, before applying for Patent, send for our free circular "Advance Confidential Service for Inventors," designed to save you money and increase your opportunities for success. Coston Gray Engineers, 59 Sixteenth Street, Southeast, Washington, D. C.

PATENTS procured; trade marks registered. A comprehensive, experienced, prompt service for the protection and development of your ideas. Preliminary advice gladly furnished without charge. Booklet of information and form for disclosing idea free on request. Richard B. Owen, 20 Owen Bldg., Washington, D. C., or 2276-R Woolworth Bldg., New York.

MONROE MILLER, Ouray Bldg., Washington, D. C. Patent Attorney; Mechanical, Electrical Expert. Before proceeding, read free Blue Book.

INVENTORS' Educator; 960 Mechanical Movements, 50 Perpetual Motions. How to procure and sell patents. Mechanical Movements greatly assist Inventors, suggest new ideas. Explains how to select an attorney and avoid Patent Sharks. Price \$1.50. Postage Free. Albert E. Dieterich, 621 Ouray Building, Washington, D. C.

WHY not have a lache of your own? See description of our Easy Payment Plan on page 286 of this issue. South Bend Lathe Works, South Bend, Ind.

INVENTORS—Write for our Guide Books and "Record of Invention Blank" before disclosing inventions. Send model or sketch of your invention for our free examination and instructions. See advertisement on pages 164 and 165. Victor J. Evans & Co., 157 Ninth, Washington, D. C.

LACEY Patent Sense. See Page 166.

PATENTS. Write for my free Guide Books "How to Obtain a Patent" and "Invention and Industry" and "Record of Invention" blank before disclosing inventions. Send model or sketch of your invention for instructions. Promptness assured. No charge for above information. Clarence A. O'Brien, Registered Patent Lawyer, 589 Security Bank Building, directly across street from Patent Office, Washington, D. C. See pages 162 and 163.

WILL finance patent (good invention) for interest. F. A., % Patent News, Washington, D. C.

TO sell your Patent. Write me; experienced handling. Immediate action. Address Arthur S. Billings, Suite 401 Dekum Bldg., Portland, Ore.

SPECIALIZED service for inventors. You furnish the idea, we'll work it out. Expert machine designing. Drafting. Opinions given on practicability of ideas. Confidential dealings. Your ideas fully protected. Write for full particulars. Otis Engineering Co., Desk C D, Omaha, Neb.

WE Develop your ideas into commercial shape for presentation to purchasers, making working models, drawings, experiments or tests. Courtesy, efficiency, secrecy and ample equipment; 39 years' experience. Duvorron-Rich Engineering Co., 504 Pacific Mutual Bldg., Los Angeles, Calif.

GET your own patents. Application blanks, complete instructions \$1. Cutting Sons, Campbell, Cal.

RESPONSIBLE established electrical manufacturer will buy outright or manufacture on royalty new inventions of household utilities or appliances. Details necessary. L. J. Effertz, 6545 Carnegie Ave., Cleveland, Ohio.

PATENTS—Send for Booklet. Contains valuable information for inventors. Our charge for search of Patent Office records \$5.00. Prompt service, twenty years' experience. Talbert & Talbert, 508 McGill Building, Washington, D. C.

HAVE You an invention? If so, write for our free book, "How to Get Your Patent," tells our terms and methods. Send model or sketch for our free examination and instructions. Randolph & Co., Dept. 144, Washington, D. C.

PATENTS FOR SALE

FOR Sale—U. S. A. and Canada—Rights on a 2-in-1 Shade and Curtain Rod Brackets. Cash or Royalty Basis. Write Frank J. Fell, 1948 Dalziel St., Detroit, Mich.

PATENT 1,505,949 — Useful Smokers' Novelty, Combination Ash Tray and Cigarette Case. Design Simple. Easy to Manufacture. Reasonable Cash Offer Bars. John J. Helm, "D" Flight Brown Field, Quantico, Va.

PATENT pending for sale. Application placed on file by Victor J. Evans & Co., Washington, D. C. U. S. Patent Application, Serial No. 739,175. This new invention, a Knee Garter, is necessary and gives comfort. It holds the stocking and will always retain the pressed line in the trousers. The first manufacturer that buys this invention will have a very large profit. A Knee Garter what every man needs. Make an offer. Address Caesar Crogmole, 129 Wilder Street, Rochester, N. Y.

PATENT Pending, Metal Cigarette Case. Takes original package; Neat, Simple, Practical. Pedro Cabangis, Bureau of Supply, Manila, Philippines.

PATENT on a new type safety razor that can be stropped or honed. Hugh James, Montrose, Ill.

ATTENTION, Patent buyer: Have pocket size cigarette case and roller combined. U. S. Patent No. 1,565,126. Endless field for sales. Outright \$50,000. Other offers solicited. Address: John Atkinson, Minneapolis, Manitoba, Canada.

NEWLY patented invention on hay tucking device. Most efficient method known. Outright or royalty. Harry A. Murray, Box 344, Wyatt, Mo.

EVER-HOT Vacuum Shaving Mug. Patents in United States and Canada. Ready sales of 75,000 of the manufactured article in United States. Will sell outright or arrange for manufacture on royalty basis. Emory D. Van Hosen, Three Forks, Mont.

INVENTIONS For Sale. Mostly improvements on Agricultural machinery, Household furniture and Automobiles. I have one Patent, another pending, a number of others not been disclosed to any one. I will sell a 40% interest in one or more for the financing of the Patents. I am a man past middle age with successful experience in planning and building. Address Box 584, Fort Angeles, Washington State.

VALUABLE inventions for sale. For full particulars, address T. Johnson, 59 O'Brien Street, North Bay, Ontario, Canada.

OUTRIGHT: Automobile mud lug. Easily and quickly applied. Will defy any mud-hole. Write Wm. Miedembauer, 120 Fairmont Ave., Waukesha, Wis.

INVENTOR wants help. Fred Petterson, Orange County Home, Orlando, Fla.

PATENT on an improved Direction Indicator for automobiles. Best device of its kind yet invented. Write N. J. Velino, 2019 Chicago Ave., Minneapolis, Minn.

ATTENTION! Saw, Wood Working Machinery, Mechanical, and Electrical Tools manufacturers, there's a great opportunity awaiting back of you to increase your manufacturing. This opportunity runs in millions of profit. This new invention is Motor-operated Hand saw in three different models and could be manufactured in any size desired. It's operated with little effort on the part of the operator—only to guide it. United States Patent Application, Serial No. 738,901, filed by Victor J. Evans & Co., Washington, D. C., September 29, 1924. Inventor's address, Thomas Szeczo, 129 Wilder Street, Rochester, N. Y.

YOU want a million. Patent 1,501,607. Sale, Royalty, Partnership. Scientifically correct Arch Support. Hand Adjustable. Dr. Lewis, 1489 Court Place, Denver, Colo.

PATENT for Sale—Something new about building masonry, sparing and facing element. Motmore Green, 112 Laurel Way, Homestead, Pa.

ATTENTION, Mfgs.: U. S. and Canada Patents for Sale or Royalty. Improved Rail Fasteners. Simple, Prevents Creeping and Spreading. Fiber Cushion; absolutely Sound. This invention will make money for its Manufacturer. John P. Gardner, West Los Angeles, Calif.

OUTRIGHT or Royalty. Simple collapsible pneumatic mattress. Market for Millions. Patent Pending. H. Potting, Gen. Idaho.

PATENTS for sale or royalty: Portable Commode with removable waxed paper lining for use in automobiles. Letter-Size Drawing-Pad Outfit. Both on the market. Circulars free. H. P. Jones, 41 Arkansas St., Buffalo, N. Y.

PATENT Ventilator; Partner wanted to help manufacture or will sell. Harold Wood, 1948 Jefferson, East, Detroit.

WONDERFUL Invention: Patent No. 1,506,556, A "Mechanical Level" with only one bead; will give a true Horizontal or Vertical line and can be set at any angle of degree from these lines or to measure the angle of things not exactly true to these original lines. Charley D. Benedict, National Military Home, Box No. 349, Marton, Ind.

OUTRIGHT or Royalty: "Auto Turn Signal." Patent Pending. John H. Williams, Box 34, Dalton, Ohio.

PATENT for Sale—New Parlor Game. Nothing similar on market. Cheaply manufactured. Outright or Royalty. C. I. Dailley, Box 496, Jeffersonville, Ind.

PATENTS For Sale: To sell, buy or obtain patents, write Patent News-P, Washington, D. C.

MR. MANUFACTURER, Larman or veteran—Side Dump Scraper Hoist, loads wagons, does ditching. E. B. Hawkins, Applegate, Oreg.

YOU have a worth-while patent, haven't you? Why don't you tell our two million readers about it? Most of them are specially interested in patents and new inventions. Ask me to tell you how other inventors successfully sold their patents. Geo. F. Baker, Manager Classified Advertising, Popular Mechanics Magazine, Chicago, Ill.

SURVEYING INSTRUMENTS

LARGEST stock of new and used surveying instruments in the country direct from factory. Satisfaction guaranteed or money refunded. Wissler, 619 N. Broadway, St. Louis.

DRAWING INSTRUMENTS AND DRAFTING SUPPLIES

FINELY made nine-piece German Precision drafting set at \$4.50. Money back if not satisfactory. Bass Camera Company, 109, N. Dearborn St., Chicago, Ill.

MODELS AND MODEL SUPPLIES

PATENTS—Write for my free Guide Books "How to Obtain a Patent" and "Invention and Industry" and "Record of Invention" blank before disclosing inventions. Send model or sketch of your invention for instructions. Promptness assured. No charge for above information. Clarence A. O'Brien, Registered Patent Lawyer, 589 Security Bank Building, directly across street from Patent Office, Washington, D. C. See pages 162 and 163.

SPECIAL machine builders, tool and die makers, inventors' models, production work of all kinds. Dept. L, Quality Hardware & Machine Co., Ravenswood and Thorndale Avenues, Chicago, Ill.

FOR lowest prices on models and machine work, write, Louis Uhler, 543 Napoleon, Detroit, Mich.

PATTERNS and models made; light manufacturing. H. W. Hathorn, Mason City, Iowa.

PATTERN Making. Wood Models. Fourteen Years' Experience. My Personal Attention. M. Herbert Heighon, Hypoluxo, Fla., Box 47.

WE Build Models, design, develop and manufacture articles in large or small quantities. Homeyer Mfg. Co., 1385 E. 17th St., Cleveland, Ohio.

MODELS, Dies, Metal Stampings, Light Manufacturing, Modern Shop, Reasonable Prices, Osborne Register Company, 123 West Pearl, Cincinnati.

DIES, Tools and General Manufacturing, Models and Manufacturing of new inventions our specialty. Logan Machine Co., 126 S. Clinton St., Chicago, Ill.

MODEL steam engine $\frac{1}{2}$ " x $\frac{1}{4}$ " \$8.50. Finished parts for same, \$7.25. Other engines, boilers, blowlamps. Catalog for 10c stamp. Model Machine Shop Co., 417 East 71 St., New York City.

HULIT & CO., Model Makers and Experimental Machinists, Tools and Dies, 625 West Jackson, Chicago, Ill. We specialize in high-grade model work on inventions of merit. New parts and repairing. Your patronage solicited.

WE make working models for inventors and do experimental work and carry a complete stock of brass gears and model supplies. Send for catalogue. The Pierce Model Works, Tinley Park, Ill.

THE Modelmaker. For those interested in making working models. Send 10 cents. Address P. M. 120 Liberty Street, New York.

MANUFACTURING

PATENTED Articles, Models, Brass Work, Machine Construction; Dies Made. Baum's Metal Specialties, Kansas City, Mo.

GET down to Wire Facts. Send us your inquiries on special or standard Wire products. Forming, splitting, pointing, welding, etc. Increased facilities make double present production possible. We know our quotations will be of interest to you. Metal-Craft Manufacturing Company, Box 259-W, Chicago.

WE design and build special machinery, make models, dies, stamping tools, do general machine work and light manufacturing. Marshall Mfg. Co., Kansas City, Mo.

WIRE goods made to order. Cooley Mfg. Co., 530 N. Western Ave., Chicago.

LIGHT Manufacturing; Let us know your wants. Shanabarger Bros., Machine Shop, 363 W. 5th St., Peru, Ind.

PATTERNS, wood and metal, models and experimental work, stamping and machine work, light manufacturing complete. Reliable Pattern Works & Mfg. Co., Cincinnati, Ohio.

BOLTS, nuts, rivets, etc. O. L. Dickey, 48 Trask, Bayonne, N. J.

WE design and build special machinery, tools, dies, figs, and fixtures. Experimental work. Reliable Machine Co., 400 W. 23rd St., New York City.

EXPERIMENTS developed, dies, models and manufacturing machine designing. Estimates and information promptly given. Address Schreier Bros. Machine Works, 2363 Holmes St., Kansas City, Mo.

METAL-CRAFT — Eventually — Metal-Craft. Competent Engineers, Designers and Producing Organization await your commands on dies, stampings, die-casting, deep pressing, screw-machine and wire products. Plating, Enameling, Burnishing, Assembling, Wrapping and Packing to your specifications. Large completely equipped plant which guarantees prompt, efficient service. It is not the quality of raw materials alone, nor the precision in manufacture, and not just the service rendered that has given Metal-Craft the good reputation they bear—but all of these, as a constant certainty, in combination. Estimates promptly furnished. Metal-Craft Manufacturing Company, Box 259-W, Chicago.

WE develop models, make dies and stampings; prices reasonable. Rapid Manufacturing Company, Pittsburgh, Pa.

IRON, Brass, Aluminum Castings, Models, Patterns, Light Manufacturing, Welch Brothers Co., North Chicago, Ill.

SCREWS, nuts, screw machine products, all metals. Autosew Works, 355 West Broadway, New York City.

LONG established manufacturer of auto accessories which are daily sold by practically all wholesale and retail accessory houses will consider manufacturing and distributing new automobile products, capable of equally wide sale through same channels. Patented articles preferred. Address Auto Accessory Manufacturer, Room 2104, 210 S. Michigan Ave., Chicago, Ill.

OUR factory will make your models, manufacture your articles as well as build your tools, dies and fixtures. Standard Die & Specialty Co., 817 W. Washington Blvd., Chicago, Ill.

PATTERNS, wood and metal. Models, tools and dies. Brass, bronze, aluminum and iron castings. Screw machine work, production work of all kinds. Write Modern Machine & Pattern Co., Terre Haute, Ind.

FOR MANUFACTURERS

MANUFACTURERS wanting English Sales, send us your proposition. Spiers Acme Co., 41, St. Paul St., London, N. 1.

MACHINERY, TOOLS AND SUPPLIES

STAR 11" x 5" Screw-cutting lathe. Chucks, dogs, toolholders, all for \$100.00. Kampen, 1027 Grant, Rockford, Ill.

13" SWING, 5' bed, Engine Lathe, swings 20" in gap, compound rest, screw cutting, fine shape, \$125.00. Norton Machinery Co., Cincinnati, Ohio.

YOU can install a lathe in your shop now under our Easy Payment Plan. See page 206 for details. South Bend Lathe Works, South Bend, Ind.

COMBINATION self-feeding bench drill and Hand-Breast drill; Capacity 0- $\frac{1}{2}$ "—\$13.00. Tool & Novelty Co., 150 Front St., Woonsocket, R. I.

ONE 12" x 6' LeBlond quick change lathe, \$200.00. 1 12" x 6" Reed lathe, \$145.00. 1 No. 60 Heald cylinder grinder, \$700.00. 1 14" Jungst crank shaper, \$185.00. Complete line machinery. Cincinnati Machinery & Supply Co., 218 E. Pearl St., Cincinnati, Ohio.

CONCRETE Building Block Machines and Molds. Catalogue free. Concrete Machine Co., 293 South Third St., St. Louis, Mo.

ENGINES, MOTORS AND DYNAMOS

PRACTICAL Steam Engines, one H. P. \$18.00; $\frac{1}{2}$ \$12.00. Excellent Christmas Presents. James Chambliss, Bessemer, Ala.

GOVERNORS to control Auto Engines when used as stationary engines. Circulars. Canby-Smith Governor Co., Springfield, N. Y.

STEAM gas, gasoline engines, 250 Kilowatt alternating generator, air compressors, pulleys, shafting, hangers, cable, belting; machine shop, factory, mill, electric, wood-working, mining and hoisting machinery. Builders of freight, passenger and hand elevators; slightly used elevators and machinery, a bargain. Raffner Elevator Works, Kansas City, Mo.

SMALL Gasoline, Steam Engines, Dynamos, Motors, Storage Batteries, etc., new and secondhand. New Catalogue free. Dynamic Manufacturing Co., First National Bank Bldg., Chicago.

BLACKSMITHS

BLACKSMITHS, Listen! Make more money doing hard jobs easy with Toy's Modern Methods of Master Machine Blacksmithing, Forging and Solid Welding, Tool Dressing and Tempering to a standard with colored tempering charts. All for One Dollar. Samples Free. W. M. Toy, Sidney, Ohio.

BENDING MACHINES

THE famous Hossfeld Wrenchless Universal Bender is the last word in bending machines; bends metal, cold or hot, into most any conceivable shape, including Eye-bolts and Automobile Spring Eyes. Bends up to 1" bars or 1 $\frac{1}{2}$ " Pipe cold. Used by the largest corporations, yet so inexpensive that even a farm shop need not be without one. Send for circular. Hossfeld Mfg. Co., Box 344, Winona, Minn.

FOR THE SHOP

MECHANICS! You will seldom if ever get stuck on a job if you keep on hand for quick reference a 14-volume set of Popular Mechanics Shop Notes. At the price of 50 cents a volume, any one of the several thousand time and labor-saving kinks may save you the cost many times over. Any of the volumes may be purchased separately at the same price. Popular Mechanics Book Dept., 296 E. Ontario St., Chicago.

WELDING Encyclopedia—New Third Edition. Complete training course for operators in all welding processes: oxyacetylene, electric arc, electric resistance and thermit. Welding of all weldable metals fully discussed. 427 pp., 400 illus. The accumulated experience of the welding brains of America is yours for \$5. Money back if not satisfied. Popular Mechanics Book Dept., 205 E. Ontario St., Chicago.

SHOP Notes Book for 1924, comprising the 550 articles that have appeared in the Shop Notes section of Popular Mechanics during the past year. Bigger and better than ever. 212 pp., 175 illus., 50 cents postpaid. Popular Mechanics Book Dept., 205 E. Ontario St., Chicago.

FOR SALE—MISCELLANEOUS

BARREL Lots slightly damaged crockery, hotel chinaware, cookingware, glassware, etc. Shipped direct from factory to consumer. Write for particulars. E. Swasey & Co., Portland, Maine.

200 LUCKY Strikes, Camels, or Chesterfield Cigarettes \$1.35, 600 divided into thirds or all one brand, \$3.95. Holland, 53 Woodward Ave., Boston 19, Mass.

"\$1 BUYS a 2,000 M German Government Bond. Wanted German Bond all issues." Frank H. Everett & Co., 35 Wall St., New York.

ELECTRIC Cooking Stove, Oil Burner, Used Ford Motor Parts, Bargains. Howard Christian, Somerville, Mass.

KARSTADT'S Mammoth Pecans. Pound \$1.50; Ten pounds \$12.50. W. Karstadt, Dayton, Ohio.

ALL Wool Yarn for Sale from manufacturer. 75c to \$2 per lb. Free samples. H. A. Bartlett, Harmony, Maine.

ADDRESSGRAPHS, Letter Folders, Multigraphs, Envelope Sealers, Duplicators, less than half price. Guaranteed. Pruitt Co., 170 N. Wells, Chicago.

BUY—Exchange—Sell! Many of our readers have for sale or exchange the article you are looking for—and lots of them are looking for the very items you want to turn into cash. Get together! Let our two million readers know your wishes—they'll help you! Send your ad today to Geo. F. Baker, Manager Classified Advertising, Popular Mechanics Magazine, Chicago.

WANTED—MISCELLANEOUS

DO YOU Write? We are eager to receive in any form Stories, Photoplays and Articles suitable for publication. Send us your manuscript for free criticism. Producers and Publishers Clearing House, Dept. P. O. Box 1182, Montreal, Quebec.

MAIL Discarded Gold, Jewelry, Diamonds, Watches, Silver, Platinum, Postage Stamps, Anything Valuable. Quick Cash Returned. Held Returnable Ten Days. If Unsatisfactory. Miller & Co., 3988 24th St., Detroit, Mich.

WANTED: Printing presses, paper cutters, etc. Any kind, size or condition. F. M. Buddick, West Newton, Mass.

MAIL Discarded Gold, Jewelry, Diamonds, Watches, Silver, Platinum, Magneto Points, Mercury, False Teeth, Bonds, Thrift, Unused Postage Stamps, Anything Valuable. Quick Cash Returned. Held Returnable Ten Days. If Unsatisfactory. Ohio Smelting Co., 315 Hippodrome Bldg., Cleveland, Ohio.

MAIL us your discarded Jewelry, Gold, Crowns and Bridges, Watches, Diamonds, Silver, Platinum, and old False Teeth. Money promptly mailed. Goods returned if offer refused. United States Smelting Works, (The Old Reliable), Dept. 71, Chicago.

REAL ESTATE, FARM AND ORCHARD LANDS

AUTO Agency, Garage and Accessory Business—\$2,000. Central location, paved street; bldg. worth \$3,000; city water, gas, electricity; 5 pleasant living rooms; employs 2 men all year. \$2,000 gets it, part cash. Details p. 93, New Illus. Catalog. Free. Strout Farm Agency, 150P Nassau St., New York City.

20 ACRES or more of our best land in Michigan; \$20 per acre; 2 1/2 per acre down, balance your own terms. 32 page book free. Swigart Land Company, P-1259 First National Bank Building, Chicago.

WANT to hear from owner having farm for sale; give particulars and lowest price. John J. Block, Chippewa Falls, Wis.

ATTENTION—"Get acquainted." Cash for your property, Farms, Hotel or Retail Store, no matter where located; confidential service. Hayes' Business Agency, Cincinnati, Ohio.

FOR Sale—Three full sections in McKenzie County and two sections in Billings County, North Dakota. Each section contains land suitable for crops, balance for cattle. Each section has valuable deposits of lignite which some day will alone be worth many times the present value of the land. This part of the state is developing very rapidly with good schools within easy access. As owner cannot use this land himself, will sell one or more sections at a price which almost anyone can afford to pay. Address W., care Popular Mechanics, 205 East Ontario St., Chicago.

PECAN-ORANGE Groves "On the Gulf" \$10 monthly. Guaranteed care. Soon produce \$300.00 yearly. Suburban Orchards, Dept. M, Biloxi, Mississippi.

SELL your property quickly for cash, no matter where located. Don't pay big commission. Particulars free. Real Estate Salesmen Co., Desk B, Lincoln, Nebr.

\$5.00 DOWN, \$5.00 monthly; 10 acres unimproved poultry, fruit, stock, woodland; \$100; Ozarks. Fishing, hunting, trapping. Alfred Zimmerman, 1800 N. Fifth, Kansas City, Kans.

ROOTS AND HERBS

HERB Doctor Book—10 cents, 250 recipes to make herb medicine. Hazzard Company, Box 1, Vanderwever Park, Brooklyn, N. Y.

DOGS AND PETS

RAISE guinea pigs. Pay better than poultry or rabbits; easy to raise; little space required. We guarantee market. Particulars and booklet how to raise free. Carles Distributing Co., 3102 Grand Ave., Kansas City, Mo.

ALL kind hunting dogs. Cheap. J. R. Thomas, Booneville, Miss.

SILVERBLACK Foxes \$350.00. Time Payments. Muskrats, Arthur Schumacher, Leekland, Ohio.

BEAUTIFUL registered bull pups cheap. Bulldogs, 501 Rockwood, Dallas, Texas.

BULLDOG puppies for Xmas. Price \$50. Monte Kennels, Huntington, Ind.

PERSONAL

LEAKY Rubbers—Mend 'em yourself with Treado prepared rubber. Apply with a knife, no soiled hands, no cement. Fills holes in heels and soles, or breaks in uppers. Wrap 50c coin in paper with name and address for 4 c. can. Money back if desired. Treado Co., 238 East 45th St., New York City.

ARE You Old at Forty? See our advertisement on page 192 of this issue. The Electro Thermal Company, 2137 Main Street, Steubenville, Ohio.

FREE to Invalids! Dominion Solitaire and Health Circulars. Dr. Swingle, 7901 Cedar, Cleveland, Ohio.

MEN—Women: You can save money on your cigarettes in ordering them by mail. Send in a trial order for 200 at a saving of 15c, then order a month's supply. 200 Lucky Strikes, Camels, or Chesterfields, \$1.35; 600 divided into thirds or all one brand, \$3.95. Holland, 53 Woodward Ave., Boston 19, Mass.

TROUBLED with Unpleasant Breath?—Send \$2.50 for guaranteed relief. The Sa-Fac Co., Dept. 1-D, 4740 Kenmore Ave., Chicago, Ill.

KNOW Thyself—and become a success! Know your character, talents, possibilities in business, love, marriage and future enterprises. Send your full birth date, specimen of your handwriting and 10c for your wonderful Three-Page Horoscope of surprising indications of your life. Write at once: Gargilis, Box 2771-DD, Boston, Mass.

TOBACCO, Liquor and morphine habits can be overcome with the aid of Hill's Chloride of Gold Preparations. Liquor remedy can be given secretly. Particulars free. Ohio Chemical Works, Dept. 9, Westfield, N. Y.

ALL men 45 or over must have my aid. No medicine, electricity or humbug. Rexus, Box 2492, Boston, Mass.

TOBACCO or Snuff Habit cured or no pay. \$1.00 if cured. Remedy sent on trial. Superior Co., TP, Baltimore, Md.

UNUSUAL Horoscope—Six pages, 2,500 words, consisting of extensive four-page Special Horoscope, Astro-Analysis, and two-page valuable guide giving daily and monthly advice covering entire year. Send 50c and birthdate. Money returned if dissatisfied. Prof. Bolles, Box 125, Cranford, N. J.

TOBACCO Kills manly Vigor. Quit easily. Cigarettes, chewing, smoking, snuff conquered or no charge. Small sum if satisfactory. Stops craving; harmless. Full treatment on trial. Perkins Co., 34-A, Hastings, Neb.

FREE—Information of a scientific nature that has brought happiness through perfect health to thousands. No charge, no obligation. Enclose stamp for reply. Fair Sales Co., Dept 246-O, Colorado Springs, Colo.

MISCELLANEOUS

THE New Systematic Calendar 1925, 28 days per month and 13 months per year. Every month besides the Old one for comparison. World's greatest novelty. Large Wall calendar 25 cents. Compiled by Rev. Louis Unger, 1412 East 29th Street, Lorain, Ohio.

MONEY Silvering Mirrors, Autolights, Radiators, tableware, stores, Outfits, Methods Free. Sprinkle Plater, 288 Marion, Ind.

CALIFORNIA Jumbo walnuts. Sack for One Dollar. Winona Products Company, 325 West Santa Barbara, Los Angeles.

KIDDE Cabinet, beautiful novelty toy; actual size patterns, including instructions 20" model, 25c, 28", 50c, 49", \$1.00. Patterns children's furniture, list free. Bogren Kidde Cabinet, 393 West 143d St., New York.

PRINTING Presses, Type, Materials, Make easy money Printing for Self and Others. Interesting Circulars, Stamp, Watson, 160 William St., New York.

LOCKSMITHING, complete 500 tricks of the trade, new edition, many added features. \$1.50, money back if dissatisfied. H. Boutson, 3406 Andover St., Oakland, Calif.

SIMPLIFIED photo-engraving. Line and half-tone cuts. Particulars 2 cts. Horton & Fisher, Princeton, Ill.

NEW Mail Order Plan Brings quick, steady income, spare time or full time. Permission, positive and profitable. Details complete, \$2. Circular telling all about it free. W. H. Blair, Box 5, Lamoni, Iowa.

I CATCH from 45 to 60 Foxes in from 4 to 5 weeks time. Can teach any reader of this magazine how to get them. Just drop me a line for particulars. W. A. Hadley, Stanstead, Quebec, Canada.

WORKING Drawings, Tracing, Catalogue and Text-Book Illustrating. Floyd Shaffer, Box 277, Arlington, N. Y.

TATTOO marks removed easily and painlessly with the new scientific preparation "Tattoooid." Complete \$3. B. Vestfold, 1123 75th St., Brooklyn, N. Y.

FORMS to cast Tin Soldiers, Indians, Marines, Trappers, Animals. Send 5c for Catalogue. Henry Schiercke, 1034 72nd St., Brooklyn, N. Y.

ROCKS and Minerals for sale—hundreds of varieties—Price List Free. Peter Zedac, 157 Wells St., Peekskill, N. Y.

ARTIFICIAL Eyes, \$3. Booklet free. Denver Optic, 539 Barclay, Denver, Colo.

CUTS anybody can make. Simple, cheap process. \$1. Specimens, particulars, 2c stamp. M. Day, Windfall, Ind.

HOMEOPATHIC and Biochemic preparations sent postpaid to all parts of the world. Manual and booklets free. Halsey Bros. Co., 111 N. Wabash Ave., Chicago, Ill. Established 1855.

OUTDOOR Sports—How to make devices for sports the year 'round. Kites, airplanes, wind wagons, swimming accessories, and dozens of other things every live boy wants. A 150-page book, jammed with ideas. Instructions are complete and can be followed by any intelligent boy. Only \$1. Popular Mechanics Press, Room 807, Popular Mechanics Building, Chicago, Ill.

JUST Out—A New Boy Mechanic Book No. 4—1309 Articles, 1320 Pictures. Tells how to make such things as Radio Receivers, Toy Airplanes, Pushcycle, Canoe Pontoons, Diving Flasks, Electromagnets, Wind Wagon and Ice Boat, Catamaran, Motion-Picture Camera, Sidesheel Motorboat, Motor-Driven Sleds, Camp Equipment and hundreds of other interesting devices. Price \$2 postpaid. Popular Mechanics Book Dept., 205 E. Ontario St., Chicago.

PERSONAL Advancement—The new magazine published by Popular Mechanics Press for all who want to get ahead. Inspiration, education, entertainment, advice. Will help you to decide upon a vocation, to get help in preparing yourself for that vocation, to get the best books on travel, mechanics, and on related subjects. One year free. Send your name and address on a postal to Popular Mechanics Press, Room 807, Popular Mechanics Building, Chicago, Ill.

Quickly Learn to Play Hawaiian Guitar

Play Like This Native

Free
'18 Hawaiian
Guitar—when
you enroll

Are You Popular? Do You Fit In This Picture?

Everyone likes popularity. It's great to be invited to many parties where young folks gather to have good times. Become an expert Hawaiian Guitarist and you will quickly become the center of attraction. It's an easy instrument to master with our short cut method of teaching.

JAZZ Your Way to Popularity and Success

Jazz has taken the country by storm. Hawaiian Guitar jazz artists are popular and successful.

Genuine \$18.00 Hawaiian Guitar Free

When you enroll as a student, you secure absolutely free a beautiful, full tone, genuine \$18.00 Hawaiian Guitar. We also furnish every bit of equipment so that it is not necessary for you to spend an extra penny outside of the cost of our course.

NEW INVENTION

Kno-All Fingerboard Chart Quickly Teaches You How to Play and Read Notes

The newest invention of our chief Hawaiian instructor, which is exclusively used by us and which we call the "Kno-All Fingerboard Chart" quickly teaches you how to play and read notes. So simple is this device that anyone can understand it and begin to play immediately.

Diploma Given to Graduates

When you graduate, you get a beautifully engraved diploma and after graduation, we also give you six months' free service and consultation.

No Forming Class to Wait For

No forming class to wait for. Start your lessons at once and join the band wagon of success and popularity. Do it through the Hawaiian Guitar.

Rush Coupon for Free Book & First Free Lesson

Sign and mail coupon to us today. You will receive your Free Book, "How to Learn Hawaiian Guitar" and your first lesson free.

Hawaiian Studio No. 5212
of New York Academy of Music

212 Fifth Ave.
New York

Bring the romantic, enchanting, entrancing and melodious strains of the great instrument of the Hawaiian Islands into your soul and you will soon become popular and successful. This short cut method of home instruction enables you to quickly master the Hawaiian Guitar, so that you will play as well as the Native Hawaiians.

Our staff of Hawaiian instructors have perfected a method of teaching that is simple that without any musical knowledge, you can quickly learn to play real music from notes. It is as simple as learning your A B C's and it will not be long before you will play latest Broadway hits such as, "Mamma Loves Papa, Papa Loves Mamma, Linger A While, I Love You, Wonderful One, Already, When Lights Are Low," and any others of your choice long before you have completed our course.

There are only four simple motions to learn and then you will be able to play any music, whether it be popular, dance or classical. Almost from your first lesson you will be able to play love songs like Aloha Oe.

To help you get started and to promote in America the popularity of this wonderful instrument, we furnish absolutely free when you enroll as a student, a beautiful, full tone, genuine, \$18.00 Hawaiian Guitar. Only 1,000 free instruments will be given away, so if you want to get in on this free offer, write for particulars at once—you must act quickly.

It's Easy to Understand Pictures Of Our Professors' Playing

Arthur Brisbane, the highest paid journalist in the world once said that "A single picture is worth a thousand words." He was right, for it sounds to reason when you take your instrument in hand along with actual photographs of our professors in action as your guide, it is easy to imitate and do the right thing.

Along with our easy to read course we also supply you with diagrams and charts, as well as many pictures of our professors' playing. This enables you to imitate the pictures. Isn't this easy?

Phonograph Records of Piece You Are Learning Included Free

As an additional guide, we also furnish you with phonograph records of our Hawaiian instructors' own playing of the piece you are learning. This practically brings our professors from our studio to your own home and enables you to listen to their playing just as if they were actually in front of you.

First Lesson Free

So positive are we that you will become one of our students and a booster for our course, that if you write at once, we will send you absolutely free, without any obligation on your part, our first lesson which will enable you to see just what you can expect when you enroll. You will also receive our big book which gives full particulars about our course. Write for your book and your free lesson today. You will be one of the lucky ones to have a free Hawaiian Guitar reserved for you—write at once, because the number of gift Hawaiian Guitars are limited.

PROOF

Expects to Play by Bed Time

Received my guitar all O.K. and was delighted to see such a fine guitar for the price. I have begun to study the first lesson and I think I will be able to play it by bed time tonight, or at least will try.—Mr. Irvine Lee, 401 East Cleveland Ave., Knoxville, Tenn.

Getting Along Fine

The guitar is O.K. and am getting along nicely in spite of the fact that I am a total novice.—St. Francis Hospital, 125 W. Green St., Pasadena, Cal.

Proud of Hawaiian Guitar

I am perfectly satisfied with your course. It is very simple indeed and above all, we proved all my Hawaiian guitar, it is a beauty. Looking forward for the other lessons to come.—Joe L. Collins, National Headliner, P. O. Box 75, Tennessee.

RUSH THIS COUPON FOR FREE BOOK AND FIRST FREE LESSON

Hawaiian Studio No. 5212
of New York Academy of Music,
212 Fifth Avenue, New York.

Please rush your book, "How to Learn Hawaiian Guitar" and my first free lesson. Also reserve a gift Hawaiian Guitar for me. This obligates me in no way whatever.

Name _____

Address _____

City _____ State _____

NOTE—This offer expires in 60 days



\$4000 to \$12000 a Year!

**I will
train you
At Home!**



**CHIEF
ENGINEER
DUNLAP**

for Dunlap-Trained ELECTRICAL EXPERTS!

GO INTO ELECTRICITY! Make \$75 to \$200 a week bossing Electrical jobs. The world's biggest, fastest growing, most fascinating business NEEDS YOU. I have made it easy for you to become a successful ELECTRICAL EXPERT, right in your own home, in spare time! And I guarantee to place you in an Electrical job, at 50% Raise in pay or to refund your money!

Learn at Home by JOB-METHOD!

With the help of 22 of the world's foremost Electrical Engineers, I have made this training the most complete, the most up-to-date, the most valuable on earth! We train you on actual Electrical JOBS, so you get the theory at the same time as you get the practice. My instruction is easy to understand, rapid. Any man under 40 years, with only common schooling, can win success and promotion with Dunlap-training.

You get 4 BIG ELECTRICAL OUTFITS!

Dunlap "Job-Method" instruction is built around 4 complete Electrical Outfits which I send you without extra charge as a part of this course. Includes motor, telephone receiver, switches, magnets, compass, wire, tools, instruments and materials. Remember I train you in every branch of Electricity, and prepare you to BOSS Electrical jobs at big pay.

\$63 Scholarship FREE!

Mail coupon immediately and save \$63 cash. Get all the facts about your opportunities in Electricity. Get my illustrated catalog and my GUARANTEE of a job and a raise. Let me show you how I will help you succeed in the great Electrical business. Write today!

50% PAY-RAISE COUPON

**Chief Engineer Dunlap, Electrical Division,
AMERICAN SCHOOL, Dept. E-974
Drexel Avenue and 58th, Chicago**

Please send me your Electrical book, the \$63 Free Scholarship offer, and your guarantee to get me a job and a 50% raise in pay.

.....Name

.....St. No.

.....City.....State

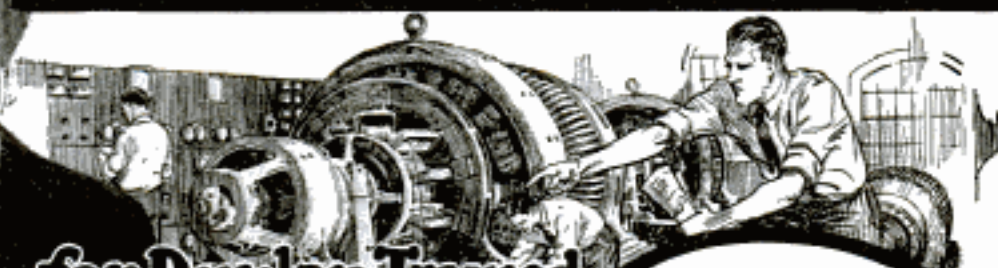

22

**Famous Electrical
Engineers helped me
prepare this Training!**

No one man on earth knows all about EVERY subject in Electricity. So Engineers of the following great corporations help me to give you the world's most complete electrical home-study training:

1. General Electric Co.
 2. Commonwealth Edison Co.
 3. Crocker-Wheeler Co.
 4. Cutler-Hammer Mfg. Co.
 5. American Telephone & Telegraph Co.
 6. Westinghouse Electric & Mfg. Co.
 7. Western Electric Co.
 8. Underwriters Laboratories, Inc.
- and Electrical Engineers of the following universities:
1. Columbia University
 2. Dartmouth College
 3. Massachusetts Institute of Technology
 4. Lehigh University
 5. University of Vermont
 6. Armour Institute of Technology
 7. University of Kansas
- and many others.

Start to make money quick!

In your eleventh lesson, within a few weeks after you START taking my training, I will give you special instruction in ELECTRICAL and RADIO JOBS, so you can go right out and make enough money in your spare time to pay for this course and have plenty left over. So don't let lack of ready cash hold you back—I will show you how to make Dunlap-training pay for itself.

My graduates are more successful!

(Read this letter)



Dear Mr. Dunlap:
I enclose a photograph of myself and the neighborhood of the 10,000 A. V. A. hydroelectric plant where I am employed.
My ability to hold this position is due entirely to the training I have received from the American School, as when I first enrolled with you I was a common laborer and details were sent mysterious to me. Now, however, I regularly use laparotomies to find the load factor of this plant.
—Oyv Viktors,
Wendell, Idaho.

The American School



as an educational institution, pledged NOT TO MAKE A PROFIT, gives the best training at the lowest possible cost. The entire resources of this 57 year old, million-dollar institution stand back of our guarantee that if you are not satisfied we will refund every penny of your money.

**I GUARANTEE
YOU A JOB and
a 50% RAISE!**

I make this agreement in writing with every student. If you are now making less than \$40 a week, I will guarantee to get you an Electrical job after you finish my training, at a salary of 50% more than you are earning today, or I will refund every cent you have paid for tuition. Only the AMERICAN SCHOOL makes this guarantee. Mine is the only home study electrical training which justifies it.

**CHIEF ENGINEER
DUNLAP
Electrical Division
American School
Dept. E-974, Drexel Ave. & 58th
CHICAGO**

MAIL TO DAY



\$100
for Single Drawings

See How Easy It Is To Learn Drawing This New Way

Through a remarkable new method *anyone* can now quickly learn to draw—right at home in spare time. No special talent needed! Become an Artist this new easy way.

YOU have always longed for it—this fascinating ability to draw. Now it can easily be yours. Illustrating, Rapid Sketching, Decorative Designing, Advertising Art, Cartooning—you can easily learn all of this right in your own home. Hundreds of our students never had a drawing pencil in their hands before starting, yet are high salaried artists today.

Big Money in Commercial Art

Trained Artists earn \$50, \$75, \$100 and even over \$200 a week! Single drawings often bring over \$100. And now, with just a few hours pleasant study each week, *you* can quickly learn to make drawings that have a real commercial value.

Hundreds of trained artists are needed today all over the country. Magazines, Department Stores, Advertising Agencies, Publishers, Manufacturers—these are just a few of the fields which are in urgent need of artists. Get into this attractive, big money field now.

It's Fun Learning Art This New Way

It's all just like a pleasant game when you learn to draw with this new method. You study right at home, yet every bit of your work receives the individual attention and criticism of a *real artist*. It's almost as though you had a famous artist standing at your elbow while you work. With this training you progress with amazing

rapidity. Starting with straight lines and curves, you quickly learn action, perspective and all the more advanced secrets of drawing. Almost before you realize it you are making drawings that *sell*.

Send for FREE BOOK

You may be considering the study of art merely for the joy you can get from it; or you may want to turn your ability into the big money which is to be found in Commercial Art. In any case—if you feel that you want to learn to draw, send for our new Free Book on art, which tells all about the wonderful opportunities for happiness and profit in art, and describes this startling new method which makes it so easy for you to learn to draw. Mail coupon for this.

Free Book and for our Special Free Offer.

**Washington
School of Art**
Room 3012-B
1115-15th St. N.W.
Washington, D. C.

Washington School of Art
Room 3012-B, 1115-15th St. N. W., Washington, D. C.
Please send me your Free Book on art which tells about your new method. Also detail of your Special Free Offer. Please write plainly.
Name
(Mrs., Miss or Mr.)
Address
City State
Age under 16 years





\$100 a Week

"Wouldn't you like to earn that much, too?"

"I know you would, Bob—think what it would mean to us! It worries me to see you wasting the best years of your life when you could make them count for so much.

"Can't you see it, Bob? Don't you see that the reason men get ahead is because they train themselves to do some one thing just a little better than others?"

"If the International Correspondence Schools can raise the salaries of other men, they can raise yours. If they can help other men to win advancement and more money, they can help you, too. I am sure of it.

"Don't let another year slip by and leave you right where you are to-day. Let's at least find out how the I. C. S. can help you. Let's mark and mail this coupon right now!"

INTERNATIONAL CORRESPONDENCE SCHOOLS Box 5661-D, Scranton, Penna.

Without cost or obligation, please tell me how I can qualify for the position or in the subject before which I have marked an X:

BUSINESS TRAINING COURSES

- | | |
|--|---|
| <input type="checkbox"/> Business Management | <input type="checkbox"/> Salesmanship |
| <input type="checkbox"/> Industrial Management | <input type="checkbox"/> Advertising |
| <input type="checkbox"/> Personnel Organization | <input type="checkbox"/> Better Letters |
| <input type="checkbox"/> Traffic Management | <input type="checkbox"/> Show Card Lettering |
| <input type="checkbox"/> Business Law | <input type="checkbox"/> Stenography and Typing |
| <input type="checkbox"/> Banking and Banking Law | <input type="checkbox"/> Business English |
| <input type="checkbox"/> Accountancy (including C.P.A.) | <input type="checkbox"/> Civil Service |
| <input type="checkbox"/> Nicholson Cost Accounting | <input type="checkbox"/> Railway Mail Clerk |
| <input type="checkbox"/> Bookkeeping | <input type="checkbox"/> Common School Subjects |
| <input type="checkbox"/> Private Secretary | <input type="checkbox"/> High School Subjects |
| <input type="checkbox"/> Spanish <input type="checkbox"/> French | <input type="checkbox"/> Illustrating <input type="checkbox"/> Cartooning |

TECHNICAL AND INDUSTRIAL COURSES

- | | |
|---|--|
| <input type="checkbox"/> Electrical Engineering | <input type="checkbox"/> Architect |
| <input type="checkbox"/> Electric Lighting | <input type="checkbox"/> Architects' Blue Prints |
| <input type="checkbox"/> Mechanical Engineer | <input type="checkbox"/> Contractor and Builder |
| <input type="checkbox"/> Mechanical Draftsman | <input type="checkbox"/> Architectural Draftsman |
| <input type="checkbox"/> Machine Shop Practice | <input type="checkbox"/> Concrete Builder |
| <input type="checkbox"/> Railroad Positions | <input type="checkbox"/> Structural Engineer |
| <input type="checkbox"/> Gas Engine Operating | <input type="checkbox"/> Chemistry <input type="checkbox"/> Pharmacy |
| <input type="checkbox"/> Civil Engineer | <input type="checkbox"/> Automobile Work |
| <input type="checkbox"/> Surveying and Mapping | <input type="checkbox"/> Airplane Engines |
| <input type="checkbox"/> Metallurgy | <input type="checkbox"/> Navigation |
| <input type="checkbox"/> Steam Engineering | <input type="checkbox"/> Agriculture and Poultry |
| <input type="checkbox"/> Radio | <input type="checkbox"/> Mathematics |

Name.....
Street..... 3-6-24
Address.....

City..... State.....

Occupation.....

Persons residing in Canada should send this coupon to the International Correspondence Schools Canadian, Limited, Montreal, Canada.

Earn Big Income Raising Poultry

BECOME
INDEPENDENT

Poultry raising is one of the fastest growing businesses in the world. Always a ready market for products. Work is easy, fascinating, healthy, profitable! Commercial poultry raisers earn

\$3,000 to \$15,000 a Year

Learn at home. Our course of instruction easy—prepared by Harry M. Lamont, the man who taught Uncle Sam how, and corps of famous poultrymen. School endorsed by State Colleges and universities.

No Matter Where You Live

we can teach you and show you how to start in business with little outlay. Not necessary to be on a farm. Many graduates now making big money—and are their own boss. YOU can do the same! Our FREE BOOK "How to Raise Poultry for Profit" will start you on the RIGHT way to financial independence and pleasure. Write for YOUR copy today!

National Poultry Institute
Dept. 151 B, Washington, D. C.



I Made \$100,000

in less than five years as a real estate specialist. Started during my spare time, with no experience, and less than \$5.00 capital. If you want to learn the secret of my success and follow money-making method, send your name and address at once to American Business Builders, Dept. A-4412, 1133 Broadway, New York. They send full information free, telling you how you can build up an independent profitable business of your own by using my amazing successful system.

Learn to **PAINT SIGNS and SHOW CARDS**

Big field—unlimited possibilities—increasing demand for men with creative ideas. Our course develops ability and originality. Work is totally interesting.

EARN \$25 TO \$75 WEEKLY

You can do it if ambitious. Successful graduates everywhere. Our course thoroughly covers every phase of work. Our graduates command big salaries. Write for catalog, samples, courses and Free Outfit Offer.

Detroit School of Lettering, Dept. P. M., Detroit, Mich.



MAKE BE AN AUCTIONEER

\$100 A DAY

Free Book tells how. We fit you by Home Study or at School, largest in world. Auctioneers make big money—work short hours. Thousands of graduates. Write today for Free Book. Enclose \$1 and we will also send our "Auctioneer's Joke," a book of 393 jokes—best yet. Address W. B. CARPENTER, President MISSOURI AUCTION SCHOOL, 818 Walnut Street, Kansas City, Mo.

No Better Christmas Present
for \$2.50
than a year's subscription to
Popular Mechanics Magazine
Containing 3600 Pictures and 3600 Articles

Much of it interests Everybody
Most of it interests Anybody
All of it interests Somebody

Order through your Newsdealer or address the Publisher
POPULAR MECHANICS COMPANY
200 East Ontario Street, CHICAGO, ILL.

BE A BIG MAN

In The Auto Business

Make \$5,000 To \$10,000 A Year



A.G. ZELLER
PRESIDENT

Do you want to get into the auto business in a way that will bring you to independence quickly? Or are you already an auto mechanic and looking for a way to get into a bigger job? My big "Master Course" (thirty weeks or more of thorough training) will put you where you can tell the world you are a real automobile man, and **prove** it.

Training for business comes down to this—the more you know the quicker you succeed. A doctor or lawyer goes to college for years, but such as this long course of mine will give you, you are fitted for a high-grade, well-paid position; to be a service manager or to run a garage or salesroom of your own. The investment of time and money will pay you **big dividends**, and bigger every year.

Seven to Eight Months' Training (MASTER COURSE) At Detroit

Make up your mind you are going to get this training **right**. Then go after the big job or start your own business. You will be your own boss because you can get a job anywhere.

The fourteen years of experience of this great School (at Detroit, the Auto Center of the World) have been put into this Master Course. No auto training course even approaches it in completeness. You need have no experience, to learn auto work thoroughly in this course. We start you at the beginning and give you both head and hand training. Auto dealers send their men to take this course, to fit them for big positions. Foreign governments send officials here to take it, to prepare them for handling their auto industries.

Complete equipment is here for you to learn on. All types of engines, electrical systems, new cars. Instructors are expert, each a specialist in his line. In addition to this 30 week course, we have a number of shorter courses. Write for outline.

15,000,000 Cars—A World-Wide, Wonderful Business

Think what opportunities are open in the servicing of over fifteen million cars in the U. S. A. alone. Men who know the business can get a job anywhere in the world.

Do What These Men Did

J. R. Navarre, Carrollton, Ohio (Service Mgr. of Dodge Station), writes: "Three years ago when I left your school I was nearly broke, and a single man. Now I have a fine job, wonderful wife and comfortable home. Mechanics think I must have had twenty years' experience. M. S. A. S. gave me all I needed."

C. K. Switzer, Harrisonburg, Va. (owner of a big garage and Reo agency), writes: "I wish you could have relieved me of the job of making the income tax return on our year in business!"

John Grahek, Chisholm, Minn.: "Before I went to your school I hardly made enough for my family to live on. Now I average \$400.00 a month."

Benn Kochler, Pulaski, Wis.: "Made net profit of \$5,000.00 my first summer in business."

H. A. Bradley (owner of garage and battery service at Cleveland), writes: "My business earning me \$500.00 a month clear, and growing all the time."

Write Me Today Send for the details of our great Master Course (and our other Courses). Use the coupon, or write. I will answer you personally. Every student here gets personal attention and is a Life Member. Write me today.

A. G. ZELLER, President

MICHIGAN STATE AUTOMOBILE SCHOOL
1512 Auto Bldg., 3729 Woodward Ave., DETROIT, MICH.



Wolverine Garage, Holland, Mich.

Run by two "Michigan State" graduates. They have the agency for Durant, Star and Flint cars and employ two more "Michigan State" men. They say: "We don't remember when we fell down on a job." Michigan State graduates make good in a big way because Michigan State training is **good** training.

Mail Coupon To Day

Michigan State Automobile School 1512 Auto Bldg. DETROIT, MICH.

Send me FREE and without obligation complete information about Detroit-training to make the most money and your 30 weeks' Master Course.

Name

Street or R. P. D.

City State



The World Famous Ludwig Trap Drum Outfit!

Thousands of young men with no previous training or knowledge of music are learning to play trap drums and are making from \$75 to \$200 a week. You can do the same if you make up your mind to start at once and secure one of these fine outfits with free instruction. Naturally, your selection will be a Ludwig—the choice of 95% of the drummers now playing with the popular bands and dance orchestras. *Ask any professional.*



Joseph Frank,
famous trap
drummer with
Isham Jones,
Brunswick Or-
chestra, uses and
recommends
Ludwig Drums

Play in Hour! Free Instruction

Trap drums are the easiest of all instruments to play. Less than an hour after you get hold of the sticks, you will be able to play ordinary beats. With a little practice, you will be "jazzing" away in approved fashion. *Music is not essential*—you don't have to know one note from another. That's why any beginner can play trap drums in a short time.

Think of the fun you can have in addition to the money you can make. No dance orchestra, band or bugle corps is complete without drums. Many enjoyable evenings can be spent at home drumming with a phonograph, radio or other instruments. Be a trap drummer and you will be popular everywhere.

Send No Money!

Take the first step today and send the coupon for full information and description of the many Ludwig Drum Outfits as well as Free Trial Offer. There is one to fit every purse. A complete set costs less than the average popular instrument.

Ludwig & Ludwig
1611 N. Lincoln St., Dept. 1359 Chicago, Ill.

Ludwig & Ludwig, 1611 N. Lincoln St., Dept. 1359, Chicago, Ill.
Gentlemen: Please send me full information on your Drum Outfits and Free Trial Offer.

Name.....

Address.....



Here's the Gold Mine of Ideas Everyone Has Hoped For

The pesky furnace fills the house with dust. How can this be avoided? Is there a way to prevent yourself and the house from being littered with soot when you take down the stove? How can you equip your home shop without much expense? How can you make your own equipment for the kitchen? Where can you go to get ideas for electric devices about the house?

These questions and dozens more just as practical are now answered in the Popular Mechanics NEW Home Mechanics Handbook No. 1. Just off the press and crammed with ideas of all sorts for everyone who has a home.

How to Make What You Need About Your Home

The book explains how to make such devices as:

Clothes hangers	Ironing board	Door stop
Portable shelves	Coal bucket	Flag pole
Indoor tent	Foot scraper	Ash tray
Power pump	Call bell	Sewing machine
Wheel barrow	Food cooler	motor
Electric whip	Tin snips	Refrigerator
Fireless cooker	Pipe wrench	Blowtorch
Pipe bender	Level	Anvil
Power grinder	Chain door lock	Window box
Medicine cabinet	Flour bin	Weather strip
Awning	Wheel chair	Ash box
Writing table	Gas burner	Fireplace screen
Stove truck	Window pole	Water heater
Shoe rack		

329 Discoveries — 203 Illustrations

Every item is a discovery made by someone who encountered an emergency just like you are likely to encounter. The devices are all home-made, and none are patented. Anyone can use them in any way he sees fit. This book is one of the biggest bargains in years, not so much because of its low price as because of its unusual contents.

50
Cents

Send for a copy today. Use the attached coupon.

50
Cents

Send me Home Mechanics, the Gold Mine of Ideas, at once.

Name.....

City.....State.....

Street.....

Mail to Popular Mechanics Press,
Room 505, Popular Mechanics Building, Chicago, Ill.

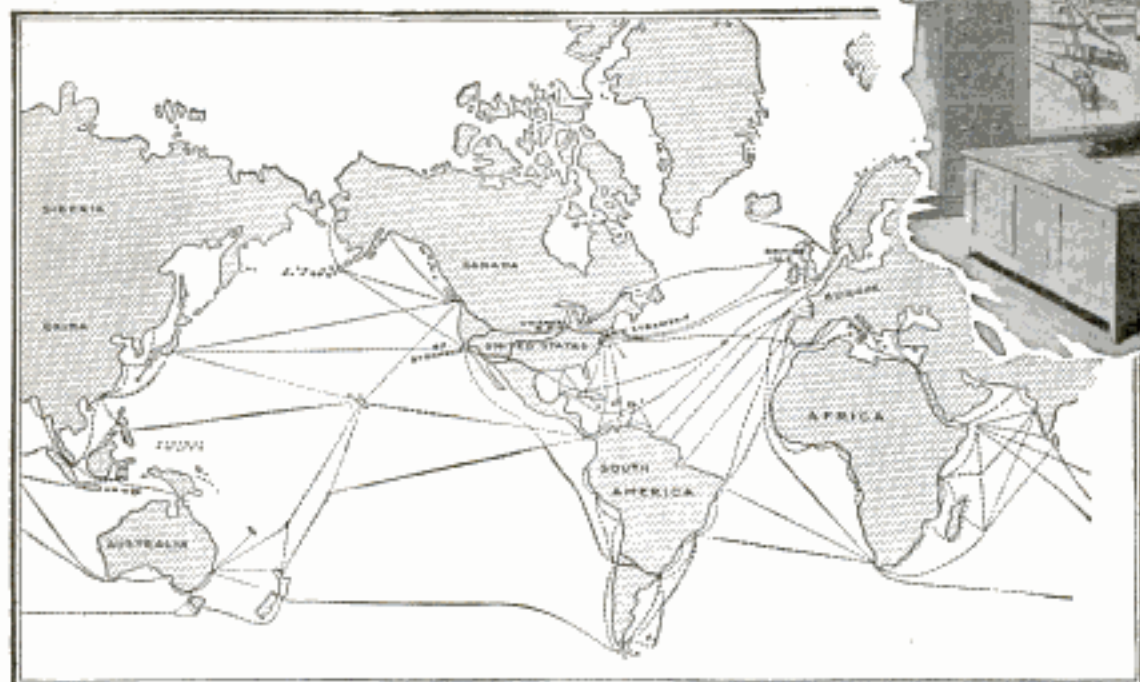

Master Traffic Management

\$ 50 to \$ 200 a Week

There is no field of business today which offers better opportunities for promotion and increased salary than the profession of Traffic Management.

Instead of growing smaller and more limited as time goes on, this field of business endeavor is becoming larger and larger every day. It is only now that thousands of business organizations, manufacturing enterprises, mills, mines, factories, railroads, chambers of commerce and municipalities are fully awakening to the absolute necessity of employing the trained traffic expert.

The salaries paid to expert traffic men are large—\$200 a week is by no means the limit—there are traffic directors and interstate commerce experts who are earning \$10,000 to \$15,000 a year and up.

As in all other branches of business, the successful traffic expert has gained his knowledge of transportation problems by having acquired specialized training which fits him to take his place among the highly paid business executives.

This specialized knowledge and training may now be acquired by any ambitious man in his spare time without interference with his everyday business duties. Any man who earnestly desires advancement can find at least one hour of spare time each day to devote to preparing himself for a bigger job. It is for the benefit of such men that the LaSalle home-training course in Foreign and Domestic Traffic Management is offered.

LaSalle training will prepare you successfully to handle important traffic work. You will be directly under the supervision of C. O. Frisbie, former Traffic Manager for Armour & Company, former President of the Illinois Tunnel Company, assisted by an able staff of 150 traffic experts.

You will be thoroly trained in Freight Rates, Classifications, Regulations and Management, Tariffs, Bills of Lading, Routing, Claims, Organization, Laws of Carriers, Interstate Commerce Rulings, R. R. Accounting, Statistics, etc. You will receive the personal attention of these experts who will answer your questions, direct your training, give you suggestions. The cost is reasonable; deferred payments can be arranged if desired. Mark and mail the coupon now, and we will send you all the facts regarding the attractive opportunities in this field.

INQUIRY COUPON

LaSalle Extension University
Dept. 1264-TR Chicago, Ill.

Please send me catalog and full information regarding the course and service I have marked with an X below. Also a copy of your book, "Ten Years' Promotion in One," all without obligation to me.

**Traffic Management—
Foreign and Domestic:**

Training for position as Railroad or Industrial Traffic Manager, etc.

Other LaSalle Training Courses

LaSalle is the largest business training institution in the world. It offers training for every important business need. If more interested in any of these courses, check here:

- | | |
|--|--|
| <input type="checkbox"/> Business Management | <input type="checkbox"/> Banking and Finance |
| <input type="checkbox"/> Salesmanship | <input type="checkbox"/> Modern Foremanship and Production Methods |
| <input type="checkbox"/> Higher Accountancy | <input type="checkbox"/> Personnel and Employment Management |
| <input type="checkbox"/> Railway Station Management | <input type="checkbox"/> Expert Bookkeeping |
| <input type="checkbox"/> Law—Degree of LL. B. | <input type="checkbox"/> Business English |
| <input type="checkbox"/> Commercial Law | <input type="checkbox"/> Commercial Spanish |
| <input type="checkbox"/> Industrial Management Efficiency | <input type="checkbox"/> Effective Speaking |
| <input type="checkbox"/> Modern Business Correspondence and Practice | <input type="checkbox"/> C. P. A. Coaching |

Name.....

Present Position

Address

Free Trial!

In your own home—

Think of it! Our free trial offer makes it possible for you to become a crack Xylorimba player right in your own home. Easiest instrument to play. In addition, we furnish you free, 14 complete lessons. Learn to play in a few hours. With a little practice you can play jazz accompaniments. Be the life of the party—anywhere. Earn \$80.00 to \$200.00 a week with a

DEAGAN Xylorimba

With this instrument you can play either for profit or for fun. Deagan instruments furnish the "spice" of the music. Used exclusively in recording studios for phonograph records.

Free Lessons—Easy Payments

Our free lessons and easy payment plan make it easy to learn at home, with the phonograph, radio, or other instrument. Send coupon below for illustrated literature and details of our special free trial offer. If you have a radio, tune in on "WGN," Chicago, between 8 p.m. and 9 p.m., Nov. 20, and hear the famous Deagan Xylorimba.

Mail Coupon Today!

J. C. DEAGAN, Inc., Dept. 1359
Berteau and Ravenswood Avenues, Chicago, Ill.
Gentlemen: Without obligation please send me full information regarding your Free Trial Deagan Xylorimba offer.

Name

Address



A Great Book Free with this pay-raising library

For a short time only we will give every subscriber to the New Library of Machine Shop Practice a copy of French's Engineering Drawing—the greatest book on mechanical drawing ever written. This book makes drawing as plain as day—tells you all about instruments, plans and methods—and prepares you to handle any drawing job you will ever have to do. It comes to you absolutely free with

Machine Shop Practice

9 volumes — 3065 pages — 3608 illustrations
(A combined home study course and reference library)

The New Machine Shop Library is written for practical men. It gives you the best methods for every kind of machine shop work. It explains machine tools and their operation, drawing and design, tool work, gears and grinding, jigs and fixtures, automatic screw machines and their tools and all of the mathematics you will ever have to use. It is plainly written, completely illustrated—the very best kind of help to the machine shop man who wants to advance himself.

Sent

**F
R
E**



No money down—
only 7c
a day

FREE EXAMINATION COUPON

McGraw-Hill Book Co., Inc., 370 Seventh Ave., New York

Send me for 10 days' free examination the New Library of Machine Shop Practice. If satisfactory I will send you \$1.50 in 10 days and \$2.00 monthly until the special price of \$19.50 is paid. If not wanted, I will return the books at your expense.

On receipt of my first payment of \$1.50 it is understood that I am to receive, free of charge, a copy of the second edition of French's Engineering Drawing.

Signed

Address

City and State

Position

Employer

P. M. 12-1-24

Make Things From Metal

IT is surprising what success an amateur can have in the making of useful and decorative metal objects. You can make such articles as: book ends, desk sets, blotting pad corners, paper knives, stationery racks, rocking blotter, desk calendars, table lamps, bracket lamps, dining room dome lamps, whisk broom holders, candle sconce, drawer pulls, and dozens of other articles if you have the simple directions in—



The Home Metal Worker's Library

This library consists of three cloth-bound books as follows:

1. Metal Work and Etching
2. Lamps and Shades in Metal and Art Glass
3. Electroplating

Each book is profusely illustrated. The books are written especially for amateurs, although the designs they contain are equally useful to professional metal workers.

Send No Money—Simply write a postal asking for the Home Metal Worker's Library to be sent C.O.D. When the postman delivers the books to you, simply hand him \$1.50 and the few cents postage. Or, send \$1.50 and the books will be sent postpaid.

POPULAR MECHANICS PRESS

Popular Mechanics Bldg. Room 711 Chicago, Ill.

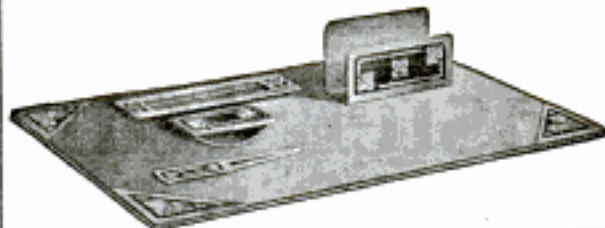

Handy Mechanic's Library

Includes four practical books, suitable either for mechanic or amateur, as follows: Lathe Handbook No. 1; Shop Notes, 1923; Auto Repairman's Handbook No. 1, and Shop Notes for 1922. The four for \$2. **Send No Money.** Simply write a postal asking that The Handy Mechanic's Library be sent. Hand the postman \$2 plus few cents postage when he delivers the books to you. POPULAR MECHANICS PRESS, Popular Mechanics Bldg., Rm. 711, Chicago, Ill.

Make Furniture at Home

—either for your own pleasure or to sell. It is easy when you have the instructions supplied in Popular Mechanics Home Furniture Making Library. This library consists of the following cloth-bound, illustrated books:

1. Wood Working for Amateur Craftsmen
2. Mission Furniture — Part 1
3. Mission Furniture — Part 2
4. Mission Furniture — Part 3
5. Arts-Crafts Lamps

These books contain full directions and drawings for the making of all sorts of furniture, including table and wall lamps for electric lights. One purchaser writes that he has made over \$1,000 worth of furniture for sale from these books. You can do the same.

SEND NO MONEY—Simply write a postal asking that Popular Mechanics Home Furniture Making Library be sent you C.O.D. When the postman delivers the books, simply hand him \$2.50 plus the few cents postage.

POPULAR MECHANICS PRESS
Popular Mechanics Building
Room 711, Chicago, Ill.



Earn \$50 to \$200 a Week in RADIO

You can! Hundreds of ambitious men are already earning thousands of dollars in this wonderful new industry—you, too, can get your share. Mail coupon below for Free Book which describes fully the amazing money-making opportunities in Radio and tells how YOU can earn from \$5,000 to over \$10,000 a year.

THE astounding growth of Radio has created thousands of big money opportunities. Millions of dollars were spent during the past year on Radio, and thousands of young men are needed right now to meet the ever-increasing demand of work.

Men are needed to build, sell and install Radio sets—to design, test, repair—as radio engineers and executives—as operators at land stations and on ships traveling the world over—as operators at the hundreds of broadcasting stations. And these are just a few of the wonderful opportunities.

Easy to Learn Radio at Home in Spare Time

No matter if you know *nothing* about Radio now, you can quickly become a radio expert, by our marvelous new method of practical instruction—instruction which includes all the material for building the latest up-to-date radio apparatus.

Scores of young men who have taken our course are already earning from \$75 to \$200 a week. Merle Wetzel of Chicago Heights, Ill., advanced from lineman to Radio Engineer, increasing his salary 100% *even while taking our course!* Emmett Welch, right after finishing his training, started earning \$300 a month and expenses. Another graduate is now an operator of a broadcasting station—PWX of Havana, Cuba, and earns \$250 a month. Still another graduate, only 16 years, is averaging \$70 a week in a radio store.

Wonderful Opportunities

Hardly a week goes by without our receiving urgent calls for our graduates. "We need the services of a competent Radio Engineer." "We want men with executive ability in addition to radio knowledge to become our local managers." "We require the services of several resident demonstrators"—these are just a few small indications of the great variety of opportunities open to our graduates.

Take advantage of our practical training and the unusual conditions in Radio to step into a big

paying position in this wonderful new field. Radio offers you more money than you probably ever dreamed possible—fascinating easy work—a chance to travel and see the world if you care to or to take any one of the many radio positions all around you at home. And Radio offers you a glorious future!

The National Radio Institute is America's



Pioneer Radio School—established in 1914. Our course is the absolutely complete one now being offered which qualifies for a government first-class commercial license. It gets you the *bigger* paying jobs in Radio.

Send for FREE RADIO BOOK

Learn more about this tremendous new field and its remarkable opportunities. Learn how you can quickly become a radio expert and make big money in radio.

We have just prepared a new 32-page booklet which gives a thorough outline of the field of Radio—and describes our amazing practical training in detail. This Free Book, "Rich Rewards in Radio," will be sent to you without the slightest obligation. Mail coupon for it *now!*

For a short time we are offering a reduced rate to those who enroll at once. Act promptly and save money.

National Radio Institute

Dept. 15MA, Washington, D. C.

National Radio Institute, Dept. 15MA, Washington, D. C.

Please send me without the slightest obligation your Free Book, "Rich Rewards in Radio," and full details of your special offer and Free Employment Service. Please write plainly.

Name.....Age.....

Address.....

City.....State.....



Pay Increases Over \$100 a Month

I am averaging anywhere from \$75 to \$150 a month more than I was making before enrolling with you. I would not consider \$10,000 too much for the course. (Richard A. N. Long, 120 N. Main Street, Greensburg, Pa.)



Doubles Salary

I can very easily make double the amount of money now than before I enrolled with you. Your course has benefited me approximately \$200 over and above what I would have earned had I not taken it.

T. Winder,
721 Bedford Ave.,
Grand Junction, Colo.



He thought he could throw me—

Dear Tom: You know how Ted Brown has always been saying he could throw me with one hand tied behind him, if he wanted to. Well, yesterday, he grabbed hold of me and we had it out. Gee, I wish you'd been there. You know how much bigger Ted is than I. He thought he had me licked dead easy—

but

I wriggled around and got a hold on him that I'd learned from the Farmer Burns School of Wrestling. The next second—KERFLOP, and I had Mister Ted Brown on the ground, yelling for me to quit. It's a cinch to handle a fellow half as big again as you are if you know the secret holds. If I were you I'd write to Burns School for their free book about wrestling. So long—FRED.

Learn Wrestling Secrets from Worlds Champions Farmer Burns and Frank Gotch

Learn the marvelous holds, breaks, blocks and tricks that will enable you to handle big, strong men with ease. The renowned FARMER BURNS—"father of scientific wrestling"—and FRANK GOTCH the world's champion, have prepared a series of lessons in which they reveal the inside secrets of training that will make YOU, too, an expert wrestler. All the great secrets of *self-defense* and *jai-jitsu* illustrated by printed word and picture. The lessons teach you how to become a *great athlete*, and secret knowledge enabling you to throw boys and men larger and stronger than yourself.

Farmer Burns School
1779 Railway Exchange Bldg., Omaha, Neb.
Please send me at once without obligation your FREE illustrated booklet on Scientific Wrestling, Physical Culture, Self-Defense, and How to Win.

Send for FREE Book

Our FREE ILLUSTRATED BOOK tells you all about the advantages in health, vigor and respect that being able to wrestle brings one. It tells you how to learn to become a skilled wrestler in your spare time. Brim full of interesting information about wrestling. Also lots of pictures. INVESTIGATE. Write today for this free book. No obligations. Tear out and mail coupon NOW!

Farmer Burns School 1779 Railway Exchange Bldg., Omaha, Neb.

LEARN TO GET DOLLARS OUT OF WATCHES.
WATCH-REPAIRING, ENGRAVING, JEWELRY REPAIRING.
WRITE NOW.
ENICAR TRADE SCHOOL
830 W MONUMENT SQUARE, RACINE, WIS.



Start Little Mail Order Business—Free Book

Home employment evenings. Beginners outfit furnished. Book Free. Pier, 842 Cortland St., NEW YORK



Make Money Drawing Cartoons

It's Easy To Learn When Shown In The Right Way

Some of the cleverest cartoonists and comic artists in America today learned to draw during their spare time by following CARTOONIST EVANS' SIMPLE AND EASY METHOD. This school is recommended by foremost cartoonists because they know the students are handled right. If you like to draw, send a sample of your work, either an original or a copy, and we will send you a portfolio of cartoons and full details. The course is NOT EXPENSIVE.

The W. L. Evans School of Cartooning 821 Leader Building CLEVELAND, OHIO

WANTED

RAILWAY POSTAL CLERKS
\$1600 to \$2300 Year
MEN—BOYS, 18 UP

Steady work. No layoffs. Paid vacations

Travel—See Your Country

Common education sufficient. Mail coupon today—SURE



MAIL CLERKS

FRANKLIN INSTITUTE, Dept. S-180, ROCHESTER, N. Y.

Sirs: Send me without charge, (1) Specimen Railway Postal Clerk Examination questions; (2) List of government jobs now obtainable; (3) Send list of examination places; (4) Send free sample coaching lessons.

COUPON

Name

Address

Do You Want \$5000 a Year



after a few weeks' training in New York?

THERE is always opportunity for the *trained* man, very rarely for the untrained. If you are earning less than \$75.00 a week it is not because there isn't a big pay job open, but because you are not *trained to earn*. Don't go along in the same old rut, waiting for something to turn up. *Make things happen* by accepting the golden opportunity that is open to you.

Read What Victor P. Klein Has Done

The Stewart Automobile School
225 West 57th Street
New York City, N. Y.

Gentlemen: After graduating from your school in April, 1924, I obtained a position as mechanic with The Auto Service Company, Pompton Lakes, N. J., and am now in partnership with the owner of this Company.

My success in this line of work I feel is entirely due to the very thorough course of training I received at The Stewart Automobile School, and I will highly recommend your course to any one desiring a very complete course in automotive mechanics.

Yours very truly,
VICTOR P. KLEIN.

You Can Do It Too

Thousands of men have found the way to success by training at the Stewart Automobile School in New York. They have done it—so can you. Many Stewart graduates own their own businesses or are in executive positions—directing other men. It is so easy, so simple to accomplish, that a man has only himself to blame if he is not on the same road to success within a few weeks.

Individual Instruction

The lack of technical education or experience does not bar you from the Stewart School. You work with tools, not books. Each student receives personal instruction; his individual characteristics are studied by our instructors. You do not leave a subject until you are satisfied that you know and understand it thoroughly. You are not rushed through the Stewart School.

Our shops are splendidly equipped. Each different phase of the automotive and garage business has a department to itself. These departments include automobile mechanics, tire vulcanizing, battery manufacture and repair, advanced electrical and ignition work, etc.

No Worry About Expenses

You can earn expenses while you are training—provided you have a clean record and can furnish satisfactory references. Our Employment Department has been very successful in getting jobs for worthy students and in placing graduates in good positions.

Our welfare manager arranges for your room and board within the limit of your purse while you are at the school.

Big Free Book

All of the above is described and explained in the fully illustrated catalogue which you may obtain free by sending in the coupon below.

A scratch of your pen will bring you this FREE book. In it you will read letters from former Stewart students telling how they have succeeded in life by grasping opportunity—the same opportunity that is yours *today*.

It tells of the advantages of training in New York—of the ideal location of the Stewart School.

Details of the courses—subjects, tuition, time, etc., are given in full.

Mail the coupon today. It will open the door to SUCCESS for you.



STEWART AUTOMOBILE SCHOOL (Founded 1909)
225 W. 57th St., Dept. 1759, New York, N. Y.

Please send me your free book that describes your school and the opportunities in the Automobile Business. I am under no obligation.

Name.....

Address.....

City.....

State.....



When will You become A Factory Manager?

YOU yourself are going to set that successful day when you become a factory manager. If you have the courage and ambition to move upward into a bigger salaried job as an expert foreman, superintendent or production manager, nothing can stop you if you are thoroughly trained in the important fundamentals of factory management. Our book.

"Advancing to Success"

tells you how you can quickly step up into one of these bigger salaried jobs. This book is now free. If you have the ambition to succeed, this very moment is the test of your will.

LINCOLN EXTENSION UNIVERSITY, Inc.

Louis S. Vosburgh, Pres.

Department A

CLEVELAND, OHIO



Are You Going to send for It ?

Name.....
Street.....
City..... State.....

How to Get A Position with the U. S. Government

Thousands of appointments are made yearly. Good salaries—short hours—liberal vacations (as much as 30 days in some branches of the service). Positions open now in Washington and other cities and in Alaska, Porto Rico, Hawaii and the Philippines.

"Pull" and influence unnecessary. Common school education sufficient as groundwork for most positions. The International Correspondence Schools will prepare you right at home to pass your Civil Service examination with a high mark.

Mail the coupon to-day for 48-page Free Civil Service booklet.

INTERNATIONAL CORRESPONDENCE SCHOOLS
Box 5653-D Scranton, Penna.

Without cost or obligation, please send me a copy of your 48-page CIVIL SERVICE BOOKLET, which tells how I can secure a good-paying position with the U. S. Government.

Name.....
Address.....

Any One Can Play the Jazzy JAZZ-O-NETTE

Absolutely New—Nothing Like It

The easiest to play wind instrument known. It's a wonder. Anybody—boy or girl, man or woman, can play any jazzy tunes they know the day Jazz-O-Nette arrives. No knowledge of music necessary. Plays like a slide trombone. Plays all flats and sharps in any key.



Become an Entertainer

This is not a toy but a real wind instrument used by vaudeville actors, entertainers and in orchestra work. Big 10 inch, highly polished, seamless brass horn gives appearance of \$50.00 instrument. Amaze your friends at home—play for parties and dances—there's lots of fun and money in it. Be popular everywhere you go. Hundreds of dance orchestras now featuring this jazzy Jazz-O-Nette. Be the first to start it in your town.

SEND NO MONEY

Send only your name and address today. When Jazz-O-Nette arrives, pay the postman our low introductory price, only \$6.50 plus a few cents postage. Satisfaction guaranteed. Be the first to play the Jazz-O-Nette—surprise your friends. You can get more real enjoyment out of this than playing piano, banjo, saxophone or other musical instrument. If not satisfied after 3-day trial—you get all your money back. All points outside U. S. send \$7.25 with order.

Musschl & Westphal, 746 W. Water St., Ft. Atkinson, Wis.

A Library of 5,600 Ideas for SHOPMEN and HANDYMEN

In 14 compact, thoroughly illustrated and indexed volumes you may have nearly 6,000 ideas that will prove of many dollars value to you. Single ideas from these books have made profits for some readers amounting to many times the cost of the entire library. Some have learned how to make things to sell. Others have learned how to make a device that lessened labor to such an extent that expense was greatly reduced.

These are books for
**Shopmen
Mechanics
Machinists
Home Owners
Farmers
Boys**

There are 14 volumes that make up Popular Mechanics Shop Notes Library. The price for the entire library is only \$6.50.

Single Volumes 50 cents



POPULAR MECHANICS PRESS

Room 507, Popular Mechanics Bldg., Chicago, Ill.

Be a Telegrapher

"Certified" MASTER-

Broker's Telegraphers
don't remain earning \$500 a month very long. They graduate into branch managers and partners. Many men who started as broker's telegraphers are millionaires today.

Brokers



Newspapers



Newspaper Telegraphers make big salaries, but you couldn't drive the bus away from the key if you stepped their pay! Imagine receiving and sending the news of the world while it's hot—sensations, features, politics, etc.

Railroads

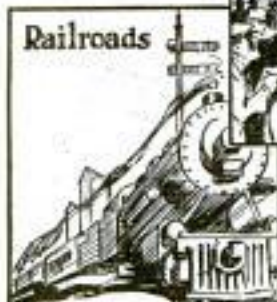

R. R. Telegraphers

enjoy what many men consider is the most fascinating work in the world. Telegraphers and Dispatchers keep traffic humming! Salaries \$165 to \$250 a month.



DEL DUNLOP

At 21, was the youngest Chief Dispatcher of a transcontinental railroad in the world. Inventor of the Dunlop System. In charge of telegraphy training during war for U. S. World's greatest telegrapher.

Commercial Telegraphers

find unlimited opportunities at \$140 to \$200 per month with such great companies as Western Union, Postal, etc. My training makes you an EXPERT, capable of holding down any job.

Commercial



Learn in 6 to 10 Months!

Men, Women, Boys, Girls! In my school, I train you under the same conditions, on the same equipment as you will find when you're out on the job! Most complete, costly equipment ever assembled under the roof of any one school.

The DUNLOP System

is the only internationally known and universally recognized standard of instruction in Telegraphy. I invented the system and the method for teaching it. It bears my name and you can get this complete, practical, rapid instruction nowhere else.

Make \$65 to \$100 Every Week

No work on earth like Telegraphy. It gets under your skin, makes you forget it's one of the best paying trades you can follow. Whether railroad, commercial, broker's or newspaper telegrapher, you're so interested in what you receive or send over the keys, many a time you'll forget it's time to eat. By the Dunlop System you can become a real Expert in only 6 to 10 months. No book-study. All practical, actual work.

Romance — Adventure for Ambitious Men!

If you want to become Telegrapher for, say, the New York Central R. R.—my training not only gives you complete Telegraphy Instruction, but in addition I train you in New York Central official rules of operating traffic and block signal. If you're out to be a Western Union or Postal Telegrapher, I prepare you for that, including training in their rules and methods. Telegraphers find work anywhere, anytime, all over the world.

Big Pay Coupon!

**D. J. K. Dunlop, Chief Dispatcher,
Chicago Telegraph Institute,
Dept. 201-1338 S. Michigan Ave.,
Chicago, Illinois.**

Rush confidential surprise offer FREE. I want to be a R. R. Commercial Broker's Newspaper's Wireless Telegrapher.

Name _____

Address _____



RADIO — WIRELESS

Big demand for Licensed Wireless Operators on great ships. Many big pay positions in Radio waiting for Experts to take them. Get ready quick here! Get my catalog and find out how easily you can become an Expert Wireless Telegrapher.

Get My EARN While You LEARN Plan!

Confidential offer to ambitious men, women, boys and girls who have the hankering to be expert Telegraphers. Most liberal, most sensational and surprising offer ever made by any school. Coupon brings it. Write for it today!

D. J. K. DUNLOP, Chief Dispatcher

Chicago Telegraph Institute

Dept. 201-1338 S. Michigan Ave., Chicago

Choose as Your Profession ELECTRICAL ENGINEERING

Electricity offers a brilliant future to the young man who is about to choose his career. Never before has there been such wonderful opportunity in this great field. Big paying positions in electrical work the world over are open to trained men.

B. S. Degree in 3 Years

Come to School of Engineering of Milwaukee. Here you are trained in both theory and practice by a faculty of experts. You learn in large, finely equipped laboratories. If you have 14 high school credits or equivalent, you can become an Electrical Engineer with a Bachelor of Science degree in 3 years. If you lack these credits they can be made up in our Institute of Electrotechnics in a short, intensive course.



A Complete, Practical, Electrical Education

Learn by the thorough approved scientific methods which our twenty years of specializing enable us to give you. In addition to Electrical Engineering, the following complete courses are given: **A. C. and D. C. Armature Winding—Wiring and Testing—Practical Electricity—Drafting—Electrotechnics—Commercial Electrical Engineering—Automotive Electrical Engineering and Automotive Electricity.**

EARN WHILE YOU LEARN

You can earn money to help defray your expenses while learning. Our wonderful co-operative plan brings an Electrical Career within the reach of every ambitious man. Our Free Employment Department secures positions for those students who wish to earn part or all of their expenses. In addition, the Department will help you get a good position in the Electrical industry when your training is completed. Daily Broadcasting W.S.O.E.

**New Term
Opens
January 5th**

Big Book FREE Mail the coupon today for our big new illustrated catalog. Mention the course that interests you most and we will send you special information. Read about the school that trains men for practical and quick success. See how easy it is for you to get the training that will enable you to step to a splendid position and a handsome income. Mail the coupon right NOW. No cost or obligation.

SCHOOL of ENGINEERING of Milwaukee

Dept. P.M. 1224 415 Marshall Street, Milwaukee, Wis.

School of Engineering of Milwaukee
Dept. P.M. 1224, 415 Marshall St., Milwaukee, Wis.

Please send me your free illustrated catalog; also details of your "Earn While You Learn" plan.

Name.....

Address.....

Town.....State.....

Age.....Education.....

Course Wanted.....

Government Positions

Those who wish to secure life positions in the United States Civil Service at from \$1,400 to \$2,500 a year, should write for the catalogue of the oldest Civil Service School in America, the

COLUMBIAN CORRESPONDENCE COLLEGE
WASHINGTON, D. C.



8 HOUR BATTERY CHARGING PAYS BIG PROFITS

HB Users everywhere are adding \$150 to \$300 monthly to their income with HB Constant Potential One-Day Battery Charging. No experience needed. Outfit comes complete with all necessary equipment for only \$35 cash. Your big monthly profits easily carry the small monthly payments. Free trial on moneyback guarantee. More HB's in use than any other make. Get ready for big winter's business in battery charging. Make those big, easy profits. Write for particulars and free bulletin 387 showing big earnings of battery shops using one day charging system.

HOBART BROTHERS COMPANY,
Box M12 TROY, OHIO



Play FREE Piano TRIAL New Way in 1 Hour



Music Without Notes

SIMPLE AS A-B-C. 300,000 children and grown-ups have learned. No knowledge of note music and no teacher required; no lessons by mail. Sent by Parcel Post, FREE, postpaid, on Trial, 100 famous vocal and instrumental selections printed in the wonderful new Easy Form Music way.

SEND NO MONEY If you don't learn in five days to play SEVEN REAL pieces, send it back. Or, if you keep it, pay only 6 1/2¢ for each selection. No extra charges. Act while SPECIAL HALF-PRICE OFFER LASTS! Be sure to state how many white keys on your piano or organ.

EASY METHOD MUSIC CO., 1239 Clarkson Bldg., CHICAGO

FREE Book on Auto Opportunities in California

Hundreds of big-pay auto jobs open in California. Be an auto mechanic, electrician or distributor salesman. Learn by actual shop practice—earn living expenses while learning. Write today for Big FREE auto book—explains everything.

NATIONAL Automotive School 4004 So. Figueroa St.
Los Angeles, Cal.

100 PARODIES ON Latest Songs 25c



Gallagher & Shean, All for Love of Mike, 3 O'clock in the Morning, Peggy O'Neil, Carolina in the Morning, Smiles, Indians, Michigan, and many others. Comic Dialects. Complete 25c, 3 for 50c p. p. J. C. Durr, 723 S. Dearborn St., Dept. 3, Chicago

RACING BODIES for FORDS at \$34⁹⁵ Up
Send today for free particulars. Our book "How to Build a Ford Racer" sent anywhere on receipt of 25 cents—cash or stamp.
Driver Agents Wanted
CENTRAL AUTO SUPPLY CO., Dept. 120A, LOUISVILLE, KY.

Fibre-Lite Limbs
Easy Payments—Do Nature's Work.
AGENTS WANTED who use Artificial Leg. GOOD PAY.
FREE Fibre Sample. DESCRIBE STUMP TO
WORMAN CO. 252-P HENNEPIN AVE. MINNEAPOLIS, MINN.

No Longer a Secret Every Man Can Have It!

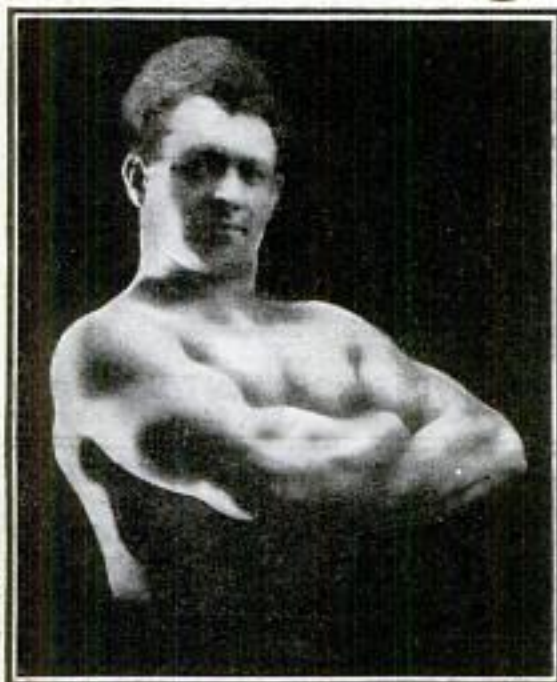

SIEGMUND BREITBART "THE SUPERMAN OF THE AGES"

Most people think I was born strong, in fact they remark, "It was born in him." Let me tell you I was not. From the time I was born I was the same as any other human being—normal. My talents were always directed toward physical development. I liked to lift, pull, perform feats of strength and to exhibit a huge muscle. Sort of natural for a boy, isn't it? As I grew older, I gave more time and study to the scientific development of strength.

A Different and Better Way!

I can spare you many a wearisome hour. I tried all manner of courses and none came up to my expectations. Naturally I could only resort to my own resources for the development of a practical scientific course which would satisfy myself. I learned by actually performing. Thus I am able to offer a course which is fundamentally sound, tried and true. I don't ask you to accept something that isn't practical.

Breitbart Reveals It All

You can acquire strength and power as I did, by simply following the methods I outline to you. And in a remarkably short time! Then you too will say, "I didn't think it possible."

What Breitbart Does

I am talking from the bottom of my heart. I am telling you only the plain truth. I bend half inch iron bands around my arm as a piece of ribbon. Bend horseshoes with my hands more easily than the village Blacksmith. Drive nails thru oak planks and metal. Support four thousand pounds of Vermont granite on my chest while six husky men slug away at it with heavy sledge hammers. Is it beyond reason that I am continually referred to as "The Super-man of the Ages?"

Do You Want Strength?

Ask for it—say "Breitbart, I want health, vitality, and pep." I will build a body possessing the super power to bend, break or crush at the mind's command.

That security in knowing that within those two arms of yours there is untold power—is yours, if you will follow my instruction. My course is simpler, quicker and more positive in its results, than any other. There isn't a red-blooded man today who doesn't want strength.

Don't Wait for this Book

The demand for it has so far exceeded my expectations, that I have already twice increased the print order, since it first went to press. It is the most remarkable and finished book on strength ever published. Contains photographs of me performing these unique feats of strength, which have caused countless prominent people to attest their genuineness. Take this book, turn to page 37. An actual photograph of me driving nails thru oak planks and metal. Now page 21. Biting a steel chain in half with my teeth. On page 39, I am supporting a moving merry-go-round mounted with six men, on my chest. On pages 32 and 33 the motorcycle race while I support the motordrome on my chest. I possess that which I teach. If you want a new strenuous life, ask for my

book, "Muscular power." It is yours. Don't hesitate—All I ask is that you enclose 10¢ to cover postage and handling.

FREE Do You Know Your Own Strength?

Something new—unique. Breitbart's famous muscle meter! Shows the size of my muscle. Compare yours with mine. See the difference. Use it three months later and see it then. Be a HE MAN. Send for it. Yours is waiting.

Here
It Is!



Clip and
Mail this
Coupon
Now!

SIEGMUND
BREITBART, Inc.
Dept. D-9
Gotham Bank Bldg.
New York City

I am enclosing a DIME for your new 64 page book Muscular Power. Together with your muscle meter which is free.

BREITBART

1819 BROADWAY NEW YORK CITY

GOTHAM BANK BUILDING

Name

Street

City..... State.....



What Will I Do With These?

TODAY, even the ordinary hammer and saw carpenter is making money. But it's the trained man, the master carpenter who draws the big pay, gets the steady job and becomes the big money contractor. Learn the new short-cuts and methods of modern carpentry. Do better work. Draw bigger pay. Make yourself an expert through spare time reading.

CARPENTRY

Five big volumes—2,200 pages, 1,000 charts, blue-prints and pictures. Big type—easy to read and learn. Covers entire theory and practice of *Carpentry, Building, Contracting*. Shows how to use tools, draw and read plans, make estimates, figure profits, etc. Practical, simple, complete.

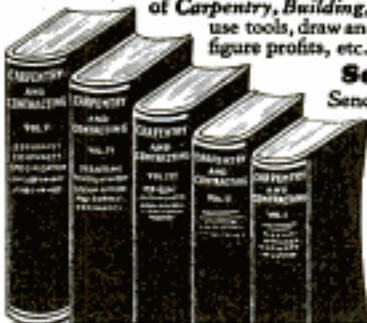

Sent To You FREE
Send no money—just the coupon. Examine set a week with our compliments—then decide. No obligations. Send coupon now and get this master Carpenter Set. Pay only \$3. monthly if you decide to keep it.

American Technical Society
Dept. G-919
Chicago, U. S. A.

AMERICAN TECHNICAL SOCIETY
Dept. G-919, Chicago, U. S. A.

Please send me the 5 volume set of Carpentry and Contracting for one week free examination. If satisfactory I will send you \$2.99 within 7 days, and \$3. monthly until the special price of \$19.95 is paid.

Name _____

Address _____

Reference _____



BARNEY OLDFIELD'S MECHANICIAN!

Loan an hour a day of your spare time to "Dash," formerly mechanic for Barney Oldfield. His demand for "Dash" trained men. He will put you in the \$100 a week class as Automotive Expert. Learn at Home—Learn by Job-Way Plan. Free tools. Success guaranteed. Free Book given all details. Write today. No obligation. CHICAGO AUTOMOTIVE INSTITUTE, Dept. 1779, 536 So. Clark Street, CHICAGO

BIG MONEY

Can Be Made At Home

Anyone can quickly learn to make show cards and window signs at home through our short cut method. Be your own boss. Our system of home instruction never fails. Make big money easily. Earn while you learn. Every dealer a customer. Signs that take half hour to make sell for \$3.00.

FREE Write for full particulars and receive free brushes, paints and dictionary free taking course. If you want to be successful, write for free leaflet.

Paramount Institute, Dept. 111, 1161 Broadway, New York



Read Jimmy De Forest's Book



The world-famous trainer and conditioner of Jack Dempsey, Longboat, Firpo, Roosevelt, Elbert Hubbard and many others has written "Physical Fitness and the Pay Envelope," a book for ambitious men.

De Forest bases his book on the accepted fact that the physically fit man commands the big income. It's full of meat. Ten cents to cover postage and mailing brings you a copy.

Jimmy De Forest Physical Training System
347 Madison Ave., Dept. 64, New York City

SEND FOR IT!



Be An Officer in the U. S. Coastguard \$1700 Up to \$7,500 Yearly

You get \$780 yearly at the U. S. Academy while training. You rank Ensign to Captain in service. We guarantee to prepare you in time for Academy Examinations. Age requirements 18 to 24. Write Dept. L-14 for free information.

Coastguard Preparatory School, 1653 Pa. Av., N. W., Washington, D. C.



Be a Diamond Expert

Do you know that of two diamonds of equal size one may be worth a hundred times as much as the other? Who can distinguish them but an expert? My short easy course will make you a diamond expert!

FREE! Genuine, uncut Jewelry houses everywhere need expert diamond men who can diamond if you name their own salary! I will show you how to make this money! enroll at once! Booklet "Paying Diamond Knowledge" sent free! Send for it!

CODINGTON SCHOOL OF DIAMONDS, Dept. 503-A
3457 Sunnyside Chicago, Illinois



RADIO Receiving Set GIVEN

This wonderful Radio Outfit is given for getting 24 large Art and Religious Pictures at 10c each; also choice of watches, silverware and many other premiums. Write quick. Extra prize for promptness. We trust you.

HOME ART CO., 428 W. 59th St., Dept. 554 Chicago

"THERE'S MONEY IN IT"

AT HOME

LEARN TELEGRAPHY

AT HOME

MORSE AND WIRELESS

TEACH YOURSELF

In half usual time, at trifling cost, with the wonderful Automatic Transmitter, **THE OMNIGRAPH**. Sends unlimited Morse or Continental messages, at any speed, just as an expert operator would. Adopted by U. S. Government, and leading Universities, Colleges and Telegraph Schools. 3 Styles. Catalog free. **OMNIGRAPH MFG. CO., 16-22 Hudson St., NEW YORK**

If you own a Radio Phone Set—and don't know the code—you are missing most of the fun.

WANTED

RAILWAY POSTAL CLERKS
\$1600 to \$2300 Year

MEN — BOYS 18 UP.
MAIL COUPON IMMEDIATELY

Steady work. No layoffs. Paid Vacations

Common education sufficient:

TRAVEL—SEE YOUR COUNTRY



FRANKLIN INSTITUTE, Dept. S177, Rochester, N. Y.

First: Send me without charge, (1) Specimen Railway Postal Clerk Examination questions. (2) Send List of U. S. Government jobs now obtainable. (3) Send free illustrated book, "How to Get Government Jobs." (4) Send free sample coaching lessons.

Name

Address

Take Your Choice—Any One FREE

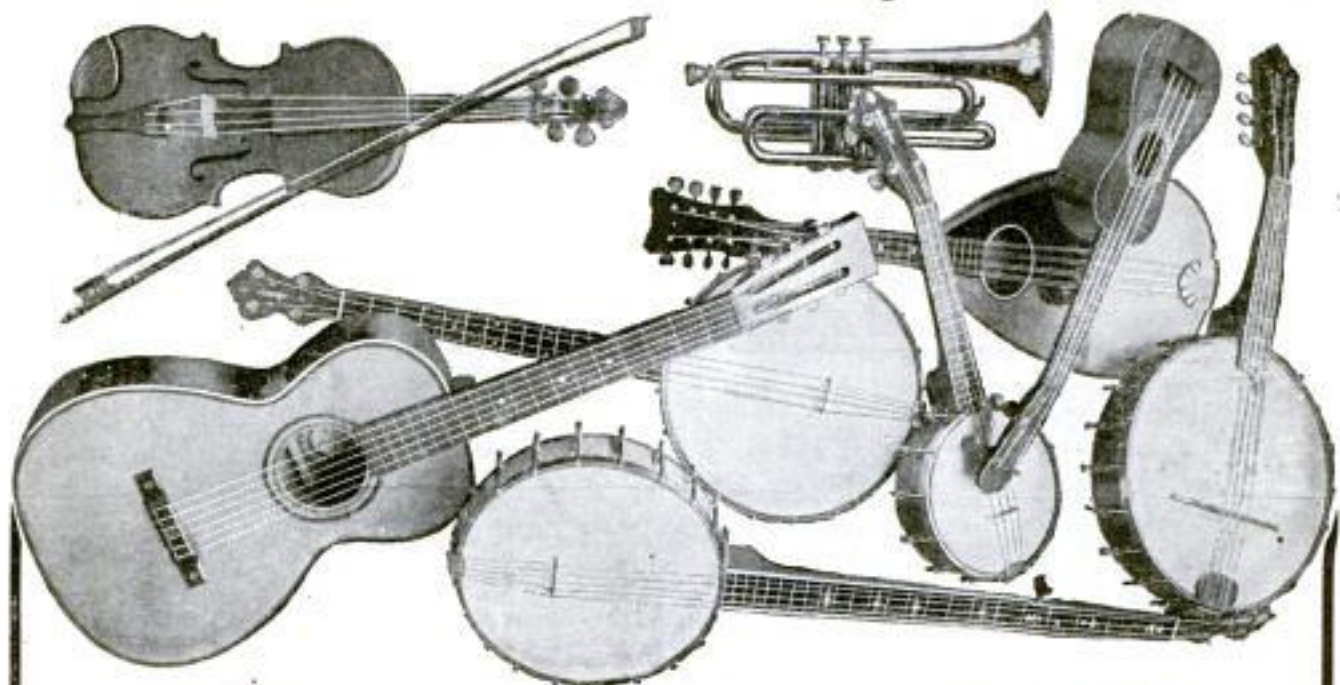

\$20 VALUE VIOLIN, MANDOLIN, GUITAR, UKULELE, HAWAIIAN GUITAR, BANJO, BANJO MANDOLIN, TENOR BANJO, CORNET or BANJO UKULELE **FREE**

And Learn to Play AT HOME in Your Spare Time for Profit or Pleasure

These high-class instruments are actually given away. They are free to pupils. Which one do you want? Which instrument do you want to learn? Send no money—just the coupon.

Everyone Loves Music

Our wonderful new system enables everyone to learn to play their favorite instrument in a few easy lessons. You can learn to play any of the instruments shown in a remarkably short time. Your spare time will do and **it only costs a few cents a week**. No charge for the instrument, just the lessons. That is your only expense. Why not mail the coupon today? You can be playing real music BY NOTE before Christmas if you do.

Play by Note in 4 Lessons

This new system is very simple. Anyone can understand it. You can be playing standard note music in 4 lessons. We guarantee this. You pay nothing if you fail and only a few cents a week for the lessons while learning, nothing for the instrument you want. Every lesson is complete; you go along in easy steps. Learn to play either for your own pleasure or for profit. Do not wait longer to become a musician and be popular among your friends.

Slingerland's Correspondence School of Music
Dept. 2 Lincoln Park P. O., Chicago, Ill.

Your Success Guaranteed

This is the most remarkable offer you ever read. Just think—the instrument FREE, only a few cents a week for the lessons and your success guaranteed or money back. Why should you delay? You have everything to gain and nothing to lose. Send the coupon now while the Free Instruments Offer is good. We reserve the right to withdraw it at any time without notice. You may never have the same chance again. **Send the Coupon.**

If you own a piano, organ or other musical instrument and want to learn to play it, write for special booklet and terms.

COUPON

Slingerland's Correspondence School of Music
Dept. 2, Lincoln Park P. O., Chicago, Ill.

I want a _____ FREE and learn how to play it by your easy method. Please send me full particulars and detailed information. This request does not obligate me in any way.

Name _____

Address _____

City _____

State _____



Sweeney To Make

I WANT you to succeed more than anything else in the world, and I know you can if you will try. I am doing my part by making my tuition price so you can come right now to this World Famous Automobile School—you've wanted long to come to this Million Dollar School, but you just couldn't see how you could make it. **Now it will be easy** and I am sure you are going to come. I've raised the salaries of thousands of other fellows—I can do it for you. Just as long as you keep drifting, it will be the same daily grind year after year, but if you decide now to come here, spend a few weeks in actual "Learn by Doing" training, there's a good job paying big money ready for you.

E. J. SWEENEY, President.

And Now Cuts The Tuition 1/2 So You Can Start Your Training At Once

I KNOW this is a radical move on my part, but it is the impossible things that I always like to do and this has been a big factor in the great success of this school in turning out over 60,000 graduates, and I estimate of that number 20,000 of them are making big money in their own business. **So if you will come right now I will cut the price just exactly one-half.** I further guarantee you the same high class practical instruction under skilled instructors that has made the Sweeney Automotive and Electrical School World Famous.

Learn A Trade But Learn It Right



Auto Mechanics \$125 Month and Up

Look at the views of my students doing actual work. These boys know they will soon be ready to take positions in any part of the country, paying from \$150 to \$300 a month and more, or owning their own business. **You can do it too.** Just picture yourself in a few weeks as a skilled mechanic holding down a big responsible high salaried job or running your own business. **Decide now to learn a trade.** There's only one way to learn if you want to save time and money and be properly trained—**The Sweeney System of Practical Instruction.** You get this at the Million Dollar Sweeney School and you get it nowhere else. These photographs show only a small part of my \$200,000 equipment. When there's anything new in mechanical equipment, Sweeney will have it.



Welding Experts \$150 Month and Up

Get the BEST and Get It for LESS

The Million Dollar Sweeney School Building is just across the Plaza from the Union Station, and stands at the foot of beautiful Memorial Hill upon which a \$2,000,000 building is being completed. It is 10 stories high and covers 12 acres of floor space. Every foot is devoted to practical instruction and floor after floor filled with the very latest gas engine, electrical and radio equipment for you to work on. Scores of expert instructors all trained under the Sweeney System to work with you. The Sweeney School is a small city in itself.

I Cut the Tuition Price One-Half to Make It Easy for You to Come Now

Mail the Coupon Right Now Or Wire Me When You Will Be Here

I want to prove that you can do what thousands of men in just your position have done as a result of **Sweeney training.** Take up the Auto Business now. **Learn it at Sweeney's.** Ask any Sweeney Man. They are in good positions all over the country, repairing and selling Autos, driving cars and trucks, mechanics running garages, tire shops, battery stations, welders, handling radio supplies. Right now over fifteen million cars and there's a big increasing demand for servicing these cars. With tuition price cut exactly in half, there is nothing to keep you from coming right now. But remember this offer holds good only for a limited time. **So, Don't Delay another day—you want to be sure of the Big Saving—If you write me now—Today—you will be sure.**



LEARN Sweeney AUTOMOTIVE & N-31 SWEENEY BLDG.

Trains Men Big Money!

This Is the Most Amazing Offer I Have Ever Made Since the Completion of My Million Dollar Building Six Years Ago

I know there are thousands of you fellows right now ready to take the first step toward independence. Former tuition price has held you back—you were afraid you could not make it. **Now I am making it easy for you—just half price.** You must **act now—not next week or next month.** This offer is for a limited time only. I've got everything here you want—expert instructors—the best equipment obtainable—over \$200,000 invested—over \$50,000 invested in my big Radio Station, WHB.

The Man Who "Knows How" Gets the Big Paying Jobs



Battery Experts \$150 Month and Up

The biggest salaries in the history of the Automotive and Electrical business are being paid to men who "Know How." The Sweeney trained man is in demand everywhere. If you are mechanically inclined, **come right now to the Million Dollar Sweeney School.** I teach you by doing actual work. You'll wear overalls, get your hands and clothes dirty and greasy, **but you'll learn** everything about all kinds of automobiles, tractors, oxy-acetylene welding, vulcanizing, battery work, electrical work, building and repairing radio sets and in a few weeks be able to cash in on your time. No previous experience or education is needed. You only need to be willing to work. **The Sweeney System of Training is practical from start to finish.** No books are used, no dry lectures. You work with your hands on most



Electrical Experts \$175 Month and up

complete equipment obtainable. From your very first day in the school you do actual work on live engines—**The Sweeney System** is the original "Learn by Doing" method.

FREE

Just send me your name and I will send you my 64-page big illustrated catalog. It is full of real pictures—shows how mechanics do all kinds of expert jobs. Lists the opportunities in the Auto business. Explains step by step how Sweeney Students learn to be skilled mechanics. Shows how easy it is to fit yourself for big paying jobs. I will send you this Free—no cost—no obligation. Write for it today. I also want to tell you how Sweeney Students enjoy themselves while training. The big swimming pool, reading and lounging rooms, entertainment, band and orchestra concerts, Radio broadcasting. You just can't appreciate the wonderful opportunities the Sweeney School offers you and how much it will mean to you, until you come. So, **answer this ad now;** I can't tell you how long my amazing offer will hold good. To be sure of this **big saving,** write me today; or, better still, wire me when you will be here. No colored Students accepted.

MAIL THE COUPON TODAY!

E. J. SWEENEY, President

A TRADE

Sweeney

**ELECTRICAL SCHOOL
KANSAS CITY, MO.**

**MAIL THE
COUPON
TODAY!**



EMORY J. SWEENEY, President
N-31 Sweeney Bldg., KANSAS CITY, MO.

Please send me Free your 64-page catalog and how I can get my tuition at Half Cost.

Name.....

P. O.....

State.....Age.....



"Another \$10 Raise!"

"THAT makes the second increase in salary in a year, and I'm earning \$45 a week now. That's pretty good for a girl. It certainly was a lucky day for me when I decided to take up that I. C. S. course."

Why don't you study some special subject and prepare to earn more money? There's no surer way to do it than by studying at home in spare time with the International Correspondence Schools.

The I. C. S. has a number of courses especially arranged for women. Some I. C. S. women students are making as high as \$50, \$75, and \$100 a week as private secretaries, artists, expert letter writers, pharmacists, assistants in chemical laboratories, high-priced sales executives, office managers, advertising writers and solicitors, and in Civil Service and banking.

Mark and mail the coupon and we'll be glad to send you interesting descriptive booklets telling what the I. C. S. can do for you.

Mail the Coupon To-day

INTERNATIONAL CORRESPONDENCE SCHOOLS
Box 5662-D, Scranton, Penna.

Without cost or obligation, please send me your 48-page booklet, *How Women Are Getting Ahead*, and tell me how I can qualify for the position or in the subject before which I have marked an X:

- | | |
|--|--|
| <input type="checkbox"/> Advertising | <input type="checkbox"/> Civil Service |
| <input type="checkbox"/> Private Secretary | <input type="checkbox"/> High School Subjects |
| <input type="checkbox"/> Assistant Bank Cashier | <input type="checkbox"/> Illustrating |
| <input type="checkbox"/> Accounting | <input type="checkbox"/> Cartooning |
| <input type="checkbox"/> Chemistry | <input type="checkbox"/> Bookkeeping |
| <input type="checkbox"/> Pharmacy | <input type="checkbox"/> Business Law |
| <input type="checkbox"/> Business English | <input type="checkbox"/> Corporation Secretary |
| <input type="checkbox"/> Spanish | <input type="checkbox"/> Architecture |
| <input type="checkbox"/> French | <input type="checkbox"/> Drafting |
| <input type="checkbox"/> Salesmanship | <input type="checkbox"/> Designing |
| <input type="checkbox"/> Better Letters | <input type="checkbox"/> Telegraphy |
| <input type="checkbox"/> Stenographer and Typist | <input type="checkbox"/> Window Trimming |
| <input type="checkbox"/> Show Card Lettering | <input type="checkbox"/> Railroad Clerk |
| | <input type="checkbox"/> Dressmaking |
| | <input type="checkbox"/> Millinery |

Name.....

Street Address.....

City.....State.....

Occupation.....

Persons residing in Canada should send this coupon to the International Correspondence Schools Canadian, Limited, Montreal, Canada.



LOUIS WIN RAPEER,
S. B., A. M.,
Ph. D., LL. D.,
PRESIDENT
(Former head of Dept. of Education at Pennsylvania State College)

University President

Offers you a College Diploma by Systematic home study courses, and you complete the last few months of your work in Classes at the University. You attend either Day or Evening courses and are helped into a position for alternate 6-week periods to support you while finishing.

Courses offered in Story Writing, Journalism, Economics, English, Business, Secretarial and 100 Other Subjects.

Write for FREE CATALOG and full information to Dept. L-14

Research University
WASHINGTON, D. C.

Learn Photography at HOME

Make \$75.00 a Week on the Side

Establish yourself as a Photographic Expert quickly—during your spare time—under a leading photographer. I'll show you how to start your own business—or command a large salary. Send for my special offer—its' costly temporary. Act at once. A postal will do. H. H. VANT.

INTERNATIONAL STUDIOS, Inc.
Dept. 1359, 3601 Michigan Ave., Chicago, U. S. A.



LEARN ENGINEERING

Great Demand for Practical-Technical Engineers. Big Salaries. Wonderful Opportunities. Thousands of our graduates holding responsible high-salaried positions. Practical-Technical Courses from 3 Months to 2 Years in Electrical and Mechanical Engineering. Simple and Condensed Method. Faculty of Trained Experts. New Building. Extensively Equipped Laboratories and Shops. Department of Architecture. Structural and Mechanical Drafting. Degrees Awarded. Positions Secured. Day and Night Sessions. Catalog D. FREE. Ask about our Earn While You Learn Plan. FINLAY ENGINEERING COLLEGE, Kansas City, Mo.

LEARN VIOLIN 3-A DAY

New Easy Way. Violin Furnished. Marvelous new Master Method teaches you by mail in 1/2 time and at 1/10th cost. No number or trick music. Costs only 3c a day. Play a real piece by note in fifth lesson. Easy as A B C. All music free. Diploma awarded. Beginners or advanced players. Money back guarantee. Send today for free booklet. Will be sent in plain wrapper. Please write plainly. MASTER VIOLIN SCHOOL 51 E. 42 St., Coxs. 704, New York, N. Y.

A Great Career!—BOOK FREE

Learn Watchwork, Jewelrywork and Engraving.

A fine trade commanding a good salary, and your services are always in demand. Address Horological, Dept. P. Bradley Institute, PEORIA, ILL., for our latest catalog.



BECOME A RAILWAY MAIL CLERK

Examinations coming. \$1600 to \$2300 a year. Easy to get the job. Common education sufficient. No "pull" necessary. Mail coupon for Free Catalog.

Patterson Civil Service School

Dept. 812 ROCHESTER, N. Y.

Send me without charge your Catalog, explaining your guaranteed preparation.

Patterson Civil Service School

Dept. 812
Rochester,
N. Y.

Name.....

Address.....

FREE

Home-Study Lesson in

DRAFTING



Expert Draftsmen Earn \$35 to \$100 a Week

Prove to yourself that Drafting is easy to learn

Here is your opportunity to try a lesson in Drafting right at home, free of cost, and to find out how well prepared you are to take up this interesting and well-paid vocation; also just how Chicago Tech. will train you at home by mail.

A knowledge of Drafting is more than a stepping-stone to a good job. It has enabled thousands of men to find their way into business for themselves—contractors, builders, architects, inventors, manufacturers, etc.

Drafting pays good, big money to start, and is a wedge that reaches to the very heart of opportunities worth while. Get into a line of work that has a real future in it for you. No occupation affords a broader field for employment—so many different lines from which to choose a specialty.

Everything built or constructed today is first planned and laid out on paper—machinery, houses, buildings, ships, factories, bridges, automobiles, radio and electrical equipment, etc. The Draftsman has the opportunity to know and to study every detail of construction long in advance of building operations.

Drafting is not hard to learn under the Chicago Tech. plan of simplified correspondence instruction. Step by step, under an easy systematic plan, you will learn how to handle every job, every piece of work, every problem that may come to the Draftsman. We have been training men for Draftsmanship successfully at home by mail, as well as in our day and evening resident classes, for more than 20 years.

We have thousands of successful graduates who secured their complete training during spare time, right at home, without loss of a single day or a single dollar of pay from their regular work.



\$25 Outfit Included

A regular full-size outfit—like those used by practical Draftsman and Engineers—comes to you when you enroll in the Chicago Tech. Home Study Drafting Course. If you have an outfit, credit is allowed on fees for the course.

Make up your mind today—now—that you are going to take this important step toward a bigger future—that you are at least going to find out all about Drafting and its opportunities. You risk nothing—not a cent. You have everything to gain and nothing to lose.

Chicago Tech. does not require enrollment and payment of fees in advance. Chicago Tech. is willing that you should try a lesson—see how you like it—before you make up your mind to enroll or send us a single penny. That is the sensible, the business-like thing to do in any event. Could any offer be more fair? Furthermore, if you enroll, and, upon completion of the course, are not satisfied in every way,

we agree to refund the entire amount of tuition paid, in accordance with the terms of our money-back guaranty.

Clip and mail the coupon now. It takes but a minute. Put it off and you may not think of it again for a week—perhaps never. Our big home-study catalog, Free Sample Lesson, Testimonials, and also the interesting success story "Fourteen Words of Magic Power," all sent without charge or obligation.

Opportunities in Chicago

Earn while you learn. For those who can come to Chicago, a splendid opportunity is open to get this training in the Chicago Tech. College Day or Evening Classes while earning expenses in part-time positions. If interested, ask for our 52 page "Blue Book." Sent free.

Special to Builders

Carpenters, Bricklayers, and Other Men in Building Trades—Send for Home-study Catalog and Free Book "How to Read Blue Prints." Improve your knowledge and worth by mastering Plan Reading, Estimating, Superintending and higher branches of building fully covered in the Chicago Tech. Builders' Course.

CHICAGO TECHNICAL COLLEGE

Dept. 1230 Chicago Tech. Bldg., 118 East 26th Street, CHICAGO, ILL.

CHICAGO TECHNICAL COLLEGE

Dept. 1230, Chicago Tech. Bldg., 118 East 26th Street, Chicago, Ill.

Without cost or obligation on me, please send catalog and instructive matter about your home-study course in Drafting; also the fascinating story book, "Fourteen Words of Magic Power," and FREE TRIAL Lesson.

Write or Print Name Plainly

Name.....

Address.....

City.....

State.....

WANTED

RAILWAY POSTAL CLERKS

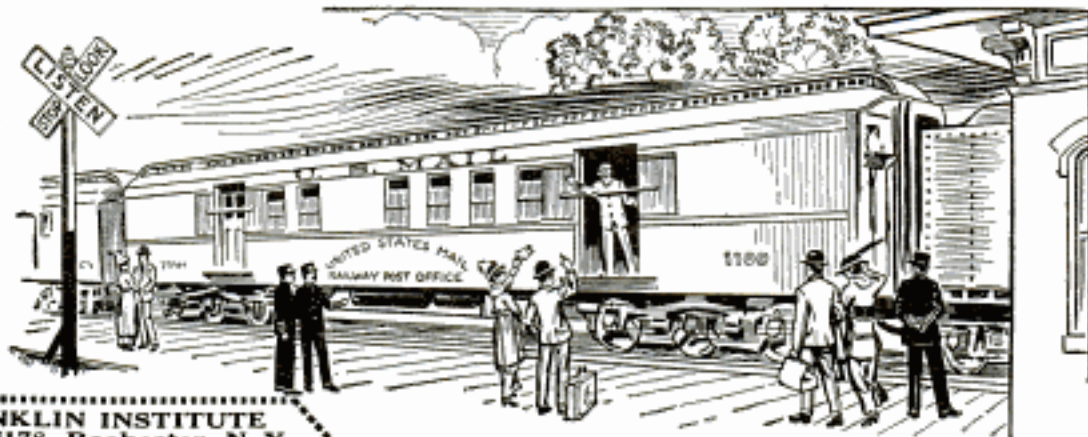

FRANKLIN INSTITUTE
Dept. S178, Rochester, N. Y.

Kindly send me, without any obligation whatever on my part, and entirely free of charge: (1) A full description of the position checked below; (2) Specimen examination questions and free sample coaching lessons; (3) Free copy of illustrated book, "Government Positions and How to Get Them"; (4) A list of U. S. Government Jobs now obtainable.

- Railway Postal Clerk..... (\$1600-\$2100)
- Post Office Clerk..... (\$1400-\$1800)
- City Mail Carrier..... (\$1400-\$1800)
- Rural Mail Carrier..... (\$1800-\$2500)
- Clerk at Washington, D. C..... (\$1140-\$1960)
- Income Tax Auditor..... (\$2040-\$3000)

TRAVEL—SEE YOUR COUNTRY
\$1600 to \$2300 a Year

Many Other U. S. Government Positions:

- City Mail Carriers
- City Postal Clerks
- Internal Revenue Clerks
- Customs Clerks
- Clerks at Washington, D. C.

MEN—BOYS 18 OR OVER

- Short Hours
- Pleasant Work
- Rapid Advancement
- Permanent Employment
- Long Vacation with Pay

MAIL COUPON NOW ACT AT ONCE
TOMORROW MAY BE TOO LATE!

Name

Address

MASONS!

Brick - Plaster - Concrete - Tile Workers

Let AUDEL'S NEW GUIDES give you a Helping Hand
Audel's Masons' and Builders' Guides give information in handy form for Bricklayers, Plasterers, Tile Setters and all Cement Workers. Contain best approved outlines of work and materials, including instructions on how to lay out and figure various jobs. A working companion for the journeyman; ready reference for the boss builder; a practical instructor for the house builder.

AUDEL'S MASONS' AND BUILDERS' GUIDES
1100 Pages, 2067 Examples

These Pocket Size Guides cover fully and completely: Brick laying, tools, materials, bonding, mortars, designs, setting frames, foundations. Tile setting, hollow tile, wall, roofing, setting beds, m. sale. Concrete mixing, placing, re-inforced work, stucco, wa. erproofing. Pla. tering in all its branches, wall board. Stone Masonry and Steel Construction for Masons. Estimating.



4 VOLS. COMPLETE \$6

FREE EXAMINATION COUPON

THEO. AUDEL & CO., Publishers, 72 Fifth Ave., New York: Send me for free examination Audel's Masons' and Builders' Guides, 4 numbers, price \$6. If satisfactory, I will mail you \$1 within 5 days and \$1 monthly until paid.

Name

Address

Occupation

Reference 12-T-30

\$100.00 EARNED BY YOUNG ARTIST IN 2 DAYS

Well-trained artists earn splendid incomes. The Federal home-study Course is a proven result-getter. If you like to draw, send 6c in stamps for 56-page book "Your Future." State your age and present occupation.

FEDERAL SCHOOL OF COM'L DESIGNING
601 Federal Schools Building
Minneapolis, Minn.

LEARN TO BE A MAGICIAN

Be popular in every crowd. It is a natural desire for all to make themselves agreeable and entertaining. A Magician is always the center of attraction, the life of a party, sought after and invited everywhere. Be able to give exhibitions at clubs, parties, lodges and theatres. No need to devote years of study and practice to be a magician. You will be entertaining your friends before you realize it. To prove what we say we will send you free 12 easy and startling Magic Tricks and teach you how to perform them. Send only 25c to cover postage, packing, etc. Our catalog is free.

A. P. FELSMAN, Dept. 15, 28 East Monroe St., Chicago, Ill.

WATCH, RING GIVEN AND CHAIN

We positively give a Genuine American Stem Wind and Set Watch, beautifully designed case, warranted time-keeper; 10-year guarantee; Sparkling Set or Plain Ring all for setting 24 large colored Art and Religious Pictures at 10c each. When sold send \$2.40 and we'll send Watch and Chain.

Home Art Co., 428 W. 59th St., Dept. 516 Chicago

I will teach you penmanship by mail

Small Cost, Spare Time, Easy Lessons. Write for my Free Book, "How to Become an Expert Penman." It contains specimens and tells how others became expert writers by the Tevis Method. Your name will be written on a card if you enclose stamp.

Write Today: **T. M. TEVIS, Box 258, Chillicothe, Mo.**

Conquer Your Weaknesses

Master yourself—correct your physical defects—banish the ailments that make your life an existence of misery and regret—throw off the shackles of Catarrh, Constipation, Indigestion, Dyspepsia, Bad Blood, Rupture, Rheumatism, Weak Heart, Vital Depletion, Weak Lungs, Anemia, Nervousness, Poor Memory, Fear, Bad Habits, etc., and the numerous other results of neglecting your body and violating natural law (see Consultation Coupon). Show them that you can and will be a healthy, vigorous man with a real man's ambition, spirit and endurance—the powerful man that Creation and Civilization demand you to become.

Get Rid of Your Handicaps

Build up your body and brain and get the joy out of life. You can't be successful, popular or wanted in the home, in business, in society—anywhere, without the health and strength and vigor of a real man. People you come in contact with instinctively analyze your physical and mental condition. If you are not vigorous and magnetic—if you lack power, endurance and vitality, everybody will know it. You know how these things affect you when you see them in other people. You know that nobody has the least bit of respect for a weakling. They can't have confidence in a man that may end up any moment on the scrap heap of worn out and useless humanity. You wouldn't have much respect for a business associate who was groggy with Constipation, yellow with Biliousness, weak, anemic and handicapped with Rupture, Flat Feet, Weak Back or some other physical defect—you wouldn't have confidence in a man whose bad living habits showed clearly in his face and bleary eyes—you wouldn't want to do business with or associate with an irritable, grouchy person with frazzled nerves and a wretched, unreasonable temper. Now look at yourself with the same eyes. Are you guilty of these physical and mental defects? Do you not recognize the many faults and weaknesses that have often robbed you of success in business, preference in society and cheated you out of the priceless benefits of real friendship and companionship? Judge yourself without favor—then get busy to root out the elements of failure and make yourself a **real** man.

Win Back Your Vigor and Vitality

Let me help you as I have thousands of others. Accept my hand in friendship as you would a brother's and I will show you Nature's Way back to Health and Happiness. I'll teach you how to get rid of the ailments and physical defects that are ruining your body and brain. I'll build you up **externally** and **internally**, by the same scientific methods that won for me the World's award as the finest specimen of physical and health attainment. I have dedicated my life to the task of rescuing sick, ailing humanity from the bog of Weakness and Poor Health and thousands of my pupils gladly testify to the wonderful effectiveness of my methods. You can apply these scientific principles with the same satisfactory and permanent results. I want to help you—I can rebuild and restore you with

STRONGFORTISM

THE NEW SCIENCE OF HEALTH PROMOTION

The Principles of **Strongfortism** are based on my discovery—that **internal muscular harmony and strength** is the Key to lasting abundant Health and Vitality. The Heart, Lungs, Stomach, Bowels, and other vital organs function thru virtue of the contracting power of the muscles contained in their structure. Circulation, Digestion, Assimilation and Elimination are largely the result of **internal muscular action**. The Strongfort Methods go to the very cause of all ailments and weaknesses and by scientifically strengthening and developing the **important internal muscles**, provide 100% results when all other methods disappoint.

Once you accept **Strongfortism**, you enter a new life. The results are immediate and positively thrilling. You feel the rich blood racing thru your body—you feel new strength and power developing in every organ and structure—you acquire new poise and a magnetic personality. You can't fail with Strongfortism. I guarantee it.

Get My New Book—It's FREE

"DO IT WITH MUSCLE"

The truth about the scientific application of natural law is contained in my wonderfully interesting book, "Do It With Muscle." It will tell you frankly and plainly how you can banish your ailments and build up 100 per cent Health, Strength and Vitality. It's absolutely free. Mark the subjects on the free consultation coupon on which you want **special confidential information**, and send a 10c piece (one dime) to help pay postage, etc. I'll do the rest. Send for my free book **Right now—TODAY.**

Lionel Strongfort

Physical and Health Specialist Over 25 Years

Dept. 1672, Newark, N. J., U. S. A.



LIONEL STRONGFORT

DR. SARGENT, of Harvard, declared that "Strongfort is unquestionably the finest specimen of physical development ever seen."

CONSULTATION COUPON

Absolutely Confidential

LIONEL STRONGFORT, Department 1672, Newark, N. J.
Send me free my private copy of "DO IT WITH MUSCLE," for which I enclose one dime (10c) towards mailing expense. I may teach me something startling about ME. Send me special information on subjects marked (X) below, without obligation.

- | | | |
|--------------------|-------------------------|------------------------|
| Cold | Diabetes | Poor Memory |
| Catarrh | Increased Height | Rheumatism |
| Asthma | Pimples | Falling Hair |
| Hay Fever | Blackheads | Weak Eyes |
| Obesity | Insomnia | Gastritis |
| Headache | Short Wind | Heart Weakness |
| Thinness | Flat Feet | Poor Circulation |
| Rupture | Stomach Disorders | Skin Disorders |
| Lumbago | Constipation | Despondency |
| Neuritis | Biliousness | Round Shoulders |
| Neuralgia | Torpid Liver | Lung Troubles |
| Flat Chest | Indigestion | Slope Shoulders |
| Deformity | Nervousness | Muscular |
| I Describe | Weakness | Development |
| Neurasthenia | (Specify) | Great Strength |

Name.....

Age..... Occupation.....

Address.....

If you have taken my "Regular" or "Advanced" courses, kindly indicate same by making a cross in box for this purpose below:

I have taken your "Regular" course I have taken your "Advanced" course

I have received your book "Promotion and Conservation of Health, Strength and Mental Energy." Date.....

\$1.00 DELIVERS to Your Home



Complete Outfit

Violet Ray

ONLY \$1.00 brings this complete, scientific Violet Rays outfit to you. Treat yourself and family at home, save delay, costly doctors and medicines. Thousands use Violet Rays at home to relieve pain and sickness. The identical outfits doctors have bought from us for years and with which they successfully treat many ailments, including those listed below.

QUICK RESULTS—No Medicine

Violet Rays work quickly, it's scientific, goes after the cause. That's why results are quick, permanent. Dr. Duncan, Kewanee, Ill., writes, "Violet Rays is the finest thing I ever used... to relieve pain, treatments are so pleasant all my patients like it." Use it yourself at home, you save Doctor's bills.

BEAUTY AID

Brings natural, magnetic beauty of health, no dieting, exercise or drugs. FREE book tells in detail how high priced beauty specialists use it to improve scalp and skin.

EARN CASH

Men, women, without experience earn liberal profits in spare time showing Violet Rays to neighbors. Proves results first demonstration. Sells on sight. Get attractive offer and wholesale prices now.

SEND FOR FREE BOOK

Explains how Nikola Tesla discovered Violet Rays, how it works, why it heals. Tells what doctors and plain folks accomplish in conquering pain, disease and nervous trouble with Violet Rays.

Reveals Marvelous Scientific Discovery Shows charts of human body, explains where pains start, how to banish them. Offered FREE for a limited time only, to introduce Violet Rays. Send for FREE copy.

Check Your Ailment Below for Free Advice Here is a partial list of ailments successfully treated with Violet Ray:

Catarrh	Eye Diseases	Lumbago	Skin Diseases
Chilblains	Falling Hair	Nervousness	Sore Throat
Colds	Hay Fever	Neuritis	Sprains
Constipation	Headache	Paralysis	Tonsillitis
Earaches	Gout	Piles	Whooping Cough
Eczema	Insomnia	Rheumatism	Asthma

Mail Coupon—Send No Money

VI-REX COMPANY
211 S. Peoria St. Dept. 222 Chicago

Please send me without cost or obligation your free book describing your VI-REX Violet Ray outfit, and details of your \$1.00 offer.

Name _____

Address _____

City _____ State _____

STOP USING A TRUSS

Do Away With Steel And Rubber Bands

FREE TRIAL

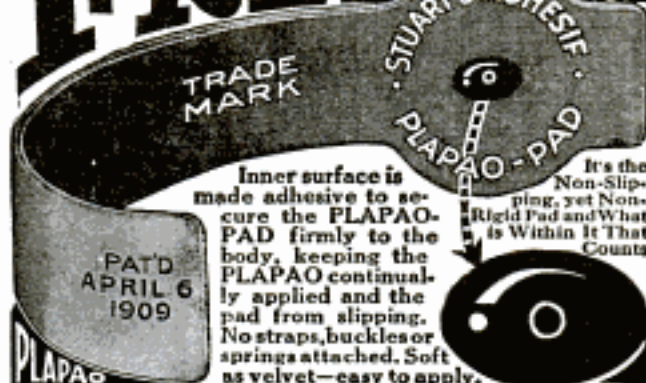

Inner surface is made adhesive to secure the PLAPAO-PAD firmly to the body, keeping the PLAPAO continually applied and the pad from slipping. No straps, buckles or springs attached. Soft as velvet—easy to apply.

It's the Non-Slip- ping, yet Non-Rigid Pad and What is Within It That Counts

FREE to 5,000 Truss Sufferers

To the extent of 5,000 sufferers who may apply I will send, ABSOLUTELY FREE, a sufficient quantity of the Plapao to positively convince them that this is the only logical, common-sense way of treating rupture. Plapao is a highly nstringent medication placed within the Plapao-Pad and being absorbed through the skin, creates a wonderful feeling of relief and at the same time tends to strengthen the weakened muscles and thus permanently close the rupture opening. The process of recovery is natural, so you'll have no use for a truss—you can throw it away forever! Old and young have testified under oath that the Plapao-Pads cured their rupture—many of them long-standing, aggravated cases—without delay from work. Patent allowed in U. S. and foreign countries. Awarded Gold Medal at Rome and Grand Prix at Paris.

Send No Money—for a sufficient quantity of the Plapao is sent without charge to enable you to give it a thorough test; you pay nothing for this trial now or ever. Write for it and full information today. Address Plapao Laboratories, Block 1427 St. Louis, Mo.

TOBACCO OR SNUFF HABIT

Any form quickly conquered. No long waiting for results. Costs \$1 if it cures. Nothing if it fails. Perfectly HARMLESS. Full treatment on approval. DR. C. M. SIMPSON, 126 W. 44th St., Cleveland, O.

How Many Pounds Would You Like to Gain in a Week?

If you are thin and scrawny and would like to gain weight, I will send you a sample of the genuine Hilton's Vitamines absolutely FREE. Do not send any money—just your name and address to W. W. Hilton, 188 Gateway Station, Kansas City, Mo.

Deafness



Perfect hearing is now being restored in every condition of deafness or defective hearing from causes such as

Relaxed or Sunken Drums, Roaring or Hissing Sounds, Perforated, Partially Destroyed Drums, etc.

Wilson Common Sense Ear Drums

—“Little Wireless Phones for the Ears”—require no medicine, but effectively replace what is lacking or defective in the natural drums. They are simple devices, which the wearer easily fits into the ears, where they are invisible. Soft, safe and comfortable to wear at all times.

Write today for our 168-page FREE book on DEAFNESS, giving you full particulars and plenty of testimonials.

WILSON EAR DRUM CO., Incorporated
349 Inter-Southern Building LOUISVILLE, KY.

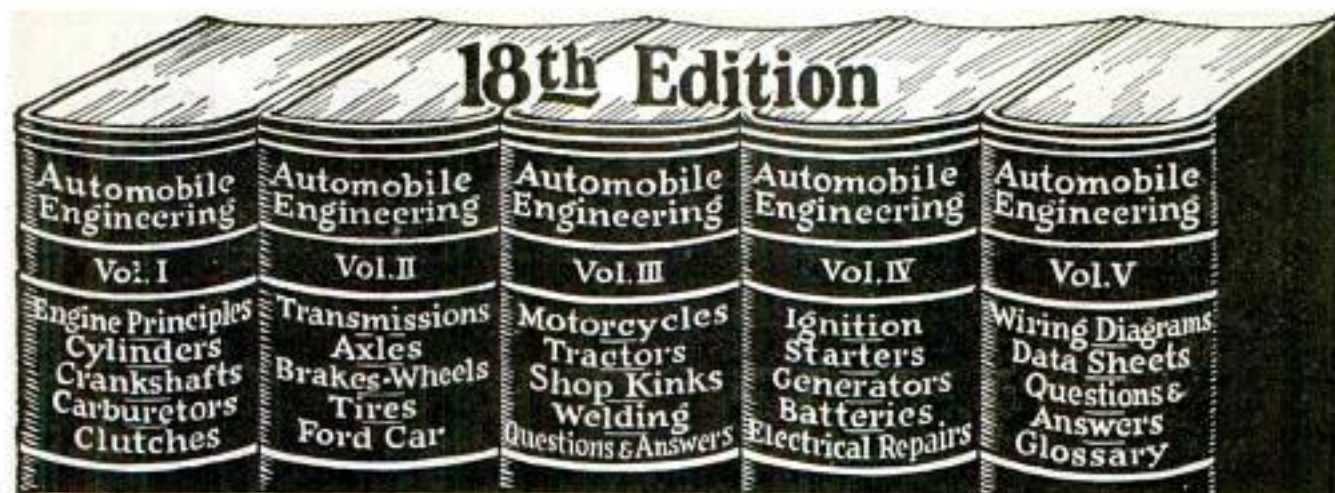

Every Automobile Man Needs These Auto Books *Yes—That Means You—Mr.*

**Garage Owner—Service Station Manager—Repairman
Trouble Shooter — Car Owner — Auto Salesman**

2200 pages of money-making automobile ideas. Shop kinks and up-to-the-minute repair methods are all here. Everything made clear and practical by the use of 2400 pictures, diagrams, and charts. From four-cylinder engines to straight-line eights—**EVERYTHING ABOUT EVERY AUTOMOBILE IS COVERED—but that is not all—**

Four Big New Features

Equipment data and specifications

Here at a glance will be found all of the data covering the car's equipment. Whether you are estimating on a repair job or ordering new parts or doing the actual repair work, the specification sheet will be worth real dollars to you.

Generator output in volts and amperes—when relay should cut-in—distance relay gaps—model number for all units for ordering parts—firing order—ignition timing—breaker contacts—valve tappet distance—size of clutch and brakes—lamps—etc.

Wiring Diagrams A complete diagram of the electrical systems on all standard cars (A separate sheet for each car) shows exact location of generator—starter—distributor—ignition coil—resistance units—ammeter—starting switch—horn—circuit breaker—relay—signals and lights—fuses—battery terminals—etc. Every connection is clearly

indicated. More than one man has built up a paying business because he could not be "stumped" on any ignition or starting job.

Trouble Shooting "What is the matter?" It may be with the ignition—battery—fuel—lubrication—or what not. 58 causes of trouble, how to detect it, and what to do to cure it. 234 definite cures are thoroughly explained with the necessary diagrams and charts. Why the trouble occurred and how to cure it make this service feature worth hundreds of dollars to the trouble shooter or repairman.

Questions and Answers Whether you're stuck on the road or bossing shop repair jobs you have wished for a quick solution of this and that trouble—a solution that is ready-made and does not compel you to read three or four pages of explanation. In the questions and answers section every conceivable automobile trouble has been stated and the right way to correct it given.

Every automobile trouble and its cure indexed for instant reference

FREE—7 days' trial—FREE

Whether you are a garage owner, a service station manager, trouble shooter, repairman, car owner, or auto salesman, I think you will agree that the income of the average man in the automobile game is in direct proportion to his ability to make good—in short, to his knowledge of automobile principles, operations, and repairs. We claim that this work with its four new features will be worth hundreds of dollars to any man thus employed and we want the chance of proving it to you. Let us send you the complete five-volume set of Automobile Engineering for one week's free use—test the books out on any one or on a dozen jobs that have been troubling you—no matter whether on repairs, wiring systems, troubleshooting, or what not. If you do not find just the help that you need in this set, send it back to us at our expense.

Send us the coupon tonight!

**American Technical Society
CHICAGO, U. S. A.**

American Technical Society Chicago, U. S. A.

Please send me a set of Automobile Engineering, for seven days' FREE EXAMINATION, shipping charges collect. I will examine these books thoroughly and, if satisfied, will send \$2.80 within seven days and \$3 a month until I have paid the special price of \$19.80. If I decide not to keep the books, I will return them within one week at your expense.

Name.....

Address.....

Reference.....

Please fill out all lines; give local merchant, banker, or employer as reference.



Learn By Doing!

Every phase of all branches of

ELECTRICITY

Taught By Actual Practice

In America's foremost institution for trade training.

Established 1902

No Books Used

Individual Instruction

Start Any Day

A SPECIAL and SEPARATE Course in Ignition, Auto Lighting and STARTER Systems.

Write for FREE 64-Page Catalog

THE NEW YORK ELECTRICAL SCHOOL
44 West 17th Street NEW YORK CITY

HOTELS WANT MEN AND WOMEN

FOR POSITIONS PAYING
\$150 TO \$500 MONTHLY

Trained Men and Women in BIG DEMAND

If your present position is not paying enough; if advancement is too slow, investigate what hotels offer you. 80,000 trained employees must be secured this year; no previous hotel experience necessary.

Wonderfully interesting work in luxurious surroundings; many opportunities for advancement to executive positions. Positions paying \$150 to \$500 per month are numerous, meals and often room furnished. We train you at home in spare time at moderate cost. Course endorsed by many leading hotel men. Hundreds of successful graduates. Write today for Free Booklet H-100.

STANDARD BUSINESS TRAINING INST.
BUFFALO, N. Y.

YOUR OWN BUSINESS

EARN \$40 to \$200 WEEKLY

Finishing Kodak Pictures. I teach this fascinating, profitable work by mail. Paraphrase everything to start. Give sound advice. Booklet on request.

CHIPMAN SYSTEM, 104 MITCHELL BLDG., SYRACUSE, N. Y.



SALESMEN WANTED!

To sell new one-price line of men's clothes. Sensational values. Finest all-wool goods. \$23.50 for suit or overcoat. Nothing higher. Big commissions paid in advance. Earnings of \$20.00 a day sure. Only a few lines left to place. Don't delay. Write at once to Dept. 129, William C. Bartlett, Inc., 850 West Adams Street, Chicago.

LEARN PIANO TUNING AT HOME

With our TUNE-A-PHONE, Action Model, tools, charts and lessons you can learn quickly and easily and be prepared to make big money. Esth., 1926. Money-back Guarantee. Diploma given. Amazing surprise in our free book, "Winning Independence." Write for it today. Niles Bryant School of Piano Tuning. 40 Bryant Bldg., Augusta, Meek.



GIVEN

22 RIFLE

This Fine 22 Cal. Sure Shot HAMILTON Rifle or Dandy Regulation Size Leather Football. Just what you need. We give them Free, prepaid, for seeing our large colored Art and Religious Pictures at 10c each. Send No Money. Just your name & address. We will send you 24 Pictures promptly. When sold choose your price according to our Big Prize List. HOME ART CO., 428 W. 59th St., Dept. 616 CHICAGO

GET GOV'T JOBS

Railway Mail Clerks, City Mail Carriers, Rural Carriers,
City Postal Clerks, Clerks at Washington, D. C.

\$1140 to \$2600 a Year STEADY, SHORT HOURS
Long Vacations With Pay
MEN - BOYS 18 OR OVER

Mail coupon immediately for full list of positions now obtainable. Don't delay.

Franklin Institute, Dept. S199, Rochester, N. Y.

Franklin Institute, Dept. S199, Rochester, N. Y.

Gentlemen: Kindly send me, at once, and entirely without charge or any obligation on my part, list of U. S. Government big paid positions obtainable. Advise me also regarding the salaries, hours, work, vacation and tell me how I can get one of these jobs. Send me also free sample coaching lessons.

Name.....

Address.....

YOU CAN PLAY THIS

Professional Style

HAWAIIAN GUITAR

JUST LIKE THE HAWAIIANS!

FREE!

THIS \$15.00
GENUINE
HAWAIIAN
GUITAR

BECAUSE OUR NATIVE HAWAIIAN INSTRUCTORS WILL SHOW YOU HOW!

Be the Most Popular Member of your Set. Play "What'll I Do", "So This Is Love", "Memory Lane", "Minding My Business", "Fair Lady", "Lazy", "Linger Awhile". All the late song and dance hits. You can play First Selection in Half an Hour and Harmonious Chords at ONCE. Entertain your friends. Play for money. Don't be a wallflower. Be the Life of the Party.

FAMOUS HAWAIIANS TEACH YOU TO MASTER QUICKLY THEIR SECRETS OF THIS FASCINATING MUSIC

The instructions you receive from such world famous experts as Lawrence Kalaluki, Walter Kolemoku, Frank Ferera, Carl Seville and others are invaluable. NO OTHER Conservatory can even begin to give you the expert teaching and knowledge you gain through us. And remember, while it is conceded that the Hawaiian Guitar produces the sweetest music, yet its mastery by you will be simple and quick. We guarantee it.

ONLY 4 EASY MOTIONS—to learn to be able to play any music, popular, dance, classical, native Hawaiian Airs or old time melodies and hymns. Just think of it! You need never have read a musical note in your life. For that matter, even though you haven't the slightest knowledge of any musical instrument, we guarantee to teach you to play just like the native Hawaiians.



NEW INVENTION MAKES IT EASY

Here is your chance to learn to play the most fascinating of all instruments, the Hawaiian Guitar. JUST AS THE HAWAIIANS DO, and in an amazingly short time. Our method is so simple, plain and easy that you begin a piece your first lesson. In half an hour you can play it! Thousands of successful students prove this to be true. No matter how little your knowledge of music may be, you can positively learn to play by our plain, easy picture method.

COMPLETE CONSERVATORY COURSE

You get 52 complete lessons. An entire conservatory course. Nothing is omitted. Success is assured. It is the best course of Hawaiian guitar lessons in the entire world. Real Hawaiians instruct you. This is the only Conservatory teaching Hawaiian Guitar exactly as played by the Hawaiians. It is your good fortune as well as ours, that these Native Masters of Hawaiian Guitar come to this Conservatory to teach. That is why we are the largest and the best known Conservatory of the kind. Your success is assured when you enroll.

ANYONE CAN PLAY

We guarantee it. 40,000 pupils prove it. You don't have to know music. Our picture method makes it easy. Don't be afraid to try it.

WE FURNISH YOU WITH EVERYTHING

When you enroll as a student in this conservatory, you receive FREE a handsome, sweet toned, Genuine Hawaiian Guitar—valued at \$15.00—52 especially arranged lessons, as well as all the necessary Picks, Steel Playing Bar, etc. There is NOTHING extra to buy; everything is furnished.



EXTRA! As a special offer to readers of this magazine, we supply 52 pieces of music as a part of the course of lessons. Study the pictures of the good times you can have at parties, etc. Get in on the fun. Don't pass up this chance. Send the coupon at once for information and proof.

FIRST HAWAIIAN CONSERVATORY OF MUSIC
Dept. 48, 233 Broadway (Woolworth Bldg.) New York, N. Y.

SPECIAL COURSES UNDER FAMOUS TEACHERS, TENOR BANJO, VIOLIN, BANJO-UKULELE AND UKULELE

THIS COUPON MAKES IT EASY



WORTH \$15.00

Yes, that is the price charged in the music stores for these beautiful Hawaiian Guitars. We can afford to give them away free of charge to every pupil because we manufacture them in huge quantities in our own factory, which is the largest stringed instrument factory in the world.

SWEET TONED

You will get the same haunting, soothing, plaintive fascinating tunes that the real native Hawaiians get on these same instruments.

Plays any kind of music. 40,000 satisfied pupils prove all our claims are true.

Yours Free! We mean it. There are no strings tied to this generous offer. You get it absolutely free as soon as you enroll for our course of 52 easy lessons, taught by real Hawaiians. You can't possibly lose, so mail the coupon at once for full information.

Be Popular You'll never be lonesome after you learn to play on this beautiful Hawaiian Guitar. You can be the life of the party. Don't be a wallflower. Use the coupon for complete information. Mail it right away.



Learn in Your Spare Time

TEAR OUT AND MAIL

FIRST HAWAIIAN CONSERVATORY OF MUSIC, Inc.
Dept. 48, 233 B'way, Woolworth Bldg., New York, N. Y.
Gentlemen: Of course I want to get this handsome \$15.00 Hawaiian Guitar free of charge, because I am interested in learning to play it. Please mail full information about your 52 easy lessons under real Hawaiians, and proof that I can play a piece after the first lesson. I am not obliged to enroll unless I want to.

Name.....
Local Address.....
City & State.....

ELECTRICITY

**Earn \$3500 to \$10000 a year
as an Electrical Expert**

What's Your Future?

Now you earn \$20 or \$30 or \$40 a week. In the same six days as an Electrical Expert you can make \$70 to \$200 and make it easier—not work half so hard. Why, then, remain in the small-pay game, in a line of work that offers no chance, no

big promotion, no big income?

Fit yourself for a "bossing" job—

**Be An
"Electrical
Expert!"**

Some Features of Cooke Training That Make SUCCESS Certain

1. Practical Money-Making Instruction—no useless, high-sounding theory.
2. Free Electrical Outfit.—Finest outfit ever sent out for home experiment and practical use.
3. Free Employment Service. (Helps you get a good job.)
4. Free Consulting Service. (No chance to get stuck on anything, while studying or afterward.)
5. Free Subscription to monthly Engineering Magazine.
6. Free use of my Big Electrical Laboratory and Free room at Y. M. C. A. while visiting here.
7. Extra Courses Free—Radio—Electrical Drafting—Business—Automobile Electricity—Mine Electricity and Special Lesson on Health and Thrift.
8. Spare Time Work—Special earn-while-you-learn lessons.
9. Reduced prices on all Electrical Supplies.
10. Cash Refund Guarantee Bond.

These features are all explained in my big Free Book—the "Vital Facts"

Today even ordinary Electricians—the "screw driver" kind—are making money—big money. But it's the trained man—the man who knows the whys and wherefores of Electricity—the "Electrical Expert,"—who is picked to "boss" the ordinary Electricians—to boss the Big Jobs—the jobs that pay \$3500 to \$10,000 a year.

Neither L. L. Cooke nor the Chicago Engineering Works are connected, directly or indirectly, with any other School or Institution teaching Electricity or any other subject, by the Home Study method. You can only get "L. L. Cooke" training through the Chicago Engineering Works.



The "COOKE" Trained Man is the

NEEDS YOU!

*I will train you at home
to fill a Big Pay Job*

\$3,500 to \$10,000 a Year

Get in line for one of these "Big-Pay Jobs" by enrolling now for my easily learned, quickly-grasped right-up-to-the-minute, Spare-Time Home-Study Course in Practical Electricity.

Age or Lack of Experience No Draw-Back

You don't have to be a High School graduate—it isn't even necessary that you should have finished the grades. As Chief Engineer of the Chicago Engineering Works, I know exactly the kind of training you need, and I will give you that training. My course in Electricity is the most simple, thorough, successful and practical in existence, and offers every man, regardless of age, education, or previous experience, the chance to become in a few short months, an "Electrical Expert," able to make from \$70 to \$200 a week.

Earn While You Learn

With me you do practical work—at once. In my first few lessons I show you how to make money doing Electrical work in your spare time. (Over half of my students are paying for their course in this way.) I show you also, how to get started in business for yourself, and then help you to get started.

FREE—Electrical Working Outfit—FREE

To do spare time work you'll need tools, etc. These I give you—Free—a whole kit including measuring instruments, a real electric motor (no toy), and other things—the greatest value ever given by any school.

Your Satisfaction Guaranteed by a Million Dollar Institution

I absolutely guarantee to return every penny paid me in tuition if when you have finished my Course, you are not satisfied in every way with my instruction. And back of me, in my guarantee, stands the Chicago Engineering Works, a million dollar institution.

Nothing Like "Cooke" Training Anywhere

"Cooke" training is different because it's the most practical and most successful. It's best because it's backed up by the greatest Service to students ever known. It's this Service, plus "Cooke" training, that makes the "Cooke" trained man the "Big Pay" man everywhere. Become a "Cooke" Trained Man yourself, and earn \$12 to \$30 a day—\$70 to \$200 a week—\$3,500 to \$10,000 a year.

Investigate! Mail Coupon

Get the Vital Facts. Let me send you free my big new book on The Future of Electricity. Let me tell you more about the big demand for "Cooke" trained Electrical Experts. Sign and send me Coupon below.

**L. L. COOKE, Chief Engineer
Chicago Engineering Works, Inc.**

2150 Lawrence Avenue

Dept. 519

CHICAGO, ILL.

"Big Pay" Man!



Send for
this FREE
book

The
Vital
Facts

mail this coupon NOW

L. L. COOKE, Chief Engineer
Chicago Engineering Works, Dept. 519
2150 Lawrence Ave., Chicago, Ill.

Dear Sir:—Send at once the "Vital Facts" containing Sample Lessons, your Big Book, and full particulars of your Free Outfit and Home Study Course—all fully prepaid, without obligation on my part.

Name.....

Address.....

City and State.....

Occupation..... Age.....



He gets \$100 a week now

A LITTLE over a year ago he was just a hand—an untrained worker doing ordinary work and getting an ordinary salary.

Then he decided to take up a course with the International Correspondence Schools. He studied at home in the evening and in spare moments during the day.

And success came, as it always comes, to men who really study their work. In three months he became assistant foreman—then foreman—and then one day they called him into the head office to supervise all blue-print work.

He's earning \$100 a week now, and to quote the head of the firm—"That's only a start. He has the brightest future of any man in the organization."

How much longer are you going to wait before taking the step that is bound to bring you advancement and more money?

One hour a day, spent with the I. C. S. in the quiet of your own home, will prepare you for the position you want in the work you like best.

Mail the Coupon for Free Booklet

INTERNATIONAL CORRESPONDENCE SCHOOLS Box 5659-D, Scranton, Penna.

Without cost or obligation, please tell me how I can qualify for the position or in the subject before which I have marked an X:

BUSINESS TRAINING COURSES

- | | |
|--|---|
| <input type="checkbox"/> Business Management | <input type="checkbox"/> Salesmanship |
| <input type="checkbox"/> Industrial Management | <input type="checkbox"/> Advertising |
| <input type="checkbox"/> Personnel Organization | <input type="checkbox"/> Better Letters |
| <input type="checkbox"/> Traffic Management | <input type="checkbox"/> Show Card Lettering |
| <input type="checkbox"/> Business Law | <input type="checkbox"/> Stenography and Typing |
| <input type="checkbox"/> Banking and Banking Law | <input type="checkbox"/> Business English |
| <input type="checkbox"/> Accountancy (including C.P.A.) | <input type="checkbox"/> Civil Service |
| <input type="checkbox"/> Nicholson Cost Accounting | <input type="checkbox"/> Railway Mail Clerk |
| <input type="checkbox"/> Bookkeeping | <input type="checkbox"/> Common School Subjects |
| <input type="checkbox"/> Private Secretary | <input type="checkbox"/> High School Subjects |
| <input type="checkbox"/> Spanish <input type="checkbox"/> French | <input type="checkbox"/> Illustrating <input type="checkbox"/> Cartooning |

TECHNICAL AND INDUSTRIAL COURSES

- | | |
|---|--|
| <input type="checkbox"/> Electrical Engineering | <input type="checkbox"/> Architect |
| <input type="checkbox"/> Electric Lighting | <input type="checkbox"/> Architects' Blue Prints |
| <input type="checkbox"/> Mechanical Engineer | <input type="checkbox"/> Contractor and Builder |
| <input type="checkbox"/> Mechanical Draftsman | <input type="checkbox"/> Architectural Draftsman |
| <input type="checkbox"/> Machine Shop Practice | <input type="checkbox"/> Concrete Builder |
| <input type="checkbox"/> Railroad Positions | <input type="checkbox"/> Structural Engineer |
| <input type="checkbox"/> Gas Engine Operating | <input type="checkbox"/> Chemistry <input type="checkbox"/> Pharmacy |
| <input type="checkbox"/> Civil Engineer | <input type="checkbox"/> Automobile Work |
| <input type="checkbox"/> Surveying and Mapping | <input type="checkbox"/> Airplane Engines |
| <input type="checkbox"/> Metallurgy | <input type="checkbox"/> Navigation |
| <input type="checkbox"/> Steam Engineering | <input type="checkbox"/> Agriculture and Poultry |
| <input type="checkbox"/> Radio | <input type="checkbox"/> Mathematics |

Name.....

Street..... 3-6-24

City..... State.....

Occupation.....

Persons residing in Canada should send this coupon to the International Correspondence Schools Canadian, Limited, Montreal, Canada.

Learn Motion Picture Photography at Home



New plan qualifies you quickly in spare time at home for this great, fascinating profession. Careers may earn \$100 to \$200 a week and more. No previous experience required. Our experts train you by mail.

MOTION PICTURE CAMERA FREE

Handsome Motion Picture Camera given free if you act quickly. Take real motion pictures on standard professional film used in all theatres. Earn money on side.

Send for Illustrated Book—FREE

Write today for handsome, illustrated book explaining great opportunities in Motion Picture Photography, also Commercial, Studio Portraiture, News Photography, with details of FREE Motion Picture or View Camera. Address: Dept. 49C 143 W. 36th St. New York Institute of Photography NEW YORK CITY

Learn to Mount Birds



Learn at home by mail, to mount birds, animals, game heads; tax furs, make rugs and robes. Complete lessons. Easily and quickly learned by men, boys and women.

FREE Write today for Free Taxidermy Book. Tells all about it. Every Sportsman, Hunter, Trapper and Nature lover should know this wonderful fascinating art. Have your trophies. Big profits. Success guaranteed. Our school is 20 years old—18,000 graduates. Investigate today. Write for Free Book.

Northwestern School of Taxidermy 9779 Elwood Bldg., Omaha, Neb.

Learn Furcraft



Learn by mail, evenings at home, to Renew, Repair and Make-up all kinds of fur garments. Learn glazing, ironing and storage. Big demand, big need for your service in every neighborhood. \$3 an hour in your spare time or a real business now and a fur shop later. We teach you secret processes. Earnings start in 30 days. Unexcelled school for men and women. FREE BOOK—send now for free book giving details. No obligation.

Northwestern Fur Co. 1779 Sunderland Bldg. OMAHA, NEBRASKA

PIANO JAZZ

By Note or Ear. With or without music. Short Course. Adult beginners taught by mail. No teacher required. Self-instruction Course for Advanced Pianists. Learn 67 styles of Bass, 180 Syncopated Effects, Blue Harmony, Oriental, Chime, Movie and Cafe Jazz, Trick Endings, Clever Breaks, Space Fillers, Sax Sturs, Triplet Bass, Wicked Harmony, Blue Obligato, and 247 other Subjects, including Ear Playing and Musical Imagination. 110 pages of REAL Jazz, 25,000 words. A Postal brings our FREE Special Offer.

Waterman Piano School, 259 Superb Theatre Bldg., Los Angeles, Cal.



Wonderful, new device, guides your hand; corrects your writing in few days. Big improvement in three hours. No failures. Complete outline FREE. Write C. J. Ozment, D-31, St. Louis, Mo.



BIG VALUE FOR 10 CTS.

8 songs, words and music; 25 Pictures Pretty Girls; 40 Ways to Make Money; 1 Joke Book; 1 Book on Love; 1 Magic Book; 1 Book Letter Writing; 1 Dream Book and Fortune Teller; 1 Cook Book; 1 Base Ball Book, gives rules for games; 1 Toy Maker Book; Language of Flowers; 1 Morse Telegraph Alphabet; 12 Chemical Experiments; Magic Age Table; Great North Pole Game; 100 Conundrums; 3 Puzzles; 12 Games; 30 Verses for Autograph Albums. All the above by mail for 10 cents, and 2 cents postage.

ROYAL SALES CO., Desk 936, Norwalk, Conn.



SIGNS BANNERS CARDS

Easily painted with the aid of Letter Patterns. Simply draw around a letter pattern. Made in a large variety of styles and sizes at surprisingly reasonable prices. Samples on request. Write today. John F. Rahn, A2433 No. Greenview Ave., Chicago



MEN WANTED

to Learn AUTO and Garage Business

Earn Up to \$20,000 per Year

\$20,000 a year is a lot of money, men. But it is being made in the Auto and Garage business. True, not every one makes it. But it's *there*—and you can go after it, neck and neck with the next fellow. Thousands of jobs and business opportunities in Automotive lines are still open. That's what I want to talk to you about.

Only 8 Weeks to Complete the Training

You owe it to yourself to get into a business where you can push ahead fast. This is the business. Men leave our shops after 8 weeks of training ready to earn up to \$125 per week. We get you a job—or show you how to start in for yourself on small capital. From there on it's up to you how much you'll earn.

Where the Big Money Is Made

One man trained here earned enough in 8 years to retire in comfort—at 40. Another Greer graduate started in business for himself 18 months ago with a capital of \$400. His business is now worth \$30,000. Another averages \$400 to \$500 per month and has only been established 8 months. You have the same opportunity, but you need Greer shop training. Over 47,000 men have been trained in the big Greer Shops—over 30,000 of these men are now in business for themselves. The others are in good jobs, earning far more than they ever earned before taking Greer training. Your opportunity is **HERE**, too.

Railroad Fare Allowed to Chicago

The City of Automotive Opportunity

There is room for thousands more trained men in the auto, garage, or accessory business. Right here in Chicago there are over 5,000 garages and repair shops. Within 10 blocks of the big Greer Shop Building there are over 40 Auto sales Agencies. Hundreds more throughout the city. Over 16,000,000 automobiles in the U. S. Plenty of work for trained men. Come to Chicago, men. I allow railroad fare to Chicago. Get my FREE BOOK. Learn all about it. Mail the coupon.

JOBS GUARANTEED

Which Job Do You Want?

Which job do you want? We train you for success in Automobile, Truck and Tractor repairing—Shop Management—Selling—Machine Shop—Automotive Electricity—Storage Batteries—Tire Repairing—Vulcanizing—Welding—Driving—every auto, shop and accessory job in the business. Take your choice of subjects. We guarantee to get you the job after we train you. And if you need assistance we'll get you an earn-while-you-learn job while training. Mail the coupon and get my Special Offer in detail.

Mail Coupon for Book and Offer

Take my word for it, men, this book will open your eyes to the possibilities I have only touched on here. Many parts of pictures and automobile facts. It's FREE. Get it, and look it over. Address me personally, ERWIN GREER, President.

GET THIS
FREE
BOOK

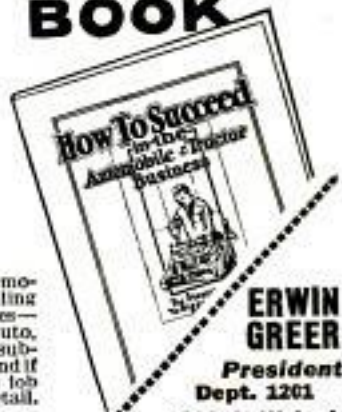

ERWIN
GREER

President

Dept. 1261

2024 S. Wabash

Avenue

CHICAGO, ILL.

Please send me FREE BOOK "How to Succeed in the Automobile and Tractor Business," and special training offer. This request does not obligate me in any way.

Name.....

Address.....



This mammoth new building, containing over 2 acres of floor space, is filled with modern shop equipment entirely devoted to training Greer students.

GREER

COLLEGE

Automotive Engineering

Dept. 1261, 2024 S. Wabash Ave.
CHICAGO, ILL.

Look Here!



I guarantee to make you a

Drafting EXPERT!

If you're earning less than \$75 a week, GO INTO DRAFTING! I guarantee to train you AT HOME the "JOB-WAY"—with actual Drafting Room Jobs. Drafting EXPERTS are close to the boss—are first in line of promotion for executive positions.

\$250 to \$400 a Month!

Common schooling all you need! My graduates are successful—employers ask for COYNE-trained Drafting EXPERTS. So I GUARANTEE satisfaction or to refund every penny you pay me.

FREE EXPERT'S DRAFTING OUTFIT

"JOB-WAY" training makes you a Drafting EXPERT quick. You do actual JOBS with the same instruments you use when employed at a big salary. To encourage you to start RIGHT NOW, I give you this complete EXPERT'S outfit FREE. Coupon brings full information.

LEARN AT HOME!

Thousands of big-salaried jobs all over the country looking for Drafting EXPERTS! Railroads, factories, builders, architects, shippards, auto plants, Cities, Counties, States and the U. S. Government all calling for Drafting EXPERTS! Mail the coupon to me personally!



CHIEF DRAFTSMAN COYNE SCHOOL OF DRAFTING Dept. 919, 1920 Sunnyside Ave., CHICAGO

Without obligation, send me your book, "Drafting, the Foundation of Industry," absolutely FREE. Also, special offer of FREE instruments and other big FREE features.

Name.....

Address.....

City..... State.....



Do Your Friends Marvel

at your physique as it stands today? Do they talk about you as the strongest man in the neighborhood? Most likely they do not; but if you had only enrolled with me three months ago, you would now be the talk of your friends and relatives. This popularity would be brought about by the harvest you would now be reaping of better health; an overflow of pep and endurance; strength that would make you a leader, even among real men; a physique that would make your friends worship you and your muscles support you; joints and muscles that would be so supple your body would possess the greatest possible agility. And besides these, you would have learned in those three short months more about your body and its needs; more about exercise and physical culture in general than you ever have in any past six months or will in the more length of time in the future.

HOW WOULD A 15-INCH UPPER ARM LOOK

in place of that frail one you now possess? How would it look as good, solid muscle instead of flabby fat? You can imagine how it would look, with other measurements in proportion, because you surely know that a 15-inch upper arm is some arm. Yes, you can imagine how it would look, but you can never put it on there with imagination. So satisfy yourself that you must "make a break," "take the step,"—anything for a start. That is it—get started. But just as important as starting—is the matter of starting right.

YOU START RIGHT When You Send for My FREE Booklet and you end right when you finish my course. The title of my booklet is "The Royal Road to Health and Strength." It has sixty-four pages, which are given to many power of myself and my pupils. It also gives a thorough explanation of my methods, as well as those of my muscle-control fans, training, food-balancing and other valuable information.

IMPORTANT
My New Booklet, "Your Muscles, Where They Are and What They Do," will be sent with my Booklet, and it is also free. Every person contemplating physical culture should get this booklet first. Then you will really know what you are doing, the look of them by return mail.

CHARLES MACMAHON
180 W. Somerset St.
Studio D-7 Philadelphia, Pa.

FREE Electrical Training Book

Mail postcard for amazing FREE book on electricity. Shows you how to earn \$150 to \$600 a month in this immense field. Famous S & H shop-type training fits you quick at home for big jobs. Exclusive system. Lack of experience or education no bar. Write

S & H Engineering Co., 1422 W. Monroe St., Dept. S-1, Chicago, Ill.

MINSTRELS

Musical Comedies and Revues, with full instructions for staging. You can stage your own show with our books. Full line of plays, stage songs, crossfire, monologues, afterpieces, vaudeville acts and make-up. CATALOGUE FREE. T. S. DENISON & CO., 623 So. Wabash, Dept. 19 Chicago

NO MORE BALD HEADS



WHEN our VACUUM CAP is used a few minutes daily. We accept no pay until you have tried the Cap 60 days and are satisfied. The Vacuum Cap is an appliance that draws the blood to the Hair Roots and starts a new healthy crop of hair. It stops Dandruff, stops the hair from falling out.

Bought by Doctors and men who know that it is the only reasonable HAIR GROWER known to science. No Drugs Used. Write for application blank, testimonials and booklet on "HAIR," sent sealed in plain envelope, FREE.

THE MODERN VACUUM CAP CO.

C559 BARCLAY, DENVER, COLO.



WANTED

MAIL CARRIERS (CITY OR RURAL)
\$1400 to \$2600 Year

Steady—common education sufficient. Big chance for men 18 up.

Mail Coupon Today Sure

Franklin Institute
Dept. S322
Rochester, N. Y.

Send me, WITHOUT CHARGE, list of places at which I may get a position as Mail Carrier—Tell me how to get the position, and send free sample examination coupon.

Name.....
Address.....



Tobacco Is Hurting You

Look at the facts square in the face, Mr. Tobacco User. You may think tobacco is not hurting you.

That is because you haven't as yet, perhaps, felt the effects of the nicotine poison in YOUR system. For you know that nicotine, as absorbed into the system through smoking and chewing tobacco, is a slow working poison. Slow, yes—but sure.

Tobacco is lowering your efficiency. It slows a man down. Makes it harder for you to concentrate your mind on your work. You haven't near the amount of "pep" and energy you would have if you stopped using it. There's many a man twice as old as you in years who's twice as young in energy, simply because he lets tobacco alone.

Some day you will realize to what an alarming extent tobacco has undermined your system.

When your hands begin to tremble—
and your appetite begins to fail—
and your heart seems to "skip a beat" now and then—
and slight exertion makes you short of breath—
then you have a right to suspect that
TOBACCO is getting the upper hand.

Any well-informed doctor will tell you that these are only a few of many symptoms of tobacco poisoning.

And YOU know that the use of tobacco in any form is an expensive, utterly useless habit. You know you ought to quit.

Tobacco Habit Banished Let Us Help You

It doesn't make a particle of difference whether you've been a user of tobacco for a single month or 50 years, or how much you use, or in what form you use it—whether you smoke cigars, cigarettes, pipe, chew plug or fine cut or use snuff—Tobacco Redeemer will positively remove all craving for tobacco in any form in a very few days. Not the slightest shock to the nervous system. Your tobacco craving will usually begin to decrease after the very first dose—there's no long waiting for results.

Tobacco Redeemer contains no habit-forming drugs of any kind and is marvelously quick, scientific and thoroughly reliable.

It is in no sense a substitute for tobacco. After finishing the treatment you have absolutely no desire to use tobacco again or to continue the use of the remedy. It helps to quiet the nerves and make you feel better in every way.

Results Guaranteed

As a single trial will convince you. Our legal-binding, money-back guarantee goes with each full treatment. We will refund every cent you pay for the treatment if after taking it according to the easy-to-follow directions, it should fail to banish the tobacco habit completely.

SEND Coupon for Free Proof

Let us send you our free booklet on the deadly effects of tobacco, together with testimonial letters from men all over the country telling how they have been absolutely freed from the tobacco habit by this simple home treatment. You could not ask for stronger proof that Tobacco Redeemer will free you from the habit than the evidence we will gladly send on request. Just mail the coupon—or a postal will do.

NEWELL PHARMACAL CO.

Dept. 300

St. Louis, Mo.



Free Book Coupon

NEWELL PHARMACAL CO.

Dept. 300

St. Louis, Mo.

Please send, without obligating me in any way, your free booklet regarding the tobacco habit and proof that Tobacco Redeemer will positively free me from the tobacco habit or my money will be refunded.

Name

Street and No.

Town..... State.....

THESE BOOKS WILL HELP YOU GET A BETTER JOB

Every one of the books listed below was written by an expert. They bring you the results of years of *practical* experience. They are, in every respect, the best and most helpful books of their kind ever written and are used by leading colleges, including Harvard, Yale, Cornell, Dartmouth, Purdue, Georgia School of Technology, Leland Stanford, etc. They contain much material that is not available in any other form—*anywhere!* New, complete, authoritative, and profusely illustrated, yet low in price.

Order them for yourself—Buy them for Christmas gifts

Shop Practice Books

- 1—Lathe Work. 312 pages—334 illustrations - - - **\$2.50**
- 2—Drilling, Boring, Bench Work, Erecting. 385 pages—343 illustrations - - - **\$3.00**
- 3—Gauges, Jigs, Dies, Tempering, Heat Treatment. 347 pages—273 illustrations - **\$3.00**
- 4—Pattermaking. 420 pages—424 illustrations - - - **\$3.00**
- 5—Foundry Work. 568 pages—222 illustrations - - - **\$4.00**

Automobile Books

- 6—Electric Starting and Lighting. 363 pages—180 illustrations - - - **\$3.50**
- 7—Electric Ignition. 245 pages—169 illustrations - - - **\$2.50**
- 8—Automobile Transmission, Mechanism, Lubrication, Tires. 351 pages - - - **\$3.00**

Drafting Books

- 9—Sheet Metal Pattern Drafting. 654 pages—394 illustrations - - - **\$5.00**
- 10—Mechanical Drafting. 504 pages—442 illustrations - **\$4.50**
- 11—Structural Drafting. 442 pages—357 illustrations - **\$4.00**

Building Trades Books

- 12—Heating and Ventilation. 313 pages—108 illustrations **\$3.00**
- 13—Brickwork, Terra-cotta, Hollow Tile, Building Stone, Plastering. 437 pages—346 illustrations - **\$4.50**
- 14—Estimating Building Costs, Specification and Contract Writing. 344 pages—38 illustrations - **\$3.00**
- 15—Geometrical Drawing, Ornamental Drawing, Architectural, Freehand and Perspective Drawing. 512 pages—245 illustrations **\$5.00**
- 16—Reading Architects' Blue Prints. (Ten blue prints free.) 618 pages—478 illustrations - - - **\$5.00**
- 17—Steel Square—How to Use It - - - - - **\$1.50**
- 18—Plastering and Stucco Work - - - - - **\$1.50**
- 19—Plain and Fancy Brickwork - - - - - **\$1.50**
- 20—Hollow Tile Construction and Stucco Finish - - **\$1.50**
- 21—Plain and Reinforced Concrete Construction - - **\$1.50**



A REAL BARGAIN

14 Good Books Only \$1 Each

- 39—Radio Handbook, 455 pages
- 40—Business Man's Handbook, 347 pages
- 41—Automobile Handbook, 347 pages
- 42—Bookkeeper's Handbook, 302 pages
- 43—Building Trades Handbook, 409 pages
- 44—Chemistry Handbook, 348 pages
- 45—Civil Engineer's Handbook, 411 pages
- 46—Concrete Engineer's Handbook, 368 pages
- 47—Machine Shop Handbook, 346 pages
- 48—Mechanic's Handbook, 330 pages
- 49—Pharmacist's Handbook, 346 pages
- 50—Poultryman's Handbook, 375 pages
- 51—Plumber's Handbook, 375 pages
- 52—Salesman's Handbook, 352 pages
- 53—Electrical Handbook, 414 pages

Business Books

- 22—Salesmanship. 369 pages **\$3.50**
- 23—Advertising. 497 pages **\$4.00**
- 24—Good English. 442 pages **\$3.00**

- 25—Money and Banking - **\$3.00**
- 26—Business Law. 300 pages **\$2.50**
- 27—Traffic Management. 310 pages—166 illustrations - **\$4.00**
- 28—How to Sell Your Services. Foreword by B. C. Forbes. **\$1.00**

Electrical Books

- 29—Electricity and Magnetism. 387 pages—309 illustrations - - - **\$3.50**
- 30—Electric Railways. 332 pages—287 illustrations - **\$3.00**
- 31—Alternating Currents. 338 pages—253 illustrations - **\$3.50**

How to Prepare for Civil Service Examinations

- 32—Civil Service Spelling, Penmanship, Reading Addresses, Letter Writing, etc. 349 pages - - - **\$3.00**
- 33—Civil Service Short-hand and Typewriting—Speed Short-hand. 339 pages **\$3.50**
- 34—Civil Service Geography, Bookkeeping, Copying, Manuscript. 332 pages - **\$3.00**

Pharmacy

- 35—Pharmacy and Materia Medica. State Board Questions. 326 pages - - - **\$3.00**
- 36—Inorganic Chemistry for Pharmacy Students. 381 pages—69 illustrations - **\$3.00**

Lettering Books

- 37—How to Design and Make Artistic Show Cards. 309 pages—254 illustrations - **\$3.50**
- 38—Artistic Alphabets for Show Cards and Signs. 338 pages—272 illustrations **\$3.50**

PLEASE ORDER BY NUMBER

Mail check, money order or stamps with coupon

INTERNATIONAL TEXTBOOK COMPANY, Box 5664-D, Scranton, Penna.

I am enclosing check money order stamps, for which please send me the following books.....

(Write the numbers above)

It is understood that if I am not satisfied with these books, I may return them in five days and you will refund my money.

Name.....

Address.....

EARN \$2,000 To TRAINED AUTO MEN

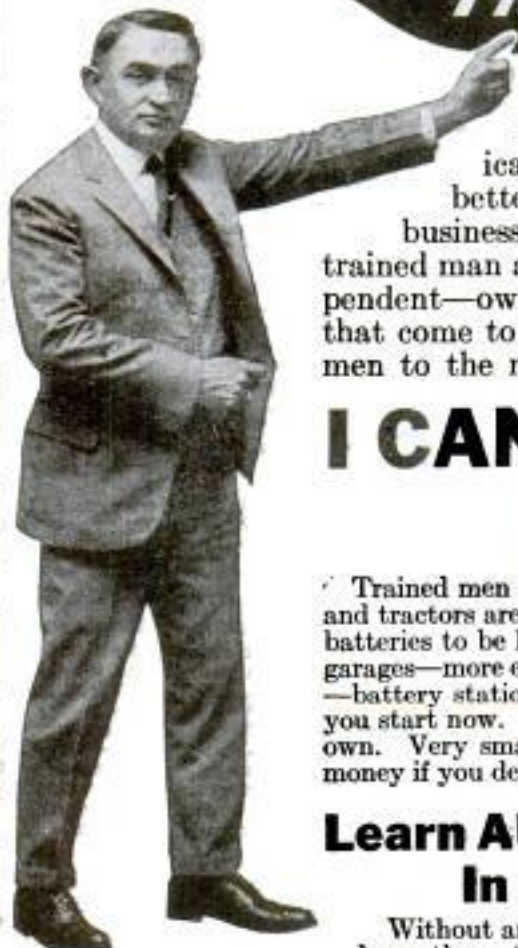

I say to you—stop plodding! **Get into work you like** and earn big money. If you are mechanically inclined I can train you in twelve weeks for a better job or a business of your own. The automobile business offers you this opportunity. Become a Detroit trained man and get in the big money class. You can be independent—own a home and a good car. Have the pleasures of life that come to the **trained man**. I have started **thousands** of men to the money-earning habit. And I say to **you**, again—

I CAN MAKE YOU A BIG MONEY MAN

Trained men are wanted everywhere! More than 15,000,000 autos, trucks and tractors are in use. All need service and repairing. Millions of tires and batteries to be kept in commission. More men needed for good jobs. More garages—more electric service stations—more tire-repair shops—welding shops—battery stations are needed. This means amazing opportunities for you if you start now. Fit yourself to win a good job, or to start a business of your own. Very small capital is needed. You are right on the threshold of big money if you decide now to make this your business.

Learn AUTOS, TRUCKS and TRACTORS In the Heart of the Industry

Without any previous experience—just a liking for mechanics—you can learn the auto business from A to Z in a few weeks here in Detroit—the heart of the industry. Then step out, equipped with knowledge and training, to a future of certain, big money making. Learning the business here gives you big advantages. Detroit is the heart of the automotive industry. You are taught under factory endorsed methods. You learn both theory and practice on latest equipment. Go through the great Ford plants. Visit the other auto factories—learn their methods first hand—and it all means greater opportunities and more certain success. The Michigan State Automobile School, in Detroit, the automobile center, is the logical place to learn the automobile business.

Quality Training Only—Start Now

A thorough training in Detroit, at the "Michigan State," fattens your pay envelope if you are working for others, or puts more profit in a business for yourself. You can take a full Automotive Course in 12 weeks. Or our big "Master Course" in 30 weeks. Or



specialize in any one of its money-making branches; you can be an Auto Electrician; a Tire Expert; a Battery Service Man; a Repair Man; a Welder; a Machinist; or specialize in motor farming, with truck, tractor and farm electric-lighting and farm engine training. Course includes training in Garage Management, Business Methods and Selling. Classes are always open. You need make no special arrangements—you can start at once—now, and that's the thing to do.

Read What Factories Say:

THE STUDERBAKER CORPORATION

OF AMERICA

"We do not know of a better automobile school than the MICHIGAN STATE."

HUDSON MOTOR CAR COMPANY

DETROIT, MICH., U.S.A.

"This school is thought very highly of by the automobile men of Detroit, and is considered one of the best equipped and most efficient schools in the country. You will make no mistake in attending the M. S. A. S."

DODGE BROTHERS

INCORPORATED

DETROIT, U.S.A.

"We believe the Michigan State Automobile School of this city to be an exceptionally high class school, and no doubt a diploma from this school would assist materially in obtaining employment with high class automobile dealers."

MICHIGAN STATE

312 Auto Building Detroit, Michigan

\$10,000 A YEAR ARE WANTED

Get into THIS BIG MONEY BUSINESS

Follow in the lead of thousands of "Michigan State" graduates who have taken advantage of the amazing money-making possibilities in the automobile, truck and tractor business. Be a garage foreman, or an auto electrician, skilled battery man, tire man, welder or machinist. These are the men who get the money. Detroit trained men are in demand. Here is a chart of facts—authentic figures which point out the opportunities. Here's your chance to cash in and satisfy your highest ambitions.

The opportunities are greater now than ever. There are more autos, more trucks, more tractors and every year adds to the money-making possibilities. You have ambition—you want success. Success is certain if you are willing to work for it, and start with proper training here at Detroit, the Auto Center. We have graduates who have made as high as \$10,000 in less than a year. These records may seem amazing, but they are true. It is all done through head and hand training at the "Michigan State." Decide now to give yourself the training that will pay you big and start you in a successful life work.

EARN WHILE YOU LEARN

If necessary we can assist students to secure part time work to earn a small amount each week. Or students who wish to take our evening course will be assisted to full time day jobs.

Ask for details, and when writing please explain your circumstances fully, and your age, nationality, height and weight.

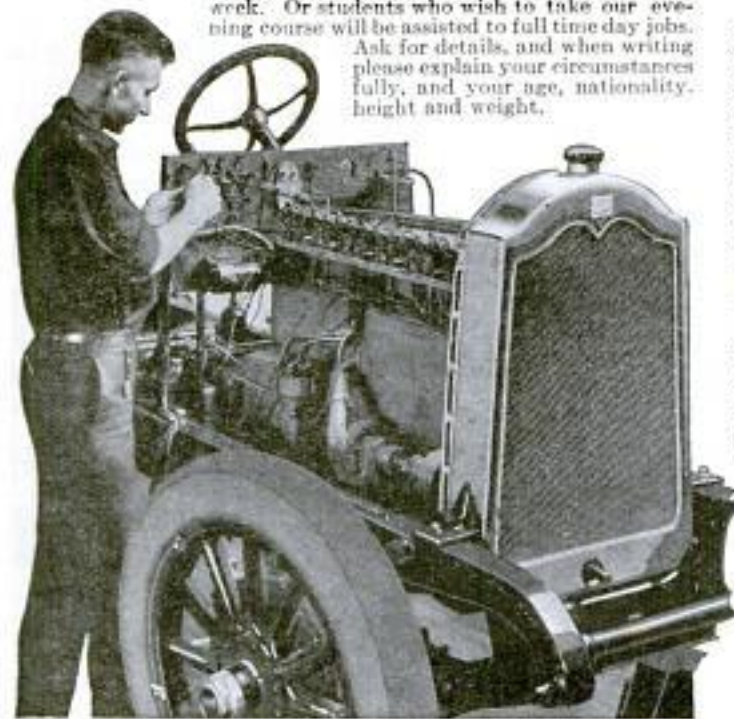

PRACTICE ON MANY FINE CARS

Here you learn on up-to-date, new equipment. All types of cars, engines, axles, transmissions, electrical systems. Some of the new cars and engines that you will find in our equipment are the new Packard Straight Eight with four-wheel brakes, Packard Twin Six, new Buick with four-wheel brakes, Oakland (four-wheel brakes), Cadillac Eight, Hupmobile, Reo, Jewett, Oldsmobile, G. M. C. truck, Hudson, Overland, and many others.

AUTOMOBILE SCHOOL

3729 Woodward Avenue, Detroit, Michigan

15,000,000
Automobiles in U.S.
70,000,000
Tires to be repaired.
15,000,000 Batteries,
15,000,000 Ignition
Systems and only
50,000 Garages.

GOOD POSITIONS OPEN

The demand for men who know auto mechanics and electric is greater than the supply. Step into any live-wire garage—everybody is busy as bees, have more work than they can do. Men working overtime, all at extra pay. That means big money for repairmen and boss. These money-making opportunities can be yours too, with "Michigan State" training. The training in Business Management and Salesmanship included in our courses makes our graduates especially valuable. The years ahead are predicted to be the biggest years of the industry. That means certain money-making advantages to men who start in the business now.

Home Study Course FREE

You can start your course here any day. Jump on the train for Detroit now. Or if you can't come at once you can begin to learn at home by my new Home Study Method, then come here later to finish. No extra charge for the Home Study training. Write me for full information. Or use the coupon. This is your opportunity to get ahead. Act now.

Mail the Coupon Today

Get all the interesting facts. Mail the coupon for information concerning your future that you must not fail to get. It's illustrated with photos of school equipment and graduates. It tells you how you can get a good paying job—how you can go into business for yourself with little capital. Mail the coupon or send us a postcard today. Write now.

(We do not enroll colored students, except for our Home Study Course.)

Mail Coupon To Day

Michigan State Automobile School 312 Auto Building
DETROIT, MICH.

Send me FREE and without obligation complete information about Detroit-training to make the most money.

Name.....

Street or R. F.....

City..... State.....

I am interested in Resident Course at your School.
 Home Study Course.



ELECTRICITY

If I Send You These New Books

WILL you look them over for a week at my risk—give them a chance to show you how a few minutes a day devoted to reading them will answer your problems—help you with your daily work—raise your pay—and put you in line for a bigger job? Prove their value—then decide if you want to keep them.

Teach Yourself at Home

These books contain every important up-to-the-minute fact about Electricity in all its branches. They're packed with new, sound, commonsense, how-to-do-it information, written by practical experts. Easy to read—easy to learn and apply. No need to take a long, expensive course of training—these books contain every thing you need to know to get and hold the best jobs. Common school education is all you need to master Electricity with these books. Order a set today for free examination.

Learn These Vital Points

Theory and Practice of Electricity—Principles of A. C. and D. C. current. Electric machinery—Dynamo and Motor Design—Measuring and Testing Instruments—Wiring—Converters—Rectifiers—Underwriters' Requirements—Electrical Estimating—Switchboards—Electric Railways, etc. Ready-Reference indexed for quickly locating any subject.

Electrical Engineering complete in eight big volumes—4,100 pages, 3,300 pictures, charts, diagrams, blue-prints, etc. Flexible binding. Gold stamped.

SEND NO MONEY!

Just the coupon. Look the books over a full week with our compliments—then decide. No obligation to buy unless you are satisfied and want to keep them.

Send coupon now—today and get this master electrical set. Pay only \$3.00 monthly if you decide to keep it.

AMERICAN
TECHNICAL SOCIETY
Dept. E. 919 Chicago, U. S. A.

FREE TRIAL

American Technical Society, Dept. E. 919
Chicago, U. S. A.

Please send me the 8 volume cyclopaedia of ELECTRICAL ENGINEERING for free examination. If satisfactory I will send you \$2.50 within 7 days, and \$2.00 monthly for nine months.

Name _____

Address _____

Employed by _____

NO. 5 \$5.88 NO. 4 \$4.98

SEND NO MONEY

NO. 7 Marvelous Mexican NO. 9
\$3.88 Blu-Flash Gems \$3.98

Latest wonderful discovery with blue-white brilliancy guaranteed 20 years that positively matches genuine Diamonds side by side. Same perfect cut, same dazzling rainbow fire. Noted experts positively need their experience to detect any difference at all. Perhaps the "Diamonds" you admire on your friends are Mexican Blu-Flash Gems and you never knew it! Test one free. You risk nothing. Wear it 3 days side by side with genuine diamond. If you see any difference send it back for quick, cheerful refund. To get new customers and agents we offer these prices which are all you pay and just half our catalog prices.

No. 4—Gent's Heavy Orpax ring, Platino finish. \$4.98
No. 5—Lady's fancy box setting, these 1/2 ct. A-1 Mex. Blu-Flash Gems, finest Platino finish. \$3.88
No. 7—Lady's Solitaire, 1 ct. 1st Water Mex. Blu-Flash Gem, engraved Platino finish. \$3.88
No. 7A—Same but fine gold 14, plain or engraved. \$2.49
No. 9—Gent's finest gold 14 heavy engraved tooth Becher, 1 ct. 1st Water Mex. Blu-Flash Gem. \$3.98

WEAR three FREE SEND NO MONEY: just name, address and slip of paper meeting around ring finger for size. State which ring wanted. We ship promptly. On approval deposit price with postman. If you decide not to keep, return in 3 days and we will refund your money. Write today.

MEXICAN GEM IMPORTING CO., Dept. P-2, Mesilla Park, N. Mex.
Importers of Fine Gems for over 19 years

Try THIS on YOUR Hair 15 Days

Let Your Mirror Prove Results

YOUR hair need not thin out, nor need you become bald, for there is a way to destroy the microbe that destroys the hair. This different method will stop thinning out of the hair, lifeless hair, remove dandruff, itching, darken gray hair and threatened or increasing baldness, by strengthening and prolonging life of the hair for men and women.

Send your name now before it is too late, for 15 days' FREE TRIAL OFFER.

AYMES CO., 3932 N. Robey St., S-234, Chicago, Ill.

No Joke To Be Deaf

—Every Deaf Person Knows That

I make myself hear, after being deaf for 25 years, with my Artificial Ear Drums. I wear them day and night. They are perfectly comfortable. No one sees them. They stop head-noises. Write me and I will tell you a true story, how I became deaf and how I make you hear. Address

GEO. P. WAY, Artificial Ear Drum Co. (Inc.)
80 Hoffman Bldg., 3529 Woodward Ave., Detroit, Mich.

DON'T WEAR A TRUSS

BE COMFORTABLE—

Wear the Brooks Appliance, the modern scientific invention which gives rupture sufferers immediate relief. It has no obnoxious springs or pads. Automatic Air Cushions bind and draw together the broken parts. No salves or plasters. Durable. Cheap. Sent on trial to prove its worth. Beware of imitations. Look for trade-mark bearing portrait and signature of C. E. Brooks which appears on every Appliance. None other genuine. Full information and booklet sent free in plain, sealed envelope.

BROOKS APPLIANCE CO., 215-A State St., Marshall, Mich.

How New Method Makes Cartooning Astonishingly Easy to Learn!

Cartoonists earn from \$50 to over \$250 a week! Why don't you make big money in cartooning when new method makes it so easy to learn—at home in spare time?

THOUSANDS who never dreamed they could make cartoons, can now earn big money in this fascinating field. Right at home in your spare time, you can now easily learn to make all kinds of cartoons—comic, sport, political, human interest and animated. You can now earn some of the big money paid for cartoons of every description.

And cartooning *does* pay enormous money! Briggs, Bud Fisher, Fontaine Fox, George McManus, Sid Smith and all the other headliners *earn more than the President*. A single cartoon idea can easily mean a splendid life-salary for you.

The World's Easiest, Pleasantest and Best Paying Profession

How could money be earned more pleasantly? A few hours a day at work that is as enjoyable as play—and there is almost no limit to the money that can be earned!

Never before have the opportunities in cartooning been so many or so varied. Never has there been such a splendid chance to earn big money for cartoons. And regardless of what you are doing at present or how poorly you draw now, you can easily and quickly learn to make cartoons through this new easy method.

New Easy Way to Learn Cartooning

It's fun learning to make cartoons this new way. It's just like a game. You learn at home, yet it is just as if an instructor stood at your elbow. You don't need to know a thing about cartooning. You start with straight lines and curves. Then you learn the little secrets of originating cartoon ideas, the methods of exaggeration, of action and expression—all the little tricks that make cartooning amazingly easy to those who know them. And soon you are making *real* cartoons. Many of our students had cartoons published before they were half thru their courses.

When learning to make cartoons is so easy, why shouldn't you too make big money and enjoy the fun of cartooning. Graduates of this school are to be found in every section of the country. Read in the panel what they are doing and what they say about this training.

Mail Coupon for Free Book

Learn more about the wonderful opportunities for making money in Cartooning and how this new method makes it easy

What Students Say:

I am now working for myself and find all I can do. I find no trouble in clearing up in the neighborhood of \$200 a week. I have my own syndicate and am gradually branching out into a good field.
R. P.—Lawrence, Mass.

Free Employment Bureau

I want to thank you for the personal interest you have taken in me while receiving instruction from your school and for referring me to this magazine.
F. M.—Muskogee, Tenn.

\$125 a Month Spare Time

I wish to take this opportunity to recommend your school. I have been doing a great deal of commercial work—making on the average of \$125 a month in spare time.
T. W. P.—Guanacota, N. C.

Earn While Learning

In two weeks I earned more than I paid for the entire course. I am more than pleased with the training I received and am certain no one can fail to make rapid progress under your instruction.
O. B.—Old Town, Ms.



for you to learn. Read about our students, how they make money while learning, and big salaries after they graduate. Our handsomely illustrated booklet is crammed full of interesting facts on Cartooning and describes in detail this remarkable method of teaching cartooning. It will be sent to you without obligation. Mail the coupon for this booklet now.

Washington School of Cartooning

Room 3012B, 1113-15th St., N. W., Washington, D. C.

WASHINGTON SCHOOL OF CARTOONING,

Room 3012B, 1113-15th St., N. W., Washington, D. C.

Please send me, without obligation, your Free Booklet on Cartooning and full details on your new easy home-study method of teaching Cartooning. (PLEASE WRITE PLAINLY.)

Name.....
(State whether Mr., Miss or Mrs.)

Address.....

City..... State.....
(If under 16, please give age.....)

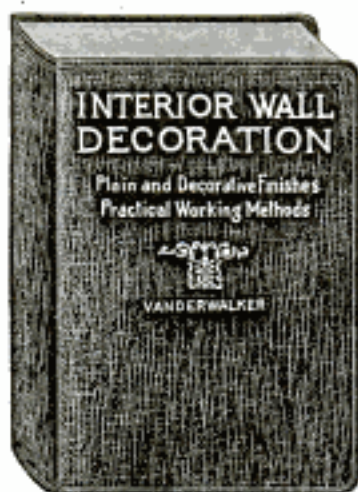

The first Authoritative Book on Interior Wall Decoration

Containing Complete Instructions for Producing the New and Unusual WALL FINISHES

Very little is known of the methods used in producing the new decorative wall finishes. Yet because of their beauty the demand for information comes from every side. This new book, "Interior Wall Decoration," by one of America's leading authorities, F. N. VANDERWALKER, is profusely illustrated, with photographs of walls finished by the most able decorators of the country. Not only is the result shown, but the process by which it is obtained is minutely described, and also the tools and materials needed.

A few items taken from the table of contents are: Color Stippling; Glaze Colors, Tiffany Blending and Mottling; Spatter Work; Plaster Staining; Sand-Float; Sponge-Stipple; Spanish Palm Finish; Roman Travertine; Old English; Holland; French Caen Stone; Italian Plaster and Other Artistic Rough Textures; Decorative Wall Panels. In addition, plain painting jobs, calcimining methods, preparing surfaces and hanging wall fabrics are completely covered.

450 pages packed full of information, bound in handsome leatherette. Price \$4.00. We prepay postage. Send in the coupon today. After five days, if you are not completely satisfied, your money will be promptly returned.

Drake's Painting Books

Art of Sign Painting.....	\$4.00	Automobile Painting.....	\$1.50
Scene Painting and Bulletin		Modern Painter's Cyclopedia	2.00
Art.....	4.00	Estimates, Costs and Profits,	
"A Show at" Show Cards..	4.00	House Painting and Interior	1.50
Art of Show Card Writing..	4.00	Decorating.....	1.50
Signet's Book of Modern		New Hardwood Finishing..	1.50
Alphabets.....	1.50	The Amateur Artist.....	1.50
Strong's Book of Designs..	4.00	The Mixing of Colors and	
New Stencils and Their Use	1.25	Paints.....	2.00

Any of the above books sent, all charges prepaid, on receipt of price—money back if not satisfied. Mail this coupon today.

FREDERICK J. DRAKE & CO., Publishers
1008 S. Michigan Ave. Chicago, Ill.

F. J. DRAKE & CO., Publishers
1008 S. Michigan Ave., CHICAGO, ILL.

Please send me "Interior Wall Decoration" by F. N. Vanderwalker. I enclose \$4.00. You are to mail the book postpaid and refund my money in full if I decide not to keep it.

My name is.....

My address is.....

FREE to the DEAF

10 Days Trial of the World Famous Acousticon



Every one who is troubled with deafness is now invited to enjoy Ten Days of Good Hearing with the world-famous Acousticon. Let us send you our latest improved model for 10 days free use entirely at our risk and expense. No deposit required—no obligation on your part. Just try it—10 days Free and let results convince you.

Mr. A. H. Herrick, of Harvard University, says: "We who suffer from impaired hearing have cause for profound gratitude to you." Rev. G. M. Rainey, the Evangelist, says: "The results have been all you claim." Mr. A. Hollander, of the Equitable Life, New York, says: "Not a day passes but what I recommend the Acousticon to friends or business acquaintances—it has made a new man of me." In like manner write thousands of others, expressing their gratitude—men and women in every state, in practically every civilized country on earth. Yet we don't ask you to believe. We simply ask that you allow us to prove the merits of the Acousticon in your own case, to your own complete satisfaction without a penny of expense or risk on your part. Just try it—free, that's all we ask. Send name and address today.

Dictograph Products Corporation
1307 Candler Bldg., 220 W. 42nd St., New York

RAISE BELGIAN HARES

NEW ZEALAND REDS—Chinchillas—Flemish Giants
MAKE BIG MONEY—We supply stock and pay you following prices for all you raise: Belgian Hares \$3 each—New Zealand \$3 each—Chinchillas \$4 each—Flemish Giants \$5 each. \$2-page illustrated book, catalog and contract, also copy of *Fur Farming* magazine, tells how to raise skunk, mink, fox, etc., for big profits, all for 10c. Address

OUTDOOR ENTERPRISE CO., Rm. 25, Holmes Park, Mo.

New Kind of Truss

No more steel springs, weighty cushions, or chafing leg straps. Amazing new kind of support, weighing less than 1/25 of an ounce, prevents coming out of rupture, which leads too often to strangulation—yet requires no tight strapping like old-fashioned ineffective devices. Offered to ruptured people on a guarantee of instant satisfaction or no cost. Free details if you will simply drop us a post-card or letter with your address, to

NEW SCIENCE INSTITUTE, 2107 Clay Street, Steubenville, Ohio

Improve Your Nose Quickly and Easily



Model No. 25 Junior for children

Trados Model No. 25, latest improved nose shaper, U. S. and Foreign Patents, corrects now ill-shaped noses quickly, painlessly and comfortably at home (excepting cases caused by an improper bone structure). It is a superior, safe, and guaranteed device that will actually give you a better looking nose. \$7,000 satisfied users. For years recommended by physicians. 16 years' experience in manufacturing nose shapers is at your service.

Write for Free Booklet

M. TRILETY, Specialist
Dept. 2194, Binghamton, N. Y.

Be A Dental Laboratory Expert



You learn in my schools with tools, instruments and materials, not with books.

I train you on actual Dental Laboratory jobs how to make Crowns, Plates, Bridges, etc. for Dentists. Mine is the only school of its kind with practicing, ethical Dentist in connection.



No classes at my schools

Individual, personal instruction guaranteed to every student. Start any time. Day or evening instruction.



So I give you this \$50 outfit absolutely free. Mail coupon for my free outfit offer.

My schools at Chicago and Detroit are the largest and most completely equipped Dental Laboratory schools. And my graduates are the most successful.

Open a Laboratory

Little capital needed when you are McCarrie-trained in every branch of Mechanical Dentistry. Big demand from 60,000 Dentists for better Dental Laboratory service account lack of skilled Mechanical Dentists. Unlimited opportunities. Hundreds of locations now open for Laboratories. My training includes Laboratory management, how to get business, how to take care of it, etc.

LOOK HERE!

What's the use of crowding into the old overcrowded trades? "Mechanical Dentistry" is quickly, easily learned by my methods and offers you tempting salaries and unlimited opportunities as soon as you are expert. No educational requirements. Fascinating mechanical profession for men and women. I will help you earn as you learn. Takes only a few months.

Earn \$65 to \$125 a Week!

When you are a McCarrie-trained Dental Laboratory Expert, capable of doing every branch of Mechanical Dentistry, the positions and the opportunities LOOK FOR YOU! Whether you work for one or several Dentists—or in a Dental Laboratory, my training will bring you top pay and that's bigger pay than you can get in other lines of work!

Mail Coupon for Valuable Book \$80 Scholarship FREE if you write me at once!

Get my big free book quick! It tells you all about the great Dental Laboratory business and how with my training you can find success and independence. It brings you complete information about my schools, my wonderful free offers to induce ambitious men and women to go into the profitable, growing business. Realize your hopes and ambitions in Mechanical Dentistry—mail coupon or write today!

H. A. McCARRIE, Director
McCARRIE SCHOOLS of
MECHANICAL DENTISTRY
 1338 S. Michigan Ave., Dept. 1601-L, Chicago
 (Also Branch at Detroit)



I will pay your R. R. fare to Chicago or Detroit and give you other valuable inducements to become a Dental Laboratory Expert. I will help you "work your way" thru my schools if necessary! But you must act quickly. The number of students I can train is of course limited, and you must write me immediately to get the benefit of these Special Offers.

H. A. McCARRIE, Director
McCARRIE SCHOOLS OF MECHANICAL DENTISTRY
 1338 S. Michigan Ave., Dept. 1601-L, Chicago

Please rush complete information and all free offers. Send one of your valuable books about Dental Laboratory work without cost or obligation.

Name

Address



I guarantee you personal, individual training in every branch of Dental Laboratory work. I will train you until you are expert, capable of earning big pay!

Will you give me 6 MONTHS? to increase Your Pay!

Your name on the coupon means "Yes"



What I Give You

Free Book. Send in the coupon today. I will immediately send you our book "Drafting—Your Success" which tells about Drafting and its opportunities and contains proof that I can raise your pay. **Free Subscription to Drafting Publication "The Compass."** I will give you free a subscription to our helpful, inspiring publication "The Compass."

Practical Problems. You will be carefully coached in practical Drafting work.

I Help You Get a Job. I will help you get a position as a practical Draftsman and will give you real, personal help, such as I have given to thousands of others.

Personal Instruction and Supervision, throughout the Course. You will receive the personal instruction and help of Roy C. Claflin, President of the Columbia School of Drafting and a practical Draftsman of many years experience.

Draftsman's Equipment. I will furnish you with a full set of first class drawing equipment and Drafting Instruments, as shown in the picture below, when you enroll. You keep both sets on completing the course.

Consultation Privileges. You are free to write me at any time for personal advice and suggestions regarding your progress.

Diploma. The diploma I will give you on completing the course attests to your proficiency as a Draftsman. It is an entering wedge to success.

Advice Regarding Government Positions. The following are a few of the many positions open in the Government Departments from time to time. The salaries are starting salaries, subject to increase:

Architectural Designer — 84,000 a year.
Chief Draftsman, Naval Aircraft Factory — \$15.04 a day.
Aeronautical Draftsman, Field Service Navy Department — \$5.20 to \$12.50 a day.

We will advise you as to other government openings from time to time.

No, I am not a wizard. I don't claim to have a "corner" on success, but here's a fact.

For fourteen years I have been helping men just like you to make more money, not just a few men here and there, but thousands of men.

Think these facts over—in just a few months time I boosted one man's pay from \$2.00 a day to over \$300 a month—another now makes as high as \$27.00 a day—another man, after securing my help, went into business for himself and, while he now hires his drafting done, he makes over \$50,000 a year.

\$275 Extra in Three Days

One man saw an ad like this—Sent in the coupon—Enrolled for the Columbia Course—and shortly after he received \$275 for one drawing that he made in his spare time in three days.

Do you make money like these men do? Does the money in your pay envelope get you the things you really want or just enough to make you wish you, too, could have the good things of life that other men have—money, independence, success, happiness?

MAKE \$50 TO \$100 A WEEK

Columbia will train you to be an expert Draftsman in your spare time at home by mail. There's a lot of room for you if you act now. This doesn't mean that you will be just an ordinary Draftsman, but a finished, Professional Draftsman, able to hold your place among the highest paid Draftsmen in the land.

PROMOTION IS QUICK

We'll qualify you for a high salaried position in the Drafting field and keep you in touch with openings for Draftsmen in the big machine shops, industrial plants and United States Government departments. Men who start as Draftsmen are often advanced to Chief Draftsmen, Chief Engineers, Production Managers, and so on. Many of my graduates are today holding such positions as a result of my help. These positions pay big money and lead on to executive positions of the highest type. Thousands of men have found Drafting to be the stepping stone to some of the biggest positions in American industry.

GET THE RIGHT TRAINING

I started this school years ago. Today it is a solidly established nationally known institution, with graduates all over the world. I stand personally in back of the Columbia School of Drafting and back of every promise, every state-

ment we make. You get the right training when you enroll at Columbia. You spend no time on long winded theories. You start on actual drawing work the day you receive your first lesson. You get right down to brass tacks and there is no lost motion, no waste time or effort at any stage of the course. From the very beginning you can feel yourself making progress, the kind of progress that makes you confident of yourself and sure of your success.

YOU NEED NO PREVIOUS TRAINING

This course of mine is easy to understand and easy to follow. It is designed for men who must have the best and who must get the right training quickly, so as to be able to make more money as soon as possible. Many of my students are qualified, even before they complete the course. Many a man has increased his pay so soon after enrolling that his course has actually cost him nothing.

SUCCESS CALLS MEN OF ACTION ONLY

If you are a man of action—if you want success bad enough to reach out and grab it, clip the coupon now and show me that you are a man of action. Keep right on top of this opportunity to make real money. Don't go looking for a pair of scissors, tear the coupon off and mail it right away. Get started now.

COLUMBIA SCHOOL OF DRAFTING

ROY C. CLAFLIN, President

Dept. G-106, 14th & T Sts., N. W.,

WASHINGTON, D. C.



FREE DRAFTING OUTFIT

We give you free with our course this professional Drafting outfit. It is yours to keep when you complete the course.

FREE BOOK COUPON

COLUMBIA SCHOOL OF DRAFTING

Dept. G-106, 14th and T Sts., N. W., Washington, D. C.

Please send me without charge your free illustrated book on Drafting, telling me how I can secure your help in securing a position as Draftsman. Also enter my name for free subscription to "The Compass."

Name.....

Address.....

City.....State.....

Auto Experts earn \$60 to \$200 a week



Boss Jobs Like This

I Guarantee to make You a Big Pay Auto Expert —Get You a Job and a Big Raise in Pay!

SAY Good-by to \$20, \$30, or \$40 a week. Go after the Big Money! Work short, easy hours—boss the job instead of being bossed—be independent—a Success! I'll show you how: Listen! Give me a little spare time each day—I'll guarantee to make you a Big Pay Auto Expert—get you a job and at least 50% raise in pay! Mail the coupon today for my amazing guaranteed job and salary offer.

I Train You at Home by Actual Shop Methods

My new SHOP-NOTE method of instruction gives you the full benefits of actual shop and garage experience, right in your own home—and with better results, quicker results! No need to quit your job until you're ready for a Big one! My training fits you to hold a dozen different auto jobs. I make you a MASTER of auto, truck and tractor. I make you a full-fledged EXPERT—not just a mechanic. I've been in the Auto business for 24 years—worked for Packard, Rolls Royce, Paige and others. I know how to train you and I guarantee your success.

Students Make Good!

R. H. Crewry, of Marion, Va., only finished the 6th grade in school, yet my training doubled his salary in 6 months. Carl F. High of Madison, Wis., is at the head of his own prosperous business. H. H. Osobec, 2220 Casspell Ave., Detroit, was advanced to Chief Engineer. I could cite scores of similar cases if space permitted. But the big point is this: What I have done for these men & hundreds like them I can do for you.

Boss Big Auto Jobs

Take my training. Then take your pick of a dozen big-pay jobs. I qualify you for Auto, Truck and Tractor repairing—Auto Electricity—Vulcanizing—Welding—Battery Work—Aviation Motor Service—Auto Salesman—Shop, Garage and Service Station Management, everything.

Start in Business

I will show you how to start in a business of your own and take in \$5000 to \$15000 profits a year. I tell you how to organize, advertise and manage the business, how to get customers etc. Write today. Get the facts—the full PROOF!

Education Unneeded

I don't care what Education or Experience you have had. Crewry only finished the 6th grade and I doubled his salary in five months! My shop methods are guaranteed simple, easy-to-learn, and easy to apply. I've taken men and boys from all walks of life and made them experts.

Results Guaranteed

Write today. Get my free book, filled with proof of everything I say. Get my guarantee to make you a big pay Auto Expert—get you a job and at least a 50 percent raise in pay. These are money-back guarantees—not idle talk! WRITE TODAY!

Auto Book Sent Free!

Investigate! Write today. Get this wonderful book. It tells about big salaries, opportunities, and my guarantee of big jobs and bigger pay. You owe it to yourself to read this book—no obligations. It's FREE! Write Today!

TOM C. PLUMRIDGE, Chief Engineer
AUTO DIVISION, AMERICAN SCHOOL
Drexel & 58th St., Dept. A-974 Chicago, Ill.



A "No-Profit" School

The American School, just like the best resident schools and colleges is chartered strictly as an educational institution and not as a money-making enterprise. This insures your getting the best Automotive Training at the lowest possible cost. 27 years reputation for integrity and square dealing plus a million dollars in resources stand back of the American School and its guarantees to you!

Mail this Coupon Today!

TOM C. PLUMRIDGE
Chief Engineer
Auto Division,
American School
Drexel Ave. & 58th St.
Dept. A-974
Chicago, Illinois

Send me your free book, your job and salary guarantee and full information on how you will get me a Big Pay Auto Job. This request is to put me under no obligation.

Name _____

Address _____

City _____ State _____

A 50% RAISE GUARANTEED

LEARN Painting and Paper Hanging and Decorating

Marbling and Graining—Auto Painting—Show Card Writing

Learn any of these big paying trades in a few weeks by practical work under competent instructors. No books—no classes—start anytime. No previous experience or education necessary. Working conditions exactly the same as "out on a job". Largest and best equipped painting shops in America—the only industry endorsed school.

Make \$10 to \$20 a Day

Or, go in business for yourself and make \$5,000 to \$15,000 a year. We train you to become an EXPERT, not an ordinary "brush hand". There are not enough trained men to go around. Be an EXPERT and get the big money.

Send Coupon for Free Book

Take the first step today and send for Free Book and Special Offer. No obligation. A few weeks practical training will fit you for this big paying trade.

CHICAGO PAINTING SCHOOL

Dept. 1359

150 W. Austin Ave., CHICAGO, ILL.

CHICAGO PAINTING SCHOOL,
Dept. 1359, 150 W. Austin Ave., Chicago, Ill.

Gentlemen: Without obligation, please send me your Free Book and Special Offer.

Name.....

Address.....



Hotels Start You With Salaries up to \$3,500 a Year — with your living

HOTELS, restaurants, clubs, apartments, everywhere need trained men and women—salaries to start up to \$3,500 a year with your living. Over 70,000 high-class positions paying up to \$10,000 a year are open every year in the hotels of the United States. Today this is the 1st INDUSTRY IN AMERICA—with over \$992,394,968 in new hotels being built in 1924—exceeding by \$200,000,000 the next largest industry. These new hotels, restaurants, etc., will need over 60,000 trained men and women.

You can have one of these high-class big-pay positions, with luxurious meals and apartment and fascinating work. No previous experience necessary. The Lewis Schools guarantee to give you the valuable knowledge that it has taken some of the most successful hotel men years to obtain—men who are now making \$5,000 to \$10,000 a year. We train you by test in your spare time at home with the Lewis Simplified Study Plan, and we put you in touch with big opportunities. Our students employed, our methods endorsed by leading hotel men everywhere. Send today for Free Book, "YOUR BIG OPPORTUNITY," showing how we can train you for one of these splendid positions in 20 weeks or less, and explaining our Money-Back Guarantee.

LEWIS HOTEL TRAINING SCHOOLS
Room A-388 Washington, D. C.

FREE BOOK COUPON

LEWIS HOTEL TRAINING SCHOOLS, Room A-388, WASHINGTON, D. C.
Send me without obligation the Free Book, "YOUR BIG OPPORTUNITY."

Name.....

Address.....

City.....

State.....

"I Would Not Part With It for \$10,000"

So writes an enthusiastic, grateful customer. In like manner testify over 100,000 people who have worn it. Conserve your body and life first.

The Natural Body Brace

Overcomes **WEAKNESS** and **ORGANIC AILMENTS OF WOMEN and MEN**. Develops an erect and graceful figure. Brings restful relief, comfort, energy and pep, ability to do things, health and strength. Does away with the strain and pain of standing and walking; replaces and supports misplaced internal organs; reduces enlarged abdomen; straightens and strengthens the back; corrects stooping shoulders; develops lungs, chest and bust; relieves backache, curvatures, nervousness, ruptures, constipation, after effects of Flu. Comfortable and easy to wear.

Costs You Nothing to Try It

Write today for illustrated book, free, with full information and measurement blank. Address

HOWARD C. RASH, Pres. Natural Body Brace Co.
223 Rash Building. SALINA, KANSAS



For Children Also



American Poultry Journal

OLDEST, LARGEST AND BEST

3 Months Free All ONE, TWO or FIVE year subscriptions received before Dec. 31st will be entered to commence with the January issue, and the Oct., Nov., and Dec. issues of this year will be mailed FREE. Order today and get them.

1 YEAR 75c. 2 YEARS \$1 5 YEARS \$2.00

Averages over 100 pages per issue. Tells how to feed, house and breed; how to secure high egg production; how to hatch and rear poultry successfully. 4 months trial subscription 25c.

American Poultry Journal, 14-523 Plymouth Ct., Chicago

FREE! ART PICTURES



of Ideal Chickens in Beautiful Natural Colors, 8 x 11 in., suitable for framing. Given only with Poultry Tribune—every issue. World's Great Poultry Paper. Chuck full of money-making ideas, articles, news by foremost poultry authorities. Pub. monthly, 50 to 120 pages. SPECIAL OFFERS

5 Big Trial Issues 25c
1 Year 50c; 3 Years \$1.00

Send stamps or coin today.

Poultry Tribune, Dpt. 41, Mount Morris, Ill.



SQUAB BOOK FREE!

Squabs are selling at highest prices ever known. Greatest market for 20 years. Make money breeding them. No mixing feed, no night labor, no young to attend. Start small, grow big. Start now. Read how our customers sell squabs for \$12 a dozen. We have been established for 24 years. Better look into this. Let us send you, at no cost to you, our big, illustrated free book telling how to make money breeding squabs. Address

Plymouth Rock Squab Co., 634 H. St., Melrose Highlands, Mass.

PLANS of Poultry Houses

All styles, 150 illustrations; secret of getting winter eggs, and copy of "The Full Egg Basket." Send 25 cents. INLAND POULTRY JOURNAL, Dept. 74 Indianapolis, Ind.

STOPS FALLING HAIR

ASK YOUR BARBER OR DRUGGIST

Millions of men, women and children have found the secret of hair-health in "Lucky Tiger"—the world's greatest remedy for falling hair, dandruff and all scalp disorders.

A single application stops that miserable itching. Always sold under a positive Money-Back Guarantee.



LUCKY TIGER

\$90 Drafting Course Free

Mail the Free Coupon Below

There is such an urgent demand for practical, trained Draftsmen that I am making this special offer to deserving, ambitious men. You get your course FREE for getting two additional students. I will teach you to become a Draftsman and Designer, until you are drawing a salary of \$250.00 a month. You need not pay me for my personal instruction or for the complete set of instruments.

\$250 a Month Starting salary according to my agreement and guarantee. Draftsmen's work is pleasant and

profitable. Positions are open paying \$3,600.00 a year in the best surroundings. They are open everywhere. Thousands of men are needed who have just the kind of training I will give you. You can get this training during spare time in your own home.

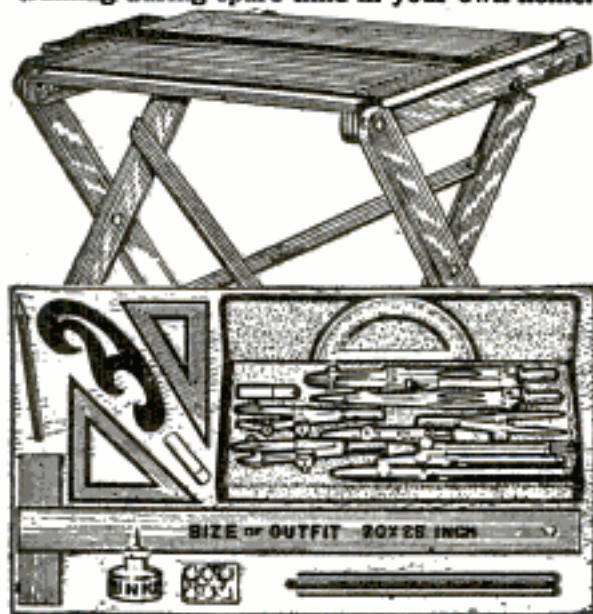

Earn While Learning

You can be earning a handsome income while learning at home. This is a special offer I am making. Absolutely no obligations of any kind in sending coupon. But you must write at once, as I limit the number of my students.

Mail the FREE Coupon at once for my book—*Successful Draftsmanship*, also list of open positions and for the free offer to be earning good money at once while learning at home. This offer is limited and in order to benefit thereby—act at once.

**Chief Draftsman
Engineers Equipment Co.**

1951 Lawrence Ave., Div. 93-59 Chicago, Ill.

Chief Draftsman Will Train You Personally

on practical Drafting-room work Until you are competent and Until you are in a permanent position at a salary paying at least \$250 per month. This is an exceptional opportunity for a few selected ambitious men, between the ages of 16 and 50 whom I will train personally.



I Guarantee

To instruct you until competent and in a permanent paying position at a regular Draftsman's salary of at least \$250 per month and guarantee to furnish you free complete Draftsman's Working Outfit at once from the start.

Free Drawing Instruments Free Drawing Table

These are the regular working instruments and the kind of table I use myself. I give them free to you if you enroll at once. Send the Free Coupon Today.

Free Course Offer Coupon Chief Draftsman Engineers Equipment Co.

1951 Lawrence Ave. Div. 93-59 Chicago
Without any obligation to me please mail your book, "Successful Draftsmanship" and full particulars of your liberal "Personal Instruction" offer to a few students. It is understood I am obligated in no way whatever.



Name

Address

Age

Become an Expert Accountant

The profession that pays big incomes

The demand for skilled accountants—*men who really know their business*—is unceasing. Big corporations are in constant need of expert counsel in matters relating to Auditing, Cost Accounting, Business Law, Organization, Management, Finance. Men who can prove their qualifications in this important branch of business are rapidly promoted to responsible executive positions—given an opportunity to earn real salaries. The range is from \$3,000 to \$10,000 a year—even to higher income-figures.

Train at Home

Under the LaSalle Problem Method

Why let the other fellow walk away with the better job, when right in your own home you can equip yourself for a splendid future in this profitable profession?

Under the LaSalle Problem Method you can acquire a thorough understanding of Higher Accountancy, master its fundamental principles, become expert in the practical application of those principles—this without losing an hour from work or a dollar of pay.

Your training will be under the direct supervision of William B. Castenholz, A. M., C. P. A., former comptroller and instructor, University of Illinois, member of American Institute of Accountants, and a director of the National Association of Cost Accountants. He is assisted by a staff of 75 in-

structors—legal staff, organization and management specialists; business efficiency engineers, including 31 Certified Public Accountants.

Preliminary knowledge of bookkeeping is unnecessary. You will be given whatever training, instruction or review on the subject of bookkeeping you may personally need—and without any extra expense to you. Our big free book on the accountancy profession fully explains how we train you from the ground up, according to your individual needs,

from the simplest bookkeeping principles to the most advanced accounting problems. All text material supplied in the course has been especially prepared in clear, easy-to-understand language, so that you can readily master the principles by home study.

If you are dissatisfied with your present equipment—if you recognize the opportunities that lie ahead of you thru home-study training—you will do well to send at once for full particulars.

The coupon will bring you an inspiring story—"Ten Years' Promotion in One"—of how one man, thru study at home, cleared the path to success; also the true facts about present-day opportunities in Accounting, all without obligation. Our convenient-payment plan places these opportunities within the reach of everyone.

The man in earnest to get ahead will find the coupon just below this text his most profitable aid to progress. It takes but a moment to fill it out and sign and mail it—and the time to START toward greater things is NOW.



LASALLE EXTENSION UNIVERSITY

The World's Largest Business Training Institution

INQUIRY COUPON

LASALLE EXTENSION UNIVERSITY Dept. 1264-HR CHICAGO, ILLINOIS

Please send me your book, "Accountancy, the Profession that Pays," and full information regarding the course and service. Also a copy of "Ten Years' Promotion in One," all without obligation to me.

Higher Accountancy:

Training for position as Auditor, Comptroller, Certified Public Accountant, Cost Accountant, etc.

Other LaSalle Training Courses: LaSalle is the largest business training institution in the world. It offers training for every important business need. If more interested in any of these courses, check here:

- | | | |
|--|---|--|
| <input type="checkbox"/> Business Management: Training for Official, Managerial, Sales and Departmental Executive positions. | <input type="checkbox"/> Personnel and Employment Management: Training in the position of Personnel Manager, Industrial Relations Manager, Employment Manager, and positions relating to Employee Service. | <input type="checkbox"/> Expert Bookkeeping: Training for position as Head Bookkeeper. |
| <input type="checkbox"/> Traffic Management—Foreign and Domestic: Training for position as Railroad or Industrial Traffic Manager, Rate Expert, Freight Solicitor, etc. | <input type="checkbox"/> Banking and Finance: Training for executive positions in Banks and Financial Institutions. | <input type="checkbox"/> Industrial Management Efficiency: Training for positions in Works Management, Production Control, Industrial Engineering, etc. |
| <input type="checkbox"/> Commercial Law: Reading, Reference and Consultation Service for Business Men. | <input type="checkbox"/> Law: Training for Bar; LL. B. degree. | <input type="checkbox"/> Business English: Training for Business Correspondents and Copy Writers. |
| <input type="checkbox"/> Modern Salesmanship: Training for position as Sales Executive, Salesman, Sales Coach or Trainer, Sales Promotion Manager, Manufacturer's Agent, Solicitor, and all positions in retail, wholesale, or specialty selling. | <input type="checkbox"/> Railway Station Management: Training for position of Station Accountant, Cashier and Agent, Division Agent, etc. | <input type="checkbox"/> Commercial Spanish: Training for position as Foreign Correspondent with Spanish-speaking countries. |
| <input type="checkbox"/> Modern Business Correspondence and Practice: Training for position as Sales or Collection Correspondent, Sales Promotion Manager, Mail Sales Manager, Secretary, etc. | <input type="checkbox"/> Modern Foremanship and Production Methods: Training for positions in Shop Management, such as that of Superintendent, General Foreman, Foreman, Sub-Foreman, etc. | <input type="checkbox"/> Effective Speaking: Training in the art of forceful, effective speech for Ministers, Salesmen, Fraternal Leaders, Politicians, Clubmen, etc. |
| | | <input type="checkbox"/> C. P. A. Coaching for Advanced Accountants. |



Name..... Present Position.....
Address.....

EVEREADY Radio Batteries

-they last longer



EVEREADY RADIO BATTERIES FOR EVERY RADIO USE

Each one supremely economical and efficient for the use for which it is designed—each one made under the supervision of the world's greatest electro-chemical battery laboratory

Eveready "B" Batteries

There are Eveready Batteries for portable sets where small size and light weight are more important than long life. There are Eveready medium size batteries that come between the small and the large sizes. There are Eveready large size "B" Batteries that afford maximum economy and reliability of service when used with average one, two, three or four tube sets. And now there is a newer Eveready heavy duty, extra large size "B" Battery that gives similar economy to owners of multi-tube heavy drain receiv-

ing sets and power amplifiers.

For maximum "B" Battery economy, buy Evereadys, choosing the large sizes (Nos. 766, 767, 772) for average home sets, and the heavy duty, extra large (No. 770) for multi-tube heavy drain receiving sets and power amplifiers. For portable sets choose the Eveready No. 764 medium size, unless space is very limited, in which case choose the Eveready No. 763 small size "B" Battery.

Eveready "C" Battery

Eveready makes a long-lasting "C" Battery with terminals

at 1½, 3 and 4½ volts. May also be used as an "A" Battery in portable sets.

Eveready "A" Batteries

Eveready offers you "A" Batteries for all tubes, both storage and dry cell. For storage battery tubes, use the Eveready Storage "A." For dry cell tubes, use the Eveready Dry Cell Radio "A" Battery, especially built for radio use.

Manufactured and guaranteed by
NATIONAL CARBON CO., INC.
Headquarters for
Radio Battery Information
New York San Francisco
Canadian National Carbon Co., Limited,
Toronto, Ontario

BUY THEM FROM YOUR DEALER

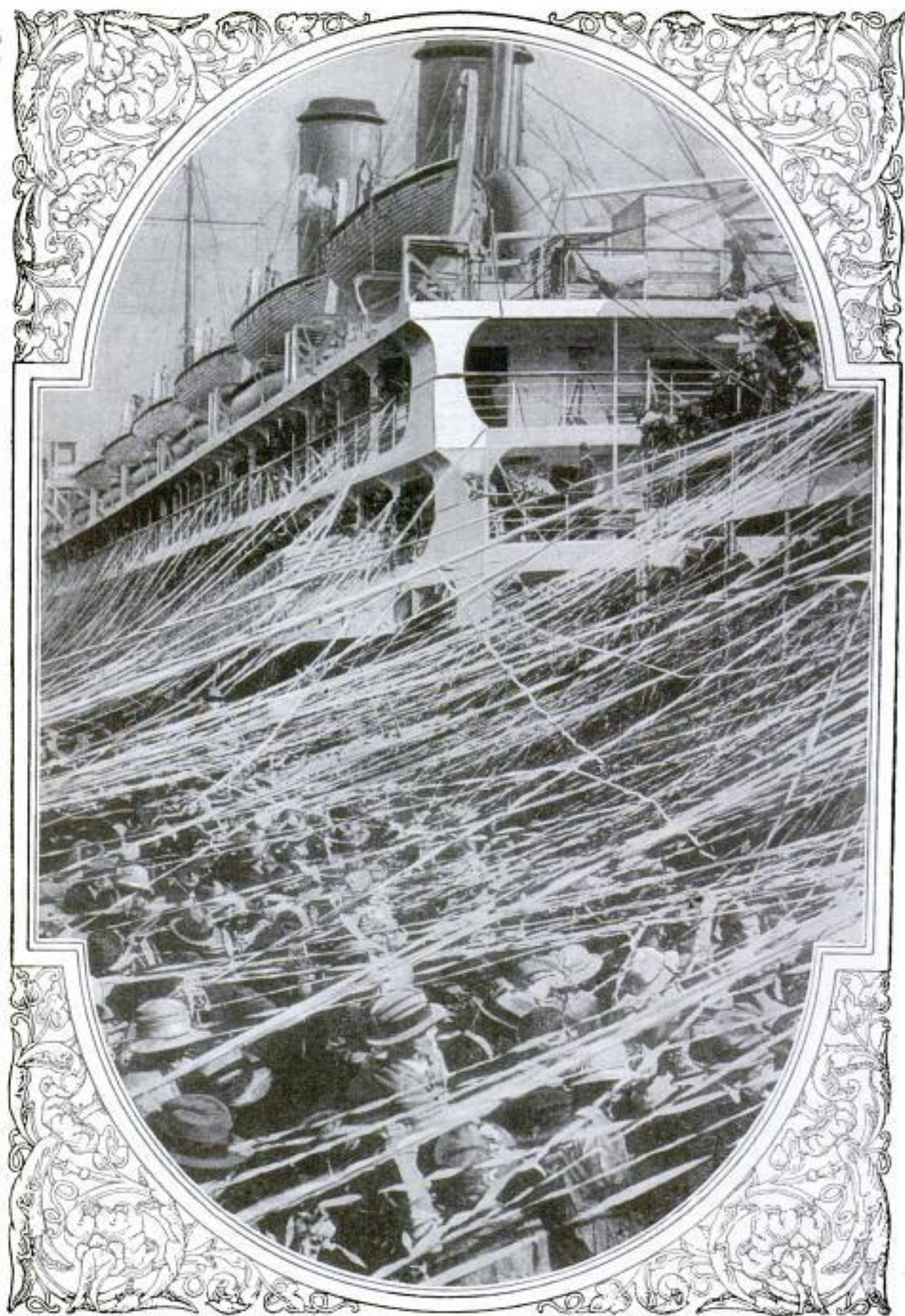

Courtesy The Illustrated London News

Multicolored Paper Streamers Link Liner to Shore at Sydney, Australia; One of the Ceremonies That Mark the Romance of a Ship Putting Out to Sea—See Page 929

Popular Mechanics Magazine

REGISTERED IN U. S. PATENT OFFICE

WRITTEN SO YOU CAN UNDERSTAND IT

Vol. 42

DECEMBER, 1924

No. 6



© U. & L.

Clusters of Amplifiers Suspended above Vast Audiences Clearly Transmit the Voices of Distant Speakers Whose Every Word Is Distinctly Received by Hearers Often Hundreds of Miles Away

Political Spellbinding by Radio *broadcast!*

ONE hundred and ten million Americans will have the opportunity next March of listening to the inauguration of the first ruler of any nation to be chosen after a radio campaign. While thousands heard the three presidential candidates in person, millions more at some time or other during the campaign heard their voices over the radio, and that same opportunity will be extended when the inaugural address is delivered. The old-fashioned spellbinder climbed down off the stump in this campaign of 1924 and settled himself in front of a microphone, and incidentally some of the political speakers had to fit themselves to an entirely new form

of public speaking. Picturesque and vivid personalities are lost on the radio audience. The speaker's individuality counts for nothing, and what he says for everything when the listener is sitting a hundred or a thousand miles away. Words have displaced gestures as vote getters. In the past, no matter how poor the speaker, he usually found that the voters who were interested enough to turn out to hear him would stay to the finish, whether they liked his arguments or not. This year the voter had but to move a dial a fraction of an inch and pick up a jazz band or a dramatic recitation instead. Getting the radio message of the rival candidates for pres-



President Coolidge's Messages Frequently Reach Remote Hamlets through Radio Loud Speakers

identally some of the political speakers had to fit themselves to an entirely new form of public speaking. Picturesque and vivid personalities are lost on the radio audience. The speaker's individuality counts for nothing, and what he says for everything when the listener is sitting a hundred or a thousand miles away. Words have displaced gestures as vote getters. In the past, no matter how poor the speaker, he usually found that the voters who were interested enough to turn out to hear him would stay to the finish, whether they liked his arguments or not. This year the voter had but to move a dial a fraction of an inch and pick up a jazz band or a dramatic recitation instead. Getting the radio message of the rival candidates for pres-

ident before the nation involved a triumph of electrical ingenuity. Only four years ago, in the Harding-Cox campaign, the number of listeners who could hear a public speech had been raised from a few hundred within sound of the speaker's voice, to many thousands, through use of the public-address system of amplifiers.

In four short years, the possible audience has leaped from thousands to millions through the development of radio broadcasting. Herbert Hoover estimates there are 5,000,000 radio-receiving sets in operation in the United States, with an average of three listeners for each. Other experts double those figures.

In the 1924 campaign, beginning with the political conventions in Cleveland and New York, radio, telephone and telegraph facilities were all linked together to carry the speeches from one end of the country to the other, and to England, too, if England cared to listen.

In the convention halls and about the platforms where the candidates addressed the crowds were amplifiers to enable 50,000 or more people, covering several acres of space, to hear every word of the speaker. From the platform delicate microphones carried the speech over telephone circuits to broadcasting stations in far distant cities, where it was put on the air for the listener-in at home.

In some of the broadcasting stations, besides the usual transmission over the customary wave lengths, the speeches

were transformed into a short wave length, at high frequency, and distributed to distant stations, where they were picked up and rebroadcast on a wave length which receiving sets could pick up. The carrier wave of the short-wave high-frequency transmitter is inaudible to the average receiving set, and so did not interfere. In one case, a speech delivered in New York was broadcast through five stations, each getting the program out of the air on one wave length and putting it back on another. Station WJZ had its microphones on the speaker's table and carried the program to the station by direct wire. There it was broadcast to listeners around New York city on a 455-meter wave length, while a lead from the amplifier panel carried it over a land wire to WGY, at Schenectady, N. Y.

From that wire WGY sent the program out through two different transmitters, one on the customary 360-meter length, and the other on the high-frequency 100-meter wave. This wave, inaudible to the listener-in, was picked up at station KDKA, at East Pittsburgh, and broadcast, once on the usual 326-meter length for listeners-in, and again at 98 meters, as a carrier wave to KFKX, a repeater station at Hastings, Nebr., and to 2-AC, in Manchester, Eng. The latter station was linked by wire with six other broadcasting plants, which in turn rebroadcast the speech to their immediate territory. At Hastings, Nebr., station KFKX again transmitted the program on a listener-in wave, and also at 104 meters, to be picked up and rebroadcast once more by station

Battery of Radio Microphones Which Broadcast Important Public Address to Listening Millions

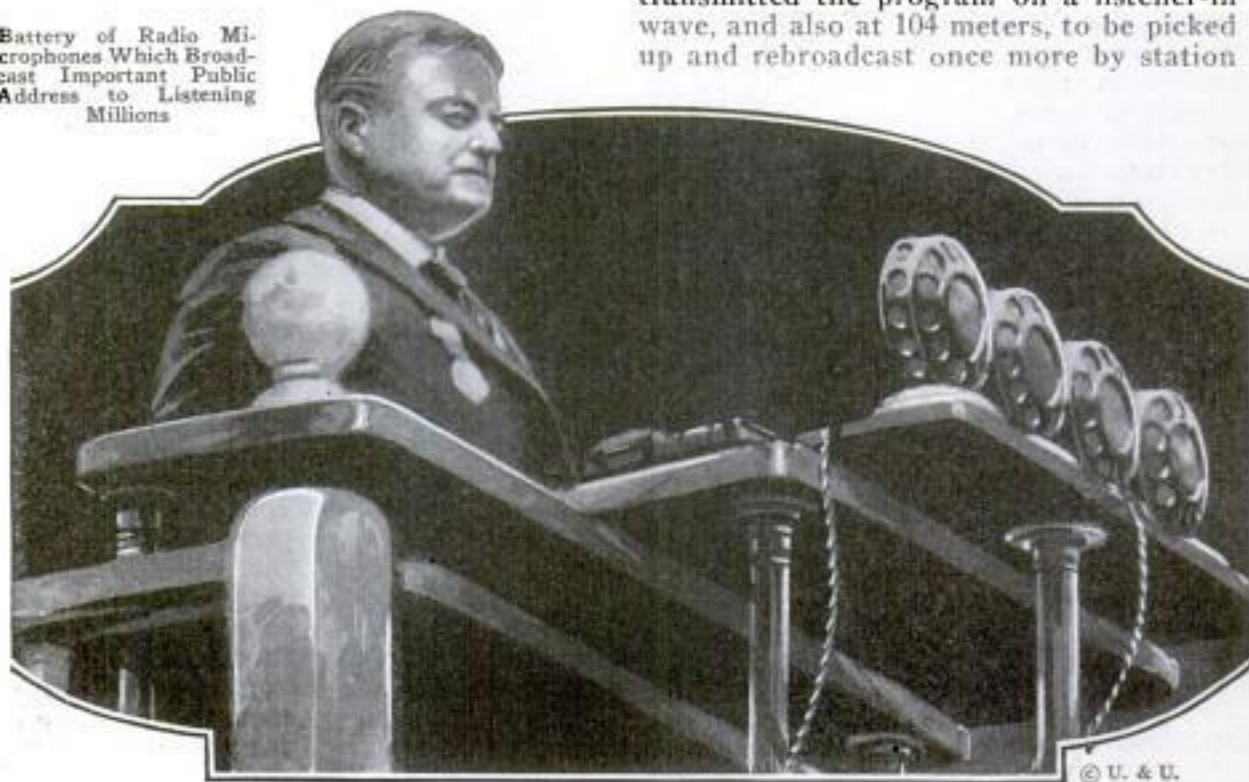

© U. & U.

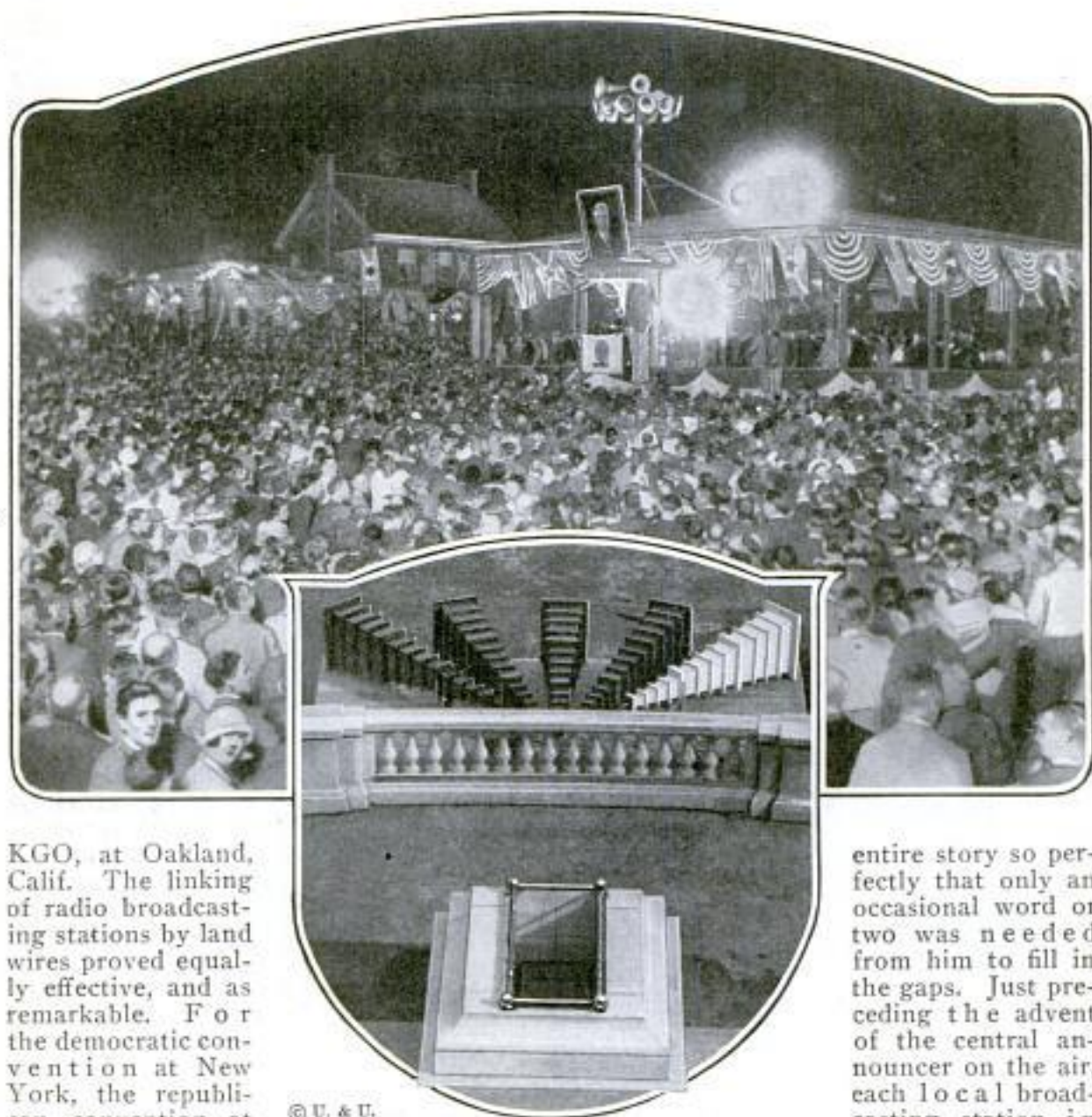

KGO, at Oakland, Calif. The linking of radio broadcasting stations by land wires proved equally effective, and as remarkable. For the democratic convention at New York, the republican convention at Cleveland, and for the principal addresses of the candidates during the campaign no less than

eighteen stations were joined by telephone wires to broadcast the speeches simultaneously. Microphones at the conventions were scattered through the hall, on the speaker's stand, in the galleries, before the band, and in the announcer's booth. Only one microphone was used at a time, but by manipulating a silent switch, the control operator could carry to his invisible audience the speech or music, the rapping of the chairman's gavel or the roars of the crowd.

Swinging from one microphone to another like an organist manipulating the stops of a mighty organ, he put the high lights and shadows of the convention picture into sound waves that carried the

entire story so perfectly that only an occasional word or two was needed from him to fill in the gaps. Just preceding the advent of the central announcer on the air, each local broadcasting station in the far-spread chain made its own announcement.

They were told when by a telegraph wire running from the convention hall.

Once, during the republican convention, the broadcasting was interrupted for a time when a storm struck several Ohio cities, making it necessary to use all available wires to dispatch relief expeditions and bring out the story of the stricken towns. Radio, however, has done more for politics than merely bring the candidate's message to millions. Perhaps its greatest contribution has been the elimination of empty phrases.

A speaker with a vivid personality can say nothing, and say it attractively, but the man who tries to deliver the same speech to the radio, where only words count, is doomed to failure.

© U. & U.

Magnifiers Installed to Aid Orators at Open-Air Assembly to Reach Hearers Hundreds of Feet Away; Below, Speaker's Stand in Arlington Cemetery

TRACKLESS TRAIN PROVIDES HIGHWAY LUXURY

To add effectiveness to an accident-prevention campaign, a luxurious trackless motor train, consisting of a realistic imitation of a steam locomotive and a buffet-parlor car, each equipped with a ninety-horsepower gasoline engine, has been constructed for a cross-country tour.

The coach is slightly more than twenty-eight feet long, eighty-six inches wide, has a wheelbase of 198 inches and is constructed of heavy oak, reinforced with steel. A four-inch flange around the chassis protects it against bumps. The motor, instrument board, pedals and steering parts are cleverly concealed under a buffet cabinet in a forward compartment

that may be used by the driver or turned into a kitchen with an electric stove. Trimmed with mahogany and blue velour, the car is provided with comfortable wicker chairs, folding seats, a bed and writing desks, and is electrically lighted. At the rear is a roomy brass-lined observation platform, and a radio set with a range of 6,000 miles and a concealed aerial is an added luxury. Underneath the coach are four compartments for baggage and tanks for water and air. A feature of the train is the hydraulic-braking installation. This is controlled entirely from the engine, although the coach has a separate brake for use when it is operated alone.

1820

*Lynch's Auto Rental System, d.m.
Indianaapolis, Ind.*

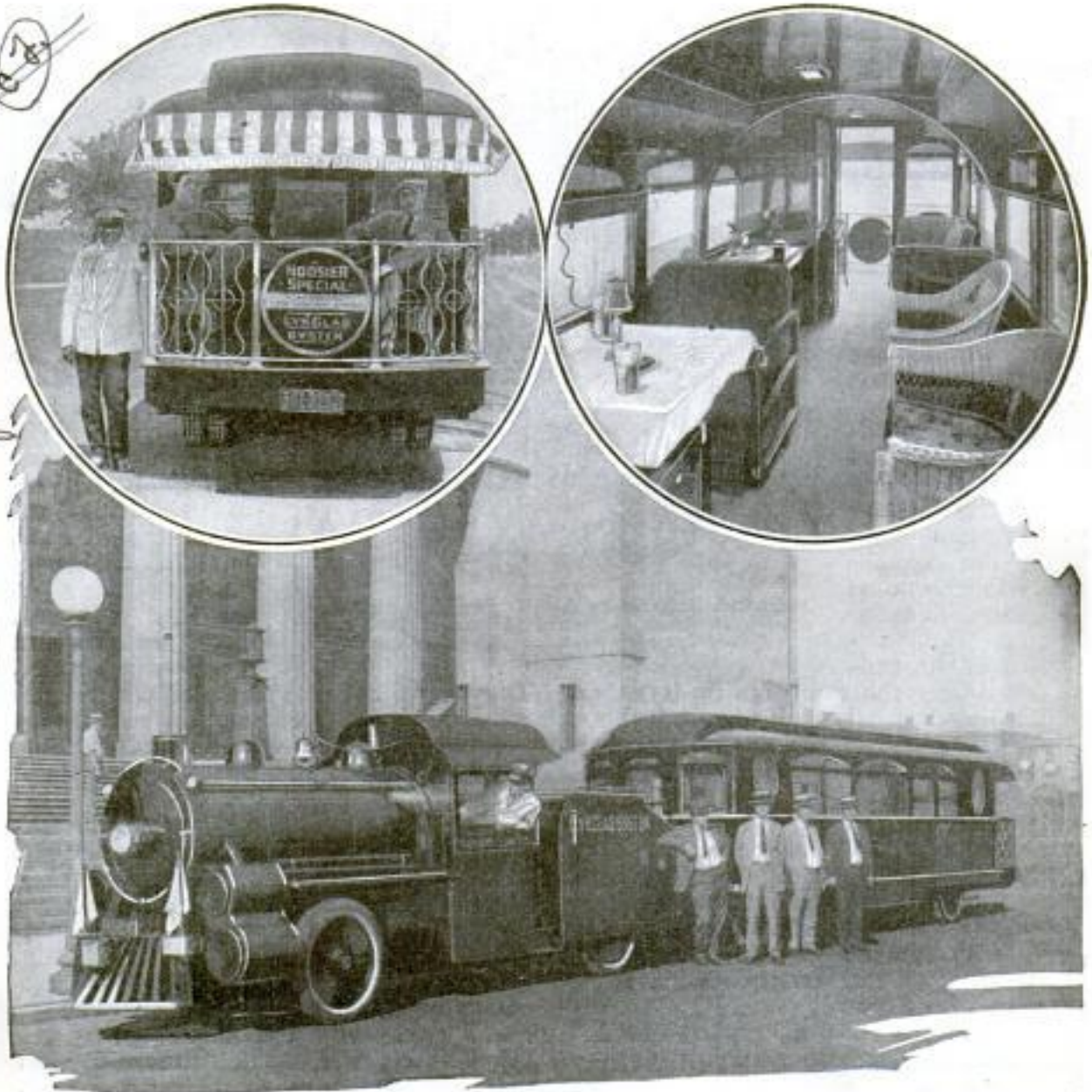

Views of Trackless Motor Train, Showing Realistic Locomotive and Parlor Car Luxuriously Equipped with Easy-Chairs, Roomy Tables and Observation Platform for Cross-Country Safety Tour

Big Coal Deposits Found in Arctic Five Hundred Miles from Pole

Coal beds twenty-five feet in thickness were found only 520 miles from the North Pole, by Capt. Donald B. MacMillan, on his trip to the far north. The deposits, however, are not available for immediate use, being 800 miles beyond reach of any transportation except by dog sled. The presence of the coal, however, proves that the far north was once covered by heavy vegetation. Shifting of the earth's poles, bringing down succeeding glacial areas, produced the change. Dr MacMillan found evidence that such a shift is going on now. The glacial ice cap is growing thicker and advancing farther every year, he reports, and has been doing so for over seventy years. Within his own experience in the arctic, inland glaciers have advanced to the sea, producing more icebergs each year.

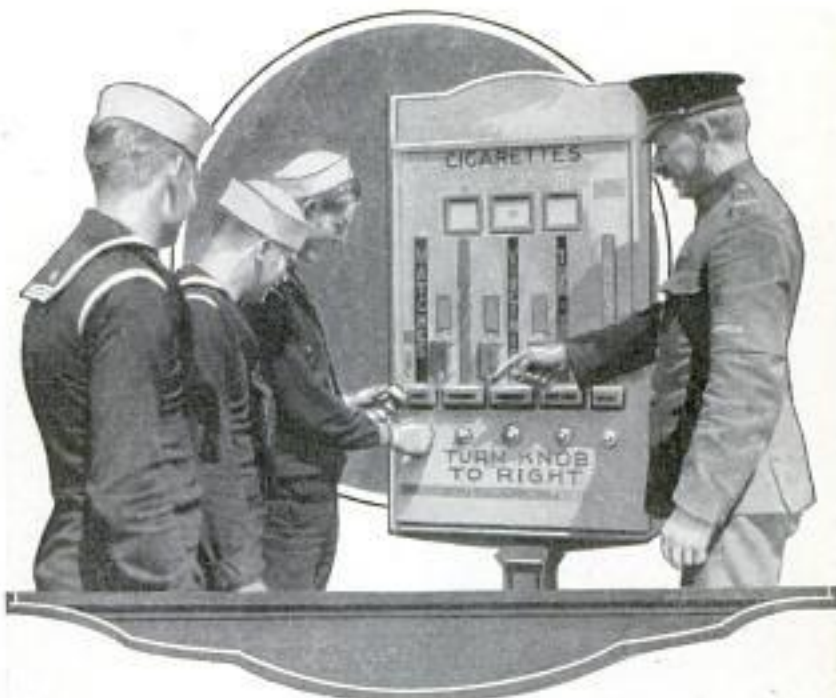

Visiting American Sailors Learning to Operate the Cigaret Slot Machine

Slot Machine Serves Cigaretts When Stores Are Closed 1842

Slot machines for vending cigarette and matches in London are a welcome novelty to visitors. The mechanism is operated

in the usual way by inserting a coin and turning a knob. There are spaces for different grades of tobacco.

Typewriter with Piano Keyboard Helps in Transcribing Music 1856

Copying music from the composer's notes is said to be greatly simplified with a typewriter arrangement devised by an eastern inventor. It consists of a portable keyboard, an exact duplicate of that on a piano, and an electrically operated transcribing apparatus somewhat similar to the mechanism of a regular writing machine. To operate it, the keyboard is placed on the piano or on a table or desk, and as it is "played," the notes are transcribed on a roll in the recording instrument.



Copyright, Keystone View Co.
Music Typewriter with Its Portable Piano Keyboard

Odor of Metals Due to Gases 1794

Experiments have been made to prove that metals have odors composed not of the atoms of the metal, but of the products of their chemical changes. At ordinary temperatures the odors frequently could not be detected or were almost imperceptible, but became more pronounced as the metal was heated, and then disappeared after the heating had been continued for a considerable length of time. The experimenters also have succeeded in isolating the odorous matter.

St. Joseph's News Press 8/18/24

Chas. Lev. Moritz Stoehr
Prof. of Bacteriology, Mt. St. Vincent College
New York City

1939

Night Golf with Luminous Balls Played on Lighted Course

Using balls and hole pins coated with phosphorescent paint, players of night golf now follow their drives almost as easily as in the daytime. The cups on the greens are indicated by luminous standards which are visible in darkness at great distances, while tees are marked with incandescent bulbs on upright sticks. The same implements can be used for both

Mimic Train Robbery Tests Mail Car Equipped to Repel Bandits

By staging a modern night holdup of a mail train to test the efficiency of a postal car equipped for defense against robbers, government officials proved the ability of the occupants to fight off attacks of bandits with little danger to themselves or the postal matter carried. The scene of the mimic battle was laid along an isolated section of the New York Central railroad,

and was selected for its resemblance to territories where genuine robberies have occurred in the past. When the band opened their attack on the car the clerks within inserted bright, automatically lighted flares through holes in the steel sides, illuminating the ground for several hundred feet around and bringing into view every one of the opposing figures. Wired, bullet-proof windows foiled attempts of the "robbers" to make an opening into the interior, while swivel, shot-proof loopholes enabled the defenders to pour rifle fire in almost any direction. To drive off any assailants who might run in close to the car and crouch out of range of the loopholes, a cone-shaped steel spreader fastened to the bottom deflects



Popular Movie Stars Playing Night Golf with Luminous Balls They Drive to Greens Marked by Phosphorescent Hole Pins

daylight and evening games, as the paint does not easily wear off. Besides aiding players to keep in good form, night games increase playing time for those otherwise limited to the early evening hours.

Collapsible Metal Air Chambers to Make Ships Nonsinkable

Working models of a device using collapsible metal chambers intended to keep ships from sinking in storms, collisions or by explosions or torpedoes have been demonstrated in the east. Their inventor claims that they can be installed on a vessel without sacrificing any of the space used for essential purposes and at a cost not greater than the amount of one year's insurance on the ship.

bullets fired from within through an armored hole in the floor, scattering them on a level with the attackers' legs. It is said the imitation holdup resulted in the "entire destruction of the highwaymen." Hundreds of rounds of blank cartridges were used in the test, and six men made up the bandit gang who first boarded the locomotive and "overpowered" the engine crew before rushing the armored car. Motion pictures of the affair were taken for future study of robber tactics. So successful was the defense on the part of the postal clerks in charge of the car that, it is reported, 3,000 mail cars are to be fitted with similar apparatus to prevent losses from banditry in the future.

☐ America imports about \$20,000,000 worth of bananas a year.

Christian Science Monitor

9/16/24

1810
Keystone Video Co.
1917th Ave. New York City

d.w. Ad on theobolias.
no address.



Bright Flares Projected from Inside the Car Illuminate the Scene of Attack



Postal Clerk Firing Repeating Rifle through Swiveled, Armored Loophole



"Bandits" Attempting a Rush on Car to Avoid Shots from Swivel-Gun Holes



Deflector Which Scatters Shots Fired through Opening in Car Floor

Staging a Mimic Battle between "Bandits" and Crew of Armored Mail Car to Test Ability of Defenders to Prevent Robberies

Skeleton Is Adopted as Symbol by Fliers of "Jinx" Air Fleet

902 To show their unbelief in the influence the squadron number thirteen may have on the luck of the unit, aviators of the



Flier of Thirteenth Air Squadron and His Plane Adorned with Skeleton Insigne of "Jinx"

organization have adopted the skeleton as their insigne. Each airplane is adorned with a large, bright painting of the "grim reaper," scythe in hand, which can be readily seen at considerable distance. One of the craft bearing the symbol was successfully piloted through a severe storm and landed at the home field without damage to operators or ship.

1878

Steam at Twelve Hundred Degrees Drives Torpedo's Power Plant

In the small but mighty steam-power plant that sends torpedoes plunging through the seas, engineers see possibilities of vastly increasing the efficiency of stationary plants in industry. Tremendous obstacles are in the way and the whole matter is largely theoretical. However, during the last decade there has been an average yearly increase of about fifteen degrees steam temperature in land use and the rate for the future is expected to be more rapid. The torpedo power plant weighs only twenty pounds, and its boiler is about eight inches long. It operates with steam heated to 1,200 degrees Fah-

Power 9/9/24

renheit at 350 pounds' pressure. When it is remembered that iron gets cherry-red at this heat and can be shaped with a blacksmith's hammer, the fact that this diminutive power plant can function at such high pressure and develop between 100 and 200 horsepower with its tiny turbine, is considered all the more remarkable. A mixture of air, compressed to 2,600 pounds to the square inch, and water is directed into a flame of atomized alcohol to generate the steam. To prevent overheating, water is sprayed into the mixture after combustion has occurred. This brings the temperature from 1,600 degrees, which would otherwise be developed and could not be used, to about 1,200 degrees. The heated gases escape at the top of the chamber to the turbine wheel which is about eleven inches in diameter and is turned at 11,000 revolutions per minute. Unlike stationary plants, this small unit is required to operate only for about five minutes at a time. Its life is only from fifty to 200 hours without repairs, and efficiency has not been a special objective as is the case in larger turbines. Furthermore, the cooling effect produced by the water in which the torpedo is submerged, would be difficult to realize in a land plant.

42-25 per hour

Snow Skates to Add a New Thrill 1337 to Winter Sports

Skates for use in snow have been designed to add another thrill to the list of winter sports. Strongly constructed of straight-grained hickory treated with oil, they are said to hold the weight of the heaviest adult while being light enough not to tire children. The runners are of rustless steel and the top is covered with corrugated rubber to provide a non-slip surface. The skates are attached to ordi-



Snow Skates Attached to Ordinary Shoes with Rawhide Straps Are Held on Firmly

nary shoes with rawhide straps and may be used more months a year because there is no waiting for ice.

Hayfield Knoll Co.
182 Elmwood St.
Pittsboro, N.C.
Copyrighted material

New York Times
9/18/24

Ruins of Pompeii Rivalled in City Found beneath Sahara Sands, 1871

Excavations now being made on the site of Leptis Magna, an ancient Roman city buried hundreds of years ago under the sands of Tripoli, are revealing relics surpassing in grandeur and in state of preservation those found at Pompeii, according to Dr. Bruno Roselli, professor of Italian in Vassar college. Besides beautiful statuary of the highest type, palaces and luxurious baths, ruins of a fine Roman harbor, the first of the sort ever to have been discovered, already have been dug out. The city was the birthplace of the emperor Lucius Septimius Severus who ruled Rome in 300 A. D., and it once held from 100,000 to 300,000 inhabitants. Following its decline and the coming of the Arabs, who did not molest it except to remove forty huge stone columns for the construction of a desert mosque, sands and earth-

Gold-Plated Stones on Skyscraper Add Beauty to Structure, 1843

Lifting its somber bulk above the sidewalks of an eastern city, a big building constructed almost wholly of black brick

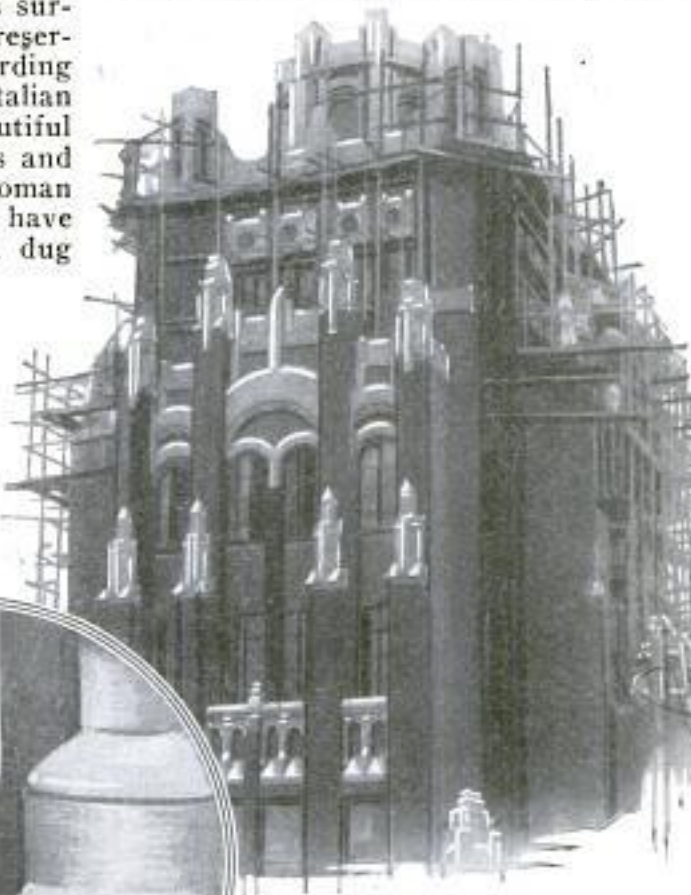

American Radiator Co. Bldg.
New York City

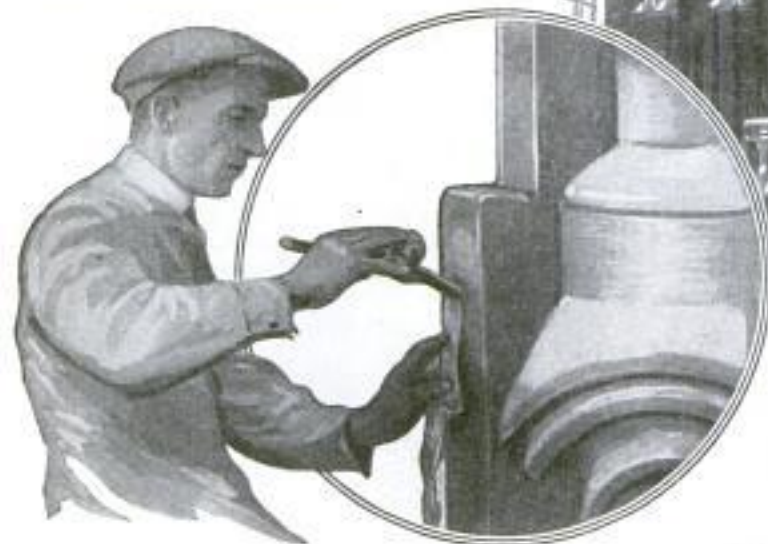

Applying the Gold Leaf and View of the Shining Trimmings

is given a striking color relief by the brilliant gold surfaces of the masonry trimmings. Real gold leaf was spread upon the stone by an improved process, which employs special brushing machines. Coatings of varnish were later applied to make the plating waterproof.

quakes contributed to its ruin and it was finally swallowed up. Only the tops of the columns were left protruding and these were discovered eighty years ago. Not until after the world war, has excavation been attempted on any large scale. Among the buildings that have been uncovered are the palace of the emperor, warehouses that held grain for shipments to Rome and a number of dwellings.

The construction of the harbor is being studied with great interest as, up to this time, archæologists are said to have been puzzled as to the methods used by the Romans in building their quays and docks. The work of removing the sand is being done by Arab prisoners of war and is expected to be completed in two years.

Clock without a Face, 1881

Striking the hours on the bell of the church over which it is hung, a wooden clock without face or hands has counted time for a London community for nearly 400 years. Made by a village blacksmith in the sixteenth century, the timepiece is of the crudest type but strongly constructed throughout. The winding gears are cut from heavy oak, and iron is used for the bearings. Recently some new metal parts and striking pins were placed in the clock which, experts declare, should continue to give accurate time for years.

Tit Bits 9/13/24

Mirror Signboard at Sharp Curve Prevents Auto Accidents

For the protection of motorists at a dangerous curve on an English highway, a large double mirror has been erected.



As Car Nears Curve, the Big Signboard Mirror Warns the Driver That Another Is Approaching

It is set at such an angle that traffic approaching from either direction is visible at some distance to a driver going toward the curve so that he has ample time to turn out or slacken speed. The arrangement is said to have reduced the number of accidents at this spot.

Heat of Breath Is Able to Release Power to Lift Many Tons

For automatic control of steam pressures, temperatures of rooms, electric currents and other factors, a mechanical regulator that takes the place of a man in a large industrial plant has been invented by a Swedish engineer. It is so sensitive that the breath of a child directed into a funnel or the heat from a man's hand held several inches away, will cause it to release sufficient energy to lift many tons. Its secret is based on the expansion and contraction of a strip of ebonite by heat or the swelling and shrinking of bands of cotton threads under different changes of

humidity. These slight movements actuate the end of a lever controlling hydraulic pressure that opens or shuts the proper valves.

Elevators' Speed Set by Machine That Serves as "Traffic Cop"

Skyscraper elevators can be built to operate in safety at mile-a-minute speed, but are not because the passenger's inner economy is not built to stand such sudden drops. Instead, about 600 feet a minute, or a mile in seven minutes, is the highest practical working speed. The makers, however, do not rely upon the inner feelings of passengers to regulate the speed. An automatic governor acts as "traffic cop" to keep the operator from exceeding the speed limit. Elevators, incidentally, start and stop much more quickly than vehicles traveling horizontally, and can reach maximum speed within a few feet.

New York Times 9/21/24

Pneumatic Tire for Giant Aircraft Will Support Ten Tons

Constructed to withstand a load of ten tons when inflated to a pressure of seventy-five pounds, what is said to be the largest pneumatic tire in the world has been completed for the United States army air service. It is sixty-four by fourteen



There's Room for Young Woman, and Some to Spare, in Giant Aircraft Tire

inches and it is expected that it will be used on the alighting gear of large airplanes.

*Photogram News Service
129 E. 27th St. New York*

*Dr. S. wedisch engineer
Magnar Carlstedt*

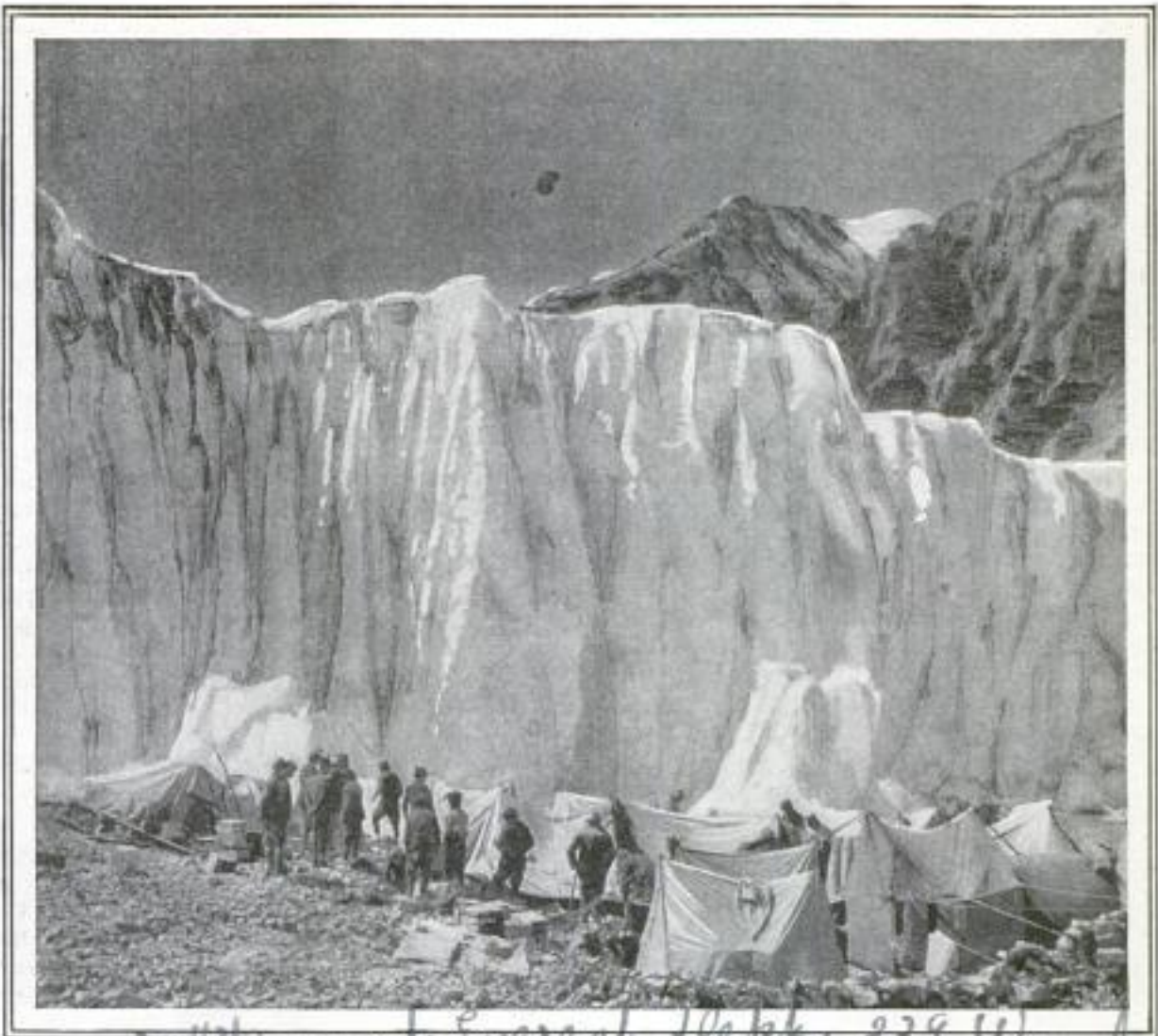

Copyright, The Times
 Explorers' Supply Camp Built on Solid Ice at "Top o' the World" Where Glacial Walls and Jagged Peaks Form Barriers to Perilous Climb toward Everest's Cloud-Draped Summit

New Climb Planned to Conquer Everest

Explorers, Undeterred by Loss of Two Companions, Determined to Go Back Again to Scale the Roof of the World

UNDAUNTED by the tragedy that claimed the lives of two members of the 1924 Mount Everest expedition, the survivors are already preparing for another assault on the highest peak of the world, to be made in 1926. Swiss alpine climbers also are planning an expedition, but will make the attempt in 1925 in an effort to beat their English rivals.

With both the earth's poles visited, the deserts crossed and lesser mountains scaled, Everest alone continues to defy man's efforts. Rearing its head 29,002 feet above sea level, the great peak was thrown open to mountain climbers after the war,

when, in 1920, the Dalai Lama issued permission for an expedition to attempt the ascent. On his warrant the mountain is given its Tibetan name, Cha-ma-lung-mo, meaning "the place where it is so high that even a bird goes blind when he gets there." Acting on this permission, the first Everest expedition went out in 1921, ascended to a height of 22,000 feet and brought back valuable maps and data—but left one of its members in a grave in a 17,000-foot pass, the first victim to the high altitude. In 1922, the second expedition, following the same trail, pushed farther ahead and three men, including George

Leigh Mallory, reached a height of 26,800 feet, while two others, armed with oxygen tanks, climbed to 27,300 feet, less than half a mile beneath the mountain crest. In the thin air at such extreme altitudes the burning sun threatened the climbers with sunstroke while their feet were being frostbitten on the glacial ice and snow. Before the work could be completed the dreaded monsoon season set in and terrible snowstorms swept across the mountain face, followed by warm winds from India which melted the snow and sent avalanches cascading down the slope. One avalanche swept seven Tibetan porters to their death and the expedition was forced to retreat. The third expedition, in 1924, was equipped with better oxygen apparatus and supplies, while the backbone of its man power was Mallory and other veterans of the preceding climbs. After heart-breaking effort, a camp was pitched at a height of 27,000 feet. Several efforts to scale the peak were frustrated by bad weather, and finally Mallory, the veteran,

and a young college student named Irvine attempted the dash for the summit. Later the same day, when the clouds on the peak lifted, their companions at the 27,000-foot camp saw the two toiling up a little ridge at the 28,200-foot level, barely 800 feet below the summit. Then the storm clouds closed in—and they were never seen again. Whether they actually reached the summit, and perished

there of cold and hunger, succumbed to exhaustion on the ridge, or fell into some glacial crevasse may never be known.

Doctor Somervell, who with Col. Norton, commander of the 1924 expedition, reached the 28,000-foot level, says the effort required to move at that height is almost beyond comprehension. In order to take a single step forward a man must first take ten deep breaths to get enough oxygen into his lungs. Each step, he says, is equal to the exertion required for a 100-yard dash at sea level.

Despite the difficulties, veteran climbers of the Alpine club are confident that Everest will be conquered. Hundreds of volunteers have offered their services for the next attempt, but only the pick of the world's athletes are eligible. The members of the expedition must practice constantly to keep in trim, and even a brief rest entails months of hard work to get back in condition.

While lecturing in America raising funds for the third expedition the ill-fated

Mallory astonished crowds by climbing up fire escapes, hanging from the lower side by his hands. That was only part of his daily exercise. He suggested at that time that it might be necessary to send an expedition to live on the slopes of Everest above the 20,000-foot level for a year or two to thoroughly acclimate themselves.

But the natives living near by are sure the spirit of the mountain will never be conquered by man.



© The Times

Monument Erected near Base of Mt. Everest in Memory of Intrepid Scientists and Faithful Porters Whose Lives Were Lost in Three Expeditions

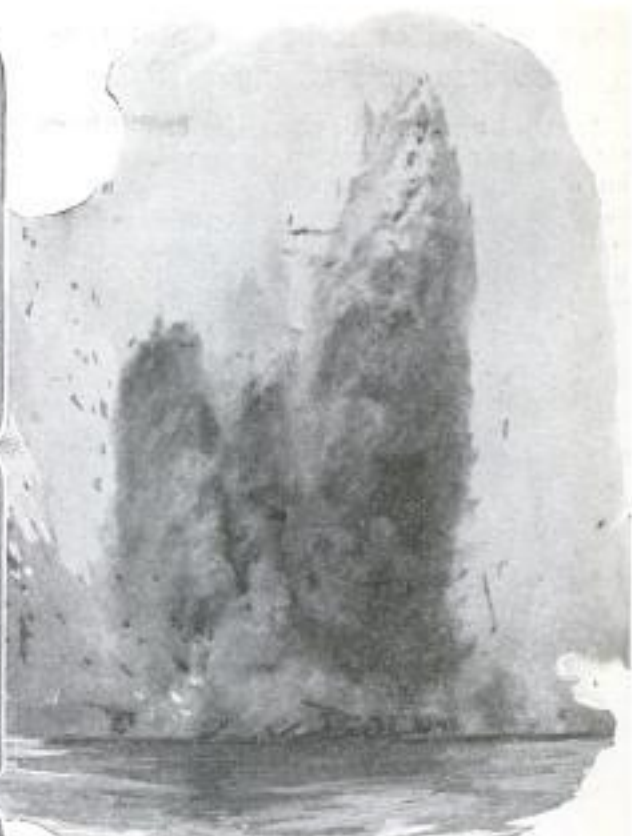

Copyright, Underwood & Underwood

Old Crib before the Blast; Unpacking the Dynamite; and Geyser That Crashed Skyward When the Heaviest Charge Exploded, Leaving Only a Heap of Crumbled Ruins

Six Thousand Pounds of Dynamite Used to Destroy Lake Crib

Wreckers employed to destroy an abandoned water crib, two miles from shore in Lake Michigan, saved much time and labor by setting off six thousand pounds of dynamite under the brick and stone. Several shots were fired, a final charge lifting tons of water and debris high into the air and reducing the ancient structure to a heap of crumbled ruins. The shots were fired by electrical means.

Blackboard Tilts to Ease Eyestrain on Pupils in Classroom

By tilting the schoolroom blackboard on a patented shaft holder, glare is eliminated and students are spared the eyestrain frequently caused by improper lighting. The apparatus can be quickly fitted to any board and is so adjusted that a child can tilt a heavy length of slate to the proper angle with the aid of a wheel on the bottom. With this device, it is not necessary to darken the room to stop the glare.

Grass Growing by Electricity

Electric lights have been used successfully at the Jumping Brook golf club, in New Jersey, to grow grass on the greens at night, and thus shorten the delay in putting the course into service. Grass lighted at night grew four inches in three weeks, while grass on the unlighted portion of the green grew but one inch in the same period. Twenty-four thousand-watt globes with special reflectors were hung four feet from the ground to give a continuous, even spread of light. On the lighted portion the seed came through in five days, while seed sown on the unlighted part of the same green did not germinate until two days later.

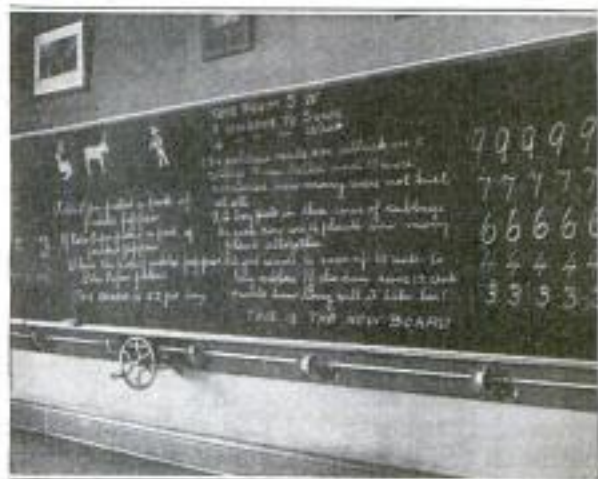

Blackboard Tilted to Give Proper Light and Aid Vision of Students

Electrical Review
9/12/24

A. W. Thomas Mellor
2513 P. Vincennes Ave.
Brandon, Manitoba, Can.

Spare Wheel at Rear of Car Solves Problem of Parking in Jam

So that automobiles may be easily handled in parking jams, a device has been

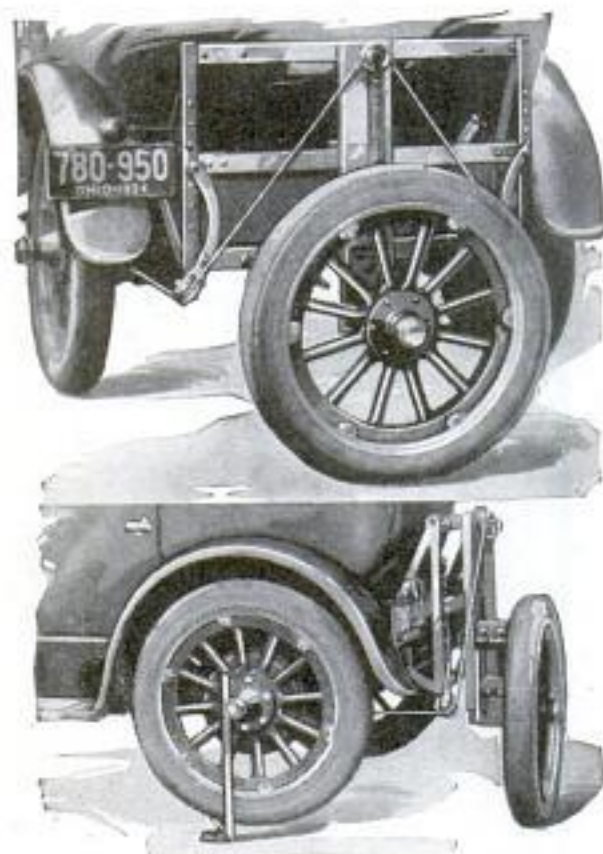

Views of Spare Wheel Used as Rudder to Steer Car in Traffic Jams

invented which makes use of a spare wheel carried on the rear of the machine. Special apparatus attached to a lifting jack, which is connected by wires to the instrument board, holds the wheel. When the car cannot be driven forward or backward, a turn of the lever will cause the jack to lower the wheel, raising the back of the car a few inches from the ground. Another switch makes the spare revolve to the right or left as desired, swinging the rear of the car to an angle of forty-five degrees from the line of parking. The machine can then be easily backed out. A pulley and cable attached to the motor furnish the power for both operations, which require but a minute.

☐ Telephone-line trouble shooters, searching for the cause of the failure of two trans-continental wires in Nevada, discovered that an eagle had built its home between the lines. Pieces of metal among the material of which the nest was built had caused a short circuit.

Growing Importance of the Tin Can 1869 Is Proved by Figures

In the light of its utility, the lowly tin can is considered one of the most important articles in modern commerce. Largely because of its efficiency, the canning industry with its millions of invested capital is possible and the United States is able to export products to all parts of the world. The value of canned foodstuffs that passed through ports of continental America in 1923 exceeded \$100,000,000, nearly four times that of the year before, while the total output for local consumption was more than a billion dollars. Canned peaches from the United States are now shipped to 100 different countries, salmon to eighty-five and beef to eighty. At the beginning of the can-manufacturing business, the work was done by hand and sixty were considered a good day's work for one man. Now, a large factory can turn out 9,000,000 a week.

Waste Steam Used in Advertising 1962 Shows Coffeepot Boiling

Waste steam from the exhaust of a laundry in a southern town has been put to good use for advertising to call attention to a display announcing a brand of coffee. The sign occupies one whole side of the laundry building and depicts two children seated at a breakfast table while from the spout of a large, mock percolator, the fumes of steam piped to the nozzle



Cozily Steaming from Laundry Exhaust. This Coffeepot Attracts Attention to Sign

from the exhaust catch the eye several blocks away and forcibly emphasize the advertisement of the coffee.

Hot Smith Coffee Co
Hot Smith, Ark. Copyrighted material

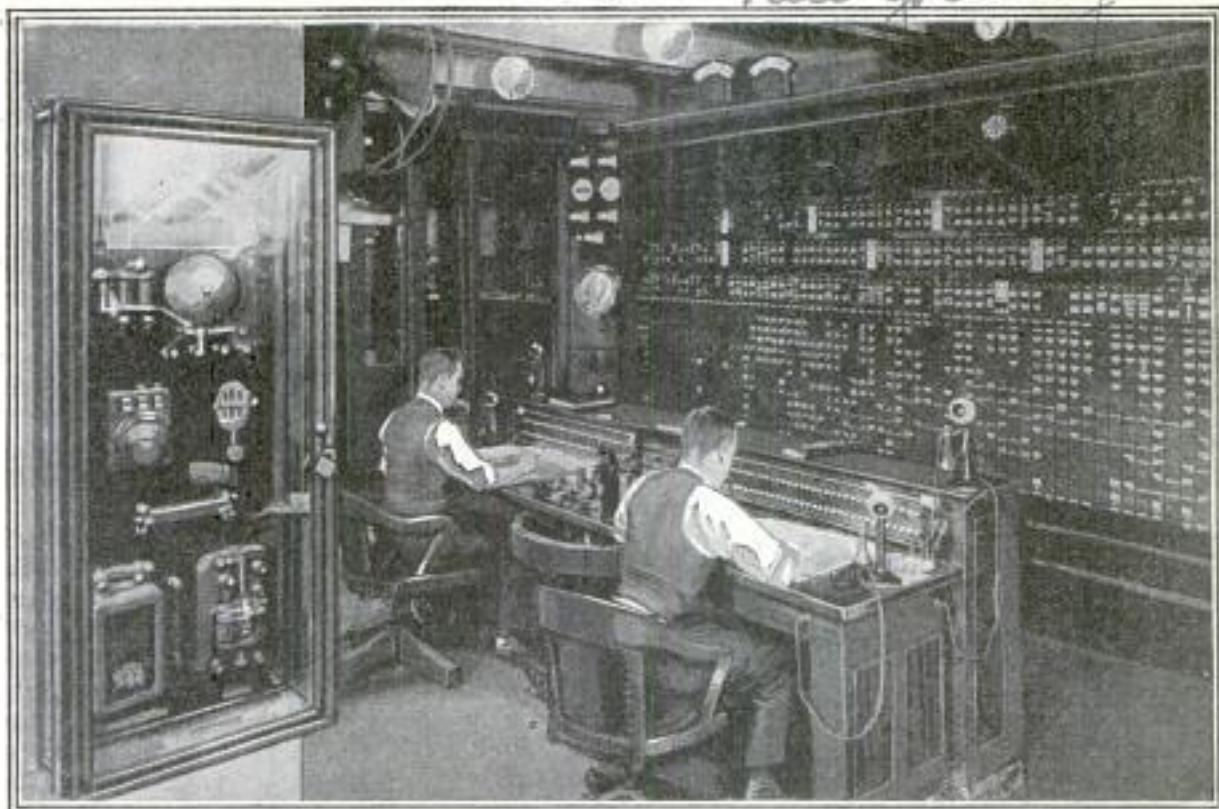

Power Dispatching Board in Big City Electric Plant; Lighted Signal Lamps Indicate to Operators Where Current Is Needed and Where It Is Available for Immediate Transfer

Radio Static Used as Weather Warning

Wireless Fan's Jinx Harnessed by Power Company to Tell in Advance When Rain Clouds Will Increase Demand for Lights

STATIC electricity, the bugbear of the radio fan, has been harnessed in a big electric-light plant to give automatic warning, hours in advance, of an approaching storm whose dark rain clouds will cause a sudden demand for an enormously increased volume of current.

The radio storm detector has replaced an observer who formerly was employed to stand on the roof and watch for approaching clouds. Besides being automatic in operation and costing little, as compared with the observer's salary, the wireless weatherman is far more efficient, because it can announce storms long before the first signs are visible to human eyes. Without some system of weather observations the arrival of every summer storm would be accompanied, in large cities, by a sudden drop in the candle-power of electric lights. Unlike gas and water—physical materials that may be stored up for emergency use—electricity is manufactured only as needed. In a big steam plant it takes some time to put reserve boilers into service and get sufficient

steam to start additional generating units. Unless these preparations have all been made in advance, the normal operating equipment could not carry the load when thousands of additional lights are turned on in homes and offices to dispel the storm darkness.

The radio warning is based on the fact that summer storms are accompanied by electrical disturbances covering a much larger field than the storm itself. These static manifestations are so strong that they whistle, wail and howl through the earphones or loud speaker of a receiving set and drown out ordinary broadcasting.

In converting the static into signals, an ordinary antenna mounted on the roof of the power house is used, while the detector itself consists of a short-circuiting switch, spark gap, coherer, relay and battery; a bell, which also acts as a decoherer; a condenser and a ground connection. The oscillating current set up by the static travels to and from the ground through the spark gap, coherer and condenser. The outfit is arranged so that the

bell automatically varies its signal as the storm approaches. From two to five hours before it arrives, the bell rings at intervals of from five to fifteen minutes. The difference in the advance signal depends on whether the storm is following a straight or roundabout course. The operator in charge of the lighting system regards the ringing at intervals merely as an advance warning, and pays no further attention to it, for it is always possible that the storm may change its direction and pass around the city.

As the clouds approach, however, the bell rings oftener, until, when the storm is less than two hours away, the bell begins striking every half minute. The reserve boilers are then ordered into service, auxiliaries of additional generating units are started, and the generators themselves begin turning over at low speed.

A half hour before the storm is due, the bell unites its periodic strokes with a continuous ringing, though the sky may still remain clear as far as the eye can see. The operator, however, orders the reserve generators synchronized with the service bus wire and prepares to carry the storm load, at the same time short-circuiting the detector to protect the instruments against lightning. A chart record of the bell's operation shows how it worked for a storm which struck the city one day last August. At 8:25 a. m. the signal began tolling every three to five minutes, and kept up that rate until 2:00 p. m. At 2:02, with the sky slightly overcast and the system load totaling 280,000 kilowatts, the bell changed to half-minute intervals, and continued that way until 2:15 p. m., when it began ringing uninterruptedly until it was short-circuited at 3:20 p. m. At 3:45 the

storm broke, and the load jumped from 280,000 kilowatts to 420,000 kilowatts. The big generating plants supplying large cities carry an enormous lighting load, which varies by hundreds of thousands of kilowatts at different hours of the day and night. A single one, recently completed on the Mississippi, can light 9,500,000 average-size lights. Some idea of the magnitude of the load carried by one of these plants is gained when it is understood that this middle-western installation has three times the year-around power that the great Muscle Shoals water-power project will develop. It consumes a ton of coal every half minute, and uses 600,000,000 gallons of water a day.

To manufacture the enormous electrical current needed, the last bit of heat value must be extracted from the coal, and for this purpose the fuel is ground to a fine powder that looks and flows like fuel oil. In the furnace this dust acts like gasoline in a carburetor, giving up its heat so completely that instead of the usual cloud of smoke only a thin haze is seen above the tall stacks of the plant.

**Needle-Finding Button Saves Cloth
868 and Simplifies Sewing**

With a sloping back and large, bell-mouthed perforations, a novel shape of button has been patented to ease the sewer's task and lessen the strain on the cloth. It is so molded that the needle slides easily into the holes on the back side, eliminating useless jabbing. The thread is more widely distributed over the cloth, the inventor claims, and this tends to decrease the pull on the fabric and, therefore, to bind the button more securely.

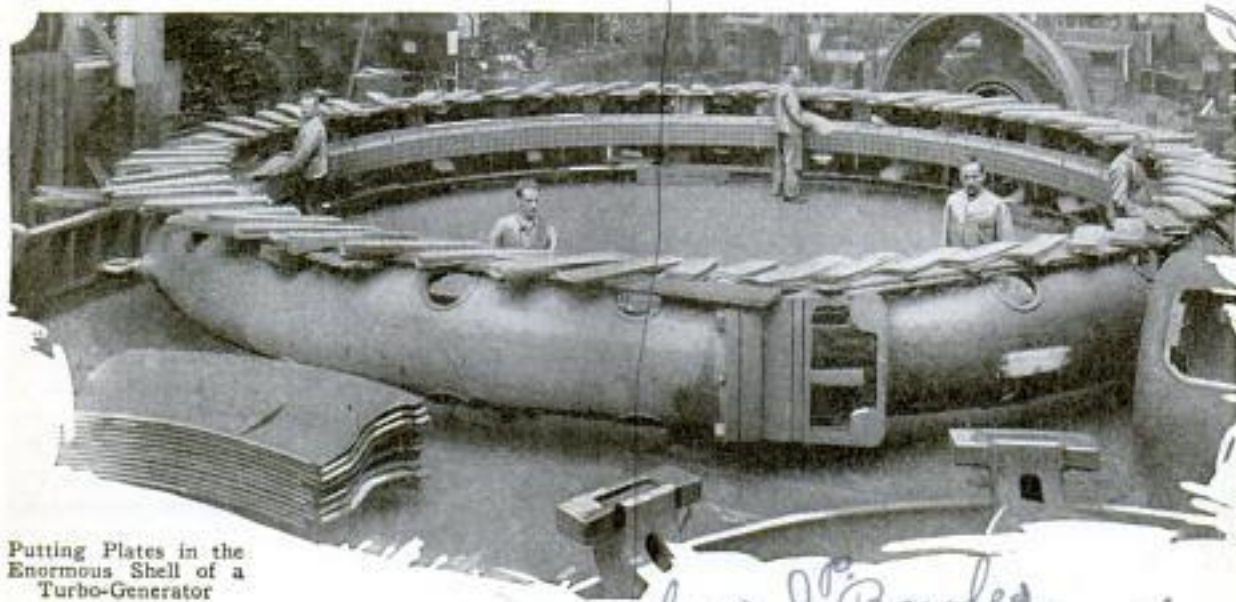

Putting Plates in the Enormous Shell of a Turbo-Generator

*Chas. J. Bowles, 531
Clove Road,
West New Brighton, N.Y.*

Clove Road, West New Brighton, N.Y.

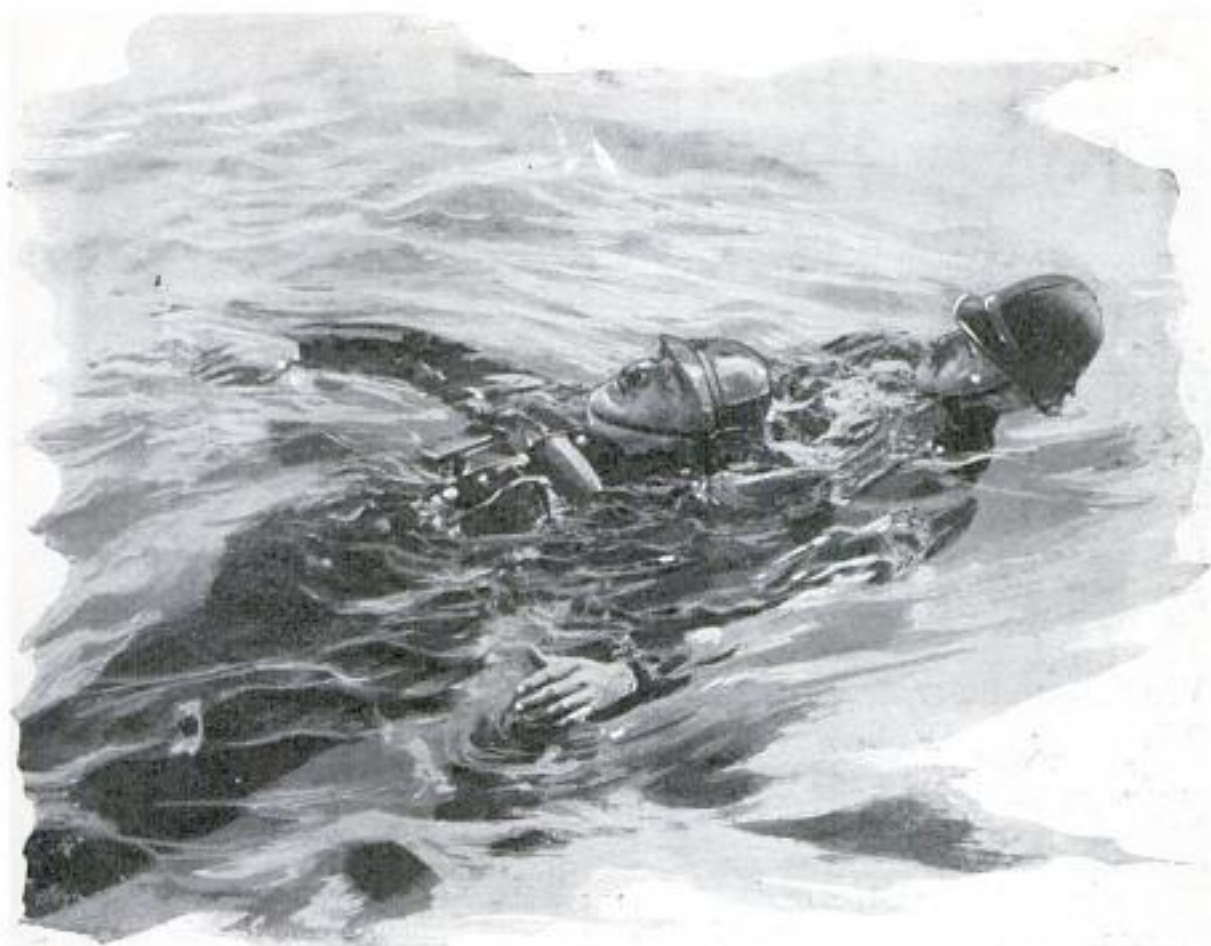

Two Policemen Demonstrating Their Ability to Swim with Ease Although Fully Uniformed, While Giving an Exhibition of Life-Saving Tactics during a Water Tournament at Brighton, England

Policemen Swim in Full Uniform during Life-Saving Stunt

Dressed in full regalia of their calling, policemen staging a life-saving exhibition at Brighton, England, showed they could swim in spite of the weight of water-soaked uniforms and other heavy accouterments. Without removing helmets or shoes and wearing tightly buckled belts and buttoned coats, they dived into the river to "rescue" others of their organization who acted as drowning persons. Using the regulation methods of recovering victims in the throes of drowning, the "bobbies" quickly dragged their burdens through the water to the first-aid stations.

Frames for Tilting Autos on Side Simplify the Making of Repairs

Tilting an automobile so that repairs or adjustments may be made easily on the underside when a pit is not available, is simplified with the aid of two steel frames with swivel screws operated by handles. The automobile is driven upon the frames,

which are placed flat on the ground, and as the handles are turned, one side is elevated to any desired angle up to forty degrees, the maximum pitch, which may be reached in five minutes. The repair man thus can easily gain access to almost any part under the car. The automobile is quickly lowered to level position again and the frames, fitting into a compact package, two inches high, fifteen and one-half inches wide and seventy-eight inches long, may be carried in the car if the autoist desires.

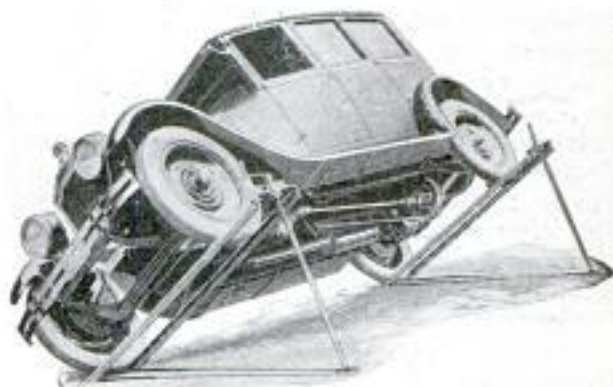

Auto Tilted in Swivel Frames to Give Repair Man Access to Under Parts

Kovveth Ave.
St. Louis, Mo.

Comb. Co. V. Kenton, 4848-a



Detectives Examining Burglar Tools, Including Guns and Acetylene Gas Outfit, Seized in Raid on Safe Blower's Apartment

Beating the Burglar at His Own Game

War-Time Tear Gas Is Added to Equipment Used to Foil Bank Robbers and Expert Safe Crackers

SCIENCE again is a lap ahead of the burglar and safe blower in the eternal race between criminals and the law.

The development of the oxyacetylene torch, coupled with the discovery that a rod of ordinary soft steel would help it burn through the hardest manganese steel ever made, for a time gave the bank robber an advantage.

Then science stepped in and produced a new metal which, so far, has resisted all efforts to melt or drill it. The composition is a closely guarded secret, but copper, apparently, is one of the materials used. Applied to vault doors, a sheet of ordinary hard steel is used on the outside, then a sheet of what appears to be a copper alloy, next a thickness of an exceptionally hard material that looks like carborundum, another sheet of the copper alloy, and finally the inside steel plate.

Science has also turned a war-time invention—tear gas—to peace-time use.

It does the burglar no good to drill or burn or blast his way into a vault equipped with tear gas, for no matter where he attacks the bank's storehouse, he is bound to release a dense cloud of blinding, choking fumes.

In the last century bank-vault and safe construction kept about twenty-five years ahead of the robber. In other words, a new vault or strong box was good for a quarter of a century of use before the im-

proved technique of the burglar rendered it obsolete. In recent years, however, the use of more complicated appliances by the robber has shortened the safety period considerably. To meet the change, the vault makers have constantly improved their product. When the vaults of the Cleveland federal reserve bank were designed, they were equipped with five-foot thick doors of chilled steel, which alone weighed 40,756 pounds. These were

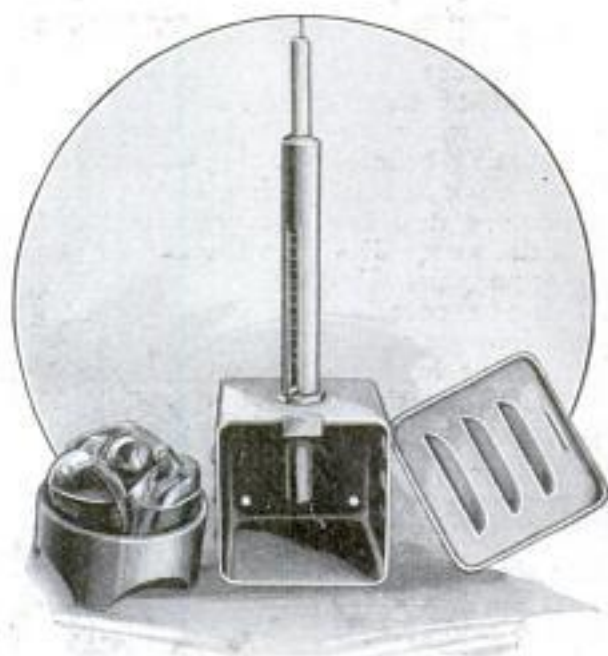

Tear-Gas Bomb, Showing Gas Vials, Such as Is Used Inside of Bank Vaults



Set Off by Acetylene Torch Which Has Cut through Steel Door, a Tear-Gas Bomb, Placed Inside, Explodes, Compelling Cracksmen to Flee

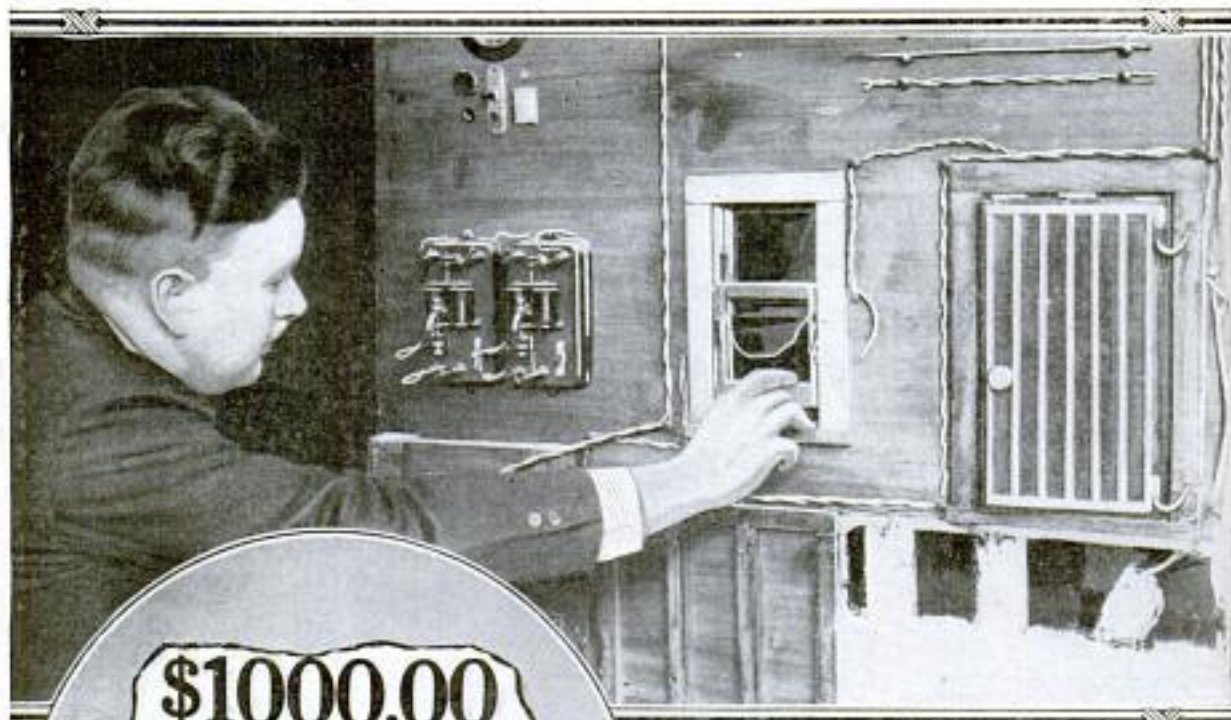

**\$1000.00
REWARD**

Below are pictures and finger prints of



WANTED FOR MURDER

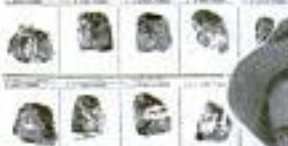

Phot. Studio of Chicago Police
L. J. L. L.



In Upper Photo, Electrician Is Testing Model of a Central-Office Burglar-Alarm System, Wired to Tiny Window and Door That Open and Close in Realistic Fashion. He Seeks Weak Spots That May Have Been Overlooked in the Signal Apparatus, Giving Burglars a Chance to Cut through Walls and Safes as They Did in Vault Door Above, Where Ho'e Large Enough for a Big Policeman to Crawl Through Was Made by Skilled Cracksmen with Acetylene Torches. At Left Is Portable Strong Box Containing Burglar Alarm That Rings Should an Attempt Be Made to Snatch the Chest from a Messenger in the Street



Left. Bullet-Proof Shelter on Wheels, with Bullet-Proof Glass Window, Protects Police Rifleman

© U. & P.



Police Wireless Operator, Above, Keeps in Touch with Flying Squads in Radio-Equipped Cars As They Cruise City or Spread Cordon about an Entire Section to Close All Roads to Fleeing Band of Bandits

© U. & P.

Combination Knob and Box of Five-Inch Safe Door after Yeggs Equipped with Acetylene Torch Burned it Out of Door to Release Bolt Action So Turn of the Handle Would Open Way to Contents of Supposedly Burglar-Proof Chest



There Is No Explosion to Awake the Neighbors When a Modern Bank Bandit Burns His Way into a Vault with His Noiseless Oxyacetylene Equipment



Automatic Telegraph Printers Connect Police Stations to Flash Details of Crimes; Right, Inside of Vault Door Wired for Burglar-Proof Locks and Tear Gas

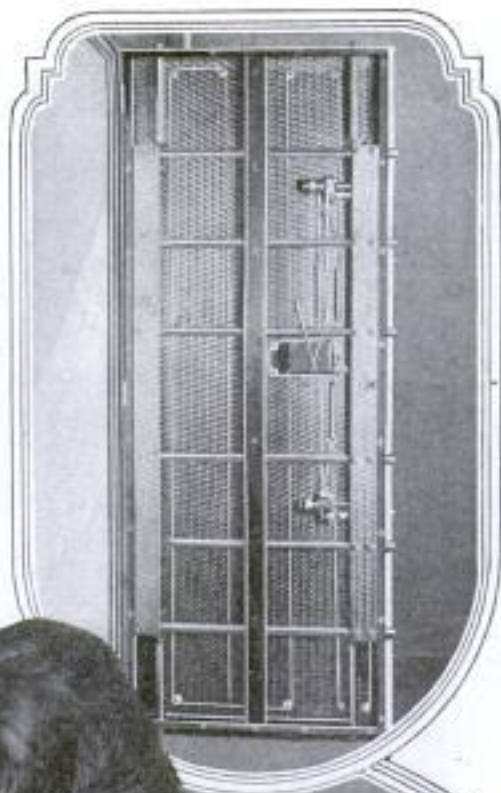

The Fingerprint Expert in a Few Minutes Can Find Any Wanted Print among Her Thousands of Records, While New Process of Sending Pictures by Wire Spreads It over Country

Massive Circular Vault Doors, Studded with Huge Bolts and Armored with Fire-Resisting Steel, Offer an Obstacle Designed to Discourage the Best Cracksmen

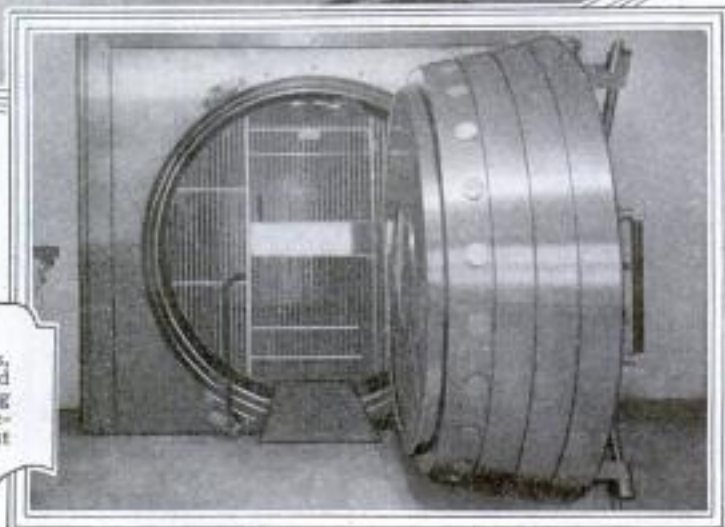

1506



Motorcycle Policemen Capturing Bandits Who Have Been Forced to Flee from Their Car by the Explosion of a Tear-Gas Grenade Tossed by One of the Pursuers

the largest made up to that time, but five years later the New York federal reserve vaults' doors were made just twice as thick—ten feet of the hardest steel known.

For a long time it was believed that the ball type of manganese safe was impregnable. It was drill-proof, and its peculiar type of door construction offered no chance to pour in liquid explosive, while the offset combination locks resisted the sledge-hammer cracksman who knocks off the dial and punches out the tumblers with a steel rod.

Then came the development of the portable gas torch and the fluxing rod. The rod is just a bar of soft steel. Held with its point against the hard steel, just where the flame is applied, this rod oxidizes with tremendous rapidity and an irresistible temperature is developed. Even then the makers of the round chest believed it was safe, because, they said, any attempt to burn through it would be useless, as the heat would destroy the contents, and so give the burglar nothing for his pains. But a clever gang of robbers melted a tiny hole through the three-inch wall of a safe, and then inserted a funnel and filled the inside with water. Then they burned out a plug, leaving a hole big enough to insert the arm, and fished up the contents through the water.

Now bankers are wheeling their manganese safes into a vault equipped with tear gas. The inside of the door is a maze of steel wires, running over small brass pulleys and held at tension by strong springs. The wires cross every section of the door,

and even crisscross over the combination box, to guard against any attempt to knock off the dial and punch out the tumblers. If the wire is broken at any place, the tension is released, two burglar-proof bolts shoot home, and one of them trips a trigger, which releases a spring-driven plunger in the tear-gas container, breaking the glass vials and releasing dense clouds of the unbearable gases.

The introduction of gas is only one of the many changes made in modern vaults. Doors in the bigger vaults are no longer made with stepped or tongue-and-grooved edges. Instead they are plain cones, which plug the opening like the stopper of a bottle. Tests revealed that explosives poured into the cracks of a stepped door would exert tremendous leverage against the sides of the steps, forcing the door out, while with the plain cone type, the blast can only blow out into the room or into the vault, without tearing off the door. While new burglar-proof locks, tear-gas bombs and special construction are being extended to protect from burglars, bankers still put much of their trust in electrical alarm systems, and some of the latest models are so complete as to be virtually proof against any sort of attack. The electrical alarms, like those used on stores and residences, are divided into two classes, local alarms with gongs on the building to attract passers-by and police, and central-office alarms, in which a silent signal is flashed to headquarters of the burglar-protection company, which dispatches armed guards to the scene.

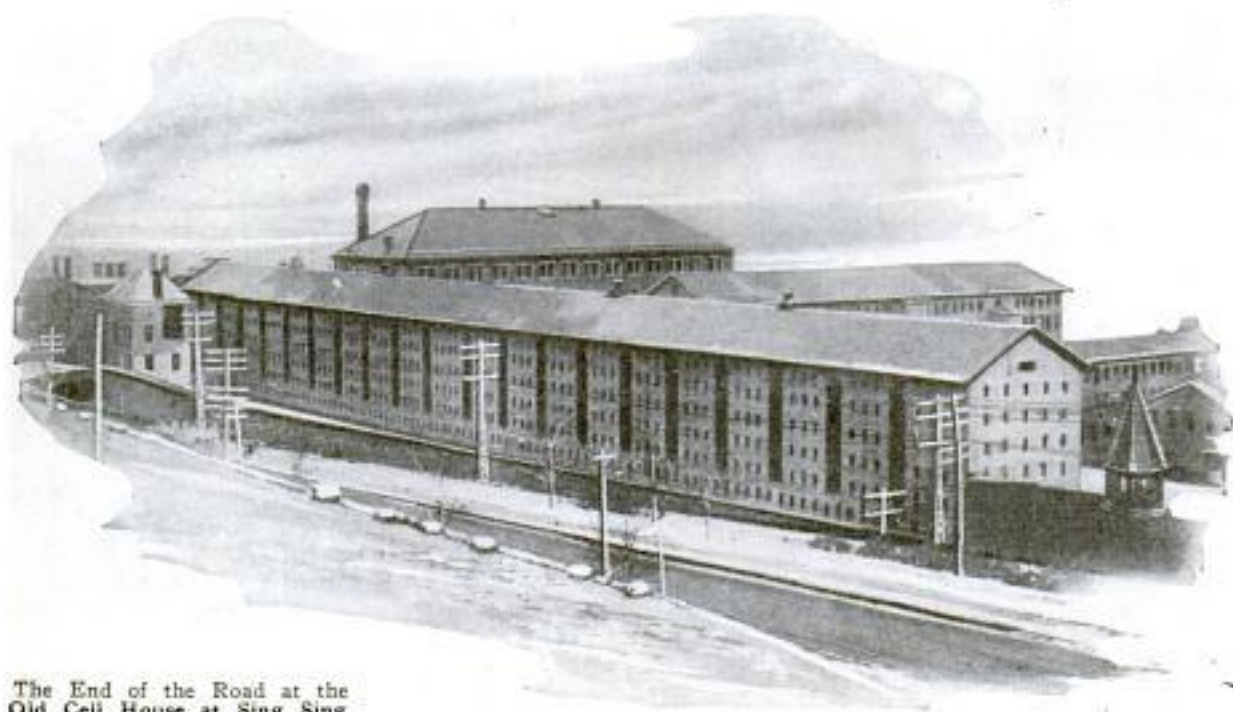

The End of the Road at the Old Cell House at Sing Sing

Ceipfung

Sold by - New Novelty Co
153 E. 42nd St
903

**Toadstones Once in Big Demand
for Use as Talismans** 1928

Certain black pebbles, known as toadstones, which toads were reputed to carry in their heads, though of little beauty as ornaments, were highly esteemed during the dark ages because of their alleged power to heal various kinds of digestive disorders and for their supposed protective influence over children. The wearer of one was thought immune from toothache; they were held as antidotes for poisons and believed to warn of the approach of a venomous reptile by imparting a stinging sensation to the flesh.



Motor... of J. J. Co
Hammelberg, N. Y.
oprobriously

1924

New York

**Twin Roller Bearings Absorb Shocks
and Reduce Amount of Friction** 1331

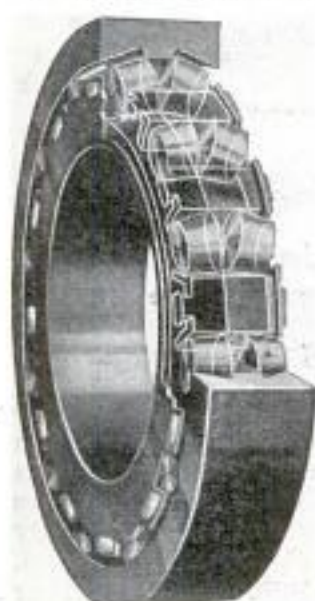

Roller bearings in conical-shaped twin units to absorb shocks and reduce breakage and friction under heavy strains, such as in railroad-car service and similar uses, have been produced. It is claimed that the additional contacts they afford take up jars, prevent slipping and consequently cause less wear. They are interchangeable with

Roller Bearings Co., 160 N. La Salle, Chicago

standard roller bearings, are not difficult to install and are said to reduce maintenance costs considerably.

**No Eggs Boiled on the Planet Mars
Temperature Tests Prove** 1741

Owing to the rare state of air on the planet Mars, it has been shown by a government scientist, water there will boil at a much lower temperature than on the earth. To determine the degree of warmth of the distant sphere, the experimenter directs a ray of the planet's light upon two thin wires, thus setting up an electric current which is measured by delicate instruments. The temperature of Mars, according to the scientist, is from twenty to forty degrees cooler than that of the earth. This would make it impossible to boil eggs on the planet.

Phila. Public Ledger
8/3/24

Worn Like Nose Glasses, the Novel Eyeshades Fit Close to Lids and Lashes

**Eyeshades Serve as Extra Lashes
to Shield against Sand and Sun**

Fitting snugly into the eye sockets and just over the lids, light celluloid eyeshades of novel design have been placed on the market. Less cumbersome than the larger kinds, they are said to afford ample protection against bright sunshine on the beach and elsewhere, and also from dust and sand. They are manufactured in a variety of colors and do not interfere with the vision.

**Auto Valve Adjusters Save "Gas"
and Keep Motor Quiet** 109

To keep valves in gasoline engines at the proper clearance, regulating notched dials that can be quickly attached without the help of tools or much work, have been invented. As the valves wear down, a turn of the adjuster with the thumb and finger quickly tightens them and secures the proper clearance, eight-thousandths of an inch, by means of carefully measured notches at the side. The attachments are said to eliminate the noise and rattle of loose valve tappets and make the motor run more smoothly.



☐ Railways in the United States use 87,500,000 new ties every year.

Wilmington, W. Va.
Wilmington Mfg. Co.
Set of 8 - \$5.00
" 12 - \$7.50



Designer of the "Family" Dolls and Assistant Painting the Faces and Attaching the Arms After Bodies Have Come from the Lathe; Typical Costumes Are Seen at Right

Fireproof Paint Preserves Building Enveloped by Flames

Covered with paint containing a solution said to make oils fireproof, a building erected for a test by flames failed to burn after straw and kerosene were scattered over it and lighted. A similar structure to which the mixture was not applied was totally consumed within a few minutes after the blaze enveloped it. It is claimed that the chemical can be used to make rugs, laces and other cloth fabrics fireproof without injuring the materials or changing their appearance in any way.



Leaving Building Painted with Fireproof Solution After Unsuccessful Attempts Were Made to Burn It

Teaching of Children Is Made Easy by Groups of Dolls

Instructing young children through their play has long been one of the most successful teaching methods. This principle is now being applied effectively in sets of small wooden dolls originated by a former teacher and already adopted by the schools of several western cities for their kindergarten and primary departments. Realizing a child's fondness for "playing house," the creator of the toys has made the dolls in "family" units, one representing the professional man and his household and others the business man, the farmer and the Indian and their families. Provided with these four groups, the child has a natural incentive to dress them according to their station in society and work out, with pasteboard and magazine cut-outs, the proper environment for each. The dolls are turned from wood and consist of a head, body and base with attached arms. The "parent" dolls are each five inches high and the "children" one inch shorter. Faces and hair are painted on with durable enamel, and the matter of dress is left entirely to the ingenuity of the children.

Church bells made of an alloy of aluminum and copper, weighing about one-third as much as those of the usual bronze, are being used in a village near Cologne.

Letter read 8/21/25
 859
 Sanoma Fire Prevention Co.,
 714 S. Hill St.,
 Los Angeles, Calif.

Made by - *L. H. Mullens*,
Columbus, Ohio

Chicago office - 5 d Wabach, Clearborn 3993 - R. J. Newman

**Sixty Thousand Pieces in Table
Only Thirty Inches High** 1801

Consisting of 69,260 pieces of hardwood of 400 different kinds gathered from all parts of the world, an elaborately inlaid library table has been completed by an Ohio cabinetmaker, who spent approximately 3,000 hours on the task. It is only thirty inches high and the top is forty-two by twenty-eight inches. The largest piece of wood used was only three-quarters of an inch square and the smallest three-sixteenths of an inch. By careful matching of the woods, many unusual color combinations were obtained.

**Pocket Microscope Has Strong Lens
to Reveal Minute Objects** 733

Folding into a case so small that it may be carried in the vest pocket, a microscope has been made for scientists, students, doctors, prospectors and others who cannot conveniently carry the heavy standard instrument on trips. The lens is strong



High-Powered Folding Microscope Extended and Being Put in Pocket in Carrying Case

enough for examining minute cell structures and for making blood counts. The instrument is equipped with a reflecting mirror, tube of standard length, invisible objective and other parts common to the laboratory device. Case and body are made of metal and special fittings shield the lens from dust.

*Spencer Lens Co.,
Buffalo, N.Y.*

**Date Book in Department Store
Aids Keeping Appointments** 922

In a San Francisco department store is a public date book for the purpose of



Telling the Date Book Where Friends Who Missed an Appointment May Find Her

relieving persons of suspense and worry, and preventing waste of time in waiting for friends. In case an appointment is not kept at the specified hour, the one who has arrived may leave a message for his companion, who has but to look at the book to tell where they may meet. Other messages may be written and the book serves as a convenient "silent secretary" for the public.

Pacific Atlantic Hotel

Anti-Dazzle Light Bulb for Auto
913 **Has Two Filaments**

Blinding glare from automobile headlights is said to be practically eliminated by using bulbs with two filaments, one giving the normal driving light and the other shaded by an ingeniously arranged metal cap to cut off the upward rays that dazzle oncoming drivers. A switch brings the shaded filament into operation at the approach of another car. The cap projects the light to the top of the reflector, resulting in a downward illumination amply sufficient for the driver. The normal beam from the other filament is said to provide plenty of side light. The bulb can be adjusted and focused to almost any headlamp with little alterations in wiring.



Price \$40.00

*C. A. Vandervell & Co., Ltd.,
Acton, London, W. 3,
England.*

1703
906

Comd. Wallace S. Wharton
Apr. 206, 2456-20th St., N.W.,
POPULAR MECHANICS
Washington D.C.

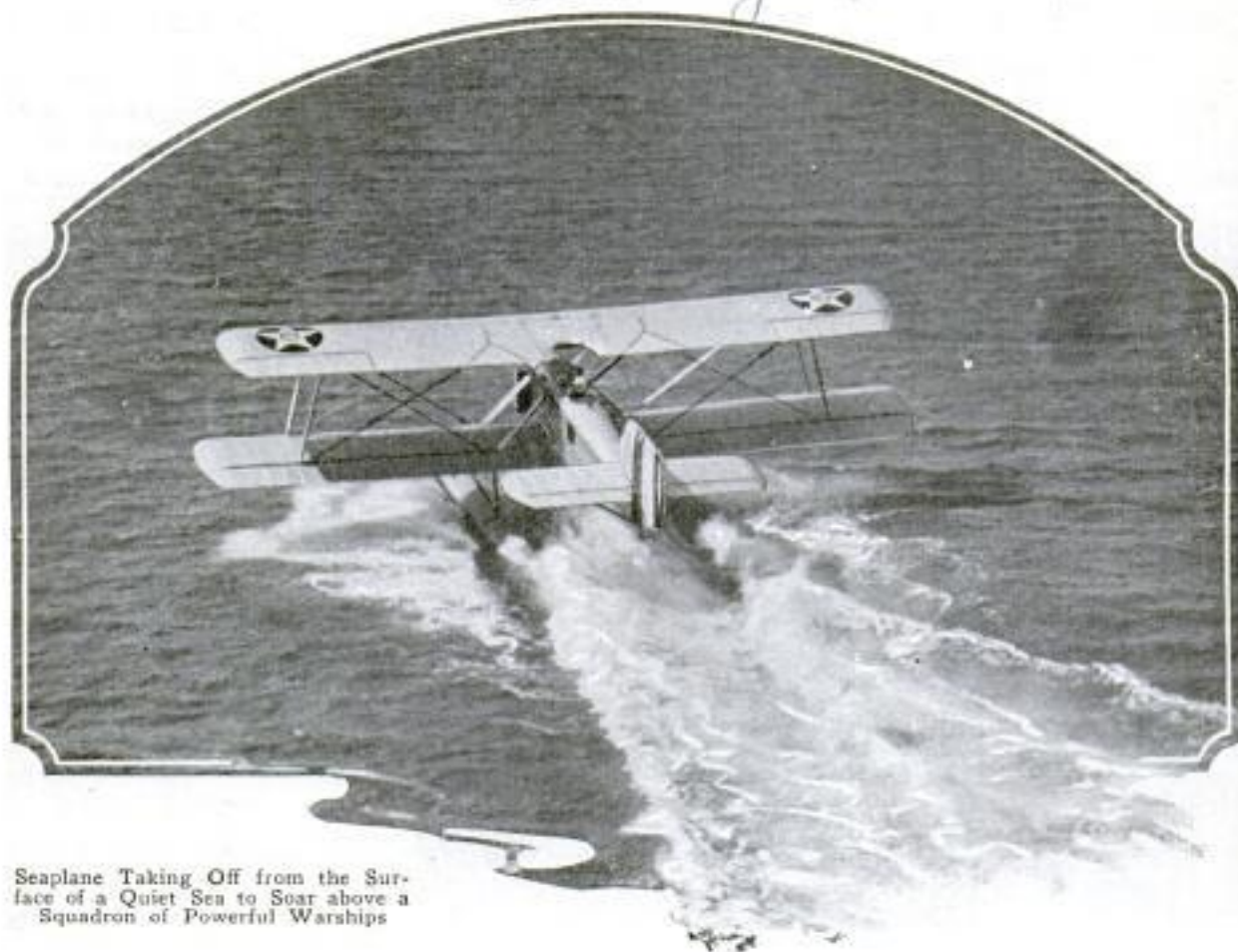

Seaplane Taking Off from the Surface of a Quiet Sea to Soar above a Squadron of Powerful Warships

With the New Mosquito Fleet

Armed Aircraft Developed as Aids to Fleets of Big Battleships It Was Believed They Might Render Obsolete

ONCE believed by many to be a weapon of warfare that would render big battleships obsolete, because of its ability to cover wide ranges at great speed while delivering destructive blows upon enemy positions and fleets, the airplane has been developed as an almost indispensable aid to naval units engaged in tactical maneuvering and long-distance firing.

Although the United States navy has made considerable progress in developing aerial mosquito fleets for bombing and torpedo attack, and to lay down effective smoke screens as an impediment to enemy offense, much attention has been paid to their value for scouting over the seas and as an aid to directing the fire of gunners who may be out of sight of the targets. Due to the tremendous range of the larger naval guns much of the firing is directed at points not visible from any part of the attacking vessels. Equipped with radio-

sending apparatus, the airplane can take up an advantageous position several thousands of feet in the air, and from such point observe the effect of the shells, communicating valuable information to the fire-control quarters.

In addition to spotting the fall of the projectiles, the airmen observe and report all changes in the course and speed of moving enemy ships. For this purpose special instruments are employed to calculate the time consumed for such maneuvers. On board the attacking craft, the range and elevation of the rifles are adjusted to conform with these data.

To combat the watchfulness of the aerial observers and scouts, opposing aircraft are set against them. To repel these, battle squadrons are launched in flight, which practice may result in spectacular conflicts in future wars far above the scenes of the principal engagements, mak-

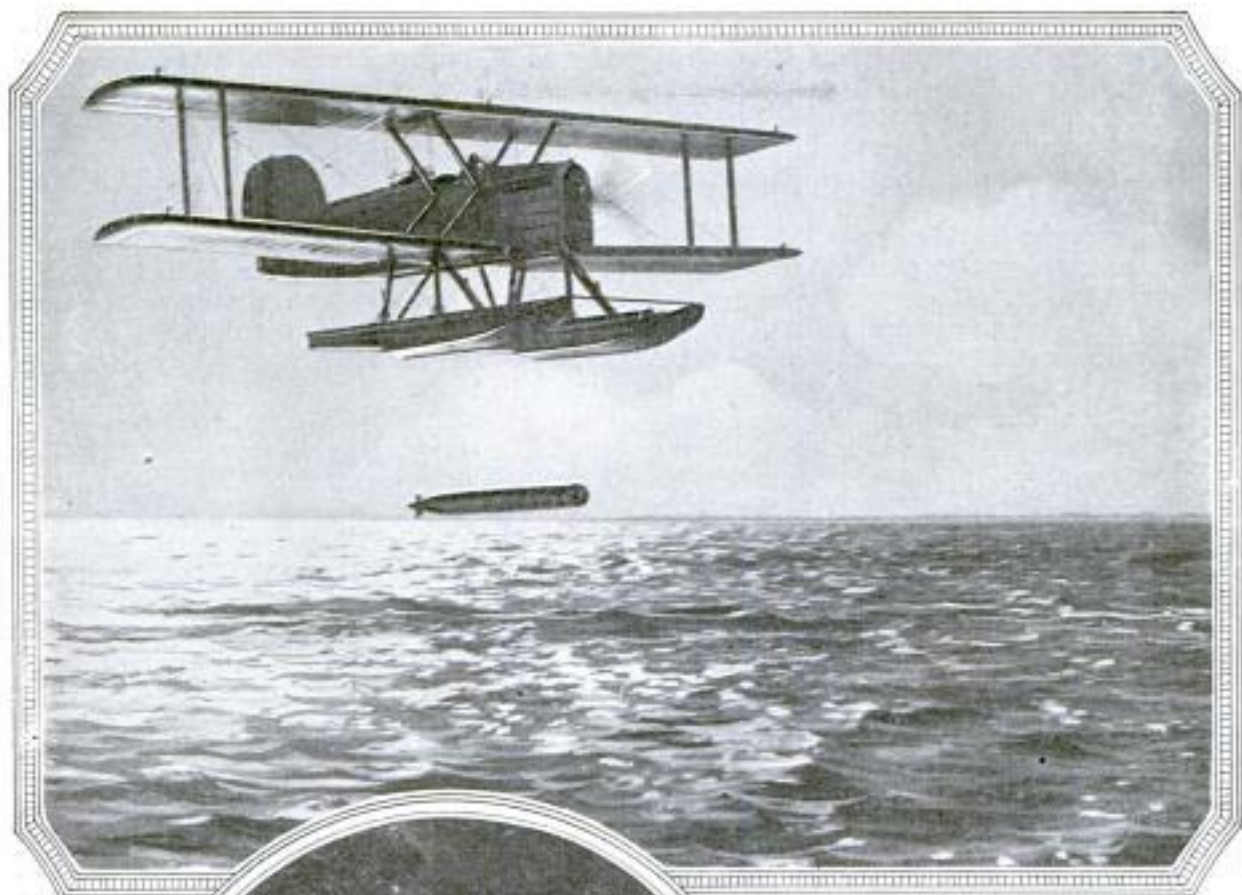

Launching a Deadly Torpedo from a Low-Flying Seaplane, Which Sends the Destructive Missile Speeding over the Sea to Explode against Hostile War Vessel Lying Helpless before the Onslaughts of the Swift, Darting Ships of the Air That Strike and Then Soar Thousands of Feet above the Scene to Watch the Effects of Their Work

A Tempting Target for the Air Warrior's Aim; Aerial View of a Giant Warship under Full Speed but Which Is Not Fleet Enough to Foil the Swarm of Powerful Bombs That Pursuing Birdmen Might Send Crashing into the Huge Hulk; Smoke Screens Are Designed to Obscure Such Vessels from the Watchful Eyes of Enemy Observers

1703

ing it necessary for large numbers of air machines to accompany the war vessels under battle conditions. For some time planes have been carried aboard the battleships, from which they take flight by means of catapulting devices that project them at great speed into the wind. Once clear of the decks, the fliers' engines take up the task of propelling the planes. When returning to the parent vessel, the seaplanes land close by on the water and are raised to their resting places on the decks by hoists. Aircraft-carrier ships are now being added to the naval fleets for the purpose of accompanying them to sea with suitable forces of flying machines. The carriers, besides providing quarters for the seaplanes, furnish them with repairs, fuel and replacement parts. Storage rooms are built in the hulls of the mother ships to accommodate unassembled machines which can be set up on short notice when needed. Quarters are also provided for the flying crews. The upper deck of the carrier offers both an unobstructed landing field for the seaplanes and a take-off runway, doing away with water landings.

Large supplies of aerial bombs and torpedoes and chemical materials for creating the dense smoke screens may be distributed to the planes from the carriers. Frequently an airplane fleet may be called upon to protect both its own units and the naval armada from the enemy by means

of the vapor curtains. In case the battleships are outnumbered and forced to withdraw speedily from the vicinity of enemy forces the screens might be employed to confuse the opposing observers, enabling the movement to be made with little or no loss to the retreating craft. The chemicals used to lay down an aerial smoke curtain, cause a dense foglike cloud to streak out behind the airplane which, being heavier than air, descends to the ocean surface in a vaporous wall practically impenetrable to the eye.

In making an aerial-bomb or torpedo raid, the purpose of the air force is to so confuse the commanders that their attention is diverted from the line of warships confronting them and to cause them to break their battle formation, thus weakening their position when actual hostilities begin. Increase in weight and power of aerial projectiles has made this form of air fighting of great worth, and efficiency in launching the missiles fairly effectively on moving targets has placed the air units in the class of capital weapons.

While it is possible to sink ships as a result of aerial attacks, the ability of the target to move freely about in any direction lessens the number of hits and might avoid serious damage even were a vessel struck by a descending charge, but where enemy seacraft are forced to dodge about on the water, the movements generally cause a break in their line formation.



Mosquito Fleet of Naval Aircraft Preparing to Rise in Battle Formation during Practice Drill in Use of Aerial Bombs against a Series of Floating Targets

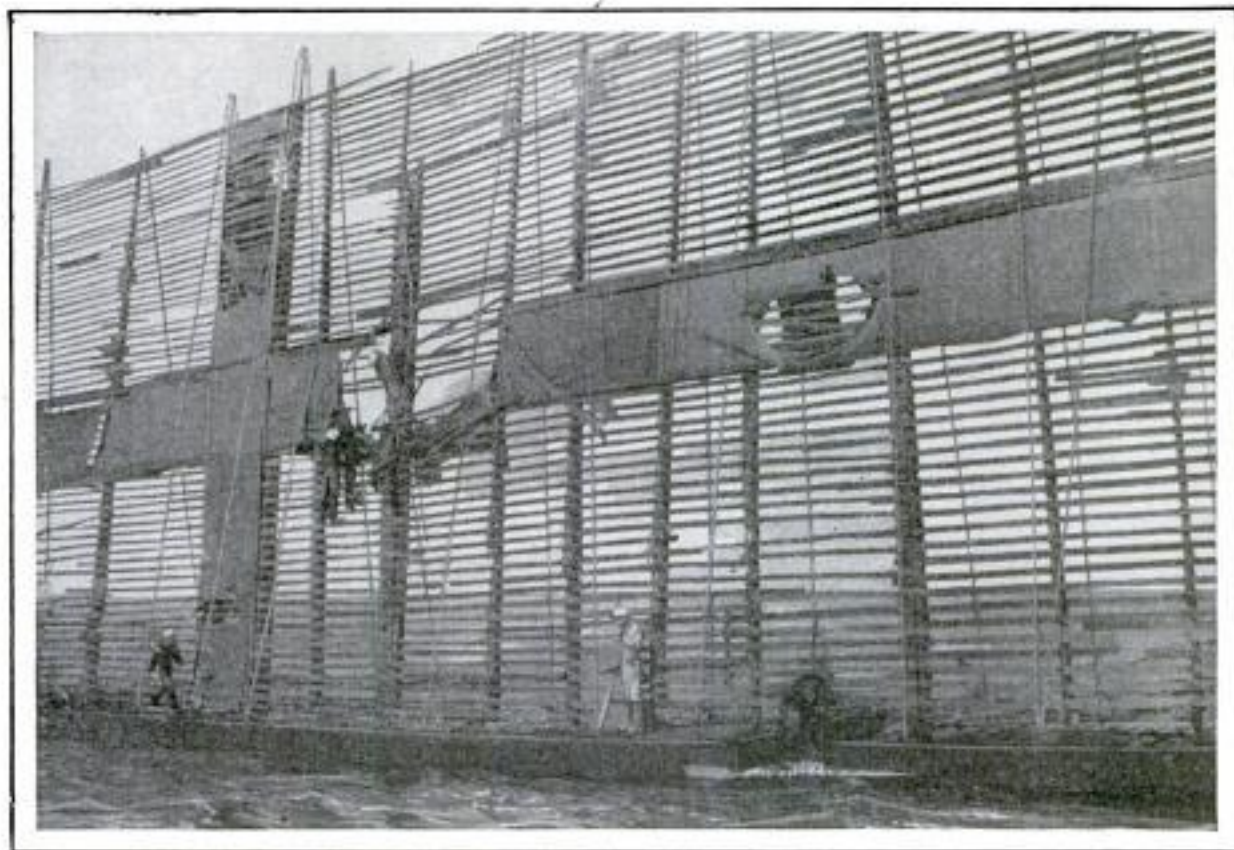

What the Big Battleship Guns Did to the Target at Range of Several Miles; Sailors Inspecting the Hits and Repairing Slats for Further Shooting

Phantom Ships Aid Naval Gunners to Perfect Marksmanship

Convincing proof of the accuracy of gunfire during maneuvers of the Pacific fleet was seen in the shattered latticework of the huge floating targets placed several miles from the firing line. About the height of a warship's side, the framework of one of the marks was found pierced several times in the center, while some shots penetrated at what would have been approximately the waterline of a real vessel. After the practice, sailors were dispatched to make exact reports of the locations of the hits and repair the slats for further shooting. Broad strips of canvas, stretched lengthwise and across the target, made it visible at great distances and increased the resemblance to an actual ship. As it bobs lightly about with almost every movement of the water, the utmost precision in aiming is necessary in order to score a direct hit.

Mesh Bags Are Woven from Wire by an Automatic Machine

After cutting rings from wire fed to it by reels, a machine that weaves mesh bags, links and solders the tiny loops at the rate

of 400 a minute. Various colored metals may be used and worked into artistic patterns, such as are found in cloth fabrics, with slight adjustments to the mechanism. Because of a core of soldering metal running through the wire, it is said the device can attain great speeds in joining the rings.

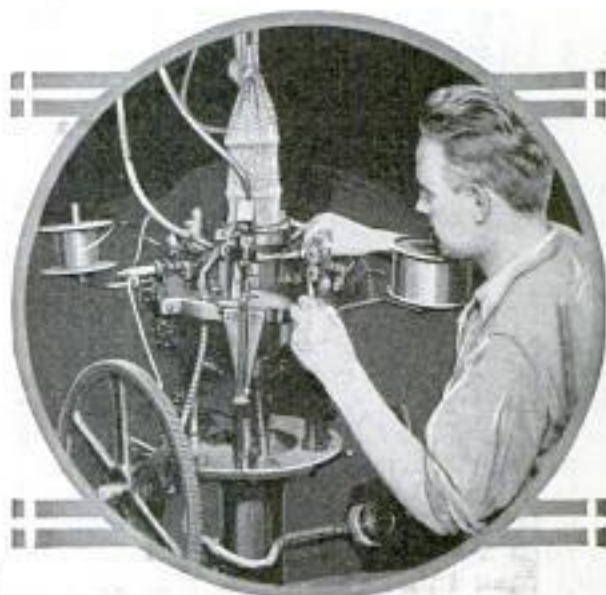

Weaving Wire Mesh Bags on Machine That Makes and Solders 400 Tiny Rings a Minute

With some sizes of mesh, the rings can be made at a rate of 700 a minute.

Whiting & Davis Company
Plainville, Conn.

Owned by E. K. S. Billings

Cent. Duby Erwin
Livingston, 711
Washington St.
Russellville, Ark

Washington D.C.

**Yacht Is Held Steady as a Liner
by Twelve-Ton Stabilizer**

1704

Seasickness is said to be next to impossible on the 250-foot yacht, completed not long ago by the Krupp plant at Kiel for an

**Paper Made from Cotton Products
Points New Use for Crop**

1996

Paper of various grades is being manufactured from cotton by a Tennessee company. In the success of the venture a possibility is seen that paper prices may be reduced while the cotton grower is afforded an additional source of revenue since use is made of the cotton-mill products and of the fibers in hulls and stalks that are now destroyed. Bond, blotting and book papers have been made, as well as an all-cotton sheet used for radio boards and fiber for noiseless automobile gears. The cotton pulp, chemically treated, is also employed by manufacturers of motion-pictures.

Southern Cotton & Paper Co.
Chattanooga, Tenn.
Allen Park

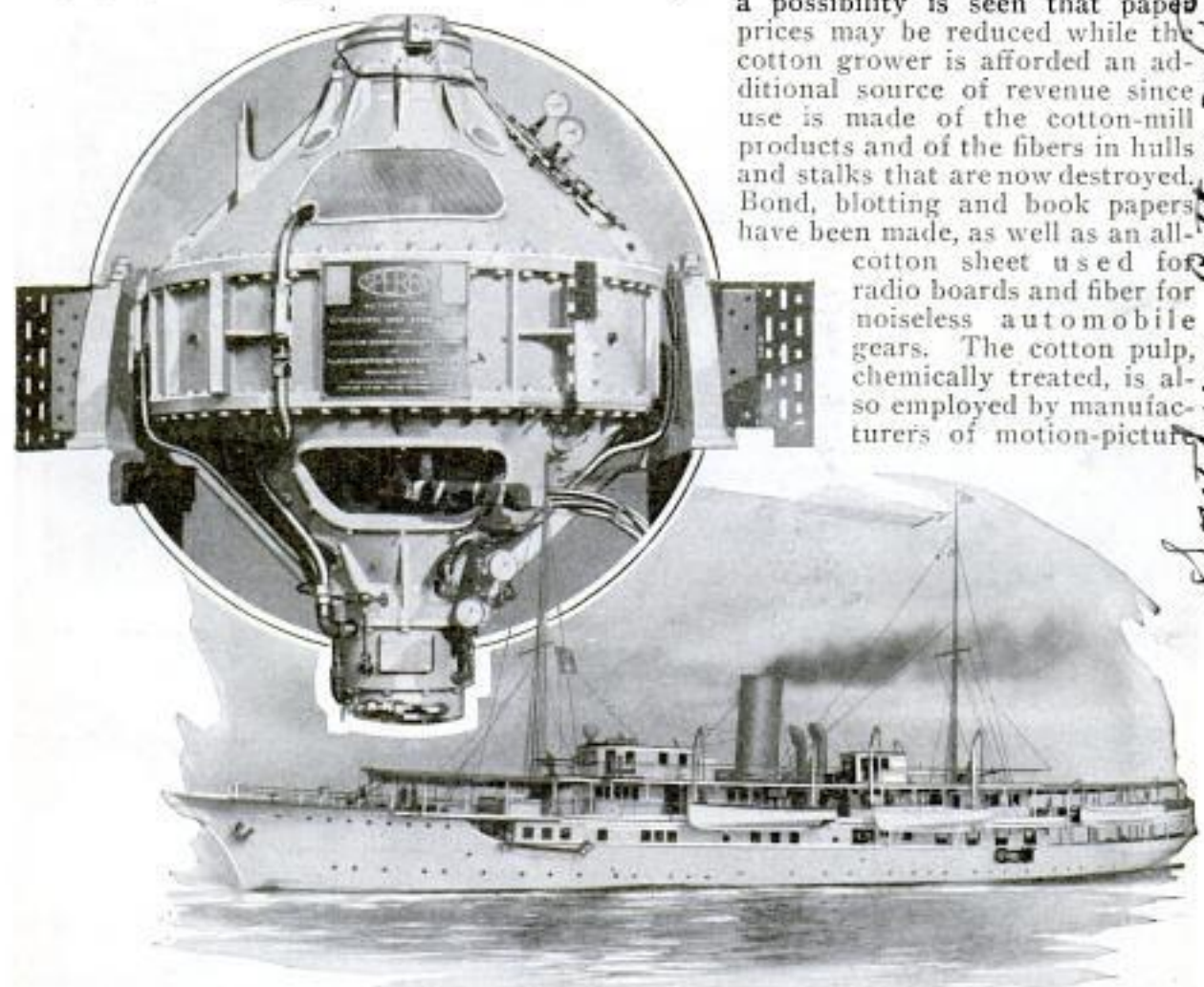

Yacht "Vanadis" and the Twelve-Ton Stabilizer of the Type Used on Ocean Liners to Keep Vessel from Rolling and Rocking on Voyages at Sea

American millionaire, due to the fact that it is steadied at all times on voyages by a twelve-ton gyroscope. This instrument, which has been in use for some time on ocean liners, is said to prevent the yacht rolling more than three degrees so that persons on board are not compelled to undergo the nervous strain of constantly seeking to maintain their balance, one of the chief causes of seasickness. The stabilizer consists principally of a heavy wheel, revolved at high speed by electricity and suspended in such a way that its motion keeps the ship from tipping to either side even in stormy weather.

Parasites usually form the nucleus of pearls about which several delicate layers of material are deposited.

films, artificial leather and silk and celluloid, and demand for it will be greatly stimulated, it is said, if the cotton paper becomes widely used.

**Wax Produced by Insects on Trees
Used for Candles in China**

1419

In some of the inland provinces of China, the only light the natives have when darkness falls is that shed by crude candles made from wax secreted by tiny insects which attach themselves to the boughs of evergreen trees. In a day or so, they begin the formation of a white, waxy substance. This is scraped off, melted and passed through strainers to remove impurities and is finally made into candles.

Journeir, 229
Thunderley, Southland
Eng.

Autos Cost More than Furniture.
Government Figures Show 1132

That the automobile industry in America has grown to such tremendous proportions that the country now spends over a billion dollars a year more on cars than for house furniture, and more in salaries to chauffeurs and garage mechanics than to public-school teachers, is shown by government statistics. Other figures disclose that the United States spends over \$500,000,000 a year for candy and ice cream, and that the value of the pearls in New York city alone is placed at \$700,000,000.

Tiny Camera Is Built under Lens
with Jewelers' Tools 1621

Requiring the use of jewelers' tools and magnifying glasses in its construction, a miniature camera with parts that work, and less than an inch in length, has been made for the royal doll house of the queen of England. Three months' continuous work by experts was necessary to complete the tiny instrument. All pieces were formed by hand and carefully checked with larger cameras to insure accurate shape. The lens is a minute disk of crystal, and the shutter may be operated the same as in the real article. A small pencil for autographing is provided in a holder on the back. The bellows can be

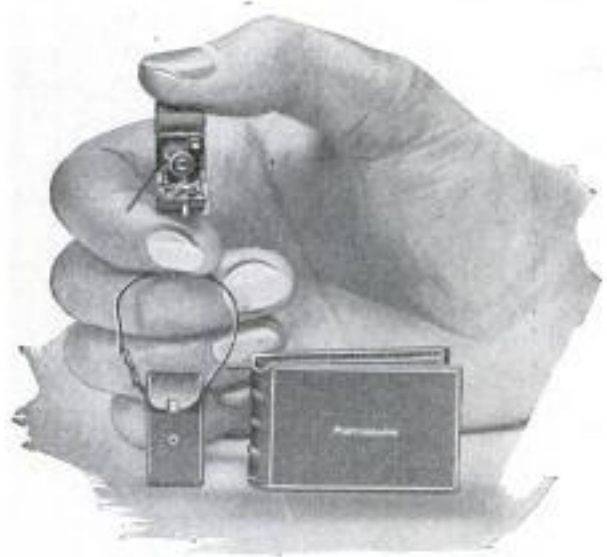

Courtesy Kodak, Ltd.
Pygmy Camera Outfit, Part of Furnishings of Queen of England's Royal Doll Palace

easily opened out and folded for inserting the camera in a carrying case which has been furnished to fit it. An album, neatly bound and decorated, is also a part of the pygmy photographic outfit.

Cmt. C. A. Aldroyd Esq.
127 Abbey Road
Barrow-in-Furness, Lancs



Realistic Figurehead of Woman in Fashions of Early '50's, Adorning Prow of Clipper Ship

Figurehead on Clipper Ship Recalls
Old Romance of the Seas

In the days before the advent of the steamer, when "ships were wood and men were iron," as old sailors like to say, one of the picturesque and romantic features of the famous American clippers and other craft of their type was the ornate figureheads that adorned their prows. Elaborately carved, these designs sometimes represented such allegorical conceptions as the "Spirit of the Sea" or the "Queen of the Winds," while others were lifelike representations of the sponsor of the vessel or the wives, daughters or sweethearts of the owners or captains. One of the few clippers still in service carries at her bow the figure of a woman quaintly dressed in the style of seventy years ago. Politics also entered into the custom to some extent for the "Constitution," or "Old Ironsides," carried as her figurehead a statue of President Jackson. One night in port the figure was beheaded by some person who believed that the statue was inappropriate for naval uses. It was repaired and now stands in the grounds of the naval academy at Annapolis.

¶ In one section of a Brazilian railroad, which is said to be the best-paying line in the world, there is a drop of 2,600 feet in seven miles.

Dr. L. Schumacher,
54 W 95th St.

912

POPULAR MECHANICS

New York City
**Paper Hat Parasol for Men Serves
as Shield from Sun or Rain**

1750

Protection from sun or rain is provided by a paper parasol that slips over the top of men's hats and is held by a rubber band



Hat Parasol in Place with Ribbed Edge Extending Well over Wearer's Shoulders

or piece of elastic. The flaps that hang over the brim can be folded in nine different ways, thus shielding the wearer at any desired angle while the exposed portions of the shade may be printed with advertisements. Special styles are manufactured also in thin sheet rubber with rigid side strips, while those made from ordinary paper or with cheesecloth backing have been found serviceable even in heavy rains. When not in use, the parasol can be folded up and placed in the pocket.

Watches Are Broken Up by Uncle Sam to Test Skill of Makers

Besides testing all kinds of timepieces, freezing them in refrigerators and baking them in ovens, Uncle Sam takes watches apart and breaks them so that they may be repaired by applicants for watchmakers' certificates. Many watches contain more than 200 pieces, about one-third of which are screws, some of them so small that 20,000 of them will go in a thimble.

Pacific & Atlantic Sholes

The man who can mend and reassemble all these delicate parts and make them run accurately, the government considers, has amply proved his skill and he is awarded a diploma. Good timepieces are expected to run accurately regardless of the season and weather. One way the government tests a watch is to run it for twenty-four hours in an oven heated to eighty-four degrees and then place it on ice for the same length of time. A gain of three seconds at one temperature and a loss of five at another is considered a total error of eight. This is corrected, if possible, by the man who "rates" the watch by moving the little screws in the balance wheel to different holes in the two sides of the rim. Notation of the change is made and the tests repeated until the watch runs the same in the oven and on the ice.

Rattling Toy That Shoots Sparks Adds to Fun at Celebrations

1814

Showers of brilliant sparks and a loud rattling noise are made simultaneously with a novel toy designed for children, or even grown-ups when they celebrate various occasions. It consists of a short bar or hollow sound chamber, at one end of which is a ratchet device and a disk of a metal preparation which sends off sparks when it is turned under a spring clamp. To operate it, a short handle just below the disk is grasped and the toy swung clockwise. The movement turns the disk and causes the ratchet to snap. The metal pieces may be renewed when the sparks grow dim. A similar device without the noise-making attachment is provided in a

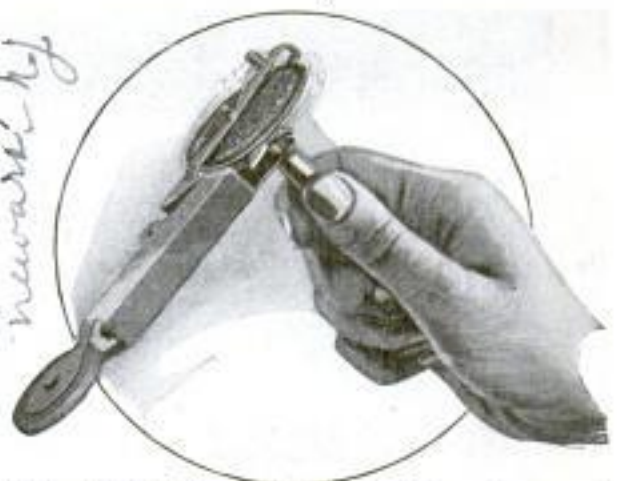

When Whirled Around, This Toy Shoots Showers of Sparks and Makes a Loud Noise

sparker wheel rotated rapidly by pulling a string that rewinds automatically within a hollow grip.

*Art Metal Works,
Arson Square,
Newark, N.J.*

*Horological Institute,
Washington, D.C.*

the metal is made by Newark, N.J.

Copyrighted material

1735



Copyright, Keystone View Co. *91-D Smith Ave New York City*
 Weighing Part of a Large Consignment of Imported Gold Bullion; the Massive Scales Are Delicately Adjusted
 So That There Is Slight Chance for Error in the Heavy Balances

World's Gold Flowing to America

Coins from Foreign Governments "Naturalized" in Melting Pot to Fit Them for Minting into American Money

WITH gold from foreign countries flowing into United States money vaults at the rate of \$37,000,000 a month, the entire output of the world's mines for the first half of 1924 was absorbed. At present the stock of the yellow metal held in this country is a little over \$4,000,000,000, a sum which requires almost \$200,000,000 additional each year to keep prices stabilized and to meet the financial needs of growing industries. Since not more than \$50,000,000 worth of gold is annually produced in the mines of this nation, the difference must be imported.

Interest on loans to European governments and payments of war debts form a great part of the stream of precious metal that pours into the coffers of Uncle Sam's money houses, while commercial exchanges help to swell the supplies coming from those nations where large mar-

kets consume immense stocks of American goods. All gold entering the country in the form of money must pass the "naturalization" process of the assay offices, as most of the other governments employ alloys in their coins of different standards from those contained in metal currency of the United States. The consignments are unloaded from the steamships under heavy guard, while a crew of workmen pile the boxes or sacks onto handtrucks on which they are conveyed to waiting vehicles and rushed to the assayers. All packages are carefully opened and the contents weighed on gigantic scales, delicately adjusted and as accurate as chemists' balances.

Great melting pots reduce the metal to a molten state in preparation for the processes of separation of the alloys before the gold is permitted to pass into the



Copyright, Keystone View Co.

One of the Huge Melting Pots in the Assay Office Where Foreign Coins Are "Naturalized" for American Mints by Extracting the Various Alloys from the Metals

hands of the mints. Piled in heaps, the coins are shoveled with large coal scoops into the smelters, where they become a semiliquid mass. Chemicals and electric treatment are then applied to divide the pure gold from the mixtures of other metals. Alloy standards of France and England being about the same as that of the United States mints, coins from those two countries can be naturalized or reminted with little difficulty. These are loaded in the pots, and when melted down, are poured into molds, a row at a time. As each layer of the casting boxes is filled up, powdered charcoal is scattered over the metal and another tier of molds is placed on top, this process being repeated until a "wall" of gold bricks remains to cool. After hard-

ening, the bars are removed from the holders and subjected to examination during which they are weighed and stamped for shipment to the mint or storage in subtreasury vaults, piled up like cordwood.

During inspection each block is carefully tested for purity by experts who certify it by stamping the letters "U. S." on the surface. Sometimes pure bullion is sent from the foreign countries in heavy bars, carefully inclosed in strong boxes. Most of the shipping containers for such consignments as well as for coins are made of one-inch lumber, but the holder itself is about the size of a cigar box. When filled, the packages require two men to lift and carry them to the trucks. The greatest gold-producing area of the world is South Africa from where the larger part of



Casting Large Ingots of Gold in Molds for Storage in the Treasury Vaults

1735



Above, the Gold-Refining Room of the U. S. Assay Office; Center, Pouring Molten Metal into Bar Molds for Storage in Vaults; Below, Overseas Shipment of Gold Being Delivered to Bank, in Boxes of One-Inch Lumber and No Larger than Those Used for Cigars; Left, Testing and Stamping Blocks of the Precious Metal



the new metal for minting and that used to reinforce the treasury holdings is purchased. Many of the big ocean liners

A large force of assayers is always kept busy in the weighing rooms, for the receipts of gold are practically always so far

Emb. Es. H. Holden. "Windy Newb", Tipton View Road, U.S. Chesterfield, England. Made by James A. Cunningham, Summer Hill, Pa.

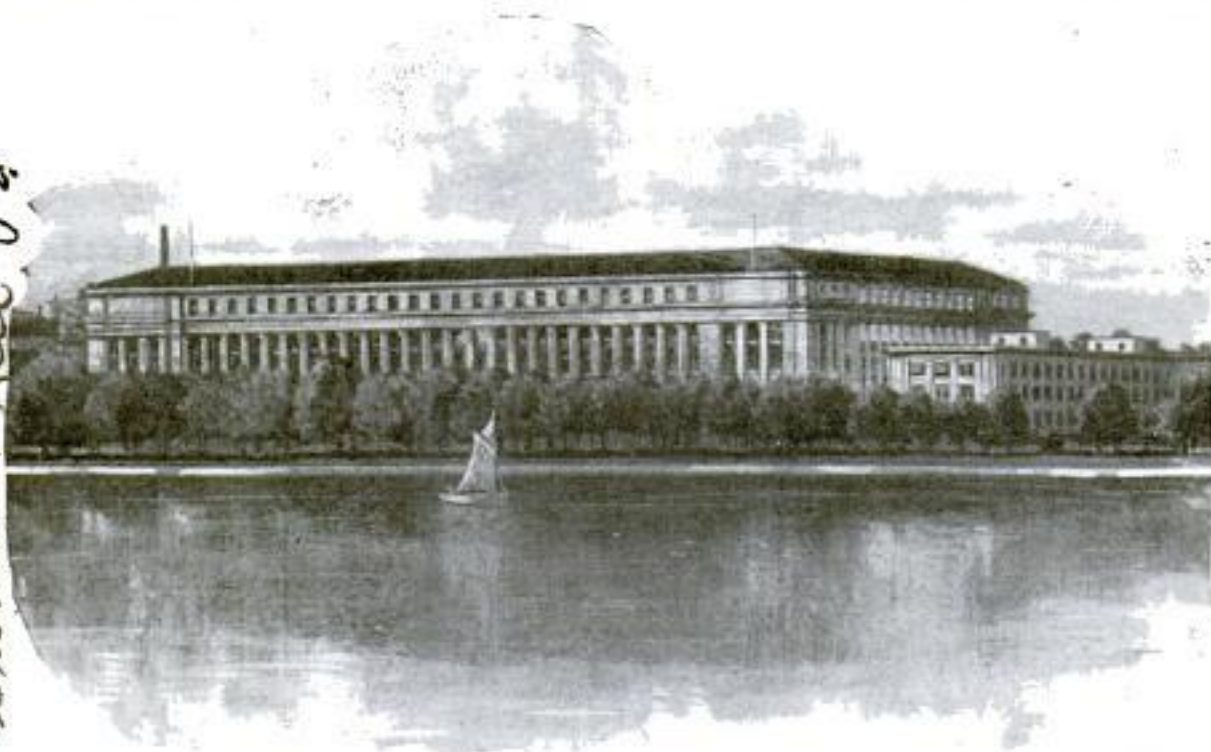

Bureau of Engraving at Washington, Where Uncle Sam Prints the Crisp New Green and Yellow Bills That Save Handling of Stacks of Gold and Silver Coins

carry millions of dollars worth of gold on every trip.

Gold consigned from foreign points to banks in this country goes immediately to the United States assaying office and experts determine its value to a penny before it is accepted by financial concerns.

in advance of the consignments sent abroad that there is seldom a quiet season, except during the tourist periods. And although these travelers leave a sum estimated at \$400,000,000 scattered among the cities of Europe and the Orient, it does not affect the balance of gold trade.

57 Egg Cups Carved from Bits of Coal with Pocket Knife and File

Working with a pocket knife and a file, an English wood-carving expert has at-



Copyright, D. H. Holden

Finished Cups, a Chunk of Coal and Simple Tools the Expert Carver Uses

tracted considerable attention with his polished egg cups and various ornaments which he cuts from pieces of hard-grained coal. In appearance, they resemble those of jet and are given added beauty by the markings which compare with the grain in costly woods. The maker is said to have spent fifty hours in fashioning the cups shown in the illustration and refused various prices up to \$200 offered by curio collectors for the unique objects.

1892

Chemist Makes Sugar as Plants Do from Carbon, Water and Light

What is declared to be "one of the greatest triumphs of modern times," is reported to have been achieved by Dr. E. C. C. Baly of the University of Liverpool, Eng., in making sugar in a way similar to that in which plants produce it. The process consists in exposing carbon monoxide and

Chicago Herald. Ex Miner 9/16/24

*Located at
Hastings, Minn.*

water to ultraviolet rays from a mercury-vapor lamp in such a way that formaldehyde, which immediately turns into sugar, is formed.

Circle

Windmill Built upon Silo Generates Power and Light for Farm 725

Mounted upon a short steel tower on top of a fifty-five foot silo, a specially designed windmill owned by a Minnesota farmer generates sufficient electricity for lighting his house and barn and for running some of the farm implements and household appliances, such as the washing machine, churn and vacuum cleaner. The current is stored in a large battery in the basement of the house and the main switchboard is conveniently placed in the kitchen. The top of the wheel is eighty-feet above ground where it catches almost every breath of wind, and just below is a platform, eight feet square, for use in oiling and in inspecting or repairing the generator. Firmly anchored to the concrete, the wheel has withstood storms. This is partly due to the fact that the blades are pivot, in such a strong blast before the speed, they the wind pass relieving

the wheel has withstood storms. This is partly due to the fact that the blades are pivot, in such a strong blast before the speed, they the wind pass relieving

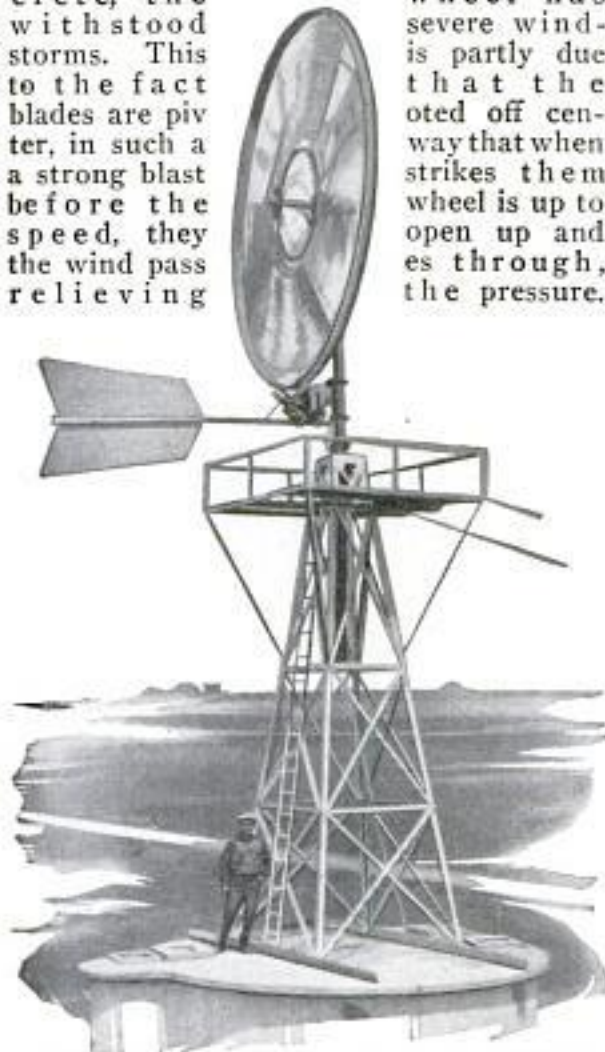

Windmill Power and Light Plant for Farm in Operation on Top of Silo

*Owner - George Manikowski
517 - 4th Ave. S. E.
Minneapolis, Minn*



White-Rooster Emblem Town Erected near Railway Station to Advertise Its Poultry Business

Fifteen-Foot Statue of Rooster Built as Emblem by Town

Announcing that it boasts the honor of being the greatest poultry-raising center in the world a California town has erected a gigantic replica of a white rooster at its railway station. The figure, with its stand, is fifteen feet high and is mounted on a wooden pedestal with a picket fence surrounding it. Plainly visible to passengers passing through, the emblem is proving a striking and effective advertiser for the town and its enterprise.

Petaluma, Calif.

Music Twenty-Seven Centuries Old Written on Earthen Tablet 833

Babylonian music, believed to have been composed about the year 800 B.C. and possibly belonging to a period much earlier, has been deciphered from an ancient earthen tablet by Dr. Kurt Sachs of the Berlin high school, according to reports. The notes are said to have many of the characteristics of the Chinese music of today and evidently were arranged for a harp of twenty-two strings. The tablet, about the size of five ordinary bricks, was unearthed on the site of Assur, the ancient Assyrian capital, and has been in a museum for some time. The inscription is arranged in three columns, the first of which long had baffled scientists until it was discovered that the odd characters represented a musical system.

*Chicago Evening Post
9/10/24*

Copyrighted material

Single-Wheeled Motorcycle Carries Rider on Inside-of-Rim

A single-wheeled, spokeless motorcycle has been invented in Italy. Engine and seat are held on a frame within a large

perts have found that the "loading" system used in telephone communication is suitable to lines laid under the sea and have therefore devised a cable about an inch in diameter, which has a metal ribbon, consisting of eighty per cent nickel and twenty per cent iron, the most highly magnetic preparation yet discovered, wound in a spiral about the central copper core. This ribbon, it is said, eliminates the "overlapping" of impulses commonly encountered on the present types of cable.



Inventor Testing Single-Wheeled Motorcycle That Carries Rider and Engine on the Rim

outer revolving tire which passes over pulleys. Power is applied directly to the outside rim, the single wheel affording the traction and carrying the load. The rider's feet are close to the ground so that he can easily regain his balance in case the vehicle should tip. It is guided by a regulation steering wheel.

Greater Speed in Cable Messages Is Promised by New Line, 1914

The speed of transmission of transoceanic messages is expected to be increased from five to eight times with the laying of a new type of submarine cable which is to connect New York directly with Italy for the first time. Since Cyrus Field linked the continents in 1858, considerable speed has been gained in transmission of messages by improvements in sending and receiving apparatus, but there have been few changes in the cable. Lately, ex-

Fog-Piercing Ray to Guide Fliers

For some time the British air ministry has been experimenting with fog-penetrating searchlights that project a ray of deep-red tint to overcome some of the hazards of aviation and navigation. The red, it has been found, travels through fog far more readily than blue or violet light, just as mariners discovered that the old-fashioned oil lamp, in a dense haze, illuminated the surrounding area better than electric lights of many times the candlepower. This is believed partly due to the longer wave length of the red and yellow lights. Tests with this ray are being watched with great interest both by fliers and sailors. At a high altitude, the aviator may be enjoying perfectly clear air but may suddenly find himself in an ever-thickening bank when his plane reaches the lower levels, while fogs are among the most common causes of collisions of ships and wrecks along rocky coasts and shoals.

Shields on Car Wheels Reduce Noise

Noise on cars in the London subways has been reduced to such a degree that a watch can be heard ticking ten inches from the ear while a train is running. This has been done partly by putting sound-absorbing materials on floors and roofs of the cars and partly by shielding one side of the wheels, thus deflecting the sound waves before they reach the passengers.

Christian Science Monitor 9/12/24 red material

Dr. M. Lando Scudaghi
Police officer Milan, Italy

Chicago Evening Post 9/2/24

Emb. Oscar W. Hallin, R. 2, Box 107, Piquette, Mich.

Metal Pottery Molded like Clay Needs No Burning or Glazing ⁸²²

Pottery manufactured from a patented composition is being put on the market in Germany. While the exact nature of the material is a trade secret, it is known to contain sand, sulphur and various metals combined in such a way that in making the articles, the mixture is simply poured into molds and allowed to dry. It needs no burning or glazing, it is said. Its natural color is a brownish-black, but other shades are obtained easily. Urns, vases, trays and cases for clocks are a few of the articles being made from the material.

Door Mats Woven of Old Auto Tires ¹³⁴⁶
Are Durable and Won't Skid

Discarded automobile tires are put to practical use as durable door mats by a western manufacturer who has patented his product. The tire walls are cut into small, oblong links each of which is perforated at both ends and then connected by galvanized wire. Mats of various sizes and proportions are easily constructed. They are said to be quickly

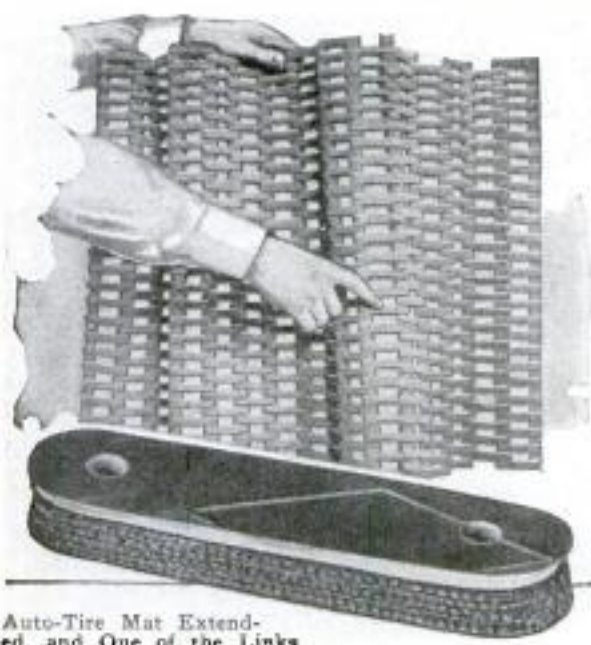

Auto-Tire Mat Extended, and One of the Links

cleaned, comfortable to stand upon, and will not slip. They have been found useful in boats, industrial plants, elevators and restaurants and are said to be so resilient that dishes dropped upon them are not likely to break.

Importation of cheese to America has trebled since 1920.

Durable Mat Co., 24 W. Connecticut St., Seattle, Wash.



Hitched to Cart with Pony, Collies Are Safe from Autos and Help Pull

Collies Trained to Pull with Pony Help Give Cripple Airing ¹⁸¹

Fearing that his trusty collie dogs, which persisted in accompanying him when he went driving with his Shetland pony, would be maimed or killed by automobiles, a cripple in a western city finally hit upon the ingenious scheme of hitching the dogs to the rig with the pony. Each collie is tied to the shafts by a rope and helps pull the car by a small single-tree and tugs. The three animals display splendid teamwork, their owner declares, and trotting along together, seem to enjoy giving their master an airing.

¹³⁸⁹
Spray for Cleaning and Painting Works at Touch of Trigger

Operated by a touch on a trigger placed conveniently in a pistol-like grip, a spray gun has been made for cleaning engines, transmission gears, rock drills and pneumatic drills of all kinds by means of compressed air in connection with kerosene or gasoline. It may be used also for applying wood preservatives, insecticides, creosote, paint or whitewash.



Cont. W. J. Wood & Son, U. S. Machine Works, 100 W. 4th St., New York
Pat. Townsend, Wash.
M. W. Coyle, 200 Church St., New York



Inspecting and Matching
Gloves in Pairs; Color,
Weight and Appearance
Must Be Identical Before
They Are Passed to the
Stock Room

Right, "Clicking" Machine That Cuts Cuffs and Linings; Below, "Laying Off" Gloves on Hot Metal Hands

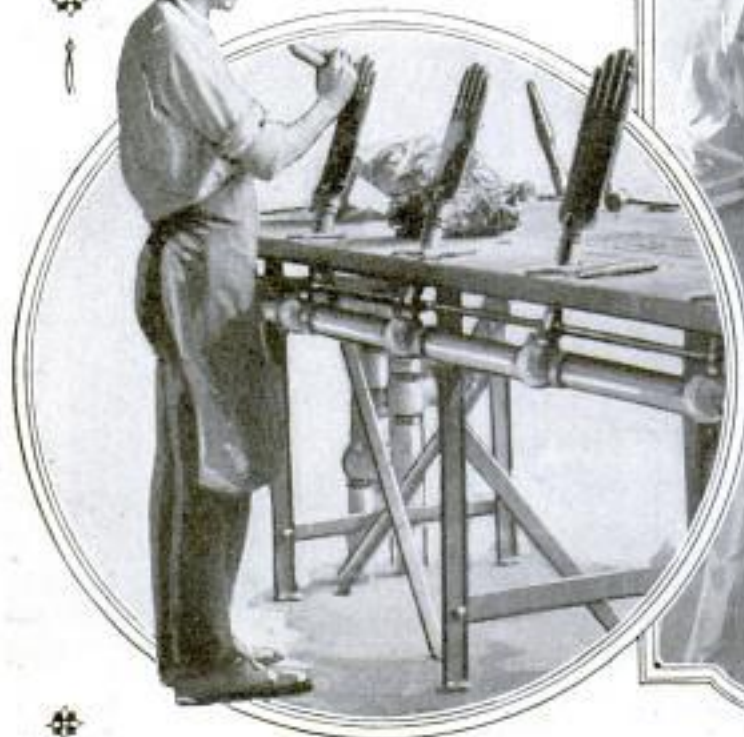

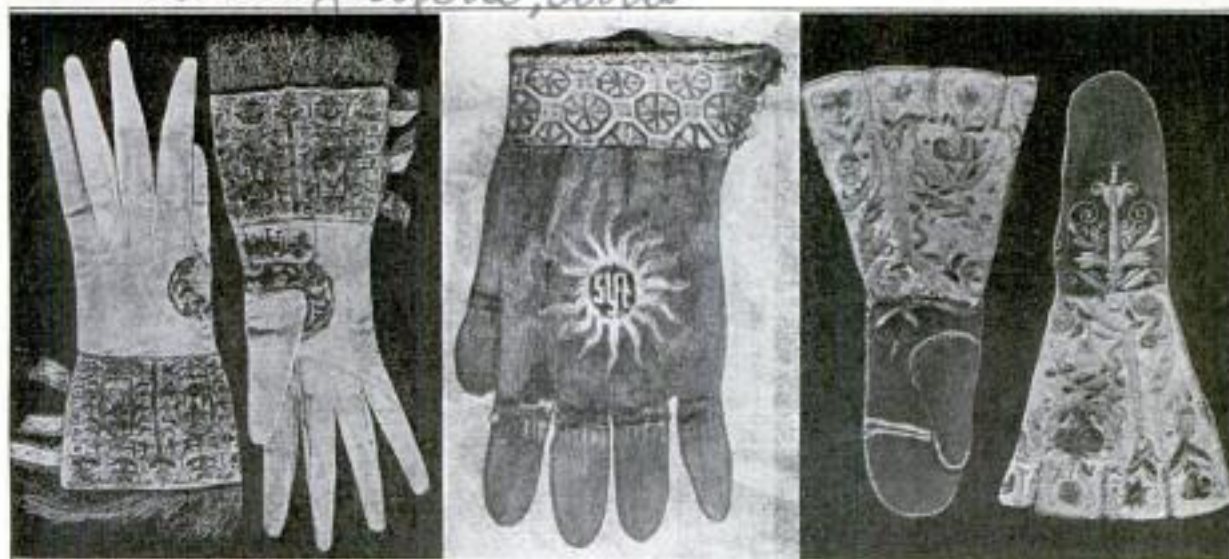

Gloves That Graced Hands of Notables of Past Ages; Pair Once Owned by Queen Elizabeth, Style Worn by Bishop of Fourteenth Century and Embroidered Gauntlets Fashionable in 1600

Tailoring Leather to Clothe Our Hands

Glove-Making Industry, Once Art of Ancients, Manufactures More than \$70,000,000 Worth of Products Each Year in U. S.

GLOVES to the number of more than 115,000,000 pairs, enough to dress the hands of every person in the United States, are now consumed yearly by the people of this nation. Despite growing demands for the fancier article, less than 8,000,000 pairs are imported from abroad. The rest are produced by the glove factories of this country which annually manufacture an output estimated to be worth \$70,000,000. Of the total product, about sixty-six per cent consist of men's leather work gloves, due to their growing use in the industries, by structural iron workers and in the making and driving of automobiles. However, the fashion of wearing gloves is said to be about equally divided between men and women.

Up to a few years ago, most of them were made of the more common leathers and the dress varieties from kidskin, a name employed to distinguish the hides of deer, sheep, goats and calves. Now the skins of dog, cat, fox, bear, horse, kangaroo, hog, rat and many other animals are made into comfortable and attractive coverings for the hands. Many of the popular grades of gloves are formed entirely of cotton, silk, wool, and similar fabrics. Of the raw hides required for the leather product about seventy per cent, as well as most of the tanning materials, are imported. Various names are applied to

the same skins subjected to different treatments in the tanning and dressing processes. The English "cape" glove is formed of the skins of sheep of South Africa. The velvetlike surface of the "suede" is achieved by buffing the natural grain of the skin against an emery-faced wooden wheel, while the pebbled finish is just the original surface highly polished. Horsehide or coltskin leathers are divided into two chief grades. The coat of the city-bred animal, because of the beast's better breed and careful grooming generally results in a hide superior to that of the country equine, where rough work, little care and exposure are likely to produce a coarse and scrubby skin.

From sheep raised near Mocha, in far-off Arabia, come the beautiful, strong leathers known by the name of that city. These animals are looked upon by the inhabitants of that territory as sacred and are permitted to be killed only during one month of the year. Those bred on the higher lands produce hides of much finer quality than the skins found on the sheep of the valleys. While numerous skins are received in this country already dressed by the tanners at foreign markets, many come almost raw, salted and dried with the hair or wool still on them. Put through the treatments that reduce them to smoothly finished sheets with soft, silky textures

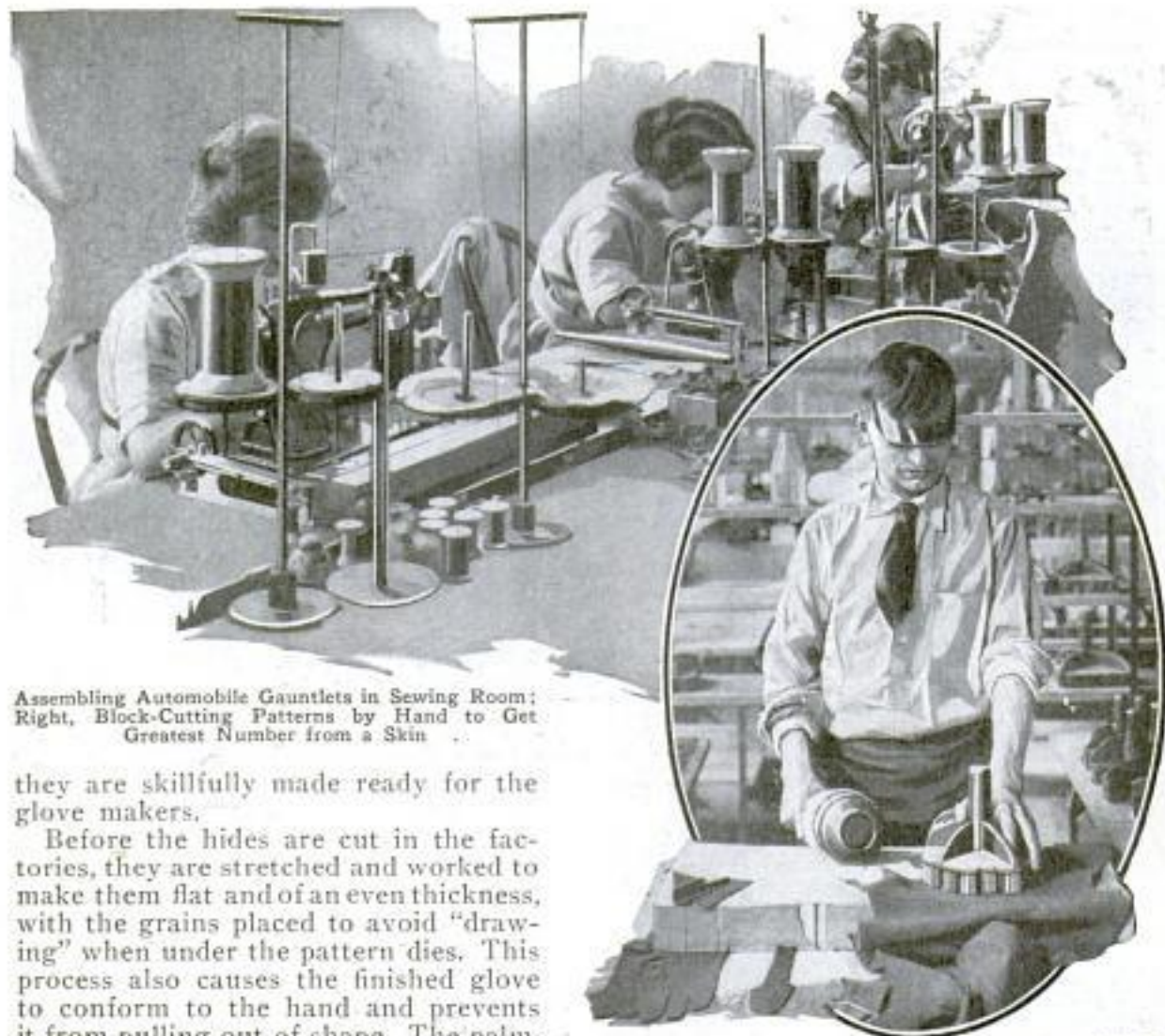

Assembling Automobile Gauntlets in Sewing Room; Right, Block-Cutting Patterns by Hand to Get Greatest Number from a Skin

they are skillfully made ready for the glove makers.

Before the hides are cut in the factories, they are stretched and worked to make them flat and of an even thickness, with the grains placed to avoid "drawing" when under the pattern dies. This process also causes the finished glove to conform to the hand and prevents it from pulling out of shape. The palm, fingers and back are cut in one piece, from a section about an inch wider than that of the completed size. In finer grades of gloves more care is taken with the cutting than for ordinary varieties. From the trimmings left, the "forchettes" or sides of the fingers are fashioned, as are the "quirks," the diamond-shaped sections inserted at the bottoms of the fingers. All pieces are marked and wrapped together for the sewers.

After they are made, the gloves must be "laid off" on hollow metal forms of hands, heated with live steam. Here they are smoothed, stretched and patted into shape. On pressing boards, the fingers of automobile gloves are creased into the accordion folds down the sides, while the cuffs of gauntlets are all ironed by hand. Then the completed articles go to inspectors where they are matched for color, weight, and general appearance.

The adoption of the glove as an article of wear is thought to have been introduced ages ago through the custom of carrying a pet falcon on the wrist, as both

a protection to the bird and its owner. Later worn by all classes, gloves were made of silk, soft leathers and worsteds, the wealthy and the nobility being distinguished by richly embroidered gauntlets that were often trimmed with lace. Discoveries made among ancient ruins point to the fact that gloves were known some time during the age of cave dwellers. Crude leather specimens have been found in long buried remains of that period, but these are about the size of a small ham, roughly held together with thongs. Although the ancient Greeks wore gloves, they were used more for the safety of the hands when engaged in manual labor than as a means of decorating the person. In Rome only those of high rank or members of the priesthood covered their hands.

France was once the home of glove-making, which was later introduced into Italy, England and Germany, but so great has been the growth of the industry in the United States that this country is rapidly becoming the world's center for the art.

Courtesy Hansen Mfg. Co.



Stretching and Working
Leather to Make Grain
Even and Reveal Unde-
sirable Blemishes

Above, Polishing
Gloves against a
Whirling Buffing
Wheel Made of
Silk; Below, Turn-
ing Inseam Models
Right Side Out



Spur-Clad Climber Walks Up Tree and Cuts Off Its Top

Climbing a hundred feet to the lower branches of a stately white-pine tree,



Copyright, Underwood & Underwood
With Saw Dangling at Heel and One Hand on Rope, Tree-Topper Pauses in Perpendicular Walk for Downward Look from Dizzy Height

sawing off the top, and then sliding back to the ground, all in eighteen minutes, gave W. H. (Slim) Hamilton the title of world's champion woodman at a celebration marking the opening of what is claimed to be the world's greatest sawmill, at Longview, Wash. With a stout rope fastened by one end to a heavy leather belt, while the other end is wrapped firmly about the wrist, and with a long "tiller-handled" saw dangling out of the way at the end of a light line, the spur-clad timber topper literally walks up the sides of the huge pines. When he reaches the lowest branches, often more than a hundred feet in the air, the lumberman fastens the free end of the rope to his belt, pulls up the saw, and leaning back with spikes braced, saws away with both hands. The job is one of the most dan-

gerous in the lumber camps, for the severed top at the best can only narrowly miss the topper, and sometimes hits him, while he is helpless to dodge. By topping off the log before felling it, damage to near-by young trees from the thrashing top can be avoided.

Fat Spark No Aid to Motorists

Tests by the bureau of standards apparently have shattered the cherished belief of motorists that a fat spark gives better ignition and more power than a lean one. The experiments were conducted under a variety of conditions, with all sizes of sparks and with the aid of a special motion-picture camera to record the results. The conclusions were that the shape of the electrode makes no difference so far as the explosion is concerned. One of the methods used was to place the gas mixture in soap bubbles and in glass tubes under pressure. These fragile containers were then fired with sparks generated in various ways. The camera showed that the gas nearest the spark was ignited first and that the flame spread in the form

of a hollow globe, growing larger until it had used up all of the mixture. So far as the rapidity of the action was involved, the spark from the feeblest flivver coil was on a par with that from the most expensive magneto.

Manless Automatic Tractor Plow Reduces Farmer's Labors

To reduce the farmer's toil and cut the cost of plowing, now estimated at \$150,000,000 a year for the entire country, an Iowa inventor has devised a manless automatic tractor plow. It is claimed that the only attention this unique implement requires after it is started, is to keep the gasoline tank replenished and to administer an occasional oiling. All the farmer

1816. d. no. Prof. J. B. Davidson, Head of

Agricultural Engineering

POPULAR MECHANICS

has to do is to plow an initial furrow. Properly set, the tractor will then travel back and forth across the field by itself, like a shuttle, spacing itself a furrow at a time at the end of each trip and following the original course accurately. The outfit consists of a two-wheeled tractor with a four-horsepower engine. Right and left plow bottoms are attached to the frame with their beams opposite and nearly at right angles to the tractor axle. They are so placed that when one share is in action, the other is carried above the surface of the soil. A reversing arm hangs over the tractor in such a way that when it comes in contact with a boundary fence, it is pushed back, actuating a spring. This

reverses the drivers and, at the same time, the plow in service is lifted out of the soil and the other descends ready to enter the ground. To space the tractor the driving wheel on the plowed side makes part of a revolution while the driver on the unbroken side serves as a pivot, thus swinging the plow over for another "bite." If for any reason, the machine should leave



Automatic Tractor Plow in Action, Showing Reversing Beam and Suspended Share near Fence

the furrow and start across the field, a small wheel comes into contact with the ground, cutting off the ignition and stopping the motor. The inventor admits that it is necessary that the field be rectangular in shape and have fence barriers to operate the reversing arm. One of these plows has already been used successfully at the Iowa State College, at Ames. Since the tractor can be operated at night, it is considered an advantage, particularly if the plowing season is limited, and as it leaves the farmer free to attend to other tasks in the day, it practically doubles his labor supply.

d. no. Prof. J. B. Davidson, Head of

Agricultural Engineering

One-Man Flivver Plane Flies One Hundred Miles an Hour

Weighing only 450 pounds and with a wing spread of eighteen feet, one of the smallest airplanes built for cross-country



Spry Flivver Plane, Built for Cross-Country Flight, Is Easily Tended by Pilot

flying has been completed at Kelly Field, Tex. On a flight to Dayton, Ohio, it attained a speed of 105 miles an hour, making twenty miles on a gallon of gasoline. The engine is designed on the same lines as that of a motorcycle and is specially geared for running the propeller. These small airplanes, some fliers assert, herald the approach of the day when the one-man flivver machine will be commonly used. Though a trifle more tricky than the larger ones, they are considered safe.

Night Driving Is Made Safer by Running-Board Lights

To decrease the dangers of night driving, red and green kick-plate lamp signals have been invented for the running boards of automobiles. They are inclosed in a wide, attractively designed aluminum casting which protects the side of the car when stepping in. The lights also provide illumination in parking, help protect the fenders and add to the appearance of the car. The bulbs are connected to the tail and headlight wires, no extra switch being required. Each is protected by fiber washers and the lenses magnify the light.



Build at Kelly Field, Texas by Robert Products Co. 224 N. Sherman St.

Robert Products Co. 224 N. Sherman St.

200 pt.

Comp. d. no.

Univ. of Iowa

not yet on market.

Bausch & Lomb
Optical Co.
Rochester, N.Y.

**Moss Matting Made as Substitute
for Linoleum and Cork**

Durable matting from common moss possessing many of the qualities of cork, is being manufactured under a process invented by a Swedish engineer. Aside from being considerably cheaper, it is said to be hard, yet flexible, much lighter in weight and offers insulation against heat, cold and sound. It can be made in much less time than is required for cork or linoleum products and is also adapted for the construction of boxes.

*Carl Oscar W. Hallin
R. 24 Box 109*

**Diesel Engine in Locomotive Hauls
Train One Hundred Miles, 800**

Used extensively for several years in stationary power plants and in steamships, the Diesel engine, because of its low consumption of oil fuel, is being adapted for railway use in England. Equipped with a sixty-horsepower unit of this type and a newly invented hydraulic transmission system, a locomotive was put through a successful 100-mile test on one of the British lines not long ago. Compactness, light weight and speed are claimed for this engine as well as cheaper operation and absence of smoke.

**Auto Hazard in Green Sunshades
Avoided by Changing Color**

An optical phenomenon, which in its application is increasing the hazards of automobile driving, has been pointed out by scientists who have found that through many shades of green visors, placed on the outside of the windshield to protect the driver's eyes from the sun, the red traffic-signal lights now used in many cities and the stop lamps on cars ahead are scarcely visible. This is caused by the fact that green is the complementary color to red and practically absorbs it when it is seen through transparent material. Recently, a smoky fog or chartreuse-colored visor has been placed on the market, which, tests have shown, permits accurate identification of red, yellow or green lights and also protects the eyes.

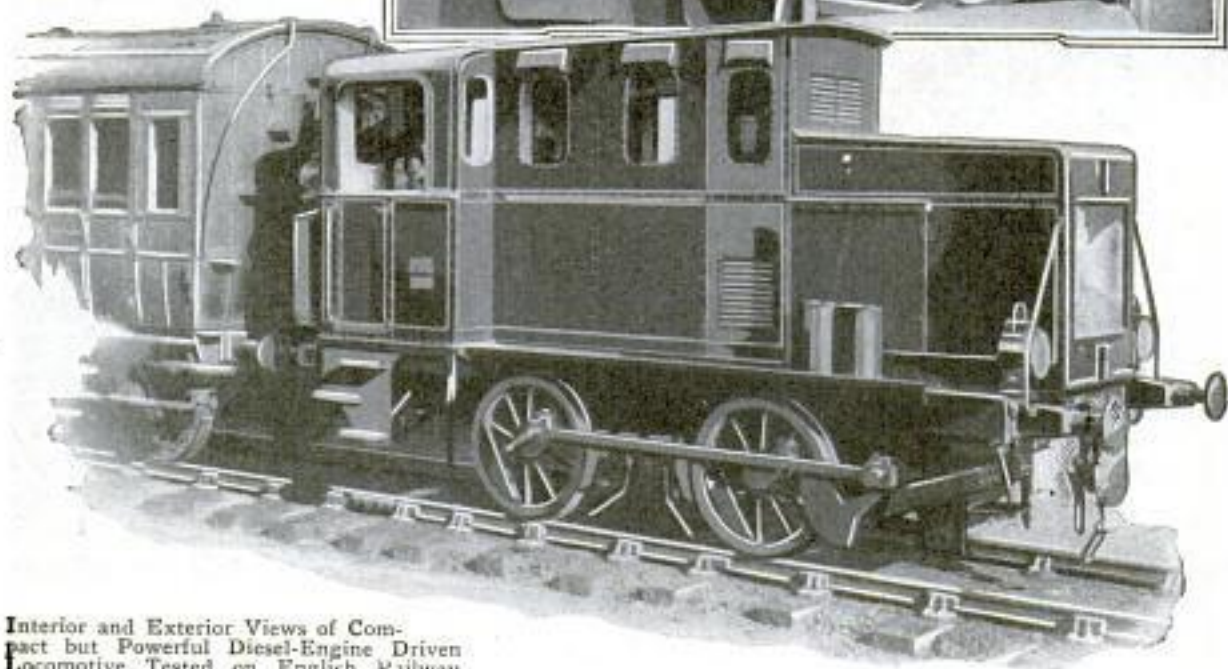
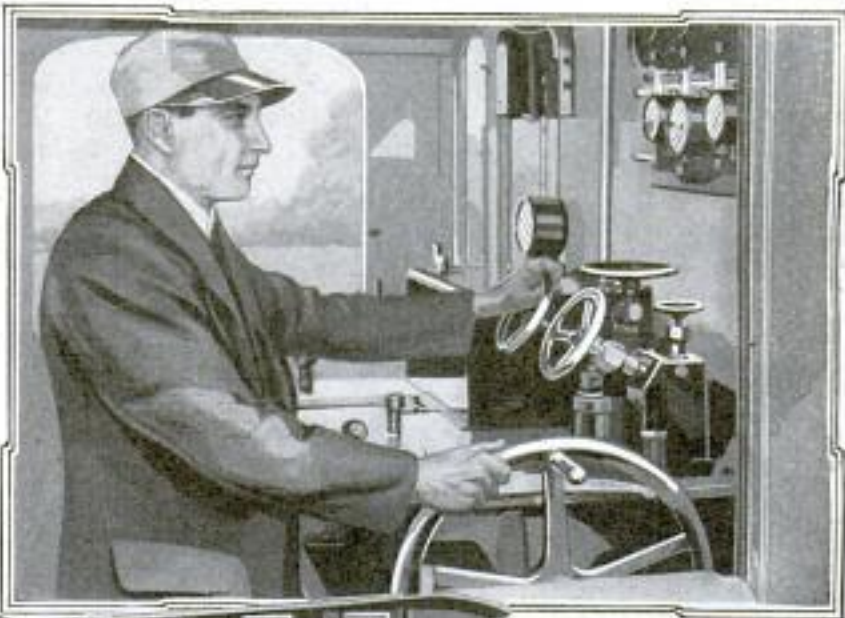

Interior and Exterior Views of Compact but Powerful Diesel-Engine Driven Locomotive Tested on English Railway

Chas. H. Lehty, Gen'l. Herman Kemp, Erie, Pa. General Electric Co.

*1981
munk
Prahem, munk*

M. W. Strude Co. 2009 St. Chicago Michigen, Ill.

Towerless Windmill on Ground with "Merry-Go-Round" Sails

Sleepily swinging in the breeze, the seven flapping sails of a quaint old towerless windmill used for irrigating near Tientsin, China, remind the traveler that

days, running and stopping automatically according to the degree of warmth in the house. It is said the heater needs lighting only at the beginning of a season, and minimum temperatures can be changed at any time by adjusting an ordinary lighting

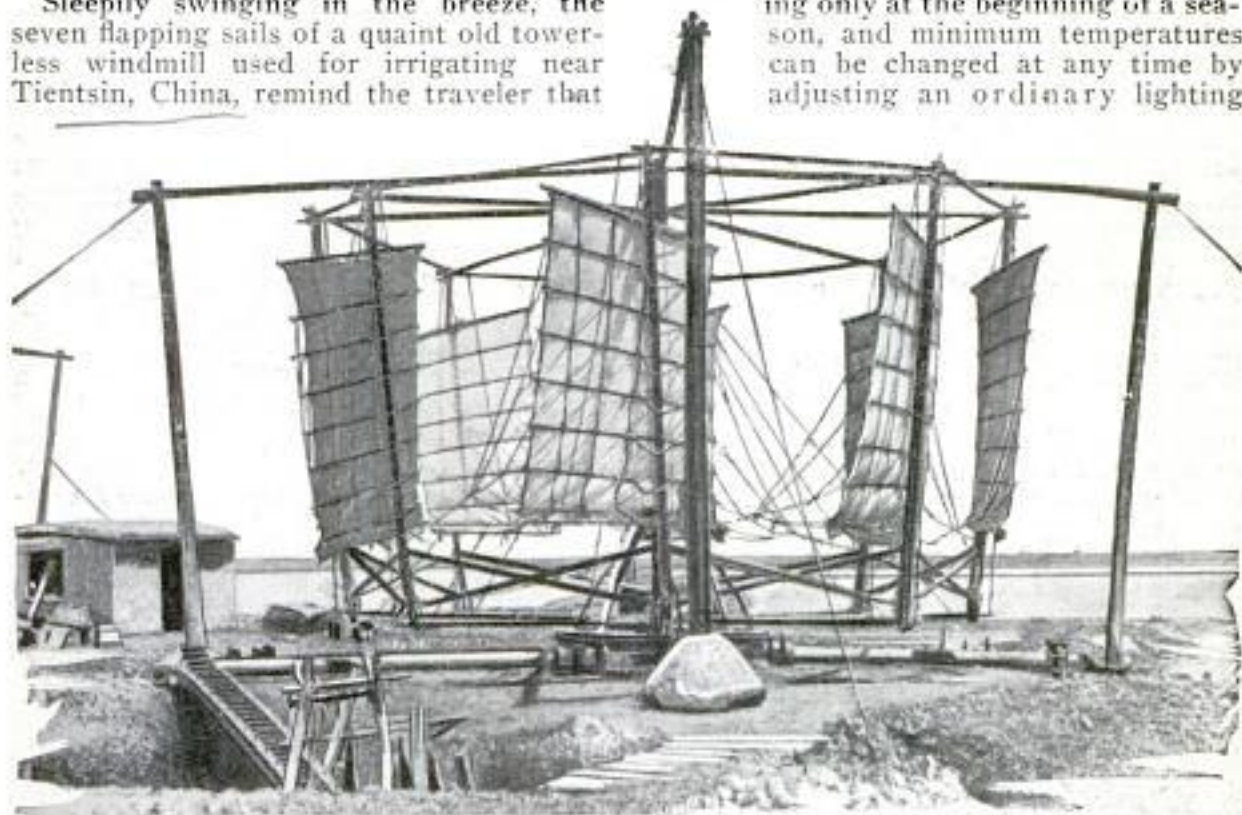

Antique Chinese Windmill Used for Irrigating; the Seven Sails Revolve in Their Framework, Turning a Shaft That Lifts Water in Bucket Chain from Stream to Canal

although the orient is rapidly adopting modern methods in industry, relics of the past are still abundant, and with characteristic tenacity many of the Chinese yet cling to the ways of their forefathers. Lashed to an elaborate framework of poles, the ponderous sails are set at such angles that if the wind blows hard enough, they manage to turn like a fantastic, creaking merry-go-round, rotating a geared shaft at the bottom of the mill. This operates an endless bucket arrangement that lifts a thin trickle of water from a ditch below into a small canal that runs to the fields.

switch controlling the air and fuel feeds. During the period of burning, the coal is always in motion and is agitated by a device that insures complete consumption, thus reducing soot deposits and waste. Having few working parts to require replacing, the burner is claimed to accomplish great savings.

Electric Coal Burner Saves Fuel and Ends Smoke Evil

To provide a means of heating building and firing small power plants automatically, an electric coal burner that feeds fuel to a furnace when the temperature drops below a certain point, draws its supply from a hopper and deposits the cinders in an ash holder. Designed to operate without other attention, the apparatus requires only the filling of the bin and removal of ashes every three or four

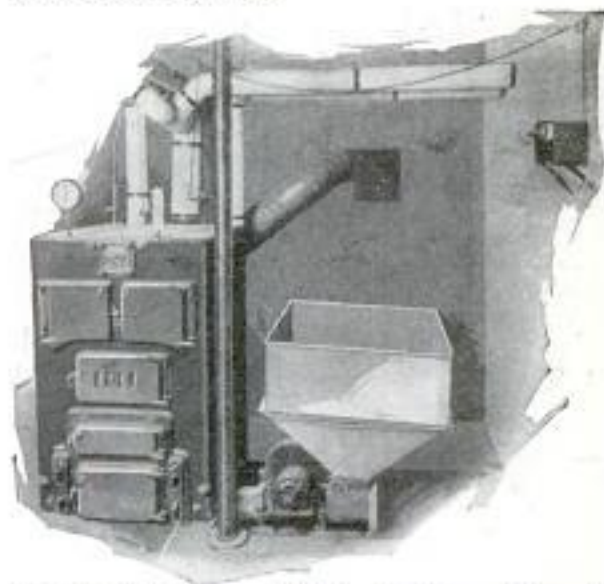

Electric Coal Burner That Feeds Fuel and Attends Fire Automatically When Temperature Decreases

*The Electric Coalburner Co., 110 C. M. Wrighted material
Deplains St. Chicago*

Concrete Lumber Co.,
 2500 San Fernando Road
 928 Los Angeles, Calif.
 Concrete "Lumber" in Place of
 1740 Wood to Cut Building Cost

Universal Traffic
 Signal Co.,
 2751 E. 51st St
 Los Angeles, Calif.
 Moving Hand-on Traffic Signal Adds
 1748 to Safety at Street Crossing

To save time and building costs, a western contractor has patented a process for making "lumber" out of concrete. The material is prepared in the form of thin, wire-meshed slabs, weighing about forty pounds less per cubic foot than ordinary concrete and designed to have better fire-resisting qualities. The pieces are made in an eight-foot standard length and in other sizes, in widths ranging from six to twenty-four inches. They are fastened by steel clamping bands and can be used not only as siding but for floors and ceilings as well. Placed on the outside of ordinary concrete columns, they are said to prevent cracking in case of fire and on interior work can be adapted for lathing and plastering and for wooden moldings. Rapidity of construction is claimed for them as they eliminate the need of sawing and driving nails and preparing concrete forms. It is estimated that on a garage, twelve by nineteen feet, they will effect a saving of nearly \$300 over lumber.

Fitted with a bell and a large visible indicator that shows how much time there is between the "stop" and "go" signs, an improved electric traffic signal has been installed in a western city and is said to have materially reduced the number of accidents at busy intersections there. The indicator is in the form of a hand moving across a large dial, the upper half of which is green with the word "go" painted in white letters on it and the lower half red with the sign "stop." To the hand is attached a metal shield which travels in a circuit and alternately covers the red and green area and the signs. The instant one side is covered, a bell rings and either the red or the green light flashes, revealing the proper legend. This traveling indicator, which can be regulated to move at various speeds, is of special service to pedestrians as they can easily tell how

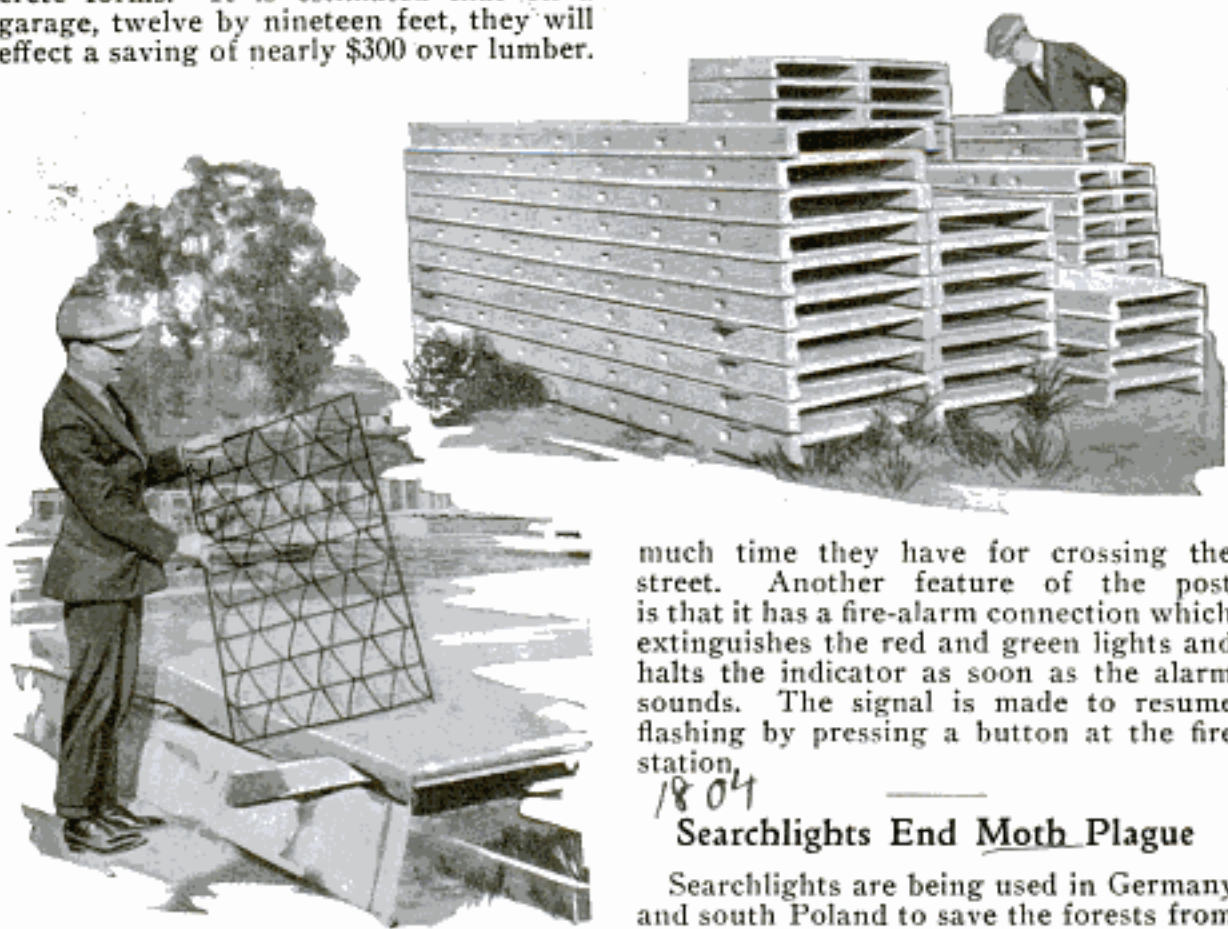

Concrete "Lumber" Pile and a Section of the Wire Meshing That Gives the Slabs Strength

No seasoning is necessary, it is claimed, and when used in house construction, an outer coating of liquid cement will effectively hide the joints.

much time they have for crossing the street. Another feature of the post is that it has a fire-alarm connection which extinguishes the red and green lights and halts the indicator as soon as the alarm sounds. The signal is made to resume flashing by pressing a button at the fire station.

1804
Searchlights End Moth Plague

Searchlights are being used in Germany and south Poland to save the forests from swarms of caterpillars, the larvae of a species of moth. When the lights were set up at night in the woods, millions of the insects, attracted by the powerful rays, were cremated when they flew into the incandescent carbons of the arc lamps, which were not sheltered by globes.

Chicago Herald-Examiner
 9/6/24
 Copyrighted material

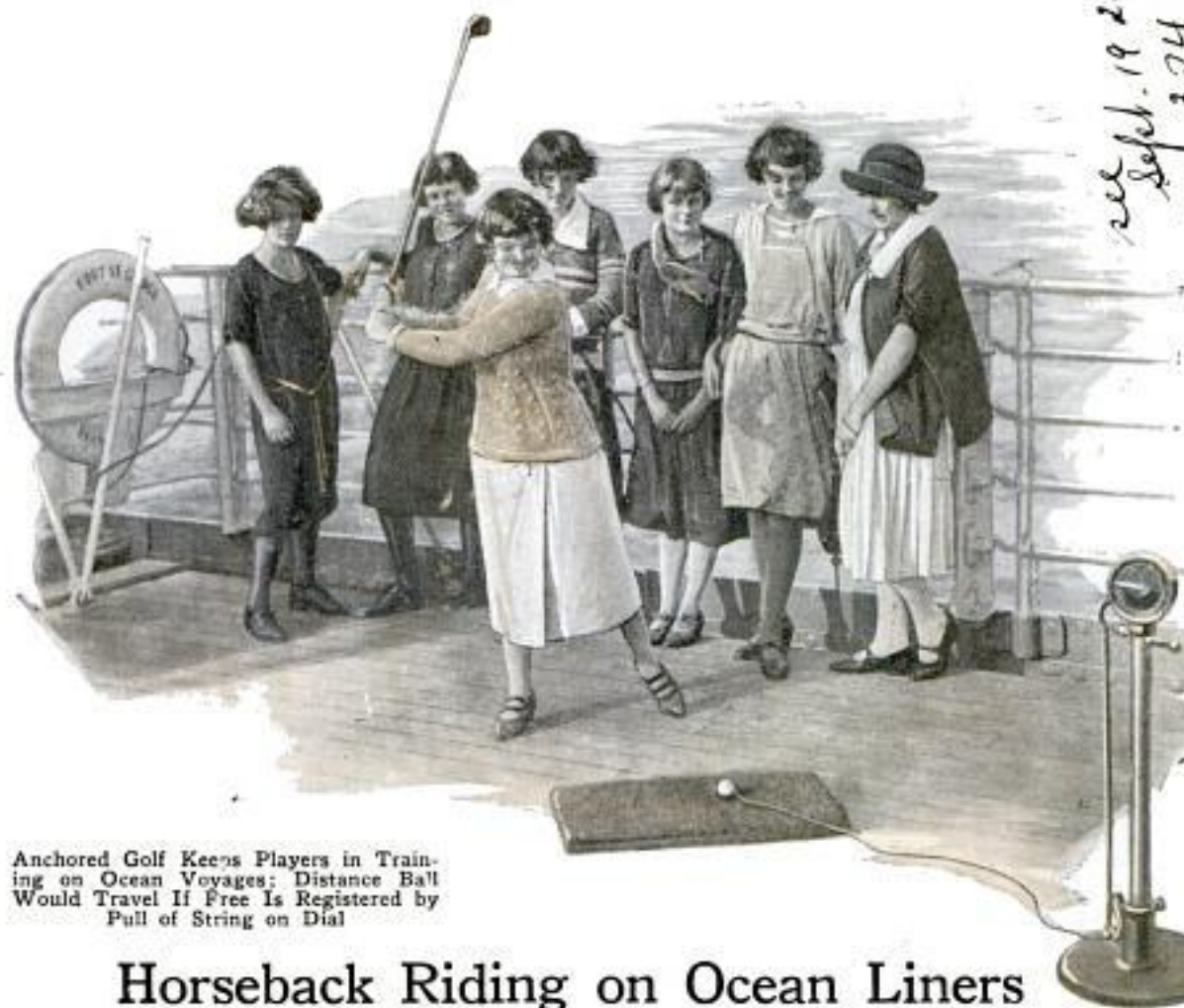

Anchored Golf Keeps Players in Training on Ocean Voyages; Distance Ball Would Travel If Free Is Registered by Pull of String on Dial

see Sept. 19 21
 Sept. 3 24
 Craig Golf Machine Co.,
 590 Howard St. - Francisco Caly.

Horseback Riding on Ocean Liners

Bicycle Races, Steeplechases, Golf, Tennis and Other Amusements Are Invented for Passengers on Steamers

PARALLELING the race for speed and size in the palatial ocean liners, there is a constant search for new amusements to keep passengers interested and contented during the voyage. The old-fashioned turn about the promenade deck, with a band concert in the evening and, possibly, amateur theatricals on the last night at sea, along with the captain's dinner and the grand ball, have been supplemented with elaborately equipped gymnasiums, swimming pools, golf, tennis and a host of other deck games.

Many passengers, for want of something else to do, get more exercise nowadays on an ocean crossing than they take on land. The sea has led in developing games that any amateur can play, from shuffleboard to racing, and it is not at all unusual to see a dignified first citizen from home or his wife indulging in such pastimes as bean bag or a three-legged race before dinner. For the passenger who takes his exercise seriously, however, the gym-

nasiums of the "Leviathan" and other big American liners; the "Berengaria," "Majestic" and sister Cunard and White Star ships, or such boats of the French and German lines as the "Paris" or "Columbus," offer a wide field of choice.

One of the newest and most popular devices is an electrically operated horse which can trot, canter or gallop at the turn of a switch. One's morning ride through the park can be done on this steed, fastened to one spot on the floor.

For the amateur boxer who isn't satisfied to keep fit on the weight machines and punching bags, there is a grotesque figure of an opponent, rocking wildly about on its rounded and weighted base at every lusty punch, but always coming back for more punishment on the rebound.

The deck games, open to the tang of fresh salt air, requiring no previous experience and skill, remain the favorites, however. A fair game of tennis can be played on the broad decks, while on some

1650



Deck Tennis Proves a Fascinating Sport for Old and Young while Crowds Gather around the "Bookies" Just before an Exciting Afternoon of Mimic Horse Races



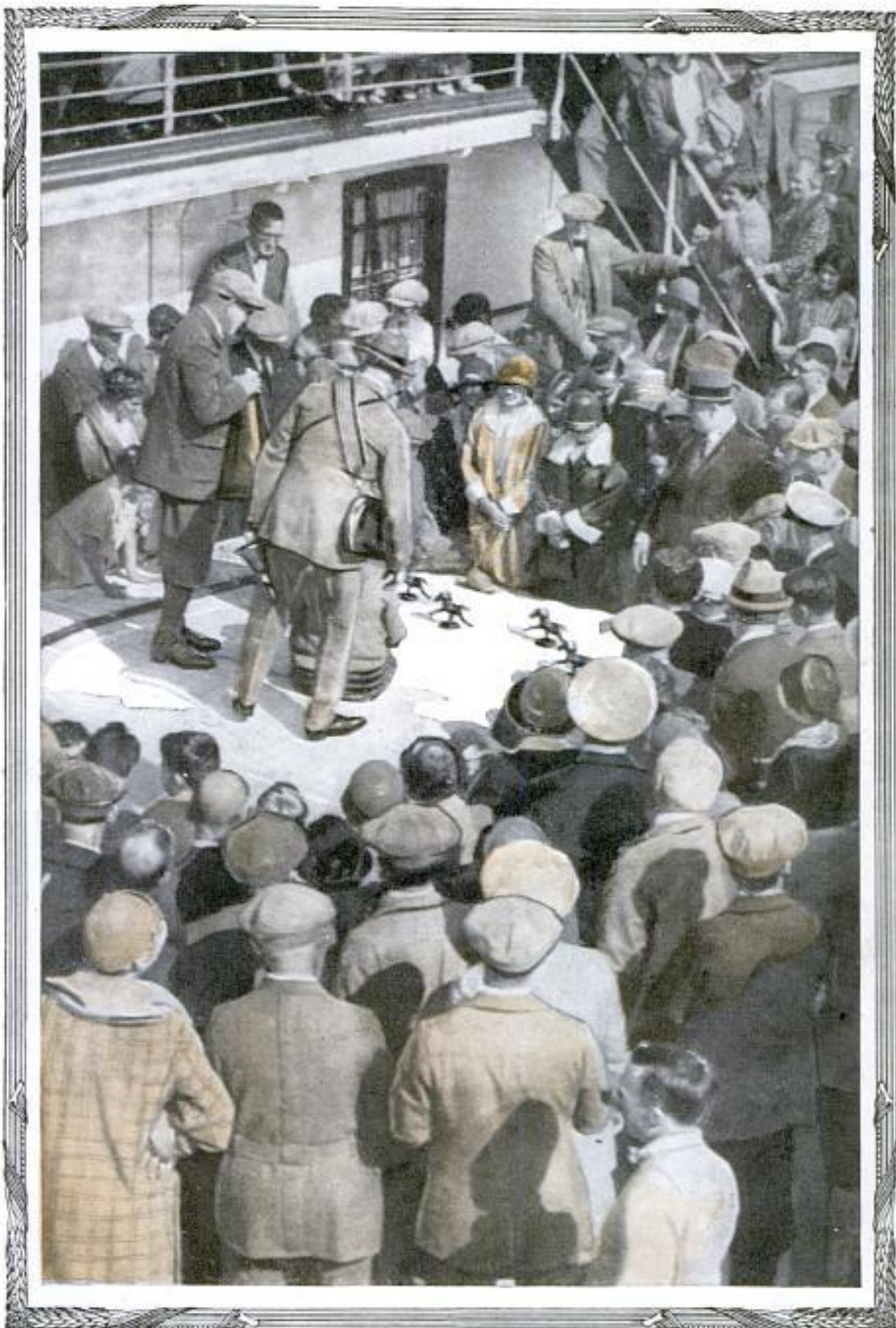

Toy Horses That "Gallop" Forward Spasmodically at Varying Distances Determined by the Throw of Dice Give Passengers Thrills of a Real Track

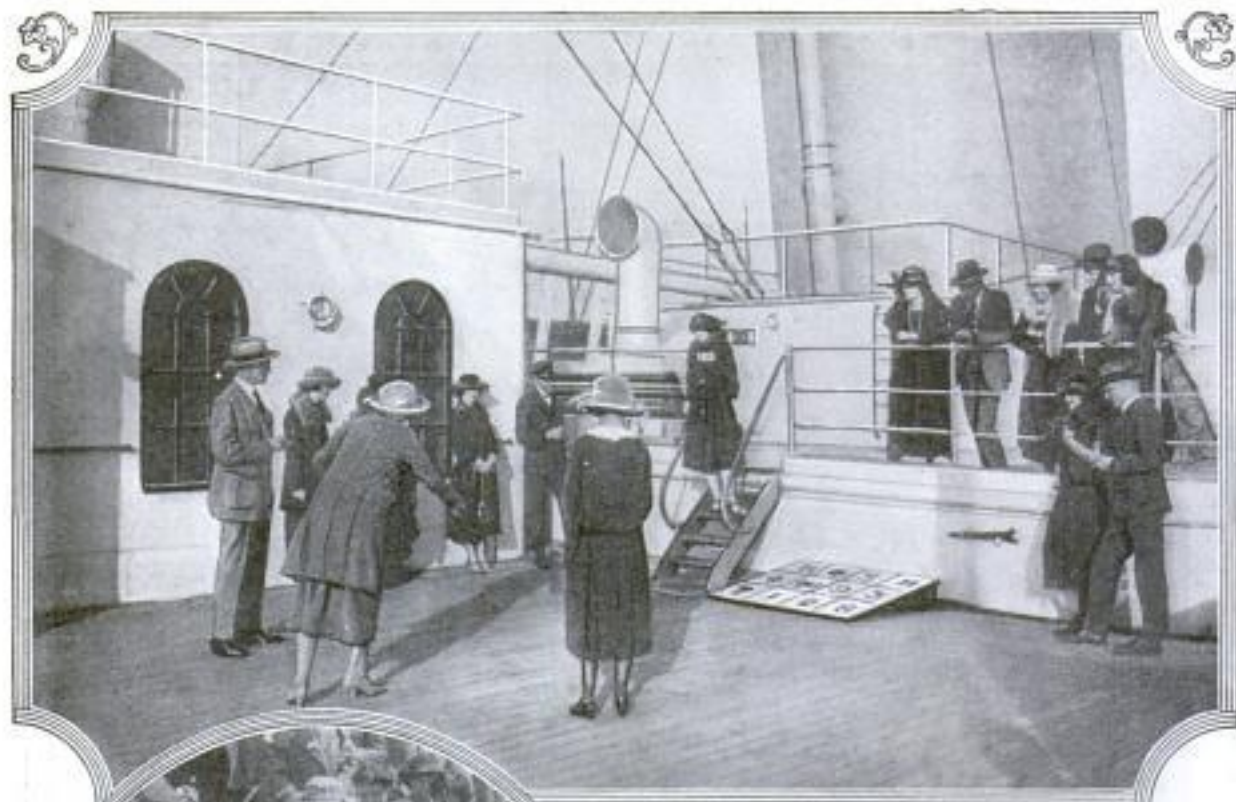

"Bull Board," Played by Pitching Weighted Pads at Figured Squares on an Inclined Plane, is a Popular Deck Game in Fair Weather as is Ring Toss, Trying to Throw Rope Loops over Numbered Pegs; Spectators and Players Both Enjoy a Spirited Deck Game, Which is a Combination Hockey and Mimic Polo Contest Played in a Wooden Frame Which Has Cross Divisions with Gates for the Passage of the Ball



1650



Salt-Water Bathing and Swimming Can Be Enjoyed While the Ship Forges Ahead by Filling Canvas Tanks Rigged to Ropes on Deck and with Ladder for Diving Board

1650



Deck Tennis Played with Rings Instead of Balls and with Net Set High over Ruled Court as in Volley Ball

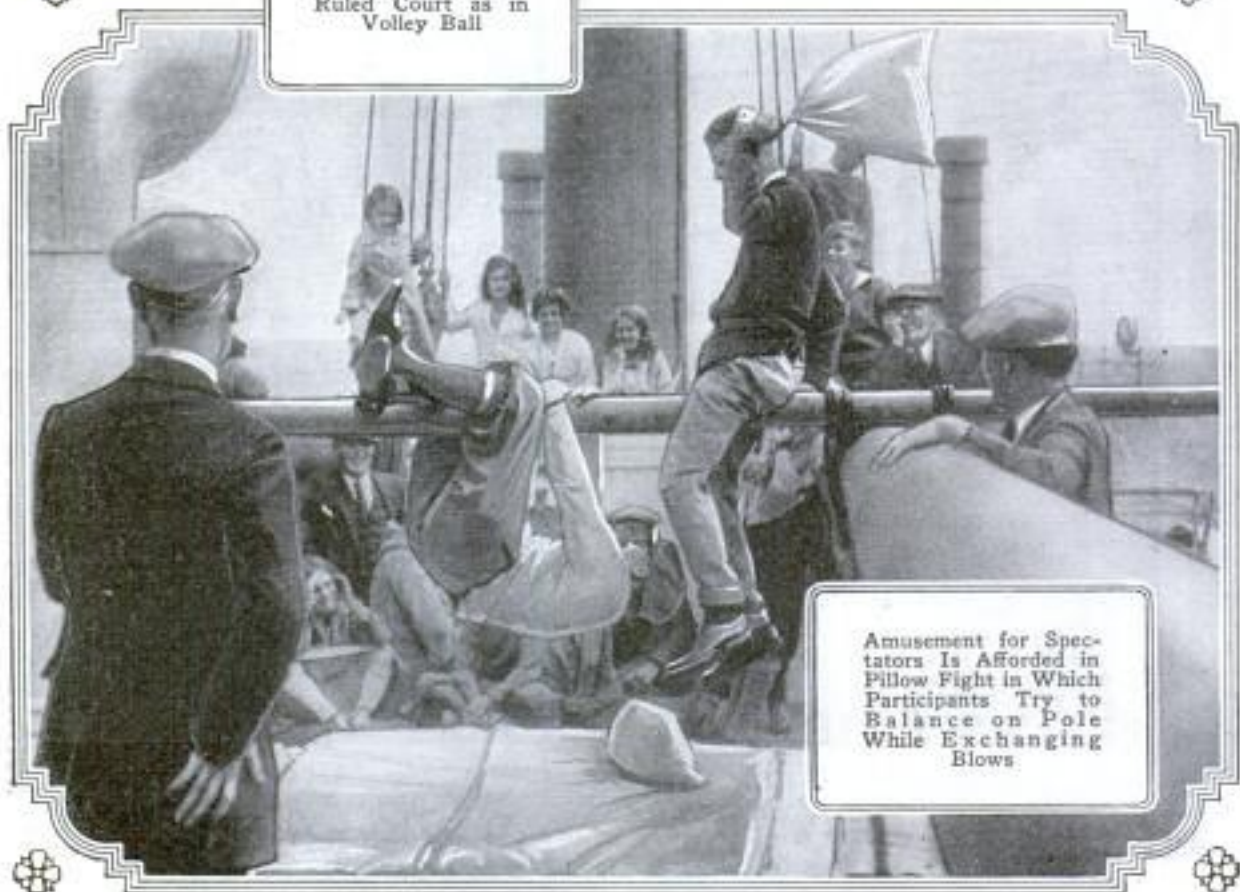

Amusement for Spectators Is Afforded in Pillow Fight in Which Participants Try to Balance on Pole While Exchanging Blows



When Big Passenger Steamers Cross the Equator, Elaborate Ceremonies, Including Mask Balls in Honor of Father Neptune, and Presentations of the Key to the Deep Are Held in Celebration of the Event; Inset and Upper Photo Show the Sea God in Costume and Party during the Action of a Pageant Ball; Below, Father Neptune Surrendering the Key to "Davy Jones' Locker" to a Voyager About to Cross the Ocean; Mask Balls of This Kind Are Favorite Amusements on Large Ships and on Long Cruises. Realistic Costumes Are Often Obtained Directly from the Countries the Fun Makers Represent.

1650



Dancing on the Waves Is as Popular as on Land and Impromptu Orchestras of Passengers Add Zest to the Pastime

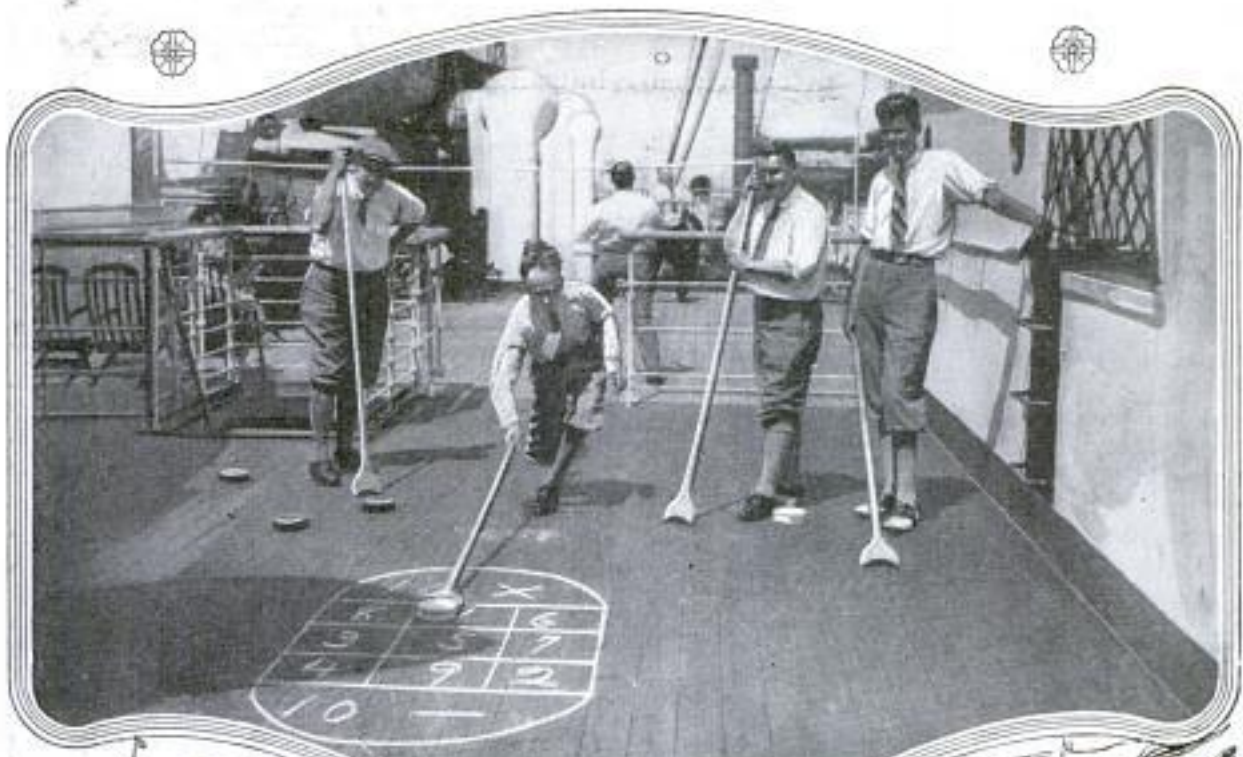

"Shuffle Board" Long Has Been Favored among Deck Diversions, and Does Not Yield Even to Jazz Such as Is Furnished by Student Orchestra Below



liners, particularly on the New York-South American runs, there is an amusing imitation in which rope quoits are used instead of balls and racquets. The net is stretched five feet from the deck and the quoits are tossed across it, to be caught by the opposing player. The rules and scoring are practically the same as in the usual tennis game.

Keeping several hundred passengers amused is a difficult task. On the bigger liners for the comparatively short run across the Atlantic the problem more or less solves itself, but on smaller ships on the longer runs, to South America, Africa and across the Pacific, the problem is more acute. On many of the long-run ships a passengers' sports committee is organized the first day out to plan masquerade balls, bridge tournaments, deck tennis, golf, shuffleboard, spar boxing and other games.

The special tours, where passengers are together for weeks, or even months, provide social directors with as many as a dozen assistants to a single ship. These social leaders are carefully selected by the tour managers, and must be men of exceptional tact and culture, attractive personalities, capable linguists, well versed in

the history of the countries to be visited, and, in addition, shrewd students of human nature.

Besides all the other amusements, there is always the sport of betting in the pool on the vessel's daily run. This lends zest to the making of new speed records. Racing has been resumed on the Atlantic during the last year, after several years of quiet. The "Leviathan" started it by hanging up a five-day seven-hour and twenty-minute record from Cherbourg to New York after being equipped with oil burners.

The "Mauretania," veteran of many speed records and sistership of the ill-fated "Lusitania," came back with a five day, three-hour and twenty-minute mark for the 3,098 miles, and later steamed from New York to Plymouth in four days, twenty-one hours and fifty-seven minutes.

Racing ships across the ocean has been a popular sport since the "Savannah," a 350-ton side-wheeler, cleared from Savannah, Ga., May 24, 1819, and docked at Liverpool twenty-six days later—the first steamer to cross the ocean. She carried sails as well as steam; in fact, sails did not entirely disappear from liners until about thirty years ago.



Girl Student Passengers Stage a Unique and Difficult Deck Race by Trying to Balance an Orange on Top of a Bottle While Hurrying to the Mark at the Farther End

Canaries Are Taught by Phonograph to Sing like Nightingales 1938

Phonograph records are being used by a German bird fancier to teach his young canaries how to sing like nightingales. Almost the minute the birds are hatched, their "lessons" begin, the records, repeatedly playing the nightingale's song, being kept going all day and sometimes far into the night. When the canaries are from six to eight weeks old, they are placed near the cages of real nightingales and are not permitted to hear the singing of any other birds. When they begin to sing, they naturally follow the notes they have always heard, and bring a price about five times as high as that of the ordinary canary.

Bowen Products Corp. Chicago, Ill.

Touch of Button Oils Auto Chassis Fitted with Lubricator Tank



For lubricating parts of the chassis, an automatic oiling system has been devised to replace grease cups. It consists of a reservoir conveniently placed beneath the floorboards, where it can be filled easily, and from which oil is distributed to the various parts through tubes by

pressing a button projecting near the driver's right foot. The tank holds sufficient oil for six months' supply and one push of the plunger a day, or less, is enough to provide thorough lubrication.

Uncle Sam Bakes Loaves of Bread to Test Qualities of Flour 691

Different kinds of flour are tested in one of the laboratories of the department of agriculture by baking loaves from various samples submitted for analysis and comparing the results for volume. There is often a noticeable difference in the size of the loaves although exactly the same quantities and proportions of ingredients have been used and they are baked under exactly the same conditions. When it is done, each loaf is weighed in special scales and carefully measured. The results are recorded and filed away with the name of the brand of flour tested. Before any

Adogram



Government Chemist-Baker and Different-Sized Loaves Produced from Various Kinds of Flour

sample is officially approved, it must meet certain requirements in the baking tests which are continually being performed to guard against adulterations and inferior qualities.

Hole Cutter for Wood and Metal Is Used Like a Wrench 1098

For cutting round holes from one and a quarter to six inches in diameter easily and neatly in metal, wood or practically any other material, a small device used like a wrench has been designed that does the work in a few minutes. A ratchet handle permits the cutter to be used in any position, against a wall, overhead, in corners or on the floor. Manual pressure is not necessary as a turn of a large nut applies heavy pressure to the knives. Weighing only five pounds, the device can be easily carried to any job or kept on a workbench in the shop.



5 sizes. Price - \$7.50 - \$20.00.

Paul W. Koch + Co., 1925 Wells, Chicago

Ride on Stationary Bicycle Tests the Efficiency of Muscles

Tobacco Grown in Western Canada Increases Dominion's Crops

1896

1922

Experiments to determine the efficiency of the human muscles are conducted in one of the laboratories at Cambridge university by putting subjects

While Canada has an annual tobacco crop which goes a long way toward meeting that country's demand for the product, the output has been greatly increased by the successful cultivation of the plant in the western prairie provinces. Although the land devoted to it in British Columbia rarely exceeds sixty to seventy acres, the harvest ranges from 60,000 to 75,000 pounds. Due to the warmth of the valleys and protection from severe weather, commercial tobacco is said to be readily produced. The plants are made up of heavy foliage, are easily cured on the farms and can be made into good cigars and other products. Even in Alberta north of the fifty-fifth degree it has been shown that the crop may be cultivated with little trouble.

England



Rider Taking Bicycle Test for Muscular Efficiency; Breath Is Exhaled into Mask Device

through tests of strength and endurance and studying their performances with special instruments. In the trials, a man mounts a stationary bicycle, which can be adjusted to give varying degrees of friction and is connected to measuring gauges to show speed and the force exerted. As the rider pedals, he exhales into a mask arrangement where the moisture of his breath is collected and later examined and measured. Means are also provided for weighing and examining the perspiration from the man's body. By computing the amount of energy required to operate the bicycle and estimating the bodily fuel consumed as shown by the breath and perspiration, scientists are able to make deductions as to the strength and efficiency of the muscles.

Unloading Freight Cars Simplified by Detachable Steel Chutes

1669

For unloading coal, sand, gravel and similar bulk materials from gondola freight cars, a detachable steel chute that fits on the side of the car and dumps directly into the trucks or wagons, has been devised to save time and labor. Reinforced by heavy steel angles and tees, the box holds a cubic yard or more, and by pressing a lever, an outer side door opens and the contents slide into the wagon. While the wagons are gone, the shovelers can fill the chutes for quick unloading when the drivers return. The chutes are easy to attach, are strong and durable and prevent scattering of the material.



Emptying Loaded Chute into Truck While Shoveler Fills Another Clamped to Side of Car for the Next Driver

The Snow Co.,
Louisville, Ky.

Copyrighted material



Copyright, Underwood & Underwood

Perfect Hit Made by a Battle Plane Using Phosphorus Aerial Bombs during an Exhibition Engagement with a Fleet of Armored Tanks Opposing the "Invading" Airmen

War Tank Is Wrecked by Airplane during Battle Maneuvers

Scoring a perfect hit, an airplane participating in an attack on battle tanks, during maneuvers of the New York national guard, dropped a phosphorus bomb directly on the "enemy." When the cloud of smoke cleared away, the moving fortress was lumbering ahead, although, according to the rules of the contest, it was "demolished and its crew destroyed." Harmless projectiles used by the aviator squadrons cause great puffs of vapor to arise when they explode to show the accuracy of the aerial fighters. Observers keep records of the "strikes" in order to determine what percentage of the missiles find their targets.

Barber Shop on Auto Calls at Homes to Save Patrons' Time

For those who prefer to have their tonorial work performed at home, an enterprising barber of Wichita, Kans., has rigged up a shop on an automobile in which he calls on his "trade." The arrangement saves time for the grown-ups,

since children's hair can be cut according to their wishes without the necessity of accompanying them to an ordinary "parlor." Advance appointments can be made with the "barber shop on wheels," avoiding long waits for the call of "next," and



Barber Shop on Wheels Which Makes the Rounds of Patrons' Homes to Do Their Hair Cutting

women with bobbed hair can get it trimmed without leaving the vicinity.

☛ Approximately 15,000,000 bananas are consumed every day in the United States.

1658



The "William Crooks," Pioneer Mogul of the "Sixties," Which Recently Hauled a Train of Old-Time Coaches on an Exhibition Run, and Group of "Passengers" Costumed in the Fashions of Its Day

1658

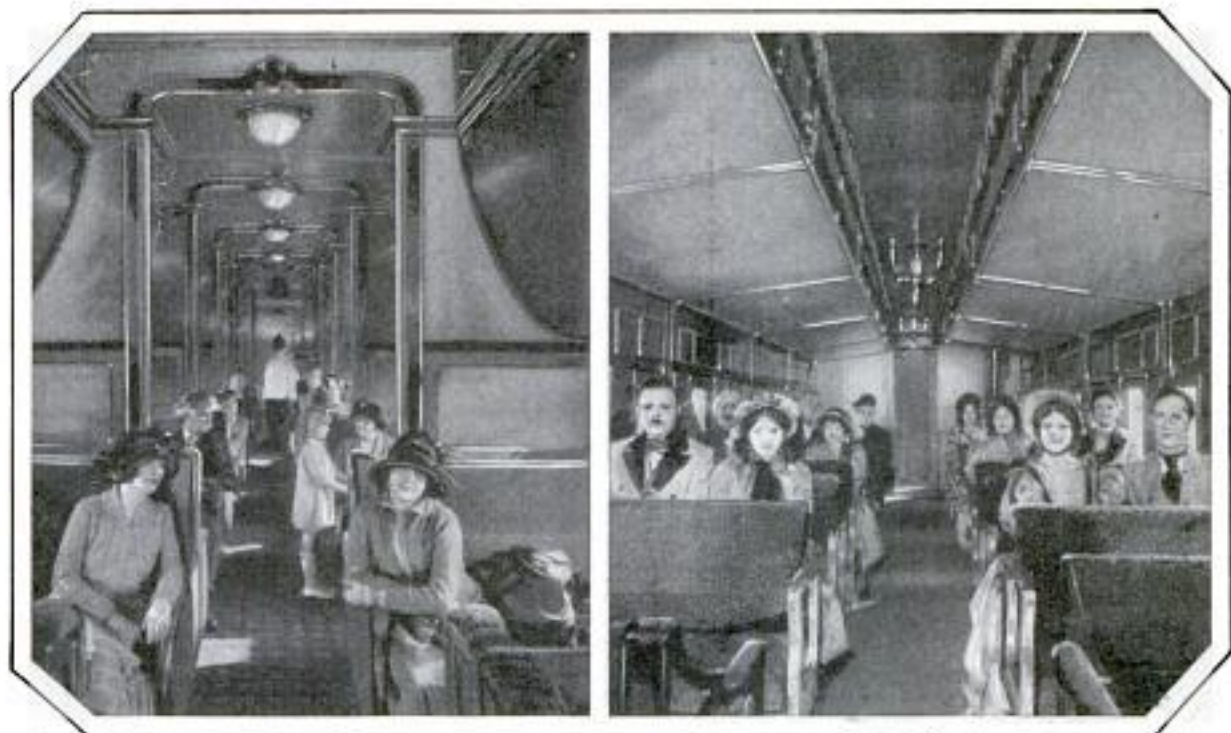

Permanent Steel Headboards for Berths of the New Mountain Type of Sleeping Car and, Right, Interior of Old "Number Nine," the First Palace Car, and, a Luxury of Sixty Years Ago

How Pullman Cars Are Named

Care and Judgment Used in Selecting Titles for Wheeled Palaces That Make Long Railroad Journeys Enjoyable

AFFORDING the tired traveler a haven of rest and comfort amid luxuries that have converted long, tedious railroad journeys into sojourns of enjoyment and safety, the Pullman car of the present severely contrasts with its boxlike ancestors of sixty years ago. The first "palace" sleeping car, built in 1858, was composed of two day coaches remodeled and combined in one. The berths were crude affairs compared to the elaborate, cosy beds which are now made up nightly by the busy porter.

While the early types of parlor and sleeping cars were less than fifty feet long, a massive length for those days, the present models stretch for almost twice that distance. Steel, both inside and outside, has taken the place of wood for construction. But the painters' art has so thoroughly disguised the metal, that it resembles highly finished mahogany where used on the interior. Soft, velvety carpet covers the floors from end to end, laid over a magnesite composition that is reinforced and protected against cracking by special corrugated steel sheets.

Approximately 300 cars are built yearly by the Pullman company at a cost of about

\$38,000 each. Although the life of the metal car has not been determined, that of the modern wooden type is placed at twenty years. Repairs and replacements of worn parts, however, often greatly increase their term of service.

Romantic and poetic names that grace the sides of the cars were early substituted for numbers to prevent mix-ups in recording rolling stock among the various railroads. Names of countries were first employed. Then, as many railways expressed desires to have their stations represented by such Pullman cars as might be allotted to them, towns and villages were selected. When dining and commissary cars made their appearance, these were given the names of popular chefs of history, among whom were such as Aberlin, Magdelin, Savarin, and Valentin, whose savory dishes once tempted the appetites of France's royalty. Prominent hotels of this and other countries also were selected as names to identify the diners.

Birds, flowers, lakes, rivers, and poets and statesmen of note have been represented in titles for the rolling parlors and lounging rooms. Recently a new type of sleeper was constructed, known as the

1658



How Overnight Travelers Enjoyed the Scant Quarters Permitted in Gloomy, Crowded Coaches before the Days of the Palace Car, as Seen by an Artist of That Time

mountain-type car, not because this model is for use in hilly sections but on account of the series of names attached to them, all of which are composed of the word "mountain" and one other, such as "Mountain Lake," "Mountain Glen," and similar combinations.

Names are selected by the Pullman company officials, who study them from every

angle before they are permitted to ornament cars. Seldom is an outside individual allowed to christen a car, and it is said the method of selecting names which might interest patrons, serves to arouse a desire in the minds of the public to learn something of the originals of them. For this reason, authors, historical figures, prominent places, rivers and provinces of

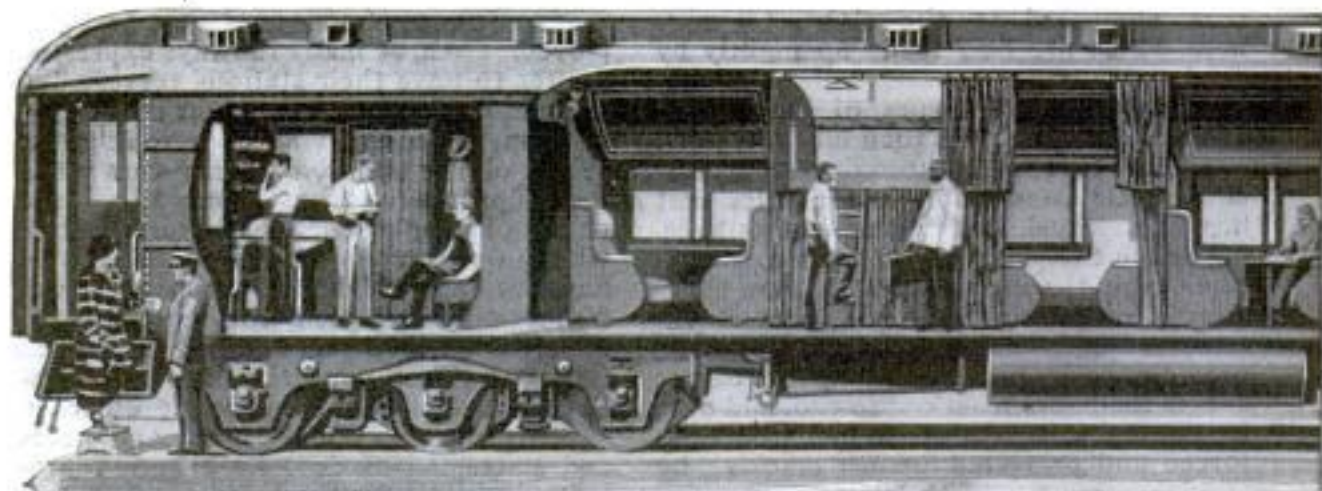

Sectional View of Pullman Car Showing Elaborate Conveniences Afforded Travelers Who May Embark on a Long Journey amid Restful Surroundings Found in Most Up-to-Date Homes

1658



Old Open-End Coaches of a Type Now Rapidly Passing from Use to Make Way for the Solid Vestibule Trains That Aid in Providing Comfort and Safety for Both Passengers and Crew

far-off lands, are believed to fill a double purpose when applied to a train of ornate coaches that help to make life comfortable for professional travelers and railroad journeys attractive to tourists. Of course many names are submitted by employes of the car builders and members of railroad staffs, but all are subjected to the test

before sanction by those charged with christening the cars. It is believed the only "outsider" considered under the rule was Joseph Jefferson, the actor, who became famous in the role of "Rip Van Winkle." At his request a car assigned to him for use during his tours was renamed with the title of his popular play.

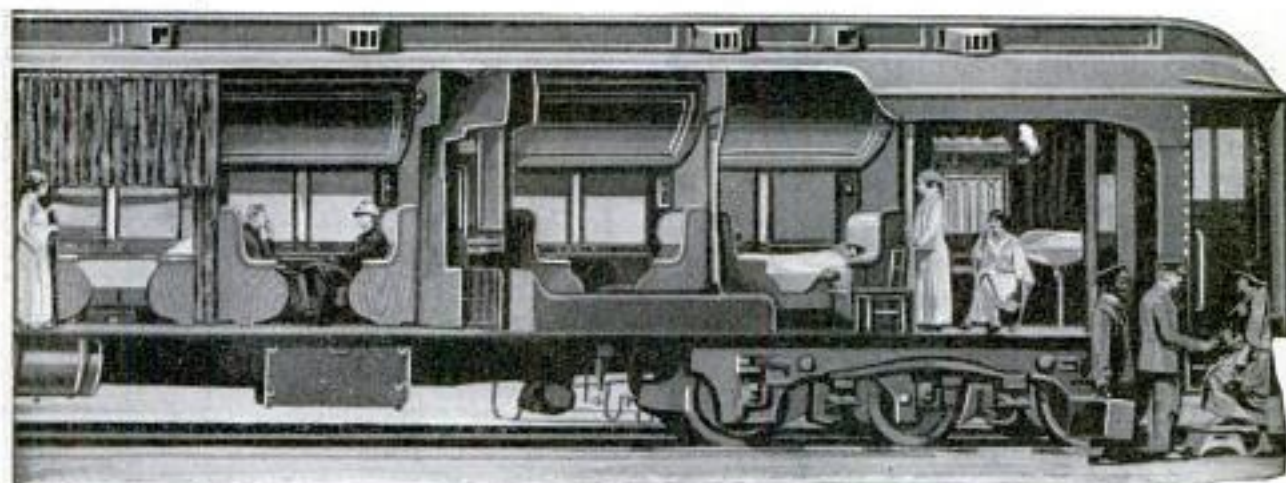

Well-Lighted Interiors and Cozy Beds, Artistically Concealed during the Day, Convert the Sleepers into Ornate Rivals of the Best-Furnished Hotels When Night Arrives

1745 **Cypress Ship, Sixty-Eight Feet Long,
to Sail around the World**

Paving the way for progress in navigation that is expected some day to make cities on the Great Lakes and along the Mississippi ports for ocean steamers, a little cypress ship, sixty - eight feet long, slipped out of Chicago recently for a two - year trip around the world. She entered from Lake



With Sails Set, the All-Cypress Ketch "Big Bill" Starts on Her Two Years' Cruise around the World for the Promotion of Commercial Relations

Michigan through the Chicago river, passed through the Illinois - Michigan canal into the Illinois river and thence to the Mississippi and the Gulf, the first ocean-going ship to make the route in several generations. While it was announced that the voyage was ostensibly for the purpose of making motion pictures of the tree-climbing fish and other wonders of tropic islands, the principal object of the undertaking is to establish commercial relations with foreign ports looking to the day when a Great Lakes-to-the-Gulf waterway will link inland United States directly to harbors abroad.

The craft is of the style known as a ketch and is designed after the boats used by Norwegians in carrying fish to England. She has a sixteen-foot beam and is equipped with a radio broadcasting apparatus with a range of 3,000 miles, a phonograph, gas stoves and an elaborate array of maps, and carries an auxiliary power plant in a kerosene-burning engine. Considerable interest was aroused by the fact that the ship was not painted above the waterline, this being thought unnecessary in view of the durability of the wood.

1806 **Making Weather for Workers Aids
Quality of Factory Products**

Manufacturing the "weather" inside large industrial plants by constant control of the temperature, humidity and circulation, has come to be a necessity in several lines. It allows routine processes to be followed regardless of the behavior of the elements outside, standardizes the product, increases the output and tends to lower costs. Many large firms have therefore installed elaborate air, heat and moisture-regulating apparatus in their workshops. In the rubber industry particularly, this has been found important. When drying rubber, for instance, a continually even temperature is essential to insure a uniform quality and, in cementing, it is necessary that

evaporation and other processes occur under even conditions to avoid weakening the rubber and causing blisters.

India Rubber World 9/1/29

1764 **Thistles Prove Profitable Crop**

Edible thistle buds, closely resembling artichokes, are among the profitable crops in certain parts of California where soil and climate seem ideally suited to the cultivation of this variety, a huge Mediterranean species with large spines and big purple flowers and which does not seem to thrive elsewhere in this country. The

New York Sun 9/2/29 copyright material

1924

buds are sold for as much as twenty-five cents apiece and are highly esteemed as a table delicacy. Growers cultivate them in such a way that they are ready for market at a time when there is little competition with other products, the harvest beginning in October and reaching its peak about the first of April. Last year, 500 carloads were shipped, the bulk of the crop going to cities in the east where the demand for artichokes has greatly increased.

Roadside Scale for Weighing Autos Aids Traffic Survey 1526

Highway inspectors engaged in a survey of automobile roads and traffic in Illinois, were aided in their work by a portable scale for weighing vehicles without causing great delays or inconvenience to the drivers. The outfit was placed under a small inclined platform at the side of the road where automobiles could be run upon it with little trouble. Weight on each wheel was plainly registered on the dial as the autos passed over the scale. While the weighing clerk was making his notations, other inspectors quizzed the drivers to find out the origin and destination of the vehicles, the kind of business engaged in and the sort of load carried. The information is to be used in making a scientific analysis of traffic conditions



Copyright, Underwood & Underwood Weighing Auto on Portable Platform Scale during Traffic and Highway Survey

looking toward the construction of improved highways.

Portable Darkroom Worn as Hood Aids Traveling Photographers

When regular darkroom facilities are not available, photographers may have a



Photographer Wearing Darkroom Hood with Square of Ruby Glass Visible in Front

practical substitute in a portable one in the form of a close-fitting piece of rubber material that slips over the head like a hood. It contains a square of ruby glass for developing and changing plates, etc. At the bottom, it fits tightly to the body so that no light is admitted, but its folds are loose enough to permit ample freedom for the arms and hands. It can be quickly wrapped into a compact package and fits in a small space in the camera case.

Green Lumber Reduces Home Cost 1973 by Using Calked Seams

A process by which green lumber can be substituted for seasoned material in building outer walls for frame houses has been discovered by a Swedish inventor who uses thin boards with straight edges instead of the tongue-and-groove joint. To take up the shrinkage and warping during the drying period after the planks have been put in place, the seams are well calked and covered by protective wood strips which are removed while the lumber is shrinking so the filler can be driven farther into the openings. When the weatherboarding has been thoroughly seasoned, which generally requires about eight years, the strips are permanently fastened.

Pool's Stringless Spectacles
329 W. 25th St. New York City

New York Times

3/21/24
Copyrighted material

Cement Guards Lights of "White Way" from Wind and Heat

To combat the heat of the lamps and jarring caused by traffic, the light sockets



Copyright, Keystone View Co.

Pouring Protective Cement over Sockets and Wire Contacts of a Newly Built Electric Sign

of electric signs seen along the nation's "white ways" are anchored in place by strong iron bolts and kept from working loose by a mixture of waxlike cement that resists the warping of metal frames due to weather changes and prevents short circuits caused by broken wires. After the signs are wired, the composition is poured over each socket, locking the connections in a mass of flinty material that can only be removed with a chisel. It is said this method keeps the apparatus in good condition for many years.

Safety Powder for Blasts in Mines Decreases Number of Fatalities

Nearly seventy-five per cent of the explosives used in the United States are consumed in the mines, according to figures prepared by William W. Adams, statistician of the department of the interior. His report, prepared for the bureau of mines, shows that coal mining last year required 270,124,438 pounds of explosives and that 56,806,709 pounds of this were of what is known as the permissible class, a dynamite that has a short flame, emits but little fume and is approved by the mine bureau after tests for use in shafts where gas and dust are likely to be found. In 1902, only 11,300 pounds of this short-

flame powder were used in coal mining, or less than one pound for every 1,000 tons of coal mined, while now from seventy-seven to ninety-three per cent of the permissible explosives manufactured are used for the coal-mine "shots," or about eighty-nine pounds for every 1,000 tons of coal. The increased consumption of safer forms of explosive is regarded as an important factor in reducing the number of deaths and injuries in mines.

Hoisting Tower on Auto Saves Time in Construction Work

Made of light angle iron, a hoisting tower has been mounted on the rear end of a small auto truck by a cement contractor to save time in moving from one job to another. The apparatus, capable of lifting and dumping a wheelbarrow load of cement, is operated by the motor of the car by means of a cable around a drum and a series of sprockets, one attached to the rear axle. When in operation, the rear

end of the machine is blocked up. To move it it is only necessary to take off the chains on the sprockets and lower the tower upon the truck.



Hoisting Tower on Rear of Auto Truck, Lifting Wheelbarrow Load of Cement



Wm. J. A. Todd, 4346
Peatona St., Denver
Colo.

1914



© U. & U.
Water Bicyclists in Formation at Sports Carnival on Seine

Queer Water Bicycles Add Thrill to River Carnival Sports

At a carnival on the Seine, spectators were given a novel entertainment by the performance of a company of water bicyclists. Supported by two boat-shaped pontoons and seated upon a strong framework rigged between them, the riders pedaled their singular craft in a series of drills, races and formations. Easily steered by the handlebars, the craft are said to be capable of considerable speed and, in quiet water, require but little exertion to operate them.

Gold-Coated Glasses Admit Light But Halt Glare and Heat 1805

Gold-coated spectacles, which admit light but bar heat and glare, have been perfected for workers who face the high temperatures and intense rays of metal-working furnaces. The coating is much thinner and more uniform than the finest gold leaf, and is placed on the glass by distillation in a vacuum. In use, the deposit gives a slight greenish tint to the light that passes through. The first application of the discovery was to motion-picture projectors, where a small disk of the glass interposed between light and film eliminates danger of fire, and makes it possible to stop at any point to view an individual picture. The discovery is expected to be particularly valuable in the use of movies to teach natural sciences in schools, the instructor being able to halt the picture to discuss any view.

Magnetic Rod Helps in Picking Up Bolts and Bits of Metal

For use in picking up nuts, screws or other bits of metal out of motor transmissions or from places hard to reach with the hand, a flexible magnetic rod has been invented. The magnetizing device is controlled by a thumb switch at the base of the handle and served with electric current through cords that can be easily clipped on any ordinary battery terminal. Because of its ability to pick up from one to two pounds at a time and the fact that it



Magnetized Rod in Use on Auto, and Diagram Illustrating Thumb Switch and Connections

can work in grease, oil or water, the rod is also useful in taking out or putting in bolts otherwise hard to reach.

Associate Professor of Physics
John Hopkins University
Baltimore - Md.

H. C. Gray Co. Seattle, Wash.
1315 Fifth

Chicago Tribune
Nov. 27, 1914
Mr. A. H. P. fund

1576
950

Carl Robert Moulton
Room 2, Board of Trade
POPULAR MECHANICS
Chicago

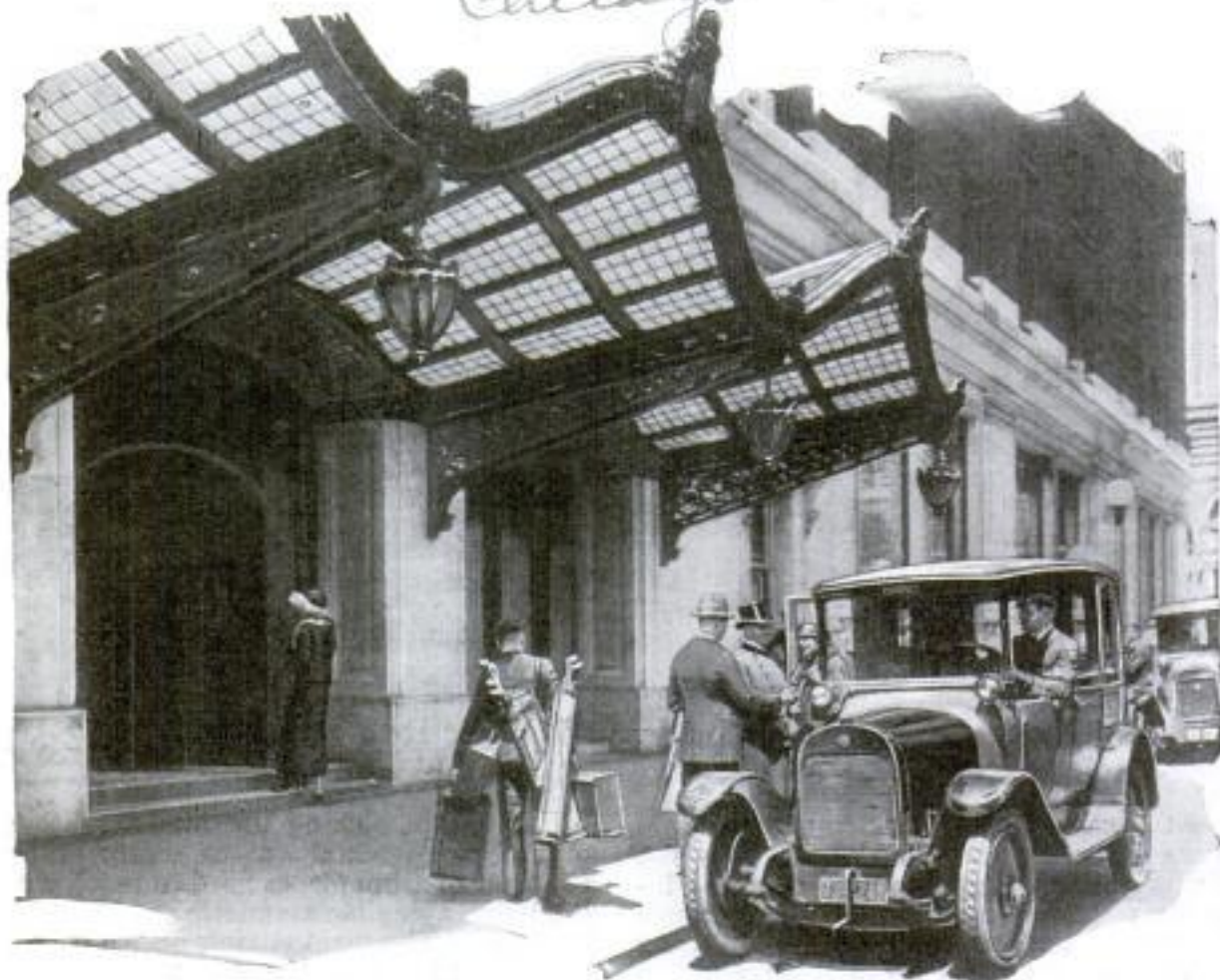

At the Portals of a Luxurious Modern Hotel Where Guests Find Comfort Arranged for Them by an Army of Watchful Attendants, Each Trained in the Part of a Host

Housekeeping on a Gigantic Scale

Factory Methods of Standardized Production Applied Even to Serving of Your Meals by Modern Hotels

TO the manager upstairs in his private office, the kitchen of a great hotel is simply a factory where perhaps 10,000 products are made to order in the space of two hours and delivered within fifteen minutes. Quantity production and standardization of service have made housekeeping possible on a wholesale scale.

If each individual waiter and bus boy were permitted to perform his tasks in what he believed the best way there would be such a scurrying and running about that hopeless disorder would result. Therefore the great restaurants and hotels have established a system to control every move. When you take your seat at the table, the bus boy and waiter perform certain tasks while you study the menu. They place the silver, provide napkins, bread, butter, possibly service plates,

glasses of chopped ice, and finally the water carafe. In one great hotel chain, when two diners are being served, the water is exactly the thirty-ninth item which goes on the table, and, before the dinner has been finished, 100 or more separate articles will have been produced, used, and then removed.

The food-service department shows housekeeping on a huge scale at its best, and here the mechanical appliances which save time primarily are most abundant. The hotel steward, looking over past records, can tell how many guests probably will order soft-boiled eggs on any given day of the year, but getting them boiled and served is another matter, which probably would keep an army of cooks busy, were it not for the mechanical egg boiler.

Clockwork, driven by a lead weight, or



Palatial Hotel Dining Room Where Scores of Alert Servants Care for Wants of Several Hundred Patrons at Once



Hotel Bakery Which Daily Prepares Stacks of Homemade Pies and Pastries



Kitchen Bulletin Board on Which Special Items Are Posted for Benefit of Waiters and Checkers



Checking and Pricing Food Orders as They Leave the Kitchens



Taking Suit from Disguised Hotel Service Lift That Delivers Articles to Floors



Expert Carvers Preparing Meats in Attractive Portions for Roasts



Beverage Counter with Hundred Pots Awaiting Steaming Coffee or Tea



During Parents' Absence Child Guests Are Entertained in Hotel Nurseries



Registering at the Desk Where Guests Are Allotted Rooms and Become Part of the Big Hotel Family

Tasty Salads Are Prepared by Expert Artists Schooled in Making Dressings and Elaborate Dishes of Fruits and Greens



Putting Music in Voices of Pages Who Call Guests



Putting Music in Voices of Pages Who Call Guests

a small electric motor, furnishes the motive power, and when an order for eggs comes, the cook drops them in a metal basket, lowers it into a tank of boiling water, and sets the indicator for the time required, at the expiration of which the eggs are automatically lifted from the water. The slicing of bread offers another opportunity for a machine to give satisfaction to the guests by a uniform product, in addition to saving material. A revolving circular disk divides the loaf with a smooth motion, while a ratchet advances the bread just the width of another slice, for the next cut. The cold-meat slicer works on a similar principle, and the vegetable parer used principally for potatoes and carrots is another example.

Aside from appliances for handling food, there are several instances of time-saving in the serving and housekeeping departments of the great hotel. The teleautograph ably supplements the intercommunication service of the telephone, saving time for messages which do not require direct conversation between sender and receiver, as the handwriting inscribed at the transmitter is reproduced at the receiving instrument.

The telephone installation is, of course, the major means of communication and it may easily equal that of a good-sized cen-

tral office. In one hotel the branch exchange serves 3,340 telephone instruments, seventy operators being required to handle the calls.

Standardization of service, equipment and supplies, however, does not stop with the kitchens and dining rooms. One hotel system, for example, has made a study of every item of equipment, from carpets to chinaware, and tries to produce anything which could be manufactured by itself more cheaply than it could be purchased in the market. This company built a decorating furnace and now buys all china in the white and does its own decorating.

The same group of hotels, in its factory operates an upholstery shop, candy factory, printing plant, a garment factory and a furniture-repair plant. Standardization also has been extended to such articles as table linen, glassware, soaps and cleaning materials, and even such staples as baking powder, olive oil, vanilla extract, coffee and canned goods. As a result \$350,000 has been released from the inventory and \$100,000 a year saved.

The modern hotel manager, therefore, is justified in thinking of his plant as a factory which takes interchangeable parts and fits them together into a custom-made product, no matter whether it is room service and equipment or your dinner.



Mail and Information Desk, a Valuable Source of Counsel for Strangers and Guests Seeking Advice and Guidance Regarding Massive Hotels and Their Maze of Halls and Departments



Highly Trained Waiters Often Render Valuable Aid to Diners Selecting Their Meals



Private Switchboard and Operators of a Hotel's Telephone System



Corps of Cooks and Their Battery of Polished Copper Pots and Pans

Great Care Is Taken to Leave Kitchens Spotless after Meals

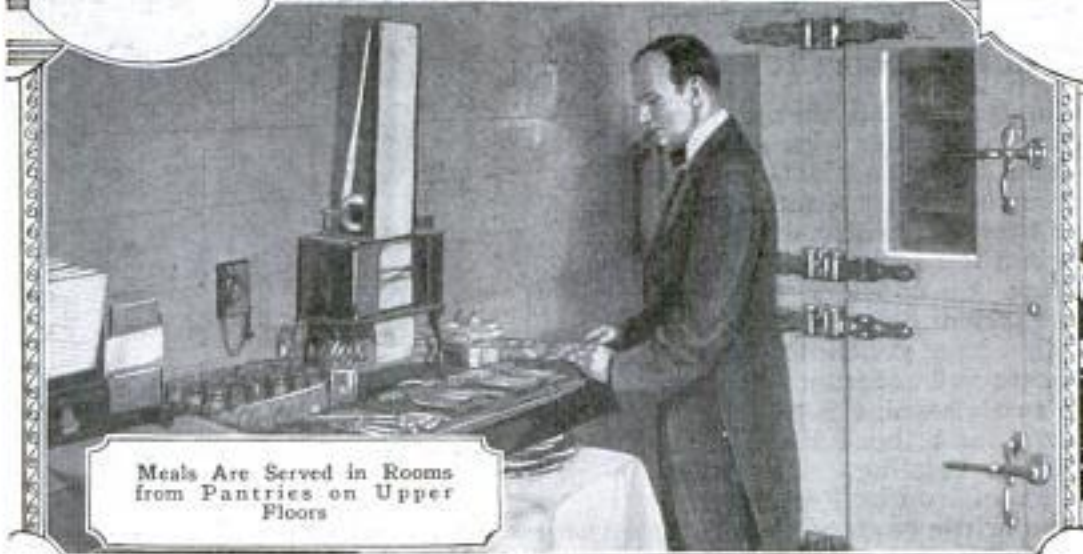

Meals Are Served in Rooms from Pantries on Upper Floors



919 **Fulton's Statue Saved from Wreck of Old Ferry Station**

One of the first objects to be cared for in dismantling the abandoned ferry building under Brooklyn bridge, was the large



Workmen Lowering Robert Fulton Statue from Abandoned Ferry Building That Bore His Name

statue of Robert Fulton for whom the structure was named. The massive monument was lowered with block and tackle and removed to a safe place. For years, the figure faced the river, teeming with craft that his genius had helped to make possible.

Safety of Shotgun Barrel Depends on Skill in Making It 1605

When the hunter fires his shotgun, exploding a charge of powder with a bursting force of from 50,000 to 65,000 pounds to the square inch against a metal strip not more than three-sixteenths of an inch thick and within a few inches of his head, he seldom stops to consider the vast amount of care, scientific knowledge and workmanship that have gone into the barrel to make it safe and accurate. In general there are two classes, the twisted or Damascus barrel, and those made from solid bars without twisting. The material is a mixture of iron and steel, since steel alone is too brittle to stand the shock of the explosion and pure iron too soft.

Checkerboard, chain, diamond and other patterns may be obtained in the barrel by different arrangements of the steel and iron rods before they are heated and welded into square bars and finally twisted. Usually the bar is heated, one end placed in a square hole, and is then given eight twists to the inch with a winch handle and cog wheel. After twisting, the rods are rolled into ribbons with the edges beveled the same way, two being required for a single barrel, the one for the breech somewhat thicker than that for the muzzle. Then they are twisted cold into a spiral, again heated, and after a steel mandrel has been inserted, hammered until cold. The "solid weldless twist" barrels, commonly seen, are made by simply twisting a bar of metal of the proper composition and boring out the center. A Damascus barrel of average quality will last about thirty years and will stand the firing of 100,000 shots provided it receives good care, it has been found.

698 **Percolator in Wash Boiler Cleans Clothes Easily and Quickly**

Out of an ordinary household boiler, an efficient washing machine can be formed by placing in it a patented automatic clothes percolator which is said to cleanse all kinds of fabrics thoroughly in thirty minutes. It consists of a copper base and two hollow upright posts, perforated with sixty-four small holes through which jets of steam and hot suds are ejected forcibly into the garments when the water

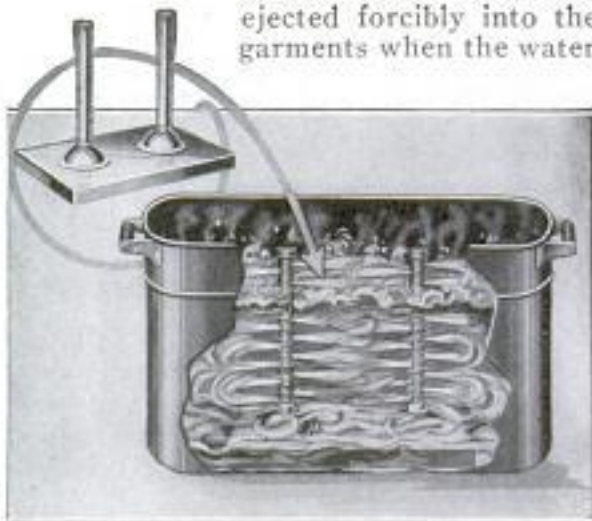

Clothes Percolator in Action; Sixty-Four Steam Jets Churning through Fabric and Water

reaches the boiling point. This action is kept up automatically, the washer requiring no further attention or handling. There are no parts to get out of order or tear delicate fabrics, the maker claims.

The Storm Royalty Co.
3610 *Enriquez St.*
St. Louis, Mo.

Emb. Edwin Jarvis, The Farragut Washington, D.C.

9/8/24

Underseas Survey of Gulf May Aid in Forecasting the Weather 425

Submarine surveys of the Gulf of Mexico, the Caribbean sea and adjacent waters are to be made by a government expedition of scientists, who, equipped with the latest sounding and other apparatus, hope to reveal many of the hidden wonders of the deep. The cruise is expected to continue through the Panama canal and down the western coast of South America to the islands off Peru. The Gulf-Caribbean region is considered of great importance to the United States as many of the weather changes in the southern and mid-western states have their origin there, and it is hoped that much will be learned of ocean currents and temperatures which will be of aid in weather forecasting. Off the Louisiana and Texas coasts and sometimes near Central America and Peru, oil spots occur on the water and it is desired to learn if there is any connection between these supposed submarine gushers and the oil fields on land. It is also pointed out that, although the gulf abounds in valuable fish, little fishing is done there, and the expedition will investigate the possibilities in this direction.

Whole-Wheat Bread without Flour Made Directly from Grain 1824

Transforming wheat directly into bread dough without the necessity of a flour-milling process, has been successfully accomplished by an ingenious contrivance of French manufacture. The apparatus consists principally of a large screw-threaded cylinder which crushes the whole grains into a mixture of the consistency of smooth paste. The wheat is first thoroughly washed and allowed to stand six hours in tepid water. Yeast and salt are then added before the soft, swollen kernels are put into the crusher.

new York Series
not available 9/7/24

Arrow Thriller in Movie Is Made by Turning Camera Backward 1755

While many of the thriller scenes in motion pictures are genuine and done at the risk of life, others are produced by



Staging the Arrow Thriller; with Threads Invisible in Finished Film, Shafts Were Pulled Out While Camera Was Cranked Backward

clever illusions that sometimes deceive the eyes of the most critical observers. In filming a recent picture, one of the characters was shown captured and bound, while arrows, evidently shot from hostile bows, traced his outline on the tree trunk as they imbedded themselves in the bark. The effect was obtained by first carefully inserting the shafts around the figure and then pulling them out while the camera was cranked backward. In the finished reel, the arrows appeared to be thudding forcibly against the tree within a hair's breadth of the actor who increased the effect by appropriate flinching and facial expressions.

☐ Nearly one-half of the world's supply of zinc is produced in the United States.

Furniture Made without Nails Wins 1959 First Prize for Boy Scout

Fashioned without the use of a single nail, a table, chair and ornamental lamp



Scout Robert S. K. Brown of Boston with Prize Furniture He Made without Nails

made of rough pieces of wood firmly joined, won first prize for a boy scout craftsman at an exhibit in an eastern city. Withes of wood were interlaced to form the seat and back of the chair and the table top, while the lamp shade was constructed of thin pieces of bark and carving on the stand added to its appearance.

Perfume Supply Is Periled by Ban on Killing of Musk Deer

Musk, one of the most costly and effective substances in "fixing" perfumes, may soon be dearer than rare jewels because the lamas of southeastern Tibet have decreed that hunters caught killing the musk deer will have their hands cut off and nailed to the temple doors. According to Dr. Joseph Rock, explorer for the National Geographic society, the animals are becoming very scarce, due to the perfumers' attempt to satisfy the demands of fashion. This has led the lamas to restrict hunters. Other animal substances commonly used in the manufacture of perfumes are the precious ambergris, from the whale, castor from the Canadian

beaver, and civet from the civet cat of Abyssinia and India. None of these odors is used by itself, but when mixed with the oils of flowers, they magnify the natural fragrance of the blossoms and serve to make more permanent perfumes that would soon become weak with age.

Portable Highway Speeds Autoists across Shifting Desert Sands

1819 In order to carry automobile tourists over a five-mile stretch of shifting sands in Death Valley, a portable highway has been devised by the California road commission. It is constructed of sections of redwood blocks and timbers laid flat on the surface and bolted together. If windstorms cover them up, a tractor, equipped with a crane and hanging hooks that fit into the eyebolts screwed into the wooden lengths, speeds to the scene, quickly lifts the sections, shakes them free of sand and re-lays them. Aside from its portability, this roadway has the advantage of not cracking under the intense heat.

Switchless Auto Stop Light Is Run by Drop of Mercury in Tube

1988 Switched on or off automatically by the movement of a little ball of mercury within a hard-rubber tube, a novel stop light for automobiles has been invented that works independently of the brake pedal and requires no attention from the driver. Resembling other lights in outer appearance, it needs no electrical connections save a wire to a storage battery and has no mechanically operated switch likely to

get out of order. In the housing just beneath the bulb, two protruding nickel contact wires are arranged within the tube in such a way that when the forward movement of the car is checked, the mercury, also enclosed in the tube,



moves against the ends of the wires, thereby closing the circuit and lighting the bulb. When the car is started, the mercury regains its former position and the light goes out. A U-shaped bend in the tube acts as a baffle, preventing the mercury from operating the light when the car is driven over rough roads.

Albert J. Atter & Sons, Inc.
18 E. 41st St. New York
Copyrighted material

Geographic news
Bulletin 968.4.8

Carl M. E. Clements
3829-13th St. N. W.,
Washington, D. C.

POPULAR MECHANICS

959

Gas-Well Fires Put Out like Candle by Smothering with Snuffer

Extinguishing the geysers of flame that shoot from natural-gas wells when they are accidentally ignited by lightning, sparks from small stones hitting the casing, brush fires, or other causes, is often successfully done by an adaptation of the old-fashioned snuffers our forefathers used to put out their candles. This means is but one of sev-

entire apparatus, assembled near the scene of the fire, is made ready for operation by adding the extensions if needed and placing the hood directly over the flames by means of block and tackle. By proper

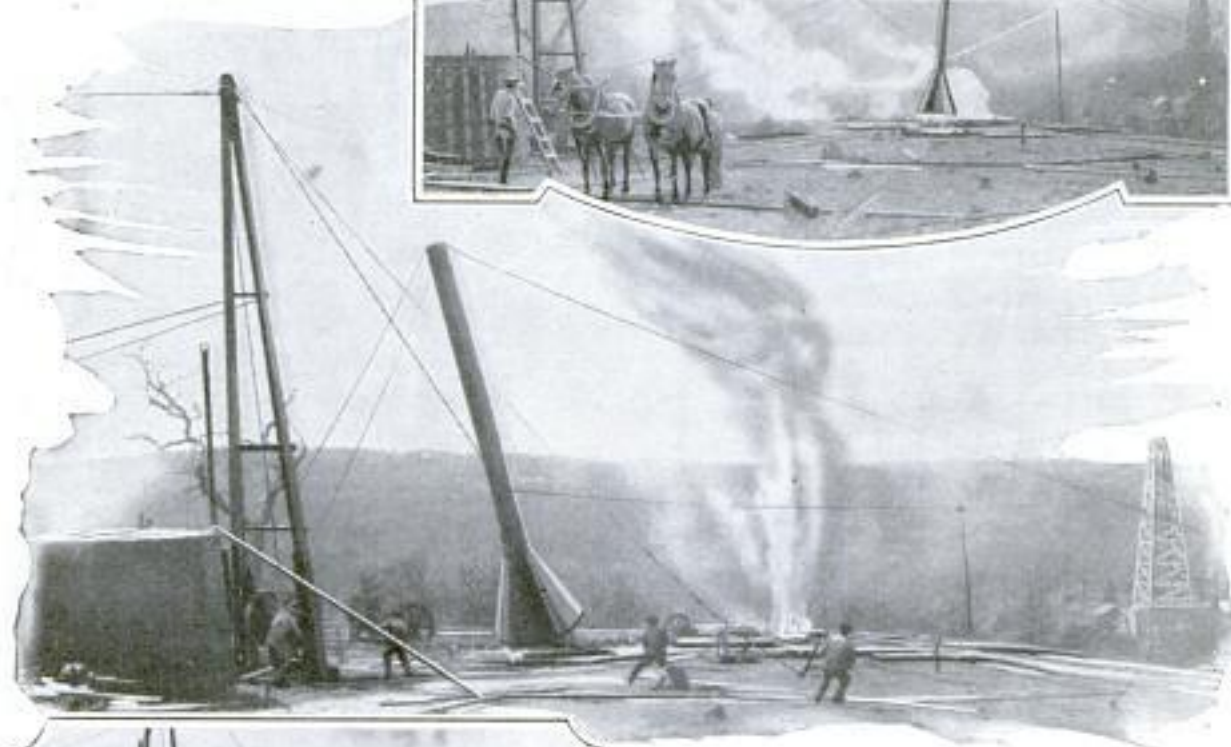
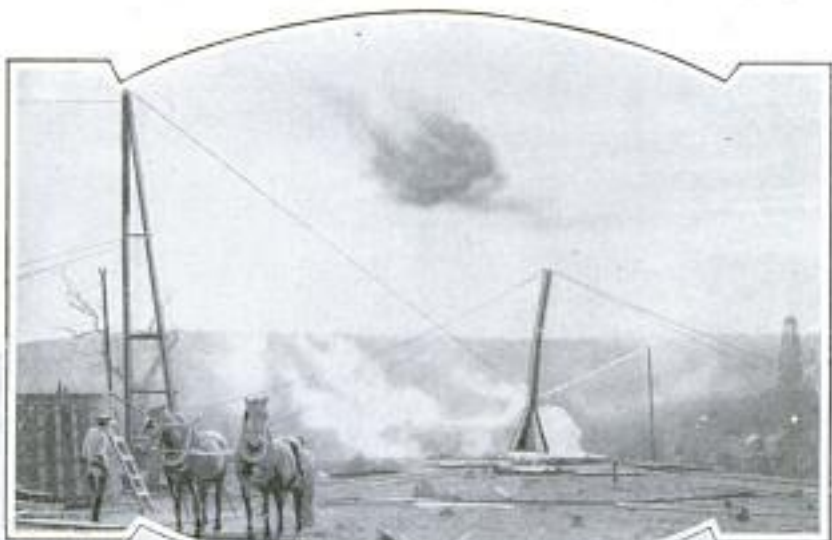

Erecting the Big Steel-Hood Snuffer over Flaming Gas Well to Extinguish the Fire

manipulation and closing of the valves, according to the size of the fire, the flow is quickly shut off and the blaze smothered inside the metal hood. Not long ago, in Oklahoma, this method was used to put out a fire and when the flames had subsided, it was found that the well produced 40,000,000 cubic feet of gas daily.

eral employed in combating the fire demon which in a ten-year period destroyed five billion cubic feet of gas and annually takes its toll in human lives and millions of dollars. The extinguisher consists of a metal hood mounted on wheels and terminating in a valve to which is attached a piece of fourteen-inch pipe, about twenty feet long. This can be extended to any desired length by screwing on more joints. On either side of the hood, midway of its height, is a short piece of ten-inch pipe also containing a valve. The

Glider in Air Nine Hours 1770

Sweeping about the sky in long, circling "figure eights" in a "flivver" airplane with the motor and propeller sealed, Lieut. Thoret, a French aviator, broke all previous gliding records when he remained up for nine hours and four minutes at the Alpilles field. At one point, he climbed to an altitude of 4,000 feet.

Chicago Tribune 8/30/24
Copyrighted material



Over the Mountains with White Coal

Mile-Long Railway Trains Sped over Top of the Continent by the Harnessed Power of the Rivers of the Rockies

By H. E. BYRAM

President, Chicago, Milwaukee and St. Paul Railway

AS the "Iron Horse" displaced the "Pony Express," so the new "King of the Rails"—the electric locomotive, drawing its white coal from the trolley wire suspended overhead—has sounded the death knell of the steam railroad engine wherever electricity is available.

In a single year, on two divisions of our road alone, forty-four electrics displaced 121 steam locomotives and moved the transcontinental traffic at a cost for power of \$672,000, as compared with the \$1,400,000 it would have required for steam. The actual saving was far greater than even these figures indicate, as the cars that once hauled fuel from the mines to the locomotives were released for revenue-paying service; the investment in coal docks and water tanks was eliminated, and that part of the motive power that was once used up in hauling around the en-

gine's fuel and water was released for other purposes.

In the days of steam operation on our mountain divisions the average size of all trains was somewhat less than 1,600 tons. Today, with our motive power cut to one-third, a mile-long freight train of 110 cars, with a total weight of 5,000 tons or better, is not the exception but the rule, while the average of all trains, passenger, freight, work and locomotives traveling "light" over the road, is around 3,000 tons.

Ten years ago it was not uncommon to see three steam locomotives toiling up the hills toward the continental divide, dragging the twelve or thirteen cars of the westward-bound Olympian flyer. Ahead labored a Pacific-type engine, one of the monarchs of the road, and behind two helpers assisted in pushing the 1,500 ton train along at a fifteen-mile-an-hour gait.

1777

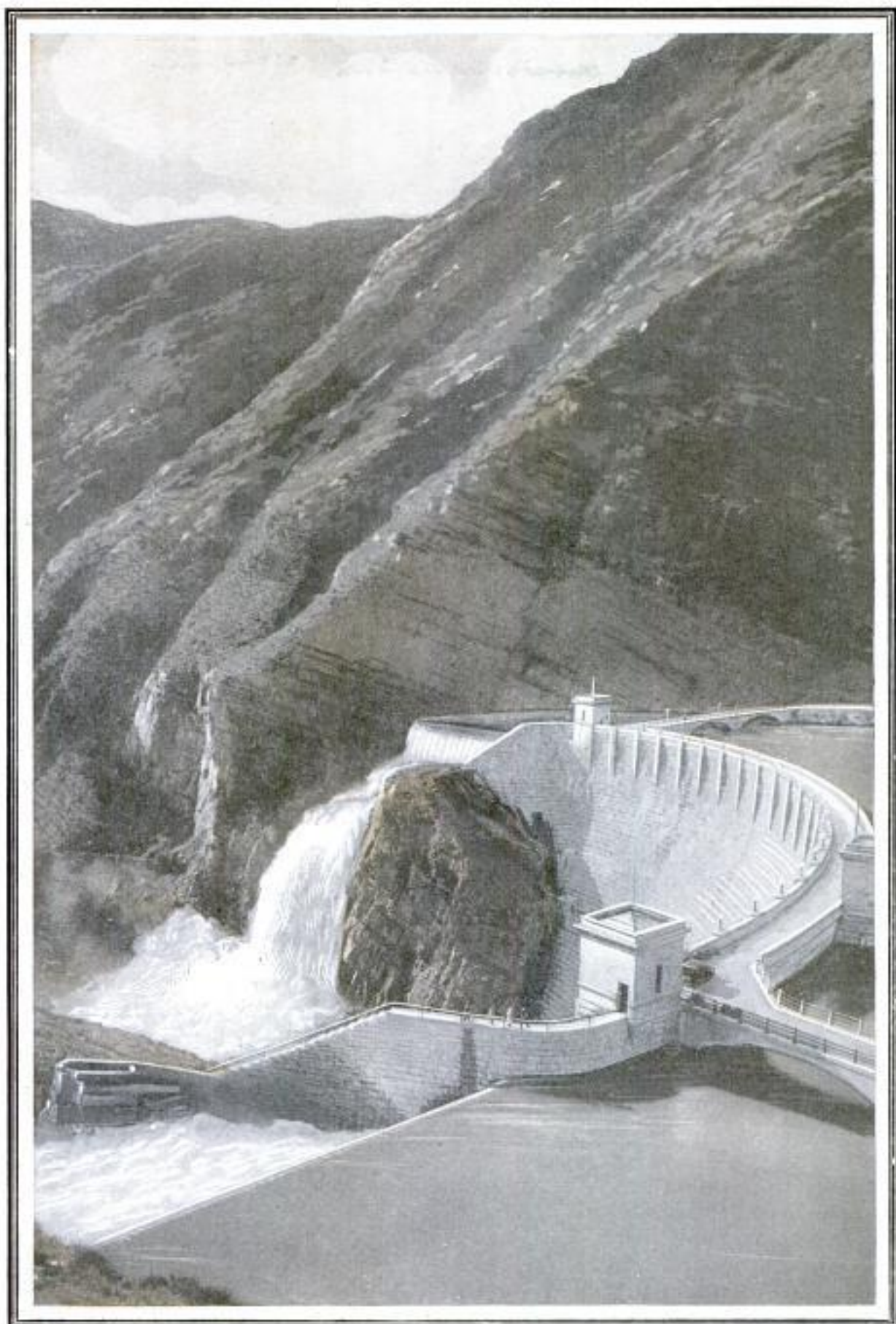

Between Canyon Walls, High Cement Barriers Such as This, the Roosevelt Dam in Arizona Which Stores 42,000,000,000 Gallons of Water for Irrigation, Are Being Built for Power

1979

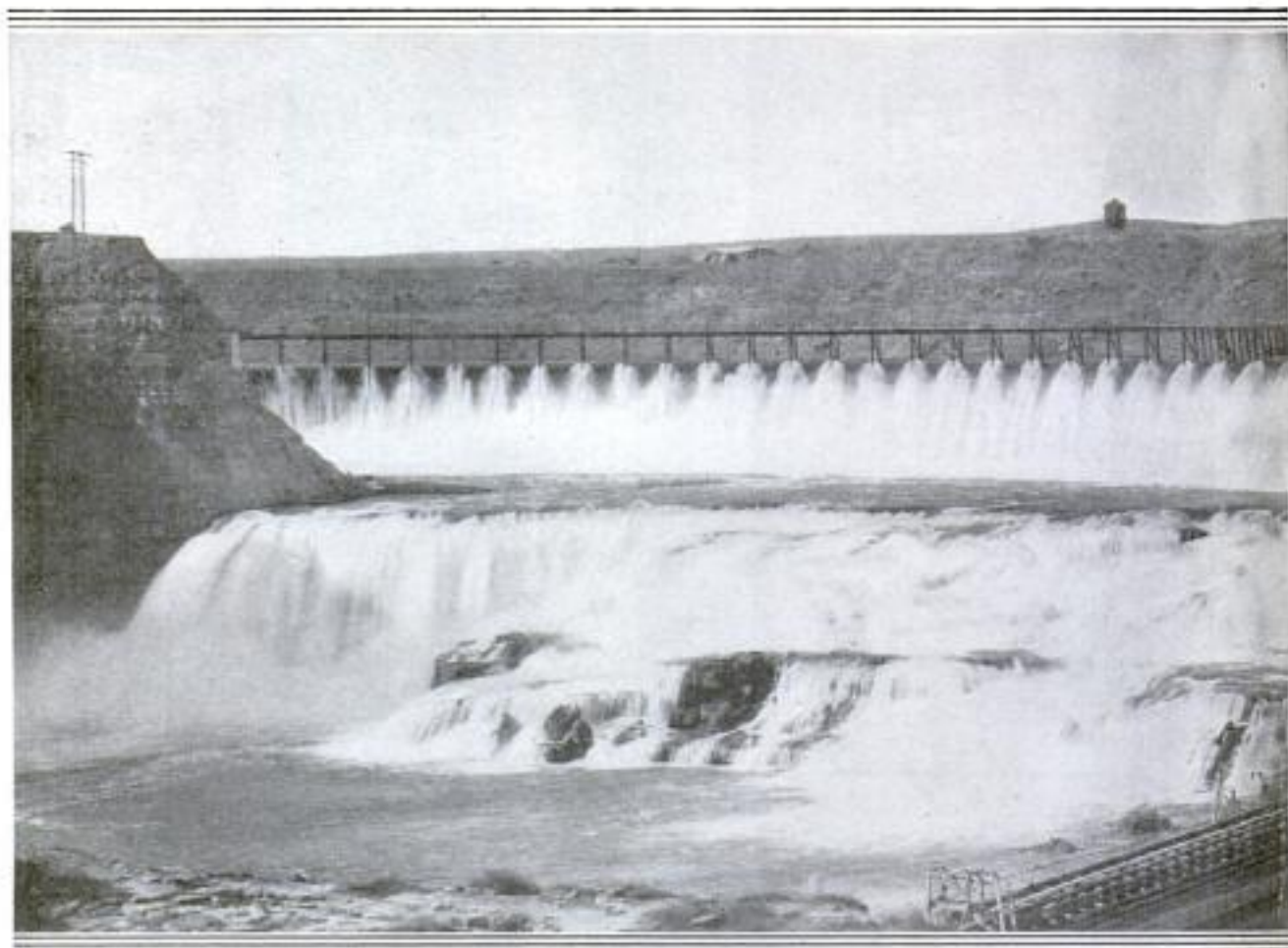

Part of the Dam and Spillway near Great Falls, Mont., Where the Missouri River Has Been Harnessed to Provide Power for Running Railway Locomotives and Mining Machinery

Today, the scene has changed. An electric locomotive purrs out of the east and pauses a moment at Three Forks, Mont., where the waters of the Jefferson, Madison and Gallatin rivers unite to form the Missouri, which winds its way 2,551 miles to the Mississippi. Along its banks, the falling waters, stored behind enormous dams, are turning the turbines of many power houses, converting the snows and the rain into power that feeds, through the trolley wire above, the big electric locomotive. A brief pause, and the long train of brilliantly lighted cars slips away into the west as silently as it came. There is no noise, no smoke; no spinning of mighty drivewheels; no clanking of draw-bars nor backing to take up the slack. In the sleepers passengers are first aware that the train is under way when they look up to find the station lights gliding past.

Away on the flat up the Jefferson valley, the train gathers speed. Its single electric locomotive, which has replaced the three engines of older days, drones contentedly along. In the operator's cab the indicator of the speedometer climbs higher—forty miles, forty-five, fifty, sixty,

and then sixty-five. There is a world of power yet uncalled for, but the engineer, in obedience to strict operating rules, checks the train there.

The lights of Piedmont, thirty-four and a half miles west of the headwaters of the Missouri, flash past, and the engineer eases his throttle back, while the hum of the motors rises to the drone of a lazy bee as the long climb to the roof of North America begins. The grade shifts from one per cent to one and one-half, then one and seven-tenths, and finally two per cent, which means a climb of 105 and six-tenths feet to the mile. The engineer checks his speed to twenty-five miles on the sharper curves, with thirty-five on the stretches and forty up the straightaways. Twenty-five or thirty-five or forty, it is all the same to the big electric with its inexhaustible supply of white coal feeding silently down from the wires above.

On the instrument board, the ammeters register a load of 200 amperes and the voltmeters show a working power of 3,000 volts. The bright, white light of Vendome block signal bores through the night the message of a clear track ahead for the

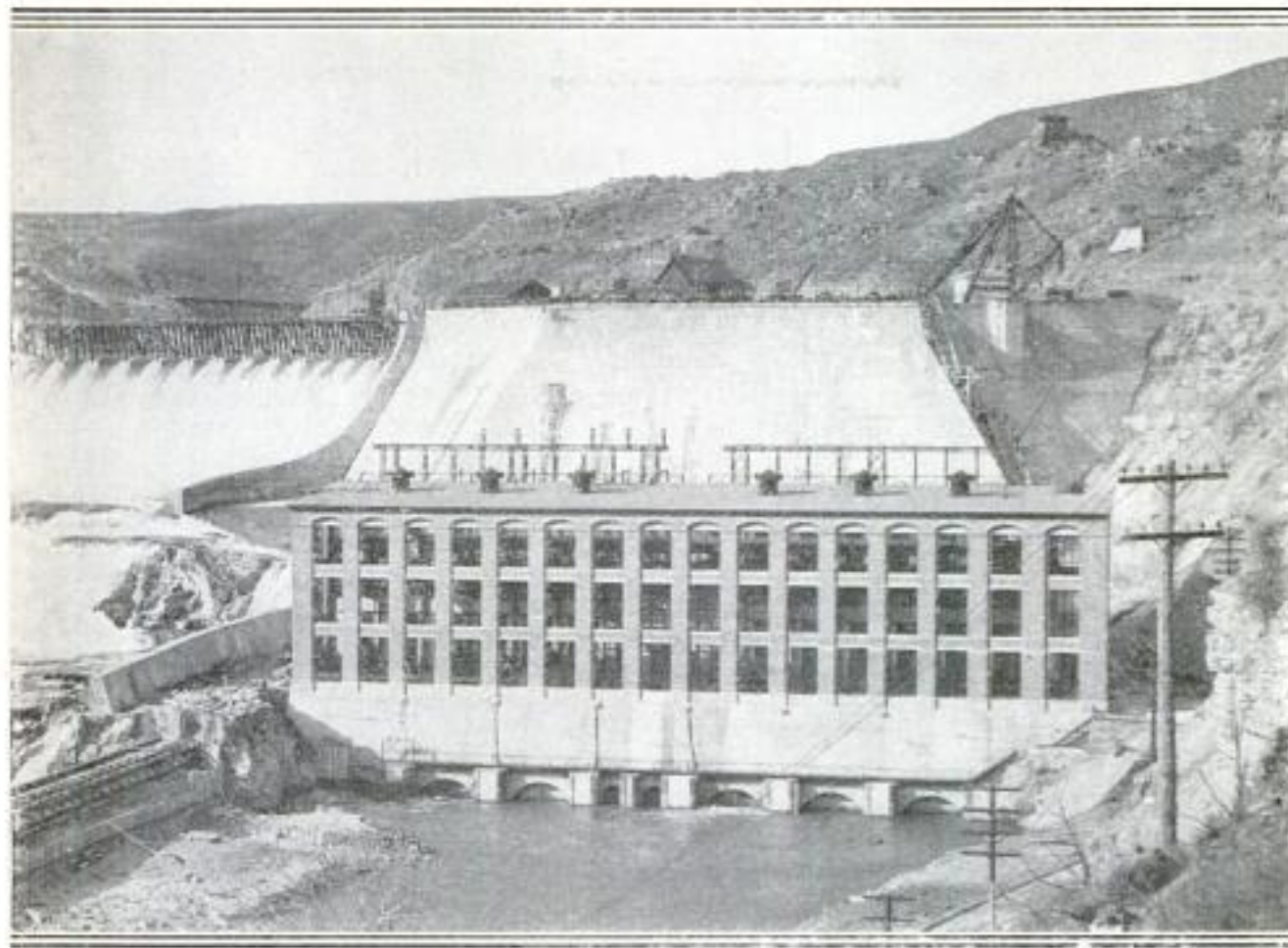

Where the River Actually Starts Its Service, the Big Power House at Great Falls, Sheltering Six Generating Units of 10,000 Kilowatts' Capacity Each

three and seven-tenths mile climb to Cedric, 361 feet above.

To the steady click of drivewheels on steel rails another climb of 486 feet to Grace slips by, four and nine-tenths miles negotiated in ten minutes. Ahead looms the crest of the divide, bathed in the final glow of the sun, which set for folks below some three hours before. A climb of 658 feet in a distance of only six and a half miles, and the flyer glides into the tunnel on the pass. Then the lights of Butte are in view and the train starts downgrade. The engineer does not touch his brake valve. Instead he shuts off the power, pulls a lever, and then, apparently, turns the power on again.

What he has actually done is start the regenerative motors, one of the most remarkable inventions in all railroad history. When he shut off the power and pulled another switch lever he changed the entire character of the big motors which drove the train up the hill. By that act he passed a powerful current through the fields of the motors—overexcited them, the electricians say. As the train gained momentum down the mountainside, the

motor armatures, which had turned the huge drivewheels coming up, were themselves turned by the drivers and actually began to manufacture electricity and return it to the trolley wire overhead. This also serves as a brake, and regulates the speed of the train. If a ten-car train starts down the mountain and a six-car train at the same moment starts up, the down-bound train would pull the other up the hill without any expense to the railroad for power. The power generated is not the only saving going downhill. Equally important is the absence of wear on brakes, wheels, rails, and on the cars.

The present electrical system embraces two sections, one of 440 miles from Harlowton, Mont., to Avery, Idaho, and another of 209 miles between Othello and Tacoma, Wash. Included in those two stretches are our three main mountain divisions, over the Rockies, Bitterroots and Cascades. As soon as possible the gap from Avery to Othello will be closed, while power-transmission lines are already available to extend the system much farther across the plains states west of the Mississippi.

Some idea of the first cost may be gained from the amount of copper used in transmission wires and locomotives. We have 22,682,000 pounds of copper in the entire electrical system, an average of seventeen and four-tenths tons per mile. On our fifteen passenger, forty-two freight and four electric engines we have 1,872,000 pounds of copper, while the trolley wire alone weighs 14,892,000 pounds. The rest of the copper is used in substations, transformers and transmission wires. The railroad does not manufacture any power, but buys its current from private corporations.

Our electric motors are of three types—heavy-duty geared freight locomotives, lighter geared passenger engines on the eastern section and bipolar gearless motors for passenger trains on the coast division. The big freight engines—the giants of the road—are 112 feet long, with a wheelbase of 102 feet eight inches. They are so big, in fact, that they are built up of two units, either one of which may be operated independently. These engines have a speed of fifteen to twenty-five miles an hour, with their low-gear ratio, and develop 3,440 horsepower. They are propelled by eight motors, turning their sixteen fifty-two inch drivewheels, and have a total weight of 576,000 pounds. The

geared passenger motors on the Rocky mountain and Missoula divisions have a weight almost as great—566,780 pounds. Besides the enormous weight of these engines, they carry 3,000 pounds of sand, for the track; 6,000 pounds of oil, to run the hot-water heater which supplies the coaches and sleeping cars, and 28,500 pounds of water for the heater.

The third, and newest type of engine, the bipolar gearless, in use on the coast, looks more like its steam rival than the others, or rather like two steam engines back to back. It has double operating cabs in the center and boiler-shaped housings at either end for the electrical machinery. The bipolars are also unique because of their gearless principle, the armatures of the motors being part of the drivewheel axles. With twelve of these motors operating their forty-four inch drivewheels they develop 3,500 horsepower.

These three types all use pantograph trolleys, while the trolley wire is made up of copper strands wound about a hemp core, the larger surface area of this type carrying more current with less loss than a single solid wire, while it is much more flexible and less likely to break in high winds or when loaded with ice and sleet.

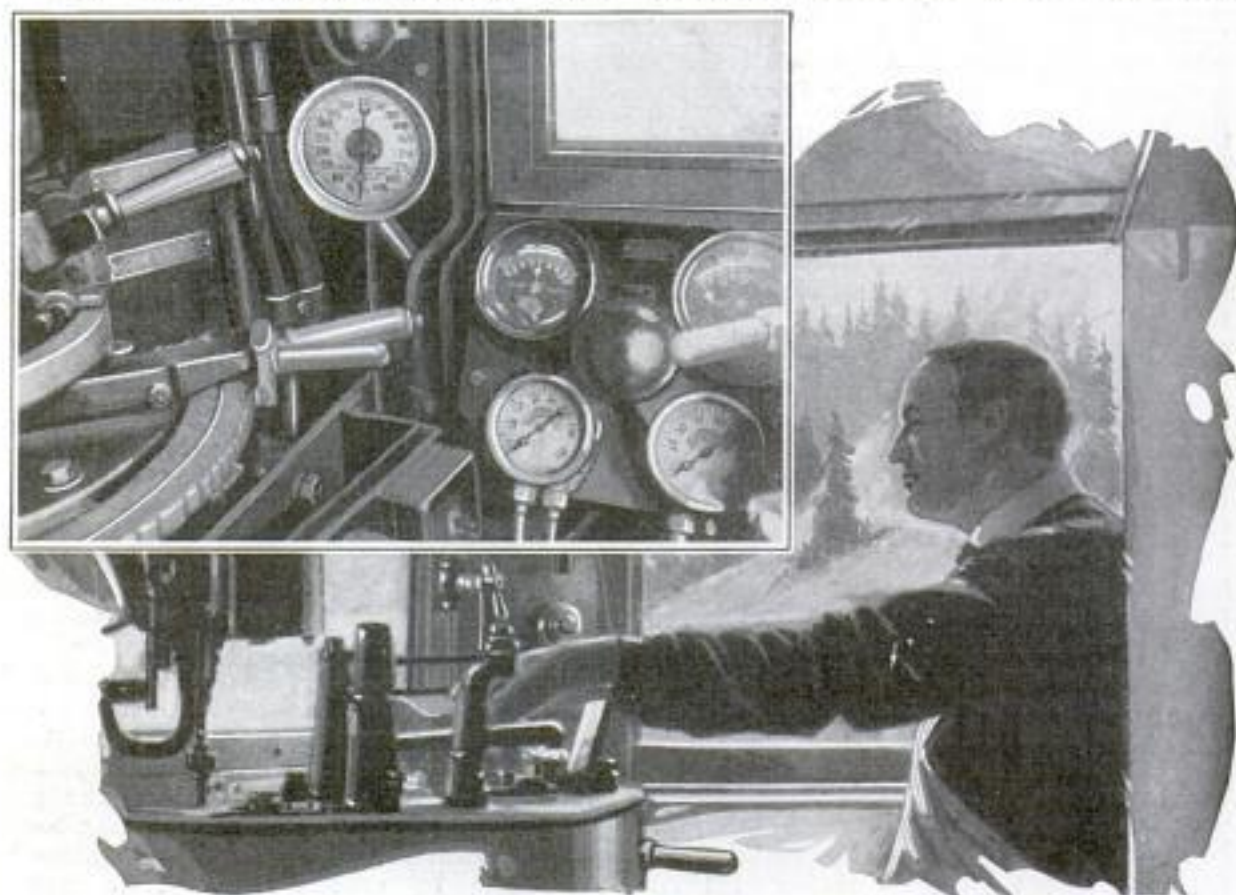

Controls of an Electric Motor, with Throttle at Left, Speed Recorder, and, at Right, Two Ammeters and Two Pressure Gauges for the Air-Brake System

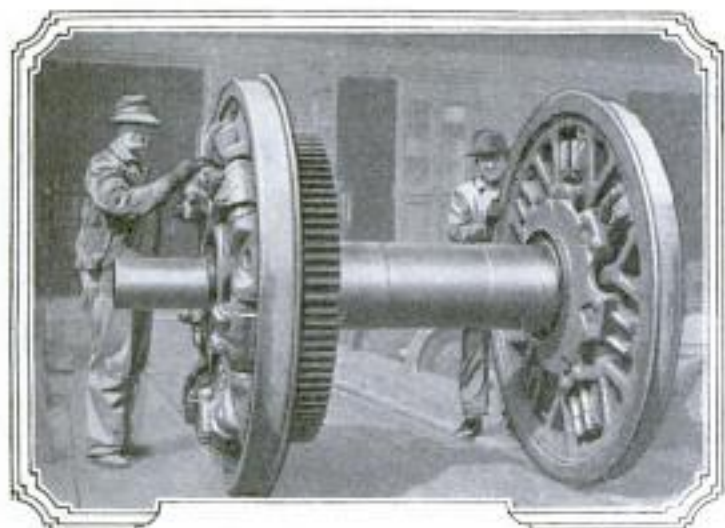

Pair of Electric-Locomotive
Wheels with Quill Spring
Drive and Huge Gear



A Steel Rod Is
Train Orders in
the Mountains

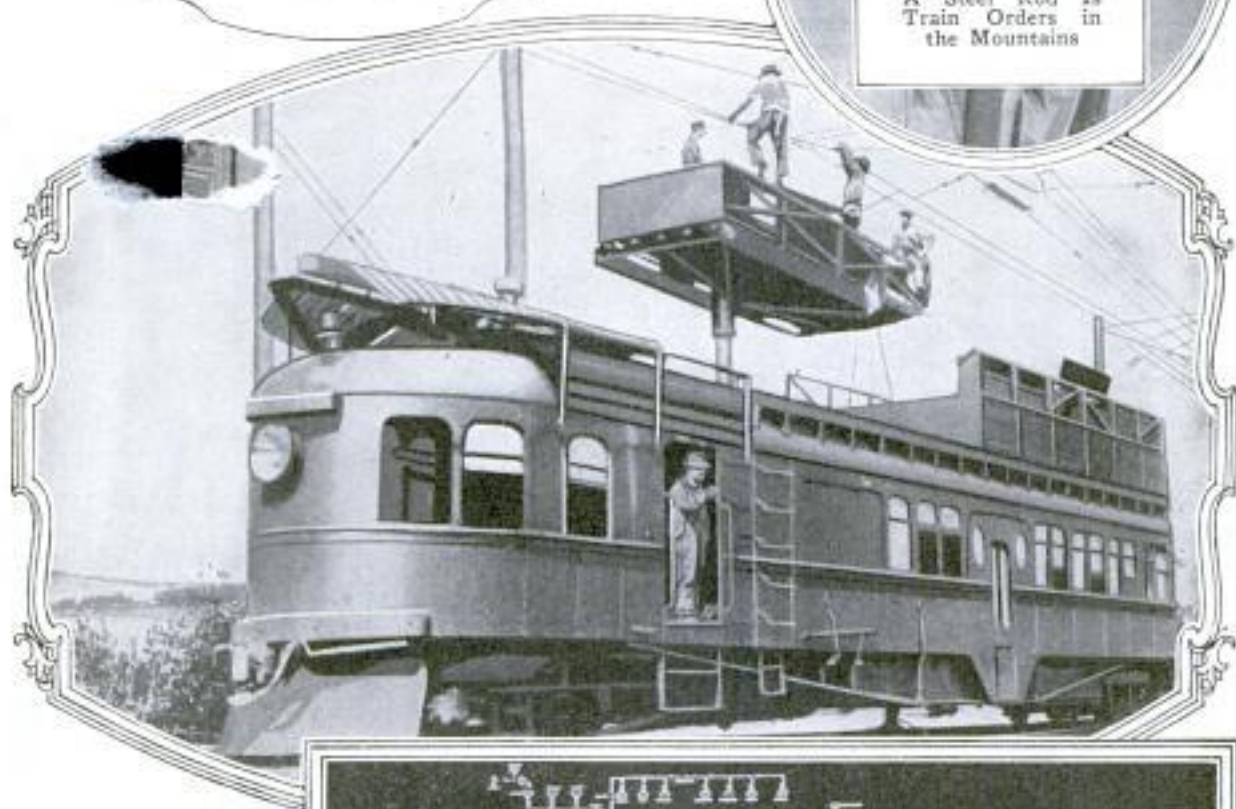

The Trouble Shooter's
Car (Above) Has Gas-
Electric Drive and a
Hydraulic Lift for the
Working Platform; the
Power Dispatcher
(Right), with His Map
of 4,000 Miles of Lines,
and a Light for Every
Switch, Sends the Cur-
rent Where It Is
Needed

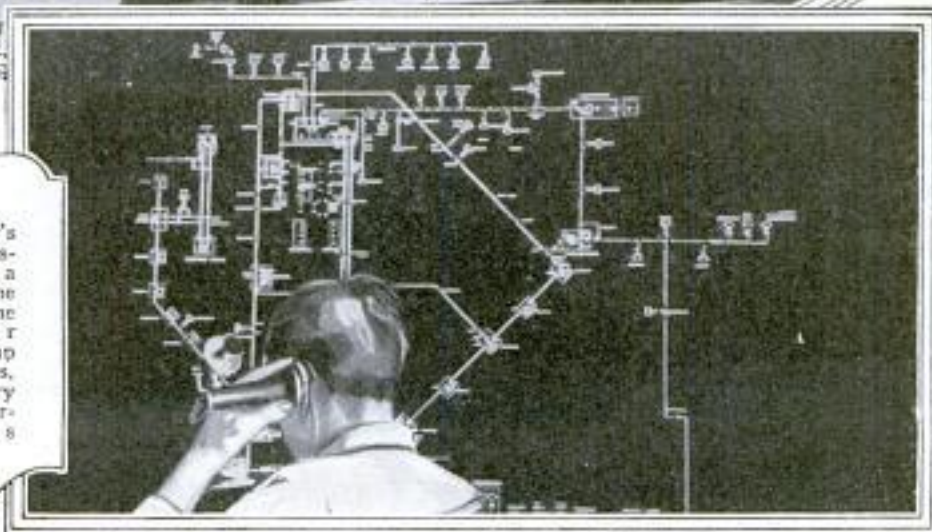

EVERY MOVE IN BALL GAME IS SHOWN ON SCREEN

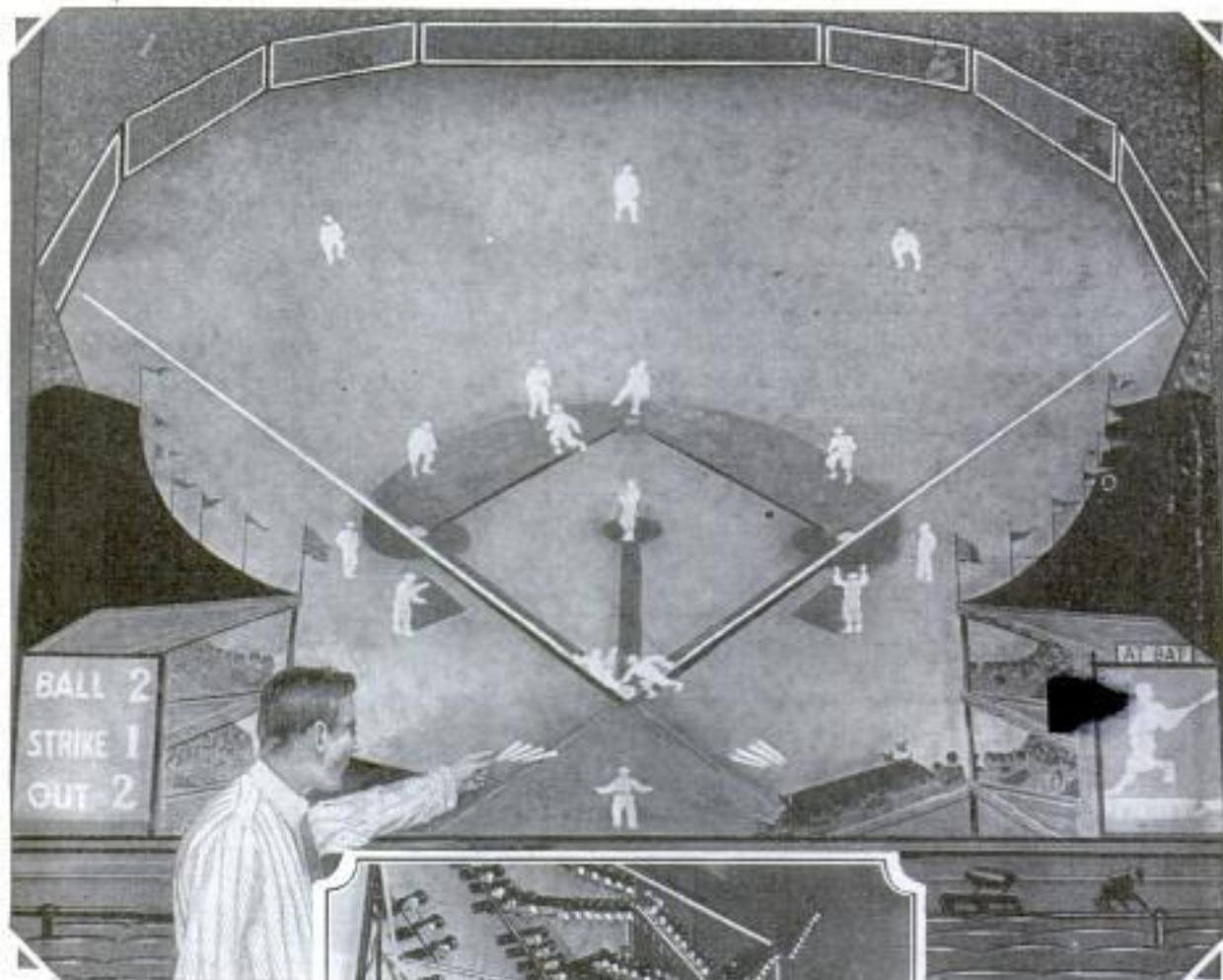

Play by play, practically every movement made in a baseball game at a distant park is reproduced with realistic accuracy on a thirty-foot screen for the enjoyment of theater patrons with the aid of an ingenious electrical apparatus invented by an eastern man. It is virtually a motion-picture machine without film or projector, the figures being made to move across the screen by a succession of quickly flashing lights which are wired to the telegraph instruments. Without the help of a vocal announcer, witnesses may watch the batter

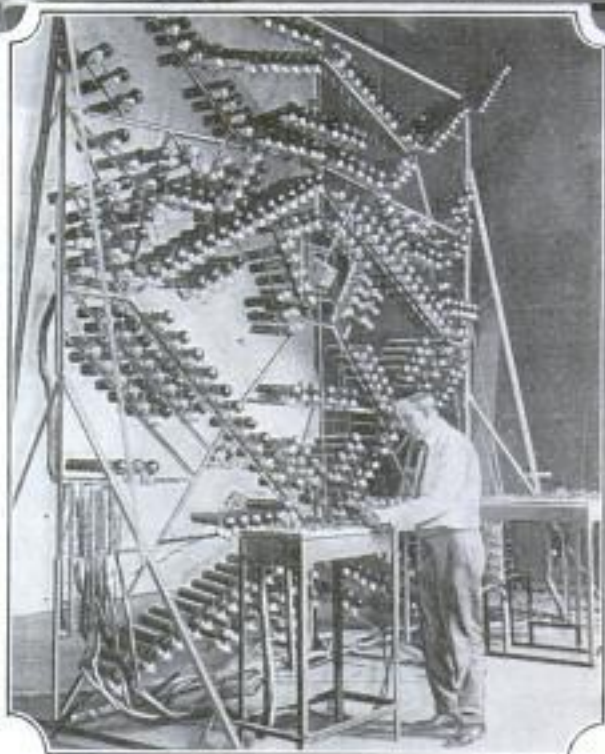

Copyright, Henry Miller

Realistic Baseball Diamond on Screen, and behind Scenes Showing Network of Bulbs

hit the ball or strike out, run bases, slide; see the pitcher "wind up" and curve the ball, and are able to tell if the player is right-handed or a "south paw." The umpire's decisions are announced on squares at the sides, while a background painted to resemble the crowds at an actual game adds to the reality of the scene. The outfit consists of 19,000 feet of wire and 400 electric-light bulbs. The inventor is said to have spent ten years in completing it and it was successfully installed in a theater for recording games played by the home team.

New York Times
8/25/24

Photograms

Tea Is Grown by the Ton to Supply Drinkers throughout the World

Mentioned in Chinese legends almost as far back as 3,000 years before Christ, tea for centuries has played an important part in the social, political and commercial history of the world, and today is one of the most valuable articles of trade to certain countries. Approximately 100,000,000 pounds are imported into the United States alone while the total exports of the tea-producing nations are estimated at more than ten times that amount. Tea is now the fourth most important product of the planters of the Dutch East Indies, according to reports of the Netherlands chamber of commerce, nearly 300 plantations there producing, in 1923, 106,260,000 pounds, of which 4,443 tons were sent to the United States.

Photo Revolver "Shoots" Pictures at Pressure on Trigger

Using cut or roll film, a compact camera that weighs less than a pound and can be operated with one hand, has been made

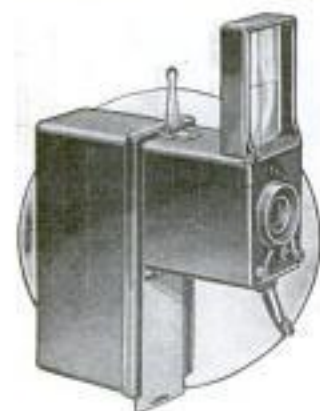

in France. It was designed especially for the convenience of bicycle riders, autoists, police and others who wish to make "quick" pictures while "in action." The operator aims through an automatic viewfinder, the exact size of the picture taken.

The shutter is pressed by a trigger and the grip holds sufficient roll film for 100 exposures. The instrument is provided with the ordinary distance and lens adjustments and enlarging apparatus is furnished for the pictures, which are about an inch square.

E. Krauss R-20 Rue de
Natalis Paris France.
Where Egg Yolks Get Color

That the yolks of hens' eggs are yellow because of the pigments in the foods the fowls eat is shown by an exhibit prepared by Prof. R. H. Plimmer of London at the Wembley exposition. So far as the hen herself is concerned, the professor finds, the yolk would be pure white were it not for the pigment in leaves, vegetables, corn and other colored grains consumed.

Chicago agent -

Barb Camera Co., 104 N. Dearborn Chicago

Air-Filter Mask Protects Painters from Lead Poisoning

To protect painters from lead poisoning, a malady commonly suffered in their profession especially when spraying im-



Painter Demonstrating a Lead-Poisoning Preventive the Air-Filter Mask Connected to Spray Gun

plements are used, a mask which completely covers the mouth and nose and filters the air has been invented. It is connected to the spray gun by a short length of rubber hose and as the painter works the trigger to spray the paint, the movement sends a supply of fresh air to his nostrils through the hose and a moist filtering sponge in the mask. Pressure is regulated and even feeding assured by needle valves. The mask is light, compact and comfortable and is easily put on or removed.

Tiny Compass Set in Ring Helps in Making Electrical Tests

To save time and to prevent loss of the instrument, a small compass has been set in a finger ring. Worn by electricians, it is always convenient for determining the polarity of motors and generators and for testing high-voltage lines. Travelers in strange or uncharted areas may employ it to indicate direction instead of the pocket varieties of the article. The mounting is strongly made of polished metal, and the dial is protected by a heavy glass cover.



Mr. unknown. mask for painters made by -
George S. Johnson
Co. 1155 W. Washington
Apt. 4 Chicago

Jacob Schmudh
225 S. Caroline St.
Baltimore Md

Sold on Sunday Times
8/10/24



A Bit of South-Sea Landscape as Background for a Picturesque Setting. All Built in the Movie Studio by Property Wizards' Magic

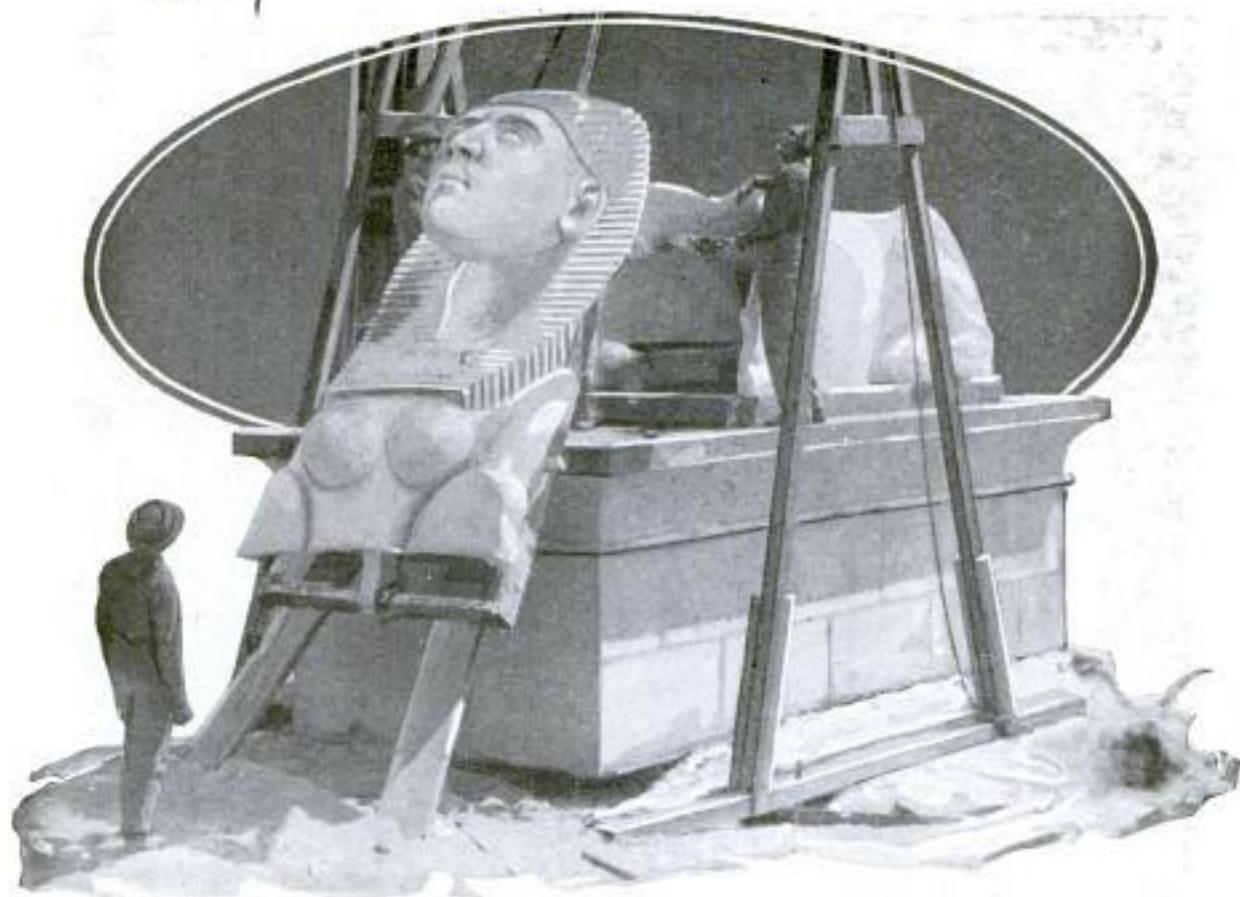

Head of a Studio-Made Sphinx Being Raised into Position; the Section Weighs 1,500 Pounds and Completes a Five-Ton Figure Copied from Those Found among Ancient Ruins

When the Movie Camera Won't Lie

Wizards of the Studios Aid Realism by Building Everything from Twelve-Ton Sphinxes to Lifelike Imitations of Flies

OF all the strange sights to be seen in movieland, the property department is one of the most wonderful. Toys of all kinds hang from the ceilings and walls. Here, a tiny castle, complete in every detail; there, an assortment of ships ranging from sections of ocean liners to submarines—each miniature made by a craftsman expert in his line.

To state that the wizards who manage these shops can make anything, is not so very far out of the way. And when you consider that daily orders from directors run from twelve-ton Sphinxes to hand-carved house flies, you can realize why these men must be skilled in almost every trade and profession.

One "prop" wizard has made mechanical ants, bees and other insects. Recently he was called upon to equip a huge live alligator with wings and tusks, thus converting it into a dragon. Again a replica of the electric chair was needed. With

only a photograph as a guide, an exact duplicate was made in a few days' time. It wasn't constructed of the same materials, of course, as the original but to the camera it registered exactly the same.

However, many of the articles demanded must be practical to a certain degree. Cannon, for instance, are so made that they can be fired. An oil gusher was needed, so the "prop" man erected a derrick on the outskirts of the town set. A pipe ran from the bottom of the derrick to a spot outside the camera's vision. A fire engine was hitched to the pipe line and at the signal, water which had previously been colored black so that it would photograph like oil, was pumped through the pipe with considerable force. The effect was that of an actual oil gusher.

The plaster shop is another department which employs men at the top of their trade. In making imitation marble a special cement is used, and before it sets, silk

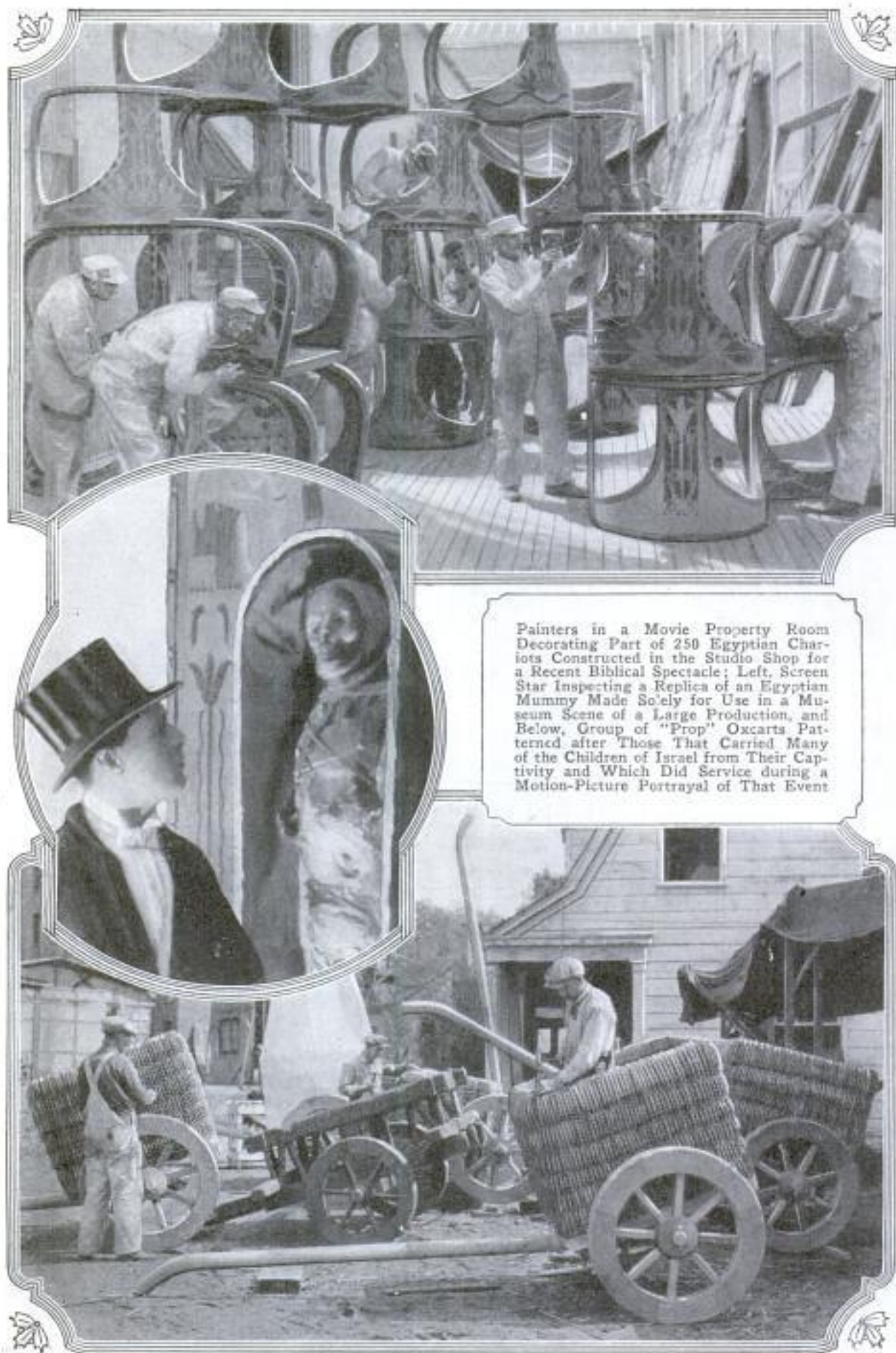

Painters in a Movie Property Room Decorating Part of 250 Egyptian Chariots Constructed in the Studio Shop for a Recent Biblical Spectacle; Left, Screen Star Inspecting a Replica of an Egyptian Mummy Made Solely for Use in a Museum Scene of a Large Production, and Below, Group of "Prop" Ox-carts Patterned after Those That Carried Many of the Children of Israel from Their Captivity and Which Did Service during a Motion-Picture Portrayal of That Event

1459



Assembling Parts of a Gigantic Plaster Statue of One of the Pharaohs of Old Egypt That Occupied a Conspicuous Place in Historical Set



Erecting a Large Oak Tree Modeled in Clay over a Wooden Framework and Transported to Its Position on a Truck

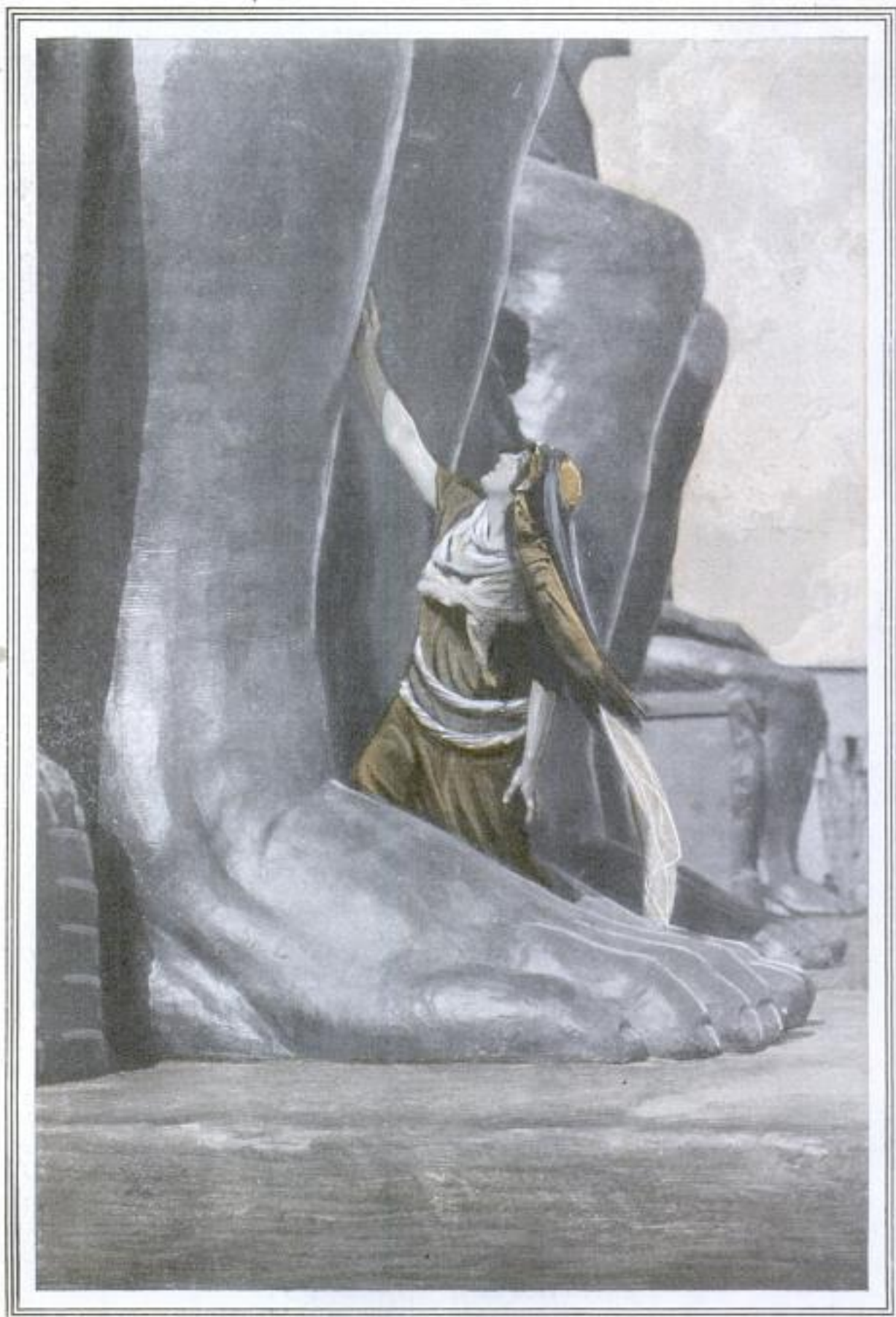

Where the Art of Unseen Property Crew Reproduces the Wonders of a Buried Age: Lower Portions of Thirty-Foot Plaster Figures Compared in Size with One of the Players

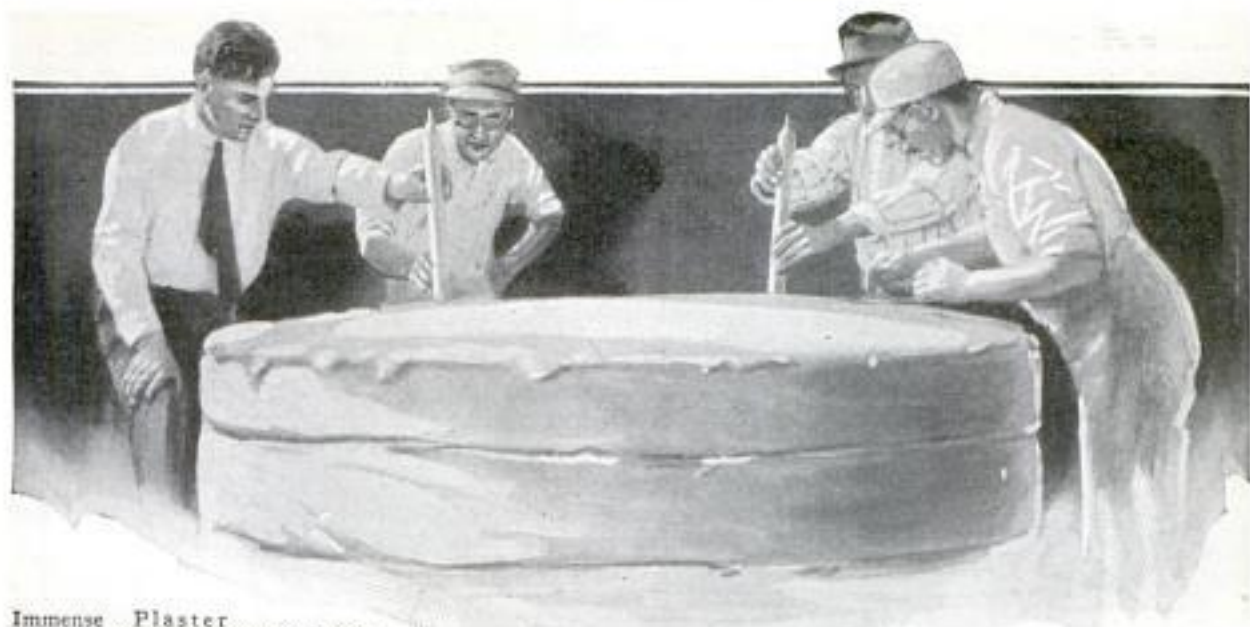

Immense Plaster
Birthday Cake into Which Edible
Portions Were Inserted

threads dyed various colors are drawn through it. This leaves the characteristic marble texture. When a piece of this composition stone is broken the colors can be seen through the entire thickness. Tons of gypsum and bales of fiber are consumed every month. Statuary that would cost thousands of dollars if purchased by the piece is molded every day.

As photoplays must not lie, research departments devote much time to the dig-

ging up of necessary data which make pictures true, faithful revelations of the actual life of the characters which people them and a correct representation of the locales of the stories.

Although the property department may receive orders for furniture of an ancient, medieval or modern period to decorate a set, the work does not begin until the research experts have supplied photographs or descriptions.

One of the Familiar Property Chests That Contains Raw Materials from Which Many of the Smaller Stage Pieces Are Formed



Brown & Sharpe
Mfg. Co.
(Providence) R.I.

Folding-Rear Windshield for Auto Gives Touring Comfort

Discomforts that frequently attend riding in the rear seat of an open car are said to be removed by means of a folding wind-



Copyright, Underwood & Underwood
Easily Folded, Useful When Extended. Rear-Seat Windshield Is Open-Car Comfort

shield which can be attached in a few moments and rolls up within a small space when not in use. The windows are of celluloid, and a long apron below them affords additional protection for the passengers' feet. Braces are clamped to the front seat and hold the shield rigidly in place. The arrangement is V-shaped, to decrease the wind resistance, is durable and cannot get out of order, it is claimed.

Strange Craft Cuts River Weeds at Depth of Seven Feet

When weeds begin to grow in the Thames river at Oxford, England, caretakers get out their submarine mowing machine, a motorboat

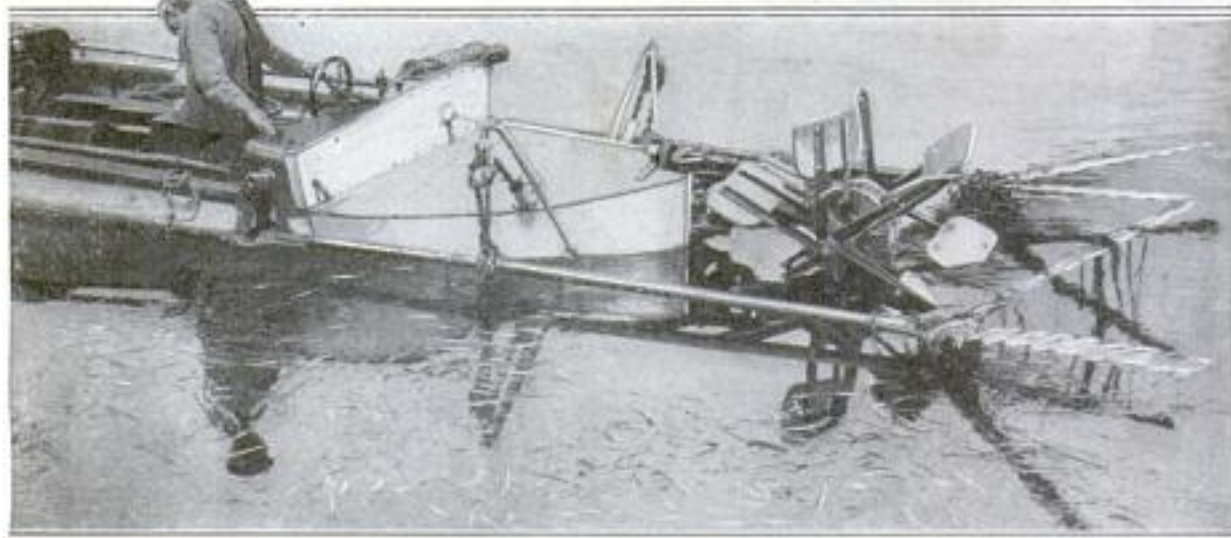

Cutting Weeds in Thames River with Motorboat Mowing Machine Fitted with Adjustable Sickles in Forward Frame That Can Be Lowered to Depth of Seven Feet

equipped with blades in front, and cut the dense growth before it menaces boating and fouls the water. The knife frames are adjusted so that they can be made to cut at a depth of seven feet. The stalks are easily collected from the surface, and those that do not rise sink to the bottom.

Gauge with Handle and Lock Clamp Simplifies Measuring Holes

Most of the difficulties encountered in determining the inside diameters of holes in cylinder blocks and other machine parts are eliminated with the use of an improved micrometer consisting of a head with one half-inch measuring screw, six rods and a spacing collar now being manufactured. In addition to a convenient hook handle fitting about the body of the tool so that it can be lowered inside holes too small to permit the entrance of the user's hand, it has a clamping

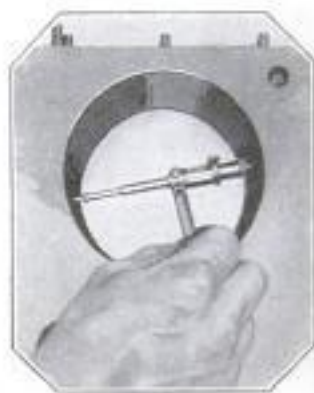

device by which the sliding rule part may be locked at any reading. This also prevents turning while the micrometer is in use. Measurements from two to eight inches by thousandths of an inch may be taken. The ends of the rods are hardened and so designed that it is possible to adjust them for wear by loosening a locknut. The handle plug is made of soft brass so it will not mar or injure the tools.

No information available

Wide World Photo

to this
very so
the in
graph
ger
id

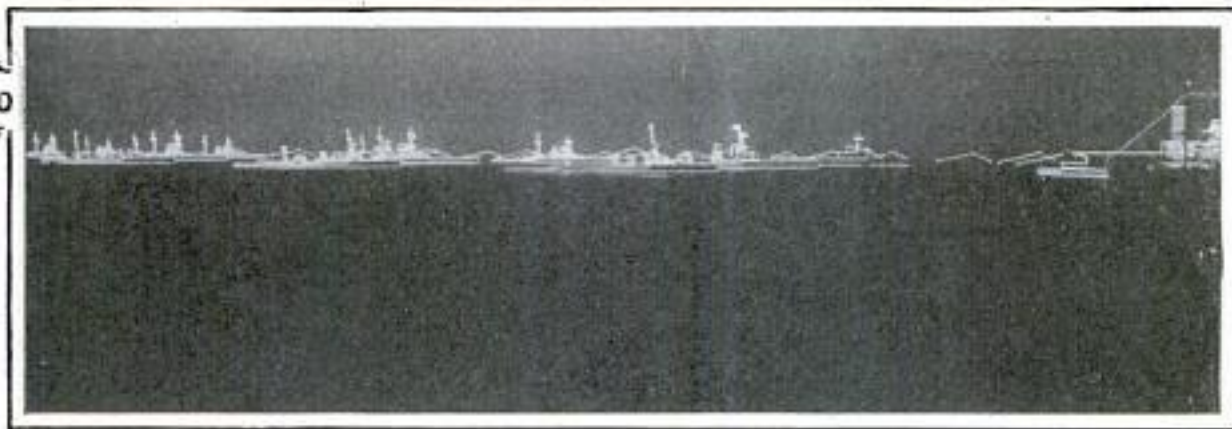

Etched against the Sky in Points of Dazzling Lights, Ships of the British Fleet Are Bathed in Luminous Splendor for a Night Review at Naval Pageant.

British Fleet Outlined in Lights in First Pageant Since War 1676

The most brilliant ²⁰⁰⁰ spectacle since the days just before the war was staged when the king reviewed the British grand fleet. The vessels had been specially decorated with streams of pennants by day and strings of electrics by night, the lights etching their hulls, masts and rigging in brilliant bands of fire. The review marked the resumption of the great naval pageants, the last of which was held in the closing days of July, 1914.

Many Tasks Done at Trifling Cost by Small Amount of Electricity 1829

What a small sum of money can do when "harnessed" to electricity is well illustrated by a recent report showing the tasks that can be performed by one kilowatt-hour of electrical energy, which in this country costs around ten cents or less depending upon the amount of electricity used. The French government after exhaustive research and experiment discovered that the unit of power will drive a sewing machine for twenty hours, clean fifteen steel tableknives for one year, clip five horses or twenty-five sheep, heat water for shaving for one month, light three cigars a day for five years, heat a flat-iron for three hours, boil 2.37 gallons of water, fry fifteen chops in fifteen

minutes, heat a curling iron for twenty mornings, incubate 250 eggs, milk twenty cows, separate 350 gallons of milk or churn 440 pounds of butter.

Wallpaper Finish for Auto Bodies Saves Task of Painting 1599

Doing away with the many coats of paint required to cover the body of an automobile, a textile material that can be decorated in almost any wallpaper pattern has been developed by an engineer in England. The sheets can be easily and quickly applied so that they will provide a closely fitted covering composed of scrolled, flowered or similarly figured surfaces. The material has a glossy finish which greatly adds to its appearance and, it is claimed, can be washed and rubbed without marring the effect.

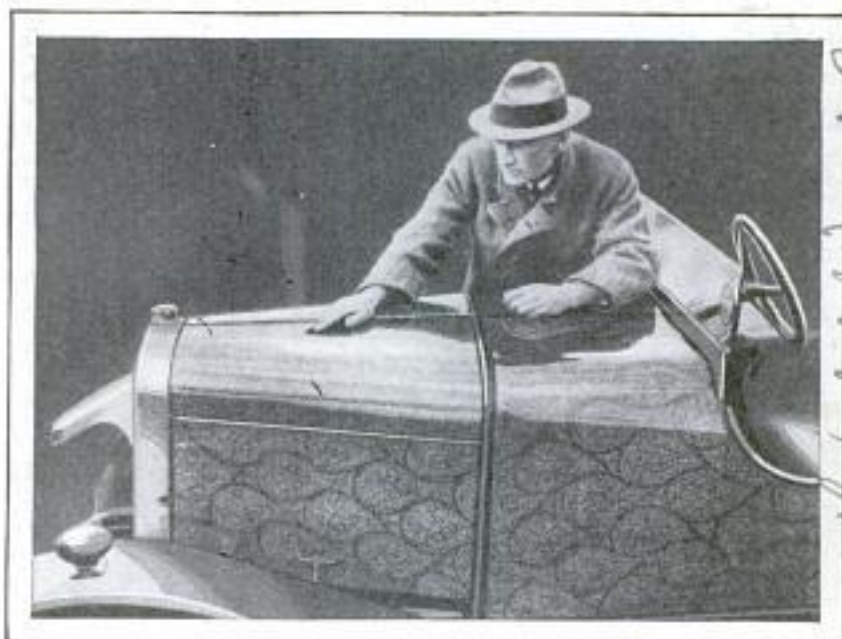

Inventor Inspecting One of His Patterned Designs of the Wallpaper Automobile Finish, Neatly Covering Hood and Body

*Commissioner
on Public Utilities*

*2 no.
Dampstead.
D no. Leopold Ward, Eng.*

One of the Special Thermometers That Records Sunshine by Expansion of Lower Black Glass Tube on a Mercury Column between Platinum Contact Points

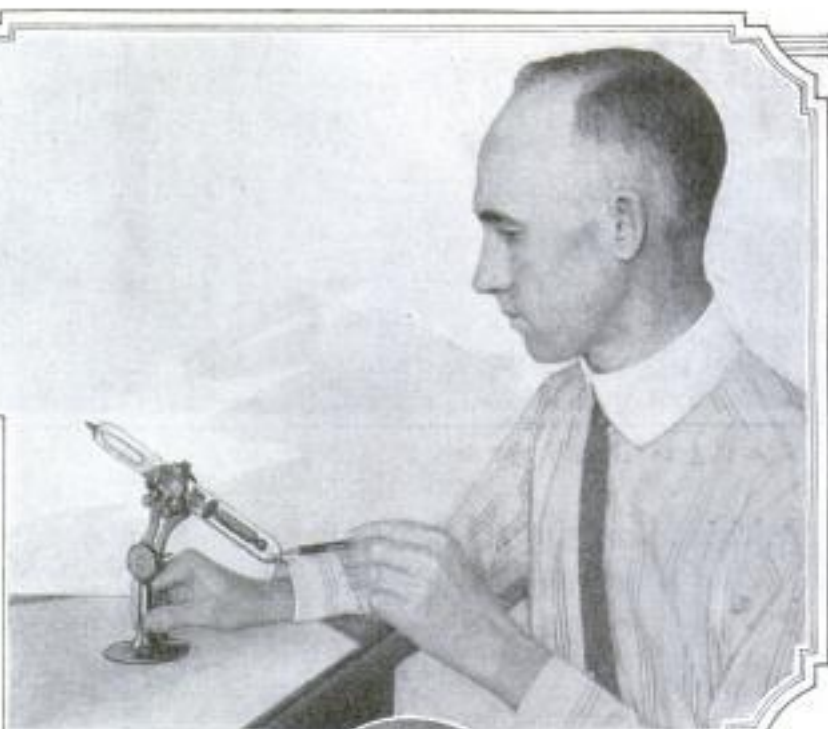

At Left, an Observer Is Sending Up Balloon Loaded with Recording Instruments That Will Show Velocity and Direction of Wind at Various Altitudes; Right, Inflating and Measuring a Weather Balloon

© U. & U.

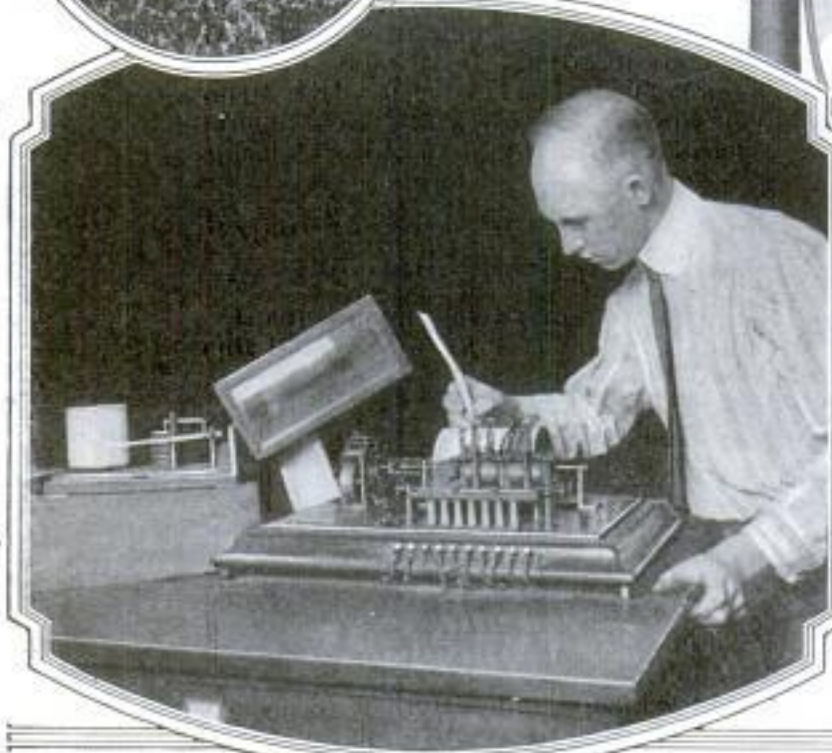
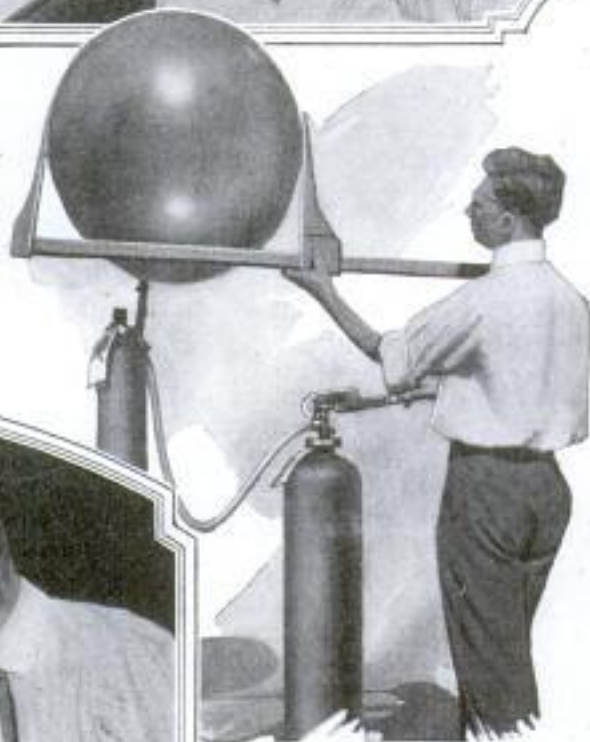

Calculating Wind's Velocity and Direction on Recording Device Connected with Instruments on Top of Building 200 Feet above Street Level; These Data, Minutes of Sunshine Each Day and Rainfall Are Shown on a Revolving Chart; to the Left Is Barometer Which Records Air Pressure on a Card That Revolves Once in Twenty-Four Hours

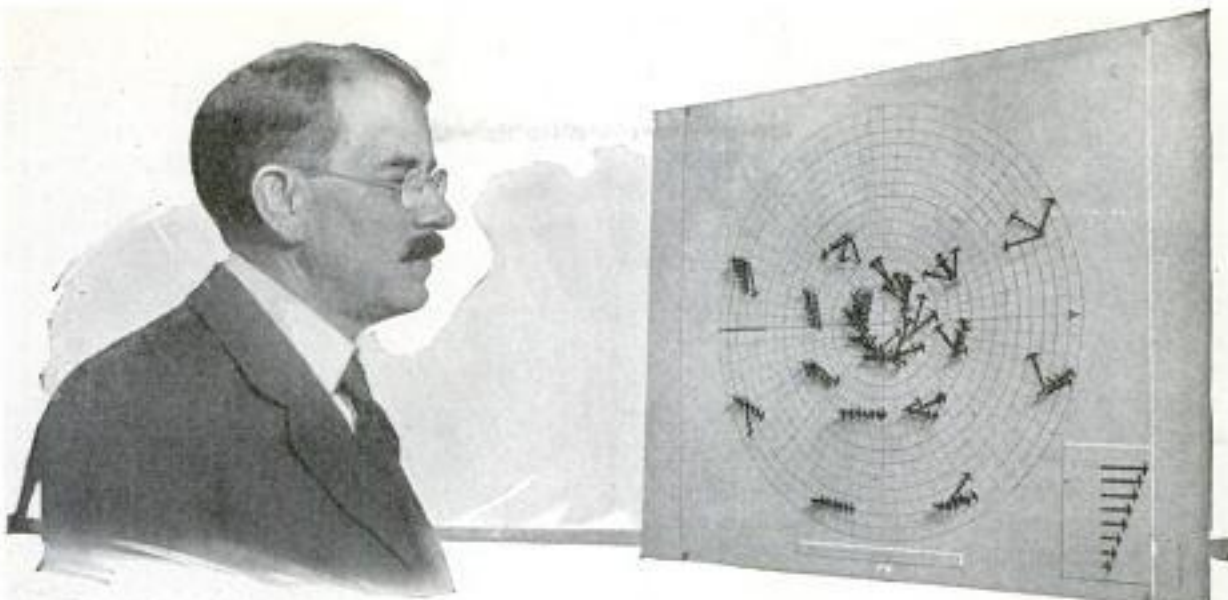

Copyright, Underwood & Underwood

Forecaster Examining Chart Which Shows Direction of the Winds at Various Altitudes, during Preparation of Aviation Weather Forecasts Now Being Made for Every Part of the Country

Making the Air Safe for Fliers

Uncle Sam's Charts of the Upper Atmosphere Enable Aviators to Avoid Storms by Flying Over or Around Them

FORECASTING weather for the air mail, army and navy fliers and civilian aviators has added a new science to the business of the department of agriculture's weather bureau. Aerological observation charts are as much in demand as the predictions of heat and cold and fair or stormy weather for business men on the ground. The importance of the aerial weather observations is due to the fact that the earth's atmosphere is a series of layers of contrary winds, which may completely "box the compass" within an altitude of a mile or two. The aviator's weather chart shows the direction and velocity of the wind on the surface and at 250, 500, 1,000, 1,500, 2,000, 3,000 and 4,000 meters. On one day recently the chart showed, for example, a gentle north wind blowing four miles an hour at Madison, Wis. For the flier going south, toward St. Louis or Memphis, Tenn., that would appear a favorable breeze, since he would have it behind his back, to help push the plane along.

But go up to 1,000 meters—a favorite flying altitude—and instead of that gentle four-mile breeze out of the north there is a gusty twenty-mile wind out of slightly north of east, ready to send a south-bound plane drifting far out of its course, unless proper allowance is made. Go up another

500 meters and the wind has fallen to nine miles an hour, but shifted to northeast. At 2,000 meters, if the flier had gone on up in search of a better wind, the breeze had shifted around to northwest, and was blowing at thirteen miles an hour. At 3,000 meters it was still out of the northwest, but was blowing twenty-two miles, while at 4,000 meters the aviator would have encountered a half gale blowing from due west at twenty-seven miles an hour.

In forecasting weather for fliers the weather bureau uses not only all the information usually gathered for other forecasts, but sends up captive balloons and box kites bearing recording apparatus to get the wind velocity and direction at various altitudes. Kites are sent up daily at Broken Arrow, Okla., Drexel, Nebr., Due West, S. C., Ellendale, N. D., Groesbeck, Tex., Royal Center, Ind., and kites or balloons twice a day at Burlington, Vt., Denver, Colo., Ithaca, N. Y., Key West, Fla., Lansing, Mich., Madison, Wis., San Juan, Porto Rico, Washington, D. C., and Scott Field, Ill.

The readings of the recording instruments are telegraphed to Washington, Chicago and San Francisco, where aerological maps and flying forecasts are made for fourteen flying zones. To save space, the observations are telegraphed in code.

As soon as a telegram arrives, it is rushed to the forecaster, who decodes it and draws in the directional arrows and marks the velocity on the sheet of aerological maps, one map for the surface and each altitude given.

A sample code telegram from the observer at Drexel, Nebr., on a recent date said: "DREXEL HOPBACK FACETY FOLEY FIXING FEEBLE NILES ROVING SABER SEABORNE TUMULOUS SADDUCER CIRNUM SEVEN." Decoded, "Drexel" and "hopback" give the place and date and each of the next eight words the velocity and direction of the wind on the surface and at 250, 500, 1,000, 1,500, 2,000, 3,000 and 4,000 meters. The word "tumulous" shows the kite reached an extreme altitude of 5,000 meters—1,000 above the highest shown on the usual maps—and "sadducer" means that it encountered a forty-four mile northwest wind blowing there, while "cirnum" means there were a few cumulus clouds in the west, and "seven" gives the visibility in miles. The wind conditions at Drexel on this day were unusual. "Facety" means an eleven-mile east wind was blowing on the surface, while at 250 meters "foley" shows it had shifted to slightly south of east without changing its velocity. At 500 meters "fixing" indicated the same direction, but

a velocity of thirteen miles an hour, while "feeble" shows that at 1,000 meters it had shifted to north of east and dropped to nine miles. The next word, "niles," hides a complete boxing of the compass, with the wind circling around to west-southwest, but keeping the same velocity of nine miles an hour, at an altitude of 1,500 meters. At 2,000 meters, "roving" shows a shift to west-northwest, with a velocity of thirteen miles again. From there up a gale began to appear. At 3,000 meters "saber" indicates a north-northwest wind blowing thirty-one miles an hour, while "seaborne" shows a forty-mile gale from the same direction at 4,000 meters. Besides the captive balloons and kites, which carry instruments aloft, the weather bureau also uses small free balloons to show the direction of the wind at various altitudes and the height of the clouds. The diameter of the balloons is carefully measured as they are filled, and their lifting power weighed on delicate scales. Delicate recording instruments also keep continual check on the wind velocity and direction at the surface, and on the sunshine and rain, and the pressure of the atmosphere. When the weather bureau announces that so many hours and minutes of sunshine have been recorded during the day, it is only giving out the facts which have been automatically marked down by one of the most delicate of its apparatus.



Copyright, Underwood & Underwood

Observers at Washington About to Release a Scout Balloon to Determine Direction and How Fast Wind Blows as Forecast Data for Guidance of Fliers throughout the Country

1697

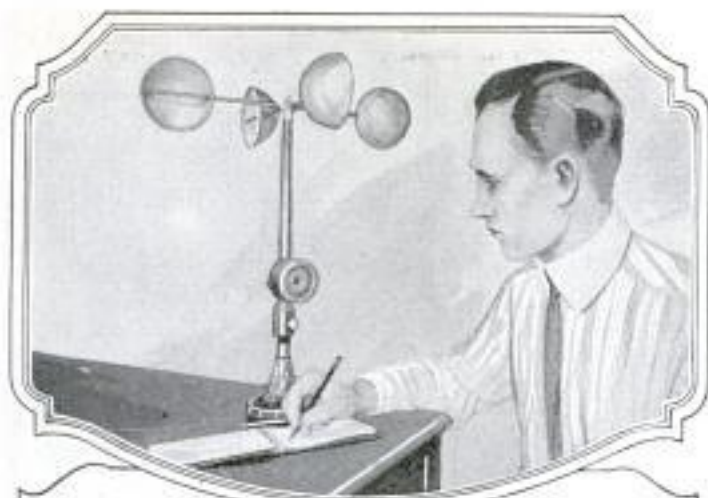

Five Hundred Revolutions of the Cups on This Instrument Indicate That a "Mile of Wind" Has Passed; the Turns Are Registered on Time Dial Showing Velocity; at Right the Lifting Power of an Observation Balloon Is Being Measured before the Ascent

© U. & U.



Temperatures in the Altitude Chamber Are Measured Outside through Thermoelectric Couples

© U. & U.

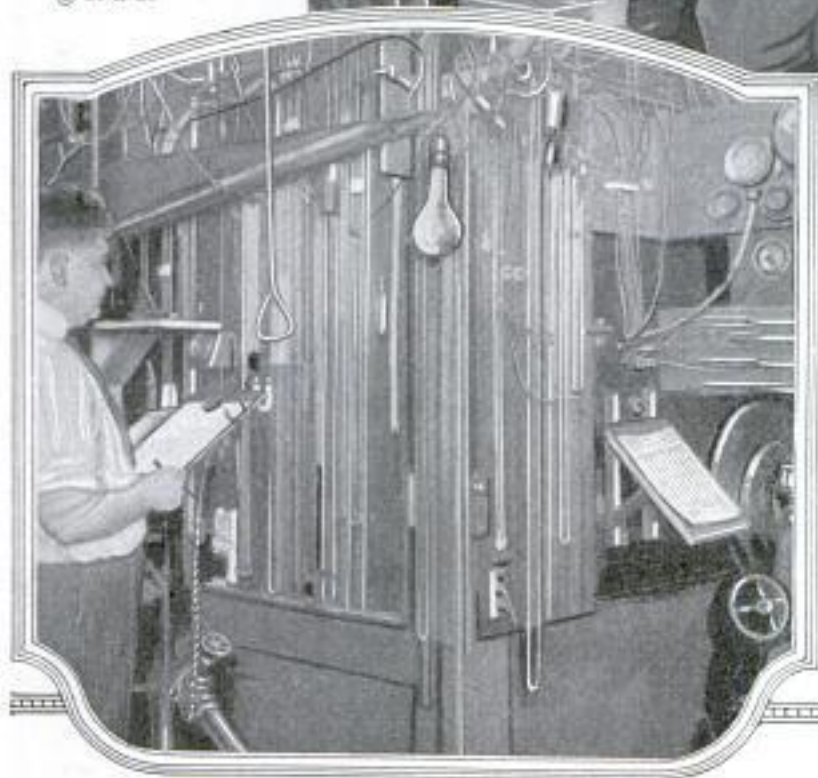

Measuring the Water and Air Flow of an Airplane Engine in an Altitude Chamber Which Duplicates Some of the Actual Flying Conditions at Different Heights, to Determine How the Motor Withstands Cold and Density at Varying Levels and to Detect Faults; Controls Are Seen at Right

© U. & U.

1942 Vanishing Furniture Fixed on Door
Doubles the Use of Rooms

Single rooms can be made to serve the purposes of two with a cleverly designed revolving-door arrangement which has a folding bed on one side and a writing table, desk or sideboard on the other. On the back, it opens into a convenient storage closet or dressing room where the side not wanted is concealed. Unlike most folding beds, this one has standard-shaped ends and when let down, cannot be told

from one of ordinary pattern, thus removing a common objection to folding furniture. The door is attractively paneled or may be finished in any style to suit the other decorations, is securely pivoted and can be turned with little effort. Houses, apartments and hotels furnished with this equipment need fewer rooms, the advantages of the "best" room in the house can be enjoyed both by day and night and the arrangement effects a great saving in space and reduces construction costs. Door and furniture swing clear of the carpet, opening and closing easily and without noise.



Bed and Sideboard Exposed and Door Swung Part Way Around to Show Storage Closet

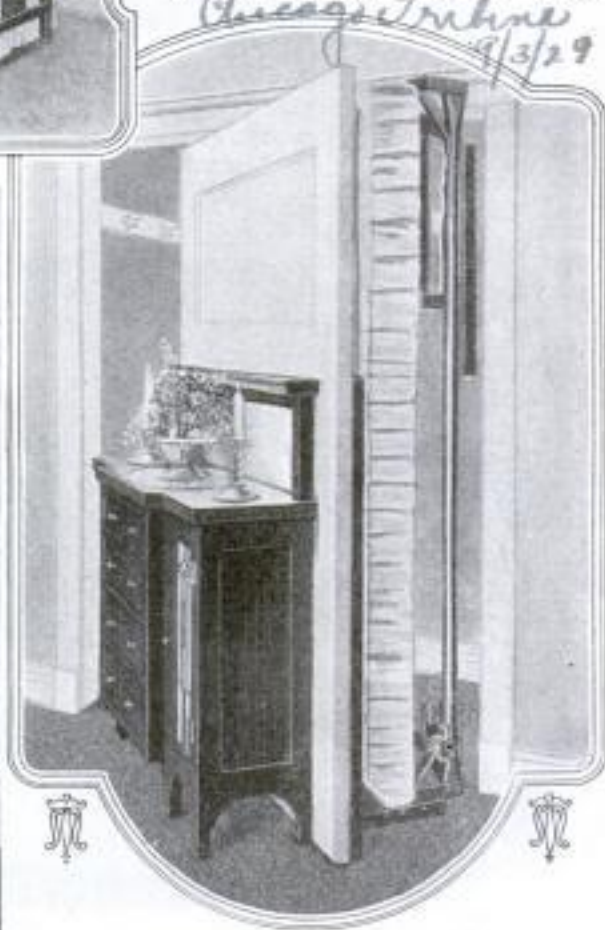

1786 Steel Walls to Stop Locusts

Thirty-nine thousand tons of galvanized steel sheets are to be used to stop the crop ravages of locusts in northern Argentina. A \$5,000,000 contract for the material has been signed with an American firm. Digging pitfalls, spraying the ground in which the eggs are deposited with chemicals and destroying the egg cases are other ways that have been employed in fighting the pests.

Chicago Tribune 9/3/29



Copyright, Underwood & Underwood

Loaded on Three Big Barges, the Schoolhouse Gets under Way for Its Seventeen-Mile Voyage through Canal and a Lock Drop of Eighteen Feet

Schoolhouse Rides on Canal Barges for Seventeen-Mile Voyage

Confronted with the task of moving a large schoolhouse near Lake Washington, not long ago, engineers solved the problem by placing the building on three huge barges and floating it within a short distance of the new site, seventeen miles away. Part of the voyage led through a canal at Seattle, Wash., and it was necessary to lower the massive load through locks from the lake, which is eighteen feet above the level of Puget Sound. Save for a few minor breakages in the stucco, the building suffered little damage.

Power of Two Handfuls of Coal Enough to Last Family a Day

Electrical generating apparatus has been developed to such a high point of efficiency that enough electricity to supply the average household for a whole day can be obtained at the big central power stations from only two handfuls of coal, according to J. F. Johnson, an engineer for a large manufacturing company. He asserts that this is chiefly due to improvements made in the steam-turbine generators, that now commonly average from 20,000 to 35,000 kilowatts and are capable of furnishing a kilowatt for every pound of coal burned. Thirty-five of these big turbines are being

new York Times 9/1/24

assembled by one plant in the east. They are taken as a good indication of the enormous electrical development that has occurred in this country in recent years.

Auto's Lights Turned Up or Down by Knob on Steering Wheel

So that automobile headlights can be adjusted quickly to fit any condition without a sudden shift from one extreme to



the other, a device designed for attachment to the steering wheel has been invented. A turn of the dial changes the lamps to any degree of dimness necessary, eliminating the momentary

blindness that follows an abrupt switch from a bright glare to semidarkness when passing machines at night, and lessening the danger of a collision or running off the road. Easily attached to any car, the control can also be used for parking lights.

Cremner Sales Corp. 332 S. Michigan Ave Chicago

Price - \$5.00 for either 6 - 8 or 12-16 volt batteries.

not 18.3 out info Electric - Mt. Washington, Pa.

Donal Philadelphia Wash Westinghouse

Copyrighted material

Dr. W. A. S. Howell of Automobile Fitting Station
Christian Science Monitor 8/22/29
POPULAR MECHANICS
North & Madison St. Portland, Or

Brush Handle Fits Hose and Sprays Water for Washing Auto

With a long hollow handle to which a garden hose can be attached, a brush holder that sprays water from a nozzle is

man spray



Brush Holder and Spray Which Gets Water Supply through Hollow Handle Attached to Garden Hose

being made for washing automobiles, walls, windows and other large surfaces. The brushes are removable so that either soft or stiff bristles can be fastened to the device. The spray is arranged to aid in dislodging dirt, and the water may be turned on with almost any degree of force needed. The great length of the holder enables the user to keep a sufficient distance from the work to avoid being splashed while manipulating the brush.

Expanding Cuff Links Save Trouble in Rolling Up Sleeves

Inconvenience of having to remove the cuff links or unfasten them before rolling up the sleeves, has been eliminated by an expanding link now on the market. The two sides are held together by a series of coil springs which stretch sufficiently to allow the sleeve to be pushed a considerable distance up the arm without having to unfasten the cuffs or take off the coat. The links are easily inserted and are attractive.



Fortune in Diamonds Found on Farm Bought for One Hundred Dollars

Chance discovery of diamond-bearing soil on a farm near Zeekoefontein on the Vaal river in South Africa, precipitated a rush of nearly 3,000 persons, including experienced diggers, students, clerks and even girls, when the government opened the surrounding territory to "claim peggers." Holders of licenses which permitted them to file on the land, formed in a line behind the mining commissioner and a squad of mounted police. At a signal, they rushed forward down a path that had been cleared to the site of the deposits and hastily drove their pegs. The farmer had obtained the land for less than \$100 and it yielded him over \$10,000 a week. The largest diamond he had discovered weighed thirty-four and one-eighth carats.

Revolving Sign Covers Water Tank and Advertises Theater

Space on an exposed water tank is to be effectively used by a mid-west theater owner for an advertising device to call attention to the building by day and night and to announce various attractions. A steel wire frame, which will be turned by an electric motor and self-winding clockwork, will entirely surround the tank and revolve around it, bearing in large letters the name of the theater and such other legends as may be displayed from time to time. Powerful searchlights will be mounted on the frame and turn with it. The lofty position of the tank suits it to advertising purposes and the frame serves as an attractive shield to cover its plain and somewhat unsightly proportions.



Capitol Theatre 179th & Halsted Chicago
 (Between 7,000 and 8,000 deaths by drowning are recorded every year in the United States.)

Cont. Jay M. Sireck, P.O. 150 4107 Chicago

Cont. W. E. Thomas, 40 W. W. W. Ave. Portland, Ore.

1654 Portsmouth Ave.

John E. Benson, Architect, Supervisor St. Chicago 1017

Dr. W. E. A. Papaschbach, 6311 N. W. 11th St. Chicago

Copyrighted material



Tense Moments during Yacht Race with the Crew Crouching on Deck to Avoid the Swing of the Boom as the Craft Comes About on the Turn in a High Wind

Yacht Modeling Teaches Seamanship

Construction and Sailing of Miniature Craft Train Scholars
for Contests of Skill with Tools and Boats

IN an effort to convert youthful landlubbers into potential seamen with a knowledge of the duties and requirements of a thoroughly trained sailor, a model-yacht club of Washington, D. C., is instructing the boys of that community in the building of toy boats and aiding them in the proper sailing of the miniature craft.

When laying out and constructing the models, great attention is paid to the detail of keels, buoyancy and minimum resistance to water. Sails are cut and fitted according to the rules that apply to large craft. Efforts are also made to gain speed for the toy vessels by experimenting with changes in the forming of hulls, and when launched in a pond or tank, the boats' performances are studied so that any new features that might disclose themselves while the model is afloat can be corrected or enlarged upon in order to produce the greatest degree of ability when the designer finally completes the miniature and submits it to the instructors or judges for inspection. Much has been done also by

an organization of yachtsmen who are giving assistance to schoolboys and others interested in the building of models as a pastime, or who have taken up the practice as an aid to the study of marine architecture and construction. Experts in the art of model building assist the craftsmen by suggestions regarding tools required and methods of doing the cutting and carving of the hulls, masts and tiny beams. When the modelers are ready to try out the boats, instruction is given them in the handling of sails, which must be set so they will carry the vessels along the courses without causing them to capsize or change direction of travel from the line desired.

Pupils have been recruited from the ranks of both old and young model enthusiasts. Classes are regularly held for instruction in management of sailing boats by those through whose efforts building of model yachts has been introduced into the schools, for the purpose of giving the students interested in carpentry and wood-working a knowledge of lumber and tools



Fleet as the Wind That Propels Them; Two Yachts Contesting for the Lead during a Race of International Interest Where Superiority Depends on the "Cut" of the Trim Craft



Prize-Winning Miniature Constructed from Blueprints by Youthful Manual-Training Student



Small Yacht Models Completed by Boy Mechanics, Ready for a Trial Run

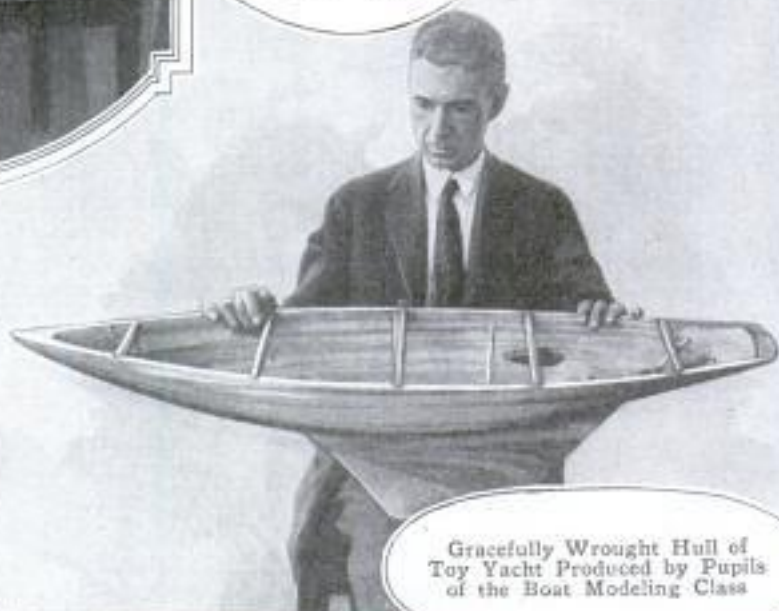

Gracefully Wrought Hull of Toy Yacht Produced by Pupils of the Boat Modeling Class

as applied to the design and construction of sailing craft. Manual-training classes receive the same systematic instruction in the making of toy sailboats as those taught metal working and similar trades.

Together with the knowledge of boat building the scholars get at the hands of special teachers, spare time in home workshops is devoted to the craft. Fairly large models can be completed in this way in from three to four months. Instead of following patterns or copying the work of expert modelers, the students are given blueprints from which to construct their toy vessels. These are prepared by a naval architect who provides the youthful craftsmen with a full set of dimensions, which serves as instruction and practice in the reading of plans.

As a general pattern for the teaching of classes, the architect drew up a design which is the outline of only one-half of a yacht, and this is divided into sections to aid in the progressive steps of the undertaking, including the sail plan for the miniature. From start to finish, each part of the work is inspected by instructors who emphasize the importance of curves and lines in the hulls. Although white pine is preferable for use in the boat

models, poplar, because of equally desirable qualities, is substituted when the other material cannot be readily procured.

It is said, after the boys have received a course in the planning and erection of a toy model of a yacht, it is easier to teach them the art of sailing large vessels, for the reason that fitting and handling of sails, important duties of a crew, is taught so the miniatures can be entered in contests held in lagoons of two or three of the city's public parks. These tournaments are arranged by the organizations of yachtsmen and those following the practice of modeling as a hobby or business. Prizes for workmanship and ability to provide speed through the arrangement of sails are offered in addition to trophies for the winners of races. An average of fifteen to twenty models are always under construction in the ordinary manual-training class. The first attempts are always made with simple designs of small size, but with progress on the part of the scholars, larger and more difficult miniatures are submitted to them for construction. Frequently groups of youthful "fans" undertake the making of models together, resulting in quicker work and often superior workmanship.

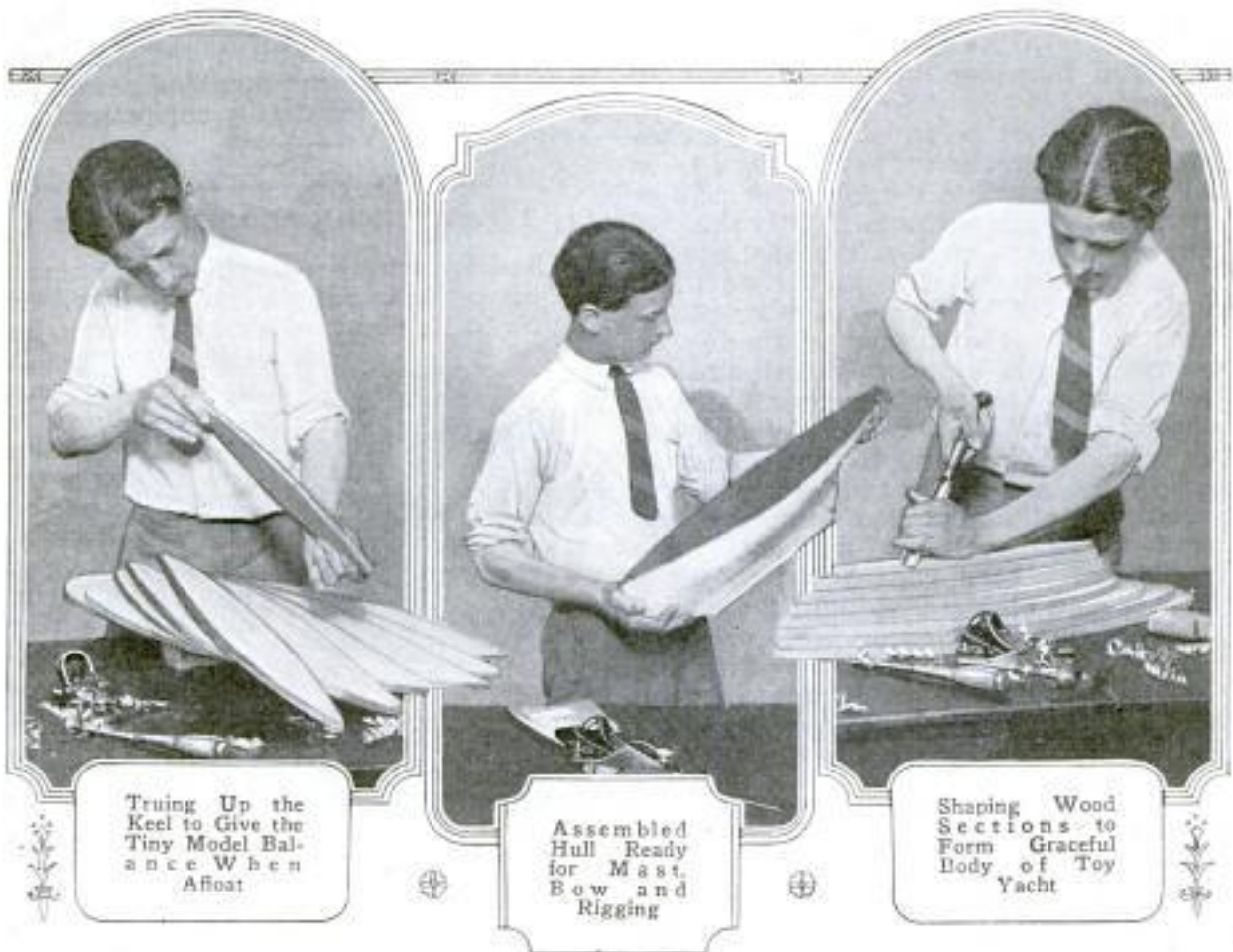

Truing Up the Keel to Give the Tiny Model Balance When Afloat

Assembled Hull Ready for Mast, Bow and Rigging

Shaping Wood Sections to Form Graceful Body of Toy Yacht

Franky Lifeboat-Releasing
911 E. Heldon Ave. Norfolk, Va.
986

POPULAR MECHANICS

Lever Release in Launching Lifeboat Increases Safety at Sea

As an aid to safety in emergencies at sea, a dependable and easily operated

cent. or about 15,000 of this number, lost their sight because of industrial accidents, according to a report recently made to the International Association of industrial accidents boards and commissions. As

a means of preventing these casualties, the association offered a five-fold code, stressing education, better lighting, eye tests and the use of glasses, prompt and efficient medical service and protection of the eyes with goggles. Three-fourths of the eye injuries suffered by workers were declared to result from preventable causes, while fifteen per cent of industrial accidents were said to result from improper illumination alone. Goggles were especially recommended in chipping operations, riveting, quarrying, blasting and stone cutting. In one of the exhibits shown at the meeting were displayed twenty-six pairs of goggles which had prevented the loss of



Copyright, National Photo

As It Strikes Flat on the Water, the Lifeboat Is Instantly Released at Both Ends Simultaneously by Tripping the Catches with Lever Seen at Side

means of releasing the lifeboats as they are lowered to the water has been devised in the form of patented spring catches hooked to the ropes and worked by a lever within easy reach of the officer or man in charge of the launching. With this arrangement, both ends of the boat are let down simultaneously, as one of the catches is placed at the bow and the other at the stern so that the danger of tipping or overturning is practically eliminated. Both trips are operated by chain and wire connections which are inclosed in pipes at the side of the boat and thus cannot be fo-
led. Only a lift on the lever will pull them, preventing the boat being dropped from the supports by accident. The catches have been constructed to withstand a load of 30,000 pounds, the equipment may be installed on large or small ships and works successfully whether the vessel is moving or still. Similar catches, which may be instantly released, are used for fastening the lifeboats to the decks.

Fifteen Thousand Persons Blinded by Industrial Accidents

There are approximately 110,000 blind persons in the United States and 13.5 per

sight of as many workmen and saved one company over \$65,000 in compensations.

Special Airplane Compass Guides Fliers When Landmarks Fade

Used for centuries to guide ships across the seas, the mariner's compass has been found to be poorly adapted to flying, be-



cause the needle swings too freely when subject to rapid vibration and sudden movement. To correct this, what is known as an earth inductor compass, which works on the same principle as a dynamo, has been invented. It consists, in part, of an armature which is kept steadily revolving on a vertical shaft and a meter on the instrument board before the pilot. The brushes of the armature are set in the direction the airplane is to fly. Any change from this course sets up an electrical current that indicates the deviation on the meter dial.

New York Times 9/2/24

Spreckels Bros. Commercial Co.
Natural City, Calif.

Cont. George J. Knoll, Jr.
Reformer office
Brattleboro, Vt. 987

Wallboard Made of Mixed Minerals Is Proof against Fire and Cold

1912
 Claimed to be able to resist fire and sudden changes of temperature to a remarkable degree, a patented wallboard for use on the outside of buildings of all kinds is being manufactured in California. It is only half an inch thick and is composed of a mixture of minerals so combined as to produce a material that effectively insulates against heat and cold. In a chemical-factory fire, not long ago, it sustained the walls until the entire inside of the building had been destroyed.

Granite Mfg. Co.

Village Laid Out in Shape of Bell to Assure Light and Air 1603

Because of its shape a community near Sheffield, Ala., is known as the "Liberty Bell village." The roads winding through the area describe the outlines of a bell and the dwellings are placed in corresponding positions. The center of the plan is almost entirely clear of buildings, while a narrow oval traced by the highway appears to be the hanging link for the top of the design. The town is of modern construction, and each residence is provided with a wide plot of ground to insure to the homes plentiful sunlight and as much air as possible.



Copyright, Eberto Goela
 Airplane View of "Liberty Bell Village," Showing the Design Traced by Roads and Streets Which Permits Plenty of Space for Homes

Ancient Treasure Chest Is Found in Wrecking Old Building

Resembling an immense pincushion, a rusted iron safe, about 120 years old, was found in the cellar of one of the oldest



Century-Old Iron Safe, Studded with Rivets, That Was Found in Wrecking Landmark

buildings in Brattleboro, Vt., when it was wrecked recently. Exclusive of the legs, it measured two feet four inches square and was made of thin and narrow strips of iron fastened together with rivets, the size of those used in boilers. Markings inside disclosed that it was built in Providence, R. I., about 1805. The keyholes in both the outer and inner doors indicate that a key of unusual size was used.

Oil Burners Cause Cinder Shortage 1747

Due in part to the great increase in oil burners, a cinder shortage occurred in New York recently, temporarily halting building operations in which millions of dollars had been invested until a regular supply of the material, which is used extensively in fireproofing, could be obtained. A breakdown in the facilities of a cartage company that handles most of the city's ashes was partly to blame for the "famine," but it was revealed that the wide substitution of oil for coal had materially depleted the supply.

New York Times
 8/25/24 material

Time and Money-Saving Tools



Worn over the Night Clothing, Chamomise-Lined Sleeping Robes for Children or Adults Have Draw Cord at the Bottom and Adjustable Hoods, Protecting Head, Feet and Shoulders and Eliminating Heavy Bedding



This Stout Rubber-Tired Baby Cart, Weighing Less than Seven Pounds, Folds Up Flat and Can Be Used Indoors Too



Fitting Closely against Wall When Not in Use, a Collapsible Shoe-Shining Stand Has Holders for Polish, a Hook for Brush and Whiskbroom, and Rag That Works on Rollers; Below, Handy Electric Double Boiler Is Also Suitable for Serving Foods at Table



No Danger of Getting Salt in the Ice Cream with This Rapid Labor-Saving Freezer That Stops Automatically When Contents Are Ready



With Fluid Held in Top Compartment and Released by Pressure on Valve, This Strong-Bristled Brush Thoroughly Cleans Clothing at Home

for Woman's Workshop in Home



For Cleaning Furniture, Curtains, Walls, Automobiles and Almost Any Part of the House. This Novel Portable Vacuum Cleaner That Connects to a Light Socket Is Practical and Effective



Dressing Table, Shelves and Drawers, and Storage Space for Linen and Other Articles, Are Combined in Handsome, Sanitary Cabinet for the Bathroom



Little Folks Have Fun and Healthful Exercise with a Small Seesaw with Strong Seat and Springs at One End That One Child Operates with Handle; Below Is Can Opener That Cuts Round Holes of Various Sizes in Square or Cylindrical Cans



Gripped Firmly by a Rubber Disk in This Collapsible Holder, Glasses on Trains, Automobiles or Ships Are Kept from Rattling and Breaking



Slippery Milk Bottles of Any Size Are Carried as Easily as Pails with This Simple Collar-and-Chain Arrangement on the Bottle Neck



Obtain it by addressing Bureau of Information, Popular Mechanics Magazine, Chicago

The Safe-T-Stat Co.
 990 *Alfred Bldg.*
 Philadelphia

POPULAR MECHANICS

Auto Motor Heat Shown by Meter on the Instrument Board

So that the exact condition of the automobile motor may be seen on the instrument board at all times, an electrically



Motor Thermometer on Instrument Board, and Inset Showing Readings

controlled spirit thermometer connected with a thermostat attached to the water-outlet pipe under the hood, has been placed on the market. A graduated scale shows when the engine is too cool, its temperature at the hottest point, when alcohol and water boil, and warns of insufficient oil, idle fan, low water and other causes of overheating in time to prevent damage, it is claimed. It can be quickly and permanently installed on any car, and is said to operate indefinitely without repair.

Metal-Numbering Machine Stamps Serial Figures by Hand 1055

For stamping numbers of several figures at the same time in metal, wood or fiber of all kinds, a small numbering machine that is operated by hand, has been designed. Weighing but four pounds, the device can be easily carried around. It saves time and all impressions are clearly defined and perfectly aligned. It is easily placed on the work, a gauge accurately locating the printing position. A blow of a hammer does the rest. The device is securely held on the spot while the impression is being made by a special plate on the bottom. Constructed of steel throughout and with the figure wheels of hardened tool steel, it is strongly built to withstand the hardest usage.



Emt. S. W. Winters
 District National Bank
 Bldg Washington, D.C.

Thirty Thousand Acres of Trees Are Needed Yearly for Toothpicks

Approximately 30,000 acres of trees are necessary for the manufacture of the toothpicks used yearly in the United States alone, according to government estimates. Maple and hickory are the chief kinds of wood used, although sweet and yellow birch are employed in some localities. After being felled, the logs are sawed into bolts, twenty-eight inches long. These are then steamed and cut into strips of veneer or thin sticks which are divided into ribbons, three inches wide. Eight or ten of these are run through machines that clip them into splinters of regulation toothpick size and shape, and they are then boxed, each container holding about 1,500. Michigan, Maine, Ohio and Oregon are the principal sources of the supply.

Tiny Stone Slab Was Butcher Bill
 684 **Forty Centuries Ago**

What are said to be the oldest and the smallest books in the world are on display at the University Library in Philadelphia.



Two Unique "Books," One of Which Was Written Four Thousand Years Ago

One is a stone tablet, about one and one-half inches square. It was written about 2350 B. C. and contains a brief statement of a butcher's bill for three lambs delivered to the temple of one of the Babylonian kings. The other is as elaborately bound as a more imposing volume and, though smaller than the tablet, contains many closely typed pages.

United Newspictures

Price \$10.00 One Model fits all cars.
American numbering machine Co. Atlantic City
Brooklyn N.Y.

144

1756

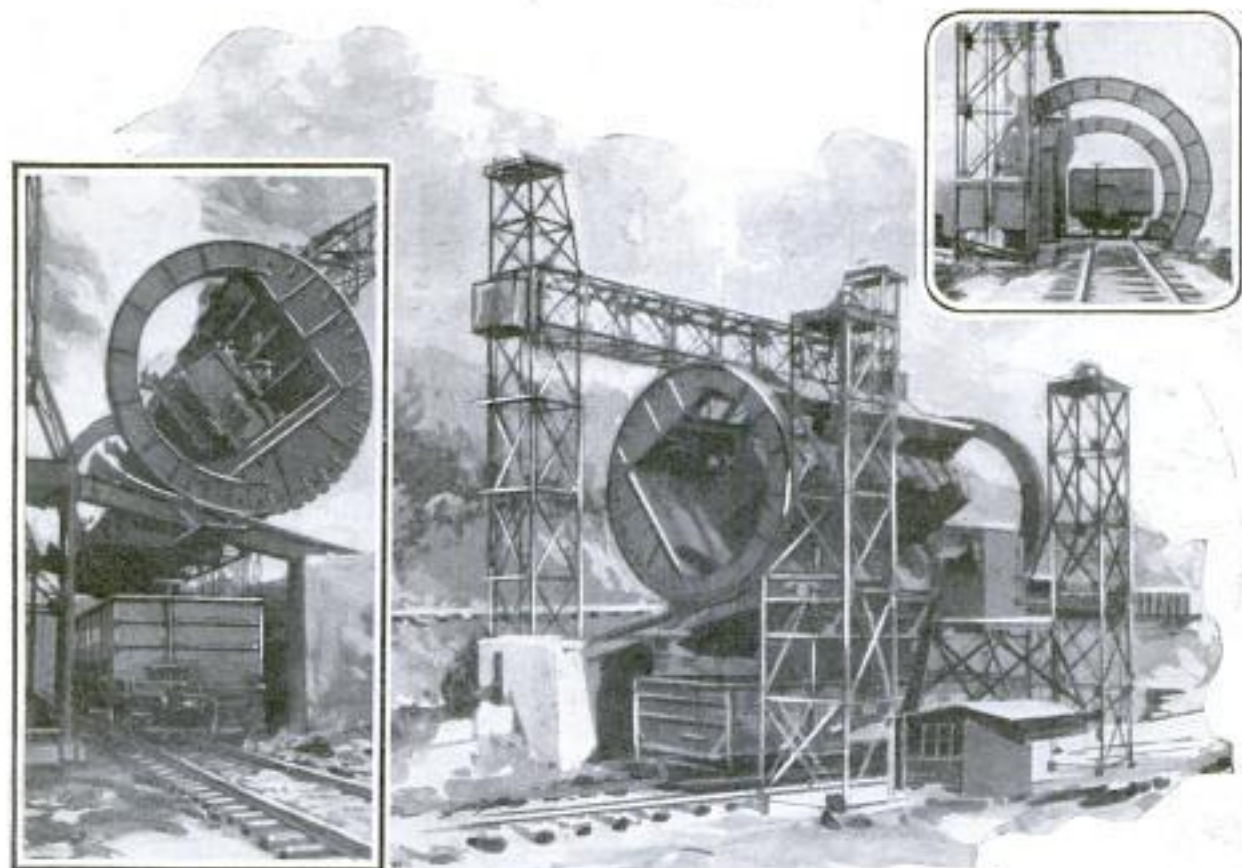

Rolling Tipple Emptying a Narrow-Gauge Coal Car into a Large Gondola; Above, Unloader Returning Its Burden to the Road Level; Left, Beginning Roll Back to Normal Position

Tipple Turns Coal Cars Over, Emptying Twenty an Hour

To transfer coal, lime rock, ore and similar bulky materials from narrow-gauge to standard-built railroad cars, a rolling tippel at Salida, Colo., turns the smaller carriers upside down over the larger ones. The device, which consists of a barrel-shaped iron "cradle," makes a half revolution, permitting its burden to unload the contents in a few seconds. When a hopper is to be emptied, it is run onto a track in the bottom of the tippel which rolls up a short incline as the operator starts the machinery. Heavy weights bring the contrivance back to normal position. Cars of different widths can be handled, since a side-slip arrangement in the track allows any type of gondola to rest against the guides as it begins to turn over. Steel beams that grip and retain the car while it is being rotated operate automatically with its movement. Run by electric power, the unloader is attended by only three men, and it is said that a single operator could manipulate the structure in emergency. Only three to five minutes are consumed for each

load, depending on the distance the cars have to travel along the storage tracks. It is estimated that 160 cars can be emptied in an eight-hour day as compared with three under the shovel system formerly used, and they can be returned in much less time to active service without the usual delay in the transfer and unloading yard.

Carriage Wheels as Window Frames 1202. Reduce Cost of Building

Utilizing discarded carriage wheels for window frames in a Massachusetts factory is claimed to have resulted in a saving to the owners in the cost of the structure. The heavy spokes are said to give added protection to the panes without obstructing the passage of light and air. Obtained at practically no expense, the wheels give an odd appearance to the building.



Wide World Photos

Brown Mills Novelty Mfg. Co.
 207 Washington Square Bldg.
 7th & Chestnut Phila.
 POPULAR MECHANICS

Coin-in-Slot Machine Sells Combs That Carry Advertising

1685

As an aid to busy patrons a penny-in-the-slot vending machine is made to sell



Penny-in-Slot Vending Machine Which Delivers Comb When Penny Is Dropped in Opening

combs in public places. Suitable to install in hotels, railroad stations, theaters and similar gathering points, the device will hold a large supply of the articles. Space is provided at the sides of the combs for the printing of advertising matter or other inscriptions. Small enough to be carried conveniently in pocket or purse, the combs can serve for repeated use.

Grease-Filled Auto Shackle-Bolt Nut Eliminates Squeaky Springs

Automobile shackle-bolt nuts, planned to eliminate squeaking and rattling springs and to make frequent tightening unnecessary, are being manufactured by a mid-western company. They consist of two cup-shaped members, telescoping into each other and inclosing a heavy coiled spring, and a nut that fits over the shackle bolt. Before applying, the cups are filled with grease which serves to eliminate noise. By



Before applying, the cups are filled with grease which serves to eliminate noise. By

screwing up the nut, tension is placed on the spring so that the nut cannot become loose, thus preventing the assembly from rattling. The attachments are easily put on, and have nicked surfaces which add to the appearance of the car.

Traffic Light Gives Fire Alarm and Tells Engines Route

569

Combining both a traffic signal and an alarm to warn pedestrians and vehicles of the direction approaching fire apparatus will take, a device for which patents have been asked, can be operated by a push button at the fire station or by a patrolman on the street. As the summons for the fire-fighting crews reach the fire houses, an attendant takes over control of the system by means of a switch. Alarms at affected street intersections may then be put in action, and colored lights started swinging at the corners. At the same time loud gongs attached to the signals call attention to them. The appliance is also made as a fire alarm only.

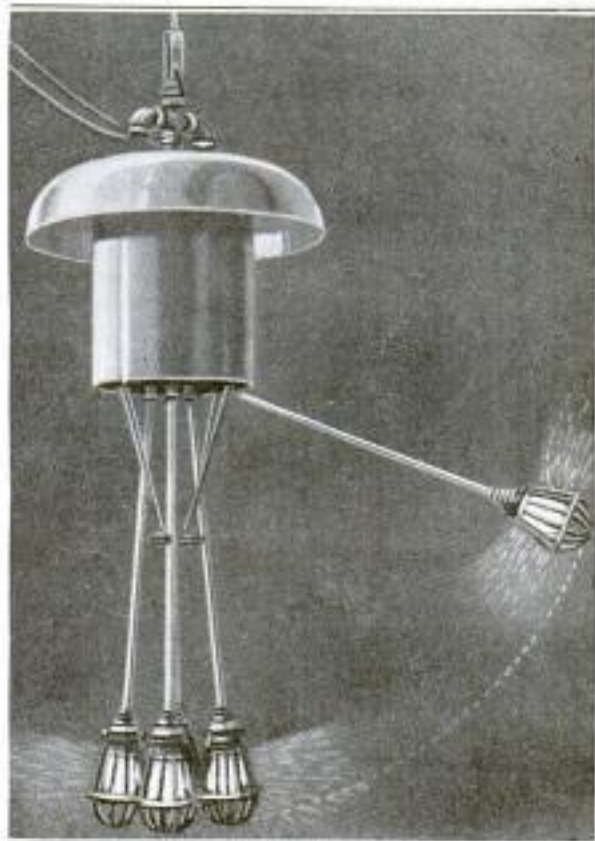

Traffic Fire Alarm in Operation at Street Crossing Showing Direction Apparatus Is Traveling

When you want anything and do not know where to get it, write Bureau of Information, Popular Mechanics, Chicago

The Heavy Cap & Steel Screw Co. Cleveland, Ohio

The Thomas-Smith Co. Copyrighted material Canton, Ohio



Broadcasting a "Struggle in the Forest"; Microphone on the Floor Transmits Sounds of Trampled Paper as Rustling of Dead Leaves, and the Striking of Sticks Supplies Beats of Horses' Hoofs

From Stage Thrills to Radio Drama

Behind the Scenes in Studio Where Weird Devices Give Realistic Effects for Unseen Listeners

A SHOT rang out on the still night air, as the old-time fiction writers used to begin their stories. A farmer's family in Maine; a banker in his library in a middle-western city, and a group of cowpunchers in a bunk house in Texas listened breathlessly; for the sound was carried by wireless. Untold thousands of radio fans scattered from the Atlantic to the Pacific and from the Canadian border to the Gulf of Mexico heard it, too, for all of them were tuned in on the drama "Pierre of the Plains," broadcast from an eastern city.

The old-time thriller of the past, that reached its glory when the box office hung out the "S. R. O." sign—standing room only—may have had as many as twelve hundred people hanging breathlessly on the actor's lines, but nowadays when a melodrama is put on the air its invisible audience may run into the millions.

They hear the shot and the heroine's scream. They listen to the galloping hoof beats of the villain's horse as he speeds

away; the gasps of the wounded hero as he drags himself to his feet and staggers to his own mount; and the rat-a-tat-tat of flying feet as the animal takes up the pursuit. And they hear the fight of hero and villain among the rustling leaves of the forest.

Equipping a radio-drama outfit with sound-producing devices would drive a regular stage-property man to desperation. Everything from a character's entrance to his exit must be interpreted in a way which will actuate a microphone and carry through the air.

The old-time theatrical producer of "Alaska," "Billy the Kid," "Call of the North," "East Lynne," "For Her Sake," "Her First False Step," "Nettie the News-girl," "Ten Nights in a Barroom" or the other melodramas which still are to be seen in the smaller towns and villages, had an easy time compared to the modern radio dramatist.

Think of the difficulty of opening and



THE BEST EVER
IS THE UNIVERSAL PRODUCT OF

NETTIE THE NEWS GIRL

WRITTEN BY
LEM IL PARRIE

A MELODRAMATIC NOVELTY
BRIMFUL OF
PATHOS, COMEDY, SENSATION

In Putting Sound of Dramatic Action into Radio Play, the Director Manipulates Noise - Producing Implements While Characters Follow His Signals with Their Lines; Left, Familiar Type of Theatrical Poster Procured from Stocks Always on Hand in Printeries That Produce "Paper" for More Popular Melodramas

HAVERLY'S THEATRE

ONE FLOOR ON GRAND ST. CHICAGO.
J. B. HAVENLY, Mgr. and Proprietor.



LIBERTY AND BIRD STREETS CHICAGO.
Largest and Finest Theatre, Grandest and Most Complete Amusement
and Entertainment Building in the World.



"DROP THAT OAR OR I'LL DROP YOU!"

Above, Once a Chief Source of Large City's Entertainment, This Theater Long Since Passed into History; Left, Billboard Display of Character Rapidly Being Relegated to Smaller Communities by Movies and Radio



Radio Dramatists Reading the Lines of an Absorbing Scene into a Pair of Microphones Provided to Insure Perfect Transmission



Poster of a Play That Is Still in Demand by Theatergoers Whose Faithful Preference for the Old Standards Is Demonstrated by Box-Office Receipts; Insert, Well-Known Stage Star in Action before a Microphone



Unseen Struggle in the Broadcasting Room Which Helps the Actors in Reading Their Lines



SAVED FROM THE TRACK

Casting a Radio Play with Director and Actors Preparing for First Rehearsal of Story That May Thrill a Million Hearers: Left, Scene That Can Be Wire'essed with the Aid of Noises



In Position before a Pair of Microphones Awaiting Cue to Begin



During Tense Situation in Studio While Thrilling Words of Play Are Being Emphasized by Property Man, Whose Important Duty Is to Follow Action of Piece with Realistic Sounds; Below, How Amusement-Seeking Public Was Attracted to Wonders of Museum of Long Ago

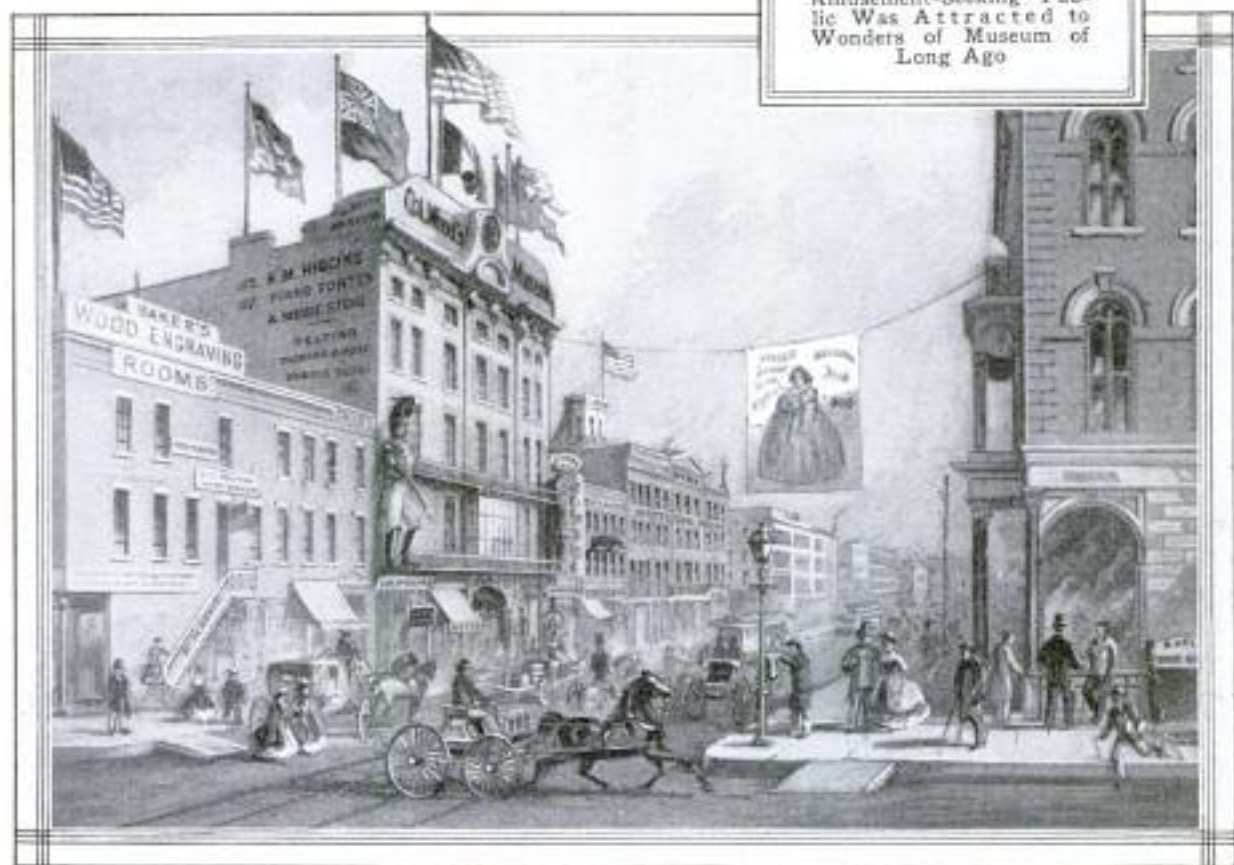

closing the door so the sound will not only carry through the air that is full of market reports, static, bedtime stories, monologists, darky quartets, pianists, saxophonists, lecturers on how to make strawberry pie, speakers on Europe's problems, jazz bands, brass bands, orchestras, and not only carry through all that, but still sound like a door opening or closing when it is received.

At the WGY studio, Schenectady, N. Y., where eighty-five plays were reproduced and broadcast in eighteen months, that problem of the entrance and exit of a character was solved by building a special portable door and door frame. The door is constructed of thin oak and has a peculiar resonant quality which makes its opening and closing readily recognizable as a door by the sound. Likewise the lock has a highly gifted click, which transmits well through the ether.

Next to the door, which heralds the arrival and departure of every character in an indoor set, the most overworked property device is the bell board. It consists of a convenient arrangement of five bells of different tones and a buzzer, with the necessary dry cells and buttons. There is a doorbell, telephone bell and an alarm gong which may be sounded for fire, ambulance or as a burglar alarm. A clock

chime and a tap bell complete the group. But getting back to Pierre, in the drama "Pierre of the Plains." The shot rings out on the still night air and Pierre falls, feigning death among the leaves. A property revolver in the hands of the stage director fired the shot, and a pile of crumpled onion-skin paper on the floor provides the rustling leaves. Beside the paper is a big microphone which carries the sound across the continent.

At the approach of the villain, who believes he has killed the hero, Pierre grapples with him and they struggle among the rustling paper. Pierre is victor, of course, and the winner finally mounts his horse and rides away. A young woman perched on the grand piano, where she will be out of the way of the action on the floor, supplies the sound of horses' hoofs by clapping two sticks together.

A revolving-barrel thunder machine produces thunder just as on the stage. Tin pans, a wire carpet beater, dishes and other homely devices are used to simulate other sounds. Frequently considerable experimenting must be done to find a device that will sound right over the radio.

There is plenty of action in many of the plays, despite the fact that the characters are reading their parts from the script, which must appeal to the ear.



Simple Means Are Employed to Imitate the Various Natural Sounds Necessary in the Production of a Play for the Radio; the Kiss Produced for Broadcasting and as Seen on the Stage



The Mysterious Submarine

By F. D. BURKE

THE interesting little toy described in this article will, when placed in water, automatically dive and come to the surface again, repeating this performance, on an average, once a minute over a long period of time. It not only makes a very good toy for a boy but can be used also for advertising purposes. Placed in a glass tank and displayed in a show window, its ac-

tions will attract the attention and interest of passers-by, who will stop to wonder how it operates.

The hull consists of an 8-in. length of 20-gauge brass tubing, 2 in. in diameter. The ends of the tubes are fitted with two water-tight wooden plugs, so shaped as to give the hull the characteristic cigar shape. These plugs are made hollow, as shown. The operation of carving out the inside of the plugs, however, should not be completed until the hull has been tested for balance. When properly balanced, the hull should sink in a perfectly horizontal

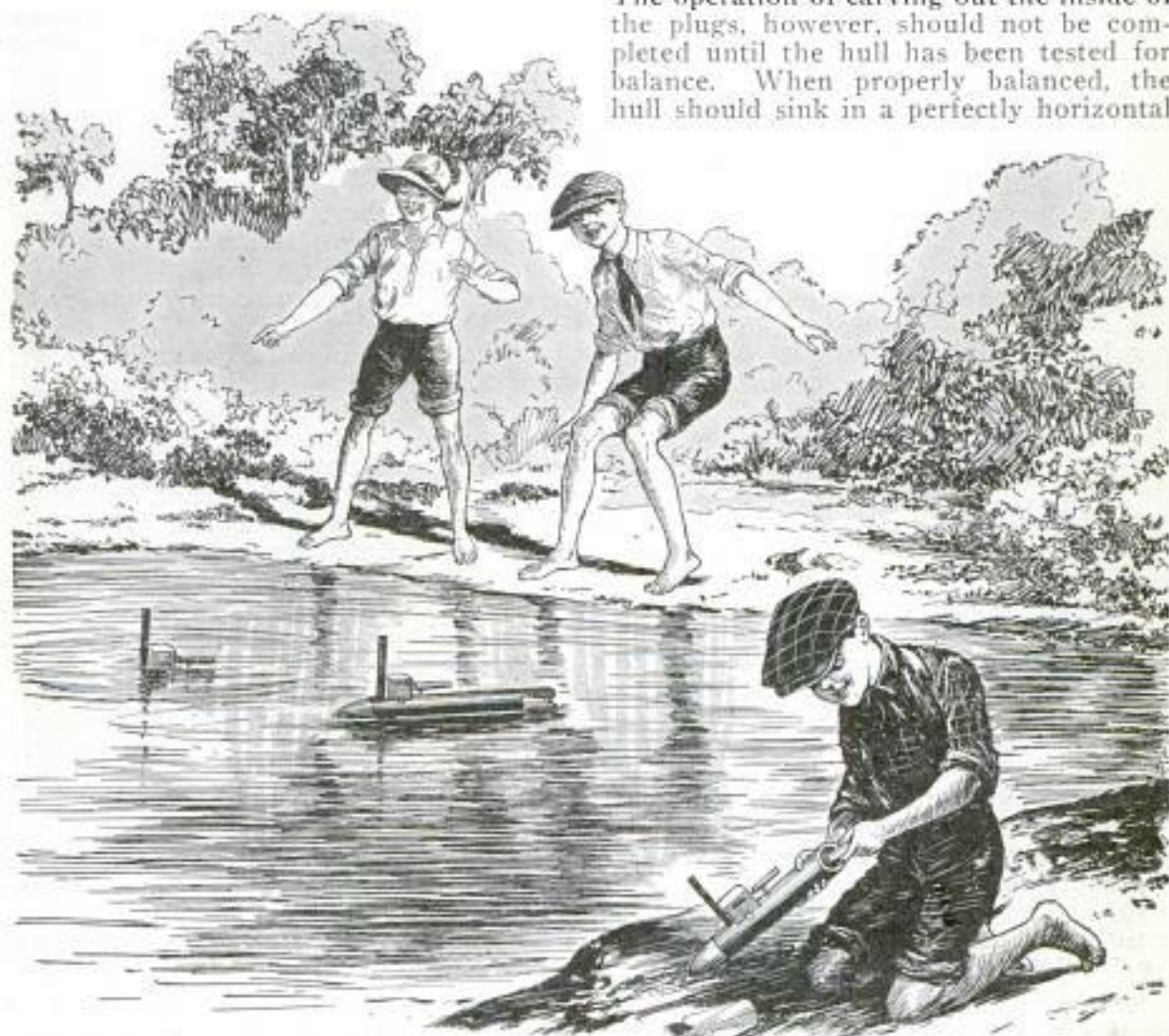

Toy Submarines That Will Submerge and Rise to the Surface Automatically Can Easily Be Made by Any Boy. They Are Also Useful as Attractions for the Store Window

position. Attached to the plug that forms the stern are two vertical fins, cut from very light tin and attached by means of No. 20 nails, $\frac{1}{2}$ in. long. The conning tower is cut from a solid block of wood.

It is fastened to the hull by means of small brass angles, nailed to the conning tower and soldered to the hull. The periscope is a 3-in. length of $\frac{1}{4}$ -in. dowel stock, and attached to the tower by three No. 20 nails, $\frac{1}{2}$ in. long. A 2-in. length of $\frac{1}{4}$ -in. dowel is hinged to the after side of the conning

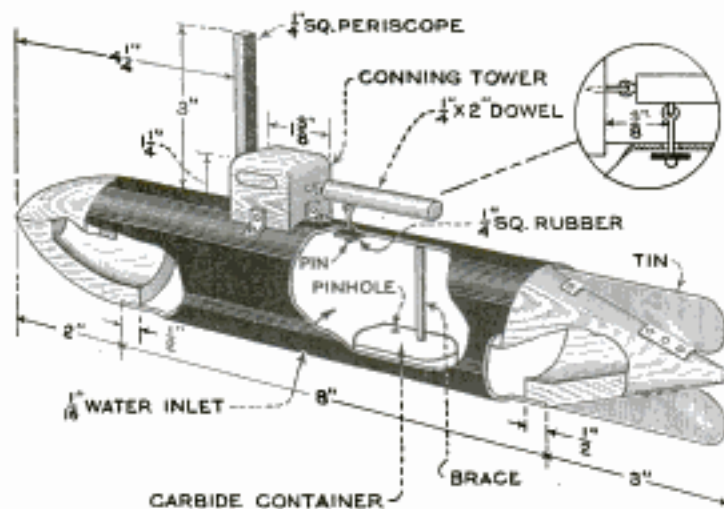

Construction of the Submarine, with Details of the Automatic Air Valve

tower by two wire staples. At the point indicated in the drawing a $\frac{1}{16}$ -in. hole is drilled in the tube of the hull. Through this hole projects a heavy brass pin, under the head of which is a $\frac{1}{4}$ -in. square cut from a heavy rubber band. The other end of the pin is bent to form an eye, and is attached to the dowel by another small staple. The action of this part of the mechanism is as follows: When the submarine is submerged, the dowel acts as a float and pulls the rubber against the hole in the tube, closing it; when the submarine is on the surface the dowel acts as a weight and drops, thus opening the hole to the air. Another $\frac{1}{16}$ -in. hole is drilled in the bottom of the hull to allow water to flow in and out.

Glucose for Anti-Freezing Solution

In tests conducted to determine the efficiency of glucose as an anti-freeze agent, it was found that a solution of one part glucose and four parts water became slushy like wet snow at 20° F., stiff at 15° F., and hard at 10° F. A solution of one part of glucose and five parts of water gave practically the same results. It is evident that the rotary pump on any car can be seriously damaged by the use of such solutions if exposed to temperatures of 15 to 10° F. On the other hand, glucose was discovered to be a good substitute for glycerin in a glycerin-alcohol mixture. One part of glucose, one part of

To operate the toy, a small 1-oz. can of a flat shape, such as can be obtained from any drug store, is filled with carbide, a pinhole having previously been drilled or punched in the cover. The loaded can is

placed in the hull in the position shown by removing one of the end plugs, and held stationary by wedging a length of match stick between the cover and the top of the hull. Upon placing the completed ship in the pond or tub, water will immediately start to flow into the hull through

the bottom opening, and the submarine will slowly sink. When it is fully submerged the automatic air valve will close. The water will then slowly seep into the carbide container and form acetylene gas, which, in a short time, creates sufficient pressure to force the water out again through the opening in the bottom. As soon as the hull is sufficiently lightened it rises to the surface again. The air valve will then open, allowing the gas to escape, and the operation will be repeated until the carbide is exhausted.

After being thoroughly tested for balance and operation, the whole ship should be given several coats of paint, and, to increase its likeness to a "sub," portholes should be painted on the conning tower.

denatured alcohol and four parts of water, by volume, make a satisfactory anti-freezing solution. It does not begin to thicken until the temperature reaches 8° F., and becomes slushy first at zero temperature. —John C. Lee, Wellesley, Mass.

Removing Odors from Ice Box

Odors in an ice box can be eliminated by placing a pan of coke in the bottom of the box. This will absorb all the gases and prevent the milk from tasting like onions or vegetables. In factories also, where bad odors are apt to spoil the men's lunches, a box can be constructed to hold them and a large pail of coke placed in it.

Linoleum Replaces Auto Carpet

Gravel, brought in on the feet, cuts and rapidly wears the floor carpet in an automobile. A piece of linoleum, preferably inlaid, and plain brown or green in color, should be substituted for the carpet. It is carefully fitted and cemented to the floorboards with linoleum cement or white lead, and will wear as long as the car is used. Before laying the linoleum, all holes in the boards should be plugged up and irregularities planed off. The linoleum is finally waxed or a coat or two of varnish applied. This will prevent stains and oil spots from being absorbed. When a dressier appearance is desired, the carpet may be replaced in a few moments.

Extra Bookshelf Economizes Space

In nearly all bookcases some space is wasted when large volumes have to be accommodated. Two shelves usually have

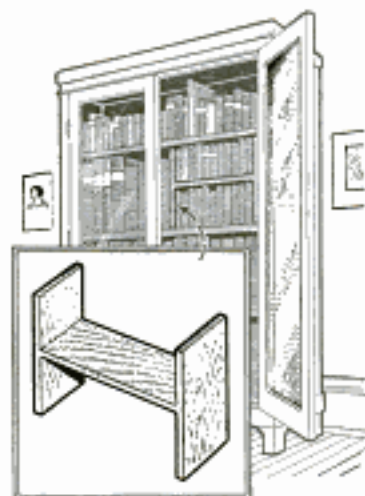

to be spaced widely apart to take the largest books. If there are not enough of these to fill the whole shelf, an extra shelf can be fitted as shown to take two or more rows of smaller books. As shown in the insert, this shelf consists of two vertical and one (or two) horizontal boards, its length being determined by the space left vacant. The horizontal board or boards are fastened to the uprights by wood screws passing through the latter. To give the whole a good finish the front of the extra shelf may be covered with veneer or varnished to match the case.—C. A. Oldroyd, Barrow-in-Furness, England.

Stretching Poultry Wire

Stretching poultry wire on frames is a difficult task if attempted with the fingers. The tool shown in the illustration, which can be made in a few moments, will save much time and work and prevent sore fingers. A 3-ft. length of 1 by 3-in. board, a piece of No. 9 iron wire and two small

staples are the only materials required. Form a hook on each end of the wire and then bend the wire around the 3-in. side of the board, about 4 in. from the end,

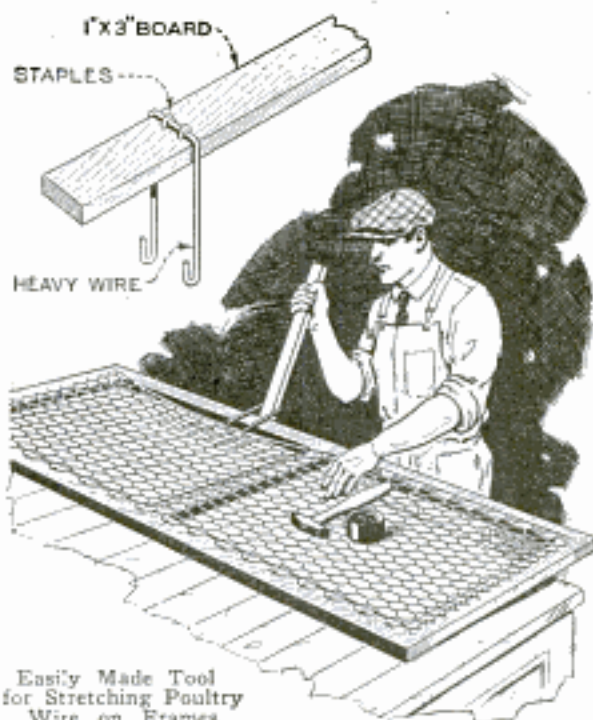

Easily Made Tool
for Stretching Poultry
Wire on Frames

tacking it in place with the staples. After the wire is tacked to one side of the frame, the stretcher is used to pull it tight. This is done by catching the hooks in the selvage of the wire and, resting the short end of the board against the outside of the frame, pulling back on the long end.—G. H. Sulzer, Rose Tree Road, Pa.

Screw Caps for Tanks

Many of the tanks sold for carrying an extra gallon of gas or oil in the auto have openings that are too small for the filling nozzle at the service station. It is a simple matter, however, to fit a new cap that will answer the purpose. Get an ordinary grease cup, such as used on heavy machinery, measuring from 2 to 3 in. in diameter. Saw off the cup just at the bottom of the large cap threads, as shown in the illustration, and discard the lower portion. Cut a hole in the tank and insert the threaded cup, allowing a thread or two to extend inside. Solder carefully all around the edge of the cup, drill a small air hole in the cap, and the job is finished.—N. T. Peterson, Corvallis, Oreg.



Effective Churn Plunger

The work of churning is hastened considerably by using a plunger with two



Churn Plunger with Two Revolving Blades Lightens Task of Butter Making

blades that revolve in opposite directions. The plunger is a wooden rod with three holes drilled through it in the lower part for wooden pins. Two square blocks, drilled to fit on the plunger rod and just wide enough to fit loosely between the pins, are attached as shown. Slots are sawed diagonally in these blocks to receive the blades, which are cut from heavy galvanized iron. The plunger is worked up and down in the usual way.—E. K. Wehry, Cedar Rapids, Iowa.

Testing Brassware



Many articles of household brassware on the market, such as candlesticks, crumb scrapers, vases, etc., are not solid brass but merely a base of sheet steel covered with a layer of brass plating or a thin sheath of spun brass. By using a small magnet as shown in the photo, the shopper can detect the steel under the brass.—C. E. Weibezahl, Syracuse, N. Y.

Simple Trick Saves Alarm Clock

Many perfectly good alarm clocks are thrown away every year because the oil with which they are lubricated collects a quantity of dust. The dust particles, although small, are sufficient to gum the mechanism, and, as a thorough cleaning often costs more than the clock is worth, it is discarded. The following kink will save the clock, however. Place it face down on a hot stove and allow it to lie in this position for several minutes. Remove it with a cloth, to avoid burning the fingers, and a few vigorous shakes will usually suffice to start the mechanism. The cure is due to the fact that the thorough heating has thinned the oil, and caused it to flow from the bearings, carrying the dust with it.

Clean-Out Tee for Furnace Smoke Pipe

In furnace smoke pipes arranged at a slight angle or in a horizontal position, a deposit of ashes, soot and other dirt always accumulates, and the heavier portions fall to the bottom, obstructing the pipe and retarding the escape of the smoke and gas. In horizontal pipes the fine ashes stirred up when cleaning out the furnace sometimes are permitted to be-



come heavy enough to cause the pipe to break, and when the furnace is not in use, they absorb moisture to such an extent that the pipe will rust through quickly. To clean out such pipes, it is usually necessary to dismantle them, which means a great deal of work and the risk of damaging the pipe. By the arrangement shown in the drawing, however, the work will be made easy. Instead of using an elbow, a tee that has a cap made to fit the open end is substituted, and the ashes become accessible by removing the cap.

Using Plywood

Plywood consists of a series of thin layers of wood, glued together with the grain of the layers running at right angles to each other, making a strong panel which will not split or break. If the layers are

glued together properly with a water-proof glue there is little danger of having the layers separated due to the action of moisture. Basswood is generally used where strength and light weight are required. Yellow pine and fir panels, as well as oak, have a bold and beautifully figured grain and are commonly used for door and window tops.

One advantage in using plywood is that unusually large surfaces are obtainable in a single piece. For example, a 3 by 6-ft. piece of plywood can readily be obtained, whereas it would be rather difficult to obtain a single, solid board of such dimensions. Also, such a big board would easily warp, but this is not the case with plywood. A disadvantage in using plywood, however, is that the edges must be concealed. This is done by mitering the edges or using molding.

In order to cut plywood smoothly a fine-toothed saw, such as a hacksaw, should be used; a coarse saw will cause raggedness on the bottom ply, as its grain is generally at right angles to that of the top layer.

Bicycle Trailer for Carrying Children

Children are often given a ride on the handlebars of a bicycle but this is not very comfortable for the rider nor easy for the driver. For this reason a Winthrop, Mass., man made the bicycle trailer shown in the photo. It consists of a wooden frame built upon the axle of a discarded baby cab. Seats for two children are provided, and a wooden tongue extends from the frame. This is high enough to be brought over the rear fender of the bicycle and attached to the seat post.



Copyright, Keystone View Co.
Simple Bicycle Trailer That Is Safe and Comfortable

Combined Garage and Boathouse

Instead of building a separate garage and boathouse one architect constructed



Combination of Garage and Boathouse Proves Economical and Convenient

the combined shelter shown in the photo. The structure was practically a two-story affair, the lower part serving as a boathouse and the upper part as a garage. Stairs are built inside, as shown. Besides its economy and convenience, an advantage of this arrangement is that it serves as a common storehouse of fuel and supplies for both engines.—Wm. B. Thompson, Pittsfield, Mass.

Removing Scratches from Auto

The finish of the auto body is often marred accidentally by screwdrivers, wrenches and other tools, and when the finish is good, the scratches stand out like the proverbial sore thumb. A simple method of removing such a scratch, or rather of hiding it so that it cannot be noticed, is to apply several light coats of shellac over it, keeping the shellac as thin as possible and applying it over just enough surface to cover the scratch completely. When the last coat has dried thoroughly, the surface is rubbed with crocus powder and olive oil on a cloth, to remove the ridges around the scratch. Crocus cloth can also be used for this purpose, taking care to use plenty of olive oil on it. When the surface has been rubbed until no trace remains of the ridges, a coat of good body polish should be applied.

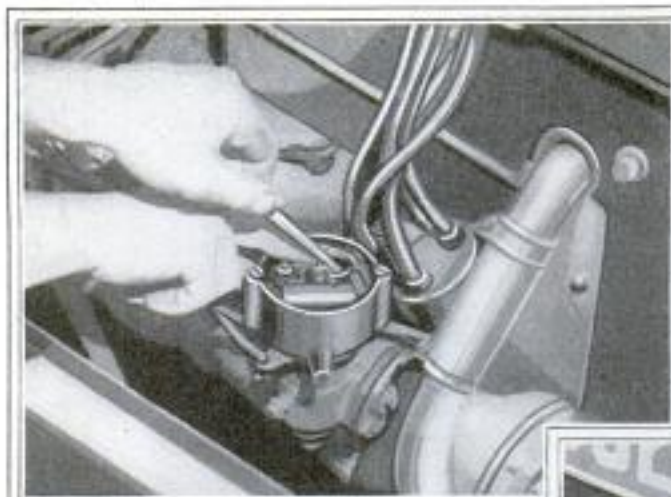

A Platinum-Point or Nail File Cures Fouled Distributor Points

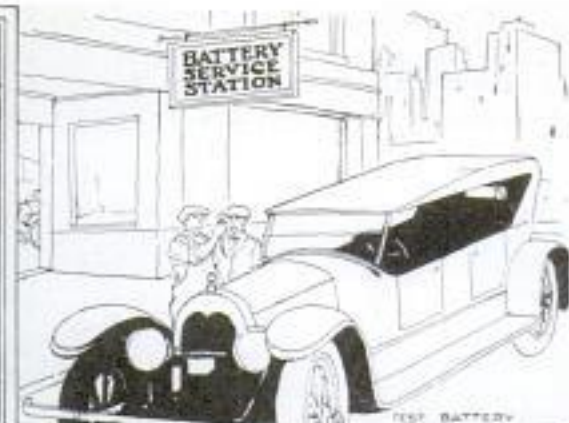

TEST BATTERY



FREEING STARTER



A Piece of Chewing Gum Stops a Hole in the Gasoline Tank

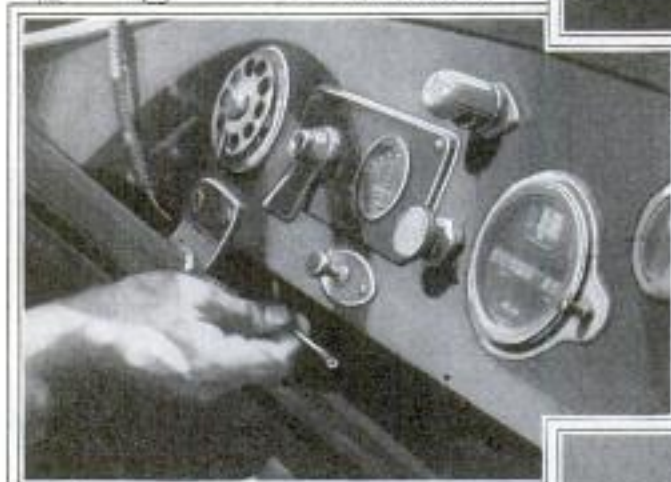

Loose Ammeter Connections Spell Trouble Often Hard to Locate Quickly



REPAIRING VACUUM TANK

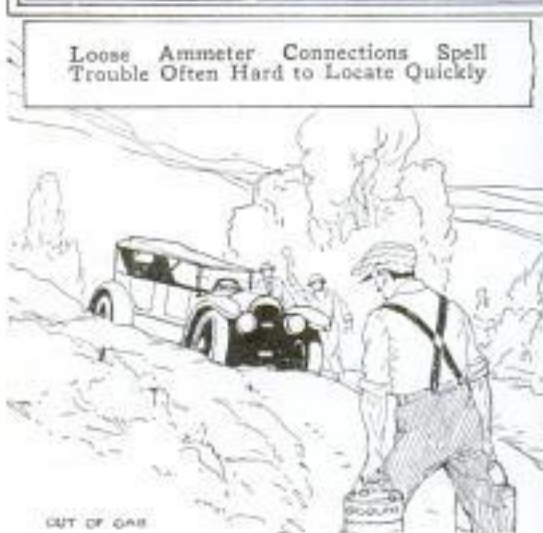

OUT OF GAS

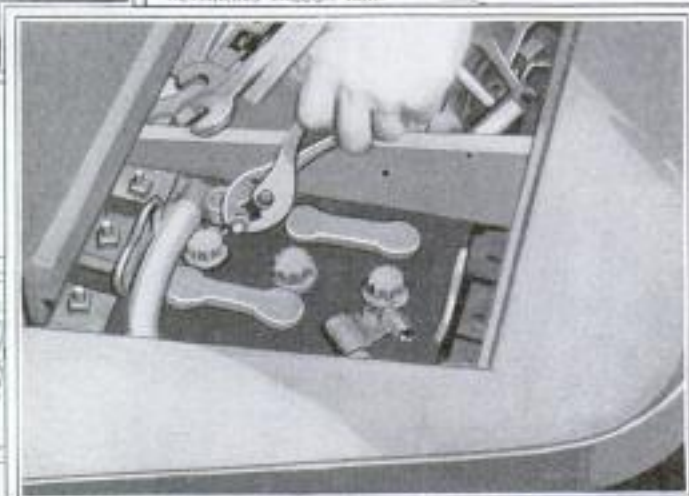

It Is a Simple Job to Tighten the Battery Terminals, If Loose



ADVENTURES OF AN AUTO TROUBLE SHOOTER

How to Prevent Breakdowns on the Road

LOOK at the gas, water and oil and give the tires a kick to see if they have enough air, when you get the old bus ready for touring. Under the seat, or in the box, is the tool kit provided by the manufacturer. If you are wise, there's a set of chains and a steel towrope, too. And if you are not only wise, but brilliant, you'll add a few extras in the side pocket. Borrow mother's manicure file and put it there, in a handy place. Beg a few sticks of chewing gum from sister, and finally get a handful of those wide rubber bands out of the desk tray. Bring along a nail, too, for it may come in handy. With those few essentials you will be ready to cope with many of the troubles that arise in a modern motor car. A nail

file, a wad of chewing gum and a rubber band are not luxuries for the car owner. Take the work of Porter Russell, head of the service department of the Chicago Motor Club, a garage chief whose emergency repair squads had 22,471 calls from

stranded motorists last year. Ignition trouble alone accounted for 10,173 of those calls, and every man on the emergency squads carried a nail file to correct the commonest of all ignition troubles—fouled points. Take off the distributor head

when the ignition goes wrong and then step on the starter. If the ignition points don't spark, spread them a bit, slip the file between them, press them tightly together, and withdraw the file, repeating the operation until the points are true. A five-cent file in the car pocket may save an expensive garage call. A regular distributor-point file is much better, of course, but more expensive and easier to break. And as for chewing gum, its uses are legion. It will stop a leak

in the gas tank, or plug a hole in the pressure-feed system. And the chewing gum or the rubber band can be used to make an emergency repair on a leaky vacuum-tank float.

The electrical system is the weakest

Popular Mechanics asked the head of the service department of the Chicago Motor Club to tell the most frequent causes of trouble to motorists on the road, and describe how the car owner could make his own simple emergency repairs.

The service department of this auto club handled 22,471 calls for help last year. Of this number, 15,548 were taken care of by repair men mounted on motorcycles with sidecar tool kits; 4,865 required service cars; 966 were answered by both motorcycle and service car; and 1,092 were canceled because the driver found the trouble. The repair crews traveled 62,616 miles and their repair jobs included:

Battery	2,903	Lock	1
Brakes locked ..	109	Mud	250
Carburetor	1,222	Oil pump	21
Cold motor	24	Out of gas	518
Frozen	365	Out of water	5
Horn	9	Starter	1,553
Ignition	10,173	Tires changed	611
Wrecks	4,125		

point in a motor car. It can go wrong in more different ways than all the other parts of the machine combined, but with a bit of knowledge and a few simple materials probably half the troubles that bring cars to a stop could be repaired by the driver, without recourse to the garage. Out of those 22,471 calls answered last year there were not only 10,173 classified as ignition troubles, but 2,903 due to the battery, 1,553 to the electrical starter and even nine cases of horns that declined to blow—all faults in the electrical system. Thirty per cent of the ignition complaints were caused by fouled points, and were corrected by the repair man with a few strokes of the handy file. Sixty per cent were the result of loose wires or battery terminals, and the other 10 per cent came from worn-out switch tumblers, burned-out coils, shorts in the wiring system or broken wires.

Of the 60 per cent due to loose wires, the majority were the result of one of three things, all of which could easily have been corrected by the driver. Loose ammeter connections came first. A single wire leads to the recording ammeter on the instrument board, and is fastened with a screw terminal. Frequently it works loose. If it comes off entirely, there is a break in the electrical system. In that case the car not only will not start, but the horn will not blow nor the lights work. If horn and lights do work, the trouble cannot be a broken circuit there, and can be traced to distributor or coil, or, possibly, corroded battery terminals. They may be corroded so badly that sufficient current will not pass to operate the engine or starter, and yet allow enough for horns or lights. The file will clean off corrosion, however, and enable a good connection to be made.

There is more trouble with an ammeter wire getting loose without coming off than there is if it becomes entirely detached. Then it may remain in contact for some distance, and suddenly jolt free. The driver experiments with the car for a bit, when perhaps the wire will establish contact again, only to break it later, and keep on repeating until the nut of the terminal is tightened.

Next to loose ammeter wires come loose battery terminals. Again the horn or light test will show whether there is a complete break in the circuit, or, like the ammeter wire, they may be only loose, so as to make and break the connection; or, again, they may be filmed over with the bluish foam of corrosion. Battery trouble, which included 2,903 of this one club's repair calls, is usually the result of neglect,

allowing the battery to run down. A stop at the garage or battery-service station every two weeks for testing and filling with distilled water would prevent most of the trouble here. To determine if the coil is burned out, it is only necessary to remove the connection leading from the center of the distributor to the coil and to hold it about $\frac{1}{4}$ in. away from its terminal. If, when the engine is cranked, a spark jumps from terminal to wire, the coil is working properly and the trouble lies elsewhere. This test should be used with intelligence, however, and only after making sure that the wires leading from battery to coil are in good shape and have good connections.

Starter trouble in 90 per cent of the 1,553 cases was confined to a stuck starter drive, while the other 10 per cent included worn-out brushes or damaged commutators. The cure for the stuck drive is simple. Put the gear in high, making sure that the ignition key is turned off, and then push the car backward and forward with a quick, rocking motion, and the drive will be loosened. The backward motion is the one that frees the drive. Never tow a car forward with the starter stuck, as the forward movement only jams it tighter. Worn-out brushes may cause considerable damage to the starter. If too low, they will cause an electric arc which will burn and pit the commutator and, in some cases, even melt the solder in the armature connections. The only preventive here is an occasional inspection by the garage man. The starter is a little too complicated, and too unhandily located for the average driver to tackle.

Carburetor troubles accounted for 1,222 calls for service. The expert's best advice is, "never fool with the carburetor of your car." No matter what may be the trouble with a car, a lot of people immediately start picking on the mixing arrangement. "A carburetor, if once adjusted right, seldom gets out of adjustment," says Mr. Russell, "but a lot of drivers let every Tom, Dick and Harry who comes along the road and offers his assistance, start fooling with the carburetor. Then when they give up the job and our repair crew is called, we not only have to find the original trouble and fix that, but readjust the carburetor as well." His advice is to confine your carburetor investigations to clean the filter screen of dirt and water.

Gas-line and vacuum-tank troubles likewise are usually the result of dirt or water, and the screen in the vacuum tank and the drainage sump in the bottom of the gas tank should be cleaned at intervals.



KEROSENE FIXES IT



An Occasional Shot of Oil on the Springs Saves Leaves



A Length of Inner Tube Protects the Distributor from Rain



THE BUCKING AUTO



HE FORGOT HIS KEY

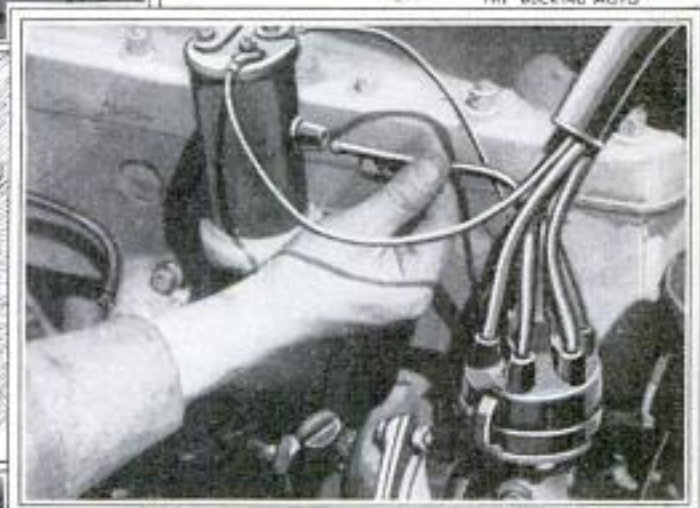

Testing the Ignition Coil to See If It Is Burned Out

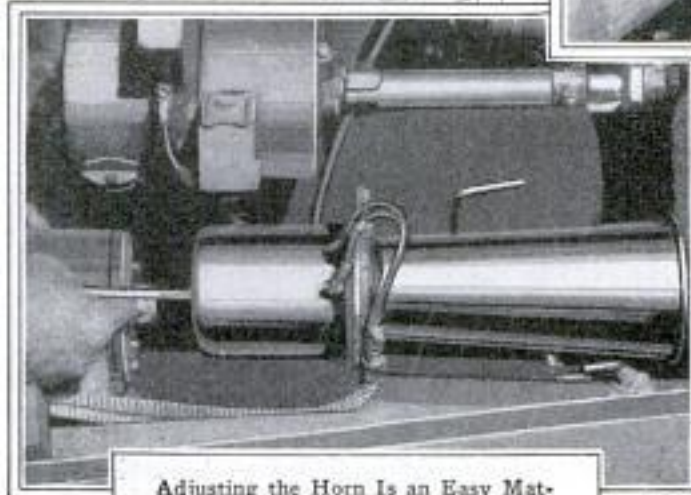

Adjusting the Horn Is an Easy Matter for Any Owner



AN EMERGENCY TANK CAP

Clogged gas lines accounted for 554 trouble calls last year. One device on the market now makes cleaning simple, reminds the motorist to do it, and likewise keeps dirt away from the vacuum tank. It is a filter with a glass bowl, so that the driver can see the gasoline passing through on its way to the vacuum tank, and can see the dirt collecting in the filter screen, where it can easily be removed.

Getting back to the chewing gum and the rubber bands, how many motorists know what to do when the solder on the vacuum-tank float works loose and opens a minute hole through which gasoline seeps into the float ball? The hole is usually so small that the gas may take days in filling the ball, but once its buoyancy is gone, trouble follows. The symptoms are flooding of the vacuum tank, the carburetor, and even leakage of gasoline from the exhaust, for the suction of the intake manifold draws raw gasoline into the cylinders in a steady stream. The motor-club repair men make an emergency repair by punching two small holes with a nail on opposite sides of the float, then blowing in one to drive the gasoline out of the other. When the ball is empty, they snap a wide rubber band around it, covering both holes, restore the float, and the car is ready to go on to the next service station to have a new float installed. In the absence of a rubber band, the two holes can be stopped up with bits of chewing gum.

The motorist who runs out of gas we have with us always, and, strange to relate, his numbers remain constant. This club carried gas to 518 drivers who were stranded far from filling stations last year. As stated, the number of careless ones is practically the same month after month and year after year. As fast as one is cured by experience, it seems another takes his place. Devices are made to warn the driver when his tank is nearly empty. One, working on a different principle, holds back a gallon of fuel, and when the last dying gasp indicates an empty tank, the driver need only pull a rod and release the reserve supply. The old reliable remedy against being caught without gasoline, however, remains a spare can under the seat. An old gallon oil tin, fitted with a cork, will do. If the driver is more particular, he can get a set of three neatly painted red, white and blue cans for spare supplies of water, oil and gas, fitted with clamps to attach to the running board, or to go under the seat or in the back of the two-passenger car.

Only five out of 22,471 motorists who

called for help last year needed water, the small number probably being due to the fact that water usually may be obtained from the nearest home.

The winter season brought 365 unlucky car owners who let their engines freeze solid, so solid that they had to be towed in for repairs to cracked cylinder jackets, or other troubles. Yet every service station sells alcohol and is equipped with a chart showing the proper amount to use to guard against freezing at any given temperature. Alcohol, unfortunately, vaporizes much more quickly than water and needs frequent replacing to keep the mixture up to standard. Failure to observe that fact accounts for most of the cases of freezing. Inability to start because of cold motors brought twenty-four appeals for help. A cold motor, a run-down battery, and add to that the wrong grade of oil—one too heavy for winter weather—and a call for the trouble man is the result.

Two hundred and fifty motorists got stuck in the mud in one year among this club's membership. The automobile clubs will rescue the member who gets stranded in the mud on a public road, but don't drive off the road into a field if you expect your club to come to the rescue. They won't do it. The service manager's advice is: Don't try bad roads. "Everybody thinks his old can has about seventeen more horsepower than anybody else's bus of the same make, and can get through where the other fellow's car can't," the service head explains. "Result, we get the calls for help. If you do get stuck, don't try to put on speed to get out, for you'll only spin the wheels and sink deeper. Put the engine in low, go slow, and don't try to turn from side to side. Keep straight ahead. If your front wheels are turned, the engine must push the car against the weight of the mud ahead. If the wheels start spinning, put on the emergency brake just enough to stop the spin. That will frequently enable them to take hold. If you can get any old rope, board, bushes, sacks, or even a quantity of paper, put it under the wheels to help give traction."

Also, he advises, if you have chains, put them on before tackling wet or muddy roads. A big cab company, operating 2,750 taxicabs of its own, and manufacturing standard cabs for similar companies all over the world, has an ironclad rule that at the first sign of rain every driver must stop and put on his chains. Experience, and not a desire to help the chain manufacturer boost his sales, is behind that order.



CARRY A SPARE GALLON



A Nail Driven between Connector and Post Tightens Battery Connection



Cleaning the Vacuum-Tank Strainer Prevents So-Called Carburetor Trouble



THE INVULNERABLE TOW ROPE



DON'T NEGLECT CHAINS

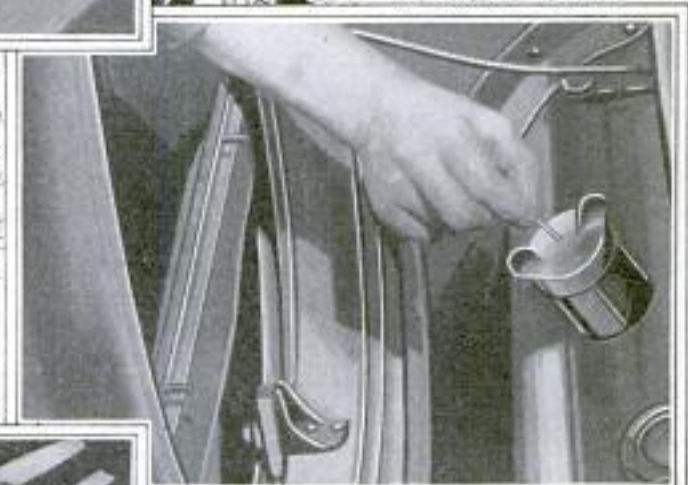

If the Hole in the Gasoline Tank Is Plugged the System Balks

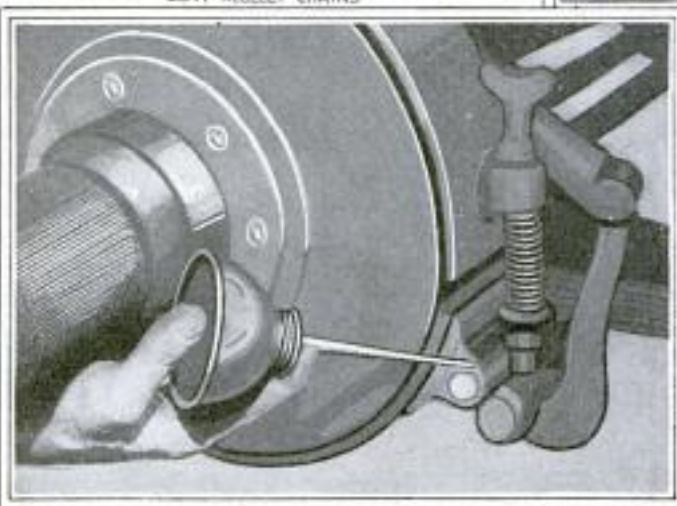

Locked Brakes Can Be Prevented by a Dose of Penetrating Oil Now and Then



LOCKED BRAKES

© 1935

The service manager also advises every driver to always carry a towrope coiled under the seat, where it won't take up much room. With it you can stop and help the other fellow out, but, more important still, the other fellow, who perhaps hasn't a towrope, will stop and help you out if you have it.

Locked brakes accounted for 109 of the club's calls for help. Every now and then locked brakes cause a bad, and sometimes fatal, accident. In a spectacular accident in a middle-western city not long ago, the brakes on a four-wheel brake car became locked on a smooth boulevard. The sedan struck a safety isle, did a neat carom, turned a somersault, and landed upside down, showering the driver with broken glass. Fortunately the sturdy top construction held up, and the owner crawled out, badly cut and bruised but alive. The damage included a broken front wheel, all windows smashed, and top and sides badly dented, while the paint job was nearly a total loss. A can of good penetrating oil and an occasional inspection of the brake rods and clevises will prevent locking of the brakes, which is usually due to rust in the joints.

Rust causes all kinds of accidents, including broken springs. The spring leaves will not slide smoothly over each other as they bend if they are badly rusted. The result is a hard-riding car, and eventually a broken leaf or two. If you change your crankcase oil at home, the service manager recommends taking the old oil, loading up the grease gun, and squirting it over the springs. To return to the car's electrical system, a hard thunderstorm will flood the service station with frantic appeals for help, when all that is the matter is a wet coil, distributor or spark plugs. An average rainstorm will bring in 600 calls in a single day—ten times the usual number. The cure is simple—an old oilcan filled with kerosene. Whenever a rain comes up, the motorcycle emergency crews get out their cans and a half gallon of kerosene, to do a job the owner could do if he knew how. Kerosene squirted over the distributor, coils and spark plugs will carry the water away, and a few swipes with a dry cloth will finish the job. Never lift the motor hood during a rain, however, unless you have an umbrella or other covering ready to hold over the engine. Likewise, if you wash your car at home, it is always wise to place a waterproof covering over the motor.

Water trouble around the distributor head can be avoided by cutting off a section of an old inner tube, 8 or 10 in. long,

and placing it over the wires, tying it at the top. The little funnel-shaped cup made by the puckered rubber above the tie can be filled with melted paraffin or wax to make a water-tight joint.

An occasional source of trouble is a plugged gas-tank cap. The vacuum-feed system will not work unless the small hole in the cap is kept open, to let air in to replace the gasoline drawn out. Occasional attention with a pin will keep it free from dirt.

Every make of car has its own quirks. When a Ford, for example, starts to bucking it may be traced to a broken timer spring. An emergency repair can be made by drawing out one coil of the spring and bending a new hook. Another frequent cause of bucking at low speed is a dirty spark plug. One popular medium-priced car has been causing considerable trouble because of broken insulation on the high-tension wires in the late models. On the car in question the trouble comes from an arrangement whereby two high-tension wires are clamped between two metal plates. The wires fit into grooves and are held in place by tightening two thumb-screws in the plates. A motorist having occasion to remove the outer plate, is apt to let the wires slip out of their grooves and then the thumbnuts will tighten against them, crushing the rubber insulation. Another, and much higher-priced car, has high-tension trouble in a different place. The wire leading from the center of the distributor to the coil passes up beneath the instrument board in front of the passenger's feet, and occasionally he will kick it off in shifting his feet.

Nine motorists who appealed to the club for help last year because their horns would not work, and who didn't dare drive through city traffic without a signal device, could have saved time by knowing a bit about electrical horns. A loose connection, lack of a drop of oil to keep the armature turning freely, or need of a few turns on the adjusting screw caused the trouble. All three can be corrected from the outside, without taking down the horn. Most signal devices for automobiles are equipped with adjusting screws to regulate their tone. Occasionally the jar will cause the screw to work loose, until finally the revolving armature does not come in contact with the diaphragm.

Lost keys occasionally bring calls for help. The service manager advises having three keys, one at home, one on the key ring for the car, and the third on the regular key ring in your pocket. The key at home is insurance against losing both

the others, and, if you have a closed car, the one in your pocket guards against shutting yourself out of your own car by leaving the other in the ignition lock. One motorist, for example, had to hunt through the dark on a lonely country road for a rock to break a \$12.50 plate-glass window of his car because he carried both keys on one ring, and left the bunch in the lock.

The list of emergency repairs that can be made on the road is legion. One driver, for example, lost the cap from the gas tank which operated on the pressure-feed system. An emergency cap was made from a section of an old inner tube, but, lacking wire to fasten it in place, he formed an air-tight seal by placing the jack on the rubber cap, and then screwing it up against the body of the car.

An Improved Shower Bath

We have found the improvised shower bath shown in the drawing very successful in the Philippines where we had no

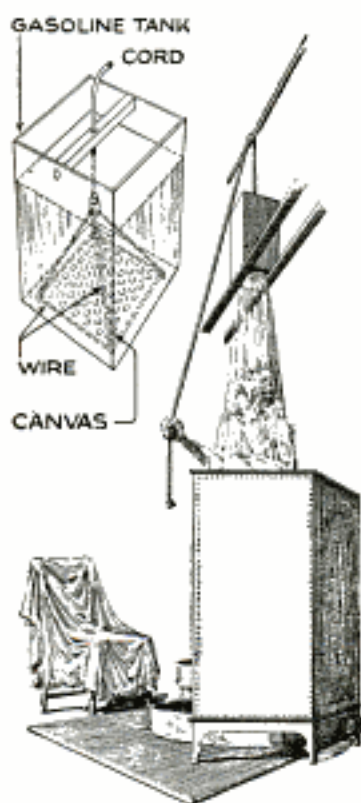

water connections, and it will be found equally effective on a camping trip. Take a 5-gal. oil or gasoline can, cut off the top, and nail a piece of stick across the opening to serve as a handle; then puncture a number of small holes in the bottom. Cut a square of heavy canvas to cover the bottom of the can, and tie a cord from each corner of the canvas to another one running over a beam or anything else

convenient in the house or tent. Support the can overhead in any suitable manner. Fill the can (the canvas will hold the water for some time), step under it, and pull the string. This lifts the canvas, and the water pours out of the holes in the bottom. An ordinary shower head may be soldered into the bottom of the can if desired.—Mrs. L. G. Smith, Iloilo, P. I.

An Arrow Parachute

An arrow parachute gives the youngsters much delight. It consists of an

ordinary arrow and a square piece of cloth, heavy cord being tied to the corners of the cloth and to the arrow, just below the head, as shown in the drawing. The arrow is handled in the usual way with the cloth folded over the head. While it is traveling upward, the cloth stays tightly around the stick, but as soon as the



arrow starts downward the cloth opens and fills up with air, causing the arrow to come down slowly. Of course, the head must not be too heavy or it will come down first and then the cloth will not open. The arrow must be shot upward vertically.—R. A. Johnson, Portland, Oreg.

Neat Spark-Plug Holder

The shell of an old lamp socket makes a good holder for carrying a spare spark plug. The shell may be attached to the inside of the dash by means of a screw or bolt, as shown in the illustration. A hole for the screw is punched or drilled through the shell opposite the slit used for the key or pull chain, and the screwdriver is inserted through this slit to drive the screw home.

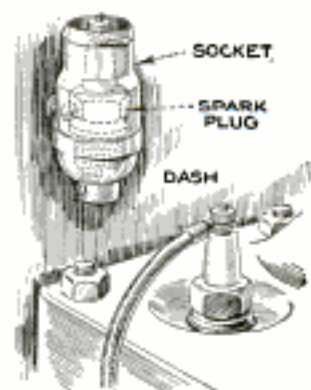

A spare plug carried in this holder will not be damaged, as the shell is lined with heavy insulating paper, and by wrapping the plug in a rag, it can be stuffed in tightly.



Part I—Routine Construction Details

THE modern home owes much of its charm to built-in furniture. This is natural, as such furniture is designed for a certain place and use in the house, harmonizing architecturally with the building and sharing the color scheme. Being readily shaped to fill nooks and corners that otherwise might be useless, built-in features are economical of space, and often serve to hide unsightly recesses in walls.

Happily, it is adaptable to most houses, whether new or old. The cost of installation, moreover, need not be prohibitive if the owner has had experience with carpenters' tools, for the building of such furniture is quite within the powers of the man who is capable of making neat joints in wood. Certainly any time so spent will yield a rich return in comfort and beauty in the house, while adding materially to the value of the property.

Since nearly all built-in furniture depends for much of its support and bracing on walls that serve either as a backing or a housing for the cabinet, there are certain routine processes common to all, which, once known, take much of the difficulty out of the construction.

The drawing illustrates two methods of joining stiles and rails. The stock used is commonly listed as $1\frac{1}{8}$ by 3 in., but actually it is more often $1\frac{1}{16}$ by $2\frac{5}{8}$ in., due to material lost in surfacing at the mill. Hence if the builder desires material exactly 2 in. wide he must mark it "net"; but, if it comes crooked, subsequent planing to straightness will make it rather undersize. For inexpensive work the nailed joint is very common; and under certain circumstances, especially if reinforced by blocks glued and nailed behind, may be quite substantial. To nail a rail to a stile in this manner, clamp it into place and drive a six-penny finish nail into each

edge, being careful to keep the face sides flush and the edges in position. Then drive another nail in each edge and set them all up. With doors and drawers in position in the completed cabinet, the nails are concealed. If the stiles are in such a position that no clamp can be used, block the lower edge of the rail while nailing, and careful work will bring a tight joint.

The doweled joint is preferable to the nailed, and should be used in home work of this kind. To lay out for the dowel holes, mark a line with the gauge on the end of the rail from the face side and on the edge of the stile, and, placing the two face to face as shown in the drawing, square across both pieces. The intersecting lines are then pricked with a nail or awl for easy centering of the bit in boring. For $1\frac{1}{8}$ -in. stock $\frac{3}{8}$ -in. hardwood dowels entering $1\frac{1}{2}$ in. into each piece are sufficient. Bore the holes $\frac{1}{4}$ in. deeper— $1\frac{3}{4}$ in. to the bottom—to allow for air and glue imprisoned below the end of the dowel. Take care that the holes enter squarely, especially in the making of panel doors, for if they are out of true the frames will twist, even though care is taken to dry them flat. It can be taken for granted in door making that if the door does not lie flat of its own accord when first assembled, it will not long remain flat when subjected to the strains of shrinking and swelling.

Narrow boards are doweled together to make wide ones, or are glued and reinforced with corrugated fasteners. These fasteners, or clamp nails, are driven into the backs of the boards across the joint while the pieces are still in the clamps. For good results the work should not be removed from the clamp until dry, as the tendency of these fasteners is to draw the back of the joint together and to open up

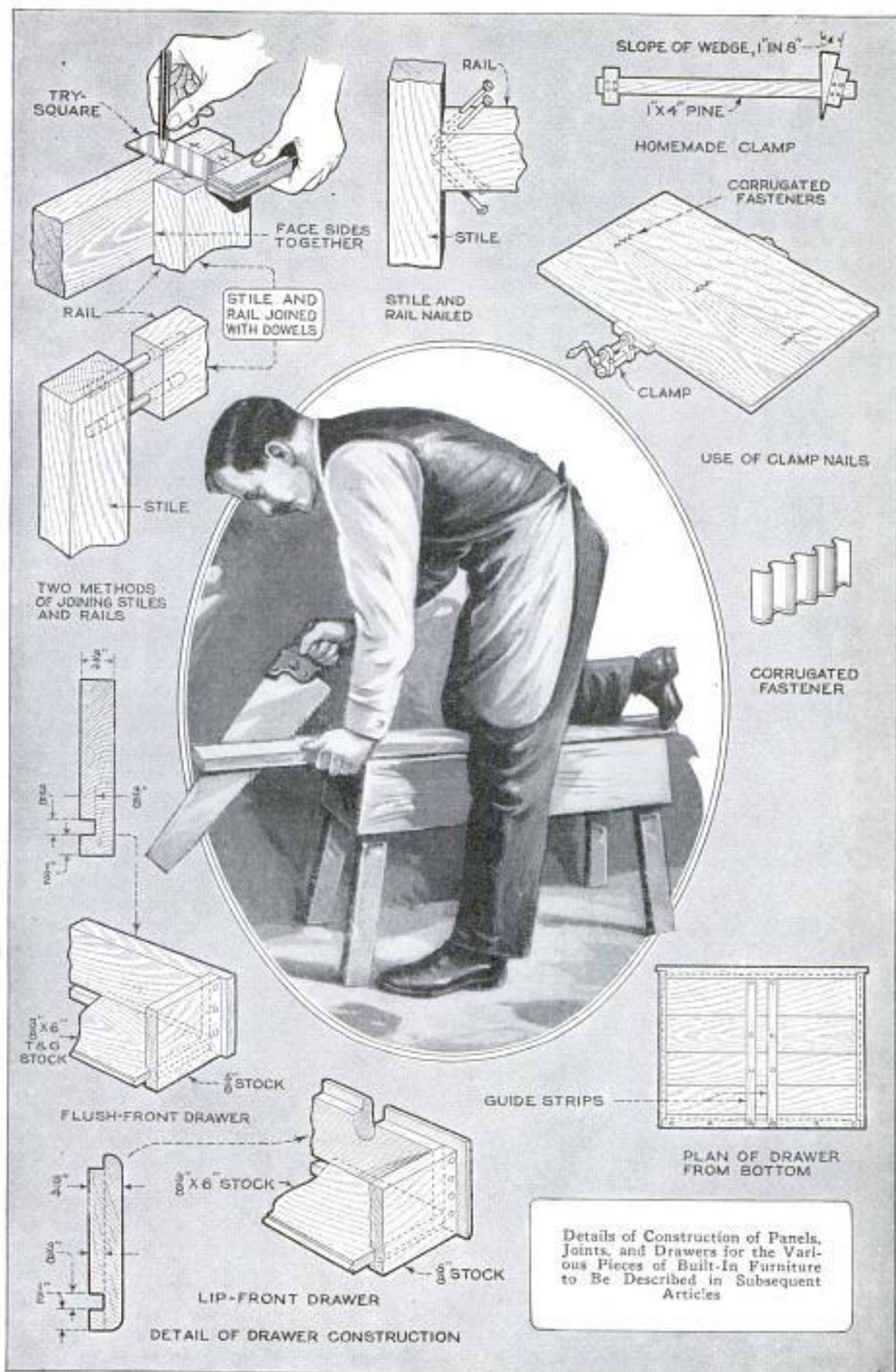

Details of Construction of Panels, Joints, and Drawers for the Various Pieces of Built-In Furniture to Be Described in Subsequent Articles

the front slightly. All waste glue should be scraped from the face side and the joint surfaced and sanded; the sanding dust caught in the glue makes the joint almost invisible.

For built-in furniture, drawer making is comparatively simple. The fronts are usually of $\frac{3}{4}$ -in. stock, and the sides, of $\frac{5}{8}$ -in. material, are rabbeted into the ends, with the back in turn set in rabbets between the sides, six-penny finish nails being used to hold the joints. The sides and front are grooved to receive the bottom which is built up of $\frac{3}{8}$ by 6-in. tongue-and-grooved pine or fir. The back is equal in height to the distance from the top of the drawer side to the groove, and is assembled with sides and front, the bottom being slid into the groove afterward, and held in position by brads. If a really high-grade bottom is desired, use three-ply panel veneer.

The front may be of the lip type, in which the top edge is rabbeted and a corresponding lip is left on both ends, the edges being rounded or chamfered for neatness. This front hides the fit of the drawer, and thus allows of some inaccuracies in size. If the front lacks a lip, the drawer must be made to fit very closely,

so that when the front slides in flush with the stiles and rails but very small clearances will show. The front is ordinarily slightly wider than the sides, with the top edge beveled inward, and the ends project sufficiently to strike against stops nailed against the stiles, thus insuring the closed drawer front being flush with the frame.

If the drawer has a center slide, thin guide strips must be put on the bottom, as shown in the drawing. To locate them, close the drawer, and, reaching upward from underneath, scribe along the bottom on both sides of the slide. Rub the runs and guides with soap or paraffin to reduce friction. A well-fitted drawer, even if wide, will close readily by pressure from either end as well as from the center.

Clamps are expensive to buy, but substitutes are easily made. On a suitable length of 1 by 4-in. pine nail solidly two crosspieces, one near each end, allowing 1 in. more of space between them than the width of the frame to be clamped, and putting one piece on at an angle of 1 in. in 8 in. Against this is driven a wedge of corresponding pitch.

Subsequent articles will describe the construction of many articles of built-in furniture in detail.

Substantial Folding Tables

Caterers, hotel keepers and others using a large number of tables, which have to be carried from place to place frequently, will appreciate the compactness and sturdiness of the folding table shown in the illustration. It is made in two parts, the

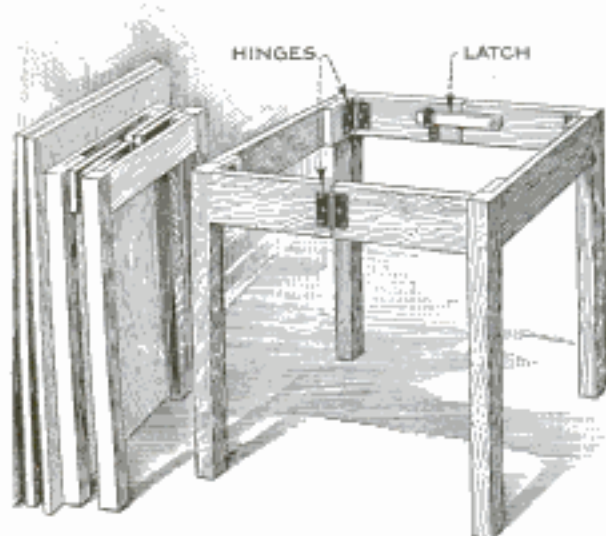

Sturdy Caterer's Tables Fold Compactly When Not in Use

top and the supporting framework. Two opposite side braces are stationary while

the other two are cut in the center as shown and provided with a hinge over this cut on the outside, and a hinge in each corner on the inside. A latch is arranged on the inside of the sidepieces to hold them rigid while in use. The method of folding the table is indicated at the left. The top has cleats on its underside to butt snugly against the inner edges of the sides so that, when it is put on, the table will stand squarely without any wiggling at the hinges.—A. C. Cole, Chicago, Ill.

Starting a Balky Ford in Cold Weather

Faulty ignition, a weak battery and cold weather in combination usually make a Ford engine very hard to start; if the vibrator points are worn or poorly adjusted, the motor may prove quite balky on either battery or magneto. In such a case the quickest way to get the engine started is to coax the coil points to vibrate by rapidly tapping the vibrator arm with the fingers, while pressing the starter button. If the battery is completely run down, the ignition should be switched over to the magneto, and another person should spin the engine while the driver manipulates the vibrators as described.

Preserving Leaves in Specimen Book

The common method of preserving leaves by pressing them with a flatiron rubbed on beeswax may be improved in the following way: Paint the underside of each leaf with linseed oil and iron it immediately; then paint and iron the upper side in the same way. This treatment gives the leaves sufficient gloss and keeps them pliable. It is not necessary to press and dry the leaves beforehand, although this may be done if desired. The tints of the leaves can even be preserved by painting the upper side with the oil and placing them, without ironing, between newspapers and under weights to dry.

Simple Water-Distilling Apparatus

Water can readily be distilled in the small laboratory or at home by the simple arrangement shown in the illustration. An aluminum pail, filled with cold water, is suspended opposite the spout of a kettle in which water is boiling. The steam from the kettle will then strike the cold side of the pail and quickly condense. The drops of water are collected in a clean porcelain dish placed underneath. An aluminum pail is a good cooler, because this metal is



Distilling Water by Directing Steam of Kettle against Cooled Vessel

a good conductor of heat and the wall is thin. Renew the water in the pail from time to time before it gets warm. Under test, 2 oz. of water were distilled every 10 minutes with this arrangement.

Golf Practice at Sea

Lieut.-Commander Davis, chief engineer of the U. S. Coastguard cutter "Tuscarora," doesn't propose to have his golf form spoiled by his long absences from

the links while at sea, so he has turned the quarterdeck into a practice course.

He took an old ball, drilled a small hole through the center, and passed a length



A Tee, a Ball, a Length of Cord and an O'd Shirt Provide This Golfer with Excellent Practice at Sea

of heavy cord through the hole, knotting it at both sides. To the other end of the cord, which is 5 or 6 ft. long, is tied an old, heavy shirt. He uses a rubber tee, which can be obtained from any sporting-goods house, and this is fastened to the bulwarks with a length of light line. He can tee his ball, take his stance, and whack the ball as hard as he pleases, and the drag of the heavy shirt prevents it from going very far, while the line prevents the tee from going overside if hit.

This provides fine driving practice, and the idea should prove of value not only to sea-going golfers, but also to those on shore who cannot get to the links often enough, or who wish to improve their stroke in spare moments. To prevent marring the deck Mr. Davis uses a sheet of heavy packing, placed under the tee.

Holder for Glue Tubes

Small glue tubes are hard to keep at hand on the desk or in the drawer without having some of the contents ooze out over the papers or on the surface of the desk. A simple holder, which eliminates this trouble, can be made by cutting three sides of the carton in which the tube is packed so that the upper end of the tube projects. The upper portion is then doubled over and tacked to the wall.

Steps Built on Drawers

Kitchen cupboards often extend to the ceiling and their highest shelves are good storage places but are hard to get at. Pulling out the drawers and standing on

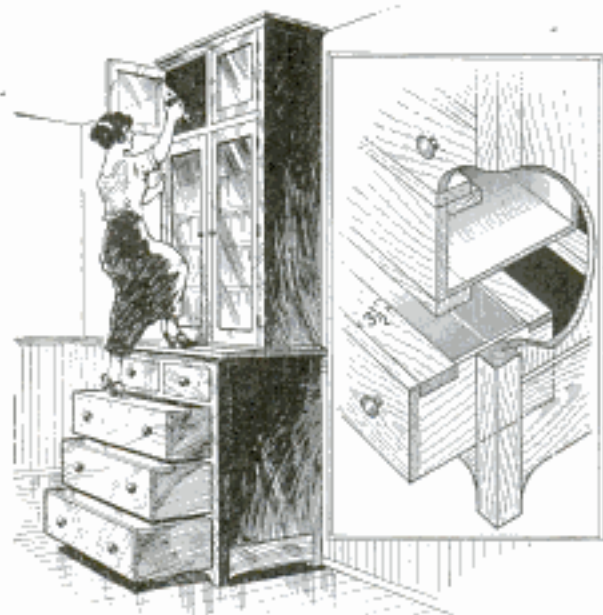

A Permanent Stepladder for Reaching the High Shelves of a Kitchen Cabinet

the edges is both awkward and dangerous, but 3½-in. ledges provided just inside of the drawers, as shown in the illustration, make it safe to use them as a stepladder. The ledges extend across the entire width of the drawers, but are narrow so that articles kept in the latter are as easily reached or stowed away as before the change was made.—A. May Holaday, San Jose, Calif.

Preventing Choker-Wire Damage on Ford Radiator

It is usually necessary to choke the carburetor of a Ford car before starting the engine and the choker wire is almost invariably placed between the radiator tubes so that it can easily be grasped when one is cranking the engine. This wire will eventually wear a hole in the soft copper tubing and cause a bad leak, which is difficult to solder. An excellent way to prevent this is to solder a small metal pipe between the radiator tubes, so that it comes flush both in front and behind the radiator. The wire is passed through this pipe and thus can no longer rub against the radiator tubes. A small amount of lubricant may be placed in the pipe when giving the car a general greasing.—Bunyan Kennedy, McCool, Miss.

Protecting Auto Upholstery

While making repairs on closed cars, it often happens that the upholstery is soiled by the workman. To prevent this, seat covers of canvas or other heavy cloth will be found useful. The covers are made in pieces to fit over the whole upholstery, including the sides and doors, large safety pins being used to keep them in place. Car owners who do their own repair work will also find covers of this kind serviceable as a protection against grease and dirt.—G. A. Luers, Washington, D. C.

Simple Roller Coaster

A roller coaster of the kind shown in the drawing will be found to give additional pleasure to children who are fond of skating, especially if they live near a hill having a smooth sidewalk on which they can coast. The coaster consists of a 1 by 4-in. board about 3 ft. long, with half of an ordinary roller skate bolted on it at one end as shown. A

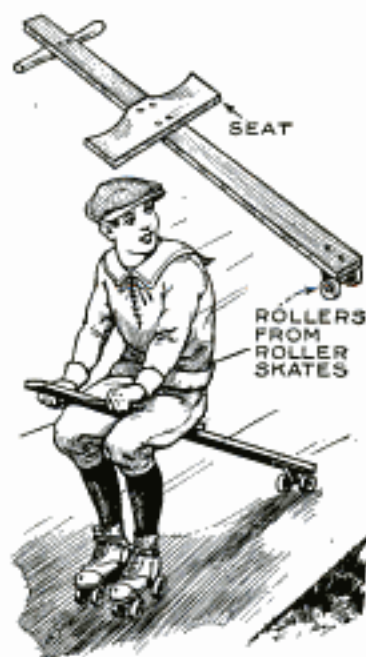

seat and handle are also bolted across the board, the seat consisting of a short length of 4-in. material and the handle of a length of broomstick. The method of using the device is apparent from the drawing.—Roscoe A. Johnson, Portland, Oreg.

Inexpensive Window Shades

On several double windows in my house I used large opaque shades, about 72 in. wide, instead of a single shade for each window. These were soiled in a few months and were almost impossible to clean. As new ones were rather expensive, I decided to substitute cheaper material, light in color and washable. So I purchased 15 yd. of 72-in. bleached sheeting of good quality and cut this into five

3-yd. lengths. After hemming them at one end to receive the slats, I starched them and stretched them out to dry in the same way as lace curtains. I then ironed them smooth and tacked them to the rollers of the discarded opaque curtains. Shades made in this way are translucent, giving the rooms plenty of light. Every time the curtains are laundered I also launder the shades.

The opaque curtains previously used cost about \$32, while the total cost of these homemade curtains was only \$12.—Mrs. Minnie T. Miller, Wells, Nev.

Support for Baby

When babies are just able to sit on the floor and play with their toys, but not strong enough to keep from falling over, they are usually propped up with pillows. These are, however, rather warm and uncomfortable, and it is much better to provide a support of the kind shown in the illustration. It is made from two wooden barrel hoops, a couple of slats, 2 in. wide and about 14 in. long, and a few narrow boards, 10 in. long. One of the hoops is cut open, one-third of the length cut off, and the ends joined to form the smaller upper loop. The hoops are fastened to the boards that form the backrest, with small bolts, and the 14-in. slats similarly attached to the hoops to brace the "baby sitter." All bolt heads should be countersunk so that they will not hurt the baby or tear its dress. The assembly is then sandpapered smooth and varnished, and

firmly fastened, at some convenient corner, to the floor by means of two



Simple Support, Made from Barrel Hoops and Slats. Prevents Baby from Falling Over

shelf brackets at the back. The upper loop holds baby upright and the lower loop gives plenty of room for its legs and playthings, which cannot roll out of its reach.—Minnie Britt Riggle, Bavaria, Kans.

Luggage Carrier for the Roadster

Farmers who own roadster automobiles find it difficult to carry egg cases, cream cans and other articles without tying them on the running

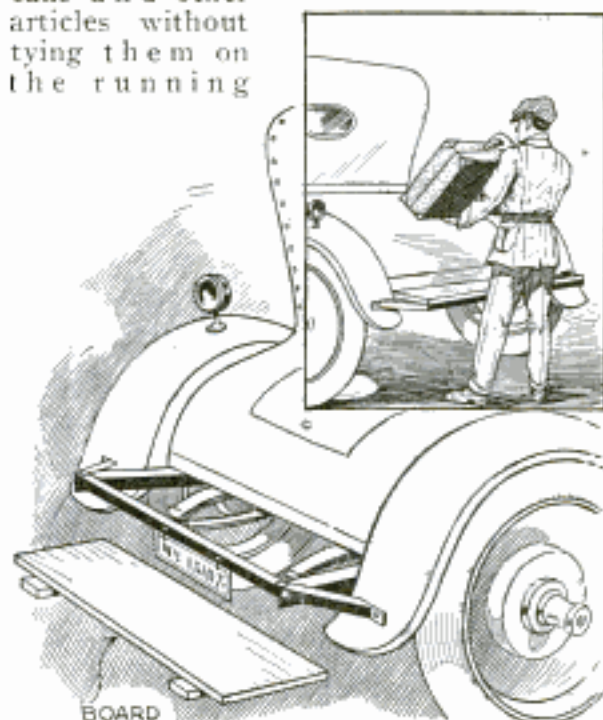

Homemade Luggage Carrier on Roadster Is Useful to Farmers and Salesmen

boards. This difficulty is overcome by providing a luggage carrier of the kind shown in the drawing, which is also convenient for salesmen. Two 30-in. lengths of 2-in. angle iron are securely bolted to the frame under the rear end of the car, with the ends projecting about 15 in. Across these ends is bolted a brace of 1-in. angle iron, long enough to be bent over to permit fastening the ends to the fenders with short bolts. A piece of 1-in. board, just long enough to fit on the frame thus made, is provided with cleats, and serves as a floor on which the luggage is carried. The carrier may be enameled to match the color of the car and will support a weight of 300 lb. safely.

Shaving-Brush Holder

A shaving brush is injured by permitting it to remain in the mug to dry. It should be suspended with the hair down. A holder can readily be made from a piece of wire bent to form a forklike clamp, with the back-bent wire ends pointed. The clamp should fit the neck of the handle snugly, and the pointed ends are driven into the wall or other support. Or a loop may be made at each end of the wire so that the holder can be attached to the wall with two small screws.

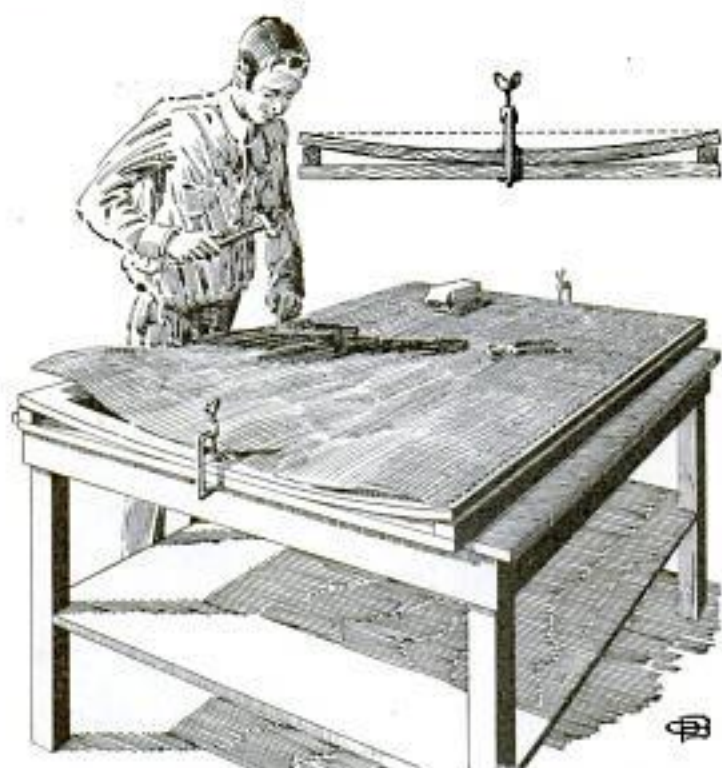

Simple Method of Stretching Screen on Wooden Frames

Pulling Screen Wire Taut

When fastening wire screening on wooden frames, one usually has difficulty in getting the screen stretched tightly. A good method of doing this is shown in the drawing. Two strips of wood, about $\frac{3}{4}$ in. thick, are laid under the sides of the frame and the ends are drawn down on the table with C-clamps, as indicated. It is then an easy matter to tack the screen on. When the clamps are removed the screen will be tight across the frame, and the ends are then tacked without difficulty.

Finishing Colonial-Stairway Handrail

The handrails on white-enameled colonial stairways always seem to be dirty, always need cleaning, and after some time commence to look the worse for wear. All this can be obviated. A black handrail, and black-capped newel posts present a splendid appearance—look better really than the all-white stair does. But the question is then how to keep it black, and to prevent it from chipping and looking ragged. The whole secret lies in the kind of finish put on it.

If the handrail has ever been painted, take a piece of fine sandpaper and rub the rail until turpentine will "take hold." The sandpaper must be fine enough to leave the rail smooth, yet cut the paint. Dissolve enough lampblack in turpentine to make a

heavy black liquid of about the consistency of water, and into this stir about 3 oz. of clear shellac, mixing it well. Too much shellac must not be used or the finish will have an undesirable gloss. Clear varnish will serve as well as shellac. When this is flowed onto the handrail it dries almost as fast as it is put on, and it does not chip off when dry. This gives a satin finish; if a gloss finish is desired more shellac or varnish may be added, but the more varnish or shellac used, the easier the finish chips off. When dusting, use a cloth with ordinary furniture polish, taking care not to leave it greasy. For new handrails, unpainted or unstained, take about $\frac{1}{2}$ pt. of gasoline; into this put a small quantity of dark-oak paste filler, and sufficient lampblack to give a jet-black color. This makes a stain that penetrates the wood cells very rapidly. Flow it on, allow it to stand a moment, then

rub it off. Repeat this process until the wood is as black as desired, taking care to touch up the light spots until the color is even. Now rub off all the stain that has not penetrated the wood. Polish with linseed or paraffin oil, rubbing in all that will penetrate the wood, but no more, or the rail will have a greasy finish.—G. O. Anders, W. Lafayette, Ind.

Skid-Chain Cross Links Make Door Handle



an application of paint.—Albert L. Ball, Niagara Falls, N. Y.

The photo shows a novel use for cross links of worn-out auto skid chains as a handgrip on sliding doors of garages and barns. They are stapled to the doors and can also be used as handles on boxes. To prevent the chains from rusting they should be given

It is much cheaper for country poultry keepers to buy the grains and by-products and mix them at home.



352- R.
Broadcasts from Ocean's Bottom

HOW a diver feels and what he sees as, clad in his heavy armor, he "plods his weary way" along the ocean floor and explores the weird submarine world of

Atlantic. To those who were listening in to station WIP he told all that he saw in his trip to Davy Jones' locker. This is the first time that such a feat has been at-



C. O. Jackson of Philadelphia Receives a Silver Cup for Broadcasting a

gloomy lights and flickering, sinister shadows, was vividly described to thousands of radio fans not long ago when C. O. Jackson, a diver from Philadelphia, successfully broadcast a talk from the bottom of the



Talk from the Ocean Floor: Below, Diver Going over the Boat's Side

tempted, and it afforded a real thrill to the listeners. The diver was equipped with a helmet in which was installed a microphone, protected by sponges and connected to the boat from which he descended.

Pacific Atlantic Photos

The boat was connected by wire to an amplifier on the Atlantic City pier near which the experiment took place, and a land wire hooked up the pier apparatus with the broadcasting station. The first thing that the listeners heard was a swirling, swishing sound, which, it was explained, was the noise of the air currents in the diver's helmet. The voice at first was weak, but grew stronger, and when the diver had reached bottom, fifty feet below the surface, they heard him say, "On my left I



The Microphone inside the Helmet, Protected by Sponges; Insert, "Coming Up"

see the wreck of an old boat. It looks like the skeleton of a huge fish. In it a school of little fish is playing. The rays of the sun, which look green at this depth, shine on their backs." After walking around a second wreck near by and describing its appearance, and that of the ocean floor in the vicinity, the diver ascended, having been under water ten minutes. Upon his arrival at the pier the diver was presented with a silver cup; as a memento of the occasion when the ocean's bottom was first described to those on shore direct from the man on the spot. The test was a complete success, and listeners had a variation from the usual programs.

238-12
Transformer Sealed in Vacuum

Experimenters have long realized the advantages of the air-core transformer for maximum amplification at a given wave length, but it has heretofore been found impossible to construct transformers of this type that could be depended upon to give uniform and satisfactory results under all conditions. Absorption of atmospheric moisture in untreated coils causes serious losses, and treatment of the coils with gums and resins to remove this difficulty introduces another set of losses equally serious. Now, it is claimed, these difficulties have been overcome by a transformer sealed in a vacuum tube. The coils are thoroughly dehydrated and accurately spaced on a glass rod, then inclosed in a tube of high-lead-content glass, evacuated to a high degree and sealed. The initial efficiency of the transformer is thus retained.



213-62
One Antenna for Several Sets

By connecting a "coupling-tube unit" devised by U. S. naval radio experts, it is possible to hook several receiving sets onto a common aerial and each set can receive signals on a different wave length without interfering with the other sets. The apparatus has been thoroughly tested and found successful on board the U. S. S. "Colorado"; the ship's operators copied simultaneously several messages from different stations even while the battleship's transmitter was in action, thus enabling the vessel to carry on several times the normal amount of business.

The unit includes a resistance so high that the strength of incoming signals is reduced considerably, and it is therefore necessary to use receiving sets with three or four tubes. A radio-frequency step in the form of a trap, which eliminates regeneration, is required and a receiving set using a detector tube. This unit has become part of standard battleship equipment. To the general public this device is also of considerable usefulness as it will eliminate the great number of aerials found on city apartment buildings.

Evening Post 5/1/24
Copyrighted material

St. James Laboratories
815 W. W. - W. W. Cheng Co.
Chicago

Connecting a B-Battery Switch *327-R*

In connecting a variable B-battery to a multiple-point switch so as to control the voltage from the front of the panel, there should be twice as many contact points as there are taps on the battery, every alternate contact being dead.

This will eliminate the shorting of the cells of the battery that takes place when every contact is connected to a tap, and the switch lever, in passing from one to another, momentarily makes contact with both. As B-batteries are of low amperage, this shorting reduces their life considerably.—D. G. Tiffany, Palo Alto, Calif.

A Balloon Aerial *233 R*

It is a well-known fact that a high aerial adds to the volume of reception on any radio set. Towers and high masts are too expensive for an amateur to build so it is usually impossible to have an aerial higher than a few feet above the roof. However, by using a rubber balloon now on the market, which is inflated with hydrogen, an aerial can be raised vertically as shown in the drawing. This method of hoisting an aerial, it is said, improves reception considerably. The balloons for this purpose are made in different sizes and the hydrogen can be obtained in tanks or



it can be generated from iron and sulphuric acid. Common illuminating gas can also be used for inflating the balloon but this gas does not possess so much lifting power as hydrogen.

Railroad Plans to Dispatch Trains by Radio *269-U*

A number of tests have recently been made by members of the American Radio Relay league and the staff of one of the eastern railways, to determine the practicability of using radio in stormy weather emergencies for dispatching trains. It is said the tests showed the scheme practical, and that radio will soon be installed for this purpose.

It is planned eventually to conduct all dispatching by radio.

H. Mather, 405 S. Ashland St. Chicago

Setting Clock by Radio *288-R*

A new advance in radio has been made with the setting of a timepiece at the bureau of standards from the Arlington

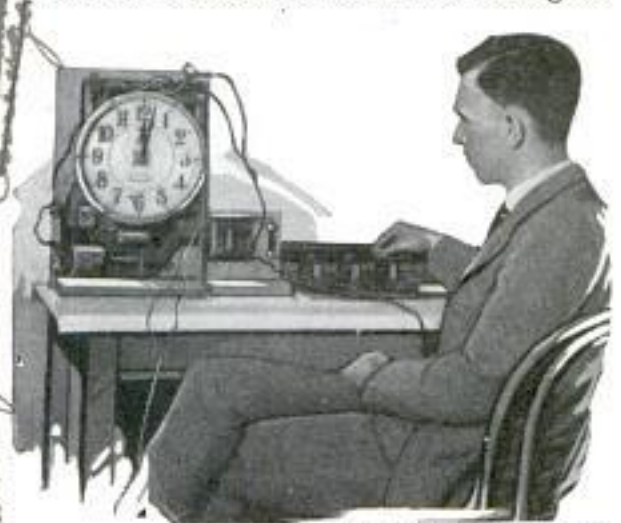

Copyright, Underwood & Underwood

Clock Wired for Automatic Setting by Radio, and Inventor of System

broadcasting station. The setting of this clock was made possible by means of a radio-relay mechanism, worked in conjunction with a series of retardation relays so that the dots sent during the radio time transmission do not operate the clock-setting mechanism, but the dash at 12 o'clock (noon) or at 10:00 p.m. will perform this operation. H. J. Walls, assistant radio engineer at the bureau, devised the retardation relays.

Making Phone Jacks Fit Properly

It sometimes happens that a phone or loud-speaker plug is too short for the jack provided on the radio set, and this causes the fiber insulating ring on the plug to come directly under one contact of the jack, with the result that the phones fail to function. The remedy is either to remove the washer behind the threaded bushing on the plug or to move the jack contacts forward, which is possible with some jacks by loosening a screw on the underside. It is a good idea to examine both plug and jack carefully before soldering the wires, in order to prevent trouble of this nature.



☐ Cold-water pipes usually make better grounds than steam pipes or radiators.

Cont. A. Col. Box 447, Chicago

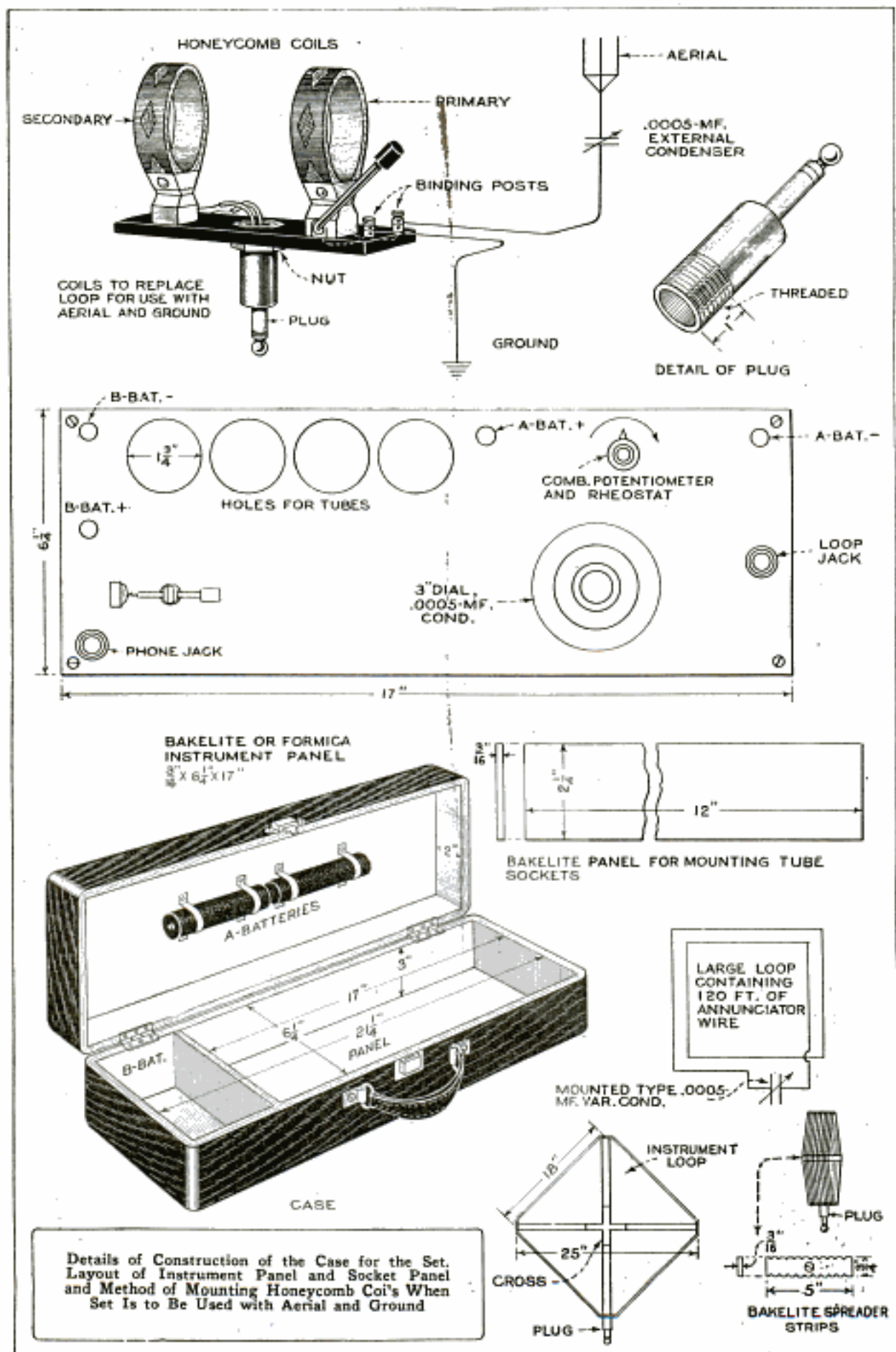

967-a



BUILDING A PORTABLE REFLEX RECEIVER

By F.L. BRITTIN



THE receiver described in this article represents a set of very high efficiency, in which four tubes do the work of seven. It has great flexibility, as it can be used both as a portable and a stationary set. It has only two controls, which means simplicity in operation, and it does not squeal, which means a great deal to those who have heard the noise produced by the majority of the apparatus now in use. The use of the loop eliminates static to a remarkable degree, as well as interference from other stations and squeals from the neighbors' sets. The instrument is simple to build and the cost is low considering the results obtained. Standard tube sockets are used, and, by using adapters, any type of tube can be utilized. For portable use, either the UV-199 or C-299 tubes are suitable; these operate on but 1½ volts and draw only .06 amp. The instrument is designed to operate on a 2-ft. loop, and will bring in on this stations up to 1,000 miles distant. By using honeycomb coils plugged in instead of the loop, much greater distances can be covered with an ordinary aerial and ground. The wave-length range is from 200 to 600 meters.

The inside dimensions of the case are

21¼ by 6¼ by 3 in., with a partition set 4 in. from one end for the B-batteries. The wood used may be selected in accordance with the desire of the builder: poplar does very well, and the stock can either be ¾ or ½ in. thick. The lid, which is 2 in. deep is hinged to the case, and it will be noted that the dry cells forming the A-battery are strapped to the inside of the lid. These are two three-cell French No. 1027 flashlight units; the zinc bottoms of the cases are butted against a little brass angle as

shown in the full-page diagram. The angle is screwed to the inside of the lid, and the negative lead soldered to it. Small brass angles are also used to form the positive connection, and are bent so as to make good contact with the center electrodes of the cells. By mounting the batteries in this way they can easily be removed when completely discharged and new ones substituted. If one cannot construct the case at home, any good cabinetmaker will do the job for a reasonable sum. It should be fitted with rubber feet to prevent marring the surface of any article of furniture on which it may be set, and should be provided with a neat nicked handle and lock. Poplar takes a good dark-oak finish,



The Complete Portable Reflex Set in Use; This Set Has a Remarkable Range and Is Simple to Build

while, if birch is used, it is possible to finish it to resemble mahogany closely. Use a good spirit stain and filler, then apply several coats of varnish, rubbing down between coats with powdered pumice, or rottenstone, and oil until a good smooth surface is obtained.

In the reflex circuit some of the tubes are used twice, once as a radio-frequency amplifier and once as an audio-frequency amplifier. The advantage of this can be seen at a glance, as great amplification can be obtained with a small number of tubes. A crystal detector is used to insure

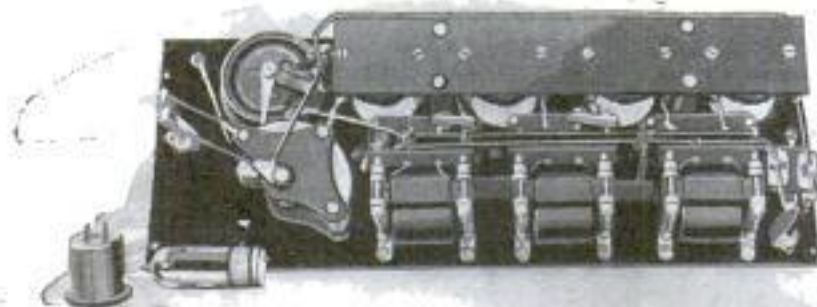

Bottom and Side Views of the "Works" of the Portable Reflex Receiver; Note the Rubber Rods That Support the Socket Panel, in the Side View

a good tone quality without distortion; the one used in this set is of the synthetic-mineral type, a number of which are to be found on the market. In this set the tubes are mounted on a small panel fastened to the main one by means of four hard-rubber rods, $\frac{1}{2}$ in. in diameter and $2\frac{1}{2}$ in. long. These are drilled and tapped at each end for small machine screws, which bind them to the panels. The rods can be seen clearly in the photo showing the "works" removed from the case. The socket panel is 12 by $2\frac{1}{4}$ by $\frac{3}{16}$ in. in dimensions. It is advisable, before beginning the actual construction of the set, to study the diagrams carefully and to note the position of every instrument. A good deal of trouble was encountered in the layout of the original set, and, while this is now worked out for the reader, a little study will make the job of mounting the instruments much easier.

The instrument panel is made of formica or bakelite and is 17 by $6\frac{1}{4}$ by $\frac{3}{16}$ in. in size. The holes for the tubes are $1\frac{3}{4}$ in. in diameter and are easily laid out from the small panel. A combination rheostat and potentiometer is mounted in the back right-hand corner; this controls all tube

filaments, and is correct for all tubes drawing not over .3 amp. If tubes drawing more than this are used, it is advisable to have separate rheostats for each tube. It will be noted that the potentiometer is connected across the A-battery, the potentiometer lever being connected to one side of the loop jack; the rheostat is connected in series with the A-battery in the usual manner. The A-battery binding posts are mounted on either side of the potentiometer-rheostat. Just below the latter the .0005-mf. tuning condenser is mounted on the panel; this is connected

across the loop jack, which is placed to the right of the condenser. The loud-speaker or phone jack is placed at the left front of the panel and the crystal detector mounted just above it. To the rear of these the B-battery binding posts are fitted,

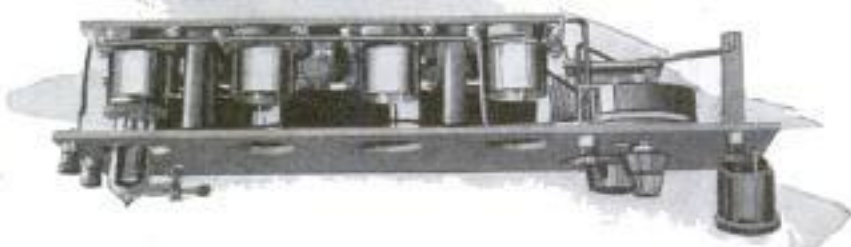

in a convenient position for connecting to the batteries in the compartment at the left of the case. Holes are drilled in the instrument panel for the transformers, which are screwed to it upside down. These are grouped as shown in the photo of the bottom of the set, to get them as close as possible while preserving the layout shown in the circuit diagram; this permits the leads to be made short, which is necessary for efficiency. The audio-frequency transformers all have the same ratio—4.25 to 1; the radio-frequency transformers are the Acme types R-2, R-3 and R-4, which are specially designed for circuits of this character.

The fixed condensers are of the mica type. One .00025-mf. condenser is used across the secondaries of each of the first and second audio-frequency transformers and one .002-mf. condenser as a by-pass for both high and low-frequency currents, to prevent howls and high-frequency losses. A .005-mf. condenser is connected across the phone or loud-speaker jack. All connections must be carefully soldered, using small copper or brass soldering lugs

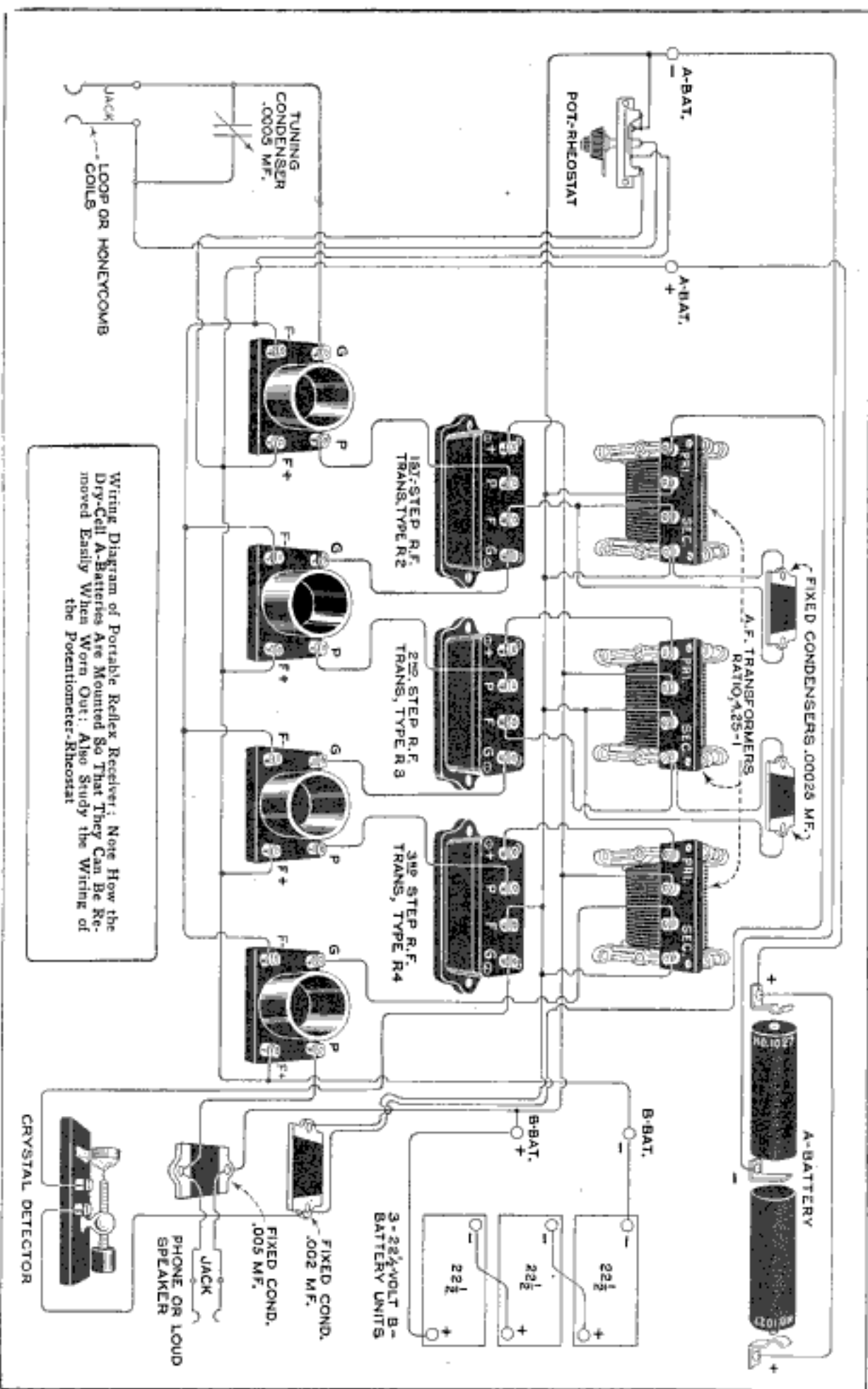

under the instrument terminals. Acid-core solder must not be used, as there is danger of corrosion, leading eventually to broken connections. Use resin-core solder,

tom stick of the loop with a wooden pin. The loop is now ready for use, and is simply plugged into the loop jack on the panel; this allows the loop to be turned

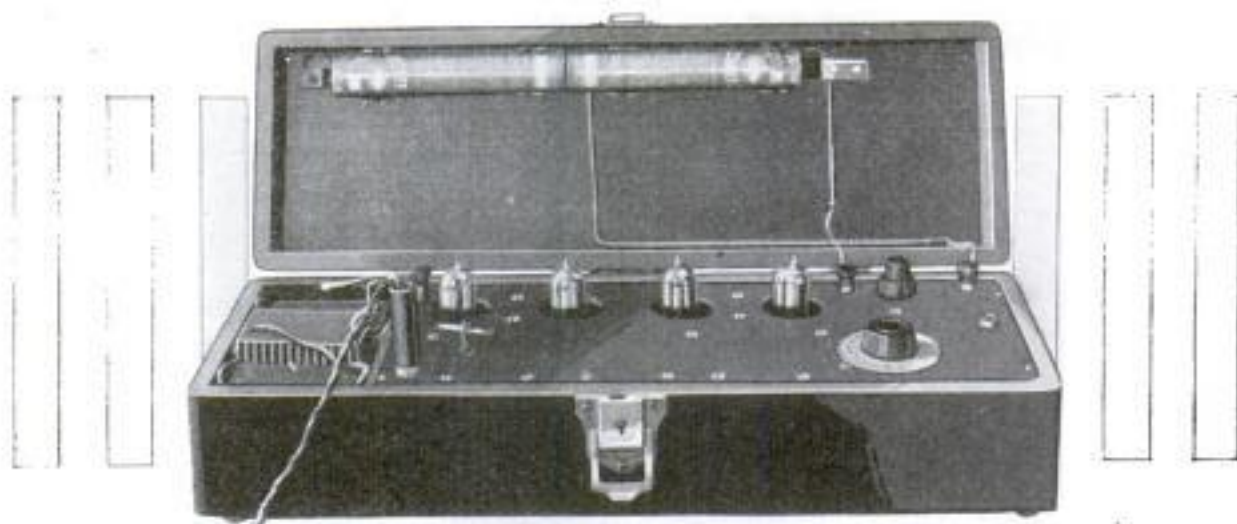

The Complete Set, Showing A and B-Batteries in Place and with Loud-Speaker Plug In, but without the Loop, Which Is Plugged In at the Right

or plain wire solder with a resin flux, and only enough solder to make a good connection. All leads should be as short as possible, and should be of No. 14 or 16 tinned copper wire, covered with a good grade of yellow varnished-cambrie tubing; don't use the black "spaghetti" tubing, as this is sometimes varnished with a compound containing lampblack, which causes a great deal of "mysterious" leakage, sometimes causing the instruments in which it is used to stop functioning.

The loop is very easy to make, and the dimensions given should be followed closely to obtain the best results. Brass tubing, cut and soldered in the form of a cross, or a brass-pipe cross fitting, if this can be obtained, is used for the center; $\frac{1}{2}$ -in. dowel stock is used for the arms, which are each $11\frac{1}{2}$ in. long. A spreader strip of bakelite, 5 by $\frac{3}{4}$ by $\frac{3}{16}$ in. in size, is screwed on the end of each arm, and 10 turns of No. 18 flexible annunciator wire wound on the loop. The ends of the wire are brought to the terminals of a common phone plug, which is fastened to the bot-

tom stick of the loop with a wooden pin. The loop is now ready for use, and is simply plugged into the loop jack on the panel; this allows the loop to be turned in any direction for tuning to a particular station, while maintaining a good connection. A new and very effective method of increasing the range and selectivity of a small loop is to place 120 ft. of insulated annunciator wire around the picture molding of the room in which the instrument is used, or on the wall, in the form of a 1 or 2-turn loop and connect a .005-mf. variable condenser across the terminals of the wire. The large loop has a greater pick-up than the small one, and the coupling between it and the small one attached to the instrument is so loose that very close tuning is possible. When this large loop is used, tuning is done with both the condenser on the instrument and the one on the large loop.

For use with a regular aerial and ground, the instrument is fitted with 35, 50 or 75-turn honeycomb coils. A stationary and a movable mounting for the coils are fitted to a bakelite strip, 6 by 3 by $\frac{3}{16}$ in. in dimensions. An ordinary phone plug with screw connections is used and the fiber or bakelite shell threaded for a

MATERIAL LIST

- | | |
|---|--|
| 1 bakelite panel, 17 by $6\frac{1}{4}$ by 3-16 in. | 1 .0005-mf. variable condenser. |
| 1 bakelite panel, 12 by $2\frac{3}{4}$ by 3-16 in. | 2 .00025-mf. fixed condensers, mica type. |
| 1 bakelite panel, 6 by 3 by 3-16 in. | 1 .002-mf. fixed condenser, mica type. |
| 1 case to dimensions given in drawing. | 1 .005-mf. fixed condenser, mica type. |
| 4 hard-rubber rods, $2\frac{1}{2}$ by $\frac{1}{4}$ in. | 2 single-circuit jacks. |
| 4 tube sockets. | 1 detector, synthetic-mineral type. |
| 3 a. f. transformers, ratio 4.25 to 1. | 3 B-battery units, 22 $\frac{1}{2}$ volts, small type. |
| 1 each r. f. transformers, Acme R-2, R-3 and R-4. | 2 flashlight batteries, French No. 1027. |
| 4 binding posts. | 1 3-in. condenser dial. |
| 1 comb. potentiometer and rheostat. | 4 UV-199 or C-299 tubes. |
- Two lengths, varnished-cambrie tubing; tinned-copper wire, wood screws, terminal lugs, machine screws and flat brass sheet for A-battery connections

cut \$71.42.

sufficient length to go through the strip and take two pipe nuts to fasten it securely. Two binding posts are mounted on the end of the strip and the connections from the aerial and ground taken through the posts to the secondary coil. The plug is connected to the primary coil. This device is plugged into the loop jack when it is desired to use a regular aerial.

Instead of the loop, a small honeycomb coil can be plugged into the loop jack, and this is sufficient to bring in near-by broadcasting stations on a loud speaker, but the use of the loop described is, of course, advised in all cases.

The best tube of the four should be used in the socket nearest the loop jack; this is the important stage of the instrument. The operator will be able to select the best tube for this position by trial.

Unusual Weather Conditions Not Radio Fault

The unusual weather conditions prevailing this summer have been attributed to radio broadcasting, by someone with more or less authority to speak. This idea seems to have spread pretty generally over the country, and, ridiculous as it is, the idea supplies a new goat on which to blame the weather conditions.

Radio broadcasting is a new science, and there are many unsolved mysteries yet to be clarified by time and experience; this makes it very easy for the semi-scientific analyst to make sage announcements that will not hold when viewed in the light of truth, with reasoning based on common sense and a knowledge of the principles involved.

It is a popular belief that a large amount of electrical energy is released by the average radio broadcasting station. This is not the fact. We will consider the 500-watt station; one flash under a trolley wheel, lasting .01 of a second, will release more power in actual electrical high-frequency radiation, than the average 500-watt broadcasting station will in one hour of continual operation.

Every arc light in the streets, or an arc light, such as used in the moving-picture industry, radiates many times as much energy as a 500-watt broadcasting station, and it is the same type of radiated high-frequency energy used in broadcasting. It is plain to see that radio furnishes a very small part of the high-frequency energy roaming around in our atmospheric envelope. The average flash of lightning between clouds and the ground will radiate more energy than all the combined

radiophone broadcasting stations and commercial wireless stations in the world will radiate in years.

Unusual weather conditions cannot be explained through any agency produced by man; we seek a reason through some phenomena we do not understand, and choose one that offers the least resistance to the popular mind.

A Thirty-Cent Radio Set 3 31- J²

At the cost of only thirty cents, the radio set shown in the photo is doing day and night duty in the elevator-control room of a skyscraper. It was made from a sawed-off curtain pole, wound with wire to form an inductance, and nailed to a baseboard; a sliding contact was arranged for tuning. A simple condenser, consisting of sheets of tinfoil flattened and held in wax envelopes, an ordinary crystal de-



Receiving Set Built at Cost of Thirty Cents and Using Ordinary Telephone Receiver

tector and a 75-ohm telephone receiver completed the outfit.

Using a C-Battery

The C or bias battery is a very useful adjunct to the audio-frequency amplifier, as it not only improves the operation of the set but also reduces the drain on the B-battery. However, if the B-battery has a potential of under 45 volts, the C-battery is unnecessary; for a 60-volt battery the C-voltage should be about 3 volts, and for a 90-volt B-battery the C-battery should have a potential of $4\frac{1}{2}$ volts, and be connected with the negative toward the grid.

345 - P. Pacific & Atlantic



Above, the Latest Novelty in Savings Banks: a Complete Crystal-Detector Set is Mounted on the Bank, and Has a Range of Forty Miles. Center, Here is the New Radio Stethoscope in Action: This Enables Any Number of Doctors to Listen to a Patient's Heartbeats at Once. Below, a Scientist of the Bureau of Standards with the Wavemeter Used as a Standard to Adjust the Instruments Used to Transmit Radio-Frequency Signals

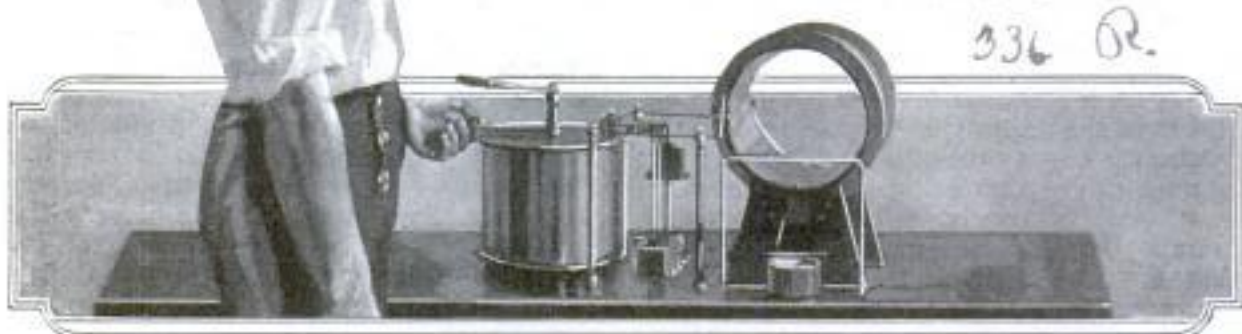

Lower Photo Copyright, Henry Miller Service

*Radio
no. 117
Patent*

*354 Or
Model & Herbert*



*354 Or
2000*

Above, the World's Smallest Loud Speaker; It Weighs Only Seven Ounces, but Works Perfectly. Center, the Babies' Band of Immanuel Sisterhood, Which Has Delighted Thousands of Radio Fans; the Oldest Is Only Seven and the Youngest Three and a Half Years. Below, the "Solemn Old Judge" of WLS, with His Famous Locomotive Whistle

325- R



Mr. Beaumont Co. France
Paris

228-R. French Engineers Produce Novel Loud Speaker

The object shown in the photo looks at first glance like an accordion-pleated fan, but it is really a new and very effective form of loud speaker, designed and built by French engineers. Radio engineers have long realized that the horn type of loud speaker was far from satisfactory, although it apparently gave excellent results. It lacks the ability to reproduce both high and low frequencies with equal tonal qualities, and it may eventually be displaced by the type shown, which, it is said, overcomes all the disadvantages of the other type. The loud-speaking unit used is connected by means of a pin to an accordion-pleated paper cone, which forms the actual diaphragm or amplifier. All the low notes on a piano or other instrument which the ordinary loud speaker loses are, it is claimed, reproduced beautifully with this instrument.



A Loud Speaker That Reproduces High and Low Notes, with Equal Clarity

the speed to a great extent. However, such a small motor can be used if it is fitted up as shown in the illustration.

A thin mica disk, about 4 in. in diameter, with a number of 3/8-in. holes drilled at equal distances along the edge, is fitted on the shaft. If it is impossible to drill holes, notches cut in the edge will do just as well. Two electrodes, cut from a wet-cell battery zinc, are mounted on a piece of bakelite or hard rubber and supported in the position indicated. The motor can readily revolve the mica disk at a speed almost equal to its normal

speed under no load. The wiring diagram of the spark coil, aerial and ground is also shown.—E. J. Bachman, Fullerton, Pa.

346-R. Battery Tips

Use a battery of a size adequate to the needs of your particular set. It is possible to get results from multiple-tube apparatus with the smallest size of B-battery, but the experiment will be costly because of the rapid depreciation of the current supply and the consequent need of frequent renewals. The number and type of tubes, as well as the range sought, should determine the size of the battery required.

Be sure that the B-battery is not connected to the A-battery terminals, as the tube filament is designed to operate on low voltage, whereas the voltage of the B-battery is many times that of the filament-voltage rating.

Use no more tubes than are sufficient for the results desired. It frequently happens that inexperienced operators will have more tubes burning than are necessary, and then detune to lessen the volume of sound. For local stations, for instance, the first audio stage is ample.

Burn your tubes at the lowest point compatible with good reception. Excess filament current not only drains the batteries unduly, but reduces the life of the tubes. Once the rheostat is fixed at the proper point, it should not be touched again. Turn off the filament the moment you stop listening. Current is flowing as long as the filament is lighted.

Small Rotary Spark Gap

A considerable amount of energy is ordinarily required to revolve a heavy spark-gap rotor. A small dry-cell motor,

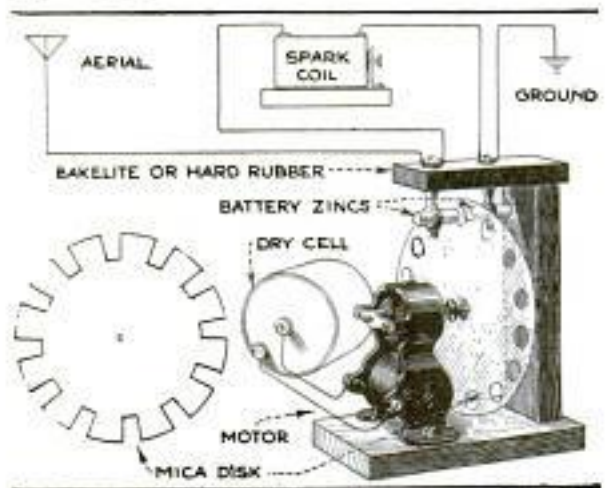

Spark Gap Made by Mounting Thin Mica Disk on Shaft of Dry-Cell Motor

which runs fast enough for the purpose, cannot rotate a flywheel without lessening

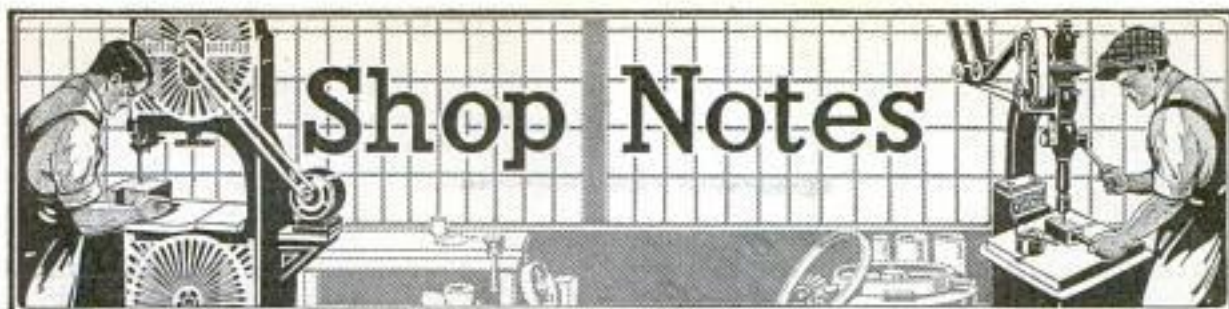

All Shop Notes published in 1923, in book form—Fifty Cents—from our Book Department

How to Make a Fireless Brooder

By J. V. ROMIG

ONE of the first and most necessary things to have after chicks have been hatched or purchased is a brooder. The poultry farmer starting in can save considerable expense by making his own; the construction is not by any means difficult, and anyone at all handy with tools can make a very efficient and creditable piece of equipment by proceeding according to the directions given in this article.

The brooder is of the fireless type, in which use is made of the principle of conservation of body heat rather than of supplying heat from an outside source. This is effected by the use of a hover board which is hung with cotton-flannel strips, under the folds of which the baby chickens can nestle. It can be used both inside and outside, but it is preferable to keep it for the first ten days of the chicks' lives in

A Simple and Easily Constructed Brooder of the Fireless Type

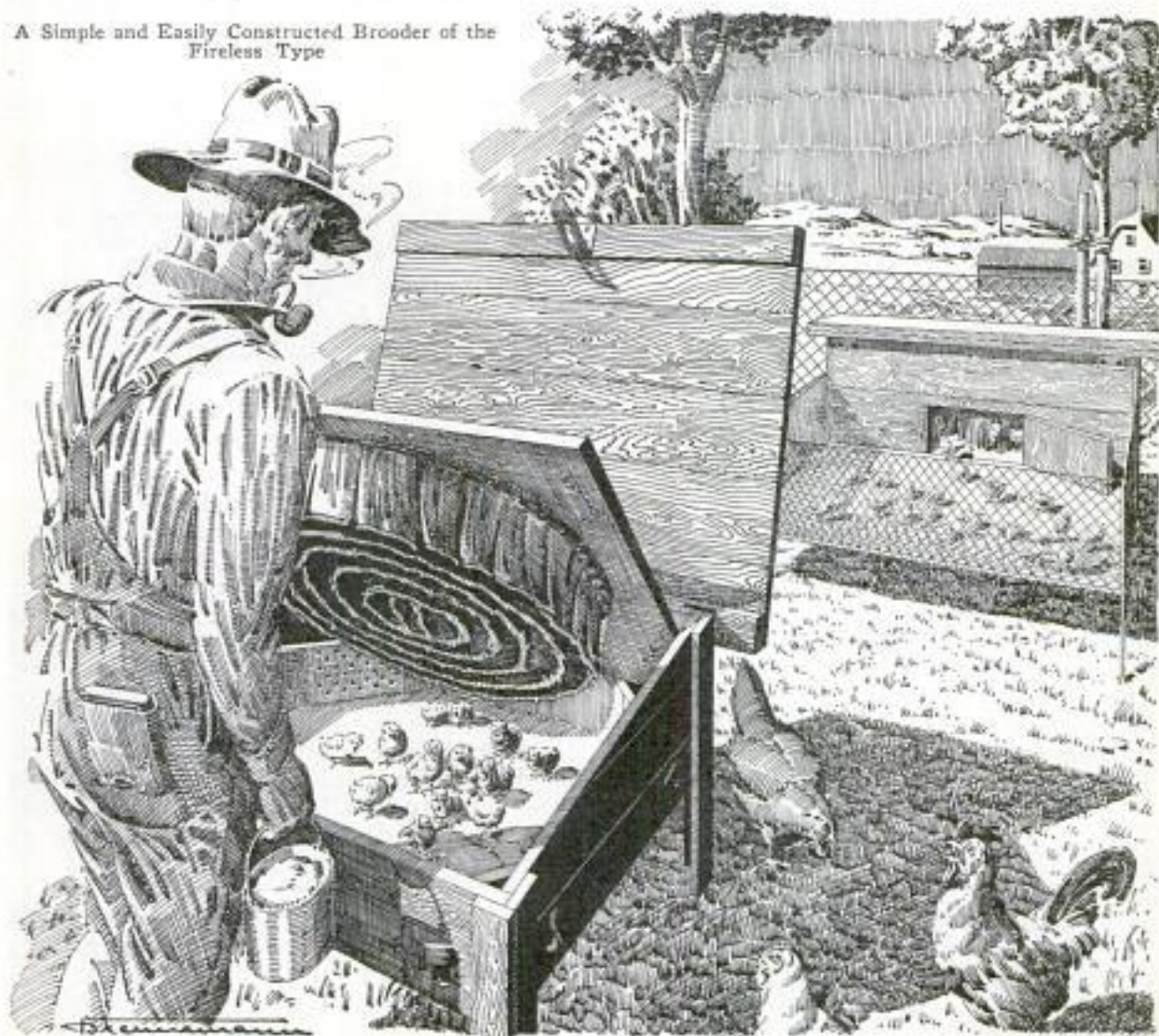

a warm building, after which it may be set out in the open.

Old packing-case boards of 1-in. thickness can be used for the sides, bottom and roof, and if they are of the tongued and grooved variety so much the better. The outer housing, or frame, is nailed together as shown in the detail drawings, and then short pieces of board are drilled with a number of $\frac{1}{4}$ -in. holes and nailed across the corners of the inside of the housing.

pivoted covers fitted over them. The air will enter through these holes and percolate through the holes in the corner boards and in the hover board, ventilating the inside of the brooder thoroughly. The canton-flannel strips should be wide enough to rest on the bottom of the brooder, so that a direct draft cannot blow through it. In warm weather, the top can be lifted and blocked up, to allow more air to reach the inside of the brooder.

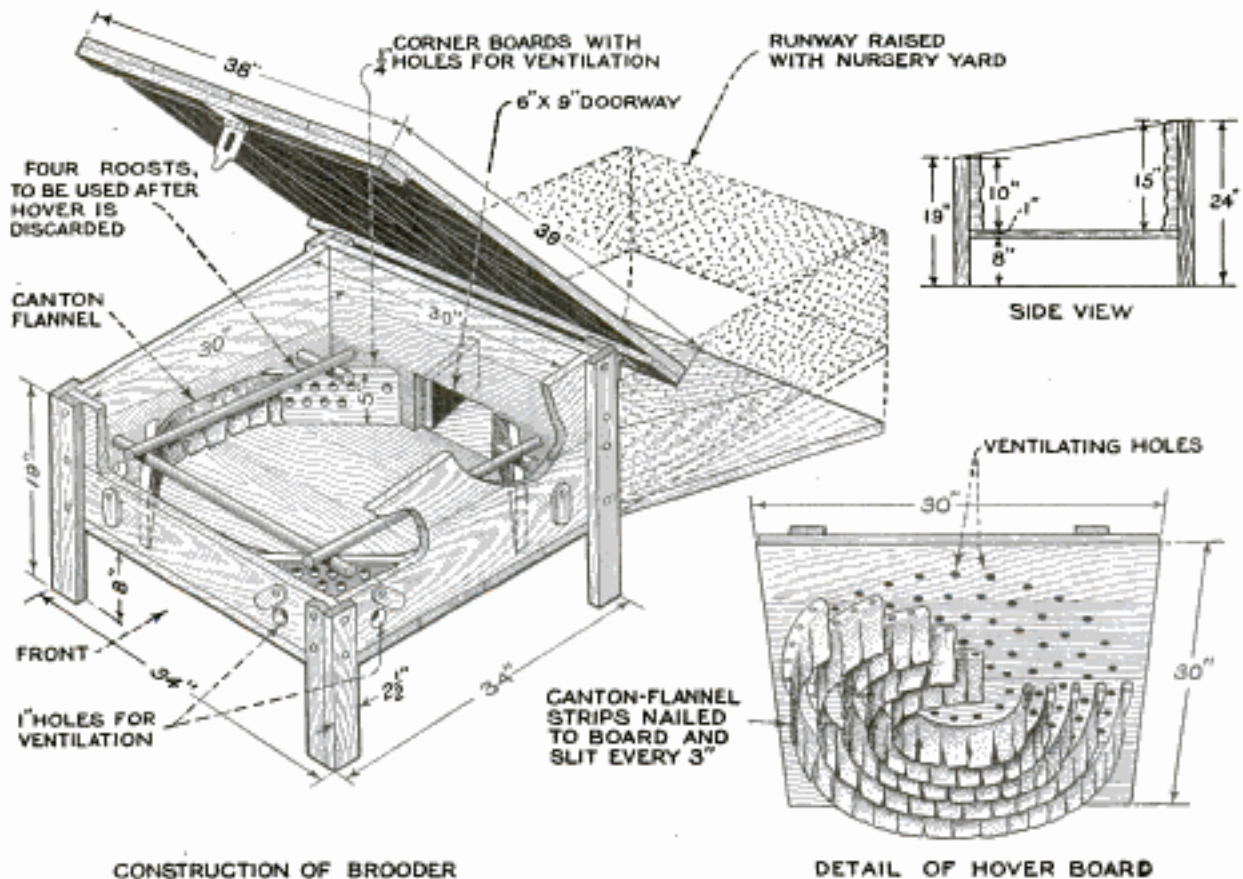

CONSTRUCTION OF BROODER

Details of the Homemade Fireless Brooder; Note the Hinged Runway, Which Serves as a Nursery Yard, and the Roosts for Use When the Chicks Outgrow the Brooder

Around the octagonal inclosure thus formed, a strip of heavy canton flannel is tacked, the tacks being driven around the upper edge. This strip is then slit every 3 in. nearly to the top edge; it should not be tacked completely around the inclosure, an opening being left at the back, where the door is cut in the housing.

The hover board is made slightly smaller than the inside of the brooder, so that it will rest on the corner boards and can be easily removed for cleaning. It is 30 in. square, and $\frac{1}{4}$ -in. holes are drilled in circles through it, as shown. Strips of canton flannel are then tacked to the underside, so that a circle of holes will come between each pair of strips, and the strips are slit every 3 in. in the manner previously described. Two 1-in. holes are drilled in each corner of the housing, and little

As the chickens grow taller, blocks can be placed under the hover board to accommodate them. After they have outgrown the necessity for the brooder, the hover board is removed, and a four-pole roost substituted.

A 6 by 9-in. opening, fitted with a door, is cut in the back of the brooder housing, and a runway, the full width of the brooder, hinged just below the door. This can then be raised when the chicks are too small to be allowed to run in the yard and surrounded with chicken netting to form a perfectly safe nursery yard.

☞ A convenient bench knife can be made from the broken blade of a jackknife by flattening one end of a piece of brass tube of suitable diameter and soldering the blade into the flattened end.

Stop for Radial Drill

For many kinds of work the stop shown in the drawing is a real timesaver on a radial drill. With the aid of this device it is possible to duplicate double holes in any number of pieces with the same accuracy as by using a jig. The parts required are a piece of round stock, tapped at one end to screw onto a bolt in the T-slot of the drill table, and fitted with a sleeve at the other end. The sleeve is tapped on opposite sides for setscrews and a hole is drilled through it to take an auxiliary arm, also made of round stock and bent to a hook shape as shown, to engage the handle by which the drill arm is swung. The parts are assembled as shown to the right in the illustration.

This stop was used successfully in the production of a number of pieces requiring two holes, the centers of which had to be located exactly alike in all the pieces. The adjustment of the stop was made as follows: A sample piece with holes already drilled was bolted in place. By swinging the drill arm backward and forward and lengthening or shortening the auxiliary arm, the drill was made to stop over the holes as the drill arm reached the end of its swing on either side as determined by the stop. The sliding auxiliary arm and the saddle carrying the spindle were then locked, and the work was

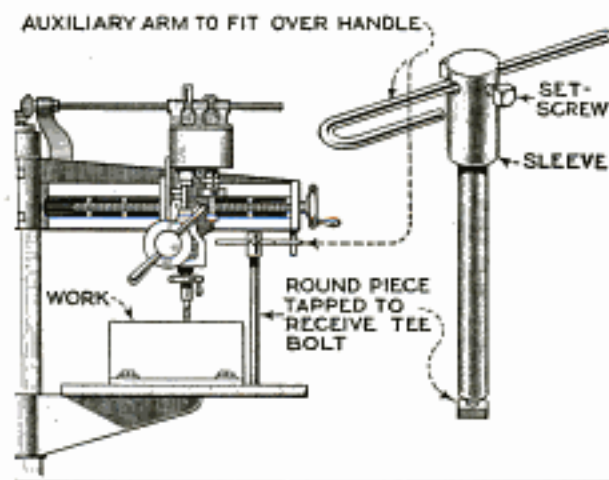

Device on a Radial-Drill Press Allows Duplication of Holes as Accurately as with a Jig

drilled and reamed with very accurate results.—Harry Moore, Montreal, Can.

Water Heater for Contractors

The drawing shows a novel and serviceable heater for running water, that will prove useful to contractors who have to heat large quantities of water for concrete

Novel Contractors' Water Heater That Is Inexpensive to Make and Convenient to Move

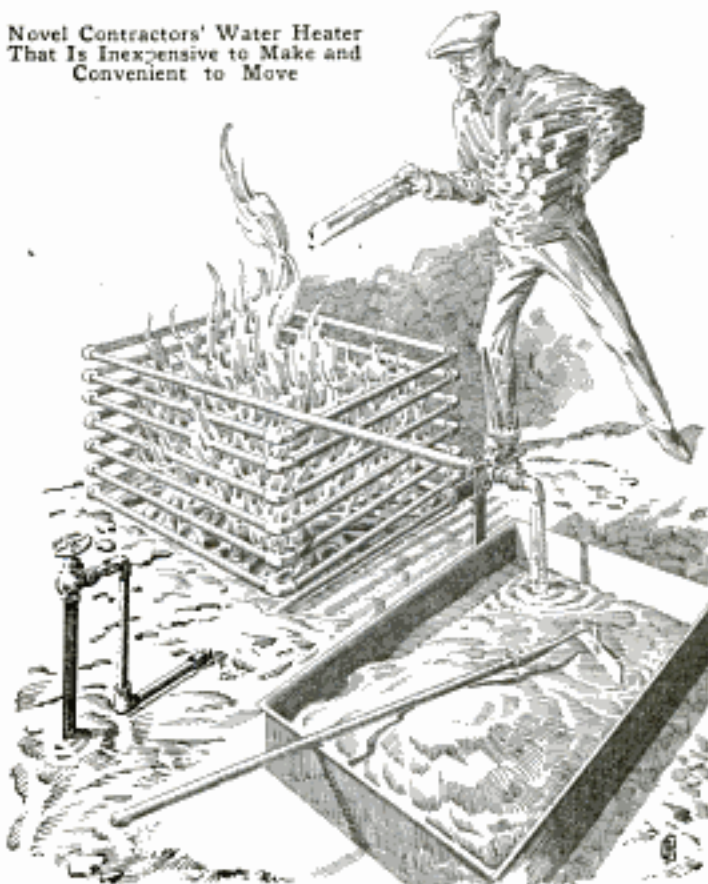

or plaster work. The heating unit consists of a number of lengths of pipe connected with elbows as shown, the bottom end being connected to the water supply and the upper end having an extension with a faucet attached. A fire is built inside of the coil and this heats the water in a short time. This heater is inexpensive to build and is light in weight, so that it can be easily moved about from one job to another.

Filling In Broken Enamel

Fine sealing wax is good for filling in cracks or broken spots on enameled surfaces, as it hardens at once, takes color without absorbing the oil and does not shrink. Use a wax of the proper color to match the surface to be repaired, fit it in, and smooth the surface down with a hot palette or putty knife. Give it one or two coats of color to make it match the remainder of the enamel exactly, and then varnish.

Tray for Beeswaxing Screws

Woodworkers and others who are accustomed to dip wood screws in beeswax to make it easier to drive them into the wood, will appreciate the usefulness of the dip-



Handy Dipping Tray and Dipper for Beeswaxing Wood Screws

ping tray and dipper shown in the drawing. The tray is made of sheet metal, bent over and riveted so that it is 1 in. deep, and stands on legs about 6 in. high. The wax is placed in the tray and melted by means of a Bunsen burner or small alcohol lamp. A dipper is used to hold the screws; this is made from a piece of sheet metal, having a number of slots cut to form tines, which hold the screws as indicated in the detail. The screws are picked up simply by running the dipper through a box of the screws.—Vernon F. Clayton, Detroit, Mich.

Worn Paving Brick Make Manholes

Bricks from worn-out street pavements need not be hauled to the city dump as worthless. They can be used in building manholes. For this purpose discarded bricks are just as good as new ones, because, in manhole construction, the spaces between the bricks, no matter how ragged, are filled with cement mortar. Such manholes will obviously cost much less than those built with new brick or concrete, and are practically as durable.—Ivan E. Houk, Denver, Colo.

Testing Crankshaft for Cracks

When overhauling the engine it is desirable to examine the crankshaft for cracks. Some cracks may be visible to the eye, but in most cases a crack is too fine to be seen, yet, if ignored, it will gradually increase in size until the shaft breaks—hence the importance of finding hair cracks. A simple method of making such cracks visible is to suspend the shaft from one end by means of a rope and then strike the crank cheeks in turn a sharp blow with a hammer. The vibration forces oil out of the crack and the shadow of the fine oil line is distinct on the clean surface of the shaft. Any crankshaft found to have a crack in it should be discarded.

Cutting Circular Holes in Sheet Metal

It is often necessary to cut circular holes in instrument boards for speedometers, clocks, etc. This cutting cannot be done very well with an ordinary saw, and therefore the circular saw shown in the photograph was made. It consists of a hacksaw blade screwed to the edge of a circular piece of wood, and the shank of an old drill bit. The piece of wood is turned down to a suitable diameter and $\frac{1}{2}$ in. wide, with a boss about $1\frac{1}{2}$ in. in diameter in which the drill shank is pinned. The material should be hardwood, such as oak, as it must withstand considerable strain. A thin, flexible hacksaw blade is bent around the edge and both ends of the blade are cut off so that the ends fit together exactly. The temper is taken out of the blade at several points, about 2 in. apart, so that screw holes can be drilled through it. Small round-head screws are used to fasten the blade to the disk. A hole is drilled through the center to receive the drill shank, or a similar piece of round steel, about $\frac{3}{8}$ or $\frac{1}{2}$ in. thick and 4 or 5 in. long. The shank should project beyond the saw teeth so that it will serve as a center guide, which is inserted into a small hole drilled first. A $\frac{1}{8}$ -in. hole is drilled through both boss and shank, and a nail is driven through to serve as a pin, the ends being flattened to keep it in place. By grinding out a number of the teeth at intervals along the edge it will be easier to turn the tool, if it must be used in a hand brace or drill.

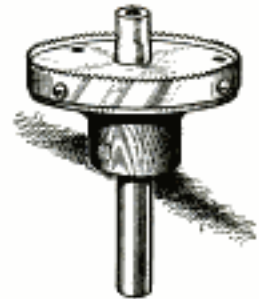

Brake for Shop Trucks

When loading hand trucks with heavy boxes it is usually necessary to slide them onto the truck, and the latter must either be held by another person or the wheels "scotched" with blocks to keep the truck from moving. Recently a small plant fitted the shop truck with a brake as shown in the drawing, and the truckman is now able to load it alone without blocking.

The attachment is easily made; two strong hinges are fastened to the underside of the truck in front of the rear wheels, one end of each hinge being allowed to hang loose. The loose ends are connected by a strip of heavy sheet metal, which is fastened to them with screws. In the center of this strip is riveted a V-shaped piece of metal to act as a catch for a piece of round rod which is bent around the axle of the rear wheels. The part of the rod between the axle and the V-piece should be so long that it will tilt the loose leaves of the hinges a trifle forward, holding their lower ends above the floor. At the other end a cylindrical weight is driven on the rod. When the truck is to be loaded, the weight is lifted with the foot, which allows the hinges to drop into contact with the floor. The truck is then given a forward push, causing the hinges to bring up against the rear wheels and raise them a little, so that the truck is securely blocked.—Harry Moore, Montreal, Can.

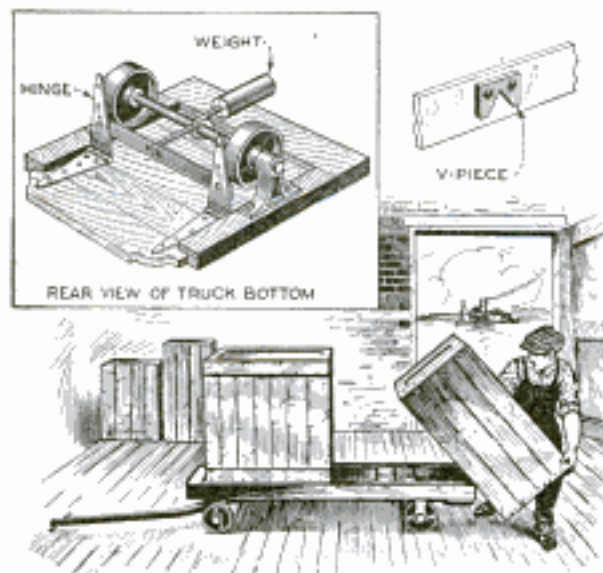

Brake on Factory Truck Enables Worker to Load It without Blocking Up the Wheels

Cattle Guard Made of Cactus

A section foreman on an Arizona railroad conceived the idea of using cactus plants for a cattle guard at railroad crossings. The first one he built proved so



Arizona Railroad Uses Effective Cattle Guards Made of Cactus

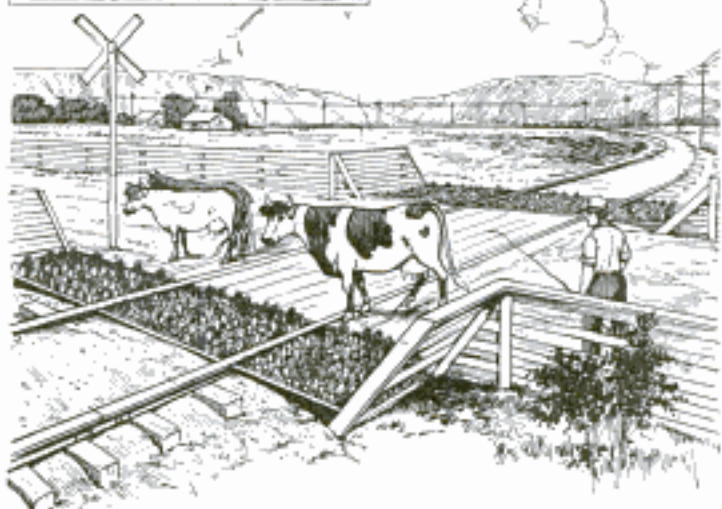

successful that the railroad company decided to use his method exclusively. The guard consisted of a wooden frame of 2 by 6-in. material under the tracks, as shown in the drawing. In this boxlike structure, sand and gravel were placed to a depth of a few inches and the cactus planted in it. As the cactus used for this purpose grows in abundance along the railroad these guards cost nothing outside of the wood and labor to construct the frames. That it is also efficient is shown by the fact that during the first six months not a single animal attempted to cross it. Both horses and cattle in this region are familiar with the sharp thorns of cactus and avoid it as they would a rattlesnake.—Robert H. Moulton, Chicago, Ill.

Keeping Record Map Up to Date

A wall map in the office of an electric-light company was used to indicate the changes and extensions in the overhead lines. It was at first found difficult to make the alterations on the map satisfactorily, but all trouble was overcome by placing it in a picture frame having a glass front and indicating the changes on the glass with various colors of waterproof ink.

Movable Workbench

In an automobile repair shop in western Maryland the writer observed a small repair table, made from an old steel oil drum and mounted on casters so that it could be



Sturdy Workbench Made from Oil Drum and Mounted on Casters

moved about. A wooden top was bolted on the drum, and on this top a small vise and hand grinder were mounted. A semi-circular opening was cut in the side of the drum so that oilcans, greasing equipment, waste and various tools for tire and other repair work could be stored when not in use. Casters were riveted to the side near the bottom, as indicated in the detail. Obviously, the use of this table saved many steps to and from the workbench and thus eliminated waste of time. It was possible even to put an engine on this sturdy table and move it to another section of the shop.—G. A. Luers, Washington, D. C.

Efficient Drawing-Pen Cleaner

Drawing pens and pens on compasses can be cleaned easily with an ordinary pipe cleaner. The cleaner is bent to form a loop, the ends being twisted together and inserted in an improvised handle. The loop is brought close together and passed between the jaws of the pen. Such a cleaner is inexpensive and will not injure the most delicate pen.

Making Small Laps

Where tubing is available, it makes very good laps, but few shops carry a supply of tubing in all sizes, and some may not have it at all. Good laps for drill-jig bushings and similar work, however, can be made of cold-rolled steel or drill rod, which comes in all sizes, and can usually be found in any shop. The rod is sawed lengthwise down the center, and adjusted by spreading the ends apart.

Safe Ladder for the Silo

Most silos have an inside ladder but not many have one on the outside, although the necessity for one here is sometimes just as great. In case the silo is made of hollow concrete blocks, a neat and durable ladder can be built integral with it on the inside, outside or both. The rungs are made from a number of lengths of $\frac{5}{8}$ -in. iron rod, bent to the shape shown. These are inserted between the blocks, which are grooved to receive the rungs snugly. The ends of the rungs are bent over into the hollows of adjacent blocks to prevent them from being pulled out, and the rungs themselves should extend out far enough to offer a sure foothold even when overshoes are worn. A sufficient number of courses of blocks at the bottom might be

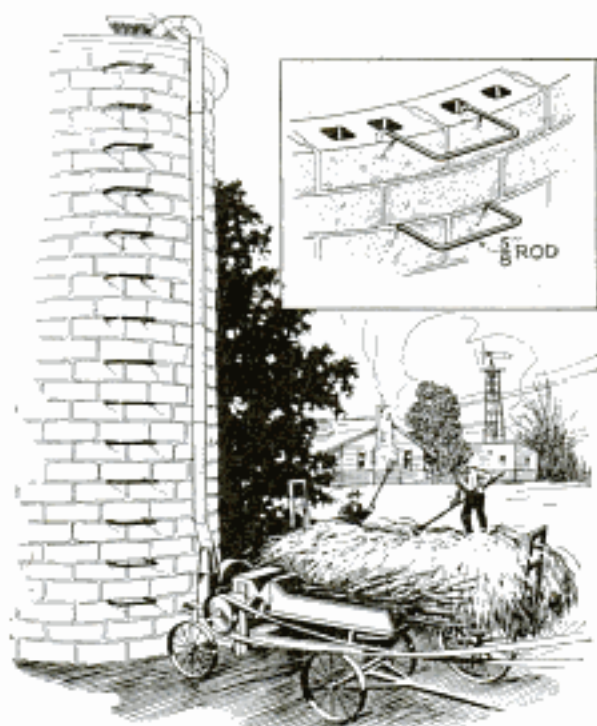

Steel Rungs in Silo Wall Make Strong and Durable Ladder

laid without rungs, to prevent youthful investigators from climbing the ladder.

EMERGENCY EJECTORS

By

FREDERICK W. SALMON

AM. SOC. NAVAL ENGRS.

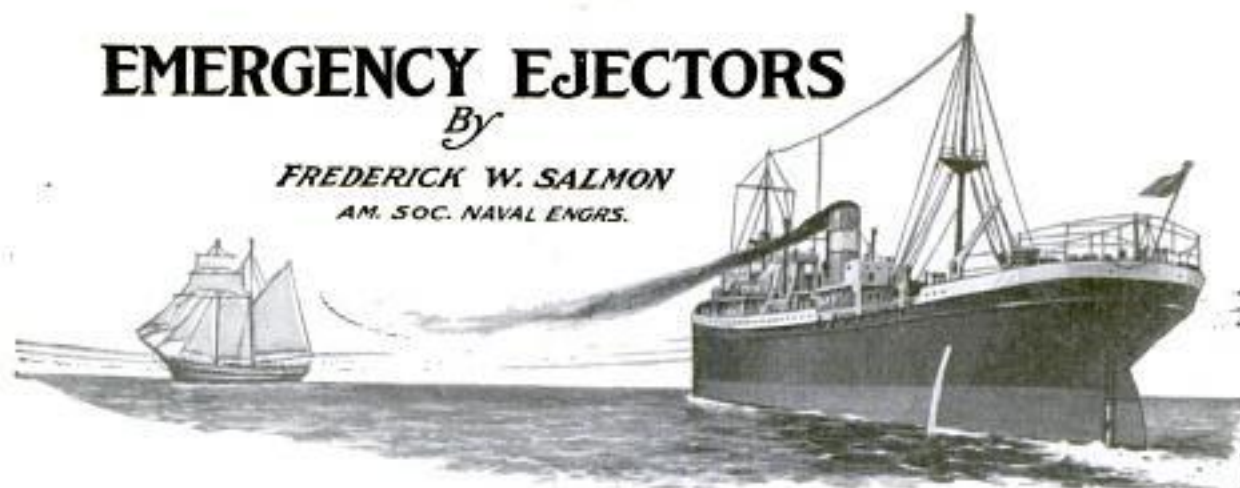

THE ejector is often a very useful device on and about ships, as it is about the only one that the ship's crew can make in a short space of time that will move a large quantity of water. Every seagoing engineer should therefore know as much about it as possible, particularly how best to construct one out of pipe and fittings and use it to get the best results. The writer has found such ejectors of great value on many occasions, and gives here the results of his experience in condensed form.

It is perhaps best to commence with a short description of the theory of the ideal ejector, and so in Fig. 1 is shown a simple elementary type. The water enters the ejector at A, and passes to the steam jet in a spiral so that the streamlines will be easy and the angular deflection small, thus keeping the hydraulic loss low. The incoming water is accelerated in the narrowing passage until it attains its maximum velocity in the throat B. The particles of the condensed steam enter the water at this point and impart to it a large portion of their energy, after which the water

moves at a decreasing velocity until it reaches the normal pipe section at C; at the same time the pressure is increased. The things to strive for in the design are: To have the water enter with the least shock or eddy loss and with the least surface or skin loss; to provide just sufficient condensing surface on the steam nozzle; to avoid all sudden changes of form in the throat; to get the water column back to normal velocity at C in the least practical distance, and to prevent radiation losses

as far as possible. Fig. 2 shows a home-made ejector of a type often seen; sometimes it will operate and sometimes not, depending on the conditions under which it is tried. Its principal faults are: The steam jet is not of nozzle shape; the water is not properly guided and meets a sudden obstruction at B; there is no throat at A nor recovery cone at C, and no relief for starting at D. In the ejector shown in Fig. 3 some effort has been made to provide a throat at A by using a nipple of smaller size than the ejector body, fitting the nipple by means of the bushings B and C, but this usually results in the steam nozzle being much too long, causing both steam and water losses. This type is open to about all the criticisms directed against that shown in Fig. 2, but it will generally drive out a little water against a higher head than Fig. 2, and so it is often used as a makeshift. Fig. 4

shows an ejector that can be made of practically the same material as that in Fig. 2, but which, experience has shown, is about as efficient a device as can be made with pipe and fittings. The steam nozzle is hammered or swaged a little to-

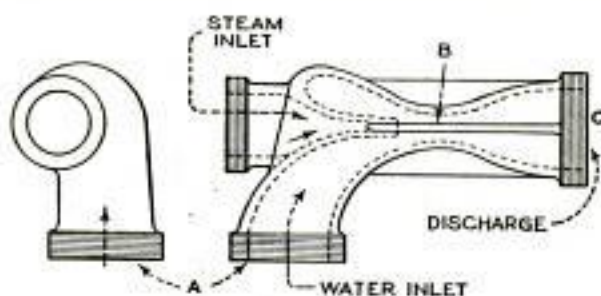

Drawing Illustrating the Principle of the Ejector

ward the proper nozzle shape, smoothed out on the inside with an improvised reamer, and turned, ground or filed on the outside (to lessen the draft or wake in the passing water) to a thin edge, say $\frac{1}{32}$ in. for the smaller to $\frac{1}{16}$ in. for the larger nozzles.

The water passages can easily be made to the shapes indicated at A and B with zinc, white metal, solder, babbitt, or even lead. To make A, screw the steam nozzle tightly into the galvanized-iron plug C, and mold A to the shape desired with

plaster of Paris, sand or even clay. As soon as this is hard, use it as a pattern and make a mold in sand, or whatever is available, with a regular cope and a runner or gate. Open the mold, take out A, C and D and remove all the plaster or whatever was used to form A; then clean the surfaces of C and D well. Fill the inside of the nozzle with sand, rammed hard, to prevent any of the metal from running into it, see that the mold and cope are in good order, put in C and D; then put on the cope and pour. Twenty minutes' work will make a good cast. To make the throat piece, drill a few holes in a galvanized nipple E to hold the fitting securely, and turn or carve a piece of soft wood to form a core for the throat. The cylindrical ends should fit the nipple easily, and the core should be cut in two and the two halves doweled together with a nail, as shown, to permit withdrawal. Place the core in position in the nipple, first coating it with paraffin or grease, and, through the holes in the nipple, fill the space between core and nipple with plaster of Paris. When this has set, withdraw the core, and the nipple can now be used to make a sand core for the actual casting. This is done by cutting some small disks of paper to fit the smallest part of the throat, slipping a wire nail through the center of the disks before they are placed in position, to act as a dowel for the sand core. The sand is now rammed in from both ends until the nipple is well filled, then withdrawn and dried thoroughly. Remove the plaster from the nipple, clean the inside surface well, replace the dried core and bed the whole nipple in sand, with one of the holes up. Pour through this hole the bab-bitt, or whatever else is used, and, when cold, remove from the sand and clean out

the core. All this can also be done in from twenty minutes to half an hour. These times only include working time, of course; in addition to this it may require several hours to dry the sand properly in order to prevent it from "blowing" when the hot metal is poured into the molds. Zinc is much more likely to blow than white metal or lead. Four tablespoonfuls

of molasses or sirup, mixed in a cup of water, and added to 2 qt. of fine, dry beach sand will generally make a good core, or a good molding sand, for this work. If either of these ingredients is not at hand, one teaspoonful of wheat flour mixed in $\frac{1}{2}$ pt. of water and gradually heated until boiling will answer the same purpose; a short piece of broomstick or the butt end of a marlinspike makes a good rammer. This

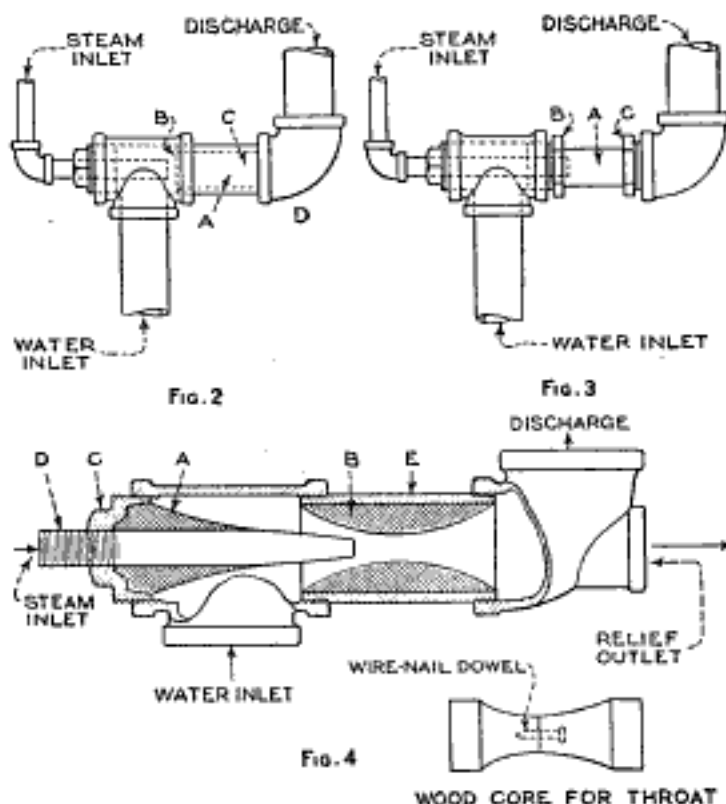

Figs. 2 and 3, Types of Ejectors Frequently Met, but Inefficient in Use; Fig. 4, Construction of Ejector Made of Pipe and Fittings

ejector will deliver from 40 to 80 times the square of the water-pipe diameter in cubic feet per hour, or from 300 to 600 times the square of the pipe diameter in U. S. gallons per hour. Commonly the suction and discharge pipes are of the same size. In the smaller sizes, the diameter of the steam pipe is half that of the water pipe; a 2-in. steam pipe, however, is large enough for a 5-in. ejector. The ejector should not be expected to deliver against a great head—probably not over 25 ft.—but, by piping the discharge like a siphon, a 15-ft. static head can be cared for over a ship's rail of from 40 to 50 ft. above the water level.

There is not much reliable data as to the steam consumption of such ejectors, but from experiment, it appears reasonable to expect that they will use about $\frac{1}{10}$ to $\frac{1}{12}$ of the weight of water they lift, when not immersed in water themselves. The discharge water will generally account for about 98 per cent of the heat in

the steam, but the useful work done, in pounds of water lifted a given number of feet in height, is rather low per pound of steam used. To get the best service, the ejector must not be submerged, but should be set as near the surface of the water as possible. It is often of advantage in starting the action of the ejector to have a relief cock provided, as shown in Fig. 5. This is operated by a rod so arranged that the weight of the rod tends to shut the cock, which should be of the same size as the steam pipe.

In Fig. 5 a good piping arrangement is shown for use when the whole unit has to be lowered into a compartment or hold. Unions are used at B and C to facilitate assembling and repairing. Four suction branches are best to use; two are shown at D and E, and the other two are screwed into the cross below these, and are placed at right angles to them. It is desirable to use a standpipe G, to prevent the end of

the suction pipe from being lowered into mud and stopped up quickly. There should be a total of about two hundred $\frac{3}{8}$ -in. holes in the five pipes; this will give a ratio of hole to pipe area of about 3 to 1; more than this would be better, and each hole should be countersunk with the point of a $\frac{5}{8}$ or $\frac{3}{4}$ -in. drill.

The steam and discharge pipes should be clamped together about every 6 ft. A simple and good way of doing this is shown in the upper detail. For temporary service, a wood block has been found satisfactory as a separator, if made amply large, cut to fit the pipes roughly, and provided with a piece of asbestos under the steam pipe. As an example of the practical application of the principles described, let us assume that we wish to remove water

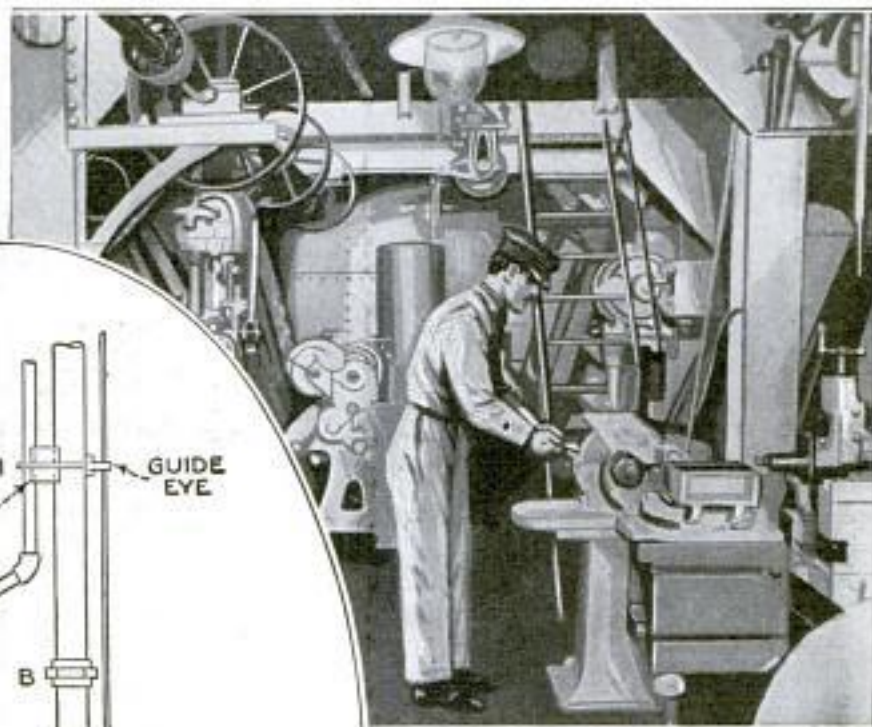
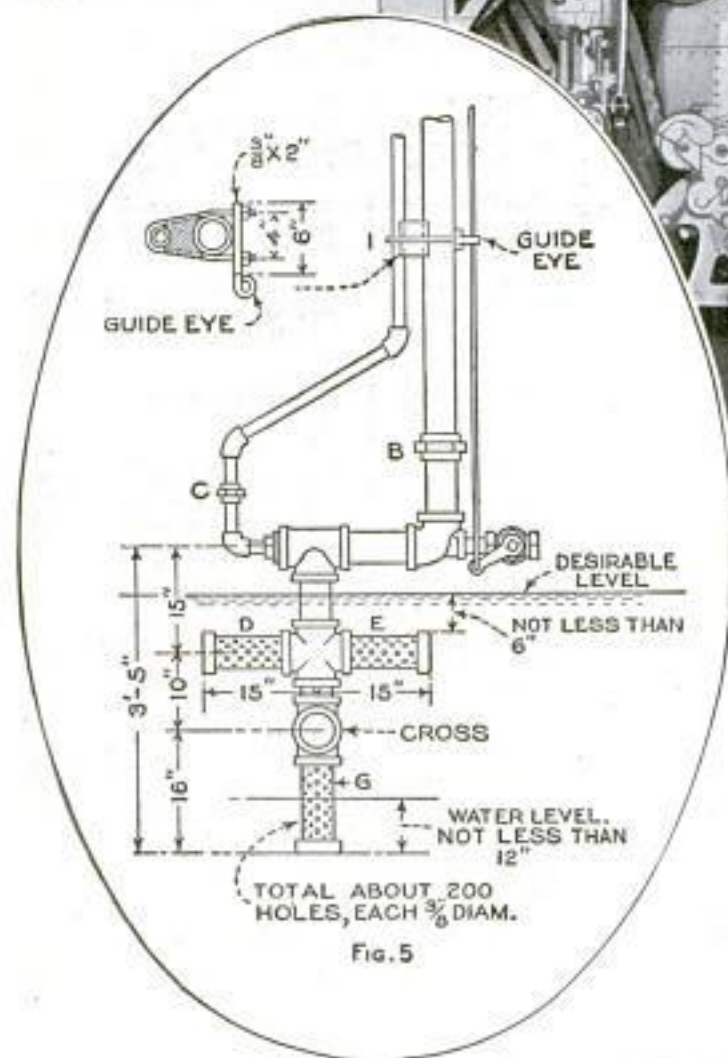

Method of Installing the Ejector Shown in Fig. 4 to Insure Best Results

as rapidly as possible from a hold, keeping the water down against a leak that is estimated at about 400 cu. ft. per hour as the maximum. We have on hand some 3-in. pipe and fittings; what can we do? Under favorable circumstances we may expect an ejector made of this pipe to deliver from 360 to 720 cu. ft. per hour, according to the rule previously given, so we proceed to make up the ejector, using a $1\frac{1}{2}$ -in. steam pipe and the same size of relief cock. This ejector will then gain rapidly on the water.

Tilting Shaker for Sand Screen

Screening of sand for use in concrete on small jobs is usually accomplished with a small screen held and shaken by hand.



A Fixed Sieve That Hastens the Riddling of Sand on Concrete Work

This process is slow and laborious, and a more expeditious and less tiresome method is to use a fixture of the kind shown in the illustration.

Either a round or square screen is adapted for the fixture, which is made simply by attaching two long handles to one end, and two "legs," which are pivoted to two pieces of 2 by 4-in. stock driven into the ground. Two bolts form the pivots, and make the sieve readily detachable when necessary. The sieve is operated by tilting, which slides the sand from one end to the other while dropping it into a barrow placed underneath.

Prolonging Life of Wooden Well Curbs

Wooden well curbs are used quite extensively in rural districts. If they are air-tight or nearly so, moisture arises during cold weather and causes the curb to mold and rot. One should, therefore, allow the moisture to escape. This can be done by cutting away part of the curb and placing a screen over the opening, or if the curb has a lid, by closing this only loosely. It has been found that with either of these precautions a curb will last longer.—Bunyan Kennedy, McCool, Miss.

Keeping Grease from Auto Brake Bands

Having grease flow out of the differential on the brake bands is objectionable in that it is difficult to clean off, catches all the dirt and dust and may prevent the brakes from functioning properly. This trouble can be remedied by means of spring washers that fit snugly on the axle shaft.

These are caught in the vise, one at a time, and the ends spread so as to form a steep spiral. They are then forced on the axle so that one end of each washer will interlock with the end of the next and form a complete screw extending from the wheel bearing on each side to the differential. It is necessary, of course, to place the washers on the axle in such a manner that the excess grease will be screwed back to the differential housing, and not away from it.—G. G. McVicker, North Bend, Nebr.

Radius-Turning Tool

Most of the tools or attachments for the forming of radii on the lathe are either too cumbersome or too large to handle small diameters, but the tool illustrated is about as small and neat as it is possible to make.

The main body is made from soft steel, of the same size as the usual lathe-tool shank, the front end being forged flat to form the base of the swivel head. The latter combines the pivot, tool-

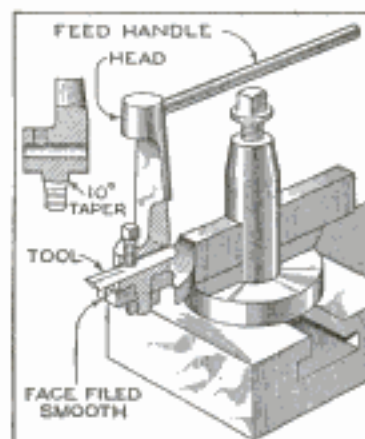

holder, extension-handle holder, setscrews for tightening the tool and pivot stud; the whole thing being worked out of cold-rolled stock. The pivot stud is turned concentric with the tool head while the extension-handle holder is turned eccentric to the whole. A piece of 1/2-in. rod about 14 in. long is screwed into the upper end of the head and serves as a handle for turning the device in an arc. The face of the body is filed off flat and true and the distance this face projects beyond the true center should be marked with stamps. This distance is then subtracted from the radius to be cut and the result will be the distance

the tool must extend beyond the face of the holder. The pivot should be tapered and rest in a taper seat as well as on the flat; a nut will hold the two together at the right tension for easy turning and without chattering.

As will be seen by a reference to the drawing, the top of the tool should pass through the same line as the regulation lathe tool. A tool of this type is a great labor and timesaver as, when removed from the toolpost, the accuracy of the setup remains undisturbed.

Reinforcing Corroded Steel Tower

A 75-ft. steel tower supporting a 20,000-gal. tank at the oil mill of the Lookout Oil and Refining Co. at Corinth, Miss., became so weak from corrosion that a collapse was imminent. The general manager, Mr. M. Reynolds, suggested a plan of repairing the tower that proved perfectly successful, and saved the cost of a new tower.

The four main columns consisted of 7-in. wrought-iron pipe, with cross members of 3½-in. pipe, spaced 12 ft. apart. Wood forms, 15 in. square inside, were built around each column, with projecting forms 12 in. square extending out on the cross members for 18 inches. The forms were finished and the concrete poured in 12-ft. sections, care being taken that the reinforcing iron lapped the points where pouring ceased on each section.

After the concrete had been poured, 10 days were allowed for it to cure, and, when the forms were removed, the columns were found to be perfect, with no evidence of honeycombing. The completed job was found perfectly satisfactory.—H. C. Harrington, Gen. Supt., Chattanooga, Tenn.

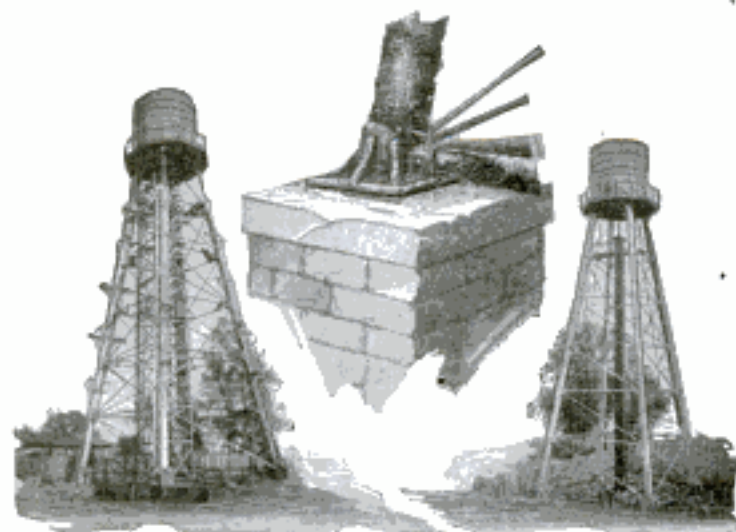

Left, the Forms in Position; Center, a Portion of the Corroded Tower; Right, the Completed Job

Seam Folder for Tin Work

One of the occasional tasks of the sheet-metal worker is to seam together sheets of tin for roofing. Of course, shop equipment can be purchased with which to do

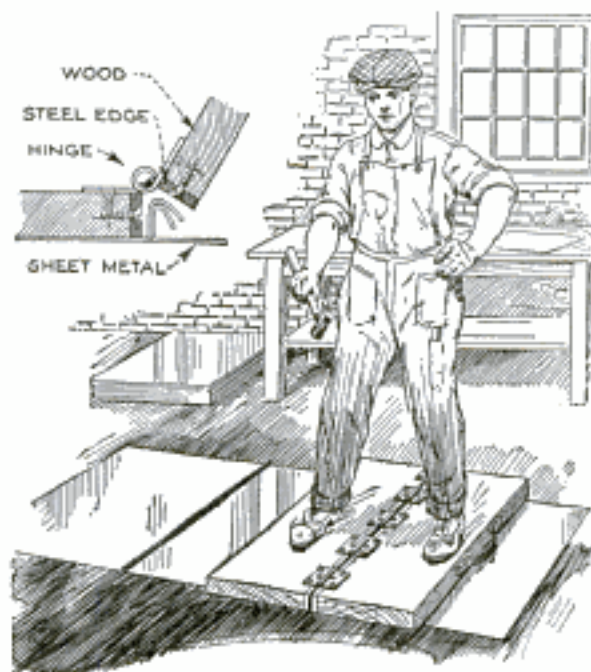

Simple Device Aids Sheet-Metal Workers in Making Seams in Tin Roofing

this work, but the small tinsmith, whose infrequent use for such a device does not justify the expense of purchasing one, will find the rig shown in the drawing just as good for his needs, and its cost is negligible. Two pieces of 1-in. wood of equal size, say, about 10 in. wide and 3 ft. long, are fitted with strips of flat iron on one edge and hinged together with several hinges, fastened to the top. In use, the boards are placed so that the iron edges are over the open seam, as indicated in the detail. Then the boards are pressed down by standing on them, and the seam is ready for soldering. A leather handle is attached to one of the boards, so that the "press" can be moved from seam to seam easily.—G. A. Luers, Washington, D. C.

☞ When a barrel of gasoline is allowed to remain in one position for a long time, it frequently happens that the last few quarts of gasoline contain sufficient water to cause trouble in the engine or stove. The water can be removed by dropping a large cotton cloth into the gas and wringing it out. The cloth absorbs the water.

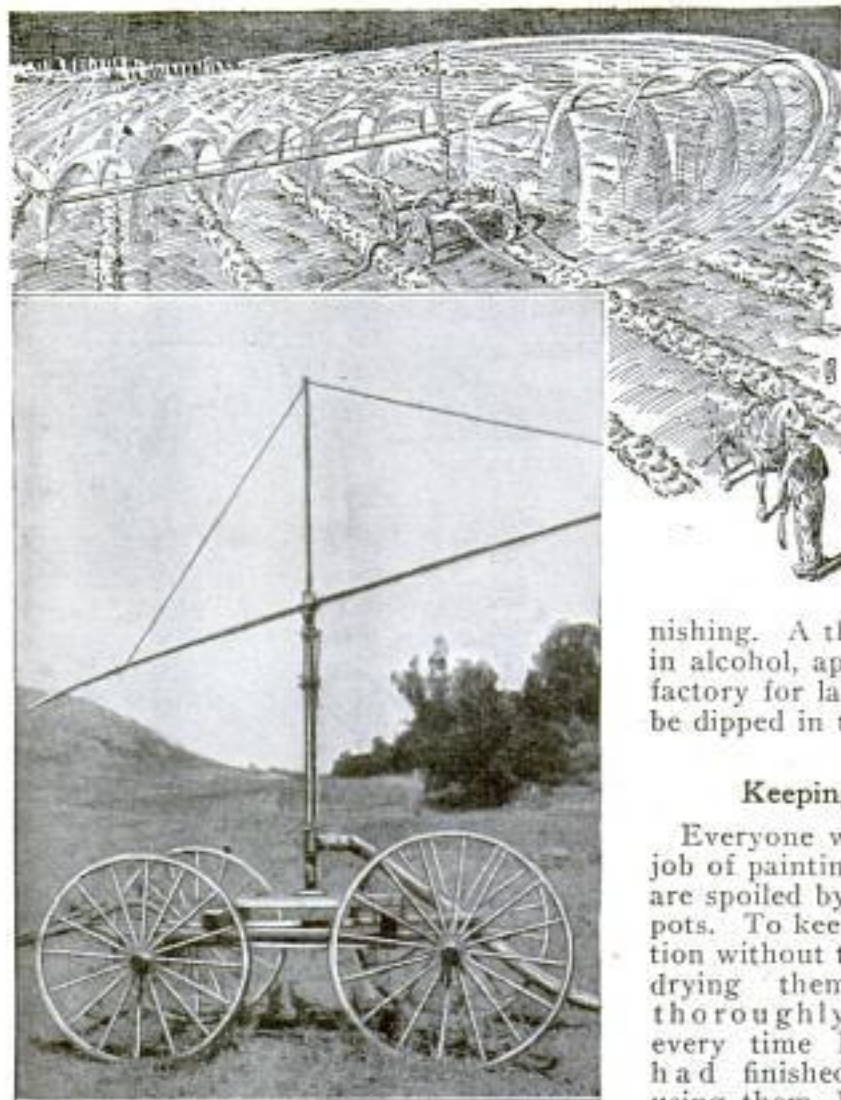

Huge Water Sprinkler Used by California Rancher to Irrigate Land

Huge Homemade Field Sprinkler

A California rancher has improvised a large field sprinkler similar in design to those commonly used on city lawns. It is built upon an old buggy chassis and is made of pipe and fittings picked up on the ranch. The sprinkler arms are 20-ft. lengths of 1-in. iron pipe, giving a spread of 40 ft. and, ordinarily, a reach of 60 ft. The ends of the arms are bent in opposite directions and five small slits are cut with a hacksaw, at regular intervals, into the side of each arm. These slits are, of course, cut on that side of the arm toward which its end is bent, so that the force of the outflowing water causes the pipe to turn. The central support for the arms is made of 2-in. pipe and fittings, and the arms are braced by guy wires from the top of a smaller pipe, as shown. A length of old fire hose is used to connect the sprinkler to the supply pipe from a power-driven pump. Sometimes the wind causes the

water to carry over a radius of 100 ft. The sprinkler is moved by hand or horse four or five times a day, and has proved a real money saver.—Geo. E. Bowers, Escondido, Calif.

Brush Finish for Brass

Brass and similar metals may be given a brush finish by rubbing them with steel wool. Care should be taken that the rubbing is done in one direction, otherwise a scratched surface will result. A lacquer should be applied to prevent tarnishing. A thin solution of white shellac in alcohol, applied with a brush, is satisfactory for large work. Small pieces can be dipped in the solution.

Keeping Paint Brushes Soft

Everyone who has to do an occasional job of painting knows how easily brushes are spoiled by letting them stand in paint pots. To keep my brushes in good condition without the necessity of cleaning and drying them thoroughly every time I had finished using them, I obtained an empty 5-lb. tin can, originally used for carbonate of soda; this can was about 5½ in. in diameter and 10 in. deep. One



inch below the top I punched eight holes in the side and inserted L-shaped lengths of wire, about 2 in. long. These I soldered to the outside, with one end projecting inside of the can to form a hook. Through the handle of each brush I drilled a small hole exactly 5 in. above the bottom end of the bristles so that these would not touch the bottom of the can. After the brushes were hung up in the can enough turpentine was poured in to submerge the bristles and the cover was then put on to prevent evaporation. In this way the brushes were kept in good condition and ready for use at any time.—C. E. Weibezahl, Syracuse, N. Y.

Making Durable Valve Washers

During a number of years as a rail-roader and general repairman I have seen much trouble that was due to faulty washers in valves, and in seeking a remedy, I have found that washers made of lead and new babbitt are both durable and leak-proof. In valves for hot or cold water I use lead alone; for steam valves, a mixture of half lead and half new babbitt. Although lead alone will hold steam, I prefer the half-and-half mixture, as it is more durable. New babbitt is used because old bearings and the like are apt to contain bits of iron and steel.

From a small ladle I pour the molten metal into the washer cup of the valve; then, when the metal is cool, I level up the surface with a file. If the valve leaks when tested, I take it out and file the washer on the side where the marks show that it bears heaviest. In this way one can form a valve washer that will last for months, or even years. If there is no screw to hold the washer, the rim of the cup can be dented slightly at the sides to hold it in place.—Clarence Uplinger, Cincinnati, Ohio.

Hinged Track Section in Barn

In a large western dairy barn, with several grain bins at one end and a double conveyor track running from these bins along two rows of mangers, the track crossed over a driveway without leaving sufficient headroom for a loaded rack to pass under it. The trouble was readily overcome by cutting off the sections of track over the driveway and mounting them on lengths of 4 by 4-in. timbers. These were hinged at one end so that they could be swung entirely out of the way to allow the load to pass. When swung back



Sections of Conveyor Track Cut and Hinged on End to Permit Passage of Loaded Rack

again, the timbers are held in line by heavy cleats.—Dale R. Van Horn, Walton, Nebr.

Getting Rid of Chinch Bugs

Chinch bugs proved to be one of the most costly pests of the corn belt last season. Damage amounting to millions



Dripping Creosote in Furrow to Protect Field from Chinch Bugs; Cyanide Hole in Foreground

of dollars was caused in the migration from wheat fields into corn, sorghum and other "row" crops. The bugs "march afoot" and methods of controlling them have been based on the establishment of barriers to stop them from reaching their objective. At the Kansas state agricultural college various systems were tested last summer, and a combination of creosote and calcium cyanide was found most effective. The creosote was dripped into a furrow along the side of the field to be protected, and every few feet along the furrow holes were dug in which flakes of calcium cyanide were deposited. Unable to cross the creosote line, the bugs crawled along it until they reached a cyanide deposit and were killed by the deadly and low-lying gas given off by that substance. Barriers of calcium cyanide, without creosote, were found ineffective.

"Working Model" Aids Drawing Students

Drawing instructors often find it difficult to explain to their students how three different views of a model or other subject

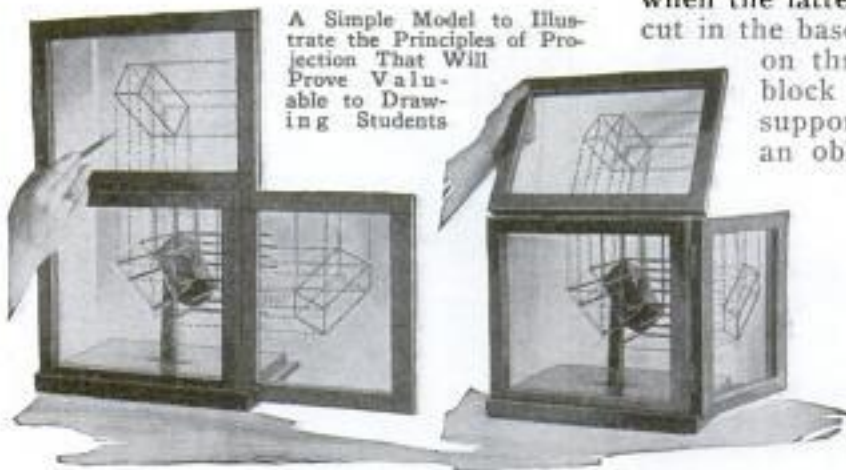

are projected on paper. The model shown in the illustration makes the task easy and the students are enabled to grasp the principles of projection very quickly.

The model consists of a substantial wooden base, about 13 in. long and 10 in.



wide, to one side of which is fastened a frame holding a sheet of glass. The frame is about 12 in. high, and to one side and the top two similar frames are hinged, the top one folding down against the side one when the latter is brought against a step cut in the base, thus inclosing the object on three sides. The object is a block 2 in. square and 4 in. long, supported on a wooden pillar at an oblique angle to each of the

three frames or planes of projection. The projection lines are represented by small brass rods, three of which are fastened to each corner of the block at right angles to each other, and running to the three glass planes. On each plane is drawn an accurate projection of

the block by simply joining the points represented by the ends of the rods behind the glass, and dotted lines running from these points to the edges of each plane show clearly how one view is projected from the other.

The swinging of the frames into one plane puts the drawings in the final position required on a flat sheet. This makes it perfectly simple to explain how the object is "swung" in the mind's eye to obtain three different views on the drawing paper. —Sherwin M. Turrill, Maywood, Ill.

A Simple Recessing Tool

An easy way to make a tool suitable for recessing caps, shouldered nuts, and the like, in the hand screw machine is shown in the drawing. The tool is made in two pieces, the shank and toolholder proper, the former being turned to fit the turret and the front end slotted across. The toolholder is milled across both sides, leaving a flat portion which fits the slot in the shank. The front is bored out to take the recessing tool and drilled at one side for a pin. The toolholder can be held to the shank by a screw

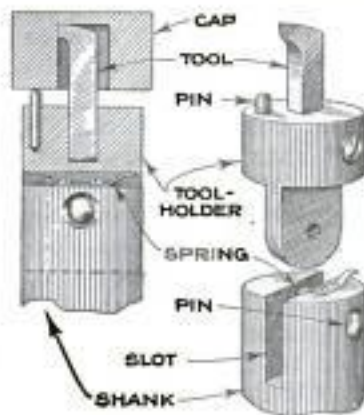

or taper pin, as desired, provided that it is allowed freedom to move in the slot. A flat spring, bent upward at each end, and fastened to the shank with two small screws, serves to keep the tool from flopping about. It can be seen that when the pin driven into the face of the toolholder reaches the face of the work it causes the tool to feed inward and thus cut the recess. It is important when setting a tool of this character to note that the tool travels a little in a direction parallel to the bore of the work after the pin touches the face of the piece. Consequently the tool should be set so that it is a trifle away from the back face of the work when the pin touches the front face. When the tool has reached the desired depth of cut it will have traveled in a slight arc and should finish the cut touching the back face.

Small articles, such as nuts and screws, that have fallen into some inaccessible place can often be picked up by means of chewing gum stuck on the end of a stick.

Getting the Most Out of the Grinder

By G. A. LUERS

MANY owners of bench hand-driven emery grinders get little out of them beyond the grinding of chisels, scrapers and an occasional screwdriver or other tool. A few men, on the other hand, with a little ingenuity, accomplish real work with them, and get the utmost in service out of the high-speed little tools. In the small shop or garage, where space is at a premium, and where the purchase of even one additional tool means a hardship at times, the hand grinder may be made into a machine of numerous uses and undoubted value.

The first thing to be done to increase its usefulness is to fit it with some kind of a foot treadle, so as to leave both hands

free to handle the work. This may be done in a variety of ways, none of which are shown, as the job is a simple one for any mechanic, and depends, to some extent, on the location of the grinder. With the treadle in place, much work can be done that would be impossible without it.

A common round wire scratch brush, fitted in place of the grinding wheel, permits the tool to be used for such work as roughening tire casings and tubes for patching. Anyone who has attempted to hold a heavy casing open while scratch brushing the inside for a patch will appreciate the saving made in time and temper by the use of the little machine. The scratch brush will also serve for free-

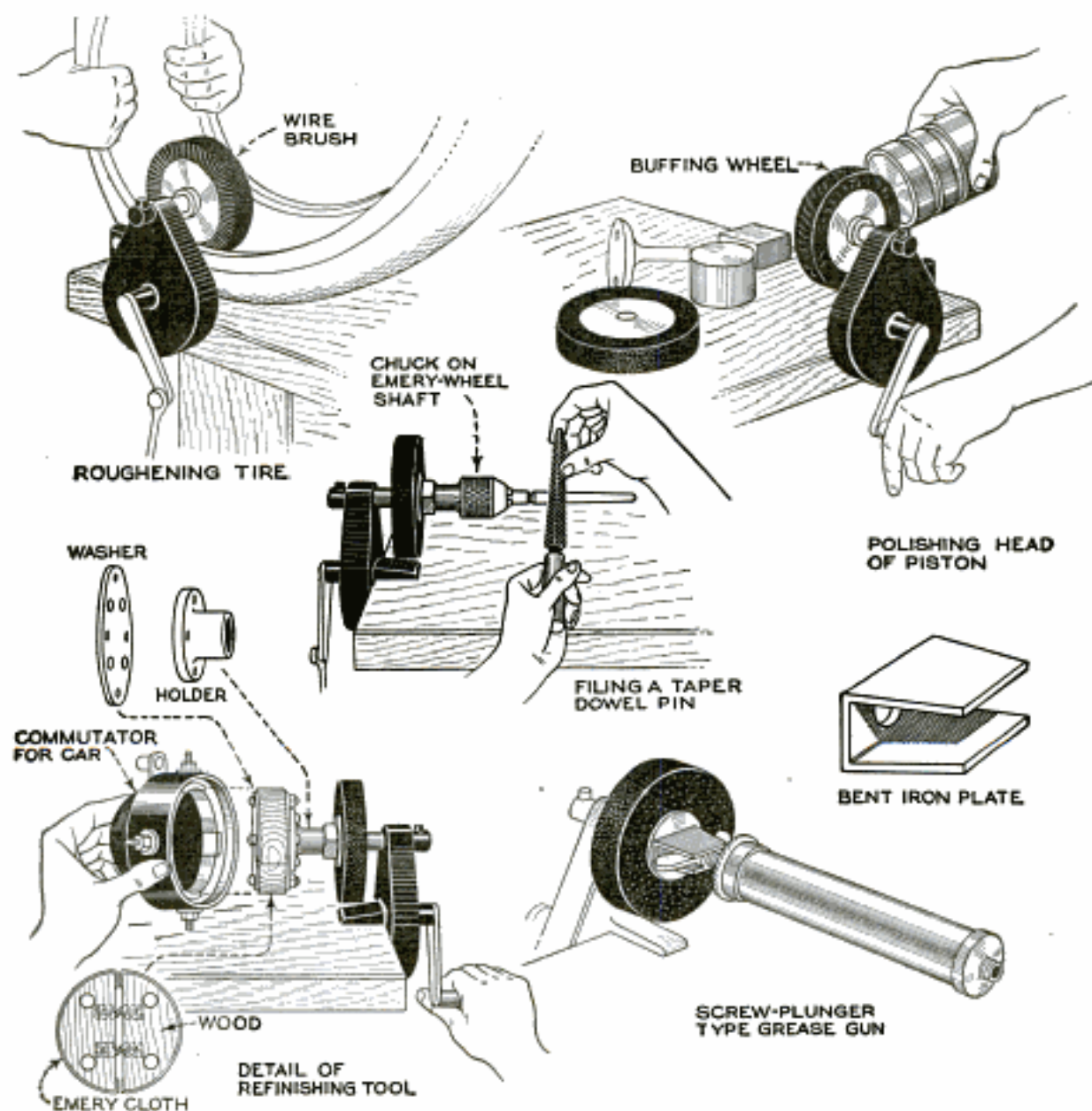

A Few Fixtures That Increase Greatly the Utility and Value of the Neglected Hand Emery Grinder, and That Save Time and Dollars in the Small Shop

Finding Loose Wristpins

A wristpin may be loose enough to knock and yet, when examined, no perceptible play may be found in it. In such a case the connecting rod should be held in a vise and the piston rocked up and down in the plane of the wristpin. If an oil film comes and goes between the pin and its bushing the pin is too loose, and new pins and bushings must be fitted. The old bushings may be reamed out and oversize pins fitted, if desired.—H. F. Blanchard, Tuckahoe, N. Y.

Auxiliary Wheels for Barrow

For certain purposes, such as sweeping cuttings from the floors of shops, and similar work, a pair of small auxiliary wheels added to the shop wheelbarrow will prove very practical.

This arrangement enables the worker to slide the barrow from machine to machine as desired, with the ease of moving a three or four-wheel truck, yet when the barrow is full, it may be lifted and rolled away in the usual manner to the yard, or through passageways where it would be impossible to handle the ordinary truck. A push moves the barrow several feet,



Small Auxiliary Wheels Added to the Barrow Lighten the Labor of Sweeping the Shop

while without the small wheels the handles must be lifted to move it.

156. In.
 A non-magnetic cast iron is being produced by a concern in England.

*Ferrante, Ltd.
 14 Colliwood Lane
 Eng.*

Tying Bundles of Wall Paper

In order to tie up bundles of wall paper quickly and conveniently, a dealer provided the novel holder shown in the photo and drawing. It is made of wood and has four arms extending from the top. Rolls of



Convenient Holder Facilitates Tying Up Rolls of Wall Paper

wall paper are placed in the space between these arms, and it is then an easy matter to tie a cord around the rolls and make a bundle. This method was found much better than the usual one of holding the rolls while attempting to tie them up.—Charles A. Goddard, Los Angeles, Calif.

Testing Fit of Rod Bearings

When adjusting a connecting-rod bearing (with the engine in the car), the simplest way to determine when the bearing is just tight enough is as follows: Remove shims or file the cap until the rod is just too tight to be moved lengthwise by hand, but not too tight to be shifted slightly by tapping with the hammer.

Repairing Leaky Spark Plugs

Spark plugs having a removable center wire sometimes leak compression at this point. Often the reason is that the insulator has chipped away where the flange on the wire seats against it. This trouble can usually be remedied by slipping a thin brass washer, of the same kind as that used on top of the plug, over the center wire and drawing it up against the porcelain. As such washers are too large for this use, they must first be trimmed down with tinner's snips.—E. T. Gunderson, Jr., Humboldt, Iowa.

An Efficient Film-Drying Cabinet

The film-drying cabinet shown in the illustration was cheaply constructed, and a similar one can easily be made by anyone handy with tools. It will hold over 100

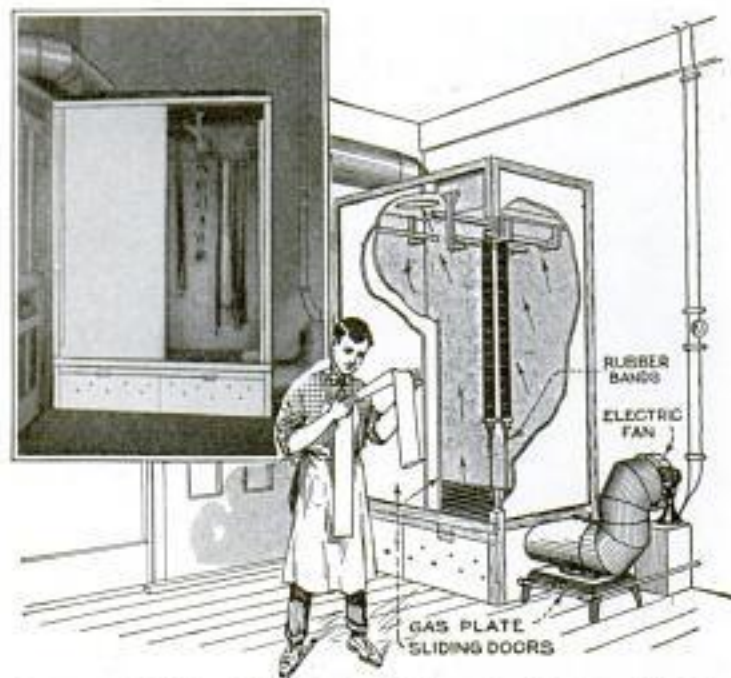

Cheap and Efficient Film-Drying Cabinet for Professional Photo Finishers That Hastens the Work

rolls of film, and will dry them in from 30 minutes to one hour.

The cabinet is made of wallboard, which can be obtained from any builders' supply house, nailed to a stout wood frame. Racks, made of 1 by 1-in. wood, are fastened to the top to hold the upper end of the films, and about 1 ft. from the floor a number of wood strips are nailed across

the cabinet to hold the bottom ends. Holes are cut in the top and bottom of the cabinet, as shown in the drawing, to receive the ends of lengths of stovepipe. The upper pipe is led outdoors, and the bottom one is connected by means of a couple of elbows to an electric fan. A gas plate is set below the bottom pipe, a little away from the cabinet, to heat the air as it passes through. The upper ends of the films may be attached to the cross strips by means of thumbtacks, or the strips may be provided with nails on which to hang regular film clips. A number of film clips, each pair of which is joined with a stout rubber band, are provided to hold the bottom ends of the films. One clip is fastened to the bottom of the roll and the other to one of the lower cross strips. As an alternative, the bottom strips may have nails part way driven into them also, and the ends of the rubber bands be hooked over the heads of the nails. It will be found desirable to provide bands of varying lengths, to take care of different films.

It will be noted in the drawing that the front of the cabinet bottom is hinged to form a door. This is convenient for removing the dust that accumulates in the bottom. The wallboard front of the cabinet is made in two sections arranged to slide in the frame. This construction has been found better than doors opening outward, as it saves considerable space and eliminates the necessity for catches on the doors.—H. C. Graves, Watertown, N. Y.

Riveting Disks to Hubs

When attaching a disk to a hub on small work the common practice is to make the hub long enough to project through the disk, which has been beveled, and then hammer the hub so that the metal spreads and holds the disk more or less tightly as shown in Fig. 1. This method has the disadvantage that the disk has a tendency to run out of true due to uneven riveting.

A better method is shown in Fig. 2. The hub is made with a cup edge and the disk is given a wide bevel. A tubular tool is turned up to the shape shown, hardened, polished, and revolved in a drill press so that when it is brought down on the hub it curls the metal out and forces it down into the bevel, and finally burnishes it neatly.

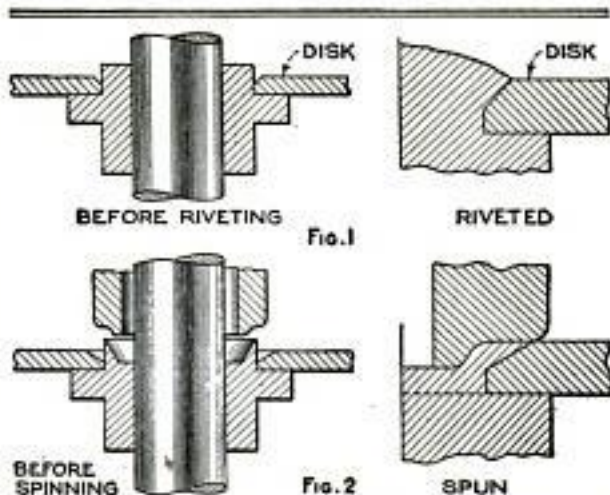

Common and Improved Method of Attaching a Disk to a Hub

Celluloid Keeps Report Sheets Clean

Anyone working in a shop where it is impossible to keep the hands clean, knows how difficult it is to keep report and record books clean if the workmen have to make entries in them. However, the difficulty is easily overcome by keeping a few sheets of thin celluloid handy on the shop desk (old photo negatives about post-card size, with the emulsion cleaned off, will do nicely). When a workman has to do some writing he lays one of these on the paper where his hand rests, and as he writes, the piece of celluloid will slide over the paper with the hand.

Spring Clip for Tank-Wagon Gasoline Hose

When required to make some kind of holder to keep the gasoline hose from coming off a tank wagon or damaging the paint, the writer devised the clip shown in the drawing, which has been in operation for some time and has proved very satisfactory. It is simple to make, instantaneous in action, and is much better than straps.

The clip itself is made of the heavy galvanized strap which comes around bundles of sheet metal; this material is good mild steel. A $\frac{1}{2}$ -in. bolt 7 or 8 in. long, with two nuts, and a light coil spring with a washer and cotter pin are the materials required for each clip, in addition to the steel. The method of mounting the clip is clearly shown in the drawing.—B. E. Dobree, Victoria, B. C., Can.

Motorcycle Wheel Improves Wheelbarrow

An ordinary wheelbarrow is difficult to handle in soft dirt or sand because the wheel sinks down into the soil, sometimes so deeply that it is almost impossible to

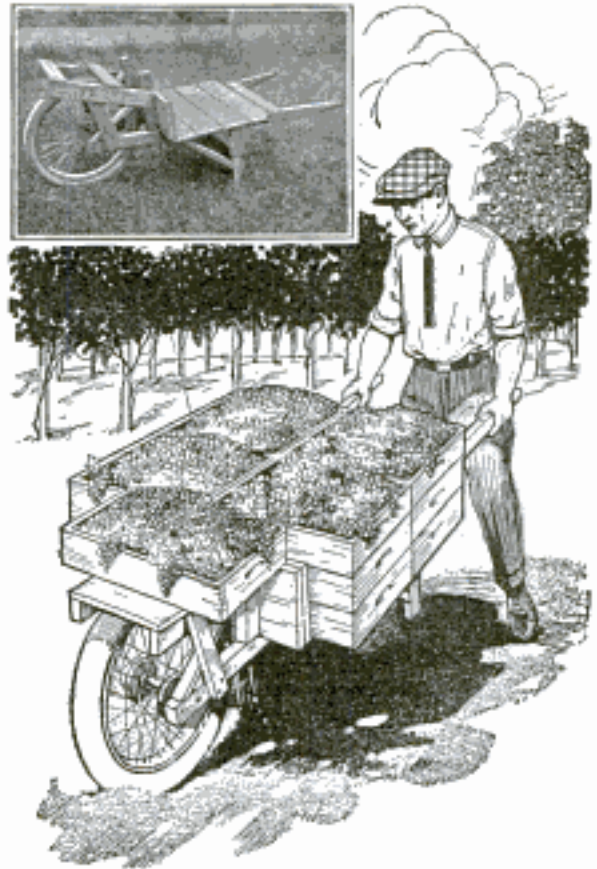

Pushing Heavily Loaded Wheelbarrow over Loose Sand Is Facilitated by Use of Motorcycle Wheel

push it, especially under a heavy load. An Oregon farmer, who experienced this trouble in transporting grapes from his vineyard, fitted a wheelbarrow with a motorcycle wheel. The tire is partly inflated and will not sink deeply into the sand, even when the barrow is loaded to its full capacity.—Ed. Fraser, Ashland, Oregon.

Cutting Slots in Small Rods

Cutting slots in small rods is usually quite a difficult task. However, a simple method of doing it is shown in the illustration. The rod is first bent sharply at the point where the slot is to be cut and is then inserted in a vise, as indicated, so that a hacksaw can be used to cut the slot. After the slot has been cut the rod is straightened.

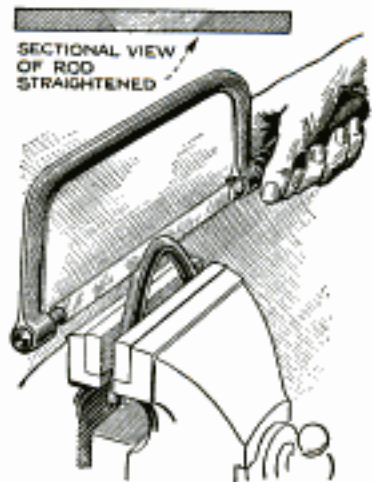

Homemade Swing Cut-Off Saw

By D. R. VAN HORN

THE swing cut-off saw is a very handy addition to the woodworking shop, and the making of one is no very hard or expensive undertaking, as the saw in the illustration shows. This saw was made from scrap, with the exception of the saw and its bearings, and the motor, which was

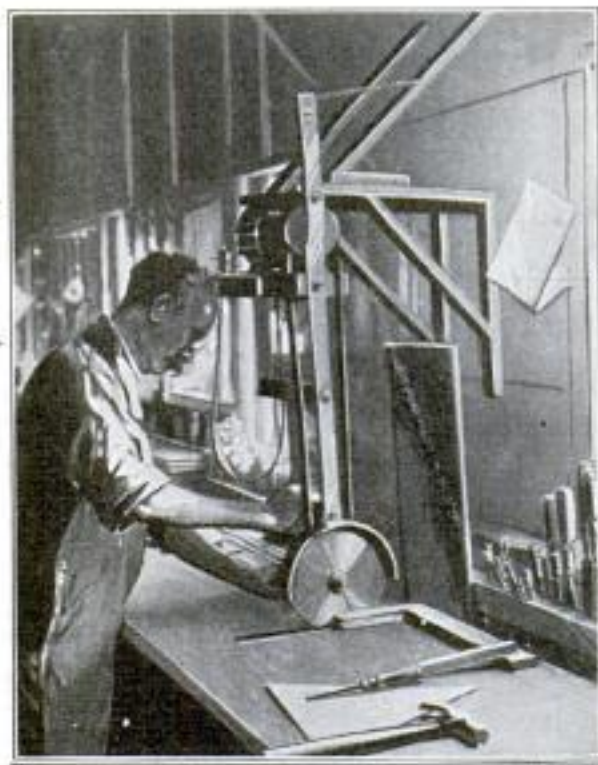

A Swing Cut-Off Saw That Is Very Simple to Build and That Will Give Just as Good Service as the Most Elaborate Commercial Saw

purchased from a secondhand dealer. The whole saw is self-contained and is so nicely balanced that a touch is sufficient to move it against the work. The saw guard makes it safe to operate, and a convenient switch permits it to be started and stopped instantly. The construction of the wall hanger is simple. Two triangular brackets, of 1 by 4-in. stock, are firmly fastened to the wall at the proper height and braced as shown in the drawing. If desired, the hanger may consist of a piece of 2 by 8-in. stock, with the braces and back members of 1 by 4-in. stuff, thus making the top of the brackets solid instead of open. To the sides of the hanger two flat side irons, one 26 in. and the other 55 in. long, are bolted, the holes for the bolts being drilled so that the irons will swing freely but without sideplay. Part of the longer iron extends above the hanger and is drilled at the top to take a strong

spring, the other end of which is fastened to one of the top braces. Between the irons the motor support, of 2½ by 8-in. stock, is fastened by means of angle irons bolted to the support and side irons. At the end of the 26-in. piece a 2 by 2-in. brace is bolted, the bolt running through the end of a 19-in. piece of flat iron, which completes the lower end of the frame.

This end carries the saw, which runs in bronze bushings salvaged from an old automobile. A 2 by 2-in. brace is bolted across the lower frame irons above the saw, and the saw spindle is fitted with a 2-in. pulley. The motor is fitted with a 4½-in. built-up wooden pulley, and the saw

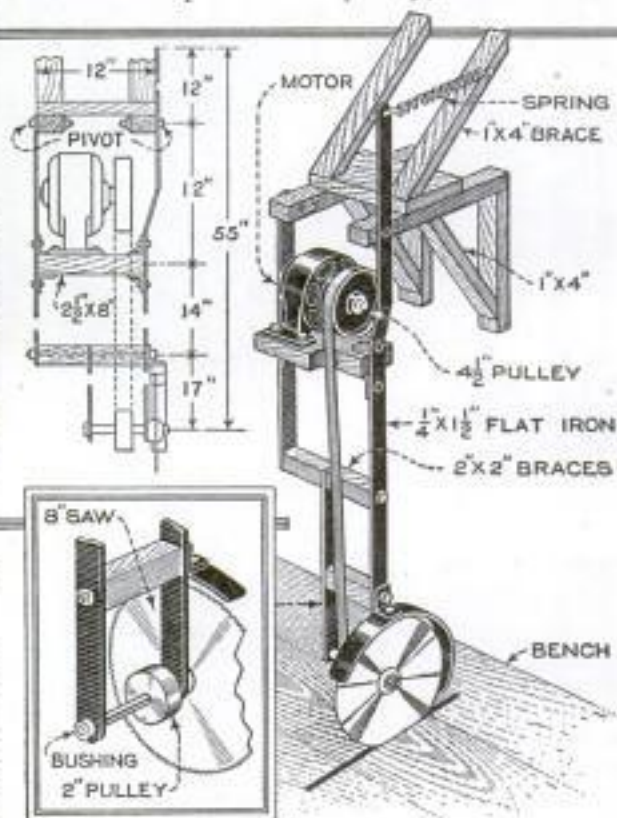

with a heavy sheet-steel guard, riveted to a small angle, which is held by the bolt that fastens the lower 2 by 2-in. brace. The 8-in. saw will handle up to 2-in. stuff and is run at 3,000 r.p.m.

It may be seen from this that the construction is exceedingly simple and inexpensive. The costliest part of the outfit is the ½-hp. motor, and even this may be picked up secondhand for very little money.

☛ A good rule to follow when grinding milling cutters is to allow 7° clearance for roughing and 5° for finishing cutters.

Breaking Up Old Concrete Pavement

When breaking up an old concrete pavement on the main street in Scottville, Mich., dynamite could not, of course, be used, owing to the proximity of the store windows on both sides of the street, so the method shown in the photo was tried and found successful. A strong chain with a hook was hitched to a powerful caterpillar tractor, the hook being placed under the edge of the pavement and a block of wood put under the chain to make the hook pull upward when the tractor moved forward. Each "bite" of concrete was several square yards in area.—M. M. VanValkenburgh, Cadillac, Mich.



Breaking Up Old Concrete Pavement with Aid of Powerful Tractor and Hook

Drawer Foils Petty Thieves

Garage men and other mechanics, who are employed in shops where the public is free to enter, are often inconvenienced by the loss of small tools and personal articles. To keep these in a locked drawer is too inconvenient and therefore the arrangement shown in the illustration was devised by one mechanic.

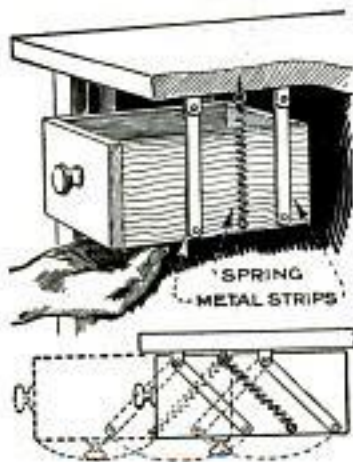

An ordinary drawer is provided with a knob on the front in the usual way and another knob on the underside, the former being merely a "dummy," while the latter is actually used to open the drawer. Two lengths of 1 by 1/8-in. flat iron are hinged to the underside of the bench top on either side of the drawer, the lower ends being fastened to the drawer with flat-head screws. A stout coil spring is also attached to the drawer and the underside of the bench top as shown; it should have enough tension to keep the drawer and its contents in the position indicated in the lower de-

tail so that a straight pull on the front knob will not open the drawer. It can, however, easily be opened by pulling downward and forward on the hidden knob underneath. A keyhole in the front of the drawer will add to the deception and lead the petty thief to believe that the drawer is locked.

Attaching Carpet to Concrete Floor

Attaching a carpet to a concrete floor is rather difficult because nails or tacks cannot be driven into the concrete. It can easily be done in the following way, which, however, requires the use of padding under the carpet: Drill holes in the concrete along the edge of the wall about 1 ft. apart, and plug these with hardwood. A tapered wooden strip of approximately the same thickness as the padding is run along the edge of the room, being screwed to the wooden plugs. The padding is then laid on the floor, and the carpet stretched over it and tacked to the strip.



When no resin is at hand, a glazed and slipping belt can be made to grip by throwing a handful of ashes on it.

A Novel Ratchet Screwdriver

In tightening screws set in the ends of square-section pieces not furnished with a through hole, use was made of the novel

ratchet screwdriver shown in the illustration. It was made by bending a length of $\frac{1}{4}$ -in. rod to clear the end of the work and flattening one end.

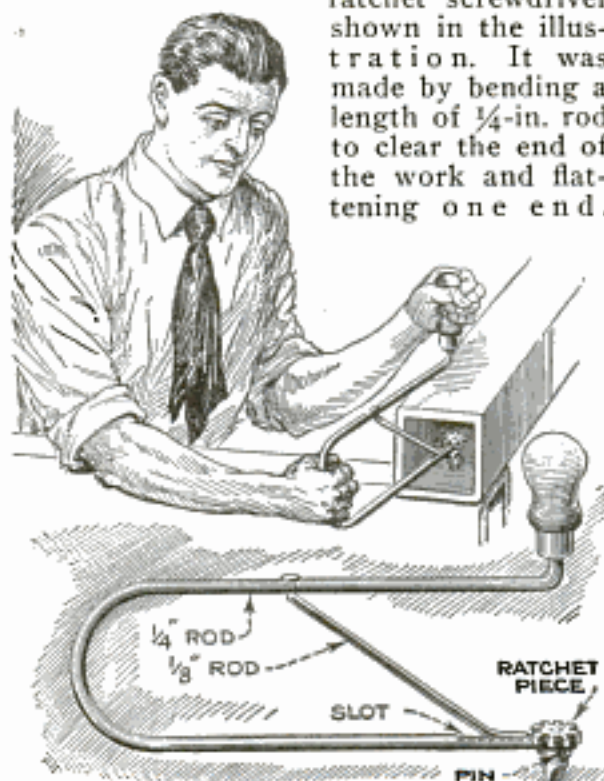

Novel Ratchet Screwdriver Used to Drive Screws Hard to Reach with the Ordinary Type

The flattened part was drilled to take a ratchet piece, slotted in the usual manner and held in place by means of a pin. A groove is cut in the top of the rod and a piece of $\frac{1}{8}$ -in. wire, attached to the top of the rod, slides in this. The ratchet action is simple; the operator presses on the handle to cause the wire to engage with one of the grooves of the ratchet. The screw is driven in by moving the rod with the other hand. To turn the rod back, the pressure on the handle is released and the wire slides out of the ratchet slot.

Making and Using Small Cone Bearings

Cone bearings are ideal for small model work for the reason that they are adjustable for wear, and for smooth-running models, a nice snug bearing, without shake, is desired. Cone bearings are also used in preference to straight bearings, as it is almost impossible to make a small bearing accurate in alignment and so that it will not wear large in a short time. The split bearing is also less desirable in model work as it makes for difficult construction.

The first type of cone bearing shown in the drawing, and the simplest, is one with a cone turned on the end having the hardest wear, such as the crank end of a small crankshaft. This bearing has a take-up collar setscrewed to the shaft, which is used to hold the latter in a proper adjustment. A solid rear bearing is used for this type. The space between the two bearings forms an ideal oil chamber which adds to their life.

The second style is of the double-cone type and has a cone turned on the shaft at one end and carries a loose or sliding cone on the opposite end. The sliding cone is setscrewed to the shaft, the screw resting on the slanting flat which prevents the cone from shifting backward when adjusted in place. This is a very good design of bearing, as wear can always be taken up on both bearings alike. Such a bearing is suitable for high-speed and precision work on such machines as small internal grinders and the like.

The third type is known as the cone-type lathe spindle. A cone having two tapers is turned on the chuck end of the spindle. The shallow taper is 15° and the steep taper or thrust angle is turned at an angle of 45° . As most thrusts are endwise on a lathe spindle, a light fiber washer and adjusting collar are provided to keep the bearing tight. The bushing of the other bearing is a taper fit in the frame of the machine and, being split, is adjustable for tightness by advancing it forward into the taper hole. This type of bearing is only found in the most accurate and ex-

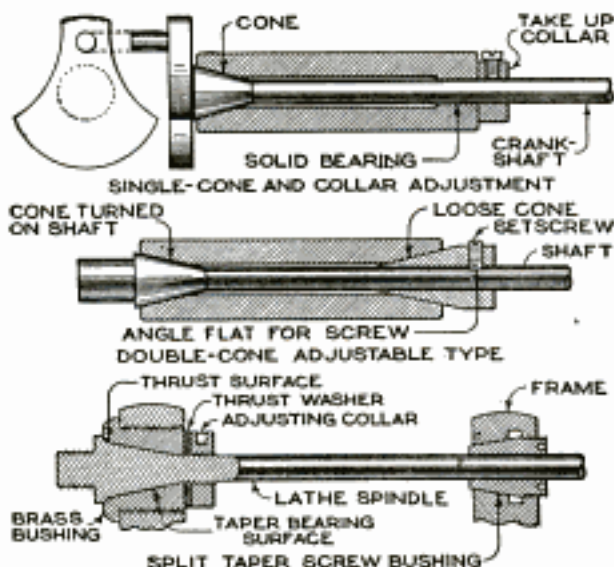

Three Types of Cone Bearings for Model Machinery of Different Types

pensive lathes and is used to best advantage on small precision machinery.

Prize Offers and Announcements

\$50—Snare for Live Fowls

In transferring live chickens from one coop to another, occasionally one or more will escape, making it necessary to be run down and caught, requiring at times considerable effort. We are now using a small wire "V"-shaped hook attached to a long wooden handle which is not very practical. We will pay the sum of \$50 for a method accepted by us, or a satisfactory designed hook, which will enable a person easily to catch the fowl around the legs or otherwise. Address Security Produce Company, 209 West South Water Street, Chicago, Illinois.

\$50—Profitable Uses for Eggshells

In our egg-breaking plant where several cars of eggs are broken each day for canning purposes, there is a large by-product of eggshells. While these have been used heretofore for chicken feed, we will pay the sum of \$50 for a satisfactory plan, process or method of otherwise profitably disposing of these eggshells. All entries for both the offers are to be judged by this concern alone, and the date of closing for each is May 1, 1925. Address Security Produce Company, 209 West South Water Street, Chicago, Illinois.

\$1,000—Cost Reduction

This concern makes the Kirstin Fil-Gage for filling Ford automobile gasoline tanks under the seat without need of removing the cushions. It has an indicating gauge in plain sight of the driver at all times and is attached to the tank opening in place of the cap. The Fil-Gage is made of black-finished sheet metal. Our factory operates in large production, and for any accepted improvements not yet tried out or developed which will increase the efficiency of this filler and gauge and decrease manufacturing costs, we will pay the sum of \$1,000. Or, we will pay this amount for any suggested changes satisfactory to us which will reduce the production cost 20 cents on each article. No theoretical suggestions will be considered. To qualify, entrants must have actually tried their improvements in operation on one of the devices and have proved it practical and workable. The Fil-Gage containing the improvement must be sent to us by registered mail for testing and upon acceptance and the assigning to us of patentable rights, we shall pay the amount stated to the entrant whose ideas we adopt. This offer expires May 1, 1925. Address, A. J. Kirstin, General Manager, A. J. Kirstin Company, Kirstin Bldg., Escanaba, Michigan.

\$1,000—Improvements to Lathes

In four awards of \$500, \$250, \$150 and \$100. These awards will be paid for the four best ideas for new and practical attachments for a screw-cutting engine lathe. The mechanical application and the idea must, of course, be heretofore untried and original and may consist of a distinct improvement on an attach-

ment now in use or a direct improvement on any part of a screw-cutting engine lathe. Value and merit of improvements or suggestions will govern the order in which the allotments of the four awards will be made. The offer expires May 1, 1925. Address all suggestions to South Bend Lathe Works, 423 East Madison Street, South Bend, Indiana.

\$50—Formula for Writing Ink

If it is possible to improve the quality of their Tar Black ink, the Hunt Pen Company, makers of Speed-ball lettering pens and inks, will pay the sum of \$50.00 for such a formula, provided the ink meets the following requirements to the satisfaction of the company. It must be jet-black and must dry moderately quickly with a slight reddish tinge, as this is desirable for reproduction purposes. It must be waterproof, must flow freely and still be dense enough to cover opaque when thinned out in the larger-sized pens. If the formula can be made to include colored inks, it will be more desirable. Address C. Howard Hunt Pen Company, Camden, New Jersey. This offer expires May 1, 1925.

\$500—Bait for Rat Poison

We have perfected and patented a new chemical composition based on cyanide, the smallest particle of which in a rat's stomach will cause the animal's instant death. By the use of this poison rats die within a foot or two of where they eat it. We desire to market this poison already prepared, so that the user has simply to spread the poisoned bait in infested areas. The bait should be a neutral one, that is, neither acid nor alkaline, and of such a nature that it can be manufactured in small particles about the size of a grain of wheat, so that the rat will be tempted to eat them where he finds them instead of carrying them away. What is required is a bait, filler, or carrier which will have either an odor or food appeal sufficient to impel rats to eat it, even in the presence of other food. It should be a bait or food which rats will prefer to any other that would ordinarily be available. For a satisfactory formula, or bait combination for the poison that passes our tests, this concern will pay the sum of \$500 in cash. This offer is good for one year from November 1, 1924. Address American Chemical Works, 720 Washington Avenue, Minneapolis, Minnesota.

\$300—Hand-Printing Press

The sum of \$300 in cash and royalties will be paid for a satisfactory design and drawings of a simple self-inking hand-operated printing press by this donor. The press should be six by nine inches in size and one which can be manufactured from cast iron at a cost not exceeding \$25.00. All designs submitted must of course meet the requirements of the donor before being considered for adoption. Address all matter to C. L. Whitfield, 429 East Bute Street, Norfolk, Virginia. May 1, 1925, is the closing date for this offer.

OFFERS ANNOUNCED IN PREVIOUS ISSUES

All of These Offers Expire May 1, 1925

ROYALTIES OF \$5,000 WILL BE PAID within the first year for method of animated drawings by which yachts and boats can be illustrated to prospective purchasers. Problem NA-1. *E. Weston, 3033 E. 1st Ave., New York*

\$1,000 WILL BE PAID BY THE HAPPINESS Candy Stores, Inc., for a method of manufacturing chocolate coating which will not turn gray or dull when exposed to atmospheric conditions. *2 Harvard St., New York*

\$10,000 IN RETURNS FROM SALES IS ALSO offered by the National Company for a highly efficient fixed radio condenser of small size and large capacity. *Cambridge 39, Mass.*

A PIECE OF NEW MERCHANDISE THAT could be sold through optical, photographic and sporting goods stores is desired by Wollensak Optical Co., who will pay royalties of \$5,000 for accepted article. *1415 Clinton Ave., Rochester, N.Y.*

FOR PROCESS OF MAKING HARD-GLOSSED candies without impairing their appearance or quality the Happiness Candy Stores, Inc., will pay the sum of \$1,000. *302 Harvard Ave., 2nd Fl., New York*

THE NATIONAL COMPANY, INC., OFFER \$10,000 in percentages from sales for a new radio static or interference eliminator. *Cambridge 39, Mass.*

CONTINENTAL CAR COMPANY OFFERS \$5,000 in royalties for hoist for dump bodies operated by motor vehicle from driver's seat with power from engine; \$1,000 under like arrangement for new toy or article of household furniture to be made from lumber scraps of truck bodies. Also \$5,000 in royalty arrangement for air-dumping device to be controlled from locomotive by engineer. *Louisville Ky.*

FOR A NEW METHOD WHEREBY SCRAP leather in a glove factory can be profitably disposed of, Eisendrath Glove Company will pay sum of \$5,000.

2001 Elston Ave., Chicago

NATIONAL SLATE ASSOCIATION WILL pay \$200 for best suggested new use for slate; other accepted suggestions paid for in proportion to value.

761 Forest St., Phila., Pa.

WILLIAM H. MITCHELL COMPANY WILL pay \$500 for three new uses suggested for low-voltage generators which they adopt as part of sales plan.

Troy, O.

FOR AN ANTI-FREEZING INGREDIENT FOR an emulsified asphaltic concrete, S. D. Holzheimer will pay the sum of \$500.

Jay's Little Bldg. Phila., Pa.

GRANITE STATE MOWING MACHINE COMPANY offers \$500 in cash and royalties for satisfactory working drawings for gasoline-motor lawn mower they accept for manufacture and marketing.

Airedale, N.H.

NATIONAL BRASS COMPANY WILL PAY \$300 for design of key guide that can be made of sheet metal and which will properly fit escutcheon plate of similar material.

Grand Rapids, Mich.

FOR A PRACTICAL INEXPENSIVE MEANS by which carbonization can be prevented in portable oil burners of vaporizing type, Aeroil Burner Company will pay \$500.

266 Hudson Ave. Union Hill, N.J.

THE YELLOW CAB MANUFACTURING company offers an award of \$50,000 for a perfected plan of traffic and pedestrian correction and regulation, including mechanical devices, regulations, etc., for the promotion of greater street safety.

5501 N. Dickens St., Chicago

\$10,000 FOR A NEW MUSICAL INSTRUMENT which can be incorporated in any orchestra or brass band and will take a place among the present family of musical instruments accepted by the rank of players.

Lyon & Healy, Inc., Chicago

ELECTRIC HEATING ELEMENT WHICH will operate and interchange with base and cover of Imperial self-heating gasoline iron, \$500. Imperial Brass Company, 1200 N. Harrison St., Chicago

DISCOVERY OF NEW USES FOR CARBON-dioxide gas or improvements to present uses. Award \$1,000.

3100 S. Kedzie Ave. Chicago

FOR AN AUTOMATIC FREEZEPROOF SODA cooler adaptable to "iceless" type of soda fountains, \$1,000. Above two problems by Liquid Carbonic Company.

\$2,000 WILL BE PAID IN SEVERAL AWARDS for processes and machines for salvaging waste lumber. National Lumber Manufacturers' Association.

Washington, D.C.

FOR SKYROCKET STICK HARMLESS IN descent, \$1,000; bombshell with illuminated flag, \$250; chemical combinations to produce smokeless fireworks colors, \$250. Thearle-Duffield Fireworks Company.

624 S. Mack Ave. Chicago

MOTOR-OPERATED HANDSAW FOR MANUFACTURE and sales; award, \$10,000 in royalties.

R. L. Barker and Company, 642 W. Washington St., Chicago

\$500 FOR SALES PROMOTION PLAN FOR absorbent, non-heat-conducting powder that can be used with other materials. The Keasby and Mattison Company, Amaler, Pa.

ROYALTIES OF \$15,000 WILL BE PAID BY the Aetna Industries, Incorporated, for improvements in their products or new articles they accept for manufacture and sales.

17 N. Dearborn St. Chicago

THE GEMCO MANUFACTURING COMPANY will pay \$250 for suitable article they can make in their general metal-working plant.

Milwaukee, Wis.

FOR THE BEST SUGGESTED IMPROVEMENT on a gasoline-heated blowtorch and soldering and branding iron combined an award of \$500 will be paid by the Everhot Manufacturing Company.

Maywood, Ill.

AWARDS OF \$500 EACH WILL BE PAID for a waterproofing process for a library paste and a method that will produce increased sales of this product.

John J. Harris and Company, 4038 W. Kenzie Chicago

\$2,000 WILL BE PAID BY THE NORTH Shore Food Products Company for a method of processing or preserving cottage cheese to keep it fresh for at least two weeks.

112 So. Morgan, Chicago

THE CARR FASTENER COMPANY WILL pay \$500 for a reservoir grease cup which can be filled with a grease gun and feed out the grease at a slow rate.

Cambridge Mass.

FOR NEW WAYS OF USING BUTTON molds \$500 will be paid by donor in Problem HA-1, and the same concern will pay \$500 for new uses for button-mold machines as stated in Problem HA-2.

C. W. Reed Roland, Nebraska Co. Mo.

A SLOGAN AND SALES PLAN IS WANTED by the Casmine Company for a medicinal ointment. They will pay the sum of \$250 for those accepted.

6 E. 12th St. N.Y.C.

TO THE PERSON SUBMITTING TO THEM an article which they can make in their machine and electrical shop, the Guyan Machine Shops will pay \$250 over and above its royalties or sales price.

1307 787 Joan, Va.

THE BENJAMIN ELECTRIC MFG. COMPANY will pay \$250 for fitting stand lamp clusters to old vases; \$150 for most practical method of using electric shop materials for lamp stands and \$100 for business boosting scheme.

547 W. Jackson Blvd. Chicago

MANUFACTURER MAKING BENT WOOD rims for wheels offers \$5,000 for proposition by which output can be taken up by other needs and uses. See Problem LR-2.

Jouis Kauteller's son Ft. Wayne, Ind.

FOR ACCEPTED IDEAS FOR NEW USES OF fans, blowers, shutters, and unit heaters Ilg Electric Ventilating Company offers \$5,000 in various awards.

2850 N. Crawford Chicago

FOR A PERFECTED METHOD BY WHICH finished silver can be coated or treated to prevent tarnishing, the Stieff Company offers the sum of \$1,000.

17 N. Liberty, Balto., Md.

TO ANYONE WHO WILL PRODUCE FOR them a saxophone reed to satisfactorily replace the present reed, the Buescher Band Instrument Company will pay the sum of \$1,000.

Research Dept. Elkhart, Ind.

THE PHENIX RADIO CORPORATION WILL pay the sum of \$1,000 for the design of a new form of condenser for radio reception.

S. Blakeman New York City

FOR A SATISFACTORY HAMMER BLOW arrangement for a portable hammer drill, the Wodack Electric Tool Corporation will pay the sum of \$500.

13 S. Jefferson Chicago

DONOR IN PROBLEM PD-1 DESIRES A DESIGN for a starting switch for an alternating-current motor and will pay \$100 for the one accepted.

Peerless Elec. Co. Warren, O.

THE SUM OF \$50 IS OFFERED BY THE Parsons Manufacturing Company for the best plan they receive for uses of ground slate.

Pen Argyl, Pa.

FOR A SIMPLE DESIGN OF A 2-KW. MOTOR generator set, or rotary converter and one which this concern will accept, the William H. Mitchell Company will pay \$500.

Troy, O.

PERFECT IMPROVEMENT IN PROCESS OF color separation employed by engravers, \$500. Jahn and Ollier Engraving Company.

354 W. Adams, Chicago

\$1,000 IS OFFERED BY MR. FRANK LESH for a detonator for explosives that set off a charge under water or oil without need of connecting lines.

204 1700, Casper Wyo.

Full Details Regarding the Previous Offers Listed Above, May Be Obtained by Addressing the Bureau of Information, Popular Mechanics Magazine

"American Flyer" Railroads

and "Structo" Hoisting Toys and Autos



"American Flyer" Railroad Equipment

shown in large illustration above

- A. Train and Track—No. 1307—Electric 12 wheel engine—an exact copy of the New York Central Electric Locomotive with headlight, automatic reverse, mail car, 2 Pullmans—all electric lighted, 20 pieces of track, length of train 48 inches—track 202 inches—Price \$26.00
- B. Electric Lighted Station No. 99—\$6.25
- C. Automatic Block Signal No. 2018—\$3.75
- D. Automatic Semaphore—lighted No. 2015—\$3.75
- E. Telegraph Pole—No. 210—\$0.50
- F. Crossing Gate—No. 2021—\$1.25
- G. Tunnel—No. 86—\$1.50
- H. Improved Transformer—No. 1250—\$3.75
- J. Bridge—No. 213—\$1.25
- K. Baggage Room—No. 104—\$3.00
- L. Danger—Bell and Light—No. 2016—\$3.75
- M. Crossing Signal—No. 206—\$0.35
- N. Platform Station—No. 91—\$1.25
- P. Billboard—No. 92—\$0.35
- R. Fence—No. 216—\$0.60
- S. Trees—No. 214—Set \$1.25
Gardens—No. 215—Set \$1.25
- T. Double Arc Light—No. 2010—\$3.25

Show this advertisement to your Toy dealer, if he hasn't got the "American Flyer" or Structo Toys and Autos that you want, and doesn't want to order them, we will ship you any Train, Hoisting Toy, Auto or Equipment illustrated, postpaid, on receipt of cash

"WHAT are you going to do this aft?" pipes up Pinkey as the three boys burst out of school on a cold winter day.

"I'm for going into the house and doing something," is little Bill's immediate response.

"Say, you birds I've got it!" suggests Frank, "C'mon over to my house. I've got my "American Flyer" train and a lot of new equipment; a new station, a new semaphore and a bear of a crossing gate. Whadda you say?"

"You're on," said Bill—and the young American Flyer trio started to Frank's house on the run.



No. 1221—Electric Engine, with headlight, 8 inches; 3 double-truck cars, 6½ inches, 14 pieces of track, semaphore, station, tunnel, rheostat and track connection. Length of train, 31 inches. Price, delivered, \$12.00



American Flyer Transformer
Price delivered, \$3.75

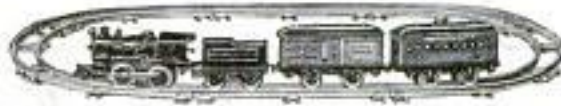

No. 2—Mechanical Engine, with brake and piston rods 6½ inches, tender 4 inches, cars 5½ inches; baggage car has sliding doors; 10 pieces of track; 105 inches; length of train, 24½ inches. Price, delivered, \$2.65



No. 13—Mechanical Engine, with brake and piston rods 7 inches, tender 4 inches, cars 5½ inches, baggage car has sliding doors; 12 pieces of track, 2 switches, length of track, 160 inches, length of train, 25 inches. Price, delivered, \$4.25

Send ten cents and we will mail you Horace Wade's famous story about "The Backyard Railroad" and the beautiful catalogue illustrated in color showing the full line of American Flyer trains and Structo Hoisting Toys and Autos.

STRUCTO Hoisting Toys & Autos

Loads and Dumps Automatically
Height 12½ inches
Length 21¼ inches
Width 6 inches
Price Delivered \$3.75



STRUCTO Giant Steam Shovel No. 110

Model of Real "Caterpillar" Type Tractor
Trailer Included—
Length Over-all 15 in.
Price Delivered \$3.25



STRUCTO "Ready-Built" Caterpillar Tractor No. 44

Loads and Dumps Automatically
Height 12 inches
Length 13 inches
Width 4½ inches
Price Delivered \$2.25



STRUCTO Grab Bucket No. 52

Powerful Spring Motor Special Body Raising Attachment
Length Over-all 12 inches
Price Delivered \$2.75



STRUCTO "Ready-Built" Contractor's Truck No. 42

American Flyer Mfg. Co. 2233 So. Halsted St., Chicago



The People's Telephone

The telephone knows no favorites. It does the bidding of the country store and of the city bank. It is found in the ranch house kitchen and in the drawing-room of the city mansion. Its wires penetrate the northern forest, stretch across the prairie, are tunneled under city streets.

The telephone knows no favorites. Its service to all the people is of the same high standard—the Bell System standard. Twenty-four hours a day it carries the voices of all. For the benefit of all, the long-distance circuits are kept in tune. Numberless discoveries and improvements devel-

oped by the Bell System have made the telephone more useful for all the people. In America, all can afford the telephone, for Bell System service is the cheapest, as well as the best, in the world.

The telephone knows no favorites. It is not owned in any one locality or by any particular group of men. It is owned by 350,000 stockholders, who represent a cross-section of the thrift of the whole country. The owners of the telephone are those it serves.

In America to-day the 15,000,000 telephones of the Bell System contribute to the security, happiness and efficiency of all the people.



AMERICAN TELEPHONE AND TELEGRAPH COMPANY
AND ASSOCIATED COMPANIES

BELL SYSTEM

One Policy, One System, Universal Service

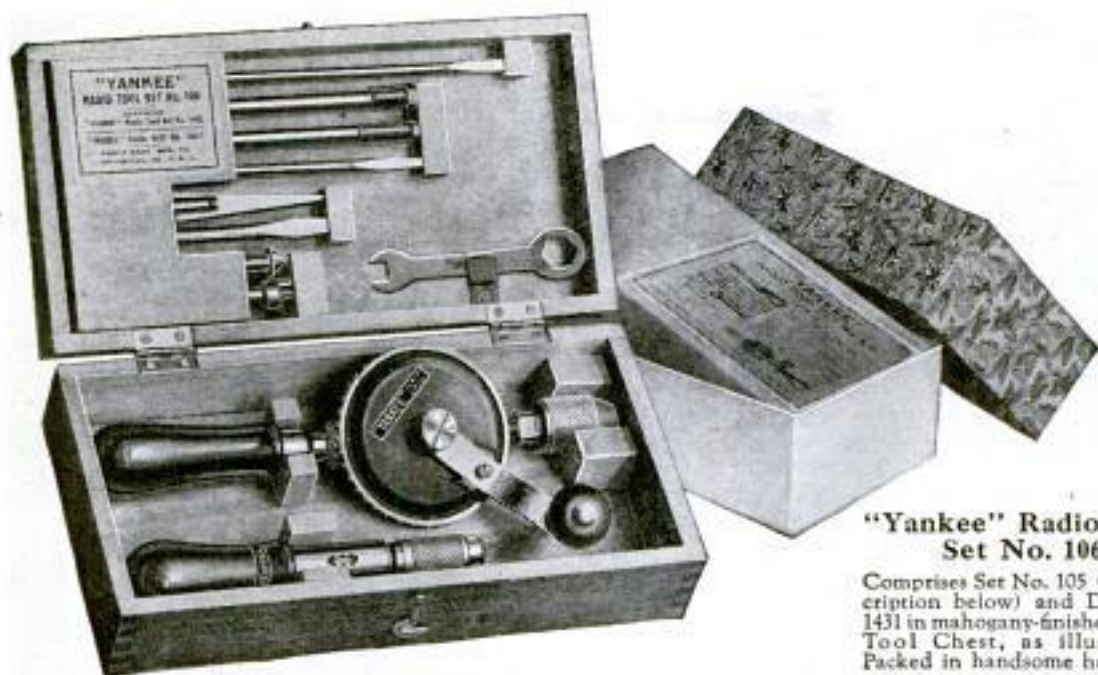

"Yankee" Radio Tool Set No. 106

Comprises Set No. 105 (see description below) and Drill No. 1431 in mahogany-finished Radio Tool Chest, as illustrated. Packed in handsome holly box.

Price, \$8.50

*The Ideal Christmas Gift
for the Radio Fan*

"YANKEE" Radio Tools

WHAT interests men the most about radio? Tinkering, of course! Building new sets; changing hook-ups on old ones; experimenting for better results . . . that's what men enjoy. So the gift of "Yankee" Radio Tools is sure to be appreciated.

"Yankee" Radio Tool Set No. 105. Price, \$3.25

Set No. 105 comprises "Yankee" Ratchet Tool Holder (a) with "Yankee" Radio Attachments as follows:

- Long Screw-driver Blade (h)—for reaching into box, between wires, etc.
 - Small Screw-driver Blade (c)—for screws on dials, etc.
 - Heavy Screw-driver Blade (g)—for putting up aeriels, etc.
 - Countersink (f)—for sinking heads of screws.
 - Reamer (b)—for enlarging holes in panel.
 - Wire Bender (j)—for making loops and turns.
 - Socket Wrenches (d e)—two sizes—to cover all small nuts.
 - Also, Flat Wrench (i)—for square or hex, one end; other end, hex, for jacks.
- Packed in holly box.

"Yankee" Radio Drill No. 1431. Price, \$3.00

No. 1431 is a compact, powerful, perfectly balanced hand drill with four to one gear for speed and special radio chuck. Capacity 9/32 inch. Packed in holly box.



Write for FREE
"Yankee" Tool
Book



Set No. 105. Price, \$3.25
Packed in gift box



"Yankee" Radio Drill No. 1431
Price, \$3.00. Packed in gift box

Your hardware dealer can supply "Yankee" Radio Tools
NORTH BROS. MFG. CO., Philadelphia, U. S. A.

"YANKEE" TOOLS

Make Better mechanics



A thoughtful, helpful, useful gift

THE Remington Portable is truly a universal gift—welcomed by people who write, much or little, the world over. It is saving the time of countless women. It is greatly assisting children in their school work, and properly training them for the future. It is indispensable to the college student of today. And men find in the Remington Portable a little helper

always ready to lighten every writing task. It is the modern way to write.

The Remington Portable, complete with case, and in a beautiful Christmas container, \$60. Easy payment terms if desired. For sale by all Remington branches and over 5000 dealers everywhere. Write for illustrated, "For You—for Everybody." Address Department 12.

REMINGTON TYPEWRITER COMPANY

374 Broadway, New York—Branches Everywhere

Remington Portable

THE RECOGNIZED LEADER—IN SALES AND POPULARITY





The Day that Europe Turned to America for Saws



A few Disston favorites



Disston D-8, "The Saw Most Carpenters Use." The most widely used saw in the world.



Disston American Boy Saw. A regular Disston-made saw for your boy. Makes an ideal Christmas gift.



Disston Nest of Saws No. 3. For carpenters and householders. Contains 10" keyhole blade, 14" compass blade, and 16" utility or pruning saw.

Disston Plumber's Nest of Saws No. 60. Same as No. 3 except large blade (18 inches) is metal-cutting saw, for imbedded nails, lead pipe, etc.

OVER at your nearest hardware dealer's there is a saw you will want to see—

For it is the make that brought Europe—and the world—to America for saws!

As though his whole future depended upon it, a young man was smithing a saw. The place was Philadelphia. The year, 1840.

The blows of the smithing hammer on that saw, in the little shop, were the real start of America's saw-making industry.

For while Henry Disston thus smithed his first saw, America was being built with saws made abroad!

The young saw maker worked on. Trying out steels in a furnace made with his own hands. Tempering and smithing blades. Setting, filing and testing saws.

Here a carpenter, there a carpenter, tried the saws with the Disston name. They found

- hang and balance they had never known in any tool;
- temper that gave spring and life;
- clearance that made work easier;
- a cutting edge that held.

They found a saw that worked with

hand and arm: sawing straight, cutting keenly without dragging, and with never a wobble.

The news spread!

And then came the day of the American-made saw—the day when Europe reached across the Atlantic for Disston Hand Saws.

Henry Disston now made his own steel—America's first crucible saw steel.

And Disston Saws of Disston Steel won the world!

All the while—a greater thing than working with metals, he worked with men: Making saw makers, passing on to them his skill, his ambitions, his tirelessness for excellence.

The little shop became the largest saw works on earth—68 buildings, 3600 craftsmen.

Remember all this, when next you visit your hardware dealer's. Ask to see the Disston Hand Saw, world famous as "The Saw Most Carpenters Use."

Grasp the handle and try the balance. Note taper and finish; filing and set.

Then make that saw your own. Don't stop until you have drawn a line across a board and sent your Disston saw singing along that line—straight and true.

Ask Disston

Tell us what kind of work you are doing, in wood, metal, stone, or other material, and we will tell you what types of saws to use. Disston issues many books to aid the user of saws and tools.

HENRY DISSTON & SONS, Inc.
Philadelphia, U. S. A.

Hardware dealers the world around sell Disston Saws, Tools, and Files

DISSTON

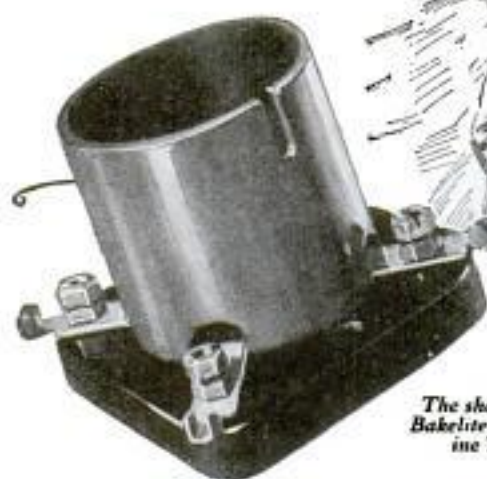

The shell is **ORANGE**
Bakelite—the base genu-
ine Thermoplox



The More You Know About Radio the Better You Will Like This Socket

If ever a device were designed to increase the efficiency of all receiving sets, it was this new socket by the Master Builder. Radio Engineers praise it—new set builders marvel at its ease of installation and the clear, loud reception obtained that bespeaks the absence of losses—many old-timers have even rewired their sets to establish new distance records and enjoy clearer reception with this better socket.

You'll like its construction, embodying a minimum of both insulation and metal—capacity absolutely minimized *without sacrifice of mechanical strength*. And its base of ebony Thermoplox in beautiful color contrast with the thin shell of orange Bakelite adds greatly to the appearance of any set as the construction does to its efficiency.

You'll like its contacts (the source of losses and noise in most sockets); they are radically new in design, formed of phosphor bronze and *silver* plated—because the contact resistance of silver does not increase as it stands exposed to air. Then, too, electrical losses are minimized by providing maximum spacing between terminals, both in insulation and in the air.

You will like the way the tube is inserted and removed without turning—which prevents twisting the bulb from its base. You will like its appearance—its small size—its neatness. You will like its silvered posts with slotted nuts that are fastened *well* with either screw driver or wrench. You will like the way these terminals are arranged for soldering—extra long so that they may be bent down where under-wiring is desired—and provided with ears to hold the wire in place for soldering. And best of all you will like the price, 90c. *This socket that meets the specifications of the most exacting radio engineer costs no more than most of those on the market today!* If your dealer has not yet been stocked, you can be supplied direct from factory at regular price plus 10c for packing and postage.

THE CUTLER-HAMMER MFG. CO.

Member Radio Section, Associated Manufacturers of Electrical Supplies
Works: MILWAUKEE and NEW YORK

"Built By The Master Builder"

C-H

*These Exclusive
Features Assure Better
Reception*



A
Perfect contact. Both sides of tube prong cleaned when inserted—no contact or wear on soldered end.

B
All metal parts *silver* plated—perfect contact for the life of the set. Silver may tarnish but its contact resistance does not change.

C
One piece contact construction. The binding post is **NOT** a part of the circuit—the wire to the socket always touches the contact strip which carries the current direct to the tube prong—no joints to cause losses.

D
Convenient terminals for soldering—full length to allow bending down for under-wiring. Ears hold wire in place for soldering.

E
Extra handy binding posts—tight connections with either wrench or screw-driver. Lock washers hold terminals rigid.

F
Wide spacing of current carrying parts both in air and insulation—true low-loss construction.

G
A minimum of both metal and insulation for low capacity. Shell of thin Bakelite—the base of genuine Thermoplox.

H
The tube is held in place by merely a vertical motion—no twisting to separate bulb from base.

The attractive orange shell helps identify this better socket, but the famous C-H trade mark both on the socket and on the orange and blue box is your genuine protection.

C-H

RADIO SOCKET

IMPORTANT BAER BROS. CO. sell all nationally advertised watches and jewelry on credit at established cash prices.

Xmas Gifts on Credit



X87—Man's flat belcher, 14 k. yellow gold ring, 7 blue white diamonds set in solid PLATINUM disc. Looks like 2 ct. solitaire **\$73.50**



X85—14 k. carved 18 k. gold white gold onyx ring, blue white diamond. Very stylish and popular **\$25**



X86—7 perfectly matched blue white diamonds, set in PLATINUM, 2 sapphires, exquisite new model richly engraved. . . **\$95**



X81—Solid PLATINUM friendship or anniversary ring, 5 perfect cut blue white diamonds, 4 triangular sapphires. Unusually attractive. **\$135**

10 Months to Pay
Our Guarantee Absolute Satisfaction or Your Money Back



X45—7 blue white diamonds set in PLATINUM, green gold 14 k. engraved ring. . . **\$52.50**



X54—18 k. white gold ring, hand pierced, perfectly cut blue white diamond. Very popular **\$73.50**



X40—Popular 18 k. white gold ring, pierced and engraved, perfect cut blue white diamond. **\$50**



X46—Solid 18 k. white gold ring, perfect cut blue white diamond. **\$22.50**



X38—Solid PLATINUM ring, large perfect cut blue white diamond in top, 4 small diamonds in heart shaped caponsides. Rarely beautiful. **\$125**

FREE

New 1925 DeLuxe Catalog. Thousands of choice gifts in diamonds, watches, pearls, silverware, toilet sets and jewelry. Prices \$10 to \$1000. Cash or easy credit terms. If you do not see what you want in this ad, we suggest that you write today for our FREE CATALOG before ordering your Xmas Gifts.



X31—PLATINUM top on 14 k. white gold scarf pin. Blue white diamond, 4 sapphires. . . **\$25**



X23—18 k. white gold ring neatly and artistically designed perfect cut blue white diamond, two sapphires. . . **\$75**



X77—2 blue white perfect cut diamonds, 1 sapphire, 18 k. hand engraved white gold ring. **\$50**



X47—18 k. white gold ring, perfect cut blue white diamond, 2 sapphires. Our leader for a low priced ring. **\$29.50**



X82—Engagement ring, 14 k. yellow gold, perfect cut blue white diamond. **\$50**



X70—Man's handsome 14 k. green gold ring, 18 k. white gold top, perfect cut blue white diamond. **\$57.50**



X30—7 blue white diamonds, 2 triangular sapphires, 18 k. white gold ring. Very showy. . . **\$75**



X24—18 k. white gold ring, perfect cut blue white diamond, octagon top, pretty design. . . **\$25**



X97—Solid PLATINUM, delicately hand engraved ring, perfect cut blue white diamond of first quality. **\$67.50**



X52—Solid 14 k. white gold watch, sapphire crown, fancy dial, adjusted 16 jewel movement, guaranteed time piece. . . **\$23.50**



X49—Engagement ring, 18 k. white gold orange blossom engraving, perfect cut blue white diamond. **\$100**



X80—18 k. white gold seamless wedding ring, 5 perfect cut blue white diamonds, ring engraved all around. **\$30**

Send No Money

No deposit required. Simply send your name and address and say what article you want. Only if satisfied pay 15th (20%) on arrival. Keep it for 10 days' **Free Trial.** Your money back if not satisfied or if you can duplicate these articles anywhere **even for cash.** Otherwise pay balance in 10 equal monthly installments. We make no claims we cannot live up to. **You take no risk.** Transactions strictly confidential. **Guarantee Value Bond with each purchase.** Don't delay—order today. **Address Dept. T-26**

Established
1890

BAER BROS. CO.
Dept. T-26, 6 MAIDEN LANE-NEW YORK

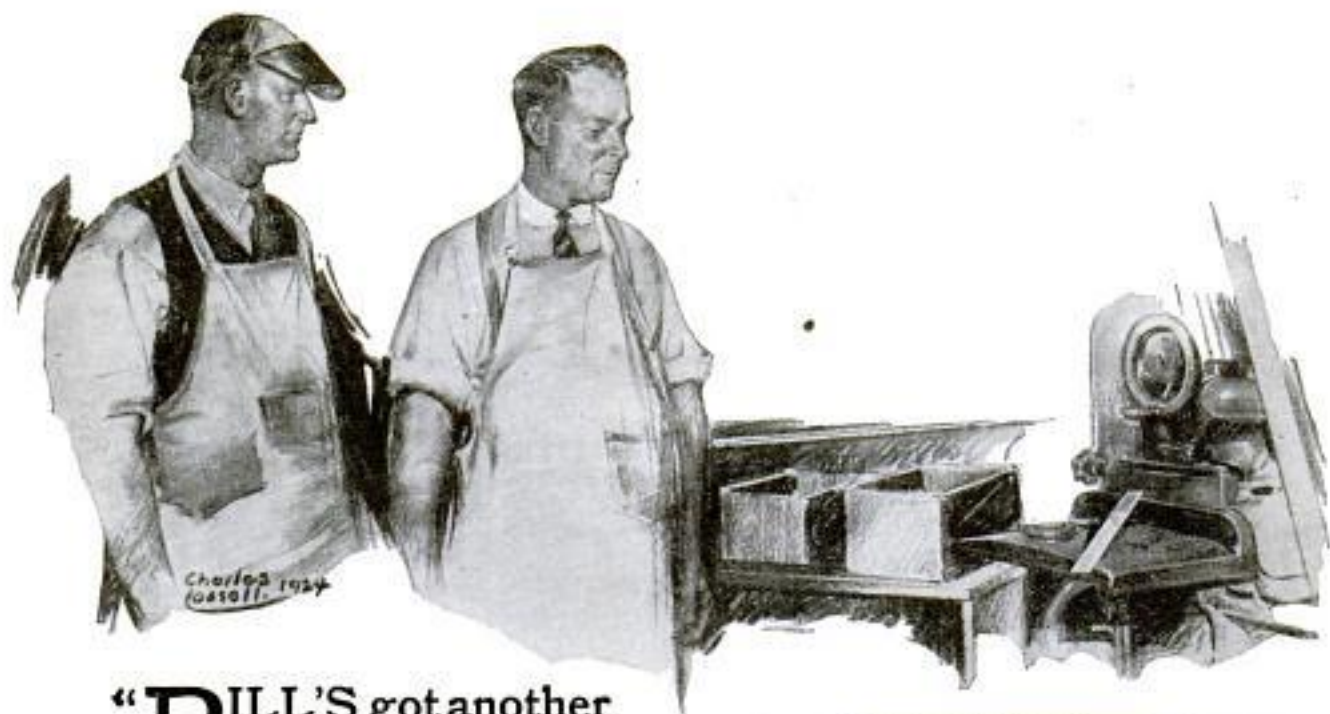

"**B**ILL'S got another new rule, I see. He sure does rust 'em out."

"Not any more—that rule is the same one he's been using for the last two years. It always looks like that—it's a Starrett Stainless."

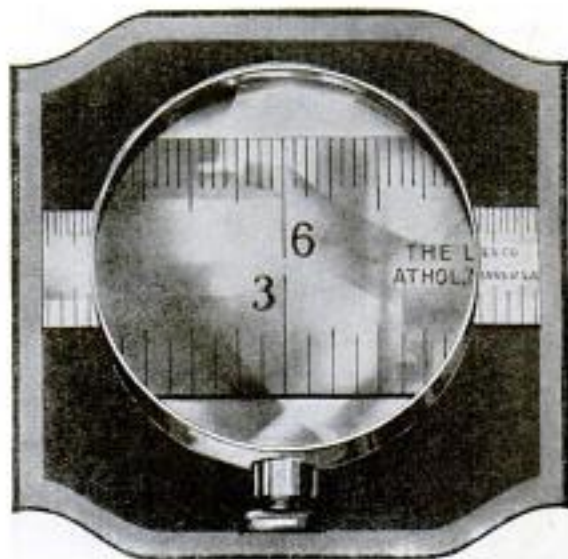

RUST PROOF

Starrett Stainless Steel Rules laugh at moisture, perspiration and certain acid fumes that soon destroy the usefulness of the ordinary rule. They are made from a fine quality non-rusting, non-staining steel. No. 1000 (hardened and tempered) is made in 6 and 12 inch lengths. No. 1020 (flexible) supplied in 6 inch length only. Like all Starrett Rules, the Stainless is graduated with extreme accuracy—a reading glass proves that even when magnified the division lines show up sharp and clean-cut—perfect in every way. Use Starrett Rules for closer and easier work.

7213

THE L. S. STARRETT CO.

World's Greatest Toolmakers—Manufacturers of Hacksaws Unexcelled
ATHOL, MASS.

FREE REFERENCE TABLES

Wire Gauge Standards, Decimal Equivalents, Allowances for Fits, Tap Drill Sizes, Color Chart for use in Tempering, Lubricants for Cutting Tools, Drill Speeds, Double Depth of Threads, Metric Conversion Tables, Miscellaneous Measurements, Tables for Computing Weight of Cast Steel.

All this and other valuable information needed by every tool-user will be found in the back of the NEW STARRETT CATALOG. Mailed FREE. Write for No. 23 "AP"



Starrett Tools

Atlas

TRADE MARK

RADIO REPRODUCTION Speaker



THE material of the horn itself plays an important part in the faithfulness of Atlas Radio Reproduction. The magnified cross-section below shows how the resilient core absorbs the vibrations of the horn material; while the rigid surface conserves the sounds you ought to hear — as you want to hear them.

Multiple Electric Products Co., Inc.
36 Spring St., Newark, N. J., Dept. W

New York, Boston, Philadelphia, Baltimore,
Pittsburgh, Detroit, Chicago, St. Louis, Denver,
550 Howard Street, San Francisco.

Marconi Wireless Telegraph Co. of Canada, Ltd.
Sole Canadian Distributors



New Atlas speaker with the exclusive and strikingly beautiful bronze ripple-finish.

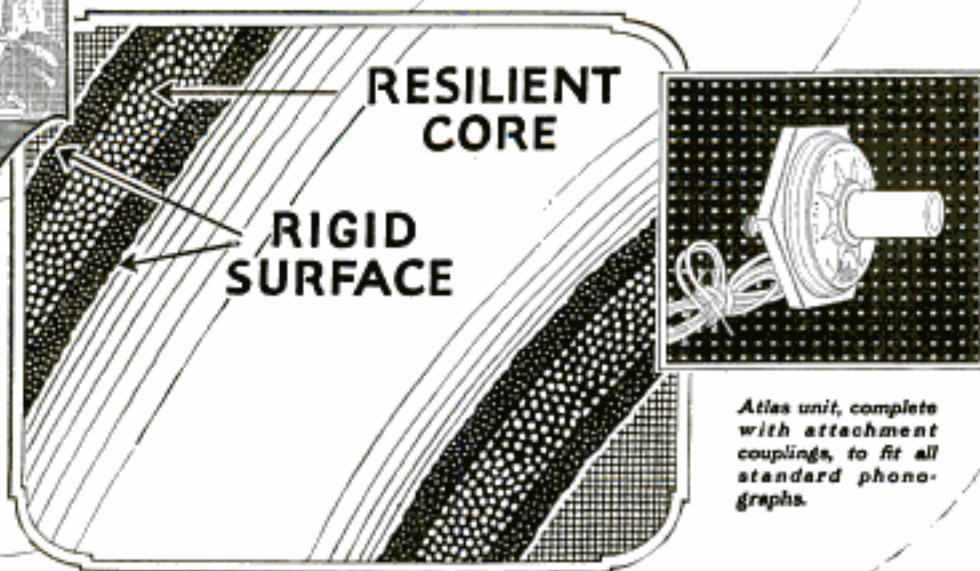

Atlas unit, complete with attachment couplings, to fit all standard phonographs.

\$2

X
M
A
SG
I
F
T
SSent
for

\$2



AZ1—Lady's hand carved 18K white gold ring set with a perfect cut blue white diamond. \$30.



AZ2—Beautiful Pansy design lady's wrist watch: solid 14K white gold fitted with guaranteed movement of 15 ruby and sapphire jewels. \$22.



AZ3—Lady's 18K white gold ring; center set with absolutely perfect, blue white diamond; two flawless diamonds on sides. \$100.



AZ13—Platinum front scarf pin set with perfect cut blue white diamond. 14K white gold pin. \$27.50.



AZ4—Lady's platinum set 7 diamond cluster ring; 20K white gold shank; resembles \$750 solitaire. \$57.50.



AZ5—Lady's 18K white gold ring; hexagon center set with perfect cut blue white diamond. \$27.



AZ6—Lacework diamond cluster ring; 18K white gold; each side of diamond center is set with a triangular shaped sapphire; looks like \$750 solitaire. \$67.50.



AZ14—Lady's 20K white gold orange blossom ring set in 3/4 Carat size 18K white gold cup with a perfect cut blue white diamond. \$75.



AZ7—Lady's lace design ring of 18K white gold; set with perfect cut blue white diamond. \$45.



AZ8—Lady's Elite ring; perfect cut blue white diamond is set in 18K white gold prongs; 14K natural gold shank. \$65.



AZ9—Solid platinum lace work design lady's ring set with a perfect cut blue white diamond of first quality. \$100.



AZ15—Diamond watch featuring on gold wrist watch; 14K solid white gold set in platinum with 4 perfect cut blue white diamonds; highest grade 15 jewel movement. Lifetime guarantee. \$42.50.



AZ10—Gentleman's platinum set 7 diamond cluster ring; 18K white gold octagon top; 14K green gold shank; resembles \$900 solitaire. \$90.



AZ11—Gentleman's 18K white gold ring; center set with a perfect cut blue white diamond; French blue sapphires on sides. \$75.

\$2.00 Brings Your Choice NO RED TAPE—NO DELAY

Simply send \$2.00 and your choice goes to you charges paid. You have ten days in which to decide. Money back instantly if you are not satisfied as to the quality and value.

Ten Days' Free Trial

Send only \$2.00 and your choice goes to you in handsome gift box all charges paid. Guarantee Bond attesting to quality and value accompanies each shipment.

A Full Year to Pay

Simply send \$2.00 and receive your selection, all charges paid. After trial pay balance in 12 monthly payments. 10% discount for Cash.

Free Royal Xmas Catalog

The most complete Catalog ever published of diamonds, Watches, Jewelry, Silverware, Cameras, Ivory Toilet Sets, etc., sent FREE. Prices from \$5.00 to \$1000—quality the highest. Ten days' trial and a full year to pay on everything you order from our \$2,000,000 stock. Send for your copy today. Dept. 1102.



AZ16—Three perfectly matched blue white diamonds set in 18K white gold top; 18K white or green gold shank. \$75.



AZ17—Wedding ring of 18K white gold set with five perfectly matched blue white diamonds. \$35.



AZ18—Lady's 7 diamond platinum set cluster diamond ring; 14K natural gold shank; resembles \$600 solitaire. \$48.50.



AZ12—Lady's genuine Bohemian onyx set with perfect cut blue white diamond; 14K white gold shank. \$18.50.

ROYAL DIAMOND & WATCH Co.
170 Broadway - New York



Swings true; cuts fast ...it's a **PLUMB**

YOU cut true to the line with a Plumb—the hatchet that carpenters choose.

The blade is tapered for fast cutting—shaped and hung just right for easy, slicing strokes.

It is forged steel, refined and toughened by armor-plate heat treatment, tempered for long, hard service.

The edge stays sharp; the head stays tight, and you need that in your hatchet!

At hardware stores, \$1.50 (except in Far West and Canada). "They're worth more."

FAYETTE R. PLUMB, Inc., Philadelphia, U. S. A.



*Red handle and Black Head Color Combination registered as PlumbTrade Mark in U.S. Patent Office

The greatest thrill you ever had!

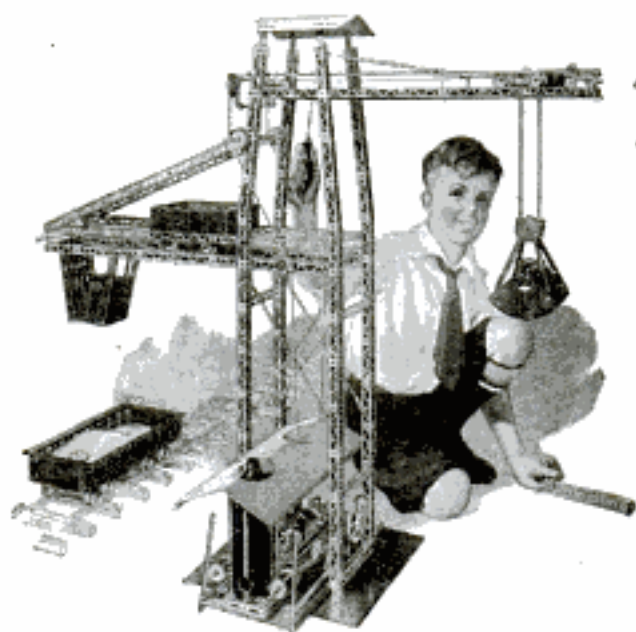

THE NEW ERECTOR

"The world's greatest toy"



NEW Erector has many new features this year. Some of them are a steam shovel that digs sand and dumps its contents, a dredge bucket or clam digger; coal loader that unloads a car and loads it in a truck, boilers to make models of steam engines and curved girders to make round models as well as rectangular ones. These parts are all additions to the standard Erector parts known for years, including the sturdy square girder which can only be built with Erector and the powerful Erector electric motor to run models.

"Five Hundred Toys in One"

YOU never saw a construction toy like the New Erector. It is brand-new this year—the latest model with hundreds of new parts. I expect to see some wonderful results this year from the things boys have made with Erector.

Erector is made of steel with most parts nickel-plated and coated with lacquer baked on by electricity to prevent rusting.

Sit right down now and send the coupon on the bottom of the page so I can tell you about this wonderful New Erector. And don't fail to put the New Gilbert Erector at the head of your Christmas list this year.

Your friend,

A.C. Gilbert
President.

500 TOYS FOR
\$5 with powerful
electric motor

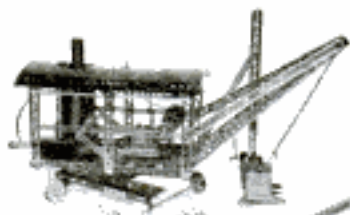

Steam Shovel made from
New Erector

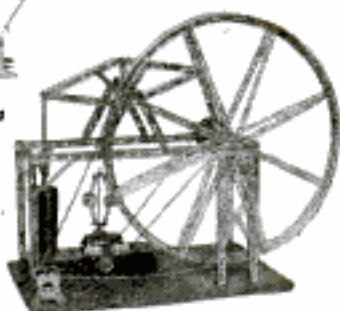

Walking Beam Engine
made from New Erector



A. C. GILBERT CO.,
341 Blatchley Ave., New Haven, Conn.
Enclosed please find 25c for the 146 page Book
(easily worth \$1.00) describing the hundreds of
wonderful models made possible by New Erector,
the World's Greatest Construction Toy.

Name

Address

*New Features of the 1924
New Erector*



CURVED Girders, Steam Shovel, Dredging Bucket, Steam Boiler, Smoke Stack, Car Trucks, Cab Top, Engine Wheels, Wagon Wheels, Propellers, Reflector, Mitre Gears, Large Gears, Crown Gears, Pulleys, Worm Gears, Drum, Eccentric Cranks, Flanged Wheels, Gear Box, Couplings, Signal Arm, Eccentric Axle, Chain, Large Steel Plates, Turret, Large Base Plates, etc.

New device makes *cold* radiators *hot*

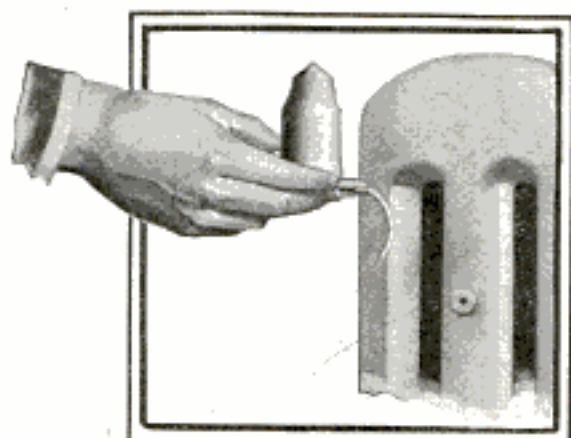

Intelligent float knows the difference between air and steam

Inside the AIRID is a metal float, and inside the float is a volatile liquid—the "brains" of the valve. Cold air flows around the float, up through the vent-hole and out. Then steam enters the chamber of the valve, and that is the signal for action. Instantly the liquid inside expands, swelling the sensitive metal bottom of the float enough to raise it from its first position and to thrust a top pin up into the vent-hole. Thus the vent is closed and stays closed as long as the steam is on!

Not even water can escape

Water is present in almost every steam heating system, and AIRID knows how to deal with it, too! The "float" literally floats on the rising water until the opening is closed by the metal pin, as before. The water runs back into the radiator, not out on the floor.



Made and guaranteed by

AMERICAN RADIATOR COMPANY

Sold at all heating and plumbing shops

AIRID

AIR-VALVES

MAKING HOT RADIATORS out of cold ones, is the achievement of an invention called AIRID. The name originates in the operation of this ingenious contrivance which "rids" the radiator of "cold air." AIRID is a perfected air valve which performs its duty under all possible conditions, permitting the steam to push the air out, but preventing the escape of the steam itself.

Despite the mechanical nicety of AIRID, it is so simple that anyone can attach it to any steam radiator without tools in about two minutes. After that, the action is entirely automatic.

Why steam radiators are partly cold

Whenever steam travels through the pipes of a heating system, it pushes air ahead of it.

The radiator is the end of the journey. There the air packs into the radiator, and acts as a barrier against the steam; hence the frequent complaint that the radiator is "half cold." AIRID lets this cold air out; but that's only half the story.

No sputtering or sizzling

Because the AIRID vent shuts absolutely tight, you are spared the misery of sputtering, bubbling and sizzling. This feature, alone, has endeared AIRID to many home owners.

\$1.60—little enough for a hot radiator!

AIRID costs only \$1.60. The installation can be made without tools in about two minutes. From the moment AIRID begins to work, your radiator is hot—*permanently*.

Send the coupon with \$1.60 and prove this to your own satisfaction in your coldest room.

AMERICAN
RADIATOR
COMPANY
Specialties Dept.
1807 Elmwood Ave.
Buffalo, N.Y.

I am enclosing \$1.60 for an AIRID Air Valve to make my coldest radiator hot.

Name.....

Address.....

Say
 "Merry Christmas"
 with a
 Waterman's

Whether you say "Merry Christmas" with a letter or a present, say it with a Waterman's—a pen that writes a perfect letter and makes a perfect gift.

**Waterman's
 Ideal
 Fountain Pen**

WHEN you give a Waterman's there is no doubt about the value or acceptability of the gift. For forty years Waterman's has been recognized as the pen of all pens.

DIFFERENT sized holders for different sized hands; different pen points for different styles of writing. May be had from \$2.50 to \$50, depending upon size and decoration. *Every pen is as perfect as a pen can be made.*

MODELS illustrated are made with our special feature, gold flexible lip-band. Holders red, mottled and black. Sell for \$4.00, \$5.50 and \$6.50, according to size.

Ask your merchant to show you a Waterman's

Look for this show-card and Waterman's pens on display in merchants' windows. 50,000 reliable merchants sell them.

W. & A. Waterman Company

191 BROADWAY, NEW YORK

CHICAGO BOSTON SAN FRANCISCO MONTREAL





The 21 Jewel Santa Fe Special

Look sent on approval

Send no Money

We will send this famous watch, express prepaid, for you to examine, to inspect, to admire, to approve, without one penny advance payment. Examine the watch and be convinced it's the best watch buy you ever saw, then just a small payment down, the balance in easy MONTHLY payments. You use the watch while paying for it.

Save $\frac{1}{3}$ to $\frac{1}{2}$ of Your Money

by purchasing this famous Santa Fe Special Watch. Not only are you saving money from the present day prices of watches, but you can still secure the "Santa Fe Special" Watch at the same low prices and terms that have made our watches famous.

Ladies' Wrist Watches—The New Elite

This Artistic, dependable Ladies' Wrist Watch, fitted with genuine Illinois Springfield movements. A perfect timepiece. Beautiful 14 Karat white or green solid gold cases. Ask for New Watch Book showing cases in all the new shapes and designs. Watch sent on approval and sold on payments.

Send for Free Watch Book

Clip the coupon, fill out and receive the FREE WATCH BOOK. All the newest watch case designs in white or green gold, fancy shapes and thin models are shown. Read our easy payment offer. Wear the watch 30 days FREE. Watch sent for your examination and approval without a penny down. Nothing to risk. See the watch before you buy.

Write for FREE book Today and Select Your Watch—
Mail Coupon.

Santa Fe Watch Company,

Dept. C-6, Thomas Building, Topeka, Kans.
The Home of the Great Santa Fe Railway

Ask for our Beautiful Diamond Book FREE. Shows all the new styles in rings and tells about our rock bottom prices and our charge account plan.



A few cents a day makes you own a diamond.

Santa Fe
Watch Co.
Dept. C-6

Thomas Building,
Topeka, Kansas

Please send prepaid and without obligation your Watch Book Free, explaining your "No Money Down" Offer on the Santa Fe Special Watch.

Name _____

Address _____

State _____

FREE BOOK COUPON

Here's Why
I Added These
NEW
BROWN & SHARPE
TOOLS
To My Kit



No. 577—Thread Tool Gauge

"The Brown & Sharpe Thread Tool Gauge is adjustable and checks any thread cutting tool from a sharp V to a one inch flat within a given angle. It eliminates my keeping a variety of slot gauges on hand for all the different pitches."

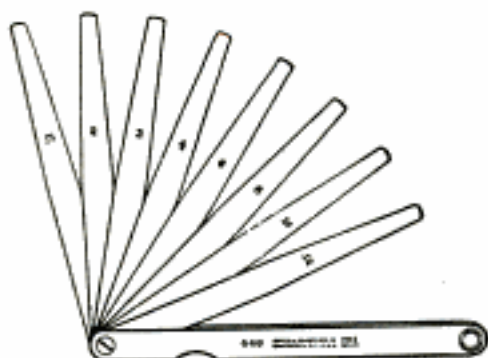

No. 649—Thickness Gauge

"I needed a thickness gauge with long blades and one that I knew was accurate, so I chose a Brown & Sharpe Thickness Gauge No. 649 because the 6" blades are accurately ground to size."

"My Brown & Sharpe Planer and Shaper Gauge No. 625, saves me much time. It is quickly set with a Micrometer, Vernier or Caliper and then the planer cutting tool is accurately set to the gauge."



No. 625—Planer and Shaper Gauge

Learn more about these and other new and useful Brown & Sharpe Tools by sending for a copy of the No. 29 Small Tool Catalog, which is yours for the asking.

Write for a copy today

BROWN & SHARPE MFG. CO.
PROVIDENCE, R. I., U. S. A.

BROWN & SHARPE TOOLS

"Standard of the Mechanical World"

Xmas Gifts on Credit

10 MONTHS TO PAY

Buy your Christmas Gifts on our Easy, Confidential Credit Plan. You pay only one-fifth after you receive and examine your purchase, and the balance in ten equal monthly payments. Thousands of customers have expressed their satisfaction with this easy payment plan.

Sweet Diamonds are noted for their fiery brilliancy, superior AAI quality, and perfect cut. Everything you buy from Sweet's is absolutely guaranteed to please you or your money will be refunded. Our watches, including every standard make are guaranteed free of repairs for one year. We challenge comparison with the prices of any other concern, either cash or credit.

OUR CHALLENGE

If you do not find that our price on any diamond ring is lower at least 10 per cent than that charged by any other house, either cash or credit, we will gladly refund your payment in full if you return the ring within two weeks.



New Diamond Book

Our beautiful new Diamond and Gift Book is now ready. It shows a wonderful assortment of gift selections—Diamonds, Watches and Jewelry, Silverware, Ivoryware, Toilet Articles and Novelties. All on Ten Months to pay. Send the Coupon for the Gift Book Today.



X2156—Sparkling AAI diamond 14K. Retroset ring. \$17.50.

X2151—Ladies' engraved 18K. white gold Acappamare ring. \$27.50.

X2152—PLATINUM SPRED-TOP ring. Fine fiery, AAI diamond. \$62.50.

X2153—Platinum set 1 diamond cluster ring 18K. prongs. \$57.50.

X2154—18K. white-gold SPRED-TOP ring. Blue white diamond. \$19.50.

X2155—Gent's 18K. white gold SPRED-TOP. Superior diamond. \$37.50.

X2157—Diamond set 18K. Black Onyx ring. \$20.00.

X2457—PLATINUM top, flexible bracelet with distinctively engraved and pierced design. Set with 2 perfectly cut and matched AAI quality diamonds and 1 sparkling, big sapphire. \$100.00.



X2458—Herald carved, 14K. Japanese diamond signed 7 1/2". Artistic oval face. \$39.00.



X2459—18K. white gold SPRED-TOP ring. Fine quality diamond. \$57.50.



X2460—14K. diamond set, girls' teeth ring. \$47.50.



X2461—14K. white gold Rectangular shape band 1 1/2". 21.00. Sapphires crown. \$22.10.



X2462—24 inch perfectly graduated, silk string Harbord Pearls. 18K. clasp set with 2 diamonds and 2 sapphires. \$10.00.

L. W. SWEET, Inc.

1656 Broadway, Dept. 64-T, New York

Please send me my Free Copy of your new Diamond and Gift Book.

Name.....

Address.....



*Sargent Steel
Block Plane*

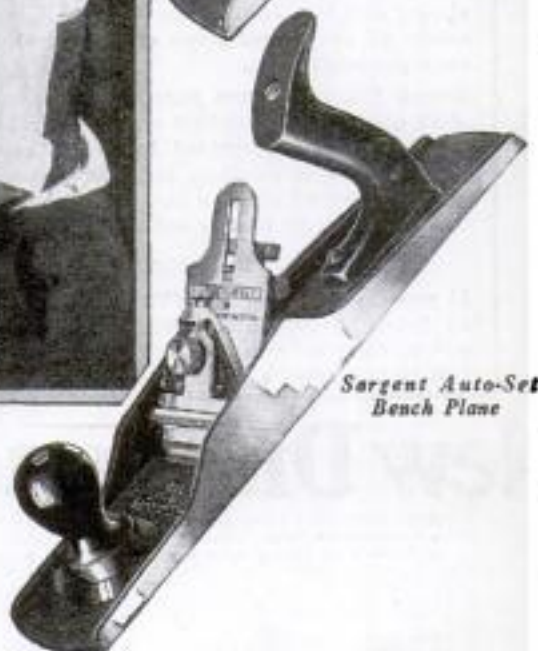

*Sargent Auto-Set
Bench Plane*

He'll have it planed in a jiffy!

IN THIS home workshop, radio is king. In fact, a goodly number of big and little sets, comparable to expensive commercial types, have gone from this bench into neighboring homes. This young man has a reputation for good workmanship. He takes particular pride in his ability to choose and use good tools.

Once you have used the handy little Sargent Steel Block Plane no other finishing plane will do. It is great for work in close quarters, for smoothing up panels, bureau drawers that have been sticking, and similar things. It is as true and clean cutting and as finely made as

the larger Auto-Set Bench Plane shown above.

The Auto-Set, of course, should be in every workshop for use on the bigger jobs. It is light in weight and remarkably easy to adjust or sharpen. The chromium steel cutter may be removed, honed and replaced without changing the original adjustment. Yet it is so firmly held in place that it never chatters even when cutting across the grain or over rough and knotty surfaces. You will find the Sargent Auto-Set Plane an aid to speed and accuracy.

See these Sargent Planes at your hardware dealer's and write us for interesting booklet.

SARGENT & COMPANY
Hardware Manufacturers

49 Water Street

New Haven, Conn.

SARGENT
Tools & Hardware



For a Merry Christmas—for a merry time every day and for many years to come—give your loved ones a Thompson Radio Receiving Set, a Thompson Speaker, or both.

THOMPSON RADIO

Thompson Radio Receiving Sets and Thompson Radio Speakers deliver the highest quality of simplified and economical radio entertainment. Both nearby and distant radio programs cannot be more faithfully reproduced than with a Thompson Radio Receiving Set. One of the many reasons for the advanced development and perfection in Thompson Radio

products is an organization composed of radio engineers who have been making radio apparatus exclusively ever since "radio" was called "wireless."

The 5-tube **GRANDETTE** is \$125. The 5-tube **PARLOR GRAND**, (shown in large picture below) is \$145. The 6-tube **CONCERT GRAND**, is \$180. Prices are without tubes or batteries. The Thompson Speaker, with conical diaphragm and other special features, is now \$28.

If your dealer does not handle Thompson Radio products, write direct to us for attractive literature and name of dealer near you.

R. E. THOMPSON MANUFACTURING CO.

Manufacturers of Radio Apparatus for the U. S. Army and Navy and many foreign governments



30 CHURCH ST.
NEW YORK, N. Y.
FACTORY:
JERSEY CITY, N. J.

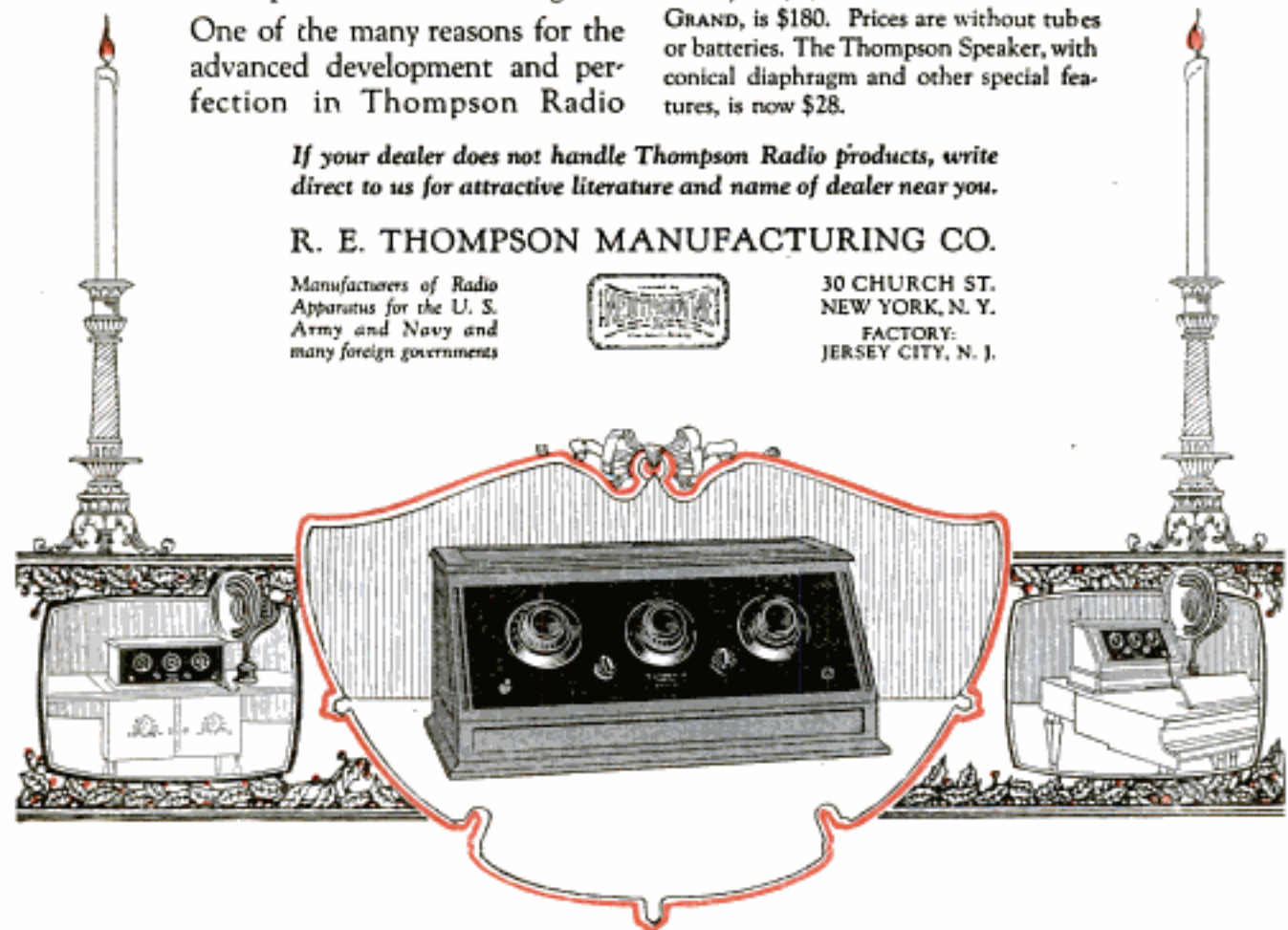

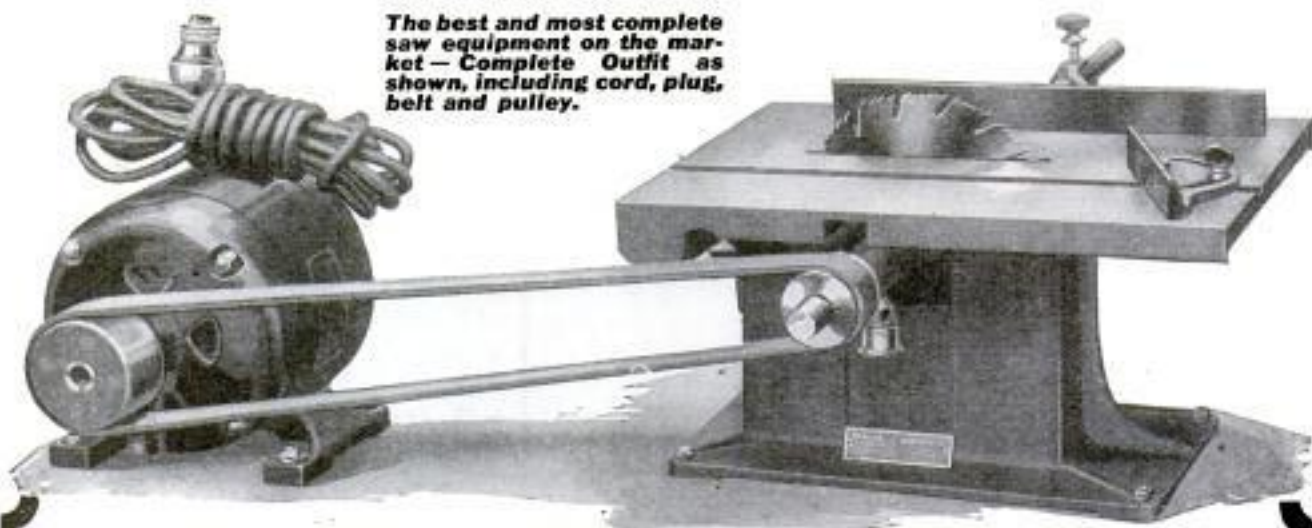

The best and most complete saw equipment on the market—Complete Outfit as shown, including cord, plug, belt and pulley.

For Handy Man and Mechanic

With this "little sawmill" you can make your own repairs in shop, home, farm or garage. In 1001 ways it will save its cost many times over. Makes a clean edge on the toughest wood—no planing necessary. Rips, crosscuts, bevels, miters, mortises, tenons, or grooves quickly and accurately. Does the work of a skilled mechanic and saves you time, labor and money.

MECHANICS' BENCH SAWS

Can be attached to any lamp socket. Weight only 61 lbs. This saw will cut up to $1\frac{1}{4}$ ". Indispensable to wood workers, carpenters, cabinet makers, pattern makers, model makers, inlaid floor makers, hardwood floor finishers, picture frame makers, farmers, printers, radio builders, schools, colleges, homes, etc. All metal. Saw-size 6 inches. Table 10x13, base 7x11, height 7 inches. Table tilts for beveling 5 degrees left, 10 degrees right. Hinged top for cutting grooves, tenons, rabbets. Bearings solid bronze with grease cup lubrication. Guides removable and adjustable rip and cut-off. Sunlight $\frac{1}{4}$ h. p. motor; 110 volts; 60 cycle; 4.5 amps; 1750 R. P. M. Current A. C. Centrifugal switch with auxiliary finger. High grade steel shaft with ground bearing surface. Water and moisture proof insulating material used throughout. Exterior connections to allow change of direction of rotation. Large grease cups with wick lubrication. Bearings of Bunting phosphor bronze metal.

COMPLETE OUTFIT

\$35.
\$60 VALUE

East of the Mississippi. We Pay Delivery Charges.

West of the Mississippi. We Pay Delivery Charges.

SAW TABLE can be purchased with 6" saw for \$22.50; We Pay Delivery Charges Anywhere in the U. S. **\$22.50**

MOTOR This heavy duty Motor can be furnished separately for \$15.90; Complete with Cord, Plug, and flat or grooved Pulley. Guaranteed 50% Overload. We Pay Delivery Charges Anywhere in the U. S. **\$15.90**

including cord, plug, pulley and belt, everything complete, ready to attach. The saw furnished with this outfit is the Diston 6" Novelty Combination Cross Cut and Rip Saw, guaranteed to run without set. No planing or sanding required after cutting. This saw is equipped with extra heavy duty motor guaranteed to handle 50% overload.

Glass Knob INSIDE LOCK Set

1 Lock, Japan case, $3\frac{1}{2}$ x $3\frac{1}{2}$ x $9\frac{1}{16}$ steel plated face.
1 pr. Glass knobs with solid brass roses.
2 Solid brass escutcheons (key plate).

\$1.39
Parcel Post charges 15c
PER SET
Per dozen sets \$15.95

GLASS DOOR KNOBS
Solid Brass Roses

A price never heard of before for a high quality glass knob. P. P. charges 10c. Per dozen pairs, \$11.00

98c
Pair

CLOSET LATCH SET
With Glass Knob

1 Mortise latch, reversible; 1 Glass knob with brass rose; 1 Inside thumb turn, steel with steel rose. P. P. charges 30c. Per dozen sets \$11.00

98c
Per Set



SUNLIGHT 1/4 H. P. Motor

\$12.90 Complete with Cord, Plug and flat or grooved Pulley

Regular Value \$30 We Pay Delivery Charges Anywhere in U. S. 110 volts; 60 cycle; 4.5 amps; 1750 R. P. M. Current A. C. Guaranteed to handle 20% overload.

PAUL J. DEVITT, 1101-1107 So. 2nd St., Phila, Pa.

HARDWARE HEADQUARTERS OF PHILADELPHIA

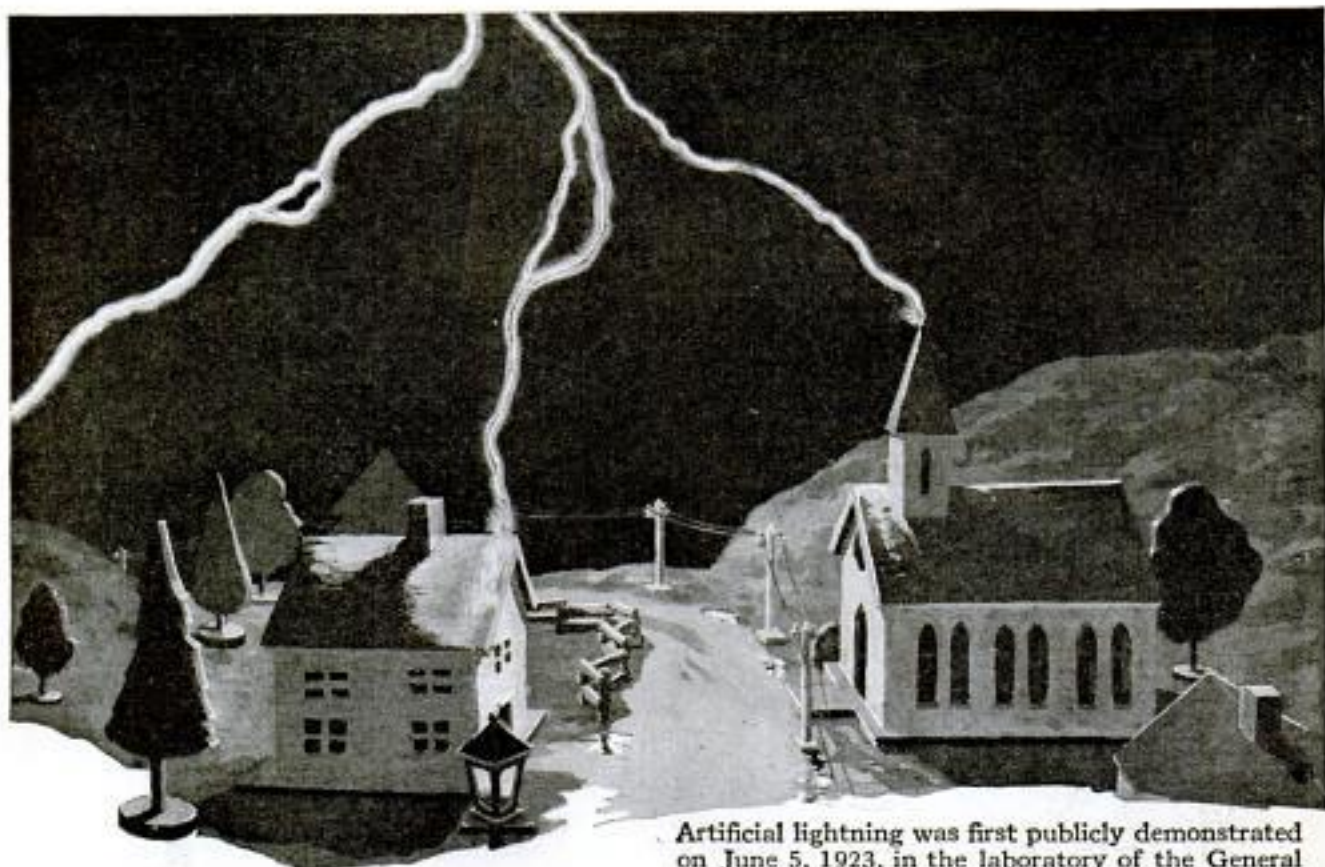

Artificial lightning was first publicly demonstrated on June 5, 1923, in the laboratory of the General Electric Company at Pittsfield, Mass., when a two-million-volt spark crashed into this miniature village.

What's the use of artificial lightning?

It is mainly experimental, aiding General Electric scientists to solve high power transmission problems. Many such experiments yield no immediate return.



When the General Electric Company was formed, there was great need of organized electrical research. The Company's laboratories, in Schenectady and elsewhere, have pioneered in increasing the service of electricity and in reducing its cost.

But in the long run this work is practical and important. It is part of the study which must go on unceasingly if this powerful force, Electricity, is to be fully tamed and enlisted in your service.

GENERAL ELECTRIC



**I'm not a
mind reader**

**but I have
a suspicion
that someone
in your home
would like**

a Corona for Christmas!

CORONA is such a satisfactory gift! To the novice at typewriting it brings a new and fascinating accomplishment—while the experienced typist finds it the most convenient, practical, sturdy writing machine the world has ever seen.

Talk Corona over with your family today. See if some face (perhaps your own) doesn't light up at the thought of a Corona for Christmas!

Now three models

The new Corona Four with standard office keyboard, \$60.

Corona Three, the original Personal Writing Machine, \$50.

XC Corona, 90 character machine for foreign language or technical writing, \$55.



This is the new **CORONA FOUR** with standard office keyboard. Look for **CORONA** in your phone book.

CORONA TYPEWRITER CO. Inc.
108 MAIN ST. CROTON, NEW YORK

Please send me
literature describing all
three CORONA models.

Name _____

Address _____

City _____



The Service Behind OZARKA Makes This Distance Possible

Why Ozarka Receives from Honolulu

OCCASIONALLY some owner of a radio instrument receives from London, England. But did you ever hear of anyone receiving Honolulu, Hawaiian Islands? We will gladly give you the names of the writers of the letters reproduced here, as well as send copies of many letters showing how other Ozarka owners have had results from London, England, Cardiff, Wales and Glasgow, Scotland.

These cases are exceptional, of course, but they must prove to every thinking person that the Ozarka is the greatest distance receiving instrument known today.

In the ownership of an Ozarka Instrument, you are assured of not only the last word in radio, but you will receive expert service, which is far more important than the instrument itself. This is a point you should keep well in mind when you buy radio. Be absolutely sure that the person or firm from whom you purchase is thoroughly capable of keeping that particular instrument in perfect condition. The situation in Radio is exactly the same as that of the automobile. Both are mechanical—both have little things go wrong at times, and both are quickly and easily fixed by the man who knows how.

The Ozarka Radio instrument is sold only by trained factory representatives who know every part, every wire of this instrument. Before he can wear the Ozarka gold button he must satisfy our engineers that he is thoroughly capable of delivering trained service.

4 Tube Ozarka Radio \$39.50 and Up

The Ozarka representative will gladly set up this Ozarka instrument in your own home on trial. He will not make any claims but will let you operate it and prove to yourself that it absolutely has no equal for volume, tone, distance and ease of operation. This will not obligate you in any way.

And as for price, you will, no doubt, be agreeably surprised because Ozarka Four Tube Instruments, for loud speaker operation, are sold as low as \$39.50.

Let us send you more information about Ozarka, including hundreds of letters giving the most marvelous results ever received on a radio instrument. Drop us a card for our free illustrated book No. 200. Please give name of your county.

OZARKA, Inc., 851 Washington Blvd., CHICAGO

Pittsburgh, Pa.
Ozarka, Inc.
Chicago, Ill.
Gentlemen:—I want you to know that I think I have received the greatest distance possible on my Ozarka—KGU, Honolulu, Hawaiian Islands.
A great many friends who have radio instruments of all kinds and bought at all kinds of prices, but no one in this city to my knowledge ever received from such a great distance. To say that I am pleased with my instrument is putting it mild. Yours very truly,
H. J. R.

Alden Bridge, La.
Ozarka Incorporated,
Chicago, Ill.
Gentlemen:—A few nights ago I heard the beautiful Hawaiian Orchestra, direct from Honolulu, territory Hawaiian. When you consider the distance that this is from Alden Bridge, I certainly think it ought to be a record. This music came in beautiful and clear, in fact, it could not have been any better.
Yours very truly,
W. H. B.



More Men Wanted To Sell Ozarka

RADIO offers today an exceptional opportunity for the right kind of a man to build up a permanent, substantial and profitable business of his own. Ozarka factory representatives are today building up very satisfactory incomes for themselves.

In territory which is not now covered there is still an opportunity for a mechanically inclined man who is willing to place himself under our training. We can show such a man how it is possible to build up a business in his own town, possibly in spare time to start with, but sooner or later will justify giving it all of his time.

We are looking for men who realize that there must be some way of improving their condition. We prefer men who know absolutely nothing about radio, because we can then train them according to our own method.

The man we are looking for has a good reputation, is well and favorably known in his community, may not be a salesman but can talk convincingly on something he knows perfectly and firmly believes in.

The Ozarka Plan will give such a man his first real opportunity to establish himself in a business of his own. Investment of money is small but necessary.

All we must make sure of is that you are determined and willing to put forth the effort. If you will do this just write and say: "Send me your Ozarka Plan Book No. 100." It may be the turning point in your life. Don't fail to mention the name of your county.

Nashville, Tenn.
May 14, 1934
Ozarka Inc.
Chicago, Ill.
Gentlemen:—I consider my best night when I successfully connected in with the following stations: CKAC—Montreal, KGU—Honolulu, WJAP—Fort Worth, WGN—Chicago, WBEZ—Springfield, WOAI—San Antonio, KDKA—Pittsburgh, WCAL—Northfield, Minn., WFAA—Dallas, WGY—Schenectady. On a recent night Station KYW—Chicago gave a special program lasting all night.
Yours truly,
O. C.



This Button identifies Ozarka Representative in your city—your assurance of complete radio satisfaction





\$3
DOWN

and it's YOURS

The Greatest Typewriter Bargain Ever Offered

Right now we are making you the greatest typewriter offer you ever dreamed of—an eye opener. This wonderful standard Shipman-Ward Rebuilt Underwood only \$3.00 down. Ten days' free trial and the easiest monthly payments, shipped direct to you from our big factory.

10 Days' Free Trial From Factory to You

Yes, only \$3.00 down puts this genuine late model Shipman-Ward Rebuilt Underwood in your home. You can try it, test it, and then decide. See for yourself how new it is, how it writes. You must be satisfied. Your \$3.00 unconditionally returned if at the end of ten days you are not satisfied. The entire transaction will not cost you one cent.

EASY Monthly Payments

Little more than rental. Balance of payments so small you will hardly notice them, while you enjoy the use of this wonderful machine. You don't have to scrimp and save to pay cash. All at a big saving to you.

5 Year Guarantee

With every typewriter we give a written guarantee. These machines are rebuilt like new by the famous SHIPMAN-WARD PROCESS. Equipped with late improvements. You can't tell them from a new machine. The world's standard typewriter, the same models as sold by the Underwood Typewriter Company today, at a big saving to you. Act now! Get this splendid offer and save money.

These machines are shipped direct from our factory—the largest typewriter rebuilding plant in the world. They are rebuilt by the famous SHIPMAN-WARD PROCESS. Developed through 30 years in the typewriter business. Through our money saving methods of rebuilding and elimination of a large expensive sales force we are able to make this wonderful money saving offer to you. ACT TODAY, take advantage of it and you will SAVE MONEY.

ACT NOW! Mail this coupon today.

Free Book of Facts

Write for this free book of facts explaining Shipman-Ward's wonderful system of rebuilding typewriters. We show you exactly how it's done. How you are able to buy them. Complete and valuable information about the typewriter industry, both instructive and educational.

FREE with Every Typewriter

A complete course in touch typewriting. You don't have to know how to operate a typewriter. You can learn to operate this machine in one day. We also give free a waterproof cover and all tools that come with a typewriter.



All Shipments made direct to you from our modern factory—the largest typewriter rebuilding plant in the world.

FREE BOOK COUPON

SHIPMAN-WARD MFG. CO.
2129 Shipman Bldg.
Montrose and Ravenswood Aves.
CHICAGO

Send by return mail your wonderful offer of Shipman-Ward Standard Rebuilt Underwood, also your book of facts. (This is not an order and does not obligate me in any way.)

NAME.....

STREET.....

POST OFFICE.....STATE.....

SHIPMAN-WARD MFG. CO.

2129 Shipman Bldg., Montrose and Ravenswood Aves., Chicago

What a Big Railroad Man Says about Lionel



M. E. Byram, President of
the Chicago, Milwaukee
and St. Paul Railway



"The boy who owns a Lionel
must get all the thrill of
operating a real railroad"



This is a photograph of the marvelous Lionel Model Locomotive referred to in Mr. Byram's letter, coupled to a long train of Lionel Model Coaches. The complete train as shown is Outfit 346



Lionel Automatic Train Control—The greatest achievement in model railroad engineering. Starts and stops trains automatically. Just one of the many wonderful realistic railroad devices in the Lionel line of Accessories.



Lionel "Multivolt" Transformers. Ever-reliable power plants. Run all trains best. A type for every size train.

THAT is the statement of a man who knows the latest developments in railroading.

He knows, too, that boys always want trains and equipment that are true to life—that not only *look* like real trains, but *operate* as real trains do.

For 25 years Lionel has specialized in the manufacture of model electric railroads—not mere "toys". Since 1900 Lionel products have been "Standard of the World". Lionel has always pioneered in the development of electric model trains.

The only difference between Lionel and real trains is the size.

Take father with you to see Lionel Trains demonstrated. He will get the same thrill out of them that you do. The power, the beauty, the *realness* of Lionel trains and Accessories is enough to delight anybody.

When a fellow buys a Lionel

Model Train, Crossing Gate, Signal Tower, Switch or any of the many other realistic Lionel railroad devices he knows that he has really *got* something of permanent and lasting interest and value.

Complete Lionel "O" Gauge Model Railroads are priced as low as **\$5.75**—and a marvelous train for Lionel "Standard" Track, with illuminated coaches, at \$16.50. (Prices slightly higher in the Far West.) There are many other complete outfits to suit every purpose.

Be sure to see these wonderful trains in your town at department, electric, sporting goods, toy or hardware stores.

Send for Catalog

And don't fail to write for your copy of the wonderful 44-page Lionel Catalog—illustrated throughout in 4 colors. It is **free**.

The LIONEL CORPORATION
Dept. D 48-52 E. 21st Street NEW YORK CITY

LIONEL ELECTRIC TRAINS

MODEL RAILROAD ACCESSORIES

"MULTIVOLT" TRANSFORMERS

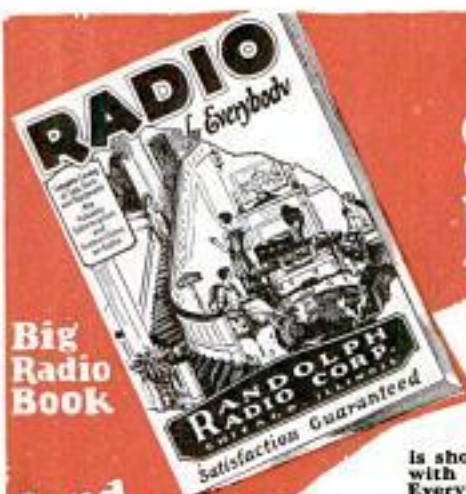

Big
Radio
Book

Send
For it
At Once

FREE

**BIG MONEY-SAVING
RADIO CATALOG**

containing a thousand bargains of everything on radio—parts, supplies, complete parts for sets, complete sets, etc., also a mine of very latest information on all different circuits, complete list of broadcasting stations, and other valuable, up-to-the-minute radio data. Send your name and address on a card or letter. We will send catalog free.

Free Service Department

Our radio engineers will help you solve all your radio problems, and furnish up-to-date information on set construction, operation and improvement. This service is free to customers.



COMPLETE PARTS FOR 5-TUBE NEUTRODYNE RECEIVING SET

Genuine Hazeltine Licensed Neutrodyne Parts Furnished

PARTS FOR 5-TUBE SET:

- | | |
|--|---|
| 1 7x24x $\frac{1}{4}$ Drilled Panel. | 1 .001 Condenser. |
| 2 Thordarson or Columbia Audio Transformers. | 1 .006 Mica Condenser. |
| 3 4" Bakelite Dials. | 35 feet Hook-up Wire. |
| 2 Precision Jacks. | 1 Kit consisting of 3 Hazeltine Licensed Neutrodyne and 2 Neutrodons. |
| 1 Bakelite Rheostat—30-ohm. | 1 Baseboard. |
| 1 Bakelite Rheostat—6-ohm. | 2 Bezels. |
| 1 Bakelite Binding Post Strip. | Complete blue-prints, working diagrams and instructions |
| 7 Marked Binding Posts. | |
| 1 Grid Leak and Condenser. | |
| 5 Bakelite Sockets. | |

\$33⁷⁵

Complete Parts for 2-Tube Harkness Set

7x14 Drilled Bakelite Panel, 2 Harkness Reflex Transformers with Condensers, 2 Dials, 2 Bakelite Sockets, 2 American Bell Transformers, 1 Single Circuit Jack, 1 R. W. Crystal Detector, 1 Bakelite Rheostat 6-ohm, 7 Binding Posts, Baseboard and Busbar Wire, Blue-prints to complete wiring. **\$17⁹⁵**

Acme 1 Tube Reflex set **\$17.45**

Acme 4 Tube Reflex set **\$39.85**

Send For This Sensational Radio Bargain Book-FREE

Order Direct from This Page! Save About One-Half!

Compare our prices with others. Only highest grade nationally known **GUARANTEED** parts. **OUR GUARANTEE PROTECTS YOU.** Money cheerfully refunded if you are not satisfied. Be sure to write your order and state prices plainly. Send post office or express money order or bank draft for total amount to insure prompt shipment. **ALL PRICES ON THIS PAGE INCLUDE SHIPPING CHARGES RIGHT TO YOUR DOOR.** Refer to any bank or commercial agency regarding our reliability. If your favorite circuit

is shown here, order direct from this ad. No skill required to build your own radio with Randolph parts. Panels are all drilled. Instructions are simple and complete. Everything comes ready to assemble. Order direct! All shipping charges prepaid.



COMPLETE PARTS FOR 3-TUBE SUPER-HETERODYNE

- | | |
|---|--|
| 2 23 Plate Bremer-Tully or Duplex Low Loss Condensers. | 1 Bakelite Potentiometer 400-ohms. |
| 3 Remler or Columbia Intermediate Frequency Transformers. | 1 Carter Double Circuit Jack. |
| 1 Remler or Columbia Tuned Circuit Transformer. | 1 Dubilier 1 mfd. Condenser. |
| 1 Special Oscillator Coupler. | 1 .006 Mica Condenser. |
| 1 Midget Condenser. | 1 .0005 Mica Condenser and 2 megohm grid leak. |
| 8 Bakelite Sockets. | 3 .0025 Mica Condensers. |
| 2 Thordarson or Columbia A. F. Transformers. | 1 .00025 Mica Condenser. |
| 1 Connecticut Filament Switch. | 9 Binding Posts. |
| 2 Bakelite 6-ohm Rheostats. | 2 4.5 Volt C Batteries. |
| 2 Bakelite 30-ohm. | 1 7 x 30 x 3-16 Drilled Bakelite Panel. |
| 1 Bakelite Terminal Strip for Binding Posts. | 1 Baseboard. |
| 1 Multicolored cable for connecting batteries. | 35 ft. Hook-up Wire. |
| 2 4" Bakelite Dials. | |

Complete wiring diagram, baseboard layout and blue-prints. **\$59⁷⁵**

Our Guarantee

Every article exactly as represented. Every article is tested before shipping. Complete satisfaction guaranteed or money will be cheerfully refunded.

Our Catalog is Filled With Bargains Like These

CONDENSERS	
23-plate plain Condenser.	\$1.29
23-plate Vernier Condensers	2.59
RHEOSTATS and POTENTIOMETERS	
Bakelite Rheostat, 6-ohm.	.38
Bakelite Rheostat, 30-ohm.	.59
Bakelite Vernier Rheostat, 200-ohm.	1.15
Bakelite Potentiometer, 200-ohm.	.59
TRANSFORMERS	
Randolph Special, 6 to 1.	2.16; 3 $\frac{1}{2}$ to 1. 1.89
Sinclair Special, 6 to 1.	2.55; 3 $\frac{1}{2}$ to 1. 2.24
TUBE SOCKETS and DIALS	
4" Hygrade Dial.	.29
Bakelite Socket.	.28
Weston Plug.	.75
VARIOMETERS	
Moulded Variometer.	2.39
Bakelite moulded.	3.45
HEADPHONES	
Randolph Special, 2200-ohms.	2.45
Blue Bird Special.	3.95
LOUD SPEAKERS	
American Bell.	3.95
With adjustable loud speaker unit.	6.95
COUPLERS and COILS	
180° Variocouplers.	.95
Reinartz Coils.	1.29
Electric Soldering Iron.	.98
Cockaday Coil.	1.65
Three-Circuit Tuner.	2.95

COMPLETE PARTS FOR THE

Improved Four Circuit Tuner
as designed by L. M. Cockaday
\$39.65



COMPLETE PARTS FOR 3-TUBE COCKADAY RECEIVING SET

- | | |
|--|---|
| 1 Cockaday Coil. | 3" Bakelite Dials. |
| 2 23-Plate Hy-Grade Cond. | Grid Leak and Mica Cond. |
| 2 Bakelite Rheostats, 30-ohm. | 7 Switch Points, 2 stops. |
| 1 Bakelite Rheostat, 6-ohm. | 1 Bakelite Binding Post Strip. |
| 3 Bakelite Sockets. | 7 Binding Posts. |
| 1 high ratio Columbia or Thordarson Transformer. | 1 Switch Lever. |
| 1 Single Circuit Jack. | 24 ft. Hook-up Wire. |
| 1 low ratio Columbia or Thordarson Transformer. | 1 7x21x $\frac{1}{4}$ Drilled Bakelite Panel. |
| 2 Double Circuit Jacks. | 3 Bezels. |
| Complete blue-prints and wiring diagrams. | 1 Baseboard. |
| 1-Tube Set. | |

\$19⁹⁵

RANDOLPH RADIO CORPORATION
159 N. Union Ave. Dept. 246 Chicago, Illinois



"Follow us, if you can!"

THEY all take your dust when you open the throttle of the new "Stream-Line" Harley-Davidson!

Everywhere, sportsmen are talking about this 1925 model of the world's greatest motorcycle. Its rakish, stream-line design makes it the classiest mount on the road. It has more speed—more power. It is more comfortable (better springs and bigger tires). *Yet the price is reduced!*

Treat yourself to the thrill of a trial ride on the new "Stream-Line" Harley-Davidson. Test the speed, power, and vibrationless comfort of this marvelous motorcycle. But look out for "speed cops"—most of them have Harley-Davidsons too!

Ask your dealer for a free demonstration ride and his Pay-as-You-Ride plan. Send us the coupon (below) today.

Harley-Davidson The Motorcycle

For a Wonderful Christmas!
A handsome, glistening Harley-Davidson "Stream-Line" for Christmas—and for service and sport the year 'round!



Money-making sales opportunity in open territory. Write for particulars.

HARLEY-DAVIDSON MOTOR CO., Dept. P. Milwaukee, Wis.

Send me free literature showing new "Stream-Line" Harley-Davidsons in actual colors.

Name _____

Address _____

City _____

Trade Mark Registered

WURLITZER

THE WORLD'S LARGEST MUSIC HOUSE

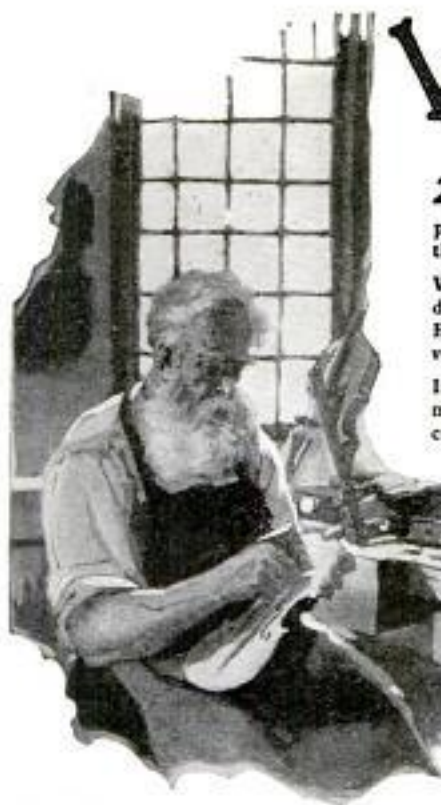

200 Years Ago in the little Saxon town of Schoeneck lived Hans Adam Wurlitzer, Master Violin Maker. His shop was a gathering place for musicians of the time, for he was a true craftsman—the artisan upon whose work the genius of the artist must depend.

When he died his shop passed into the hands of his eldest son, and for seven generations, down to the present day, the descendants of Hans Adam Wurlitzer have carried on his work. Each succeeding generation has added a wider experience as new instruments have been developed, and a greater technical skill as methods of instrument building have been improved.

In every Wurlitzer instrument you will find a quality, a character, that could not come from mere excellence of manufacture. It is the heritage of these seven generations of music-craftsmanship.

Try Any Wurlitzer Instrument in Your Own Home

YOU may now have any Wurlitzer instrument for a week's free trial in your own home. Examine the instrument, show it to your friends, play it as much as you wish. No obligation to buy—no expense for the trial. We make this liberal offer because we want you to see for yourself the superior quality of Wurlitzer instruments, the result of 200 years' experience in musical instrument building.

Leading professionals everywhere recognize the artistic quality of Wurlitzer instruments. Ysaye, the great virtuoso; Salvi, internationally famous as a harpist; Carl Preble of Sousa's band; Justin Huber, leader of the well-known syncopated orchestra of that name—artists of the highest standing in every sphere of music use Wurlitzer instruments and recommend them to others. They speak especially of the ease of playing, a feature that is of importance to the amateur as well as the professional.

Easy Payments

If you decide to buy after the week's free trial, payments are arranged in small monthly sums. A few cents a day will pay for your instrument. By buying direct you obtain genuine Wurlitzer quality at moderate prices. Special offers on complete outfits—velvet lined case, all accessories, self-instructor, etc.—all you need at practically the cost of the instrument alone.

Send for New Catalog!

The greatest musical catalog ever published! Over 3,000 articles—every known instrument described and illustrated; many of them shown in full colors. Gives you lowest prices and all details of Free Trial, Easy Payment plan. All sent FREE—no obligation. Send the coupon today.

Fill out this coupon and mail to address nearest you



THE RUDOLPH WURLITZER CO., Dept. 1779
120 W. 42nd St., New York 117 E. 4th St., Cincinnati
329 S. Wabash Ave., Chicago 250 Stockton St., San Francisco

Send me, absolutely free, your new illustrated catalog, with prices and description of every known musical instrument. Also tell me how I may try any instrument in my own home and pay for it in small monthly sums. No obligation.

Name _____

Address _____

City _____ State _____

Instrument _____
(State instrument in which you are interested)

Copyright, 1924, The Rudolph Wurlitzer Co.



Exclusive features give Erla Miniloss Condensers high efficiency. Dielectric and resistance losses absolutely minimized. Compensating plate form. 5 to 41 plates, priced \$3.50 to \$5.50 each.



Uncanny smoothness and sensitiveness bespeak the advanced design of Erla Precision Rheostats. Single hole mounting eliminates need for disassembly. 6, 25, or 40 ohm. Price, \$1.10 each.



Built for permanent true running; with Bakelite knob shaped for sensitive touch; and highly artistic calibration, Erla dials better any panel. Three sizes for $\frac{1}{4}$ " shaft. Price, 50c to \$1.25.



Adding to receiver efficiency is the advanced Erla Loop. Rigidly erected—compactly folded—easy in rotation—beautifully finished. Standard and De Luxe models, \$7.50 and \$10 respectively.



CIR-KIT builds new Supereflex— Greatest of Erla Circuits

Erla led the radio amateur out of the wilderness of circuits. Erla initially introduced exclusive circuit ideas which made radio history, particularly because those ideas have uninterruptedly kept Erla circuits in advance of contemporary radio.

Remarkably significant is the fact that so many thousands of seasoned experimenters, once attracted to Erla circuits, consistently adhere to Erla. So there is a note of finality when Erla now announces the new Erla Supereflex Circuits. They represent highest development of the inherently superior Erla principles, acknowledged responsible for the most powerful circuits ever built, tube for tube.

Bringing these latest and finest circuits within the reach of everyone is the Erla CIR-KIT, effecting not only extreme economy, but also greatest ease of construction. Only

screwdriver and pliers are needed to transform any Erla CIR-KIT quickly and skillfully into the most efficient of radio receivers.

CIR-KIT provides you with *everything*, including specially designed Erla Synchronizing Transformers, Erla Certified Capacity Condensers, Erla Cushion Sockets, and finally Erla famous Solderless Connectors, banishing all solder difficulties. Each unit and connection is unerringly located through full-size blue-prints; drilled, lettered panel; and stenciled baseboard.

With Erla CIR-KIT you yourself can confidently and proudly put into finished form the highest achievement of Erla radio engineers—Erla Supereflex Circuits. CIR-KIT receivers of one to five tubes are available, in loop and antenna types. See the Erla dealer, or write direct, mentioning your dealer.

ELECTRICAL RESEARCH LABORATORIES
Department J, 2500 Cottage Grove Avenue, CHICAGO

ERLA

Circuits of Certainty

\$3 with the coupon

Brings This Typewriter On Easy Terms



5 Year Guarantee

10 DAYS TRIAL

In Your Home or Office

Only **15c** Per Day

Buy This Royal 10

Think of it! Securing this latest model Royal 10 fully guaranteed, with all latest improvements for about half the original factory price. Simply send us \$3.00 with the coupon and we will send the Royal for ten days' trial without obligation to buy. After trial, and when entirely satisfied send us only \$5.00 per month until our low direct-from-factory price, \$58.00, has been paid and the machine is then yours. We give you the same guarantee as if you paid the original factory price.

Net cash price only \$52.20 Direct from our factory to you.

Young Process Re-Manufactured

The famous "Young Process" means a mechanically perfect operating typewriter, guaranteed like new. Every typewriter is completely torn down, cleaned thoroughly by our special process; hand-brush enameled, baked in our special ovens; highest quality nickel-plated; all worn, weak or faulty parts replaced with new parts, entire machine completely assembled, adjusted and perfectly aligned by specialized typewriter experts.

You cannot tell the "Young Process Re-Manufactured" Royal from a brand new typewriter in appearance, service and workmanship. Comes to you guaranteed for five years at about half original factory price.

Young Typewriter Co.
654 W. Randolph, Dept. 210C, Chicago

This is your opportunity to actually use this Royal 10 Typewriter for ten days without obligation to buy. Compare it and its work with all other typewriters. You will readily see why hundreds of thousands of typewriter users prefer the Royal. Simply fill in the coupon and mail at once. We will send the Royal for ten days' trial without obligation to buy. You must be entirely satisfied in every way that this is the greatest typewriter bargain ever offered.

Act Now

There are only a limited number of these Royal Typewriters at our low direct-from-factory price. So rush your order NOW.

Order Coupon

YOUNG TYPEWRITER CO., Dept. 210C
654 W. Randolph St., Chicago, Ill.

You may send me the Royal 10 Typewriter, fully guaranteed, on ten days' trial, express charges collect. I enclose \$3.00 deposit and will pay you \$5.00 monthly rental for 11 months when the machine becomes mine. It is understood that title remains with you until all payments are made. Also that I may return the typewriter, at your expense, within the trial period, if I choose not to keep it and you will refund my deposit.

Name

Street Address

City..... State.....





Without this tree modern athletics would be impossible

WHETHER it's tennis or basketball—football or baseball—nearly all sports depend to some extent on the product of one tree!

That is the rubber tree.

Without rubber many games would have to be played quite differently—or not at all.

Rubber is made from latex—a milky-white fluid—that oozes from the bark of the rubber tree. Rubber trees are now grown in well-tended plantations. The largest rubber orchard in the world is owned by the makers of Keds. In it is produced today some of the finest rubber known.

It's this rubber that gives to the Keds sole a lightness and spring that ordinary rubber can never impart. It explains why Keds soles are so tough and wear so long.

Keds vary in price according to grade, size and style—from \$1.25 to \$4.50.

It is important to remember that Keds are made only by the United States Rubber Company. And every Keds shoe has the name Keds on it. No other shoe can give real Keds service.

The Keds Hand-book for Boys is full of things every boy will want to know about—how to make things, rules for games, woodcraft, etc. Sent free if you address Dept. 736, 1790 Broadway, New York City.

United States Rubber Company



A sturdy athletic-trim Keds model—popular everywhere

Keds

Trademark Reg. U. S. Pat. Off.

They are not Keds unless the name Keds is on the shoe

Please Mention Popular Mechanics

FREE

140-page Book full of life-size ruled forms, each one completely filled in. The answer to problems of accounting and record keeping for any business or profession.

Send for this FREE Book today
John C. Moore Corporation
(Established 1839)
2168 Stone St., Rochester, N. Y.

MOORE'S LOOSE LEAF SYSTEMS

In Use In More Than 300,000 Offices

TOPS

Ford Touring Top and Back Curtain

32 oz., \$5.25; 36 oz., \$6.25; Side Curtains, \$5.95; Door-Opening type, \$6.95; Back Curtain, regular, \$2; Gypsy type, \$4. Ford One-Man Top, fits 1915 to 1922 model, all new bows and side curtains, \$25. Chevrolet, Dodge, Overland 4 tops, 34 oz., \$9.75; double texture, \$12.25. 6x18 glass Gypsy Curtain extra, \$2. Tacks, etc., furnished ready to put on. Delivered 1000 miles.

Vanderpool's Top Factory, Dept. 12P, Springfield, Ohio

Mount Birds

Taxidermy Book FREE

We teach you by mail to stuff and mount all kinds of Birds, Animals, Game Heads. Also to tax skins and make rags. Be your own taxidermist. Decorate your home with your beautiful trophies or increase your income selling specimens and mounting for others. Easily, quickly learned in spare time by men and women. Highest endorsements by thousands of students. Write today for our great free book "How to Mount Birds and Animals" Free—write today.

N. W. School of Taxidermy, 1779 Elwood Bldg., Omaha, Neb.

Diamonds Here at 60% of Market Price

Free Bulletin lists diamonds as low as \$50 per carat, also Gems of Finest Quality at higher per carat charges, but proportionately Low Bargain Prices. This 5.4 less 1-16 carat, correctly cut diamond, a snappy blurring solitaire at \$58.99. This 75 year oldest largest Diamond Enabling Firm in all the world lends money on diamonds. Thousands of unpaid loans and other bargains. Many from big cash deals direct with European Diamond Cutters. Must sell NOW.

WHY PAY FULL PRICES

Costs Nothing to See

Any Diamond sent for absolutely free examination at our risk. No obligation. No cost to you. Latest Listings—Unpaid Loans. Sent Free. Describes Diamond Bargains in Detail, gives cash loan values guaranteed. Explains unlimited exchange privilege. Write Today for your copy of Diamond Bargain List. Postal card will do.

1927 De Roy Building
Pittsburgh, Pa.

Only Deposits Post Office

\$68⁵⁰
3/4-1/16
Carat
Correctly
Cut

A Wise Old Trapper

In the state of Ohio there lived a bunch of boys who had this trapping business down to a science. They each sent for separate price lists every year and then sent all their furs to the house giving the best quotations. After five years they decided they weren't so dreadfully wise because they didn't have enough profits to make their efforts worth while.

One day they met Tom McMillan driving a new car to town. Tom said he made the price of his swell outfit shipping pelts. He told how he got wise to those funny prices and found it was better to deal with Chas. Porter because he always knew in advance just what he was sure of getting. He said that Porter never offered \$5 for a \$3 pelt but he always paid the \$3 which he promised and sometimes a little better. Chas. Porter now has five wise trappers in that section instead of one.

Don't Take a Chance With Your FURS

Send us your name and address. Get our Price Bulletin, Shipping Tags, and full particulars. Do it right now. This means real dollars to you, so don't put it off. Write today.

Your furs mean real dollars to you. Why sell them to some fellow who offers you \$1.25 when you know blame well you are lucky to get fifty cents. Ask the wise trapper who knows. Once a Chas. Porter shipper and you will always be one. You know in advance that we give a square deal and every shipment brings sure money.

CHARLES S. PORTER, INC.

123 West 27th Street

New York



CAMERAS

Over a Hundred Styles and Sizes
Send for new illustrated catalog showing latest reduced prices. It's Free.
10 days' trial given

SENECA CAMERA MFG. COMPANY
300 Central Avenue Rochester, N. Y.

TRAPPERS

Make This a Big Season!

TRAP early and long! Get full value by shipping to McCullough & Tumbach. Our graders know the market—they pay every cent a skin will bring.

We guarantee our prices to top the market—and your check goes out the day the furs come in.

SHIP FURS NOW!

For 31 years our business has grown by honest dealing. Ask any old-timer—then send us a shipment. The check will prove every word we say.

Free: Shipping tags, price lists; trappers' supply catalog.

McCULLOUGH & TUMBACH
129 N. Main St., St. Louis, Mo.



Nature's Rogues
Gallery No. 6

Weasel tracks—
two-fifths actual
size

The Weasel—One of the most ferocious little beasts alive. Kills from sheer lust of slaughter.

A sure way to bring down nature's thieves —a sharp-shooting Sporter

THERE are over thirty relentless birds and beasts that prey upon our crops and useful wild life. Stop this destruction with your Savage Sporter.

In this trim little rifle you have six shots always ready—and a smooth gliding bolt-action that will feed them up quickly and surely. And as for accuracy—that's the Sporter's middle name—for it's built with all the finest features of military rifles—to shoot straight.

Just take one look at the lines of this trim little beauty. Not an extra bit of weight anywhere—yet steady and true to hold.

No matter what you want to shoot—no matter what you want to pay—you will find a Savage .22 that is just what you're looking for. Write us today to send you an illustrated catalog describing Savage fire-arms.

SAVAGE ARMS CORPORATION

Dept. 21, Utica, N. Y.

Owners and Operators of the
J. Stevens Arms Company



The Savage Sporter

Bolt-action repeating rifle, round blued barrel, genuine American walnut stock, varnish finish, pistol grip, interchangeable magazine.

Model 23A .22 cal. \$19.50
Model 23B .25-20 cal. 23.50
Model 23C .32-20 cal. 23.50

SAVAGE STEVENS



DEAF?

Then here's
a new deal
and a
Square Deal

Amazing new hearing aid
—finest and smallest in
the world

AT HALF USUAL PRICE

FREE FULL WEEK'S TRIAL

Physicians and deaf folks have long complained of the high prices of hearing aids. Now this protest has been answered by a new and tiny device called THE AURIS —priced at less than half the price of other methods.

But the AURIS has gone further than substantial price reduction. It has fulfilled the dream of all Aurists and ear-specialists for a perfect hearing aid—in minimum size and weight.

Although the smallest device of its kind in the world, it is the most powerful and efficient. Worn practically concealed, it acts as a third ear to the deaf —enabling impaired ear nerves to hear any sound a normal ear can hear — clearly, distinctly, resonantly, without mechanical distortion. Gives natural hearing, with full tone values. Perfected by Radio Engineers from new Radio sound principles.

Know the happiness of clear, easy hearing again. End the lonely isolation of deafness. You may try THE AURIS a full week without a penny of risk or expense. Without a deposit or payment of any kind. Just send your name, address and free trial request to THE AURIS COMPANY, Room 405-F, 141 W. 40th St., New York City. If the Auris does not make you hear, return it and you will not be charged one cent.

AURIS
SCIENCE'S NEW GIFT TO THE DEAF
AURIS
TRY IT A FULL WEEK FREE

SWEATERS Any Style or Design for Men, Women, Boys, Schools, Clubs, Teams
Order direct from mill. Save 20% to 30%. Any style, color or size, from stock or to order. Finest virgin wool. Send now for free catalog of big bargains. Special offers to schools, clubs, teams.
AMERICAN KNITTING MILLS, 1536 Clayson Ave., Dept. 48, CHICAGO



"If I hadn't been all through it myself, I wouldn't have the assurance to say to you 'cheer up.'"

ERICKSON.

Those who wear them say:
ERICKSON LEGS are Wonderful
because they do not chafe, overheat or draw end of stump.



If you have had a recent amputation send for new booklet on TEST LEGS for beginners.
E. H. ERICKSON CO.
38-A Washington Av. N.
MINNEAPOLIS - MINN.

Copyrighted material

At least **20%**
Coal-Saving Guaranteed
to every user of the CROWN Fuel Saver

Put that 20% saving in dollars and cents. Figure it up on the amount you spent for coal last year. Add up how much a 20% coal saving means to you over a five or ten year period—and you'll decide that the inexpensive CROWN Fuel Saver is worth while investigating.

Money Refunded

The CROWN guarantee is absolute. Attach this amazing coal-saver and heat-producer to the feed door of your heating plant and you must make an actual saving in fuel of at least 20%—or your money will be refunded without question. 20% is the minimum coal-saving possible with the CROWN; some users obtain yearly savings of 30%; others as much as 50%.



Begin your coal and money-savings NOW

Get cleaner, steadier heat that will keep your home comfortably warm; make less trips to fire the furnace; eliminate smoke and deadly gases by attaching the CROWN to your furnace.

Write today for full details of this guaranteed coal-saver and heat-producer.

C F S CO., 412 N. 10th St., Richmond, Ind.

Distributors Wanted. High-grade men can build profitable businesses in their communities. Write for interesting proposition.

Ranger \$5 a Month

Finest bicycles built—44 Styles, colors and sizes. Factory-to-Rider prices. FREE delivery, express prepaid on 30 Days Free Trial. Cash or easy payments. Bicycles, \$21.50 and up.

Tires, lamps, wheels and equipment at half usual prices. Send no money. Write today for big catalog, special factory prices, free trial plan and marvelous offers.

Mead CYCLE COMPANY
DEPT. 108 CHICAGO

Write today for free Ranger Catalog, factory prices and marvelous easy payment terms.



Clear-Tone
FOR
PIMPLES
Your skin can be quickly cleared of Pimples, Blackheads, Acne Eruptions on the face or body, Enlarged Pores, Oily or Shiny Skin. \$1,000.00 Cold Cash says I can clear your skin of the above blemishes. WRITE TODAY for my FREE Booklet—"A Clear-Tone Skin"—telling how I cured myself after being afflicted for fifteen years.
FREE
E.S.GIVENS, 129 Chemical Bldg., Kansas City, Mo.

Genuine KEYSTONE MOVIEGRAPH

(PATENTED)

SHOWS BIG SIZE MOVING PICTURES

Safe for \$6.95 Non-Inflammable Safety Films
the Home Reel of Tom Mix Given FREE

The following reels are only a few in the film catalogue, and are genuine, posed by the actors themselves. The film is the same size as used in the theatre.

Charlie Chaplin in "Making Pies"
Wm. S. Hart in "Western Train Robbery"
Tom Mix in "The Battle on Horseback"

Also Slides, Drawing Slides, Theatre Tickets, etc., included.

Every live boy should have at home or club a Keystone Moviegraph that shows pictures the same as in the movies with powerful French lenses and constructed along professional lines.

The electric cord is included for connecting to any lamp socket your electric bulb will fit. Can also be had for any Dry Cell Batteries for the home without electricity.

Nothing to get out of order. No complicated parts. We have the largest comedy film service in the country for home machines.

Size of machine all set up is 10 by 8". Weight 3 lbs.

Send Money Order or check. Guaranteed to give good big pictures or your money back. Reference American Trust Co., Boston Mass.

Order your machine today in time for Christmas

Price for Machine and Reel \$6.95 complete, prepaid in U. S. Genuine Keystone Moviegraphs Patented 1919, 1920, 1921.

LIBBEY & NICHOLS
Dept. P

100 Boylston St., Rm. 630, Boston, Mass.

AGENTS 500% PROFIT
GENUINE GOLD LEAF LETTERS**S** guaranteed to never tarnish. Anyone can put them on stores and office windows. Enormous demand, large profits. Paul Clark says: Smallest day \$28.70. R. L. Reel made \$920 in two months. Write today for free sample and liberal offer to general agents.
METALLIC LETTER CO., 433-B N. Clark St., CHICAGO**I Offer You \$8.00 a Day and a**Write today for offer. \$8.00 a day to start and a Buick touring car if you make good. Demonstrate and take orders for Comer All-Weather Raincoats. Permanent, high-grade business. Largest company of its kind in the world. No experience required. We furnish complete outfit and instructions. Write now.
Comer Mfg. Co., Dept. BW-5101, Dayton, O.**MINT VENDING MACHINE****Pays \$10 to \$20 Day Profit****Pays Rent for Store Owner**

Install one in your store or any public place and get this easy money. Requires no attention. Always works. Machine's profits pay the rent. Write us about rebuilt penny and nickel machines. Finished like new. In excellent running order. Pay their cost in 10 days.

Write or wire today for full particulars. \$25 down payment. Balance C. O. D. Export orders full down payment. Mints \$15 per case, 1,000 5 cent packages. Single boxes, 100 5 cent packages, \$1.50.
SILVER KING NOVELTY CO.
400 Williams Bldg., Indianapolis, Ind.**LOFTIS BROS. & CO. EST'D 1858****The Best Christmas Gift of All—A Diamond Ring**Buy of **LOFTIS**, the Direct Importer. Our Diamonds are exquisitely beautiful, high-grade, **QUALITY** gems, Blue White, of dazzling brilliancy—the finest offerings of the European Diamond markets. Personally selected by our expert Diamond buyers.

We invite comparison of quality and prices

Send for Catalog

Over 2,000 illustrations of Diamond-set Jewelry, Watches, Wrist Watches, Pearls, Mesh Bags, Silverware, etc. Sent prepaid for you

FREE EXAMINATION**TERMS:** Goods delivered on first payment of one-tenth of purchase price; balance in equal amounts, payable weekly, semi-monthly or monthly, at your convenience.

Satisfaction Guaranteed or Money Refunded

Cash or Credit**WRIST WATCH**

No. 49—Gold 18-k White Gold, 17 Jewels, \$49. Delivered on first payment of \$4.00, then

\$1.00

A Week

**17-Jewel Elgin**
Guaranteed 25 Years

No. 15—Green Gold, engraved. Assorted patterns. 12 Size, gift dial, \$30. Delivered on first payment of \$3.00, then

\$1.00

A Week

No. 34
Blue White Diamond, 6 Sapphires, Platinum, \$300. Only \$20 down, then
\$7.50
A WeekNo. 33
Blue White Diamond, Solid 18-k White Gold, \$75. Only \$7.50 down, then
\$1.75
A WeekNo. 12
Blue White Diamond, Solid 18-k White Gold, \$50. Terms, \$5 down, then
\$1.25
A WeekNo. 35
Blue White Diamond, 14 18-k White Gold, \$37.99. Pay \$5.75 down, then
\$1.00
A WeekNo. 27
Dazzling Blue White Diamond, Solid 18-k White Gold. Price \$100. Pay \$10 down, then
\$2.50
A WeekNo. 36
Blue White Diamond, Solid 18-k White Gold, \$125. Only \$12.50 down, then
\$3.25
A Week**LOFTIS BROS. & CO. EST'D 1858**
NATIONAL JEWELERS
DEPT. G-894108 N. State St., Chicago, Ill.
Stores in Leading Cities**Send for Christmas Catalog today**

Please Mention Popular Mechanics

Copyrighted material

Only 127 Motors

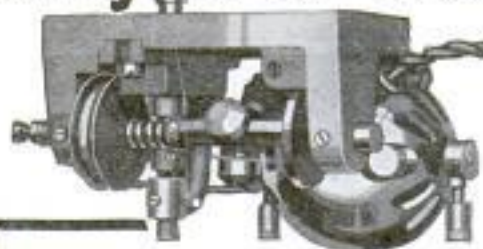

Left at
\$10
Each

Ideal for home-made phonographs, experimental purposes and combination **phonograph-radio** sets.

We have 127 small motors which are greatly under-priced for quick clearance. You will never again equal this low price, when this lot is sold.

They are **universal motors**, 110 volts, 60 cycle single phase, complete with turntable, cord and socket for immediate use. 1400 R. P. M. Motor has 1" pulley with flange for 3/4" flat belt. Housed in highly polished, nickel-plated shell.

Don't lose out on this remarkable offer. Order your motor today. Tomorrow may be too late. **DO IT NOW!** Price, **\$10.00** f. o. b. Steger, Illinois.

Industrial Division

Steger & Sons Piano Manufacturing Company
Dept. 50, Steger Building CHICAGO, ILLINOIS

FREE! NEW MONEY SAVING BOOK



RANGES
\$37.75
UP

Buy direct from factory! Save 1/4 to 1/2 on your stove, range or furnace. Take advantage of the biggest SALE in our 24 years. Kalamazoo quality is the

highest prices are at bedrock. This is the year to buy. Send for our big, new catalog—



FURNACES
\$59.95
UP



STOVES
\$27.20
UP

it's full of new ideas, new features, new models. 200 bargains in heating stoves,

gas ranges, combination ranges, coal ranges, furnaces, both pipe and pipeless, and household goods. Cash or easy payments. 30 days' trial. Money-back guarantee. Quick, safe delivery. 530,000 pleased customers.

Write today for Your FREE Book Now Ready

KALAMAZOO STOVE CO.
400 Rochester Avenue
KALAMAZOO, MICHIGAN



A Kalamazoo
Direct to You

\$1 down brings any Instrument!

Genuine Bacon Tenor Banjo
Choice of all famous Bacon Banjos. Most beautiful, excellent toned. Brand new, \$1 brings it! Balance 10 months.
\$43.50

Our Liberal Terms
make it easy to secure your Saxophone, Trumpet, Cornet, Banjo or any other musical instrument at once. Don't Wait! Small down payment, balance in amounts you won't miss. Learn to play, start a band or orchestra, enjoy real fun!

C Soprano Saxophone
The wonderful S & S with the human voice singing tone. Learn to play in a few lessons at home! It's a "Standard" — our own famous make—World's finest quality, brand new, only **\$87.50**

Clarinet
Slightly used, rebuilt like new, price less than one-half. Our catalog shows all musical instruments, brand new standard makes, and bargains in rebuilt instruments. This one only **\$16.50**

Get This Book Quick!
Easy payments on all musical instruments. Supplies, repairs, music, plating, etc. Get this money-saving Catalog immediately!

10 Months to Pay! Standard Music Co., established 19 years. Deal with reliable house which stands back of any instrument with money back guarantee. Send only \$1. Pay balance in 10 months at such prices!

STANDARD MUSIC CO., Dept. 2222
214 So. Wabash Ave. CHICAGO

Catalogue FREE!

MOVIES In Your Home

Our marvelous, practical Movie Machines sell as low as \$3.75 postpaid, and use same size film as big theatres. We also have wonderful films at lowest prices—with a new film exchange service. Don't Miss This!

Write NOW for Free Catalogue

PARAMOUNT MFG. COMPANY Dept. M7
Boston, Mass.

AGENTS—100% PROFIT

Our newly patented electrical accessories making big profits for agents. Absolute necessity in every home. Send **only 30c deposit** for sample and full details, and convince yourself. We gladly return your money as soon as you show us business—or, if you don't like our proposition, return the sample and you will get your money back. You can't lose. Don't pass this by. Write now.

THE LYMAN ELECTRICAL MFG. CO.
Flatiron Building New York City

BRILLIANT SEARCH LIGHT

Powerful Long Range Carbide Head Light, Bull's Eye Type, with darkening door, complete with gas hose and generator to wear on belt. Thousands in use all over world. Ideal for hunting, trapping, fishing or any outdoor use. Order yours today.

PRICE \$9.75
POSTAGE PAID

BRILLIANT SEARCH LIGHT MFG. CO., 508 South Dearborn Street, Dept. P, CHICAGO, ILL.

EXCEPTIONAL BARGAIN \$7.95

Limited Time Only
Gents' 14 kt. gold filled Watch. Thin model, fancy engraved case, 10 jewel Lever movement, adjusted and regulated stem wind and set. Regular \$15.00 value. Our special price only \$7.95 plus 12c postage. **FREE** a handsome 14 kt. gold filled Waldmar chain and knife if you order promptly. Pay postman on arrival. Satisfaction guaranteed or money refunded. Watch set in handsome velvet lined gift case. Order today.

SUPREME JEWELRY MFG. CO.
434 BROADWAY
New York City
Dept. 153



W. L. Douglas

'5, '6, '7 & '8 SHOES

BOYS AT \$4.50 & \$5.00

Women of fashion should know that our women's shoes are high-class, made in the most distinctive, up-to-date and exclusive styles, which appeal to those who desire stylish, comfortable and serviceable shoes at reasonable prices.



New
Tan Oxford
for Women
Attractive pattern in
light Russia calf with
Storm Welt. \$6.50



W. L. DOUGLAS PEGGING
SHOES AT 7 YEARS OF AGE



New
French Toe
for Men
Smart style in light
Russia calf at a popular
price. \$6.00

WEAR W. L. DOUGLAS SHOES AND SAVE MONEY

FOR 38 YEARS, W. L. Douglas' name and portrait have stood for quality, for economy and for satisfactory service. W. L. Douglas shoes are exceptionally good values. Only by wearing them can you appreciate their superior qualities. *The exclusive, smart models, designed especially for young men and women, are leaders everywhere.*

W. L. DOUGLAS \$7.00 SHOES are remarkably good value. Seldom have you had the opportunity to buy such *high-grade* shoes at this popular price. Shoes of equal *quality, comfort and service* are rarely found in other makes at our prices.

WHEREVER YOU LIVE, demand W. L. Douglas shoes. They are sold in 120 of our stores in the principal cities and by over 5,000 shoe dealers. For *economy and dependable value*, wear shoes that have W. L. Douglas' name and the retail price stamped on the soles. The *stamped price guarantees the value*. If not for sale in your vicinity, write for catalog.

W. L. Douglas Shoe Company, 128 Spark St., Brockton, Mass.



BUILD YOUR OWN PHONOGRAPH

WITH OUR HELP—SAVE HALF

Choraleon Aristocrats are unexcelled. Play any record. Finest motor, tone arm, case materials, blueprint, full instructions at LOW COST. Write for catalog and FREE Blueprint offer.

Choraleon Phonograph & Radio Co.
1224-1st St., Elkhart, Ind.

WANTED To refill your "MODERN" DUPLICATOR TRAY with new Composition. Mail empty tray to us today. No charge except for necessary material.

Durkin, Reeves & Co. (Formerly Pittsburgh, Pa.)
RIDGWAY, PENNSYLVANIA

SALESMEN

Salesmen wanted to sell Chase Furwove Motor Coats in every city and town in the United States. A splendid opportunity for salesmen seeking a proposition which will net \$60.00 to \$150.00 per week. For particulars, write to The Owen Company, 99 Chauncy St., Boston, Mass.

FREE Your Name **\$175 VALUE**
Inlaid in Gold NEVER SOLD FOR LESS



THE PERFECT WRITING INSTRUMENT

The New Improved **INKOGRAPH** Writes like pencil with ink better than good fountain pens. Won't scratch, leak, clog or soil hands. Makes 3 or 4 carbons. 18 kt. gold point, shaped like fine lead pencil point. Guaranteed. **SEND NO MONEY**. Pay postage \$1. plus postage. Agents wanted.

INKOGRAPH CO., Inc., 163-C Centre St., New York

PLAY INSTANTLY WITHOUT PRACTICE

PRICE CUT TO ONLY \$5.95

JAZZ-BO SAX

Not a toy but a full throated, full sized quality built reed wind instrument. One that you can be proud to own and play. Instantly made with heavy highly polished throat and bell. Can be used for Solo work, accompanying, and in bands and dance orchestras. You play the Jazz-Bo Sax at once—the secrets of success. No knowledge of music required, no tedious lessons or long months of practice, for with each Jazz-Bo Sax even at the new low price of \$5.95 you get our wonderful Method enabling you to actually play popular Jazz the first time you take this handsome sax in your hands. Entertain others and be the envious center of attraction wherever you go.

FREE receive **FREE** our wonderful new Easy Method, 30 pieces of music, and a fine Carrying Bag enabling you to take your sax with you wherever you go.

SEND NO MONEY Pay postman only \$5.95 plus a few pennies postage on delivery. If you are not satisfied just send it back and your money will be immediately refunded under the terms of our legal money back guarantee. No favor offer can be made. **Send at once.**

C. F. JOHNSON & CO. Dept. M280
19 W. Jackson Blvd. CHICAGO

© 1924
SEND NO MONEY

Make This 30 Minute Test



6 DAYS FREE TRIAL

HERE is an opportunity for you to prove to yourself that the new York Saxophone is the easiest of all instruments to play. Send no money. Simply take advantage of our offer. You will get the surprise of your life when you have played it 30 minutes. Many play popular music in a few days. Why not? The York blows easily—fingering is almost as simple as the piano keyboard.

EASY PAYMENTS

Why not give yourself this opportunity to make spare time money, to increase your popularity or even enter the pleasant money-making musical profession? If you decide to keep the Saxophone you have nearly a year to pay, under the easy York Plan. This also applies to any other York instrument. Mail coupon immediately for interesting catalog and full particulars.

J. W. YORK & SONS

Dept. 124-L Grand Rapids, Mich.

J. W. YORK & SONS,
Dept. 124-L, Grand Rapids, Mich.

Please mail without cost or obligation your beautifully illustrated literature and Free Trial Easy Payment Offer.

Name.....

Address.....

City..... State.....

Instrument.....

WHITE FLAME

BURNERS make your oil kerosene lamps and lanterns give a brilliant white light better than electricity or gas. Doubles your light. Saves oil. NO MANTLE TO BREAK. Guaranteed Safe and Reliable. Delights every user. Send now for complete sample postpaid 50 cents, stamps or coin. 3 for \$1.25. Money Back if Not Satisfactory. Live Representatives Wanted. Exclusive Territory. WHITE FLAME LIGHT CO., 68 Clark Bldg., Grand Rapids, Mich.



Hand Forged
Razor Steel
Blades, No. 57



A GENUINE \$2 KNIFE
FOR
\$1.18 POSTPAID

Direct at Factory Prices

This \$2 KNIFE \$1.18 Postpaid
Hand Forged Razor Steel Blades
Handy shaped Blade makes this knife best for mechanics, sportsmen and farmers; light but strong; re-sharpened easily. Stag handle. German silver finish; blades file tested, hand forged from razor steel and warranted.

Sample \$1.18 3 for \$3.00 Postpaid.

Send for our 100-page List and "HOW TO USE A RAZOR" FREE

MAHER & GROSH CO., 106 A St., Toledo, Ohio

BE YOUR OWN FIXER WITH SMOOTH-ON No. 1

— and save your repair money for bigger things.

Cracked heating boilers, radiators, water pipes, tanks, leaky ovens, furnaces, stove pipes, loose handles, leaky automobile radiators, hose connections, gas tanks, cracked water jackets and gear cases, loose nuts, grease cups and hub caps are usually a snap to repair with Smooth-On

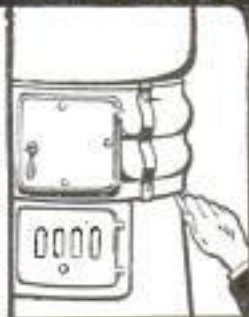

No. 1—and with a saving of anywhere from 25c to \$25 each time.

Get this Booklet Free

Get a 6-oz., 1-lb., 5-lb., or 10-lb. can of Smooth-On (from any live supply store) and you'll find that, for the few cents spent, you'll save many dollars.

The repair booklet which we send free if you mention this magazine, will help you to get good results.

SMOOTH-ON
REPAIR
BOOK

SMOOTH-ON MFG. CO.
Dept. 37, 574 Communipaw Ave.
JERSEY CITY, N. J.

YOU CAN MAKE \$26⁴⁸ DAILY

Selling Two Shirts For the Price of one

The Walton-Duplex Shirt is remarkable—exactly the same on both sides. This means double the wear of any ordinary shirt. You are really selling two shirts for the price of one! Frank Cherry, Duluth, Minn., says: "I made \$26.48 in commissions the first day. \$655 in 48 days." You can equal or better his success.

Pay Advanced — We Deliver

Build up a big business income selling the greatest development in men's shirts ever conceived. Fifty new fall patterns. Get our new booklet "Your Opportunity" and our unusually liberal proposition to wholesale retailers. Write AT ONCE.

WALTON-DUPLEX CO.

626 Brooks Bldg. Chicago, Ill.

AGENTS

Make \$10 to \$20 daily selling Premier Knife and Scissors Sharpeners.



200% PROFIT

or more. 9 out of 10 women buy. Produces keen edge quickly. Sells for 50c.

PREMIER MFG. CO.
Dept. 29, DETROIT, MICH.

FOR more than 50 years Spencerian Personal Steel Pens have been the standard of the world's writers. 50 different styles and sizes to choose from—fine, medium, stub or dome pointed. One that best fits your taste and handwriting is here. Seven hand processes and special Spencerian steel make these the smoothest writing, longest lasting pens that you can possibly buy.

Mail 10 cents to-day for 10 sample pens and interesting free booklet, "What your handwriting reveals."

SPENCERIAN PEN CO.
349 Broadway New York



One of
50 styles

No. 40—Medium point,
silvered Falcon.

Spencerian Personal Steel Pens

Beautiful HOUSES \$900
and BUNGALOWS

CAN BE BUILT FOR AND UP

This and many others in my new book, Building Plans for Modern Homes, will save you hundreds of dollars. One of the most complete and comprehensive books of plans ever published by any architect. New edition just off the press. Nearly 500 floor plans and photographs of bungalows, Colonial houses, etc., costing from \$200 up; gives sizes and cost to build. Sent postpaid for \$2.00.



FREDERICK H. GOWING
ARCHITECT
101 Tremont St., BOSTON, MASS.

Self-Filler DE LUXE Style Pen

"INDEPENDENT"

All the best features of a Fountain Pen. Lasts longer. Writes smoothly. Improves handwriting. Eliminates fatigue. GUARANTEED.

14 Kt. White Gold Point, Chased Rubber Holder, Lever Filler, Pocket Clip.

Your Name in Gold Inlay, 25c.

Write for Pen Catalog, Agents Wanted.

J. C. Ulrich & Co., 181 Washington St., New York

Known the World Over for 40 Years.

\$2.00

By Mail

Make Money Wearing THIS FREE CAP



Just Wear This Beautiful Hand-Tailored FREE Cap and Make Big Money in Your Spare Time

I want to give you a FREE Cap. I know your friends will be delighted with its class, style and fit and you'll make a generous profit taking their orders. These caps are custom hand tailored, made to individual measure. Nine out of ten men will order right away. Big profit every sale.

\$10 A DAY EASY FOR YOU
Send Name Quick—No Money

McDonald made \$38 in one week. Hampton made \$7.65 in four hours. Schmidt increased his salary from \$35 a week to almost \$75. And you can do every bit as well. Send your name right away and I'll tell you how to make \$10 a day, also secure a Taylor Cap for your use. Write at once. J. W. Taylor, Pres., Taylor Cap Mfg., Dept. 8-W Cincinnati, Ohio.

For Christmas an Ingersoll



The New Yankee
\$1.75

Dependable, as always, but with many new features of grace and beauty. With Radiolite dial that tells time in the dark, \$2.75.



Waterbury Gold-filled
\$9.50

4 jewels; stylish 1 1/2-size. Very modern green or white 14-k gold-filled case. Scratch dial. A handsome gift watch.

\$7



A Kit of Twenty High Grade Tools!

WATCH Dad's eyes gleam when he opens it Christmas morning. A welcome, practical gift for any man! Twenty glistening, high grade tools, enough for most repairs and odd jobs, in a handy canvas case. This kit is made by the world's largest producers of tool kits. Specially priced at \$7.00. Carton is wrapped in fancy holiday paper.

Other popular Tool Kits, all of Vlcck guaranteed quality:

No. 900 Mechanician Kit.....	\$20.00
No. 902 Motorist Kit.....	15.00
No. 903 Garage Kit.....	11.00
No. 908 Taxi Kit.....	4.00
No. 909 Little Roadster Kit.....	3.00

If your dealer hasn't them tell us his name, enclosing correct amount and we will see that you are supplied.

The Vlcck Tool Company

3001 East 87th Street Cleveland, Ohio

EASY TO SAY VELCHEK

VLCKEK TOOLS

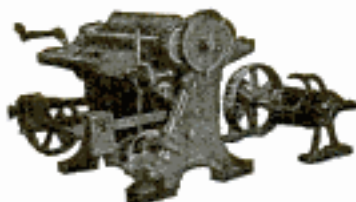

It is the well known quality of CRESCENT machines that justifies you in selecting one of them each time you have need for wood working machinery. The CRESCENT line is better than ever and will always give you satisfaction in every particular. Ask today for catalog of hand saws, saw tables, jointers, shapers, planers, borers, planers and matchers, swing saws, disk grinder, cut off table, hollow chisel mortiser, variety wood worker, Universal wood workers.

THE CRESCENT MACHINE CO., 83 Columbia Street, Leetonia, Ohio

Interlox

MASTERSIDE RULE
Takes accurate inside or outside measurements

MASTER RULE MFG. CO., 841-43 E. 136th St., New York

Dealers and Agents: request attractive proposition



Works fast. Slides in and out quickly. Durable made of brass trimmed boxwood. Any length 2 to 8 feet, 20 cents per lineal foot. If not at dealer's, sent postpaid.

TURN WASTED TIME INTO MONEY!

Every Purchaser Finds Numerous Uses for the Torit Acetylene Torch No. 13

Uses acetylene only. No oxygen or air pressure is required. Tips suck in air. Simply connect to Presto auto tank, light gas, and the outfit is put to work. Beats anything you ever



tried for soldering, heating or light brazing. Outfit consists of 4 tips for different kinds of work, soldering copper, 5 feet tubing, tank connection, and full instructions.

ST. PAUL WELDING & MFG. CO., 177 W. 3rd St., St. Paul, Minn.

\$7.50

I MAKE

The "American Universal" Way

\$150.00 A WEEK SURFACING FLOORS

says Brooks, Okla. "My profits run from \$35.00 to \$50.00 a day and I have cleared as high as \$180.00 in 17 hours," says Geseking, Ill. "I make at least \$20.00 a day," says Phillips, Ohio. "I have made \$30.00 in 8 hours," says Waynick, Texas. Hundreds of other fellows who have become "American Universal" Floor Surfacing Contractors, are doing as well, some even better.

More Good Men Needed

The field is unlimited, the demand for "American Universal" work tremendous in villages, towns and cities the country over. Every new floor must be surfaced, every old floor represents a resurfacing job. "American Universal" (electrically driven) Floor Surfacing Machine does work of six hand scrapers, saves six men's pay. Work is pleasant, interesting, requires no experience, no special training. Small amount starts you.

Here's Your Big Opportunity to get into something for yourself, be your own boss and make real money. We help you get started, show you how and where to get work, furnish office forms, stationary, advertising, everything you need. It's the big chance you've been looking for—Grab it.

Write now for free details of this rare opportunity.

The American Floor Surfacing Machine Company
523 S. Saint Clair Street
TOLEDO, OHIO



CALCULATIONS

in Office and Shop can be instantly made with the Midget Slide Rule. It gives the answer to any problem involving fractions, mixed numbers, decimals, whole numbers, roots, powers, Logs, and Trig. Functions. Thousands of these rules are used by Accountants, Engineers, Clerks, Students, etc. It is the most versatile calculator ever invented. If you have any figuring to do, order a Midget Slide Rule on trial. Made of aluminum with figures on white celluloid. Size 4".

Price with Instruction Book, \$1.50. Leather Case, 50c extra. Catalogs Free. Sent C.O.D. if desired.

Your money back if you are not satisfied.

GILSON SLIDE RULE CO., Niles, Mich.



Saw Books FREE

"Saws in the Shop," "Saw Sense," "Saws on the Farm;" just send your name and address, and say which of these helpful books you want—and we will send it FREE.

E. C. ATKINS & CO., Dept. P, Indianapolis, Ind.



You can get yourself no Better Christmas Gift than A Gerstner Tool Chest Ideal for Toolmakers and Machinists. Write for free catalog.

Gerstner & Sons

412 Columbia St., DAYTON, OHIO

BURN YOUR NAME ON TOOLS WITH ARKOGRAF

Protect your tools from theft. Write any name, engrave any design on metal with electricity like writing on paper with pen or pencil. Complete outfit \$3.50, prepaid anywhere. Interesting descriptive circular free. Write today. Agents Wanted—Arkograf Pen Company, 1171 East Stark St., Portland, Oregon.



For your home shop!



PARKS Cabinet Shop Special

\$225⁰⁰

with all attachments
and motor

Here's an all-round woodworker for the small shop. Sturdy, fast and true. The biggest little woodworker ever built. Saw table has 8-in. rip and cross-cut saw, and 4-in. jointer and borer. You can choose from these extra attachments: band saw; shaper; sander; lathe; and motor.

Send for Bulletin C-S and complete Parks catalog

The Parks Ball Bearing Machine Company
1500-1540 Knowlton St. Cincinnati, Ohio
Canadian Factory: 200 Notre Dame East, Montreal, Can.

PARKS

WOODWORKING MACHINES



PILLIOD

Tool Cases Excel

Machinists, Tool Makers and Carpenters find them most satisfactory in construction, appearance, service and price. Immediate shipment. Booklet describing 20 styles on request.
THE PILLIOD LUMBER CO.
Dept. 1 Swanton, Ohio

Make
Your Own
Repairs



Be your own repair man. Myers' wonderful Sewing Awl sews leather, canvas, shoes, mends harness, saddles, wagon covers, auto tops, blankets, belts—anything heavy or light. Speedy hand stitching. Can't get out order. Original and only awl with diamond point full grooved needle to protect the thread. Saves trips to town. **BIG MONEY FOR AGENTS**
C.A. Myers Co., 63 3/4 Woodlawn Ave., Chicago, Ill.

**NOW! New Low Engine Prices
Only \$5⁶⁹**

month for a few months—easy to own the famous standard WITTE Engine. Uses Kerosene, Gasoline, Distillate or Gas. Equipped with celebrated Troubleproof WICO Magneto. Simplest and cheapest to operate. New device makes starting easy. 50% surplus power. Sizes 2 to 25 H.P.—all styles. Sold direct from factory to you on **NINETY DAYS' FREE TRIAL.** Write today for my new illustrated engine book—sent absolutely Free. No obligation to you.

WITTE ENGINE WORKS
1742 Witte Building, - - KANSAS CITY, MO.
1742 Empire Building, - - PITTSBURGH, PA.

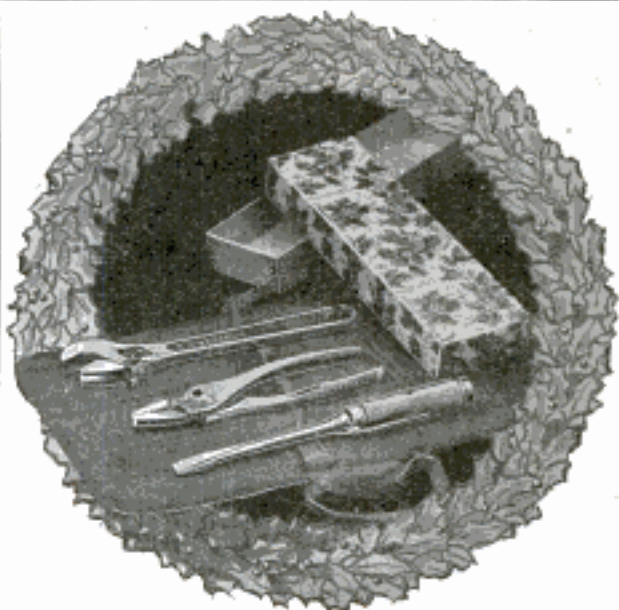

It's going to be a Crescent Kit Christmas

EVERY man—from fifteen to fifty, and beyond—who ever has occasion to touch an automobile, motorcycle, motorboat, to tinker about his own workshop, to do odd jobs of repairing about the house or on farm machinery, will be tickled to get this handy kit of genuine Crescent tools.

Eight-inch wrench, six-inch pliers, and Crescent all-steel T-type screwdriver. All covered by the Crescent guarantee of satisfaction. In attractive holiday box, at hardware or accessory stores, \$2.35.

CRESCENT TOOL COMPANY

210 Harrison St., Jamestown, N. Y.
Originators of the Crescent Wrench

Don't forget
your pliers*



Start every work day—or play day with a pair of Bernards (No. 102) at your finger tips. You'll find a dozen uses for them. They grip like a vise because of the parallel jaws. The outside cutting blades bite cleanly through metal. They are great for bending or stretching wire. Insist upon

* BERNARD

Standard High-Power Cutting
PLIERS



No. 502 "Vulcan" Side Cutting Pliers



No. 454 "Ideal" Long Nose Cutting Pliers

Catalog "P" free on request from
WM. SCHOLLHORN CO., NEW HAVEN, CONN.

.. for his Christmas

The **Simore Screwdriver or Combination Knife and Screwdriver** make an ideal gift for the man or boy. Model No. 11 has three screwdriver blades; No. 12 has a fine knife blade and two screwdriver blades—both unusually useful and beautiful tools—blued steel handles—best steel in blades. They look the part of a real gift for the boy or man who likes tools—try one on a friend of yours and watch him register joy. He'll do it, too.

Model No. 11 only \$1.50, and No. 12 for \$1.00. Send money order or your check and we will mail post prepaid at once. Each tool warranted—your money refunded if not satisfactory.

Dealers are requested to write for our new price list on these tools and the Simore Automatic Trysquare. Boost Simore tools for Christmas.

THE SIMON & SKIDMORE MFG. CO.
Dept. 4-12 SANTA ANA, CA. IORNIA



The
Tools
That are
Different

Do Your PRINTING

Cards, stationery, circulars, labels, paper. Presses \$12 up. Card and paper cutters \$1 up. Save money. Big profit printing for others in spare time. Easy with our printed rules. Write for catalog presses, type, cards, paper, etc. **THE PRESS CO., R-37, MERIDEN, CONN.**



Only \$5.45 for this \$20 value White Gold Wrist Watch

35 year 14K white gold-filled case, richly engraved, latest Tourneau shape, sapphire crown, cross grain ribbon with white gold-filled clasp, 6 jewel movement. An excellent timekeeper. Comes in beautiful velvet and silk-lined case.

AN IDEAL GIFT

that will make any girl or woman happy. We specialize in this watch exclusively and are in a position to offer it at a price lower than the usual wholesale price. If after receiving and examining this watch, you do not consider it equal to any watch priced up to \$20.00 by jewelers, send it back—we will promptly refund amount paid. Send only \$5.45 and this beautiful watch will be forwarded prepaid, or if you desire we will ship C. O. D., you to pay postman \$6.45 plus 18c charge on delivery. Order now as this offer may not be repeated.

WILLIAMS CO., 4750-10 N. Sheridan Road, Chicago



PLANS for HOMES

Let these books be your guide. Beautiful California Styles with Pictures and plans for all-climate homes.

- "South-West Stucco Homes"
Spanish, English, some 2-family—\$1
- "All-American Homes"
30 Homes—7 to 10 Rooms—\$1
- "The New Colonials"
60 Homes—6 to 10 Rooms—\$1
- "West Coast Bungalows"
30 Homes—6 and 7 Rooms—\$1
- "Little Bungalows"
75 Homes—2-4-5 Rooms—\$1

SPECIAL OFFER:

Send \$2.50 for any three of these books and get Garage Folder FREE. Money back if not satisfied.

E. W. STILLWELL & COMPANY, Architects, 123 California Bldg., Los Angeles

Earn \$500 a Month With New Gasoline Tonic

Distributors coining money selling Gasoline Fuelizers. Public already realizes that gasoline alone is not complete. Millions of dollars worth of advertising has convinced them. Most motorists already using some kind of fuel tonics. Make your fortune selling Hutch-Olene—the only real scientific fuel vitalizer. Eliminates carbon—ends carbon knock—cuts down carbon monoxide—gives more pep on hills—makes starting easy—increases mileage 20%—will outsell anything on the market, two to one. Perfected by Dr. Miller Reese Hutchison, inventor of Klaxon Horn, Dictograph and Acousticon! Write now for special offer. The Hutch-Olene Company, Dept. 412, 334 Fifth Ave., New York City.

We Pay \$12 A DAY

Introduce this wonder lamp in your locality. Make \$72 a Week.

Brilliant, white light—soft, restful to eyes.

Equals safety, brilliancy of electricity, 1-10th the cost. 20 times brighter than wick lamps.

More healthful. Easy to operate. No smoke.

No soot. No odor. Low priced. Guaranteed.

FREE outfit to workers. New plan starts you without capital. Full of spare time. No experience needed. Profits start first day. Victim, made \$400 easily in few days. So you can do it. No charge for territory. Write for Free Outfit Offer.

AKRON LAMP CO., 112 Lamp Bldg., Akron, O.



THE EASIEST WAY TO DO HARD JOBS

"Buzz Boice" will take the hard work out of hundreds of jobs with a

Boice-Crane Junior Bench Saw

This sturdy precision machine will saw, sand, grind, miter, rabbet, tenon and perform many other operations with ease and accuracy. Saws 1 1/2-inch stock. Dadoes 3/8" x 3/8". Driven by 1/2 h. p. motor attached to any light socket.

Sold on Money-Back Guarantee

Write for descriptive folder on bench saws, hand saws and jointers.

W. B. & J. E. Boice Dept. P.M. 12 Toledo, Ohio

"Largest Builders of Small Bench Machines in the World"



"Buzz Boice"
Loves his Labor



SAWS AS MUCH AS 10 MEN!

One man, now, can saw 15 or more cords of wood each day with the OTTAWA Log Saw. No more back-breaking work with a cross-cut saw; no more lugging logs to a circular saw, for it's easy to take this power saw to the wood. Over 26,000 in use. Thousands making big money sawing wood for neighbors and to sell. Coal is high and may be higher—wood is in good demand for fuel. Send your name on a post card today for full particulars about the—

Faster sawing; easier moved—easy to start in any weather. 4 H. P. Kerosene Engine—you need plenty of power. Shipped quick from nearest to you of nine branch houses.

OTTAWA 4 in 1 LOG SAW

- 1—Cuts Down Trees
2—Saws Logs
3—Buzzes Up Branches
4—Does Belt Work

Get Big Special Factory-to-User Offer!

Send at once for big 32-page Free Book telling all about this remarkable one-man outfit. Let me show you how it will save you all hard work, provide cheap fuel for yourself and to sell, and pay back its cost in a short time. Cash or Easy Terms.

30 Day Trial 10 Year Guarantee
Send your name and address on a post card. Write today.

OTTAWA MFG. CO.
1742-M Wood St., Ottawa, Kans.
Room 1742-M Magee Bldg.
Pittsburgh, Pa.

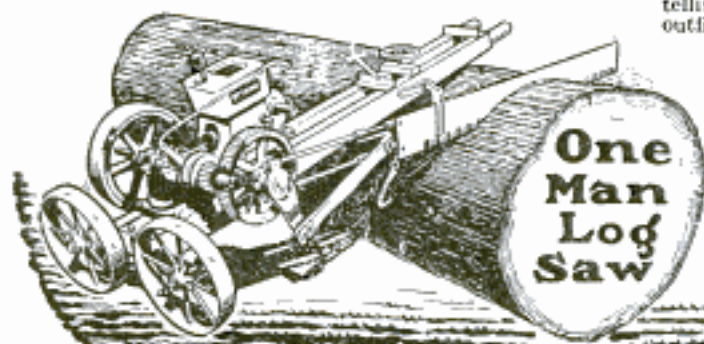

Make Your Ford a Closed Car!

Limo weather-proof sections will change your 1923-1924 Ford Touring or Roadster, into classy limousine-style closed car. Doors open from outside. Sliding front panels for ventilation. Three ply, double covered veneer frames. Color matches your top. Easily, quickly installed. Guaranteed. Low priced. Fine for bad weather. Write for prices.

BUOB & SCHEU, Dept. A-8, 216 Webster St., Cincinnati, O.

Tire AGENTS WANTED

Use and Introduce **MELLINGER CORD TIRES**
12,000 MILES GUARANTEED

Lowest Wholesale Prices in America. Shipped prepaid on approval. Make big money all or part time. No capital or experience. Sample sections furnished.

YOUR TIRES FREE! Simply send name today for valuable FREE BOOK, tells how thousands have gone into big business. **SPECIAL AGENTS' OFFER** Wholesale Prices and FREE SAMPLE KIT.

MELLINGER TIRE & RUBBER CO.

1769 Grand, Kansas City, Mo. \$600,000 Capital



AGENTS WANTED! SALESMEN — DISTRIBUTORS

to use and introduce attachment that makes Fords run on 94% air. **THERMOSTAT** on exhaust automatically turns down needle valve as engine warms, exactly as Ford Manual says do by hand. Makes Fords start easier winter or summer—saves half gas and oil—cuts repair bills one-half—eliminates carbon formation, prevents dilution of crank case oil. Installed in two minutes.

BLANCHE THERMOSTATIC CARBURETOR CONTROL
An Automatic Carburetor Control for Ford Cars and Trucks

Sells on sight to every Ford owner as easily as giving him a \$100 bill, because it saves \$100 every 10,000 miles. You can make Big Money selling this wonderful proven device. Experience not necessary. Blanche plan will start you without capital in a business of your own that makes you from \$250 to \$2,000 a month profit. Write for free circulars Now!

A. C. BLANCHE & CO.
Dept. 764, 602 W. Lake St., Chicago

The FORD'S SAVINGS BANK



Cadillac now uses as standard equipment Thermostatic Carburetor Control under Blanche license.

MAKE YOUR FORD INTO THIS SPORT CAR—SAVE \$50 to \$150 WITH Red-i-Kut Life-Size Patterns \$6.40 COMPLETE

Famous **Red-i-Kut** life-size patterns and pleasure-fit true instructions show you how you can easily convert your Ford into this **Fast, Snappy Sport Car** as thousands have done, with easily obtained materials. No need to lay up the car. **LOOK AT WILFRED ENO'S PAL**—Eno says, "I had material cut with steel and paint for me. Paid only \$11.51. It took me just 3 Sundays to build it and I sure am proud to hear them say, 'He built that snappy sport car.' I never cut any steel or did any woodwork before but you can't go wrong with Kaempel patterns." (Illustrated City) St. Louis, Mo. The "Pal" with pressed metal streamline rear,

life-size patterns for each part of the body so you can't go wrong, picture instructions and **CONICAL DISK WHEEL PATTERNS** Only \$6.40 delivered. Order now while we can make good delivery, and really enjoy these wonderful days in your "Pal." **Keen, Glassy, Up-to-the-minute.** You see build it. Over 11,000 in use. Don't hesitate. **"Swing Lo"** Underlying frame, no frame cutting kind, only \$6.59. Send for copy for new manual of other distinctive sport body patterns from \$1.85 up —"RKO" Steel, "Swing Lo" Irons, "Jiffy" Tone and "Green" Windshields. Order Right Now. Kaempel Co., 55 Kaempel Bldg., Guttenberg, Iowa



36-inch, Easy-riding seat

CLASS SNAP

Roofing Book FREE



World's Best Roofing at Factory Price

Don't buy Roofing of any kind until you get our big Free Roofing Book, describing full line of Edwards Famous "Tightcote" Galvanized Roofings, Sldings and Ceilings, and our lowest factory prices. Then see for yourself how much we save you by selling direct and saving you all in-between dealers' profits.

EDWARDS Metal Shingles "REO"

Absolutely rust proof. By our patented "Tightcote" process, edges as well as sides of metal sheets are heavily coated with zinc—not a space the size of a pin point exposed to weather. Fire and lightning proof. Outlasts three ordinary roofs. Forever wind and weather proof. Need no repairs—end all roofing expense. Patent INTERLOCKING DEVICE makes water tight seams—all nail heads covered—no chance for rust or leaks.



EDWARDS Galvanizing Test
Edwards "Tightcote" Galvanized Roofing can be bent, twisted or struck by lightning, and the galvanizing will not crack or flake. Bend it or hammer it—you can't loosen or scale the galvanizing. No other galvanized roofing can withstand this test.

Low Priced Garages

Wide variety of styles, all sizes of Portable Fireproof Metal Garages. Lowest prices ever made. Postal brings Big Garage Catalog free.

Write Today for free sample and proof that we can save you a lot of money on any kind of roofing siding or ceiling you may need. Ask for Roofing Book No. 104.

THE EDWARDS MFG. CO.,
1200-1250 Pike St., Cincinnati, O.

FREE
Samples &
Roofing Book

Tires With 500 Nail Holes Leak No AIR



A new puncture-proof inner tube has been invented by a Mr. M. E. Milburn of Chicago. In actual test it was punctured 500 times without the loss of air. This wonderful new tube increases mileage from 10,000 to 12,000 miles and eliminates changing tires. It costs no more than the ordinary tube. Mr. Milburn wants them introduced everywhere and is making a special offer to agents.

Write Sales Manager, S. T. Hansen,
336 West 47th St., Chicago

MILBURN PUNCTURE PROOF TUBE

RADIO SETS—AUTO BODIES



SEND FOR THE INTERNATIONAL CATALOG

Our net price list. Full line of Radio Sets, and auto bodies for Fords at Wholesale Prices. Have big money by buying direct from factory.

INTERNATIONAL BODY WORKS, 914 W. Ohio Street, Dept. 7, CHICAGO, ILL.

RECOVER IT YOURSELF

\$3.85 AND UP
Custom Made Make your car look like new and save a big labor bill. We have been making top recoverings, side curtains and seat covers for 15 years. We have patterns for all makes, no model too old for us. Easy to apply, simple instructions given. Write for our big money saving catalogue with samples.

THE LIBERTY TOP & TIRE COMPANY, Dept. E-7 Cincinnati, Ohio

SEND \$2 DOWN PAY \$6.70 PER MONTH



Seven brilliant, blue white, perfectly cut diamonds are set in platinum. Looks like 2 ct. solitaire worth \$600. Fully guaranteed to stand any test.

TWO BLUE SAPPHIRES are set in the shanks of this 18 kt. solid white gold engraved and pierced ring to add beauty and style.

Just send \$2.00 deposit to show your good faith (or pay postman \$2.00 on delivery) and we will send this handsome diamond ring. (Men's heavier ring, same price.) You can pay balance in ten small monthly installments of \$6.75 each—total price, \$69.00. Former price, \$199.

ALL CREDIT DEALINGS CONFIDENTIAL
No one knows you are buying on our dignified credit system unless you tell them yourself. A written guarantee accompanies each ring. You can return the ring within ten days if you are not satisfied. No risk. No delay. Makes a splendid present.

PERFECT CUT DIAMONDS AT \$197 A CARAT

1/2 Carat	\$25.00	3/4 Carat	\$147.75	Guaranteed genuine
3/8 "	\$49.25	1 "	\$197.00	blue white, Money
1/4 "	\$65.65	1 1/4 "	\$246.25	back guarantee cer-
5/8 "	\$73.75	1 1/2 "	\$285.50	tificate. Pay 10%
3/4 "	\$98.50	2 "	\$394.00	down, 10% a month.

WRITE FOR OUR NEW JEWELRY CATALOG
It brings our large jewelry store right into your home. Lowest prices. Easiest terms. Best values. SEND FOR IT TODAY!
STERLING DIAMOND & WATCH CO.
(Diamond Importers—\$1,000,000 Stock—Established 1879)
63 PARK ROW Dept. 1780 NEW YORK, N. Y.

SHAW MOTOR ATTACHMENT MAKES YOUR BIKE A MOTORCYCLE!

A high grade 2 1/2 H. P. motor attachment quickly clamped on any bike frame. Speed 4 to 40 miles an hour. 90 to 125 miles per gallon of gas.

Special Low Price Now! Write today for Complete Description and Special Low Prices on SHAW Motor Attachments and the SHAW Complete Motorcycle.
SHAW MANUFACTURING COMPANY
Dept. 37 Galesburg, Kansas



Let Hartman Feather Your Nest

FREE Bargain Catalog!

Absolutely Free—this great book with over 300 pages of amazing bargains in home furnishings, farm machinery, etc.—all on easy monthly terms and 30 days FREE TRIAL. Send postcard!
HARTMAN FURNITURE and CARPET CO., Dept. 6465, Chicago

FORDS—34 Miles

on Gallon of Gasoline Starts Easy at Zero with Air Friction Carburetor

We guarantee all other cars nearly double present mileage, power and flexibility. Models Ford 34 mi. | Chevrolet 32 mi. | Dodge 28 mi. Maxwell 30 mi. | Overland 32 mi. | Oakland 24 mi. Mileage guarantee on any other car sent on request.

SENT ON 30 DAY'S TRIAL You can drive any car in heaviest traffic without shifting gears. Starts off on high in any weather without priming or heating—No jerking or choking. Agents Wanted.
AIR-FRICTION CARBURETOR COMPANY
1360 Raymond Building Dayton, Ohio, U. S. A.

Boys, you yourselves can build this Steam Shovel — and it works!

Yes—this Shovel really works just like a big one. It's great fun to make it scoop up a load—then swing and dump its dipper. And you can build it yourself—with Meccano. Then, when you're through with it, build a Skyscraper, Crane, Bridge—for Meccano is composed of real engineering parts in miniature with which you can easily build hundreds of models. Parts are strong and accurately made and fit together perfectly.

No study is needed, for every Outfit has a big picture book that shows you just how to put models together.

For sale at most department, toy, hardware and sporting goods stores. Sent direct on receipt of price if your dealer cannot supply you. Prices of outfits from \$1.00 to \$45.00.

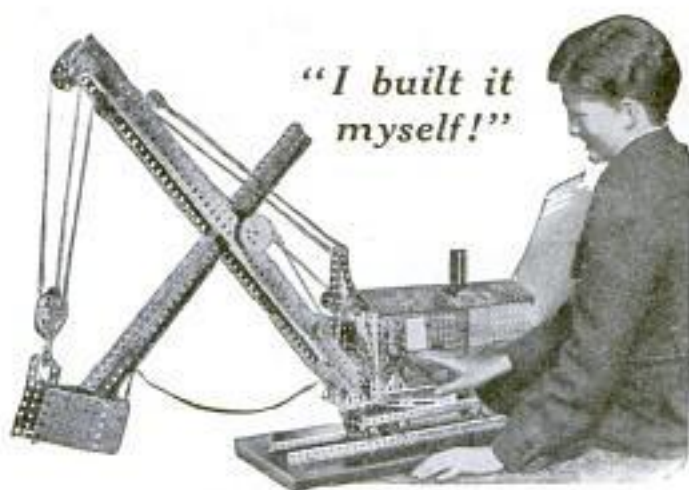

IMPORTANT NOTICE

Not all construction toys are Meccano. Meccano is the original Steel Construction Toy, has the greatest variety of parts and builds the most models. Insist on the genuine Meccano. This label is on every box.



MECCANO

Engineering for Boys

This Book
Sent
FREE

Send us your name and address with those of three of your chums and we will send you free our new book, "The Magic Carpet," which tells all about Meccano and the joys of Meccano building. Put No. 62 after your own name.

MECCANO COMPANY, INC. Division H-2 ELIZABETH, N. J.
In Canada: Meccano, Ltd., 45 Colborne St., Toronto.



MOTORCYCLES

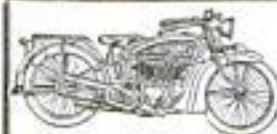

RELIABLE STANDARD MAKES that you can DEPEND on. Enjoy the glorious experience of going wherever you like—where ever you like. The price is within your means—35% to 40% less than others. These machines are strictly used, thoroughly overhauled or rebuilt, See-It-for-itself again.
MYEROW BROS.,
15 Berkeley St., Boston, Mass.

Delivered to You Free

for 30 days trial on approval. You can have your choice of 44 Styles, colors and sizes of the famous RANGER Bicycles. Express prepaid. Factory-to-Rider Prices save you \$10 to \$25 on your bicycle.

\$5 a Month if desired. Many boys and girls easily Parents often advance first payment.

best quality, at factory prices, express prepaid. Lamps, wheels and equipment, low prices. Send No Money, do business direct with makers.

MEAD CYCLE COMPANY
DEPT. 105 CHICAGO



MOTORCYCLE BARGAINS

Save 25% to 65%

on Slightly used and Rebuilt Motorcycles, Side Cars, Johnson Motor Wheels, Evans Power Cycles, Bicycles. Send for Free Bargain Bulletin and Money Saving Message, listing hundreds of Bargains in used, rebuilt and new machines, supplies, accessories, etc.

AMERICAN MOTOR CYCLE CO. CHICAGO
Dept. 1227, 2047 W. Chicago Avenue.



**MAKE MONEY
SELL MADISON SHIRTS**

Direct from our factory to wearer. Easily sold. Over one million satisfied wearers. No capital or experience required. Large steady income. Many earn \$100. to \$150. weekly. Territory now being allotted. Write For Free Samples. Madison Shirt Mill, 511 B'way, New York

Ride 30 Days Free



Roll down the road on this dandy new bike—a dashing speedster—the wheel every boy wants. It's a

BLACK BEAUTY

Shipped express prepaid—direct from factory at wholesale price. Guaranteed 5 years, 6 months accident insurance. 30 days trial. Large selection of models and colors.

SUPPLIES Tires, Lamps, Horns, Etc. Everything for the bike at wholesale prices.

FREE—Big Black Beauty Bicycle Book

HAVERFORD CYCLE CO. OF PA.

Established 25 years
Dept. 3712 Philadelphia, Pa.
Be a Black Beauty Rider Again

Write For Book About the Elto

3 H.P.—The Fastest "Light Twin"

Designed and built by Ole Evinrude
Weighs less than 17 lbs. per H. P.

Gives half more power, much more speed, yet easy to carry. Instant starting without spinning. Safe rudder steering. Trouble-proof carburetor. Push button reverse, without danger of tipping boat. The ideal family motor. Fits carrying case without taking apart. Write for catalog.

ELTO OUTBOARD MOTOR COMPANY
Manufacturers' Home Bldg.,
Dept. AA, Milwaukee, Wis.



1/2
More
Power—
Much
More
Speed





No. 6177

SAVE 25%—SEND NO MONEY

**Genuine Diamonds—Cut Stones—No Chips
Snappy, White and Brilliant—Terms if Desired**

Wedding Ring No. 6177—3-Stone
Diamond, 4/100 Each. \$25.00
20-kt. White Gold.....

Ladies' Ring No. 6405—in 18-kt.
White Gold. Exact size
of ring..... \$30.00

Our White Gold Looks and Wears Like Platinum

Men's Ring No. 6407—18-kt.
White Gold Top and Green Gold
Shank. Exact size \$35.00
of ring.....

Emblem or Initial Ring No. 6132—
Solid Gold with Two Genuine Dia-
monds, 4/100 Each..... \$25.00

No. 6132 has 14-kt. White Gold Top with Gold Emblem or
Initial inlaid in Genuine Hope Ruby or Black Onyx. Fur-
nished in all lodge emblems and in all initials (Old English).
Send size of finger and ring desired will be sent for inspection

Terms—Monthly Payments If Desired
Send for Free Catalog

BUFFALO JEWELRY MFG. CO.

"The Mail-Order House"

Dept. P, Brisbane Bldg., Buffalo, N. Y.



No. 6405



No. 6407



No. 6132

This  Reg. Trade Mark
guarantees you genuine diamonds.

Confidential

Information on how you can earn \$300.00 or more a month will be sent to the first person in each locality who writes. Become our local distributor for a recognized household necessity in rural districts and small towns. Light, pleasant work. Men or women. Full or spare time. No money needed. A million dollar firm behind it. Write quick for particulars and state territory desired. N. K. Johnson, 609 West Lake Street, Chicago, Ill.

Make \$75⁰⁰ a Week and up

Make \$75.00 a week and up, selling our fine made-to-measure, all-wool suits, direct to wearer. Biggest values—positively sell on sight. Biggest commissions paid in advance. We attend to delivery and collections. 6x9 swatch samples—over 100 styles all one price—furnished FREE. Part or full time men write at once.

W. Z. GIBSON, Inc., 161 W. Harrison St., Dept. N-11 Chicago

I Make the Best CHOCOLATE BARS

Mints and Chewing Gum. Be my agent. Everybody will buy from you. Write today. Free Samples.

MILTON GORDON, 407 Jackson St., Cincinnati, Ohio

Relieve That Rheumatic Pain

Apply Absorbine, Jr., promptly whenever pain or discomfort next threatens. Feel it ease the pain at once in muscle and joint. You will find Absorbine, Jr., safe, clean, agreeable, and effective.

All druggists', \$1.25, or postpaid.
Liberal trial bottle, 50c., postpaid.

W. F. YOUNG, INC.,
347 Lyman St., Springfield, Mass.



Absorbine, Jr.

THE ANTISEPTIC LINIMENT

for

Cuts
Bruises
Rheumatic aches
and pains
Children's burns

Every Boy Needs Them

To hang to the walls of his room
his pictures, drawings or charts.

MOORE PUSH-PINS

Glass Heads—Steel Points

Moore Push-less Hangers

"The Hanger with the Twist"
Easy to use; won't injure walls.

10c pkts. Everywhere

MOORE PUSH-PIN CO., Philadelphia, Pa.

Sells for \$1.25—Agent's Sample, 65c—IDEAL CHRISTMAS GIFT COMES IN HOLLY BOX

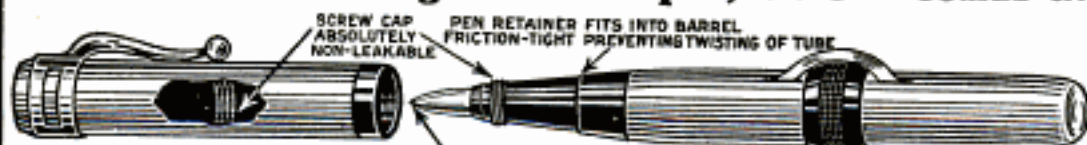

ITS THE POINT, HAS EIGHT GROOVES FOR INK TO FEED

Imported from Japan. "It makes Carbon Copies." Guaranteed for One Year. Hustlers Make \$20.00 Daily!
Money refunded if you don't think it the best pen you ever wrote with. Just Out! Comes in beautiful brown, trimmed in black. Send
for quantity price list and distributing plans.

F. SPORS & COMPANY, 335 Main Street, LESUEUR CENTER, MINNESOTA

New
Self-Filling
Bamboo
Fountain Pen
with
Stylo Point

Electric Light in Every Home

No longer necessary to burn kerosene lamps. The Cincinnati Electric Lighting Machine will generate sufficient current to light twenty-five 20 Watt lamps at an average cost of one-third of city rates.

**STARTS and STOPS
AUTOMATICALLY**



Operated by single cylinder, two cycle, air cooled engine. Has adjustable siphon valve and limiting governor to regulate charging of batteries. No carburetor—no gears—no push rods—no valves to grind. Simple, practical, highly efficient and economical in fuel consumption. Completely portable—weight 150 pounds. Suitable for homes, cottages, camps, motor boats, country schools and churches, etc. Dealers and distributors wanted. Write today.

THE E. I. PEARSON CORPORATION, 2500 Jeanette St., CINCINNATI, OHIO, U. S. A.

AMERICAN BOY SCROLL SAW

**It's Easy to Build Things
When You Use This Saw**



You will like its sturdy, mechanically correct construction; the ease of operation; the smooth, absolutely square cut. Cuts fibre, bakelite, wood up to 1" and metal up to 1/4" thick. A real tool to make your radio sets, scooters, cabinets, experimental work and lots of useful things around the house, etc. Can be motor-driven. An Ideal Xmas Gift for Your Boy

**IT'S A REGULAR TOOL
And the Price Is Right**

To get complete details, write your name plainly on this ad, clip and mail to

**Delta Specialty Co., 858 E. Third Street
MILWAUKEE, WIS.**

MORE PROFITS

To Dealers Who Buy Nationally
Advertised Radio Goods from Our
Bargain Catalog! Write for It Today!
AMERICAN RADIO MFG CO.
Dept. 6 WEST 14TH ST. KANSAS CITY, MO.

Mr. Brush Salesman Unusual opportunity is offered for aggressive, ambitious, hustling men to represent an old established manufacturer of high grade, guaranteed, fastest selling line of Sanitary Twisted in Wire Brushes, sold direct to the Home. We have openings for experienced brush men as managers in all territories. We want live wire, energetic Go-Getters. We pay larger commissions than any other Brush House in the Country. If you want to earn some real money, it will pay you to write us immediately for our proposition.

WIRE GRIP SANITARY BRUSH CORP., 15 MERCER STREET, NEW YORK CITY

Glass Bake Sets FREE



With Your
IMPERIAL RANGE

Write now for Direct from Factory Bargain Catalog and you will be in time to get this big 12-piece genuine heat-proof Glass Bake Set—a complete kitchen outfit **FREE**. It's our special limited offer to introduce Imperial Steel Ranges and their patented money, fuel, work and time saving features. Biggest money-saving opportunity of the year. Get low prices.

BARGAIN BOOK

Saves you \$20 to \$40 on Ranges, Gas Stoves, Oil Stoves, Refrigerators, Kitchen Cabinets. Home needs at rock-bottom wholesale prices. **Easy Terms. Everything sent for 30 Days' Trial.** Our offers are sensation of the year. Write quick. Just send name and address. A postcard will do.

THE IMPERIAL STEEL RANGE CO.,
469 Detroit Avenue Cleveland, Ohio



America's
Greatest Value

KERMATH

BOAT ENGINES



**Let KERMATH Owners
Tell the Story**

"Never spent a penny on it," says C. M. Weeks, who operates a marine engine machine shop and depot at Babylon, N. Y. "It is number 519, bought about 13 years ago, and it is in good running condition today."

"I have just returned from an 800 mile cruise," writes F. S. Hall of the General Electric Co., New York City. "The boat is perfect, the Kermath engine is perfect, and the trip was perfect."

For you also, a Kermath will live and work, long and hard, with never-failing dependability and rigid economy—the results of a most modern design and painstaking manufacture.

There is a lot more to our interesting story—write for it.

3 H. P. to 50 H. P., \$135 to \$1050, F. O. B. Detroit

KERMATH MANUFACTURING COMPANY
5886 Commonwealth Ave. Detroit, Mich.
Canadian address: 11 E. Wellington St. Toronto, Ontario

A Kermath Always Runs



KING

Band Instruments

WHETHER you are just learning to play or are a finished musician you will find "King" Saxophones, Trumpets, Trombones and Horns, easier to play than any other make.

Every "King" Instrument has the latest improvements—is built by experts and is laboratory-tested before being shipped. Every "King" is fully guaranteed.

It is easy to own a "King" Instrument. They are sent on trial and sold on easy payments.

"King" Band Instruments and Saxophones are fully described in beautifully illustrated catalogs. Send for free copy.

Write for list of bargains in rebuilt instruments.

THE H. N. WHITE CO.,
5211-58 Superior Avenue, Cleveland, Ohio

Please send me free, your latest catalog on

Instrument.

Name _____

Address _____

City _____

State _____

"That
Musical
Pal of
Mine"



Come On Boys— Let's Hear You Play!

There's nothing like good music for happiness; and there's nothing like a Hohner for good music. Millions of happy boys and girls are now playing Hohner Harmonicas for entertainment, popularity and education.

Anyone can quickly learn to play a Hohner with the aid of the Free Instruction Book. Get a Hohner Harmonica today—50c up—and ask for the free book. If your dealer is out of copies, write M. Hohner, Inc., Dept. 181, New York City.

If you want a musical treat ask to hear Victor Record 19421, by Borrah Minevitch.

HOHNER HARMONICAS

Thrilling Fun Every Minute

With the New Indian Scout



Gets away as quick as a flash. Goes 60-75 miles to the gallon. Tires good for 10,000 to 15,000 miles. 100 pounds lighter than average motorcycles yet powerful and perfectly balanced. 1925 Model has 20% more power and lowest price ever. Ask your Indian Dealer about it or write us for free literature and name of your Dealer.
Indian Motorcycle Co., Dept. P-12, Springfield, Mass.

SAW FILING PAYS



Buy a Foley Saw Filer and Setter and establish an independent, profitable business.

Wm. Rosell Clark, 203 N. E. 12th Terrace, Miami, Fla., writes: "It is a pleasure to file a saw with such a machine. It is easy to operate, easy to adjust, and turns out a great job in a short time with less strain on the eyes, in fact on the whole system."

Prices and catalog on request. Territory open to interested parties.

FOLEY SAW TOOL CO.
916 E. Lake St. Minneapolis, Minn.

Sell This Easy Way to Fill FORDS

PUT
ON IN

MAKE BIG PROFITS WITH THIS COMBINED GAS GAUGE & FILLER

Makes Fords as easy to fill as cars with tanks at rear. Unnecessary now to remove cushion or get out of car. Takes full flow from any pump without flooding. Has visible gas gauge, too, with luminous indicator that SHINES AT NIGHT. Guaranteed! Easy to install—clamps into regular tank opening. Make big money selling the wonderful new

Kirstin Fil-Gage

Retails at \$6. Easy seller! "Sold the first five Ford owners I called on," writes K. A. Bernier, Northampton, Mass. Exclusive territory. Full details sent free. If you wish, send \$6 (or \$1, and pay \$5 C.O.D.) for one Fil-Gage, leatherette Carrying Case, and full supply advertising matter, sent on 10-day money-back trial. Write today to address below.

10 Minutes



A Gasoline
Gauge,
Too,
Always
In
Sight



F-20

A. J. KIRSTIN CO.

1201 1st St.

Escanaba, Michigan



SPECIAL \$6.19 LIMITED TIME ONLY

25 year 14 kt. white gold filled wrist watch. Tonsorial shape. Sapphire crown, silk grosgrain ribbon with white gold filled clasp. 6 jewel movement. Sent in beautiful silk lined gift case. Pay postman ONLY \$6.19 plus 15c postage. Money refunded if not satisfied.
SUPREME JEWELRY MFG. CO.
434 BROADWAY Dept. 155 NEW YORK CITY

Marvelous New Lamp Now Only \$5⁹⁵

Biggest
Bargain
ever
known
in the
lamp
industry



An amazing low price and tremendous value.

Intense White Light

Our new 1924 burner produces a white light of marvelous brilliancy, a light so bright and clear that you'll prefer it to electric light. Nothing like it on the market; we are exclusive owners of 1924 patents on this new lamp.

Imported Shade Free—This price covers lamp only but if you write now we will include beautiful imported glass shade FREE.

Agents
Wanted

Don't Miss This Great Offer
No matter what kind of lamp you are now using, don't overlook this wonderful opportunity for better light at lower cost. Send only \$1.00 and pay the small balance upon arrival or just send your name and address for complete information. Send now.

Special Offer to Agents
The Nagel-Chase Mfg. Co., 284 E. Erie St., Chicago

SAVE MONEY
Get This Book

HANDY MAN BOOK

Install Your Own
PLUMBING & HEATING
NEW EASY WAY - SAVE HALF

25c
Reg. Price 50c

Brings you this big Plumbing and Heating Encyclopedia-Catalog. Write for your copy today without fail.

Guaranteed Heating Plants

Our Handy-Man Book shows how. Big 256-page well-bound encyclopedia of Plumbing and Heating Outfits, Systems, Supplies, Fixtures and Accessories—10,000 items—illustrated. Hundreds of floor plans, elevations, diagrams, trade secrets, money and trouble-saving kinks, etc. "How to save coal in heating." "Easy repair methods." Every householder, contractor, farmer, mechanic, institution needs this book. Shows how to save wages, work and materials.



Hot Water Boiler

Big Handy Man Book

Tells how we help you plan and install. From rough sketch or description we supply working plans and clear instructions. We loan the tools needed. Any handy man can install. This is the place to buy on money-back guaranty. Plumbing Outfits and Supplies; Water Systems; Hot-Air, Water or Steam Heating Plants; Radiators, Pipes, Boilers or Septic Disposal Tanks.

Send 25c for Yours Today

We have spared no effort or expense to complete this remarkable and instructive book. To keep from sending it broadcast to disinterested persons, we request a deposit of 25c, which will be refunded on your first order—or send for our FREE Bulletin. Write today and save half.

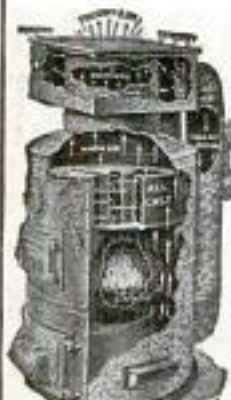

Pipeless Furnace

HARDIN-LAVIN CO.

107-17 West
Pershing Road
CHICAGO



Bathroom
Outfit

DEAFNESS IS MISERY



I know because I was Deaf and had **Head Noises** for over 30 years. My invisible Antiseptic Ear Drums restored my hearing and stopped Head Noises, and will do it for you. They are Tiny Megaphones. Cannot be seen when worn. Effective when Deafness is caused by Catarrh or by Perforated, Partially or Wholly Destroyed Natural Drums. Easy to put in, easy to take out. Are "Unseen comforts." Inexpensive. Write for Booklet and my sworn statement of how I recovered my hearing.

A. O. LEONARD, Suite 226, 70 5th Avenue, New York City



FORD SPEEDSTER
Classiest & Sapest in U.S.A. Build one like it
Lots of fun! Blueprints, Specifications,
4 Photos, etc. \$4.00 postpaid. Send
50c for 3 Glassy Photos, Racing Cars, 90 m.p.h. Ford.

★ BUD STANLEY, Box 1, Detroit, Mich. (The Motor City) ★

RADIO Buyers' GUIDE

FOR CONSUMERS

Get it now—before you buy

any set or parts to build one.

Reprints in all kinds of com-

plete Sets, Parts and Accessories. I soon want radio

LIBERTY M. O. HOUSE, Dept. 171-Z, 106 Liberty St., N. Y.

FREE 100 PAGES
Just send your name.
(Will you be so kind
as to add the name of
one or more friends
you believe will
benefit?) Thank you!

Holton
TALENT
TEST
Record

Now!
Free Proof
that You
Can Play
~that you
have Talent

AS long as you can remem-ber, music has stirred and inspired you. And so you have always hoped that you could play yourself—choose your favorite melodies and express them as your heart dictates—share in the greater pleasures and profits that come especially to those who play. But until now, you could never be sure of results in advance.

Now, however, for the first time, is provided a free method by which you can determine your talent for music. Climaxing a lifetime of study and observation, Frank Holton announces the Holton Talent-Test. By it, thousands who never dreamed they possessed musical ability will have revealed to them great, unsuspected opportunities on this easiest-to-learn of all saxophones, the

Holton

New Revelation

SAXOPHONE

In a few interesting minutes your talent is measured, so easy it is to know that you can play. You assume no obligations or responsibilities—you merely decide a question everyone should answer in fairness to his future.

Mail the Coupon—Convince Yourself!

Your request for booklet brings you Appointment Card entitling you to the Talent-Test in the privacy of any Holton dealer's studio or in your own home with the aid of a Holton Saxophone and our copyrighted phonograph record on which the Talent-Test is recorded.

FRANK HOLTON
& CO.

Elkhorn, Wis.

America's Greatest
Band Instruments.

FREE
BOOK
tells how
Test is
given



Frank Holton & Co., Elkhorn, Wis. ©

Without obligation, I want to determine my talent for the easy-to-learn Holton New Revelation Saxophone. (Check if interested in any other instrument.)

Cornet () Trombone () Baritone () Trumpet ()

Name

Street Address

Town.....State.....(8)

PATENT TRADE MARKS

ANY NEW article, machine, design or improvement thereof, or any combination of parts or improvements in any known article which increases its efficiency or usefulness, **may be patented**, if it involves invention.

IF YOU HAVE ANY NEW IDEAS

which you feel are useful, practical and novel, **take prompt action to protect your rights**. If you have invented any new machine, or new combination of parts or improvement, or any new design or process, **SEND DRAWING, MODEL OR DESCRIPTION** of it for information as to procedure to secure protection.



DRAFTING and SPECIFICATION ROOM, of CLARENCE A. O'BRIEN, Registered Patent Lawyer, Washington, D. C.

All Communications are held in strict confidence. My personal, careful and thorough attention is given to each case. I offer you efficient, reliable and prompt service—based upon practical experience. Highest references.

NO CHARGE FOR ABOVE INFORMATION

Clarence A. O'Brien

REGISTERED PATENT LAWYER

Member of } Court of Appeals, District of Columbia, United States Court of Claims;
Bar of } Supreme Court of United States, Supreme Court, District of Columbia

Practice Confined to Patents, Trade Marks and Copyrights

INVENTIONS

WRITE FOR THESE FREE BOOKS: DO IT NOW

-COPYRIGHTS

Write Today for **FREE BOOKS,**

"How to Obtain a Patent"

and

"Invention and Industry"

and **BLANK FORM,**

"RECORD OF INVENTION"

These books will give you valuable information, and they may save you much time and effort. **Send for them, NOW.** My practice is devoted **exclusively** to United States and Foreign Patents and Trade Marks. Write me freely, frankly and with full confidence; it is very probable that I can help you.

Use the Coupon Attached

and immediately upon its receipt I shall send you the form, Record of Invention, to be returned to me with drawing, description or model of your idea; promptly upon receiving your idea I shall write you as to procedure and costs.

FREE COUPON

CLARENCE A. O'BRIEN, Registered Patent Lawyer

709 Security Savings & Commercial Bank Bldg., Washington, D.C.
Directly Across Street from Patent Office

Please send me your free books, "HOW TO OBTAIN A PATENT" and "INVENTION AND INDUSTRY," and blank form "RECORD OF INVENTION," without any obligation on my part.

Name

Address

IMPORTANT—WRITE OR PRINT NAME CLEARLY.

FREE

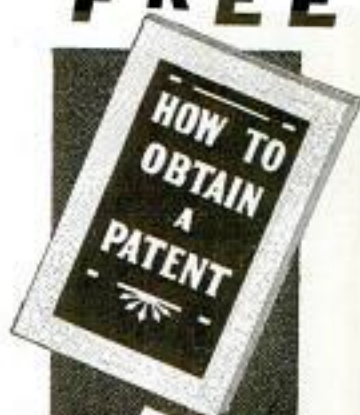

These Books Free

PATENTS TRADE-MARKS AND COPYRIGHTS

Have You An Idea?

Our Offer: No Charge for Examination and Instructions

Protect Your Invention

Your first step before disclosing or submitting your invention to anyone either for entry in a prize competition or for sale should be to write for our blank form

"RECORD OF INVENTION"

This should be signed and witnessed and returned to us together with model or sketch and description of the invention for examination and instruction and to establish Evidence of Conception.

No charge for the above information.

**Our Four Books Mailed
Free to Inventors**

Our Illustrated Guide BOOK

How to Obtain a Patent

Contains full instructions regarding U. S. Patents. Our Methods, Terms, and 100 Mechanical Movements illustrated and described.

Our Trade Mark Book

Shows value and necessity of Trade Mark Protection. Information regarding *Trade Marks and unfair competition in trade.*

Our Foreign Book

We have Direct Agencies in Foreign Countries, and secure Foreign Patents in shortest time and lowest cost.

Progress of Invention

Description of World's Most Pressing Problems by Leading Scientists and Inventors.

We Regard a Satisfied Client as our best advertisement, and furnish anyone, upon request, lists of clients in any state for whom we have secured patents.

**Highest References—Prompt Attention
—Reasonable Terms**

VICTOR J. EVANS & CO.

PATENT ATTORNEYS

Main Offices: 956 9th St., N. W., Washington, D. C.

Opposite U. S. Patent Office



Our New York Office
Suite 1007 Woolworth Bldg.



Our Philadelphia Office
Suite 714-15 Liberty Bldg.



Our Washington Office
Victor Building



PATENTS TRADE-MARKS AND COPYRIGHTS

IMPORTANT

Do not submit your invention to anyone before you furnish proof that the invention is patentable or application has been filed. In order to have **YOUR CASE MADE SPECIAL TO AVOID DELAY** you should take the precaution of having your case made **Special** in our office to secure protection, save correspondence and secure early filing date in Patent Office. To secure special preparation of your case send \$25.00 on account with model, sketch and description.



MAIN OFFICE, VICTOR J. EVANS & CO.—VICTOR BUILDING, WASHINGTON, D. C.



Our Chicago Office
Suite 1114 Tacoma Building



Our Pittsburgh Office
Suite 514 Empire Building



Our San Francisco Office
Suite 1010 Hobart Building

All Communications and
Data Strictly Confidential.
Interference and Infringe-
ment Suits Prosecuted

OUR ORGANIZATION OFFERS PERSONAL SERVICE

by registered attorneys at law members
of Bar of U. S. Supreme Court, Court
of Appeals, Supreme Court of D. C., and
U. S. Court of Claims.

**FREE
COUPON**

**VICTOR J. EVANS & CO.
PATENT ATTORNEYS**

NEW YORK OFFICES
1007 Woolworth Bldg.

CHICAGO OFFICES
1114 Tacoma Bldg.

PHILADELPHIA OFFICES
714-715 Liberty Bldg.

PITTSBURGH OFFICES
514 Empire Bldg.

SAN FRANCISCO OFFICES
Hobart Bldg.

MAIN OFFICES: 956 9th Street, N. W., WASHINGTON, D. C.

Gentlemen: Please send me *Free of Charge* your books as described on preceding page.

Name

Address

PATENTS

*Seventy-eight
Years of Practice*

THE firm of Munn & Company filed its first application for a patent in 1846, and for seventy-eight years has endeavored to keep pace with the inventive genius of the United States.

An experience of many years is at your disposal. If you have an invention which you wish to patent, send your sketches or model together with a description of your device, explaining its operation, and you will receive prompt, courteous attention.

*Write for our Handbook on
PATENTS*

A full and complete booklet on Patents, Designs, Trade-Marks, Foreign Patents, Copyrights, Labels and Patent Office Practice with an explanation about our methods, terms, etc.

All communications strictly confidential.

Keep in touch with the inventions of the world by reading

SCIENTIFIC AMERICAN

The MONTHLY MAGAZINE with a special appeal to every man of inventive genius. Recent rulings of the Patent Office, descriptions of the latest patented inventions, legislation and court decisions affecting patents, are noted in this authoritative publication.

MUNN & COMPANY

Patent Attorneys

672 Woolworth Building, New York
Scientific American Bldg., Washington, D. C.
1301 Tower Bldg., Chicago, Ill.
Hobart Bldg., 582 Market St., San Francisco, Cal.
Van Nuys Building, Los Angeles, Calif.

U.S. PATENTS



**SEND FOR
THIS FORM**

DON'T LOSE YOUR RIGHTS TO PATENT PROTECTION

Before disclosing your invention to anyone send for blank form "EVIDENCE OF CONCEPTION" to be signed and witnessed. A sample form together with printed instructions will show you just how to work up your evidence and establish the same before filing application for patent. As registered patent attorneys we represent hundreds of inventors all over the United States and Canada in the advancement of inventions. Our schedule of fees will be found reasonable. The form "Evidence of Conception," sample, instructions relating to obtaining of patents and schedule of fees sent upon request. Ask for them—a post card will do.

PATENTS AND TRADE MARKS

LANCASTER & ALLWINE

Registered Patent Attorneys in U. S. and Canada.
480 Ouray Bldg., WASHINGTON, D. C.
Originators of forms "Evidence of Conception."

PATENTS

Patent Litigation
Trade Marks
Copyrights

Handbook of instructions, "How to Protect Inventions," sent free on request.

R. H. FRAVEL, Patent Lawyer
Formerly of the U. S. Patent Office Examining Corps
Room 1503, McLachlen Bldg., WASHINGTON, D. C.

INVENTORS who derive largest profits know and heed certain simple but vital facts before applying for Patents. Our book *Patent-Sense* gives those facts; sent free. Write **LACEY & LACEY, 646 F St., Washington, D. C., Established 1869.**

PATENTS

REGISTERED PATENT ATTORNEY SINCE 1905
CHARLES W. LOVETT SECURITY BLDG. LYNN MASS.
SEND FOR FREE BOOKLET

Have You An Invention?

If so the WORLD PROGRESS will show you how to **PROTECT AND PROFIT FROM YOUR IDEAS**
Sample copy free. One year's subscription \$1.00.
Send for free book,

"WHAT TO INVENT"

containing **SUGGESTIONS TO INVENTORS** as to Inventions Needed. We invite manufacturers to address us regarding inventions they want.

WORLD PROGRESS PUB. CO., Inc.
Room 203 Victor Bldg. WASHINGTON, D. C.

PATENTS

To the Man with an Idea

I offer a comprehensive, experienced, efficient service for his prompt, legal protection and the development of his proposition.

Send sketch, or model and description, for advice as to cost, search through prior United States patents, etc. Preliminary advice gladly furnished without charge.

My experience and familiarity with various arts frequently enable me to accurately advise clients as to probable patentability before they go to any expense.

Booklet of valuable information and form for properly disclosing your idea free on request. Write today.

Richard B. Owen, Patent Lawyer
9-303 Owen Building, Washington, D. C.
2276-E Woolworth Bldg., New York City

PATENTS

C. L. PARKER
Formerly Member Examining
Corps, U. S. Patent Office
PATENT LAWYER
MCGILL BLDG.
WASHINGTON, D. C.

Patents, Trade Marks, Copyrights, Patent Litigation

Handbook for Inventors, "Protecting, Exploiting and Selling Inventions," sent free upon request.

PATENTS

Trade-Marks, Copyrights and Patent Litigation

Write for advice and instructions how to proceed, costs, etc. Hand Book with illustrations of 100 Mechanical Movements sent free on request.

ALBERT E. DIETERICH
Patent Lawyer and Solicitor

Successor to Fred G. Dieterich & Co. 621A Ouray Bldg., Washington, D. C.



PATENTS

Send us sketch or model for free patentability opinion and exact cost of patent. Our book "How to Obtain a Patent" Sent Free on request. It tells how to apply for Patents, Trade Marks, Foreign Patents, Copyrights, etc.; gives information on Patent Procedure; tells what every inventor should know. Thousands of inventors, who are our clients, are our references.

CHANDLEE & CHANDLEE, 25 Years' Experience
473 7th St. Washington, D. C.



GEARS ALL KINDS SMALL

The most accurate made and prices reasonable. We carry a complete line of gears in stock for immediate shipment. Can also quote on special gears of all kinds. Send us your inquiries.

WRITE FOR CATALOGUE.

CHICAGO STOCK GEAR WORKS
105-109 S. Jefferson St., CHICAGO

YOU CAN NOW LEARN HOW TO INVENT!

- How to develop your imagination
- How to develop your ideas
- How to get the facts you need for inventions
- How to keep legal records of ideas
- How to use scientific principles of mechanics
- How to avoid wasting time on impractical inventions
- How to apply for a patent
- How to organize a company
- How to protect your rights
- How to market a patent

and hundreds of other vitally important facts which EVERY successful inventor knows and uses. A remarkable new, and much needed course which can be studied in spare time, at home.

Make Your Ideas Pay You a Fortune

You can now learn how to train your mind along scientific inventive lines. No longer need you let your mind wander in unprofitable fields. You can learn how to think of worth-while ideas and make your ideas pay you money. The trouble with most people is that they do not know what to do with their ideas. Millions of dollars go to waste because of these undeveloped ideas. Now for the first time you can learn to harness your thoughts and make them work for you! One little invention, properly developed, may make you independent for life!

You Are Born an Inventor Develop your ability



Raymond F. Yates

Every man, woman, and child is born with creative imagination. Some develop this faculty to a greater degree than others, and those who develop it to the greatest extent are successful inventors. Invention is an orderly process of the mind, which combines two or more known facts to produce a new fact. Anyone who develops the right mental process can become an inventor. Every successful inventor has this type of mind, developed by constant experience over a period of perhaps many years. Heretofore those who succeeded in the field of invention had to discover all the principles themselves. But, now, just as any student of medicine, law, or engineering can take full advantage of all the recorded experience in these fields of study, so can YOU take the same kind of short cut to the habits of thought, and the methods of work required of successful inventors.

Says Edison!

"Invention Is a Science and Should Be Taught as a Profession"

This is the first course in practical invention that has ever been devised. Now you can take Edison's advice and actually learn HOW TO INVENT—how to make invention a profession! In simple, easy-to-understand language, you are told how successful inventors work; you learn how to use the secrets of invention that convert a simple little idea into money.

Every inventor realizes the hopelessness of groping in the dark for the habits of thought and methods of work required for successful invention. Trying to invent without knowing the fundamental requirements of invention is like trying to build a bridge without knowing engineering.

Amazing Book On Inventive Science Free

Fortunes have been made by men who have thought of a "little" idea in a flash—the bottle top, the crimped hairpin, the thin lead automatic pencil, the snap fastener—earned fortunes, yet there are as many fortunes lost by inventors who did not know just what to do about their ideas. A wonderful book explaining this wonderful new course written by 14 practical inventors has been prepared and will be sent free to those genuinely interested. If you have ever had an idea for an invention, or if you would like to become a spare-time or professional inventor, and if you would like to know what to invent, send in your name at once on the coupon or a postal NOW! Only a limited number of these books are available for free distribution.

BUREAU OF INVENTIVE SCIENCE
312 Wisner Bldg. ROCHESTER, N. Y.

Bureau of Inventive Science, 312 Wisner Bldg., Rochester, N. Y.

Please send me your free book "The Science of Invention."

Name.....

Address.....

City..... State.....

PATENTS

Booklet Free Highest References Promptness Assured Best Results
Send drawing or model for preliminary examination

ALL BUSINESS GIVEN PROMPT AND PROPER ATTENTION

WATSON E. COLEMAN, Patent Lawyer, 644 G St., Washington, D. C.

WEAR ONE 7 DAYS FREE

A \$3.52 B \$3.84 F \$4.18
C \$3.93 E \$3.48 D \$2.84

If You Can Tell It From A Genuine DIAMOND

SEND IT BACK These Amazingly Beautiful **CORODITE** GEMS match the scintillating beauty of GENUINE DIAMONDS in every way. They have the same gorgeous blazing flash and dazzling play of living rainbow fire. Standing the terrific Acid Test of direct comparison. Lifetime experts make all their experience to see any difference. Prove this yourself.

MAKE THIS TEST Wear a Genuine **CORODITE** and a Diamond side by side on the same finger for **SEVEN** days. If you and your friends can tell the difference send it back, you won't be out a single penny. That's fair enough. If you keep the ring the price printed here is all you pay. No installments. Remember **CORODITES** have the same facet cutting as Genuine Stones.

A. Ladies Hand Carved Basket Ring, Platinum effect \$3.82
B. Ladies Picured Filigree 4 Foot Ring, Platinum effect \$3.84
C. Ladies Filigree Ring, Blue Sapphire Set Sides, \$3.93
D. Ladies Irides Blossom Hand Chained Softtaille \$2.84
E. Mens Heavy Belcher 14K Gold Faced Ring \$3.48
F. Mens Massive Carved Hexagon Gypsy, Sapphire Sides \$4.18
Carat Size Gems Beautiful Hand Carved and Engraved Rings reproducing in exact and faithful detail the most modern high priced and fashionable Platinum Diamond Creations.

SEND NO MONEY Keep your money right at home. Just send name and address stating which ring you want and size as shown by slip of paper fitting snug to and around finger joint and your ring will come by return mail. Deposit amount shown above with postman. You do not risk a penny as our binding legal guarantee to refund your money in full is attached to every ring we sell. **SEND TODAY.**

E. RICHWINE CO., Dept. 248 19 West Jackson Bldg. CHICAGO, ILLINOIS
Original and Sole Importers of Genuine **CORODITE** GEMS

BLUE BOOK ON PATENTS

gives instructive information and candid advice.
MONROE E. MILLER, PATENT LAWYER
411-2 Ouray Building WASHINGTON, D. C.
ELECTRICAL AND MECHANICAL EXPERT

Factory Sale

**Durable
Strong**

**NEW Model
BOILER and
Storage Can**



Made of extra strong, heavy pure copper, with a 6-inch Solid Brass Cap and Spout. Rubber gasket between cover and shoulder makes airtight fit. Easily cleaned. No Screw Cap, no threads to get out of order. No burning of hands, no trouble in taking off cover. Cap can be put on or taken off in a second by a simple twist of the thumb-screw on the top. Safe, practical, simple and durable. No article of such quality and utility ever sold at such low price. It's a low

pressure boiler and purifier. An ideal cooker for the home. Nothing better for general usages such as storing oils, gasoline, etc. It lasts a lifetime and gives real service and satisfaction. Above are strictly cash with order Factory prices. Send money order or check. Prompt shipment in plain strong box. Only can worth having. Catalogs Free. **HOME MANUFACTURING CO.** Dept. 1441 321 W. Chicago Ave., Chicago, Illinois

Our **BUREAU OF INFORMATION** will answer all questions regarding articles appearing in this magazine.

INVENTORS PROTECT YOUR IDEAS

Send for our Guide Book, **HOW TO GET A PATENT**, and Evidence of Invention Blank, sent Free on request. Tells our terms, methods, etc. Send model or sketch and description of your invention for our Examination and Instructions without charge.

RANDOLPH & CO.
300 Victor Bldg., WASHINGTON, D. C.

NAME

STREET

CITY STATE

\$4000⁰⁰ IN TWO MONTHS

Jacob Gordon's Profit

Making and selling Crispettes. Bram bought first outfit April 5, and seven more outfits by August 28. Iwata, Cal., bought one outfit, then 10 more within a year. Mrs. Lane of Pittsburg says, "Sold 8000 packages Crispettes in one day". J. R. Bert, Ala. wrote, "Only thing I ever bought that equaled advertisement". J. M. Patillo, Ocala, writes, "Enclosed find draft to pay all my notes. Getting along fine. Crispettes all you claim and then some." John W. Culp, So. Car., writes, "Everything going lovely. Crispette wrappers lying over. It's a good old world after all."

Kellog \$700 ahead end of second week. Mesner, of Baltimore, \$250 in one day. Baker sold 3000 packages in one day. Ferrin, \$380 in 1 day.



WE'LL START YOU IN BUSINESS

Furnish secret formulas, raw material, and equipment. Very little capital required; no experience needed.

Build Paying Business of Your Own

No limit to the sale of Crispettes. Everybody likes them. It's a delicious food confection made with or without sugar. Write me for facts about a business that will make you independent. Start now, in your own town.

Profits \$1,000 a Month Easily Possible

Send postal for illustrated book of facts. In contains enthusiastic letters from others—shows their places of business, tells how and when to start, and all information needed. Free. Write now!

LONG-EAKINS COMPANY

1228 High Street Springfield, Ohio

A Fine Holiday Gift



A REAL AUTOMOBILE

Any man or boy can build it or buy it complete. Power supplied by famous 2 1/2 H. P. SHAW motor. Write for FREE Particulars and Special Low Prices or send 25c for COMPLETE BOOK OF BUILDING PLANS.

SHAW MFG. CO.
Dept. 7X GALESBURG, KANS.

I Want 700 Agents

At \$90⁰⁰ a week

Men and Women! Write me today and by this time next week I can place you in a position to make \$2.00 to \$5.00 an hour in your spare time, up to \$15.00 a day full time. Thousands of our representatives are making that and more with our New Plans. Simply introduce and take orders for famous World's Star Hosiery and Underwear sold direct from mill to home—a complete line for whole family. Permanent customers and repeat orders make you steady, big income. No delivering or collecting. No capital required.

Write Quick It's a chance to make thousands of dollars. Your profits begin at once. Exclusive territory. No experience needed. Write today and I'll send all facts and tell how to start free. (Established 29 years.)

World's Star Knitting Co.
292 Lake Street Bay City, Mich.



On Credit!



Direct from the Maker



8

Adjustments

\$1 down!

—and direct from factory

Only \$1.00 down buys the famous Studebaker Insured Watch direct from the factory at the low factory price. Choice of 54 newest Art Beauty Cases, in white gold, green gold or yellow gold effects; 8 handsome dial designs. Mail coupon for beautiful Style Book in colors—Sent Free!

21 Jewel ~ Extra thin STUDEBAKER The Insured Watch

Has 21 Jewels—8 adjustments—and is insured for the lifetime of the owner. The masterpiece of timepieces at an amazingly low price.

Watch Chain FREE!

For a limited time we are offering a beautiful Watch Chain FREE. Write while offer lasts.

Mail Coupon for FREE Book

Mail coupon today for magnificent Studebaker Book of Advance Watch Styles. Find out how you can buy direct from the factory—save money and own one of the finest watches made. The Book shows 54 newest thin-model designs in Art Beauty Cases. Sent FREE!

STUDEBAKER WATCH CO.

Dept. N-22 South Bend, Indiana

Canadian Address: Windsor, Ontario

Ask for Ladies' Bracelet Watch Folder

Ask for Jewelry Folder

STUDEBAKER WATCH CO.

Dept. N-22 South Bend, Indiana

Please send me your Free Book of Advance Watch Styles and particulars of your \$1.00 down offer.

If you live in Canada send your inquiry to our Canadian office: Windsor, Ontario.

Name

Address

City

State

Check here for Ladies' Watch Folder

Check here for Jewelry Folder



MEN BOAST about their CORNWELL TOOLS

A hundred thousand men boast that CORNWELL Hand Made Tools do work no other tools can do. They'll show you tests other tools can't stand. Try these amazing tests yourself at our risk. Use these tools in shop and home. Money back guarantee on every CORNWELL Tool.

Finest Tools in the World



CORNWELL Tools made of finest Swedish Charcoal Process Molybdenum Steel, from our famous Cornwell secret formula. Forged, heat treated and hardened and tempered in oil. Made by hand, NOT drop forged and case hardened.

Try These Strong Tests

Cut vice handle shavings with bearing scrapers. Drive 1/4 in. flat chisel through 1 1/2 in. machinery steel. Won't damage tools. Many other tests described in booklet.

MAIL THE COUPON!

Get special illustrated booklet and prices now. Then order. If you ever saw tools as good as these return your order and money refunded. Mail coupon at once.

CORNWELL QUALITY TOOLS CO.,
Dept. D, Cuyahoga Falls, Ohio

Send me illustrated booklet with prices on Cornwell Secret Formula Hand Made Tools.

..... Occupation

Name

Address

City..... State.....

MEN *Get This Sample Case* and Earn \$100 a Week



Harry I. Jacobs, Wisconsin, N. E. Snider, Michigan, found it easy to make that much and more. No Wonder.

There is a new way to become a specialist in hosiery and underwear—and to make \$50 to \$150 a week. Wearplus fine hosiery and underwear, at low factory prices, are taking the country by storm. A wonderful opportunity to become independent, with a business of your own.

Liberal commissions at the start. Repeat business, on account of the wonderful values offered and our iron-clad guarantee, will make your territory a gold mine. Bonus paid producers. Write quick for sure-fire Sales Plan and Sample Case Offer.

Arthur Huebner, President

The Wearplus Company, 560 Wearplus Ave., Bay City, Mich.



Models of Round the World Flyers Can be Built with

Ideal Model Airplane Outfits

These 3 ft. duplicates of real 'planes fly by their own power. Accurate models of the big ones, faithfully duplicating them in every essential feature.

Any Boy Can Build One!

Our catalog shows models of eight famous 'planes, and tells how to get complete construction outfits, parts and supplies with which to build them. Also tells all about the celebrated "EveryBoys" Airplane. Send 5c now for your copy, and get a Model Airplane for Christmas.

Plans and Instructions

Complete Scale Drawings, with Building-Flying Instructions for a 3 ft. Model of any of these 'Planes:

De Havilland World Flyer
Curtiss JN4D-2 Training Plane; Cur-
tiss Military Tractor; NC-4 Naval
Seaplane; Bleriot, Taube or Nieuport
Monoplane; Cecil Peel Racer.
(Set of 8 Plans, \$1.60 postpaid.)
IDEAL Catalog, 5c postpaid.

25c

EACH
POSTPAID

Ideal Aeroplane & Supply Co., 408 West Broadway, New York

BE THE MAN *Make \$24.00 a day* OF THE HOUR

selling "Jim" Foster finely tailored suits and overcoats at the smashing price of..... \$12.50
You make \$3.00 on each order. Write for samples and full information at once, for best patterns, samples—and greatest value. Address "Jim" care of

"Jim" Foster Clothes 2250 So. Spaulding Ave.
CHICAGO

Send **TRIM** Men—Women—Children—cuts, No Money trims, or bobs hair—as easy as combing. No practice necessary. Perfect barber can do. Combination hair cutter, safety razor and comb. Just send your name for our Free Trial Offer. No risk. No obligation. Write today. **AT HOME** Agents wanted. **HAIR CUTTER** Dept. 73, Jackson Bldg., Indianapolis, Ind.

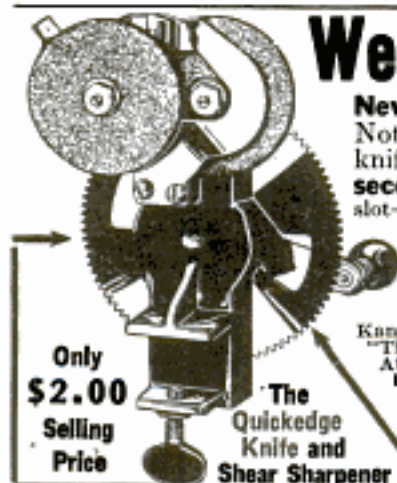

Only
\$2.00
Selling
Price

The
Quickedge
Knife and
Shear Sharpener

We Want Agents at \$50 to \$90 a Week

New Invention—Just Out. Needed in every home every day. Patented. Nothing else like it. Low priced—**Sells on sight.** Sharpens any kitchen knife, paring knife, carving knife, bread knife, or shears and scissors in **ten seconds.** Mechanical masterpiece. A child can use it. Just put knife in slot—turn crank—sharpens both sides at once automatically. **We want representatives at once—men and women hustlers.** Get this position where profits start first day.

No Experience Necessary—200% Profit

Make as much money next week as these men are making now. J. C. Lewis, of Kansas, says: "I have sold one hundred sharpeners in four days." Hobar Kerr, of Md., writes: "The women can hardly wait till they get them." Herbert Cain, of Ky., sold nine after supper. At the end of the first day, J. W. Gordon, of Pa., writes: "I sold two dozen and I sold to everyone I saw." Wm. G. Hall, of N. J., says: "I think it is great. I sold six in about one-half hour. The machine is a mighty fine proposition. I am a mechanic and I know what I am talking about." You can make this money. **WRITE TODAY. TERRITORY FREE. Get busy at once.**

QUICKEDGE SHARPENER CO.

112 Sharpener
Building

JACKSON, MICH.

VE-PO-AD *"A Little Wizard On Figures"*

FITS RIGHT IN THE VEST POCKET—DOES THE WORK OF A

\$300.00 ADDING MACHINE



VE-PO-AD

Counts Up to 999,999,999

Simplest thing you ever saw. Speedy, Accurate—just like a \$300.00 machine. Nothing to get out of order. Always works. Fully guaranteed!

Sells for Only \$ **2⁹⁵**
Special Agent's Price \$1.00 in Lots
200% Profit For You on Every Sale

Marvelous new invention. A perfect adding machine that is positively accurate, quick as lightning, easy to operate and—FITS RIGHT IN YOUR VEST POCKET. Doctors, lawyers, architects, merchants, farmers, salesmen—everybody in fact can use this little machine constantly. It's light, flat and compact. Here's a real chance for you to make \$20 to \$30 clear profit every day. Hundreds of buyers right in your territory. The most amazing, profit-producing article on the market. Nearly 200% profit on every sale you make. Exclusive territory to live wire agents. Sample machine \$2.95, cash or C. O. D. 10 days free trial. Money back if not satisfied. Order at once. Get in on this big, new money-making proposition—NOW!

Reliable Adding Machine Corporation
39 W. Washington St., Chicago, Ill.

Your Chance to Make a Cleanup

\$20 to \$30

PROFIT DAILY

Agents actually doing it. Everywhere. Get started now on this easy way to make big money quick.

WRITE TODAY!

Convert your Ford NOW and save 100%



9 attractive speedster models, 1 DE LUXE SPORT COUPE BODY

Racing Gears, Discs, etc.

Underline Package

ACT NOW! ROCK-BOTTOM WINTER PRICES! COME IN TO-DAY AND INSPECT NEW SPORT COUPE BODY AND OTHER MODELS.

I. L. FORDSPEED BODY MFRS., 250 W. 54th Street, New York

"BOW LEGS and KNOCK-KNEES" UNSIGHTLY

SEND FOR BOOKLET SHOWING PHOTOS OF MEN WITH AND WITHOUT THE PERFECT LEG FORMS

PERFECT SALES CO.

140 N. Mayfield Ave., Dept. S, Chicago, Ill.

The Famous KON-VER-TER Slide Rule

Instantly adds, subtracts, divides, multiplies, converts fractions or decimals of an inch. Given sine, co-sine, versed sine, covered sine, tangent, co-tangent, secant, cosecant of angles directly. Gives square roots, squares, cube roots, cubes and fifth roots and powers of all numbers. Logarithms, co-logarithms, anti-logarithms. Used throughout the world. About 6 inches in diameter. Most complete rule of its kind selling at a popular price. 20 page book of instructions and box with each rule. DeLUXE MODEL White Ivory Celluloid, \$3.00 Post Paid.

J. C. HAMILTON

7 Water St., Dept. A, BOSTON, MASS.

21 Jewels

Nothing less than 21 Ruby and Sapphire Jewels is good enough for the Burlington masterpiece.

Quality and Style

Adjusted to the second-temperature—synchronism—position. 25 year Gold Strada Case, in 150 exquisite designs. Only \$1 down. Balance in small monthly payments. Send for free book.

Burlington Watch Company

19th Street and Marshall Boulevard
Dept. 13-59 Chicago, Illinois



STAYS CAUGHT

GIBBS TWO TRIGGER TRAPS

kill—or hold every animal it catches. "Wring-offs" impossible.

At dealers or sent postpaid—50c each or \$1.00 a dozen in U. S. Send for CATALOG describing also the new "GIBBS DOPE TRAP" for larger animals.

W. A. GIBBS & SON, Dept. BP-12, Chester, Pa.
Branch Factory, Toronto, Canada



\$985



Order No.

M-167292

Big rich tone

A wonderful little machine. Plays 10 or 12 in. records. Splendid for dancing. Weighs only 8 lbs.; carry it anywhere. Built in sturdy steel case, mahogany finished. Has speed regulator, start-stop device like expensive machine. Powerful motor plays two records, one winding. Machine is 7 3/4 in. high, 13 in. wide, 12 in. deep.

FREE with order, 4 (Columbia Record) selections and 100 needles. Send only \$1.00 to show good faith. Pay rest plus few cents postage, to postmaster. Satisfaction guaranteed or money refunded. Get your order out now.

Free Catalog

American Novelty Co., 2455 Archer Ave., Chicago, Ill.



Vacuarm

On the Instrument Board of Your Car
**Blows Horn when
Gas is Low.**

Tells exact amount in tank. Vacuum Indicator warns of trouble in advance.

At your dealers or by Parcel Post, prepaid with complete instructions on receipt of price—\$8.90. Installed in 20 minutes. Money back in 30 days for any reason.

THE SMITH MOTOR EQUIPMENT COMPANY
1946 West 77th St. Cleveland, Ohio

Foreign
Countries
3 for \$5

No
Agents



A Pocket
**PHONOGRAPH
AT LAST!**

The Phonilo is a simple pocket device that plays all needle records. Astonish your friends and win applause. It lasts a lifetime. Sells on sound. Postpaid One Dollar in U. S.

LOTS of FUN—NOT A TOY
Hand-Phonilo Co., P 123 W. Madison Street, Chicago

Electricity
and
Magnetism

Including Graphs
Illustrated Directions
Testing

**HOW TO BUILD
YOUR OWN MOTOR**

BOYS!

Send for this
FREE Book
"Electricity
and
Magnetism"

A complete treatise, simply and clearly written on the principles of electricity and magnetism, profusely illustrated by diagrams, photographs and engineering drawings, together with complete instructions for building a small motor yourself at a cost of only \$1.50. We will send you this book **ABSOLUTELY FREE** of cost if you mention the name of the Popular Mechanics magazine.

KNAPP ELECTRIC CORP.
130 W. 42d St., Dept. 25, New York, N. Y.

Holtzer-Cabot

LOUD SPEAKER



A New
Standard
of Quality
**ONLY
\$12.00**

If you want a Loud Speaker which brings in volume so that you don't have to strain your ears to hear it—which in spite of its power does not distort, but makes music receptive a musical and artistic pleasure—which is sensitive to every tone so that a piano sounds like a piano and not like a tin pan—which is so beautiful that it harmonizes with any surroundings, this are Holtzer-Cabot National in the Loud Speaker for you. Furthermore, its price—\$12.00—has established an entirely new standard of value in Radio.

Dept. P. M.

THE HOLTZER-CABOT ELECTRIC CO.
125 Amory Street BOSTON
646 46 South State St. CHICAGO

Holtzer-Cabot

ABSOLUTELY FREE
Thousands of
RADIO BARGAINS

You Can't Equal This Anywhere
REACO loud sets—2000 Choke—head
bands and cord complete. Ear
phones—amplifier.
Write Dept. 12 for
wonderful catalog. **\$2.69**

STANDARD RADIO CORP.
227 WEST MADISON ST. CHICAGO

DYNA-MOTOR

As a dynamo it will operate induction coils, light lamps, charge storage batteries, electroplate, etc., makes an ideal machine for experimenting. As a motor they will operate heavy models, easy wheels, and other appliances.

16 Watt **\$6.50** 22-Watt **\$8.00**

64 to 200 Watt Dynamos, Armatures, Commutators, Pincushions, Parts for Schools and Students.

Send for Catalog to cover cost of mailing, etc.

LOOMIS ELECTRIC COMPANY
1427 N. Artesian Ave. CHICAGO, ILL.



Buchstein's Fibre Limb

is soothing to your stump—strong, cool, neat, light. Easy payments. Braces for all deformities.

D. BUCHSTEIN CO.

610 3rd Ave., So., MINNEAPOLIS, MINN.



GIVEN

Rush your name and address and learn how to get this handsome 14 Kt. gold filled man's watch and chain **ABSOLUTELY GIVEN**. Watch has 10 jewel Lever movement. Write today—don't delay for **FREE** watch plan.

RELIABLE SALES CO.

434 Broadway Dept. 278 New York City

BARGAIN CATALOG

Yours **FREE!** 100 Pages!

Get **It NOW!**
Crammed full of information and offers

of all kinds of complete
RADIO SETS,
Parts and Accessories

Only \$21.95 for 1-tube outfit, receiver parts unassembled; often receives over 1,000 miles. Only \$53.78 for 2-tube outfit, receiver assembled; often receives over 1,000 miles on loud speaker. Only \$89.09 for 3-tube Neutrodyne outfit, receiver parts unassembled; has received England. These prices include all accessories, serial, etc.—everything needed for receiving on loud phones. Also, **Cresley receivers, 10% off, 25 other popular sets away down.**

It's easy to do business with us, for this is "The Radio House of Friendly Service." All goods offered subject to examination and approval. No money in advance. Quick shipment. We pay transportation anywhere in U. S. Satisfaction or money back. Your radio questions answered free. **Get this wonderful catalog—you need it—write today! Don't delay!**

(And will you be so kind as to add the names of several friends you believe will soon want radio goods? Thank you!)

LIBERTY MAIL ORDER HOUSE
Dept. 163Z, 106 Liberty St., N.Y.

TOWERS

Scientific \$2.95
Plus a few cents postage

Buy a Headset you'll be proud of

RADIO TOWERS SCIENTIFIC HEADSETS

OUR \$200,000.00 COMPANY STANDS SQUARELY BACK OF EVERY HEADSET

Now \$1.95, with Noiseless Improvements
Larger Cord (3 ft.), Stronger Magnets, Higher Resistance, Increase of Sensitivity, Perfect Tone Meters
EVERY SET TESTED BY LICENSED RADIO OPERATORS

Send no money - Order on a Post-Card
THE TOWER MFG. CO. Dept. F-31 BROOKLINE AVENUE, BOSTON, MASS.

WORLD'S GREATEST HEADSET VALUE

Como Duplex Transformers
(Push Pull Power Type)

Price \$12.50 Per Pair



The Como Duplex system of audio frequency amplification (push-pull) gives the maximum volume without distortion and tube noise. There is a combined filtering action which assures perfect results when ordinary amplification transformers fail. Can be used as a single-stage, two-stage, or a three-stage amplifier.

The World's Standard Push Pull Transformer

Send for copy of "How to Build a Power Amplifier."

COMO APPARATUS CO.
446 Tremont Street - BOSTON, MASS.

Just send your name

Very interesting



APEX VERNIER DIAL

Do not bother with geared condensers, requiring many holes in the panel and careful lineup of pinion shafts, when this marvelous instrument provides the fine adjustment for tuning in distant stations. Ratio 10 to 1—quickly applied to any shaft. For sale by all good radio dealers. If unable to obtain, fill in coupon and enclose \$2.50 for nickel finish or \$3.50 for Gold Plated finish.

APPLY TO THE MANUFACTURER FOR THE COMPLETE CATALOG



Coast To Coast On An 18-Inch Loop
Assemble Your Own 7 Tube Super-Heterodyne

—on a 7 x 18 panel in three hours, \$67.50 buys the parts complete, including drilled and engraved panels, condensers, sockets, transformers—dials, connecting plugs, cables, etc.—with drawings, diagrams and instructions. Price of cabinets to fit—furnished on application. If your dealer cannot supply these parts for this complete Heterodyne Radio Set, fill in coupon, mail check or money order and send dealer's name.

Apex Electric Mfg. Co., Dept. 1201, 1410 W. 59th Street, Chicago, Ill.
Enclosure: Enclosed find \$..... for which send me.....

Name.....
Street.....
City..... State.....



Catch Everything in the Air!

Keep your radio batteries charged—and you won't miss a thing.

APCO Battery Charger does the trick over-night for less than 10c per battery. It's noiseless, clean, compact. Connects with ordinary light socket as easy as an electric "flat."

Write for interesting circular and nearest dealer's name.

APCO MFG. CO., New York Ave., Providence, R. I.

APCO BATTERY CHARGERS
for "A" and "B" Batteries



Cunningham RADIO TUBES

Quality Plus Service

Since 1915

The General Electric Laboratories produce these tubes which "Since 1915"—a Radio Lifetime—have consistently made good their claim of exceptional accuracy.

Price the same on all Five Types

C-301A C-299 C-300 C-11 C-12

Patent Notice: Cunningham tubes are covered by patents dated 2-18-08, 2-18-12, 12-30-13, 10-25-17, 10-25-17, and others issued and pending. Licensed only for amateur experimental and entertainment use in radio communication. Any other use will be an infringement.

Cunningham 40-page Data Book fully explaining care and operation of Radio Tubes now available by sending 10c in Stamps to San Francisco Office.

E. J. Cunningham Inc.

HOME OFFICE
SAN FRANCISCO

CHICAGO

NEW YORK

LATEST WHOLESALE RADIO CATALOG

FREE Simply send name
TODAY for big
48-page catalog
of latest radio goods at Wholesale.
Live dealers and agents wanted.
STANDARD RADIO CO., 102 East 13th, Kansas City, Mo.

RADIO TEXT BOOK & CATALOG FREE



Contains—
75 Radio "Hook-Ups"
300 Illustrations
556 Articles
84 Pages

"Build Your Own with RASCO Parts"

RADIO SPECIALTY CO.
98-E Park Place, NEW YORK, N. Y.



\$3.50
each

RADIO Storage "B" Battery

22 Cells 24 Volts Lasts Indefinitely—Pays for Itself

For a limited time only, and to introduce this new and superior Storage "B" Battery to the public, we are selling it direct to the consumer for \$3.50. Regular retail price is \$5.50. You save \$2.00 by ordering NOW. Equipped with Solid Rubber Case, an insurance against acid and leakage. Extra heavy glass jars. Heavy, rugged plates. Takes place of dry "B" batteries and will last indefinitely. Recharged at a negligible cost. Eliminates many noises so often blamed on "static". Order yours today!

SEND NO MONEY Just state number of batteries wanted and we will ship day order is received. **EXTRA OFFER:** 4 batteries in series (96 volts), \$13.00. Pay Expressman after examining batteries. 6 per cent discount for cash with order. Save \$2.00 by ordering NOW!

WORLD BATTERY COMPANY

1219 So. Wabash Ave., Dept. 6, Chicago, Ill.

Makers of the Famous World Radio "A" Storage Battery.
Prices: 6 volt, 100 Amp., \$12.50; 150 Amp., \$14.50; 165 Amp., \$16.00.
Guaranteed in writing for two years.

World FOR
STORAGE BATTERIES RADIO



NRKA WEAF WGN WJS KRJ NKO KFAF WJY KOP

FARAWAY RADIO



\$2950
Gets stations
Far and near
Loud and Clear

FARAWAY Radio Sets are amazing values at bargain prices. Users get stations from New York to Frisco—loud and clear. Operate with either dry cells or storage batteries. Beautiful cabinet finished in mahogany with new platinum-finished panel. **SATISFACTION GUARANTEED** Don't pay \$400 to \$100. Write for our money-saving plan and literature.

2-Tube Set - \$29.50
4-Tube Set - \$9.50

Dealers - Agents: Biggest possibilities you ever heard of. Write for plan and territory quickly.

THE FARAWAY RADIO CO., 622 W. THIRD ST., CINCINNATI, O.

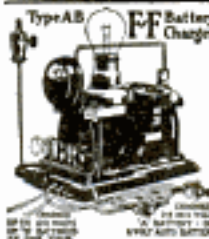

The Triple Duty Charger

Charges radio 2, 4 or 6 volt "A" battery, radio "B" battery up to 120 volts and auto batteries from lamp socket. Average cost per charge about a nickel. Solidly built—will not get out of order. Fool-proof and simple. The first successful charger—introduced over ten years ago. Type A, B, price \$20; West of Rockies, \$21. Type G for 6 volt "A" or auto batteries, price \$16; West of Rockies, \$16.50. "B" battery charging attachment, \$2.00 extra. Write for literature and names of Dealer who will supply you with the genuine FF charger.

FRANCE MFG. CO.

10424 Berra Road

CLEVELAND, OHIO

RADIO ENCYCLOPEDIA



FREE! Thousands of radio bargains, standard sets, standard parts for sets, vacuum tubes, etc., at one-third less than regular prices, and latest information on all circuits, complete list of broadcasting stations and other valuable data. Send name and address, we'll send you the book **FREE!** **FREE SERVICE DEPARTMENT.** Mr. Deane of N. Y. City World will help you solve your radio problems and furnish up-to-date information on an operation, special approval form. This service **FREE** to our customers. Write today!

NORWALK RADIO CORR

Dept. 56 66 READE ST., NEW YORK

DEALERS SAVE MONEY

By Ordering from Our Bargain
Catalog of Nationally Advertised
Radio Goods, Write for It Today!

AMERICAN RADIO MFG CO.
Dept. Q 6 WEST 14^{1/2} ST. KANSAS CITY, MO.



19⁹⁵ 1-TUBE RADIO SET COMPLETE

with 6.00 phones, tube, A and B Battery and complete antenna. Gets local stations without an aerial. Highly selective. Fine volume. GUARANTEED.

A WONDERFUL XMAS GIFT

SENSATIONAL BARGAINS!

on nationally advertised sets complete, ready to operate. Also on accessories alone. Look at these amazing values.

59⁹⁵ for guaranteed, highly selective coast-to-coast 4-tube set complete with 9.50 loud-speaker, 6.00 phones, 3 dry cells, 90 volts, B Battery, 4 tubes and complete antenna. For operation with storage battery, 69.95 complete.

49⁹⁵ for guaranteed, highly selective coast-to-coast 3-tube set with 9.50 loud speaker, 6.00 phones, 67½ volts B Battery, 3 dry cells, 3 tubes and complete antenna. For operation with storage battery, 61.95 complete.

32⁹⁵ for guaranteed 2-tube outfit with 6.00 phones, 3 dry cells, 45 volts B Battery, 2 tubes, complete antenna. For use with storage battery, 44.95 complete.

6.00 Phones for **3.38** — 4.00 tubes for **3.00** and scores of other bargains. Sets also sold alone.

Send order direct and pay on delivery or write for FREE catalog. Reference: The Atlas Nat'l Bank of Cincinnati, O.

THE MELLODYNE RADIO CO.
Dept. B CINCINNATI, OHIO

Your Crystal Set

will work 400 to 1000 miles if made by my plans. No tubes or batteries. Copyrighted plans \$1.00. Satisfied customers everywhere. Particulars free.

LEON LAMBERT 539 Kaufman Bldg. WICHITA, KANSAS

Cut Prices on Radio

Save 25 to 50 per cent. Standard Sets, all types, \$5.00 to \$79.00. Everything in accessories. Wiring diagrams and estimates free. 150,000 customers. Money-back guarantee. Immediate delivery. Illustrated catalog on request. Special proposition to community agents.

Radio Dept. 108

IMPERIAL LABORATORIES, Coca Cola Bldg., KANSAS CITY, MO.

Two Salesmen Hit Salina Not Long Ago...



They were selling household appliances from "door-to-door" . . . But the doorbells didn't ring loud enough . . . or "Papa didn't love Mamma" enough . . . or something! Any way, Salina was the end of the trail . . . We started them selling BECK-NOR Systems—a little "fool-proof" accounting system for merchants, that is sweeping the country. And these two men—totally without experience in selling to merchants—each averaged above \$100 weekly real money . . . We want more like them! Let us tell you about it.

The Beck-Nor Co.
118 S. 7th Street,
Salina, Kansas



FAHLBERG

MADISON, WIS.

for perfect
Conductivity in Radio

Reddy

HOT

Soldering Furnace

(Burns Denatured Alcohol)

AND TESTED SUPPLIES

Safe Soldering at Home. It is now possible for the amateur to get tight, clean joints in his home soldering that make the perfect conductive path necessary in radio work.

Mr. E. D. Fahlberg, former Professor of Metallography at the University of Wisconsin and Metallurgical Engineer with Western Electric Company, has developed Reddy Hot, the complete and safe home soldering furnace that this class of work demands. Reddy Hot will heat your iron ready to solder in *two minutes* and is

Safe — Non-Explosive — Portable

The complete Reddy Hot Soldering Outfit consists of the following: Large soldering copper, detachable handle—Fine soldering copper, detachable handle for delicate soldering—Reddy Flo Household Solder (highest grade general purpose solder on market)—Can Reddy Stik non corrosive Soldering Flux especially adapted for Radio—Can Reddy Prest Sal Ammoniac keeps tip clean and bright—Can Reddy Rub Abrasive Tape for quick cleaning and polishing. Complete directions with each outfit.

Ask your dealer for the Reddy Hot Soldering Furnace and supplies. If not obtainable we will send direct, for a short time only, on receipt of price.

E. D. Fahlberg Mfg. Co.
Madison, Wisconsin

JOBBERS AND DEALERS:

Write or wire for attractive Reddy Hot proposition and samples. Display carton of 12.

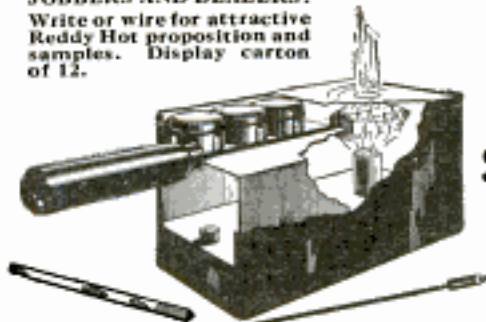

Price
\$1.50

E. D. FAHLBERG MFG. CO., Madison, Wisconsin

Send me prepaid one Reddy Hot Soldering Furnace for which I enclose \$1.50.

My dealer's name is.....

Signed: Name.....

Address.....

NATIONAL VELVET CONDENSERS VERNIER AND DIALS

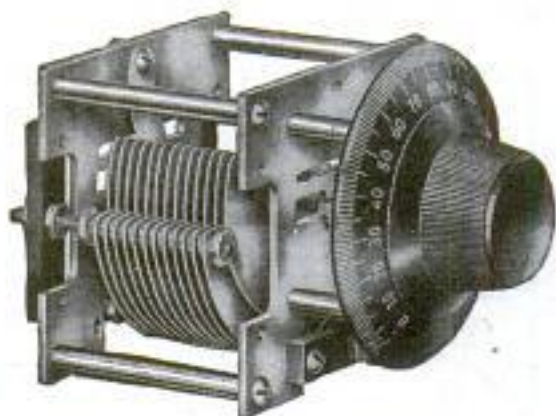

HAVE A VELVETY SMOOTHNESS HITHERTO UNKNOWN

They are made by skilled craftsmen—have the lowest losses and bring in distant broadcast with the least distortion. Home built sets using Nationals have received broadcasts from Paris—3,600 miles, and code from Buenos Aires—5,200 miles.

The condenser and dial chosen by Harvard University experts to demonstrate the Browning-Drake set before American Institute of Electrical Engineers.

SIZES:	.001	.005	.00035	.00025
PRICES:	\$7.00	\$6.00	\$5.75	\$5.50
DIALS ONLY 4" \$2.50—3" \$2.00				

Interesting Bulletin covering Browning-Drake Receiver Free. Do not experiment with unknown products. If your dealer cannot supply you, write us.

The National Company, Inc., Cambridge 39, Mass.

22½ V. "B" Storage Battery



ABSOLUTELY FOOLPROOF—Complete with instructions ready to charge at home. Cannot be harmed by overcharging or overdischarging. Plates will not buckle. An ideal battery—endorsed by hundreds of satisfied users.

SEND NO MONEY \$3.98

Simply mail us your name, and we will send you a battery. No postman upon arrival. Plus postage. IF NOT SATISFIED—MONEY BACK.

CO-OPERATIVE MERCHANDISE COMPANY
Dept. 211 Chelsea, Mass.

How to Build ULTRADYNE *The Improved* SUPER-HETERODYNE



32-page illustrated book with detailed instructions on drilling, wiring, assembling and operating Model L-2 Ultradyne Receiver. Latest authentic edition by R. E. Lacault, A.M.I.R.E., inventor of the Ultradyne, the most selective receiver known.

Write for Descriptive Circular.

PHENIX RADIO CORP.
3 Beekman St., N. Y.

50¢

FREE Greatest Catalog of Radio Bargains



Send for It Today

It contains a thousand bargains of everything in radio: parts, supplies, complete parts for sets, complete sets, etc., also a mine of very latest information on all different circuits, complete list of broadcasting stations and other valuable data. Send your name and address and we'll send FREE catalog.



\$3.95
without unit
\$6.95
with unit

American Bell Loud Speaker

With American Adjustable Unit. Wonderful volume, clear reception. Speaks for itself without coaxing. 10-inch bell—made of non-vibrating material.



HEADPHONES "Randolph Special"

2200 Ohm moulded headset, properly designed to give strong and clear reception. Biggest headphone value ever offered.

Hundreds of Other Bargains

Our catalog is filled with bargains like these. Order direct from this ad. We prepay charges. Don't buy anything in radio before you see our catalog. FREE Service Dept.

RANDOLPH RADIO CORP.
159 N. UNION AV. Dept. 252 CHICAGO, ILL.

Band Saw with Motor Only \$104



A rare bargain in a 14-inch Band Saw. Staunchly built and carrying the Boice-Crane guarantee of satisfaction. 36" high. Table, 12"x14", tilts to 35 degrees. Guides accommodate blades ¼ to ½ inch. Maximum distance between table and upper guide, 6". Complete with ¼ h. p. ball bearing motor \$104. Without motor \$65.

Sold on Money Back Guarantee

Write for descriptive catalog including Bench Saws and Jointers.

W. & J. BOICE

Dept. D-12

Toledo, Ohio

Have you begun collecting EKKO Broadcasting Station Stamps?

See your radio dealer or write to us.

The EKKO COMPANY
111 West Monroe St., CHICAGO

Built to provide loud speaker entertainment from stations vast distances off—even while nearby stations are sending.

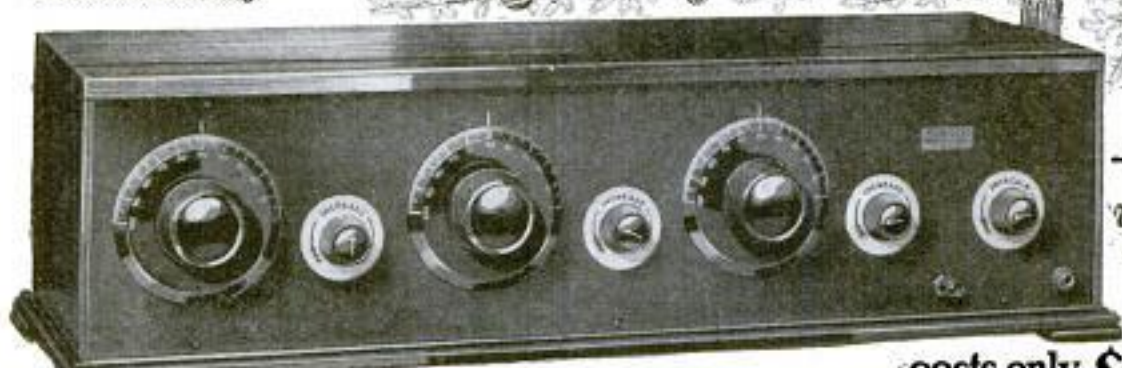

-the gift the whole family will enjoy

costs only \$75

The Marvelous MIRACO Ultra 5

[FIVE TUBE OUTFIT IN BEAUTIFUL SOLID MAHOGANY CASE]

Unsurpassed selectivity, sensitivity, range, volume and tone combined

A beautiful sweet toned, five tube, "coast to coast" loud speaker set—factory-built, factory-tested and factory-guaranteed by one of America's oldest and most reliable manufacturers of quality sets. Composed of the finest parts obtainable. Equipped with the latest improvements, refinements and features found on costliest sets. Encased in a handsome hand-rubbed solid mahogany cabinet. Looks and performs like \$200 set. Thoroughly tested and approved by radio's highest authorities. For only \$75—a price which has rocked the industry! Unquestionably the most astounding value offered radio lovers.

Simple to connect and operate. No experience necessary.

Even a beginner can quickly learn to cut through the locals, get far-off programs loud and clear on the speaker, log all stations and bring them back at will. Full directions with each set.

The Miraco "Ultra 5" is non-radiating, non-howling, non-distorting. Has cut-out switch—and a first stage phone jack, for tuning—on front of Bakelite panel. Bakelite sub-base under which all wiring is hidden, and other newest features. Operates on storage battery or dry cells.

Other Miraco Long Distance Sets \$14³⁵_{up}



The Improved Miraco 1925 Model MW—with filament switch, phone jack, etc.—is a four tube outfit that users in every state report outperforms and out-distances sets twice as expensive. Operates loud speaker on distant stations. One stage tuned r.f. amplification, detector, two stages a.f. amplification. Solid mahogany cabinet. Value beyond duplication at \$54.50.



This wonderful new Miraco Model R-3 is the three-tube, long distance, loud speaker set that has created such a sensation. Easy to tune and log. Covers wave lengths 150 to 625 meters. Detector acts also as a tuned r.f. amplifier. 2 stages a.f. amplification. Has no equal for simplicity, volume, range or clearness at anywhere near its price of \$29.50.



Miraco Model R justly deserves its title, "Radio's finest low priced quality receiver." One tube acts as a tuned radio frequency amplifier and detector combined. A great distance getter. Easy to operate and log. Covers all wave lengths 150 to 625 meters. Like all Miraco sets, it uses storage battery or dry cells. Never such value before at only \$14.35.



MIRACO
RADIO
GETS 'EM
COAST
TO
COAST

NOTE: Remember that Miraco Tuned Radio Frequency Sets are built and fully guaranteed by a reliable, long established concern, one of the best to build quality sets. Thousands of users endorse their satisfactory performance. Send for further literature of coast to coast reception and proof that Miraco Sets are radio's finest long-ranged receivers.

COLORADO HEARS N.Y. AND CALIFORNIA

I heard New York and California the first night on my Miraco.—Fred Krappendorfer, Jr., Duran, Colo.

NEW YORK HEARS ALASKA

Received 115 stations with my Miraco including W.L.V. Fairbanks, Alaska, N.W. Pezaris, KBL San Francisco, WEV Houston, Texas, and CFAC, Calgary, Canada.—E. D. Elliott, Milford, N. Y.

OHIO HEARS 12 CITIES THE FIRST NIGHT

The first night we tried out our Miraco we got Atlanta, Philadelphia, Washington, New York, Detroit, Davenport, Omaha, Hastings, Nebraska, Chicago, Schenectady, Pittsburgh and Texas. We think that was real good for beginners.—W. L. Musselman, New Carlisle, Ohio.

NORTH DAKOTA HEARS 43 STATIONS FIRST 3 DAYS

Bought a Miraco, operated it three days and received: WGR, WLW, WDAF, KFI, CHOM, WJAE, WMAI, CFAC, WTAI, KYW, KFAK, KIZ, WJZ, WOC, WFLA, KFI, KDKA, WRAP, KFXK, PWX, WGS, WHB, WDAF, WLAB, KFI, KFKB, WLAG, WBAH, WHA, KCAL, WEAF, WOAW, WCAR, KGW, WCR, WGY, KSD, WPAI, CKY, WCBD, WYAY. Who has a better record?—W. L. Johnson, Ashley, N. D.

DEALERS, AGENTS

Write for our new prospectus. The nationwide use and popularity of Miraco sets, their unusually low prices and the extensive advertising we are doing, makes them wanted everywhere. Send coupon today—good territory open.

Send coupon for free bulletins!
or order direct from this ad

MIDWEST RADIO CORPORATION, Pioneer Builders of Sets
407-D East Eight Street, Cincinnati, Ohio.

Send free literature and full particulars about your complete line of Miraco products.

() Dealer () Jobber () Agent () User

NAME.....

ADDRESS.....

All Miraco sets are factory-built, COMPLETELY ASSEMBLED, factory-tested and factory-guaranteed. They may be used with any tubes or batteries.

\$25,000 TO 1,000 MEN BIG PROFITS TO LIVE RADIO FANS

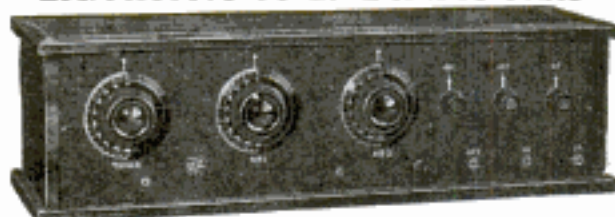

We have developed a World Beater. A five-tube set that has no equal in simplicity of operation, clarity of tone, range or volume, all of which is attained without critical adjustments or complicated parts.

To enable our agents to make the greatest possible profit, we are selling these sets fully assembled but not wired.

The efficiency of a Radio Set, no matter how good the parts or wiring system, is entirely dependent on the correct placement of the parts and arrangement of wires. These details have been carefully worked out in our laboratory, and if you follow our diagrams and blueprints, you cannot go wrong, and our simple but complete instructions make this easy for anyone.

We will train 1,000 Radio Fans in wiring and adjusting our sets to fit them to act as our agents and representatives, and handle the rush of business that is bound to come from the quality of our product and the volume and character of our advertising.

The Retail Price of the Blue Seal set as above described with engraved panel, and a beautiful cabinet, is \$90.00.

To those able to devote all or part of their time to the sale of Blue Seal sets, we offer a liberal agent's discount.

In addition to this, an excellent income may be derived from the wiring of these sets for our customers.

We want real HUSTLERS, and while our regular margin of profit and the income derived from wiring the sets sold is very attractive, in order to select and finally make permanent arrangements with the best of our agents we are offering

\$25,000.00 IN PREMIUMS AND BONUSES

BASED ON VOLUME OF SALES

WRITE TODAY for illustrated circular and full details which may be the means of putting you in a permanent and profitable business.

If you are not in a position to become our representative, but want the best radio set in your community, we will supply you direct, until such time as a local agent is appointed.

BLUE SEAL MANUFACTURING CO.

Dept. 3, 1406-08 South Michigan Ave. Chicago, Ill.

HEAR MUSIC and TALKING 1000 MILES AWAY

New Radio Set Has No Outside Wires or Storage Batteries

The new Trans-continental Radiophone which is the most simple, and the clearest toned radio set you have ever listened to, is the invention of Mr. Coats, of Chicago. This radio outfit is entirely different from all others. No outside wires needed. No troublesome storage batteries. It comes complete, in a beautiful mahogany finish cabinet (console type) and a loud speaker built right in so the entire family can listen to it just like a phonograph. It is guaranteed to have a range of 1,000 miles. Listen to the musical concerts, singing, lectures and speeches. Get the market reports, latest news and sports by radio. Mr. Coats wants to place one of his amazing new radio outfits in each locality and is making a special reduction of 40 per cent for the first outfit placed in each community.



Write Mr. H.N. Coats, 338 W. 47th St., Chicago, for his special low price offer and be the first in your locality.

It sells on sight

A two-minute demonstration will sell the nationally advertised **Whisper-It** Mouthpiece wherever a telephone is used. And you make 100% profit on each sale. Unconditional guarantee of satisfaction or money refunded protects you absolutely. Write at once for the **Whisper-It** proposition.

P. M. Colytt Laboratories
565 W. Washington Street, Chicago



Certified Leaks

Absolutely accurately calibrated, permanent fixed resistance units from $\frac{1}{4}$ to 10 megohms. Price 50c.



USE THE AUDIOHM for clarity and volume control. Kills distortion. Put one across the secondary of your transformer. Price \$1.50 with adjustable bracket.

LAMP SOCKET ANTENNA

Just plug in on any electric light line; no need of outdoor or indoor aerials. Simplest, neatest, most efficient in market. Price 75c.



INDORARIAL Hang or lay anywhere, roll up when not in use. Wonderful directional effects, cuts out local stations. Use as ground. Price \$1.50.

GET Clear, Distortionless Reception. Distortion, weak signals, lost signals are almost always caused by inferior small parts. Protect yourself from disappointment, insure getting **Distance, Clarity and Volume**

By using Electrad radio parts. Money back guarantee they will improve your set.

Electrad Parts on sale at reliable radio stores. Sold direct if dealer cannot supply you.



VARIOHM A variable grid leak. Will give you exactly the correct grid resistance. Any resistance from $\frac{1}{4}$ to 30 megohms. Made to fit standard Dubilier Condenser. Once set is permanent. Price \$1.25.

ELECTRAD Inc.

428 Broadway, New York

SOLDERALL

METAL IN PASTE FORM



The only convenient metal solder

Every Electrical Connection needs Solderall for perfect reception. **25c**

The SOLDERALL CO., NEWARK, N.J.

RADIO DEMONSTRATORS WANTED MAKE \$100 WEEKLY—NEW WAY

To Get **COMPLETE RADIO FREE** Sell for **\$15.50**



Get this complete radio genuine vacuum tube receiving set complete, direct from factory. Wired ready to operate. Demonstrate its long range receiving powers—amazing results. Makes quick sales. Get yours for nothing with big commissions. Comes complete with panel, cabinet, dials, low loss condensers, coils, rheostat, jack, head-phones, battery, supertron tube, aerial. Receiving set **\$15.90**—complete with accessories **\$23.90**. Make big money demonstrating these sets. Write for free details and selling plan. To get set Send No Money—just name and address, stating whether you want just receiving set or one complete with accessories. Pay Postman amount on arrival. Money back if not satisfied. Write quick—be first in your locality. Rush name and address.

STANDARD RADIO COMPANY
921 Broadway, Dept. P. N. 12, New York, N. Y.

THE NEW "SHAFTON" 3-CIRCUIT RECEIVER

Coast to Coast Range, Complete Parts for Building \$27⁴⁵
SEND NO MONEY

List of Standard Parts

- 1 7x18 Drilled Radion Mahoganyite Panel engraved in gold.
- 1 Brunswick Low Loss three-circuit Tuning Coil.
- 1 Genuine Brunswick Low Loss Condenser.
- 1 Brunswick Tripliod Mounting Socket and Binding Post Strip.
- 2 Brunswick Cast Foundation Brackets.
- 2 Brunswick Jacks with Gold-plated Fronts; 1 for phones; 1 for loud speaker.
- 1 Freshman Mica Grid Condenser.
- 1 Standard Glass Enclosed Grid Leak.
- 2 30-ohm Shafton Bakelite Rheostats with Gold-plated Indicators.
- 2 Moulded Mahogany Dials grained to match panel.
- 5 Lengths Professional Round Bus-bar.
- 1 Special Blueprint for this circuit. Not an ordinary hook-up, but a clear picture form that a child can understand and make.

All Assembled Ready
to Wire

ACCESSORIES

- Everything needed to operate after building is listed here:
- 3 Type 201-A Tested Tubes... \$10.35
 - 1 60-ampere Hour Storage Battery... 11.25
 - 2 45-volt Extra Large Eneo "B" Batteries... 6.50
 - 1 pr. 3000-ohm Head Phones and cord... 3.75
 - 1 Phone Plug, Double... .90
 - 1 Antenna Equipment... 1.50

Complete Outfit... \$34.25
(Parts Also Sold Separately)

CABINET FREE

Order Building Kit and Accessory Outfit both together, and we will send Fine Mahogany Finish Cabinet FREE.

ERLA

We carry the most complete stock of Erla parts and Erla factory sealed kits in the country. Send for catalog.

MAIL THIS COUPON NOW—SEND NO MONEY

RADIO SHACK, Dept. 327, 55 Vesey St., New York, N. Y.

Please send me the new Shafton Three-circuit Receiver I have marked. When it arrives I will pay the postman the amount. If I am not satisfied I will return it in 5 days, and you agree to refund my money instantly. Mark Choice in square.

(A) Complete Building Kit... \$27.45 (B) Operating Outfit... \$34.25

Name.....

Address.....

City..... State.....

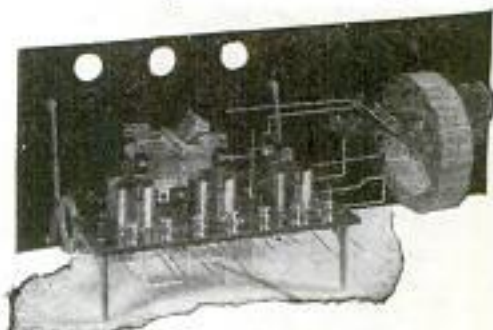

LOW LOSS THROUGHOUT

This receiver maintains two prominent features. Air insulated, with Low Loss Coil, gives you all signal strength possible. The heavy wiring throughout lowers resistance to a minimum and enables fine, sharp tuning.



LONG RANGE BEARCAT VACUUM TUBE RADIO

\$12⁹⁸

From Factory to You

Set with Vacuum Tube, all batteries, phones, aerial, ground wire and insulators. Ready to operate. \$22.88.

WORLD'S latest, most amazing radio discovery. "Truly wonderful," say experts. BEARCAT gives distance and tone of expensive sets. Most selective set ever built, bar none. In Chicago, with 200 stations on, BEARCAT brought in stations clearly 1000 miles away. Outside of Chicago, BEARCAT brings them in from all over. Easiest set to use—one dial controls all tuning. World's most efficient and lowest priced receiver.

Not a Crystal Set A real vacuum tube set—entirely new principle accounts for greater distance, wonderful tone and ultra-sensitivity. No set like BEARCAT. Beautiful mahogany finish cabinet. All batteries in inside. Hear market reports; news every 30 minutes day and night; music, opera, dance orchestras, church services, election returns. Get a BEARCAT now!

SEND NO MONEY Pay postman price plus a few cents postage on arrival. DEALERS AND AGENTS WANTED.

BEARCAT RADIO CO., 646 North Michigan Avenue, Dept. 23, CHICAGO

Jiffy Blow Torch



For the Man Who Tinkers

A practical torch for the practical man. Self blowing, lights instantly, burns with a blue hot flame and is absolutely safe. Complete soldering set; Heavy duty soldering irons, Jiffy non-corrosive flux, string solder, Jiffy Blow Torch complete with accessories. \$2⁵⁰

Dealers: Write for Proposition! At your dealer's or direct—

Apex Stamping Company
Dept. 23 Riverdale, Ill.

LARGEST RADIO STORES IN AMERICA



509 S. State St. CHICAGO, U. S. A. Dept. PM-6

We guarantee RADIO our new 68-page Catalog will save you money

on brand new fully guaranteed, nationally advertised radio apparatus. We buy up manufacturer's and government surplus stocks, jobber and dealer bankrupt stocks, etc. Our enormous buying power permits us to pay spot cash and get rock-bottom prices—even way below manufacturer's costs. That's why our catalog is crammed with thousands of wonderful radio bargains. That's why we GUARANTEE to save you money.



Write for your
FREE

copy
today!

Announcing MUSETTE

"The Stradivarius of Radio"

\$12⁵⁰

Black
finish

\$20⁰⁰

Gold
or
Silver
finish



A NEW and better loud speaker with marked refinements of design and a superlatively finer tone over the entire acoustical range. Reproduces voice and all instruments with a remarkable fidelity.

Hear MUSETTE at your dealer's

Your dealer will gladly demonstrate MUSETTE. Hear it today at his store. Note its cast aluminum base and throat—its polished Bakelite bell—its three superb styles, black, silver and gold, the latter with maroon bell.

Catalog FREE

If your dealer cannot supply our 48-page catalog of all Frost-Radio products, write us direct for your copy. Address Dept. 14F437.

HERBERT H. FROST
Incorporated
154 W. Lake St., CHICAGO

GUARANTEED
Howard
Radio Co. Inc. PRODUCTS Chicago, U.S.A.

Get Distance with Howard Guaranteed Parts

Rheostats, Potentiometers, Sockets,
Phone Plugs, Fixed Condensers,
Binding Posts, Soldering Lugs, etc.

HOWARD RADIO COMPANY
4248 No. Western Ave., CHICAGO, ILLINOIS



Moore Original
**RADIO-
DEMON**

Not new, but proven the best
of "em" all. Ask any user.

"All Wave Tuner"

NEW YORK to FRISCO, clear as a bell
The only one control tuner, 200
to 600 meters, complete with
hook-ups mailed anywhere. **\$150**

Write today for our Big Free Catalog leading radio receivers and
accessories. All makes fully described. 50% saving—all types.

ELECTRIC SERVICE ENGINEERING CO.
Dept. Radio P. M. 337 W. Madison St. Chicago, Ill.

Of Course It's
a **CROSLEY**
Better - Costs Less
Radio

For ease of tuning, selectivity and long distance
reception, you can't beat a Crosley. Actual
performances prove this day in and day out.

Here is what one of the many happy users say:

Dallas, Texas.

"The set, Model 51, has already surpassed my greatest expectations. On the night of September 13th, Oakland, California, was received with sufficient volume to be clearly heard throughout seven rooms. Kansas City, Chicago and many other stations were received with respectively greater volume." (Name upon request.)

**BEFORE YOU BUY—COMPARE.
YOUR CHOICE WILL BE A CROSLEY**

Crosley Regenerative
Receivers are
licensed under
Armstrong U. S.
Patent 1,115,149.



Prices West of
the Rockies add
10%.

Crosley two tube model 51.....\$18.50
With tubes and Crosley phones.....\$30.25

For sale by good dealers everywhere

THE CROSLEY RADIO CORPORATION

Powel Crosley, Jr., Pres.

1215 Alfred St. Cincinnati, O.

Crosley Owns and Operates Broadcasting Station WLW

N&K
Imported
LOUDSPEAKER
TYPE W

New in principle, new in
shape, new in quality of
reproduction, price \$27.50.

Made by the makers of the
famous N & K Head Set, Model
D, 4000 ohms, price \$8.50.

TH. GOLDSCHMIDT CORP.
Dept. M-12, 15 William Street, New York

MAILED ABSOLUTELY GUARANTEED



D-201A, D-200, D-199, D-12, in
standard sizes to fit any socket.
The internationally famous

Dutch Radio Valve

will be mailed for **\$2.25** plus
postage

Three sent for \$6.50 plus
postage (any type).

Approved by Popular Radio
Laboratories.

Order from nearest point.

ST. LOUIS RADIO TUBE LABORATORY
3572 Olive Street St. Louis, Mo.

D. R. V. IMPORTING CO.
Dept. D, 515 Orange St., Newark, N. J.

**FOR ANY CIRCUIT IN ANY SET
"YOU CAN'T BEAT THE DUTCH"**

HOT SELLER FOR AGENTS

to use and introduce 1X1s. Make big money part or full time. No capital or experience needed.

NEW INVENTION ENDS MOTOR TROUBLES

Makes fouled or broken spark plugs fire perfectly, banishes oil pumping troubles, carbon knocks, coughing, jerking "missing," and pounding bearings to pieces. Makes autos run slower in high gear, have quicker pick-up and greater power on hills. Users report gasoline consumption greatly reduced. Put on or taken off any car by anyone in three minutes so try a set on your car at our risk. If not satisfied, trial costs you nothing.

BIG CASH PROFITS—QUICK AND EASY
\$12 A DAY up to \$15,000 a year being made by 1X1 representatives. Boston sold 4600 in one month. Territory being snapped up fast. Write today for introductory offer.

UNIVERSAL MFG. & SALES CO.
Dept. P 552 W. Harrison Street CHICAGO, ILL.

Magnified 225 Diameters

This is what the tip of a fly's leg is like when seen through the **ULTRALENS MICROSCOPE**



Any amateur can immediately start using his Ultralens to examine the edge of a razor, the mesh of a cotton shirt, the bacteria in dirty water. No technical training required, yet hundreds of scientists and teachers are using this instrument. Gives enormous magnification and perfect definition. Send \$7.50 for complete outfit.

Send for descriptive literature.

\$7.50 for Complete Outfit Prepaid

SCIENTIFIC APPARATUS CORP.
Dept. 209 MILTON, PA.

A BETTER BLOW TORCH Absolutely Safe!

Burns gasoline or kerosene. 400 degrees more heat. Simple to operate. 11 patented features. Used by experts and biggest shops. Fearlessly guaranteed. Get yours today from your hardware dealer—or direct.

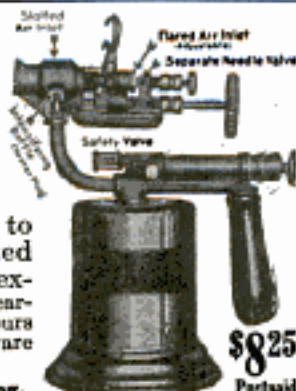

\$8.25

Postpaid

Send for Complete Catalog.

THE TURNER BRASSWORKS
Industry Ave., SYCAMORE, ILL.
The World's Largest Exclusive Manufacturers of Blow Torches, Fire Pits and Brazers

Save 1/2 Cost of New Tubes

VACUUM TUBES REPAIRED

Guaranteed equal to new. Send in your burned out or broken tubes by P. P. All repaired tubes returned P. P., C. O. D. We try to repair and return within 48 hours.

Harvard Radio Laboratories
200-204 Old Casey Ave., So. Boston, Mass.



You Can't "Blow" Out Your Tubes

Protect-O-Tube absolutely prevents tube blow outs. Saves its cost many times over. One on each B+ protects your set. Money back guarantee.

NOT A FUSE



Tested and approved by Radio News Laboratories.

ONLY \$1.35

Nothing else like it on the market. Not a fuse, cannot wear or burn out. Lasts a lifetime. Send for yours today. Use coupon. Dealers and jobbers write for proposition.

The Don-Mac Co. Dept. J
29 S. Desplaines St., Chicago, Ill.

CLIP THE COUPON AND MAIL TODAY

No. Wanted

Name

City

Address

Send No Money

Mail coupon. State No. wanted. Pay postman on arrival.

RADIO SETS \$4.95 and up

Book **FREE**

Containing a full line of complete outfits and parts at exceptionally low prices. Write immediately to

UNITED RADIO SUPPLY CO.
1346 S. Michigan Ave., Dept. R-1, CHICAGO, ILL.



HONEYCOMB COILS

The Universal all-wave inductance. Back and front panel mountings. Send 25c for Super Het., R. F. and Honeycomb Coil Circuits and Complete Catalog.

Chas. A. Branston, Inc.
853 Main St. Buffalo, N. Y.
Chas. A. Branston, Ltd., Toronto

START YOUR OWN BATTERY CHARGING BUSINESS

Only \$35 cash brings you HB 8-hour charging outfit. Easy terms. Let your profits pay balance with nice surplus besides. Thirty day free trial on money-back guarantee. HB patented voltage-regulating winding absolutely prevents reversing. Saves current. You can easily clear \$150 to \$300 every month. Hundreds of HB users, with no previous experience are making big money. You can, too. HB 8-hour Charging puts your shop ahead of competition, draws trade. Write today for Bulletin 127.

HOBART BROS. CO. Box M120 TROY, OHIO



Here's how to make **Bigger Profits** during your **Slowest Winter Months** New Easier Terms—Smaller Down Payment

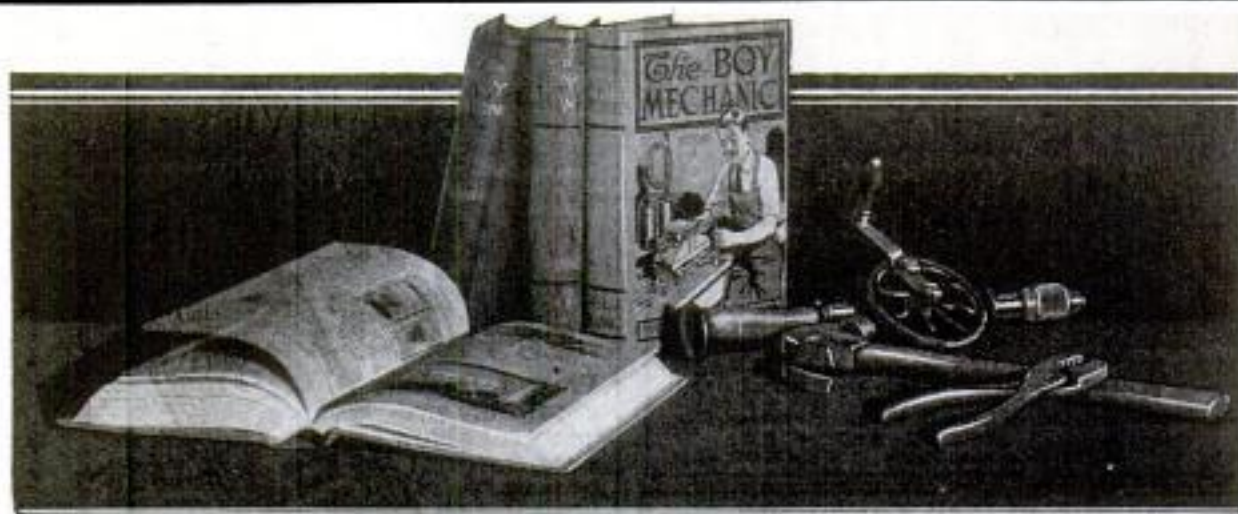

HOW TO MAKE THINGS

Fascinating to any boy, yet practical enough for men with technical skill, the four books of the NEW BOY MECHANIC LIBRARY have been recognized as the most useful books in any home. Their interest to the whole family lies in the fact that devices are described that are of use about the home, in the garden, shop, and in outdoor sports and games of all kinds.

What You Will Find to Interest You in

THE NEW BOY MECHANIC LIBRARY

3,849 Ideas

Four Beautiful Volumes

3,917 Illustrations

A faint idea of the world of useful articles in these books may be had from the following list of the main subjects treated. Look over this list. Any one or two articles that interest you may make the books worth much more than their small cost.

Electrical devices

Photography

Carpentry

Automobile

Household helps

Toys

Painting

Boats

House decoration

Camping

Drafting

China painting

Decorative metal work

Fishing

Furniture

Farming

Gardening

Poultry

Fruit growing

Laboratory helps

Models

Magic

Entertainments

Music

Outdoor games

Outdoor winter sports

Stoves

Radio

Wireless

Furnaces

Tricks

Puzzles

Bicycle

Flowers

Hunting

Trapping

Library helps

Metal working tools

Secret locks

Indoor games

Kites

Parachutes

Plumbing

Sheet metal work

Pets

Swings

Hammocks

Sleds

Wood working

Motor sleds

Toboggans

Wind wagons

Dog cart

Water sports

Tents

Skiis and skiling

Indian snowshoes

Power devices

Decorative leather work

Gymnasium

Iceboats

Skating

SEND NO MONEY

Simply send your name on the attached coupon and indicate whether you want the complete library at the special price of \$7 or a selection of individual books at \$2 each. There are four books in the library and you will be pleased with your purchase if you take them all. However, you may already have one or more of the volumes, and will want to complete the set by ordering the rest. Book 4 is brand new. It contains the latest articles on radio as well as over 3,000 other articles. Send No Money. Simply sign and mail the coupon. The books will be sent to you at once. When the postman delivers them, hand him the price of the books plus the few cents postage. That is all. If you want the books sent direct to a friend, it will be necessary for you to send the cash with the order.

The Four
Books

\$7

MAIL THE COUPON TODAY

POPULAR MECHANICS PRESS

Popular Mechanics Building, Room 712

CHICAGO, ILLINOIS

POPULAR MECHANICS PRESS

Popular Mechanics Building, Room 712, Chicago, Ill.

Please send me at once C. O. D. the Boy Mechanic Library at \$7. (Put a cross in the square); (or—the individual books you want). Book 1, \$2; Book 2, \$2; Book 3, \$2; Book 4, \$2.

Name

City

Street..... State.....



While you are giving— give health

THE greatest gift of all is health. You can give that priceless treasure of health to many this Christmas. Buy Christmas Seals. Everywhere are solitary sufferers and whole families stricken by the Great White Plague. Often they have no help except that furnished by the Tuberculosis Associations, which are financed by the annual sale of Christmas Seals.

Give—and feel the joy that comes with giving. Buy Christmas Seals. They have helped stamp out half the ravages of consumption. Buy Christmas Seals, and help stamp out the dread disease entirely.



STAMP OUT
TUBERCULOSIS
WITH
CHRISTMAS
SEALS

THE NATIONAL, STATE, AND LOCAL TUBERCULOSIS
ASSOCIATIONS OF THE UNITED STATES



RADIO is revolutionized by this new receiver. A four-tube set whose range, using loudspeaker, is practically unlimited. Basically new, employing the new *non-radiating* Paradyne Circuit. Exquisite, natural tone. Extreme sensitiveness. And the *simplest* set ever to operate—one dial control.

May be used either as a three-tube or four-tube receiver. Operates successfully with any standard tubes, either dry or storage battery type. Built as only Paragon sets have been built in the past.

And priced one third of what you would expect to pay for such value.

Ask your radio dealer to show you this new receiver. Or write for descriptive folder.



The New Paragon Four, \$65

Probably the greatest value in radio today. Employs the new Paradyne circuit—non-radiating. New type *single dial* control.

The New Paragon Three, \$48.50

An exceptionally sensitive, selective, fine-tuned receiver, with amazing loudspeaker tone and volume over long distance range.

The New Paragon Two, \$27.50

Excellent tone and volume on loudspeaker from stations within moderate radius. Range for phone reception almost unlimited.

DEALERS: Write for attractive new Dealer Proposition and address of nearest Paragon Distributor

ADAMS MORGAN COMPANY, Inc.
5 Alvin Ave., Upper Montclair, N. J.

PARAGON

Look for the



Red Triangle

Play Right Away on this Jazzy Sax

No Knowledge of Music Necessary—Sweet Jazzy Tone

You can play this beautiful imported Jazzy Sax without practice. No difficult scales and keys. Play by easy numbers or by ear (or by notes if you wish). Not a toy—but a real musical instrument! Made of metal, handsome, glistening, polished finish. Looks like regular saxophone—20 in. long. Clear ringing tones and delightful harmony. Will make you popular at parties, dances, entertainments—everywhere. No need to spend \$50 or more when you can own a Jazzy Sax for a trifle.

H. A. King writes: "Received Sax in afternoon and played lead in 9-piece orchestra same night."

H. M. Vinson writes: "Could play several old airs within an hour."

Made of solid metal 20 in. long.

\$5⁹⁸

BIG "SAX" BAG AND 87 SONGS FREE

Attractive Jazzy Sax Carrying Bag, 87 Songs, and full directions absolutely FREE with each Jazzy Sax on our special limited offer. But you must get your order in at once! Mail coupon TODAY.

SUPPLY LIMITED

Send No Money

Just fill out the coupon below. When the Sax and FREE Carrying Bag and the 87 Songs arrive, pay the postman only \$5.98 plus a few pennies postage. Play the songs right away. You don't risk a penny. Satisfaction guaranteed or money refunded. But the supply is limited—so don't delay. Mail the coupon today.

—Send This Coupon Today—

**FERRY & CO., 3224 N. Halsted Street
Dept. 9779, Chicago, Ill.**

Please send me at once your Jazzy Sax and FREE Carrying Bag and 87 Songs. On arrival I will deposit \$5.98 plus postage with the postman. If I am not satisfied, I will return all within 3 days and you will refund my money.

Name

Address

City..... State.....



5 SIZE AUTOMOBILE TAP AND DIE SET, ONLY \$3.00
DIRECT FROM THE FACTORY TO YOU! Our No. 12 Automobile Set furnished in our highly finished chestnut box contains 5 each taps and dies (1-4, 5-16, 3-8, 7-16 and 1-2"), in the S.A.E. thread, 1 die stock, and one tap and reamer wrench. Our No. 11 Set is the same as No. 12 except that the thread is U.S.S. instead of S. A. E. You are purchasing a splendid set at a very low figure. Send us your order at once and be one of our many satisfied customers. Let us also send you one of our circulars illustrating our full line of Hand Tools. **WORCESTER STEEL PRODUCTS CO., DEPT. 41, 25 UNION ST., WORCESTER, MASS., U.S.A.**

Sales Agents Wanted!



Big profits. Great invention enables housewives to COOK with OIL in ordinary coal or wood range; HEAT with OIL in regular heating stove or furnace. Biggest season now on! Big demand! Act at Once!

OLIVER OIL BURNER

Look—here's your chance. Now. Right in your community, town, city, county or territory. Selling this wonderful invention! Burns OIL, mixed with air. Makes any coal or wood range a real gas range. Quick, clean, instant heat—at the turn of a valve. Better heat than coal or wood. Attractive profit on every sale.

Into every community goes Oliver National Advertising in big magazines, helping you to sell. Over 200,000 Oliver Burners already sold! Guaranteed to give efficient service. A 15 minute demonstration makes the sale. Every sale makes others.

This is the time to start! Right now! Learn what other men are doing. Get the details of the winning Oliver Distributor and Dealer Plan. Real co-operation. A complete line. 12 Burner models—for Kitchen Ranges, Heating Stoves and Furnaces. Every householder a prospect. Get details of special attractive Sample Case Offer. Write at once!

OLIVER OIL BURNER CORPORATION
Manufacturers of Oliver Oil-Gas Burner Products
1226 Oliver Bldg., St. Louis, U. S. A.

Oldest and Largest Manufacturers of Oil-Gas Burner Products in the World

NO MORE PUMPING UP TIRES

An air-tight valve cap which prevents all loss of air in tires has been put on the market by F. C. Hughes. With this valve cap one inflation lasts the life of the tire and doubles tire mileage. Tested and approved by leading automobile manufacturers. We furnish proof of tests. Retail price \$1.25 for set of five. Great demand. Wonderful opportunity for agents. Write at once to F. C. Hughes, 2504 W. Monroe St., Chicago, Ill.

FORD RUNS 57 MILES ON A GALLON OF GASOLINE

A New Automatic Vaporizer and Decarbonizer which in actual test has increased the power and mileage of automobiles from 25 to 50 per cent, and at the same time removes carbon from the cylinders, is the proud achievement of John A. Stransky, 4302 Fourth St., Pukwana, South Dakota. A remarkable feature of this simple and inexpensive device is that its action is governed entirely by the motor. It can be installed by anyone in five minutes. With it attached, automobiles have made from 30 to 57 miles on a gallon of gasoline. Mr. Stransky wants distributors for his marvelous invention and is willing to send a sample at his own risk. Write him today. *Advs.*

\$100 to \$200 Per Week

We Teach You How to Make It

Money—big money—is waiting for you to come and get it. No matter where you live nor what your experience, we teach you how to make money. *Special Proposition Open Now*

Fireite Sells on Sight

TRADE MARK

Fireite amazes everyone who sees it used. A single demonstration often makes a dozen sales. It has saved many thousands of dollars of property damage. Men, women and children are astounded and fascinated by the ease with which it puts out an alarming fire. It is no exaggeration to state that Fireite is one of the easiest to demonstrate and fastest sellers ever made. Why? Because it is so simple a child can use it with one hand. It always works—(wonderful secret composition). No pump nor mechanism. Beautiful and long lasting. The low price is within the means of everyone—50% less than most others. Sold to every home, school, garage, factory, office, store, hotel, etc., wherever shown.

AGENTS and MANAGERS WANTED
In All Territory Not Taken

You can make big money using all or part of your time. We supply everything for your success. This is an unusual opportunity for a sound, substantial, permanent income. Write for our agent's—or manager's—special proposition today to the address:

FIREITE CO., Dept. 2, Masontown, Pa.

Special Offers

As exclusive violin experts, buying personally direct from individual European violin-makers, we offer you a selection of special values in both moderate and higher priced violins. Every instrument the work of an artist in the craft. Tone quality and workmanship that will appeal to those who want and appreciate true musical character. We also have a large collection of old violins at a wide range of prices. Liberal examination privilege—extended terms if desired. Special service on orders by mail.

Free New, handsomely illustrated brochure showing our exclusive selection, with prices direct to you and details of our special offer to out-of-town customers. Also contains valuable information on how to judge and select your violin and how to care for it; gives an interesting account of the work of European violin-makers. Sent free—no obligation. Send for it today.

WM. LEWIS & SON
(Largest Exclusive Violin House)

225 South Wabash Avenue Suite 1770 Chicago, Illinois

Teachers Professionals
Enclose your professional card or letter-head for our special proposition

SAVE TIME SPACE MONEY

Use DO-ALL

**JIG SAWS
DRILL PRESSES
CIRCULAR SAWS
FILING MACHINES**

Can be supplied in combination or separate models to suit purchasers' requirements.

Saws Wood, Bakelite, Light Metals, etc.

For schools, model and pattern makers, radio manufacturers.

Hundreds of other uses.

Let responsible Dealers, write us.

DO-ALL APPLIANCE CO.

Successors to JUNIOR MACHINE & MFG. CO., 659 No. Franklin St., CHICAGO, ILL.

Write for Circular and Price List

KESTER METAL MENDER

It's a Genuine Solder

In the Home
So simple anybody can use it. Requires only heat. Always ready—Solders all metals but aluminum.

For Home & General Use

General Soldering
Self-Fluxing—no acid nor paste needed. Sticks and stays stuck on old or new work. For light and heavy mending. Makes quick neat permanent jobs.

If your dealer cannot supply you, send us—

25¢ for full size Can

Chicago Solder Company
4219 Wrightwood Ave., Chicago, Ill.

Gentlemen: Send me one can Kester Metal Mender for which I enclose 25c in stamps.
(Postpaid anywhere in U. S. A.)

Name.....
Address.....
City..... State.....
Dealer.....



AGENTS MAKE BIG MONEY Selling Cadillac Rain-Proof Caps of Finest Woolens

The water demonstration sells Cadillac Caps. It proves they keep their shape, their color and beauty and keep clean indefinitely because they cannot be wet. More than 2 dozen patterns to select from in all newest styles. Every cap made from finest woolen fabrics equal to caps selling at much higher prices. Every Cadillac Cap has solid leather visor, full leather sweat band, tailored-to-measure. Sold on money back guarantee. Cadillac invisible "secret process" makes Cadillac Caps 100% rain and snow proof. Our men make \$5 to \$25 and more daily. Get your money when you take order. We deliver and take care of all details. We give our salesmen 100% cooperation. Beyond question the most wonderful agents proposition on the market. Send coupon for free sample of rain-proof fabric and full particulars.

CADILLAC CAP COMPANY, Dept. 912, 856 Woodward Ave., Detroit, Mich.

Please send without obligation to me free sample of material used in Cadillac Rain-proof caps, also demonstrating card and full information on your complete proposition to salesmen and agents.

Name

Address

No Carbon Gas Saver



\$7.50
Ford Owners, you have waited for this. Pays for itself first month. Doubles miles in gas on any Ford. Owners say unlike anything they ever saw, and marvel at its performance. Prevents carbon; easy starting. Burns superheated air; breaks up gas through carbon discs. No change in Ford construction. Perfect combustion gives smooth running—adds life to motor. 12 year old boy can install. Absolutely new principle. Sold on 30-day trial of satisfaction or your money back.

FREE Without cost or obligation we will send you free literature explaining full details and construction of this marvelous new invention. Simply send name today. Unusual plan for agents.

U. S. GAS SAVER CO.
200 Ryan Bldg. Kansas City, Mo.

DELTA



No. 37 BICYCLE SPOTLIGHT

A Strong Beam of Light Where the Rider Wants It When He Wants It

A Bike Light That Equals a Good Auto Spotlight

The only truly Bicycle Spotlight on the market. Strictly high powered. Not a common Bicycle light or marker, but a spotlight equal to a good auto spotlight. Throws powerful beam of light in any direction at will of rider. Head 4 1/4 inches in diameter. Improved bracket, fits any handlebar. Operates on two dry cells. At your dealer or sent prepaid for \$3.75 complete (less batteries). Packed in Christmas wrappers—makes very appropriate gift.

DELTA ELECTRIC COMPANY

100 Delta Block MARION, IND.

Standard Makers of Auto Spotlights, Motorcycle Spotlights, Bicycle Lamps, Electric Lanterns, Radio Head-Flares, Flashlights and Flashlight Batteries.

New York
Expert Dept.
30 Water St.

Chattanooga
Fawcett-Huston Co.

San Francisco
Sanford Bros.
311 Mission St.

RADIO CATALOG

Full of Information

100 Live Pages

Contains interesting explanation of marvelous benefits of Radio which you may enjoy—told in language anyone can understand. You should get it before buying.



FREE

Bargains in Sets, Parts and Accessories—

Everything you may need to build or equip any set. Satisfaction or your money back.

Don't Delay!

Send for It Today!

(And will you be so kind as to add the names of others you believe will soon want radio goods? Thank you!)

LIBERTY M. O. HOUSE Dept. 188-Z 106 Liberty St., N. Y.

Great New Invention



For Seekers of Health—Power—Beauty
Generate High Frequency Violet Rays, Mechanical Vibration, Medical Electricity and Ozone—the four greatest curative agents. Combined or separate. They operate on the electric light in your home or on their own motive power at less than 50 cents per year.

WRITE Ask for the book on these inventions which has just been prepared. It will be sent to you without cost. Re-vitalize yourself. Bring back energy. Be wholly alive. Write today!
Lindstrom & Co., 30 W. Lake St., Dept. 17-53, Chicago

"Would Be Cheap at \$50"

Says Navy Man "I cannot see," writes Mr. Harold G. Gould, of Northome, Minn., "how such a glass can be sold for anything like the price you ask; \$50 would be cheap enough for such a fine instrument."

A 10-Power Megaphos Stereo-Prism Binocular for only \$27.00

By actual test this long range, Naval Officer type binocular equals the best German 10-power instruments selling for over \$100. Large field of view with wonderful illumination and definition. Weighs but 20 oz. Central focusing with individual eye-strength and width adjustments. Amazing value. Complete with case and straps, prepaid, for only \$27. Guaranteed satisfactory or money returned. 8-power glass similar to above, only \$18.50.

Catalog Free—200 Glasses—\$1 to \$125

DU MAURIER CO., Dept. 2012, Elmira, N. Y. America's Leading Binocular House



Long Range Naval Officer Type



The Mutual Security System

The Most Efficient Selling System in Existence

IF you want to sell your business for cash quickly and privately, we take the prospective buyer directly to you at our expense, no matter where located. We specialize in selling out-of-town businesses. If your business is worth \$5,000 or more, write us.

John Glendinning, Jr.

The Mutual Security System
88 W. Washington St., CHICAGO

NEW INVENTION SAVES \$4.00 TON ON COAL

Chicago.—What is said will revolutionize the heating problem and mean a substantial saving on coal for the public is a recent invention controlled by B. E. Pearson, 155 E. Superior street, Chicago, Ill., which is a perfected coal and labor-saving device for hot air furnaces, stoves and kitchen ranges. This coal saver eliminates furnace care one-third, dust and clinkers as well. So sure is he of the absolute success of this invention that he guarantees at least 25% saving on coal and will send a device on trial. Owing to the wide spread interest it has created everywhere, the inventor is seeking a representative in each town to take care of the large demand. Any one interested in making big money should write at once for his special trial offer. Do it today.—Adv.

\$300⁰⁰ OR MORE A MONTH

Information on how you can earn \$300.00 or more a month will be sent to the first person in each locality who writes. Become our local distributor for a recognized household necessity in rural districts and small towns. Easy work for

Men or Women, Full or Spare Time

No money needed. Million dollar firm behind it. Write quick for particulars. State territory.

H. E. JOHNSON, 609 West Lake Street, Chicago, Ill.



PHONOGRAPH SENSATION!

Send No Money. This is a remarkable offer! Real phonograph, like picture. Guaranteed motor. American made. Reproduces music clearly, and loud. Plays regular 10-in. records. Durable and practical. Double-faced record and plate, of needles with each machine. Only \$4.85 complete. Cash orders to C. O. D. Plus postage. Satisfaction guaranteed.

SCHLITZ & CO., 3703 Haverford Av., Philadelphia, Pa.

SEND NO MONEY **WHITE GOLD FILLED WRIST WATCH**
GIVEN WE TRUST YOU GLADLY
SEND NAME & ADDRESS

Attractive jeweled wrist watch given for selling only 60 magnificently colored packets of highly perfumed Oriental SACHET. Great offer of five sweet, rare and lasting odors. Lavishly used to freshen linens, clothing, dresses, etc. One to five packets sold in every home. We are reliable. Write quick. Be first in town.
PERSIAN PERFUME CO., Dept. W.G.72, TYRONE, PA.



SENSATIONAL SALE GUARANTEED TYPEWRITERS

only \$4.00 a month and the machine is yours. This is absolutely the most generous typewriter offer we ever made. Do not rent a **EASY TRIAL** machine when you can pay \$4.00 a month and own one. Think of it—**TERMS** Buying a perfect, late model highest grade Typewriter at a bargain price—at only \$4.00 a month.

The **Famous L.C. Smith No. 7** Silent Model

This is the famous L. C. Smith typewriter which has set the world's standard for quality and service for over twenty years. Perfect machines. Standard size. Has the full correspondence keyboard of 76 characters—single shift—universally used in teaching the touch system. The entire line of writing completely visible at all times, has the decimal tabulator, the two color ribbon, with automatic reverse, the back spacer, ball bearing type bars, ball bearing carriage action, ball bearing shift action. Every late style feature and modern operating convenience. Comes to you with everything complete: tools, cover, operating book and instructions—nothing extra to buy. You cannot imagine the perfection of this beautiful typewriter until you have seen it. We do the most perfect and highest class job of rebuilding known to the typewriter industry. We have sold thousands of these perfect late style machines at this bargain price and every one of these satisfied customers had this splendid, strictly up-to-date machine on ten days' free trial before deciding to buy it. We will send it to you F. O. B. Chicago for ten days' free trial. It will sell itself, but if you are not satisfied that this is the greatest typewriter you ever saw, you can return it at our expense. You won't want to return it after you try it, for you cannot equal this wonderful value anywhere.

SEND NO MONEY Order Now—Before They're Gone

When the typewriter arrives deposit with the express agent \$4.65 and take the machine for ten days' trial. If you are convinced that it is the best typewriter you ever saw keep it and after 30 days send us \$4.00 a month until our bargain price of \$52.65 is paid. All cash, \$49.85, just a little more than half its original price. If you don't want it, return it to the express agent. He will return your \$4.65 deposit. We will pay the return express charges. This machine is guaranteed just as if you paid \$105.00 for it. It is standard. Over half a million people own and use these typewriters and think them the best ever manufactured. The supply at this price is limited; the price will probably be raised when next advertisement appears, so don't delay. Fill in the coupon today—the typewriter will be shipped promptly. There is no red tape. We employ no solicitors—no collectors—no chattel mortgage. It is simply understood that we retain title to the machine until full \$52.65 is paid. You cannot lose—your deposit does not leave your home town unless you are satisfied. Do not send us one cent. Get the coupon in the mails today—sure.

SMITH TYPEWRITER SALES CO.,
L. 300-360 E. Grand Ave., Chicago, Ill.

Ship me the L. C. Smith Model No. 7, F. O. B. Chicago. I will pay you \$4.00 monthly as rent until the \$48.00 balance of the Special \$52.65 sale price is paid. The title to remain in you until fully paid for. It is understood that I have ten days in which to examine and try the typewriter. If I choose not to keep it I will carefully repack it and return it to the express agent. It is understood that you give the standard guarantee.

Name.....

Street Address.....

City..... State.....

MILITARY BINOCULARS

French and German



6 and 8 Power

\$19.50 POSTPAID

Case and carrying straps included

Usual selling price \$40.00 to \$50.00. Wide angle—day and night lenses—6 and 8 power—prismatic type—finest achromatic lenses. Approved for U. S. Army officers. Guaranteed German war glasses made by the world's leading optical manufacturers. Many of these glasses received direct from the ALLIED REPAIRATIONS COMMISSION. Sold to Army and Navy officers throughout the U. S. A. Highest grade glasses—guaranteed the equal of any binocular made. Add greatly to the pleasure of motor-ing, yachting, mountain climbing, or hunting. Suitable for the races, bird study, etc.

We have sold thousands of dollars' worth of these binoculars to the U. S. Army and Navy. Glasses will be shipped promptly on receipt of check or money order for \$19.50 with positive guarantee of full cash refund on any glasses returned.

ORDER YOUR MILITARY BINOCULARS TODAY
HENDERSON BROTHERS
 Largest Importers of Field Glasses in America
 91 to 97 Federal Street Boston, Mass.



Crary Radiator Caps for Fords

This beautiful nickeled radiator cap can be lifted by merely pinching the wings together. It is easily replaced—simply reverse the operation. No matter if the cap is hot—the wings are always cool.

Complete with lock \$1.50

The Crary Gasoline Cap works on the same principle—the ends of the spring in fig. 1 bite into the thread at the sides, holding the cap tightly in place. The Gas Cap retails for 25c. Crary Caps eliminate sticky, tedious, inconvenient turning.

Write for complete information and agents' proposition

CRARY CORPORATION
 3049 Northwestern DETROIT



\$300.00 Burroughs Adding Machine

ONLY \$9.50 DOWN—
 9-Column Capacity

ONLY \$74.50

Positively the greatest bargain ever offered! Factory rebuilt by experts. Every machine perfect mechanically and in appearance. Carry same guarantee as a new machine.

SOLD ON INSTALLMENTS

Only \$9.50 down, balance paid while you use machine. Why pay big prices? Hundreds of well-known firm's customers.

10 DAYS FREE TRIAL

Write us today and learn how you can try this, or any other standard make adding machine for 10 days, absolutely free. Dalton, Waes, American, we sell them all at one-third price. Don't delay, write NOW.

RELIABLE ADDING MACHINE CORP.
 Dept. 42, 162 W. Washington St., CHICAGO, ILL.



RAISE MONEY QUICKLY

AGENTS, CHURCHES, SCHOOLS and SOCIETIES

For the next sixty days, during our annual advertising sale, 100,000—25c packages Mendets will be sold to Agents almost at cost. This is an inducement to have you make a special effort to sell Mendets to housewives not reading our magazine advertisements. During these sales, you can make \$15.00 to \$25.00 a day; churches clear debts and raise funds; schools and societies buy furniture, radio sets.

Mendets mend all leaks in all cooking utensils and rubber goods, without Heat, Solder, Cement or Rivet. Send for free sample package, or if you know Mendets, order today at following prices:

- 500—25c pkgs. at 5c cost you \$45.00—sell for \$125.00—
 your profit \$80.00
- 100—25c pkgs. at 10c cost you \$10.00—sell for \$25.00—
 your profit \$15.00
- 50—25c pkgs. at 12½c cost you \$6.25—sell for \$12.50—
 your profit \$6.25
- 20—25c pkgs. at 15c cost you \$3.00—sell for \$5.00—
 your profit \$2.00

Collette Mfg. Co., Dept. F, Amsterdam, New York

IMPORTED SPANISH LEATHER

HAND SEWN CIGARETTE CASES \$1.00



Fine Xmas Gift!

Entirely hand made in Spain. Genuine brown Morocco. Highest quality. Holds one package cigarettes. Sent prepaid for \$1 to introduce exclusive line of hand sewn Spanish leather.

Catalog of 300 articles (50c to \$4) FREE

CALIFORNIA TRADING CO., Desk L412, 747 Warehouse St., Los Angeles, Calif.

SWEATER & 2 FLANNEL SHIRTS \$3.95



Heavy winter (wool mixed) gray flannel shirts, roomy, comfortable. Turned down collar, strong flap pockets. Sizes 14½ to 17 (Extra large sizes 25c additional). Also Slip on Sweater, heavy knit wool process.

SEND NO MONEY. Pay postman only \$2.95 when 2 shirts and sweater arrive. 25¢ state sales. Money back guarantee.

International Commercial House
 433 Broadway, Dept. 80-F New York City

10 cents Gasology Chart

Brings you the famous "Gasology Chart." Auto Owners! Save Gas. Save \$50 a year. This chart shows you at a glance HOW TO SAVE AUTO EXPENSES on any make car, 150,000 now in use.

SEND 10c TODAY

STAYERS OR COYS LIMITED OFFER Chart Sent Postage Paid

Dealers and Agents Investigate
 Bullock Publishing Co.
 1503 E. 55th St., Chicago



ALURA LINGERIE PAYS HIGHEST COMMISSIONS

DISTRICT MANAGERS AND AGENTS WANTED

Finest Quality—Costs Least

Write immediately for full details of our liberal proposition. Every call a sure sale. Every sale a reorder. No experience required. We deliver and collect. Your pay daily. Sample \$2.10. Address Mr. Ahearn, ALURA TEXTILE CORP., 1674 Broadway, New York

Save Your Feet

Stop those aggravating aches and pains. Don't exhaust your energy through hurting feet. Wear our

No Metal Heefner Arch Support
 (Fully Patented)



Write for free folder and testimonials from doctors and users

Heefner Arch Support Co., 551 N. E. Taylor Bldg., Louisville, Ky.

Make \$3⁰⁰ an Hour

Sell Custom-Fit Shirts for Less than Ready Mades



Shirt salesman—Double your earnings with this wonderful shirt-making idea! New Idea shirts are guaranteed to fit like custom-made. Big manufacturer has developed new system for drafting patterns.

Astonishingly Low Prices Make Sales Come Easy
Men used to having shirts made to measure will now order New Idea shirts from you, when they compare the price. Others will order also, to get the custom-like fit of New Idea shirts. Ten other wonderful features. Free initials—an insurance policy with every shirt—special shaped neckband—and other selling points. Over 100 fine quality, never-fade fabrics. Amazingly complete selling outfit with new photographic display boards orders like magic.

Remarkably Big Earnings For You

We want full time men who want to make \$5,000 and up per season. If you qualify, we will establish territory for you, giving you exclusive rights. Commissions daily. Write today, as lines are limited.

NEW IDEA SHIRT MAKERS
DEPT. 1412 CINCINNATI, OHIO

PLAY A TUNE IN 10 MINUTES!



On Ukulele, Banjo, Ukulele, Mandolin, Tenor Banjo or Guitar. Amazing new invention. No knowledge of music necessary! No practice—you can play tunes right away. Easily attached to any instrument. Simply press numbered keys. Play tone when played the old way. Send for FREE

Free Book

BOOK and bargain catalog of musical instruments. No obligations. Have fun, money, popularity. Write today.
FERRY & CO., 3222 N. Halsted St., Dept. 8779, Chicago, Ill.

Palmolive Shaving Cream

"5 New Delights for Men"

FREE Book of Newest Styles just out. Women's, men's, children's clothing on credit and at bargain prices, less than cash prices everywhere. Very latest fashions; best materials. Open a charge account with us. Buy on credit and save money! Dress in newest styles. Send for Style Book absolutely FREE today! Elmer Richards Co., Dept. 1773, W. 35th Street, Chicago

How to Become a Successful Automobile Mechanic

That mechanic makes a good reputation who always knows how to do repair work the best way and in the least time. Help to become such a mechanic is contained in Popular Mechanics Auto Repairman's Library of the following four books:

1. Automobile Repairman's Handbook
2. Popular Mechanics Lathe Book
3. Drilling and Thread Cutting
4. Automobile Owner's Handbook

These books contain 1,023 ideas for auto repairing and shop work. They tell how to make special tools, and fixtures.

Send No Money—Simply write a postal requesting Popular Mechanics Auto Repairman's Library. When the postman delivers the four books to you, hand him \$2 plus the few cents postage.

POPULAR MECHANICS PRESS
Popular Mechanics Bldg., Rm. 711, Chicago, Ill.



Xmas Gifts FIERY REELIKE DIAMONDS

Because of special bargain prices on these rings, you can buy and give exquisitely beautiful Xmas gifts this year without going to much expense. Reelike Diamonds have a sparkle and dazzle, which only the finest diamonds possess. The rings are latest style mountings and reproductions of solid platinum models.

No. 1. Man's massive platinum finish ring, handsomely engraved. Large Reelike Diamond set in octagon shape to, \$3.87.

No. 2. Oriental Peacock Ring, sterling silver, 18 emeralds and sapphires in feathers. Ruby eye in head \$1.83.



No. 3. Beautiful gift or dinner ring. Oblong sapphire in center surrounded by 3 genuine Reelike Diamonds. Triangular sapphires in corners. Reproduction of \$100 ring. Special \$4.83.



No. 4. Ladies' solitaire, large Reelike Diamond. Platinum finish, richly engraved. \$3.27.

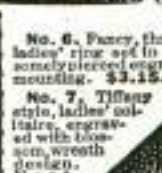

No. 5. Genuine Abalone pearl, hand engraved ring and bezel. Rare beauty. \$1.97.

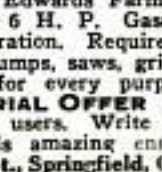
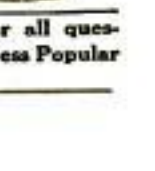

FRANKLIN JEWELRY CO., 97-B Nassau St., New York

The Traffic Cop of the Air



Add a Ferbend Wave Trap to your set and "Police" your reception. Regulate the Traffic! Guaranteed to tune out any interfering station. Sent postpaid on receipt of \$8.50, or C. O. D. plus postage. Send for Free Booklet. Ferbend Electric Co., 15 E. South Water St., Chicago



Our BUREAU of INFORMATION will answer all questions regarding articles in this magazine. Address Popular Mechanics Magazine, Chicago.

Before You Buy an Engine



Write for the facts about the wonderful Edwards Farm Engine. This marvelous engine gives from 1 1/2 to 6 H. P. Gasoline or kerosene. Light, easy to move, free from vibration. Requires no anchorage. Easy starting—no cranking. Pumps, saws, grinds, and does all chores. Plenty of power for every purpose. **LOW FACTORY PRICE—FREE TRIAL OFFER** Tremendous value. Thousands of satisfied users. Write now for details and FREE trial offer on this amazing engine. Edwards Motor Company, 118 Main St., Springfield, Ohio



Now the finest STOP WATCH Less than 1/2 of usual price

And an all-round true time-piece, too

Experts in scientific professions are using the Pastor Stop Watch in every field. The tremendous output keeps the price way down. All find it invaluable. It gives the time-fraction in every mechanical and chemical process, tells the margin between profit and loss. Fortunes are paid for this efficiency. All manufacturers demand such time-records.

Make the Pastor Stop Watch your constant companion; ready for every need. It's an all-round watch, tells the hours as accurately as the seconds. Just press the button; it tells fraction-seconds. Press again; its hand stops; the record is made. Third pressure brings hand back to zero.

GUARANTEED

The Pastor Stop Watch is supremely accurate. Seconds are divided into fifths. The blue lettered dial gives highest visibility. It is the size of ordinary pocket watch, only a trifle thicker. Heavily nickel-plated throughout, it is staunch, handy, compact.

SEND NO MONEY

Just send us postcard telling us to send you the genuine Pastor Watch. On delivery you pay the postman the small amount of \$7.50—actually less than 1/2 what similar watches cost. Remember, every watch guaranteed. Send today before the present allotment is exhausted. This is the biggest bargain ever offered in such an accurate stop-watch and time-piece combined.

STERLING WATCH COMPANY
Dept. 212 15 East 26th St., NEW YORK CITY



Necessary for
Efficiency Experts
Engineers
Inventors
Mechanics
Athletic Trainers

RADIO OUTFIT

Complete ONLY \$21.95



Long Distance 1-Tube D. K. SUPERIOR Set Complete. Nothing Else to Buy. Produces astonishing results. Receives music, speeches, information, instruction, sermons, etc., free to you, from broadcasting stations hundreds of miles away, often more than 1000. Easy to operate. Cheapest means of entertainment ever devised. No knowledge of radio required. No electricity except supplied by dry battery included in offer. Satisfaction Guaranteed. Big bargain—only \$21.95 for all parts and accessories complete. No money in advance. Your radio questions answered free. Send for 100-PAGE RADIO BOOK FREE

Crammed full of valuable information and offers of radio sets and parts at cut prices. Investigate. Don't delay. Write today.

And will you be so kind as to add the names of several others you believe will soon want radio goods? (Thank you!)

LIBERTY M. O. HOUSE, Dept. 189-Z, 106 Liberty St., N. Y. C.

"DARN-IT-ALL"



The Magic Mender

Darns stockings, mends clothes, patches all fabrics, rubber and leather. Does away with drudgery of darning and mending. Does the work cheaper, easier, quicker. Stands repeated washings. Send 50c for full size tube. Money back if not satisfied.

Agents Get our generous offer.
Dept. P. M.

DARN-IT-ALL COMPANY
1524-34th St., Des Moines, Iowa

Ford Owner

Stop that rumbous chatter on your car. MAKE THIS TEST—take out your floor boards, pull your emergency brake back and forth. If you notice play at the ball joint, you need Bredar's Ball Shim. Price \$0.50. Ask your dealer or send money order. We will ship prepaid.

Nic Bredar's Son Mfg. Co., Rock Island, Ill.



WADE BENCH LATHE

AMATEUR MECHANICS, MODELMAKERS, INVENTORS, STUDENTS
A real machine tool for the home work bench—capacity 4" dia. x 12" length. For Metal—Wood—Composition Materials—Turning—Facing—Boring—Drilling—Winding—Thread Cutting. Accurate—Strong—Quiet—Compact. Slide-rest has travel entire length of bed. Leadscrew inside bed. Send for literature—Price \$28.00. **THE GEROLD CO., Dept. P-3, 120 Liberty St., New York**

Makes Autos Go 40 Miles on Gallon of Gasoline

Sioux Falls, S. Dak.—James A. May of this city announces the perfection of an amazing device that is enabling car owners to more than double their mileage from gasoline used and at the same time remove every particle of carbon from their motors. Many cars with this device attached have made over 40 miles on a gallon.

Arthur Sollee of S. Jacksonville, Fla., says: "I made 41 miles off a gallon." Chas. Luetzen of New Holstein, Wis., says: "I made 11 miles on a quart of gas on one test, and 35 miles with three quarts of gas." Dewey S. Kagg of New Boston says: "I made 44 miles on a gallon of gas."

It is automatic and self-regulating and can be attached by anyone to any car in a few minutes.

Mr. May wants agents and is willing to send a sample at his own risk to anyone who will write him. Just send your name and address to James A. May, 1765 Lacotah Bldg., Sioux Falls, S. Dak.—Adv.

Why Burn Coal

or wood when you can burn gas in your stove or heater by installing a 1925 Improved Uni-Hete Kerosene Burner in five minutes time. It gasifies common kerosene to the hottest and cheapest fuel known. Does away with dirt and high fuel cost. Heat regulated to any degree by valve. Increases stove efficiency 100%. Has brought joy and economy to thousands. FREE TRIAL. Saves its cost in 30 days. Write quick for full particulars and introductory price.

Agents Big profit. Sells on sight. Write today for free sample offer and territory.
Acorn Brass Mfg. Co., 1267 Acorn Bldg. Chicago, Ill.

PERSONAL STATIONERY

200 SHEETS AND 100 ENVELOPES \$1.00

Printed With Your Name and Address

Clear, white bond paper, with envelopes to match. Your name and address printed in beautiful, rich blue ink, on both paper and envelopes, and sent to you postpaid for only \$1. (West of Mississippi River and outside of U. S. \$1.10.) If inconvenient to send the money, we will ship C. O. D. Money returned if you are not more than satisfied. Order today. Write name and address plainly.

Agents make big money taking orders for us. Write us today for our agent's proposition.

Elite Stationery Company 7016 Main Street SMETHPORT, PA.

Get Into Business

for yourself without capital. Exclusive Territory on guaranteed Radiator Cap Condenser and Indicator of engine trouble—Saves Alcohol—Prevents Freezing and Overheating. Fast all year round seller—for every automobile. Wonderful opportunity for Agents—Quick Sales—Big Profits—no experience necessary—work full or part time. Write today: **SENTREE, 609 N. LaSalle St., Chicago**

TAILORING \$50 to \$100 a Week

AGENTS WANTED If interested in a good opportunity to make big money let us send you our famous book, "What Others Say." It tells you about our new sales plan and shows pictures of scores of men whom we have trained and helped to build a permanent big paying business. Our plan beats owning a store and pays big profits. Success is sure for every earnest worker. J. B. Simpson's suits and overcoats at \$11.00, tailored to order, from all wool fabrics are well known and the world's greatest clothing values. They are easy to sell. We protect territory, pay commission in advance. Write for new sales plan and free copy of interesting book. **J. B. SIMPSON, Inc., Dept. 1022 843 Adams St., Chicago**

No Money Down

30 Days' FREE TRIAL!

Never before has any farm or shop engine manufacturer made a bona fide no-money down offer on his engines. We are **daring** to make such an offer because we know what OTTAWA Engines will do. We want you to prove to yourself that the OTTAWA is the easiest engine to start; uses less fuel and does more work per h-p. than any other engine you ever saw.

NOT A CENT DOWN Your request that you would like to try this engine is all we ask. You do not send a penny down—you have no papers to sign. After you have tried the engine right at your own work for full THIRTY DAYS, then send us the small payment of \$4.95 a month.

DIRECT FROM FACTORY

We don't buy our engines from someone else and then sell them to you. We build them in our own plant. We know just what goes into them and we test every engine three times before you receive it. **We keep your money while you test it.** Then pay for it in SMALL MONTHLY PAYMENTS, WITHOUT INTEREST.



OTTAWA ENGINES

Run on kerosene or gasoline without changing. New patented Venturi makes the OTTAWA easier to start. Throttling governor, WICO Magneto ignition. Thousands upon thousands of shopmen and farmers will only use the OTTAWA. It is the most reliable engine and will last longer. Investigate it now before you try any others. It costs you nothing to test it 30 days.

Write for Free Book

Just send your name and address on a post card for the New OTTAWA Catalog. It's yours FREE. We want you to have this book before you test any engine. Find out about this trial offer before you choose an engine. **WRITE TODAY.**

H. C. OVERMAN, President

OTTAWA MFG. COMPANY

538-H King Street, OTTAWA, KANSAS
Desk 538-H Magee Building, PITTSBURGH, PA.

How to
**KNOW
BETTER
ENGINES**

AFTER FREE TRIAL-

\$4.95
MONTHLY

Smallest monthly payment ever made on a 1½ H-P. engine—others sizes 2¼ to 22 H-P. at proportionally low monthly payments—a whole year to pay if you want. No interest; no C.O.D.; no mortgages to sign. Get full information, now.

HANDS UP!

Protect yourself against hold-up, rowdies, etc. with this clever cigarette case of light weight metal. Looks exactly like the real thing! Pull the trigger, back flies the lid showing your cigarettes. Lots of fun scaring your friends, and a great protector. Sold exclusively by us. **PAY POST-MAN \$1.79** on delivery plus postage. Money back if not satisfied. **PATHFINDER CO., Dep. H48 534 Sixth Ave., N.Y.**



Pat. Pending



LYON BODIES

Send For Our 1924
**FREE BOOK OF
BARGAINS**

Containing a full line of bodies and accessories at exceptionally low prices. Buy direct from the factory.

**AUTO TIRE
SALES CO.**

Body Division Dept. F27

1346 S. Michigan Ave., Chicago



\$27.50
AND UP

OXO-GAS

OIL BURNERS

FOR FURNACES RANGES HEATING STOVES And many other purposes



OXO-GAS oil burner for ranges One of 20 types for all purposes.

OXO-GAS, the cheapest, cleanest, most efficient fuel known to science is made from kerosene or distillate, and air, mostly air. Burns with a pure blue flame of high heating intensity, as silently as city gas. **Over a million in use.** Manufactured by the oldest (est. 1906), highest rated and most responsible corporation. **Ask any bank.**

Send for Catalog illustrating and describing twenty different, distinctive designs of oil burners for Furnaces, Cook Stoves, Heating Stoves, Base Burners, Hot Water Heaters, etc.

AGENTS Some choice territory for OXO-GAS **WANTED** agencies still open to thoroughly responsible parties. Your own locality may yet be unassigned.

GLORIA LIGHT COMPANY

111-12 N. May Street

Chicago, Ill.

At Last!

Radio That Satisfies the Music Critic

THE
CHICAGO DAILY NEWS
EDITORIAL ROOMS

H. W. Rauland, Pres.
Rauland Manufacturing Co.,
2650 Coyne Street., Chicago, Ill.

My dear Mr. Rauland:

I want to express my great pleasure in witnessing the recent test of amplifying transformers in your laboratory, and in selecting, from different instruments tested, the one which seemed to me to reproduce most exactly the artist's original tones. I was indeed gratified to learn, after the tests, that the instrument which I had repeatedly selected as by far the most successful in reproducing, not alone the music, but even the very personality of the artist, was none other than your own new "Rauland-Lyric" Transformer.

I feel confident that music lovers everywhere will appreciate the contribution you have made to their enjoyment in the creation of this reproducing instrument.

Very truly yours,

Maurice Rosenfeld

Music Critic,
Chicago Daily News

In placing his mark of approval upon Rauland-Lyric, Mr. Maurice Rosenfeld has invested Radio with a new beauty and dignity.

You can have, in your home, the amplifying instrument which has been commended by eminent critics. Rauland-Lyric can be installed in your present set, or one that you may buy, to replace any ordinary audio transformer.

Ask your dealer. Price, \$9.00.

The **RADIO KEY BOOK** contains the clearest explanation ever given of the nature of audio amplification and equally valuable discussion of many other subjects in Radio. Sent for 10 cents, coin or stamps.

RAULAND MANUFACTURING COMPANY
PIONEERS IN THE INDUSTRY
2656 Coyne Street • • • Chicago, Illinois

Rauland-Lyric
AN
ALL-AMERICAN
TRADE MARK
TRANSFORMER

What I Learned About Old Age

By Byron C. Kelley,
A.M., LL.D.



I recently had the most startling disclosure of my life on the subject of old age. I am approaching 40 years old myself. I had begun to wonder if I would soon begin to "break"—to lose my old-time pep and aggressiveness, my stamina and resistance against diseases, like most other men of this age. I wondered if I would soon be subject to the

class of ailments which seem so prevalent among men past 40. Then, through a mutual friend, I made the acquaintance of a certain scientist, a member of the American Association for the Advancement of Science, who has recently brought to light most interesting facts about the peculiar conditions common to men past middle age.

65% Have Gland Trouble

I learned that 65% of all men past a certain middle age have a disorder of a little gland, called the Prostate. And prostate disorder not only is the direct cause of much distress, often necessitating operation, but it displays itself in many parts of the body.

Common Middle Age Ailments

Here is an important cause for many ailments which heretofore have been simply ascribed as "old age" symptoms—sciatica, aches in back, legs, and feet, frequently nightly risings, nervousness and irritability, often go along with it. And I learned how, by an astonishingly simple new method, that these disorders could be eliminated in a short time without drugs or operation—by an amazing new treatment that reaches this gland directly—yet is so convenient that anyone can apply it in their own home.

10,000 Men Find Relief

But most surprising of all, I found that 10,000 men have already found relief through this amazing discovery. Statesmen, bankers, lawyers, doctors in every section of the country are using and endorsing the method. And it is within the reach of every one. There are no drugs, no books, no electric rays.

Explained in FREE Book

If you are troubled with any of the disorders mentioned, if you have chronic constipation or Prostate trouble, you should learn the facts about this discovery at once. A vitally interesting book written by this scientist called "Why Many Men Are Old at 40," will be sent free if you request it at once. It describes this splendid treatment and shows how you may regain much of your youthful vigor and be free from certain disorders. No obligation. But write at once—the edition is limited. Simply mail request to The Electro Thermal Company, 2140 Main Street, Steubenville, Ohio, the concern that is distributing these books for the author.

Western Office: Dept. 21E, 711 Van Nuys Bldg., Los Angeles, Calif.

Turn Your Ideas Into Profits

Whether you are interested in light manufacturing, repairing or experimental work; whether you are a mechanic, engineer, amateur, or student; whether you work in wood or metal, your ideas can be turned into profits with accuracy, speed and economy on

The *Baby Grand* Lathe

A sturdy, practical lathe of small size, high quality and at low price. Operation same as large lathes. Made of selected materials by skilled machinists who specialize on lathe building. Quantity production explains the low price. Not a toy but a practical machine for all small work. Hundreds in use in shops large and small the country over. Sold direct from factory to you on positive money-back guarantee. We also make Bench Drills and Grinders.

The Watson Mfg. Co.

112 Watson Bldg., Toledo, Ohio, U. S. A.

Write today for illustrated folder giving complete description and prices.



Let Iver Johnson Be Santa Claus

An Iver Johnson Bicycle

Just what brother or sister wants! Made to fit all sizes of men, women, boys and girls. Built with the famous Truss Bridge Frame, or Drop Bar if desired.

Iver Johnson Shot Guns

Champion Single Barrel Shot Guns in various gauges and styles including the Matted Top Rib and the .410. Also Double Barrel Hammerless Shot Guns.

An Iver Johnson Velocipede

Loads of safe fun for any little boy or girl. Made in three sizes, with brilliant baked-on enamel finish, either red or blue, with white head; full nickel fork; all nickel plating over copper.

An Iver Johnson Revolver

Always a sensible gift for home protection. The world-famous "Hammer the Hammer" Safety Revolvers—made in different calibers.

Write for Free Booklets

Catalog "B" illustrates and describes the complete line of Iver Johnson Bicycles, as well as Iver Johnson Velocipedes.

Catalog "A" illustrates and describes the complete line of Iver Johnson "Hammer the Hammer" Safety Revolvers, as well as Iver Johnson Champion Single Barrel Shot Guns and Hammerless Double Barrel Shot Guns.

DEALERS: We sell Bicycles and Velocipedes direct to retailers. A golden opportunity is yours to handle this famous line. Write for DEALER PLAN.



IVER JOHNSON'S ARMS & CYCLE WORKS

4 River Street, Fitchburg, Mass.

New York: 151 Chambers St.

Chicago: 108 W. Lake St.

San Francisco: 717 Market St.

IVER JOHNSON

BICYCLES **REVOLVERS**
VELOCIPEDES **SHOT GUNS**

Please Mention Popular Mechanics

Copyrighted material



AGENTS Make Big Money

Selling D-REX-U Safety Signal to automobile owners; complies with safety laws; guaranteed. Write today for wholesale price to agents and get territory quick. Big Winter Seller.

Address Comstock-Bolton Co., Dept. K
1925 E. 15th St., Kansas City, Mo.

A Better Shave

or your money back
-that's my Guarantee!



The Inventor of the Mercury Edgemaker

No matter what style razor you use or how tough your beard, I'll guarantee you a better shave with—

The MERCURY Edgemaker

Puts keenest barber edge on any razor or blade in a jiffy. Lasts for years. Anyone can use it. Guaranteed harmless to finest razor. Thousands of satisfied users.

Grab This Special Offer NOW!

Get a Mercury Edgemaker NOW at regular agent's price on guarantee of satisfaction or money back. No better Xmas gift than a Mercury Edgemaker for any man. Gives satisfaction every day in the year. This special offer settles the "what to give" problem.

Style	Agent's Price
C-1—For straight razors. Regular price, \$2.00	\$1.25
E-1—Complete with blade holder for all safety blades. Regular price, \$1.75	1.25
F-1—For AutoStrip razor. Regular price, \$1.00	.75

This special offer has never been made before and may not be made again, so send today. You take no risk; my guarantee protects you.

The Mercury Mfg. Co.
112 Mercury Bldg.—Adrian, Mich.

LUMINOUS PAINT

Make Your Watches, Clocks, Etc., Visible by Night

The very latest discovery in the scientific world, Hitherto, practically unobtainable except at an exorbitant price, we have at last succeeded in producing this remarkable LUMINOUS PAINT, which, applied to the surface of any article, emits rays of white light, rendering it perfectly visible in the dark. THE DARKER THE NIGHT, THE MORE BRILLIANT IT SHINES. Quite simple to use. Approve—you can do it. A little applied to the dial of your watch or clock will enable you to tell the time by night. You can coat the push buttons or switch plates of your electric lights, watch boxes, and innumerable other articles; make your own Luminous Crazettes, Luminous Hourglasses, etc. Small bottle, price 25c. Larger size, 50c and \$1 postpaid.

Serpent's Eggs

Box contains 12 eggs. When lit with a match, each one gradually hatches itself into a snake several feet long, which curls and twists about in a most lifelike manner. Price per box, 10c postpaid, 3 for 25c.

CIGARETTE MAKER



Roll your own and save money. Make them better and quicker besides saving more than half. Use your favorite brand of tobacco. Neat, useful and handy. Pocket size, weighs 1/4 oz. Made entirely of metal, nickel-plated. Price 25c postpaid.

MIDGET BIBLE

GREAT CURIOSITY
Smallest Bible in the World. Size of a postage stamp—200 Pages. Said to bring good luck to the owner. A genuine work of art. Most to be appreciated. Make good money selling them to friends, church acquaintances, etc. PRICE 15c each, 3 for 40c, 12 for \$1.35, 100 for \$7.50. Magnifying Glass for use with Midget Bible, 15c.



STAGE MONEY

With a bunch of these bills, it is easy for each person of limited means to appear prosperous by flashing a roll of these bills at the proper time and peeling off a genuine bill or two from the outside of the roll, the effect created will be found to be all that can be desired. Prices, postpaid: 25 Bills 15c, 50 Bills 25c, 125 for 50c, or \$3.50 thousand.

Wonderful X-Ray Tube

A wonderful little instrument producing optical illusions both surprising and startling. With it you can see what is apparently the bones of your fingers, the lead in a lead pencil, the interior opening in a pipe stem, and many other similar illusions. A mystery that no one has been able to satisfactorily explain. Price 10c, 3 for 25c, 1 dozen 75c. Johnson Smith & Co.



Good Luck Ring

Quaint and Novel Design

A VERY striking and uncommon ring. Silver finish, skull and crossbones design, with two brilliant, flashing gems sparkling out of the eyes. Said by many to bring Good Luck to the wearer, hence its name, Good Luck Ring. Very unique ring that you will take a pride in wearing. ONLY 25 CENTS.

Address orders for all goods on this and opposite pages to

JOHNSON SMITH & CO.
Dept. 278
RACINE, WIS.

A Deluxe Edition of our new 1925 CATALOG mailed on receipt of 25c. Handsome cloth binding. Only book of its kind. 420 pages of all the latest tricks in magic, the newest novelties, puzzles, games, sporting goods, interesting books, curiosities in seeds and plants, etc., unobtainable elsewhere. Only a limited number available.

DYING PIG



The most beautiful novelty yet produced. Made of rubber, and you have only to blow it up and stand the pig on its feet, when he begins to groan as if slowly rotting and finally lies down and dies in the most natural manner. You can blow him up as often as desired, and each time he will go through the same performance to the great amusement and delight of your friends. Price, 15 cents; 3 for 40 cents; one dozen \$1.35, mailed.

Popular Watch Charms

ONLY 15c
3 for 40c; \$1.35 doz.

Very pretty little curiosities and decidedly novel. Filled with Magnifying Lenses that enlarge the pictures to a very surprising degree; in fact, it seems almost incredible that a clear picture could be possible in such a small compass, and how sharp and distinct they show up when you look through. Come in assorted views—Artistic views of Panama Canal, Lord's Prayer in type, etc.

Mystic Skeleton

A jointed figure of a skeleton 14 in. in height, will dance to music and perform various gyrations and movements while the operator may be some distance from it. 10c & pd.

NEW BOOK ON ROPE SPLICING

Useful Knots, Hitches, Splices, etc.
A most practical handbook giving complete and simple directions for making all the most used knots, hitches, rigging, splices, etc. Over 100 illustrations. All about wire rope attachments, lashing, blocks, tackles, etc. 27 Illustrations. Illustrated. Of great value to mechanics, riggers, carpenters, boatmen. Price 20c pd.

MAGIC FLUTE

Wonderfully Sweet Toned and Musical
The Magic Flute, or Hummer, is a unique and novel musical instrument that is played with nose and mouth combined. There is just a little knack in playing it which, when once acquired, adds a little possession will enable you to produce very sweet music that somewhat resembles a flute. There is no fingering, and once you have mastered it you can play all kinds of music with facility and ease. When played as an accompaniment to a piano or any other musical instrument, the effect is as charming as it is surprising.

Post Paid 25c

BLANK CARTRIDGE PISTOL

Protection against Burglars, Tramps & Dogs



Prices
50c
\$1.00
Post-paid

Well made and effective; modeled on latest type of Revolver; appearance alone is enough to scare a burglar. When loaded it may be as effective as a real revolver without danger to life. It takes standard 22 Cal. Blank Cartridges obtainable every where. Price 50c, superior quality, \$1.00 post paid. Blank Cartridges, by express, 50c per 10 Blaster (Cowboy type) for Blank Cartridge Pistol, 50 Johnson Smith & Co., Dept. 278, Racine, Wis.

DANCING BEAUTIES

Get a Kinetograph and see the picture move. France's latest sensation. A great surprise. Is worth twice what they cost. Are made of solid brass, highly nickel-plated and very durable. Satisfactory or your money back. 50c
Price, Johnson Smith & Co., Dept. 278, Racine, Wis.

BOYS! BOYS! BOYS!

THROW YOUR VOICE

Into a trunk, under the bed or anywhere. Lots of fun fooling the teacher, policeman or friends.
THE VENTRILO
A little instrument, fits in the mouth out of sight, used with above for Bird Calls, etc. Anyone can use it.
Never Fails. A 32 page book on ventriloquism, the Ventrillo, ALL FOR 10 CENTS

1000 Silk Remnants

for patching Crazy Quilts, Sofa Cushions, Head Rests, Pin Pads etc. Large pieces, all colors and shades. Sure to delight you.
For 10 Cents stamps, we send a large package and Book of quilt designs. 3 packages 25c. 1 pound makes a lovely large quilt. Price 15c postpaid. Our silk is the best.
JOHNSON SMITH & CO., Dept. 278, RACINE, WIS.

LOOK 35¢ LOOK

Wonderful instrument. Greatest thing yet. Nine separate articles in one. Everybody delighted with it. Odd, curious and interesting. Lots of pleasure as well as very useful. It is a double Microscope for examining the wonders of nature. It is also an Opera Glass, a Stereoscope, a Burning Lens, a Reading Glass, a Telescope, a Compass, a Pocket Mirror, and a Laryngoscope—for examining eye, ear, nose and throat. It is worth all the cost to locate even one painful cinder in the eye. Folds flat and fits the pocket. Something great—you need one. Don't miss it. Sent by mail, postpaid. Only 35c or 3 for \$1.00

Resurrection Plant

One of the most wonderful plants known. Possesses the strange power of turning in a few minutes from an apparently lifeless, dry herb to a BEAUTIFUL LIVING FERNLIKE PLANT of a dark green color. Simply place the plant in saucer of water, it will open up and start to grow in 20 minutes. When taken out it will dry up and go to sleep until placed in water again. Fine house plant—summer or winter. 10 cents each or 3 for 25c. post paid. AGENTS WANTED
JOHNSON SMITH & CO., Dept. 278, RACINE, WIS.

EXCELSIOR SOLAR TELESCOPE

AND MICROSCOPE COMBINED



PRICE
\$1.85 Postpaid
to Any
Address

Guaranteed SCIENTIFICALLY PERFECT by the Makers
Over 3½ ft. long, nearly 6 ins. around **With Adjustable Solar Eye Piece**

The New Excelsior Solar Telescope is a large, powerful and serviceable instrument, well made and accurately fitted, and marvelously cheap. A Telescope with an **Adjustable Solar Eyepiece** for observing Eclipses of the Sun and examining the very interesting and mysterious Sun Spots, has never before been obtainable for less than several times the price charged; in fact, such an eyepiece alone usually costs more than the price charged for this complete Telescope. The lenses are well ground and adjusted, and the **five sections** are perfectly fitted. There is a metallic cap to protect the object glass from injury and to exclude dust. The section with the eye piece can be withdrawn and used separately as a powerful **magnifier or microscope**. The Telescope when fully extended is about 3 feet 6 inches in length, and when



closed it measures almost a foot. Tourists, residents at the seaside, farmers and others able to enjoy wide and extended views should have this excellent and wonderfully cheap Telescope. For a limited time only we are offering this Telescope, complete, postpaid, at the very remarkably low price of...
JOHNSON SMITH & CO., Dept. 278, RACINE, WIS.

Only \$1.85



MYSTERY BOAT Runs for hours without mechanism of any kind. Speed Record 9 miles an hour. Kicks up water and sounds like real motor boat. Entirely new and patented principle never before applied to boys. Just place a small lump of Canned Heat such as Sterno, obtainable anywhere, in boat and light. Costs only **One Tooth of a Cent for One Charge**. Runs wherever there is water—in a bath-tub, dishpan—anywhere at all. Any child can operate it. Made entirely of metal, attractively enamelled in colors, hull dark green and deck bright red. Indestructible, fool-proof and safe. **Price \$1.00. CANNED HEAT, 20c per can.** **JOHNSON SMITH & CO., Dept. 278, Racine, Wis.**

INVISIBLE INK VANISHING INK

The most confidential messages can be written with this ink, for the **ink MAKES NO MARK**. Cannot be seen unless you know the secret. Invisible for many reasons. Keep your postals and other private communications away from prying eyes. Great fun for playing practical jokes. **Only 15c Bottle.**

Writing written with this remarkable ink vanishes entirely in a few weeks (unless if desired, leaving the paper **QUITE BLANK**). **15c per bottle.**

LUMINOUS INK writing can be **READ ONLY IN A DARK ROOM**; writing shines like fire. Quite invisible at daylight. Very remarkable. **15c.**

LADY'S LEG KNIFE

Latest novelty, a good substantial knife made by a first-class cutlery establishment for 15c. Knife is perfect imitation of lady's leg with embossed striking and shoe. **15c postpaid.**

Pencil with Microscopic View

Definitely novel and excellent pencil with eraser, into which is fitted a tiny microscope picture, magnified to an almost incredible degree by the small but powerful lens. A great curiosity. Assorted Views: **Bathing Girls, Acres, Panama Canal, Lord's Prayer, etc.** **Price 15c, 3 for 45c, \$1.35 doz., postpaid.**



K.K.K.

Everything about the **Ku Klux Klan** told in a clear, fearless manner. Book tells all—How it started and was suppressed in 1871—The New Ku Klux Klan—How organized—How members are enrolled—Oath of the Klan—Questions for Candidates—Creed—Objects of the Order—Obedience—Fidelity—Pledge of Loyalty—**Ku Klux Klan and the Masons—The Jews—The Masons—Real K. of C. Oath—The Negro Ku Klux Klan, etc., etc.** Latest and most complete book on the Klan published. **Price, 35c, postpaid.**

SEX INDICATOR

Some time ago we received from abroad what we consider the most unique and entertaining novelty we have ever seen. It's the **MAGIC INDICATOR**. We paid 25 cents for the one we received about a year ago, and we don't believe we ever get a bigger value for our money.

SEX INDICATOR

Some time ago we received from abroad what we consider the most unique and entertaining novelty we have ever seen. It's the **MAGIC INDICATOR**. We paid 25 cents for the one we received about a year ago, and we don't believe we ever get a bigger value for our money.

in fun and interest. Hold the **MAGIC INDICATOR** over a woman's hand and it describes a complete and continuous circle. The same action can be obtained over a letter written by a man or woman, etc. It is fascinating; baffling. We have never been able to figure out how it does—but we're never seen it fail. Many novel and entertaining facts may be performed with the Sex Indicator. For example, similar results can be obtained with animals, cats, dogs, rabbits, over birds, chickens, canaries, etc. Also used to predetermine the sex of chickens and birds, etc., in fact it is sold as a patented egg tester in Europe. Take one to any gathering and see how much interest it excites. **Price 25c postpaid, or 3 for 65c, postpaid.**

All articles listed on above and previous page obtainable from **JOHNSON SMITH & CO., Dept. 278, Racine, Wis.**

THE EXPO WATCH CAMERA



The most wonderful and ingenious Camera made. It is but little larger than a watch, which it closely resembles. You can carry the **Expo** about in your pocket and take pictures without any one being the wiser.

Less Than 2 Cents a Picture
The Expo loads in daylight with 10 or 20 Exposure Films, costing 25c and 35c respectively, and thus the picture taking part of a whole day's outing may be had for a very nominal sum—Little more than one cent a picture.

Easy to Manipulate

It is simplicity itself to operate. Takes pictures through the stem, where the **Rapid Fire Lens** is located. The photos (3-2 1/2 x 50) may be enlarged to any size. Film and instantaneous starters; weighs but 3 ounces; nickel plated. Endorsed by amateurs and professionals the world over. Utters the same as ordinary cameras—in daily use by the police, newspaper reporters, detectives, and the general public. Important facts have been secured with the Watch Camera by enterprising reporters. Produces clear, sharp negatives indoors or outdoors equal to any camera on the market, also of price notwithstanding. **Sold Under a Positive Guarantee.**

Expo Watch Camera \$3.60 FILMS, 10 Exposures 25c, 20 Exposures 35c
Price Post Paid **Leather Pocket Carrying Case, 35c**
JOHNSON SMITH & CO., Dept. 278, Racine, Wis.



FLASHLIGHT MOVIES



NEW Combines (1) Moving Picture Machine; (2) Magic Flashlight. All in one. No gas; no oil. A splendid Moving Picture Machine, using standard films now shown at theatres. Shows large, clear pictures. Always ready for use; simply press the flashlight switch and you are ready for the show. Not necessary to have electricity in house. Flashlight can be disconnected and used separately if desired. The machine is arranged for use either with Films or Lantern Slides. Gives **FREE** with each machine: 1 coin Film, 1 Film Compartment slides making your own lantern slides out of old films, 1 Transparent Announcement Slide, and generous supply of admission tickets, loaders, curtains, instructions, etc., carefully packed and sent prepaid to any address for only **\$5.50**

Extra Film in 25, 50 or 100 ft. lengths at 1 cent per foot.
JOHNSON SMITH & CO., Dept. 278, Racine, Wis.

All the Latest Surprising and Joke Novelties

- | | | | |
|------------------------------------|-----------|--|--------|
| Miscellaneous Water Pistol | 10c | "Mirac" Self-filling Fountain Pen | 25c |
| Cleopatra's Snake (very effective) | 15c | Greatest Fire-eating Trick | 30c |
| Fake Mustache | 10c | Magic Ball and Yarn Trick | 20c |
| Pocket Detective (see behind you) | 15c | Naked Truth Joke (Magic Card) | 15c |
| Great Mind Reading Mystery | 10c | Children Inspector Badge | 10c |
| Thurston's Mysterious Trick Cards | 10c | Liar's License, 10c. Dancer's License, 10c | 10c |
| Fighting Boosters, pair | 10c | Famous Stencil Typewriter | \$2.50 |
| Squirt Ring | 20c | 250-shot Automatic Cap Pistol | 15c |
| Rubber Tacks (a good joke) | 10c | Surprise Matches, per box | 10c |
| Memorized Penny | 20c | Deck Marked Cards | \$1.00 |
| Cashool Snowing Powder | 10c | Everlasting Writing Pad | 15c |
| Magic Plate Lifter | 25c | Wire Pen, big size, 10c, 3 for 25c | 10c |
| Indication Gold Teeth | 3 for 10c | Stimulus Dipper, 15c. Boot Card | 6c |
| Barking Dog (imitates dog bark) | 20c | Fortune Telling Cards, per deck | 25c |
| Exploding Cigarettes, Per Box | 25c | 3- reel Moving Picture Machine | \$5.00 |
| 20-piece Set Silveroid Tableware | \$1.98 | Air Pistol, novel and decorative | 25c |

All articles listed on above and previous page obtainable from **JOHNSON SMITH & CO., Dept. 278, Racine, Wis.**

FOR HOMES-SMALL BUILDINGS-FLATS

BURNER AND THERMOSTAT \$190

ROYAL

BURNER \$150 ONLY

OIL BURNER

AUTOMATIC

Improved 1925 Model
Automatic No. 4
F. O. B., K. C., Mo.

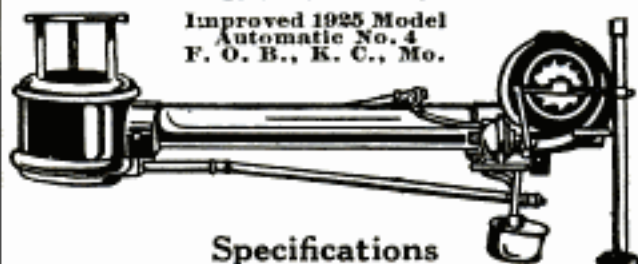

Specifications

MOTOR—1-20 H. P.—Direct connected to fan.
CAPACITY—Steam radiation—700 sq. ft. Water radiation—1100 sq. ft. Furnace—up to 4 sq. ft. grate.
FUEL—Any gasoil—distillate or kerosene—36 gravity or higher.
FEED—Gravity flow to burner.
PILOT—Oil pilot fire automatically increased to high fire by thermostat. City gas not required.
WEIGHT—Boxed for shipment—150 lbs. Tanks not included.

Can be installed by any pipe fitter—complete instructions furnished—made in three sizes—Nos. 2, 4 and 5. Dealers in many cities.

Write for catalog. Some territory still open for exclusive dealers. Oil burner firms will find the Royal a quick selling, dependable addition to their line. We refer to Dun or Bradstreet or any Kansas City bank.

Willis W. Howe Co., Manufacturers
3030 McGee Trafficway, Kansas City, Mo.

YOU CAN MAKE \$18 DAILY PROFIT

With Our Great Introductory Offer
Giving These \$1.25 Dress-Making Shears **FREE**



With each sale of our wonderful 11 piece Toilet Article Assortment for only \$1.75. TOTAL STORE VALUE \$4.60

\$18.00 a Day PROFIT on only TWENTY Sales



Lucky 11 Toilet Set—Retail Value \$3.35!

MY! HOW THEY SELL!

You get the attention with the free Shears. Walter Harris sold 800 boxes in six weeks. Profit over \$100 a week. You can do this too.

Act Now! Sell like hot cakes year round. A baby could sell Lucky 11. Don't wait a minute. Save time. Send \$1.75 for complete outfit including display case. At least write for circulars explaining our unique plans, including 30 other packages. **ACT NOW!**

E. M. DAVIS CO., Dept. 5624, CHICAGO, ILL.



"Been on a vacation Bill?"

"No, Jim—I've stopped smoking. Gained six pounds in a week. You know how I used to smoke—a package of cigarettes and a cigar or two a day—It sure had some hold on me. But I'm cured—

took a scientific home tobacco treatment—fixed me up in two weeks.

"Wasn't hard on me at all—noticed improvement the first day—I feel like a new man. It didn't interfere with my work—didn't leave any druggish after-effects—the money I saved in the last two weeks has paid for the treatment alone.

"Why don't you take it! It has cured men like you and me for over forty years—it is a doctor's individual prescription that sure fixes you up. Just send the coupon for full information NOW. No obligation. All correspondence is strictly confidential."



A Doctor's Prescription

The Keeley Institute, Dwight, Ill.

Please send me, without any obligation on my part, your free booklet which will tell me how to rid myself of the tobacco habit.

Name.....

Town.....

Street..... State..... P.M.'16

PHILMOR QUALITY SHIRTS

PAY BIG PROFITS



3 SHIRTS for \$4.95
2 for \$4.00
1 for \$2.49

THE unusual beauty, fine quality and popular prices of PHILMOR cut-to-fit shirts make them the fastest selling money-maker for agents today. Underwear stores. Quick deliveries. 300 handsome samples. Steady year-around business. No investment or experience required.

Write today and learn how to get agent's sample shirt free.

PHILMOR CO., Dept. B
2 Union Square, New York City

Our BUREAU OF INFORMATION will answer all questions regarding articles in this magazine. Address Popular Mechanics Magazine, Chicago.



"Lighting Fixtures"

READY TO HANG

(Direct from Manufacturer)

Completely wired, including glassware. Send for Catalogue No. 26. Just Off the Press.

Special proposition to DEALERS.

ERIE FIXTURE SUPPLY CO.
STA. A. ERIE, PA.

Carrying Case **FREE** with 3 ft. Telescope



See people and objects miles away just like they were close; see Moon and Stars as never before. Opens over 3 ft. long, 5 sections, brassbound, powerful lenses. Useful and entertaining.

Send No Money

Write today; on arrival of Big 3 ft. Wonder Telescope with FREE Carrying Case and Strap pay Postman only \$1.50 plus a few cents postage. Satisfaction guaranteed.

FERRY & CO., 3222 N. Halsted St., Dept. 1779, CHICAGO

"Have been watching submarines & miles off the coast." P. Gnosel

\$250.00 Weekly ~ Sullivan's Success ~ Your Opportunity

\$2.50 worth of potatoes will make \$25.00 worth "Tater-Flakes" Figure your profit!



Less than a year ago Robert Sullivan, Indiana, was a newspaper man. He was looking for an opportunity to make more money—just as you are. Sullivan read a "Tater-Flakes" ad. Investigated, saw the possibilities, and started into this wonderful business. He is averaging **\$250.00 clear every week**—in a small town!

"Tater-Flakes" Booming Everywhere

Down south Hoffman & McLeish are running around **\$100.00 daily**. Conover, Ind., averages **\$50.00 daily** except Saturdays, which average **\$100.00**. Frank Berry, Ind., says: "Using 3 barrels of potatoes daily. Have splendid wholesale and retail business. Am supplying 50 and 100 stores." Mrs. Suttleworth, Colo., averages **\$20.00 to \$25.00 daily**. Charles Schaffer, Wis., operating 5 stores, averaging **more than \$500.00 week!**

It's a Wonderful Business

"Tater-Flakes" are a new and different potato chip. Can't be compared to ordinary chip. The "Tater-Flakes" machine slices, cooks, crisps, browns and delivers Flakes entirely automatically. Anyone can easily operate. Bright girl or boy can run machine. Outfit in window attracts attention. Passing public stops and looks. Golden, crisp "Tater-Flakes" with appetizing odor whets appetite and people buy. Retail business thrives from very start. Profits simply great.

A Business You Can Handle

Write quick—get complete details of this wonderful new business. No experience needed. Moderate capital starts you. We give you every assistance—furnish machine, service men, field men, merchandising ideas, etc. All you have to supply is location. You plunge into retail and wholesale business at once. You become member of great "Tater-Flakes" organization. Have opportunity to attend annual gathering of "Tater-Flake" men—an institution national in scope.

QUICK SUCCESS POSSIBLE

The marvelous "Tater-Flakes" machine—the surpassing goodness of "Tater-Flakes"—the whole-hearted and continued co-operation of the "Tater-Flakes" organization—makes quick success possible. It's your opportunity—the chance you have been watching for—grasp it quickly. Sit down now and write for full particulars. Your territory may be taken if you delay. Address

TATER-FLAKES CORPORATION, Inc.
Dept. 39 20 E. Jackson Blvd., CHICAGO, ILL.

Sold in glassine packets, also in bulk. Big money both ways.



Cal. 30



U.S. ARMY KRAG CARBINES

All carbines have the new model 1898 stocks. The barrels, actions and parts are either new or have been refinished by the Government, and equal to new **\$15**

KRAG RIFLES, \$12.50

CALIBRE 45 CARBINES, \$3.50

KRAG SPORTING RIFLES, \$14.00

CALIBRE 45 SHOT GUNS, \$4.50

Utility Bags for Bait, Lunches, etc., 40c. Parcel Post Paid

OLIVE DRAB Wool Breeches

New—in sizes from 32 waist to 40 waist. Strong light weight wool. Made for the Home Guards **\$1.50** Parcel Post Extra

SEND FOR OUR COMPLETE CATALOG

W. STOKES KIRK

1627-PM North 10th St., PHILADELPHIA, PA.

ARMS, CLOTHING and things out of the ordinary



Harris Homes Beautiful

Bungalows — Semi-Bungalows — Cottages — Residences! If you want a real home combining an impressive exterior and comfortable, well planned, homey room arrangement, you must see the latest De Luxe Addition of our latest book of Homes and Building Materials. More than a hundred modern, attractive, livable houses, featuring all that is best in construction—each one an architectural triumph carefully planned and designed by expert architects.

All Harris Homes Beautiful have been built many times with big economy and life-long satisfaction to their owners. They present a perfect combination of approved construction, finest materials, "planned the Harris way" to save from \$500.00 to \$1,500.00 of your money. Ask for your copy of this free 400-page Building Material Book, No. CB-7, today.

Thousands of Bargains Like These



Combination Screen and Storm Door. Size 2/8 1/4 x 7/1. quickly changed, each

\$6.77



2 light 24"x 20" glass checkered windows, 1-3/8" thick, outside measure 2/4-1/8 x 3/10, each

\$2.50

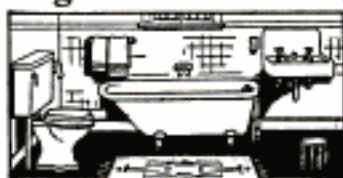

The bathroom outfit shown includes bathtub five feet long, white porcelain enameled on the inside, low pattern white tank closet outfit and white porcelain enameled lavatory complete with all fittings above floor line, special at.....

\$65.00



Clear White Pine Storm Sash with frames, 1-1/8" thick, best clear glass, each light 8x10. Outside measure 1/0x3/11 1/2, each.....

\$1.53



Economy Special paneled doors, size 2/6x6/6, 1-3/8" thick, each.....

\$3.20

HARRIS BROTHERS CO.

Dept. CB-7

35th and Iron Streets

CHICAGO, ILL.



Ed. H. Witte

Let Me Put You in Business

I have put hundreds of men in the profitable business of cord wood and log sawing. Indications point to a more prosperous season this year. Coal will be high and hard to get. Many farmers and householders in your locality will gladly give you the job of sawing their fuel wood when they learn that you can do the work in one-tenth the time with a

WITTE 3-in-1 SAW RIG

You can cut 60 to 70 cords a day easily. At from 50c to \$1.25 a cord, you can readily figure your profits for a day's work. Read what J. S. Johnson of Centralia, Mo., did.

You Won't Have to Pay a Cent

out of your present savings. You can make enough money the first 10 days to pay for your outfit. From then on, a clear profit of \$100 a week should be easy.

Write Me Today and I will gladly send you details of my plan to put you in a big paying business of your own. ED. H. WITTE, President

WITTE ENGINE WORKS



This Outfit Will Easily Make \$100.00 a Week for You!

Ed. H. Witte

FREE

Be sure to get details and actual pictures in colors of famous Witte Saw Rig. Write today without fail.

4742 WITTE BUILDING, KANSAS CITY, MO.
4742 EMPIRE BUILDING, PITTSBURGH, PA.

Popularity Plus!



Yours-with this most winning
of all musical Instruments

The model shown
is the new 1924
Alto Buescher
Saxophone.

Easy to Play
Easy to Pay

It's easy to be popular - to be in demand socially - to be welcome everywhere - with an irresistible Buescher Saxophone. Don't be a wall flower. Don't be a dawdler. Step out of the crowd and into the "picture." Be able to do something to earn your welcome. Learn to play a

BUESCHER
True Tone
SAXOPHONE

Easy? - you'll be astonished to see what you can do in a few days. Most people are able to play a few pieces of popular music in two or three weeks. **It's great fun - learning** - and you are mastering an accomplishment that will mean big money to you if you decide to use it commercially.

Easy payments to suit your convenience. Six days' free trial. Send the coupon or a postal for your copy of the free Saxophone Book described at left. Mention any other instrument in which you may be interested. No obligation whatever. Do this today.

BUESCHER BAND INSTRUMENT CO.
Everything in Band and Orchestra Instruments
353 Buescher Block Elkhart, Ind.

Buescher Band Instrument Co.
353 Buescher Block, Elkhart, Ind.
Gentlemen:
I am interested in Instrument checked below:
Saxophone... Cornet... Trombone... Trumpet...
(Mention any other instrument interested in)
Name.....
Street Address.....
Town State



Free!

Send the coupon or a postal for a free copy of our very interesting Saxophone Book. Tells all about the various styles with pictures of the famous professionals.

Everyone interested in Radio should have this
68-page book of approved
parts and sets—it's free!

Ward's New Radio Catalogue

ONE copy of Ward's New Complete Radio Catalogue is yours Free—you need merely to write for your copy.

It shows you everything new in Radio, everything that has been tested and approved by the Radio laboratories. Simple instructions are furnished with every Ward receiving set, enabling you to put up and operate it without outside help.

And the prices on everything in this book are surprisingly low!

A Price and Quality Guide

Study this Catalogue every time you need *anything* in Radio, whether parts or a complete set. See what is *the lowest price* for standard quality goods.

Everything shown in this Catalogue has been selected by an expert. Everything is standard. Remember at Ward's we never sacrifice quality to make a low price. Yet our prices are always



Write for
Your Free Copy

low because we sell direct to you by mail—and without the usual "Radio Profits."

Bring the Joy of Radio Into Your Home

You can get the most enjoyment out of Radio only by using standard, high grade equipment. You know what you are getting when you buy at Ward's. You are sure of high quality as well as a big saving when you order from this book, for our Radio equipment is sold under the same liberal guarantee we have made for 52 years on every article sold by Ward's—"Satisfaction Guaranteed or Your Money Back."

Write for your free copy of the new Radio Catalogue. Write to our house nearest you and address Dept. 6-R

ESTABLISHED 1873
Montgomery Ward & Co.

The Oldest Mail Order House is Today the Most Progressive

Chicago Kansas City St. Paul Portland, Ore. Oakland, Calif. Ft. Worth



**Boys! Ask Dad
to give you the lifetime gift this Christmas
— a wonderful Ives Electric Train**

You boys will experience one of the greatest joys of your life when you see, on Christmas morning, a wonderful Ives Electric Reversing Locomotive in front of the bright, realistic station. There it stands, waiting for its first run over your newly-established branch of the Ives Railroad System—a system with trackage sufficient to extend from New York to San Francisco, including branch lines all over the country.

Think of a locomotive that is an exact model of the giant electric locomotives used on the New York Central and other great American rail-

roads! A locomotive that will reverse itself, electrically, at any position on the track, without being touched by hand! A locomotive that switches its own cars, shunts them into sidings, or speeds—with electric headlight ablaze and each car illuminated—around the track and couples automatically to the front of the train.

Ives has the most complete railroad system ever devised. There is an unlimited variety of bridges, passenger and freight cars, switches, tunnels, stations, automatic bell signals for crossings, automatic block semaphores, etc.

THE IVES MANUFACTURING CORPORATION

196 Holland Avenue

Bridgeport, Conn.

Ives Toys make happy boys

Ask Dad to give you one of these wonderful Ives Electric Reversing Locomotives this Christmas. There's every conceivable accessory with which to equip a system. Remember, there's an Ives outfit to suit every purse. They include mechanical trains for the boy of 3 years and upward, to the most wonderful, complete electric system. Prices range from \$1.50 to \$50. At the best toy, department, electrical and hardware stores. Send for brilliantly illustrated 32-page book in full colors which shows the complete Ives line.

Mail this coupon for the Ives book—TODAY!



THE IVES MANUFACTURING CORP.
196 Holland Ave. Bridgeport, Conn.

I enclose 10 cents (U. S. Stamps or coin) for your 32-page book in full colors showing the complete line of Ives electric locomotives, freight and passenger cars, signals, etc.

Name.....

Address.....

City..... State.....

IVES ELECTRIC AND MECHANICAL **TRAINS**

UNLIKE ALL OTHERS!

ONE TO SIX PUMP-STROKES COMPRESSES AIR TO ANY SHOOTING-FORCE DESIRED

Three Strokes for
Ordinary Shooting

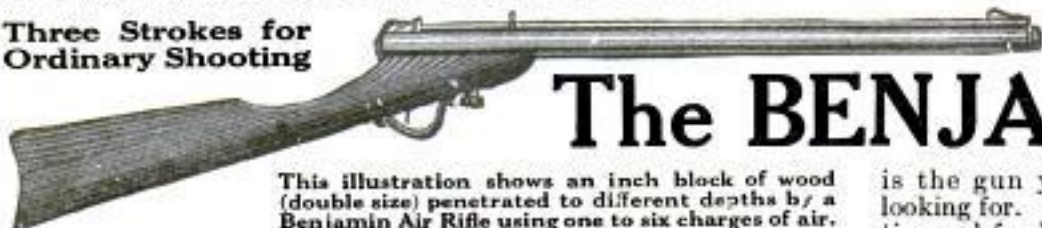

The BENJAMIN

This illustration shows an inch block of wood (double size) penetrated to different depths by a Benjamin Air Rifle using one to six charges of air.

This is a Feat No Other Air Rifle Can Duplicate

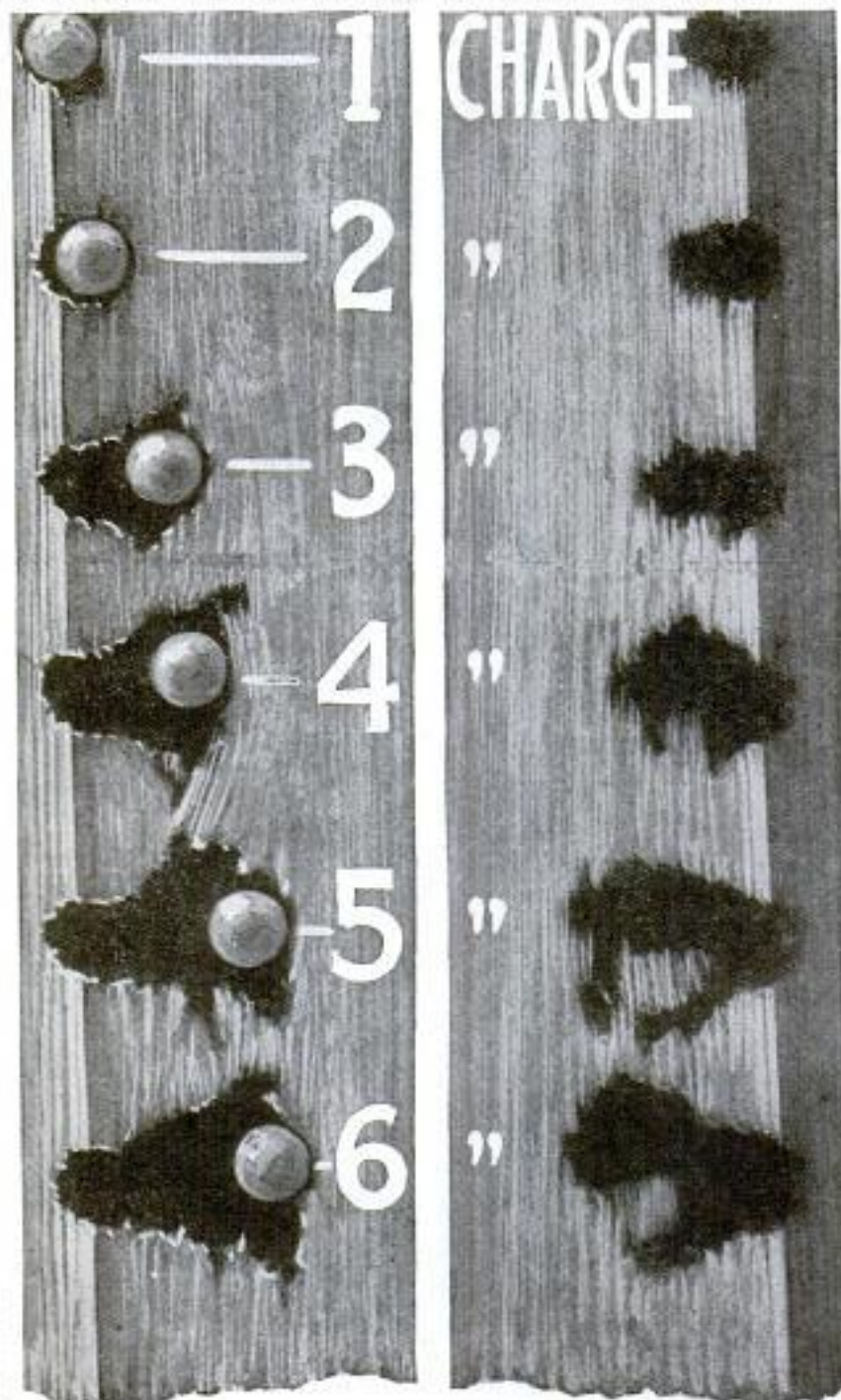

is the gun you have been looking for. For target practice and for hunting rabbits, squirrels, gophers, rats and frogs it has no equal. It is the most powerful, accurate and reliable compressed air rifle made. It has a far greater shooting range than any other. Imagine bringing down rabbits with an air rifle! You can do it with a Benjamin.

The BENJAMIN

is the ONLY PUMP GUN MADE using compressed air. SIMILAR TO AIR DRILLS AND HAMMERS. It does not lose shooting force after long use. The BENJAMIN is the only air rifle with the shooting force under the operator's control. It can be loaded to shoot weak or powerful as desired, from one to six strokes of the pump giving all the power wanted. It is absolutely safe; accidental discharge is impossible. Furthermore, after being charged with air, it is ready for instant use at any time after the shot is placed in the barrel.

The BENJAMIN

is mechanically perfect. It is the only air rifle not requiring frequent repairs, customary in all spring guns.

Price **\$5⁰⁰** Post-paid

Canvas Case \$1.00

Write for descriptive folder giving full details of this wonderful air rifle.

BENJAMIN

AIR RIFLE & MFG. CO.
651 N. Broadway
ST. LOUIS, MO., U. S. A.

Pacific Coast Representative
THAYER & BOWER
Los Angeles, Cal. & San Francisco, Cal.

60 MILES ON A GALLON OF GASOLINE

TESTS SHOW FORD CAN RUN 60 MILES ON A GALLON

The amazing fact that a Ford can run 60 miles on 1 gallon of gasoline was recently brought to light through tests conducted by America's foremost engineers, where it was shown that a gallon of gasoline contains sufficient heat units which if properly atomized and mixed with air would give this additional mileage. Great strides have already been made in this direction by the recent invention of a simple attachment which can be installed in a few minutes without any alterations to the motor. It is common for Ford Owners to make from 40 to 44 miles per gallon after this marvelous device is attached.

MOST WONDERFUL INVENTION TODAY BRINGS JOY TO FORD OWNERS

Starts Ford Instantly

Starting a Ford Car in cold or zero weather is something every Ford Owner dreads—everybody realizes that difficult starting is an abuse on the starter and battery. Thousands of Ford Cars are "laid up" during the Winter just for these reasons. This great difficulty has been overcome. "The SUPER positively starts a Ford Car instantly in the coldest weather."

Marvelous Device

The SUPER is no trick affair—requires no mechanical adjustments and contains all the scientific principles of carburetors costing \$20 to \$35 and in its natural action uses up every particle of unused gasoline and breaks it up into a perfect vapor. The hitherto impossible is now realized by the SUPER.

Everybody Satisfied

Saves 3 to 7 Dollars Per Month

The best investment I ever made. The SUPER is saving me from three to seven dollars each month, besides putting new life into my motor. A. H. WORRA, Iowa.

Makes 44 Miles Per Gallon

I have tried the SUPER and the results of the experiment are satisfactory. One quart of gasoline run my Ford 11 miles over improved roads which is just about again as far as I could run with the plain Ford Carburetor. G. E. YODER, Penn.

Finds That Our Claims Are Correct

I find that your claims for increased mileage are correct and that a big saving is made by your SUPER. In fact, the best device I have met with in that line.

M. J. VAN LEEUWEN, Mass.



The Heart of the Motor

Eliminates Oil Pumping in Front Cylinder

What a wonderful relief to Mr. Ford Owner when he realizes that he can run his car without the motor pumping oil in the front cylinder. Sounds like an awful lot to expect of any device, but that is what the SUPER does and this is only one of its many advantages because it puts real efficiency into any Ford Car.

Complete Combustion

The SUPER is so designed that it takes advantage of the present Ford Carburetor and properly atomizes the light as well as the heavy elements of the fuel, converting every atom of gasoline and kerosene into power preventing liquid fuel from passing into the cylinders, thus avoiding carbon formation and oil dilution.

Easy to Sell

Sells Like Hot Cakes

This is a recent letter from one of our distributors: "Enclosed find draft for 200 more SUPERS, rush as I need them badly. I sold and banked \$104.00 in one day. Hope to sell 1000 SUPERS next month."

A. W. LEONARD, Penn.

Making Big Profits Every Noon

I have been working the SUPER at noon only. Yesterday noon I made more money with the SUPER than I did at my 11 hours' hard work in the factory all day. J. L. LEHNER, Wis.

Had No Previous Selling Experience

This letter shows what ambition does: "I sold six SUPERS in less than 2 hours tonight. I think it's a pretty good start—for it's the first thing I ever sold."

E. MANGOLD, Ind.

\$60.00 TO \$150.00 PER WEEK EASY

You just can't help making Big Money selling the SUPER because a trial sells itself and soon everyone in the neighborhood get talking about this marvelous device. Men like Leonard, Shaw, Manner, Kinsley, Peters, Sands, Beck and Hall are not exceptional salesmen but just the type of men that saw an opportunity and were quick to grasp it when within reach. No previous selling experience is necessary, just a little ambition on your part to make money is all we ask and we will extend the same opportunity to you. Spare time will pay you well. If you can devote your entire time so much the better, because the SUPER is a whirl-wind seller and takes hold in a locality like wildfire.

Men Wanted Everywhere To Introduce

We want distributors in all parts of the country to take orders and deliver the SUPER and to look after the repeat business that is bound to follow and to such distributors we are willing to assign territory. You do not have to own a Ford to take up this proposition but if you have a Ford it is easier to explain its many advantages. However a Trial of the SUPER convinces the most doubtful person and tells a wonderful story.

A REAL FUTURE HERE

WEEKS SUPER CARBURETOR CO.
1304-715 Fond Du Lac Ave., Milwaukee, Wis.

MAIL TODAY
WEEKS SUPER CARBURETOR CO.
1304-715 Fond Du Lac Ave., Milwaukee, Wis.

GENTLEMEN:
Please mail me full free particulars about your wonderful invention.

Name.....

St. or R.F.D.....

Town.....

State.....



Bench Milling Machine

No. **644**

Price \$120.

Make yourself a present of this milling-machine

JUST the thing that every amateur mechanic and owner of a small workshop longs for.

Has a three-step cone pulley, $1\frac{1}{2}$, $2\frac{1}{2}$, and $3\frac{1}{2}$ inches in diameter, for 1-inch driving belt. Live spindle has cone bearing to take up wear.

The table measures $11\frac{1}{2}$ x $3\frac{3}{8}$ inches and can be fed three ways by hand wheels. Feedscrews have graduations for fine adjustment. Knee is elevated by a screw operated by a hand wheel at back of frame. Bench space of pan or bed, 8 x 12 inches.

This machine is furnished com-

plete with a compression chuck with $\frac{3}{8}$ -inch bushing. Countershaft, arbor, vise or centers may be purchased separately.

Other tools for amateur mechanics

The Goodell-Pratt Catalog No. 15 is a genuine paradise for tool-lovers. In it are shown all the famous 1500 Good Tools—many of special interest to the man who is building up his own workshop and who is on the lookout for more complete equipment. Catalog No. 15 is free. Write for a copy.

GOODELL-PRATT COMPANY, GREENFIELD, MASS., U. S. A.

Toolsmiths

Makers of Mr. Punch

GOODELL-PRATT

1500 GOOD TOOLS

The Greatest Advance yet made in **RADIO**

Marshall
3-4
and 5
Tube Sets

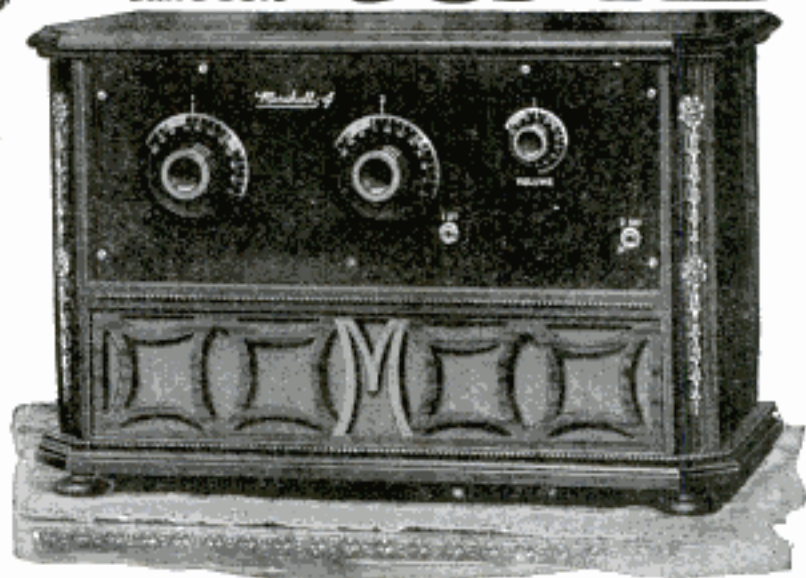

*Receiver
and Loud
Speaker in
Combina-
tion Cabinet
of Solid
mahogany*

**This Beautiful
Marshall 4 Tube
Non-Oscillating Receiver** *only \$5⁰⁰
DOWN*
Complete with all accessories

WRITE TODAY for full particulars of this most exceptional offer. Marshall Sets embody the very latest improvements known to radio. The wonderful new principal involved is proving the sensation of the 1924-25 radio season. Zero Coupling—the problem which radio engineers have been working on for years—has at last been solved. As a result, the Marshall has no need of neutralizing condensers or other make-shift methods of avoiding internal oscillations which invariably reduce efficiency. The Marshall Tuned Radio Frequency Receiver brings to radio a new degree of musical quality. Its selectivity will delight the experienced radio operator. Yet it is so easy to tune that the novice will handle it like an expert.

Small Monthly Payments—2 Weeks Free Trial

That is the remarkable offer we are prepared to make you. Two weeks to prove that the outfit you select is everything we have said for it. If it doesn't make good our claims, back it comes, and your deposit will be cheerfully refunded. But if it fulfills all your expectations, you may pay for it in easy monthly installments. You don't risk a cent when ordering from us. You *must* be satisfied, or we don't do business. Is it any wonder that radio buyers, the country over, are rushing to take advantage of such an offer? If YOU are interested, figure on getting your order in early, while prompt shipment can be made. Everyone predicts a serious shortage of radio supplies this season. Send for full particulars today.

Beautiful Solid Mahogany Combination

Compare the beautiful Combination Cabinet, pictured above, with the usual radio box and horn. Here the Receiver and Loud Speaker are contained in a single handsome cabinet. Or, if you prefer, we also have the Receiver in a separate cabinet of the same design. These cabinets are the work of a master designer—fashioned of solid mahogany. They will harmonize with the furnishings of the finest homes. In spite of the extra value, these Marshall sets are astonishingly low in price. Compare them with others which sell for cash. Then remember you can order a Marshall outfit on two weeks' free trial and pay for it on very easy terms.

Complete Outfits If Desired

In buying from Marshall, you have the choice of a set complete with all accessories, or the set alone. You have choice of dry cell or storage battery outfits. Unless you already own the accessories, you can buy them from us at less-than-market prices, with your set, on easy terms. Your outfit will come all ready to set up and operate within a few minutes—saving time and trouble—and saving money, too.

MARSHALL RADIO PRODUCTS, INC.
Marshall Blvd. and 19th St., Dept. 13-59 Chicago, Ill.

Send Coupon for Special Offer!

If you have any idea of buying a radio set this year, don't let this chance slip by. Our terms and liberal guarantees have set a new pace in the radio business. The low prices we will make you on a 3, 4, or 5 tube Marshall set will surprise you. A letter, postcard, or just the coupon will do. But send it today. We also have a most favorable offer for radio dealers. Write.

Marshall Radio Products, Inc.
Marshall Blvd. and 19th St., Dept. 13-59 Chicago

Please send me your special offer price, terms and full description of Marshall Radio Outfits. Though I may change my mind on receiving your proposition, my preference now is for a:

.....3 Tube4 Tube5 Tube (Please check)

Name

Address

SOUTH BEND LATHES

31,000 IN USE

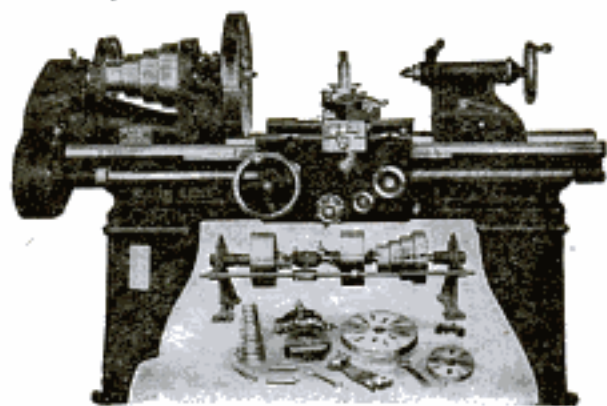

16"x8' Standard Change Gear \$438.00
16"x8' Quick Change Gear 498.00

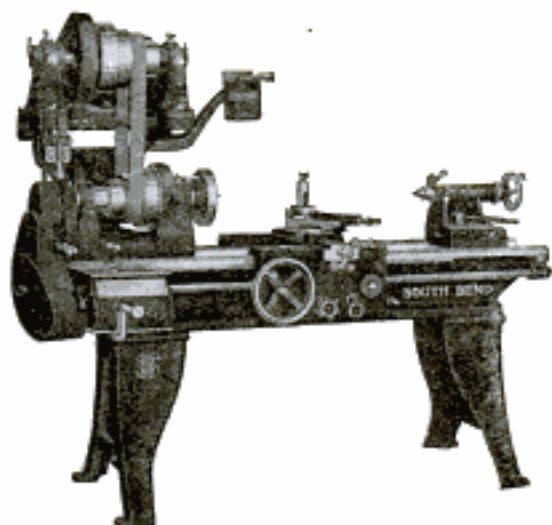

16"x8' Quick Change Gear Motor Drive \$654.00
16"x8' Standard " " " " 594.00

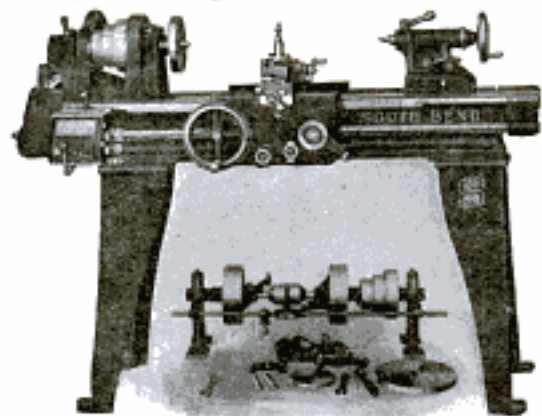

11"x4' Quick Change Gear \$288.00
11"x4' Standard Change Gear 248.00

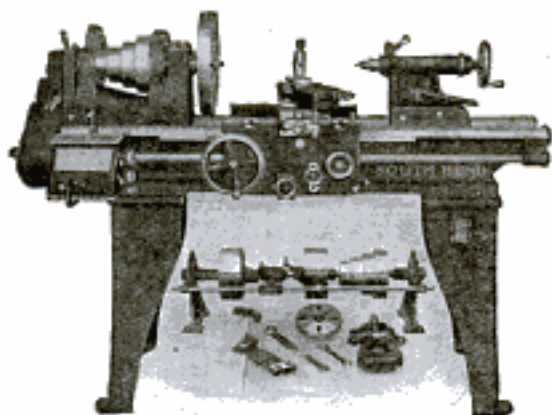

13"x6' Quick Change Gear \$366.00
16"x6' Standard Change Gear 316.00

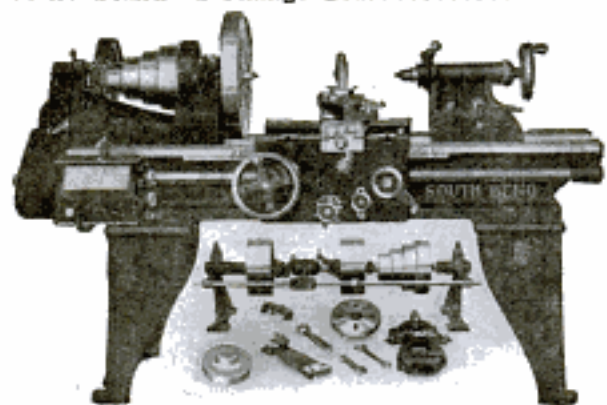

18"x10' Quick Change Gear \$721.00
18"x10' Standard Change Gear 656.00

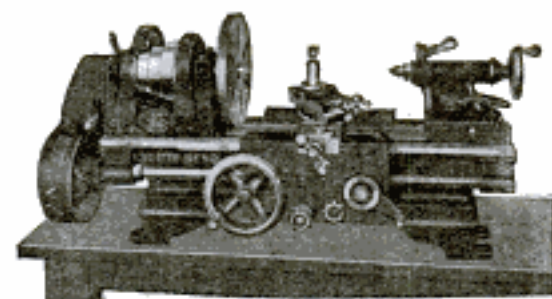

9"x3' Bench, Standard Change Gear... \$201.00
9"x3' Bench, Quick Change Gear..... 231.00

THE EASY PAYMENT PLAN

You can purchase any size or type of South Bend Lathe by making one payment with your order.
The balance to be paid monthly.

Write today for Catalog No. 82, which describes the Easy Payment Plan on any South Bend Lathe.

South Bend Lathe Works 559 EAST MADISON STREET
SOUTH BEND, IND., U. S. A.

To everyone on the list—give *Eveready* flashlights!



EVEREADY
FLASHLIGHTS
& BATTERIES
—they last longer



No. 2671
Eveready 2-cell
Focusing Spot-
light with the
200-foot range.

Eveready Unit
Cells fit and im-
prove all makes
of flashlights.
They insure
brighter light and
longer battery life.



AGAIN the Christmas season! Suggestions and counter-suggestions.

... "Give this" ...
"Give that." Here's the happy solution: "Give flashlights. Everybody wants an Eveready."

Because it is the perfect portable light for every purpose and purse; because it is a gift that is good-looking as well as practical and safe; because it appeals alike to young and old; because it does so much and costs so little.

There's the Eveready Aluminum Flashlight that fits the pocket. Fine for the Boy Scout. The Eveready Focusing Flashlights, with 200, 300 or 500 foot range. Great for motorists and motor-boatists.

Broad-beam lights for Mother and Dad to use around the house. Handsome nickel or ribbon black cases. Just take your gift-list to the nearest Eveready dealer. You'll find the right light at the right price and save hours of shopping.

The improved Eveready line comprises twenty-two fine flashlights in four general types. New designs. New features. But old prices—65c to \$4.50, complete with battery—anywhere in the U. S. A.

Buy them from any electrical, hardware or marine supply dealer, drug, sporting goods or general store, garage or auto accessory shop.

Manufactured and guaranteed by
NATIONAL CARBON COMPANY, INC.
New York San Francisco
Canadian National Carbon Co., Limited, Toronto, Ontario

How You Can Make Soft Woods Beautiful as Hardwood

IF you have a hobby for refinishing woodwork or for making furniture, radio cabinets, etc.,—you will find our Book on Wood Finishing invaluable. It tells how to stain wood artistically—how to remove old paint and varnish—how to secure a beautiful enamel finish.

Use Coupon below



OUR Book gives complete instructions for finishing all wood—hard or soft, old or new. It is the work of experts—beautifully illustrated in color. Gives covering capacities—includes color charts, etc. Tells just what materials to use and how to apply them.

Use Coupon below

JOHNSON'S WOOD DYE (Penetrating)

With Johnson's Wood Dye you can make soft woods as beautiful as expensive hardwood. It will enable you to color hardwoods most artistically. Very easy to apply—dries in four hours and will not rub off or smudge. Penetrates deeply, bringing out the beauty of the grain. Like most first class products Johnson's Wood Dye serves one purpose only—it dyes the wood—a finish should be applied over it—either Johnson's Wax or Varnish.

Johnson's Wood Dye is made in seventeen beautiful shades, all of which may be lightened, darkened or intermixed. Full instructions on every label.

Among the most popular shades of Johnson's Wood Dye are:

No. 129—Dark Mahogany	No. 125—Mission Oak	No. 124—Golden Oak
No. 127—Brown Mahogany	No. 123—Dark Oak	No. 131—Walnut
No. 126—Light Oak		No. 110—Bog-Green Oak

*Order from your dealer by name and number.
Insist on Johnson's Wood Dye—there is no substitute*

—FREE—25c BOOK ON WOOD FINISHING—



Ask for a FREE copy of the Johnson Book at stores displaying the sign shown at right. These stores all carry a complete stock of Johnson's Artistic Wood Finishes and will be glad to show you finished wood panels—and answer questions on how to properly finish wood. If no store in your locality can supply the Johnson Book—fill out and mail this coupon for a copy which we will send Free and Postpaid.

YOUR DEALER'S NAME

Your Name

Your Address

City & State

Mail to S. C. JOHNSON & SON, Dept. P. A. 12, RACINE, WIS.
"The Wood Finishing Authorities" (Canadian Factory—Brantford)



PRACTICAL ELECTRICITY

SELF TAUGHT
COMPLETE COURSE IN
ELECTRICITY FOR
FREE
EXAMINATION



HAWKINS ELECTRICAL GUIDES

3500 PAGES—4700 PICTURES—\$1 A VOLUME—\$1 A MONTH—10 VOLUMES

OVER 5000
 READERS
 HAVE
 OK'D
 THIS
 SET

Know the facts in Electricity. They mean more money and better position for you. Hawkins Guides tell you all you need to know about Electricity. Every important electrical subject covered so you can understand it. Easy to study and apply. A complete, practical working course, in 10 volumes. Books are pocket size; flexible covers. Order a set today to look over.

LEARN ALL ABOUT THESE IMPORTANT POINTS

Magnetism—Induction—Experiments—Dynamometers—Electric Machinery—Motors—Armatures—Armature Windings—Installing of Dynamometers—Electrical Instrument Testing—Practical Management of Dynamometers and Motors—Distillation Systems—Wiring—Wiring Diagrams—Sign Flashers—Storage Batteries—

Principles of Alternating Currents and Alternators—Alternating Current Motors—Transformers—Converters—Rectifiers—Alternating Current Systems—Circuit Breakers—Measuring Instruments—Switchboards—Wiring—Power Stations—Installing—Telephone—Telegraph—Wireless—Bells—Lighting—Railways. Also many Modern Practical Applications of Electricity and Handy Reference Index of the ten numbers.

**USE FREE
 COUPON
 NOW**

SHIPPED FREE

Not a cent to pay until you see the books. No obligation to buy unless you see satisfied. Send Coupon now—today—and get this great help freely and see if it is not worth \$100.00 to you—you pay \$1.00 a month for ten months or return it.

THEO. AUDEL & CO.,
 72 Fifth Ave., New York City

Please submit me for free examination, HAWKINS ELECTRICAL GUIDE, (Price \$1 a number). Ship at once prepaid, the 10 numbers. If satisfactory, I agree to send you \$1 within seven days and to further mail you \$1.00 each month until paid.

Name.....
 Occupation.....
 Employed by.....
 Home Address.....
 Reference.....

12T30



**CONN
INSTRUMENTS**
Are made differently



*To the Reader
Mechanically Inclined*



CHIEF of the exclusive processes developed by Conn in the making of band instruments, is the famous hydraulic expansion of tubing. Locked in a perfect steel die, the tubing is filled with water, subjected to tons of pressure, which expands the tubing to perfect proportions and gives a smooth-as-glass interior, a perfect carriage for sound waves.

This is the big reason for the more beautiful tone, perfect pitch, and easiest playing qualities, as well as the uniform excellence of Conn instruments. We shall be glad to tell you in detail about the many exclusive features which make Conn instruments supreme in every detail—choice of the world's great artists.

Free Trial; Easy Payments. Any wind instrument sent prepaid for six days trial. Write for details of this liberal offer. First three written lessons free on request with every new instrument purchased.

C. G. CONN, LTD.

1231 Conn Bldg. Elkhart, Ind.

CONN
BAND
INSTRUMENTS
WORLD'S LARGEST MANUFACTURERS