

NOVEMBER

THE LATEST IN RADIO

25 CENTS

N.S.E.

POPULAR MECHANICS

MAGAZINE

WRITTEN SO YOU CAN UNDERSTAND IT

REG. U.S. PAT. OFF. TRADE MARK GREAT BRITAIN No. 410428

REG. U.S. PAT. OFF.



SEE PAGE 719

Copyrighted material

Pick Your Job - I'll Train You!



Eight Weeks in Either of my Schools and You step into the Big Pay Class

This Will Start You On The Road to Independence

Get out of the rut of underpaid, no advancement jobs—get into the auto game—the field of unlimited opportunities—of big pay—of independence. Thousands of jobs are open, paying from \$150 to \$500 a month on salaries—and the sky is the limit if you go into business for yourself.

McSweeney Trained Men Are In Demand

A man who has completed the course taught in either of my schools finds the doors of the automobile, tractor and battery businesses open to him. "McSweeney Trained" means a real job at real money. Thousands of my former students who now own their own business won't hire any but McSweeney trained men. They know!

You Learn by Doing Actual Jobs

You can't learn any profession out of books, you can learn *why*, but never *how*. I teach you both the *why* and the *how* by doing actual jobs on the most modern equipment. That's why you can walk out of my schools into big paying jobs.

\$86,000 Made by a McSweeney Trained Man Last Year!

A. J. Beall, Jr., Morgantown, W. Va., made \$86,000 last year with his garage and service station. Geo. W. Smith, W. Alexandria, O., makes over \$800 a month. Thousands of others are making from \$50 to \$150 a week.

Aren't You Just as Good as They Are?

Would you admit to anyone, even to yourself, that these men are any brighter or cleverer than you? I know them—and I'll bet they aren't—the only difference is that they *know how*. Spend eight weeks in either of my two big schools and I'll teach you the same things that have made them big money makers.

Decide Today — Your Entire Future Lies in the Balance

The right decision today will either start you on the road to success, or will leave you in the ranks of the underpaid. Make your decision, fill in the coupon today!

McSweeney Auto, Tractor and Electrical Schools

Dept. 1410

McSweeney Building
CLEVELAND, OHIO
CINCINNATI, OHIO

Address Either School

R. R. Fare and Board FREE

For a limited time only, I am offering a special low tuition rate, including Free R. R. Fare and Board. Get full particulars by sending coupon today.

J. H. McSweeney, Pres., Dept. 1410, McSweeney Auto, Tractor & Electrical Schools, McSweeney Bldg., Address either Cleveland or Cincinnati

Dear Mae: Send me your big catalog and full information about your Special limited offer.

Name

Address

No facilities for colored students.



The family takes to politics

Radiola Regenoflex

Non-radiating!—It cannot interfere with your neighbor's reception. With four Radiotrons WD-11 and Radiola Loudspeaker. With compartments for the batteries. Complete except batteries. \$191.00



This symbol of quality  is your protection.

Send for free booklet that describes every Radiola

Radio Corporation of America
Dept. 5011 (address office nearest you)
Please send me your Radio Booklet,
and the name of the nearest RCA
distributor.

Name

Address

Was a time when we voted Pa's ticket 'cause he did and his Pa did. When most of us couldn't get much closer to a candidate and his ideas than the soap box orator on the corner. When bonfires and torchlight parades were as exciting a part of election day as the candidates and issues. Politics was no place for ladies, and what little the women knew about it they gleaned from scraps of the men folks' talk.

Radio has changed it all. Every farm—every city living room—every corner radio store will be a gathering place for the people, listening in. There'll be a Radiola Regenoflex on the farm, where distance demands a sensitive receiver. There'll be a Radiola Regenoflex in the city home, where selectivity is most important—to tune out conflicting stations. You'll find one wherever good, clear, dependable loudspeaker reception is bringing the candidates and the issues right into the home—building America into a real democracy.

"There's a Radiola for every purse"

Radio Corporation of America

Sales Offices:

233 Broadway, New York

10 So. La Salle St., Chicago, Ill.

433 California St., San Francisco, Cal.

Radiola

REG. U.S. PAT. OFF.



ZB9U-46U-LRHS



Tide Water
Cypress
"The Wood Eternal"

*"He who looks
before he leaps,
Builds of Cypress
and builds for keeps."*

*"Cypress for every outdoor use
Scorns weather's wear and Time's abuse."*

*"It doesn't rot, nor twist, nor swell;
It lasts, and LASTS, and LASTS—so well."*

BE SURE YOU GET GENUINE "TIDEWATER".

P. S.—Could you use some **Full Size Working Plans** for the really artistic "Pergola Garage" hinted at in the picture above, absolutely **FREE**? You can have them, together with **22** other beautiful and practical **FULL SIZE** plans for Garden and Lawn embellishments, such as Trellises, Arbors, Gates, Seats, etc. (also vine-planting charts), in the **88-page "VOL. 28"** of the **Cypress Pocket Library**—yours *free* on request by return mail.

SOUTHERN CYPRESS MANUFACTURERS ASSOCIATION

1219 POYDRAS BUILDING, NEW ORLEANS, LOUISIANA
OR 1219 GRAHAM BUILDING, JACKSONVILLE, FLORIDA



Insist on Trade-marked "TIDEWATER" CYPRESS. Accept none other.



AUTUMN!

*Building time for improvements on the home place; —a garage, a new porch, an arbor or an artistic hooded entrance, or what-not in outdoor beauty! Lumber that *don't rot out* is the kind for you. So, you *avert repair bills* by using genuine *Tide water**

Cypress,
"The Wood Eternal".

(That'll make an end of repair jobs in that particular place!)

By the way, why should any garage be homely? (It needn't be. Read a bit more.)

Bathing Helmet - 765

Popular Mechanics Magazine

200 E. Ontario Street, Chicago, U. S. A.

H. H. WINDSOR, Founder

H. H. WINDSOR, Jr., Editor and Publisher

London: Hachette & Co.,
16-17 King William Street, Charing Cross, W. C. 2

Paris: Hachette & Co.,
111 Rue Reaumur

Melbourne, Australia
The Australasian News Co.

With airplane compass 740

ISSUED MONTHLY

SUBSCRIPTION:

SINGLE COPY, 25 CENTS

In United States and its possessions, also Canada, Cuba, and Mexico, per year, postpaid - \$2.50

To all other countries in the Postal Union 3.00

All subscriptions are discontinued at expiration. Please examine the date printed on your wrapper.

Entered as Second Class Matter Sept. 15, 1903, at the Post Office at Chicago, Illinois, under Act of March 3rd, 1879.

Entered as Second Class Matter at the Post Office Department, Canada.

Published monthly by POPULAR MECHANICS CO.

Copyright, 1924, by Popular Mechanics Co.

Copyright in Australia. Copyright in France

Blocks, lime and sawdust 718
Landbag and sample case 782
Hour, remmed each 838.9

Vol. 42

Contents for November, 1924

No. 5

Accidents—thousand in hour in U. S.	753	Eiffel Tower—painters risk lives in working on	742
Airplanes		Electricity	
flap on wing eases landing of	781	drawn from air made to light lamp	809
six added to the equipment of New York police	784	eighty mile run into funnel to produce	710
Aquaplaning—airplane toboggan yields thrills	719	engineers seek way to stop loss	740
Amusement Parks—mysteries of	756	from windmills	747
Ants—work for lumbermen	809	Electric Motors—giant, tiny armature contrasted with	786
Asbestos—air mail rushes suits to oil fire fighters	733	Embroidery—woman embroiders head of Savior	809
Automobiles		Eyes—weak, cost taxpayers millions yearly for school-children	754
hitched to street car trailer hauls freight and passengers	801	Fear—childhood terrors, cure sought for	794
small three-wheeled	720	Fingerprints—national crime bureau files	736
with dials and meter surveys roads	735	Firearms—pistol hidden in auto lever	754
Automobiles—Design—inclosed, roof ventilation for	784	Fire Apparatus	
Automobiles—Driving		extinguisher, chemical, indicator on	820
eye tests for autoists proposed	798	motor pump to fight timber fires carried by two men	777
mind tests for drivers	705	Fire Engines—motor-driven, many uses of	820
toy figure of policeman serves as signal	733	o'd, made into oil rehning plant	800
Automobiles—Equipment and Supplies—windshield wiper for auto, little current required for	775	Fire Protection—fire engine moves traced on map	784
Automobiles—Ignition		Fish	
spark plug cleaner fits in pocket	736	electricity keeps from death in canals	765
stop leaks in auto wires	753	sounds produced by	748
Automobiles—Repairing—carbon, brush operated by motor removes	803	Fishing—world's yearly value of	710
Aviation		Flowers—models of, pupils taught by	743
airplanes, diseases spread by wind studied with aid of	770	Food—laws, federal, violations of	740
airplanes' range of flight limited by fuel-carrying capacity	771	Funnels—spout, flexible, serves as funnel for gas and oil	709
around the world flight	712	Games—boxing gloves on ends of stick, sailors use	721
French air progress speeded up by building of toy planes	808	Gauges	
Bicycle—trip around world begun by rider	748	liquid in can, disk and metal bar show	794
Birds		temperature of heated cylinders or rollers, instrument measures	736
grow shooters, call lures birds to	741	volt tester, electrician's, in handy case	734
jackdaws, steeples toppled by	734	Gold—mercury turned into gold	802
kiwi, has growl of dog	813	Goldplating—portable tank for	795
Blood—donors supplying hospitals a new trade	809	Golf—club with adjustable head	719
Boots and Shoes		Guns (ordnance)—monster, has removable trucks for use over railroads	718
auto tines used to make	771	Household Devices	
detachable heels and soles for	801	Houses	
Bridges		<i>fireproof, steel frame for 786</i> bungalow, folding	811
electricity burns apart	810	bungalow, weatherproof, built of newspapers	795
piers for footbridge, trees form	786	new, built to look like old	785
Building		Horses— <i>city 3-room from tree 785</i> blocks, lime and sawdust, resist fire, sound and moisture	820
steel framework for fireproof house cut and fitted on site	718	valuable race, liners provide luxuries for	734
Butterflies—pictures formed of butterfly wings	753	Hunting—hunter, armored suit protects	783
Caps—helmet, rubber, for swimmer	765	Hydroelectric Power—electricity, harnessing water giants for	766
Cathedral		Insanity—cure, fear tests to aid	740
designed by youth dedicated in England	782	Insects—arctic's, nearly half shown in one box	747
model carved in wood	803	Inventions—laboratories, inventor's ideas tested for safety	821
Chairs—easy, for workers	755	Inventors—woman, forty-seven patents granted to	781
Cistern—lid, lock, accidents prevented by	816	Junk—fortunes found in	773
Crimes		Leprosy—tree for treating cultivated in U. S.	747
banknotes, false, detected by feel	776	Locomotive—turbine, twenty per cent less coal used by	816
criminals on revolving tables, masked sleuths study	765	Luggage Carriers—bag, hand, combined with sample case	782
Dining Room—folding	752	Manikins—of thin wood, wax dummies replaced by	812
Dogs—cemetery, marked plots in	741	Maps—auto with airplane compass help to map makers	740
Drain Pipes—clog proof, water absorbed by	809	Measures and Measuring Instruments—bottle cap measures dose and tells when to take	783
Dust—model of grain elevator shows danger of	808	Meat—favor of, hams tested by smell	770

[Continued on Page 4]

crow call
coin changer 741 785

mach. for dromedaria 759

Pistol, in Auto Lever 754

Rammed Earth House 838.9

Money—coin changer, counterfeit money detected by	785
Musical Instruments—music roll boxes with hinged ends	743
Navigation—charting waters of the frozen north	796
Opera—painting scenery for	744
Orange—pipe, huge, formed of oranges	781
Organs (musical)—pitless, motor operated screws raise	720
Oven—clamps on automobile	748
Panama Canal—what it means to you	749
Parks—lake turned into land to aid	737
Patents—fourth U. S., was signed by Washington	776
Paving—rubber, streets made noiseless by	816
Postal Service	
gas masks, mail clerks to wear	794
mail boxes in gateway column is colony's post office	775
mail clerks, skill of	800
Post Cards—with flap, time saved by	799
Poultry—separator, weight of egg unlocks door of	820
Printing—type, hand, set from typewriter	819
Prisoners—score of industries run by	752
Prize Offers	827
Pump—electric motor aids use of serum	801
Radio	
aerial kinks	849
passing the plate by radio	858
size of shields	849
soldering wire to contact screws	848
Radio—Apparatus	
amplifier for ultra-audio receiver	857
clips for connecting phones	849
girl builds smallest loop aerial	849
self-supporting inductance coils	848
Radio—Broadcasting—logging stations	858
Radio—Receivers	
giant, needs no aerial or ground	848
portable, made from camera	847
Railroad	
a night run with the Gotham limited	722
freight cars, roving, railways keep records of	813
safety assure safety of travel on	773
Razors—safety blade used as knife	770
Roots—vulcanizer, electric, leaks in roots prevented by	803
Sculptors—enlarging device simplifies reproduction of models	769
Ships	
built on land is movie theater and bathhouse	733
drydock, world's largest, "Olympic" repaired in	802
Japanese, recalls canvas rigged craft	793
land sailing, air rubber bombs destroy	810
Shipwrecks	
raising from sea bed	817
ships sunk by ocean monsters	795
Silk—carried on closely guarded trains	742
Skates—land, ski jumper's teats rivaled by	709
Slavery—white slaves found in Africa	711
Sleep—insomnia victims, metal mask aids	754
Smoke—damage from in twenty years	793
Snow—stored in earth sold as ice	741
Spectacles—with square shaped lenses	782
Stamp—one cent, valued at \$30,000	769
Statues—Lee's, twenty can sit on hat	733
Steel—doom of, predicted	803
Steeple Jacks—sailors serve as steeple jacks in painting ship's funnels	776
Street Traffic—to be speeded by looped crossings	718
Submarines—giant, crosses Atlantic	735
Subways—city's foundation shaken by	769
Sugar—hiling world's sugar bowl	779
Tanks (military)—turned into tractors	747
Tennis—courts made of roofing	793
Tent—one pole, serves as raft	711
Time—day at sea to begin at midnight	784
Tools—screw holder, hard places reached by	816
Tractors—one man road grader	776
Trees—juniper, three thousand years old	735
Tunnel	
lifting lid from a city's streets	805
Oira railway	777
Volcanoes—Mount Tatso to be tapped for steam	721
War—blindfolded soldiers taught night warfare	813
Welding—tiny outfit carried by airmen	748
Wood—preserved by chemical in punctures	777
Wool—made from pine tree leaves	720
Wrenches—self-adjusting, one hand	743
Zoological Gardens—feeding animals in	787

Automobiles—Repairing—motor leads, taking strain off	837
Bakers and Bakeries—mixing machine for	825
Barns—proper ventilation for	841
Blueprints—rack for	846
Cement—for uniting metals	843
Concrete—mixer, farmer's	828
Copper—preserving color of	836
Cuspidors—handy carrier	835
Cutters—improvised sheet iron cutter	836
Drawings—cloud effects on	827
Fans—overhead, tightening guy wires on	846
Fireplaces—open, reducing hazards of	845
Gas and Oil Engines—single valve, reversing	829
Generators—compensating clutch for driving	840
Glass	
gauge glasses, cutting on lathe	842
graduates, repairing	836
Grinders—ball bearing disk grinder	844
Handles—extension for machine handle	842
Houses—rammed earth lowers cost of	839
Ironwork—painted, applying powdered cork to	843
ligs—for cutting slots in square shafts	834
joints—universal, inexpensive	837
Ladders—scaffold, portable	826
Lubrication—lathe center lubricant	826
Lumber—electric drier for kiln samples	834
Measures and Measuring Instruments—accurate measuring of irregulars	845
Oxyacetylene Welding—acetylene flame shield	827
Painting—working paint from brush on wire mesh	829
Paints—engine, cleaning paint on	834
Photography—homemade monotone glass	830
Posts—quick acting pulser	835
Poultry—non-freezing dish for	843
Radiator—hose, curb, for filling automobile	841
Reamer—made to cut oversize	829
Safety Devices and Measures—baby crib serves as guard	842
Sewers—mirrors used in repairing	837
Surveying—tin funnel used for mark	829
Tires—removing compression sleeves from auto tubing	835
Valves—attaching brass valves	836
Welding	
handy rod holder	828
homemade electric welder	831

AMATEUR MECHANICS

Ashes—dustless homemade shaker	874
Automobiles—converting touring car into sedan, Part II	865
Automobiles—Driving—changing Ford clutch lever to foot control	862
Ford, choking in cold weather	873
Automobiles—Radiators—emergency	875
Bells—mechanical call	868
Blowers—furnace blowers	870
Camping—pockets sewed to tent walls for small articles	875
Chairs	
high, attachment to dining room chair makes	863
Morris, desk attachment for	871
Clocks—old, repairing	876
Connecting Rods—caps, holding in vise	863
Containers—kerosene can, automatic air vent for	869
Disabled—invalid, wheeling into auto	861
Doors—making artistic storm	873
Furniture—repairing dents in	861
Gauges	
gasoline, homemade	876
surface, homemade	872
Glass—plate, scalloping tool for	862
Golf—nocket tee	875
Hammers—head, keeping on tight	862
Handles—nail handle, sheet metal	870
Lens Cap—hinged	861
Locks and Keys—simple methods of opening locks	873
Mailbox—packages protected by	864
Motor—outboard, testing tank for	870
Photography	
close-up, portrait lens used	863
stationary focusing cloth	869
Picture Frames—made of cardboard	876
Post—newel, storing umbrellas in	863
Puzzle—amusing	864
Scales—small, made from spoons	861
Tables—extension, locking	868
Toys—soldered fittings for toy boats	869
Tweezers—long distance	873
Typewriter—cleaning	868
Washing Machines—homemade	859

SHOP NOTES

Advertising—window advertisement	830
Automobiles—Lighting—spring bracket for tail light	843

20th Century Encyclopedia 934
Screwdriver 816

cropper

spout 797

Graffie Signal, Try Policeman 933

DRAKE'S PRACTICAL MECHANICAL BOOKS

THEY WILL RAISE YOUR PAY—

ORDER ON 5-DAY TRIAL

The books listed below will perfect you in your chosen trade—pave the way to the big positions. Written in non-technical language—easy to read and understand. **Every book covers its subject completely. An entire course of instruction condensed into one volume.** Your choice sent postpaid—you benefit 5 days—money refunded in full if not entirely satisfactory. Order direct from this page.



Automobile Books

- Automobile Starting, Lighting and Ignition, by Manly. [Pub. Jan. 1924.] 700 pp. Leatherette **\$3.00**
 Brookes' Automobile Handbook, 1924 Edition. Leatherette **\$2.00**
 Ford Motor Car, Truck and Tractor, by Manly. Cloth **\$1.50**
 Starting and Lighting Troubles, Remedies and Repairs, by Manly. Leatherette **\$3.00**
 Automobile Battery, Care and Repair, by Manly. Leatherette **\$2.00**
 Automobile Catechism and Repair Manual. Leatherette **\$1.50**
 Tires and Vulcanizing, by Tufford. Cloth **\$2.00**
 Gas and Oil Engine Handbook. Cloth **\$1.50**
 Automobile Upkeep and Care, by Manly. Cloth **\$1.50**
 Motorcycle Handbook, by Manly. Cloth **\$1.50**

Shop Practice Books

- Sheet Metal Workers' Manual. Leatherette **\$2.00**
 Oxy-Acetylene Welding and Cutting. Cloth **\$1.25**
 Slide Rule and Logarithmic Tables. Leatherette **\$2.00**
 Handbook for Millwrights. Cloth **\$2.00**
 Modern Blacksmithing. Cloth **\$1.25**
 Machine Shop Practice. Cloth **\$2.00**

ORDER DIRECT FROM THIS PAGE—ON OUR MONEY-BACK PLAN

The books listed above are only a few of the many in our catalogue, which you will receive promptly after filling out and mailing us the attached coupon. For quick action order direct from this page—cross name of each book wanted and send in with price quoted. We prepay postage and send the books on our money-back plan.

FREDERICK J. DRAKE & CO.

PUBLISHERS

1008 Michigan Ave., Chicago

Drake Books Are For Sale at All Book Stores

Mail Coupon For Free Catalogue
Your Guide to Home Study

- Mechanical Drawing and Machine Design. Cloth **\$2.00**
 Pattern Making. Cloth **\$1.50**

Carpentry Books

Cloth Binding

- Modern Carpentry, 2 vols. **\$3.00**
 The Steel Square, 2 vols. **\$3.00**
 Wooden Boat and Shipbuilding. **\$1.50**
 Modern Estimator. **\$1.50**
 Timber Framing. **\$2.00**
 Builder's Architectural Drawing. **\$2.00**
 Concretes. **\$1.50**
 Practical Hunglows. **\$1.00**
 Low Cost Homes. **\$1.00**
 Roof Framing, by Van Gasbeek. **\$1.50**
 Stair Building and Hand Railing. **\$1.50**

Electrical Books

- Telephony, Including Automatic Switching, by Smith, [Pub. Jan. 1924.] 500 pp. Leatherette **\$2.50**
 Practical Applied Electricity. **\$2.00**
 Alternating Current. **\$1.50**
 Electric Motor Control Systems. **\$1.50**
 Wiring Diagrams and Descriptions. **\$1.50**
 Electrical Tables and Data. **\$1.50**
 Armature and Magnet Winding. **\$1.50**
 Modern Electrical Construction. **\$1.50**
 Modern Electric Illumination. **\$1.50**
 Electricians' Operating and Testing, Motion Picture Operation. **\$1.50**
 Deako's Electrical Dictionary. **\$1.50**
 Electric Motors, D. & A. **\$1.50**
 Electrical Measurements and Meter Testing. **\$1.50**
 Drake's Telephone Handbook. **\$1.50**
 Easy Experiments. Cloth **\$1.25**
 Wireless Telegraph and Telephone Handbook. Cloth **\$1.25**
 Telegraphy Self-Taught. Cloth **\$1.25**

Steam Engineering

- Swingle's Handbook for Steam Engineers and Electricians. Leatherette **\$4.00**
 Examination Questions and Answers for Marine and Stationary Engineers. Leatherette **\$2.00**
 Steam Boilers. Leatherette **\$2.00**
 Swingle's Catechism of Steam, Gas and Electrical Engineering. **\$1.50**

Painting Books

- The Mixing of Colors and Paints, By Vanderwalker. Cloth **\$2.00**
 Scene Painting and Bulletin Art. Cloth **\$4.00**
 A Show at Sho' Cards. Cloth **\$4.00**
 Sign Painting. Cloth **\$4.00**
 Strong's Book of Designs. Cloth **\$4.00**
 Strong's Art of Show Card Writing. Leatherette **\$4.00**
 Signist's Alphabets. Cloth **\$4.00**
 Modern Painter's Cyclopedia. Cloth **\$2.00**
 Automobile Painting. Cloth **\$1.50**
 Estimates, Costs and Profits, Painting and Decorating. Cloth **\$1.50**
 New Hardwood Finishing. Cloth **\$1.50**
 The Amateur Artist. Cloth **\$1.50**
 New Stencils. Cloth **\$1.25**
 Chalk Talk and Crayon Presentation. Cloth **\$1.25**

Farm Books

- Farm Mechanics. Cloth **\$1.25**
 Farm Buildings. Cloth **\$1.25**
 Farm Engines. Cloth **\$1.25**
 Traction Farming. Cloth **\$1.50**

Business and Reference Books

- Better Business Letters. Cloth **\$1.00**
 Better Business English. Cloth **\$1.00**
 Better Advertising. Cloth **\$1.00**
 Finger Prints Simplified. Cloth **\$1.25**
 Practical Bricklaying. Cloth **\$1.25**
 Practical Instruction for Detectives. Cloth **\$1.00**
 Practical Plumbing. Cloth **\$1.50**
 Hot Water Heating. Cloth **\$1.50**
 Elementary Chemistry. Cloth **\$1.50**
 Courses in Civil Service. Cloth **\$1.50**
 Cyclopedia of Recipes. Cloth **\$1.50**
 American Star Speaker. Cloth **\$1.50**

Modern Languages

By Prof. P. S. Allen, U. of Chicago

- French without a Teacher. Cloth **\$1.25**
 Spanish without a Teacher. Cloth **\$1.25**
 German without a Teacher. Cloth **\$1.25**
 Everyday French. Cloth **\$1.25**
 Everyday Spanish. Cloth **\$1.25**

FREDERICK J. DRAKE & CO.
1008 Michigan Avenue
Chicago, Ill.

GENTLEMEN:—Please send me free, postage paid, your illustrated catalogue which lists and describes over 100 Practical Mechanical Books for Home Study.

My name is

and my address

Neglect of Home-Study Training Cost This Man \$47,424!

How much are you paying to stay untrained?

The other day we received a letter which every man working for a living ought to read—whether he's making \$20 a week or \$200. Here it is:

"During the forty years that I have been working, my salary has averaged less than twenty-four dollars per week with the exception of the last two years while I have been acting as foreman of a department. I made good in this position on a small scale and saw, thru the failings of others, what would happen to me unless I found a way to train for larger responsibilities.

"I had read of correspondence courses and began searching for that which I thought would benefit me. I found it in the LaSalle Modern Foremanship course, and benefited by it, my salary being nearly doubled, and I was promoted from foreman to factory superintendent.

"This happened in a period of about ten months, and by devoting only about four or five hours per week to the studies.

"I am now enrolled as a member of the Industrial Management Efficiency course, and find the work very interesting and beneficial. It can be applied every day in the factory, and brings results.

"I regret that I put it off to so late a day in life to reap the benefits I am now enjoying, and can truthfully say to younger men that if they would only profit by the experience of others they can gain more knowledge thru one year's training by LaSalle methods than can be obtained in ten years' practical experience by hard work."

SHERMAN C. WOOD, Maryland.

We quote the above letter not because Mr. Wood is now making a staggering salary as a result of his training, but because it illustrates so clearly the principle behind LaSalle training.

Here is a man who all his life had accepted the thought that he was compelled to work for little or nothing.

For one thousand, nine hundred and seventy-six weeks the writer of this letter *paid at least \$24 a week for the doubtful privilege of staying in the ranks of untrained men.*

Can anyone doubt that training would have doubled his salary just as easily when he was thirty-eight years younger—when he could attack his work with the abundant energy of a younger man?

Yet his neglect of this one main avenue of business progress cost him—leaving simple and compound interest out of the reckoning—the appalling sum of \$47,424—a fortune in itself.

**If You Could Use \$47,424,
Pause Before You Turn This Page**

Perhaps you are now making quite as much as Wood—perhaps more. Perhaps, on that account, you may think that Wood's experience does not apply to YOU.

But if training in Higher Accountancy—or Modern Salesmanship—or Business Management—or Law—or Business Correspondence—or any of a dozen other branches of business could change your forty-eight dollars into *\$96 a week*—and if you now **NEGLECT** to advance yourself thru the training you need—will you not find it difficult, thirty-eight years from now, to explain to those who are dear to you why you threw away—not \$47,424, but *fully \$95,000?*



We're not going to moralize. We're not even going to cite you any of the thousands of letters from men who have not merely doubled but tripled and quadrupled their incomes thru home-study training under the LaSalle Problem Method. We *have* the letters. We will *show* them to you, if you like. But understand, please, that they would not *alter* the facts—they would merely *emphasize* them.

Below this text there's a coupon.

We believe that if you will re-read that letter from Sherman C. Wood and will face your problem of advancement squarely, you will not turn this page until you have clipped the coupon, filled it in, and by placing it in the nearest mail-box placed *yourself* on the road to real success.

LaSalle Extension University

The Largest Business Training Institution in the World
Dept. 1164-R Chicago, Illinois

Upon request, the book, "Ten Years' Promotion in One," and material completely descriptive of the course and service that interests you, will gladly be sent without cost or obligation. Indicate your choice by checking, and write below your name and address.

- | | |
|---|--|
| <input type="checkbox"/> Business Management | <input type="checkbox"/> Modern Business Correspondence and Practice |
| <input type="checkbox"/> Modern Salesmanship | <input type="checkbox"/> Modern Foremanship and Production Methods |
| <input type="checkbox"/> Higher Accountancy | <input type="checkbox"/> Personnel and Employment Management |
| <input type="checkbox"/> Law—Degree of LL.B. | <input type="checkbox"/> Expert Bookkeeping |
| <input type="checkbox"/> Traffic Management | <input type="checkbox"/> Business English |
| <input type="checkbox"/> Railway Station Management | <input type="checkbox"/> Commercial Spanish |
| <input type="checkbox"/> Commercial Law | <input type="checkbox"/> Effective Speaking |
| <input type="checkbox"/> Industrial Management Efficiency | <input type="checkbox"/> C. P. A. Coaching |
| <input type="checkbox"/> Banking and Finance | |

Name.....

Present Position.....

Address.....

Let These Guides

Solve Your Problems

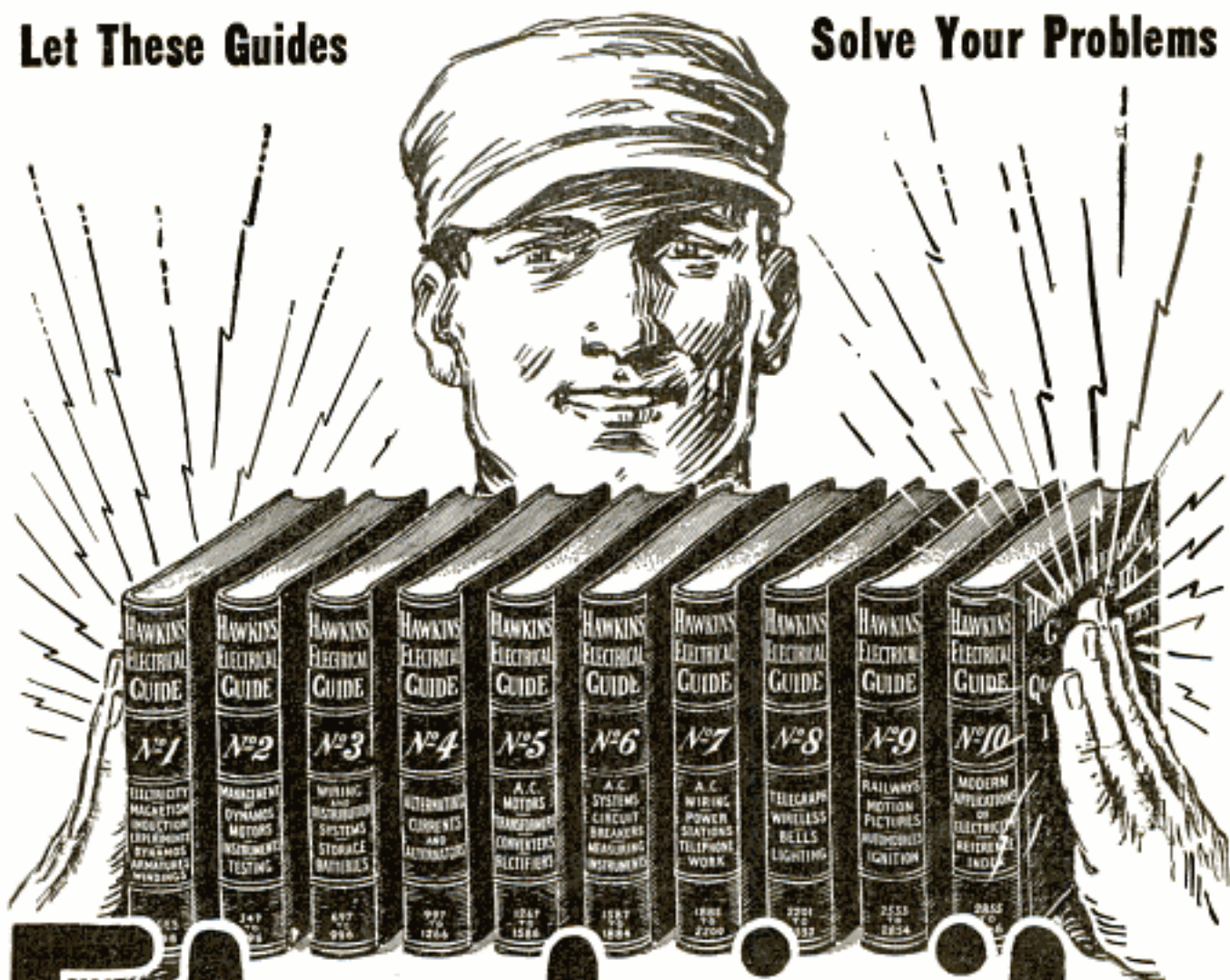

Electricity at your finger ends

HAWKINS ELECTRICAL GUIDES IN TEN VOLUMES

3500 PAGES
4700 PICTURES

\$1 A VOLUME
\$1 A MONTH

Send No Money--Send Only This Coupon

Know the facts in Electricity. They mean more money and better position for you. Hawkins Guides tell you all you need to know about Electricity. Every important electrical subject covered so you can understand it. Easy to study and apply. A complete, practical working course, in 10 volumes. Books are pocket size; flexible covers. Order a set today to look over.

LEARN ALL ABOUT

Magnetism—Induction—Experiments—Dynamoes—Electric Machinery—Motors—Armatures—Armature Windings—Installing of Dynamoes—Electrical Instrument Testing—Practical Management of Dynamoes and Motors—Distribution Systems—Wiring—Wiring Diagrams—Sign Flashers—Storage Batteries—Principles of Alternating Currents and Alternators—Alternating Current Motors—Transformers—Converters—Rectifiers—Alternating Current Systems—Circuit Breakers—Measuring Instruments—Switchboards—Wiring—Power Stations—Installing—Telephone—Telegraph—Wireless—Bells—Lighting—Railways. Also many Modern Practical Applications of Electricity and Ready Reference Index of the ten numbers.

SHIPPED FREE

Not a cent to pay until you see the books. No obligation to buy unless you are satisfied. Send Coupon now—today—and get this great help library and see if it is not worth \$100 to you—you pay \$1.00 a month for ten months or return it.

THEO. AUDEL & CO.,
72 Fifth Ave., New York City

Please submit me for free examination, HAWKINS ELECTRICAL GUIDE. (Price \$1 a number). Ship at once prepaid, the 10 numbers. If satisfactory, I agree to send you \$1 within seven days and to further mail you \$1 each month until paid.

Name

Occupation

Employed by

Home Address

Reference

11-T-30

Be a **B.W. Cooke-Trained** Auto **EXPERT!**

\$3,500.
to
\$10,000.
A YEAR

The world's biggest, most fascinating business needs you! Why slave away at small pay when there are unlimited opportunities as a *Cooke-trained* Auto Expert waiting for you? Mail coupon and I will tell you how I train you **at home** in your spare time for **AUTO EXPERTS** big-pay position.

Earn \$75 to \$200 a Week!

When you read that there are now 15 MILLION autos, trucks and tractors—that car owners are paying out SIX THOUSAND MILLION DOLLARS A YEAR for upkeep you will realize here is the business to get into! Enormous demand for *Cooke-trained* Auto Experts. My training includes Garage management, automobile salesmanship and advertising—many other special features—how to go into business for yourself and make a success of it.

FREE

2

TWO BIG REPAIR and TESTING

OUTFITS!

2 Coolly Test (ing and repair outfits free to every student for a limited time. Coupon brings special offer.

No Other Training Like Mine!

As Directing Engineer of the great Chicago Auto Shops I know what training you need to make big money, and I GIVE YOU THAT TRAINING! Right in your own home, I make you MASTER of every branch of Auto, truck and tractor work. I train you with JOBS—not books. I give you complete and practical instruction in every detail of Mechanical and Electrical work, Battery, Ignition, Farm Power Plants, Welding, Brazing, Vulcanizing, etc., and my Employment Department helps you to Position.

Go Into Business!

W. J. Morrision, without previous experience—now in business for himself—and only half-way through Cooke JOB-WAY training, writes: "I would not take \$500 for what I've already learned. Am already in business and clearing over \$50 a week, with wonderful prospects." Hundreds others have done it. Mighty little capital needed. I'll train you, too, to do it.



W. J. MORRISON
Parkersburg, W. Va.

FREE! AUTO BOOK

B. W. COOKE, Directing Engineer
CHICAGO AUTO SHOPS, Dept. 816
1916 Sunnyside Avenue, CHICAGO, ILL.
Send me FREE Auto Book and proof that I can become an Auto Expert at home in spare time. Also send your special offers of 2 FREE outfits.

..... Name
..... Address
..... City..... State
..... Occupation..... Age

Earn While You Learn! Get my big Auto Book—**it's FREE**—see what others have done after only a few months of my JOB-WAY training. In this book I prove to you under a written Money Back Guarantee that you will find your success as a *Cooke-trained* Auto Expert. Almost at the start I train you to do actual jobs and make extra money doing it. 82 out of 100 of my students report that they are doing practical work, many of them are already making more money than the entire cost of "JOB-WAY" training!

Big Auto Book FREE! I don't care how old or young you are, how much or little education you have, this training will make you a successful Auto Expert. Special inducements and many EXTRA features right now. Easy terms and low cost. Coupon brings free book and complete information. *Mail it today!*

B. W. COOKE, Directing Engineer
CHICAGO AUTO SHOPS, Dept. 816
1916 Sunnyside Avenue Chicago, Illinois



The \$12 a week mechanic who became a millionaire!

TWENTY-THREE years ago, John C. Wahl was working as a mechanic in Peoria, Illinois, at \$12 a week.

To-day, he is a millionaire—having an income that runs into six figures—nationally and internationally known as the inventor of the Wahl Adding Machine, the Wahl Fountain Pen, and president of The Wahl Company, manufacturers of the famous Eversharp pencil.

It is interesting to note that the change for the better in the life of John C. Wahl came the day he saw an advertisement that hit him straight between the eyes. As he puts it, "it told how the International Correspondence Schools could make a draftsman of a fellow without interfering with his daily work." That day, John C. Wahl enrolled and started to build for the future. His present success is proof that he builded well.

"Pick the line of work you like best," he said the other day, "and stick to it. Study hard and success will take care of itself. Nothing is impossible when a man really makes up his mind that he's going to get ahead."

John C. Wahl is just one of thousands of I. C. S. students who have made good in a big way. The lives of such men should be an inspiration and a guide to every man who wants a better job and a bigger salary.

If the I. C. S. can smooth the way to success for other men, it can help you. If it can help other men to go forward to better jobs and bigger salaries, or to success in businesses of their own, it can help you, too.

At least find out *how* by marking and mailing this coupon. It doesn't obligate you in any way to do this, but it may be the means of changing your entire life.

MAIL THE COUPON TO-DAY!

INTERNATIONAL CORRESPONDENCE SCHOOLS Box 3047-L, Scranton, Penna.

Without cost or obligation, please tell me how I can qualify for the position or in the subject before which I have marked an X:

- | | |
|--|---|
| <input type="checkbox"/> Business Management | <input type="checkbox"/> Salesmanship |
| <input type="checkbox"/> Industrial Management | <input type="checkbox"/> Advertising |
| <input type="checkbox"/> Personnel Organization | <input type="checkbox"/> Better Letters |
| <input type="checkbox"/> Traffic Management | <input type="checkbox"/> Show Card Lettering |
| <input type="checkbox"/> Business Law | <input type="checkbox"/> Stenography and Typing |
| <input type="checkbox"/> Banking and Banking Law | <input type="checkbox"/> Business English |
| <input type="checkbox"/> Accountancy (including C.P.A.) | <input type="checkbox"/> Civil Service |
| <input type="checkbox"/> Nicholson Cost Accounting | <input type="checkbox"/> Railway Mail Clerk |
| <input type="checkbox"/> Bookkeeping | <input type="checkbox"/> Common School Subjects |
| <input type="checkbox"/> Private Secretary | <input type="checkbox"/> High School Subjects |
| <input type="checkbox"/> Spanish <input type="checkbox"/> French | <input type="checkbox"/> Illustrating <input type="checkbox"/> Cartooning |
| TECHNICAL AND INDUSTRIAL COURSES | |
| <input type="checkbox"/> Electrical Engineering | <input type="checkbox"/> Architect |
| <input type="checkbox"/> Electric Lighting | <input type="checkbox"/> Architects' Blue Prints |
| <input type="checkbox"/> Mechanical Engineer | <input type="checkbox"/> Contractor and Builder |
| <input type="checkbox"/> Mechanical Draftsman | <input type="checkbox"/> Architectural Draftsman |
| <input type="checkbox"/> Machine Shop Practice | <input type="checkbox"/> Concrete Builder |
| <input type="checkbox"/> Railroad Positions | <input type="checkbox"/> Structural Engineer |
| <input type="checkbox"/> Gas Engine Operating | <input type="checkbox"/> Chemistry <input type="checkbox"/> Pharmacy |
| <input type="checkbox"/> Civil Engineer | <input type="checkbox"/> Automobile Work |
| <input type="checkbox"/> Surveying and Mapping | <input type="checkbox"/> Airplane Engines |
| <input type="checkbox"/> Metallurgy | <input type="checkbox"/> Navigation |
| <input type="checkbox"/> Steam Engineering | <input type="checkbox"/> Agriculture and Poultry |
| <input type="checkbox"/> Radio | <input type="checkbox"/> Mathematics |

Name.....

Street.....

Address..... 3-6-24

City..... State.....

Occupation.....

Persons residing in Canada should send this coupon to the International Correspondence Schools Canadian, Limited, Montreal, Canada.



In 12 Weeks

Learn

Earn \$60 to \$200 A WEEK

26 Years We Have Been Training Men for Big Pay Jobs

The Coyne School was founded 26 years ago and my thousands of SUCCESSFUL GRADUATES are living proofs of what my training can do for ANY AMBITIOUS MAN. Many of these fellows in the pages of my big free book will tell you what COYNE has done for them.

Complete Electrical Training in 12 Weeks

I train you thoroughly on the greatest outlay of ACTUAL ELECTRICAL MACHINERY ever assembled in any school. You work with your hands on all kinds of Electrical apparatus, door bells, house wiring, armatures, switchboards, dynamos, everything to make you an all around ELECTRICAL expert. This REAL WORK with REAL tools on REAL machinery trains you many times FASTER, many times MORE THOROUGH than trying to learn in the field or by books or lessons.

No Books — No Lessons — No Classes

You Do Actual Work

I do not attempt to teach you by books or lessons. I train you to work with your head and hands on the same kind of Electrical Machinery used in power houses, industrial plants and on the outside, under actual working conditions, with instructors at your side. I have no classes, every student gets individual training.

H. C. LEWIS, President



In the Great Shops of COYNE

Free Radio and Auto Courses

For a short time I am including ABSOLUTELY FREE my big new Radio and Auto Truck and Tractor Electrical course. Three big courses for the price of one for a limited time only.

YOU DON'T NEED EDUCATION OR EXPERIENCE

You don't need a lot of schooling to master my course. You don't have to be a high school graduate or even a grammar school graduate. My method of instruction is clear and plain, yet thorough, and if you can understand plain English I will make you an electrical expert even though you haven't a lot of education or no previous electrical experience.

COYNE TRAINS YOU FOR LIFE

You get FREE a life scholarship which enables you to stay longer than the required time if you care to, or you may return at any time to take up new work which is constantly being added to make my school the most modern at all times.

GET MY FREE BOOK

This big, handsome book, size 12x15 inches, just off the press, shows actual photographs of my big shops. Cost me over a dollar apiece to print, but it's yours if you will mail the coupon. Clip it now, fill out and drop in the mail box today. You owe it to yourself to get the facts.

H. C. LEWIS, Pres.

COYNE

Electrical
School

Dept. 135-88
1300-10 W.
Harrison St.
CHICAGO
ILL.



H. C.
LEWIS
Pres.

COYNE Electrical School

Dept. 135-88
1300-10 W. Harrison Street
CHICAGO, ILL.

Dear Sir: Please send me free your big new book and full particulars of your special offer of FREE RAILROAD FARE and two extra courses free.

Name.....

Address.....

Town..... State.....

Free Railroad Fare to Chicago

Come to Chicago at my expense. I will pay your railroad fare to Chicago from any point in the United States.

Big, Newly Enlarged Course

I have enlarged my course, added new departments, additional equipment and made my course even greater than ever.

EARN WHILE YOU LEARN

My Employment department will assist students to secure part time work where they can make a good part of their living expenses while training, and will assist them to get a big pay job when they graduate.

Electricity

NOW READY!

ENCYCLOPAEDIA BRITANNICA

in a New Form

at a saving of 46%

THE publication of the Encyclopædia Britannica in a New Form at a sweeping reduction in price marks a new epoch in the history of this great work.

To-day you can obtain one of these wonderful sets, the latest edition in large type, complete and unabridged, for 46 per cent less than the famous Cambridge issue. Here at last is the ideal Britannica at a price so low that every home can afford it.

This is perhaps the most important announcement that has been made in the 156 years that the Britannica has been published, and it records one of the greatest publishing achievements of all time.

Summed up, it means that it is now possible for us to offer you the complete Britannica printed in large type from the original plates at a reduction of nearly one-half—by far the lowest price at which the newest and latest large type Britannica has ever been sold to the general public.

Revolutionary changes in publishing

The steps by which the New Form has been made a successful reality is a fascinating story. Leading printers and publishers said: "If you can do it, it will be a big success." Here was an entirely new idea involving revolutionary changes in the publication of the Britannica.

But we knew we were right. This idea was the logical outcome of years of experience; it crystallized the recommendations of thousands of users and owners of the Britannica. We gave the specifications to our experts and told them to go ahead. Their success has been beyond all expectations.

Entirely new idea has revolutionized the manufacture of the Britannica and makes it possible for us to sell the large type issue in the New Form at lowest price in history.

These were the specifications—and they have been carried out to the letter:

- (1) Large type, easy to read.
- (2) Complete and latest text.
(Nothing omitted, nothing altered.)
- (3) Fully illustrated.
(All the original plates, maps, etc.)
- (4) Sweeping reduction in price.

Why the price is so low

First of all, the experts made a striking innovation—they decided to bind this issue of the Britannica in 16 double volumes instead of 32 single volumes. That one change enabled us to save nearly 50 per cent of the binding cost.

This innovation was made possible by the use of the famous Britannica Opacity Paper, which is very thin but beautifully white and opaque. We placed an order for 1200 tons—sufficient for 10,000,000 books of ordinary size—at a time when prices in the paper market were at their lowest.

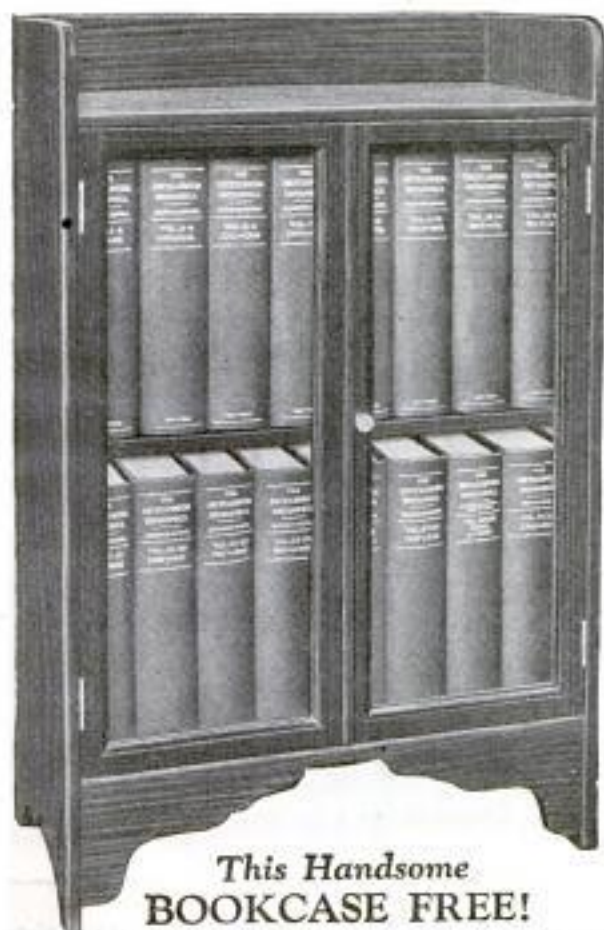

**This Handsome
BOOKCASE FREE!**

This handsome bookcase, in dark mahogany finish, especially designed for us by Maple & Co. of London, will be given free with each set of the Encyclopædia Britannica in the New Form while this offer lasts. But you must act promptly. Mail the coupon to-day.

Then it was determined to print this issue from the plates of the famous Cambridge issue, which sells for nearly twice as much. By doing this it was possible to save thousands of dollars, because we did not have to reset 33,000 pages of type.

**Contents identical with issues
selling for twice as much**

The use of these plates is your guarantee that the text is identical with that of the finest de luxe sets.

The Encyclopædia Britannica in the New Form is the newest and latest issue, containing not only a full and authoritative account of the World War and its momentous consequences, but all the latest developments in industry, art, science, invention, etc. It contains 49,000,000 words, 33,000 pages and 15,600 illustrations—as much material as 476 books of average size printed on ordinary paper.

**Only a limited edition at
this 46% saving**

Only 20,000 sets of the Encyclopædia Britannica in the New Form have been printed and more than 3000 of these were sold before a single volume was off the press!

Announcement of the New Form is being made in London, Paris and other capitals simultaneously with this announcement in America. Of the 17,000 sets hardly more than half will be available for the United States. These sets will go fast. The first subscribers will, of course, be served first.

But you must act promptly! The special Handy Volume issue (which was offered last fall and which will never be reprinted) was sold out long before the date originally fixed for the end of the sale, and thousands of people who meant to order but put it off were disappointed. There is no doubt that this present issue in the New Form will be sold just as quickly.

Easy terms—small first payment

A very small first payment will put the complete set of 16 double volumes in your home immediately and you can pay the balance in easy monthly payments, so small that they will never be missed.

Write for free booklet

It tells all about the Encyclopædia Britannica in the New Form, reproduces a number of specimen pages (many in color), explains the easy terms of payment, and tells the fascinating story of how our experts made possible such an amazing reduction in price. 56 pages of interesting, instructive reading. Free on request if you mail the coupon promptly.

Mail This Coupon To-day!

The ENCYCLOPAEDIA BRITANNICA, Inc.
342 Madison Avenue, New York PM 1-A

Please send me, without cost or obligation, a copy of your 56-page book describing the Encyclopædia Britannica in the New Form at the special 46 per cent saving and full details of your easy plan of payment.

Name

Address

.....

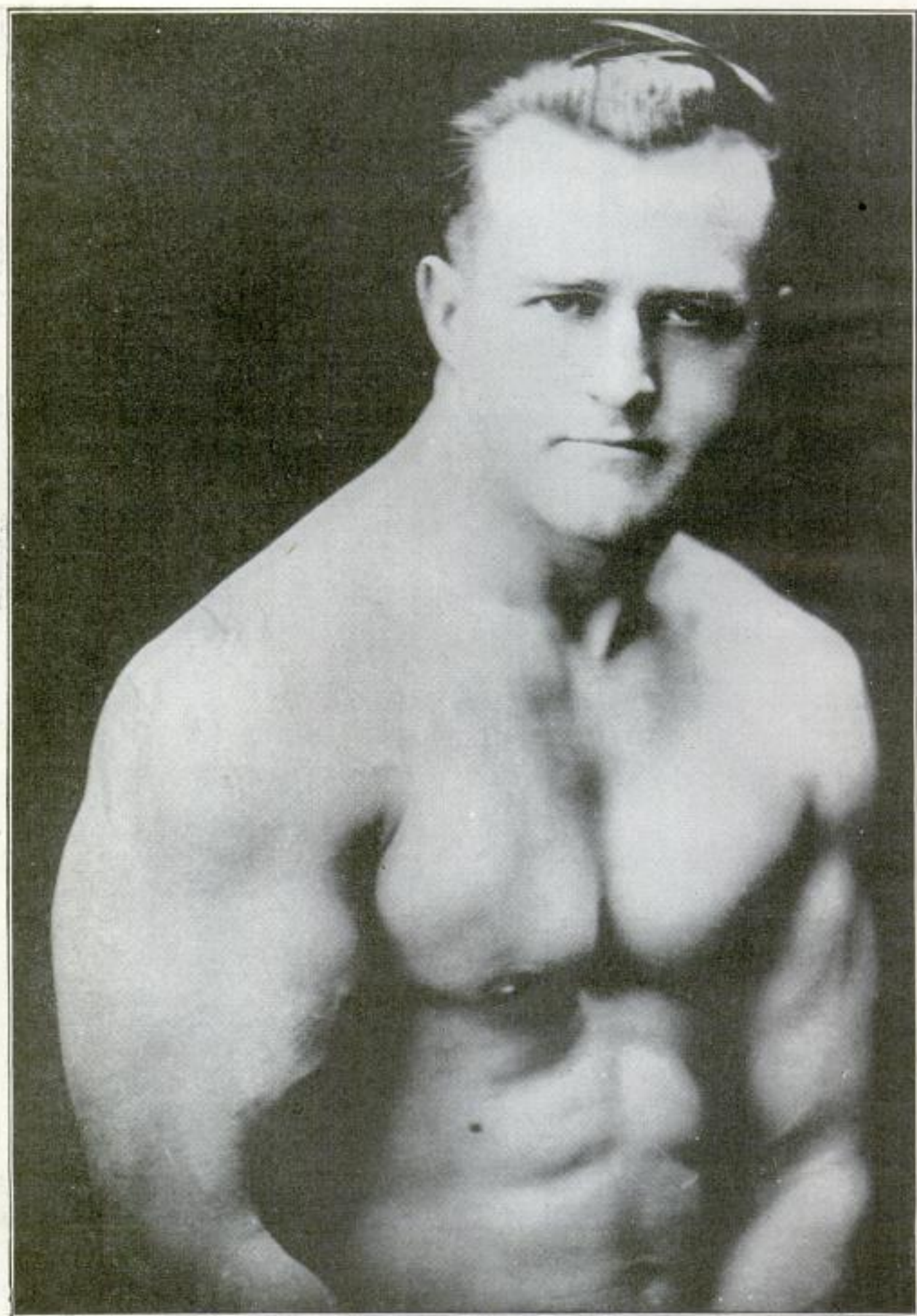

EARLE E. LIEDERMAN, *The Muscle Builder* Copyrighted material

If you were dying tonight

and I offered you something that would give you ten years more to live, would you take it? You'd grab it. Well, fellows, I've got it, but don't wait till you're dying or it won't do you a bit of good. It will then be too late. Right now is the time. To-morrow, or any day, some disease will get you and if you have not equipped yourself to fight it off, you're gone. I don't claim to cure disease. I am not a medical doctor, but I'll put you in such condition that the doctor will starve to death waiting for you to take sick. Can you imagine a mosquito trying to bite a brick wall? A fine chance.

A Re-built Man

I like to get the weak ones. I delight in getting hold of a man who has been turned down as hopeless by others. It's easy enough to finish a task that's more than half done. But give me the weak, sickly chap and watch him grow stronger. That's what I like. It's fun to me because I know I can do it and I like to give the other fellow the laugh. I don't just give you a veneer of muscle that looks good to others. I work on you both inside and out. I not only put big, massive arms and legs on you, but I build up those inner muscles that surround your vital organs. The kind that give you real pep and energy, the kind that fire you with ambition and the courage to tackle anything set before you.

All I Ask Is Ninety Days

Who says it takes years to get in shape? Show me the man who makes any such claims and I'll make him eat his words. I'll put one full inch on your arm in just 30 days. Yes, and two full inches on your chest in the same length of time. Meanwhile, I'm putting life and pep into your old back-bone. And from then on, just watch 'em grow. At the end of thirty days you won't know yourself. Your whole body will take on an entirely different appearance. But you've only started. Now comes the real work. I've only built my foundation. I want just 60 days more (90 in all) and you'll make those friends of yours who think they're strong look like something the cat dragged in.

A Real Man

When I'm through with you, you're a real man. The kind that can prove it. You will be able to do things that you had thought impossible. And the beauty of it is you keep on going. Your deep full chest breathes in rich pure air, stimulating your blood and making you just bubble over with vim and vitality. Your huge, square shoulders and your massive, muscular arms have that craving for the exercise of a regular he man. You have the flash to your eye and the pep to your step that will make you admired and sought after in both the business and social world.

This is no idle prattle, fellows. If you doubt me, make me prove it. Go ahead. I like it. I have already done this for thousands of others and my records are unchallenged. What I have done for them, I will do for you. Come, then, for time flies and every day counts. Let this very day be the beginning of new life to you.

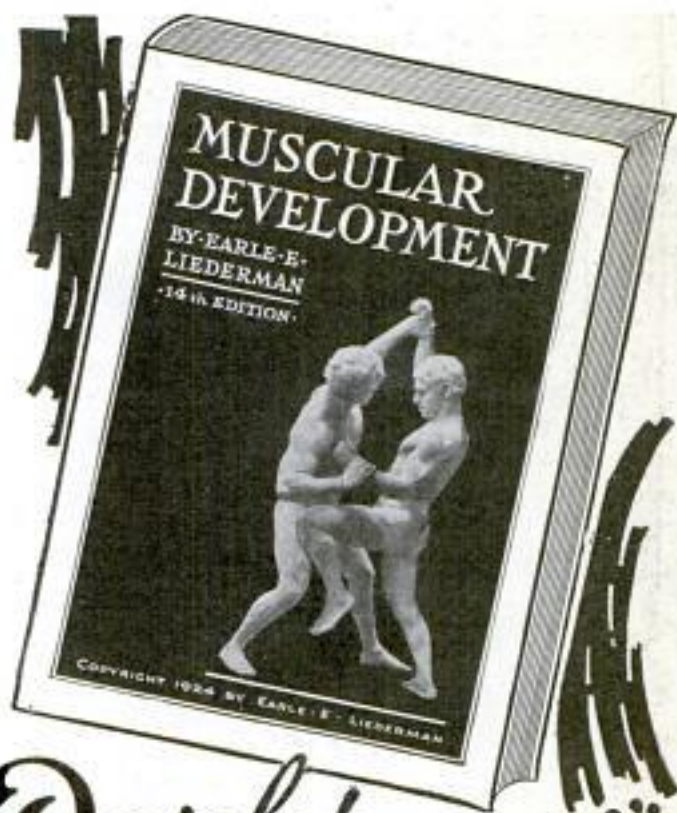

Send For My New
64 Page Book
"Muscular Development"
IT IS FREE

It contains forty-three full page photographs of myself and some of my pupils. Some of these came to me as pitiful weaklings, imploring me to help them. Just look at them now and you will marvel at their splendid physiques. This book will prove an impetus and a real inspiration to you. It will thrill you through and through. All I ask is 10 cents to cover the cost of wrapping and mailing. This will not obligate you at all, but for the sake of your future health and happiness, do not put it off. Send today—right now before you turn this page.

EARLE E. LIEDERMAN

Dept. 2011, 305 Broadway, New York

EARLE E. LIEDERMAN

Dept. 2011, 305 Broadway, New York City

Dear Sir:—I enclose herewith 10 cents, for which you are to send me, without any obligation on my part whatever, a copy of your latest book, "Muscular Development." (Please write or print plainly.)

Name.....

Address.....

City..... State.....

for Dental Laboratory EXPERTS

I'll Train You in 4 Months!

With my training any good mechanic now earning less than \$50 a week can in 4 months become a Dental Laboratory Expert and make from \$3 per hour up to \$10,000 per year! Every McCarrie-trained Dental Laboratory Expert will tell you there are more big-pay jobs than experts to fill them. So I invite every ambitious man regardless of age or education to write for my sensational training offer—mail coupon for complete information on how you can prepare for a salary of \$100 a week or more in double-quick time and at trifling cost.

Fascinating Mechanical Profession!

Biggest-paying, fastest growing profession and not overcrowded. 70,000 Dentists in U. S. but only 1,000 laboratories to do their work. More Laboratories needed everywhere, more all-around Experts trained as I will train you,



Not Correspondence Instruction—You Learn by Doing Actual Dental Laboratory Jobs

This picture shows how I train my students. No classes—no text books. You learn by working on ACTUAL laboratory jobs with standard tools, instruments and materials under my personal instruction. By this plan you can complete the entire course in 4 months.

Because of this thorough, practical training, my graduates are qualified to step right into responsible, big-pay positions and do the highest grade work. In fact, I guarantee you success. So come to Chicago or Detroit where I have built up and equipped the largest Dental Laboratory Schools in the world. Then you'll understand why McCarrie graduates, men and women, are preferred by employers—why they are so well fitted to open laboratories of their own, and build up a business of from \$6,000 to \$10,000 a year.

McCarrie Schools of Mechanical Dentistry
Dept. 1401-K, 1338-40 So. Michigan Ave., Chicago

Without obligation please send me your FREE R. R. Fare Offer and free catalog with complete information about how I may become a Dental Laboratory EXPERT.

Name.....

St. No. or R. F. D.....

City..... State.....

to master every branch of Dental Laboratory work — to make vulcanite plates, crowns, fixed and removable bridge-work, metal base dentures, parallel removable bridges, etc. Only dental laboratory school on earth with ethical practicing Dentist supplying clinical and actual cases. Work is delightfully pleasant and easy.



Look How I Help You!

I GUARANTEE My Personal Individual Training to Every Student

I will make it worth your while to start now to get ready for the big opportunities in high-salaried positions and to go into business for yourself in a good location THIS FALL.

FREE

R. R. Fare to Chicago or Detroit FREE. Big \$50 Outfit of Tools, Instruments and Supplies FREE. Free consulting Service. Post Graduate Course FREE. Free Employment Bureau.

We help you find work to pay expenses while here (if desired) and help you secure a position when you graduate.

Work Your Way Through

McCarrie Schools are open days and evenings for the convenience of students who wish to work their way through. Plenty of work in both Chicago and Detroit. We will help you find work to your liking to help pay your tuition and expenses. So don't hesitate on account of lack of ready cash. We even pay your Railroad fare to Chicago or Detroit.

Mail Coupon for Big New Book FREE

Tells you all about the surprising opportunities waiting for you when you are a McCarrie-trained Dental Laboratory Expert. Explains my rapid, practical method of training you for big-pay positions or to open your own laboratory. Contains my free offers of FREE railroad fare and \$50 Outfit. Write me personally right away!

Address, H. A. McCARRIE, Director

McCarrie Schools of Mechanical Dentistry

Dept. 1401-K, 1338-40 So. Michigan Ave., Chicago



A. H. Ward,
Chicago, Ill.

\$12,000 A Year!

A. H. Ward, Chicago, held a small pay job. Now he averages \$12,000 a year as a salesman. Last month he cleared up \$1,350—and he stepped into this kind of earnings as a result of reading this book.



What This Amazing Book Did for These 8 Men

It would be just as easy to tell the same story about 20,000 men—even more—but what this book brought these eight men is typical. If you do not get a big salary increase after reading this message you have no one but yourself to blame. This amazing book is



\$1,000 in 30 Days

"After ten years in the railway mail service I decided to make a change. My earnings during the past thirty days were more than \$1,000."—W. Hartie, Chicago, Ill.

First Month \$1000
"The very first month I earned \$1,000. I was formerly a farm-hand."—Charles Berry, Winterset, Iowa.



\$524 in Two Weeks

"I had never earned more than \$60 a month. Last week I cleared \$305 and this week \$218."—Geo. W. Kearns, Oklahoma City.

City Salesman
"I want to tell you that the N. S. T. A. helped me to a good selling position with the Shaw-Walker Company."—Wm. W. Johnstone, Jr., S. Minneapolis, Minn.



\$554.37 in One Week

"Last week my earnings amounted to \$554.37; this week will go over \$400."—F. Wynn, Portland, Ore.

\$10,000 a Year
O. H. Mallroot, of Boston, Mass. stepped into a \$10,000 position as a SALES MANAGER—so thorough is this training.



\$100 a Week in Only 3 Months
H. D. Miller, of Chicago, made \$100 a month as stenographer in July. In September, three months later, he was making \$100 a week as a salesman.

NOW FREE

IT seems such a simple thing—but the eight men on this page who did this simple thing were shown the way to quickly jump from deadly, monotonous routine work and miserable earnings to incomes running anywhere from \$5,000 to \$10,000 a year. They sent for the book, "Modern Salesmanship," that you can now get—free.

Possibly it is just as hard for you at this moment to see quick success ahead as it was for A. H. Ward of Chicago. When he was a soldier in France, wondering how he would make a living if he got back home safely, \$10,000 a year seemed a million miles away. But read what happened after he had read the book we want you to send for. Almost overnight, as far as time is concerned, he was making real money. In one year he made \$12,000.

There is nothing unusual about Mr. Ward, or about his success. Thousands after reading this book have duplicated what he did—Mr. Ward simply was willing to investigate.

The only question is—do you want to increase your earning power? If so—this book will quickly show you how to do it in an amazingly easy way.

SUCCESS INSIDE TWENTY WEEKS

Within twenty weeks you can be ready to forge ahead. This may sound remarkable—but after sixteen years of intensive investigation the National Demonstration Method has been perfected—and this

means you can now step into a selling position in one-fourth the time it formerly took to prepare for this greatest of all money-making professions.

SIMPLE AS A B C

There is nothing remarkable about the success that men enjoy shortly after they take up this result-securing system of Salesmanship training. For there are certain ways to approach different types of prospects, certain ways to stimulate keen interest—certain ways to overcome objections, batter down prejudice, outwit competition and make the prospect act. Learn these secrets and brilliant success awaits you in the selling field.

MAKE THIS FREE TEST AT ONCE

Simply send the coupon for this Free Book. Ask yourself the questions it contains. The answers you make will show you definitely whether a big success awaits you in this fascinating field. Then the road is clear before you. This amazing book will be a revelation to you.

National Salesmen's
Training Association

Dept. 12-S

53 W. Jackson Blvd.
Chicago, Ill.



National Salesmen's Training Ass'n,
Dept. 12-S,

53 W. Jackson Blvd., Chicago, Ill.

Gentlemen: I will accept a copy of "Modern Salesmanship" with the understanding that it is sent me entirely free.

Name.....

Address.....

City.....State.....

Age.....Occupation.....



Men Needed in Electricity

NO PROFESSION offers greater opportunity to-day than Electricity. Salaries of \$12 to \$30 a day are not uncommon and the opportunity for advancement is unlimited.

As Forrest Crissey said recently in *The Saturday Evening Post*—"The demand for electrical work is increasing immensely and electrical contractors assert that the supply of electrical workers cannot overtake the demand for several years."

Now is the time to prepare for a good position in this profitable, interesting profession. You can study right at home in spare time through the International Correspondence Schools—just as so many other men have done. The I. C. S. Electrical Courses have been endorsed by Thomas A. Edison and Charles P. Steinmetz—the late electrical wizard of the General Electric Co.

Just mark and mail the coupon printed below and full information about Electrical Engineering, Electric Lighting, Electric Wiring, Electric Railways, Radio or any other work of your choice will come to you by return mail.

Mail the Coupon To-day

TEAR OUT HERE
INTERNATIONAL CORRESPONDENCE SCHOOLS
 BOX 5650-D SCRANTON, PA.

Explain, without obligating me, how I can qualify for the position, or in the subject, before which I mark X.

- | | |
|--|---|
| <input type="checkbox"/> ELECTRICAL ENGINEER | <input type="checkbox"/> CHEMICAL ENGINEER |
| <input type="checkbox"/> Electrician | <input type="checkbox"/> Pharmacy |
| <input type="checkbox"/> Electric Wiring | <input type="checkbox"/> SALESMANSHIP |
| <input type="checkbox"/> Electric Lighting | <input type="checkbox"/> Show Card and Sign Painting |
| <input type="checkbox"/> Electric Car Running | <input type="checkbox"/> RAILROAD POSITIONS |
| <input type="checkbox"/> Heavy Electric Traction | <input type="checkbox"/> ILLUSTRATOR |
| <input type="checkbox"/> Electrical Draftsman | <input type="checkbox"/> DESIGNER |
| <input type="checkbox"/> Electric Machine Designer | <input type="checkbox"/> BUSINESS MANAGEMENT |
| <input type="checkbox"/> Telegraph Expert | <input type="checkbox"/> Private Secretary |
| <input type="checkbox"/> Practical Telephony | <input type="checkbox"/> Business Correspondent |
| <input type="checkbox"/> MECHANICAL ENGINEER | <input type="checkbox"/> BOOKKEEPER |
| <input type="checkbox"/> Mechanical Draftsman | <input type="checkbox"/> Stenographer and Typist |
| <input type="checkbox"/> Toolmaker | <input type="checkbox"/> Cert. Public Accountant |
| <input type="checkbox"/> Machine Shop Practice | <input type="checkbox"/> Traffic Management |
| <input type="checkbox"/> Gas Engineer | <input type="checkbox"/> Commercial Law |
| <input type="checkbox"/> CIVIL ENGINEER | <input type="checkbox"/> GOOD ENGLISH |
| <input type="checkbox"/> Surveying and Mapping | <input type="checkbox"/> Common School Subjects |
| <input type="checkbox"/> Reading Architects' Blue Prints | <input type="checkbox"/> CIVIL SERVICE |
| <input type="checkbox"/> METALLURGY | <input type="checkbox"/> Railway Mail Clerk |
| <input type="checkbox"/> ARCHITECT | <input type="checkbox"/> STATIONARY ENGINEER |
| <input type="checkbox"/> Architectural Draftsman | <input type="checkbox"/> Textile Overseer or Supt. |
| <input type="checkbox"/> PLUMBING AND HEATING | <input type="checkbox"/> AGRICULTURE <input type="checkbox"/> Spanish |
| <input type="checkbox"/> Sheet Metal Worker | <input type="checkbox"/> Navigator <input type="checkbox"/> Math's's |
| <input type="checkbox"/> Automobiles | <input type="checkbox"/> Poultry Raising <input type="checkbox"/> RADIO |

Name _____
 Present Occupation _____ Business Address _____ 3-6-24
 Street and No. _____
 City _____ State _____

Canadians may send this coupon to International Correspondence Schools Canadian, Limited, Montreal, Canada

WEALTH, HONOR, RICHES

Do not depend upon opportunity or intellectual brilliancy of any kind, because it is well known that uneducated people often acquire great wealth, while cultured and talented people remain in poverty.

Again, they do not depend upon capital, because many men with capital lose what they have, while others with no capital acquire phenomenal wealth.

Whatever finds a place in human experience is the result of the operation of natural laws, and the determining factors are therefore within your own control.

This may seem "too good to be true," but if you will consider that by the touch of a button or the turn of a lever science has placed almost infinite resources at the disposal of man, it becomes evident that there may be still other laws not generally known which contain even greater possibilities.

We have published a Remarkable little book, giving the conclusions of science concerning these laws, which we will send upon request. If you want to underwrite success on a magnificent scale, send for it.

MASTER-KEY INSTITUTE

214 Howard Bldg., ST. LOUIS, MO.

LEARN WATCH REPAIRING



You can learn by our modern and original system of instruction every part of the **Watch Repairing Trade** at home as good or better than at a shop. You can earn money while learning and secure a well paying position or start in business after completing our course of instruction. Good watch repairers are always in demand and earn from \$30 to \$70 per week. For particulars apply to the **Wisconsin School of Watch Repairing** 105 Mason St., MILWAUKEE, WIS.

SEND FOR



Art-Life

The PICTURE MAGAZINE Art, Nature, Psychology, The Body beautiful, Mind intellectual, Soul Intentional, Animals, birds, art prints, Contests, lessons, criticisms, cartoons, comics, reviews. Can't be described. YOU must see it. \$2.50 a year. CUT THIS OUT, send \$1 for 5 mo. trial sub. no free samples. LIFE, Dept. 039, Kalamazoo, Mich.



MAKE
 \$100
 a DAY

BE AN AUCTIONEER

TERM OPENS SOON: TUITION, \$100
 18 years one of the largest Auction Schools in the world. Thousands of graduates. Reference?—the first auctioneer you meet.

CATALOG FREE

W. B. CARPENTER, President
 MISSOURI AUCTION SCHOOL
 818 Walnut Street Kansas City, Missouri

NOTICE—All men, women, boys, girls, 17 to 65, willing to accept Government Positions, \$117-\$300 monthly, traveling or stationary write Mr Ozment, 111, St. Louis, Mo AT ONCE



“Now It’s My Turn To Laugh at Him!”

I’ll never forget a certain night, about a month ago. Jim had invited me to a dancing party, although knowing very well that I hardly knew one step from another. And he urged me to ask Jeanne for a dance, knowing that she was the most graceful and talented dancer in the room. I was horribly self-conscious, clumsy as a boor, stepping all over her toes and leading her right into other couples. It was torture. And then I saw Jim standing in the doorway, laughing. Other couples had stopped dancing to watch us, and were laughing too. I was the goat!

It was a humiliating experience, and the next time Jim invited me to a dance I refused. “Tired of dancing already?” he asked, laughing slyly. That laugh somehow irritated me. “I’ll be there!” I said grimly—“and I’ll dance!”

I sent for the five free lessons

That evening I sent off a coupon to Arthur Murray asking him for the five lessons that he offered free. I would show Jim—I would show all of them! They’d never make me the goat again. I’d become a good dancer, as popular as any of them.

Arthur Murray’s five free dancing lessons arrived just the evening before the dance. It was fun to follow the simple diagrams and instructions and I quickly mastered a fascinating new fox-trot step. I learned how to lead and acquired a wonderful new sense of ease and poise. I could hardly wait for Jim’s dance.

And then—what I desired above all else—a dance with Jeanne! She hesitated when I asked her, but

she was too polite to refuse. The orchestra was playing a fox-trot, and I swung her gracefully into the rhythm. She was an exquisite dancer, and we interpreted the dance like professionals. Everyone was amazed, and especially Jim. He stood in the doorway watching us—the very doorway where only a short time ago he had stood and laughed. Laughed! Well, it was my turn to laugh now!

Jeanne and I finished the dance together. Others stopped to watch us. Jeanne was smiling—others were smiling—soon everyone was smiling and applauding.

I never dreamed that knowing how to dance well could make anyone popular so quickly.

You, too, can quickly learn dancing at home, without music and without a partner. More than 200,000 men and women have become accomplished dancers through Arthur Murray’s remarkable new method.

Send today for the five free lessons. They will tell you the secret of leading, how to follow successfully, how to gain confidence, how to fox-trot and how to waltz—and are yours to keep, without obligation. Arthur Murray wants you to send for them at once, today—so that you can see for yourself how quickly and easily dancing can be mastered at home.

Clip and mail this coupon NOW. Please include 10c to cover the cost of handling, mailing and printing. Arthur Murray, Studio 308, 801 Madison Ave., New York.

**Arthur Murray, Studio 308,
 801 Madison Ave., New York.**

To prove that I can learn to dance at home in one evening you may send me the FIVE FREE lessons by Arthur Murray. I enclose 10c to pay for the postage, printing, etc. This does not obligate me in any way.

Name.....
 Address.....
 City..... State.....

BOYS

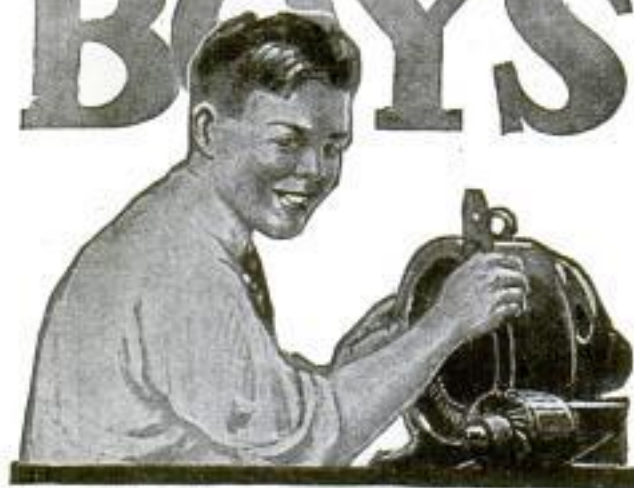

Learn Electricity

How would you like to earn two or three dollars every evening after school and prepare yourself for a fine big job at the same time? Here's the opportunity of a lifetime for you fellows who like Electricity. Begin right now to prepare yourself for a regular man's size job in this fascinating field. Your chances for a big success are simply wonderful—the pay is big (\$70 to \$200 a week) and advancement comes swift and sure.

Look What This Boy Is Doing

"Although the School term is coming to a close, and I am pretty busy with my examinations, I manage to keep up with my electrical studies and work."

"I guess I forgot to tell you I am now in business for myself. Am doing fine, but owe it all to you. If it had not been for your Course, I, being under age, could not have secured my license in this town. But I got it, and now have all the work I can do, averaging \$20 to \$30 a week thru spare time work."

"I went out on a job tonight after school on which I made \$3 and brought home another on which I made \$2.50—\$5.50 for 4 hours' work and no material furnished by me."

ROGER SMITH,
1715 Chestnut St.,
Greenville, N. C.

I Will Train You At Home

With my easily learned, spare time Electrical Course I will train you at home like I have trained hundreds of other boys who are now big successful men. It will not interfere with your school work and you can earn more than the small cost of the course doing odd electrical jobs in your spare time. The Course pays for itself. I will show you how to get this work and how to do it. Some of my boy students make \$10 to \$15 a week this way.

Tools, Apparatus and Radio Course FREE

Send me the coupon below and I will tell you all about the big outfit of tools, apparatus and instruments and a new Radio Course that I am giving to my students for a limited time. I will send you my big interesting Electrical Book and a sample lesson, too—all Free. You will be tickled with the things I will send you Free. Mail the coupon right now.

L. L. COOKE, Chief Engineer
Chicago Engineering Works
Dept. A-18 CHICAGO

Use This "FREE OUTFIT" Coupon

L. L. COOKE, Chief Engineer,
Chicago Engineering Works,
Dept. A-18 2150 Lawrence Ave., Chicago

Send me your Free Outfit Offer, your big Electrical Book, Sample Lesson and particulars of your Electrical Course and Free Radio Course. This will not obligate me in any way.

Name.....

Address.....

For use of boys 15 years old or more.

We Teach COMMERCIAL

ART

Meyer Both Company, the largest Commercial Art Organization in the World offers you a practical training based upon twenty-five years of success. This nationally known organization each year produces and sells to advertisers over 15,000 commercial drawings.

This well paid profession equally open to men and women. Home study instruction.

Get Facts Before You Enroll in Any School

Ask the Advertising Manager of the leading newspapers in your city about Meyer Both Company—let them tell you about us. Send four cents in stamps for illustrated book telling of the success of our students.

MEYER BOTH COMPANY

Department of Art Instruction
CHICAGO, ILL.

Michigan Ave. at 28th St. Dept. 16

Note—To Art and Engraving Firms: Secure artists among our graduates. Write us.

LEARN WATCH REPAIRING

Be a watchmaker—you can learn this profitable trade by correspondence in a few weeks in your own home by the DeSelms Chart System. After you complete the course you will know a watch from A to Z. You will know just what the matter is and how to repair one. When you graduate you will be a practical watchmaker and repairer and competent in all any position. Positions for our graduates. Ask for our Free Book. It explains our system and terms.

THE DeSELMS WATCH SCHOOL
23 Perry Street ATTICA, INDIANA



FREE BOOK



Learn Piano!

This interesting Free Book shows how you can become a skilled player of piano or organ at quarter usual cost. It shows why one lesson with an expert is worth a dozen other lessons. Dr. Quinn's famous Written Method includes all of the

great advantages of conservatory study. For the beginner or experienced player. Highly endorsed. Successful graduates everywhere. Scientific yet easy to understand. Fully illustrated. All music free. Diploma granted. Write today for freebook. Quinn Conservatory, Studio P.M. 91, 598 Columbia Road, Boston, 25, Mass.

Ride A Ranger

The finest bicycle ever built. 44 Styles, colors sizes; made in our new factory. SAVE \$20 to \$25 by direct from the factory purchase. Delivered free on approval, express prepaid, for 30 Days' Free Trial. Easy Payments, if desired.

Tires best quality, at factory prices, express paid. Lamps, wheels, horns, equipment and repairs at unusually low prices. Send No Money, do business direct with makers.

MEAD CYCLE COMPANY
DEPT. A-108 CHICAGO

Write today for free Ranger Catalog, factory prices and marvelous easy payment terms



STAMMER

If you stammer attend no Institute till you get my large FREE book entitled "STAMMERING, its Origin and The Advanced Natural Method of Treatment." Ask for special tuition rate and a FREE copy of "The Natural Speech Magazine," published monthly in the interest of those afflicted with stammering, stuttering and other speech impediments. Largest, best equipped and most successful school in the world for the cure of stammering. Established 20 years. No sing-song or time-beat. Write today. Millard Institute of Normal Speech, 2317 Millard Bldg., Milwaukee, Wis.



FOR YOU—MR. SIGN PAINTER

It's the very newest and latest help for Sign Painters and Show-card Writers. Letter Patterns. Helps the inexperienced and aids the finished expert. Make Sign Painting and Show-card Writing as easy as A, B, C. Sample for stamp. John F. Rahn, A 2433 Greenview Ave., Chicago

MECHANICS!

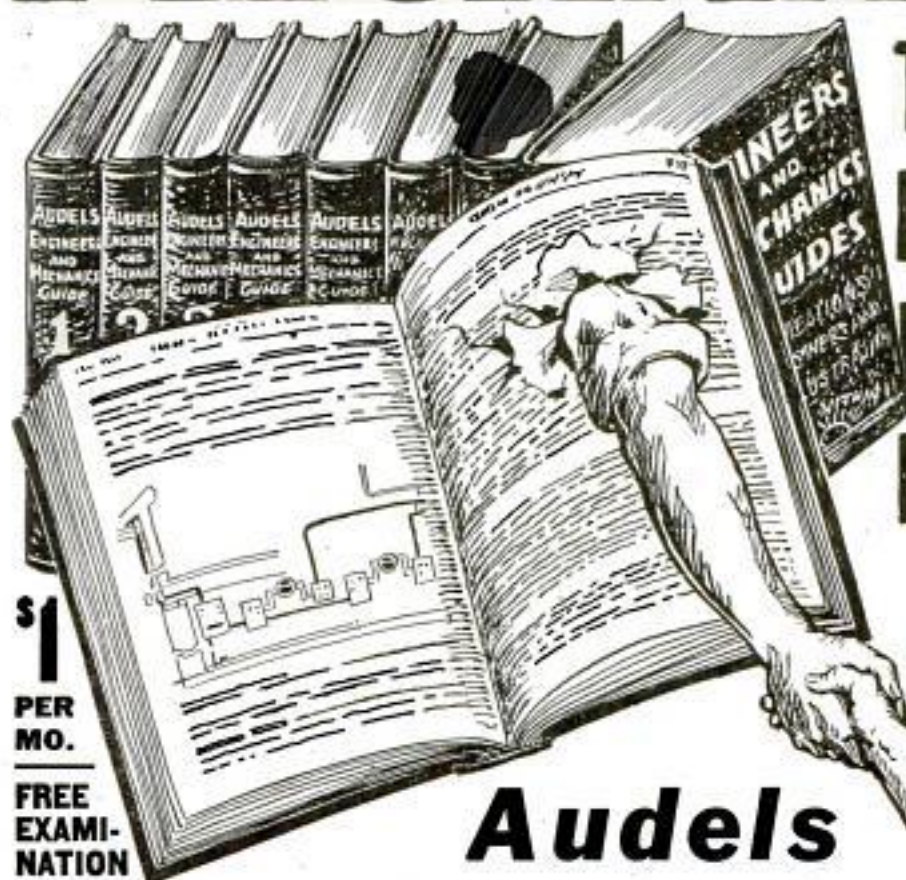

TAKE THIS HELPING HAND TO BETTER PAY

Hundreds of Engineers, Electricians and Machinists write us that this Set, **Audels Engineers & Mechanics Guides**, has been the means of quick advances in grade, position and pay.

\$1
PER
MO.
FREE
EXAMI-
NATION

Audels

Engineers and Mechanics Guides

**Guides Tell
you all about:**

THEORY, PRACTICE and OPERATION of ALL Steam Engines; UNIFLOW and POPPET VALVE ENGINES and LOCOMOBILES, Locomotive-Marine Engines; Turbines; Rotary Engines—the Indicator—Lubrication—PRACTICAL MANAGEMENT. GAS, GAS ENGINES—Aeroplanes and Aviation—HOW TO SELECT AN ENGINE. STEAM ENGINE rules and formulae. Steam Boilers; Heat-Combustion; Fuel and Flue Gas Analysis—CO₂ Recorder—Construction of all types of Boilers—Mechanical Stokers—Oil Burners—Setting—Chimneys—Mechanical Draught—HOW TO SELECT A BOILER—BOILER DESIGN based on A.S.M.E BOILER CODE—OPERATION FIRING. Pipes, Fittings—Heating and Ventilation—Refrigeration—Cooling Towers—Condensers—Distilling Apparatus—Elevators—Cranes—Hoopes and Cables—Splicing—Practical Electrical Engineering as an aid for engineers and electricians in obtaining a license—ready reference index, covering entire field of Modern Electricity.

Every Engineer, Mechanic and Electrical Worker will find real help in these books. Daily problems are quickly solved. Short cut methods are explained that save time and labor. Complete, up-to-date information on modern engineering practice is clearly given. Fifteen minutes a day of study will prepare you quickly for a better job and better prospects.

**Pocket Size
Flexible Covers**

8 Numbers, \$12

FREE EXAMINATION

\$1 a Month

**8754 Illustrations
4750 Pages**

"With the help of your Set, I am holding a position of chief engineer, and am under 21."—J. F. Hoffman, Columbia City, Ind.

No obligation to buy unless you are satisfied. Not a cent to pay until you see the books. Use coupon now and start on the way to better pay.

FREE
Exam-
ination



THEO. AUDEL & CO., 72 Fifth Ave., New York

Send me for free examination, AUDELS ENGINEERS AND MECHANICS GUIDES—8 Numbers, \$12. If satisfied, I agree to send \$1 in 5 days, and \$1 a month until paid.

Name.....

Address.....

Occupation.....

Employed by.....

Reference.....11-T-30

Look Here!



I guarantee to make you a

Drafting EXPERT!

If you're earning less than \$75 a week, GO INTO DRAFTING! I guarantee to train you AT HOME the "JOB-WAY"—with actual Drafting Room Jobs. Drafting EXPERTS are close to the boss—are first in line of promotion for executive positions.

\$250 to \$400 a Month!

Common schooling all you need! My graduates are successful—employers ask for COYNE-trained Drafting EXPERTS. So I GUARANTEE satisfaction or to refund every penny you pay me.

FREE EXPERT'S DRAFTING OUTFIT

"JOB-WAY" training makes you a Drafting EXPERT quick. You do actual JOBS with the same instruments you use when employed at a big salary. To encourage you to start RIGHT NOW, I give you this complete EXPERT'S outfit FREE. Coupon brings full information.

LEARN AT HOME!

Thousands of big-salaried jobs all over the country looking for Drafting EXPERTS! Railroads, factories, builders, architects, shipyards, auto plants, Cities, Counties, States and the U. S. Government all calling for Drafting EXPERTS! Mail the coupon to me personally!



CHIEF DRAFTSMAN
COYNE SCHOOL OF DRAFTING
 Dept. 819, 1920 Sunnyside Ave., CHICAGO

Without obligation, send me your book, "Drafting, the Foundation of Industry," absolutely FREE. Also, special offer of FREE Instruments and other big FREE features.

Name.....

Address.....

City..... State.....

MEN WANTED

to become Professional Photographers



Great new opportunity to enter one of the most interesting and best paying professions on earth. No previous experience needed. Thousands of big money positions in all branches of photography: Motion Picture, Commercial, Studio Portraiture, News.



\$100 to \$250 a Week

There's practically no limit to the salaries paid in this fascinating field. Expert photographers receive as high as \$500 a week! Or go into business for yourself. Opportunities everywhere to start Commercial or Portrait Studio.

LEARN AT HOME New plan qualifies you quickly in spare time at home without interfering with present work. Start earning money at once on the side and in just a few short weeks you are ready for your career in Professional Photography.

Motion Picture or View CAMERA FREE



Your choice of Motion Picture or View Camera absolutely FREE if you act quickly. Motion Picture Camera takes real motion pictures on standard professional film used in all theatres. View Camera is 5 x 7, anastigmatic lens for real professional work.

Write for New Book Send today for free, illustrated book explaining great opportunities in all branches of Photography. Also particulars of free Camera and special offer to those starting at once. This may be the big opportunity you have been looking for.

Send postcard or letter for free book NOW. Address: New York Institute of Photography, Dept. 4911, 143 W. 36th St., N. Y. City

BE AN ARTIST

WE CAN TEACH YOU DRAWING in your own home during your spare time. Twenty-five years of successful teaching proves our ability. Artists receive large salaries.

Write Today for Art Year Book

SCHOOL OF APPLIED ART
 ROOM NO. 2 BATTLE CREEK MICH.



LEARN ACCOUNTING

Bryant & Stratton NEW Training System fits you to earn BIG money. Learn in your own home. Short course for everybody. New method TELLS HOW and SHOWS HOW. Full credit given in our Chicago school for all work under OUR NEW TRAINING SYSTEM.

WRITE TODAY!

BRYANT & STRATTON BUSINESS COLLEGE
 116 S. Michigan Ave. Dept. 5 Chicago, Ill.

PIANO JAZZ

By Note or Ear With or without music. Short Course. Adult beginners taught by mail. No teacher required. Self-Instruction Course for Advanced Pianists. Learn 67 styles of Bass, 180 Syncopated Effects, Blue Harmony, Oriental, Chime, Movie and Cafe Jazz, Trick Endings, Clever Breaks, Space Fillers, Sax Slurs, Triple Bass, Wicked Harmony, Blue Obligato, and 247 other Subjects, including Ear Playing and Musical Invention. 110 pages of REAL Jazz, 25,000 words. A Postal brings our FREE Special Offer.

Waterman Piano School, 253 Super Thruway Bldg., Los Angeles, Cal.

Learn to Mount Birds



Learn at home by mail, to mount birds, animals, game heads; tax furs, make rugs and robes. Complete lessons. Easily and quickly learned by men, boys and women.

FREE Write today for Free Taxidermy Book. Tells all about it. Every Sportsman, Hunter, Trapper and Nature lover should know this wonderful fascinating art. Save your trophies. Big profits. Success guaranteed. Our school is 20 years old—15,000 graduates. Investigate today. Write for Free Book.

Northwestern School of Taxidermy

1778 Elwood Bldg., Omaha, Neb.

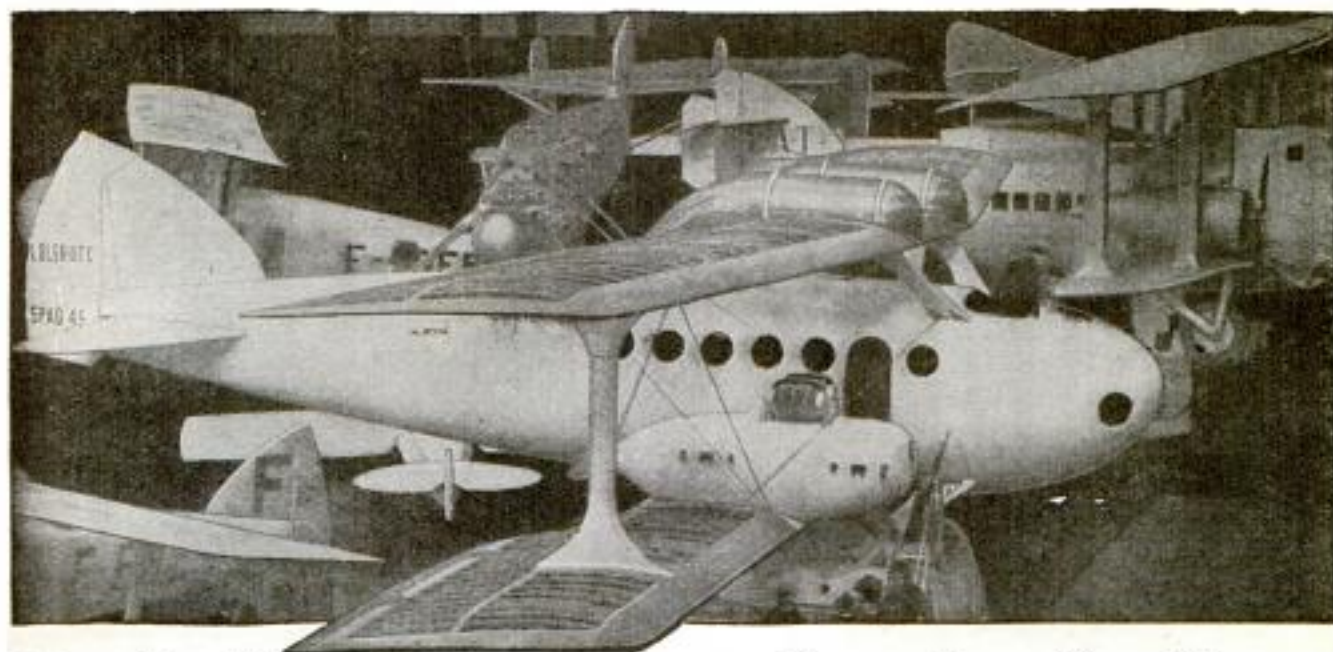

Quick Success in Aviation Fascinating—Daring—Big Paying

To young men of daring, no other field of work will offer such a fascination, such high pay, nor such opportunities for quick success as the field of Aviation. As yet, aviation is practically in its infancy. NOW is the time to get in.

Amazing Opportunities in Airplane Industries

In the automobile industry and in the moving picture business hundreds of men got rich by getting in at the start. They made their success before others woke up. Today, these lines offer no greater opportunities than a hundred and one others. BUT AVIATION IS NEW. Get in while the opportunity is big. All over the country there will be a clamor for trained men. It will not be a question of pay, but of getting capable men.

Here are Real Positions —\$50 to \$150 Per Week

Aeronautical Instructor, Aeronautical Engineer, Aeronautical Contractor, Airplane Repairman, Airplane Mechanician, Airplane Inspector, Airplane Salesman, Airplane Assembler, Airplane Builder



View in an Airplane Factory

A Sure and Easy Way to Learn Aviation—at Home



A New Job—The Aerial Postman

The study of aviation is almost as fascinating as the actual work. Every lesson is full of interest. That is why it is easy to learn aviation. You do not have to make yourself study—it is like reading an in-

teresting book that tells you things you have always wanted to know. Only one hour each evening will give you the basic training in a surprisingly short time. You need only a common school education.

One of my students, James Powers, Pa., says, "I am indeed surprised that such a valuable Course can be had from such practical men for so little cost."



A New Seven-Passenger Airplane

Personal Instruction by Experienced Men

Men who have had actual experience give you personal attention. They select the lessons, lectures, blueprints and bulletins. They tell you things that are essential in everyday practice. Each lesson is easy to read and understand.

BIG BOOK FREE of Opportunities

Send coupon below for New Book, just out, "Opportunities in the Airplane Industry." It is interesting and instructive. It will show you many things you never knew before about aviation. Due to shortage of paper we could get only a limited supply of these books—send the coupon before they are all gone.

AMERICAN SCHOOL OF AVIATION
3601 Michigan Avenue, Dept. 13-58, Chicago, Ill.

AMERICAN SCHOOL OF AVIATION
3601 Michigan Ave., Dept. 13-58, Chicago, Ill.

Without any obligation, send me your Free Book, "Opportunities in the Airplane Industry," also information about your Course in Practical Aeronautics.

Name.....

Street.....

City..... State.....



IN DRAWING CARTOONS

Why spend your time doing work that is drudgery, and get little money for it when you can enter this well paid profession? You can learn cartooning at home with this amazing easy method, which teaches you to draw cartoons that sell. You can also earn while you learn.

A steady income—\$3000 to \$15,000 a year—your own boss—easy hours—no off seasons—that's the life of a good cartoonist. Right now you may be earning only a pitifully small salary—but with this training you can soon be on easy street—dependent. There's always a demand for good cartoonists.

Easy To Learn Cartooning At Home In Spare Time

There is a knack about learning cartooning which you can master in your spare time with this simple home study method. It starts you at the very beginning—on simple fundamental principles—then takes you through every branch of humorous and serious cartooning. You will be surprised how quickly you can draw cartoons that will sell. Many earn even while learning.

Send for Free Book

Get this handsomely illustrated booklet which gives the details of this remarkable home study course in Cartooning. Gives thorough outline of the cartooning field and market for cartoons. Shows how to become a cartoonist. No obligation. Send for it today.

WASHINGTON SCHOOL OF CARTOONING
Room 3011 1113-15th St., N. W. Washington, D. C.

WASHINGTON SCHOOL OF CARTOONING
Room 3011, 1113-15th St., N. W., Washington, D. C.

Please send me without obligation, your Free Booklet on Cartooning, and full details of your home study method of teaching Cartooning.

Name.....
(Print Name Plainly)

Address.....

City..... State.....
(If under 16 please give age)

JAZZ

Your Way to Popularity— Learn to Play Tenor Banjo

Jazz has taken country by storm. Jazz artists are popular and successful. We teach you to master jazz Tenor Banjo at home, in your spare time for few cents a day. Write now for particulars and receive \$48 Tenor Banjo FREE when you enroll a student. Prof. Harry S. Six's simple picture, diagram method and our professors' phonograph records enables you to play right away. Write before free Tenor Banjo offer is withdrawn. N. Y. Academy of Music, Studio 112, 212 Fifth Ave., New York.

A FILE

Stop Forgetting

Make Your Mind an index from which you select facts, figures, names, faces. Develop concentration, self-control; overcome bashfulness, forgetfulness. Write today for FREE memory and concentration test and illustrated booklet, "How to Remember."

PROF. HENRY DICKSON
Dept. 70511 Evanston, Ill.

NOT A FILE

Wanted Men and Women to Learn Photography!

Photographers and Photo-Engravers earn \$200 to \$500 a month. The field is uncrowded. Learn these profitable and fascinating professions. Taught by largest and best college of its kind in the world. Established over 30 years. Demand for our graduates far exceeds supply. Good positions secured. Tuition and living expenses low.

Get this FREE Book! beautifully illustrated book describing wonderful opportunities in this field.

Illinois College of Photography, Box 4114, Effingham, Ill.

LEARN WATCHMAKING AND ENGRAVING

ALSO JEWELRY REPAIRING BY OUR PROFIT-SHARING PLAN

OUR GRADUATES SUCCEED

One of our best students started in a very small way—now doing over \$20,000 a year. Another in Wisconsin over \$10,000 the first year. Day or night classes. Write for FREE BOOK.

CHICAGO SCHOOL OF WATCHMAKING Dept. 20 4844 Lincoln Avenue, CHICAGO

Joy—STOMACH for SUFFERERS

I positively guarantee Macerated Wheat to relieve the worst cases of stomach trouble and banish constipation or it costs you nothing. Soothing to a weak stomach as a poultice to inflammation. Stays down and nourishes. Testimonials without number. My reputation of 25 years backs my guarantee. Write to prof.

BYRON TYLER 172 Gibraltar Bldg. KANSAS CITY, MO.

PIMPLY SKIN made WELL

When a few applications of this wonder-working lotion has cleared faces of pimples,

FREE BOOK
Clear-Tone

blackheads, acne eruptions on the face or body, barbers itch, eczema, enlarged pores, oily or shiny skin, you can realize why CLEAR-TONE has been tested and approved in over 100,000 Test Cases.

The simplicity of the treatment, and The Story of How I Cured Myself are all explained in my free booklet, "A Clear-Tone Skin." Write for your copy today and learn of the results gotten by thousands of men and women.

E. S. GIVERS, 128 Chemical Bldg., Kansas City, Mo.



man understood and used those fourteen words, *they* made him worth HALF A MILLION DOLLARS IN FIVE YEARS.

READ ABOUT IT FOR YOURSELF

Here are just a couple of pages. The **BOOK** you may have **FREE** if you like.

“Listen, young man, you have saved my life. . . .” Arthur had forgotten that in his interest in the conversation. “. . . and I want to reward you.”

“I hope you won’t—” began Arthur, fearing that he was about to be dismissed with some small present of money.

The other understood. “No, I am not going to insult you by offering you a few dollars. I couldn’t give you a great deal of money without taking from you with the same hand most of your incentive to make something of yourself and of your life.”

Arthur would have liked to argue that point,

but obviously there was something more coming, and he was too keenly interested.

“Instead, then, I am going to give you something which will give you *whatever you want*. Call it an amulet . . . a talisman . . . a magic rune . . . call it whatever you like, but believe me when I tell you that this . . . secret . . . which I am going to give you is the secret of my success and of the success of everyone in the history of mankind who has ever really succeeded . . . even of nearly all of those who only thought they did.”

—Read the rest of the story—the **FOURTEEN WORDS** and what they did—and may do for **YOU!**

It won’t cost you a cent to do so and it may be worth half a million to you as it was to Arthur Holmes. You can understand these Magic Words, and you can use them; if you do they will make you rich and famous, useful and happy, indeed *they will bring you whatever you want.*



Actual size: 8-1/2" x 5-1/2"

FREE to YOU
in return for
This Coupon

Chicago Technical College
118-132 East 26th Street
Chicago, Illinois

CHICAGO TECHNICAL COLLEGE,
Dept. 1130, 118-132 East 26th Street, CHICAGO

Send me **FOURTEEN WORDS OF MAGIC POWER**. It’s agreed that I pay you nothing and owe you nothing in return.

Your name.....Age.....

Present occupation.....

Home address.....

City..... State.....

To get this interesting and valuable little book absolutely free fill out this coupon or give same information on card or in letter.



"I'm making real money now"

"SEE that coupon? Remember the day you urged me to send it to Scranton? It was the best thing I ever did. "Mr. Carter called me in to-day. Said he'd been watching my work for some time—ever since he learned I was studying with the International Correspondence Schools.

"Then he asked me if I thought I could take over Bill Stevens' job. I told him I was sure that I could—that I had had that goal in view ever since I started my I. C. S. course.

"I start to-morrow, Mary, at an increase of \$60 a month. It's wonderful how spare-time study helps a man to get ahead."

FOR thirty-three years, the I. C. S. has been helping men to win promotion, to earn more money, to get ahead in business and in life.

You, too, can have the position you want in the work you like best. Yes, you can.

All we ask is the chance to prove it. Without cost, without obligation, just mark and mail this coupon.

INTERNATIONAL CORRESPONDENCE SCHOOLS Box 5651-D, Scranton, Penna.

Without cost or obligation, please tell me how I can qualify for the position or in the subject before which I have marked an X:

BUSINESS TRAINING COURSES

- | | |
|--|---|
| <input type="checkbox"/> Business Management | <input type="checkbox"/> Salesmanship |
| <input type="checkbox"/> Industrial Management | <input type="checkbox"/> Advertising |
| <input type="checkbox"/> Personnel Organization | <input type="checkbox"/> Better Letters |
| <input type="checkbox"/> Traffic Management | <input type="checkbox"/> Show Card Lettering |
| <input type="checkbox"/> Business Law | <input type="checkbox"/> Stenography and Typing |
| <input type="checkbox"/> Banking and Banking Law | <input type="checkbox"/> Business English |
| <input type="checkbox"/> Accountancy (Including C.P.A.) | <input type="checkbox"/> Civil Service |
| <input type="checkbox"/> Nicholson Cost Accounting | <input type="checkbox"/> Railway Mail Clerk |
| <input type="checkbox"/> Bookkeeping | <input type="checkbox"/> Common School Subjects |
| <input type="checkbox"/> Private Secretary | <input type="checkbox"/> High School Subjects |
| <input type="checkbox"/> Spanish <input type="checkbox"/> French | <input type="checkbox"/> Illustrating <input type="checkbox"/> Cartooning |

TECHNICAL AND INDUSTRIAL COURSES

- | | |
|---|--|
| <input type="checkbox"/> Electrical Engineering | <input type="checkbox"/> Architect |
| <input type="checkbox"/> Electric Lighting | <input type="checkbox"/> Architects' Blue Prints |
| <input type="checkbox"/> Mechanical Engineer | <input type="checkbox"/> Contractor and Builder |
| <input type="checkbox"/> Mechanical Draftsman | <input type="checkbox"/> Architectural Draftsman |
| <input type="checkbox"/> Machine Shop Practice | <input type="checkbox"/> Concrete Builder |
| <input type="checkbox"/> Railroad Positions | <input type="checkbox"/> Structural Engineer |
| <input type="checkbox"/> Gas Engine Operating | <input type="checkbox"/> Chemistry <input type="checkbox"/> Pharmacy |
| <input type="checkbox"/> Civil Engineer | <input type="checkbox"/> Automobile Work |
| <input type="checkbox"/> Surveying and Mapping | <input type="checkbox"/> Airplane Engines |
| <input type="checkbox"/> Metallurgy | <input type="checkbox"/> Navigation |
| <input type="checkbox"/> Steam Engineering | <input type="checkbox"/> Agriculture and Poultry |
| <input type="checkbox"/> Radio | <input type="checkbox"/> Mathematics |

Name.....

Street..... 3-6-24

City..... State.....

Occupation.....

Persons residing in Canada should send this coupon to the International Correspondence Schools Canadian, Limited, Montreal, Canada.

HOTELS OFFER YOU \$150 TO \$500 per Month

Trained Men and Women in BIG DEMAND



If your present position is not paying enough; if advancement is too slow, investigate what hotels offer you. 80,000 trained employees must be secured this year; no previous hotel experience necessary.

Wonderfully interesting work in luxurious surroundings; many opportunities for advancement to executive positions. Positions paying \$150 to \$500 per month are numerous, meals and often room furnished.

We train you at home in spare time at moderate cost. Course endorsed by many leading hotel men. Hundreds of successful graduates.

Write today for Free Booklet H-166.

Standard Business Training Inst.
BUFFALO, N. Y.



We have a wonderful new copyrighted system of teaching note music by mail! To first pupils in each locality we will give free a \$20 superb Violin, Tenor Banjo, Ukulele, Hawaiian-Guitar, Banjo, Mandolin, Banjo-Ukulele, Banjo-Mandolin, Cornet or Banjo-Guitar absolutely free. Also teach Piano and Organ. Very small charge for lessons only. Four lessons will teach you several pieces. Over 100,000 successful players. We guarantee success or no charge. Complete outfit free. Write today, Dept. 167. No obligation. SLINGERLAND SCHOOL OF MUSIC, 1819 Orchard Street, CHICAGO, ILLINOIS



Wonderful, new device, guides your hand; corrects your writing in few days. Big improvement in three hours. No failures. Complete outfit FREE. Write C. J. Orment, D-34, St. Louis, Mo.

LEARN ENGINEERING

Great Demand for Practical-Technical Engineers. Big Salaries. Wonderful Opportunities. Thousands of our graduates holding responsible high-salaried positions. Practical-Technical Courses from 3 Months to 2 Years in Electrical and Mechanical Engineering. Simple and Condensed Method. Faculty of Trained Experts. New Building. Extensively Equipped Laboratories and Shops. Department of Architecture. Structural and Mechanical Drafting. Degrees Awarded. Positions Secured. Day and Night Sessions. 22nd Year Begins September 17. Write for Catalog D.

FINLAY ENGINEERING COLLEGE, Kansas City, Mo.

LEARN PIANO TUNING AT HOME

WITH our TUNE-A-PHONE, Action Model, tools, charts and lessons you can learn quickly and easily and be prepared to make big money. Estbl., 1898. Money-back Guarantee. Diploma given. Amazing surprise in our free book, "Winning Independence." Write for it today. Miles Bryant School of Piano Tuning, 49 Bryant Bldg., Augusta, Mich.

BIG NOVELTY BARGAIN! 10c



Throw Your VOICE

Into a trunk, under the bed or anywhere. Lots of Fun fooling the Teacher, Policeman or Friends. Save of Fun.

THE VENTRILO,

a little instrument, fits in the mouth out of sight, used with above for Bird Calls, etc. Sent with full instructions; anyone can use it. NEVER

FAILS. Also a 32-PAGE BOOK ON VENTRILOQUISM. Formula for Secret Writing, 12 Money Making Secrets and the marvelous.

NOVELTY X-RAY WONDER

With it you can apparently see the bones in your fingers, lead in pencil, etc. 1 bit of fun with this outfit.

Also 10 Big Magic Tricks Free with every order. All the above Novelties by prepaid mail for 10c

VENTRILO COMPANY

Dept. 716, Norwalk, Conn.

LARGEST and OLDEST Mail Order House in Connecticut

\$3500 to \$5000 a Yr.

3 Months' Training
Will Qualify You for Success in the Most
Rapidly Growing Professional Trade—

MECHANICAL DENTISTRY

The very best opportunity for men who like to use tools. There is need right now for 2500 more Dental Mechanics and the demand is rapidly growing. There are now approximately 56,000 practicing Dentists in the U. S. and only about 4000 full-fledged Dental Mechanics! At the present time the shortage of Mechanical Dentists runs into the thousands with no immediate prospects of this demand being filled. Unequaled opportunity—pleasant, dignified work—steady income—rapid advancement—no "slack seasons" as in most other trades.

You Learn by Doing

We train each student individually—no classes whatever. Instruction is practical from the very beginning. From the start you use the tools and instruments of the trade and work on practical dental work. But we do not make the serious mistake of depending on practical work alone as some schools do. You are given a definite theoretical training as well, so that you become familiar with both the theory and the practical working methods of Mechanical Dentistry used throughout the Dental Profession.

Unequaled Curriculum

All phases of Vulcanite Denture construction, with clasp technique, bars, and patented attachments. Occlusion of teeth and anatomical articulation. Crowns of all types—Seamless, Two-piece, Darby, Richmond, Telescope, Carmichael, etc. Fixed Bridges—with and without interchangeable teeth; Sanitary Bridges; Dummy Bridges. Removable Bridges—Nesbit and Bonwell styles; Peco, Brown-Maier and Gollobin attachments using the Parallelometer. Metal Plates—Bodee Span Swedged Plate with attachments, partial rim and full upper swedged Plates, Partial rim Plates with tagged tooth and metal dummy, etc. Casting—every phase of this branch including crowns, bridges, saddles, clasps, plates, etc. Both direct and indirect methods used. Also the technique of carved teeth.

Why Bodee-Trained Men Lead the Field

The Dental Profession recognizes the Bodee course as the highest standard of efficiency. This institution has maintained its leadership for over 30 years and is the oldest and largest school of Mechanical Dentistry in the world. It is and always has been the chief source of supply for competent dental mechanics. Compare the cost of our course with the charges of other schools offering to teach Mechanical Dentistry. Ask your own dentist to examine the course we give and tell you just how thorough and valuable it is.

FREE PARTIAL SCHOLARSHIPS

In order to meet the urgent demand for the men we train, we are offering for a limited time Free Partial Scholarships. Be sure to ask immediately for this exceptional offer. It will very much reduce the cost of your training. Remember, this offer will be discontinued soon—so act NOW while it is still in effect.

SEND FOR CATALOG AND SCHOLARSHIP OFFER

Catalog No. 2 fully describes the field and why the demand. Shows how students "Learn by Doing" actual work through practical, individual instruction, day or evening sessions. Shows how you can "Earn while Learning." This catalog is your First Step to Success in Mechanical Dentistry. IT IS FREE. SEND THE COUPON TODAY.

BODEE DENTAL INSTITUTE

136 West 52d Street, NEW YORK
1305 No. Broad St., PHILADELPHIA
1226 Main Street, BUFFALO
85 Court Street, BROOKLYN



The Shortest
Way to
Professional
Earnings

WE DO NOT

1—Offer "Free" Railroad Fare—

It is plain that any such expense would have to be added to charges for tuition.

2—Offer "Free" Sets of Tools—*Our regular tuition covers the cost of a Complete Set of Standard Tools of the trade. (See catalog page 25.)*

HERE'S WHAT WE DO

We give the Most Thorough Course in the Most Practical way. Ask your Dentist about the High Standing of the School and the Quality of the instruction given.

SEND THIS COUPON

BODEE DENTAL INSTITUTE:
Without obligation to me send me a Free Copy of your catalog and complete details of the Free Partial Scholarship Plan No. 2.

Name.....

Address.....

Make Money Taking Pictures



New Commercial Demand Offers Big Opportunities to Trained Men and Women

Tremendous big paying opportunities are open for every man or woman who knows Modern Photography. Every manufacturer uses high priced pictures of his products in his catalog.

Salesmen carry photographs instead of samples. (The picture above was made for a lingerie catalog, and brought the photographer big returns both from the original plate and from many extra prints.)

There are thousands of other opportunities. Every home wants portraits. Magazine and newspaper publishers buy thousands of photographs each year. Everyone has snap-shots to be developed and finished, and there is big money in this line. Modern Photography is a business running into millions of dollars every year. Yet there is an amazing shortage of trained men and women. Here is your opportunity to get into this business easily and quickly.

Got \$100 for Flood Pictures

"I took pictures of a flood and sold them for \$100. I have been able to buy my house and lot from the sale of pictures."
C. M. COLE,
Washington.

\$97 in Two Days!
"I made \$285 in December. Went out two days last week on home portrait work and made \$97."
A. G. HUGHES,
Kentucky.

Wonderful New and Easy Method—Learn at Home

No matter where you live, I can teach you how to do the kind of work turned out by the biggest and most exclusive Chicago and New York studios. I can show you where the big opportunities are in Commercial Photography, and prepare you to benefit by them. And you can earn while you learn! One of my students, Joe Canaras, cleared \$500 in his spare time while studying. Thousands of others have done as well; I show you how. I am so sure you will be satisfied that I guarantee under bond to return every cent of your tuition if you are not satisfied.

FREE—Professional View Camera



Write at once for my remarkable offer. I give you this professional view camera FREE. Just the kind of camera you need to give you a fine start in our work. This offer is open for only a limited time, so fill out and send in the coupon below now, TODAY. You will also be interested in the limited special offer I am making to those who enroll at once. Act NOW.

DIRECTOR INTERNATIONAL STUDIOS, Inc.

3601 Michigan Ave., Dept. 13-58, Chicago, Ill.

Director, International Studios, Inc.
3601 Michigan Ave., Dept. 13-58, Chicago, U. S. A.

Without obligation send me complete information about the wonderful opportunities awaiting in New Fields of Photography. Explain amazing temporary offer and tell me how I can get a PROFESSIONAL CAMERA FREE.

Name _____

Address _____

City _____ State _____

STOP Making Mistakes in English

Every time you speak or write you show just what you are. Mistakes in English reveal you as a person who lacks education and refinement. Lack of language power prevents you from presenting your thoughts in the strongest possible way. No matter what you do, real command of English will help you to your goal. Stop making mistakes in spelling, punctuation, pronunciation. Increase your vocabulary.

WONDERFUL INVENTION

Only 15 minutes a day with Sherwin Cody's New Invention—and you can actually SEE your English improve. It teaches by HABIT—makes it easier to do the RIGHT way. Wonderful self-correcting lessons include Spelling, Punctuation, Grammar, and Expression.

FREE BOOK ON ENGLISH AND 15 MINUTE TEST Lack of language power may easily be costing you thousands of dollars every year. See what Mr. Cody can do for you. It costs nothing to find out. Mail a postal card or letter this very minute for free book, "How to Speak and Write Masterly English," and 15 Minute Test, which you can take in your own home. It will prove a revelation to you. WRITE NOW. Address Sherwin Cody School of English, 511 Searle Building, Rochester, N. Y.



LAW STUDY AT HOME

Become a lawyer. Legally trained men win the highest positions and biggest success in business and public life. Be independent. Greater opportunities now than ever before. Big corporations are headed by men with legal training. Earn \$5,000 to \$10,000 Annually. We guide you step by step. You can train at home during spare time. Degree of LL. B. conferred. LaSalle students practicing law in every state. We furnish all text material, including fourteen-volume Law Library. Low cost, easy terms. Get our valuable 108-page "Law Guide" and "Evidence" books free. Send for them NOW. LaSalle Extension University, Dept. 1164-L Chicago. The World's Largest Business Training Institution.

LEARN VIOLIN 30 DAY

New Easy Way. Violin Furnished. Marvelous new Master Method teaches you by mail in 1/2 time and at 1/20th cost. No numbers or trick music. Costs only \$6 a day. Play a masterpiece by note in fifth lesson. Easy as A B C. All music free. Diploma awarded. Beginners or advanced players. Money back guarantee. Send today for free booklet. Will be sent in plain wrapper. Please write clearly. MASTER VIOLIN SCHOOL, 31 E. 42 St., Coor. 704, New York, N. Y.

A Great Career!—BOOK FREE

"I WANT YOU"

MEN—BOYS 18 UP
\$1140 to \$2600 A YEAR
Many U. S. Government jobs obtainable. Experience unnecessary. Common education sufficient. Write today sure for free list of positions.

FRANKLIN INSTITUTE, Dept. R-198, ROCHESTER, N. Y.

"BECOME A LIGHTNING TRICK CARTOONIST"

MAKE MONEY CHECK TALKING. SEND \$100 FOR SNAPPY, MODERN TRICK DRAWINGS WITH INSTRUCTIONS BY A PROFESSIONAL CARTOONIST. SATISFACTION GUARANTEED. CIRCULAR FREE. BALDA ART SERVICE, 61 OSHKOSH WIS.

Comedies, Dramas, Musical Comedies, and Revues, Minstrel Choruses, Songs, Blackface plays. Everything for Burnt Cork Shows and All Amsterg Entertainment. Monologs, Dialogs, Speakers. CATALOGUE FREE.
T. S. DENISON & CO., 623 So. Wabash, Dept. 9, CHICAGO

AGENTS BIG WINNER JUST OUT!

New Invention—Marvelous Quickedge Knife and Shear Sharpener. Needed in every home. Sells on Sight. Sharpens any knife or shears in ten seconds. Just put knife in slot—turn crank—sharpens both sides at once. We want men and women hustlers in every county. Profits start first day.

\$90 A WEEK

No Experience Necessary—200% Profit. This means \$15 a day up to \$7500 a year to agent who gets your county. J. C. Lewis, of Kansas, says: "I have sold 100 Sharpeners in four days." Herbert Cain, of Kentucky, sold nine after supper. Wm. G. Hall, of N. J., sold six in a half hour. You can make this money. WRITE TODAY. Territory Free. Get busy at once.

QUICKEDGE SHARPENER CO.
111 Sharpener Bldg.
JACKSON MICHIGAN

Only \$200 Selling Price

Write for Sample Offer

BARBERING

Now One of the
Highest Paid
Professions!

**\$90 to \$150
Every Week!**



William McClintock, President Master Barbers' Ass'n of Chicago and proprietor of the highest priced rented shop in the world, says, "My son, who learned at Moler's, is top man in my shop every week. I gladly recommend the Moler System as the proper place for men to become successful barbers."
—WM. McCLINTOCK.

**BE A "WHITE-COLLAR" MAN—
Earn \$90-\$150 a Week—CLEAN Money!**

What's the use of doing dirty, greasy, hard work, when you can NOW make TWICE as much money in a manly profession that is CLEAN, profitable and full of opportunities?

**Easy to Learn—
Quick to Earn!**

That's BARBERING for YOU! And the best part of it all is this—scientific barbering, as taught the modern MOLER way, makes YOU a Master Barber in a short course of intensive training, at small expense! You soon step out as your own Boss, if you wish, in your own Shop, which we will gladly help you equip.

See the World, Too!

Or, if you prefer, we will help you step into a real job, with good pay the first day, after you graduate. Ocean Liners, crack trans-continental passenger trains, big luxurious hotels and skyscrapers all over the world, as well as thousands of Barber Shops everywhere, demand MOLER trained men.

**MOLER Graduates
Are Always Busy!**

MOLER trained Men are always given the preference, for they alone possess the valuable, thor-

ough MOLER training in the application of all the latest scientific Barbering methods including the Electric hair cutter, the mechanical massage, and the latest vogue in ladies' hair bobbing. MOLER also gives special training in ladies' marcelling and an easy practical course in the treatment of skin diseases.

**Earn While
Learning!**

"Where there's a Will there's a Way" to earn BIG pay! Write to the nearest MOLER College, there is one near you, and learn how you can earn while you learn the barber trade. Ask for the new FREE MOLER Barbering Booklet B. Find out HOW MOLER helps you help yourself AFTER you graduate, as well as BEFORE! Find out why MOLER Men are making DOUBLE the money others made last year, before Ladies' Shingle Bobbing became so popular. You're NEXT in line for big pay—the MOLER way. Send Coupon TODAY!

MOLER SYSTEM OF COLLEGES

30 Branches in United States and Canada

New York, N. Y.
Chicago, Ill.
St. Louis, Mo.
Kansas City, Mo.
Cincinnati, Ohio.
Cleveland, Ohio.
Detroit, Mich.

Denver, Colo.
Omaha, Nebr.
Milwaukee, Wis.
New Orleans, La.
Atlanta, Ga.
Memphis, Tenn.

Dallas, Tex.
Houston, Tex.
San Antonio, Tex.
Seattle, Wash.
Tacoma, Wash.
Spokane, Wash.



"The XXth Century...
"Oriental Limited"
and other crack
trans-continental
trains carry barbers."



The Majestic, Levantian and U. S. Shipping Lines all carry barbers.

**NEXT!
For BIG Pay**

Mail THIS

MOLER SYSTEM OF COLLEGES

← Address Nearest Branch
(Street Address NOT Needed)

Please send me without obligation on my part your Booklet B.

Name.....

Address.....

City..... State.....



An Easy Way to Learn PHARMACY AT HOME

Graduate pharmacists are always in demand. The work is interesting and pleasant and salaries are good. Many young men open drug stores of their own and become independent.

There's an easy way to learn pharmacy right in your own home in spare time, without losing a day or a dollar from your present work.

The International Correspondence Schools course in Pharmacy supplies the knowledge which it will be necessary for you to have in order that you may pass your State Board Examination.

Just mark and mail the coupon printed below to the International Correspondence Schools, Box 5648-D, Scranton, Pa., and full particulars about the Pharmacy Course or any other work of your choice will come speeding to you by return mail.

INTERNATIONAL CORRESPONDENCE SCHOOLS Box 5648-D Scranton, Penna.

Without cost or obligation, please send me full information about the subject before which I have marked an X in the list below:

TECHNICAL AND INDUSTRIAL COURSES

- | | |
|--|--|
| <input type="checkbox"/> PHARMACY | <input type="checkbox"/> Civil Engineer |
| <input type="checkbox"/> Chemistry | <input type="checkbox"/> Surveying and Mapping |
| <input type="checkbox"/> Automobile Work | <input type="checkbox"/> Mine Foreman or Engineer |
| <input type="checkbox"/> Navigation | <input type="checkbox"/> Steam Engineer |
| <input type="checkbox"/> Agriculture and Poultry | <input type="checkbox"/> Gas Engine Operating |
| <input type="checkbox"/> Mathematics | <input type="checkbox"/> Wireless <input type="checkbox"/> Airplane Engine |
| <input type="checkbox"/> Electrical Engineering | <input type="checkbox"/> Architect |
| <input type="checkbox"/> Electrician | <input type="checkbox"/> Contractor and Builder |
| <input type="checkbox"/> Mechanical Engineer | <input type="checkbox"/> Architectural Draftsman |
| <input type="checkbox"/> Mechanical Draftsman | <input type="checkbox"/> Concrete Builder |
| <input type="checkbox"/> Machine Shop Practices | <input type="checkbox"/> Structural Engineer |
| <input type="checkbox"/> Railroad Positions | <input type="checkbox"/> Plumbing and Heating |

BUSINESS TRAINING COURSES

- | | |
|---|---|
| <input type="checkbox"/> Business Management | <input type="checkbox"/> Salesmanship |
| <input type="checkbox"/> Industrial Management | <input type="checkbox"/> Advertising |
| <input type="checkbox"/> Personnel Organization | <input type="checkbox"/> Better Letters |
| <input type="checkbox"/> Traffic Management | <input type="checkbox"/> Foreign Trade |
| <input type="checkbox"/> Business Law | <input type="checkbox"/> Stenography and Typing |
| <input type="checkbox"/> Banking and Banking Law | <input type="checkbox"/> Business English |
| <input type="checkbox"/> Accountancy (Including C.P.A.) | <input type="checkbox"/> Civil Service |
| <input type="checkbox"/> Nicholson Cost Accounting | <input type="checkbox"/> Railway Mail Clerk |
| <input type="checkbox"/> Bookkeeping | <input type="checkbox"/> Common School Subjects |
| <input type="checkbox"/> Private Secretary | <input type="checkbox"/> High School Subjects |
| <input type="checkbox"/> Business Spanish <input type="checkbox"/> French | <input type="checkbox"/> Illustrating <input type="checkbox"/> Cartooning |

Name
Street
Address

City State

Occupation

Persons residing in Canada should send this coupon to the International Correspondence Schools Canadian, Limited, Montreal, Canada

Learn to Write



I Teach by Mail

I can make a good penman of you at your home during spare time, no matter where you live or how poorly you now write. My simplified system has shown thousands the way to good penmanship during the past twenty-five years — it CAN and WILL do the same for YOU.

My beautifully illustrated 32-page Book
"How to Become a Good Penman" FREE!!

It contains many beautiful specimens of penmanship showing what others have accomplished by the Tamblin System, with testimonials and general information about our courses. (Your name elegantly written on a card if you enclose stamp for postage.) Ladies taught as successfully as men. Write Today. Address
F. W. TAMBLIN
 418 Ridge Bldg. Kansas City, Mo., U. S. A.

F. W. Tamblin

ELECTRICAL ENGINEERING

Course for men of ambition and limited time. Over 4000 men trained. Condensed course in Theoretical and Practical Electrical Engineering including the closely related subjects of Mathematics and Mechanical Drawing taught by experts. Students construct motors, install wiring, test electrical machinery. Course complete.

IN ONE YEAR

Established in 1893. Prepare for your profession in the most interesting city in the world. Free catalog.
BLISS ELECTRICAL SCHOOL
 104 Takoma Ave. WASHINGTON, D. C.

HOME STUDY

Become More Efficient

through courses in Chemistry, History, Mathematics, English, Psychology, Education, Business and 35 other subjects which the University gives by mail. They command credit toward a Bachelor degree and may be begun at any time.

The University of Chicago 15 Ellis Hall Chicago, Ill.

MUSIC LESSONS FREE



You can read Music like this quickly

IN YOUR OWN HOME

Piano, Organ, Violin, Mandolin, Guitar, Banjo, etc. Beginners or advanced players. One lesson weekly. Illustrations make everything plain. Only expense about 2c per day to cover cost of postage and music used. Write for FREE booklet which explains everything in full.

AMERICAN SCHOOL OF MUSIC, 51 Lakeside Building, CHICAGO

LEARN WATCHMAKING

and become independent. Good-paying positions secured. Easy to learn. Send for FREE CATALOG.

ST. LOUIS WATCHMAKING SCHOOL, Dept. 5, ST. LOUIS, MO.

Learn Expert Auto Painting



There is Big Money in auto painting and refinishing. Our Home Study Course in Practical Auto Painting will enable you to do the finest work and earn big money, or come here for training under our experts. Wonderful opportunity.

FREE circular tells all about this big new business. Be first. Write quick.

CHICAGO COLLEGE OF AUTO PAINTING
 Dept. 114, 140 S. Dearborn St., CHICAGO, U.S.A.



The Magic Power of A Few Little Lines

Have you ever noticed a cartoonist draw? A short line here. Another there. A small curve. A splash of shading—and you have a wonderful picture! It was all so easy—because he knew how—he knew which lines to use and just where to put them. Through this New Easy Way to Draw you too can learn the Magic Power of a Few Little Lines and how to make big money in drawing them!



New Easy Way to DRAW

How Easy!



Note how these few little lines are transformed into a picture.

One of the most fascinating, best paid businesses—yours after a few minutes training a day.



Delightful pastime. Endless fun. Acquire the knack in your spare time.

Invaluable asset in your present business. A few lines can drive home your intangible ideas. New way makes it easy to learn drawing.



THIS wonderful new method makes it possible for **anyone** to learn Illustrating, Cartooning, or Commercial Art. Hundreds of our students are now making splendid incomes. And most of them never **touched** a drawing pencil before they studied with us.

The simplicity of this method will astound you. You will be amazed at your own rapid progress. You learn by mail—yet you receive **personal** instruction from one of America's foremost Commercial Artists of 30 years' successful experience.—Frank Godwin and Wynn Holcomb (Wynn), the famous artists, are but two of his many successful students. Get into this fascinating game, **NOW**. You can easily qualify and make big money. A few minutes' study each day is all that is needed.

Newspapers, advertising agencies, magazines, business concerns—all are looking for men and women to handle their art work. Cartoonists and designers are at a premium. Dozens of our students started work at a

high salary. Many earn more than the cost of their course while they are learning.

YOU—with a little spare time study in your own home—can easily and quickly get one of these big-paying artists' jobs.

This amazing method has exploded the old idea that talent is an absolute necessity in art—that "It's all a 'gift.'" Just as you have learned to write, this new method teaches you to draw. We start you with straight lines, then curves. Then you learn how to put them together. Now you begin making pictures. Shading, action, perspective, and all the rest follow in their right order, until you are making pictures that bring you splendid prices. Prominent artists get as high as \$1,000 for a single drawing.

Big money is gladly paid and big money is waiting for anyone with foresight enough to prepare for this pleasant profession. Through our new easy method of teaching, **YOU** can earn big money as an artist, **regardless of your present ability**. Mail coupon today for interesting booklet telling all about it.

Coupon Brings Fascinating Booklet

An interesting and handsomely illustrated booklet, "New Easy Way to Become an Artist," has been prepared and will be sent to you without cost. It tells how you can easily become an artist in a few minutes' daily spare time and at a cost of a few cents a day. Explains about this amazing method in detail. Tells of our students—and their wonderful progress—and how we can qualify you for a high-salaried artist's position. Booklet gives full particulars about our "Free Artists' Outfit" Offer. This booklet will be sent free, and without obligation. Read all about this amazing New Easy Way to Draw and how you can quickly learn at home in your spare time. Fill out the booklet-coupon now. Mail it **TODAY**.



Mail coupon today for this fascinating booklet, and learn how you can become an Artist in a few minutes a day of your spare time. Cut out coupon and mail NOW.

The Washington School of Art, Inc.
Room 3011, 1115-15th St. N. W., Washington, D. C.

Please send me, without cost or obligation on my part, your free book, "New Easy Way to Become an Artist" and full details about your special Short-Time Offer.

Name.....
(State whether Mr., Mrs., or Miss)

Address.....

City.....State.....

Washington School of Art, Inc., Room 3011, 1115-15th St., N. W., Washington, D. C.

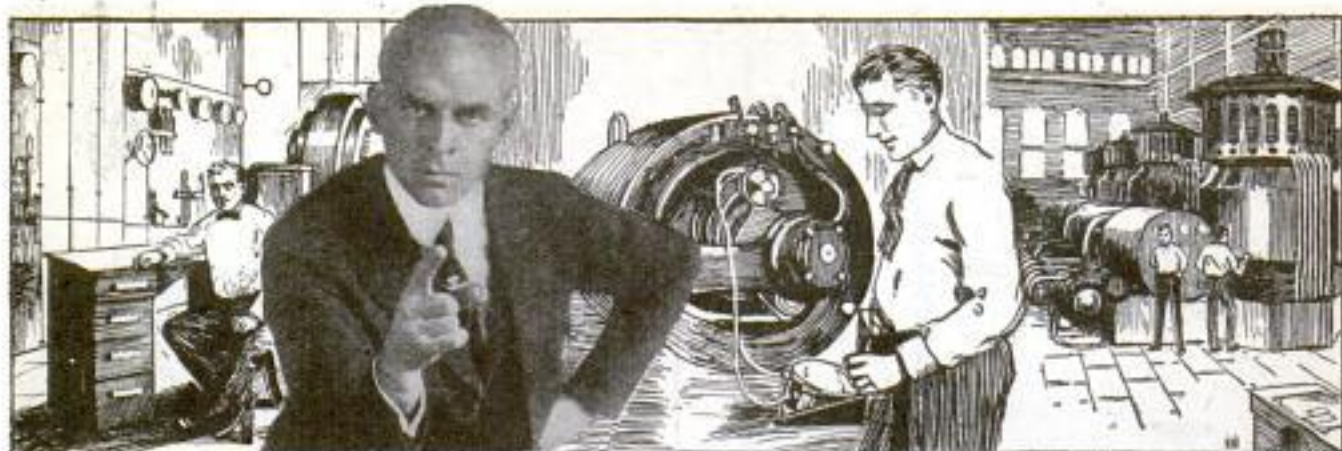

Electricity Needs You I WILL TRAIN YOU AT HOME

Stop right here. This is YOUR opportunity! Electricity is calling you, and the Electrical Business is in for a tremendous increase. But it needs more trained men—at big pay. By my Home Study Course in Practical Electricity I can train you for these positions.

Earn \$70 to \$200 a Week

You've always had a liking for Electricity and a hankering to do electrical jobs. Now is the time to develop that talent; there's big money in it. Even if you don't know anything at all about Electricity you can quickly grasp it by my up-to-date, practical method of teaching. You will find it intensely interesting and highly profitable. I've trained and started hundreds of men in the Electrical Business, men who have made big successes. YOU CAN ALSO

Be a Big Paid ELECTRICAL EXPERT

What are you doing to prepare yourself for a real success? At the rate you are going where will you be in ten years from now? Have you the specialized training that will put you on the road to success? Have you ambition enough to prepare for success, and get it?

You have the ambition and I will give you the training, so get busy. I am offering you success and all that goes with it. Will you take it? I'll make you an ELECTRICAL EXPERT. I will train you as you should be trained. I will give you the benefit of my advice and 20 years of engineering experience and help you in every way to the biggest, possible success.

.....
Chief Engineer Cooke
Chicago Engineering Works
 Dept. 18, 2154 Lawrence Avenue
 CHICAGO, ILL.

Dear Sir: You may send me, entirely free and fully prepaid, a copy of your book, "How to Become an Electrical Expert," and particulars about your Home Study Course in Electricity.

Name.....

Address.....

Occupation..... Age.....

Valuable Book Free

My book, "How to Become an Electrical Expert," has started many a man on the way to fortune. I will send a copy, free and prepaid, to every person answering this advertisement.

Act Now! Good intentions never get you anywhere. It is action, alone, that counts. NOW IS THE TIME TO ACT.

L. L. COOKE, Chief Engineer

**CHICAGO
ENGINEERING
WORKS**

2154 LAWRENCE AVENUE
 Dept. 18, Chicago, U. S. A.

FREE! BIG ELECTRICAL OUTFIT

A fine outfit of Electrical Tools, Instruments, Materials, etc., absolutely FREE to every student. I will also send you FREE and fully prepaid—Proof Lessons to show you how easily you can learn Electricity and enter this splendid profession by my new, revised and original system of Training by Mail.

RADIO COURSE FREE

Special newly-written wireless course worth \$45.00 given away free.

Earn Money While Learning

I give you something you can use now. Early in my Home Study Course I show you how to begin making money in Electricity, and help you get started. No need to wait until the whole course is completed. Hundreds of students have made several times the cost of their course in spare time work while learning.

Classified Advertisements

WORLD'S BEST WANT AD MEDIUM

Advertisements in this section, 25 cents per word, each; insertion, minimum 10 words, payable in advance. To be inserted under proper classification in December issue, copy should be in our office October 18th.

ADVERTISING AGENCIES

TO secure agents or salesmen or for selling farms and reaching investors, use classified (want) ads in largest newspapers and magazines. Price list No. 30 sent free. Ankrum Advertising Agency, 20 W. Jackson Blvd., Chicago, Ill. The largest classified advertising agency in the U. S.

25 WORDS—355 Rural Weeklies \$14.20. Ad-Meyer Agency, 4112-M Hartford, St. Louis.

25 WORDS—151 Weekly Newspapers \$6.40. Information free. Shaw, 221A Northeast, Washington, D. C.

FOR ADVERTISERS

GUARANTEED Addresses, Agents, Rural Housewives, School Teachers, Etc. Neatly typed on gummed stickers. 75c per 100; \$5.00 per 1,000. 10% discount 5,000 or more. Taber Bros., 309 Fifth Avenue, New York.

MAILING List, 30,000 guaranteed mail order buyers names. Write. John Smelter, 2342 West 19th, Chicago.

INCH Display 100 magazines three \$8. Reck, 5400 Alaska, St. Louis.

ADVERTISEMENT four weeks Twenty newspapers 40c word. Affiliated Newspapers, Bedford Building, Chicago.

35 WORDS seventy magazines \$1.00. Three \$2.50. Smith's Service, 1194, West-nathee, Wash.

ADVERTISE in 24 Big Sunday Newspapers, 24 words \$15.00. Catalog listing 1,000 leading Dailies, Weeklies, Magazines, 4c stamps. Union Advertising, Baltimore Bldg., Chicago.

ADVERTISE, hundred magazines, three issues, 10c word. Pennell-Company, Covington, Ky.

SALES PROMOTION

FIVE Essentials will make your business letters successful. Fifty "Don't's" warn you away from frequent faults. Both, 50c postpaid. Cutler, Limited, Reading, Pa.

STOP—Look and Listen! I write sales letters that command attention, and compel action, \$3 a letter. Robert Hoagland, 1217 West 47 Street, Kansas City, Mo.

AUTOMOBILE SUPPLIES

BIG Profits in Eight Hour Battery Service. Only \$16.50 monthly. Postal brings particulars. Hobarts, Troy, Ohio.

AUTOMOBILE Parts—Used parts for most any car at half factory list prices. Allen, Briscoe, Buick, Cadillac, Chalmers, Chevrolet, Dodge, Dort, Grant, Hudson, Huppmobile, Oakland, Overland, Oldsmobile, Rex, Studebaker and many others. Send list of parts wanted. Century Auto Parts Co., 4196 Olive St., St. Louis, Mo.

AUTO and Truck Parts. Save 25-80%. New and used motor, gears, axles, bearings, springs, generators, \$10 up. New Zenith, Johnson, Rayfield, Stromberg carburetors, \$7.50 up; new waterproof Simms and Berling magnets, \$15; Ford retooling, \$4-\$6; other cars, \$12 up. Brighton Auto Exchange, 321 Windsor Ave., Hartford, Conn.

AUTO Parts at cut prices! All kinds of new and used, for all cars. Engines, Clutches, Transmissions, Axles, Radiators, Magnets, Generators, Batteries, Shafts, Gears, Bearings, Springs, etc., etc. If you have never known the house of Warshawsky, you had better write us and get acquainted. Think of buying the Shaler lens for 85c a pair and rims for any car at \$2.00 each. Windshields from \$8.00 to \$10.00. Spotlights \$1.75. Welding outfits at a low price. Specify make and model of car when writing. "Ask for Bargain List." Warshawsky & Co., 1935 S. State St., Chicago, Ill.

BARGAINS—Radiators—Sport Bodies built to order—send sketch. All standard makes radiators furnished at bargain prices. State make and model. We guarantee satisfaction. Independent Radiator Co., 1119 Wabash Ave., Chicago.

MOTORISTS save 50% on oil. Agents big money. Write Anderson, 1903 Parallel, Kansas City, Kans.

MILLERITE-ETHYL-Super-Fuel Ingredient for Gasoline. Increases Power and Mileage—Saves Gas. Make it yourself by my simple Formula and clean up fire to fifty thousand a year. This and eighteen other High Class Automobile Specialties described in the valuable literature I'll send you upon request—Hurry! Exclusive Territory!! Miller, Chemist, 1109-1111 Grand Central, Tampa, Fla.

COMPRESSORS, Air Twin Cylinder, Fully Automatic. Only \$20 monthly. Postal brings full information. Hobarts, Troy, Ohio.

CARBON-X makes sluggish motors peppy. Consumes carbon deposits. Guaranteed to satisfy you. Liberal supply postpaid \$1.00. C-P Sales Co., Box 1933, Chicago.

VULCANIZERS, tools, materials, supplies, tires, tubes direct from factory. Miller-Anderson Rubber Works, Anderson, Ind. Dist. P.M.-2.

AUTOMOBILE SUPPLIES AND ACCESSORIES—WANTED

DISTRIBUTOR entire state of Pennsylvania desires Automobile Supplies and Accessories of real merit. Pennsylvania buys 1-12 of all Automobiles made. Controls names of one million Automobile Owners including Retail Stores, Service Stations, Garages and Individuals. Do you want Your Product featured vigorously to this list of a Million Prospective Buyers? If so submit for consideration sample, full details and Best-Book Prices based on State Wide Distributor's Service. James C. Johnson, 118B Woodbridge Ave., Buffalo.

AUTOMOBILES

PATENTS—Write for our Guide Books and "Record of Invention Blank" before disclosing inventions. Send model, or sketch and description of your invention for our free Examination and Instructions. Highest references. Reasonable terms. See advertisement on pages 182 and 183. Victor J. Evans & Co., 185 Ninth, Washington, D. C.

JYKE'S Automobile Encyclopedia, 13th edition, new, greater than ever, entirely rewritten and rearranged. Contains greatest array of automobile facts ever published in one volume. Separate books containing same information cost \$21. Over 1200 pages and 4100 illus. Cloth \$6. Flex. Amer. Morocco \$7.50 postpaid. Popular Mechanics Book Dept., 206 E. Ontario St., Chicago.

AUTO Side Curtains—1924 Invention. Fits all open cars—Inexpensive—storm proof—classy. Blueprinted building instructions \$1.00. Particulars. Faber, 5 No. La Salle, Chicago.

RACING Bodies for Fords and Chevrolets 490. Send for free particulars. Our book "How to Build a Ford Racer" sent on receipt of 25c. Central Auto Supply Company, Dept. 120-C, Louisville, Ky.

A REAL trouble shooter motor book. Shows the car owner how to make adjustments and minor repairs in every case where the services of an expert repairman are not actually required. \$1 postpaid. Popular Mechanics Book Dept., 206 E. Ontario St., Chicago, Ill.

POTENTIAL Battery Charging Brings added business, bigger profits. Costs \$16.50 monthly. Write us. Hobarts, Troy, Ohio.

PATENTS. Write for my free Guide Books "How to Obtain a Patent" and "Invention and Industry" and "Record of Invention" blank before disclosing inventions. Send model or sketch of your invention for instructions. Promptness assured. No charge for above information. Clarence A. O'Brien, Registered Patent Lawyer, 588 Security Bank Building, directly across street from Patent Office, Washington, D. C. See pages 180 and 181.

AUTOMOBILE Owner's Handbook containing 286 ideas for making your car longer lived and more comfortable. Also tells how to make emergency repairs on the road. 221 illustrations. 50 cents. You should also have Automobile Tourist's Handbook which has dozens of ideas on auto camping and touring. 50 cents. Both books for \$1. Popular Mechanics Press, Room 807, Popular Mechanics Building, Chicago, Ill.

FOR FORD OWNERS

SMALL But Mighty is the arm that regulates the spark on your Ford with an Atkinson Automatic Timer. It is always on the job and makes driving easy. Price \$3.00. From your Dealer or by Mail. Dealers and Salesmen wanted. Write for information. Atkinson Automatic Timer Co., Cynthiana, Ky.

FORD Repair Book Free: A very complete and well illustrated book explaining how to make repairs on most every part of your Ford. We offer this book free with a nine months' subscription to Ford Owner and Dealer Magazine—at only \$1.50. Everyone interested in the Ford car should read this big magazine of about 200 pages monthly. It clearly explains the things you want to know about cutting down the cost of operation, the engine, ignition, transmission, carburetor, etc. Send today and get the valuable Repair Book Free. Ford Owner and Dealer Magazine, 547 Montgomery Bldg., Milwaukee, Wis.

2½ MORE volts than any ordinary Ford Timer. More power, more pep, better pick-up, and instant starting. Wipe Ford Brush—replaces roller in any standard Ford Timer. Smooths out worn timer shells. Positive contact—strong, steady spark—uses no oil or grease. Highest grade carbon steel lip, or wearing surface, is harder than glass. Helps keep spark plugs clean. Eliminates much carbon and coil trouble. Sent prepaid for 75c. Fully guaranteed. Order one today. A A Products Company, Mfrs., Department A, Denver, Colo.

PROFITABLE Business Quickly built. One Day Battery Service. \$16.50 monthly. Write us. Hobarts, Troy, Ohio.

FORD Battery Cables complete with Non-Corrosive Connectors. Anyone can attach. Sent Postpaid for \$1.00. Agents Wanted. Hiawatha Sales Company, Atchison, Kans.

UNDERSLING with "RKO" Swing Lo Irons. See "Red-i-Kut" ad page 151.

CALIFORNIA Tops for Ford Roadster and Touring. Stylish—Noiseless. Cool in Summer. Warm in Winter. Easily Installed. High Quality. Low Prices. Write Factory Today. Koupet Auto Top Company, Belleville, Ill.

MOTORCYCLES, BICYCLES AND SUPPLIES

SEND for our Bargain Bulletin and Money Saving Message. It will save you money on Motorcycles, Side Cars, Motor Wheels, Repair Parts and Accessories. Some used parts at less than half. Cleveland and Ace Motorcycles our specialty. See our ad on page 150. American Motor Cycle Co., 2045-5-7 W. Chicago Ave., Chicago.

SAFE Opening, Gum and Locksmithing; Trade Secrets, Literature Free. Nelson Carter, Shreveport, La.

USED parts for all motorcycles, cheap. State wants. Schuck Cycle Co., 1923 West-lake, Seattle, Wash.

SEND for Bargain Bulletin. All makes of rebuilt motorcycles at lowest prices. Used parts half-price. Ash Motor Corporation, Rochester, N. Y.

USED Motorcycle Bargains; Lists free. Seeber-Hofheins, Buffalo, N. Y.

1922 HARLEY-DAVIDSONS, \$135; 1921, \$115; 1920, \$85; 1919, \$65; 1917, \$50; 1916, \$45; 1915, \$40; 1914, \$35. Guaranteed. Money refunded if not satisfied. Circular free. Wisconsin Cycle Sales Co., 725 National Ave., Milwaukee, Wis.

DON'T buy a Bicycle Motor Attachment until you get our new catalogue and prices. Also runs washers, pumps, and shop machinery. Shaw Mfg. Co., Dept. 27, Galesburg, Kans.

OVERSTOCKED—200 Used Motorcycles. Must be sold at once. We have Harley-Davidsons, Indians, Hendersons, Excelsiors, Cleverlands. Write for our Bargain List. Myerow Brothers, Dept. B, 15 Berkeley St., Boston, Mass.

SEND for big list of slightly used motorcycles on the easy payment plan. Howard Cycle Co., Trenton, N. J.

NEW and used parts for Motorcycles and Bicycles. Get our prices on parts needed. Kingshighway Motor Co., 1166 N. Kingshighway, St. Louis, Mo.

SIDE-CARS (New Rogers) with extension axle and fittings for all motorcycles, \$49.00 crated. Engines, Single, \$8.00—Twins \$10 and \$12. Erickson, 438 W. 79th, Chicago.

AVIATION

A NEW Motor for Seventy-Five Dollars. We will sell new two-cylinder Lawrence motors, 28 horse-power, complete with new mahogany Lang propeller, has Duplex Zenith Carburetor, Deleo Ignition System. Cost the Government almost thousand dollars—\$75.00. Spilldorf Magnets, new, with platinum points, one or two cylinder, \$5.00 each—lots of fifty to five-hundred \$3.75 each. Brand new Altimeters, luminous dial, twenty thousand feet or more, suitable for auto as well as aeroplane, 3½-inch dial, worth twenty dollars easily—only \$8.00 while they last. OX5 Motor Cylinders, guaranteed equal to new, 8 for \$20.00 or \$2.00 each. OX5 Gaskets, 8 intake, 8 exhaust, for \$1.00. New spark plugs, Champion A. C. Bethlehem, Raja, etc., 10 for \$3.00. We carry in stock parts for any make of motors, speed boats or airplanes. Crawford Airplane Co., Venice, Calif.

HEATH propellers represent the most efficient method of aerial drive. Each propeller individually designed for the particular work to be done, as laid out by America's oldest aeronautical engineers. Propeller catalog 4c. Sled blue prints \$2.00. Jersey aviator helmets 95c; resistal goggles \$2.90. Heath Airplane Co., Chicago, Ill.

OPPORTUNITY is at your door. Learn Airplane Engineering Now. The World Flyers were Airplane Engineers. Write for free catalog, Western Airplane Corporation, Dept. K, Monadnock Block, Chicago.

PATENTS. Write for my free Guide Books "How to Obtain a Patent" and "Invention and Industry" and "Record of Invention" blank before disclosing inventions. Send model or sketch of your invention for instructions. Promptness assured. No charge for above information. Clarence A. O'Brien, Registered Patent Lawyer, 588 Security Bank Building, directly across street from Patent Office, Washington, D. C. See pages 180 and 181.

COMPLETE Scale Plans, with Building-Flying Instructions for following 5-ft. Model Aeroplanes, 25c each postpaid: JN4D-2; DeHavilland; N. C.-4; Curtiss Tractor; Bleriot; Nieuport or Taube Monoplanes; Cecil Peoli Racer. Complete 48-pp. catalogue 5c. Ideal Aeroplane Co., 145½ Spring St., New York.

"TWO-SEATER Sportford" Efficient and Economical. Complete plans and parts for Builders. Blueprints and Instructions, \$5. Motorcycle Engine Monoplanes Plans, \$2.50. Circular Free. Aviation Engineering Co., Lawrence, Kans.

NEW JN4-Ds complete in original crate \$1250.00. Perfect condition. Used JN4-Ds wonderful condition \$800.00. Flying tuition \$100.00 extra. Complete stock Curtiss parts. Sterling Silver Wings mounted on bar pin \$1.00. Catalogue on application. Wallace Aero Co., Bettendorf, Iowa.

AIRPLANES, Flying Boats, Motors, Aircraft Supplies. New 80 H. P. LeRhone Rotary Motor \$77.50; Balloon Baskets \$50; OX5 Motor \$400; Zenith Carburetor \$12.50; Compass \$15; Unshatterable Goggles—Jumbo \$3.50; side-vision \$5; Leather Helmets \$4.50; 26x4 Wire Wheels \$6.50; Cord Tires, Slightly Used, \$3; Moderately Used \$2; New Tubes \$2; Airplane Cloth, 65c Yd. Floyd Logan, 710 W. Superior, Cleveland, O.

TEN lessons in the air, of twenty minutes each will make you a pilot, by our advanced method of training. This together with our five week shop course at \$100.00 makes America's oldest aircraft factory, the most popular flying school. Work after class hours guaranteed. Heath Airplane Co., Chicago, Ill.

BOYS get a three-foot model aeroplane free. Nothing to sell. Write to Aero Shop, 3050 Hurbit Ave., Detroit, Mich.

ONE Dollar Bill Buys Both "Aerodrive" Boat, "Aerodrive" 75mph guaranteed Sled Blueprints. Aircraft Supplies. Unshatterable goggles \$3.00 pair. Wing done \$2.50 gallon. Ostergaard Aircraft, 4269 North Narragansett, Chicago.

WANTED to trade excellent overhauled OX5 motor complete with toothpick-propeller for Fordson Tractor, Freddie Carlsson, Wallace Aero Co., Bettendorf, Iowa.

HUNDRED horsepower, Gnome aeroplane engine, practically new. Will exchange for good radiophone. Box 702, Mobile, Ala.

THE American School of Aviation announces a new correspondence course in Mechanics of Aviation. A thorough training in Practical Aeronautics, American School of Aviation, Dept. 1865, 3601 Michigan Ave., Chicago, Ill.

SEND 10c for our latest aeronautical catalog, listing a complete line of airplane goods at reduced prices, Ford or Motorcycle motored airplane catalog 4c each. Heath Airplane Co., Chicago, Ill.

WELDING AND SOLDERING

WELDING Encyclopedia—New Third Edition. Complete training course for operators in all welding processes; oxyacetylene, electric arc, electric resistance and thermit. Welding of all weldable metals fully discussed. 437 pp., 600 Ills. The accumulated experience of the welding brains of America is yours for \$5. Money back if not satisfied. Popular Mechanics Book Dept., 200 E. Ontario St., Chicago.

BOOKS AND PERIODICALS

AUTOMOBILE, motorcycle, aviation magazines. Everything. What's wanted? List free! Toepf Magazine Agency, Middletown, N. Y.

ENCYCLOPEDIA Britannica, India Paper, or Harvard Classics, half price. Dalton Bldg., Crilly Bldg., Chicago.

SAVE Money on magazine subscriptions; catalogue free. Osley, New Vienna, Ohio.

"THEOLOGY and Creation vs. Evolution and Darwinism." Just the book you want to read to get a clear, comprehensive view of both sides of this much discussed subject. Well bound, 224 pages. \$1.00 postpaid. Smaller book 201 pages, 50c. From best bookstores or Stephen O. Bryant, Bethesda, Md.

EDUCATIONAL Books and Correspondence Courses. Bargain prices. Bulletin free. Instruction Correspondence Exchange, 1940 Broadway, New York.

MILES Standish's Automobile Storage Battery Book, 50 cents. Heald's Engineering School, 1101 Sutter Street, San Francisco.

THE Vest Pocket Lawyer, in plain language, 335 pages, 112 forms; \$1.50. Satisfied or money back. Hazzard Company, Box 1, Yandereer Park, Brooklyn, N. Y.

HYPNOTISM wins your wishes. Controls, amuses, astounds, 25 Easy Lessons \$1.00. "Mindreading" (any distance), wonderful. Success guaranteed, 50c. Popular Institute, N1014 Belmont, Chicago.

MAGAZINE Subscription Bargains. Limited offers. List free. Dunbar, Dorchester Center, Mass.

WRITERS: Study at home; 30 text books; criticism and advice regarding markets for manuscripts. Catalogue free. Correspondence invited. James Knapp Reese (former editor The Editor), 50 Alexander Bldg., Franklin, Ohio.

INDUSTRIAL Alcohol. Wright's book. Full directions for making drawings. \$2.50. Spoon & Chamberlain, 120 P. M. Liberty Street, New York, N. Y.

FREE—Send for my Newthought, Self-culture, Occult, Mystic and Scientific book literature. Martens Publisher, Burlington, Iowa.

"NATURE'S Finer Forces"; Vibrations; Lights; Colorlines; Electromagnets; Odicuras; Radio; Coldlights; Inventions; Wonderful Opportunities; Fifty Lessons; Marvelous Cures; Illustrated. Satisfaction Guaranteed. 270 pages. \$2.00. DeLuxe \$3.00. M. Stevens, 242 Powell, San Francisco, Calif.

PICTURES AND POSTCARDS

25 **BEAUTIFUL** post card views of Washington. White House included, 25 cents. Capitol Views, 629 Second Street, N. W., Washington, D. C.

JOIN Popular Friendship Club. Exchange view postcards with our enthusiastic members everywhere. Fascinating pastime. Membership two months 10c; six months 25c. Oliver Gandy, 24 Calendar, Providence, R. I.

ATTRACTIVE art beauties, 6 for 25c. Hacketts, 410 W. 23rd, New York.

JOIN Live Postcard Club; Membership lists including Catalog, 10c. Harvey Teeple, Decatur, Ind.

IMPORTED Art Study Cards, 100 assortment \$2.00; 50, \$1.25; 15, 50c. 14 Karat Gold Self-Filling Fountain Pens, \$1.50. Your name engraved free. John Huze, Importer, 347-PM East 73rd Street, New York.

10 **COLORED** historical view cards, 20 cents. Gronberg, 1913 South 32nd, Philadelphia, Pa.

WONDER city of the world, New York. 27 beautiful colored views 25c. Large illustrated, pictorial book of New York's wonders, \$1.00. Hackett's Service, 410 W. 23rd, New York.

JOIN International League, largest correspondence club. Membership 10c. One year 25c. L. Hurgins, Box 44, Philadelphia, Pa.

75 **BEAUTIFUL** Art Pictures and Bathing Beauties 25c (each). Photo Sales Co., 6975 Pingree, Suite 391, Chicago, Ill.

JOIN—Old Reliable Card Club. Membership 10c. Riverside Club, 1408 Meridian, Washington, D. C.

ENGRAVED Greeting Cards. List and Seven Samples Worth 75c for 25c. Miller Company, Chatham, N. Y.

GAMES, ENTERTAINMENTS AND PLAYS

VENTRILOQUISM taught almost anyone at home. Small cost. Send 2c stamp today for particulars and proof. George W. Smith, Room M-912, 125 N. Jefferson Ave., Peoria, Ill.

PLAYS, musical comedies and revues, minstrel music, blackface skits, vaudeville acts, monologs, dialog, recitations, entertainments, musical readings, stage handbooks, makeup goods. Big catalog free. T. S. Denison & Co., 623 So. Wabash, Dept. 11, Chicago.

ENTERTAIN Your Friends! Get "The Mystery Book" by Horace Goldin. (Inventor of "Sawing a Woman in Half.") Also Containing Forms for Reading Individual Character. Fifty Cents Postpaid. Ellis Antkes, Columbia Theatre Building, Dept. B, New York.

MYSTIFY your friends and make money. Ventriloquism made easy by new Scientific Method. Write today for free information. Whittle Institute of Ventriloquism, Dept. 69, Bloomfield, N. J.

LEARN Trick Cartoosing. Entertain at Clubs, Schools, Parties. Go on the Stage. Two complete programs Comedy Trick Cartoons with Beginners Instructions sent for One Dollar. Footlight Cartoonist System, Portsmouth, Ohio.

POPULAR MECHANICS new illustrated Book Catalog lists books of entertainments and games. A copy is free. Address Popular Mechanics Press, Room 807, Popular Mechanics Building, Chicago, Ill.

NOVELTIES, CURIOS, ETC.

MEXICAN Revolutionary (Pancho Villa) Money; Photo Views Mexico and Southwest. Quarter brings sample package and lists. Sam Alfman, B824, El Paso, Tex.

FRENCH souvenirs, novelties, curios, war medals, coins, stamps. Lists free—L. Nicolas, 3 Rue Primatire, Paris.

NEW, Rare, Miracle—Water Plant. Lives forever. Sample with wholesale terms to Agents 25c, with Illustrated Catalogue of Desert Plants. Canutillo Carlo Co., Canutillo, Texas.

MYSTERIOUS Novelties, when dropped into water, expand twice original size, turning into fish, flowers, animals. Pretty Package twelve, assorted, 15 cts. Heinemann, 7242 Pingree, Chicago.

MAGIC TRICKS, BOOKS AND JOKER NOVELTIES

WONDERFUL Trick Cards Dime. Catalogue Free. Larry Dodge, 21 Leppold St., Lawrence, Mass.

MAGIC goods, cards, books, novelties, tricks. Catalog free. C. Penner, 2401 Jefferson, Louisville, Ky.

SPIRIT Medium's Table Lifting—mystifying trick—complete, with instructions, 10c. "250 Magic Tricks," (illustrated), 10c. G. Elges, Bowling Green, Ohio.

AMAZE and Mystify your friends; New 64-page Copyrighted Book tells how, "33 Card Mysteries" just published, including New 1924-5 Catalog of 300 Mystifying Magical effects, prepaid 10c. Send now! Lyle Douglas, Station A, Dallas, Texas.

200 **KINDS** of Iron, Wood and Wire Puzzles. Leader and Illustrated folder 10c. Western Puzzle Works, C. St. Paul, Minn.

DIMINISHING Billiard Ball, 50c. Secrets, Pocket Tricks, Small Magic. Lowest Prices. Catalogue free. C. Penta, Minneapolis.

MAGIC—Tricks, Books and Supplies. For Amateurs as well as the great professionals. Anyone can learn through our instructions. Feature Acts in Mind Reading, Spiritism, Rope Ties, etc. Large Illustrated Professional Catalog, 20c. Chicago Magic Co., 140 S. Dearborn St., Dept. B, Chicago, Ill.

FLYING model airplane with 15 magician tricks \$4. James Sinclair, Tacoma, Wash.

TRICKS, puzzles, jokes, magical apparatus, plays, stage supplies, mind-reading, sensational escapes, large illustrated professional catalog, 10c. Oaks Magical Co., Dept. 548, Oshkosh, Wis.

SEVEN Magic Effects. Four Catalogs—25c. Gilmaglio, Morgan Park, Ill.

STAMP COLLECTING

TEN Large Showy Stamps Free; Postage 2c. Stamp collections bought. Payn Stamp Co., 945 Vista Drive, Los Angeles, Calif.

FOUR unused sets, including "Prisoners of War," 55 different, hinges, premium, 15c. Deering, Newton St., Marlborough, Mass.

FREE! World's smallest stamp. Postage 2c. Approvals. Cannon Company, Davenport, Ill., Iowa.

BARGAINS! 100 unused all different stamps, only 5 cents, another 1,000 mixed stamps from Europe, Asia, Africa, etc., 20 cents. Nielsen, 3244 Whipple St., Chicago, Ill.

50 VAR. Scandinavian 10c. Try my recent approvals. N. Gronberg, 1012 S. 52 Philadelphia, Pa.

POSTAGE Stamps. 200 Mixed Foreign 10c; 50 U. S. Each different, 10c. Marie Stamp Exchange, Villa Park, Ill.

50 DIFFERENT Scandinavian stamps 10c. Phil Landsted, Cape Cottage, Maine.

FREE—Two Sets Nyassa. Also 20 dif. British Colonies, Barbadoes and Jamaica pictorials and packet of hinges for a request for my 1, 2, 3c net approvals. None better. Charles T. Egner, 4821 Frankford Avenue, Frankford, Phila., Pa.

1901 NYASSA set, 10 mint beauties, 10c to approval applicants! Edward Hammond, Auburndale, Mass.

2,000 DIFFERENT \$5.00; 1,000, \$1.50; 500, 50c; 300, 25c. Fred Oaken, 630 79th Street, Brooklyn, N. Y.

1,000 ALL different fine stamps, \$1.00. Claud Demey, Box 315, Dallas, Texas.

FREE! 10 beautiful Rhein-Ruhr stamps to approval applicants only. Penna. Stamp Co., Manor, Pa.

35 DIFF. Europe for 5 cts., to applicants for my 1, 2, and 3 cent approvals, and also my 50% discount. Chas. W. Schmidt, 3227 Renner St., Wissinoming, Phila., Pa.

FIFTY British, French and Portuguese Colonials only fifteen cents to net approval applicants. Davies Stamp Co., Box 108, Toledo, Ohio.

SEND for Price List No. 13 of Packets, Sets and Supplies. Approvals for Beginners. Inwood Stamp Company, 218 Inwood Avenue, Upper Montclair, N. J.

FREE—50 Different Stamps to approval applicants sending two cents postage. Neumann, Box 893, Houston, Texas.

STAMPS on approval at 60% discount. References please J. A. Flaten, Fertile, Minn.

PALESTINE: 7 distinct varieties, 15c. Like approvals! Allion, Anzola, Ind.

CANADA imperforate 3-cent carmine free to new approval applicants sending reference. Majestic Stamp Co., Grimshy, Ontario.

SUPERB Newfoundland Stamps sent on approval. References please. Rev. Butler, St. Georges, Newfoundland.

JAMAICA—8 bicolor and 100 different, 10c. Walter Oliver, 813 Richmond, Buffalo, N. Y.

FREE—25 different U. S. Stamps with 60% approvals to reliable parties. 75 different U. S. Stamps 25c. C. Seidenberg, Merton, Wis.

100 DIFFERENT stamps free to applicants for Popular Approvals, postage 2 cents. Christensen, Milwaukee, Wis.

BREAKING up Stamp Collection. Particulars free. Surprise Packet 10c. P. M., Box 214, Marietta, Ohio.

FREE! Three cent orange, red Canada 1872 unlisted guide dot. Variety to applicants for approval selections. E. E. Goodchild, 116 Sherbrooke West, Montreal, Canada.

FREE—Dandy foreign packet, including White Russia, British Guiana, Newfoundland, Dutch Indies, Travancore, Etc., to approval applicants sending 2c. Acme Stamp Company, Rock Island, Ill.

1,000 MIXED 150 Var. 25c; 100 Var. U. S. 17c; 100 Var. Precancelled 15c. Charles Penagh, Elms, Wash.

100 AUSTRIA, 100 Hungary, 50 Unused Germany, 19 cents to Approval Applicants. Laurence Burgess, 255 Sixth Ave., Newark, N. J.

500 MIXED U. S. old and new 10c. Album 15c, 1,000 Hinges 10c, 100 different Foreign 10c. Approvals, Weatherby, Medina, Ohio.

PARAMOUNT 10c Outfit! Contains: air mail set; stamp from smallest republic; famous "confiscated" set of Bulgaria; 2 triangle stamps; perforation gauge, millimetre scale, ruler; stamp from most savage country on earth; set 3 large Crete revolutionary; 2 scarce Hayti, catalogued (1923) \$2.00; big price list; packet from Dutch Indies, Argentina, Bosnia - Herzegovina, British Guiana, Chile, Guatemala, Luxembourg, Newfoundland, Stamps—all for 10c to approval applicants! Paramount Stamp Co., 1540 Broadway, New York, N. Y.

BOYS! Bet you haven't got a single stamp from the Irish Republic! We offer this month only to approval applicants: Packet of 100 different from Cape of Good Hope, San Marino, Plume (triangle), Travancore, Malay (tiger), Guatemala, Congo (Savage), etc., etc.; also a fine set of 5 dif. Ireland. Perforation gauge and ruler, scale, and 250 peelable hinges—all for eight cents! Supply limited, order at once. Paul Berere Stamp Co., Watertown, Mass.

BIG 12c Offer! 98 different, many unused; 5 French Colonies; 5 Portuguese Colonies; 10 Danzig; 10 Czechoslovakia; packet from obscure countries of Transvaal, Travancore, New Zealand, White Russia, Cape Good Hope, Turkey, Siam, Guatemala, Mexico, Bosnia - Herzegovina, perforation gauge; small album for duplicates. This big outfit for 12c to approval applicants! A. R. Perry, 107 Westminster St., Providence, R. I.

WESTERN Wonderlot! Nothing like it ever before offered! Contains: packet fine stamps from Newfoundland, old Canada, \$1.00 U. S., Mexico, Venezuela, Nicaragua, Guatemala, Chile and other countries of the Western Hemisphere; perforation gauge and millimetre scale, triangle stamp, small album. All for 5c to approval applicants giving references. H. P. Huson, Laramie, Wyo.

MYSTIC'S "Mysterious" Packet! Contains stamps from the lands of cannibals, heathens, sun worshippers, and wild savages. Included are Kenya and Uganda, Persia, Africa, Dutch Indies, Gold Coast, Federated Malay States, Abyssinia, Nyassa, Travancore, Siam, Congo, etc. This wonderful packet containing 105 all different (mostly unused) for only 8 cents to approval applicants. Mystic Stamp Co., Dept. 8, Camden, New York.

40 STAMPS from Sweden, 35 Denmark, 30 Finland, 20 Norway, 8 Iceland, 4 new Belgian Congo, 40 France, 9 Georgia, 20 U. S. envelopes, set of 3 Hungarian prisoners, 10c each, 100 French Colonies, 30c, 10 Barbadoes, 15c. Postage extra. No duplicates. Rowland Hill Stamp Co., 3675 Washington St., San Francisco.

BOYS! Have you ever owned a nice, shiny, new pair of steel stamp tongs? Lakeriew offers: Famous "Confiscated" set of Bulgaria (stamps that nearly started a war); set of new Germany with (pre-war) face value over forty million dollars; perforation gauge; small album; packet 100 different from Argentine, British Guiana, etc., etc.—and last but not least, a dandy pair of stamp tongs! The entire big outfit only 15c to approval applicants! Lakeriew Stamp Co., 338 Columbia Street, Toledo, Ohio.

ANCHER'S \$\$\$ Outfit—only 12c! Fine triangle stamp; set German stamps with (pre-war) value forty million dollars (interesting!); perforation gauge, mm. scale; small album; 2 approval sheets; airmail set; scarce stamp from smallest republic on earth; newspaper set; packet good stamps from Travancore, Johore, Dutch Indies, etc. Entire outfit for 12c to approval applicants! (Nice pocket stock book, value 25c, with every order!) Ancher Stamp Co., 148 1/2 Clerk St., Jersey City, N. J.

FAMOUS Fenway Outfit — 2 triangle stamps, small album, 5 blank approval sheets, 250 hinges, perforation gauge, 5 large French Colonials, 2 special deliveries, animal set, red cross set, packet 55 different, including Abyssinia, Azores, Cape of Good Hope, Bosnia, Crete, Congo, etc., 16-page price list, all for 12c to new approval applicants. Fenway Stamp Co., Fenway Station, Boston, Mass.

\$3.00 FOR 12c! 100 different Neurope. Catalogued \$2.00 Red Cross set, Airplane set, Perforation gauge, Millimetre scale, Fine wallet, 5 approval sheets, 250 hinges, scarce packet from Nyassa, Abyssinia, etc., price list and approvals—all for 12c to approval applicants. Atlanta Stamp Co., Box 532, Atlanta, Ga.

PACKET of 23 stamps, no two countries alike. Packet hinges. Set of \$1 and \$2 U. S. Rev., all for 5c. P. M. Miami Stamp Co., Toledo, Ohio.

SURPRISE packet of stamps free to approval applicants, postage 2 cents. Badger Stamp Co., Milwaukee, Wis.

NYASSA Giraffes and packet of 52 different scarce stamps. Plume Triangle, large \$1.00 U. S. Rev., millimetre scale, perforation gauge and ruler for only 9c. To introduce our Sudden Service approvals. Fennell Stamp Company, Dept. P, Fullerton Bldg., St. Louis, Mo.

FREE—Genuine Mexican Dollar Bill and 25 different Poland stamps for a dime. Old Confederate States Bill and 10 different Aeroplane mail stamps for a dime. B. Nagle, 1101 Marlon, Reading, Pa.

SNAPS—200 different stamps, 10c; 60 different United States Stamps, 12c. With each order we give free our price list of sets, packets, albums, etc., and our pamphlet which tells "how to make a collection properly." Queen City Stamp Company, Room 36, 604 Race, Cincinnati, Ohio.

50 DIFFERENT stamps, 2 Malay Tiger Stamps, 5c. Fox Stamp Company, Dept. M, Detroit, Mich.

FREE—20 Luxemburg stamps to general collectors requesting my net approvals. Reference required. J. de Jong, 539 West 162nd St., New York City, N. Y.

FREE! Rare stamp to approval applicants. Albert Behnke, Davenport, Iowa.

500 DIFFERENT stamps cataloguing \$30.00, Special \$2.00, 50 different stamps from 50 different countries, cataloguing \$12.00, Special 50c. Martel, 306 Station "C," Montreal, Canada.

FREE—29 Mint Germany, to approval applicants. Lampe, 423 West 42nd, New York.

100 DIFFERENT Germany 15c; 100 different Austria 15c; 20 different Bosnia 25c; 200 different stamps 15c. R. H. Carlton, 366 W. So. Temple, Salt Lake, Utah.

UNIVERSAL Packet, 100 varieties, all over the world, 10 cents. Covert Stamp, 39 State, Rochester, N. Y.

STAMPS—large variety at exceptional prices—surprise package free with approvals. Fred Brahand, Spring Valley, N. Y.

FREE. Stamps from Siam, China, etc. Send postage. H. Burkholtz, Norwood, Ohio.

BEST one-cent approvals in America. F. P. Hand, 1117 So. 60th St., Philadelphia, Pa.

STAMPS sent on approval at 70% discount. Reference required. Emory Renoll, Hanover, Pa.

60 STAMPS from 30 different countries, 10c. Mogensen, 414 North 14th, Omaha, Nebr.

ALL for 9c: Midget stamp case, 250 hinges, 5 blank approval sheets, perforation gauge, approval card, 100 different stamps from Epirus, etc.; price list sent to honest serious applicants for my 50% approvals. Maitland Millikin, Foster Bldg., Denver, Colo.

HAVE you an Abyssinia in your collection? 3 varieties 5c, 1,000 all different stamps \$1.00. Approvals sent upon request. Edgewood Stamp Co., Millford, Conn.

24 VARIETIES Cuban stamps, 10 cents. List of 6,000 low-priced stamps free. Address Chambers Stamp Co., 111P, Nassau St., New York City, N. Y.

STAMPS, 100 all different. Postage 2c. Lists free. P. M. Quaker Stamp Co., Toledo, O.

158 GENUINE Foreign Stamps, Mexico War Issues, Venezuela, Salvador and India Service, Guatemala, China, etc., only 5c. Finest approval sheets 50 to 60%. Agents Wanted. Big 72-p. Lists Free. We Buy Stamps. Estab. 20 years. Hussman Stamp Co., Dept. 54, St. Louis, Mo.

FOREIGN Stamp Collection Sent Free. Cornish Co., Schenectady, N. Y.

FREE! Loose Leaf Postage Stamp Album at rate of 8 pages each month given with subscription to monthly Journal. Send 2c stamp for prospectus. United Stamp Co., Marquette Bldg., Chicago, Ill.

FREE—50 varieties to approval applicants sending 2c. Richard P. Lamprecht, Valparaiso, Ind.

STAMPS, 50 varieties, Africa, Brazil, Peru, Cuba, Mexico, etc., 10c. 50 different U. S., 25c; 1,000 mixed, 40c; 1,000 hinges, 10c. List free. C. Stegman, 5948 Cote Brillante, St. Louis, Mo.

ZAMBESIA, Zanzibar, Abyssinia, Herzegovina, Allenstein stamps, menagerie collection, album, 10c. Liberty, 3974 Arsenal, St. Louis, Mo.

105 CHINA, etc., stamp dictionary, list, 2c. Album (500 illustrations), 3c. Bullard, Sta. A, Boston.

BIG Variety Packet Foreign Stamps Free for 2c postage. Gray Stamp Company, Station E10, Toronto, Canada.

FRENCH Colonies Free.—Pretty Picture Set, Native Chiefs, Tigers, 2c Postage. Empire Stamp Company, 342 Lippincott, Toronto, Canada.

BIG \$4.00 outfit and premiums to approval applicants 10c. Buckley, 712 Bowen, Dayton, Ohio.

20 UNUSED stamps free. All different. Postage, 2c. P. M. Fisk Stamp Co., Toledo, Ohio.

STAMPS on approval 1/4 cent up. Free Premium. Herbert Keigwin, Middletown, N. Y.

DANZIG Free—Nice Set Danzig Stamps with Biggest Lists issued, 2c postage. Midland Stamp Co., Station E2, Toronto, Canada.

FREE, ten Stamps to new approval applicants. Liberal Discounts. Reference required. Tower Stamp Co., 42 Westville St., Dorchester, Mass.

FREE—100 different to approval applicants. P. M. Gillespie, 1302 S. Madison St., Bloomington, Ill.

101 DIFFERENT, including Fiume Triangle and Germany 200 Million Mark Stamps, 10 Cents. Seneca Stamp Co., 675 Ivy, St. Paul, Minn.

RARE COINS

OLD Money Wanted. Will pay Fifty Dollars for nickel of 1913 with Liberty Head (not Buffalo). We pay cash premiums for all rare coins. Send 4c for large Coin Circular. May mean much profit to you. Numismatic Bank, Dept. H, Fort Worth, Texas.

50,000 COINS, medals. Lists free. Collectors Exchange, 1536 Willington, Philadelphia.

\$1.00 BRINGS Pound of Samples; Bonds, Banknotes, Coins; 10 countries; 57 varieties; 100 pieces. Agents Cleaning Up, Hirsch, 70 Wall St., N. Y.

100 MIXED foreign copper coins from Holland, France, Russia, Finland, German East Africa, Norway, Denmark, Sweden, Switzerland; all bright new condition; postpaid, 75 cents. Nagy, 33P South 18th Street, Philadelphia.

CHINESE, Japanese and Egyptian coins 25c. Duren, 25 Mulberry, N. Y. City.

40 OLD coins, all different, \$1.00. 200 different Germany City Bills, \$1.00. 500 Different Germany Bills, \$3.00. Claud Demsey, Box 315, Dallas, Texas.

44 DIFFERENT foreign Coins \$1.00. Postpaid. Otto Oddehon, Independence, Mo.

309 ALL Different Austrian City bills \$1.50. Weiss, 1115 Lamar, Memphis, Tenn.

CALIFORNIA gold quarter 27c; Half 52c; Confederate \$5, \$10 or \$20, 10c. A. Wylie, Wheaton, Ill.

RARE Coins, Medals, Paper Money, United States, Foreign and Ancient Mexican Bill and New Catalogue, 10c. Alexis Menzies, Box 387, Colorado Springs, Colo.

OLD Coins. Large Spring selling catalogue of coins for sale, free. Catalogue quoting prices paid for coins, 10c. William Haskin, 101 A Tremont St., Boston, Mass.

CALIFORNIA gold, 3/4 size, 27c; 1/2 size, 52c; three-cent-piece and catalogue, 10c. Norman Shultz, Colorado Springs, Colo.

GET Profit and Pleasure in collecting Old Coins. Send 10c for Sample Old Coin, together with my Large Illustrated Coin Catalogue. You'll be delighted with it. Send for it right now. B. Max Mehl, Professional Numismatist, Mehl Bldg., Dept. P, Fort Worth, Texas. Largest Rare Coin Firm in U. S.

FOR BOYS

GIRLS—Boys, Earn Xmas Money. Write for 50 Sets St. Nicholas Christmas Seals. Sell for 10c a set. When sold send us \$3.00 and keep \$2.00. No Work—Just Fun. St. Nicholas, 2814 Glenwood Rd., Dept. 43, Brooklyn, N. Y.

JUST Out—A New Boy Mechanic Book No. 4—1309 Articles, 1320 Pictures. Tells how to make such things as Radio Receivers, Toy Airplanes, Pushcyle, Canoe Pontoon, Diving Rafts, Electromagnets, Wind Wagon and Ice Boat, Catamaran, Motion-Picture Camera, Sidewheel Motorboat, Motor-Driven Sleds, Camp Equipment, and hundreds of other interesting devices. Price \$2 postpaid. Popular Mechanics Book Dept., 200 E. Ontario St., Chicago.

MOUTH-ORGAN Instructor (16 big pages), 25c. Eighteen good selections of music, including "Mocking Bird," with complete instructions for playing immediately. Thousands sold. Order today—become popular. 150 Song Parodies, 10c. 55 Famous Songs (with music), 10c. G. Elsea, Bowling Green, Ohio.

CAMERAS AND PHOTO SUPPLIES

ENORMOUS Profits from Small Camera. Write for Details. Press Studio, Box 132, Lincoln, Nebr.

PHOTOGRAPHIC equipments and accessories of every description are listed and illustrated in our 228-page catalogue. It will pay you to secure a copy which is issued free, as our prices are low. We also deal in used goods which are sold under the same guarantee as new goods. Ask for our Bargain Book. Central Camera Co., Dept. E-87, 112 S. Wabash Ave., Chicago, Ill.

FILMS developed, Prints made. Pictures that look good and last, are worth having. Write for Price List and sample print today. Z. Koscielnik, Box 1361, Detroit, Mich.

CAMERAS—Photographic—3 1/4 x 5 1/2 Kodak Anastigmat lens \$15—Reflex, F. 4.5 lens \$35. Cameras exchanged. Ray, 324 5th Ave., New York.

IF you are interested in pictures you are interested in Camera Craft (15c a copy), 703 Market Street, San Francisco, Calif.

BECOME a "Colorist." Earn Money Tinting Photographs. Your photo enlarged free. Particulars 2c stamp. Colored sample 25c. Radiographic Productions, Studio A, Box 417, Los Angeles, Calif.

SUPERIOR quality finishing and enlarging. Trial offer: Any size 6 exposure roll developed and printed, 25 cents. 8x10 enlargement unmounted, 30 cents. Carhuff Photo Finishing Co., 2129 W. Van Buren St., Chicago, Ill.

BIG Money Saved on Photographic Lenses and Apparatus—goods exchanged; repairing done. Ralph J. Golsen, 1128 Argyle St., Chicago, Dept. P.

KODAK Films—Special trial offer: your next kodak film developed, 5c—prints, 2c each. Moser & Son, 1917 St. James Ave., Cincinnati, O.

AMAZING Trial Offer! Any one Kodak Roll Film Developed; 6 Glossy Prints; only 15c. Associated Photo, Box 1463-W, Cincinnati, O.

SPECIAL Trial Offer—Films developed correctly 10c. Prints 3c each. F. R. B. Photographers, 1503 Lincoln Avenue, Cincinnati, Ohio.

MODERN Photography in all its branches now taught by mail. New Successful Method. Students earning \$300.00 while learning. Big opportunity. Write for particulars and unusual offer open for short time. Dept. 13-56, International Studios, Inc., 3601 Michigan Ave., Chicago.

HAVE You a Camera? Write for Free sample of our big magazine, showing how to make better pictures and earn money. American Photography, 116 Camera House, Boston, 17, Mass.

FILMS Developed, Special Trial Offer. Any Size Kodak film developed 5c, prints 3c each. Trial 6x10 Enlargement in handsome folder 40c. Overnight Service. Roanoke Photo Finishing Co., 209 Bell Ave., Roanoke, Va.

MOTION PICTURES

FILM—Million Feet for Sale. Cowboy—Drama—Comedy and Feature Specials. Mix—Hart—Chaplin and best Movie Stars. \$2.00 per reel up. Genuine List Free. We Supply the World. Dept. G, Monarch Films, Memphis, Tenn.

MOVIE Camera \$40—Tripod \$3—Sept. automatic Movie Camera \$75—Home Projector \$25—Films \$3 a reel. Ray, 324 5th Ave., New York.

FOR Sale—New \$250 Motor-Driven Suit Case Projector, Accommodates 1,000 - ft. Reels. \$125. Arnold Werner, High Ridge, Mo.

BIG Money Nightly—Good assortment. Complete outfits, installment plan. Splendid Home Outfit, \$25.00. Good Movie Camera, \$35.00. Ralph J. Golsen, Dept. M, 1128 Argyle St., Chicago.

DON'T fail to send for the big Free Bass Book of Cinema Apparatus. The Cyclopedia of M. P. Cameras and Projectors. Get in the game that has made thousands independent. Write or wire for your copy. Bass Camera Company, 105 N. Dearborn St., Chicago, Ill.

WONDERFUL Opportunities for Making Fortunes in this Business. No Experience needed. Complete Theatre Outfits sold on Easy Terms. Free Catalog. Monarch Theatre Supply Co., Dept. P, Memphis, Tenn.

GENUINE Kresmann M. P. Home Projector, Mazda Illumination. Complete with full reel of film, \$35.00. Bass Camera Company, 109 N. Dearborn St., Chicago, Ill.

EVERYTHING for "Movie Man," including Film Service, Catalogs Free. Grobarick, Dept. P, Eldridge Park, Trenton, N. J.

AMERICA'S Greatest Fortunes made in the Motion Picture business. We furnish complete theatre equipment on easy payments. Openings everywhere. Catalog free. Monarch Theatre Supply Co., Dept. A, 724 So. Wabash Av., Chicago, Ill.

\$35.00 PROFIT nightly. Small capital starts you. No experience needed. Our machines are used and endorsed by government institutions. Catalog free. Atlas Moving Picture Company, 482 Morton Bldg., Chicago.

\$\$\$ FOR Ideas. Photoplay plots accepted any form; revised, criticized, copyrighted, marketed. Advice free. Universal Scenario Corporation, 206 Security Bldg., Santa Monica and Western, Hollywood, Calif.

MAKE money writing photoplays; details free to beginners. No correspondence course. Producers League, 250 Wauwright, St. Louis.

ELECTRICITY—Make it yourself with our auto generator. Write for particulars. Monarch Theatre Supply Co., Dept. 7, 724 So. Wabash Av., Chicago.

SCENERY TO RENT

SETTINGS for Opera, Plays, Minstrels. Push drops. Address Amelia Grain, Philadelphia.

EDUCATIONAL AND INSTRUCTION

"MODEL Engineering," a book on the design and use of Scientific Models and Experimental Apparatus. Send for circular. Lightning Method Publishers, Box 999, Long Beach, Calif.

USED educational matter bought, sold, exchanged. Bulletin free. Instruction Correspondence Exchange, 1968 Broadway, New York.

ROPP'S Calculator and Short-Cut Arithmetic shows the answer as quickly as a watch shows the time to all problems likely to occur in office, store, shop, bank, farm or factory. Price, pocket size, paper 35 cents; cloth 50 cents; leatherette \$1. Desk size, cloth \$1.50 postpaid. Popular Mechanics Book Dept., 206 E. Ontario St., Chicago.

SHOWCARD Writing Made Easy. Instruction Book and Complete Outfit \$1.00. D. Gale, Box 315, White Plains, N. Y.

STUDY Patent Solicitation. Become Patent Attorney. Full particulars, Patent Law, Jordan, Miss.

USED educational matter, books, etc., bought, sold, rented and exchanged. Big list free. Lee Mountain, East Chattanooga, Tenn.

"WHAT to Invent for Profit" free. Patent News-N, Washington, D. C.

YOUR Memory Needs Training. Complete Course Fifty Cents. L. & M. Company, Kingston, Oka.

USED Educational Matter; save over half. Bargain catalogue 1,000 courses free. Used courses bought. Students' Exchange, Dept. A, 47 West 42nd St., New York.

WORLD-ROMIC System, Masterkey to All Languages. Primers, \$1.94; Chinese, French, Spanish, Pronunciation-Tables, 30c. Languages, 8 West 46th Street, New York.

ARTIFICIAL Marble sanitary flooring instructions, ornamental casting, concrete, plaster, papier-mache decorations, garden furniture, statuary, Rubber-moulds. 15 years' instruction the public, particulars and 200 illustrations free. Chris Mahler, Huntington, N. Y.

DRAFTING, Tool Designing and Mathematics taught by mail; combined course or separate subjects. Harding School, Box H, Highland Park, Mich.

"SIGN Painting Simplified" teaches you this big paying trade. Beautifully illustrated book and working outfit \$1. Sign-Book Shop, 910 N. 18th St., St. Louis, Mo.

DOUBLE Entry Bookkeeping mastered in 60 hours with 8 keys; guaranteed; diplomas. International Bookkeeping Institute, Dept. 8, Springfield, Mo.

BOOKKEEPING in a Week, \$2 complete. Dukes, 1857 Walton Av., New York.

YOU can have a business profession of your own and earn big income in service fees. A new system of foot correction; readily learned by anyone at home in a few weeks. Easy terms for training; openings everywhere with all the trade you can attend to. No capital required or goods to buy, no agency or soliciting. Address Stephenson Laboratory, 1 Back Bay, Boston, Mass.

CARTOONISTS—Improve your style by following the work of the greatest cartoonists found in the bound volumes of Cartoons Magazine. Three volumes, each covering six months, Jan-June 1919 to Jan-June 1920, inclusive, 1200 cartoons, 900 pages to a volume, 7 by 9 1/2 in., 3 in. thick. New books, durable and attractive binding. Sold separately at \$2 per vol. postpaid. Supply limited. Send at once. Popular Mechanics Book Dept., 206 E. Ontario St., Chicago.

RADIO OUTFITS AND SUPPLIES

RADIO Receiving Sets easily built by anyone—it is inexpensive and takes but two hours of your time. No experience necessary. Under the free personal guidance and instruction of our experts you can build your own radio receiver and can hear music, lectures, news; also weather, market and foreign reports from thousands of miles away. Our bargain list, diagrams, hook-ups, illustrations and a wealth of other information while they last, sent to you for a two-cent stamp. Address the Radio Shack, 53 Vesey St., Dept. PMN, New York City.

RECHARGING Radio Batteries in Eight Hours pays big profits. Particulars free. Radio Hobart, Troy, Ohio.

MAKE Good Money selling radio parts and sets to yourself and friends. Write for catalog 6-P. Western Radio Corporation, Cedar Rapids, Iowa.

DON'T Scrap your crystal or tube set. Wonderful volume with our amplifiers \$8. Theodore Burwell, Middletown, N. Y.

RADIO Bargains. New \$35.90 Radiola Grands \$150.00. New \$150.00 Ectophones \$75.00. Complete in cabinets. Guaranteed. 10% with order. Write Powers Radio Co., 713 N. Michigan, Chicago.

DICTIONARY of Radio words and terms, electrical symbols, wiring diagrams, radio diagrams and complete electrical dictionary, new, up-to-the-minute, just published, 188 pages, cloth cover, vest-pocket size, 35c postpaid. Popular Mechanics Book Dept., 206 E. Ontario St., Chicago.

RADIO \$10.00 Complete. Other bargains. Trego Mfg. Co., Tiffin, Ohio.

BLUR Generators, brand new, 6 volts; maximum output 22 amperes at 2000 r.p.m.; complete with automatic cutoff for charging a battery. Government surplus, price \$10.00. Cook County Sales Company, 2454 Calumet Avenue, Chicago, Ill.

60 STAMPED Applause Cards, prepaid, \$1.00. Powell Radio, Prescott, Ariz.

THOUSANDS of Bargains in Radio Supplies and Sets. Write for Free Complete Catalog. Stone Electric Company, Dept. P, 714 Pine St., St. Louis, Mo.

RADIO Applause Cards 75c per 100. Sample Free. Weatherby, Medina, Ohio.

DEMONSTRATORS, Radio, wanted. Amateurs, professionals, see Radio Shack advertisement, page 140.

NEW Bearcat Vacuum Tube Radio Sets. Tremendous range. Marvellous clearness. Simple. Mahogany finish. \$9.98. With batteries, phones, aerial, etc., ready to operate, \$18.88. Money back guaranteed. Order now or write. Agents wanted. Bearcat Radio, 646 North Michigan, Dept. 19, Chicago.

WE Allow \$1.00 each for burned-out Radio Tubes in exchange for new. Radio Exchange, 6029 Euclid Ave., Cleveland, Ohio.

RADIO tubes repaired like new—\$2.00 all makes. New tubes \$3.00. Types 201A-200-199-12; written guarantee with each tube. Radio Tube Manufg. Co., Dept. 10, 154 Nassau St., New York City. Mail orders promptly filled.

LOUD Speaking Crystal Set. Broadcastings heard throughout house. Easily constructed. Book, diagram, 25c. Catalog free. Steinmetz Wireless Mfg. Co., Eastend, Pittsburgh, Pa.

RADIO Sets—\$30 to \$300. Super Heterodynes Neutrodyne and other types. All makes, at 50% off list. Why pay more? Send for Bulletin 244. Radio Exchange, 925 Broadway, N. Y.

CRYSTAL Radio Receiving Set. Guaranteed to work. 50c postpaid. Tru-Blu Supply Company, 23 Tacoma, Rochester, N. Y.

RADIO Generators—500V, 100 watt \$28.50. Battery Charging Generators \$8.50. High Speed Motors—Motor Generator Sets, all sizes. Motor Specialties Co., Crafton, Penna.

2,650 MILES Distance with one tube. Any Novice understands our Simplified Instructions, including Panel Layout and Photo 25c. Vesco Radio Co., Box PM-117, Oakland, Calif.

TELEGRAPHY

TELEGRAPHY—Both Morse and Wireless—taught thoroughly and quickly. Tremendous demand. Big salaries. Wonderful opportunities. Expenses low; chance to earn part. School established fifty years. Catalog free. Dodge's Institute, 11 St. Valparaiso, Ind.

TRADE AND TECHNICAL SCHOOLS

BE an Auto Expert. Biggest profession in world. Tremendous demand for my trained men, \$75 to \$175 a week. Boss the job, own your own business. I train you at home, spare time, the famous "Job-Way." Free 2 big Outfits and Employment Service. Write for Big Auto Book Free. B. W. Cooke, District Engineer, Chicago Auto Shops, Dept. 816X, 1916 Sunnyside Avenue, Chicago, Ill.

ELECTRICITY—Learn at home in your spare time. Get into this great field of opportunity and big pay. No special experience or education necessary. \$3,000 to \$10,000 a year paid to experts. This is your one big chance to get out of the low pay rut. Send for big free book on Electricity—it is Free. S. & H. Engineering Co., Dept. CN-1, 1422 W. Monroe St., Chicago, Ill.

LEARN Sign Painting, Decorating, Paper-hanging, Marbling and Graining—Auto Painting. Practical course takes only few weeks. Write for Free Book and Special Offer. Chicago Painting School, Dept. 9158, 150 W. Austin Ave., Chicago.

GET a Foreman's Job in any trade. Train yourself to earn more money. Become an expert Blue Print Reader. You can do it in spare time. My training will give you advancement in a few weeks. Write now—tell me what trade you want—I will send my plan at once. Carroll Ramsey, 105 Drexel Bldg., Philadelphia, Pa.

EARN Ten to Fifteen Dollars per Day laying Brick. Any intelligent man can become a bricklayer with three months' training in our school, and three to six months' practical experience, during which he can earn 60 to 90 cents per hour. No age limit. Tuition reasonable. Send for catalogue. Associated Building Employers, 112 A. B. E. Bldg., Grand Rapids, Mich.

NO Matter What Trade you are interested in, you can get help from Personal Advancement magazine, published by Popular Mechanics and sent free to all who request it. Will help you decide upon a vocation. Send your name and address on a postal to Popular Mechanics Press, Room 807, Popular Mechanics Building, Chicago, Ill.

BUSINESS OPPORTUNITIES

MONEY-MAKING Plans 60. Hundreds of Formulas. Wholesale Directory. All for \$1.00. Particulars free. G. Gemmer, 726 Julia, Jacksonville, Fla.

POPCORN Machine—Concession Model, self-seasoning, very speedy. Money maker, \$60. Northside's Co., 1306 Fifth, Des Moines, Iowa.

START a Real Business of your own! Write for full particulars concerning a liberal proposition. Monarch Specialties Co., 425 North Leamington, Chicago.

BE independent! "Selected Opportunities" tells you how. \$1.00. Edwin Ashford, Georgetown, Ky.

LEARN Tarnish Mirror Silvering—It Pays Big! Long, closely guarded secret. Particulars free. Wm. Barstow, 514 23rd Street, Oakland, Calif.

\$25,000 FROM three schemes, \$10,000 from one, subscribers to Popular Schenker Alliance, Ohio, report. Try your luck. Three special copies, 86 pages, only 25c.

NEW Mail Order Plans and ideas in "Business Progress" each month. Three months' trial subscription, 25c. 734 Cherry, Kansas City, Mo.

START Business—Make, Sell Auto Polishes, Wall Paper Cleaner, 3c Coffee substitute, Salves, Liniments, Creams, Silvering Mirrors, 150 selected formulas, etc., and Digest three months 25c. Digest, Grand Rapids, Mich.

PATENTS—Write for our Guide Books and "Record of Invention Blank" before disclosing inventions. Send model or sketch and description of invention for examination and instructions. No charge for the above information. See advertisement on pages 182 and 183. Victor J. Erans & Co., 192 Ninth, Washington, D. C.

WE Want a Man in every City, who knows the heating business and is financially responsible, to take agency to sell and install our Draft Conditioners for low pressure heating plants; guaranteed to save from 15 to 35% fuel (either coal or oil) and improve heating conditions on new or old boilers of any make, 4800 installations in Chicago's finest buildings. Approved by Architects, Engineers, Heating Contractors, Boiler and Oil Burner Manufacturers, Coal Dealers, Chicago Real Estate Board and Yellow Cab Co. Wolff Coal Saver Co., 1328 W. Congress St., Chicago.

PUBLISH small mail order magazine; sample, plan, free. Harvey Toepke, Decatur, Ind.

MECHANICS and Repair Shops—Get into a profitable business for yourself by establishing an Authorized Simplicity Cylinder Grinding Station, reconditioning automobiles, trucks and tractors. Also become direct factory representative, \$600.00 investment required—installment plan. Be the first in your community to get our plan. Write—Simplicity Mfg. Co., Port Washington, Wis.

A TEA Room or Cafeteria will make you a fortune—you can operate one of your own or manage one for others. We teach you in a few weeks and put you in touch with positions and money-making opportunities—earn \$5,000 a year—be independent. Write today for book "Pouring Tea for Profit." Lewis Tea Room Institute, Bureau B-31, Washington, D. C.

MANUFACTURE Millerite! Ethyl-Super-Fuel Ingredient for Gasoline. Increases Power, Mileage—saves gas—easily mixed—profits great—valuable Formula Literature of this, Lightning Electrolyte, Kor-Kit, Pro-Tex-U, Amazon Rubber Repair, and fifty other Biggest selling Specialties in all lines will be sent on request. Miller, Chemist, 1115 Grand Central Ave., Tampa, Fla.

SIGNS, Banners, Showcards, Easily Painted with the aid of Letter Patterns. Samples for stamp. John A. Rahn, 2433 Greenview Ave., Chicago.

FOR territory and machine to manufacture 20,000 Eclipse Rubber Wrapping Bands per hour of inner tubes, address C. B. Martin, 1129 6th, N. W. Canton, Ohio. Small investment required.

OPPORTUNITY for starting business at home. Pays from start. Lifetime employment for whole family. Postal brings information. Walland Supply, Box 4338, Station B, Kansas City, Mo.

50 SUCCESSFUL mail-order enterprises and 150 practical formulas in book form for 50 cents. Portland Service, Norwalk, Conn.

\$100 A WEEK operating a Radio tube hospital. No capital required; exclusive territory. Dept. B, 208 Broadway, New York City.

"HOW to Sell Patents" free. Patent News-H, Washington, D. C.

3,384 MONEYMAKING Plans, Formulas, Trade-Secrets, "Encyclopedia Business Opportunities," 3 Volumes 98c. "Ideal," 5501-V11, North Robey, Chicago.

COMMON Sense and \$100 or more will establish cash business. Dept. M, Paul Kaye, 149 Broadway, New York.

START for yourself a profitable business at home. For particulars—Silverite Process Co., 218 W. Pleasant Ave., Syracuse, N. Y.

AGENTS can make good money selling the Fin Twister to Ford owners. Sells easily for 50c each, 100% profit. Sample postpaid 25c. Bonney, Meadow and Green Sts., Albion, Pa.

EARN money at home spare time or evenings. No peddling. Permanent. Work in your own home. Write Dooms Co., 2323 Myrtle, St. Paul, Minn.

MONEY! Silvering Auto-lights, Radiators, Mirrors, tableware, stores. Outfits. Methods Prot. Sprinkle Plater, 288, Marion, Ind.

GET Money in Your Mail. "Lambert's Mail Order Secrets" contains successful methods never before published. Particulars free. Leon Lambert, 539-D Kaufman Bldg., Wichita, Kans.

START Mail Order Business—Practical information concerning its wonderful opportunities obtainable through The Mail Order News, America's leading mail-trade publication. Yearly subscription \$3.00. Sample 25c. Booklet free. Mail Order News, 1636 Bristol Bldg., New York.

METAL Articles Manufactured. We specialize in stamping, drilling and assembling. Inventions financed, patents obtained. Address with description or sample. Burritt & Bates, A-1821 Berceau Ave., Chicago, Ill.

I MADE \$100,000 as Real Estate Specialist. Free information tells how. American Business Builders, Dept. A4411, 1133 Broadway, New York.

PATENTS—Write for my free Guide Books "How to Obtain a Patent" and "Invention and Industry" and "Record of Invention" blank before disclosing inventions. Send model or sketch of your invention for instructions. Promptness assured. No charge for above information. Clarence A. O'Brien, Registered Patent Lawyer, 588 Security Bank Building, directly across street from Patent Office, Washington, D. C. See pages 180 and 181.

SUCCESS With Your Own Products—Formulas, Processes, Different, Dependable, Profitable. Catalog Free. B. Thaxly Co., Washington, D. C.

BOOKS Explaining Mail Order Business; Circulars Free. Harvey Teepie, Decatur, Ind.

MAKE big profits by operating a specialty candy factory. My wonderful formulas how to make potato chips, popcorn crisp, salted peanuts, etc., that is your guarantee for success, will be mailed to you on receipt of \$1.00. Carl Hook, 2526 Warsaw St., Ft. Wayne, Ind.

120 MONEY-MAKING Plans Free! Wolverine Bureau, G-7, Muskegon, Mich.

INCH Display Advertisement 166 Magazines Year \$36. Wood's Popular Services, Atlantic City (N. J.)

PATENTS Procured; Trade Marks Registered—A comprehensive, experienced, prompt service for the protection and development of your ideas. Preliminary advice gladly furnished without charge. Booklet of information and form for disclosing idea free on request. Richard B. Owen, 30 Owen Bldg., Washington, D. C., or 2270-R Woolworth Bldg., New York.

"INCOME Increaser" Magazine, Wabash, Indiana. Profitable to subscribers. Copy 10c.

"WHAT to Invent for Profit" free. Patent News-C, Washington, D. C.

MAKE money with your camera. Lancaster-B, Box 436, Los Angeles.

FREE Book—Start Little Mail Order business anywhere; home employment evenings; beginner's working outfit furnished; 500 circulars; samples; novelties to sell; you deal with manufacturers; no stock to carry; also tell how to secure agents to sell your novelties. Instructive booklet free. Pier, 833 Cortland Street, New York.

A \$12.00 DANCHE "Call-Me" Electric Alarm Clock free. Write us for particulars. Danche Mfg. Co., 643 Washington Blvd., Chicago, Ill.

SLOT Machines; Headquarters for Premium Machines, 1016 Germantown Ave., Philadelphia.

WHY Wait for Promotion? Promote yourself. I did. You can. I'll help you as I was helped. Complete outline \$1. Scott Wilkerson, Mills Bldg., Washington, D. C.

EARN \$5,000 per year in the Real Estate business. Training at home prepares you in short time. Graduates make good everywhere. Bulletin free. Penn Realty School, Ellsworth and 19th Sts., Philadelphia, Pa.

WHY Not Be Your Own Boss? Manufacture and sell your own products. Small capital starts you. Particulars \$1. Write Richard C. Stark, 1216A College St., Bowling Green, Ky.

EVERYBODY knows of the remarkable success of the 10c Stores. Now comes the 25c and 50c Mail Order Business. Stamp brings further information. Taber Bros, 311 Fifth Avenue, New York.

SIGN work made easy with "Perfect" Letter Patterns. Beautiful and exact gold-leaf lettering on glass now easy. We teach you. Samples and information free. Ross System, 47th and Vincennes, Chicago.

ATTENTION!! You can have a business of your own. Establish and operate New System Real Estate Business, brokerage and insurance agency in your community. Office at home. Earn \$5,000 year. Representatives wanted everywhere. Send stamp free booklet. Hayes Realty Association, Cincinnati, Ohio.

MAKE Money at Home—making toys. We show you how. Send \$1 for complete working drawings and instructions. Dekalb Designing Co., Decatur, Ga.

MAKE \$100 to \$1,000 Monthly. Free booklet tells how. Address The U. C. Service, Honesdale, Pa.

UNPATENTED Ideas Can Be Sold. I tell you how and help you make the sale. Free particulars (Copyrighted). Write W. T. Greene, 810 Jenifer Building, Washington, D. C.

BIG money writing photoplays, stories, poems, songs. Send for free copy America's greatest magazine for writers. Tells you how to write and sell. Writer's Digest, 603 Butler Bldg., Cincinnati, Ohio.

ENTER a new business. Earn \$3,000 to \$5,000 yearly in professional fees making and fitting a foot specialty, openings everywhere, with all the trade you can attend to; easily learned by anyone at home in a few weeks, at small expense; no further capital required, no goods to buy, job hunting, soliciting or agency. Address Stephenson Laboratory, (1) Back Bay, Boston, Mass.

INVENTORS—Write for our Guide Book, "How to Get Your Patent" and Evidence of Invention Blank. Send model or sketch of your invention for our free Examination and instructions. Randolph & Co., Dept. 435, Washington, D. C.

EXCEPTIONAL Opportunity for Sales Manager capable of handling state distribution. Marvelous new Adding Machine. Retail \$15. Work equals \$350 machine. Tremendous possibilities. Unlimited Profits. Write quick for details. Lightning Calculator Co., Dept. B, Grand Rapids, Mich.

MAIL Order Business is your opportunity. Brenner's Famous Handbooks teach how to start small, grow big. Sell merchandise, service, ideas; enormous profits. Spare time to begin. Get complete set, 11 books, \$3.00, and be posted. Brenner, 335 Walnut, Philadelphia. Descriptive Catalog and big batch interesting mail order information, 25c. None free.

I MADE \$30 a Week Home. French Breadmaking. 15 years' experience; Free booklet tells. Ashbrook 67, Marango, O.

CHEMICAL Expert will furnish Formulas and Trade Secrets. All lines. Lists Free. W. L. Cummings, Ph. D., 228 Gordon Ave., Syracuse, N. Y.

MAKE toys and novelties at home. Big profits. Instructions and 200 illustrations, 25c. Astrolite Company, Sharnburg, Pa.

WE Start You in Business, furnishing everything; men and women, \$30.00 to \$100.00 weekly operating our "New System Specialty Candy Factories" anywhere. Opportunity lifetime; booklet free. W. Hillyer Ragsdale, Drawer 4, East Orange, N. J.

START a Real Estate Office of your own. Earn from \$3,500 upwards. Our course of 21 lessons tells you how. Booklet M on application. Frederick Jenkins, Corlaer Heights, Schenectady, N. Y.

DOLLARS Yearly in your Backyard. No mushroom dope. Particulars free. Metz, 313 East 80th, New York.

PUBLISH a Monthly Magazine. We will tell you how. Very interesting, profitable. Information free. P. M. Lutz Printing Co., York, Pa.

"STEPPING Stones to Wealth"—New book of 1000 Plans, Formulas and Trade Secrets. Biggest and best mail order book ever published. \$1.00 postpaid. Large descriptive circular free. Thompson Publishing Co., Cincinnati, Ohio.

PRINTING Presses, Type, Materials. Make easy money Printing for Self and Others. Interesting Circulars, Stamp. Watson, 169 William St., New York.

EARN \$10 daily silversmithing, plating and refinishing metalware, autos, chandeliers, bedsteads, headlights. Outfits furnished. E. Deale Laboratories, 1133 Broadway, New York.

MARBLE mixing instructions, covering wood or cement flooring 1/2 in. thick, fireproof, waterproof, low cost, sanitary, all colors. Particulars, 200 illustrations free. Chris Mahler, Box 122, Huntington, N. Y.

LEARN the collection business. Good income, quick results. Interesting booklet, "Skillful Collecting" free. National Collectors Assn., Long St., Newark, O.

PATENTBOOK, 133 mechanical movements and illustrations, sent free. Labimero, 3 Parkrow, New York.

GOLD Window Sign Letters. Manufacture them at home. Unlimited profits and business opportunities. Complete instructions and patterns. No experience required. Particulars, Wilterding, 1144 Pleasant Street, Oak Park, Ill.

WANTED—BUSINESSES FOR SALE

IF You Want to Sell Your Business for Cash quickly and privately, we take the prospective buyer directly to you at our expense, no matter where located. We specialize in selling out-of-town businesses. If your business is worth \$5,000 or more, write us The Mutual Security System, 65 W. Washington St., Chicago.

CHEMISTRY

YOUR chemical problem solved and working process furnished Five Dollars. Write me. W. Stedman Richards, Consulting Chemist, address, Box 2402, Boston, Mass.

TECHNICAL information, analyses, formulas, trade secrets. Jacob Sluyter, Chemist, 2325 East St., Davenport, Iowa.

FORMULAS AND TRADE SECRETS

"MECHANICS Soap," "Picture Transfer," "Spitfire," Elenen formulas, \$1.00. Chrs. Owsley, Amlin, Ohio.

BALDNESS Cure, German Formula Guaranteed to Grow Hair, \$3. The Process Co., Denver, Colo.

500 FORMULAS, including Luminous Paint—Renewing Dry Batteries—Mechanics' Soap—Gas Tonic—25c. Catalog Free. Ideal Book Shop, 5501-P11, North Robey, Chicago.

ANY Formula a self-addressed envelope and dime. Formula Wizard, Parkville, Ky.

INSTANT Corn—Bunion Extractor—25c. Meye, 1234 Clay, Paducah, Ky.

FORMULAS The best Chemical Science can devise—Guaranteed Reliable Processes in all lines. Stamp brings big bunch valuable literature, interesting lists. Don't buy till you see what I can give you. 27 years supplying the best. Miller, Chemist, 1113 Grand Central, Tampa, Fla.

STOP the corrosion on the positive terminal of your battery. Formula 25c pp. The Trading Post, Box 176, Chebeyan, Mich.

FORMULAS, new ones, different. Free lists. Meriden Co., Box 1151, Tacoma, Wash.

1,000,000 FORMULAS, 1,016 pages, \$1.98. 500 Formulas Free if you order quick. Ideal Book Shop, 5501-M11, North Robey, Chicago.

10,000 SELECTED chemical, technological and practical recipes and processes, including hundreds of so-called trade secrets for every business, alphabetically arranged in one large volume of 800 pages. Price \$4 postpaid. Popular Mechanics Book Dept., 206 E. Ontario St., Chicago.

AGENTS WANTED

NO Dull Times in the Food Business. Selling Federal Pure Food Products is the greatest, surest and safest business in the world today, and here is your opportunity to get into it. You can make \$3,000, \$5,000, \$10,000, or more per year—the only limit is your ability to take care of the business. You will need no experience or money to get into this business as we send you our handsome \$15.00 Sample Case on Trust and teach you everything you need to know. No Dull Times, for the People Must Eat, and our food products are the fastest selling, surest and quickest repeat order goods in the world. Sell on sight in every home where food is used—repeat orders immediately and every week thereafter. A real big business all your own. Every new customer adds a great deal to your weekly income. Your business once established, has a market value just like a store and can be easily sold. The greatest money making opportunity of your lifetime because you risk absolutely nothing as we guarantee your sales, and we will not let you fail. Remember! Guaranteed! Best products, biggest sellers, surest repeat orders. No capital or experience is required. We furnish capital and everything necessary for you to become a Federal Distributor. Exclusive territory will be given honest men or women who write at once. Federal Pure Food Company, 2309 Archer Avenue, Dept. A, Chicago, Ill. Largest packers of Pure Food specialties in the world. Reference, any bank, Dun or Bradstreet rating agency, Express or Railway Company in America.

AT Last a Lifetime Job! Stop shifting around—the Peggy Ann line of beautiful House and Street dresses will satisfy you with its limitless selling possibilities and generous commissions. Every woman a buyer. No heavy sample case to lug around. No investment necessary. You get your commissions At Once—we deliver and collect. Hundreds of men and women making independent incomes. You can do just as well, whether experienced or not. Write today for bulletin 30. The Peggy Ann Dress Co., 412-416 East Eighth, Cincinnati, Ohio.

300% PROFIT: Whirlwind Seller. Tremendous repeater. "Kleanrite." Marvelous Discovery. Washes clothes without rubbing. Premiums for customers. Sells 20c. You make 15c. Free samples make easy sales. Write quick. Bestever Products Co., 1911-K11 Irving Park, Chicago.

CLOTHING Sensation! Now comes a one-price line of men's clothes that offers such remarkable values, such fine goods, at so low a price it makes the others look sick by comparison. No wonder old experienced men handling other lines are dropping them to take hold of this new and amazing powerful proposition. It makes no difference what you are now selling or have sold—it makes no difference how many lines you now have or have had—it makes no difference how much or how little experience you have or how much or how little time—you simply must look into this proposition of ours. Not to do so would be a serious mistake—an injustice to yourself. Write today for the facts. We say Facts. Address Dept. 107, William C. Bartlett, Inc., 850 West Adams, Chicago.

WOOD'S Portable Truck—brand new necessity in every factory, store, home, taxi, truck, etc. Sells on sight; weighs 1½ pounds; over 100% profit; send \$3.00 for delivered sample and special terms before your territory is taken; Agents wanting big easy money write to Wood's Portable Truck Co., Berwyn, Ill.

\$1.00 BRINGS Pound of Samples: Bonds, Banknotes, Coins; 10 Cigarettes; 57 varieties; 100 pieces. Agents Cleaning Up. Hirschbill, 70 Wall St., N. Y.

AGENTS and Specialty salesmen: Go in to business for yourself. Put out a line of products under your own private label. Get all the repeat business yourself instead of building up a trade for someone else. We will supply you with a full line of high-class toilet articles, food products, household specialties, medicinal preparations, etc., packed under your own private trade name. There is a big margin of profit in this business and you could employ several subagents to help you sell the goods as well as selling them yourself. Write now for our low wholesale prices. National Scientific Laboratories, 251 Monroe, Richmond, Va.

AGENTS \$45 a week. Our full line of Guaranteed Hosiery for men, women, children is the finest you ever saw. Must satisfy customer or new hose free. Our new shades of finest silk hose leads them all. Write for samples. Parker Mfg. Co., Sample 1378, Dayton, Ohio.

AGENTS Wanted—Something New—Fire Fighter sells easily. Makes a spectacular demonstration; car owners, homes, factories, stores, practically buy on sight. Our men make \$10.00 to \$50.00 a day. If you wish to establish a business of your own with unlimited possibilities for making big money, write us today. Fry-Fryer Co., 414 Fry-Fryer Bldg., Dayton, Ohio.

AGENTS: \$10 a day. Latest improved portable talking machine. Does more than machines costing five times its price. Built in just like a suitcase. Fully guaranteed. Pay you daily. Write Perry-Ludlow Co., Class 1963, Dayton, Ohio.

AGENTS—\$50 a week taking orders for guaranteed hosiery for men, women and children. Must wear 12 months or replaced free. All styles and finest lines of silk hose. Write for sample outfit. Thomas Mfg. Co., Class 262, Dayton, Ohio.

AGENTS—\$15 a day—Easy, quick sales—Free Auto—Big Weekly Bonus—\$1.50 premium Free to every customer. Simply show our Beautiful 7-piece Solid Aluminum Handle Cutlery Set. Appeals instantly. We deliver and collect. Pay daily. New Era Mfg. Co., 803 Madison St., Dept. 21-BP, Chicago.

AGENTS—Men and Women. 35 Million women are anxiously waiting to buy the 3 in 1 Hot Water Bottle—Icebag—Fountain Syringe combination. Commissions daily. No delivering. Write for startling money making plan. Lobl Manufacturing Corporation, Middleboro, Mass.

CIGARETTE Smokers. Tobacco Users Read "Tobacco Facts." Worth a fortune. Mailed for 10c. Leonard, 2875 California St., San Francisco, Calif.

AGENTS, Salesmen, Demonstrators. you will have the devil's own time trying to find a better seller than "Zippo." If there was such a thing we'd have it. Splendid profit on 50c "Go Getter" repeat article that sells on ten second demonstration. Works While You Watch It. Demonstrates value, while others waste time making claims. New discovery! Greatest Scientific Triumph of the age. It's the berries. Haven't room to tell our story here. Write immediately. Karam-Smith Co., 611 Bozart St., Ft. Wayne, Ind.

GENUINE Gold Leaf Letters anyone can put on Store windows. Guaranteed to never tarnish. Large Profits. Enormous Demand. Free Samples. Write today. Metallic Letter Co., 438-A North Clark, Chicago.

"BARGAINS"! The Magazine for Money Makers. Sample Copy Free. Bargain, 1206 South Oakley, Chicago.

MILLERITE: Here it is! You've read about this New Wonderful Ethyl-Super-Fuel Ingredient for Gasoline—Increases Mileage—Saves Gas—Knecks Carbon—Easily Mixed from my simple Formula—profits great—\$5,000.00 to \$50,000.00 for you if you hurry!! Don't pass this by you'll be sorry—but send today for full descriptive literature of this and other valuable Formula Lists describing latest, biggest selling specialties in all lines as Mendit, Fabric Mending Cement, Marcel Permanent Hair Curling Fluid; Denta-perl Tooth Whitener; Balloons and other thin dipped rubber goods; Plynox—few drops kills rounful files; Amazon Self Vulcanizing Repair; Pro-Tex-U only Guaranteed Fire Extinguisher; Pure Food Products; Toilet, Medical, Household, Automobile Office Specialties—best in all lines. 27 years supplying the best in Formulas and manufacturing information. Highest References. Miller, Chemist, Tampa, Fla.

We want one ambitious man in each county as Sales Representative. Our salesmen make big money taking orders for the Cole Visible Gasoline Gauge. Only scientifically accurate gasoline gauge that fits on instrument board—always in sight—prevents short measure—stops running out of gas—low price—in class by itself—sells on sight. \$10 to \$20 a day for six to eight hours. You get your pay in advance. We deliver and collect. Commissions paid on repeat orders. Exclusive territory. Capital not necessary. Write The Stearns Engineering Co., 203 Webb St., Daxton, Ohio.

WHY not sell us your spare time? \$11.80 daily in advance (send for sworn proof) Introducing New Insured Hosiery—47 styles, 35 colors—guaranteed seven months—Winter line now ready—All the latest shades—Made—Airdale—Peach—Bamboo—Beaver—French Nude—50 others. No capital or experience required—You simply take orders—We deliver and collect (or you can deliver, suit yourself), credit given—Pay You Daily—Monthly bonus besides. We furnish samples. Maschsee Textile Company, Room 25811, Cincinnati, Ohio.

DUSTLESS Sponge Cloth. New Invention. (1) Rub—Dusts, Cleans and Polishes Automobiles, Furniture, Pianos. Retail 150¢—Costs 10¢c. "Sample Free." NoLife (E) Sponge, Hartford, Conn.

CALIFORNIA Roadshows selling like hot cakes. Agents earning money; new stuff. Big profits. Catalog free. Mission Factory PM. 519 No. Halsted, Chicago, Ill.

YEAR'S Sensation! \$1.25 Dressmaker's Shears Free with every sale of 11-piece Cosmetic Assortment at \$2.00. 100% Profit! Manufacture 250 Items. Davis Products Co., Dept. 56, Chicago.

100% PROFIT—New Fast Seller. Powdered Hand Cleaner. "Sample Free." Best-er, 1941-C11 Irving Park, Chicago.

WANT Distributing Agents for Handlik, the new original powdered handsoap. Removes grease, grime, ink, paint, and most anything from the hands without injury to skin. Every mechanic and auto-owner, everybody who gets his hands dirty, will be a customer. Great opportunity for hustler to get in business. Full information and sample free. Solar Products Company, A-124 West Lake, Chicago.

\$50,000 PICTURE Man Friedman made outrageous. Beginners can make \$100.00 weekly with my sales talk. Experienced men make more. Free book "Profits in Portraits" explains. Samples Free. Picture Man Friedman, Dept. 8-A, 541 W. Lake, Chicago.

REPRESENTATIVES—Sell guaranteed silk hose—\$15.00 to \$25.00 per day. Easy opportunity to earn Ford. S. Schuster, 606 W. Main St., Louisville, Ky.

TOOT Sweet keeps the feet sweet. New Edge for razor strops. Agents wanted. Big profits. Toot Sweet Co., Mason City, Iowa.

We need 500 responsible men and women at once to handle our business in all localities and send us orders for our 350 products. New plan. \$15 a day. We furnish car. If you mean business write now. American Products Co., 1988 American Bldg., Cincinnati, Ohio.

BOBBED hair has increased our sales. Crew-managers can make \$6.00 per day. Kingsbury Company, Fort Wayne, Ind.

AT last! Complete home products. Folks want guaranteed spices, extracts, cocoa, baking powder, toilet articles, soaps, famous Edrings Herb Tablets. Catalogue, Jet, Pharmaceutical Company, Allentown, Pa.

SELLS at sight. Prints the Merchants Ad. on Wrapping paper, Sacks, Blotters, Boxes, etc. Good commission collected with order. Automatic Ad-Stamp Company, Joplin, Mo.

\$20 PROFIT daily selling needlebooks; costs 2c-5c each; sells 25c, value 50c; Three samples 25c. Catalogue Free. Needlebook Specialty Co., 661 Broadway, New York.

AGENTS 100% Profit selling Imported Pearl Necklaces. Big Demand. D. Brandt Co., Importers, 1691 President St., Brooklyn, N. Y.

EXCLUSIVE agents \$225 weekly. Genuine gold letters for store windows. Free samples; selling instructions. Chicago Window Sign System, 4326-A Kimbark Avenue, Chicago.

AT Last! Diamond Rival Discovered! Amazing blue white Rajah Gem astounds jewelry world and deceives experts! Beautiful Sample case Free! \$100 weekly! Write Quick! Rajah Diamond Co., Dept. F-7, Salisbury, N. C.

BRING Home the Bacon—selling Stuart's Stain Remover. Removes ink, iron rust, grass and fruit stains. Write for free samples and terms today. C. H. Stuart & Co., 5967 Broadway, Newark, New York.

AGENTS—Big profits. Easy selling, sure repeats. We furnish the money. Full or part time. Crew managers and established agents. We'll show you how to make more money and get more customers. Write for limited offer. Leonita, Box 508, 167 E. Ontario St., Chicago, Ill.

FREE Samples over 100 Styles and Colors in Hosiery and Neckwear. 30% Commission. Free Hosiery and Ties to Customers. 10% Bonus. Write today. S. Q. S. Company, Dept. 1458, Lexington, Ky.

LINGERIE and Hosiery—\$15.00-\$20.00 daily in advance. Complete line direct to wearer at factory prices. Donda Company, 812 Lees Bldg., Chicago.

AGENTS: 500% profit. "Happy Home Maker Shampoo" builds your own big business. Martin of Indiana made \$75.00 in one day. Missouri man made \$750.00 one month. Exclusive territory. Geo. A. Schmidt & Co., 236 W. North Ave., Chicago.

AGENTS, \$20 daily easy selling household necessity every woman wants. New invention reduces price. Big profit. Fagley & Halton, 303 Cherry Street, Dept. 5, Philadelphia, Pa.

AGENTS, Mosco Corn and Calous Remover will build you a steady repeat business. Send today for pocket size trial outfit. The Moss Company, 221 Searle Building, Rochester, N. Y.

AGENTS—Biggest Money Taking Orders for newest style written guaranteed hosiery. Complete line, men, women, children's, including silks. No competition. Not sold in stores. Written guarantee with each pair. You display samples and write order. We deliver and collect. Pay you daily in advance. No experience necessary. Spare time satisfactory. Write for samples. Jennings Mfg. Co., Dept. N-14, Dayton, Ohio.

YOU can make \$100 a week selling our new specialties: Ivoryplak and Lykolt Paintings; also complete line of photo novelties. 600% profit. Marvelous opportunity. Experience unnecessary. Perry Photo Novelty Corp., Sec. PM-11, 360 Bowery, New York.

AGENTS Make Big Money selling new auto invention. Hoffenberg's sold 900 in 2 months Profit \$2,700. For full particulars write Stransky Co., Dept. R-12, Pukwana, S. Dak.

FREE Samples. Charges Prepaid. Fit-to-Measure \$8.45 shoes. Full or side line. Hustlers making \$5,000 yearly. Extra commissions appointing sub-agents. Satisfactory Shoe Co., Chicago.

AGENTS, 100% profit selling "Swingsup" Headlight Glare Deflector. The Great Accident Preventer; better than Insurance. Every Auto Driver wants one. Clean, light-weight proposition. \$15-\$35 daily easy. Write for free special offer. Industrial Development Corp., Bridgeport, Conn.

AT LAST—A Correct Arch. Kappner's Ventilating Foot-Form Cushion Arch—Remedies, Corrects and Relieves All Foot Troubles. Write to Kappner Mfg. Co., 1319 Main St., Cincinnati, Ohio, with enclosed Stamp. (Agents Wanted.)

EXCLUSIVE agents \$50 to \$200 weekly. Sell Burnished Gold Leaf Window Letters; experience unnecessary. Free samples. Premier Sign Letter Co., 121 N. Francisco, Chicago.

AGENTS: Your Credit is Good for 30 days; send name and address; receive ten pkgs of Native Herbs; for constipation, rheumatism, blood, liver, kidneys and family use; sell friends and neighbors; 10c each; keep 50c as your profit and remit 50c; special offer. Melrose Co., Dept. 108, Columbus, Ohio.

IMPORTED Manila Cigars from \$2.50 per hundred up. Write for Agents' proposition. American Products Supply Co., General P. O. Box 461, New York City.

\$12 DAILY easy. Introducing Ladies' and Men's sweaters in silk, wool and artificial silk—23 colors. Latest novelties—Going like wildfire—You simply show samples we furnish—take orders—We deliver and collect. Your Pay Daily. Macroebe Sweater Company, Form 11011, Cincinnati, Ohio.

AGENTS—Make quick, easy money—\$10 and more a day, selling Comfort Shirts. A new idea that doubles sales. Biggest Commission, finest outfit, quickest service. Write for details. Comfort Shirt Co., 647-N Broadway, New York.

INSYDE Tyres in your old casings give from 3 to 5 thousand miles more service. Positively prevent punctures and blowouts. Used over and over again. Low priced. Big money saver. Agents wanted. Write for terms. American Accessories Co., Dept. 478, Cincinnati, Ohio.

MOST Wonderful Seller, 96¢ profit every dollar. No stock to carry. License unnecessary. Sample free. Mission Factory PM, 519 No. Halsted, Chicago, Ill.

\$60-\$200 A WEEK. Genuine Gold Letters for store windows. Easily applied. Free samples. Liberal offer to general agents. Metallic Letter Co., 438-D North Clark, Chicago.

EVERYBODY Needs and Buys the "Business Guide." Well cleared \$1,150 in 35 days. Send for sample. It's Free. Nichols Co., Dept. 4B, Naperville, Ill.

FREE Sample, "Rain Shield Wiper." Retail \$1.00—costs (25c). Just Invented. No Cloth—No Paste—No Attachment. Sold Clear and Rainy Days. (1) Rub keeps Windshield Clear (24) hours. Automobiles buy quickly. Riley made \$198 three days. Experience unnecessary. Wonderful Sideline. NuLife Corporation, Hartford, Conn.

GOODYEAR Mfg. Co., 1749 Goodyear Bldg., Kansas City, Mo., is making an offer to send a handsome raincoat free to one person in each locality who will recommend it to friends. Write today.

MAN wanted in each town to wear and introduce C. T. A. suits in spare time. We furnish samples and free suit to hustlers. Write for our great offer. Chicago Tailors Assoc., Dept. 646, Sta. C, Chicago.

PORTRAITS, photo pillow tops, frames, sheet pictures, medallions, merchant's signs, food products, rubber aprons, guaranteed hose, toilet requisites, luminous crucifixes. Catalog 50 specialties free. 30 days' credit. Jas. C. Bailey Co., Desk A-11, Chicago.

AMERICAN Woolen Mills Co., Dept. 4601, Chicago, are making a free suit for one agent in each community to introduce their fine tailored to order suits at \$18 and up. Write them today for their offer.

EXCLUSIVE Agent: We want an Agent in every territory to sell the famous K-W Road Smoother, a combined Shock Absorber and Squeegee for Ford Cars. Set of four sells to car owner for \$20.00. Will make arrangements with right party for exclusive territory to sell Ford Owners, Dealers and Garages. Send for literature and write us all about yourself. The K-W Ignition Corp., Department "M," Cleveland, Ohio.

OIL Burners for every purpose; exclusive Territory; 100% profit; set quick. Economy Mfg. Co., 616 West Monroe, Chicago.

\$3.00 AN Hour Easy—all or spare time—no capital or experience required—homes, churches, stores will buy the "Diamond Light"—300 Candle Power—beats electricity—burns kerosene or gasoline—lamps, lanterns—write for free outfit offer. The Akron Lamp Company, 441 Lamp Bldg., Akron, Ohio.

WONDERFUL Seller, \$1.40 profit every \$1.50 sale, monogramming autos; experience unnecessary; free samples. Worcester Monogram Co., Worcester, Mass.

AGENTS—Sell Gloss Oil Veneer—The Wonder Polish. Cleans and polishes cars, furniture, etc. Sells in every home. Get your field at once. Duo Co., Dept. G1, Attica, N. Y.

AGENTS! Sell the amazing new discovery for quickly waving bobbed hair! Big profits, big seller. Liberal sample and literature 25c. Parisian Products Company, Union Traction Bldg., Kokomo, Ind.

MONEY! Silvering Autolights, Radiators, Mirrors, tableware, steves. Outfits. Methods Free. Sprinkle Plater, 288, Marion, Ind.

BIG sellers, big profits. Our popular line of liniments, hair tonics, coconut oil shampoo, hay rum, etc., sell like wild fire. Net you 100%. Write for details. Felhorn Pharmaceutical Co., 17p Fulton St., Brooklyn, N. Y.

"HOW to Sell Patents" free. Patent News-O, Washington, D. C.

AGENTS, Salesmen—Sell New Thermo-static Automatic Carburetor Control Attachment for Fords. Big Profits, full or part time. Burns 95% air. Doubles Mileage. Attached in 2 minutes. No drilling. Does automatically exactly what Ford manual says do by hand. Cadillac now using Thermo-static Carburetor Control under Blanket license. Write today. A. C. Blancke & Co., Dept. 450C, 402 Lake St., Chicago.

27,000 PHONOGRAPH needles eliminated by one Everplay. Nothing like it. Preserves records. Abolishes scratching. Day's supply in pocket. \$20 Daily. Everplay, Desk B-11, McCburg Bldg., Chicago.

ONE Dozen New Blades for Gillette Razor 50c Postpaid. Agents' Prices Only with Order. Hurry. Smith's Service, 1194, Wenatchee, Wash.

BIG Profits, 50 Fast Sellers Rubber Specialties—Everybody needs and buys; \$50 weekly easily made. B. & G. Rubber Co., Dept. 459, Pittsburgh, Pa.

PORTRAIT Agents! Get busy on the biggest profit proposition you've ever seen! The new sensation in the portrait field—Artoil Portrait Paintings—exactly like oil paintings. Easy, big seller, great for "repeats." A "clean-up" in combination with famous P. & G. Photo Medallions. Write now. Padlin & Goldstein, Dept. "A," 239 Bowery, New York.

ABSOLUTELY free box Bassett's Native Herbs sent to introduce. For Constipation, indigestion, headache, rheumatism. Big money selling, all or part time. Established 1879. Bassett, Dept. 8, Columbus, Ohio.

AGENTS—Wonderful opportunity, newest line Perfumes, Creams, Compacts, Soaps, Extracts, Remedies, Jewelry. Protected territory. Catalog free. Van Ouden, Inc., 1918 VanBuren, Chicago.

NEW \$1.00 Office Specialty. Biggest Seller Going. Agents coinng money. Write quick for territory. Odiorne, 119 South Fourth, Philadelphia.

AGENTS—I'll pay you \$1.25 for your spare time. Easy, pleasant work in your locality showing samples and distributing teas, coffees and food products among friends and neighbors. Complete sample outfit to first person answering from your territory. Harley Co., M-2016 Harley Bldg., Dayton, Ohio.

NEW Sanitary Milk Bottle Cover. Protects milk. Sell to stores or homes. Big profits. Sample 25c. Stewart-Petite Co., 1720 East 90th St., Cleveland, Ohio.

MEN'S Shirts—\$25 to \$75 Weekly—Factory to Wearer. Big Sellers. Undersell stores. Free samples. Pay advanced. Illinois Shirt Mfgs., 510 So. Wells, Factory 204, Chicago.

AGENTS wanted for the Money Saver Patch ("The patch that made the tube immortal"). One-minute, self-vulcanizing, no-cement, guaranteed. For inner tubes and all rubber goods. A real, dependable efficiency article at the right price. Investigate for yourself. Money Saver Patch Co., 39 Pearl Street, New York.

BIG money now—sells faster than ever—hard times improve sales—Darn E-Z Universal Fabric Cement finds a buyer in every home, office, store and factory. Exclusive territory open. Darn E-Z Laboratories, Dayton, Ohio, Dept. P. M.

\$35.00 PROFIT on \$1.50 Outfit; Gold Monograms for Automobiles, etc. National, Station D, Brooklyn, N. Y.

AGENTS: Big Profits Selling Brushes House to House. Write for Details. Frank Holub, 1645 Blue Island Ave., Chicago, Ill.

YOU can sell every merchant in town our Electric Window Signs. Large profits; easy sales; send for sample and proposition. Re-Beetograph Sign Co., 214 W. Kinzie St., Chicago.

YOUNG Men who want to make their spare time pay from \$20 to \$50 a week are offered an opportunity to sell an article which every man buys on sight, made by Ingersoll, the dollar watch man; retails for \$1; you don't need to be a salesman; merely to show is to sell; big profits, quick sales and constant repeat business. Write today. Robt. H. Ingersoll, 476 Broadway, Dept. 206, New York.

AGENTS—You can make \$1.00 per sale, selling our line of Wringer and Dust Mops to the housewife. Ten to Twenty sales per day. Samples—Wringer Mop \$1.00—Dust Mop \$1.50—Both \$2.50 Postpaid. The E. & N. Manufacturing Co., Delphos, O.

SAFETY Comfort Seat for Cleaning windows sell to every home and building where windows must be cleaned. Prevents Slinger and accidents. Big profits; quick sales, no competition. Super-Sete Mfg. Co., Dept. 46, 303 Fifth Avenue, New York City.

A SNAP. Make big money selling Wunrub, the Perfect Polish for automobiles and furniture. Quick and easy to apply. Large profits. Free sample. Wunrub Company, 26 Belloc Place, Chicago.

THE Clothing Business is the second largest business in the country. Men have made fortunes in it. So can you if you go into it right. We'll put you into it right, without one penny of expense to you, supply everything you need to get into the business and clear from \$100.00 to \$200.00 a week, right from the start. This is a wonderful opportunity, for the right man. If interested, write at once. Address Dept. 311, Goodyear Chicago, Inc., West Adams Street at Peoria, Chicago.

CHRISTMAS Greeting Cards—Religious Art Calendars. Manufacturer, 1235 Arch, Philadelphia, Pa.

EARN \$15 daily at home. Doing a legitimate mail-order business, only costs \$1 to start. Tick, 3338 Arkansas St., Oakland, Calif.

AGENTS—Sell "Instant Shine" Metal Polishing Cloths, 25c; costs 8 1/2c. Sample free. Instant Shine Polish Co., Albany, N. Y.

AGENTS—Coin money selling our new fabric table cover; needs no laundering; housewives wild about them; send for free offer. Mfg., Box 67, Medford, Mass.

"PEPPY-PORTER" Products—Necessities in every household. List of Formulas, Labels, Free. Monarch Specialties Co., 425 North Leamington, Chicago.

MAIL-ORDER Houses and Distributors: We pack French made beauty creams, face powders, perfumes, toilet preparations with your label. Chemist, 844A North Clark, Chicago.

MAKE extra money. Xmas postal, folder, tag combination packs, 10th season. Sell 25c. Sample 15c. Big profits. Ufert, 133 West 15th, New York.

WE Pay \$26 a Week and expenses and give a Ford Auto to men to introduce poultry and stock compounds. Imperial Co., D-23, Parsons, Kan.

NEW Invention. Cleans whole house from cellar to attic, inside and out. All complete only \$2.95. Over 100% profit. Write Harper Brush Works, 326 Grimes St., Fairfield, Iowa.

CREW Managers;—Distributors;—Magie Washing Compound. Your name on package. Sells Fast. Great Repeater. 300% Profit. Samples with your name on furnished free. Besco, 1913-W, Irving Park, Chicago.

SELL Goods by Mail. Get our Money-Making Circulars at one-fourth cost. Big profits on sales. Particulars Free. Elfeo, 525-F S. Dearborn, Chicago.

\$15 DAILY easy—Your Pay in Advance—Introducing New Insured Hosiery—Must wear or replaced free—No capital or experience required—Just show samples, write orders—Outfit furnished—All colors—grades including silks. Macoebe Textile Company, Room 58011, Cincinnati, Ohio.

ANY man handy with paint brush can start furniture refinishing, job painting and handyman business on nearly nothing; mostly all profit; experience not required. John Braceland, 1457 So. Ninth, Philadelphia, Pa.

AUT-O-GLO Agents make 100% profit quick; Send \$1.00 for outfit. Particulars free. Aut-o-glo, Murphysboro, Ill.

NEW Novelties from all over the world. \$20 a day easy. Write for wholesale Prices. List Free. Spors Co., Lesuer Center, Minn.

PUMSO, The fastest selling product on the market. Nothing else like it. Something entirely new. Make Big Money. Used by every auto-driver, mechanic, and necessary to every household. Repeat orders. A twenty-five cent article. Quick sales. Big Profits. Pumsco Manufacturing Company, 128 West 75th St., New York City.

AGENTS: Imported Champagne baskets containing six bottles genuine French perfume. \$3 value for \$1.00. Sample postpaid 75c. Free particulars. Thayer, 729 S. Wabash, Chicago.

EASY money applying gold initials monograms on automobiles. Anyone can do it. Simply transferred from paper, takes 5 minutes. Make \$1.50, cost 5c. Samples Free. "Bakon," 323 Harrison, Boston, Mass.

AGENTS' Side Line: Good Profits; New Novelty Game Just Out. Sensational Hit. Sample 35c. Kahn (Manufacturer), 99 Nassau Street, New York City.

AGENTS—Make big money selling wonderful new auto accessory. Every owner a prospect. Write today for free booklet. Art quick, Abel Company, Abel Bldg., Mediapolis, Iowa.

DASH control Gas Reserve Valves for Fords; \$25.00 to \$50.00 per day permanent income established; customers do the selling. Write today. The Will-Bart Co., Orrville, Ohio.

SELL our Sanitary household and auto brushes. Lower retail prices. Larger commissions. Write for our proposition. Union Brush Co., 317 Dwight St., Springfield, Mass.

AGENTS—Be independent, make big profit with our soap, toilet articles and household necessities. Get free sample case offer. Ho-Ro-Co., 2725 Dodier, St. Louis, Mo.

AGENTS—Best seller; Jen Rubber Repair for tires and tubes; superseded vulcanization at saving of over 800 per cent; put it on cold. Vulcanizes itself in two minutes, and is guaranteed to last the life of the tire or tube. Sells to every auto owner and necessary dealer. For particulars how to make big money and free sample, address Amazon Rubber Co., Amazon Bldg., Philadelphia, Pa., Dept. 503.

AGENTS Wanted—The best selling and most modern Automobile sliding glass enclosure on the market. Simon-Flynn Co., 1834 McGee, Kansas City, Mo.

AGENTS wanted by Manufacturer of exclusive Novelty Knitted Sport Dresses and other knitted fabrics, selling direct to consumer. Attractive commission—large sample outfit free. Straightline Mills, Inc., 364 Broadway, New York City.

WANTED: Agents to sell manifold heater quick cold weather starting. Good seller. Write for exclusive territory and circular. The Higgins Mfg. Co., Bellevue, Ohio.

AGENTS—Hot Spark Transformers for all cars. More power, speed, less gas. Quick sales, big profits. 25c for sample set. Demonstrating outfit free. Ignition Mfg. Co., Box M-229, Omaha, Neb.

CHRISTMAS Cards are big sellers. Beautiful assortment packed in attractive boxes. Quick sales—big profits. Get your share of the Christmas Money spent. To get started at once, send 50c for sample assortment that sells for \$1.35. Pitkin Art Company, 697 Com'l Bldg., Newark, N. Y.

AGENTS and Side Line Salesmen wanted to sell the Easy Fill Gasoline Tank Cap and Gauge for Fords. A big proposition for live men. Write today. Easy Fill Cap Co., 829 Lawrence Ave., Chicago.

AGENTS: Big Profits! Braided Rugs all the rage. Sell direct 1/2 store prices! Quick returns. Tremendous demand. Alpern Bros., 48A, 12 Summer, Chelsea, Mass.

AGENTS: \$12.85 daily. Introducing "Kut-Easy" Self-Sharpening Shears. Cut to the end. Automatic. Guaranteed 20 years. Not for sale in stores. Every housewife interested. Quick, startling demonstration makes sales easy. Spare-time workers make enormous profits. No capital or experience needed. Write quick for demonstrating outfit. Macoshee Manufacturing Company, Shear 15411, Cincinnati, Ohio.

MARVELOUS new invention. 400% profit. Johnson's Liquid Quick Mend. Tremendous demand. Plan unique. Act quick. Over hundred other fast selling specialties. J. E. Johnson & Co., Dept. 31, 321 W. Chicago Ave., Chicago.

TWELVE Dollars starts you in profitable spare or full time manufacturing line; sell by mail; get all the profits. No cramping. We furnish everything. Details free. Spicer Chemical Co., Box 162P, Joplin, Mo.

CAN you sell to colored people? Write, Eston Co., Dept. 101, 2500 Second Ave., Birmingham, Ala.

AGENTS: \$15-\$30 daily selling "Swing-up," the great accident preventer. Every auto driver wants one. 100% profit. Free offer. Industrial Development Corp., Dept. 15, Bridgeport, Conn.

AGENTS, my proposition is backed by ironclad guarantee. Coining money for others, why not for you? Be in the money class; particulars, West Coast Rubber Co., Hayward, Calif.

JEFFORDS sold 25 cans his first 4 hours; profits \$7.50. Hundreds of others doing as well, or better. Particulars and sample free. Write today. The Mallard Chemical Company, Dept. EX, Saint Louis, Mo.

SUCCEED With Your Own Products—Formulas, Processes, Different, Dependable, Profitable. Catalog Free. B. Thaxly Co., Washington, D. C.

\$100 WEEKLY easy selling Oriental perfumes and cosmetics; 100 per cent profit. Sample case absolutely free. Write for catalog. Ronola Parfumerie, Inc., Woodlawn, Chicago.

AGENTS: Write for free sample of our easy and quick selling products, which reap 300 percent profit. The Hair-Silk Co., Grand Rapids, Mich.

WILL \$8-\$15 per day interest you in taking orders for men's Guaranteed Shoes from factory to wearer. Quality and savings of \$2-\$3 per pair sell them on sight. Representatives wanted. Sample line and exclusive territory to agents with A-1 bank references. Perry Shoe Company, 709-709 1/2 East Lake St., Minneapolis, Minn.

AGENTS, write for particulars of our Agent's Money-Making Plan. Pioneer Sales Co., Marietta, Ohio.

AGENTS—Liberal Commissions Insure Big profits selling Dress Goods, Hosiery, yarns, Handkerchiefs and Household Necessities. Outfit free. Local canvassers wanted. Security Co., Dept. M, Weedsport, N. Y.

\$15 DAILY sure profit. Dawn made \$207 in 3 weeks. Daily commissions—we deliver—valuable prizes. Send for complete catalog and New Sales Plan. Crafts Co., 443 S. Dearborn St., Chicago.

AGENTS, sell Motto Cards. Samples Free. Master Card Co., 816-18 Chestnut, St. Louis.

MANUFACTURE new, fast selling articles. List of plans, patterns, molds 10c. Morton Barter, 3937-A, Tracy, Kansas City, Mo.

ARE you old at forty? See our advertisement on page 146 of this issue. The Electro Thermal Company, 2137 Main St., Streuberville, Ohio.

PATENTS. Write for my free Guide Books "How to Obtain a Patent" and "Invention and Industry" and "Record of Invention" blank before disclosing inventions. Send model or sketch of your invention for instructions. Promptness assured. No charge for above information. Clarence A. O'Brien, Registered Patent Lawyer, 588 Security Bank Building, directly across street from Patent Office, Washington, D. C. See pages 180 and 181.

SALVES and Ointments in bulk. Frank Shilling, 1017 Duober, Canton, Ohio.

HOT Breese Room Heater and Hair Dryer. Retail \$6.00. A knockout money maker. Send \$3.25 for sample. Sloughon Mfg. Corp., Sloughon, Wis.

NEEDLES—Self threading; sell easy; 100% profit. Sample free. Other fast sellers. P. Miller, Box 3, Tremont Station, New York.

AGENTS Wanted—Made-to-order Christmas Cards. Customer selects design and message. Name on. Raised printing. Half usual price. Commissions daily. Samples free. The Fletcher Co., Orleans, Vt.

AGENTS—Big Profits on Soap, Flavoring extracts, toilet articles. Free perfume offer starts you quickly. Write for free particulars. Brown Chemical Co., Dept. 271, St. Louis, Mo.

AGENTS—Year 'round, quick seller. Limashine, the perfect auto-furniture polish. Exclusive. New. Free sample and proposition. Limashine Co., 129-L West Market, Lima, Ohio.

YOU Can Make Good Durable Paint and Varnish 45c per gallon. Write Dept. 2, Emmelmann Bros. Mfg. Co., Indianapolis, Ind.

GOLD-LEAF Sign Letters; make and sell; 1,000% profits. Particulars, Johnston Co., Quincy, Ill.

AGENTS—Sell rubber goods demanded everywhere. Fast Sellers. Big Profits. Household Fancy Aprons—Woman's Necessities—Baby Goods—Household Specialties, etc. Details free. American Rubber Products Company, Dept. 208, Pittsburgh, Pa.

WOULD \$500 Monthly Profit interest you? New automobile necessity. Every auto owner buys on sight. Sells for \$1. Boone Specialty Co., Dept. 22, Boone, Iowa.

SIGN Agents, Name and Number Plate Agents. Don't fail to answer this advertisement. We have something great for you. Ross System, 47th and Vincennes, Chicago.

\$8.00 TO \$20.00 per day. A wonderful seller. Any man, woman, boy or girl can make big wages Selling Crimp Grip Clothes Line Fasteners. It is a perfect rope holder and can be used for many purposes. Crimp Grips are a simple, time-saving device. They last a life time and will not rust; it holds the line tight, and saves time on wash days. Every buyer is a booster. Send 50c for Mounted Sample and one pair of Crimp Grip Clothes Line Fasteners. Write for particulars. Crimp Grip Company, Belvidere, Ill.

\$25.00 A DAY Easy! Best Line of Brushes on the market. 90 varieties, including famous Auto Fountain Washer. Excellent territory available. Write immediately. Philadelphia Brush Co., Dept. 25, Vineland, N. J.

\$2 AN Hour for your full or spare time supplying demand for established line. Extracts, Toilettes, Food Products, Medicines and Brushes direct-to-the-homes in your own vicinity. Every product guaranteed. Backed by a million dollar company. Liberal territory. A straightforward, clean-cut business proposition for men or women. No experience necessary. No red tape. Write for samples and particulars. Dept. P. M., Furst & Thomas, Freeport, Ill.

\$75 A WEEK. Man Wanted with ambition and industry, to distribute Rawleigh's Household Products to steady users. Several fine openings now available. We train and help you so you can make up to \$100 a week or more. No experience necessary. Pleasant, profitable, dignified work. Write to-day, W. T. Rawleigh Co., Dept. IL8253, Freeport, Ill.

AGENTS, Men—Women; Sell Photo-Philow-Tops. \$1.50 for sample roll starts you in business for yourself. Write today. Canvassograph Co., 6215 Wentworth Ave., Chicago.

AGENTS—Brand new Self-Sharpening Shears. Every housewife buys. Not sold in stores. Demand enormous. Agents having wonderful success. \$450 a week made by Remor. Kraft took 61 orders first week. Biggest and easiest seller we have offered. Write quick for terms. Thomas Mfg. Co., Class 3362, Dayton, Ohio.

\$120 WEEKLY earned from 10 average sales daily. Guaranteed shirts 3 for \$4.25 up. Undersell stores. Year round fast sellers, beautiful Christmas Specials. Phillimore Company, One Union Square, New York.

EARN \$40 to \$60 Weekly. Sell our complete line Guaranteed Hosiery Direct to the Wearer, all or part time. Prices that sell. Advancement to Manager. Write Royal-Knit Hosiery Co., Suite P-313, 1507 Arch St., Philadelphia, Penna.

AGENTS—here's your chance to make big money introducing the latest novelty—the Extension Collar button—Exceptional opportunity for live wires. Extension Corporation, 154 West 27th, New York.

AGENTS, Take orders for attractive rugs. Sell Rapidly. New Plan Makes Sales Easy. Catalog Free. Write Malsley Payne Mfg. Co., 22 Sudbury St., Boston, Mass.

WILLIAMS No Water Hand Soap, in tubes, has taken Auto owners by storm; washes dirtiest hands perfectly clean without water. Easy demonstration makes quick sales; 150% profit. Williams Co., Box 265, Montclair, N. J.

SELL Household Necessities. Big Line. 100% to 200% Profit. Quick Easy Sales. Handsome sample case furnished to agents. General Products Company, Dept. 7, Newark, New Jersey.

BIG Money selling shirts. Factory to wearer. Profits with first order. Write for particulars. Swanson Sales Co., Dept. 12, 1270 Broadway, New York.

SELL Beautiful \$7.00 Red and Black Overized hand made Fountain Pens for \$3.50. Cost you \$1.75. With bonus \$1.55. Post card brings full details, or C. O. D. sample, at wholesale price. Johnson Pen Co., 117 So. First St., Rockford, Ill. Dept. P.

SELL Christmas Cards. All Your Friends Use Them. Make your Christmas money. Engraved cards exclusively; best value in design, quality, and price. Customer's name printed or engraved. Good commission. No money needed. Write for selling outfit and particulars at once. No replies considered after Nov. 20, or outside of U. S. Knight & Co., Box M-76, Riverton, N. J.

KU KLUX KLAN Agents mopping up selling our KKK novelties at outdoor celebrations. Klan pocketpiece 25c; pennant 50c, knife \$1.50. Catalog Free. National Emblem Co., Box 524-D, Omaha, Nebr.

AGENTS, wanted to hand out our fire extinguishers at one dollar each. Big money. Sample fifty cents. Vonco, Box 55, Stroudsburg, Pa.

BIG Money selling new Household cleaner. Washes and dries windows. Sweeps, scrubs, mops. Complete outfit less than brooms. Over 100% profit. Harper Brush Works, 132 3rd St., Fairfield, Iowa.

AGENTS, both sexes, we manufacture and control new household article. Fast seller. Big profits. Exclusive territory. Write now. Connolly, 123 Liberty St., New York.

AGENTS clear \$50.00 weekly selling Opaline Portraits. Expense money advanced. Credit given. Big line now ready. Samples and Catalog free. Consolidated Portrait Co., Desk 2, Chicago.

AGENTS—Steady Income. Large manufacturer of handkerchiefs and dress goods, etc., wishes representative in each locality. Factory to consumer. Big profits, honest goods. Credit given. Send for particulars, Proport Mfg. Co., 59 Main St., Brooklyn, N. Y.

SELL Shirts and Overalls direct to wearer. Big profits. Work full or spare time. No experience required. Big variety dress shirts with splendid line Union-made work and flannel shirts, overalls, coveralls and khaki pants. Write today for free selling outfit, The Nimrod Shirt Co., Dept. 8, 4712 N. Kedzie Ave., Chicago.

AGENTS—Steady Income. Exceptionally useful Household Article. Handycap Co., Newark, N. J.

AGENTS Our new Fire Extinguisher sells for \$4.95 with big commissions. Mechanically perfect—can't leak. Exclusive territory. Free outfit. Write, Nichols Co., Naperville, Ill., Dept. F. 1.

MAKE \$25.00 showing "Consumers All-Weather Coats" Special introductory price \$2.95. Complete outfit free. Consumers Manufacturing, 728 Roosevelt, Chicago.

AGENTS—line up with better Felt Rugs now. Our new rug novelties increase your income. Here's your chance! Newark Felt Rug Co., 27C, 16th Ave., Newark, N. J.

SPIRAL Curtain Rods and large line wire and metal specialties; get our latest price list. Hunt Mfg. Co., Box 14524, Paterson, N. J.

AGENTS: Men and women, in spare or full time, make big money selling household necessity. Every home a prospect. Quick sales, big profit. Territory open. Write for particulars, Judd & Lehard Manufacturing Company, Box 21, Clifton Springs, N. Y.

WONDERFUL Miniature X-Ray shows bones in fingers, lead in pencil, etc. Sells itself. Simply show it, everybody buys. Immense profit. Sample ten cents. Particulars free. Bialto, 1012-P Fitzgerald Bldg., New York.

SOMETHING new: Patent Padlock—can be opened in dark by turning combination and listening to click. Used on garage doors, tool boxes. Pioneer Products, Roehling, N. J.

BIG Money—Selling Fiber House Brooms. Sure-Fire Seller and Repeater. Biggest Season Here. Write Today, Bartlett, Van Tine & Jones, Hillsdale, Mich.

AGENTS—Make \$25.00-\$100.00 weekly selling Comet Sprayers and Autowashers to Farmers and Autoists. All brass. Throws continuous stream. Established 30 years. Particulars free. Rusler Co., Johnston, Ohio, Box C16.

WONDERFUL Scientific Discovery—"Sapphires," Blue White; also one Changeable Color, \$3 per carat. Fire, Goldens, others \$2. Rival Diamonds. Any kind of ring wanted—will quote wholesale. Write Watches, Pearl Ropes, Imitation Diamonds, Rings. Want Agents, Passer (Importers), 152 Denton, Buffalo, N. Y.

HEATING with oil is in its infancy. Get in while the getting is good. Our burners make good. Agents wanted. Exclusive rights. Economy Oil Burner Co., 718-720 Second St., Webster City, Iowa.

SELF-THREADING Needles, Needle Books, Machine needles, find sales in every home. Fine side lines, easily carried, big profits, sample and catalogues free. Prentice Lee, 145 East 23rd St., New York.

AGENTS wanted everywhere, sell Shoes That Wear Longer. Big Seller. Restricted territory. Maryland Shoe Mfg. Co., Hagerstown, Md.

AGENTS make 500% profit handling auto novelties, window letters, transfers, novelty signs. Catalog free. Hinton Co., 1153 N. Wells St., Chicago.

HOT-WATER Heaters for all Cars and Busses with Water-Pump Equipment. No competition. Money-back Guarantee. 3rd Successful Season. American Water Heater Co., East Chicago, Ind.

AGENTS—Three neckties, boxed singly \$1.00. Retail \$2.00, cash with order. Maxwell, 461 Searle Bldg., Rochester, N. Y.

AGENTS—Sell \$25.50 suits—overcoats, all wool, one price. Wonderful values, liberal commissions in advance, money-back guarantee. 9x13 swatch outfit free. Write A. Harvey, Manager, Box 90, Chicago.

MAKE \$10.00 to \$25.00 daily selling our Standard Books, Bibles and Testaments. Easy to sell. Big profits. Permanent position for responsible producers. Write National Book & Bible House, Desk 1, 36 S. State, Chicago, Ill.

BIG Money Selling Gold Initials. Quick Sales. Every Car Owner Buys. You Charge \$1.50—Make \$1.44 Every Sale. Your Profit \$20 Daily. No License. No Experience. "Samples Free." Nulife (0) Monogram Company, Hartford, Conn.

AGENTS: Sell witch hazel and lemon cream at 2¢; Repeater; 100% profit. Howard Teel, Biggs, Ind.

AGENTS—Write for Free Samples. Sell Madison "Better-Made" Shirts for large Manufacturer direct to wearer. No capital or experience required. Many earn \$100 weekly and bonus. Madison Mills, 564 Broadway, New York.

AGENTS—\$10 to \$25 daily. No investment. Free outfit. Best values. Largest commissions. World Raincoat Co., 659-B Morris Park Ave., New York.

BIG Profits. New \$2.50 Automatic Adding Machine. Quick Sales. No competition. Ten daily easy. Absolutely accurate. Fully guaranteed. Pocket size. Business people everywhere positive customers. Exclusive territory to workers. Act quick, Bassett Company, 1458-L Hollywood Ave., Chicago.

AGENTS—\$25.00 Weekly Selling Nustile Guaranteed Hosiery direct to wearer. You pay daily in advance, we deliver and collect. All styles and colors. No experience necessary. Special extra monthly bonus. Sample outfit furnished. Write for particulars. Nustile Hosiery Mills, Dept. 175, Philadelphia, Penna.

CLARKE made \$18 an hour selling pocket windshield cleaner, needed by every autoist, motorist, engineer; one rub keeps glass clear 24 hours. 90,000 sold; amazing proposition free. Security Mfg. Co., Dept. 591, Toledo, Ohio.

EVERYBODY Buys new, instant stain and rust remover. For clothing, table linen, etc. Fine premium with every sale. Big, Quick Profits. Free Outfit. Write today. Christ, 51 Union, Newark, New York.

SAMPLES Free and a Sale in Every Home. Everybody uses Food Flavors. There are already thousands of satisfied purchasers of Pitkin's Guaranteed Tube Flavors who will have no other. We are the originators of the process that saves every purchaser \$2.79. The sales are quick—the profits big. Ask about the Free outfit. J. M. Pitkin & Co., 621 Com'l Bldg., Newark, N. Y.

A BUSINESS of Your Own. Make Sparkling Glass Name and Number Plates, Medallions, Checkboards, Signs. Big Illustrated Book Free. E. Palmer, 512, Wooder, O.

AGENTS—Make a dollar an hour. Sell Menpats, a patent patch for instantly mending leaks in all utensils. Sample package free. Collette Mfg. Co., Dept. 401, Amsterdam, N. Y.

10,000,000 FORDS need "Teuscher" fan belts. 50% profit selling dealers; 250% selling owners. Write quick. Teuscher Belting Co., St. Louis.

BIG profits selling our practical patented specialties. Write for particulars. Welch Brothers Co., North Chicago, Ill.

CASH in on this quick seller. Wingo cleared \$1,980 with Never Fail Razor Sharpener in six weeks; Purdy, \$40.50 first day. Applewhite, also inexperienced, six orders in thirty minutes. No end to ready buyers. Exclusive territory for quick workers. Be first. Address Never Fail Company, 166 Allen Bldg., Toledo, Ohio.

MEN'S Shirts. Easy to sell. Big demand everywhere. Make \$15.00 daily. Undersell stores. Complete line. Exclusive patterns. Free Samples. Chicago Shirt Manufacturers, 229 W. VanBuren, Factory 211, Chicago.

BIG Profits with Exclusive Territory—\$50 to \$100 weekly easy. More has often been made in one day's work. A hot or cold running water bath equipment for any home at only \$7.50. No plumbing or water works required. Investigate. Send no money. Write today. Sanitary Supply Co., 721 Allen Building, Toledo, Ohio.

AGENTS—Good salary and commission selling "Ratskill," new rat and mouse exterminator; ready for use; no bait required; non-poisonous; rodents die outside premises; no odor. Empire Specialties Co., 1549 N. Wells, Dept. 301, Chicago, Ill.

AGENTS: \$50 to \$100 a week guaranteed. World's greatest value, tailored to order all wool suits and overcoats—\$31.50, none higher. Fall line greatest ever. Write for new sales plan. Details free. J. H. Simpson, Dept. 989, 843 Adams, Chicago.

ASTOUNDING invention. Ford's use kerosene, start instantly. Mileage doubled. Big profit. Super, 1206 Fondulac, Milwaukee, Wis.

EASY, pleasant work for Mechanics, Shoe Men, Clerks, during spare hours; will add many dollars to their salaries. Also want persons who can give full time. Big wages assured. Novelty Cutlery Co., 67 Bar St., Canton, Ohio.

POLMET—The Wonderful Polishing Cloth that cleans all metals without liquid, paste or powder. Approved by "Good Housekeeping" and "Modern Housewife"—sells fast at 25c. Sample free. Gale & Co., Inc., 15 Edinboro St., Boston.

AUTO owner tire agent wanted each locality to use and take orders for handmade Mellinger fabric and cord tires; guarantee bond 8,000 and 12,000 miles (no seconds); shipped prepaid on approval; get your tires free; no capital or experience required; make \$100 to \$500 weekly. Write for wholesale prices and sample kit. Address, Mellinger Tire Co., Dept. 200, Kansas City, Mo.

AGENTS—Clever Invention! Inkspoon makes every pen a fountain pen. Fast office seller; big profit, demand increasing everywhere. Exclusive territory offered. Sample free. H. Marul Company, Tribune Bldg., New York, N. Y.

AT Last—World's Greatest Adding Machine. Almost human. Retail \$15; work equals \$300 machine. \$500 monthly easily made, demonstrating to stores, offices, garages, factories. Simple, easy; adds, subtracts, multiplies, divides automatically. Speedy, accurate, durable, handsome. Five year guarantee. Tremendous demand, amazing profits. Liberal trial offer. Protected territory. Write quick. Lightning Calculator Corp., Dept. F, Grand Rapids, Mich.

GET Our Free Sample Case—Toilet articles, perfumes and specialties. Wonderfully profitable. La Derma Co., Dept. A, St. Louis, Mo.

AGENTS—Stamping names on Pocket Key Protectors; sample Check with your name and address, 25c. Stamping Outfits, Emblem Checks, Check Pads, Name Plates, Hart Mfg. Co., Desk 2, 303 Degraw St., Brooklyn, N. Y.

125% CLEAR profit selling neckties; 2 samples \$1.00; satisfactory or money refunded. Raymond Mfg. Co., 132nd St. and Madison Avenue, New York.

AGENTS. Household necessity. Sells rapidly. Large Profit, Square Deal, Premier Mfg. Co., Dept. 813, Detroit, Mich.

MAKE \$17 daily—Finest Extracts, Food Products, Toilet Preparations, Household Necessities. Credit: Sample Case Free. Write for amazing offer. Perkins Products, B-6, Hastings, Neb.

AGENTS: Big Money Monogramming by Transfer Method. Catalog Showing Over 50 Styles and Particulars Free. Motorists Accessories Co., Mansfield, Ohio.

AGENTS: Big Profits, Best and cheapest window letters made. Easily applied. Dina brings five samples. Particulars free. Scat-brite Co., 1115 Second Ave., New York.

MAKE \$25 to \$50 Week, representing Clow's Famous Philadelphia Hosiery, direct from mill—for men, women, children. Every pair guaranteed. Prices that win. Free book "How to Start" tells the story. George Clow Company, Desk 31, Philadelphia, Pa.

YOU can be your own boss with our Key-Check outfit. Good for \$3 a day stamping names on pocket key checks, fobs, etc. Sample check with your name and address, 29 cents. Pease Die Works, Dept. M, Winchester, N. H.

INSTANT Weld. Repairs largest punctures without cement or heat. Leen's profit one day, \$56. Write quick. Free sample; territory going fast. Tourists' Pride Mfg. Co., Desk T, Minneapolis, Minn.

EARN \$10 daily silvering mirrors, plating and refinishing metalware, autos, chandeliers, bedsteads, headlights. Outfits furnished. E. Debie Laboratories, 1133 Broadway, New York.

AGENTS sell Wolverine Laundry Soap. Wonderful repeater and good profit maker. Free Auto to hustlers. Wolverine Soap Co., Dept. B37, Grand Rapids, Mich.

EVERYBODY uses extracts. Sell Duo Double Strength Extracts. Complete line household necessities. Big repeaters. Write today. Duo Co., Dept. B1, Attica, N. Y.

PATENTED Cigar Lighters with Glass Advertising Front. Also Electric Cigar Moisteners. Wonderful Sellers. No Competition. Big Steady Profits. Proof, Cuts, Sales Plan Free. Drake Mfg. Co., Dept. M, Milwaukee, Wis.

BIG Money and Fast Sales. Every owner buys Gold Initials for his auto. You charge \$1.50; make \$1.35. Ten orders a day easy. Write for particulars and free samples. American Monogram Co., Dept. 49, East Orange, N. J.

IF you want good live agents—fellows who can get the business—ask me how others are doing it. I'll gladly render the necessary assistance. Gen. F. Baker, Mgr. Classified Advertising, Popular Mechanics Magazine, Chicago.

AGENTS—Send for free sample "Fretnet"—washday wonder. You can clear at least \$20 to \$100 weekly, according to spare or whole time. You don't have to talk; if she doesn't buy at sight, leave sample; she will be looking for you long before you are able to make the rounds again. Samples furnished free. Premiums for your customers. Exclusive territory. Credit given. Empire Specialties Co., 1549 N. Wells, Dept. 101, Chicago.

BUILD permanent business. Men's, Women's, Children's guaranteed shoes direct to wearer. A. P. Condon, Sales Manager Allen Shoe Co., 110 Summer, Boston.

WE Start You Without a Dollar. Soaps, Extracts, Perfumes, Toilet Goods. Experience unnecessary. Carnation Co., Dept. 201, St. Louis.

TO secure agents or salesmen for selling farms and reaching investors, use classified (want) ads in largest newspapers and magazines. Price list No. 28 sent free. Ankrum Advertising Agency, 20 W. Jackson Blvd., Chicago, Ill. The largest classified advertising agency in the U. S.

AGENTS: A sale in every home for our beautiful dress goods, silks and general yard goods. Quick sales! Big profits. Large book of nearly 1,000 handsome fabric samples furnished to agents. Write today. National Importing & Mfg. Co., Dept. 6X, 573 Broadway, New York, N. Y.

AGENTS—Men and Women. Establish permanent business. 34c money order brings can of Gravy Crystals, a wonderful Gravy and Steam Improver. Try it and convince yourself. Every Store and Home a prospect. New product with big future. Exclusive territory to live representatives. Smith & Gray, Manufacturers, Guinda, California.

WONDERFUL! Startling! Amazing! Our Ex-Cel Luminous Crucifix and Magical (Luminous) Necklaces shine brilliantly in the dark. Sell on first demonstration. Big profits to you. Write for further particulars, or better still, send for sample and territory protection immediately. Crucifix \$1.50, Necklaces \$1.00, postpaid. W. G. Hannan Co., Dept. B, 57 E. 18th St., Chicago.

LIVE Agents make \$10 day selling Eureka Strainer and Splash Preventer for every water faucet. Takes on sight. Widely advertised and known. Get details today. A. B. Seed Filter Company, 73 Franklin, New York.

MAN in each town to plate auto parts, reflectors, bathroom fixtures, refinish beds, mirrors, chandeliers; by new method. No capital or experience required. Simple plan of manufacturing at home starts you in big money-making business. Outfit furnished. Free particulars and proofs. Gun Metal Co., Ave. H, Decatur, Ill.

SELL the Largest, Quickest Selling Specialties Ever Known—Famous "Halfway" self-lighting pocket Cigar Lighters and Gas Lighters. Low Prices. Easily Demonstrated. Sell to Dealers. Employ Sub Agents. Exclusive Territory. Make over 100% Profit. P. Bernhardt, 148 Chambers Street, New York.

EARN big money fast applying gold initials to autos. Every owner buys—\$1.35 profit on \$1.50 sale—particulars and samples free. Write quick. Lithogram Co., Dept. 17, East Orange, N. J.

HIGH GRADE SALESMEN WANTED

FACTORY Distributors. Wonderful envelope sealer, seals 3500 hour! Retail \$4 only! Tremendous profits. Consolidated Co., Dept. FG, 100 Boylston, Boston, Mass.

A WONDERFUL Seller! Any man, woman, boy or girl can make big wages. Some agents make from \$8.00 to \$20.00 per day. Crimp Grip Clothes Line Fasteners are a simple, time-saving device for holding a rope—also used for many other purposes. It pays for itself quickly in time saved on wash days. No knots—it fastens and releases quickly. Every home a prospect. Every housewife who uses Crimp Grips—and there are thousands of them—is a booster. There is but one Crimp Grip. Write for particulars, or send 50c for one pair and a mounted sample, with full particulars to agents. Crimp Grip Company, Bethesda, Ill.

SALESMEN—To sell popular J-V all-wool overcoats direct from mill to wearer at \$29.50. Made where the wool is grown. \$5.00 commission each sale, and bonus. Write today for samples of fabrics, style photos, and selling plan. Jordan Valley Woolen Co., 50 Post Office Place, Salt Lake City, Utah.

WE Feed Ambition with Gold. Walter Morris earned in nine months' actual working time commission amounting to \$23,251.17. Others are earning from \$1,000 to over \$1,800 a month. Demand for Alexander Film Publicity is so Great anyone with spark of ambition and the itch to Sell can do as well or Better. We want more live wires to develop our service in rich territory. It pays to work with Successful people. To get Real Money you must go where Money is Pivotal. Records of our sellers read like a romance of Arabian Nights. Ours is a \$1,000,000,000 market a year. Renewals of business provide permanent income. No investment required. We have an opening for you that is well worth while trying to get. Write for the most interesting business story ever told, "Feeding Ambition with Gold." Alexander Film Co., 3389 S. Broadway, Denver, Colo.

SALESMAN—Local Representative. Sell grape juice in 5 and 10 gallon kegs. Port type, Sherry type, Claret type, Tokay type, Riesling type, Catawba type, Burgundy type, Sauterne type (non-alcoholic), also our famous Catawba (white) and Concord (red) grape juice, 4 oz. 8 oz. 16 oz. and quart bottles, manufactured by the oldest and most responsible winery in America, with a high rating in Dun's and Bradstreet's; sold in compliance with the law. Our salesmen are making \$30 to \$60 per day. Repeat orders will surprise you. Be independent; work for yourself. No investment required. State full particulars. Taylor Wine Co. (formerly producers of high grade wines), 152 W. 42nd St., New York.

SALESMEN and District Managers to sell constantly used, repeating building specialties to factories, public institutions and building owners of all kinds. Products established over twelve years among thousands of largest users, including U. S. Government. Immediate big earnings and promotion with \$100,000.00 company to ambitious, capable men. Write at once. The Colorcraft Company, 870 W. 70th, Cleveland, Ohio.

MEN wanted to take orders for fast selling, tailored to measure, moth-proofed, all-wool men's suits and overcoats at \$18.50 and \$28.50. Fit and fabric guaranteed. Selling outfit of 125 (6 x 9) samples with advertising helps, measuring chart, business cards, order blanks, etc. In leather case, sent for Free examination. \$40 to \$60 weekly—bonus and protected territory; experience unnecessary; we deliver and collect. Write today—give two business references—for details and Free examination. Wholesale Direct Tailors, Dept. 37, 83 Ellicott St., Buffalo, N. Y.

WANTED—Tailoring Salesmen, make \$60 to \$125 per week. Biggest merchants in many towns have started with our line. We are the largest made-to-measure tailoring house in the country, furnishing elaborate sample equipments, including 500 all-wool fabrics. You make your own profits from \$8.00 to \$15.00 on each order. Guaranteed absolute satisfaction, perfect fit, best workmanship, or no sale. Write for line and all accessories to be sent free. Tell us all about yourself. Address N. O. Perry, Sales Manager, Box 483, Chicago, Ill.

WERE You Ever Offered a Grocery Store? Our proposition is better. You can handle flour, canned goods, dried fruit, coffee and entire line of groceries as well as radio sets, paints, roofing and automobile oils and tires with no rent to pay; no money invested; take large orders from samples. Goods are guaranteed and proven quality. Selling experience not necessary. Steady, profitable work for "workers." Address Hitchcock-Hill Co., Dept. 226, Chicago, Ill. Reference: Any bank or Express company.

TAILORING Salesmen—Amazing earnings, \$75 to \$150 weekly, with Crown tailored-to-order \$29.50 suits and overcoats. All wool fabrics. Linen canvas fronts. Hand made button-holes. Unequaled quality—Satisfaction guaranteed or money back. Big commissions daily. Extra bonus for producers. Write quick for outfit and protected territory. Crown Tailoring Co. Established 1908, 38 W. 3rd St., Cincinnati, Ohio.

OPPORTUNITY knocks but never opens the door. You have to do that. The key that opens this door is a letter from you giving details of your past business experience to prove you are the type of man we want to join the successful distributors of our nationally advertised product. C. F. S. Co., 15 N. 10th St., Richmond, Ind.

DOES Your Trade Use Salesboards? Send for free catalog. Finest and largest ever published. Big commissions! Lincoln Sales Co., Dept. L, 212 N. Sheldon, Chicago.

SALESMEN Wanted—We Have It. Something new, different, in demand, repeats, nationally adv., handled by all dealers, used by everybody. Pays big comm. in advance, credits for orders. Samples easily carried in grip, sideline or regular. A surprise waiting. World's Products Co., Spencer, Ind., Room 10.

BEST Seller. Jem Rubber Repair for tires and tubes; supersides vulcanization at saving of over 80%; put it on cold, vulcanizes itself in two minutes, guaranteed to last life of tire or tube; sells to every auto owner and accessory dealer. Get particulars how to make big money and free sample. Amazon Rubber Co., Philadelphia, Pa., Dept. 510.

MR. BRUSH Salesmen—Old Established New York Brush Manufacturers requires the services of men in all territories to sell their extensive line of Sanitary Twisted in Wire Brushes. We pay larger commissions than any other Brush House in the country. Write immediately for proposition. Wire Grip Sanitary Brush Corp., 15 Mercer St., New York.

STATE Distributor, Wonderful newly invented Ford necessity. Two million prospects waiting. Jewel Auto Products, 6714 Denison, Cleveland, Ohio.

SALESMEN—Sell Four Square Suits, \$12.50. All wool overcoats \$19.50. Make \$1.00 to \$5.50 each sale. Five different patterns of cloth. Complete line, coats, vests, pants, riding pants, slip-ons, overcoats, caps. Three-day delivery. Write today. Stone-Field Corporation, 2556 S. Wabash Ave., Chicago.

SALESMEN! Moccasin Footwear in demand for Street, Sport and Workman's use. Join our Manufacturer's Sales force to Wearer. Earn \$50 to \$80 Weekly. Immediate Commission. Write for Attractive proposition. Moccasin Footwear Company, 500 Fifth Avenue, New York.

THE Jackson Mfg. Co., 1331 16th St., Denver, Colo., has salesmen clearing as high as \$85.00 daily selling their newly patented auto specialty. Write them for free sample and particulars.

SALESMEN—Sell high-grade line of shoes direct to wearer. We shoe the entire family. Excellent repeat business. Write today for details. Sales Manager, 321 Marion Bldg., Cleveland, Ohio.

DISTRICT Managers Wanted—Appoint Local Agents for us in your locality. No canvassing or delivering. \$100.00 weekly easily made. Commissions advanced. Bob Russell, A-2307 Archer, Chicago, Ill.

SALESMEN, \$15 a day; no investment, no deliveries, commissions daily; envelope sealer, seals 50 a minute; retail \$3.50; sell on demonstration; new selling plan. Kendall Sealer Co., Dept. B-31, Jaffrey, N. H.

SALESMEN: Part or spare time. Make 150% profit selling Gas-O-Pep tablets for Auto and Tractor. Guaranteed to remove carbon, increase mileage and power. Big gas saver. Fast selling established line. Get your territory now. Taylor Products Mfg. Co., 24 West Nagitten, Columbus, Ohio.

ADD \$75-\$150 weekly to your bank account. Selling Reliable Brushes. P-1814 No. Ashland, Chicago.

SALESMAN: If You Think in Terms of \$6,000 the First Year, Write Me Personally. Strong line for retail stores. Nationally advertised. Established concern has unusual opportunity. Liberal weekly advance to producer. Geo. R. Williams, Mgr., 1923 Euclid Avenue, Cleveland, Ohio., Dept. 206.

SPECIALTY Salesmen, High-grade, to handle new fast-selling proposition to grocery and drug trade. Write for details. Penna. Soap Co., Lancaster, Pa.

EXCLUSIVE State Distributor. \$20,000 yearly. Newly invented pricing system, retail \$4.90. Tremendous demand! Big repeats. Miller Mfg., Dept. GG, Colonial Bldg., Boston, Mass.

SALESMEN—New Specialty, just out; every merchant a prospect; good for \$25.00 to \$50.00 daily. St. Louis Novelty Co., 1304 South Grand Ave., St. Louis, Mo.

SALESMEN—Openings for hustlers calling on merchants, city or country. Big self-selling daily necessity attractively displayed; merchants buy on sight. Enormous repeat business. Permanent employment or side line. Elcor Products Corporation, Department 128, Washington, D. C.

MEN—Women—Sell rubber aprons and rubberized goods, direct from manufacturer; every woman buys—100% profits—big sales. Get our proposition first. P. M. Breaux Co., 414 Broadway, New York.

FOUR \$7.50 sales to merchants net you \$20.00 daily. Sayers Systems, 2803 Sheffield Ave., Chicago, Ill.

SALESMEN—sell "Amenz" made to measure and ready made shirts; wonderful features; highest commissions. Samples Free. Menzies Shirt Co., 479m East Tremont Avenue, New York.

AGENTS: \$50 to \$100 a week guaranteed. World's greatest value, tailored to order all-wool suits and overcoats—\$31.50 one higher. Full line greatest ever. Write for new sales plan. Details free. J. B. Simpson, Dept. 990, 813 Adams, Chicago.

\$40-\$200 A WEEK. Genuine Gold Letters for store windows. Easily applied. Free samples. Liberal offer to general agents. Metallic Letter Co., 438-B North Clark, Chicago.

MAKE \$100 Weekly in Spare Time. Sell what the public wants—long distance radio receiving sets. Two sales weekly pays \$100 profit. No big investment, no canvassing. Sharpe of Colorado made \$955 in one month. Representatives wanted at once. This plan is sweeping the country—write today before your county is gone. Ozark, 502 Washington Blvd., Chicago.

\$19.50 DAILY from three \$10.00 sales. General Protection service universally demanded. Federal Detective Association, New Orleans, La.

SALESMEN—Become Independent. Own your business; experience unnecessary; selling our \$7,500 Accidental Death, \$50 Accident, \$25 Sick Weekly Benefits; \$12.50 yearly; other amounts proportionate. Guaranteed steady income from renewals. \$250,000 deposited Insurance Department. Registration Dept. A. Newark, N. J.

TRAVELING Salesmen calling on retail stores wanted by large manufacturer to sell unique line of business-boosting articles. Year round, fast selling, main or side line. If not earning \$150 weekly, address Elsaszer Works, 222 Charles St., Roorville, N. Y.

SALESMEN sell sales and order books, auto, reg. rolls and bill findings. Large demand. Liberal commission. Wirth Sales Book Co., Dept. PM, Chicago.

SALESMEN—sideline pays five to ten dollars a day taking orders for Specialty printed gummed advertising and Match Box Stickers. Write for proposition, samples, etc., today. Beardsley's Printery, Rock Island, Ill.

\$4.00 PROFIT on Every \$5.00 sale. "Free Sample"—New Specialty. (Money Getter.) Every Storekeeper, Doctor buys quickly. Experience unnecessary. Territories open. Box 596, Hartford, Conn.

SALESMEN Can make \$5.00 a day selling our Calendars, Pencils, Signs, Advertising Novelties, Yardsticks, Whistles, etc. Liberal terms. Sells entire year. Fine side line. Local and traveling agents. Model Calendar Co., Dept. 226, South Bend, Ind.

CALIFORNIA Rosebuds selling like hot cakes. Agents coinng money. Absolutely new. Big profits. Catalog free. Mission Factory SP, 519 No. Halsted, Chicago, Ill.

HELP WANTED

BECOME a Landscape Architect. Un- crowded profession of wonderful opportunity for money-making. Easily mastered by mail. Earn while you learn. Write for book. American Landscape School, 56-E, Newark, N. Y.

MEN: We will establish you in a per- manent business paying big income. Your credit is good for merchandise people must buy every day. No special experience necessary. Write today for free booklet "Mc- Connors System." McCann & Co., Factory M34, Wilson, Minn.

WANTED—Boys—Men. Learn Auto Re- pairing. \$30.00 week. Sample lessons free. Franklin Institute, Dept. R-408, Rochester, New York.

BE a Finger Print Expert. Write, Ameri- can Finger Print System, 1966 Broadway, New York.

FIREMEN, Brakemen, Baggage men. Sleeping Car, Train porters (colored). \$140-\$200. Experience unnecessary. 810 Railway Bureau, East St. Louis, Ill.

MONEY! Silvering Mirrors, Autolights, Radiators, tableware, stoves, Outfits. Meth- ods free. Sprinkle Plater, 288 Marion, Ind.

\$133 MONTH. Steady. Railway Postal Clerks. We'll coach you. Particulars Free. Write immediately. Franklin Institute, Dept. R-19, Rochester, N. Y.

MEN wanting positions firemen, brakemen, colored train or sleeping car porters, write for application blank; experience unneces- sary, first class roads, no strike. Name position wanted. Railway Institute, Dept. 53, Indianapolis, Ind.

\$5 TO \$15 daily easy—Your Pay in Ad- vance—Introducing New Style Guaranteed Hosiery—Must wear or replaced free—No capital or experience required—Just show samples, write orders—We deliver and col- lect—Elegant outfit furnished—All colors—grades including silks, Maroon Textile Company, Room 26911, Cincinnati, Ohio.

GOVERNMENT Railway Postal Clerks, \$133-\$192 monthly. Many other openings, \$140 upward. Full information free. Write immediately. Chicago Civil Service College, A-11 Kenne, Chicago.

MEN to Build Radio Sets for me in spare time. Leon Lambert, 538-H Kauf- man Bldg., Wichita, Kansas.

U. S. GOVERNMENT Life Positions. Over 20,000 positions filled yearly. Steady work. Men—women, 18 up. \$1140 to \$2300 year. Railway Postal Clerks—City Carriers—Clerks, etc. Pleasant work. Influence unnecessary. Common education sufficient with our coaching. Experience unnecessary. List positions obtainable—Free. Write immediately. Franklin Institute, Dept. R-3, Rochester, N. Y.

HOTELS Need Trained Men. Nation- wide demand for high-salaried men; past experience unnecessary. We train you by mail and put you in touch with big oppor- tunities. Big pay, fine living, interesting work, quick advancement; permanent. Write for Free Book, "Your Big Opportunity." Lewis Hotel Training Schools, Suite B-351, Washington, D. C.

MEN, Women, Spare Time, Big Money. No canvassing. Stamp for particulars, Whit- ney, Box 55R, Station C, Cincinnati, Ohio.

ARE You Old at Forty? See our adver- tisement on page 146 of this issue. The Electro Thermal Company, 2137 Main Street, Steubenville, Ohio.

RAILWAY Postal Clerks. \$133 month. 25 men coached free. Write. Franklin In- stitute, Dept. R-19, Rochester, N. Y.

LOCOMOTIVE Firemen for railroads nearest their homes—everywhere; beginners \$150-\$250 monthly; later as Locomotive Engineers, \$300-\$400. Best paying posi- tions on Railroads. Railway Association, Desk M1, Brooklyn, N. Y.

BE a Forest Ranger, Postal Clerk or Carrier. Steady positions. Particulars free. Write McKane, Dept. A-12, Denver, Colo.

CLERKS: for Government Postal and other good positions \$1400-\$2300 yearly. Experience unnecessary. Full particulars free by writing G. W. Robbins, Civil Service Expert, 411 Burchell Bldg., Washington, D. C.

GET a United States Government Position. Good Pay, Short Hours, Vacation, Sick Leave, Pension, etc. Prepare for Railway Mail, Post Office, Custom House, Internal Revenue, Rural Carrier or other branches. Examination all the time. Common educa- tion sufficient. Let our expert (Former U. S. Civil Service Secretary-Examiner) train you. Guaranteed Preparation. Write today for Free Booklet. Patterson Civil Service School, Dept. 8, Rochester, N. Y.

MEN—Age 18-40, wanting Railway Sta- tion-Office positions, \$115-\$250 month, free transportation, experience unnecessary. Write Baker, Supd., 41 Wainwright, St. Louis.

YOU Are Wanted. Government Jobs. \$95- \$192 month. Steady. Sample coaching lessons—Free. Write immediately. Franklin Institute, Dept. R-19, Rochester, N. Y.

RAILWAY Postal Clerks—Start \$133 month. Railroad pass; expenses paid; ques- tions free. Columbus Institute, E-2, Colum- bus, Ohio.

\$40-\$200 A WEEK. Genuine Gold Let- ters for store windows. Easily applied. Free samples. Liberal offer to general agents. Metallic Letter Co., 438-C North Clark, Chicago.

FINGER Print Experts—Excellent paying positions; particulars free. Finger Print Headquarters, 188 East 70th, New York.

SILVERING Mirrors, French plate. Easy- ly learned; immense profits. Plans free. Address, Wear Mirror Works, Excelsior Springs, Mo.

OUR genuine gold window sign letters are an excellent money-making proposition for handy men. Shann Sign System, Bethune Ave. E., Detroit, Mich.

MAKE money writing Photo-plays; de- tails free to beginners. No correspondence course. Producers' League, 250 Wainwright, St. Louis.

INVENTORS desiring to secure patents should write for our book "How to Get Your Patent," tells our terms and methods. Send sketch for our examination and instructions without charge. Randolph & Co., Dept. 418, Washington, D. C.

MEN 18-35. Become Railway Postal Clerks. Commence \$1400 Year. Common education sufficient with our coaching. Particulars free. Write immediately. Franklin Institute, Dept. R-19, Rochester, N. Y.

EARN \$10 daily silvering mirrors, plating and refinishing metalware, autos, chandeliers, bedsteads, headlights. Outfits furnished. E. Decis Laboratories, 1133 Broadway, New York.

ALL men, women, boys, girls, 17 to 65, willing to accept Government Positions, \$117-\$250 traveling or stationary. Write Mr. Ozment, 101 St. Louis, Mo., immediately.

EARN \$1.20 an hour cutting blanks at home; spare time. Men only. Send ad- dressed reply envelope. Goodyear Sa., 147 W. 23d St., New York.

STORIES, poems, plays, etc., are wanted for publication. Good ideas bring big money. Submit manuscripts or write Literary Bureau, 522, Hamibal, Mo.

INFORMATION

INFORMATION, Advice, Any Subject. Accurate, Complete, Prompt Answers. \$1.00. Rose Research Bureau, 12365 Edmonton, Cleveland, Ohio.

CORRECT, detailed, expert information promptly. Any subject. \$1.00. Inter- national Information Institute, 15 Moore Street, New York.

COMPLETE information on any book pub- lished. Or will supply lists of books that are the best on any subject. Information is free. Room 807, Popular Mechanics Build- ing, Chicago, Ill.

BUSINESS SERVICE

DELAWARE Incorporator. Charters; Fees Small; forms. Chas. G. Gayer, 901 Orange St., Wilmington, Del.

TYPEWRITERS AND SUPPLIES

UNDERWOOD Typewriters — only \$3.00 down. Easy monthly payments. Low prices at less than manufacturers. 10 days' free trial. Rebuilt, all worn parts replaced. Just like a new machine. 5-year guarantee. Write for big free catalogue C-171. Shipman-Ward Mfg. Co., 1518 Shipman Bldg., Chicago, Ill.

TYPEWRITERS All Makes. Save one- half. Thoroughly rebuilt in our factory by the famous "Young Process." Fully guar- anteed. Free Trial. We handle all standard makes. Cash or sold on easy terms. Write for Catalog. Young Typewriter Co., Dept. 562B, Chicago, Ill.

BLACK Record Ribbons, visible typewrit- ers. 50c; Two \$1.00. Typewriters Supply, 170 Monon Bldg., Chicago.

TYPEWRITERS, all makes; real bar- gains; guaranteed. Dees Typewriter Sales Co., Ada, Okla.

TYPEWRITERS, All makes, \$15 up. Guaranteed. Write for our bargain price list and Free Trial offer. Department 16, Man- ufacturers Typewriter Clearing House, 193 N. Dearborn Street, Chicago.

TYPEWRITERS, all standard makes, \$10 up. Fully guaranteed. Free trial. Write for complete illustrated lists. Northwestern Typewriter Exchange, 121 N. Francisco Ave., Chicago.

TYPEWRITING

I DO Typing—Charge: 60c Thousand Words. "Lewis," Eland, Wis.

PRINTING, ENGRAVING AND MULTIGRAPHING

500—50c; 3x6 CIRCULARS. Our adver- tisements on back. Mail Salesman, 124 North Bentonway, Los Angeles.

PERSONAL Stationery, 200 sheets, 100 Envelopes, printed to order, \$1.00. Weather- by, Medina, Ohio.

MULTIGRAPHING, Letterheads, En- velopes, \$2.75—1,000; 5,000—\$10.00. Force- ful Sales Letters \$1.00. Advertising, Rubber Stamps, Universal Printers, 309-311 Fifth Avenue, New York.

250 EACH—bond letterheads and envelopes—\$3.00. Service Printer, 128 N. Wilbomet, Dallas, Texas.

500 EACH "Neatgrave," Letterheads— Envelopes, \$1.75 postpaid. Soliday's, Knox, Ind.

HELLE Printers welcome inquiries. Print anything; any quantity. 3446 Lemay, De- troit, Mich.

1M LETTERHEADS 8 1/2x11, printed on 20 lb. paper, \$4.00; 1M 6 1/2 x 9, W. W. en- velopes, \$3.50. Neat work, prompt service; postpaid. Commercial Press, 236E Big- low St., Newark, N. J.

5,000 BOND Letterheads \$12. Ewan, 49 Pearsall, Jersey City, N. J.

ALL Printing Prices Smashed. 5,000 Letterheads or envelopes \$13.83. Samples, Quality Printshop, Marietta, Ohio.

GUMMED Labels, 3,000 \$1.00. Catalogue 2c. MacTaggart, 1235 Arch, Philadelphia, Pa.

MULTIGRAPHING. Prices lowest; let us quote. Printing. Walter Miller, Berwick, Pa.

200 VELLUM Finish Cards (4 lines), \$1.00. John Arnold, 2455 N. Spaulding Ave., Chicago.

500 BOND letterheads, 8 1/2 x 11, \$2.75; 500 business cards, \$2.25. West of Denver add 10%. Superior Printing, Todd Co., 19 East Second St., Cincinnati, Ohio.

500 LETTERHEADS, 500 Envelopes and 100 Business Cards neatly printed \$4.50. 250 Letterheads and envelopes \$2.50, postpaid. Cash with order. Cole Bros., 400 South Halsted, Chicago.

FOUR Color Personal Christmas Cards with Envelopes, Guaranteed or money back. 25—\$1.50. 50—\$2.75. 75—\$3.50. 100—\$4.25. Community Printery, 2645 Lafayette, Saint Louis, Mo.

PERSONALIZED Checks. Your name and address on your bank checks gives you prestige, protection and instant identification. Four books (100 checks) beautifully printed on National Safety Paper (alteration proof) with genuine black or gray leather cover, postpaid, \$1.75. Sample and booklet free. Crescent Calendar Co., Dept. A, Wyoming, Iowa.

5,000 BOND Letterheads \$12.50. Samples free. Fred A. Pitz, Amama, Iowa.

BOND Letterheads—\$2.00 per 500. Small size \$1.50. Pears, Harding, Mass.

100 LETTERHEADS, 100 Envelopes, \$1.00 Postpaid. V. Binella, 129 Bertrand, Newwood, Man., Canada.

"ARISTOCRAT" embossed business, personal stationery. Different. Reputation. Samples for Stamps. Apex Company, 261 South Main, Wilkes-Barre, Penna.

250 BOND Letterheads, 250 Envelopes, \$3.00. Samples. Midland Press, 543 West Hickory Kankakee, Ill.

1,000 CIRCULARS, 6x9, Inked 150 words, \$1.80. 1,000 Bond letter heads or envelopes, \$3.00 prepaid. National Press, Dept. 49, 510 E. 77th, New York City, N. Y.

GILT lettered Advertising-Pencils for you. Buy direct; save entire middleman's profit. Samples free (no agents). Address S. Mustal & Co., 10-12 Lincoln St., Yonkers, N. Y.

250 BOND Letterheads or Envelopes, \$1.25. W. E. Meyer Supply House, Milton, Pa.

250 LETTERHEADS, 250 white envelopes, printed and mailed, \$3.00. Samples printing free. Sisco, Mohawk, N. Y.

QUALITY Printing! Reasonable Prices! Send for Free Standardized samples and prices. Folders, Circulars, Catalogs our specialty. Ernest Fantus, 525 South Dearborn, Chicago.

WE print Stationery, Booklets, Catalogs, Circulars, Campaign printing. Samples. Commercial Press, Batavia, Ohio.

225 BOND letterheads, envelopes, bill-headers, cards, \$1.25 each. Combination, \$4.00. Economic Press, Leonia, N. J.

200 PRINTED 8 1/2 x 11 Hammermill Letter-heads, Envelopes, Billheads or Business Cards \$1.00. Postpaid. Race Printery, Hudson, N. Y.

PRINTING and Multigraphing of the Sort That Boosts Your Business. Send Copy for Estimate. Miller Company, Chatham, N. Y.

PRINTING OUTFITS AND SUPPLIES

PRINT your own cards, stationery, circulars, paper, etc. Press \$12.00. Larger \$35.00. Job press \$150.00. Save money—Print for others, big profit. All easy, rules sent. Write for catalog presses, type, paper, etc. Press Co., R-11, Meriden, Conn.

PRINTING Outfits—Presses, type supplies, type novelties. Send stamp for catalogue. Model Press, York, Penna.

PRE-USED Printing Presses. Type and supplies. List for stamp. Popular Bargains, Richland, Pa.

DUPLICATORS AND DEVICES

STENCIL Duplicating Outfit—Typewriting, Handwriting, Letter \$4.00, Note \$3.00, Card \$2.00. Returnable. Primes Specialty Co., 3-M, Primos, Pa.

YOU can make 50 to 100 copies of a letter, notice, etc., at a cost of three cents on a Hoyer Quality Duplicator. Write for free trial offer. The Hoyer Duplicator Co., 14 E. Wells St., Chicago, Ill.

ADDING MACHINES

NEW \$3.50 Automatic Adding Machine. Adds, Subtracts, Multiplies. Absolutely accurate. Capacity \$999,999.99. Fully guaranteed. 75,000 pleased users. Makes adding easy, positive, quick. Eliminates Mistakes. Saves Time. Postpaid \$3.50. Bassett Co., 1458-N Hollywood Ave., Chicago.

FREE Trial. Marvelous new Adding Machine. Adds, Subtracts, Multiplies, Divides, automatically. Work equals \$350.00 machine. Price only \$15.00. Speedy, durable, handsome. Five-year guarantee. Used by largest corporations. Write today for catalogue and free trial offer. Lightning Calculator Co., Dept. E, Grand Rapids, Mich.

FOR SMOKERS

200 CAMELS, Chesterfields, or Lucky Strike Cigarettes, \$1.40 mailed in U. S. A. Economy Tobacco Bulletin free. Richard Lavery, Ashbury Park, N. J.

CIGARETTE Smokers, Tobacco Users. Read "Tobacco Facts." Worth a fortune. Mailed for 10c. Leonard, 2875 California St., San Francisco, Calif.

SMOKERS—New tobacco preparation absorbs nicotine, makes smoking pleasure; less harmful. Sample and instructions, 25 cents. E. J. Wilson, Box 188, Griffith, Ind.

FOR MEN

CHRISTMAS Suggestion! Men's Imported Handkerchiefs, Warranted Pure Linen, 50 cents Each; 8ix \$2.75. Postage and Insurance Extra. Irish Manufacture. Alexis Mengelle, Box 387, Colorado Springs, Colo.

BOATS AND LAUNCHES

SPEED boat for small engine. Plans and directions 25 cents. Free catalog of boat plans and books, The Rudder, 9 Murray Street, New York City.

BOATS that always go are propelled by Ford Engines. Ford engine booklet free to boat owners. Harry Rider, 201B East Avenue, South Norwalk, Conn.

10-FOOT Rowboat—easily made. Construction blueprint 30c. Weesho-Uco, 31st Office, Detroit, Mich.

NEW Boat Book telling how to make 21 kinds of boats. Also many other helpful ideas for those who like boats. Profusely illustrated. 50 cents. Popular Mechanics Press, Room 897, Popular Mechanics Building, Chicago, Ill.

RAZORS AND BLADES

BLADES Resharpened 3c any make. Guaranteed Service. Standard Safety Razor Corp., Pittsburgh.

BLADES for Gillette razor 35c per dozen. Brand new. Live agents wanted. Razorblade Co., 2743K Broadway, New York.

BLADES sharpened. Single edge 2c; double 3c. New York Edge Co., Glen Cove, N. Y.

ONE Dozen Blades, 35c. 5t Gillette Razors. Schultz, Box 1038, Rockford, Ill.

GEM Safety Razor—Triple Nickel frame \$5.00. Send no Money; pay Postman on arrival. A. Mattax, Trenton, La.

GILLETTE Safety blades sharpened 3c each. Work guaranteed. D. Cera, Junction, Wis.

OPTICAL GOODS

BINOCLULAR Telescope eight-power, 7 1/2 in. long extended 5 1/2 in. closed \$22.00. Joseph Novak, Lonsdale, Minn.

GENUINE 6X Schutz Prism Binoocular in Leather Case, \$19.50. Worth \$45.00; Bass Guarantee protects you. Binoocular Catalog Free. Bass Camera Company, 169 N. Dearborn St., Chicago, Ill.

FOR THE HOME

HOME Mechanic Attention! We specialize in unusual cabinet hardware and mechanical devices for home furniture construction; copper chest tinning, transfer designs, knock down chests, tea wagon wheels, scooter wheels, wood and silk lamp shades, bridge lamp arms and electrical fixtures, cane and reed, porcelain table tops, upholstery supplies, finishing materials, office chair and typewriter desk fixtures, casters, steel rails for wood beds, locks, hinges, catches, dowels, costume hooks, smoking stand trimmings, etc. Most complete line entire country this class material. Send ten cents stamps for Tenth Annual Catalog "Hard-to-Get" materials. Thurston Manual Training Supply Company, Anoka, Minn.

LOOMS—Only \$9.90—Big money in weaving rugs, carpets, portieres, etc., at home, from rags and waste material. Weavers are rushed with orders. Send for free loom book. It tells all about the weaving business and our wonderful \$9.90 and other looms. Union Loom Works, 480 Factory St., Ironville, N. Y.

KEEP your home comfortably warm; get quicker, steadier heat; make a coal saving of 20% or more, by attaching the Crown Fuel Saver to the feed door of your heating plant. Write today for details of this amazing heat-producer and coal saver. Special low price, backed by guarantee to make 20% coal-saving or money refunded. CFSKO, 15 N. 10th St., Richmond, Ind.

CONCRETE Handbook, for the Amateur. We have just published a book describing 173 ways of using concrete in the home, shop and on the farm, with full directions for doing these things yourself with ordinary tools, 138 illustrations. It is "written so you can understand it." Price 50 cents, postpaid. Popular Mechanics Book Dept., 206 E. Ontario St., Chicago.

DIAMONDS, WATCHES AND JEWELRY

MILOLET—The nearest diamond you will ever see. Guaranteed for always "double diamond cut" Mile-away-flash reflects \$500. Costs \$10, two payments; diamond-gold mine to agents, Rich McGinnis, Dept. 89, Hot Springs, Ark.

ANTIQUES, WAR RELICS AND INDIAN GOODS

FOR Dens; Relics collected from Europe's Battlefields. Also Medals, Insignia, etc. Illustrated catalogue with sample War Photographs 25c. Lieut. Welsh, 2117 Regent Pl., Brooklyn, N. Y.

INDIAN Made Baskets, Blankets, Beads, Curios. Catalog. Gilham, Kelseyville, Calif.

SELLING Out! 1085 Arrowheads. Price \$25.00. \$3.50 per 100. H. Daniel, Lamar, Ark.

SEND 5c for free, new list Indian relics, antique firearms. P. E. Ellis, Webster Groves, Mo.

PHONOGRAPHS AND RECORDS

EDITH Portables and Table Phonographs at Cost. Circumstances upon request. A. E. Shearer Mfg. Co., Station E, Box 9, Cleveland, Ohio.

BUILD Your Own Phonograph with Our Help—Save Half. The Choraleon Aristocratic Phonograph is unequalled. Plays any record. Finest motors, tone arms, case materials cut to fit, ready to put together and blueprint and full instructions furnished at small cost. Satisfaction guaranteed. Write for catalog. Choraleon Phonograph & Radio Co., 915 5th Street, Elkhart, Ind.

SAVE money! Finest quality Phonograph Builders' Equipment. Instructions, Catalogue. Superior Phonoparts Co., Erie, Pa.

BUILD your own Phonograph. We furnish everything. Write for Phonographs and Radio Parts Catalog. American Phonograph Co., 3752 Belmont, Chicago.

BUILD Your Phonograph. Quality phonoparts. Quality Sereenads motor and motors of other types. Electric Motors, tonearms, reproducers, amplifiers, case materials, accessories. Free blueprints and building instructions. Big saving. Wonderful results. Prompt delivery. Catalog mailed for ten cents. Hooster Manufacturing & Supply Co., 313 Baldwin Block, Indianapolis, Ind.

MUSIC AND MUSICAL INSTRUMENTS

JAZZHARPS; Played with beaters, Great Testimonials. Retail \$27. Introductory price \$19. \$1 with order, bal. C. O. D. Examination. Write, F. M. Reifus Co., LaCrosse, Wis.

SACRIFICE Large Stock new musical instruments. Saxophones, trumpets, banjos, violins, etc. Bugles, \$4.25. Write for low prices, mentioning instrument. Winn School of Music, 2117 Regent Pl., Brooklyn, N. Y.

I WRITE beautiful songs. Expert composer, arranger. Advice on matters musical. Evans, 1658 Broadway, New York.

I WANT Song Poems. Casper Nathan, 1252 Bryn Mawr, Chicago.

WRITE Songs. Big money and reputation. Write for information. J. Gordon Pub. Co., 201 N. Hoyne Ave., Chicago.

"MUSIC Composed" in words. Bauer Bros. (formerly of Sousa's Band), Oshkosh, Wis.

VIOLINS, Deep, Mellow, Souful—on credit. Easy terms for wonderful instrument. Get details today. Gustav F. Henning, 2424 Gaylord St., Denver, Colo.

CORNETISTS—Trumpetists—Saxophonists—Clarinetists. Get "Free Pointers." Name instrument. Virtuosi School, Concord, Mass.

PATENT ATTORNEYS

PATENT Procured. Prompt Service. Personal, careful and efficient service. Highest references. Moderate fees. Send sketch or model for actual search and advice. George P. Kimmel, Master of Patent Law, 54-K Loan and Trust Bldg., Washington, D. C.

PATENTS—Write for our Guide Books and "Record of Invention Blank" before disclosing inventions. Send model or sketch of your invention for Examination and Instructions. No charge for the above information. See advertisement on pages 182 and 183. Victor J. Evans & Co., 931 Ninth, Washington, D. C.

PATENTS. Write for my free Guide Books "How to Obtain a Patent" and "Invention and Industry" and "Record of Invention" blank before disclosing inventions. Send model or sketch of your invention for instructions. Promptness assured. No charge for above information. Clarence A. O'Brien, Registered Patent Lawyer, 588 Security Bank Building, directly across street from Patent Office, Washington, D. C. See pages 180 and 181.

MONROE MILLER, Ouray Bldg., Washington, D. C. Patent Attorney; Mechanical, Electrical Expert. Free Blue Book gives candid advice.

THE PATENTOME. Impartial advice to Inventors and Manufacturers. Mailed on request. Anderson & Son, Patent and Trade Mark Lawyers, Established 1865, 635 F St., Washington, D. C.

H. F. LOWENSTEIN, Registered Patent Attorney. Technical expert. McLachlen Building, Washington, D. C.

PATENTS, patent litigation, trademarks, copyrights. Handbook of Instructions "How to protect inventions" free on request. R. H. Favel, Patent Attorney, formerly of the U. S. Patent Office Examining Corps., Room 503 McLachlen Bldg., Washington, D. C.

PATENTS, Trade-Marks Designs. This firm has 27 years' experience and gives expert personal service at reasonable rates. We properly protect your invention. Write for free information and exact cost of procuring patent before proceeding. John B. Thomas & Co., 902 F St., N. W., Washington, D. C.

PATENTS—Let me assist you in obtaining your Valid Patent Rights. Personal Service. Promptness assured. George Van Den Berg, Barrister Bldg., Washington, D. C.

MILLIONS spent annually for ideas. Hundreds now wanted! Patent yours and profit! Write today for free books—tell how to protect yourself, how to invent, ideas wanted, how we help you sell, etc. American Industries, Inc., 500 Kroeger Bldg., Washington, D. C.

PATENTS and Trade-marks obtained. Prompt service. Write for our new book on patents. Established in 1880. D. Swift & Co., 309 7th St., Washington, D. C.

ESTABLISHED 1864, Milo B. Stevens & Company, Registered Attorneys (No. 826), Patents—Trade Marks—Copyrights. Full information upon request. Moderate fees. Offices: Barrister Building, Washington; Lander Building, Cleveland; Monadnock Block, Chicago.

INVENTORS—Send for form "Evidence of Conception" to be signed and witnessed. Form, fee schedule, information free. Lancaster and Allwine, Registered Patent Attorneys in United States and Canada, 221 Ouray Bldg., Washington, D. C.

INVENTORS, before applying for Patent, send for our free circular "Advance Confidential Service for Inventors," designed to save you money and increase your opportunities for success. Coston Guay, Engineers, 30 Sixteenth Street, Southeast, Washington, D. C.

PATENTS, Trade-Marks, Copyrights, and Patent Litigation. Write for advice and instructions how to proceed, costs, etc. Hand Book with Illustrations of 100 Mechanical Movements sent free on request. Albert E. Dieterich, Patent Lawyer and Solicitor, 621-B Ouray Bldg., Washington, D. C.

PATENTS Procured; Trade Marks Registered—A comprehensive, experienced, prompt service for the protection and development of your ideas. Preliminary advice gladly furnished without charge. Booklet of information and form for disclosing idea free on request. Richard B. Owen, 30 Owen Bldg., Washington, D. C., or 2276-R Woolworth Bldg., New York.

PATENT Application Blanks free to inventors. Patent News-D, Washington, D. C.

CASH for Patents and Pending Patents. American Patents Corporation, Barrister Building, Washington, D. C.

PATENT SENSE—"The book the inventor keeps." Free. See Lacey ad, page 184.

UNPATENTED Ideas Can Be Sold. I tell you how and help you make the sale. Free particulars (Copyrighted). Write W. T. Greene, 806 Jenifer Building, Washington, D. C.

INVENTORS: Send sketch or model for free opinion concerning patentable nature and exact cost of patent. Book "How to Obtain a Patent," sent free. Tells what every inventor should know. Established twenty-eight years. Highest references. Prompt service. Reasonable charges. Chandler & Chandler, 474 Seventh, Washington, D. C.

TRADEMARKS \$35; Design patents \$35; Copyrights \$5; Booklet Free; 20 years' experience. Sanders, Registered Patent Attorney, 7 Rand-McNally Building, Chicago.

PATENTS—Send for Booklet. Contains valuable information for inventors. Our charge for search of Patent Office records \$5.00. Prompt service, twenty years' experience. Talbert & Talbert, 508 McGill Building, Washington, D. C.

INVENTORS—Write for our Guide Book, "How to Get Your Patent" and Evidence of Invention Blank. Send model or sketch of your invention for our prompt examination and instructions free. Randolph & Co., Dent, 439, Washington, D. C.

"INVENTOR'S Advisor", the valuable Patent book with 139 mechanical movements and illustrations, sent free upon request. M. M. Labiner, Patent Attorney, 3 Parkrow, New York.

PATENTS, Booklet free. Highest references. Best results. Promptness assured. Send model or drawing for preliminary examination. Watson E. Coleman, Patent Lawyer, 641 G Street, Washington, D. C.

PATENTS, Trade marks, copyrights. Prompt, personal, reliable service. Over 20 years' active practice. Write for terms. Book free. Address E. G. Siggers, N. U. Bldg., 318 F St., Washington, D. C.

HERBERT JENNIE, patent attorney and mechanical expert, 605 F Street, Washington, D. C. I report if patent obtainable and exact cost. Send for circular.

"INVENTORS' Guide" sent free on request; this book contains illustrations of patented inventions and gives valuable information and advice for all who have original ideas or improvements. Frank Lederman, Registered Attorney and Engineer, 15-P Park Row, New York.

PERCY S. WEBSTER, Savings and Loan Building, Stockton, California, Long established organization. Send for free book on Patents.

PATENTS, My fees in installments. Advice book free. Frank Fuller, Washington, D. C.

FOR INVENTORS

PATENTS. If you have an invention which you wish to patent you can write fully and freely to Munn & Co. for advice in regard to the best way of obtaining protection. Please send sketches, or a model of your invention and a description of the device, explaining its operation. All communications are strictly confidential. Our vast practice, extending over a period of seventy-eight years, enables us in many cases to advise in regard to patentability without expense to the client. Our Hand-Book on Patents is sent free on request. This explains our methods, terms, etc., in regard to Patents, Trade Marks, Foreign Patents, etc. "Scientific American" contains Patent Office Notes, Decisions of Interest to Inventors and particulars of recently patented inventions. Munn & Company, Solicitors of Patents, 623 Woolworth Building, New York; Scientific American Bldg., Washington, D. C.; Tower Bldg., Chicago, Ill.; Hobart Bldg., 582 Market St., San Francisco, Calif.; Van Nuys Building, Los Angeles, Calif.

CANADIAN and foreign patents secured. Fine references. Reasonable rates. Prompt, personal service. The Ramsay Co., 273 Bank St., Ottawa, Canada.

HOW to sell your Invention Without Being Swindled. Free Instructions. Write Today, Scholtz & Co., Wyandotte, Mich.

DUNKIN Engineering Co., Patents Developed—Models Furnished. Spec. Machinery, 13090 Superior Avenue, Cleveland, Ohio.

ENGINES and machines designed, patents developed, 20 years' experience. John H. Platt, Consulting Engineer, 256 Cambridge Ave., Jersey City, N. J.

CASH for Patents and Pending Patents. Write promptly. American Patents Corporation, Barrister Building, Washington, D. C.

RESPONSIBLE established electrical manufacturer will buy outright or manufacture on royalty new inventions of household utilities or appliances. Details necessary. L. J. Effertz, 6545 Carnegie Ave., Cleveland, Ohio.

I PREPARE patent specifications without any advance fee to prove satisfaction. Send description of invention for specification within 2 days. Alexander Wedderburn, Patent Attorney (30 years), Washington, D. C.

WILL finance patent (good invention) for interest. F. A., % Patent News, Washington, D. C.

WANTED: Patented articles of practical merit to manufacture and sell. Purchase or royalty basis. Correspondence invited from inventors. Willcutts & Cummins, Box 323, Sidney, Ohio.

PHOTOSTAT Copies. Five exact facsimiles your patent drawings 8"x11" for \$1.50. Quick. Dependable. Keller's Photostat, Box 269, Charleston, W. Va.

PRACTICAL information on method of construction, and materials for inventions. Also where obtainable. \$1.00. Technical Research Bureau, 377 National Ave., Milwaukee.

PATENTS wanted. Must have merit. Boss, 52 Vanderbilt Ave., New York City.

LACEY Patent Sense. See Page 184.

INVENTORS—Write for our Guide Books and "Record of Invention Blank" before disclosing inventions. Send model or sketch of your invention for our free examination and instructions. See advertisement on pages 182 and 183. Victor J. Evans & Co., 157 Ninth, Washington, D. C.

PATENTS. Write for my free Guide Books "How to Obtain a Patent" and "Invention and Industry" and "Record of Invention" blank before disclosing inventions. Send model or sketch of your invention for instructions. Promptness assured. No charge for above information. Clarence A. O'Brien, Registered Patent Lawyer, 588 Security Bank Building, directly across street from Patent Office, Washington, D. C. See pages 180 and 181.

INVENTORS' Educator: 990 Mechanical Movements, 50 Perpetual Motions. How to procure and sell patents. Mechanical Movements greatly assist Inventors, suggest new ideas. Explains how to select an attorney and avoid Patent Sharks. Price \$1.50. Postage Free. Albert E. Dieterich, 621 Ouray Building, Washington, D. C.

MONROE MILLER, Ouray Bldg., Washington, D. C. Patent Attorney; Mechanical, Electrical Expert. Before proceeding, read free Blue Book.

INVENTORS, before applying for Patent, send for our free circular "Advance Confidential Service for Inventors," designed to save you money and increase your opportunities for success. Coston Guay, Engineers, 30 Sixteenth Street, Southeast, Washington, D. C.

PATENTS Procured; Trade Marks Registered—A comprehensive, experienced, prompt service for the protection and development of your ideas. Preliminary advice gladly furnished without charge. Booklet of information and form for disclosing idea free on request. Richard B. Owen, 30 Owen Bldg., Washington, D. C., or 2276-R Woolworth Bldg., New York.

WANTED—Inventors' Experimental work, wood, metal patterns, Machine work, rubber mold under one roof. Send drawings. Miller-Anderson Rubber Works, Anderson, Ind. Dept. F. M.-2.

UNPATENTED Ideas Can Be Sold. I tell you how and help you make the sale. Free particulars (Copyrighted). Write W. T. Greene, 807 Jenifer Building, Washington, D. C.

To sell your Patent, Write me; experienced handling, immediate action. Address Arthur S. Billings, Suite 401 Dekum Bldg., Portland, Ore.

SPECIALIZED service for inventors. You furnish the idea, we'll work it out. Expert machine designing. Drafting. Opinions given on practicability of ideas. Confidential dealings. Your ideas fully protected. Write for full particulars. Otis Engineering Co., Desk C D, Omaha, Neb.

WE develop your ideas into commercial shape for presentation to purchasers, making working models, drawings, experiments or tests. Courtesy, efficiency, secrecy and ample equipment; 30 years' experience. Duroc-Rich Engineering Co., 504 Pacific Mutual Bldg., Los Angeles, Calif.

GET your own patents. Application blanks, complete instructions \$1. Cutting Sons, Campbell, Cal.

PATENTS—Send for Booklet. Contains valuable information for inventors. Our charge for search of Patent Office records \$5.00. Prompt service, twenty years' experience. Talbert & Talbert, 560 McGill Building, Washington, D. C.

I SELL Patents. Established in 1900. My Service is employed by inventors who are also Bankers, Lawyers, Patent Attorneys, Mechanics. Men in all walks of life—and Corporations with patents to sell. Why not you? Charles A. Scott, 773PM Garson Avenue, Rochester, N. Y.

HAVE you an Invention? If so, write for our free book, "How to Get Your Patent," tells our terms and methods. Send model or sketch for our free examination and instructions. Randolph & Co., Dept. 144, Washington, D. C.

PATENTS FOR SALE

FOR Sale—Patent No. 1,397,670. Garment Holder. Manufacturers interested in wire goods, write for Copy and particulars. Inventor, D. W. Y., 3 Temple St., No. Abington, Mass.

PATENTS For Sale: To sell, buy or obtain patents, write Patent News-P, Washington, D. C.

FOR Sale outright. Combination Perforators, Closures and Pouring Attachments for Containers, such as milk cans, milk bottles, etc. Very useful novelty for the kitchen. I. T. Skiles, 111 Garfield Ave., Pasadena, Calif.

FOR Sale—Two patented auto accessories: A semaphore glare-shield and a connection for attaching lawn hose to radiator to flush same clean under regulated pressure. Box 988, Ponca City, Okla.

OUTRIGHT or royalty. Cotter Pin Puller, Different. Very powerful. Patented. Alfred Danjelson, Black River Falls, Wis.

FOR Sale outright. Improved Burglar Alarm, patented June, 1924. Serial No. 538,358. C. Rist, 311 N. Commonwealth Ave., Los Angeles, Calif.

OUTRIGHT or royalty: U. S. Patent No. 1,480,726. Non-Corroding automobile storage battery. Proof against terminal corrosion and broken covers. Ballou Battery Co., Orlando, Fla.

1,433,832. **TOY**, movable legs and arms; clappers in hands. Alfred Lynch, 938 Lamberston St., Trenton, N. J.

OUTRIGHT or Royalty—Combination Safety Razor and Stropper. Highest commercial value. A. R. Kenagy, Charlelot, Pa.

FOR Sale—Patent No. 1,499,392. Improved on a Pneumatic Vehicle tire with lugs. Outright or royalty: Air Compressed pump. J. L. Melton, 24 Dewey St., Portsmouth, Va.

FOR Sale—Patent Electric Machine for renovating Brick, Marble, Brownstone Fronts and Cemetery work. Will consider Partner. Geo. B. Vernon, 2451 N. 10 St., Philadelphia.

SIMPLE Celluloid device for holding women's lingerie straps from falling over shoulders. Something new. Market for millions. Outright or royalty. Low cost manufacture. Mrs. Henrietta Wyeth, South Hanson, Mass.

FOR Sale—Patent on leveling device for furniture, especially billiard tables. Field unlimited. Prefer selling patent outright, but will consider royalty. For further details address F. E. Henry, 715 S. Front St., Salina, Kans.

OUTRIGHT or royalty—hand operated cloth washer, cone-shaped with movable piston inside to force air and water through cloths. Less than \$1.00 to make out of tin; sell for \$5.00 or \$6.00 twice as fast as washboard. Patented. Con. Vasgreen, Mogolton, N. Mex.

PATENTED July. "Combined Slide and Clamping Castings," 7 inches long, weighs pound, adds eighty percent to safety of fire escape rope, now legally compelled in hotels in thirty states. Write Express Agent, Burlington, Kansas, for details.

OUTRIGHT or Royalty: "Auto Turn Signal," Patent Pending. John H. Williams, Box 54, Dalton, Ohio.

OUTRIGHT or Royalty: Pat. Pending Novelty Shoe Polisher—everything to shine shoes contained in one device. Will be great seller. Can be manufactured reasonably. Harvey Wombold, Jermyn, Pa.

ROYALTY basis. Patent pending on Combination Pliers, Socket Wrench and Cotter Pin Puller. Write for particulars. W. M. Wells, 314 Carroll Street, Carroll, Iowa.

COLLAPSIBLE Tube Manufacturer. Improvement on Collapsible tube. Great advertising possibilities for first user. Clive Spittler, Eldorado, Ohio.

PATENT Pending: Sanitary Waste Receptacle and Toilet Paper Holder Attachment for hospital beds. Lee Huebner, New Ulm, Texas.

FOR Sale—Patented in U. S. and Canada—a Mechanical Scientific Advertising Device. Operated by gravity at very little cost. Very attractive and interesting. David Maxwell, 49 Marmaduke St., Toronto, Can.

A NEW original and ornamental vehicle signal. Outright or royalty. Frank Cannon, Rhine Cliff, N. Y.

ICE-CREAM Machine. New Idea Makes present Method look silly. Half interest for development. Clive Spittler, Eldorado, Ohio.

ARE you looking for safe investment? Newly patented mechanical item—will take royalty or sell outright. For particulars address, E. K. Howell, 5106 Sheridan Road, Chicago, Ill.

NEW, powerful wind motor. Self-regulating. Stands close to ground. Patent 1,562,950. H. Greenbrook, 1636 N. Francisco Ave., Chicago, Ill.

PATENT for sale on Bolt and Nut lock, U. S. and Canada. For Sale or Royalty. Peter Malosky, 13570 McDougall, Detroit, Michigan.

AN invention to invade a few fields. 42,600 customers waiting. E. B. Johnson, 8511 16 N. E., Seattle, Wash.

ATTENTION Mfrs. U. S. and Canada Patents for Sale or Royalty. Improved Ball Fasteners. Simple, Prevents Creeping and Spreading. Fiber Cushion Absolutely Sound. John P. Gardner, West Los Angeles, Calif.

MR. MANUFACTURER, Layman or veteran—Side Dump Scraper Hoist, loads wagons, does ditching. E. B. Hawkins, Applegate, Oreg.

POCKET Check Protector Patent, proven success. Bargain. Fred Botho, 3919 Metropolitan, Chicago.

YOU have a worth-while patent, haven't you? Why don't you tell our two million readers about it? Most of them are especially interested in patents and new inventions. Ask me to tell you how other inventors successfully sold their patents. Geo. F. Baker, Manager Classified Advertising, Popular Mechanics Magazine, Chicago, Ill.

SURVEYING INSTRUMENTS

LARGEST stock of new and used surveying instruments in the country direct from factory. Satisfaction guaranteed or money refunded. Wissler, 619 N. Broadway, St. Louis.

DRAWING INSTRUMENTS AND DRAFTING SUPPLIES

FINELY made nine-piece German Precision drafting set at \$4.50. Money back if not satisfactory. Bass Camera Company, 109 N. Dearborn St., Chicago, Ill.

DRAWING instruments—slide rules. Highest quality—lowest prices. Direct from importer. Circular free. Automotive Engineering Co., Castle Hill, Indianapolis, Ind.

MODELS AND MODEL SUPPLIES

PATTERN Making. Wood Models. Fourteen Years' Experience. My Personal Attention. M. Herbert Heighton, Hypoxux, Fla., Box 47.

WE Build Models, design, develop and manufacture articles in large or small quantities. Honeyver Mfg. Co., 1385 E. 17th St., Cleveland, Ohio.

SEND sketch and get lowest prices on Model and Experimental work. Ideal Company, 165½ Spring St., New York.

STEEL, Brass, Iron, Models, Tools, Gears, Castings. Send sketch for estimate. Arthur Schmidt, 400 Canal St., New York.

MODELS, Dies, Metal Stampings. Light Manufacturing. Modern Shop. Reasonable prices. Osborne Register Company, 125 West Pearl, Cincinnati.

MODEL Marine engines, boilers and ships' fittings. We also specialize in reliable boiler and pipe line fittings in miniature. Large comprehensive catalogue, 20c. Balbe Mfg. Co., Dept. D., 5214 Woodland Ave., Philadelphia, Pa.

PATENTS—Write for my free Guide Books: "How to Obtain a Patent" and "Invention and Industry" and "Record of Invention" blank before disclosing inventions. Send model or sketch of your invention for instructions. Promptness assured. No charge for above information. Clarence A. O'Brien, Registered Patent Lawyer, 588 Security Bank Building, directly across street from Patent Office, Washington, D. C. See pages 180 and 181.

HULIT & CO., Model Makers and Experimental Machinists, Tools and Dies, 625 West Jackson, Chicago, Ill. We specialize in high-grade model work on inventions of merit. New parts and repairing. Your patronage solicited.

WE make working models for inventors and do experimental work and carry a complete stock of brass gears and model supplies. Send for catalogue. The Pierce Model Works, Tinley Park, Ill.

DIES, Tools and General Manufacturing. Models and Manufacturing of new inventions our specialty. Logan Machine Co., 126 S. Clinton St., Chicago, Ill.

MODEL steam engine ½" x ½" \$8.50. Finished parts for same, \$7.25. Other engines, boilers, blowlamps. Catalog for 10c stamp. Model Machine Shop Co., 417 East 71 St., New York City.

SPECIAL machine builders, tool and die makers, inventors' models, production work of all kinds. Dept. L, Quality Hardware & Machine Co., E. Ravenswood and Thorndale Avenues, Chicago, Ill.

THE Modelmaker. For those interested in making working models. Send 10 cents. Address P. M. 120 Liberty Street, New York.

MANUFACTURING

PATTERNS, wood and metal, models and experimental work, stamping and machine work, light manufacturing complete. Reliable Pattern Works & Mfg. Co., Cincinnati, Ohio.

WANTED, Some Summer or Sport Specialty which can be made by Art Workers in a small factory. The Butterfly Box, 70 Franklin St., Boston, Mass.

BOLTS, nuts, rivets, etc. O. L. Dickey, 48 Trask, Bayonne, N. J.

WE design and build special machinery, tools, dies, jigs, and fixtures. Experimental work. Reliable Machine Co., 400 W. 23rd St., New York City.

EXPERIMENTS developed, dies, models and manufacturing machine designing. Estimates and information promptly given. Address Schroer Bros. Machine Works, 2303 Holmes St., Kansas City, Mo.

METAL-CRAFT—Eventually—Metal-Craft. Competent Engineers, Designers and Producing Organization await your commands on dies, stampings, die-casting, deep pressing, screw-machine and wire products. Plating, Enameling, Burnishing, Assembling, Wrapping and Packing to your specifications. Large completely equipped plant which guarantees prompt, efficient service. It is not the quality of raw materials alone, nor the precision in manufacture, and not just the service rendered that has given Metal-Craft the good reputation they bear—but all of these, as a constant certainty, in Combination. Estimates promptly furnished. Metal-Craft Manufacturing Company, Box 259-W, Chicago.

WE develop models, make dies and stampings; prices reasonable. Rapid Manufacturing Company, Pittsburgh, Pa.

WIRE goods made to order. Cosley Mfg. Co., 524 N. Western Ave., Chicago.

IRON, Brass, Aluminum Castings, Models, Patterns, Light Manufacturing. Welch Brothers Co., North Chicago, Ill.

LONG established manufacturer of auto accessories which are daily sold by practically all wholesale and retail accessory houses will consider manufacturing and distributing new automobile products, capable of equally wide sale through same channels. Patented articles preferred. Address Auto Accessory Manufacturer, Room 2104, 310 S. Michigan Ave., Chicago, Ill.

SCREWS, nuts, screw machine products, all metals. Autoscrew Works, 355 West Broadway, New York City.

OUR factory will make your models, manufacture your articles as well as build your tools, dies and fixtures. Standard Die & Specialty Co., 817 W. Washington Blvd., Chicago, Ill.

PATTERNS, wood and metal. Models, tools and dies. Brass, bronze, aluminum and iron castings. Screw machine work, production work of all kinds. Write Modern Machine & Pattern Co., Terre Haute, Ind.

MACHINERY, TOOLS AND SUPPLIES

COMBINATION self-feeding bench drill and hand-brest drill, Capacity 0-¾. Price \$13.00. The Tool & Novelty Mfg. Co., 150 Front St., Woonsocket, R. I.

CONCRETE Building Block Machines and Molds. Catalogue free. Concrete Machine Co., 303 South Third St., St. Louis, Mo.

1-15" x 8 MONARCH Engine lathe complete \$190.00. 1 20" Metal Shaper complete \$225.00. 1 No. 60 Head Auto Cylinder grinder, complete, \$650.00. Complete line of machinery and supplies. Cincinnati Machinery Supply Co., 218 E. Pearl St., Cincinnati, Ohio.

ENGINES, MOTORS AND DYNAMOS

NEW General Electric $\frac{1}{2}$ H.P. 110-220 Volt, 60 cycle, 1750 R. P. M. Single Phase repulsion induction motors. These are late type continuous duty motors all in original boxes. Price \$29.50 each F. O. B. Chicago. 25% with order, balance C. O. D. Quantity limited. Queen City Electric Co., 1734 Grand Ave., Chicago, Ill.

MOTORS, twentieth horsepower, 115 volt alternating direct current \$2.98. Hamilton-Bear Sewing Machine Motors, complete with foot control \$10.00; used but good condition. Electric heating pads, 3 heat control, new \$5.00; $\frac{1}{2}$ H.P. 220 volt, Westinghouse new \$10.00. Order now. Par Postman, Perry Trading Company, 815 Lake, Racine, Wis.

SMALL Gasoline, Steam Engines, Dynamometers, Motors, Storage Batteries, etc., new and secondhand. New Catalogue free. Dynamic Manufacturing Co., First National Bank Bldg., Chicago.

UNIVERSAL 1-40 H.P., 60 or 25 Cycles, \$5-220 Volt, 60 or 40 Cycle, \$7. Ray, 324 5th Ave., New York.

PRACTICAL Steam Engines, one H. P. \$18.00; $\frac{1}{2}$ \$12.00. James Chambliss, Bessemer, Ala.

MOTORS—Manufacturers' Surplus Sale; $\frac{1}{2}$ hp. \$8.50. $\frac{1}{4}$ hp. \$12.50. 1 hp. \$14.50. 8-volt Charging Generators \$8.50. Complete Lighting Plants, Generators, Light Machinery. Write for Catalog. Motor Specialties Co., Crafton, Penna.

BLACKSMITHS

BLACKSMITHS, Listen! Make more money doing hard jobs easy with Toy's Modern Methods of Master Machine Blacksmithing, Forging and Solid Welding, Tool Dressing and Tempering to a standard with colored tempering charts. All for One Dollar. Samples Free. W. M. Toy, Sidney, Ohio.

ELECTRICAL

YOUR electrical problems solved. Anything on design, application, operation, and repair of electrical apparatus. Complete understandable solutions, five dollars. John P. Garvin, E. E., 200 Colburn, Pittsburgh, Pa.

FOR THE SHOP

JUST Out! Shop Notes Book for 1924, comprising the 550 articles that have appeared in the Shop Notes section of Popular Mechanics during the past year. Bigger and better than ever. 242 pp., 455 illus., 50 cents postpaid. Popular Mechanics Book Dept., 206 E. Ontario St., Chicago.

MECHANICS! You will seldom if ever get stuck on a job if you keep on hand for quick reference a 15-volume set of Popular Mechanics Shop Notes. At the price of 50 cents a volume, any one of the several thousand time and labor-saving hints may save you the cost many times over. Any of the volumes may be purchased separately at the same price. Popular Mechanics Book Dept., 206 E. Ontario St., Chicago.

FOR SALE—MISCELLANEOUS

KARSTADT'S Mammoth Pecans, Medium grade, Pound \$1.15; Five pounds \$5.00. W. Karstaedt, Dayton, Ohio.

ALL wool yarn for sale from manufacturer, 75c to \$2 per lb. Free samples. H. A. Bartlett, Harmony, Maine.

BARREL lots slightly damaged crockery, hotel chinaware, cookingware, glassware, etc. Shipped direct from factory to consumer. Write for particulars. E. Swasey & Co., Portland, Maine.

NAME Lists For Sale. All Live. Fresh names at 50c hundred or \$5.00 per Thousand. Leola Sigrist, Rapid City, So. Dak.

ADDRESSOGRAPHs. Letter Folders, Multigraphs, Envelope Sealers, Duplicators, less than half price. Guaranteed. Pruitt Co., 170 N. Wells, Chicago.

BUY—Exchange—Sell! Many of our readers have for sale or exchange the article you are looking for—and lots of them are looking for the very items you want to turn into cash. Get together! Let our two million readers know your wishes—they'll help you! Send your ad today to Geo. F. Baker, Manager Classified Advertising, Popular Mechanics Magazine, Chicago.

WANTED—MISCELLANEOUS

MAIL Discarded Gold, Jewelry, Diamonds, Watches, Silver, Platinum, Magneto Points, Mercury, False Teeth, Bonds, Thrift, Unused Postage Stamps, Anything Valuable, Quick Cash Returned. Held Returnable Ten Days, If Unsatisfactory. Ohio Smelting Co., 315 Hippodrome Bldg., Cleveland, Ohio.

MAIL us your discarded Jewelry, Gold, Crowns and Bridges, Watches, Diamonds, Silver, Platinum, and old False Teeth. Money promptly mailed. Goods returned if offer refused. United States Smelting Works, (The Old Reliable), Dept. 71, Chicago.

MUSIC Boxes, Aeolian Organ Rolls, Telescopes, Small Lathes, Box One, Hertel Station, Buffalo, N. Y.

WANTED: Light Machinery—Lathes—Drill Presses—Model High-Speed Gasoline and Steam Motors. Best Cash Prices Paid. Motor Specialties Co., Crafton, Penna.

REAL ESTATE, FARM AND ORCHARD LANDS

\$900 FULL Price; 25 Acres, Furn'd Home, Season's Crops, Horse, equipment included; excellent farming and home community, near town; good 6-room house, basement barn. Low price \$900, part cash. Details page 24 New Illus. Catalog. Free. Strong Farm Agency, 150P Nassau St., New York City.

20 ACRES or more of our best land in Michigan; \$20 to \$30 per acre; near town 3,000 population, \$10 down, balance long time. 32 page book Free. Swigart Land Company, P-1250 First National Bank Building, Chicago.

LATE Opening Oregon Homesteads offer exceptional opportunities, map and details, \$1.00. F. G. Thompson, Sheridan, Oregon.

FOR Sale—Three full sections in McKenzie County and two sections in Billings County, North Dakota. Each section contains land suitable for crops, balance for cattle. Each section has valuable deposits of lignite which some day will alone be worth many times the present value of the land. This part of the state is developing very rapidly with good schools within easy access. As owner cannot use this land himself, will sell one or more sections at a price which almost anyone can afford to pay. Address W., care Popular Mechanics, 200 East Ontario St., Chicago.

ATTENTION—"Get acquainted." Cash for your property, Farm, Hotel or Retail Store, no matter where located; confidential service. Hayes' Business Agency, Cincinnati, Ohio.

PECAN-ORANGE Groves "On the Gulf" \$10 monthly. Guaranteed care. Soon produce \$500.00 yearly. Suburban Orchards, Dept. M, Biloxi, Mississippi.

SELL your property quickly for cash, no matter where located. Don't pay big commission. Particulars free. Real Estate Salesmen Co., Desk B, Lincoln, Neb.

\$5.00 DOWN, \$5.00 monthly; 10 acres unimproved poultry, fruit, stock, woodland; \$100; Ozarks, Fishing, hunting, training. Alfred Zimmerman, 1809 N. Fifth, Kansas City, Kans.

ROOTS AND HERBS

GENSENG, \$12 lb.; grow in back yard. Free particulars and planting instructions. O. Titchell, Berlin, N. H.

DOGS AND PETS

THE Southern Farm Coonhound Kennel, Selmer, Tennessee, offer Coonhounds and Combination Hunters; also squirrel and rabbit dogs on free trial.

BEAUTIFUL registered bull pups cheap. Bulldogs, 501 Burkwood, Dallas, Texas.

IMPORTED pups now for sale. Entire kennel of trained dogs. Veri-Best Police Dog Kennels, Portland, Ind.

COLLIES for Sale—Some fine puppies from prize winners. Write for prices and description. Oak Run Collie Kennels, Boston, Ky.

SILVERBLACK Foxes \$50.00. Time Payments. Muskrats. Arthur Schumacher, Lockland, Ohio.

FOR Sale: Puppies from Imported Bulldogs. Monte Kennels, Huntington, Ind.

FOR Sale—German Police puppies. Northwestern Kennels, Nora Springs, Iowa.

PERSONAL

KEEP FIT—19 Keep-Well Resolutions 10c. Dr. Swingle, 7901 Cedar, Cleveland, Ohio.

LOOK Here, I Mean You! Did you ever realize how little you have done for your future? Would you spend few cents for a knowledge given you by Science? How to Succeed in Life. Write today your birth date, Experience, Your Photo, Color of Eyes and full description. Inclose One Dollar for Information, Science and Human Nature, Dept. U. 2783 Francis Pl., Chicago, Ill.

KNOW Thyself—and become a success! Know your character, talents, possibilities in business, love, marriage and future enterprises. Send your full birth date, specimen of your handwriting and 10c for your wonderful Three-Page Horoscope of surprising indications of your life. Write at once: Gargilla, Box 2771-DD, Boston, Mass.

YOUR Handwriting Portrays Your Character. Send Ink Sample of own or friend's writing for expert analysis with 25c for astounding demonstration of dominant characteristics. Real guide to success. D. Pencraft, Collins, New York.

TOBACCO, liquor and morphine habits can be overcome with the aid of Hill's Chloride of Gold Preparations. Liquor remedy can be given secretly. Particulars free. Ohio Chemical Works, Dept. 9, Westfield, N. Y.

ALL men 45 or over must have my aid. No medicine, electricity or humbug. Rexus, Box 2402, Boston, Mass.

TOBACCO or Snuff Habit cured or no pay. \$1.00 if cured. Remedy sent on trial. Superior Co., 717, Baltimore, Md.

UNUSUAL Horoscope—81x pages, 2,500 words, consisting of extensive four-page Special Horoscope, Astro-Analysis, and two-page valuable guide giving daily and monthly advice covering entire year. Send 50c and birthdate. Money returned if dissatisfied. Prof. Boites, Box 125, Cranford, N. J.

TOBACCO Kills manly Vigor. Quit easily. Cigarettes, chewing, smoking, snuff conquered or no charge. Small sum if satisfactory. Stops craving; harmless. Full treatment on trial. Perkins Co., 34-A, Hastings, Neb.

FREE—Information of a scientific nature that has brought happiness through perfect health to thousands. No charge, no obligation. Enclose stamp for reply. Fair Sales Co., Dept 246-0, Colorado Springs, Colo.

MISCELLANEOUS

MONEY! Silvering Mirrors, Autolights, Radiators, tableware, stoves, Outfits. Methods free. Sprinkle Plaster, 288 Marion, Ind.

I CATCH from 45 to 60 Foxes in from 4 to 5 weeks time. Can teach any reader of this magazine how to get them. Just drop me a line for particulars. W. A. Hadley, Stanstead, Quebec, Canada.

BEAUTIFUL Child's china closet or curio cabinet, 29" high, 25c. 26", 50c. 46", \$1.00, actual size patterns, including instructions; easy, simple to make, dresser, settee, desk, 25c each; smoking stand, tabourette, miniature tea wagon, chair, 10c each; others. Bogren Kiddie Cabinet, 305 West 143rd St., New York.

WORKING Drawings, Tracing, Catalogue and Text-Book illustrating. Floyd Shaffer, Box 277, Arlington, N. Y.

SIMPLIFIED Photo-engraving process. Line and half-tone cuts. Particulars 2c. Horton and Fisher, Princeton, Ill.

ARE You Old at Forty? See our advertisement on page 146 of this issue. The Electro Thermal Company, 2137 Main Street, Steubenville, Ohio.

TATTOO marks removed easily and painlessly with the new scientific preparation "Tattooid." Complete \$3. B. Vestfold, 112 1/2 5th St., Brooklyn, N. Y.

LOCKSMITHING, complete 500 tricks of the trade, new edition, many added features. \$1.50; money back if dissatisfied. H. Routsen, 2406 Andover St., Oakland, Calif.

FORMS to cast Tin Soldiers, Indians, Marines, Trappers, Animals. Send 3c for catalogue. Henry Schiercke, 1034 72nd St., Brooklyn, N. Y.

ROCKS and Minerals for sale—hundreds of varieties—Price List Free. Peter Zodia, 157 Wells St., Peekskill, N. Y.

ARTIFICIAL Eyes, \$3. Booklet free. Decker Optic, 539 Barclay, Denver, Colo.

CUTS anybody can make. Simple, cheap process, \$1. Specimens, particulars, 2c stamp. M. Dar, Windfall, Ind.

HOMEOPATHIC and Biochemic preparations sent postpaid to all parts of the world. Manual and booklets free. Halsey Bros. Co., 111 N. Wabash Ave., Chicago, Ill. Established 1855.

McGraw-Hill Home Study Courses

"Know your work as experts know it and get an experts pay"

These famous books will help you win a big-pay job in your chosen work

Over 100,000 men are stepping ahead in their work with the aid of McGraw-Hill Home Study Courses. These courses enable a man to skip over the long years of hard work and low pay—they show him how to fit himself, easily and quickly, for bigger things in electricity, machine shop work, electrical maintenance and repair, power plant engineering, and telephone work.

Practical subjects taught by practical men without the aid of correspondence instruction

Each of these courses is a complete educator in itself. All the facts—all the information you may wish to have about any particular subject is before you ready for instant use. The courses are practical with only the necessary theory, and every line and illustration will be found clear and understandable even by the beginner.

A lifetime of experience packed within these books

These courses contain more information than any one man could acquire in a whole lifetime of practice. The books have been written by men who are leaders in their field—men who have lived and worked with the very problems they write about. They are books by experts, and by studying them, you, too, can become an expert and earn an expert's pay.

Only 7c a day for the course you select

Check on the coupon the course you wish to see and we will send it to you, all charges prepaid. No expense—no obligation. If you keep the books, pay for them on our easy terms. If they are not what you want, send them back to us at our expense.

FREE EXAMINATION COUPON

McGRAW-HILL BOOK CO., Inc.
370 Seventh Ave., NEW YORK

Send me for ten days' free examination the library checked below. If satisfactory, I will send first payment in 10 days and the balance at the rate of \$2 a month until the full price has been paid.

- () Practical Electricity, 8 Vol. \$19.50
 () Machine Shop Practice, 9 Vol. \$19.50
 () Electrical Maintenance and Repair, 5 Vol. \$14.00
 () Power Plant Practice, 9 Vol. \$19.50
 () Telephony, 5 Vol. \$12.00
 () The New Tully, 3 Vol. \$7.50

Name.....

Address.....

City and State.....

Employer.....

Occupation.....

P.M. 11-1-24



FREE
TRIAL



NO
MONEY
DOWN



SMALL
MONTHLY
PAYMENTS



Mail this FREE Examination Coupon

Electrical Maintenance and Repair

5 Vol. 1736 pages—1018 illustrations.
The only library of its kind. Contains the largest collection of practical methods for electrical repair and maintenance men ever put together. Covers wiring diagrams, armature winding, motor repair, connecting induction motors, electrical machinery and electrical methods of all kinds.
\$14, payable \$2 in 10 days and \$2 a mo.

Machine Shop Practice

9 Vol. 3978 pages—3408 illustrations.
This is the new edition of this famous work—completely revised and brought up-to-date, with many new volumes added. The set is packed to the covers with the kind of information that every machinist, every apprentice, every toolmaker and shop foreman wants.
\$19.50, payable \$1.50 in ten days and \$2.00 a month.

Croft's Library of Practical Electricity

8 Vol. 3000 pages—2100 illustrations.
40,000 sets of this great library are now in use—without a doubt the greatest sale ever attained by an electrical library. The books cover the entire field of electricity, from the fundamental principles to central station work—from the operation of electrical machinery to outdoor and indoor electrical illumination.
\$19.50, payable \$1.50 in ten days and \$2.00 a month.

Power Plant Practice

9 Vol. 3978 pages—3778 illustrations.
These books cover everything that the power plant engineer needs to know to fill a big-pay position. Thousands of first-hand facts—thousands of specially drawn illustrations. Practical from preface to index.
\$19.50, payable \$1.50 in ten days and \$2.00 a month.

The New Tully

3 Vol. 1155 pages—543 illustrations.
The boiled-down information of steam and electric power plant engineering for practical men. One of the greatest helps a power plant man can have.
\$7.50, payable \$1.50 in ten days and \$2.00 a month.

Mitchell's Principles and Practice of Telephony

5 Vol. 1436 pages—317 illustrations.
A complete course in modern telephone practice covering everything from the basic principles to the most complicated apparatus used today. Clearly written—easily understood—practical from cover to cover. A great help to anyone wishing to succeed in the telephone business.
\$12.00, payable \$2.00 in ten days and \$2.00 a month.

Learn at Home to



**I Will Help
\$75⁰⁰ to \$200**

THE Automotive Industry is the greatest in the world. There's a place for you in this fascinating Big-Money Field—a real job—an Auto Expert's job—at \$3500 to \$10,000 a year. Do you want it?

I'll teach you, right at home, so you can earn this money. My practical training will make you a big money-winner when you have finished my Automotive Course.

My Introduction to You

And this is why I can do this job better than any other man in America: I have had to earn my own living since I was a boy—have learned my trade in four of the biggest automobile factories of England and America. I started as an apprentice at one dollar a week and worked up to Experimental Engineer with one of the most prominent manufacturers. Everything I know I have learned through hard work and study. As a machinist and Auto Expert who has been through the mill, I can give you the full benefit of my 24 years' practical experience.

I'll Be Your Partner My Graduates Get Big Pay

But you won't need to go through the grind that I did to achieve success. Your way will be easier and more profitable. It is my desire to spend the rest of my life teaching ambitious men how to succeed BY THE SHORTEST ROUTE in this great Auto field. My graduates are earning big money all over the country. Why not you?

Practical Training—Easy to Learn Your Success Is Guaranteed

I can teach you in one year, or less, what it took me many years to learn—teach you RIGHT AT HOME, while you still keep your present job. Just spend a few hours of your spare time each week. My lessons will be practical, easy to understand, easy to apply.

My Record

Two years with the Daimler Co.; five years with Rolls Royce, Ltd.; both in England. Then several years with the Packard Company of America and three years with another great company as Experimental Engineer. For the past few years Consulting Engineer and Chief Instructor American School Automotive Division.



Free Auto Books

This big five-volume Auto Reference Library is FREE to you. 2200 pages, 2350 pictures, charts, photos, etc. Finest Auto Library in the world. Covers every subject. Most valuable reference books. Alone worth the cost of the Course, but ALL FREE!

Free Tools and Instruments



Complete equipment for repair work—socket, wrench set, special ratchet wrenches, extensions, adapters and universal joint, a valuable "Bozo-scope" for detecting engine irregularities, a volt-ammeter and a Willard Hydrometer for Battery work, and a set of high-grade feeler gauges. This FREE outfit would cost you \$22 retail.

Free Employment Service

Through close touch with manufacturers and agencies—who are always looking for trained men—we help our students and graduates to good jobs. We are glad to do this for you—use it before or after you graduate—any time you wish.



MECHANICAL EXPERT
\$ 75 TO \$125 A WEEK



ELECTRICAL EXPERT
\$ 75 TO \$150 A WEEK

be an Auto Expert

**You Earn
\$20 A Week!**

*The Big Pay
Field*

You'll learn the game from A to Z. I guarantee success and satisfaction, or refund every cent you have paid me.

Earn as You Learn

Almost from the start you'll be able to earn as you learn—getting *real* money for odd jobs—doing repair jobs for auto owners in your neighborhood. Then, soon, will come

The Big Pay Job Go to Work Anywhere

This industry knows no locality—you can find a big job anywhere you want it—I'll even help you get it. Age or lack of education does not bar you. Ambition to learn is all you need to be a Boss in the Big Pay Field.

The Auto Field Needs You Trained Men Are Scarce

Are you ready to tackle it? Do you want me as a business partner—to teach you everything I know about this Automotive business, where the opportunity is big and the demand steady? If so, I'll show you how to climb the ladder and pick the plums of success.

The Door to Your Success Is Open

If you want to enter this BIG MONEY FIELD—THEN ACT TODAY! Waste no time in idle dreaming. Let's go RIGHT NOW! Fill out the coupon for big FREE BOOK—"The Easy Way To Bigger Pay"—and start at once on the road to business success. Fortunes are being made every day in this business. Come on in and get yours!

Tom C. Plumridge, Chief Engineer

Automotive Division, American School

58th Street & Drexel Ave., Dept. A-874

Chicago, Ill.



Boss Jobs Like This



GARAGE OWNER
\$100 TO \$300 A WEEK



TROUBLE SHOOTER
\$75 TO \$150 A WEEK

Automotive Division,
American School
Dept. A-874, Drexel
Av. & 58th St., Chicago

Send me at once the
FREE auto book and
all information about
your automotive course.
This request obligates me
in no way whatever.

Name.....

Address.....



TRACTOR EXPERT
\$75 TO \$125 A WEEK



SALESMAN
\$75 TO \$200 A WEEK

He thought he could throw me—



Dear Tom: You know how Ted Brown has always been saying he could throw me with one hand tied behind him, if he wanted to. Well, yesterday, he grabbed hold of me and we had it out. Gee, I wish you'd been there. You know how much bigger Ted is than I. He thought he had me licked dead easy—

but

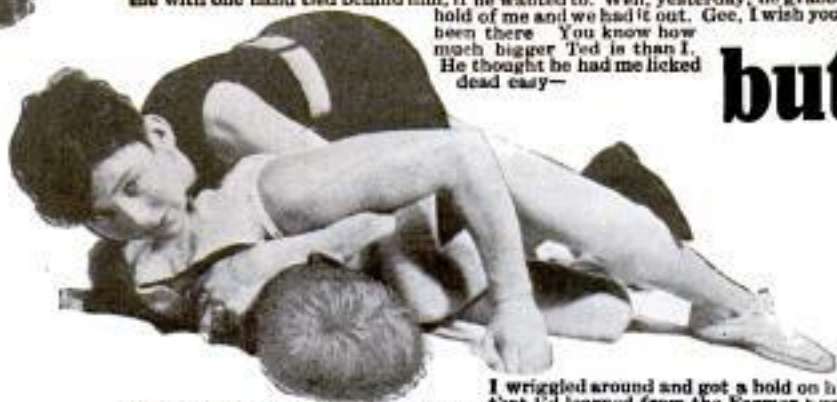

I wriggled around and got a hold on him that I'd learned from the Farmer Burns School of Wrestling. The next second—KERFLOP, and I had Mister Ted Brown on the ground, yelling for me to quit. It's a cinch to handle a fellow half as big again as you are if you know the secret holds. If I were you I'd write to Burns School for their free book about wrestling. So long—FRED.

Learn Wrestling Secrets from Worlds Champions Farmer Burns and Frank Gotch

Learn the marvelous holds, breaks, blocks and tricks that will enable you to handle big, strong men with ease. The renowned FARMER BURNS—"father of scientific wrestling"—and FRANK GOTCH the world's champion, have prepared a series of lessons in which they reveal the inside secrets of training that will make YOU, too, an expert wrestler. All the great secrets of self-defense and jui-jitsu illustrated by printed word and picture. The lessons teach you how to become a great athlete, and secret knowledge enabling you to throw boys and men larger and stronger than yourself.

Farmer Burns School
1778 Railway Exchange Bldg., Omaha, Neb.

Please send me at once without obligation your FREE illustrated booklet on Scientific Wrestling, Physical Culture, Self-Defense, and How to Win.

Name.....

Address.....

Send for FREE Book



Our FREE ILLUSTRATED BOOK tells you all about the advantages in health, vigor and respect that being able to wrestle brings one. It tells you how to learn to become a skilled wrestler in your spare time. Brim full of interesting information about wrestling. Also lots of pictures. INVESTIGATE. Write today for this free book. No obligations. Tear out and mail coupon NOW!

Farmer Burns School 1778 Railway Exchange Bldg.
Omaha, Neb.

Music Lessons
WITH ACCREDITED SCHOOL
At Home

Any Instrument Write naming course you are interested in: Violin, Cornet, Mandolin, Guitar, Banjo or Reed Organ—and we will send FREE CATALOG. SEND for it NOW!

University Extension Conservatory, 18 Siegel-Myers Bldg., Chicago

Complete Conservatory Course by Mail

Wonderful home study music lessons under great American and European teachers. Endorsed by Paderewski. Master teachers guide and coach you. Lessons a marvel of simplicity and completeness.

Rider Agents Wanted

Select from the 44 Styles, colors and sizes of Ranger Bicycles. Ride and exhibit sample Ranger and make money. Delivered free, express prepaid, on approval. Factory-to-Rider bicycles \$21.50 up, \$5 a Month on any Ranger if desired. Boys and girls easily save the small monthly payments. Parents often advance first payment.

Tires best quality, at factory prices, express prepaid. Lamps, wheels and equipment, low prices. Send No Money, do business direct with makers.

Mead CYCLE COMPANY
DEPT. A-106 CHICAGO

Write today for free Ranger Catalog, factory prices and marvelous easy payment terms



WANTED—RAILWAY MAIL CLERKS

\$1600 to \$2300 a Year for Life

Every second week off with full pay—no "lay offs" because of strikes, poor business, etc.—sure pay—rapid advancement to higher positions. City and country residents stand same chance. Common sense education sufficient—no political influence.

TRAVEL—SEE YOUR COUNTRY DON'T DELAY—ACT AT ONCE

Mail Coupon today—80%. Every day's delay means so much less chance of appointment from the next examinations—so write at once.

FRANKLIN INSTITUTE, Dept. R176, ROCHESTER, N. Y.

Take this First Step for a U. S. Government Job
Use Coupon Before You Lose It

COUPON

FRANKLIN INSTITUTE, Dept. R176, Rochester, N. Y. Kindly send me, entirely free of charge, (1) A full description of the position checked below; (2) Sample examination questions; (3) Free sample coaching lessons; (4) A list of U. S. Government Jobs now obtainable; (5) Tell me how to get the position here checked.

..... Railway Mail Clerk (\$1600 to \$2300) Customs Positions (\$1100 to \$2000)
..... Post Office Clerk (\$1400 to \$1800) Internal Revenue (\$1100 to \$2000)
..... City Mail Carrier (\$1400 to \$1800) Rural Mail Carrier (\$1800 to \$2600)
..... Income Tax Auditors (\$2040 to \$3000)

Name



Be a "Certified" MASTER - Telegrapher

Broker's Telegraphers
don't remain earning \$200 a month very long. They graduate into branch managers and partners. Many have also started as broker's telegraphers are millionaires today.

Brokers



R. R. Telegraphers

enjoy what many men consider to be the most fascinating work in the world. Telegraphers and Dispatchers keep the big American! Salaries \$165 to \$250 a month.

Newspapers



Newspaper Telegraphers

make big salaries, but you wouldn't drive the boys away from the log if you stopped their pay! Imagine receiving and sending the news of the world while at a hot-pressing, features, politics, etc.

Railroads



R. R. Telegraphers

enjoy what many men consider to be the most fascinating work in the world. Telegraphers and Dispatchers keep the big American! Salaries \$165 to \$250 a month.

Commercial



Commercial Telegraphers

find unlimited opportunities at \$150 to \$200 per month with such great companies as Western Union, Postal, etc. My training makes you an EXPERT, capable of holding down any job.

DEL DUNLOP

At 21, was the youngest Chief Dispatcher of a trans-continental railroad in the world. Inventor of the Dunlop System. In course of telegraphy training during war for U. S. World's greatest telegrapher.

Learn in 6 to 10 Months!

Men, Women, Boys, Girls! In my school, I train you under the same conditions, on the same equipment as you will find when you're out on the job! Most complete, costly equipment ever assembled under the roof of any one school.

The DUNLOP System

is the only internationally known and universally recognized standard of instruction in Telegraphy. I invented the system and the method for teaching it. It bears my name and you can get this complete, practical, rapid instruction nowhere else.

Make \$65 to \$100 Every Week

No work on earth like Telegraphy. It gets under your skin, makes you forget it's one of the best *paying* trades you can follow. Whether railroad, commercial, broker's or newspaper telegrapher, you're so interested in what you receive or send over the keys, many a time you'll forget it's time to eat. By the Dunlop System you can become a real Expert in only 6 to 10 months. No book-study. All practical, actual work.

Romance — Adventure for Ambitious Men!

If you want to become Telegrapher for, say, the New York Central R. R.—my training not only gives you complete Telegraphy Instruction, but in addition I train you in New York Central official rules of operating traffic and block signal. If you're out to be a Western Union or Postal Telegrapher, I prepare you for that, including training in their rules and methods. Telegraphers find work anywhere, anytime, *all over the world.*

RADIO — WIRELESS

Big demand for Licensed Wireless Operators on great ships. Many big pay positions in Radio waiting for Experts to take them. Get ready quick here! Get my catalog and find out how easily you can become an Expert Wireless Telegrapher.

Get My EARN While You LEARN Plan!

Confidential offer to ambitious men, women, boys and girls who have the hankering to be expert Telegraphers. Most liberal, most sensational and surprising offer ever made by any school. Coupon brings it. Write for it today!

D. J. K. DUNLOP, Chief Dispatcher

Chicago Telegraph Institute
Dept. 101-1338 S. Michigan Ave., Chicago

**\$2000 to
\$5000 A
YEAR for
TELEGRAPHERS**

Big Pay Coupon!

**D. J. K. Dunlop, Chief Dispatcher,
Chicago Telegraph Institute,
Dept. 101-1338 S. Michigan Ave.,
Chicago, Illinois.**

Rush confidential surprise offer FREE. I want to be a R. R. Commercial Broker's Newspaper's Wireless Telegrapher.

Name.....

Address.....

I CAN MAKE YOU

NO EXPERIENCE



A.G. ZELLER
PRESIDENT

WHY take small pay from uncertain jobs? Why be knocked around from this to that, and not know whether you are going to have a job tomorrow or not? You can change all that. Learn a trade. Know autos—how to repair them, and take advantage of the countless opportunities to make big money. Pave the way for a business of your own—a business that can make you independent for life. You can do it with a few weeks' training at the Michigan State Automobile School—the great auto-trade school in the heart of the auto industry.

Be a Trained Man — Successful!

Fellows just like you step out and make great successes. Trained men are wanted all the time—everywhere! More than 15,000,000 autos, trucks and tractors in use. All need service and repairing. Millions of tires and batteries to be kept in commission. More men needed for good jobs. More garages—more electric service stations—more tire-repair shops—welding shops—battery stations needed. This means amazing opportunities for the men who start now. Fit yourself to win a good job, or to start a business of your own. Very small capital is needed. You are right on the threshold of big money if you decide now to make this your business.

Learn Autos, Trucks and Tractors in the Heart of the Industry

Without any previous experience—just a liking for mechanics—you can learn the auto business from A to Z in a few weeks here in Detroit—the heart of the industry. Then step out, equipped with knowledge and training, to a future of certain, big money making. You have big advantages, learning the business here. It's the fountain head of the automotive industry. You are taught under factory endorsed methods. You learn both theory and practice on latest equipment. Go through the great Ford plants. Visit the other auto factories—learn their methods first hand—and it all means greater opportunities and more certain success. The Michigan State Automobile School, in Detroit, the automobile center, is the logical place to learn the automobile business.

Learn in a Few Weeks — Start Now

A thorough training in Detroit, at the "Michigan State," is the thing that fattens the pay envelope if you are working for others, or puts more profit in business for yourself. You can take a full Automotive Course, or specialize in any one of its money-making branches; you can be an Auto Electrician; a Tire Expert; a Battery Service Man; a Repair-Man; a Welder; a Machinist; or specialize in motorized farming, with truck, tractor and farm electric-lighting and farm engine training. Course includes training in Garage Management, Business Methods and Selling. Classes are always open. You need make no special arrangements—you can start at once—now—and that's the thing to do.



PRACTICE ON PACKARD STRAIGHT EIGHT

Here you learn on up-to-date, new equipment. All types of cars, engines, axles, transmissions, electrical systems. Some of the new cars and engines that you will find in our equipment are the new Packard Straight Eight with four wheel brakes, Packard Twin Six, new Buick with four wheel brakes, Oakland (four wheel brakes), Cadillac Eight, Hopmobile, Reo, Oldsmobile, G. M. C. truck, Hudson, Overland, and many others.

MICHIGAN STATE

311 Auto Building Detroit, Michigan

A BIG MONEY MAN REQUIRED

Get into This Big Money Business

Follow in the lead of thousands of "Michigan State" graduates who have taken advantage of the amazing money-making possibilities in the automobile, truck and tractor business. Here is a chart of facts—authentic figures which point out the opportunities. If you are ambitious and seeking a money-making opening, here's your chance—a chance to cash in to a degree that will satisfy your highest aims.

The opportunities are greater now than ever. There are more autos, more trucks, more tractors and every year adds to the money-making possibilities. You have ambition—you want success. Success is certain if you are willing to work for it, and start with proper training. You can have independence—be your own boss—stop the plodding and get into work you like. You can earn big money, be prosperous, happy and independent. We have graduates who have made as high as \$10,000 in less than a year. These records may seem amazing, but they are true. It is all done through head and hand training at the Michigan State. Decide now to give yourself the training that will pay you big and establish you in a successful life work.

Good Positions Open The demand for men who know automotive mechanics and electricians is greater than the supply. Step into any live-wire garage—everybody is busy as bees, have more work than they can do. Men working overtime, all at extra pay. That means big money for repairmen and boss. These money-making opportunities can be yours too, with "Michigan State" training. We have more calls for men than we can fill. The training in Business Management and Salesmanship included in our courses makes our graduates especially valuable. The years ahead are predicted to be the biggest years of the industry. That means certain money-making advantages to men who start in the business now.

EARN WHILE YOU LEARN

If necessary we can assist students to secure part time work to earn a small amount each week. Or students who wish to take our evening course will be assisted to full time day jobs. Ask for details, and when writing please explain your circumstances fully.

HOME STUDY COURSE FREE

You can start your course here any day. Jump on the train for Detroit now. If you can't come at once you can begin to learn at home by my new Home Study Method. Then come here later to finish. No extra charge for the Home Study training. Write me for full information. Or use the coupon. This is your opportunity to get ahead. Act now.

MAIL THE COUPON TODAY

Get all the interesting facts. Mail the coupon for information concerning your future that you must not fail to get. It's illustrated with photos of school equipment and graduates. It tells you how you can get a good paying job—how you can go into business for yourself with little capital. Mail the coupon or send us a postcard today. Write now.

(We do not enroll colored students, except for our Home Study Course)

AUTOMOBILE SCHOOL

3729 Woodward Avenue, Detroit, Michigan

15,000,000
Automobiles in U.S.
70,000,000
Tires to be repaired.
15,000,000 Batteries,
15,000,000 Ignition
Systems and only
50,000 Garages.

Read What Factories Say:

THE STUDEBAKER CORPORATION OF AMERICA

"We do not know of a better automobile school than the MICHIGAN STATE."

HUDSON MOTOR CAR COMPANY

DETROIT, MICH. U.S.A.

"This school is thought very highly of by the automobile men of Detroit, and is considered one of the best equipped and most efficient schools in the country. You will make no mistake in attending the M. S. A. S."

DODGE BROTHERS

INCORPORATED

DETROIT, U.S.A.

"We believe the Michigan State Automobile School of this city to be an exceptionally high class school, and no doubt a diploma from this school would assist materially in obtaining employment with high class automobile dealers."

Mail Coupon To Day

Michigan State Automobile School 311 Auto Building
DETROIT, MICH.

Send me FREE and without obligation complete information about Detroit-training to make the most money.

Name.....

Street or R. F. D.....

City..... State.....

I am interested in Resident Course at your School.
 Home Study Course.



"Mary, I Owe It All to You"

"MR. WILLIAMS called me into his office today and told me he was going to raise my salary \$50 a month.

"I am glad to give you this opportunity," he said, "for the best reason in the world. You deserve it.

"You may not know it, but I've been watching your work ever since the International Correspondence Schools wrote me that you had enrolled for a course of home study. Keep it up, young man, and you'll go far. I wish we had more men like you."

"And to think, Mary, I owe it all to you! I might still be drudging along in the same old job at the same old salary if you hadn't urged me to send in that I. C. S. coupon!"

How about you? Are you always going to work for a small salary? Are you going to waste your natural ability all your life? Or are you going to get ahead in a big way? It all depends on what you do with your spare time.

More than 180,000 men are getting ready for promotion right now in the I. C. S. way. Let us tell you what we are doing for them and what we can do for you.

Mail the Coupon To-day

INTERNATIONAL CORRESPONDENCE SCHOOLS
Box 5654-D, Scranton, Penna.

Without cost or obligation, please tell me how I can qualify for the position or in the subject before which I have marked an X:

BUSINESS TRAINING COURSES

- | | |
|--|---|
| <input type="checkbox"/> Business Management | <input type="checkbox"/> Salesmanship |
| <input type="checkbox"/> Industrial Management | <input type="checkbox"/> Advertising |
| <input type="checkbox"/> Personnel Organization | <input type="checkbox"/> Better Letters |
| <input type="checkbox"/> Traffic Management | <input type="checkbox"/> Show Card Lettering |
| <input type="checkbox"/> Business Law | <input type="checkbox"/> Stenography and Typing |
| <input type="checkbox"/> Banking and Banking Law | <input type="checkbox"/> Business English |
| <input type="checkbox"/> Accountancy (including C.P.A.) | <input type="checkbox"/> Civil Service |
| <input type="checkbox"/> Nicholson Cost Accounting | <input type="checkbox"/> Railway Mail Clerk |
| <input type="checkbox"/> Bookkeeping | <input type="checkbox"/> Common School Subjects |
| <input type="checkbox"/> Private Secretary | <input type="checkbox"/> High School Subjects |
| <input type="checkbox"/> Spanish <input type="checkbox"/> French | <input type="checkbox"/> Illustrating <input type="checkbox"/> Cartooning |

TECHNICAL AND INDUSTRIAL COURSES

- | | |
|---|--|
| <input type="checkbox"/> Electrical Engineering | <input type="checkbox"/> Architect |
| <input type="checkbox"/> Electric Lighting | <input type="checkbox"/> Architects' Blue Prints |
| <input type="checkbox"/> Mechanical Engineer | <input type="checkbox"/> Contractor and Builder |
| <input type="checkbox"/> Mechanical Draftsman | <input type="checkbox"/> Architectural Draftsman |
| <input type="checkbox"/> Machine Shop Practice | <input type="checkbox"/> Concrete Builder |
| <input type="checkbox"/> Railroad Positions | <input type="checkbox"/> Structural Engineer |
| <input type="checkbox"/> Gas Engine Operating | <input type="checkbox"/> Chemistry <input type="checkbox"/> Pharmacy |
| <input type="checkbox"/> Civil Engineer | <input type="checkbox"/> Automobile Work |
| <input type="checkbox"/> Surveying and Mapping | <input type="checkbox"/> Airplane Engines |
| <input type="checkbox"/> Metallurgy | <input type="checkbox"/> Navigation |
| <input type="checkbox"/> Steam Engineering | <input type="checkbox"/> Agriculture and Poultry |
| <input type="checkbox"/> Radio | <input type="checkbox"/> Mathematics |

Name.....
Street.....
Address..... 3-6-24
City..... State.....

Occupation.....
Persons residing in Canada should send this coupon to the International Correspondence Schools Canadian, Limited, Montreal, Canada.

TENOR BANJO
FREE! FULL SIZE **WORTH \$18.**
EASY TO PLAY
JAZZ

YOU CAN PLAY IT IN 30 MINUTES

40,000 successful students back up our guarantee that you can play a piece in 30 minutes by following our printed instructions. You get this \$18.00 TENOR BANJO, FREE, as soon as you enroll for 52 easy lessons. New low prices and easy terms!

PICTURE LESSONS MAKE IT EASY

You can't fail to learn because the pictures explain every move. You don't have to be able to read notes. Better than oral instructions. We teach you in the largest conservatory, by mail.

PLAY FOR FUN OR MONEY

Don't be a wallflower. Get in on parties. Entertain your friends. Be popular. Play for dances, etc. Form an orchestra. Our 52 lesson course will make you an expert. Earn money in spare time.

WRITE FOR SPECIAL FREE OFFER

Famous teachers will explain how we can positively teach you to play. You get the free \$18.00 Tenor Banjo with the first lesson. Pay while you play. Write for other special courses under famous teachers for Hawaiian Guitar, Violin, Banjo Ukulele, Ukulele.

FIRST HAWAIIAN CONSERVATORY OF MUSIC, Inc.
Woolworth Bldg., Dept. 60, New York, N. Y.

I will teach you penmanship by mail

Small Cost, Spare Time, Easy Lessons. Write for my Free Book, "How to Become an Expert Penman." It contains specimens and tells how others became expert writers by the Tevis Method. Your name will be written on a card if you enclose stamp. Write today. T. M. TEVIS, Box 28H, Chillicothe, Mo.

T. M. Tevis

\$1000 REWARD!!

Big awards like this are being made every day to the trained Finger Print Expert. Share in these rewards. There is a wonderful opportunity for the trained Finger Print man. Besides, high grade secret service men are usually Finger Print Experts. Enroll now under my personal training and I will give you a fine professional Finger Print outfit and a valuable course in Secret Service Intelligence—both FREE

Write Today I will send you Free Secret Service Reports and tell you about the fine jobs waiting for the trained Finger Print Expert. Write Today.

U. S. SCHOOL OF FINGER PRINTS
7003 North Clark Street, Dept. 13-58, Chicago, Illinois

MINSTRELS

Musical Comedies and Revues, with full instructions for staging. You can stage your own show with our books. Full line of plays, stage songs, crossfire, monologues, afterpieces, vaudeville acts and make-up. CATALOGUE FREE.

T. S. DENISON & CO., 623 So. Wabash, Dept. 19 Chicago

TELEGRAPHY

(Horse and Wireless) and RAILWAY ACCOUNTING taught thoroughly. Big salaries; great opportunities. Oldest, largest school. Endorsed by Telegrams, Railway, Radio, and Government officials. Expenses low—opportunities to earn large position. Catalog free. DODGE'S INSTITUTE, Jones St., Valparaiso, Ind.

Anyone CAN LEARN

No talent or experience necessary. Fascinating work. Pays big money. Complete instruction book sold about: Alphabet, Colors, How to Mix Paints, Show Cards, Window Board and Wall Signs, Ready made letters, Gliding, Tricks of the Trade, also gives 100 Alphabets and Designs. Book bound in flexible int. leather-gold edges, and four ball bearing Show Card Pens. Sent postpaid \$3.00. C. O. D. 10c ex. Ogilvie Pub. Co., 57 Ross St. Dept. 58, N. Y. City

EARN MONEY IMMEDIATELY—WE FURNISH EQUIPMENT TO START!!

SKILL

SKILLED CARPENTERS GET THE STEADY JOBS

KNOW your job and you'll never be without one. The man that takes pride in his personal skill is the man that is always in demand. The skilled carpenter's work is the easiest because he knows the practical short cuts and modern methods. His pay is higher because he does more and better work with less effort. *Audel's Carpenters' & Builders' Guides* gives you a Helping Hand into the Master Class. A complete Carpenters' and Builders' Course for study and ready reference.

Helping Hand Is Extended to You

Carpenters everywhere are using AUDEL'S CARPENTERS' & BUILDERS' GUIDES as a helping hand to easier work, better work and better pay. To get this assistance for yourself you need only use the coupon below without risk. Find out for yourself whether they will be a valuable daily assistant in your work. If you find that the hundreds of charts, tables, diagrams, specifications and instructions will help you, keep the books, sending \$1 a month for 6 months.

Strong, flexible covers—easy to carry in the pocket. Clear white paper. A handsome set of practical, helpful books that every carpenter will be proud to own.

4 HANDY POCKET SIZE GUIDES
BIG TYPE—EASY TO READ AND LEARN
1500 PAGES—3700 EXAMPLES

Condensed Contents of Audel's New Guides

Guide No. 1—431 Pages 1200 ILLUSTRATIONS

Use of tools, different woods, nails, and screws, filing saws, chalk line, plumb and level, rules and scales, mitre boxes, steel square, laying-out work, joints and joinery, how to build work bench and furniture.

Guide No. 2—455 Pages 400 ILLUSTRATIONS

Carpenters' Arithmetic, how to build houses, barns, garages, bungalows; reading plans, drawing up specifications, estimating cost, proportioning beams, estimating strength of timbers, mensuration, geometry, trigonometry.

Guide No. 3—255 Pages 400 ILLUSTRATIONS

Excavating foundations, how to build concrete forms, framing houses, setting girders and sills, framing joists, well holes, how to lath, types of roofs, tanents, skylights, and scaffolding and hoisting.

Guide No. 4—448 Pages 400 ILLUSTRATIONS

Shingling, how to lay roofs, hung doors, frame windows; building stairs; cornice work, exterior and interior trim, laying floors, putting on siding, painting, and first aid to the injured.

Use This Free Coupon Now!

Take this step now into the Skilled Carpenter Class. Don't keep on doing hard or unnecessary work that you don't have to do. Learn the short cuts and easier modern methods. Be a Master Worker. Let these Practical Guides give you a helping hand into the class where you belong.

**FREE
EXAMINATION
COUPON**

THEO. AUDEL & CO.
72 Fifth Avenue, New York City

Please submit me for approval and free examination: **AUDEL'S CARPENTERS' AND BUILDERS' GUIDES**. Ship at once, prepaid, the 4 numbers. If satisfactory I agree to send you \$1 within five days and to further mail you \$1 monthly until \$6 is paid.

Name

Address

Occupation

Employed by

Copyrighted material

11-T-30





I Will Fit You For \$5,000 A YEAR ELECTRICAL JOBS OR NO COST!

Right in your own home you can now train for the highest paid jobs in Electricity. No experience necessary. It only takes a few weeks. You get a diploma endorsed by the famous Lincoln Institute of Technology—also Free employment service.

Only 20 Weeks

My students are completing this course and entering the profession in twenty weeks, so plain and simple is the course. Don't miss this chance to forsake small pay work and start upon a career of certain, big money.

Legal Binding Guarantee

Remember, you have the absolute guarantee of both the S & H Engineering Company and the Lincoln Institute of Technology back of this training. If you are not satisfied when you have finished you can get every cent of your money refunded.

FREE ELECTRICAL OUTFIT

Mail the coupon at once and I will tell you how you can get a free electrical outfit and be equipped for actual Shop Type training right at the start. I have another amazing offer; mail the coupon today and I will tell you what it is.



S & H ENGINEERING COMPANY

Affiliated with Lincoln Institute of Technology

1422 W. Monroe St. Dept. N-1 CHICAGO, ILL.

S & H ENGINEERING COMPANY

1422 W. Monroe St., Dept. N-1, Chicago, Ill.

Gentlemen: Please send me full particulars of your training in Practical Electricity and of your free electrical offer. I am not obligated in any way.

Name.....

Address.....

City..... State.....



Do Your Friends Marvel

at your physique as it stands today? Do they talk about you as the strongest man in the neighborhood? Most likely they do not; but if you had only enrolled with me three months ago, you would now be the talk of your friends and relatives.

This popularity would be brought about by the harvest you would now be reaping of better health; an overflow of pep and confidence; strength that would make you a leader, even among real men; a physique that would make your friends worship you and your enemies respect you; joints and muscles that would be so supple your body would possess the greatest possible agility. And, besides these, you would have learned in those three short months more about your body and its needs; more about exercise and physical culture in general than you ever have in any past six months or will in the same length of time in the future.

HOW WOULD A 15-INCH UPPER ARM LOOK

in place of that frail one you now possess? How would it look as good, solid muscle instead of flabby fat? You can imagine how it would look, with other measurements in proportion, because you surely know that a 15-inch upper arm is some size. Yes, you can imagine how it would look, but you can never put it on there with imagination. So satisfy yourself that you must "make a break," "take the step," "something for a start." That is it—get started. But just as important as starting—is the matter of starting right.

YOU START RIGHT When You Send for My FREE Booklet and you are right when you finish my course. The title of my booklet is "The Royal Road to Health and Strength." It has sixty-four pages, which are given to many poses of myself and my pupils. It also gives a thorough explanation of my methods, as well as those of my non-orthodox friends, including, land-skiing and other valuable information. You receive all this FREE, and never in the history of physical culture was there paid out a booklet worth more to the eye, mind and body. You need this booklet.

IMPORTANT

My New Booklet, "Your Muscles, Where They Are and What They Do," will be sent with my Booklet, and it is also free. Every person contemplating physical culture should get this Booklet first. They are willfully deceiving what you are doing. Get each of them by return mail.

CHARLES MACMAHON
180 W. Somerset St.
Studio D-6 Philadelphia, Pa.

BE A JAZZ MUSIC MASTER



PLAY PIANO BY EAR

Play popular song hits perfectly. Hum the tune, play it by ear. Self-instruction—no teacher required. No tedious ding-dong daily practice—just twenty brief, entertaining lessons which you master.

At Home in Your Spare Time

Send for FREE BOOK. Learn many styles of songs and arrangements—trick endings. So strange begins interesting CHART also.

NIAGARA SCHOOL OF MUSIC
Dept. 745, Niagara Falls, N. Y.

Send for this Free Book

THE COMMERCIAL ART SCHOOL

"The Oldest Professional Art School in America"

Individual Progress—Student Sales Bureau
Dept. 755 116 So. Michigan Blvd. CHICAGO, ILL.

Make \$25.00 a day Selling Tailoring



Get into the tailoring game

—One of the most profitable of all lines in the selling field. Experience isn't necessary and spare time will do. We teach you how to sell our line and supply you with everything necessary to go out and make from \$10 to \$20 a day from the very first day. Our selling outfit is the finest ever gotten together and shows more than 150 large samples of finest quality woolsens. You do no delivering with our line. You just write your orders. We do the rest. Your profits run big and you get them cash with order. If you want to get into this most profitable business, write us quick. Add. Dept. 310

GOODWEAR Chicago, Inc. Chicago

Please send me complete information about your Line and the opportunity you offer. 310

Name.....

Address.....

City..... State.....

\$50 a Week and More

Train in New York for a Big-Pay Job

WM. H. STEWART, JR., PRES.,
STEWART AUTOMOBILE SCHOOL,
225 West 57th St., N. Y. C.

Dear Mr. Stewart:—

Just a line to let you know how I am getting along since I graduated from THE STEWART AUTOMOBILE SCHOOL two weeks ago.

You know that I finished my course of instruction two weeks ago last Friday. The very next Monday I was in a good job in an automobile repair shop where I am making 85c an hour and over-time besides. The job pays me on an average of over \$50.00 a week and I have the promise of a raise in the near future.

I feel that my ability to hold this job is due directly to the thoroughness of the training I received at your School.

Wishing you and The Stewart Automobile School all possible success, I am,

Sincerely yours,

GEORGE MOORE.

THIS letter (original on file in our office) is typical of hundreds we have received. Stewart-trained men are in executive positions or own their own businesses. They realized that they had to *train to earn*. They knew that the secret of success is in "knowing how". If you are not making from \$3000 to \$5000 a year it isn't because you can't *but because you don't know how*.

Individual Instruction

The lack of technical education or experience does not bar you from the Stewart School. You work with tools, not books. Each student receives personal instruction; his individual characteristics are studied by our instructors. You do not leave a subject until you are satisfied that you know and understand it thoroughly. You are not rushed through the Stewart School.

Our shops are splendidly equipped. Each important phase of the automotive and garage business has a department to itself. These departments include automobile mechanics, tire vulcanizing, battery manufacture and repair, advanced electrical and ignition work, etc.

No Worry About Expense

You can earn expenses while you are training. Our Employment department finds a job for you, if necessary. It is also very successful in placing graduates in good positions.

Our welfare manager arranges for your room and board, within the limit of your purse, while you are at the school.

Big Free Book

All of the above is described and explained in the fully illustrated catalogue which you may obtain free by sending in the coupon below. It tells of the advantages of training in New York—of the ideal location of the Stewart School. Details of the courses—subjects, tuition, time, etc., are given in full.

Mail the coupon today. It will open the door to SUCCESS for you.



STEWART AUTOMOBILE SCHOOL (Founded 1909)
225 West 57th St., Dept. 1758, New York, N. Y.

Please send me your free book that describes your school and the opportunities in the Automobile Business. I am under no obligation.

Name

Address

City

State



WANTED

U.S RAILWAY MAIL CLERKS

FRANKLIN INSTITUTE
Dept. R177, Rochester, N. Y.

Kindly send me entirely free of charge
(1) a full description of the position checked
below; (2) Free specimen examination
coaching instructions; (3) Free copy of book,
"Government Positions and How to Get
Them"; (4) A list of U. S. Government Jobs
obtainable; (5) Tell me how to get a position.

..... Railway Mail Clerk..... (\$1600-\$2300)
..... Post Office Clerk..... (\$1400-\$1800)
..... City Mail Carrier..... (\$1400-\$1800)
..... Rural Mail Carrier..... (\$1800-\$2600)
..... Clerk at Washington, D. C..... (\$1140-\$1800)

NAME.....

ADDRESS.....

**Learn Watchwork, Jewelrywork
and Engraving.**

A fine trade commanding a good
salary, and your services are always
in demand. Address **Morological**,
Dept. P, Bradley Institute, PEORIA, ILL., for our latest catalog.

\$1600 to \$2300 a Year

MANY GOVERNMENT POSITIONS

City Mail Carriers

Customs Clerks

Rural Carriers

City Postal Clerks

Clerk at Washington, D. C.

Short Hours

Rapid Advancement

Pleasant Work

Permanent Employment

Long Vacation With Pay

MEN—BOYS, 18 UP

Fill out and mail the attached
coupon now. Act at once.

VALUABLE COUPON

WRITE FOR FREE BOOKLETS describing and
illustrating complete line of **IVER JOHNSON**
Bicycles, Velocipedes, Revolvers and Shot Guns.
IVER JOHNSON'S ARMS & CYCLE WORKS
4 River Street FITCHBURG, MASS.

"THERE'S MONEY IN IT"

AT HOME LEARN TELEGRAPHY AT HOME

MORSE AND WIRELESS

TEACH YOURSELF in half usual time, at trifling cost, with the wonderful Automatic Transmitter, **THE OMNIGRAPH**. Sends unlimited Morse or Continental messages, at any speed, just as an expert operator would. Adopted by U. S. Government, and leading Universities, Colleges and Telegraph Schools. 3 Styles. Catalog free. **OMNIGRAPH MFG. CO., 16-22 Hudson St., NEW YORK**

If you own a Radio Phone Set—and don't know the code—you are missing most of the fun.

LEARN CARTOONING

Successful cartoonists earn big salaries. Many of the most popular cartoonists of today learned to draw in their spare time, at home, through the Landon Course of Cartooning and now earn \$75 to \$200 a week.



The Landon Picture Chart Method of teaching ORIGINAL drawing makes cartooning easy to learn. Hundreds of sketches like the above explain every step in creating ORIGINAL heads, figures, animals, etc. Write today for Sample Landon Picture Chart, long list of successful Landon students and full information showing possibilities for you. Please state your age. **The LANDON SCHOOL, 738 National Building, CLEVELAND, OHIO**

Four Successful Landon Students From One Village

Here is the record of four boys—all from Nappanee, Ind. (2200 population)—who, after taking the Landon Course, won national reputations:

Merrill Blosser is now nationally famous as creator of "Freckles and His Friends."

Henry Maust's work appears in Saturday Evening Post, Cosmopolitan, etc.

Francis Parks, following their advice, is now a cartoonist for the Omaha News.

Fred Neher is comic artist with the Universal Feature Co.

GARAGE

MEN WANTED

to Learn AUTO and Garage Business

Earn Up to \$20,000 per Year

\$20,000 a year is a lot of money, men. But it is being made in the Auto and Garage business. True, not every one makes it. But it's *there*—and you can go after it, neck and neck with the next fellow. Thousands of jobs and business opportunities in Automotive lines are still open. That's what I want to talk to you about.

Only 8 Weeks to Complete the Training

You owe it to yourself to get into a business where you can push ahead fast. This is the business. Men leave our shops after 8 weeks of training ready to earn up to \$125 per week. We get you a job—or show you how to start in for yourself on small capital. From there on it's up to you how much you'll earn.

Where the Big Money Is Made

One man trained here earned enough in 8 years to retire in comfort—at 40. Another Greer graduate started in business for himself 18 months ago with a capital of \$400. His business is now worth \$30,000. Another averages \$400 to \$500 per month and has only been established 8 months. You have the same opportunity, but you need Greer shop training. Over 47,000 men have been trained in the big Greer Shops—over 30,000 of these men are now in business for themselves. The others are in good jobs, earning far more than they ever earned before taking Greer training. Your opportunity is **HERE**, too.

Railroad Fare Allowed to Chicago

The City of Automotive Opportunity

There is room for thousands more trained men in the auto, garage, or accessory business. Right here in Chicago there are over 5,000 garages and repair shops. Within 10 blocks of the big Greer Shop Building there are over 40 Auto sales Agencies. Hundreds more throughout the city. Over 16,000,000 automobiles in the U.S. Plenty of work for trained men. Come to Chicago, men. I allow railroad fare to Chicago. Get my **FREE BOOK**. Learn all about it. Mail the coupon.

JOBS GUARANTEED

Which Job Do You Want?

Which job do you want? We train you for success in Automobile, Truck and Tractor repairing—Shop Management—Selling—Machine Shop—Automotive Electricity—Storage Batteries—Tire Repairing—Vulcanizing—Welding—Driving—every auto, shop and accessory job in the business. Take your choice of subjects. We guarantee to get you the job after we train you. And if you need assistance we'll get you an earn-while-you-learn job while training. Mail the coupon and get my Special Offer in detail.

Mail Coupon for Book and Offer

Take my word for it, men, this book will open your eyes to the possibilities I have only touched on here. Many parts of pictures and automobile facts. It's **FREE**. Get it, and look it over. Address me personally, **ERWIN GREER, President.**

GET THIS
FREE
BOOK

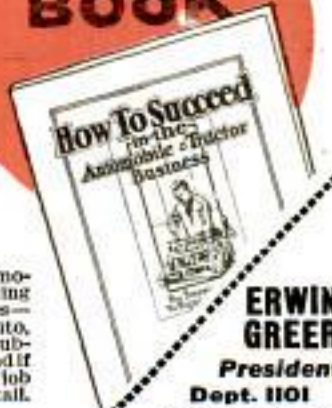

ERWIN GREER

President
Dept. 1101
2024 S. Wabash
Avenue

CHICAGO, ILL.

Please send me **FREE BOOK** "How to Succeed in the Automobile and Tractor Business," and special training offer. This request does not obligate me in any way.

Name.....

Address.....

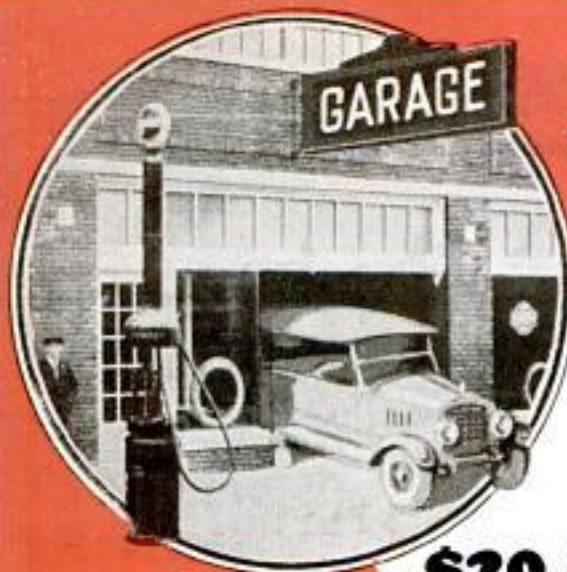

Mr. Greer, President and Director of Training, explaining repair of cylinder head



This mammoth new building, containing over 8 acres of floor space, is fitted with modern shop equipment entirely devoted to training Greer students.

GREER

COLLEGE

Automotive Engineering

Dept. 1101, 2024 S. Wabash Ave.,
CHICAGO, ILL.

Mechanical Engineering



Learn at Home!

EMLOYERS everywhere are looking for men with mechanical ability. Splendid salaries and rapid advancement are offered those with special training.

There is an easy, delightful way in which you can learn right at home in spare time. For 33 years the International Correspondence Schools have been giving men and women just the training they need for success in mechanical engineering and more than 300 other subjects. Hundreds of thousands have stepped into good positions through I. C. S. help, but never were opportunities so great as now.

Let the I. C. S. help you. Choose the work you like best in the coupon below, then mark and mail it to-day. This doesn't obligate you in the least and it will bring you information that will start you on a successful career. This is your chance. Don't let it slip by. The most important thing you have to do is to mark and mail this coupon now.

YEAR OUT HERE

INTERNATIONAL CORRESPONDENCE SCHOOLS

BOX 5649-D

SCRANTON, PA.

Explain, without obligating me, how I can qualify for the position, or in the subject, before which I mark X.

- | | |
|--|---|
| <input type="checkbox"/> ELECTRICAL ENGINEER | <input type="checkbox"/> CHEMICAL ENGINEER |
| <input type="checkbox"/> Electrician | <input type="checkbox"/> Pharmacy |
| <input type="checkbox"/> Electric Wiring | <input type="checkbox"/> SALESMANSHIP |
| <input type="checkbox"/> Electric Lighting | <input type="checkbox"/> Show Card and Sign Painting |
| <input type="checkbox"/> Electric Car Running | <input type="checkbox"/> RAILROAD POSITIONS |
| <input type="checkbox"/> Heavy Electric Traction | <input type="checkbox"/> ILLUSTRATOR |
| <input type="checkbox"/> Electrical Draftsman | <input type="checkbox"/> DESIGNER |
| <input type="checkbox"/> Electric Machine Designer | <input type="checkbox"/> BUSINESS MANAGEMENT |
| <input type="checkbox"/> Telegraph Expert | <input type="checkbox"/> Private Secretary |
| <input type="checkbox"/> Practical Telephony | <input type="checkbox"/> Business Correspondent |
| <input type="checkbox"/> MECHANICAL ENGINEER | <input type="checkbox"/> BOOKKEEPER |
| <input type="checkbox"/> Mechanical Draftsman | <input type="checkbox"/> Stenographer and Typist |
| <input type="checkbox"/> Toolmaker | <input type="checkbox"/> Cert. Public Accountant |
| <input type="checkbox"/> Machine Shop Practice | <input type="checkbox"/> Traffic Management |
| <input type="checkbox"/> Gas Engineer | <input type="checkbox"/> Commercial Law |
| <input type="checkbox"/> CIVIL ENGINEER | <input type="checkbox"/> GOOD ENGLISH |
| <input type="checkbox"/> Surveying and Mapping | <input type="checkbox"/> Common School Subjects |
| <input type="checkbox"/> Reading Architects' Blue Prints | <input type="checkbox"/> CIVIL SERVICE |
| <input type="checkbox"/> METALLURGY | <input type="checkbox"/> Railway Mail Clerk |
| <input type="checkbox"/> ARCHITECT | <input type="checkbox"/> STATIONARY ENGINEER |
| <input type="checkbox"/> Architectural Draftsman | <input type="checkbox"/> Textile Overseer or Supt. |
| <input type="checkbox"/> PLUMBING AND HEATING | <input type="checkbox"/> AGRICULTURE <input type="checkbox"/> Spanish |
| <input type="checkbox"/> Sheet Metal Worker | <input type="checkbox"/> Navigator <input type="checkbox"/> Math'm't's |
| <input type="checkbox"/> Automobiles | <input type="checkbox"/> Poultry Raising <input type="checkbox"/> RADIO |

Name _____

Present Occupation _____ Business Address _____ 3-6-24

Street and No. _____

City _____ State _____

Canadians may send this coupon to International Correspondence Schools Canadian, Limited, Montreal, Canada



LEARN BY DOING

Every phase of all branches of

ELECTRICITY

taught by

Actual Practice

In America's foremost and oldest institution for trade training

No Books Used

Individual Instruction
Start Any Day

Write for FREE 64-page catalog

THE NEW YORK ELECTRICAL SCHOOL

44 West 17th St., New York City



Hotels Start You With Salaries up to \$3500 a Year — with your living

HOTELS, restaurants, clubs, apartments, everywhere need trained men and women—salaries to start up to \$3500 a year with your living. Over 70,000 high-class positions paying up to \$10,000 a year are open every year in the hotels of the United States. Today this is the 1st INDUSTRY IN AMERICA—with over \$992,394,968 in new hotels being built in 1924—exceeding by \$200,000,000 the next largest industry. These new hotels, restaurants, etc., will need over 60,000 trained men and women.

You can have one of these high-class big-pay positions, with luxurious meals and apartment and fascinating work. No previous experience necessary. The Lewis Schools guarantee to give you the valuable knowledge that it has taken some of the most successful hotel men years to obtain—men who are now making \$5,000 to \$50,000 a year. We train you by mail in your spare time at home with the Lewis Simplified Study Plan, and we put you in touch with big opportunities. Our students employed, our methods endorsed by leading hotel men everywhere. Send today for Free Book, "YOUR BIG OPPORTUNITY," showing how we can train you for one of these splendid positions in 20 weeks or less, and explaining our Money-Back Guarantee.

LEWIS HOTEL TRAINING SCHOOLS

Room B-388 Washington, D. C.

***** FREE BOOK COUPON *****

LEWIS HOTEL TRAINING SCHOOLS, Room B-388, WASHINGTON, D. C.

Send me without obligation the Free Book, "YOUR BIG OPPORTUNITY."

Name _____

Address _____

City _____ State _____

YOU CAN PLAY THIS

Professional Style

HAWAIIAN GUITAR

JUST LIKE THE HAWAIIANS!

BECAUSE OUR NATIVE HAWAIIAN INSTRUCTORS WILL SHOW YOU HOW!

Be the Most Popular Member of your Set. Play "What'll I Do", "So This Is Love", "Memory Lane", "Minding My Business", "Fair Lady", "Lazy", "Linger Awhile". All the late song and dance hits. You can play First Selection in Half an Hour and Harmonious Chords at ONCE. Entertain your friends. Play for money. Don't be a wallflower. **Be the Life of the Party.**

FAMOUS HAWAIIANS TEACH YOU TO MASTER QUICKLY THEIR SECRETS OF THIS FASCINATING MUSIC

The instructions you receive from such world famous experts as Lawrence Kalaluki, Walter Kolomoku, Frank Ferera, Carl Seville and others are invaluable. NO OTHER Conservatory can even begin to give you the expert teaching and knowledge you gain through us. And remember, while it is conceded that the Hawaiian Guitar produces the sweetest music, yet its mastery by you will be simple and quick. We guarantee it.

ONLY 4 EASY MOTIONS—to learn to be able to play any music, popular, dance, classical, native Hawaiian Airs or old time melodies and hymns. Just think of it! You need never have read a musical note in your life. For that matter, even though you haven't the slightest knowledge of any musical instrument, we guarantee to teach you to play just like the native Hawaiians.

NEW INVENTION MAKES IT EASY

Here is your chance to learn to play the most fascinating of all instruments, the Hawaiian Guitar, JUST AS THE HAWAIIANS DO, and in an amazingly short time. Our method is so simple, plain and easy that you begin a piece your first lesson. In half an hour you can play it! Thousands of successful students prove this to be true. No matter how little your knowledge of music may be, you can positively learn to play by our plain, easy picture method.



COMPLETE CONSERVATORY COURSE

You get 52 complete lessons. An entire conservatory course. Nothing is omitted. Success is assured. It is the best course of Hawaiian guitar lessons in the entire world. Real Hawaiians instruct you. This is the only Conservatory teaching Hawaiian Guitar exactly as played by the Hawaiians. It is your good fortune as well as ours, that these Native Masters of Hawaiian Guitar come to this Conservatory to teach. That is why we are the largest and the best known Conservatory of the kind. Your success is assured when you enroll.

ANYONE CAN PLAY

We guarantee it. 40,000 pupils prove it. You don't have to know music. Our picture method makes it easy. Don't be afraid to try it.

WE FURNISH YOU WITH EVERYTHING

When you enroll as a student in this conservatory, you receive FREE a handsome, sweet toned, Genuine Hawaiian Guitar—valued at \$15.00—52 especially arranged lessons, as well as all the necessary Picks, Steel Playing Bar, etc. There is NOTHING extra to buy; everything is furnished.



EXTRA! As a special offer to readers of this magazine, we supply 52 pieces of music as a part of the course of lessons. Study the pictures of the good times you can have at parties, etc. Get in on the fun. Don't pass up this chance. Send the coupon at once for information and proof.

FIRST HAWAIIAN CONSERVATORY OF MUSIC
Dept. 48, 233 Broadway (Woolworth Bldg.) New York, N. Y.

SPECIAL COURSES UNDER FAMOUS TEACHERS, TENOR BANJO, VIOLIN, BANJO-UKULELE AND UKULELE

THIS COUPON MAKES IT EASY

FREE!

THIS \$15.00
GENUINE
HAWAIIAN
GUITAR



WORTH \$15.00

Yes, that is the price charged in the music stores for these beautiful Hawaiian Guitars. We can afford to give them away free of charge to every pupil because we manufacture them in huge quantities in our own factory, which is the largest stringed instrument factory in the world.

SWEET TONED

You will get the same haunting, soothing, plaintive fascinating tones that the real native Hawaiians get on these same instruments.

Plays any kind of music, 40,000 satisfied pupils prove all our claims are true.

Yours Free! We mean it. There are no strings tied to this generous offer. You get it absolutely free as soon as you enroll for our course of 52 easy lessons, taught by real Hawaiians. You can't possibly lose, so mail the coupon at once for full information.

Be Popular You'll never be lonesome after you learn to play on this beautiful Hawaiian Guitar. You can be the life of the party. Don't be a wallflower. Use the coupon for complete information. Mail it right away.



Learn in Your Spare Time

TEAR OUT AND MAIL

FIRST HAWAIIAN CONSERVATORY OF MUSIC, Inc.
Dept. 48, 233 B'way, Woolworth Bldg., New York, N. Y.
Gentlemen: Of course I want to get this handsome \$15.00 Hawaiian Guitar free of charge, because I am interested in learning to play it. Please mail full information about your 52 easy lessons under real Hawaiians, and proof that I can play a piece after the first lesson. I am not obliged to enroll unless I want to.

Name.....
Local Address.....
City & State.....

\$4000 to \$12000 a Year!

**I will
train you
At Home!**

**CHIEF
ENGINEER
DUNLAP**

for Dunlap-Trained ELECTRICAL EXPERTS!

Ordinary ELECTRICIANS are today earning \$12 a day. The FOREMAN gets more! The SUPERINTENDENT gets more than the Foreman, THE BOSS makes more than the Superintendent. CHIEF ELECTRICIANS, POWER PLANT SUPERINTENDENTS are earning from \$4,000 to \$12,000 a year. My training prepares you at home, in spare time, for these wonderful executive positions and enormous salaries. THE AMERICAN SCHOOL said, "Dunlap, we want the biggest, best and MOST COMPLETE Electrical home-study training on earth," and that is what 22 of America's greatest Electrical Engineers and Executives have helped me produce. We train you TO BOSS THE JOB, to earn TOP PAY!

Learn at HOME! Big Electrical Outfit FREE!

Just give me a part of your spare time! Don't quit your job—don't leave home. By short cuts, remarkable new ideas in instruction, I give you everything you need to earn \$75 to \$200 a week as an Electrical Expert—give it to you in only a few short months. Almost as easy to learn as reading your newspaper.

Big Demand—Get Ready!

It doesn't do you a particle of good today if I tell you there are hundreds of BIG-PAY EXECUTIVE positions open for trained Electrical Experts. These opportunities and thousands more ahead in the next 10 years mean nothing to you—UNLESS and UNTIL you are trained as I train you! Get my book and find out why you should prepare RIGHTAWAY for the unlimited opportunities in the Electrical field!

Get My FREE SCHOLARSHIP Offer Quick!

Most liberal, most astonishing offer ever made. Mail coupon right away—get this wonderful offer—find out all that I give in this great home-study training and compare it with others—find out what I mean when I say TRAIN TO BOSS THE JOB—let me tell you how I help you

to find a BIG-PAY position, how you can turn spare minutes and spare pennies into MONEY-MAKING TRAINING. Mail coupon immediately for big Free Book, complete information and Special Free Offers!

**CHIEF ENGINEER
DUNLAP**
Electrical Division
American School
Dept. E-874, Drexel Av. & 58th
CHICAGO

MAIL TO-DAY

Why you will choose Dunlap Training

1 22 of the world's greatest Electrical Engineers helped me to prepare it

No one man on earth knows all about EVERY subject in Electricity. So Engineers help me to give you the world's most complete electrical home-study training:

1. General Electric Co.
 2. Commonwealth Edison Co.
 3. Crocker-Wheeler Co.
 4. Cutler-Hammer Mfg. Co.
 5. American Telephone & Telegraph Co.
 6. Westinghouse Electric & Mfg. Co.
 7. Western Electric Co.
 8. Underwriters Laboratories, Inc.
- and 1 electrical engineers of the following universities:
1. Columbia University
 2. Dartmouth College
 3. Massachusetts Institute of Technology
 4. Lehigh University
 5. University of Vermont
 6. Armour Institute of Technology
 7. University of Kansas
- and many others.

2 Because The American School



as an educational institution, pledged NOT TO MAKE A PROFIT, gives the best training at the lowest possible cost. The entire resources of this 27 year old, million dollar institution stand back of my guarantee that if you are not satisfied we will refund every penny of your money.

3 Because I help you start to make money quick!

Almost from the start, I show you how to go out and make money, how to make this training pay for itself. Terms are made so easy that lack of ready cash need not hold you back a minute!

4 Because my graduates are more successful (Read this letter)



Dear Mr. Dunlap:
I enclose a photograph of myself and the switchboard of the 10,000 K. V. A. Hydroelectric plant where I am employed.
My ability to hold this position is due entirely to the training I here received from the American School, as when I first enrolled with you I was a common laborer and classmates were a total mystery to me. Now, however, I regularly use logarithms to find the daily load factor of this plant.
—Gay Vidars,
Wendell, Idaho

**Chief Engineer Dunlap, Electrical Division,
AMERICAN SCHOOL, Dept. E-874
Drexel Avenue and 58th, Chicago**

Please tell me how I can train at home in spare time for Executive positions in Electricity, also send me your big Free Book, Free Scholarship and Free Outfit Offer.

.....Name

.....St. No.

.....City.....State

How I Average \$12 a Day in RADIO WORK

By Howard Houston

"YES, Mr. Crosby, I'll have the set installed tonight . . . yes, all ready to 'listen-in' . . . sure, you'll be able to get Washington by 9 o'clock."

Another hour and a half job! And another ten dollar bill in my pocket! It all seems like a dream. But let me tell you the whole story from the very start.

A few months ago, I was driving a bread wagon, selling bread to retail stores. I had a good route though, and if I do say so myself, I had built up a pretty good business. But try as I could thirty-five dollars a week was all I could make that job pay.

I'd be working there now if it hadn't been for Mary. We'd been "keeping company" for about two years, and everything was all set for our getting married as soon as I would be earning more money. But the old job didn't hold out much promise—and I didn't see how I was qualified for any other work that would pay more.

It was Mary who gave me the tip. "You can't earn big money," she said, "unless you're some kind of a specialist. Learn some line of work—become an expert in it." But what business, profession or trade was there that wasn't overcrowded? Where could an ambitious fellow stand a good chance to earn big money and get ahead? Stenographers, accountants, clerks—all down the line—every well established line of work was overcrowded, and the pay was small.

Then Mary said, "Why not find a new field?" That was a good thought. The men who went into the railroad business early "cleaned up." The same was true of the movie game, the automobile business—but what was the coming field? What new development was there that looked like a new promising industry?

We both jumped to our feet.
"RADIO!"

Why hadn't we thought of it before? All around us was the evidence of the tremendous development of Radio. The broadcasting stations sprouting up all around—the rapid increase in Radio Stores—new radio manufacturing plants—everybody talking about the latest program. Radio had captured America almost overnight—and thousands of men who were on their toes were due to make fortunes out of it.

Thousands of Men Needed

The very next day after I had finished my route, I went to several radio business firms. "Sure, there was an opening. Oh, they'd pay big money—but did you know Radio?"

That was my cue. Learn Radio. Become a Radio Expert—and I did!

Well, that really is my whole story. I've only started. I've

followed the path of least resistance. Sort of built up a business of my own installing, building, and repairing radio sets. Any small job pays me at least \$5—and usually \$10. I can easily make from \$50 to \$100 a week—and more as I get my work systematized.

What Mary and I have got to decide after our honeymoon—oh, yes, we are soon having a very quiet wedding—what we must decide after that—is which end of Radio will be best. You see, there are dozens of different kinds of work in this field, it's so big. I've already had several offers—one to take charge of a radio department, another with a broadcasting station, another to give radio demonstrations, and a good offer as superintendent of construction in a radio plant. What we want to decide on is which will not only pay the most money now but will lead to the most rapid advancement in the future.



"Ah! there's Washington coming in clear as a bell."

has been teaching Radio ever since 1914. The government recognizes its course by allowing credits to its graduates applying for a commercial license, so you see you can be confident you're getting the best training possible—and that means a lot.

This course is the only absolutely complete one now being offered which qualifies for a government first class commercial license. It gets you the bigger paying jobs in Radio.

Send for Free Book "RICH REWARDS IN RADIO"

Incidentally, the National Radio Institute publish a mighty interesting book on Radio. They send it out without cost to anyone who wants to learn about Radio. It is filled with facts, photos and figures, on the Radio Industry, and tells all about its course, which quickly prepares you right at home in spare time for one of the big pay positions in Radio.

Take my advice—and Mary's—and send for that, no matter how little you know of Radio, or what your plans are. For a short time they are offering a reduced rate for those who enroll now. Act promptly and save money. Just mail the coupon today. Address the National Radio Institute, Dept. 15LA, Washington, D. C.

NATIONAL RADIO INSTITUTE,
Dept. 15LA, Washington, D. C.

Please send me without cost or obligation your Free Book, "Rich Rewards in Radio," which tells all about the opportunities in Radio, and how spare time study at home will qualify me for a big paying radio position. Also full details on your Free Employment Service.

Name.....Age.....

Address.....

City.....State.....

Swear Off Tobacco



Tobacco Tells on Nervous System



Tobacco Ruins Digestion



Tobacco Stunts Boy's Growth



Tobacco Robs Man of Vitality



Tobacco Steals from You the Pleasures, Comforts, Luxuries of Life

Tobacco Habit Banished Let Us Help You

Quick Results

Trying to quit the tobacco habit unaided is often a losing fight against heavy odds, and may mean a serious shock to your nervous system. So don't try it! Make the tobacco habit quit you. It will quit you if you will just take **Tobacco Redeemer** according to directions.

It doesn't make a particle of difference whether you've been a user of tobacco for a single month or 50 years, or how much you use, or in what form you use it. Whether you smoke cigars, cigarettes, pipe, chew plug or fine cut or use snuff—**Tobacco Redeemer** will positively remove all craving for tobacco in any form in a few days. Your tobacco craving will usually begin to decrease after the very first dose—there's no long waiting for results.

Tobacco Redeemer contains no habit-forming drugs of any kind and is marvelously quick, scientific and thoroughly reliable.

Not a Substitute

Tobacco Redeemer is in no sense a substitute for tobacco, but is a radical, efficient treatment. After finishing the treatment you have absolutely no desire to use tobacco again or to continue the use of the remedy. It helps to quiet the nerves, and will make you feel better in every way. If you really want to quit the tobacco habit—get rid of it so completely that when you see others using it, it will not awaken the slightest desire in you—you should at once begin a course of **Tobacco Redeemer** treatment for the habit.

Results Absolutely Guaranteed

A single trial will convince the most skeptical. Our legal, binding, money-back guarantee goes with each full treatment. If **Tobacco Redeemer** fails to banish the tobacco habit when taken according to the plain and easy directions, your money will be cheerfully refunded upon demand.

Let Us Send You Convincing Proof

If you are a slave of the tobacco habit and want to find a sure, quick way of quitting "for keeps" you owe it to yourself and to your family to mail the coupon below or send your name and address on a postal and receive our free booklet on the deadly effect of tobacco on the human system, and positive proof that **Tobacco Redeemer** will quickly free you from the habit.

Newell Pharmacal Company
Dept. 300 St. Louis, Mo.



Free Book Coupon

NEWELL PHARMACAL CO.,

Dept. 300

St. Louis, Mo.

Please send, without obligating me in any way, your free booklet regarding the tobacco habit and proof that **Tobacco Redeemer** will positively free me from the tobacco habit or my money will be refunded.

Name.....

Street and No.....

Town..... State.....



Here's Positive Proof That I Can Grow New Hair

These are true, unretouched photographs showing Mr. Murray Sandow's hair before—and 60 days after using my remarkable new treatment for baldness and falling hair. This is not a rare instance. Many others report equally astonishing results. To try my new discovery you need not risk a cent. For I positively guarantee results or charge you nothing. Mail coupon below for booklet describing my treatment and 30 Day Trial offer in detail.

By ALOIS MERKE

Founder of Merke Institute, Fifth Ave., N. Y.



FOR many months you have seen announcements concerning my new treatment for baldness and falling hair. If you are bald and have tried other treatments without results then naturally you are skeptical. All right, I don't blame you.

But what better PROOF is there that I can *actually grow new hair* than these two photographs reproduced above. They illustrate a result that hundreds of others have written us they too have secured through use of my marvelous discovery.

In this particular case, Mr. Murray Sandow, of New York City, started my treatment January 23, 1924, and sixty days later—as you can see—he had an almost entirely new growth of hair.

Entirely New Method

My invention involves the application of new principles in stimulating hair growth. It proves that in many cases of baldness—the hair roots are not *dead*—but merely *dormant*. The reason tonics and other treatments fail to grow new hair is because they do not *reach* these *dormant hair roots*, but instead simply treat the *surface* of the scalp.

To make a tree grow you could not rub "growing fluid" on the bark. Instead you would get right to the roots. And so it is with the hair.

No Excuse for Most Baldness

At the Merke Institute on Fifth Avenue, New York, I've treated scores of prominent stage and social celebrities—some paying as high as \$500 for

the results my methods produced. Yet now by means of The Merke Thermocap Treatment, adapting the same principles to home use, thousands of men and women everywhere are securing the desired results—right in any home where there is electricity—*and for just a few cents a day!*

I don't say my treatment will grow hair in every case. There are some cases that nothing in the world can help. But since so many others have regained hair this new way, isn't it worth a trial—especially since you do not risk a penny? For at the end of a month, if you are not more than delighted with the growth of hair produced, you won't be out a cent. That's my absolute *Guarantee*. AND YOU ARE THE SOLE JUDGE.

Coupon Brings FREE Book

No matter how thin your hair may be—no matter how many methods you have tried without results, send at once for the 32-page book telling about this wonderful SCIENTIFIC TREATMENT. It gives scores of reports from others which indicate what this treatment will mean to you. Merely fill in and mail the coupon below and I will gladly send you the vitally interesting 32-page booklet giving full details about the famous Merke Thermocap Treatment. Clip and mail the coupon today. **Allied Merke Institutes, Inc., Dept. 1611, 512 Fifth Avenue, New York City.**

Allied Merke Institutes, Inc., Dept. 1611, 512 Fifth Avenue, New York City.

Please send me, without cost or obligation on my part, the free copy of the new booklet describing in detail the Merke Thermocap treatment.

Name.....
(State whether Mr., Mrs., or Miss)
Address.....
City..... State.....



"I Made Myself HEAD

"I used to be one of the hands.

Luck? Pull? There's no such thing in business! Training is everything. Only three years ago I had your very job! A. T. S. books put me where I am today!

"Take a tip from one who knows. Buy a set of A. T. S. books and let them fit you for a big job, as I did. They're crowded with pay-raising facts written by noted experts. They are easy to read, too—charts, diagrams and illustrations make them as simple as A. B. C.

"But don't take my word for it. Investigate for yourself—it won't cost a cent!" Pick the set you want, mail the coupon and the books will be shipped to you for 7 days' free inspection.

PAY RAISING BOOKS at Greatly Reduced Prices

Automobile Engineering, 6 volumes, 2600 pages, 2000 pictures. Was \$37.50.....	Now \$19.50
Carpentry and Contracting, 5 volumes, 2188 pages, 1000 pictures. Was \$37.50.....	Now 19.50
Civil Engineering, 9 volumes, 3500 pages, 6900 pictures. Was \$67.50.....	Now 34.50
Business Management, 8 volumes, 2500 pages, well illustrated. Was \$62.50.....	Now 29.50
Fire Prevention and Insurance, 4 volumes, 1500 pages, 600 pictures. Was \$30.00.....	Now 14.50
Electrical Engineering, 8 volumes, 3800 pages, 3000 pictures. Was \$60.00.....	Now 29.50
Machine Shop Practice, 6 volumes, 2300 pages, 3500 pictures. Was \$45.00.....	Now 21.50
Steam and Gas Engineering, 7 volumes, 5300 pages, 2500 pictures. Was \$52.50.....	Now 24.50
Law and Practice (with reading course), 13 volumes 6000 pages, illustrated. Was \$57.50.....	Now 42.50
Telephony and Telegraphy, 4 volumes, 1728 pages, 2000 pictures. Was \$30.00.....	Now 14.50
Sanitation, Heating and Ventilating, 4 volumes, 1454 pages, 1400 pictures. Was \$30.00.....	Now 14.50
Drawing, 4 volumes, 1578 pages, 1000 pictures, blue-prints, etc. Was \$30.00.....	Now 14.50
Employment Management and Safety Engineering, 7 volumes, 1800 pages, 540 illustrations, charts and diagrams. Was \$62.50.....	Now 24.50

SEND NO MONEY Shipped for 7 Days' Trial

You be the judge of these books. Don't send us a penny, but mail the coupon and we'll ship you any set you want for 7 days' free examination. Use them a whole week. If you don't want them, return the books at our expense. If you decide to keep them, remit only \$2.50 at the end of the week and \$3.00 a month until the balance is paid. Take the step toward bigger pay today. Mail the coupon—NOW!

American Technical Society, Dept. X-819 Chicago, U. S. A.

American Technical Society,
Dept. X-819 Chicago, U. S. A.

Please send me set of.....

for 7 DAYS' examination, shipping charges collect. I will examine the books thoroughly and, if satisfied, will send \$2.50 within 7 days and \$3.00 each month until I have paid the special price of..... If I decide not to keep the books I will return them at your expense at the end of one week. Title not to pass to me until the set is fully paid for.

Name.....

Address.....

Employed by.....
(Please fill out all three lines)

Are You Fitted for Salesmanship?



Hundreds of talented men and women are wasting their time, energy and the best years of their lives in positions for which they are not fitted. The highest salaried men in this country are men of only average ability who have found the right job. Let us help place you. We will test your qualifications and give you private written report by Salesmanship Expert with 27 years' experience.

Send No Money Details Free. Write Dept. 7

SALESMEN'S REGISTRY,
63 East Adams St. CHICAGO

LEARN TO GET DOLLARS OUT OF WATCHES.
WATCH-REPAIRING, ENGRAVING, JEWELRY REPAIRING.

WRITE NOW.

ENICAR TRADE SCHOOL
530 W MONUMENT SQUARE, RACINE, WIS.

Learn to Become an Artist **Learn to Draw**

Study in spare time at home. **Be your own boss.** Easily make \$100 per week and more. Earn while you learn. Artists are in big demand. Advertisers pay big prices. Jobs that take half hour to make sell for as high as \$5.00. Anyone can learn.

DURANT SYSTEM NEVER FAILS
Simplified short cut method permits anyone to learn quickly and positively. Have successfully taught many through my system. **No previous art knowledge necessary.**

FREE WRITE TODAY FOR FREE BOOKLET AND PARTICULARS. WRITE AT ONCE IF YOU WANT TO BE SUCCESSFUL.

MANHATTAN ACADEMY OF ART
Dept. 106 185 Madison Ave. New York

When will You become A Factory Manager?

You yourself are going to set that successful day when you become a factory manager. If you have the courage and ambition to move upward into a bigger salaried job as an expert foreman, superintendent or production manager, nothing can stop you if you are thoroughly trained in the important fundamentals of factory management. Our book,

"Advancing to Success"

tells you how you can quickly step up into one of these bigger salaried jobs. This book is now free. If you have the ambition to succeed, this very moment is the test of your will.

LINCOLN EXTENSION UNIVERSITY, Inc.

LOUIS S. VOSBURGH, Pres.

85th Street at Detroit
CLEVELAND, OHIO



Are You Going to send for It ?

Name.....

Street.....

City..... State.....

Let Me Make A Man of You

Are you dragging yourself about from day to day always ailing and complaining—always tired and despondent—suffering from Backache, Indigestion, Constipation, Dyspepsia, Nervousness, Vital Depletion, etc., etc., your Biliousness showing in your face—your lack of energy in your eyes? Have you and your family given up hope that you will ever be a real man again, achieve success and amount to anything in the world? Have you lost ambition and allowed your youthful ideals to slip down into the bog of physical defects and unfitness? Then, **you** are the man I want to help.

Pull Yourself Together

Brace up—you can come back—there is a way out—you can be a real man again. You can regain your vigor and vitality, your health and strength—you can conquer the weaknesses that are undermining your body and brain—you can root out the results of Bad Habits and neglect and fill your life with the success and joy of abundant health.

It is Not Too Late. There is hope for you. It doesn't matter what brought you to your present physical condition—it doesn't matter how many methods you have tried in vain—or how often you have been disappointed. You can be saved from the scrap heap of worn-out humanity and be rebuilt into a red-blooded specimen of vital, magnetic Manhood.

I Can Re-create You

There isn't the least doubt about it. I know that my scientific methods will make you a 100% man. I have helped and am helping thousands of men and women, boys and girls, many of whom had given up all hope of relief. I can do the same for you. I have no pills or powders, dope or drugs to offer you—no foolish fads or fancies—no starvation diets or tedious, expensive routines. My methods are safe, sensible and scientific and are based on the immutable laws of Nature. These are the principles that I applied to my own body and won the World's Award as the Finest Specimen of Physical and Health Attainment. Look at my picture and note the evidences of rugged health, strength, vigor and endurance. You can be as I, if you will, thru the application of the same wonderfully effective principles that made me successful. I want to help you—I can rebuild, rehabilitate and restore you with

STRONGFORTISM

THE NEW SCIENCE OF HEALTH PROMOTION

Strongfortism will go directly to the root of your trouble and remove the cause. **Strongfortism** will purify and enrich your blood, revitalize your nerves, strengthen your Heart, Lungs, Stomach, Liver, Kidneys, Bowels and other vital organs. **Strongfortism** will send the rich, red blood to every corner of your being, bringing the nutrient and vital force necessary to restore the half-dead cell life and build up muscle and bone. **Strongfortism** will drive out the poisonous waste matter that has been accumulating for years in your body and brain and make you clean, wholesome and normal, **externally** and **internally**.

Come to Me in Full Faith as You Would to a Brother

Open up the secret chambers of your heart and tell me all of your troubles without reservation. You can confide in me with full faith—I will never betray you. Come to me with your problems as you would to your father, mother, brother or closest friend and let me show you the way out of your difficulties with **Strongfortism**—The Beacon Light of Health, Happiness and Success. Once you accept **Strongfortism** you enter a new life. The results are immediate and positively thrilling. You feel the rich red blood pulsating thru your body—you acquire poise, confidence, and a magnetic personality. You feel new power developing in every organ and function. I personally guarantee your success, irrespective of your sex, age, occupation or surroundings.

Send for My New Free Book

"Do It With Muscle" is the most interesting and instructive book you can ever read.

It will tell you in understandable, non-technical language just how you can banish your ailments—conquer your weaknesses and make yourself over into a splendid specimen of magnetic, robust Manhood with 100% pep and power. It is absolutely free. Just mark the subjects on the free consultation coupon on which you want **special confidential information** and send to me with a 10c piece (one dime) to help pay postage, packing, etc. It's a man-builder—a success maker and a life-saver. Send for my new free book **Right Now—TODAY.**

Lionel Strongfort

Physical and Health Specialist over 25 Years
Dept. 1640, Newark, N. J., U. S. A.



LIONEL STRONGFORT

DR. SARGENT, of Harvard, declared that "Strongfort is unquestionably the finest specimen of physical development ever seen."

CONSULTATION COUPON

Absolutely Confidential

LIONEL STRONGFORT, Department 1640, Newark, N. J.

Send me free my private copy of "DO IT WITH MUSCLE" for which I enclose one dime (10c) towards mailing expense. It may teach me something startling about ME. Send me special information on subjects marked (X) below, without obligation.

..... Colds Skin Disorders
..... Catarrh Debility
..... Too Fat Torpid Liver
..... Too Thin Vitality Restored
..... Stomach Trouble Muscular Development
..... Flat Chest Great Strength
..... Bad Blood Rupture
..... Nervousness Lumbago
..... Constipation Neuralgia
..... Dependency	

Name.....

Age..... Occupation.....

Address.....

If you have taken my "Regular" or "Advanced" courses, kindly indicate same by making a cross in box for this purpose below:

I have taken your "Regular" course I have taken your "Advanced" course

I have received your book "Promotion and Conservation of Health, Strength and Mental Energy." Date.....



"There's One Man We're Going to Keep"

"Ed Wilson, there, is one of the most ambitious men in the plant. I notice that he never fools away his spare time. He studies his International Correspondence Schools Course every chance he gets.

"It's been the making of him, too. He hasn't been here nearly so long as Tom Downey, who was laid off yesterday, but he knows ten times as much about this business.

"I'm going to give him Tom's job at a raise in salary. He's the kind of man we want around here."

HOW do you stand in your shop or office? Are you an Ed Wilson or a Tom Downey? Are you going up? Or down?

No matter where you live, the International Correspondence Schools will come to you. No matter what your handicaps or how small your means, we have a plan to meet your circumstances. No matter how limited your previous education, the simply-written, wonderfully-illustrated I. C. S. textbooks make it easy to learn.

This is all we ask: Without cost, without obligating yourself in any way, put it up to us to prove how we can help you. Just mark and mail this coupon.

INTERNATIONAL CORRESPONDENCE SCHOOLS Box 5653-D, Scranton, Penna.

Without cost or obligation, please tell me how I can qualify for the position or in the subject before which I have marked an X:

BUSINESS TRAINING COURSES

- | | |
|--|---|
| <input type="checkbox"/> Business Management | <input type="checkbox"/> Salesmanship |
| <input type="checkbox"/> Industrial Management | <input type="checkbox"/> Advertising |
| <input type="checkbox"/> Personnel Organization | <input type="checkbox"/> Better Letters |
| <input type="checkbox"/> Traffic Management | <input type="checkbox"/> Show Card Lettering |
| <input type="checkbox"/> Business Law | <input type="checkbox"/> Stenography and Typing |
| <input type="checkbox"/> Banking and Banking Law | <input type="checkbox"/> Business English |
| <input type="checkbox"/> Accountancy (including C.P.A.) | <input type="checkbox"/> Civil Service |
| <input type="checkbox"/> Nicholson Cost Accounting | <input type="checkbox"/> Railway Mail Clerk |
| <input type="checkbox"/> Bookkeeping | <input type="checkbox"/> Common School Subjects |
| <input type="checkbox"/> Private Secretary | <input type="checkbox"/> High School Subjects |
| <input type="checkbox"/> Spanish <input type="checkbox"/> French | <input type="checkbox"/> Illustrating <input type="checkbox"/> Cartooning |

TECHNICAL AND INDUSTRIAL COURSES

- | | |
|---|--|
| <input type="checkbox"/> Electrical Engineering | <input type="checkbox"/> Architect |
| <input type="checkbox"/> Electric Lighting | <input type="checkbox"/> Architects' Blue Prints |
| <input type="checkbox"/> Mechanical Engineer | <input type="checkbox"/> Contractor and Builder |
| <input type="checkbox"/> Mechanical Draftsman | <input type="checkbox"/> Architectural Draftsman |
| <input type="checkbox"/> Machine Shop Practice | <input type="checkbox"/> Concrete Builder |
| <input type="checkbox"/> Railroad Positions | <input type="checkbox"/> Structural Engineer |
| <input type="checkbox"/> Gas Engine Operating | <input type="checkbox"/> Chemistry <input type="checkbox"/> Pharmacy |
| <input type="checkbox"/> Civil Engineer | <input type="checkbox"/> Automobile Work |
| <input type="checkbox"/> Surveying and Mapping | <input type="checkbox"/> Airplane Engines |
| <input type="checkbox"/> Metallurgy | <input type="checkbox"/> Navigation |
| <input type="checkbox"/> Steam Engineering | <input type="checkbox"/> Agriculture and Poultry |
| <input type="checkbox"/> Radio | <input type="checkbox"/> Mathematics |

Name.....
Street.....
Address..... 3-6-24

City..... State.....

Occupation.....
Persons residing in Canada should send this coupon to the International Correspondence Schools Canadian, Limited, Montreal, Canada.

EARN BIG INCOME RAISING POULTRY

**\$3,000
to
\$15,000
a
year**

Poultry raising is one of the fastest-growing businesses in the world. Always a ready market for products. Work is easy, fascinating, healthy, profitable! Commercial poultry raisers earn \$3,000 to \$15,000 a year. Learn at home. Our course of instruction easy—prepared by Harry M. Lamco, the man who "taught Uncle Sam how" and corps of famous poultrymen. We teach you and show you how to start in business with little capital. School endorsed by colleges and universities. Many graduates now making big money. Write TODAY for FREE, interesting book, "How to Raise Poultry for Profit." National Poultry Institute, Dept. 151A, Washington, D.C.

STATEMENT OF THE OWNERSHIP, MANAGEMENT, CIRCULATION, ETC., REQUIRED BY THE ACT OF CONGRESS OF AUGUST 24, 1912, of Popular Mechanics Magazine, published monthly at Chicago, Ill., for October 1st, 1924.

State of Illinois, County of Cook, ss.
Before me, a notary public in and for the state and county aforesaid, personally appeared H. H. Windsor, Jr., who, having been duly sworn according to law, deposes and says that he is the editor and business manager of the Popular Mechanics Magazine and that the following is, to the best of his knowledge and belief, a true statement of the ownership, management, etc., of the aforesaid publication for the date shown in the above caption, required by the Act of August 24, 1912, embodied in section 463, Postal Laws and Regulations, printed on the reverse of this form, to wit: First. That the names and addresses of the publisher, editor, managing editor, and business manager are: Publisher, Popular Mechanics Co., 200 East Ontario St., Chicago, Ill. Editor, H. H. Windsor, Jr., 200 East Ontario St., Chicago, Ill. Managing Editor, J. R. Weber, 200 East Ontario St., Chicago, Ill. Business Manager, H. H. Windsor, Jr., 200 East Ontario St., Chicago, Ill. Second. That the owners are: (If the publication is owned by an individual his name and address, or if owned by more than one individual the name and address of each, should be given below; if the publication is owned by a corporation the name of the corporation and the names and addresses of the stockholders owning or holding one per cent or more of the total amount of stock should be given.) L. H. Windsor, 200 East Ontario St., Chicago, Ill. H. H. Windsor, Jr., 200 East Ontario St., Chicago, Ill. First Trust and Savings Bank, Trustee for H. H. Windsor, Jr., Chicago, Ill.; Lisa B. Windsor and Henry H. Windsor, Jr., Executors of the Estate of Henry H. Windsor, deceased, Chicago, Ill. Third. That the known bondholders, mortgagees, and other security holders owning or holding 1 per cent or more of total amount of bonds, mortgagees, or other securities are: (If there are none, so state.) None. Fourth. That the two paragraphs next above, giving the names of the owners, stockholders, and security holders, if any, contain not only the list of stockholders and security holders as they appear upon the books of the company but also, in cases where the stockholder or security holder appears upon the books of the company as trustee or in any other fiduciary relation, the name of the person or corporation for whom such trustee is acting, is given; also that the said two paragraphs contain statements embracing affiant's full knowledge and belief as to the circumstances and conditions under which stockholders and security holders who do not appear upon the books of the company as trustees, hold stock and securities in a capacity other than that of a bona fide owner; and this affiant has no reason to believe that any other person, association, or corporation has any interest direct or indirect in the said stock, bonds, or other securities than as so stated by him. H. H. WINDSOR, Jr., Editor and Business Manager. Sworn to and subscribed before me this 20th day of September, 1924. J. GRAHAM, Notary Public. (My commission expires June 17, 1925.)

\$13800 in one week!

Amazing new ways to make money - NOW

This \$138 was made by a small town man who started a small business which is growing daily. He read **OPPORTUNITY**—he grabbed a chance it offered, just as you would—and won success.

Do you want to start your own business?—or run a profitable side line with your present job? Or secure an exclusive agent's specialty to earn luxury-money in your spare time? **Read OPPORTUNITY**—it tells you how!

MONEY-MAKING SECRETS!

OPPORTUNITY is a big, handsome new magazine addressed to money-makers. 64 pages every month tell you how other men, situated just like yourself, are making good. It informs you of actual business chances all over the country. It offers advice, encouragement, inspiration. It starts you on the road to success.

3 MONTHS' SUBSCRIPTION ONLY 25 CENTS

This is an acquaintance offer—for a limited time only. Regular subscription is \$1.50 a year. Mail the coupon with 25 cents and receive **Opportunity** for three months. These three issues open a new world of prosperity and success—hand you the key.

MAIL THE COUPON NOW

OPPORTUNITY MAGAZINE Pop. Mech. 11
750 North Michigan Ave., Chicago, Illinois

Enclosed is 25 cents for three months' subscription to **Opportunity**.

Name.....

Address.....

City..... State.....

Master Electricity

by the Associated Electrical Engineers' Remarkable, New "Experience Method" and quickly prepare yourself for Electrical Jobs paying \$2,500, \$5,000 a year and up



Electricity is the fastest growing industry on earth. Thousands of trained men are needed to fill the NEW JOBS constantly opening—the most fascinating and highest paid work, and offering the biggest future. There is a big-money job ready for you in

Electricity just as soon as you are ready for it. The A. E. E. "Experience Method" will quickly prepare you for your big opportunity in Electricity right in your own home, in your spare time.

The A. E. E. "Experience Method" is the Biggest and Most Revolutionary Advance in the History of Electrical Training

Under ordinary "school" methods, you first get your training and then have still to get your experience—a long, hard grind. The Famous A. E. E. "Experience Method" has changed all that. You can now get your Electrical training and experience together and thus cut in half the distance between you and the big jobs in Electricity. This real fact is being proven every day by A. E. E. trained men.

The A. E. E. "Experience Method" is the greatest and most remarkable advance ever made in home study Electrical training. There is nothing like it anywhere. It is the result of the lifetime work of Chief Engineer W. N. Littlewood, and over-100 big, successful Electrical Engineers have certified that it is RIGHT.

The quick success of men trained under the Famous A. E. E. "Experience Method" is amazing. James DuVall, Fort Niagara, Ont., writes: "How you can put so much information in such a few lines is beyond me." Julio Fuentes, Cleveland, Ohio, just beginning his training, writes: "I am already doing a lot of wiring and repairing and making real money." J. A. Hoekzema, Grand Rapids, Mich., not a third through his training, writes: "I have started my own business and am doing fine." Hundreds of such letters are pouring in from A. E. E. trained men, who began making money almost from the start.

You Get Real Electrical Experience While Training

The reason for these remarkable successes is that A. E. E. training is not "schooling"—it is EXPERIENCE. You work on practical jobs with practical tools and equipment right from the start—everything that you need is furnished you FREE, as you need it, including the biggest and most practical outfit ever given anywhere. The A. E. E. "Experience Method" is the exclusive development of the A. E. E. and can be had nowhere else.

Success in Electricity Made Easy

YOU can master Electricity quickly and easily under the amazingly interesting and practical "Experience Method." We

guarantee that with a binding Money Back Guarantee Bond. If you can read and write English and are ambitious to make good and qualify for the big jobs that Electricity offers by the thousand, then we will guarantee to do the rest.

Send for This Great Book

It is impossible to tell the remarkable story of the Associated Electrical Engineers on this page. The story is too big—too important. We have published a big new 48-page Book, "Electricity and its Opportunities for YOU" which has a vitally important message for you.

Send for your copy today—it is absolutely free. No matter what your ideas regarding training may be; no matter what your plans are, you should have this book before you decide. It is filled from cover to cover with vital information that every ambitious man should have.

This great book tells of the great opportunities that the amazing growth of the Electrical Industry is creating. It tells you of the many exclusive features of the A. E. E.—the World's Greatest Electrical Training Organization—features that can be had from no other source whatever, and gives you 22 BIG, SMASHING PROVEN REASONS WHY A. E. E. TRAINING IS THE BEST AND MOST COMPLETE AND PRACTICAL IN EXISTENCE.

Your copy of this important book is ready—send for it today.

MAIL THE COUPON

Here is the coupon that will bring you face to face with your BIG OPPORTUNITY. If you are really ambitious, if you wish to get out of crowded, low-pay futureless work and get into the biggest, most interesting and highest paid field on earth—Electricity—then clip and mail the coupon right now.

Five years from now you will be either taking orders or giving them. The coupon will bring the sure way to Independence and Success in Electricity.

Associated Electrical Engineers (Dept. 1114)
537 S. Dearborn Street, Chicago

Without any obligation send me your big, new 48-page book, telling about the marvelous development of Electricity, and how I can quickly and surely qualify for the great opportunities in this field through the A. E. E. "Experience Method."

Name.....
Address.....
City..... State.....

MEN WANTED

POSITION at \$110 per mo. GUARANTEED TO START

BE A RAILWAY TRAFFIC INSPECTOR

Earn Up to \$250.00 PER MONTH Expenses Paid



Many Chances for Advancement

A wonderful new profession in which hundreds of men have already advanced to excellent positions. Railways (steam and electric) need many trained men for confidential work, reporting to high officials.

Travel—see the country or remain near home. Fascinating outdoor work; something new every day. Advancement rapid with experience.

Good-Paying, Pleasant Work

Mr. Dewey Burcham says: "The chances for advancement in this work are unlimited. I find the work very interesting and I like it better than anything I ever did."

Stanley W. Dress writes: "There is no other work that gives more opportunities to travel than that of a Traffic Inspector and at the same time is interesting and instructive. There is no end of advancement to the person who sticks to it."

Leo Banning states: "My experience with the Standard Business Training Institute has been most gratifying and absolutely satisfactory in every respect."

Start at \$110 per Month Expenses Paid

Upon graduation, we guarantee you a position paying at least \$110 per month and expenses or refund your tuition. You take no risk! Prepare in spare time at home. Any average man can qualify in three months.

Railways need more trained traffic inspectors—we must supply them. Investigate this big opportunity—send for free booklet No. D-63.

Standard Business Training Institute

BUFFALO, N. Y.

MAIL TODAY

Standard Business Training Institute

Buffalo, N. Y.

Send me, entirely free, Booklet No. D-63 giving full particulars about course in Railway Traffic Inspection.

NAME

STREET

CITY

Be a Diamond Expert!

Do you know that of two diamonds of equal size one may be worth a hundred times as much as the other? Who can distinguish them but an expert? My short, easy course will make you a diamond expert in a few months! Get it before you buy your next diamond—it will save you money!

FREE! GENUINE Diamonds if you enroll at once \$5,000 to \$15,000 a Year! Be a diamond expert and go into business for yourself on only \$25 or \$50 capital! We will show you how! Be a diamond expert and become independent. The diamond business is a gentleman's business. Success in any other line of business means \$5,000 a year—success in the diamond business means up to \$15,000 a year! Millions of dollars are paid out every year for diamonds! Jewelry houses everywhere need diamond experts—always pay high for expert opinions. Diamond experts are rare! Write for Free Booklet "Paying Diamond Knowledge" will be sent to you absolutely FREE! Contains new and amazing and startling facts about diamonds. Write now!

CODINGTON SCHOOL OF DIAMONDS
3457 Sunnyside, Dept. 303 CHICAGO, ILLINOIS

VACUUM TUBE RADIO, \$9.98

Get a Bearcat. Wonderful new, long range, genuine vacuum tube set—easy to operate—marvelous results. One dial controls all tuning. Beautiful mahogany finish cabinet. Set without accessories \$9.98. Set with tube, batteries, aerial, phones, etc., all ready to operate \$18.88. SEND NO MONEY. Order from this ad. Pay postman on delivery. Satisfaction guaranteed or money back.

BEARCAT RADIO CO., 646 N. Michigan Ave., Dept. 20, Chicago



Minstrel Show Guide

350 End-men's Jokes, 26 Songs, 9 Complete Sketches, 8 Monologues, 4 Stump Speeches, besides Complete instructions on stage and program arrangements, rehearsals and "make-up" from beginning to end. Price 15c postpaid.

J. C. DORN, 701 S. Dearborn Street, Dept. 39, CHICAGO, ILL.



Start Little Mail Order Business—Free Book

Home employment evenings. Beginners outfit furnished. Book Free. Pier, 542 Cortland St. NEW YORK

Deafness



Perfect hearing is now being restored in every condition of deafness or defective hearing from causes such as

Relaxed or Sunken Drums, Roaring or Hissing Sounds, Perforated, Partially Destroyed Drums, etc.

Wilson Common Sense Ear Drums

—"Little Wireless Phones for the Ears"—

require no medicine, but effectively replace what is lacking or defective in the natural drums. They are simple devices, which the wearer easily fits into the ears, where they are invisible. Soft, safe and comfortable to wear at all times.

Write today for our 168-page FREE book on DEAFNESS, giving you full particulars and plenty of testimonials.

WILSON EAR DRUM CO., Incorporated
240 Inter-Southern Building LOUISVILLE, KY.

NO MORE BALD HEADS



WHEN our VACUUM CAP is used a few minutes daily. We accept no pay until you have tried the Cap 60 days and are satisfied. The Vacuum Cap is an appliance that draws the blood to the Hair Roots and starts a new healthy crop of hair. It stops Dandruff, stops the hair from falling out.

Bought by Doctors and men who know that it is the only reasonable HAIR GROWER known to science. No Drugs Used. Write for application blank, testimonials and booklet on "HAIR," sent sealed in plain envelope, FREE.

THE MODERN VACUUM CAP CO.
B 559 BARCLAY, DENVER, COLO.



\$2500 Reward!

For the Capture of an Unknown Man

Twice he had entered the St. Clair Mansion. What was he after? Who? What was in danger?

Berteau, the famous detective, had warned St Clair that *the mysterious marauder would come again*. And now—a noise in the passage! The creak of an opening door. A shot in the dark! A capture!

Is this wounded stranger the mysterious intruder? Who could tell? Yet Berteau identified the man without hesitation and won the \$2500 reward.

How did he do it? Easy enough for the Finger Print Expert. He is the specialist, the leader, the *cream* of detectives. Every day's paper tells their wonderful exploits in solving mysterious crimes and convicting dangerous criminals.

Course in Secret Service

For a limited time we are making a special offer of a *professional Finger Print Outfit, absolutely Free, and Free Course in Secret Service Intelligence*. Mastery of these two kindred professions will open a brilliant career for you.

Write quickly for fully illustrated free book on Finger Prints which explains this wonderful training in detail. Don't wait until this offer has expired—mail the coupon now. You may never see this announcement again! You assume no obligation—you have everything to gain and nothing to lose. Write at once—address

University of Applied Science

Dept. 13-58, 1920 Sunnyside Ave., Chicago, Ill.

More Trained Men Needed

The demand for trained men by governments, states, cities, detective agencies, corporations, and private bureaus is becoming greater every day. Here is a real opportunity for YOU. Can you imagine a more fascinating line of work than this? Often life and death depend upon finger print evidence—and big rewards go to the expert. Many experts can earn regularly from \$3,000 to \$10,000 per year.

Learn at Home in Spare Time

And now you can learn the secrets of this science at home in your spare time. Any man with common school education and average ability can become a Finger Print Expert in a surprisingly short time.

FREE

UNIVERSITY OF APPLIED SCIENCE
Dept. 13-58, 1920 Sunnyside Ave., Chicago, Ill.

Gentlemen:—Without any obligation whatever, send me your new, fully illustrated, **FREE** book on Finger Prints and your offer of a **FREE** course in Secret Service Intelligence and the Free Professional Finger Print Outfit.

Name.....

Street Address.....

City and State.....



HE EARN'S \$1000 A MONTH AS AN AUTOMOTIVE ELECTRIC EXPERT

50 DAYS training—that's all Fred Ellerd needed at AMBU ENGINEERING INSTITUTE, Chicago, to make him a big money-maker. Remarkable—but not unusual. You can do the same. Ambu trains a small number of men **thoroughly**—only 50 days needed. Then you are master of a trade where pay is big—demand for men great. Ludlow earns \$175 a week—Duffy and his son \$1200 a month. Hundreds of other Ambu men earning \$65 to \$100 a week. Ambu can do equally as well for YOU. My free book tells all.

NO SPECIAL EXPERIENCE NEEDED

All you need is a spark of ambition—a willingness to forge ahead. Then AMBU will make you. You needn't know a thing about cars or electricity—and then you'll step out from the mass of untrained low class pay into a highly specialized field where you are paid for what you know.

BIG JOBS WAITING FOR YOU OR START YOUR OWN BUSINESS

Right now the field is unlimited for automotive electrical experts. 13,000,000 cars in this country need constant attention—but there is **only one** automotive electrical expert for every 1000 cars. Think of it! The woods are full of \$35 a week auto mechanics—but the high pay \$60 a week automotive electrical experts in big demand are hard to find. Right here is your golden opportunity. That's why men like Ellerd, Ludlow, Duffy (above) and hundreds of others are earning real money—without grease, dirt and back-breaking labor. My free book tells you all!

COME TO CHICAGO—OR TRAIN AT HOME

You have your choice now. AMBU formerly was strictly a resident school, where Ambu graduates got their expert training in the great Ambu shops. But now if you prefer, you may have the same training at home—during your spare time—and while you are still working. And I guarantee my Home Training Course to satisfy you or refund your money.

FREE

A complete course in Radio prepared by the expert AMBU Staff for Ambu Students exclusively. Worth at least \$50—but free to Ambu Students for a very limited time. Free book tells all. Send for it today—use the coupon now!

AMBU ENGINEERING INSTITUTE
Dept. 111, 2632 Prairie Ave., CHICAGO, ILL.

AMBU ENGINEERING INSTITUTE
Dept. 111, 2632 Prairie Ave., Chicago, Ill.

Gentlemen: Please send me your free book explaining how I can become an Automotive Electrical Expert with only 50 days training—and also details about your special free radio course—without any obligation on my part.

Name

St. or P.O. Box No.

Town.....State.....



Pick Your Own Job!

Uncle Sam Needs Men

Quit worrying about your job or your pay. Uncle Sam wants you in his Civil Service in a fine job you can't lose for political, personal or religious reasons. No experience needed. Start at \$1600 to \$2300. Short hours, 30-day vacations, sick leave with full pay. Pick the job you want—Railway Mail Clerk, Letter Carrier, Postal Clerk, Customs Inspector, etc., etc. Arthur R. Patterson, once member of Official Board of Examiners, coaches you at home. Guarantee that you pass with high mark so you get job quick or you pay nothing. Write for **BIG FREE BOOK** today, tells all about Civil Service and how to get job you want.

PATTERSON CIVIL SERVICE SCHOOL
Dept. 811 Rochester, N. Y.

LEARN Painting Paper Hanging and Decorating

Marbling and Graining—Auto Painting—Show Card Writing

Learn any of these big paying trades in a few weeks by practical work under competent instructors. No books—no classes—start anytime. No previous experience or education necessary. Working conditions exactly the same as "out on a job". Largest and best equipped painting shops in America—the only industry endorsed school.

Make \$10 to \$20 a Day

Or, go in business for yourself and make \$5,000 to \$15,000 a year. We train you to become an **EXPERT**, not an ordinary "brush hand". There are not enough trained men to go around. Be an **EXPERT** and get the big money.

Send Coupon for Free Book

Take the first step today and send for Free Book and Special Offer. No obligation. A few weeks practical training will fit you for this big paying trade.

CHICAGO PAINTING SCHOOL

Dept. 1358
150 W. Austin Ave., CHICAGO, ILL.

CHICAGO PAINTING SCHOOL,
Dept. 1358, 150 W. Austin Ave., Chicago, Ill.

Gentlemen: Without obligation, please send me your Free Book and Special Offer.

Name.....

Address.....



**Says
Goodbye
to \$22 a Week**

—At 27 Earns \$4,500 a Year

"Three years ago," writes A. J. Klick, "I was just an average young man of 24, possessing a fair education, liking a (so-called) good time, occupying a bookkeeper's high stool and receiving \$1,100 a year.

"A crisis in my affairs woke me up and I began the serious study of Higher Accountancy.

"Before the year was over, I was making progress financially. Interested in my work, advancing steadily, more confident of myself, by the time I had finished the course, I had an executive position and \$3,000 a year.

"Last year I became comptroller of a good-sized corporation. My work became a pleasure; salary increased to \$3,800.

"This year I accepted a similar position with a larger corporation, with broader responsibilities and an initial salary of \$4,500. The future years are full of promise."

Unusual Opportunities in Accounting

Klick is *right*. His future years are full of promise! Never in the history of business has the need for trained accountants been so great or the rewards so attractive. The files of LaSalle Extension University contain literally thousands of letters reporting rapid advancement—incomes doubled, tripled and quadrupled as the result of a comparatively few months of home-study training. Where these men were getting \$1,500 or \$2,000 a short time ago, they are earning from \$3,000 to \$10,000 today, and they are on the up-grade.

Their chance is yours—if you will take it!

Train by the "Problem Method"

Why let the *other* fellow walk away with the better job when the training you need is readily within your reach?

Right in your own home you can master Higher Accounting just as well as they! By the LaSalle Problem Method, you will be trained under the direct supervision of William B. Castenholz, A. M., C. P. A., former Comptroller and Instructor, University of Illinois, assisted by a large staff of Certified Public Accountants, including members of the American Institute of Accountants. You will be guided step by step through every phase of modern accounting practice—Auditing, Cost Accounting, Business Law, Organization, Manage-

ment, Finance and Income Tax Procedure. You will handle practical accounting problems lifted bodily from business life. You will be given special preparation for the C. P. A. examinations.

Send for further information regarding the opportunities in accounting; read the enthusiastic testimony of men still in their twenties and early thirties who have broken away from the low-pay ranks and today are expert accountants—with incomes ranging from \$5,000 to \$10,000 a year. With this information we will send you particulars of our *convenient-payment plan*; also a copy of that inspiring book, "Ten Years' Promotion in One." "Get this book," said a prominent Chicago executive, "even if you have to pay five dollars for it." We will send it *free*.

Mark—Sign—Mail the coupon—NOW.

LaSalle Extension University

The Largest Business Training Institution in the World

Dept. 1164-HR

Chicago, Illinois

Please send me catalog and full information regarding the course and service I have marked with an X below. Also a copy of your book, "Ten Years' Promotion in One," all without obligation to me.

Higher Accountancy

Training for positions as Auditor, Comptroller, Certified Public Accountant, Cost Accountant, etc.

Other LaSalle Training Courses

LaSalle is the largest business training institution in the world. It offers training for every important business need. If more interested in any of these courses, check here:

- | | |
|--|--|
| <input type="checkbox"/> Business Management | <input type="checkbox"/> Banking and Finance |
| <input type="checkbox"/> Modern Salesmanship | <input type="checkbox"/> Modern Foremanship and Production Methods |
| <input type="checkbox"/> Traffic Management | <input type="checkbox"/> Personnel and Employment Management |
| <input type="checkbox"/> Railway Station Management | <input type="checkbox"/> Expert Bookkeeping |
| <input type="checkbox"/> Law — Degree of LL. B. | <input type="checkbox"/> Business English |
| <input type="checkbox"/> Commercial Law | <input type="checkbox"/> Commercial Spanish |
| <input type="checkbox"/> Industrial Management Efficiency | <input type="checkbox"/> Effective Speaking |
| <input type="checkbox"/> Modern Business Correspondence and Practice | <input type="checkbox"/> C. P. A. Coaching |

Name.....

Present Position.....

Address.....

Yours Without Cost

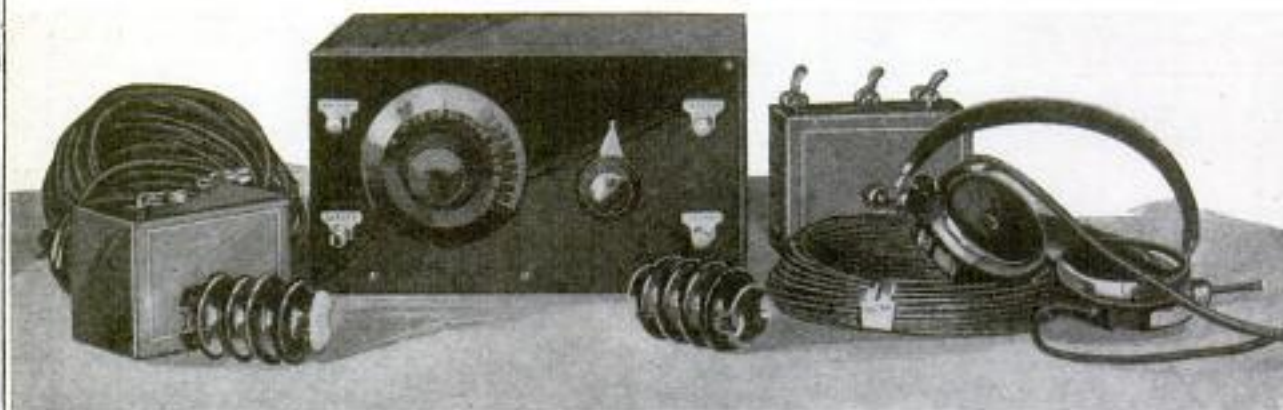

This compact one-tube (C-299) Long-distance Receiver has brought in stations 1,000 miles away while five high-power local stations were broadcasting. One dial controls all tuning. Batteries fit inside cabinet.

POPULAR MECHANICS MAGAZINE

will send you this Receiver for only nine yearly subscriptions. Accessories for this set can be obtained for additional subscriptions. This is only one of the many remarkable offers in POPULAR MECHANICS MAGAZINE'S new Radio Catalogue, which includes

SETS

1-, 2- and 3-tube Crosley
3-, 4- and 5-tube Fada Neutrodynes
5-tube Howard Neutrodynes
1-, 3-, and 4-tube Tuska Superdynes
Ozarka 3-tube Portable, 4-tube
"Junior" and 5-tube "R.C. 201"

PARTS

Low Loss Condensers
Long-Wave Transformers
Variometers Phones
Variocouplers Tubes
"A" Storage Batteries
"B" Storage Batteries

HOOKUPS and KITS

Acmeflex, 4-tube
Bremer-Tully "Nameless"
Grimes Inverse
R. C. S. Rayflex
Erla Duoflex
Superheterodynes

In fact, anything you want in the Radio Line

Do not delay. GET YOUR SET, HOOKUP, or ACCESSORIES NOW and be the first to pick up 2LO and Honolulu. Name two references on the attached coupon and we will send you Popular Mechanics Radio Catalogue and subscription outfit, free, by return mail.

Popular Mechanics Radio Offer Will Amaze You!

POPULAR MECHANICS MAGAZINE,

Room 408, 200 East Ontario Street, CHICAGO, ILLINOIS

Please send me your Radio Catalogue and subscription outfit—Free and Postpaid.

Name

Street

City State

MY TWO REFERENCES ARE:

(1) Name

Business Address

City State

(2) Name

Business Address

City State



Popular Mechanics building is devoted exclusively to the production of this great magazine.

18th Edition

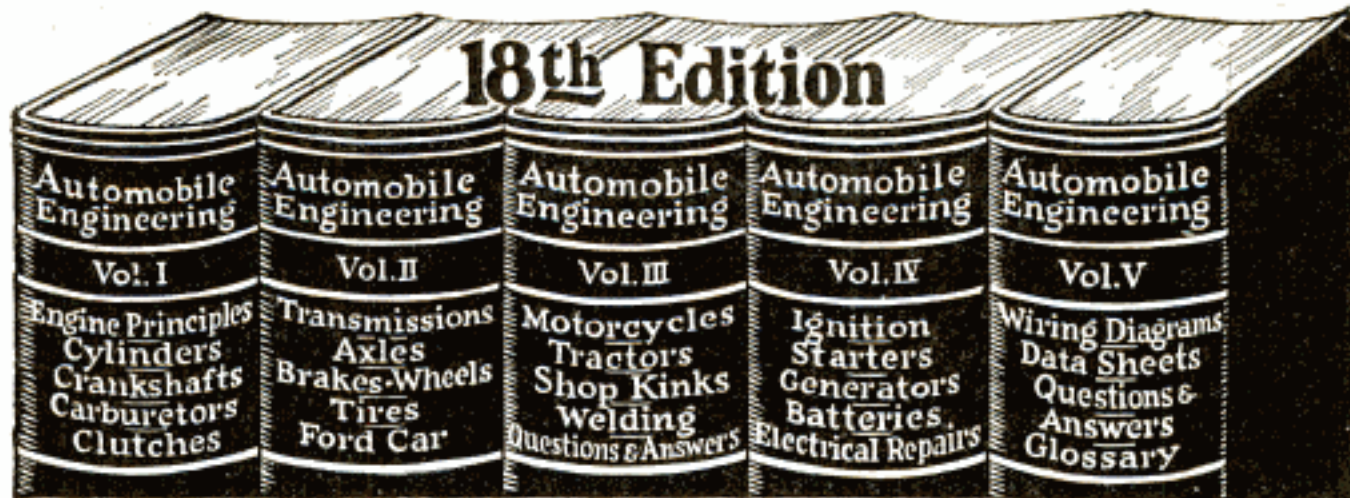

Every Automobile Man Needs These Auto Books *Yes—That Means You—Mr.*

Garage Owner—Service Station Manager—Repairman
Trouble Shooter — Car Owner — Auto Salesman

2200 pages of money-making automobile ideas. Shop kinks and up-to-the-minute repair methods are all here. Everything made clear and practical by the use of 2400 pictures, diagrams, and charts. From four-cylinder engines to straight-line eights — EVERYTHING ABOUT EVERY AUTOMOBILE IS COVERED—but that is not all—

Four Big New Features

Equipment data and specifications

(A separate sheet for each car)

all of the data covering the car's equipment. Whether you are estimating on a repair job or ordering new parts or doing the actual repair work, the specification sheet will be worth real dollars to you.

Generator output in volts and amperes—when relay should cut-in—distance relay gaps—model number for all units for ordering parts—firing order—ignition timing—breaker contacts—valve tappet distance—size of clutch and brakes—lamps—etc.

Wiring Diagrams A complete diagram of the electrical systems on all standard cars (A separate sheet for each car) shows exact location of generator—starter—distributor—ignition coil—resistance units—ammeter—starting switch—horn—circuit breaker—relay—signals and lights—fuses—battery terminals—etc. Every connection is clearly

Here at a glance will be found

indicated. More than one man has built up a paying business because he could not be "stumped" on any ignition or starting job.

Trouble Shooting "What is the matter?" It may be with the ignition—battery—fuel—lubrication—or what not. 58 causes of trouble, how to detect it, and what to do to cure it. 334 definite cures are thoroughly explained with the necessary diagrams and charts. Why the trouble occurred and how to cure it make this service feature worth hundreds of dollars to the trouble shooter or repairman.

Questions and Answers Whether you're stuck on the road or bossing shop repair jobs you have wished for a quick solution of this and that trouble—a solution that is ready-made and does not compel you to read three or four pages of explanation. In the questions and answers section every conceivable automobile trouble has been stated and the right way to correct it given.

Every automobile trouble and its cure indexed for instant reference

FREE—7 days' trial—FREE

Whether you are a garage owner, a service station manager, trouble shooter, repairman, car owner, or auto salesman, I think you will agree that the income of the average man in the automobile game is in direct proportion to his ability to make good—in short, to his knowledge of automobile principles, operations, and repairs. We claim that this work with its four new features will be worth hundreds of dollars to any man thus employed and we want the chance of proving it to you. Let us send you the complete five-volume set of Automobile Engineering for one week's free use—test the books out on any one or on a dozen jobs that have been troubling you—no matter whether on repairs, wiring systems, trouble shooting, or what not. If you do not find just the help that you need in this set, send it back to us at our expense.

Send us the coupon tonight!

American Technical Society
CHICAGO, U. S. A.

American Technical Society
Chicago, U. S. A.

Please send me a set of Automobile Engineering, for seven days' FREE EXAMINATION, shipping charges collect. I will examine these books thoroughly and, if satisfied, will send \$2.80 within seven days and \$3 a month until I have paid the special price of \$19.80. If I decide not to keep the books, I will return them within one week at your expense.

Name.....

Address.....

Reference.....

Please fill out all lines; give local merchant, banker, or employer as reference. A819 T-246

\$90 Drafting Course FREE

There is such an urgent demand for practical, trained Draftsmen that I am making this special offer to deserving, ambitious men. You get your course *Free* for getting two additional students. I will teach you to become a Draftsman and Designer until you are drawing a salary of \$250.00 a month.



Chief Draftsman Dobe

I Guarantee
To train you until you are placed in a position paying up to \$250 and \$300 a month

\$300 a Month Salary \$450 on the Side at Home

That's the kind of money my drafting students make. Read what this one says:

"As a beginner I am doing fine. Am earning a salary of \$3.00 per month, besides I made over \$450 at home the last two months, drawing plans for private parties. The practical drafting training you gave me by mail put me where I am in less than six months' study. Thank you for all your personal interest and help you gave me so far." (Signed) J. B. (Name and address upon request)

Write and I'll tell you how I make you a first-class, big-money-earning draftsman in a very few months! I do this by a method no other man or institution can imitate. I give you personal training at home by mail until you are actually placed in a position paying up to \$250 and \$300 a month. Six thousand draftsmen wanted every month.

FREE—Drafting Outfit Drawing Table

I give you a whole set of drafting tools and a drafting table the minute you become my student. Every tool you need. All you require to build your success in draftsmanship.

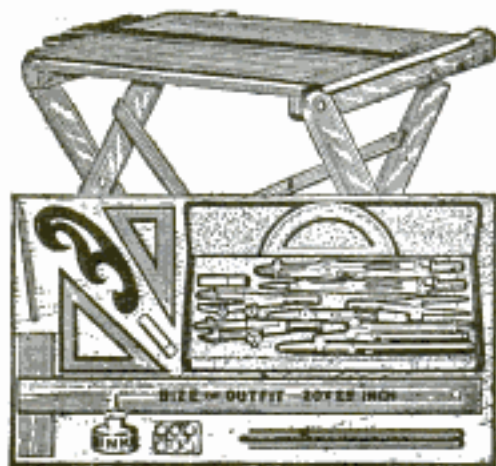

Mail Coupon Now

at once for my great book—"Successful Draftsmanship." Find out about the simply marvelous opportunities ahead now. What great salaries and possibilities there are! Send coupon TODAY!

CHIEF DRAFTSMAN DOBE

1951 Lawrence Ave., Div. 13-58 Chicago, Ill.

Without any obligation to me please mail your book, "Successful Draftsmanship" and full particulars of your liberal "Personal Instruction" offer to a few students. It is understood I am obligated in no way whatever.

Name.....Age.....

Address.....



\$100.00 EARNED BY YOUNG ARTIST IN 2 DAYS

Well-trained artists earn splendid incomes. The Federal home-study Course is a proven result-getter. If you like to draw, send for in stamps for 50-page book "Your Future."

FEDERAL SCHOOL OF COM'L DESIGNING
701 Federal Schools Building
Minneapolis, Minn.



Music Instructor

These books are illustrated and gotten up to make the method of self-teaching so simple that any one without any knowledge of music could learn to play any of the following:

SAXOPHONE	25c	MANDOLIN	25c
ACCORDEON	25c	PIANO	25c
BANJO	25c	UKULELE	25c
GUITAR	25c	VIOLIN	25c

The above prices are postpaid. 1-: Any above 5 titles, \$1.00 postpaid.
J. C. Dorn, 725 So. Dearborn St. Dept. 17, CHICAGO

21 Jewels

Nothing less than 21 Ruby and Sapphire Jewels is good enough for the Burlington masterpiece.

Quality and Style

Adjusted to the second-temperature—(isochronous)—positions. 25 year Gold Streets Case, in 100 exquisite designs. Only \$1 down. Balance in small monthly payments. Send for free book.

Burlington Watch Company
10th Street and Marshall Boulevard
Dept. 92-50 Chicago, Illinois

YOUR OWN BUSINESS

EARN \$40 to \$200 WEEKLY

Finishing Kodak Pictures. I teach this fascinating, profitable work by mail. Finish everything to start. Give sound advice. Booklet on request.

CHIPMAN SYSTEM, 104 MITCHELL BLDG., SYRACUSE, N. Y.

How to Get A Position with the U. S. Government

Thousands of appointments are made yearly. Good salaries—short hours—liberal vacations (as much as 30 days in some branches of the service). Positions open now in Washington and other cities and in Alaska, Porto Rico, Hawaii and the Philippines.

"Pull" and influence unnecessary. Common school education sufficient as groundwork for most positions. The International Correspondence Schools will prepare you right at home to pass your Civil Service examination with a high mark.

Mail the coupon to-day for 48-page Free Civil Service booklet.

INTERNATIONAL CORRESPONDENCE SCHOOLS
Box 5635-D, Scranton, Penna.

Without cost or obligation, please send me a copy of your 48-page CIVIL SERVICE BOOKLET, which tells how I can secure a good-paying position with the U. S. Government.

Name.....

Address.....

Makes \$800 to \$1,000 a Month

In business for himself doing Electrical work, John Jirinec, 1133 Fourth Ave., Astoria, L. I., New York, makes over \$10,000.00 a year.

Jumps From \$5 a Day to \$5000 a Year

This is the eighteen months' record of A. F. Klemz, 25 Chase Blk., Saginaw, Michigan. Now State Superintendent for Miller York Construction Co.

**\$30 to \$56 a Day in Business for Himself**

J. R. Morgan, 36 Prescott St., Columbus, O., formerly a \$4.50 a day mechanic now averages over \$40.00 a day doing electrical work.

Makes \$750 in Spare Time

Before completing course, John J. Burke, 3332 East Baltimore St., Baltimore, Md., made \$750 doing odd electrical jobs in spare time.

**Earns \$800 in 23 Days**

Earl R. Montrose, Mono Lake, Calif., gets electrical contract, completes it in 23 days and collects \$800.00 profit.

Automotive Electricity Pays Him Over \$750 a Month

W. E. Pence, Albany, Ore., specializes in Auto Electricity and makes \$750.00 a month. Was formerly a mechanic earning \$30.00 a week.

**\$7,000 a Year From Electricity on the Farm**

Herbert Dickerson used to earn \$30 a week. Now Superintendent of Electrical equipment at North Walls Farm, Warrenton, Va., at \$7,000 a year.

These Men are Doing It— You Can Do It Too!!! Earn \$3500 to \$10,000 a Year in ELECTRICITY

It's your own fault if you don't earn more. Blame yourself if you stick to your small pay job when I have made it so easy for you to earn \$3,500 to \$10,000 a year as an electrical expert. Electrical Experts are badly needed. Thousands of men must be trained at once. One billion dollars a year is being spent for electrical expansion and everything is ready but the men. Will you answer the call of this big pay field? Will you get ready now for the big job I will help you get? The biggest money of your life is waiting for you.

I Will Train You at Home

I will train you just like I trained the men whose pictures you see here. Just like I have trained thousands of other men—ordinary, everyday sort of fellows—pulling them out of the depths of starvation wages into jobs that pay \$12 to \$30 a day. Electricity offers you more opportunities—bigger opportunities—than any other line and with my easily learned, spare time course, I can fit you for one of the biggest jobs in a few short months' time.

Quick and Easy to Learn

Don't let any doubt about your being able to do what these other men have done rob you of your just success. Pence and Morgan and these other fellows didn't have a thing on you when they started. You can easily duplicate their success. Age, lack of experience or lack of education makes no difference. Start just as you are and I will guarantee the result with a signed money back guarantee bond. If you are not 100% satisfied with my course it won't cost you a cent.

Free Electrical Working Outfit and Tools

In addition to giving my students free employment service and free consultation service, I give them also a complete working outfit. This includes tools, measuring instruments, material and a real electric motor—the finest beginners' outfit ever gotten together. You do practical work right from the start. This outfit is all FREE.

"Cooke" Training Is Not Expensive

For a small down payment and only 17 cents a day for a few months' time you get the complete training. It's less than most men waste every day of their lives. Besides this I show you how to make extra money while you learn. Early in my course I show you how to get and how to do spare time electrical work that will pay you many times the cost of your training. Some of my students make as high as \$30 a week extra in this way.

Mail Coupon for Free Book

The coupon below will bring you my big free electrical book—over 100 interesting pictures. The real dope about your opportunities in electricity—positive proof that you, too, can earn \$3,500 to \$10,000 a year. Send for it now. Along with the book I will send you my guarantee bond and particulars of the most wonderful pay-raising course in the world. Send it while the desire for a better job and more money is upon you, to

L. L. Cooke, Chief Engineer
Chicago Engineering Works
Dept. 518
2150 Lawrence Ave. • Chicago

L. L. Cooke, Chief Engineer
Chicago Engineering Works, Dept. 518
2150 Lawrence Ave., Chicago, Ill.

Without obligating me in any way send me the "Vital Facts," your Free Book, and particulars of your Free Outfit Offer, Free Employment Service, and proof that you can fit me for a big-pay electrical job.

Name.....
Address.....
Age..... Occupation.....

The "Cooke" Trained Man is the "Big Pay" Man



High School Course in Two Years!

You Want to Earn Big Money!

And you will not be satisfied unless you earn steady promotion. But are you prepared for the job ahead of you? Do you measure up to the standard that insures success? For a more responsible position a fairly good education is necessary. To write a sensible business letter, to prepare estimates, to figure cost and to compute interest, you must have a certain amount of preparation. All this you must be able to do before you will earn promotion. Many business houses hire no men whose general knowledge is not equal to a high school course. Why? Because big business refuses to burden itself with men who are barred from promotion by the lack of elementary education.

Can You Qualify for a Better Position

We have a plan whereby you can. We can give you a complete but simplified high school course in two years, giving you all the essentials that form the foundation of practical business. It will prepare you to hold your own where competition is keen and exacting. Do not doubt your ability, but make up your mind to it and you will soon have the requirements that will bring you success and big money. YOU CAN DO IT.

Let us show you how to get on the road to success. It will not cost you a single working hour. Write today. It costs you nothing but a stamp.

American School

Dept. H874, Drexel Ave. and 58th St., Chicago

American School

Dept. H874, Drexel Ave. and 58th St., Chicago

Send me full information on the subject checked and how you will help me win success.

- | | |
|-----------------------------|---------------------------|
|Architect |Lawyer |
|Building Contractor |Machine Shop Practice |
|Automobile Engineer |Photoplay Writer |
|Automobile Repairman |Mechanical Engineer |
|Civil Engineer |Shop Superintendent |
|Structural Engineer |Employment Manager |
|Business Manager |Steam Engineer |
|Cert. Public Accountant |Foremanship |
|Accountant and Auditor |Sanitary Engineer |
|Bookkeeper |Surveyor (& Mapping) |
|Draftsman and Designer |Telephone Engineer |
|Electrical Engineer |Telegraph Engineer |
|Electric Light & Power |High School Graduate |
|General Education |Fire Insurance Expert |
|Vocational Guidance |Wireless Radio |
|Business Law |Undecided |

Name.....

Address.....

"STAMMERING Its Cause and Cure"

You can be quickly cured if you stammer. Send 10 cents, coin or stamps, for 238 page cloth bound book on Stammering and Stuttering. It tells how I cured myself after Stammering and Stuttering for 20 years. BENJAMIN N. BOGUE
6915 Beque Building, 1147 N. Ill. St. Indianapolis



MEN WANTED

Prepare as **Firemen, Brakemen, Electric Motormen,** and colored **Train Porters.** Hundreds put to work—good wages to start on. No experience necessary. **500 more wanted.** Name position you want.
RAILWAY INSTITUTE, Dept. 49, INDIANAPOLIS, IND.

No Joke To Be Deaf



—Every Deaf Person Knows That
I make myself hear, after being deaf for 25 years, with my Artificial Ear Drums. I wear them day and night. They are perfectly comfortable. No one sees them. They stop head-noises. Write me and I will tell you a true story, how I became deaf and how I make you hear. Address

GEO. P. WAY, Artificial Ear Drum Co. (Inc.)
50 Hoffman Bldg., 2529 Woodward Ave., Detroit, Mich.

PIMPLES

CAN BE CURED. If you suffer from pimples, acne, blackheads, brown spots or eruptions, I want to send you my simple home treatment under plain wrapper. It gave me a soft, velvety, smooth and radiant complexion, and cured thousands of men and women, after everything else failed. Simply send name for generous 10 day free trial offer of my secret home treatment.

W. H. WARREN, 451 Gateway Station, KANSAS CITY, MO.

STOP USING A TRUSS

Do Away With Steel And Rubber Bands

FREE TRIAL



Inner surface is made adhesive to secure the PLAPAO-PAD firmly to the body, keeping the PLAPAO continually applied and the pad from slipping. No straps, buckles or springs attached. Soft as velvet—easy to apply.

It's the Non-Slip- ping, yet Non-Rigid Pad and What is Within It That Counts

FREE to 5,000 Truss Sufferers

To the extent of 5,000 sufferers who may apply I will send, ABSOLUTELY FREE, a sufficient quantity of the Plapao to positively convince them that this is the only logical, common-sense way of treating rupture. Plapao is a highly astringent medication placed within the Plapao-Pad and being absorbed through the skin, creates a wonderful feeling of relief and at the same time tends to strengthen the weakened muscles and thus permanently close the rupture opening. The process of recovery is natural, so you'll have no use for a truss—you can throw it away forever! Old and young have testified under oath that the Plapao-Pads cured their rupture—many of them long-standing, aggravated cases—without delay from work. Patent allowed in U. S. and foreign countries. Awarded Gold Medal at Rome and Grand Prix at Paris.

Send No Money—for a sufficient quantity of the Plapao is sent without charge to enable you to give it a thorough test; you pay nothing for this trial now or ever. Write for it and full information today. Address **Plapao Laboratories, Block 1427 St. Louis, Mo.**

It Was REAL FUN

-Learning to Play the Piano in 90 Days

By a Wife

BOB'S love for me was slipping—and we had been married only 3 years. Entirely indifferent to me, he would generally spend his evenings at the club, or devote his time to his violin. I was utterly miserable in my loneliness.

One day, I made an amazing discovery that changed my life—that regained Bob's love for me. I read the story of a woman who had learned to play the piano by herself, in her spare time, in just 90 days! That made me wake up! I determined to do the same, for inwardly I thought, "Perhaps that would help!"

And help it did! Really, words can't describe the change that came over Bob when one day, a few months later, I played for him in accompaniment. Then did I realize just what music had meant to him. He loved his violin, but, as he expressed it, playing the violin was absolutely flat without the accompaniment of a piano. Today Bob and I are happily re-united, and our musical evenings are a marked success.

Play Any Instrument in 90 Days

No matter what musical instrument you're interested in, through the easy, short-cut, print-and-picture method of the U. S. School of Music, you can master it within an amazingly short time! More than 300,000 students have learned to play by mail in their spare time at home, and there's no reason why you can't.

Just think! No monotonous exercises, no heart-breaking scales—no finger technique! All the difficult, confusing, tiresome parts of music have been eliminated, and the playing of melodies has been reduced to a simple, easy-to-understand method that anyone can follow with ease.



FREE Book Explains New Method

Write for "Music Lessons In Your Own Home" TODAY. It gives you complete information about this wonderful course in music, also about our special, short-time Reduced Price Offer. With it, you also receive an illustrated folder, explaining our easy print-and-picture method. Send the coupon below TODAY. It opens the way to endless pleasure for you.

U. S. School of Music, 711 Brunswick Building, New York, N. Y.

U. S. SCHOOL OF MUSIC, 711 Brunswick Bldg., NEW YORK CITY

Please send me your free book, "Music Lessons In Your Own Home," with the folder illustrating your easy print-and-picture method, also full particulars of your special short-time offer. I am interested in the following course:

(Name of Instrument or Course)

Name.....

(Please Write Plainly)

Address.....

City.....

State.....

"BE THE LIFE OF THE PARTY"

Play a Saw

With Our Free Course of Instruction You Can
-Play in 3 Days-

Just think of it! In 3 days, without any musical ability—without knowing one note from another—you can quickly play such songs as "Long, Long Trail," "Till We Meet Again"—all the old and new time favorites—the day Saw arrives. Yes, indeed, within 3 days you will be playing all the popular songs, hymns and classical music you and your friends love. The sweet, mellow, pleasing tone from our Musical Saws you have heard in Vaudeville, over the Radio and on Phonograph Records. Now over 10,000 men, women, boys and girls are playing our Musical Saws at parties, dances, lodges, church entertainments, everywhere. Over 100 famous dance orchestras are using our Saws.

Play or No Pay

We guarantee that you can play our Musical Saw within 3 days by following our simple, easy course of instruction. The Musical Saw is guaranteed to be perfect and satisfactory in every way. If not, return in 3 days and your money will be refunded under our Bank Guarantee. The Musical Saw is specially tempered by a Special Process, to produce soft, sweet, mellow tones, obtainable from no other source under our specific guarantee.

This is your opportunity to quickly become a master Saw Musician and entertainer—the "Center of Attraction" and in demand, in your neighborhood your own town, in cities everywhere.

SEND NO MONEY

Simply send coupon today. We will send you our special Tempered Musical Saw, Special Soft Musical Hammer and Free Course of Instruction by return mail. The complete outfit is only \$4.85 C. O. D. Pay on arrival \$4.85, plus a few cents postage. Former price \$13.50. Nothing like this ever offered before. This reduction due to great demand and low producing cost.

The musical saw is one of the greatest bargains ever offered in music. Be the one to furnish the "Big Surprise" at your next party, lodge or entertainment. Rush coupon TODAY. Money back if not satisfied.

MUSSEHL & WESTPHAL, Ft. Atkinson, Wisconsin

Start a Saw Club in Your Town

Now Only
\$4.85

Former Price \$13.50

MUSSEHL & WESTPHAL
706 W. Water St. Ft. Atkinson, Wis.

You may send me the Musical Saw, Soft Hammer and Free Course of Instruction. I will deposit with postman \$4.85 plus postage. If not entirely satisfied I will return the shipment within three days and you will refund my money.

Name.....

Address.....

Shipments to Canada, Cuba, Philippine Islands, and all points outside the U. S. cannot be made C. O. D. Send \$5.25 with this coupon. We pay postage.

Earn \$100 a Week in California

COME to California, the land of sunshine and prosperity. Make big money and enjoy life. Amazing opportunities right now in this greatest retail auto center—crowded with a million cars—where one in every four owns an auto. Be an auto expert. Jobs open for mechanics, electricians, salesmen-demonstrators, lathe operators, battery experts, garage foremen, etc.—all at big pay, \$40 to \$100 a week.

We Train You for Big-Pay Jobs

National Automotive's tested system of practical shop practice guarantees your success. You benefit by our twenty years' training experience. You do actual construction work and repairs on Packards, Cadillacs, Fords, etc. Actual practice, no books. You get the training, knowledge and experience that enable you to earn big pay as auto expert, run your own business, or earn large salary and commission demonstrating and selling autos.

**BE AN
AUTO
EXPERT**



National Automotive

LOS ANGELES

ESTABLISHED 1905

Special Offer! Hurry!

For a short time only, we make this remarkable special offer. Mail the coupon now for the big, free auto book which explains everything. **Hurry!**—for not every man can qualify for National Automotive. We urge only men who are sincere and ambitious to answer this announcement. This may be your opportunity to get auto training that thousands of men endorse as best in America. **Be first to mail coupon.**

We'll help you come to California. We've done it for others, and we'll do it for you. Hundreds of men write: "I have increased my earnings 100%." "I am now making \$100 a week." "I have been promoted to salesmanager at \$6000 a year." "I have built a wonderful garage business and owe it all to National." "I have made good in California—it's the only place in the world to live."

FREE

**Wonderful
big auto
book**

Facts and figures on auto industry in California.
84 pages.
150 illustrations.



NATIONAL AUTOMOTIVE

Dept. 65, 4004 S. Figueroa, Los Angeles, Calif.

Please send me, absolutely free, postpaid, your big 84-page, illustrated auto book and full information about your special offer.

Name

Address

City State



Ford Owner

Stop that rumpus chatter on your car. MAKE 11115 TUBS!—take out your floor boards, pull your emergency brake back and forth. If you notice play at the ball joint, you need Bredar's Ball Shim. Price \$0.50. Ask your Dealer or send money order. We will ship prepaid.

Nic Bredar's Son Mfg. Co., Rock Island, Ill.

Shop Notes—50c

Nearly 250 pages of valuable ideas for everyone who likes to make things. Profusely illustrated. New volume issued each year. 14 back numbers available, 50 cents each. POPULAR MECHANICS PRESS, Popular Mechanics Bldg., Rm. 711, Chicago, Ill.



Make Money Drawing Cartoons

It's Easy To Learn When Shown In The Right Way

Some of the cleverest cartoonists and comic artists in America today learned to draw during their spare time by following **CARTOONIST EVANS' SIMPLE AND EASY METHOD**. This school is recommended by foremost cartoonists because they know the students are handled right. If you like to draw, send a sample of your work, either an original or a copy, and we will send you a **portfolio of cartoons and full details**. The course is **NOT EXPENSIVE**.

The W. L. Evans School of Cartooning 821 Leader Building CLEVELAND, OHIO

Whatever Your Question;—be it the pronunciation of Fascista, the spelling of a puzzling word, the location of Esthonia the meaning of soviet, realtor, vitamin, etc., this Supreme Authority—

WEBSTER'S NEW INTERNATIONAL DICTIONARY

contains an accurate, final answer. 407,000 Words 2700 Pages, 6000 Illustrations. Regular and India-Paper Editions. G. & C. MERRIAM CO., Springfield, Mass. "The Magic of Words" and Pocket Maps FREE if you mention Popular Mechanics.



WANTED

RAILWAY POSTAL CLERKS

\$1600 to \$2300 Year

MEN — BOYS 18 UP.

MAIL COUPON IMMEDIATELY

Steady work. No layoffs. Paid Vacations

Common education sufficient:

TRAVEL—SEE YOUR COUNTRY



FRANKLIN INSTITUTE, Dept. R179, Rochester, N. Y.

Sirs: Send me without charge, (1) Specimen Railway Postal Clerk Examination questions. (2) Send List of U. S. government jobs now obtainable. (3) Send free illustrated book, "How to Get Government Jobs." (4) Send free sample coaching lessons.

Name

Address

Will you give me 6 MONTHS? to increase Your Pay!

Your name on the coupon means "Yes"



No, I am not a wizard. I don't claim to have a "corner" on success, but here's a fact.

For fourteen years I have been helping men just like you to make more money, not just a few men here and there, but thousands of men.

Think these facts over—in just a few months time I boosted one man's pay from \$2.00 a day to over \$300 a month—another now makes as high as \$27.00 a day—another man, after securing my help, went into business for himself and, while he now hires his drafting done, he makes over \$50,000 a year.

\$275 Extra in Three Days

One man saw an ad like this—Sent in the coupon—Enrolled for the Columbia Course—and shortly after he received \$275 for one drawing that he made in his spare time in three days.

Do you make money like these men do? Does the money in your pay envelope get you the things you really want or just enough to make you wish you, too, could have the good things of life that other men have—money, independence, success, happiness?

MAKE \$50 TO \$100 A WEEK

Columbia will train you to be an expert Draftsman in your spare time at home by mail. There's a lot of room for you if you act now. This doesn't mean that you will be just an ordinary Draftsman, but a finished, Professional Draftsman, able to hold your place among the highest paid Draftsmen in the land.

PROMOTION IS QUICK

We'll qualify you for a high salaried position in the Drafting field and keep you in touch with openings for Draftsmen in the big machine shops, industrial plants and United States Government departments. Men who start as Draftsmen are often advanced to Chief Draftsmen, Chief Engineers, Production Managers, and so on. Many of my graduates are today holding such positions as a result of my help. These positions pay big money and lead on to executive positions of the highest type. Thousands of men have found Drafting to be the stepping stone to some of the biggest positions in American industry.

GET THE RIGHT TRAINING

I started this school years ago. Today it is a solidly established nationally known institution, with graduates all over the world. I stand personally in back of the Columbia School of Drafting and back of every promise, every state-

ment we make. You get the right training when you enroll at Columbia. You spend no time on long winded theories. You start on actual drawing work the day you receive your first lesson. You get right down to brass tacks and there is no lost motion, no waste time or effort at any stage of the course. From the very beginning you can feel yourself making progress, the kind of progress that makes you confident of yourself and sure of your success.

YOU NEED NO PREVIOUS TRAINING

This course of mine is easy to understand and easy to follow. It is designed for men who must have the best and who must get the right training quickly, so as to be able to make more money as soon as possible. Many of my students are qualified, even before they complete the course. Many a man has increased his pay so soon after enrolling that his course has actually cost him nothing.

SUCCESS CALLS MEN OF ACTION ONLY

If you are a man of action—if you want success bad enough to reach out and grab it, clip the coupon now and show me that you are a man of action. Keep right on top of this opportunity to make real money. Don't go looking for a pair of scissors, tear the coupon off and mail it right away. Get started now.

What I Give You

Free Book. Send in the coupon today. I will immediately send you our book "Drafting—Your Success" which tells about Drafting and its opportunities and contains proof that I can raise your pay. **Free Subscription to Drafting Publication "The Compass."** I will give you free a subscription to our helpful, inspiring publication "The Compass."

Practical Problems. You will be carefully coached in practical Drafting work.

I Help You Get a Job. I will help you get a position as a practical Draftsman and will give you real, personal help, such as I have given to thousands of others.

Personal Instruction and Supervision, throughout the Course. You will receive the personal instruction and help of Roy C. Claflin, President of the Columbia School of Drafting and a practical Draftsman of many years experience.

Draftsman's Equipment. I will furnish you with a full set of first class drawing equipment and Drafting instruments, as shown in the picture below, when you enroll. You keep both sets on completing the course.

Consultation Privileges. You are free to write me at any time for personal advice and suggestions regarding your progress.

Diploma. The diploma I will give you on completing the course attests to your proficiency as a Draftsman. It is an entering wedge to success.

Advice Regarding Government Positions. The following are a few of the many positions open in the Government Departments from time to time. The salaries are starting salaries, subject to increase:

Architectural Designer — \$4,000 a year.

Chief Draftsman, Naval Aircraft

Factory—\$15.04 a day.

Aeronautical Draftsman, Field

Service Navy Department —

\$5.20 to \$12.50 a day.

We will advise you as to other

government openings from time to time.

COLUMBIA SCHOOL OF DRAFTING

ROY C. CLAFLIN, President

Dept. G-100, 14th and T Sts., N. W.,
WASHINGTON, D. C.



FREE DRAFTING OUTFIT

We give you free with our course this professional Drafting outfit. It is yours to keep when you complete the course.

FREE BOOK COUPON

COLUMBIA SCHOOL OF DRAFTING
Dept. G-100, 14th and T Sts., N. W., Washington, D. C.

Please send me without charge your free illustrated book on Drafting, telling me how I can secure your help in securing a position as Draftsman. Also enter my name for free subscription to "The Compass."

Name.....

Address.....

City.....State.....

If you have any of these symptoms— Watch Out!

If you have "just a little cold," a "trifling indigestion," or some other small ailment, *don't neglect it*, for it probably means that some serious trouble is trying to get a foothold in your system.

When you realize that most cases of fatal tuberculosis start with catching a "little" cold, you have to admit that even the smallest bodily disturbance is really a DANGER SIGNAL.

Fatal Illnesses Often Develop Almost Unseen

Pneumonia, kidney diseases, tuberculosis, influenza, intestinal disorders and other *preventable* diseases will kill 800,000 people this year, simply because people do not realize the seriousness of "trifling" ailments until it is TOO LATE! A large proportion of these victims of ignorance would not have died if they had known *at once* what the danger signals meant, and how to treat themselves.

Learn to Recognize the First Signs of Disease

Get This FREE BOOK

Bernarr Macfadden, "the Father of Physical Culture," has made it possible for you to protect yourself and your family easily, through his latest, greatest work—"The Encyclopedia of Physical Culture." It will show you how to interpret all symptoms and how to apply effective measures for relief and prevention, without using a single drug. It will teach you to enjoy such health as you have never known before.

Whether you are now sick, or *apparently* quite well, you should not miss getting this remarkable book, "The Most Valuable Thing in the World." It gives you a complete synopsis of Macfadden's wonderful "five-volume education" in healing and body building. And it also gives several *remarkable tests for you to take, in order to determine where you now stand physically.* This splendid, big book is sent free, without obligation. Satisfy the curiosity you feel by mailing the coupon below, right away.

Macfadden Publications, Inc.
1926 Broadway, Dept. 411
Macfadden Bldg.,
New York City



Please send me, free and postpaid, a copy of your book, "The Most Valuable Thing in the World," containing the revealing physical tests. It is understood that this does not obligate me in any way.

Name.....
Address.....
City..... State.....

LOOK YOURSELF OVER NOW

**Catarrh
Colds
Indigestion
Constipation
Headaches
Biliousness
Rheumatism
Nervousness
Neuralgia**

Read Jimmy De Forest's Book



The world-famous trainer and conditioner of Jack Dempsey, Louie, Firpo, Roosevelt, Albert Hubard and many others has written "Physical Fitness and the Pay Envelope," a book for ambitious men.

De Forest bases his book on the accepted fact that the physically fit man commands the big income. It's full of meat. You come to cover postage and mailing brings you a copy.

Jimmy De Forest Physical Training System
347 Madison Ave., Dept. 47, New York City

SEND FOR IT!

DRAW FACES AND FACE THE FUTURE

with a pleasant and profitable profession. Anyone can learn rapidly thru the new courses by mail, evolved from our resident school. Individual criticisms given. There's big money in becoming an expert artist or cartoonist. **Send 4c in stamps for FREE SAMPLE LESSON and complete outline of courses.**

THE OHIO SCHOOL OF COMMERCIAL ART
1763 Euclid Ave. Cleveland, Ohio



Choose as Your Profession ELECTRICAL ENGINEERING

Electricity offers a brilliant future to the young man who is about to choose his career. Never before has there been such wonderful opportunity in this great field. Big paying positions in electrical work the world over are open to trained men.

B. S. Degree in 3 Years

Come to School of Engineering of Milwaukee. Here you are trained in both theory and practice by a faculty of experts. You learn in large, finely equipped laboratories. If you have 14 high school credits or equivalent, you can become an Electrical Engineer with a Bachelor of Science degree in 3 years. If you lack these credits they can be made up in our Institute of Electrotechnics in a short, intensive course.



A Complete, Practical, Electrical Education

Learn by the thorough approved scientific methods which our nineteen years of specialising enable us to give you. In addition to Electrical Engineering, the following complete courses are given: **A. C. and D. C. Armature Winding—Wiring and Testing—Practical Electricity—Drafting—Electrotechnics—Commercial Electrical Engineering—Automotive Electrical Engineering and Automotive Electricity.**

EARN WHILE YOU LEARN

You can earn money to help defray your expenses while learning. Our wonderful co-operative plan brings an Electrical Career within the reach of every ambitious man. Our Free Employment Department secures positions for those students who wish to earn part or all of their expenses. In addition, the Department will help you get a good position in the Electrical industry when your training is completed. The new Students' Loan Fund offers financial aid to worthy men. Daily Broadcasting W.S.O.E.

New Term Opens Nov. 10th

Big Book FREE Mail the coupon today for our big new illustrated catalog. Mention the course that interests you most and we will send you special information. Read about the school that trains men for practical and quick success. See how easy it is for you to get the training that will enable you to step to a splendid position and a handsome income. Mail the coupon right NOW. No cash or obligation.

SCHOOL OF ENGINEERING OF MILWAUKEE

Dept. P.M. 1124 415 Marshall Street, Milwaukee, Wis.

School of Engineering of Milwaukee
Dept. P.M. 1124, 415 Marshall St., Milwaukee, Wis.

Please send me your free illustrated catalog; also details of your "Earn While You Learn" plan.

Name.....
Address.....
Town..... State.....
Age..... Education.....
Course Wanted.....

You! can be a \$5000 Auto Expert!



Garage Owner or Manager

Automotive Expert

Automotive Electrician

Salesman, Demonstrator

"What Big-Pay Work Can I Learn Quickest?"

LOAN me an hour of your spare time a day! I'll guarantee to put you in the \$100.00 a week class quicker than you can learn any other big-pay work! **Don't quit your job! Stay home!** Thousands of men no better than you are making big salaries, holding down important jobs, earning enormous profits in their own business. I know how you can do the same, and I'll tell you how!



R. G. DASBACH, "Dash"

Formerly Mechanician
for Barney Oldfield now
Directing Engineer
for C. A. I.

I give you this Tool Kit FREE
and train you to use it



18 Piece Master Mechanics' Tool Kit FREE!

This Complete outfit doesn't cost you one penny! Full size, everything you need to do the "Jobs." 25 lessons, 150 Jobs, 12 lectures and many Free features in the C. A. I. course, and "Cigarette Money" pays for it!

"THE C. A. I. JOB-WAY
TO BIGGER PAY!"

LEARN AT HOME

Learn Auto Repairing! Learn Automotive Electricity! Learn Vulcanizing, Welding, Battery!

My copyrighted "Job-Way" system teaches you in an hour what ordinarily takes a month to learn! The speed with which C. A. I. students get ALL the work of the complete course has astonished educators everywhere! So simple a school-boy can understand it. Think of it! 15,000,000 autos to repair each year—15,000,000 batteries to service—15,000,000 ignition systems to keep going—65,000,000 tires to sell and repair—3,000,000 trucks to overhaul. Do you realize how hungry employers are for competent men? Do you know what they're willing to pay for Automotive Experts? Can you imagine the opportunities today to make big money in a business of your own?

Coupon Brings FREE BOOK and FREE LESSON!

I don't ask you to risk a penny. I know you can learn to earn \$3,000 to \$8,000 a year as an Automotive Expert. So I guarantee in writing to return every cent of your money if you don't think it's the most profitable investment you ever made. I want you to send for my free book, read the free lesson, find out about my wonderful "Job-Way" method. See why I offer this complete Automotive course for the least money, and on easiest payments. Mail Coupon or postal today!

MEN WANTED!

Thousands of big-pay jobs open right now, all over the U. S. Our Employment Service FREE to both students and graduates, reaches employers in every part of the Country. Look at this:

Master Mechanics	\$3,000 to \$8,000
Electrical Experts	\$3,500 up
Garage Manager	3,000 up
Battery Expert	2,400 up
Expert Welder	2,400 up
Salesman	3,000 up
Tractor Engineer	2,400 up

My graduates earn money fast enough to go into business. Own your own Garage, Battery Station, Lamination Service, Repair or Welding plant.



Mail Coupon for
FREE BOOK!

Bigger-Pay Coupon!

R. G. Dasbach, Directing Engineer
Chicago Automotive Institute
Dept. 1778 536 So. Clark St., Chicago

Without a penny of expense or the slightest obligation, please send me Free Book about your rapid course in Automotive Master Mechanics, and Free Tool Kit offer. Explain your money back guarantee. I want to see a Free Lesson, too.

Name.....

Address.....

.....

CHICAGO AUTOMOTIVE INSTITUTE

Dept. 1778, 536 So. Clark St., CHICAGO

LEARN AT HOME THE C.A.I. JOB-WAY



FREE!

This Ad-Writer's Wonderful Working Outfit

Yes, FREE, to you, a complete Ad-Writer's Working Outfit! Not a penny to pay. You get this superb outfit as a FREE gift on our sensational new offer. We want to interest 5,000 more men in the great profession of ad-writing. The field needs more good men and needs them badly. We want to interest 5,000 men quickly in the opportunity—hence this amazing free offer. The 5,000 ad-writer's outfits will go fast. Immediate action is necessary if you want one free. Mail coupon today for full details.

\$200-A-Week Ad-Writers Use the Same Tools

These are real ad-writer's "tools"—the very same kind used by the men who are getting \$100, \$200, \$300 a week. There's inspiration in handling these instruments. You work at your best. "Just the thing," say successful ad-writers, "to start ad-men off right."

Learn the Business of Advertising

Advertising is the best paying profession in the world. Statistics prove it. One ad-writer, formerly a book-keeper, makes over \$1,000 a week. Another, an ex-shophand, earns over \$200 a week. Scores step right into Ad-writing from other lines. No special "gift" required—just common sense plus some training. Let Page-Davis experts train you—by mail. Learn in your spare time, how to lay out and write ads that "ring the bell."

Now! Mail the coupon for our FREE Ad-writer's working outfit offer. Don't delay—thousands will speak for one of these outfits. Only 5000 to be given free. Get the coupon in the mails today. It brings also full information on the famous Page-Davis Course in Advertising—postpaid and free. No obligation. ACT NOW.

Free Coupon

Page-Davis School
Dept. A47, Chicago, Ill.

I want an Ad-Writer's working outfit free. Give me the details of this offer and also particulars of your course in Ad-Writing. This places me under no obligation.

Name

Street and Number

City.....State.....

All These Articles FREE!

- 1 Drawing Board
- 1 T Square
- 2 Triangles
- 2 Drawing Pencils
- 1 Double Line Ruling Pen
- 1 Single Line Ruling Pen
- 1/2-Dozen Thumb Tacks
- 20 Sheets of Drawing Paper
- 1 Ad Rule
- 1 Binder
- 1 Compass
- 50 Envelopes (Self-Addressed)
- 50 Sheets of Paper
- 1 Eraser
- 1 Bottle Higgins India Ink
- 1 Bottle Red Ink
- 1 Bottle Library Paste
- 1 Straightline Rule
- 1 Pair 6-in. Shears
- And Other Useful Articles

Page-Davis School

Dept. A47
Chicago Ill.

LEARN TO BE A MAGICIAN



Be popular in every crowd. It is a natural desire for all to make themselves agreeable and entertaining. A Magician is always the center of attraction, the life of a party, sought after and invited everywhere. Be able to give exhibitions at clubs, parties, lodges and theatres. No need to devote years of study and practice to be a magician. You will be entertaining your friends before you realize it. To

prove what we say we will send you free 12 easy and startling Magic Tricks and teach you how to perform them. Send only 25c to cover postage, packing, etc. Our catalog is free. A. P. FELSMAN, Dept. 12, 28 East Monroe St., Chicago, Ill.



Be An Officer in the U. S. Coastguard \$1700 Up to \$7,500 Yearly

You get \$780 yearly at the U. S. Academy while training. You rank Ensign to Captain in service. We Guarantee to prepare you in time for Academy Examinations. Write Dept. K-14 for free information.

COASTGUARD PREPARATORY SCHOOL
1953 Pa. Ave., N. W. Washington, D. C.

Build a Boat Popular Mechanics Boat Book tells how to make 21 kinds of boats and canoes. Fully illustrated. You can build a boat any time of the year. Many do the building in winter. Price 50 cents. POPULAR MECHANICS PRESS, Popular Mechanics Bldg., Rm. 711, Chicago, Ill.

I make Champs

I can do for you what I have done for thousands in every branch of athletics—whether it be for pleasure or as a profession, I can guide you. Ask Charles Daniels, champion swimmer, Tim Jordan, home run hitter, Oswald Kirby, former golf champion, Harry Babcock, World's champion pole vaulter, and

28 Champs to my Credit



a long list of others. They will tell you that my system always starts a man right and keeps him right. My system never fails. Over 25 years as a trainer in all branches of sports is my record—and I can still make the present day record holders step some to keep up with me.



"Pep Up"—Let Me Help You
I hold the all-around world's championship. Picture No. 1 is a photo of myself. It shows my perfect body development. I don't just develop you so that you can show off. I pep you up, so that you are better able to do your daily work. I don't try to make you do something you don't like. I let you pick the exercise or sport you like best—whether it be body development, boxing, golf, running, swimming, baseball or any of the fifty other sports. I tell you how to become perfect in the sport of your own choice. When you get fun out of something, you surely get all of the real exercise, body development and liberating no amount needs. I actually guarantee to make you expert in the sport you select. You will find several sports pictured here, but these are only a few of the many I can help you in.



Booklet FREE
Write me telling what sport you are interested in and I will advise you personally and send you a booklet describing your needs and my system. Do it now. My system never fails.



DR. P. M. SEIXAS

SEIXAS ATHLETIC SYSTEMS, Inc.

Suite 503T, 280 Broadway, New York

Please send me Free Booklet by return mail. I am interested in..... This obligates me in no way whatever.

Name

Address

City.....State.....

EVEREADY Radio Batteries

-they last longer



EVEREADY RADIO BATTERIES FOR EVERY RADIO USE

Each one supremely economical and efficient for the use for which it is designed—each one made under the supervision of the world's greatest electro-chemical battery laboratory

Eveready "B" Batteries

THERE are Eveready Batteries for portable sets where small size and light weight are more important than long life. There are Eveready medium size batteries that come between the small and the large sizes. There are Eveready large size "B" Batteries that afford maximum economy and reliability of service when used with average one, two, three or four tube sets. And now there is a newer Eveready heavy duty, extra large size "B" Battery that gives similar economy to owners of multi-tube heavy drain receiv-

ing sets and power amplifiers.

For maximum "B" Battery economy, buy Evereadys, choosing the large sizes (Nos. 766, 767, 772) for average home sets, and the heavy duty, extra large (No. 770) for multi-tube heavy drain receiving sets and power amplifiers. For portable sets choose the Eveready No. 764 medium size, unless space is very limited, in which case choose the Eveready No. 763 small size "B" Battery.

Eveready "C" Battery

Eveready makes a long-lasting "C" Battery with terminals

at 1½, 3 and 4½ volts. May also be used as an "A" Battery in portable sets.

Eveready "A" Batteries

Eveready offers you "A" Batteries for all tubes, both storage and dry cell. For storage battery tubes, use the Eveready Storage "A." For dry cell tubes, use the Eveready Dry Cell Radio "A" Battery, especially built for radio use.

Manufactured and guaranteed by
NATIONAL CARBON CO., INC.
Headquarters for
Radio Battery Information
New York San Francisco
Canadian National Carbon Co., Limited,
Toronto, Ontario

BUY THEM FROM YOUR DEALER

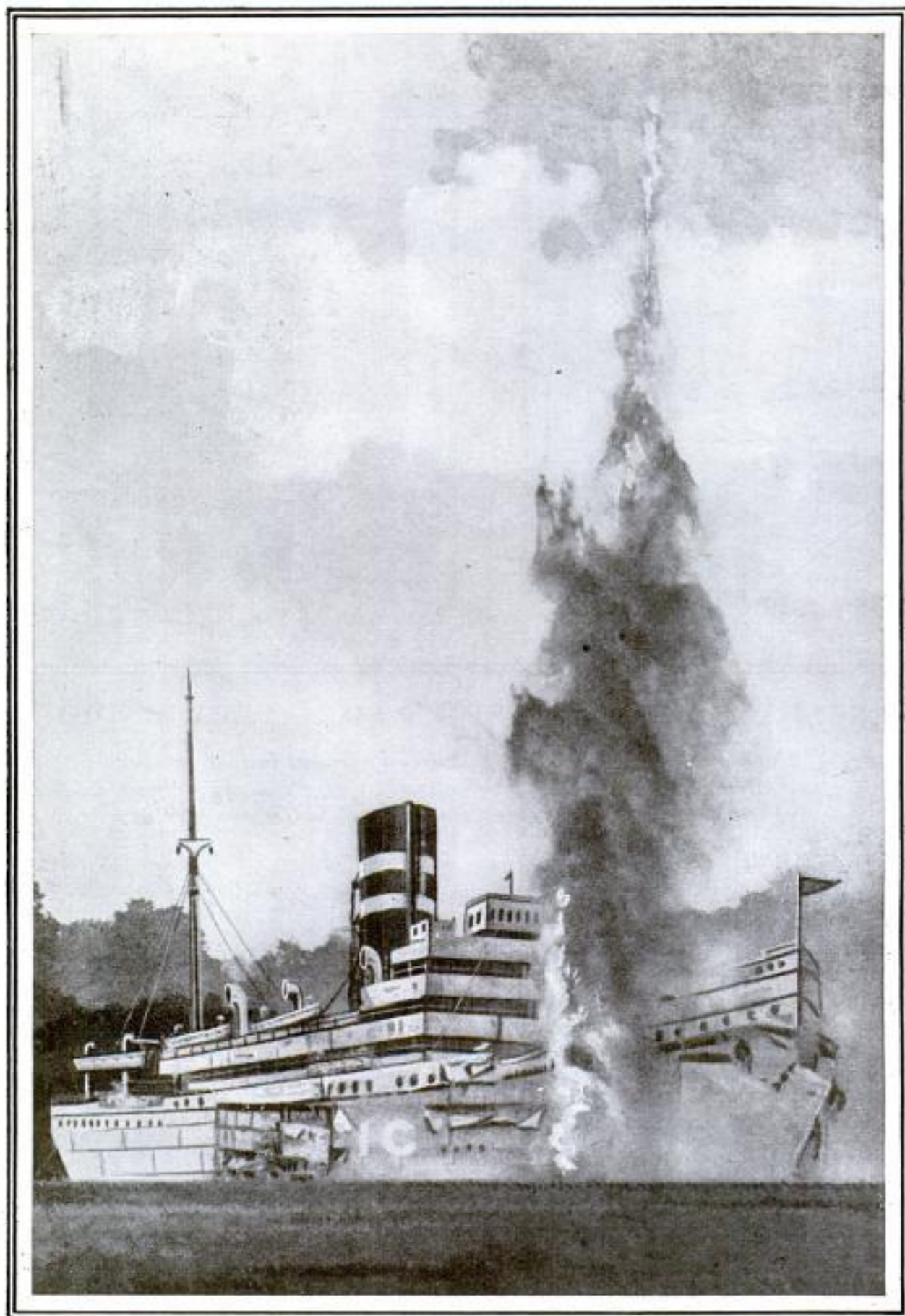

Aerial Bomb Finds Its Mark during Exhibition by British Air Force; the Imitation Naval Fight Was Staged on Land and This Target "Rode the Sea" in a Wide Meadow—See Page 810

Popular Mechanics Magazine

REGISTERED IN U. S. PATENT OFFICE

WRITTEN SO YOU CAN UNDERSTAND IT

Vol. 42

NOVEMBER, 1924

No. 5

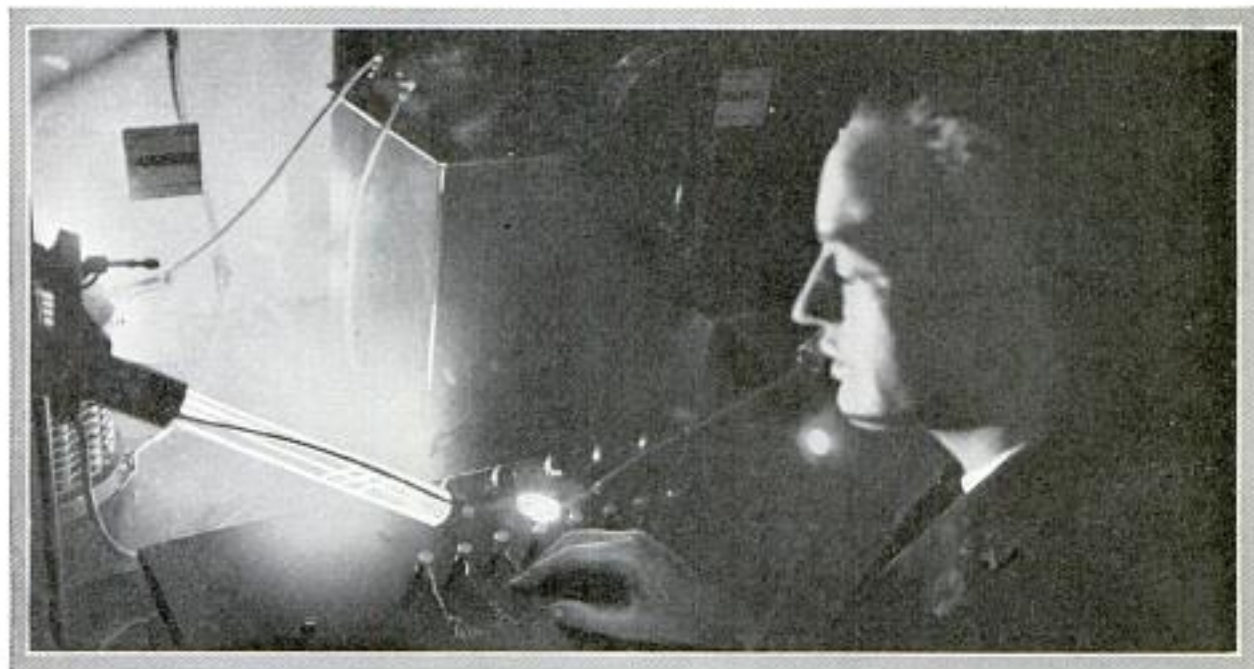

Shooting a 25,000-Volt Spark before the Eyes of a Motorist Alone in a Darkened Cabinet to Test His Nerve and Power of Self-Control

Mind Tests Given Automobile Drivers

Queer Instruments Are Designed to Reveal Judgment, Power of Self-Control and Reaction to Fear

SCIENTIFIC tests for the selection of automobile drivers and designed to eliminate the mentally unfit and the reckless man, have been perfected by Dr. A. I. Snow, consulting industrial psychologist for the National Association of Taxicab Owners.

These tests measure the prospective driver from three angles, intelligence, carefulness and reaction to sudden danger. After getting a job as a driver and operating a cab for some time to study his fellow drivers and their problems, Dr. Snow, who is a member of the department of psychology of Northwestern University, is now applying his tests to the 5,000 drivers of a large taxicab company. The secret of the "fear test," showing the driver's reaction to sudden danger, is closely guarded by Dr. Snow and his associates, in order to keep the drivers off guard when they take it. In the tests,

the driver is cautioned to avoid certain things which, however, have no bearing on the result. This is to divert his mind from more important details.

A high-frequency machine, developing 25,000 volts and operating at several million cycles, is used. The driver being tested is placed before the machine in a tiny dark room. Two foot pedals on the floor correspond to the operating pedals of the car. The driver's left hand is placed on a telegraph key, which closes the circuit to a tiny red lamp on a switchboard in front of him.

By the light of the small globe he is required to manipulate a series of wires, sticking the ends into binding posts and screwing down the tops to hold them. As each connection is made by the driver's right hand, another red globe lights and a tiny telltale light on the control board outside the booth flickers to record the

Evanston, Ill.

163/706

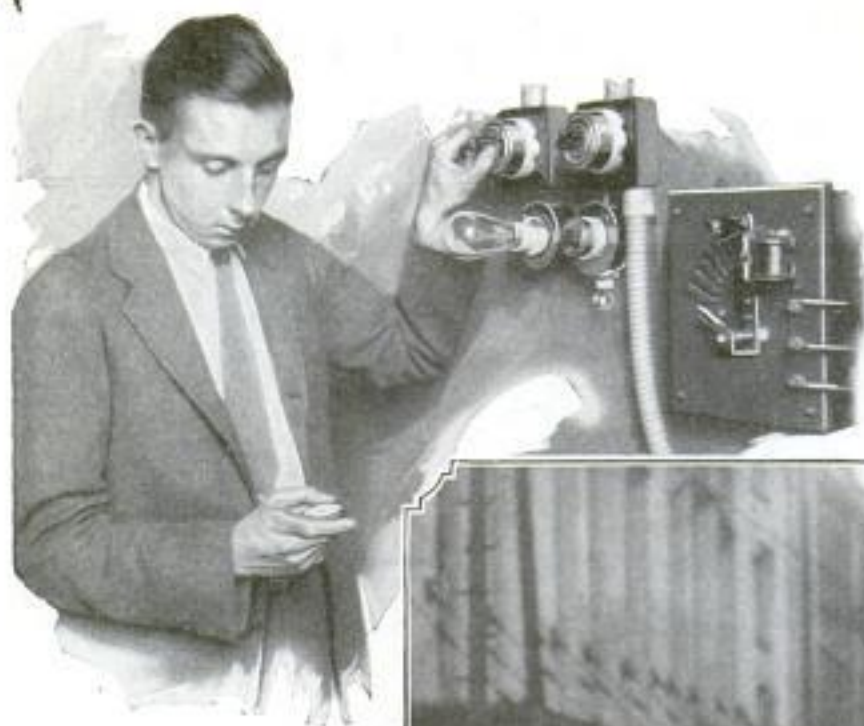

fact. The telltale burns only when the man in the test booth has both feet and hands in the places assigned. After a few seconds the operator outside turns a switch to the high-frequency machine and a brilliant blue spark leaps across a gap a few inches from the startled chauffeur's nose. Another and larger spark sputters within the glass-fronted cabinet of the machine and a third darts toward the hand resting on the telegraph key.

The driver is instructed when anything happens to startle him, to remove hand and feet from the controls, step on another pedal and turn a switch with his right hand. As soon as the pedal is depressed and the switch turned the electrical discharge stops. The operator outside, armed with a stop watch, records the time elapsing between the instant the test is started and the time the driver reacts properly. A written test is given to measure the applicant's intelligence, memory and capacity to observe things and follow simple directions. The test, patterned much along the lines of those given in the army during the war, requires twelve minutes and may be given to large classes of a hundred or more at a time or to individuals. "We eliminate persons of weak

mentality at the start through this test," Dr. Snow explains. "The examination is simple, showing whether the man has a normal mentality, can follow simple directions, solve very simple problems, can adjust himself to new situations, whether he can learn simple things and whether he can pay attention when sub-



Timing the Chauffeur's Reactions at the Controls Outside the Dark Room, and an Emergency on Slippery Streets Where Quickness Wins

jected to slight distractions." The test problems include simple exercises in dividing lines into specified groupings of equal or unequal parts; simple problems of arithmetic; a memory test in which pictures of a dozen objects, including a house, man, girl, dog, hand, etc., are exhibited for ten seconds and the driver is then required to write down the names of as many as he can remember.

The third part of the examination is unusual. Thirteen objects are placed, according to a carefully worked out scheme, on one table and the driver is instructed to transfer them to three smaller tables. One small table has a pan of water for a top, the second has a lighted candle in the center and the third is built with legs askew so that it will only sustain light weights. The test is designed to show the subject's intelligence in picking light ob-

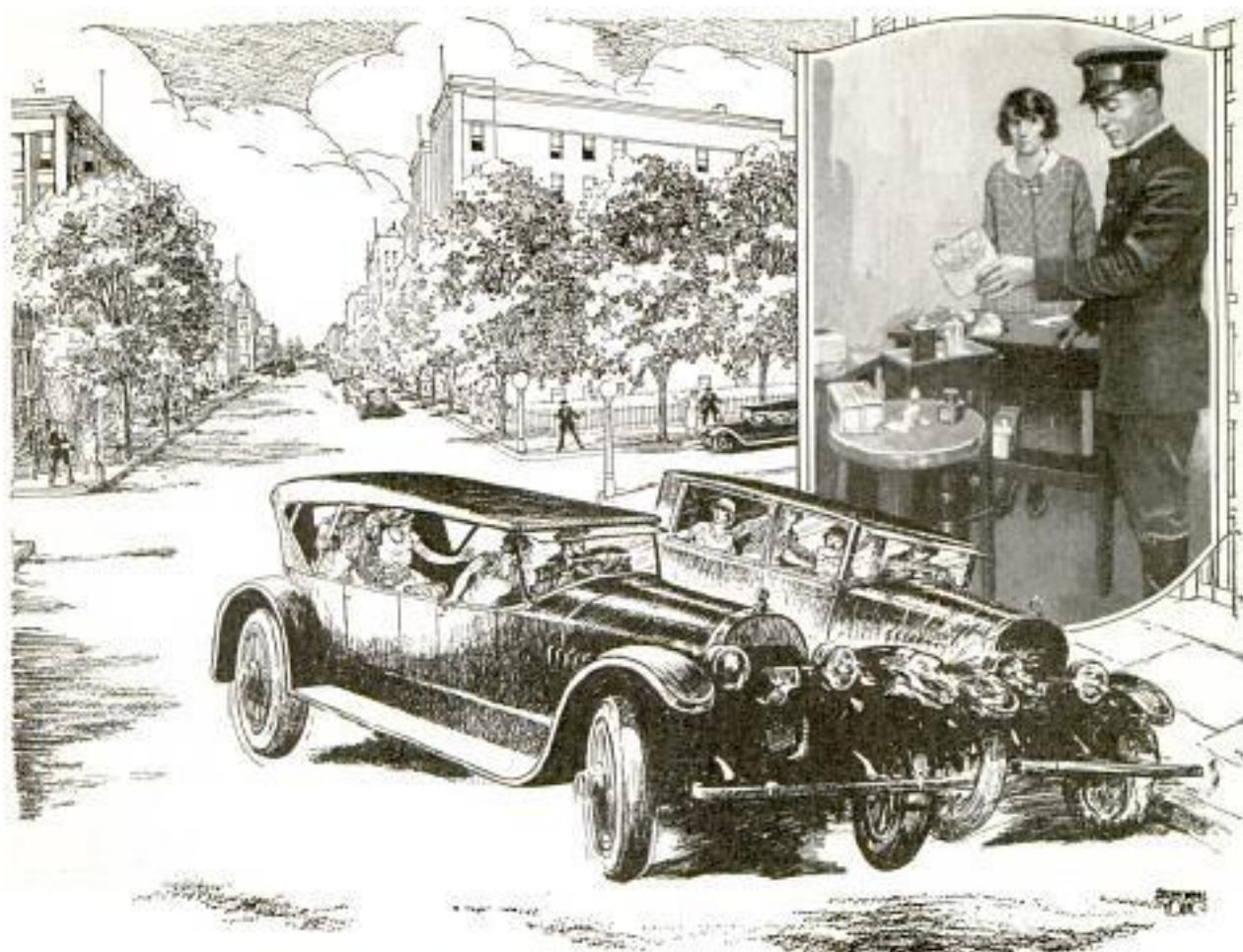

A Fear Test Would Have Shown Whether These Drivers Could Keep Their Heads; Inset Shows Laboratory Assistant Giving Judgment Test to Taxicab Driver, Using Trick Tables

jects for the weak table, noncombustibles for the table with the candle and waterproof articles for the third. The objects used in the test include a bar of soap, a picture, book, lamp, pound box of butter, bottle of gasoline, a small can, box of eggs, bottle of ink, bottle of oil, sack of sugar, sack of flour and a small bottle. An additional test is being developed in which the driver is given a problem in choosing the quickest and safest route between two points. A large brass plate has been designed, with a starting point in the upper left-hand corner and a destination point in the lower right-hand section. Between the two run four

curved and winding paths, cut through the brass. The first, and shortest path, is very narrow and each of the others is wider, the longest being the widest of all. Along the sides of the paths at intervals



Dr. Snow, the Inventor, Giving Fear Test to Driver, Showing Apparatus Outside of Dark Room

projections imitate other cars. The driver is given a brass pencil and told to trace the path by which he can reach the destination in the least time with the greatest safety. He is warned that each time his pencil touches the side of the path or one of the "cars" along the route he will receive an electrical shock and an automatic counter will record the "accident." An automatic clock likewise records the

163 | time of starting and the time of arrival. While the clock and counter are visible to the driver, most of the value of the test, according to Dr. Snow, lies in a moving roll of paper, which is passed under the plate by clockwork. The moving paper records the path of the pupil's pencil and, with the sheet advancing at a fixed speed, shows the time taken to traverse any section of the path.

"The applicant does not need to be an intellectual heavyweight to pass these tests," Dr. Snow says, "but he must be able to carry out simple directions, recognize objects under unusual conditions, learn simple things and have a normal memory. The person of very low intelligence is quickly discovered and eliminated.

"Intelligence, however, is not the only qualification for a safe driver. A man may have a very alert mind and at the same time be naturally careless or reckless. These two failings are largely a matter of nature and training—or rather lack of training.

"Even if a man is naturally careful he may lose his head in an emergency. To determine his presence of mind, he is told to operate the electrical board, which may give him an unexpected scare. The driver's quickness and steadiness under this test give an accurate estimate of his ability to meet the emergencies of modern street traffic. If a driver passes all three tests satisfactorily, he is presumed to be a safe and competent person to operate a taxicab. While these tests have not yet been developed to the stage where they can be considered infallible, re-

sults of experiments already conducted indicate their value. When the tests made of drivers for one company were checked against the accident records of these men, it was found they tallied in more than 90 per cent of all cases. Many changes in detail are being made in the tests before making them available for general use, but their correctness in principle has been established."

In addition to the special tests, Dr. Snow has also made an investigation of the accident records of 2,000 drivers to determine whether the fact that a man was single without dependents, married, or single with dependents, made any difference in his qualifications as a driver. The investigation disclosed that there was no difference in the records, upsetting the old belief that a married man was a steadier and more careful driver.

An investigation is now being made from the accident records of 5,000 drivers to determine whether the belief of the taxicab owners that men of certain races think more quickly and make better drivers than men of more stolid races is in fact true. It represents the first study into racial characteristics in relation to mental equipment of chauffeurs.



Chauffeurs Who Pass Psychological Tests Are Expected to Think Quickly in Emergencies, as When Street-Car Passenger Trips While Alighting and Falls in Front of the Taxicab



A Modern Version of the "Seven-League Boots"; Swift and Sturdy Three - Wheeled Roller Skates Being Demonstrated on Rough Side Hill with and without Staves, by Enthusiastic German Sportsmen



Closer View of Side-Hill Jump Showing How Skates Are Attached, and Rubber Tires

Land Skates Run on Rough Ground —and Rival Ski Jumpers' Feats

Feats that rival those of the ski jumpers or snowshoe devotees are said to be possible on a new style of roller skate being manufactured for sportsmen in Germany. They have a broad support for the foot and three rubber-tired wheels, two in front and one behind, and are said to be well adapted to traveling over rough ground, a speed of seven and one-half miles an hour on uneven surfaces being common and ten miles an hour on pave-

ments easily achieved. Coasting on side hills and jumping either with or without staves are possible with the skates because of the ease with which they roll over rough country. The pair weighs about seven and one-half pounds.

Grub of Beetle Lives Thirty Years without Ever Growing Up

After living thirty years without undergoing transformation into an adult, the grub of an unknown species of beetle died recently in an English museum. For six years, the odd specimen had been kept in a pencil case, and been in the care of a special keeper with whom it had traveled nearly halfway around the world.

Cont. W. B. West
710 200 Broadway
New York City

Cont. Laura Jane
Livshis, 30 E
Ontario, Chicago

Eighty-Mile River Run into Funnel to Produce Electricity

World's Yearly Fish Catch Valued at About Billion Dollars

1698
Pouring the surplus water of the Deerfield river down a giant funnel, with a mouth 160 feet across and a twenty-two and one-half foot shaft below, has been accomplished at the Davis Bridge power

1712
The fish catch of the world approximates a billion dollars a year in its cost to the final consumer, according to estimates. Twenty-five per cent of this amount is allotted to the cost of cold storage, transportation and the profits of retailers and wholesalers. Japan leads all other nations in the value of its catch with a total of \$89,000,000; the United States is second with \$86,000,000; France is third with \$85,000,000, and Spain fourth with \$72,000,000. Of recent years, there has been a large increase in the amount of capital invested in the industry. Since 1908, the total for the United States alone, exclusive of Alaska, rose from \$38,000,000 to \$60,000,000. Most of the world's fish supply comes from the shallow "banks" adjacent to the shores of the continents.

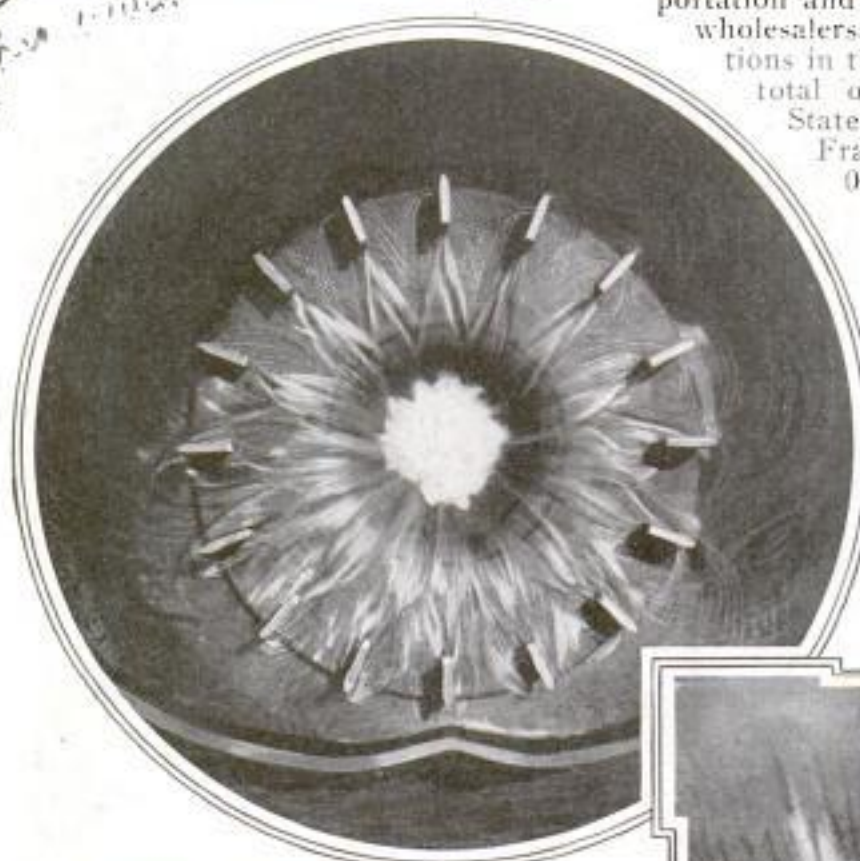

Model to Illustrate Water's Course Flowing into Funnel, and View of Actual Spillway

development in Vermont. The Deerfield river, which is only eighty miles long, falls 2,000 feet, and the upper half, where the power plant is located, flows between high and narrow banks. An immense earth-fill dam was built, giving a power head of from 300 to 390 feet, but, because of the high walls and narrow channel, it was found difficult to locate a spillway. In building the dam, a diversion tunnel was constructed through the rock wall at one side of the river to carry the flow during construction. The engineers tapped this tunnel with a vertical shaft which culminated in the giant horn-shaped spillway studded with concrete pillars to break up formations of ice or other obstructions. The project develops 60,000 horsepower, has a reservoir capacity of five billion cubic feet and cost \$10,000,000.



Of England's 42,000 doctors, only 2,000 are women.



Pitching the One-Pole Tent for Convenient Shelter; Using It as a Buoyant Raft, and Its Appearance Folded on Back with Pole Serving as Walking Stick

One-Pole Tent Also Serves as Raft and May Be Carried on Back

A one-pole tent which looks like a greatly enlarged sleeping bag and which is not only easily carried on the back, but can be transformed into a raft by filling it with brushwood, is a Norwegian invention which is finding favor with English campers and hikers. Four pegs and a collapsible pole are all that is needed to erect the tent, which presents an unusual appearance because, like a sleeping bag, it goes under as well as over the occupant. Folded up, the canvas makes a light package for the back, and the collapsible pole can either be rolled inside, or used as a walking stick. When a stream is reached, a quantity of dry brushwood to fill the canvas will transform it into a raft.

¹⁷³⁰
Whites, Enslaved by Negro Tribe, Discovered in Depths of Africa

Slaves of an African chieftain and his followers, a company of about fifty white men and women, believed to be descendants of old Dutch pioneers who lost their way while trekking across the wilderness, have been reported by a British expedition at Molopolole, in the interior of the Kalahari desert in southern Africa. The unfortunates have no right to own property, are given no privileges and are virtually serfs of the natives, tilling the soil in return for small quantities of grain as wages. Chief Sebele, head of the tribe, was found to be fairly well educated and both he and his wife wore European clothes. The blacks carry rifles, but none of the whites are allowed to possess firearms.

Christian Science Monitor
 8/19/24

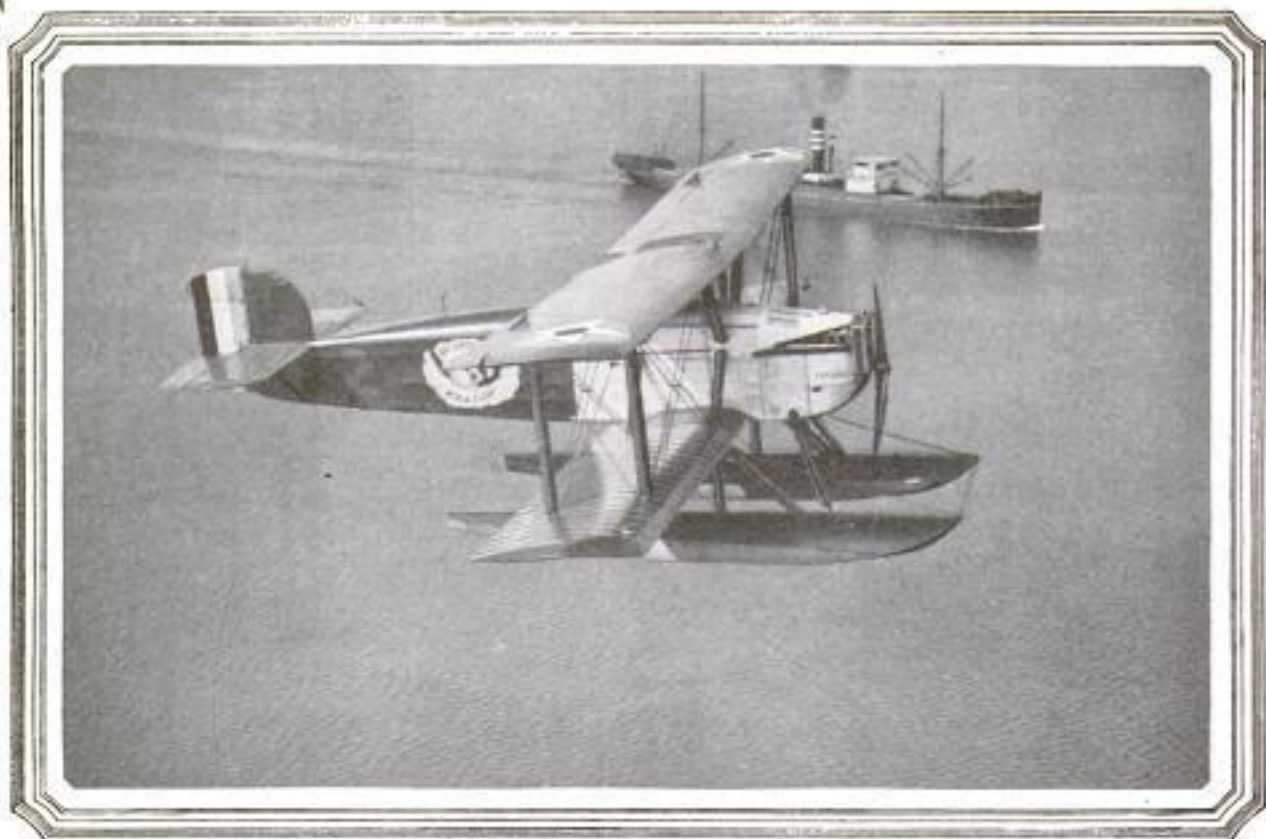

Copyright, Lester Rounds

Pontoons Attached, the Gleaming "Chicago" Noses Northward over Puget Sound after Hopping Off from the Sand Point Flying Field at Seattle on April 6

Round World in Eight Days Next?

*Aeroflight
wire*

History-Making Journey Is Declared to Have Proved the Practicality of Air Transportation between Continents

WITH the triumph of the American army fliers' effort to circumnavigate the world, greater developments in the realm of aviation are predicted for the next few years than in all of the twenty years that have passed since the Wright brothers first began, clumsily but miraculously, to skim over the Atlantic coast.

Sixteen-hour airplane service between New York and San Francisco and round-the-world passenger service in 170 hours, including a sixty-five-hour air route between Gotham and Peking, China, are some of the developments which may be expected, according to Brig. Gen. William Mitchell.

In circling the globe, covering a distance of approximately 24,000 miles in less than six months, the army fliers are declared to have proved the practicability of air transportation between continents with the present type of craft, to have

stimulated the adoption of planes for the needs of commerce and to have brought to the United States the great honor of being the first to accomplish this feat.

The flight of these modern Magellans was started March 17 from Clover field, Santa Monica, Calif., the squadron being made up as follows: "Seattle," flag plane, with Maj. Fred L. Martin as pilot and Sergt. Alva Harvey as mechanician; "Chicago," Lieut. Lowell H. Smith and Leslie P. Arnold; "Boston," Lieut. Leigh Wade and Lieut. H. M. Ogden; "New Orleans," Lieut. Eric Nelson and Lieut. John Harding, Jr.

On the first day the squadron hopped to Sacramento, covering 370 miles. The second leg was 550 miles to Seattle where the fliers arrived on March 20. From there the route led northward to Alaska where Maj. Martin was forced to abandon the race, having encountered engine trouble

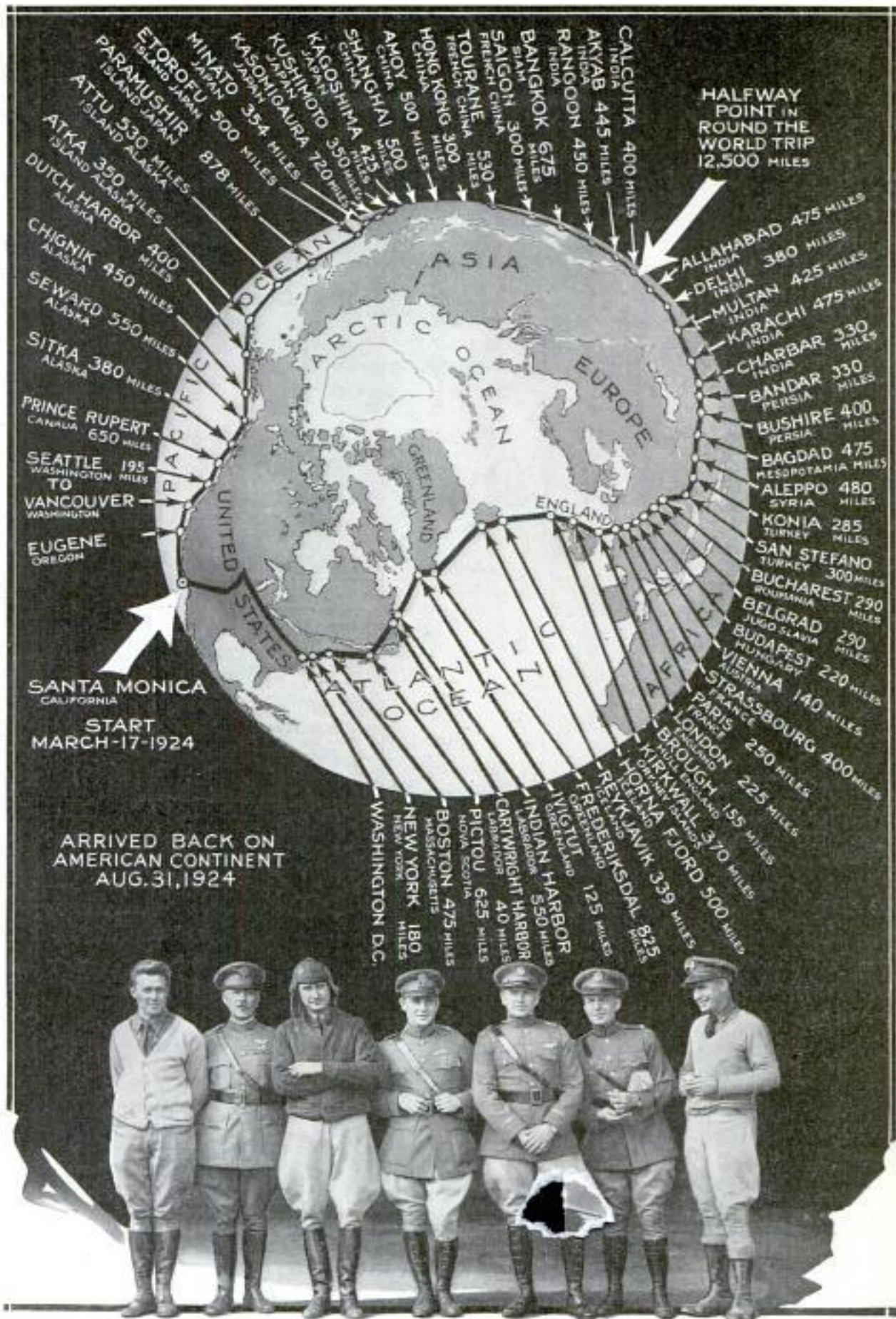

Copyright, Underwood & Underwood

Trail of the Air Magellans, and Fliers Lieut. Harding, Gen. Mason Patrick, Who Welcomed Their Return, Squadron Commander Lieut. Smith, and Lieuts. Wade, Ogden, Arnold and Nelson

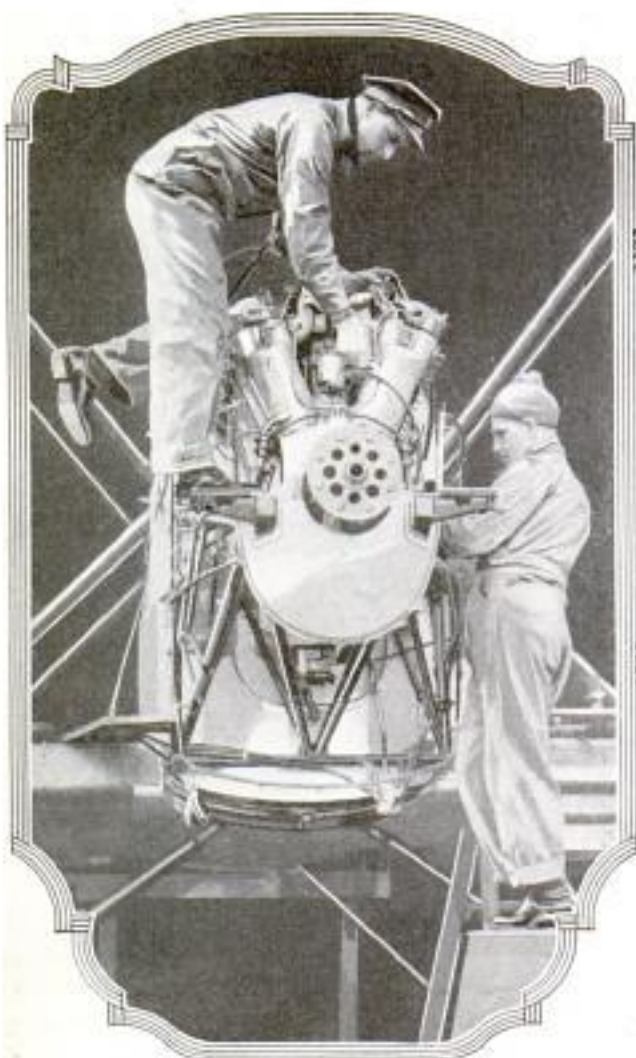

Mechanics and Their Skill Were Important Factors in the Epoch-Making Flight for, by Frequent Overhauls and Changing of the Engines, They Insured the Safety of the Planes So That They Would Not Fail the Fliers on Long and Arduous Tests; Maj. Davidson and Lieuts. Smith and Wade with Map, Point Out to an Interviewer Where a Thick Fog Stopped Them; Below, Lieuts. Schulze and Wade Inspect a Pontoon

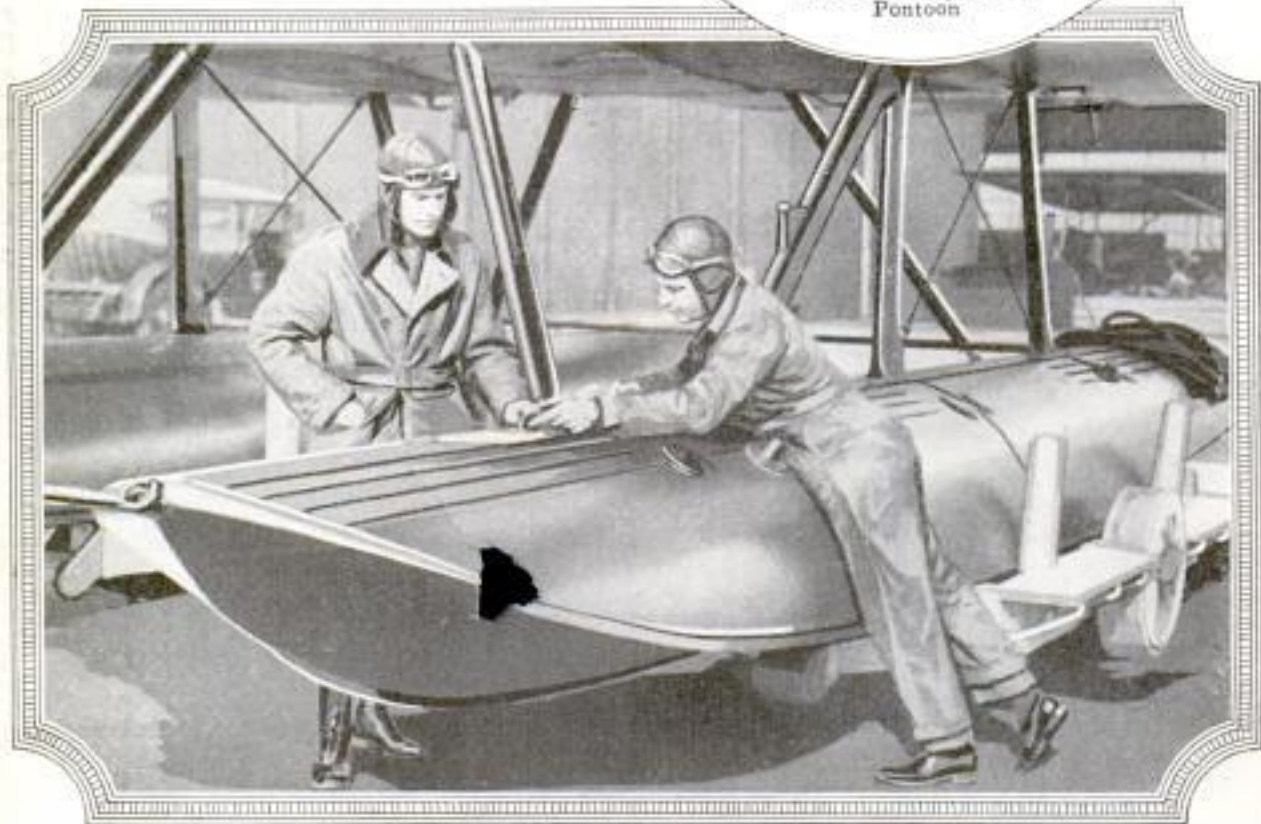



World Fliers Swept by Snowstorm in Siberia

Curious Natives Nearly Wreck Planes in Asia

Encountering Hundreds of Storks in Turkey

Long Battle with Icy Sea on Alaska Coast

near Cape Igvak. The other planes continued their flight through the gales and snow of the Aleutian islands, the typhoons and torrential rains of the China sea, the equatorial heat of Indo-China and even through a desert sandstorm.

The great surprise of the flight was that the planes survived the rigors of the weather. During the journey along the Aleutian islands, ice formed on the wings several inches thick. It was chopped off and a few days later the wings were subjected to the heat of Japan, China and India, but when the "Chicago" and "New Orleans" ended the journey they had the same wings with which they started. The latter machine, however, had changed a lower panel in Burma after a native had rowed his sampan into the anchored airplane. The only big changes made were in the engines. Eighteen Liberty motors were placed around the world for emergency uses. These had been selected from a lot of seventy rebuilt ones in storage. They were of war-time vintage, but were the best available, producing 410 horsepower. The gasoline was supplied by two power-driven pumps and a handpump for emergency. The latter proved valuable across Davis Strait, when Arnold operated his handpump for two hours after the other two had failed. The first trouble came from a broken connecting rod in

Major Martin's machine. Next, Wade's motor developed cylinder trouble and he installed a new one at Dutch Harbor, Alaska. Over the Sind desert a broken rod punched four holes in Nelson's crankcase.

En route to Japan, Smith's airplane developed a shorted battery. He landed on the water, fixed it in a few minutes, and rejoined the flight. This was the first repair ever made at sea with a continued flight following. The greatest troubles encountered, aside from the weather, were leaky cylinders, water, gasoline and oil-pump failures, broken connecting rods and one case of stripped motor gears.

Upon the arrival at the nation's capital, September 9, the flight had covered 22,874 miles and the airplanes had been in the air 320 hours and nineteen minutes, during which time they had consumed approximately 19,200 gallons of gasoline and 4,800 quarts of oil.

One of the chief lessons of the flight was the need for better communication facilities. Radio weather reports covering large areas would make such a flight safe and radio direction-control apparatus would conquer the densest fog.

It has been demonstrated that the airplanes themselves can withstand the rigors of such a trip and the motors will also stand up, but more reliable and less complicated engines are needed.



Maj. Ira A. Rader, Chief of the Information Division, Who Received First Reports from the Fliers, Pointing to Section Where Ice Barriers Almost Halted the Journey



Above, Lieut. Erik Nelson's Plane at Dutch Harbor, Unalaska, Where the Three Ships, after Maj. Martin's Accident, Resumed Flight for Atka Island, One of the Stepping Stones across the Bering Sea with Lieut. Nelson in Command of the Fleet; Center, Lieut. Smith and Two of the French Officers Who Greeted the Fliers in Paris; Below, a Pause in the Flight Shows the Size of the Fuselage of One of the Planes Emblazoned with Its Decorative Emblem

U. S. No. 9. Herbert Knapp and W. A. Freret
 718 149 N. Edgeware Road Consulting Engineer
 Los Angeles, Calif. POPULAR MECHANICS National Building Ass'n
 York, Pa.

648 Loops at Street Crossings to Speed Traffic and Avoid Wrecks

Enabling vehicles to turn in any direction or to cross a street without cutting the path of other traffic or slowing up for



Designer and Model of Street Intersection with Looped Roads at Side for Turning

intersections, an arrangement that does away with right-angle junctions of roadways has a two-plane crossing. If drivers wish to turn off the highway in either direction, looped roads that circle each corner permit them to make the change without traveling against other traffic, and progress straight ahead can be maintained without being, as a rule, forced to reduce speed while passing a street. The system, it is said, is designed to increase movement on much-used thoroughfares and to eliminate the meeting of cars that run in opposite directions.

Lime and Sawdust Building Blocks Resist Fire, Sound and Moisture

Building blocks made of lime and sawdust, which engineers believe may revolutionize present methods of fireproof construction, are being manufactured at an eastern research plant. It is claimed that they not only resist intense heat but also are sound and moisture-proof, can be sawed, eliminate the need of lath for plastering and can be used for roofs as well as for walls. To the lime and sawdust or other wood fiber, ashes, sand or fine limestone is added, and the mixture is treated in such a way as to prevent the lime from carbonating. The bricks, in a few days, become uniformly hard and crystalline.

1675 Monster Gun Has Removable Trucks for Use over Railroads

Uncle Sam's biggest movable gun was inspected by the American Society of military engineers when they visited the Aberdeen, Md., proving grounds to see the new sixteen-inch weapon, and other cannon, in action. The railway gun is equipped with detachable trucks, which are removed after it is placed on its revolving platform. Steel braces at either end of the car may be lowered to take up part of the shock of the recoil. A special derrick lifts the huge shells to the loading platform behind the breech. One of the features of the engineers' visit was the firing of the big weapon, while another was the destruction of two captive balloons.

Monster Portable Coast Defense Gun with Its Shell Derrick, as It Appeared When Detached from Railroad Trucks, at Right, and Mounted on Revolving Platform, at Aberdeen Proving Grounds

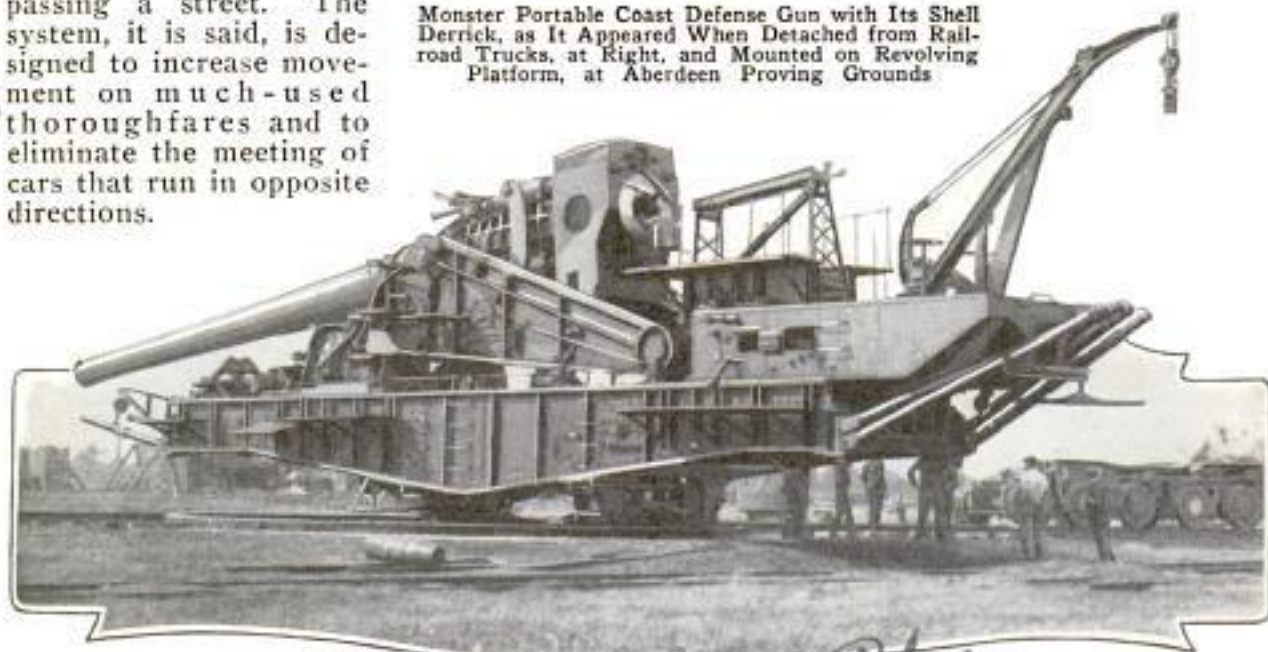

Pacific + Atlantic Photos
 25 Park Place, New York
 Copyrighted material

J. Herbert Knapp, 149 Edgeware Road, Los Angeles, Calif.

1478

Cmt. Francis Slickie

POPULAR MECHANICS

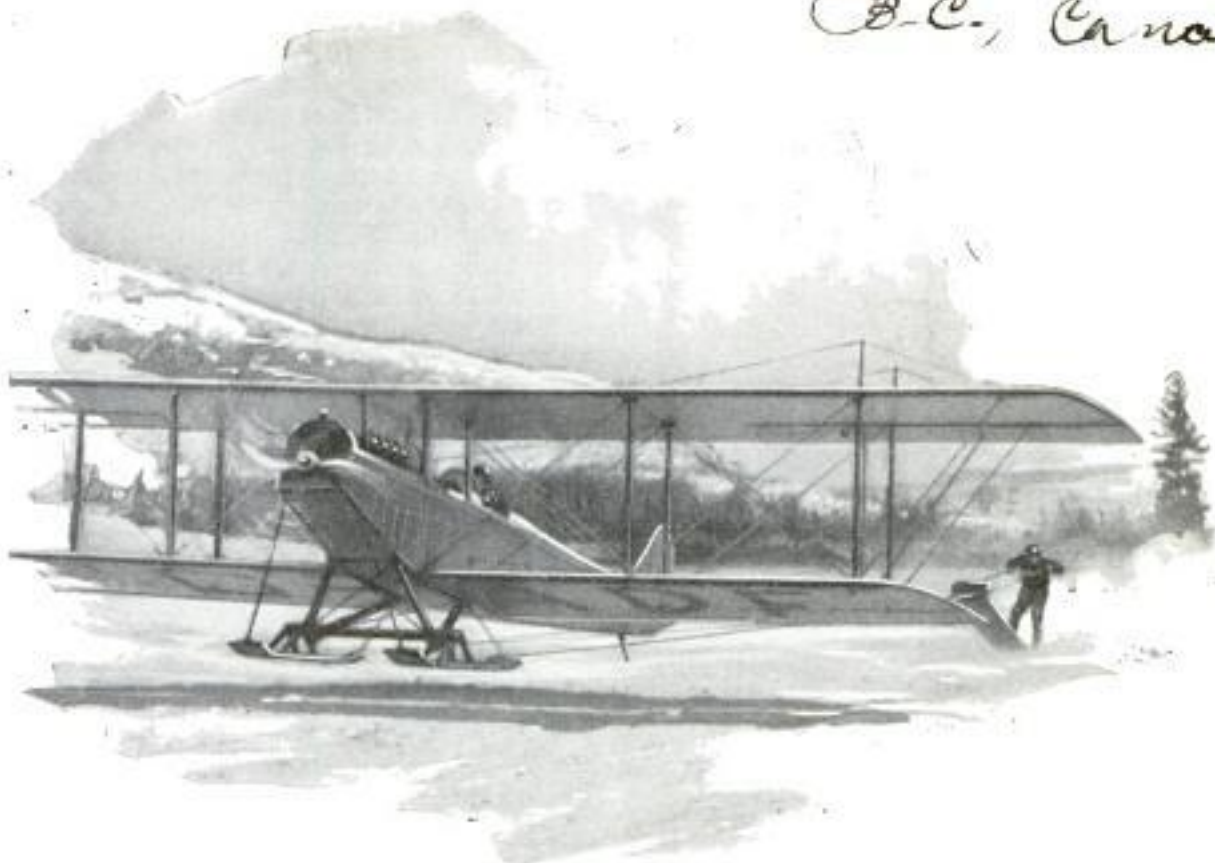
Herbert Day
B.C., Canada

Skimming across Snow-Dusted Ice behind a Roaring Airplane, a Daring Tobogganer Tastes the Joys and Hazards of Winter "Surf Riding" in the Crisp, Biting Air

Airplane Toboggan Rides Yield Thrills for Winter Sportsmen

"Skikjoring," a novel joy ride for those who care to risk life and limb on the ice in the wake of a speeding airplane, is proving an exciting sport for visitors at Lake Tremblant, near Montreal. It is the winter form of surf riding. The airplane, equipped with broad runners for landing, zooms close to the snow-covered surface of the lake. Clinging to ropes attached to the wings, the "skikjorer," perilously standing on a toboggan or balancing himself on skis, bounds and sways in the rear as the ship approaches a seventy-mile-an-hour speed. The tang of the keen air is intensified by the blast from the propeller and as the motor roars, the gritty rider, fighting to avoid a spill, finds ample chance to test his nerve and dexterity, while the aviator must also exercise skill.

Golf Club with Adjustable Head — Takes Place of Bagful 1626

To eliminate the carrying of a heavy bag of clubs while playing a game of golf, a stick has been devised with a changeable head that can be adjusted for almost any stroke. The blade may be set in a

few seconds at an angle to loft the ball in long drives or to propel it in a straight line along the level of the green. Graduated marks on the socket of the shank, into which the head fits, indicate the various positions at which the "pitch" of the iron can be put, and the joint is arranged to prevent clogging by dirt and grass. It is claimed that when using the single club for entire games, a player can greatly improve his accuracy since he need not suit his swing to various weights for different



Adjustable Golf-Club Head Showing Socket Which Is Marked to Indicate Proper Positions

strokes. The employment of the changeable stick also does away with the services of a caddy.

H. E. Sanders,
Walla Walla, Wash.

720

POPULAR MECHANICS

*Extra Cars. Ltd
45 London Street, Eng
Chertsey, Surrey, England*

Small Three-Wheeled Auto Runs Eighty Miles on Gallon of Gas

Many of the comforts of a large roadster or touring car are found in a single-passenger, three-wheeled runabout made

*1666
Letter rec'd.
2/2/26*



Well Suited to Women Drivers, the Little Runabout Is Practical for Visiting and Shopping

in England. Designed on graceful lines, with folding top and windshield, the little vehicle is run by a two and three-quarters horsepower gasoline motor, applying power to the rear wheel through a chain and two sprockets, to which are attached two cork-faced friction wheels for high and low gear. The power plant, a single assembly, can be entirely removed in a short time and is so slung as to minimize road vibrations. Luxuriously upholstered, the car is capable of a speed of more than twenty miles an hour. Economical and easy to operate, it will run eighty miles on a gallon of gasoline, it is claimed, and the car is so light that an able-bodied man can easily lift it clear of the ground.

*Emb. N. Townner's Eng
Thundersley, England*

"Wool" Made of Pine-Tree Leaves Rivals Natural Product

By chemically treating the long, slender spines of the Scotch fir, German scientists have found a way to manufacture a substance which is said to have many of the qualities of natural wool. It can be curled, felted and spun or woven into carpets, and, mixed with a canvas warp, makes excellent blankets. The coarser qualities are used for stuffing mattresses and have been found proof against insects, while the aromatic odor is said to be agreeable and beneficial to patients. Large plantations of the trees are being cultivated. The

leaves are gathered every second year while they are still green, and in such a way that the growth of the trees is not injured. The resinous substance in them is dissolved by boiling and with chemicals, leaving the fibers, which are easily separated and cleansed of all foreign matter. A woolly substance is left, the best quality of which can be spun into threads, like that of hemp and almost as strong. One of the by-products of the process is a valuable oil which can be used in the manufacture of varnish and perfumes and for dissolving rubber. This oil is said to differ greatly from the ordinary turpentine.

929

Pitless Organ Raised into View by Motor-Operated Screws

Quickly raised to any desired position on large worm screws concealed in posts at the corners, a pipe organ for theaters has been designed that requires no pit or hydraulic lifting jacks. It rests nearly flush with the floor and when power is applied from a central motor, player and organ rise before the eyes of the audience. Reversing the switch causes them to sink to the level of the orchestra pit. When the organ is lowered, the screws are hidden in the hollow posts that form part of

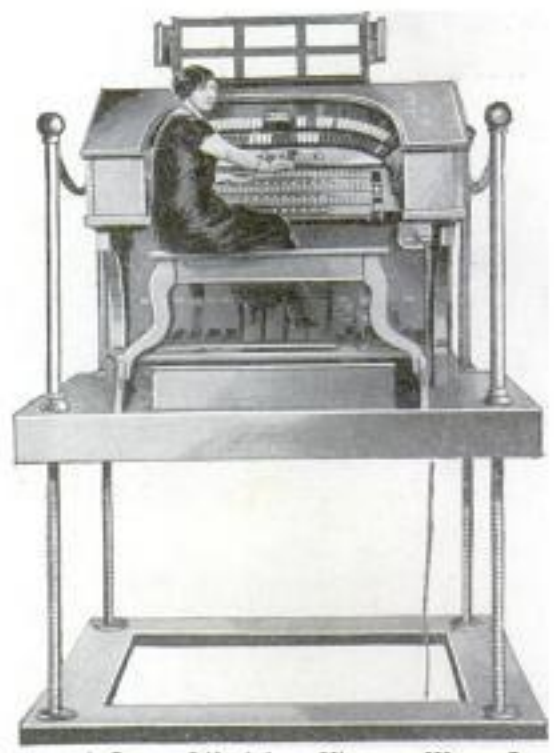

Player and Organ Lifted into View on Worm Screws Concealed in Corner Posts

the decorations. Greater compactness and decreased installation cost are claimed for this arrangement.

*Bartola Musical
Instrument Co.
313 Wablers Bldg. Chicago*

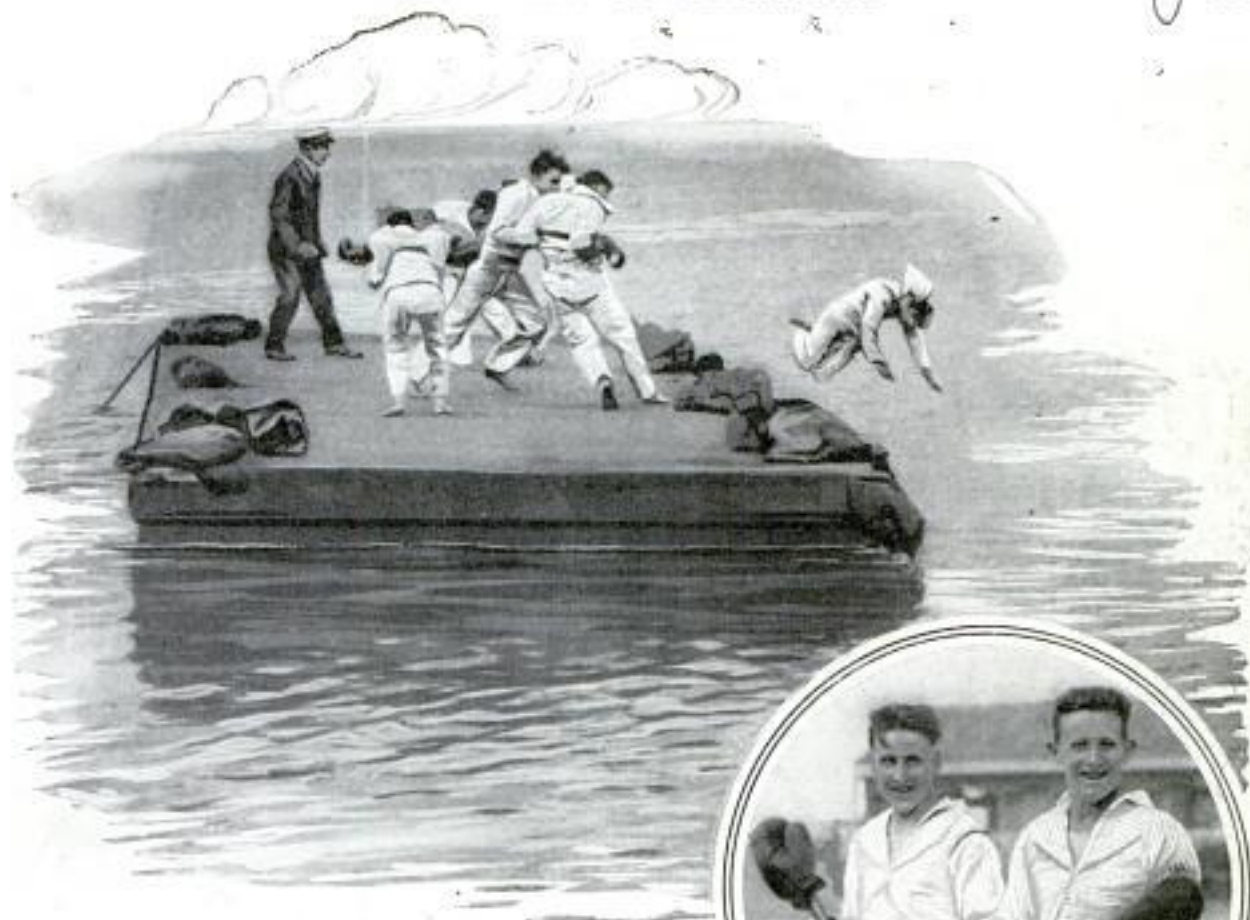

Barge Boxing Bout at Its Height and Close-Up to Show Position of Gloves

Boxing Gloves on Ends of Sticks Provide Thrill for Sailors 1530

Sailors stationed at Goat island, on the Pacific coast, have developed a novel form of boxing to while away their leisure hours. The gloves are laced upon short sticks which are held behind the back and between the arms. Sides are chosen and at a signal, the opposing teams, using a floating barge as the ring, engage in a combination wrestling, boxing and pushing contest. A forced header into the sea scores a knockout blow for the "gob" who delivered the wallop, and always brings shouts from the delighted spectators who have "ring-side seats."

Sahara to Be Bridged by Railroad Two Thousand Miles Long

Already conquered by the camel and the motor car, the Sahara desert will be traversed by fast passenger and freight trains, if plans being made by French engineers to bridge the shifting sands with a railroad are successful. The line will be 2,000 miles long and will extend from the Algerian port of Oran to Wagadugu in the French Sudan, the capital of the

1638
Com. J. Christie, Station
356 Union, Manitoba
Winnipeg, Canada



fertile Upper Volta region, and conveniently situated for the establishment of a center to link up the Niger colonies. Seven years will be required to complete the work.

Volcano to Be Tapped to Get Steam 1655 from Nature's Boilers

Plans are under way to pierce the sides of Mount Tatio, an active volcano on the west coast of South America, to get the steam generated by the natural fires beneath the mountain. Most of the energy will be piped out for use in making electricity. Estimates show that as much current can be produced in this manner each year as would require the consumption of a half million tons of coal in an ordinary plant. It is said the steam is so pure that it can be run directly into turbine engines without the usual costly cleaning processes. In Italy thousands of horsepower have been developed in this way.

new York Times
8/3/24

1165

722

Pacific + Atlantic Photos Inc,
25 Park Place

POPULAR MECHANICS

New York City



A Night Run with the Gotham Limited

How Nation's Fastest Trains Are Protected on Runs and Guided through Busy Terminals

*At night...
operation*

SURROUNDED by loud-speaking telephones, telegraph instruments and electric lights, the train director in the interlocking tower is a commanding general who is in constant touch with every movement in the gigantic railway terminals developed to meet the constantly increasing demands of modern transportation. Before him is a long case, covered with frosted glass, on which is outlined the entire track and switch layout of the territory under his command. It is drawn to scale and little lights tell the condition of each track, whether it is occupied or vacant. Under his command are many men who manipulate the 400 levers that operate the switches and signals.

To put the average train onto its track in a big station requires the movement of from twenty to sixty levers. At one terminal there are 238 different points and crossings, 570 signals and 1,200 train movements on 113 tracks every railroad day. And yet the lever men handle this traffic without seeing the tracks or the trains on

them. "No. 54 ready," is the word that reaches the tower after the station gates have closed behind the last passenger.

"Put 'er on track twenty," the train director orders and, as the levers are set, the signals flash along the bewildering maze of tracks in the yard before the eyes of the engineer waiting with his hand on the throttle. The conductor swings aboard one of the coaches and pulls the signal cord twice.

Two short, singing squeaks of the little air whistle in the cab interrupt the pounding of the air pump, the engineer tugs gently on the throttle, the eighty-inch drivers move and the Gotham limited rolls forward on the first leg of its 908-mile journey from Chicago to New York.

As the train swings under the last of the terminal viaducts, the fireman catches the gleam from a lantern swung high over the head of a switchman and shouts across to the engineer:

"Highball," the railway code for a clear track in answer to an arm or lantern sig-

1165



Flying Down the Track into a Dumb, Dark World or across Sunny Plains, the Fear of Grade-Crossing Accidents Keeps Enginemen Always on the Alert

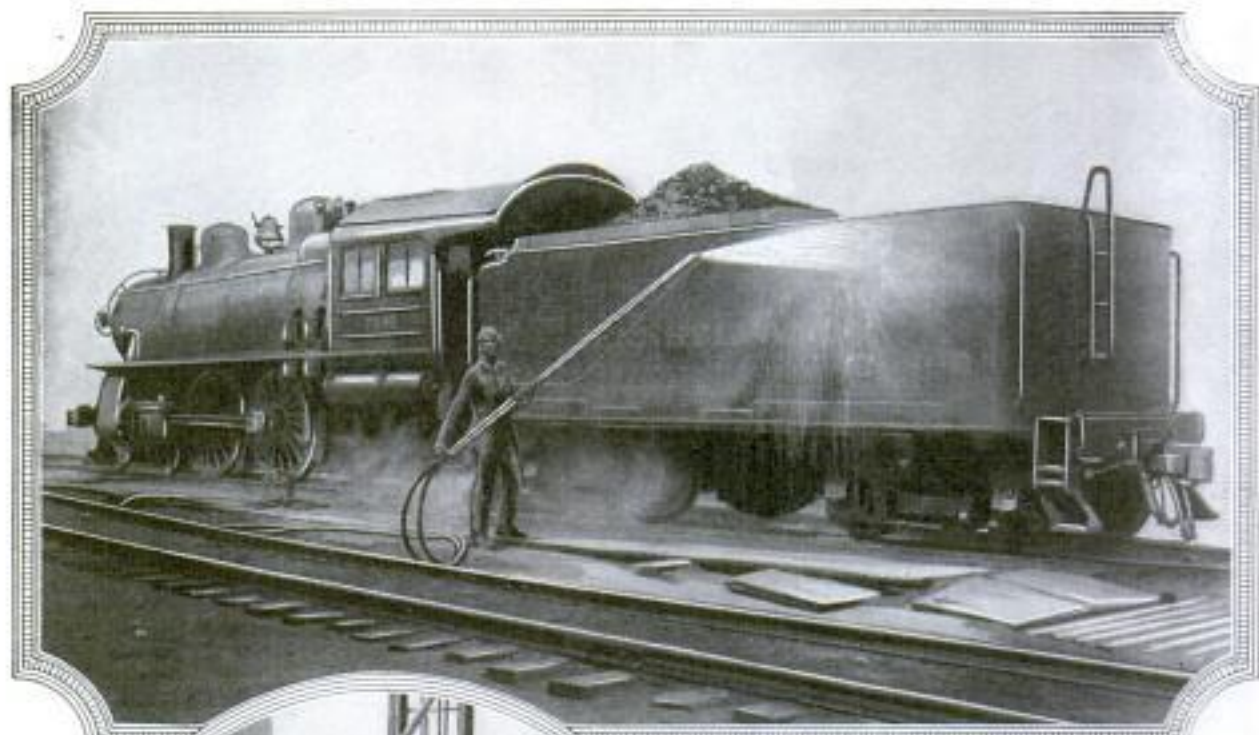

Cleaning an Engine and Emptying Ash-
Pit Boxes

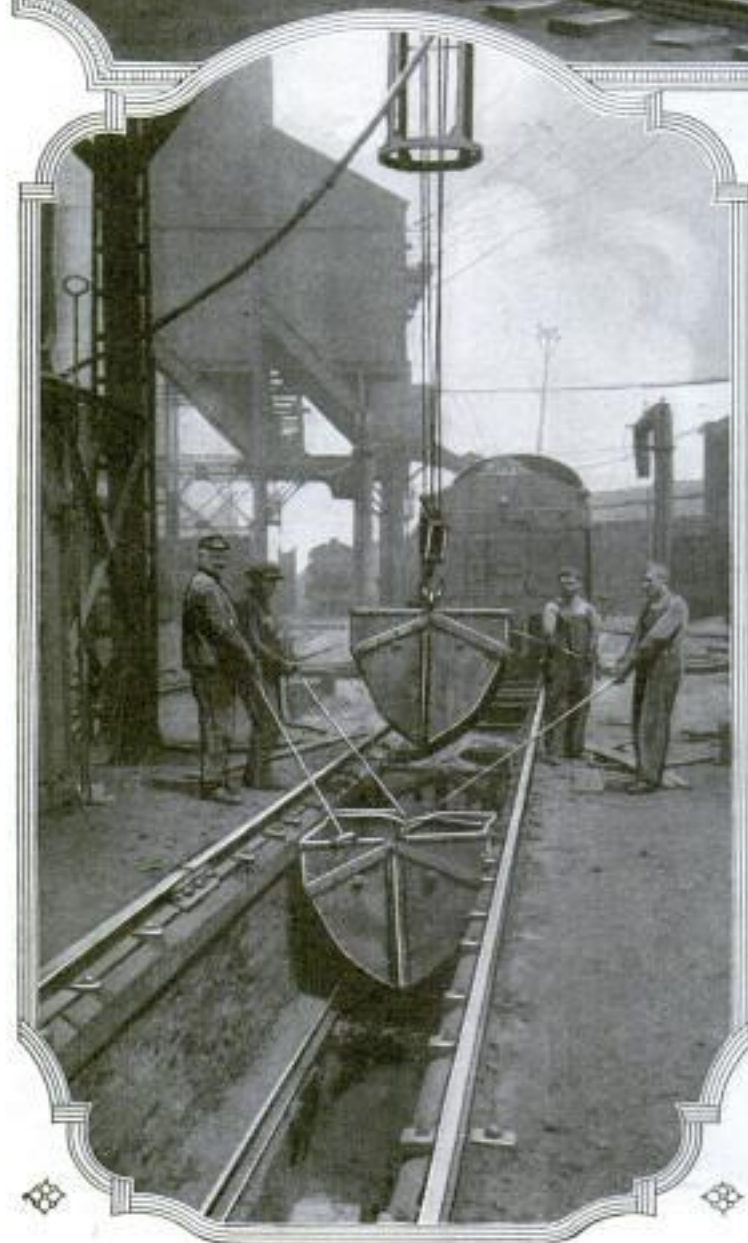

nal, and Engine 5353's whistle answers with two short blasts. As the train picks up speed, the engineer, a keen-eyed, gray-haired, bulky figure of a man who, in different garb, might be taken for a banker or corporation head, spies a green light burning over a red one at the approach to a bridge.

"Clear block," he shouts to the fireman who echoes back the call as the train roars past the gloomy network of girders, flying down the track into a dumb, dark world.

Above, the stars are blotted out by a black ribbon of smoke. Behind, the bunched electrics in the coaches are blinking out. In the cab, the needles of the dials flicker to and fro, cinders rattle on the roof and the rails begin to hum as the 250-ton racing locomotive settles down to its work.

Every three miles or so the fireman takes his eyes from the track ahead long enough to tend his fire—a white-hot blast that leaps and curls under the crown sheet. It is a constant battle to keep the gauge between 190 and 205 pounds' pressure. To maintain an average speed of forty-five miles an hour requires from

seventy to eighty tons of fuel in the 900-mile run.

So that the flames will not scorch his hands, the fireman skillfully lets the edge of his shovel graze the bottom of the door, sending the coal evenly over the seething surface where the flames are fanned by a powerful blower. In front of the speeding

engine, the rails glisten in the glare of the 900,000-candlepower electric headlight, the beam of which cuts the darkness for 1,000 feet ahead and is visible for fifteen miles on a clear night.

The train is now running under the advance lighting system, which means that as it passes into each block the lights at the entrance of the one ahead flash out of the darkness. A "clear" signal shows that the track is open for at least two blocks ahead, giving the train two miles of unrestricted running. A caution signal is always set a mile ahead of a closed block so that only in case of an emergency is a train brought to a sudden stop.

One of the Pennsylvania's stringent rules is that the engineer and fireman verbally repeat the signals. This is an extra precaution to insure that both are on the alert and to prevent any mishap should

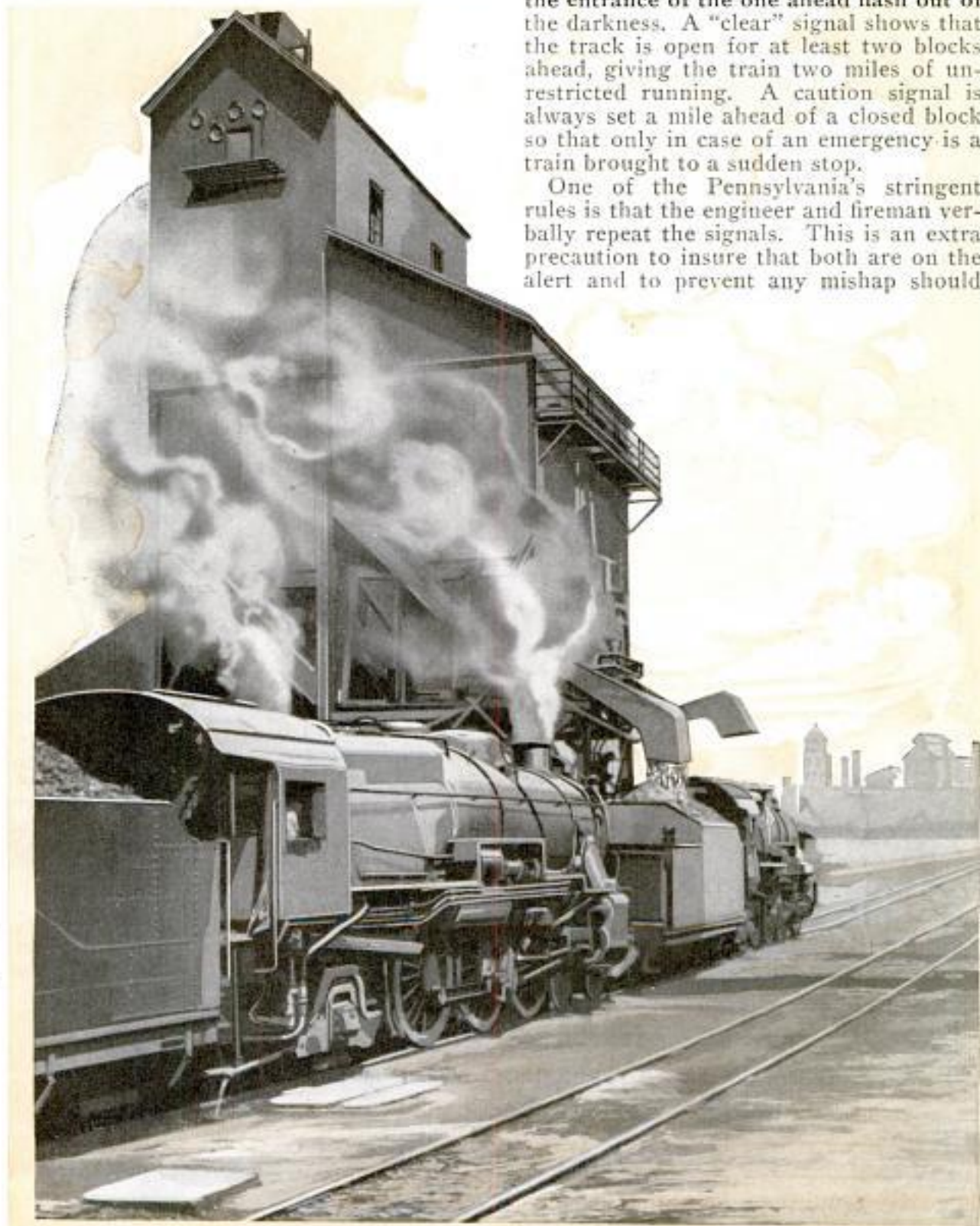

Coaling Pennsylvania Engines from an Eighty-Ton Capacity Electrically Filled Chute That Dumps on a Tender a Load of Four Tons in Two Minutes

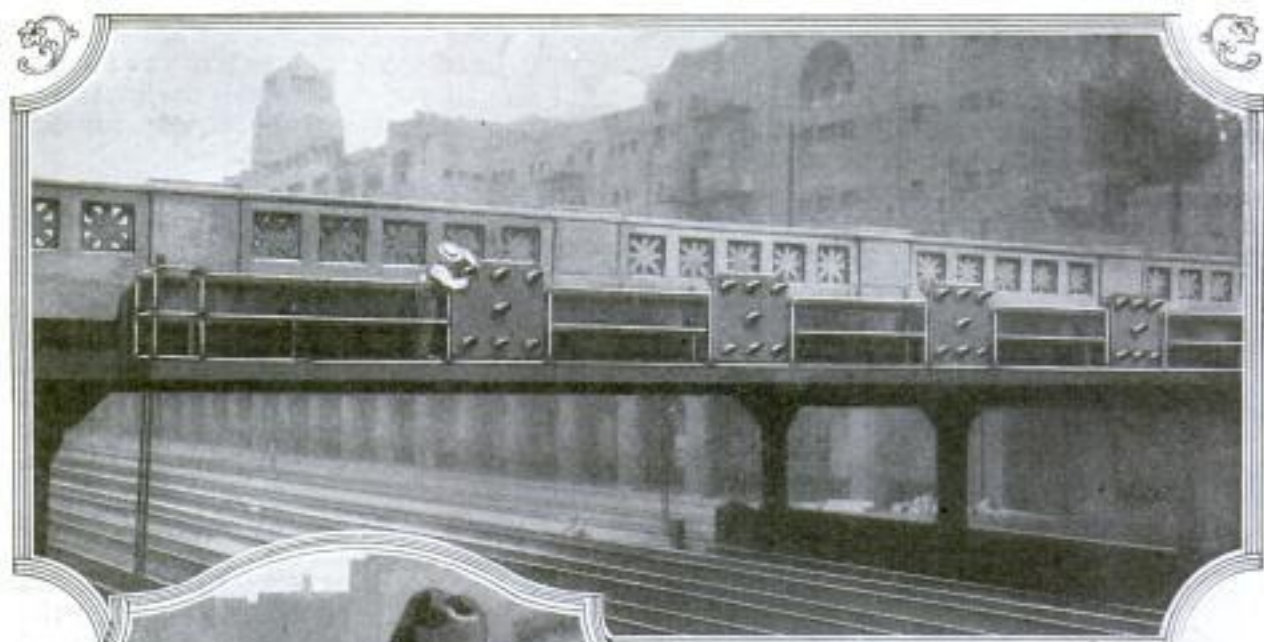

Contrasting Views of Modern Rail-
roading; Brakeman Stopping a Freight
Car on Downgrade by Turning the Hand
Brake with Aid of Lever; Above Is a
Row of "High" Signals in One of the
Big Terminal Yards; Their Shaded
Amber Lights Burn by Day and Night
and Show, by Varying Positions, Clear,
Caution, Low-Speed, Stop and Other
Signs; They and the Yard Switches
Are Controlled from the Interlocking
Tower Room Shown in Operation Be-
low, Where Lever Men, Guided by Il-
luminated Map of Tracks, Direct More
than 300 Trains Daily

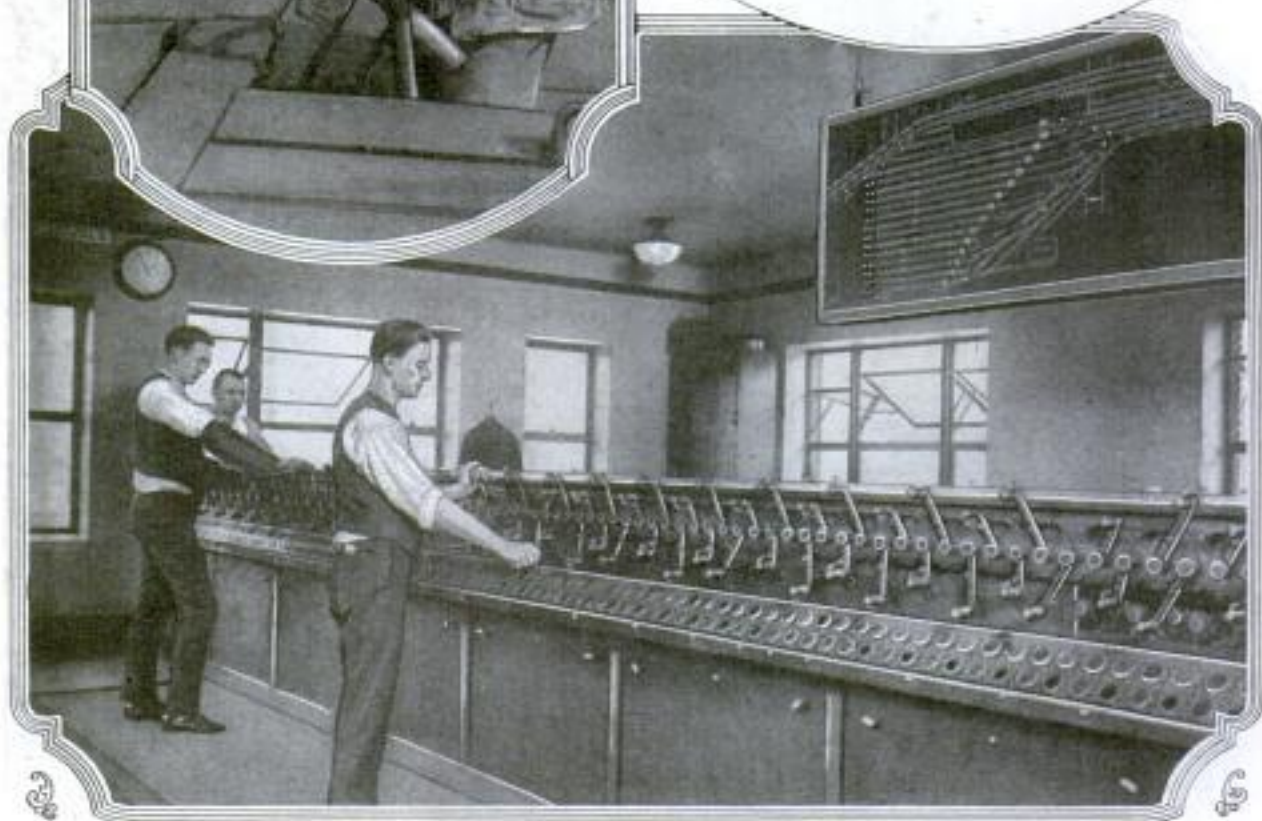

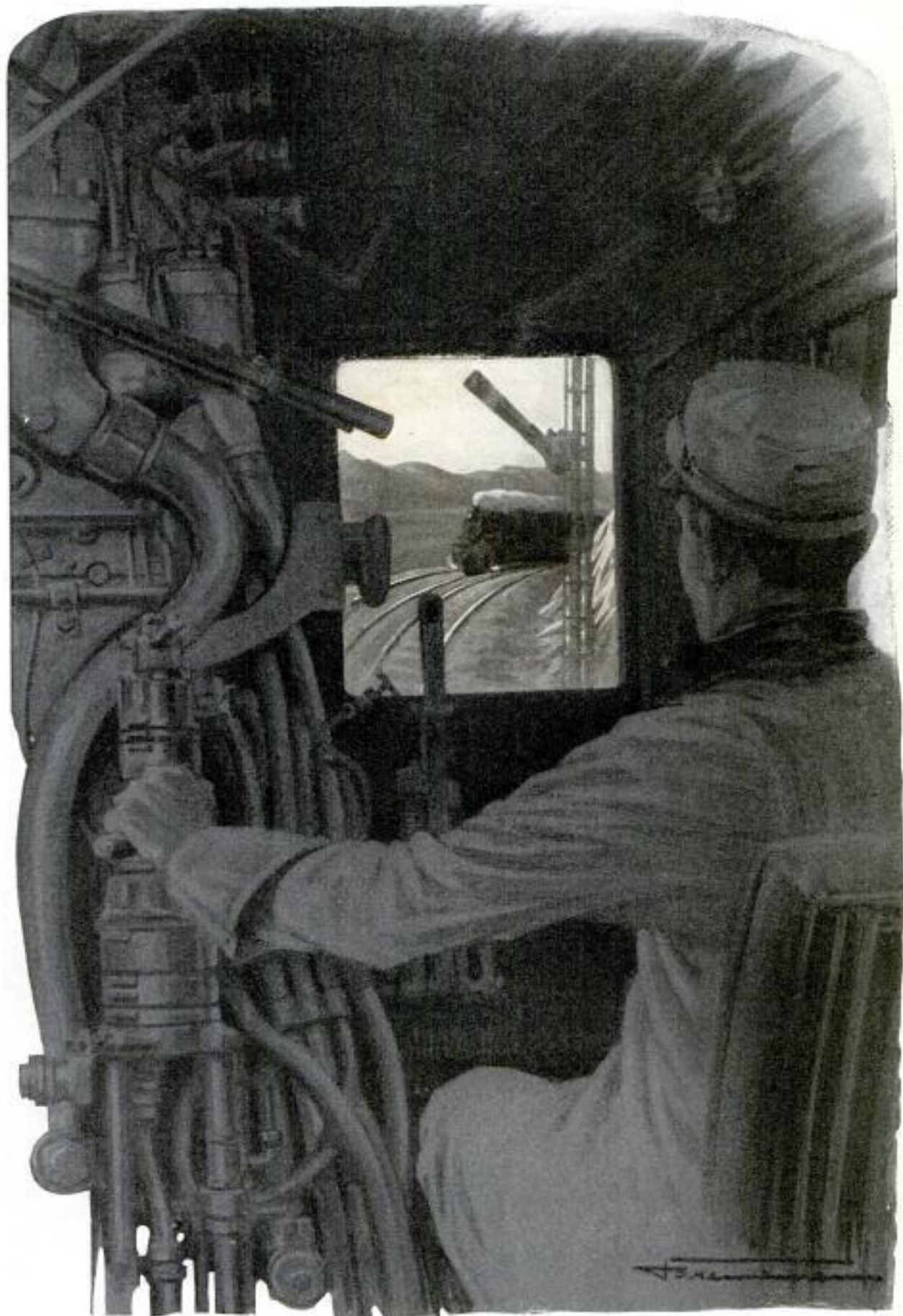

Beside the White-Hot Blast That Leaps and Curls and Foams at the Crown Sheet, the Engineer of the Big Racing Locomotive Keeps Ceaseless Vigil

1165



Hundreds of Men the Passengers Rarely See Are Constantly at Work on Railroad Switching Apparatus and Tracks to Insure Their Safety, as Are the Signal-Battery Inspectors Shown Above and Below; Making His Rounds Day after Day, the Track Walker, by Detecting Faulty Rails, Loose Joints and Ties, Is Often the Unsung Hero Who Prevents Serious Accidents



Left and Lower Photos, Copyright, Ewing Galloway

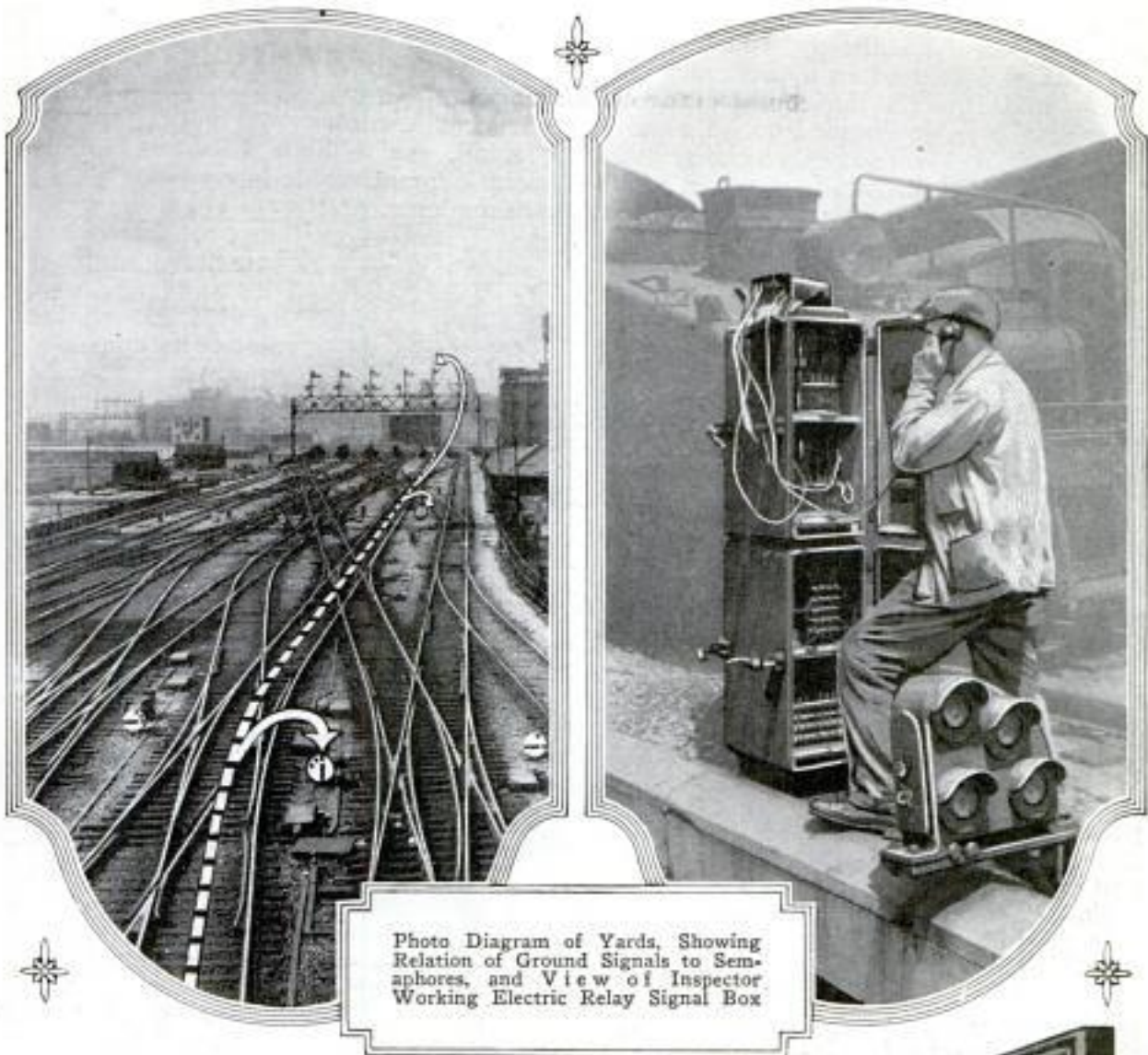
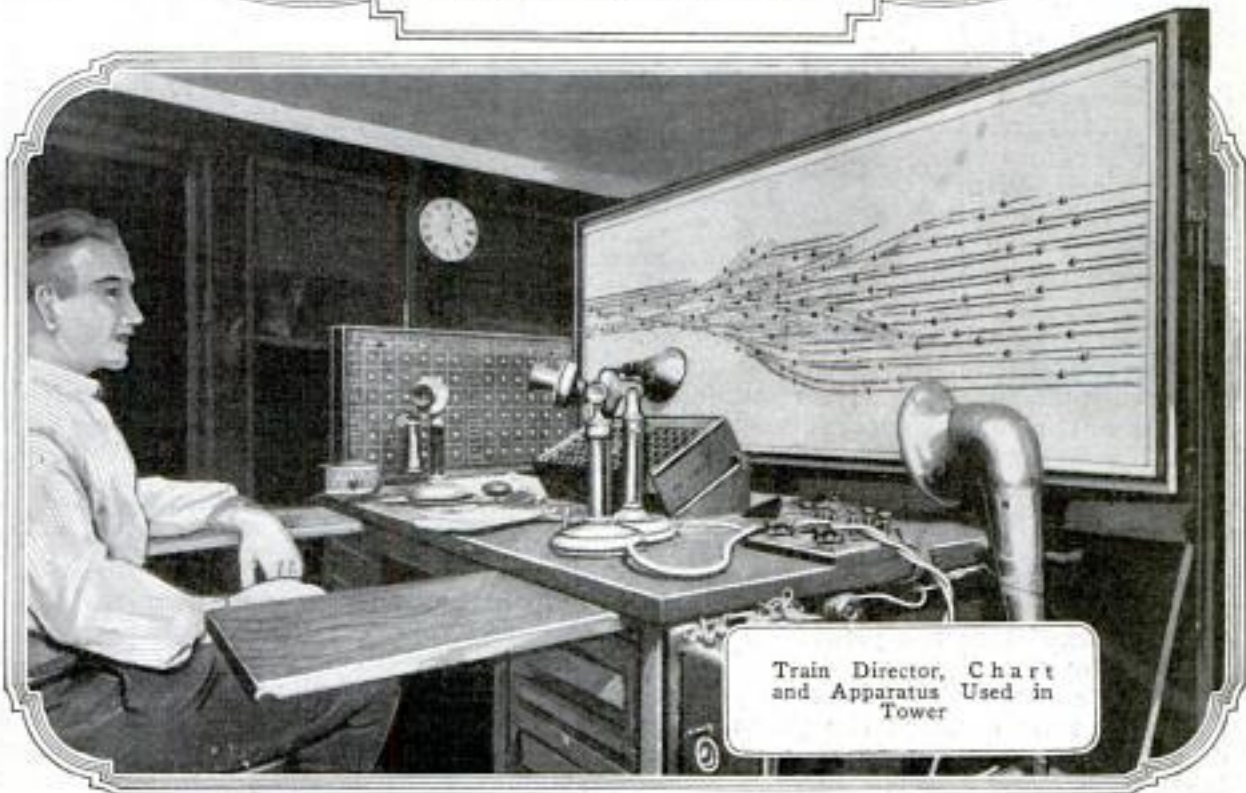

Photo Diagram of Yards, Showing Relation of Ground Signals to Semaphores, and View of Inspector Working Electric Relay Signal Box



Train Director, Chart and Apparatus Used in Tower

the engineer die at his post—a thing that is not unknown in the history of railroading.

Ahead, the light of an approaching engine twinkles on the horizon, grows to a blaze and then is dimmed to an almost imperceptible glow as the two trains pass. Dimming the headlights is required of all trains passing each other at night. At

Davis, Ind., two dark slits appear between the rails, the 900-foot reservoirs from which the tender tanks are filled while the train is running. The Gotham slows down to thirty miles an hour and the fireman opens a flat door in the side of the tender and exposes a small lever. At a blast of the whistle, he pulls it, lowering a grooved tongue. As the train speeds along some 6,000 gallons of water shoot up the trough and into the engine tank, the overflow cascading down the sides of the tender, a reminder of the fact that it was less than a hundred years ago that Peter Cooper's first locomotive carried its water in two apple barrels. With the hum of giant bees the swaying cars move through the night. The

wind roars past with the sweep of a gale. In the cab there is a dizzy clatter of noise, the occasional throb of the air pump and the hiss of the boiler cocks as the engineer tests his water level.

Above all the din comes the scream of the whistle—two long and two short blasts for the deadly grade crossing and a single note to warn the busy mail clerks in the cars behind to put out the arm for "snatch bags" that are picked up on the run. Soon a dull glow on the horizon signals the approach to Fort Wayne and the train rolls through the yards at reduced speed to the beckoning of swinging lanterns, and grinds to a stop, having

covered the 148 miles in 198 minutes. Another engineer and fireman climb aboard for the run to Crestline, Ohio, where a second engine will pick up the train and hurry it eastward.

In all, the 22-hour trip requires five steam locomotives and one electric. Superintendents, master mechanics, engineers, dispatchers, hostlers, wipers, crossing guards and track walkers watch constantly over its safety. At every stop clinking hammers try the wheels and the air-brakes are tested. A glance at one of the four gauges in the cab shows that the train is carrying 110 pounds of air for actual operation of the brakes in running and a red arrow on the same dial indicates 140 pounds for use in case the emergency brakes are applied. The steam gauge shows a boiler pressure of nearly 205 pounds at the time of departure. A third dial tells how much steam is being sent back to heat the train and a fourth shows how much pressure is used on the engine brakes when operated independently of the train. The throttle

and whistle cord are at the engineer's left hand. The reverse lever is in front of him and the air-brake levers, a big brass handle set below a smaller one for controlling the engine alone, at the left. Three boiler cocks are at different levels high up toward the top of the cab. The glass water gauge shakes as the engine sways and is considered only a "fifty-fifty" indication of the boiler's contents, so that the chief reliance is placed on the cocks.

Opening the cocks is a certain way of measuring. By the sound of the outrushing mixture, the engineer can easily tell if dry steam is escaping where water should be. He endeavors to keep the

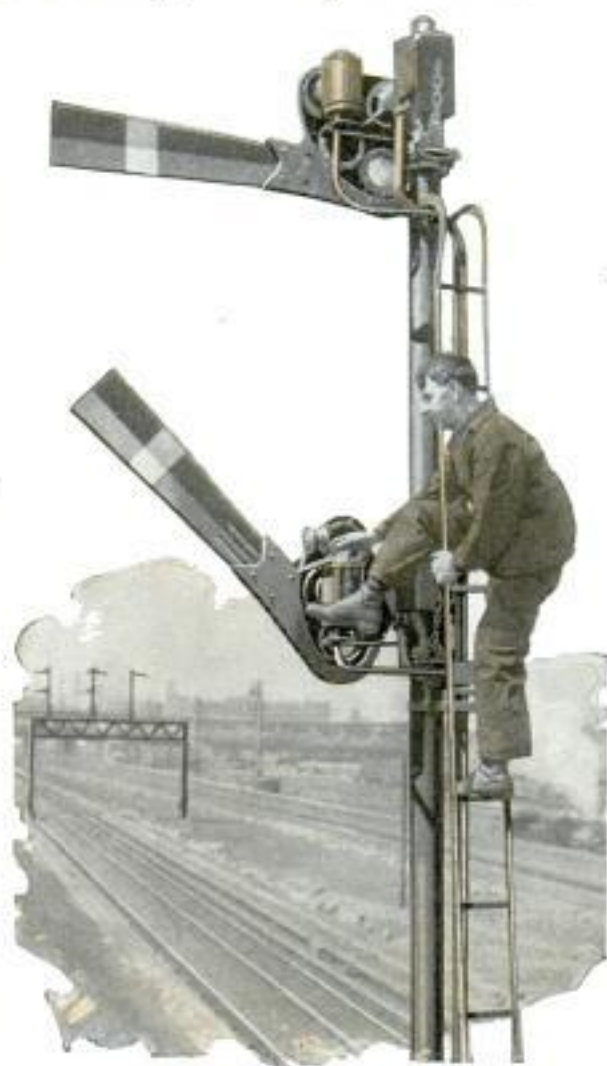

Copyright, Ewing Galloway
Another Guardian of the Traveling Public's Safety, a Semaphore Signal Repair Man at Work

boiler filled just above the middle cock. This insures against too wet steam and water getting into the cylinders, cuts down on coal consumption and increases general efficiency.

Starting smoothly and without slipping or shaking the fire to pieces, stopping with a fine stream of sand running under the drivers to insure a firm hold for the wheels when the train starts again, keeping a speed that will fulfill the requirements of the schedule and get the most out of the coal and the engine and not cause the fireman useless labor are other points that are mastered only after years of experience. Making up the limited and getting it into the terminal before the engine is hooked on is the task of the yardmaster and his helpers. The Broadway limited normally consists of eight cars and the engine and tender. Once assembled, the train is generally kept intact as much as possible, although last minute orders may be received for an additional car or two to handle

heavy traffic. If so, the yardmaster is informed and issues the required orders for alterations or additions to the train's equipment. In general, the yards are laid out so that the stubs from the main leads contain cars that have been switched and stored away according to their class so that they can be picked out and hooked to the train with a minimum loss of time.

Every car in the train has been subjected to a rigid inspection and cleaning and the engine itself, as part of the round-house routine, has been washed thoroughly with an emulsion of steam and oil, shot from a double-nozzled hose under ninety pounds' pressure. The blast rids all parts of the jacket, pistons and wheels of accumulated oil and dust and with a little wiping leaves the engine free from grime and rust. With this apparatus, two men can

easily clean from twelve to fourteen engines a day. Under constant inspections and frequent repairs an engine will last thirty years and more. Its life largely depends upon the

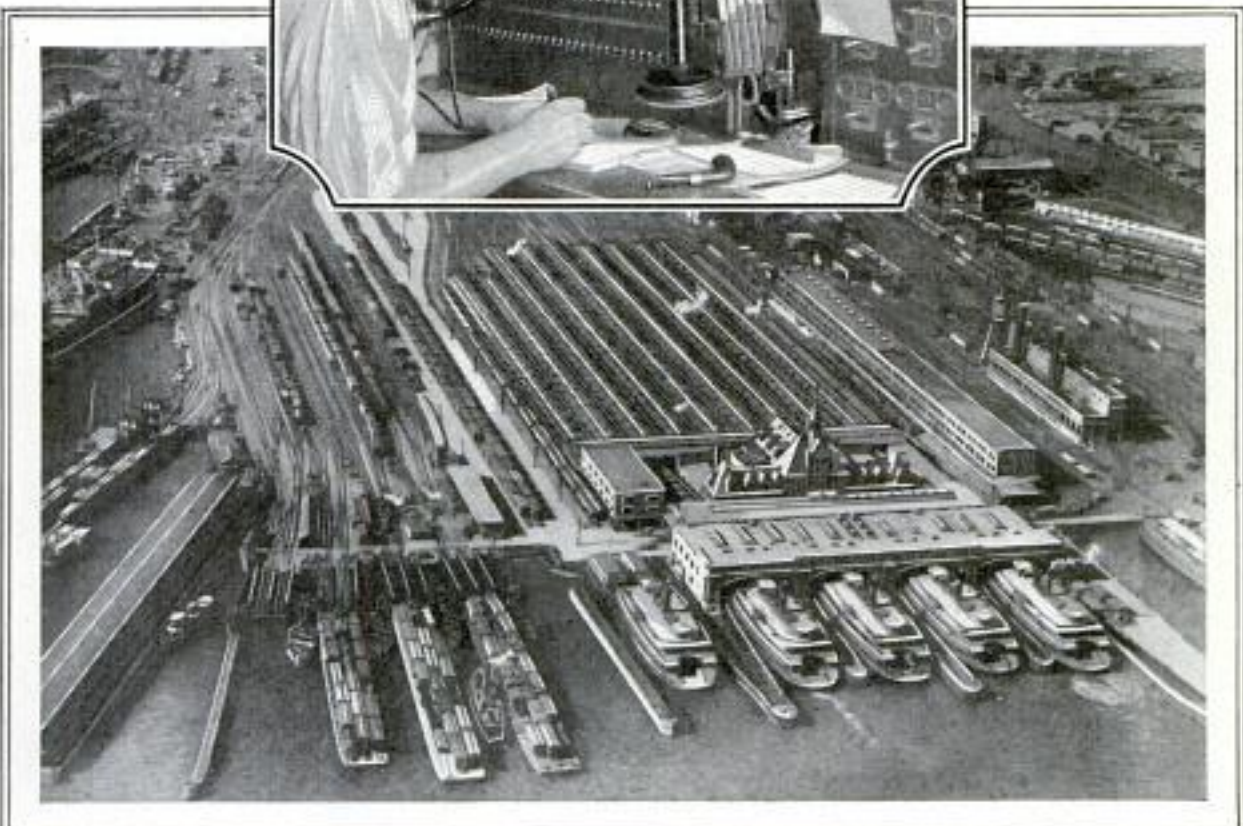

Upper Photo Copyright, Ewing Galloway

From Their Offices, Cool Dispatchers, by Orders Spoken through Selective Telephones, Keep Main-Line Traffic Moving on Their Divisions and Guide Trains Safely into Busy Terminals

boiler, the vital part of the whole mechanism. Physical examinations of the engineer and firemen are conducted yearly after the men are past forty years old and they are constantly kept on the alert for the chance visit of an inspector.

When the train pulls out, its entire passage through the terminal is marked on a chart by the little green lights set at intervals along the pattern of the actual course of the track so that the lever men may follow the train's procedure through the area and set the signals properly as directed by other lights that flash below the lever handles. As the train puffs along past the switchtenders' stations, word of its passage is relayed by telephone from each station to the next one in advance. The dispatcher receives no report of it until it is outside the yards when it comes under his supervision.

"Alton Junction—No. 54—8:18" is the cryptic message the dispatcher receives. This gives him the name of the station calling, the number of the train and the time that it passed. He enters this information on his daily report of the train movements kept on a huge closely ruled sheet lying on the desk in front of him.

Similar messages come in as the train flashes by other stations. The dispatcher is the czar of all train movements in so far as they affect the main tracks on his

division. In his mind he has a picture of every foot of track and siding in his territory; he knows just how long a train can be accommodated in a certain block; he knows the running time and class of every train and is also able to judge almost to the second just how fast any engineer could get his train to the next point in case of emergency, a bit of strategy being necessary frequently and aided in successful operation by the fact that the names of the train crew also have been entered on the report sheet. His work is done entirely by telephone, the telegraph conveniently installed on his desk being used only when the telephone breaks down. Before him is a selective switchboard on which by the turn of a key he can call any one of the stations under his supervision. His wire is directly connected to each of the stations and they in turn have separate connections to each other.

Although today there are 375,000 miles of rails in the United States, carrying the lifeblood of commerce to the ends of the nation, in 1830 there were only twenty-three miles. What has been accomplished has been the result of the skill and genius of one of the nation's greatest industries.

According to veteran railway men, however, the day of the steam locomotive is passing and the shadow of the giant electric engine is on the rails.

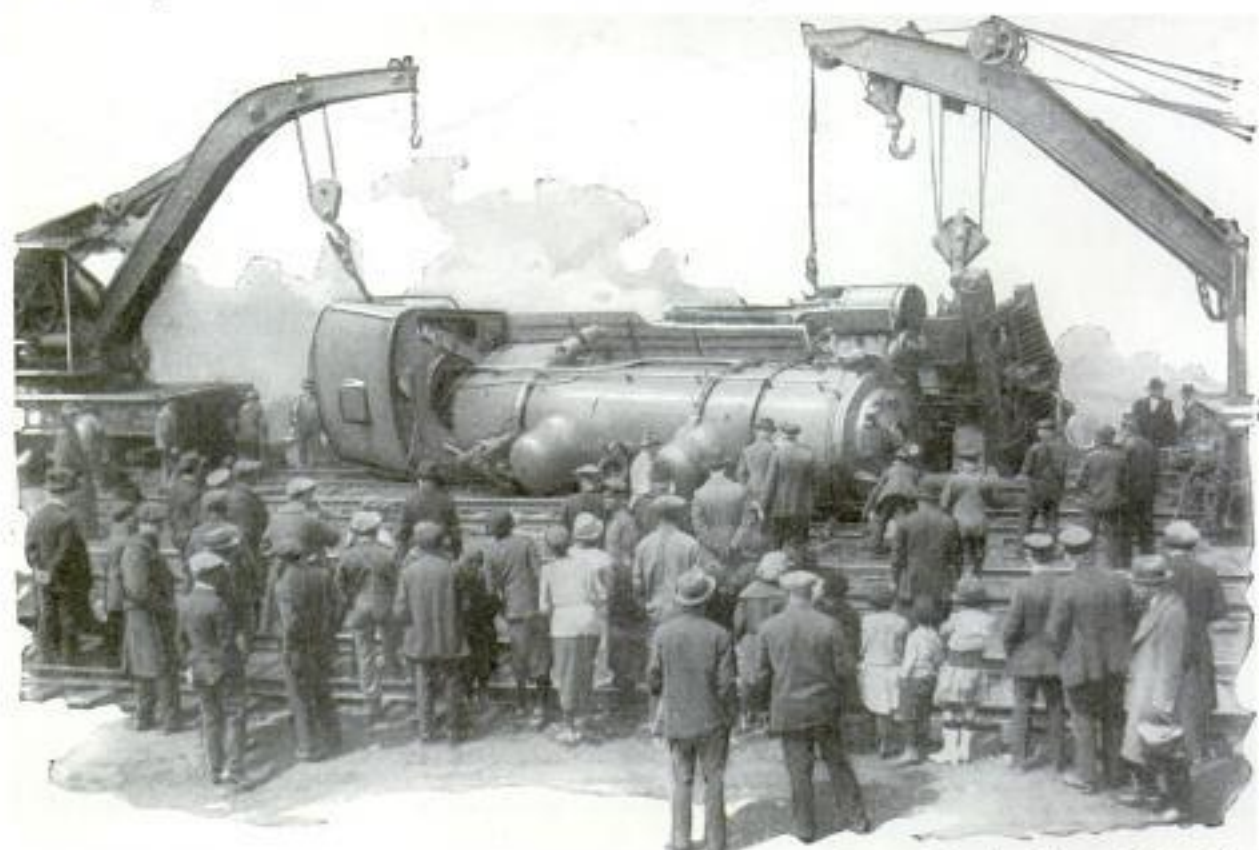

When Every Safeguard Human Ingenuity Has Devised Fails, and Wrecks Occur, Wrecking Cars and Powerful Cranes Quickly Clear the Tracks and Raise the Fallen Giants of the Rails

Lee's Statue on Mountain So Big Twenty Could Sit on Hat

So large are the figures being carved for the Confederate memorial in the granite side of Stone Mountain, in Georgia, that on the hat brim of the statue of General Robert E. Lee, the center of the group, twenty people could be comfortably seated. The excavation between two of the heads of the statues is seventy feet high, sixty feet wide and seventeen feet deep. With only a small part of the sculpturing accomplished, fifty-five carloads of stone have been cut out already. The work is laid out to be carried on from the top downward, the legs of the horses on which the figures are seated being the last to be finished. The heads of the characters each cover an area of almost thirty square feet, while the animals' heads measure fifty feet from ear tip to nostril. Along the neck of one of the horses, a large banquet table and 120 people could be easily accommodated. The task is said to require three years to complete.

Ship Built on Land Is Movie Theater and Bathhouse Combined

Built in the form of a ship, a structure at Portsmouth, N. H., has wide sun decks and serves as a movie theater and bath-

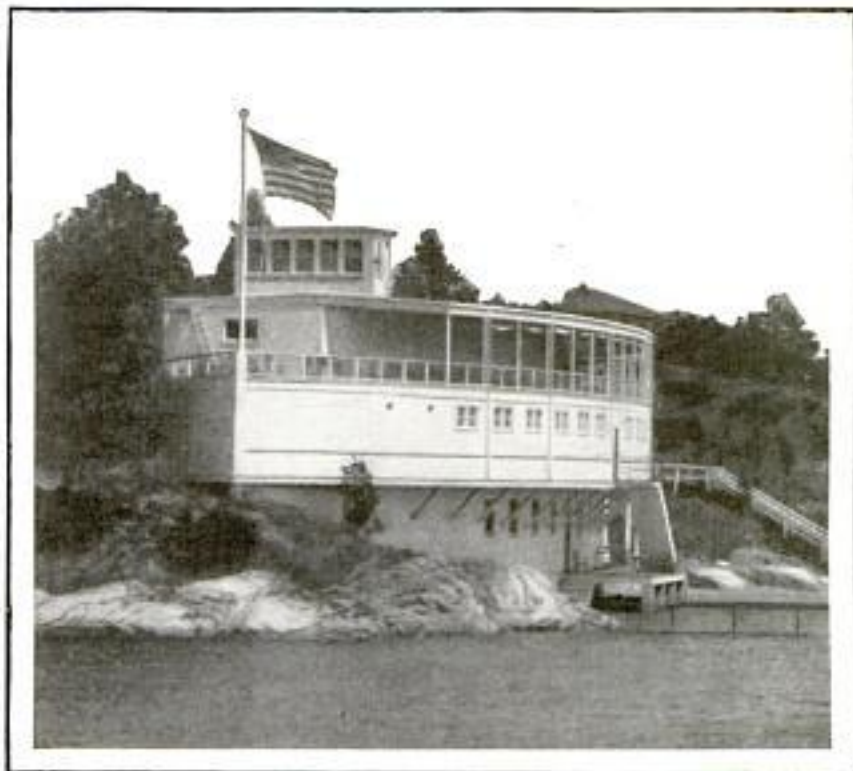

Ship-Shaped Bathhouse and Movie Theater Combined Where Guests of Resort May Lounge on Shaded Decks Overlooking Sea

Toy Figure of Policeman on Auto Serves as Traffic Signal

Fitting over the auto taillight, a stop-signal device modeled after a traffic policeman, has been placed on the market by a western company. Movements of the arms of the figure indicate stops and right or left turns and are easily controlled from the dashboard of the car. The model is about a foot high, and is finished in blue, to match the regulation police attire, or may be had in aluminum. Signals are plainly visible to motorists in the rear and the device is easily installed.



house combined. It is 150 feet long and lies close to the water's edge. The lower sections are devoted to accommodations for those partaking in water sports, while the upper part is arranged with awnings and chairs where guests may lounge or promenade on deck. The inclosed auditorium also can be used for the staging of theatricals and similar purposes. Motion-picture shows are held regularly for entertainment of the visitors.

Air Mail Rushes Asbestos Suits to Oil-Fire Fighters

Asbestos suits for the use of fire fighters combating a burning gas well near Cheyenne, Wyo., were rushed to the scene by air mail planes. Manufactured on an emergency order at the rate of one a day, each garment was sent to the postal flying field as soon as finished, and started on its way, traversing the entire length of the night-flight zone of the cross-continent route. Delivered to waiting automobiles at the destination, the suits were speedily carried to the fire.

The Clark Signal Co. Joplin, Mo.
313 E. 3rd St.

Chicago Herald Ex-aminer
7/29/24
1617

Pacific Atlantic Photos
25 Park Place

734

POPULAR MECHANICS

New York City
**Liners Provide Luxury for Horses
on Trips across Atlantic**

1531

Transport of valuable race horses between foreign and American tracks annually involves tremendous expense to the

a specially constructed crate is used. It is just large enough for one horse and a groom and is slung from the ship's crane by four chains, one at each corner. The crate is swung to the deck in front of the stall, the end removed and the horse coaxed and petted until it will enter. Tied securely and soothed by the groom, the racer is generally blindfolded before the signal for hoisting is given. The transfer to the docks takes only about two minutes and the horse is put into a motor van that speeds directly to the stables.



Unloading Epinard, a \$300,000 Racer, from the "Beren-garia" at New York City Docks

owners and to steamship companies in preventing injury to the high-strung animals. Special box stalls are built on the baggage decks of the liners and are padded with pneumatic cushions. The upper halves of the quarters are detachable and are removed during the day to permit entrance of light and air. Often quantities of hand-picked fodder and supplies of drinking water from the home stables are taken along to prevent stomach disorders on the voyage. Veterinarians and grooms are in constant attendance, watching over their charges as vigilantly as the most attentive traveling companion to a pampered millionaire. Landing the racers is a ticklish job. For this purpose,

1654

Birds That Topple Steeples

The stopping of the large clock in the tower of an English church, due to jackdaws having built their nests in the works, has called attention to the damage done by these birds. They seem to have a special liking for steeples and similar high places, and often cause such structures to become weakened and to tip owing to constant pecking at the mortar of the masonry. One spire threatened with collapse was found to be crumbling from the attacks of swarms of young jackdaws housed in the interior. They were gathered and lowered to the ground in buckets and the openings through which the old birds gained entrance to the tower were screened.

Chicago Daily News
8/2/24

Pocket Volt Tester in Handy Case
1475 Saves Electrician's Time

For electrical mechanics and repair men, a pocket volt tester has been devised to save time and eliminate the danger of breakage. It consists of a durable case which holds two low-voltage lamps entirely inclosed and protected. Low signal circuits from six to twelve volts and higher voltages from forty to 700 can be tested by switching the plug. In case one of the lamps is put out of commission, it may be short-circuited and the other used. The leads may easily be extended to any length. Tests for high-resistance ground indication, field discharges and other inspections may be performed.



Mfr. George W. Weisford Jr.
5415 Thomas Ave
Phila



Measuring the Scarred and Stalwart Trunk of the Venerable Juniper Tree That Scientists Say Is at Least 3,000 Years Old and Possibly Antedates the California Redwoods

Juniper Twenty-Eight Feet Around Is Three Thousand Years Old

Possibly more ancient than the venerable California redwoods and known to be at least 3,000 years old, a scarred and weather-beaten juniper tree near Logan, Utah, is twenty-eight feet in circumference. Ordinarily, this species does not grow to be more than six or seven feet around. Those who have examined its twisted branches and trunk declare that it may have sprouted 6,000 years ago. It is still vigorous and defiant to storms.

"Scout" Car Measures Auto Roads with Many Dials and Meters 1262

To obtain complete information about motor roads and driving conditions across the country, an automobile equipped with an elaborate array of special instruments was sent out from the east not long ago for a survey of several transcontinental highways. In addition to the regulation gauges, the auto carried a grade meter, altitude meter, thermometer, barometer,

an adding machine, special gasoline, oil and water gauges, memoranda pads and other devices. The lubricating system was so adjusted that the car could be oiled completely by simply pressing three but-

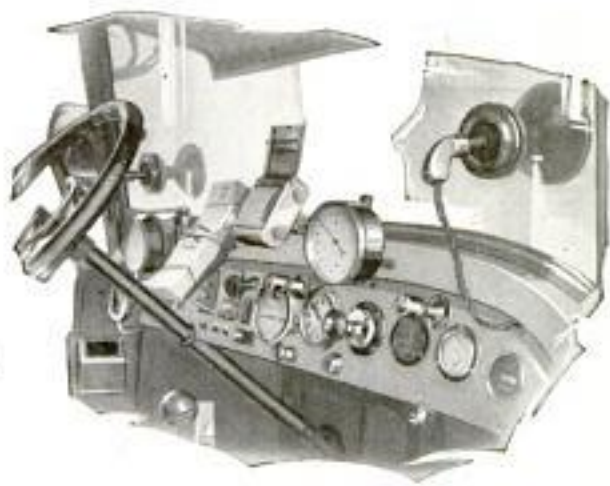

Instrument Board of Auto Specially Equipped to Register Wide Range of Motoring Information

tons. From the detailed "log" of the journey, motoring information for the public is to be compiled.

Kadel & Herbert.
153 E. 42nd St. New York

Pacific + Atlantic Photos, Inc.

136

*25 Park Place
New York City*

Millions of Fingerprints Filed in National Crime Bureau

1623

To co-operate with police at home and abroad in tracing and identifying criminals, a national fingerprint bureau has



C. D. McKean, Chief of the Federal Identification Bureau, Examining Fingerprint Records

been established by congress as a branch of the department of justice. Already over \$50,000 has been appropriated for the work, and more than 1,000,000 fingerprints are now on file there. The bureau is to serve as a central information office, and its records at all times will be accessible to the proper officials. It is expected that this office will be of great help to cities that do not now have complete identification files of this sort, and greatly assist in the capturing of international crooks.

Spark Plug Cleaner Has Many Uses and Fits in Pocket

1435

With a long, tapering metal point at one end and a small hard wire brush at the other, a novel little device has been

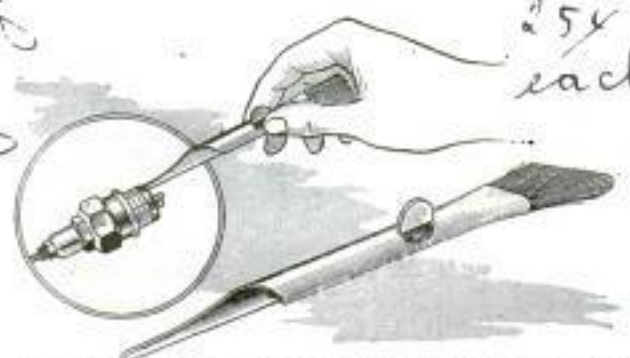

Pocket-Size Cleaner with Brush Tip and Sharp Point for Scraping Spark Plugs

*E. H. Engineering Co.,
Chicago, Ill.*

25¢ each

placed on the market which can be used for cleaning spark plugs or smoking pipes, repairing punctures and doing many other things, it is claimed. Carbon is scraped from the inside and bottom of the spark plug with the sharp point, while the brush will give a cleaner finish to firing and electrical-contact points than can be obtained with emery cloth. It is not necessary to take the plug apart and the tool will not break, chip or crack the porcelain. When repairing punctures, the wire bristles will thoroughly clean the tube around the tear, leaving a rough surface so that the cement will hold the patch securely. With the pointed end, the hard cake in a pipe can be easily loosened, and the brush will rub away the smaller pieces, leaving the sides smooth. About the size of a fountain pen, the device can be carried in a vest pocket.

1174

Surface Temperature Is Measured by Generating Electricity

To determine quickly and easily the temperature of heated cylinders or rollers, a novel hand instrument has been introduced by a British firm. A small casting provided with a handle is supported on four wheels made of heat-insulating material. Underneath the casting, fitted to a springy steel strip and touching the surface of the cylinder, is a thermocouple, or wires of dissimilar material that will produce electricity by the direct action of heat.



When brought into contact with the hot surface, the wires quickly generate electricity and the voltage produced indicates the temperature. A small cable leads from the device to a meter that measures the thousandth of a volt. The scale is graduated in degrees, so that no further calculations are necessary. To eliminate any corrections for the temperature of the room, provision is made for setting the indicator of the meter to the same degree before any readings are taken. The instrument is said to have proved of great value to industries which require cylinders maintained at a certain temperature. Another advantage claimed is that it can be run over the whole surface to learn whether the entire cylinder has been heated evenly.

London, D.W.I., England.

*The Cambridge and
Paul Instrument Co.
45, Grosvenor Place*

Lake Turned into Land to Add Vast Area to Park System

ADDING another 1,500 acres to a city's parks, at the expense of Lake Michigan, a novel project now under way, will, when completed, furnish an unrivaled system of island boulevards, linked together and to the mainland by bridges.

In the days of the first settlers at old Fort Dearborn, the mouth of the Chicago river was located where Michigan boulevard now crosses the stream. Today the river mouth is a half mile east, pushed farther and farther into the lake by the need of water-front land for warehouses and terminals.

North of the river a tract approximately one-half mile wide and three-quarters of a mile long is all made land, and, with the improvements upon it, is valued at far in excess of \$150,000,000. Great hotels and clusters of huge apartment buildings have pushed up where once the fish played in the lake. One of the largest



Navy Photographer Shooting the "Picture Gun" in Cockpit of Flying Boat

U.S.N.

office buildings in the world is nearly a half mile out into what was the lake. Popular Mechanics building itself is on made land, for a survey in 1821 by Captain Crim, an army officer, shows the lake shore to have been fifty feet west of



Copyright, Chicago Aerial Survey

Building an Island Inclosed by Concrete Sea Walls and Piles, While Sand Dredges Pump New Land into Place; Square Approaches on Shore and Island Show Future Bridge Sites

it. Opposite the business section of the city, Grant Park, a broad, treeless expanse which is to be converted into botanical gardens, and the yards and warehouses of the lake-front railroads have been reclaimed from the waters. On the north side, much of Lincoln Park, with its system of lagoons, was once in the lake. South of Grant Park the new Field Museum and the huge stone municipal stadium, now under construction, stand on recovered soil. The new projects now under way, however, are more important still.

Southward from the Field Museum, for over five miles and a half, an outer parkway is being built along the shore, while paralleling it, out in the lake, dredges, pile drivers and sand suckers are raising a chain of five long islands, to be joined to each other and to the shore parks by bridges. Over these islands will pass a direct boulevard from the far south side to the center of the city. This project alone will add 1,100 acres to the park system. Between the islands and the shore parks will be a series of connecting lagoons, for canoeing and small-boat races, and on each island will be one or more of a series of public bathing beaches. When the entire project is completed the lake front will be lined with a chain of public beaches for more than ten miles, capable of accommodating more than a million bathers at one time. Eventually, the island parks will be continued northward, with a bridge across the river, to connect with the outer park system of Lincoln Park, where a good part of the lake drives are already in operation. To the north of Lincoln Park the lake front is being shoved eastward 1,100 feet for a distance of three miles, adding 400 acres of parks and a series of bathing lagoons and boat harbors. The romance of the invasion of the lake has had many stirring figures, but none more so than that of Captain Streeter, who laid claim to the area which now houses hotels, apartment houses and other buildings valued at more than one hundred million dollars. Captain Streeter, a lake sailor, was driven ashore one stormy night more than

thirty years ago, his schooner coming to rest on a sandbar. Unable to put to sea again the captain settled down to make his home on his dry-land boat. Then the lake began drifting sand about the boat, and gradually an island took form. Captain Streeter, with the assistance of other squatters who had rallied around him, gave the lake a bit of help, and soon a sand spit joined the island to the mainland, and gradually acre after acre arose from the lake's depths. Streeter laid claim to the territory, which he named the "District of Lake Michigan" and contended it was outside the jurisdiction of the state of Illinois.

For years he defended his claims in the courts and on the scene, fighting several pitched battles with police and detectives who tried to evict him. The captain and his "army" of squatters wrote many pages of colorful history before the highest courts eventually ousted him, upholding the principle that natural accretions belonged to the property owner with riparian rights on the shore, but that the lake itself belonged to the state, and any artificial tampering with its bed to raise it above the surface did not affect the state's ownership. From the earth the gradual conquest of the lake proceeds so evenly and covers so great a territory that it passes almost unnoticed, but from the air the mag-





Photo by Aerial Photographic Service, Inc.

Dotted Line Shows Old Lake Front before City Began Reclaiming Land: All Work Is Complete Except Three Upper Lagoons

nitude of the project becomes visible. From above, long rows of piles, placed with exactness in long curving scallops, etch the shore lines of the future parks. At intervals they thrust their way out into the future lagoons.

Where the invasion of the lake by the city will stop, no one can tell. The lake, being navigable, is under the control of the war department, and no work can be done without a special permit from Washington, as well as a permit from the state.

The ground already reclaimed, since Captain Crim made his survey in 1821, is estimated at 130,680,000 square feet, while 2,613,600,000 cubic feet of lake water has been displaced by land. The flow of the Chicago river, which, since the city turned it around, now empties out of the lake into the drainage canal, is regulated at 10,000 cubic feet a second. At that rate the water displaced from the lake by new land would be sufficient to keep this river, with its twenty-two-foot-deep navigable channel, going for seventy-two hours and thirty-six minutes.

Aerial photography, with its all-seeing eye, has become so important in recent years that the dredging companies have frequent aerial views taken to show the progress of their work. The photographs are superseding blueprints and maps, because they show every line of the work.

1660 Auto Club of
Southern California

740

POPULAR MECHANICS

Figueroa and Adams St. Los Angeles, Calif.

Auto with Airplane Compass Helps Map Makers Survey Roads

Fitted with an airplane compass, an altimeter and various other instruments, an automobile has been sent through southern California to chart roads and make



Instrument Board of the "Pathfinder" Automobile, Showing Compass, Altimeter and Other Devices

maps for the members of an auto club. The machine's apparatus greatly simplifies the task, as most of the information necessary is furnished on the dials. By keeping careful watch of these, the mappers can gather data for their purpose.

Federal Pure-Food Law Violations Now Total Twelve Thousand

Since the passage of the pure-food and drugs act in 1906, there have been 12,000 seizures and prosecutions based on adulterations or misbranding of foods and medicines, according to reports from the federal bureau of chemistry. More than 600 of these cases have concerned shipments of eggs; 100 and more, adulterations in flour and approximately 1,000 court actions were necessary to deal with lots of dairy products of all kinds. Canned goods have been subjected to rigid scrutiny, and vigilance in this regard, according to government officials, has been rewarded by noticeable improvements in the quality of canned tomatoes, catsups and fish, especially salmon. The act requires that all foods in package form be clearly labeled to show their contents and quantity, so that purchasers may know just what they are getting. Failure to print labels according to the law caused many prosecutions.

Out. Mrs. Frances S. Coleman,
3315 Montgall Ave.,
Kansas City, Mo.

Fear Tests with a Breaking Chair 1705 to Aid Insanity Cure

With the aid of a collapsible chair, Dr. W. E. Blatz, of the University of Chicago, is able to arouse experimentally the emotion of fear. The seat is electrically operated and made to break down with the weight of the occupant when a control is released. Unaware of the impending collapse, the patient clutches wildly for support and delicate electrodes, strapped to his arms and connected with a recording device in another room, register the effects of the fright on heartbeats and breathing organs. The inventor believes that the chair may be employed to study and treat various forms of insanity which make themselves evident in abnormal emotional states.

Way to Stop Loss of Electricity 1031 Is Sought by Engineers

With engineers advocating plans by which all large power plants in one section of the country will be interconnected into a common system to distribute the power, more attention than ever before is being directed to high-tension lines. Careful tests are being carried on to determine the character of high voltages. New types of insulators are being designed, built and tested. All kinds of cable are being subjected to high test voltages to determine the leakage under various conditions, and the whole tendency is to discover the best means of transmitting electrical energy

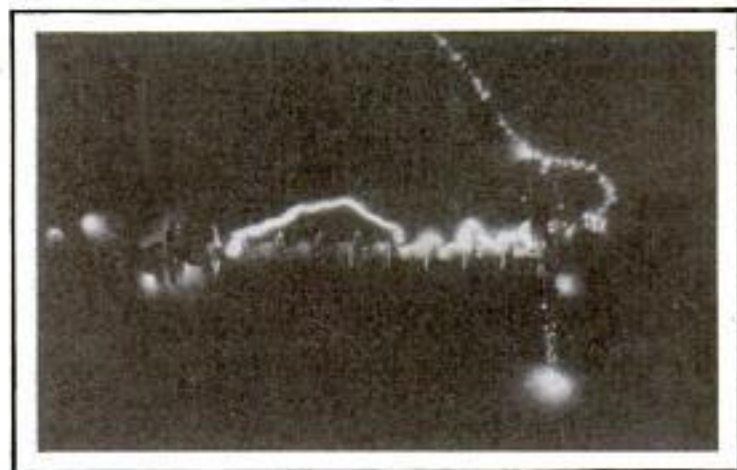

Aurora-Like Glow Caused by the Escape of Current from High-Voltage Electrical Contacts

from the large central station to the consumer, who only demands the best service. The highest tension in use at present is upward of 120,000 volts.

Cont. L. Scribin,
123 State St.,
W. Lafayette, Ind.



Rows of Canines' Graves in Dog Cemetery, Where Headstones and Wooden Markers Indicate the Tiny Mounds

Cemetery for Dogs Has Marked Plots to Indicate Pets' Graves

Containing the graves of nearly a thousand dogs, a cemetery in Pennsylvania, established exclusively for canine pets, has each plot marked with the name of the animal buried in it. Most of the burial spots are indicated by neat wooden signs but many have elaborate marble headstones. The inscriptions show the ages of the dogs and their owners' names. The mounds are kept in repair and fresh flowers and plants are regularly added.

Snow Is Stored in Earth in Winter and Sold as Ice in Summer

In some of the smaller towns of Europe where a supply of ice for cooling foods and drinks during the long, hot summers is important and where neither artificial nor natural ice is available, snow is stored and packed into cone-shaped pits dug in the earth where it freezes into solid lumps. After storms, gangs of men shovel the snow into carts and haul it to the pits and pack and tramp it down as hard as possible. When the heap is nearly level with the top of the pit, it is covered with a foot-thick layer of earth as a means of protection and insulation. In summer it is sawed into oblong blocks and sold in the town.

Call to Aid Crow Shooters Lures Birds toward Gunners

745 For the use of sportsmen and farmers, a crow call has been made that can be easily taken apart and adjusted to either a coarse or fine tone. It is said that variations of the birds' cries have different meanings and the device is constructed to imitate almost any note. By moving the mouthpiece of the instrument, the pitch of the sound may be raised or lowered easily. The call was designed to aid in efforts to keep down the numbers of the crows which, in many neighborhoods, have become a menace to game and useful birds.



Crow Call, Which Can Be Adjusted to Imitate Various Signals to Lure Birds to Gunners

E. d. du Pont de Nemours Co.,
Wilmington, Del.

Painters on Top of Eiffel Tower Risk Lives on Slender Cables

1569 Overlooking Paris, the Eiffel tower, 984 feet high, one of the world's tallest structures, is kept safe for visitors by steeplejacks and periodically risk their lives on slender cables and in fragile steel beams and girders as protection against

stakes are millions of dollars and to speed the precious cargoes, the swiftest steamships and specially guarded trains, known as "reefers," for which speed limits are waived and tracks are cleared even to palatial passenger limiteds, participate with seaplanes and airplanes in carefully arranged, secret schedules. The world's record on the Yokohama-New York silk course was established not long ago when the orient was brought within thirteen

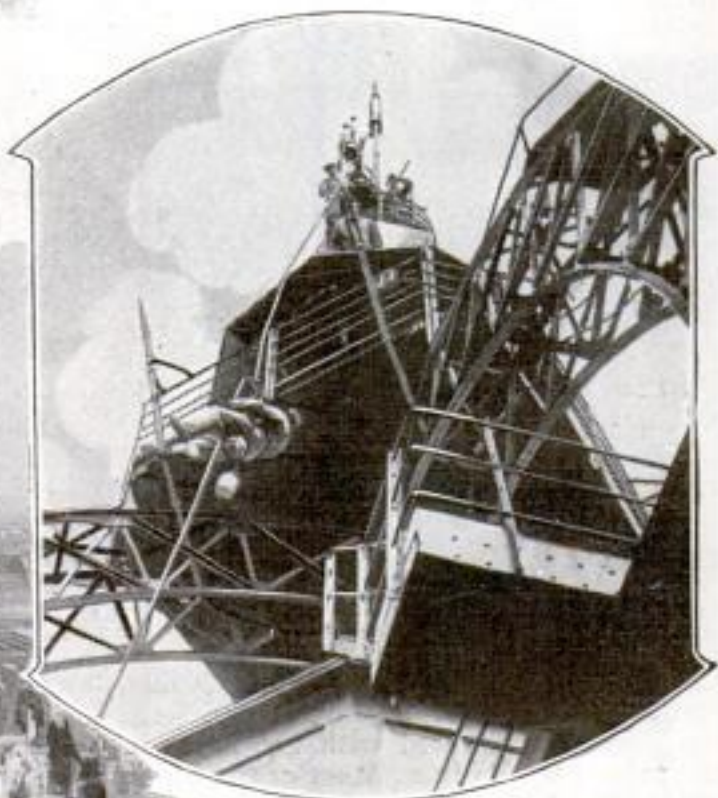
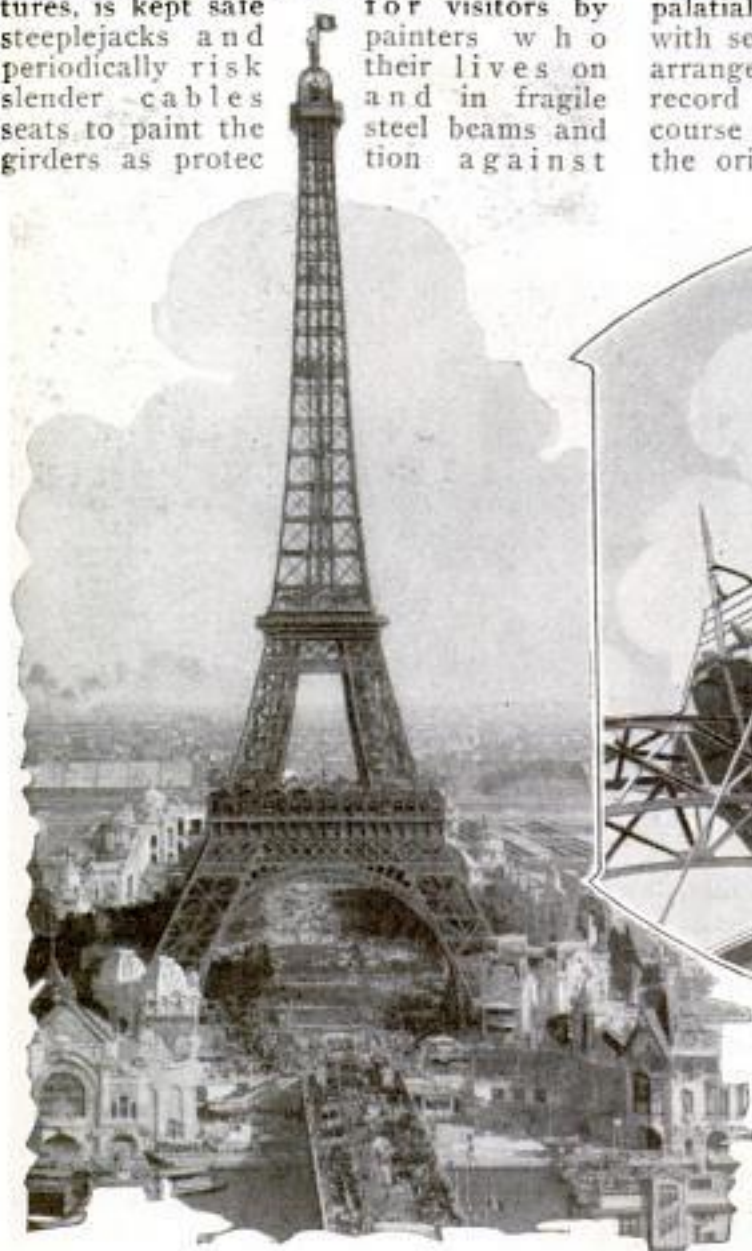

Copyright, Underwood & Underwood
Swinging from Slender Cables at Dizzy Heights Near the Tip of the Eiffel Tower, Painters Search Out Every Niche and Crevice in the Vast Network of Steel and Apply Protective Coatings to Combat Rust

rust. With their buckets slung at their sides, the workers sit in bos'n's chairs which are attached to the cables by a clamp arrangement to permit lowering as the work advances. Breezes sometimes blow with considerable force here and helpers are on hand to steady the ropes.

Precious Cargoes of Silk Carried on Closely Guarded Trains

1699 One of the most dramatic of all the races staged by trade against time occurs in the shipping of silk from Japan to New York. The course is 8,300 miles; the

days, three hours and eight minutes of Manhattan. Loaded with five and one-half million dollars worth of raw silk, the steamer "President Jackson" made Seattle on the ninth day. A mail seaplane met the boat at Victoria, then flew to Seattle, one hundred miles away, with port documents and cargo papers to be forwarded to New York before the steamship docked. In three hours, the silk was inside a 12-car train waiting with steam up and its armed guards ready for the dash eastward. Fast passenger trains make the trip to Chicago in seventy hours but the "reefer" clipped five hours from this schedule. In the shipping of silk, which, weight for weight, is the most precious commodity carried next to gold and silver bullion, time is literally money.

Kansas City Star
8/11/24

**Death of Laughter and Jokes Seen
1656 As World Becomes Wiser 1656**

An age when everyone will be too intelligent to see humor in anything is predicted by Dr. C. G. Shaw, of New York university. When all people are fully educated and developed, no one will smile if a man loses his hat in the wind, slips on a banana peel or sits down on the headpiece, in the opinion of the scientist. People laugh at what they do not understand, he says, or what seems to be inferior to them, as was the case when scoffers derived a great deal of amusement from the theories of Columbus and Galileo. Jest and funny drawings to illustrate jokes will be preserved in public institutions for the benefit of visitors who may learn of the "age of laughter" only from such relics and historical works, he declares.

*New York Times
8/3/24*

**Music-Roll Boxes with Hinged Ends
Permit Easy Access to Records**

For the convenience of piano-player owners, music-roll boxes with hinged ends have been manufactured so that records can be withdrawn or put back with little trouble. The exposed drop front bears the name of the roll and is pulled out easily

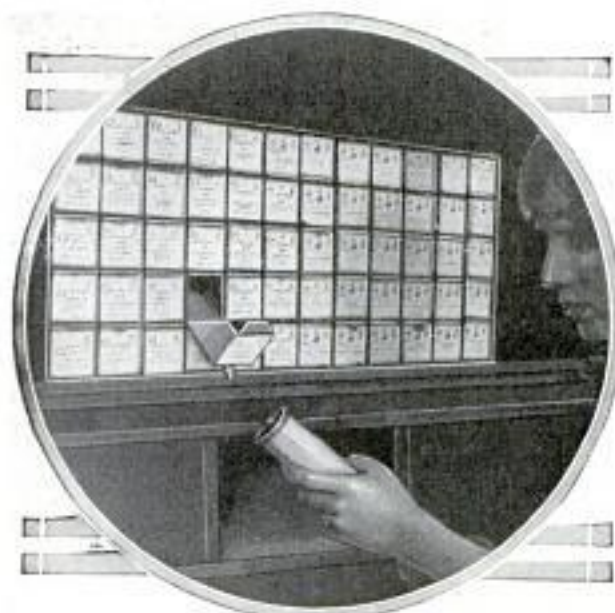

Selecting a Piano-Player Record from Pile of Boxes without Disturbing the Others

with a tab. Piled on top of the piano or in any other convenient position, rows of the containers are as handy as a filing cabinet. Any record can be quickly selected without removing the box or disturbing the others.

*I. B. S. Music Co.
Kymball Hall, Jackson
Blvd. + Wabash Ave
Chicago*

**Models of Flowers Teach Pupils
Beauties of Plant Life 727**

To teach school children the beauty of wild flowers and the importance of preserving them, the public school ex-



Copyright, Underwood & Underwood
Floral Modeler of the Field Museum and Case of Blood-

A. B. Wilcox

Root Blossoms
tension department of the Field Museum of Natural History has prepared life-size models of plants and blossoms common to the middle west. They are arranged in groups and sent to the schools in cases about two feet square together with an enlarged colored photograph of a woodland scene that may be set up as a background. The blossoms and leaves are modeled in wax, cotton and celluloid and are carefully colored in natural hues. With each case, the museum supplies a brief story of the flower as the basis for the teacher's talk.

**Self-Adjusting, One-Hand Wrench
1057 Grips Pipe or Bolts**

Quickly adjusted to various sizes of pipe or nuts, without thumbscrews or other devices, a strong steel wrench that grips from the front between especially tempered ratchet jaws, has been designed for many purposes. It is prevented from slipping off while being turned or when the hands are removed by a stout spring that holds the jaws tightly to the work when once adjusted. This wrench has been found specially convenient in close quarters, for instance, where a pipe lies against the wall, and for many purposes about the automobile.



\$1.20 - \$2.95

*How Corporation,
Copyrighted material
Poughkeepsie, N.Y.*

Cont. Esardner Wilson
 1816 Straus Bldg.
 POPULAR MECHANICS
 Michigan + Jackson Blvd.
 Chicago

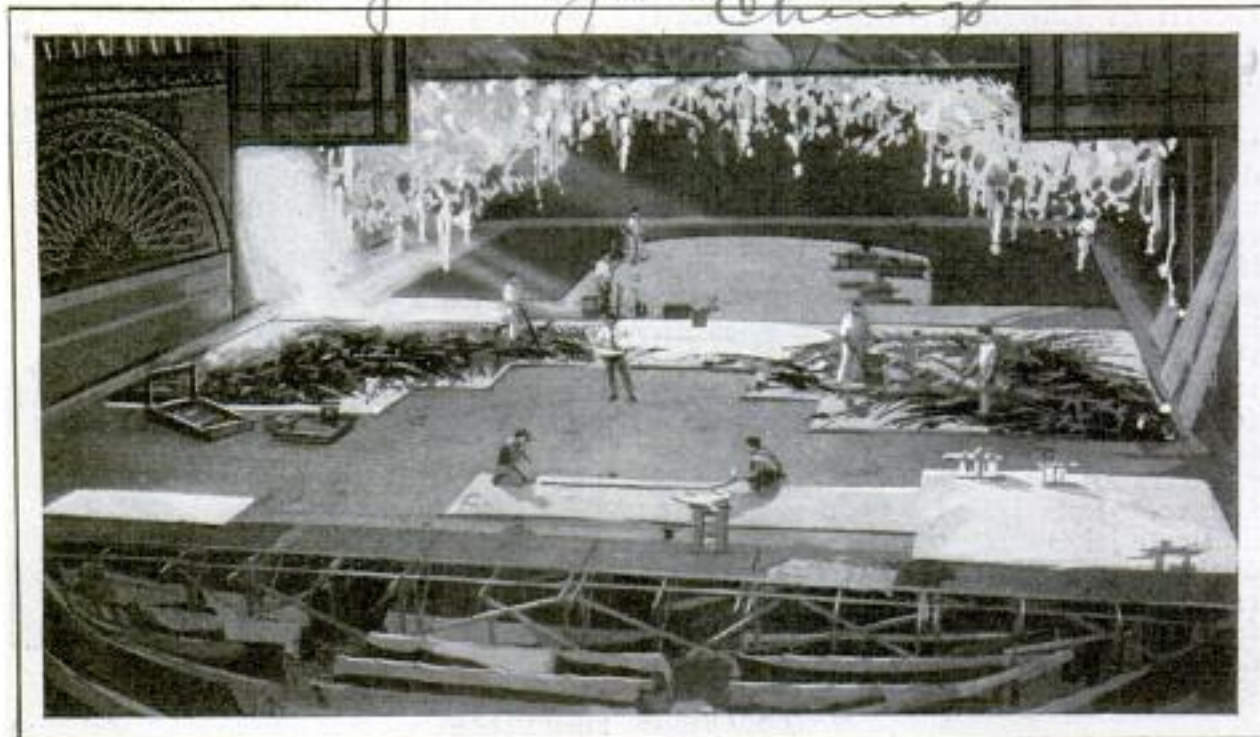

In Turning a Large Theater into a Studio, Platforms Built over the Seats and Joined to the Stage Form Gigantic Easels to Hold the Canvases while Busy Painters Ply the Brush

Painting Acres of Scenery for Opera

Close of Season Begins Work of Corps of Artists Who Give Life of Color to Canvas Walls

IF it were not for the skill of the scenic painters and a corps of other stage artisans who ply their crafts during the summer months, the beginning of the opera seasons might not find the brilliant array of properties and settings necessary to an elaborate repertoire, awaiting the first flourish of a conductor's baton and the ascension of the "opening" curtain.

When the last aria has been sung and the final orchestral crash marks the end of the "run," swarms of artists and draftsmen set upon the task of creating new settings for the following season's program of plays, converting the dimmed theater to a gigantic studio where overalls, paint cans and brushes replace glittering costumes and gilded scepters of strutting actors on the stage. The "wings" and "flies" are dismantled, curtains are taken down and properties stored to make room for large palettes on wheels, which are pushed back and forth across the floor of the platform by busy painters wielding long-handled brushes they dip in large containers of color carried by the squat trucks.

Unlike ordinary picture artists, the scenic painter does his work while the

canvas is spread out on the floor and for the preliminary grounds and coats the broomlike brushes are used. About thirty-five tons of paint and 45,000 square yards of gauze, netting and linen are required annually by the Chicago Civic Opera company to complete its scenes for each season's productions. The framework upon which this expanse of colored fabric is fastened consumes more than 80,000 feet of lumber.

The settings for the various operas are first built in miniature by designers whose study of the subjects results in true copies in the finished structures. These models are painted and fitted together in the same way they are to appear on the stage, even small doll figures and lights being provided to demonstrate desired effects. When ready for the artists and builders, the models are given to the stage draftsmen, who make blueprints of the plans, covering in detail every step of construction. The surfaces to be painted are divided into squares one yard wide, which correspond to similar checkered patterns on the blueprints. By this arrangement the outlining artists can see how much

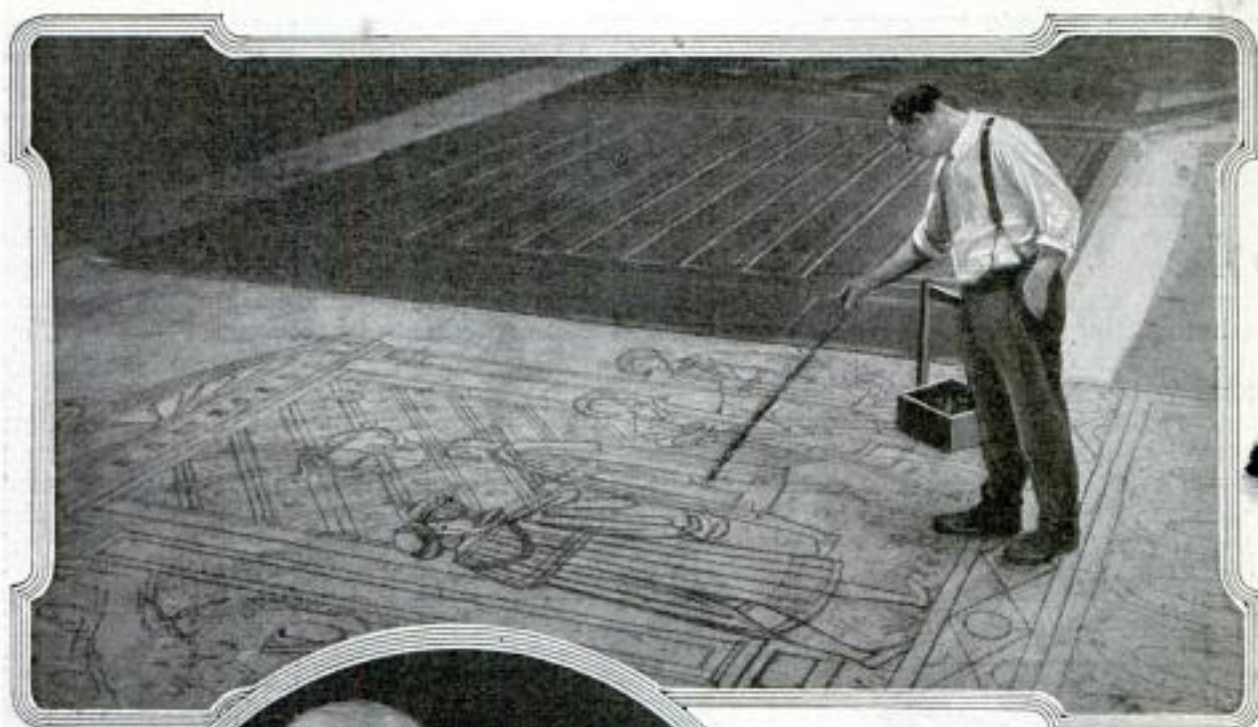

Outlining a Drawing for an Interior Set That Will Serve as a Fitting Background for Brilliant Ensemble. Left, Miniature Model of Opera Stage Made to Accurate Scale for Guidance of Scenery Builders

Scenic Artists Painting Linen and Gauze Fabrics with Long-Handled Brushes They Dip in Troughlike Paint Pots Carried by a Palette That Rolls on Casters So It Can Be Easily Pushed About

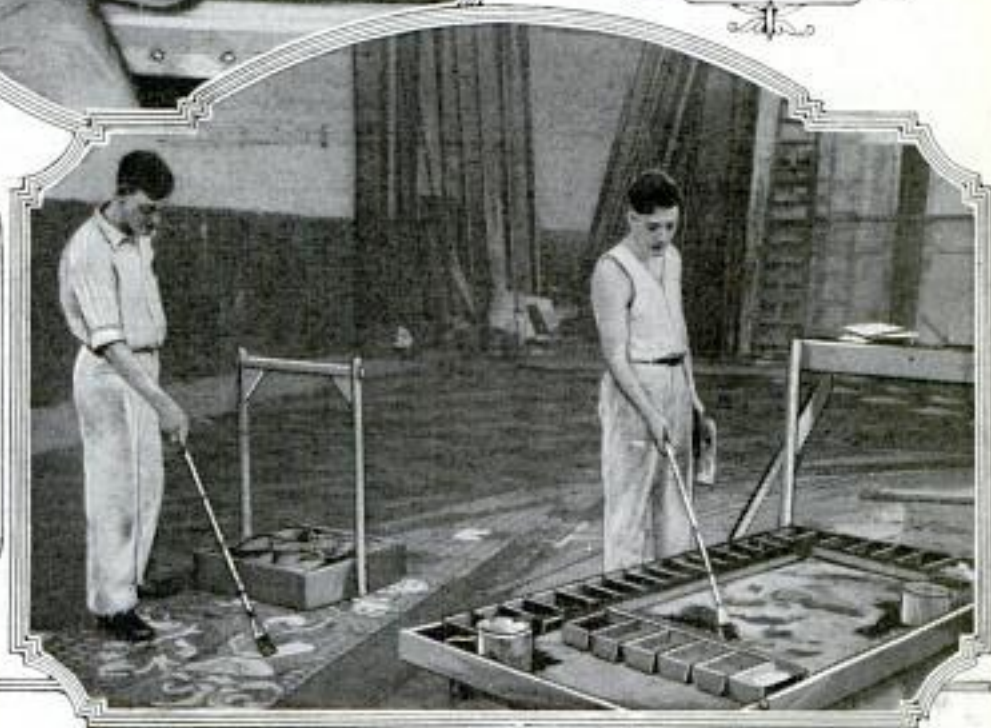

space is permitted for each figure, scroll, or other object which is to grace the canvas wall and aid the painter to follow the drawings with a great degree of accuracy. Following the rougher preliminary coats come the ornamental shadings, edgings and the filling-in of delicate tints. This is done with brushes nearer the ordinary sizes, since careful work is required to prevent a daubed appearance of the finished settings.

As the scenes are completed, they are sent to the carpenter shop where they are cut and trimmed to sizes suitable to the stage. No piece of scenery can be more than five feet nine inches wide, although when viewed from the front of the theater many settings appear to be a

the number of the scene, and its position in the assembled background. This precaution speeds up the erection of the settings and in plays consisting of many scenes results in a great saving of time in getting the stage prepared with the various changes.

During extensive tours the company makes use of many stages of varying dimensions and to take care of these differences, the scenes are constructed so they can be telescoped and "shrunk" to fit. By a system of planning before the painting is started, the designs are formed so that nothing can be concealed or distorted when the pieces are shortened. Careful grooving and constant reference to the scaled miniatures insure this "elasticity"



Scenic Painters Working Up Scrolled Designs on Section of Gorgeous Drop Which Is to Add Color and Reality to Classic Setting for One of the Operas of Elaborate Repertoire

solid unbroken mass of decorated material. This effect is the result of hinging the separate sections together so that when they are opened out, the edges will seem to blend with each other. Cutting and joining the different parts require skill of experienced craftsmen, as the beauty of design cannot be sacrificed to size. As a guide to the trimmers, the models are again brought into service, giving the carpenters an accurate scale from which to work.

All windows built in the settings are backed with strong wire netting and when the canvas is attached to this with rubber screen, the appearance of genuine glass panes is obtained. Each section of a set is plainly marked on the back with the name of the opera to which it belongs,

while the canvases are being adjusted to the frameworks in the carpenter shop.

In a single summer season between five and ten operas are painted by the artists. Such a task generally calls for more than a hundred workmen. At the large operatic theaters the stage is enlarged to accommodate the painters, notwithstanding that the platform is among the largest in the country. Scaffolding is erected over the seats of the main floor of the theater and temporary flooring is laid down to extend more than halfway across the house. Using this as an easel, the canvas and other fabrics are spread out, allowing plenty of room for the artists and their wheeled paint pots to move freely about the tasks. When finished, the scenery is carefully stored in protecting racks.

Conl. Laura Jane Zivshig
30 E. Ontario St.
Chicago

Electricity from Windmills Seen as Relief from Coal Cost 1911

Further attempts to harness the winds are reported from France where engineers are said to be contemplating the construction of a number of two-bladed windmills, each with a radius of 100 or 300 feet, to generate electricity for light and power and thus escape the excessive cost of imported coal. The type was devised after a series of experiments on top of the Eiffel tower to find the best means for utilizing the power of the wind. It is estimated that the smaller mill will give fifty horsepower in a thirteen-mile wind and the larger ninety. They are expected to afford 240 and 400 horsepower respectively when the wind blows twenty-two miles an hour. At a central control station, the varying currents from a number of the mills will be transformed into one of constant intensity for the consumers.

Military Use

War Tanks Turned into Tractors Fill Thirty-Acre Lot 1068

French tanks that were originally intended to sweep over "no man's land" were recently unloaded at Los Angeles, solidly packing thirty acres of ground. The entire lot had been transformed into tractors for tilling American farms. The huge collection had lost the wartime armor and

Harbor



Thirty Acres of Wartime Tanks Transformed into Fleet of Powerful Tractors for Tilling the Farms

taken on the appearance of efficient "caterpillars," each with power enough to do the work of several horses.

Pacific + Atlantic

Nearly Half of the Arctic's Insects Represented in One Box 782

Within the space of a small box, specimens said to represent nearly one-half of the living creatures found in Arctic



Copyright, Underwood & Underwood
Case Containing Specimens of Nearly Half of the Insects to Be Found in Arctic

regions are preserved in the National Museum, at Washington, D. C. They form a collection of flies and mosquitoes, some of them having been obtained within 550 miles of the north pole. There is no vegetation in most parts of this region, so the insects prey on animals and men. Mosquitoes encountered in these northern latitudes are said to be unusually large and have an insatiable appetite during the short summer. Scientists estimate that the insect world has five times as many different species as all other living things put together.

Tree for Treating Leprosy Cultivated in U. S. 1726

Cultivation of chaulmoogra trees, the oil from which has been found effective in combating leprosy, has been started at a government station in Maryland. About 670 of the plants are now being tended and more than 2,000 have been shipped to Hawaii, the Philippines, the Canal Zone and

Porto Rico for transplanting, as there is no place in this country where they will develop fully.

Chicago Evening Post
8/19/24

Rider, Chained to Bicycle, Begins 1244 Trip around World

Chained and manacled to his bicycle, an Ohio man has started to pedal his way around the world. He already has com-



Bound to Bicycle by Chain and Wrist Manacle, Rider Starts Trip around World

pleted several hundred miles of the journey which he expects will take three years, as his progress is limited by his bonds. He must eat, sleep, bathe, shave and do everything within six feet of his bicycle—the length of the chain that holds him. At the start of the trip, the chief of police of Toledo snapped the manacle in place on the rider's right wrist and filled the keyhole with molten lead so that it cannot be unlocked.

896 Camp Oven Holds Cooking Utensils and Clamps on Automobile

So it can be carried on tours, a cooking oven for campers has legs that clamp securely to the running board of an automobile. Made to burn wood, the stove contains compartments holding many necessary utensils. Its size is such that it

Kohl, Hardware Co.,
Ripon, Wis

cannot block the entrance to the car, and it is constructed to protect the contents from dirt and dust. The oven can be easily and quickly set up and dismantled and has a chimney that fits neatly on the inside for packing. Made of strong metal it is said to resist much of the rough usage of camp life.

1688 Sounds Produced by Fish Are Heard through Water Microphone

What sort of a noise does a fish make? This question has been answered in part, at least, as a result of experiments performed not long ago by dropping a water-tight microphone into the tanks at an English aquarium. Each tank seemed to give a different basic tone. With the crayfish, there were noises like the snapping of a watch case. The question as to whether fishes actually emit sounds other than those made in feeding, was not decided.

413 Airman Carries Tiny Welding-Outlet for World Flight Emergencies

One of the most important items of the equipment carried by squadron leader MacLaren, one of the British contestants in the flight around the world, was a small but complete welding outfit. The source of the heat is acetylene gas in the dissolved state stored in a cylinder seven inches long and three inches in diameter. No oxygen tanks are needed as the speed of the gas when entering the burner is used to draw sufficient air into the interior. Two torches are included in the outfit, a "pencil" blowpipe and a high-temperature tube for bigger flame. For connecting the gas cylinder and torches, thirty-five feet of high-pressure rubber tubing are included. The entire apparatus is contained in a neat leather case with shoulder straps.



Innes, Allen, Liversidge, & Co.
106, Victoria St.,
London, E.C. 1, Eng.

1479 Capt. John H. Brant,
2179 E. 35th St.

Cleveland
Ohio

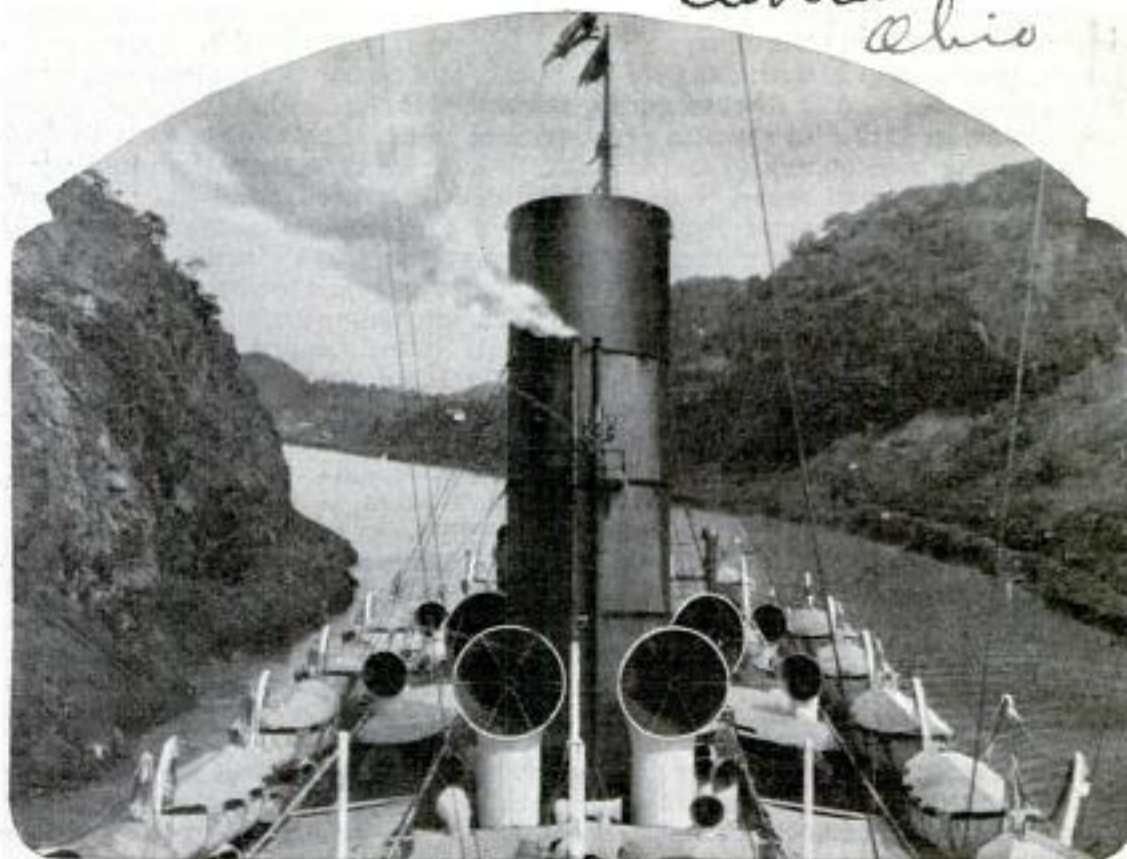

View Taken from the Crow's Nest of Round-the-World Steamer in Gaillard Cut

What the Panama Canal Means to You

WITH the celebration of the tenth anniversary of the opening of the Panama canal just a few weeks ago, it was announced that more than 25,000 vessels had passed through the waterway. Over one-fifth of that number made the trip between the Atlantic and Pacific in the single year ended June 30, last.

Despite all handicaps, such as landslides, the traffic has increased so rapidly that tolls during the last fiscal year reached \$24,290,963.54, as compared with \$4,367,550.19 in 1915, and the vessels which have utilized the canal saved 196,825,000 miles by not having to go around South America, a distance equivalent to 7,873 voyages around the entire earth. Operating expenses last year were only one-third of the gross revenue.

Due to the stupendous growth in traffic, plans have been completed for additional locks, bigger than any now in use and capable of lifting the "Leviathan" or "Majestic," more storage reservoirs and an auxiliary steam-electric plant to curtail the waste of water in generating hydroelectric power.

Four hundred and twenty-two years ago Christopher Columbus, on his fourth and last voyage to the new world he discovered, sailed into a little Central American bay in search of a "secret strait" to the East Indies. He failed to find that waterway, as did Balboa and others who followed after, for nature had neglected to build it, but this year's celebration of the realization of the great mariner's dream was held in that same little sheltered cove, Limon Bay, now the Atlantic terminus of the canal.

Four hundred and twelve years passed from the day of his arrival until the canal was formally opened to the ships of the seven seas, but in the ten years that have since elapsed the old navigator's estimate of the value of such a link between the oceans of the east and the west has been so abundantly proved that congressmen are even considering plans for a second canal, to be ready against the day when the present route cannot handle the stream of traffic.

The present canal is a mechanical marvel and a monument to man's triumph over nature. When Columbus sailed into Limon Bay he faced an impenetrable jungle, filled not only with dangerous animals and poisonous snakes, but, worst of all, the most deadly disease germs known. Not until Balboa came, eleven years later, in 1513, did a white man succeed in crossing the isthmus to look down on the blue waters of the Pacific. For more than three hundred years the short route from ocean to ocean remained little used, until the gold-maddened forty-niners, bound for California, utilized the mule road across the heights to cut months from the long journey around Cape Horn.

Another three decades, and a French company undertook to build a canal. They started work in 1882, gave it up in 1889, started again, but yielded to the disease germs, and finally, in 1904, the United States stepped in. In ten years the canal was completed, locks built, dams erected, and machinery installed, but not until General Gorgas had fought and won one of the greatest battles of all times, resulting in the rout of the army of yellow-fever germs.

Opening, as it did, within a fortnight after the start of the European war, the waterway leaped into immediate need as a quick route from the far-flung outposts of the world to the battlefields of France. When America entered the war the traffic doubled and trebled. It is in its peace-time uses, however, that the canal has proved its commercial value. In the fiscal year ended June 30, the number of vessels using the route increased more than thirty per cent. Part of this was due to the fact that the canal has made Vancouver an ocean wheat port for western Canada. It is cheaper to send the grain by rail to the Pacific and then by boat through the canal than to route it for the long haul eastward across the continent.

At present the canal utilizes the water from its giant lakes and reservoirs to develop the electric power to operate lock gates and other mechanism, but to cope with the great fleets of the near future, it will be necessary to install an auxiliary steam plant to reduce the wastage of water now used for power purposes. Each time a lock is filled and opened its contents is wasted, and with



Midway between the Atlantic and Pacific Oceans, Where Large Ships Can Navigate under Their Own Power

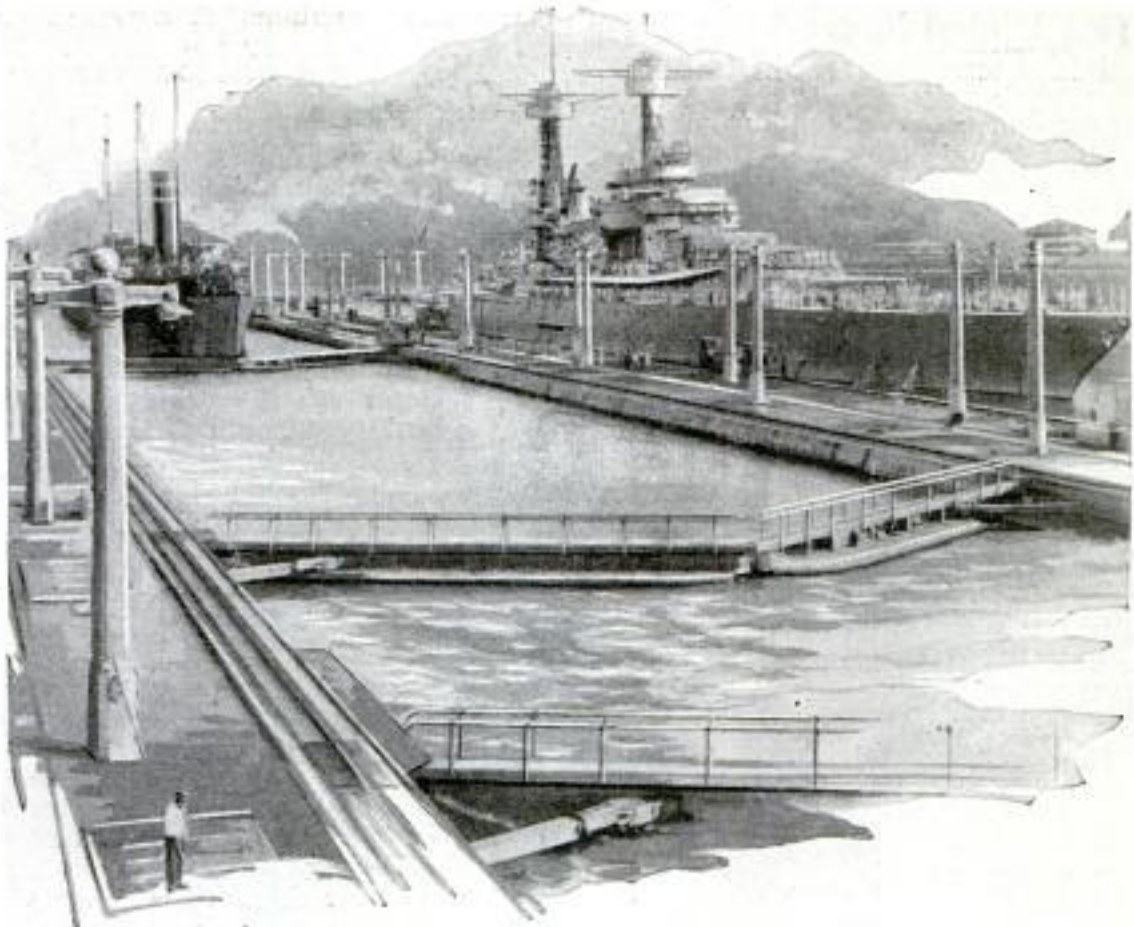

U. S. Battleship "California," Passing through Miraflores Lock from the West on the Way to Meet the "Opposing" Fleet during a Series of Naval Maneuvers Held in Panama Waters

more ships to handle, it will be necessary to save all the water for lockage purposes only. Other changes which experts advise include a new storage dam on the Alhajuela river to control and husband the flood water emptying into the Chagres river; another reservoir near the locks on the Pacific side, and also an additional set of longer locks to handle vessels of great size.

Even these changes, Captain A. W. Hinds, U. S. N., marine superintendent of the canal, says will be in the nature of temporary relief, and eventually we should have another canal. This being the case, there has been recent agitation in Washington for the revival of the Nicaraguan project. The navy department is particularly interested in this, as the Panama canal is not easily fortified against aerial attack, lacking outlying islands and headlands for defensive purposes, while the Nicaraguan route has the Corn islands in the Caribbean and the Bay of Fonseca headlands on the west coast for defensive purposes. Since the completion of the canal American naval strategy has been based on the possibility of shifting the fleet hurriedly from one coast to the other, but if an enemy could destroy one canal the fleet might be caught divided and annihilated. Naval strategists claim with two canals, the second easily defensible, the danger would be reduced, while the additional route would care for the traffic which the present canal eventually will not be able to handle.

The success of the Panama route was assured from the start because of the enormous saving in mileage which it makes possible. From New York to San Francisco, via the Strait of Magellan, is 13,135 nautical miles, while the distance by the canal is 5,262, a saving of 7,873 miles.

Among the benefits given the United States by the canal are reduced freight rates, quicker delivery of goods, closer relations with South America and a short cut for its fleet in war times as well as peace.

Sept. 1, 1924.

H. H. WINDSOR, Jr.

Folding Dining Room Saves Space and Lightens Household Labors

For serving breakfast or any meal informally, a folding table and two benches

Prisoners Run Score of Industries Earning a Million Yearly

Twenty-two industries that last year manufactured products which sold for more than \$1,000,000, are now being operated as part of the penal system of Ohio to provide employment for the prisoners. Busy workshops, manned almost entirely by convict labor, provide food, clothing and shelter for the inmates of the state institutions. Last year, more than \$100,000



Built-In Dining Room Niche Open, Ready for Meal



From Their Hiding Place behind Curtained Doors, Hinged Dining Table and Benches Are Easily Let Down When Needed



that fit within a small space in the wall and are entirely concealed behind two attractive doors when they are not in actual use, have been invented. For dwellers in small apartments and for all households that appreciate saving in space, time and trouble, this set, which practically makes two rooms out of one, has been found especially suitable. There is ample space for four persons, and it takes but a few moments to prepare the table and seats or to hide them again. They are hung securely on hinges and rest in a niche six inches deep. The doors, curtained with attractive material, resemble French windows. Decorative wall lights within the recess furnish illumination for the table.

was paid to the prison workers in wages calculated on a basis of from one to five cents an hour. Furniture, clothing and shoe factories and a sheet-metal and structural-iron plant that makes all the beds used in the state institutions are maintained, and at the state penitentiary alone, there are thirteen well-defined industries including textile and planing mills. Last year, more than 1,000,000 automobile license plates were made by prisoners. The state also owns 13,223 acres of land, of which 7,208 acres are under cultivation.

Shipwrecks occurred at the rate of one every day last year, according to statistics.

Stop Electric Leaks in Auto Wires by Using Braided Covers *1505*

Experiments conducted by the Underwriters' Laboratories to solve the mystery of why insulated wires on the high-tension systems of automobiles break down in use have revealed that the breakdown is due to the electrical "corona," which is sometimes seen on dark nights around high-tension transmission wires. The experiments also disclosed that the corona effect was practically removed when wire with a braided cotton cover was used, while wire with plain cotton cover broke down, in some instances, in six minutes of use. A braided-cover wire was operated 240 hours during the tests without destroying the insulation. In the experiments the wire to be tested was wrapped around a one-inch steel bar which had been grounded, and the ends were connected to form a circuit with a motor-driven magneto and a spark gap. The high voltage created by the magneto, intensified by the "piling up" which occurred each time it jumped across the spark gap, produced the necessary tension. The corona was plainly visible in a dark room and no difficulty was encoun-

Pictures Formed of Butterfly Wings Match Painters' Art *1596*

Formed of brilliantly colored butterflies' wings, artistic designs created by a watchmaker in England are used by the craftsman to decorate plaques, trays and similar articles. After collecting hundreds of the insects, of all sizes and hues, the art-



Copyright, Keystone View Co.

Artist Working Up Picture of Dahlia with Minute Petals He Cuts from Butterflies' Wings Taken from Hundreds of Various Species

ist cuts the wings into small petal-shaped sections. With these the gorgeous figures are carefully worked out, each piece being glued to the foundation. Each design is accurately outlined before the tiny scales are attached and the colors are matched as closely as possible with those in the original of the picture. Most of the wing "drawings" are reproductions of popular flowers.

Over Thousand Accidents an Hour Cause Heavy Loss in U. S. *1616*

An average of twenty-one accidents occur every minute in the United States, according to figures compiled by the government, those caused by automobiles leading in number. Baseball is said to head the list of mishaps in athletics and sports, while polo has the lowest figure, in a similar report made up by an insurance body. This record does not include accidents to campers or persons on hiking trips or pleasure tours. One insurance company reports that fifty-six policy holders were accidentally killed in the past ten years while engaged in recreation.

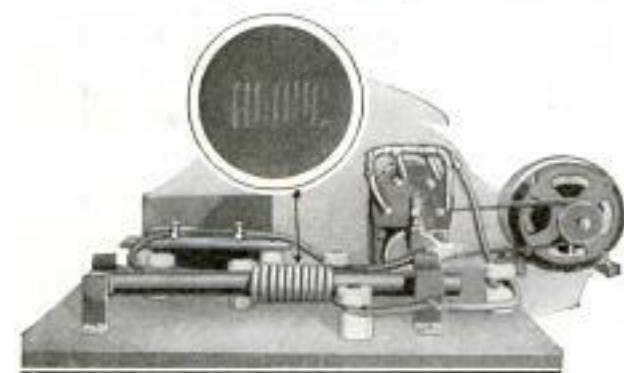

Electric Testing Apparatus Trying Out Insulation on Wire Wrapped around a Charged Steel Bar

tered in photographing it. The laboratory is continuing the experiments to determine why the braided covering on wire checks the leakage. As a result of the experiments it is hoped to eliminate the leakage which has caused much trouble.

St. Moore, Mitchellway Road, Eng.

Chicago Evening Post
7/28/24
Copyrighted material

maker unknown

Pistol Is Hidden in Auto Lever Ready for Quick Defense

Designed for instant use, a double-barreled .22-caliber pistol is contained in the detachable handle of an automobile gear-



Inserting Pistol in Gear-Shift Lever, and Diagram Illustrating How It Could Be Used

shift lever now manufactured in France. A quarter-inch turn of a metal band next to the knob separates the handle and pressure on a section of the stem discharges the weapon. The pistol is automatically cocked when the handle is replaced. An alternative model for the hand brake has also been placed on the market. Attached to any standard automobile, it is claimed that the weapon can be brought into action more quickly than one the driver may have on his person.

Pupils' Weak Eyes Cost Taxpayers Millions of Dollars Yearly

Defective eyesight of pupils in the public schools of this country costs the taxpayers at least \$130,000,000 every year, according to reports of the eyesight-conservation council of America. This huge cost is due to the fact that thousands of students are compelled to take two or more years for a single grade because faulty vision has made them backward in their work. It is figured that the cost of public elementary and secondary education in the United States averaged, in 1920, \$64.16 per pupil per year. On the basis that each of the 6,000,000 retarded children dropped back for only one year,

the cost would be \$390,000,000. It is estimated that about one-third of the number of delays were caused by poor eyesight, thus causing an expense of \$130,000,000. The report further states that this estimate is believed to be too low, as studies made in two cities of 5,815 retarded pupils showed that a total of 12,970 school years were lost, making an average of more than two years for each pupil. These figures do not include the tremendous loss to the child due to lower earning power. In one large city, it was shown that of 7,319 pupils found with defective vision, seventy-two per cent were backward in their studies, while correction of visual defects among a large number of others resulted in from seventy to eighty per cent of them taking their places in classes with average normal children of their own age.

Metal Mask Aids Insomnia Victims 1148 by Quickly Inducing Sleep

To aid insomnia sufferers, a Norwegian inventor has perfected an aluminum mask that is said to quickly induce sleep when worn by a patient. Fitting snugly over the face with only an opening at the nose for air to be inhaled, the mask prevents any light from distracting the attention of the wearer while the warm breath of the



Copyright, Keystone View Co. Aluminum Mask over Face That Induces Sleep by Forcing Warm Breath to Eyes

mouth is forced to the eyes. In a short time, it is claimed, the patient will be asleep.

Dr. W. N. Niles
Copyrighted material

1226
Emb. Edw. J. Beck, c/o Paul H. Beck, 210 S. Taylor Ave. Oak Park, Ill.
Chicago Daily News 7/10 5/24

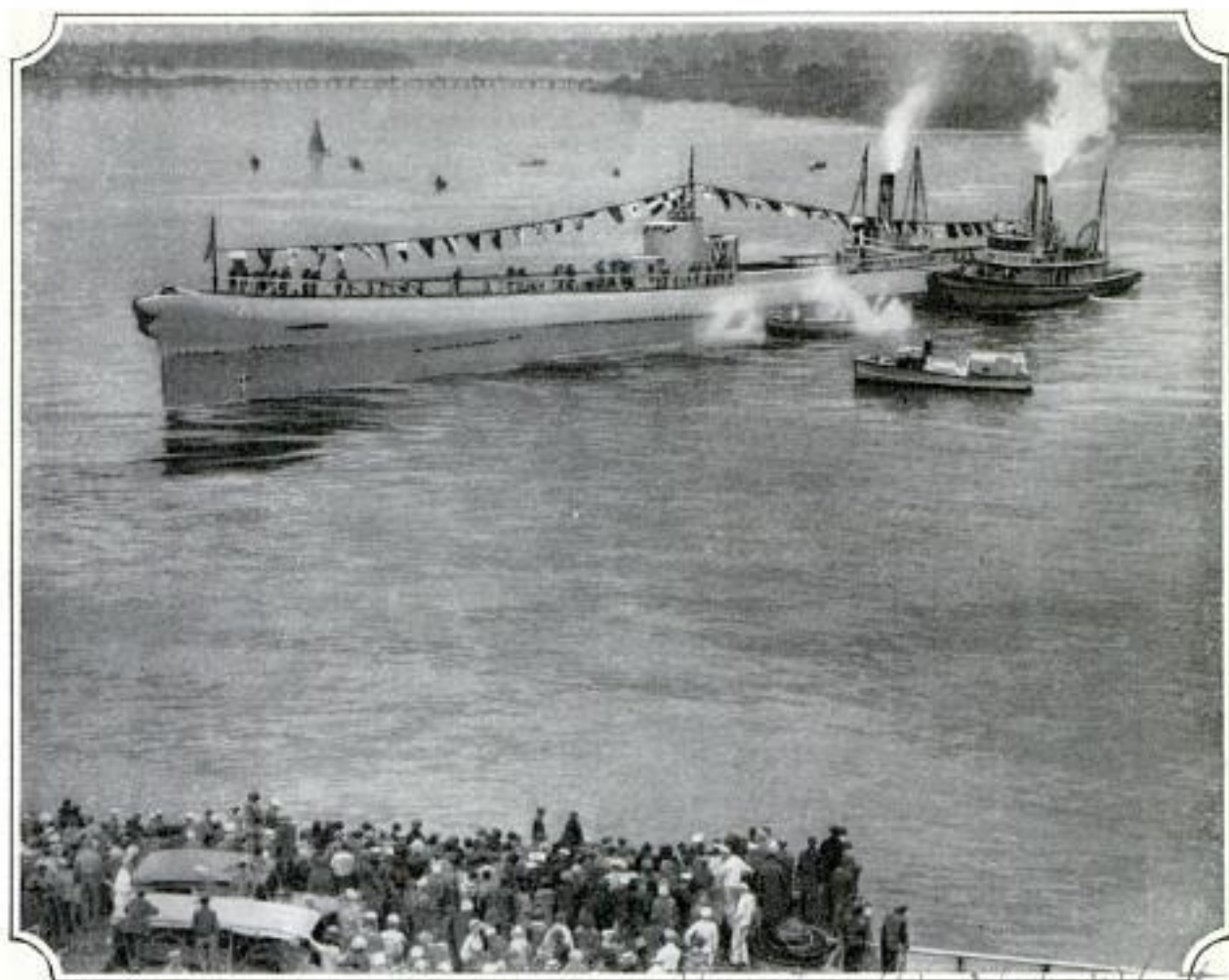

Shortly after Launching; the Giant Submarine "V-1" with Its Gay Pennants Is Welcomed to the Sea and Preparations Are Made to Complete It for Voyage across the Atlantic

Giant Sub Able to Cross Atlantic with Crew of Eighty-Seven

The fighting efficiency of Uncle Sam's navy will be greatly increased, officials believe, by the "V-1," the giant submarine, nearly twice as large as any previously built here. It is said to be capable of sailing as fast and as far as the battle fleet in any kind of weather and will not need the services of a "mother ship." The huge boat, the first of a fleet of nine similar fighters to be built, can cross the Atlantic and return without replenishing its supplies of fuel. With a displacement of 2,164 tons, it develops a speed of twenty-one knots at the surface and nine knots an hour submerged. It is 341 feet six inches long, has a maximum breadth of twenty-seven feet eight and five-eighths inches and will carry a crew of seven officers and eighty men.

Jupiter, the largest planet, is 86,500 miles in diameter while Mercury, the smallest, is only 3,030 miles.

Adjustable Easy-Chair for Workers Reduces Toilers' Fatigue

To reduce fatigue of persons who work sitting, an adjustable chair with seat and back that can be made to fit almost any individual is being manufactured by an English concern. Both the height and angle of the backrest can be quickly changed to relieve strains on the occupant, and when not in use, the chair may be folded and stored under low benches or desks or will serve as a table to support trays, packages and similar objects. It is said that with the use of the easy-chair workers do not tire as quickly as with the ordinary types.



San Ltd.
 1, Albert St.
 Birmingham

More World Photos
 American
 Elmore Chair, U.S. agent.
 Elbert A. Smith, 105 W. Monroe, Chicago.
 Number 5440

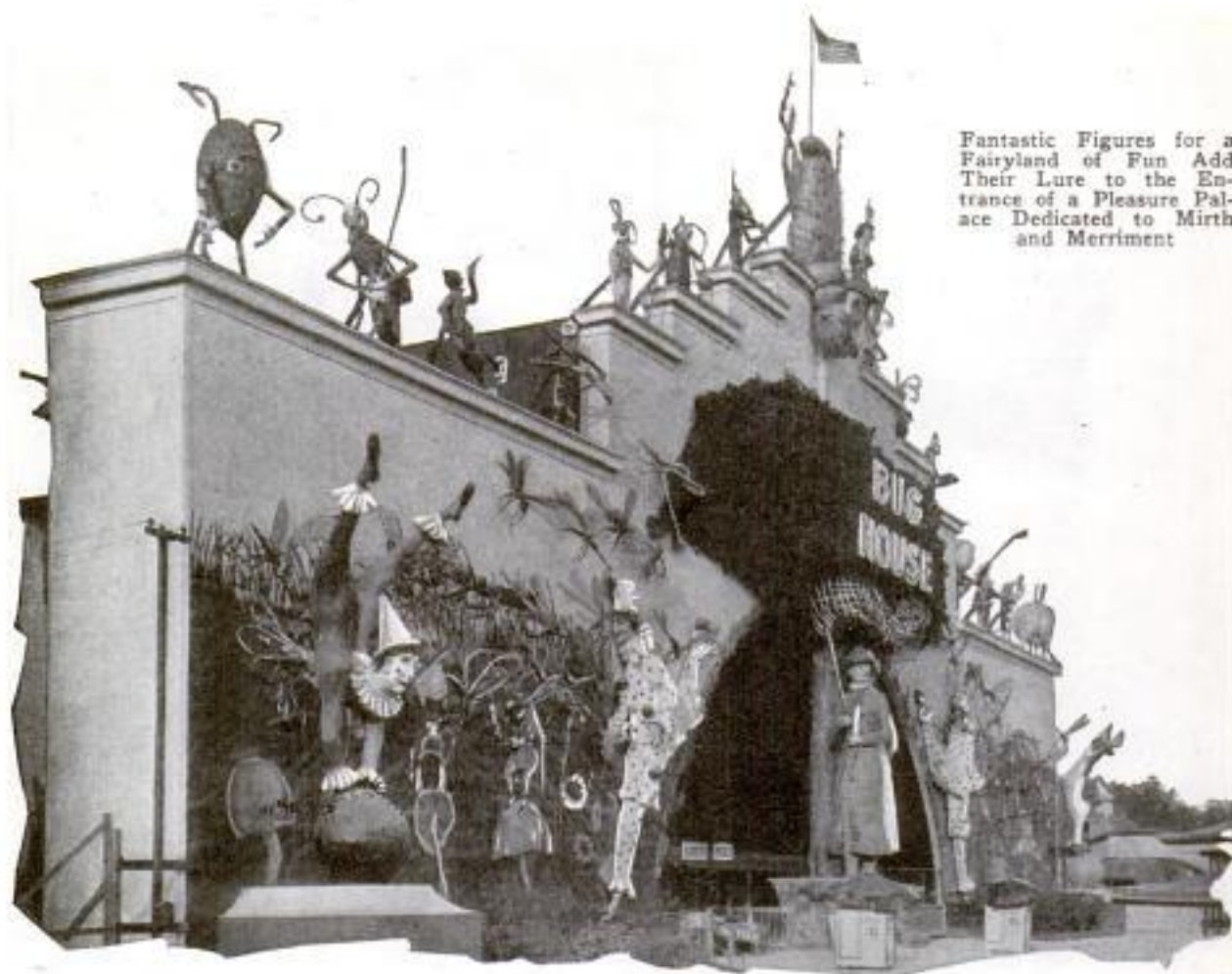

Fantastic Figures for a Fairyland of Fun Add Their Lure to the Entrance of a Pleasure Palace Dedicated to Mirth and Merriment

From Cyclones to Houses of Mystery

How the Mechanical Wonders in Modern Outdoor Amusement Parks Are Invented and Constructed

ALTHOUGH dedicated to pleasure, the modern outdoor amusement park makes use of the genius of the inventor, the skill of the engineer, the knowledge of the keenest students of human nature and every mechanical device known to science. Behind its tinsel scenes, glowing lights and the picturesque figure of the "ballyhoo" are to be found some thirty large manufacturing plants and thousands of skilled craftsmen, all of whom are constantly seeking new ways to amuse the public. In the parks themselves—and there are more than 500 in the United States, with a yearly income estimated at more than a billion dollars—are to be found almost everything needed for human existence.

Such an organization, for instance, has its own ice plant, fire department, police service, hospital with doctor and nurses, and vast storehouses that resemble the

quartermaster's department of an army post where supplies for restaurants and concessions are kept.

In addition, there are private bottling works, butcher shops, a printing plant that prepares all the tickets used and turns out a weekly newspaper for the park, and elaborate business offices where busy clerks sometimes have to count and wrap upward of \$50,000 in small coins a day.

Many parks operate their own power plants and the weekly bill for electricity runs into untold thousands of dollars. In one of them there are more than thirty motors, ranging from twenty-five to 500 horsepower, which operate the rides. Three motors are required for some of the larger coasters. A big Ferris wheel, ninety-eight feet in diameter, with twenty-four cars and weighing 200 tons, is so perfectly balanced that a twenty-five horsepower motor is sufficient to operate

it. Combined, the motors will carry a peak load of more than 2,000 horsepower. Then there are millions of electric lights. In one tower alone 20,000 are used, part of the approximate 100,000 that are strung about the buildings and grounds. An-

other large park pays \$2,000 a week for electric lights alone. But momentum and not glitter is the chief use for electricity at these pleasure cities and the attention of owners and inventors, as well as the public, is centered on the rides. More than any other one feature, they have increased the total attendance figures to approximately 100,000,000 persons a year. Coasters are acknowledged to be the most popular, although the merry-go-round, invented

in 1837 by Michael Dentzel, a German wheelwright, who got his idea from spinning a cart wheel about a pivot to allow the rims to cool, is often the most reliable money-maker. This season, a wholly new set of thrills was made possible from the coaster, which is the development of the old "switch-back" built by L. A. Thompson, father of the gravity ride, for Coney Island in 1884, by the invention of a two-wheeled train.

With this patented equipment most of the difficulties of the old four-wheeled car have been eliminated and engineers say a new standard for speed has been established. It is safe to snap about a hair-pin curve in one of these trains at express-train speed and not only turn, but drop at the same time, the track being built at an extreme bank to make the twist. One park with this apparatus, packed 3,250 feet of breath-taking ride into a small lot. Trains descend from a height of fifty-five

feet and plunge into a startling whirl of curves and dips. At places, a drop of twelve feet to a ten-foot straightaway was achieved. Safety brakes and balances at all times guard the train which is estimated to weigh over seven tons when the

cars are loaded. Over \$22,000 was spent for the lumber in this ride alone and the structure was put together and certified by an expert engineer before the public was admitted. A small car ahead of the first passenger seats serves to give balance and direction to the load and under the rails a projecting flange of the car trucks acts as a double protection on the curves. One variation of the coaster has been provided in the "Cyclone Bowls," two sets of spiral

tracks about a hundred feet in diameter across the top. Pushed by an electrically operated beam, the cars whirl up the tracks on one bowl, are dismissed and sent speeding across to the descent in the other bowl where they go thundering down the spiral decline to the bottom under the pull of gravity. The merry-go-round has been duplicated in its essentials and thrills added by the "Caterpillar," a comparatively new and ingenious contraption, that spins its occupants about a circle full of ups and downs and at the moment maximum speed is achieved, shuts them from the outside world by a canopy suddenly raised and dropped from the back side. The rest of the ride is in complete darkness and to the outside, the device resembles a huge, undulating, green caterpillar spinning in a frenzied circle.

In the construction of rides, park owners say, the day of haphazard methods is over and the modern "thriller" is always



Mechanical Butterflies with Gilded Wings and Seats for Two Soar Gaily around Happy Circuits

*Traver Engineering Co.
Allentown, Pa.*



Inside Studio Where Skilled Artists Design and Construct Floats for Mardi Gras Parades; at Left, Converting Old Show Bills into Tons of Confetti



Laying Outer Paper Covering on Wire Framework at Base of Float before Applying Finishing Paints and Decorations; Batteries and Switches for Illuminating Piece Are Put in Opening above Worker's Hand

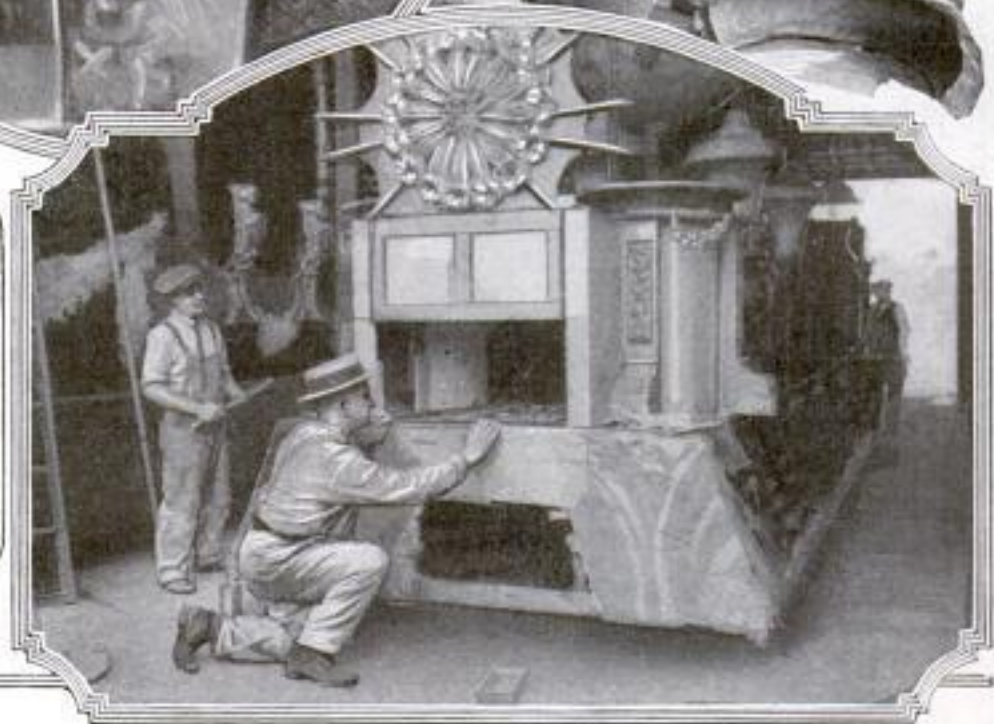

1555



Toy Airplanes Whirl the Little Tots in Safe and Joyous Circles



Bumps and Giddy Twists Thrill Riders in the Electric "Dodgem" Cars

Proud and Gaudy Carnival Cars Add Splendor to Amusement Park Parades



1555 Mfr. Traver Engineering Co,
 760 POPULAR MECHANICS
 Beaver Falls, Pa.

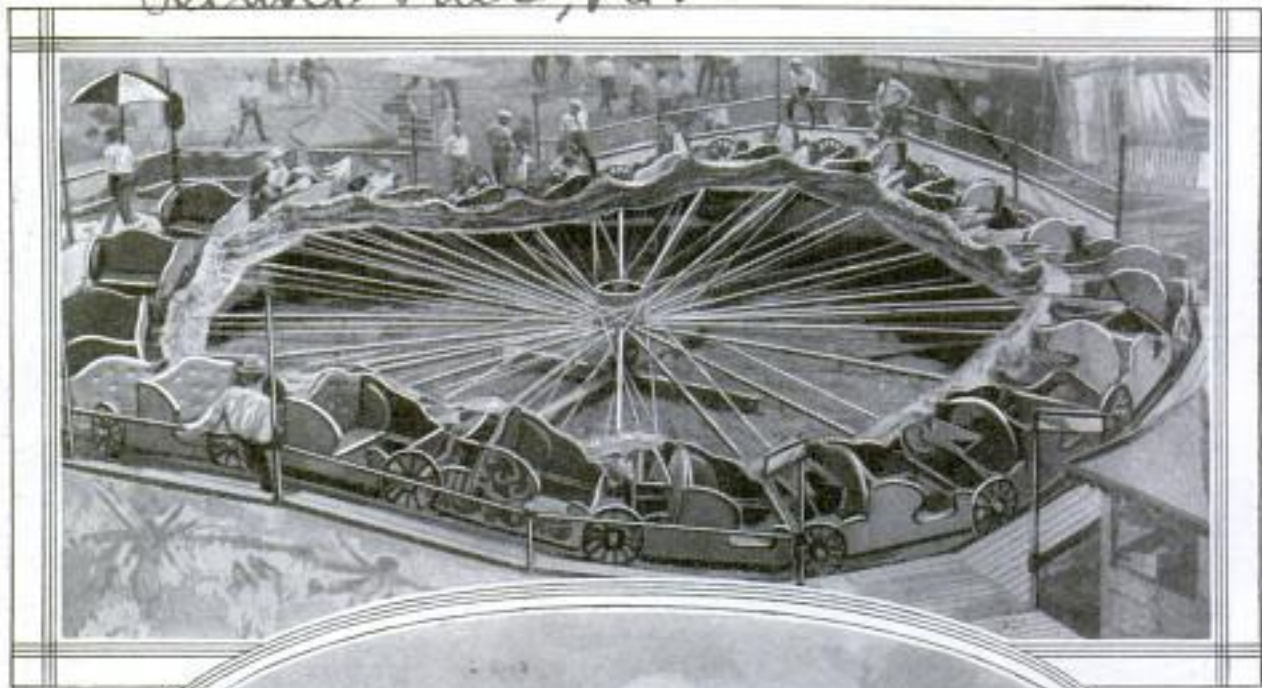

The "Caterpillar" Open and Closed; as the Cars Whirl around the Undulating Track, an Arching Green Canopy, Fixed to Braces as Seen Above, is Suddenly Raised from the Inside and Falls over the Occupants, Plunging Them into Darkness while They Spin about Their Uneven Course; It is Quickly Drawn Back Just before the Cars Stop

Traver Engineering Co
 Beaver Falls, Pa.

Testing Model of the "Whirling Dip" That Gives Patrons Sensations of a Rough Sea



Roller Coasters with Dips and Sudden Twists That Call Forth Gasps and Shrieks of Joy Never Fail to Please



A Mechanical Fox Chase Gives Excitement and Offers the Sportsman a Chance for Speculation on the Winner

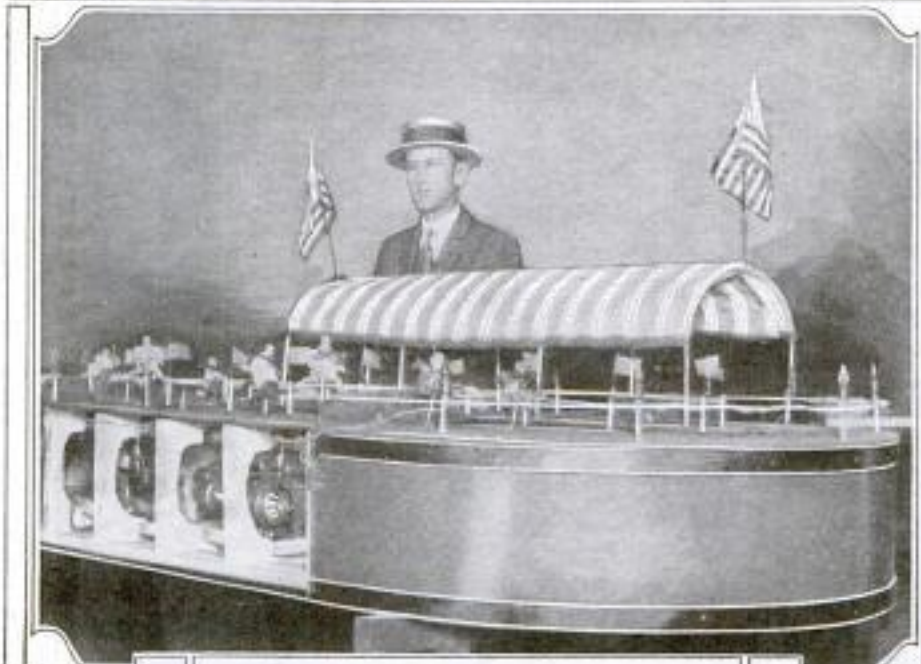

1555

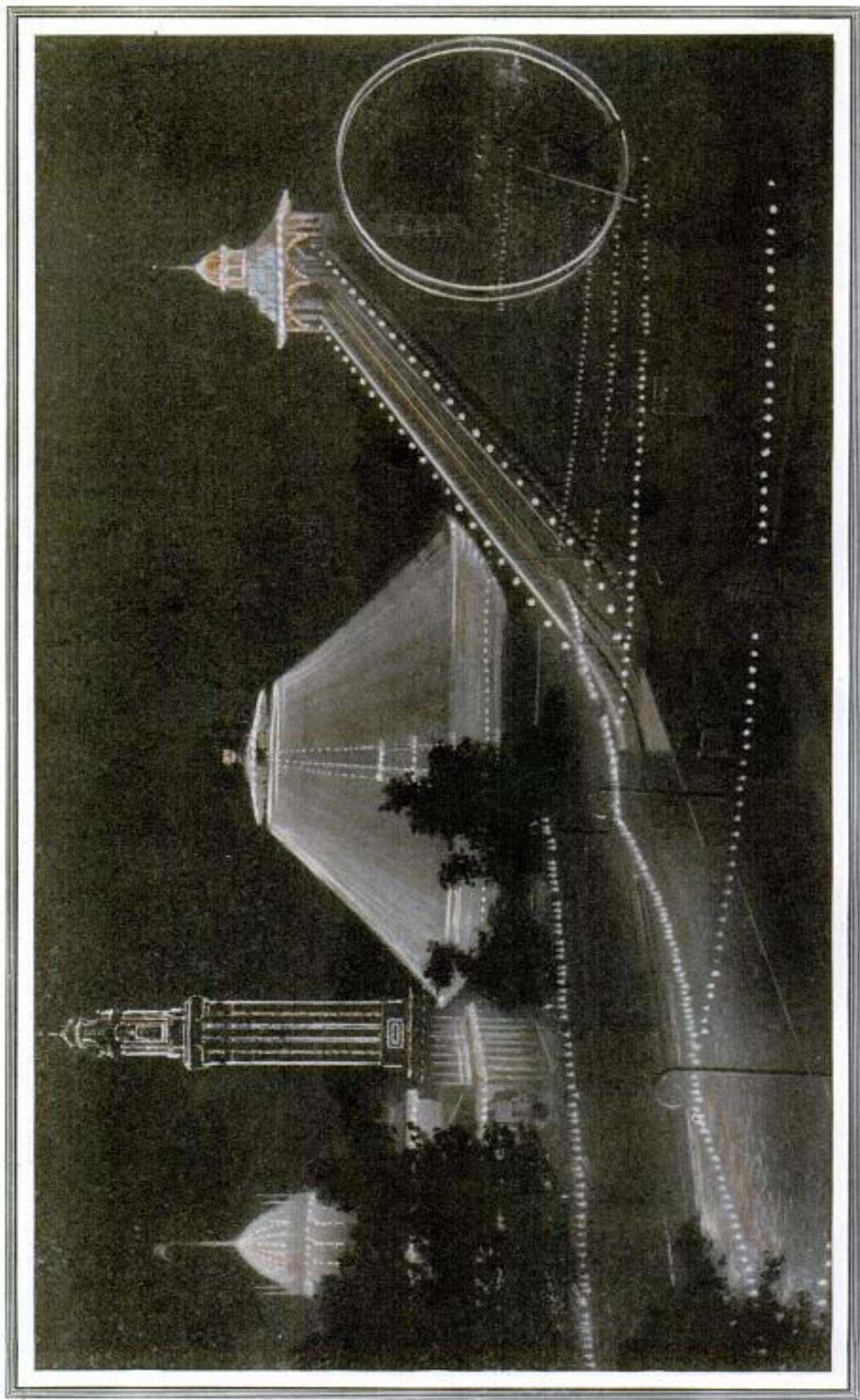

When Darkness Falls, Enchanting Festoons of Light Add Their Lure to the Pleasure Seeker to the Summer Park's Delights

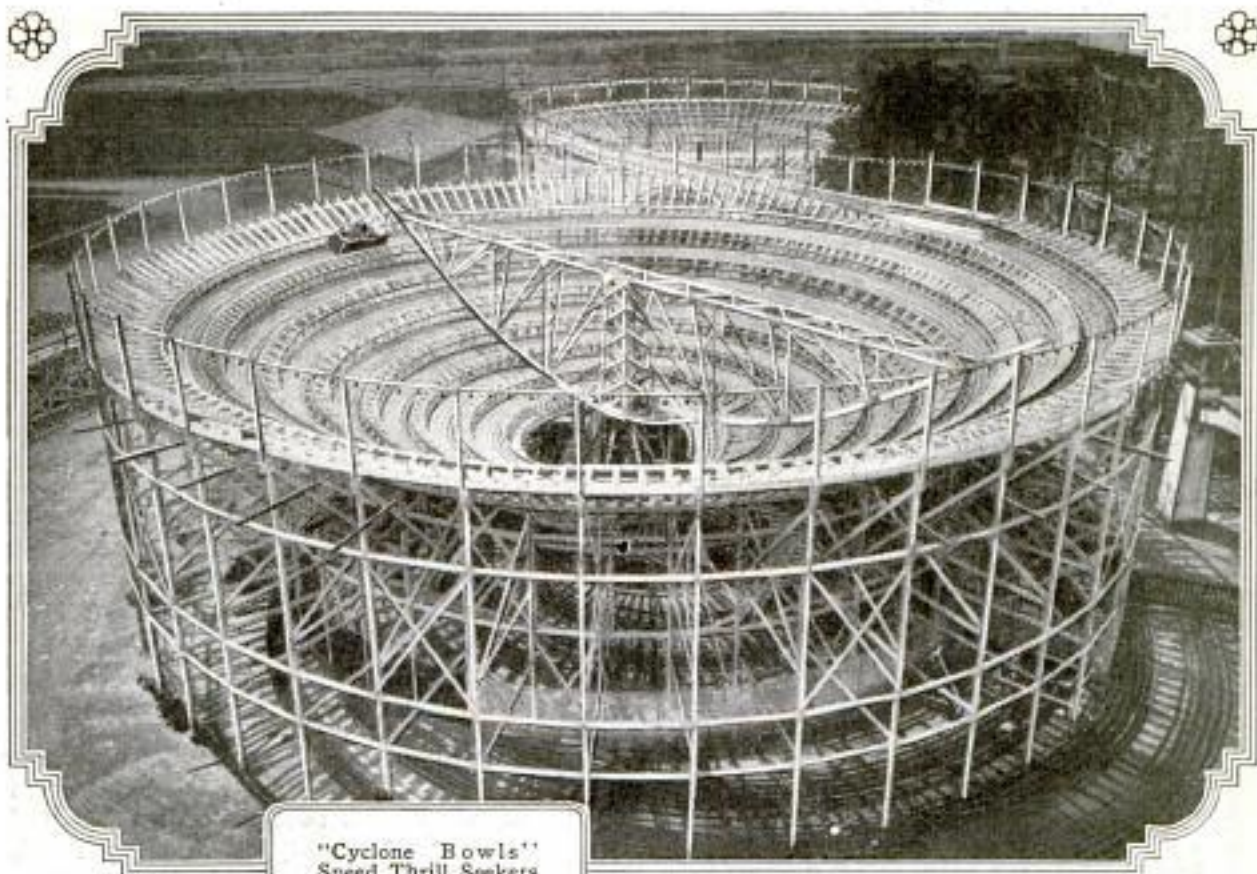

"Cyclone Bows"
Speed Thrill Seekers
Up and Down Precipitous Whirlpools
of Delirious Motion
while Others May
Enjoy an Orgy of
Dish-Breaking



built on safe and sound engineering principles. Rigid inspections of all rides are frequently made and caution signs are displayed. One large park has operated for more than twenty years, handling over 25,000,000 persons in that time and has had but three fatalities, none of them being due to faulty equipment.

With the new rides, a quieter but no less amusing device appeared this season known as the "Mysterious Sensation." Here, people were enabled to entertain themselves to a great extent, a point that the fun merchants are emphasizing more each year. The device is said to have been inspired indirectly by a cyclone. An architect chancing through a village that had been wrecked by the storm entered one of the leaning houses. The sensations he experienced in trying to walk across the floor gave him the idea for the amusement device. Mystification starts with a turn at the entrance to what appears to be an ordinary room. The steeply inclined passageway and another abrupt turn add to the sense of confusion. Another turn reveals a wide room set with railings and with the floor leaning at a steep angle.

In the center is a trough that appears to be slanting upward at an angle of at least forty degrees to the upper corner at the opposite side of the room. A bowling ball at the bottom is slightly touched and solemnly proceeds to mount the apparent incline as though drawn by a hidden magnet. At the top, it drops through a slot and rolls in a reverse direction on another trough that seems steeper than the first.

Lurching toward the exit, holding to the railings and constantly endeavoring to get their bearings, the mystified occupants of the room finally manage to gain the doorway and are saved from a headlong dash against the wall by a conveniently placed divan in the hallway. A glimpse through a round window reveals the outside world evidently upside down with pedestrians marching up steep ascents and all the buildings leaning backwards. A moment's recovery in the open air and a glance about tell the story.

The room is built within an outer shell at a steep angle and passage is arranged diagonally across it so that the occupants are subjected to a sort of double "pull." The troughs, in reality, are nearly level.

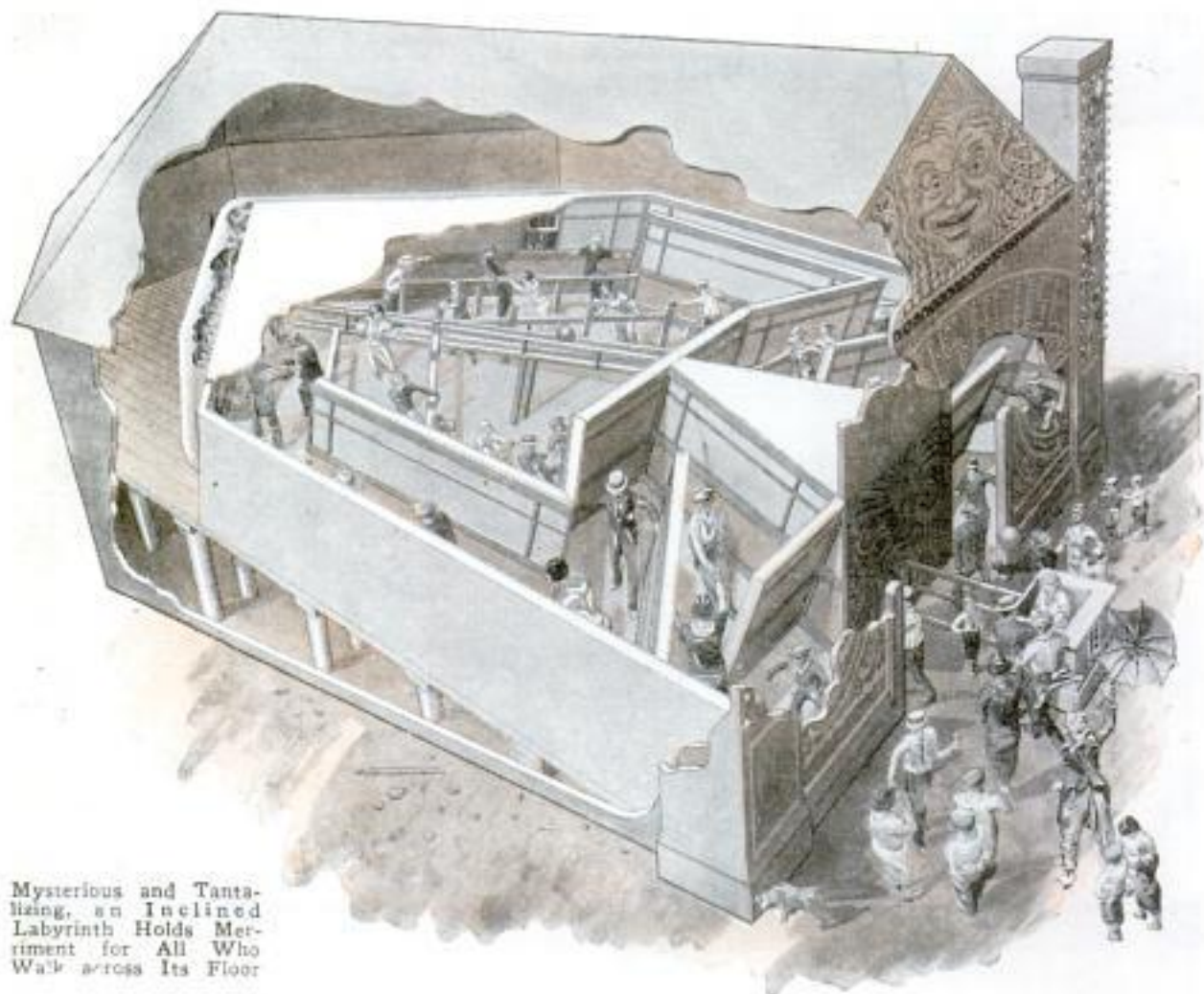

Mysterious and Tantalizing, an Inclined Labyrinth Holds Merriment for All Who Walk across Its Floor



Inspector Brinton of Philadelphia Police Department Giving Masked Detectives Demonstration of Identification Turntable He Devised for Inspecting Suspects

Masked Sleuths Study Criminals Placed on Revolving Tables

Part of the routine for criminals and suspects captured by the Philadelphia police is a ride on a turntable while masked detectives, grouped about the room, thoroughly study their figures and features from every angle. The ordeal is calculated to confuse a suspect who may be hiding under a false identity and gives the detectives ample chance to recognize the prisoner and identify him more easily later, should the need arise.

Electricity Keeps Fish from Death in Irrigation Canals

To prevent fish from entering irrigation canals of the west, a method has been devised by which electrodes are immersed in the water at the mouths of the ditches and an electric current sent through them. When fish swim in the vicinity of these devices they are subjected to slight shocks which cause them to instantly dart away in other directions.

Rubber Bathing Helmet Protects Swimmer's Eyes and Ears

Fitting snugly over the upper part of the head and face, leaving only the mouth exposed, a rubber bathing cap, somewhat like a diver's helmet has been invented, to protect the eyes, ears and nostrils in diving and swimming under water. It permits the user to open his eyes without difficulty or danger of infection as they are guarded by water-tight goggles, attached to the rubber, and glasses may be worn while swimming as the sides of the cap fit tightly enough to hold the bows in place. The lower edge of the helmet effectively excludes all water from the ears and nose and may be rolled up over the forehead if the user wishes to shield only part of his face.



*new York Sun
7/23/24*

*d. w. a. r. johnson,
Cardenas, N.C.*

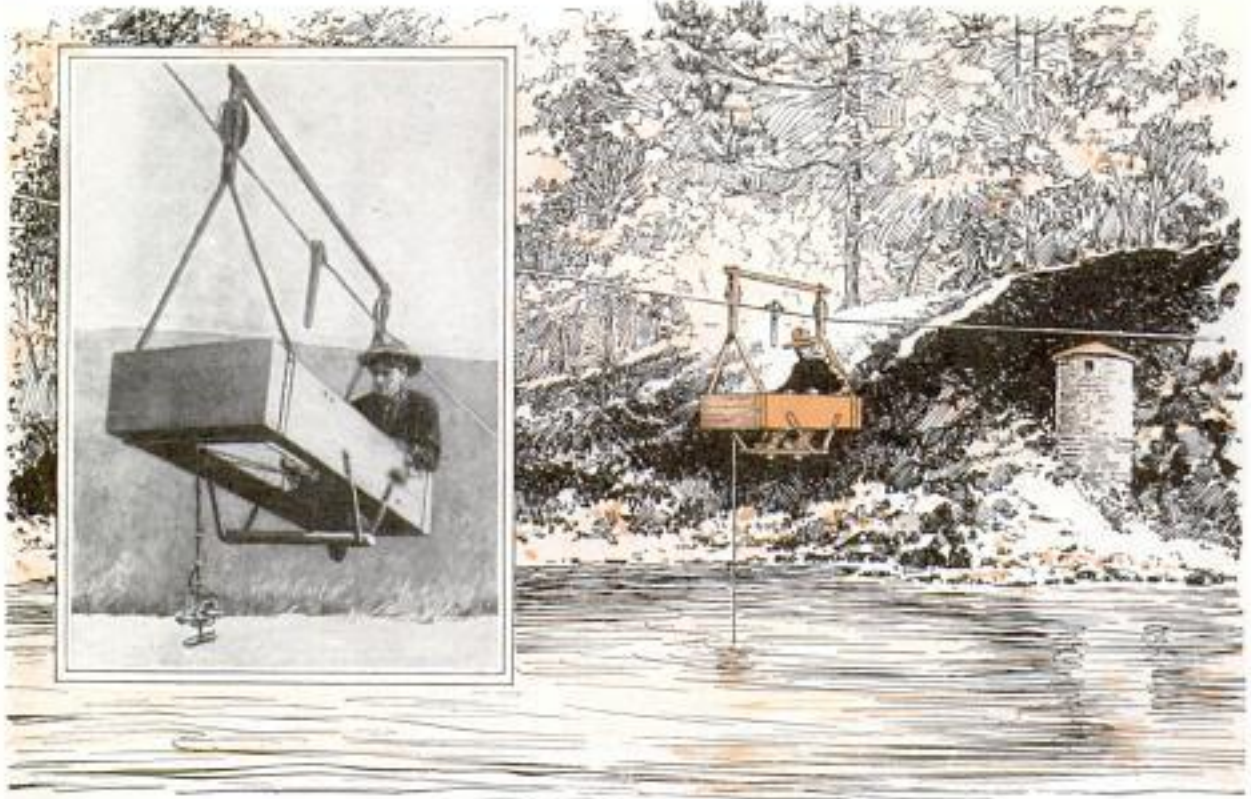

Where Bridges Are Absent, the Water-Power "Scout" Spans the Stream with a Cable and Basket Car, Dropping and Raising the Gauge as He Propels the Carrier along the Aerial Track

Harnessing Water Giants to Do Your Work

Government Scientists Pave Way for Engineers by Measuring Speed of Current in Streams

INSURING almost inexhaustible supplies of electric current to practically every nook and corner of the country, gigantic super-power systems combining hundreds of plants in expansive networks of energy sources, are planned as an achievement to lighten the tasks of households and reduce the operating costs of industry. Already accomplishing the work of more than 170,000,000 men, the force that lies behind the switch of the electric circuit, is to be garnered into large central "reservoir" stations placed at strategic points throughout vast areas. This means a mobilization of power, whereby the tying together of producing electric plants will eliminate waste and permit surplus energy to be sold from one plant to another that might experience a shortage. This, it is expected, will greatly reduce the cost to the user, and it may even be that the feed line carrying power for the transportation of a big city's bustling life will also transmit force to the farm dweller's dishwasher, thresh-

er, reaper and to do the work of the butter churn at the same time it supplies the operating element to a painter's spray brush high up on a skyscraper on the other side of the state.

The ready availability of electric power to the needs of every department of industrial and agricultural life, it is held out, will permit the lessening of hand labor, both in home and factory. The seamstress will find it more to advantage to use power for sewing, while all the work of the kitchen can be accomplished in a short time at low cost by the electric servant, leaving the housewife free to pursue activities more to her liking. And the automatic hammer in the hand of the mechanic may strike more blows at less expense per blow.

To determine the definite possibilities that lie awaiting development throughout the entire country, the government is constantly studying the streams in all parts of the nation. Velocity of the current, volume of water, and the depth, are all

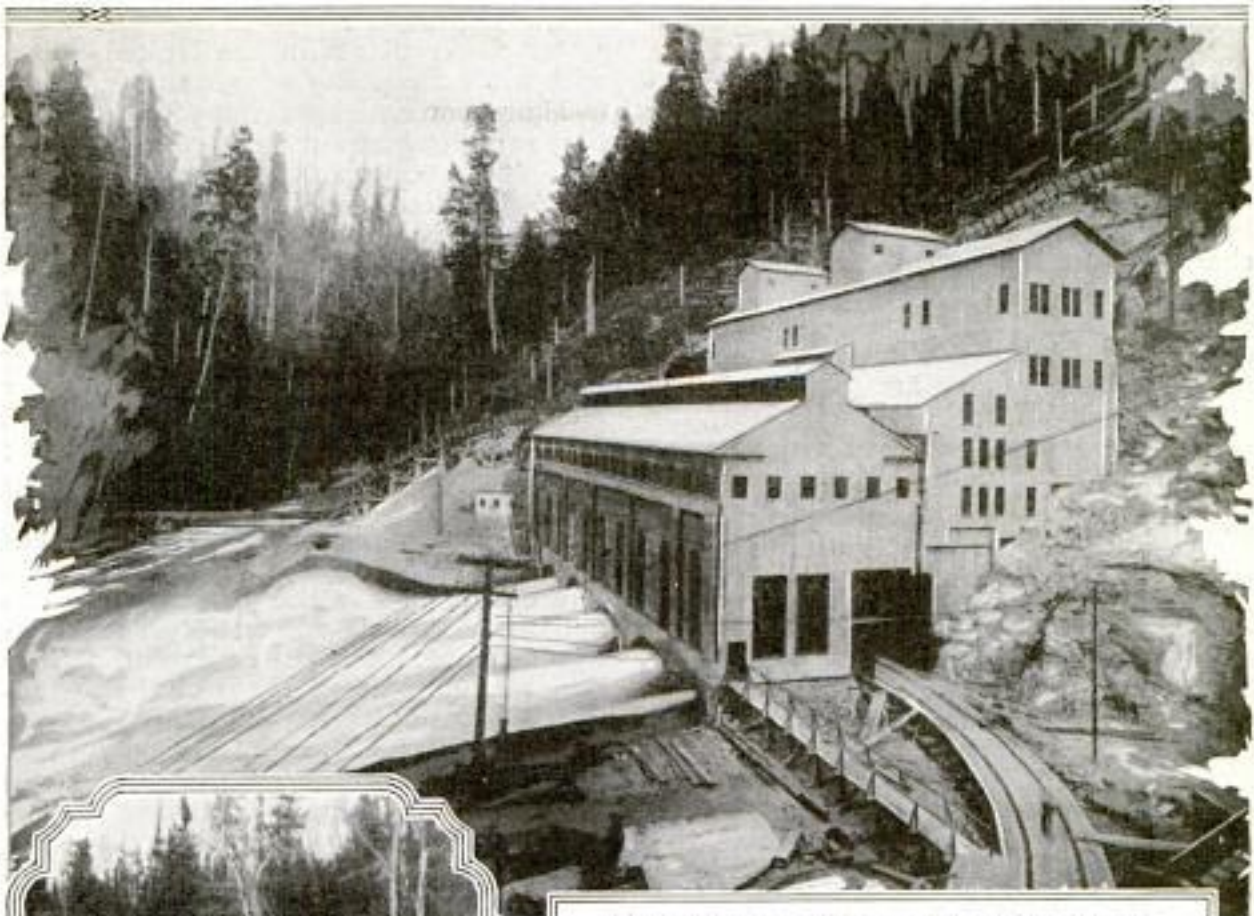

Hydro-Power Plant Where Energy from Remote Mountain Streams Is Harnessed to Produce 20,000 Horsepower of Electric Force; the Current Is Developed under a High Head of Water, as Is Shown by the Rush of the Tailrace



Digging Holes in the Frozen Surface of a Wide River through Which the Measuring Instrument Can Be Lowered to Register the Winter Flow of the Stream



Water-Power Surveyor Seated in a Traveling Chair, Swinging above a Swollen River, While He Takes Soundings of Its Depths and Gauges Its Velocity; Similar Apparatus Are Installed at Hundreds of Points throughout the Country and Are Regularly Read by Inspectors

combined to show just what energy could be derived from the normal flow. Even in winter when the surfaces are frozen to considerable depths the survey proceeds, since the season makes it important from the standpoint of needed power for heating and lighting. A series of holes is cut in the ice stretching the full width of the channel, and through these the instruments taking measurements are thrust.

Cables are swung across swift rivers and from these the current meters are suspended. Readings are taken at regular intervals during day and night, for where the streams are fed from snow-capped mountains, the volume of water varies with the rising and setting of the sun. Small cars are hung from the stretched lines in which the inspectors can traverse the width of the streams to check the figures registered by the instruments. In isolated sections and along the courses of the most important streams, automatic self-registering gauges are installed and are operated by a clock-like arrangement which records the changing depths of the water on a roll of paper. Resident attendants inspect the apparatus twice a month and engineers visit it several times during a year.

There are now something like 3,200 water-power plants in the United States with a total capacity of more than 9,000,000 horsepower. As a result of the stream-flow investigations, it is an easy matter to estimate the possible resources yet untouched. Reports show that there are at least 34,000,000 horsepower yet unmobilized for industrial purposes, which can be made available for nine-tenths of the time.

In computing the estimates and seeking out the remote sources of water-power energy, hardly a stream is overlooked. Cascades and swirling rapids racing along between towering walls of deep gorges are spanned by the wire bridges to carry the tiny swinging cars of adventurous engineers over the treacherous depths. Shore anchors for the cables are tested, but occasionally a weak spot in the contrivance precipitates the "explorer" into the stream, as a line snaps or the fastenings give way. Where permanent bridges are in place, fixed gauges are set up and daily readings recorded from these, so that the survey bureau is always in possession of information that shows the exact condition of the stream at any time of a day or year.

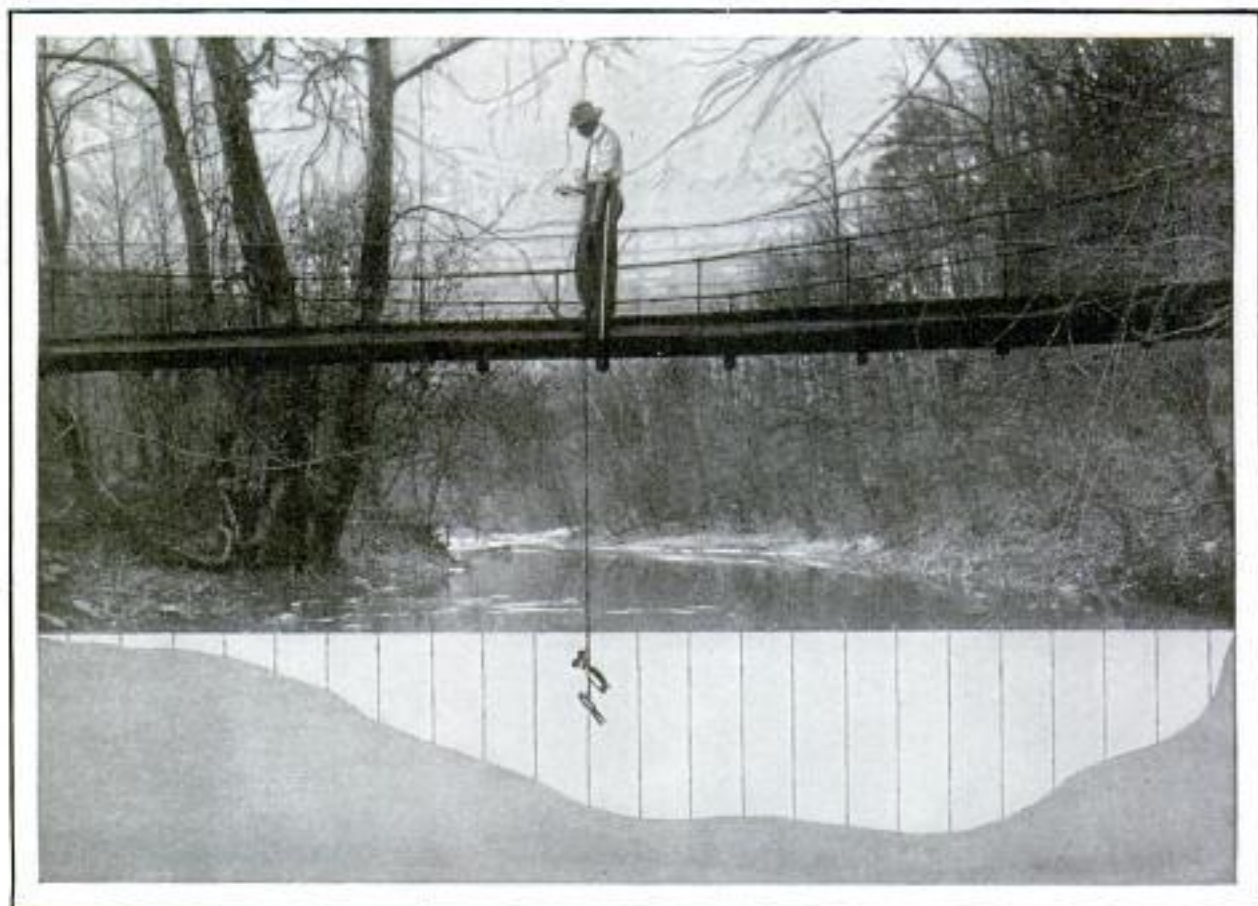

Taking Readings of Water Current and Depths from a Footbridge, Showing a Cross Section of the Stream and the Meter Which Registers the Speed and Volume Passing through the Channel

Cont. Homer S. Trearton,
15 Church St.
Paterson, N.J.
769
J. J.

One-Cent Postage Stamp Is Valued at Thirty Thousand Dollars 1690

Sold for a cent in 1856, a British Guiana postage stamp about the size of one of our two-cent variety and bearing a black-ink impression of a crude woodcut on red paper, is now valued at \$32,500. It is the only one of its denomination of that issue and is said to be the most valuable stamp in existence. This tiny bit of paper is to the world of stamp collectors what the Cullinan and Kohinoor are to the realm of diamonds. The British Guiana stamp is now owned by a New York man who is also the possessor of the second most valuable stamp known as the Mauritius, No. 2, valued at \$15,000, issued in 1847. Mauritius, No. 1, a one-cent stamp printed in orange on a bluish white background, is valued at \$12,500 and another very valuable issue is that of 1851-52 of the Hawaiian Islands, a two-cent blue stamp worth \$10,000. The most valuable stamp ever printed in the United States is one of a five-cent issue from the town of Boscawen, N. H., in 1846 and is valued at \$12,000.

Mechanical Fingers for Sculptors Simplify Reproducing Models 7467

Modeling large figures from small originals in plaster has been simplified by the

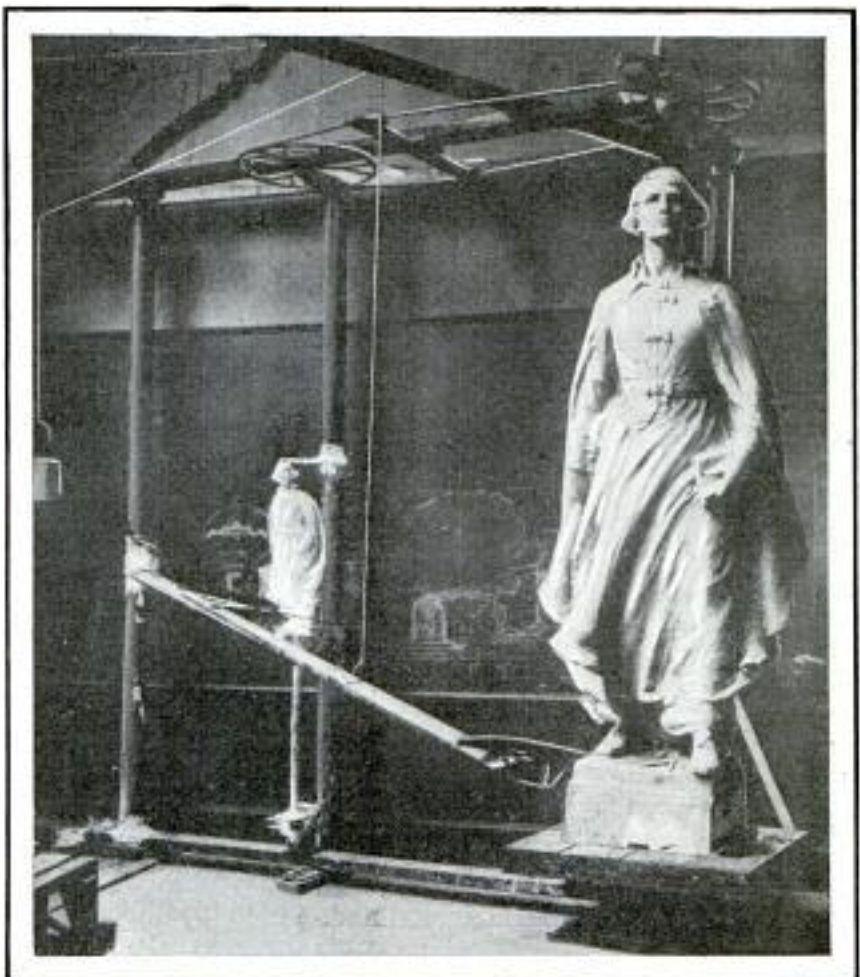

Sculptor's Enlarging Apparatus, Showing Big Piece That Has Been Reproduced with Help of Mechanical Finger Pointing from Tiny Model

use of an enlarging device, which consists of three posts or bars in a frame arrangement, two of them connected by a chain passed over pulleys. Extending from the fixed bar is an arm attached by a ball-and-socket joint. At the free end are finger-like extensions. As the arm is swung to different points on the model, the fingers indicate a corresponding position over a platform, and the sculptor builds the clay up to that point. Thus he is able to duplicate mechanically every line and depression in the original. When the larger figure is done, it is reproduced in plaster and from this, the bronze is cast.

Subways Shake City's Foundations to Depth of Forty Feet 1659

Down to its clay foundations, forty feet below the surface, the English metropolis is being constantly shaken by the jar of subway trains and street traffic, according to Prof. J. A. Fleming, of the University of London. In time, he says, this steady vibration will weaken the structure of the buildings. His observations have been made with the help of a delicately adjusted concave mirror so suspended that when a sound wave strikes it, the vibration causes it to move and project a ray of light upon a screen above it. By the motion of this beam, the intensity of the disturbance can be determined. In early mornings, when traffic is quiet, the quakings subside.

*New York Times
8/4/24*

No information available

Perches placed on a lighthouse by the British Royal Society for the protection of birds have reduced the destruction of birds that become confused by the lights, from nearly 1,000 a night to less than that number in a whole season.

Used on New York State
Highway, near Haverstraw
770

New York Times
8/9/24

POPULAR MECHANICS

1630 One-Man Tractor Grades Roads, Digs Ditches and Cuts Grass

An efficient road grader, operated by one man and run by a farm tractor, has been put into use in New York. Both



Copyright, Underwood & Underwood
Compact One-Man Road Grader That Is Pushed Along by Tractor Engine and Heavy Wheels

engine and scraper are slung on an arching steel frame that connects the big rear tractive wheels with the two smaller ones in front used for steering. The operator stands on a center platform where he can regulate the blade and control the machine. The grader can dig ditches, cut and scrape grass at the roadsides, and effectively level off bumps, it is claimed.

1643 Airplanes Aid in Studying Diseases Spread by Wind among Plants

Exploring the upper altitudes with airplanes to determine what part the wind plays in spreading diseases among plants, investigators for the department of agriculture have found pollen grains and minute spores floating at heights of 10,000 feet and more. The planes were equipped with spore traps, the most successful being in the form of slides treated with vaseline and arranged in compartments so they could be exposed or closed at will. The tiny particles were gathered as the air came in contact with the slides and were found relatively abundant at altitudes up to 11,000 feet, while two spores were found at a height of 16,500 feet. Aerial explorations of this kind already have been performed in Texas, Nebraska, Wyoming and Minnesota and have demonstrated, officials say, that the airplane is a great aid in studying the distribution of plant diseases.

1686 Flavors of Hams Are Told by Smell While Teas Are Tasted

The quality of freshly cured hams prepared by large meat packers is determined by expert "ham-smellers" who test each piece by its aroma before permitting it to be taken from the storeroom. Many years of experience are necessary to develop skill in the art of distinguishing between the properly cured article and that which requires additional treatment. Among the bigger concerns many thousands of hams are turned out each day, all of which must pass through the hands of a corps of inspectors whose sense of smell proves the condition of the product. In a similar manner, teas and coffees are tasted by experts, who select the beverages for wholesale firms.

1001 Stropper for Safety-Razor Blades May Be Used as Knife

Any safety-razor blade may be resharpened easily and quickly with a hand stropper that may be carried in the pocket. Being the same thickness at the back as a straight razor, the device fits the hand and allows a firm grip. The blade lies flat on

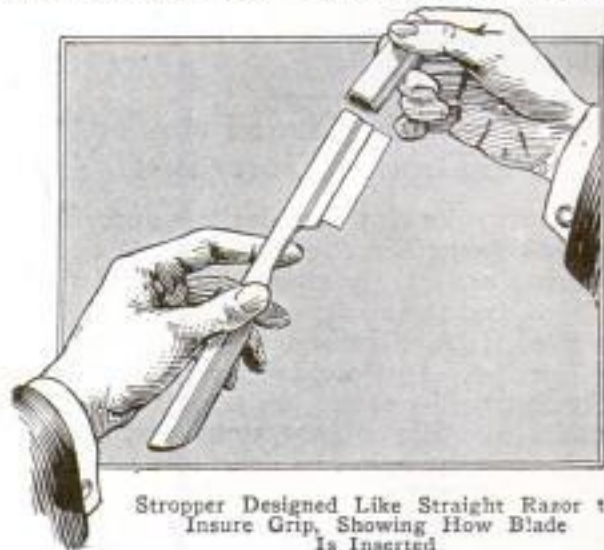

Stropper Designed Like Straight Razor to Insure Grip, Showing How Blade Is Inserted

the hone at the correct angle to give a keen edge. By using the ridged back and replacing the clip, an excellent ripping and cutting knife is made.

Chicago Daily News
7/31/24
The Radio Stropper Co.
63 West Chicago St.
Chicago

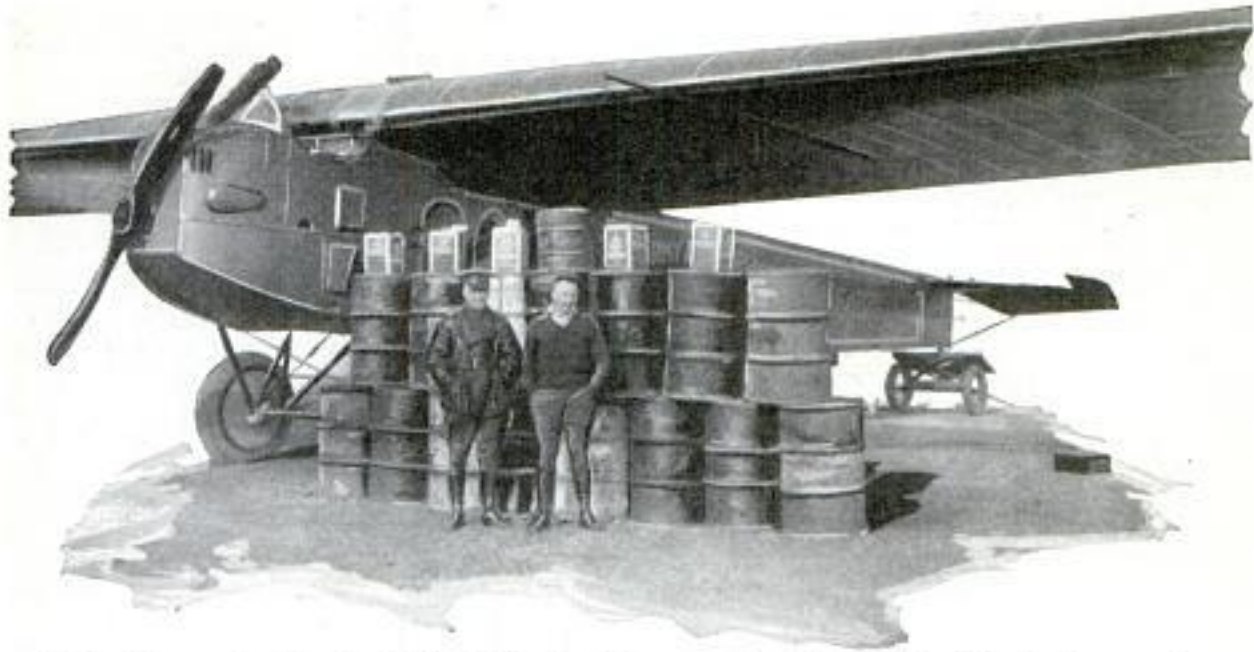

Airplane Compared to Supply of Oil and Gasoline Necessary to Lubricate and Fuel Its Engine on a Cross-Country, Non-Stop Flight from New York to San Francisco

Planes' Range of Flight Is Limited by Fuel-Carrying Capacity ¹⁶³³

The army's "dawn-to-dusk" flight across the continent on June 23 and the round-the-world trip have revived discussion of the possible limits which new and spectacular flights may reach. The non-stop journey from the Atlantic to the Pacific last year by Lieuts. Macready and Kelly demonstrated that the weight of fuel and oil is at present the biggest factor in determining the limits of cross-country flying. Their previous experience in breaking the world's duration record by flying thirty-five hours and eighteen minutes in the same plane, showed that the limits of the ship had not been reached on the twenty-six hour and fifty minute cross-continent voyage. Some idea of the amount of fuel needed for a flight across the United States is gained from the fact that they carried 10,850 pounds of load when they left New York, including 737 gallons of gasoline and forty gallons of oil. In previous attempts they had been unable to fly from the Pacific to the Atlantic because the plane could not lift this immense load over the tall mountain ranges along the California coast. By starting from the east, however, they burned up enough of the weight to let the plane cross the ranges of the Rockies. Lieut. Russell Maughan, who succeeded June 23 in making the dawn-to-dusk flight, burned almost as much fuel as the non-stop fliers, but was not troubled by the weight, as he made the journey in five hops, the longest of which, from Chey-

enne, Wyo., to Salduro, Utah, was 585 miles, and was therefore able to refuel frequently. He also traveled a shorter route than the non-stop fliers, who were forced to go far south into Texas and New Mexico to find low mountain passes which their loaded ship could cross.

Footgear from Old Automobile Tires Replaces Leather Shoes ¹⁵⁴⁴

Among the peasants and workmen of Spain, shoes made from cast-off automobile tires are being worn instead of the leather and wooden varieties. Cobblers make the footgear to order for their customers, using the outer tread for soles and the inside fabric for the uppers. A strong strip of the lining serves to hold the shoe to the foot. It is said that such articles



Shoes Made by a Spanish Cobbler from Treads and Inner Fabrics of Cast-Off Auto Tires

are suitable for wear in almost any kind of weather met with in that country, and are much cheaper than those made from other materials.

Herbert
Kadel +
153 E. 42nd St
New York

1441

772

Carl F. H. Kingsworth
213 County Bldg.,
168 Marlborough St. Boston, Mass

POPULAR MECHANICS



At Right, Sorting Cast-Off Garments for Charitable Society for Mending and Distribution

Doll Hospital of Benevolent Institution Where Damaged Toys Are Gathered after Rescue from Trash Bins of Big City and Undergo Repairs at Hands of Experts Who Make Them Good as New for Needy Youngsters



Off to the Rubbish Heap; Load of Mixed Waste Materials That Will Be Subjected to Scrutiny of "Pickers" at the Dump; Right, Once Beautiful Chair Reclaimed from Junk Pile for Repair and Sale



1441



Mending a Cast-Off Phonograph Taken from a Rubbish Heap



Trimming Old Burlap Bags into Covers for Open-Head Barrels



Cutting Up Iron Strips with Power Shears in Junk Shop

Fortunes Found in Nation's Junk Heaps

Cast-Off Materials Once Thought Worthless Become Basis of Industry That Gathers Them for Sale to Manufacturers

THAT the familiar rag picker, crying his wants in city alleyways and bartering for junk along country roads, is part of a great industry, is shown by the fact that hundreds of millions' worth of scraps and waste is annually gathered by these "prospectors," and others who search the trash piles and rubbish dumps of the nation for cast-off materials they sell to be reclaimed and converted to new uses. Millions of tons of

such junk are gathered every year from all parts of the country, and thousands of people are kept employed in handling it and making it into other products that

will ultimately be scrapped in their turn. Buying as cheaply as they can, the wandering "collectors" sell to others who maintain "junk shops." Every city and town has at least one of these. In Chelsea, Mass., a space of thirteen acres is devoted to



Sorters Weighing Rags Gathered on a City Dump, Using a Salvaged Wash Boiler as a Receptacle

what is said to be the largest junk market in the world. In the smaller places, the materials are sorted for sale to specialists. Wool rags go into one pile, cotton and linen into others, bottles into barrels according to size, and miscellaneous articles are thrown into classified heaps.

In the waste-paper business in New England alone, a total amount of \$10,000,000 each year is received in payment for the more common product which the packers sort into forty-two separate classifications, each with a different name to indicate the grade. From a city the size of Boston, thirty to forty tons of newspaper waste paper are collected every day and shipped to mills where it is made into high-grade paper board. Colored printers' clippings, such as tissue and light stock, are sent to concerns that cut it up into confetti, while heavier stuff goes to the manufacture of wallboard. During one year paper mills spent over \$50,000,000 for waste paper. Old news stock is even exported to China, where it is used to make a cheap form of clothing.

Regularly published market quotations on old and waste materials include mixed papers, old rope and strings, heavy and light scrap metals, scrap rubber, mixed rags, painted aluminum, printers' rags, dark cotton and

Dissecting Huge Anchor with Acetylene Torch in Naval Junk Yard Where Dealers Perform Much Preliminary Work before Carting Materials Away to Be Sold for Manufacture into Other Products



pewter. Many such classifications are to various cleaning processes the art undergo before being offered to trades.

Much waste is also imported, but must go through fumigation and inspection by government agents. Scrap iron often referred to as the "steel industry's second line of defense," is considered a vital link in steel production. Big metal dealers buy it in vast quantities from railroads, mills and building wreckers, selling it to plants who use between one and three hundred and 30,000 tons a month. Altogether about 7,000,000 tons of scrap junk are purchased yearly by the industry.

For many years the United States War Department sold its scrap metal and other waste to the highest bidder, regardless of what the huge piles of material contained. Then it was decided to call in an expert junk dealer, who established a system of grading and appraising the accumulations before offering them for sale. The result was a remarkable revision in dealers' bids and the receipt of more money for the scraps.

Formerly the large hotels in New York had to pay cartage for the removal of broken china and crockery, but now this is done for them without charge by concerns that buy this material and melt it down for the gold they derive from the edges, monograms and decorative lines. City dumps yield fortunes to many junk dealers, who employ hundreds of people to pick over and sort the stuff.

New York Times
5/5/24

Carl Earl Bullock
4327 Park Ave
Indianapolis, Ind.
775

POPULAR MECHANICS

**Skill of Scientists Assures Safety
of Travel on American Trains** 1684

Provisions made by American railroads for safeguarding the lives of their passengers go far beyond the watchful engineer and the elaborate and accurate system of automatic signals. Before material for the locomotives is bought, before a car is constructed or a tie laid, chemists and engineers are at work over test tubes and burners in their laboratories, subjecting the raw materials used to rigid examinations to detect any possible flaws. Metals are tested with special care and pulling and weight-dropping machines are employed for testing rails and axles. Locomotive and car axles are required to withstand a blow resulting from the fall of a ton weight from a height of forty-three feet. Among other materials and objects which must pass through the laboratory are engine and stay bolts, paints, lubricating and burning oils, coal, coke, wool waste for the journal packings, caustic soda for the electric batteries and even drinking water at the stations and in the cars is tested.

Aut. Access

**Electric Windshield Wiper for Auto
Requires Little Current** 924

Operating electrically from a storage battery, a windshield wiper has been marketed which will remove snow, sleet, rain or mist from the glass regardless of engine speeds or road conditions. Of simple construction, the wiper works with a back and forth movement with a current consumption less than that required for a headlight. The device will also work while the automobile is parked, a switch from the driver's seat controlling it. A metal spring insures close contact of the wiper arm with the windshield, preventing it from sidelashing or springing away from the glass.

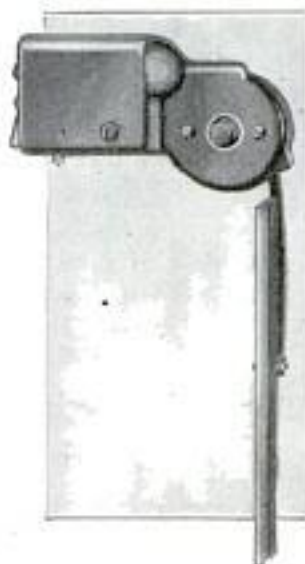

Colorado has the greatest average altitude and Delaware the least of the states in the Union.

*Stromberg Motor
Devices Co., 58 E.
25th St, Chicago*

**Mail Boxes Set in Gateway Column
Serve Colony as Post Office** 1592

Honeycombed with tiers of mail boxes, large concrete posts marking the entrance to a rural-residence division near Indian-



Concrete Column at Entrance to Rural Subdivision Which Serves as Post Office for Colony

apolis act as a safe repository for postal matter for the entire colony. Sixteen small compartments and two large vaults for papers and parcels are built in each column, one post being provided for the dwellers on each side of the street. Heavy doors guard the interiors of the receptacles, keys to which are held by the owners. Wide slots in the covers permit rapid distribution of mail by the postman, and the contents of the boxes are protected from all kinds of weather. Being close to the sidewalk, any section of the post can be conveniently reached.

U. S. Tire Output Increasing 1615

While the combined production of rubber tires for automobiles and motorcycles in the principal countries of the world amounts to 54,500,000, more than four-fifths are consumed by vehicles in the United States. About 46,000,000 casings are manufactured here each year, of which a little over a million are exported. It is said that this difference is due to the number of machines in this country.

*Chicago Evening Post
Copyrighted material
7/28/24*

*Com. Edwin Jurise
of the Farragut,
Washington, D. C.*

U. S. Sailors Serve as Steeplejacks While Painting Liner's Funnels

Riding in bos'n's chairs or clinging to ladders, sailors on the "Leviathan," at least once a year assume the role of

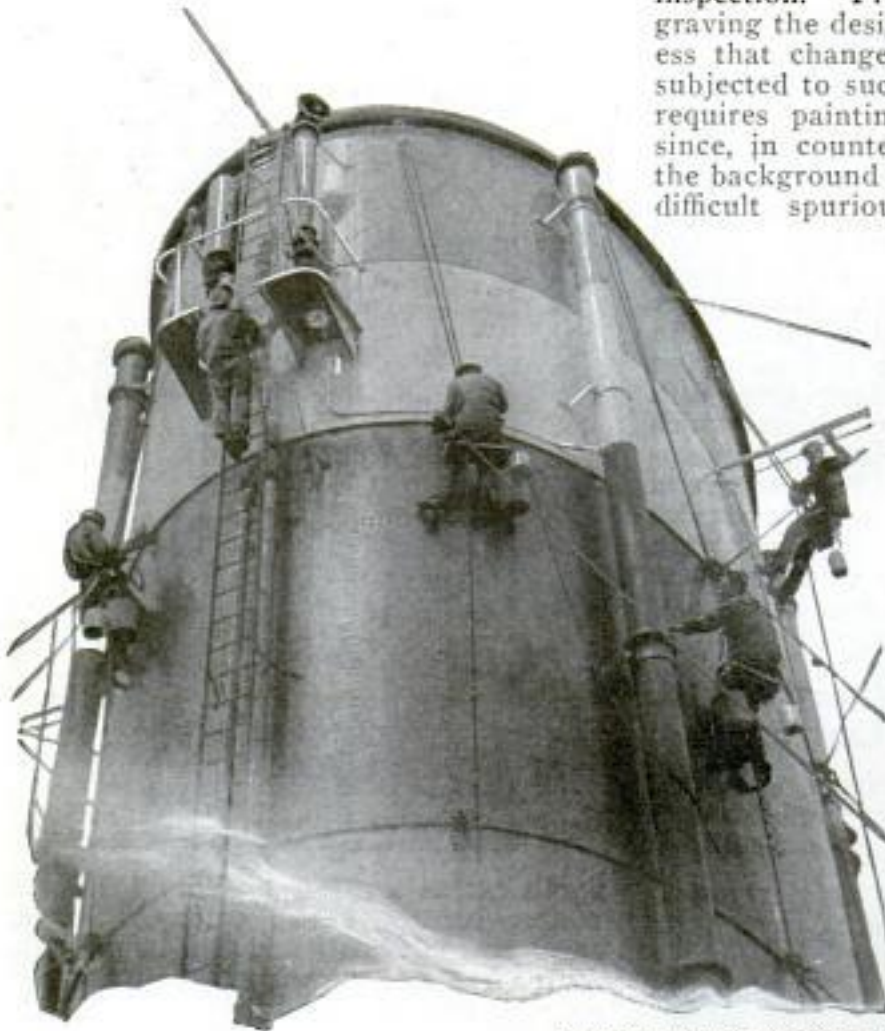

Copyright, Underwood & Underwood
Squad of Nimble "Steeplejack" Sailors of the U. S. S. "Leviathan," Painting
One of the Liner's Gigantic Funnels from Bos'n's Chairs

steeplejacks when they paint the liner's towering funnels. The three smokestacks are nearly seventy feet high and each is large enough to permit the largest locomotive ever built to pass safely through its interior. Thousands of gallons of paint are required to cover the huge liner, which is 950 feet long and 100 feet from keel to top deck.

False Banknotes Detected by "Feel" in Hands of Experts

Because of the secret treatment of paper stock when printing banknotes in the government bureau of engraving, counterfeiting is said to be made more difficult, since bank clerks, business men,

and others familiar with the characteristic "feel" of paper-money, can easily detect the imitation article when handling it. Although the usual silk threads found in paper currency may be traced in by pen and ink, they may be revealed by close inspection. Protection from photo-engraving the designs is obtained by a process that changes the color values when subjected to such treatment, and the seal requires painting in with water colors, since, in counterfeits, the black lines of the background show through. The most difficult spurious bill to detect, it is

claimed, is one of low denomination which has been bleached out and replaced with a false print of higher value. Sometimes the only test which can reveal the fraud is the system of numbering and lettering that marks each note. Each one bears a treasury number, and if this figure is divided by four, the remainder should be 1, and the serial letter A. If the remainder is 2 the letter should be B; when 3 is left, C designates the series, and D in case there is no remainder. Results that show otherwise denote a counterfeited bill. One of the most usual methods of fraud in gold coins is the practice of sawing the disks in half, extracting the metal on the inside and replacing it with some cheap material before carefully joining the two pieces again.

662

Copy of Fourth U. S. Patent Found; Was Signed by Washington

Written in longhand, a copy of the fourth patent granted by the United States government has been found among the archives at Washington. It covers a device for making punches and matrices in the manufacture of printing types and was awarded to Francis Bailey, a Philadelphia printer, in January, 1791. It bears the signatures of President George Washington, Secretary of State Thomas Jefferson and Attorney-General

*Detroit News
9/4/24*
Copyrighted material

Capt. John Anderson,
6 Percival St., Papanui,
Christchurch, New Zealand.

POPULAR MECHANICS

Edmund Randolph and also the seal of the nation. Since that time, about 1,500,000 patents have been issued and the task of hearing and passing on the applications has become one of the most important government activities and requires the services of hundreds of workers.

Quarter Million Tons of Explosives Used in Building Tunnel

In the construction of the Otira railway tunnel, through the Southern Alps of New Zealand, more than a quarter of a million tons of explosives were used to blast the cavity and about sixty miles of copper cable were required to equip the tube for electric-locomotive operation. The engines, arranged to work singly or in pairs, get their power supply from overhead feed lines carrying 1,500 volts. The tunnel was built in two sections, boring being carried on from both ends. When the divisions met, it was found that they varied only one and a half inches from the center line established by surveyors. Each part is more than two and a half miles long and passes through rugged rock deposits. The completion of the



Electric Locomotive in Otira Tunnel Passing under Forest of Icicles Caused by Winter Weather

tube marks the first step in the electrification of the New Zealand railways.

Wintrude Motor Co.
200 Florence St.
Milwaukee, Wis.

Motor Pump to Fight Timber Fires May Be Carried by Two Men

For quick transportation through narrow forest trails and over wooded areas, a portable pump operated by a gasoline

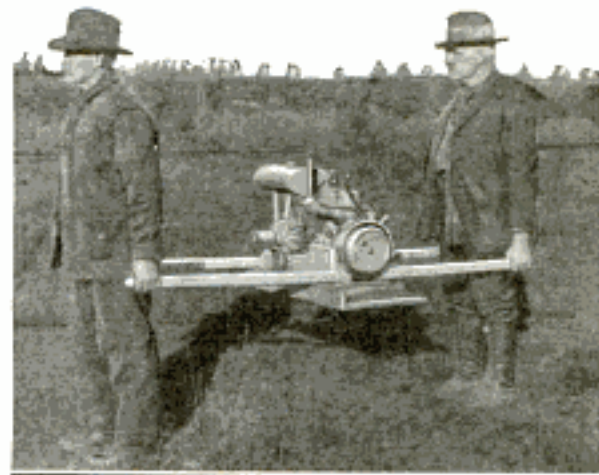

Transporting Portable Fire Pump to Aid in Fighting Blaze in Isolated Stretch of Woods

motor is being used by timber guards of New York. It is light and powerful and can draw its water supply from almost any shallow stream. When in operation, the device is said to do the work of a corps of men with shovels and buckets. Weighing only 100 pounds, the apparatus can be easily taken from place to place by two men. Three hose may be attached to the machine in case of need.

Life of Wooden Poles Is Lengthened by Chemical in Punctures

Although the practice of treating poles, posts, ties and other timbers with chemicals to prevent decay is an old one, a recent, patented improvement is said to add from fifteen to twenty-five years to the life of the wood. The apparatus consists mainly of an arrangement of forty-two independent iron bars set with sharp points which puncture the butt of the pole with rows of holes, about half an inch deep and an eighth of an inch wide, before the preservative is applied. The evenly spaced holes act as those in a sponge, soaking up the preservative and allowing it to penetrate to an equal depth everywhere in the fiber when the pole is placed in the treatment vats. According to government estimates, proper preserving of structural timbers will effect an annual saving of \$72,000,000 in America. The adoption of better methods in this direction is urged not only to reduce repairing costs but also to protect dwindling timber supplies.

B. J. Carney & Co.,
Spokane, Wash.

1029
778

Cont. Earle W. Isage, Asheville, N.Y.
Photos - K. W. Isanaway c/o Camera Exchange,
POPULAR MECHANICS
26 Quincy St. Chicago

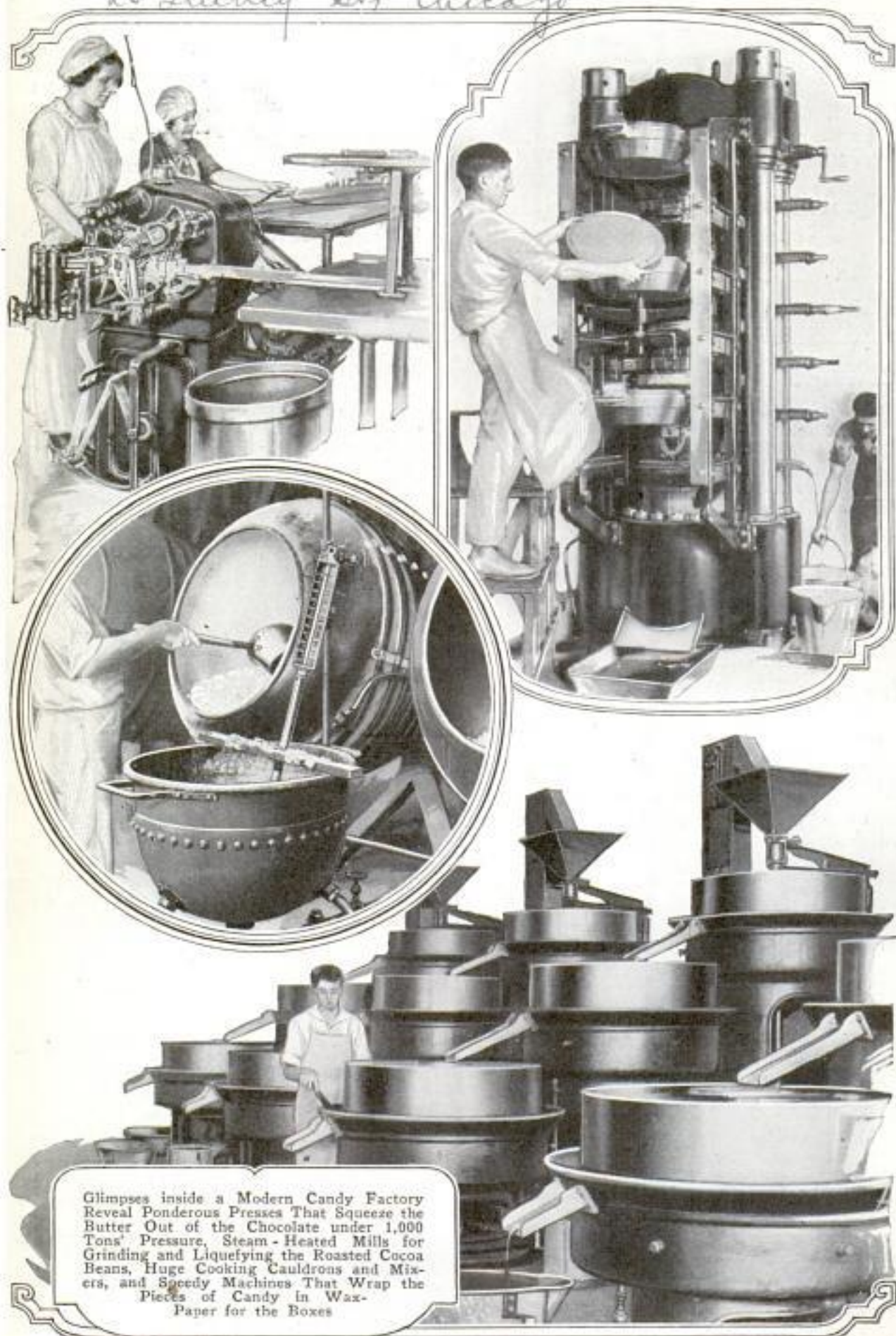

Glimpses inside a Modern Candy Factory
Reveal Ponderous Presses That Squeeze the
Butter Out of the Chocolate under 1,000
Tons' Pressure, Steam-Heated Mills for
Grinding and Liquefying the Roasted Cocoa
Beans, Huge Cooking Cauldrons and Mixers,
and Speedy Machines That Wrap the
Pieces of Candy in Wax-
Paper for the Boxes



Display Cabinet Showing a Few of the 1,200 Varieties One Candy Factory Makes

Filling the World's Sugar Bowl

Sweet Crystals, Once a Luxury Only Nobility Could Afford, Now Are to Be Found in Every Home

FROM a delicacy that just a few generations ago was so rare that only royalty could afford it, sugar is now a familiar food article of universal consumption. At first refined from a plant that grew wild in India, production from cane and beet roots has grown to an annual output of more than 23,000,000 tons. Of this amount the United States consumes twelve billion pounds a year, enough to supply each person with 100 pounds.

Even a century ago, sugar in any form was a luxury and the granulated product was unknown. Improvements in cultivation of the cane and great advances in the art and science of refining the raw article have resulted in the manufacture of a score of different grades suited to almost every purpose. While its value as food is popularly known, sugar now enters into the industries as an aid to manufacture, becoming a vital part of many chemical mixtures and even being treated and made up into compositions from which useful articles are made.

As in early colonial days, the sap of the cane must be gathered by pressing. When extracted and crystallized, the raw prod-

uct still requires melting, clarifying and filtering, but modern machinery has been developed which greatly facilitates these processes. Instruments have been devised by which the raw product can be tested for impurities, revealing to the slightest degree its content of undesirable ingredients. Although it is possible to obtain sugar from certain species of the maple tree, sorghum, broom corn, many fruits and some palms, the world's supply mainly comes from cane and beets. While the cane is generally grown in tropical and semi-tropical climates, beet sugar is a product of the temperate zones, its cultivation occupying countless thousands of acres in Europe, Canada and the United States. While it has been only 175 years since the homely beet root was discovered to contain a great volume of sugar, the Chinese are said to have known of the sugar cane nearly 3,000 years before. On one of his voyages to the New World, Columbus brought a collection of the plant for introduction to the fertile soils of the West Indies. So rapid was its spread among those islands that, in the seventeenth century, Cuba possessed

more than a hundred plantations. Today vast tracts of that country are given to the cultivation of the plant, with an output that is larger than that of any other nation. The trail of sugar cane may be said to follow the equator in a wide belt around the earth, since almost every tropical territory possesses it to some degree.

Perhaps the most popular use of sugar is in the manufacture of candies and similar confections. More than a billion pounds are consumed annually by hundreds of candy makers found in practically every city and town of the nation, and their products range from the enticing lollypop to elaborate tidbits arranged in gorgeously ornamented containers, the manufacture of which has become an industry employing many artistic designers and thousands of workers.

Experts in candy making are constantly striving to produce new and novel mixtures and forms, and ally practically every popular fruit, nut, and flavor with the indispensable sugar to attain the best effects in sweetmeats. So wide is the use of chocolate in manufacture of confectionery, that many large factories have their own refining plants where tons of cocoa beans are reduced to tasty coatings and appetizing bars, through roasting, grinding and extracting processes that alone rival the activities of the rest of industry. Giant presses squeeze the undesirable oils from the raw chocolate, which is molded in cakes for melting into coverings and mixing with other flavors,

while huge vats are kept in constant turmoil by revolving blades that stir the hot masses. Coatings of chocolate are applied to the pieces in the "enrobing" room. Carefully shaped centers, traveling on an endless belt, are passed beneath a cascade of liquid chocolate flowing from raised tanks and are cooled by chilled air to harden the covering, so they may be wrapped by machine or hand before they cease their journey to grace the display counters of a "sweet shop."

In other parts of the factories, sugar is prepared into taffies, stick candies, and the more common varieties. Made into large masses of sticky, pliable molasses taffy, it is worked by a crew of white-clad "chefs" who replace the customary spoons with crowbars, jabbing, crushing and stretching it until the proper consistency is obtained.

In a single large factory, to prepare 15,000,000 pounds of sugar in more than 1,200 different forms of hard and soft candies it makes each year, 3,000,000 pounds of cocoa beans are required to produce the necessary chocolate coatings and ingredients. Milk and cream to the amount of 400,000 gallons are poured into the sweet masses that are mixed, stirred and molded by 1,500 operators. Heat, light and power are furnished by 25,000 tons of coal, while an ice plant of 300 tons' capacity insures sufficient refrigeration to keep the mountains of sweetmeats secure against melting until they are moved to the "avenue" shops.



Packing and Weighing Five-Pound Boxes of Chocolates for Bulk Shipments

Woman Inventor Gets Many Patents for Aids to Home and Office

With forty-seven patents to her credit, thirty-three of which are on the market,

select a landing place. Owing to the effect of the gear, smaller fields can be employed for emergencies and when traveling at reduced speeds, the tail of the plane does not tip down as is the case



Above, Convenient Memorandum for Fastening to Telephone Transmitter Showing Manner of Use

Left, Lady Inventor and Fan Guard; Above, Rubber Sponge with Pocket for Cake of Soap

Miss Beulah Henry, of Raleigh, N. C., has originated many helpful devices for home and office. Among the lady inventor's achievements is a guard for electric fans, which prevents injury from the whirling blades when moving or adjusting it, without impeding the passage of air current. Patents also have been issued to her for a rubber sponge into which a cake of soap can be inserted while in use, and a convenient memorandum chart for attaching to transmitters of telephones, where it can always be readily referred to by anyone talking over the instrument.

with ordinary wings. In tests, minimum speeds for flights

and landings were lessened from six to ten miles an hour under velocities required for craft not furnished with the flap gear.

Huge Pipe Is Formed with Oranges as Feature of Pageant 1047

Hundreds of oranges of varying sizes, attached to a frame, were used to make an immense pipe that was a novel feature at a recent festival in California. From bowl to the tip of the stem, the pipe measured several feet. Darker-shaded fruit for the mouthpiece and bowl added to its attractiveness. It formed part of the coronation ceremonies attendant to crowning California's citrus queen, an annual affair of much beauty.

Flap on Plane Wing Eases Landing and Increases Lifting Power 1437

Slower and safer landings by airplanes are said to be possible with an automatic "flap gear," by which the rear parts of the wings are hinged and pulled downward by springs when air resistance decreases or the machine is at rest. When the craft gathers speed the wind pressure on the flap adds to the lift of the wing and at the same time causes the springs to give, allowing the section to take a level position as motion is increased. Slower speeds than usual are claimed to be sufficient to keep the machine in flight, with the use of the flap, and if forced descents are necessary, the pilot can take more time to



Pipe Formed with Oranges That Was a Novel Feature at Annual California Show

Carl H. Christie, 356
Union Station, Winnipeg, Can.

Pacific & Atlantic
copyrighted material

Max Hamm Co, Inc,
88 St. Francis St

782

POPULAR MECHANICS

Newark, N.J.

Hand Bag and Sample Case in One Reduces Packing and Luggage

So it may be used as a container for wearing apparel and small samples at the same time, a traveling bag is being made



Packing Merchandise Samples and Clothing in Hand Bag Which Has Adjustable Pockets and Cannot Sag to Crush Contents

with removable partitions that can be adjusted to form several sizes of pockets. Easy to pack, the holder keeps the contents in perfect order and cannot sag or be crushed readily. As it may also serve as a brief case, it reduces luggage necessary on short trips where documents or other valuable papers are to be carried. Constructed of heavy leather, the bag can be opened out at the top on four sides, giving great freedom for proper placing of materials when filling it.

Great Cathedral Designed by Youth Is Dedicated in England

Twenty-three years ago Giles Gilbert Scott, an English youth just out of school, entered a competition for designs for Liverpool's cathedral—and won. Recently, after twenty years of work, he saw one-third of his edifice completed and dedicated, with the king and queen of England heading the notables in attendance. The work has already cost \$3,600,000 and another \$9,600,000 will be needed to complete it. Standing on the peak of a tree-grown quarry site on St. James Mount, overlooking the city and the Mersey river, the cathedral marks an epoch in English architecture. The two eastern

transepts and the chancel, which have been completed, are 300 feet long and the chancel is 116 feet high. The immense vaulted roof is said to be the finest in England. Two similar transepts and a nave remain to be built, while a great central tower, 350 feet high, is to rise between the four transepts. The whole, when finished, will be a symmetrical structure about both main axes, and will, therefore, be more monumental, in the classical sense, than any modern cathedral. The northeast transept has been dedicated as a memorial chapel to Liverpool's war dead, with an altar and a cenotaph and illuminated roll of honor. The cathedral windows are arresting in their beauty of design and coloring and, furthermore, are remarkable for their unique grouping of modern and ancient prophets. In one group John Wesley and John Keble appear. In a

group of martyrs is shown a Christian missionary killed by order of the king of Uganda. Another window depicting the activities of man shows Bach, representing a Christian musician; Lord Roberts, a soldier; and Sir Matthew Hale, a

lawyer. The cathedral organ, which is nearing completion, dwarfs the organ of Albert Hall, hitherto the largest in England. It has 168 speaking stops, as compared with 114 for the Albert Hall organ.

Glasses with Square-Shaped Lenses Designed to Fit the Face

Rectangular-shaped spectacles have appeared in Germany and are said to be winning popularity, as they permit shifting of the lenses to improve the vision, and their form is considered better adapted to the outlines and shape of some faces than the regulation elliptical style.



Style of Horn-Rimmed Glasses with Rectangular Lenses Now Finding Favor in Germany

Rims of moderate width and a comfortable nose piece are points in their favor.

Kansas City Times 7/16/24

1619.

Suit made by - J. St. Odgrass,
 St. Paul Moccasin Co,
 POPULAR MECHANICS-
 2496 W. University Ave. 783

St. Paul
 Minn

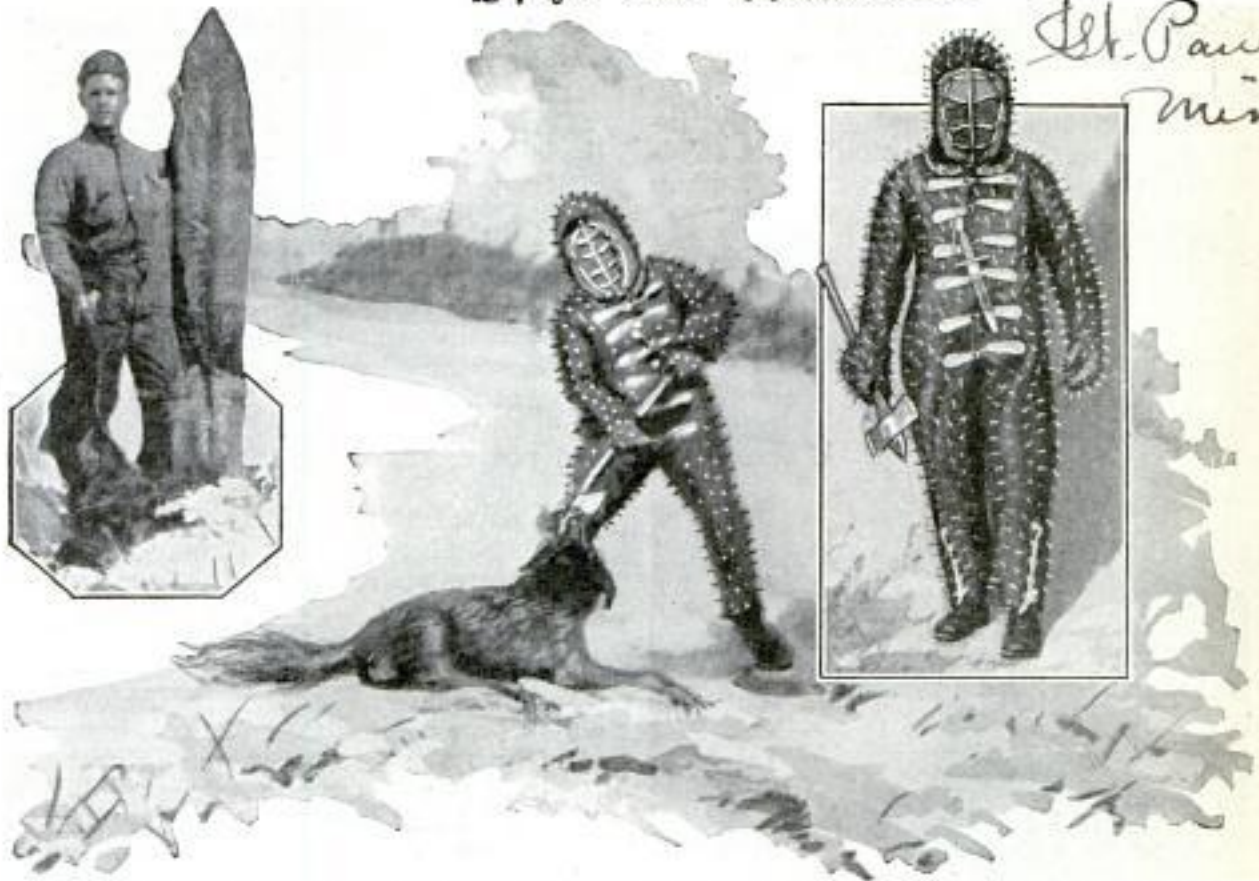

Daring Hunter as He Appeared in Bristling Spike Armor, a Pose Illustrating How Wolves Were Killed, and at Upper Left, a Trophy of the Hunt

Hunter Protected by Armored Suit Tells of Battle with Wolves

Details of one of the strangest experiments in the history of animal hunting are related by Stanley Clarkson, of St. Paul, Minn., who spent a winter in the Canadian wilderness seeking "hand to hand" combats with hungry timber wolves. Dressed in an armor made of heavy leather studded with 1,200 needle-sharp steel spikes, he invited attacks from wolf packs while armed only with a short double-bladed ax and a hunting knife. Although handicapped by an exceptionally open winter and an unusually large number of wild rabbits, which kept the wolves from suffering from hunger, he killed a number of the beasts with his ax. During a snowstorm on Steep Rock Lake, north of Atikokan, he was set upon by five timber wolves. He killed two of them and wounded a third. The wolves seized the hunter's arms and legs in their jaws, but could not do him injury because of the protruding spikes of the armored suit, which is made of specially tanned thick cowhide that will turn water and will not harden from rain or snow. There also is a helmet and heavy wire mask that can be raised to protect the face.

Bottle Cap Measures Dose, Shows Time It Should Be Taken 1405

Fitted with a stopper that measures the doses and shows when the next one should be taken, a bottle used by the manufacturers of a medical preparation aids the patient in taking the proper amount at the correct time. The cap has numbers from one to twelve on the rim.

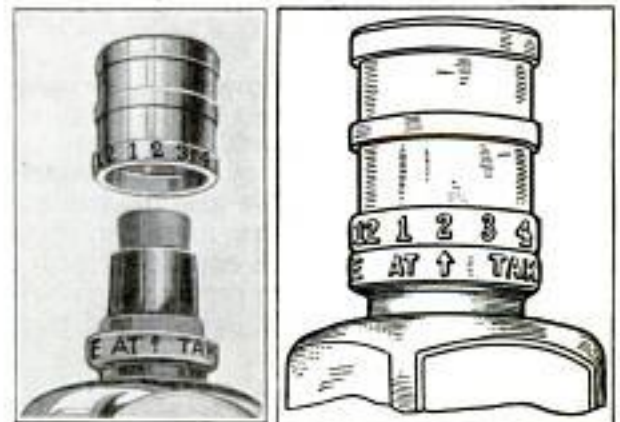

Bottle with Measuring Cap and Stopper Turned to Show Time of Next Dose

These are turned to a mark at the top of the container to indicate the hour that the medicine is to be taken again.

Chas. M. W. Lowry,
 Athens, Ga.

New York Times
7/13/24

160 Fire Engines' Moves Traced by Tags on the Map of a City

To keep headquarters constantly informed as to the distribution of the apparatus, the fire department of Boston



Distribution Chart of the Boston Fire Department Which Indicates Exact Location of Apparatus

traces the location of each machine by means of small colored disks placed at points on a map of the city corresponding to those occupied by the equipment. Hooks on the chart designate district stations and the disks hung on them show what apparatus is assigned to the sections. Each check carries the number of the piece it represents and is colored to indicate the type. Knowing what companies answer the various alarms, the attendant in charge of the map transfers the tags to a board as the engines respond to the call. Units in the repair shops are noted on a row of hooks in a special part of the rack.

¶ Six airplanes have been added to the equipment of the New York police to enforce the ordinance against low flying over the city, and to aid in the campaign against boats that discharge oil into the harbor and surrounding waters.

160 Day at Sea to Begin at Midnight Instead of Starting at Noon

Days at sea will begin at midnight like those on land, according to government orders which are to go into effect in January. The change from the customary way of figuring time on board ships, where days for ages have commenced at noon, is expected to result in confusion at first, and already opinion on the order is divided. Many old sailors point out that the world of the sea is radically different from that of the land, so it is only natural and proper that time should be recorded differently. Men who go down to the sea in ships tell time by bells while landlubbers look at clocks; seafarers go topside and below while others go up and down stairs; nautical men steer by starboard and port, except in the navy, while right and left are the guiding directions for land dwellers, and the course of the sun by which bearings are taken at sea, fits naturally into the ancient system of keeping track of time. On the other hand, it is expected that when schedules and calculations are once adjusted, fewer errors will be made in determining correct dates.

1553 Roof Ventilation for Inclosed Cars Is Automatic in Action

To insure a supply of fresh air to the interior of closed automobiles, a ventilator to be installed in the roof and which operates when the car is in motion, is being made. Besides setting up circulation on the inside of the machine as it moves against the air, the device draws out any



Ventilator in Roof of Auto Which Keeps Air Circulating on Interior When Car Travels

impurities, and completely changes the atmosphere every few minutes, even in the largest sedans. It is easily and quickly put in place, and cannot be entered by rain or snow. The outer surfaces are finished in black or aluminum, and it is designed so as not to mar the appearance of the vehicle.

*National Aluminum Co.,
Racine, Wis.*

Copyrighted material

no further information
POPULAR MECHANICS

*Architect - Edward Langley,
Mechanical Director at
785
Franklin's studio,
7100 Santa Monica
Blvd., Los Angeles,
Calif.*



Apparently Weather-Beaten and Stained by the Storms of Ages, This Quaint Dwelling Has Just Been Completed for a California Builder Who Desired "Something Different" in Design

New House Is Built to Look as Old —as an Ancient Castle 1582

Radical departures from ordinary types of architecture are not uncommon in California cities, where builders and artists have ample opportunities to combine their skill in producing novel effects. One of the most striking examples is a high-gabled house, completed not long ago near Los Angeles. The owner desired a home that would suggest age and ruin. By clever handling of materials, the architect satisfied his client and at the same time achieved proportions and contours which blend harmoniously with the surrounding hills and country. Shielding the narrow and odd-shaped windows are cumbersome dark-stained shutters. The roof with its shingles set somewhat awry in imitation of thatching, rises to a steep peak and is apparently supported on one side by an ingenious prop anchored to a pile of cobble stones. Before the doorway is a little bridge that suggests the carefully guarded structures that spanned the moats of castles centuries ago.

☐ Sufficient lumber to build fifty ordinary five-room bungalows was cut from one giant redwood tree, recently felled near Portland, Oreg.

Automatic Coin Changer Saves Time and Detects Counterfeit Money 1290

To lessen delays, automatic money-changing machines are being installed in New York subway stations. The device, which will detect counterfeit money and slugs, changes ten, twenty-five and fifty cent pieces into coins of smaller denom-



Machine That Automatically Changes Ten, Twenty-Five and Fifty-Cent Pieces into Smaller Denominations

inations. The machine was recently demonstrated and proved to be practical.

no further information

Copyrighted material

**Giant Armature for Steel-Mill Power
 854 Has Copy in Tiny Motor**

To show relative size of the smallest and largest types of armatures made by one concern, a six-and-one-fourth ounce wind-

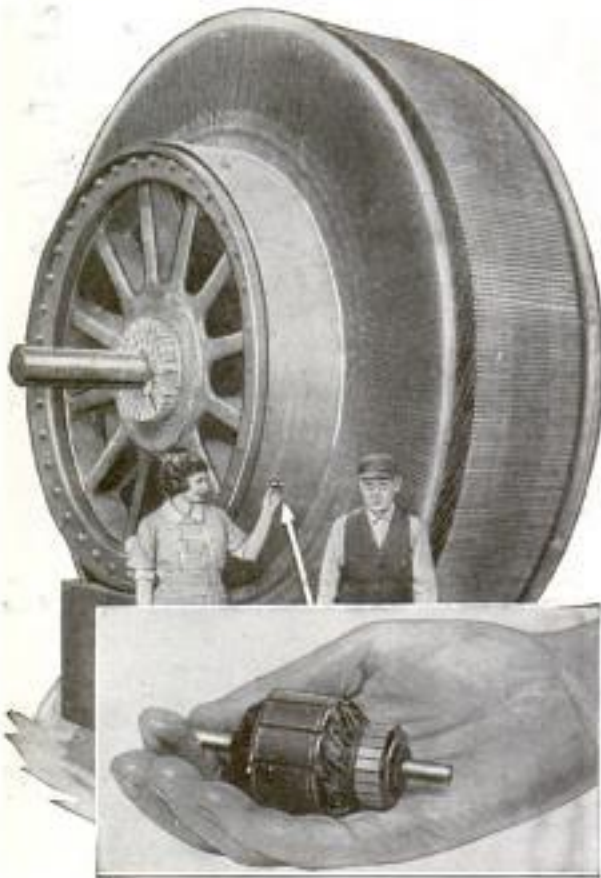

How Tiny Armature for Small Blower Motor Looks When Contrasted with Forty-Eight Ton Winding

ing was contrasted with one weighing forty-eight tons. The big apparatus was built to generate power for a steel mill, while the tiny specimen is part of a motor that runs a blower. Both parts are constructed along similar principles of design and operate in much the same way. The diameter of the larger armature is thirteen feet four inches and it will revolve sixty-seven times a minute.

**Steel Framework in Fireproof House
 1670 Cut and Fitted on Site**

Constructed entirely of fireproof materials, a bungalow in Toledo, Ohio, has a steel framework that adds to the sturdiness of the house. Cost of the metal work was considerably reduced, it is said, by devising a few standard forms from which the builders could fabricate the various sections on the site of the job. To cut any extra holes needed in the mate-

E. H. Dexheimer
 Built by C. H. Dexheimer
 1420 Parkside Blvd
 Toledo, Ohio

rial a punch press was provided, greatly decreasing the expense required by having the steel prepared at the mill. Under the plan used, construction consisted of five steps, laying out the steel parts and punching the necessary holes for assembling, building of the steel frame, applying metal outside to receive the concrete wall, concreting the subfloor and finishing the interior. It is believed that special shapes and lengths of steel may soon be regularly made for the rapid and inexpensive fabrication of such metal skeleton work for bungalows and similar residence structures.

**Trees Form Piers for Footbridge
 1588 across Wide River**

Swung between big trees that grow on both sides of the Quinalt river in Washington, a narrow suspension bridge, about 1,000 feet long and but two feet in width, affords foot passage over the stream. Said to be the longest structure of its kind in the world, the span, supported at the land ends by forest giants, is secured in the middle to a pier fifty-four feet high resting on a "mat" of rocks and tree branches, a foundation made necessary by the continual changes in the river channel. Heavy cables are stretched on each



Footbridge Swung between Trees on Banks of River to Give Passage from Waterlocked Farmland

side of the bridge to prevent swaying, while the platform is protected by high wire netting for safety of pedestrians.

Olympic Peninsula

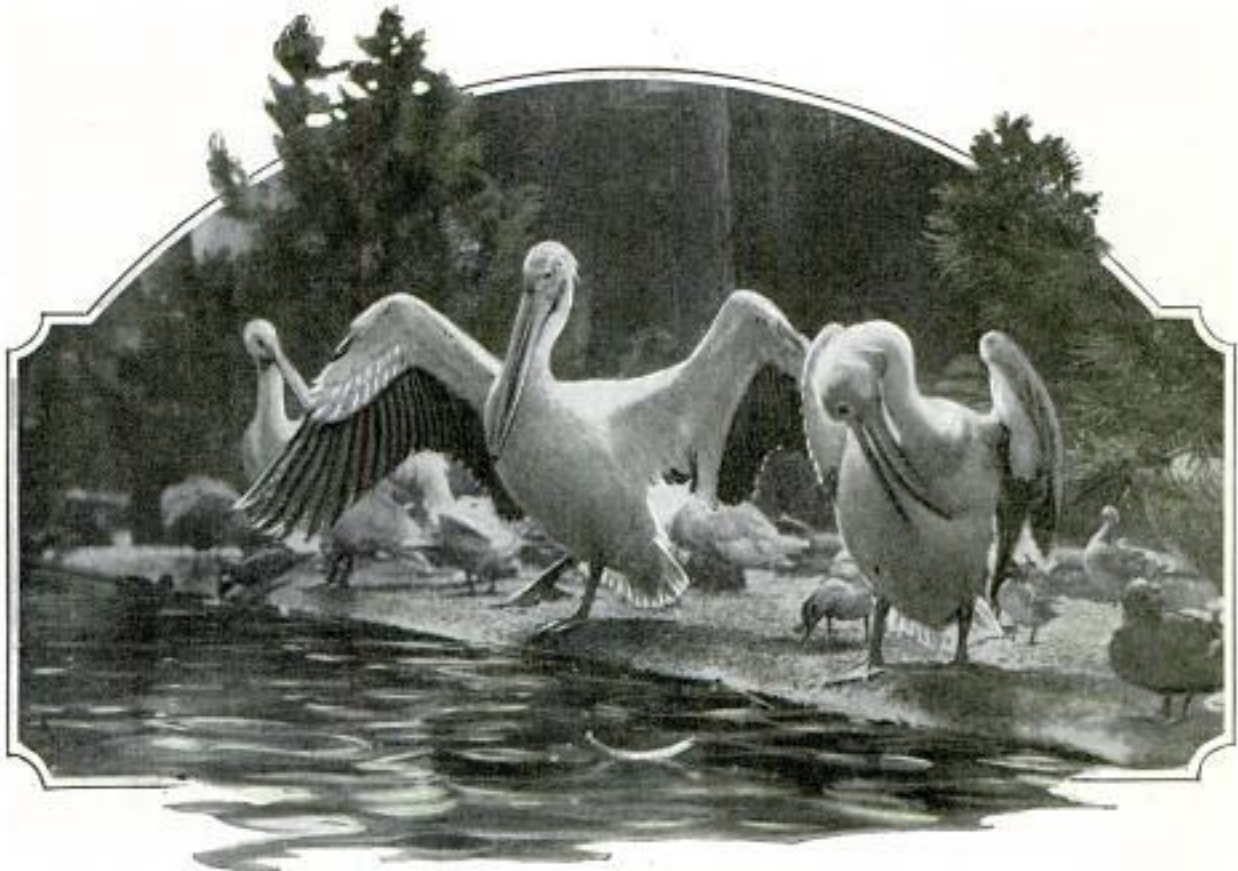

Group of Sociable Pelicans Pluming Themselves after a Dip in the Pond

Feeding the Animals in a Zoo

Costs Nearly as Much to Feed a Sea Lion as an Elephant, and the Lions and Tigers Outeat the Hippopotamus

IT costs almost as much a day to feed a sea lion in captivity as it does to satisfy the hunger of an elephant. A ton or so of first-class hippopotamus costs less for upkeep than a lithe Bengal tiger or a tawny, sleepy-eyed lion from Africa.

The reason whereof is the difference in their diet, and the diet kitchen of a zoological garden can tell you these and many other strange and interesting facts about the feeding of captive birds and animals.

The daily order of "groceries and meats" for the Lincoln Park zoo in Chicago includes more than thirty different kinds of food, ranging from hay for the elephant, buffalo herd, zebras, gnu and zebu, or sacred cattle, through meat and fish for the carnivorous tribes, to eggs, oranges, apples, carrots, celery, onions, Mellin's food, cod-liver oil, olive oil, bananas, milk, bread, and, occasionally, pills for stomach ache and other disorders.

The zoo's bill for feed for its 239 animals and 758 birds, amounted to \$17,356.62 last year, according to Albert E. Parker,

the director. Only the best of everything is purchased, and extreme care is used in its preparation to guard against the myriad ills which beset animals and birds, especially in captivity.

When they do get ill, Parker treats them homeopathically, for their symptoms rather than the disease. The reason is that the same disease rarely hits two animals in the same way. The chimpanzee in one cage may have chills with his pneumonia, and his mate in the adjoining hospital ward will take his pneumonia with fever. The success of Parker's method of doctoring is attested by the fact that "Toto," the big chimpanzee, has come safely through three sieges of pneumonia—two more than most monkeys ever survive.

Medicine for the animals comes under the head of food because it is administered with the meals. Getting six feet of squirming tiger to swallow a nerve pill is a difficult task, but if the pill is hidden in a lump of lard and the lump then concealed



Twenty-Three Feet of Python from India; This Nervous Reptile's Meals Consist of Plenty of Ground Meat Fed to the Snake with a Sausage-Stuffing Machine



Catering to the Tastes of a Zoo Family Calls for Everything from Hay to Honey



Daily Fish Courses Compose the Diet of the Quaint Penguins Whose Habitual Foraging Grounds Is the Sea, near Which They Settle in Great Colonies among Rocky Ledges



Graceful Rose-Tinted Flamingoes Lunching on a Bucket of Feed Served from the Zoo's Larder

© P. & A.



Where the Bottle Is Mightier than the Trap; a Forest Ranger Treating a Young Bear to a Drink of Honey and Water. Right, Pouring Food into a Cobra through a Bone Pipe Inserted in the Serpent's Mouth

U. & U.



Cinnamon Bears Performing Clownish Antics in Their Zoo Den to Persuade Rewards of Fruit and Candy from the Host of Amused Visitors. Left, Mother Kangaroo Indulging in a Noonday Feed; Her Youngster Safely Tucked in Her Pouch Partakes of a Few Morsels Overlooked





Butcher Shop of the Animal House Where Choice Meats Are Appor-tioned to Hun-gry Captives

Young Pet Orang-Utan En-joying a Milk Repast; Below, Master of the Zoo, the Lord-ly Lion Awaiting a Visit from Its Keeper

© U. & U.

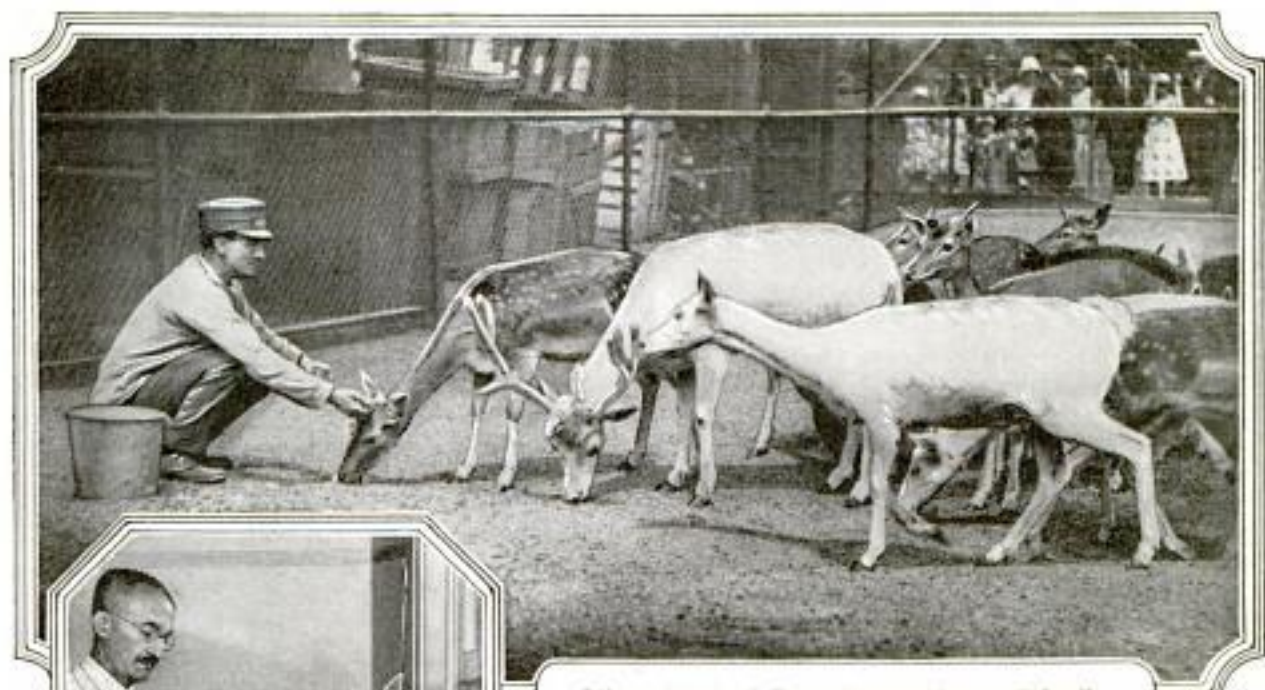

Mixed Herd of Deer Approaching a Friendly Attendant Whose Feed Bucket Easily Wins the Animals' Attention. Left, Pure, Sweet Milk Rationed Out by the Gallon for Old and Young Inmates of the Zoo

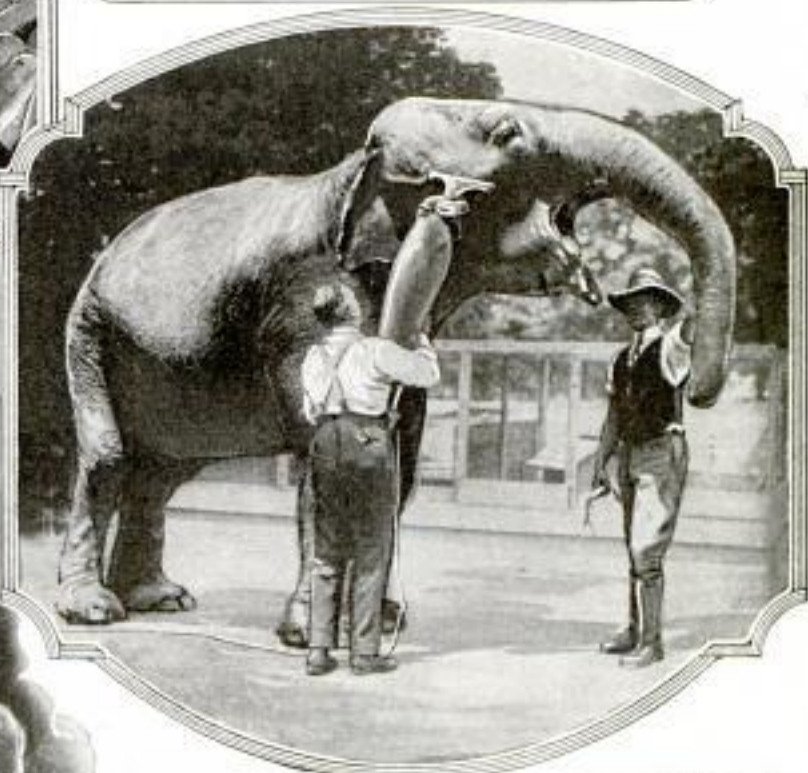

Modern Vacuum-Cleaning Methods Applied to "Jumbo's" Hide Are Enjoyed by This Elephant Which Gets a Daily Sweeping to Keep It Neat. Left, "Bottle Baby" Walrus Taking a Meal from Its Watchful Keeper Who Cares for the Ugly Youngster's Every Want

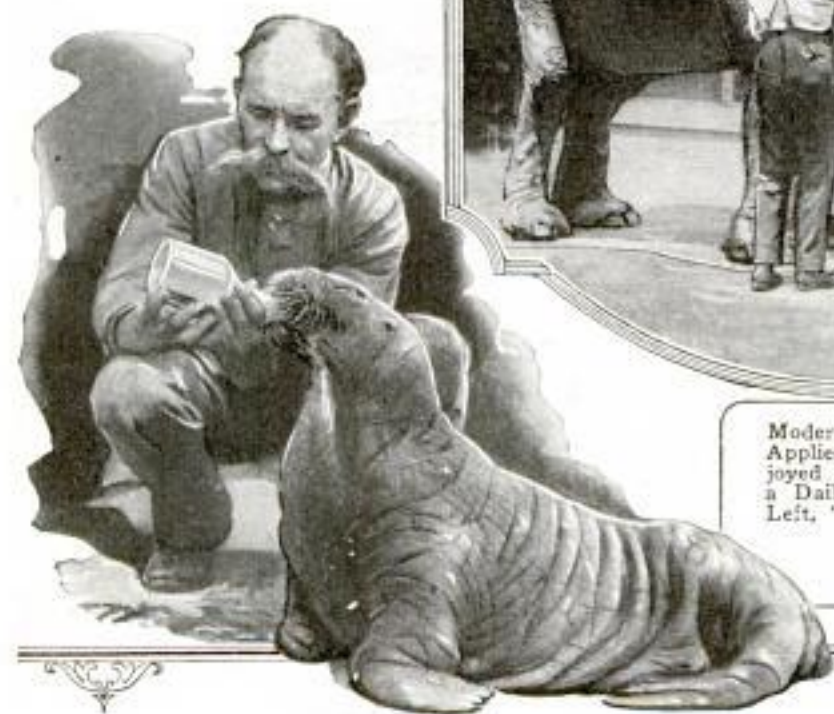

in a nine-pound piece of meat, Mr. Tiger takes his medicine without knowing it.

The big eaters of the zoo are not the most expensive ones. A prime young elephant thinks nothing of tossing down from 75 to 125 pounds of hay in a day and then finishing off on a bushel or so of peanuts contributed by children. Hay, however, is relatively cheap, and the park concessionaires grow wealthy selling the peanuts which the children contribute toward keeping down the zoo's food bill.

The food bill begins to mount, though, when a full-grown male tiger gulps down nine pounds of best beef, while even the youngsters take their five-pound chunk every day but Sunday. Sunday is fast day for all the big cats, the one-day-in-seven rest keeping them in good health.

A big male lion takes six pounds of beef on weekdays, and his mate a four-pound piece. Leopards and the smaller members of the cat tribe, including the American puma, or mountain lion, get along on from two and one-half to three and one-half pounds for their one meal a day.

A quarter of beef is delivered to the zoo each weekday morning and is immediately cut up by the butcher, who lays the pieces out on a table to get warm before the four p.m. feeding hour. The carnivora like their meat warm, and it is necessary to remove the chill of refrigeration.

The sea lions are fish eaters, and get their five pounds every day, including Sundays. At feeding time, they contribute a special program of diving, climbing and swimming for the benefit of the spectators, getting one fish for each stunt. The sea lions are the best time tellers in the zoo and regularly at fifteen minutes before feeding time one mounts his lookout perch on the rocks to announce the coming of the waiter with his basket of fish. At the hippo den, two bushels of mixed feed a day will keep the doctor away. The hippo's mixture includes apples, bread, bran, hay, crushed oats, carrots and other vegetables.

The bears get a varied diet, with fish for the big white polar bears and bread as the mainstay for the rest. All of them supplement their regular meals with peanuts and crackerjack furnished by the visitors. A bear will eat so many peanuts in a day that his regular rations are cut in half on Saturdays, and omitted entirely on Sundays.

The birds and the monkeys are the most particular eaters in the zoo. The big pelicans get a pound and a quarter of fish a day, and the eagles, hawks and vultures take the same diet.

Part of the zoo's food bills include 150 loaves of bread weekly for the bears, birds, young deer and kangaroos; six carloads of baled hay each year and, during the winter months, thirty tons of carrots and two tons of sugar beets.

Tempting a Newly Imported Giraffe, Which Is Quiet and Curious, with Dainty Candies from Atop a High Ladder.

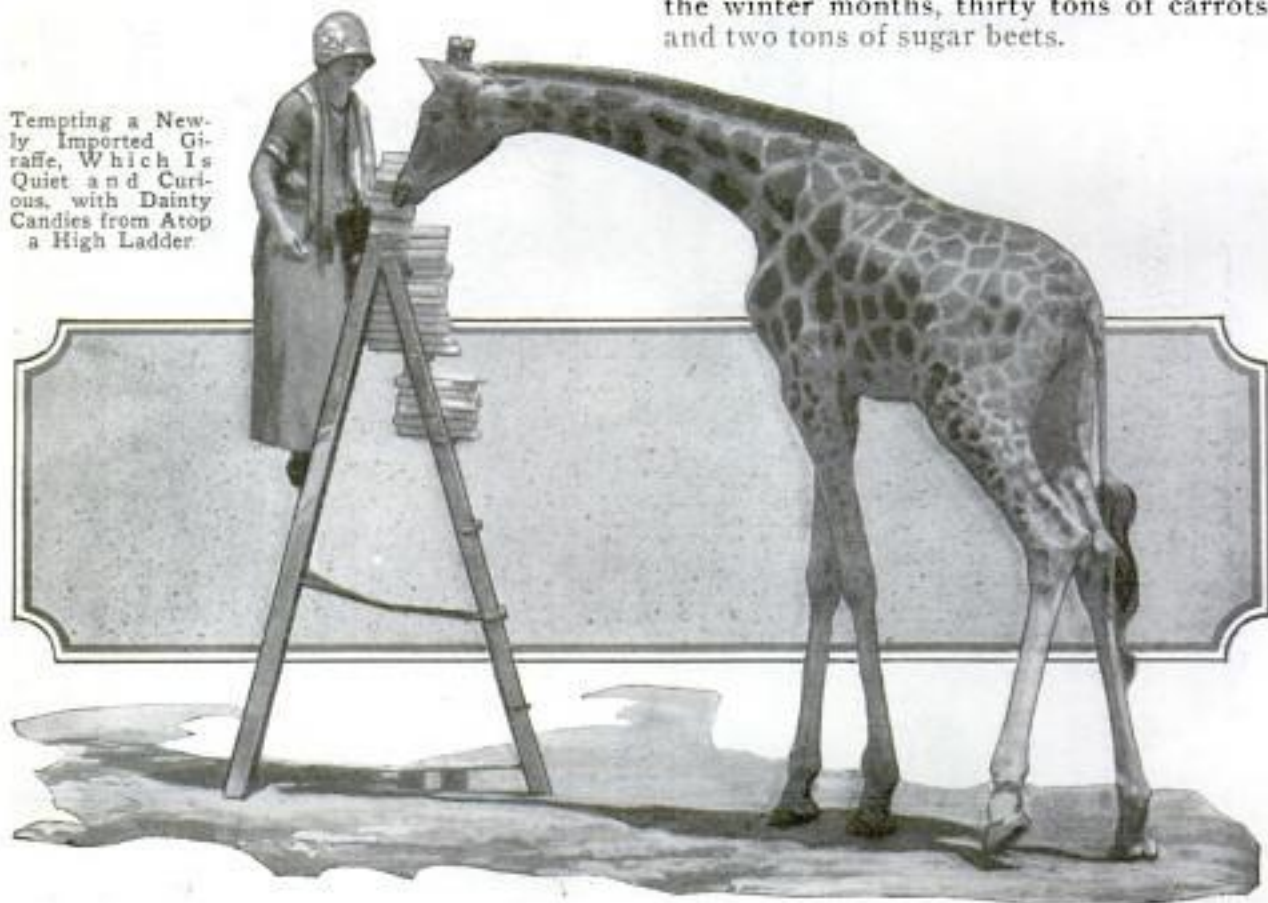

Damage by Smoke in Twenty Years Equals Century of Decay *1648*

In the last twenty years, Westminster Abbey has suffered almost as much damage from smoke as time inflicted in all the previous 650 years of the building's existence, according to the reports of engineers. Even some of the new stones used to repair it a score of years ago have begun to crumble, indicating that much of the cathedral's decay has been caused during the last half century. The city of Manchester also reports heavy damage from smoke. To combat the evil, authorities in England have been urging the substitution of gas wherever possible and this is believed partly responsible for a decrease in the death rate, by reducing smoky fogs favorable to the development of bronchial and tubercular diseases. In Glasgow, the amount of gas used during 1901-20 rose from 5,500,000,000 to 8,000,000,000 cubic feet and during the same period, the death figures fell from 21.2 to 15.3 per thousand.

Japanese School Ship Recalls Days of Canvas-Rigged Craft *1647*

With acres of canvas spread to the wind, recalling the romantic age of sailing vessels, the barkentine "Shinkoku Maru," training ship for officers of Japan's merchant fleet, recently completed its maiden voyage. Regarded as among the finest



Tennis Courts Are Made of Roofing *1646*

Because rains prevented tennis playing by leaving clay courts too soft for use until they dried, a St. Louis club surfaced its grounds with asphalt roofing. The covering is said to give a better footing to the players and to permit games within a short time after rainfalls. The sheeting is easily and quickly applied and held flat in place by cement. Besides insuring a uniform court surface the year around, the material is said to withstand rough usage. Requiring little expense for upkeep, the roofing is said to greatly increase the number of games during a season.

Pacific & Atlantic
With Full Canvas Spread, the Japanese Training Ship Gliding Swiftly through the San Francisco Bay on a Visit during Its Maiden Voyage

craft of its class afloat, the school ship is commanded by one of that country's most noted sailors. During a period at sea, the student-officers are taught management of crews and administration of almost every type of merchant vessel, under the instruction of veteran seamen. On its first cruise, the barkentine carried a class of sixty cadets.

☐ Dried mushrooms constitute one of Poland's most important exports.

Certainated Products Corp. (Triple A Club)
Boatmen's Bank Bldg. - 1000 - 1100

Gas Masks for Mail Clerks to Foil Attacks of Train Bandits

To defeat the attacks of gas-bomb-throwing bandits who already have invaded Uncle Sam's mail cars, the govern-



Copyright, Henry Miller
Shielded by Gas Mask and Armed with Revolver, Mail Clerk Ready for Bandit Attack

ment proposes to equip clerks with masks as protection from the poisonous fumes. The hoods are to be purchased from the war department under plans discussed by officials and are to be the same type that were used in the trenches during the World War.

Cure for the Terrors of Childhood Is Sought by Scientists

Fear of the dark, of snakes and many other terrors common to childhood are usually acquired and are not inherent, according to deductions drawn from experiments that have been performed on a number of children by investigators of the teachers' college at Columbia university. They have been trying to discover ways to combat some of the distressing mental agonies that the child frequently suffers and that often warp the life in later years. Most of these fears, it is believed, are entirely unnecessary, being acquired from bogey-man tales and environment. Their existence is often a sign of some lack in the parent. Repeated experiments showed that children under two years old had no sign of

fear of fire or darkness. A snake was shown to fifteen small children. Seven of them, from fourteen to twenty-seven months old, betrayed no fear at all, eight evinced guarded reactions and two were afraid. Some of the youngest ones tried to pick up the snake and play with it. Ways were discovered to break down some of the childish fancies. For instance, a baby boy that had a dread of anything resembling fur was cured of his fear by having animals about when he was fed. A lump of sugar was given to him and an animal was brought near at the same time. Gradually, he associated the two, his love of the sugar overcoming his fear, and he finally laughed at white rats and played gleefully with a badger rug, head and all.

Amount of Liquid in Can Is Shown by Disk and Metal Bar

Accurate measurements of the amount of liquid contained in a can of fruit or other foods are easily and quickly made, without emptying the container, by means of a gauge devised by a government scientist. It consists of a perforated metal disk in which is inserted a bar carrying a graduated scale. When the top of the can is removed, the disk is placed over the contents and the bar allowed to settle of

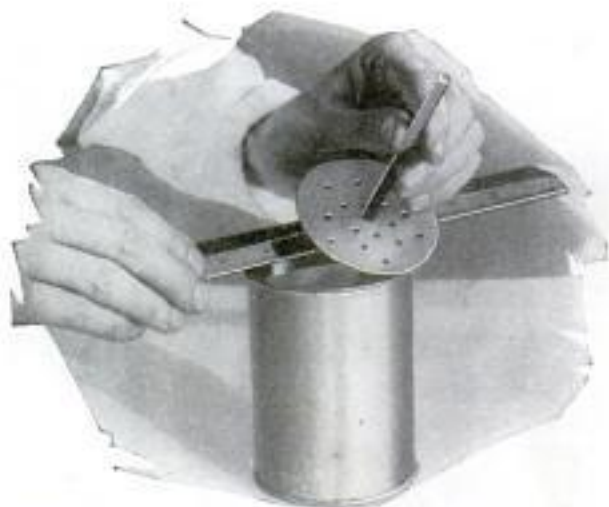

Measuring Proportion of Liquid Content of Can with Graduated Bar Gauge and Ruler

its own weight to the solid matter. By placing a ruler or other straight edge across the top of the can and reading the scale shown on the bar, it is possible to tell the proportion of liquid the can contains. It is proposed to devise a standard scale for each kind of food as the proportion of liquid varies with the character of the contents.

Emb. H. C. Inc. Loud
1719 St. Paul St.
Baltimore, Md.



Summer Bungalow Entirely Covered with Shingles of Newspapers Which Were Folded Flat and Glued



Nailing the Paper Lumber to the Wooden Frame

Annual
Bungalow Built of Old Newspapers Is Thoroughly Weatherproof

Constructed of old newspapers, pressed flat and glued, a bungalow built at Rockport, Mass., serves as a cozy summer home for the family of its owner. Both inside and exterior of the dwelling are composed of the paper "shingles" which have been heavily coated with waterproof varnish. The news pages were first folded tightly into regular-size squares and treated with glue to keep them flat and stiff. The newspaper lumber was easily attached to the wooden framework with ordinary shingle nails. The structure was erected by three members of the family, and besides presenting an attractive appearance, was less expensive than those of ordinary materials.

Portable Tank for Goldplating Uses Two Dry Cells 889

To enable jewelers, dentists and other manufacturers of small metal articles to goldplate their products quickly and cheaply, a portable plating tank is being made that does its work in from seven to ten minutes. Weighing only eight and a half pounds, the outfit is equipped with small batteries to supply current and applies a substantial coating of gold on almost any metal object it can hold. The veneering is of such a nature, it is said, that it takes



Bob White Mfg. Co.,
 1004 Hume Mansur Bldg
 Indianapolis, Ind.

Wide World Photos
 a lasting polish simply by being rubbed dry after removal from the solution.

Ships Sunk by Ocean Monsters 1629

While wrecks at sea caused by collisions with whales may seem fantastic, there are several records of such accidents. One of the most disastrous was the wreck of the whaler "Essex" that went down in the Pacific ocean, 2,000 miles from land, after striking a huge sperm whale which rose to the surface in front of the ship's bow. The monster, enraged, swam away a short distance, then returned at terrific speed and deliberately rammed the vessel. Only one of the lifeboats with a few of the crew reached safety. The pilot ship "Bonita," several years ago, also was sunk by a whale which was traveling at great speed. A few days later, a whale, thought to have been the same that smashed into the "Bonita," collided with a large steamer in San Francisco bay. In 1900, a whale was mortally wounded when it struck the sharp cut-water of a steamer. It has been said that the animals in charging ships do so because of an impression that the vessel is another whale.

Chicago Daily News 7/27/24

Cont. O. H. Franklin, Mundorf
1108 Asher Ave
POPULAR MECHANICS
Kansas City, Mo

796
305

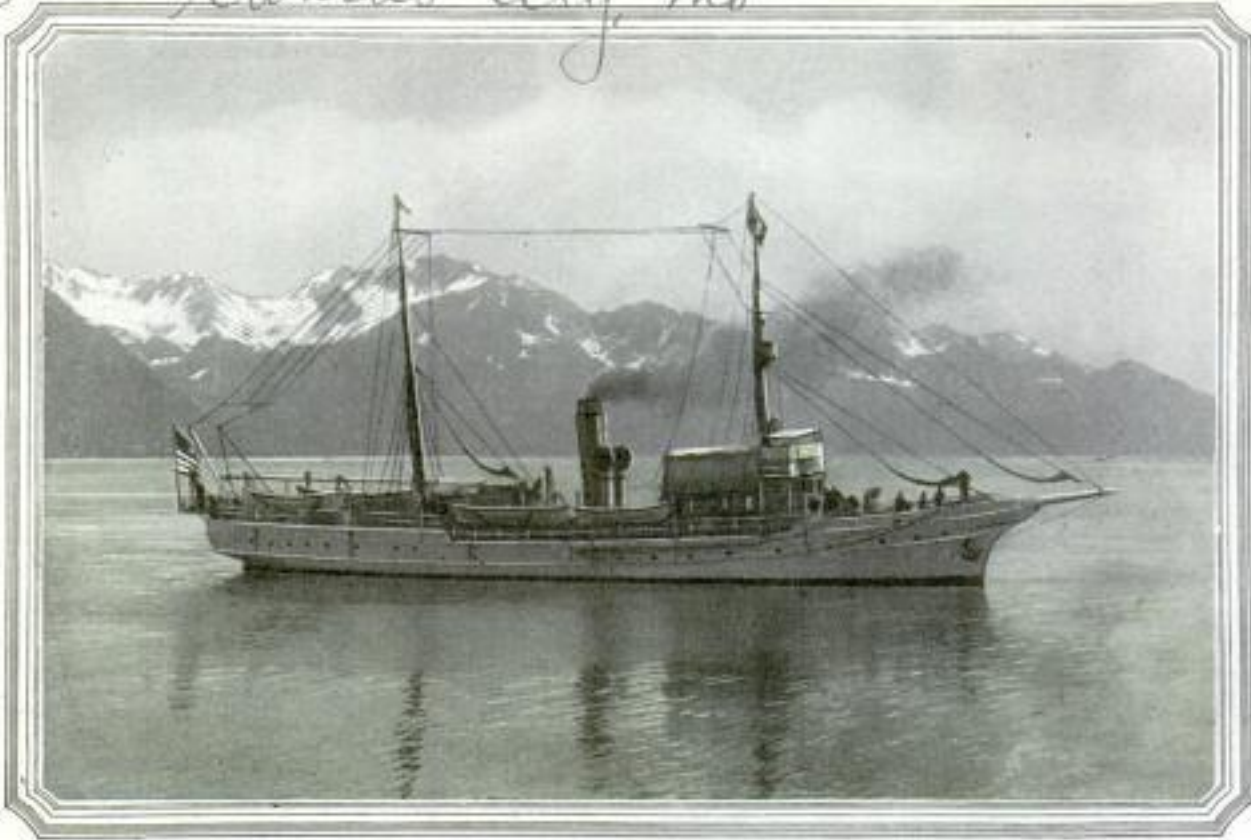

One of the Coast-Charting Steamers That Ply Unknown Seas about the Shores of the Frozen North, Beating New Trails to Safeguard Ocean Traffic through Tortuous Channels

Charting Waters of the Frozen North

Intrepid "Scouts of the Oceans" Search Hidden Depths for Rocks, Ledges and Bars That Menace Navigation

THAT men may go down to the sea in ships and come home to port again unharmed by the jagged formations that infest the waters about Alaska, the United States coast and geodetic survey is charting an inside route and the coast line of that peninsula.

Industries are springing up constantly and the commerce of the territory is becoming an extremely important one, depending almost entirely upon the development of shipping between those often frozen-in shores and the rest of the world. Until the seas contiguous to the country have been fully and completely charted, considerable risk attends attempts to navigate those waters that remain unsounded and unmapped.

Far longer than the combined coast lines of the Atlantic and Pacific sides of the United States, Alaska's shore line, if detailed and extended, would reach around the world at the equator. To thoroughly feel out every foot of sailing ground, measuring jagged pinnacles that

rear their needlelike points to within a few feet of the surface, and to sound the shallows requires not only expertness, but also a lack of fear that challenges the tortuous courses winding between rugged mountain sides which sometimes drop from dizzy heights to the water's edge and continue unseen in a forest of massive peaks that stretch across navigable channels just far enough below the surface to escape the wary eye of the mariner.

To reveal the presence of such obstructions, the charting crews sweep the waters with a wire drag stretched between buoys that are towed by small ships. When it strikes an object, a signal instantly warns those on the boats, who apply to the barrier measuring instruments and apparatus that register the approximate shape of the obstacle. Its location is then set down on the chart, a standard symbol representing its exact nature. A deviation of the slightest part of an inch from the true position on the map may result in untold future hardships to sailors, who

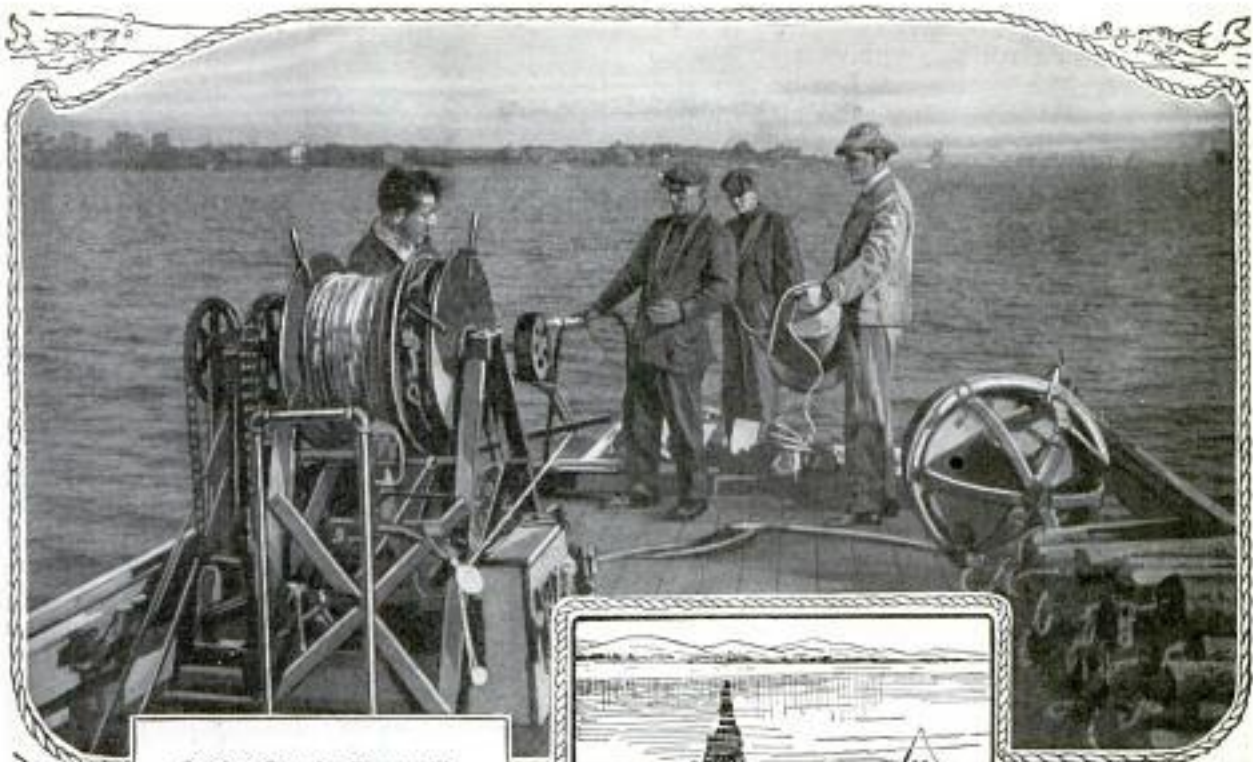

Setting Out the Drag with the Aid of a Power Reel, and Attaching Buoys as It Unwinds over the Side

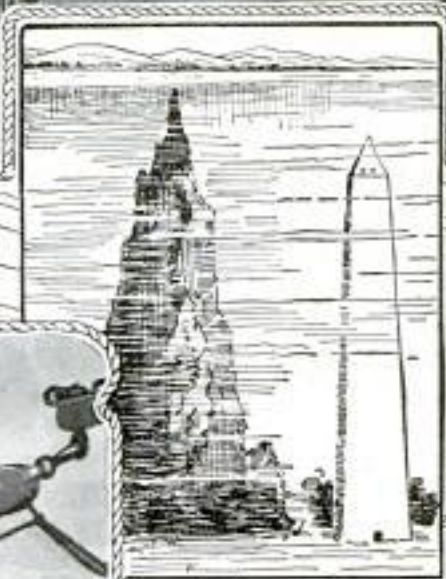

Pinnacle Rock Discovered in Alaskan Waters in 1915. Compared with Washington Monument; It Is But Seventeen Feet Below Surface

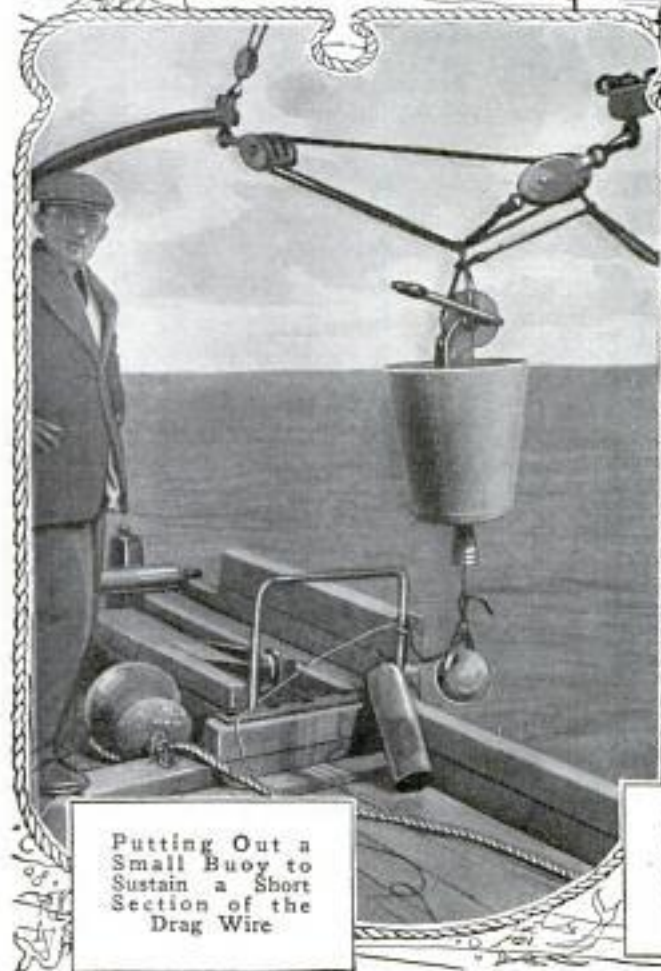

Putting Out a Small Buoy to Sustain a Short Section of the Drag Wire

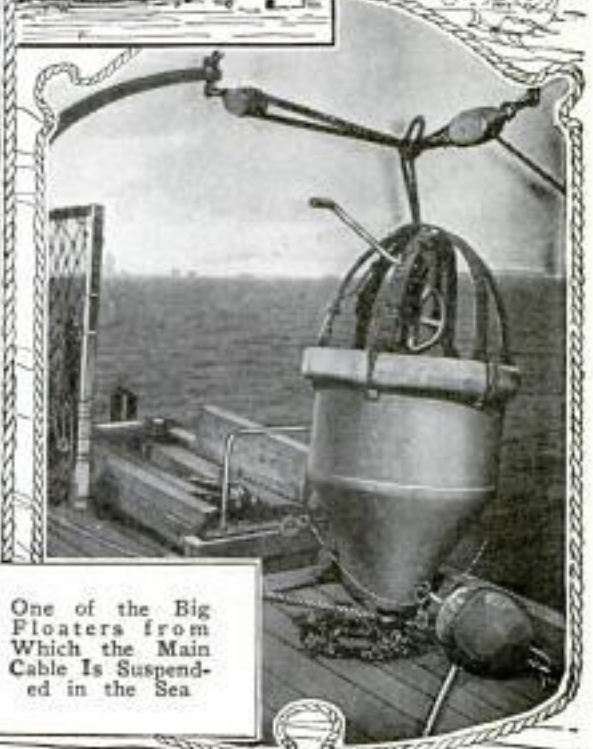

One of the Big Floaters from Which the Main Cable Is Suspended in the Sea

follow faithfully the network of contour lines and signs on the charts that guide them along the courses. But in all the 104 years of its existence, the survey department has not had one accident attributed to inaccuracy of its records.

In plotting the seas, the wire drag is allowed to swing at about a hundred feet

way ahead or swept the lanes with their unflinching drags. These consist of a wire called the bottom cable, maintained at any desired distance below the surface, and weights suspended by lines attached to floating buoys. This "feeler" is made up in hundred-foot sections and can be added to from time to time to conform with

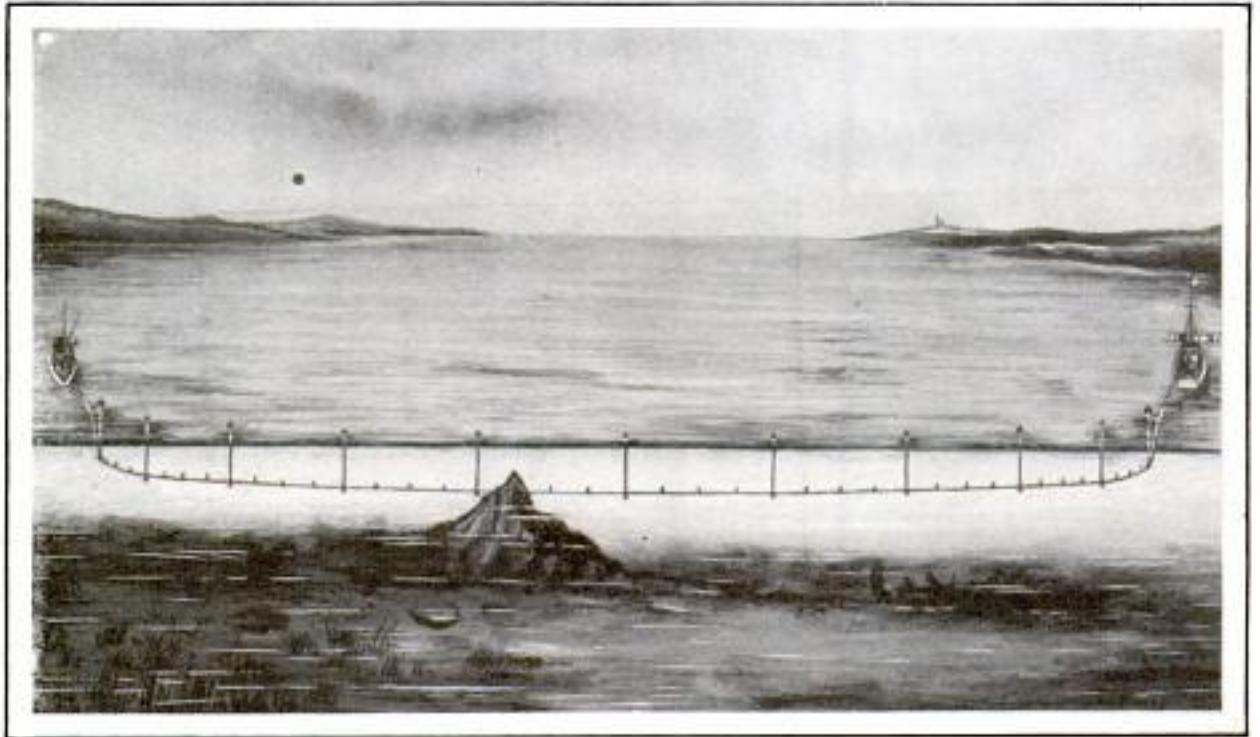

How Hidden Obstructions That Menace Ships at Sea Are Found by Dragging the Waters with a Wire "Feeler" Which Signals the Surveyors When It Strikes an Obstacle

beneath the surface, not only to cover the depth of the ordinary ship's hull, but to take care of the probable need of submarines which at any time may be ordered to cruise these seaways. Commanders of vessels plying northward are reluctant to hazard the narrow channels until the sounding craft have picked the

profile of the ocean floor at any spot. Even small obstructions cannot escape the drag, which easily informs those above of the presence of peaked rocks, bowlders, sharp ledges and coral formations that might prove a menace to shipping and an impediment to commerce but for the safe guidance of charts.

Eye Tests Proposed for Autoists to Reduce Motor Mishaps

That about half of all automobile accidents are due to faulty eyesight is reported by the California league for the conservation of vision. Only two per cent of the accidents in that state were attributed to defective brakes, while approximately twenty-five per cent were said to have been caused by speeding or recklessness. Similar findings are reported from Cleveland and Detroit. As an additional safety measure to reduce the number of motor mishaps, park officials, in a large western city have proposed that all persons be re-

quired to pass rigid optical examinations before they are allowed to operate cars. It is pointed out that this would weed out color-blind persons likely to go blundering past light signals and would detect all those who by reason of extreme far or nearsightedness or night blindness would be considered unfit to handle a steering wheel. Legislation along this line in Massachusetts is already said to have reduced the number of automobile accidents by half and equally good results are predicted if all motorists were required to pass physical and optical tests such as are now given by most taxicab companies to prospective drivers.

Chicago Evening Post
8/18/24
1674

1661 **Abandoned Fire Engine Remodeled into Oil-Refining Plant**

Thrown upon the scrap heap after serving a California city for several years, an old fire engine was rescued and after a few alterations, was fitted out as an efficient oil-refining plant. Lengths were added to the smokestack, a few necessary tank connections installed, the wheels blocked and the outfit was soon ready for operations. The portable feature of



Discarded for Motor-Driven Equipment, Gallant Old Horse-Drawn Fire Engine Remodeled, on Duty as Oil-Refining Plant

the equipment was found desirable, as the whole plant was easily hauled from place to place.

Great Skill Shown by Mail Clerks in Distributing Letters

Standing at ease twelve feet from mail racks or pouches, expert postal clerks distributing thousands of letters and packages a day can toss parcels into their proper compartments without appearing to raise their eyes from the rapid work of scanning the addresses. Some of the workmen in post offices of large cities can throw the matter accurately from almost

any position, using the overhand, underhand or side-arm motion. The men chosen for this task are subjected to physical as well as mental examination and on entering the service must go through a probationary drilling period before they are finally accepted as members of the fast-working crews. With each toss the nimble-minded clerks accomplish some lightninglike calculations. They must know at a glance where a piece of matter is to go, by what route it must travel to

reach its destination, and the time of departure for trains, boats, trolley cars, auto trucks and airplanes, all of which transport the tons of mail daily received and sent out by the post offices of the nation. In New York, for instance, "outside" mail is separated by states and then turned over to the railroads, where clerks continue the process of sorting it into pouches for cities, towns and hamlets, while it is speeding toward its destinations. It is estimated that at most a letter passes through about fifteen handlings between the time it is mailed and its delivery.

1635

Clog-Proof Drain Absorbs Water

Made of porous material through which water can pass to the interior, drain pipe being manufactured has no opening to admit dirt, leaves and particles of soil. Laid along roadways or in marshy ground it absorbs moisture through its sides and conducts it rapidly from the area. Because no channels are necessary at the edges of highways equipped with the tubes, more space is permitted for traffic, and dangerous ruts due to rainfall are prevented, eliminating the hazard of ditching vehicles. Claimed to be frost-proof, the pipe is said not to be expanded or damaged by freezing weather, and also to carry off a volume of water several times the capacity of ordinary drains. It will quickly dry up swampy lands and prevent effects of washouts in the neighborhoods of railway cuts, canals and similar localities.

Rapid Drainage Pipe Corp., 50 Maiden Lane, New York City

Kansas City Star
7/5/24
1499

Vertical text on the right edge of the page, possibly a page number or reference code.

*Imp. Esustave
Littenfeldt
422 East 71st Ave
New York City*

"Upkeep Cost" of Shoes Is Reduced by Detachable Heels and Soles

Shoes with detachable soles and heels that, it is claimed, cannot rip off and that anyone can put on in a few moments have been patented by an eastern inventor, to cut repair bills and to obtain full service from the uppers. The parts are held by tapered screws inserted from the inside of the shoe through holes in the inner sole and the fringe of the upper that overlaps it. Tapered nuts attached on the outside sole bind the layers together. Either rubber or leather heels are used and, with the soles, may be renewed as often as desired. They can be used with tan, brown or black shoes and fit tightly to exclude water. A handy screwdriver wrench for attaching them is provided, and both screws and nuts have flat tops so that they leave a smooth surface on the inner and outer sole. The soles are also said to be more flexible than the ordinary style, and the shoes more easily "broken in."

Electric Motor Pump Feeds Sick and Aids Use of Serum

To help physicians in giving quantities of liquid nourishment to patients, injecting serum into the veins and in operations

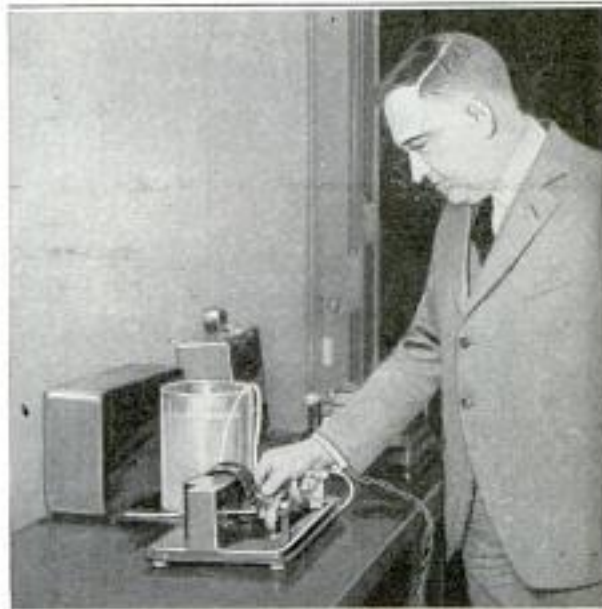

Inventor and Motor-Pump Syringe for Injecting Quantities of Serum and Liquid Nourishment

that require transfusion of blood, a tiny electric motor pump has been invented by William Gaertner of Chicago. The instrument operates a syringe to force liquids into the system. Its speed and stroke can be adjusted to the condition of the patient and to various kinds of treatment. It is said to be more accurate than other methods, and saves doctors and nurses considerable time in cases where prolonged feeding or injections are necessary.

*Gaertner Scientific Laboratories,
1201 W. Rightwood Ave.,
Chicago*

Auto Hitched to Street-Car Trailer Hauls Freight and Passengers

Freight and passengers both are hauled and an abandoned street-car line is put to good use in Amsterdam by an ingenious combination "train" composed of a motor truck and a surface-car trailer. Packages of farm products are carried in the former, while persons ride in the trolley car. A fair rate of speed is developed and economy of operation is claimed for the line, which serves an outlying district.



Motor-Bus Street-Car "Train" with Its Trolleyless Passenger Trailer on Track

Wide World Photos

**Drydock Lifts 46,000-Ton Liner
Forty Feet for Repairs**

1614 The greatest British-built liner, the "Olympic," holds the honor of being the first big ocean vessel to be repaired in the world's largest floating drydock, recently

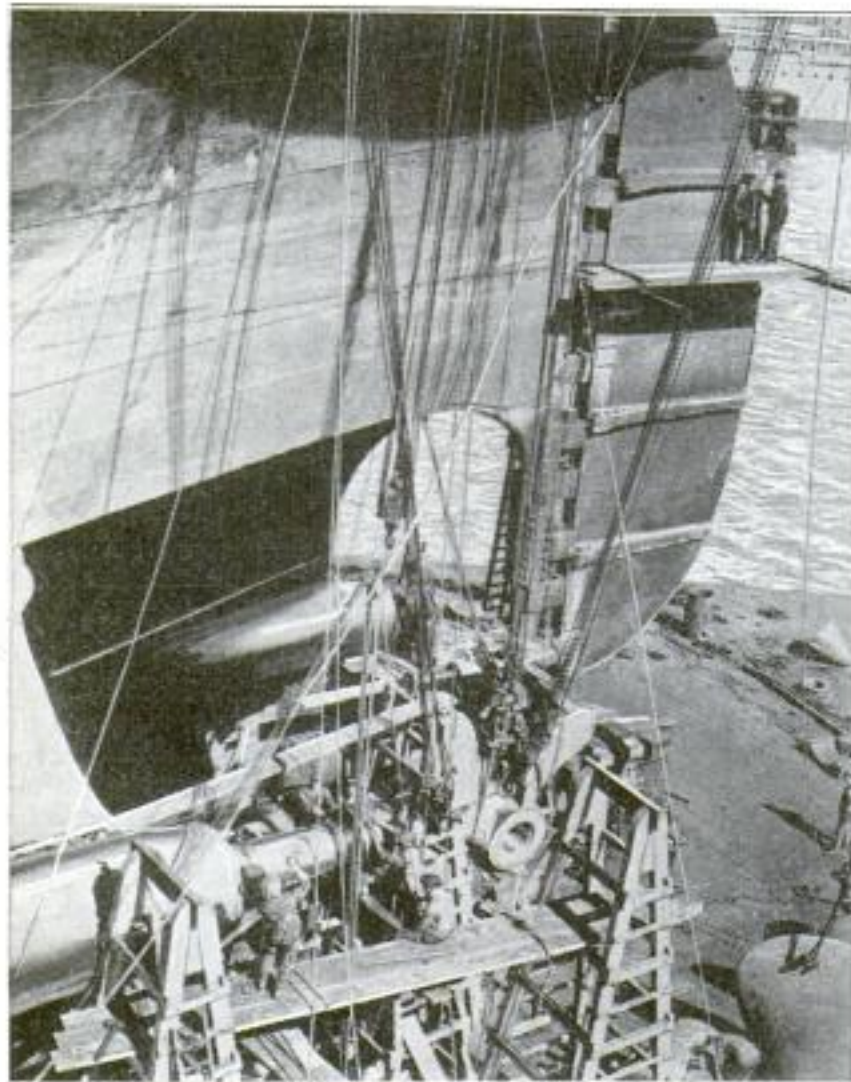

Slipping a New Propeller into Place on the Steamship "Olympic" after It Was Raised from the Water by the Giant Drydock

opened at Southampton by the Prince of Wales. The huge dock raised the ponderous 46,000-ton liner forty feet in three hours and forty-five minutes, furnishing a dry platform on which the ship's bottom could be overhauled. Some idea of the size of the ship can be gained from the comparison of the men in the foreground with the new propeller which they are slipping into place. The "Olympic" was not an especially big burden for the dock, for it was built to handle 60,000 tons, sufficient to take care of the 56,000-ton "Majestic," German-built but British-owned since the war. The "Majestic" is virtually the same size as the "Leviathan."

The dock is 960 feet long, as compared to the "Majestic's" 956 feet, and has a clear inside width of 131 feet, while the "Majestic's" beam is 100 feet. Provision was made in building the dock for the addition later of another middle section, enabling it to handle a larger vessel. Any two

of the sections can be detached and self-docked in the remainder, so that the dock can "repair itself." The dock is moored to concrete dolphins on the shore with four huge steel booms, the tops of two of which form gangways for men passing back and forth between shore and the dock floor. Traveling cranes run on top of the sides of the dock, and flying gangways at either end can be opened while a vessel enters the submerged dock, and then closed after the lift to permit workmen to travel from one side to the other. The dock is so big that after the Prince of Wales, who officiated at the christening, had pulled the lever and submerged it, the official party boarded a good-sized ocean-going ship, which steamed through the dock.

**Mercury Is Turned
1665 into Gold**

Have the dreams of the alchemists been realized? This possibility is seen in reports from Berlin announcing that gold has been produced from mercury through which an electric current had been passed from twenty to 200 hours. The discovery was made in the laboratory of Prof. G. R. R. Miethe, of the Berlin technical high school. A quartz mercury-vapor lamp was used and after the experiments a small quantity of gold was found in the black deposit in the lamp. Careful investigation showed that there was no precious metal in the mercury used in the construction of the lamp and that its appearance was accounted for by the disruption of the atoms of the mercury under the prolonged electric current.

Electrical Review
7/23/24
Full, Lundry, C. C. H. Eng.,
Ludgate Hill,
4

Michael Moly

Albertson + Co,
Sioux City, Iowa. 803

POPULAR MECHANICS

Model of Cathedral Carved in Wood Shows Maker's Skill 1583

With a small hand scrollsaw and strips of wood, a Los Angeles craftsman, after hours of painstaking labor in his spare time, has completed a miniature of the famous Ulm cathedral in Wurttemberg, Germany. Proportions and rich decorations of the majestic spire of the edifice, which in reality is 528 feet high, taller by twenty-one feet than the graceful twin steeples of the Cologne cathedral, have been accurately reproduced, as have the flying buttresses, lattice windows and other parts of the building. The model stands nine feet high.

Auto Carbon Is Removed by Brush Operated by Electric Motor 1351

For removing carbon from automobile cylinders and valves, a brush operated by electricity has been placed on the market.



Removing Carbon Deposits from Cylinder Head with Stiff Wire Brush Operated by Electricity

Vulcanizer Prevents Leaks in Roofs and Waterproofs Concrete 1375

For waterproofing concrete surfaces and laying roofs that will not leak, a portable electric vulcanizer has been patented. It is designed to be used with the ordinary lighting current or with a special generator, and consists of a roller with shoe and trowel-like parts, which, when heated to a high temperature and run over the surface, effectively weld layers of felt or paper roofing mixed with asphalt firmly to the roof boards. The vulcanizer also irons out wrinkles in the material and prevents the formation of gas and air blisters, which commonly develop after certain kinds of roofing have been applied in the ordinary manner, and burst open causing leaks which may necessitate costly repairs. The heat is controlled by thermostats and the vulcanizer can be used satisfactorily in mending asphalt pavements, laying various kinds of composition flooring and for applying felt and tar mixed with crushed rock over old shingle roofs.

Made of stiff, heavy wire, the bristles overlap each other, resulting in a double contact so that the brush can be handled either tilted or in a vertical position to aid in cleaning the corners. Finer wires on another model similarly operated, give a high polish to machine surfaces and aluminum pistons.

Steelless World Is Predicted 1589

Corrosion and increasing costs spell the doom of great steel-bridge constructions for the future, in the opinion of Gustav Lindenthal, the well-known consulting engineer, who predicts that within a span of time shorter than that from King Tutankhamen's day to this, the great metal viaducts of our age will have disappeared through rust and neglect and that iron ships and railroads will be curiosities. The zenith of large bridge building, it is said, will be reached within the next fifty or one hundred years because of the increased cost of iron and coal.



Waterproofing a Concrete Floor by Applying Composition and Treating It with Portable Electric Vulcanizer

Vulcan Roofing Co., 1834 W. Washington St. Los Angeles, Calif.

Orange County Roofing Co. Cal.

agents, Keystone Roofing Co. Alhambra, Calif.

Chicago Evening Post Copyrighted material

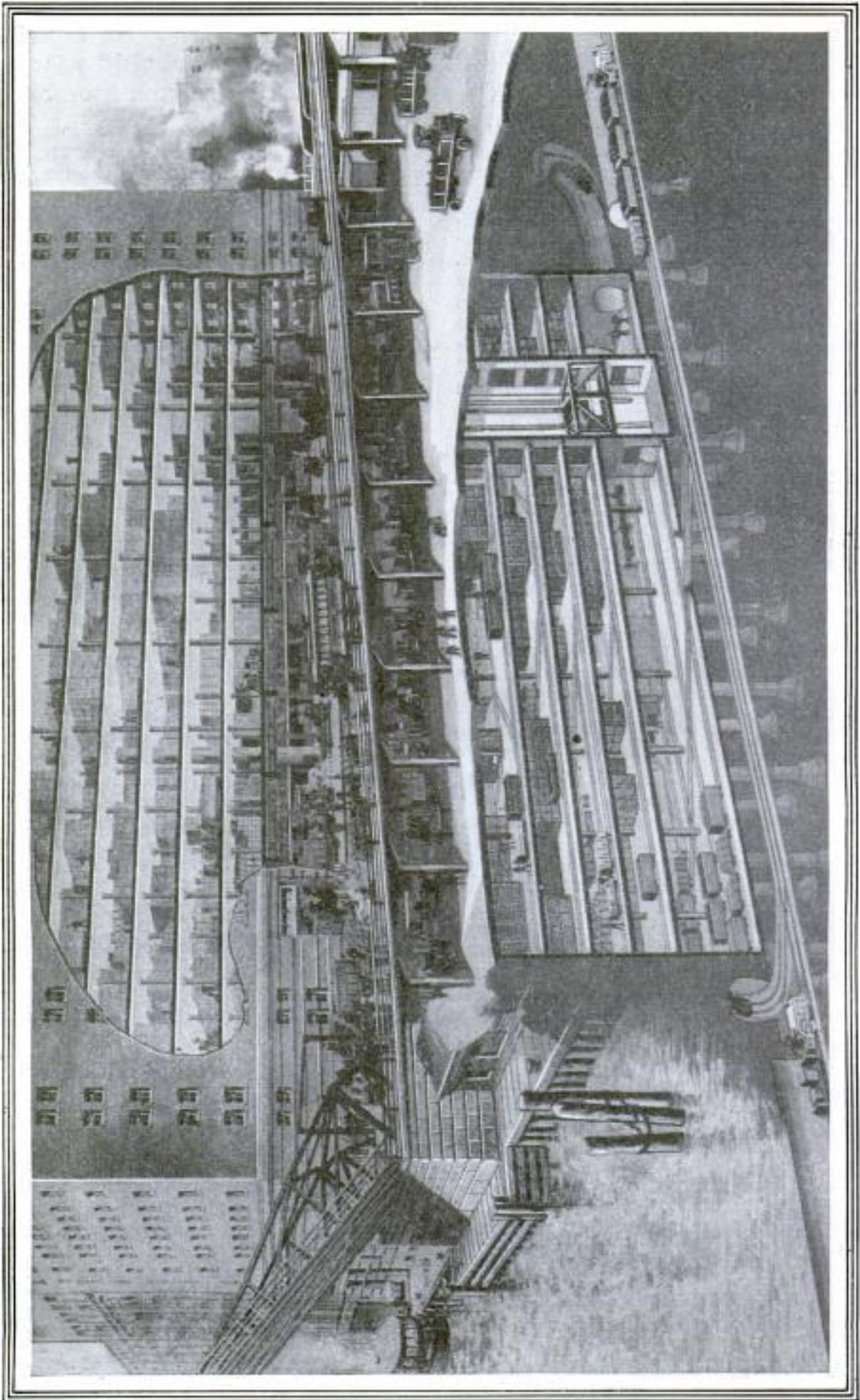

Freight Station in Sub-Basements under Wholesale House; Trains Made Up in Upper Basements Are Lowered by Elevator to Tunnel, on Fifth Underground Level



Rumbling Along, Fifty Feet beneath Congestion at One of the World's Busiest Surface Crossings, Swift Tunnel Trains Speed through Dim Passages

Lifting Lid from a City's Streets

Electric Trains in Sixty Miles of Tunnels Carry On Enormous Freight Traffic under Busiest Thoroughfares

FIFTY feet under the business district of Chicago there is in operation the world's most unique subway—sixty miles of electrified tunnels given over entirely to the transportation of freight. So silently and efficiently does it carry on its work of transporting hundreds of thousands of tons of freight every year that comparatively few persons know of its existence. In twenty-one years there has never been a collision in this subway, despite the fact that it is a single-track system. Only once in many years has the tunnel figured in the newspaper headlines, and that was when a gang of enterprising store burglars conceived the idea of using it as a means of escape and were caught.

It started in 1901, without any fanfare of trumpets. In 1903 the original company ran out of money, after building twenty miles of tunnels, and sold out to a new company. By 1909 the project was practically complete, with sixty miles of subway underlying practically every street in the downtown district. Today 145 electric locomotives and more than 3,000 miniature cars carry more than a million tons of freight each year through the tun-

nels. Approximately a hundred shafts connect with the sub-basements of downtown stores, office buildings and hotels, with the city hall and post office and all railroad stations but one, as well as four public freight-receiving stations.

From the railroad stations incoming freight is delivered direct to the basements of department stores and outgoing packages taken back to the depots. There is a constant movement of freight from one station to another and to both stores and railroads. At two coal depots, railroad cars dump their contents into hoppers to feed down to the tunnel cars. Thousands of tons of coal are thus delivered direct to the boiler rooms of stores and hotels. The ashes, in turn, are hauled away through the tunnel, lifted in car-load lots to the surface on the lake front and dumped to fill in new land. Five thousand trucks and teams are kept out of the congested downtown district every day because their contents are transported by tunnel. How much time is saved for shippers, it is impossible to estimate. As the railroads pay the cost of tunnel transportation to their freight stations, the



Carving a New Tunnel into the Clay with a Scraping Knife Is Strenuous Work but Overcoats Are Not Uncomfortable

shipper can send his truck to the nearest tunnel shaft, and thus save the delay that would be encountered if the truck had to pass through the busy downtown area.

One of the public receiving stations for freight is located in the fifth sub-basement beneath a large wholesale grocery house. The tunnel company occupies the third, fourth and fifth basement levels, the lower one being the tunnel level. Two immense electric elevators raise and lower the tunnel freight cars, four feet wide and twelve feet long.

From the upper floors the grocery company receives and dispatches its own freight. On the ground level railroad tracks and a truck platform take care of freight cars, motor trucks and teams. Alongside the building is a dock where lake steamers and lighters of the merchants' transport service can discharge and load cargoes.

The third and fourth sub-basements are a maze of tracks, the two-foot gauge of the tunnel below. Here freight is classified and the cars loaded. Each of the one hundred stores, railroads and other

customers has a number and, when the trains are made up, the motorman of the electric locomotive, who constitutes the entire train crew, is able to drop his cars off at the proper shafts. Because of the one-way traffic rule, adopted to avoid accidents, trains move in one direction under every other street, and in the opposite under the intervening thoroughfares. Electric block signals protect from head and rear-end collisions, and to guard against accidents at the 652 crossing intersections red and green mirror reflectors, similar to those used on dangerous highways, reflect the headlights of unseen trains in the intersecting tunnels. One of the unusual services of the freight subway is the disposal of earth excavated from new building sites. Instead of hauling the dirt away through the streets, a two-foot shaft is sunk until it intersects the tunnel, a train

of cars backed into place and the material dropped down the chute, to be hauled away, lifted to the surface on the lake front and there used to fill in new land.

The construction of the tunnel itself was a triumph of engineering skill. Fifty feet under the city is a stratum of soft blue clay, of about the consistency of putty. Because of its softness, blasting was not effective, nor could picks and shovels dig it out. The tunnel engineers solved the problem by creating steel knives, with blades eight inches across and heavy handles on either side. With two miners wielding the knife the clay was literally shaved away from the tunnel heading.

To guard against an inrush of water in case of fire in one of the buildings served, automatic, water-tight fire doors are located at the foot of each shaft. Firemen may flood the building and fill the shaft, but little of the water can escape into the tunnel. In the hottest summer the crews, on arriving for work, change to woolen underwear and put on heavy overcoats with fur collars, add thick caps and mittens, and then are ready for work.

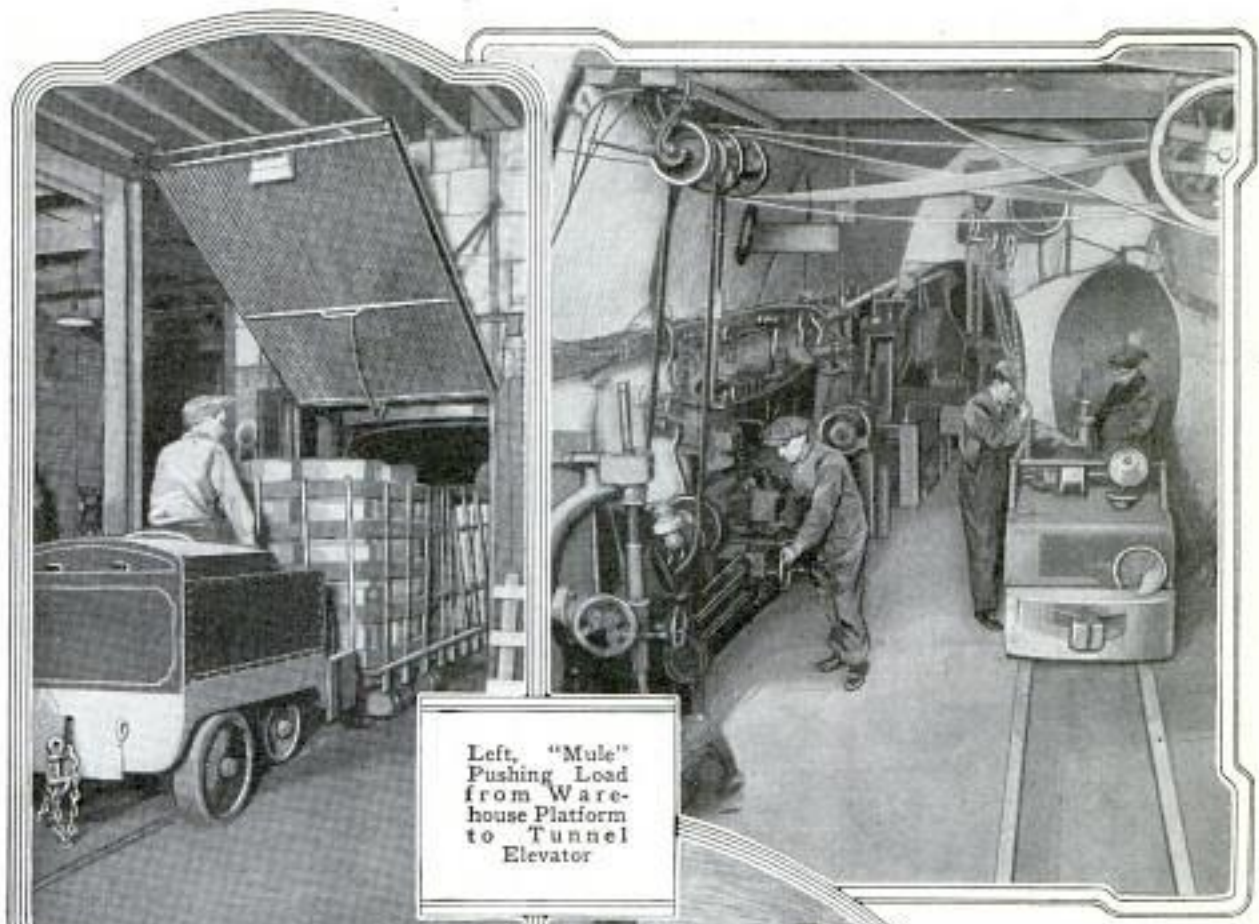

Left, "Mule" Pushing Load from Warehouse Platform to Tunnel Elevator

Far below Street Noises Hums an Underground Machine Shop and though It May Be Summer Outside, Motormen Find Need for Gloves and Fur Coats

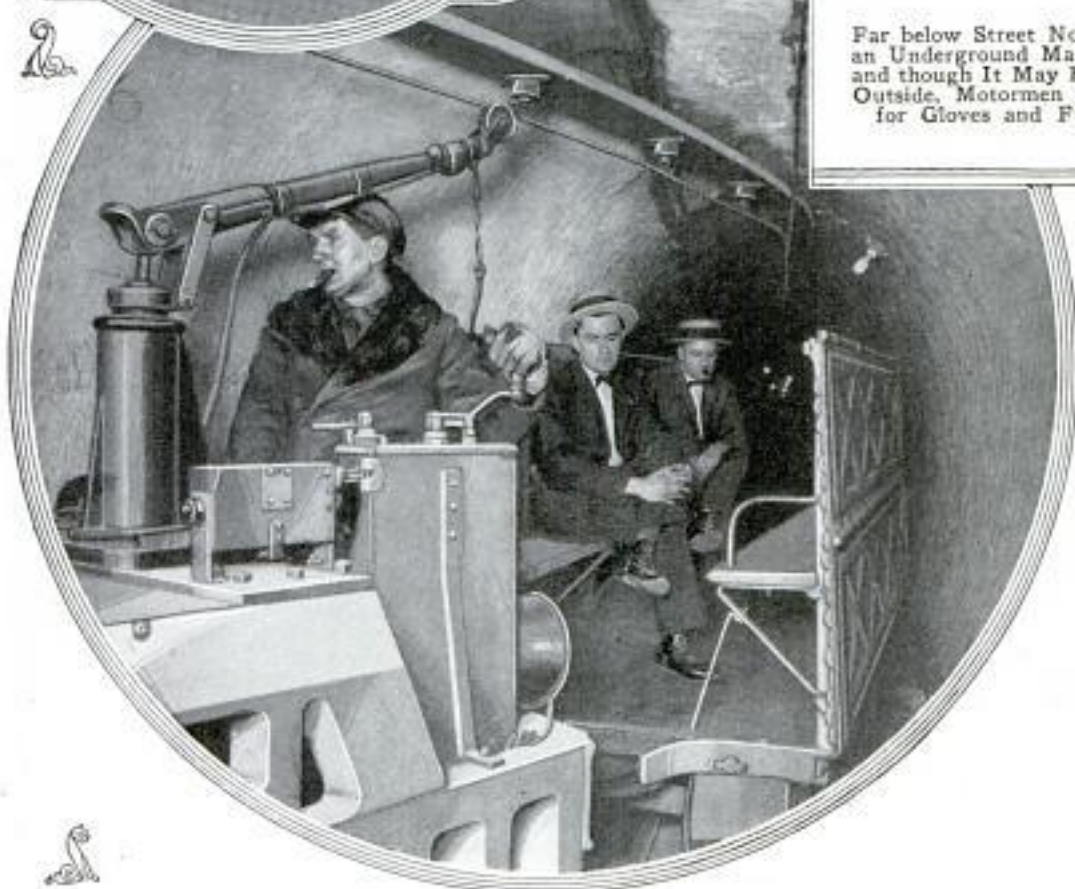

Emt. O. S. Thackwell,
319 Monroe Bldg.
Chicago.

808

POPULAR MECHANICS

Havoc Lurking in Grains of Dust

1599. Shown by Man-Made Blasts

It is estimated that there are about 21,000 factories and business establishments in the United States at present, subject to hazards from dust explosions. Most of them teach their workmen that dust in the air when exposed to a naked

spark or flame is fully as dangerous as gasoline. But there are numerous records of destructive explosions, resulting from

the accumulation of combustible dusts, provision of all lights with dustproof guards and the avoidance of accidental sparks are some of the steps being developed, while generation of static electricity in whirling machinery and speeding belts comes in for its share of attention from those striving to cut down fire losses. As part of a campaign of safety, experts have visited a number of plants where the dangerous dusts were present, taking with them one of the small models of grain elevators. When the workmen were gathered about the apparatus, the demonstrators collected some of the dust from the floors and produced strong explosions in the miniature building. In this way,

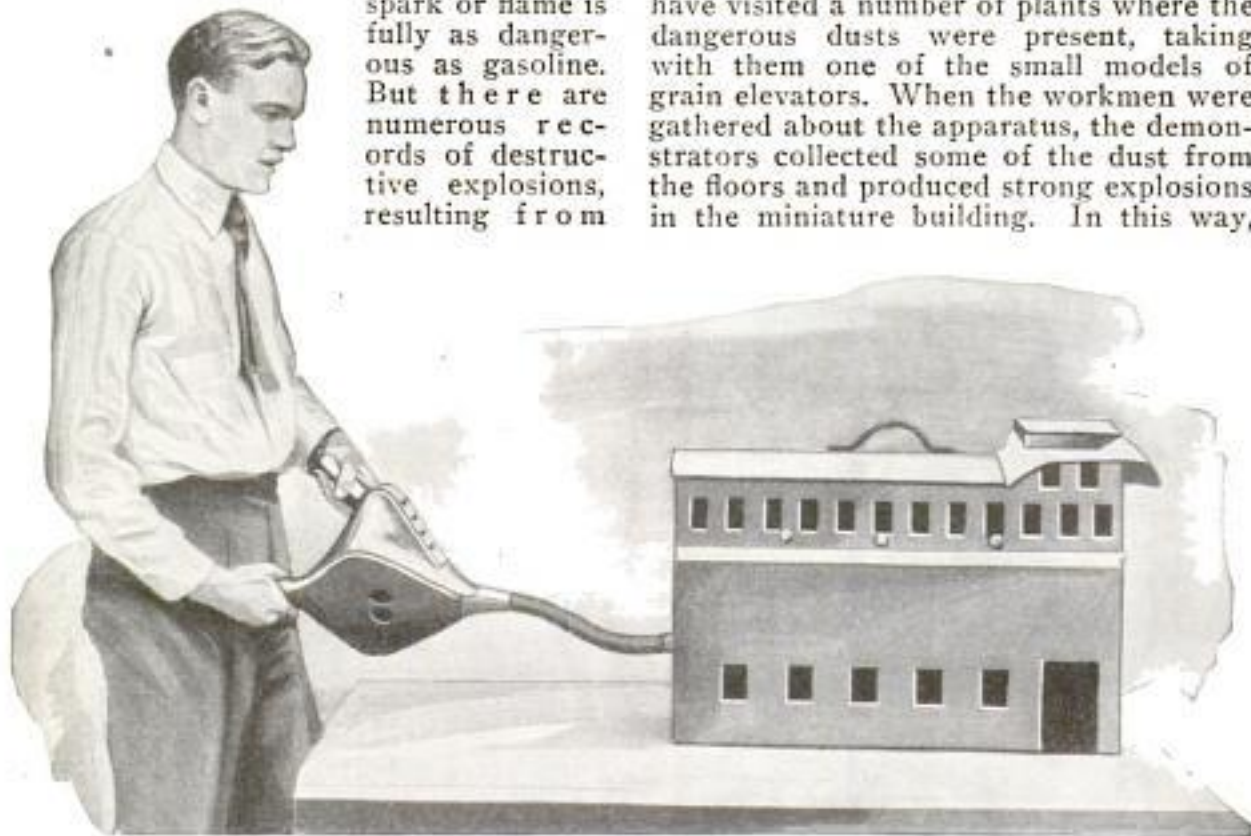

Shooting a Charge of Combustible Dust into a Miniature Model of a Grain Elevator, Where It Explodes When It Meets the Flame of a Burning Candle

powdered milk, grain, aluminum, rubber, cork, bark, cocoa, spice, fertilizer, and even soap. Researches by government experts show that where so-called "spontaneous combustion" has been held responsible for many fires, the real cause, especially of mysterious explosions, was dust. Seeking the remedies for such accidents, investigators have constructed miniature industrial buildings like grain elevators, and have duplicated factory conditions and produced explosions similar to those that actually occur. In these experiments, a lighted candle is set inside one of the tiny structures. With a bellows a small "charge" of dust is blown into the building and the explosion follows. To prevent the force from wrecking the structure, a paper section is set into the side or top. This is ripped off by the blast. In addition to these tests, plans for precautionary measures are being worked out. Methods of preventing

those toiling in such plants were clearly shown the dangers of carelessness.

Flying and Building of Toy Planes— 1609 to Speed French Air Progress

The flying and building of toy airplanes has been taken up by aviation enthusiasts in France, where contests are held under the supervision of the air ministry. The small machines are planned and constructed by the owners, who are encouraged in their work by a series of prizes offered by the government. Although numerous miniatures of aircraft are on the market, most of the "fans" prefer to originate their own models. It is believed that the wide-spread popularity of airplane modeling will soon cause many large cities to set aside flying fields where contests and try-outs can be held for the youthful builders of toy aircraft.

New York Times
7/27/24

Copyrighted material

Blood Donors Establish New Trade in Supplying Hospitals 1687

Since transfusion is now used in the treatment of about thirty ailments, professional blood donors have built up a profitable trade with hospitals. It is said that the operation is practically painless and causes no discomfort; besides, the "giver" receives a good price for his part in the affair. It has been discovered that even among men and women of the same race and family the quality of blood differs. For this reason, tests of the blood must be made to determine the particular kind required to combine properly with that of the patient. Many large hospitals have lists of fifty or more men upon whom they can call for an amount of blood. These are available any hour of the day or night. Among them are a number of college men who are working their way through school and take this method of adding to their finances.

Electricity Is Drawn from the Air and Made to Light Lamp 648

In an effort to collect electricity from the atmosphere, a French inventor has designed queer-looking apparatus that consists of batteries, a regulating device, and aerials branched in such a way that one points toward the zenith and the other toward the south. To stimulate the flow from the air, positive and negative charges

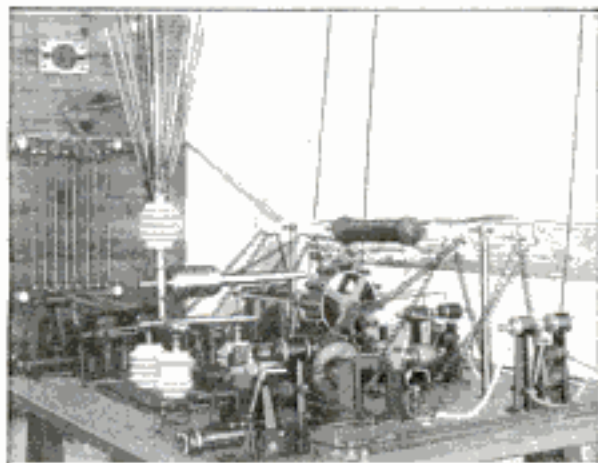

Insulated Aerials, Transformers and Batteries of Apparatus to Gather Electricity from the Air

first are sent through the antenna. These are stopped when the current is sufficiently strong to light a lamp.

Bean beetles, a Mexican pest, are said to be spreading northward at the rate of 150 miles a year.

Embroidering Head of the Savior Takes Woman Two Years 1377

Stories from the Bible and episodes in the life of Christ have been depicted in embroidery by a Russian woman, a sample



Silk-Embroidered Christ-Head Banner on Which Russian Woman Worked Two Years

of whose work, "The Savior," was shown in the church of St. John the Evangelist in Boston, Mass. Two years were spent in completing the piece. Beginning in primitive times, this branch of the textile arts was known to the Romans as "paintings with the needle" and was widely employed in the Middle Ages and later times for religious purposes.

Ants Work for Lumbermen 1707

While ants are generally considered a nuisance and often are destructive pests, natives of Burma have found a way to make the insects help them in preparing sandal wood for exportation. Only the hard, fragrant heart of the tree has any commercial value. After it is cut down, it is stripped of its branches and allowed to lie where the ants can reach the soft, outer covering of sappy wood. In a short time, the billions of tiny creatures have carried off the useless outer layers, leaving the center, which they do not molest because of its hardness, ready for the woodsmen.

London Answers
8/2/24

Land-Sailing Ships Are Destroyed by Air Raiders' Bombs

As fine a tramp steamer as ever sailed a peaceful meadow was saved recently when British royal air force fliers bombed and destroyed an "enemy" commerce raider caught sailing down a field beside a railroad embankment. The two dry-land ships were constructed, life-size and perfect in all their external details, for the annual pageant at Hendon airdrome. The enemy ship, which was named the "Slevic," was a huge single-funnel vessel, with high bridge, full-sized masts, realistic lifeboats and all the other details of

novel feats that humanity's wonder-working ally has been called upon to perform. The owner of a wooden toll-bridge had agreed with county authorities to remove it in thirty days so that steel spans could be built on the old piers and abutments. How to wreck the bridge in the short time allowed without spoiling the foundations proved a problem. Professional wreckers were visited but all agreed that dynamiting would spoil the supports and fire would crack and injure the masonry.

The thirty days were up, but the authorities finally granted a week's extension of time. An electrician appeared with a novel suggestion which was finally adopted and carried out with

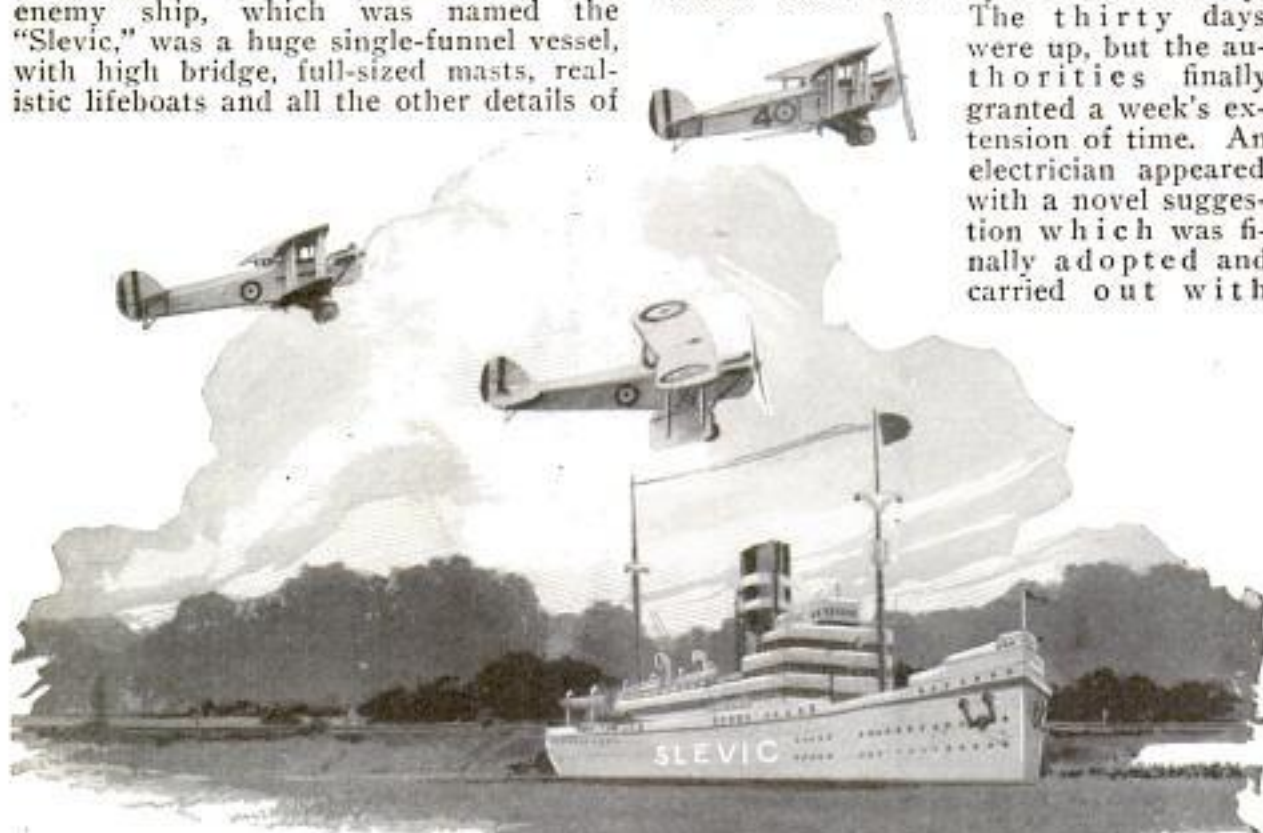

Defense Airplanes Attacking
Commerce Raider in Mimic Sea
War Held on Land

a ship in active service. The merchant ship was the conventional type of British tramp freighter, with a single funnel, well decks fore and aft, and cargo booms swung from the masts. The naval aircraft opened the attack with aerial torpedoes, which tore great holes in the sides and decks of the "Slevic." Bombs which fell alongside sent towering columns of earth squirting high above the masthead, giving a realistic imitation of the water column thrown up by a similar burst alongside a ship at sea.

Bridge Burned Apart by Electricity without Damaging Piers

How electricity plus Yankee ingenuity helped a man fulfill a contract has been told recently, adding to the long list of

complete success. The bridge timbers were burned apart with electricity. Fifty-four iron loops were constructed and placed about the sills of each span. They were connected with wires and current turned on. In a short time, the loops, acting as resistance coils, became red-hot and seared their way into the wood, cutting as an acetylene torch eats its way through metal. In an hour and forty minutes from the time the current was turned on, the mass of timbers crashed into the water beside the piers without the slightest injury to the latter and leaving a sharp, clean cut, charred only for a short distance. By 2 o'clock in the afternoon, nine hours after the burning was started, the last span fell amid the shouts of spectators who had gathered to watch the novel feat.

1559. *Annual* Adam Cant-Holt, Architect,
566 W. Congress, Chicago.
Folding Bungalow Saves Space in Home

House with Movable Walls and Cupboards That Shift at Touch of Buttons Saves Labor and Lowers Cost

WITH revolving walls, sliding china cabinets and tables that disappear as if by magic after meals are served, a folding bungalow residence erected in Chicago contains six rooms practically all of which can be converted for any of several purposes in a few moments. Motion of the partitions and furniture is controlled with push buttons or levers and all parts are so balanced in their positions that very little effort is required to swing a portion of the kitchen into the dining room or to whisk a heavily laden table from one side of a wall to the other. The house is twenty-six feet square and stands in the center of a spacious tree-shaded lot. Divided into living room, kitchen, downstairs bedroom,

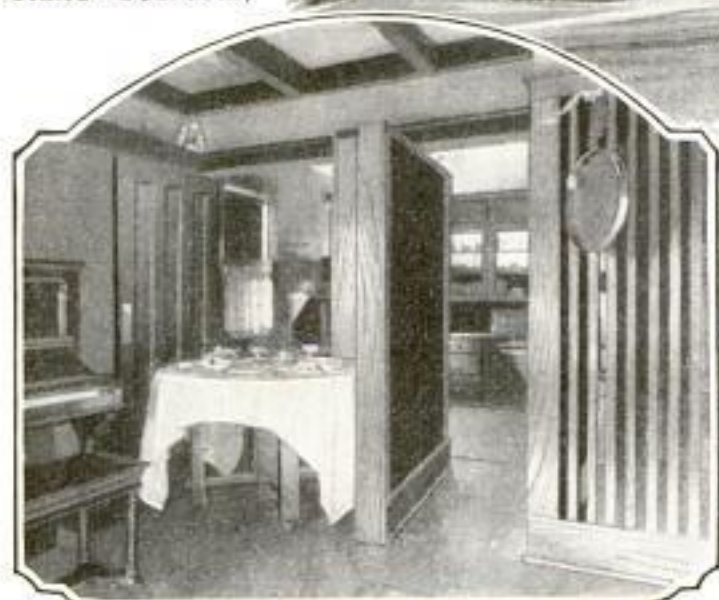
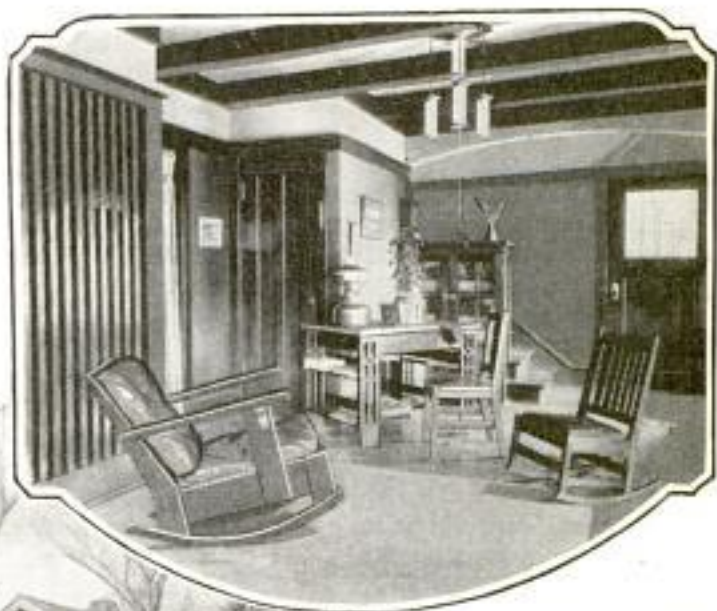

Attractive verandas surround the structure on two sides, one of which is arranged for use as a living porch. On the inside, near the entrance, a stairway runs to the second story, the lower part of the balustrade continuing into a set of bookshelves resting on the ground floor. No dining room is apparent, having been left out of the plan, but when meal time arrives, the wall between the living room and kitchen is caused to swing around, bringing into view a table prepared with all proper accessories of the repast. This convenience permits the table to be laid with cloth and china in the kitchen eliminating continual walking back and forth by the housewife. On the side of the wall above the table, a china cabinet has been set with one or two small shelves beneath, on which any extra articles

may be put until needed. When the wall has turned completely into the new position, the table is released by a lever and

Top, Interior of Folding Bungalow; Center, House and Grounds, and Below, Table Set Swinging into Dining Room

bath, and furnace compartment, on the lower floor, it has an upper room which opens onto two cozy sleeping porches.

slides noiselessly into the center of the room. As the meal progresses, used dishes can be removed to the shelves of the china cabinet and when finally the table is no longer wanted, it is caused to resume its position against the wall and the whole structure rotated into the kitchen to its original place. The sink being built near the partition, the table can be quickly cleared and the dishes rinsed and replaced in the cabinet.

It is estimated that this one arrangement alone saves a total of half a mile of walking back and forth per day by the housekeeper. Fueling of the furnace is also reduced to very little labor, the heater being inclosed in a neat grating compartment which allows the escape of warmth into all parts of the home. The coal is held in a two-foot space behind the furnace and when delivered can be transferred from a truck outside through a window and piled up on a sloping surface that causes it to fall to the door of a chute near the furnace opening, necessitating but a half turn on the part of the

attendant when shoveling the material into the fire.

The rear room of the house is equipped with a revolving dustpan so fixed that the dirt gathered up need only be put in it and a button pressed to deliver the rubbish to a container. Stationary laundry tubs in the kitchen lend their top as a drip board for the sink, while the provision cabinet is set with drawers and swinging doors in the lower section. Built into the back wall, this cabinet is prevented from impeding the entrance of light by having its back made of glass doors, which can be opened to allow any contents to be cooled without admitting cold air to the interior of the room.

Water and gas meters and the medicine chest for the bathroom are all combined into a small section of one of the walls and are out of the way except at such time as they need be reached. Swinging doors are inserted into the walls where convenient, and all of them can be easily fastened back when sections of the partitions are to be moved.

Manikins of Thin Wood Replace Wax Dummies in Paris Shops

For showing materials and garments in shop windows and display rooms, Paris merchants are posing manikins cut from thin slabs of wood instead of the expen-

sive wax affairs. The models are painted in lifelike colors after they are carved, the fashion design being faithfully reproduced by skilled artists to show its effect when worn. In some cases the fabrics from which the clothing is made are draped over the forms.



Studio Where Manikins and Ornamental Display Material Are Cut from Thin Wood to Replace Wax and Clay Models Used in Shop Windows and Show-Room Exhibitions



Blindfolded with Pillowcases, Platoon of Officer Candidates at Plattsburg Practices Night-Fighting Tactics by Day under the Watchful and Critical Eyes of Commanders and Comrades

Night Warfare Taught during Day by Blindfolding Soldiers

Blindfolded by pillowcases, student soldiers at the Plattsburg training camp, by day learn some of the fine points of fighting at night. The hoods are so adjusted that practically all light is excluded, and to the soldier the effect is approximately the same as though he were in actual darkness or were passing through dense woods. Without seeing their instructors or each other, the rookies learn to group themselves in various positions, maintain their formations, prepare and execute charges and go through other maneuvers. Their actions can be more accurately studied by the officers than in real night practice, and the identity of any recruit that fails to execute the orders properly is readily ascertained.

Roivings of Freight Cars Are Shown by Records of Railways 1668

Keeping track every day of the approximate 2,500,000 freight cars in the United States is one of the most intricate problems of modern railroading, but so well is the task performed, that a lost box car is practically unknown on American lines. Although it is the greatest rover of the rails, the whereabouts of a freight car is known at almost every hour of its twelve or fifteen years of actual service through an accurate checking system in the car-accounting departments of the individual lines. These offices not only keep track of the cars, but enable the roads to tell how much is due them from other lines and how much they owe other companies for the use of cars, a fixed charge of a dollar a day per car being the rate. When the train reaches a foreign line, the car accountant supplies the home road with the date of arrival. Thus at any time, officials can tell exactly where the cars are.

New York Times
1/3/24

Strange Bird Has Growl of a Dog. Sleeps Days and Can't Fly 1528

One of the strangest birds known to man, a "kiwi," survivor of a family that flourished more than a million years ago, has been obtained by the government from New Zealand in exchange for a cage of rare owls. About the size of a large domestic fowl, it has no wings and sleeps or remains inactive during the day. At night, it drives its long bill into the soil in search of worms to which it apparently is directed by the sense of smell. It can run swiftly and sometimes makes use of its sharp claws as weapons of defense by raising the foot to the breast and striking downward with considerable force. When the kiwi sleeps, it supports part of its weight by its bill which is rested on the ground. If disturbed, the bird yawns in a grotesque manner and makes sounds resembling the growls of a dog.



Drowsy "Kiwi" in Typical Daytime Position Which It Holds for Hours without Moving

Kadit + Herbert

Time and Money-Saving Tools



Creaming Corn Is Easy with Safety Knife That Shaves Kernels from Cob

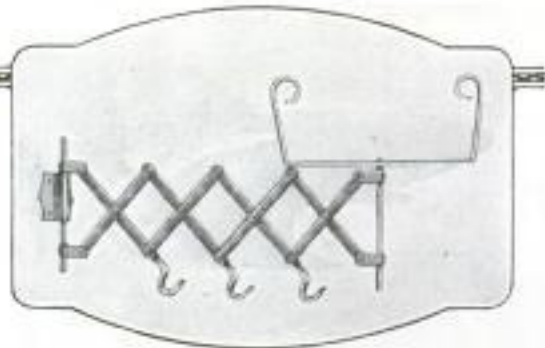

There Is Room for Two Hats and Three Garments on This Collapsible Steel Hanger, Designed Especially for Limited Spaces; Clothing Cannot Touch the Walls, the Bracket Swings About and Is Easily Attached

In Baking Pot at Left Housewives Have a Practical and Fuel-Saving Oven for Top of Electric, Oil or Gas Stove



Sanitary Glass Bracket Holder Keeps the Shaving Brush Handy

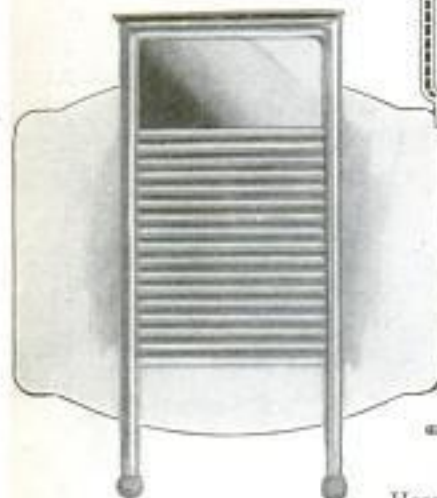

No Germs or Dirt Can Collect in All-Metal Washboard and It Lasts a Lifetime



Catch Basin Fitted to Drain Pipe Keeps Refuse from Clogging the Sink



Here Is a Pair of Folding Scissors with Collapsible Finger Grips Fitting into a Neat Metal Case for the Pocket, and There Is Also a Ring for a Chain

for Woman's Workshop in Home



Although Only Three Inches Long and One Inch Wide in Its Leather Case, This Efficient Pocket Clothes Brush Spreads Out When Removed and Just Suits Travelers



Waffles and Pancakes Both Are Cooked at Table on This Combination Iron



Mud Is Quickly Removed from Soles and Heels with This Portable Scraper That Can Be Used Anywhere

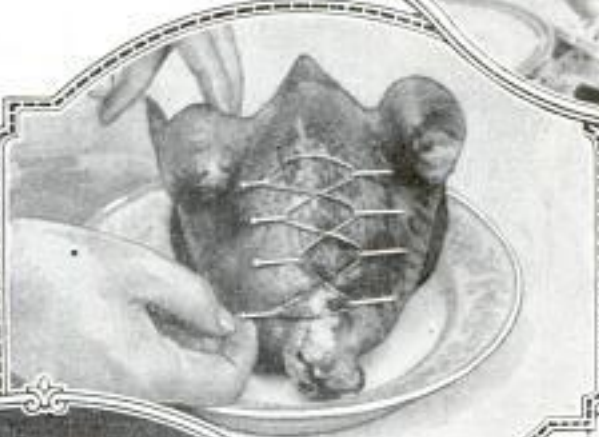

Aluminum Pins and a String Save Trouble of Sewing Fowl



Burns Are Avoided with Pronged Handle for Lifting Hot Plates

Teeth and Trouble Are Spared in Sewing by Handy Thread Cutter on Thimble



Days of the Makeshift Kitchen Table Are Over; Here Is a Compact and Serviceable Unit Equipped with Center Pail for Refuse, Adjustable Seat That Swings Out of the Way, Spacious Drawers and Cutting Boards, and a Sanitary Composition Top



obtain it by addressing Bureau of Information, Popular Mechanics Magazine, Chicago.

"Soft-Pedal" Paving of Rubber to Make Streets Noiseless

1145

To deaden traffic noises, paving blocks of rubber have been tested in Boston to show their wearing qualities. It is claimed



Inspecting Rubber Paving "Stones," with Which Much of Traffic Noise May Be Silenced

this material will outlast almost any other kinds now in use. Thoroughfares in the vicinity of churches, hospitals, schools and courtrooms, it is said, can be made practically silent in spite of heavy traffic. Being flexible, such surfaces will require less repairs and replacing if paved with the rubber blocks, which are an inch thick.

Powerful Turbine Locomotive Runs on Twenty Per Cent Less Coal

1481

Faced with a decreasing fuel supply and the ever urgent necessity for reducing operating costs, engineers are constantly seeking improved locomotives, a need made more imperative by the competition

offered by the gasoline-motor cars. The Krupp factories, famed for their war-time products, have built a compact and efficient turbine type of engine which is said to mark a distinct advance in locomotive design. It develops 2,000 horsepower, is capable of great speed and is said to effect a coal saving of twenty per cent over the usual type.

Lock Cistern Lid Prevents Accidents and Insures Clean Water Supply

1044

Cistern lids that can be fastened securely by means of a padlock passed through a strong iron clasp have been designed to prevent accidents and contamination of the water. They allow a twenty-inch opening, have an over-all measurement of twenty-seven inches and can be employed for covering cesspools, coal holes and other apertures where accidents are likely to occur. They are of special protection to children, can be fitted with little trouble and are designed to last a long time.

A. W. Clark Co., Malvern, Pa.

Screw Holder Saves Time and Labor in Reaching Hard Places

1625

Inserting or removing screws in difficult places is simplified by means of a slender holder which is held conveniently with one hand while the other turns the screwdriver. The grip fastens securely to the shoulder of the screw just above the threads so that it cannot drop out and the tool can be adjusted to various lengths and angles. It is especially adapted to piano work, building and repairing radio sets and to all sorts of electrical jobs.

*W. B. Elsworth & Son,
200 41,
Hudson, N. J.
Price \$3.50.*

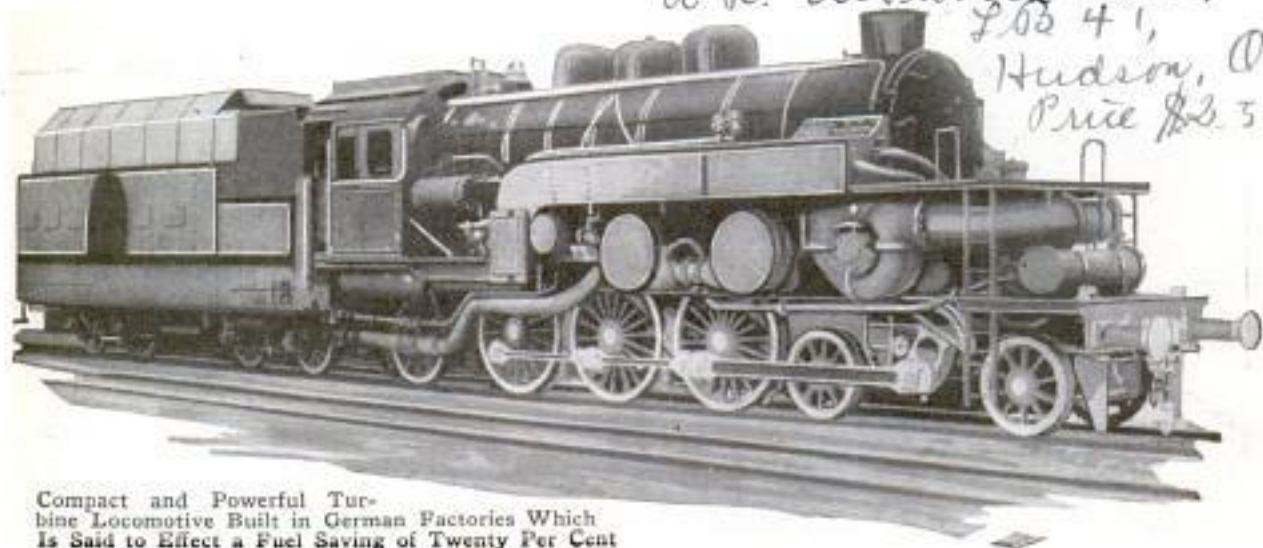

Compact and Powerful Turbine Locomotive Built in German Factories Which Is Said to Effect a Fuel Saving of Twenty Per Cent

Williams Service

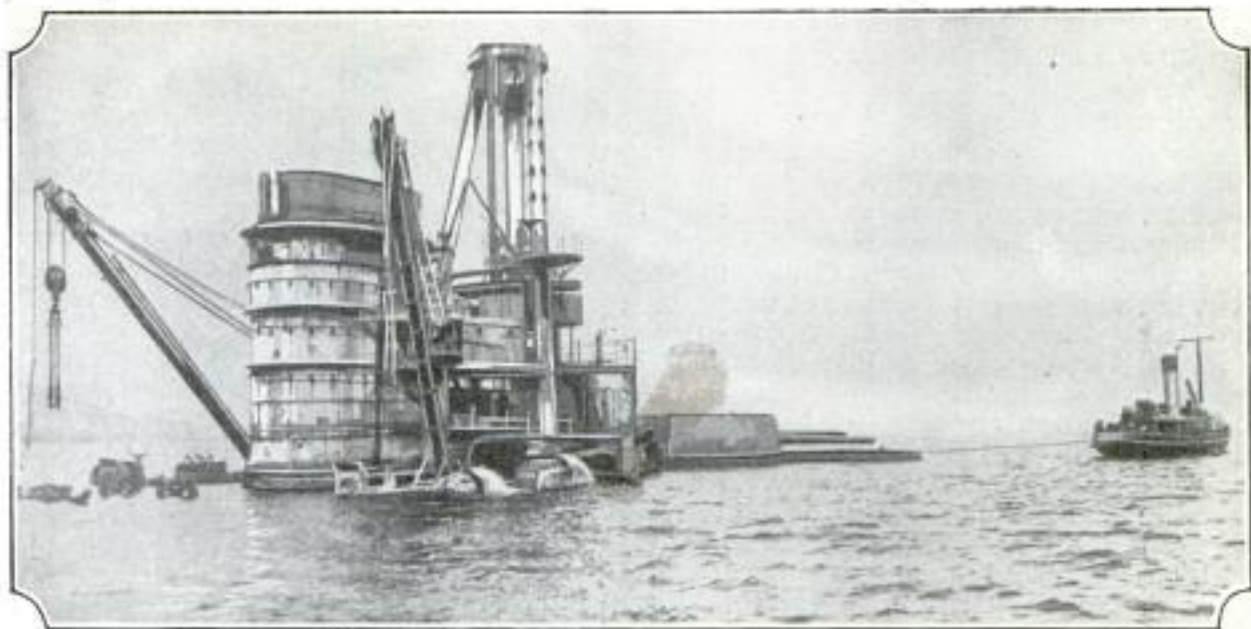

Salvaging the Former German Battleship "Hindenburg" from the Muddy Bottom of Scapa Flow, Where It Was Sunk with More Than a Half Hundred Similar Craft Over Five Years Ago

Raising Wrecks from the Sea Bed

Romance and Science of Modern Diver *Salving* Germany's Drowned Fleet at Scapa Flow

TWENTY-FIVE fathoms deep beneath the icy, green waters of a northern sea, land-locked in part and flanked by towering cliffs, lie the rotting hulls of sixty-eight German battleships whose sea cocks were opened on June 21, 1919. Mountains of silt cover their armor plate, and their turrets and decks, fore, aft and amidships, bristle with barnacles and other forms of marine life and vegetation.

At the moment a big firm of British salvors is engaged on the gigantic task of raising these submerged vessels, for the purpose of securing the costly metals—copper, bronze, brass, nickel, iron and selenium, the latter an exceedingly rare metal used in the construction of their wireless and other electrical apparatus. It is thought possible, too, that somewhere in the admiral's flagship, hidden in water-tight receptacles, may be valuable secret documents of importance. The salvage work at Scapa Flow started in April, 1924.

Most of these submerged vessels lie at a depth which is well within that at which useful diving operations can be undertaken. The greatest depth so far attained by the British admiralty is thirty-five fathoms. The great German battleships "Seidlitz," "Hindenburg" and the rest of the high-sea fleet lie in some twenty-two fathoms of water, and the limit of time for which the diver may remain under

water is about thirty minutes. He has to breathe compressed air forced down to him by powerful air pumps, since otherwise his lungs would instantly stop working and blood flow from his nose and mouth. To enable him to stand firmly on the bottom and resist the very powerful thrust and pressure of the water, he carries forty pounds of lead on his chest, the same on his back, sixteen pounds on each boot and altogether wears an equipment of 175 pounds' weight.

The diver's sensation on first entering the water is an uncomfortable one. The sea seems to be gripping him all round. His breath comes with a gasp as his helmet submerges and there is a pressure of water at his chest and abdomen greater than that at the valve outlet of his helmet. One of the first things he has to do is to adjust the spring of the outlet valve and so regulate the pressure that he may quickly shoot down to the sea bed, clutching the "shot rope." There he finds he can breathe more easily by crawling on the slime than standing and walking upright.

Submarine accidents to divers are really strangely few, considering the conditions under which they work. Their most dangerous foe is the grisly octopus which is apt to fasten its tentacles to an arm or a leg, and then a violent struggle follows on the bottom of the sea. Making super-

human efforts to free himself from the creature's suckers, the diver is hauled to the surface and the crew of the diving vessel hack with an ax at the limbs of the furiously lashing devilfish.

Divers at the salving of the sunken German war vessels at Scapa Flow, in the Orkney islands north of Scotland, where lay the base of the grand fleet in the great war, are not likely to encounter devilfish, sharks or other terrors of the deep sea, nor will they wander amidst entrancing scenes and marine landscapes where fantastic vegetation and many-colored organisms wave to and fro in ocean's green translucent tides. The sun's rays penetrate but a short distance below the surface of the water and all the divers will see will be the silted hulls looming darkly through the dim shades, twenty fathoms deep. When they blast their way through the barnacled plates, they will find no heaped-up doubloons as in the treasure room of a Spanish galleon of the sixteenth century, nor any gold bars such as it took three years to raise from the storeroom of the liner "Laurentic," torpedoed off the northwest Irish coast in 1918.

Mechanical "grabs" worked by electricity from the salvage vessel, shift the wreckage, and by means of the modern oxyhydrogen torch, steel plate can be melted under water. This is done by the aid of a strong jet of compressed air which forces back the water. The great hulls of the battleships will be raised by stopping every hole except two cavities into one of which compressed air is forced; out of the other is driven the salt water. As for the thirty German destroyers whose wrecks lie in the shallower water, they will be salvaged

by the use of great pontoons on either side of their hulls. A wire hawser is slung under the keel and passed over drums on the pontoons, at low tide. As the water rises, the pontoons haul up the wreck and are then towed in until the wreck strikes bottom again, when the process is repeated; thus gradually with each tide, the destroyer is drawn nearer the surface.

Before this entire high-seas fleet of a once great marine power was sent to the bottom, interest of salvaging concerns and untiring treasure hunters, who hoped to find untold wealth in the long-hidden hulk of some ancient galleon, was centered in the old Spanish Main and in and about waters where noteworthy naval maneuvers were known to have taken place in the long ago. Hundreds of thousands of dollars of private wealth have been poured into such undertakings since the first diving suit was successfully demonstrated. Some of the quests proved profitable to their sponsors, while the most of them turned out to be in vain. Either charts supposed to contain exact information as to the whereabouts of the sunken hoards were false, or in cases where the submerged vessels were really located, the reported treasure was absent from the wreck. Almost annually at-

tempts have been made by groups of individuals and legitimate salvaging firms to locate certain wrecks of craft sunken in storm or battle centuries ago and popularly reputed to have been loaded with gold, jewels or other treasure when they went down. These expeditions are generally well organized and financed. Expert divers are employed, crews of veteran seamen recruited, and the best-equipped ships chartered.

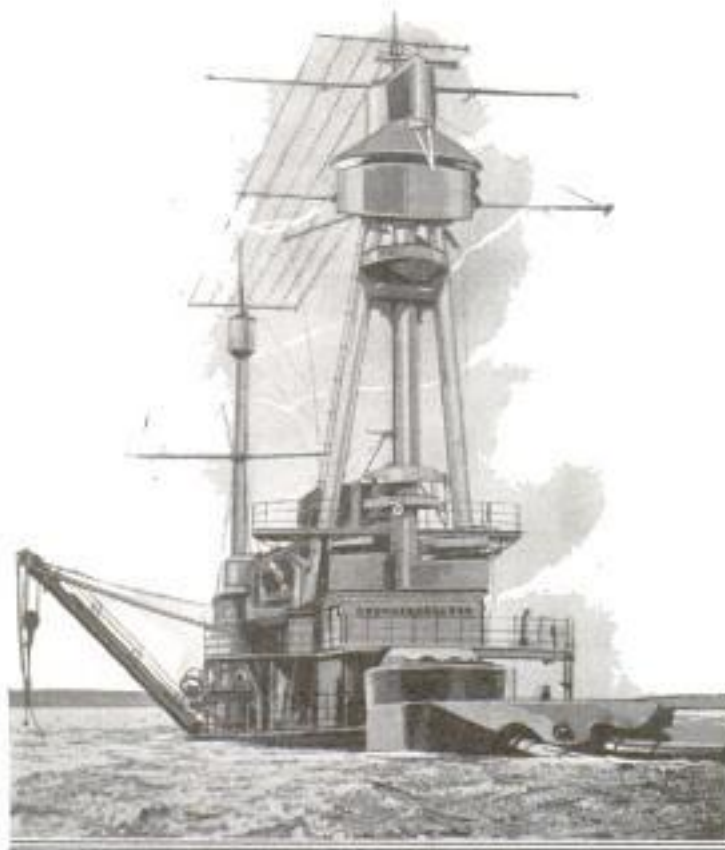

Copyright, Underwood & Underwood
Sea-Stained Superstructure of the "Hindenburg" Protruding from the Sea Which Failed to Engulf Entirely the Monster Vessel

Weavers. Miss Beatrice Abbott
and Miss Edith H. Small
New York

65 E. 56 St.
New York

POPULAR MECHANICS

**Rugs Woven in the United States
Rival Those of the Orient /580**

Rivaling in workmanship and design the costly products of eastern looms, "oriental" rugs are being woven in a New York studio by two women who have mastered the intricate art. Their accomplishment has led to the suggestion that American women forsake other less enduring forms of handiwork for this difficult but fascinating craft and, by devoting to weaving time that they now put on fancy work and other more trivial pastimes, create beautiful and lasting heirlooms. A sample is hung on the studio wall—a little rug fourteen by twenty-two inches. Those who have seen it declare that it might easily be mistaken for a century-old creation of a Persian artist. Cotton threads were tied with wool strands into as many as a hundred knots to the square inch and finer wool was woven among them. Finally, the scraggly ends had to be clipped, a task more difficult than mowing a lawn even with a scythe. Weavers of the Orient, it is explained, are able to live on a few cents a day so that American domestic labor never can hope to compete with them.

**Hand Type Is Set from Typewriter
and Automatically Distributed /501**

Setting hand type into forms with any standard-keyboard typewriter is accom-

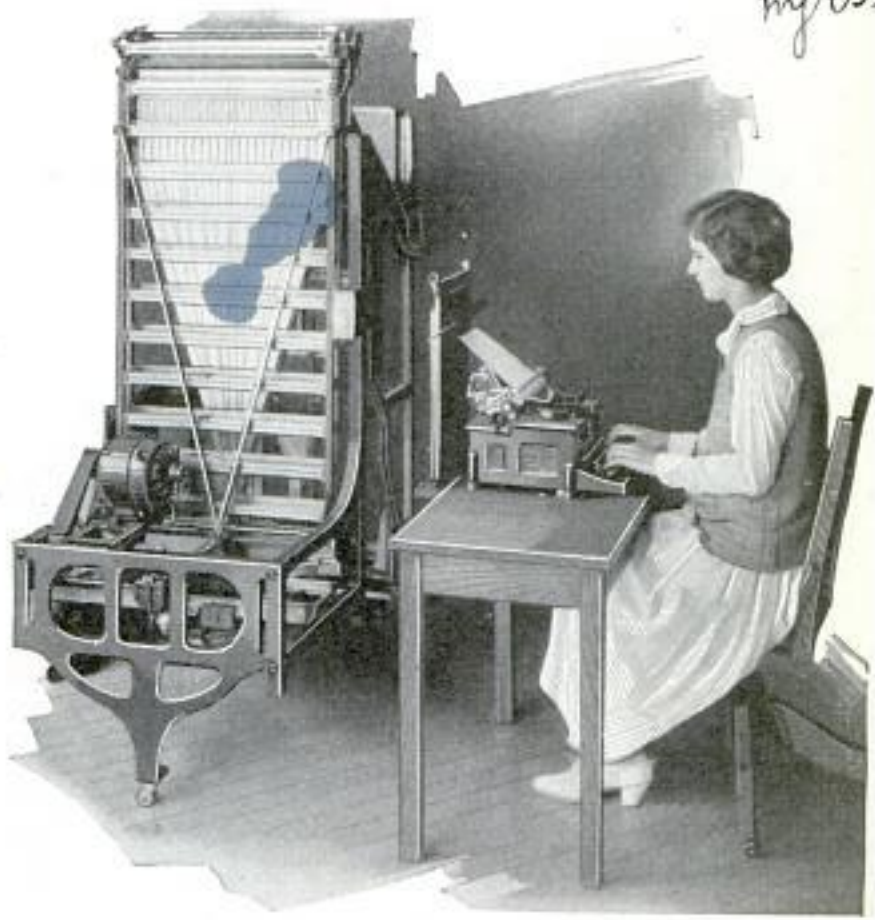

As Stenographer Taps Out Copy, Her Keyboard Sets Type Simultaneously in the V-Shaped Machine in Front of Her

plished by an ingenious apparatus which automatically returns used characters to their respective places in the type case at the same time. Machine and typewriter are electrically connected, and as the typist taps the keys, plungers beneath each of the type arms and the space bar complete electric circuits which cause corresponding characters in the machine to slide out of V-shaped cases into their proper positions. One of the setters, it is said, can keep from four to six presses busy on duplicating work. The type is distributed by an endless-chain arrangement without interfering with the setting, and as the typewriter is operated, it prepares copy for proofreading.

**Fastener Cuts Hole, Rivets Eyelet
for Binding Papers 674**



Originally intended for office use only, an eyelet fastener is now being used by bookbinders, printers, manufacturers and business institutions for binding, fastening and sealing. With its assistance, holes are punched in cloth, cardboard, leather and metal and the eyelets inserted and clinched.

punched in cloth, cardboard, leather and metal and the eyelets inserted and clinched.

☐ Telephone lines are becoming busier every year, according to figures of the census bureau which show that in 1922, 24,738,000 calls originated in the United States, an increase of nearly 3,000,000 over 1917.

Has
 Sten Service Co, Dayton, Ohio

Bates Mfg. Co. Hudson
Terminal Bldg. 50 Church St.
New York City

Hoister automatic
2916 Otis Ave Berkeley Calif
POPULAR MECHANICS

Weight of Egg Unlocks Door of Pen
1442 Automatically Separating Hens

Separating the hens that lay from unproductive ones is simplified by a nest now being manufactured for poultry raisers.



Poultry Separator Showing Exit for Non-Laying Hens, Entrance and Egg Drawer

It is a sanitary metal-box arrangement with an aperture through which the hen may enter from the yard in which all the fowls are kept. The door automatically closes behind her. If she lays, the weight of the egg falling upon a trap unlocks an exit into an adjoining pen. If she does not, the layer's exit remains locked and another door through which she returns to the general pen is unlocked. The weight of the hen, leaving by either door, opens the entrance for the next hen. This separator is designed to eliminate breakage in the nest and the egg-eating habit that frequently follows, to prevent the incubation of fertile eggs and to save the expense and labor of putting complicated traps in the nests. It is entirely automatic, is easily cleaned and cannot get out of order, it is claimed. By arranging a succession of these separators in different pens, in a few days the poultryman will have segregated his producing fowls.

Motor-Driven Turbine Fire Engine
1270 Is Light and Has Many Uses

Equipped with a centrifugal turbine pump, a fire engine has made its appearance in England that is said to weigh only one-third as much as the usual type and yet is of equal capacity and strength.

It may be drawn either by hand or by a light motor car and is intended mainly as an auxiliary to large fire stations, or for country estates and villages remote from efficient fire departments as well as for factories. The pump delivers 200 gallons of water a minute at 135 pounds' pressure, and 400 gallons at sixty pounds. It can, of course, be used for many other purposes besides fighting fires, as for draining places during floods.

\$6.00 - \$6.50 - \$6.75

Folding Steel Horses Carry a Ton and Occupy Little Space
1423

Folding steel horses have been placed on the market for the convenience of mechanics and owners of home workshops. As the legs fold up into the body, the device is convenient to store and to haul to and from the job.

Although weighing only sixteen pounds, each horse will support more than a ton, and, being quite flexible, it readily adapts itself to uneven surfaces.



A series of "keyhole" perforations in the top permit the attaching of clamps for holding boards in place for gluing jobs. Its field of usefulness is even greater than that of the ordinary wooden horse, owing to its greater strength and compactness.

Topp. Appliances Corp.
1307 1537 Syracuse, N.Y.
Condition of Fire Extinguisher
1045 Is Shown at Glance

To indicate at a glance whether a chemical fire extinguisher is ready for use, a small indicator has been made. The device includes a ball in a glass tube that disappears into an upper compartment when the extinguisher is tipped over and remains there until the tank has been recharged or repaired.



Rough handling during fire drills or tampering may spill the sulphuric acid from the bottle into the soda solution, thus neutralizing the contents. A glance at the indicator by a passing observer will show at once whether this has happened.

rough handling during fire drills or tampering may spill the sulphuric acid from the bottle into the soda solution, thus neutralizing the contents. A glance at the indicator by a passing observer will show at once whether this has happened.

Mess. Dennis Bros. Ltd.
1212 Walnut St.
Cincinnati, Ohio

Start of a Laboratory Efficiency Test on Automatic Fire Sprinklers; Attached to Water Pipes, They Are Heated by Electric Furnace While Expert Notes Melting Temperature and Time Required



How Science Protects You from Danger

Huge Laboratories Devoted to Testing Inventors' Ideas in Flame-Proof, Thief-Proof and Danger-Proof Appliances

A HUGE furnace door, ten feet square, built of fire brick and steel, swings open on giant hinges, and out of the flaming pit workmen drag a hand car on which reposes a big office safe, cherry-red from an hour's subjection to a heat of 2,000 degrees. The car is trundled down the track and comes to a halt beneath a towering shaft which pierces the upper floors of the building. Out of the darkness overhead slips a block and tackle to snatch up a chain cradle placed beneath the glowing safe.

With its burden the block disappears back up its shaft, and the workmen drag the hand car aside. A lever is jerked back and the steel floor of the shaft, with the rails of the hand-car track, opens in two giant leaves, exposing an eleven-foot thick block of concrete. Thirty feet up the shaft the red-hot safe has halted.

"Time," a voice calls.

With a terrific crash the safe drops thirty feet to the solid concrete, battering its sides and breaking off the casters and feet. Just two minutes have elapsed since

the gas was turned off in the furnace. The hoist jerks it into the air again, the leaves of the steel floor glide back into place, the hand car is trundled forward, and then back into the furnace with its burden, still red-hot. The furnace door closes, the gas is lighted, and another hour's "cooking" of the steel mass begins.

The day's work is well under way in the Underwriters' Laboratories, at Chicago. In an adjoining room there is another splintering crash. A 2,000-pound cylindrical weight, with wedge-shaped nose and mounted on ball-bearing wheels, has just dashed down an inclined track at terrific speed and crashed into a beautifully nickelplated automobile bumper, mounted on a chassis below. The bumper bends far inward, and then, as the good steel takes up the blow, it rebounds with a force that hurls the ton weight a half dozen feet back up the incline, where a ratchet catches and holds it. A stylus, though, has traveled over a paper mounted on the side of the engine and recorded the exact amount the bumper bent at the

1503
 Repeated Twists
 around Pulleys Test
 Qualities of Gasoline-
 Filling Hose; Man
 Is Pointing to Counter
 That Registers
 Turns

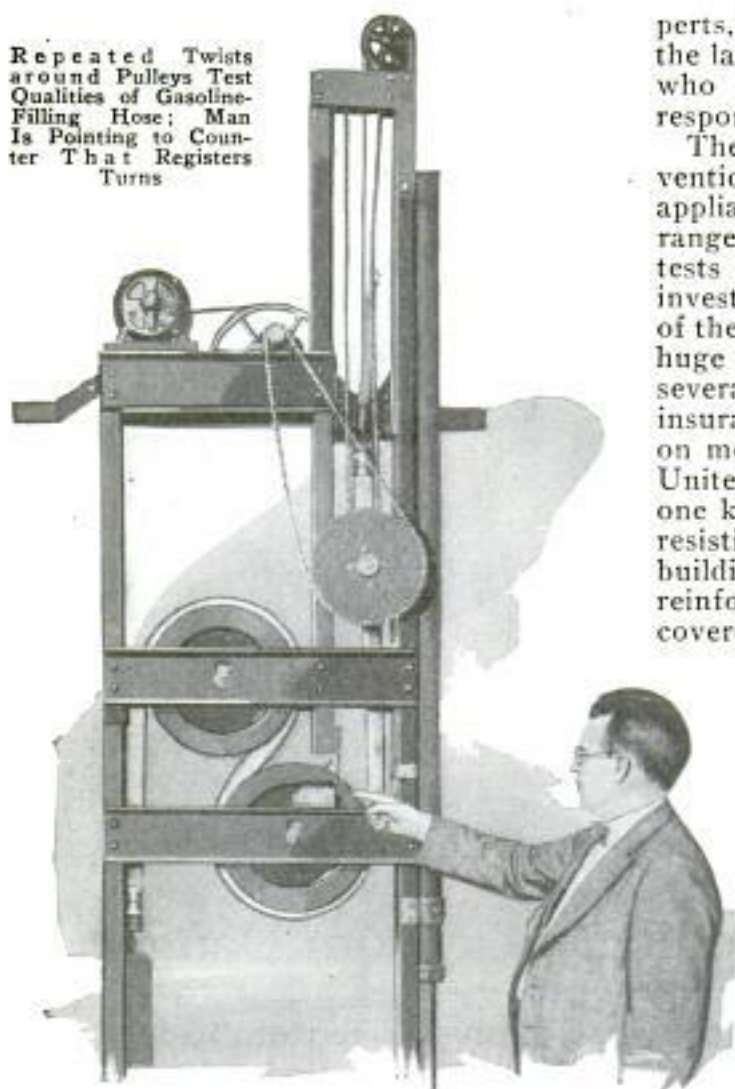

moment of greatest strain. The automobile-safety department is on the job measuring how much rebate on your insurance you should get if your car is equipped with that make of bumper.

Upstairs a little machine is methodically and automatically sticking keys into three automobile-transmission locks, turning them around, turning them back, withdrawing them and then repeating the operation, over and over, while an automatic counter records the number of times the operation is repeated before friction and wear breaks down the locks. The result will be passed on to you when the insurance agent figures the reduction in the premium on your car because you have an efficient burglar-proof lock.

The laboratories, a block of big three-story buildings, is a unique establishment, a topsy-turvy land where experts devote their lives to burning, breaking, smashing or otherwise wrecking the things that other experts have created. If the inventor's wits and skill can defeat, for a given time, the wits and skill of these ex-

perts, his device will be entitled to display the label of the underwriters, and the user who buys insurance will benefit correspondingly.

The work covers the range of fire-prevention, safety and burglar-prevention appliances. Anything coming within its range will be tested, and in addition to the tests arranged by manufacturers, special investigations are conducted at the request of the insurance companies themselves. A huge column-testing furnace was installed several years ago at the expense of the insurance companies guaranteeing risks on modern fireproof buildings and of the United States bureau of standards. No one knew at the time the fire and strain-resisting qualities of various kinds of building columns, including plain steel, reinforced concrete and steel pillars covered with concrete. For practically

all of the work special machinery must be designed and built, and for this purpose a completely equipped machine shop is maintained. Some of the testing appliances are so small that they may be carried in the palm of one hand, and others so big special buildings were designed to house them. One of the smallest is a tiny trip hammer used to test matches. The underwriters' specifications require that a match must light only when struck on the head. Placed under the little

hammer, the weight falls on the side of the head, and, if the match is safe, mashes the head to a pulp without lighting it.

Another little trip hammer tests the strength of the match stick, to insure that it comes from good stock which will not break, causing a lighted head to fly off through the air, to drop, possibly, among inflammable papers in your waste basket, or oil-soaked rags in the garage or shop. A good match stick should have no after-glow, and an expert sticks rows of matches in holes in a steel block, then lights them and watches the flames die out.

In the past fire investigators explained all unexplainable fires by attributing them to rats or mice gnawing matches. The laboratories decided to inquire into the matter. A supply of rats and mice was caught and placed in cages, strewn with inflammable straw. In each cage fifty matches were scattered. Not a single rat or mouse was found that did not prefer to starve to death rather than eat match heads; so another belief was exploded.

For many years the underwriters have

conducted exhaustive inspection tests of every length of fire hose manufactured, but recently the manufacturers asked for information about the wearing qualities of the hose from which automobile gasoline tanks are filled at service stations. A special machine was designed, and now, all day long, it automatically pulls a length of hose up and down, around two pulleys, to determine how soon the constant bending and rebending will break down the cotton covering. An automatic counter records the number of times the operation is repeated.

Another machine, almost human in the things it does, takes any kind of electric-light switch, whether turn-key, push-button, knife or toggle, and turns them on and off countless times to see how soon they will break down from wear. The machine requires no attention, for again the counter tells the story.

In the electrical department everything, from curling irons to baby incubators, is tested for freedom from fire danger and accident risks of other nature.

With the recent remarkable turning from coal to fuel oil for heating purposes in the family furnace, burners for the purpose came on the market so rapidly that the fire-insurance companies called for special data on their freedom from fire danger. A half dozen secondhand furnaces, obtained from a wrecking company, were set up and samples of all the oil burners called for. The samples came so fast that it was necessary to add another half dozen furnaces to the battery, so that twelve tests could be conducted simultaneously. For years a special department has been devoted to testing acetylene-lighting outfits designed for farm-home use. On one occasion an inventor, after being told that his outfit would blow up if subjected to the test, because of structural defects, asserted his confidence in

his brain child by offering to stand beside it during the experiment. Unable to dissuade him, the engineers gave in, and after the explosion used a two-inch fire hose to wash the mess of carbide off the inventor. On another occasion the inventor of a "burglar-proof" automobile lock applied for a test. The chief feature of his lock was a siren, concealed in the car, which was supposed to start blowing if the lock was tampered with, and keep on blowing until the owner appeared to shut it off. While the inventor arranged for the experiment one of the experts of the lock-testing division slipped outside, picked the lock of the inventor's own car without starting his siren device, and moved the car behind the building. When the inventor appeared to claim his car and couldn't find it, he was informed that the test was over.

Since the work of the laboratory is to defeat the purpose of any invention, if it is humanly possible to do so, the engineers are experts at such tasks. They match their wits against inventors to pick flaws in their products. In the burglar-alarm department every effort is made to

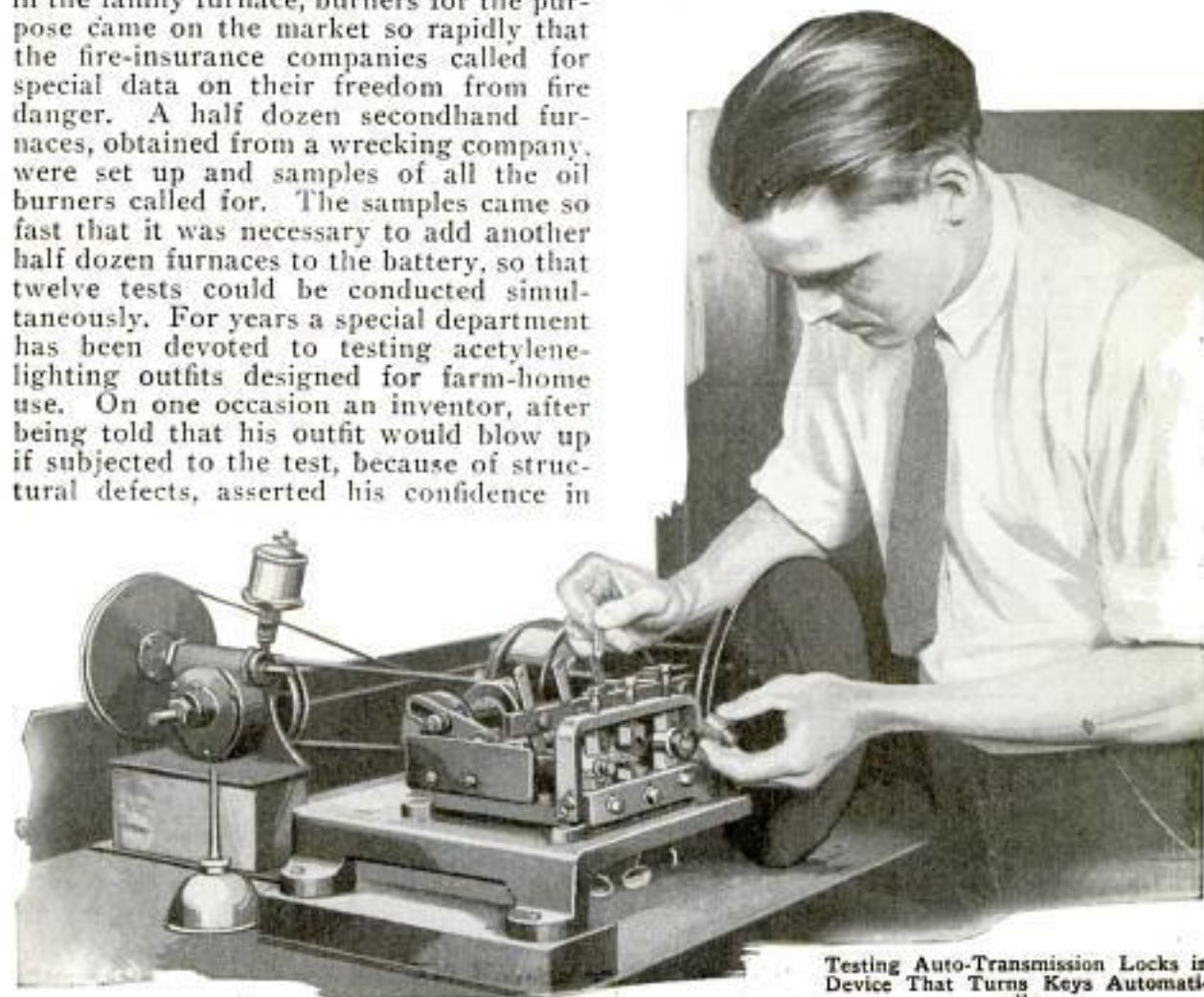

Testing Auto-Transmission Locks in Device That Turns Keys Automatically

keep one jump ahead of the burglars by finding new ways to defeat the alarms, and then developing ways to prevent that defeat. The developments are passed on to the manufacturer, and the alarms changed to checkmate the burglar.

Fire-prevention devices utilize a large part of the laboratory equipment. Huge furnaces, twenty feet high, are equipped with fronts which slide on overhead tracks. A fire door or wire-glass fire window to be tested is built up in the door, with a brick frame around it, just as in actual use, and then locked in front of the furnace gas jets. Electrical thermometers and elaborate measuring devices record the progress of the test, and if the device withstands all of the heat tests, it is wheeled to one side and subjected to a stream of water from a fire hose to see if it will break down from too rapid cooling when the firemen arrive. One of the most interesting devices tested in recent years was a small glass disk, coated with pure gold, to prevent inflammable moving-picture film from catching fire, even though the film came to a complete stop. Ordinarily such film bursts into flame if

the machine even slows down. The principle of the device is that the gold coating prevents the red heat rays from passing through to the film. In use, it will be released and drop into place before the light if the machine slows down to the danger point.

In the test it was found that a piece of dangerous film could be left for hours in front of the gold-coated screen without catching fire, but that it would burst into flame the instant the screen was removed. The same principle of repelling heat rays is used in the hangars for dirigible airships. The skylights are fitted with amber glass to keep the sun's heat rays from expanding the gas in the airship.

One enterprising inventor recently submitted for testing a wire-glass window which embodied the same principle. His glass had a yellow cast, and he believed it would keep the heat rays from passing through. The laboratory found it would do all the inventor claimed for it, but unfortunately the glass, while preventing the heat rays from passing, absorbed them itself, and therefore melted more quickly than ordinary glass.

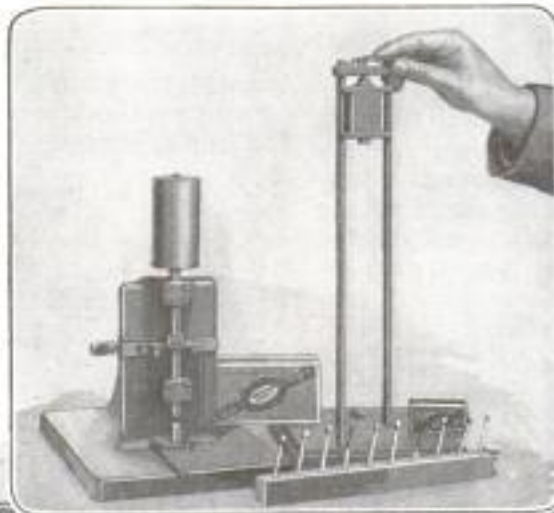

Testing Safety-Match Sticks and Heads, and View in Busy Furnace Room Where Oil-Burning Attachments Are Put on Trial to Protect Makers, Merchants and Buyers

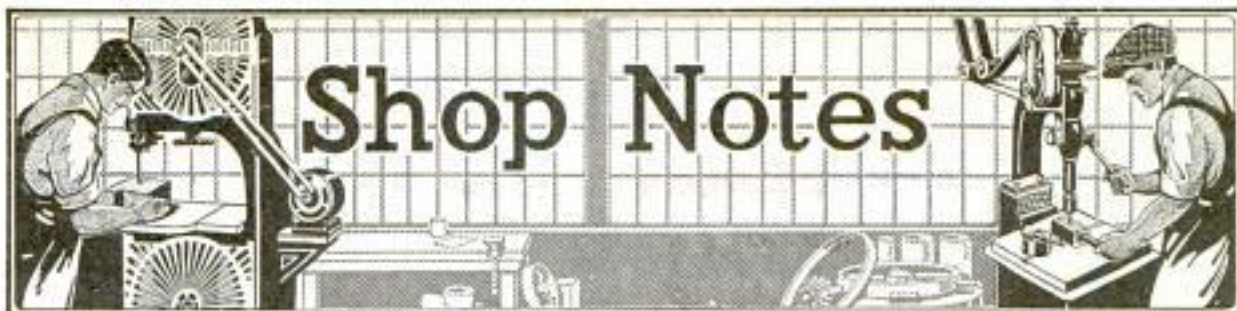

All Shop Notes published in 1923, in book form—Fifty Cents—from our Book Department

Mixing Machine for Small Bakery

By GEO. W. VAUGHTERS

THE illustrations accompanying this article show a homemade cake and dough-mixing machine that cost me less than \$10, counting the cost of all the new material used. This included two $3\frac{1}{2}$ -in. tees, $4\frac{1}{2}$ ft. of $3\frac{1}{2}$ -in. pipe, 8 ft. $\frac{1}{4}$ by 2-in. flat iron, two lengths of 1-in. steel rod, and two pieces of 1-in. pipe, 8-in. long. The remainder of the material was taken from the junk pile. The base of the machine is an old coffee-mill base; into this is screwed the $3\frac{1}{2}$ -in. pipe upright, and on top of this a tee. A short length of pipe connects this tee with another one, as shown in the drawing. The horizontal shaft, that runs inside the

tees, and the short pipe were taken from an old auto transmission, using the direct-drive gears as a clutch. A slot is cut in the top of the tee on the top of the column, to allow the end of the bent rod that acts as a clutch handle or shifter to enter and engage with a groove cut around one side of the clutch. This part of the clutch slides on a square shaft, to which an additional 8-in. length is welded, to allow the driving pulleys to be attached to it. The transmission case had round sleeves screwed into it to contain the shaft roller bearings, and these just fitted inside the pipe. By drilling and tapping the tees, I was able to

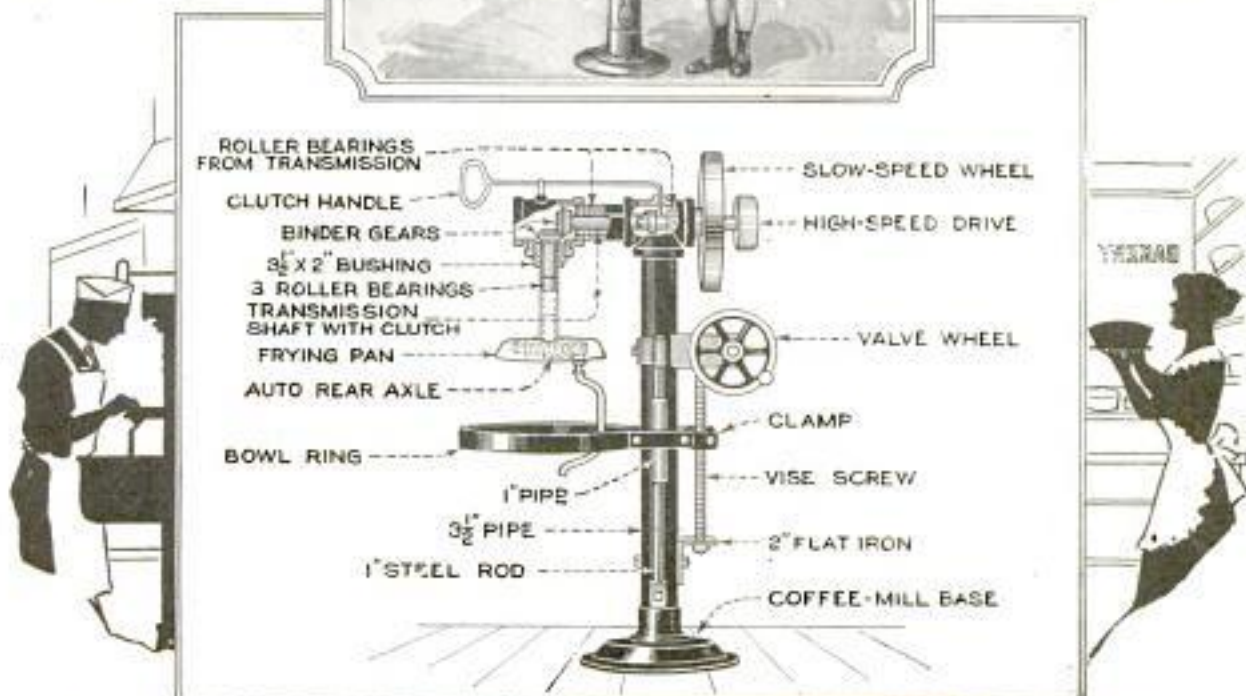

A Mixing Machine for the Small Bakery That Cost Less than \$10, and Mixes Dough, Mashes Potatoes and the Like, Much Quicker than the Operations Can Be Done by Hand

use setscrews to adjust the bearings. On the outer end of the shaft a binder bevel gear is keyed, engaging with a similar

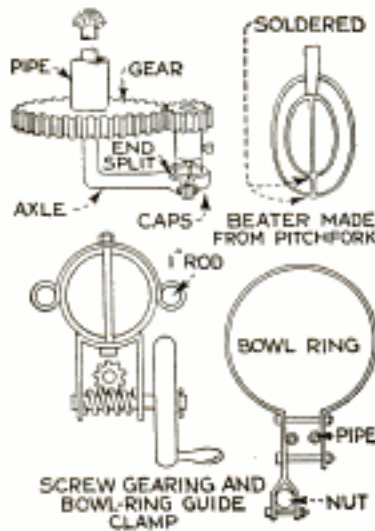

gear keyed to the end of an old Ford axle shaft. This shaft was bent 4 in. from the opposite end, the bent end slit lengthwise, and the two ears thus formed bent back at right angles to the shaft. The ears were then drilled, and two old

connecting-rod caps bolted in place as shown in the detail, to form a bearing for a 2½-in. gear or pinion taken from the transmission. This pinion has a long hub that runs in the bearing, and is drilled and tapped below the latter for a setscrew to hold the beater.

Into the outer tee a 3½ by 2-in. bushing is screwed, and a length of 2-in. pipe is screwed into this. On the end of the

pipe an 8-in. gear, also from the transmission, is screwed, and this meshes with the 2½-in. gear, which travels around it. Roller bearings are fitted inside the 2-in. pipe for the axle. A hole is cut in an old frying pan to fit over the 2-in. pipe, and the pan is bolted to the 8-in. gear to serve as a guard.

The gearing for raising and lowering the bowl is mostly scrap, with the exception of the bowl ring, which is made of the ¼ by 2-in. iron. This is fitted with two pieces of 1-in. pipe, which slide on the two 1-in. rods fastened to the column; the wheel is one taken from an old valve. The method of making and mounting the bowl ring and gearing is quite apparent from the drawing.

The beater rod shown in the large drawing is made of 5/8-in. round-steel rod, and is used for stiff dough. This can be removed and a beater made from a five-tine fork substituted for it; the latter is used for soft dough, batter, and for mashing potatoes. The drive is arranged so that when the belt is on the large pulley, the beater travels around the bowl 16 times a minute, and when on the smaller one 60 times a minute.

This machine will mash 1½ bu. of potatoes in a few minutes, and will mix 40 qt. of cake dough in a surprisingly short time.

Portable Ladder Scaffold

Cleaning and repairing skylights, hanging fixtures, painting and papering ceilings and other work that requires scaffolding, can often be done easily on an improvised ladder scaffold of the type shown in the illustration. It consists of two ladders,

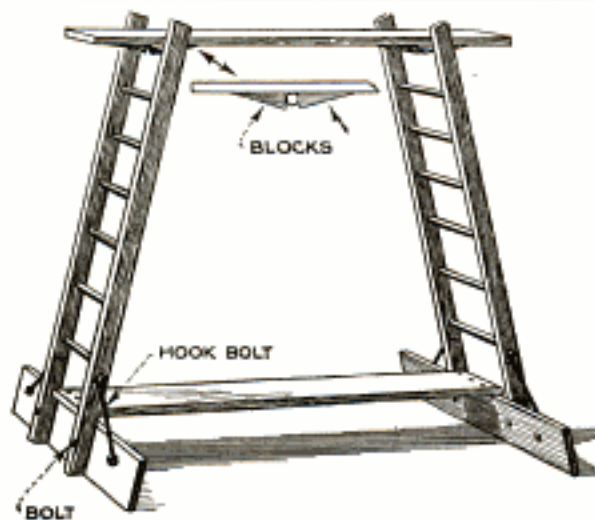

Portable Ladder Scaffold that Has Been Found Very Convenient for Reaching High Ceilings

four planks, and a few bolts and bolt hooks, to hold the ladders and planks together securely, and can be set up much more quickly than a scaffold made entirely of planks. Besides this, it is easily portable.

To the legs of each ladder a plank is bolted so that the edge rests on the floor as shown, holes being drilled through the legs and planks to receive the bolts. The hook bolts are used as braces to provide additional stability. A crosspiece is securely nailed to the top of the planks in order to keep the ladders from slipping apart, and another crosspiece, with cleats nailed on one side to receive the top rung of each ladder as shown in the detail, holds the tops of the ladders apart. The height of the ladders may, of course, vary and the length of the planks should be proportional.—G. A. Luers, Washington, D. C.

Lathe-Center Lubricant

White lead and sperm oil, mixed together with just enough graphite to give it a dark color, makes a good lubricant for lathe centers. This grease can be kept in a tin box and oil added when necessary, to keep it from becoming too thick.

Acetylene-Flame Shield

Much use is now being made of the acetylene torch for tool hardening and in this connection the shield shown in the illustration will be found handy. When heating up the ends of short, round pieces it is necessary to keep the work turning around so that the heat will be applied evenly. To do this by means of tongs held in the hand is a difficult matter, but with the aid of a shield to protect the hands from the heat, the work can easily be done. The shield is made from a short length of 6-in. iron pipe with the bottom end closed with a piece of sheet metal, and a piece of the side cut out, as shown in the back view. A number of holes of various diameters are drilled in a diagonal line through the side of the pipe, as shown, and the same thing done to the piece cut out, with the difference, however, that the holes in this piece slant in the opposite direction.

In use, the loose or sawed-out portion is placed inside of the main piece, as shown, resting on the plugged end. It will be seen that if two holes are brought in line to take a certain size of work all the other holes are out of line and therefore closed. To accommodate various sizes in this way the inside piece is turned around until both holes of the particular size required are

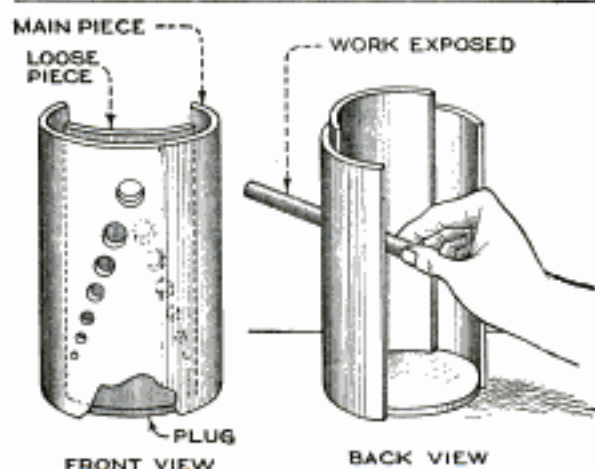

Hardening Small Tools with Acetylene Torch Is Aided by Flame Shield

brought together. The work to be heated is then inserted through these holes and can be turned by means of tongs, or held by hand. The danger of burns from the flame is entirely eliminated with this shield.

☛ For tightening bicycle-spoke nipples, use an ordinary screwdriver with a slot in the center and of a width equal to the thickness of the spoke.

Cloud Effects on Drawings

In a studio where quantity of production was a prime factor an unusual method was resorted to for putting cloud effects on drawings. An ordinary sponge was cut



Cloud Effects Put on Drawings with Sponge Speed Up Production in Drafting Room

with a pair of scissors so as to leave several flat spots on the surface. India ink, diluted so that the color was very faint, was then applied to the drawing with a flat side of the sponge. In this way little spots of clouds were printed on the drawing. The sponge was, of course, turned around each time to prevent making each print identical. The objects on the drawing were protected by covering them with a sheet of paper cut to the same shape. Almost any cloud effect can be produced in this way in a very short time.—G. M. Beerbower, Tarrytown, N. Y.

Cementing Leather to Iron

To cement leather to an iron surface, paint the iron with a mixture of white lead and lampblack in oil. Then cover with a cement made of the best glue soaked in water until soft, and dissolved in vinegar. This is thoroughly mixed with one-third of its bulk of white-pine turpentine, and thinned with vinegar until it can be spread with a brush. The cement should be applied to the iron hot and the leather put on and quickly pressed into place; the parts should be held tightly in a clamp while drying.

Farmer's Concrete Mixer

Mixing concrete by hand was too slow and tedious a job for an Indiana farmer, so he made the novel horse-drawn mixer

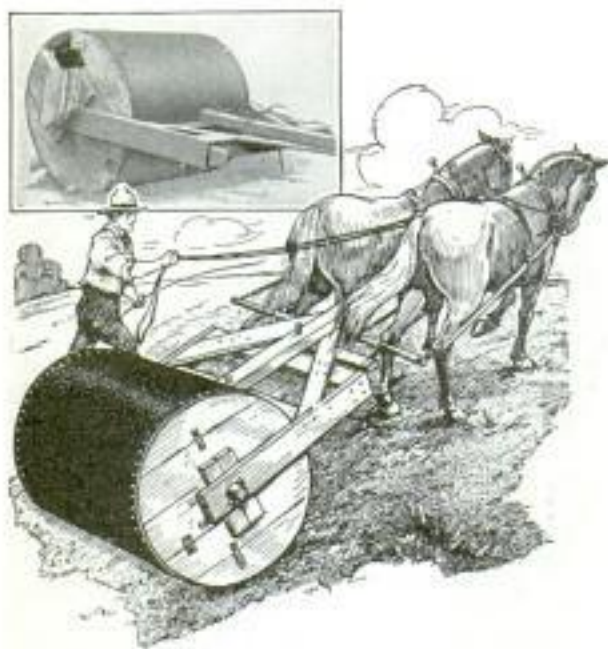

Metal Cylinder, Drawn by Team of Horses, Used to Mix Concrete

shown in the illustration. It consists of a large metal cylinder the ends of which are closed with 2-in. boards. A shaft of 1½-in. pipe is run through the center and a wooden frame is made, as shown, an ordinary doubletree being attached to it. A small opening is cut at one end to permit shoveling in cement, sand and gravel, in the proper proportions, and adding water, and a door is provided to close the opening. After these ingredients have been put in the door is closed and a team of horses is hitched on to roll the cylinder a few hundred feet, which thoroughly mixes the concrete. The end opposite the opening is driven up on a log or some other slight elevation to cause the mixture to run out as soon as the door is opened. If the concrete is to be used for foundation work, very little extra handling is necessary as the mixer can be driven close enough to run the concrete directly into the forms.—J. C. Allen, West Lafayette, Ind.

Handy Welding-Rod Holder

I do considerable welding along with other work, and was bothered a good deal by having to weld the end of one welding stick onto another in order to avoid waste and to prevent burning my fingers and gloves. In steel welding also the rod had

to be bent to keep the hands away from the heat, so I made the holder shown in the drawing from old material, and it works splendidly.

The material used is one burnt-out 600-volt, 60 to 100-amp. cartridge-type fuse; one piece of ¾-in. pipe, 1½ in. long; one ⅛-in. coupling; one piece of coil spring, 3 in. long; ⅛-in. pipe, 12 in. long; one piece of cold-rolled steel rod, 15 in. long to fit inside the ⅛-in. pipe; one piece of flat iron, ¼ by ⅜ in., 7 in. long, and scrap material for the trigger. To make the holder proceed as follows: Remove the caps from the fuse and push out the copper contacts from them; then fit the ⅛-in. coupling into one cap, as shown, and weld the cap and coupling together so that the coupling comes flush with the outside of the cap. File the end of the ⅛-in. pipe to an angle of 45°, then drill a hole in the center of the ¾-in. pipe, fit the end of the ⅛-in. pipe into the hole, and weld. Make a yoke from the ¼ by ⅜ in. stock, as shown, the width being about ¾ in. over the outside, so that it will fit inside the fuse, drilling a hole in the back of the yoke to fit the cold-rolled rod, and a loose-fitting hole on one side for the end of the trigger. A slot is cut opposite this hole, through which the trigger works. Two small pieces of the same stock are welded to the tips of the yoke, to make it a neat fit in the cap in which the coupling was

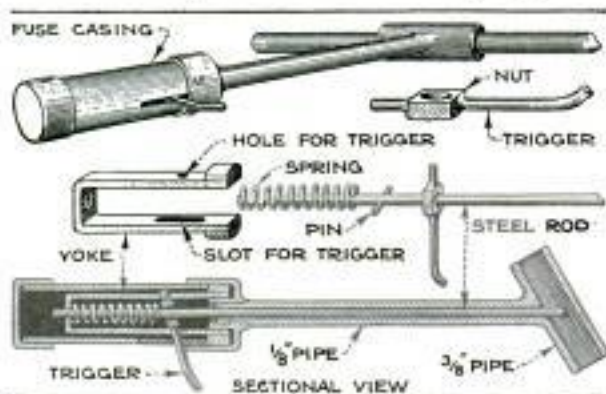

A Welding-Rod Holder Made from Scrap Parts That Will Be of Value in Any Shop

welded. When fitted, the yoke is welded in place.

Cut the cold-rolled rod long enough so that it will touch the front side of the ¾-in. pipe and pass through the hole in the yoke. Make a trigger, as shown in the detail, by welding two pieces of cold-rolled rod to a nut that will pass over the rod in the cap. The end of the trigger passes through the slot in the yoke, and a similar slot in the cap. The remainder of the assembly is obvious from the drawing.

To operate the holder, pull back the trigger and insert the welding rod in the angular pipe. Releasing the trigger causes the spring to push it forward and with it the steel rod, which locks the welding rod in the holder.—A. S. Jamieson, Springfield, Mass.

Making a Reamer Cut Oversize

When a smooth round hole of small diameter is required, a hand reamer is used to produce it, and many times the reamer is from .001 to .004 in. undersize. The reamer may be made to cut oversize in the following manner: With a scraper made of a medium-size half-round file, burnish the face of each flute, using the oval side of the scraper. This will raise a burr and cause the reamer to make the hole larger by an amount depending upon how hard the faces were burnished. It does not make a permanent edge, but serves very well in an emergency.

Reversing a Single-Valve Engine

To reverse a single-valve engine put the crank on either dead center and scribe a line on the valve stem next to the stuffing box; loosen the eccentric and turn it on the shaft until the mark on the valve stem is again even with the face of the stuffing box. Then tighten the eccentric, and the engine will run in the opposite direction. Care should be taken not to move the stuffing box during the operation and to see that the crank is on the same dead center when tightening the eccentric as at the outset.

Working Paint from Brush

Paint is usually worked out of a brush by rubbing it on a board. The objection to this practice is that the paint accumulates and gives the board a smooth surface, which is not effective for the purpose. A better method is to rub the brush over $\frac{1}{2}$ -in. wire mesh, stretched and nailed over the open top of a box. This makes a handy accessory that every painter will appreciate.—J. H. Shadek, Oradell, N. J.

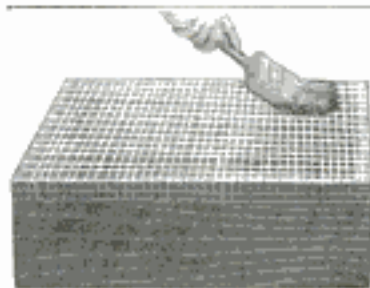

Useful Surveyor's Mark

Every surveyor engaged in running the level on paved streets and highways knows how difficult it sometimes is to establish a satisfactory mark upon which to sight the instrument. This is particularly true in traffic, where vehicles break off stakes

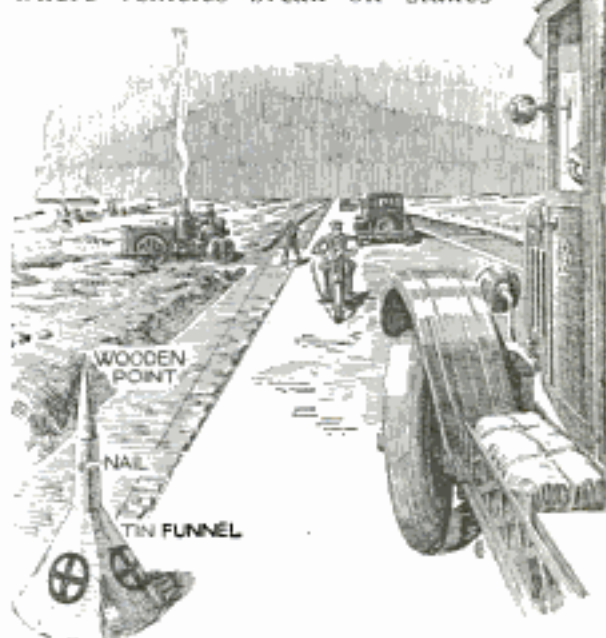

Tin Funnel Makes Handy Mark for Surveyors Doing Street and Road Work

or throw aside stones and other objects set up to be sighted. To them the method devised by Roger Sweier, an engineer with the Los Angeles county-road department, will prove of interest. He experienced endless trouble in maintaining surveying marks until he hit upon the idea shown in the illustration. A large tin funnel was painted white, and after the paint was dry, four black sighting marks were painted on the conical part, as indicated. Into the small end of the funnel he fitted a soft-wood stick, whittled to a needle point. Now, when out surveying for pipe trenches and similar work, he sets the mark down on the pavement wherever desired. It does not blow over in the wind and is seldom disturbed by traffic because of its visibility. Motorists have to strike the funnel squarely to damage it, but they do not do that because the dangerous-looking but harmless wooden spike suggests a puncture, so that, as a rule, they avoid it. The device is light, compact and always ready for use.—J. E. Hoag, Los Angeles, Calif.

☛ A good filler for cracks in stoves and furnaces is made by mixing equal parts of salt and wood ashes into a paste.

Novel Window Advertisement

A novel method of attracting attention to a window display was used by a druggist. To all appearances the plate-glass

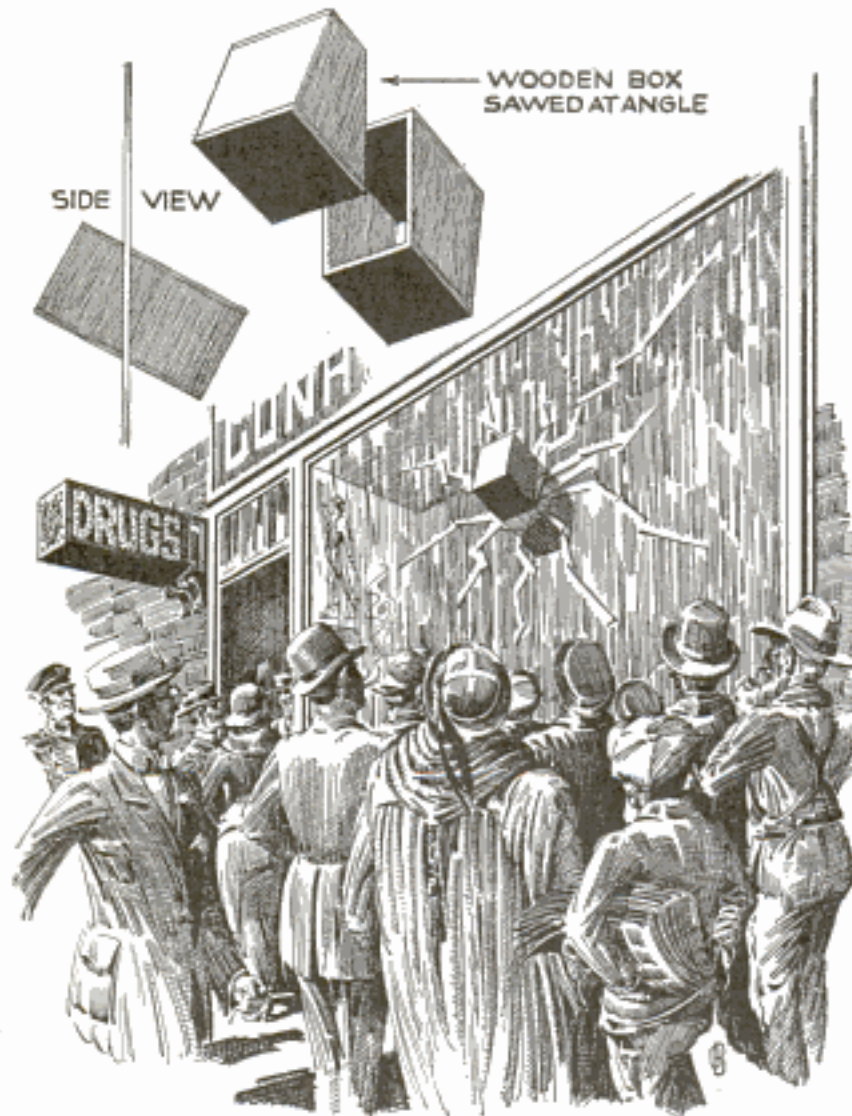

Novel Window-Advertising Scheme Attracts Attention of Curious Crowd and Increases Sales

window had been broken and a wooden box, which apparently just fitted the hole, inserted in it to keep out the cold, while the cracks radiating from the hole had been covered with adhesive tape. All day groups of people gathered in front of the window, and, of course, could not help observing the merchandise in it, so that the druggist's sales increased considerably.

The window was really not broken at all, but the box was cut in two at a slight angle, and the parts glued to the glass, one on the inside and one on the outside. Dark-gray adhesive tape concealed the edges of the box and was pasted on the window, radiating from the box, to convey the impression of cracks in the glass. Tape was, of course, used on both the inside and the outside.

A Homemade Monotone Glass

To the amateur photographer colors seen on the ground glass of a camera are very deceptive and contrast with each

other much more than their tones do on the negative. Seemingly charming views, clusters of brightly colored flowers, and the like, often prove disappointing after being developed. To see the true tone values of colored objects, a monotone glass is used, and anyone can easily make one himself. A piece of waste film, preferably cut film, which has been fixed in the hypo bath and thoroughly washed, is soaked in a tray containing enough blue fountain-pen ink to cover the film, which should be submerged long enough to stain the emulsion a deep shade. When this shade is obtained, the film is washed to clear it of surplus ink, and when dry, it is mounted between two pieces of clear glass, which are bound together with adhesive tape. Two small glass plates that have "missed fire" can be dyed blue and bound together in the same way, the emulsion sides being in contact. However, when

plates are used, they should not be given such a deep blue tint as when a single film is used, as the depth of the shade when the plates are laid together will be doubled. When the subject of the picture is viewed through the monotone glass, it appears as it will in the print, in black, white and half-tone, so that the effect can be judged much more accurately than when the ground glass only is used.—M. E. Hopkins, Corry, Pa.

☛ About as good a belt dressing as can be had is made by mixing melted beeswax and neat's-foot oil in the proportion of $\frac{1}{2}$ lb. of wax to $\frac{1}{2}$ gal. of oil. Melt the wax first, then add the oil slowly, stirring constantly to get it thoroughly mixed.

Can be used only with 110. volt transformer design in detail.

A HOMEMADE ELECTRIC WELDER

BY J.P. NIKONOW

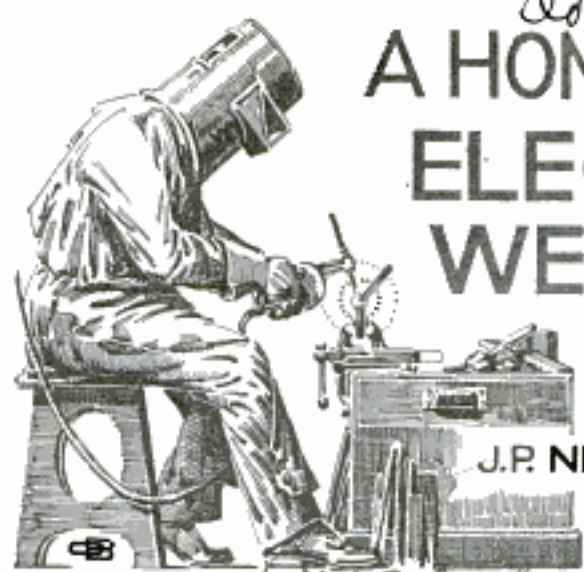

3425 Miles Place, New York City.

ELECTRIC welding, while it has certain limitations, in many respects is much superior to acetylene welding. We all have heard of the wonderful work of repairing what appeared to be hopelessly damaged engine parts on big German liners. Complete new portions of cylinder walls had to be made in some cases, welded into places and finished smooth inside for the piston. All this work was done with the help of the electric welder.

Of course, the apparatus for this kind of work is bulky, expensive and requires great electrical energy. But it is possible to construct a simple and light portable electric welder that can cover a large range of jobs on light pieces of metal.

The apparatus described here is of the arc-welding type, as it utilizes an arc flame to produce the high temperature. For this reason, it might also be called an "electric torch," the arc having actually the effect of the hot flame of a torch. It may be used for a variety of work, not only welding, but also brazing, etc. This welder consists of two carbons of $\frac{5}{8}$ -in. diameter, such as are used for arc lamps but without cores (the cores produce too much smoke and are generally undesirable for welding service). The carbons are held in clamps, F, attached to the ends of holders, D and E; D is made of a brass strip, $\frac{3}{16}$ by $\frac{1}{4}$ in. and about 8 in. long. The holder D is placed between blocks, A and B, of hardwood or fiber and is clamped with 8-32 machine screws (8-32 screws are used throughout for this device). The screw heads should be sunk in counterbores, so that they cannot come in contact with the operator's hands. The other holder E is made of a lighter strip, $\frac{1}{16}$ by $\frac{1}{2}$ by 8 in., and is fastened to the block B with screws and nuts. These (and all the other) nuts should be sunk in the counterbores so as to prevent any pos-

sibility of a short circuit. A piece of wood, C, is fastened to the holder and forms a convenient handle. It should be wider than the strip (Fig. 2), to keep the operator's hand from touching the metal of the holder. The latter is bent outward, so that normally there is a large clearance between the ends of the holders D and E, also about $\frac{3}{4}$ -in. clearance between the tips of the carbons. This strip E should be made of hard or spring brass; then it will stay in its bent-out position, and the carbons will come together only when the operator squeezes together the handles A and C. The rear ends of the strips are provided with contact screws, under which the ends of the cables 13 are clamped. These cables are made of rubber-insulated stranded copper wire of about 4,000 or 5,000 circular mils. The contact screws with the wire ends and the rear end of the welder are protected with a double layer of insulating tape.

This welder can be used with direct or alternating current. When using direct current, it is necessary to use a rheostat, R (see diagram Fig. 9). The current should be adjusted for about 10 amp. for lighter work, and for about 20 to 30 amp. for heavier work. For light work, 15-amp. fuses should be used, and a 50-amp. fuse for heavy work. Heavier wires should also be used for stronger current. Fig. 3 represents the strip D; Fig. 5, strip E; Fig. 4, clips F before bending; Fig. 6, central wooden block B; Fig. 7, block A, and Fig. 8, block C. Fig. 9 represents diagrammatically electrical connections from the line and fuse to the welder W, with rheostat R connected in series with one of the wires.

The rheostat (Fig. 10) can be easily built on a 24 by 24-in. wooden frame and a long spirally wound iron wire supported on porcelain insulators. Dimensions are

Auto transformers - Jefferson Electric Mfg. Co. 4531 S. Lawrence Chicago. Standard Electric Mfg. Co.

given on the drawing. The wire should be from No. 14 to 16 gauge, thinner wire being used for lighter work, wound in a spiral about $\frac{3}{4}$ in. in diameter. It will take about 50 feet of this wire for a circuit of 110 volts. Current may be adjusted by placing jumpers 13, which represent pieces of copper wire tied between two adjacent spirals, so as to short-

circuit them and to reduce the resistance.

At first all of the wire should be included, then the carbons drawn quickly together and apart again. A good arc will be maintained with about 10 amp., with the carbons from $\frac{1}{8}$ to $\frac{1}{4}$ in. apart. When the carbons are close together, the arc will draw more current, and will be hotter and shorter. In this condition it is more suitable for welding small pieces of iron or cast iron. Soft iron and steel weld the best; harder steel does not weld so readily. Nails are much harder to weld than a

soft-iron rod or sheet iron. The arc concentrates at the tips of the carbons and flame from it plays outward, so that it can be used very conveniently for heating pieces to be welded. With increased distance between the electrodes, the current decreases, and the arc lengthens and becomes unstable. It is difficult to maintain the arc at currents below 5 or 4 amp. Smaller diameters of carbon are not satisfactory, even for very light work.

It is not necessary to use any flux when welding pieces of iron. But the same apparatus may be used for brazing, in which case powdered borax should be used on

the surfaces. For instance, with this apparatus the ends of a handsaw may be brazed together. For this purpose they should be tied together by means of an iron wire, and then the borax spread on. The heat of the arc should be applied carefully so as not to burn the saw. A good joint will be obtained by this method much quicker than by a regular torch.

It is absolutely necessary to protect the eyes with dark-blue or red glasses, the red glasses being better because they stop most of the very injurious ultraviolet chemical rays. When working for any length of time—say, a few hours at a stretch—it is necessary to employ a mask for the face, otherwise, the chemical rays from the arc will cause severe burns on the skin, like a bad case of sunburn. The same rheostat may be used for an alternating current of 110 volts. It has the disadvantage, however, of uselessly wasting a considerable

amount of energy, dissipating it in heat. A much more efficient arrangement can be made with alternating current by using a choke coil instead of a rheostat. The choke coil lowers the voltage without wasting energy. Or a still better arrangement would be the use of an auto transformer, which not only saves the energy, but can actually give more amperes than the main fuse will stand (the auto transformer converts the electrical energy of high voltage and low current into a low voltage and high current with but little loss). For ordinary practice, a choke coil will be sufficient. It can be made



Fig. 1—Assembly View of the Portable Electric Welder. This Is an Easily Made Tool and One of Considerable Usefulness

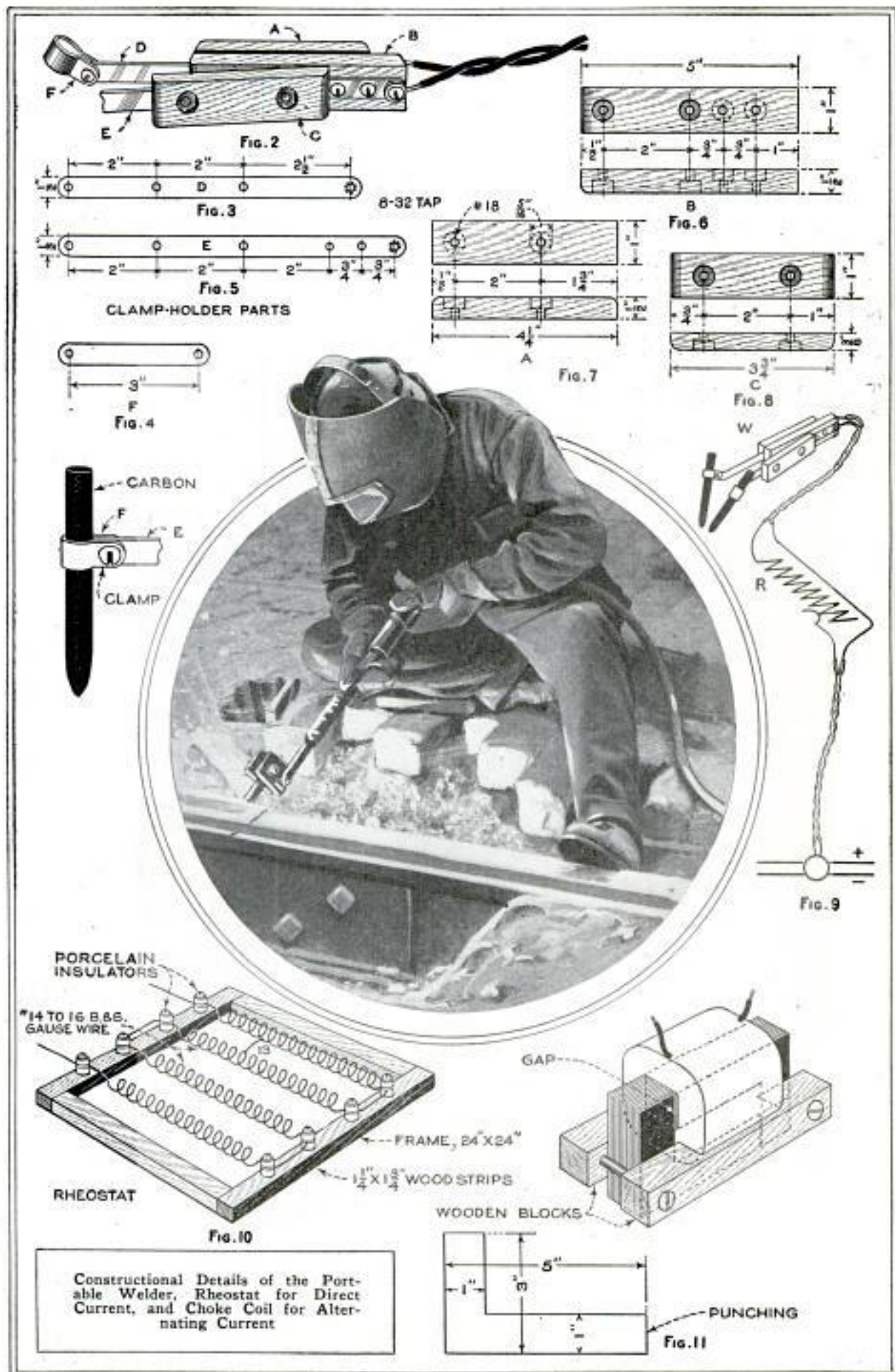

Constructional Details of the Portable Welder, Rheostat for Direct Current, and Choke Coil for Alternating Current

easily (Fig. 11) by making a coil of insulated d.c.c. copper wire, No. 10 gauge, about 80 turns. This coil should then be taped all over, and sheet-iron punchings assembled in it, forming a closed "ring." The L-shaped punchings used for two sides of the ring should have their long legs shorter than the ones on the other two sides, so that a $\frac{1}{8}$ -in. gap will be found on one side of the ring, as indicated. Without this gap the choke coil will have too much reluctance, so that there would not be enough current in the line for the

arc. By changing the gap the coil may be regulated for any current desired. The punchings should then be clamped between two wooden blocks with screws, and the coil heavily coated with an insulating varnish.

This welder represents a very interesting device, and it can be used with a little practice for some very remarkable work on light pieces of metal, wires, bolts, sheets, etc. But it cannot be used successfully for heavier jobs, such as the welding of cracks in a cylinder.

Quick-Action Slot-Drilling Jig

The slot-drilling jig shown in the drawing is somewhat different in design, and much quicker in action than the usual type. Eccentric bushings, sliding pieces, and

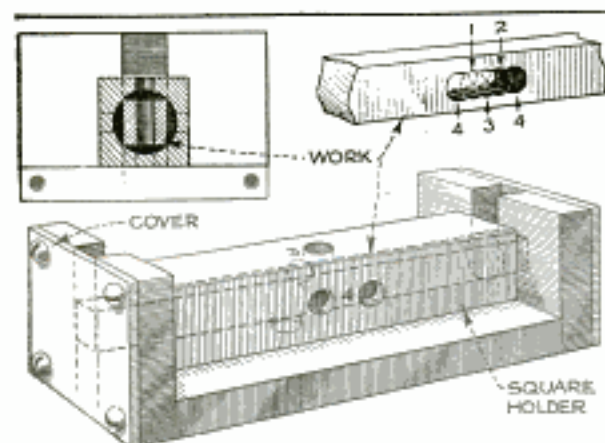

Quick-Action Slot-Drilling Jig for Cutting Slots in Square Shafts

other similar methods for drilling holes close together, or to break into each other to form slots, are generally slow in action; but as many different holes as are necessary to form a slot of any length can be drilled by using this jig, and only one movement is required between holes. The job for which it was used was the cutting of a slot in the middle of a square shaft.

The main part consists of a base with two endpieces screwed to it; these are slotted in the center to the size of the shaft, and afterward thin metal covers are screwed to the outside faces. Next a square holder is cut to fit nicely between the endpieces and drilled along its axis to suit the corner-to-corner dimension of the shaft. The sides of the holder are then drilled and reamed as indicated to take the drill and counterbore necessary to make the slot. This is done in the following way: Hole 1 is drilled first; the holder is lifted enough to clear the bottom of the jig so

that it can be turned over to bring the next side uppermost, when hole 2 is drilled. The holder is turned again and a counterbore used to drill hole 3 between the two holes just drilled. The half holes, 4, at each end are then cut with the counterbore.

Cleaning Paint on Engines

A compound with which engines or other oily machinery can be cleaned thoroughly is made as follows: To 1 gal. of water add $\frac{1}{4}$ pt. of lard oil. Mix them thoroughly, forming an emulsion. Rub the painted surfaces with the compound and remove it before it dries with a cloth.

Electric Drier for Kiln Samples

The U. S. forest products laboratory at Madison, Wis., has devised a portable electric drier for moisture-determination disks. It consists of a sheet-iron box, 4 by 13 by $6\frac{3}{4}$ in. in dimensions, lined with

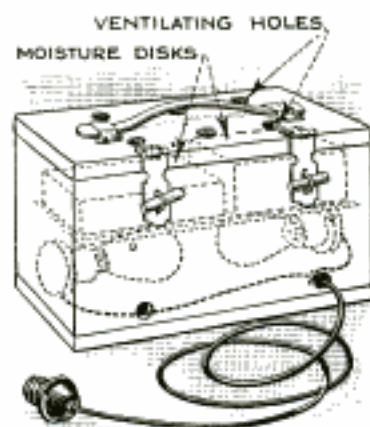

a layer of $\frac{1}{2}$ -in. asbestos, and divided into two compartments by a wire rack. The heat is supplied by two 40-watt carbon-filament lamps, placed in the bottom compartment, the sockets being

screwed to the sides. Ventilation is obtained by eleven holes, $\frac{3}{8}$ in. in diameter; six of these are drilled in the cover, three in the back near the bottom and two in the front. A cord and plug attachment makes it possible to connect it to any available lamp socket.

The 1-in. wooden disks used in moisture tests are easily dried in this box in about 24 hours. The maximum temperature attained is 230° F., which is reached only if the disks are allowed to remain in the drier for several hours after they are bone-dry. A slight scorching of the disks occurs under these conditions, but for all practical purposes this does not cause any appreciable error in the moisture calculations. The weight lost by the disk in drying is the weight of the moisture that was in it. This weight, divided by the weight of the dry disk multiplied by 100, gives the percentage of moisture in the stock in the kiln at the time the sample was removed. This drier is very well adapted to commercial practice. It can be carried around and used in any place where a lamp socket is available.

Effective Post Puller

Of all the post-pulling devices I have ever seen, the one shown in the illustration is the simplest and quickest-acting. It consists of a discarded sleigh runner, provided with a clevis, chain and a double-tree so that a team of horses can be hitched on, and a wooden lever with a sharp steel point, bolted to the runner as shown; in this particular instance the point was the tip of a discarded plowshare. To pull a post, the runner is placed close beside it with the point of the lever driven into the post as shown. When the

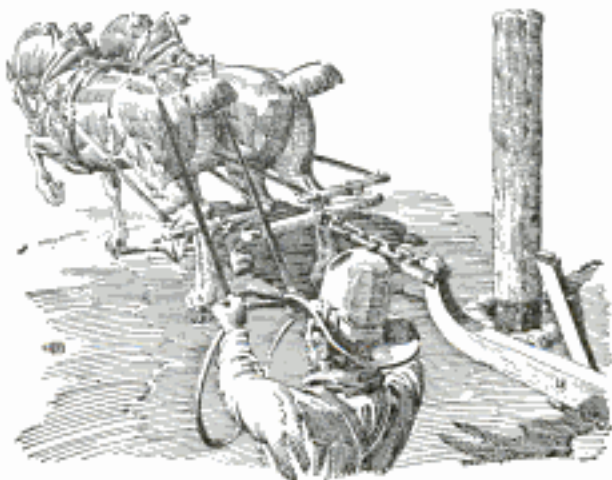

Simple Device Pulls Out Row of Posts in Rapid Succession

horses are then urged ahead and the runner slides forward, the lever pulls out the post. This operation is repeated for each post. The absence of loose parts and the elimination of tackle and chain make this device well worth the time and labor necessary to make it.—G. E. Hendrickson, Argyle, Wis.

Handy Cuspidor Carrier

Janitors of public buildings can make the task of collecting and carrying cuspidors much easier by using a holder of

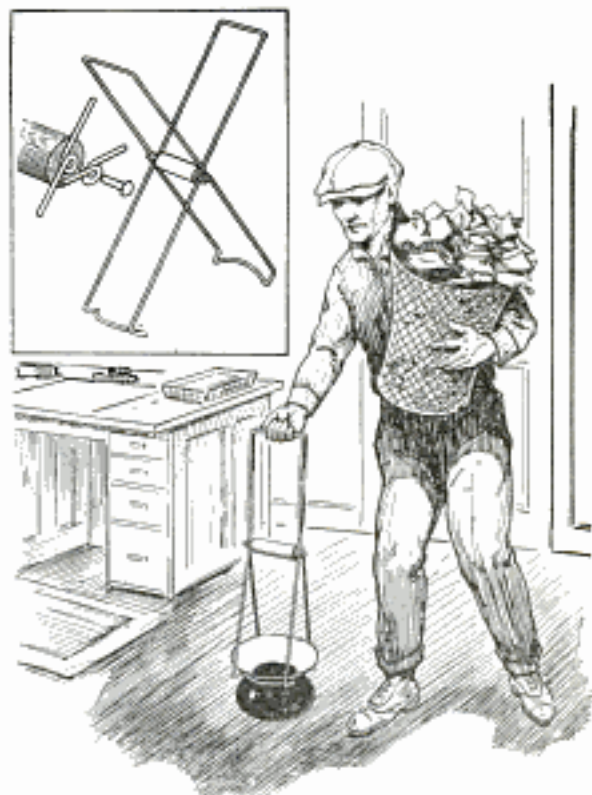

Cuspidors Can Be Conveniently Carried Around with This Wire Holder

the kind shown in the drawing. It is made of stiff galvanized-iron wire, bent to the shape indicated, and a small piece of wood, with a pin driven in at both ends, to serve as a pivot for the jaws. In use, the jaws are hooked around the neck of the cuspidor and the opposite ends brought together; this causes the jaws to grip the cuspidor tightly and it can then be carried away.—A. C. Cole, Chicago, Ill.

Removing Compression Sleeves from Tubing

The cones or sleeves used on automobile tubing become firmly fixed after being used a few times. This results from their compressing the tubing directly under them, while leaving it the original diameter on both sides. Such sleeves are applied from $\frac{3}{16}$ to $\frac{1}{2}$ in. from the open end of the tubing and can easily be removed by slitting the tubing into quarters lengthwise and pressing the ends together. If the sleeves cannot be pulled off by hand after this treatment, pliers may be used with care.—E. T. Gunderson, Jr., Humboldt, Iowa.

Improved Sheet-Iron Cutter

The writer discovered the homemade sheet-iron cutter shown in the drawing in a small country shop, where it had origi-



An Improved Sheet-Metal Cutter That Has Proved of Value in a Small Shop

inally been hastily made to cut up a lot of old roofing into sheets of suitable size to use for the same purpose on another building. Since that time it has come in handy many times, and for iron of light weight, it is rapid, reliable and convenient to use, besides being very simply made.

Two harrow disks form the cutters. These are mounted on heavy shafts running in holes bored through the ends of heavy uprights made of maple. For a permanent construction, of course, it would be necessary to use bushings in the holes. The shafts are so mounted that the edges of the disks overlap about 1 in. The upper shaft carries a heavy coil spring that bears against a collar and keeps the upper disk against the one below. On the end of the lower shaft is fitted a large wooden pulley, which is belted to an overhead shaft to drive the disks at a speed of about 10 revolutions a minute. The upper disk revolves without the aid of a belt.—D. R. Van Horn, Walton, Nebr.

☞ The addition of phosphorus and manganese to molten bronze purges the metal of metallic oxides, and produces an alloy of greater purity and strength.

Attaching Brass Valves

In screwing iron pipe into a brass-body valve, little or no pipe-joint compound need be used, as the brass is softer than iron and gives enough to form a tight joint. If white or red lead or pipe-joint compound is used, it should be placed on the pipe end rather than in the valve, so that it will not be carried by steam to the bearing parts of the valve where it may catch and hold scale and grit on the seats and disks.

Wrenches or tongs should be placed on the hexagon nearest the pipe end when screwing brass valves onto pipe; otherwise they are apt to spring the seats out of line. When screwing pipe into gate and other valves always close them tightly to make the bodies rigid.

Preserving Color of Copper Trimmings

For preserving the color of copper trimmings, such as cornices and leaders, there is probably no better application than boiled linseed oil, to which is added a small amount of Venetian red to give it color, but not enough to make it a paint. For coloring the copper to a dark brown, a solution of one ounce of sulphate of copper, one ounce of hypophosphate of soda and two drams of muriatic acid to one pint of water, or larger quantities in the same proportion, may be used on the copper surface once or twice, and the color can then be preserved by a coating of boiled linseed oil.

Repairing Glass Graduates

Although the small sizes of glass graduates which are used extensively by photographers and chemists, are not expensive, there are times when it is worth while to repair them if possible, especially if they are needed at once.

One common occurrence is a broken base, so that the glass will not stand. A good repair is as follows: Two concentric circles are scribed on an old phonograph record, the inner one equal in size to the bottom of the graduate and the outer one to its top.

The circles are cut out with a fine saw and a radial slot is cut from one circle to the other. The piece of record thus cut



is warmed up on a greased iron plate until it is sufficiently flexible to be bent with the fingers. It is then bent into place about the glass, a wedgelike section being whittled out along the slot so that when the adjacent edges are brought together a cone is formed. These edges are fused together by means of a hot stove-lid lifter or poker. After the cone has hardened, the graduate is put on the table, bottom side up, and melted sealing compound, such as is used in storage batteries, or ordinary sealing wax, is poured into the cone to make a solid base. This heats the whole mass so that it can be formed to the correct shape and the bottom pressed flat against a level surface. The compound left on the edges is trimmed off with a wet knife. It is obvious, however, that graduates repaired in this way should not be left in hot places, nor should hot liquids be poured into them.—Chas. M. Doten, Plymouth, Mass.

Taking Strain off Motor Leads

The leads to small electric motors are often subject to considerable strain where they are connected to the motor terminals, and this causes the wires to break or become loose. A simple method of eliminating this trouble is to wrap the cord with tape and then clamp it securely to the motor or to the base on which the motor is mounted. Both methods are shown in the drawing. If the motor is portable, a metal strip and a small hose clamp are attached to one of the screws holding the end plate of the frame, and the hose clamp is tightened around the cord. If the motor is attached to a wooden base, as is often the case, a small wooden clamp, consisting of two pieces, notched in the center to hold the cord, is screwed to the base.—E. T. Gunderson, Jr., Humboldt, Iowa.

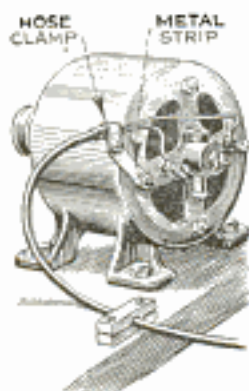

Mirrors Used in Repairing Sewers

Minor repairs in sewers or in other underground conduits, can often be made much more easily with the aid of re-

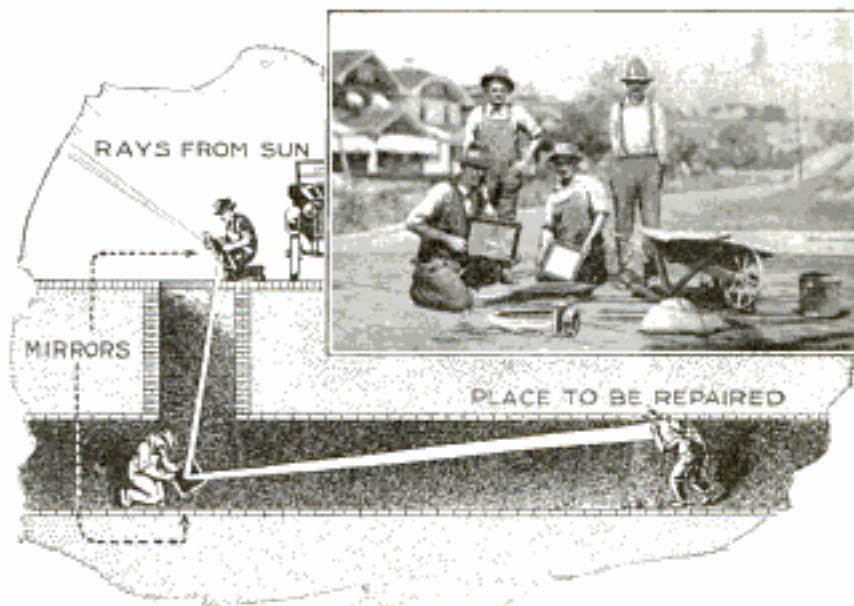

Sun's Rays Reflected Inside of Sewer with Aid of Mirrors Give Workers Plenty of Light

flected sunlight. Two mirrors are used; one at the street surface and the other in the sewer at the foot of the manhole, a beam of light being directed as shown. This method gives better illumination than flashlights.—Ivan E. Houk, Denver, Colo.

An Inexpensive Universal Joint

In light and medium-heavy machinery, a cheap, durable and efficient universal joint may be made from three straight chain links of round section. In connecting this form of a joint, the ends of the shafts must be slotted to receive the end links, and a bolt put through each to prevent the links from pulling out. A reinforcing collar is shrunk over the end of the shaft to strengthen the slotted part. Such a joint will drive at almost right angles and with very little friction.

Hardening Thin Steel

Thin strips of steel that must be hardened are difficult to handle without causing them to warp. A method used in a small shop for hardening saw blades, and which is applicable to other jobs of the same nature, is to clamp the blade between two heavy pieces of cold-rolled steel or iron and heat and quench the whole.

Authority. Karl J. Ellington, Irving Vista Ranch
Redding, Wash.

POPULAR MECHANICS

110 Cherry St. Seattle
Wash

838

Book - Modern Pisé Building or House Building with compressed or rammed earth (Pisé de Terre) Price \$2.00 Sold by

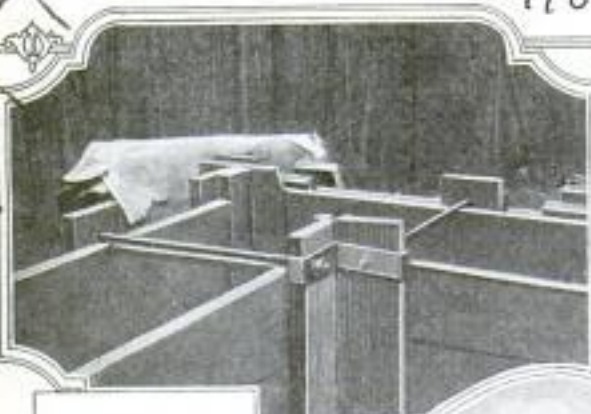

The Forms Are Stronger and More Rigidly Fastened and Braced than for Concrete Walls

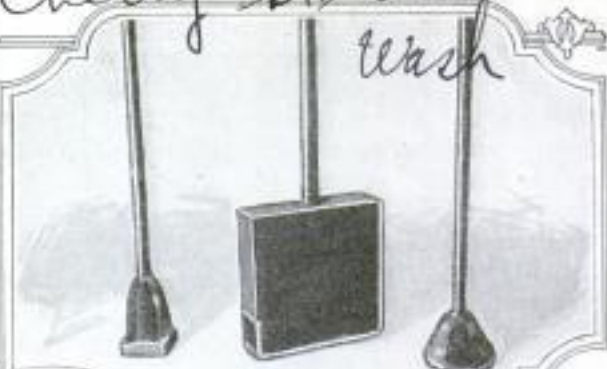

The Rams Are Made of Beech and Oak Root



General View of the Earth House, Which Is Now Covered with a Coat of Cement

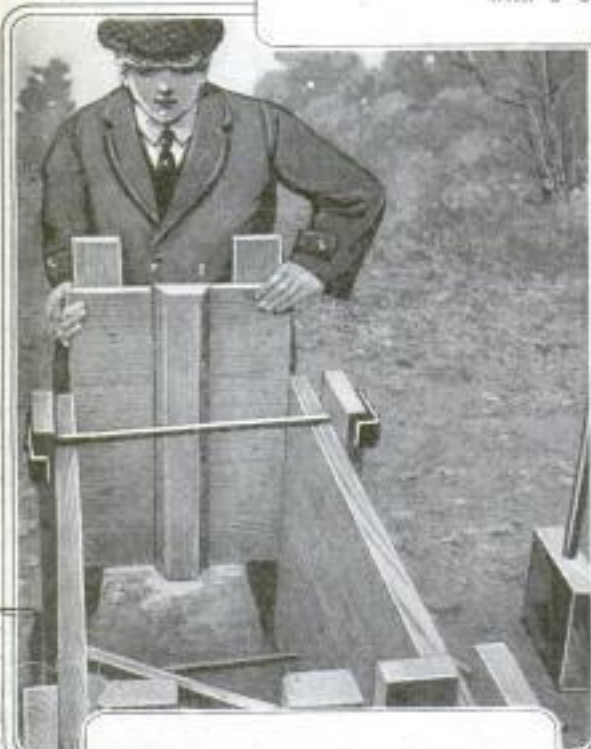

Setting the End Board into the Form; Note Solid Construction

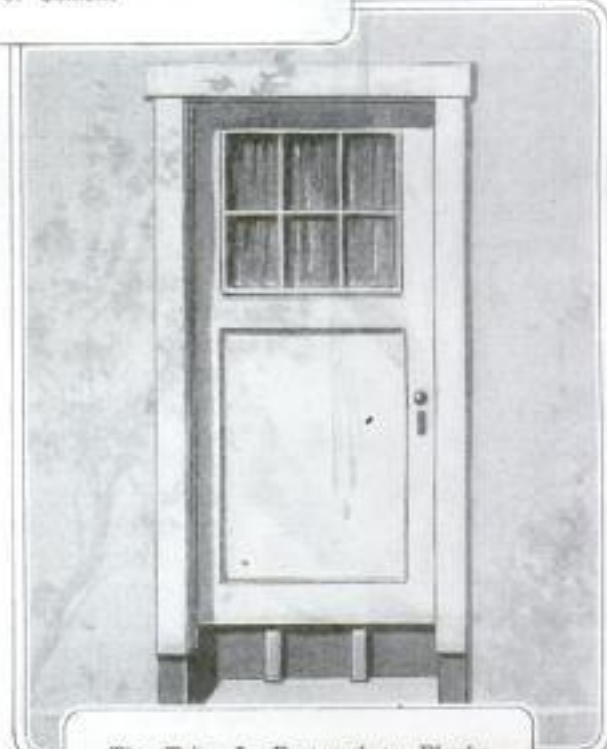

The Trim Is Fastened to Planks Held by the Rammed Earth

Previous articles - July, 1921 - 92
 February, 1924 - 169
Rammed Earth Lowers House Cost

By G. H. DACY

Mr. A. B. Humphrey, Esq. Echo, Md.

A WASHINGTON scientist has lately built a new style of house with walls of rammed earth, at a great saving over all other forms of permanent construction, thus reviving a building style of the ancient Greeks and Romans in order to curtail construction costs.

This home builder made a careful study of all the books he could find in our national libraries pertaining to "pise de terre" or rammed-earth houses. Then he communicated with builders in England, South Africa and New South Wales, where such houses are still in use. He learned all about the rudiments and advantages of such construction. Employing a trio of unskilled laborers who had never previously even heard of rammed-

earth walls, he then embarked on his building adventure. Rammed-earth houses are cool in summer, warm in winter, vermin-sound and rat-proof, fire-proof, weather-worthy and the cheapest durable structures that can now be built. The process is free to all, as it is unpatented.



The Walls of This House, Built by a Washington Scientist, Are Made of Rammed Earth at a Great Saving over Concrete, Brick or Wood

The building material is the earth excavated in digging the basement. Strong wooden forms are built similar to those used in concrete work, as the accompanying illustrations show. A mixture of loam and clay is best, with not more than one-fifth of the latter material, as too much clay makes the walls crack easily after they are dry. The top six inches of soil are discarded. The remainder of the soil is carefully screened to remove all large stones, vegetable matter and other organic material. A layer of the soil, 4 in. deep, is then shoveled into the form. The workmen, armed with 15-lb. rams, made of root wood of oak or beech and shod with metal plates, then tamp the soil firmly in place until it is reduced to one-half its original volume and rings when struck with the rammer. Then another layer of soil is added and compacted. Three men can build two cubic yards of

pise wall in eight hours, at a labor cost of \$10. As soon as one course of wall is completed, the three-foot forms are raised and work on the next course is begun. The walls of the Washington house are 18 in. thick and 12½ ft. high. The house is 32 by 48 feet in floor dimensions. When rammed earth dries, it has the strength of reinforced concrete. A technical test of the pise from the soil used showed that a column of rammed earth, 18 in. square and 42 in. high, after drying for 16 days had a crushing strength of 18½ tons. A small block, 1¾ in. in diameter and 2 in. high, supported 280 lb. before it fractured. When the walls were finished, the owner desired to bore a small hole. He tried an auger, but it had no

effect. Finally, he had to resort to a hammer and cold chisel and found that the task was as difficult as though he had attempted to cut through a stone wall. According to the home builder's experiences, pise gives an absolutely solid-walled house at about

one-fourth the cost of a similar brick structure, one-half the cost of a concrete one, and seven-tenths that of a substantial frame building. Pise becomes stronger as years pass and finally turns as hard as stone. The oldest home on the American continent, built in 1556 in St. Augustine, Fla., is made of rammed earth. Hannibal built fortifications and watch towers of rammed earth in Africa and Spain, in 124 B. C., which are still standing and durable. Lyons, France, a city internationally famous for its venerable buildings, consists in large part of rammed-earth structures. In England are many homes which have been used for four to five centuries and are still habitable and weather-resistant. Thomas Jefferson, more than a century ago, investigated the possibilities of using pise construction in the United States. He found it practical and urged his friends

manini, 28a - 4639 Montgomery Ave, Bethesda, Md.

and neighbors, and the colonists at large, to build rammed-earth walls. The forests were thick, however, and logs were abundant, so the settlers elected to build of wood instead of earth.

Pise houses are best built on concrete or masonry foundations, although the basement partition walls that carry the beams may be of rammed earth. The walls can be carried safely to a height of 50 feet. The first floor wall should be 18 in. thick, the second floor 14 in., and thus the walls can be tapered to a minimum thickness of 10 in. After drying, the exterior of the wall should be weatherproofed with a mixture of lime and tallow, cement wash or hot tar. Plaster can be applied directly to the inside walls and will adhere better

than to wooden lath. Molding, mopboards and other woodwork may be held in place by the rammed earth, as there is no danger of the wood rotting. Wood taken from wrecked pise buildings in Europe has shown no damage from wear, worms or decay after two centuries of use.

Building contractors furnished bids on the brickwork on the house made of earth, the lowest of these estimates being \$3,800. The actual cost of the rammed-earth walls of this building amounted to \$1,800. By reviving a system of construction which is as old as the most ancient Roman ruins, this Washingtonian made a remarkable saving in construction costs and has paved the way for other house builders to do likewise.

Compensating Clutch for Driving Generators

When driving a small d.c. generator directly from a one or two-cylinder 4-cycle gasoline engine the lamps alternately

This trouble can be eliminated by means of the compensating clutch shown in the illustration. It is a separate unit driven by the engine and in turn drives the generator. The compensating action is accomplished by means of a spiral spring

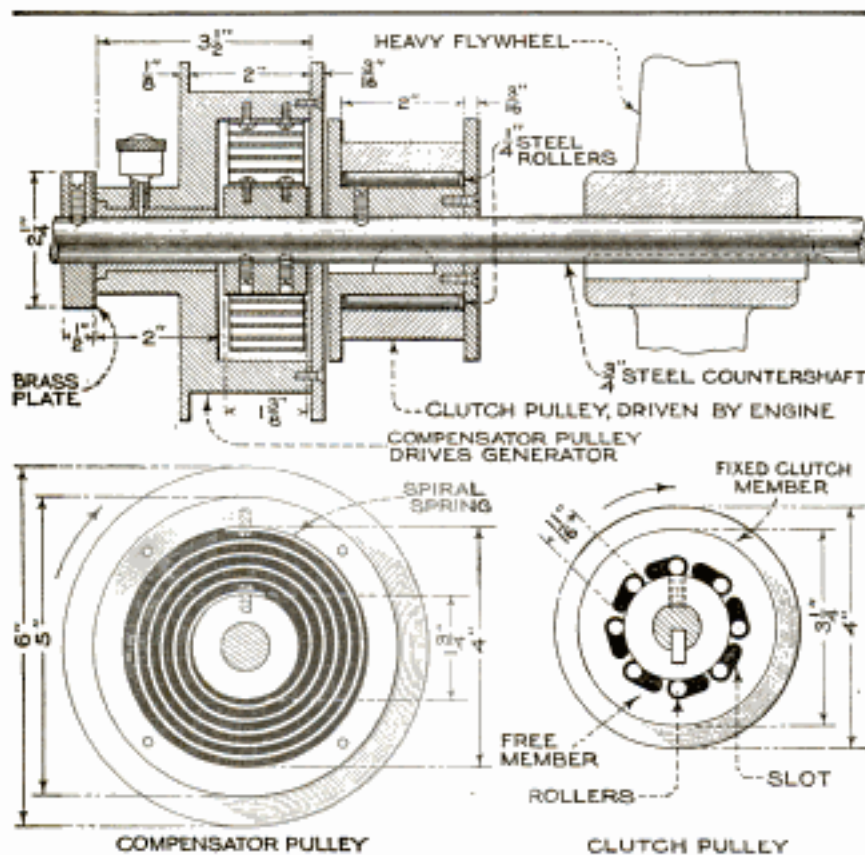

A Spring-Controlled Compensating Clutch on Countershaft with Separate Flywheel Prevents Fluctuation of Lights Connected Directly to Generator

brighten up and become dull, respectively, at the explosion and compression strokes, and unless these changes take place at a rapid rate the effect is very tiresome to the eyes.

made from two phonograph springs in tandem, riveted together at their ends and screwed to the core and shell of the compensator pulley, as shown in the lower left-hand detail. These springs are strong enough for loads up to 1 hp. When the engine speeds up on the power stroke the excess energy is stored up in the compensating spring instead of being transmitted to the generator, and when the engine speed is retarded at the compression stroke, this energy is expended; the action of the spring thus keeps the generator running at a constant rate of speed. The whole assembly, including a pulley driven by the engine, the compensating pulley which drives the generator, and a heavy flywheel, are mounted on a countershaft which is placed between the engine and the generator and is belted to both. The rollers of the clutch are made from drill-rod stock. The entire assembly should be made of steel and the clutch members should be casehardened on the friction

surfaces, the parts being held together by setscrews or by steel keys. The particular design and dimensions given are suitable for a 500-watt generator, and only a slight alteration is necessary for larger sizes. The pulleys are faced with leather to prevent slipping, this facing being fastened by means of flat-head countersunk screws. The flywheel should weigh 40 lb. for a 1-hp. engine, and 100 lb. for a 2-hp. engine, and the size of counter-shaft should be $\frac{3}{4}$ in. for a 1-hp. and 1 in. for a 2-hp. engine.—A. N. Capron, Quebec, Canada.

Ventilating the Barn

Most barns are poorly ventilated, and this is both bad policy and a discredit to the owner. In cases where provision for ventilation has not been made when the barn was built, the arrangement shown in the drawing can be installed. The space between two studdings of the outer wall is boarded up, a vent being left at both top and bottom, which can be closed by means of a hinged board whenever necessary. A hole is cut in the roof above the boarded space, the plate over the studdings being avoided by the construction shown in the detail. A sheet-metal pipe, 4 to 6 in. in diameter and provided with a hood, is attached to the roof over the hole. The vents can be closed or opened according to

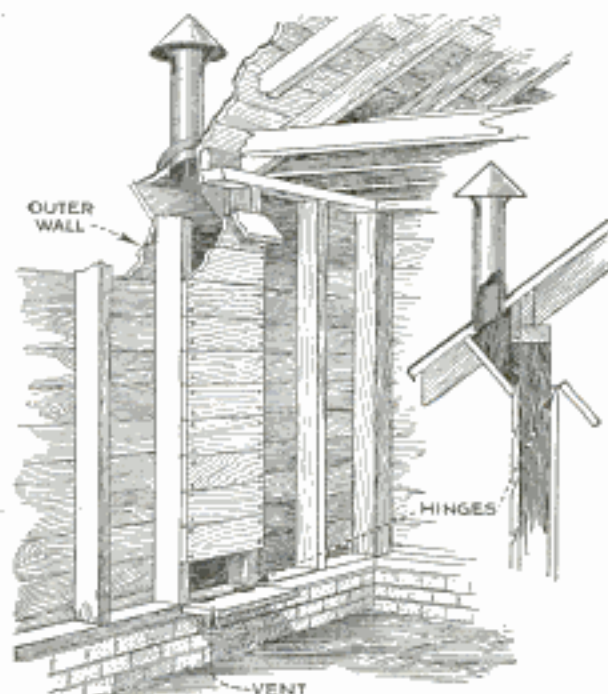

Proper Ventilation in Barns Provided by Means of a Simple Installation

weather conditions.—Robert Page Lincoln, Minneapolis, Minn.

Novel "Free-Water" Curb Hose

Neat appearance and protection against wear feature the "free-water" hose ar-

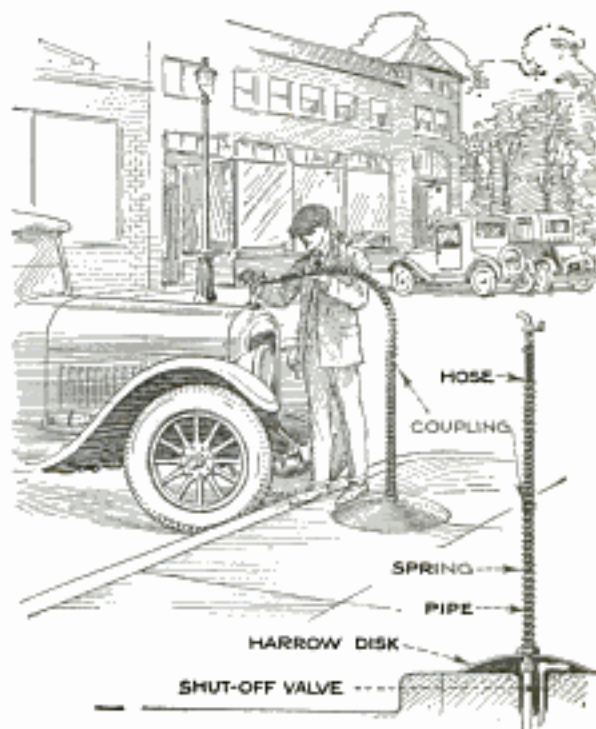

Novel and Convenient Curb Hose for Filling Automobile Radiators

angement for a garage shown in the drawing, as contrasted with the common method. It is constructed and installed as follows:

The pipe from the underground water main is brought up to 1 in. above the surface of the curb, where a coupling is attached. A discarded harrow disk is placed over this, covering the handle of the winter shut-off valve, and a 2-ft. length of pipe is inserted through the center hole of the disk and screwed into the coupling. A locknut, with the threads filed out so that it will slide easily over the pipe, is put in place against the disk, and after a suitable length of hose with a faucet on the end is attached, a stout coil spring is slipped over both hose and pipe as shown. With this arrangement the hose is held upright or nearly so, and out of the way when not in use, while at the same time it is easily bent so that the faucet end will reach the filling cap of the radiator. During cold weather the harrow disk can be raised to close the shut-off valve.

☞ For general purposes in the home workshop it will be found that ordinary water glass (silicate of soda) is an excellent glue. It has also many uses as an adhesive and therefore should be kept on hand.

Baby Crib Serves as Machine Guard

When an inspector visited an eastern hospital, he objected to the open installation of the brine pump, with its motor and

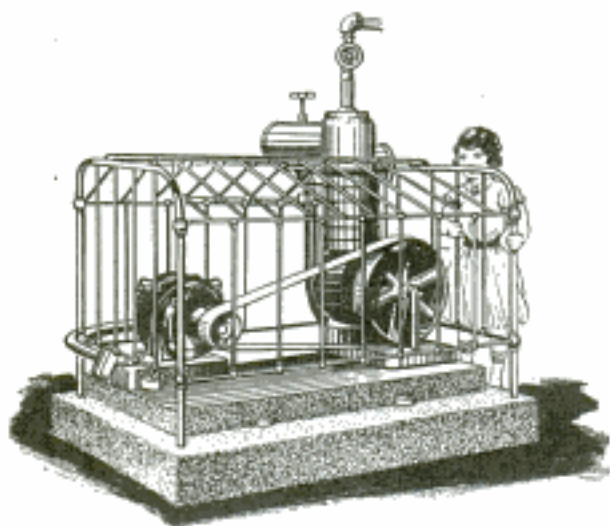

Old Baby Crib Used as Guard around Refrigerating Machinery in Hospital

belt, in the refrigerating plant, and called attention to the law requiring a suitable covering for such machinery as a safeguard against accident. As the hospital is a charitable institution and depends on state aid, its expenditures must be economized, and for this reason it was desirable to avoid the cost of guard rails, etc. A simple solution to the problem was found by setting up a discarded baby crib around the apparatus, as shown. The same method of protection can be employed on farms, where the engine and generator of the electric-lighting plant are usually found in an unguarded condition in the basement.—Edmund A. Knoll, Erie, Pa.

Cutting Gauge Glasses on Lathe

Gauge glasses for showing the height of liquid in tanks and boilers are usually cut to length by hand, with one of the simple glass cutters that are to be had on the market. But, when glasses are to be cut in

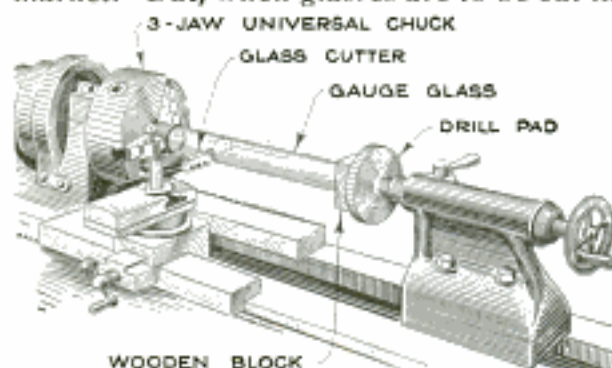

Lathe Set Up for Cutting Quantities of Gauge Glasses into Any Desired Length

quantities it is better to rig up a lathe for doing the work, as shown in the drawing. A drill pad is placed in the lathe tailstock spindle and the long piece of glass tubing is chucked lightly but firmly in the three-jaw universal chuck. Actual experience has proved that leather strips under the chuck jaws will prevent breakage better than felt, which is generally used. A heavy glass cutter is then placed in the toolpost and set in the right position when the carriage is clamped to the shears. A piece of wood is then put against the drill pad and the glass pushed against the wood firmly. Only one revolution of the spindle is necessary and this can be made by hand. After the glass has been nicked in this manner, a sharp, light tap on the end of the tube with the wooden block is all that is necessary to make it break off cleanly at the cut. If, for any reason, the glasses are cut too long they can be shortened by grinding them on a sandstone wheel, using plenty of water.

Extension for Machine Handle

It is often necessary to use an extension piece on the end of the feed screw on a hand milling machine so that the handle

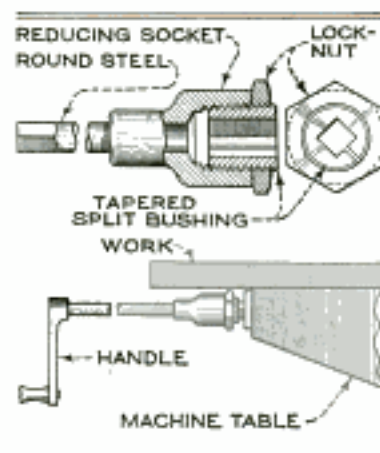

will clear a piece of work of unusual shape. An extension piece used for this purpose is shown in the illustration. It can be tightened up on the square of the feed screw, which eliminates the annoyance of the device working off the square while in use, as is apt to occur with the usual extension. The piece consists of a reducing socket, a locknut, a taper-threaded bushing, and a length of round steel rod. The bushing is drilled and squared out to fit the feed screw of the machine, then sawed in two with a hacksaw. The rod is screwed tightly into the small end of the socket and the other end squared to fit the handle. When tightening the extension piece in place it is slipped on the square and the table locked. The handle is then turned, which tightens the socket on the split bushing, the latter gripping the square. The nut is then screwed back against the face of the socket.—Harry Moore, Montreal, Can.

Corking Painted Ironwork

Sweating or condensation of vapor on the surface of ironwork may be prevented on ships and other structures which are in or near the water, by applying a layer of powdered cork over the paint. Several coats of red lead are first applied, and while the last coat is still wet, as much finely ground cork as the paint will absorb is dusted on. When this is dry a final coat of paint mixed with turpentine is applied. This method may also be used for protecting iron or steel roofs from moisture on the underside.

Spring Bracket for Truck Tail Light

Drivers of trucks equipped with solid-rubber tires and oil-burning tail lights, frequently find the light out after driving for a short distance. This

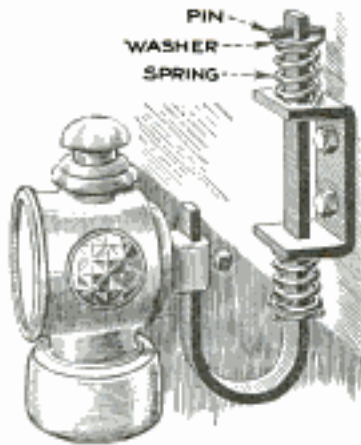

trouble is caused by the thumping of the solid tires and can be prevented by mounting the light on a shock-absorbing spring bracket as shown in the drawing. The bracket is

made of flat iron; one piece has both ends bent over at right angles and is bolted or screwed to the truck. The other part is bent to a U-shape with one leg longer than the other so that it can be passed through the first piece, slots being cut for this purpose. Small holes for pins are drilled in the U-shaped piece to hold short coil springs as indicated. The bracket is then assembled and the lamp is securely bolted on.

Cement for Metals

A very good cement for uniting metal parts consists of $2\frac{1}{2}$ parts zinc oxide, 1 part zinc chloride and 5 parts pulverized limestone and slag. The whole is mixed to a thick paste with water. If a slow-setting cement is desired, use 1 part of zinc sulphate instead of the zinc chloride. The adhesive power of this cement may be increased by adding 2 per cent of ferrous sulphate to the whole.—Frank N. Coakley, Buffalo, N. Y.

Non-Freezing Water Dish for the Poultry

A non-freezing water dish for the poultry is a necessity in late fall and winter, and it is a very simple matter to make one.

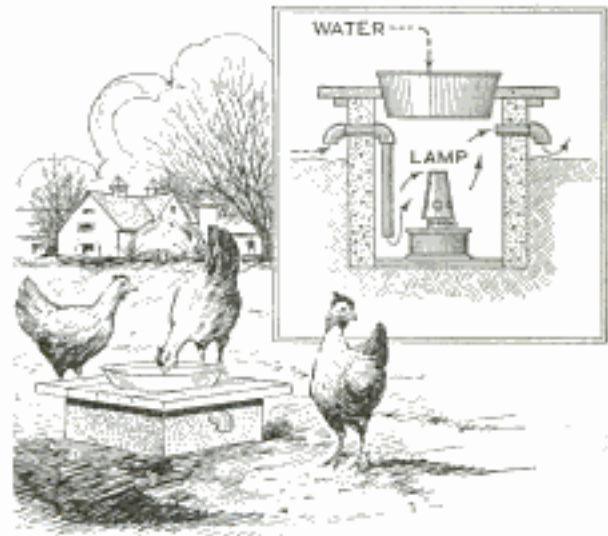

A Simple and Effective Non-Freezing Water Dish for the Poultry House

As shown in the drawing, a pit is dug, in the ground or poultry-house floor, to a depth sufficient to accommodate the lamp it is intended to use, and lined with concrete, the concrete extending upward to a height of about 10 in. above the ground. Through one wall, a pipe fitted with two elbows and a long nipple is placed, while the opposite wall carries a short pipe that merely extends outside, although it may be fitted with an elbow with the outlet turned down. The outside elbows prevent dirt from being scratched into the pit. Over the opening is placed a tight-fitting wooden cover, in which a hole is cut to fit the drinking pan snugly. The heating element is an old incubator lamp. A very small flame will keep the water warm even in zero weather. Fresh air follows the long pipe to the bottom of the pit and the hot air and gases pass out of the short pipe. There is room enough on the platform for a number of fowls, but, because of the height of the pan above the floor, no litter can be tossed into the water.

Remedy for Overheating Bearings

Persistent overheating of bearings that are in constant duty may be overcome by applying a paste of flour of sulphur mixed with lubricating oil. This permits the use of an oil cup. The mixture will also be found useful on heavy-duty bearings in cam rolls and similar machine parts.

A Ball-Bearing Disk Grinder

By J. V. ROMIG

ONE of the most useful machine tools for the small workshop is a good substantial disk grinder. On it the workman can do many jobs in a minimum of time and with little labor, and also have the benefit of an accurate and finished appearance on the work.

The disk grinder, as almost everyone knows, is a cast-iron disk or plate, mounted on an arbor or spindle, which has its working face covered with an abrasive sheet, using garnet or sandpaper for wood finishing and emery or carborundum

ment. While solid bearings will operate for a time at least, the ball bearing is the ideal type to use.

In order to secure the benefit of a good ball-bearing installation in this case, without going to great expense, use is made of the front-wheel hub assembly of a Ford car. This can be purchased complete with balls and races for a few dollars, and the ball races, being of the cup-and-cone type, carry thrust loads as well as radial ones. In place of the regulation front-wheel spindle, a new shaft is turned out

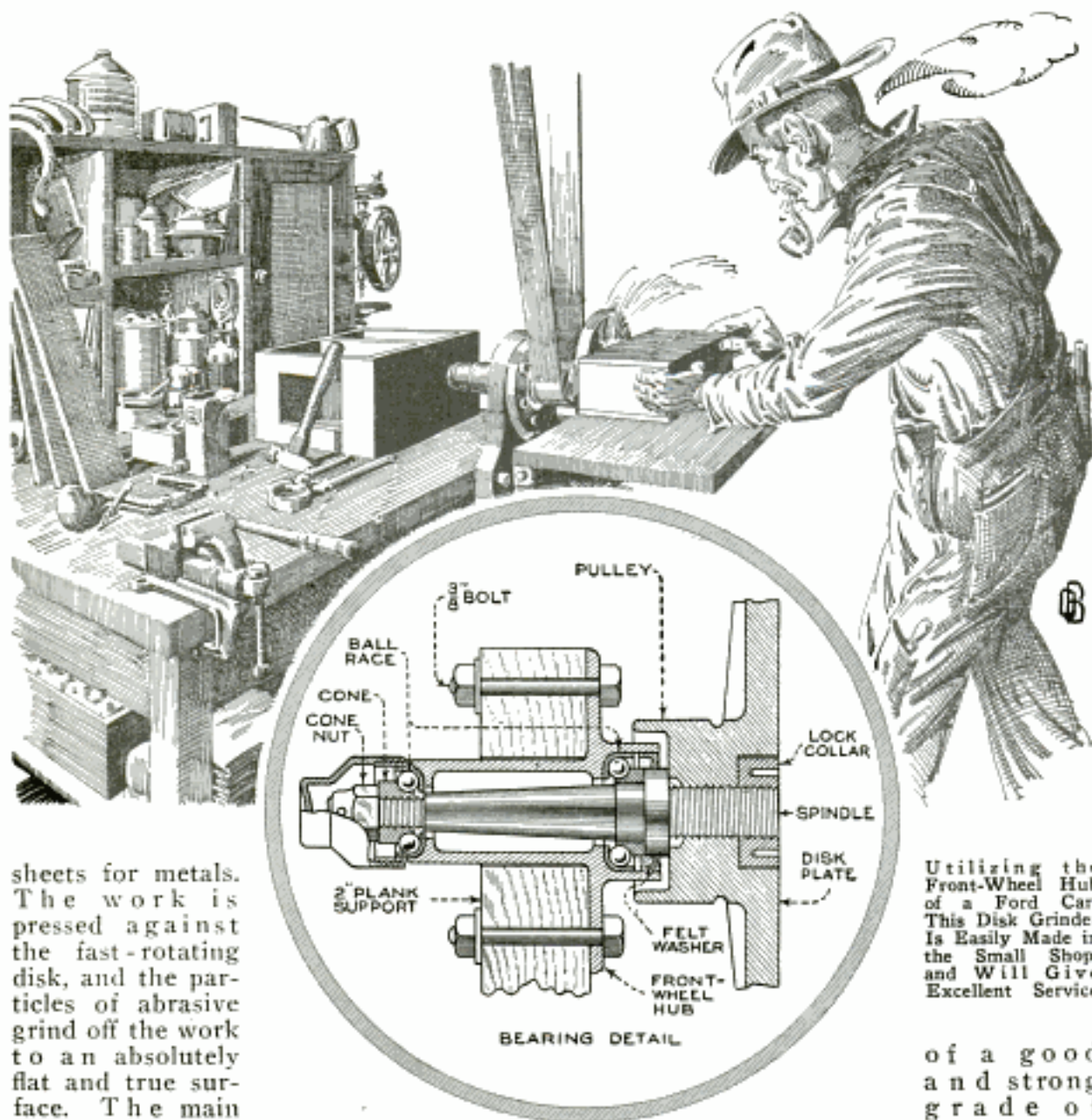

sheets for metals. The work is pressed against the fast-rotating disk, and the particles of abrasive grind off the work to an absolutely flat and true surface. The main objection to most homemade disk grinders lies in their makeshift construction. For perfect work, a disk grinder must have good bearings, without any play or end move-

of a good and strong grade of steel, to the shape shown in the accompanying drawing, and hardened and ground. The bearing end is similar to the wheel spindle in all its threads, lengths and diameters, but

Utilizing the Front-Wheel Hub of a Ford Car, This Disk Grinder Is Easily Made in the Small Shop, and Will Give Excellent Service

is extended at the front end so as to carry the disk plate, as shown. This end is threaded up to the shoulder for the large front-cone collar, and the disk plate is bored and threaded to fit. The disk is made of good gray iron, and is accurately threaded and turned, so that when screwed home on the spindle and rotated, it will run perfectly true and in balance. If out of balance, the plate will vibrate at high speed, and the builder is advised to find the heavy side, and chip the back of the plate until the plate balances in any position. The pulley is cast integral with the plate, as shown. In order to hold the plate tight on its threads, a recess is turned in it to take a collar. This collar locks the plate tightly, and should come just flush when screwed up tight with a pin spanner.

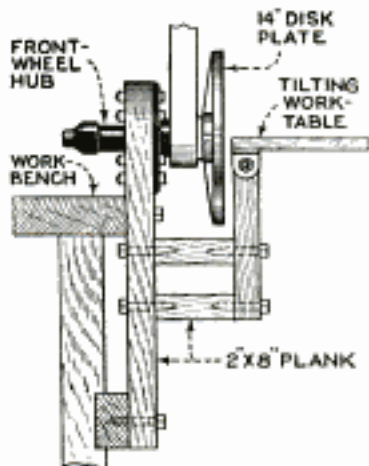

The mounting is simple in the extreme. A plank is screwed to the edge of the workbench, and a hole is bored through with an expansion bit large enough to al-

low the hub extension to pass through. Six $\frac{3}{8}$ -in. bolts hold the flange of the wheel hub firmly against this support. A worktable is made out of wood, as shown in the small drawing, and mounted on pivot brackets to allow it to be tilted at an angle for tapered or bevel work.

Even a ball bearing will wear in time, and this installation is the handiest possible for the purpose of adjustment. The hub cap is removed and the front cone is drawn up tight, so that the disk and spindle can be rotated freely without binding, after which the locknut is screwed home and the adjustment made permanent. The hub cap is also an automatic oiler in a way, as when it is filled with grease or vaseline and screwed into place, it drives the grease through the whole bearing and keeps the races perfectly lubricated. (Still better lubrication is assured by fitting an alemite coupling in a hole drilled and tapped into the hub shell behind the plank support, and using the gun to fill the shell, and to keep it filled.)

Disk grinders of this size should run at 2,000 r.p.m., which will give uniform results on both metals and wood. Abrasive sheets are listed in all catalogs of machinery-supply houses, and if the builder so desires, he can get quotations direct from any big abrasive house, who then will refer him to a local dealer. The sheets are easily applied, and give efficient service if used according to directions of the maker and distributor.

Measuring Irregular Objects

Accurate measurements of irregular objects can be made quickly and easily with the aid of photography. The illustration shows the method of doing this, and the inserts show some of the work.

The sensitized paper is put in a printing frame and this is laid face up on a table. The object is then placed on the paper and a cardboard tube of suitable diameter to fit within the frame is set up as indicated. The printing is done by holding an electric lamp at the other end of the tube for about 30 seconds. Care must be taken to hold the lamp over the center of the tube so that the rays striking the paper will be nearly vertical. The inside of the tube should be painted dull black to prevent reflection. After exposure, the paper is developed in the usual way and an accurate outline of the object will show up on the prints. By this method gear-wheel teeth, keys, etc., can be measured much more quickly than by using a scale

and calipers. When very accurate measurements are required, as is the case with small clock gears, etc., film should be used instead of paper and the resulting negative should then be enlarged.

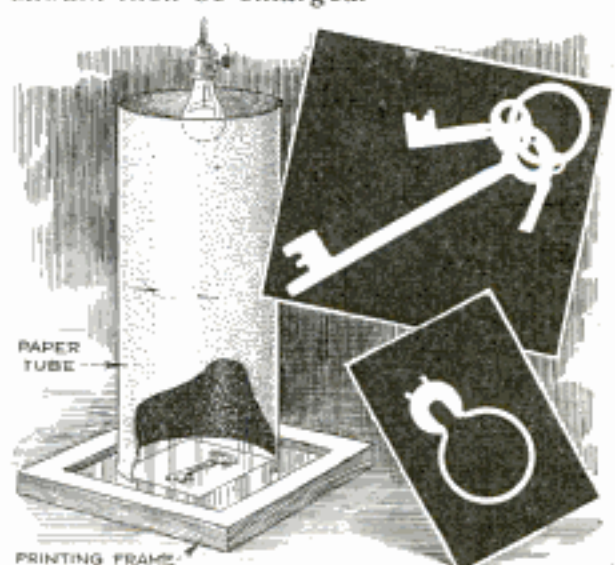

Printing Outline of Irregular Objects on Sensitized Paper to Aid in Measuring Them

Rack for Blueprints

In shops and drafting rooms, blueprints can be handled conveniently by binding them together and keeping them on a rack of the kind shown in the drawing. Each

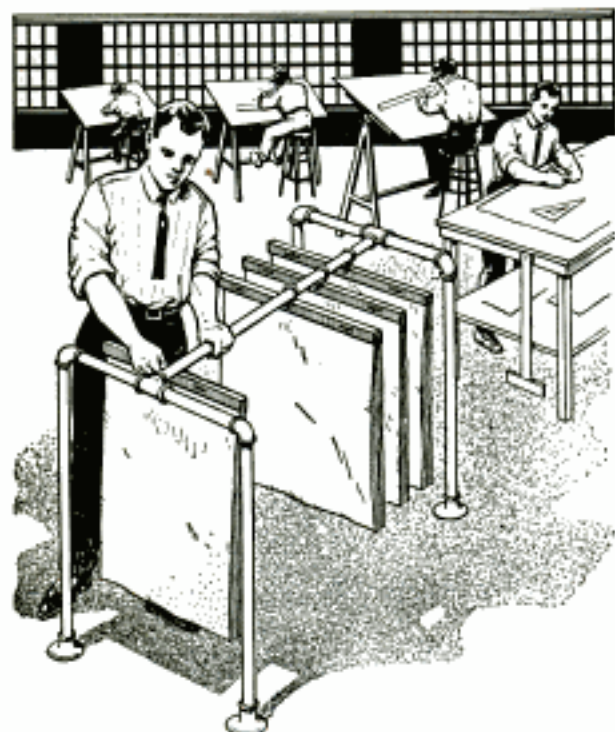

Convenient Rack Made of Pipe and Fittings Keeps Blueprints in Orderly Arrangement

set of blueprints is bound together at one side by means of two slats, through which three stove bolts are inserted. A galvanized-iron hook is provided in the center to enable the holder to be hung up on the rack. The rack is made of lengths of 1-in. pipe and fittings; the legs are provided with floor flanges, which are screwed to the floor. The construction is clearly shown in the drawing.—G. A. Luers, Washington, D. C.

Reducing Open-Fireplace Hazards

No single fire hazard affects the home and family more closely than defective chimneys, flues and fireplaces. People do not intentionally live in dwellings harboring a constant hazard of this kind, yet hundreds of thousands of these are in existence now, and new ones are being built every day. They are common in all types of construction. No so-called "fire-proof" or "permanent" exterior walls will prevent interior fires where it is impossible to dispense with inflammable objects. Defective chimneys and fireplaces hold second place in the list of known causes of fire in order of importance.

To insure satisfactory results from an

open fireplace, it is essential that the flue have the proper area; that the throat be correctly proportioned and located; that a properly constructed smoke shelf and chamber be provided; that the chimney be carried high enough to avoid interference, and that the shape of the fireplace be such as to direct a maximum amount of radiated heat into the room.

A fireplace properly constructed will carry all the smoke up the chimney and radiate the maximum amount of heat into the room. Woodwork for mantels, shelves or lumber framing should be carefully placed to avoid fire hazards. Several details which will minimize danger may be inexpensively included in the design for any house. To secure best results the following proportions are recommended: For fireplaces up to 48 in. wide, a height of 32 in. and a depth of 22 in. are ample. The sides should be splayed in about 3 in. on each side. Starting about 8 in. from the hearth, the back should slope forward under the rear flange of the damper. The higher the opening, the greater the chance of a smoky fireplace.

Tightening Guy Wires in Fan

Guy wires on a suspended overhead fan were tightened in a novel way as shown in the illustration. Two screws were used for

each wire, one a flat-head screw and the other a screwhook. The former is driven into the wall nearly home, and the latter driven in to the right of it at a distance slightly greater than

the length of the hook. The wire to the fan is twisted around the flat-head screw, leaving a short end, then passed over and around the screwhook, as shown. It is not necessary to pull the wire tight when doing this as it is evident that, when the screwhook is turned to the right it will coil the wire once at each revolution and so tighten it to any desired degree. For the final tightening, the handle of the screwhook is brought in alignment with the wire running to the flat-head screw, and the loose end of the wire is twisted around the screwhook to lock it.

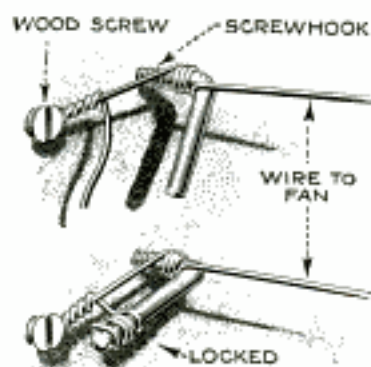



34 2-00

Makes Portable Radio from Camera

MR. W. O. Runcie of Philadelphia was once a camera enthusiast, so what more natural, when he fell for the spell of radio, than that he should build a set that would remind him of his former inseparable companion—his camera? He took a common pocket camera, removed the "works," and proceeded to build his radio set in it; the resulting receiver really is an excellent job, easy to carry and exceptionally neat and compact. The set itself is a two-tube reflex hookup, with a stage of radio-frequency amplification, a crystal detector, and two stages of audio-frequency amplification. The two tubes, which are of the UV-199 type, occupy the space formerly taken by the film spools; the knob of the control rheostat takes the place of the film-winding key, and the controls for the two book-type condensers are fitted to the removable back of the case. In a plate in one edge of the camera case

set are mounted a number of cord-tip jacks for the headphone and battery connections, the batteries being contained in a separate box not much larger than the camera. As may be judged from the photos, it took some planning to get the various instru-

ments neatly arranged, but it must be confessed that the job was done in a very workmanlike manner. In building a radio set of this kind, it is necessary to use a camera case of not less than post-card size, in order to accommodate the transformers, etc.; an old stereo-camera case would be still better. The condensers should be of the book type, as compact as possible, and the transformers should be selected with regard to size and shape, so as to be as economical of space as possible. It will also be noted that the rheostat knob is smaller than usual. Then,

by careful execution, there is no reason why the amateur should not be able to build as neat a set as that shown.

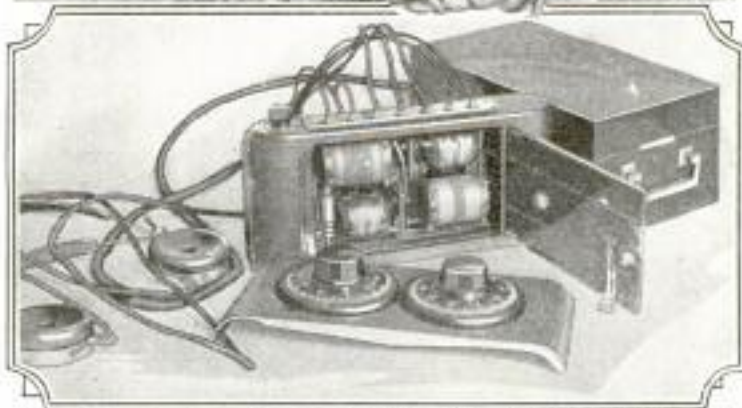

Above, Mr. Runcie with His Portable Reflex Set; Below, View of the Interior and the Removable Back with the Control Condensers

20.47-32
**Giant Radio Set Needs
 No Aerial or Ground**

A "whale" of a set is that owned by Mr. F. R. Greene of New York City. One of



A Giant Set. Using a Combination of Either Eight, Nine, Eleven or Fourteen Tubes

the most complete and effective receiving stations ever built, it is a super-heterodyne unit employing either eight, nine, eleven or fourteen tubes. At least eight tubes, super-heterodyned, are used, in combination with either one, two, three or six stages of amplification. The B-battery supplies current at 275 volts, and two A-batteries are used, one of 6 volts at 150 amperes, the other 6 volts at 100 amperes. The set requires no ground or aerial.

Self-Supporting Inductance Coils

Ordinary single-layer inductance coils, which are self-supporting, are easily constructed if the following method is used: First obtain a cardboard tube, or other suitable form, which is slightly smaller than the desired diameter of the coil. Then wind ordinary cord around and through the tube, lengthwise, spacing it rather closely as shown in the illustration. After doing this wind on the desired amount of wire, spacing it closely and tightly, over the cord.

When winding the coils insert pins of wood in the tube at both ends, and wind the wire around these. These form holes for mounting. Next give it a coat of good insulating cement, which has a low capacity effect (there are several good kinds on the market). When nearly dry cut the string



at the ends of the tube and carefully pull out the pieces, taking them out from all points of the circumference, until only four pieces are left, equally spaced on the surface of the tube. Withdraw the pins and the remaining pieces of cord and the coil may be slid off the tube. If this has been done very carefully the coil will be perfectly self-supporting. Next give the entire coil, both inside and out, several coats of the cement previously used. Stand on end till thoroughly dried out.

This completes the coil, and the holes at the ends serve to mount it in any manner desired by means of suitable screws and short lengths of brass rod. If made to the proper dimensions, it can be used for the primary of a variocoupler and also for inductance variometers, and will be found altogether reliable if constructed properly.—T. W. Heine, Baltimore, Md.

Soldering Wire to Contact Screws

Most radio fans who "make their own" desire neat as well as properly soldered connections. The usual method of soldering wire to contact screws is to lay the wire on the threaded portion and then solder it. If considerable care is exercised in doing this, the job looks quite presentable, but it is usually rather difficult to get the wires just right, especially where there are a number of contact screws close together. Besides this, there is always the danger of damaging the panel with the hot soldering copper. The method shown in the illustration makes a neat job, and the extra work is offset by the freedom with which the wires and screws can be handled. A hole, large enough to receive the wire and about $\frac{1}{8}$ in. deep, is drilled in the end of the screw. A little flux and a bit of solder are dropped into the hole and the screw heated with a blowtorch until the solder runs. Then the wire is inserted in the hole and after cooling, any surplus solder is wiped off. The resulting connection will be as neat as can be desired. The screws are inserted through the panel holes and the nuts screwed on to hold them. When drilling

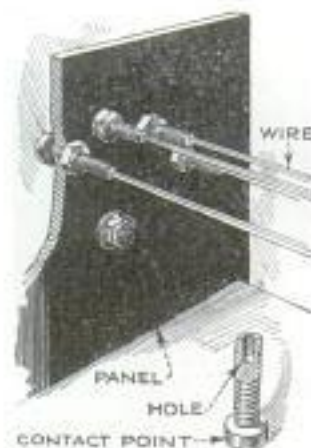

the screws, they may be held in a vise, a piece of wood being used on each side to protect the threads. It is a good plan to have the nut screwed up to the head of the screw before soldering the wire, because some of the solder may get into the threads at the end, and this will make it difficult to screw the nut on, whereas the nut can always be unscrewed though a little more force is required. This method of soldering results in a much stronger connection than by using the old method.—Walter Chas. Michel, Jersey City, N. J. *1023 Summit Ave.*

Aerial Kinks

It is often quite a problem how to attach a pulley to the top of the aerial mast properly, especially if it is made of pipe. An excellent method of doing this is shown in the illustration. The end of the pipe is threaded and a floor flange with a hole drilled through it is screwed on; it is then an easy matter to attach the pulley to the pipe.

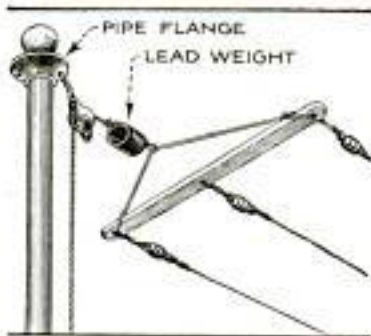

Another trouble frequently experienced is that the bridle breaks where it is tied to the rope or the rope itself breaks near this point, and both aerial and rope then come down, making it necessary to "shin" the pole to thread the rope through the pulley again. To prevent this trouble a small piece of pipe or other metal weight should be tied to the end of the rope, as shown, so that the rope cannot slip through the pulley but can be lowered and then tied to the bridle again.—M. E. Duggan, Kenosha, Wis.

Size of Shields

When shielding is resorted to in order to eliminate interference from body capacity, etc., it is much better to use a small shield for each instrument than a large one covering the whole panel, as a loss of efficiency, due to intercapacity between the instruments, is likely to result in the latter case.—A. C. Cole, Chicago, Ill.

Box 4-97
 [As early as 1909, Dr. Lee de Forest, broadcast Caruso's voice in "Cavalleria Rusticana."]

Girl Fan Builds Smallest Loop Aerial *236-02*

The miniature loop aerial shown in the photo was built by Miss Helen M. Ober-



This Miniature Loop Aerial Works Efficiently on a Three-Tube Set

millier, of New York, whose father is a noted radio engineer. It is called a variometer loop, as the inner winding of the antenna revolves. Although small in size, it contains an astonishing amount of wire, and Miss Obermiller uses it on her three-stage radio-frequency set with great success, bringing in Chicago and other distant stations loud and clear while using the loop alone.

Clips for Connecting Phones

When it is desired to connect more than one pair of headphones to a receiving set, the phone terminals are generally connected by means of short pieces of wire from the junk box, if no regular fixture for this purpose is at hand. However, if one keeps on hand a few of the inexpensive clips shown in the illustration, which are now on the market, the phone terminals can be connected without the annoyance of having them come loose, as is commonly the case when they are tied together with wire. The clips are also useful for connections inside the set.



216-R Chicago
H. L. Mather Co. 405 S. Ashland.

H. L. Mather Co. 1438 W. Jackson Chicago

303-R
850

J. Kogans, 124 E. 27th St.
New York City
POPULAR MECHANICS

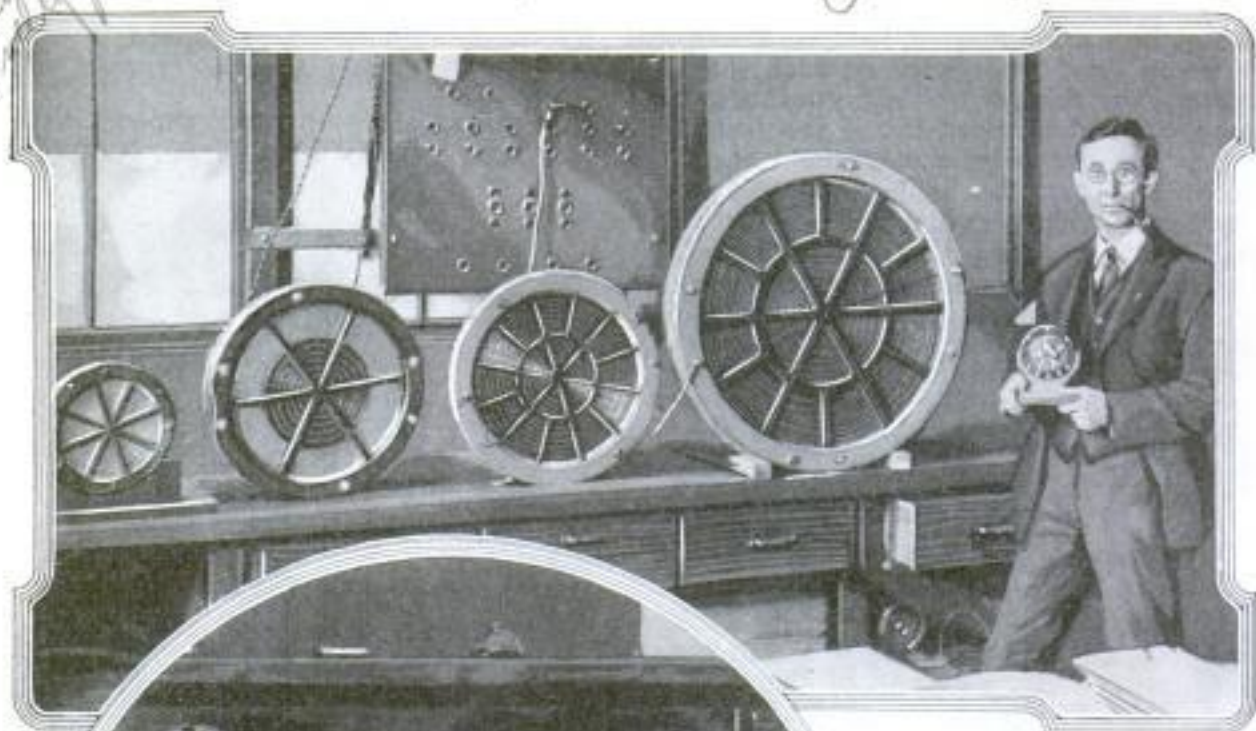

255-R



Loud Speaker
That Employs
Induction and
Needs No
Horn; It Is the
Invention of
Dr. C. W. Hew-
lett. Left, John
Coolidge, with
His Set, and
the Lamp and
Bible Used
When the Presi-
dent Was
Sworn In
© Keystone

285-R

All the Old Sea-
men at Sailors'
"Snug Harbor"
on Staten Island
Are Ardent
Radio Fans; So
Much So That
the Harbor Set
Is Inclosed in
a Steel Cage to
Prevent the Old
Salts from
Tinkering
with It

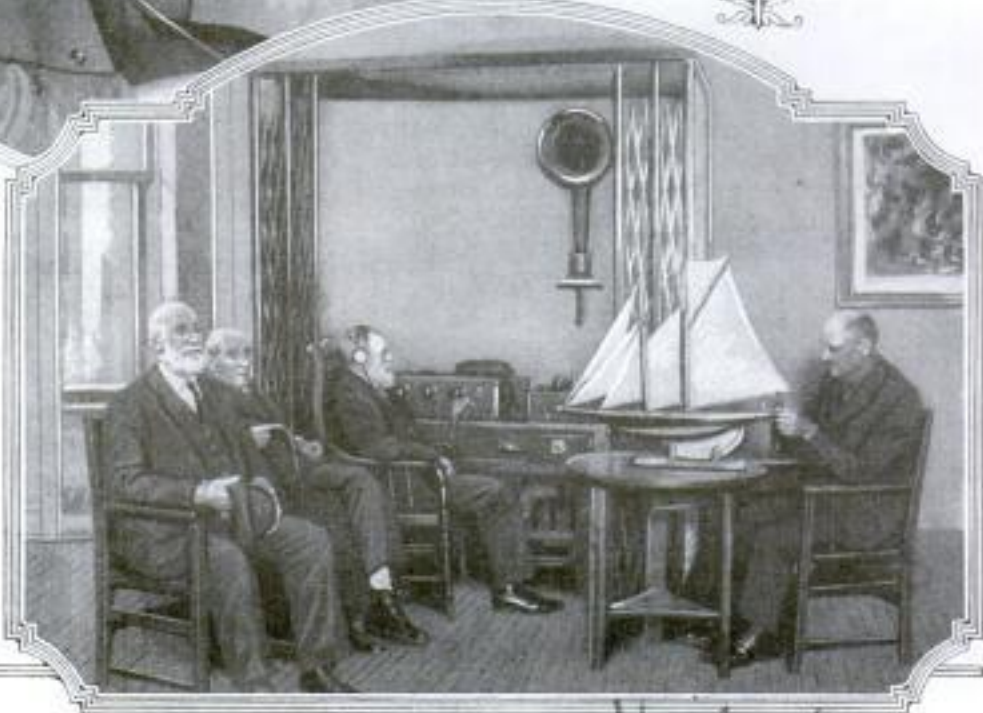

Kadel + Herbert

* Novelty
 Photos



Great Loud Speaker
 That Announced
 the Results of the
 Olympic Games

319-B United
 Newspictures
 309 Printing Craft
 Bldg.,
 461-8th Ave
 New York



An Enterprising
 Cincinnati Shoe-
 Repairing Shop
 Provides Radio En-
 tertainment for its
 Customers While
 Waiting for Their
 Shoes to Be Done



301-A
 63 Dartmouth St. (9)

Frank Ferris of Boston,
 Wearing His Headphones,
 inside Which He Has Built
 a Crystal Detector. Two
 Crystals Are Used; This
 Will Reflex Any One-
 Tube Set

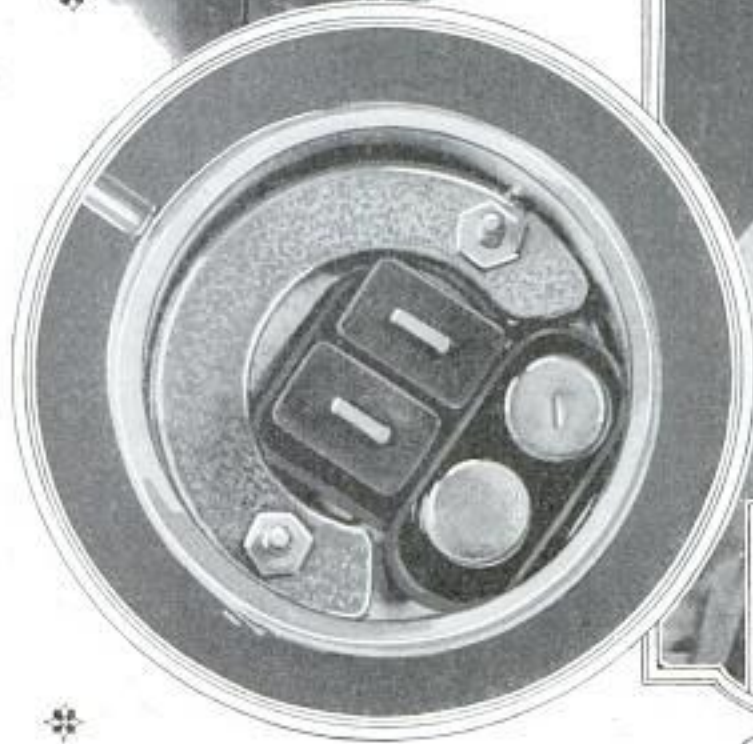

Wide World Photos
 229 W 43rd
 New York

852

316-R. *Radio Photo*

Photo Copies
229 W. 52nd
New York

324-R



Above, a Class in a Swimming Pool Taking Advantage of the Swimming and Diving Lessons Broadcast from W.E.A.F. by Prof. Dalton; Below, Joseph Camarato, a New York Bootblack, Found Competition So Keen That He Built a Radio Set in His Box to Entertain His Customers

Kadel + Oberberk 15 38.42 nd - N.Y.

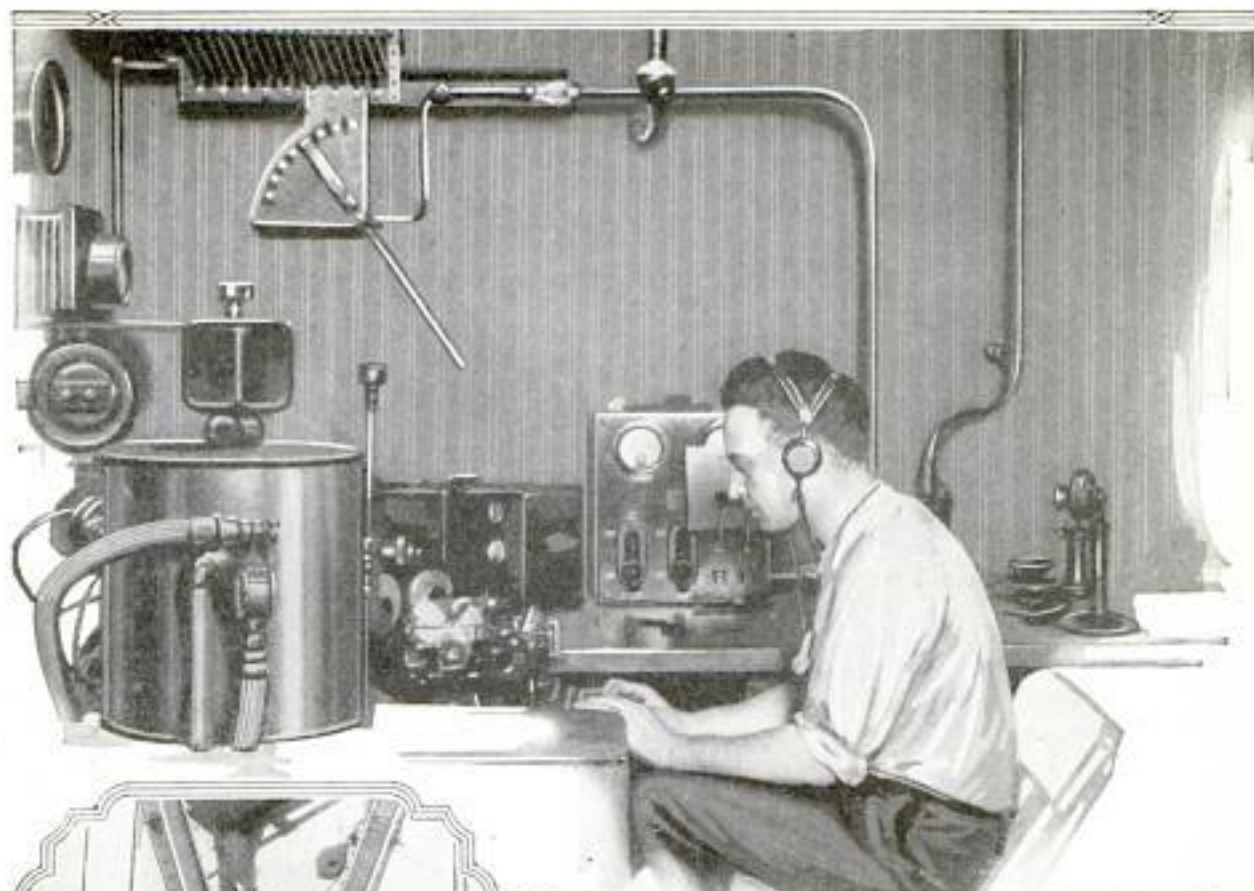

Chief Operator Dudley, of the Air-Mail Station
KDQA, Which Will Aid in the Coast-to-Coast Air
Service of the Post Office Department

© U. & F.

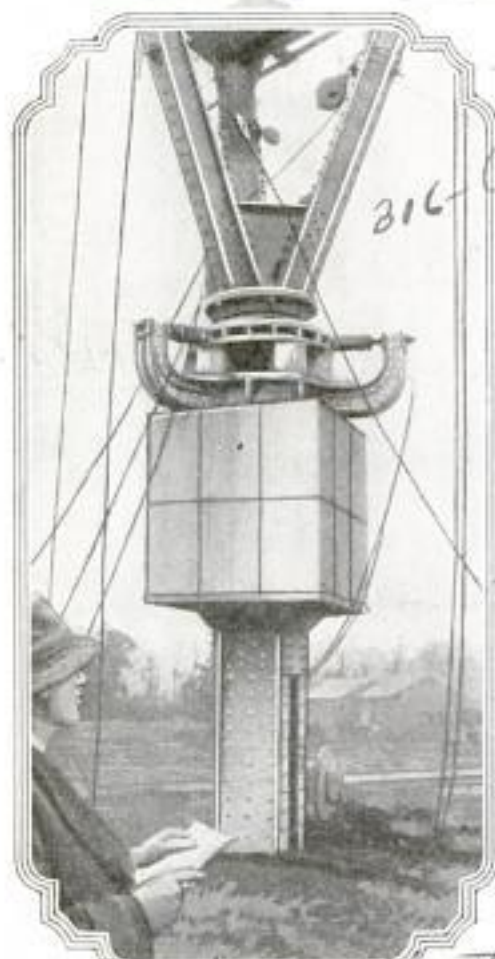

Pacific & Atlantic

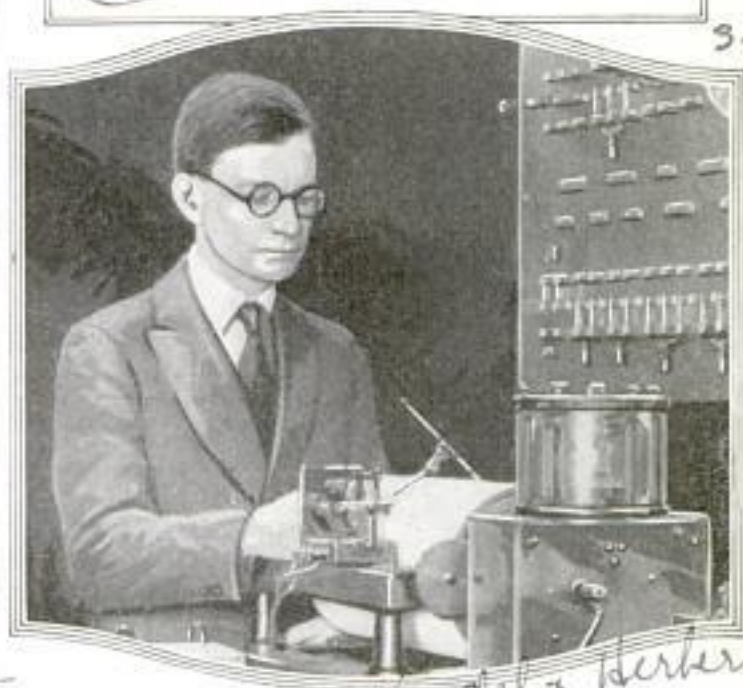

Cadet & Herbert

© U. & F.

Left, the Enormous Base and Pivot of One of the Aerial Masts at Rugby, England, for the New York-London Radio-Telephone Service; Right, Paul Sollenberger, the Man Who Tells the United States When It Is Noon, at the Instruments in the U. S. Naval Observatory, Washington

Andy
muel
315-R

Kadel's Herbert

POPULAR MECHANICS

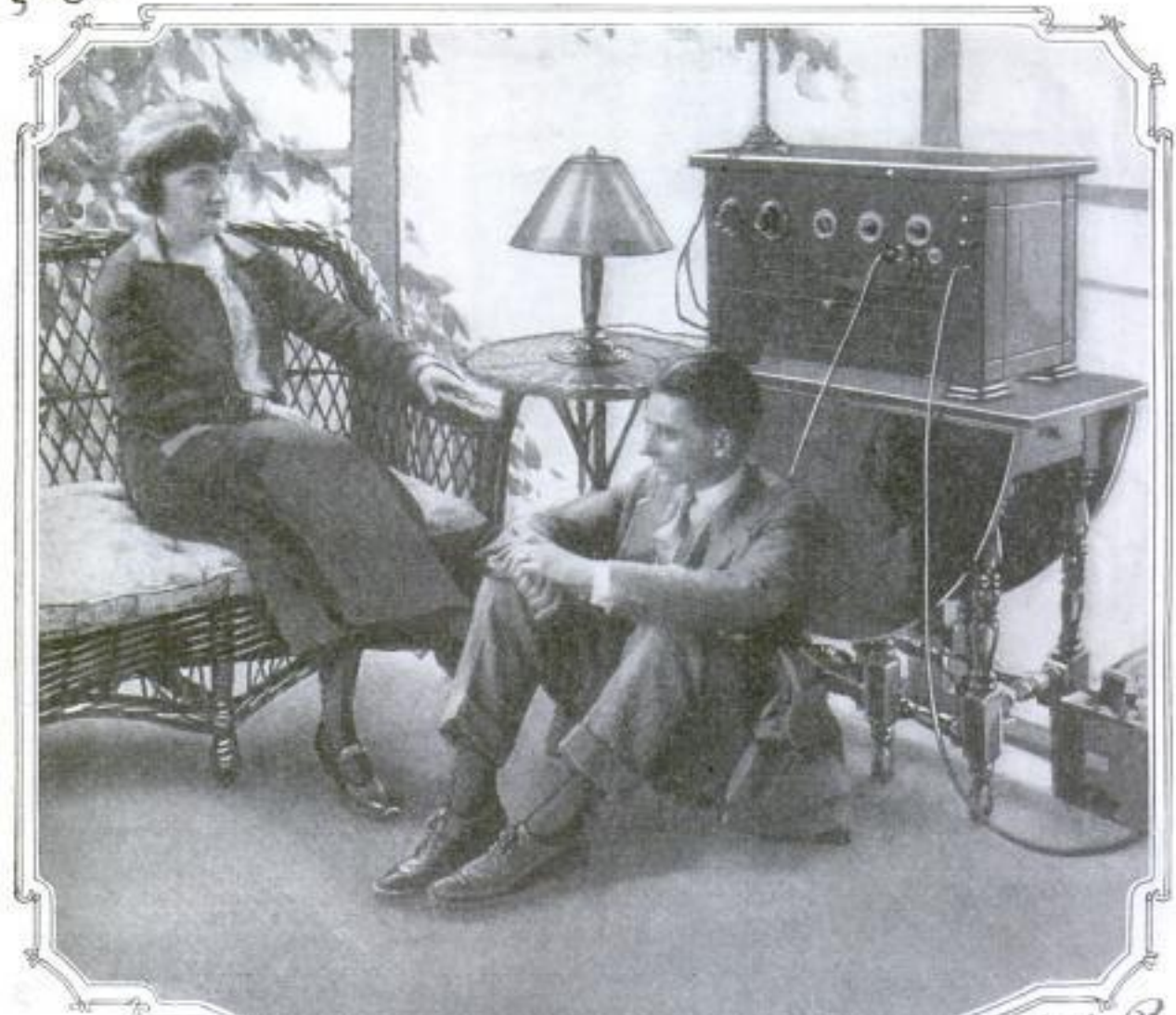

314-R

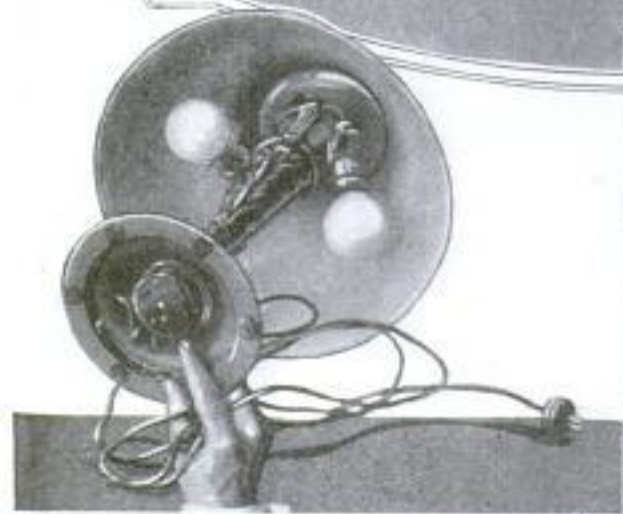

Above, the Latest in Loud Speakers Combined with a Table Lamp: There Is Nothing about the Lamp to Indicate Its Dual Purpose, and It Solves a Problem for Those Who Dislike the Appearance of the Ordinary Loud Speaker: an Inside View Is Shown at the Left. Right, in Germany the Street Peddler Vending Radio Parts Is Already an Institution

Williams

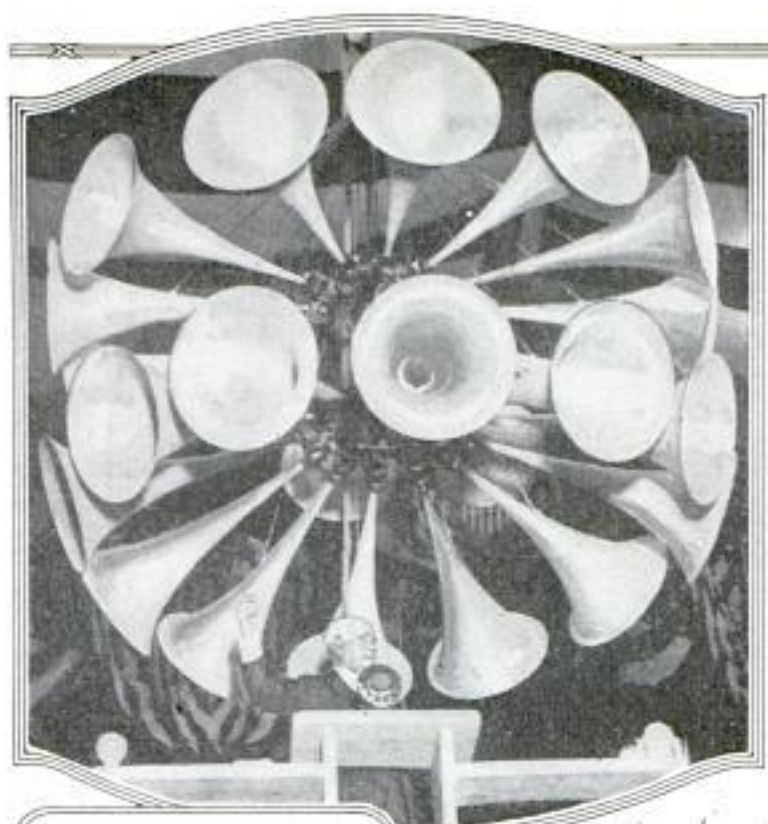

This Huge Bunch of What Looks like Easter Lilies Is the Mammoth Amplifier That Was Used in Madison Square Garden during the Democratic National Convention; There Are Twenty-Four Horns in the Cluster, and the Voice Is Amplified One Billion Times

Kadel Herbert



Pacific & Atlantic

And Here Is a View of the Set That Carried the Proceedings of the Democratic Convention to Listeners All over the Country; This Was Made Possible through the Efforts of a Number of Other Stations in the Principal Cities

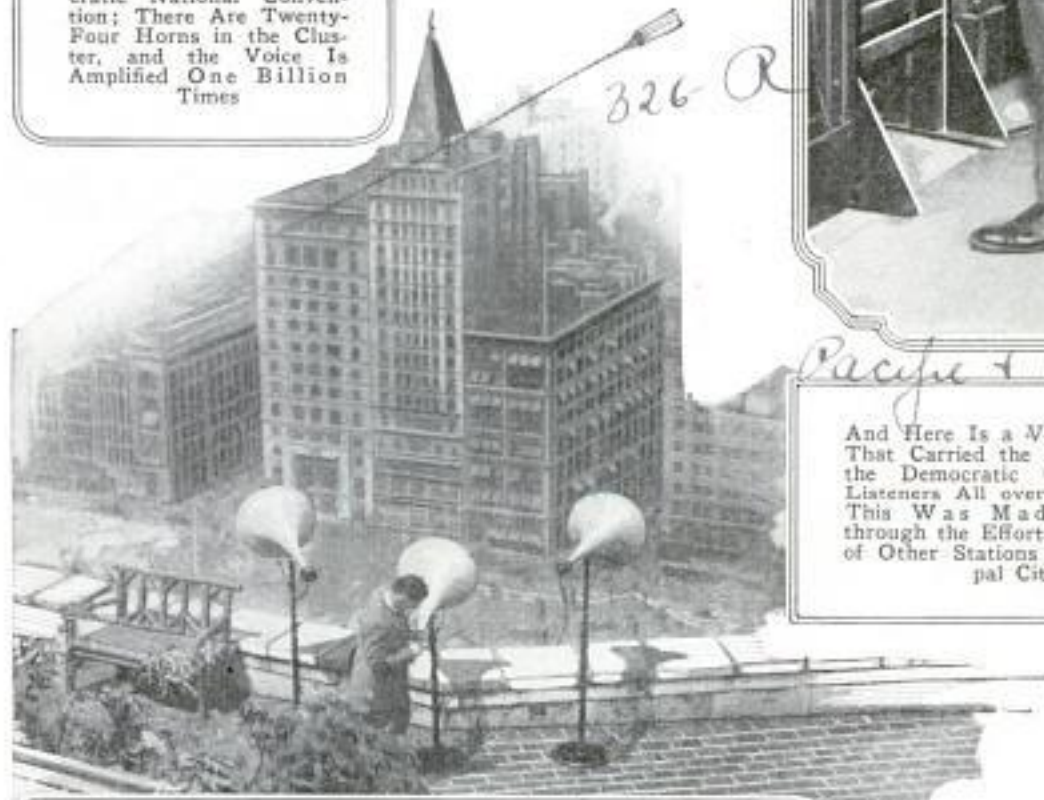

Loud Speakers on the Roof of the Municipal Building in New York, Which Entertain Passers-By with Music from WNYC

Kadel Herbert

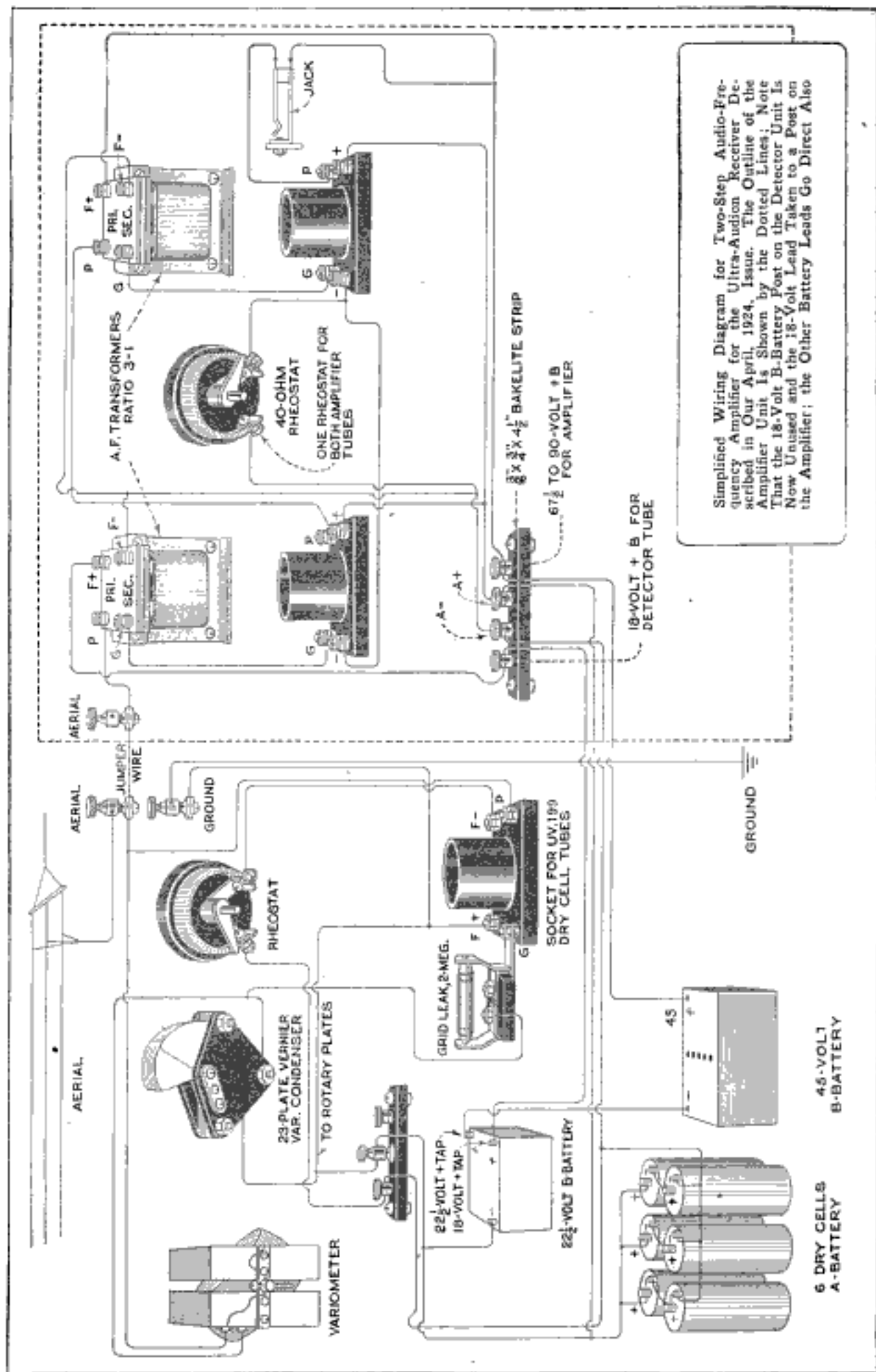

Simplified Wiring Diagram for Two-Step Audio-Frequency Amplifier for the Ultra-Audion Receiver Described in Our April, 1924, Issue. The Outline of the Amplifier Unit Is Shown by the Dotted Lines; Note That the 18-Volt B-Battery Post on the Detector Unit Is Now Unused and the 18-Volt Lead Taken to a Post on the Amplifier; the Other Battery Leads Go Direct Also

Amplifier for Ultra-Audion Receiver

By F. L. BRITTIN

*1409 Rosemont Ave
Chicago*

THIS article is printed in response to the demand for a two-step amplifier for the simple ultra-audion receiver described in our April issue, a set that has proved a universal favorite.

The detector and amplifier can be mounted on a single panel, but for those who do not wish to do this, the full-page diagram shows how the amplifier is connected to the detector already built, the

goes to a terminal on the amplifier strip, and thence to the positive-filament post on the first transformer. The 18-volt post on the detector unit is not used.

For those who prefer to build the set on one panel, a template drawing and wiring diagram is given. Those who wish to do so may employ a two-way jack in the detector circuit instead of the single-circuit jack shown in the diagrams, but

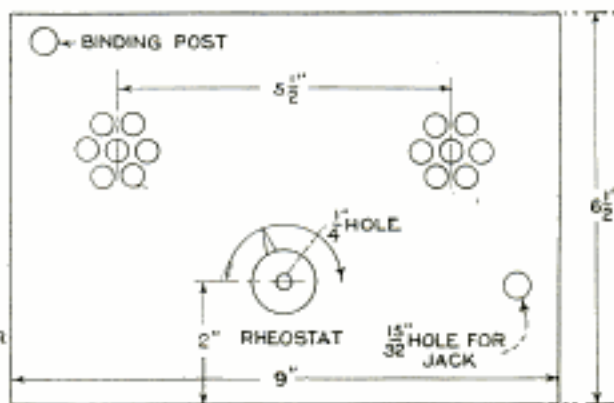
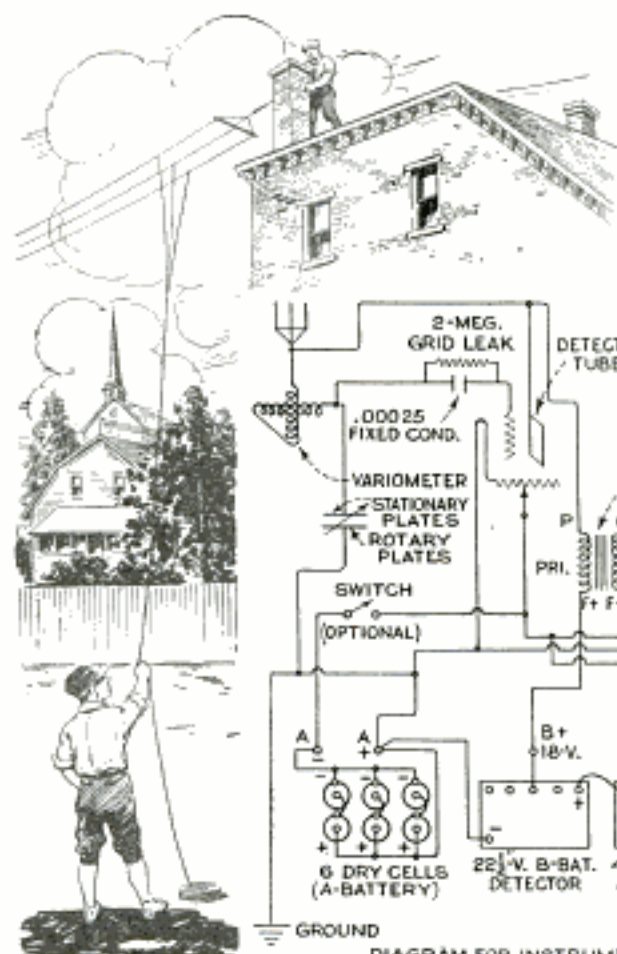

SIMPLE PANEL TEMPLATE FOR TWO-STEP AMPLIFIER UNIT

DIAGRAM FOR INSTRUMENT ON SINGLE PANEL

Panel Template for Separate Unit and Diagram of Wiring to Be Used When Detector and Amplifier Are Mounted on One Panel

outline of the amplifier unit being shown by the dotted lines. In this case the amplifier panel is 3/8 by 6 1/2 by 9 in., and the baseboard 3/8 by 6 by 8 1/2 in. The binding post in the upper left-hand corner is for the continuation of the detector plate lead, and is connected to the aerial post on the detector unit by a jumper. To simplify the wiring, the A and B-battery leads are connected to terminals mounted on a bakelite strip on the baseboard. The lead from the 18-volt B-battery tap now

the wiring for the latter is simpler, and the arrangement just as satisfactory.

Now that two more tubes are added, it is necessary to employ six dry cells as the A-battery, connected as shown in the diagram, to keep the voltage correct for the UV-199 or C-299 tubes employed, while increasing the amperage. A 45-volt B-battery is added also, connected in series with the detector B-battery from the 22 1/2-volt tap. More B-battery voltage can be used if desired, but not to exceed

90 volts on the plates of the amplifier tubes.

The 40-ohm rheostat in the amplifier circuit controls both tubes, eliminating one rheostat and simplifying the wiring, besides being more efficient than two.

This set can be operated with standard 6-volt tubes without any change other than the replacing of the dry cells with a 6-volt storage battery. With these tubes, however, control will be better if a 6-ohm

rheostat is used in the detector unit and a 25-ohm rheostat in the amplifier. A UV-200 or C-300 tube should be used for the detector, and UV-201A or C-301A tubes for the amplifier. The filament switch shown may be used or not, just as desired.

The instructions as to care in wiring, soldering, etc., given for instruments previously described apply to this one also. When such care is used in assembly this will prove to be a very fine set.

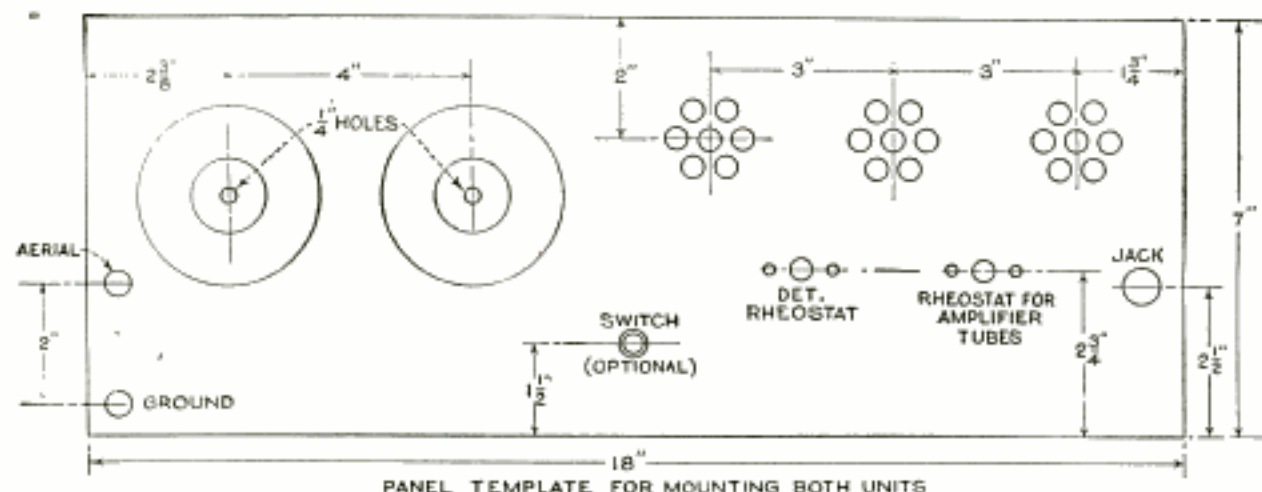

PANEL TEMPLATE FOR MOUNTING BOTH UNITS

Template for Drilling Panel for Instruments When Detector and Amplifier Are Combined in One Unit

MATERIAL LIST

- | | |
|--|--|
| 1 bakelite panel, 3-16 by 7 by 18 in., or | 2 tube sockets. |
| 1 bakelite panel, 3-16 by 6 1/2 by 9 in. | 6 binding posts. |
| 1 bakelite strip, 3-16 by 3/4 by 4 1/2 in. | 1 filament switch (optional). |
| 1 baseboard, 3/8 by 6 by 17 1/2 in., or | 2 audio-frequency transformers, ratio 3 to 1 |
| 1 baseboard, 3/8 by 6 by 8 1/2 in. | or 4 to 1. |
| 1 40-ohm rheostat. | Soldering lugs. |
| 2 UV-199 or C-299 tubes. | Wire. |

Logging Radio Stations

Neatness and compactness are the outstanding features of a new device for logging radio stations.

The call letters and other data concerning the various stations are printed on a strip of paper, which is held on two rolls and turned forward or backward by means of two small knobs. When a station is received as loudly and distinctly as possible, one of the knobs is turned until the call letters of that station are found, and the dial readings are jotted down so that the same station can be tuned in later without delay. There is plenty of blank space on the paper so that call letters, etc., of new broadcasting stations can be added.



Passing the Plate by Radio

Pessimists say radio broadcasting can not continue indefinitely because there is no way to collect the cost from the ultimate consumer—the listener-in. The Sunday Evening Club, of Chicago, has disproved the assertion by successfully passing the plate to the radio fans when the weekly religious services of the club are broadcast each Sunday night from October to May. The club has never asked the radio enthusiasts to contribute, but each week gets a flood of letters containing donations. "I heard the plate being passed, and here is my donation," is a typical letter. The contributions range from a few cents to as high as \$25, and the appreciation of the audiences was proved by the fact that the total amount of their gifts during the eight months of the 1923-24 season was between \$1,200 and \$1,300.

if pie.



A Homemade Washing Machine

By D. O. WOODBURY

THE domestic handy man will, if he is ambitious, sooner or later try to build a washing machine. The accompanying illustrations show a home-built machine the first cost of which—about \$10—was saved in a few weeks. There is nothing very difficult about this job, and, while it may be impossible to duplicate the design exactly, due to differences in the materials and motor employed, the same general idea may be followed.

A small galvanized garbage can was first obtained, together with a secondhand vacuum-cleaner motor, an 80-tooth, 5-in.

diameter worm gear and worm to fit, and an aluminum bowl of 6-in. diameter. The worm gear was fitted on the end of a $\frac{3}{8}$ -in. brass rod to run freely, and an oil hole drilled down at an angle through the hub. The gear may be held between two thin



Here Is a Small Washing Machine Easily within the Ability of the Amateur Mechanic to Build, and That Will Wash Articles Up to Bath-Towel Size

collars on the rod, or a thin collar on one side and a washer held by a screw in the rod end on the other. The end of the rod, or stationary shaft, is flattened and held to the cover of the can by a bolt passing through a spacing washer at the flattened end, and a screw driven into a hole tapped in the end of the vertical member

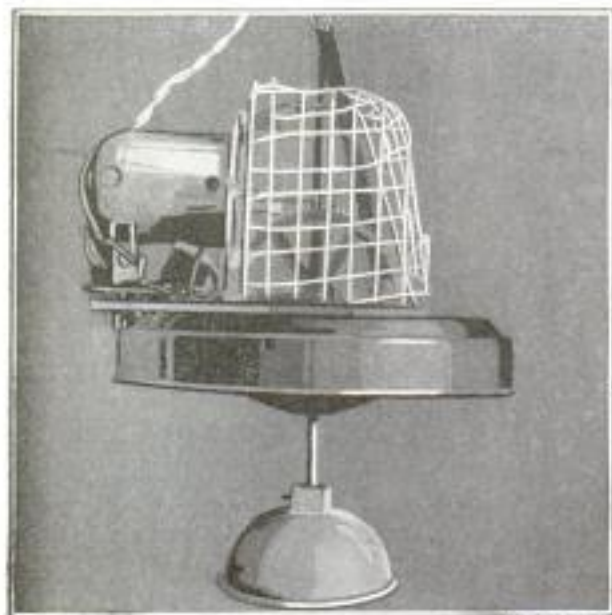

TILTING SCREW

motor are bolted through a spacing strip to the "bedplates" at the front; at the back, however, the strip is omitted, and the ends of the strips drilled and tapped for screws that tilt the motor to permit fine adjustment of the worm and gear.

A brass tube, in which a $\frac{1}{4}$ -in. brass rod slides snugly, is fitted securely in a hole drilled through the center of the cover. To the bottom of the rod the aluminum bowl is fitted, and the top is flattened and pivoted by means of a bolt and spacer to a $\frac{1}{8}$ by $\frac{1}{2}$ -in. connecting rod; the other end of the latter is connected to the worm gear by means of a clamp and pin.

The motor is braced at the top as shown in the sectional drawing, and the cover is strengthened by means of flat strips screwed to the underside. A housing (not shown) is soldered around the bottom of

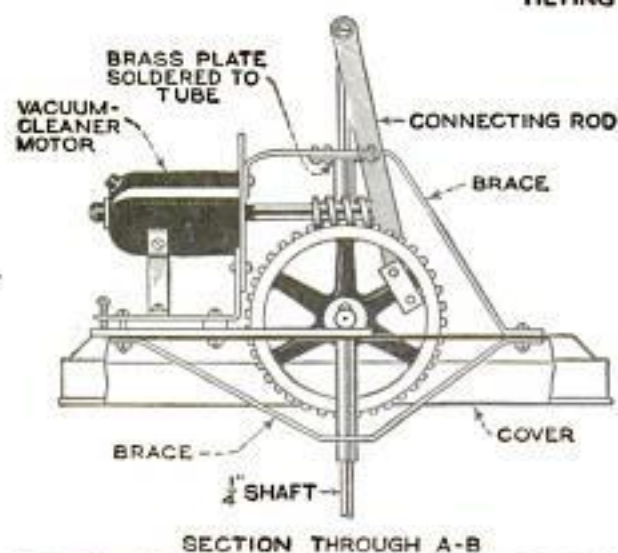
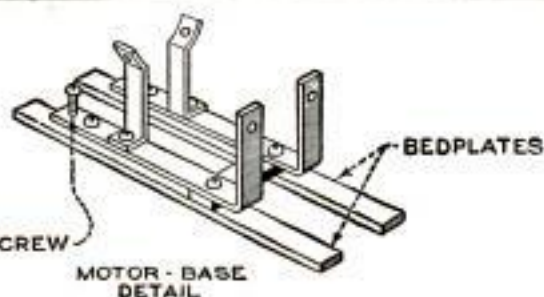

SECTION THROUGH A-B

Details of Construction of the Homemade Washing Machine; Insert, View of Top of Can with Mechanism Attached

or strut of the lower brace, as shown in the front view. This strut is made of $\frac{1}{2}$ -in. round rod, and the remainder of the brace of flat stock.

The gear passes through a slot in the cover. The worm is fitted tightly to the motor shaft, and the motor fastened to the cover by means of the motor base or cradle, which is made of $\frac{1}{8}$ by $\frac{1}{2}$ -in. flat stock. The strips that are screwed to the

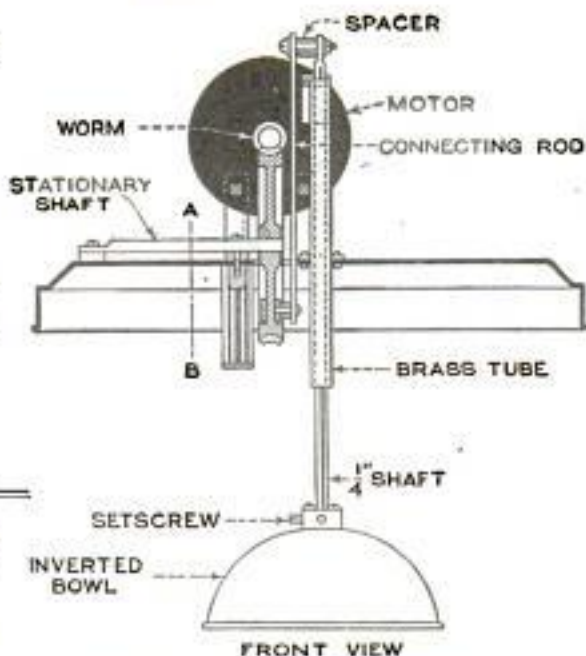

the gear to prevent water from splashing through the slot in the cover, and a wire-netting guard fastened over the worm and gear. The motor, which is $\frac{1}{16}$ hp., was too powerful for the work, so a 60-ohm resistance was connected in series with it.

This machine will produce snow-which

wash in five minutes when used with good soap. It handles pieces up to bath-towel size, and will pay in a few weeks for the time and money spent in its construction. Exact measurements cannot, of course, be given, as these will depend almost entirely on the size and design of the motor and the size of the can, but, with these directions, any amateur mechanic can easily adapt the motor he may have or can procure to the job.

Hinged Lens Cap

Many cameras of the more expensive kind are equipped with a lens cap, but the majority of photographers do not like the trouble of using one, and rather allow the lenses to become fogged and dusty. Besides, such a cap is easily lost or mislaid as it is not attached to the camera. Losing it can, however, be prevented by hinging it to the camera as shown. The hinge is made of sheet brass riveted to the lens cap and screwed to the camera.



Small Scales Made from Spoons

Small scales for weighing minute quantities of material can readily be made from two tin teaspoons and a razor blade. The handles are straightened out and soldered together as shown in the drawing. The balancing point is found and a groove is filed at this point on the underside of one spoon handle, as indicated. A wooden base of suitable size is made to hold a double-edge razor blade, which serves as a fulcrum. The small block holding the blade should be about 2 in. high. Any slight overweight on one side can be remedied by pasting paper to the bottom of the lighter bowl.

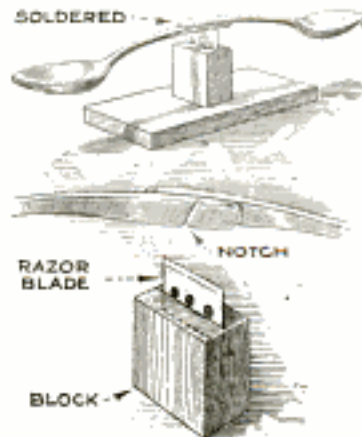

Wheeling Invalid into Auto

Invalids unable to stand up need not forego the pleasures of auto riding. The



Invalid Wheeled into Automobile over Portable Folding Gangway

photo shows how to overcome the difficulty of getting them into the car. A two-door Ford sedan with a folding front seat allows space for the light wheel chair to be pushed inside, and the left arm of the chair is dropped down to slide the invalid off onto the seat. An inclined gangway is used to run the chair onto the car; this is provided with hooks that grip the door sill. The gangway and chair, which are both foldable, can conveniently be strapped on a luggage carrier at the back of the car.—Mrs. Louise M. Berry, San Diego, Calif.

Repairing Dents in Furniture

In refinishing a small cherry-wood table, which was an antique and a valued heirloom, many dents in the surfaces had to be removed. Most of the smaller ones disappeared after the surface had been smoothed down with glass and sandpaper but the deeper ones remained. These were then removed in a rather unusual way: A piece of coarse blotting paper was soaked in water and laid upon the dents and a very hot flatiron was set on the blotter. The shallower dents disappeared with one application and the deeper ones also became less noticeable after half a dozen applications. Where the wood had not been gouged out entirely, every dent finally disappeared, and after scraping, sandpapering, waxing and polishing, the beautiful grain of the table top was again brought out and its luster restored.—Truman R. Hart, Ashtabula, Ohio.

Changing Ford Clutch Lever to Foot Control

The clutch or hand-brake lever on the Ford is seldom used for emergency stops, as it is in a very awkward position to reach in a hurry. The average owner simply

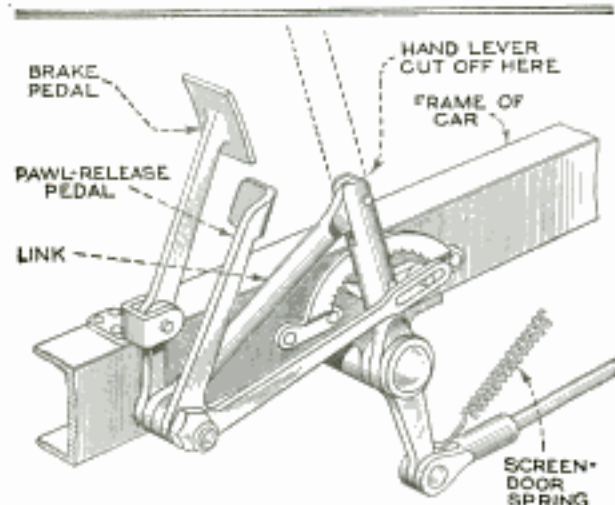

This Simple Attachment Replaces the Hand Lever on the Ford Car

uses it to throw the clutch into neutral and to brake the car when at a standstill. By means of the simple attachment shown in the illustration, however, the hand lever is modified so that it can be applied with the foot without interfering with its clutch-releasing function. If the emergency-brake bands are removed after this is done, and bands substituted that can be faced with the brake lining used on other cars, a double braking system is made that is very effective in emergencies. The change from the ordinary brake shoes is not essential, of course, but, as these wear out quickly under constant use, it will be found better in the end to make the change suggested.

The attachment consists of a pedal that actuates the rear brakes and releases the clutch at the same time. The hand-brake lever is cut off above the top of the pawl sector. A pedal is made of forged steel, to the shape shown, and pivoted on the frame forward of the brake lever. The top of the latter is slotted and drilled for a pin, and connected to the bottom of the pedal lever with a link. A forward movement of the foot throws the brake lever back, thus releasing the clutch and applying the brakes as before the change was effected. To release the pawl that holds the brake lever set, a small auxiliary pedal is necessary. This is made in the form of a bell-crank lever and pivoted on the pin at the bottom of the pedal lever. The back

end of the lever is slotted to fit over a pin in the side of the pawl, and pressing the pedal forward throws the point of the pawl down and permits the brake lever to come forward. The auxiliary pedal is so shaped and mounted that it may be operated by the driver's heel. When the car is brought to a full stop, only the ball of the foot is used, and the pawl then locks the brake on. When using the brake to slow down the car in conjunction with the service brake, the whole foot is used, and the pressure keeps the pawl from engaging, so that the brake pedal returns to the same position when pressure is released.

A screen-door spring should be fitted to the brake lever, as shown, so that it will be pulled forward as soon as the pawl is released.—G. A. Luers, Washington, D. C.

Keeping Hammer Head on Tight

A hammer head can be kept on the handle snugly and permanently by dipping the end of the handle in glycerin to thoroughly moisten the surfaces where the head touches. Also dip the wedge in glycerin and then drive it home. The glycerin absorbs moisture from the air and transfers it to the wood, which will swell out and grip the head securely.

Plate-Glass Scalloping Tool

Few people understand how the edges of plate-glass signs are scalloped. The tool for doing this work is very simple and can be made in a half hour at the cost of a few cents. Although such a tool has been used by sign makers for more than

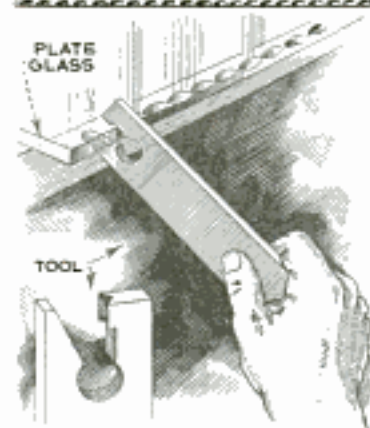
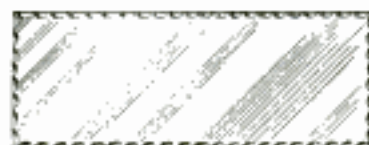

20 years, no special ability or experience is required to do this work. For $\frac{1}{4}$ -in. plate glass, the tool is made from a piece of ordinary tool steel, $1\frac{1}{2}$ in. wide, 10 in. long and $\frac{3}{16}$ in. thick. A $\frac{3}{8}$ -in. hole is drilled near one end and a slot of the shape shown is cut from

file is used to form the upper hook and vee, and to smooth the edges of the slot. When completed, the tool is tempered. In use, the plate glass is placed on a flat surface, and a piece of wood, fastened to the bench top with thumbscrews, is clamped down over the glass, which is allowed to project a little so that the tool can be applied to the edge as shown. It is given a quick downward jerk and a segment of glass will be snapped out, leaving a clean-cut, smooth surface. In this way the tool is used all along the edge of the glass. Before trying to do the work on a perfect piece of plate glass, it is best to practice on a broken or left-over piece until the "knack" of using and spacing the tool to form uniform scallops is acquired.—James E. Noble, Toronto, Can.

Making the Newel Post Useful

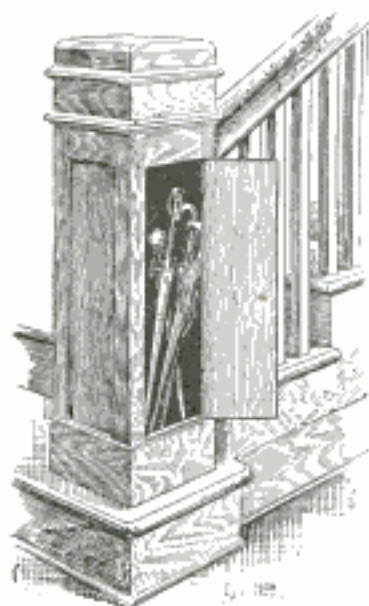

to permit it to be opened and closed conveniently.—L. H. Georger, Buffalo, N. Y.

Close-Up Photos

By using an auxiliary lens, commonly known as portrait lens, close-up photos can be taken, as this lens shortens the focus. The same results can be obtained, in many cases, without such a lens if it is possible to pull out the bellows of the camera a little farther than the last mark on the scale. By doing this good pictures can often be taken at as close a range as three feet. If there is a stop on the focusing scale, this can often be filed off to permit extending the bellows without affecting the use of the scale for its purpose.—Duard E. Scott, Wellington, Tex.

Attachment Enables Baby to Use Dining-Room Chair

A neat portable high chair, which may readily be stored away on the closet shelf,

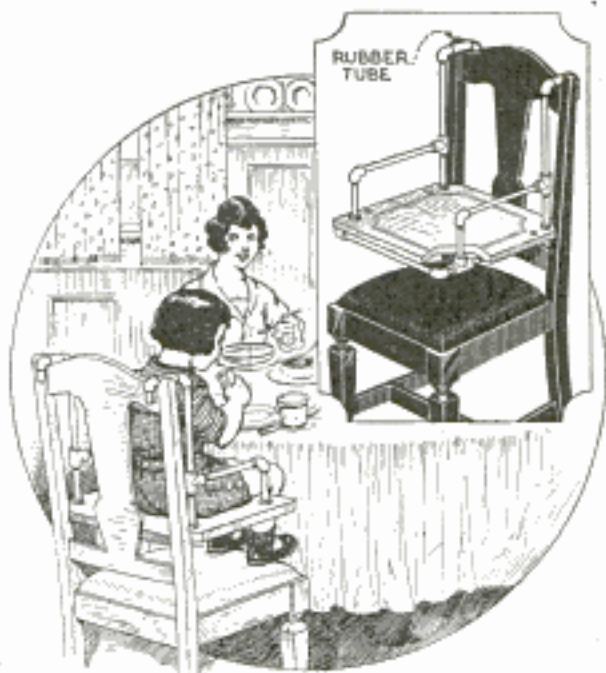

Portable High Chair Made Almost Entirely of Pipe, Is Hooked on Back of Ordinary Chair

can be made by anyone without the use of any special tools. It is made almost entirely from lengths of pipe and fittings, with a small board used for a seat; $\frac{1}{4}$ -in. pipe is strong enough for this purpose. Elbows and tees are used to connect the short lengths together, and holes are drilled through the board where the pipe passes through it. Holes for stove bolts are drilled through both seat and pipe to fasten the seat. A short length of rubber tubing is slipped over the upper ends of the pipe frame in order to prevent scratching the finish of the chair on which it is hung. The whole high chair is neatly painted or enameled in black, which adds considerably to its appearance.

Holding Connecting-Rod Caps in Vise

Connecting-rod caps can be held in the vise securely by means of cap screws as shown in the illustration. The ends of the screws are placed in the holes in the cap and the heads are then pinched toward each other and clamped between the vise jaws. This holds the cap solidly enough for scraping.—Chas. Waldo Knight, South Windham, Me.

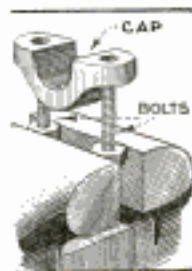

Mailbox Turntable Protects Packages

In rural districts where mailboxes are located along the roadside, sometimes a considerable distance from the farmers'

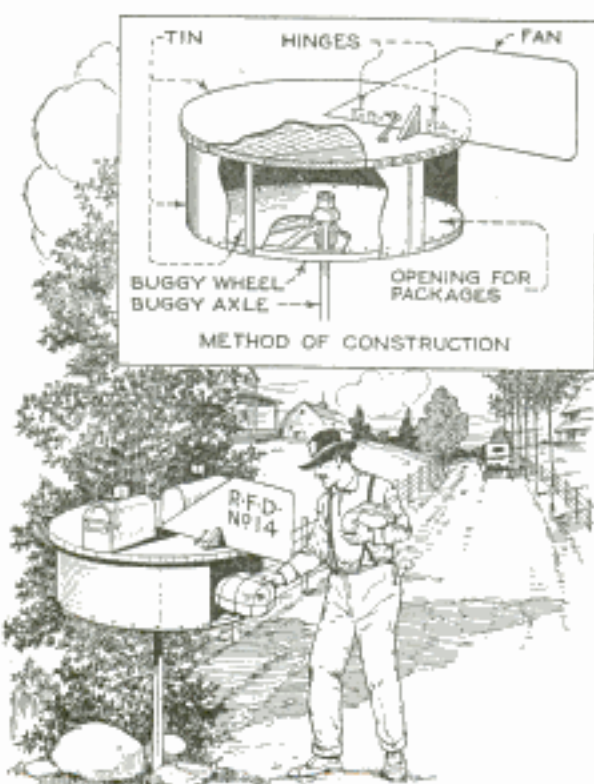

Mailbox Turntable Has Large Circular Space Underneath for Parcel-Post Packages

homes, it is almost a necessity to provide a large box to hold parcel-post packages, as these would otherwise be exposed to the weather. Such a receptacle, in the form of a turntable on which one or more mailboxes are mounted, is shown in the illustration. It consists of an old buggy wheel and axle, the latter being driven into the ground securely. A circular box, about 18 in. deep, is built up on the wheel as shown. The top is made of $\frac{3}{4}$ -in. lumber and is supported on uprights of the same material. The top, sides and bottom of the box are covered with galvanized iron. An opening about 2 ft. wide is left in the side and a vane is set up radially on the top, directly above the opening; this permits the wind to force the turntable around so that the opening is always sheltered.

An Amusing Puzzle Toy

Children will find considerable amusement in operating the puzzle toy shown in the illustration, which is old enough to be new to the youngsters. It consists of a number of small blocks fastened to-

gether with narrow strips of tape, arranged so that one will appear to be tumbling over the others when the top one is turned over. The blocks are all of equal size, about $1\frac{1}{2}$ in. by 2 in. in dimensions, being cut from material about $\frac{1}{4}$ in. thick. Not less than six blocks should be used to make the trick effective. The method of fastening the tape is clearly shown in the upper detail. When all are attached, the top block, marked No. 1, is grasped between the index finger and the thumb as indicated, its original position being shown by the dotted lines in Fig. 1, and it is brought down until its top edge strikes the lower edge of the second block, which will then fall over and strike the third block in the same way, and so on until the sixth has fallen over. The movement of the blocks is so rapid that it appears as if the second block moves all the way down to the bottom.

Fig. 2 shows another trick. Hold the first block in the right hand just as described above and the sixth block in the left, the blocks being stretched taut as indicated by the heavy lines in Fig. 2. While holding the blocks in a horizontal position these two blocks are turned over toward

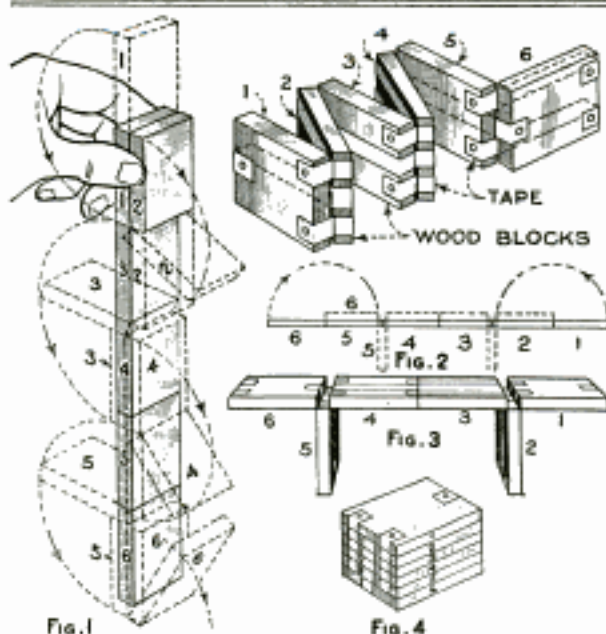

Simple Puzzle Toy Made of Small Blocks Is Amusing and Perplexing

the center at the same time, and when they strike the blocks next to them the latter ones will drop down to the position shown in Fig. 3. Fig. 4 shows the blocks piled together.—H. H. Siegele, Emporia, Kans.

☛ Vinegar is the best substance for cleaning the mica panels of stove doors.



By RAY F. KUNS
PRINCIPAL, AUTOMOTIVE TRADE SCHOOL,
CINCINNATI, OHIO

Part II

IT might appear that the doors are hard to make and hang. This is not necessarily true. While the methods given are not those used in production in factories, they do insure a good job. Commercial inclosed cars always have a rabbet of 1 in. on the lock side of the door. In this case, the rabbet is omitted because it is very difficult to cut without special machinery and also makes the fitting of the door harder. By providing some stop blocks, the absence of the rabbet will not be noticed. One and one-fourth to 1½-in. hardwood is used for the door-frame sides. Cut the pieces so that they will just fit into the doorway, and clamp one to each side of the doorways. These pieces will be 3 in. wide. With the sidepieces thus held in position, use a pencil to scribe a curve on them. Mark each piece to identify it for its proper position, since the pieces are not interchangeable.

Next cut the top and bottom as well as the center rails, and fit them into position, having first removed and cut the sidepieces to the curves marked. Again have these a snug fit in their respective places and mark according to your system of identification. Remove a set of the rails, and half-lap the corners and the center-rail joints. Do not cut the joints quite to a seat, since there may be—in fact, there is sure to be—a certain amount of wind or twist in each door which must be provided for in the fitting of the half-lap joints. With a little extra material to spare or cut on, the proper wind can be worked into the door.

Another kink in fitting the doors is to have all pieces originally cut to fit without clearance, but, when half-lapping, the

joints on each end of each cross rail are cut $\frac{3}{16}$ in. wide. This allows the side rails to come away from their companion posts by that amount, which is just the proper amount of clearance. Cut the side top-end laps $\frac{1}{16}$ in. wide, which is sufficient clearance for the top, and allow $\frac{3}{16}$ in. at the bottom.

With all parts of a door thus fitted, it is placed in position and rigidly secured with clamps so that it cannot move. Clamp $\frac{3}{16}$ -in. strips between the sidepieces and the posts. With the door held together in this position, the lapped joints are screwed together, and a stay strip is nailed inside the door frame. Leave the door frame in position while fitting the one next to it, so as to prevent springing the central post. If, as in this case, there are curves encountered, an iron brace will hold that corner of the door frame, as shown in one of the photos.

Hinging the door is the next job, and should be done before sawing off the long ends of the rails and sidepieces. Since the upper outside ends of the door sidepieces are square and plumb, the two top hinges are first fitted; and then the lower one is so arranged that the pin is in line with the two upper ones. Fit to the door first, and then place the door in position so that the vertical location of the hinges may be marked on the post. Hinges and locks may be obtained from the parts departments of many automobile agencies, or in the larger centers from dealers' or carriage builders' supply houses.

Now fit the sheet metal to the doors. If the body of the car is baked enamel, the panels for the doors may be enameled, and then fastened in place. In nailing,

use $\frac{3}{4}$ -in. flat-head nails and fasten as close to the edge as possible. Have the metal turn in only at the top over the center rail. Obtain some T-rail molding from the supply house, and bind both sides and the bottom of the door with this. This insures a neat-appearing job, hiding all nail heads and stopping the $\frac{3}{16}$ -in. openings when the doors are closed. The steel used to cover doors and body is silver-finish auto-body stock.

The door-detail drawing shows the inside of the door with the molding strips (A) indicated that hold the window felt in place. This, too, is purchased from the dealer or supply house and must be on hand when planning the width of the groove to receive it. It is more satisfac-

on occasion over a piece of hardwood or on a post. In this case, bring the edge of the metal to the edge of the window opening. Very little trouble will be found with either the doors or rear of the top, since there are only simple curves encountered. All sheet metal tends to bulge or buckle just a little, and this fact may be used to advantage by springing the bulge out, and, if need be, adding to it just a little after the metal is nailed in place by driving from the inside with a rubber mallet. Great care must be used, however, in this operation.

When applying the covering to the rear part of the top, a waterproof glue is used, and the covering cut long enough to run all the way around the two rear side and

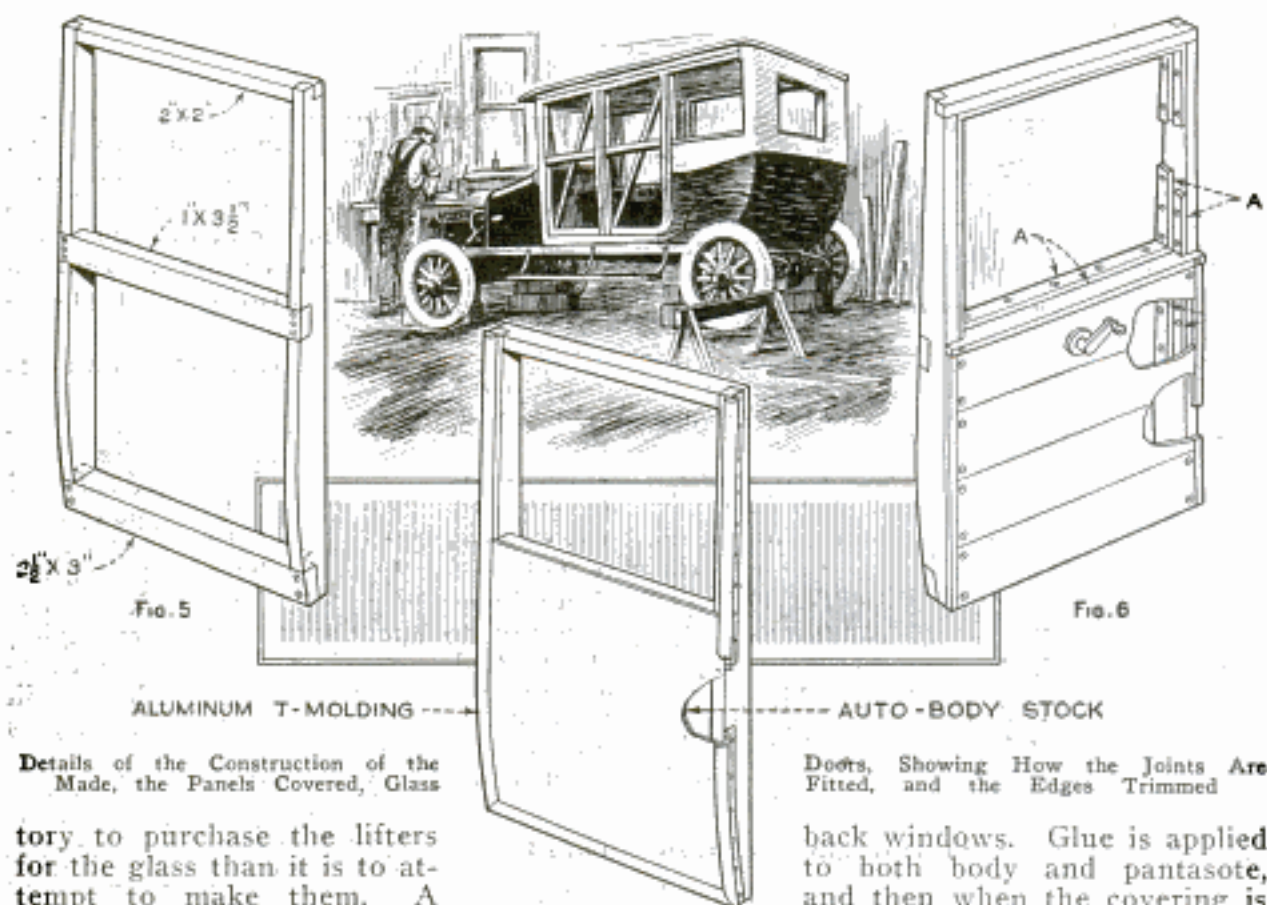

Details of the Construction of the Panels Covered, Glass

Doors, Showing How the Joints Are Fitted, and the Edges Trimmed

tory to purchase the lifters for the glass than it is to attempt to make them. A grooved strip of wood is glued or shellacked to the lower edge of the $\frac{1}{4}$ -in. plate glass, for the roller of the lifter to rest under. If desired, straps may be attached to these strips for lifters, as was the usual practice some years ago.

If it is desired to paint the body, the sheet-metal covering for the rear must be applied in one piece, and the windows, side and rear, cut out, allowing 1 in. to turn in over each edge. If the job is to have a covering of pantasote or similar material, the sheet metal may be nailed on with the flat-head nails, and even joined

back windows. Glue is applied to both body and pantasote, and then when the covering is applied, it is certain to hold.

Cut out the windows, allowing 1 in. to turn in, and tack. Trim along the lower edge of the new metal and cover the joint with "hidem" welt, held in place with tacks, or short bolts in all-metal construction jobs.

The top covering is made in three pieces. Two seams, one on either quarter of the roof, will show, but this adds to rather than detracts from the appearance. When laying on the roof, start at the center of each end and work to the sides. Stretch the pantasote tight every inch of

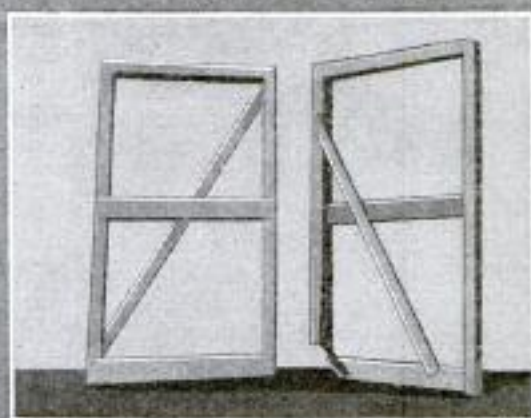
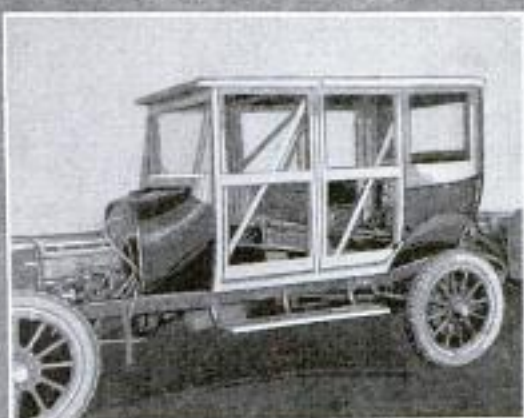

Upper Left, View of Car with Framing and Door Frames Completed, Ready for Covering; Upper Right, Frames of Front and Rear Doors, Showing Temporary Bracing; the Remainder of the Photos Are of the Finished Car and Prove That a Good Job of Body Building Is by No Means beyond the Power of the Amateur Who Is at All Handy with Tools; This Body Was Built on a Chassis Salvaged after an Accident That Destroyed the Original Touring Body, but Left the Frame Intact

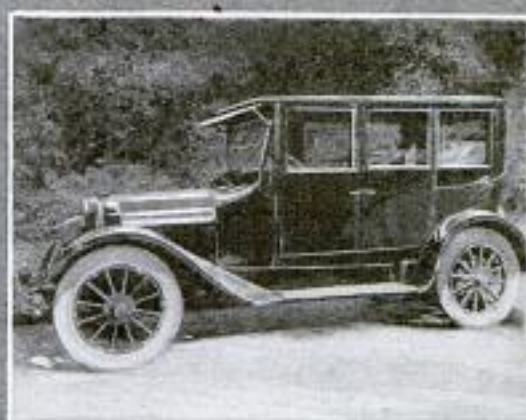

the way and, at the rear, it will be necessary to use extra force to pull out the wrinkles. Nail the top within $\frac{1}{2}$ in. of the bottom of the plates. These tack heads are covered by the eave trough which is run on around the front and along the sides. The rear joint is covered with the welt.

The rear side windows and the rear window are finished with mahogany molding. Where possible, it is advisable to arrange the rear side windows to drop down to the wheel housing at least. Otherwise all three glass panes are set in some of the felt strips held between the mahogany strips.

The whipcord lining and trimming for the inside are readily tacked in place, and all edges secured under the window moldings, or covered with gimp to match. The lower part of the doors (inside) is covered with pantasote. The front-seat shell is brought around and joined to the inside of the center posts. The springs are returned to the seat shells, and the upholstery is replaced. It is very likely that there will be more than enough of the material, in which case the surplus is easily cut away. After the leather is again in place, all raw edges are bound with new gimp. While velours and similar materials are much used in inclosed cars,

leather is finding increasing favor. If the leather does not quite meet the approval of the critical family, the seats may be covered just as readily as the velour cushions, and the appearance is identical.

Painting on a job of this sort, if the job is enameled, is a very small item, since it means merely touching up the inside edges of doors, etc. If the body job is paint, it would be well to turn it over to the professional, though some amateurs can do creditable paint work. If all the paint of the old body is removed, and the body sanded smooth, one or two coats of fast-drying enamel will make a good-looking job.

The following dimensions or allowances will help the beginner in planning his work. They need not be taken as unalterable. They are given as a standard from which to work, and are the exact dimensions in use in one certain car of undoubted good design: Height over all, 77 in.; rear window, 32 by 16 in.; rear side windows, 17 by 22 in.; door-glass height, 17 in., width, 23 in.; door width, 28 in.; door height, 46 in.; door top to roof top, 4 in.; floor to seat-cushion top, $13\frac{1}{2}$ in.; top of seat cushion to ceiling, 36 in.; width of body at windshield, 46 in.; wheelbase, this car, 136 in.; and ground to frame top, 25 inches.

A Mechanical Call Bell

My workshop is on the floor above the office, and when anyone arrived in the office while I was in the shop, it was necessary to have some means of announcing his presence. Having no electrical

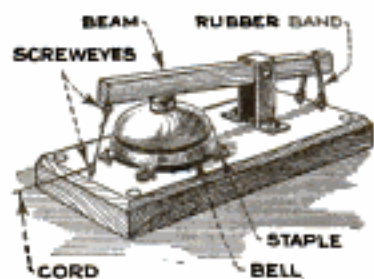

mechanism at hand, I was forced to use other material. I quickly rigged up the device shown in the drawing, using an ordinary desk tap bell, a few pieces of wood and metal and a length of cord. This worked so well that it has been retained in service to date. The device consists of a wooden base, to which the bell is fastened by staples. Near one end of the base is screwed a support for a small wooden beam, which is pivoted to the support, and notched at one end to receive a rubber band which acts as a spring. A screw eye

at the other end holds the end of the cord, which is led through other screw eyes to the floor below. As the beam rests over the plunger of the bell, a pull on the cord causes the bell to ring.—Paul E. Garber, Washington, D. C.

Locking an Extension Table

To prevent the two ends of an extension table from pulling apart when not desired, an ordinary window catch can be fastened and locked in place to the underside of the table top, with one part on each end of the table. If only one catch is used and fastened in the center, it is best to mark it off first and then pull the table ends apart to fasten the catch more easily. For very heavy tables it may be necessary to use two catches. In such cases one is placed on each side of the center.

Cleaning a Typewriter

Irregularities in feeding the paper into a typewriter are often due to slippery spots on the platen. To overcome this trouble, clean the platen thoroughly with a mixture of two parts of denatured alco-

hol to one part of ether. Rub the polished parts with No. 2 emery cloth, then smooth the surface with No. 0 emery cloth. In cleaning a typewriter with gasoline, the effect is to leave the parts dry. A better method is to use a mixture of one part of typewriter oil to 50 parts of gasoline. This will leave a coating of oil, which is too fine to collect dust, on the working parts.

Soldered Fittings for Small Toy Boats

The appearance of small toy boats is greatly improved by providing a neat rail and cleats as shown in the illustration. These fittings are made from wire and brads; the square wire used in radio work looks especially neat for this purpose. It is bent to follow the curve of the hull at the deck and soldered to the heads of brads, driven partly into the wood a suitable distance apart. Careful soldering makes neat joints and a strong rail. Cleats are made by driving in two brads, not too closely together, and soldering across their tops a short length of wire which is bent up slightly at both ends. The wire and nails should be selected with due regard to the size of the toy.—William T. Miller, Roslindale, Mass.

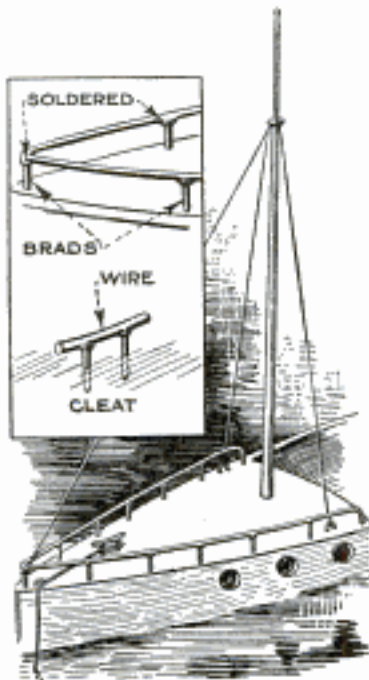

Stationary Focusing Cloth

Every photographer whose work has progressed beyond the guessing stage knows how troublesome the use of a focusing cloth is on a windy day, as he can hardly hold the cloth around tightly to exclude the light and at the same time adjust the camera. This trouble may be eliminated by sewing a 1-in. hem on one side and providing an elastic band in the hem so that it can be snapped around the camera as shown. The other end is trimmed off and sewed so that only the

bottom remains open; this can easily be held closed with one hand while the

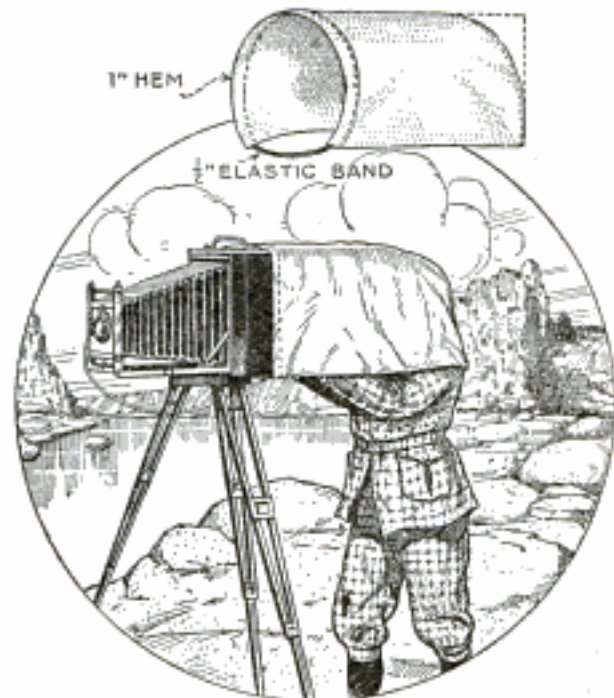

Elastic Band Holds Focusing Cloth in Place on Windy Days

camera is adjusted with the other hand.—J. E. Hoag, Los Angeles, Calif.

Automatic Air Vent for Kerosene Can

When pouring oil from a can it is necessary to unscrew the cap to admit air, and this takes considerable time, besides involving the possibility of losing the cap or forgetting to replace it. A simple method of providing an air vent without removing the cap is shown in the illustration. A small hole is punched in the center of the cap, and the top is dented in around the hole to accommodate a small steel ball. Two short pieces of wire are bent to a semicircular shape and soldered to the top of the cap, as indicated, to keep the ball in place. In use, the tipping of the can causes the ball to roll out of its seat and allows air to enter through the hole.—Adolph Rieter, Marinette, Wis.

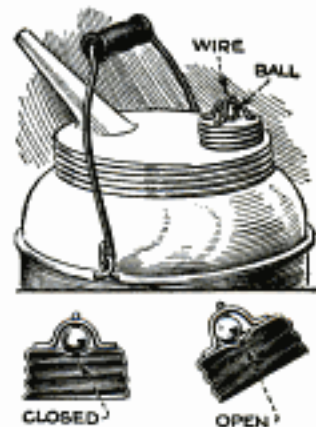

☛ Pure glycerin will remove coffee and tea stains on silks and woollens.

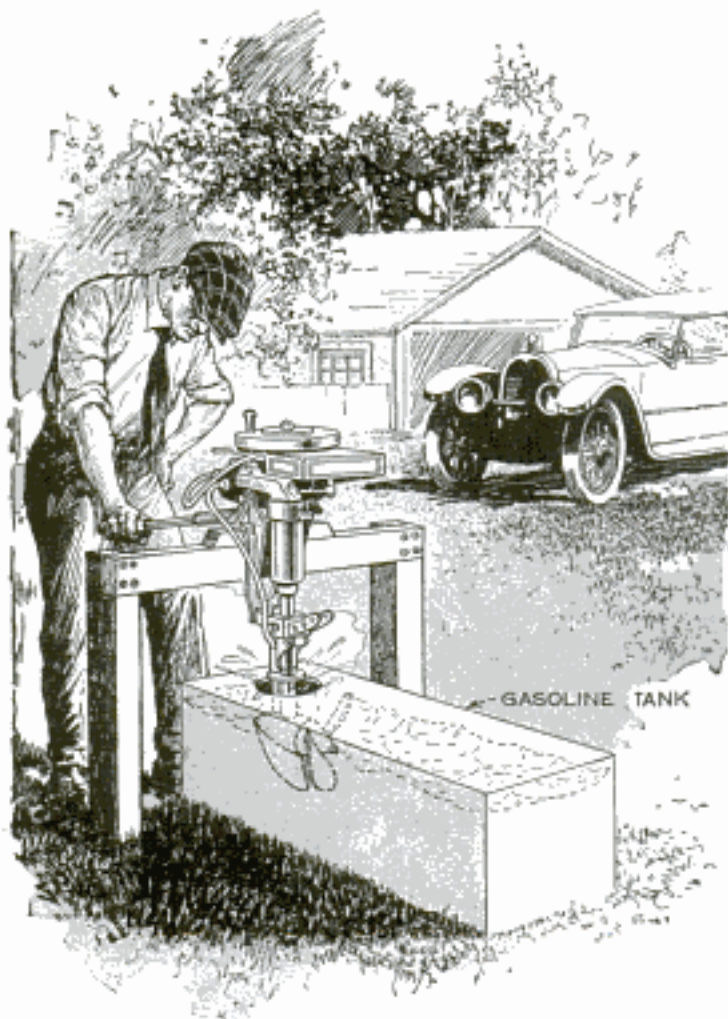

Convenient Testing Tank for Outboard Boat Motor Made from Old Gasoline Tank

Testing Tank for Outboard Motor

After repairing an outboard motor, it should be tested when the propeller is submerged in water so that the motor will pull a load. When the lake or stream in which the boat is kept is rather far distant, a testing tank can be made from an old automobile gasoline tank. A circular hole is cut in the top near one end, to allow the propeller to be inserted. A wooden rack to hold the motor is made by nailing a 2 by 4-in. crosspiece to the top of two posts driven into the ground. The motor is mounted on the rack with the propeller in the tank, which is filled with water. Running the motor will then show whether it is working properly.—J. E. Hoag, Los Angeles, Calif.

Removing Iodine Stains

A good way to remove iodine stains from the hands or linen is to wash the stains in a strong solution of hyposulphite of sodium, commonly known as hypo, which is procurable at any photographic supply house or drug store. The best results are obtained with a solution of 1 oz. of hypo and 2 oz. of water.

Simple Pail Handle

Most pails used on the farm for carrying feed, water and milk are equipped with plain wire bails. This makes it rather uncomfortable to carry them for any distance when filled. Handles can, however, be made from sheet metal, cut in pieces about 6 in. long to the shape shown in the illustration, and with holes punched and slots cut at the ends, large enough to receive the bail. The ends are bent upward along the dotted lines and the whole piece curved both ways, as shown, to form a comfortable handgrip. The edges are then filed



smooth, and the handle is attached by opening the slots and pinching them around the bail as indicated.—G. E. Hendrickson, Argyle, Wis.

Blower for the Furnace

When the furnace is slow to start, due to poor fuel or insufficient draft, an effective blower which will boost the fire quickly can be improvised from an electric vacuum cleaner. The dirt-receiving bag is removed, and the vacuum cleaner placed in front of the draft opening of the furnace so that it forces a draft. Another place to put the vacuum cleaner is in front of the clean-out door of the chimney. In both cases the check door of the furnace must, of course, be kept closed. It will be found that either of the two methods will fan an apparently dead fire into a roaring blaze quickly.—H. E. Benson, Boulder, Colo.

☐ Ventilation is a necessity for stored potatoes to keep them in good condition.

Desk Attachment for Morris Chair

By F. M. ARTHUR

THE attachment shown in the accompanying illustrations forms a welcome addition to the morris chair, especially for the student, as he can make notes from a textbook while sitting in a comfortable position. The construction is simple, and there is no elaborate wood-working necessary.

The attachment consists of a wide board, C, resting on the arms of the chair, and fitted with a reading leaf, B, and a writing leaf, D. The board C, which in this case was made from a filing board with the clip removed, is provided with two triangular supports, F; these rest on the chair arms, and the board is prevented from moving sidewise by

strips, screwed to the inner sides of F and bearing against the inner edges of the arms of the chair.

The reading leaf is 16 by 12 by $\frac{3}{8}$ in. in dimensions, and is hinged to a strip of wood of the same length, which is screwed to the main board C. This strip is tapered on the top side so that, when the leaf is dropped, the top edge will come against the main board, as shown by the dotted lines in the side view. The leaf is fitted with two supports, H and L, made of heavy sheet metal; these are hinged to board C, and serve to adjust the leaf to two different heights. Two small round-head screws are driven into the center of the leaf, on the underside, and the

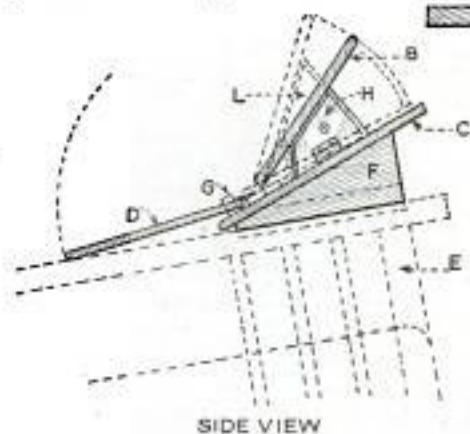
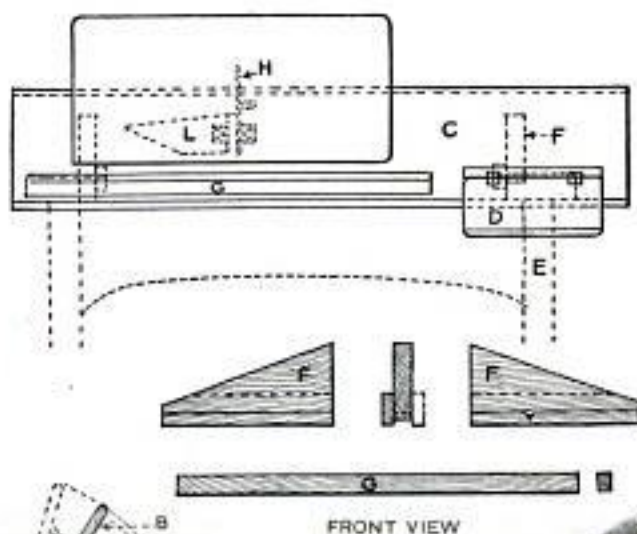

WRITING AND READING LEAVES AND SUPPORTS



An Easily Made Reading and Writing Attachment for the Morris Chair That Will Prove a Boon to the Student, or to Anyone Fond of Reading

supports, when raised, are held between these. When the reading leaf is in use, the book rests against strip G, which is screwed to the board below the leaf.

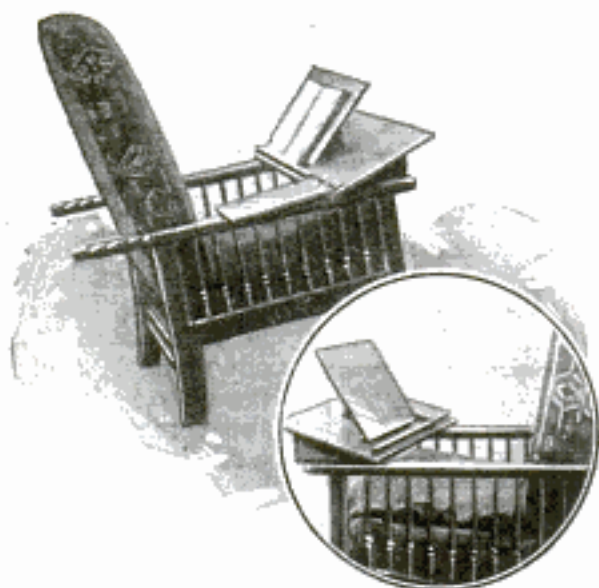

Above, Reading and Writing Leaves in Position for Use; Inset, Writing Leaf Folded Out of the Way

The writing leaf D, 7 by 9 by $\frac{3}{8}$ in. in size, is also hinged to a small tapered strip, which is screwed to the board at the right-hand side. When in position for writing, it rests on the chair arm, and the latter forms a rest for the user's arm in writing. All pieces that come in contact with the chair are faced with thin felt to protect the arms, and the whole attachment is then stained and finished to match the woodwork of the chair.

Stopping Leaks in Radiators

Radiator leaks are hard to repair. Sometimes they may be fixed temporarily by putting ground flaxseed, corn meal or very fine sawdust in with the cooling water, but such methods inevitably lead to the permanent impairment of the radiator. The following method, however, if carefully followed, can be depended on in many cases:

Remove the radiator from the car, and lay it, front down, on a pair of sawhorses. Put on the filler cap, and fill the radiator through one of the hose connections. Hold a droplight under the radiator and watch for the source of the drips, then mark the spots. If these are in the tubes, and not more than five tubes are affected, pinch the tubes top and bottom with a pair of thin-nosed pliers, thus cutting them off from the rest of the cooling system. If the leaks are in the top and bottom tanks, or in the headsheets where the tubes enter

the tanks (a very frequent occurrence), be sure they are marked so that the places can be found later, then drain the radiator. Now, with a torch warm the radiator all over until it is certain that the water is all dried out, but be careful not to get it hot enough to melt the solder.

Through the hose connection nearest the leak pour two tablespoonfuls of common yellow sulphur. Place the radiator in such a position that the sulphur will fall around the leaks, then heat the radiator at these points to a temperature that will melt the sulphur, which has a melting point much lower than solder. Rock the radiator during this operation so that the melted sulphur will cover all the metal around the leaks, then allow the radiator to cool. If the sulphur has run down into the tubes and congealed there, heat the tubes until it runs out. It is possible to repair leaks in the tubes themselves in this manner. As soon as the sulphur melts, work as fast as possible, taking care at the same time not to set it on fire, as sulphur ignites very easily, is hard to extinguish and makes nasty burns.

Finally, make sure that the overflow drain or vent tube is not stopped up, as fully as many radiators are ruined through steam pressure bursting the joints as from vibration or freezing.—Carleton F. Worfolk, Royal Oak, Mich.

A Homemade Surface Gauge

An apprentice in a machine shop did not like the idea of buying a surface gauge, which he needed, but decided to make one himself. He obtained an old pair of spring calipers with one leg broken off and the other leg worn down. After grinding both legs down to the same length he made a wedge-shaped block with a groove in the top to fit one leg, and drilled and counterbored two small holes through the block for eyebolts, which were used to hold the leg on the block securely, as shown. He also drilled and tapped a small hole through the other leg for a thumbscrew, which was used to hold a scratch pin slipped in a slot cut lengthwise in the end. The resulting gauge gave just as good service as a regular one would have done.—Frank N. Coakley, Buffalo, New York.

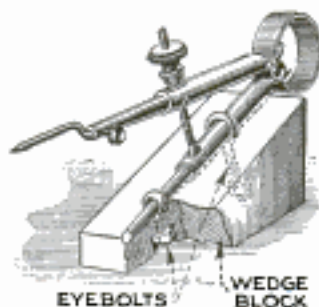

WEDGE BLOCK

An Artistic Storm Door

There seems to be no happy medium between the expensive glassed-in porch and the ugly, drab storm doors used on the more modest houses. We could not afford the glass porch, but we could see no reason why we could not make the storm door as artistic as possible.

Almost every storm door on the street was painted a dull gray, regardless of the color of the house or its trimmings. Our house had rich brown shingles, trimmed with cream, so we made the storm door of tongued and grooved cypress, which has a pretty grain, put in a generous window, and stained the door with a dark-oak oil stain, then finished it with spar varnish. The door was hung with iron T-hinges painted with gold-bronze paint, which gave a pretty effect against the dark-brown stain.

The result was a sturdy storm door which harmonized with the quiet tones of the house, and was not an eyesore. This hint may be useful to other householders who are dissatisfied with the appearance of the front of the house in storm-door time. Mrs. Lydia L. Roberts, Winthrop, Mass.

"Long-Distance" Tweezers

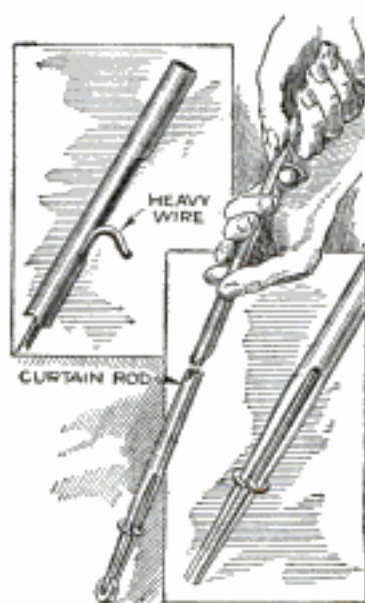

Small articles that have fallen into more or less inaccessible places can easily be picked up with the aid of "long-distance" tweezers such as shown in the drawing. This tool is made from an old brass curtain rod and a piece of heavy iron wire. The end of the

curtain rod is slotted by means of a hacksaw to form two jaws and the wire is bent at one end to form a loop, which when pulled over the jaws draws them together. The other end of the wire is made to project through a slot cut in the curtain rod, and is bent over so that it can be pulled back with the fingers. The method of using the tool is sufficiently evident from the drawing.

Opening Locked Desks and Drawers

When the key of a desk or drawer has been lost, it is, of course, not desired to mar the finish of the piece of furniture by

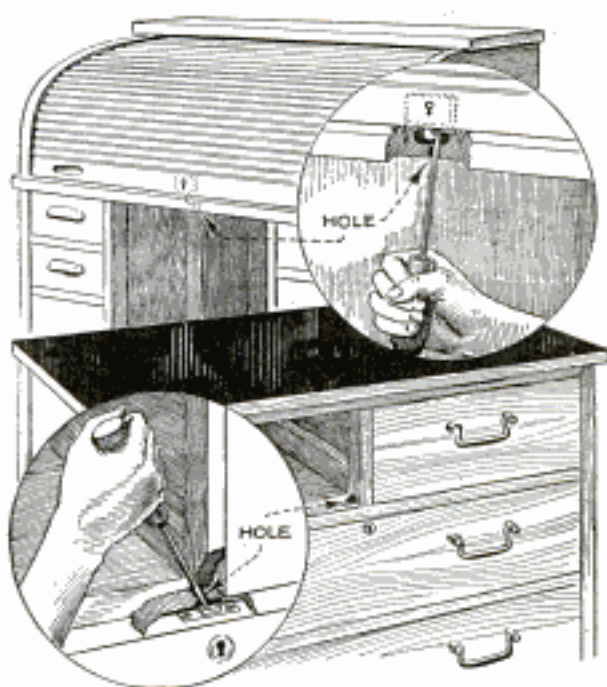

Simple Methods of Opening Locked Desks and Drawers without Injuring Them

trying to force it open. In many such cases the simple methods shown in the illustration are applicable. The upper part of the drawing shows how a roll-top desk was opened. A small hole was drilled a little to the side of the catch on the inside, and a pointed tool used to throw the catch open so that the top could be raised. A wooden dowel was then driven into the hole to conceal the opening. The same method was used to open a drawer lock. A small hole was drilled above the lock in this case and a punch or nail used to push the bolt down.

Choking Fords in Cold Weather

An adjustable choker of the kind shown in the illustration has been devised for Ford automobiles, and found very satisfactory during cold weather. It can be made by removing the rivet from the original bracket and inserting a stove bolt in its place, with a fiber washer between the arms and the bracket proper. The tension on the bolt forces the choker to remain where set.—R. Metayer, Alexandria, La.



A Homemade Dustless Ash Shaker

One of the greatest conveniences in the home is a dustless ash shaker in the basement. The installation shown in the drawing permits the dust to escape up the chimney, thus elim-

ment easy. A slot is cut in the back of the sieve and an arm, which in the present case is of wood, but may be of flat iron, is fastened to the front to engage the handle, which stands vertically and is swung back and forth. A slot must also be cut down in the front of the box, as shown, to allow the arm to extend; this, of course, should be covered after the arm is in place. The handle is a length of 1 by 1-in. wood, rounded at one end to form a comfortable handgrip; two flat-iron strips are screwed or bolted to its lower end

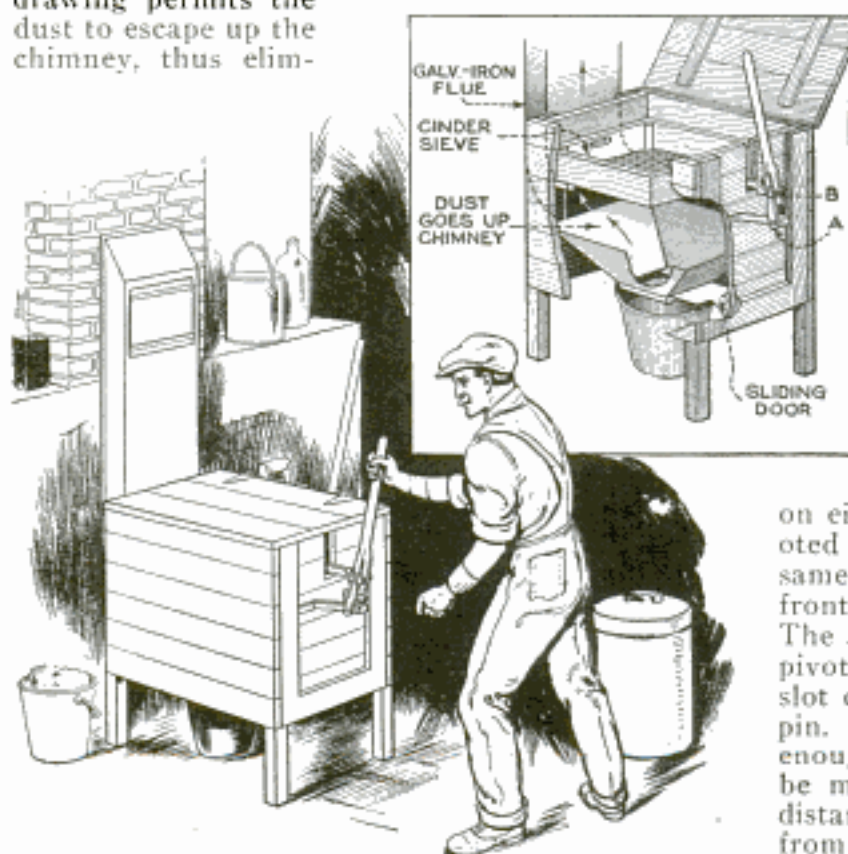

Homemade Dustless Ash Shaker near the Furnace Separates Ashes and Cinders and Permits Escape of Dust through Chimney

inating the accumulation of it all over the basement, or even in the rooms above. This ash shaker was made by a practical man and proved entirely satisfactory. It consists of a strong wooden box made of $\frac{3}{4}$ -in. material. Legs of 2 by 2-in. material should be provided to raise the box just high enough to allow an ordinary galvanized-iron pail to be pushed under it, leaving the smallest clearance practicable. Cleats are nailed or screwed to the inside to hold a cinder sieve, which is made of $\frac{3}{4}$ -in. material, about 4 in. wide and covered with $\frac{1}{2}$ -in. wire mesh at the bottom. The sieve is about 8 in. shorter than the length of the box. Short pieces of quarter-round molding are nailed at the inside corners, while tin or galvanized iron is nailed around the outside corners, making the sieve strong and durable. Thin slats are nailed to the bottom edges of the sides over the mesh and small roller casters, which can be obtained at any hardware store, are fastened underneath to run on the cleats; these greatly reduce the friction and make the reciprocating move-

on either side, and these are pivoted to a bracket made of the same material and attached to the front end of the box, as shown. The arm on the sieve is similarly pivoted to the handle, and has a slot cut in it to receive the pivot pin. These slots must be long enough to permit the handle to be moved in and out the entire distance without lifting the sieve from the cleats. In the bottom of the shaker a sheet-metal or wooden chute is provided, the sides of which all slant toward the center, where a hole is cut and a sliding door provided underneath. The ashes accumulating in this chute are dropped into a pail by pulling the door open. The ash box should be located near a chimney so that it can be connected to the latter with a galvanized-iron flue, a hole being cut in the back of the ash box to permit the escape of dust up the flue and into the chimney. This hole must be located between the bottom of the cinder sieve and the top of the chute. A sliding door is also provided in the top end of the flue to permit it to be cleaned easily. A tight-fitting wooden cover is hinged to the top of the ash box to prevent dust from escaping.

Cleaning Pearls

Pearls can be cleaned by moistening them with alcohol and then drying them in magnesia powder or French chalk, which can be purchased at any drug store and is absolutely harmless. It polishes and cleans colored pearls without bleaching them.

Emergency Auto Radiator

Smashing his radiator while in the middle of the Great Salt Lake desert on a hot summer day put one automobile driver in a bad fix. The motor, of course, would not run very long without water to cool it, and no motorists, from whom help might be expected, were in sight. His car had skidded in loose sand and run against a huge rock, which crushed the radiator. He plugged up all the broken tubes, but it still would not hold water. No one came along and Salt Lake City was about 150 miles away.

A ranch house lay about five miles down the road, and the driver, of course, walked over there in the hope of obtaining help, but found it a tumble-down shack, long deserted. There was a water hole near it, but the only object on the premises that seemed likely to be useful was an old barrel, apparently in good condition. So he decided to take it along even though he had to roll it over the loose sand back to the machine. Then he removed the hood and radiator, and, resting the barrel partly on the bumper and partly on the front cross member of the frame, fastened it with wire, rope and straps, as shown. By means of rubber hose, canvas strips, adhesive tape and old pipe connections, the barrel was hooked up to

the engine in the same way as the radiator, and after making several trips to the ranch for water until the barrel was filled above the top hose, he could resume his journey. The hood was stuck into the top of the



Barrel Substituted for Smashed Radiator on Auto Enabled Desert Tourist to Continue Trip

barrel to prevent the water from splashing out. With this emergency repair, the trip was completed, and the motorist was so pleased with his job that he drove the car all the way to Salt Lake City before he had the radiator properly fixed.—Hal. G. Borland, Carson City, Nev.

Pocket Golf Tee

With this simple golf tee, which anybody can make in a few minutes without any special tools, no time is lost in playing the game and by carrying such a tee in the pocket of one's golfing costume, the player is always ready to "tee off," regardless of the nature of the course, and the location of the sand pails. The tee is made from an ordinary spool, cut in half and a short length of garden hose, slipped over it as shown, a small nail being driven through both to keep them together.—J. E. Hoag, Los Angeles, Calif.



Convenient Pocket Golf Tee Made from Spool and Short Piece of Garden Hose

When camping, a few pockets sewed to the tent walls at the back end provide a convenient means to hold the soap, mirror, razor and other small articles that are easily lost. The pockets can be made of the same material as the tent and sewed on like a patch.

Cardboard Picture Frames

It often happens that pictures printed on calendars and in magazines are really too good to be thrown away and for this

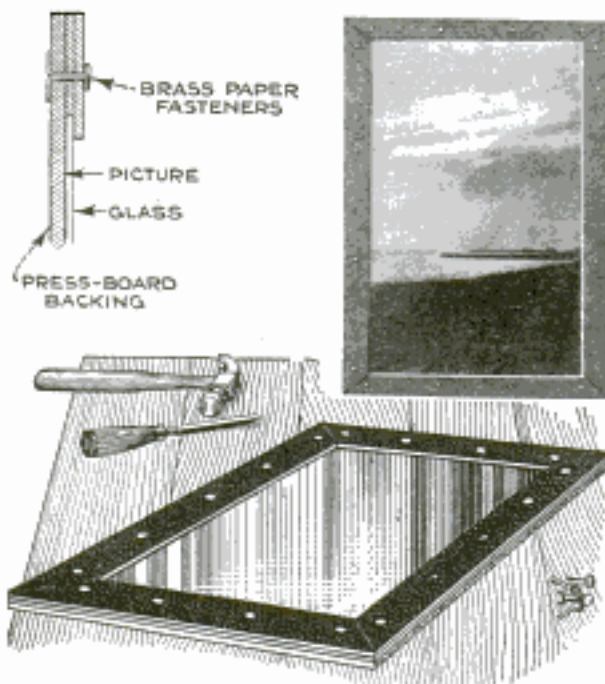

Neat and Attractive Picture Frames Made of Cardboard at Little Expense

reason many people cut them out and frame them. A new frame for each picture is, however, a rather expensive item. Neat and attractive frames can be made of cardboard, which may be painted and decorated to suit one's fancy. Heavy press board is used as a backing, the picture being attached to it with a little paste dabbed on at the corners. Borders of cardboard, of suitable width and color, are then cut and mitered at a 45° angle, so that when the strips are laid on the edges of the picture, the joints will fit snugly. Several slits are punched through the strips and the backing with a sharp-pointed knife or, better, with a thin 1/8-in. chisel; these holes must be equidistant from each other and also from the edge. To hold the frame and picture together, brass paper fasteners are pushed through the slits and bent over on the back. If desired, a piece of glass or a sheet of thin transparent celluloid may be used to cover the picture to prevent it from being soiled. In case a piece of glass is used, the edges are slipped under the inside edges of the border, and other strips as thick as the glass, are inserted under the outer edges, which are then fastened securely as explained above.

The picture shown in the photo was framed in this way. It was a bromide

enlargement, 13 by 20 in. in dimensions. A dark-brown mottled cardboard was used to harmonize with the color of the picture. A pleasing contrast was also produced by using brass fasteners with large heads.—Leslie H. Phinney, Springfield, Mass.

Repairing Old Clocks

When an ordinary clock has served its usefulness and is apparently worn-out, the jeweler's price to overhaul it frequently amounts to almost as much as the original cost. One weak part of a clock is the escapement wheel. The teeth soon wear down, which allows a greater escapement and pendulum movement, and results in an increased strain and wear on the clock. If the tips of the teeth on the wheel are bent up slightly with a pair of pliers, the swing of the pendulum will again be reduced and the life of the clock prolonged.

Homemade Gasoline Gauge

The illustration shows a gasoline gauge that was made by a motorist for use on a small car. The gauge consists of a strip

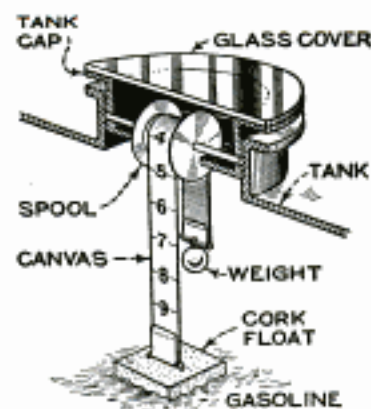

of canvas with the graduations marked on it, rolling over a spool mounted in the cap itself. One end of the strip is attached to a cork float with a staple, and the other to a small weight, which

is just heavy enough to keep the strip taut, but not so heavy as to lift the float out of the gasoline. The spool is 1/2 in. in diameter and 1/2 in. long, and each end is provided with a wide tin disk to prevent the strip from coming off; the spool is mounted on a wire running through the cap as shown. To prevent evaporation and exclude dust, the top of the cap is covered with a glass disk sealed with shellac.—D. R. Van Horn, Walton, Nebr.

☛ "Dead" whetstones can be renewed by burying them in the ground and leaving them there for four to six months; when uncovered, they will be found as porous again as they were when new.

Prize Offers and Announcements

\$2,000—Preservative for Cheese

We are packers and distributors of cottage cheese which is sold to the grocery trade in stone jars and sealed paper cups. This cheese spoils rapidly and its maximum life is one week in cool weather; one or two days in hot weather. This makes it impossible for the product to be marketed beyond a local area. We will pay the sum of \$2,000 for a method of processing or preserving cottage cheese, satisfactory to us, to keep it sweet and fresh for at least two weeks after packing, regardless of room temperature. Such method must be in accord with all pure-food laws and must not alter the flavor or appearance of the cheese. This treatment might possibly be accomplished by some method of pasteurization and then vacuum packing in individual glass containers. This offer ends May 1, 1925. Address, North Shore Food Products Company, 112 South Morgan Street, Chicago, Illinois.

\$500—Automatic Grease Cup

The Carr Fastener Company, manufacturers of the "Dot" high-pressure lubricating system for automobiles and industrial equipment, will pay the sum of \$500 for a reservoir grease cup which can be filled through a Dot grease gun, and which will thereafter feed out the grease onto a bearing at a slow and constant rate. There is a tendency in spring-actuated self-feeding grease cups for the grease to feed rapidly when the cup is full, due to the tight compression of the spring, but as the cup empties the spring expands and has less tension and the grease is fed more slowly. If a spring is used, this tendency must be compensated for in some way, or else some principle other than a spring must be devised. All plans or models submitted are to be judged for their value solely by this concern. This offer expires May 1, 1925. Address, Carr Fastener Company, Cambridge, Massachusetts.

\$1,000—Detonator for Explosives

This donor, Mr. Frank Lesh, will pay the sum of \$1,000 for a method of exploding a gun cap or mercury cap or which will cause a charge to explode under 3,000 feet of water and crude oil, without need of any connecting lines or other similar attachments. The process must not be prohibitive in cost and must do the work without any failures. This concern has a place on which to try out any methods and will act as sole judge as to the worth of any plans offered. It may be that such an arrangement could be brought about by radio. This offer holds good until May 1, 1925. Address Frank Lesh, Box 1700, Casper, Wyoming.

\$500—Use for Button Molds

An amount up to \$500, depending on the proved value of ideas, will be paid by a concern equipped to make button molds, for new ways of using molds from which buttons formerly were made. Samples of the molds sent on request. Address, Problem HA-1, Popular Mechanics Magazine, Chicago, Illinois.

\$500—Uses for Button-Mold Machines

In proportion to the merit of the suggestion, a sum up to \$500 will be paid for satisfactory suggestions leading to new uses for the machines employed in manufacturing button molds. Address Problem HA-2, Popular Mechanics Magazine, Chicago, Illinois. The two foregoing offers expire May 1, 1925.

\$250—Slogan and Sales Plan

The Casmine Company manufactures and markets a medicinal ointment called "Menthine," which possesses properties for clearing the head and voice and benefiting

public speakers and singers, also improves the voices of those afflicted with colds, catarrh, hay fever, etc. This concern desires to adopt a slogan or phrase which will adequately explain the above properties in a very few words and be easily remembered. For a satisfactory slogan or phrase and a plan that will aid in largely increasing our sales to the retail druggists through their jobbers, we will pay the sum of \$250. The Casmine Company will alone determine the value of slogans, phrases and plans to their business. May 1, 1925, will be the closing date of this offer. Address Casmine Company, 6 East Twelfth Street, New York City.

\$250—Article to Manufacture

The Guyan Machine Shops will pay the sum of \$250 to the person submitting to them an article that can be manufactured in their fully equipped machine and electrical shop. Forging and welding departments completely equipped, and brass foundry capable of 100-pound castings are included. The electric division is fitted to make all coils and parts for motors and generators, transformer coils, commutators and allied equipment. We would like an article at least partially developed and prefer that it be something useful in or around coal mines, or that can be sold through jobbing and hardware trade. We would consider parts of mining machines or locomotives or improved attachments for same. Value of articles submitted will be passed upon solely by members of our organization. The award here offered will be in addition to any contract entered into with owner of said article. The offer expires May 1, 1925. Address Guyan Machine Shops, Box 757, Logan, West Virginia.

\$50—Snare for Live Fowls

In transferring live chickens from one coop to another, occasionally one or more will escape, making it necessary to be run down and caught, requiring at times considerable effort. We are now using a small wire "V"-shaped hook attached to a long wooden handle which is not very practical. We will pay the sum of \$50 for a method accepted by us, or a satisfactory designed hook, which will enable a person easily to catch the fowl around the legs or otherwise. Address Security Produce Company, 209 West South Water Street, Chicago, Illinois.

\$50—Profitable Uses for Eggshells

In our egg-breaking plant where several cars of eggs are broken each day for canning purposes, there is a large by-product of eggshells. While these have been used heretofore for chicken feed, we will pay the sum of \$50 for a satisfactory plan, process or method of otherwise profitably disposing of these eggshells. All entries for both the offers are to be judged by this concern alone, and the date of closing for each is May 1, 1925. Address Security Produce Company, 209 West South Water Street, Chicago, Illinois.

\$25—Substitute for Nickel Plating

The Duplex Timer Manufacturing Company will pay the sum of \$25.00 for a satisfactory substitute for nickel plating Ford roller timers. We believe that there should be a suitable lacquer, enamel or metallic dip of white or some bright color which will add individuality to the appearance of the timer, and eliminate the expense of nickel. It must be remembered that the timer roller has a grooved contact surface, and any lacquer or dip that is used will have to be applied thin enough to allow the flow of electric current when contact is made with the timer gage-way. For a substitute that meets these requirements and proves satisfactory the award will be paid. Address Duplex Timer Manufacturing Company, 1927 East Lynn Street, Seattle, Washington.

OFFERS ANNOUNCED IN PREVIOUS ISSUES

All of These Offers Expire May 1, 1925

FOR AN INK THAT WILL PRINT CLEARLY and can be erased from tracing cloth without marring the surface, \$100 in cash, or as payment toward patent, will be paid. Address Problem NA-1. *W. C. Nelson, 3035 Fremont Ave., Chicago, Ill.*

ROYALTIES OF \$5,000 WILL BE PAID within the first year for method of animated drawings by which yachts and boats can be illustrated to prospective purchasers. Problem NA-1.

FOR THE BEST LIST OF SALIENT AND glaring faults now found in practice in large drafting rooms with their remedies, \$100 will be paid by donor of Problem NA-1.

THE NATIONAL COMPANY, INC., OFFER \$10,000 in percentages from sales for a new radio static or interference eliminator. *Cambridge 39, Mass.*

\$10,000 IN RETURNS FROM SALES IS ALSO offered by the National Company for a highly efficient fixed radio condenser of small size and large capacity.

A PIECE OF NEW MERCHANDISE THAT could be sold through optical, photographic and sporting goods stores is desired by Wollensak Optical Co., who will pay royalties of \$5,000 for accepted article. *145 Belmont Ave. Rochester, N.Y.*

FOR PROCESS OF MAKING HARD-GLOSED candies without impairing their appearance or quality the Happiness Candy Stores, Inc., will pay the sum of \$1,000. *202 Harris Ave. N. Y. C.*

\$1,000 WILL BE PAID BY THE HAPPINESS Candy Stores, Inc., for a method of manufacturing chocolate coating which will not turn gray or dull when exposed to atmospheric conditions.

CONTINENTAL CAR COMPANY OFFERS \$5,000 in royalties for hoist for dump bodies operated by motor vehicle from driver's seat with power from engine; \$1,000 under like arrangement for new toy or article of household furniture to be made from lumber scraps of truck bodies. Also \$5,000 in royalty arrangement for air-dumping device to be controlled from locomotive by engineer. *Louisville Ky.*

\$1,000 IS OFFERED BY KIRSTIN COMPANY for improvements in Fil-Gage and reductions in cost of manufacture and distribution amounting to twenty per cent. *Kirstin Bldg. Casanova, Mass.*

FOR A NEW METHOD WHEREBY SCRAP leather in a glove factory can be profitably disposed of, Eigendath Glove Company will pay sum of \$5,000. *2001 Clinton Ave. Chicago*

NATIONAL SLATE ASSOCIATION WILL pay \$200 for best suggested new use for slate; other accepted suggestions paid for in proportion to value. *761 Euclid Bldg. Phila Pa.*

WILLIAM H. MITCHELL COMPANY WILL pay \$500 for three new uses suggested for low-voltage generators which they adopt as part of sales plan. *Ind. O.*

FOR AN ANTI-FREEZING INGREDIENT FOR an emulsified asphaltic concrete S. D. Hoheimer will pay the sum of \$500. *Food Value Bldg. Phila. Pa.*

GRANITE STATE MOWING MACHINE COMPANY offers \$500 in cash and royalties for satisfactory working drawings for gasoline-motor lawn mower they accept for manufacture and marketing. *Harris Pa.*

NATIONAL BRASS COMPANY WILL PAY \$300 for design of key guide that can be made of sheet metal and which will properly fit escutcheon plate of similar material. *Grand Rapids, Mich.*

IN FOUR AWARDS OF \$500, \$250, \$150 AND \$100, the South Bend Lathe Company offers payment for four best ideas for new and practicable attachments for screw-cutting engine lathe. *423 E. Madison St. S. Bend, Ind.*

FOR A PRACTICAL INEXPENSIVE MEANS by which carbonization can be prevented in portable oil burners of vaporizing type, Aeroil Burner Company will pay \$500. *266 Hudson Ave. Union Hill, N. J.*

THE YELLOW CAB MANUFACTURING company offers an award of \$50,000 for a perfected plan of traffic and pedestrian correction and regulation, including mechanical devices, regulations, etc., for the promotion of greater street safety. *580 W. Dickens Ave. Chicago*

\$10,000 FOR A NEW MUSICAL INSTRUMENT which can be incorporated in any orchestra or brass band and will take a place among the present family of musical instruments accepted by the rank of players. *Lyon & Healy, Inc., Chicago, Ill.*

ELECTRIC HEATING ELEMENT WHICH will operate and interchange with base and cover of Imperial self-heating gasoline iron, \$500. *Imperial Brass Company, 1200 W. Harrison St. Chicago*

\$100 FOR PLAN OF PROFITABLY DISPOSING of champps skin scraps. *Basick Manufacturing Company, 2600 N. Crawford Ave. Chicago*

DISCOVERY OF NEW USES FOR CARBON-dioxide gas or improvements to present uses. Award \$1,000.

FOR AN AUTOMATIC FREEZEPROOF SODA cooler adaptable to "iceless" type of soda fountains, \$1,000. Above two problems by Liquid Carbonic Company *3100 S. Kedzie Ave. Chicago*

\$2,000 WILL BE PAID IN SEVERAL AWARDS for processes and machines for salvaging waste lumber. *National Lumber Manufacturers' Association, Wash. D.C.*

FOR SKYROCKET STICK HARMLESS IN descent, \$1,000; bombshell with illuminated flag, \$250; chemical combinations to produce smokeless fireworks colors, \$250. *Thearle-Duffield Fireworks Company, 624 S. Michigan Ave. Chicago*

MOTOR-OPERATED HANDSAW FOR MANUFACTURE and sales; award, \$10,000 in royalties. *R. L. Barker and Company, 642 W. Washington St. Chicago*

\$500 FOR SALES PROMOTION PLAN FOR absorbent, non-heat-conducting powder that can be used with other materials. *The Keasby and Mattison Company, Ambler, Pa.*

ROYALTIES OF \$15,000 WILL BE PAID BY the Aetna Industries, Incorporated, for improvements in their products or new articles they accept for manufacture and sales. *117 N. Dearborn St. Chicago*

THE GEMCO MANUFACTURING COMPANY will pay \$250 for suitable article they can make in their general metal-working plant. *Milwaukee, Wis.*

FOR THE BEST SUGGESTED IMPROVEMENT on a gasoline-heated blowtorch and soldering and branding iron combined an award of \$500 will be paid by the Everhot Manufacturing Company. *Maywood, Ill.*

\$200 WILL BE PAID BY THE ABOVE CONCERN for the best suggested new use for the device named in the next preceding. Other cash awards in proportion.

PROCESS BY WHICH ZINC THAT OXIDIZES and is lost in brass foundries can be saved and used. Award \$500. *A. M. Allen, W. P. Allen Mfg. Co. 566 W. Lake St. Chicago*

PLAN BY WHICH LEATHER WASTED IN making of belting, etc., can be disposed of at profit to manufacturer. Award \$100. *4 A*

AWARDS OF \$500 EACH WILL BE PAID for a waterproofing process for a library paste and a method that will produce increased sales of this product. *John J. Harris and Company, 4035 W. Kenzie St. Chicago*

Additional Offers Will Appear in
the DECEMBER ISSUE

What It Does—

Climbs practically all grades on "high"; goes through heavy, muddy roads with ease.

Provides remarkable flexibility for city driving and congested traffic.

Eliminates vibration; changes ratios at any speed; meets all varying road conditions.

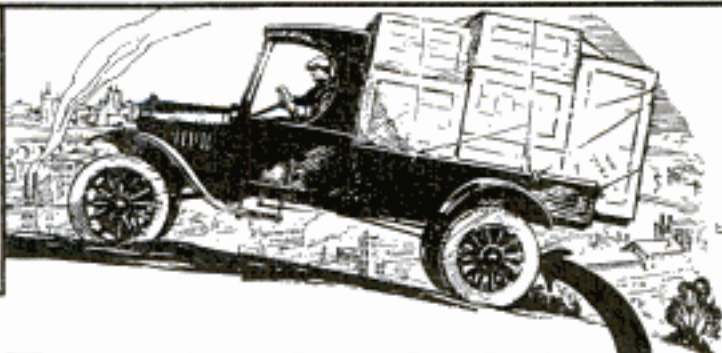
**Two Cars or Trucks in ONE!**

Wonderful Automotive Invention Gives TWO-PURPOSE PERFORMANCE by Combining POWER and SPEED

The Only Two-Speed Axle in the World—

The RUCKSTELL AXLE is installed in the rear housing and becomes an integral part of your car or truck. No cutting of drive shaft; no welding; no brazing; no change in principle of car or truck. Planetary in operation—not an auxiliary sliding gear transmission.

Write at Once

Know how the RUCKSTELL AXLE increases power 55% in the car and 60% in the truck. Have 20 to 40% GREATER speed if you need it. Free Booklet, Prices, etc., sent on receipt of coupon below. Your nearest Dealer in light cars and trucks knows about the RUCKSTELL AXLE.

Free Demonstration

Nearly 10,000 Dealers can now install Ruckstell Axles. Your Dealer can order for you, if out of stock, from his nearest of thirty-nine Authorized Distributors. Most Dealers are now demonstrating Ruckstell Axle performance. See yours without delay.

HUNDREDS of owners of light cars and trucks are having the RUCKSTELL TWO-SPEED AXLE installed daily. Nearly 100,000 are now enthusiastic boosters of this marvelous device. It revolutionizes the performance of light cars and trucks. Get all the facts NOW.

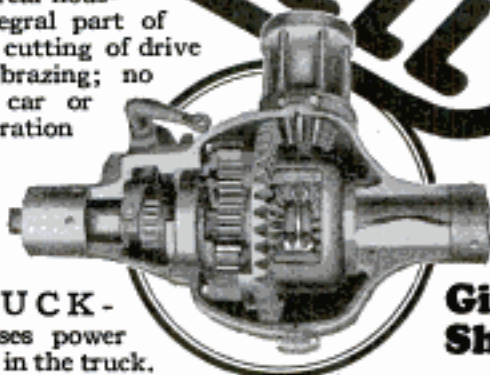
**Gives You a Handy Shift Lever—**

Simply move the Ruckstell lever backward or forward for POWER or SPEED. Change speeds, no matter how fast you are driving, without stripping or clashing. Write at once for complete information. Address Dept. 20-F, or our nearest office.

**Ruckstell Sales & Mfg. Co.**

NEW YORK CITY
512 Fifth Avenue

KANSAS CITY, MO.
1302 Waldheim Bldg.

BERKELEY, CALIF., 819 Snyder Ave.

In Canada: RUCKSTELL AXLE CO., Ltd., Montreal

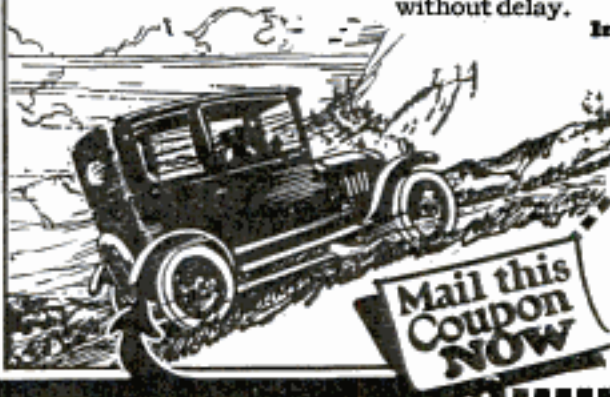

FREE This coupon good for Free Demonstration of the Ruckstell Axle at nearest Dealer, or for Free Booklet giving full particulars. (20-F)

Name

Address

Make of car or truck



Keeping the Telephone Alive

Americans have learned to depend on the telephone, in fair weather or in foul, for the usual affairs of the day or for the dire emergency in the dead of night. Its continuous service is taken as a matter of course.

The marvel of it is that the millions of thread-like wires are kept alive and ready to vibrate at one's slightest breath. A few drops of water in a cable, a faulty connection in the wire maze of a switchboard, a violent sleet, rain or wind storm or the mere falling of a branch will often jeopardize the service.

Every channel for the speech currents must be kept electrically intact.

The task is as endless as housekeeping. Inspection of apparatus, equipment and all parts of the plant is going on all the time. Wire chiefs at "test boards" locate trouble on the wires though miles away. Repairmen, the "trouble hunters," are at work constantly wherever they are needed in city streets, country roads or in the seldom-trodden trails of the wilderness.

Providing telephone service for this great nation is a huge undertaking. To keep this vast mechanism always electrically alive and dependable is the unending task of tens of thousands of skillful men and women in every state in the Union.



AMERICAN TELEPHONE AND TELEGRAPH COMPANY
AND ASSOCIATED COMPANIES

BELL SYSTEM

One Policy, One System, Universal Service

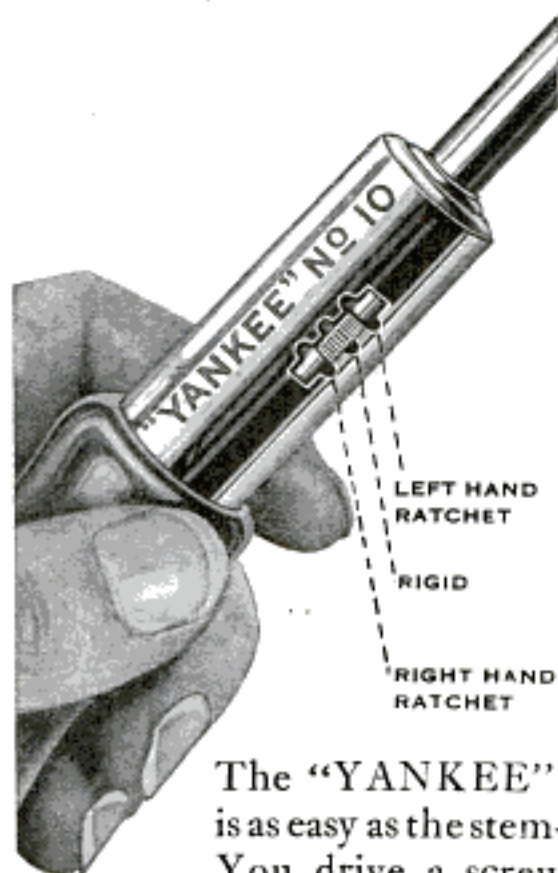

Let the
“YANKEE”
 Ratchet
 save your muscle

The “YANKEE” Ratchet Movement is as easy as the stem-wind on your watch. You drive a screw simply by turning the handle forward and back. No need to let go your first good grip.

“YANKEE” Ratchet Screw-Drivers

- No. 10** (illustrated) 2 in. to 12 in. blades.
No. 11 Same as No. 10 except ratchet shifter moves across instead of parallel to blade.
No. 15 (illustrated) has knurled thumb turn for starting small, wobbly screws, 2 in. to 8 in.

With “Yankee” Spiral Screw-drivers you just push on handle and screw goes in.

- No. 30-A** Standard size. (Improved No. 30).
No. 31-A Heavy pattern. (Improved No. 30).

Dealers everywhere sell
 “Yankee” Tools

Some other “YANKEE” Tools

Ratchet Hand Drills
 Ratchet Breast Drills
 Ratchet Chain Drills
 Automatic Push Drills
 Ratchet Tap Wrenches
 Vises—removable base
 Plain Screw-drivers 1½ to 30 in. blades.



FREE TOOL BOOK

Write for interesting book about “Yankee” time and labor saving tools.



NORTH BROS. MFG. CO., Philadelphia, U. S. A.

“YANKEE” TOOLS
Make Better mechanics

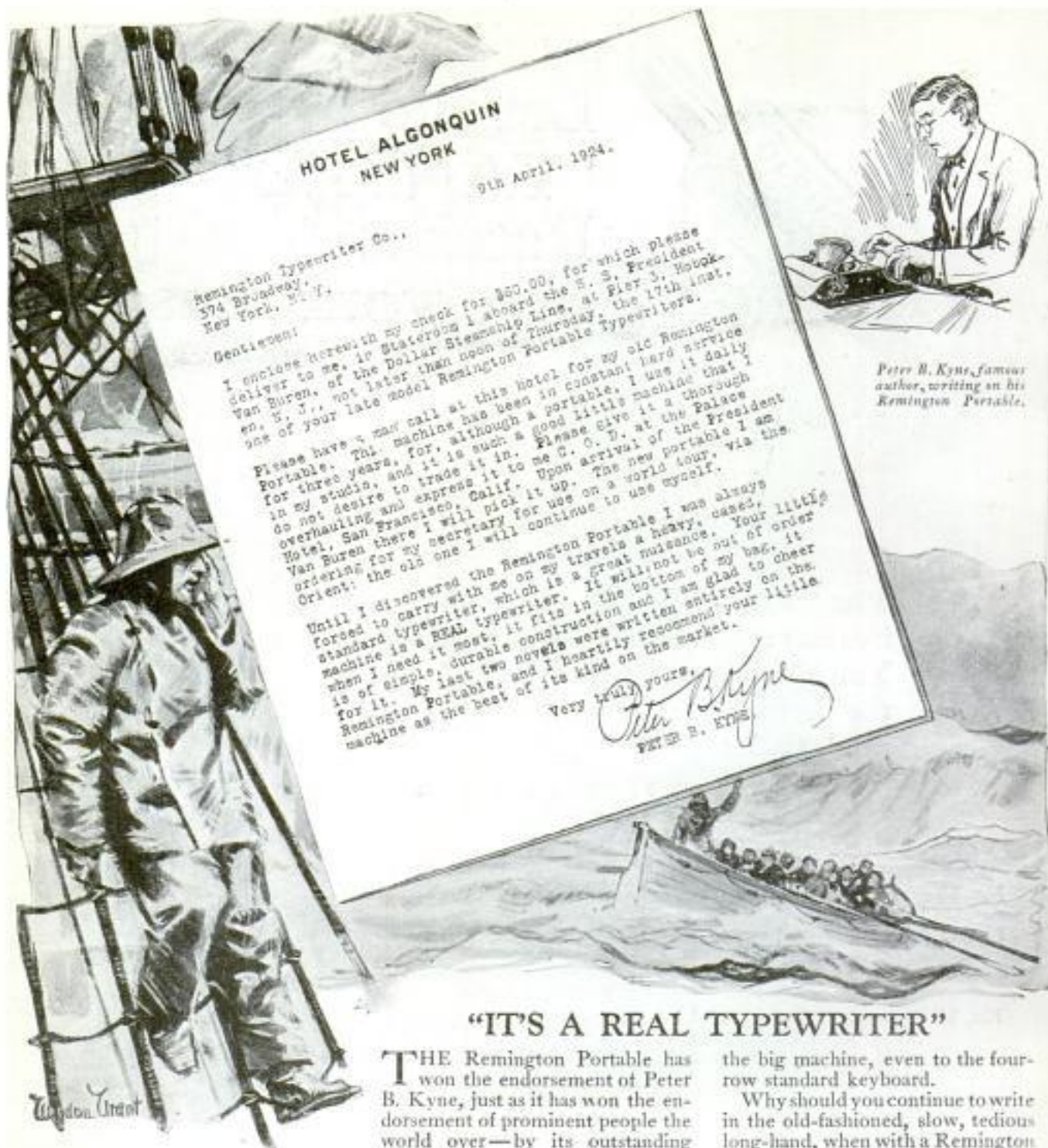

Peter B. Kyne, famous author, writing on his Remington Portable.

HOTEL ALGONQUIN
NEW YORK

9th April, 1924.

Remington Typewriter Co.,
374 Broadway,
New York, N. Y.

Gentlemen:

I enclose herewith my check for \$85.00, for which please deliver to me, in Stateroom 1 aboard the S. S. President Van Buren, of the Dollar Steamship Line, at Pier 3, Hoboken, N. J., not later than noon of Thursday, the 17th inst. one of your late model Remington Portable Typewriters.

Please have a man call at this hotel for my old Remington Portable. This machine has been in constant hard service for three years, for, although a portable, I use it daily in my studio, and it is such a good little machine that I do not desire to trade it in. Please give it a thorough overhauling and express it to me C. O. D. at the Palace Hotel, San Francisco, Calif. Upon arrival of the President Van Buren there I will pick it up. The new portable I am ordering for my secretary for use on a world tour, via the Orient; the old one I will continue to use myself.

Until I discovered the Remington Portable I was always forced to carry with me on my travels a heavy, cased, standard typewriter, which is a great nuisance. Your little machine is a REAL typewriter. It will not be out of order when I need it most, it fits in the bottom of my bag, it is of simple, durable construction and I am glad to cheer for it. My last two novels were written entirely on the Remington Portable, and I heartily recommend your little machine as the best of its kind on the market.

Very truly yours,

Peter B. Kyne
PETER B. KYNE

"IT'S A REAL TYPEWRITER"

THE Remington Portable has won the endorsement of Peter B. Kyne, just as it has won the endorsement of prominent people the world over—by its outstanding superiority.

Many present owners, like Mr. Kyne, have operated other typewriters. In the Remington Portable they have found a compact machine which meets every requirement, built to do beautiful work, and possessing every feature common to

the big machine, even to the four-row standard keyboard.

Why should you continue to write in the old-fashioned, slow, tedious long-hand, when with a Remington Portable you can turn out a beautifully clear and legible printed page, with far less time and effort? Sold by all Remington branches, and over 5,000 dealers. Easy terms.

Illustrated "For You—For Everybody" will be sent upon request. Address Department 12.

REMINGTON TYPEWRITER COMPANY

374 Broadway, New York City

Remington Portable

THE RECOGNIZED LEADER—IN SALES AND POPULARITY



The Resolution that protects you when you go to buy a saw

Among many Disston favorites are these:



Disston D-8. The world's standard for all around work.



Disston No. 7. A general purpose Saw for those who like the straight back style.



Disston Back Saw No. 4. An efficient Saw for cutting mitres, fine joints or stock of small dimensions.



Disston Novelty Saw. A bench saw for cutting any kind of wood. Insures a smooth, even cut. Used for cross cutting and ripping.

AGAIN the Disston Saw Works was overwhelmed with orders for "The Saw Most Carpenters Use."

The directors—sons and grandsons of Henry Disston—were in session. What could they do to satisfy hardware merchants whose customers were demanding Disston Saws?

Every man present had served in the shops. Each knew that saw steel, and saws, could be made faster and cheaper.

Yet such steel would not have been Disston Steel, nor such saws Disston Saws. So the heads of the industry reaffirmed the Disston policy, and spread it on the minutes of the board.

"No changes shall be made . . . in steel . . . not standards" except for betterment.

That was years ago, but the order stands today, to safeguard the users of Disston Saws.

Disston craftsmen know only one standard of workmanship. They never will know any other.

Henry Disston, father of modern saw-making, won fame with the saws that he made with his own hands. Then, with years of training, he taught others to make saws just as he made them.

These men taught their sons, and they their grandsons. For those who make Disston

Saws look upon their skill as a legacy, to be handed down through the years.

In the Disston Shops today are 304 men who have been making Disston Saws 30 years or longer; 80 with 40-year records; 36 with 50 to 62 years of service.

You, as a saw user, want a hand saw that will give you life-long service. A saw that runs easy, cuts straight to the line, cuts fast without binding. A saw balanced so nicely that you feel it was made for you alone!

To get this saw, be sure you see the Disston name on it.

Disston put balance into the hand saw; gave it the taper that makes your work easy; created the Disston steel that, fortified with Disston tempering, holds the keenest cutting edge.

Disston Circular Saws, Band Saws, Hack Saws, Circular Metal-Cutting Saws, etc.—hundreds of kinds, for thousands of uses—all are made with the same care and skill as "The Saw Most Carpenters Use."

Ask Disston

Tell us what kind of work you are doing, in wood, metal, stone, or other material, and we will tell you what types of saws to use. Disston issues many books to aid the user of saws and tools.

HENRY DISSTON & SONS, Inc.
Philadelphia, U. S. A.

Hardware dealers the world around sell Disston Saws, Tools, and Files

DISSTON



The famous 20th Century Limited,
New York to Chicago in 18 hours.

The Famous "Lionel Standard" Limited No. 403. Compare this with the picture at left—the only difference between Lionel and real trains is the size!

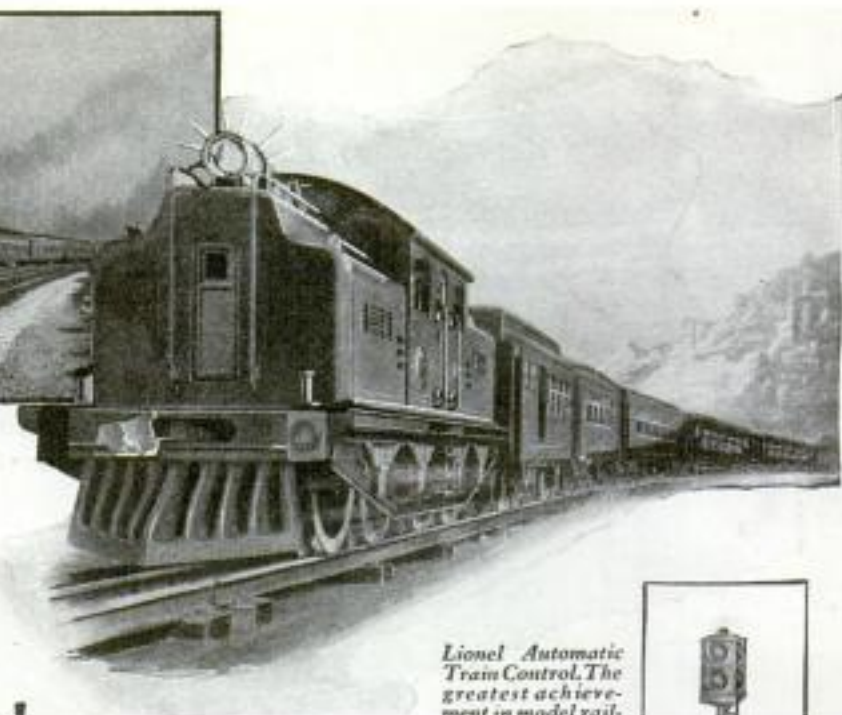

YOU BOYS be the Judge!

LIONEL Standard vs. "Toy Railroads"

HERE is a photograph of the new Lionel "Super Twin Motor" Locomotive. It is an exact reproduction of the great, powerful N.Y. Central locomotive shown beside it.

Compare it with any ordinary "toy" locomotive and you'll see why Lionel locomotives, cars and equipment are better—you'll understand why more Lionel Trains are sold than any other make.

For 25 years Lionel has specialized exclusively in the manufacture of model electric railways—not mere "toys". Since 1900 Lionel products have been the world's standard of comparison. Lionel has always pioneered in originating new mechanical and electrical refinements and improvements.

The only difference between Lionel and real trains is the size.

The maker of a "toy" expects you to play with it for a while

and then break it or lose it or forget all about it.

But Lionel wants you to enjoy operating your Lionel Model Railroad for years and then be able to pass it along to your younger brother or even your own son—as good, as strong and as beautiful as when you get it on Christmas morning.

And you'll be surprised, too, at the low prices of Lionel Model Trains and equipment—the lowest on the market consistent with their design, workmanship and materials.

Complete Lionel Model Railroads are priced as low as **\$5.75**. There's an outfit to suit every purse. (Prices are slightly higher in the far west.)

See "Lionel Standard" Model Railroads at any leading toy store, department store, electric shop, sporting goods or hardware store.

Lionel Automatic Train Control. The greatest achievement in model railroad engineering. Starts and stops trains automatically. Just one of the many wonderful realistic railroad devices in the Lionel line of Accessories.



Lionel "Multi-volt" Transformers. Ever-reliable power plants. Run all trains best. A type for every size train.

Send for this Catalog

Be sure to send a postcard today for this wonderful 44-page catalog, beautifully illustrated in 4 colors. It is FREE!



The LIONEL CORPORATION

Dept. D

48-52 East 21st Street New York City

LIONEL ELECTRIC TRAINS
MODEL RAILROAD ACCESSORIES
"MULTIVOLT" TRANSFORMERS

Concentrated energy—rarin' to go

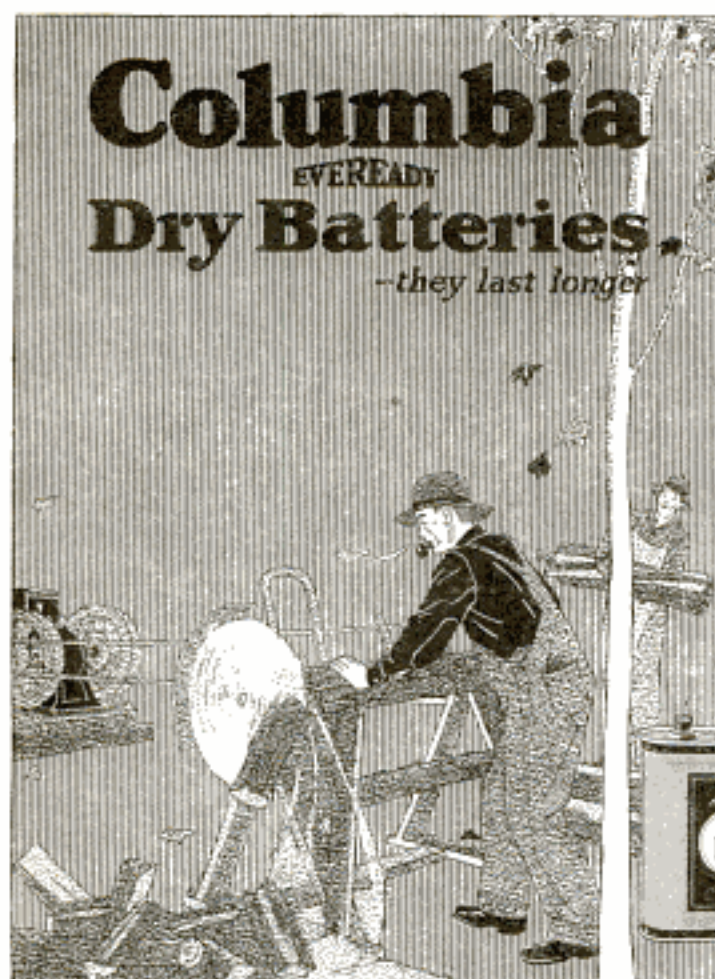

Columbia
EVEREADY
Dry Batteries.
—they last longer

for

- gas engine ignition ✓
- telephone and telegraph
- doorbells
- buzzers
- motor boat ignition
- heat regulators
- tractor ignition
- starting Fords
- ringing burglar alarms
- protecting bank vaults
- electric clocks
- calling Pullman porters
- firing blasts
- lighting tents
and outbuildings
- running toys
- radio "A"



Columbia Hot Shot contains 4, 5 or 6 cells in a neat water-proof steel case.

POWER and pep set on a hair trigger, that's what the Columbia Hot Shot brings you. Hitched to a gas engine these electrical huskies hop on the job instantly. Their fat, hot sparks explode the whole charge, bringing to the work power that makes saws zip through the heaviest logs. For farm and mine and camp; at home and afield, Columbia Eveready Dry Batteries are ever-ready to put their last ounce of energy into the job.

When idle, Columbia Evereadys do not fret away their strength. Resting, they renew their energy and store up fresh pep to zip through the circuit at the word "go."

Don't just ask for "a dry cell." Ask for "Columbia Eveready" by name and get 100% battery efficiency. Columbia Eveready Dry Batteries are sold by implement dealers, electrical, hardware and auto accessory shops, radio and marine supply dealers, garages and general stores—Columbia Eveready Ignitors can be purchased equipped with Fahnestock spring clip binding posts at no extra cost to you.

Manufactured and guaranteed by
NATIONAL CARBON COMPANY, INC.
New York San Francisco
Canadian National Carbon Co., Limited, Toronto, Ontario

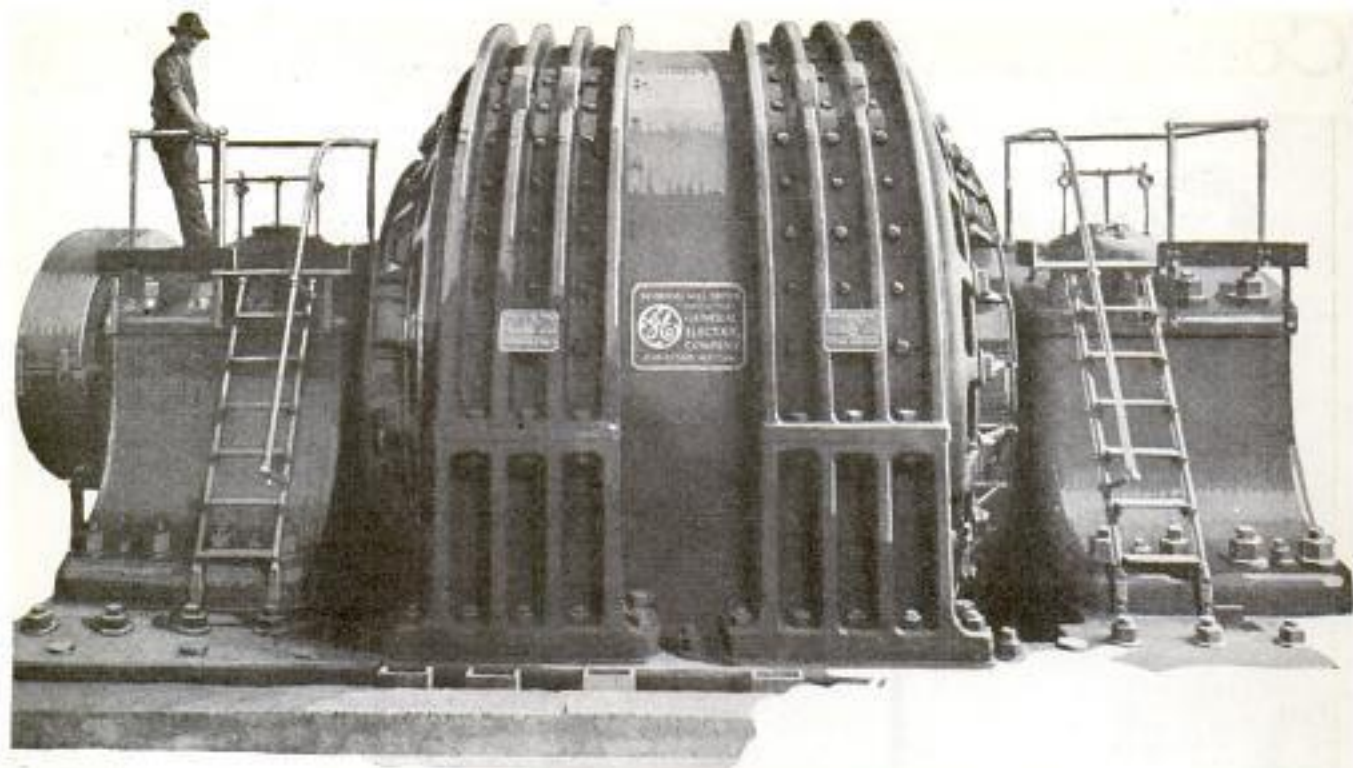

In spite of its size and the enormous power developed by this reversing blooming mill motor it reverses many times a minute. Its maximum rating is 22,000 h.p., equivalent to the muscle power of 176,000 men.

“The 100,000 Man”



Look closely at the picture of this great motor installed in the plant of a large steel company, and you will see the monogram of the General Electric Company, an organization of men and women who produce equipment by which electricity does *more and better* work.

Of Napoleon it was said that his presence on the battlefield was equivalent to 100,000 additional men. “The 100,000 man,” his enemies called him.

Napoleon dealt in death. Big General Electric motors, like the one in the picture, lift heavy loads off human shoulders, and contribute to the enrichment of life.

GENERAL ELECTRIC



Atlas

TRADE MARK

RADIO REPRODUCTION

speaker

ATLAS floods the room with the best that's in your set. Write for the interesting booklet you ought to read before buying any speaker.

Multiple Electric Products Co., Inc., 36 Spring Street, Newark, N. J., Dept. W.
New York, Boston, Philadelphia, Baltimore, Pittsburgh, Detroit, Chicago, St. Louis, Denver, 550 Howard Street, San Francisco.

Marconi Wireless Telegraph Co. of Canada, Ltd.
Sole Canadian Distributors

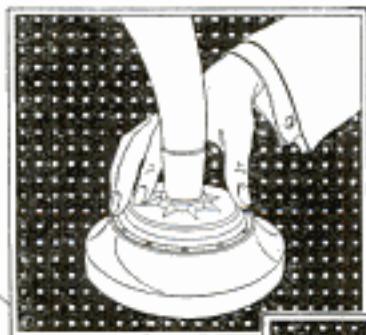

A slight turn of the exclusive Atlas harmonizer (Pat. applied for) — and your speaker is harmonized with the broadcast you are hearing and the set you are using. It gives you radio — as you ought to hear it.

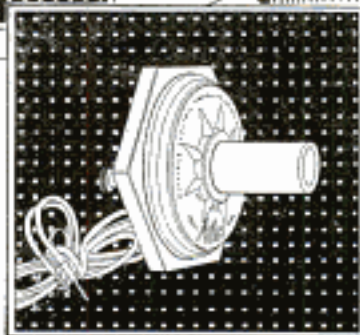

Atlas unit, with attachment couplings to fit all standard phonographs.

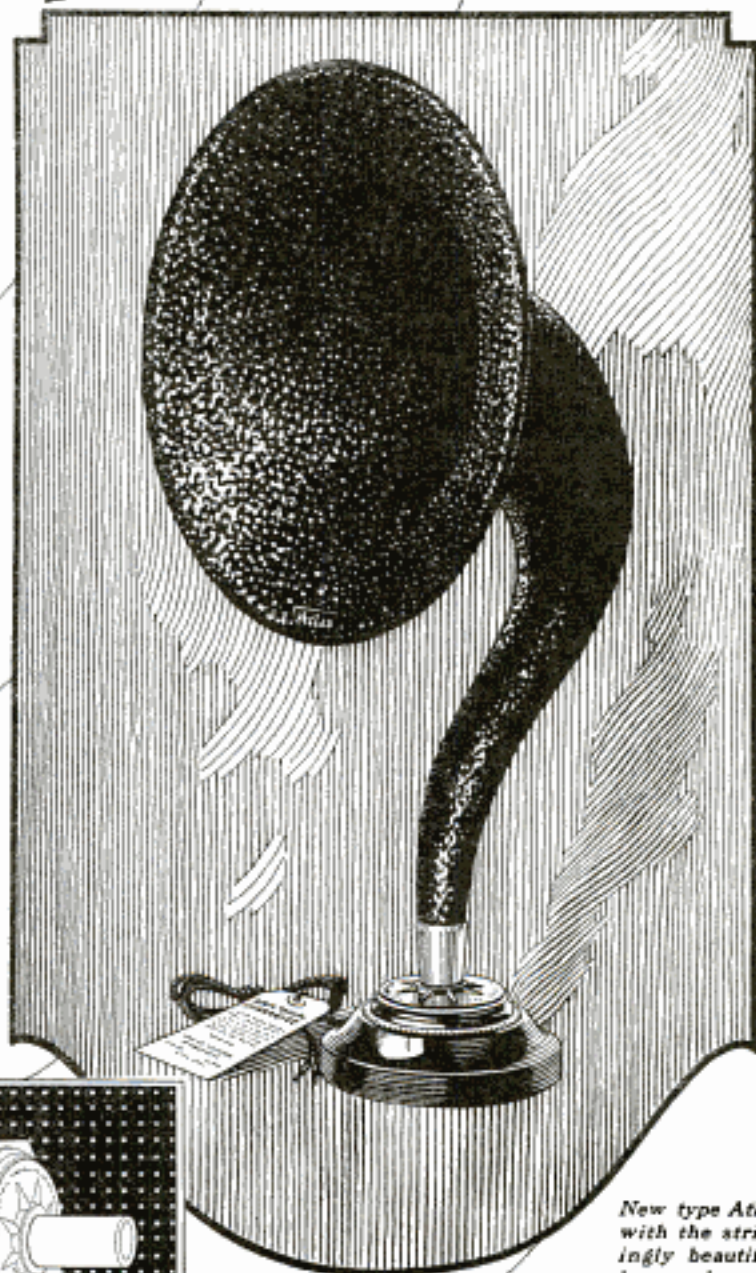

New type Atlas with the strikingly beautiful bronze-brown ripple-finish gooseneck horn.

NEW TOOLS ~

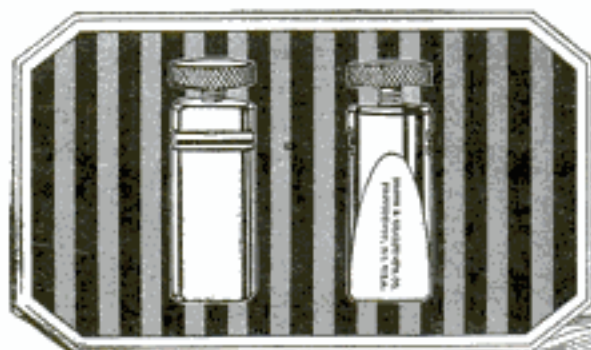

Key Seat Clamps No. 377

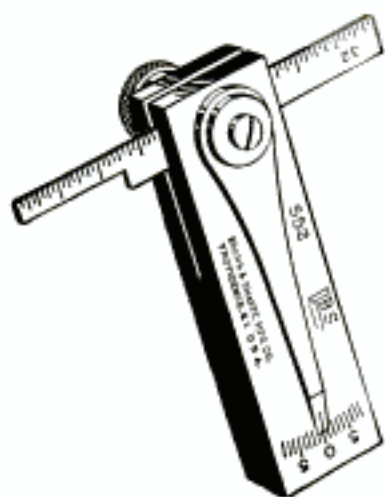

Die Maker's Square No. 552



Inside Micrometer No. 264



Designed to help you do more accurate work

These new Brown & Sharpe Tools contain the time and labor saving features in which you are interested. The new features help you to do more accurate work.

Experienced tool designers have made possible these tools for you. They have studied your more exacting requirements and experimented with new designs and models—always with the one object of providing tools that will enable you to accomplish your work in an easier and more accurate way. They are tools from which you will receive the accuracy and efficiency that you must depend upon.

A few of these new tools are illustrated on this page. Many others are described in our new No. 29 Small Tool Catalog.

Write for a copy today.

BROWN & SHARPE MFG. CO.
Providence, R. I., U. S. A.

BROWN & SHARPE TOOLS

"Standard of the Mechanical World"

*The
new*

CORONA FOUR

STANDARD four-row keyboard!
Office sturdiness! As wide as the
heavier makes, but built lower.
Corona now brings you, for the first
time in typewriter history, a model
that meets every office requirement
—and yet is portable.

Look for "Corona" in your phone book
or send the coupon below for the whole
story of Corona Four.

CORONA TYPEWRITER CO., INC.
108 Main Street, Groton, N.Y.



CORONA TYPEWRITER CO., Inc.
108 MAIN ST. GROTON, NEW YORK

Please send me full information
about Corona Four and the address
of the nearest Corona Store

Name _____

Address _____

City _____

“What a whale of a difference
just a few cents make!”



—*all the difference*
between just an ordinary cigarette
and—**FATIMA**, the most skillful
blend in cigarette history.

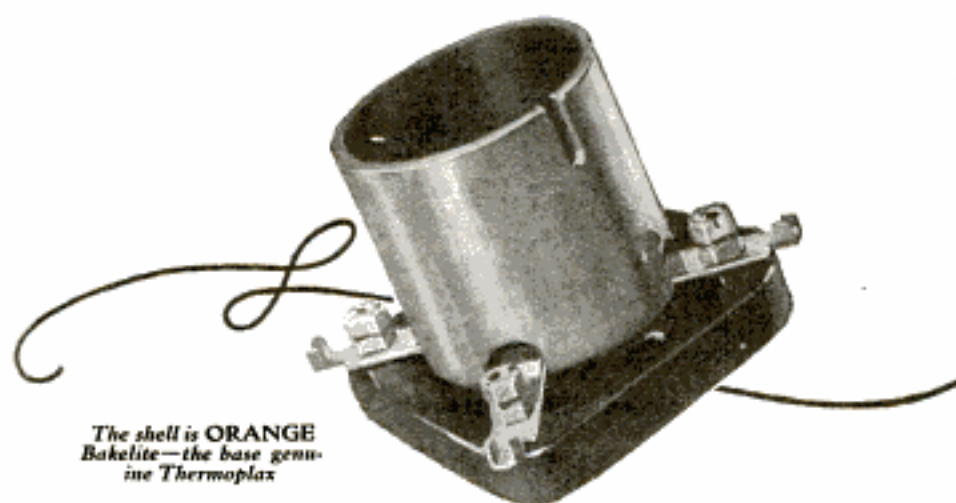

The shell is ORANGE
Bakelite—the base genuine
Thermoplas

At Last—A Radio Socket Worthy of This Famous Trade Mark

After months of experiment and research the Cutler-Hammer engineers announce this masterpiece of radio socket design. With features never before found in any socket, it brings to your set a degree of efficiency that means added miles of range and hours of clearer, more enjoyable reception.

Capacity has been absolutely minimized—without sacrifice of mechanical strength, and its base of ebony black Thermoplas in beautiful color contrast with the thin shell of orange Bakelite adds as much to the appearance of any set as this socket's construction does to its efficiency.

You'll like all of its many exclusive features—the silvered bronze contacts that afford *permanently* perfect contact; the slotted binding nuts; the handy terminals for soldering; the wide spacing of current carrying parts.

You'll like its appearance—neatness—small size. You'll like the way the tube is inserted and removed without twisting. And best of all, you'll like the price, 90c. *This socket that meets the specifications of the most exacting radio engineer costs no more than most of those on the market today.* Until all dealers have been stocked, you can be supplied direct from the factory at the retail price plus 10c for packing and postage. Be sure you have the genuine—it will pay you in every way to refuse all substitutes.

THE CUTLER-HAMMER MFG. CO.

Member Radio Section, Associated Manufacturers of Electrical Supplies

MILWAUKEE, WISCONSIN



*These Exclusive
Features Assure Better
Reception*

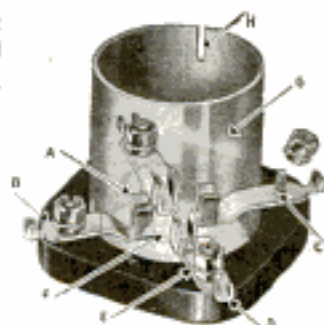

A

Perfect contact. Both sides of tube prong cleaned when inserted—no contact or wear on soldered end.

B

All metal parts silver plated—perfect contact for the life of the set. Silver may tarnish but its contact resistance does not change.

C

One piece contact construction. The binding post is NOT a part of the circuit—the wire to the socket always touches the contact strip which carries the current direct to the tube prong—no joints to cause losses.

D

Convenient terminals for soldering—full length to allow bending down for under-wiring. Ears hold wire in place for soldering.

E

Extra handy blading posts—tight connections with either wrench or screw-driver. Lock washers hold terminals rigid.

F

Wide spacing of current carrying parts both in air and insulation—true low-loss construction.

G

A minimum of both metal and insulation for low capacity. Shell of thin Bakelite—the base of genuine Thermoplas.

H

The tube is held in place by merely a vertical motion—no twisting to separate bulb from base.

The attractive orange shell helps identify this better socket, but the famous C-H trade mark both on the socket and on the orange and blue box is your genuine protection.



RADIO SOCKET

OXO-GAS OIL BURNERS

OXO-GAS OIL BURNERS

For

Furnaces
Cook Stoves
Large Ranges
Heating Stoves
Base Burners
Shipmates
Bake Ovens
Vulcanizers
Hot Water Heaters
Hot Plate Heaters
Water Coil Heaters
Camp Stoves

And many other
purposes

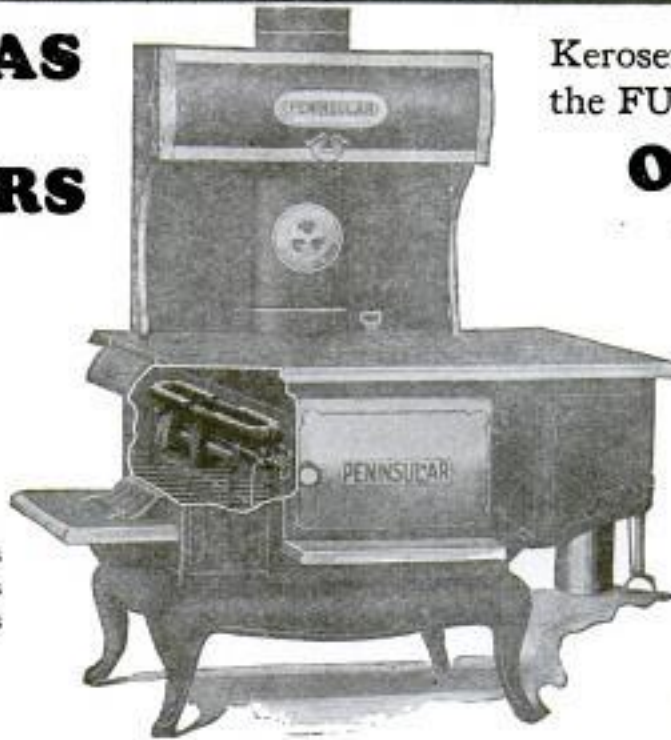

Kerosene or Distillate and Air
the FUEL.

OXO-GAS

the RESULT!

A pure blue flame of
high heating efficiency.

Burns as silently as city
gas. The cheapest,
cleanest and most
efficient fuel known to
science.

*Illustrating OXO-GAS Burner
in Cook Stove—installed in a few
minutes—lasts a lifetime—pays
dividends in money, health and
happiness.*

OVER A MILLION IN EVERY DAY USE

Big Four Furnace Burner



The BIG FOUR
Furnace Burner
will operate
perfectly in any
standard furnace for heating homes up to twelve
rooms. Easily and quickly installed without any
change in the furnace. No noisy motors or other
machinery. Will give a lifetime of clean, cheap,
efficient service. So low in price that anyone
can afford it.

Heat, plenty of it, in
base burner or heat-
ing stove. Clean,
satisfactory, econom-
ical, convenient as
steam heat. Brings
happiness, plus.



Agents Wanted Some
choice
territory for OXO-GAS agencies still open
to thoroughly responsible parties. Your
own locality may yet be unassigned. Just
write and ask us for our agent's proposition,
and we will discuss the matter with you
either by mail or in person.



Hot water in any
quantity—The simplest
method of heating water
ever conceived. Just
light the heater, then no
more bother. Its price
within the reach of all.

Gloria Light Company

[Established 1906]

111-11 North May Street

CHICAGO, ILLINOIS

Clever mechanical contrivance makes cold radiators HOT

AT LAST steam has conquered its greatest enemy—*cold air!* A newly perfected and improved *air valve*, known as AIRID, has been produced after many years of experimenting in the Institute of Thermal Research at Buffalo, N. Y. This valve not only rids steam radiators of cold air under all conditions of operation, but automatically prevents the escape of the steam itself. The result is hot radiators.

*Installed by anyone in 2 minutes—
and works without adjustment*

No tools are needed to install AIRID. It is made to fit the same hole provided for old-fashioned air valves, and is tightly screwed on in a few seconds.

After that, it need never be touched. There is nothing to adjust and no one can tamper with it. AIRID works automatically and permanently to keep the radiator hot.

Why many radiators are half cold

Coming up from the boiler, steam pushes cold air ahead of it. Unless the air can get out, it fills the farther end of the radiator, and acts as a wall to keep back the steam. Hence many good radiators are continually half-cold.

If you examine AIRID closely, you will notice a tiny hole at the very top of its nickel-plated cone. Out of this hole the air can pass freely, until the radiator is full of hot steam. But this is only half the story.

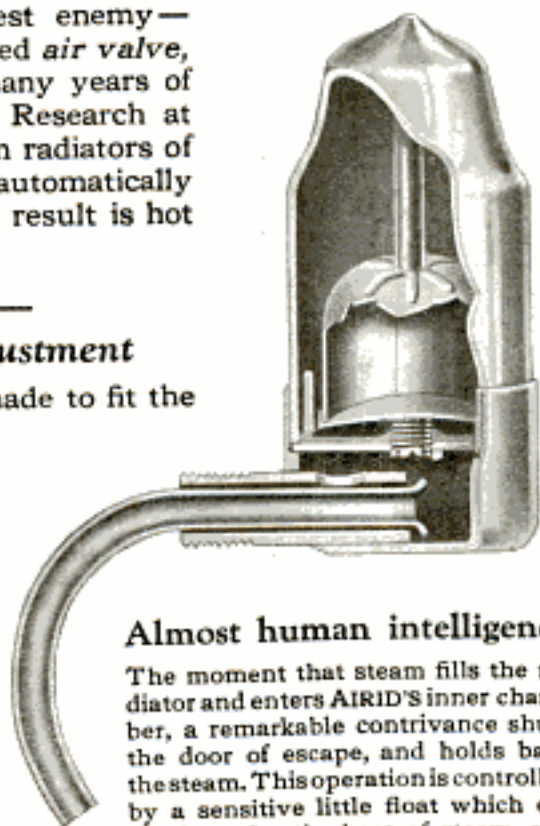

Almost human intelligence

The moment that steam fills the radiator and enters AIRID'S inner chamber, a remarkable contrivance shuts the door of escape, and holds back the steam. This operation is controlled by a sensitive little float which expands under the heat of steam, and forces a pin up into the vent-hole—making the valve absolutely tight.

Water, always present in the steam pipes, will very often get into the chamber of the air valve. This menace has been foreseen and provided for: the float rises on the water and immediately shuts the vent. A glance at the illustration of AIRID will show you the ingenious syphon-pipe which draws the water back into the radiator. Because the valve chamber is free from water, the path of escape is always open for cold air.

SEND COUPON with \$1.60 and watch AIRID work

AIRID is guaranteed by the American Radiator Company. The only way to appreciate how different it is from all other air valves is to see it work. Try it on your coldest radiator; transform your chilliest room. Fill in the coupon, attach \$1.60,

and your first AIRID will come to you by return mail. Your heating contractor can sell you more AIRIDS at the same price, after this one has demonstrated its magic power to make a cold radiator hot.

Made and guaranteed by
AMERICAN RADIATOR COMPANY

Sold at all heating and plumbing shops

AMERICAN
RADIATOR
COMPANY
Specialties Dept.
1807 Elmwood Ave.
Buffalo, N. Y.

I am enclosing \$1.60 for an
AIRID Air Valve to make my
coldest radiator hot.

Name.....

Address.....

AIRID

1934 Trained Factory Representatives

Are Now Entitled to Wear That Button

Ozarka
Four Tube Sets
As Low As
\$39⁵⁰



Today 1934 factory trained representatives are authorized to wear the Ozarka button. These men know the Ozarka perfectly; more are now being trained; soon there will be one in every town.

Without obligation to you, the Ozarka representative will set up an Ozarka in your home on trial. He won't claim that it is better than others. All he asks is the opportunity of letting the Ozarka do its own selling. With *your own operating* you must satisfy *yourself* that it has no equal for volume, tone, distance and ease of operation.

The Ozarka Representative will erect the most effective aerial possible. He will teach every member of your family how to receive results from your Ozarka which will make you the envy of your radio friends. More than this, he *can* and *will* keep your instrument working perfectly at all times. Ozarka quality speaks for itself. Ozarka prices, quality considered, are low. \$39.50 and up.

Let us send you the stories of Ozarka long distance reception—from many people who have heard London and Manchester, Eng., Cardiff, Wales, Glasgow, Scot., Buenos Aires, So. Am. and even Honolulu, Haw. Is. Write for Free illustrated book No. 200. Please give name of your county.

OZARKA, INC., 851 Washington Blvd., Chicago, Ill.



Radio With Service

OZARKA radio instruments are demonstrated, sold, installed and serviced by direct factory representatives only. These men have been thoroughly trained by our own engineers who designed and perfected Ozarka.

The success of any radio instrument, like the automobile, depends on the quality of service rendered.

No matter how perfect any radio instrument leaves the factory, little things may sometimes go wrong. You've no doubt learned, by costly experience, that the ordinary handy man cannot properly service your automobile. The same is true of Radio. Troubles are generally caused by very little things which are exasperating to the owner, but are quickly corrected by the man who is trained on that instrument.

More Ozarka Representatives Wanted

1934 factory representatives are today making a success under the Ozarka plan and are building up a profitable, substantial business of their own. Many started by giving us only their spare time, but their profits soon justified breaking away from their salary job for all time.

Possibly Ozarka is just the opportunity you have been looking for. A technical knowledge is not essential. In fact, we prefer men who know nothing of radio that we may teach them our way.

Compensation is on a commission basis only. The investment to start is small but absolutely necessary.

The man we want is mechanically inclined and willing to learn. He may not be a salesman but he can talk convincingly on something he knows perfectly and firmly believes in.

The Ozarka Plan will give such a man more money, more independence, and a real opportunity for a permanent, profitable business of his own, which will quickly justify giving it all of his time.

The Ozarka Plan is fully described in a large illustrated book. A copy will be sent to men who are willing to tell us fully about themselves. The Ozarka book is a true and interesting story of life, of men, of why some fail, while others succeed.

In territory not now covered the right man is wanted—one who is determined and willing to put forth the necessary effort to obtain a splendid, profitable business of his own. If you are that kind, simply write and say "Send me your Ozarka Plan Book No. 100." It may be the turning point in your life. Don't fail to mention the name of your county.





This new IVES electrically-reversing locomotive is a wonder!

All aboard, Boys - for the best fun ever!

YOU boys like something new — something different. Ives wonderful electrically-reversing locomotive is both. It's a new and revolutionary invention—the only toy locomotive in the world that will reverse electrically without being touched by hand. The same control switch regularly operating any electric locomotive also operates the reverse mechanism in this new one on any regular $2\frac{1}{4}$ -gauge track.

Open the control and, with headlight blazing, each car illuminated, speed over your own branch of the Ives Railway Lines—a system with trackage sufficient to extend

from New York to San Francisco, including branch lines, indoors and out, all over the country.

Ives Toys make happy boys

THERE'S an Ives Train to suit every purse and to give pleasure to boys of every age. No matter whether you have the train illustrated above, No. 704-R, with electrically-reversing locomotive and individually lighted cars, running on $2\frac{1}{4}$ -gauge track—or train No. 505, a snappy little train that costs only \$5.75 and runs on 0-gauge track—your fun will be all the same.

Send for fascinating booklet

Our new 32-page book in color illustrates and describes the complete line of Ives Trains and accessories, including the electrically-reversing locomotive, passenger and freight cars, bridges, switches, stations, new electric signals, etc. A copy will be sent you for 10c. Mail the coupon today.

Ives Trains are sold by toy, department, electrical and hardware stores everywhere.



THE IVES MANUFACTURING CORPORATION,
196 Holland Ave. Bridgeport, Conn.
Please mail me your 32-page railroad book illustrated in colors, showing the complete line of Ives Trains, Locomotives, New Signals and Accessories. I enclose 10c (U.S. stamps or coin).

Name.....
Address.....
City..... State.....

THE IVES MANUFACTURING CORPORATION
196 Holland Avenue Bridgeport, Conn.

IVES AND MECHANICAL TRAINS



“That’s the Efficiency Expert”

“Going to show us how to speed up production and eliminate lost motion in the shop.”

“And trying to get accurate measurements with a woven tape! For Pete’s sake, let him take your Starrett. If he thinks as much about *his* time as he does ours, he’ll thank you for it.”

QUICK READING

The steel-bright figures and graduation marks on a Starrett Tape show up plainly against the jet-black background. As a further aid to fast, accurate reading the foot figure is placed alongside each inch mark so that the measurement in feet and inches can be seen at a glance. And Starrett Tapes being made of a fine quality steel do not shrink or stretch—they are indispensable where close measurements are required over comparatively long distances. For sale at good hardware stores everywhere. Write for the Starrett Catalog No. 23 “AP” for description of the many different sizes, graduations, etc.

THE L. S. STARRETT CO.

World’s Greatest Toolmakers—Manufacturers of Hacksaws Unexcelled
ATHOL, MASS.



AUTO-MECHANICS!

Get “The Starrett Book for Motor Mechanics and Auto-Repairmen” at any hardware store selling Starrett Tools. Or write us. Costs only 75 cents and a good buy at four times the price.



6956

Starrett Steel Tapes





The 21 Jewel Santa Fe Special Look sent on approval

Send no Money

We will send this famous watch, express prepaid, for you to examine, to inspect, to admire, to approve, without one penny advance payment. Examine the watch and be convinced it's the best watch buy you ever saw, then just a small payment down, the balance in easy MONTHLY payments. You use the watch while paying for it.

Save $\frac{1}{3}$ to $\frac{1}{2}$ of Your Money

by purchasing this famous Santa Fe Special Watch. Not only are you saving money from the present day prices of watches, but you can still secure the "Santa Fe Special" Watch at the same low prices and terms that have made our watches famous.

Ladies' Wrist Watches—The New Elite

This Artistic, dependable Ladies' Wrist Watch, fitted with genuine Illinois Springfield movements. A perfect timepiece. Beautiful 14 Karat white or green solid gold cases. Ask for New Watch Book showing cases in all the new shapes and designs. Watch sent on approval and sold on payments.

Send for Free Watch Book

Clip the coupon, fill out and receive the FREE WATCH BOOK. All the newest watch case designs in white or green gold, fancy shapes and thin models are shown. Read our easy payment offer. Wear the watch 30 days FREE. Watch sent for your examination and approval without a penny down. Nothing to risk. See the watch before you buy.

Write for FREE book Today and Select Your Watch—Mail Coupon.

Santa Fe Watch Company,

Dept. B-6, Thomas Building, Topeka, Kans.
The Home of the Great Santa Fe Railway

Ask for our Beautiful Diamond Book FREE. Shows all the new styles in rings and tells about our rock bottom prices and our charge account plan.



A few cents a day makes you own a diamond.

Santa Fe
Watch Co.
Dept. B-6

Thomas Building,
Topeka, Kansas

Please send prepaid and without obligation your Watch Book Free, explaining your "No Money Down" Offer on the Santa Fe Special Watch.

Name

Address

State

FREE BOOK COUPON



Photo by Underwood & Underwood

"He kept his feet!"

It means as much in basketball as to say "he kept his head!"

Sureness of foot—it's just as important in basketball as speed, endurance or good "head work." Shoes that can't grip the smoothest floor with dead certainty are worse than useless in a fast game.

By actual measurement the "non-skid" quality of the new Keds basketball shoe is greater than any other basketball shoe on the market today. That's why leading coaches endorse this shoe and why many college basketball teams are using it.

Keds come in many styles and models. There's a Keds model suitable for every sport purpose. They are designed by men who know athletics and athletic requirements.

When you get your sport shoes this season—get the shoes athletic leaders are using!

IMPORTANT: Keds are made only by the United States Rubber Company. While there are other shoes that may at first glance look like Keds, no other shoe can give you Keds service. If the name Keds isn't on the shoes they are not real Keds.

The 1924 Keds Hand-book for Boys is full of things every boy will want to know about. How to make things—rules for games—woodcraft, etc. Sent free if you address Dept. 636, 1790 Broadway, New York City.

United States Rubber Company



*They are not Keds
—unless the name Keds
is on the shoe.*



The special Keds basketball shoe. Its tough, springy sole grips the smoothest floor.

Keds

Trade Mark Reg. U. S. Pat. Off.

Why not YOU?



Isham Jones is one of the many popular stars who use and endorse the Conn saxophone.



Isham Jones, the famous soloist and orchestra leader, has made a fortune with his Conn saxophone. You can learn to play a Conn quickly and easily. Then great opportunities for pleasure and profit are open to you.

Conn saxophones, used by the most famous stars, recognized as supreme in tone, tune and easy playing qualities, may be had on Free Trial; Easy Payment plan. Write for catalog and details.

C. G. CONN, Ltd., 1131 Conn Bldg., Elkhart, Ind.

CONN

BAND INSTRUMENTS
WORLD LARGEST MANUFACTURERS

Delivered to You Free

for 30 days trial on approval. You can have your choice of 44 Styles, colors and sizes of the famous RANGER Bicycles. Express prepaid. Factory-to-Rider Prices save you \$10 to \$25 on your bicycle.

\$5 a Month if desired. Many boys and girls easily save the small monthly payments.

Parents often advance first payment. Best quality, at factory prices, express prepaid. Tires, wheels and equipment, low prices. Send No Money, do business direct with makers.

Mead CYCLE COMPANY
DEPT. 105 CHICAGO

Write today for free Ranger Catalog, factory prices and marvelous easy payment terms.



Thrilling Fun Every Minute

With the New Indian Scout



Gets away as quick as a flash. Goes 60-75 miles to the gallon. Tires good for 10,000 to 15,000 miles. 100 pounds lighter than average motorcycles yet powerful and perfectly balanced. 1925 Model has 20% more power and lowest price ever. Ask your Indian Dealer about it or write us for free literature and name of your Dealer.

Indian Motorcycle Co., Dept. P-11, Springfield, Mass.

Marvelous New Lamp

Now Only \$5⁹⁵

Biggest Bargain ever known in the lamp industry



An amazing low price and tremendous value.

Intense White Light

Our new 1924 burner produces a white light of marvelous brilliancy, a light so bright and clear that you'll prefer it to electric light. Nothing like it on the market; we are exclusive owners of 1924 patents on this new lamp.

Imported Shade Free—This price covers lamp only but if you write now we will include beautiful imported glass shade FREE.

Don't Miss This Great Offer

No matter what kind of lamp you are now using, don't overlook this wonderful opportunity for better light at lower cost. Send only \$1.00 and pay the small balance upon arrival or just send your name and address for complete information. Send now.

Special Offer to Agents

The Nagel-Chase Mfg. Co., 242 E. Erie St., Chicago

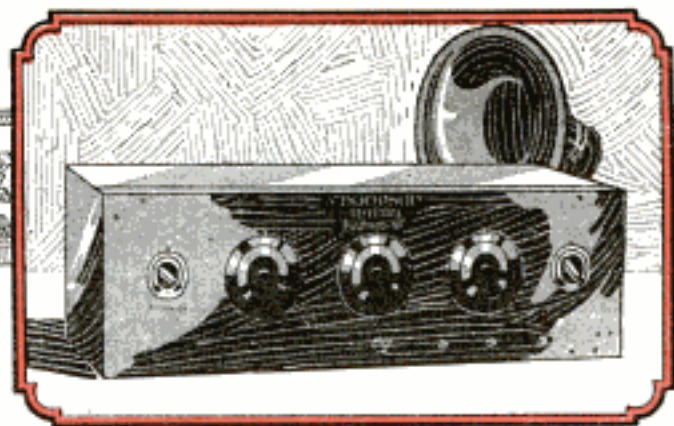

"EXPERIENCE IS THE VITAL FACTOR IN EXCELLENCE"

THOMPSON RADIO

Thompson radio products are as fully developed and as standardized in radio as is the telephone in wire communication. Thompson owners do not worry about how their set and speaker will compare with "next year's model." Perfection remains Perfection.

Thompson simplicity of operation as well as Thompson range and power makes it possible to receive the desired radio program just exactly as it is given before

the microphone. Those who wish real radio entertainment at low cost will be decidedly interested in the Thompson Neutrodyne Radio Receiving Set—NOW \$125—and the Thompson Speaker—NOW \$28.

The fully developed Thompson Radio Products at such reasonable prices are possible only to an organization that has been making radio products exclusively for many years.

If your dealer does not handle Thompson radio products, write to us for descriptive literature and the name of a Thompson dealer near you.

R. E. THOMPSON MANUFACTURING CO.
Manufacturers of Radio Apparatus for the U. S.
Army and Navy and numerous foreign governments
30 CHURCH STREET • NEW YORK, N. Y.
FACTORY: JERSEY CITY, N. J.

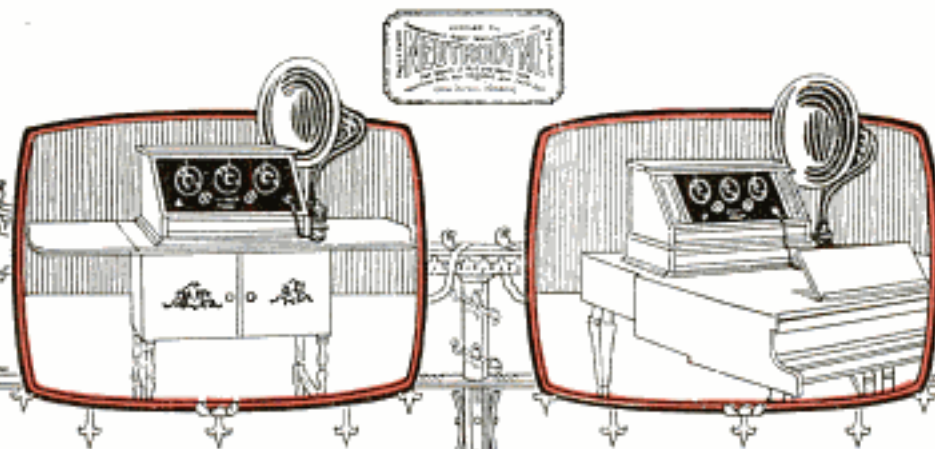



**Saw 15 Cords
a
Day
—Easy
!**



**"Men! Let Me Tell You About
this New Improved Power Saw!"**

**New
Selling at
Very Low
Prices**

HERE, folks is my new model OTTAWA Log Saw—my greatest achievement in over 20 years' experience in building machines to make farm work easier! It's a labor-saver that every farmer with wood or timber to cut needs right now! Easy to

own! I sell it Direct from my Factory—at a Low Factory Price! Makes 350 saw cuts a minute! Does the work of 10 good hired men. Fastest sawing, easiest moved, lightest weight, most powerful! Saws the human way.

Make Money! Coal is now price and wood in demand for fuel. Saw 15 cords a day. Just think, wood selling for only \$1 a cord would bring owner \$45!

OTTAWA 4 in 1 LOG SAW

SHIPPING POINTS

- OTTAWA, KANSAS
- Pittsburgh, Pa.
- St. Paul, Minn.
- Dallas, Texas
- Atlanta, Ga.
- Indianapolis, Ind.
- Portland, Ore.
- San Francisco, Cal.
- Memphis, Tenn.
- Albany, N. Y.
- Pueblo, Colo.



1-Falls Trees 2-Saws Logs 3-Buzzes Up Branches 4-Does Belt Work

Try 30 Days. Try a whole month at your own work. You can pay cash, or I'll arrange Easy Terms to suit. And remember, every OTTAWA is backed by my 10-Yr. Guarantee.

Send me a post card with your name and address for my new "Wood Sawing Encyclopedia." Big Special Offer and my Low Factory Prices. Right now's the time! Send today!



HARRY OVERMAN, Gen'l. Mgr.
OTTAWA MFG. CO.,
1742-0 Wood Street, OTTAWA, KANSAS
Room 1742-0 Magee Bldg., PITTSBURGH, PA.

SWEATERS Any Style or Design for Men, Women, Boys, Schools, Clubs, Teams. Order direct from mill. Save 20% to 30%. Any style, color or size, from stock or to order. Finest virgin wool. Send now for free catalog of big bargains. Special offers to schools, clubs, teams.
AMERICAN KNITTING MILLS, 1538 Clyburn Ave., Dept. 37, CHICAGO



GIVEN

Rush your name and address and learn how to get this handsome 14 Kt. gold filled man's watch and chain **ABSOLUTELY GIVEN**. Watch has 10 jewel Lever movement. Write today—don't delay for **FREE** watch plan.

RELIABLE SALES CO.
434 Broadway Dept. 277 New York City

**Save 1/2 on
PLUMBING AND
HEATING SUPPLIES**



If you are going to build or remodel let us show you how to cut your plumbing and heating bills in half.

Furnaces, Hot Water Heaters, Toilets, Bathroom Sets and fittings at way below regular prices. Our enormous buying power saves you money on Standard Grade "A" material. We furnish complete plans for installation without additional cost. Every article is guaranteed or money back. Send today for our big free book.

Book Free!



Just your name and address will bring you this free book—no obligation whatever. We want you to know about our plan and money saving prices. 25 years of experience at your service. Write us today.

**GOLDBERG
SUPPLY COMPANY**
Dept. A, Kansas City, Mo.

**PLAY INSTANTLY
WITHOUT
PRACTICE**

**PRICE
CUT TO
ONLY**

\$5.95

JAZZ-BO SAX

Not a toy but a full throated, full sized quality built reed wind instrument. One that you can be proud to own and play. Substantially made with heavy highly polished throat and bell. Can be used for solo work, accompanying, and in bands and dance orchestras. You play the Jazz-Bo Sax at once the minute it arrives. No knowledge of music required, no tedious lessons or long months of practice. For with each Jazz-Bo Sax even at the new low price of \$5.95 you get our wonderful Method enabling you to actually play popular Jazz the first time you take this handsome Sax in your hands. Entertain others and be the envid center of attraction wherever you go.

FREE Send today and you will receive **FREE** our wonderful new Easy Method, 30 pieces of music, and a fine Carrying Bag enabling you to take your sax with you wherever you go.
SEND NO MONEY Pay postman only \$3.95 plus a few pennies postage on delivery. If you are not satisfied just send it back and your money will be immediately refunded under the terms of our legal money back guarantee. No fairer offer can be made. Send at once.



**C. F. JOHNSON & CO., Dept. M133
10 W. Jackson Blvd. CHICAGO**



\$3 and it's YOURS

DOWN

The Greatest Typewriter Bargain Ever Offered

Right now we are making you the greatest typewriter offer you ever dreamed of—an eye opener. This wonderful standard Shipman-Ward Rebuilt Underwood only \$3.00 down. Ten days' free trial and the easiest monthly payments, shipped direct to you from our big factory.

10 Days' Free Trial From Factory to You

Yes, only \$3.00 down puts this genuine late model Shipman-Ward Rebuilt Underwood in your home. You can try it, test it, and then decide. See for yourself how new it is, how it writes. You must be satisfied. Your \$3.00 unconditionally returned if at the end of ten days you are not satisfied. The entire transaction will not cost you one cent.

EASY Monthly Payments

Little more than rental. Balance of payments so small you will hardly notice them, while you enjoy the use of this wonderful machine. You don't have to scrimp and save to pay cash. All at a big saving to you.

5 Year Guarantee

With every typewriter we give a written guarantee. These machines are rebuilt like new by the famous SHIPMAN-WARD PROCESS. Equipped with late improvements. You can't tell them from a new machine. The world's standard typewriter, the same models as sold by the Underwood Typewriter Company today, at a big saving to you. Act now! Get this splendid offer and save money.

These machines are shipped direct from our factory—the largest typewriter rebuilding plant in the world. They are rebuilt by the famous SHIPMAN-WARD PROCESS. Developed through 30 years in the typewriter business. Through our money saving methods of rebuilding and elimination of a large expensive sales force we are able to make this wonderful money saving offer to you. ACT TODAY, take advantage of it and you will SAVE MONEY. ACT NOW! Mail this coupon today.

Free Book of Facts

Write for this free book of facts explaining Shipman-Ward's wonderful system of rebuilding typewriters. We show you exactly how it's done. How you are able to buy them. Complete and valuable information about the typewriter industry, both instructive and educational.

FREE with Every Typewriter

A complete course in touch typewriting. You don't have to know how to operate a typewriter. You can learn to operate this machine in one day. We also give free a waterproof cover and all tools that come with a typewriter.



All Shipments made direct to you from our modern factory—the largest typewriter rebuilding plant in the world.

FREE BOOK COUPON

SHIPMAN-WARD MFG. CO.
2128 Shipman Bldg.
Montrose and Ravenswood Aves.
CHICAGO

Send by return mail your wonderful offer of Shipman-Ward Standard Rebuilt Underwood, also your book of facts. (This is not an order and does not obligate me in any way.)

NAME.....

STREET.....

POST OFFICE.....STATE.....

SHIPMAN-WARD MFG. CO.

2128 Shipman Bldg., Montrose and Ravenswood Aves., Chicago



W. L. Douglas

\$5, \$6, \$7 & \$8 SHOES

BOYS AT \$4.50 & \$5.00

Women of fashion should know that our women's shoes are high-class, made in the most distinctive, up-to-date and exclusive styles, which appeal to those who desire stylish, comfortable and serviceable shoes at reasonable prices.

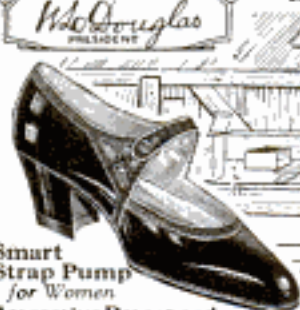

Smart Strap Pump for Women
Attractive Patent and black Suede one-strap pump. **\$6.50**



W. L. DOUGLAS PEGGING SHOES AT 7 YEARS OF AGE



New Fall Style for Men
Made in black Velour also light Russia calf. **\$7.00**

WEAR W. L. DOUGLAS SHOES AND SAVE MONEY

FOR 38 YEARS, W. L. Douglas' name and portrait have stood for quality, for economy and for satisfactory service. W. L. Douglas shoes are exceptionally good values. Only by wearing them can you appreciate their superior qualities. *The exclusive, smart models, designed especially for young men and women, are leaders everywhere.*

W. L. DOUGLAS \$7.00 SHOES are remarkably good value. Seldom have you had the opportunity to buy such *high-grade* shoes at this popular price. Shoes of equal *quality, comfort and service* are rarely found in other makes at our prices.

WHEREVER YOU LIVE, demand W. L. Douglas shoes. They are sold in 120 of our stores in the principal cities and by over 5,000 shoe dealers. *For economy and dependable value, wear shoes that have W. L. Douglas' name and the retail price stamped on the soles. The stamped price guarantees the value.* If not for sale in your vicinity, write for catalog.

W. L. Douglas Shoe Company, 128 Spark St., Brockton, Mass.

SAW FILING PAYS

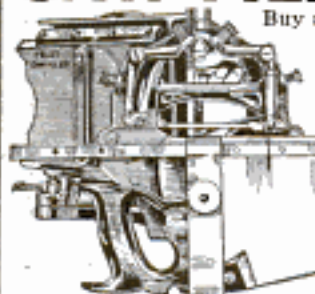

Buy a Foley Saw Filer and Setter and establish an independent, profitable business.

Wm. Russell Clark, 263 N. E. 15th Terrace, Miami, Fla., writes: "It is a pleasure to file a saw with such a machine. It is easy to operate, easy to adjust, and turns out a great job in a short time with less strain on the eyes, in fact on the whole system."

Prices and catalog on request. Territory open to interested parties.

FOLEY SAW TOOL CO.
916 E. Lake St. Minneapolis, Minn.



Do Your PRINTING

Cards, circulars, labels, tags, book, menus, paper, Press, \$12, Larger \$35, Job Press \$150 up. Save money. Print for others. BIG PROFITS. All easy, rules sent. Write factory TODAY for press catalog, TYPE, cards, paper. **THE PRESS CO. D-37, MERIDEN, CONN.**

LYON BODIES

Send For Our 1924 FREE BOOK OF BARGAINS



Containing a full line of bodies and accessories at exceptionally low prices. Buy direct from the factory.

AUTO TIRE SALES CO.

Body Division Dept. P26

1346 S. Michigan Ave., Chicago

\$27⁵⁰ AND UP

Stolps Heaters

for Chevrolet and Ford Cars

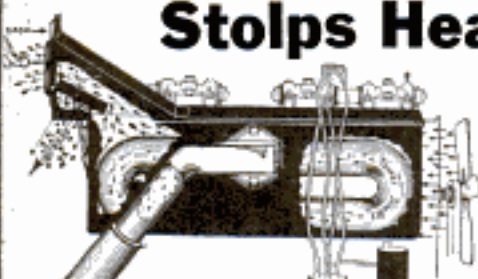

STOLPS HOT BLAST FOR CHEVROLET

Write for descriptive literature, or send us \$6.50 and we will send you the heater postpaid. Two weeks after you receive it and have used it, if you are not satisfied that it delivers 20% more heat than any other heater on the market, or you are in any way dissatisfied, you may return it to us and we will refund your money, including return postage. Ask your dealer, he may have it.

CHAS. H. STOLP, Manufacturer, AURORA, ILL.



DIVINE RED DEVIL Water Motors

Simple—strong—durable. Wonderful little workers for all sorts of household and shop uses. Thousands in use. For all light power purposes. Attaches to faucet.

Two sizes: 4"—\$4.25
6"—\$6.75

The higher the water pressure the more work they do.

Send today for catalogue.
Divine Water Motor Company
Utica, N. Y.

WURLITZER

ESTABLISHED 1854
THE WORLD'S LARGEST MUSIC HOUSE

Try Any Wurlitzer Instrument in Your Own Home

EXAMINE IT, show it to your friends, play it as much as you wish. A week's free trial — no obligation to buy. We make this liberal offer because we want you to see for yourself this superior quality of Wurlitzer instruments, the result of 200 years' experience. Noted musicians praise them for unusual tone quality, artistic workmanship and ease of playing. They are used in the finest bands and orchestras throughout the country.

Easy Payments

If you decide to buy, payments are arranged in small monthly sums. A few cents a day pays for your instrument. Special offers on complete musical outfits.

SEND FOR New Catalog

The greatest musical catalog ever published! Over 3,000 articles—every known instrument described and illustrated; many of them shown in full colors. Gives you lowest prices and all details of Free Trial, Easy Payment plan. All sent FREE—no obligation. Send coupon below.

Clip and Mail

THE RUDOLPH WURLITZER CO., Dept. 1778

120 W. 42nd St., New York 117 E. 4th St., Cincinnati
329 S. Wabash Ave., Chicago 250 Stockton St., San Francisco
Send me, absolutely free, new illustrated catalog, with prices and details of Free Trial Easy Payment plan. No obligation.

Name _____

Address _____

City _____

State _____

Instrument _____

(State Instrument—add in which you are interested)

Red Devil Tools  **Better Made**



The "Red Devil" trade mark is a big thing to look for when you buy pliers. It sets the standard by which other tools are judged.

No. 1024
6 1/2 in.



Red Devil Slip Joint Plier

YOU'LL approve of the scientifically designed handles, the smooth working jaws, the beautifully nickel plated finish—in fact, you'll admire it as much as you'll like to work with it.

The thin nose is adapted for close work. The slip-joint gives a wider range to the plier's usefulness.

"Red Devil" No. 1024 5 inch size, 90c. 6 1/2 inch size, \$1.10. At all hardware dealers, or from our factory.

Mechanic's tool booklet free

SMITH & HEMENWAY CO., Inc.
Manufacturers of "Red Devil" Tools
260 Broadway, NEW YORK, N. Y.

"Red Devil" Glass Cutters—the glaziers' standard tools of the world. "It's all in the wheel." Made in 40 styles. No. 024 shown here, 20c.

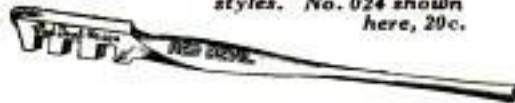

KERMATH

BOAT ENGINES

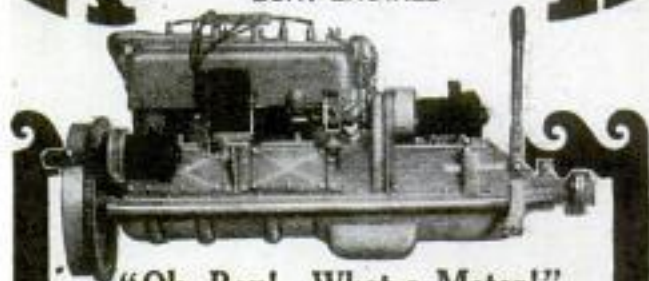

"Oh, Boy! What a Motor!"

That's what an enthusiastic Kermath owner writes us.

Using a Kermath 20 for 5 years, he naturally bought a 50 when he wanted more speed for his 25 ft. by 5 ft. 9 in. heavily constructed cruiser.

At a speed of 20 miles per hour he gets 15 miles on two gallons. No perceptible consumption of oil. That's why 80% of the good boat builders use Kermaths.

For economy with power and absolute reliability, "Oh, Boy! What a Motor!"

Write us for more information.

3 H. P. to 50 H. P., \$135 to \$1050, F. O. B. Detroit.

"A Kermath Always Runs"

KERMATH MANUFACTURING COMPANY
1886 Commonwealth Ave. Detroit, Mich.
Canadian address: 11 E. Wellington St. Toronto, Ontario

A Kermath Always Runs

SOLDERALL

METAL IN PASTE FORM



Every Electrical Connection needs Solderall for perfect reception. **25¢**

The SOLDERALL CO., NEWARK, N.J.

DEAFNESS IS MISERY

I know because I was Deaf and had Head Noises for over 30 years. My invisible Antiseptic Ear Drums restored my hearing and stopped Head Noises, and will do it for you. They are Tiny Megaphones. Cannot be seen when worn. Effective when Deafness is caused by Catarrh or by Perforated, Partially or Wholly Destroyed Natural Drums. Easy to put in, easy to take out. Are "Unseen comforts." Inexpensive. Write for Booklet and my sworn statement of how I recovered my hearing.

A. O. LEONARD, Suite 226, 70 5th Avenue, New York City

NEW VEST POCKET ADDING MACHINE

Add as rapidly and accurately as a \$300 machine, yet fits the vest pocket. Mechanically perfect. Easy to operate. Everyone who uses figures should own one.

COUNTS UP TO 999,999,999

\$ 2.95

Total visible at all times. A pull of the finger, clears it. Don't carry a pocket full of pencil stubs and scrap paper to do your figuring. Carry a Ve-Po-Ad.

10 DAYS TRIAL SEND NO MONEY. Just name and address and we will send machine postpaid. Pay postman on delivery \$2.95. Use it for 10 days to prove it does all we claim. If not perfectly satisfied we will refund your money. Limited supply. Order today.

RELIABLE ADDING MACHINE CORP.
170 C West Washington Street CHICAGO, ILL.

AGENTS Here's a money maker for you. Everybody wants one. Splendid profit. Write for special offer. **DO IT NOW.**

60% of Market Price

will buy

Diamonds here



For Weddings, for occasions, for anniversaries, for engagements, etc.

\$50.00
1/2 Ct. White Gold



\$45.00
Colored Center

\$98.00
American Diamond



Why Pay Full Prices Costs Nothing to See

This famous 75-year old firm—the *Largest and Oldest Diamond Banking Institution* of its kind in the world—must sell the diamonds on which we loan money. This firm rated highest, at over \$1,000,000.00 capital, having made loans on diamonds, watches, other jewels in unpaid loans and other special advantage bargains that we must sell to get back our cash. Many of these bargains are from big cash deals direct with European Diamond cutters at sacrifice prices. Buy here where loan values are the price basis, not market values. Send now for bargain list.

FREE—On Approval! The Buys of a Lifetime!

The diamond bargains pictured here are merely a few of the many unusual offers on our lists, all with full and complete descriptions. At our risk—we send you any bargain you wish for *Absolutely FREE Examination*. No obligation. Compare it carefully, have it valued any way you wish. If you decide not to buy, you are not out one penny.

As Low As \$60 Per Carat

Not all, but some. Yes, some even lower priced, but also diamonds of finest qualities at higher per carat charges. Get a diamond now around half its market price.

Send for Latest List of Diamond Loans

Unlike the ordinary catalog. Hundreds of Diamond Bargains described in full detail with exact weight, color, quality, etc. You know what you're buying before you buy. Besides it tells of *Guaranteed Loan Value*, unlimited exchange privilege at full price paid, and complete details of free examination offer.

Use Coupon NOW!

We'll send our latest Bargain list. It's free. No obligation. No expense to you. Write Now!

Jos. De Roy & Sons
1926 De Roy Building
Only Opposite Post Office
Pittsburgh, Pa.

References by permission:—
Bank of Pittsburgh—N.
A. Marine Nat'l Bank
—Union Trust Co.,
Pittsburgh, Pa.
Your bank can
look us up in mer-
cantile agencies.



Jos.
DeRoy
& Sons
1926 DeRoy
Building
Only Opposite
Post Office
Pittsburgh, Pa.

Gentlemen: Please
send me free and pre-
paid, your latest bar-
gain list of diamonds,
watches and other jew-
elry. It is understood I
accept no obligation of
any kind.

Name _____

Guaranteed Cash Loan!

Diamonds bought here are like insurance policies. You know what you can borrow before you decide to buy—SEE OUR CASH BACK GUARANTEE!

THIS CLEAR, STEADY, ACCURATE, POWERFUL 6-POWER WOLLENSAK POCKET TELESCOPE



Money back if not thoroughly satisfied in every respect. A wonderful little scope for beach, woods, motor boats, hunting, athletic games and general use.

\$2 Postpaid with Excellent Leather case! Length closed 3 1/4 in., maximum diameter 1 3/16 in.

Every One Brand New and GUARANTEED by both this company and the maker

Made by the Wollensak Optical Company, one of the finest makers of lenses and optical goods in the world. Thoroughly tried and tested in actual use before putting on the market. No bigger'n a jack-knife, easily carried in vest pocket, yet a powerful, precise monocular that brings distant objects close, in full detail, without the "Vibration" present when higher power telescopes are used. Adjustable twice as quickly as binoculars. Nothing cheap in appearance or construction. Mighty neat, black, baked-in enamel with non-slip grip. Glove leather case included. \$2.00 prepaid.

Send Check or Money Order, or We Will Ship C. O. D.

BOSTON SPORTING GOODS CO., Dept. "P," 80 Boylston St., BOSTON, MASS.

AGENTS \$200 PER WEEK



Latest Heating Burner Fits any Stove, Boiler or Furnace

Agents and distributors wanted at once—full or spare time—to introduce the **NEEDHAM OIL BURNER** for heating stoves, boilers or furnaces. Eliminates coal and wood, ashes, dirt, dust and grime. No more cleaning of furnaces, building of fires or frozen pipes. Gives three times the heat of ordinary coal or wood fires. No noisy motors, no moving parts, no need of gas or electricity for operation. Fits any heating stove, boiler or furnace converting it into a modern oil heating plant. Easily installed. No fuss—no muss. No worry about machinery getting out of order. Money back if not satisfied after trial.

BIG MONEY in advance

Sales are easily made. Every home needs one of these burners. You can sell two or three each day. You get your big profit right when you take the order. Pleasing, dignified work. Get started today. Distributors, Sales Agents and Spare-time workers earn from \$100 to \$250 a week easy. Some choice territory still open. Write at once and ask for free sample offer and Agent's proposition.



NEEDHAM OIL BURNER CO.
337 W. Madison St., Dept. K, Chicago, Ill.

Our BUREAU OF INFORMATION will answer all questions regarding articles appearing in this magazine.

DEMONSTRATORS WANTED For 5-Tube Neutrodyne Set RADIO

Live young man in every town and neighborhood, to own, operate and take orders for the licensed, standardized, synchronized "De Luxe 5-Tube Coast-to-Coast Neutrodyne" made famous in "The Radio Digest." Complete assembly retails only \$34.49. Thousands sold. Furnished you at discount. Liberal financial arrangements. Write us at once all about yourself. Ask for plan. Also illustrated description of set. Be First.

The Radio Shack America's LARGEST Radio Dealers Dept. PM11, 55 Vesey Street, New York City

HANDS UP!

Protect yourself against hold-up, rowdies, etc. with this clever cigarette case of light weight metal. Looks exactly like the real thing! Pull the trigger, back flies the lid showing your cigarettes. Lots of fun scaring your friends, and a great protector. Sold exclusively by us. PAY POST.



MAN \$1.79 on delivery plus postage. Money back if not satisfied. PATHFINDER CO., Dep. HK7D 534 Sixth Ave., N.Y.



Pat. Pending

TAILORING \$50 to \$100 a Week

AGENTS WANTED If interested in a good opportunity to make big money let us send you our famous book, "What Others Say." It tells you about our new sales plan and shows pictures of scores of men whom we have trained and helped to build a permanent big paying business. Our plan beats owning a store and pays big profits. Success is sure for every earnest worker. J. B. Simpson's suits and overcoats at \$11.50, tailored to order, from all wool fabrics are well known and the world's greatest clothing values. They are easy to sell. We protect territory, pay commission in advance. Write for new sales plan and free copy of interesting book. J. B. SIMPSON, Inc., Dept. 1009 843 Adams St., Chicago

Jascha Heifetz says:

"It does improve the tone and quality"

A remedy to reinforce the Tone of your Violin.

"VIRZI" Tone Violin on Trial

If this is not found in your local Music Stores, send direct, for goods, explanation, or free catalogue to E., J. & J. VIRZI, 503 Fifth Ave. & 42nd St., New York City



"VIRZI" Tone Violin on Trial U. S. and Foreign Pat.

Sells for \$1.25 — Agent's Sample 65c!

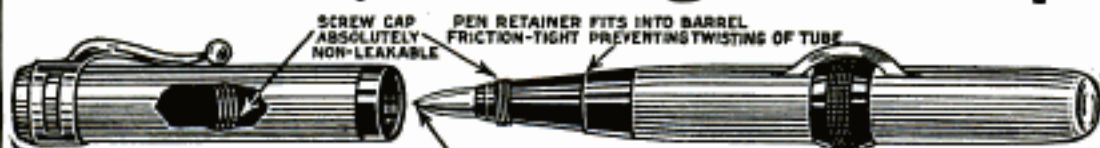

ITS THE POINT,

HAS EIGHT GROOVES FOR INK TO FEED

Imported from Japan. "It makes Carbon Copies." Guaranteed for One Year. Hustlers Make \$20.00 Daily! Money refunded if you don't think it the best pen you ever wrote with. Just Out! Comes in beautiful brown, trimmed in black. Send for quantity price list and distributing plans.

F. SPORS & COMPANY, 335 Main Street, LESUEUR CENTER, MINNESOTA

New Self-Filling Bamboo Fountain Pen with Stylo Point

Send For This Sensational Radio Bargain Book-FREE

Order Direct from This Page! Save About One-Half!

Compare our prices with others. Only highest grade nationally known GUARANTEED parts. OUR GUARANTEE PROTECTS YOU. Money cheerfully refunded if you are not satisfied. Be sure to write your order and state prices plainly. Send post office or express money order or bank draft for total amount to insure prompt shipment. ALL PRICES ON THIS PAGE INCLUDE SHIPPING CHARGES RIGHT TO YOUR DOOR. Refer to any bank or commercial agency regarding our reliability. If your favorite circuit is shown here, order direct from this ad. No skill required to build your own radio with Randolph parts. Panels are all drilled. Instructions are simple and complete. Everything comes ready to assemble. Order direct! All shipping charges prepaid.



Big Radio Book

Send For it At Once

FREE

BIG MONEY-SAVING RADIO CATALOG

containing a thousand bargains of everything on radio—parts, supplies, complete parts for sets, complete sets, etc., also a mine of very latest information on all different circuits, complete list of broadcasting stations, and other valuable, up-to-the-minute radio data. Send your name and address on a card or letter. We will send catalog free.

Free Service Department

Our radio engineers will help you solve all your radio problems, and furnish up-to-date information on set construction, operation and improvement. This service is free to customers.



COMPLETE PARTS FOR 8-TUBE SUPER-HETERODYNE

- 1 23-plate Lo-loss Venier Bremer-Tully or Duplex Condenser.
- 1 43-plate Lo-loss Vernier Bremer-Tully or Duplex Condenser.
- 1 400-ohm Frost Potentiometer.
- 2 6-ohm Rheostats.
- 2 30-ohm Bakelite Rheostats.
- 1 .00025 Fixed Condenser.
- 4 .002 Condensers.
- 1 .006 Condenser.
- 1 I-Meg. Leak.
- 2 4" Bakelite Dials.
- 1 Single Circuit Jack.
- 1 Bakelite Terminal Strip for Binding Posts.
- 1 Multicolored Cable for connecting batteries.

\$59⁷⁵

- 3 All-American or Columbia Long-wave Transformers.
 - 2 All-American or Columbia Audio Transformers.
- Instructions, blue-prints and complete layout.

Our Guarantee

Every article exactly as represented. Every article is tested before shipping. Complete satisfaction guaranteed or money will be cheerfully refunded.

Our Catalog is Filled With Bargains Like These

- 23-plate plain Condenser \$1.29
- 23-plate Vernier Condens'r 2.59
- RHEOSTATS and POTENTIOMETERS
- Bakelite Rheostat, 6-ohm. .38
- Bakelite Rheostat, 30-ohm. .59
- Bakelite Vernier Rheostat 1.15
- Bakelite Potentiometer, 200-ohm. .59
- TRANSFORMERS
- Randolph Special, 6 to 1. 2.16; 3 1/2 to 1. 1.89
- Stclair Special, 6 to 1. 2.55; 3 1/2 to 1. 2.24
- TUBE SOCKETS and DIALS
- 4" Hygrade Dial. .29
- Bakelite Socket. .28
- Weston Plug. .75
- VARIOMETERS
- Moulded Variometer. 2.19
- Bakelite moulded. 3.45
- HEADPHONES
- Randolph Special, 2200-ohms. 2.45
- Blue Bird Special. 3.95
- LOUD SPEAKERS
- American Bell. 3.95
- With adjustable loud speaker unit. 6.95
- COUPLERS and COILS
- 180° Variocouplers. .95
- Reinartz Coils. 1.25
- Electric Soldering Iron. 1.29
- Cockaday Coil. 1.65
- Three-Circuit Tuner. 2.95
- Ambassador Coils. 2.95



COMPLETE PARTS FOR 3 AND 5-TUBE NEUTRODYNE RECEIVING SET

Genuine Hazeltine Licensed Fada, Freed-Eiseman, or other Genuine Licensed Parts

PARTS FOR 5-TUBE SET:

- 1 7x28x 1/4" Drilled Panel.
- 3 4" Bakelite Dials.
- 3 Filament Control Jacks.
- 1 Vernier Rheostat—30-ohm.
- 1 Plain Rheostat—6-ohm.
- 1 strip Bakelite, 6x1x 1/4".
- 8 Binding Posts.
- 1 Grid Leak and Condenser.
- 2 Bakelite Sockets.
- 2 All American or Columbia Audio Transformers.
- 1 .001 Condenser.
- 1 Dubilier By-Pass Condenser.
- 3 Gang Bakelite Socket.
- 3 1/2 feet Hook-up Wire.
- 1 Wave Control Neutroformer.
- 2 R. F. Neutroformers.
- 1 Baseboard.
- 2 Neutrodons.
- 3 Bezels.

\$33⁷⁵

Complete Parts for 2-Tube Harkness Set

- 7x14x 1/8" Drilled Bakelite Panel, 2 Harkness Flexoformers with Condensers, 2 Dials, 2 Bakelite Sockets, 1 Connecticut Battery Switch, 2 American Bell Transformers, 1 Jack, 1 R-W Detector, 1 Bakelite Rheostat, 3 Binding Posts, Baseboard and Bus Bar Wire. \$17⁹⁵

Acme—1 Tube Reflex Set.....\$17.45

Acme—4 Tube Reflex Set.....39.85

Complete Parts for Two-Stage Amplifier Diagram & Instructions For Wiring \$10.90



COMPLETE PARTS FOR 3-TUBE COCKADAY RECEIVING SET

- 1 Cockaday Coil.
- 2 23-plate Hy-Grade Cond.
- 1 Bakelite Rheostat, 30-ohm.
- 1 Bakelite Rheostat, 6-ohm.
- 3 Bakelite Sockets.
- 1 high ratio Columbia or All-American Transformer.
- 1 Single Circuit Jack.
- 1 low ratio Columbia or All-American Transformer.
- Complete blue-prints and wiring diagrams.
- 1-Tube Set. \$10.45
- 2 Double Circuit Jacks.
- 2 3" Bakelite Dials.
- 1 Grid Leak and Mica Cond.
- 7 Switch Points, 2 stops.
- 1 Bakelite Binding Post Strip.
- 8 Binding Posts.
- 1 7x21x 1/4" Drilled Bakelite Panel.
- 3 Bezels.
- 1 Baseboard.
- 3-TUBE SET \$19⁹⁵

RANDOLPH RADIO CORPORATION

159 N. Union Ave.

Dept. 68

Chicago, Illinois

FAHLBERG

MADISON, WIS.

Radio News for August, 1924

A soldering iron, even one of the smaller electric ones, is rather a clumsy tool for soldering small wires and parts such as are used in a radio set. It is a much more convenient method to use an alcohol lamp, such as a jeweler uses, for this class of work; and a much better job will be the result.

Reddy HOT

Soldering Furnace
—a complete soldering outfit for every home use

Mr. E. D. Fahlberg, former professor of Metallography at the University of Wisconsin and Metallurgical Engineer of Western Electric Company now announces the Reddy Hot Soldering Furnace for all around home use and especially in radio work.

All supplies in this self-contained soldering outfit are made from tested formulas that are being used commercially by the biggest radio manufacturing companies and laboratories.

Reddy Hot soldering supplies are obtainable through the same dealer that will show you the Reddy Hot Soldering Furnace.

If not yet obtainable through your present source of supply, we will, for a short time only, ship postpaid upon receipt of price. Absolutely safe solder and flux.

Safe — Non-Explosive — Portable
E. D. Fahlberg Mfg. Co.
Madison, Wisconsin

one large general purpose copper
one small soldering copper
one ingot Reddy No. 1 Household Solder
one can Reddy Stick Non Corrosive Solder-
ing Flux
one ingot Reddy Melt Radio Solder
one can Reddy Prest Soldering Paste
one can Reddy Rub Abrasive Tape

Jobbers and dealers
write or wire
for the Reddy Hot
Proposition and
Samples. Display
carton of 12.



Price
\$1.50

E. D. FAHLBERG MFG. CO., Madison, Wisconsin
Send me prepaid one Reddy Hot Soldering Furnace for
which I enclose \$1.50.

My dealer's name is.....

Signed: Name.....

Address.....

NATIONAL VELVET CONDENSERS VERNIER AND DIALS

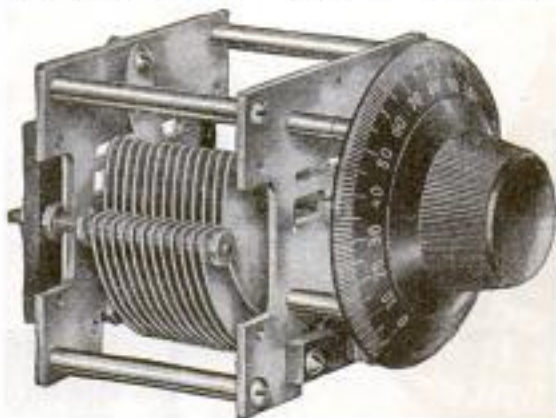

HAVE A VELVETY SMOOTHNESS HITHERTO UNKNOWN

They are made by skilled craftsmen—have the lowest losses and bring in distant broadcast with the least distortion. Home built sets using Nationals have received broadcasts from Paris—3,600 miles, and code from Buenos Aires—5,200 miles.

The condenser and dial chosen by Harvard University experts to demonstrate the Browning-Drake set before American Institute of Electrical Engineers.

SIZES: .001 .005 .00035 .00025
PRICES: \$7.00 \$6.00 \$5.75 \$5.50

DIALS ONLY 4" \$2.50—3" \$2.00

Write for Free Bulletin 104-P

The National Company, Inc., Cambridge 39, Mass.

SAMBER VOLT B-BATTERY METER

10 TO 50 VOLTS

A RADIO NECESSITY
For Measuring B-Battery Voltage

\$1.00 Post Prepaid
In U. S. and Canada

SAMBER RADIO PRODUCTS CO.
27 School St., BOSTON, Dept. B

Como Duplex Transformers

(Push Pull Power Type)



The Como Duplex system of audio frequency amplification (push-pull) gives the maximum volume without distortion and tube noise. There is a combined filtering action which assures perfect results when ordinary amplification transformers fail. Can be used as a single-stage, two-stage, or a three-stage amplifier.

The World's Standard Push Pull Transformer
Send for copy of "How to Build a Power Amplifier."

COMO APPARATUS CO.
246 Tremont Street - BOSTON, MASS.

Startling Free Booklet of CORNWELL Hand Made Tools

GUARANTEED superior to any tools made in the world. Booklet illustrates and describes full line, explaining unbelievable tests which no other tools will stand. Made of the finest Swedish Charcoal Process Molybdenum Steel. Forged, heat treated and hardened and tempered in oil; NOT drop forged and case-hardened.



Hand Made
from our
Famous
CORNWELL
Secret
Formula

Make These Amazing Tests at OUR Own Risk!

Cut shavings off vise handles with bearing scrapers! Drive plain or drift punches through steel $1\frac{1}{2}$ times thickness of their face! Drive $\frac{1}{4}$ in. flat chisel clear through $1\frac{1}{2}$ in. machinery steel! These tests won't damage tools! CORNWELL wrenches break any other wrenches, locked size for size!

Money Back if Not Satisfied!

If you ever saw tools as good as these, return your order and get your money back. All tools covered by this amazing guarantee. Money refunded if tools do not stand our startling tests.

Write Today! Get this booklet at once. Every picture and word vitally interesting to any user of tools. Write NOW.

Cornwell Quality Tools Co., Dept. C, Cuyahoga Falls, Ohio

ELECTRIC RADIO SOLDERING IRON \$1
Send \$1.00 now for this regular \$2.50 value, postpaid anywhere in U. S. A. Write for Big Free Radio Catalog. Atwood-King, Inc., Dept. C 115, 163 W. Washington St., Chicago. **POST PAID**

ATWOOD KING
INC.

Make Your Own Repairs Myers Sewing Awl
Be your own repair man. Myers' wonderful Sewing Awl sews leather, canvas, shoes, mends harness, saddles, wagon covers, auto tops, blankets, belts - anything heavy or light. Speedy hand stitching. Can't get out order. Original and only awl with diamond point full grooved needle to protect the thread. Saves trips to town. **BIG MONEY FOR AGENTS**
C.A. Myers Co., 6329 Woodlawn Ave., Chicago, Ill.

Glass Bake Sets FREE



With Your IMPERIAL RANGE

Write now for Direct from Factory Bargain Catalog and you will be in time to get this big 12-piece genuine heat-proof Glass Bake Set—a complete kitchen outfit FREE. It's our special limited offer to introduce Imperial Steel Ranges and their potent saving features. Biggest money-saving opportunity of the year. Get low prices.

BARGAIN BOOK

Saves you \$20 to \$40 on Ranges, Gas Stoves, Oil Stoves, Refrigerators, Kitchen Cabinets. Here needs at rock-bottom wholesale prices. Easy Terms. Everything sent for 30 Days Trial. Our offers are constant of the year. Write quick. Just send name and address. A postcard will do.

THE IMPERIAL STEEL RANGE CO.
369 Detroit Avenue Cleveland, Ohio



America's
Greatest Value



Why Not

Accept this test now? Find out if this Shaving Cream is all that men claim?

By V. K. CASSADY, Chief Chemist

GENTLEMEN:

The other day a man wrote in to thank me for the 10-day tube his wife had sent in for! Said it had given him a new conception of a shaving cream.

90% of the men who come to Palmolive Shaving Cream start from that point.

We rest our case on a test. Won't you do me the kindness to mail in the coupon and to make it?

Excels in 5 big ways

Over 130 formulas were discarded before the right one was found.

It embodies the 4 requirements 1000 men told us that they wanted. And a fifth, strong bubbles.

- 1—Multiplies itself in lather 250 times.
- 2—Softens the beard in one minute.
- 3—Maintains its creamy fullness 10 minutes on the face.
- 4—Strong bubbles hold the hairs erect for cutting.
- 5—Fine after-effects, due to palm and olive oil content.

Now a test—please

Now in justice to yourself and us, we ask the courtesy of a trial.

Mail the coupon for 10-shave tube free.

To add the final touch to shaving luxury, we have created Palmolive After Shaving Talc—especially for men. Doesn't show. Leaves the skin smooth and fresh. Sample free with tube of Shaving Cream. Clip coupon now

PALMOLIVE SHAVING CREAM



10 SHAVES FREE

and a Can of Palmolive After Shaving Talc

Simply insert your name and address and mail to

Dept. 31-952

Address for residents of Wisconsin, The Palmolive Company (Wis. Corp.), Milwaukee, Wis. Address for residents other than Wisconsin, The Palmolive Company (Del. Corp.), 3702 Iron St., Chicago, Ill.

2635



The best and most complete saw equipment on the market—**GENUINE \$60 VALUE**
Complete Outfit as Shown

\$35.

East of the Mississippi. We Pay Delivery Charges. \$38 west of the Mississippi. We Pay Delivery Charges.



For Handy Man and Mechanic

With this "little sawmill" you can make your own repairs in shop, home, farm or garage. In 1001 ways it will save its cost many times over. Makes a clean edge on the toughest wood—no planing necessary. Rips, crosscuts, bevels, miters, mortises, tenons, or grooves quickly and accurately. Does the work of a skilled mechanic and saves you time, labor and money.

MECHANICS' BENCH SAWS

Can be attached to any lamp socket. Weight only 61 lbs. This saw will cut up to 1 1/4". Indispensable to wood workers, carpenters, cabinet makers, pattern makers, model makers, inlaid floor makers, hardwood floor finishers, picture frame makers, farmers, printers, radio builders, schools, colleges, homes, etc. All metal. Saw-size 6 inches. Table 10x13, base 7x11, height 7 inches. Table tilts for beveling 5 degrees left, 10 degrees right. Hinged top for cutting grooves, tenons, rabbets. Bearings solid bronze with grease cup lubrication. Guides removable and adjustable rip and cut-off. Sunlight 1/4 h. p. motor; 110 volts; 60 cycle; 4.5 amps; 1750 R. P. M. Current A. C. Centrifugal switch with auxiliary finger. High grade steel shaft with ground bearing surface. Water and moisture proof insulating material used throughout. Exterior connections to allow change of direction of rotation. Large grease cups with wick lubrication. Bearings of Bunting phosphor bronze metal.

COMPLETE OUTFIT \$35.

including cord, plug, pulley and belt, everything complete, ready to attach. The saw furnished with this outfit is the Diston 6" Novelty Combination Cross Cut and Rip Saw, guaranteed to run without set. No planing or sanding required after cutting. This saw is equipped with extra heavy duty motor guaranteed to handle 50% overload.

\$60 VALUE.

East of the Mississippi. We Pay Delivery Charges.

\$38 west of the Mississippi. We Pay Delivery Charges.

SAW TABLE can be purchased with 6" saw for anywhere in the U. S. \$22.50; delivered prepaid \$22.50

MOTOR This heavy duty Motor can be furnished separately for \$15.90; Complete with Cord, Plug, and flat or grooved Pulley. Guaranteed 50% Overload. We Pay Delivery Charges Anywhere in the U. S. \$15.90

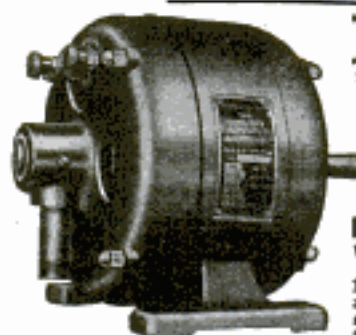

This **SUNLIGHT**
1/4 H. P. Motor
Complete with
Cord, Plug and Pulley

\$12.90

Regular Value \$30
We Pay Delivery Charges
Anywhere in U. S.
110 volts; 60 cycle; 4.5
amps; 1750 R. P. M. Current
A. C. Guaranteed
to handle 20% overload.

PAUL J. DEVITT HARDWARE HEADQUARTERS
of Philadelphia
1101-1107 South 2nd St., Philadelphia, Pa.

YOU CAN MAKE \$18 DAILY PROFIT

With Our Great Introductory Offer
Giving These \$1.25 **FREE**
Dress-Making Shears



With each sale of our wonderful 11 piece Toilet Article Assortment for only \$1.75. TOTAL STORE VALUE \$4.60

VALUE \$1.25
Self-Sharpening
SHEARS

\$18.00 a Day PROFIT on only **TWENTY** Sales



Lucky 11 Toilet Set—Retail Value \$3.35!

MY! HOW THEY SELL!

You get the attention with the free Shears. Walter Harris sold 800 boxes in six weeks. Profit over \$100 a week. You can do this too.

Act Now! Sell like hot cakes year round. A baby could sell Lucky 11. Don't wait a minute. Save time. Send \$1.75 for complete outfit including display case. At least write for circulars explaining our unique plans, including 30 other packages. **ACT NOW!**

E. M. DAVIS CO., Dept. 5623, CHICAGO, ILL.



GEARS ALL KINDS SMALL

The most accurate made and prices reasonable. We carry a complete line of gears in stock for immediate shipment. Can also quote on special gears of all kinds. Send us your inquiries. WRITE FOR CATALOGUE.

CHICAGO STOCK GEAR WORKS
105-109 S. Jefferson St., CHICAGO

FREE Wonderful Book

Tells how to learn taxidermy—how to mount birds, animals, game-animals, fishes, fur skins. Learn by mail. A necessity for hunters and nature lovers. Best methods, quickly learned, very fascinating. Success guaranteed. Decorate your home and den with splendid art. Make big profits. Write today for this fine illustrated, free book and our amazing offer. Northwestern School of Taxidermy, 9778 Elwood Blvd., Omaha, Neb.



"BOW LEGS and KNOCK-KNEES" UNSIGHTLY

SEND FOR BOOKLET SHOWING PHOTOS OF MEN WITH AND WITHOUT THE PERFECT LEG FORMS
PERFECT SALES CO.
140 N. Mayfield Ave., Dept. S, Chicago, Ill.

\$985 Improved New Model
Only **DOWN**

1 1/2 H-P PULLS OVER 2H-P
(Burns Kerosene or Gasoline)

You can get any size OTTAWA from my factory at lower prices and on easy monthly payments. Earn its cost as you use it.

No Interest to Pay 30 days Free Trial on your farm. Thousands in use today. Easy engine to start. Sizes 1 1/2 H-P, 2 1/2 H-P, 3 1/2 H-P, 4 1/2 H-P, 5 1/2 H-P, 6 1/2 H-P, 7 1/2 H-P, 8 1/2 H-P, 9 1/2 H-P, 10 1/2 H-P, 11 1/2 H-P, 12 1/2 H-P, 13 1/2 H-P, 14 1/2 H-P, 15 1/2 H-P, 16 1/2 H-P, 17 1/2 H-P, 18 1/2 H-P, 19 1/2 H-P, 20 1/2 H-P, 21 1/2 H-P, 22 1/2 H-P, 23 1/2 H-P, 24 1/2 H-P, 25 1/2 H-P, 26 1/2 H-P, 27 1/2 H-P, 28 1/2 H-P, 29 1/2 H-P, 30 1/2 H-P, 31 1/2 H-P, 32 1/2 H-P, 33 1/2 H-P, 34 1/2 H-P, 35 1/2 H-P, 36 1/2 H-P, 37 1/2 H-P, 38 1/2 H-P, 39 1/2 H-P, 40 1/2 H-P, 41 1/2 H-P, 42 1/2 H-P, 43 1/2 H-P, 44 1/2 H-P, 45 1/2 H-P, 46 1/2 H-P, 47 1/2 H-P, 48 1/2 H-P, 49 1/2 H-P, 50 1/2 H-P, 51 1/2 H-P, 52 1/2 H-P, 53 1/2 H-P, 54 1/2 H-P, 55 1/2 H-P, 56 1/2 H-P, 57 1/2 H-P, 58 1/2 H-P, 59 1/2 H-P, 60 1/2 H-P, 61 1/2 H-P, 62 1/2 H-P, 63 1/2 H-P, 64 1/2 H-P, 65 1/2 H-P, 66 1/2 H-P, 67 1/2 H-P, 68 1/2 H-P, 69 1/2 H-P, 70 1/2 H-P, 71 1/2 H-P, 72 1/2 H-P, 73 1/2 H-P, 74 1/2 H-P, 75 1/2 H-P, 76 1/2 H-P, 77 1/2 H-P, 78 1/2 H-P, 79 1/2 H-P, 80 1/2 H-P, 81 1/2 H-P, 82 1/2 H-P, 83 1/2 H-P, 84 1/2 H-P, 85 1/2 H-P, 86 1/2 H-P, 87 1/2 H-P, 88 1/2 H-P, 89 1/2 H-P, 90 1/2 H-P, 91 1/2 H-P, 92 1/2 H-P, 93 1/2 H-P, 94 1/2 H-P, 95 1/2 H-P, 96 1/2 H-P, 97 1/2 H-P, 98 1/2 H-P, 99 1/2 H-P, 100 1/2 H-P, 101 1/2 H-P, 102 1/2 H-P, 103 1/2 H-P, 104 1/2 H-P, 105 1/2 H-P, 106 1/2 H-P, 107 1/2 H-P, 108 1/2 H-P, 109 1/2 H-P, 110 1/2 H-P, 111 1/2 H-P, 112 1/2 H-P, 113 1/2 H-P, 114 1/2 H-P, 115 1/2 H-P, 116 1/2 H-P, 117 1/2 H-P, 118 1/2 H-P, 119 1/2 H-P, 120 1/2 H-P, 121 1/2 H-P, 122 1/2 H-P, 123 1/2 H-P, 124 1/2 H-P, 125 1/2 H-P, 126 1/2 H-P, 127 1/2 H-P, 128 1/2 H-P, 129 1/2 H-P, 130 1/2 H-P, 131 1/2 H-P, 132 1/2 H-P, 133 1/2 H-P, 134 1/2 H-P, 135 1/2 H-P, 136 1/2 H-P, 137 1/2 H-P, 138 1/2 H-P, 139 1/2 H-P, 140 1/2 H-P, 141 1/2 H-P, 142 1/2 H-P, 143 1/2 H-P, 144 1/2 H-P, 145 1/2 H-P, 146 1/2 H-P, 147 1/2 H-P, 148 1/2 H-P, 149 1/2 H-P, 150 1/2 H-P, 151 1/2 H-P, 152 1/2 H-P, 153 1/2 H-P, 154 1/2 H-P, 155 1/2 H-P, 156 1/2 H-P, 157 1/2 H-P, 158 1/2 H-P, 159 1/2 H-P, 160 1/2 H-P, 161 1/2 H-P, 162 1/2 H-P, 163 1/2 H-P, 164 1/2 H-P, 165 1/2 H-P, 166 1/2 H-P, 167 1/2 H-P, 168 1/2 H-P, 169 1/2 H-P, 170 1/2 H-P, 171 1/2 H-P, 172 1/2 H-P, 173 1/2 H-P, 174 1/2 H-P, 175 1/2 H-P, 176 1/2 H-P, 177 1/2 H-P, 178 1/2 H-P, 179 1/2 H-P, 180 1/2 H-P, 181 1/2 H-P, 182 1/2 H-P, 183 1/2 H-P, 184 1/2 H-P, 185 1/2 H-P, 186 1/2 H-P, 187 1/2 H-P, 188 1/2 H-P, 189 1/2 H-P, 190 1/2 H-P, 191 1/2 H-P, 192 1/2 H-P, 193 1/2 H-P, 194 1/2 H-P, 195 1/2 H-P, 196 1/2 H-P, 197 1/2 H-P, 198 1/2 H-P, 199 1/2 H-P, 200 1/2 H-P, 201 1/2 H-P, 202 1/2 H-P, 203 1/2 H-P, 204 1/2 H-P, 205 1/2 H-P, 206 1/2 H-P, 207 1/2 H-P, 208 1/2 H-P, 209 1/2 H-P, 210 1/2 H-P, 211 1/2 H-P, 212 1/2 H-P, 213 1/2 H-P, 214 1/2 H-P, 215 1/2 H-P, 216 1/2 H-P, 217 1/2 H-P, 218 1/2 H-P, 219 1/2 H-P, 220 1/2 H-P, 221 1/2 H-P, 222 1/2 H-P, 223 1/2 H-P, 224 1/2 H-P, 225 1/2 H-P, 226 1/2 H-P, 227 1/2 H-P, 228 1/2 H-P, 229 1/2 H-P, 230 1/2 H-P, 231 1/2 H-P, 232 1/2 H-P, 233 1/2 H-P, 234 1/2 H-P, 235 1/2 H-P, 236 1/2 H-P, 237 1/2 H-P, 238 1/2 H-P, 239 1/2 H-P, 240 1/2 H-P, 241 1/2 H-P, 242 1/2 H-P, 243 1/2 H-P, 244 1/2 H-P, 245 1/2 H-P, 246 1/2 H-P, 247 1/2 H-P, 248 1/2 H-P, 249 1/2 H-P, 250 1/2 H-P, 251 1/2 H-P, 252 1/2 H-P, 253 1/2 H-P, 254 1/2 H-P, 255 1/2 H-P, 256 1/2 H-P, 257 1/2 H-P, 258 1/2 H-P, 259 1/2 H-P, 260 1/2 H-P, 261 1/2 H-P, 262 1/2 H-P, 263 1/2 H-P, 264 1/2 H-P, 265 1/2 H-P, 266 1/2 H-P, 267 1/2 H-P, 268 1/2 H-P, 269 1/2 H-P, 270 1/2 H-P, 271 1/2 H-P, 272 1/2 H-P, 273 1/2 H-P, 274 1/2 H-P, 275 1/2 H-P, 276 1/2 H-P, 277 1/2 H-P, 278 1/2 H-P, 279 1/2 H-P, 280 1/2 H-P, 281 1/2 H-P, 282 1/2 H-P, 283 1/2 H-P, 284 1/2 H-P, 285 1/2 H-P, 286 1/2 H-P, 287 1/2 H-P, 288 1/2 H-P, 289 1/2 H-P, 290 1/2 H-P, 291 1/2 H-P, 292 1/2 H-P, 293 1/2 H-P, 294 1/2 H-P, 295 1/2 H-P, 296 1/2 H-P, 297 1/2 H-P, 298 1/2 H-P, 299 1/2 H-P, 300 1/2 H-P, 301 1/2 H-P, 302 1/2 H-P, 303 1/2 H-P, 304 1/2 H-P, 305 1/2 H-P, 306 1/2 H-P, 307 1/2 H-P, 308 1/2 H-P, 309 1/2 H-P, 310 1/2 H-P, 311 1/2 H-P, 312 1/2 H-P, 313 1/2 H-P, 314 1/2 H-P, 315 1/2 H-P, 316 1/2 H-P, 317 1/2 H-P, 318 1/2 H-P, 319 1/2 H-P, 320 1/2 H-P, 321 1/2 H-P, 322 1/2 H-P, 323 1/2 H-P, 324 1/2 H-P, 325 1/2 H-P, 326 1/2 H-P, 327 1/2 H-P, 328 1/2 H-P, 329 1/2 H-P, 330 1/2 H-P, 331 1/2 H-P, 332 1/2 H-P, 333 1/2 H-P, 334 1/2 H-P, 335 1/2 H-P, 336 1/2 H-P, 337 1/2 H-P, 338 1/2 H-P, 339 1/2 H-P, 340 1/2 H-P, 341 1/2 H-P, 342 1/2 H-P, 343 1/2 H-P, 344 1/2 H-P, 345 1/2 H-P, 346 1/2 H-P, 347 1/2 H-P, 348 1/2 H-P, 349 1/2 H-P, 350 1/2 H-P, 351 1/2 H-P, 352 1/2 H-P, 353 1/2 H-P, 354 1/2 H-P, 355 1/2 H-P, 356 1/2 H-P, 357 1/2 H-P, 358 1/2 H-P, 359 1/2 H-P, 360 1/2 H-P, 361 1/2 H-P, 362 1/2 H-P, 363 1/2 H-P, 364 1/2 H-P, 365 1/2 H-P, 366 1/2 H-P, 367 1/2 H-P, 368 1/2 H-P, 369 1/2 H-P, 370 1/2 H-P, 371 1/2 H-P, 372 1/2 H-P, 373 1/2 H-P, 374 1/2 H-P, 375 1/2 H-P, 376 1/2 H-P, 377 1/2 H-P, 378 1/2 H-P, 379 1/2 H-P, 380 1/2 H-P, 381 1/2 H-P, 382 1/2 H-P, 383 1/2 H-P, 384 1/2 H-P, 385 1/2 H-P, 386 1/2 H-P, 387 1/2 H-P, 388 1/2 H-P, 389 1/2 H-P, 390 1/2 H-P, 391 1/2 H-P, 392 1/2 H-P, 393 1/2 H-P, 394 1/2 H-P, 395 1/2 H-P, 396 1/2 H-P, 397 1/2 H-P, 398 1/2 H-P, 399 1/2 H-P, 400 1/2 H-P, 401 1/2 H-P, 402 1/2 H-P, 403 1/2 H-P, 404 1/2 H-P, 405 1/2 H-P, 406 1/2 H-P, 407 1/2 H-P, 408 1/2 H-P, 409 1/2 H-P, 410 1/2 H-P, 411 1/2 H-P, 412 1/2 H-P, 413 1/2 H-P, 414 1/2 H-P, 415 1/2 H-P, 416 1/2 H-P, 417 1/2 H-P, 418 1/2 H-P, 419 1/2 H-P, 420 1/2 H-P, 421 1/2 H-P, 422 1/2 H-P, 423 1/2 H-P, 424 1/2 H-P, 425 1/2 H-P, 426 1/2 H-P, 427 1/2 H-P, 428 1/2 H-P, 429 1/2 H-P, 430 1/2 H-P, 431 1/2 H-P, 432 1/2 H-P, 433 1/2 H-P, 434 1/2 H-P, 435 1/2 H-P, 436 1/2 H-P, 437 1/2 H-P, 438 1/2 H-P, 439 1/2 H-P, 440 1/2 H-P, 441 1/2 H-P, 442 1/2 H-P, 443 1/2 H-P, 444 1/2 H-P, 445 1/2 H-P, 446 1/2 H-P, 447 1/2 H-P, 448 1/2 H-P, 449 1/2 H-P, 450 1/2 H-P, 451 1/2 H-P, 452 1/2 H-P, 453 1/2 H-P, 454 1/2 H-P, 455 1/2 H-P, 456 1/2 H-P, 457 1/2 H-P, 458 1/2 H-P, 459 1/2 H-P, 460 1/2 H-P, 461 1/2 H-P, 462 1/2 H-P, 463 1/2 H-P, 464 1/2 H-P, 465 1/2 H-P, 466 1/2 H-P, 467 1/2 H-P, 468 1/2 H-P, 469 1/2 H-P, 470 1/2 H-P, 471 1/2 H-P, 472 1/2 H-P, 473 1/2 H-P, 474 1/2 H-P, 475 1/2 H-P, 476 1/2 H-P, 477 1/2 H-P, 478 1/2 H-P, 479 1/2 H-P, 480 1/2 H-P, 481 1/2 H-P, 482 1/2 H-P, 483 1/2 H-P, 484 1/2 H-P, 485 1/2 H-P, 486 1/2 H-P, 487 1/2 H-P, 488 1/2 H-P, 489 1/2 H-P, 490 1/2 H-P, 491 1/2 H-P, 492 1/2 H-P, 493 1/2 H-P, 494 1/2 H-P, 495 1/2 H-P, 496 1/2 H-P, 497 1/2 H-P, 498 1/2 H-P, 499 1/2 H-P, 500 1/2 H-P, 501 1/2 H-P, 502 1/2 H-P, 503 1/2 H-P, 504 1/2 H-P, 505 1/2 H-P, 506 1/2 H-P, 507 1/2 H-P, 508 1/2 H-P, 509 1/2 H-P, 510 1/2 H-P, 511 1/2 H-P, 512 1/2 H-P, 513 1/2 H-P, 514 1/2 H-P, 515 1/2 H-P, 516 1/2 H-P, 517 1/2 H-P, 518 1/2 H-P, 519 1/2 H-P, 520 1/2 H-P, 521 1/2 H-P, 522 1/2 H-P, 523 1/2 H-P, 524 1/2 H-P, 525 1/2 H-P, 526 1/2 H-P, 527 1/2 H-P, 528 1/2 H-P, 529 1/2 H-P, 530 1/2 H-P, 531 1/2 H-P, 532 1/2 H-P, 533 1/2 H-P, 534 1/2 H-P, 535 1/2 H-P, 536 1/2 H-P, 537 1/2 H-P, 538 1/2 H-P, 539 1/2 H-P, 540 1/2 H-P, 541 1/2 H-P, 542 1/2 H-P, 543 1/2 H-P, 544 1/2 H-P, 545 1/2 H-P, 546 1/2 H-P, 547 1/2 H-P, 548 1/2 H-P, 549 1/2 H-P, 550 1/2 H-P, 551 1/2 H-P, 552 1/2 H-P, 553 1/2 H-P, 554 1/2 H-P, 555 1/2 H-P, 556 1/2 H-P, 557 1/2 H-P, 558 1/2 H-P, 559 1/2 H-P, 560 1/2 H-P, 561 1/2 H-P, 562 1/2 H-P, 563 1/2 H-P, 564 1/2 H-P, 565 1/2 H-P, 566 1/2 H-P, 567 1/2 H-P, 568 1/2 H-P, 569 1/2 H-P, 570 1/2 H-P, 571 1/2 H-P, 572 1/2 H-P, 573 1/2 H-P, 574 1/2 H-P, 575 1/2 H-P, 576 1/2 H-P, 577 1/2 H-P, 578 1/2 H-P, 579 1/2 H-P, 580 1/2 H-P, 581 1/2 H-P, 582 1/2 H-P, 583 1/2 H-P, 584 1/2 H-P, 585 1/2 H-P, 586 1/2 H-P, 587 1/2 H-P, 588 1/2 H-P, 589 1/2 H-P, 590 1/2 H-P, 591 1/2 H-P, 592 1/2 H-P, 593 1/2 H-P, 594 1/2 H-P, 595 1/2 H-P, 596 1/2 H-P, 597 1/2 H-P, 598 1/2 H-P, 599 1/2 H-P, 600 1/2 H-P, 601 1/2 H-P, 602 1/2 H-P, 603 1/2 H-P, 604 1/2 H-P, 605 1/2 H-P, 606 1/2 H-P, 607 1/2 H-P, 608 1/2 H-P, 609 1/2 H-P, 610 1/2 H-P, 611 1/2 H-P, 612 1/2 H-P, 613 1/2 H-P, 614 1/2 H-P, 615 1/2 H-P, 616 1/2 H-P, 617 1/2 H-P, 618 1/2 H-P, 619 1/2 H-P, 620 1/2 H-P, 621 1/2 H-P, 622 1/2 H-P, 623 1/2 H-P, 624 1/2 H-P, 625 1/2 H-P, 626 1/2 H-P, 627 1/2 H-P, 628 1/2 H-P, 629 1/2 H-P, 630 1/2 H-P, 631 1/2 H-P, 632 1/2 H-P, 633 1/2 H-P, 634 1/2 H-P, 635 1/2 H-P, 636 1/2 H-P, 637 1/2 H-P, 638 1/2 H-P, 639 1/2 H-P, 640 1/2 H-P, 641 1/2 H-P, 642 1/2 H-P, 643 1/2 H-P, 644 1/2 H-P, 645 1/2 H-P, 646 1/2 H-P, 647 1/2 H-P, 648 1/2 H-P, 649 1/2 H-P, 650 1/2 H-P, 651 1/2 H-P, 652 1/2 H-P, 653 1/2 H-P, 654 1/2 H-P, 655 1/2 H-P, 656 1/2 H-P, 657 1/2 H-P, 658 1/2 H-P, 659 1/2 H-P, 660 1/2 H-P, 661 1/2 H-P, 662 1/2 H-P, 663 1/2 H-P, 664 1/2 H-P, 665 1/2 H-P, 666 1/2 H-P, 667 1/2 H-P, 668 1/2 H-P, 669 1/2 H-P, 670 1/2 H-P, 671 1/2 H-P, 672 1/2 H-P, 673 1/2 H-P, 674 1/2 H-P, 675 1/2 H-P, 676 1/2 H-P, 677 1/2 H-P, 678 1/2 H-P, 679 1/2 H-P, 680 1/2 H-P, 681 1/2 H-P, 682 1/2 H-P, 683 1/2 H-P, 684 1/2 H-P, 685 1/2 H-P, 686 1/2 H-P, 687 1/2 H-P, 688 1/2 H-P, 689 1/2 H-P, 690 1/2 H-P, 691 1/2 H-P, 692 1/2 H-P, 693 1/2 H-P, 694 1/2 H-P, 695 1/2 H-P, 696 1/2 H-P, 697 1/2 H-P, 698 1/2 H-P, 699 1/2 H-P, 700 1/2 H-P, 701 1/2 H-P, 702 1/2 H-P, 703 1/2 H-P, 704 1/2 H-P, 705 1/2 H-P, 706 1/2 H-P, 707 1/2 H-P, 708 1/2 H-P, 709 1/2 H-P, 710 1/2 H-P, 711 1/2 H-P, 712 1/2 H-P, 713 1/2 H-P, 714 1/2 H-P, 715 1/2 H-P, 716 1/2 H-P, 717 1/2 H-P, 718 1/2 H-P, 719 1/2 H-P, 720 1/2 H-P, 721 1/2 H-P, 722 1/2 H-P, 723 1/2 H-P, 724 1/2 H-P, 725 1/2 H-P, 726 1/2 H-P, 727 1/2 H-P, 728 1/2 H-P, 729 1/2 H-P, 730 1/2 H-P, 731 1/2 H-P, 732 1/2 H-P, 733 1/2 H-P, 734 1/2 H-P, 735 1/2 H-P, 736 1/2 H-P, 737 1/2 H-P, 738 1/2 H-P, 739 1/2 H-P, 740 1/2 H-P, 741 1/2 H-P, 742 1/2 H-P, 743 1/2 H-P, 744 1/2 H-P, 745 1/2 H-P, 746 1/2 H-P, 747 1/2 H-P, 748 1/2 H-P, 749 1/2 H-P, 750 1/2 H-P, 751 1/2 H-P, 752 1/2 H-P, 753 1/2 H-P, 754 1/2 H-P, 755 1/2 H-P, 756 1/2 H-P, 757 1/2 H-P, 758 1/2 H-P, 759 1/2 H-P, 760 1/2 H-P, 761 1/2 H-P, 762 1/2 H-P, 763 1/2 H-P, 764 1/2 H-P, 765 1/2 H-P, 766 1/2 H-P, 767 1/2 H-P, 768 1/2 H-P, 769 1/2 H-P, 770 1/2 H-P, 771 1/2 H-P, 772 1/2 H-P, 773 1/2 H-P, 774 1/2 H-P, 775 1/2 H-P, 776 1/2 H-P, 777 1/2 H-P, 778 1/2 H-P, 779 1/2 H-P, 780 1/2 H-P, 781 1/2 H-P, 782 1/2 H-P, 783 1/2 H-P, 784 1/2 H-P, 785 1/2 H-P, 786 1/2 H-P, 787 1/2 H-P, 788 1/2 H-P, 789 1/2 H-P, 790 1/2 H-P, 791 1/2 H-P, 792 1/2 H-P, 793 1/2 H-P, 794 1/2 H-P, 795 1/2 H-P, 796 1/2 H-P, 797 1/2 H-P, 798 1/2 H-P, 799 1/2 H-P, 800 1/2 H-P, 801 1/2 H-P, 802 1/2 H-P, 803 1/2 H-P, 804 1/2 H-P, 805 1/2 H-P, 806 1/2 H-P, 807 1/2 H-P, 808 1/2 H-P, 809 1/2 H-P, 810 1/2 H-P, 811 1/2 H-P, 812 1/2 H-P, 813 1/2 H-P, 814 1/2 H-P, 815 1/2 H-P, 816 1/2 H-P, 817 1/2 H-P, 818 1/2 H-P, 819 1/2 H-P, 820 1/2 H-P, 821 1/2 H-P, 822 1/2 H-P, 823 1/2 H-P, 824 1/2 H-P, 825 1/2 H-P, 826 1/2 H-P, 827 1/2 H-P, 828 1/2 H-P, 829 1/2 H-P, 830 1/2 H-P, 831 1/2 H-P, 832 1/2 H-P, 833 1/2 H-P, 834 1/2 H-P, 835 1/2 H-P, 836 1/2 H-P, 837 1/2 H-P, 838 1/2 H-P, 839 1/2 H-P, 840 1/2 H-P, 841 1/2 H-P,

A Wise Old Trapper

In the state of Ohio there lived a bunch of boys who had this trapping business down to a science. They each sent for separate price lists every year and then sent all their furs to the house giving the best quotations. After five years they decided they weren't so dreadfully wise because they didn't have enough profits to make their efforts worth while.

One day they met Tom McMillan driving a new car to town. Tom said he made the price of his swell outfit shipping pelts. He told how he got wise to those funny prices and found it was better to deal with Chas. Porter because he always knew in advance just what he was sure of getting. He said that Porter never offered \$5 for a \$3 pelt but he always paid the \$3 which he promised and sometimes a little better. Chas. Porter now has five wise trappers in that section instead of one.

Don't Take a Chance With Your FURS

Send us your name and address. Get our Price Bulletins, Shipping Tags, and full particulars. Do it right now. This means real dollars to you, so don't put it off. Write today.

Your furs mean real dollars to you. Why sell them to some fellow who offers you \$1.25 when you know blame well you are lucky to get fifty cents. Ask the wise trapper who knows. Once a Chas. Porter shipper and you will always be one. You know in advance that we give a square deal and every shipment brings sure money.

CHARLES S. PORTER, INC.

123 West 27th Street

New York

TRAPPERS

Send for our new catalog of The Gibbs "TWO TRIGGER" TRAP and the NEW GIBBS HUMAN TRAP. They are the only traps that absolutely prevent "WRING OFFS." Catalog also contains useful information to TRAPPERS.

W. A. GIBBS & SON, Dept. B.P.-11, Chester, Pa.
Branch Factory, Toronto, Canada

TRAPPERS

Make This a Big Season!

TRAP early and long! Get full value by shipping to McCullough & Tumbach. Our graders know the market—they pay every cent a skin will bring.

We guarantee our prices to top the market—and your check goes out the day the furs come in.

SHIP FURS NOW!

For 31 years our business has grown by honest dealing. Ask any old-timer—then send us a shipment. The check will prove every word we say.

Free! Shipping tags, price lists, trappers' supply catalog.

McCULLOUGH & TUMBACH
129 N. Main St., St. Louis, Mo.

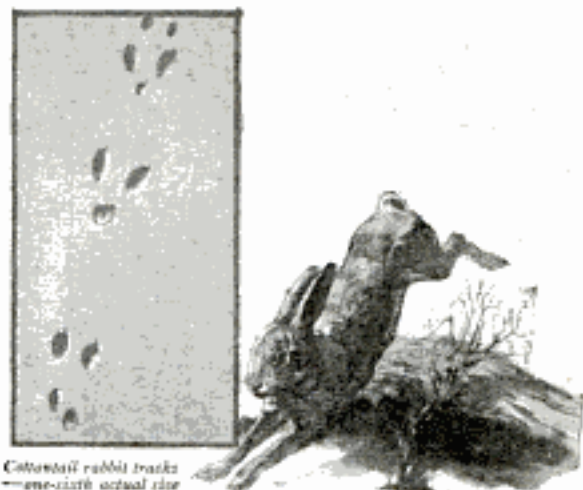

Cottontail rabbit tracks—one-sixth actual size

RABBIT—One of the finest little game animals in the United States because of its excellent food value and the cunning with which it eludes capture. Tracking rabbits requires great skill, a good deal of patience and the ability to shoot quick and straight.

Real Sport—

A thrilling chase—

A quick, sure kill with your .22

WHEN you finally get a shot at that foxy old jack-rabbit you haven't a second to waste!

That's just the moment when you thank your lucky stars for your Stevens Junior.

Just take a look at this new little brother of the famous Stevens family of .22's. Here is a real Stevens from stock to muzzle—built with a barrel made the Stevens way—that is rifled to less than a thousandth of an inch in accuracy. The lowest priced real rifle on the market, only \$4.50.

No matter what kind of a rifle you're looking for—single shots or repeaters—somewhere in the Stevens family you'll find one that exactly fits your needs and your pocket-book. Ask at your dealer's or write us today for an interesting illustrated catalog.

J. STEVENS ARMS COMPANY

Dept. 70

Chicopee Falls, Mass.



STEVENS JUNIOR

—20-inch barrel, round-blued finish—military stock—knife blade front sight—open rear sight. Shoots C. B. caps. .22 short, long, or long rifle. Weight 2¼ lbs. Price only.....\$4.50

SAVAGE STEVENS

On Credit!



Direct
from the
Maker



8

Adjustments

\$1 down!

—and direct from factory

Only \$1.00 down buys the famous Studebaker Insured Watch direct from the factory at the low factory price. Choice of 54 newest Art Beauty Cases, in white gold, green gold or yellow gold effects; 8 handsome dial designs. Mail coupon for beautiful Style Book in colors—Sent Free!

21 Jewel ~ Extra thin STUDEBAKER The Insured Watch

Has 21 Jewels—8 adjustments—and is insured for the lifetime of the owner. The masterpiece of timepieces at an amazingly low price.

Watch Chain FREE!

For a limited time we are offering a beautiful Watch Chain FREE. Write while offer lasts.

Mail Coupon for FREE Book

Mail coupon today for magnificent Studebaker Book of Advance Watch Styles. Find out how you can buy direct from the factory—save money and own one of the finest watches made. The Book shows 54 newest thin-model designs in Art Beauty Cases. Sent FREE!

STUDEBAKER WATCH CO.
Dept. P-22 South Bend, Indiana
Canadian Address: Windsor, Ontario

Ask for Ladies' Bracelet Watch Folder
Ask for Jewelry Folder

STUDEBAKER WATCH CO.
Dept. P-22 South Bend, Indiana
Please send me your Free Book of Advance Watch Styles and particulars of your \$1.00 down offer.
If you live in Canada send your inquiry to our Canadian office: Windsor, Ontario.

Name

Address

City..... State.....

Check here for Ladies Watch Folder Check here for Jewelry Folder

Now **\$49.50** Genuine Silent No. 8
L.C. SMITH

You **SAVE \$55.50**

30 DAYS FREE TRIAL

You can save \$55.50 on a Model No. 8 L. C. SMITH—the genuine "Silent Smith"; or you can save \$60.00 on a Model No. 51

Like New in Looks and Service

Both are literally like new! Guaranteed for 5 years. Each has all latest improvements. Standard keyboard; 84 characters. Ball bearing shift, carriage and keys; two-color ribbon, etc. No. 8 "Silent Smith," in addition, is SILENT. It has the newest decimal tabulator, with column selector.

30-day Free Trial; Satisfaction Guaranteed

Try either model 30 days. If it does not please you in every way, send it back at our expense and we will refund every dollar you have paid. Send postcard for full details at once.

Get Prices On All Standard Makes

LINCOLN TYPEWRITER COMPANY
INCORPORATED

America's Leading Independent Typewriter House

Dept. 45B 298 Broadway, New York City

AGENTS: MAKE \$2,000
NEXT FEW MONTHS



NEW OIL BURNERS
\$15.00 Daily Profit
For Only 3 Sales A Day

Fits any Heating Stove, coal or wood range. No changes to make in stove. Just set in—start it off. No tools needed to install. Clean, intense, even blaze. Burns kerosene. Three times heat of coal at half the cost. Absolutely safe. Popular price seller. Sample free plan. Get yours free. Write.

THURSTON MFG. CO.

Dept. 278

Dayton, O.

Are You Old at 40?



A very common cause of early old age is the disturbed condition of an important gland. Even big, strong men are not exempt from this serious irregularity. Our plainly written, interesting, educational

FREE BOOK

"Why Many Men Are Old at 40"

may bring a priceless message to you. It tells of a sensible way

by which thousands have relieved this prostate gland condition. It tells how sciatica, backaches, foot pains, interrupted sleep, mental depression, etc., are so often due to this gland. Sold for over five years upon a money-back-if-not-satisfied plan. Do not confuse it with massage, medication, violet rays, etc. No obligation. Write today.

THE ELECTRO THERMAL CO. 2139 Main Street
Thermalaids Steubenville
Ohio

Western Office: Dept. 21D, 711 Van Noy Building, Los Angeles, California

Don't forget
your pliers*



Take a pair of Bernards (No. 102) to the office. You will find them of constant use for repairing typewriters, desks, straightening telephone wires, cutting wire and doing the countless little jobs for which fingers are inadequate. Be sure you get

* BERNARD

Standard High-Power Cutting
PLIERS



No. 130—Bernard "Wunaxion"
Eyelet Punches

Catalog "P" free
on request from

WM. SCHOLLHORN CO., New Haven, Conn.

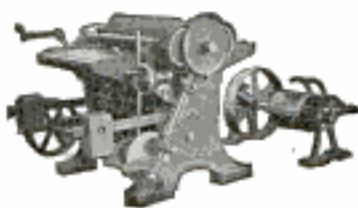

It is the well known quality of CRESCENT machines that justifies you in selecting one of them each time you have need for wood working machinery. The CRESCENT line is better than ever and will always give you satisfaction in every particular. Ask today for catalog of hand saws, saw tables, jointers, shapers, planers, borers, planes and matchers, coping saws, disk grinder, cut off table, hollow chisel mortiser, variety wood worker. Universal wood workers.

THE CRESCENT MACHINE CO., 93 Columbia Street, Leetonia, Ohio



High Quality Long Life
Right Prices
These are found in all Gerstner
TOOL CASES AND CHESTS
for Machinists and Toolmakers.

A postal brings free catalog
Gerstner & Sons

411 Columbia St., DAYTON, OHIO

—it's So Handy

You will say so just as others have as soon as you see the Simore screw-driver or combination knife and screw-driver. Model No. 11 has three screw-driver blades. No. 12 has a fine steel knife blade and two screw-driver blades. Both tools unusually useful around the house or car, or on a camping trip.

Blades are selected and produced by gravity action thru the chuck, and cannot be lost, or misplaced. When in place for use the blades are rigid and dependable. Handle blued to prevent rust.

Model No. 11 for \$1.00, and No. 12 for \$2.25. Send money order or your check and we will ship post prepaid at once. Each tool guaranteed, and your money refunded if not satisfactory.

Dealers are asked to write for information on this tool and the Simore Automatic Trysquare.

THE SIMON & SKIDMORE MFG. CO.
Dept. 4-11 SANTA ANA, CALIFORNIA



The
Tools
That are
Different

New!

Here it is, your handiest file. Just what you've wanted. The only file of its kind.

It files everything, sharpens anything, with its two faces—double-cut (coarse) on one side; single-cut (fine) on other side. Two files in one.

PLUMB

DOUBLE-LIFE

All-Work* File

with sheath

* Trade Mark Reg. U. S. Patent Office

Handle, forged as part of file, fits your hand, guides your stroke, saves your knuckles, makes work easy.

Carry a Plumb All-Work File in your kit or in your pocket. Sheath comes with every file, to protect the teeth from damage or rust.

You want this file for every job around the house, for your radio, to sharpen your knives and your tools.

Only **35c**
at your
dealer's
or by mail
(40c west of Rocky Mts.)

It's no trouble to supply you if your dealer can't. Just send 35 cents and we'll see that you get your Plumb All-Work File by the next mail. Your money back if you want it.

FAYETTE R. PLUMB, Inc.

4811 James Street

Philadelphia

Length
10 inches
Width $\frac{7}{8}$ "
Handle is
part of file.



PLUMB

DOUBLE LIFE

Hammers Hatchets
Files Sledges Axes

EASY NOW TO OWN THE FAMOUS WITTE ENGINE

Plan of Only \$5.69 for a Few Months Sets Record Low Price.

The rugged, dependable Witte Throttling Governor Engine—known for over 42 years as the standard of farm power—surely is within the reach of every progressive farmer now, according to a new plan just announced by Ed H. Witte, world-famous engine builder.

Now only \$5.69 a month for a short time buys the standard Witte Throttling Governor Engine, fully equipped with the celebrated waterproof WICO Magneto. In spite of this low price, which sets a record, the engine has nearly 40 new improvements, including a new device that makes starting easy at even 40 degrees below zero.

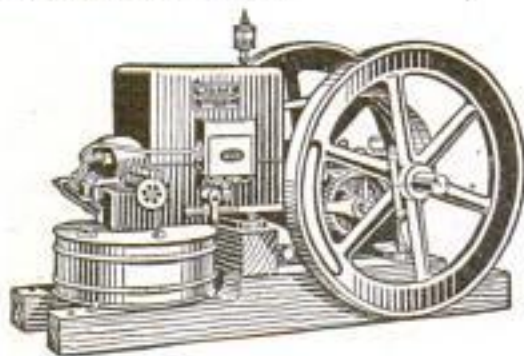

Long regarded as the cheapest and most dependable farm engine built, the WITTE develops 50% extra power on either kerosene, gasoline, distillate or gas. Operation on full load figures under 2c an hour. Trouble-proof and so simple that the women folks can operate it. Easily moved from job to job. More than 150,000 WITTES are in daily use.

To introduce this remarkable engine to a million new users, Mr. Witte will send it anywhere, direct from factory, for a guaranteed 90-day test.

Every reader of this magazine who is interested in doing all jobs by engine power should write today for a free copy of a remarkable new, illustrated book just issued by Mr. Witte, which explains the engine fully. You are under no obligations by writing. Just send your name, a postcard will do, to the Witte Engine Works, 1746 Witte Bldg., Kansas City, Mo., or 1746 Empire Bldg., Pittsburgh, Pa., and receive this interesting and valuable book that gives you valuable information about the application of engine power on your farm.

Our BUREAU of INFORMATION will answer all questions regarding articles in this magazine. Address Popular Mechanics Magazine, Chicago.

\$25.00 a DAY CLEAR

SURFACING FLOORS



Write Quick for Details

Scores of inexperienced men whom we started as American Universal Floor Surfacing Contractors are making up to \$10,000 a year in this wonderful, new, uncrowded field. Electrically driven American Universal Machines do 500% more work and 100% better work than most expert hand scraper, and earn six men's pay. Work is plentiful, fascinating, immensely profitable. Experience unnecessary. Small amount starts you. We furnish everything, teach you, help you succeed. Opportunity of lifetime to be your own boss and make big money.

AMERICAN FLOOR SURFACING MACHINE CO.
523 So. St. Clair St. TOLEDO, OHIO



Saw Books FREE

"Saws in the Shop," "Saw Sense," "Saws on the Farm;" just send your name and address, and say which of these helpful books you want—and we will send it FREE.

E. C. ATKINS & CO., Dept. P, Indianapolis, Ind.

THE SCREWDRIVER THAT HOLDS THE SCREW

As Good as a Third Hand in Assembling anything from a Watch to an Automobile



Appeals Especially to Radio amateurs and professionals. A wonderful (patented) Improvement.

Jobbers, Dealers and Agents. Favorable discounts

\$1.00 Postpaid **THE COBURN TOOL CO., Inc., 739 Boylston St., Boston, Mass.**



PILLIOD

Tool Cases Excel

Machinists, Tool Makers and Carpenters find them most satisfactory in construction, appearance, service and price. Immediate shipment.

Booklet describing 20 styles on request.

THE PILLIOD LUMBER CO.
Dept. 1 Swanton, Ohio

SARGENT PLANES

See them at your hardware store.

Write for booklet.

SARGENT & CO., 49 Water Street, New Haven, Conn.

DYNA-MOTOR

As a dynamo it will operate induction coils, light lamps, charge storage batteries, electroplate, etc., makes an ideal machine for experimenting. As motors they will operate heavy models, motor wheels, and other appliances.

10 Watt Dyna-Motor	\$6.50	30-Watt Dyna-Motor	\$8.00
--------------------	--------	--------------------	--------

64 to 200 Watt Dynamos, Armatures, Commutators, Pumps, etc. Parts for School and Students. Send for Catalogue to cover most of mailing, etc.

LOUIS ELECTRIC COMPANY
1427 N. Artesian Ave. CHICAGO, ILL.



"Buzz Boice" Introduces His Latest Achievement

A staunch, sturdy saw built for heavy duty, at a remarkable price.

Boice-Crane Utility Saw

Saws, miters, rabbets, bores, sands, grinds and many other operations with ease and accuracy. Saws 2½" stock. Dados 1" wide by 1½" deep. Table elevates for grooving. Driven by ½ to ¾ h. p. motor.

Sold on Money-Back Guarantee

Write for descriptive folder on bench saws, band saws, drills and jointers.

W. B. & J. E. BOICE Dept. P. M. 11 Toledo, O.



Saw Your Way to Success



PARKS

"Cabinet Shop Special"

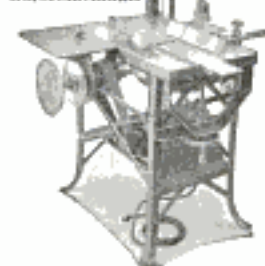
\$225As illustrated with motor
L. S. Cincinnati**The biggest little woodworker ever built!**

You'll want this sensational Parks combination woodworker right away for your shop—it includes 8-inch rip and cross-cut saw, 4-inch jointer, band-saw, borer, shaper, sander and universal motor. Complete with lathe attachment only \$225. First-class Parks

angle-steel construction, all joints electric-welded. Steel table-top. The newest thing in small shop equipment. Guaranteed 10 years.

Send for Bulletin C-5, describing this machine in detail.

The Parks Ball Bearing Machine Company
1500-1540 Knowlton St. Cincinnati, Ohio

(Canadian Factory: 200 Notre Dame East, Montreal, Can.)

PARKS

WOODWORKING MACHINES

BURN YOUR NAME ON TOOLS
WITH
ARKOGRAF

Protect your tools from theft. Write any name, engrave any design on metal with electricity like writing on paper with pen or pencil. Complete outfit \$3.50, prepaid anywhere. Interesting descriptive circular free. Write today. Agents Wanted. Arkograf Pen Company 1171 East Stark St. Portland, Oregon

**MATHEMATICS**

can be easily mastered with the Midget 5 in 1 Slide Rule. With this calculator you can instantly add, subtract, multiply and divide any combination of decimals, fractions, whole and mixed numbers. Also obtain all roots, powers, Logs, and Trig. Functions. It is used at all colleges, 200 at Harvard, 200 at Cornell, etc. The Knife-Divided Scales are on white celluloid, mounted on aluminum and are grease and waterproof. Diameter 4 inches. Price with Instruction Book..... \$1.50 Leather Case 50c extra. Catalogue free. Your money back if you are not satisfied. GILSON SLIDE RULE CO., Niles, Mich.



Take inside or outside measurements quickly with

Interlox

MASTER SLIDE RULE



MASTER RULE MFG. CO., R41-43 E. 136th St., New York

Many advantages. Non-folding—it slides in and out. Fine box-wood, brass bound. Any size, 3 to 8 ft., 20c per lineal foot. If not at dealer's, sent postpaid. Dealers and Agents: Request attractive proposition

21 Jewels

Nothing less than 21 Ruby and Sapphire Jewels is good enough for the Burlington masterpiece.

Quality and Style

Adjusted to the second-temperature-isochronism-positions. 25 year Gold Strata Case, in 100 exquisite designs. Only \$1 down. Balance in small monthly payments. Send for free book.

Burlington Watch Company
19th Street and Marshall Boulevard
Dept. 12-68 Chicago, Illinois

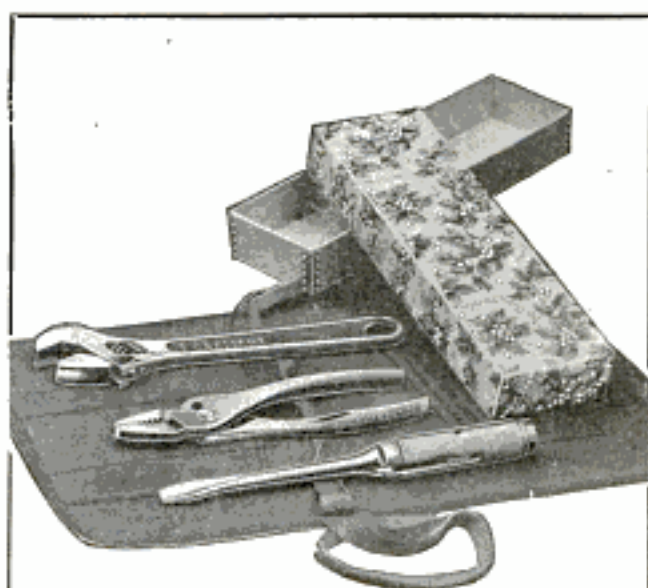

When you make up your Christmas list—

THERE'S nothing at anything like the moderate price of the Crescent Kit that will be sure of such a welcome. Motorists, amateur mechanics, repair men, and electricians will appreciate it. It is popular among women as a household kit.

For concerns which have a long Christmas list of employees or customers, it is the ideal gift.

Eight-inch wrench, six-inch pliers, and all-steel screwdriver, each one covered by the Crescent guarantee of satisfaction.

At hardware or accessory stores
\$2.35

CRESCENT TOOL CO.
210 Harrison St., Jamestown, N. Y.

Originators of the Crescent Wrench and
the CRESCENT KIT

Tire AGENTS WANTED

Use and introduce **MELLINGER CORD TIRES**
12,000 MILES GUARANTEED

Lowest Wholesale Prices in America. Shipped prepaid on approval. Make big money all or part time. No capital or experience. Sample sections furnished.

YOUR TIRES FREE! Simply send name today for valuable **FREE BOOK**, tells how thousands have gone into big business. **SPECIAL AGENTS' OFFER** Wholesale Prices and **FREE SAMPLE KIT**.

MELLINGER TIRE & RUBBER CO.
1769 Grand, Kansas City, Mo. \$600,000 Capital



You-and This New Machine Can Earn \$500 a Month



Operate a **Tire Repair Shop**

70,000,000 Tires in use. America's greatest opportunity for men with small capital. We furnish everything—\$100 and up. **Easy payments.** We train you **FREE** right at home. Start making money at once. Write today for **Free Book of Opportunity.**

Haywood Tire Equipment Co. 1344 S. Oakley, Chicago



\$3.85 AND UP
Custom Made

RECOVER IT YOURSELF

Make your car look like new and save a big labor bill. We have been making top recoverings, side curtains and seat covers for 15 years. We have patterns for all makes, no model too old for us. Easy to apply, simple instructions given. Write for our big money saving catalogue with samples.

THE LIBERTY TOP & TIRE COMPANY, Dept. E-7 Cincinnati, Ohio

SEND for the INTERNATIONAL CATALOG

FOR FORD PRICES FROM \$27.85 UP.

Factory to Consumer direct—Pay only one profit.



Our net price list. Full line of auto bodies and accessories for Fords at Wholesale Prices.

Save big money on bodies by buying direct from factory.

INTERNATIONAL BODY WORKS, Dept. 7, 914 W. Ohio Street, CHICAGO, ILL.

I Offer You \$48 a Week and a

Buick TOURING CAR

We want men and women as local representatives to demonstrate and take orders for **Comer All-Weather Raincoats.** New offer enables you to earn \$48 a week and Buick touring car. No experience necessary. Write quick.

Comer Mfg. Co., Dept. BW-5100, Dayton, O.



\$25 A DAY SELLING SHOES



The **Tanners Shoe Mfg. Co.** want representatives: Men and Women to sell the famous **Tanners Shoes** direct to consumer. Over 70 latest styles for men, women and children. Sell on sight, commissions in advance. Experience unnecessary as we train men and women who are honest, industrious and ambitious.

TANNERS SHOE MFG. CO.
3082 C Street, Boston, Mass.

Genuine DIAMONDS

Sent for

BARGAINS

These articles cannot be equalled anywhere even for cash.

Guarantee

with each article—absolute satisfaction or money back

10 Day's FREE Trial



No. 5 Set in Platinum
Seven fiery, blue white diamonds resembling \$750 solitaire. 14 k. green gold lady's ring. Only **\$52.50**

No. 7 Lady's Ring
18 kt. white gold, hand engraved and pierced. Perfect cut diamond, sapphire on each side. Special at **\$29.85**



No. 6 14 kt. white gold watch. sapphire crown. 15 jewel guaranteed movement. Only **\$23.50**



No. 8 Gent's Ring
14 k. green gold with 18 k. white gold top. Perfect cut blue white diamond. Wonderful value at **\$57.50**

Simply Send \$2

We will then send you your choice of these articles. Wear it ten days and if you don't agree it is an amazing bargain, we will refund your money. If satisfied, pay balance in 10 equal monthly installments. **You take no risk.**

Order today—don't delay.

Free Send today for big catalog showing thousands of other bargains in diamonds, watches and jewelry. Prices \$10 to \$1000. Wonderful values. **Cash or Credit.**

Established 1890

Write Dept. H-26

BAER BROS. Co.

6 MAIDEN LANE - NEW YORK



Make Your Ford a Closed Car!

Limo weather-proof sections will change your 1923-1924 Ford Touring or Roadster, into classy limousine-style closed car. Doors open from outside. Sliding front panels for ventilation. Three-ply, double covered veneer frames. Color matches your top. Easily, quickly installed. Guaranteed. Low priced. Fine for bad weather. Write for prices.

BUOB & SCHEU, Dept. A-8, 216 Webster St., Cincinnati, O.

MAKE YOUR FORD INTO SPORT CAR—SAVE \$50 to \$150 WITH **Red-i-Kut** Life-Size Patterns \$6.40

Patience **Red-i-Kut** life-size patterns and picture-fit **Red-i-Kut** instructions show you how you can easily convert your Ford into this **Fast, Spicy, Sport Car** as thousands have done, with easily obtained materials. No need to lay up the car. **LOOK AT WILFRED ENO'S PAL.** Eno says: "Total material cost with steel and paint for my Pal only \$12.50. It took me just 2 Sundays to build it and I was on road to hear them say, 'He built that snappy sport car.' I never cut any steel or did any woodwork before but one can't go wrong with Kuempel patterns." (Overland City) St. Louis, Mo. The "Pal" with pressed metal streamline rear,

life-size patterns for each part of the body so you can't go wrong, picture instructions and **CONICAL DISK WHEEL PATTERNS** Only \$4.95 delivered. Order now while we can make good delivery, and really enjoy these wonderful days in your "Pal." Keen, Classy, Up-to-the-minute. You can build it. Over 11,000 in use. Don't hesitate. **Bring Le's Underlaid Irons, no frame cutting kind, only \$4.95.** Send for copy for new manual of other distinctive sport body patterns from \$3.50 up. "Red-i-Kut" Street, "Survo-La" Irons, "Jiffy" Tops and "Gorram" Windshields. Order Right Now. **Kuempel Co., 54 Kuempel Bldg., Guttenberg, Iowa**



30-inch, Easy-riding seat

COMPLETE

For a Generation of Daily Use



A generation of daily usage is built into every WHITING-ADAMS Shaving Brush.

WHITING-ADAMS BRUSHES work perfectly and hold together until actually worn out.

WHITING-ADAMS BRUSHES

The satisfaction of using a WHITING-ADAMS Shaving Brush increases day by day. They satisfy—serve—and survive!

JOHN L. WHITING-J. J. ADAMS CO., BOSTON, U. S. A.
Brush Manufacturers for Over 116 years and the Largest in the World

Make \$60 to \$100 A WEEK

New 300 Candle Power Lamp—Burns 96% Air

Introduce wonderful patented invention. Burns only 4% fuel—cheap kerosene or gasoline. Uses less than wick lamps. Greatest advancement in lighting of the age. Table lamps, wall lamps, hanging lamps, lanterns. Powerful, brilliant, soft, restful white light—like daylight. Brighter than a score of wick lamps. No Smoke—No Soot—No Odor.

FREE Outfit Offer Easy to earn big money. No experience—no capital required. Work all or spare time. Simply take orders. We deliver and collect—pay you big commission same day. Vivian of Minn. made \$400 in 39 days. Green of N. Y. made \$33 in one day. Hundreds making \$10 to \$40 a day. Get territory quick. Big season now on. Write today for Free catalog and special agents offer.

The Akron Lamp Co., 111 Luz St., Akron, O.



Lighte with Match

STOP LEAKS! REPAIR BREAKS! MAKE LOOSE PARTS STAY TIGHT!

Smooth-On No. 1

STOPS leaks and repairs breaks in pipes, furnaces, radiators, tanks, bursted water jackets, etc., with one simple application.



Keeps bolts, nuts, grease cups, etc., from loosening and dropping off—makes loose handles tight—joins wood, metal or glass to each other tightly—holds on iron, brass, lead, aluminum, etc.

For quick, cheap, lasting joints and repairs and stopping many nuisances in every home, automobile and workshop, Smooth-On is in a class by itself.

144 pages
This Book
FREE

SMOOTH-ON
REPAIR
BOOK

Get Smooth-On No. 1 in 6-oz., 1-lb. or 5-lb. tin at any hardware store.

SMOOTH-ON MFG. CO.
574 Communipaw Ave., Dept. 37
JERSEY CITY, N. J.

Self-Filler

DE LUXE

Style Pen

"INDEPENDENT"

All the best features of a Fountain Pen. Lasts longer. Writes smoother. Improves handwriting. Eliminates fatigue. GUARANTEED.

14 Kt.

White Gold Point, Chased Rubber Holder, Lever Filler. Pocket Clip.

Your Name in Gold Inlay, 25c.

Write for Pen Catalog. Agents Wanted.

J. C. Ulrich & Co., 161 Washington St., New York
Known the World Over for 40 Years.

\$2.00
By Mail

In the Boy's Workshop
He easily fastens to walls his drawings or his plans with

MOORE PUSH-PINS

Glass Heads—Steel Points
and all his heavier articles with
Moore Push-less Hangers
"The Hanger with the Twist"
10c pkts. Everywhere

MOORE PUSH-PIN CO., Philadelphia, Pa.

\$2 Brings This Genuine DIAMOND RING

Simply send \$2.00 for the most sensational, price-smashing diamond ring offer ever made.

A perfectly cut, guaranteed, blue white, fiery diamond is set in an 18 Karat white gold cup; 3/4 Karat size. Latest design, hand engraved mounting.

10 DAYS' FREE TRIAL

We take all chances—if you are not satisfied at the end of ten days for any reason whatsoever, return the diamond ring to us and your deposit will be refunded to you. Send only \$2.00, and receive this genuine steel blue white diamond ring exactly as illustrated; in a handsome gift box charges paid. A legal guarantee bond as to quality and value accompanies each ring. After ten days' trial pay balance \$6.95 a month for twelve months. Price only \$79.50.



NO RED TAPE—NO DELAY

Order Now! This offer is limited. It may never appear again. Don't delay. Just send \$2.00 as a deposit. If you wish to return the diamond ring after trial, your deposit will be refunded.

FREE BOOK OF GEMS

Most complete Jewelry Catalog ever issued of Diamonds, Watches and Jewelry—newest designs at lowest prices.

A full year to pay on everything you order from our TWO MILLION DOLLAR STOCK.

Address Dept. 1144. Est. 1895

ROYAL DIAMOND & WATCH CO.
35 Maiden Lane - New York

Different from all others—the NEW BENJAMIN



AIR RIFLE

Made on a different principle from all other Air-Rifles.

The Benjamin is really a strong air-pump used to compress the air in the air chamber to any degree of power desired. From one to six strokes of the pump give all the force necessary. Each additional stroke gives increased power. The Benjamin works on the same principle as all air-drills and air-hammers—with this difference:

You control the shooting force as you desire. Look at this block of hardwood. It shows how Benjamin power is regulated as you wish.

You can't have accidents with a Benjamin. It's safe, always, because you control the power. The Benjamin never loses shooting force, and has no springs to get out of order or shake your aim. Write us for an interesting folder about this wonderful air-gun.

If your dealer does not handle yours, send direct to factory.

(PRICE \$5) POSTPAID

BENJAMIN AIR-RIFLE & MFG. CO., 415 N. Broadway, St. Louis, Mo.

Ask your dealer for demonstration.

Pacific Coast Representatives
THAYER & BOWER
Los Angeles, Calif., and
San Francisco, Calif.





Men's Shirts

From factory to wearer. Easy to sell. Big demand everywhere. Make \$15 daily. Under-sell stores complete line. Exclusive patterns. No experience necessary. Free samples.

Chicago Shirt Manufacturers,
229 W. Van Buren St., Chicago, Factory 433

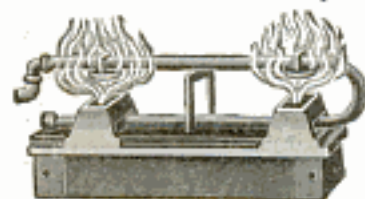
AGENTS: \$9.00 A DAY



Newest Invention Coal-Oil Burner Cheapest Fuel Known

Most perfect burner ever invented for heating, cooking, baking. Fits any stove. Heats oven to baking point in 10 minutes.

Low priced. Make \$6 to \$12 a day. You take orders. We deliver and collect. Pay you daily. Write for terms and sample.

PARKER MFG. CO., BURNER 3278, DAYTON, OHIO

AGENTS

Make \$10 to \$20 daily selling Premier Knife and Scissors Sharpeners.



200% PROFIT

or more. 9 out of 10 women buy. Produces keen edge quickly. Sells for 50c.

PREMIER MFG. CO.
Dept. 29, DETROIT, MICH.

WHITE FLAME

BURNERS make your old kerosene lamps and lanterns give a brilliant white light better than electricity or gas. Doubles your light. Saves oil. NO MANTLE TO BREAK. Guaranteed safe and reliable. Delights every user. Send now for complete sample postpaid 50 cents, stamps or coin. 3 for \$1.25. Money Back if Not Satisfactory. Live Representatives Wanted. Exclusive Territory.

WHITE FLAME LIGHT CO., 68 Clark Bldg., Grand Rapids, Mich.



TYPEWRITER SENSATION! \$3 Down Brings This Typewriter

This is your opportunity to actually use in your home or office this Remington typewriter for ten days without obligation to buy. Think of it! Only 15c per day buys this Remington. Simply send us \$3.00 with coupon and we will send you the Remington for ten days' trial. After trial and when entirely satisfied send us only \$5.00 per month until our low direct-from-factory price, \$53.00, has been paid and the machine is then yours. We give you the same guarantee as if you paid the original factory price. Net cash price only \$47.70.

SELF-STARTING No. 10 REMINGTON 10

Perfect machines. Correspondence size. Keyboard of Standard Universal arrangement. 42 Keys, writing 84 characters. The entire line of writing completely visible at all times, has the tabulator, the two color ribbon, with automatic reverse, the back spacer, variable spacer, self-starter, in fact, every late style feature and modern operating convenience. Comes to you with everything complete; cover, operating book and instructions—nothing extra to buy.

Young Process Re-Manufactured

The famous "Young Process" means a mechanically perfect operating typewriter, guaranteed like new. You cannot tell this Remington from a brand new typewriter in appearance, service and workmanship. You must be entirely satisfied in every way that this is the greatest typewriter bargain ever offered you.

You cannot imagine the perfection of this beautiful re-manufactured typewriter until you have seen it! We have sold thousands of these perfect late style machines at this bargain price and every one of these thousands of satisfied customers had this beautiful, strictly up-to-date machine on ten days' free trial before deciding to buy it!

Only 100 Typewriters at This Price

Act now. There is no time to lose. This is the greatest typewriter opportunity you will ever have. Rush your order now.

YOUNG TYPEWRITER CO.

654 W. Randolph, Dept. 210B, Chicago, Ill.

FREE TRIAL ORDER COUPON

Young Typewriter Co., 654 W. Randolph, Dept. 210B, Chicago, Ill.

You may send me the Remington typewriter, fully guaranteed, on ten days' trial, express charges collect. I enclose \$3.00 deposit and will pay you \$5.00 monthly rental for 10 months when your \$53.00 price will be paid in full and the machine becomes mine. It is understood that title remains with you until all payments are made. Also that I may return the typewriter at your expense, within the trial period, if I choose not to keep it and you will return my deposit.

Name.....
Street Address.....
City..... State.....
Occupation.....

SWEET'S

New SPREDDTOP RING



\$1⁰⁰-a Week

10 MONTHS TO PAY

The new and exquisitely beautiful Spredtop ring, (sold exclusively by Sweet) is designed to give the diamond greater brilliancy and the appearance of a much larger stone. The mounting is of 18K white gold, beautifully hand carved. A wonderful value at \$45. Pay by the month.

Our Challenge If you do not find our price on any diamond ring is at least 10 per cent lower than that of any other concern, either cash or credit, we will gladly refund your payment in full if you return the ring within two weeks.

Send No Money We will send you for Free Examination. If satisfied pay only \$5.00 down and \$4.00 a month until the \$45.00 is paid.

FREE Our beautiful new Diamond, Jewelry and Gift Book showing thousands of wonderful (100) selections. Write for it Today. Address Dept. 64-S.



"THE HOUSE OF QUALITY"
AUTHORIZED CAPITAL \$1,000,000.

L.W. SWEET INC.

Dept. 64-S, 1660 BROADWAY, NEW YORK

I Want 700 Agents



At \$90⁰⁰ a week

Men and Women! Write me today and by this time next week I can place you in a position to make \$2.00 to \$5.00 an hour in your spare time, up to \$15.00 a day full time. Thousands of our representatives are making that and more with our **New Plans**. Simply introduce and take orders for famous **World's Star Hosiery and Underwear** sold direct from mill to home—a complete line for whole family. Permanent customers and repeat orders make you steady, big income. No delivering or collecting. No capital required.

Write Quick It's a chance to make thousands of dollars. Your profits begin at once. Exclusive territory. No experience needed. Write today and I'll send all facts and tell how to start **Free**. (Established 29 years.)

World's Star Knitting Co.
281 Lake Street Bay City, Mich.



"If I hadn't been all through it myself, I wouldn't have the assurance to say to you 'cheer up.'"

ERICKSON.

Those who wear them say:
ERICKSON LEGS are Wonderful
because they do not chafe, overheat or draw end of stump.



If you have had a recent amputation send for new booklet on **TEST LEGS** for beginners.
E. H. ERICKSON CO.
38-A Washington Av. N.
MINNEAPOLIS - MINN.

\$1 down ! brings any Instrument !

Genuine Bacon
Tenor Banjo

Choice of all famous Banjo Solists. Most beautiful, sweetest sound. Brand new. \$1 brings it! Balance 10 months.
\$63.50

Our Liberal Terms

make it easy to secure your Saxophone, Trumpet, Cornet, Banjo or any other musical instrument of once. Don't Wait! Small down payment, balance in amounts you won't miss. Learn to play, start a band or orchestra, enjoy real fun!

C Soprano Saxophone

The wonderful Sax with the human voice singing tone. Learn to play in a few lessons at home! It's a "Standard"—our own famous make—World's finest quality, brand new, only
\$87.50

Clarinet

Slightly used, rebuilt like new, price less than one-half. Our catalog shows all musical instruments, brand new standard makes, and bargains in rebuilt instruments. This one only **\$16.50**

Get This Book Quick!

Easy payments on all musical instruments. Supplies, repairs, music, etc. Get this money-saving Catalog immediately!

10 Months to Pay! Standard Music Co., established 19 years. Deal with reliable house which stands back of any instrument with money back guarantee. Send only \$1. Pay balance in 10 months at cash price!

STANDARD MUSIC CO., Dept. 2122
214 So. Wabash Ave. CHICAGO

Catalogue
FREE!

Young Men Read!

\$2.50 an Hour—Easy Work
FREE FORDS to HUSTLERS

We want a young hustler in every community in the United States. We are ready to pay young men \$2.50 an hour for their time—hustlers can get **Ford Touring Cars Free**—no contest, no prizes, no guesswork. It's easy—just show samples and distribute famous Harley products—things people eat—among your friends and neighbors. Full or spare time—big earnings—prompt pay. Write today for big **FREE Sample Outfit**—19 full size packages. Learn how you can make big money in pleasant, easy work. Costs you nothing to start—we furnish everything. Be first to get this money-making offer.



THE E. C. HARLEY CO., M-398 Harley Bldg., Dayton, Ohio

AGENTS 500% PROFIT

GENUINE GOLD LEAF LETTERS

S guaranteed to never tarnish. Anyone can put them on stores and office windows. Enormous demand, large profits. Paul Clark says: Smallest day \$28.70. R. L. Reel made \$920 in two months. Write today for free sample and liberal offer to general agents.
METALLIC LETTER CO., 433-B N. Clark St., CHICAGO

AGENTS MAKE \$100⁰⁰ A WEEK

Write at once for newest, greatest money maker ever offered. Wonderful article—quick seller—big profits. Can be sold in every home. **Tateishi of California** made \$200 weekly—other agents cleaning up. If you mean business, here's the chance of your life. Address Mr. Lloyd Sales Man., Dept. I-K, 119 S. 14th St., St. Louis, Mo.

I made \$180 my first week



As reported by Underwriters

Any MAN can sell them

"And am able to average over \$100 PER WEEK. Could do more only I do not put in much over half-time. Personally I think it is the easiest solid article I ever handled as it has merit and is a necessity," says L. R. Graham, Illinois. A. H. Robey of W. Va. made over \$500 in one month. Frank DePrie has been with us six years—averages over \$150 a week. Hundreds of our men making \$60, 75, \$100 a week. We need more men to fill unoccupied territory. Hundreds of prospects make selling easy—garages, stores, factories, shops, farms, homes, auto and truck owners, hospitals. Single sales bring big commissions. Write quick.

THE FYR-FYTER CO., 403 Fyr-Fyter Bldg., Dayton, O.

MAKE MONEY SELL MADISON SHIRTS

Direct from our factory to wearer. Easily sold. Over one million satisfied wearers. No capital or experience required. Large steady income. Many earn \$100. to \$150. weekly. Territory now being allotted. Write For Free Samples. Madison Shirt Mill, 511 B'way, New York

CLASS 25¢ PINS

BUY DIRECT FROM THE MAKER CATALOG FREE

Either pin shown made with any 3 letters and 2 figures. 1 or 2 colors enamel. Silver plate 25¢ ea. \$2.50 doz. Sterling silver. 40¢ ea. \$4.00 doz.

BASTIAN BROS. CO.
650 590 Bastian Bldg., Rochester, N. Y. 3214

BUILD YOUR OWN PHONOGRAPH

WITH OUR HELP—SAVE HALF

Choraleon Aristocrats are unexcelled. Play any record. Finest motor, tone arm, case materials, blueprint, full instructions at LOW COST. Write for catalog and FREE blueprint offer.

Choraleon Phonograph & Radio Co.
1124-1st St., Elkhart, Ind.

How Many Pounds Would You Like to Gain in a Week?

If you are thin and scrawny and would like to gain weight, I will send you a sample of the genuine Hilton's Vitamines absolutely FREE. Do not send any money—just your name and address to W. W. Hilton, 188 Gateway Station, Kansas City, Mo.

Clear-Tone FOR PIMPLES

Your skin can be quickly cleared of Pimples, Blackheads, Acne Eruptions on the face or body, Enlarged Pores, Oily or Shiny Skin. \$1,000.00 Cold Cash says I can clear your skin of the above blemishes. WRITE TODAY for my FREE Booklet—"A Clear-Tone Skin"—telling how I cured myself after being afflicted for fifteen years.

FREE

E.S. GIVENS, 129 Chemical Bldg., Kansas City, Mo.

FREE! NEW MONEY SAVING BOOK

RANGES \$37⁷⁵ UP

Buy direct from factory! Save 1/4 to 1/2 on your stove, range or furnace. Take advantage of the biggest SALE in our 24 years. Kalamazoo quality is the highest; prices are at bedrock. This is the year to buy. Send for our big, new catalog—

FURNACES \$59⁹⁵ UP

STOVES \$27²⁰ UP

it's full of new ideas, new features, new models. 200 bargains in heating stoves, gas ranges, combination ranges, coal ranges, furnaces, both pipe and pipeless, and household goods. Cash or easy payments. 30 days' trial. Money-back guarantee. Quick, safe delivery. 530,000 pleased customers.

Write today for Your FREE Book Now Ready

KALAMAZOO STOVE CO.
399 Rochester Avenue
KALAMAZOO, MICHIGAN

A Kalamazoo Direct to You

"Been on a vacation Bill?"



"No, Jim—I've stopped smoking. Gained six pounds in a week. You know how I used to smoke—a package of cigarettes and a cigar or two a day—it sure had some hold on me. But I'm cured—

took a scientific home tobacco treatment—fixed me up in two weeks.

"Wasn't hard on me at all—noticed improvement the first day—I feel like a new man. It didn't interfere with my work—didn't leave any druggish after-effects—the money I saved in the last two weeks has paid for the treatment alone.

"Why don't you take it! It has cured men like you and me for over forty years—it is a doctor's individual prescription that sure fixes you up. Just send the coupon for full information NOW. No obligation. All correspondence is strictly confidential."

A Doctor's Prescription

The Keeley Institute, Dwight, Ill.

Please send me, without any obligation on my part, your free booklet which will tell me how to rid myself of the tobacco habit.

Name.....

Town.....

Street..... State..... P.M.-11

Use **LEPAGE'S** for
permanent mending



WHEN you mend an article of useful household value, if you want to be sure of making a *permanent* repair, use LePage's Glue. The quantity of glue you use is so little, and the cost so small, why risk using anything but the best? As in everything else, the best is cheapest in the end. LePage's insures *permanent* repairs. *Insist on LePage's.*

LEPAGE'S GLUE

I Make the Best **CHOCOLATE BARS**
Mints and Chewing Gum. Be my agent. Everybody will buy from you. Write today. Free Samples.
MILTON GORDON, 186 Jackson St., Cincinnati, Ohio

200 Sheets—100 Envelopes

High grade, clear, white bond paper—unusually smooth writing surface. Size 6 x 7 inches with envelopes to match. Packed in special handy box. Unusual value. **\$1.00**

Your Name and Address Printed Free on every sheet and envelope as shown, in rich dark blue, 10 to 4 lines. Makes a personal stationery you will be delighted to use. An ideal gift printed with your friend's name. Send name and address with \$1.00 (west of Denver) and outside the U. S. \$1.10. We prepay postage. Money returned if not satisfied. Order today.

National Stationery Co., 1778 Lincoln Highway, Batavia, Illinois



THE No. 1 pen shown here was used to start the Spencerian system of writing. It is an unusually smooth-writing, double-elastic pen which has never been successfully copied. But this is only one of fifty popular Spencerian styles—built for every taste and purpose—fine, medium, stub or dome pointed. Seven hand processes fashion them from special Spencerian steel. There is one designed for your particular handwriting.

10 sample pens for 10 cents and free booklet, "What your handwriting reveals." Write to-day.

SPENCERIAN PEN CO., 349 Broadway, New York

Spencerian Personal Steel Pens

No. 1—College,
fine point,
double elastic.



One of
50 styles

Beautiful HOUSES \$900
and BUNGALOWS
CAN BE BUILT FOR AND UP

This and many others in my new book, Building Plans for Modern Homes, will save you hundreds of dollars. One of the most complete and comprehensive books of plans ever published by any architect. New edition just off the press. Nearly 500 floor plans and photographs of bungalows, Colonial houses, etc., costing from \$200 up; gives sizes and cost to build. Sent postpaid for \$2.00.



FREDERICK H. GOWING
ARCHITECT
101 Tremont St., BOSTON, MASS.

CAMERAS

Over a Hundred Styles and Sizes
Send for new illustrated catalog showing latest reduced prices. It's Free.

10 days' trial given

SENECA CAMERA MFG. COMPANY
300 Central Avenue Rochester, N. Y.



We Want Agents at \$50 to \$90 a Week

New Invention—Just Out. Needed in every home every day. Patented. Nothing else like it. Low priced—**Sells on sight.** Sharpens any kitchen knife, paring knife, carving knife, bread knife, or shears and scissors in **ten seconds.** Mechanical masterpiece. A child can use it. Just put knife in slot—turn crank—sharpens both sides at once automatically. **We want representatives at once—men and women hustlers. Get this position where profits start first day.**

No Experience Necessary—200% Profit

Make as much money next week as these men are making now. J. C. Lewis, of Kansas, says: "I have sold one hundred sharpeners in four days." Hobart Kerr, of Md., writes: "The women can hardly wait till they get them." Herbert Cain, of Ky., sold nine after supper. At the end of the first day, J. W. Gordon, of Pa., writes: "I sold two dozen and I sold to everyone I saw." Wm. G. Hall, of N. J., says: "I think it is great. I sold six in about one-half hour. The machine is a mighty fine proposition. I am a mechanic and I know what I am talking about." You can make this money. **WRITE TODAY, TERRITORY FREE. Get busy at once.**

QUICKEDGE SHARPENER CO. 111 Sharpener Bldg. 159 West Pearl St. Jackson, Mich.

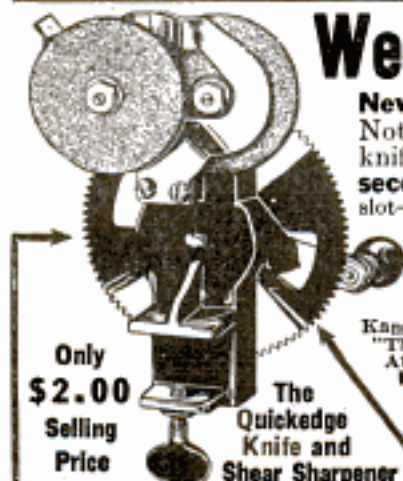

Only
\$2.00
Selling
Price

The
**Quickedge
Knife and
Shear Sharpener**

LOFTIS BROS. & CO. INC.

Diamonds Watches

Cash or Credit

MAKE WORTH-WHILE CHRISTMAS GIFTS

A Genuine Diamond Watch, Wrist Watch, Pearl Necklace, Silverware, etc., are pure to please. We have endless assortments of gifts appropriate for everyone.

Send For Catalog

Select as many articles as you wish and have all charged in one account. Sent prepaid for your Free Examination.

Diamonds in these Rings are high-grade Quality Gems, brilliant and Blue White. The mountings are all Solid 18-k White Gold except No. 20, which is Platinum.

TERMS: Goods delivered on first payment of one-tenth of purchase price; balance in equal amounts, weekly, semi-monthly or monthly, at your convenience.

Satisfaction Guaranteed or Money Back

No. 49—WRIST WATCH, Solid 18-k White Gold, 17 Jewels, \$40. Delivered on first payment of \$4.00.

\$1.00 A Week Many styles in Catalog

LOFTIS BROS. & CO.
National Jewelers
DEPT. F294
108 N. State St., Chicago, Ill.
Stores in Leading Cities

No. 30 \$100 \$250 A Week
No. 33 \$75 \$175 A Week
No. 35 \$37.50 \$100 A Week
No. 12 \$50 \$125 A Week
No. 20 \$200 \$500 A Week

MOVIES TAKE AND SHOW YOUR OWN MOVIES

Movies of your family and interesting events offer endless possibilities. Send 10c for big catalogue of home moving picture machines, home movie cameras and best radio sets. Very reasonable prices. This catalogue is a treat for lovers of home amusement. We also sell best movie film and have a film exchange service for lease users.

PARAMOUNT MFG. COMPANY Dept. MG
Boston, Mass.

YOUR FUTURE

WHAT WILL IT BE?

I can't foretell your future. But I can help you to big money and a bright future. How? With CRISPETTES. They've made the future rosy for others. Let them do it for you. A simple machine, secret formula, my advisory service and a little money as you need. Own a real business—one that will assure your future. Write for "Book of Facts."

H. W. EAKINS, 1028 High St., Springfield, Ohio

Make \$75⁰⁰ a Week and up

Make \$75.00 a week and up, selling our fine made-to-measure, all-wool suits, direct to wearer. **Biggest values—positively sell on sight. Biggest commissions paid in advance.** We attend to delivery and collections. 6x9 swatch samples—over 100 styles all one price—furnished FREE. Part or full time men write at once.

W. Z. GIBSON, Inc., 161 W. Harrison St., Dept. L-11 Chicago

Have part of this winter's coal delivered to your bank



15,000 users of coal are going to do that very thing this winter. Why not you? Instead of depositing the actual "black diamonds" they will bank the difference between what they now pay for coal and what they paid before attaching the CROWN Fuel Saver to their heating plants. **AND THAT DIFFERENCE IS CONSIDERABLE**—always 20%, often 35% and in some cases even 50%. Nothing in your strong box will compare with the CROWN as a dividend producer.

A coal saving of at least 20% GUARANTEED or your money refunded

That's our ironclad guarantee. Simply attach the inexpensive CROWN Fuel Saver to the feed door of your furnace and you either burn 80% or less of the coal you ordinarily use, and get more heat, quicker heat and steeper heat—or we will immediately refund the small purchase price of the CROWN.

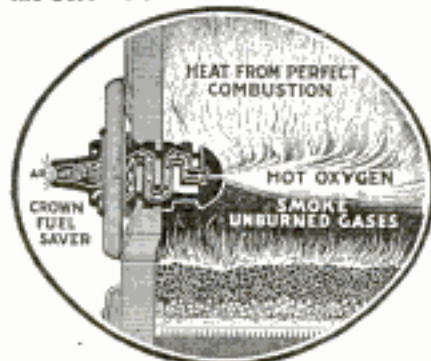

What the CROWN FUEL SAVER Does

The CROWN Fuel Saver is a device that you can easily attach to the feed door of your heating plant. It provides by means of natural draft a supply of hot oxygen (air) over the fuel bed. This pre-heated air burns the rich gases which ordinarily go up the chimney as "smoke." The CROWN burns this "smoke" creating an intense but slow fire that gives steady heat and plenty of it on the minimum of coal. You can keep your home cozy, comfortable and warm by using the CROWN and make real money saving.

Write today for full details and price of this wonderful device—and for FREE Booklet "Making the Coal Bill Look Like 30 Cents."

C. F. S. Co., 411 N. 10th St., Richmond, Ind.

DISTRIBUTORS WANTED.—Responsible men are invited to write for interesting exclusive territory proposition.

\$85 a Week like play

Man or Woman Profits in Advance

Big Money for you quick showing my line of charming ladies' silk lingerie and hose, receive profits in advance. No experience required. Miss Grace James averaged \$36 a day spare time. R. G. Thompson earned \$33 in 1 day. The secret of success is offering exclusive articles women love at sight.

SELL PRINCESS RADIUM Lingerie and Hose

These dainty garments, exclusive in design, not carried by any store, our low mfr's direct prices unbeatable. Splendid opportunity, big cash quick, write for exclusive territory, build a steady income. District managers wanted, territorial rights going fast, don't delay, write now.

ROBERTS - FRANK & CO.
1733 Irving Park Blvd. Dept. L-12 Chicago

Free

Handsome photos from actual models and actual samples of genuine "PRINCESS RADIUM" silk, free.

BUNN SPECIAL

21 JEWEL ILLINOIS RR. WATCH

SEND **\$2.00** DOWN
 PAY ONLY **\$5.50** FOR TEN MOS.



FREE TRIAL

NO RED TAPE—NO DELAY

Just send \$2.00 deposit and we'll send the watch. If satisfied pay only \$5.50 a month for ten months until total price of \$57.50 is paid. Choose either dial illustrated above or the Montgomery dial.

TEN DAYS' FREE TRIAL

You can test this watch in your own pocket for 10 days with the distinct understanding that if you return the watch, we will refund every penny you paid. Order it now or write for additional information desired. Ask most any railroad man.

ADJUSTED TO SIX POSITIONS



Despite the fact that railroad regulations call for adjustment to only five positions, the famous BUNN SPECIAL is adjusted to six positions, making it superior to five-position watches now on the market. It's guaranteed to pass inspection on every railroad in the United States. Guarantee bond free.

GUARANTEED 25 YEARS

The famous Bunn Special 21-jeweled movement is put in a 25-year gold filled case that will wear like solid gold for more than 25 years. We guarantee it against any defect in material or workmanship. These movements are built to give a lifetime of satisfactory service. Famous for accuracy and long service.

WRITE FOR NEW CATALOG

Our new catalog is ready now. Sent FREE on request. It brings our large jewelry store right into your home. Exact weights and quality of diamonds given, enabling you to buy like an expert. Many other bargains in watches and jewelry. Write for it today.

STERLING DIAMOND & WATCH CO.

Diamond Importers—\$1,000,000 Stock—Established in 1879
 63 Park Row Dept. 1762 NEW YORK

STERLING DIAMOND & WATCH CO.
 63 Park Row, Dept. 1762 New York.

Gentlemen: Please send the famous BUNN SPECIAL, 21 jeweled Illinois Watch, as described above, to me on 10 days' free trial. I enclose \$2.00 deposit to show my good faith. If I am not satisfied and return the watch within 10 days, you will return my money. If I keep the watch I will pay you \$5.50 every month for ten months until the total price of \$57.50 is paid. Title to this watch remains with you until I have paid you in full. It is understood that you fully guarantee this watch to be as described. Please send your catalog.

YOUR NAME _____

LOCAL ADDRESS _____

CITY & STATE _____

Genuine KEYSTONE MOVIEGRAPH

(PATENTED)

SHOWS BIG SIZE MOVING PICTURES

Safe for \$6.95 Non-Inflammable Safety Films
 the Home Reel of Tom Mix Given FREE

The following reels are only a few in the film catalogue, and are genuine, posed by the actors themselves. The film is the same size as used in the theatre.

Charlie Chaplin in "Making Pies"
 Wm. S. Hart in "Western Train Robbery"
 Tom Mix in "The Battle on Horseback"

Also Slides, Drawing Slides, Theatre Tickets, etc., included.

Every live boy should have at home or club a Keystone Moviegraph that shows pictures the same as in the movies with powerful French lenses and constructed along professional lines.

The electric cord is included for connecting to any lamp socket your electric bulb will fit. Can also be had for any Dry Cell Batteries for the home without electricity.

Nothing to get out of order. No complicated parts.

We have the largest comedy film service in the country for home machines.

Size of machine all set up 10 by 8". Weight 3 lbs.

Send Money Order or check. Guaranteed to give good big pictures or your money back.

Reference American Trust Co., Boston Mass.

Machine and Reel of Film Complete for \$6.95

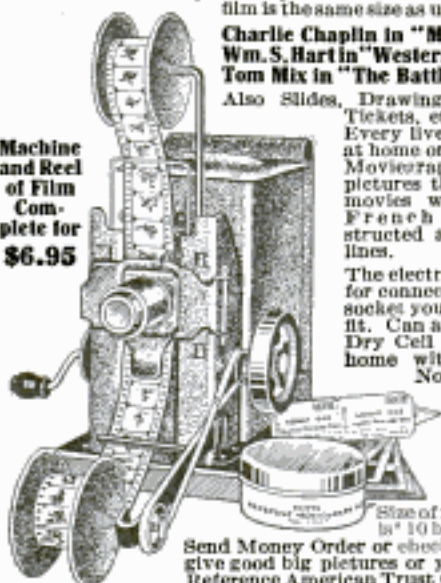

Order your machine today in time for Christmas

Price for Machine and Reel \$6.95 complete, prepaid in U. S. Genuine Keystone Moviegraph Patented 1919, 1920, 1921.

LIBBEY & NICHOLS

Dept. P

100 Boylston St., Rm. 630, Boston, Mass.

Build and Fly Model Aeroplanes



Build your own Model Aeroplane; make trial flights and learn the principles of Aerodynamics. With IDEAL Scale Drawings and Building and Flying Instructions you can easily build exact 1/4 ft. duplicates of Real Planes. Send now for Plans for the one you want to build.

"EVERY-BOY'S" Airplane clip together without nails, wire or screws. Ready to fly in 2 hours. The smallest one. Send for scale logic and find out all about it. IDEAL AEROPANE & SUPPLY CO., 408 West Broadway, cor. Spring St., NEW YORK

Curtiss JN4D-2 Training Plane; DeHavilland Battle Plane; NC-4 Naval Seaplane; Curtiss Military Trainer; Bleriot, Niport or Taube Monoplanes; also Cecil Peall Racer! 25 cents each, postpaid. Catalogue IDEAL Model Aeroplanes and Supplies, 5c postpaid.

PLANS AND INSTRUCTIONS 25¢

Mr. Brush Salesman

Unusual opportunity is offered for aggressive, ambitious, hustling men to

represent an old established manufacturer of high grade, guaranteed, fastest selling line of Sanitary Twisted in Wire Brushes, sold direct to the Home. We have openings for experienced brush men as managers in all territories. We want live wire, energetic Go-Getters. We pay larger commissions than any other Brush House in the Country. If you want to earn some real money, it will pay you to write us immediately for our proposition.

WIRE GRIP SANITARY BRUSH CORP., 15 MERCER STREET, NEW YORK CITY

FREE Your Name A \$175 VALUE
 Inlaid in Gold NEVER SOLD FOR LESS



THE PERFECT WRITING INSTRUMENT

The New Improved Inkograph Writes like pencil with ink better than good fountain pens. Won't slip, blot, scratch, leak, clog or soil hands. Makes 1 or 4 carbons. 14 kt. gold point, shaped like fine lead pencil point. Guaranteed. SEND NO MONEY Pay postman \$1. plus postage. Agents wanted.

INKOGRAPH CO., Inc., 163-B Centre St., New York

SAVE MONEY
Get This Book

HANDY MAN BOOK

Install Your Own
PLUMBING & HEATING
NEW EASY WAY - SAVE HALF

25c
Reg. Price 50c

Brings you this big Plumbing and Heating Encyclopedia-Catalog. Write for your copy today without fail.

Guaranteed Heating Plants

Our Handy-Man Book shows how. Big 256-page well-bound encyclopedia of Plumbing and Heating Outfits, Systems, Supplies, Fixtures and Accessories—10,000 items—illustrated. Hundreds of floor plans, elevations, diagrams, trade secrets, money and trouble-saving hints, etc. "How to save coal in heating," "Easy repair methods." Every householder, contractor, farmer, mechanic, institution needs this book. Shows how to save wages, work and materials.



Hot Water Boiler

Big Handy Man Book

Tells how we help you plan and install. From rough sketch or description we supply working plans and clear instructions. We loan the tools needed. Any handy man can install. This is the place to buy on money-back guaranty. Plumbing Outfits and Supplies; Water Systems; Hot-Air, Water or Steam Heating Plants; Radiators, Pipes, Boilers or Septic Disposal Tanks.

Send 25c for Yours Today

We have spared no effort or expense to complete this remarkable and instructive book. To keep from sending it headfirst to disinterested persons, we request a deposit of 25c, which will be refunded on your first order—or send for our FREE Bulletin. Write today and save half.



Pipeless Furnace

HARDIN-LAVIN CO.

50 Years at
4547-57
Cottage Grove Ave.
CHICAGO



Bathroom Outfit

SQUAB BOOK FREE!



Squabs are selling at highest prices ever known. Greatest market for 20 years. Make money brooding them. No mixing food, no night labor, no young to attend. Start small, grow big. Start now. Read how our customers sell squabs for \$12 a dozen. We have been established for 24 years. Better look into this. Let us send now, at no cost to you, our big, illustrated free book telling how to make money brooding squabs. Address

Plymouth Rock Squab Co., 634 H.St., Melrose Highlands, Mass.

MINT VENDING MACHINE

Pays \$10 to \$20 Day Profit

Pays Rent for Store Owner

Install one in your store or any public place and get this easy money. Requires no attention. Always works. Machine's profits pay the rent. Write us about rebuilt penny and nickel machines. Finished like new. In excellent running order. Pay their cost in 10 days.

Write or wire today for full particulars. \$25 down payment. Balance C. O. D. Export orders full down payment. Mints \$15 per case, 1,000 5 cent packages. Single boxes, 100 5 cent packages, \$1.50. **SILVER KING NOVELTY CO.**
409 Williams Bldg. Indianapolis, Ind.



Why? Pay More!



Big Saving!

Take advantage of the great saving we offer on the genuine, world-famous ball-bearing, long-wearing L. C. Smith Typewriter. Late model machines, standard size, up-to-date in every way, at remarkably low prices.

Free 10 Days' Trial

Just ask us to send you a machine. Then test it thoroughly for 10 days in your own home or office. If you are not more than satisfied that it is the finest typewriter and the greatest bargain you ever saw, just return it with absolutely no obligation to you. All our machines are sent for 10 days' free trial—they must sell themselves.

Send No Money

Do not send us a cent—just mail the coupon below. There are no strings tied to this unusual offer. Thousands of people have taken advantage of it and all are highly pleased.

A Year to Pay

Our special price is extraordinarily low and yet you have a full year to pay on easy installments. There is no "red tape." We employ no solicitors—no collectors—no chattel mortgage.

PERFECT MACHINES AT LOWEST PRICES

we have ever offered.

Guaranteed 5 Years

We do the most perfect and highest class job of rebuilding known to the typewriter industry. Our machines do perfect work and last for years and years. Just like new. The L. C. Smith is the easiest machine to operate and you can easily type your own letters. Complete lessons on typewriting, also our 5 Year Guarantee with every machine.

FREE—Send today for Free Booklet of Valuable Typewriter Information, Big Catalog and our Special Offer.

SMITH TYPEWRITER SALES CO.
300-360 East Grand Avenue CHICAGO

MAIL COUPON AT ONCE.

SMITH TYPEWRITER SALES CO.,
300-360 E. Grand Ave., Chicago, Ill.

Please send me your Free Booklet of Valuable Typewriter Information, Catalog, Special Offer and Free Trial Application.

Name _____

Address _____



Science's new gift to the DEAF

**HALF THE COST—
twice the efficiency**

world's newest, finest and
smallest Hearing Aid—at
AMAZINGLY LOW PRICE

For years, deaf-folks, physicians and Aurists have been protesting against the high cost of hearing aids for the deaf.

Now comes an answer to this protest. A new and better Hearing Aid at half the cost of other methods.

No matter what you have ever tried, there's a delightful surprise awaiting you in THE AURIS. Though the smallest of all Hearing Aids, it is the most powerful and efficient. Perfected by Radio engineers, using sound-amplifying principles borrowed from the Radio. Picks up every sound within hearing of normal ear and carries it distinctly, clearly, resonantly to impaired ear-drum. Articulates every syllable. Preserves full, natural tone values—without mechanical distortion. Light, comfortable, inconspicuous, indoors or out. A joy to wear and use.

FREE FULL WEEK'S TRIAL

Know the happiness of clear and easy Hearing again! You may try THE AURIS a full week, without a penny of risk or expense. No red tape to go through. No deposits or payments of any kind. Just send your name, address and free trial request to THE AURIS COMPANY, Room 205-F, 141 W. 40th St., New York City. If THE AURIS does not make you hear, return it, and you will not owe one penny.

AURIS
SCIENCE'S NEW GIFT TO THE DEAF
TRY IT A FULL WEEK FREE

Leather Cigarette Case

\$1 BEAUTIFULLY EMBOSSED PATTERN
YOUR NAME STAMPED IN 22-KARAT GOLD
Very Compact; holds full package of 20. Sent anywhere for \$1
BOUTON MFG. CO. 850 Noble St., Chicago

Make \$2.50 an Hour YOUR PROFITS IN ADVANCE

STAY-PREST TROUSER PRESSER sells quick—everywhere. Thousands in use. Salesmen and saleswomen cleaning up. Sells on eight-minute demonstration. Reasonable price. 40% clear profit for you. You take orders. We deliver.

Wonderful New Invention
Puts perfect crease in trousers. Takes out wrinkles and baggy knees. Easy to use—takes less than a minute. Folds into small size. Finely finished. Looks rich. Saves clothes and tailor bills. Every man wants one or two.

Make Big Profits—Others Do
Jack Ames made \$24.00 in four hours. Randle sold twenty-five the first day. Mary Roberts made \$10.00 in one evening. Others making good in full or spare time. So can you.

FREE Write us quick for free sample offer and full details.

Four Patents
The Getgey-Jung Co., Dept. 2111 G. & J. Bldg. Cincinnati, O.

WEAR ONE 7 DAYS FREE



If You Can Tell It From A Genuine DIAMOND

SEND IT BACK From Amazingly Beautiful CORODITE GENUINE DIAMONDS in every way. They have the same gorgeous blazing flash and dazzling play of living color as diamonds. The terrific Acid Test of direct comparison. Lifetime experts need all their experience to see any difference. Prove this yourself.

MAKE THIS TEST Wear a Genuine CORODITE and a Diamond side by side on the same finger. If you and your friends can tell the difference send it back, you won't be out a single penny. That's fair enough. If you keep the ring the price printed here is all you pay. No installments. Remember CORODITEs have the same facet cutting as Genuine Stones.

A. Ladies Hand Carved Bucket Ring, Platinum effect \$352
B. Ladies Pierced Filigree 4 Post Ring, Platinum effect \$384
C. Ladies Filigree Ring, Blue Sapphire Set Sides, \$393
D. Ladies Bridal Blossom Hand Chased Solitaire \$284
E. Mens Heavy Heilcher 14K Gold Piled Ring \$348
F. Mens Massive Carved Helicoid Gyrate, Sapphire Sides \$418

Carat Size Gems. Beautiful Hand Carved and Engineered Rings reproducing in exact and faithful detail the most modern high priced and fastidious Platinum Diamond Creations.

SEND NO MONEY Keep your money tight at home. Just send name and address stating which ring you want and size as shown by slip of paper. Return end to end around finger joint and your ring will come by return mail. Deposit amount shown above with booklet. You do not risk a penny as our binding legal guarantee to refund your money in full is attached to every ring we sell. **SEND TODAY.**

E. RICHWINE CO., Dept. 247 19 West Jackson Blvd. CHICAGO, ILLINOIS

Original and Sole Importers of Genuine CORODITE GEMS



"Lighting Fixtures"

READY TO HANG

(Direct from Manufacturer)

Completely wired, including glassware. Send for Catalogue No. 26. Just Off the Press. Special proposition to DEALERS.

ERIE FIXTURE SUPPLY CO.
STA. A ERIE, PA.



RAISE BELGIAN HARES

New Zealand Reds - Flemish Giants - American Blues
FOR US—BIG PROFITS—WE SUPPLY STOCK AND PAY \$2 TO \$6 EACH. Also other fur bearing animals easily raised anywhere. Large Catalog and Contract **FREE!** Big Illustrated Rabbit Book, and copy of our large small stock magazine free. **OUTDOOR ENTERPRISE CO., 1031 G. St., E. Side, Kansas City, Mo.**

Let
**Hartman
Feather
Your Nest**

FREE Bargain Catalog!

Absolutely Free—this great book with over 300 pages of amazing bargains in home furnishings, farm machinery, etc.—all on easy monthly terms and 30 days FREE TRIAL. Send postcard!
HARTMAN FURNITURE CO., Dept. 6465, Chicago
and CARPET

BRILLIANT SEARCH LIGHT PRICE \$9.75
POSTAGE PAID

Powerful Long Burner Carbide Head Light. Bull's Eye Type, with darkening door, complete with gas hose and Generator to wear on belt. Thousands in use all over world. Ideal for hunting, trapping, fishing or any outdoor use. Order yours today.
BRILLIANT SEARCH LIGHT MFG. CO., 526 South Dearborn Street, Dept. P, CHICAGO, ILL.

Salesmen Wanted for Movies

One of our salesmen made \$69,680.57 in three years selling movie advertising. He tells you how to make \$5,000 to \$20,000 yearly in new free book. Full equipment, films, sales helps, etc. furnished. Protected territory.

LIBERAL OFFER awaits you—just write for free book telling secrets of selling movie ads.
Address, **KINEMAART STUDIOS, Inc.**
1430 Beachwood Drive, Hollywood, Cal.





Your money goes
farther with **Murdock**

MURDOCK Radio Phones are one of the best 'phone values on the market. They are famous for their ruggedness, clarity and volume reproduction. The new flat headband permits you to wear Murdocks for hours without discomfort.

Get a pair of Murdocks today and test them out. They are fully guaranteed. Write for **FREE BOOKLET**—"The Ears of Radio."

WM. J. MURDOCK CO.
349 Washington Avenue, Chelsea, Mass.
Branch Offices: Chicago and San Francisco

STANDARD SINGE 1904



The Triple Duty Charger

Charges radio 2, 4 or 6 volt "A" battery, radio "B" battery up to 120 volts and auto batteries from lamp socket. Average cost per charge about a nickel. Solidly built—will not get out of order. Fool-proof and simple. The first successful charger—introduced over ten years ago. Type A. B., price \$23; West of Rockies, \$22. Type C for 6 volt "A" or auto batteries, price \$15; West of Rockies, \$16. "B" battery charging attachment, \$2.50 extra. Write for literature and name of dealer who will supply you with the genuine FF charger.

FRANCE MFG. CO.

10424 Bares Road CLEVELAND, OHIO



Catch Everything
in the Air!

Keep your radio batteries charged—and you won't miss a thing.

APCO Battery Charger does the trick over-night for less than 10c per battery. It's noiseless, clean, compact. Connects with ordinary light socket as easy as an electric "flat."

Write for interesting circular and nearest dealer's name.

APCO MFG. CO., New York Ave., Providence, R. I.

APCO BATTERY CHARGERS
for "A" and "B" Batteries

THIS \$22 VICTOR PURE FIBER Loud Speaker \$9.50



GUARANTEED to receive clearly any broadcasting station your set brings in.

Sent **PRE-PAID** to you direct from manufacturer. Shipped promptly and insured at our cost.

Scientific construction and guaranteed performance of the **VICTOR SPEAKER**, plus this extraordinary low price makes it unquestionably one of the greatest loud speaker values on the radio market. Its unusual volume and clarity of tone insures you the height of radio enjoyment.

The **VICTOR SPEAKER** is backed by an absolute factory guarantee.

Dominating Features in the VICTOR Speaker

1. Our fiber horn has a crystalline finish, coupled with an adjustable loud-speaking unit that permits wide range and clear resonant tone quality without distortion.
2. Metal parts are of heavy cast aluminum, brilliantly polished.
3. Base is of cast iron, producing an even balance to the whole horn.
4. A year's guarantee from purchasing date against mechanical defect.
5. There is no necessity for auxiliary batteries of any kind. Just plug right in on the second stage.

VICTOR SALES CO., 210 Bigelow St., NEWARK, N. J.

GENTLEMEN: Send me one **VICTOR** speaker on ten days trial, subject to conditions you advertise. I shall pay postman \$9.50 upon delivery.

Name.....

Address.....

FARAWAY RADIO



\$29.50

Gets stations
Far and near
Loud and Clear

FARAWAY Radio Sets are amazing values at bargain prices. Users get stations from New York to Frisco—loud and clear. Operate with either dry cells or storage batteries. Beautiful cabinet finished in mahogany with new platinum-finished panel. **SATISFACTION GUARANTEED**—Don't pay \$100 to \$150. Write for our money-saving plan and literature.

2-Tube Set - \$29.50

4-Tube Set - 59.50

Dealers - Agents: Biggest possibilities you ever heard of. Write for plan and territory quickly.

THE FARAWAY RADIO CO., 662 W. THIRD ST., CINCINNATI, O.

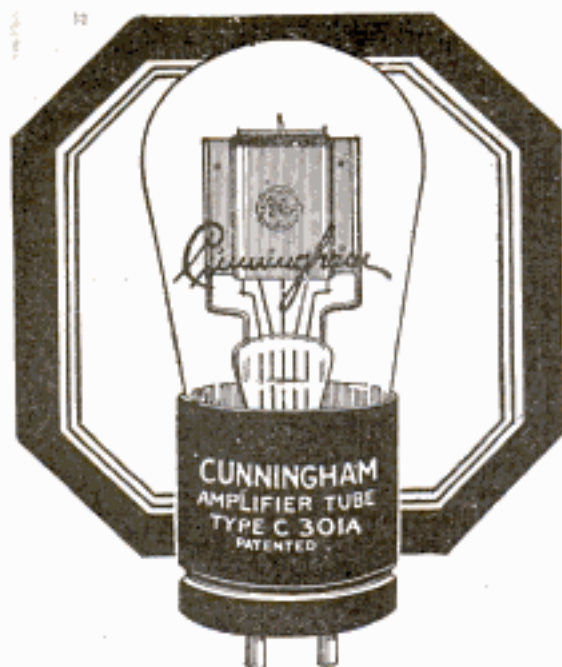

Cunningham RADIO TUBES

Amazing Accuracy

governs every step in Cunningham manufacture. Testing is carried to extremes in order to give to every purchaser a tube as nearly perfect as is humanly possible.

Price the same on all five types—
C-301A, C-299, C-300, C-11, C-12.

Patent Notice: Cunningham tubes are covered by patents dated 2-18-08, 2-18-12, 12-30-13, 10-23-17, 10-23-17, and others issued and pending. Licensed only for amateur experimental and entertainment use in radio communication. Any other use will be an infringement.

Cunningham 40-page Data Book fully explaining care and operation of Radio Tubes now available by sending 10c in Stamps to San Francisco Office.

E. J. Cunningham Inc.

HOME OFFICE SAN FRANCISCO CHICAGO NEW YORK

LATEST WHOLESALE RADIO CATALOG

FREE Simply send name
TODAY for big
48-page catalog
of latest radio goods at Wholesale.
Live dealers and agents wanted.
STANDARD RADIO CO., 102 East 13th, Kansas City, Mo.

RADIO TEXT BOOK & CATALOG FREE

Contains—
75 Radio "Hook-Ups"
300 Illustrations
556 Articles
84 Pages

"Build Your Own with RASCO Parts"

RADIO SPECIALTY CO.

98-E Park Place, NEW YORK, N. Y.

FREE Greatest Catalog of Radio Bargains

Send for It Today



\$3.95
without unit
\$6.95
with unit

It contains a thousand bargains of everything in radio: parts, supplies, complete parts for sets, complete sets, etc., also a mine of very latest information on all different circuits, complete list of broadcasting stations and other valuable data. Send your name and address and we'll send FREE catalog.

American Bell Loud Speaker

With American Adjustable Unit. Wonderful volume, clear reception. Speaks for itself without coaxing. 10-inch bell—made of non-vibrating material.

Hundreds of Other Bargains

Our catalog is filled with bargains like these. Order direct from this ad. We prepay charges. Don't buy anything in radio before you see our catalog. **FREE Service Dept.**



HEADPHONES "Randolph Special"

2200 Ohm moulded headset, properly designed to give strong and clear reception. Biggest headphone value ever offered.

RANDOLPH RADIO CORP.
159 N. UNION AV. Dept. 84 CHICAGO, ILL.

TOWER'S

Scientific \$2.95
plus postage
a few cents postage

Buy a Headset you'll be proud of!

RADIO TOWER'S SCIENTIFIC HEADSETS

OUR \$200,000.00 COMPANY STANDS SQUARELY BACK OF EVERY HEADSET

WORLD'S GREATEST HEADSET VALUE

Longer Cord (30 ft.), Stronger Magnets, Higher Resistance, increase of sensitivity, Perfect Tone Mass
EVERY SET TESTED BY LICENSED RADIO OPERATORS

Send no money - Order on a Post-Card
THE TOWER MFG. CO. DEPT. F. 833 BROOKLINE AVENUE, BOSTON, MASS.

Scientific

RADIO long-distance COMPLETE sets

THESE are the *best* long distance sets at the lowest prices in history. Wonderful new circuit that brings amazing results. **SATISFACTION GUARANTEED.** Everything furnished with complete sets. There's a set for every pocket-book.

- | | |
|---|----------------|
| 4 tube set—with 2 dry cells, B Battery, 4 tubes, loud speaker, loud phone, antenna..... | \$57.95 |
| 3 tube set—with 3 dry cells, B Battery, 3 tubes, loud phone, loud speaker, antenna..... | \$49.95 |
| 2 tube set—with 3 dry cells, B Battery, 2 tubes, loud phone, antenna..... | \$32.95 |

The above 3 sets can also be furnished for use with "A" storage battery instead of dry cells, \$2.00 extra.

- | | |
|--|----------------|
| 1 tube set—with dry cells, B Battery, 1 tube, loud phone, antenna..... | \$19.95 |
|--|----------------|

Sets also sold without accessories. Also full line of radio accessories, 1 and 2 stage amplifiers and portable sets. Write for FREE catalogue—don't let any set you see it.

THE MELODYNE RADIO CO., Dept. B CINCINNATI, O.

Write for free catalog today

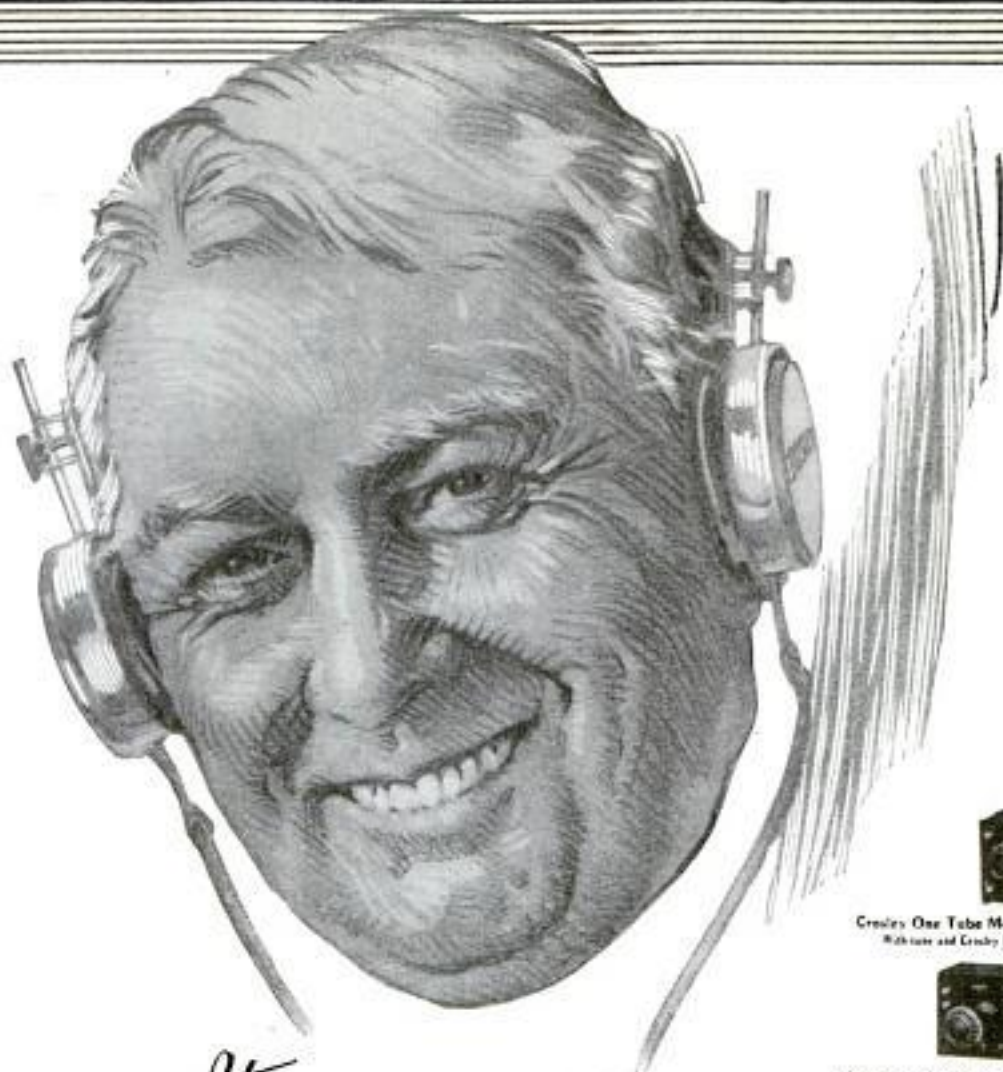

Of Course It's
a **CROSLEY**
Better—Costs Less
Radio

To combine the two most desirable things in radio—distant, clear reception at the lowest possible price—there is only one receiver for you. That is a Crosley.

During the past twelve months Crosley made and sold more sets than any manufacturer in the world, we believe. This is self-evident proof of Crosley Quality and Crosley Performance.

From the one tube Armstrong Regenerative Receiver Crosley 50 at \$14.50, the lowest priced regenerative set on the market, to the three tube Armstrong Regenerative and Reflex Tridyn Regular at \$65—in special mahogany cabinet \$75—Crosley Receivers, each in its own class, assure you as good or better reception than any other instrument of the same number of tubes. At the same time they are the least expensive sets ever offered to the public.

The Tridyn Regular has especially come through the summer with flying colors. The combination of one stage of tuned radio frequency, with regenerative detector and reflexed amplification, has proven beyond a doubt that the features of selectivity, volume and ease of operation can be obtained with three tubes better than heretofore has been possible with five tubes. We believe no other receiver combines these features so well incorporated in the Tridyn.

Before You Buy—Compare

Your Choice Will Be a Crosley

For Sale by Good Dealers Everywhere

Crosley regenerative receivers are licensed under Armstrong U. S. Patent 1,113,149. Prices West of Rockies—add 10%.

Send for Complete Catalog

THE CROSLEY RADIO CORPORATION

POWEL CROSLEY, Jr., President
1115 Alfred St., Cincinnati, O.

Crosley Owns and Operates Broadcasting Station WLW.

Crosley
Head Phones
Better—Cost Less
\$3.75



Crosley One Tube Model 50, \$14.50
With tubes and Crosley Phones \$22.25



Crosley Two Tube Model 51, \$18.50
With tubes and Crosley Phones \$26.25



Crosley Three Tube Model 52, \$20.00
With tubes and Crosley Phones \$28.75



Crosley Two Tube
Model 51-P, \$25.00
With tubes and Crosley Phones \$33.75



Crosley Tridyn Regular, \$65.00
With tubes and Crosley Phones \$98.75



Crosley Tridyn Special, \$75.00
With tubes and Crosley Phones \$99.75

Mail
This
Coupon
At Once

The Crosley
Radio Corp.,
1115 Alfred St.,
Cincinnati, O.

Mail me, free of
charge, your catalog
of Crosley receivers
and parts with booklet
entitled "The Simplicity
of Radio."

Name _____

Address _____

ALL-AMERICAN

now brings you

DISTANCE, VOLUME AND QUALITY
with **ONE TUBE**

Self-Tuned

Radio Frequency Transformers
—Wound to Suit the Tube

OUT of a year of many experiments and numerous failures to achieve in a practical instrument the theoretical possibilities of broad-tuned Radio Frequency Amplifiers, has come a simple but far-reaching discovery. Radio Frequency Transformers can and must be adapted to the characteristics of the particular vacuum tube whose grid voltage they supply. That truth—with All-American scientific research and All-American precision manufacturing—has made radio history.

Self-Tuned Radio Frequency Transformers have arrived—and All-American, naturally enough, has brought them. Never before has an instrument been built which will amplify so effectively, over the entire radiocast range, as will the new All-American Types R-199 and R-201A. Together with the new Type R-140 All-American Universal Coupler, they have made possible a new standard of efficiency in Radio Frequency and Reflex receivers.

As an example of this, we offer ALL-AMAX JUNIOR (1 tube) and ALL-AMAX SENIOR (3 tube). Both are All-American-coupled throughout, and both exemplify the new standard of performance.

Build an ALL-AMAX—using the complete panel scheme and wiring plan shown in your **KEY BOOK**—and you will never go back to an ordinary reflex set. Distance and power are yours!

All-Americans—Precision-Made for Reliability
Sold by all the Better Dealers



Audio Frequency Transformers

"All-American for Reliability"
Ratio 3 to 1 R-12, \$4.50
Ratio 5 to 1 R-21, 4.75
Ratio 10 to 1 R-13, 4.25
Built by Precision Methods in a Modern Plant, All-American Audios are Unsurpassed at any price for Quality Reproduction and Dependable Service.

Long Wave Transformer
For High Amplification and no distortion of side bands at 4,000 to 20,000 meters (75 to 15 Kilocycles) R-110, \$6.00

Power Transformers
For Tone Quality in a Third Stage, or for Loud Volume with Clearness.
Input Type R-30, \$6.00
Output Type R-31, 6.50.

Radio Frequency Transformers

"Self-Tuned—Suited to the Tube"
Effectively amplifying all Frequencies with the Radiocast Range.
For "199" Tubes R-199, \$5.00
For "201A" Tubes R-201A, 5.00

10,000 Meter Transformer
It gives superior results in beat reception, filtering out a 30 Kilocycle Frequency with high selectivity and no side-band distortion. R-120 . . . \$6.00

Radio Frequency Coupler
(Oscillator Coupler.) A uniform output at 150 to 650 meters. R-139 . . . \$5.00

Universal Coupler
Sets a new standard of efficiency as an antenna coupler; as a radio frequency transformer in tuned stages it is unsurpassed. R-140 . . . \$4.00



The **RADIO KEY BOOK** costs only 10 cents, coin or stamps

ALL-AMERICAN
TRADE MARK

RAULAND MFG. CO.
2656 Coyne St. Chicago, U.S.A.

Largest Selling Transformers in the World

Please Mention Popular Mechanics

LARGEST RADIO STORES IN AMERICA

CHICAGO SALVAGE STOCK STORES

509 S. State St. CHICAGO, U. S. A. Dept. PM-6

We guarantee our new 68-page **RADIO** Catalog will save you money

on brand new fully guaranteed, nationally advertised radio apparatus. We buy up manufacturer's and government surplus stocks, jobber and dealer bankrupt stocks, etc. Our enormous buying power permits us to pay spot cash and get rock-bottom prices—even

way below manufacturer's costs. That's why our catalog is crammed with thousands of wonderful radio bargains. That's why we **GUARANTEE** to save you money.



Save 1/2 Cost of New Tubes

VACUUM TUBES REPAIRED

Guaranteed equal to new. Send in your burned out or broken tubes by P. P. All repaired tubes returned P. P., C. O. D. We try to repair and return within 48 hours.

Harvard Radio Laboratories
200-204 Old Colony Ave., So. Boston, Mass.



The Traffic Cop of the Air



Add a Ferbend Wave Trap to your set and "Police" your reception. Regulate the Traffic! Guaranteed to tune out any interfering station. Sent postpaid on receipt of \$8.50, or C. O. D. plus postage. Send for free booklet. Ferbend Electric Co., 15 E. South Water St., Chicago



FROST-RADIO

Ask Your Neighbor

TWO popular items of **FROST-RADIO** are shown: The No. 608 Push Pull Battery Switch, list 30c, and the No. 139 Cord Tip Plug, list 50c. Your dealer has them in stock. Order these and other radio needs from him today.

FROST-RADIO
HERBERT H. FROST, Inc.
154 W. Lake Street Chicago, Illinois



The World's Largest Store is

Radio Headquarters

No matter what you need for your radio—whether it's a complete set or the smallest part—it can be had from **RADIO HEADQUARTERS** at prices that save you money.

Our new **RADIO Catalog** is ready. Your copy is waiting for you; so fill in and mail the coupon below. We would like you to see the many radio bargains that the World's Largest Store has to offer. We don't think there is a store in America that has a more complete line.

We would like to have you see the famous **SILVERTONE Neutrodyne**, the most perfect radio set yet built. Get all the comfort and enjoyment that a good radio set can deliver. Make sure of your satisfaction. You can do it if you deal with **RADIO HEADQUARTERS**.

Reduced Prices on Radio Tubes.

Radio tubes—standard equipment—can be had from us at the new low price of \$3.65. This is just an example of the values that our RADIO catalog offers. Get your copy. Mail the coupon TODAY.

Mail the coupon TODAY to the store nearest you.

Sears, Roebuck and Co. 8CP87
Chicago Philadelphia Dallas Seattle

Send Latest Radio Catalog.

Name

Postoffice

Rural Route.....Box No.....

State

Street and No.....

Sears Roebuck and Co.

The World's Largest Store owns and operates Broadcasting Station W.L.S. Wavelength 345 Meters. Tune in.

BALDWIN PHONES FREE

for best long distance record on my hook-up. Other prizes, too. Particulars free.

LEON LAMBERT

539-K Kaufman Bldg. WICHITA, KANSAS

DEALERS SAVE MONEY

By Ordering from Our Bargain Catalog of Nationally Advertised Radio Goods, Write for It Today!

AMERICAN RADIO MFG CO.
Dept. U 6 WEST 14th ST. KANSAS CITY, MO.

all free! RADIO LIBRARY

JUST SEND A POST CARD YOU GET absolutely free—the A-K "Library of Latest Radio Literature," written by foremost radio authorities. Contains HUNDREDS of valuable wiring diagrams, HOOR-UPS, illustrations, articles, data, etc.

EXPLAINS in clear, understandable language the popular new circuit: reflex, neutrodyne, push-pull, "nameless," super-heterodyne, etc., and how to build sets. Covers long and short wave amplification, push-pull and radio amplifiers. Latest information on multistage of other radio subjects. **LOG BOOK INCLUDED FREE.** Also our latest Radio Catalog featuring **NATIONALLY ADVERTISED** lines at attractive savings. Write today—offer limited. Address

ATWOOD-KING, INC.
Dept. C 11 163 W. Washington St., Chicago

ATWOOD KING INC.

8 Hour Battery Charging Pays Big Profits

**YOU
Can Clear
\$150 to \$300
Profit Every Month**

You can quickly build a big money-making business of your own with HB 8-Hour Constant Potential Battery Charging. 8-Hour Charging Service is the biggest development in automotive service. Without any previous experience, you can cash in on the universal demand by getting an HB Outfit. Thousands are making big money with HB Battery Charging. You can, too!

\$35 puts complete HB 8-Hour Charging Outfit in your shop

Only \$35 cash brings you an HB Constant Potential charging outfit complete with bus bars, bench, connectors, cables, etc. No extras to buy. Your big battery charging profits easily carry small monthly terms on balance. This HB outfit quickly pays for itself while building big money-making business for you. This is the lowest-priced complete outfit on the market. Prompt delivery, guaranteed HB factory service because built complete in HB factories.



30 Days' Trial ON MONEY-BACK GUARANTEE

This new HB comes on 30 days' free trial to prove its value to you, subject to return and your money back if for any reason whatsoever you do not want to keep the outfit. 90 days to exchange. HB excels in design, construction and service. No batteries needed to start. Absolutely cannot reverse.

Send the Coupon
for Free Bulletin.

HOBART Bros. Company
Box M 11 Troy, O.

Successful
Manufacturers
Since 1893

Send for FREE Bulletin

HOBART
BROS. CO.
Box M11, TROY, OHIO
Send me Bulletin 117 on Battery
Charging Profits.

Name _____
Address _____

RADIO

HOLTZER - CABOT

**Loud Speakers
Phonograph Attachments
and Head Phones**

Holtzer-Cabot Reproducing Units make Radio reception artistic and satisfying. They contain positive technical advantages not found in other instruments. Regardless of the type of your set, and whether you use a Loud Speaker, Phonograph Attachment or Head-phones, Holtzer-Cabot receiving units will give you greater volume, more sensitive reception, and clearer tone. A comparison test will prove this to your satisfaction. Your dealer will be glad to demonstrate.

 Loud Speaker
 Phonograph Attachment
 Head Phones

WRITE FOR BOOKLET
Dept. PM

THE HOLTZER-CABOT ELECTRIC CO.
135 Amory Street BOSTON 601-55 South State St. CHICAGO



ABSOLUTELY FREE

Thousands of
RADIO BARGAINS

You Can't Equal This Anywhere
SHAWCO loud sets—2000 Gram—loud
hands and cord complete. Ex-
tremely sensitive. Write Dept. 11 for
wonderful catalog. **\$2.69**

STANDARD RADIO CORP.
227 WEST MADISON ST. CHICAGO

Howard

Radio Co. Inc. CHICAGO, U.S.A.

**Get Distance with
Howard Guaranteed Parts**

**RHEOSTATS
SOCKETS
POTENTIOMETERS**

HOWARD RADIO COMPANY
4248 No. Western Avenue, CHICAGO, ILLINOIS



Erla Solderless Connectors make child's play of receiver construction, eliminating difficult soldering entirely.

Most Efficient Circuits Built By Methods Most Advanced



With lowest dielectric and resistance losses ever known, Erla Miniloss Condensers, with new compensating plate form, lead in efficiency. 5 to 41 plates, \$3.50 to \$5.50.



Smoothness, excess capacity, freedom from noises distinguish Erla Precision Rheostats and Potentiometers. Rheostat, \$1.10—Potentiometer, \$1.25 and \$1.40.



In frosted silver or gold, with Bakelite knob proportioned for utmost delicacy of touch, Erla Dials improve any receiver. 2", 3", 4" dia. 1/8" shaft. Prices 50c to \$1.25.

A thousand and one circuits and theories have been dangled before the amateur radio builder. Erla engineers, from the beginning, dedicated themselves to creating those particular circuits which the radio public could select as the last word—circuits with the inherent superiority to *remain* in the forefront of radio advancement.

From this fixed purpose came Erla Duo-Reflex Circuits, rated the most powerful in radio, tube for tube. Now research and development have intensified every original Erla advantage in the latest Erla circuits, ranging from one to five tubes, in loop and antenna models. Beyond present Erla perfection it is not possible to go in range, volume, tonal purity, selectivity or ease of control.

These very finest circuits are now also easiest to build! Available in factory-sealed cartons, under warranty, are the complete Erla Knockdown Receivers, ready for correct assembly, in truly professional manner, by anyone, with pliers and screwdriver.

Erla precision apparatus, vital to matchless Erla results is furnished complete, right down to Erla solderless connectors, which banish soldering. The panel is drilled and lettered, while the baseboard is stenciled, correctly locating every unit and connection.

You yourself, therefore, can construct the most advanced radio circuits, by the most efficient and most economical method, confident that your receiver, sponsored by Erla, is unsurpassed. Ask your dealer, or, if writing direct to us, give dealer's name.

ELECTRICAL RESEARCH LABORATORIES
Department J, 2500 Cottage Grove Avenue, CHICAGO

ERLA



Apex Vernier Dial

Do not bother with geared condensers, requiring many holes in the panel and careful lineup of pinion shafts, when this marvelous instrument provides the fine adjustment for tuning in distant stations. Ratio 10 to 1—quickly applied to any shaft. For sale by all good radio dealers. If unable to obtain, fill in coupon and enclose \$2.50 for nickel finish or \$3.50 for Gold Plated finish.



Coast To Coast On An 18-Inch Loop

Assemble Your Own 7 Tube Super-Heterodyne

—on a 7 x 18 panel in three hours, \$97.00 buys the parts complete, including drilled and engraved panels, condensers, sockets, transformers, dials, connecting plugs, cables, etc. with drawings, diagrams and instructions. Price of cabinets to fit—furnished on application. If your dealer cannot supply these parts for this complete Microdync Radio Set, fill in coupon, mail check or money order and send dealer's name.

Apex Electric Mfg. Co., Dept. 1101
1410 W. 59th Street, Chicago, Illinois.

Gentlemen: Enclosed find \$..... for which send me

Name

Street

City

State

\$5.00 VALUE FOR \$1.00

FOUR RARE DESERT PLANTS, with illustrated Catalogue, with \$1.00 Premium Free. All for only \$1.00.

CANUTILLO CURIO CO., Canutillo, Texas

Have you begun collecting
EKKO
Broadcasting
Station Stamps?

See your radio dealer or write to us.

The EKKO COMPANY
111 West Monroe St., CHICAGO



The ONLY Safe Bltorch in the World

Automatic Safety Valve (Turner Patent) eliminates all possibility of leaks or bursting pressure. Separate Needles for fuel control and ejection prevent orifice enlargement, a common annoyance with ordinary blow torches.

Pistol-Grip Handle assures maximum comfort—fits any hand. Patented Turner Baffle and heater plug gasifies present-day gasoline or kerosene—400 degrees more heat. Don't be without a Turner—get it TODAY from your dealer. Fearlessly Guaranteed!

TURNER BLOTORCH

Safe as a Candle



No. 45

Capacity (1 Quart)

\$8.25

THE TURNER BRASSWORKS

Industry Ave., Sycamore, Illinois

The World's Largest Exclusive Manufacturers of Blow Torches, Fire Pots and Brazers



"Radio" with Volume and Distance

A "COLYTT" Adjustable Grid-Leak improves receiving. Proper value of leak in grid circuit—gives greater distance—louder and clearer signals.

Try a "COLYTT" Grid-Leak tonight. MONEY BACK GUARANTEE. Sent postpaid with full directions for \$1.00.

THE COLYTT LABORATORIES

565 West Washington Street, CHICAGO, ILL.

Watch for



Imported

LOUDSPEAKER

TYPE W

announcement in the November magazines. New in principle, new in shape, new in quality of reproduction, price \$27.50.

Made by the makers of the famous N & K Head Set, Model D, 4000 ohms, price \$8.50.

TH. GOLDSCHMIDT CORP.
Dept. M-11, 15 William Street, New York



Moore Original

RADIO-DEMON

Not new, but proven the best of "em" all. Ask any user.

"All Wave Tuner"

NEW YORK to FRISCO, clear as a bell

The only one control tuner, 200 to 600 meters, complete with hook-ups mailed anywhere. **\$1.50**

Write today for our FREE Encyclopedia of leading radio receivers. All makes fully described. 50% saving—all types.

ELECTRIC SERVICE ENGINEERING CO.

Dept. Radio P. 337 W. Madison St. Chicago, Ill.

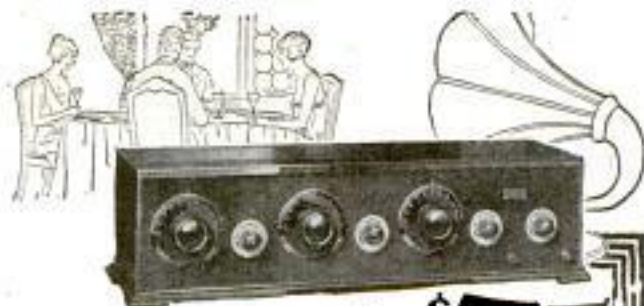

and now! for only \$75

The Marvelous
MIRACO
Ultra 5

Send for
Bulletin
Today

[FIVE TUBE OUTFIT]

Built for loud speaker reception from stations thousands of miles distant through local interference; composed of the finest parts; beautifully wired; encased in a beautiful hand rubbed solid mahogany cabinet; and fully guaranteed. At \$75 this fine, handsome, efficient Miraco "Ultra 5" five-tube outfit offers unquestionably the most astounding value the radio world has ever known.

UNSURPASSED SELECTIVITY, SENSITIVITY, RANGE, VOLUME AND TONE COMBINED

Non-radiating, non-howling, non-distorting. Equipped with filament switch, phone jack for tuning, bakelite panel, bakelite sub-base under which all wiring is concealed and other latest refinements. Two stages tuned radio frequency amplification, detector and two stages audio frequency amplification.

OTHER MIRACO LONG DISTANCE SETS \$14.95

3 tube loud speaker outfit, \$29.50. Write for latest bulletins, testimony of users growing coast to coast reception. Agents, Dealers, write!

MIDWEST RADIO CORPORATION

Planner Builders of Sets
407-C East 8th Street, Cincinnati, Ohio

**MIRACO
RADIO
GETS 'EM
COAST to
COAST**

**AGENTS ECLIPSE
\$20 a Day OIL-GAS
BURNERS**

An amazing new invention that does away with Coal and Wood in Stoves, Ranges and Furnaces. Write today for 30-day Free Trial Offer, limited time.
SPECIALTY SALES CO., 1550 Main St., Buffalo, N. Y.

Jiffy Blow Torch



For Heavy Duty Work!

Jiffy Blow Torch is the handy man's torch. A real practical self-blowing torch for all kinds of soldering. Burns with blue, hot flame and is absolutely safe! Complete outfit—Copper soldering iron, solder, non-corrosive flux and all accessories—\$2.50.

At your dealer's or direct

Apex Stamping Company
Dept. E2 Riverdale, Ill.

FREE!
THIS MILLION DOLLAR BOOK
OF CHRISTMAS BARGAINS

How 8¢ a Day Buys a Gift
That Will Never Lose Its Charm

LET DIAMONDS SAY MERRY CHRISTMAS



XM 0131—14 Karat White Gold 18 jewel rectangular wrist watch guaranteed to give absolute satisfaction. Special Price, \$37.95.



XM 0132—14 Karat White Gold 18 jewel diamond ring with brilliant cut diamond set in platinum. Special Price, \$18.95.



XM 0133—14 Karat White Gold 18 jewel diamond ring with brilliant cut diamond set in platinum. Special Price, \$18.95.



XM 0134—14 Karat White Gold 18 jewel diamond ring with brilliant cut diamond set in platinum. Special Price, \$18.95.



XM 0135—14 Karat White Gold 18 jewel diamond ring with brilliant cut diamond set in platinum. Special Price, \$18.95.



XM 0136—14 Karat White Gold 18 jewel diamond ring with brilliant cut diamond set in platinum. Special Price, \$18.95.



XM 0137—14 Karat White Gold 18 jewel diamond ring with brilliant cut diamond set in platinum. Special Price, \$18.95.



XM 0138—14 Karat White Gold 18 jewel diamond ring with brilliant cut diamond set in platinum. Special Price, \$18.95.



XM 0139—14 Karat White Gold 18 jewel diamond ring with brilliant cut diamond set in platinum. Special Price, \$18.95.



XM 0140—14 Karat White Gold 18 jewel diamond ring with brilliant cut diamond set in platinum. Special Price, \$18.95.



XM 0141—Attractive 14 Karat White Gold 18 jewel nickel movement in 18 year guaranteed watch with filled case. Special Price, \$33.95.

No Money in Advance Any of the wonderful Christmas Diamond Values pictured above sent you for FREE EXAMINATION—not one penny in advance. If you keep your selection, pay at the rate of

Only a Few Cents a Day Merely the "small waste on trifles will soon pay for a wonderful diamond, 8% yearly increase in value on all diamond exchanges absolutely guaranteed. Also 5% bonus privileges.

Big Million Dollar Get it now. Make 125¢ a day while you choose from **Bargain Book FREE** the Greatest Bargains in America. Send coupon for your copy today. Get the benefit of our liberal Charge Account Plan. Write Dept. 1778.

J.M. LYON & CO. INC.
2 - 4 MAIDEN LANE, NEW YORK
In Business Nearly 100 years

Name _____
Address _____
City _____ State _____

J.M. LYON & CO.
2 - 4 Maiden Lane,
Dept. 1778
New York
Please send me at once your big 125¢ a day while you choose from BARGAIN BOOK, showing thousands of America's Greatest Diamond and Jewelry Bargains.

3 TUBE RADIO SET \$22.50

COMpletely ASSEMBLED

Coast to Coast



10 DAYS FREE TRIAL

Direct from factory to you at less than jobber's cost. Marvelous three tube radio set. Has a coast to coast range—1,000 to 1,500 miles. Most simple tuning system you ever saw. Only one dial. Vernier control. Tune in your favorite station instantly. Dial can be logged. Stations come in on same numbers all the time. No guessing. Brings in many distant stations on loud speaker horn. Clear and distinct as a bell. Hear Opera, Orchestras, Theatricals, Jazz music, Campaign Speeches, Stock Reports—all in the comfort of your own home.

DESCRIPTION: 3 tube set. Comes completely assembled in beautiful mahogany cabinet, size 19x8x8. Genuine bakelite panel. One switch controls the 3 tubes. Use any standard tubes and batteries, either 6 volt, 3 volt or 1½ volt "A" battery or dry cells.

10 DAYS' FREE TRIAL

Don't miss this chance to buy this high grade 3 tube set direct from factory. Regular value \$60.00. Our factory price only \$22.50. Send no money. Sign and mail coupon. Pay only \$22.50 when delivered, plus small transportation charges. Try it 10 days. If you are not delighted with results—if you do not consider it equal or better than any \$60.00 set, send it back and we will cheerfully refund your money.

Only a Limited Number at This Price. Order at Once.

COUPON

Wireless Corp. of America, 2301-2309 W. Erie St., Chicago, Ill.

Gentlemen: Ship me on approval your 3 tube, long distance radio set. I will pay \$22.50 on arrival, plus transportation charges, with the understanding that if I am not fully satisfied after ten days' trial, I may return it and you will refund my money.

Name.....
Address.....

Electric Light in Every Home

No longer necessary to burn kerosene lamps. The EIPCO Electric Lighting Machine will generate sufficient current to light twenty-five 20 Watt lamps at an average cost of one-third of city rates.

STARTS and STOPS AUTOMATICALLY



Operated by single cylinder, two cycle, air cooled engine. Has adjustable siphon valve and limiting governor to regulate charging of batteries. No carburetor—no gears—no push rods—no valves to grind. Simple, practical, highly efficient and economical in fuel consumption. Completely portable—weight 120 pounds. Suitable for homes, cottages, camps, motor boats, country schools and churches, etc. Dealers and distributors wanted. Write to-day.

THE E. I. PEARSON CORPORATION, 2900 Jeanette St., CINCINNATI, OHIO, U. S. A.



WADE BENCH LATHE

AMATEUR MECHANICS, MODELMAKERS, INVENTORS, STUDENTS
A real machine tool for the home work bench—capacity 4" dia. x 12" length. For Metal—Wood—Composition Materials—Turning—Facing—Boring—Drilling—Winding—Thread Cutting. Accurate—Strong—Quiet—Compact. Slide-rest has travel entire length of bed. Leadscrew inside bed. Send for literature—Price \$28.00. THE GEROLD CO., Dept. P-2, 120 Liberty St., New York

NO MORE "B" BATTERIES

Amazing New Kind of Radio Tube

Bell-Like Clearness Greater Volume



THE IMP

No more expense and trouble with "B" batteries! No more howling, screeching or garbling of speech, song and music! Clear as a crystal come the tones through this marvelous new Radio Tube! Gets longer distances! Greatest improvement ever made in Radio!

Fits Standard Sets With Simple Changes You Can Make

No complicated changes are necessary to fit your present standard hook-up with Imp Tubes. Simply throw away your "B" batteries and shift one or two connections. Only "A" storage battery necessary. Full simple instructions furnished free. Fit Standard Bases. You will be amazed at marvelous improvement! No more "tube noises" which "fatten" musical and vocal tones, but strong, clear signals—just like they enter the microphone!

Proven by Tests — No Experiment—Guaranteed

These amazing Imp Tubes are the results of years of effort by Prof. Kolb, an expert of known ability. They are, therefore, no longer experimental but proven and tested. We guarantee them. Try them 10 days, after which they may be returned and your money refunded, if filament still burns. Little likelihood of "burning out" because only 6 volts from "A" Battery is all current used. Tipless globe not easily broken.

Send \$1 for each tube ordered, balance C. O. D. on delivery by Postman. We prepay postage. Made in two styles, Detector Type 205A or Amplifier Type B14. Fil. volt 5 to 6. Fil. Amp. 25. (No plate voltage.) Price each \$5.00. Give name or diagram of your set, so we can advise new connections properly.

IMP RADIO CORPORATION
Dept. 101 6 East Lake St. CHICAGO
Build Your New Set With Imps!

THE Whisper-It Mouthpiece insures telephone privacy. Safeguard your confidential conversations. Put The Whisper-It Mouthpiece in place of the one now on your phone; then you can whisper if you wish. The Whisper-It Mouthpiece is sanitary—only highly polished glass can touch the lips. Bring telephone privacy to your own desk. \$1.00 prepaid. Money back if not satisfied.

Live agents wanted.



Whisper-It

MOUTHPIECE

P. M. COYTT LABORATORIES
805 W. WASHINGTON ST. CHICAGO, ILL.

GET A BEARCAT RADIO NOW ONLY \$9.98

And the Agency for Your Territory. Deal direct with factory and make money selling your friends and neighbors. Wonderful new long range genuine vacuum tube set—easy to operate—marvelous results.

Send No Money Just write: "Send me a Bearcat Radio" and pay postage only \$9.98 plus postage on arrival. ACT QUICK. Write now. BEARCAT RADIO CO., 646 N. Michigan Ave., Dept. 21, Chicago

We Save You Money on Radio

**ATLAS
RADIO
STORES**

One of the largest and most complete stocks of radio goods in the country. Seven retail stores in Chicago, and our large wholesale business enable us to get and give radio sets and parts at lowest prices. *Every set and part absolutely guaranteed first class and perfect*

WE PAY ALL TRANSPORTATION CHARGES

KIT FOR REINARTZ CIRCUIT

Best circuit for distance—and easy to tune. Brings in coast to coast on loud speaker. Kit for complete set—everything you need to build this 3 tube set. Including drilled panel and blueprints—only **\$19.75**

KIT FOR FRESHMAN MASTERPIECE

This is the new wonder set. Long distance and highly selective. Kit for complete 5 tube radio frequency receiver, including genuine Freshman parts, drilled panel and blue prints—only **\$39.85**

ATLASHEAD PHONES

3000 Ohms—very sensitive and clear. **\$3.25**

Atlas Specials

Hydrometers 45c
Atlas Loud Speakers . . . \$7.95
Sockets . . . 29c
Brandes Navy Head Set . . . \$6.25
Atlas 2-way plug 42c
Voltmeter 0-50 85c
Radio switch 22c
Eria Crystal 80c
2 in. dials . . . 25c
3 1/2 in. dials . 45c
Eveready "C" Bats 50c

Electric Soldering Iron

"The Assembler's Joy" Quick, even heat. 90c

Berwick Loud Speaker

Finest clear tone. No distortion. Recognized leader. **\$7.95**

"B" Batteries

Atlas Super Quality Long life—22 1/2 V. small . 95c
22 1/2 V. large . 5 taps . \$1.45
45 V. large . all taps . \$2.85

Send for complete catalog of Atlas Bargains

ATLAS RADIO STORES, 345-C S. Clark St., CHICAGO, ILL.

FREE RADIO I-Tube Set



Rush your name and address and learn how you can get a Guaranteed one tube vacuum set **Complete**

ABSOLUTELY FREE

Write today for Free Radio Plan

RELIABLE SALES CO., DEPT. 310 434 BROADWAY, N. Y. C.

NEW KIND OF TRUSS

No more steel springs, weighty cushions, or chafing leg straps. Amazing new kind of support, weighing less than 1-25 of an ounce, prevents coming out of rupture, which leads too often to strangulation—yet requires no tight strapping like old-fashioned ineffective devices. Offered to ruptured people on a guarantee of instant satisfaction or no cost. Free details if you will simply drop us a postcard or letter with your address to **NEW SCIENCE INSTITUTE, 2108 Clay Street, STEU ENVILLE, OHIO**

EXCEPTIONAL BARGAIN \$7.95

Limited Time Only

Gents' 14 kt. gold filled Watch. Thin model, fancy engraved case, 10 jewel Lever movement, adjusted and regulated stem wind and set. Regular \$18.00 value. Our special price only \$7.95 plus 15c post-charge. **FREE** a handsome 14 kt. gold filled Waldmar chain and knife if you order promptly. Pay postman on arrival. Satisfaction guaranteed or money refunded. Watch set in handsome velvet lined gift case. Order today.

SUPREME JEWELRY MFG. CO. 434 BROADWAY New York City

Dept. 152



Great New Invention for seekers of Health Power Beauty



Elco Health Generators at last are ready for you! If you want more health—greater power to enjoy the pleasures and delights about you, or if more beauty is your desire—write! Ask for the book on these inventions which has just been prepared. It will be sent to you without cost. It tells you how Elco Health Generators aid you in leaving the lethargy and hopelessness of bad health and weakness behind forever. Re-vitalize yourself. Bring back energy. Be wholly alive. Write today!

10 Days Free Trial—Write for FREE BOOK

Elco Electric Health Generators

These great new inventions generate *High Frequency Violet Ray, Mechanical Vibration, Medical Electricity and Ozone*. Combined or separate.

They operate on the electric light in your home or on their own motive power at less than 50 cents per year. Elco Health Generators are positively the only instruments which can give you in one outfit *Electricity, Violet Ray—Vibration and Ozone*—the four greatest curative agents. Send coupon below. Get the Free Book NOW!



For All These:

Rheumatism	Asthma
Gout	Hay Fever
Lumbago	Sore Throat
Neuralgia	Cataract
Sciatica	Deafness
Headache	Insomnia
Neuritis	Pain
Nervousness	Development
Circulation	Skin Disease
Weakness	Pimples
Paralysis	Scalp Disorders
Eye Trouble	Obesity

MAIL the COUPON for FREE Book!

Do not put this paper down without sending the coupon. Don't go on as you are with pains and with almost no life and energy. You owe it to yourself to be a better man or woman. You were put here to enjoy life—not just to drag through it. So do not rest another day until you have put your name on the coupon here. That will bring the whole story of these great new inventions. Do it today—now.



Lindstrom & Company

30 W. Lake St. Dept. 13-58 Chicago, Ill.

Please send me your free book, "Health—Power—Beauty" and full information on your 10-Day Free Trial Offer.

Name _____

Address _____

State your ailment and promise our expert advice
REPRESENTATIVES WANTED

GENUINE BLUE WHITE DIAMONDS

NO RED TAPE

10 MOS. TO PAY

Looks Like
2ct. Solitaire
Worth \$750.00



SET IN SOLID PLATINUM

Seven, best quality, perfectly cut, sparkling, genuine blue-white diamonds are set in solid platinum and matched so expertly, they resemble a single diamond, 2 carat size. This handsome cluster of diamonds is attractively set off by two French blue sapphires set in the shanks of the mounting. The rings 18 Kt. solid white gold.

\$2.00 DOWN; \$6.50 A MONTH

Just send \$2.00 as a down payment (or pay the \$2.00 to the postman on delivery) and we will send this handsome Diamond Ring. If satisfied after trial, pay the balance in ten, convenient monthly installments of only \$6.50 each until bargain price of \$67.00 is paid. Ring has a guaranteed value of \$100.00. Order it!

WRITE FOR FREE CATALOG

It brings our large jewelry store right into your home. Exact weights of diamonds given.

STERLING DIAMOND & WATCH CO.

(Diamond Importers—\$1,000,000 Stock—Est. 1879)
63 PARK ROW, Dept. 1764, NEW YORK



Get More Power and Greater Distance

On Your Set Equipped With This

Powerful Radio Frequency

PRE-AMPLIFIER

Price Complete Prepaid \$25.00

S. A. TWITCHELL CO.

1923 Western Ave. Minneapolis, Minn.

FORD RUNS 57 MILES ON A GALLON OF GASOLINE

A New Automatic Vaporizer and Decarbonizer which in actual test has increased the power and mileage of automobiles from 25 to 50 per cent and which also removes carbon from the cylinders is the proud achievement of John A. Stransky, 3941 4th St., Pukwana, S. D. A remarkable feature of this simple and inexpensive device is that its action is governed entirely by the motor. It can be installed by anyone in five minutes. With it attached, automobiles have made from 35 to 57 miles on a gallon of gasoline. Mr. Stransky wants distributors for his marvelous invention and is willing to send a sample at his own risk. Write him today.—Adv.

Turn Your Ideas Into Profits

Whether you are interested in light manufacturing, repairing or experimental work; whether you are a mechanic, engineer, amateur, or student; whether you work in wood or metal, your ideas can be turned into profits with accuracy, speed and economy on

The Baby Grand Lathe

A sturdy, practical lathe of small size, high quality and at low price. Operation same as large lathes. Made of selected materials by skilled machinists who specialize on lathe building. Quantity production explains the low price. Not a toy but a practical machine for all small work. Hundreds in use in shops large and small the country over. Sold direct from factory to you on positive money-back guarantee. We also make Bench Drills and Grinders.

The Watson Mfg. Co.

111 Watson Bldg., Toledo, Ohio, U. S. A.

Write today for illustrated folder giving complete description and prices.



BINOCULARS



Very powerful. Large clear field of view. Finest quality achromatic lenses. Black leather covered. Center focus, hinged frame. Complete with case and carrying straps.

See Objects Miles Away
SPECIAL \$8.50 PRICE

Check, money order or C. O. D. Satisfaction guaranteed or money back.

J. L. SMEAD & CO., 1871 Kinney Ave., CINCINNATI, OHIO

Stop Glare on all Cars



Set of 2 \$1.00 POST PAID

Little Wonder Light Shield



Shield on Bulb

Shield only

J. A. Packard's wonderful new invention—every car needs it. If the cost was ten times the service would be cheap. Stops glare on all cars in the best possible way—makes night driving safe for all, coming or going. Does not reduce the light—gives you all the light on the road—eliminates the nuisance of dimming. Fits in any bulb socket with light. Send only \$1.00 for a set of 2. Money back guarantee. Very easily put on.

AGENTS Wanted. Send price for sample proposition, and complete agent's proposition. Our men sell as easy as a hundred sets a day. Approved by our police dept. and safety commission.
J. A. PACKARD PRODUCTS and MFG. CO.
401 Sue Building DETROIT, MICH.

\$250.00 Weekly ~ Sullivan's Success ~ Your Opportunity

82.50 worth of potatoes will make \$25.00 worth "Tater-Flakes". Figure your profits!



Less than a year ago Robert Sullivan, Indiana, was a newspaper man. He was looking for an opportunity to make more money—just as you are. Sullivan read a "Tater-Flakes" ad. Investigated, saw the possibilities, and started into this wonderful business. He is averaging **\$250.00 clear every week**—in a small town!

"Tater-Flakes" Booming Everywhere

Down south Hoffman & McLeish are running around **\$100.00 daily**. Conover, Ind., averages **\$50.00 daily** except Saturdays, which average **\$100.00**. Frank Berry, Ind., says: "Using 3 barrels of potatoes daily. Have splendid wholesale and retail business. Am supplying 5c and 10c stores." Mrs. Suttleworth, Colo., averages **\$20.00 to \$25.00 daily**. Charles Schaffer, Wis., operating 5 stores, averaging **more than \$500.00 week!**

It's a Wonderful Business

"Tater-Flakes" are a new and different potato chip. Can't be compared to ordinary chip. The "Tater-Flakes" machine slices, cooks, crisps, browns and delivers Flakes entirely automatically. Anyone can easily operate. Bright girl or boy can run machine. Outfit in window attracts attention. Passing public stops and looks. Golden, crisp "Tater-Flakes" with appetizing odor whets appetite and people buy. Retail business thrives from very start. Profits simply great.



Snow-white sides, bright nickel trimmings. A thing of beauty.

A Business You Can Handle

Write quick—get complete details of this wonderful new business. No experience needed. Moderate capital starts you. We give you every assistance—furnish machine, service men, field men, merchandising ideas, etc. All you have to supply is location. You plunge into retail and wholesale business at once. You become member of great "Tater-Flakes" organization. Have opportunity to attend annual gathering of "Tater-Flake" men—an institution national in scope.

QUICK SUCCESS POSSIBLE

The marvelous "Tater-Flakes" machine—the surpassing goodness of "Tater-Flakes"—the whole-hearted and continued co-operation of the "Tater-Flakes" organization—makes quick success possible. It's your opportunity—the chance you have been watching for—grasp it quickly. Sit down now and write for full particulars. Your territory may be taken if you delay. Address

TATER-FLAKES CORPORATION, Inc.
Dept. 36 20 E. Jackson Blvd., CHICAGO, ILL.



Sold in glassine packets, also in bulk. Big money both ways.

\$2.49 Everybody is Playing **Saxophone**
Most Beautiful **Weird Music**

Sounds just like the Saxophone. Will play any tune. So simple a child can learn quickly. Amusement and fun every evening. (Value \$3.) While they last—Only **\$2.49**. 15 Popular Songs given absolutely **FREE**.
SEND NO MONEY Just your name and address. On arrival pay postman \$2.49 and a few cents postage. If not delighted return and we'll gladly refund your money.
FREE CATALOG—Write for one today. It contains Everything Musical, Mention Instrument.

FREE 15 POPULAR SONGS

Saxophone

C. H. TAYLOR & CO.
210 S. Wabash Ave.
Dept. 512, Chicago, Ill.

INSTANT STARTING BRINGS JOY TO FORD OWNERS

Wonderful Invention starts Ford instantly in the coldest weather—users say doubles mileage—common to get from 40 to 44 miles per gallon—gives motor more power and quicker pick-up—VAN LEEUWEN of MASS. says: Your claims for increased mileage are correct; a big saving is made—WORRA of IOWA says: The SUPER is saving me three to seven dollars each month, putting new life into motor.

MARVELOUS DEVICE—COMPLETE COMBUSTION
Automatic in its action—easy to install—no changes necessary—a few minutes and the SUPER will perform the hitherto impossible—converts every atom of Gasoline and Kerosene into real power—prevents liquid fuel from passing into the cylinders, thus avoiding carbon formation and oil dilution.

EVERYBODY SATISFIED—EASY TO SELL
Everyone praises the SUPER—users say it performs miracles to a Ford—Distributors say "everybody buys and is pleased"—sells like hot cakes, every order is a **RUSH** order. **\$50.00 TO \$150.00 PER WEEK EASY**

The SUPER is a whirlwind seller and takes hold in a locality like wildfire. Big money is possible because a trial sells itself—after that everybody talks about it—spare time or full time—they all pay well. A trial of the SUPER convinces anyone.

Men Wanted Everywhere To Introduce Sent On 30 Days' Trial

WEEKS SUPER CARBURETOR CO.

1304-704 Fond Du Lac Ave. Milwaukee, Wis.

"I'd promote him to-day if he used better English"



"There isn't a man in the office who knows more about his work than Jim Roberts, but I just can't make up my mind to promote him. We understand him around here and recognize his ability, but I'd be afraid to introduce him to our customers. Too bad, too, for he's a fine fellow and I'd like to see him get ahead."

DO YOUR employers think of you as this man thought of Jim Roberts? Are they afraid to promote you because you use poor English? Are you constantly making mistakes in your speech and in writing that reveal your lack of schooling and cause people to judge you unfairly?

The correct use of the English language is regulated by certain definite rules. In the past, these rules have been taught in such a dry and formal way that the student never really understood their practical benefit.

Through the new method introduced by the International Correspondence Schools, you learn by doing. We teach the laws of English by illustrating their use. Just as a man may learn a trade by practicing it, we teach English by showing the student how to write and speak English.

Day by day you will feel and see the improvement in your English—you will make new friends—your employers will have greater confidence in you—you will never again be ashamed to speak for fear that you will make embarrassing mistakes.

Mail the Coupon To-day for Free Booklet

INTERNATIONAL CORRESPONDENCE SCHOOLS
Box 5652-D, Scranton, Penna.

Without cost or obligation, please send me a copy of your 48-page booklet describing your course in **GOOD ENGLISH.**

Name.....

Address.....

NO. 5 \$5.88 NO. 4 \$4.98

SEND NO MONEY

NO. 7 **Marvelous Mexican** NO. 9
\$3.88 **Blu-Flash Gems** \$3.98

Latest wonderful discovery with blue-white brilliancy guaranteed 20 years that positively matches genuine Diamonds side by side. Same perfect cut, same dazzling rainbow fire. Noted experts positively need their experience to detect any difference at all. Perhaps the "Diamonds" you admire on your friends are Mexican Blu-Flash Gems and you never knew it! Test one free. You risk nothing. Wear it 3 days side by side with genuine diamond. If you see any difference send it back for quick, cheerful refund. To get new customers and agents we offer these prices which are all you pay and just half our catalog prices.

No. 4—Gent's Heavy Orrey ring, Platino finish, Black inlay on sides, 1 7/8 ct. 1st Water Mex. Blu-Flash Gem. 4.98
No. 5—Lady's fancy box setting, three 1/2 ct. A-1 Mex. Blu-Flash Gems, finest Platino finish. 5.88
No. 7—Lady's Solitaire, 1 ct. 1st Water Mex. Blu-Flash Gem, engraved Platino finish. 3.88
No. 7A—Same but fine gold f., plain or engraved. 2.49
No. 9—Gent's finest gold f. heavy engraved tooth Belcher, 1 ct. 1st Water Mex. Blu-Flash Gem. 3.98

WEAR FREE SEND NO MONEY! Just name, address and size of paper meeting around ring finger for size. State which ring wanted. We ship promptly. On arrival deposit price with postman. If you decide not to keep, return in 3 days and we will refund your money. Write today.

MEXICAN GEM IMPORTING CO., Dept. P-2 Mesilla Park, N. Mex.
Importers of Fine Gems for over 18 years

NO MORE PUMPING UP TIRES

An air-tight valve cap which prevents all loss of air in tires has been put on the market by F. C. Hughes. With this valve cap one inflation lasts the life of the tire and doubles tire mileage. Tested and approved by leading automobile manufacturers. We furnish proof of tests. Retail price \$1.25 for set of five. Great demand. Wonderful opportunity for agents. Write at once to F. C. Hughes, 2520 W. Monroe St., Chicago, Ill.

Makes Autos Go 40 Miles on Gallon of Gasoline

Sioux Falls, S. Dak. — James A. May of this city announces the perfection of an amazing device that is enabling car owners to more than double their mileage from gasoline used and at the same time remove every particle of carbon from their motors. Many cars with this device attached have made over 40 miles on a gallon.

Arthur Sollee of S. Jacksonville, Fla., says: "I made 41 miles off a gallon." Chas. Luetzen of New Holstein, Wis., says: "I made 11 miles on a quart of gas on one test, and 35 miles with three quarts of gas." Dewey S. Kagg of New Boston says: "I made 44 miles on a gallon of gas."

It is automatic and self-regulating and can be attached by anyone to any car in a few minutes.

Mr. May wants agents and is willing to send a sample at his own risk to anyone who will write him. Just send your name and address to James A. May, 1703 Lacotah Bldg., Sioux Falls, S. Dak.—Ads.

Send For

FREE RADIO CATALOG YOU Need it!

100 Pages

Get it now!
Crammed full of information and offers of all kinds of complete

RADIO SETS, Parts and Accessories

including everything needed to construct the popular "Knock-Out" Sets developed and approved by Radio Broadcast magazine, published by Doubleday, Page & Co.— anything you may need to build or equip any set.

It's easy to do business with us, for this is "The Radio House of Friendly Service." All goods offered subject to examination and approval. No money in advance. Quick shipment. We pay transportation anywhere in U. S. Satisfaction or money back. Your questions answered free. Get this wonderful catalog— you need it— write today! (And will you be so obliging as to add the name of one or more friends you believe will soon want radio goods? Thank you!)

LIBERTY M. O. House
Dept. 163V, 106 Liberty St.
N.Y.C.

No letter needed — just write your own name and other names, if any, on margin, tear out ad and mail—now!



FREE WITH THIS BIG 3 FT. TELESCOPE

Yes—absolutely free! This substantial leatherette covered Carrying Case complete with strap; case measures 12 inches long, 2 3/4 inches in diameter. FREE with big 3 ft. Wonder telescope. Powerful achromatic lenses bring people and objects a long way off right close to you. See things miles away on land and sea. See moon and stars as never before.

OVER 3 FT. LONG This big telescope opens out over 3 ft. long and measures 12 inches when closed. It is brass bound and has powerful achromatic lenses. Just think of a big telescope over a yard long! Have barrels of fun entertaining your friends day and night. The "Wonder" Telescope gives new pleasures to home, farm, camp, travel, sport. Used by Auto Tourists, Boy Scouts, Sailors, etc. Biggest telescope value ever offered. Philip Brush, Beverly, Mass., writes: "I am delighted with the 'Wonder' telescope. Today I have been watching submarines 3 miles off the coast." "I am very much pleased with telescope. I saw a Light House 18 miles away."

—Clyde Scribner, Taunton, Mass. "Far above my expectations. Can see men working 7 miles away."
—S. M. Gearhart, Bolan, Iowa.

Useful and Entertaining

SEND NO MONEY

and we will send the "Wonder" 3 ft. achromatic Telescope and FREE Carrying Case by Parcel Post. On arrival pay postman only \$1.85 plus a few pennies postage. Satisfaction guaranteed or money refunded. Order today while the supply lasts.

FERRY & CO., 3224 N. Halsted St., Dept. 9778, Chicago, Ill.

Mail this coupon now for 3 ft. Telescope and FREE Carrying Case
FERRY & CO., 3224 N. Halsted St., Dept. 9778, Chicago, Ill.

Send me 3 ft. "Wonder" Telescope and FREE Carrying Case. On arrival I will deposit \$1.85, plus postage, with postman. If I am not satisfied you will refund my money.

Name.....
Address.....
City..... State.....

Read What Delighted Users Say:

"The telescope I received last month is very fine. I live on a bluff and can see across the Mississippi 3 miles and see people fishing."—M. L. Thorn, St. Louis, Mo.

"I am nearly 80 years old and if I could not get another would not take \$10.00 for it."—A. R. Walker, Dayton, Ohio.

"I have had my 'Wonder' Telescope 6 months. I can tell time on the church clock 5 miles away."—Edw. Foster, Baltimore, Md.

"Could tell color of aeroplane 4 miles away."—Mrs. L. M. Yarrbrough, Stringer, Mass.

Actual copies of these testimonials and hundreds of others on file!

LUMINOUS PAINT

Make Your Watches, Clocks, Etc., Visible by Night

The very latest discovery in the scientific world, LUMINOUS PAINT, practically unobtainable except at an exorbitant price, we have at last succeeded in producing this remarkable LUMINOUS PAINT, which, applied to the surface of any article, emits rays of white light, rendering it perfectly visible in the dark. **THE DARKER THE NIGHT, THE MORE BRILLIANT IT SHINES.** Quite simple to use. Agree—**you can do it.** A little applied to the dial of your watch or clock will enable you to tell the time by night. You can coat the push buttons or switch plates of your electric lights, match boxes, and insensurable other articles; make your own Luminous Candles, Luminous Razors, etc. Small bottle, price 25c. Larger sizes, 50c and \$1 postpaid.

Serpent's Eggs

Box contains 12 eggs. When lit with a match, each one gradually hatches itself into a snake, several feet long, which curls and twists about in a most life-like manner. Price per box, 10c postpaid, 3 for 25c.



CIGARETTE MAKER



Roll your own and save money. Makes them better and quicker besides saving more than half. Use your favorite brand of tobacco. Neat, useful and handy. Pocket size, weighs 75 cts. Made entirely of metal, nickel-plated. Price 25c postpaid.

MIDGET BIBLE

GREAT CURIOSITY
Smallest Bible in the World. Size of a postage stamp—200 Pages. Said to bring good luck to the owner. A genuine work of art. Must be seen to be appreciated. Make good money selling them to friends, church acquaintances, etc. PRICE 15c each, 3 for 40c, 12 for \$1.35, 500 for \$7.50. Magnifying Glass for use with Midget Bible, 15c.



STAGE MONEY



With a bunch of these bills, it is easy for each person of limited means to appear prosperous by flashing a roll of these bills at the proper time and peeling off a genuine bill or two from the outside of the roll, the effect created will be found to be all that can be desired. Prices, postpaid: 25 Bills 15c, 50 Bills 25c, 125 for 50c, or \$3.50 thousand.

Wonderful X-Ray Tube

A wonderful little instrument producing optical illusions both surprising and startling. With it you can see what is apparently the bones of your fingers, the lead in a lead pencil, the interior opening in a pipe stem, and many other similar illusions. A mystery that no one has been able to satisfactorily explain. Price 10c, 3 for 25c, 1 dozen 75c. Johnson Smith & Co.



Good Luck Ring
Quaint and Novel Design

A VERY striking and uncommon ring. Silver fish, skull and crossbones design, with two brilliant, flashing gems sparkling out of the eyes. Said by many to bring Good Luck to the wearer, hence its name. **Good Luck Ring.** Very unique ring that you will take a pride in wearing. **ONLY 25 CENTS.**

Address orders for all goods on this and opposite pages to
JOHNSON SMITH & CO.
Dept. 178 RACINE, WIS.

A Deluxe Edition of our new 1925 CATALOG mailed on receipt of 25c. Handsome cloth binding. Only book of its kind. 420 pages of all the latest tricks in magic, the newest novelties, puzzles, games, sporting goods, interesting books, curiosities in seeds and plants, etc., unobtainable elsewhere. Only a limited number available.

DYING PIG



The most laughable novelty yet produced. Made of rubber, and you have only to blow it up and stand the pig on his feet, when he begins to squeal as he slowly collapses and finally lies down and dies in the most natural manner. You can blow him up as often as desired, and each time he will go through the same performance to the great amusement and delight of your friends. Price, 15 cents; 3 for 40 cents; one dozen \$1.35, mailed.

Popular Watch Charms

15c
ONLY 3 for 40c; \$1.35 doz.

Very pretty little curiosities and decidedly novel. Fitted with Magnifying Lenses that enlarge the pictures to a very surprising degree; in fact, it seems almost incredible that a clear picture could be possible in such a small compass, and how sharp and distinct they show up when you look through. Colors in assorted views—Actresses, views of Panama Canal, Lord's Prayer in type, etc.

Mystic Skeleton

A jointed figure of a skeleton 14 in. in height, will dance to music and perform various gyrations and movements while the operator may be some distance from it. **10c + pd.**

NEW BOOK ON ROPE SPLICING

Useful Knots, Hitches, Splices, etc.
A most practical handbook giving complete and simple directions for making all the most useful knots, hitches, splices, etc. Over 100 illustrations. All about wire rope attachments, lashing, blocks, tackle, etc. 37 Heraldic Knots Illustrated. Of great value to mechanics, riggers, engineers, boatmen. Price 20c ppd.

MAGIC FLUTE

Wonderfully Sweet Toned and Musical
The Magic Flute, or Harmonium, is a unique and novel musical instrument that is played with nose and mouth combined. There is just a little trick in playing it which, when once acquired after a little practice will enable you to produce very sweet music that somewhat resembles a flute. There is no fingering, and once you have mastered it you can play all kinds of music with facility and ease. When played as an accompaniment to a piano or any other musical instrument, the effect is as charming as it is surprising.

Post Paid 25c

BLANK CARTRIDGE PISTOL

Protection against Burglars, Tramps & Dogs



Prices
50c
\$1.00
Post paid

Well made and effective; loaded on latest type of Revolver; appearance alone is enough to scare a burglar. When loaded it may be as effective as a real revolver without danger to life. It takes standard .22 Cal. Blank Cartridges obtainable everywhere. Price 50c, superior quality, \$1.00 post paid. Blank Cartridges, by express, 50c per 10 Holster (Cowboy type) for Blank Cartridge Pistol, 50c. Johnson Smith & Co., Dept. 178, Racine, Wis.

DANCING BEAUTIES

Get a Kinetograph and see the picture move. France's latest sensation. A great surprise. Is worth twice what they cost. Are made of solid brass, highly nickled and very durable. Satisfactory or your money back. **50c** Price. Johnson Smith & Co., Dept. 178, Racine, Wis.

BOYS! BOYS! BOYS!

THROW YOUR VOICE

Into a trunk, under the bed or anywhere. Lots of fun fooling the teacher, policeman or friends.

THE VENTRILO
a little instrument, fits in the mouth out of sight, used with above for Bird Calls, etc. Anyone can use it. Never Fails. A 32 page book on ventriloquism, the Ventrilo, ALL FOR 10 CENTS

1000 Silk Remnants

for patching Crazy Quilts, Sofa Cushions, Head Rests, Pin Pads etc. Large pieces, all colors and shades. Sure to delight you. For 10 Cents, we send a large package and Book of quilt designs. 3 packages 25c. 1 pound makes a lovely large quilt. Price 10c postpaid. Our silk is the best. JOHNSON SMITH & CO., Dept. 178, RACINE, WIS.

LOOK 35¢ LOOK

Wonderful instrument. Greatest thing yet. Nine separate articles in one. Everybody delighted with it. Odd, curious and interesting. Lots of pleasure as well as very useful. It is a double Microscope for examining the wonders of nature. It is also an Opera Glass, a Stereoscope, a Burning Lens, a Reading Glass, a Telescope, a Compass, a Pocket Mirror, and a Laryngoscope—for examining eye, ear, nose and throat. It is worth all the cost to locate even one painful cinder in the eye. Folds flat and fits the pocket. Something great—you need one. Don't miss it. Sent by mail, postpaid. **Only 35c or 3 for \$1.00**

Resurrection Plant

One of the most wonderful plants known. Possesses the strange power of turning in a few minutes from an apparently lifeless, dry herb to a BEAUTIFUL LIVING FERNLIKE PLANT of a dark green color. Simply place the plant in saucer of water, it will open up and start to grow in 20 minutes. When taken out it will dry up and go to sleep until placed in water again. Fine house plant—summer or winter. 10 cents each or 3 for 25c. **AGENTS WANTED** JOHNSON SMITH & CO., Dept. 178, RACINE, WIS.

EXCELSIOR SOLAR TELESCOPE

AND MICROSCOPE COMBINED

PRICE

\$1.85 Postpaid
to Any
Address



Guaranteed SCIENTIFICALLY PERFECT by the Makers
Over 3½ ft. long, nearly 6 ins. around With Adjustable Solar Eye Piece



The New Excelsior Solar Telescope is a large, powerful and serviceable instrument, well made and accurately fitted, and marvelously cheap. A Telescope with an Adjustable Solar Eyepiece for observing Eclipses of the Sun and examining the very interesting and mysterious Sun Spots, has never before been obtainable for less than several times the price charged; in fact, such an eyepiece alone usually costs more than the price charged for this complete Telescope. The lenses are well ground and adjusted, and the five sections are perfectly fitted. There is a metallic cap to protect the object glass from injury and to exclude dust. The section with the eye piece can be withdrawn and used separately as a powerful magnifier or microscope. The Telescope when fully extended is about 3 feet 6 inches in length, and when



SUN SPOTS

closed it measures almost a foot. Tourists, residents at the seaside, farmers and others able to enjoy wide and extended views should have this excellent and wonderfully cheap Telescope. For a limited time only we are offering this Telescope, complete, postpaid, at the very remarkably low price of...
JOHNSON SMITH & CO., Dept. 178, RACINE, WIS.

Only \$1.85



MYSTERY BOAT Runs for hours without mechanism of any kind. Speed 9 miles an hour. Kicks up water and sounds like real motor boat. Entirely new and patented principle never before applied to toys. Just place a small lump of Canned Heat such as Borden, obtainable anywhere, in boat and light. Costs only **One Tenth of a Cent for One Charge.** Runs wherever there is water—in a bathtub, dishpan—anywhere at all. Any child can operate it. Made entirely of metal, attractively enameled in colors, hull black green and deck light red. Indestructible, leak-proof and safe. 50-cents box. Price \$1.00. CANNED HEAT, 20c per can. **JOHNSON SMITH & CO., Dept. 178, Racine, Wis.**

INVISIBLE INK

The most confidential messages can be written with this ink, for the writing **MAKES NO MARK.** Cannot be seen unless you know the secret. Invaluable for many reasons. Keep your postals and other private memoranda away from prying eyes. Great fun for playing practical jokes. Only 15c Bottle.

VANISHING INK

Writing written with this remarkable ink vanishes entirely in a few weeks (except on waxed paper), leaving the paper **QUITE BLANK.** 15c and 30c bottles. **LUMINOUS INK** writing can be **READ ONLY IN A DARK ROOM!** Writing shines like fire. Quite invisible at daytime. Very remarkable. 15c.

LADY'S LEG KNIFE

Latest novelty, a good substantial knife made by a first-class cutlery establishment for 15c. Knife is perfect imitation of lady's leg with embossed stockings and shoe. 15c postpaid.

Pencil with Microscopic View

Decidedly novel and excellent pencil with eraser, into which is fitted a tiny microscopic picture, magnified to an almost incredible degree by the small but powerful lens. A great curiosity. Assorted Views: Bathing Girl, Addressess, Panama Canal, Lord's Prayer, etc. Price 15c, 3 for 45c, \$1.25 doz., postpaid.



Everything about the Ku Klux Klan told in a clear, fearless manner. Book tells all—How it started and was suppressed in 1871—The New Ku Klux Klan—How organized—How members are enrolled—Oath of the Klan—Questions for Candidates—Creed—Objects of the Order—Obedience—Fidelity—Pledge of Loyalty—Ku Klux Klan and the Masons—The Jews—The Masons—Real K. or C. Oath—The Negro Ku Klux Klan, etc., etc. Latest and most complete book on the Klan published. Price, 35c, postpaid.



SEX INDICATOR

Some time ago we received from abroad what we consider the most unique and entertaining novelty we have ever seen. It's the **MAGIC INDICATOR.** We paid 50 cents for the one we received about a year ago, and we don't believe we ever got a bigger value for our money. Hold the **MAGIC INDICATOR** over a man's hand—in a woman's hand and it describes a complete and continuous circle. The same action can be obtained over a letter written by a man or woman, etc. It is fascinating; baffling. We have never been able to figure out how it's done—but we've never seen it fail. Many novel and entertaining tests may be performed with the Sex Indicator. For example, similar results can be obtained with animals, cats, dogs, rabbits, even birds, chickens, geese, etc. Also used to predetermine the sex of chickens and birds, etc. In fact it is sold as a patented egg tester in Europe. Take one to any gathering and see how much interest it excites. Price 25c postpaid, or 3 for 65c, postpaid.

All articles listed on above and previous page obtainable from

JOHNSON SMITH & CO., Dept. 178, Racine, Wis.

THE EXPO WATCH CAMERA



The most wonderful and ingenious Camera made. It is but little larger than a watch, which it closely resembles. You can carry the Expo about in your pocket and take pictures without any one being the wiser.

Less Than 2 Cents a Picture

The Expo loads in daylight with 10 or 20 Exposure Films, costing 25c and 35c respectively, and thus the picture taking part of a whole day's outing may be had for a very nominal sum—Little more than one cent a picture.

Easy to Manipulate

It is simplicity itself to operate. Takes pictures through the stem, where the **Rapid Fire Lens** is located. The photos (E-327-50) may be enlarged to any size. **Operated as Quick as a Flash**—Time and instantaneous shutter; weight but 3 ounces; nickel plated. Endorsed by amateurs and professionals the world over. Especially popular in printing and developing of films just the same as ordinary cameras—in daily use by the police, newspaper reporters, detectives, and the general public. Important tests have been secured with the Watch Camera by enterprising reporters. Produces clear, sharp negatives indoors or outdoors equal to any camera on the market, size or price notwithstanding. Sold Under a Positive Guarantee.

Expo Watch Camera \$3.60 FILMS, 10 Exposures 25c, 20 Exposures 35c
Price Post Paid Leather Pouch Carrying Case, 35c
JOHNSON SMITH & CO., Dept. 178, Racine, Wis.

FLASHLIGHT MOVIES

NEW Combines (1) Moving Picture Machine; (2) Magic Lantern; (3) Flashlight. All in one. No gas; no oil. A splendid Moving Picture Machine, using standard films same as shown at theatres. Shows large, clear pictures. Always ready for use! Simply press the flashlight switch and you are ready for the show. Not necessary to have electricity in house. Flashlight can be disconnected and used separately if desired. The machine is arranged for use either with Films or Lantern Slides. Given **FREE** with each machine! 1000 Films, 1 Film Compartment (Slide) for making your own lantern slides out of old film! 1 Transparent Announcement Slide, and generous supply of admission tickets, badges, guarantee, instructions, etc., carefully packed and sent prepaid to any address for only **\$5.50**

Extra Film in 25, 50 or 100 ft. lengths at 1 cent per foot.
JOHNSON SMITH & CO., Dept. 178, Racine, Wis.

All the Latest Surprising and Joke Novelties

- | | | | |
|-----------------------------------|-----------|-------------------------------------|-----------|
| Miniature Water Pistol | 15c | "Mason's" Self-filling Fountain Pen | 25c |
| Cleopatra's Snake (very lifelike) | 15c | Great Fire-eating Trick | 30c |
| False Mustache | 10c | Magic Ball and Vase Trick | 30c |
| Pocket Detective (see behind you) | 15c | Naked Truth Joke (Magic Card) | 15c |
| Great Mind Reading Mystery | 10c | Chicken Inspector Badge | 10c |
| Thurston's Mysterious Trick Cards | 10c | Lila's Lissome 10c Boogie Lissome | 15c |
| Fighting Roosters, pair | 15c | Famous Simplex Typewriter | \$12.50 |
| Spout Ring - 20c Trick Pistol | 15c | 250-shot Automatic Cap Pistol | 15c |
| Rubber Tacks (a good joke) | 10c | Surprise Matches, per box | 30c |
| Memorized Penny | 20c | Deck Marked Cards | \$1.00 |
| Cashew Snuffing Powder | 10c | Everlasting Writing Pad | 15c |
| Magic Plate Lifter | 25c | Wire Puzzles, big set | 3 for 25c |
| Imitation Gold Teeth | 15c | Shirley Dinner, 15c. Sock Card | 4c |
| Barking Dog (imitates dog bark) | 2 for 10c | Fortune Telling Cards, per deck | 25c |
| Exploding Cigarettes, Per Box | 25c | 3-Reel Moving Picture Machine | \$3.00 |
| 20-piece Set Silverware Tableware | \$1.50 | Air Plant, novel and decorative | 25c |

Genuine Imported
SCHÜTZ
Pocket Telescope

4 1/2
Power



Post-paid **\$1.00**

Guaranteed German telescope. Clear and powerful. For use when hunting, boating, automobiling. Ideal for the races. Carefully and accurately made with brass slide and hard rubber casing. Equipped with high grade lenses. Objectives are 24 m.m.

Exceedingly favorable rates of exchange make possible this unusual offer. Shipped promptly on receipt of check, money order or dollar bill.

*Positive guarantee of full refund
if not satisfactory.*

PLACE YOUR ORDER AT ONCE

HENDERSON BROTHERS, Importers
97 Federal Street, Boston, Mass.

**Sell This Easy Way
to Fill FORDS** PUT ON IN

**MAKE BIG PROFITS WITH THIS
COMBINED GAS GAUGE & FILLER**

Makes Fords as easy to fill as cars with tanks at rear. Unnecessary now to remove cushion or get out of car. Takes full flow from any pump without flooding. Has visible gas gauge, too, with luminous indicator that SHINES AT NIGHT. Guaranteed! Easy to install—clamps into regular tank opening. Make big money selling the wonderful new

Kirstin Fil-Gage

Retails at \$6. Easy seller! "Sold the first five Ford owners I called on," writes E. A. Bernier, Northampton, Mass. Exclusive territory. Full details sent free. If you wish, send \$6 (or \$1, and pay \$5 C.O.D.) for one Fil-Gage, leatherette Carrying Case, and full supply advertising matter, sent on 10-day money-back trial. Write today to address below.



*A Gasoline
Gauge,
Too,
Always
In
Sight*

F-20

A. J. KIRSTIN CO.

1101 1st St. Escanaba, Michigan

**AGENTS HOT SELLER
JUST OUT**

**STOPS HEADLIGHT GLARE
OF APPROACHING AUTOS**

A simple, inexpensive device called "Glaroff" protects auto-drivers from the blinding headlights of the other fellow's car or a low, direct sun. Prevents serious accidents. Applied to inside of windshield instantly; held fast without bolts or screws; will not work off on rough roads. Try one on your own car a week; if it does not make driving easier, safer, trial costs you nothing.

SPECIAL OFFER TO AGENTS to use and introduce Glaroff. Enormous, uncrowded field. Sells like wild fire—every car owner buys.

\$12 A DAY up to \$7,500 a year to agent who gets your county. Territory going fast. Write for **SPECIAL FREE GLAROFF OFFER** and further details. This is a big opportunity, so don't delay, write today.

GLAROFF MFG. CO., 105 Plumbers Bldg., Sioux Falls, S. Dak.

TURN WASTED TIME INTO MONEY



Every purchaser finds numerous uses for
**Torit Acetylene
Torch No. 13**

Uses nothing but acetylene. No oxygen or air pressure required. Tips suck in air. Simply connect to Presto auto tank, light gas, and outfit is put to work.

Beats anything you ever tried for soldering, heating, melting, and light brazing.

Outfit consists of 4 tips for different kinds of work, soldering copper, 5 ft. tubing, tank connection, and full instructions.

\$7.50 in U. S. A.
\$10.00 in Canada
ST. PAUL WELDING & MFG. CO.
177 W. Third Street ST. PAUL, MINN.

**Turn Your
Spare Hours
Into Real Money**

HAVEN'T you often wished for a spare-time way of making more money than comes in the regular pay envelope? Of the various ways which present themselves none is more pleasant or profitable than playing engagements in a Band or Orchestra.

Send the Coupon
For particulars of our Easy Payment Plan that tells How You Can Pay While You Play. Free Trial—We want you to try out a "King" in your own home, without obligation, and if you do not find the "King" the very best instrument you ever played—returns it.

Trade-in-Proposition—Turn in the instrument you now own as part payment on a new "King". Our latest catalogs show many new model "Kings" and tell why they are the best instruments to learn on and play on. Use the coupon to order your copy.

THE H. N. WHITE CO.
5211-57 Superior Avenue, Cleveland, Ohio

Please send me free, your latest catalog on

Instrument.

Name _____

Address _____

City _____

State _____



Harris Homes Beautiful

Bungalows — Semi-Bungalows — Cottages — Residences! If you want a real home combining an impressive exterior and comfortable, well planned, homey room arrangement, you must see the latest De Luxe Addition of our latest book of Homes and Building Materials. More than a hundred modern, attractive, livable houses, featuring all that is best in construction—each one an architectural triumph carefully planned and designed by expert architects.

All Harris Homes Beautiful have been built many times with big economy and life-long satisfaction to their owners. They present a perfect combination of approved construction, finest materials, "planned the Harris way" to save from \$500.00 to \$1,500.00 of your money. Ask for your copy of this free 400-page Building Material Book, No. CB-189, today.

Thousands of Bargains Like These



Combination Screen and Storm Door. Size 2/8x7/1, quickly changed, each

\$6.77



2 light 24"x20" glazed, checkrail windows, 1-3/8" thick, outside measure 24-1/8 x 3/10, each

\$2.50

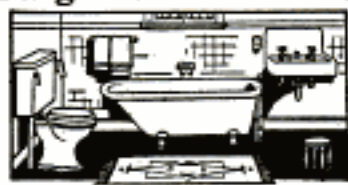

The bathroom outfit shown includes bathtub five feet long, white porcelain enameled on the inside, low pattern white tank closet outfit and white porcelain enameled lavatory complete with all fittings above floor line, special at.....

\$65.00



Clear White Pine Storm Sash with frames, 1-1/8" thick. Best clear glass, each light 2x10. Outside measure 1/2x2/11/16, each.....

\$1.53



Economy Special paneled door, size 2/8x6/8, 1-3/8" thick, each.....

\$3.20

HARRIS BROTHERS CO.

Dept. CB-7

35th and Iron Streets

CHICAGO, ILL.

Shot Guns, Breech Loading Like Cut **\$4.50**



U. S. Cal. 45 B. L. Rifles. Barrels cut to 22-inch length. Rehored smooth for Bird shot. Bird shot Cartridges for these guns..... **\$3.00** hundred Rifle Barrels, interchangeable, same length..... **\$2.00** extra Ball Cartridges..... **\$3.00** hundred

Send for Catalog **W. STOKES KIRK** 1627-PM North 10th Street PHILADELPHIA, PA.

SAVE TIME SPACE MONEY

Write for Circular and Price List

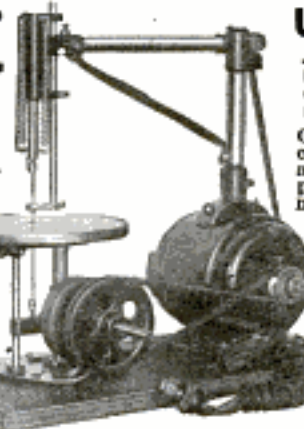

Use JUNIOR

JIG SAWS
DRILL PRESSES
CIRCULAR SAWS
FILING MACHINES

Can be supplied in combination or separate models to suit purchasers' requirements.

Saws Wood, Bakelite, Light Metals, etc.

For schools, model and pattern makers, radio manufacturers.

Hundreds of other uses.

Lite responsible Dealers, write us.

JUNIOR MACHINE & MFG. CO., 4620 Hazel Ave., Chicago, Ill.



Be a Diamond Expert

Do you know that of two diamonds of equal size one may be worth a hundred times as much as the other? Who can distinguish them but an expert? My short easy course will make you a diamond expert!

\$5,000 to \$15,000 a Year!

FREE! Genuine mount Jewelry houses everywhere need expert diamond men who can name their own salary! I will show you how to make this money! Booklet "Pay for Diamond Knowledge" sent free! Send for it!

CODINGTON SCHOOL OF DIAMONDS, Dept. 403-A Chicago, Illinois 3457 Sunnyside

THAT WET BOILER PIT CAN BE MADE DRY!

MAKE and keep your cellar walls, floor and boiler and drain pits thoroughly dry by filling the cracks and coating the surface with Smooth-On No. 7, the only practical waterproofing material that can be effectively applied *from inside* and bonds perfectly on *wet or dry* surface. Excellent also for patching concrete floors, water-proofing garage, stable and wash-room floors, brick walls, cisterns, septic tanks, water troughs, fountains, fish ponds, swimming pools, manure pits, etc.

Requires about 25 lbs. Smooth-On per 100 sq. ft. of surface and you can do the work yourself.

Sold in 5 and 10-lb. cans and 25, 50 and 100-lb. kegs

SMOOTH-ON MFG. CO.

Dept. 61

574 Communipaw Ave., Jersey City, N. J.



Write for
FREE BOOK



Do it with
SMOOTH-ON No 7

Attractive sport and
speed bodies
for the Ford.



9 Different
Models

Overhead Valves

Outstanding Features

Prices Slashed! Large Variety! COME IN TODAY!!!
H. K. FORDSPEED BODY MFRS., 250 W. 54th St., NEW YORK

We Pay \$8 a Day

Taking orders for new Serenola. Going big. Your money sure every day. No collecting or delivering. No capital needed. Easy to take orders, low priced. Everybody can afford one.

\$60 a Week Easy

Greatest musical invention the world has ever known. Carry it with you anywhere. Built-in and looks like a fancy leather suit case. Plays any Record. Fully guaranteed. Does more than machines costing 5 times its price. Take orders in your spare time. Gratz took 43 orders in one week. His profit over \$300. We have hundreds of representatives making \$8 to \$16 a day. Write for sample and territory.
PERRY-LUDLOW CO., S-6848, Dayton, Ohio



AGENTS

Make
\$25 a Day

Selling
OLIVER

OIL-GAS BURNERS



Wonderful Invention Every Housewife

Agents selling Oliver Oil-Gas Burners are making *Wants!* attractive profits. Some make \$25 a day. Others make even more. Here's a wonderful invention every housewife wants. Makes any range a real gas range. Does away with dirty, costly coal and wood. Gives better heat than either. Just turn a valve. It takes only fifteen minutes to demonstrate it. A demonstration invariably means a sale. Write today and let us tell you all about the success other men are enjoying—and about the Oliver Distributor and Dealer Plan.

A Real Chance

for Men Alert to Big Opportunities

Already more than 200,000 Oliver's are in use. Burn ordinary oil—mixed with air. A complete line. A burner for every type of cooking range, heating stove and furnace. Every householder is a prospect. Season is 12 months long. We want "go-getters" to cover cities, counties and sections, to fill orders created by our big national advertising campaign in leading magazines. If you know you can sell a worth-while product write at once.

OLIVER OIL-GAS BURNER

Oliver Oil Burner Corporation

Manufacturers of Oliver Oil-Gas Burner Products

1126 Oliver Bldg., ST. LOUIS, MO.

Oldest and Largest Manufacturers of Oil-Gas Burners in the World



SPECIAL \$6.19 LIMITED TIME ONLY

25 year 14 kt. white gold filled wrist watch. Treason shape. Sapphire crown, silk grosgrain ribbon with white gold filled clasp. 6 jewel movement. Sent in beautiful silk lined gift case. Postage **ONLY \$6.19 plus 10c postage.** Money refunded if not satisfied.

SUPREME JEWELRY MFG. CO.
434 BROADWAY Dept. 154 NEW YORK CITY

**No Better Christmas Present
for \$2.50**

than a year's subscription to

Popular Mechanics Magazine
Containing 3600 Pictures and 3600 Articles

Much of it interests Everybody
Most of it interests Anybody
All of it interests Somebody

Order through your Newsdealer or address the Publisher

POPULAR MECHANICS COMPANY

200 East Ontario Street, CHICAGO, ILL.

\$100 to \$500 Weekly and a Good Time

It's not unusual for Saxophone players of ability to earn \$100 to \$500 a week. You might do as well and enjoy this most pleasant of vocations.

Besides, think of the fun you can have! There is always a good time for the Saxophone player. It's the ideal instrument for social entertainment. It is a key to social popularity. At parties, everywhere, the Saxophone player is the center of attraction.

Easy to Play Easy to Pay



Thousands of young men and women right now are learning at home, without a teacher, to play one of these professional Buescher Saxophones—Acquiring a wonderful and profitable profession and at the same time having a barrel of fun. In every neighborhood, the young man with a Buescher is the one who is stepping forward socially and in a business way - the young man who is worth watching, because he is lifting himself above the level of his associates.

And Just See How Easy It Is

You can play the scale in an hour's practice and in a few weeks you can play popular music. If you like, you can join a band or orchestra in 90 days. It's fun to practice because you learn so rapidly. Even though you may not be interested in becoming a professional, you will never regret being able to play a Saxophone,

because of the pleasure and social advantages it affords you. You are always welcome everywhere with a sweet-toned Buescher Saxophone. Write today for full information and prices. Mention any other instrument in which you may be interested.

BUESCHER BAND INSTRUMENT CO.

Everything in Band and Orchestra Instruments

321 Buescher Block

Elkhart, Ind.

Free! Saxophone Book

Just Send Your Name

We have a very interesting book on the Saxophone that every boy should have. It contains pictures of many of the famous saxophone players and popular orchestras of America, and tells all about the entire family of Buescher Saxophones. Send coupon for a free copy.



Buescher Band Instrument Co.
321 Buescher Block, Elkhart, Ind.

Gentlemen:

I am interested in the instrument checked below:

Saxophone... Cornet... Trombone... Trumpet...
(Mention any other instrument interested in)

Name.....

Street Address.....

Town.....State.....

FREE to the DEAF

10 Days Trial of the World Famous Acousticon



Every one who is troubled with deafness is now invited to enjoy Ten Days of Good Hearing with the world-famous Acousticon. Let us send you our latest improved model for 10 days free use entirely at our risk and expense. No deposit required—no obligation on your part. Just try it—10 days Free and let results convince you.

Mr. A. H. Herrick, of Harvard University, says: "We who suffer from impaired hearing have cause for profound gratitude to you." Rev. G. M. Rainey, the Evangelist, says: "The results have been all you claim." Mr. A. Hollander, of the Equitable Life, New York, says: "Not a day passes but what I recommend the Acousticon to friends or business acquaintances—it has made a new man of me." In like manner write thousands of others, expressing their gratitude—men and women in every state, in practically every civilized country on earth. Yet we don't ask you to believe. We simply ask that you allow us to prove the merits of the Acousticon in your own case, to your own complete satisfaction without a penny of expense or risk on your part. Just try it—free, that's all we ask. Send name and address today.

Dictograph Products Corporation
1307 Candler Bldg., 220 W. 42nd St., New York

ELECTRIC SOLDERING IRON

\$3.50
delivered

IDEAL FOR RADIO & ELECTRICAL REPAIRS



Every mechanic, motorist, and radio man needs it. With it you can make repairs yourself that you would otherwise pay to have done. Compact, efficient—universal screw driver tip. 50 Watts—110 Volts. Complete with cord and plug. Satisfaction guaranteed, or money refunded. Send P. O. or Exp. M. O. to ARRANDALE ELECTRIC CO., 100 Schley Street Newark, N.J.

Play a Tune In 10 Minutes

Anyone can play the Ukulele, Banjo, Mandolin, or Guitar in ten minutes with this wonderful new device. Works like a typewriter—just press the keys. No knowledge of music required. Play by numbers instead of notes. (See by notes if you wish.)

Amazing New Invention

Revolutionizes string instrument playing. No more expensive lessons. No more weeks of tiresome practice. So simple a child can use it. Praised by prominent musicians. Thousands of delighted users.

Write Today



Astonish Your Friends

by learning to play a string instrument in 10 minutes! Play the latest music on the Ukulele, Banjo, Mandolin, or Guitar. Become popular. New pleasures. New money-making opportunities. Send at once for

FREE BOOK

Send just your name and we will send a FREE BOOK explaining this marvelous device. Also catalog of unusual values in musical instruments. No obligation. Send today for free particulars. FERRY & CO., 630 Jackson Blvd., Dept. B778, Chicago, Ill.

DELTA



No. 37 BICYCLE SPOTLIGHT

A Strong Beam of Light Where the Rider Wants It When He Wants It
A Bike Light That Equals a Good Auto Spotlight

The only truly Bicycle Spotlight on the market. Strictly high powered. Not a common Bicycle light or marker, but a spotlight equal to a good auto spotlight. Throws powerful beam of light in any direction at will of rider. Head 4 1/4 inches in diameter. Improved bracket, fits any handlebar. Operates on two dry cells. At your dealer or sent prepaid for \$3.75 complete (less batteries).

DELTA ELECTRIC COMPANY
100 Delta Block MARION, IND.

Standard Makers of Auto Spotlights, Motorcycle Spotlights, Bicycle Lamps, Electric Lanterns, Radio Head-Phones, Flashlights and Flashlight Batteries.
New York: Export Dept., 30 Water St.
Chattanooga: Faucette-Huston Co.
San Francisco: Sanford Bros., 311 Mission St.

TOBACCO OR SNUFF HABIT

Any form quickly conquered. No long waiting for results. Costs small sum. Nothing if it fails. Perfectly HARMLESS. Full treatment on approval.
DR. C. M. SIMPSON, 107 W. 44th St., Cleveland, O.



\$10 A DAY Selling Shirts

Yes—it is easy selling Packard Shirts of Quality. Individual patterns and remarkable values. Direct from our own modern factory. Big demand. Steady, increasing repeat business. No capital or experience required. We furnish everything, including FREE Sample Case and opportunity to get an AUTO.
PACKARD MFG. CO., Dept. 311, 829 Orleans St., CHICAGO, ILL.

Use Your Ford

**TO SAW YOUR WOOD
TO GRIND YOUR FEED
TO FILL YOUR SILO
TO SHELL YOUR CORN
TO PUMP YOUR WATER
TO ELEVATE YOUR GRAIN**
And for all other belt-power jobs



Why Buy an Engine When a Low-Priced

"WORK-A-FORD"

can be used with your Ford for all belt work? Your Ford has a powerful engine. It will outlast the car and you might as well use it and save your money. No wear on tires or transmission. Just drive up and hook on in three minutes. **Friction Clutch Pulley.** Governor regulates engine speed. Write for free circular and 10-day trial offer.

WORK-A-FORD CO., 839 Madison Terminal, CHICAGO

500 PUNCTURES Yet Leaks No Air



We Want Agents

A new Puncture Proof inner tube has been invented by Mr. Milburn of the Milburn Puncture Proof Tube Company, Chicago. In actual test it was punctured with 500 nail holes without the LOSS OF AIR. This amazing new inner tube increases mileage from 10,000 to 12,000 miles; eliminates changing tires and makes riding a real pleasure. Many users have run over 20,000 miles without removing a tire from the wheel.

These wonderful, no-trouble, puncture proof inner tubes cost no more than ordinary tubes and Mr. Milburn wants agents everywhere to help him introduce them.

CAR OWNERS WANTED

To sell and demonstrate this wonder tube. Interests everyone immediately. Automobile owners buy on sight. It makes no difference what car they drive or what tires they use. Our salesmen are coining money on our "DIRECT FROM FACTORY" scheme of selling. Absolutely no competition. We control all basic patents. No capital required to start. Previous selling experience not necessary.

EARN \$5,000 to \$10,000 A YEAR

Read What These Men Say

J. D. Cooper—"I have made 30,000 miles with my Milburn Puncture Proof Tubes and have not as yet removed a rim or casing and my casings are still in excellent condition."

J. C. Jerves—"I sold 50 Milburn Tubes in the first three days."

Chas. Cayton—"I sold twelve tubes yesterday in ten minutes."

L. S. Knapp—"My first few hours out I sold eight tubes, no trouble at all to sell them. The most wonderful tube on the market today, I think. I am hoping you will give me the agency for a big territory."

D. Edeler—"I have driven seventy-five miles in one of the 30x3 tubes and twenty were spike nails. It has gone above the test that you recommended to me it would do."

Earn \$5,000 to \$10,000 yearly or more. Get into business for yourself. Sell Milburn Puncture Proof Inner Tubes. Every car owner is a prospect. Your field is unlimited. Get in while it is good. Be independent. Find out all about it now and get started at once.

FREE TUBE SPECIAL FREE TUBE OFFER

Send coupon or write today for special free tube offer and further details. References, Industrial State Bank of Chicago, National Bank of the Republic, Chicago, Baker State Bank of Chicago. Don't hesitate. Fill out the coupon and send it in or write and send name and we will send you all details. This is your opportunity, so don't delay. Address

N. A. HANSEN, Sales Mgr.

**MILBURN PUNCTURE
PROOF TUBE CO.**

**331 West 47th Street
CHICAGO, ILLINOIS**

MR. N. A. HANSEN, SALES MANAGER, CHICAGO, ILLINOIS
331 West 47th Street, Chicago, Illinois

Dear Sir: If the money-making opportunity is as big as you claim I am interested in getting the facts so that I can get a share of the profits with Milburn Puncture Proof Tubes. Without obligating you in any way, please send me the information about your business and make it plain. OFFER NO. 1000

Name

Address

City

State

Electrical Course

In
Book
Form

Here is the quickest, easiest, cheapest way to learn electricity. Think of it! A complete electrical course in book form. No tiresome lessons with a lot of mathematics. Just plain everyday electrical facts—the very things and the only things you need know to hold down a good paying job. Written and simplified by 27 of the biggest men in the electrical field. 8 big books—4100 pages and 3300 pictures.

Electricity Means Success

—Good Pay and a Good Job. You can succeed in electricity. It's one of the best paying fields open to young men who know.



You do not have to give up your present position, just a few pleasant hours spent in the evenings on this subject, and success is yours.

FREE TRIAL!

Just mail the coupon—don't send a cent. We send books for a week's free use. Look them over yourself, and see how thoroughly and completely everything about electricity is explained in them.

American Technical Society
58th St. & Drexel Ave. Dept. E-319

American Technical Society, Dept. E-319, Chicago

Send me your 8 volume set of Electrical Books for a week's free use. I will either return the books in 7 days or remit \$2.00 and pay you \$3.00 each month until a total of \$29.50 is paid.

Name.....

Address.....

Employed by.....
Copy this coupon on larger sheet if more convenient

only **\$1.00** DOWN

Brings this 1/8 H.P. SpeedWay Electric Drill

No 1/4 inch drill will drill a hole faster or cleaner than the SpeedWay. Therefore our challenge—"try to stall it." Think of the hundred-and-one jobs you can do with this handy, portable drill. A money maker and a time saver. Universal motor. Operates from any light socket and we furnish 7-foot connector cord. Switch under operator's finger.

FREE—3 DRILL BITS

If you order direct from this announcement, we will include absolutely Free, 3 Drill Bits, size 1/4 in., 3/8 in., and 1/2 in., thus giving you a complete outfit with no extras to buy.

SEND THIS COUPON AND \$1.00

Order at once and we will ship direct to your home with transportation prepaid. Our special direct-to-you rock bottom price is far below any other portable electric drill now on the market. Satisfaction guaranteed or your money back.

R. G. HASKINS CO.

Dept. 248-516 W. MONROE ST. CHICAGO

R. G. HASKINS CO.,

Dept. 248-516 W. Monroe St., Chicago.

Gentlemen: I enclose \$1.00. Send me the SpeedWay Electric Drill. When delivered, I will pay the postman \$18.75 for the drill; you are to include the 3 Drill Bits Free.

Name.....

Address.....

Genuine Bargain SALE



Smartly tailored, handsome, stylish broadcloth Dress Overcoat. FUR LINED—FUR COLLAR. Manufactured to sell for \$75.00 and up. For this sale ONLY

\$37⁷⁵

Delivered to you all charges prepaid with privilege of examination. See for yourself what an extraordinary bargain you get. Order quick for this bargain offer won't last long. Simply send the size of overcoat you now wear and tell us whether you are stout, medium or thin. Write me personally.

JOSEPH B. SHAPIRO, General Manager
ROSANN MANUFACTURING COMPANY
1025 Capitol Building Chicago, Illinois
Manufacturers and Distributors

Certified Leaks

Absolutely accurately calibrated, permanent fixed resistance units from 1/4 to 10 megohms. Price 50c.



VARIOHM, a variable grid leak will give you exactly the correct grid resistance. Any resistance from 1/4 to 30 megohms. Once set is permanent. Price 75c.



USE THE AUDIOHM for clarity and volume control. Put one across the secondary of your transformer. Price \$1.50 with adjustable bracket.

GET DISTANCE CLARITY VOLUME

Stop the leaks, stop the distortions in your set that are preventing you from getting distant stations clear and loud. A money back guarantee that any set will be improved by Electrad products.

Electrad products on sale at most all reliable radio stores. Sold direct if your dealer cannot supply you. Money back guarantee.



LEAD-IN. Don't ruin your window frames or sills. Use an Electric Lead-in. Guaranteed 3000 volt test. Insulation not skimmed. Fits under closed windows. Can be bent any shape. Fahnestock clips. Soldered connections.

ELECTRAD Inc.
Dept. 5F, 428 Broadway, New York

Special Offer

\$6⁹⁸

Regular Value \$10.00



Write for our Free Bargain Catalog of men's, women's and children's clothing and shoes. Everything on small monthly payments.

\$1⁰⁰ Down!

All Wool Heavy Jumbo Sweater Coat

Send only \$1.00 with the coupon for this All-Wool—heavy jumbo sweater. Money back instantly if you ask for it. Order NOW!

Heavy Pure Wool

This is a splendid big sweater at a bargain price. Every fibre pure wool. Heavy rope stitch. Large fashioned shawl collar. Two large lined pockets. Close knitted wristlets. Ivory buttons to match. Made in big, full size, in rich fast colors. Nothing so practical for fall and winter wear. Sold by most stores for \$10.00, all spot cash. Sizes 34 to 46. Colors: Maroon, Navy Blue or Seal Brown.

Order by No. F-12. Send \$1.00 with coupon; \$1.00 monthly. Total, \$6.98.

Six Months to Pay!

Buy the Elmer Richards way, on credit, as thousands of well satisfied men do. Everything you need in clothing or shoes and you pay in small monthly sums. Open a charge account with us. Let us send you this heavy all-wool Sweater. See for yourself what a big value it is—think how comfortable it will be on cold days. Then—if satisfied—pay only \$1.00 a month

Send Coupon before it is too late

Don't miss this bargain. The supply is limited. You take no risk. We stand back of this sweater. Money back if you say so. Send the coupon now with \$1.00. Don't be too late for this Special Offer. Send the coupon NOW.

Elmer Richards Co.
Dept. 1778
West 35th St., Chicago

Elmer Richards Co., West 35th Street, Dept. 1778 — Chicago, Ill.

I enclose \$1.00. Send All Wool Sweater, No. F-12. If I am not delighted with the sweater, I may return it and get my money back. Otherwise I will pay the bargain price on your terms; \$1.00 with coupon, and only \$1.00 monthly. Total price, \$6.98.

Size Name

Maroon Address

Navy Blue

Seal Brown

Post Office State

I have lived And before
in this town years that I lived in

For years. Rent Own or Nationality
Present or Color

Occupation Age Married
Give names of merchants who know you personally Single

Name Town State

Name Town State

If you have ever bought goods on credit by mail, tell us from whom. If there is anything else you wish to tell us about yourself, write on a piece of paper and enclose it with this coupon. But the coupon alone, fully filled out, will do. That's all we want to know and we're ready to send the sweater at once. No red tape. No C. O. D.

Tools for radio building

Half the fun of having a radio is in building it yourself. Here are a few essential tools that every radio fan should own.

Sensitive Drill No. 656. Price \$2.30

The handiest tool ever designed for drilling small holes in and behind radio panels where space is congested.

The forward and backward movement of the traveling handle drives the spiral and chuck continuously to the right. The all-steel chuck holds all round-shank drills from 0 to $\frac{3}{4}$ inch.

"Hex" Socket Wrench Set No. 673. Price \$1.50

Has three interchangeable "hex" sockets $\frac{3}{16}$, $\frac{3}{8}$ and $\frac{1}{4}$ inch between flats. Also a four-jawed socket for tightening and loosening thumb screws on dry cells, etc.

Square end of shank is split and spread so that sockets are held tightly. Sockets are drilled sufficiently deep to allow plenty of room for screw ends.

Tool Set No. 674. Price \$2.40

Wrench set as described above with additional equipment of a $6\frac{1}{2}$ inch and an 8 inch slim screwdriver for binder screws, etc.

Countersink No. 652. Price 40c

Made with round shank to fit three-jawed chucks of $\frac{1}{4}$ inch capacity or more (such as the No. 656 Sensitive Drill shown above).

This is a two-lipped cutter with unusually large chip clearance. Cuts fast in bakelite, fibre, iron, copper or wood.

GOODELL-PRATT COMPANY
GREENFIELD, MASS., U. S. A.

Toolsmiths

Makers of Mr. Punch



No. 656



No. 652



No. 673

GOODELL-PRATT

1500 GOOD TOOLS

Marshall ⁴ and ⁵ Tube Sets

The Greatest Advance yet made in RADIO

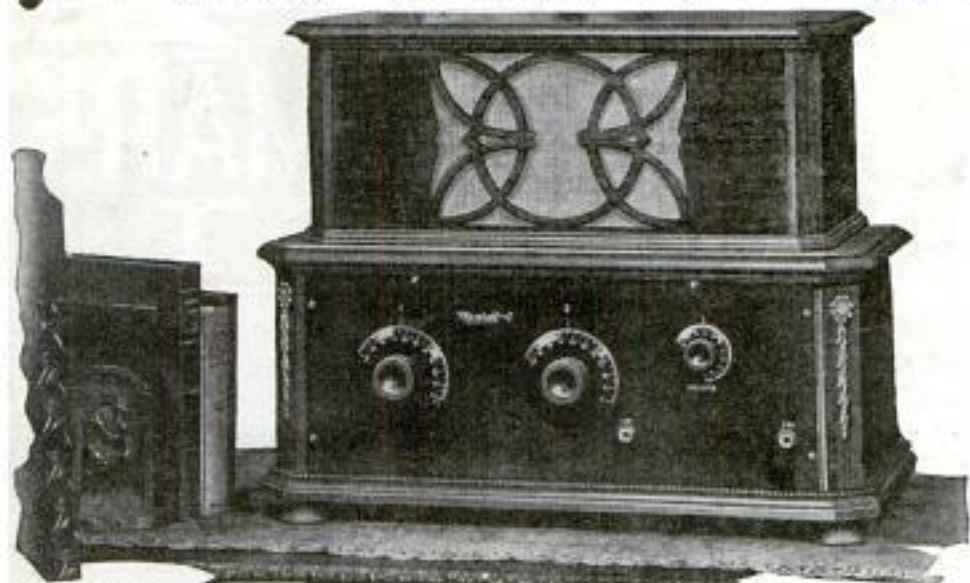

Solid Mahogany Cabinets of unique and artistic design

Sold with or without the Loud Speaker Combination

This Beautiful Marshall 4 Tube Non-Oscillating Receiver *only \$5⁰⁰ DOWN*
Complete with all accessories

WRITE TODAY for full particulars of this most exceptional offer. Marshall Sets embody the very latest improvements known to radio. They are licensed under Pfanstiehl Patents Pending, and utilize the wonderfully efficient Pfanstiehl Non-Oscillating System.

This discovery of Carl Pfanstiehl is the big sensation of the 1924-25 radio season. It brings the first real improvement over the Neutrodyne, Superhetrodyne, Regenerative, and Reflex circuits. It is positively non-regenerative. It brings to radio a new degree of musical quality. Its selectivity will delight the experienced radio operator. Yet it is so easy to tune that the novice will handle it like an expert.

Small Monthly Payments—2 Weeks Free Trial

That is the remarkable offer we are prepared to make you. Two weeks to prove that the outfit you select is everything we have said for it. If it doesn't make good our claims, back it comes, and your deposit will be cheerfully refunded. But if it fulfills all your expectations, you may pay for it in easy monthly installments. You don't risk a cent when ordering from us. You *must* be satisfied, or we don't do business.

Is it any wonder that radio buyers, the country over, are rushing to take advantage of such an offer? If YOU are interested, figure on getting your order in early, while prompt shipment can be made. Everyone predicts a serious shortage of radio supplies this season. Send for full particulars today.

Beautiful Solid Mahogany Cabinets

Just compare the beautiful outfit pictured above with the usual radio box and horn! The speaker cabinet appears as part of the combination unit. Designed by a master designer—fashioned of the finest solid mahogany, it will harmonize with the furnishings of the finest homes. Yet through our different way of merchandising, you get this exceptional cabinet value—plus the unequalled mechanical qualities of the Marshall set—plus easy terms—you get them all for actually less money than ordinary sets sell for on a cash basis.

Complete Outfits If Desired

In buying from Marshall, you have the choice of a set complete with all accessories, or the set alone. You have choice of dry cell or storage battery outfits. Unless you already own the accessories, you can buy them from us at less-than-market prices, with your set, on easy terms. Your outfit will come all ready to set up and operate within a few minutes—saving time and trouble—and saving money, too.

MARSHALL RADIO PRODUCTS, INC.
 Marshall Blvd. and 19th St., Dept. 13-58 Chicago, Ill.

Send Coupon for Special Offer!

If you have any idea of buying a radio set this year, don't let this chance slip by. Our terms and liberal guarantees have set a new pace in the radio business. The low prices we will make you on a 4 or 5 tube Marshall set will surprise you. A letter, postcard, or just the coupon will do. But send it today.

We also have a most favorable offer for radio dealers. Write.

Marshall Radio Products, Inc.
 Marshall Blvd. and 19th St., Dept. 13-58 Chicago

Please send me your special offer price, terms and full description of Marshall Radio Outfits. Though I may change my mind on receiving your proposition, my preference now is for a:

.....4 Tube5 Tube (Please check)

Name

Address

PATENT TRADE MARKS PROTECT

ANY NEW article, machine, design or improvement thereof, or any combination of parts or improvements in any known article which increases its efficiency or usefulness, **may be patented**, if it involves invention.

IF YOU HAVE ANY NEW IDEAS

which you feel are useful, practical and novel, **take prompt action to protect your rights**. If you have invented any new machine, or new combination of parts or improvement, or any new design or process, **SEND DRAWING, MODEL OR DESCRIPTION** of it for information as to procedure to secure protection.



DRAFTING and SPECIFICATION ROOM of CLARENCE A. O'BRIEN, Registered Patent Lawyer, Washington, D. C.

All Communications are held in strict confidence. My personal, careful and thorough attention is given to each case. I offer you efficient, reliable and prompt service—based upon practical experience. **Highest references.**

NO CHARGE FOR ABOVE INFORMATION

Clarence A. O'Brien

REGISTERED PATENT LAWYER

Member of { Court of Appeals, District of Columbia, United States Court of Claims;
Bar of { Supreme Court of United States, Supreme Court, District of Columbia

Practice Confined to Patents, Trade Marks and Copyrights

NTS

COPYRIGHTS YOUR IDEAS

WRITE TODAY FOR FREE BOOKS,

"How to Obtain a Patent" and "Invention and Industry"

These books will give you valuable information, and they may save you much time and effort. **Send for them, NOW.** My practice is devoted **exclusively** to United States and Foreign Patents and Trade Marks. Write me freely, frankly and with full confidence; it is very probable that I can help you.

WRITE TODAY FOR **BLANK FORM "RECORD OF INVENTION"**

USE THE COUPON attached, and immediately upon its receipt I shall send you this form to be returned to me with drawing, description or model of your idea; promptly upon receiving your idea I shall write you as to procedure and costs.

FREE COUPON

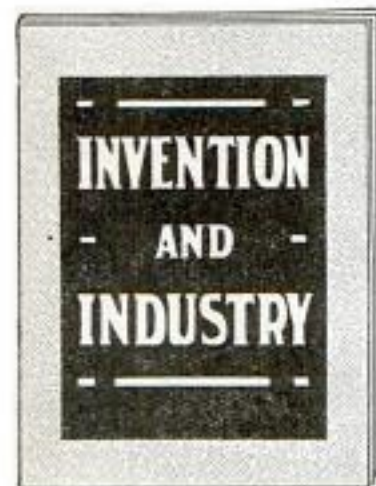

CLARENCE A. O'BRIEN
Registered Patent Lawyer

708 Security Savings & Commercial
Bank Building
Directly Across Street from Patent Office
WASHINGTON, D. C.

Please send me your free books, "HOW TO OBTAIN A PATENT" and "INVENTION AND INDUSTRY" and blank form, "RECORD OF INVENTION," without any obligation on my part.



Name.....

Address.....

IMPORTANT — WRITE OR PRINT NAME CLEARLY.



Our New York Office
Suits 1007 Woolworth Bldg.



Our Philadelphia Office
Suits 714-15 Liberty Bldg.



Our Washington Office
Victor Building

PATENTS TRADE-MARKS AND COPYRIGHTS

Have You An Idea?

Our Offer: No Charge for Examination and Instructions
Protect Your Invention

Your first step before disclosing or submitting your invention to anyone either for entry in a prize competition or for sale should be to write for our blank form

"RECORD OF INVENTION"

This should be signed and witnessed and returned to us together with model or sketch and description of the invention for examination and instruction and to establish Evidence of Conception.

No charge for the above information.

**Our Four Books Mailed
Free to Inventors**

Our Illustrated Guide BOOK

How to Obtain a Patent

Contains full instructions regarding U. S. Patents. Our Methods, Terms, and 100 Mechanical Movements illustrated and described.

Our Trade Mark Book

Shows value and necessity of Trade Mark Protection. Information regarding *Trade Marks and unfair competition in trade.*

Our Foreign Book

We have Direct Agencies in Foreign Countries, and secure Foreign Patents in shortest time and lowest cost.

Progress of Invention

Description of World's Most Pressing Problems by Leading Scientists and Inventors.

We Regard a Satisfied Client as our best advertisement, and furnish anyone, upon request, lists of clients in any state for whom we have secured patents.

**Highest References—Prompt Attention
—Reasonable Terms**

VICTOR J. EVANS & CO.
PATENT ATTORNEYS

Main Offices: 956 9th St., N. W., Washington, D. C.

Opposite U. S. Patent Office

PATENTS TRADE-MARKS AND COPYRIGHTS

IMPORTANT

Do not submit your invention to anyone before you furnish proof that the invention is patentable or application has been filed. In order to have **YOUR CASE MADE SPECIAL TO AVOID DELAY** you should take the precaution of having your case made **Special** in our office to secure protection, save correspondence and secure early filing date in Patent Office. To secure special preparation of your case send \$25.00 on account with model, sketch and description.



MAIN OFFICE, VICTOR J. EVANS & CO.—VICTOR BUILDING, WASHINGTON, D. C.

All Communications and
Data Strictly Confidential.
Interference and Infringe-
ment Suits Prosecuted

OUR ORGANIZATION OFFERS PERSONAL SERVICE

by registered attorneys at law members
of Bar of U. S. Supreme Court, Court
of Appeals, Supreme Court of D. C., and
U. S. Court of Claims.

**FREE
COUPON**

**VICTOR J. EVANS & CO.
PATENT ATTORNEYS**

NEW YORK OFFICES
1907 Woodworth Bldg.

CHICAGO OFFICES
1114 Tacoma Bldg.

PHILADELPHIA OFFICES
714-715 Liberty Bldg.

PITTSBURGH OFFICES
514 Empire Bldg.

SAN FRANCISCO OFFICES
Hobart Bldg.

MAIN OFFICES: 956 9th Street, N. W., WASHINGTON, D. C.

Gentlemen: Please send me *Free of Charge* your books as described on preceding page.

Name

Address



Our Chicago Office
Suite 1114 Tacoma Building



Our Pittsburgh Office
Suite 514 Empire Building



Our San Francisco Office
Suite 1010 Hobart Building

PATENTS

*Seventy-eight
Years of Practice*

THE firm of Munn & Company filed its first application for a patent in 1846, and for seventy-eight years has endeavored to keep pace with the inventive genius of the United States.

An experience of many years is at your disposal. If you have an invention which you wish to patent, send your sketches or model together with a description of your device, explaining its operation, and you will receive prompt, courteous attention.

*Write for our Handbook on
PATENTS*

A full and complete booklet on Patents, Designs, Trade-Marks, Foreign Patents, Copyrights, Labels and Patent Office Practice with an explanation about our methods, terms, etc.

All communications strictly confidential.

Keep in touch with the inventions of the world by reading

SCIENTIFIC AMERICAN

The MONTHLY MAGAZINE with a special appeal to every man of inventive genius. Recent rulings of the Patent Office, descriptions of the latest patented inventions, legislation and court decisions affecting patents, are noted in this authoritative publication.

MUNN & COMPANY
Patent Attorneys

672 Woolworth Building, New York
Scientific American Bldg., Washington, D. C.
1301 Tower Bldg., Chicago, Ill.
Hobart Bldg., 582 Market St., San Francisco, Cal.
Van Nuys Building, Los Angeles, Calif.

PATENTS

To the Man with an Idea

I offer a comprehensive, experienced, efficient service for his prompt, legal protection and the development of his proposition.

Send sketch, or model and description, for advice as to cost, search through prior United States patents, etc. Preliminary advice gladly furnished without charge.

My experience and familiarity with various arts frequently enable me to accurately advise clients as to probable patentability before they go to any expense.

Booklet of valuable information and form for properly disclosing your idea free on request. Write today.

Richard B. Owen, Patent Lawyer
9-303 Owen Building, Washington, D. C.
2276-E Woolworth Bldg., New York City

BLUE BOOK ON PATENTS

gives instructive information and candid advice.
MONROE E. MILLER, PATENT LAWYER
411-2 Ouray Building WASHINGTON, D. C.
ELECTRICAL AND MECHANICAL EXPERT

PATENTS

As one of the oldest patent firms in America we give inventors at lowest consistent charge, a service noted for results, evidenced by many well known Patents of extraordinary value. Book, *Patent-Sense*, free. Lacey & Lacey, 646 F St., Wash., D.C. Estab. 1869.

PATENTS

C. L. PARKER
Formerly Member Examining
Corps, U. S. Patent Office
PATENT LAWYER
MCGILL BLDG.
WASHINGTON, D. C.

Patents, Trade Marks, Copyrights, Patent Litigation

Handbook for Inventors, "Protecting, Exploiting and Selling Inventions," sent free upon request.

Have You An Invention?

If so the WORLD PROGRESS will show you how to
PROTECT AND PROFIT FROM YOUR IDEAS
Sample copy free. One year's subscription \$1.00.
Send for free book,

"WHAT TO INVENT"

containing SUGGESTIONS TO INVENTORS as to Inventions Needed. We invite manufacturers to address us regarding inventions they want.

WORLD PROGRESS PUB. CO., Inc.
Room 203 Victor Bldg. WASHINGTON, D. C.

PATENTS

Booklet Free Highest References Promptness Assured Best Results

Send drawing or model for preliminary examination

ALL BUSINESS GIVEN PROMPT AND PROPER ATTENTION

WATSON E. COLEMAN, Patent Lawyer, 644 G St., Washington, D. C.

PATENTS

Patent Litigation
Trade Marks
Copyrights

Handbook of instructions, "How to Protect Inventions," sent free on request.

R. H. FRAVEL, Patent Lawyer

Formerly of the U. S. Patent Office Examining Corps

Room 1503, McLachlen Bldg., WASHINGTON, D. C.



PATENTS

Send us sketch or model for free patentability opinion and exact cost of patent. Our book "How to Obtain a Patent" sent free on request. It tells how to apply for Patents, Trade Marks, Foreign Patents, Copyrights, etc.; gives information on Patent Procedure; tells what every inventor should know. Thousands of inventors, who are our clients, are our references.

CHANDLEE & CHANDLEE, 25 Years' Experience
473 7th St. Washington, D. C.

PATENTS

Trade-Marks, Copyrights and Patent Litigation

Write for advice and instructions how to proceed, costs, etc. Hand Book with illustrations of 100 Mechanical Movements sent free on request.

ALBERT E. DIETERICH

Patent Lawyer and Solicitor

Successor to Fred G. Dieterich & Co. 621A Ouray Bldg., Washington, D. C.

PATENTS

REGISTERED PATENT ATTORNEY SINCE 1905
CHARLES W. LOVETT SECURITY BLDG. LYNN MASS.
SEND FOR FREE BOOKLET

U.S. PATENTS



SEND FOR THIS FORM

**DON'T LOSE YOUR RIGHTS
TO PATENT PROTECTION**

Before disclosing your invention to anyone send for blank form "EVIDENCE OF CONCEPTION" to be signed and witnessed. A sample form together with printed instructions will show you just how to work up your evidence and establish the same before filing application for patent. As registered patent attorneys we represent hundreds of inventors all over the United States and Canada in the advancement of inventions. Our schedule of fees will be found reasonable. The form "Evidence of Conception," sample, instructions relating to obtaining of patents and schedule of fees sent upon request. Ask for them—a post card will do.

PATENTS AND TRADE MARKS

LANCASTER & ALLWINE

Registered Patent Attorneys In U. S. and Canada.

480 Ouray Bldg., WASHINGTON, D. C.

Originators of forms "Evidence of Conception."

INVENTORS PROTECT YOUR IDEAS

Send for our Guide Book, **HOW TO GET A PATENT**, and Evidence of Invention Blank, sent Free on request. Tells our terms, methods, etc. Send model or sketch and description of your invention for our Examination and Instructions without charge.

RANDOLPH & CO.

300 Victor Bldg., WASHINGTON, D. C.

NAME

STREET

CITY STATE

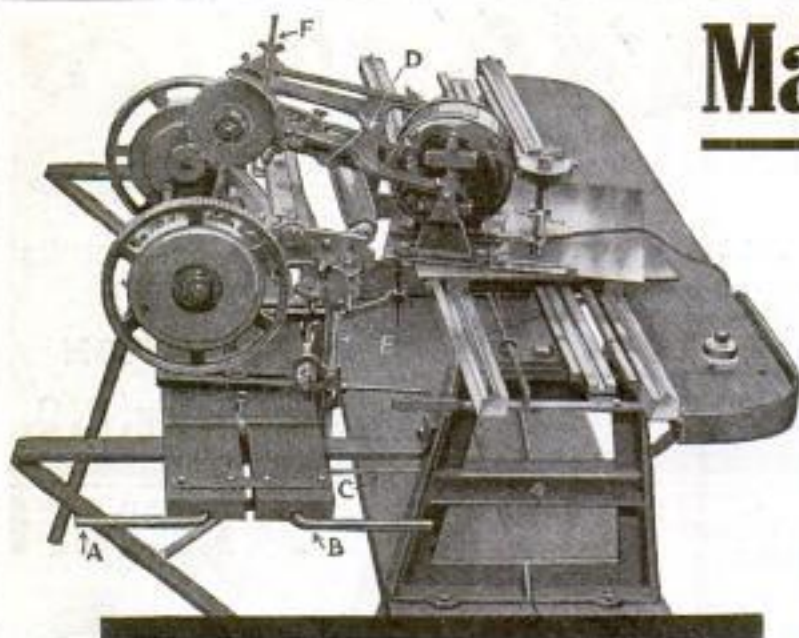

Make \$2000

OWN A BUSINESS OF YOUR OWN

Write today for our Big Profit Plan

A "Little Savage" GRINDER

will make BIG MONEY for you grinding Lawn Mowers, sharpening Skates, Tools and Cutlery

Sharpens quickly, scientifically, accurately. Anyone can operate it. Start in your own home. Soon have a shop of your own.

The "LITTLE SAVAGE" handles any size reel. Track bed, 54 in., 1/4 H. P. Motor, 5" and 6" emery wheel.

Write now for free information and how you can realize big money with this wonder Machine

BROWN MANUFACTURING COMPANY, Greeneville, Tennessee

Western Representative: A. L. BERRY & CO., 68 West Monroe, Chicago, Ill.

Canadian Representative: STEEL SPECIALTIES FOR CANADA, LTD., 1835 D Ontario St.



5 SIZE TAP AND DIE SET, ONLY \$3.00 FOR THE HOME - THE FARM - THE WORKSHOP DIRECT FROM THE FACTORY TO YOU!

Our No. 12 Automobile Set furnished in our highly finished chestnut box contains 5 each taps and dies (1-4, 5-16, 3-8, 7-16 and 1-2"), in the S. A. E. thread, 1 die stock, and one tap and reamer wrench.

Our No. 11 Set is the same as No. 12 except that the thread is U. S. S. instead of S. A. E. You are purchasing a splendid set at a very low figure.

Send us your order at once and be one of our many satisfied customers

LET US SEND YOU A CIRCULAR

Worcester Steel Products Co., Dept. 40, 25 Union St., Worcester, Mass., U. S. A.



Buchstein's Fibre Limb

is soothing to your stump—strong, cool, neat, light. Easy payments. Braces for all deformities.

D. BUCHSTEIN CO.

610 3rd Ave., So., MINNEAPOLIS, MINN.

Send for Catalog Today

Why Burn Coal

or wood when you can burn gas in your stove or heater by installing a 1925 Improved Uni-Hot Kerosene Burner in five minutes time. It gasifies common kerosene to the hottest and cheapest fuel known. Does away with dirt and high fuel cost. Heat regulated to any degree by valve. Increases stove efficiency 100%. Has brought joy and economy to thousands. FREE TRIAL. Saves its cost in 30 days. Write quick for full particulars and introductory price.



Agents Big profit. Sells on sight. Write today for free sample offer and territory.

Acorn Brass Mfg. Co., 1167 Acorn Bldg. Chicago, Ill.

Build YOUR OWN TRAILER

Build your own camping trailer. Send 50c for complete plans, instructions and price list of genuine "Auto-Kamp" parts. You can build a high grade, serviceable trailer at home during your leisure time and save money by using our parts.

AUTO-KAMP TRAILER CO., SAGINAW, MICH.
Mfgs. of the Famous "AUTO-KAMP" TRAILER

Hand Forged Razor Steel Blades, No. 57



Direct at Factory Prices

This \$2 KNIFE \$1.18 Postpaid
Hand Forged Razor Steel Blades
Handy shaped Blade makes this knife best for mechanics, sportsmen and farmers; light but strong; re-sharpened easily. Stag handle. German silver finish; blades fit tested, hand forged from razor steel and warranted.

Sample \$1.18 3 for \$3.00 Postpaid.

Send for our 100-page List and "HOW TO USE A RAZOR" FREE

MAHER & GROSH CO., 106 A St., Toledo, Ohio

HEAT Without Coal!

An amazing new invention that does away with Coal and Wood in Stoves, Ranges, and Furnaces. Manufactured by the old, reliable INTERNATIONAL HEATING CO. Cost surprisingly low. Without waste, it burns Instant-Gas, a safe, superheated mixture of cheap fuel-oil and air.

THE FIRST INEXPENSIVE FURNACE OIL BURNER WITH LOW OPERATING COST

Here is a Furnace Oil Burner that is "different!" Does all the work of the complicated, high-priced Burners, but at far less cost. Thousands of delighted users all over the country hail it as the greatest Oil Burning Device of the age. Hundreds more are enthusiastically installing it every day because of its amazing simplicity, efficiency, and unequalled economy.

Write for 30 Day Free Trial

The new INTERNATIONAL Burner fits any hot air, steam or hot water furnace, and is the cheapest to install and operate. Burns without waste most economical fuel known, 96% air and 4% oil. The new INTERNATIONAL has no noisy motors, no moving parts, nothing to get out of order; action purely automatic, eliminating odors and smoke. The new INTERNATIONAL is always ready and safe. Cost unbelievably low. Installation quick and easy without damage to furnace. Can be moved if you move. Try the new INTERNATIONAL, and you'll never use any other. Low introductory price and 30 day free trial offer to those who write at once. This offer is for limited time only.

FITS ANY STOVE, RANGE OR FURNACE

Recommended and endorsed by leading institutions. Given highest rating.



Thousands of testimonials from 48 states.

It's amazing what this new burner can do. Four special models of this wonderful invention are made to fit any heating stove or range. Simply sets in firebox, and transforms oil and air into Instant-Gas, giving three times the heat of coal, and cheaper. Can be turned on or off in a jiffy. Better cooking and baking. Installed in five minutes; no damage to stove. Absolutely safe; lasts a lifetime. Sold on money-back guarantee. Over 60,000 INTERNATIONAL Burners in use. Write today for 30 day free trial offer and Free Book, "Scientific Oil Burning." Specify whether for stove or furnace. Use coupon for quick action.

INTERNATIONAL HEATING CO.

Dept. 2-K, 117 So. 14th St.

ST. LOUIS, MO.



The International's combination safety and indicator valve, approved by Underwriters Laboratories of National Board of Fire Underwriters.

AGENTS WANTED

Agents, distributors and salesmen wanted at once. Write or wire for exclusive free territory quick. Now is the time to get started—jump into this immediately for a big season. Hundreds of men and women are making big money with the new INTERNATIONAL Burner. Adrian of Pennsylvania made \$150 the week after he started, Fleurant of Rhode Island made \$90 the first week, so did Clark of Nebraska. Palley of Iowa made \$65 in three days. Bible of Wyoming earned \$30 in two hours. Meade of Mexico made \$126 in one day. Arnel of California runs up \$40 in two days, and hundreds of others are cashing in big with the new INTERNATIONAL Burner. Highpowered salesmanship not necessary. The new INTERNATIONAL practically sells itself. Write at once for free sample offer and special agents' proposition.

INTERNATIONAL HEATING CO.,
Dept. 2-K, 117 So. 14th St., St. Louis, Mo.
Mail me, postpaid, your Free Book, "Scientific Oil Burning" and further information about your burner for:—

..... Stoves For agent's sample offer, place (2) below.

..... Furnaces
(Check style desired)

Name.....

Street or P. O. Box.....

City..... State.....

TOPS

Ford Touring Top and Back Curtain

32 oz., \$5.25; 36 oz., \$6.25; Side Curtains, \$5.95; Door-Opening type, \$6.95; Back Curtain, regular, \$2; Gypsy type, \$4. Ford One-Man Top, fits 1915 to 1922 model, all new bows and side curtains, \$25. Chevrolet, Dodge, Overland 4 tops, 34 oz., \$9.75; double texture, \$12.25. 6x18 glass Gypsy Curtain extra, \$2. Tucks, etc., furnished ready to put on. Delivered 1000 miles. Vanderpool's Top Factory, Dept. 11P, Springfield, Ohio

MORE PROFITS

To Dealers Who Buy Nationally Advertised Radio Goods from Our Bargain Catalog! Write for It Today!
AMERICAN RADIO CO.
Dept. 6 WEST 14th ST. KANSAS CITY, MO.

Write For Book About the Elto

3 H.P.—The Fastest "Light Twin"

Designed and built by Ole Evinrude
Weights less than 17 lbs. per H. P.

Gives half more power, much more speed, yet easy to carry. Instant starting without spinning. Safe rubber steering. Trouble-proof carburetor. Push button reverse, without danger of tipping boat. The ideal family motor. Fits carrying case without taking apart. Write for catalog.

ELTO OUTBOARD MOTOR COMPANY
Manufacturers' Home Bldg.,
Dept. AA, Milwaukee, Wis.



1/2
More
Power—
Much
More
Speed





Ward's Radio Catalogue

Write for your FREE copy

We want you to have a copy of Ward's new Radio Catalogue.

You will find it a storehouse of information — a dependable guide to the newest and most important radio developments.

It shows all improved parts and diagrams of the best hook-ups for the man or boy to build his own set, as well as the very best ready-built sets at surprisingly low prices.

Montgomery Ward & Co. are Headquarters for *everything* in Radio. And this Catalogue shows complete — everything in Radio

equipment. Remember we sell only standard goods — direct to you by mail, and without the usual Radio profits.

For 52 years, "Satisfaction guaranteed or your money back," has stood behind every Ward sale. At Ward's, quality is never sacrificed to make a low price.

Write for your copy of this 68-page Radio Catalogue. See for yourself the low prices. You may as well profit by the savings it offers.

Address our house nearest you: Dept. 6-R

ESTABLISHED 1872
Montgomery Ward & Co.

The Oldest Mail Order House is Today the Most Progressive

Chicago Kansas City St. Paul Portland, Ore. Oakland, Calif. Ft. Worth



The World's Greatest Watch—Bar None

The New Marine 21 Jewel Special!

21 Selected Jewels
Adjusted to Temperature
Adjusted to Positions
Adjusted to Isochronism
Adjusted to The Second

*A Special Product of the
Great Illinois Factory*

*and Our Special Introductory
Price Saves You About Half!*

Do we mean that? Every word of it. Our price is the lowest in America on this standard, high-grade watch—so low, in fact, that we have agreed with the factory not to publish our special price broadcast for one year—but we will give it to you, if you send your name today. And in order to accommodate the greatest number of people, we go a step further, and upon request send you this watch on approval. And if you wish, you can

Pay Only \$5 a Month! Our offer is very simple. Nothing at all confusing. You get your choice of a great array of new-style gold cases and new-style art craft dials—all the same price. You get the watch at once. You get your choice of 12 or 16 size. You get it tax free. You have no red tape. You buy for less and get more. You have easy terms Free. You select on approval. You are always sure of a square deal.

Write for Catalog Today! We have thousands of accounts in all parts of the country. For a quarter of a century we have trusted wage-earners everywhere. We conduct a chain of stores—our volume enables us to buy for less and sell for less.

Send your name today, and see how much you can save.

HARRIS-GOAR CO., Dept. 361 **Kansas City, Mo.**



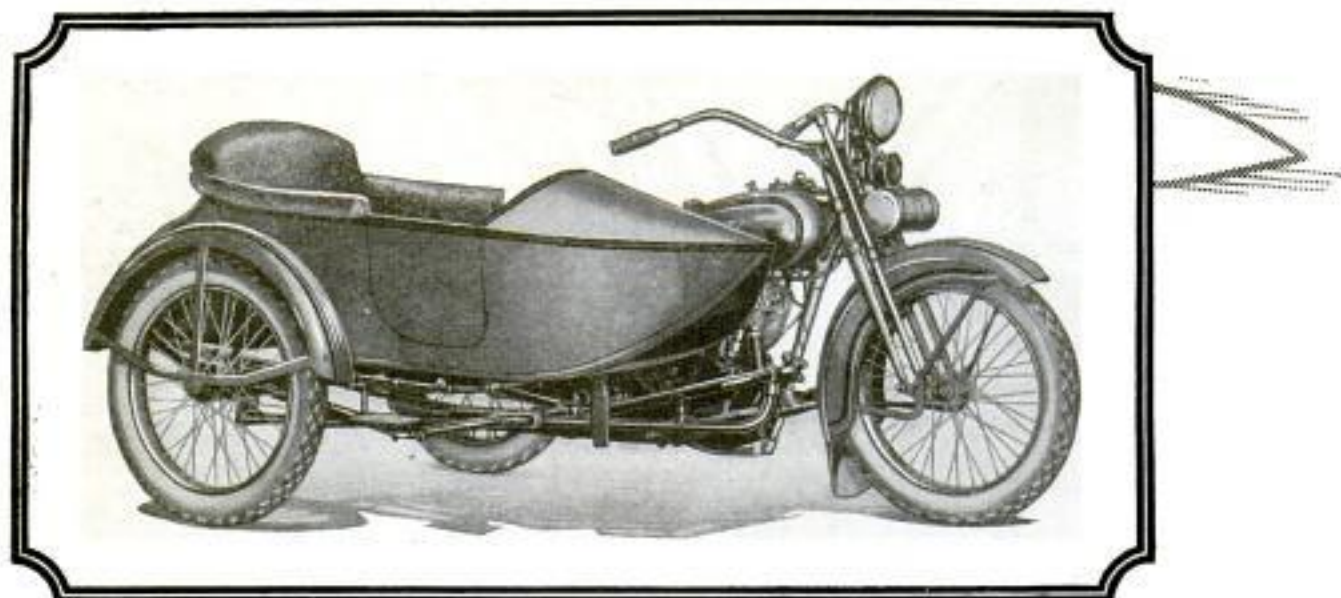

New
Low Riding
Position

Classiest Mount on the Road— the New "Stream-Line"

New
Truss-Loop
Frame

HAVE you seen the latest, greatest motorcycle—Harley-Davidson's 1925 "Stream-Line"? To see it is to crave to get in the saddle—to feel its pulsing, eager power. To ride it is to want it—want it for its thrilling speed, its greater comfort, its rakish, stream-line beauty.

New
Riding
Comfort

Improvements—27 of them—make the "Stream-Line" the motorcycle sensation of years. Low hung for safety and easy control; better springs and bigger tires that give "Pullman comfort" to you and your sidecar pal; and the same economy that has made Harley-Davidson famous—50 miles for a dollar (gas, oil, tires and all)!

New
Larger Tanks

Ask your dealer for a free Demonstration Ride. Get the facts about his Pay-as-You-Ride plan. And send us the coupon (below).

New
Lower
Price

HARLEY-DAVIDSON MOTOR CO.

Dept. P.

MILWAUKEE, WISCONSIN

Money-making sales opportunities in open territory. Write for particulars.

Harley-Davidson The Motorcycle

Harley-Davidson Motor Co., Dept. P. Milwaukee, Wis.

Please send me free literature showing new "Stream-Line" Harley-Davidsons, in actual colors.

Name _____

Street or P. O. Box _____

City _____





Built Complete
in a Console
Type Cabinet
Like a
Phonograph

Hundreds of Sets in Use

There are hundreds of Trans-Continental Sets in use today. Read what some of their owners say.

H. M. Ross of West Virginia says: "I got Chicago, Kansas City, Detroit, Washington, Pittsburgh and others. Am delighted with the Trans-Continental."

E. C. Patterson of Texas, says: "My father gets local stations so loud he can hear them out in the yard. He also gets Chicago, Omaha, and all the strong stations on his loud speaker."

At Last!
the
RADIO
Set You Have Been
Waiting For
Trans-Continental
RADIOPHONE

No Outside Wires
No Storage Batteries
No Extras to Buy

The TRANS-CONTINENTAL RADIOPHONE, which is one of the most simple and clearest toned radio sets you have ever listened to, is the latest achievement of Mr. A. D. Coats of Chicago.

This radio outfit is entirely different from all others and just the kind of a set you have been waiting for. No outside wires needed. No troublesome storage batteries. It is built complete in a beautiful mahogany finished cabinet, Console type, with the loud speaker built right in so the entire

family can listen to it just like a phonograph. No unsightly wires, or batteries lying around—no wires to connect up—no extras to buy. Everything is inside the cabinet. It is a real piece of furniture. You can set this attractive Radio Set in any room in the house and it will harmonize with your best furniture perfectly.

Hear Music and Talking 1000 Miles Away

The TRANS-CONTINENTAL RADIOPHONE is guaranteed to have a range of 1000 miles and it will "tune in" stations covering all broadcasting wave lengths within a thousand mile radius of your home. It is a 4-tube set—yet so simple in construction, so compact in make-up—so loud and clear in tone, and yet so easy to operate that even a child can use it without any trouble whatever. Just imagine the unique pleasure of sitting with your family or

friends in your home with the Trans-Continental and listening to the musical concerts and speaking. Hear the Presidential speeches and election returns this fall. Get the weather and market reports, the football and baseball returns, the latest news bulletins. And best of all, The TRANS-CONTINENTAL is built in our own factory—sold direct to you without any middlemen's profits, at a price that is just about half what others ask for a similar outfit.

Special Introductory Offer

40% Off Regular Price on First Set Placed in Each Community

To quickly introduce his wonderful TRANS-CONTINENTAL Radiophone everywhere Mr. Coats will for a limited time make a special reduction of 40% in price on the FIRST outfit placed in each community. Send coupon or postcard today for descriptive folder and special introductory offer. Mr. Coats also has a proposition for agents that is a world-beater—his Demonstrator Agents make from \$60.00 to \$200.00 per week in spare time. Mail coupon today for full particulars.

A. D. COATS, President

Trans-Continental Radiophone Company
340 West 47th Street Chicago, Ill.

Be First-Mail this NOW

A. D. COATS, President
Trans-Continental Radiophone Co.
340 West 47th St., Chicago

Please send me complete information on your Trans-Continental Radiophone. Also full particulars about your 40 per cent discount offer.

Name

St. or R. F. D.

Town State

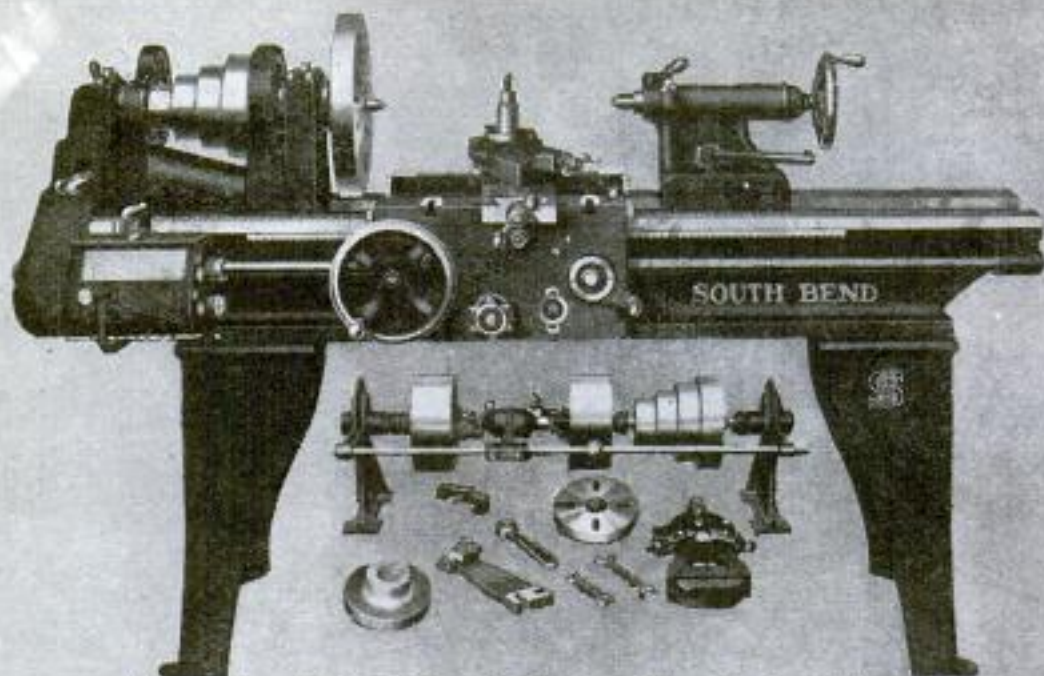

16" x 8' South Bend Quick Change Gear Lathe, \$498.00
WRITE FOR OUR EASY PAYMENT PLAN

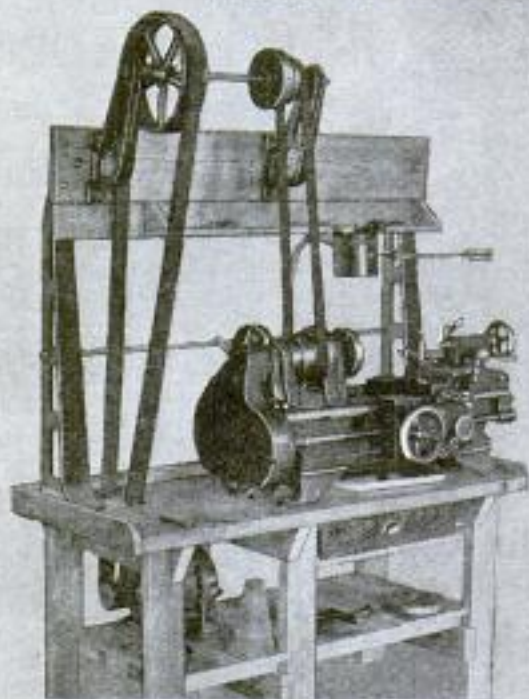

11" x 3½' Bench Lathe Unit
Complete with D. C. Motor, \$315.50
WRITE FOR OUR EASY PAYMENT PLAN

EASY PAYMENT PLAN

Our Easy Payment Plan allows you to install a South Bend Lathe in your shop, by making one payment with the order; the balance to be paid month by month, the amount depending upon the size of the Lathe.

South Bend Lathes are made in all sizes from 9" swing to 24" swing inclusive and in bed lengths from 2½' to 16' inclusive.

Write today for Catalog No. 82 which describes the Easy Payment Plan. Mention size of lathe desired.

SOUTH BEND LATHE WORKS

559 East Madison Street
SOUTH BEND, IND., U. S. A.

— 31,000 IN USE —

SOUTH BEND LATHES

EVEREADY
FLASHLIGHTS
& BATTERIES
-they last longer

For safety's sake—*use your flashlight!*

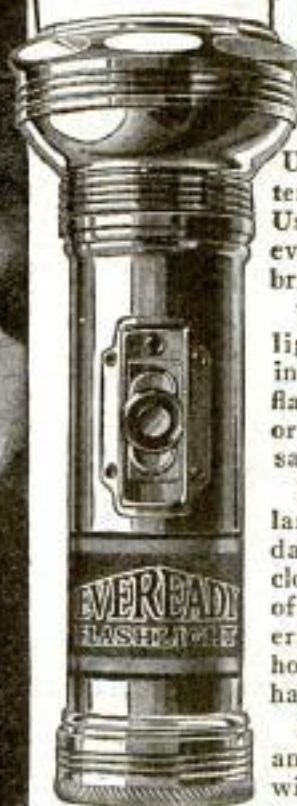

No. 2624—Eveready 3-cell Broad-beam Flashlight.

* *
Eveready Unit Cells fit and improve all makes of flashlights. They insure brighter light and longer battery life.



THE heavy, nauseating odor of gas. Leak in the line somewhere. Use your flashlight! Trace the deadly fumes to their source. Use your flashlight! (Meter-readers always do.) Use your Eveready wherever there is need for safe, brilliant, portable light.

You can safely poke a lighted Eveready right into places where an open flame would cause a fire or an explosion. So, play safe. Use your flashlight!

Use it on those dark cellar stairs. Use it in that dark attic. Flood that dark closet with the brilliance of high noon. Keep several Evereadys about the house. And keep them handy!

Reload your flashlights and keep them on the job with fresh, strong Eveready Unit Cells. And if you haven't a flashlight, see the nearest Eveready dealer at once.

Buy the improved Eveready Flashlights from electrical, hardware and marine supply dealers, drug, sporting goods and general stores, garages and auto accessory shops. 65c to \$4.50, complete with battery—anywhere in the U. S. A.

Manufactured and guaranteed by
NATIONAL CARBON CO., INC.
New York San Francisco
Canadian National Carbon Co.
Limited, Toronto, Ontario

FREE—25c Book on Wood Finishing



Tells You How To Finish Radio Cabinets

If you have a hobby for making cabinets, furniture, porch swings—radio boxes, etc.,—you will find our book invaluable. Naturally, you want to give your handiwork a beautiful finish. Our Book gives complete instructions for finishing all wood—hard or soft, old or new. It is the work of experts—beautifully illustrated in color. Gives covering capacities—includes color charts, etc. Use coupon below.

JOHNSON'S WOOD DYE (PENETRATING)

Johnson's Wood Dye is very easy to apply—it dries in four hours and will not rub off or smudge—penetrates deeply, bringing out the beauty of the grain without raising it. Made in seventeen popular shades, all of which may be easily lightened or darkened. Full directions on every label. Read and follow them.

Johnson's Wood Dye has many uses for both the artisan and amateur. *Architects* and *contractors* specify it for coloring woodwork and flooring in new buildings. *Painters* and *decorators* use it with equal satisfaction on new and old woodwork of all kinds. *Housewives* delight in it for doing over old furniture and for coloring reed and wicker baskets, etc. *Manual training teachers* and *pupils* use it for finishing their models. *Upholsterers*, *furniture repairers* and *cabinet makers* find it "just the thing" for their work—old and new.

Ask for a FREE copy of the Johnson Book on Wood Finishing at any store displaying the sign shown at right. If no store in your locality has a Johnson Service Department, mail this coupon to us.

DEALER'S NAME.....

Your Name.....

Address.....

City and State.....

Mail to

S. C. JOHNSON & SON, Dept. P. A. 11, RACINE, WIS.



S. C. JOHNSON & SON
"The Wood Finishing Authorities"
Racine, Wisconsin, U. S. A.

**This Book
FREE!**



There may be a fortune for you in this **FREE** book about Inventions

Invention is the easiest way to earn a fortune. Little ideas have made millions of dollars for their inventors. This wonderful book explains how fifteen famous inventors now teach you the secrets of successful invention — in your own home

HOW would you like to be the inventor of the Gillette Safety Razor, who makes **TWO AND ONE-HALF MILLION DOLLARS a year?** Wouldn't you gladly be the inventor of the snap fastener whose profits were so big that he paid an *income tax* of \$29,000? Wouldn't you willingly change places with the inventor of the President Suspenders who is now worth \$5,000,000?

Other inventors have made thousands of dollars from such common things as the crimped hair-pin, the metal tip shoe-laces, the paper safety match, the ordinary wire paper clip. These inventions are so simple that probably *thousands* of people thought of them but only *one* man DID anything about the idea when it came to him.

Proof YOU Can Invent

Perhaps even now you have splendid ideas for inventions but the only reason you have not developed them is because you believe you were not born to be an inventor; that inventors are men who invent things as naturally as other people work as bookkeepers, mechanics, doctors or farmers.

Invention is not guesswork or blind luck. Inventors themselves say that invention is based upon exact laws which *anyone* can learn. It is merely a matter of first *seeing* something to be fixed and then of *thinking* of some principle which will fix it. That is all—that is *everything* to invention. Brought down to its plainest definition, invention is merely the science of "fixing things."

What Edison Says

Could you ask the advice of any greater authority than Thomas A. Edison? He says: "*Invention is a Science and should be taught as a profession.*"

And now, for the first time, you can actually learn invention as a profession—exactly as other people are learning electricity, mechanics, law,

medicine. The Bureau of Inventive Science offers you the first course in practical invention ever devised. No special mechanical or technical training is needed. Fifteen famous inventors have written down the easy-to-learn principles of Inventive Science so that everybody can read them and learn to use them. The ability to invent was *born* in you. All you need to become successful is this easy, fascinating training which will develop your ability so it will be worth real money.

New FREE Book

This wonderful course teaches invention by actual practice right in your own home. With each lesson you are sent at least one practical problem in invention. This absorbing exercise in solving actual inventive problems sharpens your instinct to fix things and gives you an unforgettable, instinctive habit of thinking inventively which is worth more than you realize. The lessons and exercises are so simple, so easy to understand, so interesting that they seem more like a pleasant game than like instruction which can make you a successful inventor.

A wonderful new book, just printed, tells you more about the Bureau of Inventive Science and its simple new course in invention. It costs nothing, so send the coupon at once. This bureau is not connected with patent attorneys or manufacturers. Its only purpose is to teach you the principles of practical invention used by every successful inventor. Write for the FREE BOOK now. There may be a fortune in it for you.

BUREAU OF INVENTIVE SCIENCE

Dept. 311, Wisner Bldg. Rochester, N. Y.

BUREAU OF INVENTIVE SCIENCE

Dept. 311, Wisner Bldg., Rochester, N. Y.

Please send me your free book, "The Science of Invention."

Name..... Age.....

Address.....

City..... State.....

15 great inventors teach you every step in inventive science.

- How to develop your imagination
- How to develop your ideas
- How to get the facts you need for inventions
- How to keep legal records of ideas
- How to use scientific principles of mechanics
- How to avoid wasting time on impractical inventions
- How to apply for a patent
- How to organize a company
- How to protect your rights
- How to market a patent

and hundreds of other vitally important *facts* which EVERY successful inventor knows and uses.



Sweeney Graduates Make Big Money!

You can do it, too There Are Thousands of Big Money Making Opportunities for the Sweeney Trained Man

For fifteen years I have been training men by the Sweeney System—a method of practical training by tools instead of books. \$200,000 worth of equipment; \$50,000 Radio Station WHB. You don't need experience or education. But you've got to work in overalls and with greasy, grimy hands. Will you do that? I teach you by actual work, everything about automobiles, tractors, oxy-acetylene welding, vulcanizing, radio, electrical work. You get all this at the World's Greatest Trade School, the Million Dollar Sweeney School and you get it nowherelse. **I save you both time and money.**

\$250 Life Scholarship \$125

If you have JUST ENOUGH determination to better yourself, to clip the coupon or send a postcard and do it now, I will give you a \$250 Life Scholarship and a free Radio Course for \$125.00. This offer may be the turning point in your life. I dare you to investigate.

Send-this NOW

EMORY J. SWEENEY, President
Dept. M-31, Sweeney Bldg., Kansas City, Mo.

Send me free your 64-page Catalog and full particulars of your \$125.00 offer.

Name.....

P. O.

State..... Age.....

My Amazing Offer Never before have I ever made such an offer. I want you to write me quick. You won't need to wait any longer. I now mail it possible for you to come to this Million Dollar School right now. I further guarantee you the same expert practical instruction under skilled instructors that has made the Sweeney School World Famous.

FREE Just send me your name and I will send you my 64-page big illustrated book. I have put into this fascinating book a lifetime of mechanical experience. It is full of real pictures—shows how mechanics do all kinds of expert jobs. Lists the opportunities in the business. Tells just what to do—where to go—to make good. Explains step by step how to learn to be a skilled mechanic. Answers every question. Many a mother and father reading this book have been inspired to make sacrifices and help their sons out. Tells all about the world famous Sweeney System—adopted by U. S. GOVT. during the war to intensively train soldier motor mechanics. Shows how easy it will be for you to FIT YOURSELF for real job, independence and prosperity. I will send this to you free—no cost—no obligation. Write for it today. No colored students accepted. Answer this NOW!

E. J. SWEENEY, President

LEARN A TRADE -
Sweeney
AUTOMOTIVE & ELECTRICAL SCHOOL
M-31 SWEENEY BLDG. KANSAS CITY, MO.